

DOCUMENT RESUME

ED 103 638

CE 003 236

AUTHOR Doyle, Timothy C.; Enberg, Janice R.
TITLE An Inventory of Health Manpower Models: Volume II.
INSTITUTION Health Resources Administration (DHEW/PHS), Bethesda, Md. Bureau of Health Resources Development.; Vector Research, Inc., Ann Arbor, Mich.
REPORT NO DHEW-(HRA)-75-19
PUB DATE May 74
NOTE 313p.; For Volume One, see CE 003 235
EDRS PRICE MF-\$0.76 HC-\$15.86 PLUS POSTAGE
DESCRIPTORS *Delivery Systems; Evaluation; *Health Personnel; *Health Services; Human Resources; *Manpower Needs; Medical Services; *Models; Nurses; Physicians

ABSTRACT

Volume Two of the report presents an inventory of 56 models directly or peripherally related to health manpower supply and requirements problems. The report is organized into four main sections: (1) a description of the contents of the inventory, methods used in its development, model inventory descriptors, and model selection rationale; (2) a discussion of the health manpower model classification scheme used to categorize the models; (3) the inventory itself; (4) four indexes to assist in locating individual models: name of developer, data source, health manpower model bibliography, and input and output variables for each model category. Each description includes purpose and sponsor, scope and subject, model assumptions, model structure, inputs and outputs, computer characteristics, and modeling techniques employed. The majority of the models were found to have been developed using some form of regression analysis. The remaining models are a mixture of organization models or descriptive models. Classification by subject area indicates over one-half concerned with health care delivery organizations, less than one half with health manpower resources and consumer service behavior. Of the manpower models the majority are concerned with physicians or nurses. (Author/SA)

ED 070 708

U.S. DEPARTMENT OF HEALTH,
EDUCATION & WELFARE
NATIONAL INSTITUTE OF
EDUCATION

THIS DOCUMENT HAS BEEN REPRO-
DUCED EXACTLY AS RECEIVED FROM
THE PERSON OR ORGANIZATION ORIGIN-
ATING IT. POINTS OF VIEW OR OPINIONS
STATED DO NOT NECESSARILY REPRESENT
OFFICIAL NATIONAL INSTITUTE OF
EDUCATION POSITION OR POLICY.

AN INVENTORY OF HEALTH MANPOWER MODELS

Monographs and Data for Health Resources Planning Series

U.S. DEPARTMENT OF HEALTH,
EDUCATION, AND WELFARE
Public Health Service
Health Resources Administration
Bureau of Health Resources Development
May 1974

DHEW Publication No. (HRA) 75-19

Volume II

**AN INVENTORY OF HEALTH
MANPOWER
MODELS**

Final Report of Contract No. MI-24313 by Vector Research Inc., Ann Arbor, Michigan

The Division of Manpower Intelligence, contractor for this study, was dissolved as of March 1, 1974 in conjunction with reorganization of the Bureau of Health Resources Development (BHRD).

Inquiries concerning this material should be addressed to the Resource Analysis Staff, Office of the Bureau Director, BHRD, at the National Institutes of Health, 9000 Rockville Pike, Bethesda, Maryland 20014.

PREFACE

A major program objective of the Division of Manpower Intelligence during the 2½ years of its existence was the analysis of current and future health manpower resources and requirements. In pursuit of this objective, the Division engaged in the development and support of various modelling activities aimed at developing improved techniques and analytical tools. These activities were carried out both by Division staff and by contract studies.

The present report on work performed by Vector Research, Inc. for the Division of Manpower Intelligence under contract number MI-24313, "A Health Manpower Model Evaluation Study," consists of two volumes. This second volume presents an inventory of models directly or peripherally related to health manpower supply and requirements problems that were developed and/or results reported during the period 1960-73. The first volume contains a comparative analysis of problem areas in health manpower analysis and the subject matter treated by the models described in Volume II. It is believed that the information contained in this report should be of value to persons interested in health manpower analysis.

The material presented in Volume II was prepared by Timothy C. Doyle and Janice R. Enberg of the Vector Research, Inc.

Any conclusions and/or recommendations expressed herein do not necessarily represent the views of the Division of Manpower Intelligence, the Bureau of Health Resources Development, the Health Resources Administration, or the Department of Health, Education, and Welfare.

TABLE OF CONTENTS

	Page
1.0 INTRODUCTION.....	1
1.1 Document Retrieval and Model Descriptor Development...	2
1.2 Model Selection.....	4
1.3 Models Cataloged.....	8
2.0 A HEALTH MANPOWER MODEL CLASSIFICATION SCHEME.....	11
2.1 Classification Structure.....	15
2.2 Model Classification Problems.....	27
2.3 Model Classification.....	31
3.0 INVENTORY OF HEALTH MANPOWER MODELS.....	35
4.0 INVENTORY INDICES.....	287
4.1 Model Index by Principal Developer.....	289
4.2 Data Source Index.....	295
4.3 Health Manpower Model Bibliography.....	309
4.4 Input and Output Variables for each Model Category....	327
4.4.1 Population Dynamics Models.....	329
4.4.2 Educational Choice Models.....	329
4.4.3 Health Education Models - Administration.....	331
4.4.4 Manpower Resource Models - Manpower Pool (Aggregates).....	333
4.4.5 Manpower Resource Models-Labor Force Behavior..	335
4.4.6 Health Care Delivery Organization Models - Administration.....	336
4.4.7 Health Care Delivery Organization Models - Service Delivery.....	341
4.4.8 Consumer Service Behavior Models - Utilization Behavior.....	342
4.4.9 Incidence of Illness Models.....	345

1.0 INTRODUCTION

As a part of VRI's contract with the Bureau of Health Resources Development, VRI is to compile an inventory of models directly or peripherally related to health manpower supply and requirements problems. In order to accomplish this task VRI has: (1) completed a comprehensive search for material describing these models, (2) retrieved all available documentation identified as potentially relevant to this study, (3) developed a set of model inventory descriptors to characterize each model, and (4) constructed an inventory of health manpower models in terms of these descriptors. This technical report documents the results of these activities.

The report is organized into four main sections. The first or introductory section describes the contents of the inventory, methods used to develop the inventory, model inventory descriptors, and model selection rationale. In the second section a health manpower model classification scheme is discussed and used to categorize the models in the inventory. The inventory of health manpower models in terms of the model descriptors is presented in the third section. The final section consists of four indices to assist the reader in locating or describing individual models in the inventory, an index of the models contained in the inventory (ordered by surname of the developer), a data source index delineating the data sources used by the model builders, a model bibliography listing the documents relevant to the development of this inventory, and a list of model input and output variables organized in terms of the model categories presented in section 2.0.

1.1 Document Retrieval and Model Descriptor Development

Shortly after notification of contract award, VRI began an exhaustive review of all secondary and primary sources of health manpower model information. Journals, abstracts, and indices in the health, economic and engineering fields were searched for any information relevant to this study. An effort was made to include as many abstracts and indices as possible to insure complete coverage of all important published or unpublished material on health manpower models. Figure 1 provides a list of the documents reviewed (abstracts and indices as well as the individual journals which were not indexed or abstracted or which were specifically examined for pertinent research notes and for references to new or forthcoming publications). As can be seen in this table, the search covered the period 1960 to 1973, however, very little relevant information was found in material published prior to 1964. Copies of potentially relevant publications were obtained from the University of Michigan Library, University Microfilms, Incorporated, National Technology Information Service or directly from the author if the material was unavailable in these document repositories. The bibliographies of each document received were examined and relevant publications or reports identified and then acquired using similar retrieval procedures. As a result of these activities, approximately 95% of the documents identified were retrieved.

Paralleling the identification and retrieval of documents, a complete set of model descriptors was developed and tested against the material received. As a result of these tests, the descriptor list was modified from

Abstracts of Contributed Papers, American Public Health Association, 1968-1970
 Abstracts of Hospital Management Studies, 1965-1972
 American Economic Association - Index of Economic Articles, 1960-1968
 American Economic Review, 1960-1973
 Applied Economics, 1969-1972
 Applied Statistics, 1962-1971
 Biological Abstracts, 1969-1972
 Dissertation Abstracts International, 1960-1973
 Econometrica, 1960-1972
 Economic Abstracts, 1964-June, 1972
 Economica, 1966-1970
 Health Services Research, 1966-1973
 Index Medicus, January 1960-October 1972
 Industrial and Labor Relations Review, 1962-1971
 Inquiry, 1966-1972
 International Abstracts in Operations Research, 1965-1968
 Journal of Economic Literature, 1969-1973
 Journal of Human Resources, 1966-1972
 Journal of Political Economy, 1966-1973
 Manpower, January 1969-September 1972
 Manpower Journal, 1967-1971
 Manpower Research Projects sponsored by the US Department of Labor,
 Manpower Administration, 1967-1970
 Medical Care, 1966-1972
 Monthly Catalog of US Government Publications, July 1971-June 1972
 National Bureau of Economic Research Publications, 1920-1970
 Nursing Research, 1966-1972
 Operations Research, 1963-1973
 Quarterly Journal of Economics, 1960-1972
 Review of Economics and Statistics, 1960-1972
 Review of Economic Studies, 1960-1971
 Social Security Bulletin, 1966-1972
 Southern Economic Journal, 1965-1972
 US Government Research & Development Reports Index, Jan. 1968-December 1969
 Western Economic Journal, 1962-1970

**FIGURE 1. LIST OF JOURNALS, ABSTRACTS, AND INDICES REVIEWED
 FOR INFORMATION ON HEALTH MANPOWER MODELS**

time to time by removing, redefining, or adding descriptors to improve the applicability of the categories to individual models and the general utility of the contents of the model inventory. The final set of descriptors chosen and a brief definition of the information contained in each category are provided in figure 2. The first descriptor shown in figure 2 is the model identification code which is simply a two character alphanumeric code intended to provide a concise reference to each model in the inventory. The remainder of the descriptors listed in this figure are divided into three major groups: Identification, General Descriptors, and Technical Descriptors. The Identification Descriptors provide information to enable the reader to differentiate between individual models, identify the model developers, and delineate the relevant documents describing the model. The second group of descriptors presents a general overview of the model and includes such information as development status, purpose, sponsor, scope, narrative abstract, etc. In the Technical Descriptor section the analytic structure of the model is described in terms of major model modules, mathematical techniques employed, input and output variables, characteristics of computing equipment, and verification procedures used.

1.2 Model Selection

Approximately 85% of the documents obtained as a result of our identification and retrieval activities were sufficiently relevant to this study to be incorporated in the Health Manpower Model Bibliography presented in section 4.3. Of these references, however, only about one half contain information which characterizes individual health manpower models,

MODEL IDENTIFICATION CODE

1.0 IDENTIFICATION

1.1 Descriptive Title

Brief title containing key words to identify the subject area of the model and to enable the reader to differentiate each member of the simulation inventory. Generally this title is a minor modification of the major reference title, however, for several models a completely new, more definitive title is formulated.

1.2 Developer's Name(s)

The names and organizational affiliations of developers. The organizational affiliations given are those at the time of publication of the model references.

1.3 References

List of all model references included in the Health Manpower Model Bibliography, by last name(s) of developer(s) and dates of publication.

2.0 GENERAL DESCRIPTORS

2.1 Development Status

The degree of completion of the model. The development status given is that provided in the most recent model reference.

2.2 Purpose and Sponsor

Why the model was developed; the general uses of the model (e.g., prediction of health services utilization, analysis of physician migration patterns, etc.). The model sponsor is the organization identified as having provided financial support for the development of the model. In the cases where no such organization is identified, the reason for the work, as well as can be determined, is given (e.g., model is part of a PhD dissertation, or reported on in the proceedings of a particular conference.)

FIGURE 2. SIMULATION CATALOG DESCRIPTORS

2.3 Scope and Subject

Specific information on the range and type of health manpower information manipulated by the model. The information includes subject area of the model, category of health manpower, geographic area, aggregation level, year of applicability or development, etc.

2.4 Abstract

Brief narrative description of the model and its development, including application areas, development rationale, development methodology, major model characteristics, etc. Where appropriate, portions of the abstract are drawn directly from the summary text provided in references.

2.5 Major Outputs

A general description or list of the information provided by the model, closely related to the model output variables listed in section 3.5, but usually not as detailed.

2.6 Assumptions/Constraints/Hypotheses

List of assumptions, constraints, and hypotheses of the model. It was often difficult to differentiate between assumptions and hypotheses and assumptions and constraints. Generally, assumptions, constraints, and hypotheses identified as such by the developer were so listed. Otherwise, a hypothesis was taken to be a proposition presented and then tested by the developer, while an assumption was a statement accepted as valid without verification. Assumptions which analytically bound or limit the model were classified as constraints.

3.0 TECHNICAL DESCRIPTORS

3.1 Model Type

Identification of model techniques employed (regression, linear programming, simulation, Markov model, or any combination of these techniques, deterministic or stochastic, open or closed, etc.).

FIGURE 2 (CONT.)

3.2 Model Characteristics

A detailed description of the model structure, including number and type of equations, states, and variables, and identification of major modules and processes. For regression models containing several dependent and independent variables, a chart is provided relating the independent variables to the dependent so that the structure of the model may be more clearly visualized. In large multi-equation models this chart is omitted to preclude cumbersome tabulations.

3.3 Data Utilized

Identification of the data sources utilized in the construction or estimation of the model. Sources utilized by only one model are generally listed in full, while other sources are referred to by their identification number in the Data Source Index.

3.4 Input Variables

List of input variables of the model.

3.5 Output Variables

List of output variables of the model.

3.6 Verification/Applicability/Reliability

Studies performed by the developer for model verification are described. Applicability of the model, given the data used to estimate or construct the model, is discussed. If the model is applicable only to a specific population, constitution, or geographic area, its limitations are noted. All regression models of questionable applicability due to "old" data may be applicable if reestimated using the appropriate current data. A statement is included on the reliability of the model for short- or long-range planning, if the reliability can be determined from the information provided in the references.

3.7 Computer Characteristics

Identification of hardware and software characteristics of the model, i.e., type of machine, program language, storage requirements, running time, etc. In most cases, little or no information on these characteristics was provided in the references utilized.

FIGURE 2 (CONT.)

i.e., references which contain analytic descriptions of health manpower models or which describe the information generated by or the information used by these models. The remaining references in the bibliography contain articles outlining studies relevant to health manpower planning, but were generally devoid of explicit modeling components or were descriptions of health models which focus on subject matter essentially unrelated to health manpower.

In order to keep the contents of the model inventory (section 3.0) both manageable in size and consistent with the scope of the study, only those model descriptions which met a predetermined acceptance criteria were incorporated in the inventory. The general criteria chosen was to include in the inventory all health process descriptions which analytically define the mathematical relationships between variables directly related to health manpower problems. Using this general acceptance procedure models which did not contain any discernible analytic components and models which describe health processes essentially unrelated to health manpower planning, e.g., a hospital facilities design model or a model of a specific disease were excluded from the inventory. In addition, this acceptance criteria was sufficiently indiscriminate to permit incorporation into the model inventory most of the broad spectrum of current and previous health manpower modeling developments.

1.3 Models Cataloged

An analysis of the models described in the inventory reveals that the majority of the models are developed using some form of regression analysis.

The remaining models are of a mixture of optimization models (e.g., linear programming) or process models (e.g., queueing, Markov, Monte Carlo or deterministic simulation models). In addition, the majority of the models were developed by individuals working in economic disciplines. This latter observation is only significant in that economists tend to view the health manpower system in terms of traditional economic phenomena such as the health manpower supply and demand in educational, health service, and labor markets as determined by prices, wages, socio-economic and demographic variables; hence, many of the models are described in terminology characteristic of this discipline.

Since many of the models in the inventory are concerned with several health disciplines and other models simply treat health manpower as a general input required to provide health services, it is difficult to classify the models inventoried in terms of the health disciplines they address. However, of the models in the inventory which deal directly with health manpower, the overwhelming majority are primarily concerned with two health disciplines - physicians and nurses. Topics covered in these models include factors which influence geographic distribution of physicians, hospital demands for medical residents, supply of physicians and medical specialists, supply of and demand for nurses (RNs, LPNs, etc.), future supply of nurses, nurse staff planning and scheduling, etc. Four models in the inventory quantitatively deal with dental parameters such as geographic location of, demand for, and supply of dentists, and five models are directly concerned with allied health problems (e.g., demand for, absenteeism in length of service of, and utilization of allied health manpower). The

remaining models in the inventory are models of health processes or areas of the health system closely related to manpower requirements such as health consumer requirements by illness category, simulation of health service activity in terms of personnel, facilities and consumables, etc.

Finally, it should be noted that this document is intended to provide a descriptive inventory of current health manpower models, rather than a subjective or objective assessment of the quality or worth of specific modeling efforts. In this regard, the reader should use this inventory to identify the collection of models which could be employed to assist with the accomplishment of particular tasks or with various decision-making activities. Furthermore, it is hoped that the inventory contains sufficient detail concerning specific model attributes to enable the reader to discern which of the models are most appropriate or applicable to his specific needs; however, the depth of characterization which is needed to adequately compare and select the "best" model for a specific task may require much more information than is presented here. Such additional information should be obtained from the individual model developer or from the references listed in section 4.3 of this technical report and not from VRI or its sponsor.

2.0 A HEALTH MANPOWER MODEL CLASSIFICATION SCHEME¹

In this section the general classification structure which will be used to characterize health manpower models is discussed. The discussion concentrates on the overall conceptual framework of this structure, the characteristics of its individual components and the problems of classifying the cataloged models in this framework. The assignment of specific models to relevant modules in this classification is accomplished in subsequent sections.

The primary purpose for inclusion of a health manpower modeling structure is to facilitate reader comprehension of the overall magnitude and scope of the health manpower modeling spectrum and the relationships between individual modeling efforts. This classification structure will also provide a mechanism for delineating comparative groupings of models which manipulate similar health manpower system parameters. These groupings or structural elements will then provide a framework for defining important causal relationships between various model classes, identifying information gaps or deficiencies in the model spectrum and specifying the structural attributes of the models which might fill these gaps. Furthermore, by grouping similar modeling efforts, the relationships between BHME policy variables, performance measures, and information requirements and the general model classes can be delineated.

A schematic of the classification scheme chosen is provided in figure 3. This structure consists of eight blocks characterizing eight health manpower

¹Initial health manpower model classification structure was developed with the assistance of Dr. Richard Smallwood, Xerox Corporation, in preparation for a DMI workshop on Development of Technology for Health Manpower Intelligence.

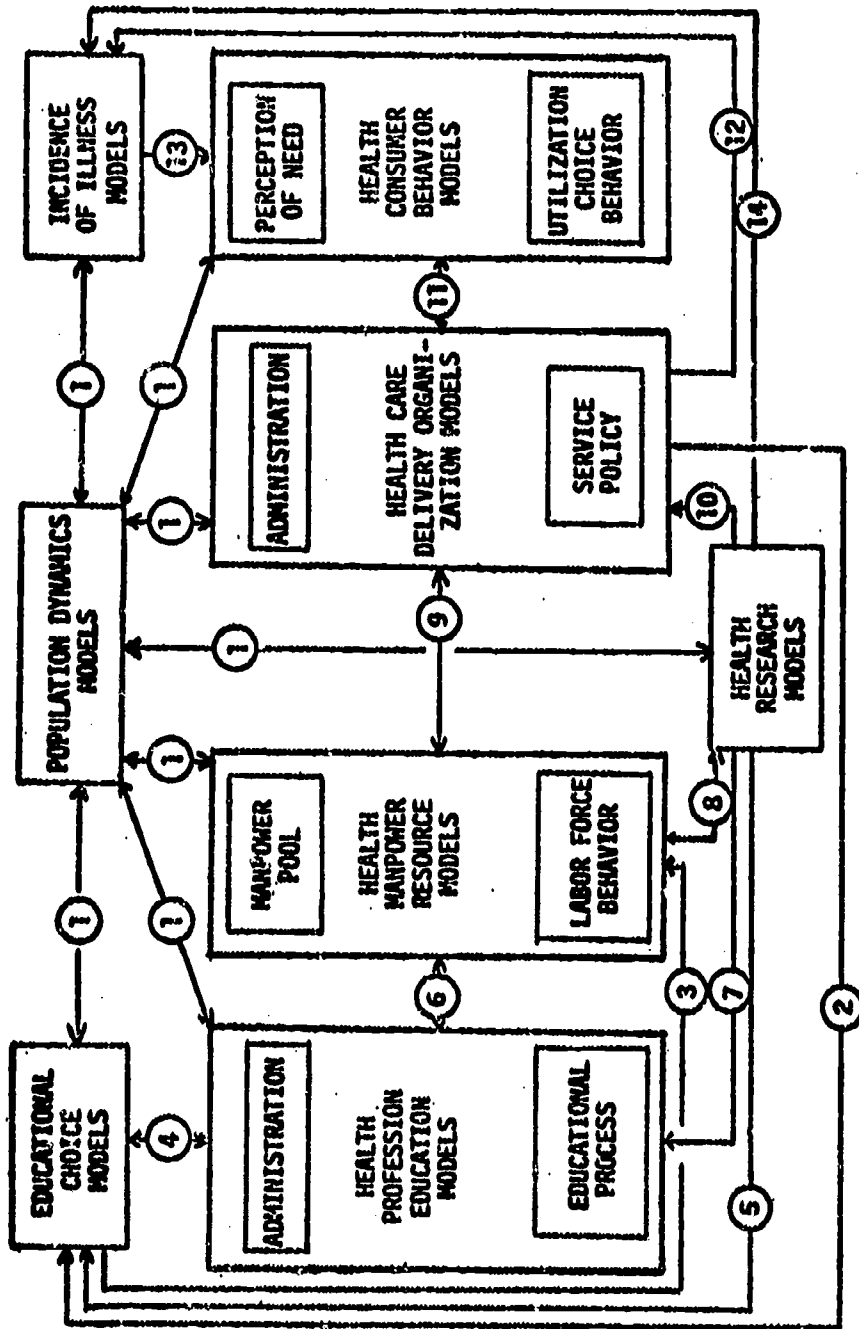

FIGURE 3: HEALTH MANPOWER MODEL CLASSIFICATION SCHEME

model subject areas and fourteen connecting branches (arrows) representing major information flows between the subject blocks. Although the transfer of information between blocks may be considered unilateral in specific cases, counter-flow examples exist for many branches shown in the diagram. Thus, bidirectional arrows are used to depict these bilateral information flows. Each of the subject categories and the numbered information flows associated with that category is presented in section 2.1. First, however, we will discuss the inherent shortcomings of the classification scheme shown in figure 3.

The subject categories in the classification scheme selected do not define mutually exclusive model domains nor does the sum of individual blocks necessarily encompass the total spectrum of distinct health manpower models. Additional limitations of the scheme presented here are noted as follows:

- (1) Although the limited number of structural compartments facilitate conceptualization and comprehension, many additional categories within and between these compartments must be developed to differentiate between the distinct characteristics of closely related models.
- (2) Many models do not fall conveniently into one subject block, rather, they may encompass more than one classification, concern only parts of individual blocks, or manipulate data which essentially might be characterized as belonging to the undefined space between blocks.
- (3) Economic markets (a topic discussed later) are not explicitly defined on the structure, and
- (4) The classification scheme used provides a conceptual model structure rather than describing the actual process governing the health manpower system.

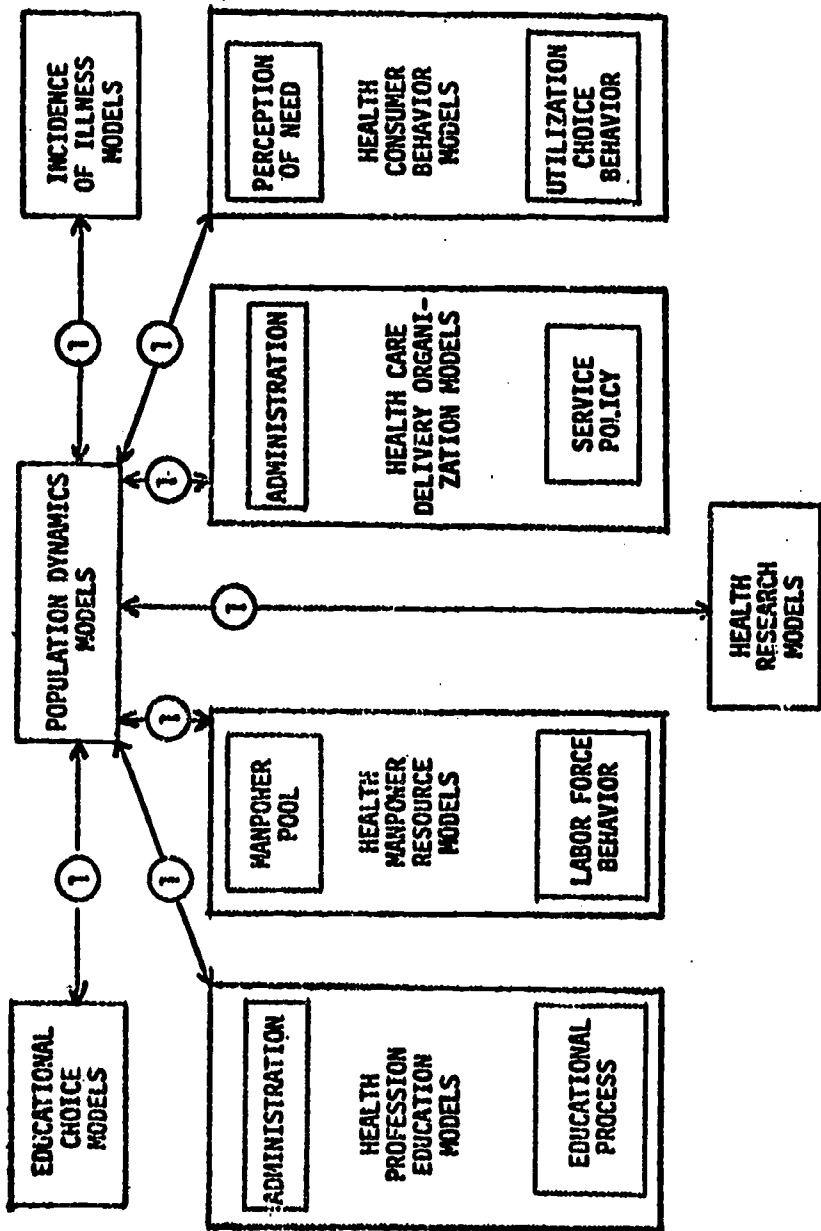

FIGURE 4: HEALTH MANPOWER MODEL CLASSIFICATION SCHEME
POPULATION DYNAMICS MODELS

In spite of the above limitations, the scheme does satisfy many of the aforementioned purposes for its incorporation in this document. First, we feel this structure provides a model classification scheme which is simplistic enough to be easily visualized, yet comprehensive enough to delineate the essential characteristics of the several health manpower model efforts. Second, although the domains of the subject groupings chosen may slightly overlap in certain areas, they are conceptually differentiable. Third, specific federal program or policy actions can easily be identified with one or more of the structure categories. Finally, and probably most important, given the block definitions provided below, the scheme is amenable to classifying the individual models identified for incorporation in this inventory.

2.1 Classification Structure

In the following paragraphs the general types of models in each of the blocks of the classification scheme as well as the information flows between these models are described.

Population Dynamics Models. Any model which generates current or future demographic, socioeconomic or other population characteristics would generally be included in this category. In particular, models included in this block might describe population parameters typifying various characteristics of health manpower or define health consumer variables pertinent to assessing the demand for health manpower. Since the models in this category could provide information for or obtain data from any of the other subject blocks, information flow lines are connected between all other blocks and the population dynamics model block. That is, models which fall into

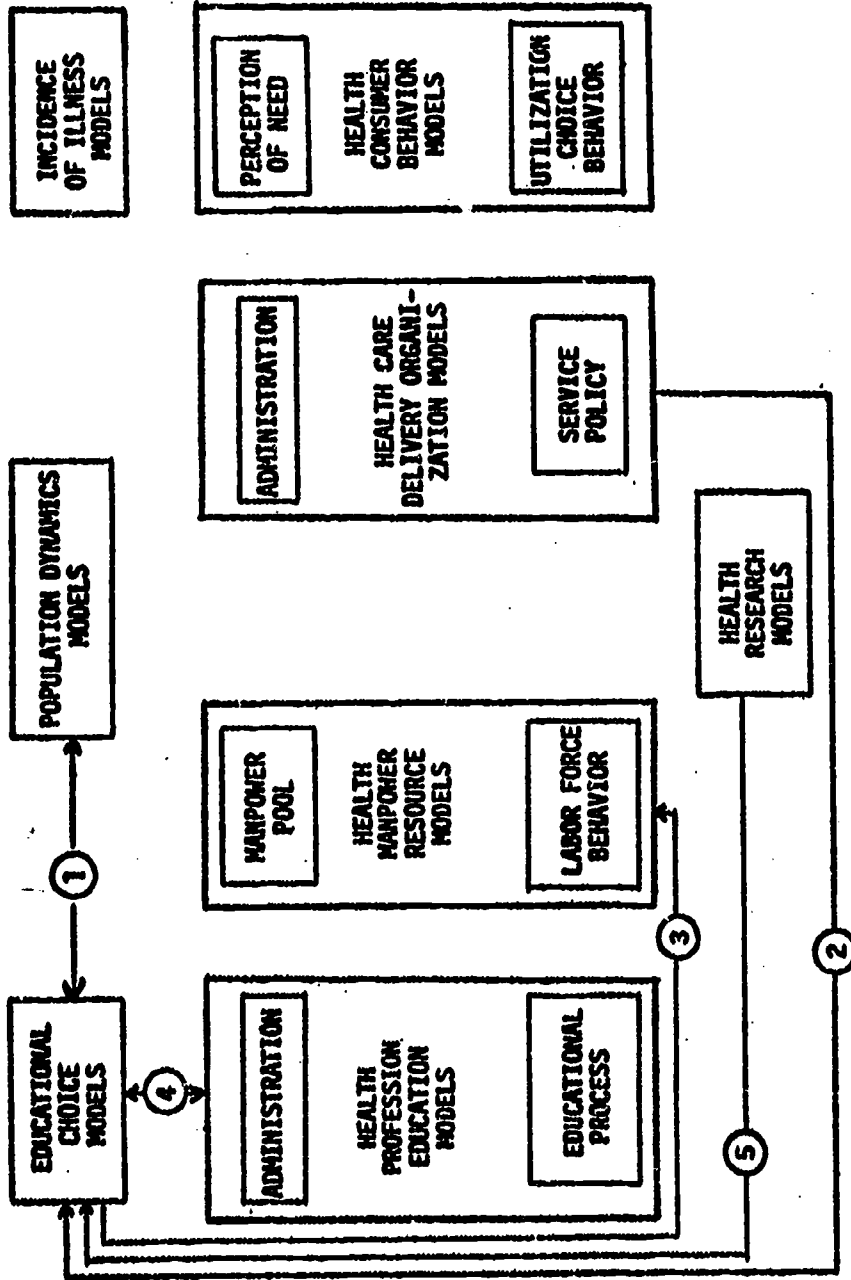

FIGURE 5: HEALTH MANPOWER MODEL CLASSIFICATION SCHEME
EDUCATIONAL CHOICE MODELS

any of the subject category blocks in figure 3 may use socioeconomic, demographic, or other parameters derived by population models to describe the relationship between these parameters and other model variables. Similarly, the results generated by these models may provide more accurate, current, or detailed estimates of population characteristics which would be feedback to the population models to upgrade or update their information base. For example, an educational choice model might require information on family income, father's occupation, sex, etc., as input variables and provide information to population dynamics models to update population characteristics in the model on number of medical school applicants, number of persons entering nonprofessional health occupations, etc. The information transfers between population models and the other model subject categories are schematically shown in figure 4.

Educational Choice Models. This category encompasses models which manipulate behavioral, motivational and decision parameters governing the individual choices of type, location, and level of health professions education; e.g., nurse incomes, number of medical school spaces, tuitions and fees. There are four information flow lines emanating from this block as shown in figure 5. Arrow number two (2) depicts a unilateral flow of information from health care delivery models concerning working condition descriptors such as wages, working hours, job prestige factors, etc., which could provide inputs to models determining factors relevant to an individual's choice of education. Arrow number three (3) indicates a flow of data describing persons electing health professions not requiring formal education which could be used in models of health manpower resources, described later. The bidirectional arrow, number four (4), infers a bilateral data exchange between educational choice and health profession education models concerning prices of education, entry requirements, and characteristics of

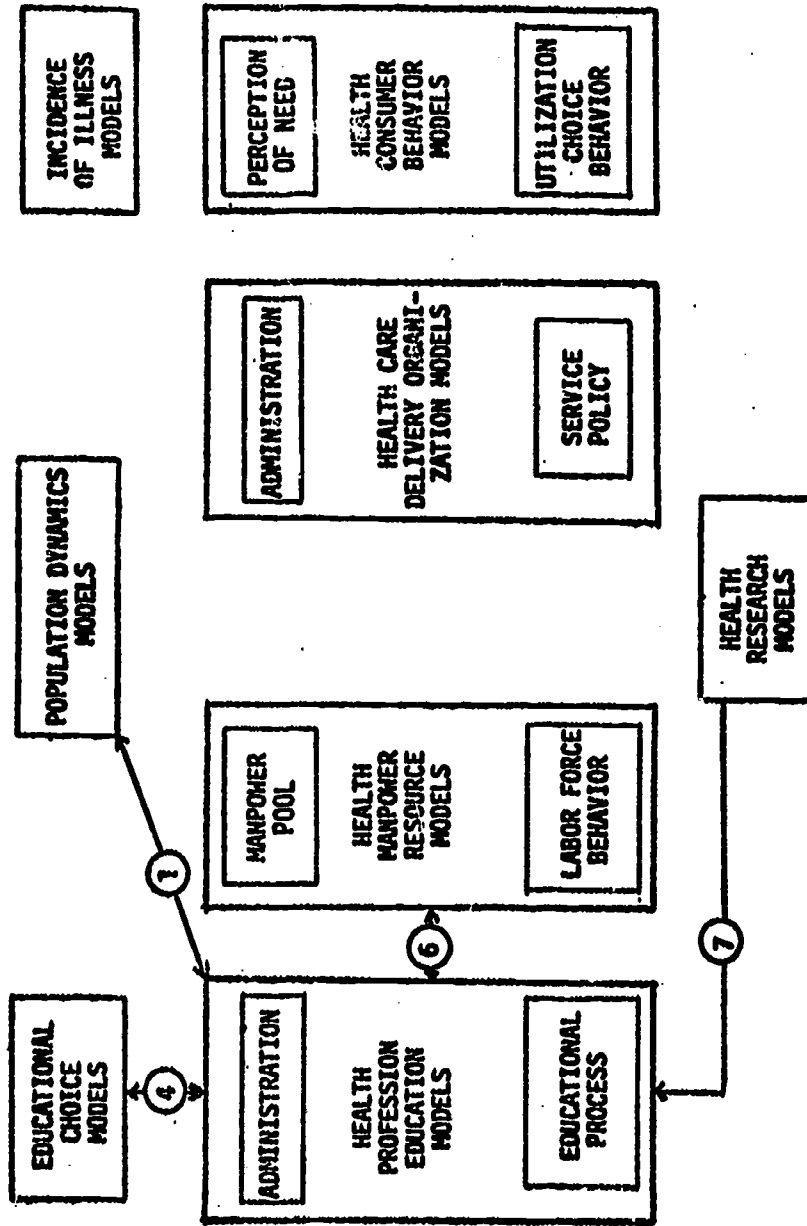

FIGURE 6: HEALTH MANPOWER MODEL CLASSIFICATION SCHEME
HEALTH PROFESSION EDUCATION MODELS

students selecting formal health training. Arrow number five (5) again indicates essentially a unilateral flow of data on working conditions detailed in health research models which might influence individuals to obtain sufficient education to perform research.

Health Profession Education Models. As is shown in figure 6, two general classes of interrelated education models have been assigned to this category: models concerned with the administration of health profession education and models which describe the actual education process. Administration models manipulate variables concerned with the price of education, entry requirements, optimal mix and size of staff, number of students, etc. The educational process models incorporate parameters describing the quality and effectiveness of health profession education, such as the size of classes, subject material taught, minimum degree requirements, etc. In addition to the information link (4) with the educational choice model noted above, two other educational model information interfaces are identified in figure 6. Data characterizing the new entries into each manpower category (e.g., medical, nurse, dental, allied health and other graduates or dropouts) as well as data characterizing manpower selecting educational occupations (e.g., medical school professors, administrators, secretaries, etc.) could be transferred (6) between education and manpower resource models. Another information flow concerned with health research innovations or discoveries impacting on health profession education and educational parameters, i.e., availability of a research environment, facilities, subjects, funding, etc., is shown as arrow number (7) in figure 6.

Manpower Resource Models. Models in this category can be visualized as belonging to two classes: manpower pool models which provide estimates or predictions of the number or distribution of personnel in terms of discipline,

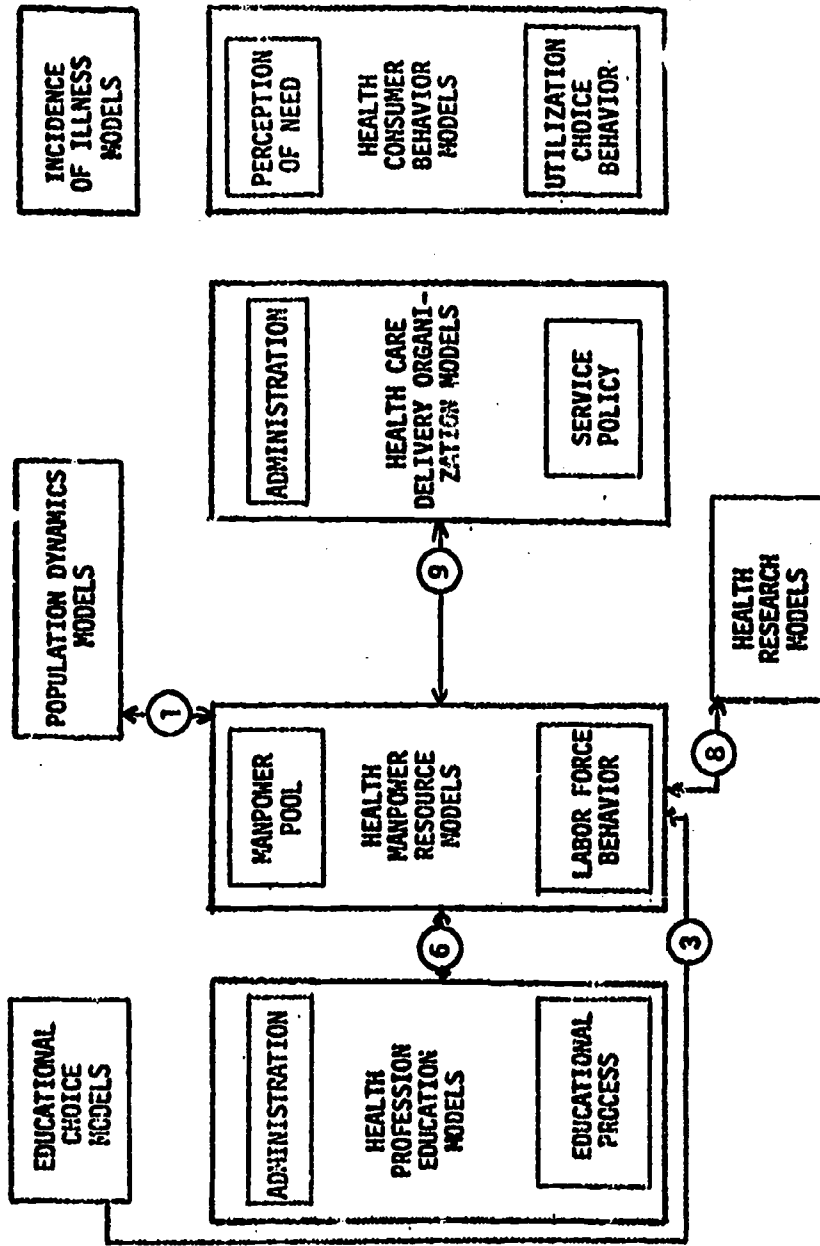

FIGURE 7: HEALTH MANPOWER MODEL CLASSIFICATION SCHEME
MANPOWER RESOURCE MODELS

geographic location, occupational specialty, etc.; and labor force behavior models which deal with the factors influencing individual behavior patterns and decisions concerning participation in the labor force (including variables concerned with general labor force participation as well as selection of a particular job; e.g., income of health manpower, hours worked per week, participation in specialty practice). In addition to the information flows between this module and the educational model block (6) and the educational choice block (3), the manpower resource models have information links with the health research models (8) and health care delivery organization models (9) as is shown in figure 7. These data transfers essentially consist of information on working condition parameters (e.g., wages, hours, relative prestige, etc.) and on the number, distribution and characteristics of individuals in the health manpower disciplines entering particular working environs, such as research, private practice, hospital services, etc.

Health Care Delivery Organization Models. The two general classes of models associated with this category are HCDO administration models and health service delivery models as is shown in figure 8. Administration models are concerned with optimal, organizational management and planning structures, staff mixes, allocations or scheduling, cost and profits on services rendered, etc. Service delivery models include simulation or prediction of services provided by the private practitioner or delivery organization in terms of the supply of physician or dental visits, types of services provided, price for services, and effectiveness of services. Information flows, in addition to those previously identified, i.e., (1), (2), and (9), potentially exist between HCDO models and health research (10), consumer service behavior (11) and incidence of illness models (12). Health research models provide estimates of

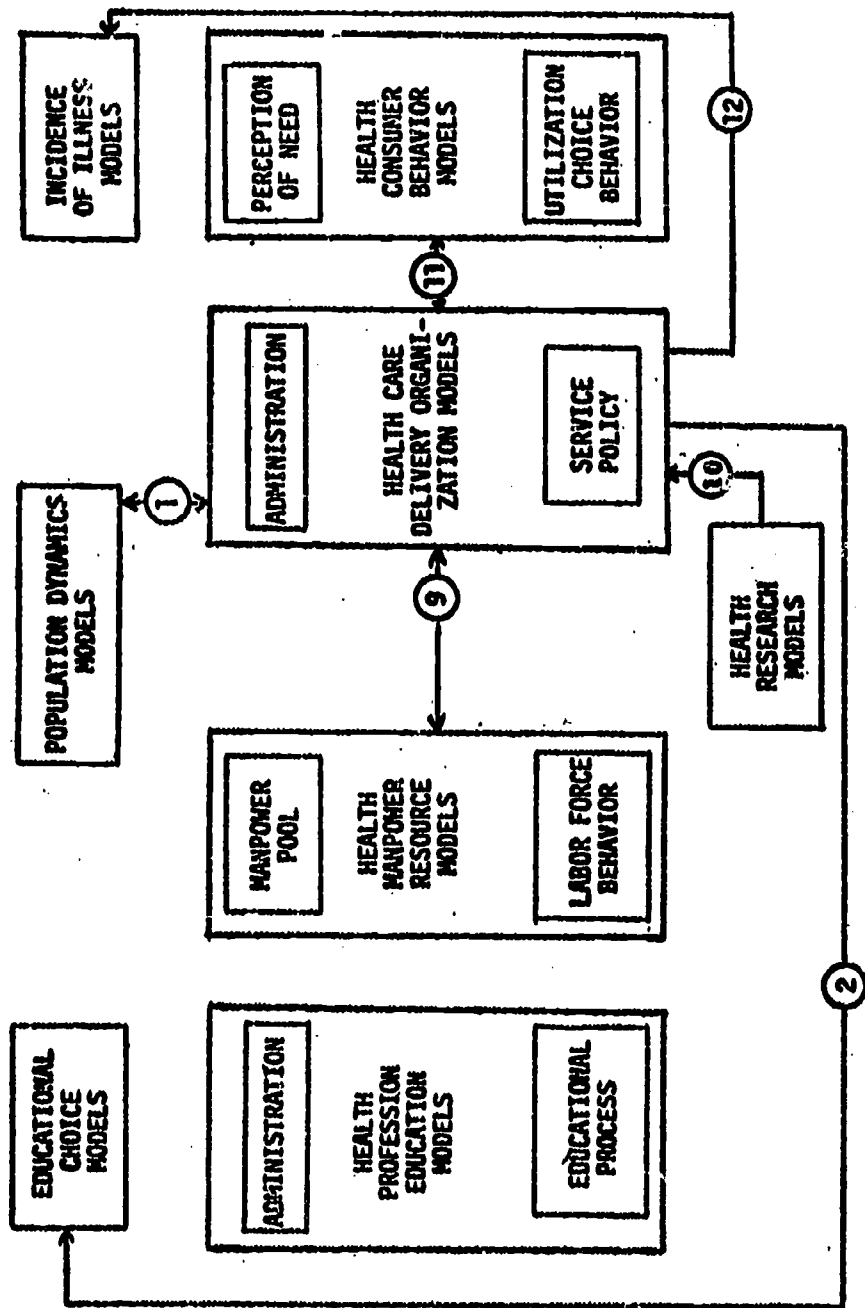

FIGURE 8: HEALTH MANPOWER MODEL CLASSIFICATION SCHEME
HEALTH CARE DELIVERY ORGANIZATION MODELS

218

future research findings in health care which could affect the methods of health care delivery, such as technological innovations in health care delivery (e.g., computer assisted diagnosis, microform record storage, high speed blood analyzers, etc.), cost-effective analysis of alternative practice settings (e.g., group practice, health maintenance organizations and solo-fee-for-service practice) and new modes of health treatment (e.g., chemotherapy, nuclear medicine, artificial organs, etc.). The bilateral exchange of information between HCDO models and health consumer models might include: health service prices, type of services provided (e.g., diagnostic, referral, auxiliary, etc.), geographic distribution of these services, as well as socioeconomic, health status and other characteristics of patients demanding health services. The flow of information from HCDO models to incidence of illness models would consist of data on specific health treatments offered which could influence the incidence of particular illnesses.

Consumer Service Behavior Models. Two classes of interrelated models are identified with this grouping: perception of need models, and service utilization behavior models. Perception models describe the factors which influence the individual's perception of his health state; i.e., demographic variables such as educational background, health history, age, as well as external parameters such as medical advice, the extent of information disseminated concerning specific illnesses (e.g., televised material on symptoms of heart disease), etc. Service utilization models characterize factors governing patients' decision processes concerning the type, location, and quantity of service sought (e.g., wages, savings, health insurance, social beliefs, etc.). Consumer service models primarily exchange information with the health care delivery models (11) discussed previously, and incorporate the data (13)

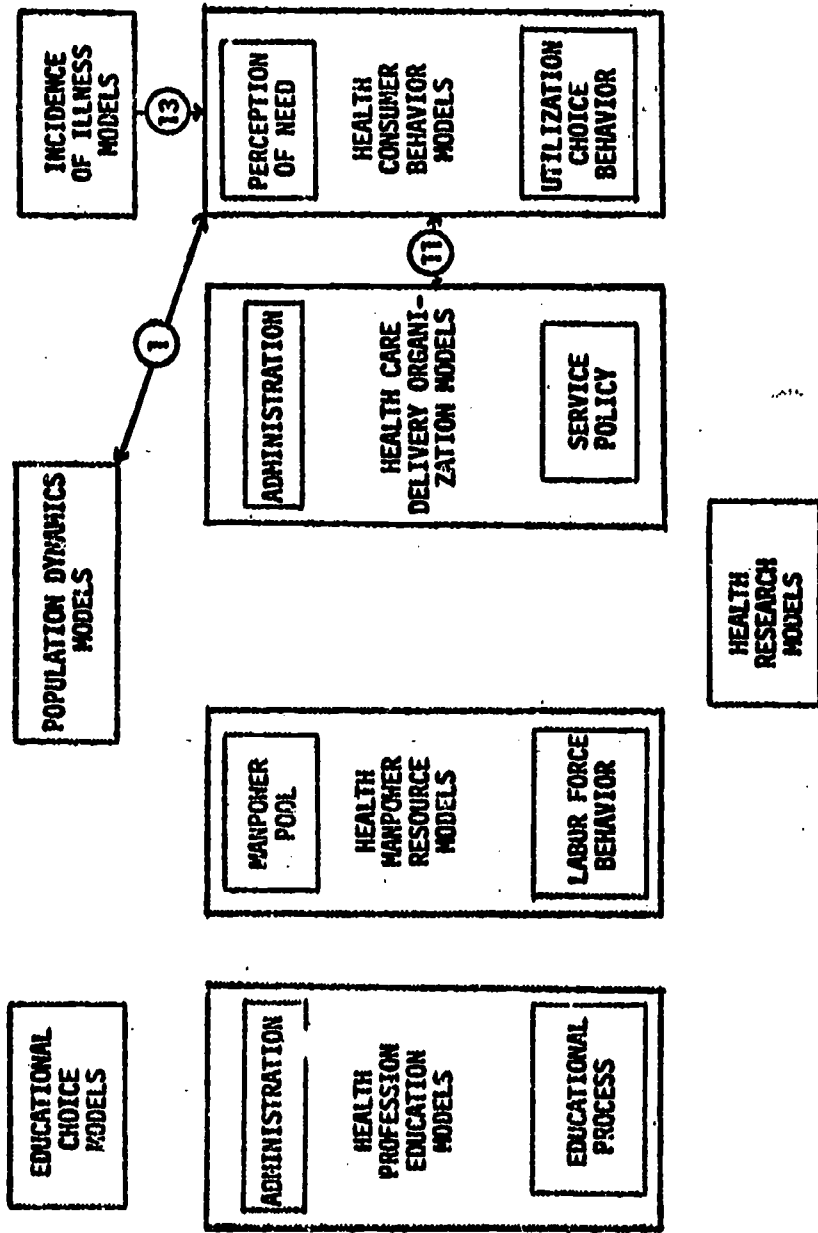

FIGURE 9: HEALTH MANPOWER MODEL CLASSIFICATION SCHEME
CONSUMER SERVICE BEHAVIOR MODELS

concerning the health status of a population provided by Incidence of Illness models as is depicted in figure 9.

Incidence of Illness Models. Models classified in this category are essentially simulations describing the health status of individual members of a population. As such, they could be categorized as a specialized form of population dynamic models; however, because of their relative importance in determining demands for health manpower services, a separate subject category block is provided. These simulations primarily utilize information provided by population dynamics models (e.g., age, sex, economic status, race, place of residence, etc.) indicated by information transfer number (1) in figure 10, to generate health characteristics of the population (e.g., mortality rates, proportion of the population in various diagnostic categories, etc.). As noted previously, this information is supplied to health consumer behavior models (13) which in turn provide modifications of this data to health care delivery organization models (11). Additional information flows are: data concerning preventive or episodic treatments or health services provided by health care delivery organizations (12) which might influence incidence of illness; and information from research models (14) concerning potential breakthrough in disease prevention.

Health Research Models. The group of models which supply information on research discoveries or which identify research demands for health manpower are classed as health research models. This somewhat anomalous model category is included in the classification scheme because of the influence of health research on health manpower productivity (e.g., technological or methodological improvements in health care delivery) which affects the supply of health manpower services, as well as, the impact health research on the health status of a nation, which

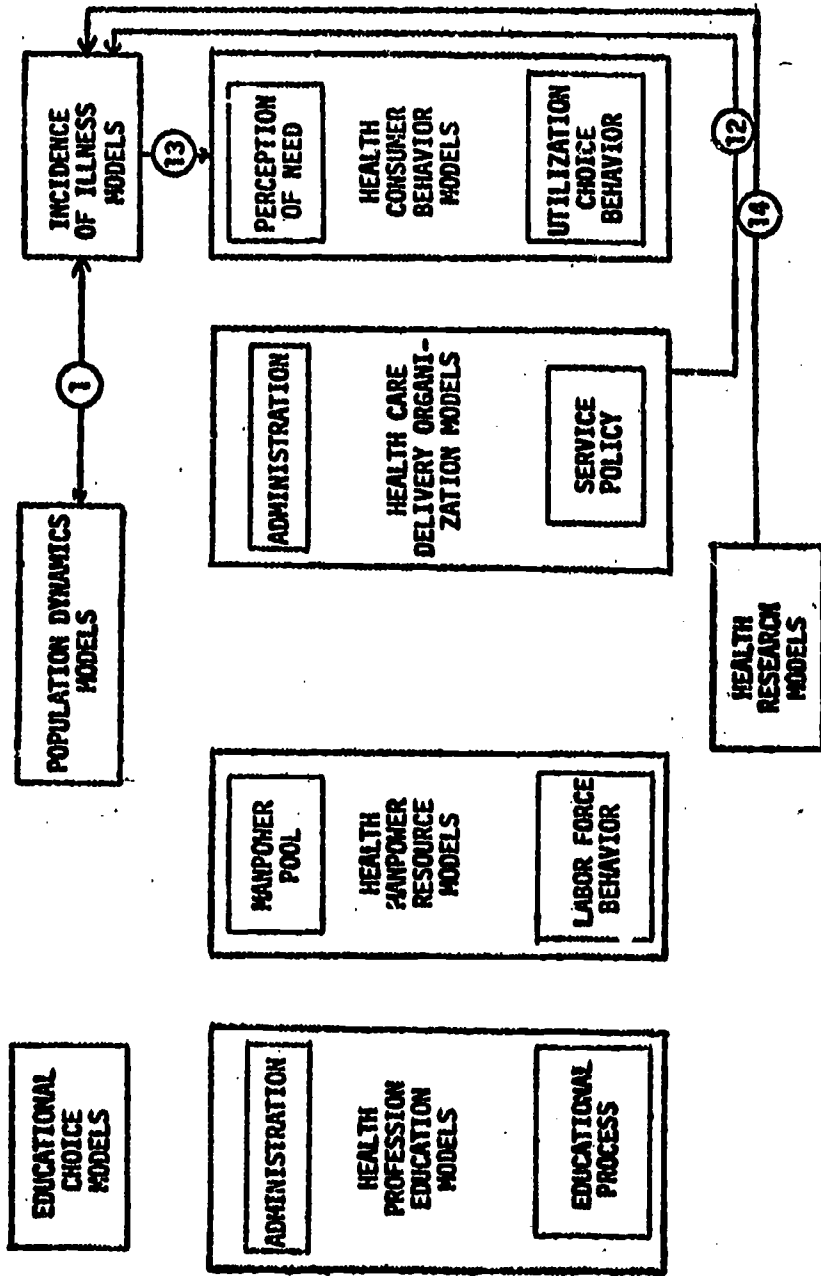

FIGURE 10: HEALTH MANPOWER MODEL CLASSIFICATION SCHEME
ILL-HEALTH INCIDENCE MODELS

modulates the demand for these services. Since health research is conducted in a variety of locations (health care delivery organizations, health-related industries, and educational institutions), we decided to isolate the research element in a single component rather than partition its specialized segments across several categories in the conceptual structure. The information transfers between research models and other model categories, discussed previously, are shown in figure 11.

2.2 Model Classification Problems

Although most of the models identified are conveniently placed into one or several of the above categories, five of the problems associated with classification of the models in the inventory are:

- (1) Discrimination between HCDO administration and service delivery models -- All health care delivery organization models identified could be visualized as administration models (i.e., all models provide information ostensibly to describe level of service demanded, number of bed days provided, staff required as well as optimizing the use of organization resources to maximize profit, minimize cost, etc.). For our purposes optimization or planning models concerned with management or scheduling of staff or services or allocation of facilities or material are classified as administration models. Models which simulate or describe health services provided in terms of the number, distribution, type or price of services provided as well as the personnel categories involved in the service are classified as health service modules (e.g., a model estimating the number of office visits supplied by a physician).

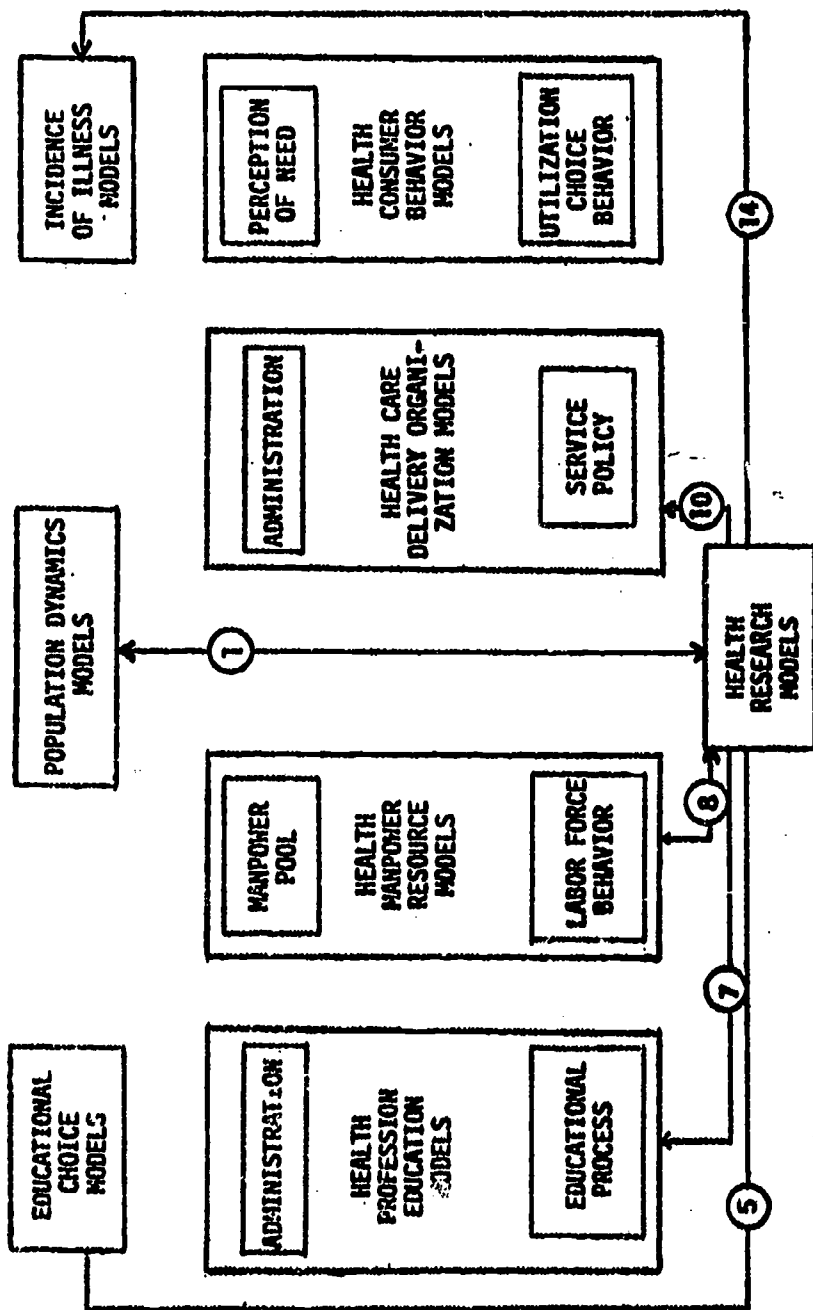

FIGURE 11: HEALTH MANPOWER MODEL CLASSIFICATION SCHEME
HEALTH RESEARCH MODELS

- (2) Discrimination between manpower pool characteristics and labor force behavior in the health manpower resource models -- Manpower pool models are estimates or predictions of number of personnel in a region, occupation, or at a point in time. Prediction of manpower location could be considered behavioral, but the two types are differentiated here by level of aggregation. Locational models based on aggregate variables (e.g., total number of physicians as a function of total population, total income, percent urban, etc.) are classified Manpower Pool; locational models based on individual characteristics (e.g., state of birth, medical school location, etc.) are classified Labor Force Behavior. Labor force behavior models are those dealing with the individual's decisions concerning participation in the labor force (including variables influencing general participation in the labor force and participation in a specific job or location).
- (3) Classification of Supply of and Demand for Residencies -- Supply of residencies could be considered as health care delivery organizations' demand for physicians or as educational institution supply of higher education. Since not all hospitals offering residencies are affiliated with medical schools, supply of residency models are classified HCDO - Administration. Choice of specialty (demand for residencies) can also be considered an educational choice and a labor force behavior choice. Since the physician choosing a specialty is already in the labor force, and not all hospitals offering residencies are affiliated with educational institutions, choice of residency is classified Labor Force Behavior.
- (4) Location of Economic Market Models -- Although specific economic

markets are not identified in the diagram (figure 3) of the classification structure, the three traditional markets, health profession education markets, health manpower markets and health service markets can be associated with combinations of the subject category blocks. For example, education markets concerned with the supply of and demand for health profession education and the associated cost or price of this education can be viewed as encompassing parts of educational choice and education models blocks as well as those portions of the manpower resource block defining the substitutes for health education. The health manpower market consists of the health manpower resource models block defining the supply of health manpower and the educational, research and HCDO models blocks describing the demand for health manpower. The health services market is primarily defined by the interrelationship between the demand for services detailed in the consumer behavior models block and the supply of these services which fall in the HCDO models' domain. Individual market models are, therefore, classified into one or multiple subject groupings depending upon the subject orientation of the major modules. That is, models which purport to describe the market, but which emphasize attributes associated with a particular subject category are classified within this category. Similarly, market models concerned with material reasonably distributed among several of the classification groupings will be classified in each of these categories.

- (5) Large-scale Models -- The classification problem introduced by models whose principle scope of interest extends beyond the borders of any of individual categories will be handled in the same

method employed on market models. For example, models which develop population dynamics, describe incidences of illness, and estimate consumer service demands, etc., will be identified in multiple subject areas, as appropriate.

2.3 Model Classification

Using the previously discussed health manpower model classification scheme the models in the model inventory (section 3) can be classed as shown in figure 12. In this figure each classification area is followed by a list of the models in the inventory which fall in this area. Each model is identified in terms of its model identification code found at the top of each model descriptor list. Section 4.1 of this report provides a cross reference index between these identification codes, the model developer, and the descriptive model title.

As can be seen in figure 12, there is a heavy concentration of models in the area of administration of health care delivery organizations; over one half of the models in the inventory cover topics which fall in this category. Also notable is the absence of any models in the health profession educational process, health consumer perception of need, and health research model classification areas. There are a variety of reasons which could be responsible for this apparent maldistribution of health manpower modeling efforts. First, the classification scheme chosen may contain a certain amount of inherent bias resulting in a greater portion of the models identified being classed in one or more subject areas. Second, the model builders may have concentrated on areas where the data was more accessible or the processes better defined. That is, health care delivery organizations are more amenable to process

<u>Classification Area</u>	<u>Models</u>
Population Dynamics Models	L2, R2, Y1
Educational Choice Models	F5, S6, Y1
Health Profession Education (Administration) Models	A3, F4, F5, L3, Y1
Health Profession Education (Educational Process) Models	None Identified
Health Manpower Resource (Manpower Pool) Models	B5, E2, F1, F4, F5, H1, H3, M1, S1, F8
Health Manpower Resource (Labor Force Behavior) Models	B4, B6, S2, S6, S8, Y1
Health Care Delivery Organization (Administration) Models	A1, A2, B1, B2, B3, C1, F1, F5, F6, F7, H2, H4, J1, K1, L1, L4, M1, M2, R2, S3, S4, S6, S7, T1, U1, W1, Y1, Z1
Health Care Delivery Organization (Service Delivery) Models	F2, F4, R1, Y1, F8
Consumer Service Behavior (Utilization Choice Behavior) Models	A4, D1, E1, F3, F5, F7, H5, L2, N1, R2, R3, Y1
Consumer Service Behavior (Perception of Need) Models	None Identified
Incidence of Illness Models	A5, A6, L2, N1, O1, Y1
Health Research Models	None Identified

FIGURE 12: CLASSIFICATION OF MODELS IN INVENTORY

descriptions in terms of input and output parameters which are readily available (e.g., number and type of services provided, time required to provide services, manpower required, etc.) than the less structured processes employed in health profession education or health research. Similarly, health care delivery is easier to analytically define than the complex subjective parameters which govern an individual's perception of his health status. Third, the results provided by models of the delivery processes could be much more applicable to decision making activities associated with these organizations. Whatever the reason, the concentration of modeling effort on administration of health care delivery organizations is readily apparent with even the most cursory examination of the models described in the inventory.

The two model categories which border the Health Care Delivery Organization category, Health Manpower Resource and Consumer Service Behavior models, together contain slightly less than half of the models identified in the inventory. Of the 26 models in these two classes, eight are also classified as Health Care Delivery Organization models. This multiplicity of classifications is due in part to the high degree of dependence of Health Care Delivery Organization models on the supply of manpower (i.e., health manpower resource models) and on the demand for health services (i.e., Health Consumer Behavior) which clearly influence the models of these processes. In addition there are two economic markets easily identifiable which concern the interaction of these three model categories. The market for health manpower deals with the behavior and supply of manpower selecting specific working conditions or organizations depending on the wages offered, job location, etc. The health services market is described by the behavior of health consumer as a function of price, availability, desirability, etc. of the services offered.

The models identified in the inventory are fairly evenly divided among the remaining subject categories with the exception that only three models are concerned with the mechanisms of choosing specific educational disciplines and only two models are classed as Population Dynamics models. Although there are many models concerned with simulation of population characteristics, the only models identified here are those which are principally health manpower models which happen to contain a population generation module. A further characterization of the models in each of the classification categories is provided in section 4.4 which lists the input and output variables manipulated by the models in each category.

3.0 INVENTORY OF HEALTH MANPOWER MODELS

This section contains the inventory of health manpower models described in terms of the objective descriptors presented in figure 2. Models included in the inventory are those identified in the literature review as analytically defining the mathematical relationships between variables directly or indirectly related to health manpower. The 56 cataloged models are arranged alphabetically by surname of the principal developer rather than by subject area due to the multiplicity of topics covered in the larger models.

1.0 IDENTIFICATION

1.1 Descriptive Title

Nurse Allocation Planning and Scheduling Model

1.2 Developer's Names

William J. Abernathy, Nicholas Baloff, John C. Hershey and Sten Wandel,
Stanford University

1.3 References

Abernathy et al, 1972, Hershey et al, 1972

2.0 GENERAL DESCRIPTORS

2.1 Development Status

Completed

2.2 Purpose and Sponsor

To present a staff planning and scheduling model for use in the nurse staffing process in acute hospitals, to evaluate the relative benefits of variable and fixed staffing policies. Model development was partially supported by Booz, Allen and Hamilton, Inc.

2.3 Scope and Subject

Nurse staffing processes in acute hospitals

2.4 Abstract

A three-stage nursing staff planning and scheduling model is developed. The process for staffing services is divided into three decision levels: (1) policy decisions including the operating procedures for service centers and for the staff control process, (2) staff planning including hiring, discharge, training and reallocation decisions, and (3) short term scheduling of available staff within the constraints determined by the two previous levels. The planning and scheduling decision models

are formulated as a stochastic programming problem incorporating policy decision variables. The problem is reduced and reformulated in terms of two models: (1) a Monte Carlo model for determining minimal staff capacities to meet a specified level of service, and (2) a linear programming model to determine the optimum staff allocations to satisfy minimal staffing levels for specified staffing policy. Hypothetical data is employed to illustrate model potential in hospital decision-making activities.

2.5 Major Outputs

Determination of optimum allocation and scheduling for a nursing staff given certain staffing policies.

2.6 Assumptions (a)/Constraints (c)/Hypotheses (h)

General Staff Planning and Scheduling Model

- (a-1) The demand for full-time equivalent employees at a particular location is assumed to be generated by a stochastic process that is stationary during each planning period.
- (a-2) On any particular day the demand for service in a particular ward may exceed the available staff level with a resulting penalty for unmet demand.
- (a-3) There is no benefit for overstaffing.
- (a-4) Utility is dependent on the chosen policy and the expected cost.

Short Term Scheduling Model

- (a-5) Two policies available for consideration are fixed staffing and controlled variable staffing.
- (a-6) The distribution function for nurse workload in a particular ward on a specified month exists and is continuous.

Staff Allocation Planning Model

- (c-1) The inflow of staff equals service demands and outflow for each ward during each planning period.
- (c-2) The effective availability of nurses is greater than or equal to the minimal staff capacity.
- (c-3) Movement or effective allocation of staff during the planning period is greater than or equal to zero.

3.0 TECHNICAL DESCRIPTORS

3.1 Model Type

Monte Carlo simulation for short term nurse scheduling model and linear programming for nurse staff planning model.

3.2 Model Characteristics

- (1) Monte Carlo Model - two policy alternatives, fixed staffing and controlled variable staffing are modeled. In both cases a risk level is defined in terms of the fraction of days when the number of assigned nurses to a particular ward in a specified month are less than required services (the model random variable). The model determines the minimum staff levels for each planning period to meet a specified risk criterion.
- (2) Linear Programming Model - The single objective function is to minimize the cost associated with staff allocation policies subject to the three constraints listed in section 2.6.

3.3 Data Utilized

Hypothetical data is utilized to test analytic formulation.

3.4 Input Variables

Short Term Scheduling Model

- (1) Mean, standard deviation and distribution function governing workload in ward j during planning period i ,
- (2) Number of wards (j),
- (3) Number and duration of planning periods (i), and
- (4) Additional unidentified variables.

Staff Allocation Planning Model

- (5) Number of persons to be moved from one location to another,
- (6) Cost of salary, moving and training a person,
- (7) Fraction left during period i of entering number of persons after attrition during t periods of training in location j and coming from source k ,
- (8) Efficiency in full-time equivalent persons during period i after t periods of training in location j and coming from source k ,
- (9) Output of short-term scheduling model, the required minimum effective staff level in period i and location j ,

- (10) Set of sources k from which persons can be moved to location j in the beginning of period i .
- (11) Set of sinks j to which persons in location k can be moved in the beginning of period i ,
- (12) Set of staffing locations,
- (13) Set of all training lengths for persons that enter the training pools in ward j in period i .

3.5 Output Variables

Short Term Scheduling Model

Required minimum effective staff level in period i and location j .

Staff Allocation Planning Model

The staffing costs associated with the allocations of personnel necessary to provide the effective staff level.

3.6 Verification/Applicability/Reliability

Subject to empirical validation of underlying model distributions and availability of data on input parameters, the model may have specific application in the nurse staffing process in acute hospitals and may be generally applicable to other service organizations with similar demand and production characteristics. The model structure is applicable to short-term assignment decisions and longer-term staff allocation decisions.

3.7 Computer Characteristics

None identified

1.0 IDENTIFICATION

1.1 Descriptive Title

Hospital Ancillary Services Planning Model

1.2 Developer's Name

Wynn Anthony Abranovic, Rensselaer Polytechnic Institute

1.3 References

Abranovic, 1969

2.0 GENERAL DESCRIPTORS

2.1 Development Status

Completed

2.2 Purpose and Sponsor

To develop a methodology to assist hospital administrators in predicting gross demand for hospital ancillary services, and to link service demands to departmental resource needs. PhD dissertation, supported by the Albany Medical Center Hospital.

2.3 Scope and Subject

Demand for services of the following departments: physical medicine and rehabilitation, hematology, microbiology, radiology, clinical chemistry, and the operating room.

2.4 Abstract

Regression analysis is used to obtain equations that predict the number of services requested in various hospital departments. The equations are incorporated into a deterministic simulation model of daily inpatient census to determine resource needs (manpower, equipment, floor space, costs, and revenues), associated costs, and revenues required in specified ancillary departments as a function of management decisions.

2.5 Major Outputs

See section 3.5

2.6 Assumptions (a)/Constraints (c)/Hypotheses (h)

- (a-1) There is a set of quantifiable relationships which can be embodied in a model such that the number of hospital inpatients at a particular time may be used to estimate the demands for services of certain hospital departments. Furthermore, the service demands can be linked to the departmental resource requirements so that financial conditions may be estimated.
- (a-2) Each department is treated independently; decisions for one department do not influence the consequences of decisions in any other departments.

3.0 TECHNICAL DESCRIPTORS

3.1 Model Type

Deterministic simulation model in conjunction with empirical regression equations.

3.2 Model Characteristics

Simulation model used to predict the daily inpatient census is combined with selected program controlled management decisions and empirical regression equations to estimate demands, resource requirements.

3.3 Data Utilized

Statistics for development of the model equations were obtained from 215 observations on each input variable from July 1, 1967 through January 31, 1968 at the Albany Medical Center Hospital.

3.4 Input Variables

- (1) Projected daily inpatient census for each service category (related to type of patient and hospital department) and number of admissions and transfers into these categories.

- (2) Number of employees in a department,
- (3) Previous year's direct depreciation,
- (4) Present floor space,
- (5) Previous year's cost of supplies,
- (6) Previous year's overhead cost,
- (7) Number of hours in a standard day,
- (8) Number of hours for each person of a class to work overtime,
- (9) Fractions of equivalent numbers of employees in each class to work part time and overtime,
- (10) Number of hours for each person of a class to work part time,
- (11) Total number of units of service in the past year,
- (12) Fraction of employees in Management, Middle Grade, and Lower Grade groups,
- (13) Average pay rate for each salary range, and
- (14) Average revenue per request for service.

3.5 Output Variables

For a particular day of the simulation period:

- (1) Number of employees in each pay grade,
- (2) Corresponding pay rates per hour,
- (3) Yearly direct depreciation,
- (4) Cost of supplies per service request,
- (5) Average revenue per service request,
- (6) Floor space,
- (7) Number of requests for service in each department,
- (8) Declaration of when the need arises to add and/or lay off employees, buy or sell equipment, increase or decrease floor space,
- (9) Accumulated man-days of employment,
- (10) Hours,
- (11) Wages,
- (12) Total requests for services,
- (13) Revenue,
- (14) Labor cost,
- (15) Depreciation,
- (16) Cost of supplies,
- (17) Cost of overhead
- (18) Surplus (profit or loss),
- (19) Break-even number of service units,
- (20) Surplus above the break-even point,
- (21) Days and man-days of non-full work loads, and
- (22) Total profits or loss in all departments simulated.

3.6 Verification/Applicability/Reliability

The methodology may be applied to any hospital; the specific equations developed in this work apply only to the Albany Medical Center Hospital. The model may be used for short-range or long-range planning.

3.7 Computer Characteristics

Written in Fortran IV

1.0 IDENTIFICATION

1.1 Descriptive Title

Present and Future Supply of Registered Nurses

1.2 Developer's Name

Stuart H. Altman

1.3 References

Altman, 1971

2.0 GENERAL DESCRIPTORS

2.1 Development Status

Completed and used to project 1970-1980 admissions.

2.2 Purpose

To determine the importance of the factors influencing high school graduates to enter nursing.

2.3 Scope and Subject

Projection of admissions to associate degree programs, diploma admissions, and baccalaureate admissions.

2.4 Abstract

A supply model for new admissions to nurse training programs is developed. Two versions of the model and their reduced forms were estimated, one including the variable "diploma admission rate in year t" in the equation for associate degree admissions, and the other version excluding the variable. The models were estimated using 1956-69 data, and used to project admissions in the period 1970-1980.

2.5 Major Outputs

Projection of new admissions to nurse training programs.

2.6 Assumptions (a)/Constraints (c)/Hypotheses (h)

- (a-1) The demand for health services will continue to grow relative to other sectors requiring large numbers of female professionals, leading to continued greater wage increases for nurses; the differential growth rate will slow down.
- (a-2) Wages for baccalaureate nurses will grow at a rate relative to teacher earnings equal to the average recorded for the last 5 years, reaching a ratio of 1.2 by 1980.
- (a-3) The growth in earnings will be slower for the associate degree and diploma graduate.

3.0 TECHNICAL DESCRIPTORS**3.1 Model Type**

Regression Analysis

3.2 Model Characteristics

Two models, 3 equations each; 6 independent variables and 3 dependent variables. The following are the specific variables included in each regression equation. The dependent (output) and independent (input) variables are those identified in sections 3.5 and 3.4 respectively.

	Dependent Variable	Independent Variables
Model 1	$\begin{pmatrix} (1) \\ (2) \\ (3) \end{pmatrix}$	$\begin{pmatrix} (1) \\ (1) \\ (1) \end{pmatrix}, \begin{pmatrix} (5) \\ (3) \\ (4) \end{pmatrix}, \begin{pmatrix} (2) \\ (6) \end{pmatrix}$
Model 2	$\begin{pmatrix} (1) \\ (2) \\ (3) \end{pmatrix}$	$\begin{pmatrix} (1) \\ (1) \\ (1) \end{pmatrix}, \begin{pmatrix} (2) \\ (6) \\ (4) \end{pmatrix}, (3)$

3.3 Data Utilized

Data sources for the development of the models are listed in the Data Source Index number (133) and (90).

3.4 Input Variables

- (1) Ratio of average beginning level wages of general nurses in period t to average beginning level wages of public school teachers in period t ,
- (2) Growth function representing the growth process of associate degree nursing programs,
- (3) Growth function representing the growth process of diploma nursing programs,
- (4) Growth function representing the growth process of baccalaureate degree nursing programs, and
- (5) Diploma admission rate, and
- (6) Associate degree admission rate.

3.5 Output Variables

- (1) Associate degree admission rate in year t ,
- (2) Diploma admission rate in year t ,
- (3) Baccalaureate admission rate in year t ,

3.6 Verification/Applicability/Reliability

Both versions of the model were used to project admission rates and number of admissions for 11 years (1970 to 1980), and the forecasts were compared. The developer states that "the relative value of the alternative projection models should be evident within the next few years."

3.7 Computer Characteristics

None identified

1.0 IDENTIFICATION

1.1 Descriptive Title

Behavioral Model of Families' Use of Health Services

1.2 Developer's Name

Ronald Andersen

1.3 References

Andersen, 1968

2.0 GENERAL DESCRIPTORS

2.1 Development Status

Completed

2.2 Purpose and Sponsor

To contribute to research into the interrelationships of social factors and use of health services. Model development sponsored by the US Public Health Service.

2.3 Scope and Subject

Families' total use of health services.

2.4 Abstract

A theoretical foundation of a behavioral model of health service use is developed and the construction of the variables discussed. Three proposed hypotheses are tested with 1964 data, and the results (correlation and variance) analyzed.

2.5 Major Outputs

The relationships of units of use of five health services: hospital, physician, drugs, dental, and other services, to the input variables.

2.6 Assumptions (a)/Constraints (c)/Hypotheses (h)

- (h-1) The amount of health services used by a family will be a function of the predisposing and enabling characteristics of the family and its need for medical care. Each component will make an independent contribution to the understanding of differences in use.
- (h-2) The explanatory components of the model will vary in their contribution to the explanation of total use. Need will be more important than the predisposing and enabling components because it represents factors most directly related to use.
- (h-3) The contribution of each component will vary according to type of health service: (1) the contribution of need will be greatest for hospital service; (2) the contribution of predisposing and enabling components will be greatest for dental services; and (3) all will contribute to understanding physician services.

3.0 TECHNICAL DESCRIPTORS

3.1 Model Type

Correlation and variance analysis

3.2 Model Characteristics

The model consists of three components: a predisposing component (including subcomponents: family composition, social structure and health beliefs), an enabling component (including subcomponents: family resources and community resources), and a need component (including illness and response subcomponents). Relationships between the independent and dependent variables are examined using correlation and variance analysis; no equations are developed.

3.3 Data Utilized

Data was obtained from the Bureau of Labor Statistics (hospital daily service charges) and the California Medical Association (physician use).

3.4 Input Variables

- (1) Family size,
- (2) Sex of head of family,
- (3) Marital status of head,
- (4) Age of the head,
- (5) Age of oldest and youngest members,
- (6) Employment,
- (7) Social class,
- (8) Occupation of main earner,
- (9) Education of head,
- (10) Ethnicity,
- (11) Race,
- (12) Value of health services,
- (13) Value of physicians,
- (14) Value of good health,
- (15) Value of health insurance,
- (16) Attitude toward health services,
- (17) Attitude toward physician use,
- (18) Knowledge of disease,
- (19) Income,
- (20) Savings,
- (21) Health insurance,
- (22) Regular source of care,
- (23) Welfare care,
- (24) Physician ratio,
- (25) Hospital bed ratio,
- (26) Residence,
- (27) Region,
- (28) Symptoms,
- (29) Disability days,
- (30) Health level,
- (31) Free care for major illness,
- (32) Seeing doctor for symptoms, and
- (33) Regular physical examinations.

3.5 Output Variables

Outputs developed consist of the Pearson product moment correlations variance analysis between the following dependent variables and the variables listed in section 3.4:

- (1) Units of use of hospitals,
- (2) Units of use of physicians,
- (3) Units of use of drugs,
- (4) Units of use of dentists, and
- (5) Units of use of other services to the inputs.

3.6 Verification/Applicability/Reliability

Since no model is constructed, no verification of the model can be made. Reliability of the correlation and variance analysis is dependent on the applicability of the 1964 data to the present time.

3.7 Computer Characteristics

None identified

1.0 IDENTIFICATION

1.1 Descriptive Title

Model of Health Status in New Mexico

1.2 Developer's Name

James G. Anderson, Purdue University

1.3 References

Anderson, 1972

2.0 GENERAL DESCRIPTORS

2.1 Development Status

Completed

2.2 Purpose and Sponsor

Prediction of direct and indirect effects on health status of changes in population structure resulting from natural causes or the intervention of health programs. Model development supported by the National Center for Health Services Research and Development and the Purdue Research Foundation.

2.3 Scope and Subject

Causal model of health status in New Mexico

2.4 Abstract

A model of causal relationships among eleven linearly related social, demographic, and economic variables is hypothesized to describe the health status of the population. The model consists of seven linear regression equations with the dependent variable of the first equation becoming an independent variable in the second, etc., until the final equation relates the mortality from accidents, suicide and cirrhosis of the liver in 1968 to the remaining ten variables.

2.5 Major Outputs

Hospital beds available to the population and mortality from accidents, suicide and cirrhosis of the liver.

2.6 Assumptions (a)/Constraints (c)/Hypotheses (h)

- (a-1) There are no unmeasured variables except the residual variables.
- (a-2) These residuals are uncorrelated.
- (a-3) Each dependent variable is directly linked to all other variables that precede it in the postulated causal sequence.

3.0 TECHNICAL DESCRIPTORS

3.1 Model Type

Regression Analysis

3.2 Model Characteristics

7 equations, each with 1 dependent variable and 4 to 10 independent variables. The following provides the functional relationship between the dependent (output) and independent (input) variables listed in sections 3.5 and 3.4 respectively.

Dependent Variable	Independent Variables
(1)	(1)-(4)
(2)	(1)-(5)
(3)	(1)-(6)
(4)	(1)-(7)
(5)	(1)-(8)
(6)	(1)-(9)
(7)	(1)-(10)

3.3 Data Utilized

Data for estimation of the equations was obtained from the New Mexico State Department of Health and Social Services, the US Census, and the New Mexico Bureau of Business Research.

3.4 Input Variables

- (1) Per cent of labor force in agriculture 1968,
- (2) Per cent urban 1960,
- (3) Per cent Spanish-American or Mexican-American 1960,
- (4) Per cent non-white 1960,
- (5) Net migration 1960-69,
- (6) Median age 1960,
- (7) Median education 1960,
- (8) Per cent unemployed 1968,
- (9) Per capita income 1967,
- (10) Hospital beds/population ratio 1968.

3.5 Output Variables

- (1) Net migration 1960-69,
- (2) Median age 1960,
- (3) Median education 1960,
- (4) Per cent unemployed 1968,
- (5) Per capita income 1967,
- (6) Hospital beds/population ratio 1968,
- (7) Mortality from accidents, suicide and cirrhosis of the liver 1968.

3.6 Verification/Applicability/Reliability

The methodology may be applied to any population; the specific model developed applies to the health services system serving the state of New Mexico.

3.7 Computer Characteristics

None identified

1.0 IDENTIFICATION

1.1 Descriptive Title

The Production of Health, An Exploratory Study

1.2 Developer's Names

Richard Auster, City College of the City University of New York,
Irving Leveson, New York City Department of City Planning, Deborah Saracheck

1.3 References

Auster, Leveson & Sarachek, 1969

2.0 GENERAL DESCRIPTORS

2.1 Development Status

Completed

2.2 Purpose and Sponsor

To estimate the elasticity of the age-adjusted death rate with respect to medical services; to determine the causes of geographic variation in health. Model development was supported by the Ford Foundation, the Commonwealth Fund, and IBM Corporation.

2.3 Scope and Subject

The relationship of mortality of whites to medical care and environmental variables.

2.4 Abstract

The relationship of mortality of whites to both medical care and environmental variables is examined in a regression analysis across states using 1960 census data. Medical care is alternatively measured by expenditures and by the output of a Cobb-Douglas production function combining the services of physicians, paramedical personnel, capital, and drugs. Both two-stage least squares and ordinary least squares estimates are presented. Possible explanations of the absence of an expected decline in the age-adjusted death rate in recent years are given.

2.5 Major Outputs

Determination of age-sex adjusted death rates.

2.6 Assumptions (a)/Constraints (c)/Hypotheses (h)

- (a-1) Genetic factors either are reasonably constant across states, or do not vary systematically with the independent variables, so that the other variables are assumed not to be influenced by genetic effects on health.
- (a-2) The amount of medical services produced in an area equals the amount consumed there.
- (a-3) Health is a function of this year's medical services only.
- (a-4) The production function of medical services exhibits constant returns to scale.
- (a-5) A constant proportion of medical services is devoted to prolonging life as opposed to reducing pain or other health-related goals.
- (a-6) Per capita usage of medical services by whites in a state is the same as for the entire population.
- (a-7) Medical schools disseminate information and provide continuous training to physicians in the community.
- (c-1) The analysis is restricted to whites.
- (h-1) Health is a function of the amount of medical services consumed in the state and certain environmental variables.
- (h-2) The quality of medical care will be higher and the technology more advanced in hospitals associated with medical schools than in others.

3.0 TECHNICAL DESCRIPTORS

3.1 Model Type

Regression Analysis

3.2 Model Characteristics

The basic model is a production function for health. Model I measures medical care by expenditures on medical care per capita; in Model II a production function for medical services is specified. Model I is estimated by ordinary and two-stage least squares, linear and in logarithms. Model II, which disaggregates medical services into four components, number of physicians per capita, number of paramedical personnel per capita, medical capital per capita, and prescription drug expenditures per capita, is estimated by ordinary and two-stage least squares in logarithms. The following are the specific variables included in each regression equation. The dependent (output) and independent (input) variables are those identified in sections 3.5 and 3.4 respectively.

	Dependent Variable	Independent Variables
Model I	(1) (1) (1)	(1)-(7), (10), (11) (2)-(7), (10), (11) (2)-(11)
Model II	(1)	(2)-(7), (10), (12)-(16)

3.3 Data Utilized

Data source for the regression was the US Bureau of the Census, *Statistical Abstract of the United States, 1967*, Washington, D. C., US Government Printing Office.

3.4 Input Variables

- (1) Per cent white,
- (2) Income,
- (3) Education,
- (4) Per cent of population inside standard metropolitan statistical areas,
- (5) Per cent employed in manufacturing,
- (6) Alcohol consumption per capita,
- (7) Cigarette consumption per capita,
- (8) Per cent in white-collar occupations,
- (9) Married women out of the labor force,
- (10) Medical school presence in state,
- (11) Expenditures on medical care per capita,
- (12) Number of physicians per capita,
- (13) Number of paramedical personnel per capita,
- (14) Medical capital per capita,
- (15) Prescription drug expenditures per capita, and
- (16) Per cent of practicing physicians in group practice.

3.5 Output Variables

Age-sex adjusted death rate

3.6 Verification/Applicability/Reliability

Since the data used to estimate the model parameters was obtained from the 1960 census, it is questionable whether the model is applicable to current problems.

3.7 Computer Characteristics

None identified

1.0 IDENTIFICATION

1.1 Descriptive Title

Patient Characteristics, Hospital Services and Length of Stay

1.2 Developer's Name

Ronald R. Baer, University of Minnesota

1.3 References

Baer, 1971

2.0 GENERAL DESCRIPTORS

2.1 Development Status

Completed

2.2 Purpose and Sponsor

To measure the simultaneous effect on length of stay of selected patient characteristics and consumption of selected hospital services. The research was undertaken to fulfill requirements of the Administrative Residency, School of Public Health, University of Minnesota.

2.3 Scope and Subject

Length of hospital stay in the internal medicine service of a private, voluntary teaching hospital.

2.4 Abstract

Multiple least squares and stepwise regression with analysis of variance is used to test two hypotheses concerning the relationship of patient characteristics and hospital service utilization to length of stay. Two groups of 100 patients each are studied, special care unit admissions and regular nursing unit admissions. The first hypothesis is partially accepted for medical special care unit admissions and accepted for regular nursing unit admissions; the second hypothesis is also accepted.

2.5 Major Outputs

Estimation of length of stay.

2.6 Assumptions (a)/Constraints (c)/Hypotheses (h)

(a-1) If hospital output is the treatment or resolution of a patient's problem(s), then the time involved (length of stay) can be a proxy indicator of the difficulty of diagnosing and/or treating the problem(s).

(a-2) Patients who have longer lengths of stay should have problems which are more difficult to resolve, will have different personal characteristics, and will have more hospital services generated on their behalf.

(h-1) The following patient characteristics and consumption of the following hospital services will have an effect on length of hospital stay for patients in both groups:

- (1) Age,
- (2) Sex,
- (3) Race,
- (4) Living with someone or living alone,
- (5) Employed or unemployed,
- (6) Method of paying hospital bill,
- (7) Discharge diagnosis,
- (8) Number of days in special care unit,
- (9) Mode of admission to the hospital,
- (10) Pathology Laboratory,
- (11) Radiology,
- (12) Nuclear medicine,
- (13) Electrocardiology,
- (14) Special procedures,
- (15) Inhalation Therapy,
- (16) Electroencephalography,
- (17) Physical Therapy,
- (18) Medications.

(h-2) Given that patients come to the hospital with differing degrees of illness, patients characteristics and consumption of hospital services will not provide equal explanations of variations in length of stay for patients of differing degrees of illness.

3.0 TECHNICAL DESCRIPTORS

3.1 Model Type

Regression Analysis

3.2 Model Characteristics

- 2 equations, each with one dependent variable.
 Special care unit - 3 significant independent variables
 Regular nursing unit - 7 significant independent variables

3.3 Data Utilized

Data for the study was obtained from a computer printout showing total days of hospitalization and individual units of service, and from the patient's medical record, for two groups of 100 patients each in a general acute voluntary hospital of over 500 beds, located in Cleveland, Ohio.

3.4 Input Variables

- (1) Living with someone, living alone or unreported,
- (2) Method of payment,
- (3) Mode of admission,
- * (4) Pathology Laboratory,
- (5) Radiology,
- (6) Physical Therapy,
- * (7) Number of medication orders,
- * (8) Days spent in Special Care Unit (Special Care Unit Model only).

*Special Care Unit variables

3.5 Output Variables

Length of stay

3.6 Verification/Applicability/Reliability

The model is based on a single private, voluntary, teaching hospital; the developer states that general inferences should be accepted cautiously.

3.7 Computer Characteristics

None identified

1.0 IDENTIFICATION

1.1 Descriptive Title

Linear Programming Model to Determine Optimum Mix of Hospital Patients

1.2 Developer's Names

Helmy H. Baligh, Danny J. Laughhunn

1.3 References

Baligh & Laughhunn, 1969

2.0 GENERAL DESCRIPTORS

2.1 Development Status

The theoretical model is developed; the parameters have not been estimated.

2.2 Purpose and Sponsor

To develop an economic measure of hospital output, distinguishing between the relative value of various patient classes to the hospital. This report is based on a paper presented at the Tenth Annual Hospital Executive Development Institute, March, 1969. Sponsor not identified.

2.3 Scope and Subject

Planning hospital admissions by patient equivalence class.

2.4 Abstract

A theoretical linear programming economic model of the hospital for planning admissions is constructed. The model is based on the concept of patient equivalence classes which are defined by requirements for goods and services and by sets of weights assigned by the hospital to fulfilling those requirements. The objective function to be maximized is the weighted sum of patients treated in equivalence classes subject to the constraints listed in section 2.6. The empirical parameters of the model have not been estimated.

2.5 Major Outputs

Number of patients to be admitted that maximizes the hospital's terminal output consistent with its resources and goals.

2.6 Assumptions (a)/Constraints (c)/Hypotheses (h)

- (a-1) Each potential patient can be assigned to one of m equivalence classes on the basis of his "value" and his requirements for hospital-supplied goods and services.
- (a-2) The objective of the hospital is to maximize a weighted sum of the number of patients admitted from the equivalence classes.
- (a-3) The technology of the hospital is adequately described by a linear relationship between outputs of services and inputs of resources.
- (a-4) The quantities of some of the necessary resources are fixed and unalterable.
- (a-5) The time period for the analysis is fixed but arbitrary.
- (a-6) Patient admissions can be completely controlled by the hospital.
- (a-7) The requirements of all patients in an equivalence class are homogeneous.
- (a-8) The technology used for each good or service is independent of the receiving equivalence class.
- (a-9) The hospital administration places equal emphasis on the treatment of regular and indigent patients within equivalence classes.
- (c-1) Limits of technology and fixed resources.
- (c-2) Upper limit on the number of patients available for admission within each equivalence class.
- (c-3) Maximum constraint on aggregate budget of the hospital.
- (c-4) Lower limit on the minimum acceptable number of patients from each equivalence class for teaching purposes (policy constraint).
- (c-5) Prespecification of the fraction of indigent patients in each equivalence class which must be treated (policy constraint).

3.0 TECHNICAL DESCRIPTORS

3.1 Model Type

Linear programming

3.2 Model Characteristics

The model consists of maximization of a linear objective function (weighted value sum of patient classes treated) subject to five constraint inequalities, a resource constraint, patient constraint, budgetary constraint, and two policy constraints.

3.3 Data Utilized

No data is utilized.

3.4 Input Variables

- (1) Patient weights,
- (2) Prices,
- (3) Target profit level,
- (4) Patient restrictions (minimum number acceptable, total number),
- (5) Resource limits,
- (6) Input costs,
- (7) Fixed costs,
- (8) External subsidy,
- (9) Requirements vectors,
- (10) Technological coefficients, and
- (11) Data on patient requirements and uses.

3.5 Output Variables

The optimum mix of patients which will maximize the weighted sum of patients treated in all equivalence classes subject to the constraints noted in section 2.6.

3.6 Verification/Applicability/Reliability

Subject to data availability, the model may be applied to hospitals for short-range decision planning problems.

3.7 Computer Characteristics

None identified

1.0 IDENTIFICATION

1.1 Descriptive Title

Prediction of Future Hospital Bed Needs

1.2 Developer's Name

Henri L. Beenhakker, Purdue University

1.3 References

Beenhakker, 1963

2.0 GENERAL DESCRIPTORS

2.1 Development Status

Completed

2.2 Purpose and Sponsor

Development of a reliable, accurate method for prediction of future hospital bed needs. Model development was sponsored by Community Hospital, Indianapolis, Indiana.

2.3 Scope and Subject

Prediction of future demand for beds in the Community Hospital.

2.4 Abstract

The relationship between number of patients and 117 factors believed to influence this number was tested graphically and by simple regression analysis, and the factors that seemed to be of sufficient influence on the number of patients were included in regression equations. Seventeen multiple regression analyses were run, one for each case classification.

2.5 Major Outputs

Prediction of number of patients per month

2.6 Assumptions (a)/Constraints (c)/Hypotheses (h)

None identified

3.0 TECHNICAL DESCRIPTORS**3.1 Model Type**

Regression Analysis

3.2 Model Characteristics

7 equations, 17 dependent variables, 22 independent variables. The following are the specific variables included in each regression equation. The dependent (output) and independent (input) variables are those identified in sections 3.5 and 3.4 respectively.

Dependent Variables

(1)
(2)
(3)
(4)
(5)
(6)
(7)
(8)
(9)
(10)
(11)
(12)
(13)
(14)
(15)
(16)
(17)

Independent Variables

(1), (2), (3), (4),
(5)
(1), (6),
(1), (6), (7), (8),
(10), (11),
(1),
(1), (12),
(13),
(1), (14),
(15),
(9),
(1),
(6), (16), (17),
(18),
(16), (19),
(1), (20), (21),
(17), (22),

3.3 Data Utilized

Data for the study was obtained from the Community Hospital, Indianapolis, Indiana. Fifty-seven data sets, monthly data during the period September 1957 to May 1962, were available for the analysis

3.4 Input Variables

- (1) Payment nonprivate,
- (2) Occupancy of voluntary hospitals,
- (3) Age group 20-29 years,
- (4) Number of unemployed people,
- (5) Interaction of effective buying income and income per patient day,
- (6) Age group 70 years and older,
- (7) Total number of physicians in Indianapolis,
- (8) Number of specialists in hospital,
- (9) Number of births in Indiana,
- (10) Effective buying income,
- (11) Average length of stay,
- (12) Percentage of deaths,
- (13) Interaction of number of GPs and number of physicians in Indianapolis,
- (14) Indiana population,
- (15) Income per patient day,
- (16) Interaction of average length of stay and payment nonprivate,
- (17) Interaction of average length of stay and effective buying income,
- (18) Number of automobile accidents in Marion County,
- (19) Number of GPs,
- (20) Marion County population,
- (21) Interaction of average length of stay and age group 70 years and older, and
- (22) Interaction of number of physicians in Indianapolis and number of births in Indiana.

3.5 Output Variables

Number of patients per month for the following classification of cases:

- (1) Obstetrics,
- (2) Newborn,
- (3) Medicine,
- (4) Cardiology,
- (5) Communicable,
- (6) Dermatology,
- (7) Neurology,
- (8) Psychiatry,
- (9) Surgery,
- (10) Ear-Nose-Throat,
- (11) Gynecology,
- (12) Neuro-surgery,
- (13) Ophthalmology,
- (14) Orthopedics,
- (15) Proctology,
- (16) Urology,
- (17) Pediatrics (children under 14 years)

3.6 Verification/Applicability/Reliability

Since the model was estimated using data for a single hospital, from the late 1950's and early 1960's, it is unlikely that the model is generally applicable to current problems or long-range planning.

3.7 Computer Characteristics

IBM 7090

1.0 IDENTIFICATION

1.1 Descriptive Title

A Three-Equation Model for the Registered Nurse Labor Market

1.2 Developer's Name

Lee Benham, Stanford University

1.3 References

Benham, 1970 & 1971

2.0 GENERAL DESCRIPTORS

2.1 Development Status

Completed

2.2 Purpose and Sponsor

To provide estimates of the net effects of shifts in demand, changes in the cost of substitutes, and changes in the supply of training facilities on the market behavior of female registered nurses (RN). PhD dissertation, supported by the Ford Foundation and the University of Chicago.

2.3 Scope and Subject

A supply and demand model for RNs

2.4 Abstract

The model provides information on the labor market for female registered nurses by specifying three equations: demand (registered nurses' median income as a function of labor force participation rate, stock of nurses, attendant's wage rate, and per capita income), supply (labor force participation rate as a function of wage rate, husband's income, and number of small children), and supply-geographical distribution (stock of nurses as a function of wage rate, husband's income, and nursing graduates). The parameters were estimated by three-stage least-squares for 1950 and 1960 data and the results compared. To

measure the net impact of the exogenous variables on the endogenous variables, the equations were solved for the endogenous variables in terms of the exogenous variables, and the 1950 and 1960 coefficients were analyzed and compared to determine the effect of individual variables on demand and supply and the changing magnitude of the effect. Using the estimates of the coefficients it is possible to examine the impact on this labor market of such factors as rising per capita income, falling birth rates, rising incomes of husbands of registered nurses, increases in the number of substitutes for registered nurses, and increases in the number of nursing schools.

2.5 Major Outputs

Estimates of median RN wage rate, total stock of nurses, and RN labor force participation rate.

2.6 Assumptions (a)/Constraints (c)/Hypotheses (h)

Demand Side:

- (a-1) The change in wages paid to RNs w.r.t. the change in per capita stock of RNs in a state is less than zero.
- (a-2) The change in wages paid to RNs w.r.t. the change in labor force participation rate of RNs is less than zero.
- (a-3) The change in wages paid to RNs w.r.t. the change in per capita income is greater than zero.
- (a-4) The change in wages paid to RNs w.r.t. the change in income of practical nurses is greater than zero.
- (a-5) The change in wages paid to RNs w.r.t. the change in income of physicians is greater than zero.
- (a-6) The change in wages paid to RNs w.r.t. the change in income of attendants is greater than zero.
- (a-7) The change in wages paid to RNs w.r.t. the change in hospital beds per capita is greater than zero.

Supply Side:

- (a-8) The change in labor force participation rate of RNs w.r.t. the change in wages paid to RNs is greater than zero.
- (a-9) The change in labor force participation rate of RNs w.r.t. the change in the number of children under 5 per 1000 and women age 15-49 ever married by state is less than zero.

- (a-10) The change in labor force participation rate of RNs w.r.t. the change in median annual incomes of male heads of families in the experienced labor force is less than zero.
- (a-11) The change in labor force participation rate of RNs w.r.t. the change in percentage of urbanization is greater than zero.
- (a-12) The change in labor force participation rate of RNs w.r.t. change in male unemployment is less than zero.
- (a-13) The change in per capita stock of RNs in a state w.r.t. the change in wages paid to RNs is greater than zero.
- (a-14) The change in per capita stock of RNs in a state w.r.t. the change in median annual incomes of male heads of families in the experienced labor force is greater than zero.
- (a-15) The change in per capita stock of RNs in a state w.r.t. the change in percentage of urbanization is greater than zero.
- (a-16) The change in per capita stock of RNs in a state w.r.t. the change in the number of registered nurses graduating within a state is greater than zero.
- (c-1) The coefficients of per capita stock of RNs in a state and labor force participation rate of RNs are constrained to be equal.

3.0 TECHNICAL DESCRIPTORS

3.1 Model Type

Regression Analysis

3.2 Model Characteristics

Three major modules, a demand module which provides the median RN income and two supply modules which estimate the RN labor force participation rate and the geographical distribution of RNs. The demand equation includes 4 independent variables; each supply equation includes 3 independent variables.

Dependent Variables

(1)
(2)
(3)

Independent Variables

(1), (2), (7), (8)
(3), (5), (6)
(3), (4), (6)

3.3 Data Utilized

Data for estimation of the model was obtained from (117), (115), and (140) in the Data Source Index.

3.4 Input Variables

- (1) Per capita personal income in state.
- (2) Median earnings of hospital and other institutional attendants in the experienced civilian labor force with known income in state.
- (3) Median income of male heads of families in state.
- (4) Number of children under 5 years of age/number of women between ages of 15 and 49 ever married in state.
- (5) Total graduations from schools of nursing in state ten years earlier per 100,000 current population in state.
- (6) Median income of female registered nurses in the experienced civilian labor force in state.
- (7) Total female registered nurses per 100,000 population in state.
- (8) Labor force participation rate of female registered nurses in state.

3.5 Output Variables

- (1) Median income of female registered nurses in the experienced civilian labor force in state.
- (2) Total female registered nurses per 100,000 population in state.
- (3) Labor force participation rate of female registered nurses in state.

3.6 Verification/Applicability/Reliability

Since the data used to specify the parameters of the model applies to 1950 and 1960, and some of the data were only crude proxies for the desired information, it is questionable whether the model is applicable to current problems. The model is intended for use in short-range planning.

3.7 Computer Characteristics

IBM 7094 computer

1.0 IDENTIFICATION

1.1 Descriptive Title

Migration, Location and Remuneration of Physicians and Dentists

1.2 Developer's Names

L. Benham, A. Maurizi and M. W. Reder, Stanford University

1.3 References

Benham, Maurizi & Reder, 1968

2.0 GENERAL DESCRIPTORS

2.1 Development Status

Completed and estimated with 1950 data

2.2 Purpose and Sponsor

To investigate how well the distribution of the national stocks of physicians and dentists among areas corresponds to the distribution of population, and to investigate other factors influencing distribution. Model development was sponsored by the Ford Foundation.

2.3 Scope and Subject

Number of all physicians, self-employed physicians, and dentists.

2.4 Abstract

The influence of various factors on number, change in number, and per capita number of physicians and dentists is examined by considering cross-sectional regressions for 1930, 1940, 1950, and 1960. Possible explanations for the observed regression coefficients are discussed. A two equation supply and demand model to determine the location of physicians and dentists is developed. The findings suggest that physicians and dentists migrate with the effective

demand for their services, and that effective demand for medic services within a state has depended mainly upon its population, and secondarily upon its per capita income.

2.5 Major Outputs

Estimates of supply of and demand for self-employed physicians.

2.6 Assumptions (a)/Constraints (c)/Hypotheses (h)

(a-1) The volume of training facilities in the state and percentage of applicants for licensure who fail the examinations in the state are exogenous variables.

3.0 TECHNICAL DESCRIPTORS

3.1 Model Type

Regression Analysis

3.2 Model Characteristics

Two equations, estimated by two-stage least squares, with 1950 data. One dependent variable and 3 independent variables in the demand equation; one dependent variable and 5 independent variables in the supply equation.

3.3 Data Utilized

Sources for the data utilized in the regressions include reference numbers (20), (113), (55), (151), (59), (62), (150), (5), (140), (16), (25), (117), (44) and (153) in the Data Source Index.

3.4 Input Variables

- * (1) Population of the i^{th} state,
- * (2) Total personal income of the i^{th} state,
- (3) Number of places in medical classes in the i^{th} state,

(4) Percentage of applicants for licensure who fail examinations in the i^{th} state,

(5) Population in i^{th} state living in urban areas of more than 2,500 persons, and

* (6) Average income of physicians and dentists.

* demand equation

Supply equation - all variables except (2)

3.5 Output Variables

Number of physicians and dentists in the i^{th} state.

3.6 Verification/Applicability/Reliability

The model is internally valid, although the developers note that they have grave misgivings about the specification assumption that the number of places in medical classes in a state and the percentage of applicants for licensure who fail examinations are exogenous variables. Since the data used to estimate the parameters is of poor quality and is from the year 1950, it is unlikely that the model is applicable to current problems.

3.7 Computer Characteristics

None identified

1.0 IDENTIFICATION

1.1 Descriptive Title

Hours of Labor Offered by the Registered Nurse

1.2 Developer's Name

Mario Bognanno, University of Iowa

1.3 References

Bognanno, 1969

2.0 GENERAL DESCRIPTORS

2.1 Development Status

Completed

2.2 Purpose and Sponsor

To develop a separate economic decision model for the single and married professional nurse which explains her market work behavior. PhD dissertation, supported by the US Public Health Service.

2.3 Scope and Subject

Hours per week of nursing services offered by the individual single and married professional nurse.

2.4 Abstract

Two theoretical decision models for hours of nursing services offered by married and single professional nurses are developed and tested using data from a cross-sectional random sample of professional nurses. A market work-leisure choice model was used to explain hours of service offered by single nurses; a more generalized model of utility maximization was used to explain the market work behavior of married nurses. Cross-section data is obtained from a random sample of 2,002 individual nurses in Iowa for August and September, 1968. Estimates of the parameters were computed by using multiple regression analysis, and the estimated coefficients were interpreted.

2.5 Major Outputs

Estimates of hours of nursing service worked per week.

2.6 Assumptions (a)/Constraints (c)/Hypotheses (h)

- (a-1) Wages are determined by market forces and the individual nurse's market work decision will leave them unaffected,
- (a-2) All single and married nurses are alike in every other respect and all jobs are similar,
- (a-3) The included variables will not be biased by omitting factors of individual differences in tastes.

3.0 TECHNICAL DESCRIPTORS**3.1 Model Type**

Regression Analysis

3.2 Model Characteristics

2 equations (one for single nurses, one for married nurses), one with 7 independent variables, the other with 11 independent variables.

3.3 Data Utilized

Data was obtained from a mail questionnaire survey of a 10 per cent random sample of all registered nurses who were (1) residents of Iowa, (2) 65 years old or under, and (3) non-members of any religious order, resulting in 1,273 questionnaires acceptable for analysis.

3.4 Input Variables

- * (1) "Expected" hourly wage rate,
- * (2) Reported non-wage income,
- * (3) Age of the nurse,
- * (4) Age of the nurse squared,
- * (5) Community size (under 10,000, 10,000 or more),

*Independent variable used for single nurses

*(6) and *(7) Rents dwelling unit, buying dwelling unit, or owns dwelling unit or room "rent free".

(8) "Expected" or "permanent" husband's income,

(9) "Transitory" husband's income,

(10) Presence of child under 6; no child under 6,

(11) Number of children residing at home, and

(12) Number of children residing at home squared.

*Independent variable used for single nurses

3.5 Output Variables

Reported hours of nursing services worked per week.

3.6 Verification/Applicability/Reliability

Model is internally valid. The theoretical models are applicable to various populations of nurses; since the parameters of the models are estimated using 1968 data for nurses in Iowa, it is questionable whether the specific models are generally applicable to current problems.

3.7 Computer Characteristics

None identified

1.0 IDENTIFICATION

1.1 Descriptive Title

A Hospital Inpatient Classification System

1.2 Developer's Name

Robert J. Connor, The Johns Hopkins University

1.3 References

Connor, 1960

2.0 GENERAL DESCRIPTORS

2.1 Development Status

Completed

2.2 Purpose and Sponsor

To examine the behavior of nursing units and hospitals for improved understanding of the hospital inpatient system. PhD dissertation, supported by the Johns Hopkins Hospital and the US Public Health Service.

2.3 Scope and Subject

Development of a patient classification system and its use for estimating staffing needs.

2.4 Abstract

A methodology to assign hospital inpatients to different categories according to their degree of illness is described. A patient's degree of illness (and therefore his need for direct nursing care) is reflected by his degree of self-sufficiency, which can be determined from observable characteristics. These primary factors were identified and grouped into combinations so as to form three categories of patients, self-care, partial care, and total care. Work measurement and work sampling studies were done to determine the direct patient care requirements of each group and the relationship of the direct patient case load to the total nursing

work load. Implications for staffing systems are discussed, and it is concluded that a controlled variable staffing system has the potential to reduce personnel requirements and to better utilize personnel than a fixed staffing system. The patient classification system developed in this study is the basis of later hospital studies.

2.5 Major Outputs

Estimation of time spent by nurses in productive activity and a system for classifying hospital inpatients.

2.6 Assumptions (a)/Constraints (c)/Hypotheses (h)

None identified

3.0 TECHNICAL DESCRIPTORS

3.1 Model Type

Regression Analysis

3.2 Model Characteristics

Two models, one bivariate and one trivariate, explaining 61% and 80% respectively of the variation in time spent in productive activity.

3.3 Data Utilized

Data for the study was obtained from single-observer work sampling studies of medical, surgical and ophthalmological wards at the Johns Hopkins Hospital during 1958 and 1959.

3.4 Input Variables

- (1) Index (weighted sum of numbers of patients in each category indicating amount of direct care required per staffing period).
- (2) Number of personnel hours scheduled.

3.5 Output Variables

- (1) Amount of time spent in productive activity.

3.6 Verification/Applicability/Reliability

The results of analysis of variance and t-tests used to test the variability of the classification scheme were accepted. The model is of use for day-to-day staff scheduling; its reliability is dependent on the agreement of the direct care requirements of each patient category in the hospital in which the model is being applied to the requirements determined in the specification of the model.

3.7 Computer Characteristics

Regression analyses were performed on an IBM 704.

D1

1.0 IDENTIFICATION

1.1 Descriptive Title

Demand for Health and Medical Care: An Econometric Model

1.2 Developer's Name

Lewis Dars, New School for Social Research

1.3 References

Dars, 1971

2.0 GENERAL DESCRIPTORS

2.1 Development Status

The theoretical models have been completed and tested empirically by regression analysis.

2.2 Purpose and Sponsor

To develop a theoretical and empirical framework for analyzing the demand for medical care. Model development is part of a PhD dissertation, field of Economics.

2.3 Scope and Subject

Demand for health and demand for medical care.

2.4 Abstract

Theoretical investment and consumption models of the demand for health and medical care were developed and used to make predictions about demand. These models were used as the framework for two empirical models of the demand for medical care, a health insurance model using time-series data and a medical care model using cross-section data. The health insurance model was estimated under the assumption that consumers could adjust to their desired level of medical expenditures each year, and also under the assumption that a period of

adjustment was required. The medical care model was estimated for different regions and different educational groups. The models were estimated by ordinary least squares, indirect least squares, and two stage least squares, and used to test the predictions made.

2.5 Major Outputs

Expenditures on medical care, health status, insurance benefits.

2.6 Assumptions (a)/Constraints (c)/Hypotheses

- (a-1) Consumers choose the optimal stock of health and the optimal rate of investment in health that would maximize net earnings over the life cycle (investment model).
- (a-2) Marginal cost and investment in health are positively correlated.
- (a-3) The production function is homogeneous to a degree less than one.
- (a-4) Out-of-pocket medical expenditures by each group was directly proportional to their respective populations (health insurance model).
- (a-5) Health investment production function is homogeneous to degree one (health insurance model).

3.0 TECHNICAL DESCRIPTORS

3.1 Model Type

Regression Analysis

3.2 Model Characteristics

Health insurance: 7 regression equations, each with 5 independent variables, each estimated in 5 ways: time series regression, short and long run distributed lag, and short and long run distributed lag replacing the income variable with consumption. Each dependent variable is regressed on all independent variables.

Medical care: 3 equations with dependent variables expenditures, expenditures/ill health days, and health status; estimated by regression, reduced form regression, two stage least squares, and indirect least squares, by region and education.

Expenditures: 33 estimating equations. For all regions each dependent variable was regressed on either input variable (1) or (2) and all remaining input variables. For regional estimation each dependent variable was regressed on input variables (1) or (2) and variables (3)-(7). Input variable (1) was included in 24 equations; variable (2) was included in 9 equations.

Expenditures/111 health: 9 estimating equations. For all regions the dependent variable was regressed on inputs (1), (4)-(10); by region the dependent variable was regressed on inputs (1), (4)-(7).

Health Status: Same as expenditures/111 health variables.

3.3 Data Utilized

Data source for estimation of the models is listed in the Data Source Index: (134).

3.4 Input Variables

Health Insurance:

- (1) Income,
- (2) Price of medical care,
- (3) Relative price of health insurance (lagged one period),
- (4) Health insurance coverage (lagged one period), and
- (5) Time.

Medical Care:

- (1) Log of family total consumption of medical care,
- (2) Log of average family income,
- (3) Log of family's health status,
- (4) Family size,
- (5) Education of the head of the household,
- (6) Number of children under 18 years of age,
- (7) Age of head of the household,
- (8) North Central region,
- (9) Western, and
- (10) Southern.

3.5 Output Variables

Health Insurance:

- (1) Total medical expenditures,
- (2) Uninsured expenditures,
- (3) Insured expenditures,
- (4) Benefits,

- (5) Benefits/out-of-pocket expenditures,
- (6) Benefits/total expenditures, and
- (7) Coverage.

Medical Care:

- (1) Medical care expenditures,
- (2) Health status,
- (3) Expenditures/days of ill health, by region and by education of head.

3.6 Verification/Applicability/Reliability

Since the data used to estimate the parameters of the models applies to the early 1960's, it is questionable whether the models are applicable to current problems.

3.7 Computer Characteristics

None identified

1.0 IDENTIFICATION

1.1 Descriptive Title

Econometric Model of Market for Nurses

1.2 Developer's Name

Robert T. Deane, UCLA

1.3 References

Deane, 1971

2.0 GENERAL DESCRIPTORS

2.1 Development Status

Model is completed and tested by comparison to historical data.

2.2 Purpose and Sponsor

To generate conditional forecasts of the endogenous variables to provide a basis for choosing among policy alternatives, based on their impact on the nurse market. Model is part of a PhD dissertation in the field of Economics.

2.3 Scope and Subject

Market for nurses in ten fields: general duty nurses, directors of nursing service, nursing supervisors, head nurses, office nurses, private duty nurses, public health nurses, school nurses, nurse educators and industrial nurses.

2.4 Abstract

A 126-equation stock-flow model of the market for nurses is developed. The model treats the nurse market as ten separate fields of nursing: general duty nurses in hospitals, directors of nursing service in hospitals, nurse supervisors in hospitals, head nurses in hospitals, office nurses, school nurses, nurse educators, and industrial nurses.

For each of these fields, the model estimates nurse wages, employment, desired employment, vacancies, vacancy rates, quits, retirements and annual hires. In addition, total nurse employment, the nurse labor force, the total stock of nurses, participation rates, unemployment, annual graduations, entrants to nursing school, and several other quantities are also estimated by the model. The model was used to simulate the market during the period 1947-1966, and these results are compared to historical data. Prediction abilities of the aggregate variables and model sensitivity are explored through experimental policy tests (introduction of Medicare and subsidy to nurse training). The model's performance was tested with conditional predictions for 1967-1976 using data on the exogenous variables available in 1966.

2.5 Major Outputs

Prediction of the change in the labor force, desired employment of nurses (by field), number employed, number hired, nurse graduations, quits, deaths and retirements, participation rates, number of vacancies and vacancy rate, mean monthly wage.

2.6 Assumptions (a)/Constraints (c)/Hypotheses (h)

- (a-1) All basic nursing school programs are 3 years in length.
- (a-2) Participation rates applicable to the stocks of nurses in each of the six age groups are uniform.

3.0 TECHNICAL DESCRIPTORS

3.1 Model Type

Regression analysis

3.2 Model Characteristics

A simultaneous block of 126 equations containing 65 identities (true by definition) and 61 behavioral equations (true by assumption). Each equation has a unique endogenous variable as a dependent (output) variable. Parameters in these equations were assigned from *a priori* knowledge, found through unspecified analytical procedures or determined by regression analysis. The 126 endogenous (output) variables and 86 exogenous (input) variables are listed in sections 3.5 and 3.4 respectively.

3.3 Data Utilized

Data used to estimate the parameters and simulate the model were obtained from (154), (133), (115), (152), (28), (136), (91), (117), (126), (140), (14), (47), (77), (90), in the Data Source Index.

3.4 Input Variables

- (1) Median monthly wage of all females in current dollars,
- (2) Median monthly wage of all professional females in current dollars,
- (3) Number of beds in nonfederal short-term general hospitals in the US, in thousands,
- (4) Average daily patient census in non-federal short-term general hospitals in the US, in thousands,
- (5) Dropout rate in nursing school,
- (6) Residual adjustment dummy variable, 1947 = 1,
- (7) Korean war dummy variable, 1950 and 1951 = 1,
- (8) Medicare dummy variable, 1966 = 1,
- (9) Annual number of female high school graduates,
- (10) Annual mean income of physicians, in thousands of current dollars,
- (11) Number of nonfederal physicians in private practice,
- (12) Population of the US, in thousands,
- (13) Index of daily hospital service charges, 1966 = 1.0,
- (14) Consumer Price Index, 1966 = 1.0,
- (15) Number of elementary school pupils, in thousands,
- (16) Number of secondary school pupils, in thousands,
- (17) Slope of the general duty nurse supply curve,
- (18) Slope of the directors of nursing service supply curve,
- (19) Slope of the nurse supervisors supply curve,
- (20) Slope of the head nurses supply curve,
- (21)-(79) Survivor rate - age 21 through 79,
- (80) Number of beds in all hospitals, in thousands,
- (81) Value added of manufacturing in US, in millions of current dollars,
- (82) Median monthly wage of public health nurses in current dollars,
- (83) Median monthly wage of school nurses in current dollars,
- (84) Median monthly wage of nurse educators in current dollars,
- (85) Mean monthly wage of industrial nurses in current dollars,
- (86) Wholesale price index, 1966 = 1.0.

3.5 Output Variables

- (1) Annual change in labor forces,
- (2) Desired employment of general duty nurses,
- (3) Desired employment of directors of nursing service,
- (4) Desired employment of nursing supervisors,
- (5) Desired employment of head of nurses,
- (6) Desired employment of office nurses,
- (7) Desired employment of private duty nurses,

- (8) Desired employment of public health nurses,
- (9) Desired employment of school nurses,
- (10) Desired employment of nurse educators,
- (11) Desired employment of industrial nurses,
- (12) Number leaving the stock of trained nurses annually via death and retirement,
- (13) Number of general duty nurses employed,
- (14) Number of directors of nursing service employed,
- (15) Number of nursing supervisors employed,
- (16) Number of head nurses employed,
- (17) Number of office nurses employed,
- (18) Number of private duty nurses employed,
- (19) Number of public health nurses employed,
- (20) Number of school nurses employed,
- (21) Number of nurse educators employed,
- (22) Number of industrial nurses employed,
- (23) Number of nurses employed by hospitals,
- (24) Total number of nurses employed,
- (25) Annual entrants into nursing schools,
- (26) Annual graduates from nursing schools,
- (27) Number of general duty nurses hired,
- (28) Number of directors of nursing service hired,
- (29) Number of nursing supervisors hired,
- (30) Number of head nurses hired,
- (31) Number of office nurses hired,
- (32) Number of private duty nurses hired,
- (33) Number of public health nurses hired,
- (34) Number of school nurses hired,
- (35) Number of nurse educators hired,
- (36) Number of industrial nurses hired,
- (37) Number of nurses in the labor force,
- (38)-(43) Participation rate of nurses, ages 20-24, 25-34, 35-44, 45-54, 55-64, 65-79,
- (44) Number quitting general duty nurse positions,
- (45) Number quitting director of nursing service positions,
- (46) Number quitting nurse supervisor positions,
- (47) Number quitting head nurse positions,
- (48) Number quitting office nurse positions,
- (49) Number quitting private duty nurse positions,
- (50) Number quitting public health nurse positions,
- (51) Number quitting school nurse positions,
- (52) Number quitting nurse educator positions,
- (53) Number quitting industrial nurse positions,
- (54) Total quitting all nurse positions,
- (55) Total deaths and retirements from nurse employment,
- (56) Number of trained nurses not in the labor force,
- (57) Deaths and retirements of general duty nurses,
- (58) Deaths and retirements of directors of nursing service,
- (59) Deaths and retirements of nurse supervisors,

- (60) Deaths and retirements of head nurses,
- (61) Deaths and retirements of office nurses,
- (62) Deaths and retirements of public health nurses,
- (63) Deaths and retirements of school nurses,
- (64) Deaths and retirements of nurse educators,
- (65) Deaths and retirements of industrial nurses,
- (66)-(71) Number of trained nurses, ages 20-24, 25-34, 35-44, 45-54, 55-64, 65-99,
- (72) Total number of trained nurses,
- (73) Total desired employment of nurses,
- (74) Total number of actual vacancies,
- (75) Total number of effective vacancies,
- (76) Total number of reported vacancies,
- (77) Number of unemployed nurses,
- (78) General duty nurse vacancies created during year,
- (79) Director of nursing service vacancies created during year,
- (80) Nurse supervisor vacancies created during year,
- (81) Head nurse vacancies created during year,
- (82) Office nurse vacancies created during year,
- (83) Private duty nurse vacancies created during year,
- (84) Public health nurse vacancies created during year,
- (85) School nurse vacancies created during year,
- (86) Nurse educator vacancies created during year,
- (87) Industrial nurse vacancies created during year,
- (88) Equilibrium vacancy rate for general duty nurses,
- (89) Equilibrium vacancy rate for directors of nursing service,
- (90) Equilibrium vacancy rate for nurse supervisors,
- (91) Equilibrium vacancy rate for head nurses,
- (92) Total vacancies for general duty nurses,
- (93) Total vacancies for directors of nursing service,
- (94) Total vacancies for nurse supervisors,
- (95) Total vacancies for head nurses,
- (96) Effective vacancies for general duty nurses,
- (97) Effective vacancies for directors of nursing service,
- (98) Effective vacancies for nurse supervisors,
- (99) Effective vacancies for head nurses,
- (100) Effective (total, reported) vacancies for office nurses,
- (101) Effective (total, reported) vacancies for private duty nurses,
- (102) Effective (total, reported) vacancies for public health nurses,
- (103) Effective (total, reported) vacancies for school nurses,
- (104) Effective (total, reported) vacancies for nurse educators,
- (105) Effective (total, reported) vacancies for industrial nurses,
- (106) Reported vacancies for general duty nurses,
- (107) Reported vacancies for directors of nursing service,
- (108) Reported vacancies for nurse supervisors,
- (109) Reported vacancies for head nurses,
- (110) Reported vacancy rate for general duty nurses,
- (111) Reported vacancy rate for directors of nursing service,
- (112) Reported vacancy rate for nurse supervisors,

- (113) Reported vacancy rate for head nurses,
- (114) Reported (total, effective) vacancy rate for office nurses,
- (115) Reported (total, effective) vacancy rate for private duty nurses,
- (116) Reported (total, effective) vacancy rate for public health nurses,
- (117) Reported (total, effective) vacancy rate for school nurses,
- (118) Reported (total, effective) vacancy rate for nurse educators,
- (119) Reported (total, effective) vacancy rate for industrial nurses,
- (120) Mean monthly wage of all nurses in current dollars,
- (121) Median monthly wage of general duty nurses in current dollars,
- (122) Median monthly wage of directors of nursing service in current dollars,
- (123) Median monthly wage of nurse supervisors in current dollars,
- (124) Median monthly wage of head nurses in current dollars,
- (125) Mean monthly wage of office nurses in current dollars,
- (126) Median monthly wage of private duty nurses in current dollars.

3.6 Verification/Applicability/Reliability

The model was used to simulate the market during the historical period 1947 to 1966. Two types of error statistics were calculated to compare actual data values with those simulated by the model. By excluding three outlying values used to estimate model parameters, the largest mean per cent of error was 3.6 per cent and the largest mean squared percentage error was 27.66 per cent. The model was used to forecast variable values up to 1976 using the model parameter estimated with 1966 data. The model estimates of the past 1966 "predictions" compared favorably with the actual data available. Sensitivity of the model to various policies and its ability to forecast future market values reasonably well, are factors supporting the applicability of the model as a long-range planning tool.

3.7 Computer Characteristics

None identified

1.0 IDENTIFICATION

1.1 Descriptive Title

Model Predicting Population Demands for Medical Services

1.2 Developer's Name

Sam A. Edwards, Health Resources Planning Unit, Texas Hospital Association

1.3 References

Edwards, 1972 (a), 1972 (b)

2.0 GENERAL DESCRIPTORS

2.1 Development Status

Under development with initial model completed.

2.2 Purpose and Sponsor

Provide a method for predicting the demand for medical care, a simulation model for measuring medical care requirements. Model development sponsored by the National Center for Health Services Research and Development.

2.3 Scope and Subject

Demand of a population of over 500,000 for medical care.

2.4 Abstract

Progress on a health services simulator under development is reported. The basic structure of the model is as follows: population demand for medical services is predicted by initial visits of nine age groups using multivariate regression equations. These equations use demographic, economic, and social factors and existing health resources of the population. The simulation model processes by age groups the transitions of patients between levels of care, recovery, and death by classification of conditions based upon morbidity. Resource utilization is matched to

the level and duration of care. The model now has the capability to predict the demand for medical care for a standard metropolitan statistical area of one-half million population, and to estimate the demand characteristics for medical care generated by a given population in terms of level of care, duration, and disposition for the majority of the population.

2.5 Major Outputs

Prediction of demand for medical care - type and number of visits, admissions, costs and personnel requirements by care categories, births and deaths.

2.6 Assumptions (a)/Constraints (c)/Hypotheses (h)

None identified

3.0 TECHNICAL DESCRIPTORS

3.1 Model Type

Regression analysis and simulation

3.2 Model Characteristics

Insufficient information in this report to determine characteristics.

3.3 Data Utilized

Annual estimates of initial visits to private physicians were obtained from reference (60) in the Data Source Index.

3.4 Input Variables

- (1) Physicians per 1000 population,
- (2) Short-term general and other special hospital beds/1000 population,
- (3) Public expenditures for health and hospitals spent by state and local governments per person,

- (4) Percent of the families with annual cash income less than \$7000,
- (5) Percent of the families with annual cash income between \$7000 - 10,000,
- (6) Percent of the families with annual cash income greater than \$10,000,
- (7) Household income,
- (8) Per capita income,
- (9) Percent of the population under 65 years old with insurance,
- (10) Percent of the population living in a metropolitan area,
- (11) Average household size,
- (12) Percent of the population aged 0-17,
- (13) Percent of the population aged 18-44,
- (14) Percent of the population aged 45-64,
- (15) Percent of the population aged 65 and older, and
- (16) Average price of an initial visit by a general practitioner.

3.5 Output Variables

- (1) Outpatient initial visits,
- (2) Subsequent visits,
- (3) Visits subsequent to inpatient care,
- (4) Total visits,
- (5) Short-term inpatient admissions,
- (6) Patient days (with and without surgery),
- (7) Inpatient days intensive care,
- (8) Inpatient operations,
- (9) Average length of stay (with and without surgery),
- (10) Dispositions - discharge, death, and transfer to other levels of care,
- (11) Long term care admissions,
- (12) Patient days,
- (13) Average length of stay,
- (14) Dispositions,
- (15) Vital statistics - birth,
- (16) Hospital non-surgical deaths,
- (17) Hospital surgical deaths,
- (18) Nursing home deaths,
- (19) Neonatal, infant and maternal deaths,
- (20) Other deaths,
- (21) Annual health system costs by care category,
- (22) Nursing personnel requirement by care category - surgical, medical, pediatric, obstetrical, etc., and
- (23) Hospital cost and personnel use by hospital administrative services categories.

3.6 Verification/Applicability/Reliability

Insufficient information is provided in the above references to determine model validity. Parts of the model have been tested for predictive capability for 1967, 1968, and 1969, with an average error at approximately 4% to 6%. The model appears to be useful for long-range planning.

3.7 Computer Characteristics

None identified

E2

1.0 IDENTIFICATION

1.1 Descriptive Title

Distribution of Physicians in an Urban Area

1.2 Developer's Names

David Elesh, Paul T. Schollaert, Joanne Lazarz, The University of Wisconsin

1.3 References

Elesh and Schollaert, 1972; Elesh and Lazarz, 1972

2.0 GENERAL DESCRIPTORS

2.1 Development Status

Completed

2.2 Purpose and Sponsor

To further the analysis of the distribution of physicians in urban areas. Model development sponsored by the Office of Economic Opportunity.

2.3 Scope and Subject

Geographic distribution of full-time, private practice physicians (GPs and specialists) within two urban areas, Chicago and Detroit.

2.4 Abstract

A demand-supply model for the distribution of private physicians within a city is developed. Eight factors, 4 affecting demand and 4 affecting supply, are included: population, 4 population composition factors, and 3 ecological factors. The supply or spatial

distribution of physicians is taken to be a function of the demand for their services and environmental factors which facilitate or limit the supply. The model is applied to full-time, private practice specialists and general practitioners in Chicago and Detroit in 1960.

2.5 Major Outputs

Number of all physicians, GPs, and specialists within an urban area.

2.6 Assumptions (a)/Constraints (c)/Hypotheses (h)

(c) The study is limited to full-time, private practice physicians age 70 or less.

3.0 TECHNICAL DESCRIPTORS

3.1 Model Type

Regression Analysis

3.2 Model Characteristics

The two versions of the Chicago model each relate 3 dependent variables to the 8 independent variables. There are four versions of the Detroit model: each version consists of 3 equations, each equation relates the dependent variable to 8, 9, or 10 independent variables depending on the version of the model.

3.3 Data Utilized

Data on the 2461 physicians included in the Detroit study and 4208 physicians in the Chicago study, and on the other variables, was obtained from the *Chicago Land Use Map*, Chicago Plan Commission, 1961, the Southern Michigan Council of Governments, Detroit Regional Transportation and Land Use Study Report: "A Profile of Developed Land: 1965 Land Use," the directory of the American Hospital Association, and from numbers (16) and (119) in the Data Source Index.

3.4 Input Variables

- *{1} Population of the census tract,
- *{2} Per cent of tract's population 25 years old or older,
- *{3} Per cent of tract's population 25 years old or older with at least a high school education,
- *{4} Per cent of tract families with \$6,000 or more annual income (\$10,000 or more in revised versions),
- *{5} Number of hospitals per tract,
- *{6} Per cent of tract's area devoted to commercial use,
- *{7} Whether the tract is black (at least 90% of the population is black) or white (otherwise),
- *{8} Whether the tract is a central business district tract,
- {9} Number of hospitals in adjacent tracts, and
- {10} Race and adjacent hospital interaction term.

All variables are included in the final version of the Detroit models. Variables marked * are included in the Chicago model.

3.5 Output Variables

- (1) Number of all physicians with office location in the census tract,
- (2) Number of general practitioners (defined as all those who call themselves general practitioners, internists, obstetrician-gynecologists, or pediatricians), and
- (3) Number of specialists (all other specialists).

3.6 Verification/Applicability/Reliability

The Detroit model explained 45-50% of the variance in physician location; the Chicago model explained 35-40% of the variance. Since the data was obtained for two cities in 1960, it is unlikely that the model is generally applicable to current problems.

3.7 Computer Characteristics

None identified.

1.0 IDENTIFICATION

1.1 Descriptive Title

An Aggregate Planning Model of the Health Care Sector

1.2 Developer's Name

Martin S. Feldstein, Harvard University

1.3 References

Feldstein, 1967

2.0 GENERAL DESCRIPTORS

2.1 Development Status

Developer notes that the model is "too crude to be of practical use".

2.2 Purpose and Sponsor

To study the relation between supply and demand for hospital inpatient care on the basis of cross-sectional information for individual states for 1960. The project sponsor is not identified.

2.3 Scope and Subject

Demand for and supply of hospital inpatient care, including supply equations for general practitioners and specialists.

2.4 Abstract

The concepts and uses of a fully-developed econometric model of the health care sector are explained in terms of a six-equation model of demand and supply for hospital inpatient care. The equations were estimated by two-stage least-squares, and the insurance variable analyzed as a guide to interpretation of the results. The model is used for conditional forecasting, predicting policy effects, monitoring information, and making planning decisions. It is concluded that with additional data, an econometric health sector model could provide a useful framework for conditional prediction planning.

2.5 Major Outputs

Prediction of numbers of GPs, medical specialists, available hospital beds, admissions, duration of stay, and numbers of persons with health insurance.

2.6 Assumptions (a)/Constraints (c)/Hypotheses

(a-1) All equations in the model assumed to be linear in the logarithms of the variables.

3.0 TECHNICAL DESCRIPTORS**3.1 Model Type**

Regression Analysis

3.2 Model Characteristics

6 equations, 6 dependent variables, 8 independent variables. The following are the specific variables included in each regression equation. The dependent (output) and independent (input) variables are those identified in sections 3.5 and 3.4 respectively.

Dependent Variables	Independent Variables
(1)	(1), (5), (6), (7)
(2)	(1), (2), (6)
(3)	(1), (3), (4), (5), (6)
(4)	(1), (2), (3), (4), (6), (7)
(5)	(4), (5), (7), (8)
(6)	(1), (2), (4), (7), (8)

3.3 Data Utilized

Sources of the data utilized in the regressions are listed in the Data Source Index: (10), (11), (52), (115), (146), (14).

3.4 Input Variables

- (1) Past values of number of persons with health insurance,
- (2) Past values of number of general practitioners,
- (3) Past values of number of medical specialists,
- (4) Past values of number of available short-term general hospital beds,
- (5) Percentage of persons aged 65 and above,
- (6) Percentage of families with incomes below \$2,000,
- (7) Percentage of persons living in urban communities, and
- (8) Percentage of married females in the population

3.5 Output Variables

- (1) Number of persons with health insurance,
- (2) Number of general practitioners,
- (3) Number of medical specialists,
- (4) Number of available short-term general hospital beds,
- (5) Number of admissions, and
- (6) Mean duration of stay per case.

3.6 Verification/Applicability/Reliability

The developer notes that before the model is operationally useful it must be specified in more detail on the basis of studies of individual behavioral relations, additional variables should be included to extend the model to other institutions, personnel, and to costs and prices, time-series data should be used, and the measurement of variables should be improved.

3.7 Computer Characteristics

None identified

1.0 IDENTIFICATION

1.1 Descriptive Title

The Rising Price of Physician's Services

1.2 Developer's Name

Martin S. Feldstein, Harvard University

1.3 References

Feldstein, 1970

2.0 GENERAL DESCRIPTORS

2.1 Development Status

Preliminary; based on a relatively small sample of aggregate data.

2.2 Purpose and Sponsor

To improve understanding of the pricing and supply of physician's services. Model development was sponsored by the National Center for Health Services Research and Development.

2.3 Scope and Subject

Model of the supply of physicians and the pricing of physicians' services.

2.4 Abstract

Three basic traditional models of price and quantity determination are examined, an annual equilibrium model and two dynamic adjustment models, and the parameters estimated by regression using aggregate time series for 1948 to 1966. The coefficients of the parameters imply that none of the models are satisfactory. The results and the implications are discussed, and it is concluded that aggregate pricing and use of physicians' services can be understood best by assuming that permanent excess demand prevails.

2.5 Major Outputs

Indices of supply and price of private physicians' services

2.6 Assumptions (a)/Constraints (c)/Hypotheses (h)

(a-1) Patients are assumed to be price takers.

3.0 TECHNICAL DESCRIPTORS**3.1 Model Type**

Regression Analysis

3.2 Model Characteristics

22 equations (4 demand, 9 price and 9 supply equations) with 3 dependent variables, 12 independent variables.

The following are the specific variables included in each regression equation. The independent and dependent variables are those identified in the input and output lists, sections 3.4 and 3.5.

		Dependent Variables	Independent Variables
Demand Equations		(1)	(1), (2), (3), (4)
2 each		(1)	(2)-(7)
Price Equations	2 equations	(2)	(7), (2), (3), (8)
		(2)	(7), (2), (3), (8), (5)
		(2)	(7), (2), (3), (8), (9)
		(2)	(7), (2), (3), (8), (10)
		(2)	(2), (3), (5), (7)-(10)
	2 equations	(2)	(7), (2), (3), (8), (4)
		(2)	(2)-(5), (7)-(10)
Supply Equations	3 equations	(3)	(2), (8), (5), (11), (12), (4)
	2 equations	(3)	(2), (5), (11), (12), (4)
	2 equations	(3)	(2), (5), (11), (12), (8), (9), (4)
	2 equations	(3)	(2), (4), (8), (11), (12)

3.3 Data Utilized

Sources of the data utilized in the regressions are listed in the Data Source Index numbers (18), (140), (53), (86), and also include Bureau of Labor Statistics interviews with physicians.

3.4 Input Variables

- (1) Net price index,
- (2) Cost of other goods,
- (3) Median per capita income,
- (4) Government provision of medical services per capita,
- (5) Time,
- (6) Average price index,
- (7) Insured, uninsured,
- (8) Quantity of inputs (paramedical personnel, supplies, etc.),
- (9) Doctor - population ratio,
- (10) Lagged ratio of services provided per physician,
- (11) Average fee, and
- (12) Reference income.

3.5 Output Variables

- (1) Index of private physicians' services per capita,
- (2) Index of average price of private physicians' services, and
- (3) Index of services provided per private practice physician.

3.6 Verification/Applicability/Reliability

The data used to estimate the parameters applies to the years 1948-1966, and the developer emphasizes it is a small sample of quite imperfect data; therefore, it is questionable whether the model is applicable to current problems without respecification of the parameters.

3.7 Computer Characteristics

None identified

1.0 IDENTIFICATION

1.1 Descriptive Title

An Econometric Model of the Medicare System

1.2 Developer's Name

Martin S. Feldstein, Harvard University

1.3 References

Feldstein, 1971

2.0 GENERAL DESCRIPTORS

2.1 Development Status

Completed

2.2 Purpose and Sponsor

To contribute to the development of an overall model of the health care sector by presenting a system of equations focusing on the allocation of health care resources under Medicare. Model development was supported by the National Center for Health Services Research and Development.

2.3 Scope and Subject

Aggregate model of use and benefits received under Medicare.

2.4 Abstract

Regression model describes interstate variations in proportion of enrollees with supplementary insurance, hospital and extended care admission rates per thousand enrollees, and average levels of hospital and medical insurance benefits. Equations were estimated by a two-stage least-squares procedure using data from annual reports of the Medicare program, July 1, 1966 to June 30, 1968. The reduced form of the equations are obtained and the results analyzed.

2.5 Major Outputs

Explanation of variation in use and benefits under Medicare in terms of demographic and economic characteristics of the population, state health policy variables, and characteristics of local health care system.

2.6 Assumptions (a)/Constraints (c)/Hypotheses (h)

- (a-1) All equations specified to be linear in the logarithms of the original variables.
- (a-2) "Buying in" is a local political decision explained in terms of political variables and characteristics of state government finance.

3.0 TECHNICAL DESCRIPTORS

3.1 Model Type

Regression Analysis

3.2 Model Characteristics

9 equations (4 of which are reduced form), 16 independent variables, 7 dependent variables. The following are the specific variables included in each regression equation. The dependent (output) and independent (input) variables are those identified in sections 3.5 and 3.4 respectively.

Dependent Variables

(1)
(2)
(3)
(4)
(5)
(6)
(7)
(4)
(5)

Independent Variables

(1), (3), (2), (4), (5), (7)
(8), (9), (10), (11)
(13), (8), (9), (1)
(14), (15), (8), (9), (1), (3), (16)
(8), (15), (16), (3), (6)
(8), (9), (14), (10), (1), (3), (11)
(12), (6), (13)
(9), (3), (6), (12), (8), (13),
(1), (10), (11)
(12), (8), (9), (14), (1), (2),
(3), (6), (11), (13)
(9), (1), (2), (3), (6), (12),
(11), (8), (13),

3.3 Data Utilized

Data on Medicare is published in the annual reports of the Medicare program.

3.4 Input Variables

- (1) Proportion of enrollees who are white,
- (2) Proportion living in cities of over 100,000 population,
- (3) Proportion of population over 75 relative to those over 65,
- (4) Proportion of population under 65 with medical and surgical insurance,
- (5) Median per capita income in the state,
- (6) Proportion of males among those over 65,
- (7) Proportion of Medicare enrollees not bought in by the government,
- (8) Per capita availability of short-term general hospital beds,
- (9) Number of private practice physicians per capita,
- (10) Population density,
- (11) Per capita state and local welfare expenditures on health care for the aged in the pre-Medicare period,
- (12) Number of months during the period that the state participated in Medicare,
- (13) Number of extended care beds per enrollee,
- (14) Average cost per patient day for all patients in short-term general hospitals,
- (15) Hospital admissions per enrollee, and
- (16) Extended care admissions per hospital admission.

3.5 Output Variables

- (1) Proportion of enrollees with supplementary insurance,
- (2) Hospital admissions per enrollee,
- (3) Extended care admissions per hospital admission,
- (4) Hospital insurance benefits per hospital episode,
- (5) Supplementary benefits per enrollee with supplementary insurance,
- (6) Hospital insurance benefits per enrollee, and
- (7) Supplementary insurance benefits per enrollee.

3.6 Verification/Applicability/Reliability

The applicability of the model is dependent on the applicability of the 1967 data used to estimate the model parameters of interest to the potential users of the model.

3.7 Computer Characteristics

None identified

1.0 IDENTIFICATION

1.1 Descriptive Title

Econometric Model for Forecasting and Policy Evaluation in the Dental Sector

1.2 Developer's Name

Paul J. Feldstein, University of Michigan

1.3 References

P. Feldstein, 1972

2.0 GENERAL DESCRIPTORS

2.1 Development Status

Theoretically specified with preliminary empirical estimation of certain parameters.

2.2 Purpose and Sponsor

To forecast the market for dental care in 1975 and evaluate the impact of the Health Professions Education Act in this market. Model development supported by the US Public Health Service.

2.3 Scope and Subject

Supply and demand for dental care, dental manpower, and dental and auxiliary training facilities, in the context of the financing of dental care.

2.4 Abstract

The markets for dental care, dental manpower, and dental professions training facilities are examined to gain insight into the issue of financing dental care. Through economic analysis of the different sectors, the interrelationships of various factors affecting supply, demand,

and pricing are explored and used to determine the costs and benefits of alternative policies. A model of the dental sector was developed to evaluate policies and to make predictions for the dental care market in 1975. Econometric modeling techniques used are compared to dentist-population ratio analysis.

2.5 Major Outputs

Prediction of dental prices, utilization, total dental expenditures and dentists' incomes.

2.6 Assumptions (a)/Constraints (c)/Hypotheses (h)

(c-1) Number of dental school entrants is equal to dental school spaces.

3.0 TECHNICAL DESCRIPTORS

3.1 Model Type

Regression Analysis

3.2 Model Characteristics

This is an econometric model consisting of two levels, dental visits and dental manpower training facilities. The model is made up of thirteen equations, one of which is a production function previously estimated by A. Maurizi; four of these equations are also estimated in logarithms. Nineteen variables are included in the model.

3.3 Data Utilized

Sources for the data utilized include numbers (4), (117), (6) in the Data Source Index and various Department of Health, Education and Welfare, Public Health Service Publications.

3.4 Input Variables

- (1) Price per dental visit,
- (2) Per capita personal income,
- (3) Dentists per 1000 population,

- (4) Number of dentists in the previous year; change in stock,
- (5) Dental school graduates per 1000 population,
- (6) Dentists dying or retiring per 1000 population,
- (7) Dental school dropouts per 1000 population,
- (8) First year dental school students per 1000 population four years ago,
- (9) Dental school spaces per 1000 population,
- (10) Additions to dental school spaces per 1000 population,
- (11) Construction subsidy funds,
- (12) Matching construction funds,
- (13) Civilian population,
- (14) Number of full-time auxiliaries employed by a dentist,
- (15) Number of annual hours work by a dentist, and
- (16) Number of chairs in the office.

3.5 Output Variables

- (1) Demand for dental visits per 1000 population,
- (2) Supply of dental visits per 1000 population,
- (3) Price per dental visit,
- (4) Number of dentists per thousand population,
- (5) Number of dental school spaces per 1000 population,
- (6) Additions to dental school spaces per 1000 population,
- (7) Annual patient visits per dentist, and
- (8) Dental visits per 1000 population.

3.6 Verification/Applicability/Reliability

The model is intended for long-range planning and has three basic uses, estimation of dental utilization and prices, evaluation of alternative policies, and indication of future research areas. The model utilizes recent data in a forecast to 1975; however, the developer states that results based on the model should be considered as tentative due to the unavailability of some data.

3.7 Computer Characteristics

None identified

1.0 IDENTIFICATION

1.1 Descriptive Title

An Econometric Model of Medical Care Sector

1.2 Developer's Names

Paul J. Feldstein, University of Michigan, and Sander Kelman, Cornell University

1.3 References

Feldstein & Kelman 1972, Klarman 1970

2.0 GENERAL DESCRIPTORS

2.1 Development Status

Completed

2.2 Purpose and Sponsor

To describe the interrelationships of the medical care sector and to illustrate the possible impacts of various public policies on the provision of medical care, its components, the price level, and the level and character of employment. Model development supported by the US Public Health Service.

2.3 Scope and Subject

The market for medical care (supply of and demand for services of hospitals, nursing homes, out-patient clinics, doctors' offices, and patients' homes; derived demand for and supply of physicians, nurses, and paramedical personnel).

2.4 Abstract

A three level model of the medical care sector was specified: an identity expressing the value of medical care rendered as the sum of the values of medical care provided in each of the five institutional

settings which provide medical care; an analysis of the supply and demand for the services of these institutions; and the derived demand for and supplies of health manpower. The parameters of the equations were determined, and the regression equations and coefficients were constructed. Applications of the model were used to illustrate its usefulness for policy and planning analysis. A national health insurance program was simulated and its effects on medical care expenditures, the price of medical care, price and utilization changes, and the derived demand for health manpower were examined. A program of subsidies to medical schools was also simulated, and its effects seen on the additional number of physicians, use of other medical personnel, changes in the price for each institutional setting, changes in utilization, and total expenditures for medical care.

2.5 Major Outputs

Total cost of medical care and Laspeyres Medical Care Price Index (1960 = 1.00).

2.6 Assumptions (a)/Constraints (c)/Hypotheses (h)

- (a-1) The distribution of illnesses remains constant.
- (a-2) The relative institution-specific productivities in treating these illnesses remains constant.
- (a-3) Administrators set prices so as to cover expected average costs.
- (a-4) There is proportionality between stocks and services.
- (a-5) There is a neo-classical production function for the supply of doctor's office visits.
- (a-6) For doctor's office visits there are constant returns to scale and equal output elasticities.
- (a-7) Demand for home care is an inferior good.
- (a-8) The nurse spends 1/10 of her weekly efforts for each home visit.
- (a-9) For health manpower no individual input category constitutes a substantial portion of the total cost of any output; all output elasticities are equal.
- (a-10) The weekly hours of nurses and paramedical personnel are fixed and the same.

- (a-11) The capacity constraint of medical schools will be effective for at least the next decade.
- (a-12) The AMA assumes a 0.2% annual increase in the number of physicians to be accounted for by foreign medical graduates.
- (a-13) The average cost of expanding the capacity of medical schools is \$30,000 per entering student.
- (a-14) Deaths and retirements from the stock of practicing physicians are proportional to the stock of practicing physicians.
- (a-15) All equations are linear.
- (a-16) For the subsidy simulation the constraint to increases in the stock of physicians is the medical education sector.

3.0 TECHNICAL DESCRIPTORS

3.1 Model Type

Regression Analysis

3.2 Model Characteristics

A forty-five linear equation model concerned with:

- (1) The market for care by nursing homes, doctor's office visits, outpatient visits, home care and short term general hospitals.
- (2) The market for services provided by professional nurses and practicing clinical physicians. The outputs or endogenous variables of these equations provide the independent variables for two aggregate equations which specify the total cost of medical care and Laspeyres Medical Care Price Index.

3.3 Data Utilized

Data on input (exogenous) variables listed in section 3.4 to determine regression coefficients.

3.4 Input Variables**(Exogenous Variables)**

- (1) Proportion of population over 65 years of age,
- (2) Average size of short-term hospitals (in beds),
- (3) Average size of nursing homes,
- (4) Increase in the number of non-practicing physicians per thousand population,
- (5) Number of female high school graduates per thousand population three years previously,
- (6) Proportion of population with insurance to cover doctor's office visits,
- (7) Proportion of population covered by hospitalization insurance,
- (8) Proportion of population covered by insurance defraying the costs of home care,
- (9) Proportion of population over 65 years of age covered by nursing home insurance,
- (10) Proportion of population covered by insurance for outpatient visits,
- (11) Average lifetime of hospital physical assets, in years,
- (12) Proportion of females 14 years of age and older who are married,
- (13) Proportion of females 65 years of age and older who are married,
- (14) Short-term hospital service mix,
- (15) Construction cost index,
- (16) Price of a day of nursing home care,
- (17) Thousand population 65 years of age and over,
- (18) Thousand population,
- (19) Weekly social security retirement benefits to retired female workers,
- (20) Proportion of employed registered nurses over 60 years of age,
- (21) Number of public school children per thousand population,
- (22) Nursing school scholarships in proportion to tuition covered,
- (23) Proportion of population 14 years of age or older who are male,
- (24) Proportion of nurses who are married and under 40 years of age,
- (25) Federal subsidies to aid medical school construction,
- (26) Proportion of population living in urban areas,
- (27) Weekly income of physicians practicing in foreign countries,
- (28) Weekly income of retail trade personnel,
- (29) Average weekly income of school teachers,
- (30) Public assistance for medical purposes per capita,
- (31) Median family income,
- (32) Number of doctor office visits per thousand population per year: lagged one year,
- (33) Constant of 10,000,
- (34) Days of home care received per thousand population: lagged one year,
- (35) Contribution of the medical care sector to the GNP: lagged one year,
- (36) Number of practicing physicians per thousand population: lagged one year,
- (37) Number of first-year medical school spaces per thousand population: lagged one year,

- (38) Number of first-year medical school entrants: lagged four years,
- (39) Outpatient visits per thousand population: lagged one year,
- (40) Hospital patient days per thousand population: lagged one year,
- (41) Nursing home patient days per thousand population over 65:
lagged one year,
- (42) Stock of hospital beds per thousand population: lagged ten years,
- (43) Stock of trained nurses per thousand population: lagged one year,
- (44) Stock of nursing home beds per thousand population over age 65:
lagged five years,
- (45) Consumer price index,
- (46) Average family size,
- (47) Average size of nursing homes: lagged five years,
- (48) Average size of short-term hospitals (in beds): lagged ten years,
- (49) Civilian resident population (in thousands): lagged one year,
- (50) Civilian resident population over 65 years of age (in thousands):
lagged one year,
- (51) Constant of 1,000,
- (52) Weekly income of nurses in Canada.

3.5 Output Variables

(Endogenous Variables)

- (1) Desired stock of nursing home beds per thousand population over
65 years of age,
- (2) Stock of nursing home beds per thousand population over 65 years
of age,
- (3) Shortage of nursing home beds per thousand population over 65
years of age,
- (4) Occupancy rate in nursing homes,
- (5) Nursing home patient days per thousand population over 65 years
of age,
- (6) Number of doctor office visits per thousand population per year,
- (7) Number of physicians with a hospital practice per thousand popu-
lation (interns, residents, and hospital staff physicians),
- (8) Number of physicians with a private practice per thousand population,
- (9) Price per doctor office visit,
- (10) Number of outpatient visits per thousand population,
- (11) Price of an outpatient visit,
- (12) Days of home care received per thousand population,
- (13) Price of a day of home care,
- (14) Number of employed nurses per thousand population,
- (15) Weekly income of nurses,
- (16) Proportion of the stock of nurses actively employed as nurses,
- (17) Stock of trained professional nurses per thousand population,
- (18) Increase in the stock of nurses per thousand population,
- (19) Number of nursing school graduates per thousand population,
- (20) Net immigration of foreign trained nurses per thousand population,
- (21) Number of nurses retiring or dying per thousand population,
- (22) Annual hours of patient care by practicing physicians per thousand
population,

- (23) Weekly income of practicing physicians,
- (24) Annual hours of patient care by practicing physicians per physician,
- (25) Number of practicing physicians per thousand population,
- (26) Increase in number of practicing physicians per thousand population,
- (27) Number of medical school graduates per thousand population,
- (28) Number of dropouts per thousand population from the medical school class entering four years previously,
- (29) In-flow of foreign medical school graduates per thousand population,
- (30) Number of first year medical school entrants per thousand population,
- (31) Number of first year medical school spaces per thousand population,
- (32) Increase in the number of first year medical school spaces per thousand population,
- (33) Number of practicing physicians per thousand population having retired or died,
- (34) Number of employed paramedical personnel per thousand population,
- (35) Weekly income of paramedical personnel,
- (36) Desired stock of hospital beds per thousand population,
- (37) Stock of hospital beds per thousand population,
- (38) Construction and equipment cost per bed of US non-federal short-term general and other hospitals,
- (39) Current undepreciated value of hospital fixed assets,
- (40) Total depreciation charges per year in US non-federal short-term general and other special hospitals,
- (41) Shortage of hospital beds per thousand population,
- (42) Hospital charge per patient day plus separate billings by physicians and surgeons,
- (43) Hospital charge per patient day,
- (44) Occupancy rate per non-federal short-term general and other special hospitals,
- (45) Hospital patient days per thousand population,
- (46) Contribution of the medical care sector to the GNP (in millions of dollars),
- (47) Laspeyres Medical Care Price Index (1960 = 1.00).

3.6 Verification/Applicability/Reliability

Quasi verification of the model was performed by using 1960 data on input parameters to predict 1965 values of the outputs and comparing these values to actual data. Since the model coefficients were constructed using 1960 and 1965 data, the acceptability of this test is questionable subject to a valid verification of the model. The model should be applicable to long-range planning.

3.7 Computer Characteristics

None identified

1.0 IDENTIFICATION

1.1 Descriptive Title

A Language to Aid in Manpower Planning

1.2 Developer's Name

Robert B. Fetter and Ronald E. Miles, Peter Associates, Inc.

1.3 References

Fetter & Miles, Undated

2.0 GENERAL DESCRIPTORS

2.1 Development Status

Completed

2.2 Purpose and Sponsor

Study of the application of the Conversational Modeling Language (CML) to health manpower modeling, intended to allow the user to specify the kinds of information needed in a way which is natural in the context of the problem. Model development supported by the US Public Health Service.

2.3 Scope and Subject

Application of general modeling strategy to health manpower training programs, health manpower types, and health care methods and demands.

2.4 Abstract

A system resulting from the application of the CML modeling strategy to health manpower modeling is described. The model is formulated as a linear program in which the basic activities (decision variables) are the number of units of each specified health service (method or vector of manpower used) in any model year (period). Implementation of the model is described in two parts: the syntax of the program language.

used is given, followed by the operating instructions necessary to check and implement the model's specification either by simulation or by the solution to the mathematical program.

2.5 Major Outputs

Optimal values of the model variables, to minimize a discounted, weighted sum of the amount of care of each type not delivered over the horizon specified.

2.6 Assumptions (a)/Constraints (c)/Hypotheses (h)

- (c-1) Total students in all program years is less than or equal to the given capacity.
- (c-2) There are upper and lower bounds on matriculants as desired.

3.0 TECHNICAL DESCRIPTORS

3.1 Model Type

Linear programming

3.2 Model Characteristics

The model consists of an objective function, 6 equation types, and 3 constraint inequality types and includes 23 types of input variables.

3.3 Data Utilized

An example model is given using hypothetical data.

3.4 Input variables

- (1) Units of service of type h delivered by method g in year t,
- (2) Units of manpower k required to deliver service of type h by method g in year t,
- (3) Available manpower of type k in year t,
- (4) Manpower of type k not utilized in year t,
- (5) Units of service h demanded in year t,

- (6) Units of service h not delivered in year t ,
- (7) Students in year j of training program i in year t ,
- (8) Matriculants (first year students) in training program i in year t ,
- (9) Graduates of training programs who enter manpower pool k in year t ,
- (10) Transfer rate of students from training program i , program year j into training program i' in program year j' in model year t ,
- (11) Drop rate in training program i in program year j in model year t ,
- (12) Proportion of students in year j of program i who enter manpower pool k in year t ,
- (13) Faculty-student ratio for manpower type k in training program i in year t ,
- (14) Amount of manpower k who are faculty in year t ,
- (15) Proportion of manpower k who do not deliver health care in year t ,
- (16) Migration rate from manpower pool k in year t ,
- (17) Capacity of training program i in year t ,
- (18) Excess capacity of training program i in year t ,
- (19) Lower bound on matriculants of program i in year t ,
- (20) Upper bound on matriculants of program i in year t ,
- (21) Discount rate,
- (22) Relative value of health service h , and
- (23) Length of program i .

3.5 Output Variables

Values of the input variables which minimize a discounted, weighted sum of the amount of care of each type not delivered over the horizon specified.

3.6 Verification/Applicability/Reliability

No verification studies have been performed.

3.7 Computer Characteristics

Language: CML (Conversational Modeling Language) and MPPL (Manpower Planning Language). Machine: IBM MPS/360.

F7

1.0 IDENTIFICATION

1.1 Descriptive Title

Demand for Hospital Services

1.2 Developer's Name

J. M. Fitzmaurice; University of Maryland

1.3 References

Fitzmaurice, 1972

2.0 GENERAL DESCRIPTORS

2.1 Development Status

Model is completed and its hypothesized relationships tested for the period 1965-68

2.2 Purpose and Sponsor

Explanation of the variation in the consumption of hospital patient days of care among communities, to provide insight into the areas of planning, social policy, substitution, and price sensitivity. Model is part of a PhD dissertation, field of Economics.

2.3 Scope and subject

Demand for and supply of short term general, nonprofit hospital patient days among Maryland communities, tested at the county level of aggregation.

2.4 Abstract

A model is developed which relates patient days consumed per 1000 community population to variables measuring economic and socio-demographic characteristics and the availability of alternative sources for medical care in each community. The model is empirically estimated by ordinary least-squares regression for the time period 1965-1968. Two forms of

the basic model are estimated; Model I includes the Medicare and Medicaid variables and is estimated for 1967-68, while Model I' omits the Medicare and Medicaid variables but includes a proxy for year (1965-68). The relative magnitudes of the coefficients of the input variables can be utilized to assess the degree of influence (positive or negative) that these factors have on the demand for short term general hospital services (in terms of patient days).

2.5 Major Outputs

Quantity of patient days consumed annually by each county's population.

2.6 Assumptions (a)/Constraints (c)/Hypotheses (h)

- (a-1) Average length of stay is the same for out-of-county patients as for county-resident patients.
- (a-2) The proportions remained constant over the time period 1965-68
- (a-3) Use of out-of-state hospitals by Maryland residents is negligible (except for adjustments made for two counties).

3.0 TECHNICAL DESCRIPTORS

3.1 Model Type

Regression Analysis

3.2 Model Characteristics

Two models, one equation each. Model I has one dependent and 16 independent variables; Model I' has one dependent and 15 independent variables.

3.3 Data Utilized

Patient days, beds, and nursing home data obtained from *Maryland State Medical Facility and Plan*, a report submitted annually to the Public Health Service. Additional data obtained from "Schedule of Adult Bed Room Rates", *Medicare*, 1968; *Health Insurance Enrollment Under Social Security*, July 1, 1966 (Office of Research and Statistics, Social Security Administration, US Department of Health, Education and Welfare).

US Census of Population: 1960, Vol. I; Characteristics of the Population, Part 22, Maryland; Maryland Statistical Abstract (Maryland Department of Economic Development, 1967); Distribution of Physicians, Hospitals and Hospital Beds in the United States (Chicago: American Medical Association 1965, 1966, 1967, 1968), Services and Facilities in Maryland (Gilbert Sanford, Townson, MD, Hospital Council of Maryland, 1968), and from the Bureau of Special Services, Medical Facilities Department in the Maryland State Department of Health; the Regional Economics Division, Office of Business Economics, Department of Commerce; the Maryland State Department of Health, Division of Biostatistics; and the Health Facilities Planning Council for Metropolitan Washington.

3.4 Input Variables

- (1) Price - semi-private room rates for one day,
- (2) Income - annual per capita personal income.

Remaining Inputs by County

- * (3) Proportion of residents 65 and over enrolled in Medicare,
- * (4) Proportion under Medicare with Supplementary Medical Insurance,
- * (5) Average enrollment in Medicaid,
- (6) Proportion of population 65 and over,
- (7) Male proportion of population 18 and older,
- (8) Non-white proportion of population,
- (9) Proportion of population 25 and over with high school education or better,
- (10) Population density,
- (11) Number of non-federal, non-hospital based physicians per 1000 population,
- (12) Proportion of non-federal, non-hospital based physicians who are in general practice,
- (13) Number of licensed short-term community hospital beds per 1000 population,
- (14) Presence of 10 or more special hospital outpatient facilities or services,
- (15) Number of nursing home and extended care facility beds per 1000 population.

*omitted in Model I .

3.5 Output Variables

Quantity of patient days consumed annually by each county's population.

3.6 Verification/Applicability/Reliability

Since the data used to estimate the parameters of the model applies to Maryland for 1965-1968, it is questionable whether the model is generally applicable to current problems in Maryland or other states.

3.7 Computer Characteristics

None identified

F8

1.0 IDENTIFICATION

1.1 Descriptive Title

Expenditures for Physician's Services

1.2 Developer's Names

Victor R. Fuchs, Marcia J. Kramer, National Bureau of Economic Research

1.3 References

Fuchs and Kramer, 1972

2.0 GENERAL DESCRIPTORS

2.1 Development Status

Completed

2.2 Purpose and Sponsor

To gain an understanding of variations in the quantity of services per capita, number of physicians per capita, quantity of services per physician, and insurance coverage; to examine the rise in expenditures for physician's services and attempt to explain the pattern of change. Model development supported by the National Center for Health Services Research and Development, US Department of Health, Education, and Welfare.

2.3 Scope and Subject

Behavior of patients and physicians in the market for physician's services.

100

100

2.4 Abstract

An econometric model of the market for physician's services in 1966 is developed. The model, estimated in double-logarithmic form by two-stage least squares regression, consists of four structural equations and two identities. Each structural equation establishes a general framework within which a broad range of hypotheses regarding the behavior of patients and physicians can be investigated, and offers an explanation for the determinants of a particular aspect of the market for physician's services: variations in demand, number of physicians, physician productivity, and amount of insurance coverage. The finding is that supply factors (technology and number of physicians) appear to be of decisive importance in determining the utilization of and expenditures for physician's services.

2.5 Major Outputs

Estimates of the number of physicians, number of visits per physician, quantity of visits demanded per capita, and insurance benefits.

2.6 Assumptions (a)/Constraints (c)/Hypotheses (h)

- (c-1) The study is limited to physicians in a private practice.
- (h-) Physicians are able to generate a demand for their services without lowering price.

3.0 TECHNICAL DESCRIPTORS

3.1 Model Type

Regression Analysis

3.2 Model Characteristics

Six equations (4 structural equations and 2 identities), each with 3-5 independent variables. The dependent (output) and independent (input) variables are those identified in sections 3.5 and 3.4 respectively.

Dependent Variable	Independent Variables
(1)	(1)-(5)
(2)	(1), (4)-(7)
(3)	(1), (3), (5)
(4)	(1), (4), (8)-(10)

3.3 Data Utilized

Cross-sectional state data from 33 states representing 90% of the total population was used to estimate the model. Data sources are listed in the Data Source Index: (20), (18), (53), (14), (117), (113), (57), (86).

3.4 Input Variables

- (1) Average price per visit,
- (2) Insurance benefits per capita,
- (3) Private physicians per 100,000 population,
- (4) Disposable personal income per capita,
- (5) Short-term hospital beds per 1,000 population,
- (6) Quantity of visits per private physician,
- (7) Number of medical schools,
- (8) Quantity of visits per capita,
- (9) Union members per 100 population, and
- (10) Ratio of health insurance premiums to benefits.

3.5 Output Variables

- (1) Quantity of visits per capita,
- (2) Private physicians per 100,000 population,
- (3) Quantity of visits per private physician, and
- (4) Insurance benefits per capita.

3.6 Verification/Applicability/Reliability

The developers state that due to the varying reliability of the data, conclusions derived from this study can only be suggestive of the true underlying relationships.

3.7 Computer Characteristics

None identified

1.0 IDENTIFICATION

1.1 Descriptive Title

Physician Distributions

1.2 Developer's Name

Charles A. Hawkins, Jr., University of Rochester

1.3 References

Hawkins, 1969

2.0 GENERAL DESCRIPTORS

2.1 Development Status

Completed

2.2 Purpose and Sponsor

"To examine physician distributions as an element of social welfare, to determine the extent of maldistributions and their causes, and to explore alternative means for correction of imbalance". Model is part of a master's thesis, Systems Analysis Program.

2.3 Scope and Subject

Physician-population ratios by physician type: engaged in patient care, general practice, and surgical specialist.

2.4 Abstract

Socio-economic and demographic data was examined to determine economic and other relationships influencing the geographic distribution of physicians. Regression equations were obtained relating population per physician to several independent variables for the United States and New York State for 1963 and 1967, and suggestions for remedying physician maldistribution were made.

2.5 Major Outputs

Physician population ratios

2.6 Assumptions (a)/Constraints (c)/Hypotheses (h)

None identified

3.0 TECHNICAL DESCRIPTORS**3.1 Model Type**

Regression Analysis

3.2 Model Characteristics

44 separate equations relating population per physician to different independent variables. United States - 24 equations, New York State - 20 equations. Half of each set of equations was estimated using 1963 data; the other half was estimated using 1967 data.

3.3 Data Utilized

Sources of the data utilized in the regressions are listed in the Data Source Index as numbers (101), (37), (100), (53), (117), (113), (18), and (19).

3.4 Input Variables

- (1) Per capita income,
- (2) Per cent population with regular medical insurance coverage,
- (3) Per cent population admitted to hospitals per year,
- (4) Number of medical schools per unit,
- (5) Population per square mile,
- (6) Median education,
- (7) Median age,
- (8) Per cent employment - professional and technical, and
- (9) Per cent employment - agricultural.

3.5 Output Variables

- (1) Population per physician - patient care,
- (2) Population per physician - general practice,
- (3) Population per physician - surgical specialist, and
- (4) Population per physician engaged in activities other than patient care.

3.6 Verification/Applicability/Reliability

Since the data used to estimate the model parameters applies to 1963 and 1967, it is questionable whether the model is applicable to current problems.

3.7 Computer Characteristics

IBM System 360/65

H2

1.0 IDENTIFICATION

1.1 Descriptive Title

Simulation of Hospital Medical Care

1.2 Developer's Names

Catherine Rhys Hearn; J. M. Bishop, University of Birmingham, Queen Elizabeth Hospital, Birmingham, England

1.3 References

Hearn & Bishop, 1970

2.0 GENERAL DESCRIPTORS

2.1 Development Status

Completed

2.2 Purpose and Sponsor

Demonstrate use of a simulation model to (1) describe activities and events concerned with the care of hospital patients, and (2) examine the consequences of changes in hospital operations. Model development sponsored by Nuffield Provincial Hospitals Trust.

2.3 Scope and Subject

Hospital services required by patients.

2.4 Abstract

Simulation model is used to describe hospital patient care. Data was obtained by observation and from records on 94 patients on two medical wards to generate service requirement statistics. Limited information is available on the selection of service parameters and modeling techniques employed and outputs of simulation.

2.5 Major Outputs

Schedule of patient services, type and number of services performed and availability of medical and nursing staff.

2.6 Assumptions (a)/Constraints (c)/Hypotheses (h)

(c-1) Limits set on number and kind of procedures a patient could receive on one day.

(c-2) Capacities of service departments.

(c-3) Availability of medical staff.

3.0 TECHNICAL DESCRIPTORS**3.1 Model Type**

Simulation, based on empirical data.

3.2 Model Characteristics

Insufficient information available.

3.3 Data Utilized

Data concerning items of service received by a sample of 94 patients and observations of clinical decisions regarding sequence of services are used to classify patient services received in terms of timing, location, priority, etc.

3.4 Input Variables

- (1) All items of service given,
- (2) Day given,
- (3) Reasons for the sequence observed and limits within which this might have been allowed,
- (4) Department of service,
- (5) Complexity of service,
- (6) Service priorities,
- (7) Service times, and
- (8) Other variables not identified.

3.5 Output Variables

Specific information not provided.

3.6 Verification/Applicability/Reliability

The model was verified by comparison at various simulated frequency distributions to distributions observed in the real situation, by comparison of output profiles with input profiles, and by examination of the effects of alterations in limits. There was no significant difference between the simulated and observed mean values or frequency distributions, output and input profiles agreed within 14 days in 81% of patients, and considerable variation in the limits produced little effect on length of stay. The model is intended for short-run planning. Insufficient information is provided to determine validity and reliability.

3.7 Computer Characteristics

Written in FORTRAN to be run under the EG-DON III system on a KDF 9 computer.

Running time - 90 minutes for 60 simulated days.

1.0 IDENTIFICATION

1.1 Descriptive Title

Migration of the 1955-1965 Graduates of American Medical Schools

1.2 Developer's Name

Philip J. Held, University of California, Berkeley

1.3 References

Held, 1973

2.0 GENERAL DESCRIPTORS

2.1 Development Status

Completed

2.2 Purpose and Sponsor

Analysis of the migration patterns of physicians with no previous state contact and with previous state contact "place of graduate training". Model development supported by the Ford Foundation.

2.3 Scope and Subject

Migration of family practice physicians and specialists who are non-federal, non-academic physicians in direct patient care, and who have had either graduate training in the state or no previous contact with the state.

2.4 Abstract

The movement and location patterns of recent medical graduates is analyzed within the context of the overall demographic, social and economic changes occurring within the US. Based on the literature review, a model is developed which contains measures of the economic,

professional and non-pecuniary attractions of an area for 1955-1965 medical school graduates. Cross-sectional data from 38 states is used to estimate the model equations. Estimates of the number of physicians locating in a state as a result of a unilateral increase in that state's public medical school graduates are provided. It is concluded that the migration patterns of physicians are consistent with reasonable hypotheses of economic and professional behavior. The results indicate that there is a market operating to allocate physicians and that there are instruments amenable to public policy.

2.5 Major Outputs

Estimates of the rate of physician migration relative to the white male migration.

2.6 Assumptions (a)/Constraints (c)/Hypotheses (h)

(c-1) Only non-federal, non-academic physicians in direct patient care are considered.

3.0 TECHNICAL DESCRIPTORS

3.1 Model Type

Regression Analysis

3.2 Model Characteristics

There are two types of equations, in-migration and out-migration, each estimated for public medical school graduates and public and private medical school graduates, by type of migrant (state of graduate training or no previous state contact) and by "family practice" or "specialist", for a total of 16 equations. Each equation contains the same 8 independent variables.

3.3 Data Utilized

Data for the model was obtained from the American Medical Association, April 1971. Additional data sources were L. S. Reed, *Studies of the Incomes of Physicians and Dentists*, US Department of Health, Education, and Welfare, Social Security Administration, Office of Research and Statistics, 1968; US Department of Housing and Urban Development, Federal Housing Administration, Division of Research and Statistics, *FHA Homes 1967*, Data for States and Selected Areas, Washington, D.C., US Government Printing Office, 1967, and numbers (117), (115), (140), (17), (18) in the Data Source Index.

3.4 Input Variables

- (1) Net profit of solo-practice physicians in state i in 1966.
- (2) Average price of land for existing FHA housing in 1967 in state i (a proxy for non-pecuniary benefits).
- (3) Natural rate of population increase between 1960 and 1967 in state i .
- (4) Ratio of non-federal physicians in category r per 100,000 population in state i in 1963. Category r has two values which correspond to the form of the dependent variable, family practice and specialists.
- (5) Number of public medical school graduates graduating from schools in state i in 1966 per 100,000 population.
- (6) Number of private medical school graduates graduating from schools in state i in 1966 per 100,000 population.
- (7) Number of house staff (interns, residents, fellows) who were graduates of American medical schools and were on duty in state i in 1966, and
- (8) Number of hospital beds in institutions used for teaching medical students (including graduate students) in state i in 1966.

3.5 Output Variables

- (1) Number of 1955-1965 medical school graduates in category k practicing in state i in 1971 relative to the number of white males who migrated into state i between 1955 and 1960.
- (2) Number of 1955-1965 medical school graduates in category k whose state of residence prior to attending medical school was i , but whose state of practice was not equal to i , relative to the number of white males who migrated out of state i between 1955 and 1960.

Category k refers to "place of graduate training" or "no previous state contact" and family practice or specialist practice, i.e., four categories.

3.6 Verification/Applicability/Reliability

Since the cross-sectional data results in average values for all states, the model's applicability to individual states is questionable. No verification studies were performed.

3.7 Computer Characteristics

None identified

1.0 IDENTIFICATION

1.1 Descriptive Title

Demand and Supply of Professional Hospital Nurses' Services

1.2 Developer's Name

Jesse S. Hixson, Michigan State University

1.3 References

Hixson, 1969

2.0 GENERAL DESCRIPTORS

2.1 Development Status

Completed

2.2 Purpose and Sponsor

To conceptualize and measure the effects of managerial discretionary behavior on the demand and supply of nurses' services. The model is part of a PhD dissertation, field of Economics.

2.3 Scope and Subject

Demand and supply of general duty RNs, practical nurses, and nursing aides in medical, surgical, intensive care and cardiac units in relation to the objective functions of short-term general hospitals.

2.4 Abstract

The economic structure of the hospital as a firm is described with particular emphasis on the decision processes and discretionary behavior of the hospital. Theoretical specification of individual physician utility functions are maximized and amalgamated to construct a set of demand functions for hospital services. The theoretical model is further specified in terms of the hospital departmentalized structure. Preference function and fund allocation are maximized to establish the department budget constraints, nursing service budget:

and nursing care production function, thus establishing the hospital's demand for nurses. The supply of nurses is derived by maximizing nurse utility functions which include working condition arguments in addition to the traditional income and leisure variables. Using 1960 and 1964 data from 40 counties in Michigan, underlying assumptions of the theoretical model are tested and elasticity of the supply of nursing services estimated.

2.5 Major Outputs

Turnover rates of nurses in hospitals, ratios of nurses to average daily census and to other classifications of nurses.

2.6 Assumptions (a)/Constraints (c)/Hypotheses (h)

- (a-1) Nurses are perfectly immobile between markets.
- (a-2) The stock of nurses is fixed during the time period under consideration.
- (a-3) The demand for hospital nurses was derived under the assumption the nursing service department maximizes output subject to a budget constraint determined by the utility-maximizing allocation of funds yielded in the hospital decision process.
- (a-4) The physician acts to maximize his utility, which is a function of income and leisure.
- (a-5) The objective of non-profit hospitals is to maximize output, that is, hospital output is extended to the point where total cost equals total revenue.
- (a-6) Private practitioners favor expenditure on medical care inputs.
- (a-7) Nursing staff prefer expenditures on patient care inputs when the working conditions in the nursing service department are determined by the volume of these expenditures.
- (h-1) The supply of nurses' service to a hospital is affected by the technical magnitudes utilized in its production of nursing care.
- (h-2) A hospital's demand for nurses relative to its patient load will vary with the influence of the nursing staff in its decision process.
- (h-3) The "shortage" of professional hospital nurses is not a result of imperfections in the labor market.

3.0 TECHNICAL DESCRIPTORS

3.1 Model Type

Formulation of theoretical structure tested by use of regression analysis on empirical data.

3.2 Model Characteristics

For the testing of the first hypothesis (turnover rate of the dependent variable), linear, semi-logarithmic, and logarithmic functional forms were employed in regressions for all combinations of the explanatory variables. Two groups of regressions were run, one including ratios of registered nurses to auxiliary nursing personnel. Seven "best-fit" equations were reported for the first set of staffing ratios (personnel to patients); six "best fit" equations were reported for the second set of staffing ratios (RNs to auxiliary personnel). For the testing of the second hypothesis (hospital demand for nurses as represented by the staffing ratios), each dependent variable was regressed into all pairs, all 3-tuple and all 4-tuple combinations of the explanatory variables, resulting in 9 "best-fit" equations for the six dependent variables.

3.3 Data Utilized

Data utilized in the regressions was collected from a sample of fourteen short-term general hospitals in Michigan. All hospitals included in the sample were accredited by the Joint Commission on the Accreditation of Hospitals and were participating Blue Cross Hospitals, and none were primary teaching hospitals.

3.4 Input Variables

- (1) Average daily census in medical, surgical, ICU, and cardiac nursing units,
- (2) General duty RNs per average daily census,
- (3) Practical nurses per average daily census,
- (4) Nursing aides per average daily census,
- (5) Ratio of general duty RNs to practical nurses,
- (6) Ratio of general duty RNs to nursing aides,
- (7) Minimum or starting monthly wage of general duty RNs,
- (8) Maximum attainable monthly wage of general duty RNs,
- (9) A binary variable coded 0 to 1 according as the nurse force was "permanent" or "transitory" to indicate the stability of the population from which the nurse was drawn.

- (10) A binary variable coded 0 to 1 according as nurses were or were not shifted between services with changes in patient loads,
- (11) Ratio of physicians with special clinical privileges to total active medical staff,

Binary coded hospital variables are:

- (12) Presence or absence of an ICU,
- (13) Presence or absence of a cardio-pulmonary unit,
- (14) Presence or absence of practical nurse training,
- (15) Presence or absence of professional nurse training,
- (16) Presence or absence of an organization consisting of clinical departments with chiefs-of-services,
- (17) Presence or absence of a patient care committee,
- (18) Presence of a authoritarian administrator or presence of an administrator who delegated authority with respect to the Nursing Service Department, and
- (19) Presence or absence of explicit budget negotiations for the nursing service.

3.5 Output Variables

- (1) Turnover rate of general duty RNs in per cent per year,
- (2) Total nursing personnel per average daily census in medical, surgical, ICU and heart units,
- (3) General duty RNs per average daily census,
- (4) Practical nurses per average daily census,
- (5) Nursing aides per average daily census,
- (6) Ratio of general duty RNs to practical nurses, and
- (7) Ratio of general duty RNs to nursing aides.

3.6 Verification/Applicability/Reliability

Underlying hypothesis and conceptual model structure were tested in terms of the confidence levels on the estimated coefficients of the regression equations. These regressions were further tested for possible specification errors or biases. Results of these tests appear to confirm the hypothesis that working conditions affect the supply functions of nurses services to hospitals and that the demand for nurses is affected by the relative independency of the nurse department actions.

3.7 Computer Characteristics

None identified

1.0 IDENTIFICATION

1.1 Descriptive Title

Linear Regression Model - Estimating Hospital Bed Needs in California

1.2 Developer's Name

Carl E. Hopkins et al, UCLA

1.3 References

Hopkins, 1967

2.0 GENERAL DESCRIPTORS

2.1 Development Status

Completed

2.2 Purpose and Sponsor

To provide the state of California with a study of methods for estimating hospital bed needs. Project sponsored by the US Public Health Service.

2.3 Scope and Subject

Hospital bed needs for 58 California counties in 1960 and 1965

2.4 Abstract

This study explores the methodology of estimating present and future hospital bed needs to serve a given client population. Multiple linear correlation/regression analysis was used to determine the influence of several variables on hospital bed use, and a three-variable simplified regression model for estimating per capita patient days was developed for illustrative purposes. The model explained 35% of the variance in per capita hospital use.

2.5 Major Outputs

Patient days of hospitalization used by county.

2.6 Assumptions (a)/Constraints (c)/Hypotheses (h)

None identified

3.0 TECHNICAL DESCRIPTORS**3.1 Model Type**

Regression Analysis

3.2 Model Characteristics

One equation, three variable (deaths age 65 and over per capita, births per capita, effective buying income per capita).

3.3 Data Utilized

Data collected for each of 58 California counties. Variables selected on basis of availability for intercensal years.

3.4 Input Variables

For correlation/regression analysis - variables 6, 18 and 21 used in regression model.

- (1) Total population (thousands),
- (2) Number of households (thousands),
- (3) Urban population (thousands),
- (4) Total retail sales (\$000),
- (5) Drug stores sales (\$000),
- (6) Net effective buying income (\$000),
- (7) Per cent of families with incomes under \$4000,
- (8) Per cent of families with incomes of \$7000 or more,
- (9) Persons in the population between the ages of 25 and 64 (thousands),
- (10) Persons in the population aged 65 and over (thousands),
- (11) Per cent nonwhite population,
- (12) Average annual unemployment rate,
- (13) Male median educational level,

- (14) Female median educational level,
- (15) Square mile area of county,
- (16) Total constructed rural and urban state highway mileage,
- (17) Total number of deaths (by place of residence),
- (18) Total number of live births (by place of residence),
- (19) Total number of marriages (by place of occurrence),
- (20) Number of deaths under age 5 (by place of residence),
- (21) Number of deaths aged 65 and over (by place of residence),
- (22) Number of hospital beds,
- (23) Number of hospitals,
- (24) Number of physicians in private practice, and
- (25) Number of physicians in general practice.

3.5 Output Variables

Patient days of hospitalization used by county.

3.6 Verification/Applicability/Reliability

Model predictions are compared to actual data, and a sizable error term is observed. The methodology developed in the study can be generally applied; the specific parameters were estimated using 1960 and 1965 data for California counties and general applicability is unlikely.

3.7 Computer Characteristics

None identified

1.0 IDENTIFICATION

1.1 Descriptive Title

Allocation of Nursing Time to Patient Care Model

1.2 Developer's Name

Richard C. Jelinek, University of Michigan

1.3 References

Jelinek, 1964, 1967

2.0 GENERAL DESCRIPTORS

2.1 Development Status

Completed

2.2 Purpose and Sponsor

To characterize the behavior of the nursing unit as it relates to the quantitative aspects of nursing care. The model can be used for analysis of operation, prediction, and planning. Model development supported by the W. K. Kellogg Foundation.

2.3 Scope and Subject

Analysis of hours per day devoted to direct patient care, indirect care, and miscellaneous activity by RNs, LPNs, nursing aides, and student nurses.

2.4 Abstract

The model characterizes the structural behavior of a nursing unit as it relates to the amount of the nursing staff's time (on a per patient basis) devoted to various nursing activities. The model consists of a series of simultaneous regression equations relating the number of hours per patient day devoted to a given nursing activity to the various

other parameters (e.g., available staff, number of patients, patient conditions, etc.). The results of the regression analysis are compared to hypothesized relationships between variables concerning the characteristics of the nursing unit. The hypothesized relationships were used to provide the theoretical basis for the model.

2.5 Major Outputs

Hours devoted to various activities by different nursing categories.

2.6 Assumptions (a)/Constraints (c)/Hypotheses (h)

- (h-1) Added increments of nursing staff yield progressively lesser increments in the amount of time devoted to direct patient care by the nursing staff.
- (h-2) The disproportion of change due to hypothesis 1 is greater for the more highly trained nursing staff, i.e., professional, practical and student staff, than it is for the lesser trained staff, i.e., nurses aides.
- (h-3) Added increments of nursing staff yield progressively greater increments in the amount of time devoted to nonproductive activity by the nursing staff.
- (h-4) The disproportion of change due to hypothesis 3 is greater for the more highly trained nursing staff, i.e., professional, practical and student staff, than it is for the lesser trained staff, i.e., nurse aides.
- (h-5) There exists a substitution effect between the various nursing categories in the amount of direct patient care rendered; for example, an increase in the number of practical nurses on the nursing unit will increase the amount of direct patient care rendered by the practical nurses (by hypothesis 1), which, due to this hypothesis, will reduce the amount of direct patient care that the professional nurses would otherwise have given.
- (h-6) The substitution effect (i.e., the reduction in direct patient care) due to hypothesis 5 is proportionally greater for the more highly trained nursing staff, i.e., professional, practical and student staff, than it is for the lesser trained staff, i.e., the nurse aides.
- (h-7) The amount of time devoted to direct patient care by the nursing staff will increase with an increase in the level of patients' need for nursing care.

- (h-8) The increase in direct patient care due to hypothesis 7 is proportionally greater for the more highly trained nursing staff, i.e., professional, practical and student staff, than it is for the lesser trained staff, i.e., nurse aides.
- (h-9) There exists an inverse relationship between the amount of time devoted to direct patient care and the amount of time devoted to non-productive activity (i.e., an increase in time devoted to direct patient care is associated with a decrease in time devoted to non-productive activity).

3.0 TECHNICAL DESCRIPTORS

3.1 Model Type

Regression Analysis

3.2 Model Characteristics

12 equations, 12 dependent variables, 11 independent variables

Dependent Variables

(1)
(2)
(3)
(4)
(5)
(6)
(7)
(8)
(9)
(10)
(11)
(12)

Independent Variables

(1), (5)-(9), (4)*, (7)*, (10)*
(2), (5)-(9), (1)*, (7)*, (10)*
(3), (5)-(9), (1)*, (4)*, (10)*
(4)-(9), (1)*, (4)*, (7)*
(1), (5)-(9), (1)*
(2), (5)-(9), (4)*
(3), (5)-(9), (7)*
(4)-(9), (10)*
(1), (1)*
(2), (4)*
(3), (7)*
(4), (10)*

*endogenous variables

3.3 Data Utilized

Data to test the hypothesized characteristics of the nursing unit was obtained from observation of 33 nursing unit days on 6 medical, surgical, and orthopedic units of Saint Joseph Mercy Hospital, a 520 bed general care hospital in Ann Arbor, Michigan.

3.4 Input Variables

- (1) RN hours per patient day,
- (2) LPN hours per patient day,
- (3) Nursing aides hours per patient day,
- (4) Student nurse hours per patient day,
- (5) Fraction of partial care patients,
- (6) Fraction of total care patients,
- (7) Number of patients in nursing unit,
- (8) Newly admitted patients (within a 24 hour period) as fraction of census, and
- (9) Type of nursing unit - orthopedic, urology and neurosurgery, general surgical, and other.

3.5 Output Variables

- (1) Number of hours per patient day devoted to direct patient care by RNs,
- (2) Number of hours per patient day devoted to direct patient care by LPNs,
- (3) Number of hours per patient day devoted to direct patient care by nursing aides,
- (4) Number of hours per patient day devoted to direct patient care by student nurses,
- (5) Number of hours per patient day devoted to indirect care by RNs,
- (6) Number of hours per patient day devoted to indirect care by LPNs,
- (7) Number of hours per patient day devoted to indirect care by nursing aides,
- (8) Number of hours per patient day devoted to indirect care by student nurses,
- (9) Number of hours per patient day devoted to nonproductive and miscellaneous activities by RNs,
- (10) Number of hours per patient day devoted to nonproductive and miscellaneous activities by LPNs,
- (11) Number of hours per patient day devoted to nonproductive and miscellaneous activities by nursing aides,
- (12) Number of hours per patient day devoted to nonproductive and miscellaneous activities by student nurses.

3.6 Verification/Applicability/Reliability

Individual hypotheses listed in section 2.6 were compared to the curves and data generated in model development, however, quantitative analysis of absolute or relative magnitudes of this comparison or contrast is not performed. Confidence measures and levels of significance concerning the validation of these hypotheses are not therefore provided. Since the model was estimated using data from a single hospital, the parameter coefficients are not generally applicable to all hospitals.

3.7 Computer Characteristics

None identified

1.0 IDENTIFICATION

1.1 Descriptive Title

Maternal and Child Care Simulation Model

1.2 Developer's Name

F. D. Kennedy, Research Triangle Institute

1.3 References

Kennedy, 1968a, 1968b, 1968c, 1968d

2.0 GENERAL DESCRIPTORS

2.1 Development Status

The maternal and infant care simulation model is completed and tested by comparison to actual data.

2.2 Purpose and Sponsor

To investigate the problems associated with the development of a community health service system simulation model and to determine the feasibility of using simulation techniques in community health planning. Model development sponsored by the US Public Health Service, Division of Community Health Services, Bureau of Health Services.

2.3 Scope and Subject

Simulation of a maternal and infant care

2.4 Abstract

A model of community health services was developed to investigate the merits of using simulation techniques in health planning and to evaluate the validity of the total health systems framework previously developed, by constructing a model of a selected subsystem. The maternal

and infant care subsystem was selected, and a simulation model developed. Regression analysis of data from North Carolina Counties yielded four equations concerned with (1) prediction of number of mothers' visits to prenatal clinic, (2) prediction of total number of home and extra service visits, (3) prediction of birth weight of infant, and (4) prediction of number of infant illnesses. Using these equations and simulated values of requisite data, the model calculates the number of pregnancies generated in a particular month and assigns characteristics to them, builds a schedule of clinic visits for the mother, allocates resources for these visits and records their utilization and costs, creates a record for each pregnancy that terminates in a live birth and assigns appropriate characteristics to this infant's record, generates an illness pattern for the infant, builds a schedule of clinic and office visits by the mother and infant, allocates resources for these visits, and records resource utilization and costs.

2.5. Major Outputs

Four basic report types: maternal clinic utilization, infant clinic utilization, yearly summary report, and pregnancy termination report.

2.6 Assumptions (a)/Constraints (c)/Hypothesis (h)

- (a-1) The need arising from pregnancies can be sufficiently predicted by a crude pregnancy rate multiplied by the appropriate socio-populations.
- (a-2) Demand is a function of socio-acceptability (which remained constant) and spread of information concerning the clinic (which increased with time to some upper limit).
- (a-3) Resource utilization can be adequately portrayed in an aggressive manner.
- (a-4) Clinic service times can be adequately represented by a truncated exponential function.
- (a-5) Patient attitudes toward the clinic are a function of clinic loading and the resulting time available for clinic personnel/patient communication.
- (a-6) The model assumes maternal and infant mortality rates to be stationary and emphasizes, instead, the reduction of infant abnormality and infant morbidity.

3.0 TECHNICAL DESCRIPTORS

3.1 Model Type

Simulation, Regression Analysis

3.2 Model Characteristics

The model consists of four linear regression equations and a series of simulation programs written in SIMSCRIPT which generate specific maternal and child care data values from gross inputs such as population size, pregnancy rate, hospital stay characteristics and other distributional parameters. Minimum simulation time interval is one week. Each simulated month has three sets of maternal/pediatric patients associated with it: mothers eligible to attend the maternal care clinic, mothers scheduled for delivery for the month and the collection of infants available to attend the infant care clinic. The program distributes these mothers and children into the weekly clinics according to the case load distribution. Clinic operations are defined by the various types of personnel in terms of the number assigned to the clinic, allocation of work hours, and length of time spent with patients. The program also defines visit costs and services times for pediatrician offices and hospital outpatient operations.

3.3 Data Utilized

The model was derived using data from the North Carolina Project for Comprehensive Maternal and Infant Health Care in Wayne County for the period July 1965 to December 1966.

3.4 Input Variables

- (1) Population class characteristics (size, crude pregnancy rate),
- (2) Characteristics of the pregnancy for each class (age distribution for mother, marital status distribution, parity distribution, pregnancy outcome distribution),
- (3) Initial visit distribution,
- (4) Economic and educational distribution,
- (5) Resource list (personnel resources used in the maternal and infant care clinics, pediatrician office resources),
- (6) Hospital stay distribution (mother and child at the time of delivery),
- (7) Cost data for clinic and hospital operations, and
- (8) Infant illness data (illness outcome, where treated, conditional probability of having subsequent illness).

3.5 Output Variables

- (1) Maternal clinic utilization report (case load, amount of resources used, maximum clinic running time, cost of clinic operation, for each month),
- (2) Infant clinic utilization report (data for the infant clinic, the hospital and pediatrician office visits),
- (3) Yearly summary report (summarizes clinic operations for a year and includes effectiveness measures), and
- (4) Pregnancy termination report (number of pregnancies that terminate during the year and their outcome, for the target population and the population at large).

3.6 Verification/Applicability/Reliability

The predictive ability of the model was treated by comparing actual caseload data from Wayne County for the 1967 calendar year with data generated by the model for that county for the equivalent time period. The universality of the model was given an initial test by comparing the simulated data with actual data from the other project counties, Warren and Halifax. All predictions were within acceptable limits; however, the developers state that additional data subsequent to 1967 for all three counties should be obtained to further verify the model before it can be accepted without any reservations. The regression equations of the model may not be applicable to time periods or geographic areas different from the time and area in which they were derived.

3.7 Computer Characteristics

Run on the IBM 7094 and the CDC 3600. Language: SIMSCRIPT. Run times of approximately 4 minutes on the 3600, 10 minutes on the 7094, have been experienced in simulating 5 years of operation with an average monthly case load of 200 mothers and 100 infants. A program listing of the model is included.

1.0 IDENTIFICATION

1.1 Descriptive Title

Model of Patient Care Demands for Nurse Manpower

1.2 Developer's Names

Claire Laberge-Nadeau, Marie Feuvrier, Ste. Justine Hospital, Montreal

1.3 References

Laberge-Nadeau, Feuvrier, 1972

2.0 GENERAL DESCRIPTORS

2.1 Development Status

Completed and verified by comparison to actual hospital operations.

2.2 Purpose and Sponsor

Analyze nursing tasks in order to maximize efficient utilization of nurse personnel. Model development sponsored by Ste. Justine Hospital.

2.3 Scope and Subject

Patient demand for nursing staff and supply of tasks by nursing staff category.

2.4 Abstract

A time-study is used to determine direct care needs of patients and a simulation model is used to estimate demand for activities other than direct care. The model was developed to test the effect of variations in the number and class of patients on the number and type of nursing staff needed. The developers believe there is a possibility of reorganizing various tasks to optimize patient care, and feel there is need for a staffing allocation method based on patients' requirements.

2.5 Major Outputs

A sample of 30 work days for each personnel category.

2.6 Assumptions (a)/Constraints (c)/ Hypotheses (h)

- (a-1) Tasks not related to direct patient care are independent of the number and class of patients when the "ward functions under normal conditions".
- (c-1) Routine assignments must be conducted during regular hours.
- (c-2) Assignments ordered by most probable order of occurrence.
- (c-3) Occasional assignments identified.

3.0 TECHNICAL DESCRIPTORS**3.1 Model Type**

Monte Carlo, Simulation, Empirical

3.2 Model Characteristics

A UCLA transportation model TRANSIM which has been generalized for use in industrial and institutional systems is used to simulate activities of a nursing staff. Frequency distributions internal to the model and other technical descriptors are not provided in the above reference.

3.3 Data Utilized

- Data on the duration and frequency distribution of tasks assigned to each type of personnel was obtained through interviews with experienced personnel at Ste. Justine Hospital, Montreal.

3.4 Input Variables

List of all tasks carried out by each category of personnel, order of occurrence, frequency, and time required to complete each task.

3.5 Output Variables

- (1) Listing of every activity carried out by a person in each category, in the order and at the time of their occurrence for each day of the period simulated.
- (2) Breakdown of total time spent by the personnel in the hospital - shows maximum, minimum, and average day length, and
- (3) Amount of time spent carrying out activities (individual and by activity group) as outlined in the activity lists.

3.6 Verification/Applicability/Reliability

The model was verified by comparing the model results to actual hospital operations on four levels. The simulation contains a validation stage during which a model is run, its results are analyzed and, if necessary, the model is corrected using new data. Information required to determine internal validity is not provided in this reference.

3.7 Computer Characteristics.

Run time - 3 minutes on UNIVAC 1108

1.0 IDENTIFICATION

1.1 Descriptive Title

An Econometric Production Function Model for Health

1.2 Developer's Name

Mary Lou Larmore, Northwestern University

1.3 References

Larmore, 1967

2.0 GENERAL DESCRIPTORS

2.1 Development Status

Completed and estimated using 1959 and 1960 data.

2.2 Purpose and Sponsor

To explain differential mortality rates among the counties of the US and to estimate a health production function focusing on the individual person. Model is part of a PhD dissertation, field of economics.

2.3 Scope and Subject

Empirical production function for health, estimating mortality rates, physician visits, family income, and health status.

2.4 Abstract

Two models of health production are constructed. The first is a one equation model explaining differential mortality rates, using cross-section data from United States counties. The second model examines health production at the level of the individual, studying health status as influenced by personal characteristics and utilization of medical care. The three equations in this model are a production function for health, a demand function for physician visits and an income-generating function. The model is empirically estimated using alternative identifying assumptions, and the set of assumptions which yielded the most reasonable results is selected.

2.5 Major Outputs

Estimates of mortality rates, number of physician visits, annual family income, and two proxy variables for health.

2.6 Assumptions (a)/Constraints (c)/Hypotheses (h)

Model 1: Mortality Rate Model

- (h-1) Number of non-federal physicians per thousand residents is largely unresponsive to mortality rate.
- (h-2) Income structure of a county is not significantly influenced by the mortality rate.

Model 2: Three Equation Model

- (a-1) Sex is not an important variable in explaining disability or mortality.
- (a-2) Residence in the South influences health; differences among other regions are unimportant.

3.0 TECHNICAL DESCRIPTORS

3.1 Model Type

Regression Analysis

3.2 Model Characteristics

Model 1: one linear equation, relating mortality rate to the seventeen independent variables listed in section 3.4.

Model 2: three equations relating each of the three dependent (output) variables listed in section 3.5 to the eleven input variables listed in section 3.4.

3.3 Data Utilized

Data for estimation of Model 1 was obtained from the Census Bureau publication *County and City Data Book 1988* and from reference #25 in the Data Source Index. Data for Model 2 was obtained from reference #s (115), (118), (86), in the Data Source Index and US National Health Survey Publications Series 10, Numbers 21 and 24.

3.4 Input Variables**Mortality Rate Model**

- (1) Number of non-federal physicians per thousand residents,
- (2) Population density,
- (3) Per cent of population having urban residence,
- (4) Per cent of population having rural farm residence,
- (5) Per cent of population nonwhite,
- (6) Per cent of population under 5 years of age,
- (7) Per cent of population between ages of 21 and 65,
- (8) Per cent of population 65 years of age and over,
- (9) Per cent of families having yearly income under \$3000,
- (10) Per cent of families having yearly income of \$10,000 and over,
- (11) Per cent of population 25 and over having completed less than 5 years of school,
- (12) Per cent of population 25 and over having completed high school or more,
- (13) Per cent of population having migrated from a different county in 1960,
- (14) Per cent of employed persons in agriculture,
- (15) Per cent of employed persons in construction,
- (16) Per cent of employed persons in manufacturing,
- (17) Per cent of employed persons in white collar occupations.

Three equation Model 2 (all are dummy variables)

- (1) 1 if male, 0 otherwise,
- (2) 1 if a person's age is 5-14, 0 otherwise,
- (3) 1 if a person's age is 15-24, 0 otherwise,
- (4) 1 if a person's age is 25-44, 0 otherwise,
- (5) 1 if a person's age is 45-64, 0 otherwise,
- (6) 1 if a person's age is 65-74, 0 otherwise,
- (7) 1 if a person's age is 75 or more, 0 otherwise,
- (8) 1 if a person resides in North Central region, 0 otherwise,
- (9) 1 if a person resides in South region, 0 otherwise,
- (10) 1 if a person resides in West region, 0 otherwise,
- (11) 1 if a person is a member of the white race, 0 otherwise.

3.5 Output Variables

Model 1 - Number of deaths per thousand residents,

- Model 2 - (1) Alternative proxy variables for health
- (a) Number of bed disability days per person per year,
 - (b) Number of deaths per hundred persons per year
- (2) Number of physician visits per person per year,
 - (3) Annual family income of persons in the sample.

3.6 Verification/Applicability/Reliability

Since the data used to estimate the parameters of the model applies to the early 1960's, it is questionable whether the model is applicable to current problems.

3.7 Computer Characteristics

None identified

1.0 IDENTIFICATION

1.1 Descriptive Title

Cost of Medical Education

1.2 Developer's Name

Robert J. Latham, University of Iowa

1.3 References

Latham, 1971

2.0 GENERAL DESCRIPTORS

2.1 Development Status

Completed

2.2 Purpose and Sponsor

- (1) To analyze in detail the production process by identifying all factors of production and all production activities of the medical college and to estimate production functions for each production activity.
- (2) To provide an accurate estimate of the cost of each production activity in the medical college and to use these estimates for predicting budgeting requirements of expanding medical enrollments.
- (3) To estimate the optimal output mix of the medical college given production functions, inputs available, budget limitations, and institutional constraints on production alternatives.

Supported by the University of Iowa Medical College with US Public Health Service funding. The model is part of a PhD dissertation, field of Economics.

2.3 Scope and Subject

Production, costs, and allocation in the University of Iowa Medical College, Iowa City, Iowa, 1967-68 and 1968-69.

2.4 Abstract

Theoretical questions are posed concerning the relationships between inputs and final outputs in a medical college. To answer these questions an input-output model with inventories is developed, cost functions for production outputs (e.g., research, medical education, patient services, intern and resident education, graduate education, etc.) are specified, and 3 linear programming models for determination of optimal mixes of these outputs are specified. Activities, outputs, and technological production relationships of the medical college are specified in detail and estimated using two observations on one medical college. Price parameters are determined, and empirical solutions to the theoretical questions obtained. The empirical results are not generally applicable to other medical colleges.

2.5 Major Outputs

Solutions to optimal output mix questions.

2.6 Assumptions (a)/Constraints (c)/Hypotheses

- (a-1) The models used in this study are static under conditions of certainty.
- (a-2) There are fixed production coefficients in the production of each output.
- (a-3) The production function is homogeneous of degree one in factor inputs - the given set of production processes are the most efficient.
- (a-4) Additional factors of production can be purchased on the market without affecting factor prices.
- (a-5) The cost function for any given output is homogeneous of degree one (marginal cost-average cost).
- (a-6) There are no stochastic processes affecting input coefficients.
- (a-7) For predictive purposes, the input coefficients are assumed to remain constant over the planning period.

- (a-8) There is no cost of adjustment of fixed factors to alternative production activities.
- (a-9) Educational inventories (students) are assumed to be fixed factors of production in any given time period.
- (a-10) There is no inventory cost to the medical college of carrying educational inventories over to future periods of production.
- (a-11) Equipment services and personnel services are assumed to be used at full capacity.
- (a-12) There are no factor indivisibilities in production processes.
- (c-1) For individual constraints see discussion in section 3.2.

3.0 TECHNICAL DESCRIPTORS

3.1 Model Type

Linear Programming

3.2 Model Characteristics

Three linear programming models, each with the same objective function -- to maximize the total sales (market price times quantities of final outputs) of medical education. In the first model the objective function is maximized, subject to the constraints that: (1) factor input requirements must not be greater than fixed primary inputs available, (2) the required number of students in a given year of training must be no greater than those who have completed preparation for those years of educational programs, (3) the final output demands for some outputs are fixed, and (4) the quantities of final outputs are non-negative. The second model is identical to the first, with the exception that one additional constraint concerned with the quality of education has been added, i.e., (5) research and patient service must not be less than amounts sufficient to maintain fixed research-student and patient-student ratios. In the third model the first constraint noted above is modified to factors which only include fixed building equipment and building services, and the second constraint is replaced by the constraint that the total cost of production must be no greater than the budget available to the medical college. The rationale for developing this latter model is to provide a model more realistic than the initial model for medical college planning purposes.

3.3 Data Utilized

Data for the study was obtained from effort reports submitted by faculty members and other personnel of the University of Iowa Medical College in 1967-68 and 1968-69.

3.4 Input Variables

- (1) A complete list of primary medical education inputs.

The inputs chosen are:

Professional services by subject taught
 Associates in teaching and research
 Assistants in teaching and research
 Residents by year of residency
 Interns
 Administrative personnel
 Other professional personnel
 Technical service personnel
 Office clerical personnel
 General service personnel
 Direct supplies services
 Equipment services
 Building services

- (2) A complete list of medical college activities (outputs).

The activities chosen are:

General administration
 Undergraduate medical courses by subject
 Medical education by year
 Medical degrees
 Other education by type
 Research
 Special service and programs by type
 Patient services by type

- (3) Estimates of prices associated with medical education inputs.
 (4) Estimates of prices associated with output activities of medical colleges.
 (5) Desired levels of future medical college outputs.
 (6) Input coefficients of medical school production.
 (7) Educational quality measures (i.e., patient-student and research-student ratios).
 (8) Total medical college budget.
 (9) Other medical college parameters associated with various classes of students, subject categories taught, type of medical service provided, etc. which are listed in illegible charts in above reference.

3.5 Output Variables

Solution to optimal output mix for the medical college given the resources available and institutional constraints.

3.6 Verification/Applicability/Reliability

Subject to the availability of data and the applicability of the model to other medical colleges, the model should provide a mechanism to evaluate the cost of alternative medical college production modes.

3.7 Computer Characteristics

None identified.

1.0 IDENTIFICATION

1.1 Descriptive Title

Hospital Planning Model

1.2 Developer's Name

Stephen S. Lazarus, University of Rochester

1.3 References

Lazarus, 1971

2.0 GENERAL DESCRIPTORS

2.1 Development Status

Completed

2.2 Purpose and Sponsor

Implementation of a linear programming model for hospital planning. Model development was supported by US Bureau of Naval Personnel.

2.3 Scope and Subject

Hospital planning model used to evaluate a proposed hospital plan for three different objective functions.

2.4 Abstract

A hospital planning model is developed with a linear programming structure. The planning variables include the number of beds allocated to each service, operating room capacity for each surgical specialty and capacity for each of the ancillary services. The model is used to evaluate a proposed new hospital plan for an 805 bed teaching hospital.

2.5 Major Outputs

Optimal values of decision variables to maximize objective function.

2.6 Assumptions (a)/Constraints (c)/Hypotheses (h)

- (a-1) Each potential patient to arrive at the hospital can be unambiguously assigned to one admitting service.
- (a-2) Classification of a potential patient by his age, sex, and admitting service is sufficient to estimate his expected "social welfare value" to the community and requirements for hospital-supplied goods and services (one technology).
- (a-3) The objective of the community is to have the hospital maximize the net difference in perceived social benefit of hospitalization and the cost of providing that care.
- (a-4) The technology of the hospital is adequately described by a linear relationship between output of services and inputs of resource.
- (a-5) The time period for the analysis is fixed but arbitrary.
- (a-6) Patient admissions can be completely controlled by the hospital.
- (a-7) Purchase and operation of equipment and personnel is controlled by the hospital administration.
- (a-8) The social welfare resulting from hospitalization is adequately described by a linear function of patients and resources.
- (a-9) A maximum demand for each patient class can be forecasted for the time period under analysis.
- (a-10) Medical technology and acceptable medical practice procedures are constant during the time period under analysis.
- (a-11) There is no discrimination between paying and nonpaying patients.
- (a-12) The hospital is an independent health care system.
- (a-13) Rates and fees are held constant in the analysis.
- (c-1) Total requirement of fixed resources must equal the available fixed resources.
- (c-2) Total requirement of variable resources (staff and supplies) must equal the available variable resources.
- (c-3) The amount of capital facilities from the current planning period must not exceed current capacity.

- (c-4) Specified space constraints cannot be exceeded in the planning period.
- (c-5) The maximum number of patients in each group is less than or equal to a preselected bound.
- (c-6) The total cost of purchasing new facilities or equipment replacing existing equipment is less than or equal to the capital budget.
- (c-7) The total staff and supply costs must not exceed the operating budget.
- (c-8) The hospital income equals hospital costs.
- (c-9) Number of beds required for patients in each group is bounded by the maximum number of beds allowed.
- (c-10) The maximum number of beds to meet residency and training program requirements is greater than or equal to the number of beds available.
- (c-11) The total number of staff in each category has an upper bound.
- (c-12) Patient mix must be compatible with current medical practice (e.g., newborns are admitted with their mothers).
- (c-13) The numbers of patients, facilities, supplies, personnel are all non-negative.

3.0 TECHNICAL DESCRIPTORS

3.1 Model Type

Linear Programming

3.2 Model Characteristics

Optimal solutions are derived for three objective functions, a social welfare function formulating the perceived net gain in value to hospitalizing a patient belonging to a particular class, a quasi production function concerned with hospital income from patient billings, and a total hospital admissions function. Each function is maximized for a planned 805 bed hospital subject to the thirteen constraints listed in section 2.6. In this application there are 258 constraint rows

(206 of which are upper bounding for single variables) and 180 patient variables, 56 capital facility variables, and 3 staff variables. Model extensions are given to modify the assumptions of hospital independence from other components and the linear relationship describing hospital technology.

3.3 Data Utilized

Data was obtained from computer accounting records of Strong Memorial Hospital, Rochester, New York.

3.4 Input Variables

Patient variables:

- (1) Sex,
- (2) Age, (less than one year, 1-14, 15-44, 45-64, more than 65),
- (3) Admitting service (general surgery, neuro, ENT, eye, plastic, urology, orthopedic, oral, pediatrics, intensive, general medicine, neurology, intensive, pediatrics, psychiatry, rehabilitation, gynecology, obstetrics).

Capital facility variables:

- (4) Beds (bassinets, pediatric, adult, intensive care, extended care, obstetric),
- (5) Operating rooms (general, neurology, ENT, eye, plastic, TUR, orthopedic, gynecology, minor surgeries),
- (6) Ancillary services (blood bank, chest lab, clinical chemistry, heart station, hematology, inhalation therapy, microbiology, obstetrics/gynecology, pathology, pharmacy, rehabilitation, x-ray, therapy),
- (7) Capital budget.

Staff variables:

- (8) Personnel (bed and operating room support personnel, laboratory technicians, physicians),
- (9) Minimum bed requirements for 6 residency programs.

3.5 Output Variables

Optimal bed service allocations for different objective functions - maximize billings, maximize social benefit at least equals cost, and maximize admissions.

3.6 Verification/Applicability/Reliability

No verification studies were performed.

3.7 Computer Characteristics

IBM 360/65 - Each run required 120K and less than 1 minute of CPU time

1.0 IDENTIFICATION

1.1 Descriptive Title

Forecasting Model of Manpower Requirements in the Health Occupations

1.2 Developer's Name

Dennis Maki, Iowa State University

1.3 References

Maki, 1967

2.0 GENERAL DESCRIPTORS

2.1 Development Status

Completed and the employment forecast tested by comparison to actual employment data.

2.2 Purpose and Sponsor

To develop a model within which to analyze the nature of the supply of and demand for health manpower. The model is part of a PhD dissertation, field of Economics.

2.3 Scope and Subject

Forecasting manpower requirements and employment in the health industry in 7 health services: short-stay hospitals, nervous and mental hospitals, "other" hospitals, physicians' services outside hospitals, dental services, environmental health services, "other health" services and 20 health occupations listed in section 3.5.

2.4 Abstract

A quadratic programming model is developed to estimate demand, supply, excess demand, and employment for each of twenty health occupations.

A detailed methodology is presented for the estimation of employment, utilization of services, technical coefficients, and the demand coefficients for 1950, and the estimation of regression equations for forecasting these variables to 1960. The quadratic objective function to be minimized in the model represents health manpower requirements as modified by supply restrictions. Employment forecasts are generated by recursive solution of the quadratic program for 1951-1960 and tested by comparison to actual employment levels.

2.5 Major Outputs

Forecasts of employment, supply, demand, and excess demand in the health occupations.

2.6 Assumptions (a)/Constraints (c)/Hypotheses (h)

- (a-1) The objective function is the objective of the health industry, not of society as a whole.
- (a-2) Age and sex distributions remained constant over the forecast period.
- (a-3) Relative wage rates are measures of relative marginal value products.
- (a-4) There exists some form of total resource constraint.

3.0 TECHNICAL DESCRIPTORS

3.1 Model Type

Quadratic Programming

3.2 Model Characteristics

The model minimizes a quadratic objective function of excess demand for health manpower (the difference between demand and employment for each manpower category at some target date T) subject to four constraint inequalities; maximum percentage increase and decrease possible in number of workers each time period, non-negative employment levels, and a total resources constraint. The model forecasts 5-15 years into the future.

3.3 Data Utilized

Sources for the data used in the regression equations include (5), (14), (20), (115), (140), (126), (142), (86), and several US Public Health Service Publications, Series 10 and Series B.

3.4 Input Variables

- (1) Utilization of services,
- (2) Technical coefficients (number of health personnel by occupation that the industry actually employs per unit level of demand),
- (3) Demand coefficients (number health industry would like to employ per unit level of demand),
- (4) Average annual earnings in occupation,
- (5) Total resources available to health industry for earnings.

3.5 Output Variables

- (1) Employment by occupation,
- (2) Demand for health manpower by occupation,
- (3) Supply of health manpower by occupation, and
- (4) Excess demand for health manpower by occupation.

Occupations Treated

- (1) physicians (active, non-military),
- (2) Pharmacists,
- (3) Chiropractors,
- (4) Dieticians and nutritionists,
- (5) Medical laboratory technicians and technologists,
- (6) Medical X-ray technicians and technologists,
- (7) Opticians,
- (8) Lens grinders and polishers,
- (9) Optometrists,
- (10) Psychologists (clinical and other health),
- (11) Occupational therapists,
- (12) Physical therapists,
- (13) Dentists,
- (14) Dental office assistants,
- (15) Dental hygienists,
- (16) Dental laboratory technicians,
- (17) Professional nurses,
- (18) Practical nurses
- (19) Aides, orderlies and attendants, and
- (20) Sanitary engineers and sanitarians.

3.6 Verification/Applicability/Reliability

The employment by occupation in 1960 is "predicted" by the model utilizing base period data. These prediction figures are compared with actual figures and against the accuracy of results obtained using a "naive" regression model. The naive model forecasts total employment for the twenty occupations considered with an error of 2.3% while the quadratic program model forecast error was only 0.02%. The individual percentages of error for each of the occupational demands with both models are compared and the quadratic programming model is shown to definitely outperform the naive model. The model developed is intended to be useful for a five to fifteen year planning period.

3.7 Computer Characteristics

IBM series 360 computer used.

1.0 IDENTIFICATION

1.1 Descriptive Title

A Simulated Health Service Queue

1.2 Developer's Name

John H. Moss, Center for the Environment and Man, Inc.

1.3 References

Moss, 1970

2.0 GENERAL DESCRIPTORS

2.1 Development Status

Completed, and a number of different types of runs made.

2.2 Purpose

To develop measures of efficiency of health service nodes in terms of skill level requirements, skill level usage, and slack times as opposed to service times, to develop cost factors associated with health service nodes, to provide the basis for evaluating alternative personnel structures, skill type, and skill level requirements for providing health services, and to provide the basis for developing optimal service unit size for rural beneficiary populations.

2.3 Scope and Subject

Simulation of health service activity in terms of personnel, facilities, and consumables.

2.4 Abstract

The simulated health service node essentially consists of a queueing model with parallel service channels with randomly distributed arrival and service times. Each service node is characterized by a

set of parameters describing the type of service, the nature of service, the skill level required, the cost of service, the form of service time distribution (i.e., negative, experimental, normal, etc.) and service time distribution characteristics (i.e., mean, standard deviation, etc.). The model is used to describe requirements for a utilization of personnel services, medical facilities and equipment and consumable supplies. In each case the model characteristics are identical (i.e., nature of service, facility or consumable all described as diagnostic, therapeutic, preventive, etc.). Given the statistical distributions governing arrival and service characteristics, the model provides such information as the number of arrivals and departures in a time period, number in queue, total service time, etc. With additional information such as cost of service, facility or consumable, and personnel skill merit figures, the model also provides estimates of efficiency and cost.

2.5 Major Outputs

Nature, cost and efficiency of the service.

2.6 Assumptions (a)/Constraints (c)/Hypotheses (h)

(a-1) Service is a stochastic process

3.0 TECHNICAL DESCRIPTORS

3.1 Model Type

Simulation, queueing model

3.2 Model Characteristics

A simulation model of a standard queue whose arrival and service times are governed by random variables. Four random variable distributions, negative exponential, normal, uniform, and constant value are incorporated in the model which has provisions for six additional distribution forms. Argument presented for considering constant value arrival times.

3.3 Data Utilized

The simulated health service node was tested using empirical data developed from local health service units.

3.4 Input Variables**Type of Service**

- (1) Diagnostic
- (2) Therapeutic
- (3) Preventive
- (4) Administrative
- (5) Housekeeping

Nature of Service

- (6) General Physical
- (7) Dental
- (8) Nutritional
- (9) Environmental
- (10) Social
- (11) Mental
- (12) Administrative
- (13) Housekeeping

Skill Level

- (14) Years of training after high school

Cost of Service

- (15) Cost per specified period

Type of Service Time Distribution

- (16) Negative Exponential
- (17) Normal (Gaussian)
- (18) Constant Value
- (19) Rectangular
- (20) Empirical

Service Time Distribution Characteristics

- (21) Mean and standard deviation as well as distribution shift

Arrival Time Distribution Characteristics

- (22) Constant value

3.5 Output Variables

- (1) Cost of service per unit time,
- (2) Characteristics of service time (mean and standard deviation),
- (3) Type of distribution accessed,
- (4) Clock reading to date

- 5) Number of arrivals in the time period,
- 6) Number of departures in the time period,
- 7) Unexpired time in service channel,
- 8) Number in queue,
- 9) Average number in queue for period,
- 10) Average number in queue to date,
- 11) Total slack time to date,
- 12) Total service time to date,
- 13) Efficiency rate,
- 14) Cost to service to date,
- 15) Cost to date,
- 16) Total number of arrivals to date,
- 17) Total number of departures to date.

3.6 Verification/Applicability/Reliability

The results of this development have been tested on a computer using empirical data developed from local health service units and have been found to provide good replication of the health activity.

3.7 Computer Characteristics

The simulation is coded in Fortran IV and runs on an IBM 360/40 computer. The program occupies approximately 40,000 bytes of core storage. Operating time per service channel per unit time, excluding print-out, is less than 1 millisecond. Program operating instructions are included.

1.0 IDENTIFICATION

1.1 Descriptive Title

A Markov Model of Medical Care Utilization

1.2 Developer's Names

Vicente Navarro, Rodger Parker and Kerr L. White, Johns Hopkins University

1.3 References

Navarro, 1969, 1970, Navarro & Parker, Undated, Navarro, Parker & White, 1970

2.0 GENERAL DESCRIPTORS

2.1 Development Status

Theoretical models formulated and illustrated by hypothetical examples.

2.2 Purpose and Sponsor

To develop a model for health planning, taking into consideration the interrelationships among the subsystems of the health care system. Model development sponsored by the National Center for Health Services Research and Development.

2.3 Scope and Subject

Model predicting proportions of the population in different health care states, for prediction, simulation, and goal seeking. Demand for health care (utilization), demand for resources.

2.4 Abstract

The Markov model for health planning consists of seven health services states (type of medical care currently being received). This model of health services utilization is expanded to include varying rates of utilization among age groups and the stochastic

and deterministic processes that determine changes in size and age structure of the population. Using hypothetical data, the model's use in health planning is illustrated by (1) forecasting the fractions of the population expected to be in the various health service states requiring preestablished amounts of resources, (2) simulating the effects of changing the patterns of referral between two or more population states, i.e., varying the relevant transitional probabilities, and (3) minimizing or maximizing a chosen objective function on cost, service etc., by selecting the optimum transitional probabilities between states. In each case, productivity parameters must be chosen to predict the amount of resources (manpower and facilities) required by each group for each component of the health care system.

2.5 Major Outputs

Dependent on inputs and use of the model, prediction of health services utilization, utilization patterns as a result of changes in the system, or optimal transitional probabilities.

2.6 Assumptions (a)/Constraints (c)/Hypotheses (h)

- (a-1) Transitional probabilities do not vary with time.
- (a-2) Each person in the population at any point in time belongs to one and only one of several mutually exclusive states of a health services system.
- (a-3) The transitional probability of going from one health services state to another depends solely on the patient's current state.

3.0 TECHNICAL DESCRIPTORS

3.1 Model Type

Finite state space, discrete time, homogeneous Markov chain.

3.2 Model Characteristics

The model consists of equations to determine the fractions of the population at each state at different time periods, the birth rate, and the death rate, and a series of transitional probability matrices. The number of health service states have been chosen arbitrarily and can be extended in accord with the

complexity and comprehensiveness desired and data available. The fractions of the population at each state, at different time periods, equals the number of people in that health services state at that time, divided by the total number of people in the region served by the system at that time. The transitional probability equals the number of people who are transferred from state i to state j during the defined time period divided by the number of people in the state i at the beginning of that period; it defines the movement of people within the system and reflects functional relationships among the states.

3.3 Data Utilized

The model was developed using data from *Scottish Hospital Inpatient Statistics, 1965*, Edinburgh: Scottish Home and Health Department, 1967. Examples are given using hypothetical data.

3.4 Input Variables

- (1) Population's initial distribution among health care states by age groups,
- (2) Utilization of health resources by this population,
- (3) Number of physician visits to each person in various states or similar productivity parameters,
- (4) Demographic parameters of population growth,
- (5) Transitional probabilities representing all possible movements of people among the health service states,
- (6) For simulation: new set of transitional probabilities reflecting simulated changes in the system,
- (7) For goal seeking; desired future steady states, desired number of resources in that state, and chosen objective function.

3.5 Output Variables

- (1) Prediction: utilization of health services in each state of care by each age group during a selected period of time, and the resources required to satisfy this demand.
- (2) Simulation estimates of effects of changes in the demographic utilization or productivity parameters on the resources required in each health service state.
- (3) Goal-seeking: solution of the objective function; the transitional probability matrix which defines the alternative designed to minimize the constraint selected.

3.6 Verification/Applicability/Reliability

The model is internally valid and may be applied to any period of time over which the transition probabilities may be considered constant. The model is flexible, potentially applicable to various populations for the purpose of prediction, simulation, and goal seeking.

3.7 Computer Characteristics

None identified

1.0 IDENTIFICATION

1.1 Descriptive Title

A Birth-Death Markov Process Model of Mortality Caused by Specific Causes

1.2 Developer's Names

Jorge Ortiz and Rodger Parker, Johns Hopkins University

1.3 References

Ortiz & Parker, 1971

2.0 GENERAL DESCRIPTORS

2.1 Development Status

Completed

2.2 Purpose and Sponsor

To develop a mathematical model in which changes of decision or control variables representing health status or population programs are related to changes in the measures of mortality, life span, and quality of life. Model development sponsored by the Pan American Health Organization.

2.3 Scope and Subject

Model for describing fertility rates and mortality rates by disease and age for a given population.

2.4 Abstract

A Markovian model of mortality and fertility is used to describe the life expectancy of a population given the consequences or outcomes of various possible decision variables in terms of fertility and mortality rates. The impact of specific decisions can be evaluated in terms of the life expectancy of the population and estimates of future mortality caused by specific diseases. Model is used in

conjunction with 1963 data from Costa Rica to estimate life expectancy gains due to hypothesized mortality reductions and provide both transient (immediate effect) and steady-state (long range) estimates of mortality, fertility and life expectancy.

2.5 Major Outputs

Predictions of life expectancy, deaths by age and disease, and population structure.

2.6 Assumptions (a)/Constraints (c)/Hypotheses (h)

- (a-1) At any given time a person can be in only one state.
- (a-2) Women younger than 10 or older than 50 are assumed infertile.
- (c-1) Only the female population is considered in the study.

3.0 TECHNICAL DESCRIPTORS

3.1 Model Type

Simulation, life-death Markov process

3.2 Model Characteristics

Finite homogeneous Markov chain with absorbing barriers (the five states of death) and a forcing function representing births. Transition probabilities between age brackets and to various death states are assigned or empirically estimated.

3.3 Data Utilized

The methodology was applied to data from Costa Rica for 1963 obtained from (48) in the Data Source Index and from Keyfitz, N. and Fleeger, W., *World Population and Analysis of Vital Data*, Chicago, University of Chicago Press, 1968, and from the World Health Organization's *World Health Statistics Annual-1963*, Vol. 1, 1964.

3.4 Input Variables

- (1) Specific mortality rates by age interval and group of diseases,
- (2) Specific fertility rates by age interval, and
- (3) Transition probabilities between life and specific types of death.

3.5 Output Variables

Determination of life expectancy

3.6 Verification/Applicability/Reliability

The model may be used for long-range planning. The original simulation was not verified. The model's reliability is dependent on the reliability of the transition probabilities and the length of time over which the transition probabilities may be considered constant.

3.7 Computer Characteristics

None identified

R1

1.0 IDENTIFICATION

1.1 Descriptive Title

A Production Function for Physician Services

1.2 Developer's Name

U. E. Reinhardt, Yale University

1.3 References

Reinhardt 1970, 1972; Reinhardt & Yett, 1972

2.0 GENERAL DESCRIPTORS

2.1 Development Status

Completed

2.2 Purpose and Sponsor

To measure the influence of inputs, especially medical aides, on physician output. PhD dissertation, supported by the US Public Health Service, Medical Economics, Inc., and the Canada Council. Study also supported in part by Community Profile Data Center.

2.3 Scope and Subject

The production function of the general practitioner, in solo or single-specialty group practice.

2.4 Abstract

Production function analysis is used to examine the feasibility and profitability of substituting paramedical personnel for physician effort and the relative effectiveness of solo and group practice. Physician production functions are estimated and regression equations empirically obtained estimating the functions. Output indices estimated are total weekly patient visits and annual

patient billings. Using these results, the effects of group practice, physician hours, capital and number of aides on physician output are examined and the optimal level of paramedical personnel determined. Possible ways in which physician productivity may be enhanced are indicated. The findings are quite consistent with the economic theory of rational utility maximization, and imply that public policy measures to alleviate a physician shortage through increases in production must encourage the use of more aides by practicing physicians.

2.5 Major Outputs

Measures of physician output in terms of income and expenses, physician's weekly rate of office, hospital and home visits with patients, the number of hours per week spent by the physician on various professional activities, number of aides employed and their salaries, physician's medical specialty, formal organization of practice (solo or group).

2.6 Assumptions (a)/Constraints (c)/Hypotheses (h)

- (a-1) The physician seeks to maximize a utility function in income and leisure.
- (a-2) There exists a strong correlation between the number of patients a physician sees and/or his annual patient billings and the volume of service he renders.
- (a-3) Physician's capital can be treated as a substitute for physician hours and aides.
- (a-4) The technology involved is common to all physicians of the same specialty and mode of practice.
- (a-5) The mix of services provided by responding physicians was roughly constant over the sample.
- (a-6) Either there are no essential differences in the quality or services provided by the various physicians in the sample, or such differences will not systematically affect the input-output relationship as it is expressed in this analysis.
- (a-7) Two part-time employees are equivalent to one full-time employee.
- (a-8) An increase in the physician's hourly patient load, if achieved through added employment of paramedical aides, will not cause a deterioration in the quality of services produced by the practice.

3.0 TECHNICAL DESCRIPTORS

3.1 Model Type

Regression Analysis

3.2 Model Characteristics

Single equation multiple regression estimates of production functions for 4 specialities (GPs, Pediatricians, OBG specialists and Internists), 8-16 inputs for each function. The following provides the functional relationship between the dependent (output) and independent (input) variables listed in sections 3.5 and 3.4 respectively.

Dependent Variables

- (1) - General Practitioners
- (1) - Pediatricians
- (1) - Obstetricians-Gynecologists
- (1) - Internists
- (2) - All Specialties

Independent Variables

- (1)-(9), (14)-(16)
- (1)-(5), (7)-(9), (14)-(16)
- (1)-(10), (14)-(16)
- (1)-(9), (14)-(16)
- (1)-(9), (11)-(16)

3.3 Data Utilized

Data was obtained from two nationwide surveys of self-employed American physicians undertaken by Medical Economics, Inc., 1965 and 1967.

3.4 Input Variables

- (1) Number of strictly practice-related hours worked by the physician per week,
- (2) Number of registered nurses per physician,
- (3) Number of technicians per physician,
- (4) Number of office aides per physician,
- (5) An index of capital usage, in hundreds of dollars,
- (6) Physician population ratio of state in which physician practices,
- (7) Percentage of hospital visits in total visits,
- (8) Percentage of home visits in total visits,
- (9) Single-specialty groups or solo practitioners,
- (10) Years the physician has been in practice (less than 2, 25 or more),
- (11) Per capita income of state in which physician practices,

- (12) Log of average fee per visit,
- (13) Year of observation (1967 or other),
- (14) Total number of aides, squared,
- (15) Log of capital usage, and
- (16) Log of number of hours worked.

3.5 Output Variables

- (1) Patient visits per week, and
- (2) Aggregate annual patient visits.

3.6 Verification/Applicability/Reliability

Applicability of the model is dependent on the degree to which medical technology and other variables have changed since 1965 and 1967, the survey years from which data was obtained for parameter estimation. The developers state that interpretation must be made with caution due to conceptual difficulties and data limitations.

3.7 Computer Characteristics

None identified

1.0 IDENTIFICATION

1.1 Descriptive Title

Health Manpower Requirements Simulation Model

1.2 Developer's Names

Research Triangle Institute

1.3 References

Horvitz 1970, Kennedy 1970, Research Triangle Institute 1972, Horvitz 1969, Shah 1972, Kennedy 1972, Cameron 1972, Cooley 1972, Hartwell et al 1972, Horvitz et al 1972.

2.0 GENERAL DESCRIPTORS

2.1 Development Status

Completed

2.2 Purpose and Sponsor

To develop simulation models to be used in the estimation of health manpower requirements.

2.3 Scope and Subject

Health manpower requirements of five hospital functions.

2.4 Abstract

The computer simulation hospital manpower model has three component models.

- (1) POPSIM: A demographic model for projecting populations, such as the civilian resident population of the US, forward year by year by age, race, sex, marital status, residence (metropolitan vs. non-metropolitan) and family income. POPSIM, a microsimulation model, consists of two computer programs. The first is

POPGEN which is a program to create or generate a sample population of individuals in the computer from some base population, such as the US 1970 resident population, specified by a set of parameters. The second program is SIMRUN which projects or advances the computer population (created by POPGEN) forward in time, generating births, deaths and changes in marital status for each individual by the Monte Carlo method and on a competing risks basis. The levels of these risks are defined by means of conditional transitional probabilities, the principal input parameters to SIMRUN. The resultant computer population is equivalent to a random sample of a future population at the end of the time period, provided the model and the parameter values chosen are, in fact, an accurate reflection of the current and future reality for the simulated base population. The output of POPSIM for a given simulation period, such as a year, provides the input to HOSPEP, the second component of the hospital manpower model.

- (2) HOSPEP: A stochastic model for simulating utilization of short-term general hospitals for a selected time period by a computer population projected for the same time period by POPSIM. The HOSPEP computer program classifies each individual in a population file by hospital insurance status and generates a hospital episode history; that is, hospital admission and discharge dates for the individual during the time period, together with the diagnosis (18 classes), whether surgery was performed or not, and the bedsize of the hospital for each episode. By varying the input parameters which determine admission rates, diagnosis, surgery status, hospital size and length of stay, the model projects the resultant changes in utilization. It is not self-adaptive in the sense of having parameters which adjust automatically through interaction with resource constraints in the hospital care delivery system.
- (3) HOMAN: An aggregate deterministic model which converts hospital utilization data for a specified time period (e.g., the HOSPEP output) into the manpower required to provide particular hospital services, such as laboratory analyses or physical therapy. Four factors enter into the estimate of manpower requirements; namely,
- (a) demand for services (admissions, days of care),
 - (b) care requirements (units of work or service per unit of demand)
 - (c) personnel performance (man-hours per work unit)
 - (d) personnel utilization (conversion to a specific manpower category)

The product of these factors, together with a personnel-man-hours conversion factor, provides the number of personnel required by diagnosis, type of service and hospital size. The total manpower required in a given category is estimated by summing over diagnosis and hospital size.

2.5 Major Outputs

Creation and projection of population characteristics, a hospital episodes history for each individual in the initial population, and estimates of the number of required hospital personnel and personnel man hours by hospital size and personnel category.

2.6 Assumptions (a)/Constraints (c)/Hypotheses (h)

- (a-1) There is a hospital bed available for every episode generated.
- (a-2) In generating the date of an event it is assumed that no other events happen to the individual in the interval.
- (a-3) For a given race, residence, type and household and age of head, the log-normal distribution adequately represents the distribution of family income.
- (a-4) Mean family income can change over time.
- (a-5) Full-time employees are paid 40 hours per week.
- (a-6) The personnel man-hour ratio does not change with time.
- (a-7) Manpower requirements are linearly related to some measure of demand.
- (a-8) The time trend exhibited in the requirements and performance parameters is linear.
- (a-9) The interaction among the model factors is insignificant.
- (a-10) The resources of personnel and facilities are limitless.

The following assumptions apply to PØPSIM

- (a-11) The parity distribution is a mixture of Poisson and geometric distributions.
- (a-12) The distribution of the age of the spouse is assumed to be log normal with mean μ and standard deviation σ ; the parameters μ and σ are assumed to be the polynomial functions of the age of the individual.

- (a-13) The distribution of the duration of marriage is assumed to be a beta distribution; the two parameters are assumed to be polynomial functions of the age of the wife.
- (a-14) For husbands of a given age, the wives' ages have a lognormal distribution, with mean μ and standard deviation σ . The parameters μ and σ are adequately represented by a fourth-order polynomial function of the age of the married males.
- (a-15) For a fixed age of wife and number of times married, the distribution of length of marriage can be described adequately by a beta distribution scaled to cover the whole interval from age 15 to current age. The two parameters are assumed to be polynomial functions of the woman's age.
- (a-16) No births can occur to females under 15 years of age.
- (a-17) The proportion married once only and married more than once is a function of age.
- (a-18) Birth rates in previous time periods for each age-parity are quadratic functions of time.
- (a-19) Death rates are constant over time.
- (a-20) Proportions change linearly from midpoint of one age group to the next.
- (a-21) Birth probabilities remain constant over the entire simulation period.
- (a-22) Marriage probabilities remain constant throughout the simulation for women with given age and marital status.
- (a-23) Divorce probability remains constant over each interval of duration of marriage specified by the user.
- (a-24) Distribution of age of groom remains same over time for the given age of bride.

Hospital Service Model

- (a-25) The variance of the model parameters does not have a significant effect on the model's estimates.
- (a-26) The measurement of personnel manpower requirement to treat each disease is a constant value even when alternative methods may be employed by different personnel to treat the same ailment.
- (a-27) Each size hospital has the same care requirement distribution but with different average care requirement values.

3.0 TECHNICAL DESCRIPTORS

3.1 Model Type

Stochastic Simulation

3.2 Model Characteristics

The general form of the hospital service model is given by:

$$M_{hj} = \sum_s [\sum_i D_{is} R_{ish}] P_{sh} K_{sh} U_{shj}$$

where M = estimated manpower requirements at time t
 D = demand for hospital services during time period t
 R = care requirements on the number of work units per unit demand
 P = man hours required to perform a unit of work
 K = conversion factor for changing man hours into personnel
 U = personnel utilization or delegation of personnel to a specific manpower category
 j = index for specific manpower category (12 categories included in the model)
 s = index of hospital size (8 categories included in model)
 i = index for diagnosis (18 categories included in model)
 h = index for hospital service (5 modeled)

Five hospital services are modeled: clinical laboratory, radiology, pharmacy, physical therapy, and nursing.

3.3 Data Utilized

Data from the Health Interview Survey and the Hospital Discharge Survey, both conducted by the National Center for Health Statistics, and from the Bureau of the Census Current Population Survey was used in the hospital episodes model. Sources for other data used include (115), (88), and (89) in the Data Source Index. Data for the Hospital Manpower Model was obtained from the American Hospital Association, Hospital Administrative Service (representing approximately 2000 hospitals for the time period July 1968 to September 1971), and from the Survey of Manpower Resources in Hospitals conducted during the week of April 17, 1966. Care requirement data as a function of diagnosis was obtained for a specific hospital, Charlotte Memorial Hospital, from Medi-Data, representing data on all patients admitted and discharged between March 21, 1972 and April 30, 1972.

3.4 Input Variables

Population simulation model: (PØPSIM)

- (1) Size of initial population,
- (2) Proportion of individuals in each of eight sex-marital status groups,
- (3) Proportion of individuals in specific age groups for each sex and marital status class,
- (4) Probabilities with which married females are classified as re-married or not,
- (5) Parameters to assign age of husband given age of wife,
- (6) Parameters to assign age of wife given age of husband,
- (7) Parameters to assign date of current marital status,
- (8) Monthly birth probabilities by age, parity and marital status,
- (9) Monthly death probabilities by age group, sex and marital status,
- (10) Parameters to assign parity to widowed or divorced females,
- (11) Monthly divorce probabilities by interval since marriage or by age,
- (12) Annual marriage probabilities for females by age and marital status,
- (13) Parameters to determine the marital status of the groom given that of the bride,
- (14) Bivariate distributions of ages of brides and grooms for first marriages and remarriages.

Hospital episodes model

- (1) Conditional probabilities of having health insurance by age, race and family income.
- (2) Parameters to determine hospital admission dates by race, age, family income and hospital insurance status.
- (3) Conditional probability distribution of diagnosis by age and sex,
- (4) Conditional probability of surgery status by age, hospital insurance status, diagnosis, and residence,
- (5) Conditional probability distribution of bedsize of hospital by diagnosis and surgery status,
- (6) Parameters to determine length of stay in the hospital based on age, surgery, diagnosis, family income, hospital insurance status, and size of hospital,
- (7) Daily probabilities for hospital admission for persons in their last year of life,
- (8) Parameters to update family income by age, race, residence and type of household,
- (9) Information in the population file for each individual to be processed.

Hospital services model

- (1) Input to this model is the output from the Hospital Utilization Program. See section 3.2 for general form of the model.

3.5 Output Variables

Population simulation model

- (1) Distribution of primary individuals by sex, marital status, and age group,
- (2) Distribution of currently married women, classified by whether they have married only once or more than once and by age groups identical to those used in 1,
- (3) Distribution of currently married women by age groups and parity,
- (4) Distribution of never married women by age groups and parity,
- (5) Distribution of currently married women married only once by age at marriage and duration of marriage,
- (6) Distribution of currently married women who have been married more than once by age at marriage and duration of marriage,
- (7) Distribution of the deaths in the population (primary individuals only) by age, sex and marital status,
- (8) Distribution of births during the interval by age of mother and marital status of mother,
- (9) Distribution of marriages by age, sex, and marital status of the primary individual involved.

Hospital episodes model

- (1) Hospital admissions,
- (2) Duration of stay (for each individual),
- (3) Reason for hospitalization (diagnosis),
- (4) Whether or not surgery is performed,
- (5) Bedsize of hospital individual is admitted to,
- (6) Distribution of the average population for the simulation period by age, sex, race, family income, and hospital insurance status,
- (7) Distribution of hospital discharges by:
 - (a) age, family income, hospital insurance status, and days in hospital,
 - (b) age, race, sex, and days in hospital,
 - (c) age, sex, diagnosis, surgery status, and days in hospital,
 - (d) diagnosis, surgery status, and days in hospital,
- (8) Distribution of sample population by:
 - (a) number of hospital admissions, age, race, and sex,
 - (b) number of hospital admissions, age, family income, and insurance status,
- (9) Hospital admission rates per 1000 persons by age, race, sex,
- (10) Hospital days per 1000 persons by age, race, and sex,
- (11) Hospital days by:
 - (a) age, race, and sex,
 - (b) age, family income, and insurance status,
 - (c) age, sex, diagnosis, and surgery status,
 - (d) hospital diagnosis, and surgery status,
- (12) Average length of stay by age, race, and sex,

Hospital services model

Forecasts of health care demand, resulting manpower requirements, the interacting effects upon manpower supply, and the marketplace phenomena which provide system equilibrium for 12 personnel categories (registered nurses, licensed practical nurses, qualified nurses' aides, pharmacists, physician's assistants, qualified physical therapists, other physical therapists, pharmacist's assistants, medical technologists, cytotechnologists, laboratory aides, radiology technologists and nuclear medicine and other assistants) and by hospital size.

3.6 Verification/Applicability/Reliability

A single simulation run was carried out with PØPSIM for the period 1960-1970 and compared to census estimates. The HOSPEP computer program was run for the years 1962, 1965 and 1968 using the trended parameter values and the PØPSIM output, and comparisons were made with NCHS data. Duplicate simulation runs were made to observe PØPSIM and the combined PØPSIM and HOSPEP stochastic variation. HOMAN manpower estimates were computed for short-stay general hospitals for 1962, 1965, 1966, and 1968 and compared with other estimates available in the literature; the model estimates tended to be low.

3.7 Computer Characteristics

Population simulation model: written in Fortran for use on IBM 360 System/Model 50 computers.

The PØPSIM program which establishes the initial population can generate 12 samples of 2000 individuals, each with at least 7 characteristics in less than 2 minutes, using an IBM 3601 Model 75.

The programs for PØPSIM have been tested under ØS and FORTRAN IV level G compiled with a core memory of 100K bytes and two magnetic tapes or disk units in addition to a card reader and printer. Charts are included in the PØPSIM users manual of CPU time for the two PØPSIM models, (POPGEN and SIMRUN) for various population sizes. A program listing and a description of program logic is included.

R3

1.0 IDENTIFICATION

1.1 Descriptive Title

Demand for General Hospital Facilities

1.2 Developer's Name

Gerald D. Rosenthal

1.3 References

Rosenthal, 1964

2.0 GENERAL DESCRIPTORS

2.1 Development Status

Completed

2.2 Purpose and Sponsor

To design a formula for allocation of hospital facilities in accordance with expected demand. Estimates utilization of hospital facilities and bed needs. Sponsor unidentified.

2.3 Scope and Subject

Demand for (utilization of) short-term general and special non-federal hospitals.

2.4 Abstract

Utilization of hospital facilities is estimated by least-squares linear multiple regression for 1950 and 1960 data, and the results analyzed and compared over time. A methodology for estimating bed needs for each state is presented.

2.5 Major Outputs

Estimates of patient days, admissions and average length of stay.

2.6 Assumptions (a)/Constraints (c)/Hypotheses (h)

None identified

3.0 TECHNICAL DESCRIPTORS

3.1 Model Type

Regression Analysis

3.2 Model Characteristics

The model is a least-squares linear multiple regression model relating the utilization of hospital facilities in a state area to characteristic variables of that state area. Regression equations are estimated for each of 3 dependent variables, with 12 independent variables each, for 1950 and 1960 data. Each dependent variable is regressed on all input variables.

3.3 Data Utilized

The data sources utilized in the regressions are listed in the Data Source Index: (10), (11), (52), (115), (146), (14).

3.4 Input Variables

- (1) % over age 64,
- (2) % under age 15,
- (3) Marital status,
- (4) Sex distribution (% male),
- (5) Degree of urbanization (% urban),
- (6) Distribution by race (% nonwhite),
- (7) Educational level (% over 12 years education),
- (8) Population per dwelling unit,
- (9) Charges for 2-bed room,
- (10) % over \$5,999 income,
- (11) % under \$2,000 income, and
- (12) Proportion with insurance (% hospital coverage).

3.5 Output Variables

- (1) Patient days per 1000 population,
- (2) Admissions per 1000 population,
- (3) Average length of stay (days).

3.6 Verification/Applicability/Reliability

Since the data used to estimate the model parameters applies to 1950 and 1960, the applicability of the model to current problems is questionable.

3.7 Computer Characteristics

None identified

1.0 IDENTIFICATION

1.1 Descriptive Title

Geographic Distribution of Physicians and Specialists

1.2 Developer's Name

Richard M. Scheffler, New York University

1.3 References

Scheffler, 1971

2.0 GENERAL DESCRIPTORS

2.1 Development Status

Completed

2.2 Purpose and Sponsor

Description of the state-wide number of physicians per capita. The model is part of a PhD dissertation, field of Economics.

2.3 Scope and Subject

Distribution of physicians and specialists in the United States.

2.4 Abstract

Three linear regression models are developed. The first relates the distribution of physicians to variables representing demand for physician services, mobility of physicians, and the need for medical facilities. The second model is an expanded and disaggregated version of the first, estimating distribution of all physicians, G.P.'s, medical specialists, interns and residents. Finally, equations explaining the income differentials of physicians across the states for 1960 and 1966 are developed.

2.5 Major Outputs

Physician-population ratios, net-average income of physicians in each state.

2.6 Assumptions (a)/Constraints (c)/Hypotheses (h)

- (a-1) The physician location pattern determines the geographic distribution of medical services.
- (a-2) The supply of medical education will not be unused.

3.0 TECHNICAL DESCRIPTORS

3.1 Model Type

Regression Analysis

3.2 Model Characteristics

The first model consists of 12 equations: one equation for each of the years 1956-1967, regressing number of physicians per capita in each state on five independent variables. In the second model, two regression equations using 1960 and 1966 data relate the physician's average income to four independent variables. The third model consists of six equations, one for each of six specialist fields, regressing per capita number on seven independent variables, using pooled data (1963-1967).

3.3 Data Utilized

Sources of the data utilized in the regressions are listed in the Data Source Index (14), (16), (17), (18), (20), (112), (27), (21), (117), (140), and (151).

3.4 Input Variables

Physician per capita model (PCM), geographic distribution of physicians income model (PIM), specialist model (SM).

- (1) Per capita income of each state (PCM & PIM) (SM),
- (2) Number of seats in freshman class in medical school divided by the population of each state (PCM) (PIM) (SM),

- (3) Total number of long-term and short-term hospital beds, divided by the population of each state (PCM) (SM),
- (4) Failure rate of state licensing examination (PCM) (PIM) (SM),
- (5) Percentage of population living in urban areas (PCM) (SM),
- (6) Physician-population ratio in each state, lagged ten years (PIM),
- (7) Percentage of internships filled in each state (SM), and
- (8) Percentage of residencies filled in each state (SM).

3.5 Output Variables

- (1) Number of physicians per 1000 population,
- (2) Net average income of physicians in each state, and
- (3) Per capita number of all physicians, general practitioners, medical specialists, surgical specialists, interns, and residents (in the US).

3.6 Verification/Applicability/Reliability

Since the data used to estimate the parameters applies to 1956-1967, it is questionable whether the model is applicable to current problems.

3.7 Computer Characteristics

None identified

1.0 IDENTIFICATION

1.1 Descriptive Title

Forecasting Hospital Personnel Availability

1.2 Developer's Name

David R. Shaw, Georgia Institute of Technology

1.3 References

Shaw, 1967

2.0 GENERAL DESCRIPTORS

2.1 Development Status

Completed

2.2 Purpose and Sponsor

Mathematically describe and forecast employee absenteeism and length of service for selected classifications of hospital employees. Model development supported by the US Public Health Service.

2.3 Scope and Subject

Absenteeism (days per month) for full-time employees in 10 categories of personnel: clerks, porters, orderlies, maids, licensed practical nurses (white and non-white), secretaries, technologists, messengers, and elevator operators. Length of service for full-time employees in 3 categories of personnel, technologists, messengers, and laboratory assistants in a general acute hospital.

2.4 Abstract

Multiple linear regression analysis, the t-test, and analysis of variance techniques were used to ascertain the relative importance of selected employee variables in explaining the variability in length of service

and absenteeism in the 14 job classifications: clerks, porters, orderlies, registered nurses, (white and non-white), maids, licensed practical nurses (white and non-white), secretaries, technologists, messengers, maintenance assistants, elevator operators, technicians, and laboratory assistants. Data used to develop the model was obtained from records of terminated employees at the University of Alabama Hospitals and clinics. For length of service, the regression coefficients were significantly different from zero in the equations for the 10 categories noted in section 2.3 with significant independent variables, salary, age, length of service on previous job and absenteeism rate. For absenteeism the regression coefficients were significantly different from zero for the 3 categories noted in section 2.3.

2.5 Major Outputs

Prediction of absenteeism rate and length of service

2.6 Assumptions (a)/Constraints (c)/Hypotheses (h)

- (a-1) Differences in length of service are caused by differences in salary.
- (h-1) Mathematical relationship exists among absenteeism, length of service and other quantitative employee factors and the resulting relationship can be used to describe and forecast personnel absenteeism and length of service.

3.0 TECHNICAL DESCRIPTORS

3.1 Model Type

Regression Analysis

3.2 Model Characteristics

28 linear regression equations (14 length of service, 14 absenteeism) one for each occupational category), each with 5 independent variables were developed. Of these 10 length of service and 3 absenteeism equations were within the confidence limits established. The model essentially consists of these significant equations.

3.3 Data Utilized

Data was obtained from records of terminated employees at the University of Alabama hospitals and clinics for the selected occupational classifications for the calendar year 1964. The specific variables are those listed in section 3.4.

3.4 Input Variables

- * (1) Annual salary at date of termination,
- * (2) Age in months at date of termination,
- * (3) Number of dependents at date of termination,
- * (4) Length of employment (in months) on job prior to position with the hospital, and
- (5) Length of service (in months).

*Indicates variables included in the length of service equations.
All variables are included in the absenteeism equations.

3.5 Output Variables

- (1) Length of service in months for each occupation category noted in section 2.3, and
- (2) Absenteeism rate - days per month for each occupation category noted in section 2.3.

3.6 Verification/Applicability/Reliability

The methodology may be applied to any hospital and any employee classification; the specific model parameters developed in this study apply only to full-time employees in specific occupational classifications at the University of Alabama Hospitals and Clinics. The model can be used for short-range decision making.

3.7 Computer Characteristics

Burroughs - 5500

1.0 IDENTIFICATION

1.1 Descriptive Title

Mathematical Models for Health Manpower Planning

1.2 Developer's Name

Larry J. Shuman, Johns Hopkins University

1.3 References

Shuman, 1969

2.0 GENERAL DESCRIPTORS

2.1 Development Status

The analytical models have been formulated; validation was unrealizable due to a lack of available and accurate data.

2.2 Purpose and Sponsor

The models were constructed to symbolically depict the health services delivery system and to investigate the relative attributes of proposed alternatives for increasing the efficiency and productivity of the system. PhD dissertation supported by the US Public Health Service.

2.3 Scope and Subject

Four mathematical models concerned with increasing productivity through the addition of auxiliary personnel and equipment, or by direct substitution of personnel classes.

2.4 Abstract

Four basic mathematical models are formulated to enable health researchers to investigate the relative merits of various methods of increasing physician productivity. The Basic Regional Health Planning Model and its extension, the Total Regional Planning Model, are cataloged under a separate title, "Optimum Health Manpower Mix Model." Therefore, only the

remaining two models, the Modified Assignment Model and Maximum Quality Model, will be discussed here. The objective function of the Modified Assignment Model is the minimization of the cost of the assignment policy (the substitution of various personnel classes). The Maximum Quality Model has as its objective the function of maximization of the total quality level of the health services provided. The quality of service provided is specified by determining a utility factor for type i personnel providing service j .

2.5 Major Outputs

Optimum values of parameters listed in section 3.5 which either (1) minimize personnel assignment cost or (2) maximize the quality of health services provided.

2.6 Assumptions (a)/Constraints (c)/Hypotheses (h)

Assignment Model

- (a-1) The cost or disutility of having a specific person provide a given service is known.
- (a-2) The number of service units personnel are able to provide may be controlled by varying the amount of technology and equipment available, and the relationship between the service units and technology is linear.
- (a-3) Personnel costs are composed of the salary and overhead expenses and the cost of personnel changes.
- (c-1) An individual must not provide more than a specified number of service units.
- (c-2) The number of personnel allocated must not exceed a specified number.
- (c-3) The total number of a particular type service must at least equal the demand for this service.

Maximum Quality Model

- (a-1) The quality level of a service is a function of both the average time that it takes to provide the service, and the person providing the service. The decision maker can control this average service time and the number of each type of personnel.

- (c-1) The number of services provided equals the number demanded.
- (c-2) The number of hours personnel may work is less than a specified value.
- (c-3) The number of personnel available for employment is less than or equal to a specified value.
- (c-4) The total cost of hiring and firing is less than or equal to the funds available for personnel changes.
- (c-5) The total cost of personnel salaries and overhead cost is less than or equal to the funds available for this purpose.

3.0 TECHNICAL DESCRIPTORS

3.1 Model Type

Linearized nonlinear programming model.

3.2 Model Characteristics

Assignment Model: minimize cost of providing health manpower specified by $I(J+1)$ variables, listed in section 3.4 and subject to $2I + J$ constraints noted in section 2.6.

Maximum Quality Model: maximize the quality of health services provided specified by $I(2J+3)$ variables listed in section 3.4 and subject to $3I + J + 2$ constraints noted in section 2.6.

(See section 3.4 for definitions of I and J)

3.3 Data Utilization

No data was utilized for formulation or testing, examples are given using hypothetical data.

3.4 Input Variables

Assignment Model

- (1) Annual salary and overhead of each type i personnel,
- (2) Cost of recruiting, hiring, and training of type i personnel,

- (3) Cost of releasing type i personnel,
- (4) Cost of supporting the level of output of personnel i providing services,
- (5) Cost of increasing the level of output of personnel i providing services,
- (6) Cost of decreasing the level of output of personnel i providing services,
- (7) Total number of type i personnel available for allocation, and
- (8) Number of type j services demanded.

Maximum Quality Model

- (1) Utility level for type i personnel providing service j ,
- (2) Number of man-hours type i personnel devote to service j ,
- (3) Expected number of type j services demanded during the planning period,
- (4) Number of hours personnel i may work each week,
- (5) Number of personnel i available for employment,
- (6) Salary of type i personnel in dollars per man hour,
- (7) Hiring and training cost (per man-hour) of type i personnel,
- (8) Firing cost of type i personnel, and
- (9) Overhead and assistance cost for providing service j (dollars per man-hour).

3.5 Output Variables

Modified Assignment Model: values of the following which minimize the objective function.

- (1) Number of type i personnel, and
- (2) Number of type j service units provided by type i personnel.

Maximum Quality Model: values of the following which maximize the objective function.

- (1) Number of type i personnel,

232

- (2) Number of personnel hired,
- (3) Number of personnel fired,
- (4) Average time a person of type i devotes to providing one type j service, and
- (5) Corresponding total time per week (or day) type j services are provided by i .

3.6 Verification/Applicability/Reliability

Theoretical specification of the Assignment Model is not empirically verified or applied to actual situations. Subject to this verification and availability of data, model may be modified to multiple nursing ward assignment problems. The assumption that a linear relationship holds between productivity and the number and type of personnel providing a given service in the Maximum Quality Model is supported by empirical data on dentists and physicians. Physician productivity parameters were also empirically (objectively and subjectively) examined, and the results supported model assumptions.

3.7 Computer Characteristics

None identified

1.0 IDENTIFICATION

1.1 Descriptive Title

Optimum Health Manpower Mix Model

1.2 Developer's Names

Larry J. Shuman, John Young, Eliezer Naddor, University of Pittsburgh

1.3 References

Shuman, Young & Naddor 1970, Shuman 1969

2.0 GENERAL DESCRIPTORS

2.1 Development Status

Theoretical mathematical framework of the model developed and tested against a hypothetical neighborhood health center.

2.2 Purpose and Sponsor

To determine the mix of manpower and technology needed to provide health services of acceptable quality at a minimum total cost to the community. Model development supported in part by the US Public Health Service.

2.3 Scope and Subject

The model provides an analytic scheme to relate the number and distribution of personnel categories, type of health service, technology levels and cost for each of these parameters to the total cost of community health services.

2.4 Abstract

A linear programming model is formulated to determine the mix of manpower and technology needed to provide health services of acceptable quality at a minimum total cost to the community. Total costs include both the direct costs associated with providing the services and with

developing additional manpower and the indirect costs (shortage costs) resulting from not providing needed services. The model is applied to a hypothetical neighborhood health center, and its sensitivity to alternative policies is investigated by cost-benefit analyses. Possible extensions of the model to include dynamic elements in health delivery systems are discussed, as is its adaption for use in hospital planning, with a changed objective function.

2.5 Major Outputs

Number and distribution of personnel categories providing different types of service with several levels of technology at different facilities and the minimum cost to society of these services.

2.6 Assumptions (a)/Constraints (c)/Hypotheses (h)

- (a-1) The change in personnel during the planning period equals the number hired minus the number released.
- (a-2) The number of services produced is a linear function of the physicians and auxiliary personnel involved.
- (c-1) No auxiliary personnel can be utilized without the presence of a physician (i.e., the number of auxiliary personnel is less than or equal to the maximum number of personnel per physician times the number of physicians.)
- (c-2) The need for health services is always equal to or greater than the demand and the number of services provided is always less than or equal to the need but greater than or equal to the demand for these services. (i.e., the optimal solution should satisfy demands without exceeding needs.)
- (c-3) The number of personnel types allocated throughout the health region is limited by the number available.
- (c-4) The service capacity of the system is limited by the available service area.
- (c-5) The operating expenses of each facility must be less than or equal to patient revenues and community contributions.
- (c-6) The community expenses may not exceed the community budget.

3.0 TECHNICAL DESCRIPTORS

3.1 Model Type

Linear programming model

3.2 Model Characteristics

The objective function of the model is the total cost to society of producing health services. The cost is composed of direct cost, (i.e., patients fee including incentive payments for indigent persons, construction costs, community payment to the facility and development cost for additional personnel) and indirect cost of not providing the needed service. Analytic expressions for this function and the assumptions and constraints in 2.6 are developed for variables with indeterminate dimensionality. The model is a linear programming problem with $IJKM + 2K(IJ + 1) + I$ variables and $JK(I + M) + 2(J + K) + I + 1$ constraints (see 3.4).

3.3 Data Utilized

Several data elements which must be specified numerically are generally unavailable (i.e., productivity of an individual working at a particular technology level) and thus must be approximated by the user (see 3.4). Examples are given using hypothetical data.

3.4 Input Variables

The following must be specified:

I different personnel types who provide J different types of health services in K different health facilities using M possible levels of technology

in terms of:

- (1) Unit productivity and salaries of person i, j, k, m ,
- (2) Cost of hiring and releasing person i, j ,
- (3) Community demand and need for service j ,
- (4) Cost to patient receiving service j ,
- (5) Incentive prices paid to indigent patients for service j ,
- (6) Estimated cost to society for not providing service j ,
- (7) The current number of personnel i, j ,
- (8) The maximum number of auxiliary personnel per physicians i, j ,
- (9) The amount of space required by service j .

In addition, the following input information is needed:

- (10) The number of units of space presently available,
- (11) The cost of additional space units, and
- (12) The total amount of community funds.

3.5 Output Variables

- (1) Number and mix of personnel categories,
- (2) Distribution of technology levels,
- (3) Amount of construction, and
- (4) Amount of community financial support for the community to provide required health services at minimum cost.

3.6 Verification/Applicability/Reliability

Only the theoretical structure of the model has been developed and the model has not been applied to actual problems or empirically tested. Subject to this verification and accessibility of data, model may be applicable to a variety of manpower mix problems in both short and long-range planning.

3.7 Computer Characteristics

None identified

1.0 IDENTIFICATION

1.1 Descriptive Title

Model of the Variation of Patient Categories Within a Hospital

1.2 Developer's Name

Sidney Singer, Johns Hopkins University

1.3 References

Singer, 1961

2.0 GENERAL DESCRIPTORS

2.1 Development Status

Completed

2.2 Purpose and Sponsor

To predict the number of patients in each of three categories at some future time based on the number present at the beginning of the prediction period. Model development supported by the US Public Health Service.

2.3 Scope and Subject

Model estimates the total number of patients in three categories: partial care, intermediate care and intensive care, in four medical wards which are used to predict hospital nursing workload and staffing requirements.

2.4 Abstract

A theoretical queueing model is developed to determine the number of patients in each of three medical condition categories, given the number of patients initially in each category. Empirical data was used to test stationary Poisson arrival process and exponential service time assumptions; the data indicated the assumptions are valid approximations of the actual random process of the system. Numerical results obtained from the model

provided an "adequate" description of real system behavior. Previously developed relationship between average nursing time required for a patient in each category is used to estimate nurse workload requirements.

2.5 Major Outputs

Prediction of numbers of patients requiring partial care, intermediate care and intensive care.

2.6 Assumptions (a)/Constraints (c)/Hypotheses (h)

- (a-1) Inputs to the three subpopulations are independent Poisson processes.
- (a-2) The duration in each patient category before transition to another category follows negative exponential distributions.
- (a-3) The model assumes a theoretically infinite hospital patient capacity.

3.0 TECHNICAL DESCRIPTORS

3.1 Model Type

Discrete state continuous time Markov process.

3.2 Model Characteristics

Model consists of three infinite capacity parallel service channels which are interconnected in a reciprocal series arrangement. Inputs to each channel are independent Poisson processes and the service times (lifetime in each channel or patient category) follow negative exponential distributions.

3.3 Data Utilized

Data was collected from four twenty-nine bed public wards at Johns Hopkins Hospital concerning the medical care category of each patient. Patient categories were determined from questionnaire completed daily by head nurses on each ward.

3.4 Input Variables

- (1) Initial number of patients in each medical care category,
- (2) Rates of transition from one category to another,
- (3) Rates of entry into each category (hospital admissions),
- (4) Rates of exit from each category (hospital discharges).

3.5 Output Variables

Predicted number of patients in each category at some later time.

3.6 Verification/Applicability/Reliability

The model may be used for short-range planning (one day in advance). Actual data was analyzed, and the assumptions made in the development of the model were shown to be valid approximations of the random processes governing the behavior of the system. The analytical model applies only to the Osler Medical Clinic of the Johns Hopkins Hospital.

3.7 Computer Characteristics

None identified

1.0 IDENTIFICATION

1.1 Descriptive Title

Three models on Physician Educational and Occupational Behavior Patterns

- (1) Demand for Medical Education - Study of Medical School Applicant Behavior
- (2) Lifetime Earnings and the Physician's Choice of Specialty
- (3) Migration Patterns of Recent Medical School Graduates

1.2 Developer's Names

Frank A. Sloan, University of Florida
Donald E. Yett, University of Southern California

1.3 References

Sloan, 1969, 1969, 1971; Yett & Sloan, 1971

2.0 GENERAL DESCRIPTORS

2.1 Development Status

Medical school applicant behavior and physician's choice of specialty models are completed, migration pattern model is under development.

2.2 Purpose and Scope

Explanation of the locational choices of recent medical school graduates, determination of whether lifetime earnings in physician specialties influence choice of field, and provision of policy instruments which may be used to affect production levels of the medical education system. Models (1) and (2) are based on parts of Sloan's PhD dissertation. Model (3) development was supported by New York University.

2.3 Scope and Subject

- (1) Market for medical education,
- (2) Supply response to lifetime earnings in specialties and general practice,

- (3) Supply side of physician maldistribution problem - location decisions made by new entrants into stock of private practitioners.

2.4 Abstract

Factors influencing applications of "A" students and all applicants to medical schools, decisions regarding choice of specialty, and decisions about recent medical graduate location are investigated through regression models. Variables to be included and hypotheses to be tested are specified, and the models are estimated in linear and logarithmic form.

2.5 Major Outputs

Prediction of the number of applicants to medical school in a given year, number of residents in a particular specialty, and probabilities of practice location in a particular state, given previous contact with the state.

2.6 Assumptions (a)/Constraints (c)/Hypotheses (h)

Model 1

- (a-1) Desired enrollment levels will be ascertained by the public policy decision-maker and medical educator,
- (a-2) All "A" students are accepted and attend,
- (a-3) An equilibrium level of demand is associated with values of the explanatory variables,
- (a-4) A fixed proportion of the discrepancy between actual and equilibrium demand is made up in each year,
- (a-5) The decision-maker expects the incentives to enter medicine to be the same in period $t + n$ as it is in period t .

Model 2

- (a-1) Earnings are discounted to the age the medical school graduate is assumed to begin a residency (27) and are assumed to terminate at age 65,
- (a-2) Earnings begin at age 22 (general practice), and terminate at age 65,
- (a-3) Military service is two years,

- (a-4) Income during medical school is one-fourth of the median college graduate estimate.

Model 3

- (a-1) The policy recommendations assume that only one state implements the policy,
- (h-1) The more contact a physician has with a state prior to his first practice location decision, the more likely he is to locate in the state. The probability of locating in a state varies directly with the number of previous contacts with the state,
- (h-2) In addition to the number of contacts, the sequencing of contacts influences the probability that a physician will locate in a state of previous contact. More recent "events" have a stronger impact than earlier ones,
- (h-3) Licensure considerations are more important to the general practitioner than to physicians as a whole,
- (h-4) Physicians will be more inclined to settle where a given level of income can be achieved with the least number of hours in the office.

3.0 TECHNICAL DESCRIPTORS

3.1 Model Type

Regression Analysis

3.2 Model Characteristics

- Model 1: 19 equations, 2 dependent variables, 9 independent variables.
 Model 2: 11 equations, 2 dependent variables, 8 independent variables.
 Model 3: 8 equations, 2 dependent variables, 23 independent variables.

The following are the specific variables included in each regression equation. The dependent (output) and independent (input) variables are those identified in sections 3.5 and 3.4 respectively.

Equation Variables:

	Dependent Variables	Independent Variables
Model 1	2 equations	(1), (2)
		(1), (2), (7)
	2 equations	(1), (2), (3), (5)
	2 equations	(1), (2), (3), (5), (7)
	2 equations	(1), (2), (3)
		(1), (2), (3), (4), (5)
		(1), (2), (3), (8)
		(1), (2), (3), (4), (8), (9)
		(1), (2), (3), (4), (8), (9)
		(1)-(4), (7)-(9)
		(1), (2), (3), (4), (8)
		(2), (3)
		(1)-(4), (8)
		(1), (4), (8), (9)
		(1), (2), (3), (4)
Model 2	2 equations	(1), (3), (4)
		(1), (2), (4)
		(2), (4)
		(1), (5)
		(1), (4), (5)
		(1), (4), (5), (6)
		(2), (7), (8)
		(2)
	(7), (8)	
Model 3		(1)-(7)
		(9)-(11), (13)-(17)
		(1)-(7), (9)-(11), (13)-(17)
		(1)-(7), (9), (10), (12)-(17)
		(18), (19), (21)
		(9), (10), (11), (13)-15), (22), (23)
		(18), (19), (21), (9), (10), (11)
		(18), (19), (21), (9), (10), (11), (13)-(15), (22), (23)
	(18), (19), (21), (9), (10), (12)-(15), (22), (23)	

3.3 Data Utilized

Model 1: Income information is derived from three sources: mean physician income from independent professional practice, 1929-1951, published by the Office of Business Economics of the Department of Commerce; medians from *Medical Economics* for selected years in the 1950's and 1960's; and means from Internal Revenue Services, published in a recent Organization for Economic Cooperation and Development publication.

Model 2: Asset values of specialty training in various fields for the years 1955, 1959 and 1965 are calculated from reported earnings in private, independent practice in *Medical Economics* and stipend data from education volumes of the *Journal of the American Medical Association* and the *Hospital Physician*. Statistics on salaries in the military are found in the *Official Army Register*, Adjutant General's Office, and the *Hospital Physician*, and survivor rates, in annual volumes of *Vital Statistics of the United States*, United States Public Health Service. The internship salary is from the *Journal of the American Medical Association*. Earnings in military service are from the *Official Army Register*. Income of general practitioners is from *Medical Economics*. The cost stream includes tuition and fee information from education volumes of the *Journal of the American Medical Association* and age-specific median income of white male college graduates from the Census Bureau.

Model 3: Data sources used are listed in the Data Source Index (117), (21), and unpublished data from the American Medical Association.

3.4 Input Variables

- Model 1: (1) Number of male college graduates,
 (2) Tuition and fees in year applicant begins professional education,
 (3) Physician's income in independent professional practice,
 (4) Starting salaries of male college graduates in general business,
 (5) PhD stipends,
 (6) Median incomes of PhD's in biological sciences,
 (7) Applicants in the previous year,
 (8) Biologist's income growth, and
 (9) Biologists income level.
- Model 2: (1) Number of residencies in the current year,
 (2) Present value of lifetime earnings, discounted at 5%,
 (3) Present value of lifetime earnings, discounted at 10%,
 (4) Total number of foreign graduates,
 (5) Absolute difference between median specialty and general practice income,
 (6) Monthly stipend offered by hospitals to first year residents,
 (7) Number of specialists in a given field seeking employment divided by the number of vacancies in the field, and
 (8) Measure of physician dissatisfaction with their respective specialities.
- Model 3: (1) Proportion of medical specialists with previous state contacts of birth,
 (2) Proportion with previous contacts, medical school, residency, and internship or birth, medical school and residency.
 (3) Proportion with previous contacts, birth, internship and residency.

- (4) Proportion with previous contacts, birth, medical school and internship, or birth and internship,
- (5) Proportion with previous contacts, birth and residency, or medical school and residency, or internship and residency,
- (6) Proportion with previous contacts, birth and medical school or medical school and internship,
- (7) Proportion with previous contact residency,
- (8) Proportion with previous contacts, internship, or medical school, or birth,
- (9) % of active physicians who are "old" (graduated from medical school prior to 1935),
- (10) Change in per capita income, 1960-1966,
- (11) % increase in number of beds in voluntary proprietary hospitals, 1962-1966,
- (12) Net migration over population,
- (13) Annual degree days,
- (14) % population living in SMSA's,
- (15) Medical exam failure rate,
- (16) Mean professional hours for all specialists in private practice,
- (17) Mean net income for all specialists in private practice,
- (18) Proportion of general practitioners with previous state contacts of birth, medical education, and internship,
- (19) Proportion with previous contacts, medical school and internship, or birth and internship, or birth and medical school,
- (20) Proportion with previous contacts, medical school or birth,
- (21) Proportion with previous contact internship,
- (22) Mean professional hours for a private general practitioner per week, and
- (23) Mean net income for a private general practitioner.

3.5 Output Variables

- Model 1: (1) Applicants planning to enter in year t,
(2) "A" college record applicants planning to enter in year t.
- Model 2: (1) Number of residents in a particular specialty in a given year who are graduates of American or Canadian medical school,
(2) Residents in a specialty divided by number of residencies offered in that field in a given year.
- Model 3: (1) Overall retention probability for specialists,
(2) Overall retention probability for general practitioners.

3.6 Verification/Applicability/Reliability

Actual values and values estimated by Model (1) are plotted for comparison purposes. Since the data used to estimate the parameters of the models applies to 1950-1965, 1955-1965, and 1966, it is questionable whether the models are applicable to current problems.

3.7 Computer Characteristics

None identified

1.0 IDENTIFICATION

1.1 Descriptive Title

Hospital Demand for Residents

1.2 Developer's Name

Frank A. Sloan, RAND Corporation

1.3 References

Sloan, 1970

2.0 GENERAL DESCRIPTORS

2.1 Development Status

Completed

2.2 Purpose and Sponsor

- (1) To present estimates of a hospital demand for ophthalmology residents schedule, and
- (2) To place the demand for residents equation in a larger framework (other professional disciplines) which could be used as the basis for an empirical investigation when more data becomes available.

This report is adapted from the developer's PhD dissertation, Harvard University, 1968.

2.3 Scope and Subject

Demand for ophthalmology residents - 1 equation.

2.4 Abstract

Hospital demand for ophthalmology residents is estimated by a regression relating the number of residencies offered to stipends, hospital medical school affiliation, average daily inpatient service census, and number of outpatient visits. Data was obtained from 99 hospitals for 1966-1967. The results indicate a response of the number of residencies offered in a department to resident salary and hospital department production of patient-related services.

2.5 Major Outputs

Estimates of the number of residencies offered for the academic year.

2.6 Assumptions (a)/ Constraints (c)/Hypotheses (h)

(a-1) The demand for residents equation is assumed to be linear, and

(a-2) Demand for labor equations are not linear.

3.0 TECHNICAL DESCRIPTORS

3.1 Model Type

Regression Analysis

3.2 Model Characteristics

One equation, four independent variables

3.3 Data Utilized

Data for the regressions was obtained from data sources (17) and (14).

3.4 Input Variables

- (1) Stipends,
- (2) Medical school affiliation,
- (3) Average daily inpatient census, and
- (4) Outpatient visits.

3.5 Output Variables

Estimates of the number of residencies offered for the academic year.

3.6 Verification/Applicability/Reliability

All coefficients are significant at the 1% level; since the data used to estimate the parameters applies to 1965-1967, it is questionable whether the model is applicable to current problems.

3.7 Computer Characteristics

None identified

S8

1.0 IDENTIFICATION

1.1 Descriptive Title

Short-Run Supply Responses of Professional Nurses

1.2 Developer's Name

Frank A. Sloan and Roger D. Blair, the University of Florida

1.3 References

Sloan & Blair, 1973

- 2.0 GENERAL DESCRIPTORS

2.1 Development Status

Completed

2.2 Purpose and Sponsor

Determination of the relationships between several variables and the short-run supply responses of professional nurses. Model development sponsor is not identified.

2.3 Scope and Subject

Supply of married and single female registered nurses.

2.4 Abstract

Neoclassical consumer theory, where goods and leisure are arguments in the household's utility function, is used as a framework for an empirical study of the wages and supply responses of registered nurses, both active and inactive. Two nurses' wage equations, two spouse wage equations, and four nurse supply equations (hours and weeks worked by married and single nurses) are estimated by linear regression. Four additional supply equations were estimated

including a squared wage variable; however, the coefficients were not significantly different from zero. It is concluded that nurses are approximately as responsive to wages as are women in other occupations.

2.5 Major Outputs

Weekly wages, hourly wages, spouse wages, and nurse weeks and hours worked.

2.6 Assumptions (a)/Constraints (c)/Hypotheses (h)

(c-1) All male nurses are excluded from the study.

(c-2) All spouses over age 65 are excluded from the study.

3.0 TECHNICAL DESCRIPTORS

3.1 Model Type

Regression Analysis

3.2 Model Characteristics

8 equations, 8 dependent variables, 24-29 independent variables each. The following are the functional relationships between the dependent (output) and independent (input) variables listed in sections 3.5 and 3.4 respectively.

Dependent Variable

(1)
(2)
(3)
(4)

Independent Variables

(1), (2), (7), (9)-(11), (14)-(23)
(1)-(15)
(1), (2), (15), (24)-(32)
(1), (2), (15), (24), (26), (28),
(29), (31), (32)

3.3 Data Utilized

The data consists of a random sample of 1,988 nurses (1,396 married and 592 single) selected from the Public Use Sample (a one per cent sample) of the U.S. Census, 1960.

3.4 Input Variables

- (1) Race (black or other),
- (2) Whether or not foreign born,
- (3) Highest grade attended,
- (4) Whether or not attended twelfth grade,
- (5) Whether or not attended four years of college,
- (6) Age (31-40, 41-50, 51-60, 61-65),
- (7) Whether moved within or between states,
- (8) Whether or not immigrated,
- (9) Whether works in central city of an SMSA,
- (10) Whether works in ring of an SMSA,
- (11) Whether works in outside ring of an SMSA and resides in an urban area,
- (12) Whether occupation is farmer or farm manager,
- (13) Whether occupation is farm foreman or farm laborer,
- (14) Whether worked less than 1500 hours,
- (15) Geographic region (New England, Mid-Atlantic, East North Central, West North Central, South Atlantic, East South Central, West South Central, Mountain, Pacific),
- (16) Per capita income,
- (17) Registered nurses per 1,000 in state,
- (18) Whether attended fourth year of college,
- (19) Practical nurses per 1,000 in state,
- (20) Whether a government employee,
- (21) Whether self-employed,
- (22) Age and number of children,
- (23) Whether currently married,
- (24) Predicted nurse weekly wage,
- (25) Predicted spouse weekly wage,
- (26) Predicted nurse hourly wage,
- (27) Predicted spouse hourly wage,
- (28) Sum of non-wage income of nurse and spouse plus income of children living in household plus income of other relatives,
- (29) Number of children by age (less than 2, 2-5, 6-15, 16-19),
- (30) Whether spouse unemployed at least one year,
- (31) Age (less than 30, 30-39),
- (32) Number of other adults living in household by age (less than 65, 65-74, 74 and over).

3.5 Output Variables

- (1) Nurse wages (hourly and weekly),
- (2) Spouse wages (hourly and weekly),
- (3) Married nurse supply (hours and weeks worked), and
- (4) Single nurse supply (hours and weeks worked).

3.6 Verification

Since the data used to estimate the equations was obtained from the 1960 census and pertains to 1959, it is questionable whether the model is applicable to current problems.

3.7 Computer Characteristics

None identified

1.0 IDENTIFICATION

1.1 Descriptive Title

Demand for Nursing Resources

1.2 Developer's Name

Warren H. Thomas

1.3 References

Thomas 1964, 1968

2.0 GENERAL DESCRIPTORS

2.1 Development Status

Completed

2.2 Purpose and Sponsor

Development of a mathematical model for the prediction of patient recovery states to determine demands for the nursing resources. The model is part of a PhD dissertation, field of Engineering.

2.3 Scope and Subject

Recovery of coronary patients and their demands for nursing resources.

2.4 Abstract

A mathematical model is developed which represents the recovery characteristics of a homogeneous class (coronary) of patients. A Markov model of a multiple phase six-stage patient recovery process is used to predict the patients' future recovery state, given knowledge of his present state. The durations of patient stay within each recovery state and overall length of stay were fitted to a combination of log normal and exponential distributions. The model is constructed by calculating the Markov transitional probabilities from these theoretical distributions. Two primary

models, one for patients discharged alive and the other for those who died, are combined to represent the recovery patterns of (1) patients less than 65 years old, and (2) patients 65 and older. From the recovery status, expected demand for nursing resources can be predicted several days into the future.

2.5 Major Outputs

Prediction of patients' future recovery states

2.6 Assumptions (a)/Constraints (c)/ Hypotheses (h)

- (a-1) Any patient who died within the first three days never progressed medically beyond state 1.
- (a-2) The demand for nursing and other resources, although different from state to state, is the same for all days a patient spends in the same state.
- (a-3) A nurse is equally productive on any unit.
- (a-4) The model would be installed only in hospitals which enjoy the use of a digital computer.

3.0 TECHNICAL DESCRIPTORS

3.1 Model Type

Analytic, stochastic, Markov model.

3.2 Model Characteristics

This is a 14-state Markov model. The states are an entry state, four recovery states (acute, primary activity, secondary activity, normal activity) and an exit state. Each recovery state is composed of three recovery phases. Deterioration in patient status is treated as a relapse to the initial recovery state, therefore, all return transitional probabilities are zero except for those returning to the initial recovery state. The expected demand for a hospital resource, particularly nurses, can be computed by determining the demand required by each patient state using the model to predict the number of patients in each state.

3.3 Data Utilized

Data was obtained from medical records of 81 patients at Community Hospital, Indianapolis, Indiana. Events include number and type of medication, occurrence and results of EKG's, number, type, and interpretation of x-rays, occurrence of special laboratory tests, number of hours of oxygen support, patient's temperature, type and amount of activity permitted, diet prescribed, patients' mental attitude, nurses' comments, etc.

3.4 Input Variables

- (1) Initial number of patients in each of the recovery states.
- (2) The nursing care or other resource requirements for patients in each recovery state.

3.5 Output Variables

- (1) Predicted future number of patients in each recovery state.
- (2) Determination of the expected demand for nurses or other hospital resources.

3.6 Verification/Applicability/Reliability

The model is intended for use in short-range scheduling decision making. The specific results are applicable only to Community Hospital, Indianapolis, Indiana.

3.7 Computer Characteristics

Language - Fortran II
Hardware - IBM 7090 and IBM 1620 computers

1.0 IDENTIFICATION

1.1 Descriptive Title

Design of Primary Health Care Teams

1.2 Developer's Name

Dean H. Uyeno, Northwestern University

1.3 References

Uyeno, 1971

2.0 GENERAL DESCRIPTORS

2.1 Development Status

Completed

2.2 Purpose and Sponsor

To develop a method with which to evaluate alternative organizational structures for primary patient care units. Model development supported by Northwestern University and the US Public Health Service.

2.3 Scope and Subject

Composition of primary health care teams for differing patient demand levels and health care facilities.

2.4 Abstract

A simulation model of a general primary health care delivery unit is developed which, given alternative patient care requirements, team compositions and facilities, provides statistics concerning patient waiting time, personnel utilization, facility utilization, etc. An application of the model and evaluation procedures was made to the area of pediatrics. A suggested use for the model is to estimate the effects of increasing the number of allied health personnel in pediatric clinics.

2.5 Major Outputs

Data on the utilization of personnel and facilities and patient service and waiting times by priority class.

2.6 Assumptions (a)/Constraints (c)/Hypotheses (h)

- (c-1) Minimum utilization of the assistant is 10%,
- (c-2) Minimum utilization of the associate is 10%,
- (c-3) Minimum utilization of the last room added is 10%,
- (c-4) Work day is less than or equal to 7.50 hours,
- (c-5) Average waiting time is less than or equal to 30 minutes,
- (c-6) Maximum waiting time is less than or equal to 90 minutes, and
- (c-7) Utilization of the MD is less than or equal to the time available for patient contact.

3.0 TECHNICAL DESCRIPTORS

3.1 Model Type

Simulation

3.2 Model Characteristics

Task occurrence frequency and distribution of task lengths by patient are developed from empirical data. These statistics are used to generate schedules of patients and to generate their associated activities and their lengths. These parameters are then employed in a computer simulation to generate personnel and facility utilization data and patient service data.

3.3 Data Utilized

Observation of the person giving primary care throughout entire work periods starting from the arrival of the first patient or staff member through the departure of the last staff member at the end of the work period, for enough periods to establish a reliable data base.

3.4 Input Variables

- (1) Determination of task categories,
- (2) Determination of patient and physician data sufficient to discriminate patient classes,
- (3) Relationship between task categories and patient classes,
- (4) Service times for different tasks, and
- (5) Frequency of occurrence of each task.

3.5 Output Variables

- (1) Hourly data on the utilization of personnel and facilities (percentage of time occupied),
- (2) Service times,
- (3) Waiting times,
- (4) Total time in the system,
- (5) Average time in queues, and
- (6) Number of patients to pass through each queue.

3.6 Verification/Applicability/Reliability

Actual and simulated waiting times in a pediatrician's office were compared; very good correspondence was found between the model and this data.

3.7 Computer Characteristics

CDC 6400 Computer

Two preliminary data analysis programs: language - COBOL; each under 200 statements in length with execution times of under 10 seconds.

Patient frequency distributions: language - SIMSCRIPT; 700 statements, 35,000 words of computer memory; running time - 20 seconds for analysis of 150 patients.

Schedule generation: language - SIMSCRIPT; 1200 statements, 43,300 words of computer memory; running time - 40 seconds to generate 4 schedules of 100 patients each.

Actual model: language - SIMSCRIPT; over 1900 statements grouped in over 40 subroutines; compilation time: approximately 5 minutes; the program could process 100 patients for one team in approximately 35 seconds and process 100 patients each for two teams in approximately 45 seconds.

1.0 IDENTIFICATION

1.1 Descriptive Title

Multiple Assignment Model for Staffing Nursing Units

1.2 Developer's Name

Harvey Wolfe, Johns Hopkins University

1.3 References

Wolfe, 1964

2.0 GENERAL DESCRIPTORS

2.1 Development Status

~ Completed

2.2 Purpose and Sponsor

To provide nurse staffing guidelines, detailing the allocation of staff according to quantitative and qualitative requirements for nursing resources. Model development supported by the US Public Health System.

2.3 Scope and Subject

Mix of nursing personnel best able to care for the demands for a given configuration of patient classifications.

2.4 Abstract

A linear programming model is developed which minimizes staff allocation costs to meet stochastic demands of patients for any combination of three classes of patients developed previously (see model by Connor). The model concentrates on the determination of an optimal staff allocation system which minimizes the cost or utility measures of quantitative and qualitative patients needs. The

qualitative aspects of nursing care are incorporated into the model by constructing cost coefficients reflecting the nurse and administration judgment criteria concerning the necessary qualifications to perform a particular set of tasks adequately. These costs, combined with salary costs and costs of idle time, define the model objective function parameters.

2.5 Major Outputs

Total cost of making assignments for use as guideline for allocating staff and assigning tasks.

2.6 Assumptions (a)/Constraints (c)/Hypotheses (h)

- (a-1) All individuals must work a full day if they are hired at all.
- (a-2) A hospital has the ability to hire as many individuals in each personnel category as it needs.
- (c-1) No overtime is permitted under any circumstances.
- (c-2) No single task complex may be carried out by more than one classification of personnel.
- (h-1) No difference exists between the average time required to perform a particular task for selected pairs of personnel categories. Accepted at the .05 significance level.

3.0 TECHNICAL DESCRIPTORS

3.1 Model Type

Linear programming

3.2 Model Characteristics

Model minimizes a linear objective cost function of nurse task allocation consisting of salary costs, assignment cost (utility value of assigning a particular type nurse to various tasks), and non-productive costs of idle time; subject to the constraints noted in section 2.6.

3.3 Data Utilized

Data for determination of the model parameters was obtained from observation of several persons in each personnel classification and from judgments of 10 administrators and registered nurses at the Johns Hopkins Hospital.

3.4 Input Variables

- (1) Salary cost per unit time for i^{th} classification,
- (2) Time required to perform task j ,
- (3) Length of work day for i^{th} classification,
- (4) Number of individuals in the i^{th} classification, and
- (5) Cost of assigning the i^{th} classification to the y^{th} job (composed of salary cost and value cost).

3.5 Output Variables

Total cost of making multiple assignments.

3.6 Verification/Applicability/Reliability

124 hypotheses concerned with combinations of pairs of personnel categories (see section 2.6) were tested using student "t" and normal distributions depending upon sample size of available data. All but six of the hypotheses tested were accepted at the .05 significance level, supporting the credibility of an assumption that no difference in speed of personnel performance exists. Since the model parameters developed may have internal biases particular to Johns Hopkins Hospital, applicability of the model in other hospital environments without modification is questionable. The effectiveness or quality measures associated with the assignments provided by the model cannot be discussed without comparisons with different assignment methodologies and development of criteria concerning the quality of nursing care.

3.7 Computer Characteristics

IBM 7094. Fortran program listing included. This program takes 0.45 hours to solve 55 multiple assignment problems, each with 6 personnel classifications and 16 task complexes.

1.0 IDENTIFICATION

1.1 Descriptive Title

Micro-Simulation Model of Health Manpower

1.2 Developer's Names

USC Research Team: Donald E. Yett, Leonard Drabek, Larry Kimbell,
and Michael Intriligator

1.3 References

Yett, et al, 1970, 1972, Undated; Human Resources Research Center, 1972

2.0 GENERAL DESCRIPTORS

2.1 Development Status

A preliminary operational model has been developed. Mark I is proposed for the mid to end 1970's.

2.2 Purpose and Sponsor

The model is intended to be useful for structural analysis of the health care system, forecasting effects of demographic and social changes and policy measures, policy analysis and evaluation, and as a guide to future research areas.

2.3 Scope and Subject

Micro-simulation of the health care system; supply and demand of health services, health manpower, and health education.

2.4 Abstract

Three versions of a micro-simulation model of the health care system are developed. The first, "Mark I", represents the "ideal" model for analyzing and forecasting demand and supply of health manpower. The second, "Mark II" is a version of Mark I keyed to available data, known methodologies and existing computer capabilities. The third version,

Mark II-A, is a "scaled-down" version of Mark II, modified during implementation so that the model will be operational within a year's development period. A population of individuals is assigned to diagnostic categories by means of a probability distribution. Equations are formulated to determine the needs and demands of the population; production functions, supply equations for institutions and services, manpower (physician, nurse, and allied health personnel) demand and supply equations, and equations for the demand for health education are developed. Reasons for the selection of variables are given. The major simplifications of the Mark II as compared with the Mark I are the reduced number of population and institutional attributes, the reduced number of markets, and the modification of the representation of the production processes. A preliminary version of the model is now operational.

2.5 Major Outputs

See section 3.5

2.6 Assumptions (a)/Constraints (c)/Hypotheses (h)

- (a-1) Health events do not influence demographic events.
- (a-2) Outpatient institutions behave so as to maximize an objective function, subject to technological and resource constraints.
- (a-3) The behavior of outpatient institutions can be predicted on the basis of objective functions characteristic of the type of institution under consideration.
- (a-4) The typical physician's behavior can be stated in a functional form which relates the amount of patient visits he will supply to his preference pattern with respect to different combinations of net income and leisure.
- (a-5) Hospital-based clinics and emergency rooms maximize the value of output subject to constraints imposed by existing technology, total revenue at their disposal, and target goals for capital expansion.
- (a-6) Shadow prices by which output is valued, and the constraints on their maximizing behavior will vary by type of hospital.
- (a-7) The proprietary hospital approximates the behavior of a profit maximizing firm.
- (a-8) Length of visit is constant for each diagnostic category in each type of outpatient institution.
- (a-9) The physician is not buying and selling in perfectly competitive and continuously clearing markets.

- (a-10) Length of stay is constant for each diagnostic category in a given type of inpatient institution.
- (a-11) All inpatient institutions choose the combination of inputs they employ so as to minimize the costs of producing any particular set of outputs,
- (a-12) Government hospitals are assumed to admit patients on the basis of priorities assigned to the different types of diagnostic conditions.
- (a-13) When demand expands, the reserve positions of voluntary and state and local hospitals improve, and pressures will mount on elected officials and community leaders to provide more services.
- (a-14) Institutions with relatively large manpower vacancy rates will be the most aggressive in reducing their vacancies.
- (a-15) All medical schools will be able to find enough salaried physicians to fill their previous period's demand.
- (a-16) Non-medical school salaried physicians do not have a systematic preference for employment in private offices or hospitals.
- (a-17) There will be "shortages" in both areas of employment.
- (a-18) All medical-school-affiliated hospitals fill their demands for interns and residents first.
- (a-19) The structure of the markets for allied health personnel can be treated as being essentially the same as that for nursing personnel.

3.0 TECHNICAL DESCRIPTORS

3.1 Model Type

Simulation; analogue; open model; Mark II-A is non-stochastic

3.2 Model Characteristics

The model consists of five interacting submodels, consumers, physician services, physicians, hospital services, and non-physician manpower, each largely self-contained from a computer programming standpoint. Separate subroutines are used to generate US and foreign medical

graduates. The submodels which project the population of consumers and physicians over time are run first, and the output used as input to the other three submodels. Coefficients of the individual equations of the model are determined by regression; the actual number of equations depends on the category specifications of types of individuals, health services, etc. The preliminary operational micro-simulation model includes 86 age categories for the population of consumers, 2 race categories, 3 income categories, 14 physician specialties, 9 physician age categories, 8 physician visit and 3 hospital visit categories, 6 patient condition categories, 4 short-term hospital categories, and for the non-physician manpower population, 28 physician practice types, 16 hospital types, and 4 health manpower categories. The preliminary model does not treat health education endogenously.

3.3 Data Utilized

Sources for the type of data required by the model are listed in the Data Source Index: (14), (28), (31), (17), (20), (35), (36), (38), (40), (46), (51), (53), (60), (68), (65), (67), (93), (95), (110), (112), (21), (118), (64), (139), (74), (75), (76), (121), (79), (81), (82), (83), (84), (141), (147), (148).

3.4 Input Variables

Mark I - Attributes of individuals - variables

- (1) Age,
- (2) Sex,
- (3) Ethnic group,
- (4) Marital status,
- (5) Residence,
- (6) Family income,
- (7) Health insurance status by type and extent of services covered,
- (8) Illness or condition,
- (9) Number of visits to outpatient institutions,
- (10) Expenditures on physician visits,
- (11) Waiting time for an appointment (in days),
- (12) Number of days in inpatient institutions,
- (13) Expenditures on inpatient services,
- (14) Waiting time for a bed (in days),
- (15) Outpatient and inpatient services needed or demanded but not obtained.

Outpatient - Supply of Health Services - Attributes and Variables

- (16) Physician's offices (specialty),
- (17) Group practices (size, specialty, nature of payment),
- (18) Hospital-based clinics (size, ownership or control),
- (19) Number of patient visits,

- (20) Number of patient visits by diagnostic category,
- (21) Fees,
- (22) Number of employees by occupation,
- (23) Hours worked by employees,
- (24) Employee's salaries,
- (25) Budgeted vacant positions,
- (26) Revenues from patients,
- (27) Other sources of revenue,
- (28) Operating expenses,
- (29) Capital expenditures,
- (30) Total expenses.

Inpatient Supply of Health Services - Attributes and Variables

- (31) Size (number of beds),
- (32) Ownership or control,
- (33) Nature of payment,
- (34) Length of stay,
- (35) Medical school affiliation,
- (36) Medicare certification,
- (37) Average daily census,
- (38) Average daily census by diagnostic category,
- (39) Charges for care by diagnostic category,
- (40) Number of employees by occupation,
- (41) Hours worked,
- (42) Budgeted vacant positions,
- (43) Salaries of employees,
- (44) Revenues from patients,
- (45) Other revenues,
- (46) Total expenditures,
- (47) Operating expenses,
- (48) Capital expenditures,
- (49) Sources of funds for capital expenditures.

Supply of Physicians

- (50) Specialty,
- (51) Age,
- (52) Ethnic group,
- (53) Medical school attended,
- (54) Career status,
- (55) Type of employment,
- (56) Participation,
- (57) Hours worked,
- (58) Income.

Supply of RNs and LPNs

- (59) Age,
- (60) Ethnic group,
- (61) Marital status,

- (62) Children by age,
- (63) Education,
- (64) Licensure status,
- (65) School attended,
- (66) Type of employment,
- (67) Participation (active, inactive),
- (68) Hours worked,
- (69) Income,

Supply of Allied Health Personnel

- (70)-(80) Same as variables (59)-(69)

Demand for Health Professions Education - Student Attributes

- (81) Age,
- (82) Sex,
- (83) Marital status,
- (84) Ethnic group,
- (85) Previous education,
- (86) Number of applications,
- (87) Number of admissions,

Supply of Health Professions Education

- (88) Ownership or control,
- (89) Affiliation,
- (90) Accreditation,
- (91) Enrollment,
- (92) Enrollment vacancies,
- (93) Length of training,
- (94) Graduates,
- (95) Tuition,
- (96) Stipends,
- (97) Number of faculty,
- (98) Hours of faculty time by type of activity,
- (99) Faculty salaries,
- (100) Teaching laboratory spaces,
- (101) Budgeted vacant positions,
- (102) Expenditures,
- (103) Revenues.

Mark II - Individual Attributes

- *(1) Age,
- *(2) Sex,
- *(3) Ethnic group,
- *(4) Marital status,
- (5) Residence,
- (6) Family income

*Variables included in Mark II-A model

*(7) Health insurance status.

Institutions and Services

- *(8) Physicians offices (size of practice, specialty),
- *(9) Hospital based outpatient clinics,
- (10) Inpatient services,
- *(11) Size,
- *(12) Ownership or control,
- *(13) Length of stay,
- *(14) Nature of payment,
- (15) Health insurance status.

Physicians

- (16) Type (MD or DO),
- *(17) Specialty (general practice, specialist),
- *(18) Age,
- *(19) Medical school attended (domestic or foreign),
- *(20) Career status,
- (21) Type of employment.

Nurses (RN and LPN)

- *(22) Age,
- *(23) Marital status,
- *(24) Education.

Health Professions Education - Medical Students (Medical Students and Nursing, Students in Mark II-A)

- *(25) Age,
- *(26) Sex,
- *(27) Ethnic group.

Nursing Students

- *(28) Age,
- (29) Marital status,
- (30) Ethnic group,
- (31) Previous education.

Institutions

- (32) Type of school (MD or DO),
- *(33) Ownership or control,
- (34) Affiliation.

Nursing School

- *(35) Type of program,
- *(36) Ownership,
- (37) Size of affiliated hospital.

*Variables included in Mark II-A model

Preliminary Operational Model

Population of Consumers

- (1) Mortality rates by age, sex and race,
- (2) Birth rates by age of mother, race, and sex,
- (3) Population for 1960 by age, sex, race, and income, and
- (4) Annual net immigration.

Physician Supply

- (5) Stock of US trained physicians and foreign medical graduates by activity, specialty and age,
- (6) Survivor rates,
- (7) Projected specialty distribution of US medical school graduates and foreign medical school graduates,
- (8) Number of interns and residents by specialty,
- (9) Projected graduates from US medical schools, and
- (10) Percentage growth rate of stock of foreign medical graduates.

Manpower Markets

- (11) Coefficients for the wage adjustment equations,
- (12) Historical values of the wage rates paid per week by type of health manpower.

Registered Nurse Supply

- (13) Mortality rates (by age),
- (14) Participation rate equations coefficients,
- (15) Stock of registered nurses (by age),
- (16) Graduates from schools of nursing,
- (17) Foreign nurses,
- (18) Nurse faculty,
- (19) Private duty nurses,
- (20) School nurses,
- (21) Industrial nurses,
- (22) Public health nurses,
- (23) Lagged values of participation rates,
- (24) Lagged values for the stock of nurses.

Supply of Other Health Manpower

- (25) Supply of licensed practical nurses by year,
- (26) Supply of allied health professionals by year,
- (27) Weekly wage rates for non-medical personnel by year.

Demand for Inpatient Hospital Services

- (28) Coinsurance rates by age group, hospital type, and year,
- (29) Demand elasticities for length of stay,

- (30) Admission rates by age, sex, race, hospital type, diagnostic condition, and surgical treatment,
- (31) Average length of stay by age, sex, race, hospital type, diagnostic condition, and surgical treatment.

Physician Services

- (32) Fraction of physicians in group practice by specialty,
- (33) Average hours worked per week by specialty and type of practice,
- (34) Average weeks worked per year by specialty and type of practice,
- (35) Weekly office visits per physician by specialty and type of practice,
- (36) Weekly hospital visits per physician by specialty and type of practice,
- (37) Fees charged for specific procedures by specialty and type of practice.

Demand for Physician Services

- (38) Doctor visit rates by age, sex, race, income, site,
- (39) Demand elasticities by site,
- (40) Coinsurance rates by age group and year,
- (41) Adjustment factors by site,

Supply of Physician Services

- (42) Coefficients for physician services supply and manpower demand equations by specialty and type of practice.

Supply of Hospital Services

- (43) Annual patient days by type of hospital,
- (44) Number of hospitals by type of short-term hospital,
- (45) Number of beds by type of short-term hospital,
- (46) Distribution parameters for outpatient visits,
- (47) Distribution parameters for patient days,
- (48) Distribution parameters for admissions,
- (49) Distribution parameters for births,
- (50) Distribution parameters for surgical operations,
- (51) Distribution parameters for adjustments over time,
- (52) Constructed data on hospital prices per patient day,
- (53) Manpower ratios (full-time equivalent personnel per thousand patient days) for long-term hospitals,
- (54) Manpower demand equation coefficients for short-term hospitals,
- (55) Non-labor cost equation coefficients by type of short-term hospital,

- (56) Price adjustment equation coefficients by type of short-term hospital,
- (57) Bed adjustment equation coefficients by type of short-term hospital,
- (58) Plant assets per hospital bed by type of hospital, and
- (59) Correction factors for price adjustment equations.

3.5 Output Variables

Mark II

- (1) Probability that i^{th} individual will be in the j^{th} diagnostic category.
- (2) Quantity of k^{th} outpatient services needed by individuals in i^{th}
- (3) Quantity of k^{th} outpatient services demanded by individuals in the i^{th} cohort.
- (4) Quantity of k^{th} outpatient services received by individuals in the i^{th} cohort.
- (5) Amount of patient visits that can be feasibly produced by the j^{th} type of outpatient institution, given the available resources.
- (6) Quantity of patient visits supplied by an institution in the j^{th} attribute class.
- (7) Change in price of patient visits in the k^{th} type of outpatient market.
- (8) Quantity of the k^{th} inpatient services needed by individuals in the i^{th} cohort.
- (9) Quantity of the k^{th} inpatient services demanded by individuals in the i^{th} cohort.
- (10) Quantity of the k^{th} inpatient services received by individuals in the i^{th} cohort.

- (11) Amounts of bed days supplied by inpatient institutions of the n^{th} type of inpatient institution.
- (12) Quantity of bed days supplied by inpatient institutions of the k^{th} type.
- (13) Number of bed days of capacity added by the n^{th} type of inpatient institution.
- (14) Change in price of bed days in the k^{th} type inpatient market.
- (15) Quantity of the m^{th} type of manpower demanded by the l^{th} class of outpatient institution.
- (16) Quantity of the m^{th} type of manpower demanded by the n^{th} type of inpatient institution.
- (17) Number of hours of labor supplied by the m^{th} type of manpower in the n^{th} cohort.
- (18) Change in the wage paid to the m^{th} type of manpower.
- (19) Number of hours of m^{th} type of manpower received by l^{th} type outpatient institution.
- (20) Number of hours of m^{th} type of manpower received by n^{th} type inpatient institution.
- (21) Number of hours of m^{th} type of manpower received by n^{th} type education institution.
- (22) Probability that an individual in the o^{th} population cohort will demand medical education.
- (23) Probability that an applicant in cohort class o will be accepted to medical school.
- (24) Supply of first year spaces at medical schools of type n .
- (25) Hours of physician faculty time demanded by medical schools of type n .
- (26) Probability that an individual of the o^{th} population cohort will demand nursing education in program type n .

- (27) Number of first year openings supplied by nurse training programs of type n.
- (28) Number of training programs of type n.
- (29) Hours of faculty time demanded by nurse training programs of type n.
- (30) Number of vacancies in a nurse training program of type n.

Preliminary Operational Model

- (1) Total population by age, sex-race, and income in a given year,
- (2) Number of physicians: age by specialty,
- (3) Number of physicians: age by activity,
- (4) Physician's activity by specialty,
- (5) Number of active office-based physicians by specialty, for each year,
- (6) Foreign medical graduates by activity and specialty,
- (7) Quantity of health services demanded by age and site,
- (8) Quantity of health services demanded by sex and site,
- (9) Quantity of health services demanded by race and site,
- (10) Quantity of health services demanded by income and site,
- (11) Number of physicians in office-based practice, by specialty,
- (12) Visits supplied by physicians in office-based practices,
- (13) Employment of aides, RNs, LPNs and technicians in office,
- (14) Physician fees by specialty,
- (15) Hospital admissions,
- (16) Average length of stay,
- (17) Annual number of patient days for specific population groups,
- (18) Number of RNs by age,
- (19) Participation rates for RNs by age, and
- (20) Supply of RNs by age (total less exogenous employment).

3.6 Verification/Applicability/Reliability

Predictions of the model were compared to historical data. Sufficient information does not exist for all years to assess the correspondence between the model and historical data. The population of consumers submodel corresponded well to census estimates for 1970; due to revision of data, meaningful comparisons are not possible between the physician supply submodel projections and historical data. The physicians' services and hospital services submodels both performed well; the accuracy of the predictions of specific output variables and refinements suggested by the results of the historical run are discussed.

3.7 Computer Characteristics

The model is coded in FORTRAN IV; all execution was performed on the IBM 370/155. Other IBM equipment with 300K of core storage may be used.

1.0 IDENTIFICATION

1.1 Descriptive Title

Community Health Service Utilization and Resource Allocation Model

1.2 Developer's Name

Rita Zemach, Michigan State University

1.3 References

Zemach, 1970

2.0 GENERAL DESCRIPTORS

2.1 Development Status

Model structure developed provides generalized matrix formulation of equations. Further empirical development required to establish significant variables, estimate numerical relationship of parameters and acquire data to test model.

2.2 Purpose and Sponsor

To provide a tool for monitoring the health-care system; to aid in evaluating the results of changes in resource allocation, use of services, or method of delivery in health care systems. Model development sponsored by Michigan State University.

2.3 Scope and Subject

Structure of model provides theoretical formulation of the functional relationships regarding: utilization of personal health and medical services by the population of a region; allocation of resources used to provide these services, and the cost of health care as derived from the prevailing costs of resources.

2.4 Abstract

The model developed consists of a series of linear equations with n variables which describe the functional relationships at a specific period in time for: (1) the production of health services relating the allocation of resources to n types of units of service; (2) the cost of services relating the average unit cost for a particular service to the average unit costs of each type of resources; (3) the utilization of health services relating the n type of unit services to "appropriate" categories of patients, and (4) the cost of providing services relating the average unit cost of providing health services to each patient category to the average cost of resources. The model can be used to forecast changes in community population if appropriate data is available. The model primarily is a formulation of mathematical functions and has been exercised only in an artificial environment using a combination of available and hypothetical data.

2.5 Major Outputs

- (a) Average unit cost of producing each type of service (Dental visits, Nurse visits, Laboratory procedures, etc.)
- (b) Annual cost per person of providing health care to each population group (i.e., age, sex category).
- (c) Prediction of amount and type of health service required based on projected changes in population categories.

2.6 Assumptions (a)/Constraints (c)/Hypotheses (h)

- (a-1) All relations assumed to be linear.
- (a-2) The community being described forms a closed system in the sense that all services produced are used by the population of the community and that the population uses only the services produced within the community.
- (c-1) The model considers only aggregated flows of resources, manpower, and services. It also considers average unit cost and aggregated population groups.

3.0 TECHNICAL DESCRIPTORS

3.1 Model Type

n state deterministic linear equation model based on rationale that the cost and/or utilization of a unit of service is the linear sum of the products of the resource requirements per type service and the cost or use of each type.

3.2 Model Characteristics

The model consists of three components: health resources, health services and population serviced. These components are modeled by sets of linear equations describing the relationship between production, utilization, cost of providing and cost of producing health services and health resources or population serviced. The model parameters are also formulated in terms of a series of linear difference equations to simulate fluctuations in health service requirements.

3.3 Data Utilized

Since the model is primarily a mathematical formulation to describe the allocation of health resources used by a community, the magnitude of data necessary to manipulate this model is strictly a function of scope of investigation. A hypothetical example of the model's use is given using numbers provided by the developer.

3.4 Input Variables

All input variables are referenced to specific time:

- (1) Number of community members in each population category.
- (2) Quantity of services used in each population category.
- (3) Distribution of community resources used (type of personnel, building space, technological equipment and materials) in producing services.
- (4) Amount and type of service provided.
- (5) Average unit cost of each resource.
- (6) Average unit cost.
- (7) Transitional changes in population makeup.

3.5 Output Variables

- (1) Average unit cost of services based on average unit cost of resources.
- (2) Average annual cost per person of providing health service.
- (3) Projected health service and health resource requirements based on projected variations in population distribution.

3.6 Verification/Applicability/Reliability

Model intended for long-range decision planning. The model has not been exercised with empirical data; its reliability and external validity are unknown.

3.7 Computer Characteristics

None provided in above reference.

4.0 INVENTORY INDICES

This chapter is organized into four sections:

- 4.1 *Model Index by Principal Developer*
- 4.2 *Data Source Index*
- 4.3 *Health Manpower Model Bibliography*
- 4.4 *Input and Output Variables for each Model Category*

4.1 *Model Index by Principal Developer*

This section provides an index to the models in the inventory alphabetically ordered by developer surname. The index also provides a list of model descriptor titles listed under model descriptor 1.1 in the inventory. A model identification code precedes each entry; the page number of the model description in the inventory follows each entry.

MODEL INDEX BY PRINCIPAL DEVELOPER

<u>CODE #</u>	<u>AUTHOR</u>	<u>DESCRIPTIVE TITLE</u>	<u>PAGE #</u>
A1	Abernathy	Nurse Allocation Planning and Scheduling Model	37
A2	Abranovic	Hospital Ancillary Services Planning Model	41
A3	Altman	Present and Future Supply of Registered Nurses	45
A4	Andersen	Behavioral Model of Families Use of Health Services	49
A5	Anderson	Model of Health Status in New Mexico	53
A6	Auster	The Production of Health, An Exploratory Study	57
B1	Baer	Patient Characteristics, Hospital Services, and Length of Stay	61
B2	Baligh	Linear Programming Model to Determine Optimum Mix of Hospital Patients	65
B3	Bennhakker	Prediction of Future Hospital Bed Needs	69
B4	Benham	A Three-Equation Model for the Registered Nurse Labor Market	73
B5	Benham	Migration, Location, and Remuneration of Physicians and Dentists	77
B6	Bognanno	Hours of Labor Offered by the Registered Nurse	81
C1	Connor	A Hospital Inpatient Classification System	85
D1	Dars	Demand for Health and Medical Care: An Econometric Model	89
D2	Deane	Econometric Model of the Market for Nurses	93
E1	Edwards	Model Predicting Population Demands for Medical Services	99

<u>CODE #</u>	<u>AUTHOR</u>	<u>DESCRIPTIVE TITLE</u>	<u>PAGE #</u>
E2	Elesh	Distribution of Physicians in an Urban Area	103
F1	Feldstein, M.	An Aggregate Planning Model of the Health Care Sector	107
F2	Feldstein, M.	The Rising Price of Physician's Services	111
F3	Feldstein, M.	An Econometric Model of the Medicare System	115
F4	Feldstein, P.	Econometric Model for Forecasting and Policy Evaluation in the Dental Sector	119
F5	Feldstein, P.	An Economic Model of Medical Care Sector	123
F6	Fetter	A Language to Aid in Manpower Planning	129
F7	Fitzmaurice	Demand for Hospital Services	133
F8	Fuchs	Expenditures for Physician's Services	137
H1	Hawkins	Physician Distributions	141
H2	Hearn	Simulation of Hospital Medical Care	145
H3	Held	Migration of the 1955-1965 Graduates of American Medical Schools	149
H4	Hixson	Demand and Supply of Professional Hospital Nurses' Services	153
H5	Hopkins	Linear Regression Model - Estimating Hospital Bed Needs in California	157
J1	Jelinek	Allocation of Nursing Time to Patient Care Model	161
K1	Kennedy	Maternal and Child Care Simulation Model	165
L1	Laberge-Nadeau	Model of Patient Care Demands for Nurse Manpower	169

<u>CODE #</u>	<u>AUTHOR</u>	<u>DESCRIPTIVE TITLE</u>	<u>PAGE #</u>
L2	Larmore	An Econometric Production Function Model for Health	173
L3	Latham	Cost of Medical Education	177
L4	Lazarus	Hospital Planning Model	183
M1	Maki	Forecasting Model of Manpower Requirements in the Health Occupations	189
M2	Moss	A Simulated Health Service Queue	193
N1	Navarro	A Markov Model of Medical Care Utilization	197
O1	Ortiz	A Birth-Death Markov Process Model of Mortality Caused by Specific Causes	201
R1	Reinhardt	A Production Function for Physician Services	205
R2	Research Triangle Institute	Health Manpower Requirements Simulation Model	209
R3	Rosenthal	Demand for General Hospital Facilities	217
S1	Scheffler	Geographic Distribution of Physicians and Specialists	221
S2	Shaw	Forecasting Hospital Personnel Availability	225
S3	Shuman	Mathematical Models for Health Manpower Planning	229
S4	Shuman	Optimum Health Manpower Mix Model	235
S5	Singer	Model of the Variation of Patient Categories Within a Hospital	239
S6	Sloan	Three Models on Physician Educational and Occupational Behavior Patterns	243
S7	Sloan	Hospital Demand for Residents	251

<u>CODE #</u>	<u>AUTHOR</u>	<u>DESCRIPTIVE TITLE</u>	<u>PAGE #</u>
S8	Sloan	Short-Run Supply Responses of Professional Nurses	253
T1	Thomas	Demand for Nursing Resources	257
U1	Uyeno	Design of Primary Health Care Teams	261
W1	Wolfe	Multiple Assignment Model for Staffing Nursing Units	265
Y1	Yett	Micro-Simulation Model of Health Manpower	269
Z1	Zemach	Community Health Service Utilization Resource Allocation Model	283

4.2 *Data Source Index*

The Data Source Index presented in this section consists of the data sources identified as having been utilized in the development or verification of the models included in the health manpower model inventory. Additional data sources identified during the literature search are included if they contain the type of data potentially useful for the estimation, verification, or utilization of health manpower and other health-related models. Some of the data sources are one-time publications; others are published annually, biannually, etc. Certain models in the inventory utilize information from data sources which, because of their one-time use or otherwise limited applicability, are not reported here but are listed under descriptor 3.3 (Data Utilized) in the inventory.

DATA SOURCE INDEX

- (1) American Council on Education, Commission on the Survey of Dentistry in the United States, *The Survey of Dentistry*, Washington, D.C., 1961.
- (2) American Dental Association, *The Annual Report on Dental Education 1970-71, Financial Information*, Chicago, 1971.
- (3) American Dental Association, *Directory of Dentists*, Chicago, yearly editions.
- (4) American Dental Association, *Distribution of Dentists in the United States by State, Region, District, and County*, Chicago, 1970.
- (5) American Dental Association, *Journal of the American Dental Association 1914 - , Chicago*.
- (6) American Dental Association, *Survey of Dental Practice*, Chicago, 1950, 1953, 1956, 1959, 1962, 1965, 1968 and 1971 editions.
- (7) American Dental Association, Council on Dental Education, *Annual Report on Dental Auxiliary Education*, Chicago, 1967-68, 1968-69, 1969-70 editions.
- (8) American Dental Association, Council on Dental Education, *Applicants to Dental School in 1967 and previous years*, (unpublished).
- (9) American Dental Association, Council on Dental Education, *Data from Dental Student's Register Questionnaire for 1961-62, and Dental Student's Register, 1959-60 through 1966-67*, (unpublished).
- (10) American Hospital Association, *Annual Survey of Hospital Room Rates*, Chicago, 1951 and 1952.
- (11) American Hospital Association, *Average Daily Service Charges in Hospitals*, Chicago, 1961.
- (12) American Hospital Association, *Hospital Salary Survey, 1960*, Chicago, 1960.
- (13) American Hospital Association, *Hospital Statistics, 1971*, Chicago, 1972.
- (14) American Hospital Association, *Hospitals: Guide Issue*, yearly editions 1949 - .

- (15) American Hospital Association, *Survey of Personnel Turnover in Voluntary Hospitals, 1962, An Abstraction from the Final Report*, Chicago, 1963.
- (16) American Medical Association, *American Medical Directory*, 18th edition, Chicago, 1950, 1958.
- (17) American Medical Association, *Directory of Approved Internships and Residencies, 1971-72*, Chicago, 1971.
- (18) American Medical Association, *Distribution of Physicians, Hospitals and Hospital Beds in the United States*, Chicago, 1963, 1964, 1965, 1966, 1967 editions.
- (19) American Medical Association, *Fact Sheet on Physician Population and Medical Education in the United States*, Chicago, 1968.
- (20) American Medical Association, *Journal of the American Medical Association*, editions 1883 - , Chicago.
- (21) American Medical Association, *Medical School Alumni, 1967*, Chicago, 1968.
- (22) American Medical Association, *National, State, and SMSA Distribution of Physicians in the United States*, Volumes for 1963-1967, Chicago.
- (23) American Medical Association, *The Profile of Medical Practice*, Chicago, 1971 and 1972.
- (24) American Medical Association, Department of Allied Medical Professions and Services, *Allied Medical Education Directory 1969/70*, Chicago, 1971.
- (25) American Medical Association, Department of Economic Research, *Distribution of Physicians in the United States by State, Region, District and County, 1959*, Chicago, 1962.
- (26) American Medical Association, Department of Survey Research, *Foreign Medical Graduates in the United States, 1970*, Chicago, 1971.
- (27) American Medical Association, Department of Survey Research, Special Statistical Series, *Survey of Medical Groups in the United States, 1965*, Chicago, 1968.
- (28) American Nurse's Association, *Facts about Nursing: A Statistical Summary*, New York, 1967, 1968, 1969 editions.
- (29) American Nurse's Association, *LPNs 1967: An Inventory of Licensed Practical Nurses*, New York.

- (30) American Nurse's Association, *The Nation's Nurses: Inventory of Professional Nurses*, New York, 1965.
- (31) American Nurse's Association, *RNs 1966: An Inventory of Registered Nurses*, New York.
- (32) American Nurse's Association, *Survey of Employment Conditions as of January 1, 1966*, New York.
- (33) American Nurse's Association, *Survey of Salaries and Personnel Practices for Teachers and Administrators in Nursing Education Programs, October 1963*, New York, 1964.
- (34) American Nurse's Association, *Survey of Salaries and Personnel Practices in Effect October 1960 for Teachers and Administrators in Nursing Education Programs*, New York, 1961.
- (35) American Osteopathic Association, *A Statistical Study of the Osteopathic Profession*, Chicago, 1968.
- (36) Andersen, R., and Anderson, O. W., *A Decade of Health Services*, the University of Chicago Press, Chicago, 1967.
- (37) "Annual Survey of Buying Power", *Sales Management*, 1964 & 1968.
- (38) Association of American Medical Colleges, "Datagrams: Faculty Salaries, 1964-69," *Journal of Medical Education*, XLIV (April, 1969).
- (39) Association of Personnel Administrators of Greater New York, *Wages and Benefits in Hospitals in Greater New York*, New York, 1965.
- (40) Balfe, B. E., and McNamara, M. E., *Survey of Medical Groups in the US, 1965*, American Medical Association, Chicago, 1968.
- (41) Bureau of Economic Research and Statistics, *Facts about States for the Dentist Seeking a Location, 1970*, American Dental Association, Chicago.
- (42) *California Public Health Statistical Report*, California, 1960.
- (43) *California State Plan for Hospitals, July 1, 1961 to June 30, 1962*, California.
- (44) Carnegie Foundation for Advancement of Teaching, *Bulletin 19-20, 1926-1927*.
- (45) "Changes in the Distribution of Dentists, 1956-1960," *Journal of the American Dental Association*, 63 (Nov. 1961).

- (46) Commission of Professional and Hospital Activities, *Length of Stay in FAS Hospitals, 1963-1964*, McGraw-Hill, New York, 1966.
- (47) Committee on the Grading of Nursing Schools, *Nurses, Patients, and Pocketbooks*, New York, 1928.
- (48) Costa Rica, Direccion General de Estadistica y Censos, *Censos de poblacion, 1963*, San José, 1964.
- (49) Denison, E. F., and A. Slater, "Income in Selected Professions: Part 4, Medical Service," *Survey of Current Business*, 23, (Oct. 1943), Department of Commerce.
- (50) Division of Dental Health, *Second National Survey of Licensed Dentists 1967-70*.
- (51) Haug, J. N., and Roback, Martin, *Distribution of Physicians in the United States, 1970*, American Medical Association, Chicago, 1971.
- (52) Health Insurance Council, Survey Committee, *Report on Annual Survey of Voluntary Health Insurance*, New York, 1960.
- (53) Health Insurance Institute, *Source Book of Health Insurance Data*, New York, 1967 and 1968.
- (54) Interagency Conference on Nursing Statistics.
- (55) Internal Revenue Service, *US Business Tax Returns, July 1960 - June 1961*, Washington, 1963.
- (56) *Journal of the American Veterinary Medical Association*, Vol. 158, February, 1971.
- (57) *Journal of Medical Economics*, various issues, 1923 - .
- (58) *Journal of Medical Education*, spring issues, 1927 - .
- (59) Lasken, H., "Incomes of Dentists and Osteopathic Physicians," *Survey of Current Business*, 19, (April 1939), US Department of Commerce.
- (60) Lea Associates, Inc., "The Current Impact of Medicare on US Private Medical Practice," *National Disease and Therapeutic Index*, Medical Report No. 25, Ambler, Pennsylvania, May 1967.
- (61) Leland, R. G., "Income from Medical Practice," *Journal of the American Medical Association*, 96, (May 16, 1931).
- (62) Leven, M., *The Practise of Dentistry and Incomes of Dentists in Twenty States: 1929*, University of Chicago Press, Chicago, Illinois, 1932.

- (63) Lile, S. and Soule, D. "Interstate Differences in Family Tax Burdens," *National Tax Journal*, XXII, (December, 1969).
- (64) *Manpower Resources in Hospitals, 1966*, Report of a survey conducted by the Bureau of Health Manpower, Public Health Service, United States Department of Health, Education, and Welfare, and the American Hospital Association, June 1967.
- (65) Mattson, D. E., Johnson, D. G., and Sedlacek, W. E., "The Study of Applicants 1966-67," *Journal of Medical Education*, XLIII (January, 1968).
- (66) Mason, H. R., "Manpower Needs by Specialty," *Journal of the American Medical Association*, March 20, 1972.
- (67) Medical Economics, Inc., *Unpublished Questionnaire for the Medical Economics Continuing Survey*, Oradell, New Jersey, 1970.
- (68) Mills, L. W., "Educational Supplement," *Journal of the American Osteopathic Association*, LXIII (January, 1969).
- (69) Moen, B. D., American Dental Association, Bureau of Economic Research and Statistics, "Distribution of Dentists in the United States," *Journal of the American Dental Association*, 39. (Oct. 1949).
- (70) National Academy of Sciences, *New Horizons in Veterinary Medicine*, 1970.
- (71) National Association of Boards of Pharmacy, Annual Proceedings, *Licensure Statistics and Census of Pharmacy*.
- (72) National Center for Educational Statistics, *Associate Degrees and Other Formal Awards Below the Baccalaureate*, US Government Printing Office, Washington, D.C., 1969 and 1971 editions.
- (73) National Center for Health Statistics, *Development and Maintenance of a National Inventory of Hospitals and Institutions*, (Public Health Service Publication No. 1000 - Series 1, No. 3:), US Government Printing Office, Washington, D.C., 1965.
- (74) National Center for Educational Statistics, *Digest of Educational Statistics - 1969 Edition*, US Government Printing Office, Washington, D.C., September 1969.
- (75) National Center for Educational Statistics, *Earned Degrees Conferred: 1967-68*, US Government Printing Office, Washington, D.C., June 1969.
- (76) National Center for Health Statistics, *Health Interview Survey, 1968*.

- (77) National Center for Health Statistics, *Health Resources Statistics, 1971*, Public Health Service Publication No. 1509, 1972.
- (78) National Center for Health Statistics, *Hospital Discharge Survey, 1965*.
- (79) National Center for Health Statistics, *Patients Discharged from Short-Stay Hospitals by Size and Type of Ownership, United States 1965*, Public Health Service Publication No. 1000 - Series 13, No. 4., US Government Printing Office, Washington, D.C., 1968.
- (80) National Center for Health Statistics, *Pharmacy Manpower: United States 1966*, Series 14, No. 2.
- (81) National Center for Health Statistics, *Unpublished Questionnaire for the 1968 Nursing and Personal Care Facilities Survey*, Rockville, Maryland, August 31, 1968.
- (82) National Center for Health Statistics, *Unpublished Questionnaire for the 1969 Annual Survey of Hospitals*, Rockville, Maryland, November, 1969.
- (83) National Center for Health Statistics, *Unpublished Questionnaire for the 1969 Health Interview Survey*, Rockville, Maryland, October 17, 1969.
- (84) National Center for Health Statistics, *Unpublished Questionnaire for the 1969 Survey of Long-Term Care Facilities*, Rockville, Maryland, August 31, 1969.
- (85) National Center for Health Statistics, *Vision and Eye Care Manpower Survey*.
- (86) National Center for Health Statistics, *Volume of Physician Visits*, National Center for Health Statistics, Series 10, No. 18, 1965.
- (87) National Center for Health Statistics, *Survey of Podiatrists, 1970*.
- (88) National Center for Health Statistics, *Vital and Health Statistics, Health Insurance Coverage: US - July 1962 - June 1963*, US Department of Health, Education, and Welfare, Series 10, No. 11, August 1964.
- (89) National Center for Health Statistics, *Vital and Health Statistics, Persons Hospitalized by Number of Hospital Episodes and Days in a Year: US - July 1960 - June 1962*, US Department of Health, Education and Welfare, Series 10, Number 20, 1965.
- (90) National Education Association, *Biennial Survey of Salary Statistics of Public Schools, 1966 - 1969*.

- (91) National Education Association, *National Education Association Research Bulletin*, yearly editions 1947-1957.
- (92) National League for Nursing, *The Nurse Career-Pattern Study, Biographical Data Reported by Entering Students Fall 1967*, New York, 1969.
- (93) National League for Nursing, *Nurse-Faculty Census*, biennial editions, New York, 1964-1970.
- (94) National League for Nursing, *Report of Applicants and Facilities in Basic Programs of Nursing, 1965-1966*, unpublished manuscript, 1966.
- (95) National League for Nursing, *State Approved Schools of Nursing - RN*, (annual editions), New York, 1959 - .
- (96) National League for Nursing, *Statistical Data: Associate Degree Programs in Nursing*, The League, Department of Associate Degree Programs, New York, 1967.
- (97) National League for Nursing, *Study on Cost of Nursing Education, Part 1*, New York, 1965.
- (98) National League for Nursing, *Survey of Nursing Student Financing 1969-1970*, New York.
- (99) New York City Department of Hospitals, Division of Nursing Education and Nursing Service, *1966 Final Annual Report*, New York.
- (100) New York State Department of Commerce, *Business Fact Book 1963*, Part 2, New York.
- (101) New York State Medical Society, *Medical Directory*, 1968.
- (102) Office of Education of the American Osteopathic Association, *Educational Supplement*, January 1972, Vol. 24, No. 1, and January 1971, Vol. 23, No. 1.
- (103) Pennell, "Podiatric Education and Manpower," *Journal of the American Podiatry Association*, Vol. 1, No. 2, June 1970.
- (104) Pennell, *Statistics in Physicians 1950-63*, Public Health Reports, No. 79, October 1964.
- (105) Pennell; DeLong, "Optometric Education and Manpower," *Journal of the American Optometric Association*, Vol. 41, No. 11, November 1971.
- (106) Pennell; Eyestone, *Veterinary Medical Education and Manpower*, (unpublished).

- (107) Pennell; Renshaw, "Distribution of Women Physicians, 1970," *Journal of the American Medical Women Association*, Vol. 27, No. 4.
- (108) "Salaries of Professional Registered Nurses," *American Journal of Nursing*, L, June, 1950.
- (109) Scottish Home and Health Department, *Scottish Hospital Inpatient Statistics, 1965*, Edinburgh, 1967.
- (110) Tate, B. L., and Knopf, L., *Nurse Career-Pattern Study, Part 1: Practical Nursing Programs*, No. 19-1335, National League for Nursing, New York, 1968.
- (111) Theodore, C. N., et al, *Reclassification of Physicians, 1968: New Base for Health Manpower Studies*, American Medical Association, Chicago, 1971.
- (112) Theodore, C. N., and Haug, J. N., *Selected Characteristics of the Physician Population, 1963 and 1967*, Special Statistical Series, American Medical Association, 1968.
- (113) US Department of Commerce, *Survey of Current Business*, National Income Issues, 1967 and 1968, 1971.
- (114) US Department of Commerce, Bureau of the Census, *Government Finances*, Annual Report.
- (115) US Department of Commerce, US Bureau of the Census, *United States Census of Population, 1940, 1950 and 1960*, US Government Printing Office, Washington, D.C.
- (116) US Department of Commerce, *Projections of School and College Enrollment 1971 to 2000*, Current Population Reports, Series P-25, No. 475, January 1972.
- (117) US Department of Commerce, *Statistical Abstract of the United States*, yearly editions 1956 - , US Government Printing Office, Washington, D.C.
- (118) US Department of Commerce, *US Census of Population, 1960: Subject Reports, Characteristics of Professional Worker*, Final Report, PC(2)-7E, US Government Printing Office, Washington, D.C. 1964.
- (119) US Department of Commerce, *US Census of Population, 1960: US Summary - Detailed Characteristics*, Final Report, PC(1)-10, US Government Printing Office, Washington, D.C. 1963.
- (120) US Department of Health, Education and Welfare, *Health Manpower Perspective: 1967*, Public Health Service Publication, US Government Printing Office, Washington, D.C., 1967.

- (121) US Department of Health, Education, and Welfare, *Health Resource Statistics*, Public Health Service Publication No. 1509, 1969 edition.
- (122) US Department of Health, Education, and Welfare, Office of Education, *Digest of Educational Statistics*, US Government Printing Office, Washington, D.C. 1963.
- (123) US Department of Health, Education, and Welfare, "Operating Statistics," *Social Security Bulletin*, 31, April, 1968.
- (124) US Department of Health, Education, and Welfare, *Progress Report on Nurse Training, 1970*, US Government Printing Office, Washington, D.C., 1970.
- (125) US Department of Health, Education, and Welfare, *Report on Licensure and Related Health Personnel Credentialing*, DHEW Publication No. (HSM) 72-11, 1971.
- (126) US Department of Health, Education, and Welfare, *A Report to the President on Medical Care Prices*, US Government Printing Office, Washington, D.C., 1967.
- (127) US Department of Health, Education, and Welfare, Office of Research and Statistics, *Research and Statistics Note*, Note No. 13, August 1, 1969.
- (128) US Department of Health, Education, and Welfare, Public Health Service, Division of Nursing, *Nursing Personnel in Hospitals - 1968*, US Government Printing Office, Washington, D.C., May 1970.
- (129) US Department of Health, Education, and Welfare, Public Health Service, Division of Nursing, *Toward Quality in Nursing: Needs and Goals*, Report of the Surgeon General's Consultant Group on Nursing, US Government Printing Office, Washington, D.C. 1963.
- (130) US Department of Health, Education, and Welfare, Public Health Service, *Health Manpower in Hospitals*, Washington, D.C., 1970.
- (131) US Department of Health, Education, and Welfare, Public Health Service, *Report of the Health Subcommittee of the Department Task Force on Manpower Requirements and Training Programs*, Washington, D.C.
- (132) US Department of Health, Education, and Welfare, Public Health Service, National Institutes of Health, Bureau of Health Manpower Education, Division of Manpower Intelligence, *Selected State and Regional Reports on Allied Health Manpower Supply and Requirements*, Report No. 73-55, November, 1972.

- (133) US Department of Labor, Bureau of Labor Statistics, *Area Wage Study, Hospitals, Selected Years 1956-69*, US Government Printing Office, Washington, D.C.
- (134) US Department of Labor, Bureau of Labor Statistics, *Consumer Expenditures and Income, Reports 237-34-38*, US Government Printing Office, Washington, D.C., July, 1964.
- (135) US Department of Labor, Bureau of Labor Statistics, *Consumer Price Index*, US Government Printing Office, Washington, D.C.
- (136) US Department of Labor, Bureau of Labor Statistics, *The Economic Status of Registered Professional Nurses, 1946-47*, BLS Bulletin No. 931, US Government Printing Office, Washington, D.C., 1948.
- (137) US Department of Labor, Bureau of Labor Statistics, *Handbook of Labor Statistics, 1968*, US Government Printing Office.
- (138) US Department of Labor, Bureau of Labor Statistics, *Health Manpower 1966-76: A Study of Requirements and Supply*, Washington, D.C., 1967.
- (139) US Department of Labor, Bureau of Labor Statistics, *Industry Wage Survey, Hospitals*, Mid 1963 (No. 1409, June, 1964) and July 1966 (No. 1553, June, 1967).
- (140) US Public Health Service, *Health Manpower Source Book, Sections 1-20*, Public Health Service Publication No. 263, US Government Printing Office, Washington, D.C.
- (141) US Public Health Service, *United States Statistics on Medical Economics*, Public Health Service Publication No. 1125, US Government Printing Office, Washington, D.C., 1964.
- (142) US Public Health Service, *Volume of Dental Visits, US, July 1963 - June 1964*, US Public Health Service Series 10, No. 23, US Government Printing Office, Washington, D.C., 1964.
- (143) US Public Health Service, Bureau of Health Manpower, *Manpower Resources in Hospitals, 1966*, US Public Health Service, Bureau of Health Manpower, Department of Health, Education, and Welfare, and the American Hospital Association, Chicago, 1967.
- (144) US Public Health Service, Division of Nursing, *Nurses in Public Health*, biennial editions, 1960 - .
- (145) US Public Health Service, Division of Nursing, *Planning for Nursing Needs and Resources*, Department of Health, Education, and Welfare Publication No. (NIH) 72-87, 1972.

- (146) US Senate Committee on Labor and Public Welfare, *Health Insurance Plans in the United States*, Senate Report 359, 82nd Congress, First Session, Part I, US Government Printing Office, Washington, D.C., 1951.
- (147) US Social Security Administration, Office of Research and Statistics, "Current Medicare Survey Report," *Health Insurance Statistics*, No. CMS-12, January 27, 1970.
- (148) US Social Security Administration, Office of Research and Statistics, "Utilization of Short-Stay Hospitals Under Medicare," by I. L. Hellman, *Health Insurance Statistics*, No. HI-12, February 28, 1969.
- (149) Weddige, Dorothy, *Unpublished Personnel Data from the Division of Nursing Service*, New York City Department of Hospitals, 1965.
- (150) Weinfeld, W., "Income of Dentists, 1929-48," *Survey of Current Business*, 30 (Jan. 1950), US Department of Commerce.
- (151) Weinfeld, W., "Incomes of Physicians, 1929-49," *Survey of Current Business*, 31 (July 1951), US Department of Commerce.
- (152) West, Margaret D., *Basic Professional Nurses - Graduates*, US Public Health Service, Division of Nursing, January 10, 1963, unnumbered, (processed).
- (153) World Health Organization, *World Directory of Dental Schools*, Geneva, 1961.
- (154) Yett, Donald E., *An Economic Analysis of the Nurse Shortage*, (Forthcoming).

4.3 *Health Manpower Model Bibliography*

The Health Manpower Model Bibliography consists of the references used to develop the information provided in the health manpower model inventory, plus publications identified during the literature search that are relevant to health manpower modeling, but were not used in the model inventory development. The inclusion of these additional publications is intended to provide the reader interested in health manpower modeling with background material in the area, and to provide reference to other health-related studies. For example, some of these references are well-known manpower studies (e.g., Fein 1967, M. Feldstein 1968), while others are models or analytic studies of areas on the periphery of health manpower that were not sufficiently relevant or did not contain enough information to be included in the inventory (e.g., Au, Parti and Wong 1971, Dowling 1971, Grossman 1972, Williams 1967 and Wilson 1972). Still others are health manpower studies which do not contain analytical components, but which are relevant to health manpower planning (e.g., Baker and Perlman 1967, Hall 1969, Kehrer 1970, and Stevens and Brown 1971). The subsequent pages present a list of the references to the cataloged models, as indicated by a suffix (C), and the additional background reference material identified in this study.

HEALTH MANPOWER MODEL BIBLIOGRAPHY

Abernathy, Baloff, Hershey & Wandel, 1972 (C)

Abernathy, William J., Baloff, Nicholas, Hershey, John C., Wandel, Sten, *A Three-Stage Manpower Planning and Scheduling Model -- A Service Sector Example*, Graduate School of Business, Stanford University, September 1972.

Abernathy & Hershey, 1972

Abernathy, William J., and Hershey, John C., "A Spatial-Allocation Model for Regional Health-Services Planning," *Operations Research*, Vol. 20, No. 3, May-June 1972.

Abranovic, 1969 (C)

Abranovic, Wynn A., *A Computer Simulation Approach for Planning in Hospital Ancillary Services*, PhD Dissertation, Rensselaer Polytechnic Institute, 1969, UMI 70-11,310.

Altman, 1971 (C)

Altman, Stuart H., *Present and Future Supply of Registered Nurses*, DHEW Publication Number (NIH) 72-134, US Department of Health, Education and Welfare, November, 1971.

Andersen, 1968 (C)

Andersen, Ronald, "A Behavioral Model of Health Service Use," *A Behavioral Model of Families' Use of Health Services*, University of Chicago Research Series No. 25, Center for Health Administration Studies, 1968.

Anderson, 1972 (C)

Anderson, James G., "Causal Model of a Health Services System," *Health Services Research*, Spring 1972.

Au, Parti & Wong, 1971

Au, Tung, Parti, E. W., and Wong, A. K. C., *Hospital System Design Simulation*, NTIS PB 201 132, 1971.

Auster, Leveson & Sarachek, 1969 (C)

Auster, Richard, Leveson, Irving, and Sarachek, Deborah, "The Production of Health, An Exploratory Study," *The Journal of Human Resources*, Vol. IV, No. 4, 1969.

Baer, 1971 (C)

Baer, Ronald R., *Patient Characteristics, Hospital Services and Length of Stay: A Pilot Study*, PhD Dissertation, The University of Minnesota, 1971, UMI 07830 HE.

Baker & Perlman, 1967

Baker, Timothy D. and Perlman, Mark, *Health Manpower in a Developing Economy: Taiwan, A Case Study in Planning*, Johns Hopkins Press, Baltimore, Maryland 1967.

Baligh & Laughhunn, 1969 (C)

Baligh, Helmy H. and Laughhunn, Danny J., "An Economic and Linear Model of the Hospital," *Health Services Research*, Vol. 4, No. 4, 1969.

Beenhakker, 1963 (C)

Beenhakker, Henri, "Multiple Correlation - A Technique for Prediction of Future Hospital Bed Needs," *Operations Research*, Vol. 11, No. 5, September-October, 1963.

Benham, 1970 (C)

Benham, Lee K., *An Economic Analysis of the Labor Market for Registered Nurses*, PhD Dissertation, Stanford University, 1970, UMI 71-12,850.

Benham, 1971 (C)

Benham, Lee, "The Labor Market for Registered Nurses: A Three-Equation Model," *Review of Economics and Statistics*, Vol. LIII, No. 3, August, 1971.

Benham, Maurizi & Reder, 1968 (C)

Benham, Lee, Maurizi, A. and Reder, M. W., "Migration, Location and Remuneration of Medical Personnel, Physicians, and Dentists," *Review of Economics and Statistics*, Vol. L, No. 3, August, 1968.

Bognanno, 1969 (C)

Bognanno, Mario Frank, *An Economic Study of the Hours of Labor Offered by the Registered Nurse*, PhD Dissertation, The University of Iowa, 1969, UMI 69-21,669.

Cameron, Shah & Pisirchia, 1972 (C)

Cameron, K.R., Shah, B.V. and Pisirchia, P.V., *Estimation of Parameters for POPSIM Model*, Technical Report #2, Prepared for the Bureau of Health Manpower Education, National Institutes of Health, December 1972.

Chen, 1972

Chen, Milton Men-lang, *A General Approach to Health System Modeling*, PhD Dissertation, New York University, Graduate School of Business Administration, 1972, UMI 72-32,745.

Colley, Hallan & Packer, 1967

Colley, John L., Hallan, Jerome B. and Packer, Arnold H., *A Simulation Model of a Saturated Medical System*, Proceedings of the Conference of the American Institute of Industrial Engineers, 1967.

Connor, 1960 (C)

Connor, R. J., *A Hospital Inpatient Classification System*, PhD Dissertation, Johns Hopkins University, 1960, UMI 60-3319.

Connor, Flagle, Hsieh, Preston & Singer, 1961

Connor, Robert J., Flagle, Charles D., Hsieh, Richard K.C., Preston, Ruth A. and Singer, Sidney, "Effective Use of Nursing Resources," *Hospitals*, May 1961.

Cooley & Jones, 1972 (C)

Cooley, P.C. and Jones, D.C., *Estimation of Parameters for HOMAN Model*, Technical Report #4, Prepared for the Bureau of Health Manpower Education, National Institutes of Health, December, 1972.

Dars, 1971 (C)

Dars, Lewis, *The Demand for Health and the Demand for Medical Care: An Econometric Model*, PhD Dissertation, New School for Social Research, 1971, UMI 72-4030

Davey, 1970

Davey, John M., *Impact of Medicare and Medicaid on Existing Health Facilities*, Working Paper Series S7001, Systems Analysis Program, The Graduate School of Management, The University of Rochester, May, 1970.

Davis & Russell, 1972

Davis, Karen and Russell, Louise B., "The Substitution of Hospital Outpatient Care for Inpatient Care," *The Review of Economics and Statistics*, Vol. LIV, No. 2, May 1972.

Deane, 1971 (C)

Deane, Robert T., *Simulating an Econometric Model of the Market for Nurses*, PhD Dissertation, UCLA, 1971, UMI 72-13,601.

Dowling, 1971

Dowling, William L., *A Linear Programming Approach to the Analysis of Hospital Production*, PhD Dissertation, The University of Michigan, 1971, UMI 71-23,741.

Edwards, 1972 (C)

Edwards, Sam A., *Toward a Health Services Simulation: Second Interim Report*, National Center for Health Services Research and Development, Grant No. HS-0314, March 1, 1972.

Edwards, 1972 (C)

Edwards, Sam A., *A Health Services Simulator: A Report*, National Center for Health Services Research and Development, Grant No. HS00314, November 1, 1972.

Elesh & Lazarz, 1972 (C)

Elesh, David and Lazarz, Joanne, "Race and Urban Medicine: A Replication and Extension," Institute for Research on Poverty at the University of Wisconsin, March, 1972.

Elesh & Schollaert, 1972 (C)

Elesh, David and Schollaert, Paul T., "Race and Urban Medicine: Factors Affecting the Distribution of Physicians in Chicago," *Journal of Health and Social Behavior*, September 1972.

Fabrega, 1972

Fabrega, Horatio Jr., *Towards a Model of Illness Behavior*, Unpublished paper, Michigan State University, 1972.

Fein, 1967

Fein, Rashi, *The Doctor Shortage: An Economic Analysis*, The Brookings Institution, Washington, D.C., 1967

Feldstein, M., 1967 (C)

Feldstein, Martin S., "An Aggregate Planning Model of the Health Care Sector," *Medical Care*, Vol. V, No. 6, November-December 1967.

Feldstein, M., 1968

Feldstein, Martin S., *Economic Analysis for Health Service Efficiency*, Markham Publishing Company, Chicago, 1968.

Feldstein, M., 1970 (C)

Feldstein, Martin S., "The Rising Price of Physicians' Services," *The Review of Economics and Statistics*, Vol. LII, No. 2, May 1970.

Feldstein, M., 1971 (C)

Feldstein, Martin S., "An Econometric Model of the Medicare System," *The Quarterly Journal of Economics*, Vol. LXXXV, No. 1, February, 1971.

Feldstein, M., 1971

Feldstein, Martin S., "Hospital Cost Inflation: A Study of Nonprofit Price Dynamics," *American Economic Review*, December 1971.

Feldstein, M., 1973

Feldstein, Martin S., "Econometric Studies of Health Economics," Discussion Paper Number 291, Harvard Institute of Economic Research, Harvard University, Cambridge, Massachusetts, April, 1973.

Feldstein, P., 1972 (C)

Feldstein, Paul J., *Financing Dental Care: An Economic Analysis*, Unpublished paper, August, 1972.

Feldstein, P. & German, 1965

Feldstein, Paul J. and German, Jeremiah J., "Predicting Hospital Utilization: An Evaluation of Three Approaches," *Inquiry*, Vol. 2, No. 1, June, 1965.

Feldstein & Kelman, 1972 (C)

Feldstein, Paul J. and Kelman, Sander, *An Econometric Model of the Medical Care Sector: A Description of the Model and Illustrative Application*, Bureau of Hospital Administration, School of Public Health, University of Michigan, August 1972.

Fetter & Mills, Undated (C)

Fetter, Robert B. and Mills, Ronald E., *A Language to Aid in Manpower Planning*, Unpublished paper, Puter Associates, Inc., New Haven, Connecticut.

Fetter & Thompson, 1965

Fetter, R. B. and Thompson, J. D., "The Simulation of Hospital Systems," *Operations Research*, September-October, 1965.

Fitzmaurice, 1972 (C)

Fitzmaurice, James M., *The Demand for Hospital Services: An Econometric Study of Maryland Counties*, PhD Dissertation, The University of Maryland, 1972, UMI 72-18,947.

Fottler, 1970

Fottler, Myron David, *Manpower Substitution in the Hospital Industry: An Exploratory Study of the New York City Voluntary and Municipal Hospital Systems*, PhD Dissertation, Columbia University, 1970, NTIS PB 197 740.

Fuchs & Kramer, 1972 (C)

Fuchs, Victor R. and Kramer, Marcia J., *Determinants of Expenditures for Physicians' Services in the United States 1948-68*, DHEW Publication No. (HSM) 73-3013, December, 1972.

Grossman, 1972

Grossman, Michael, "On the Concept of Health Capital and the Demand for Health," *Journal of Political Economy*, Vol. 80, No. 2, March/April, 1972.

Gupta, Zoreda & Kramer, 1971

Gupta, Ishwar, Zoreda, Juan and Kramer, Nathan, "Hospital Manpower Planning by Use of Queueing Theory," *Health Services Research*, Spring, 1971.

Hall, 1969

Hall, Thomas L., *Health Manpower in Peru: A Case Study in Planning*, Johns Hopkins Press, Baltimore, Maryland, 1969.

Hardison, 1968

Hardison, Jasper H., Jr., *A Simulation Model of a Hospital System Under "Management by Fiscal Information"*, M.S. Thesis, Georgia Institute of Technology, 1968, UMI MN 3068.

Hartwell, Batto & Clayton, 1972 (C)

Hartwell, T.D., Batto, J.R., and Clayton, C.A., *Estimation of Parameters for HOSPEP Model*, Technical Report #3, Prepared for the Bureau of Health Manpower Education, National Institutes of Health, December, 1972.

Hawkins, 1969 (C)

Hawkins, Charles Jr., *The Econometrics of Physician Distributions*, Working Paper Series S6905, Systems Analysis Program, The Graduate School of Management, The University of Rochester, 1969.

Hearn & Bishop, 1970 (C)

Hearn, Catherine Rhys, PhD and Bishop, J. M., MD, DSc, FRCP, "Computer Model Simulating Medical Care in Hospitals," *British Medical Journal*, No. 3, 1970.

Held, 1973 (C)

Held, Philip J., *The Migration of the 1955-1965 Graduates of American Medical Schools*, PhD Dissertation, University of California at Berkeley, 1973.

Hershey, Abernathy & Baloff, 1972 (C)

Hershey, J. C., Abernathy, W. J. and Baloff, N., *Comparison of Nurse Allocation Policies - A Monte Carlo Model*, Graduate School of Business, Stanford University, August 1972.

Hixson, 1969 (C)

Hixson, Jesse S., *The Demand and Supply of Professional Hospital Nurses: Intra-Hospital Resource Allocation*, PhD Dissertation, Michigan State University, 1969, UMI 69-16,146.

Hopkins, et al, 1967 (C)

Hopkins, Carl E., et al, *Methods of Estimating Hospital Bed Needs*, USPHS Grant No. AP-04,03c, The University of California, Los Angeles, California, 1967, UMI HE 1094.

Horowitz, 1972

Horowitz, Dr. M. A., *Restructuring Paramedical Occupations*, Northeastern University, Department of Economics, Boston, Massachusetts, January, 1972.

Horvitz, Giesbrecht, Shah & Lachenbruch, 1969 (C)

Horvitz, D. G., Giesbrecht, F. G., Shah, B. V. and Lachenbruch, P. A., *Popsim, A Demographic Microsimulation Model*, Paper presented at the International Union for the Scientific Study of Population, General Conference, London, September 1969.

Horvitz, Shah, Hartwell, Jones & Cooley, 1972 (C)

Horvitz, D.G., Shah, B.V., Hartwell, T.D., Jones, D.C. and Cooley, P.C., *Ten Year Projections of US Manpower Requirements for Short Term General Hospitals in Five Personnel Categories*, Prepared for the Bureau of Health Manpower Education, National Institutes of Health, December, 1972.

Human Resources Research Center, 1972 (C)

Human Resources Research Center of the University of Southern California, Research Institute for Business and Economics, *Implementation of Micro-Simulation Model of Health Manpower Demand and Supply*, Quarterly Progress Reports to Division of Health Manpower Intelligence on US Public Health Service Contract No. NIH 71-4065, May 31, 1972, August 31, 1972, December 1, 1972.

Ingbar & Taylor, 1968

Ingbar, Mary Lee and Taylor, Lester D., *Hospital Costs in Massachusetts: An Econometric Study*, Harvard University Press, Cambridge, Massachusetts, 1968.

Jelinek, 1964 (C)

Jelinek, Richard C., *Nursing: The Development of an Activity Model*, PhD Dissertation, University of Michigan, 1964, UMI 65-5912.

Jelinek, 1967 (C)

Jelinek, Richard C., "A Structural Model for the Patient Care Operation," *Health Services Research*, Vol. 2, No. 3, Fall-Winter, 1967.

Kehrer, 1970

Kehrer, Barbara Holtz, *The Nursing Shortage and Public Policy: An Economic Analysis of the Demand for Hospital Nurses in Connecticut*, PhD Dissertation, Yale University, 1970, UMI 70-25,100.

Kennedy, 1968 (C)

Kennedy, F. D., *The Development of a Simulation Model of a Community Health Service: Volume I, Introduction and Summary*, Research Triangle Institute, North Carolina, 1968, UMI AR 1030.

Kennedy, Gentry & Packer, 1968 (C)

Kennedy, F. D., Gentry, J. T. and Packer, A. H., *The Development of a Simulation Model of a Community Health Service System: Volume II, The Health Service System*, Research Triangle Institute, North Carolina, 1968, UMI AR 1031.

Kennedy & Woodside, 1968 (C)

Kennedy, F. D. and Woodside, M. B., *The Development of a Simulation Model of a Community Health Service System: Volume III, The Maternal and Infant Care Simulation Model*, Research Triangle Institute, North Carolina, 1968, UMI AR 1032.

Kennedy, 1969 (C)

Kennedy, F. D., *The Maternal and Infant Care Simulation Model*, Paper read at the joint national meeting of the American Astronautical Society and the Operations Research Society, Denver, June, 1969, UMI OB 0059.

Kennedy, 1970 (C)

Kennedy, F. D., *Simulation of Health Manpower Requirements*, Research Triangle Institute, Operations Research and Economics, Division, North Carolina, 1970.

Kilpatrick, Mackenzie & Delaney, 1972

Kilpatrick, Kerry E., Mackenzie, Richard S. and Delaney, Allen G., *A Computer Simulation of Expanded Function Auxiliaries in General Dentistry*, Unpublished report, University of Florida, Gainesville, Florida, 1972.

Klarman, 1969

Klarman, Herbert E., "Economic Aspects of Projecting Requirements for Health Manpower," *Journal of Human Resources*, Vol. IV, No. 3, Summer 1969.

Klarman, 1970 (C)

Klarman, Herbert E., *Empirical Studies in Health Economics*, Proceedings of the Second Conference on the Economics of Health, The Johns Hopkins Press, Baltimore, Maryland, 1970.

Laberge-Nadeau & Feuvrier, 1972 (C)

Laberge-Nadeau, Claire and Feuvrier, Marie, "Nursing Staff Utilization," *Canadian Hospital*, May 1972.

Laberge-Nadeau & Feuvrier, 1972 (C)

Laberge-Nadeau, Claire and Feuvrier, Marie, "Utilization of a MEDSIM Program in a task study of Nursing Staff," *Canadian Hospital*, May 1972.

Larmore, 1967 (C)

Larmore, Mary Lou, *An Inquiry into an Econometric Production Function for Health in the United States*, PhD Dissertation, Northwestern University, 1967, UMI 68-3200.

Latham, 1971 (C)

Latham, Robert J., *The Cost of Medical Education: An Empirical Analysis of Production Costs and Optimal Output Mixes in a Medical College*, PhD Dissertation, The University of Iowa, 1971, UMI 71-22,054.

Lazarus, 1970 (C)

Lazarus, Steven S., *Hospital Facilities Utilization as a Function of Patient Age, Sex and Admitting Service*, Working Paper Series S7023, Systems Analysis Program, The Graduate School of Management, The University of Rochester, 1970.

Lazarus, 1972 (C)

Lazarus, Steven S., *A Linear Hospital Planning Model*, Working Paper Series S7135, Systems Analysis Program, The Graduate School of Management, The University of Rochester, 1972.

Lindsay, 1968

Lindsay, C. M., *Supply Response to Public Financing of Medical Care in the United States*, PhD Dissertation, The University of Virginia, 1968, UMI 68-18,219.

McKnight & Steorts, 1969

McKnight, E. M. and Steorts, R. C., *Nursing Home Simulation Model Final Report*, Consolidated Analysis Centers, Inc., June 1969, NTIS PB 190 795.

Maki, 1967 (C)

Maki, Dennis, *A Forecasting Model of Manpower Requirements in the Health Occupations*, PhD Dissertation, Iowa State University, 1967, UMI 68-5964.

Milly, 1970

Milly, George H., *A Computer Simulation Model for Evaluation of the Health Care Delivery System*, June 1970, NTIS PB 195 132.

Moss, 1970 (C)

Moss, John H., *A Simulated Health Service Node: A Building-Block Approach to Health Systems Simulation*, The Center for the Environment and Man, Inc., Hartford, Connecticut, CEM-1251-406, June, 1970.

Moyer, 1972

Moyer, M.E., *Estimating the Cost and Distributional Effects of National Health Insurance Proposals*, Unpublished paper, September 20, 1972.

Nadler & Sahney, 1969

Nadler, Gerald and Sahney, Vinod, "A Descriptive Model of Nursing Care," *American Journal of Nursing*, February, 1969.

Nathan, 1970

Nathan, Robert R., *Transferability of Military-Trained Medical Personnel to the Civilian Sector*, July 1970, NTIS PB 192 690.

National Center for Health Statistics, 1966

National Center for Health Statistics, *Computer Simulation of Hospital Discharges*, Public Health Service Publication No. 1000, Series 2, No. 13, February 1966.

Navarro, 1969 (C)

Navarro, Vicente, MD, DMSA, Dr. PH, "Planning Personal Health Services: A Markovian Model," *Medical Care*, May-June 1969.

Navarro, 1969 (C)

Navarro, Vicente, "A Systems Approach to Health Planning," *Health Services Research*, Summer, 1969.

Navarro & Parker, Undated (C)

Navarro, Vicente and Parker, Rodger, *A Mathematical Model for Health Planning: Prediction, Simulation and Goal Seeking*, The Department of Medical Care and Hospitals, The School of Hygiene, The Johns Hopkins University, Baltimore, Maryland, Undated.

Navarro, Parker & White, 1970 (C)

Navarro, Vicente, Parker, Rodger and White, Kerr L., "A Stochastic and Deterministic Model of Medical Care Utilization," *Health Services Research*, Summer 1969.

Newhouse & Sloan, 1971

Newhouse, Joseph P. and Sloan, F. A., *A Model of Physician Pricing: Comment and Reply*, The RAND Corporation P-4011-2, February, 1971.

Ortiz & Parker, 1971 (C)

Ortiz, Jorge and Parker, Roger, "A Birth-Life-Death Model for Planning and Evaluation of Health Services Programs," *Health Services Research*, Vol. 6, No. 2, Summer 1971.

Packer, 1969 (C)

Packer, A. H., *Modeling the Community Health Service System*, Paper read at the joint national meeting of the American Astronautical Society and Operations Research Society, 1969, UMI MN 2043.

Parker, 1968

Parker, William R., *A Review of Epidemiological Data, Data Systems, and Sources for Estimating Nurse Requirements for Short Stay Hospitals*, 12 August 68, NTIS PB 179 345.

Reinhardt, 1970 (C)

Reinhardt, U. E., *An Economic Analysis of Physicians Practices*, PhD Dissertation, Yale University, 1970, UMI 71-48.

Reinhardt, 1972 (C)

Reinhardt, U., "A Production Function for Physician Services," *The Review of Economics and Statistics*, Vol. LIV, No. 1, February, 1972.

Reinhardt & Yett, 1971

Reinhardt, Uwe E. and Yett, Donald E., "Physician Production Functions under Varying Practice Arrangements," Community Profile Data Center, Technical Paper No. 11, January, 1971 (Revised August, 1972).

Report of the Commission on the
Cost of Medical Care, 1964

Report of the Commission on the Cost of Medical Care, The American Medical Association, Volume 1, Chicago, June 1964.

Research Triangle Institute, 1972 (C)

Research Triangle Institute, *Simulation of Hospital Utilization and Health Manpower Requirements*, Volumes 1, 11, Technical Report #1, Prepared for the Bureau of Health Manpower Education, National Institutes of Health, December 1972.

Revzan, 1971

Revzan, Lawrence H., *Evaluation of Data Resources for Planning Allied Health Manpower Needs*, August 1971.

Rimlinger & Steele, 1963

Rimlinger, Gaston V. and Steele, Henry B., "An Economic Interpretation of the Spatial Distribution of Physicians in the US," *Southern Economic Journal*, Vol. 30, No. 1, July, 1963.

Rosenthal, 1964 (C)

Rosenthal, Gerald D., *The Demand for General Hospital Facilities*, Hospital Monograph Series No. 14, 1964.

Scheffler, 1971 (C)

Scheffler, Richard M., *An Empirical Investigation into the Geographic Distribution of Physicians and Specialists*, PhD Dissertation, The New York University, 1971, UMI 71-24,766.

Shah, 1972 (C)

Shah, B. V., *User's Manual for POPSIM*, Prepared for National Center for Health Statistics, US Department of Health, Education, and Welfare, Contract HSM 110-70-334, June, 1972.

Shaw, 1967 (C)

Shaw, David R., *Mathematical Models for Forecasting Hospital Personnel Availability*, M.S. Thesis, Georgia Institute of Technology, 1967, UMI PE 0058.

Shonick, 1970

Shonick, William, "A Stochastic Model for Occupancy-Related Random Variables in General-Acute Hospitals," *Journal of the American Statistical Association*, Applications Section, Vol. 65, No. 332, December 1970.

Shuman, 1969 (C)

Shuman, Larry J., *Mathematical Models for Health Manpower Planning*, PhD Dissertation, The Johns Hopkins University, Baltimore, Maryland, 1969.

Shuman, Young & Naddor, 1971 (C)

Shuman, Larry J., Young, John P. and Naddor, Eliezer, "Manpower Mix for Health Services: A Prescriptive Regional Planning Model," *Health Services Research*, Vol. 6, No. 2, Summer 1971.

Shuman, Wolfe & Hardwick, 1972

Shuman, Larry J., Wolfe, Harvey and Hardwick, C. Patrick, "Predictive Hospital Reimbursement and Evaluation Model," *Inquiry*, Vol. IX, No. 2, 1972.

Shuman, Wolfe & Speas, 1972

Shuman, Larry J., Wolfe, Harvey and Speas, R. Dixon, *The Role of Operations Research in Regional Health Planning*, unpublished report, University of Pittsburgh, 1972.

Singer, 1961 (C)

Singer, Sidney, *A Stochastic Model of Variation of Categories of Patients within a Hospital*, PhD Engineering Dissertation, The Johns Hopkins University, 1961, UMI 61-3839.

Sloan, 1969 (C)

Sloan, Frank A., *The Demand for Medical Education - A Study of Medical School Applicant Behavior*, April 1969, NTIS P 4075.

Sloan, 1969 (C)

Sloan, Frank A., *Lifetime Earnings and the Physician's Choice of Specialty*, May 1969, NTIS P 4068.

Sloan, 1970 (C)

Sloan, Frank A., "Hospita' Demand for Residents," *Inquiry*, Vol. VII, No. 3, September 1970.

Sloan, 1971 (C)

Sloan, Frank A., "The Demand for Higher Education: The Case of Medical School Applicants," *The Journal of Human Resources*, VI-4, 1971.

Sloan & Blair, 1972 (C)

Sloan, F.A. and Blair, R.D., "Short-Run Supply Responses of Professional Nurses: A Microanalysis." Paper presented at the Econometric Society Meetings, Toronto, Canada, December 28, 1972.

Smallwood, Sondik & Offensend, 1971

Smallwood, Richard D., Sondik, Edward J. and Offensend, Fred L., "Toward an Integrated Methodology for the Analysis of Health-Care Systems," *Journal of the Operations Research Society of America*, Vol. 19, No. 6, October 1971.

Stevens & Brown, 1971

Stevens, Carl M. and Brown, Duane G., "Market Structure Approach to Health Manpower Planning," *American Journal of Public Health*, Vol. 61, No. 10, October 1971.

Stevens, 1971

Stevens, Carl M., "Physician Supply and National Health Care Goals," *Industrial Relations*, Vol. 10, No. 2, May 1971.

Taylor, Dirican & Deuschle, 1968

Taylor, Carl E., Dirican, Rahmi and Deuschle, Kurt W., *Health Manpower Planning in Turkey: An International Research Case Study*, Johns Hopkins Press, Baltimore, Maryland, 1968.

Thomas, 1964 (C)

Thomas, W. H., *Model for Short-Term Prediction of Demand for Nursing Resources*, PhD Dissertation, Purdue University, 1964, UMI 64-8720

Thomas, 1968 (C)

Thomas, Warren H., "A Model for Predicting Recovery Progress of Coronary Patients," *Health Services Research*, Fall 1968.

Uyeno, 1971 (C)

Uyeno, Ian H., *Health Manpower Systems: An Application of the Management Sciences to the Design of Primary Health Care Teams*, PhD Dissertation, Northwestern University, 1971, UMI 71-30,971.

Weaver, 1968 (C)

Weaver, Cynthia, *The Development of a Simulation Model of a Community Health Service System: Volume IV, General and Annotated Bibliography*, Research Triangle Institute, North Carolina, 1968, UMI AR 1033.

Weckwerth, 1969

Weckwerth, Vernon E., *A Conceptual Model of the Real World of Health Care Service Delivery from Outcomes Conference I-II: Methodology of Identifying, Measuring, and Evaluating Outcomes of Health Service Programs, Systems and Subsystems*, California Center for Health Services Research, The University of California, 1969.

Williams, Covert & Steele, 1967

Williams, William J., Covert, Richard P., PhD and Steele, James D., "Simulation Modeling of a Teaching Hospital Outpatient Clinic," *Hospitals*, Vol. 41, No. 21, November 1967.

Wilson, 1972

Wilson, Douglas, *The National Health Insurance Model*, Unpublished paper, August 24, 1972.

Wing, 1972

Wing, Paul, *Planning and Decision Making for Medical Education: An Analysis of Costs and Benefits*, University of California, Ford Foundation Program for Research in University Administration, Paper P-28, January, 1972.

Wirick & Barlow, 1962

Wirick, Grover, Barlow, Robin, "The Economic and Social Determinants of the Demand for Health Services" in W. J. McInerney et al, *Hospital and Medical Economics*, Hospital Research and Educational Trust, American Hospital Association, Chicago, 1962.

Wirick, 1966

Wirick, Grover C., Jr., "A Multiple Equation Model of Demand for Health Care", *Health Services Research*, Vol. No. 3, Winter 1966.

Wolfe, 1964

Wolfe, Harvey, *A Multiple Assignment Model for Staffing Nursing Units*, Operations Research Division, The Johns Hopkins Hospital, Baltimore, 1964.

Yett & Folk, 1968

Yett, Donald E., Folk, Hugh, "Methods of Estimating Occupational Attrition", *Western Economic Journal*, September 1968.

Yett, Drabek, Kimbell & Intriligator, 1970 (C)

Yett, Donald E., Drabek, Leonard, Kimbell, Larry, Intriligator, Michael, *The Development of a Micro-Simulation Model of Health Manpower: Supply and Demand*, Proceedings and Report of Conference on a Health Manpower Simulation Model, Vol. 1, December 1970.

Yett & Sloan, 1971 (C)

Yett, Donald E., Sloan, Frank A., *Analysis of Migration Patterns of Recent Medical School Graduates*, New York University, HEW-OS-69-94.

Yett, Drabek, Intriligator and Kimbell, 1973

Yett, Donald E., Drabek, Leonard, Intriligator, Michael D., Kimbell, Larry J., *The Preliminary Operational HRRC Microsimulation Model*, Final Report to Division of Health Manpower Intelligence on US Public Health Service Contract No. NIH-71-4065, 1973

Zemach, 1970 (C)

Zemach, Rita, "A Model of Health-Service Utilization and Resource Allocation", *Operations Research*, Vol. 18, No. 6, November-December 1970.

4.4 *Input and Output Variables for Each Model Category*

This section consists of model input and output variables for each sub-component of the model classification structure described in section 3.1 (i.e., population dynamics models, educational choice models, health profession education models, manpower resource models, health care delivery organization models, consumer service behavior models, and incidence of illness models). These lists provide information on the type of parameters included in each model classification area, and also provide reference to models utilizing the parameters (i.e., following each variable is a list of model identification numbers which refer to the specific models in the inventory which include the variable). As in the model classification scheme, models encompassing multiple subject areas are multiply listed in the input and output lists. An effort was made to include only those parameters of the model relevant to the specific classification group in each list. Due to the great number of specific inputs and outputs included in the models (especially the large-scale models), each parameter is not listed separately; rather, parameters are aggregated in the following way: specific input and output variables listed in the model inventory are combined with similar parameters from other models in the classification subcomponent to form an aggregate parameter group (e.g., "administrative cost data" would include surplus, overhead, salary costs, supply costs, etc.; the variables "hospital bed days per thousand population" and "hospital bed days per month" would both be classified "hospital bed days").

INPUT AND OUTPUT VARIABLES FOR EACH MODEL CATEGORY

4.4.1 Population Dynamics Models

Inputs

- | | |
|---|--------|
| 1. Size of initial population | R2, Y1 |
| 2. Parameters to assign age, marital status, or parity given other demographic variables (age, parity, sex, marital status) | R2 |
| 3. Birth, death, marriage and divorce probabilities by age, sex, etc. | R2 |
| 4. Distribution of ages of brides and grooms for first marriages and remarriages | R2 |
| 5. Race | L2, Y1 |
| 6. Age | L2, Y1 |
| 7. Sex | L2, Y1 |
| 8. Geographic Region | L2 |
| 9. Annual net immigration | Y1 |
| 10. Birth and mortality rates | Y1 |

Outputs

- | | |
|---|--------|
| 1. Income | L2 |
| 2. Various distributions of primary individuals by sex, marital status, age group, parity, etc. | R2, Y1 |

4.4.2 Educational Choice Models

Inputs

- | | |
|---|--------|
| 1. Number of male college graduates | S6 |
| 2. Tuition and fees in year application begins professional education | S6, Y1 |

3.	Physician's income in independent professional practice	S6, Y1
4.	Starting salaries of male college graduates in general business	S6
5.	PhD stipends	S6
6.	Median incomes of PhD's in biological sciences	S6
7.	Applicants in the previous year	S6, Y1
8.	Biologist's income growth	S6
9.	Biologist's income level	S6
10.	Number of residencies in the current year	S6
11.	Present value of lifetime earnings, discounted at 5% and 10%	
12.	Total number of foreign graduates	S6
13.	Absolute difference between median specialty and general practice income	S6
14.	Monthly stipend offered by hospitals to first year residents	S6
15.	Number of specialists in a given field seeking employment divided by the number of vacancies in the field	S6
16.	Measure of physician dissatisfaction with their respective specialties	S6
17.	Population socioeconomic and demographic variables	S6, Y1
18.	Increase in the number of hospital beds	S6
19.	Annual degree days	S6
20.	Medical exam failure rate	S6
21.	Mean professional hours for private physicians	S6
22.	Number of first year medical school entrants	F5
23.	Available financial support	Y1
24.	Nurse incomes	Y1
25.	Incomes in alternative occupations	Y1

Outputs

- | | |
|--|----|
| 1. Applicants planning to enter medical school in year t | S6 |
| 2. "A" college record applicants planning to enter in year t | S6 |
| 3. Number of residents in a particular specialty in a given year who are graduates of American or Canadian medical schools | S6 |
| 4. Residents in a specialty divided by number of residencies offered in that field in a given year | S6 |
| 5. Drop outs from medical school | F5 |
| 6. Probability that an individual will demand nursing or medical education | Y1 |

4.4.3 Health Education Models -- Administration

Inputs

- | | |
|--|--------|
| 1. Dental school spaces per 1,000 population | F4 |
| 2. Additions to dental school spaces per 1,000 population | F4 |
| 3. Construction funding (including subsidies) | F4, F5 |
| 4. Government support of nurse education | Y1 |
| 5. Number of school scholarships | F5 |
| 6. Number of high school girls | F5 |
| 7. Income of nurses relative to income of teachers | F5 |
| 8. Number of first year medical school spaces | F5 |
| 9. Supply of first-year spaces supplied by nurse training programs or at medical schools | Y1 |

- | | | |
|-----|--|----|
| 10. | Hours of faculty time demanded by nurse training programs or medical schools | Y1 |
| 11. | Number and type of nurse training programs | Y1 |
| 12. | Number of vacancies in a nurse training program | Y1 |

Outputs

- | | | |
|-----|---|--------|
| 1. | Solutions to optimal output mix for the medical college given the resources available and institutional constraints | L3 |
| 2. | Number of dental school spaces per 1,000 population | F4 |
| 3. | Additions to dental school spaces per 1,000 population | F4 |
| 4. | Number of nursing school graduates | F5 |
| 5. | Increase in number of first year medical school spaces | F5 |
| 6. | Nursing school admission rate, by type of program | A3 |
| 7. | Quantity and type of manpower received by type of education institution | Y1 |
| 8. | Probability that an applicant will be accepted to medical school | Y1 |
| 9. | Growth of junior colleges and universities | Y1 |
| 10. | Professorial services and personnel, by type | L3, Y1 |
| 11. | Undergraduate medical courses | L3 |
| 12. | Medical education by year | L3 |
| 13. | Medical degrees | L3 |
| 14. | Other education (graduate education, dental, etc.) | L3 |

253

15. Research	L3, Y1
16. Services and programs (e.g., physical therapy, library services, etc.)	L3
17. Quantity of medical or nursing education demanded and supplied	Y1
18. Revenues	Y1
19. Medical undergraduate enrollment	Y1
20. Size distribution of hospitals	Y1
21. Input cost data	Y1
22. Total nurse program enrollment	Y1

4.4.4 Manpower Resource Models -- Manpower Pool (Aggregates)

Inputs

1. Income of health manpower, by type	A3, F5, B5, H4, Y1
2. Growth of various nursing programs	A3
3. Admission rates to various nursing programs	A3
4. Population socioeconomic and demographic variables	F5, B5, H1, S1, F1, Y1, E2, F8
5. Number of places in medical classes in state	B5, S1
6. Medical examination failure rate	B5, S1
7. Percentage of internships and residencies filled	S1
8. Dental school dropouts	F4
9. Number of first year dental school students	F4
10. Number and type of health manpower	F5, F4, H3
11. Social security retirement benefits	F5
12. Number of medical or dental school graduates	F4, H3

13. Hospital admission rate	H1
14. Number of hospital beds	H3, F8
15. Number of dentists dying or retiring	H3
16. Net profit of solo-practice physicians	H3
17. Average price of land for existing FHA housing	H3
18. Rate of population increase	H3
19. Percentage of commercial area in the city	E2
20. Number of hospitals or hospital beds	E2, F8
21. Census tract location (central business district or other)	E2
22. Number of medical schools	F8
23. Average price per visit	F8

Outputs

1. Number of physician visits	F5
2. "Stock of nurses" parameters (employment, migration, turnover, retiring, etc.)	F5
3. Number of physicians and/or dentists	B5, S1, F4, F1, H1, E2, F8
4. Inflow of foreign medical school graduates	F5
5. Medical school graduates practicing in state	H3
6. Physician income	S1
7. Number of hospital beds	F1
8. Number of admissions	F1
9. Length of stay	F1
10. Health insurance status	F1
11. Supply of health manpower by occupation	M1, Y1

200

4.4.5 Manpower Resource Models -- Labor Force Behavior

Inputs

1. Population socioeconomic and demographic variables	B6, B4, Y1, S2, S8
2. Number of nursing school graduates	B4, Y1
3. Income of health manpower by type	B4, S8, Y1
4. Number of female RNs and/or LPNs	B4, S8, Y1
5. Labor force participation rate of female RNs	B4, Y1
6. Husband's income and/or occupation	B5, S8
7. Length of employment on job prior to position with the hospital	S2
8. Length of service	S2
9. Physician specialty	Y1
10. Medical school attended (domestic or foreign)	Y1
11. Physician career status	Y1
12. Type of employment of physician	Y1
13. Proportion of medical specialists and GPs with previous state contacts of birth, medical school, internship, and/or residency	S6
14. Employment location within an SMSA	S8
15. Total hours worked during the year	S8
16. Government employee or self-employed	S8

Outputs

1. Reported hours of nursing services worked per week and number of weeks worked	B6, S8
2. Length of service	S2

3. Median income of female RNs	B4
4. Total female RNs	B4, Y1
5. Labor force participation rate of female RNs	B4, Y1
6. Absenteeism rate	S2
7. Overall retention probability for specialists and GPs	S6
8. Hourly and weekly wages of nurses and spouses	S8
9. Number of physicians by age, activity, and specialty	Y1
10. Employment of aides, RNs, LPNs, and technicians in the office	Y1

4.4.6 Health Care Delivery Organization Models -- Administration

Inputs

1. Distribution of workload	A1
2. Hospital size (number of beds, wards)	A1, F5, R2, Y1
3. Number and duration of planning periods	A1
4. Cost of personnel (salary, recruiting, moving, training)	H4, A2, F5, W1, A1, S3, S4
5. Efficiency or utility in full-time equivalent persons	A1, S3
6. Required minimum staff level	A1
7. Set of various staffing locations	A1
8. Manpower training length	A1, M2, F6
9. Hospital daily census (by category)	A2, J1, S7, H4, B3
10. Number of hospital admissions and transfers (by mode and/or category)	A2, R2, B1
11. Hospital administrative cost statistics	A2, B2, K1, S4, Z1, M2, Y1

12. Floor space	A2, S4
13. Number of hours worked (including part time and/or overtime)	J1, S3, W1, A2, L1, C1
14. Number and type of hospital services	M2, Y1, F5, H4, F6, A2, B1, L4, H2, L4
15. Hospital revenues and prices	A2, B2, B3, Y1
16. Population socioeconomic and demographic variables	B1, F1, F5, K1, L4, R2, Z1, B3
17. Method of payment	B1, B3
18. Patient characteristics; number in each care class (patient category weights indicating direct care requirements or "value" to hospital)	B2, C1, J1, S5, T1
19. Length of stay (by category)	B1, K1, R2, B3
20. Target profit level	B2
21. Patient restrictions	B2
22. Resource limits	B2, L4, M1
23. Hospital funding	B2, S4, Y1
24. Technological coefficients	B2, M1
25. Patient requirements data	B2, S3, T1
26. Number of nursing home and extended care facility beds	F5
27. Type of activity, time, complexity, priority, and sequence rationale	H2, L1, M2, V1
28. Service times	H2, L1, U1, W1
29. Type of nursing unit	J1
30. Resources used	K1, Z1
31. Distribution of visits	K1, S7, Y1
32. Infant illness data	K1

33. Bed requirements for specific programs	L4
34. Personnel (number and type)	L4, S4, S3, W1 A2, H4, F6, Y1
35. Service queue arrival and service time distributions	M2
36. Personnel characteristics (productivity, number required per physician, etc.)	S4
37. Demand for services	S4, F6
38. Rates of entry, exit, and transition for each care category	S5
39. Amount of service provided	Z1, Y1
40. Health insurance status	Y1
41. Prices (doctor's office visit, nursing home care)	F5
42. Hospital construction costs	F5
43. Number of public school children	F5
44. Stipends	S7
45. Medical school affiliation	S1
46. Demand coefficients (desired personnel employment per unit level of demand)	M1
47. Utilization of services	M1, Z1
48. "Permanent" or "transitory" nature of the nurse force	H4
49. Number of physicians with special clinical privileges	H4
50. Number of physicians	B3, L4
51. Non-specific inputs to the health care delivery system	Y1
52. Previous bed shortages	Y1
53. Quantity and type of manpower supplied and demanded	Y1, F6

54. Number of students and type of training program	F6
55. Student data (matriculants, transfers, drops, graduates)	F6
56. Faculty student ratio	F6
57. Capacity of training programs	F6
58. Proportion of manpower who do not deliver health care	F6
59. Migration rate from manpower pool	F6
60. Discount rate	F6
61. Relative value of health service, by type	F6

Outputs

1. Required minimum staff level	A1
2. Number and type of employees	A2
3. Hospital administrative cost data	A2, A1, M2, Z1, W1
4. Hospital revenue assets and prices	A2, F5, Y1
5. Cost of personnel (salary, etc.)	A2
6. Floor space	A2
7. Administrative decision variables	A2
8. Number of hours worked (by type of activity)	A2, L1, C1, U1
9. Requests for services	A2
10. Number and type of hospital or physician services	A2, F5
11. Amount of workload	A2
12. Length of stay	B1, F1, Y1
13. Weighted sum of patients treated in all equivalence classes	B2
14. Health insurance status	F1
15. Number and type physicians	F1, F5

16. Number of hospital beds	F1, F5
17. Hospital admissions	F1, Y1
18. Hospital patient days or bed days	F5, Y1
19. Personnel and facility utilization data	K1, U1
20. Type of service activity, time, sequence, by category	L1, M2
21. Optimal bed service allocations for different objective functions	L4
22. Service queue parameters (arrivals, departures, time in channel, etc.)	U1, M2
23. Predicted number of patients in each care category	S5, T1
24. Expected demand for nurses or other hospital resources	T1, R2
25. Projected health service and resource requirements	Z1
26. Nursing home parameters (beds, patient days, occupancy rate, etc.)	F5
27. Number of outpatient visits	F5, Y1
28. Days of home care	F5
29. Construction costs	F5
30. Number and type of health manpower (other than physicians)	F5, M1
31. Number of residencies offered	S7
32. Average price of private physicians services	F5
33. "Stock of nurses" parameters (employment, migration, turnover, retiring, etc.)	H4
34. Number of patients in various departments	B3
35. Amount of services (patient visits, bed days) that can be feasibly produced, given available resources	Y1

- | | |
|---|----|
| 36. Bed days of capacity added | Y1 |
| 37. Quantity and type of manpower demanded and/or received | Y1 |
| 38. Values of the input parameters which minimize the cost of assignment policy (substitution of various personnel classes) | S3 |
| 39. Values of the input parameters which maximize the total quality level of the health services provided | S3 |
| 40. Values of the input variables which minimize the total cost to a community of providing health services of acceptable quality | S4 |
| 41. Values of the input variables which minimize a discounted, weighted sum of types of care not delivered over the horizon specified | F6 |

4.4.7 Health Care Delivery Organization Models -- Service Delivery

Inputs

- | | |
|---|----------------|
| 1. Number of physicians or dentists | F4, R1, F8 |
| 2. Number of aides or auxiliaries | F4, R1 |
| 3. Number of work hours of physician or dentists | F4, R1, Y1 |
| 4. Number of chairs in the office | F4 |
| 5. Price index | F2 |
| 6. Cost of other goods | F2 |
| 7. Quantity of inputs (paramedical personnel, supplies, etc.) | F2 |
| 8. Services provided per physician | F2, R1, Y1 |
| 9. Average fee | F2, R1, Y1, F8 |
| 10. Reference income | F2 |
| 11. Capital stock | R1 |
| 12. Government provision of medical services | F2 |
| 13. Health insurance status | F2 |

14. Per capita income	F2, R1
15. Type of practice (group or solo)	R1, Y1
16. Length of practice, in years	R1
17. Physician specialty	Y1
18. Number of hospital beds	F8

Outputs

1. Supply of dental visits per 1,000 population	F4
2. Price per dental visit	F4
3. Physician output in terms of office visits, patient visits, and billings	R1, Y1, F8
4. Index of private physician's services	F2
5. Index of average price of private physician's services	F2
6. Index of services provided per private practice physician	F2
7. Physician fees by specialty	Y1

4.4.8 Consumer Service Behavior Models -- Utilization Behavior

Inputs

1. Price of medical care	D1, E1, F5, F3, Y1
2. Price of health insurance	D1
3. Health insurance coverage	D1, E1, Y1
4. Consumption of medical care	D1
5. Health status	D1, A4
6. Value judgments and attitudes toward health, health services, and health insurance	A4
7. Individual's knowledge of disease and personal care habits	A4

- | | |
|---|--|
| 8. Welfare care or free care for major illness | A4 |
| 9. Symptoms | A4 |
| 10. Disability days | A4 |
| 11. Population socio-economic and demographic variables | F3, H5, R3, F7, L2, F5, D1, A4, E1, N1, Y1 |
| 12. Population's initial distribution among health care states | N1 |
| 13. Utilization of health resources | N1 |
| 14. Number of physician visits | N1, Y1 |
| 15. Transitional probabilities representing all possible movements of people among the health states | N1 |
| 16. Number of hospital-based outpatient clinics | Y1 |
| 17. Conditional probabilities of having health insurance by age, race and family income | R2 |
| 18. Parameters to determine hospital admission rates by race, age, family income and hospital insurance status, etc. | R2, Y1 |
| 19. Conditional probability distribution of diagnosis by age and sex | R2 |
| 20. Conditional probability of surgery status by age, hospital insurance status, diagnosis and residence | R2 |
| 21. Conditional probability distribution of bedsize of hospital by diagnosis and surgery status | R2 |
| 22. Parameters to determine length of stay in the hospital based on age, surgery, diagnosis, family income, hospital insurance status, and size of hospital | R2, Y1 |
| 23. Daily probability of hospital admission for persons in their last year of life | R2 |

24. Number of hospital admissions and transfers	F3
25. Number and type of hospital services	F3, F7
26. Number of nursing home and extended care facility beds	F3, F7
27. Medicare data (participation, government buying in, etc.)	F3

Outputs

1. Units of use of hospitals and hospital services	A4
2. Units of use of physicians (e.g., visits)	A4, F5, L2
3. Units of use of drugs	A4
4. Units of use of dentists	A4
5. Medical expenditures	D1
6. Health status	D1
7. Outpatient visits	E1, F5
8. Hospital admissions	E1, R2, F3, R3
9. Patient days by age, race, sex, etc.	E1, R2, H5, R3, F7, L2
10. Inpatient operations	E1
11. Length of stay	E1, R2, R3
12. Discharge, death, and transfer to other levels of care	E1
13. Vital statistics- birth, deaths	E1
14. Health system costs	E1
15. Hospital cost and personnel use by hospital administrative services categories	E1
16. Utilization of health services in each state of care, and resources required to satisfy the demand	N1, E1

- | | |
|---|----|
| 17. Estimates of changes in demographic utilization or productivity parameters on the resources required | N1 |
| 18. Solution of the objective function; the transitional probability matrix which defines the alternative designed to minimize the constraints selected | N1 |
| 19. Surgery status | R2 |
| 20. Bed size of hospital | R2 |
| 21. Hospital discharges by age, race, sex, income, etc. | R2 |
| 22. Health insurance status | F3 |
| 23. Health insurance benefits | F3 |
| 24. Hospital administrative cost data | F3 |
| 25. Quantity of inpatient or outpatient services received by individuals | Y1 |
| 26. Quantity of inpatient or outpatient services needed by individuals | Y1 |
| 27. Quantity of inpatient or outpatient services demanded by individuals | Y1 |

4.4.9 Incidence of Illness Models

Inputs

- | | |
|---|----------------|
| 1. Race | A6, A5, L2 |
| 2. Income | A6, A5, L2, Y1 |
| 3. Education | A6, A5, L2, Y1 |
| 4. Urbanization | A6, A5, L2 |
| 5. Employment classification (e.g., manufacturing, agriculture) | A6, A5, L2 |

6. Alcohol consumption	A6
7. Cigarette consumption	A6
8. Occupation classification (i.e., white-collar, blue-collar)	A6, L2
9. Participation in the labor force (including employment rate)	A6, A5
10. Medical school presence in state	A6
11. Expenditures on medical care per capita and prescription drugs	A6
12. Number of physicians	A6, L2
13. Number of paramedical personnel	A6
14. Medical capital per capita	A6
15. Practicing physicians in group practice	A6
16. Ethnic group	A5, Y1
17. Net migration	A5, L2
18. Age	A5, L2, Y1
19. Number of hospital beds	A5
20. Population density	L2
21. Sex	L2, Y1
22. Geographic region	L2
23. Mortality rates	O1
24. Fertility rates	O1
25. Marital status	Y1

Outputs

1. Mortality from accidents, suicide, and cirrhosis of the liver	A5
2. Net migration	A5
3. Median age	A5
4. Median education	A5
5. Percent unemployed	A5
6. Income	A5, L2
7. Hospital beds/population ratio	A5
8. Age-sex adjusted death rate	A6
9. Number of deaths	L2
10. Determination of life expectancy	O1
11. Probability that an individual will be in a specific diagnostic category	Y1