

DOCUMENT RESUME

ED 103 259

SE 018 638

TITLE The Basics of Boiler Operation and Maintenance. Part 2, Air Pollution Training Institute Self-Instructional Course SI-466.

INSTITUTION Environmental Protection Agency, Research Triangle Park, N.C. Air Pollution Training Inst.; Sage (David) Inc., New York, N.Y.

PUB DATE [73]

NOTE 41p.; Related documents are SE 018 637-643

EDRS PRICE MF-\$0.76 HC-\$1.95 PLUS POSTAGE

DESCRIPTORS *Air Pollution Control; Environment; *Environmental Education; Environmental Technicians; *Independent Study; Maintenance; Pollution; Post Secondary Education; Programed Instruction; Programed Materials; Technology

IDENTIFIERS Boiler Maintenance; Boiler Operation; *Boilers

ABSTRACT

This workbook is part two of a self-instructional course prepared for the United States Environmental Protection Agency. The student proceeds at his own pace and when questions are asked, after answering, he either turns to the next page to check his response or refers to the previously covered material. The purpose of this course is to prepare the student for the APC Training Certificate, instill in him the basics of safe boiler operation and maintenance, and help him keep the boiler system operating smoothly.

(BT)

BEST COPY AVAILABLE

ED103259



Air Pollution Training Institute Self-Instructional Course SI-466

Part 2 The Basics of Boiler Operation and Maintenance



United States
Environmental Protection Agency
Office of Air and Water Programs

Training Manual
Self-Instructional Course SI-466

Air Pollution Training Institute



United States
Environmental Protection Agency
Contract No. 68-02-0321
David Sage, Inc.
New York City, New York

● Part Two:
The Basics of Boiler
Operation and Maintenance

David Sage, Project Manager, DSI
Mariland Ruppert, Writer Analyst, DSI
C. George Segeler, P. E., Staff Engineer, DSI
and
William Todd, Project Officer, USEPA

Prepared for the
United States Environmental Protection Agency
Office of Air and Water Programs
Control Programs Development Division
Air Pollution Training Institute

2

THIS IS PART
THE BASICS OF BOILER OPERATION
AND MAINTENANCE

● Additional units of this self-instructional course are:

PART ONE
The Basics of Preventing Air
Pollution Emissions from Boilers

PART THREE
Troubleshooting, Section One
Boilers: Correcting Oil Temperature

PART FOUR
Troubleshooting, Section Two
Boilers: Flame Reading

PART FIVE
The Incinerator: Section One
Basic Parts and Fundamentals

PART SIX
The Incinerator: Section Two
Maintenance and Troubleshooting

SUPPLEMENT A:
Operator's Manual, Boiler Room
Operations and Maintenance

INTRODUCTION

This is lesson 2.

You need your Handbook and a pencil.

Write all the answers.

Correct when you make a mistake.

You can keep this when you're finished.

1. IS YOUR BOILER ROOM IN GOOD SHAPE?

Get your upgraded boiler room off to a good start and keep it clean!

DOORS MUST LOCK	Keep strangers out
OIL SLICKS GONE	Floor dry – no puddles or oil slicks
GAUGES EASY TO READ	Clean instruments
TOOLS PUT AWAY	You're bound to get hurt in a cluttered room
AIR INTAKES CLEAN	Never block outside air intakes
GARBAGE CLEANED UP	No mess

To be sure you've got it, fill in the blanks below:

_____ must lock. _____ put away.
_____ slicks gone. _____ intakes clean.
_____ easy to read. _____ cleaned up.

Write the first letter of the first word of each sentence in this space: _____

Check your answers

Answers to Exercise 1: DOG TAG

See if DOGTAG will help you remember the six rules for keeping your boiler room in shape. Write them below.

**Check and correct your answers
from preceding page, then go
to next exercise.**

2. CHECK THESE THINGS EVERY DAY

To keep the boiler running right you'll need:

- FUEL in the tank
- WATER in the boiler
- OIL hot enough to flow and burn properly

FUEL

You should check your fuel gauge every day, especially in winter. Keep a five-day supply on hand. Draw a needle on the fuel gauge below showing a five-day supply of oil for you in winter (refer to Boiler Handbook you've started).

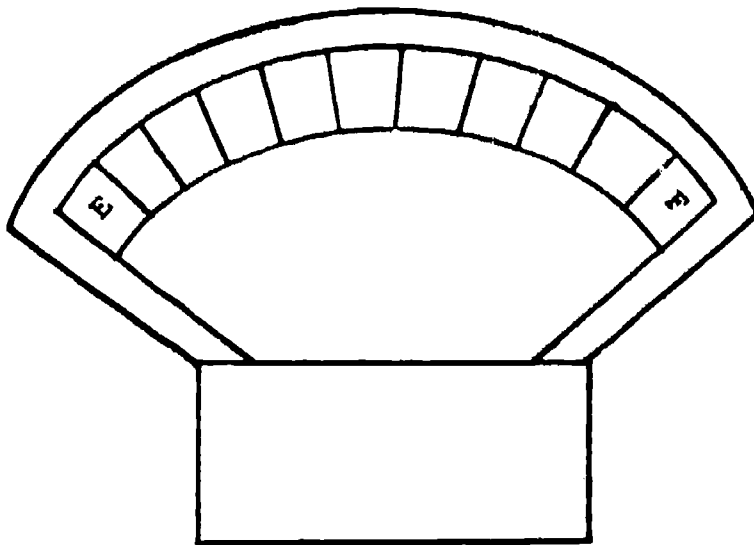

What is your fuel supplier's telephone number:

- Go on to next page

WATER

Check the water level by looking at the gauge glass on the outside of the boiler. If the gauge glass registers half full or more, there is enough water; add water if the glass registers under half.

CIRCLE THE CORRECT WORD under each gauge glass below:

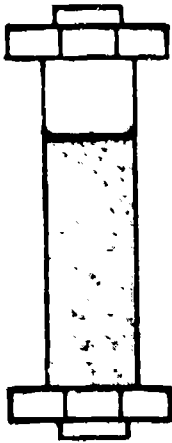

Water
OK/NEEDED

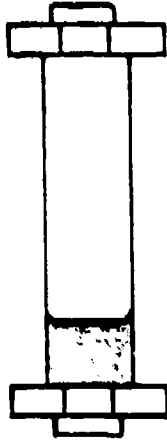

Water
OK/NEEDED

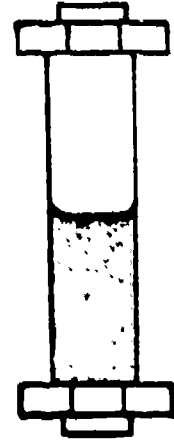

Water
OK/NEEDED

You would have to add water to the second glass only, one and three are OK. When you need water, what do you do?

Turn on feed pump: _____

Open city water valve: _____

Other: _____

(describe)

Go to next page

OIL TEMPERATURE (in electric heater)

Low-sulphur oil – like the kind you are burning now – atomizes at lower temperatures but still must be heated.

What is the atomization temperature you now use? _____

Here is an electric heater (with cap removed):

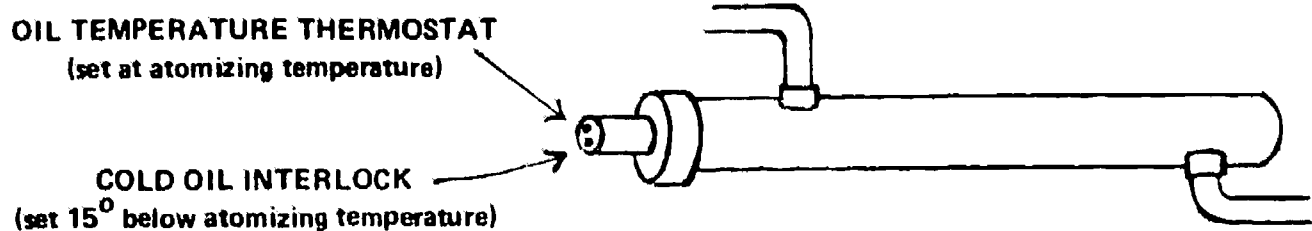

CHECK EVERY DAY:

- Thermostat – puts oil into burner at right temperature
- Cold Oil Interlock – shuts burner down if oil is not hot enough

At what temperature should your oil temperature thermostat be set? _____

At what temperature should your cold oil interlock be set? _____

Your thermostat should be set at your atomizing temperature. The cold oil interlock should be 15° lower. Correct settings if necessary.

What are the three things to check each day? _____

Check and correct
your answers.

1. Fuel
2. Water
3. Oil Temperature

3. CLEAN YOUR SMOKE ALARM EVERY FEW DAYS - AT LEAST ONCE A WEEK

Here's how your smoke alarm works:

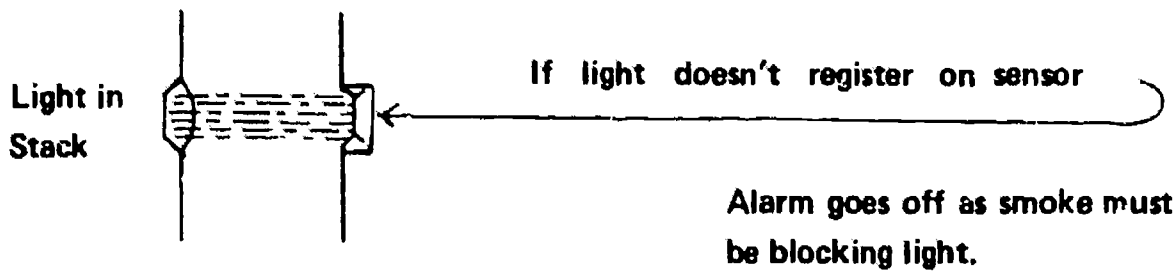

The Smoke Alarm is going off at the two stacks below. Only one is really smoking.

CIRCLE THE CORRECT WORDS UNDER THE STACKS – if there is a true alarm or a false alarm.

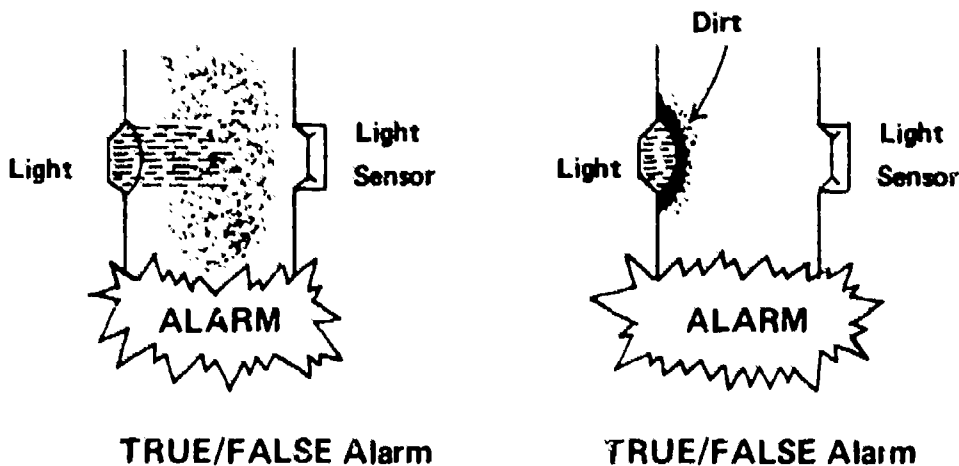

The first picture shows what should happen with smoke. The light in the second picture does not get through to the sensor because of dirt on the lens and the alarm goes off when there is no smoke!

What must you do frequently to keep a false alarm from sounding? _____

–Check and correct
your answers.

Answer to Exercise 3: Clean the smoke alarm lens.

4. REVIEW: DAILY BOILER TASKS

1. List the six things that keep your boiler room in good shape:

2. What three things must also be checked every day?

_____ in the tank
_____ in the boiler
_____ hot enough to burn properly

3. On what piece of equipment must you check the settings of the oil temperature thermostat and the cold oil interlock?

4. What happens if smoke alarm lens is dirty? _____

Check and correct
your answers.

Answers to Exercise 4:

1. Doors must lock

Oil slicks gone

Gauges easy to read

Tools put away

Air intakes clean

Garbage cleaned up

2. Fuel

Water

Oil

3. Electric Heater

4. False Alarm

5. GETTING READY TO START

You may have to start a cold boiler. First look at the OIL PRESSURE GAUGE. It is not working right if it shows a pressure reading when the system is off. Look at the gauges below.

CIRCLE THE CORRECT WORDS UNDER EACH.

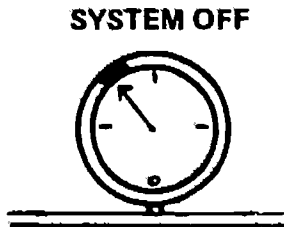

Gauge IS/IS NOT working correctly.

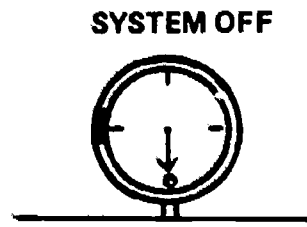

GAUGE IS/IS NOT working correctly.

The first gauge above is out of order. If you replace this gauge, keep a spare on hand.

TWO SWITCHES TO THROW:

Two more things must be turned on and given time to work before you start. Study the diagram, then answer the questions below:

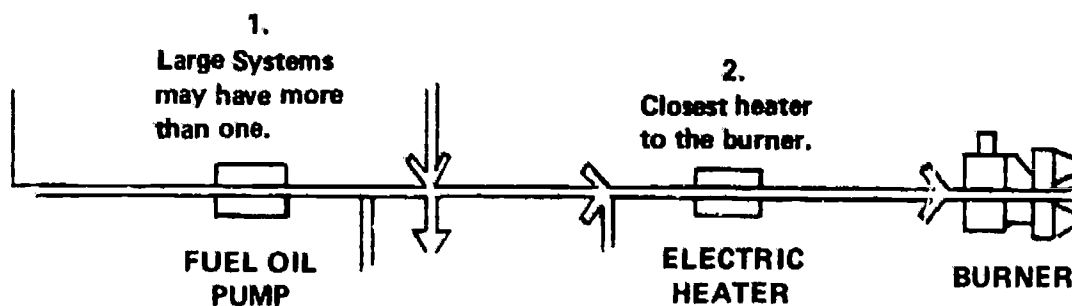

1. What piece of equipment gets the oil up to proper burning temperature? _____
2. What piece of equipment moves the oil out of the tank to the burner? _____
3. What 2 pieces of equipment must be turned on before you can start the burner? _____

Check and correct
your answers.

- Answers to Exercise 5:
- 1) Electric Heater
 - 2) Fuel Oil Pump
 - 3) Heater & Pump

6. CHECK OUT THE BURNER

Burners on a manual stop/start schedule should be cleaned before shut-down and left with the burner out of the furnace (with the furnace opening covered). Before starting up the burner again, do these three things:

1. Inspect burner cup and clean if necessary.
2. Swing burner assembly into furnace.
3. Reset linkage, lock burner in position.

Correct linkage settings are important; they control the air/oil ratio. Mark the settings so that you can reset them perfectly each time.

A. Study the three pictures. Write the number and description from above of the step it shows:

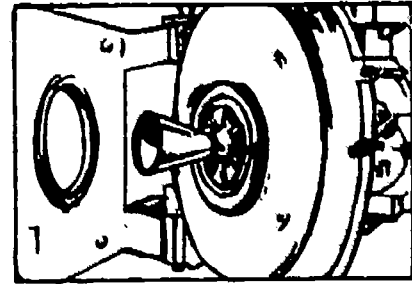
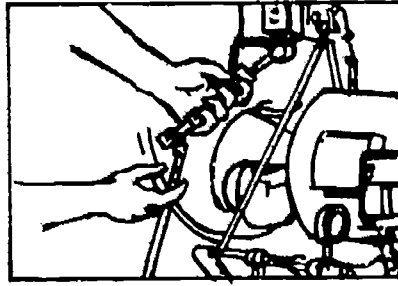
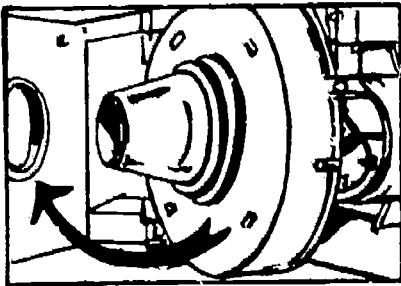

_____ lock burner _____ and
 _____ into furnace. _____ in position. _____ clean if necessary.

B. Answer these questions:

What do you get if the burner cup is dirty? _____

What do you get if the air/oil ratio is wrong? _____

Check and correct
 your answers .

Answers to Exercise 6.

- A. 2. Swing burner assembly back into furnace
- 3. Reset linkage, lock burner in position.
- 1. Inspect burner cup, clean if necessary

- B. Smoke
- Smoke

7. FIFTEEN MINUTES LATER

1. CHECK THE FLAME

Remember a good flame? CIRCLE GOOD or BAD under each flame, whichever is true:



GOOD/BAD



GOOD/BAD



GOOD/BAD

A good flame is a steady, orange one which fills the furnace but does not touch the walls, like the middle one above.

- 2. CHECK OIL TEMPERATURE AND
- 3. CHECK OIL PRESSURE

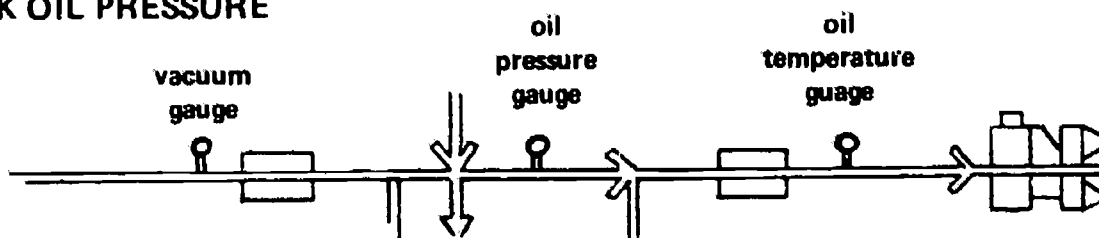

The oil temperature and pressure right for your boiler will depend on the oil you are using.

- 1. What instrument in the diagram checks oil temperature? _____
- 2. What instruments in the diagram let you check the oil pressure? (more than one) _____

Check and correct
your answers

Answers to Exercise 7:

- 1) Oil Temperature Gauge (thermometers, aquastats)**
 - 2) Pressure Gauge, Vacuum Gauge**
-

About 15 minutes after your boiler has been operating, what basic things should you check?

If you find any of these out of line, you will follow troubleshooting guides that will appear later in this program.

**Check and correct
your answers**

1. The Flame
 2. Oil Temperature
 3. Oil Pressure
-

8. REVIEW: DAILY BOILER TASKS & COLD STARTS

1. What key word reminds you of the six checks you should make in the boiler room every day?

2. What two settings on the electric heater should be checked every day?

3. How many days fuel supply should you have on hand at all times?

4. Check the _____ in the boiler every day.

5. Before turning on the burner, check the _____ gauge.

6. Before turning on the burner, what two pieces of equipment must be turned on?

7. What three things should be checked after the boiler has been running for 15 minutes?

Check and correct
your answers

Answers to Exercise 8:

- 1. DOGTAG**
- 2. Oil Temperature Thermostat, Cold Oil Interlock**
- 3. 5 Days**
- 4. Water**
- 5. Oil Pressure**
- 6. Fuel Pump, Electric Heater**
- 7. Flame**
 - Oil Temperature**
 - Oil Pressure**

9. CLEANING THE CUP

The burner cup should be: **CLEAN**
UNDAMAGED
and **SPIN PERFECTLY**

Check the cup when it is **HOT** and the oil is still **LOOSE**. Plan a convenient time to do this every few days, at least once a week.

OPENING THE BURNER — Remember accurate linkage setting.

WHEN DISCONNECTING
RIGID LINKAGE

Mark settings if necessary so
replacement is accurate.

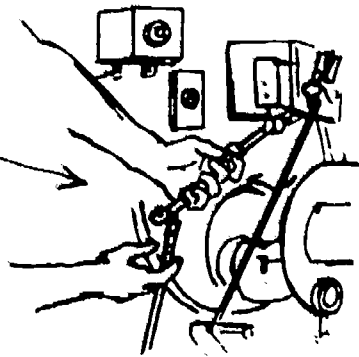

After the burner is out, cover the opening. Cool air will weaken or crack the refractory walls.

NUMBER THE FOLLOWING in the correct order:

- _____ Swing burner out
- _____ Open latch
- _____ Cover burner opening
- _____ Disconnect twist plugs ("dogs") and linkage

1. How could you lose the proper air/oil ratio when cleaning the cup? _____
2. How could you damage the refractory when cleaning the cup? _____

Check and correct
your answers.

- 3 1. by not marking the linkage
- 2 2. by not covering the furnace opening
- 4
- 1

CLEANING THE CUP

Use materials that will not scratch it.

1. Wipe cup with clean rag and solvent.

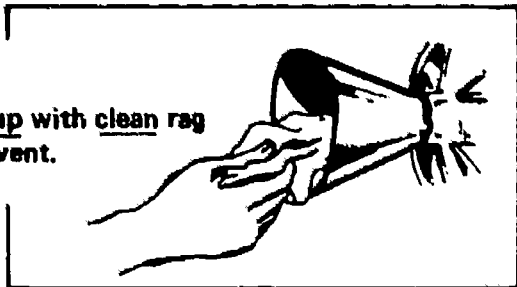

2. Remove deposits with a wooden stick.

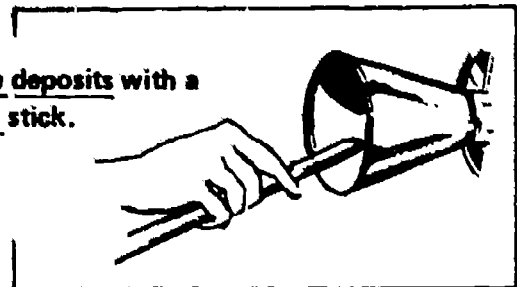

3. Spin cup slowly by hand to check for wobble.

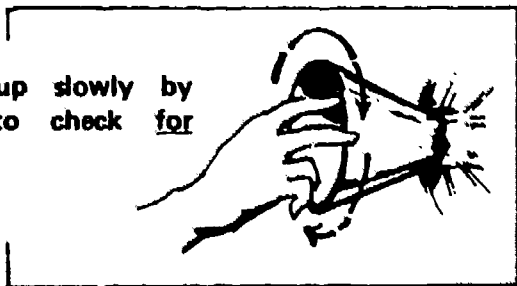

4. Check surface and edge for nicks, scratches, dents.

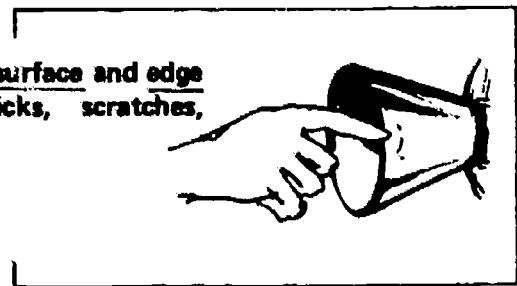

Wobble in the cup (3 above) often means that the shaft or cup is bent. Call Service.

A nick on the cup surface or edge (4 above), even small, will cause a problem in atomization. Call Service.

1. Why must you use a clean cloth to clean the cup? _____
2. What do you do with a wooden stick? _____
3. How do you check for wobble? _____
4. Will a small scratch or nick on the edge cause a noticeable problem? _____

Check and correct
your answers

1. A dirty cloth will scratch the cup
 2. Remove deposits on cup
 3. Spin cup slowly by hand
 4. Yes
-

COMPLETE THE PROCEDURE FOR CLEANING THE CUP:

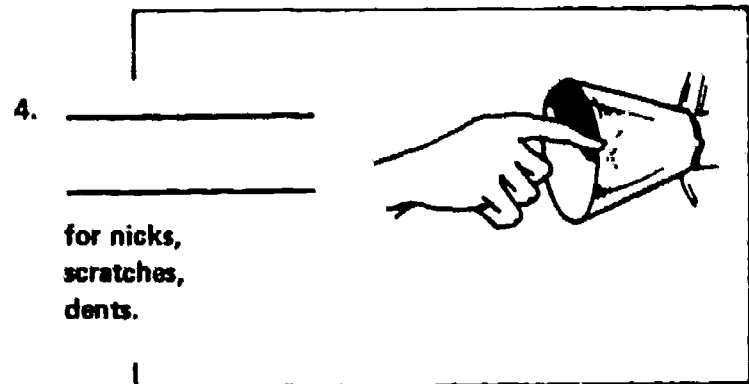
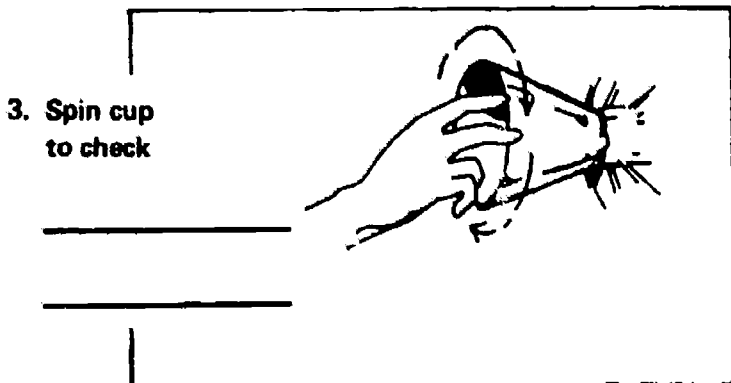
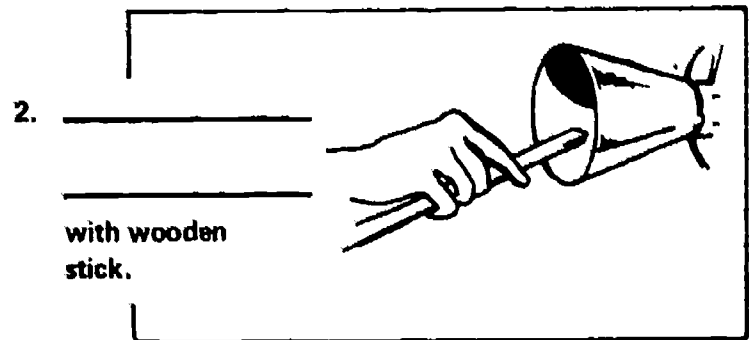
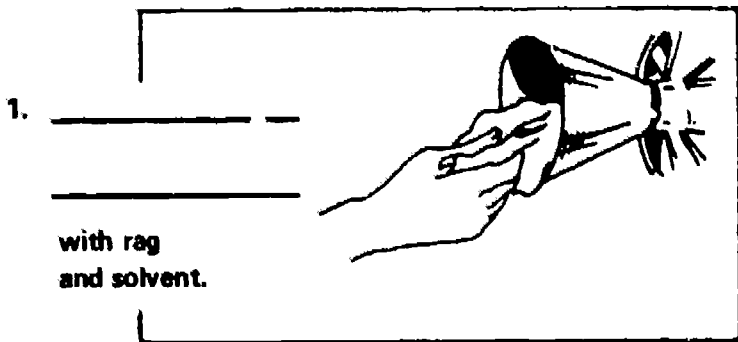

Check and correct
 your answers.

Cup Cleaning Procedure:

1. Wipe cup
2. Remove deposits
3. For wobble
4. Check surface and edge

CHECK IN AND AROUND CUP

CLEAN AIR AND OIL INPUT

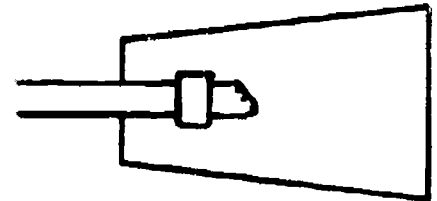
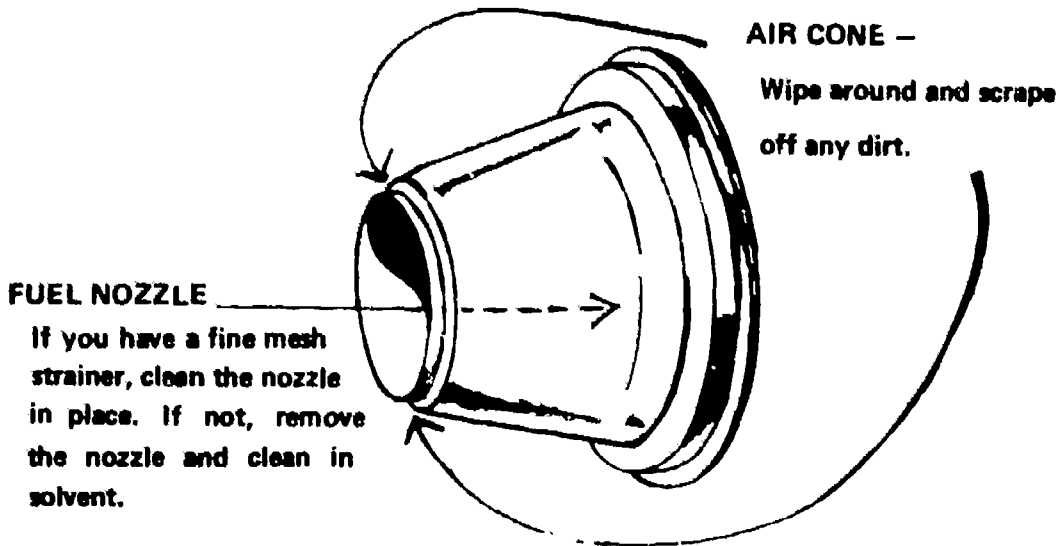

Now, the burner is ready to go again.

Answer these questions with regard to your system:

1. What might collect in the fuel nozzle?

2. Is it sufficient to clean your fuel nozzle in place or must you remove it?

3. What might collect in the air cone?

Check and correct
your answers.

1. Dirt in the oil
 2. Yes, if you have a fine mesh strainer, otherwise no
 3. Dirt in the air or from the fan
-

CUP CLEANING REVIEW

1. The cup should be cleaned when it is (hot, cold). _____

2. In opening the burner to clean the cup, what two things should you be careful of to avoid smoke and/or damage to your boiler?

3. Complete the four things to do or check in cleaning the cup?

1. _____ with rag and solvent.
2. _____ with wooden stick.
3. _____ by spinning the cup.
4. _____ for nicks, scratches.

4. What two other cup related things do you clean after cup cleaning?

Check and correct
your answers.

Answers – Cup Cleaning Review

- 1. Hot**

- 2. Mark your linkage settings**
Cover the burner opening

- 3. Clean the cup**
Remove deposits
Check for wobble
Check edge and surface

- 4. Fuel nozzle**
Air cone around cup

10. CLEAN OIL STRAINERS ONCE A WEEK

You need to keep your oil strainers clean, in order to have clean oil and a good flame.

Most systems have two strainers. They may be either single basket or double basket.

CROSS OUT THE INCORRECT WORDS UNDER EACH PICTURE:

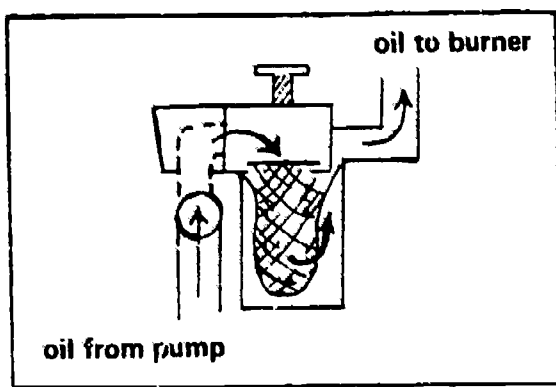

SINGLE/DOUBLE BASKET

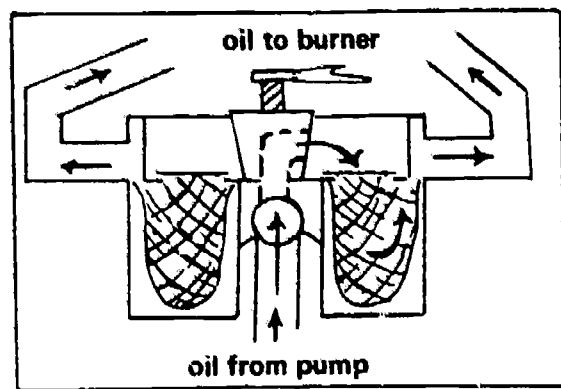

SINGLE/DOUBLE BASKET

You may have single baskets (as in the first picture), double baskets (as in the second picture) or both.

How many strainers do you have?

Are they single or double basket?

CLEAN EACH DIFFERENTLY

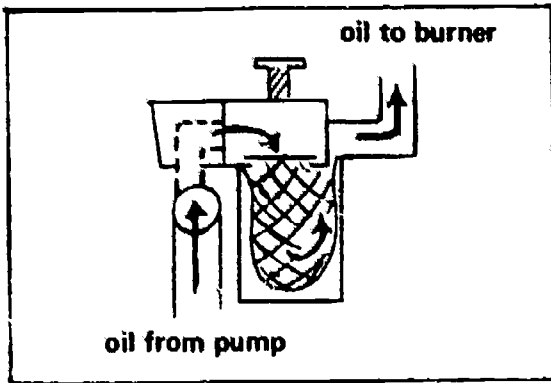

SINGLE BASKET CLEANING

1. TURN OFF OIL VALVE
2. SHUT DOWN BOILER
3. TAKE OUT BASKET and CLEAN
4. REPLACE BASKET
5. OPEN OIL VALVE
6. START BOILER

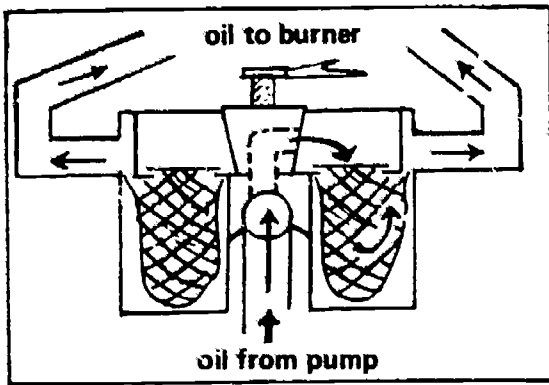

DOUBLE BASKET CLEANING

1. SWITCH OIL to empty basket
2. TAKE OUT DIRTY BASKET and CLEAN
3. REPLACE BASKET
(empty basket clean)

Answer these questions:

1. With what kind of strainer must you shut down the oil flow and boiler?
2. With what kind of strainer can you keep oil flowing while cleaning a basket?
3. How do you keep oil from being in the single basket strainer while cleaning it?
4. Do you need to shut down your boiler to clean your strainer(s)?

Check and correct
your answers.

1. Single basket
 2. Double basket
 3. Turn off the preceding oil valve
 4. Check your own answer
-

Clean strainers with a wire brush and solvent (kerosene). Place something under the strainer when cleaning to avoid dripping oil on the floor.

Complete the procedure for cleaning the strainers below:

SINGLE STRAINER

1. Turn off _____ valve.
2. Shut down _____.
3. Take out _____ and clean.
4. Replace _____.
5. _____ oil valve.
6. _____ boiler.

DOUBLE STRAINER

1. Switch _____ to empty basket.
2. Take out dirty _____ and clean.
3. Replace _____.

Check and correct
your answers.

Single Strainer

1. Turn off oil valve
2. Shut down system
3. Take out basket and clean
4. Replace basket
5. Open oil valve
6. Start boiler

Double Strainer

1. Switch oil to empty basket
2. Take out dirty basket and clean
3. Replace basket

11. LUBRICATE EACH WEEK

Weekly lubrication is necessary for a smooth running system.

Check and lubricate if necessary:

EQUIPMENT	PROCEDURE
1. Burner Gear Case	Check oil level (visually or with finger) and add oil if reservoir not full
2. Motors	1 or 2 drops at oiling points for bearings
3. Linkage Joints	1 or 2 drops

Answer the following questions:

1. What equipment usually has a lube oil level indicator showing if oil is needed? _____

2. Do not over oil bearings and joints. How much is needed? _____

3. List the equipment in your boiler system needing lubrication:

Check and correct
your answers.

1. Burner Motor Gear Case
 2. 1 or 2 drops
 3. Check your own answers
-

12. WEEKLY MAINTENANCE SUMMARY

WEEKLY TASKS: CLEAN OIL STRAINERS

LUBRICATE

CIRCLE THE CORRECT underlined words below:

1. The boiler should/need not be shut down when cleaning a single basket oil strainer.
2. In a double basket oil strainer the oil is always flowing through one/both of the baskets.
3. You may need to lubricate:gear case/all motors/switches on control panel/linkage joints.

Check and correct
your answers.

1. should
 2. one
 3. gear case/all motors/linkage joints
-

13. HOW ARE YOUR TUBES CLEANED?

If you have an automatic soot blower you can easily blow your tubes. If not, they must be cleaned manually.

If you clean manually, check every month and punch the tubes when soot builds up about 1/8 inch.

CLEANING METHOD	INSPECT	PERFORMED BY
Automatic Soot Blower	Every two weeks	Boiler Operator
Manual Cleaning	Every month	Boiler Operator/ Contract Maintenance

1. How are your tubes cleaned?

2. How often do you need to inspect them?

3. Who cleans your boiler tubes?

Check and correct
your answers.

1. Automatic soot blower or by hand
 2. Every two weeks (automatic), every month (manually)
 3. Me or maintenance service
-

14. DO YOU HAVE AN AUTOMATIC SOOT BLOWER?

If you have an automatic soot blower, this page will give you the basics. If you don't have one, turn to the next exercise.

Blow your tubes during daylight hours, while the boiler is running, and about once every two weeks.

Start the AIR COMPRESSOR and let it reach the 50 # – 100 # range. The SMOKE ALARM should be turned off and the AIR CONTROL VALVE opened for the system to blow automatically.

The smoke alarm is turned off because soot blown from the tubes would set it off when you don't want it to.

Number these steps in the right order:

- _____ Start air compressor
- _____ Blow tubes (open air valve)
- _____ Turn smoke alarm off
- _____ Turn smoke alarm on
- _____ Shut off air compressor

Check and correct
your answers.

- 1 Start air compressor
 - 3 Blow tubes (open air valve)
 - 5 Turn smoke alarm on
 - 2 Turn smoke alarm off
 - 4 Shut off air compressor
-

15. PUNCHING THE TUBES

Either you or contracted maintenance will clean or tubes.

GETTING READY:

1. CLOSE DAMPERS manually or set draft control at zero.
2. SHUT DOWN THE SYSTEM 1/2 hour before cleaning.
3. COVER BURNER with heavy cloth or canvas.
4. PROVIDE TRASH CANS lined with plastic or paper bags for soot.

Which of the above (1, 2, 3, 4) is particularly important when you realize:

1. That tubes and clean-out doors are often located directly over the burner. _____
2. The difficulty in handling loose soot. _____
3. That the boiler is hot inside! _____
4. Moving air in the tubes will send billows of soot through the clean-out door when it's open. _____

Check and correct
your answers.

1. 3
 2. 4
 3. 2
 4. 1
-

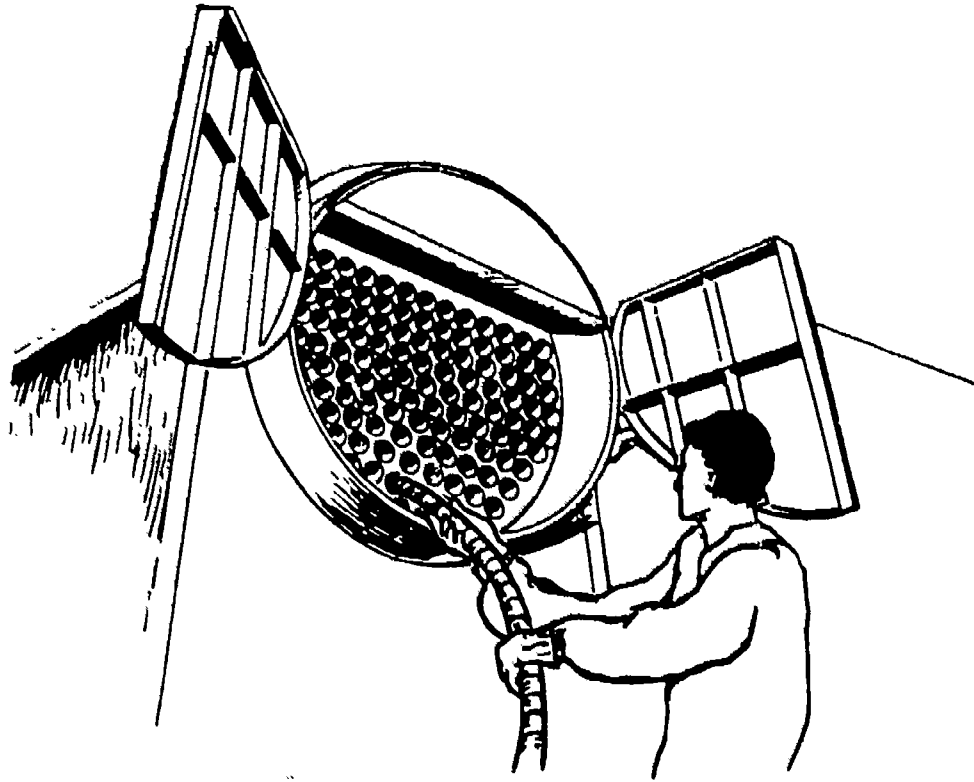

Clean your boiler tubes with a WIRE BRUSH attached to a VACUUM LANCE, carefully pulling the soot toward you into a lined trash can. Avoid getting soot into the stack, breeching or burner.

Number manual tube cleaning steps in the right order:

- _____ Clean tubes and close cleanout door.
- _____ Tie necks of can liners and put out for removal.
- _____ Getting Ready – shut burner down 1/2 hour before cleaning
 - close dampers
 - cover burner
 - provide trash cans with liners
- _____ Remove cloth from burner; put equipment away.

**Check and correct
your answers**

16. TUB CLEANING REVIEW

AUTOMATIC SOOT BLOWING STEPS:

1. Start air compressor
2. Turn off smoke alarm
3. Blow tubes (open air valve)
4. Shut off air compressor
5. Turn smoke alarm on

MANUAL TUBE CLEANING STEPS:

1. Getting Ready: Shut burner down 1/2 hr. before cleaning
close dampers
cover burner
provide trash cans with liners
2. Clean tubes and close clean-out door
3. Remove cloth from burner; put equipment away
4. Tie necks of can liners and put out for removal

LIST THE STEPS YOU TAKE when cleaning your tubes:

OPERATION AND MAINTENANCE SUMMARY

Below is a summary of the tasks included in this section.
They are listed in your Boiler Handbook for future reference.

BOILER ROOM CLEAN-UP

- Doors must lock
- Oil slicks gone
- Gauges easy to read

- Tools put away
- Air intakes clean
- Garbage cleaned up

DAILY CHECKS

1. FUEL in the tank
2. WATER in the boiler
3. HEATER SETTINGS – Oil Thermostat and Cold Oil Interlock

FREQUENT CLEANING

1. SMOKE ALARM LENS
 2. ATOMIZING CUP
-
- | | | |
|---------------|---|---------------------------------------|
| Getting Ready | { | 1. Disconnect twist plugs and linkage |
| | | 2. Open latch |
| | | 3. Swing burner out |
| | | 4. Cover burner opening |
-
- | | | |
|------------------|---|---|
| Cleaning the Cup | { | 1. Clean cup with rag and solvent |
| | | 2. Remove deposits with wooden stick |
| | | 3. Spin cup to check for wobble |
| | | 4. Check cup surface and edge for nicks |
-
- | | | |
|--------------|---|------------------------------|
| Other Checks | { | 1. Clean fuel nozzle |
| | | 2. Clean air cone around cup |

STARTING A COLD BOILER

- Getting Ready { 1. Check oil pressure gauge
2. Turn on fuel oil pump
3. Turn on electric heater

- Check Burner { 1. Inspect cup, clean if necessary
2. Swing burner into place
3. Reset linkage, lock in burner

- After Start Checks { 1. Flame
2. Oil Temperature
3. Oil Pressure

WEEKLY MAINTENANCE

1. CLEAN OIL STRAINERS

SINGLE BASKET

1. Turn off oil valve
2. Shut down boiler
3. Remove basket and clean
4. Replace basket
5. Open oil valve
6. Start boiler

DOUBLE BASKET

1. Switch oil to empty basket
2. Remove dirty basket and clean
3. Replace basket

2. LUBRICATE WHERE NEEDED

MONTHLY MAINTENANCE

1. CLEAN BOILER TUBES

SUMMARY OF PART II

These questions review the important things in this section:

1. What basic supply should you check in the boiler each day? (Without it the boiler cannot operate.)
2. What basic supply to the burner should you check each day? (Without it the burner cannot operate.)
3. What should you check each day to be sure of good oil flow and proper burn?
4. What should you clean frequently to guard against a false smoke alarm?
5. Which heater do you need to turn on and heat up when starting a cold boiler?
6. What piece of equipment moves the oil and must be turned on when starting a cold boiler?
7. What instruments let you check the oil temperature?
8. What does the oil pressure gauge and the vacuum gauge let you check?
9. When cleaning the atomizing cup, should you use a wooden or metal stick to scrape off deposits?
10. Will a 1/4" or smaller nick on the cup surface hurt proper atomization?

11. What will you prevent by using a clean cloth with solvent in cleaning the cup?
12. When cleaning the cup, what are you checking for when you give it a spin?
13. Dirt build-up should be removed from what two places & in and around the cup?
- 14.
15. Must the oil flow be turned off when cleaning a single basket strainer?
16. Must the oil flow be turned off when cleaning a double basket strainer?
17. What should be done about once a week to be sure that motors and linkage joints operate smoothly?
18. Should boiler tubes be cleaned on the average of once a week, once a month, or once a year?
19. What are the two methods or ways of cleaning the boiler & tubes?
- 20.

Check your answers.

ANSWERS TO REVIEW QUESTIONS

- 1. water**
- 2. oil**
- 3. oil temperature**
- 4. smoke alarm lens**
- 5. electric heater**
- 6. pump**
- 7. oil temperature gauges**
- 8. oil pressure**
- 9. wooden**
- 10. yes**
- 11. cup damage (scratches, poor atomization, smoke)**
- 12. wobble**
- 13. fuel nozzle in cup**
- 14. air cone around cup**
- 15. yes**
- 16. no**
- 17. lubrication**
- 18. once a month**
- 19. manual cleaning**
- 20. automatic soot blower**