

DOCUMENT RESUME

ED 102 874

FL 006 767

**TITLE** Comparative Study of the Syntactic Characteristics of Formal/Informal Discussion and Administrative Correspondence.

**INSTITUTION** Public Service Commission of Canada, Ottawa (Ontario).

**PUB DATE** Oct 74

**NOTE** 418p.

**EDRS PRICE** MF-\$0.76 HC-\$20.94 PLUS POSTAGE

**DESCRIPTORS** \*Business Correspondence; Computational Linguistics; Computer Programs; Descriptive Linguistics; English; \*Language Research; \*Language Styles; Language Usage; \*Language Variation; Research Methodology; \*Speech; Standard Spoken Usage; Statistical Analysis; \*Syntax

**ABSTRACT**

This study was conducted to provide descriptive, comparative, quantitative, and statistical information on the syntactic characteristics of two English registers: (1) formal and informal discussion and (2) administrative correspondence. In chapters 1 and 2 the background and purpose of the study are discussed. The composition of the major spoken and written corpus, the analytical data of which formed the basis of the study, is described in chapter 3. Chapter 4 outlines the multilevel analytical model adopted and its characteristic features. In chapter 5 the format of the computer printout containing the primary data is explained. Chapter 6 represents a statistical comparison of the spoken and written corpora at various levels, utilizing the analytical and quantitative information presented in the printout. Results are interpreted and conclusions summarized in chapter 7. Appendixes 1-11, in volume 2, consist of supplementary material prepared for readers desiring further details of different aspects of the study. (Author/PHP)

ED102874

BEST COPY AVAILABLE

COMPARATIVE STUDY OF THE SYNTACTIC CHARACTERISTICS

OF

FORMAL/INFORMAL DISCUSSION AND ADMINISTRATIVE CORRESPONDENCE

Project #8840-0017-081

U.S. DEPARTMENT OF HEALTH,  
EDUCATION & WELFARE  
NATIONAL INSTITUTE OF  
EDUCATION

THIS DOCUMENT HAS BEEN REPRODUCED EXACTLY AS RECEIVED FROM THE PERSON OR ORGANIZATION ORIGINATING IT. POINTS OF VIEW OR OPINIONS STATED DO NOT NECESSARILY REPRESENT OFFICIAL NATIONAL INSTITUTE OF EDUCATION POSITION OR POLICY.

Project Director: Rosaline K. Chiu  
Project Members: Darien Neufeld  
Marjorie Button  
Shirley Van Vliet  
Ron Smyth  
John Jarema

Research Division  
Directorate of Studies  
Staff Development Branch  
Public Service Commission of Canada.

October, 1974

2/3

FL 006 767

ACKNOWLEDGEMENT

This study could hardly have been completed without advice, encouragement and services from many associates and friends. We owe much to all our colleagues in the Research Division. We should like to take this occasion to thank them all.

We should make special mention, however, of our colleagues, assistants who were, at one time or other, closely involved in different phases of the study. We are grateful to Victor Barbeau for familiarising us with the tagmemic model; George Terroux for the design through which the formal/informal discussion corpus was compiled; Glenn Barker and Helen Sorhus for transcribing the spoken corpus; to Stewart Holden and Bob Hopwood for handling the computer processing; and to the "tagmemicists" for analysing the 10,000-sentence spoken corpus and the 5,000-sentence written corpus, on parts of which our present study is based. They are: Allan Bennett, Jean-Claude Boudreau, Wendy Broadridge, Daniel Clément, Marina Devine, Paula Irving, Renée Joyal, Hilary Kensley, Diane Latrémouille, Colleen Mahoney, Bill McVee, Susan Hampson Piper, Bernard Proulx, Ruth Richardson, Marie Rouleau, Len Satov, Raymond St-Laurent, Sharon Yoneda.

While acknowledging our indebtedness to all our colleagues listed above we must assume full responsibility for all defects and errors of any sort that might have escaped our notice in this report.

RESUME

Chapter I presents the background and rationale for the study and Chapter II states its aims.

The composition of the major spoken and written corpus, the analytical data of which formed the basis of the present study, is described in Chapter III.

Chapter IV attempts to outline the multi-level analytical model adopted and its characteristic features.

Chapter V gives an account of the format of the Computer Printout (Phase III) to aid readers who would like to study, or to retrieve further information from, the primary data.

Chapter VI represents a statistical comparison of the spoken and written corpora at various levels, utilizing the analytical and quantitative information presented in the Computer Printout (Phase III). It is written mainly for fellow researchers and readers who are interested in the methodological aspect of stylistic or register study. Readers who are not interested in this aspect of the study could disregard this chapter and move on to the next.

Chapter VII consists of our original observations on the syntactic characteristics of two distinct registers of English: formal/informal discussion and administrative correspondence, both of which our students will have to master.

Appendices 1 to 11 consist of Supplementary material to the above Seven Chapters, mainly prepared for readers who would like to have access to fuller details of different facets of the study.

TABLE OF CONTENTS

	<u>Page</u>
I. BACKGROUND AND RATIONALE.....	1
II. AIMS.....	14
III. THE CORPUS.....	15
1. The Nature and Compilation of Formal/Informal Discussion Corpus.....	15
2. The Nature and Compilation of the Administrative Correspondence Corpus.....	19
IV. NOTES ON THE ANALYTICAL MODEL.....	22
1. What is a Tagmeme?.....	22
2. Format of the Manual Analysis.....	23
3. Components at Each of the 5 Levels.....	28
V. FORMAT OF THE PHASE III PRINTOUT.....	36
1. Notes on Sequencing.....	37
2. Notes on Complexity.....	41
3. Information Retrieval.....	41
VI. STATISTICAL COMPARISON OF SAWE-A and SASE-A-B.....	44
1. Objectives.....	44
2. Choice of Statistical Measure.....	44
3. Homogeneity of SASE-A and SASE+B.....	45
3.1 Sentence Functions.....	45
3.2 Sentence Forms.....	47
3.3 Clause Forms.....	47
3.4 Phrase Forms.....	47
3.5 Number of Nuclear Tagmemes in Clauses.....	51
3.6 Conclusion.....	51
4. Comparison of SAWE-A and SASE-A+B.....	51
4.1 Sentence Functions.....	51
4.2 Sentence Forms.....	56
4.3 Clause Types by Group.....	57
4.4 Phrase Types.....	57
4.5 Number of Nuclear Tagmemes.....	67
4.6 Strings of Nuclear Tagmemes.....	67
4.7 General Categories of Clauses Without Regard to Semantic Categories.....	76
4.8 Semantic Categories of Dependent Clauses.....	89
4.9 Types of Noun Phrase Modification.....	100
4.10 Forms Filling Pre-Modification Slots in Noun Phrases.....	102
4.11 Forms Filling Post-modification Slots in Noun Phrases.....	102
4.12 Forms Filling Pre and Post-modification Slots in Noun Phrases.....	102

	<u>Page</u>
4.13 Strings of Functions Making up Noun Phrases.....	106
4.14 Ratio Comparisons.....	109
<b>VII INTERPRETATION OF THE RESULTS: SAWE-A (ADMINISTRATIVE CORRESPONDENCE) v.s. SASE A-B (FORMAL and INFORMAL DISCUSSION).....</b>	<b>111</b>
1. Level 1: Discourse.....	111
1.1 Sentence Function Definitions.....	111
1.2 Distribution of Sentence Function.....	113
1.3 Characteristic Features of SASE-A+B.....	113
1.4 Characteristic Features of SAWE-A.....	119
2. Level 2: Sentence.....	124
2.1 Sentence Form Definitions.....	124
2.2 Distribution of Sentence Forms and Comparison of Features at Level 2.....	130
3. Level 3: Clause.....	138
3.1 Notes on Clause Functions.....	138
3.2 Clause Form Definitions.....	140
3.3 Distribution of Clauses According to Form and Comparison of Features at Level 3.....	142
3.4 Distribution of Clauses According to Number of Nuclear Tagmemes.....	149
4. Level 4: Phrase.....	155
4.1 Definition of Phrase Forms.....	156
4.2 Distribution of Phrase Forms.....	160
4.3 Forms Filling Nuclear Slots in PHNs.....	162
4.4 Modification in Phrases.....	168
4.5 Summary.....	176
5. Level 5: Expression.....	178
5.1 "Fixed" Expressions.....	178
5.2 Verbal Expressions.....	187

TABLE OF FIGURES

<u>Chapter I</u>	Page
1. Major Spoken Corpus: Syntactic Analysis of Spoken English.....	7
2. Major Written Corpus: Syntactic Analysis of Written English.....	8
3. Typical Sentence Analysis.....	9
 <u>Chapter V</u>	
1. Criteria for Sequencing of Structures in Phase III printout.....	38
2. Criteria for Sequencing of Function Groups.....	39
 <u>Chapter VI</u>	
1. Sentence Functions: SASE-A vs. SASE-B.....	46
2. Sentence Forms: SASE-A vs. SASE-B.....	48
3. Clause Types by Groups: SASE-A vs. SASE-B.....	49
4. Phrase Types: SASE-A vs. SASE-B.....	50
5. Number of Nuclear Tagmemes in Clauses: SASE-A vs. SASE-B.....	52
6. Sentence Functions: SAWE-A vs. SASE-A+B.....	53
7. Sentence Functions: SAWE-A (graph).....	54
8. Sentence Functions: SASE-A+B (graph).....	55
9. Sentence Forms: SAWE-A vs. SASE-A+B.....	58
10. Sentence Forms: SAWE-A (graph).....	59
11. Sentence Forms: SASE-A+B (graph).....	60
12. Clause Types by Groups: SAWE-A vs. SASE-A+B.....	61
13. Clause Types by Groups: SAWE-A (graph).....	62
14. Clause Types by Group: SASE-A+B (graph).....	63
15. Phrase Types: SAWE-A vs. SASE-A+B.....	64



VII

	Page
16. Phrase Types: SAWE-A (graph).....	65
17. Phrase Types: SASE-A+B (graph).....	66
18. SAWE-A and SASE-A+B Clauses: Number of Nuclear Tagmemes.....	68
19. SAWE-A Clauses: Number of Nuclear Tagmemes (graph).....	69
20. SASE-A+B Clauses: Number of Nuclear Tagmemes (graph).....	70
21. Clauses: 5 Most Frequent Strings of <u>SAWE-A</u> Nuclear Tagmemes Compared with <u>SASE-A+B</u> .....	71
22. Clauses: 5 Most Frequent Strings of <u>SASE-A+B</u> Nuclear Tagmemes Compared with <u>SAWE-A</u> .....	72
23. Clauses: 10 Most Frequent Strings of <u>SAWE-A</u> Nuclear Tagmemes Compared with <u>SASE-A+B</u> .....	73
24. Clauses: 10 Most Frequent Strings of <u>SASE-A+B</u> Nuclear Tagmemes Compared with <u>SAWE-A</u> .....	74
25. SAWE-A vs. SASE-A+B: Overall General Categories of Clauses Without Regard to Semantic Categories.....	77
26. SAWE-A: Overall General Categories of Clauses Without Regard to Semantic Categories (graph)..	78
27. SASE-A+B: Overall General Categories of Clauses Without Regard to Semantic Categories.....	79
28. SAWE-A vs. SASE-A+B: General Categories Within <u>Clause Basic Group</u> Without Regard to <u>Semantic Categories</u> .....	80
29. SAWE-A: General Categories Within <u>Clause Basic</u> <u>Group</u> Without Regard to <u>Semantic Categories</u> (graph).....	81
30. SASE-A+B: General Categories Within <u>Clause</u> <u>Basic Group</u> Without Regard to <u>Semantic</u> <u>Categories</u> (graph).....	82
31. SAWE-A vs. SASE-A+B: General Categories Within <u>Clause Equative Group</u> Without Regard to <u>Semantic Categories</u> .....	83
32. SAWE-A: General Categories Within <u>Clause Equative</u> <u>Group</u> Without Regard to <u>Semantic Categories</u> (graph).....	84

	Page
33. SASE-A+B: General Categories Within <u>Clause Equative Group</u> Without Regard to Semantic Categories (graph).....	85
34. SAWE-A vs. SASE-A+B: General Categories Within <u>Clause Passive Group</u> Without Regard to Semantic Categories.....	86
35. SAWE-A: General Categories Within <u>Clause Passive Group</u> Without Regard to Semantic Categories (graph).....	87
36. SASE-A+B: General Categories Within <u>Clause Passive Group</u> Without Regard to Semantic Categories (graph).....	88
37. Overall Comparison of Semantic Categories of Dependent Clauses: SAWE-A vs. SASE-A+B.....	90
38. Semantic Categories of Dependent Clauses I. <u>CAUSE</u> : SAWE-A vs. SASE-A+B.....	91
39. Semantic Categories of Dependent Clauses II. <u>COND</u> : SAWE-A vs. SASE-A+B.....	92
40. Semantic Categories of Dependent Clauses III. <u>CONS</u> : SAWE-A vs. SASE-A+B.....	93
41. Semantic Categories of Dependent Clauses IV. <u>MAN</u> : SAWE-A vs. SASE-A+B.....	94
42. Semantic Categories of Dependent Clauses V. <u>OPPOS</u> : SAWE-A vs. SASE-A+B.....	95
43. Semantic Categories of Dependent Clauses VI. <u>PURP</u> : SAWE-A vs. SASE-A+B.....	96
44. Semantic Categories of Dependent Clauses VII. <u>RESTR</u> : SAWE-A vs. SASE-A+B.....	97
45. Semantic Categories of Dependent Clauses VIII. <u>SIT</u> : SAWE-A vs. SASE-A+B.....	98
46. Semantic Categories of Dependent Clauses IX. <u>TIME</u> : SAWE-A vs. SASE-A+B.....	99
47. Types of Noun Phrase Modification in SAWE-A vs. SASE-A+B.....	101
48. Forms Filling <u>Pre-Modification</u> Slots in Noun Phrases: SAWE-A vs. SASE-A+B.....	103
49. Forms Filling <u>Post-Modification</u> Slots in Noun Phrases: SAWE-A vs. SASE-A+B.....	104

50.	Forms Filling <u>Pre &amp; Post Modification</u> Slots in Noun Phrases: SAWE-A vs. SASE-A+B.....	105
51.	Noun Phrases: 5 Most Frequent Strings of <u>SAWE-A</u> Compared With SASE-A+B.....	107
52.	Noun Phrases: 5 Most Frequent Strings of <u>SASE-A+B</u> Compared with SAWE-A.....	108
53.	SAWE-A vs. SASE-A+B: Ratio Comparisons.....	110

### Chapter VII

1.	Sentence Functions: SAWE-A vs. SASE-A+B.....	114
2.	High Ranking Sentences According to Number of Words per Sentence.....	137
3.	Distribution of Clauses According to Form <ul style="list-style-type: none"> <li>a) SAWE-A: Administrative Correspondence</li> <li>b) SASE-A+B: Format/Informal Discussion.....</li> </ul>	143
4.	CLIMBERS Structures.....	144
5.	Frequencies of Clauses Grouped According to Number of Nuclear Tagmemes. <ul style="list-style-type: none"> <li>a) SAWE-A: Administrative Correspondence</li> <li>b) SASE-A+B: Format/Informal Discussion.....</li> </ul>	150
6.	Distribution of Phrase Forms.....	160
7.	Forms Filling Nuclear Slots in Phrase Constructions.....	163
8.	Noun Phrase Modification.....	168
9.	Distribution of "Fixed" Expressions.....	179
10.	Distribution of "Adjectival" Expressions.....	180
11.	Distribution of "Verbal" Expressions.....	188

TABLE OF APPENDICES (Vol. 2)

	Page
1. The fifteen government departments and agencies from which administrative correspondence (the source for Genre "A" of the Corpus) was received.	i
2. Random Selection: procedure	2
3. Function Labels	3
4. Form Labels	8
5. Descriptive Definitions: SASE-A+B	14
6. Descriptive Definitions: SAWE-A	90
7. Sequencing of Structures in the Computer Printout (Phase III)	162
8. Complexity	171
9. Administrative Correspondence: Exhaustive List of Clause Structures (Nuclear Tagmemes, Ordered)	187
10. Formal/Informal Discussion: Exhaustive List of Clause Structures (Nuclear Tagmemes, Ordered)	191
11. Types of Noun Phrase Modification.	195

## I BACKGROUND AND RATIONALE

In the field of linguistics, there has been much discussion of intra-lingual varieties in the last fifteen years. Much attention has been devoted to the identification and description of varieties of language within the same speech community, and there is a movement towards establishing overt criteria, both linguistic and extra-linguistic, to this end. Among the representative works are Bright, (1966), Bernstein, (1964), Ellis and Ure, (1969), Gregory (1967), and Fishman, (1968, 1971).<sup>1</sup>

Strevens<sup>2</sup> (1965) has this to say about the English language: "In countries where English is the mother tongue, it is usual for both the general public and those who teach English to talk about the language as if it were a single, identifiable consistent entity. We learn and teach sets of rules, (purporting to be 'the grammar of English'), when a relatively small quantity of factual observation should convince us that every rule is consistently broken in one or another set of circumstances, by one or another set of speakers or writers." As he sees it, English, just as any other natural language, exists, not as a single uniform entity, but as a constellation of varieties, each functioning in a particular way. Crystal<sup>3</sup> in an article entitled "New Perspectives for Language Study" published in English Language Teaching, 1970, writes "one of the main criticisms that can be justifiably and usefully directed at traditional approaches to English language study is that they are too restricted in scope, too monolithic, to provide an adequate picture of the language."

The central issues are nowadays quite familiar; the concentration on written English to the exclusion of spoken, and on formal, literary styles of the language at the expense of the informal and conversational. It is only recently that linguistic approaches to the study of English have begun to do anything more than pay lip-service to the need for a more comprehensive eclectic account of the language as a whole. One of the clearest indications of a movement in this direction is the recent efforts in the studies of English in use, focusing on the description and classification of varieties of English according to the user, as well as the varieties of English according to use.

English can be classified and subdivided into dialects according to its users, similarly it can also be classified and subdivided into registers according to the many uses to which it is put.

Language varies as its function varies; it differs in different situations. The label given to a variety of a language according to use is "register". When we observe language activity in the various contexts in which it takes place, we find differences in the types of language selected as appropriate to different types of situations. 'Scientific' English is different from 'colloquial' English. And 'religious' English is again different from both. In various degrees, there are correlations between recurrent linguistic features and situational features. As mentioned before many attempts have been made recently to establish conceptual frameworks and theoretical categories of the uses of language to enable better understanding

of the functioning of a language in a particular situation: who says or writes what, to or for whom, when, in what circumstances, and why? Scholars in the field see that the study of registers, which is quite recent in origin, is crucial to both our understanding of how language works and our understanding of its applications: specifically to literary criticism, translation and language teaching, both native and second.

Pioneers in the field of register-study have recognized the applicability and importance of their work to language teaching, especially to the preparation of teaching programs. Halliday (1964) writes "The choice of items from the wrong register, and the mixing of items from different registers, are among the most frequent mistakes made by non-native speakers of English... If we failed to note the differences of registers, we should be ignoring an important aspect of the nature and functioning of language. Our descriptions of language would be inaccurate and our attempts to teach them to foreigners made vastly more difficult."<sup>4</sup> Ure (1969) writes "No one register can serve as an all purpose model... A range of varieties must be the aim of any teaching program... If a foreign language speaker does not know the appropriate register, there is more than one way of going wrong."<sup>5</sup> Crystal (1970) also notes that information from variety-study is highly important for TESOL,<sup>6</sup>

Even though in recent years breakthroughs have been made

in the establishment of useful theoretical models and categories of register, there has been a lack of substantial analytical data to test the effectiveness of these models and categories. Theoreticians in the field have been aware of this obvious lack and inadequacy. Halliday, McIntosh and Strevens, (1964), write "...up to now we know very little about the various registers of spoken English. Even studies of the written language have only recently begun to be made from this point of view. For this reason we are not yet in a position to talk accurately about registers; there is much work to be done before the concept is capable of detailed application... Very large samples of text have to be subjected to detailed formal analysis if we wish to show which grammatical or lexical features are common to all uses of the language and which are restricted to, or more frequent in, one or more particular registers."<sup>7</sup> Ellis and Ure, (1969), write "...in the sheer description of registers of one language, large-scale research using enough text for significant statistics is called for. The development of computer methods in linguistic analysis should make possible the effective application of, and feedback to, variety and especially register theory."<sup>8</sup> Elsewhere in the same article they write: "...register-based linguistic analysis of texts can equally provide the teacher with a selection of material appropriate to the situational needs of the student, together with a statement of frequency of occurrence and co-occurrence of items and categories."<sup>9</sup> Crystal and Davy, (1969), state: "We cannot but conclude that stylistic theory,



at the time of writing, has reached a stage where it would do well to wait for practical analysis to catch up, so that the theoretical categories may be tested against a wide range of data, and more detailed analysis of text carried out."<sup>10</sup> Again in 1970, Crystal, who prefers to use the label 'stylistics' to cover the whole complex of varieties and styles that make up 'a' language, writes about the importance of stylistics information for English language teaching. He writes: "... it is still rare to find any attempt being made to incorporate it systematically into a course. This is understandable, in view of the absence of any 'dictionary of stylistic features' which the teacher may turn to in order to find out exactly what it is that is idiosyncratically 'scientific' about scientific English, what is 'colloquial' about colloquial English, and so on. The big dictionaries are of some help as far as vocabulary is concerned, in that they very often label restricted lexical usage, but you cannot rely on any consistency here. And grammar books on the whole do not give stylistic information."<sup>11</sup>

Thus, conscious of the current movement towards a more realistic and less monolithic approach to the study of the English language and its manifold implications to the teaching of English as a second language, and responding to the call for practical register-based linguistic analysis, the Research Section, formerly of the English Curriculum Division, Language Bureau, and presently under the Directorate of Studies, Staff Development Branch, Public Service Commission, has carried out two large-scale, corpus-based, register-oriented, descriptive linguistic studies on the syntax of

spoken and written English: The Syntactic Analysis of Spoken English Project (SASE) and Syntactic Analysis of Written English Project (SAWE). SASE was begun in the spring of 1971 while SAWE was begun in the spring of the following year. Both projects were completed by the fall of 1974. The present project, Comparative Study of the Syntactic Characteristics of Formal/Informal Discussion and Administrative Correspondence, which was implemented by the Research Division, Directorate of Studies in the months of April to September, 1974, is a spin-off from and a follow-up of the major studies, SASE and SAWE.

The major spoken corpus (SASE) consists of over 10,000 sentences of Canadian Speech. The speakers were taped in unscripted and unrehearsed formal and informal situations. The spoken corpus is composed of four sections A,B,C, and D. Section A consists of about 500 sentences of formal boardroom discussion; Section B consists of 700 sentences of informal boardroom discussion; Section C consists of about 2,500 sentences of dialogues taken from ESL textbooks; and Section D consists of over 6,000 sentences of media discussions and interviews. Within each section, the sentences fall into 100 sentence samples. Except for section C, textbook dialogues, within each sample the sentences represent continuous speech. The tapes were transcribed in long-hand, typed and checked against the tape. The following is a schematic representation of the corpus of the project Syntactic Analysis of Spoken English.<sup>12</sup>

Figure 1

<u>Major Spoken Corpus</u>			
<u>Syntactic Analysis of Spoken English Corpus</u>			
<u>Sections</u>	<u>Materials</u>	<u>No. of Sentences</u>	<u>No. of Samples</u>
A	Formal Boardroom Discussion = public servants	507	5
B	Informal Boardroom Discussion = public servants	759	6
C	ESL Textbook Dialogues	2,437	24
D	Media Discussions and Interviews	6,389	53
	TOTAL:	10,072	88

The major written corpus (SAWE) consists of over 5,000 sentences. It is composed of two parts. The government half of our written corpus consists of four sections: Administrative correspondence, bulletins and information sheets, annual reports for internal consumption and publications for external consumption. The non-government half is also composed of four sections. They are newspaper articles, newspaper editorials, magazine articles and magazine editorials. Their common theme is media reaction to government policy. The composition of the corpus of this Project, Syntactic Analysis of Written English may be presented schematically as follows:

Figure 2

Major Written Corpus  
Syntactic Analysis of Written English Corpus

<u>Sections</u>	<u>Materials</u>	<u>Number of Sentences</u>	<u>Number of Samples</u>
I GOVERNMENT			
A	Administrative Correspondence	1,000	20
B	Bulletins and Information Sheets	500	10
C	Annual Reports	500	10
D	Publications	<u>1,000</u>	<u>20</u>
	TOTAL GOVERNMENT	3,000	60
II NON-GOVERNMENT			
E	Newspaper Articles	1,000	20
F	Newspaper Editorials	500	10
G	Magazine Articles	1,000	20
H	Magazine Editorials	<u>500</u>	<u>10</u>
	TOTAL NON-GOVERNMENT	3,000	60

The analytical model adopted is a tagmemic model, as expounded by Kenneth Pike<sup>13</sup> and as modified by Victor Barbeau<sup>14</sup> who analysed a corpus of spoken and written French for the Language Bureau, Public Service Commission of Canada. The tagmemic model used is a multi-level analytical model and at each level the sentence and its parts are analysed in terms of both function and form. The analysis at

each of the five levels of the model is briefly outlined as follows:

- Level 1 - Discourse level - Analysis of the function of the sentence within the discourse, as well as its form.
- Level 2 - Sentence level - Analysis of the sentence into clauses.
- Level 3 - Clause level - Analysis of each clause into subject, predicate, direct object, indirect object, etc.
- Level 4 - Phrase level - Analysis of noun and pronoun phrases, verb phrases, adjectival phrases and adverbial phrases.
- Level 5 - Expressional level - Listing of all verbs and "fixed expressions" (nominal, verbal, adverbial, adjectival, etc.)

A typical sentence analysis is as follows:

Figure 3

TYPICAL SENTENCE ANALYSIS

---

B.1.42	What did (you) think of that Frank?		
1.1	↑SENINTERROG /SENSIM		
2.1	SENSIM ↑CLIND /CLBAS		
3.1	CLBAS ↑OD /PRONINTERROG	↑PRED /XVCOMP	[↑S /PRONP]
	↑OI /PHPREP	↑VOC /NP	
	What did (you) think of that Frank?		
4.1	PHPREP ↑IPP /PREP of	↑NUC /PRONDEM that	
5.1	XVCOMP ↑AUX /XVAUX did	&    ↑NUC /XVIV ...think	
5.2	XVAUX    1 did		
5.3	XVIV    1 think		

---

The analysis of SASE and SAWE was done manually, and the data processing was done by computer. (See: D. Neufeld's report on Implementation and Data Processing of SASE and SAWE, 1974). The projects provide computerized data which among other practical applications, can be used for comparative and contrastive study of spoken and written English at each of the five levels. The data of the projects consists of: (1) an ordering of syntactic structures from the simple to the complex for both major corpora; (2) an ordering of syntactic structures from the simple to the complex for all individual Sections of the corpora; (3) statistical information on frequency of occurrence and distribution of syntactic structures at all levels; and (4) an inventory of examples of each structure systematically laid out.

Based on the data of the major studies, further inter-corpus, intra-corpus and inter-section comparative studies could be made to obtain register information at all levels provided by the analytical model. From level 1, the discourse level, we would expect to get such register information as whether a variety makes use of a particular type of sentence to the exclusion of others, for instance, whether it consists solely of 'declarative sentences' to the exclusion of 'imperatives' and 'interrogatives'; or whether it has a high proportion of 'simple sentences', or shows a preference of 'complex sentences'. At level 2, the sentence level, we will be able to get comparative data on sentence typology and structure. There, we are concerned with the 'placement' or 'ordering' of the clause within a sentence. At Level 3,

the clause level, we will be able to get comparative data on clause typology and structure. At this level, we are looking for distinctiveness in a given variety, which involves how linguistic functions within a clause are realised formally, for instance, the proportion of nouns to verbs, the frequency of pronouns as opposed to noun phrases, etc. At Level 4, the phrase level, we will be able to get comparative data on phrase typology and structure for the varieties. For instance, it is easy to see the potential of 'noun phrases' for making register contrasts in terms of complexity, and the potential of 'verb phrases' for making contrasts in the distribution of tense forms. At Level 5, the expression level, our analysis will yield information on 'frozen expressions', such as nominal expressions, adverbial expressions, etc. as well as all verbs.

The present project, Comparative Study of the Syntactic Characteristics of Formal/Informal Discussion and Administrative Correspondence, is based on the data of Sections A and B : Formal and Informal Boardroom Discussion of the Syntactic Analysis of Spoken English Corpus; (see: Figure 1) and Section A: Administrative Correspondence of the Syntactic Analysis of Written English Corpus. (See: Figure 2) More specifically, it represents an attempt to compare the register-characteristics of Formal/Informal Discussion and Administrative Correspondence.

BEST COPY AVAILABLE

NOTES

1. Bright, William (ed) Sociolinguistics, Paris; The Hague: Mouton, 1966  
Bernstein, Basil. "Elaborated and restricted codes: their social origins and some consequences" in The Ethnography of Communication, (eds.) J.J. Gumperz and D. Hymes (Am. Anthropol. Spec. Publ. 3 Menasha: American Anthropological Association), 1964  
Ellis, J.O. and J.N. Ure. "Language Varieties: Register" in Encyclopedia of Linguistics, Information and Control, Oxford: Pergamon Press, 1969  
Gregory, M. "Aspects of Varieties Differentiation" in J. Ling. 3, 1967, pp. 177 - 197  
Fishman, J.A. (ed) Advances in the Sociology of Language, The Hague: Mouton, 1971  
Fishman, J.A. (ed) Readings in the Sociology of Language, The Hague: Mouton, 1968
2. Strevens, P.D. "Varieties of English" in Papers in Language and Language Teaching (ed) Strevens P.D., O.U.P. 1965 p. 74 f.
3. Crystal, David "New Perspectives for Language Study 1. Stylistics" English Language Teaching Vol. 24, No. 2, 1970 pp. 99 - 106
4. Halliday, M.A.K., A. McIntosh and P. Strevens. The Linguistic Sciences and Language Teaching, London: Longmans, 1964 p. 88
5. Ure, Jean. "Practical Registers (A)", English Language Teaching, Vol. 23, No. 2, 1969 pp. 108,113
6. Crystal, D. op. cit.
7. Halliday, M.A.K., A. McIntosh and P. Strevens, op. cit. p. 152
8. Ellis, J.D. and J.N. Ure, op. cit. p. 354
9. Ellis, J.D. and J.N. Ure, op. cit. p. 258
10. Crystal, D. and D. Davy. Investigation-English Style, Longmans, 1969 p. 62
11. Crystal, D. op. cit. p. 101
12. For more details on the compilation of the corpus, see: Darien Neufeld's report on: Implementation and data processing: Syntactic Analysis of Spoken English and Syntactic Analysis of written English, June, 1974 pp. 1-3



13. Pike, Kenneth L. Language in Relation to a Unified Theory of Human Behaviour, Janua Linguarum, Series Major 24, 2nd Revised Edition, The Hague, Mouton
14. Barbeau, Victor. "Analyse Syntaxique du Français Parlé"  
Paper presented to the 1971 Annual Meeting of the Canadian Linguistic Association, St. John's, Newfoundland.

## II AIMS

In the English Program of the Language Bureau, one of the teaching targets is to enable French-speaking public servants to function in English at work. The students are expected to understand and write in the register of 'administrative correspondence'. High-ranking public servants are also expected to participate in formal and informal discussions at 'official' meetings. Thus, it is the aims of the present study to provide descriptive, comparative, quantitative and statistical information on the syntactic characteristics of these two registers of English so that suitable teaching materials can be designed to meet the specific requirements of our students in their context.<sup>1</sup>

It is also the aim of the present study to demonstrate the procedures involved in the register study: descriptive linguistic, comparative and statistical techniques were used.<sup>2</sup>

### NOTES

1. See: Chiu, Rosaline K. Measuring Register Characteristics, in IRAL, Vol. XI/1, 1973 pp. 51-68
2. Compare: Leech, Geoffrey N. English in Advertising, London: Longmans, 1966  
and Crystal, David and D. Davy. Investigating English Style, London: Longmans, 1969

### III THE CORPUS

As mentioned before, the present study is a comparative study based on two sets of analytical data: Sections A and B of the project Syntactic Analysis of Spoken English, representing the register of "formal and informal government boardroom discussion" and Section A of the project Syntactic Analysis of Written English representing the register of "government administrative correspondence".

#### 1. The nature and compilation of the Formal/Informal Discussion Corpus

It was decided to tape-record samples of actual Government Boardroom Discussion. In order to identify and describe the register of "middle or upper-middle management echelon topic-oriented Boardroom discussion" as used by Canadian public servants, the criteria for the suitability of the language specimens were as follows:

- (i) The Field of Discourse should be non-technical topic-oriented discussion.
- (ii) The Mode of Discourse should be a structured discussion by several participants with an agenda.
- (iii) On the dimension of Manner of Discourse, the 'social roles' of the participants should be their 'official roles' at the "middle or upper-middle management echelon" within the governmental hierarchy. The participants should be more than two in number. Their 'social attitudes' should be as 'formal' as is 'appropriate' in the presence of a superior, since a senior officer would be present during the discussions.<sup>1</sup>

It was also planned that the samples collected according to the above criteria were to be compared and contrasted with samples

recorded under similar conditions with the following minor changes and adjustments.

- (i) On the dimension of the Mode of Discourse, instead of a structured discussion, a more spontaneous discussion should be elicited. The rest of the agenda need not be adhered to, even though the topic of discussion should remain about second language training and learning in the public service of the Canadian context. As a result, a 'freer' and 'conversational' register was expected to emerge.
- (ii) On the dimension of Manner of Discourse, due to the absence of the senior officer from the situation, the "social role" of the participants would be adjusted to that of public servants of middle management level, functioning at a Boardroom Discussion among a group of peers. Accordingly, the 'social attitudes' of the participants would be re-aligned to that of being 'consultative' and/or 'casual', as 'appropriate' in the company of colleagues rather than being 'formal', as 'appropriate' in the presence of a superior.

Besides the criteria mentioned above, it was specified that the participants were to be Canadian public servants whose mother-tongue was Canadian English to ensure the collection of a corpus of present-day Canadian English in the register of "middle or upper-middle management echelon topic-oriented boardroom discussion".

Samples of this register of English were to be elicited and recorded in several rigorously-controlled sessions.<sup>2</sup>

Three roles were involved in these Formal/Informal Discussion sessions:

- (i) the moderator, who was to be a member of the research team.
- (ii) the participants in the discussion, who were to be Canadian public servants of middle or upper-middle management.
- (iii) the VIP (for lack of a better designation), who was to be either senior in rank, or else

holding a position of authority vis-a-vis the participants, and he was to be deferred to by the 'moderator'.

The participants were told that an analysis of spoken English was to be carried out for programme development purposes at the English Curriculum Division of the Language Bureau, and they were invited to contribute towards a corpus of genuine Canadian spoken English. At the beginning of the taping sessions, the participants would be taken to a boardroom with taping equipment where they met the moderator and the VIP. The participants were given an agenda, which read as follows:

- (i) The effects of English language teaching on departmental personnel.
- (ii) The effects of French language teaching on departmental personnel.
- (iii) Consideration of teaching methods.
- (iv) The relevance and effectiveness of current methods in the context of the Canadian public service.

At the beginning of the sessions, the moderator might ask the VIP to comment on the first item of the agenda, or, alternatively, the VIP would act merely as an observer, depending on the number of participants. The VIP was the one who set the degree of 'formality' along the 'formality scale' in the 'manner of discourse' of the participants. He was expected to set the 'formal' level required by making serious and thoughtful comments on the first item of the agenda. Or, he might merely look on inscrutably while the discussion progressed. The presence of the VIP, the agenda, the deference of the moderator to the VIP, and the 'polite' and 'professional' manner of the moderator toward the participants were expected to elicit the required register

from the native English-speaking participants, who would have both the intuition and experience to behave 'appropriately', linguistically and otherwise, in such a situation.

After approximately 30 minutes, the discussion would be interrupted and the VIP would leave with a valid excuse. It was designed that at this juncture, efforts would be made on the part of the moderator to 'deformalize' the situation, ie, to reduce the degree of 'formality' in the situation. The moderator would remove his jacket and loosen his tie. Coffee would be served, and during coffee the moderator would chat with the participants in a 'friendly' and 'relaxed' manner. After ten minutes or so, the discussion would be resumed and led by the moderator. (The VIP would be absent throughout the second half of the session). The moderator would have frequent eye-contacts with the participants while soliciting their opinions. He would smile and need not adhere as closely to the agenda as before, even though the topic of the discussion should still be oriented to second language teaching and learning. If enough rapport was already established during the coffee break, the moderator could address the participants by their first names. A less 'formal' manner of discourse would result.

If Joos' 5-point scale of 'formality': Frozen--Formal--Consultative--Casual--Intimate is taken as an index,<sup>3</sup> the first half of the discussion was designed to reflect spoken English at the point of being 'formal', possibly shading into that of being 'consultative', while the second half of the discussion was designed to reflect spoken English at the point of being 'consultative', possibly shading into that of being 'casual'.

About five hours each of Formal Discussion and Informal Discussion was taped, the former being Section A of the Syntactic Analysis of Spoken English Corpus and the latter, Section B of the same corpus. The combined data from both Section A and B represent the 'Spoken' data of the present project.

	<u>No. of Sentences</u>	<u>No. of Samples</u>
Section A = Formal Discussion	507	5
Section B = Informal Discussion	759	6
	<hr/> 1,266	<hr/> 11
Sections A&B = Formal/Informal Discussion		

2. The nature and the compilation of the Administrative Correspondence Corpus

A letter from the Directorate of the Pedagogical Services and Research of the Language Bureau was sent to the Advisors on Bilingualism of 30 randomly selected Government Departments requesting the supply of about 100 pieces of everyday correspondence in the files of the departments with the following specifications:

- (i) The correspondence supplied must not be dated further back than 1968 to ensure synchronicity.
- (ii) The correspondence should be either intra-departmental, interdepartmental or from government departments to outside concerns. This is to ensure that the corpus collected could be regarded as a register of Standard Canadian English.
- (iii) The pieces of correspondence supplied should be a more or less random sampling of letters and memoranda reflecting various everyday administrative activities, which generally range over the categories of:
  - Authorizing and directing correspondence
  - Informing and reporting correspondence
  - Requesting correspondence
  - Sending, forwarding or covering correspondence

As the result of the request, about 1,400 documents were received from fifteen government departments (See Appendix 1 for a listing of these departments.) About 20 samples of 50 sentences each were chosen by the process of random selection outlined in Appendix 2 out of a common pool of 1,372 documents. Each of the samples was composed of as many documents as necessary to make up the required 50 sentences. 157 documents were used in the 20 samples.

With one exception, only complete documents were used. This was possible because the documents varied considerably in length but were relatively short. When a given sample was being put together, documents were taken according to random choice until a document caused the sample to exceed the 50 sentence limit. For example - if the first six documents chosen totalled 47 sentences and the seventh had 10 sentences, then document #7 was put aside, and the other randomly chosen documents were looked at, in turn until a three-sentence document was found. This then became the last document in that sample. Those documents which had been passed over became part of the next sample, and the process continued.

The 157 documents thus sampled make up Section A of the Syntactic Analysis of Written English corpus, the analytical data of which represents the 'written' data of the present project.

	<u>No. of Sentence</u>	<u>No. of Samples</u>
Section A-Administrative Correspondence	1,000	20



NOTES

1. For definitions of Field of Discourse, Mode of Discourse, and Manner of Discourse see: Chiu, Rosaline K. Measuring Register Characteristics, in IRAL Vol. X1/1, 1973 pp.51-68
2. The design of the taping sessions was formulated by George Terroux, now of McGill University. The tapings took place in the summer of 1970.
3. Joos, Martin. The Five Clocks, Bloomington, 1962.

IV NOTES ON THE ANALYTICAL MODEL

1. What is a Tagmeme?

Within the tagmemic model of analysis, the tagmeme is the most basic unit. Each tagmeme is seen and described as being composed of a function slot combined with a form filling that slot. The function slot defines the role of the form filler in relation to the other units in the construction. Thus, the function slot labelled SUBJECT would define the role of its filler in relation to the PREDICATE or OBJECT slots. The forms of a particular tagmeme belong to a class which may fill the particular function slot or, in other words, which may perform the role defined by that slot. Thus, the subject slot may be filled by pronouns, proper nouns, nominal expressions, noun phrases, clauses, etc., all of which may function as a SUBJECT within a construction.

EX. 1.    SAWE-A 7.44    we    have    no further information  
                              +S    +PRED    +OD  
                              /PRONP /XVI    /PHN

EX. 1 is a clause construction containing a subject slot, filled by a proper pronoun, a predicate slot filled by a verb, and a direct object slot filled by a noun phrase. (For more information on these labels see APPENDIX 3, Fun. on Labels and APPENDIX 4, Form Labels.)

Within each level of analysis (i.e. sentence, clause, phrase, etc.), certain tagmemes are designated as nuclear tagmemes. According to Cook: "a nuclear tagmeme is a tagmeme that is diagnostic of the construction in which it occurs."<sup>1</sup> In our analysis, the criteria for nuclear tagmemes is slightly different for each type of construction, or for each level of analysis.

This will be explained more thoroughly in the following section on the format of the manual analysis.

## 2. Format of the Manual Analysis

One of the most important stages in the tagmemics project was the manual analysis of the sentences comprising the corpus in order to prepare them for computer processing. Therefore, an understanding of certain procedural aspects as well as definitions of the basic components is necessary to fully understand the data provided in the computer printout. These will be outlined in this section.

The tagmemic model provides a multi-level analysis. In our analysis, there are 5 levels: 1) discourse 2) sentence 3) clause 4) phrase 5) expression. At each level there occurs in general a mapping of the next lower level constructions into those at the higher level. For example, the discourse is analyzed into sentences; a sentence is analyzed into clauses, etc. Thus, in the manual analysis of the corpus, the procedure was to systematically analyze the constructions at each level into their constituents, usually at lower levels.

In our analysis, the discourse was analyzed into sentences, and each sentence was given an identification number according to its order of occurrence within a particular sample of a particular section of the discourse. For example, for sentence identification within SAWE-A, the section is represented by the block letter "A", the samples are numbered from 1 to 20 and the sentences within each sample run from 1 to 50.

EX. 1

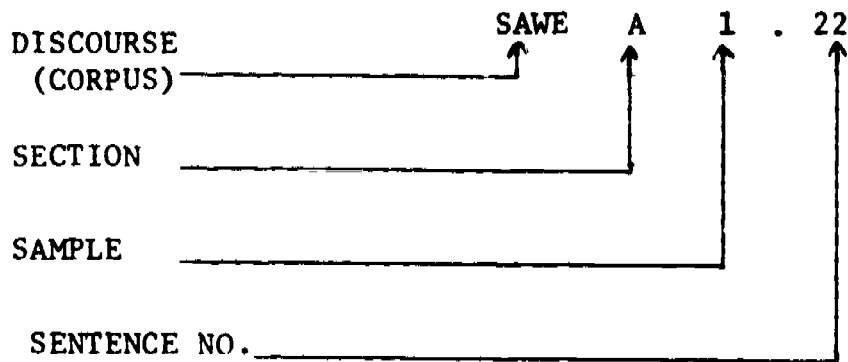

The manual analysis then involved analysing each sentence at the five different levels. At level one, the tagmemes describe the sentences within the discourse according to function (i.e. declarative, interrogative, etc.) and form (i.e. simple, complex, etc.). At level 2, sentence forms are described according to their clause constituents. Level 3 describes the various clauses according to their constituents, and so on. At each level, the constituents are commonly tagmemes with fillers (or forms) which are constructions of the next lowest level. However, this is not always so. In some cases, levels may be skipped. For example, terminal elements may be fillers for constituents at any level lower than the sentence level. A terminal element filling the SUBJECT slot of a clause construction is an example of this "level skipping".

EX. 2 SAWE-A 7.44 we have no further objection  
 +S  
 /PRONP

The construction in EX. 2. is a clause with a terminal element (proper pronoun) filling the subject slot.

Also, in some cases, the constituents of a construction may be filled by forms of the same level as that construction. This is called "layering" and an example would be a phrase filling, say, a modifier slot or a nuclear slot of a construction which is itself a phrase.

EX. 3. SASE-A 5.52 the approach of teaching

The construction in EX. 3 is a noun phrase. The underlined part is a prepositional phrase filling a modification slot within the noun phrase.

Another thing which may occur is a higher level construction as a filler in a construction at a lower level. This is called "back-looping" and occurs, for example, when a clause is a filler for a slot within a phrase.

EX. 4 SAWE-A 17.26 for taking the time to write

The construction in EX. 4 is a prepositional phrase. The underlined part is a participial clause occurring within that phrase.

Thus, the manual analysis proceeds from level 1 through level 5 for each sentence, breaking down each construction into its function-form constituents. The following is an example of the manual analysis showing the format used and exemplifying the concepts described above. (See Appendices 3 and 4 for explanations of the labels used).

EX. 5

SASE-A 2.93. Well, I think it depends an awful lot on what office you're in.

1.1 +SENANS  
/SENSIM

2.1 SENSIM

+ELTRANS +CLIND  
/ADVTRANS /CLBAS

Well, I think it depends an awful lot on what office you're in.

3.1 CLBAS

+S +PRED +OD  
/PRONP /XVI /CLBASWH

I think it depends an awful lot on what office you're in.

3.2 CLBASWH

+S        +PRED    +CVDEG    +OI  
/PRONP   /XVII    /ADVDEG   /PHPREP

it depends an awful lot on what office you're in

4.1 PHPREP

+IPP    +NUC  
/PREP   /PHN

on what office you're in

4.2 PHN

+QUAL    +NUC    +QUAL  
/ADJIND   /N       /CLBASWH

what office you're in

3.3 CLBASWH

+S        +PRED    +CVLOC  
/PRONP   /XVIII   /ADVLOC

you're in

5.1 XVI 1

think

5.2 XVII 1

depends

5.3 XADVDEG 3

an awful lot

5.4 XVIII 1

're

In EX. 5, the numbering system (i.e., 1.1, 2.1, etc.) refers to the level and the actual order of occurrence of the construction in relation to other constructions of the same level in the sentence. That is, 3.1 would refer to the first level 3 construction in the text (i.e. the first clause in the sentence).

Level 1 in this example (i.e. 1.1) tells us that the sentence functions within the discourse as an answer (+SENANS), and that it is a simple sentence in form as opposed to compound or complex etc. At level 2 (2.1), this simple sentence is analyzed into its two constituents, an element of transition (+ELTRANS) filled by an adverb of transition (/ADVTRANS), and an independent clause (+CLIND) filled by a basic clause (/CLBAS). This clause is the first level 3 construction (3.1) and is broken down at level 3 into its constituents. The first constituent of this clause is a subject slot (+S) filled by a proper pronoun (/PRONP). This is an example of level-skipping, since the proper pronoun is a terminal element occurring in a constituent at the clause level. The second constituent is a predicate (+PRED) filled by a verb. (/XVI: Expression Verbal No. 1). There are five categories of lexical verbs, labelled XVI through XVV, and these will be explained later in a discussion of the components at each of the five levels of analysis. All verbs are treated as "expressions" (as we have decided to store as much analytical information on the verb system as possible) and thus they are handled once again at level 5, the expression level. The third constituent of the clause 3.1 is a direct object (+OD) with a clause form as a filler (/CLBASWH: Clause Basic WH). This is an example of layering, where a level 3 construction (i.e. a clause) occurs as a constituent at level 3. Since this clause constituent is the second clause, or level 3 construction, occurring in the text, it is then analyzed at 3.2 into its constituents. One of these constituents is a verbal complement of degree (+CVDEG) filled by an adverbial expression (/XADVDEG). This is handled further at the expression level (level 5). This second clause also contains an indirect object slot (+OI) filled by a prepositional phrase (/PHPREP). Since this is the first phrase, or, level 4 construction, to occur, it is labelled 4.1 and analysed there into its constituents. Once again there is an example here of layering,

since another level 4 construction (a noun phrase, /PHN) fills the nuclear slot (+NUC) of this prepositional phrase. The noun phrase is therefore labelled 4.2 and is analyzed. At 4.2 we see that the qualifier slot (+QUAL) is filled by a clause (/CLBASWH). This is an example of back-looping, since the clause is a level 3 construction occurring as a constituent of a level 4, a lower level, construction. This clause is then labelled as a level 3 construction (3.3) and is analysed accordingly. At level 5 all the verbs and other types of expressions are listed sequentially according to their order of occurrence (i.e. 5.1, 5.2, 5.3, etc.) and a numerical value is assigned to them according to the number of units (words) involved. For example, the Adverbial Expression of Degree (XADVDEG) has 3 words, hence, XADVDEG 3.

This format of the manual analysis - the careful numbering of levels, ordering, etc. was all very important in order to prepare the data for computer processing. The procedure involved also has implications for obtaining the data in the computer printout. For example, we see that all clauses listed together at level 3 in the printout are not necessarily constituents at level 2. They may be from level 3 or level 4 environments as well. This is an important consideration for the retrieval of information from the printout, as well as for the interpretation of the data.

### 3. Components at Each of the 5 Levels

At each of the 5 levels of analysis, the components are different, hence, those tagmemes considered to be "nuclear" at each level are different.

At level 1, the concept of nuclear and non-nuclear does not apply. Here the sentence is merely labelled according to its function within the discourse and the form it takes. Some sentence functions are:



interrogative (+SENINTERROG), declarative (+SENDECL), etc. For an exhaustive list of sentence functions that occur see Appendix 3, Function Labels.

A sentence form may be simple, complex, compound-complex, compound or complex elliptical. These are defined at level 2 in the chapter on interpretation.

At level 2, sentences are analyzed into next lower-level tagmemes. The major function slots here are clauses (+CL), elements of transition (+ELTRANS), correlators (+CORR) and occasionally verbal complements (+CV). At this level the only tagmeme considered as 'nuclear' is the nuclear clause (+CLNUC) occurring only within complex sentences or compound-complex sentences. Thus, the criterion here for a tagmeme to be considered 'nuclear' is that another tagmeme be dependent upon it. (For descriptive definitions of level 2 tagmemes in SASE-A&B and SAWE-A, see Appendices 5 and 6)

At level 3, the major function slots of clauses are subjects, (+S), objects (+O), predicate (+PRED), verbal complements (+CV), agents (+AGENT), complementizers (+COMPL), subordinators (+SUB), specifiers (+SPEC), predicative adjectives (+PREDADJ), and predicative nominatives (+PREDNOM). Of these, subject (+S), predicate (+PRED), direct object (+OD), indirect object (+OI), agent (+AGENT), predicative adjective (+PREDADJ), and predicative nominative (+PREDNOM) are all considered to be 'nuclear'. Thus, following Cook's definition, nuclear tagmemes at the clause level, are those tagmemes which are "diagnostic" of the clause structure. (For descriptive definitions of level 3 tagmemes in SAWE-A and SASE-A&B, see Appendices 5 and 6.)

At level 4, phrases are analyzed into their tagmemic constituents. The constituents of each type of phrase are somewhat different. However, for all head-modifier type constructions, such as noun phrases, adjective phrases,

adverbial phrases, pronoun phrases and some verb phrases, the 'nuclear' component (+NUC) is the head. The modifier components are usually modifiers of the nucleus (+MODNUC) or specifiers of the nucleus (+SPECNUC). In the case of noun phrases, however, modifiers of the nucleus (+MODNUC) are divided into two distinct categories; quantifiers (+QUANT) and qualifiers (+QUAL). Some other major constituents at this level are deictics (+DEIC), elements of specification (+ELSPEC), reinforcers (+REINF), and appositions (+APP).

In the case of verb phrases, there are only two possible major constituents other than the nucleus (+NUC). These are a semi-auxiliary (+SAUX) or a subject (+S) and the two are mutually exclusive. (For a more detailed discussion of verb phrases see the level 4 section of Chapter VII:

Interpretation)

In the case of a prepositional phrase (+PHPREP), a relator-axis construction, there are only two components: 1) the slot for an introducer to a prepositional phrase (+IPP), which may be filled by a preposition (/PREP), or a prepositional expression (/XPREP), such as "to", "for", "in", "before", "according to", etc. 2) the remaining component of the phrase, be it a clause, another phrase, or a terminal element, is designated as the nucleus. (+NUC).

As mentioned before, level 5 lists all verbs, including lexical verb forms, complex verbal expressions (/XVCOMP, /XVAUXCOMP, /XVSAUXCOMP), as well as listing modals (/XVMODE), auxiliaries (/XVAUX) and semi-auxiliaries (/XVSAUX).

Complex verbal expressions are broken down into their tagmemic constituents here in the same way as are tagmemes at the other levels. In these constructions, the nuclear component is that which is "diagnostic" of the construction as a whole. That is, the lexical verb is the nucleus in a complex verb (XVCOMP); the main auxiliary is the nucleus in a complex auxiliary (XVAUXCOMP) and the

semi-auxiliary is the nucleus in a complex semi-auxiliary (XVSAUXCOMP).

EX. 1

1. XVCOMP: SASE-A 2.37 do feel

+AUX +NUC  
/XVAUX /XVI

2. XVAUXCOMP: SASE-B 2.58 has been

+AUX +NUC  
/XVAUX /XVAUX

3. XVSAUXCOMP: SASE-A 5.49 would have

+MODAL +NUC  
/XVMODE /XVSAUX

The other component of such complex verbal expressions may be an auxiliary (+AUX) or a modal (+MODAL).

Other verbal expressions whether they consist of one word or more than one word are simply listed at level 5 in the manual analysis in order that they may be compiled by the computer. Other than auxiliaries and semi-auxiliaries, this includes the five categories of lexical verbs. These are:

- (i) /XVI - Transitive, direct: with direct object e.g. The boy hit the ball.
- (ii) /XVII - Transitive, indirect: with indirect object e.g. I thought about it.
- (iii) /XVIII - Intransitive: without any object  
e.g. She went to town yesterday.  
The village is in the alps.
- (iv) /XIV - Ditransitive: with both direct and indirect objects  
e.g. He gave her the ball.

(v) /XVV - Copulative: with predicate adjective or predicate nominative.

e.g. He is good.

John is the president of the club.

Also occurring at level 5 are other types of "fixed" expressions. These include idiomatic expressions such as, "year-round", "a few", etc., as well as addresses, dates, and names of people and places.

The term "terminal element" has already been mentioned a number of times and will now be defined. A terminal element is any form in a function-form unit which cannot be further analyzed according to the analytical model adopted. This, then, includes words as well as expressions (except for complex verbal expressions) as described above. Sometimes however, for the purpose of information retrieval it is necessary to distinguish between one-word terminal elements and expressions which are also terminal forms.

Elliptical elements are another feature of the analytical model. These occur in constructions where a certain portion or constituent is not overtly expressed, but is taken as understood. Thus, the function-slot is there but it is not correlated with a form-filler.

EX. 2 SASE-B 3.115

This is a problem deeply rooted in history of course, because the French in Europe have colonized the world on this principle, the cultural aspect first, the economic second.

In EX. 2, the underlined part is a noun phrase having an elliptical nucleus (+NUC), since it is understood that "economic" is a modifier of a head. Thus the construction has a nuclear function slot (+NUC) but this slot does not have a form.

Another type of elliptical element is the elliptical clause. This is the case where a clause does not contain a predicate, yet the predicate is understood. This type of clause is labelled ELL, meaning elliptical, but the predicate slot is not filled by any form when it is analysed into its constituents.

EX. 3 SAWE-A 4.9

if necessary

The above example is a typical elliptical clause. We understand this to mean "if it is necessary". However, the predicate as well as the subject is not overtly expressed.

Another concept to be explained in this section is that of discontinuities. A discontinuity occurs where a construction is interrupted by some element, called "the bracketted element", which is not a constituent of that construction. The most common type of discontinuity is where a negator interrupts the two constituents of an XVCOMP or complex verbal expression.

EX. 4 SASE-A 1.96

Well, I wo(n't) say the only one.

Here, the predicate of the underlined clause is filled by an /XVCOMP consisting of a modal form "wo" and a nucleus "say". The negator is another constituent of the clause which interrupts the discontinuous predicate.

Discontinuous elements may occur at any level, however. In the manual analysis, square brackets are placed around the element that is interrupting, thus the term "bracketted" element. An ampersand marks the place in the lower level construction where the bracketted element actually occurs in the sequence of words. The following is the manual analysis of a sentence containing a different type of discontinuous element.

EX. 5 SASE-A 1.56 Perhaps Andy (has comments on that) having gone to level three.

1.1 +SENDECL  
/SENSIM

2.1 SENSIM  
+CLIND  
/CLBAS

3.1 CLBAS  
+CVOPIN +S [ +PRED +OD  
/ADVOPIN /PHN [ /XVI /PHN ]

Perhaps Andy has comments on that, having gone to level three.

4.1 PHN  
+NUC  $\in$  +QUAL  
/NP /CLBASPART

Andy ... having gone to level three.

3.2 CLBASPART  
+PRED +CVSIT  
/XVCOMP /PHPREP

having gone to level three.

4.2 PHN  
+NUC +QUAL  
/N /PHPREP

comments on that

4.3 PHPREP  
+IPP +NUC  
/PREP /PRONDEM

on that

4.4 PHPREP  
+IPP +NUC  
/PREP /XN  
to level three.

5.1 XVI 1

has

5.2 XVCOMP

+AUX        +NUC  
/XVAUX      /XVIII

having gone

5.3 XVAUX 1

having

5.4 XVIII 1

gone

5.5 XN 2

level three.

In the above example, the discontinuity occurs in the clause construction at level 3.1. The noun phrase (/PHN) filling the subject slot (+S), is discontinuous, since two other constituents at the same level, the predicate (+PRED) and the direct object (+OD) come between the nucleus (+NUC) and the qualifier (+QUAL). Thus, the predicate (+PRED) and the direct object (+OD) are the bracketted element. At level 4.1 when the discontinuous noun phrase is analyzed an ampersand (&) interrupts the nucleus (+NUC) and the qualifier (+QUAL) signalling that the bracketted element occurs in that position in the actual text.

NOTES

1. Cook; Walter A., S.J. Introduction to Tagmemic Analysis, New York: Holt, Rinehart and Winston, Inc., 1969, p. 18

### V. FORMAT OF THE COMPUTER PRINTOUT (phase III)

The Phase III printout represents the computerized data of the manual analysis. The printout lists groups of constructions at each level of the analysis along with their sentence identification number, according to a fixed order. Page 1, in both the SAWE-A and SASE-A&B printouts presents level 1 analytical data. Here, under each sentence function, is listed the class of forms filling that function, along with their frequency of occurrence.

Level 2 data begins on pages 4 and 5 in SAWE-A and SASE-A&B respectively. Here, under the heading of each different sentence form, all occurring structures are listed along with their frequency of occurrence. Under each structure, all the actual linguistic manifestations are listed according to a set of criteria, (for detail, see below) and to the numerical sequence of the sentence identification numbers.

There are two level 3 listings in the printout. The first one, starting on page 70 in SAWE-A and page 62 in SASE-A&B, lists the various clause constructions, grouped according to the clause form. Similar to level 2, each structure is listed along with its frequency of occurrence and under each structure type the actual linguistic manifestations are listed.

The second level 3 listing begins on page 331 in SAWE-A and page 305 in SASE-A&B. Here the clause structures are listed without being grouped according to the clause form they comprise. Other than this, they follow the same general criteria for sequencing as does the first listing. (See below for details of sequencing).



At level 4, starting in SAWE-A on page 521 and in SASE-A&B on page 482 the various phrase constructions are grouped under the headings of the phrase forms. Once again, the frequency of occurrence is listed along with each structure and under each structure, the actual linguistic manifestations are listed.

Level 5 data starting on page 777 in SAWE-A and page 630 in SASE-A&B, is different in nature and presentation. Here, all "expressions", including verbal expressions, are listed in alphabetical order, except for the complex verbal expressions (i.e. XVCOMP, XVAUXCOMP, XVSAUXCOMP) which come at the end. Under each different expression type, the actual linguistic manifestations are listed along with their frequency of occurrence. If the frequency of a particular type is 10 or less, sentence identification numbers are listed for reference purposes.

For the complex verbal expressions, the structures (i.e. the strings of constituents) are listed along with their frequency of occurrence. The actual linguistic manifestations are listed under each construction type and those occurring only 10 times or less are provided with sentence identification numbers.

#### 1. Notes on Sequencing

The sequencing of structures within each type of construction follows somewhat different criteria for each level. The following is a schematic representation of the format. The second part describing the "Criteria for Sequencing of Function Groups" is actually an integral part of the whole and fits in where it is indicated in the more general "Criteria for Sequencing of Structures in the Phase III Printout". For more detailed information regarding terminology used, see the full document on sequencing, Appendix 7.

Figure 1

CRITERIA FOR  
SEQUENCING OF STRUCTURES IN PHASE III PRINTOUT

1. DISCOURSE LEVEL

1. FUNCTION: alphabetic sequence
2. FORM: predetermined sequence.

2. SENTENCE LEVEL )

) Sequencing is the same except for

3. CLAUSE LEVEL )

) FUNCTION GROUPS

4. PHRASE LEVEL )

1. TITLE: Level 2 - Sentence forms in predefined sequence  
Level 3 - clause forms in alphabetic sequence  
Level 4 - phrase forms in alphabetic sequence
2. FUNCTION: \*see "Criteria for Sequencing of Function groups" (Figure 2)
3. DEPTH: ascending maximum relative depth
4. FORM: alphabetic order of entire string
5. DISCONTINUITY: count
6. VALUE OF BRACKETTED ELEMENT \*see "Variables Associated with Complexity" (Appendix 8)
7. REFERENCE: numerical order of sentence identification numbers.

5. EXPRESSION LEVEL

NOTE: Level 5 is primarily a listing by form of all verbs, and expressions consisting of more than one word (e.g. XVI, XPREP, XN, XCONJCOORD). Only XVCOMP, XVAUXCOMP and XVSAUXCOMP can be sequenced by FORM and FUNCTION since they are the only tagmemes at this level.

1. TITLE: expression forms in alphabetic sequence except XVCOMP, XVAUXCOMP and XVSAUXCOMP, which are last.
2. FUNCTION: XVCOMP, XVAUXCOMP, XVSAUXCOMP only - alphabetic order of entire string.
3. FORM: XVCOMP, XVAUXCOMP, XVSAUXCOMP only - alphabetic order of entire string.
4. TEXT: alphabetic order  
Sentence identification numbers are included where the number of occurrences is 10 or less.

Figure 2

CRITERIA FOR  
SEQUENCING OF FUNCTION GROUPS

1. DISCOURSE LEVEL

Predefined sequence: SENSIM  
SENCOMPOUND  
SENCOMPLEX  
SENCOMPLEXELL  
SENCOMPOUNDCOMPLEX

2. SENTENCE LEVEL

1. Number of NUCLEAR TAGMEMES
2. Number of NON-NUCLEAR TAGMEMES beginning with CL
3. Alphabetic order of STRINGS of NON-NUCLEAR TAGMEMES beginning with CL

4. Number of OTHER NON-NUCLEAR TAGMEMES
5. Alphabetic order of STRING of OTHER NON-NUCLEAR TAGMEMES
6. Alphabetic order of ENTIRE STRING.

3. CLAUSE LEVEL

1. Number of NUCLEAR TAGMEMES
2. Alphabetic order of ALPHABETIC ARRANGEMENT OF NUCLEAR TAGMEMES
3. Number of ORDER DEVIATION of NUCLEAR TAGMEMES \*See "Terminology Associated with Sequencing of Structures" (Appendix 7)
4. Alphabetic order of STRINGS of NUCLEAR TAGMEMES
5. Number of NON-NUCLEAR TAGMEMES
6. Alphabetic order of ENTIRE STRING

4. PHRASE LEVEL

1. Number of NUCLEAR TAGMEMES
2. Number of NON-NUCLEAR TAGMEMES
3. Alphabetic order of ENTIRE STRING

5. EXPRESSION LEVEL

1. Alphabetic order of ENTIRE STRING (XVCOMP, XVAUXCOMP, XVSAUXCOMP only).

## 2. Notes on Complexity

In Figure 1, entitled "Criteria for Sequencing of the Phase III Printout", we see that three of the criteria for sequencing at the sentence, clause, and phrase levels are: Depth (3), Discontinuity (5) and value of the Bracketted Element (6). These are the three variables which our analysis associates with the "complexity" of constructions. We may also note from Figure 2, "Criteria for Sequencing of Function Groups", that at levels 2, 3, and 4 structures are also sequenced according to the number of nuclear tagmemes as well as the number of non-nuclear tagmemes they contain. That is, structures having fewer constituents appear before longer constructions in the printout. Thus, complexity as such is represented in the sequencing of the Phase III printout, and within each structure type of a particular construction at a particular level and having a particular number of constituents, a gradation of complexity from lowest to highest can be found. An index of complexity may be found in the phase III computer printout in the left-hand margin. Each sentence is assigned a three part complexity value on the basis of the three variables mentioned above.

For fuller information as to terminology, the index of complexity, as well as what these complexity variables entail, see Appendix 8, a document on Complexity.

## 3. Information Retrieval

One of the major purposes for this analysis and the one to which the Phase III printout lends itself is comparison. Comparative studies may be inter-corpus, as is the case with this SAWE-A/SASE-A&B comparison where written and spoken versions of the English language are being compared. On the other hand, they may be intra-corpus comparisons studying the various types of constructions

within a single corpus. For example, one may wish to compare different types of phrase forms as to their environments etc., within a particular corpus.

Within the Phase III printout, which we may call our "primary data", there are a number of ways to retrieve information. For one, since the printout keeps the five levels separate we may find information about constructions at each level, using only the portion of the printout dealing with that level. For example, to retrieve information about sentence structures we look at level 2, clause structures appear at level 3, etc. Within this mode of information retrieval, we may find general information about the structural components of the various constructions.

Another way to retrieve information from the printout is across levels. In this way we may learn about the environments of the various constructions at each level. For example, we may discover which function slots are commonly filled by participial clauses over levels 1, 2, and 3.

Essentially, there are three basic types of information to be found in the Phase III printout. These are analytical information, quantitative information, and illustrations. Analytical information refers to the structural components of the various constructions at each level. Quantitative information is important for any type of statistical comparison. Frequencies are listed throughout the printout for each construction and for each different type of structure within each construction. Illustrative information refers to the actual linguistic manifestations of the constructions listed for each structure along with the identification numbers of the sentences in which they occur. This is helpful in defining constructions and makes typical examples readily available.

Basically the method for retrieving information depends on the type of information to be retrieved. With creative thinking and a general knowledge of the printout much is readily available.

#### IV STATISTICAL COMPARISON of SAWE A and SASE A & B

##### 1. OBJECTIVES

Statistical tests of significance were needed for two purposes. First, we wanted to determine whether the two sub-varieties of spoken English represented by corpus SASE A (Formal Discussion) and corpus SASE B (Informal Discussion) were actually so similar that they could be considered as one corpus. If this proved to be true, we wanted to compare the pooled data of SASE A and B with that of SAWE A, the corpus representing Administrative Writing, to see if they differed significantly and could thus be considered as different varieties of English.

##### 2. CHOICE OF STATISTICAL MEASURE

Three authorities were consulted concerning the appropriate statistical measure for these purposes. Because our data comes from natural language, whose distribution does not follow a normal bell-shaped curve, a nonparametric or distribution-free statistic was required. All the authorities consulted, Frank Kinrade (Head, Testing Division of English Programmes), Abe Finkelstein (Personnel Psychology Centre, Staffing Branch) and Dr. Gerald Neufeld (Department of Linguistics and Modern Languages, University of Ottawa), agreed that Chi Square was the most powerful test of significance appropriate to this data.



### 3. HOMOGENEITY OF SASE A and SASE B

To test whether SASE A (Formal Discussion) and SASE B (Informal Discussion) could be treated as one overall spoken corpus, Chi Square tests were run on the data for a number of key points of comparison. The results on each test are outlined below. In each case a Chi Square figure was obtained for the overall set of results and for the individual pairs which make up that total.

3.1 Sentence Functions: The overall Chi Square proved to be non-significant. All of the individual pairs of labels were also non-significant except for SENINTERROG, which was used significantly more (at the .05 level) in SASE A, Formal Discussion. The usage of interrogative sentences may well be a minor stylistic variation between more formal and less formal discussion and as such bears investigation. However, we feel that for the present purpose this can be safely disregarded and the overall non-significant Chi Square figure taken to indicate that from the sentence function point of view, SASE A and SASE B data can be considered one corpus.

FIGURE 1  $\chi^2$  TEST

SENTENCE FUNCTIONS: SASE A vs SASE B

	<u>A</u>	<u>B</u>	<u><math>\chi^2</math></u>
1. SENDECL	415	660	0.5406 NS
2. SENDECLINC	29	37	0.3853 NS
3. SENIMPER	1	5	1.3655 NS
4. SENIMPERINC	1	0	1.4923 NS
5. SENINTERJEC	21	24	.7800 NS
6. SENINTERROG	38	31	6.0741 NS
7. SENINTERROGINC	3	2	0.8209 NS
TOTAL $\chi^2$	<u>508</u>	<u>759</u>	<u>12.3429 NS</u>

TOTAL: d.f. = 6

cut-off at .05 = 12.59

PAIRS: d.f. = 1

cut-off at .05 = 3.84 \*

.01 = 6.64 \*\*

.001 = 10.83 \*\*\*

- 3.2 Sentence Forms: Both the overall Chi Square and individual pairs were non-significant at the .05 level of significance. See Figure 2. Thus, from the sentence form point of view, SASE A and B data can be considered part of the same corpus.
- 3.3 Clause Forms: Both the overall Chi Square and the individual pairs of clause types by groups (CLBAS group, CLEQUAT group, etc.) were non-significant at the .05 level of significance. See Figure 3. Thus, from the general point of view of clause groups, SASE A and B data can be considered part of the same corpus. (Clauses can be investigated from many other points of view, but this gives an overall picture.)
- 3.4 Phrase Forms: The overall Chi Square proved to be significant at the .01 level of significance. The Chi Square test on the pairs showed that the significant difference was accounted for by the PHV group, which was used disproportionately frequently in SASE B, Informal Discussion (significant at the .001 level). See Figure 4.

FIGURE 2  $\chi^2$  TEST

SENTENCE FORMS: SASE A vs SASE B

	<u>A</u>	<u>B</u>	<u><math>\chi^2</math></u>	
1. SENSIM	426	629	0.029	NS
2. SENCOMPOUND	17	31	0.408	NS
3. SENCOMPLEX	59	88	0.008	NS
4. SENCOMPLEXELL	5	11	0.000	NS
5. SENCOMPOUNDCOMPLEX	1	2	0.054	NS
<u>TOTAL <math>\chi^2</math></u>	<u>508</u>	<u>761</u>	<u>1.041</u>	<u>NS</u>

TOTAL: d.f. = 4

cut-off at .05 = 9.49 \*

PAIRS: d.f. = 1

cut-off at .05 = 3.84 \*

.01 = 6.64 \*\*

.001 = 10.83 \*\*\*

FIGURE 3

$\chi^2$  TEST

CLAUSE TYPES BY GROUPS: SASE A vs SASE B

	<u>A</u>	<u>B</u>	<u><math>\chi^2</math></u>	
1. CLBAS GROUP	833	1,195	0.028	NS
2. CLCOMPLEX - CLCOMPLEXELL	31	47	0.136	NS
CLCOMPOUND	2	0		
CLCOMPOUNDCOMPLEX	3	1		
3. CLELL GROUP	44	50	1.343	NS
4. CLEQUAT GROUP	181	281	0.447	NS
5. CLIMPERS GROUP	53	93	1.177	NS
6. CLMONO	28	37	0.132	NS
7. CLPASS GROUP	44	63	0.000	NS
<u>TOTAL = <math>\chi^2</math></u>	<u>1,219</u>	<u>1,767</u>	<u>3.472</u>	<u>NS</u>

TOTAL: d.f. = 6

cut-off at .05 = 12.59 \*

PAIRS: d.f. = 1

cut-off at .05 = 3.84 \*

.01 = 6.64 \*\*

.001 = 10.83 \*\*\*

FIGURE 4

$\chi^2$  TEST

PHRASE TYPES: SASE A vs. SASE B

	<u>A</u>	<u>B</u>	<u><math>\chi^2</math></u>	
1. PHADJ	99	149	0.886	NS
2. PHADV GROUP	56	69	0.167	NS
3. PHN	1,016	1,318	0.203	NS
4. PHPREP	639	794	1.184	NS
5. PHPRON	45	51	0.583	NS
6. PHV GROUP	103	219	14.830	***
TOTAL:	<u>1,958</u>	<u>2,600</u>	<u>19.388</u>	**

TOTAL: d.f. = 5

cut-off at .05 = 11.07 \*

.01 = 15.09 \*\*

.001 = 20.52 \*\*\*

PAIRS: d.f. = 1

cut-off at .05 = 3.84 \*

.01 = 6.64 \*\*

.001 = 10.83 \*\*\*

Again, the use of verbal phrases may be a stylistic maker of informal discussion and should be looked into further. The use of impersonal verb phrases, a subcategory of the PHV group, should be investigated especially. With the exception of the PHV group, then, for which SASE A and SASE B must be considered separate corpora, from the general point of view of phrase groups, SASE A and B data can be considered part of the same corpus.

3.5. Number of nuclear tagmemes in clauses: The total Chi Square figure for number of nuclear tagmemes in clauses was non-significant, as were the Chi Squares for the individual pairs. (See Figure 5). Thus, from this point of view as well, the data of SASE A and SASE B can be considered one corpus.

3.6. Conclusion: For our purposes, SASE A and SASE B are sufficiently similar to constitute one corpus of spoken English which can be contrasted with the corpus of administrative writing, SAWE A.

#### 4. COMPARISON OF SAWE A AND SASE A & B

4.1. Sentence functions: The overall Chi Square for sentence functions showed the set to be significantly different at the .001 level of significance. The Chi Squares of all the major sentence functions treated as pairs were also significantly different, as were two major functions with the -INC specification added. (See Figure 6 for the level of significance and Figures 7 and 8 for the proportions within each corpus). The only Chi Square which was non-significant was for

FIGURE 5

X<sup>2</sup> TEST

SASE A vs SASE B: NUMBER OF NUCLEAR TAGMEMES IN CLAUSES

	<u>SASE A</u>	<u>SASE B</u>	<u>X<sup>2</sup></u>	
No nuclear tagmemes	43	56	0.291	NS
1    "    "	72	112	0.182	NS
2    "    "	428	565	1.724	NS
3    "    "	601	920	0.608	NS
4    "    "	33	57	0.596	NS
5    "    "	3	6	0.203	NS
6    "    "	1	3	0.409	NS
	<u>1,181</u>	<u>1,719</u>		

TOTAL X<sup>2</sup> at 6 d.f. = 4.971 NS

cut-off at .05 = 12.59 \*

PAIRS: d.f. = 1

cut-off at .05 = 3.84 \*



FIGURE 6

X<sup>2</sup> TEST

SENTENCE FUNCTIONS: SAWE A vs SASE A&B

	<u>SAWE A</u>	<u>SASE A&amp;B</u>	<u>X<sup>2</sup></u>
1. SENDECL	937	1,051	4.1560 *
2. SENDECLINC	0	65	49.9983 ***
3. SENIMPER	34	5	28.8950 ***
4. SENIMPERINC	0	1	0.7851 NS
5. SENINTERJEC	0	71	54.5094 ***
6. SENINTERROG	8	69	34.3643 ***
7. SENINTERROGIMPER	17	0	21.4219 ***
8. SENINTERROGINC	0	5	3.9236 *
TOTAL X <sup>2</sup>	<u>996</u>	<u>1,267</u>	<u>205.9209 ***</u>

TOTAL: d.f. = 7

cut-off at .05 = 14.07 \*

.01 = 18.48 \*\*

.001 = 24.32 \*\*\*

PAIRS: d.f. = 1

cut-off at .05 = 3.84 \*

.01 = 6.64 \*\*

.001 = 10.83 \*\*\*

FIGURE 7

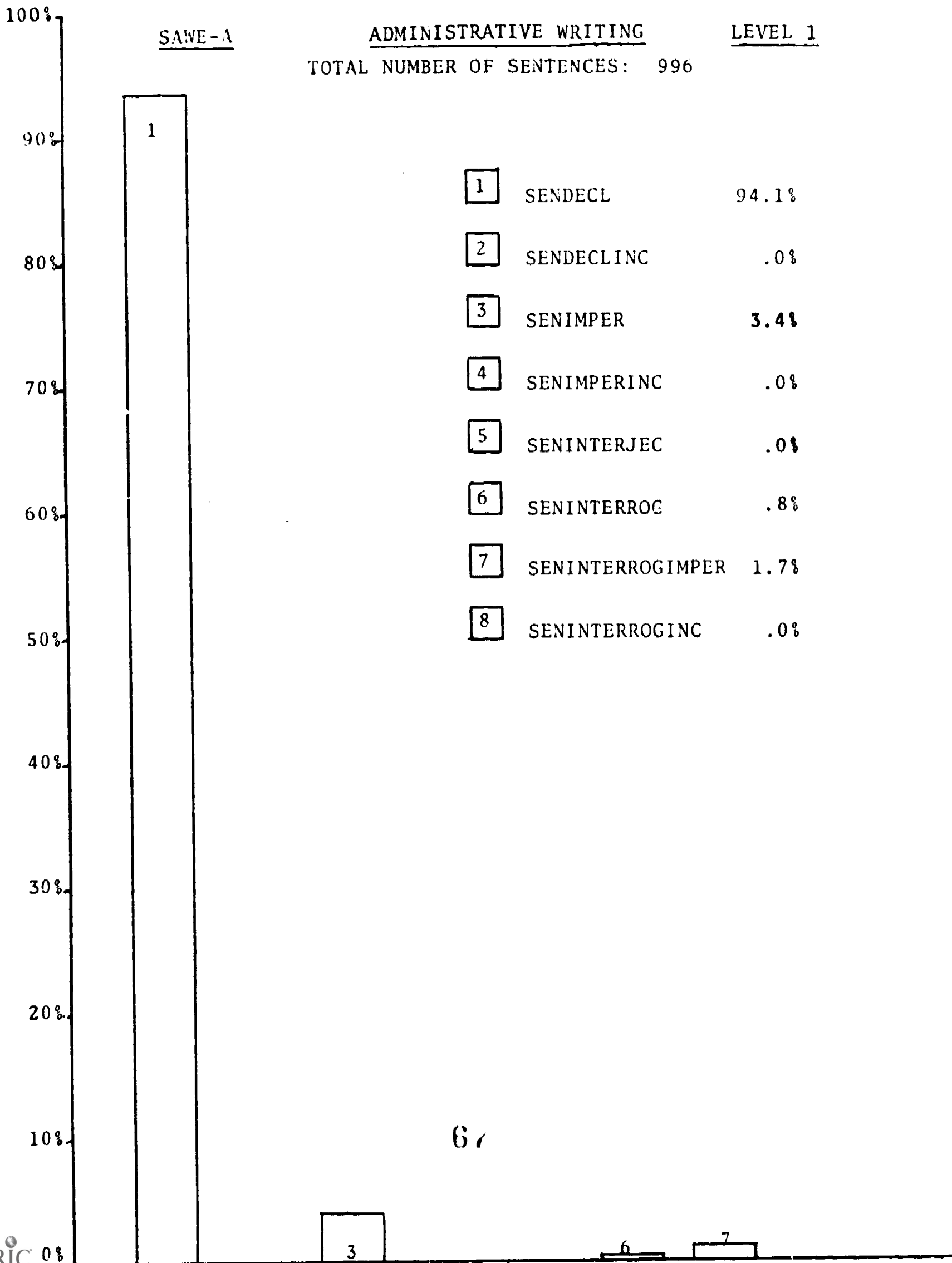
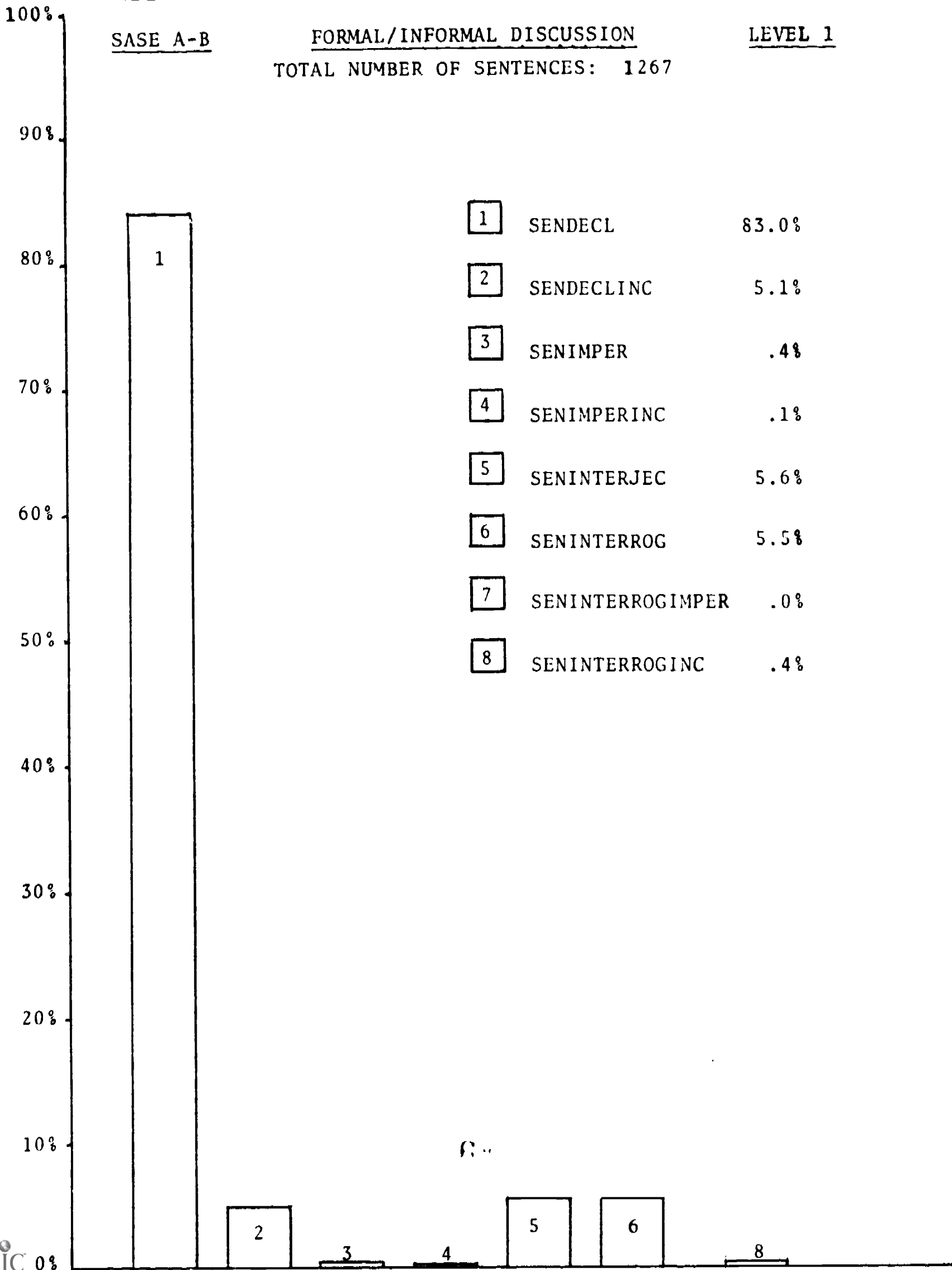

FIGURE 8



SENIMPERINC which occurred only once in SASE A&B and not at all in SAWE A. SENINTERROG and SENINTERJEC, as well as two labels with the "incomplete" specification, SENDECLINC and SENINTERROGINC, occurred significantly more frequently in SASE A&B than in SAWE A. As might have been expected, incomplete sentences occurred only in SASE A&B. SENIMPER, SENINTERROGIMPER (representing polite requests), and SENDECL occurred significantly more frequently in SAWE A.

- 4.2. Sentence forms: Both the overall Chi Square and three of the five individual pairs were significant at the .001 level of significance, while the remaining two pairs were significant at the .01 level. (See Figure 9). The sentence functions SENCOMPOUND, SENCOMPLEX and SENCOMPOUNDCOMPLEX were used proportionately more frequently in SAWE A than in SASE A&B, while SENSIM and SENCOMPLEXELL were used more frequently in SASE A&B than in SAWE A. See Figures 10 and 11.

- 4.3. Clause types by group: The overall Chi Square for clause types by group was significant at the .001 level. See Figure 12. Of the pairs of Clause groups, the CLBAS, CLELL, CLEQUAT and CLMONG groups appeared significantly more frequently in SASE A & B than in SAWE A, while the CLPASS group alone appeared significantly more frequently in SAWE A than in SASE A & B. See Figures 13 and 14. Only the Chi Square figures for CLIMPERS and the combined total of CLCOMPLEX, CLCOMPLEXELL, CLCOMPOUND, and CLCOMPOUNDCOMPLEX were non-significant.
- 4.4. Phrase Types: The overall Chi Square for phrase types was significant at the .001 level. See Figure 15. Of the individual pairs of phrases, PHADJ, PHPRON and the PHADV and PK' groups appeared significantly more frequently in SASE A & B than in SAWE A, while PHN and PHPREP appeared significantly more frequently in SAWE A than in SASE A & B. See Figures 16 and 17. Only the Chi Square for PHGERUND was non-significant because the frequencies were so low; however, it is interesting to note that PHGERUND occurred only in SAWE A (frequency of 4).

FIGURE 9

X<sup>2</sup> TEST

SENTENCE FORMS: SAWE A vs SASE A & B

	<u>SAWE A</u>	<u>SASE A &amp; B</u>	<u>X<sup>2</sup></u>
1. SENSIM	666	1,055	11.084 ***
2. SENCOMPOUND	129	48	55.311 ***
3. SENCOMPLEX	160	147	7.289 **
4. SENCOMPLEXELL	2	16	7.827 **
5. SENCOMPOUNDCOMPLEX	38	3	38.667 ***
TOTAL X <sup>2</sup>	995	1,269	135.103 ***

TOTAL: d.f. = 4

cut-off at .05 = 9.49 \*

.01 = 13.28 \*\*

.001 = 18.46 \*\*\*

PAIRS: d.f. = 1

cut-off at .05 = 3.84 \*

.01 = 6.64 \*\*

.001 = 10.83 \*\*\*

FIGURE 10

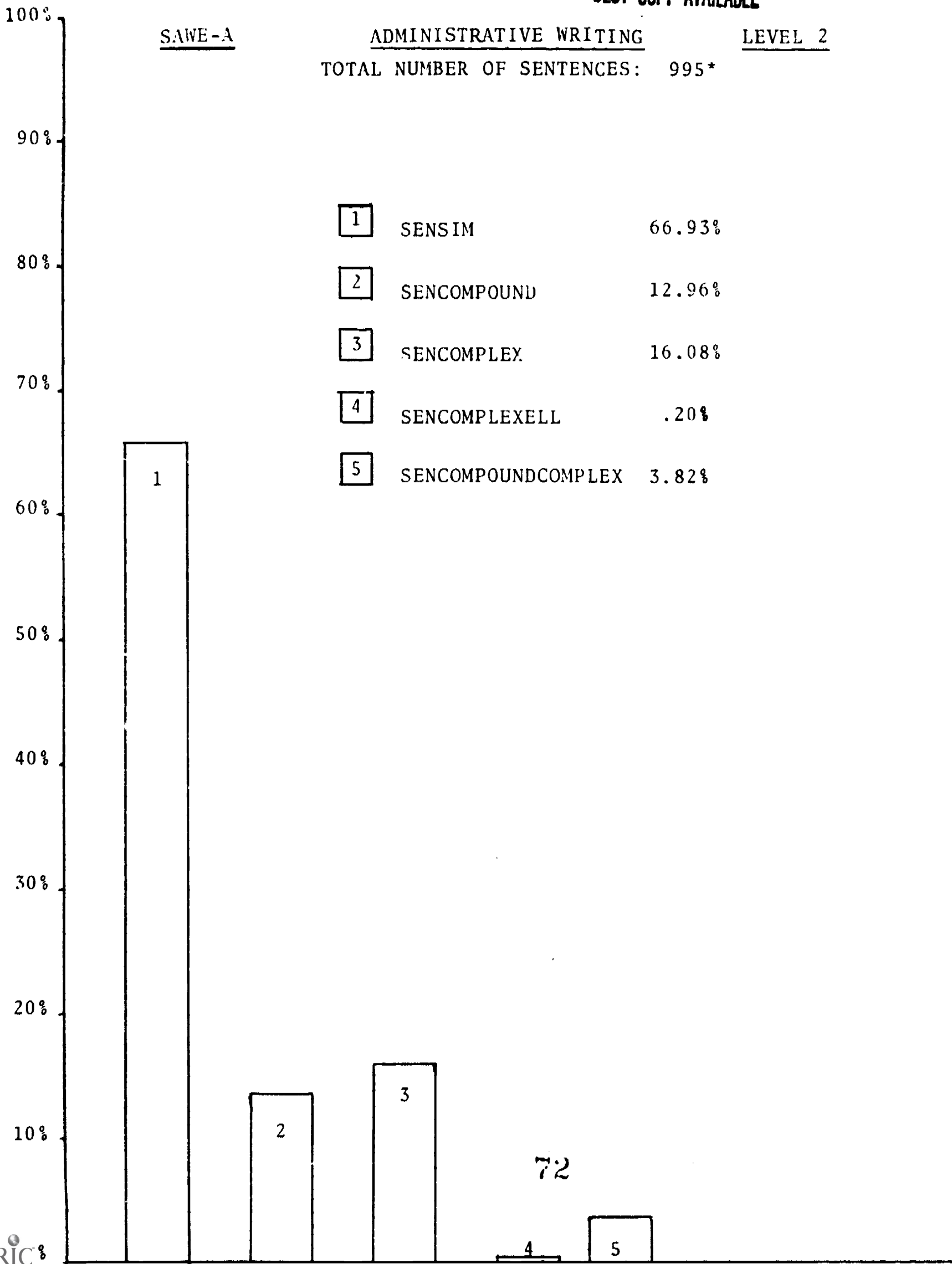

\*one fewer than total number of form labels

FIGURE 11

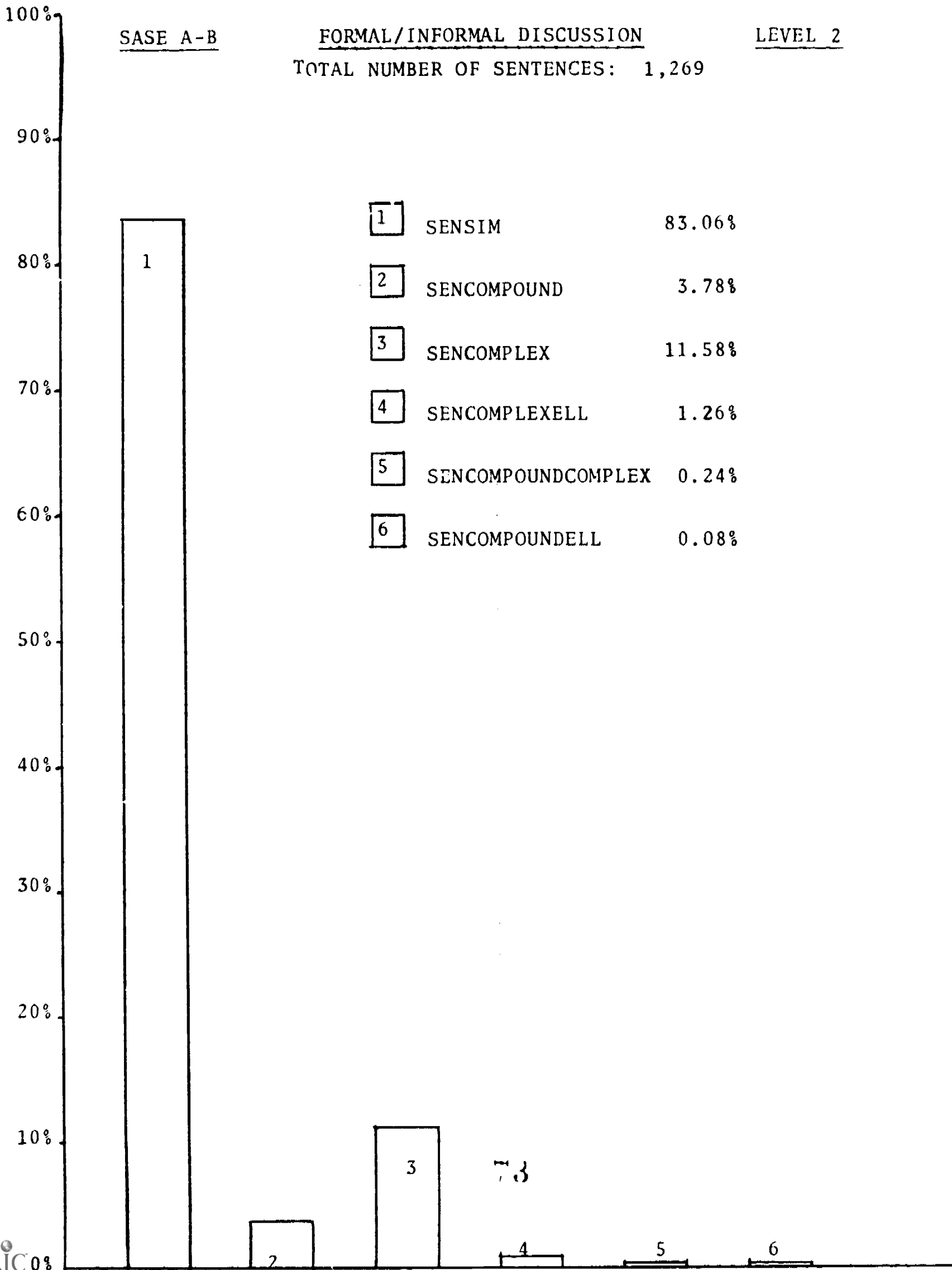

SASE A-B

FORMAL/INFORMAL DISCUSSION  
TOTAL NUMBER OF SENTENCES: 1,269

LEVEL 2



FIGURE 12

$\chi^2$  TEST

CLAUSE TYPES BY GROUPS: SAWE A vs SASE A & B

	<u>SAWE A</u>	<u>SASE A &amp; B</u>	<u><math>\chi^2</math></u>	
1. CLBAS GROUP	1,553	2,028	28.209	***
2. CLCOMPLEX - COMPLEXELL	96	78	NS 2.584	
CLCOMPOUND	0 } 97	2 } 84	NS 1.916	1.484 NS
CLCOMPOUNDCOMPLEX	1 } 97	4 } 84	NS 1.676	
3. CLELL GROUP	64	94	4.430	*
4. CLEQUAT GROUP	335	462	13.384	***
5. CLIMPERS GROUP	136	146	0.060	NS
6. CLMONO	3	65	53.472	***
7. CLPASS GROUP	679	107	389.336	***
TOTAL $\chi^2$	<u>2,867</u>	<u>2,986</u>	<u>560.484</u>	<u>***</u>

TOTAL: d.f. = 6

cut-off at .05 = 12.59 \*  
 .01 = 16.81 \*\*  
 .001 = 22.46 \*\*\*

PAIRS: d.f. = 1

cut-off at .05 = 3.84 \*  
 .01 = 6.64 \*\*  
 .001 = 10.83 \*\*\*

FIGURE 13

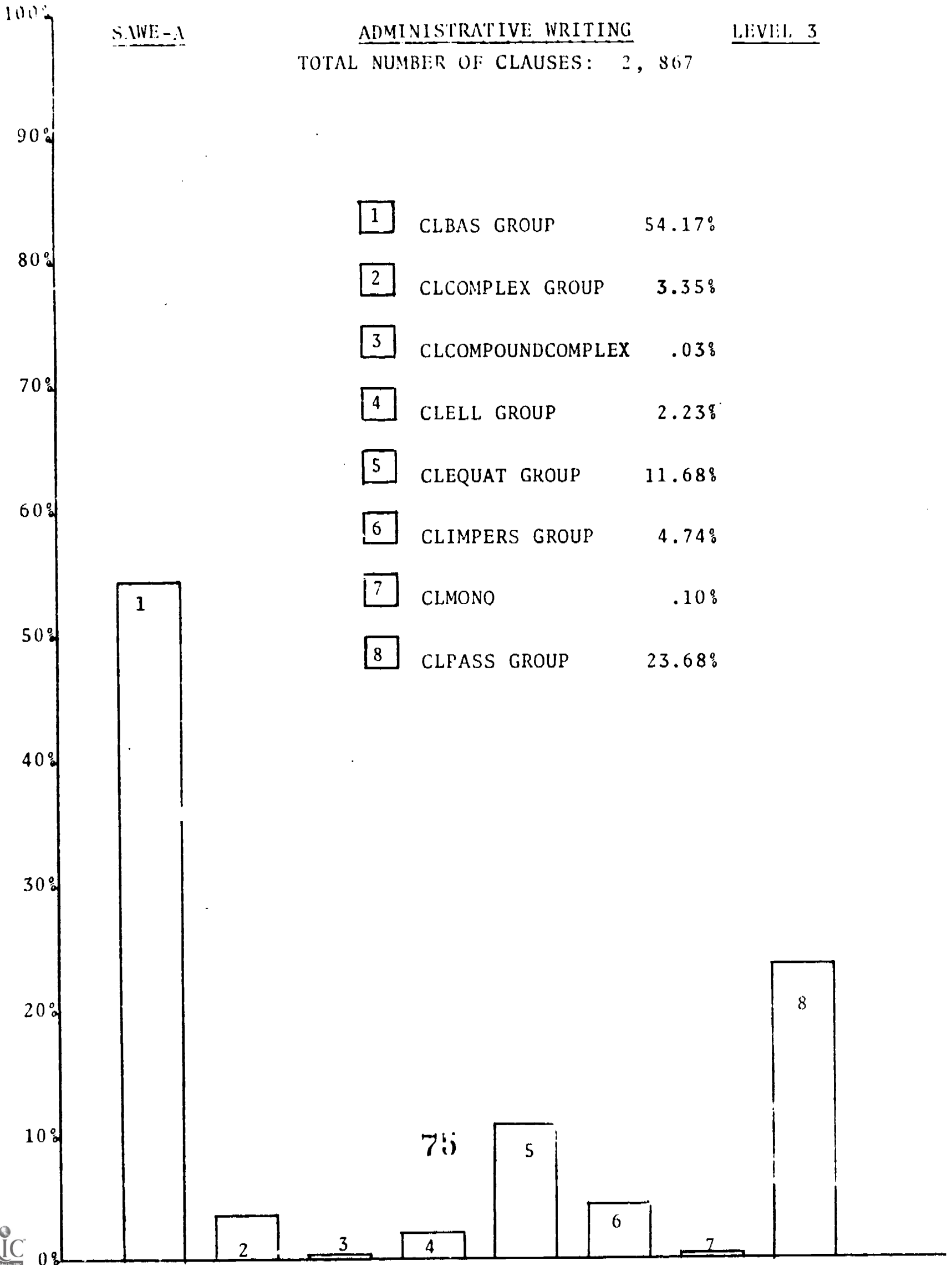

SAWE-A

ADMINISTRATIVE WRITING

LEVEL 3

TOTAL NUMBER OF CLAUSES: 2, 867

FIGURE 14

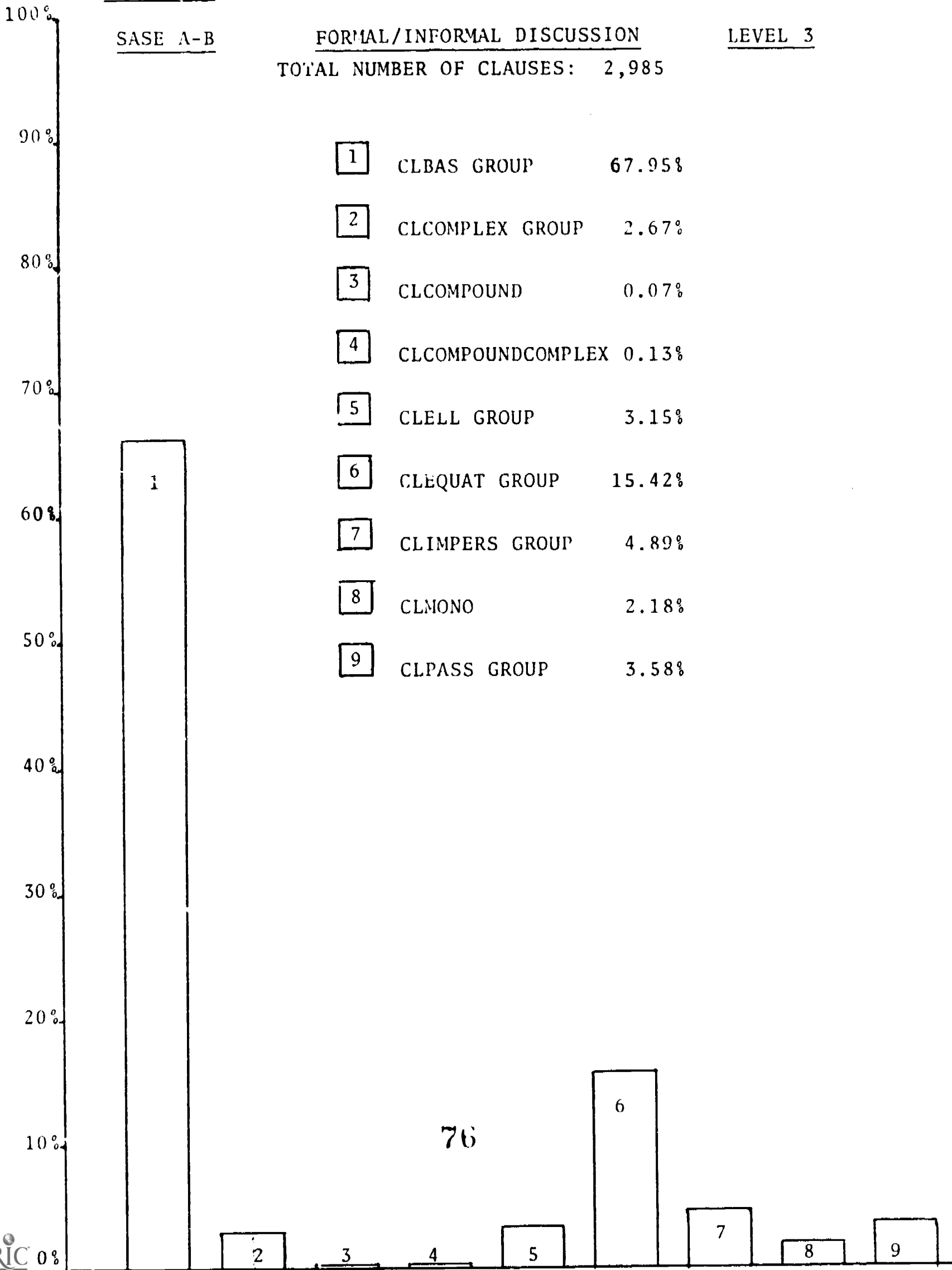

FIGURE 15  $\chi^2$  TEST

PHRASE TYPES: SAWE A vs SASE A & B

	<u>SAWE A</u>	<u>SASE A &amp; B</u>	<u><math>\chi^2</math></u>	
1. PHADJ	156	248	112.164	***
2. PHADV GROUP	41	125	111.713	***
3. PHGERUND	4	0	0.165	NS
4. PHN	4,892	2,334	22.698	***
5. PHPREP	2,886	1,433	8.533	**
6. PHPRON	42	96	68.224	***
7. PHV GROUP	213	322	133.388	***
TOTAL $\chi^2$	<u>8,234</u>	<u>4,555</u>	<u>489.157</u>	<u>***</u>

TOTAL: d.f. = 6

cut-off at .05 = 12.59 \*  
 .01 = 16.81 \*\*  
 .001 = 22.46 \*\*\*

PAIRS: d.f. = 1

cut-off at .05 = 3.84 \*  
 .01 = 6.64 \*\*  
 .001 = 10.83 \*\*\*

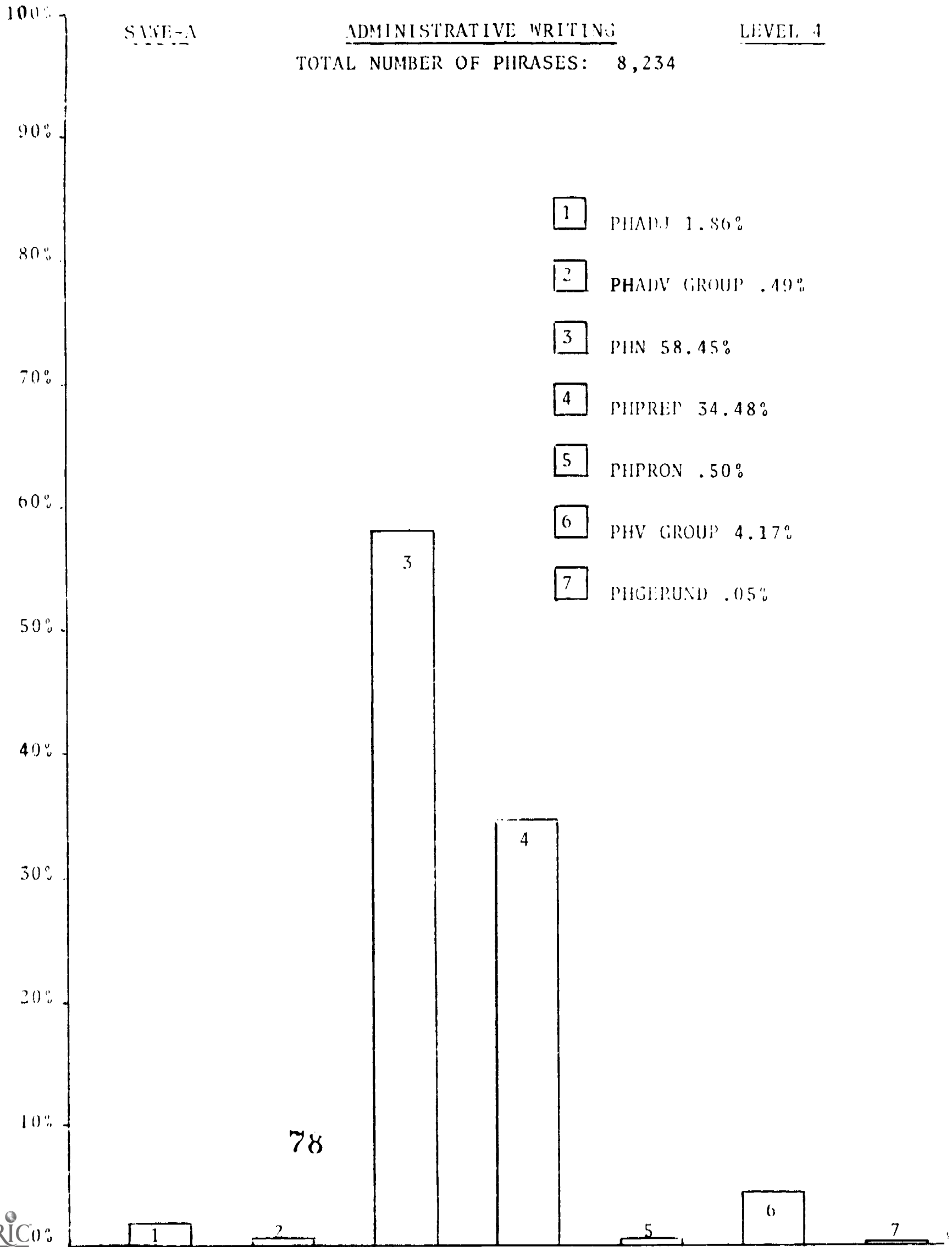
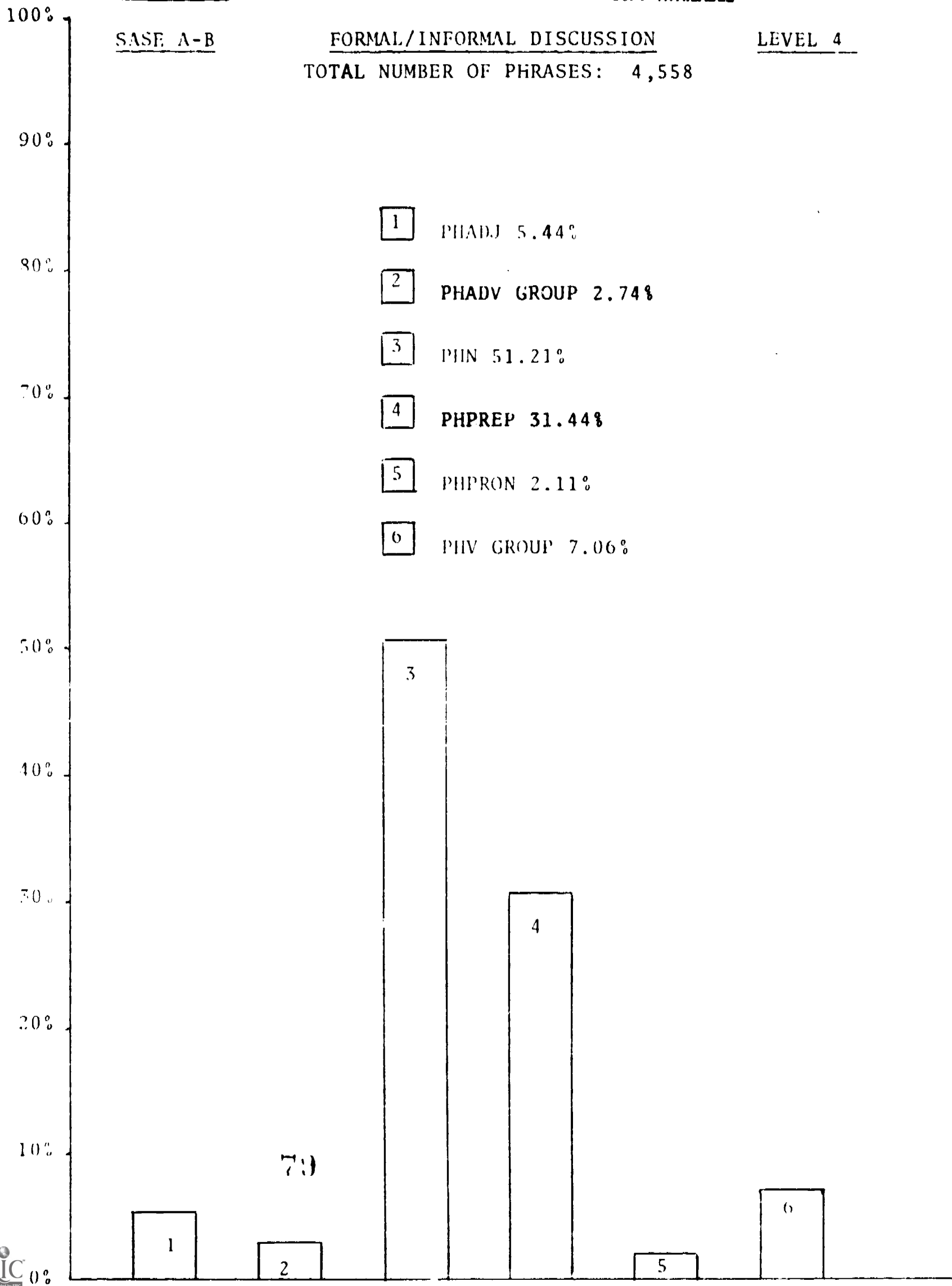

FIGURE 17



4.5. Number of Nuclear Tagmemes: The overall Chi Square for the number of nuclear tagmemes contained in the clauses was significantly different at the .001 level of significance. See Figure 18. Individually, the occurrences of "no nuclear tagmemes", 1, 3, and 4 nuclear tagmemes were significantly different at the .001 level, but the occurrence of 2, 5, 6, 7, 8 and 9 nuclear tagmemes were all non-significant. "No nuclear tagmemes" and 3 nuclear tagmemes occurred significantly more often in SASE A & B than in SAWE A, and 1 and 4 nuclear tagmemes occurred significantly more often in SAWE A than in SASE A & B. Although statistically speaking the occurrences of 5 - 9 nuclear tagmemes were non-significant, it is interesting to note that the occurrences of 5 and 6 nuclear tagmemes were more frequent in SAWE A and that 7, 8, and 9 nuclear tagmemes occurred only in SAWE A. See Figures 19 and 20.

4.6. Strings of nuclear tagmemes: The most frequent strings of nuclear tagmemes of which clauses are composed were compared, first considering the five most frequent of SAWE A against SASE A & B (Figure 21) and the five most frequent of SASE A & B against SAWE A (Figure 22), then the ten most frequent of each against the other (Figure 23 and 24). In all of these comparisons the overall Chi Square proved to be significant at the .001 level

When considering the first five individual pairs, the highest ranking string in both corpora, +S +PRED +OD, was used significantly more frequently in SASE A & B than in SAWE A;

FIGURE 18

$\chi^2$  TEST

SAWE A and SASE A & B CLAUSES: NUMBER OF NUCLEAR TAGMEMES

	<u>SAWE A</u>	<u>SASE A &amp; B</u>	<u><math>\chi^2</math></u>	
No Nuclear Tagmemes	11	99	65.2512	***
1 Nuclear Tagmeme	307	184	33.7840	***
2 Nuclear Tagmemes	1,018	994	1.8035	NS
3 Nuclear Tagmemes	1,241	1,521	11.4600	***
4 Nuclear Tagmemes	173	90	28.8022	***
5 Nuclear Tagmemes	12	9	0.5750	NS
6 Nuclear Tagmemes	3	4	0.1004	NS
7 Nuclear Tagmemes	2	0	2.0930	NS
8 Nuclear Tagmemes	3	0	3.1387	NS
9 Nuclear Tagmemes	1	0	1.0465	NS
	<u>2,771</u>	<u>2,901</u>		

Total  $\chi^2$  at 8 d.f. = 159.753 \*\*\*

cut-off at .05 = 15.51 \*

.01 = 20.09 \*\*

.001 = 26.12 \*\*\*

Pairs: d.f. = 1

cut-off at .05 = 3.84 \*

.01 = 6.64 \*\*

.001 = 10.83 \*\*\*





FIGURE 20

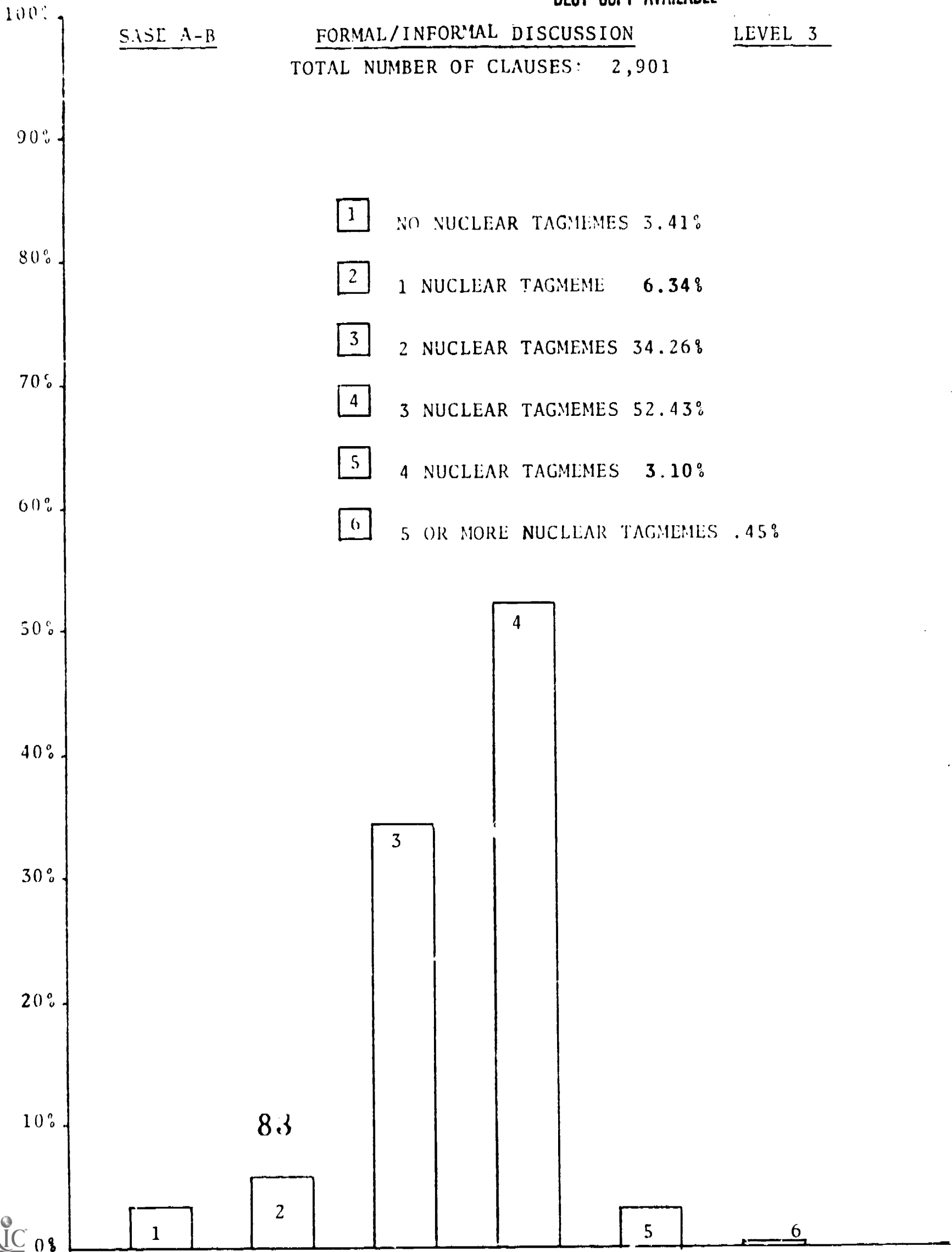

FIGURE 21

$\chi^2$  TEST

CLAUSES: 5 MOST FREQUENT STRINGS OF SAWE A NUCLEAR TAGMEMES COMPARED WITH SASE A & B

	<u>SAWE A</u>	<u>SASE A &amp; B</u>	<u><math>\chi^2</math></u>	
1. S PRED OD	590	842	22.4439	***
2. S PRED	418	525	5.0722	NS
3. PRED OD	384	299	14.7878	**
4. PRED	250	125	46.6003	***
5. S PRED PREDADJ	182	227	2.2265	NS
	<hr/>	<hr/>		
	1,824	2,018		

Total  $\chi^2$  at 4 d.f. = 104.1513 \*\*\*

cut-off at .05 = 9.49 \*

.01 = 13.28 \*\*

.001 = 18.45 \*\*\*

FIGURE 22

$\chi^2$  TEST

CLAUSES: 5 MOST FREQUENT STRINGS OF SASE A & B NUCLEAR TAGMEMES COMPARED WITH SAWE A

	<u>SASE A - B</u>	<u>SAWE A</u>	<u><math>\chi^2</math></u>	
1. S PRED OD	842	590	16.8963	**
2. S PRED	525	418	2.9262	NS
3. PRED OD	299	384	18.7865	***
4. S PRED PREDADJ	227	182	1.2436	NS
5. S PRED PREDNOM	165	196	6.4587	NS
	<hr/>	<hr/>		
	2,058	1,770		

Total  $\chi^2$  at 4 d.f. = 53.3108 \*\*\*

cut-off .05 = 9.49 \*

.01 = 13.28 \*\*

.001 = 18.45 \*\*\*

FIGURE 23

$\chi^2$  TEST

CLAUSES: 10 MOST FREQUENT STRINGS OF SAWE A NUCLEAR TAGMEMES COMPARED WITH SASE A & B

	<u>SAWE A</u>	<u>SASE A &amp; B</u>	<u><math>\chi^2</math></u>	
1. S PRED OD	590	842	22.4439	***
2. S PRED	418	525	5.0722	*
3. PRED OD	384	299	14.7878	***
4. PRED	250	125	46.6003	***
5. S PRED PREDADJ	182	227	2.2265	NS
6. S PRED OI	131	69	22.5831	***
7. S PRED PREDNOM	96	165	13.2422	***
8. PRED S	93	114	0.9263	NS
9. PRED OI	59	26	14.8292	***
10. PRED OD OI	45	10	24.3780	***
	<hr/>	<hr/>		
	2,248	2,402		

Total  $\chi^2$  at 9 d.f. = 183.4546 \*\*\*

cut-off at .05 = 16.92 \*

.01 = 21.67 \*\*

.001 = 27.88 \*\*\*

Pairs: 1 d.f.

cut-off at .05 = 3.84 \*

.01 = 6.64 \*\*\*

.001 = 10.83 \*\*\*

FIGURE 24

$\chi^2$  TEST

CLAUSES: 10 MOST FREQUENT STRINGS OF SASE A & B NUCLEAR TAGMEMES COMPARED WITH SAWE A

	<u>SASE A &amp; B</u>	<u>SAWE A</u>	<u><math>\chi^2</math></u>	
1. S PRED OD	842	590	16.8963	***
2. S PRED	525	418	2.9262	NS
3. PRED OD	299	384	18.7865	***
4. S PRED PREDADJ	227	182	1.2436	NS
5. S PRED PREDNOM	165	196	6.4587	*
6. PRED	125	250	51.8747	***
7. PRED S	114	93	0.4734	NS
8. No Nuclear Tagmemes	99	11	60.3538	***
9. OD S PRED	73	29	14.3770	***
10. S PRED OI	69	131	25.2954	***
	<hr/>	<hr/>		
	2,538	2,284		

Total  $\chi^2$  at 9 d.f. = 214.2882 \*\*\*

cut-off at .05 = 16.92 \*

.01 = 21.67 \*\*

.001 = 27.88 \*\*\*

PAIRS: d.f. = 1

cut-off at .05 = 3.84 \*

.01 = 6.64 \*\*

.001 = 10.83 \*\*\*

while the third ranking string in both, +PRED +OD, was used significantly more frequently in SAWE A than in SASE A + B, as was the fourth ranking string of SAWE, +PRED. The Chi Square figures for the other strings were non-significant: the second ranking string in both corpora, +S +PRED; the string which ranked fourth in SASE A + B and fifth in SAWE A, +S +PRED +PREDADJ; and the fifth ranking string of SASE A + B, +S +PRED +PREDNOM.

When considering the first ten individual pairs, substantially the same pattern emerged. The high-ranking SAWE A strings +PRED +OD, +PRED, +S +PRED +OI, +PRED +OI, and +PRED +OD +OI were significantly more frequent in SAWE A than in SASE A+B. The high-ranking SASE A + B strings +S +PRED +OD, "no nuclear tagmemes", and +OD +S +PRED, were significantly more frequent in SASE A + B than in SAWE A. The Chi Square figures for the remaining three strings were non-significant:

+S +PRED, +S +PRED +PREDADJ, and +PRED +S.

4.7. General categories of clauses without regard to semantic categories:

This refers to classification of clauses into infinitival, participial, WH or ordinary clause without any of these qualifications. When general categories were considered overall (not considering clause groups such as PASS, BAS, etc.), the Chi Square figure was significant at the .05 level. See Figure 25. However, none of the individual pairs were significant, so the source of the difference cannot be established. Presumably there was some small difference in each category which totalled to make a Chi Square figure which was significant. See Figures 26 and 27 for the proportions.

In figure 28 the general categories within basic clauses were considered. The overall Chi Square was significant at the .001 level, as were CLBASINF and CLBASPART, both of which were used significantly more often in SAWE A than in SASE A + B. The distributions of CLBAS and CLBASWH were not significantly different. See Figures 29 and 30 for the proportions.

In Figures 31, 32 and 33 the general categories within equative clauses were considered. The overall Chi Square was non-significant.

In Figures 34, 35 and 36 the general categories within passive clauses were considered, where the overall Chi Square was also non-significant. (Note that this comparison considers proportional distribution of -INF, -PART and -WH within passive clauses; the fact that SAWE A has six times as many passives as SASE A + B is not being considered here.)



FIGURE 25

$\chi^2$  TEST

SAWE A vs. SASE A + B: OVERALL GENERAL CATEGORIES OF CLAUSES WITHOUT REGARD TO SEMANTIC CATEGORIES

	<u>SAWE A</u>	<u>SASE A + B</u>	<u><math>\chi^2</math></u>	
1. Clause	1,464	1,608	2.398	NS
2. INF clause	299	284	0.756	NS
3. PART clause	183	161	2.631	NS
4. WH clause	819	785	1.385	NS
	<u>2,770</u>	<u>2,838</u>		

TOTAL  $\chi^2$  at 3 d.f. = 9.1215 \*

cut-off at .05 = 7.82 \*

.01 = 11.34 \*\*

.001 = 16.27 \*\*\*

PAIR:: d.f. = 1

cut-off at .05 = 3.84 \*

.01 = 6.64 \*\*

.001 = 10.83 \*\*\*

FIGURE 26  
SAWE-A LEVEL 3  
All Clauses

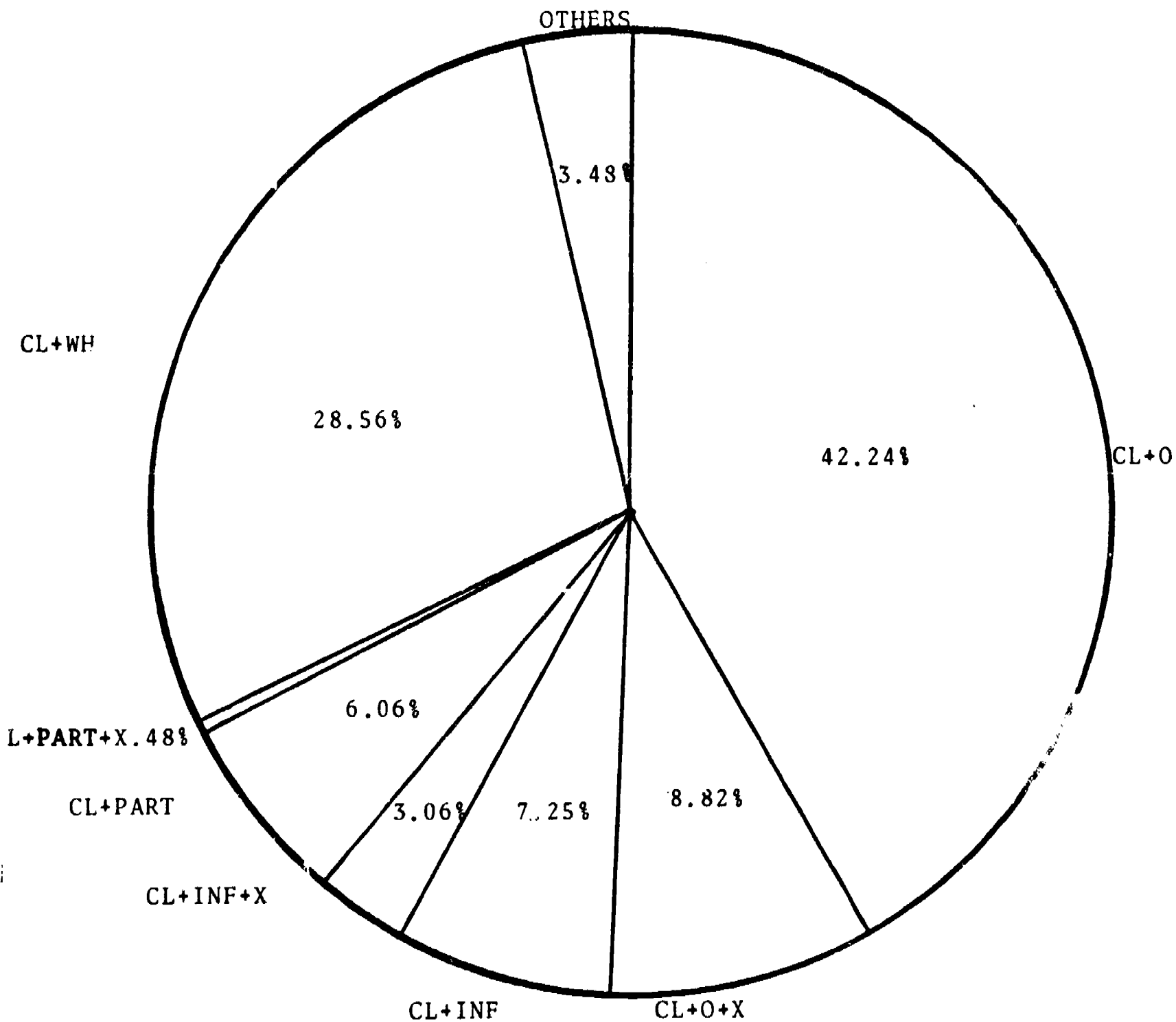

X= CAUSE, COND, CONS, MAN, ETC.

FIGURE 27  
SASE A-B LEVEL 3  
All Clauses

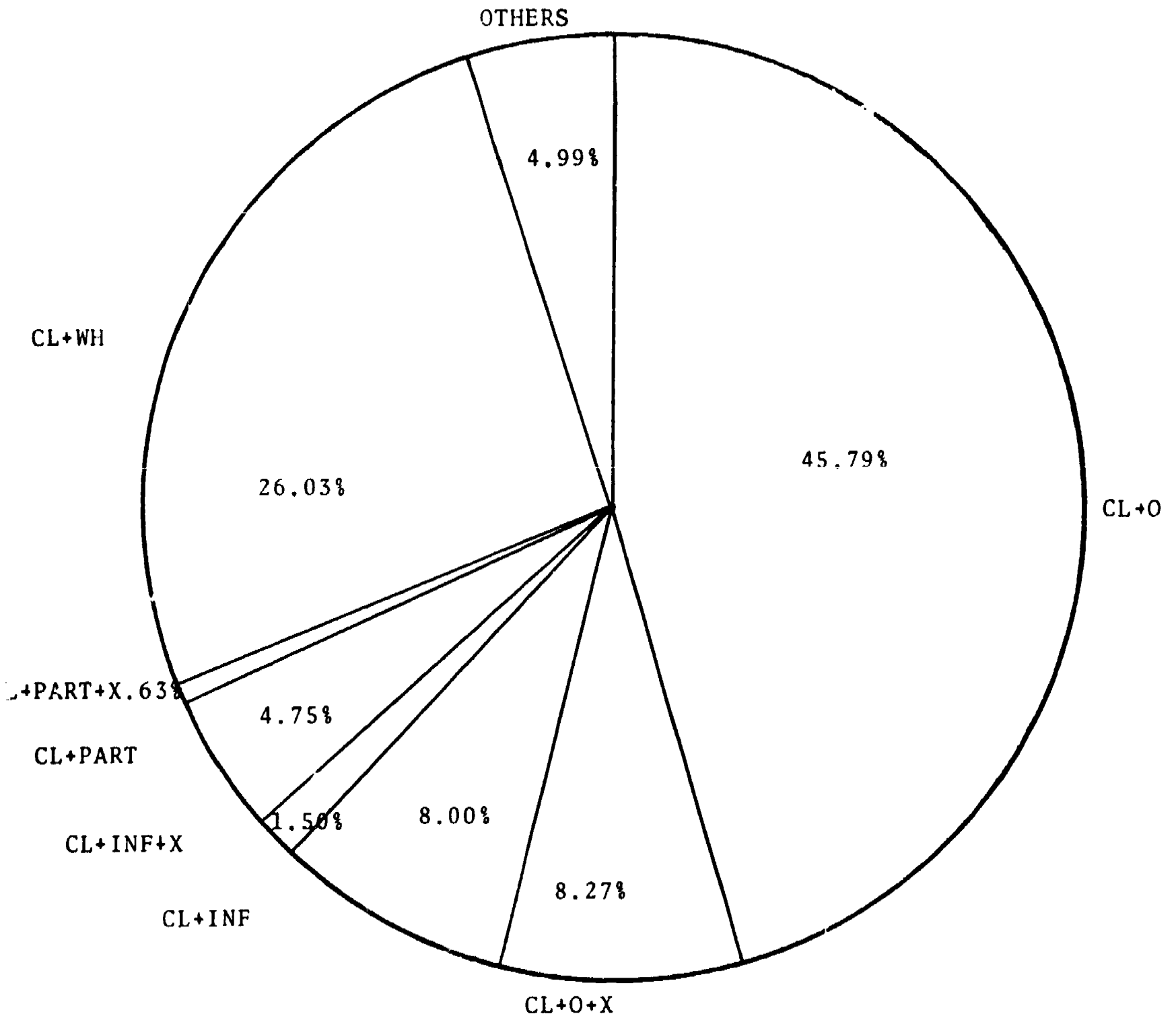

X= CAUSE, COND, CONS, MAN, etc.

FIGURE 28

$\chi^2$  TEST

SAWE A vs SASE A+B: GENERAL CATEGORIES WITHIN CLAUSE GROUPS (without regard to semantic categories)

I CLBAS

	<u>SAWE A</u>	<u>SASE A+B</u>	<u><math>\chi^2</math></u>	
1. CLBAS	770	1110	2.9300	NS
2. CLBASINF	287	272	11.5926	***
3. CLBASPART	174	154	11.4190	***
4. CLBASWH	325	492	3.5001	NS
	<hr/>	<hr/>		
	1556	2028		

Total  $\chi^2$  at 3 d.f. - 34.7071\*\*\*

cut-off at .05 = 7.82\*

.01 = 11.34\*\*

.001 = 16.27\*\*\*

Pairs: d.f. = 1

cut-off at .05 = 3.84\*

.01 = 6.64\*\*

.001 = 10.83\*\*\*

FIGURE 29

SAWE-A LEVEL 3  
CLBAS

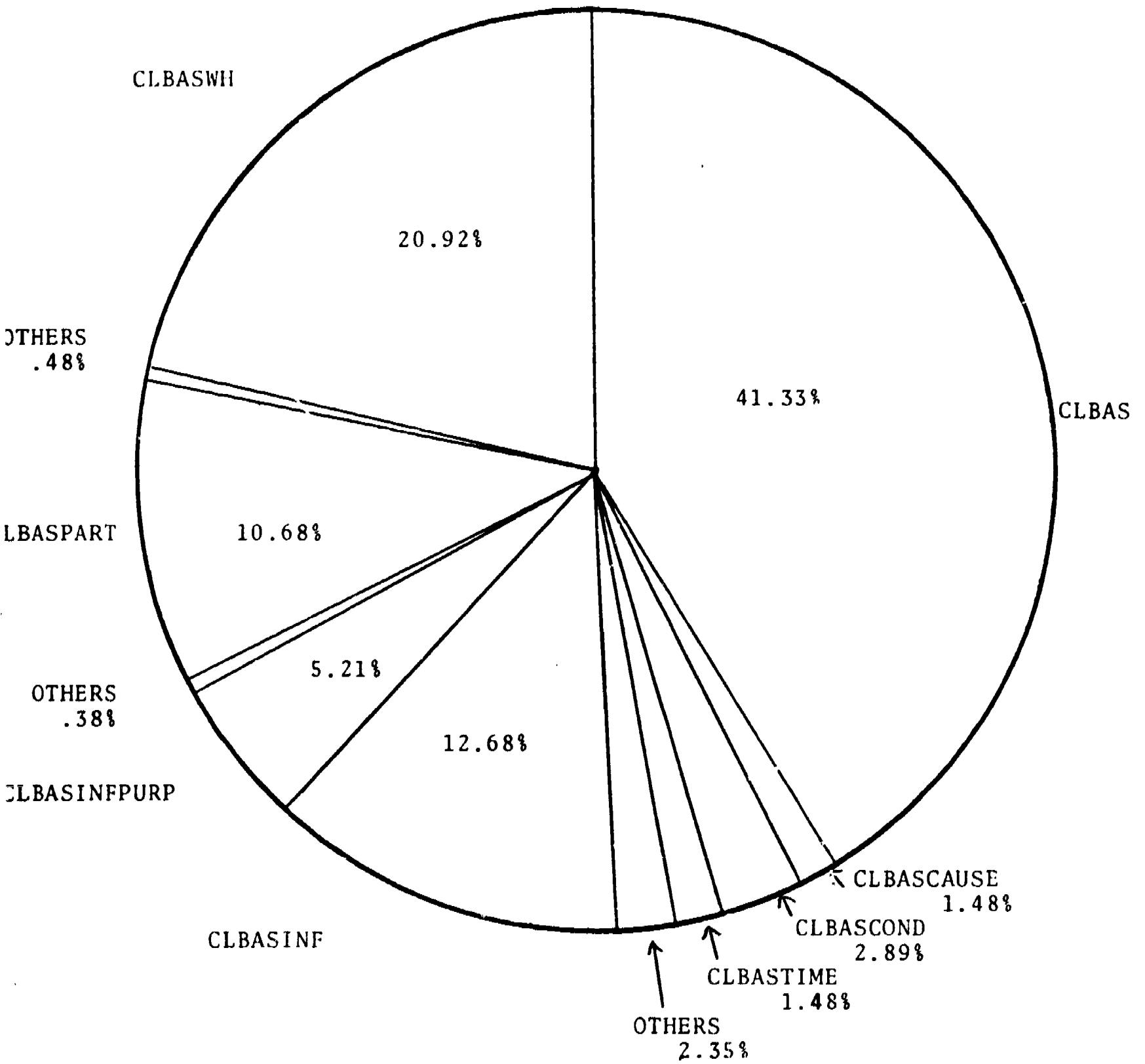

CLBAS' OTHERS'  
CLBAS-CONS  
-MAN  
-OPPOS  
-PURP  
-RESTR  
-SIT

CLBASINF' OTHERS'  
CLBASINF-MAN  
-REFL  
**94**

CLBASPART' OTHERS'  
CLBASPART-COND  
-OPPOS  
-PURP  
-RESTR  
-SIT

FIGURE 30

SASE A-B LEVEL 3

CLBAS

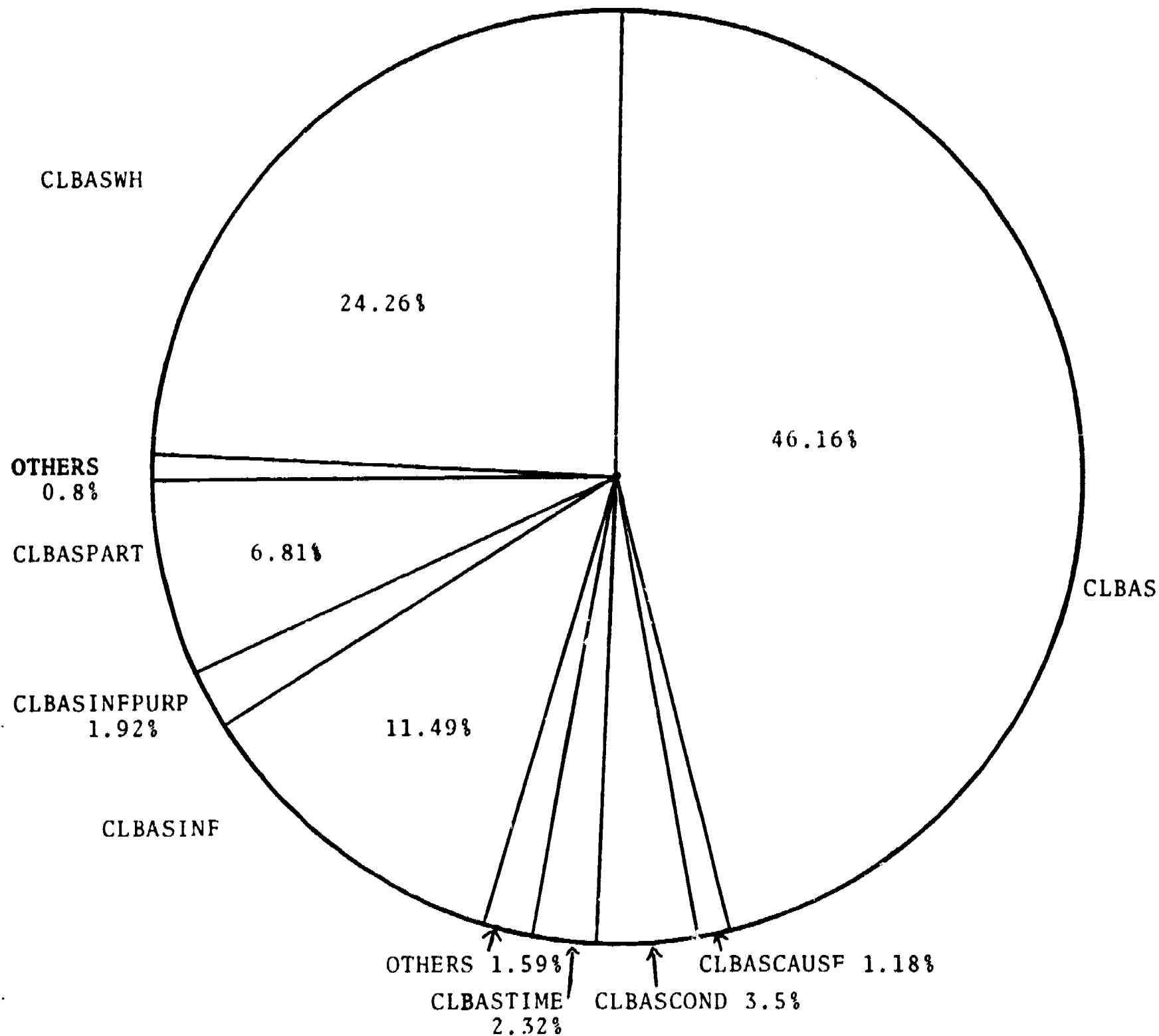

CLBAS 'OTHERS'  
 CLBAS-CONS  
 -MAN  
 -OPPOS  
 -PURP  
 -RESTR  
 -SIT

CLBASPART 'OTHERS'  
 CLBASPART-CAUSE  
 -COND  
 -MAN  
 -RESTR  
 -SIT  
 -TIME

FIGURE 31

$\chi^2$  TEST

SAWE A vs SASE A&B GENERAL CATEGORIES WITHIN CLAUSE GROUPS

(without regard to semantic categories)

II. CLEQUAT

	<u>SAWE A</u>	<u>SASE A&amp;B</u>
1. CLEQUAT	216	279
2. CLEQUATINF	3	9
3. CLEQUATPART	9	5
4. CLEQUATWH	107	168
	<hr/>	<hr/>
	335	461

Total  $\chi^2$  at 3 d.f. = 5.8949 NS

cut-off at .05 = 7.82\*

FIGURE 32

SAWE-A LEVEL 3

CLEQUAT

BEST COPY AVAILABLE

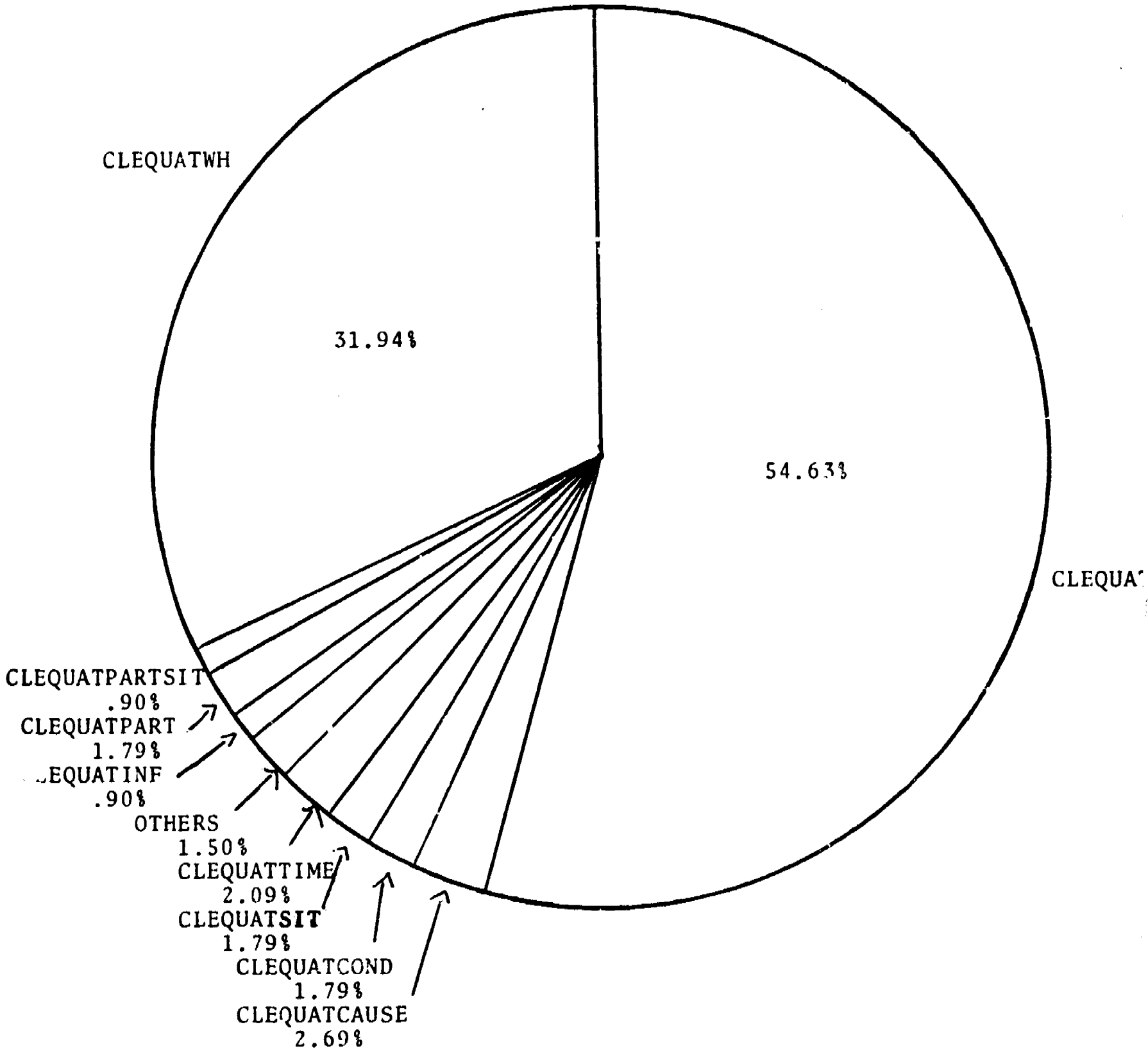

CLEQUAT 'OTHERS'  
CLEQUAT-CONS  
-MAN  
-PURP  
-RESTR

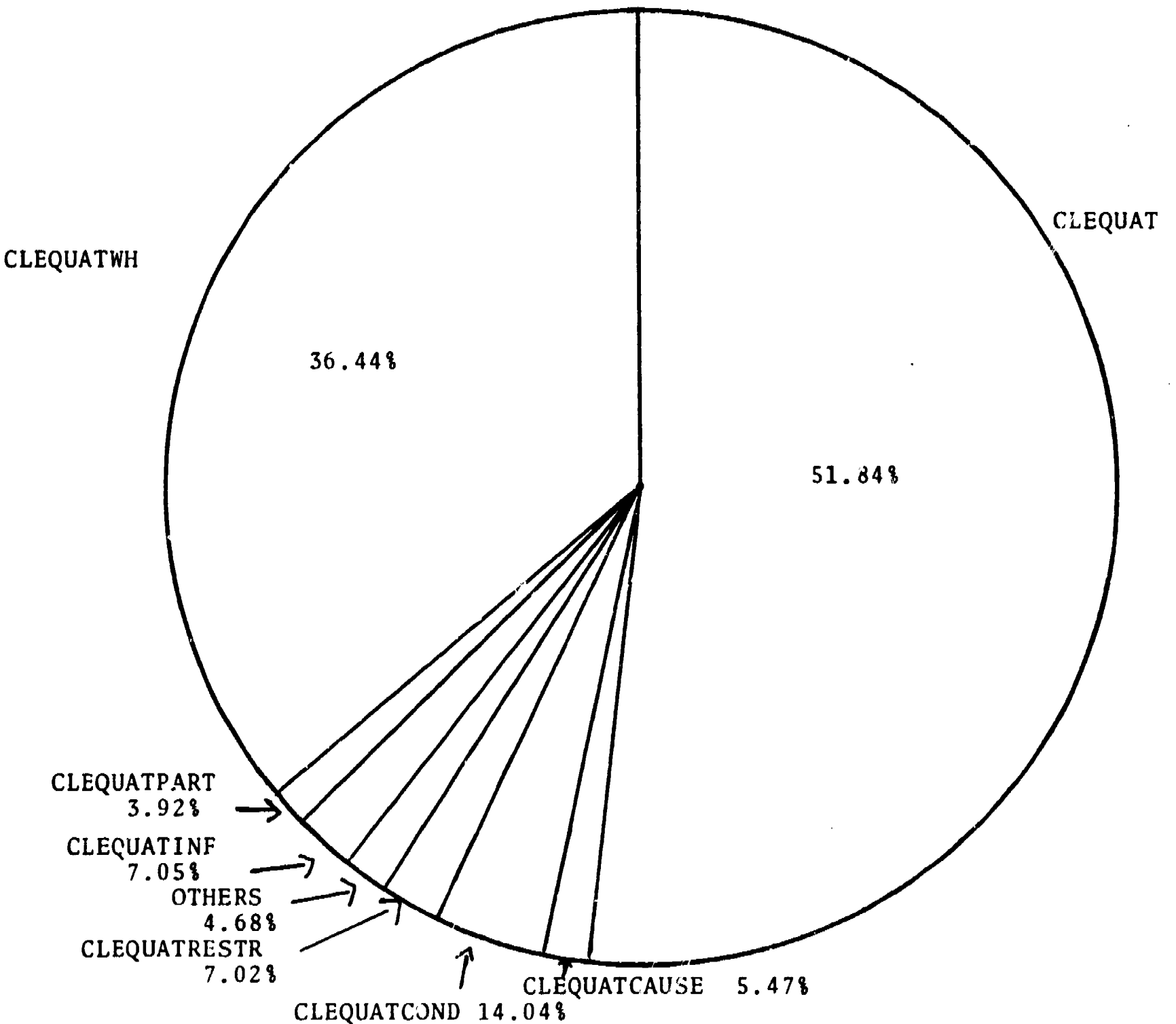

FIGURE 33

SASE A-B  
CLEQUAT

LEVEL 3

BEST COPY AVAILABLE



CLEQUAT 'OTHERS'  
 CLEQUATCONS  
 CLEQUATTIME

CLEQUATINF  
 CLEQUATINF  
 CLEQUATINFPURP  
 CLEQUATINFSIT

CLEQUATPART  
 CLEQUATPART  
 CLEQUATPARTCAUSE

FIGURE 34

$\chi^2$  TEST

SAWE A vs SASE A-B GENERAL CATEGORIES WITHIN CLAUSE GROUPS  
(without regard to semantic categories)

III CLPASS

	<u>SAWE A</u>	<u>SASE A+B</u>
1. CLPASS	330	53
2. CLPASSINF	8	3
3. CLPASSPART	5	2
4. CLPASSWH	336	49
	<hr/>	<hr/>
	679	107

Total  $\chi^2$  at 3 d.f. = 3.3494 NS

cut-off at .05 = 7.82\*

FIGURE 35

SAWE-A LEVEL 3  
CLPASS

BEST COPY AVAILABLE

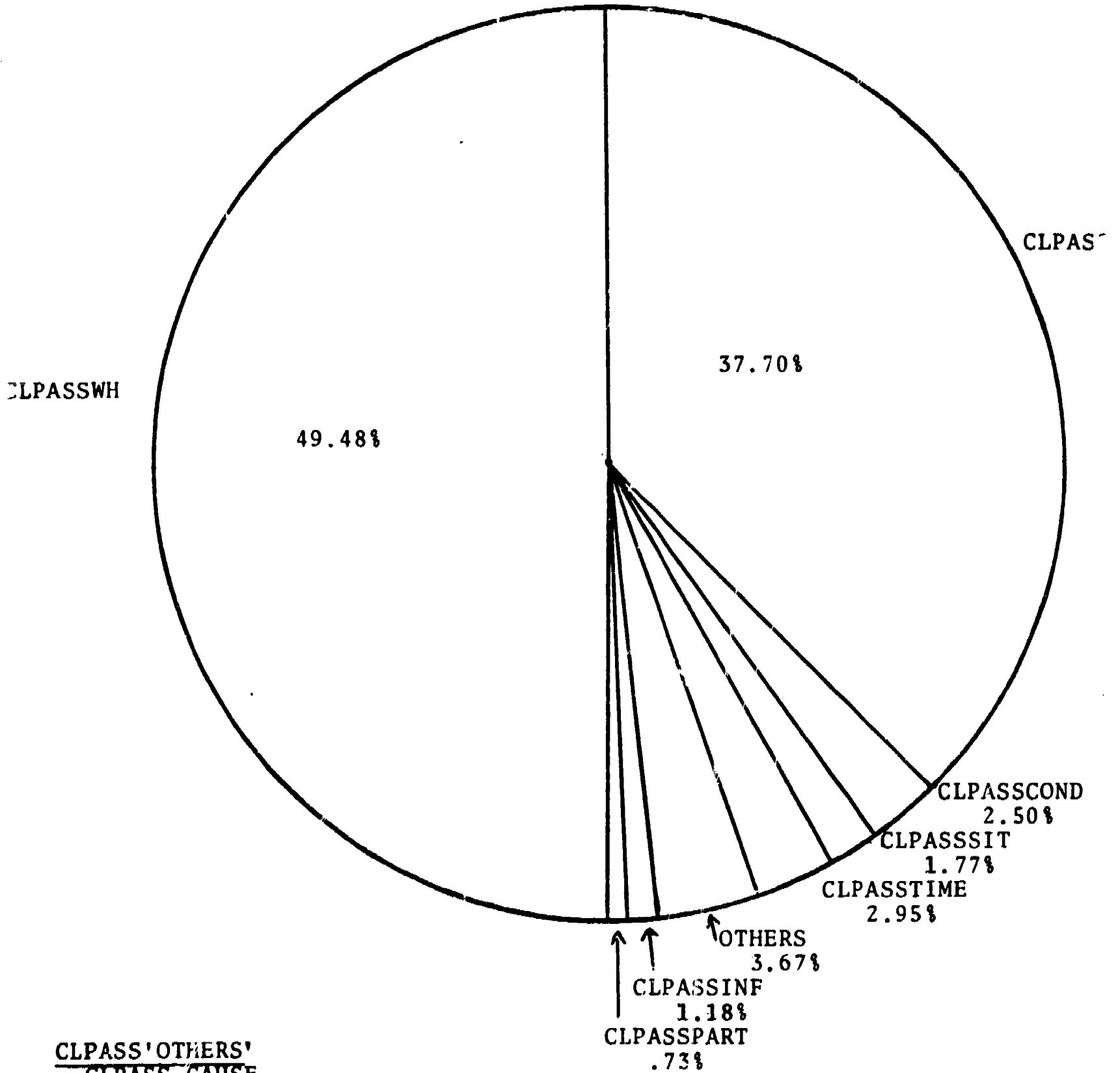

CLPASS' OTHERS'  
CLPASS-CAUSE  
-MAN  
-CPPOS  
-PURP  
-RESTR

CLPASSINF  
CLPASSINF  
CLPASSINFPURP

CLPASSPART  
CLPASSPART  
CLPASS

FIGURE 36

SASE A-B LEVEL 3  
CLPASS

BEST COPY AVAILABLE

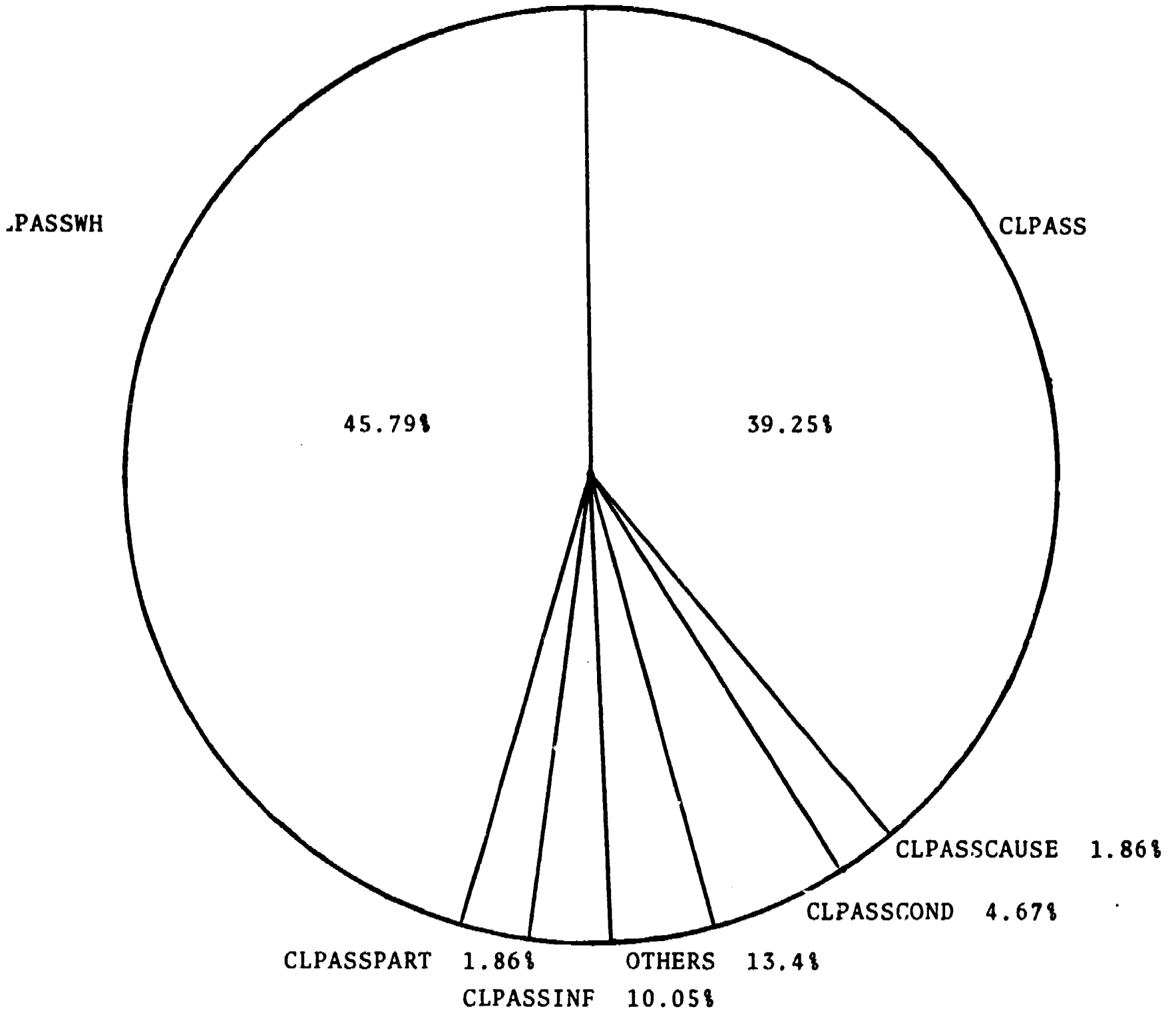

CLPASS OTHERS

CLPASSMAN  
CLPASSRESTR  
CLPASSSIT  
CLPASSTIME

CLPASSINC

CLPASSINF  
CLPASSINFPURP

4.8. Semantic categories of dependent clauses: "Semantic categories" refers to the labels of cause, time, manner, etc. which are affixed to dependent clauses. An overall comparison of semantic categories, without considering the type of clause they appear in, revealed a total Chi Square which was significant at the .001 level. See Figure 37. Among individual pairs of categories, the Chi Square figures for PURP, RESTR, and SIT were significant at the .01 level, while those for COND and OPPOS were significant at the .05 level. The semantic categories PURP, SIT and OPPOS were used proportionately more often in SAWE A; the categories RESTR and COND were used more often in SASE A + B. The Chi Square figures for the categories CAUSE, CONS, MAN and TIME were non-significant.

Figures 38-46 show the Chi Square calculations for the distribution of each individual semantic category over different types of clauses. The category TIME had a Chi Square which was significant at the .001 level. The Chi Square figures for the individual types of TIME clauses showed this difference to be located in two types of clauses: CLPASSTIME which was far more frequent in SAWE A than in SASE A + B; and CLBASTIME, which was disproportionately frequent in SASE A + B. The category COND had a Chi Square which was significant at the .01 level. This difference was located entirely in CLPASSCOND, which occurred significantly more frequently in SAWE A than in SASE A + B; all other types of clauses had a non-significant Chi Square. The categories SIT and MAN has Chi Squares which were significant at the .05

FIGURE 37

$\chi^2$  TEST

OVERALL COMPARISON OF SEMANTIC CATEGORIES OF DEPENDENT CLAUSES:

SAWE A vs. SASE A+B

	<u>SAWE A</u>	<u>SASE A+B</u>	<u><math>\chi^2</math></u>	
1. CAUSE	39	38	0.3730	NS
2. COND	80	102	6.1162	*
3. CONS	6	7	0.3423	NS
4. MAN	15	12	0.0157	NS
5. OPPOS	13	3	4.5743	*
6. PURP	101	47	9.5224	**
7. RESTR	8	23	9.6567	**
8. SIT	37	10	10.6884	**
9. TIME	53	54	0.8464	NS
	<hr/>	<hr/>		
	352	296		

Total  $\chi^2$  at 8 d.f. = 47.325\*\*\*

cut-off at .05 = 15.51\*

.01 = 20.09\*\*

.001 = 26.12\*\*\*

Pairs: d.f. = 1

cut-off at .05 = 3.84\*

.01 = 6.64\*\*

.001 = 10.83\*\*\*

FIGURE 38

$\chi^2$  TEST

SEMANTIC CATEGORIES OF DEPENDENT CLAUSES: SAWE A vs. SASE A+B

I CAUSE

	<u>SAWE A</u>	<u>SASE A+B</u>
1. CLBASCAUSE	23	24
2. CLBASPARTCAUSE	0	1
3. CLELLCAUSE	0	2
4. CLEQUATCAUSE	9	7
5. CLEQUATPARTCAUSE	0	1
6. CLIMPERSCAUSE	1	1
7. CLPASSCAUSE	6	2
	<hr/>	<hr/>
	39	38

$\chi^2$  at 6 d.f. = 6.2593 NS

cut-off at .05 = 12.59\*

FIGURE 39

$\chi^2$  TEST

SEMANTIC CATEGORIES OF DEPENDENT CLAUSES: SAWE A vs. SASE A+B

II COND

	<u>SAWE A</u>	<u>SASE A+B</u>	<u><math>\chi^2</math></u>	
1. CLBASCOND	45	71	0.7753	NS
2. CLBASPARTCOND	2	2	0.0580	NS
3. CLELLCOND	7	3	2.5947	NS
4. CLEQUATCOND	6	18	3.1329	NS
5. CLIMPERSCOND	3	3	0.0859	NS
6. CLPASSCOND	17	5	8.7353	**
	<hr/>	<hr/>		
	80	102		

$\chi^2$  at 5 d.f. = 17.5698\*\*

cut-off at .05 = 11.07 \*  
 .01 = 15.09 \*\*  
 .001 = 20.52 \*\*\*

Pairs: 1 d.f.

cut-off at .05 = 3.84 \*  
 .01 = 6.64 \*\*  
 .001 = 10.83 \*\*\*



FIGURE 40

$\chi^2$  TEST

SEMANTIC CATEGORIES OF DEPENDENT CLAUSES : SAWE A vs. SASE A+B

III CONS

	<u>SAWE A</u>	<u>SASE A+B</u>
1. CLBASCONS	3	5
2. CLELLCONS	1	0
3. CLEQUATCONS	2	2
	<hr/>	<hr/>
	6	7

Total  $\chi^2$  at 2 d.f. = 1.4316 NS

cut-off at .05 = 5.99 \*

FIGURE 41

$\chi^2$  TEST

SEMANTIC CATEGORIES OF DEPENDENT CLAUSES: SAWE A vs. SASE A+B

IV MAN

	<u>SAWE A</u>	<u>SASE A+B</u>	<u><math>\chi^2</math></u>	
1. CLBASMAN	5	5	0.0905	NS
2. CLBASINFMAN	3	0	2.2220	NS
3. CLBASPARTMAN	0	6	6.1112	*
4. CLEQUATMAN	1	0	0.7778	NS
5. CLPASSMAN	6	1	2.1409	NS
	<hr/>	<hr/>		
	15	12		

Total  $\chi^2$  at 4 d.f. = 13.4034\*

cut-off at .05 = 9.49 \*  
.01 = 13.28 \*\*  
.001 = 18.46 \*\*\*

Pairs: 1 d.f.:

cut-off at .05 = 3.84 \*  
.01 = 6.64 \*\*  
.001 = 10.83 \*\*\*

FIGURE 42

$\chi^2$  TEST

SEMANTIC CATEGORIES OF DEPENDENT CLAUSES: SAWE A vs. SASE A+B

V OPPOS

	<u>SAWE A</u>	<u>SASE A+B</u>
1. CLBASOPPOS	8	3
2. CLASPARTOPPOS	1	0
3. CLPASSOPPOS	4	0
	<hr/>	<hr/>
	13	3

Total  $\chi^2$  at 2 d.f. = 1.6777 NS

cut-off at .05 = 5.99 \*

FIGURE 43

 $\chi^2$  TEST

SEMANTIC CATEGORIES OF DEPENDENT CLAUSES: SAWE A vs. SASE A+B

VI PURP

	<u>SAWE A</u>	<u>SASE A+B</u>
1. CLBASPURP	8	5
2. CLBASINFPURP	81	39
3. CLBASPARTPURP	2	0
4. CLEQUATPURP	1	0
5. CLEQUATINFPURP	0	1
6. CLIMPERSPURP	1	0
7. CLPASSPURP	7	0
8. CLPASSINFPURP	1	2
	<hr/>	<hr/>
	101	47

Total  $\chi^2$  at 7 d.f. = 9.2547 NS

cut-off at .05 = 14.07 \*

FIGURE 44

$\chi^2$  TEST

SEMANTIC CATEGORIES OF DEPENDENT CLAUSES: SAWE A vs. SASE A+B

VII RESTR

	<u>SAWE A</u>	<u>SASE A+B</u>
1. CLBASRESTR	4	10
2. CLBASPARTRESTR	1	1
3. CLEQUATRESTR	1	9
4. CLIMPERSRESTR	0	2
5. CLPASSRESTR	2	1
	<hr/>	<hr/>
	8	23

$\chi^2$  at 4 d.f. = 5.2833 NS

cut-off at .05 = 9.49 \*

FIGURE 45

$\chi^2$  TEST

SEMANTIC CATEGORIES OF DEPENDENT CLAUSES: SAWE A vs. SASE A+B

VIII SIT

	<u>SAWE A</u>	<u>SASE A+B</u>	<u><math>\chi^2</math></u>	
1. CLBASSIT	9	4	0.5126	NS
2. CLBASPARTSIT	2	4	5.6389	*
3. CLELLSIT	1	0	0.2685	NS
4. CLEQUATSIT	6	0	1.5736	NS
5. CLEQUATINFSIT	0	1	3.4350	NS
6. CLEQUATPARTSIT	3	0	0.7975	NS
7. CLIMPERSIT	3	0	0.7975	NS
8. CLPASSIT	12	1	1.2549	NS
9. CLPASSPARTSIT	1	0	0.2685	NS
	<hr/>	<hr/>		
	37	10		

Total  $\chi^2$  at 8 d.f. = 16.9947\*

cut-off at .05 = 15.51 \*

.01 = 20.09 \*\*

.001 = 26.12 \*\*\*

Pairs: 1 d.f

cut-off at .05 = 3.84 \*

.01 = 6.64 \*\*

.001 = 10.83 \*\*\*

FIGURE 46

$\chi^2$  TEST

SEMANTIC CATEGORIES OF DEPENDENT CLAUSES: SAWE A vs. SASE A+B

IX TIME

	<u>SAWE A</u>	<u>SASE A+B</u>	<u><math>\chi^2</math></u>	
1. CLBASTIME	23	47	4.8025	*
2. CLBASPARTTIME	0	2	1.9282	NS
3. CLELLTIME	1	0	1.0092	NS
4. CLEQUATTIME	7	4	0.7938	NS
5. CLPASSTIME	20	1	14.9639	***
6. CLPASSPARTTIME	2	0	2.0005	NS
	<hr/>	<hr/>		
	53	54		

$\chi^2$  at 5 d.f. = 31.2299\*\*\*

cut-off at .05 = 11.07 \*  
 .01 = 15.09 \*\*  
 .001 = 20.52 \*\*\*

Pairs: d.f. = 1

cut-off at .05 = 3.84 \*  
 .01 = 6.64 \*\*  
 .001 = 10.83 \*\*\*

level. The clause type CLBASPARTSIT, which occurred significantly more frequently in SASE A+B than in SAWE A, accounted for the difference in the former, while CLBASPARTMAN, which also occurred significantly more frequently in SASE A+B, accounted for the latter. The remaining categories, CAUSE, CONS, OPPOS, PURP and RESTR all had Chi Squares which were non-significant.

It should be noted that the figures for semantic categories used in different types of clauses were generally quite small, the majority having frequencies under 10. The lower the frequencies, the greater the tendency of the Chi Square to be non-significant, that is, to assume that the differences are due to chance. Thus, the results of the Chi Square tests on these semantic categories should be interpreted with caution.

- 4.9. Types of noun phrase modification: The overall Chi Square figure for types of noun phrase modification was significant at the .001 level. See Figure 47. The proportion of noun phrases which were both pre-and-post-modified was not significantly different in SAWE A and SASE A+B, but the other three types of modification were significant at the .001 level. Post-modified noun phrases occurred significantly more frequently in SAWE A than in SASE A+B, while pre-modified and unmodified noun phrases occurred significantly more frequently in SASE A+B than in SAWE A. For a full explanation of this collection of data, see "Types of Noun Phrase Modification", Appendix 11.



FIGURE 47

$\chi^2$  TEST

TYPES OF NOUN PHRASE MODIFICATION in SAWE A vs. SASE A&B

	<u>SAWE A</u>	<u>SASE A+B</u>	<u><math>\chi^2</math></u>	
1. Unmodified	1,146	660	11.2898	***
2. Premodified	1,732	987	13.6236	***
3. Post modified	1,431	439	55.4856	***
4. Pre + Post modified	563	247	1.1865	NS
	<hr/>	<hr/>		
	4,872	2,333		

Total  $\chi^2$  at 3 d.f. = 102.4167 \*\*\*

cut-off at .05 = 7.82 \*  
 .01 = 11.34 \*\*  
 .001 = 16.27 \*\*\*

Pairs: d.f. = 1

cut-off at .05 = 3.84 \*  
 .01 = 6.64 \*\*  
 .001 = 10.83 \*\*\*

Number of Nuclei in PHN disregarded

- 4.10 Forms filling pre-modification slots in noun phrases: The overall Chi Square for all forms filling pre-modification slots was non-significant. See Figure 48. Of the individual pairs, PH pre-modifiers were barely significantly more frequent in SASE A + B than in SAWE A (at the .05 level). All the other pre-modifier types were not significantly different in the two corpora.
- 4.11 Forms filling post-modification slots in noun phrases: The overall Chi Square for all forms filling post-modification slots was significant at the .001 level. See Figure 49. Of the individual pairs of post-modification forms, T (terminal) and PH forms occurred significantly more frequently in SAWE A than in SASE A + B, while CL and ELL forms occurred significantly more frequently in SASE A + B than in SAWE A. The Chi Squares for the remaining forms, the combinations T + PH, T + CL and PH + CL, were all non-significant.
- 4.12 Forms filling pre & post-modification slots in noun phrases: The overall Chi Square figure for forms filling pre & post-modification slots was significant at the .001 level. See Figure 50. This difference was accounted for by three of the twelve occurring combinations; the remaining nine showed non-significant Chi Square figures. The combination of a terminal pre-modifier with a PH post-modifier occurred significantly more frequently in SAWE A than in SASE A + B. The combinations of terminal pre-modifier with CL post-modifier, and PH pre-

FIGURE 48

$\chi^2$  TEST

FORMS FILLING PRE-MODIFICATION SLOTS IN NOUN PHRASES:

SAWE A vs. SASE A + B

	<u>SAWE A</u>	<u>SASE A + B</u>	<u><math>\chi^2</math></u>	
1. T	2023	1059	0.3176	NS
2. PH	248	165	3.9207	*
3. T + PH	23	12	0.0079	NS
4. T + CL	1	0	0.5388	NS
5. ELL	0	1	1.8543	NS
	<hr/>	<hr/>		
	2295	1237		

Total  $\chi^2$  at 4 d.f. = 7.4042 NS

cut-off at .05 = 9.49 \*

Pairs: d.f. = 1

cut-off at .05 = 3.84 \*

.01 = 6.64 \*\*

.001 = 10.83 \*\*\*

FIGURE 49

$\chi^2$  TEST

FORMS FILLING POST-MODIFICATION SLOTS IN NOUN PHRASES:

SAWE A vs. SASE A + B

	<u>SAWE A</u>	<u>SASE A+B</u>	<u><math>\chi^2</math></u>	
1. T	179	18	26.9004	***
2. PH	1,222	332	9.6501	**
3. CL	470	306	56.2898	***
4. T + PH	18	6	0.0047	NS
5. T + CL	8	0	2.7493	NS
6. PH + CL	97	22	3.0476	NS
7. ELL	0	2	5.8010	*
	<hr/>	<hr/>		
	1,994	686		

Total  $\chi^2$  at 6 d.f. = 132.3722 \*\*\*

cut-off at .05 = 12.59 \*  
 .01 = 16.81 \*\*  
 .001 = 22.46 \*\*\*

Pairs: d.f. = 1

cut-off at .05 = 3.84 \*  
 .01 = 6.64 \*\*  
 .001 = 10.83 \*\*\*

FIGURE 50

$\chi^2$  TEST

FORMS FILLING PRE & POST MODIFICATION SLOTS IN NOUN PHRASES

SAWE A & SASE A + B

	<u>SAWE A</u>	<u>SASE A + B</u>	<u><math>\chi^2</math></u>	
1. T/T	13	9	1.082	NS
2. T/PH+CL	25	8	0.593	NS
3. PH/PH+CL	2	1	0.011	NS
4. T/PH	331	97	8.631	**
5. T/CL	145	104	10.841	***
6. PH/T	1	0	0.439	NS
7. PH/PH	21	9	0.004	NS
8. PH/CL	12	12	4.123	*
9. T/T+CL	2	0	0.878	NS
10. T+PH/CL	6	0	2.629	NS
11. T/T+PH	2	4	3.648	NS
12. T+PH/PH	2	3	2.028	NS
	<hr/>	<hr/>		
	562	247		

Total  $\chi^2$  at 11 d.f. = 43.044 \*\*\*

cut-off at .05 = 19.68 \*  
 .01 = 24.72 \*\*  
 .001 = 31.26 \*\*\*

Pairs: d.f. = 1

cut off at .05 = 3.84 \*  
 .01 = 6.64 \*\*  
 .001 = 10.83 \*\*\*

modifier with CK post-modifier, occurred significantly more frequently in SASE A + B than in SAWE A.

- 4.13 Strings of functions making up noun phrases: The overall Chi Square figure for the 5 most frequent strings of functions occurring in SAWE A compared to the same strings in SASE A + B was significant at the .001 level. See Figure 51. All of the individual strings were used significantly differently in the two corpora except for the third-ranking string, +DEIC+NUC+QUAL, which was proportionately distributed. The string which ranked first in SAWE A, +DEIC+NUC, was nevertheless used significantly more frequently in SASE A + B than in SAWE A, as was the fourth-ranking string, +DEIC+QUAL+NUC. The second-ranking string, +QUAL+NUC, and the fifth-ranking string, +NUC+QUAL, were used significantly more frequently in SAWE A than in SASE A + B.

In the comparison of the 5 most frequent functions occurring in SASE A + B with the same strings in SAWE A, the overall Chi Square was significant at the .001 level, and all of the individual strings were also significantly differently distributed in the two corpora. See Figure 52. The string which ranked first in SASE A + B, +DEIC+NUC, was used significantly more frequently in SASE A + B than in SAWE A, as were the second-ranking string, +DEIC+NUC, and the fifth-ranking string, +QUANT+NUC. The third-ranking string, +DEIC+NUC+QUAL, and the fourth ranking string, +QUAL+NUC, were used significantly more frequently in SAWE A than in SASE A + B.

FIGURE 51

$\chi^2$  TEST

NOUN PHRASES: 5 MOST FREQUENT STRINGS OF SAWE A COMPARED WITH SASE A + B

	<u>SAWE A</u>	<u>SASE A + B</u>	<u><math>\chi^2</math></u>	
1. DEIC NUC	1,103	652	13.6376	***
2. QUAL NUC	849	287	21.6075	***
3. DEIC NUC QUAL	673	290	1.8142	NS
4. DEIC QUAL NUC	469	316	19.2364	***
5. NUC QUAL	342	96	312.1125	***
	<hr/>	<hr/>		
	3,436	1,641		

Total  $\chi^2$  at 4 d.f. = 90.9786 \*\*\*

cut-off at .05 = 9.49 \*  
.01 = 13.28 \*\*  
.001 = 18.46 \*\*\*

Pairs: d.f. = 1

cut-off at .05 = 3.84 \*  
.01 = 6.64 \*\*  
.001 = 10.83 \*\*\*

FIGURE 52

$\chi^2$  TEST

NOUN PHRASES: 5 MOST FREQUENT STRINGS OF SASE A + B COMPARED WITH SAWE A

	<u>SASE A+B</u>	<u>SAWE A</u>	<u><math>\chi^2</math></u>	
1. DEIC NUC	652	1,103	4.2014	*
2. DEIC QUAL NUC	316	469	10.0630	**
3. DEIC NUC QUAL	290	673	6.6926	**
4. QUAL NUC	287	849	35.1521	***
5. QUANT NUC	134	104	47.4583	***
	<hr/>	<hr/>		
	1,679	3,198		

Total  $\chi^2$  at 4 d.f. = 118.2123 \*\*\*

cut-off at .05 = 9.49 \*  
.01 = 13.28 \*\*  
.001 = 18.46 \*\*\*

Pairs: 1 d.f.

cut-off at .05 = 3.84 \*  
.01 = 6.64 \*\*  
.001 = 10.83 \*\*\*



4.14 Ratio comparisons: In addition to Chi Square tests, two types of ratios were calculated. See Figure 53. In the comparison of average number of clauses per sentence, SAWE A proved to have slightly more clauses (2.9 to 1) than SASE A + B (2.4 to 1). In the comparison of the average number of phrases per sentence, SAWE A turned out to have twice as many as SASE A + B: 8.3 to 1 for SAWE A and 3.6 to 1 for SASE A + B. Of course, when interpreting any figures concerning number of phrases, the unique way in which tagmemic analysis counts phrases must be borne in mind.

**FIGURE 53**

**SAWE A vs SASE A + B RATIO COMPARISONS**

**1. Ratio of clauses to sentences (functions)**

SAWE A: 2867 CL  $\div$  996 SEN 2.9 to 1

SASE A + B: 2986 CL  $\div$  1,269 SEN 2.4 to 1

**2. Ratio of phrases to sentences (functions)**

SAWE A: 8.234 PH  $\div$  SEN 8.3 to 1

SASE A + B: 4,558 Ph  $\div$  1,269 SEN 3.6 to 1

VII INTERPRETATION OF THE RESULTS: REGISTER CHARACTERISTICS OF  
ADMINISTRATIVE CORRESPONDENCE AND FORMAL/INFORMAL DISCUSSION

1. Level 1: Discourse

1.1 Sentence Function Definitions

In Level 1 of the computer printout, sentences are grouped together according to their function labels. There are four main sentence function labels:

- (i) SENDECL (declarative sentence) unmarked sentence function, covering a wide variety of sentence structures.
- EX. 1 SAWE-A 2.3 Of particular interest to the Department is "Metal Powder".
- EX. 2 SASE-A 1.7 From the point of view of the young Francophone people coming in, again I don't think there's any general reaction.
- (ii) SENIMPER (imperative sentence) - these sentences usually have the function of giving orders or directives; formally, the nuclear clause of an imperative sentence contains a predicate but no subject.
- EX. 3 SAWE-A 3.16 Please advise if further action is required by this office.
- EX. 4 SASE-A 3.38 Go back a little bit to a point Mr. Buchanan made earlier ...
- (iii) SENINTERJEC (interjective sentence) - short, independent sentences, usually interjections.
- EX. 5 SAWE-A 13.36 Thank you.
- EX. 6 SASE-A 1.57 Yes.

(iv) SENINTERROG (interrogative sentence) - functions as a request or question. In formal terms, interrogative sentences are characterized by an inversion of the subject and the verb.

EX. 7 SAWE-A 13.15 May I please have your approval to do so?

EX. 8 SASE-A 3.70 Do you think it should be more selective?

In SASE-A&B only (the spoken corpus), the additional label - INC (incomplete) is added to a sentence function label if the sentence was incomplete.

EX. 9 SASE-A 4.36 I think again one thing that you will find as this develops is ...

In SAWE-A, an additional sentence function label is used to describe a structure unique to that corpus: SENINTERROGIMPER - a sentence which functions both as an interrogative and imperative.

EX. 10 SAWE-A 8.41 Would you kindly let me know the number of copies you may want for your region.

## 1.2 Distribution of Sentence Functions

The Chi square figures of the sentence functions in SAWE-A and SASE-A&B were significant for virtually every type of sentence.

As might be expected, however, by far the greatest number of sentences in both corpora functioned as declarative sentences (93.78% in SAWE-A, 82.95% in SASE-A&B). See Figure 1 for the complete distribution of sentence functions. We can conclude from this that the declarative type of sentence is the most common, useful and productive of all sentence types.

## 1.3 Characteristic Features of SASE-A&B

There are higher frequencies in SASE-A&B of SENDECLINC (incomplete declarative sentences - 5.13% compared to a zero frequency in SASE-A), of SENINTERJEC (5.60% compared to .30% in SAWE-A), and SENINTERROG (5.45% compared to .80% in SAWE-A). Also, there were 5 occurrences of SENINTERROGINC in SASE-A&B, as opposed to no occurrences in SAWE-A.

- (1) Incomplete sentences - When the frequencies of all incomplete sentences are totalled (SENDECLINC, SENINTERROGINC, SENIMPERINC), we find that 5.61% of SASE-A&B sentences are incomplete. No similar phenomena occurred in SAWE-A; thus we can say that this is a feature unique to SASE-A&B.

The usual criteria for the INC label was that the speaker did not finish what he or she started to say, because of an interruption or perhaps because the thought about to be expressed was felt by the speaker to be self-evident. Some typical examples in context are:

Figure 1

SENTENCE FUNCTIONS: SAWE-A/SASE-A&B

	<u>SAWE-A</u>		<u>SASE-A&amp;B</u>	
	<u>Frequency</u>	<u>Percentage</u>	<u>Frequency</u>	<u>Percentage</u>
SENDECL	934	93.78%	1051	82.95%
SENDECLINC	0		65	5.13%
SENIMPER	34	3.41%	5	0.39%
SENIMPERINC	0		1	0.08%
SENINTERJEC	3	0.30%	71	5.60%
SENINTERROG	8	0.80%	69	5.45%
SENINTERROGIMPER	17	0.71%	0	
SENINTERROGINC	0		5	0.39%
<hr/>				
TOTAL NO. OF SENTENCES:	996	100.00%	1267	99.99%
<hr/>				

EX. 1 A 4.35 " ... the ... French Canadian who speaks English fluently ... would be eliminated #UH UH # and conversely anyone else # I th - I think again one thing that UH you will find ... is ..." (# indicates a pause)

EX. 2 A 3.62 " ... I haven't got the time to devote to it which I would like to have # because UH even on the basis of UH well in the past year since June of last year I've had only six weeks of French training ..."

Also in many cases this type of utterance represents the speaker abandoning the expression of an idea, or a particular means of expressing an idea, in favour of a more appropriate or better thought-out utterance.

EX. 3 B 4.1 "I've ... I have thought a lot about this ..."

EX. 4 B 4.36 "I think again one thing that UH UH you will find as this develops is that UH # take a person born in Newfoundland ..."

EX. 6 B 4.62 "Yes. Now this is really the #UH #

I don't know whether this is the kind of an answer you want but what I would say is that ..."

An interesting feature of spoken language which is indicated by incomplete sentences is that a series of short or incomplete sentences sometimes substitutes for what might be found in written language as one or two longer sentences with co-ordinations and subordinations. Look at the following consecutive SASE-A&B sentences,

several of which are labelled as incomplete (breaks between sentences as analysed are marked by slashes /):

EX. 7 B 4.90 - B 4.97 'Yes/#UH We have in # in our branch UH three days a week/a # a chap comes up from/# I think he's going to Ottawa "U" #/and UH he's a French-Canadian #/and for UH the last hour of the day UH # you can go over and sit UH around a table with him/and UH there'll usually be UH # half a dozen of us there/and we'll just # carry on a conversation #."

A comparative written passage might appear something like this:

"In our branch, we have a French-Canadian Ottawa University student who comes for the last hour of the day three times a week to help us maintain our spoken French by having informal conversations with us."

Notice that what is expressed in the actual spoken corpus in the form of several short sentences can be expressed as elements qualifying a noun within one sentence - either a compound adjective or a relative clause.

EX. 8 B 4.94 And he's a French Canadian → French-Canadian student

EX. 9 B 4.93 I think he's going to Ottawa "U" → Ottawa University student

EX.10 B 4.95 B 4.96 And for the last hour of the day you can go over and sit around a table with him. And there'll usually be half a dozen of us there. And we'll just carry on a conversation → A student who comes for the last hour



of the day three times a week to help us maintain our spoken French by having informal conversations with us.

While these kinds of structures are acceptable and understandable in the context of a discussion, they would not be appropriate to written correspondence. We would expect administrative correspondence to be carefully and efficiently structured so as to convey the desired meaning most effectively. Since incomplete sentences do not in fact occur in SAWE-A we can claim that they are a unique feature of SASE-A&B.

- (11) SENINTERJEC - The higher frequency of interjections in SASE-A&B reflects the relatively high frequency of short, truncated utterances which would be expected in a spoken corpus. Many utterances labelled SENINTERJEC are not interjections in the traditional sense of the word - that is, utterances which interrupt the flow of language and which usually carry some emotional impact. For example, many SENINTERJEC's in SASE-A&B are "Yes" or "No" at the beginning of a sentence, or in answer to a question.

EX. 1 A 1.17 Have you noticed any problems in this area? No.

This is also the case in SAWE-A, where the only three examples of what can be called SENINTERJEC are:

EX. 2 A 14.48 Thanks.

EX. 3 A 13.36, A 13.45 Thank you.

All three examples occur at the end of a letter, just before the "Yours truly...". Usually, the kind of thing that is expressed partly or wholly by a SENINTERJEC in SASE-A&B would tend to be

expressed by one or more full sentences in SAWE-A. The agreement expressed by these two consecutive SAWE-A sentences

EX. 4. 1) A 17.43 "My secretary informed your office yesterday that I approve both the loan of Mr. Guy Côté's services for one month, and the mandate proposed by Mr. Weilbrenner."

2) A 17.44 "This will confirm the arrangement officially."

might be expressed in speech, at least in part, by "Yes."

Other examples of utterances labelled SENINTERJEC in SASE-A&B, in context, are:

EX. 5) A 2.28 "I haven't had any experience with anyone who took English.  
I see."

EX. 6) A 1.6<sup>o</sup> "Have you ever felt this kind of resentment being too deep in or ... this anomie ...  
have you ever personally felt it Mr. Redmond? Have you ...  
Could you say if you have? Generally speaking, no."

We can thus state that the kind of abbreviated, often monosyllabic type of utterance labelled SENINTERJEC is a feature all but unique to SASE-A&B.

(111) SENINTERROG The higher frequency of interrogative sentences in SASE-A&B (5.45% compared to SAWE-A: 0.80%) is understandable because question/answer interaction is a feature of speech and not particularly of writing, especially administrative correspondence, where a whole letter might function as a question and another letter as a reply.

Some typical SASE-A&B interrogative sentences are:

EX. 1 A 2.29 What about you Mr. Tucker?

EX. 2 B 5.37 How about you, Sir?

EX. 3 B 6.11 Do you feel the same way?

EX. 4 Now then, how do we encourage this learning aspect?

EX. 5 Have you noticed this Mr. Richardson ...

EX. 6 I'll say it here, eh?

These sentences are marked as interrogatives by subject/verb inversion (EX. 3, EX. 4, and EX. 5), an XVPRESIMPERS (impersonal verbal expression of presentation - EX. 1 and EX. 2: "what about", "how about") or by the question particle "eh" (EX. 6)

Other SENINTERROG's are signalled by intonation:

EX. 7 B 3.98 In Ottawa?

EX. 8 A 2.26 You haven't had?

We can conclude that interrogative sentences, of the varieties noted above, are a characteristic feature of SASE-A&B relative to SAWE-A.

#### 1.4 Characteristic Features of SAWE-A

In SAWE-A there are higher frequencies, relative to SASE-A&B, of three sentence types: SENDECL, SENIMPER and SENINTERROGIMPER.

(declarative (imperative (interrogative-imperative  
sentences) sentences) sentences)

##### (1) SENDECL

93.78% of SAWE-A sentences are declaratives, as opposed to 82.95% of SASE-A&B sentences. However, this does not really seem to be a distinct characteristic of SAWE-A. The SASE-A&B percentage is lower because there are more sentence function labels occurring, therefore the distribution of frequencies is more widely spread. If the

incomplete declarative sentences were added to the declarative sentences, the percentage of SENDECL in SASE-A&B would rise to 88.08%, a figure not significantly different from the SAWE-A figure of 93.78%. And if the incomplete sentences were subtracted from the total number of SASE-A&B sentences, the declarative sentences would form 93.31% of the total number of SASE-A&B sentences. Therefore, the only legitimate observation we can make about SENDECL is that it forms the bulk of both SAWE-A and SASE-A&B.

- (11) SENIMPER, SENINTERROGIMPER The other 6.22% of SAWE-A sentences is made up almost entirely of two sentence types which although not occurring very often, can be said to be characteristic features of SAWE-A.

SENIMPER (3.41% of SAWE-A sentences, .39% of SASE-A&B) has a typical form in SAWE-A: the subjectless predicate is almost invariably preceded by "Please". Examples follow:

- EX. 1 A 1.10 Please do not hesitate to call ...
- EX. 2 A 1.44 Please be advised that this supplement can be obtained from the Carswell Company Limited, Toronto, Ontario.
- EX. 3 A 3.39 Please contact Mr. C. Howland, Room 340, Hunter Bldg. regarding this matter.
- EX. 4 A 3.37 Please find attached your Division's Construction Program for 1970-71.
- EX. 5 A 3.16 Please advise if further action is required by this office.

Notice that not all of the example sentences actually function as imperatives. EX. 2, 4 and 5, while they exhibit formal similarities

with the others which do function as imperatives, are almost "frozen" expressions (i.e. Please find attached/enclosed, please be advised) and are not functionally imperatives. Compare the polite, formally-phrased SAWE-A imperatives with this not impolite, but blunter SASE-A&B imperative:

EX. 6. A 3.38 Go back a little bit to a point Mr. Buchanan made earlier...

It is thus clear that not only is there a higher frequency of imperative sentences in SAWE-A, but that the type of imperative sentence occurring in SAWE-A is different than the type occurring in SASE-A&B.

The type of sentence that was labelled SENINTERROGIMPER did not occur at all in SASE-A&B; its SAWE-A frequency was 1.71%. The characteristic pattern was: "Would/will you kindly/please + VERB"

EX. 7 A 8.41 Would you kindly let me know the number of copies you may want for your region.

EX. 8 A 6.41 Would you kindly adjust your mailing list.

EX. 9 A 6.35 Would you please ensure that ...

EX. 10 A 16.20 Will you therefore remind your staff and district offices about this subject ...

EX. 11 A 14.41 Would you kindly place on your agenda and forward your report at your convenience.

Basically this type of sentence functions as an imperative (disseminates orders or requests that certain actions are to be taken), but is phrased, somewhat more diplomatically, as a question (i.e. with subject/verb inversion)

As this type does not seem to occur at all in SASE-A&B, we can say that it is probably a unique feature of SAWE-A.

(111) SENINTERROG Although interrogative sentences occur more frequently in SASE-A&B, those interrogative sentences which do occur in SAWE-A (comprising less than 1% of the 996 SAWE-A sentences) are of a characteristic form: May/Can + SUBJECT + MAIN VERB..."

EX. 1 A 13.15 May I please have your approval to do so?

EX. 2 A 3.45 May I, therefore, suggest that you delete the phrase "which is still..." from page 3... Appendix III.

EX. 3 A 10.8 May we please have a copy of the waybill ...

EX. 4 A 15.10 Can I have your statement of activities ...

One exception which is more typical of speech than of administrative writing, but which comes from a letter that was written in a particularly informal style, was

EX. 5 A 18.20 But what can you do when they are all standing around dying to see something, anything, on the lightboard?

These sentences function as requests (EX. 1, EX. 3, EX. 4)

or as in EX. 2, as a directive, phrased politely in terms of a suggestion. All of these sentences are of a type that is more polite, diplomatic and impersonal than the SASE-A&B interrogative types. So even though interrogative sentences themselves are not characteristic of SAWE-A, the particular form occurring in SAWE-A is unique to that corpus.

In summary, the distribution of sentence functions in both administrative correspondence and boardroom discussion is characterized by a very large percentage of declarative sentences (roughly 90%). However, the approximately 10% of sentences remaining is comprised of small numbers of sentence types which characterise each variety of the language, or each register. Administrative correspondence is

characterized by the sentence types labelled SENINTERROGIMPER and SENIMPER, whereas boardroom discussion is characterized by the types labelled SENINTERROG, SENINTERJEC, and SEN...INC. It is these kinds of structures which at this level of analysis constitute distinctly different register-characteristics of the two varieties of English.

## 2. Level 2: Sentence

### 2.1 Sentence Form Definitions

In level 2 of the computer printout, sentences are formally classified according to the number and functional type of their constituent clauses. The two major types of clauses are independent clauses which do not have a subordinate relationship to any other clauses and dependent clauses which are subordinate to other clauses at the sentence level.

A nuclear clause is an independent clause within a structure in which there is a dependent clause that is subordinate to it. A parenthetical clause is one which functions as a parenthesis in relation to the rest of the sentence, and may be either dependent or independent. Thus, according to the above clause types, sentence forms are defined as follows:

#### (1) Simple Sentence

SENSIM  $\longrightarrow$  + CLIND    ++CLINDPAREN

read: A simple sentence consists of a single independent clause and optionally one or more parenthetical clauses (NOTE: Only Nuclear Tagmemes and Non-Nuclear Tagmemes beginning with CL are considered here; others are generally optional.)

Although a simple sentence may only contain one independent clause at the sentence level, other clauses may be embedded at the clause level, filling the same slots as words or phrases, or they may be embedded at the phrase level filling modifier slots.

In the following examples of simple sentences, the underlined parts are obligatory.



EX. 1.    +CLIND

SASE A 2.3   We're doing an analysis of spoken English

EX. 2.    +CLIND   +CLINDPAREN

SASE B 4. 163   He'd reached the point, you see

EX. 3.    +CLIND

SAWE A 9.33   I hope that this information will be helpful.

In EX. 3, the simple sentence has an overall structure of a single independent clause which is composed of the functional elements +S, +PRED, and +OD. In this case, the +OD slot is filled by a clause, /CLBASWH which is underlined twice. This clause is embedded at the clause level, and is not a sentence level structure, thus the resulting sentence is still defined as a simple sentence.

(11) Compound Sentence

SENCOMPOUND → +CLIND   +CLIND   ++CLIND   ++CLINDPAREN

read: A compound sentence consists of at least two independent clauses and optionally one or more parenthetical clauses.

The independent clauses in a compound sentence are usually linked by a correlator.

EX. 4.    +CLIND +CORR   +CLIND

SAWE A 17.14   The National Parks are public lands and belong to all the people of Canada

In SAWE-A, the independent clauses may be linked by an element of transition.

EX. 5    +CLIND   +ELTRANS   +CLIND

SAWE-A 3.15   It is quite possible that the vessel in question did

strike this marker; however, it is a fact that the winter marker was dragged off station into slightly deeper water and was submerged.

In both SAWE-A and SASE-A&B, there are cases where the independent clauses have no relational element linking them at all. In SAWE-A these are considered compound sentences rather than two entirely separate sentences since they are separated by a semi-colon rather than a period. In SASE-A&B, the second independent clause in the structure is typically a tag.

EX. 6 +CLIND +CLIND

SASE A 4.14 You're Mr. Wilson, aren't you?

In EX. 6, the second clause is a question tag.

Within compound sentences, as within simple sentences, other clauses may be embedded at the clause or phrase level. However, it is only the constituents at the sentence level which are considered in classifying sentence forms.

EX. 7 +CLIND +CORR +CLIND

SAWE A 9.10 They have recently sold this company and are no longer in a position to consider supplying complete upgrading units.

In EX. 7, the second independent clause, beginning "are no longer..." contains a clause which fills a qualifier at the phrase level ("to consider...")

(iii) Complex Sentence

SENCOMPLFX → +CLNUC +CLDEP +CLDEP +CLNUC +CLINDPAREN

read: A complex sentence consists of at least one nuclear clause and one dependent clause and optionally a parenthetical clause.

A sentence is considered to be complex if and only if one clause is subordinate to another at that level. In other words dependent clauses must be embedded in the sentence structure. As pointed out in the discussion of simple sentences, one or more clauses may be embedded in the clause structure (level 3), or the phrase structure (level 4) and yet the resulting structure is not a true complex sentence.

EX. 8 SENSIM

SAWE-A 4.15 I hope that you have now received them.

In EX. 8, the functional constituents at the clause level are +S, +PRED, +OD. The underlined clause is a /CLBASWH filling the +OD slot, thus it is a clause which is embedded at the clause level. The overall structure at the sentence level is a single independent clause, resulting in the formal classification +SENSIM.

EX. 9 SENCOMPLEX

SAWE-A 12.49 If I can find the relevant newspaper clippings at home  
I will bring them into the office.

In EX. 9, the underlined conditional clause is subordinate to the rest of the sentence. Thus, it is a clause which is embedded at the sentence level and the overall structure of the sentence consists of a dependent clause and a nuclear clause, resulting in the formal classification +SENCOMPLEX.

(iv) Elliptical Complex Sentence

SENCOMPLEXELL → +CLDEP +CLDEP +CLINDPAREN

read: An elliptical complex sentence consists of at least one dependent clause and optionally a parenthetical clause.

An elliptical complex sentence is one in which the nuclear clause is ellided so that we have a clause showing a dependent relationship, as indicated by a subordinator, but no other clause in the sentence to which it is subordinate.

EX. 10 +CLDEP

SASE B 2.63 Because they have French all day here.

In EX. 10 "because" is a subordinator, indicating a causal relationship, but there is no other clause in the sentence on which it is dependent.

EX. 11 +CLDEP +ELTRANS +CLINDPAREN

SASE A 4.44 If we may begin with the first item on the agenda

(and as you suggested it's rather a general one) The Effects of English Language Teaching on Staff.

In EX. 11, a conditional relationship is indicated by the subordinator "if", but there is no other clause on which this clause is dependent.

NOTE: Only two examples of SENCOMPLEXELL exist in SAWE-A, neither of which is typical.

(v) Compound-Complex Sentences

SENCOMPOUNDCOMPLEX → +CLDEP +CLNUC +CLIND

read: A compound-complex sentence must contain a nuclear clause, a dependent clause, and an independent clause.

A compound-complex sentence is essentially an independent clause compounded with a complex sentence structure. The independent clause is usually linked by a correlative, but there are examples in SAWE-A where it is merely separated by a semi-colon.

EX. 12 +CLIND +CORR +CLDEP +CLNUC

SAWE A 2.6 I understand a copy of this paper was forwarded to you  
but in case it has been mislaid I am forwarding an extra copy.

In EX. 12, the first clause, which is underlined once, is the independent clause. It is linked by a correlator to the rest of the sentence. The rest of the sentence consists of a dependent clause, underlined twice, which is subordinate to the nuclear clause, underlined three times, resulting in the overall structure of a SENCOMPOUNDCOMPLEX.

EX. 13, +CLIND +CLNUC +CLDEP

SAWE A 20.8 I have indicated my suggested corrections in red pencil;  
please feel free not to accept if you disagree with them.

In EX. 13, the first clause is the independent clause. The rest of the sentence, following the semi-colon, has the overall structure of a SENCOMPLEX.

2.2. Distribution of Sentence Forms and Comparison of Features at Level 2

The distributions of sentence forms in SASE-A&B and SAWE-A were found to be different at the .001 level of significance. This implies that we are in fact, dealing with two populations representing two different registers of the language, rather than two samples actually belonging to the same population. Having determined that such a difference exists between the two corpora, it is necessary to further investigate where, in terms of the individual forms, the contrasts occur and the implications that are involved.

Within the two corpora, SENCOMPOUND, SENCOMPLEX, and SENCOMPOUNDCOMPLEX are proportionately more frequent in SAWE-A. On the other hand SENSIM and SENCOMPLEXELL are more frequent in SASE-A&B. Thus, in an overview of sentence forms, it appears that in SAWE-A sentences are constructed in a more complex manner, making greater use of coordination and subordination in order to combine clauses into sentences. SASE-A&B, on the other hand appears to have more simple sentences; that is clauses are not closely coordinated and subordinated at this level to form sentences. Furthermore, minor sentences are more frequent in SASE, indicating the tendency to leave portions of sentences unsaid.

However, it is not clear whether this tendency toward simplicity is actually a feature of the spoken corpus or whether it has been imposed by the analyst in breaking up the discourse. Whereas punctuation provides strict criteria for sentences in SAWE, in SASE the approach is not as clear-cut. The decision as to what constitutes a "sentence" in spoken language could not be clearly formulated in the analysis of SASE-A&B. The decision leans rather heavily on the intuition of the individual analyst. Crystal and Davy also recognized this problem in their study of English stylistics. "Informal

conversation is characterized by a large number of loosely coordinated clauses, the coordination being structurally ambiguous: it is an open question as to whether one takes these as sequences of sentences or as single compound sentences." Obviously, how we interpret our data must depend on which of these solutions was previously decided upon. It seems that with the SASE-A&B corpus, the former solution was decided upon. That is, what could be interpreted as coordinated clauses tended to be broken up into sequences of sentences, loosely linked by elements of transition.

This poses a problem in comparing the SASE data with the SAWE data since the same criteria were not used for both.

EX. 1 SENCOMPOUNDCOMPLEX → +CLIND +ELTRANS +CLIND +CORR +CLNUC +CLDEP

SAWE-A 18.49 Those public servants, through exigencies of duty, who are not granted leave by their supervisors, having made prior application to their supervisors, shall be permitted to carry over that leave which was not granted into the following fiscal year, however, it is intended vacation leave should be taken during the fiscal year it is earned and every effort will be made to see this leave is granted during the period requested.

EX. 2

SASE A 2.33 I suppose he did absorb a lot of English culture (so to speak) in Toronto.

SASE A 2.34 However he has been employed in the Toronto headquarters in the meteorological service since that time.

SASE A 2.35 And well I recently had the occasion to read a paper he had prepared.

SASE A 2.36 And I was rather impressed with his use of English.

EX. 1 is a compound-complex sentence from SAWE-A which is linked together in two places, by an element of transition and a correlator. EX. 2, on the other hand, is a set of four simple sentences from SASE-A in sequential order, which are linked by elements of transition. In SASE, the decision whether it is a "logical relator" which linked together two sentences, or it is a "correlator" between clauses was largely left up to the analyst. Although it was not entirely explicit as to what a SENCOMPOUND actually was it is apparent from the divisions in the transcripts (see EX. 2) that there was a strong tendency to break compound structures into simple sentences.

Thus we see how the apparent tendency toward simplicity, based on our analytical data may not be representative of the characteristic feature of speech. The relatively high proportion of SENSIM (simple sentences) and the relatively low proportion of SENCOMPOUND (compound sentences) in SASE-A&B as compared to SAWE-A will have been affected by this. Similarly, the relatively low proportion of SENCOMPLEX (complex sentences) and the relatively high proportion of SENCOMPLEXELL (elliptical complex sentences) in SASE-A&B as compared to SAWE-A may have been affected by the breaking up of structures with dependent relationships to be analyzed as separate sentences in SASE-A&B.

EX. 3

1) SENCOMPLEX

SASE B 2.52 But if I have my family along there are objections.

2) SENCOMPLEXELL

SASE B 2.53 Because they'd rather listen to an English language.



In EX. 3, sentence (2) has been labelled SENCOMPLEXELL on the criterion that there is no nuclear clause in the sentence to which the dependent clause is subordinate. However, when we look at its context within the discourse, we find that it is actually dependent on the previous sentence. Since there were no rigid criteria previously set up as to the breaking up of dependent relationships between clauses into dependent relationships between sentences, we do not know whether this was done in any consistent manner. Furthermore, the discourse was divided into sentences mainly according to the transcripts and not the original tapes, so that non-verbal cues, such as intonation, were not taken into account. Thus it seems that our inferences based on the SENCOMPLEX and SENCOMPLEXELL data are also dependent on the criteria for dividing the discourse into sentences.

Possibly a better way to approach this entire issue of coordination and subordination would be to disregard sentence breaks altogether and concentrate on the system of clause linkage within the discourse. Cook, when talking about coordination in tagmemic analysis, poses the problem in the following manner. "The schema is accurate for compound words and coordinate phrases, but suggests some indeterminacy between clause and sentence levels, where the coordination of clauses results in a compound sentence and raises the question whether clauses and sentences are really distinct levels."<sup>2</sup> Thus, in ridding ourselves of sentence constraints, we might be able to get a more accurate picture of the systems of coordination and subordination within the discourse. Furthermore, it would provide us with common ground for comparing such relationships in SAWE-A and SASE-A&B.

Another consequence arising from the breaking up of the discourse in SASE-A&B is that the data on elements of transition is difficult to interpret. In SASE-A&B, elements of transition occur initially in 31.07% of all sentences, as compared with 2.4% in SAWE-A. Thus, we see an apparent tendency within the spoken discourse to link sentences to each other by means of relators such as "and", "but", "now", "however", "well", "so", etc. However, many of the elements of transition which link sentences in SASE-A&B are formally identical to the correlators and elements of transition between clauses in SAWE-A and in terms of the discourse, have the same function as well. In fact, we do find that there are more elements of transition (+ELTRANS) in medial positions in SAWE-A (0.6% of all sentences in SAWE have elements of transitions between clauses as compared with 0.07% in SASE-A&B), but this does not account for those correlators (+CORR) which are actually the same thing as +ELTRANS in SASE. Again, disregarding sentence constraints we may get a better view of the types and distribution of logical relators in the discourse. If we may consider +ELTRANS and +CORR as having the same function at level 2, we may integrate the two labels and compare the entire system of logical relationships between the two corpora, starting off with common criteria for what we are looking at.

Thus it seems reasonable to group correlators and elements of transition all together and look at them as "logical relators" between clauses. As a result of this, we find a greater tendency within the SASE-A&B discourse to link clauses by means of such relators. In SASE-A&B, 28.11% of all clauses at level 2 are linked to the previous clause by means of a "logical relator" as compared with 14.88% in SAWE-A.

Within this class of logical relators, there are two major types -  
1) those filled by adverbs or adverbial expressions and 2) those filled by

coordinate conjunctions. The adverbial type includes such manifestations as: well, however, now, so, for example, furthermore, additionally, in other words, that is. The coordinate conjunction forms are basically "and", "but", "so". SASE-A&B has proportionately more of the adverbial type of relators, and the difference in the coordinate conjunction type is insignificant. This may be due to the fact that we tend to fill "pauses" in spoken language by means of "logical relators", especially those of the adverbial type. Without the use of these relators, which are often totally meaningless, linguistically speaking, our speech lacks fluency. In written language, on the other hand, these relators tend to be used more discriminately.

A second point of comparison at level 2 is the system of subordination. Subordinate clauses may be of three types:

- (i) Dependency is overtly marked by a subordinator

EX. 1 SAWE A 2.46

If additional information is required please let me know.

The underlined clause is the subordinate clause, marked by the condition subordinator "if".

- (ii) Participial clause with subordinate relationship to nuclear clause.

EX. 2. SASE B 3.103

At the same time, I feel sometimes very embarrassed to speak my French correctly thinking it's so faulty.

The underlined clause is subordinate, having a causal relationship to the nuclear clause.

(iii) Infinitive clause with subordinate relationship to nuclear clause

EX. 3 SASE-B 2.102

You've got enough to do that.

The underlined clause is subordinate, its relationship to the nuclear clause being one of purpose.

These three types make up the group of dependent clauses at level 2. SAWE-A has significantly more dependent clauses than SASE-A&B, thus we may say that the written corpus shows a greater tendency towards subordination than does the spoken corpus. This may reflect a greater tendency towards organization in writing in that dependencies are well thought out and represented in the sentence structure. In spoken language, on the other hand, we may tend to lose sight of closely linked dependent relationships, expressing them independently of each other.

Another aspect of level 2 sentence structure is complexity. (For an explanation of the variables influencing complexity and the indexing system, see Appendix 8 on Complexity). The lowest ranking structures in both SASE and SAWE have complexities of 1/0 (i.e. depth = 1, no discontinuities). In SASE, the highest ranking structure is about 15/1.1 (depth = 15, 1 discontinuity, value of bracketted element = 1); in SAWE the complexity may go as high as 18/0. These figures are only tentative since the entire complexity index is not as yet in the printout, but they would indicate that structures may grow more complex in SAWE. The major question, however, is that of the distribution of complexities. (i.e. Are there a greater number of more complex structures occurring in SAWE than in SASE?) With the index of complexity in the printout, we may access this information easily.

At level 2, we may also be interested in the distribution of sentences according to the number of words per sentence. This information as compiled by computer, is available along with the Phase III printout.

In SAWE-A, the average number of words per sentence is approximately 29, as compared with 14 in SASE-A+B. Sentences in SAWE-A range from 1 word to 84 words. In SASE-A+B, they range from 1 - 77 words. Thus we see a general tendency for sentences to be shorter within the spoken corpus. That is, longer sentences are more frequent in SAWE-A. (See: Figure 2).

The interpretation of this information depends on the validity of the sentence breaks within the discourse, as explained previously. However, in as much as the criteria for sentences may not correspond between the two corpora, the sentence breaks in SASE-A+B do represent some sort of break in fluency within the discourse. These breaks in fluency are more common within the spoken corpus than within the written corpus, thus we may conclude that written language is somewhat more coherent than speech.

Figure 2

HIGH RANKING SENTENCES ACCORDING TO  
NUMBER OF WORDS PER SENTENCE

<u>SAWE-A</u>		<u>SASE-A&amp;B</u>	
<u>NO. OF WORDS</u> <u>PER SENTENCE</u>	<u>TOTAL</u> <u>SENTENCES</u>	<u>NO. OF WORDS</u> <u>PER SENTENCE</u>	<u>TOTAL</u> <u>SENTENCES</u>
24	49	7	72
20	43	6	66
16	38	10	66
14	34	9	64
15	34	1	62
23	34	14	61
21	39	15	61

3. Level 3: Clause

3.1 Notes on Clause Functions

There are four categories of clause functions. These are: 1) Independent Clauses (CLIND) 2) Nuclear Clauses (CLNUC) 3) Dependent Clauses (CLDEP) and 4) Parenthetical Clauses (CLINDPAREN).

- (i) An Independent Clause is a clause which is neither subordinate to any other clause nor has any other clause subordinate to it.

EX. 1. SASE-B 5.94

I suppose it's not an insurmountable problem .

- (ii) A Nuclear Clause is a clause within a sentence construction in which there is a dependent clause that is subordinate to it.

EX. 2. SASE-A 4.52

When he joined us he spoke nothing but French .

- (iii) A Dependent Clause is a clause which is subordinate to another clause in the sentence construction.

EX. 3. SAWE-A 5.29

As previously stated this is no longer in existence.

- (iv) A Parenthetical Clause is one which functions as a parenthesis in relation to the rest of the sentence and, despite the "IND" in the label, may be either dependent or independent.

EX. 4. 1) SASE-A 1.88

I have too many notions about the subject, I'm afraid .

2) SASE-A 2.13

Now, you can answer this, if you wish, from a personal point of view.

Clause functions are found at levels two or three in the analysis. At level two, they describe the functional components of sentences and define the sentence form. For example, a simple sentence is one which is composed of one independent clause and optionally one or more parenthetical clauses. At level three, clauses may be constituents of complex clauses, compound clauses, or compound-complex clauses. That is, a complex clause may be composed of nuclear and dependent clauses; a compound clause is one in which independent clauses are coordinated; and a compound-complex clause is a complex clause coordinated with an independent clause. These compound-complex clause forms occur only where there is more cohesion between the constituents than there is between other clauses at the sentence level. This usually occurs with a complex clause form filling a dependent clause in a complex sentence construction. Thus, since the entire complex clause is a dependent clause, the nuclear clause at level three may have certain properties that are not possible at level two. For example, at level three, a nuclear clause may contain a subordinator, which is indicative of a dependent function. This is not possible at level two since nuclear clauses are never subordinate to another clause.

EX. 5. SAWE-A 11.20

I am afraid you will have to visit Montreal in order to carry out detailed research as you would have to refer to a large variety of sources here to cover the career of McLaren.

In EX. 5, the underlined clause is a CLCOMPLEX filling a CLDEP (dependent clause) at the sentence level. The nuclear clause at level 3 (i.e., the nuclear constituent of the complex clause) is underlined once and the dependent clause is underlined twice. However, since the whole complex clause has a subordinate relationship at level two, the nuclear clause begins with the subordinator "as".

### 3.2 Clause Form Definitions<sup>3</sup>

In Part 1 of the Level 3 printout all clauses are listed, grouped according to their form labels. Each clause was analyzed as one of the following clause forms.

(i) CLBAS (Basic Clause)

- a clause unmarked by any features such as passive, elliptical, etc.
- must constitute one +PRED (predicate)
- PRED must constitute one of the following verb forms /XVI, /XVII, /XVIII, or /XIV (i.e. verbal expressions I, II, III or IV)
- may also constitute +S (subject), +OD (direct object) +OI (indirect object)

(ii) CLEQUAT (Equative Clause).

- unmarked clause, constituting an equative verb form (XV)
- must constitute one +PRED, and either +PREDADJ (predicate adjective) or +PREDNOM (predicate nominative)
- may also constitute +S (subject).

(iii) CLPASS (Passive Clause)

- clause marked by a passive transformation.
- must constitute one +PRED
- may also constitute +S, +AGENT, +OD, +OI

(iv) CLIMPERS (Impersonal Clause)

- clause marked by +PRED filled by /PHVIMPERS (impersonal verbal phrase)
- must constitute one +PRED, and at least one +S
- may also constitute +OI, +AGENT, +PREDADJ, +PREDNOM



(v) CLELL (Elliptical Clause)

- clause constituting an elliptical (or understood) predicate.
- may constitute +S, +OD, +OI, +PREDADJ, +PREDNOM

(vi) CLMONO ("Mono" clause)

- does not constitute a +PRED, either present or understood
- short, interjection-type utterance.

(vii) CLCOMPLEX, CLCOMPOUND, CLCOMPOUNDCOMPLEX

- clauses consisting of two or more predicates
- structures parallel with SENCOMPLEX, SENCOMPOUND, etc.

3.3 Distribution of Clauses According to Form and Comparison of Features at Level 3. (See Figure 3)

As might be expected, CLBAS (Basic Clause), the major group of unmarked clause forms, is the most commonly-occurring clause form in both SASE-A&B (67.95%) and SAWE-A (54.17%). The CLBAS label applies to a vast range of structures, including structures constituting four out of five possible kinds of verb types /XVI (with +OD), /XVII (with +OI), /XVIII (no OI or OD), and /XIV (both +OD and +OI)<sup>4</sup>. CLMONOs ("mono" clause) occur least frequently in both corpora (2.18% of SASE-A&B clauses, and only .10% of SAWE-A clauses). The kind of structure represented by CLMONO is not strictly a clause construction, and is quite limited in terms of varieties of forms.

In order to discover what significant differences exist between the distribution of clause forms in SASE-A&B and in SAWE-A, a Chi Square test of statistical significance was done. It was found that:

- (i) There is no significant difference in distribution between the two corpora for two kinds of clause form groups; the CLIMPERS group (4.89% of SASE-A&B clauses, 4.74% of SAWE-A clauses), and the CLCOMPLEX/CLCOMPOUND/CLCOMPOUNDCOMPLEX group (2.81% SASE-A&B, 3.38% - SAWE-A). However upon closer examination of the kinds of clauses actually represented by the CLIMPERS label, it becomes evident that within the CLIMPERS group there are structures occurring more frequently in SASE-A&B and others occurring more frequently in SAWE-A.

Figure 3

DISTRIBUTION OF CLAUSES ACCORDING TO FORM

a) SAWE-A: ADMINISTRATIVE CORRESPONDENCE

<u>RANK</u>	<u>CLAUSE FORM</u>	<u>FREQ.</u>	<u>PERCENTAGE</u>
1	CLBAS GROUP	1553	54.17
2	CLPASS GROUP	679	23.68
3	CLEQUAT GROUP	335	11.68
4	CLIMPERS GROUP	136	4.74
5	CLCOMPLEX* (etc.) GROUP	97	3.38
6	CLELL GROUP	64	2.23
7	CLMONO	3	.10
		<u>2867</u>	<u>99.98%</u>

\*including CLCOMPLEX, CLCOMPOUNDCOMPLEX.

b) SASE-A&B: FORMAL/INFORMAL DISCUSSION

<u>RANK</u>	<u>CLAUSE FORM</u>	<u>FREQ.</u>	<u>PERCENTAGE</u>
1	CLBAS GROUP	2028	67.95
2	CLEQUAT GROUP	461	15.42
3	CLIMPERS GROUP	146	4.89
4	CLPASS GROUP	107	3.58
5	CLELL GROUP	94	3.15
6	CLCOMPLEX* (etc.) GROUP	84	2.81
7	CLMONO	65	2.18
		<u>2985</u>	<u>99.98%</u>

\*including CLCOMPLEX, CLCOMPOUND, CLCOMPOUNDCOMPLEX.



This type occurs very infrequently; it is characterized by an XVPRESIMPERS (verbal expression of presentation) which includes such expressions as "how about", "what about", "here's", etc. It is probably a very limited class.

The last type is unique to SASE-A&B, although it occurs infrequently there as well (4 examples, 2.74%). It would seem to be a characteristic structure of spoken language, although it would probably be found occurring more frequently in informal speech than in formal speech.

The first type "there are ..." occurs more frequently in SASE-A&B. (59.59% as opposed to SAWE-A 31.62%). It would seem to be a typical spoken expression. SASE-A&B examples:

- EX. 4 1) A 3.75 There wouldn't be time.  
2) B 4.96 There'll usually be a half dozen of us there.

The second type - "it is ..." occurs more frequently in SAWE-A (68.38% compared to 36.30% in SASE-A&B). It is a form which would seem to be very useful in administrative writing, as it is a construction which does not necessitate identifying persons involved. Somehow, it is considered more "polite", "businesslike", "official" and more "appropriate" to communicate requests, orders, denials of permission, suggestions, etc., using impersonal, non-committal forms such as:

- EX. 5 1) SAWE-A 12.29 it would be appreciated if ...  
2) SAWE-A 18.13 it is desirable that ...  
3) SAWE-A 1.17 it is requested that ...  
4) SAWE-A 14.35 it should be noted that ...

Many of these constructions also have a passive form (as in 1, 3 and 4 of EX. 5 above), a form which is highly favoured in administrative correspondence.

Constraints imposed by the analytical model specified that clauses constituting both impersonal and passive structures be labelled as impersonals.

- (ii) Clearly unique features of SASE-A&B, in relation to SAWE-A are higher frequencies of CLBAS (Basic Clause) (67.95%: 54.17%), CLEQUAT (Equative Clause) (15.42%: 11.68%) and CLMONO ("Mono" Clause) (2.18%: .10%), as well as a slightly higher frequency of CLELL (Elliptical Clause) (3.15%: 2.23%)

- EX. 6 CLBAS 1) A 5.17 You never finish learning English.  
2) B 5.36 You can usually find that there's a little bit of time.  
3) B 4.24 I'd review them again.

EX. 7 CLEQUAT

- 1) A 1.12 That's perfectly acceptable.  
2) A 3.26 He's normally subordinate to me.  
3) B 4.115 It's a move in the right direction.

EX. 8 CLMONO

- 1) A 1.17 No.  
2) B 2.107 Alright.  
3) B 1.56 Oh, definitely.

EX. 9 CLELL 1) B 4.136 Yes, terribly frustrated.

- 2) A 2.50 if any

We would expect a spoken variety to make great use of the two basic, "unmarked" clause types, CLBAS and CLEQUAT.

The other two kinds of clauses which occur more frequently in SASE-A&B, CLMONO and CLELL, are even simpler structures, to the point of lacking a predicate. Both types rely heavily on fuller linguistic contexts beyond the sentence in the speech situation for interpretation. All four clause types probably represent the simplest ways of saying things, of communicating. In speech situations such as discussions, where the need to communicate is immediate, the speaker is more likely to choose simple, uncomplicated structures which are efficient and economical to code and decode. Listeners do not have as much time to go back over what has been said in order to decipher messages as readers of a piece of writing can go back over what they have read. Listeners must rely on their memories to recall the previous sentence, whereas readers have only to glance back at the previous line.

(iii) One unique feature of SAWE-A is apparent in the area of clause forms - a considerably higher frequency of CLPASS (23.68% as opposed to 3.58% in SASE-A&B). Some typical passive clause constructions in SAWE-A are:

- EX. 10 +S +PRED 1) A 2.21 Your application is approved  
2) A 4.35 A brief explanation is required  
3) A 9.50 A survey will be carried out ...

EX. 11 +PRED (mainly a CLPASSWH construction)

- 1) A 1.27 We have received the attached reports of the  
Conciliation Boards established to deal with the  
above disputes.  
2) A 3.18 We have received the cost details submitted.  
3) A 6.44 Attached please find letter dated 26-6-69.

There are several possible explanations for this high percentage of passive clauses in administrative writing. First of all, even though they are more complicated transformationally, passive clauses are considered by native speakers as befitting and appropriate to this particular style.

Secondly, a passive clause construction often represents, as do the impersonal clauses, a more polite, diplomatic, less confrontation-oriented choice than a parallel basic or equative clause construction. It makes it possible for the writer to avoid making reference to him- or herself as authorizer, requester, etc., or to the person(s) who are the object of the authorization, request, etc., thus softening the impact of orders and other such messages. For example, compare these actual SAWE-A passive clauses with the following parallel basic or equative clauses:

- EX. 12 1) A 2.24 Your application will be cancelled.  
2) A 2.43 Your cooperation is appreciated.  
3) A 7.81 No overtime is to be worked.
- 1a) We/I/the Selection Board (etc.) will cancel your application.  
2a) We/I/the Department (etc.) would appreciate your cooperation.  
3a) The employees are not to work overtime.

The second set is blunter, less polite, more personal and seems to have a more emotional tone. It would therefore tend to be met with more emotional reactions (thus, possibly less cooperation) than the passive counterparts which are impersonal and dispassionate.

The passive form also allows more evasiveness and non-commitment, which are often essential for smoothing out intricate administrative processes.

Consider the following SAWE-A clause:



EX. 13 SAWE-A 1.39 In due course the report will be published.

Here the writer is not constrained to specify who will be responsible for publishing the report, whereas in a parallel basic clause construction, the expected publisher's name would be obligatory, as it would fill the subject slot, (     will publish the report in due course.)

3.4 Distribution of clauses according to number of nuclear tagmemes (see Figure 5)

At Level 3 the nuclear tagmemes are:

+S (subject) +PRED (predicate), +OD (direct object), +OI (indirect object), +PREDADJ (predicate adjective), +PREDNOM (predicate nominative) and +AGENT (agent in passive clauses). In Part 2 of the Level 3 printout, clauses were grouped together according to the number of nuclear tagmemes manifested in each clause construction. (See Notes on the Analytical Model and Format of Phase III Printout, Chapters IV and V).

Although the number of nuclear tagmemes constituting a clause is not necessarily related to its complexity<sup>5</sup>, on an overall basis, we would expect to find higher frequencies of clauses with few nuclear tagmemes in the spoken corpus, and higher frequencies of clauses with more nuclear tagmemes in the written corpus.

Figure 5

FREQUENCIES OF CLAUSES GROUPED ACCORDING TO  
NUMBER OF NUCLEAR TAGMEMES

a) SAWE-A : ADMINISTRATIVE WRITING

	<u>Freq.</u>	<u>Percentage</u>
No Nuclear Tagmemes	11	.40
1 Nuclear Tagmeme	307	11.08
2 Nuclear Tagmemes	1,018	36.74)
3 Nuclear Tagmemes	1,241	44.79)
4 Nuclear Tagmemes	173	6.24)
5 Nuclear Tagmemes	12	.43)
6-9 Nuclear Tagmemes	9	.33)
TOTAL NO. OF CLAUSES	2,771	100.01%

b) SASE-A&B: FORMAL/INFORMAL DISCUSSION

	<u>Freq.</u>	<u>Percentage</u>
No Nuclear Tagmemes	99	3.41
1 Nuclear Tagmeme	184	6.34
2 Nuclear Tagmemes	994	34.26)
3 Nuclear Tagmemes	1,521	52.43)
4 Nuclear Tagmemes	90	3.10)
5 Nuclear Tagmemes	9	.31)
6 Nuclear Tagmemes	4	.41)
TOTAL NO. OF CLAUSES	2,901	99.99%

Clauses with two or three nuclear tagmemes comprise the highest percentage of all clauses in both SAWE-A (81.53%) and SASE-A&B (86.69%). High-frequency clause constructions of this core group are listed here with examples.<sup>6</sup> (For fuller details, see Appendix 9 and Appendix 10)

SASE-A+B

(i) +S +PRED +OD (29.02% of all clauses)

EX. 1 1) B2.69 .. this makes quite a difference.

2) A5.16 I would say pretty much the same for English

(ii) +S +PRED (18.09% of all clauses)

EX. 2 1) A3.98 I see.

2) B4.51... ways whereby this is done.

(iii) +PRED +OD (10.30% of all clauses)

EX. 3 1) B6.49 ...it takes six years to learn the language.

2) A2.85 ...hearing French in the hallway really doesn't bother anybody.

(iv) +S +PRED +PREDADJ (7.82% of all clauses)

EX. 4 1) B5.109 I'm very fortunate in my case.

2) A2.31 And this one, I think, was rather unique in that...

(v) +S +PRED +PREDNOM (5.68% of all clauses)

EX.5 1) B5.1 That's a good beginning.

2) A2.88 Most of these civil servants are our former students.

SAWE-A

(i) +S +PRED +OD (21.29% of all clauses)

EX. 6 1) A2.6 I am forwarding an extra copy.

2) A15.32 The forecast should reflect the most likely situation in the following categories.

(ii) +S +PRED (15.08% of all clauses)

EX. 7 1) A 12.10 ... the features you have proposed.

2) A 3.49 Copies of the replies and comments received are attached.

(iii) +PRED +OD (13.86% of all clauses)

EX. 8 A 14.7 The committee formed to review the code stress basis...

(iv) +S +PRED +PREDADJ (6.57% of all clauses)

EX. 9 1) A 6.19 Supported material is dutiable.

2) A 3.28 I am aware that there has been some dissatisfaction concerning rates charged for this equipment.

Clauses with four or more nuclear tagmemes occur with a higher frequency in SAWE-A (7.00%) than in SASE-A&B (3.55%). Also, clauses with 7, 8, and 9 nuclear tagmemes occur only in SAWE-A (although they occur very infrequently). Some examples of clauses with many nuclear tagmemes ...

SAWE-A

(i) +S +PRED +OD +OD +OD +OD

EX. 10 A 15.35 This forecast should be based on normal progress, average length of time for approval, good working conditions, etc.

(ii) +S +S +S +S +S +S +PRED

EX. 11 A 15.34 Possible delays in program approval, the tender or design stage, site problems, bad weather, strikes, etc. are to be considered.

Note that even when multiple +S or +CD occur in SAWE-A, each one can be filled by up to 6-word nominal expressions, whereas similar examples of multiple nuclear tagmemes in SASE-A&B (below) tend toward one-word expressions.

SASE-A&B

(i) +S +PRED +PREDADJ +PREDADJ +PREDADJ +PREDADJ

EX. 12 A 3.18 His attitude has been rigid, dogmatic, arrogant, and rather uncomplimentary.

(ii) +S +S +S +S +PRED +PREDADJ

EX. 13 B 1.106 ... music, intonation, pronunciation, and so on are extremely important.

Clauses with no nuclear tagmemes occur with a higher frequency in SASE-A&B (3.41%) than in SAWE-A (.40%). Some SASE-A&B examples are:

EX. 14 +CVLOC  
/PHPREP  
B 4.109 In this area.

EX. 15 +CVPURP  
/PHPREP  
B 3.23 To what end?

EX. 16 +INTERJEC  
/INTERJ  
A 1.31 Fine.

Some SAWE-A examples are:

EX. 17 +CVTIME +CVSIT  
/ADVTIME /XADVSIT  
A 12.10 ... the system now in use.

EX. 18 +CVCAUSE  
/PRONREL  
A 11.11 ... a request...stating...reasons why.

Notice that the SASE-A&B 0-nuclear tagmeme clauses are more or less independent utterances, whereas the SAWE-A clauses tend to be "embedded" elliptical clauses. That is, the SAWE-A 0 nuclear tagmeme clauses are part of complex sentence construction, whereas the SASE-A&B clauses represent minor sentence constructions.

Two unexpected features of the distribution of clauses are that there are more clauses with only one nuclear tagmeme in SAWE-A and there are more clauses with three nuclear tagmemes in SASE-A&B. However, these patterns are accounted for by the distribution of clauses according to clause type (CLBAS vs. CLEQUAT vs. CLIMPERS vs. CLPASS, etc.) Because there are so many CLPASS in SAWE-A as opposed to SASE-A&B, and because the "PRED" construction is one of the typical CLPASS constructions in SAWE-A (especially CLPASSWH), the large number of 1-nuclear tagmeme clauses is largely a reflection of this large group of CLPASS constructions (PRED).

Similarly, there are significantly higher frequencies of CLBAS and CLEQUAT in SASE-A&B, and since the high-frequency constructions of both these clause types are 3-nuclear tagmeme constructions (CLBAS: +S +PRED +OD; CLEQUAT: +S +PRED) +PREDADJ/+PREDNOM), it is only natural for there to be a higher number of 3-nuclear tagmeme clause constructions in SASE-A&B.

The results therefore show that SASE-A&B is characterised by a higher percentage frequency of clauses with no nuclear tagmemes, and basic, equative, "mono", and elliptical clauses. SAWE-A is characterized by a higher percentage of clauses with four or more nuclear tagmemes, and clauses with one nuclear tagmeme (because of the high-frequency CLPASS construction constituting of only one +PRED), as well as by a high frequency of passive clauses.

Over 80% of all clauses in both SAWE-A and SASE-A&B have two or three nuclear tagmemes, and more than half of all clauses in both are basic clauses (almost 70% in SASE-A&B, and approximately 55% in SAWE-A). Thus, even though there are characteristic differences between the two corpora in the areas outlined above, it can be seen that both registers of government English in two different media exploit equally commonly the two- or three-nuclear tagmeme constructions and the CLBAS constructions.

4. Level 4: Phrase

4.1 Definition of Phrase Forms

In the level 4 printout, phrases are grouped according to their form labels. The possible form labels are:

(i) PHADJ (adjectival phrase)

An adjectival phrase is a head-modifier construction with an adjectival element filling the head slot.

EX. 1 1) SASE-B 5.79 pretty big  
 +MODNUC +NUC  
 /ADVDEG /ADJ

2) SAWE-A 19.24 mutually satisfactory  
 +MODNUC +NUC  
 /ADVMAN /ADJ

(ii) PHADV... (adverbial phrase group, listed alphabetically according to further semantic labels e.g. CAUSE, COND.)

An adverbial phrase is a head-modifier construction with an adverbial element filling the head slot.

EX. 2 1) SASE-A 3.42 very much  
 +MODNUC +NUC  
 /ADVDEG /ADVDEG

2) SAWE-A 1.6 more fully  
 +MODNUC +NUC  
 /ADVDEG /ADVMAN

(iii) PHN (noun phrase)

A noun phrase is a head-modifier construction with a nominal element filling the head slot.

EX. 3 1) SASE-B 3.44 another country  
 +QUAL +NUC  
 /ADJIND /N



2) SASE-B 1.133 the things that I say  
+DEIC +NUC +QUAL  
/ARTDEF /N /CLBASWH

3) SAWE-A 1.9 an interpretation  
+DEIC +NUC  
/ARTIND /N

4) SAWE-A 1.34 working conditions peculiar to each division  
+NUC +QUAL  
/PHN /PHADJ

(iv) PHPREP (prepositional phrase)

A prepositional phrase is a relater-axis construction with a prepositional element filling the relater slot labelled +IPP (introducer to prepositional phrase). The axis labelled +NUC may be manifested by a word, a phrase, an expression or an embedded clause.

EX. 4 1) SASE-B 3.109 about it  
+IPP +NUC  
/PREP /PRONP

2) SASE-A 2.61 by watching television  
+IPP +NUC  
/PREP /CLBASPART

3) SAWE-A 4.32 in the foreseeable future  
+IPP +NUC  
/PREP /PHN

4) SAWE-A 15.50 after January 1, 1970  
+IPP +NUC  
/PREP /XNDATE

(v) PHPRON (pronoun phrase)

A pronoun phrase is a head-modifier construction with a pronominal element filling the head slot.

EX. 5 1) SASE-B 4.131 something new  
+NUC +QUAL  
/PRONIND /ADJ

2) SAWE-A 18.23 that which I brought.  
+NUC +QUAL  
/PRONDEM /CLBASWH

(vi) PHV (verb phrase)

There are two basic types of verb phrases. The first type consists of a semi-auxiliary slot filled by a verbal element and a nuclear slot filled by the main verb or verbal element. Examples of this type of PHV are:

EX. 6 1) SAWE-A 9.20 agreed to extend  
+SAUX +NUC  
/XVSAUX /XVI

2) SASE-A 2.31 had use  
+SAUX +NUC  
/XVSAUX /XVI

3) SASE-B 2.71 expected you to carry on  
+SAUX +NUC  
/XVSAUX /PHV

The verb phrases in EX. 6 are all of the first type, representing +SAUX +NUC constructions. The nucleus may be filled by a verb as in 1 and 2, or a verb phrase as in 3. The semi-auxiliary (+SAUX) functions in the same manner as regular auxiliary (+AUX) as found in XVCOMP's (complex verbal expressions).

However, it is not a member of the closed class of the English auxiliaries (i.e. have, be, do). Typical SAUX's are: "going to", "allowed to", "have to". An exhaustive list appears at level 5 of the Phase III printout.

The second type of verb phrase consists of nuclear slot filled by a verbal element preceded by a subject slot filled by a nominal form. This type occurs only when embedded in the first type of verb phrase, where the subject is actually the direct object of the semi-auxiliary. The third example in EX. 6 shows one such embedded verb phrase. Another example is as follows:

EX. 7 SASE-B 1.2 ... habituating students to say ...

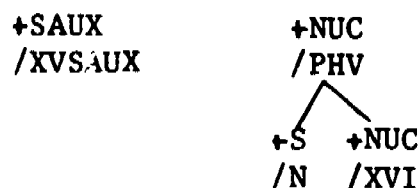

In EX. 7, the PHV "students to say" is an example of the second type of verb phrase. It is embedded within a verb phrase of the first type "habituating students to say", as its nuclear element.

(vii) PHVIMPERS (impersonal verb phrase)

An impersonal verb phrase is composed of a nucleus filled by a verbal element and a subject slot filled by a PRONIMPERS (impersonal pronoun, i.e. 'It' or 'there') a nominal element which doesn't have a direct referent.

EX. 8 1) SASE-B 2.55    there            are  
                           +S                    +NUC  
                           /PRONIMPERS    /XVIII

2) SAWE-A 12.29    it                    would be appreciated  
                           +S                    +NUC  
                           /PRONIMPERS            /XVCOMP

(viii) PHGERUND (gerund phrase)

A gerund phrase consists of a deictic filled by a possessive adjective followed by a nucleus consisting of a participial clause, functioning as a nominal element. Thus it is similar to a noun phrase.

EX. 9 SAWE-A 3.3    his            reporting for duty  
                           +DEIC            +NUC  
                           /ADJPOSS        /CLBASPART

Figure 6.

DISTRIBUTION OF PHRASE FORMS

	<u>SAWE-A</u>	<u>%</u>	<u>SASE-A&amp;B</u>	<u>%</u>
1. PHADJ	156	1.89	248	5.44
2. PHADV GROUP	41	0.49	125	2.74
3. PHGERUND	4	0.04	0	0
4. PHN	4,892	59.41	2,334	51.20
5. PHPREP	2,886	35.04	1,433	31.43
6. PHPRON	42	0.51	96	2.10
7. PHV GROUP	213	2.58	322	7.06
	<u>8,234</u>		<u>4,558</u>	

4.2 Distribution of Phrase Forms

Looking at the distribution of phrase forms, we find that the highest ranking type in both corpora is PHN (Noun Phrase). This probably reflects a more common occurrence of nominal elements in general over adjectival, verbal and adverbial ones. According to the two registers under study, we may say that nominals are the most frequent element in our language.

Prepositional phrases rank second in both corpora. They most commonly occur as verbal complements at the clause level (e.g. SAWE-A 14.41 Forward your report at your convenience) or as adjectivals filling modification slots at the phrase level (e.g. SAWE-A 15.10 activities in this regard.) These appear to be very common constructions.

The distribution of phrase forms, however, are not entirely similar between SAWE-A and SASE-A&B. The SASE-A&B corpus has greater proportions of PHADJ (Adjectival Phrases), PHADV GROUP (Adverbial Phrases), PHV GROUP (Verb Phrases), including PHVIMPERS (Impersonal Verb Phrases) and PHPRON (Pronominal Phrases). This leaves SAWE-A with greater proportions of PHN (Noun Phrases) and PHPREP (Prepositional Phrases). According to the Chi Square Test these differences are significant.

We may interpret this to mean that in spoken language we tend to elaborate more on our adjectives and adverbs, using more adjectival and adverbial phrases instead of simple adjectives and adverbs. On the other hand this may simply reflect a higher frequency of adjectival and adverbial forms in general. In order to discover which of these explanations is most valid we would have to determine the proportions of adjectival and adverbial forms at level 3 and level 4 in both corpora. A preliminary study of adjectival forms within PHNs alone indicates the second explanation for the higher frequency of PHADJ in SASE-A&B. It was found that there is a greater proportion of adjectival forms within noun phrases in SASE-A&B. (1: 2.7 in SASE-A&B as compared with 1:3.39 in SAWE-A. No such compilation has yet been done to indicate the possible explanation for PHADVs.)

The higher frequency of pronoun phrases in SASE-A&B may also indicate a greater tendency to elaborate on pronouns or, on the other hand, a greater

proportion of pronouns in general. Further compilation would be necessary in order to find a more positive solution.

PHGERUND (gerund phrases), although infrequent, are unique to SAWE-A. (4 examples of PHGERUND in SAWE-A). There are no similar construction of such head-modifier phrases in SASE-A&B where an entire clause fills the nuclear slot and only one other example in SAWE-A, within PHNs.

#### 4.3 Forms filling nuclear slots in PHs<sup>7</sup>

Nuclear slots of phrase constructions (i.e. level 4), may be filled by single words, expressions, phrases, clauses, or elliptical forms. Examples of these types of fillers are:

- EX. 1 1) SASE-A 2.23 any better  
2) SASE-A 3.33 varying degrees  
3) SASE-B 2.49 at home

In EX. 1, the underlined parts are examples of single words filling nuclear slots in 1) an adjectival phrase, 2) a noun phrase and 3) a prepositional phrase.

- EX. 2 1) SASE-A 4.32 the Canadian Public Service  
2) SASE-B 2.93 at five o'clock

In EX. 2, the underlined parts are examples of expressions filling nuclear slots in 1) a noun phrase and 2) a prepositional phrase.

- EX. 3 1) SASE-A 4.63 the kind of an answer you want  
2) SASE-B 1.60 about a certain situation

In EX. 3, the underlined parts are examples of phrases filling nuclear slots in 1) a noun phrase and 2) a prepositional phrase.

- EX. 4 1) SASE-A 1.33 for taking courses  
 2) SAWE-A 7.13 your forwarding any such requests to Montreal

In EX. 4, the underlined parts are examples of clauses filling nuclear slots in 1) prepositional phrases and 2) gerund phrases.

- EX. 5 1) SASE-B 4.81 very \_\_\_\_\_  
 2) SASE-A 4.82 another \_\_\_\_\_

In EX. 5, the nuclear slot is represented by a line. Here, the nuclear elements are understood from the contexts, but the forms are ellided. These are examples of elliptical forms filling nuclear slots in 1) adjectival phrases and 2) noun phrases.

In both SAWE-A and SASE-A&B, the nuclear slots in phrase constructions are most commonly filled by single word terminal forms. However, SAWE-A does have a higher proportion of phrases and expressions in this position than does SASE-A&B. Clauses filling nuclear forms, which occur almost uniquely in PHPREPS (except for 1 PHN in SAWE-A and 4 PHGERUNDS in SAWE-A) are more frequent in SASE-A&B. SASE-A&B also has a higher proportion of elliptical forms filling nuclear slots.

Figure 7

FORMS FILLING NUCLEAR SLOTS IN PHRASE CONSTRUCTIONS

(not including PHVs)

	<u>SAWE-A</u>	<u>%</u>	<u>SASE-A&amp;B</u>	<u>%</u>
Single word	4,648	56.35	2,708	64.86
Expression	695	8.43	174	4.17
Phrase	2,779	33.69	1,088	26.06
Clause	89	1.02	129	3.09
Elliptical	41	0.5	75	1.8
D-QUOT.	<u>1</u>	<u>0.01</u>	<u>1</u>	<u>0.02</u>
	8,252	99.9%	4,175	100.00%

This seems to suggest that, considering all phrase constructions together (i.e. lumping PHNs, PHPREPs, PHADJs, etc. all into one overall group), the nuclear tagmemes in SAWE-A are more complex than those in SASE-A&B. However, if we look at each phrase type individually, we find that these overall proportions are heavily influenced by PHNs and PHPREPs alone. That is, while these two phrase types do have a higher proportion of more complex nuclear elements in SAWE-A, the outcome is just the opposite for PHADJ, PHADV, and PHPRON. Within these three phrase types, SASE-A&B has higher proportions of the more complex forms in nuclear slots.

Thus within noun phrases the nuclear tagmemes tend to be more complex in SAWE-A. The high frequency of expressions here is clearly due to frequent use of titles, names of companies, places, etc., and dates which commonly occur in administrative writing.

- EX. 6 1) SAWE-A 19.41 'Eight Variations on a Dance Theme' by the  
American film-maker Hilary Harris.
- 2) SAWE-A 3.40 the 3rd of January.
- 3) SAWE-A 6.20 Transworld Trading Co. Limited, 16 Lower O'Connell  
Stree, Dublin 1.

In EX. 6, the underlined portions are all expressions filling nuclear slots in PHNs. Forms of address, such as "Mr. G.R. Doucet" or "Mr. George Orser" analyzed as phrases, commonly occur as fillers of nuclear slots of PHNs in SAWE-A. That is, they are, themselves, modified or specified.

- EX. 7 1) SAWE-A 10.40 Mr. George Orser, Director of Personnel
- 2) SAWE-A 20.25 D.S. Tysoe, Industry Specialist, West Coast  
Longshoring.



In EX. 7, nos. 1 and 2 are PHNs. The underlined portion is a PHN in the nuclear slot. This is typically a written construction which does not occur often in spoken language, and could account for the higher frequency of phrases in nuclear position in noun phrases in SAWE-A as compared with SASE-A&B.

Prepositional phrases in SAWE-A also contain a higher frequency of expression and phrase forms in the nuclear slot than they do in SASE-A&B. Here, XNDATES occur much more frequently in the written corpus than in the spoken, and could explain the overall higher frequency of expressions.

- EX. 8 1) SAWE-A 9.32 in October 1968  
2) SAWE-A 15.50 after January 1, 1970

In EX. 8, the underlined portions are XNDATES filling nuclear slots in prepositional phrases. The constructions have a frequency of 118 in SAWE-A, as compared with only 5 in SASE-A&B.

Phrases filling nuclear slots in prepositional phrases are most commonly PHNs, and this is the same for both corpora. The fact that these occur more frequently in SAWE-A than in SASE-A&B is indicative of a general higher degree of complexity of PHPREPs within SAWE-A, since on the other hand, SASE-A&B has a higher proportion of single word terminal elements in this position.

- EX. 9 1) SAWE-A 8.40 for internal distribution  
2) SASE-A 1.92 in the public service

In EX. 9, the underlined portions are phrases filling nuclear slots in PHPREPs. This type of construction occurs more frequently in SAWE-A.

- EX. 10 1) SASE-A 2.12 on staff  
2) SASE-B 4.2 about this

In EX. 10, the underlined portions are single word terminal elements filling nuclear slots in PHPREPs. This very simple type of prepositional phrase has a higher proportion of occurrence in SASE-A&B.

SASE-A&B also has more clauses filling nuclear slots in PHPREPs. These are mainly participial clauses but also include some WH clauses and some infinitive clauses.

- EX. 11 1) SAWE-A 5.23 in achieving their objectives  
2) SASE-B 3.69 in finding people to talk French to me  
3) SASE-B 1.7 by what we should be doing.

In EX. 11, the underlined portions are clauses filling nuclear slots in prepositional phrases. This occurs in 8.8% of PHPREPs in SASE-A&B as compared with 2.8% in SASE-A. Intuitively, this seems to be a less formal and more spontaneous mode of expression. In writing, it is felt that an attempt would be made to nominalize the verbal element. For example:

- EX. 12 SAWE-A 13.35 in consultation with Marcel Martin

In EX. 12, this prepositional phrase could alternatively be expressed "by consulting with Marcel Martin". It seems, however, that this construction in written language is secondary to the nominalized form. In spoken language, the clause form is used more frequently.

Within adjectival phrases in both corpora, the highest ranking fillers of nuclear slots are terminal elements. However SASE-A&B has proportionately less terminal fillers and more expressions and phrases than does SAWE-A.

Examples of these are:

- EX. 13 1) SASE-A 5.30 completely well thought out  
+MODNUC +NUC  
/ADVDEG /PHADJ
- 2) SASE-A 3.49 about thirty-five  
+MODNUC +NUC  
/ADVDEG /XADJNUM
- 3) SASE-B 2.81 a lot easier said than done  
+MODNUC +NUC  
/XADVDEG /XADJ

In EX. 13, the underlined portions are phrases or expressions filling nuclear slots in PHADJ's.

Similar to adjectival phrases, adverbial phrases in SASE-A&B appear to have proportionately more expressions and less single-word terminal elements in nuclear position. However, the figures here are misleading due to incongruencies in the analysis between SASE-A&B and SAWE-A.

- EX. 14 1) SASE-A 5.91 more...than others.  
+NUC +MODNUC  
/XADVDEG /CLELL
- 2) SASE-B 5.43 as ... as it is now  
+NUC +MODNUC  
/XADVDEG /CLEQUAT

In EX. 14, the underlined portions are expressions filling nuclear slots in PHADVs in SASE-A&B. As the examples suggest, these occur mainly in comparative constructions. Similar constructions in SAWE-A, however, do not occur as PHADVs at all.

- EX. 15 1) SAWE-A 9.4 as (much) as possible
- 2) SAWE-A 14.32 more (reliable) than if we insist on...

+COMPARAT

In EX. 15, the underlined portions are labelled /XCOMPAR, and occur as modifiers of PHADJs. This is quite different from the SASE-A&B analysis

where "as...as possible" and "more...than if we insist on..." would be PHADVs, with the underlined expressions as their nuclei. This then, could account for the greater number of adverbial phrases in SASE-A&B as well as the larger proportion of expressions filling nuclear slots in the PHADVs. This is a major problem area and cannot be dealt with accurately until the analyses have been changed so that the two corpora have the same criteria.

#### 4.4 Modification in Phrases

PHNs, PHPRONS, PHADJs, and PHADVs are all head-modifier constructions. Having already looked at the nuclear slots within these, we shall now examine their properties of pre- and post-modification.

- (i) Noun Phrases may be: 1) unmodified (including +DEIC +NUC constructions) 2) premodified 3) post-modified or 4) pre and post-modified (For more explicit information on these categories, see Appendix 11, "Types of PHN Modification"). Of these categories, the unmodified and pre-modified type have been found to be more frequent in SASE-A&B than in SAWE-A; the post-modified type occurs more often in SAWE-A, and the difference in PHNs which are both pre- and post-modified is insignificant.

Figure 8

	<u>NOUN PHRASE MODIFICATION</u>			
	<u>SAWE-A</u>	<u>%</u>	<u>SASE-A&amp;B</u>	<u>%</u>
Unmodified	1,146	23.52	660	28.29
Pre-modified	1,732	35.55	981	42.31
Post-modified	1,431	29.37	439	18.82
Pre & Post modified	563	11.56	247	10.59
	<u>4,872</u>	<u>100.00%</u>	<u>2,333</u>	<u>100.01%</u>

The distribution of forms filling pre-modifier slots is not significantly different between the two corpora. In both, terminal elements (including expressions) are most frequently fillers in this position, with phrases ranking second. Other types of fillers occur only in slightly more than 1% of all pre-modified PHN constructions. Thus, the following are typical noun phrase constructions that occur frequently in SASE-A&B:

EX. 1 (a) Unmodified (+DEIC +NUC)

1) SASE-B 1.111 this case

2) SASE-A 5.80 the language

(b) Premodified (+QUAL +NUC)

1) SASE-B 3.44 another country

2) SASE-A 5.22 about three years

Within post-modifier slots, we find that the highest ranking forms in both corpora are phrases. Clauses rank second as post-modifiers and terminal elements rank third. However, when we look at the distribution of these post-modification forms, we find that it is not the same between the two corpora. Proportionate to the total number of post-modification slots in PHNs, SASE-A has a higher frequency of terminal and phrase fillers in this position. SASE-A&B has more clause fillers. The following are typical post-modified PHN constructions in the two corpora:

EX. 2 Terminal Post-modifiers

1) SASE-A 13.9 area code 519

2) SASE-A 9.26 National and Historic Parks Branch, Room 201,  
400 Laurier Avenue West, Ottawa 4, Ontario.

- 3) SAWE-A 5.46 Chalk River, Ontario
- 4) SASE-A 3.9 age twelve
- 5) SASE-B 1.50 the students themselves
- 6) SASE-B 3.115 the cultural aspect first

In EX. 2, the underlined parts are terminal post-modifiers that occur in SAWE-A and SASE-A&B. Expressions such as the /XNADDRESS in 2 account for a major portion of terminal post-modifiers in SAWE-A and are probably unique to administrative writing. Specifiers such as those in 3 are also much more likely to be found in written rather than spoken language. Thus, the higher proportion of terminal post-modifiers in SAWE-A can be accounted for by these types of constructions.

EX. 3 Phrase Post-modifiers

- 1) SAWE-A 15.25 Ralph Arlyk of California
- 2) SAWE-A 8.1 fisheries research responsibilities in the Northwest Territories
- 3) SAWE-A 15.49 General Manager, Product Development, H.J. Heinz Company of Canada, LTD.
- 4) SASE-A 4.68 his chances of advancement
- 5) SASE-A 3.15 the streets in Montreal

In EX. 3, the underlined parts are phrase post-modifiers of PHNs that occur in SAWE-A and SASE-A&B. As the examples show, these are most often PHPREPs filling QJAL slots. No. 3, however is a typical example of a PHN specifying the nucleus. This type of phrase post-modifier occurs quite frequently in SAWE-A and is probably unique to that corpus. There are very few specifiers of the nucleus within PHNs in SASE-A&B and most of these are

terminal forms such as nos. 4, 5, 6 in EX. 2. This is quite understandable since these PHN constructions, with nuclei specified by noun phrases (as in no. 3, EX. 3), are commonly typical written forms of address. Thus, this construction may be the major factor in accounting for the higher frequency in SAWE-A of phrase post-modifiers in PHNs. It would be interesting to discover if there is a significant difference in the number of PHPREP post-modifiers between the two corpora.

EX. 4 Clause Post-modifiers

- 1) SASE-A 2.21 French Canadians taking the English course
- 2) SASE-B 5.86 work that somebody has to do
- 3) SASE-A 3.00 people who took the course who didn't want to take it
- 4) SAWE-A 18.7 people to prepare papers for predistribution
- 5) SAWE-A 16.12 any project requiring RCMP consideration
- 6) SAWE-A 9.27 your letter dated March 26 which asked for information about revenues expected by the government of Canada during the fiscal year 1969-70.

In EX. 4, the underlined parts are clause post-modifiers of PHNs that occur in SAWE-A and SASE-A&B. According to the study on noun phrase modification, these constructions have a higher frequency of occurrence in SASE-A&B, in relation to the total number of post-modified PHNs, than in SAWE-A. (Refer to Chapter VI on Statistical Analysis.) WH-clauses are the highest ranking type in this position in both corpora, whereas participials are more frequent than infinitives in SAWE-A and infinitives are more

frequent than participials in SASE-A&B. In the PHN study, clusters of more than one clause in a post-modification slot were counted as one clause post-modifier. For example, nos. 3 and 6, EX. 4 have two clauses both post-modifying the nucleus. This would be counted as one post-modification slot filled by a clause form.

To summarize the overall picture of modification in PHNs, we find that SASE-A&B (spoken register) has a higher proportion of simpler PHNs than does SAWE-A (written register). These may be either unmodified constructions (+DEIC +NUC) or pre-modified constructions (pre-modifiers in English tend to be far shorter and less involved than post-modifiers). SAWE-A, on the other hand has a greater proportion of post-modified constructions which are, in general, more complex.

- (ii) Adjectival Phrases may also be 1) unmodified (two or more coordinated nuclear tagmemes) 2) pre-modified 3) post-modified or 4) pre- and post-modified. Of these categories, the pre-modified type is the most common in both corpora. However, this type is proportionately more frequent in SASE-A&B while SAWE-A has a greater proportion of the post-modified and unmodified type. The pre- and post-modified type occurs more often in SASE-A&B.

Terminal elements are the highest ranking pre-modification form in both corpora. SASE-A&B has a slightly higher proportion of expression and phrase fillers in this slot than does SAWE-A, but these occur only when the /PHADJ is post-modified as well. Examples of pre-modified adjectival phrases are:



- EX. 5 1) SASE-B 5.79 pretty big  
+MODNUC +NUC  
/ADVDEG /ADJ
- 2) SAWE-A 19.42 more effective  
+MODNUC +NUC  
/ADVDEG /ADJ
- 3) SASE-A 1.88 too many  
+MODNUC +NUC  
/ADVDEG /ADJIND

From the examples in EX. 5 we see that pre-modified adjectival phrases are relatively short and uncomplicated constructions. This is the most common type of PHADJ in both corpora.

Post-modified adjectival phrases are somewhat more complex constructions. The highest ranking fillers of post-modification slots are clauses and phrases, in that order in both corpora. Expressions and terminal elements also occur, although infrequently in this position in SAWE-A, however not in SASE-A&B. Examples of post-modified adjectival phrases are:

- EX. 6 1) SAWE-A 17.16 able to make use of these lands  
+NUC +MODNUC  
/ADJ /CLBASINF
- 2) SAWE-A 1.34 peculiar to each division  
+NUC +MODNUC  
/ADJ /PHPREP
- 3) SAWE-A 1.18 130.53 monthly  
+NUC +MODNUC  
/ADJNUM /ADVTIME
- 4) SAWE-A 1.36 effective January 1, 1969  
+NUC +MODNUC  
/ADJ /XNDATE

5) SASE-A 5.3 able to communicate with his counterpart

+NUC  
/ADJ

+MODNUC  
/CLBASINF

6) SASE-A 3.77 incapable of learning a language

+NUC  
/ADJ

+MODNUC  
/PHPREP

From the examples in EX. 6, we see that most of the post-modified adjectival phrases are somewhat longer, in terms of number of words, than the typical pre-modified constructions. These do not seem to be the type of construction that would pre-modify a nominal element as do the pre-modified PHADJs (i.e. pretty big dog; more effective management), but rather they are probably fillers of PREDADJ slots or possibly, noun phrase post-modification slots (i.e. he is able to make use of these lands; working conditions peculiar to each division.) Thus, the higher proportion of post-modified PHADJs in SAWE-A may be affected by the environment in which they are found. Thus, the fact that SAWE-A has a relatively higher frequency of post-modified noun phrases than SASE-A&B, may influence the fact that it also has more post-modified adjectival phrases. It would be interesting to discover the environments of these PHADJs according to their modification properties in order to retrieve this information. Other than this, the expressions and terminal elements filling post-modifier slots in PHADJs in SAWE-A (see nos. 3 and 4, EX. 6) are unique to the written corpus.

Pre- and Post-modified adjectival phrases are either constructions with typical pre-modifiers and post-modifiers, or on the other hand, they may be comparative constructions. Examples of pre- and post-modified PHADJs are:

EX. 7 1) SASE-A 4.66 any more satisfied with his work

+MODNUC  
/PHADVDEG

+NUC  
/ADJ

+MODNUC  
/PHPREP

- 2) SASE-B 3.91 particularly peculiar to Ottawa  
 +MODNUC +NUC +MODNUC  
 /ADVEMPH /ADJ /PHPREP
- 3) SASE-B 1.102 as (normal) as possible  
 +COMPARAT +NUC +MODNUC  
 /XCOMPAR /ADJ /CLELL
- 4) SAWE-A 12.45 very similar to that of drunkenness  
 +MODNUC +NUC +MODNUC  
 /ADVDEG /ADJ /PHPREP
- 5) SAWE-A 9.4 as (much) as available  
 +COMPARAT +NUC +MODNUC  
 /XCOMPAR /ADJIND /CLELL

In EX. 7, nos. 1, 2, and 4 are typical pre- and post-modified adjectival phrases. Nos. 3 and 5 are comparative constructions. The higher proportion of these constructions in SASE-A&B is mostly influenced by the greater frequency of the comparative construction in that corpus.

The differences between the two corpora in dealing with adjectival comparative constructions as discussed previously under forms filling nuclear slots in PHADVs, yielded a great many more adverbial phrases in SASE-A&B than in SAWE-A. Since this is not really representative of their true proportions, it is felt that the modification data for PHADVs is not accurate enough to be informative. (These differences were compensated for in dealing with the modification of PHADJs).

- (iii) Pronominal Phrases are most often post-modified in both corpora. This is interesting since other noun phrases have a great tendency toward pre-modification. SASE-A&B has proportionately more pre-modified PHPRONS than SAWE-A as well as more unmodified PHPRONS.

Examples of post-modified PHPRONs are:

EX. 8 1) SAWE-A 5.7 that which was approved

+NUC +MODNUC  
/PRONDEM /CLPASSWH

2) SAWE-A 1.28 one to deal with the company and each of the  
above divisions of the union

+NUC +MODNUC  
/PRONIND /CLBASINF

3) SASE-A 3.53 no one who is a francophone

+NUC +MODNUC  
/XPRONIND /CLEQUATWH

The examples in EX. 8, are the most common type of PHPRON in both corpora. However, SASE-A&B has relatively fewer of this type than SAWE-A, and more of the pre-modified and unmodified type. Examples of these are:

EX. 9 a) Unmodified

1) SASE-B 1.5 this many

2) SASE-B 1.72 the other

b) Pre-modified

1) SASE-A 2.49 either one

2) SASE-B 5.59 a good one

Thus we may say that the spoken corpus shows a greater tendency toward the more simple PHPRON constructions than does the written corpus.

#### 4.5 Summary

In summary, it should be pointed out that, in most respects, SAWE-A phrases are more complex than SASE-A&B phrases. That is, there is a greater tendency in the written corpus for expressions and phrases to fill both

modification and nuclear slots in phrases rather than the usual terminal forms. Also there is a greater tendency toward post-modification in general in SAWE-A phrases, which are more complex constructions than pre-modified or unmodified forms. On the other hand, SASE-A&B does have more clauses filling nuclear slots in PHPREPs as well as more clauses filling post-modification slots in PHNs. (see Section 4.3, EX. 11 and Section 4.4, EX. 4) This could be evidence of a more "action-oriented" form of expression in spoken language. For example, we may say "in achieving our objectives" whereas we may write "in the achievement of our objectives", where the verbal component has been nominalized.

It is felt that this tendency toward more complex phrase constructions as well as the tendency away from an "action-oriented" form of expression in written language may be evidence of a more organized style of language. Spoken language seems to be more spontaneous, reflecting less careful and tidy plans.

5. Level 5: Expression

At level 5 in our analysis, the expression level, all "fixed" expressions are listed. The criterion for a "fixed" expression is that it be considered by a native speaker of English to function as a minimal unit, analogous to a 'word'. The structural components of a fixed expression do not adequately describe the construction. For example, the expression "in general" is not considered a prepositional phrase on the analogy of "in the house" simply because they are structurally similar. "In general" is somehow more of a composite unit as far as its meaning is concerned. Besides idiomatic expressions, names, addresses, dates, measurements, etc., which are considered as "fixed" expressions, level 5 also includes all lexical verbs, auxiliaries, semi-auxiliaries, and modals. In the level 5 section of the phase III computer printout these expressions are grouped according to form and each linguistic manifestation is listed along with its frequency of occurrence as well as sentence identification numbers if it occurs ten times or less.

5.1 Fixed Expressions

In SAWE-A, the ratio of fixed expressions to clauses at level 2 is approximately 1:1, as compared to 1:2.7 in SASE-A+B. (Clauses at level 2 are used as a basis of comparison here, since the criteria for sentences are different in the two corpora. See chapter VII, section 2.2) Thus, SAWE-A has a higher proportion of "fixed"

expressions in general and this is mainly due to the frequency of nominal expressions. The types of "fixed" expressions which occur in both corpora are described below.

Figure 9

DISTRIBUTION OF "FIXED" EXPRESSIONS

	<u>SAWE-A</u>	<u>%</u>	<u>SASE-A+B</u>	<u>%</u>
XADJ...	83	5.74	94	16.29
XADV...	83	5.74	165	28.59
XCOMPAR	12	0.83	—	—
XCONJCOORD...	39	2.70	14	2.42
XCONJSUB	51	3.53	41	7.10
XINTERJ	5	0.34	30	5.19
XN...	993	68.76	157	27.20
XPREP	177	12.25	52	9.01
XPRON...	<u>1</u>	<u>0.06</u>	<u>24</u>	<u>4.15</u>
	1,444	99.95%	577	99.95%

(i) XADJ...

Adjectival expressions constitute 5.74% of all "fixed" expressions in the SAWE-A corpus and 16.29% in the SASE-A+B corpus. These may be divided into four separate types: 1) unspecified (XADJ) 2) indefinite (XADJIND) 3) numerical (XADJNUM) and 4) proper (XADJP). In the two corpora, these are distributed as follows:

Figure 10

DISTRIBUTION OF ADJECTIVAL EXPRESSIONS

	<u>SAWE-A</u>	<u>RANK</u>	<u>SASE-A+B</u>	<u>RANK</u>
XADJ	74	1	22	3
XADJIND	6	2	39	1
XADJNUM	2	3	10	4
AADJP	1	4	23	2

In the SAWE-A corpus (Administrative Correspondence), the unspecified type is by far the most frequent. In the SASE-A+B corpus (Formal/Informal Discussion), however, they only rank third. Examples of these are:

- Ex. 1. a) SAWE-A: 1) "as follows"  
 2) "up to date"  
 3) "self-explanatory"  
 4) "tax-free"
- b) SASE-A+B: 1) "mixed up"  
 2) "at large"  
 3) "easier said than done"  
 4) "so-called"

Indefinite adjectival expressions (XADJIND) are the highest ranking type in SASE-A+B. In SAWE-A, on the other hand, they are fairly infrequent. Manifestations of XADJINDS are as follows:

- Ex. 2. a) SAWE-A: 1) "a few"  
 2) "a great deal"  
 3) "quite a"\* \*Exhaustive
- b) SASE-A+B: 1) "a lot"  
 2) "a few"  
 3) "quite a"  
 4) "a bit"\*\*\* \*Not Exhaustive



Numerical adjectival expressions (XADJNUM) are quite similar in type in both corpora, although they occur more frequently in SASE-A+B. These include expressions such as "forty-five", "forty million", etc.

Proper adjectival expressions (XADJP) such as "French-speaking", "French Canadian", "Non-Canadian", etc. are much more common within the SASE-A+B corpus.

(ii) XADV...

Adverbial expressions constitute 5.74% of the "fixed" expressions in the SAWE-A corpus and 28.59% in the SASE-A+B corpus. These are also divided into categories (eg. additive, XADVADD; consequence, XADVCONS; degree, XADVDEG; etc.) However, the application of these further labels was largely left up to the intuition and judgment of the individual analyst so that many of the finer categories are rather debatable. For example, the expression "at least" within different sentences has been assigned to three different categories of adverbial expressions.

Ex.3. a) XADVEMPH

SASE-B5.98 But it might at least keep one from becoming too rusty during the period between courses.

b) XADVDEG

SAWE-A 5.11 This at least gives an indication of the period of our involvement.

c) XADVRESTR

SAWE-A1824 At least the latter when run today was much better accepted by all, including Reid.

On the other hand, an expression may be analysed differently with different contexts. Many expressions may be adjectival in one context and adverbial in another. For example, look at the expression "a bit".

EX.4. a) XADJIND

SASE-B2.6 And others find that it's a bit of a drag.

b) XADVDEG

SAWE-A15.9... and we hope it will sound a bit better this year.

In EX.4 the two different analyses of the expression "a bit" are justified by the context. However, within adverbial expressions, as in EX.3, the differences are due to the fact that the finer categories cannot be strictly defined. Basically, adverbial expressions are expressions filling slots or functions which could be filled by adverbs. Typically they have manifestations such as:

- EX.5. 1) "at least"  
2) "of course"  
3) "on the other hand"  
4) "in general"  
5) "as such"  
6) "at all"

Although the expressions in EX.5 have typically been analysed as adverbial expressions they have, in some cases been analysed in other ways, mainly as interjections (XINTERJ). This must also be attributed to the intuition and judgment of different analysts.

(iii) XCOMPAR

Comparative expressions constitute 0.83% of the expressions in SAWE-A. These are manifested by "as...as" and "more... than" in constructions such as "as big as" and "more beautiful than". (The XCOMPAR label does not occur in SASE-A+B at all since comparative constructions have been analysed differently in that corpus. In SASE-A+B these expressions would occur as adverbial expressions of degree, XADVDEG.)

(iv) XCONJCOORD...

Coordinate conjunction expressions constitute 2.7% of the "fixed" expressions in SAWE-A and 2.42% of those in SASE-A+B. The following are manifestations of the general or unspecified type:

- EX.6. a) SAWE-A
- 1) and...or
  - 2) as well as
  - 3) both...and
  - 4) either...or
  - 5) instead of
  - 6) not only...but
  - 7) together with
- b) SASE-A+B
- 1) as well as
  - 2) both...and
  - 3) either...or
  - 4) if not
  - 5) not...but
  - 6) not only...but

Other coordinate conjunction expressions are further labelled as "restrictive" (XCONJCOORDRESTR). These are expressions such as "rather than", occurring in both corpora, "in place of", only in SAWE-A, and "as against", only in SASE-A+B. The expression "not only...but" has been analysed in both ways. (XCONJCOORD XCONJCOORDRESTR)

(v) XCONJSUB

Subordinate conjunction expressions constitute 3.53% of SAWE-A "fixed" expressions and 7.10% of those in SASE-A+B. Common manifestations of these in both corpora are:

- EX.7.    1) "so that"  
          2) "in order to"  
          3) "whether or not"

(vi) XINTERJ

Interjection expressions are basically interjections of more than one word. These constitute 0.34% of the "fixed" expressions in the SAWE-A corpus and 5.19% of those in the SASE-A+B corpus. This proportion in SASE-A+B is not entirely accurate however since many expressions analysed as XINTERJ there have been analysed otherwise (usually XADV...) in both SAWE-A and SASE-A+B. Once again this reflects the analyst's intuition. In SAWE-A, the only manifestations listed under XINTERJ are "of course" and "thank you". In SASE-A+B they include other expressions such as "in other words", "mind you", "so to speak".

However, if we look at all the manifestations of XINTERJ in both corpora and calculate their frequency of occurrence regardless of what they have been labelled as, we find that they constitute 1.17% of the "fixed" expressions in SAWE-A as compared with 10.22% of those in SASE-A+B. Thus we may conclude that the proportion actually is higher in the spoken corpus. We also find that there are still twice as many types occurring in SASE-A+B.

(11 types occurring in SAWE-A, 23 types occurring in SASE-A+B).

(vii ) XN...

There are 6 types of nominal expressions: 1) unspecified (XN) 2) addresses (XNADDRESS) 3) dates (XNDATE) 4) measurements of time (XNHOUR) 5) measurements of area, volume, etc. (XNMEASURE) and 6) proper noun expressions, including names of people, places, companies, etc. (XNP). These constitute 68.76% of the "fixed" expressions in the SAWE-A corpus and 27.20% of those in SASE-A+B. The higher proportion of nominal expressions in SAWE-A is attributable mainly to the greater frequencies of XNP (proper noun expressions), XNDATE (dates) and XNADDRESS (addresses). XNADDRESS does not occur in SASE-A+B at all. Typical examples drawn from these XN... categories are:

- EX.8. a) XN: 1) sub-contractors  
2) high school
- b) XNADDRESS: 16 Lower O'Connell St, Dublin 1
- c) XNDATE: 1) December 5, 1968  
2) '66
- d) XNHOUR: 1) 7:40 A.M.  
2) five o'clock
- e) XNMEASURE: 1) parts-per-million  
2) at a time
- f) XNP: 1) Public Service Commission  
2) Quebec City

(viii) XPREP

Prepositional expressions are basically expressions of more than one word filling the same slot or function as a preposition. These constitute 12.25% of "fixed" expressions in SAWE-A and 9.01% in SASE-A-B. Examples of these are:

- EX.9. a) SAWE-A
- 1) "in connection with"
  - 2) "from...to"
  - 3) "prior to"
  - 4) "as to"
  - 5) "in accordance with"
- b) SASE-A-B
- 1) "out of"
  - 2) "because of"
  - 3) "in between"
  - 4) "as to"
  - 5) "in terms of"

(ix) XPRON...

Pronominal expressions constitute 0.06% of the "fixed" expressions in SAWE-A and 4.15% of those in SASE-A+B. The only example in SAWE-A is an indefinite pronominal expression (XPRONIND) manifested by "as follows." This expression has, in other cases, been analysed as XADJ (adjectival expression) and XADVMAN (adverbial expression of manner). In SASE-A+B, XPRONIND has manifestations such as "and so on", "so on", and "what not". Two other types of pronominal expressions occurring in SASE-A+B are: 1) XPRONINDNEG (indefinite negative pronominal expression) manifested by "no one", and 2) XPRONRECIP (reciprocal pronominal expression) manifested by "each other" and "one another".

5.2 Verbal Expression

The label "verbal expression" does not necessarily mean that the unit consists of more than one word as does the term "fixed" expression. As mentioned previously, the 5 categories of lexical verbs, whether they consist of one, two, or many constituents, as well as all auxiliaries, semi-auxiliaries and modals are included here. Thus, the verb "go" as well as the two-word verb "go through" would both be listed as verbal expressions (XV...) at level 5. Complex verbal expressions (XVCOMP XVAUXCOMP, XVSAUXCOMP) are analysed into their structural components at level 5 and their manifestations are listed at this level too. The following are the various types of verbal expressions occurring in SAWE-A AND SASE-A/B:

Figure 11

DISTRIBUTION OF VERBAL EXPRESSIONS

	<u>SAWE-A</u>	<u>%</u>	<u>SASE-A+B</u>	<u>%</u>
XVI	1121	18.73	1313	26.47
XVII	208	3.47	117	2.35
XVIII	873	14.59	722	14.55
XIV	132	2.20	49	0.98
XV	381	6.36	494	9.95
XVCOMP	1505	25.15	971	19.57
XVAUX	840	14.03	604	12.17
XVAUXCOMP	89	1.48	25	0.50
XVSAUX	163	2.72	145	2.92
XVSAUXCOMP	90	1.50	75	1.51
XVMODE	581	9.71	437	8.81
XVPRESIMPERS	—	—	4	0.08
XVEMPH	—	—	4	0.08
	<u>5,983</u>	<u>99.94%</u>	<u>4,960</u>	<u>99.94%</u>

(i) XVI

The first category of lexical verbs includes all transitive verbs having direct objects. These constitute 18.73% of the verbal expressions in SAWE-A and 26.47% of those in SASE-A+B. The five highest ranking manifestations of XVI's in both corpora are as follows:

- EX.1. a) SAWE-A: 1) have  
 2) appreciate  
 3) enclosing  
 4) suggest  
 5) think



- b) SASE-A+B: 1) think  
2) have  
3) had  
4) know  
5) say

(ii) XVII

The second category of lexical verbs includes transitive verbs having an indirect object. These constitute 3.47% of SAWE-A verbal expressions and 2.35% of those in SASE-A+B. The highest ranking manifestations of XVIIIs are as follows:

- EX.2. a) SAWE-A: 1) sent  
2) received  
3) refer  
4) referred  
5) relating

- b) SASE-A+B: 1) depends  
2) talking  
3) listening  
4) agree  
5) think

(iii) XVIII

The third category of lexical verbs is the intransitive type, having no objects at all. These constitute 14.59% of verbal expressions in SAWE-A and 14.55% of those in SASE-A+B. The highest ranking manifestations of XVIIIIs are as follows:

- EX.3. a) SAWE-A; 1) is  
2) made  
3) dated  
4) required  
5) attached

- b) SASE-A+B: 1) 's  
2) go  
3) are  
4) he  
5) know

(iv) XVIV

The fourth category of lexical verbs is ditransitive, having both direct and indirect objects. These constitute 2.2% of the verbal expressions in SAWE-A and 0.98% of those in SASE-A+B. The highest ranking manifestations of XVIVs are:

- EX. 4. a) SAWE-A: 1) send  
2) sending  
3) inform  
4) to provide  
5) forward
- b) SASE-A+B: 1) teaching  
2) giving  
3) ask  
4) gave  
5) think

(v) XVV

The fifth category of lexical verbs are the copular verbs complemented by predicate adjectives (+PREDADJ) or predicate nominatives (+PREDNOM). Such verbs occur in equative clauses and constitute 6.36% of the verbal expressions in SAWE-A and 9.95% of those in SASE-A+B. The highest ranking manifestations of XVVs are:

- EX. 5. a) SAWE-A: 1) is  
2) be  
3) are  
4) am  
5) to be
- b) SASE-A+B: 1) is  
2) 's  
3) be  
4) are  
5) was

Less frequent forms of XVVs are manifestations such as "feels", "becomes", "sounds", "represents".

(vi) XVCOMP

Complex verbal expressions are composed of a lexical verb along with an auxiliary (+AUX) or a modal (+MODAL). These constitute 25.15% of the verbal expressions in SAWE-A and 19.57% of those in SASE-A+B. Typical examples of XVCOMPs are:

- EX.6. 1) am enclosing  
2) 'd be  
3) has been received.

(vii) XVAUX

Auxiliaries constitute 14.03% of the verbal expressions in SAWE-A and 12.11% of those in SASE-A+B. The highest ranking manifestations of XVAUXs are:

- EX.7. a) SAWE-A: 1) be  
2) is  
3) are  
4) been  
5) has  
b) SASE-A+B: 1) do  
2) have  
3) 've  
4) 're  
5) be

(viii) XVAUXCOMP

Complex auxiliary expressions are composed of a main (or nuclear) auxiliary along with either another auxiliary or a modal. These constitute 1.48% of the verbal expressions in SAWE-A and 0.5% of those in SASE-A+B. Typical examples of XVAUXCOMPs are:

- EX.8. 1) has been  
2) have been  
3) 've been.

(ix) XVSAUX

Semi-auxiliaries constitute 2.72% of the verbal expressions in SAWE-A and 2.92% of those in SASE-A+B. The highest ranking manifestations of XVSAUXs are:

- EX.9. a) SAWE-A: 1) find  
2) is to  
3) to  
4) have to  
5) let
- b) SASE-A+B: 1) have to  
2) going to  
3) had to  
4) has to  
5) allowed to

(x) XVSAUXCOMP

Complex semi-auxiliaries are composed of a nuclear semi-auxiliary along with either an auxiliary or a modal. These constitute 1.5% of the verbal expressions in SAWE-A and 1.51% of those in SASE-A+B. Typical examples of XVSAUXCOMPs are:

- EX.10. 1) 're going to  
2) 've got to  
3) are required to  
4) would have to

(xi) XVMODE

Modals constitute 9.71% of the verbal expressions in SAWE-A and 8.81% of those in SASE-A+B. The highest ranking manifestations of XVMODE are:

- EX.11. a) SAWE-A 1) will  
2) would  
3) should  
4) may  
5) must

- b) SASE-A+B: 1) would  
2) can  
3) 'd  
4) might  
5) may

There are two other types of verbal expressions which occur infrequently, and only in SASE-A+B. These are: 1) XVPRESIMPERS (presentative impersonal verbal expressions) constituting 0.08% of the verbal expressions in SASE-A+B. Manifestations are "here is", "how about" and "what about". 2) XVEMPH (verbal expression of emphasis) constituting 0.08% of the verbal expressions in SASE-A+B. Manifestations are "it's that" and "it was that".

NOTES

1. Crystal, D. and Davy, D. Investigating English Style, Longmans, 1969, pp. 110.
2. Cook, Walter A. Introduction to Tagmemic Analysis, Holt, Rinehart and Winston, Inc., 1969, pp. 33.
3. Only nuclear tagmemes are enumerated in the description of the constituents of the clause forms in this section. Optional non-nuclear tagmemes, such as CVs (verbal complements) can occur as constituents of the various clause forms.
4. The most frequent clause construction in both SASE-A&B and SAWE-A: +S, +PRED, +OD, is a /CLBAS construction.
5. For example, the construction consisting of 2 nuclear tagmemes, +S, +PRED, can represent a long complex clause structure such as this clause in SAWE-A:  
  
SAWE-A 4.2 ... if a balanced proposal were made in which the responsibilities of the St. Andrews and Halifax laboratories were defined and the brief proposals made in support of application for IDS funding of development projects for 1968-69 re-examined and brought up to date in the context of a "demonstration" to industry that our present fundamental research can be profitably applied to reduction of lobster losses.  
  
(For details see Format of the Phase III Printout)
6. Clause constructions are defined by the presence of the nuclear tagmemes only.
7. In looking at the forms filling nuclear slots in phrases, PHVs have not been included in the total since these are actually a different type of word grouping, called phrases for lack of a better word. The second type of PHV has neither the endocentric relationship of PHNs, PHADJs, PHADVs and PHPRONs, nor the exocentric relationship of PHPREPs. They cannot be described as either head-modifier constructions or as relator-axis constructions.

APPENDICES TO  
COMPARATIVE STUDY OF THE SYNTACTIC CHARACTERISTICS  
OF  
FORMAL/INFORMAL DISCUSSION AND ADMINISTRATIVE CORRESPONDENCE  
PROJECT #8840-0017-081

RESEARCH DIVISION  
DIRECTORATE OF STUDIES  
STAFF DEVELOPMENT BRANCH  
PUBLIC SERVICE COMMISSION OF CANADA  
OCTOBER, 1974

APPENDIX 1

The fifteen government departments and agencies from which administrative correspondence (the source for "Genre" A of the Corpus) was received:

Agriculture

Atomic Energy of Canada, Ltd.

Consumer and Corporate Affairs

Fisheries and Forestry

Indian Affairs and Northern Development

Industry, Trade and Commerce

Labour

Manpower and Immigration

National Film Board

National Health and Welfare

National Revenue

Public Works

Royal Canadian Mounted Police

Transport

Treasury Board



RANDOM SELECTION: The procedure outlined in A Million Random Digits with 100,000 Normal Deviates (New York: Rand Corporation, 1955) was adhered to throughout.

A. RANDOM SELECTION OF DOCUMENTS:

These are the steps which were followed:

1. numbering all collected documents consecutively;
2. randomly flipping the "random digits" section of the above book until lighting on a number by blind choice;
3. using that number to find the row and then the column as the starting point;
4. continuing horizontally from the number thus obtained to get each random number as needed: considering as many digits as necessary, and looking for a number no greater than the maximum number in the common pool ("universe") from which the choice is made.

Example from Genre A:

- 1) Letters collected were numbered from 1 to 1372.
- 2) The number 27,593 was obtained by blind choice.
- 3) The first digit determined the row number, the second digit the column number. This gave us the number 89042 as our starting point.
- 4) Since this number was too high, we continued, considering only the first four digits of each number as it appeared horizontally like this:

89042      46030      07927 .

Thus Document 792 became the first document of Genre A.

B. RANDOM SELECTION OF STARTING POINT WITHIN DOCUMENT:

When documents were short, as in Genres A, B, F, H and I, complete documents were used, starting from the first word of the first sentence.

In longer documents, as in Genres C, D, E and G, it was necessary to choose which portion was to be used. In these cases, random selection of page and line was made by blind choice, and the next 50 running sentences made up the sample.

APPENDIX 3

FUNCTION LABELS

The following are the major function labels used in the analysis of SAWE-A (Administrative Correspondence) and SASE-A&B (Formal/informal Discussion).

<u>LABEL</u>	<u>FUNCTION</u>	<u>EXAMPLE</u>
+ AGENT	AGENT	The expenses will be paid <u>by the Department of Labour</u>
+ APP	APPOSITION	Well, of course we progressed from lockheeds to DC-3's to North Stars to the first turbine airplane in North America, <u>the Viscount.</u>
+ AUX	AUXILIARY	They <u>have</u> gone.
+ CLDEP	DEPENDENT CLAUSE	I left <u>because he came in.</u>
+ CLIND	INDEPENDENT CLAUSE	<u>The cat hates the black dog.</u>
+ CLINDPAREN	INDEPENDENT PARENTHETICAL CLAUSE	<u>You know</u> , there are so many levels of speech, depending on the levels of people.
+ CLNUC	NUCLEAR CLAUSE	<u>I left</u> because he came in.
+ COD	COMPLEMENT OF DIRECT OBJECT	We find it <u>very difficult</u> to set up lines of communication down there on Western Problems.
+ COMPL	COMPLEMENTIZER	We feel <u>that</u> they have(n't) looked after us as far as freight rates are concerned.
+ CORR	CORRELATOR	I came in <u>and</u> sat down.
+ CPREDADJ	COMPLEMENT OF PREDICATE ADJECTIVE	I'm proud <u>of you</u> , Tom.
+ CPREDNOM	COMPLEMENT OF PREDICATE NOMINATIVE	My Ted is the same way <u>about his hockey.</u>
+ CVACCOMP	VERBAL COMPLEMENT OF ACCOMPANIMENT	Is Peggy going to go to the station <u>with her father.</u>
+ CVADD	VERBAL COMPLEMENT OF ADDITION	I would <u>also</u> suggest that Mr. Agar contact Dr. Butler of the Department of National Health and Welfare in Edmonton.

<u>LABEL</u>	<u>FUNCTION</u>	<u>EXAMPLE</u>
+ CVCAUSE	VERBAL COMPLEMENT OF CAUSE	I enclose <u>at your request</u> , information regarding the Contra-Service Arrangement between the NFB and Associated Screen Industries Ltd.
+ CVCONS	VERBAL COMPLEMENT OF CONSEQUENCE	What <u>then</u> do you think are going to be the political consequences on the Prairies.
+ CVDEG	VERBAL COMPLEMENT OF DEGREE	I would <u>very much</u> like to take that step.
+ CVEMPH	VERBAL COMPLEMENT OF EMPHASIS	The Branch would <u>definitely</u> recommend a visit to Canada.
+ CVLOC	VERBAL COMPLEMENT OF LOCATION	We find it very difficult to set up lines of communication <u>down there</u> on Western problems.
+ CVMAN	VERBAL COMPLEMENT OF MANNER	I have indicated my suggested corrections <u>in red pencil</u> .
+ CVMEASURE	VERBAL COMPLEMENT OF MEASURE	At the present rates, approval of this request would cost the department <u>\$130.53 monthly</u> .
+ CVOPIN	VERBAL COMPLEMENT OF OPINION	There's <u>likely</u> to be a Federal election in 1972 or 1973.
+ CVOPPOS	VERBAL COMPLEMENT OF OPPOSITION	And <u>yet</u> you find a great variety in types of writing.
+ CVPURP	VERBAL COMPLEMENT OF PURPOSE	And I went up <u>for a lesson</u> and I guess I was hooked.
+ CVRESTR	VERBAL COMPLEMENT OF RESTRICTION	Where Trudeau is working on his own <u>without a ghost-writer or speech-writer</u> , he seems to be more Trudeau.
+ CVSIT	VERBAL COMPLEMENT OF SITUATION	I heard it <u>on the news</u> .
+ CVTIME	VERBAL COMPLEMENT OF TIME	This can ( <u>always</u> ) be a solution, if you're referring to Canada.
+ DEIC	DEICTIC	<u>The</u> cat hates the black dog.
+ ELTRANS	ELEMENT OF TRANSITION	<u>However</u> I'm a little hesitant.
+ EMPH	EMPHASIZER	They talked <u>and talked</u> .
+ INTERJEC	INTERJECTOR	Can (I <u>please</u> ) try on that lovely blue dress in the window?

<u>LABEL</u>	<u>FUNCTION</u>	<u>EXAMPLE</u>
+ IPP	INTRODUCER OF PHRASE PREPOSITIONAL	Can (I please) try on that lovely blue dress <u>in</u> the window?
+ MODAL	MODAL	He <u>should</u> have gone.
+ MODNUC	MODIFIER OF NUCLEUS	<u>Completely</u> well thought-out
+ NEG	NEGATOR	We feel that they have(n't) looked after us as far as freight rates are concerned.
+ NUC	NUCLEUS	A <u>supply</u> of monthly reporting forms.
+ OD	OBJECT DIRECT	The cat hates <u>the black dog</u> .
+ OI	OBJECT INDIRECT	He gave <u>her</u> dog biscuits.
+ POSS	POSSESSOR	That's particularly true of Mr. Benson's <u>proposed</u> tax reforms as outlined in the White Paper.
+ PRED	PREDICATE	The cat <u>hates</u> the black dog.
+ PREDADJ	PREDICATE ADJECTIVE	I'm <u>proud</u> of you Tom.
+ PREDNOM	PREDICATE NOMINATIVE	This can (always) be <u>a solution</u> if you're referring to Canada.
+ QUAL	QUALIFIER	The cat hates the <u>black</u> dog.
+ QUANT	QUANTIFIER	I think <u>most</u> discussions are people talking to themselves.
+ REINFDEIC	REINFORCER OF DEICTIC	I'll think of it from my <u>own</u> background.
+ REINFNEG	REINFORCER OF NEGATOR	They're not <u>at all</u> very happy about the prospect of the Federal Government that will make more and more decisions for them.
+ REINFS	REINFORCER OF SUBJECT	I did it <u>myself</u> .
+ RELAT	RELATOR	Mr. Benson has been taking an awful lot <u>of</u> heat in the last couple of months to try to make (this system) work a little better.

<u>LABEL</u>	<u>FUNCTION</u>	<u>EXAMPLE</u>
+ S	SUBJECT	<u>The cat</u> hates the black dog.
+ SAUX	SEMI-AUXILIARY	What (then do (you) think) <u>are going to be</u> the political consequences on the Prairies?
+ SENDECL	SENTENCE DECLARATIVE	<u>The cat hates the black dog.</u>
+ SENDECLINC	SENTENCE DECLARATIVE INCOMPLETE	<u>You can't because all the time my little -</u>
+ SENIMPER	SENTENCE IMPERATIVE	<u>Go back to what you said earlier.</u>
+ SENINTERJEC	SENTENCE INTERJECTIVE	<u>Wow!</u>
+ SENINTERROG	SENTENCE INTERROGATIVE	<u>Can (I please) try on that lovely blue dress in the window?</u>
+ SENINTERROGINC	SENTENCE INTERROGATIVE INCOMPLETE	<u>Is it necessary to -</u>
+ SPECCLDEP	SPECIFIER OF CLAUSE DEPENDENT	And that is what I mean by its self-defeating move, to initiate the commercial mode of financing broadcasting, <u>particularly</u> when you keep in mind that only about one-sixth of their revenue now comes from advertising sources.
+ SPECCVCAUSE	SPECIFIER OF VERBAL COMPLEMENT	I find myself even looking at Public Affairs programmes on issues of which I'm very interested in turning it off because the calibre of programming is so poor, and turning it to American issues <u>just</u> because of, you know, the quality of reporting.
+ SPECCVLOC	SPECIFIER OF VERBAL COMPLEMENT OF LOCATION	We have about two hundred companies ( <u>up</u> in the north now) looking for minerals.
+ SPECCVMAN	SPECIFIER OF VERBAL COMPLEMENT OF SITUATION	Our responsibilities are going up <u>just</u> repeatedly and continuously.
+ SPECCVRESTR	SPECIFIER OF VERBAL COMPLEMENT OF RESTRICTION	I mean it wasn't <u>just</u> for us.

<u>LABEL</u>	<u>FUNCTION</u>	<u>EXAMPLE</u>
+ SPECCVSIT	SPECIFIER OF VERBAL COMPLEMENT OF SI- TUATION	It doesn't go <u>up</u> to eighty.
+ SPECCVTIME	SPECIFIER OF VERBAL COMPLEMENT	And then <u>later on</u> the Vanguard, and, of course, now the DC9's, DC8's.
+ SPECNUC	SPECIFIER OF NUCLEUS	... what I said about the as- pirations of <u>particularly</u> the younger Francophone generation.
+ SPECOD	SPECIFIER OF OBJECT DIRECT	But what <u>exactly</u> is he doing in the basement?
+ SPECREDADJ	SPECIFIER OF PREDI- CATE ADJECTIVE	Sixteen, seventeen, <u>somewhere</u> <u>around there</u> .
+ SPECS	SPECIFIER	And they were <u>all</u> wonderful people.
+ SUB	SUBORDINATOR	I left <u>because</u> he came in.
+ VOC	VOCATIVE	I'm proud of you, <u>Tom</u> .

APPENDIX 4

FORM LABELS

The following are the major form labels used in the analysis of SAWE-A (Administrative Correspondence) and SASE-A&B (Formal/informal Discussion).

<u>LABEL</u>	<u>FORM</u>	<u>EXAMPLE</u>
/ADJ	ADJECTIVE	They were <u>special</u> people.
/ADJNEG	ADJECTIVE NEGATIVE	Well, firstly, there were <u>no</u> runways on the airport yet.
/ADJDEM	ADJECTIVE DEMONSTRATIVE	Can I please try on <u>that</u> lovely blue dress in the window?
/ADJIND	ADJECTIVE INDEFINITE	Again I don't think there's <u>any</u> general reaction.
/ADJNUM	ADJECTIVE NUMERAL	1. And one of the <u>first</u> assets purchased was a link Trainer which was lifted up to the seventh floor and put in an office there to start training pilots. 2. <u>732</u> days.
/ADJPOSS	ADJECTIVE POSSESSIVE	These were experienced people they had on airlines for over ten years in the States, and they brought the benefit of <u>their</u> experience to Canada.
/ADVADD	ADVERB OF ADDITION	I have completed level three and I'm <u>also</u> fortunate inasmuch as...
/ADVDEG	ADVERB OF DEGREE	But it was <u>quite</u> modern for its day.
/ADVEMPH	ADVERB OF EMPHASIS	<u>Certainly</u> they were able people
/ADVLOC	ADVERB OF LOCATION	It was lifted up to the seventh floor and put in an office <u>there</u> .
/ADVMAN	ADVERB OF MANNER	You became involved <u>commercially</u> in aviation.
/ADVNEG	ADVERB OF NEGATION	This is <u>not</u> the same sort of acceptance.

<u>LABEL</u>	<u>FORM</u>	<u>EXAMPLE</u>
/ADVOPIN	ADVERB OF OPINION	<u>Perhaps</u> Andy has comments on that, having gone to level three.
/ADVRESTR	ADVERB OF RESTRICTION	Well, <u>firstly</u> , there were no runways on the airport yet.
/ADVTIME	ADVERB OF TIME	What was the state of the art <u>then</u> ?
/ADVTRANS	ADVERB OF TRANSITION	<u>Well</u> , it took quite a while.
/ARTDEF	ARTICLE DEFINITE	And how ere <u>the</u> early pilots in Trans-Canada Airlines chosen.
/ARTIND	ARTICLE INDEFINITE	This was <u>an</u> acceptance flight.
/CLBAS	CLAUSE BASIC	<u>You mentioned instrument flying.</u>
/CLBASCAUSE	CLAUSE BASIC OF CAUSE	I'm also fortunate <u>inasmuch as I have the opportunity to speak French fairly frequently.</u>
/CLBASINF	CLAUSE BASIC INFINITIVE	Well, it took quite a while <u>to get a private license.</u>
/CLBASINFPURP	CLAUSE BASIC INFINITIVE OF PURPOSE	It was put there <u>to start training pilots.</u>
/CLBASPART	CLAUSE BASIC PARTICIPIAL	Were you ever involved in <u>accepting Aircraft for the company?</u>
/CLBASPARTCAUSE	CLAUSE BASIC PARTICIPIAL OF CAUSE	Perhaps Andy has comments on that, <u>having gone to level three.</u>
/CLBASTIME	CLAUSE BASIC OF TIME	<u>After you learned to fly, how long did it take you before you became involved commercially in aviation?</u>
/CLBASWH	CLAUSE BASIC WH	The things <u>that we watched</u> for were the ashtrays and the cigar lighters and this sort of thing.
/CLCOMPOUNDCOMPLEX	CLAUSE COMPOUND COMPLEX	And one of the first assest purchased was a Link Trainer <u>which was lifted up to seventh floor and put in an office there to start training pilots.</u>



<u>LABEL</u>	<u>FORM</u>	<u>EXAMPLE</u>
/CLCOMPLEX	CLAUSE COMPLEX	<u>He will learn very quickly when he's hungry.</u>
/CLELL	CLAUSE ELLIPTICAL	<u>1937</u>
/CLELLPURP	CLAUSE ELLIPTICAL PURPOSE	He was one of four Americans brought in by Mr. Howe <u>to ...</u>
/CLEQUAT	CLAUSE EQUATIVE	<u>What was the state of the art then?</u>
/CLEQUATCOND	CLAUSE EQUATIVE CONDITIONAL	And years later they have the Concord set for delivery <u>if they're acceptable.</u>
/CLEQUATWH	CLAUSE EQUATIVE WH	I Don't think <u>that he's prepared for this.</u>
/CLIMBERS	CLAUSE IMPERSONAL	<u>And there were no control towers.</u>
/CLMONO	CLAUSE MONO	<u>No.</u>
/CLPASS	CLAUSE PASSIVE	And <u>how were they chosen?</u>
/CLPASSCAUSE	CLAUSE PASSIVE OF CAUSE	It took quite a while <u>because money was involved.</u>
/CLPASSTIME	CLAUSE PASSIVE OF TIME	How long did it take you <u>before you became involved commercially in aviation?</u>
/CLPASSWH	CLAUSE PASSIVE WH	And it was a wonderful thing <u>that they were invited up.</u>
/CONJCOORD	CONJUNCTION OF COORDINATION	We can ask any questions <u>and</u> therefore we can ask this one..
/CONJSUB	CONJUNCTION OF SUBORDINATION	And it was a wonderful thing <u>that</u> they were invited up.
/INTERJ	INTERJECTION	<u>Okay.</u>
/N	NOUN	And they trained <u>pilots.</u>
/NP	NOUN PROPER	They were brought in by <u>Mr. Howe</u> (2 proper nouns).
/PARTPOSS	PARTICLE OF POSSESSION	They took over Western-Canada Airways' <u>Vancouver-Seattle</u> run.

<u>LABEL</u>	<u>FORM</u>	<u>EXAMPLE</u>
/PHADJ	PHRASE ADJECTIVAL	And they're the <u>most reliable</u> Thing <u>in the world</u> .
/PHADVTIME	PHRASE ADVERBIAL OF TIME	And <u>years later</u> , they have the Concord ready.
/PHADVMAN	PHRASE ADVERBIAL OF MANNER	I have completed level three and I'm also fortunate inasmuch as I have the opportunity to speak French <u>fairly frequently</u> during my working day.
/PHGERUND	PHRASE GERUNDIVE	The party ended without <u>John's</u> <u>making a scene</u> .
/PHN	PHRASE NOMINAL	What was <u>the state of the art</u> then'
/PHPREP	PHRASE PREPOSITIONAL	Well, firstly, there were no run- ways <u>on the airport yet</u> .
/PHPRON	PHRASE PRONOMINAL	<u>The odd few</u> had worked for Im- perial Airways overseas.
/PHV	PHRASE VERBAL	You <u>are going to have to correct</u> those errors.
/PHVIMPERS	PHRASE VERBAL IMPERSONAL	And <u>there were</u> no control towers.
/PREP	PREPOSITION	Well, <u>most of</u> them were former bush-pilots.
/PRONDEM	PRONOUN DEMONSTRA- TIVE	<u>That's</u> right.
/PRONIMPERS	PRONOUN IMPERSONAL	And <u>there</u> were no control towers.
/PRONIND	PRONOUN INDEFINITE	And they were <u>all</u> wonderful people.
/PRONP	PRONOUN PERSONAL	So <u>you</u> became a pilot.
/PRONREL	PRONOUN RELATIVE	The things that we watched <u>or</u> were the ashtrays and the cigar lighters and this sort of thing.
/PRONREFL	PRONOUN REFLEXIVE	May be I'm not addressing <u>myself</u> directly to your question.
/SENCOMPLEX	SENTENCE COMPLEX	<u>Did you have to have any sort of a</u> <u>licence to do this?</u>
/SENCOMPLEXELL	SENTENCE COMPLEX ELLIPTICAL	<u>Because I was tired out.</u>

<u>LABEL</u>	<u>FORM</u>	<u>EXAMPLE</u>
/SENCOMPOUND	SENTENCE COMPOUND	<u>They were able to exercise judgment and they had experience.</u>
/SENCOMPOUNDCOMPLEX	SENTENCE COMPOUND COMPLEX	<u>I left and she waited while the children were sleeping.</u>
/SENSIM	SENTENCE SIMPLE	<u>So you became a pilot?</u>
/XADJ	EXPRESSION ADJECTIVAL	It was a <u>two seater</u> biplane, open cockpit.
/XADJIND	EXPRESSION ADJECTIVAL INDEFINATE	Please give me <u>a little bit.</u>
/XADVDEG	EXPRESSION ADVERBIAL	Life would have been <u>a great deal</u> easier for them.
/XADVEMPH	EXPRESSION ADVERBIAL OF EMPHASIS	Well <u>of course</u> we progressed from Lockheeds to DC-3's to North Stars to the first turbine airplane in North America, the Viscount.
/XADVTIME	EXPRESSION ADVERBIAL OF TIME	And you've been flying <u>ever since?</u>
/XADVTRANS	EXPRESSION ADVERBIAL OF TRANSITION	<u>Then again</u> later the Boeing Super Sonic.
/XCOMPAR	EXPRESSION OF COMPARISON	Probably a few <u>more</u> failures <u>than</u> today.
/XCONJSUB	EXPRESSION CONJUNCTION OF SUBORDINATION	Here's a whole area that I don't think he is prepared for <u>even when</u> he's finished the third degree.
/XINTERJ	EXPRESSION INTER- JECTIVE	Well, to me it was a very beautiful airplane <u>of course.</u>
/XN	EXPRESSION NOMINAL	Well, most of them were former <u>bush-pilots.</u>
/XNDATE	EXPRESSION NOMINAL OF DATE	<u>1937.</u>
/XNP	EXPRESSION NOUN PROPER	The odd few had worked for <u>Imperial Airways</u> overseas.

<u>LABEL</u>	<u>FORM</u>	<u>EXAMPLE</u>
/XPREP	EXPRESSION PREPOSITIONAL	I want to reserve the right to <u>choose the values on the basis of</u> my frequent interaction with French speaking people.
/XVI	EXPRESSION VERBAL 1	You <u>mentioned</u> instrument flying.
/XVII	EXPRESSION VERBAL 2	Let's <u>hear</u> about this acceptance flight.
/XVIII	EXPRESSION VERBAL 3	I'll let you know when we <u>decide</u> .
/XIV	EXPRESSION VERBAL 4	These were experienced people they had on airlines for over ten years in the States, and they <u>brought</u> the benefit of their experience to Canada.
/XV	EXPRESSION VERBAL 5	They <u>were</u> special people.
/XVAUX	EXPRESSION VERBAL AUXILIARY	The odd few <u>had</u> worked for Imperial Airways overseas.
/XVAUXCOMP	EXPRESSION VERBAL AUXILIARY COMPLEX	I <u>have been</u> sitting here for hours.
/XVCOMP	EXPRESSION VERBAL COMPLEX	The odd few <u>had worked for</u> Imperial Airways overseas.
/XVMODE	EXPRESSION VERBAL OF MODE	He <u>can</u> certainly make a good contribution.
/XVPRESIMPERS	EXPRESSION VERBAL PRESENTATIVE IMPER- SONAL	<u>Here is</u> a whole area that he is prepared for.
/XVSAUX	EXPRESSION VERBAL SEMI-AUXILIARY	They <u>were able to</u> exercise judgment.
/XVSAUXCOMP	EXPRESSION VERBAL SEMI-AUXILIARY COMPLEX	<u>Did you have to</u> have any sort of a licence to do this?

## APPENDIX 5

SASE A + BFORMAL/INFORMAL DISCUSSION

Sentence Forms (Level 1 forms defined by level 2 functions -  
Nuclear tagmemes only)

- I. SENSIM → + CLIND ++ CLINDPAREN  
(1, 4)
- II. SENCOMPOUND → + CLIND + CLIND ++ CLIND † CLINDPAREN  
(1, 2)
- III. SENCOMPLEX → + CLNUC + CLDEP † CLDEP † CLINDPAREN † CLNUC  
(1, 2, 3, 4)
- IV. SENCOMPLEXELL → + CLDEP ± CLDEP ± CLINDPAREN  
(1)
- V. SENCOMPOUNDCOMPLEX → + CLDEP + CLNUC + CLIND  
(1, 2)

NON-NUCLEAR TAGMEMES

1. ELTRANS
2. CORR
3. VOC
4. INTERJEC

Note: order of clauses not represented.

SASE A + B

I. SENSIM → + CLIND ++ CLINDPAREN

eg. + CLIND

A2.3 We're doing an analysis of spoken English.

+ CLIND + CLINDPAREN

B4.163 He'd reached the point you see.

+ ELTRANS + CLIND + CLINDPAREN

A2.13 Now, you can answer this (if you wish)  
from a personal point of view.

\* NON-NUCLEAR TAGS:

ELTRANS  
INTERJEC

SASE A + B

II. SENCOMPOUND → + CLIND + CLIND ++ CLIND + CLINDPAREN

eg. + CLIND + CLIND

A4.14 You're Mr. Wilson, aren't you?

+ CLIND + CORR + CLIND

B1.88 You get these one words often enough and you become very shy of continuing a discussion.

+ ELTRANS + CLIND + CORR + CLIND

B4.83 And a French-Canadian comes along and wishes to join the threesome.

+ CLIND + CLIND + CLINDPAREN

B5.118 I could run a reel through or do some exercise which would just keep this sort of academic atmosphere (you know) going.

\* NON-NUCLEAR TAGMEMES:

ELTRANS  
CORR

SASE A + B

III. SENCOMPLEX → + CLNUC + CLDEP + CLDEP + CLINDPAREN + CLNUC

eg. + CLDEP + CLNUC

A4.52 When he joined us, he spoke nothing but French.

+ ELTRANS + CLNUC + CLDEP

B3.102 However, they prefer to speak to me in English so that they can practice their English.

+ CLDEP + CLNUC + CLDEP

A4.69 As far as our management is concerned he would advance just as quickly if he spoke only French.

+ CLDEP + CORR + CLDEP + CLNUC

B.2.120 If we were living in Hull and doing nothing but French I agree that this would be much better.

+ CLNUC + CLDEP + CLINDPAREN

B5.104 They're waiting for me to get the right word out, you know.

+ ELTRANS + CLDEP + CLNUC + CORR + CLNUC

A5.84 And when two people are not communicating, the student isn't learning and the teacher isn't teaching.

## \*NON-NUCLEAR TAGMEMES:

ELTRANS  
CORR  
VOC  
INTERJEC



BEST COPY AVAILABLE

SASE A + B

IV. SENCOMPLEXELL → +CLDEP † CLDEP † CLINDPAREN

eg. † CLDEP

B2.63 Because they have French all day here.

† CLDEP † ELTRANS † CLINDPAREN

A4.44 If we may begin with the first item in the agenda (and as you suggested it's a rather general one), The Effects of English Language Teaching on Staff.

\*NON-NUCLEAR TAGMEMES:

ELTRANS

SASE A + B

V. SENCOMPOUNDCOMPLEX → + CLDEP + CLNUC + CLIND

eg. + CLDEP + CLNUC + CORR + CLIND

A3.56 When he's away, i'm there and vice versa.

\*NON-NUCLEAR TAGMEMES:

ELTRANS  
CORR

SASE A + B

VI. SENCOMPOUNDELL → + CLIND

eg. + CLIND + CORR

only example A1.16 I don't know what your experience has been,  
and...

\*NO NON-NUCLEAR TAGMEMES

SASE A + B

FORMAL/INFORMAL DISCUSSION

LEVEL 2

CLAUSE FUNCTIONS

FORMAL DESCRIPTIVE DEFINITIONS

(level 2 functions defined by level 2 forms -  
Nuclear Tagmemes only).

I. CLIND → /CL BAS  
EQUAT  
IMPER  
PASS  
ELL  
MONO  
COMPLEX

\*cannot have COMPL or SUB .

SASE A + B

- 1) + CLIND  
/CLBAS
- B5.94 I suppose it's not an insurmountable problem.
- A2.28 I see.
- A3.72 I think it should be more selective.
- B3.21 All of the foreign service officers, as far as I know, did receive the international test.

SASE A + B

2) + CLIND  
/CLEQUAT

A1.12 That's perfectly acceptable.

B1.47 Mind you, that's essential too.

B4.110 It's a big department though.

SASE A + B

- 3) + CLIND B1.57 There's no reason in my mind.  
/CLIMPERS
- B1.75 There has to be a happy medium someplace.
- B3.4 It follows that if the learning is not  
adequate then the teaching is not adequate.

SASE A + B

4) + CLIND  
/CLPASS

B1.59 It can be based on what they've been  
mastering orally.

B5.113 I wasn't awakened to it the way I am now  
you know.



SASE A + B

5) + CLIND  
/CLELL

A4.24 Mr. Stuart...

A3.48 All this in the basis of my highschool French.

B4.136 Yes, terribly frustrated.

SASE A + B

6) + CLIND  
/CLMONO

A1.17 No.

B1.1 Alright.

A4.43 Yes, of course.

SASE A + B

7) + CLIND  
/CLCOMPLEX

(\*only 2 examples)

B3.46 You can take the most idiotic jack-ass  
in the world and he will learn very  
quickly when he's hungry.

A1.58 Well, I have completed level three and  
I'm also fortunate in as much as I have  
the opportunity to speak French fairly  
frequently during my working day.

SASE A + B

CLAUSE FUNCTIONS (con't)

II. CLNUC → /CL BAS  
EQUAT  
IMPERS  
PASS  
ELL  
COMPLEX

SASE A + B

D + CLNUC  
/CLBAS

- B3.70 As long as they get the message, they go on in the conversation.
- A4.52 When he joined us, he spoke nothing but French.
- B4.130 By the time we got finished what language would we be speaking?

SASE A + B

2) + CLNUC  
/ CLEQUAT

A4.58 It's okay while I'm learning.

B3.84 That's the term that I use because it's appropriate to my situation.

B3.103 At the same time, I feel sometimes very embarrassed to speak my French correctly thinking it's so faulty.

SASE A + B

3) + CLNUC  
/ CLIMPERS

A1.67 There is a whole area that I don't think he's prepared for even when he's finished the third degree.

B2.52 But if I have my whole family along there are objections.

A2.4 And in order to effect this analysis, there are many things we want to do.

SASE A + B

4) + CLNUC  
/ CLPASS

A3.65 My bilingual work is piled up when  
I get back to the office.

A4.42 These differences will tend to be  
eliminated although they won't be  
altogether of course.

B2.42 And then my name was put up to resume  
French language training in September  
of '68.



SASE A + B

5) + CLNUC  
/ CLELL

B1.111 In other words if he could say something in French, fine.

B1.68 Well, the reading itself as you mentioned there.

SASE A + B

6) + CLNUC  
/ CLCOMPLEX

B1.20 However, as far as myself is concerned  
I've spent most of my life learning  
primarily through the eyes, eh?

B1.115 And when he comes in, he has the choice  
to come in in French if he wishes to  
try it out to see how the other person  
reacts.

SASE A + B

CLAUSE FUNCTIONS con't.

IV CLINDPAREN → /CL

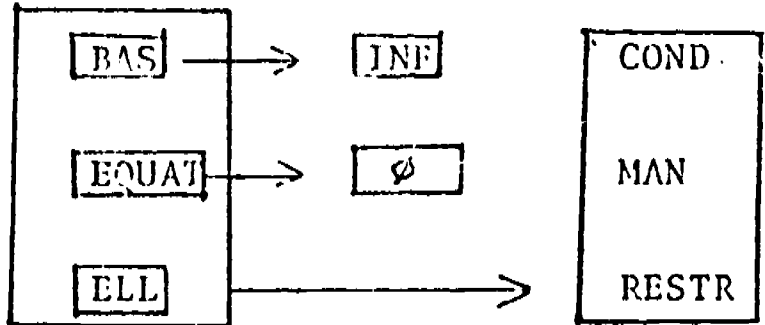



SASE A & B

IV B CLINDPAREN → /CL [BAS] + [INF]

- 1) + CLINDPAREN B 4.139 I was just thinking (to revert to the  
/CLBASINF earlier question) that if you could  
p. 35 only example. restrict this to very small groups,  
say no more than three to five, I  
think it would be more beneficial.

SASE A & B

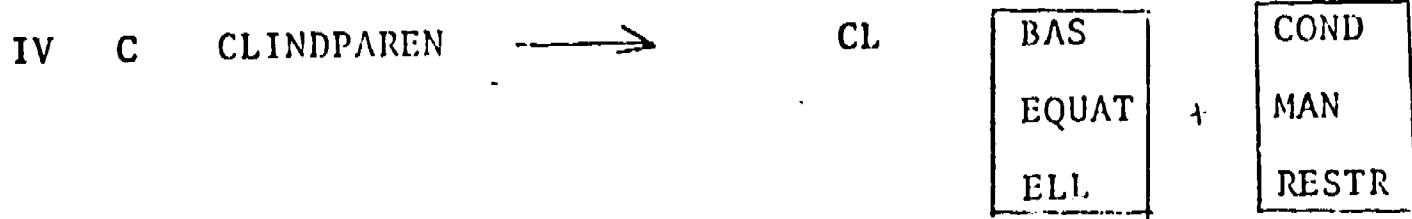

- 1) + CLINDPAREN      A2.13 Now, you can answer this (if you wish)  
    /CLBASCOND            from a personal point of view.
  
- 2) + CLINDPAREN      B3.91 I think it is particularly peculiar to  
    /CLBASMEN            Ottawa because (as you said) one  
                              doesn't encounter the same reaction in  
                              Montreal.
  
- 3) + CLINDPAREN      B2.55 And so there are certain very defi-  
    /CLEQUATRESTR       nite difficulties alright, so far as  
                              I'm concerned, in maintaining con-  
                              tinuity.
  
- 4) + CLINDPAREN      B2.31 But like Miss Churchja, I have come  
    /CLELLCOND           down to the sad realization that pro-  
    \*only example       gress (if any) has in the last three  
                              years been very slow.

SASE A + B

CLAUSE FUNCTION (con't)

III

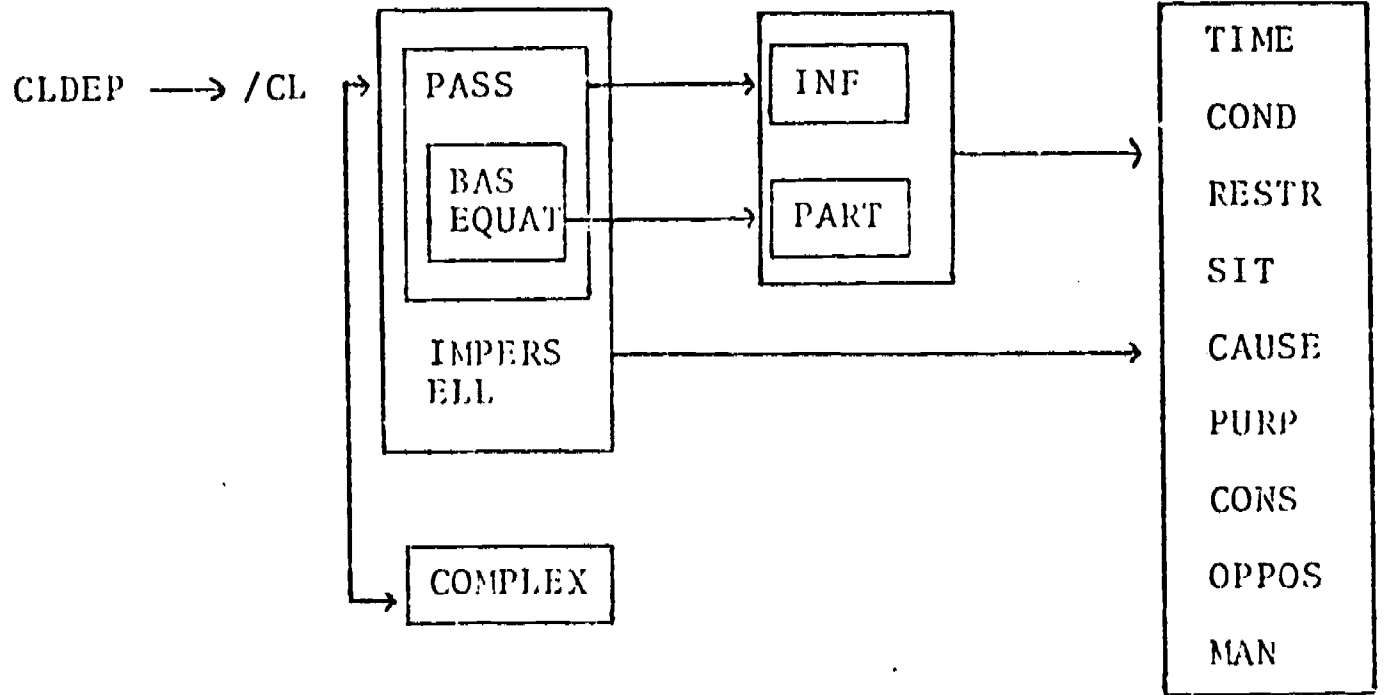





SASE A + B

- 4) + CLDEP B2.88 If you were able to have a total  
/CLEQUATCOND immersion situation where you took  
one individual and put him in a  
situation where there is no one who  
could speak English, he had to learn  
French in order to just live.
- 5) + CLDEP B3.36 You can legislate anything you choose  
/ CLEQUATCAUSE because Parliament is supreme.
- 6) + CLDEP A2.106 And although half my neighbours are  
/CLEQUATRESTR French they just don't have the patience  
to let me practice.



SASE A + B

- 9) + CLDEP B1.52 And even if this could be assigned at  
/ CLPASSCOND night time at least you'd have something  
to go over.
- 10) + CLDEP B2.95 And as we'd be encouraged we'd have an  
/ CLPASSCAUSE incentive to speak French French much  
more so than here is Ottawa.
- 11) + CLDEP A1.93 And they came to quite distinctly different  
/ CLPASSMAN sorts of conclusions as reflected in  
Volume 2 and Volume 3 of the Royal  
Commission's report.

SASE A + B

12) + CLDEP  
/ CLELLCAUSE  
(p. 48 only one)

A3.52 I'm not in quite the same situation  
as Mr. Buchanan because in our  
particular directorate we ...

SASE A + B

III B. + CLDEP → /CL

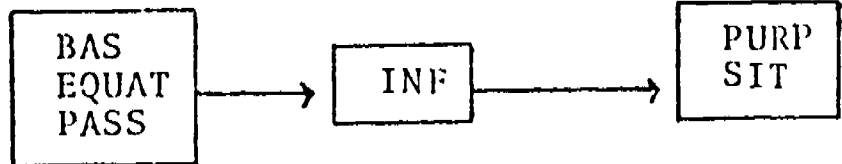

1) + CLDEP  
/ CLBASINFPURP

A2.4 And in order to effect this analysis,  
there are many things we want to do.

2) + CLDEP  
/ CLPASSINFPURP

A3.96 I happen to have sufficiently strong  
recommendations from the language  
school to be allowed to continue.

SASE A + B

III C. CLDEP → /CL

BAS  
EQUAT

PART

RESTR  
CAUSE  
SIT  
MAN

1) + CLDEP  
/ CLBASPARTMAN

A2.80 And they come back telling us this  
and wanting us to do something about  
it.

2) + CLDEP  
/ CLEQUATPARTCAUSE

A5.9 Not being an inspector or a  
professor I don't know certainly  
the reaction from the people who  
speak French to this person.

SASE A + B

III D. + CLDEP → /CLCOMPLEX

1) + CLDEP  
/ CLCOMPLEX

A5.37 I made various efforts from time to time  
to go to private evening classes to try  
to learn French.

A3.55 And actually we rarely see one another  
because when I'm...

SASE - A B

FORMAL/INFORMAL DISCUSSION

CLAUSE FUNCTIONS

Level 3 functions defined by level 3 forms

(the following all fill CLCOMPLEX, CLCOMPOUNDCOMPLEX, etc. at level 3)

I CLNUC

- I A CLNUC → /CL BAS
- EQUAT
- IMPERS
- PASS
- ELL
- COMPLEX

1) +CLNUC B1.20 However, as far as myself is concerned  
 /CLBAS I've spent most of my life learning primarily  
 through the eyes, eh?

2) B3.46 You can take the most idiotic jack-ass  
 in the world and he will learn very quickly  
 when he's hungry. +CLIND  
 /CLCOMPLEX





SASE A+B

3) +CLNUC B5.101 I think if I had a bit more vocabulary  
/CLEQUAT and a bit more usage, I might be able to get along  
a little better.

4) (\*Change A 1.58 Well, I have completed level three and  
in original I'm also fortunate inasmuch as I have the oppor-  
analysis so tunity to speak French fairly frequently during  
that this my working day.  
occurs at  
level 2)

\*N.B. also B3.4, A3.14, B1.122, A4.88 (analysis changes)

SASE A+B

5) +CLNUC BS.108 And I think there will be more oppor-  
/CLIMPERS tunities to practice as time goes on.

\*N.B. only example - should be WH?

SASE A+B

IB +CLNUC → /CL BAS + INF

- 1) +CLNUC /CLBAS:INF B1.3 I think in the earlier stages it has always been convenient and perhaps more acceptable to work to emphasize this philosophy there.
  
- 2) A5.37 I make various efforts from time to time to go the private evening classes to try to learn French.

SASE A+B

I C +CLNUC → /CL [BAS] + [PART]

- 1) +CLNUC B2.129 But I don't know about giving people  
/CLBASPART exercises at night at work while they're in the  
milieu where they're expected to do a lot of other  
things.

\*only example

SASE A+B

I D +CLNUC

→ /CL

BAS
EQUAT
IMPERS
PAS

+ 

WH
----

1) +CLNUC  
/CLBASWH

A5.67 Now it may have been necessary that he do this to keep us awake.

2)

B2.98 And I found that when I first went there I couldn't even order my breakfast in French.

3)

A3.58 I know that (from the standpoint of hearing French spoken,) whenever I hear it spoken, well my ears stick up.

SASE A+B

- 6) +CLNUC B1.39 As a student I found that it was much  
/CLIMPERSWI easier for me to talk to the rest of the students  
in coffee break or even during the class if I  
had the opportunity to do so in a small group  
or in a discussion.

\*only example

SASE A+B

7) +CLNUC A3.68 I think I am scheduled to take nine weeks  
/CLPASSWH of this starting this coming fall.

B4.5 I believe that we were probably being pushed  
a little bit more perhaps because we're nearing  
the end of the first degree

SASE A+B

I E +CLNUC → /CL 

BAS
IMPERS

 + 

COND
OPPOS

1) +CLNUC A5.90 And I would think that if possible these  
 /CLBASCOND types of individuals (if they are sincerely  
 wanting to learn French) should be segregated  
and probably given a different kind of course.

2) +CLNUC B2.94 And I speak to my roommate in English  
 /CLBASOPPOS and to my friends in English, whereas in Quebec  
City (although I would be with my friends) I'd  
realize they're in there for the same purpose,  
to learn French.





SASE A+B

- 3) +CLNUC B4.65 I think that what he says that if in the  
/CLIMPERSCOND intervening period there would be groups formed  
up in the departments so that you could sit  
down with a French-speaking student just simply  
to converse in French using what French they have,  
but not using it in a formal way.

SASE A+B

I. F +CLNUC → /CL BAS + INF + PURP

- 1) +CLNUC B4.65 ...so that you could sit down with a  
/CLBASINFPURP  
French-speaking student just simply to converse  
in French using what French they have, but not  
using it in a formal way.

\*only example

SASE A+B

Level 3

CLAUSE FUNCTIONS con't.

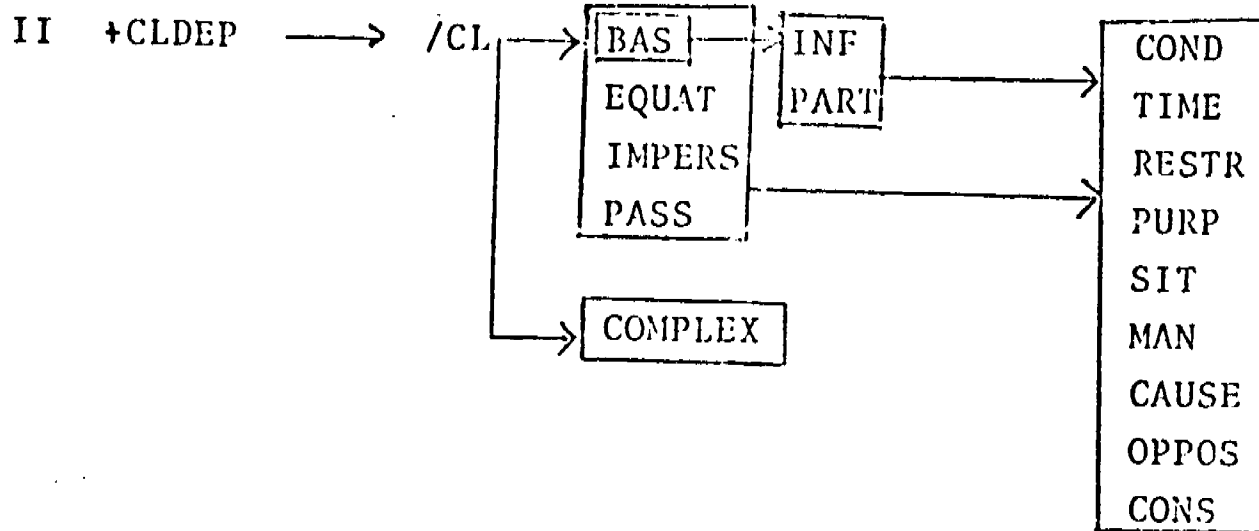

SASE A+B

II A. +CLDEP → /CL

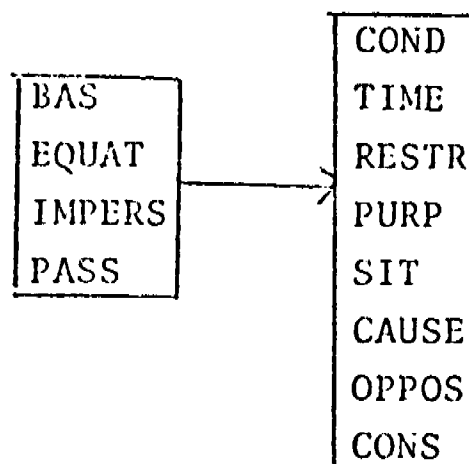

- 1) +CLDEP      B1.116 But too, I think if he's speaking the  
/CLBASCOND    target language too early he is quite possibly  
                 forming bad habits
  
- 2) +CLDEP      B2.98 And I found that when I first went there  
/CLBASTIME    I couldn't even order my breakfast in French.

SASE A+B

- 3) +CLDEP B3.46 You can take the most idiotic jack-ass  
/CLEQUATTIME in the world and he will learn very quickly when  
he's hungry.
- 4) +CLDEP B2.66 But I don't know whether it was of any  
/CLEQUATCAUSE assistance to him or not because he was very  
fluent anyway.

SASE A+B

- 5) +CLDEP B2.115 And I still feel that (if there were a  
/CLIMPERSCOND language school still at Bronson-Carling and  
everyone in the Energy, Mines, and Resources  
complex who were on French course went there  
two, three, four, or five half days a week)  
their work would not suffer.

SASE A+B

II B +CLDEP → /CL BAS + INF + PURP

- 1) +CLDEP B1.3 I think in the earlier stages it has  
/CLBASINF+PURP (always) been convenient and perhaps more acceptable to work to emphasize this philosophy there
  
- 2) B5.68 And I think to get maximum utilization of it, it would have to be more or less in my building or in the area

SASE A+B

II C. +CLDEP → /CL BAS + PART + SIT  
MAN  
TIME

- 1) +CLDEP B1.20 However, as far as myself is concerned I've  
/CLBASPARTMAN spent most of my life learning primarily through  
the eyes, eh?



SASE A+B

II D. +CLDEP            →    /CL + COMPLEX

+CLDEP  
/CLCOMPLEX

B4.65. I think that what he says that if in the intervening period there would be groups formed up in the departments so that you could sit down with a French-speaking student just simply to converse in French using what French they have but not using it in a formal way.



SASE A + B

I. A. CLBAS → + PRED ± S ± OD ± OI

+PRED → /XVI	Direct object	}	Transitive
/XVII	Indirect Object		
/XVIII	No object	}	Intransitive
/XIV	Direct & Indirect objects	}	Ditransitive

(	/PHV	+SAUX +XV	)
	/XVCOMP	+AUX +MODAL +XV	

1) + PRED  
/ XVI

A3.11 My wife is an anglophone also but took  
a degree in French and Italian

B4.59 And then of course the teacher takes out  
certain expressions and puts you through a course  
of variations of those expressions

2) +PRED  
/XVII

B5.10 And we discussed about having a certain  
amount of help.

B3.32 Again I refer back to what I've come to feel

SASE A+B

3) +PRED  
/XVIII

B3.75 And all he docs is ask me to repeat it again until he gets the meaning and then we go on.

A2.77 People come here and they get a certain amount of fluency in a language.

4) +PRED  
/XIV

B5.25 It gave you the written and grammatical instructions.

A2.95 And they would speak it to us or to the groups who were learning French.

SASE A+B

IB CLEQUAT → †PRED + 

PREDADJ
PREDNOM

 † S

†PRED → /XVV  
(/XVCOMP or /PIV containing XVV)

†PRED

- 1) A2.103 If you're in the office and your secretary is French-Canadian, she wants to please or feels obligated to please you.
- 2) B4.60 And this is fine.
- 3) A2.108 And this becomes impossible for speaking French.
- 4) B2.1 My name is George Hazzlen.
- 5) B2.5 Some are keen to get on with it.
- 6) B6.31 So conceptually it looks#sounds good.

SASE A+B

IC. CLIMPERS → +PRED ±S ±OD ±OI ± $\begin{bmatrix} \text{PREDADJ} \\ \text{PREDNOM} \end{bmatrix}$

+PRED → /PHVIMPERS  
/XVPRESIMPERS

1) +PRED  
/PHVIMPERS

B5.108 And I think there will be more opportunities to practice as time goes on.

2)

A1.95 It seems to me that our experience here has demonstrated pretty conclusively that the behavioural approach to learning language is the only one.

3)

B2.11 And it's a matter of huge battles to see who gets on first and who gets favourable treatment on schedule.

4)

B3.4 It follows that if the learning is not adequate then the teaching is not adequate.

5) +PRED  
/XVPRESIMPERS

B5.37 How about you sir?

6)

A1.67 Here is a whole area that I don't think he's prepared for even when he's finished the third degree.

SASE A+B

1D CLPASS → +PRED ±AGENT ±S ±OD ±OI

+PRED → /XVCOMP containing XVI  
/PIV XVII  
or XVIII

- 1) A5.56 But so many improvements have been made<sup>XVIII</sup> that I feel it's much easier.
- 2) B4.116 For example you might go one evening a week and might be asked<sup>XVI</sup> to speak only English not French.
- 3) A5.47 I know there comes a point well towards the end of the day when (no matter how much pressure is put<sup>XVII</sup> on you) you sort of go blank.





SASE A+B

III CLMONO → No Nuclear Tagmemes (4 INTERJEC)

- 1) A1.17 No
- 2) B3.52 Yes
- 3) B5.35 Uh uh
- 4) A4.43 Yes, of course

SASE A + B

CLAUSE FORMS

I to define INF

a) CLBASINF → PRED

to XVI  
to XVII  
to XVIII  
to XVIV

b) CLEQUATINF → to be (to XVV)

c) CLPASSINF → to 

XVCOMP
PHV

 ed



SASE A + B

I (b) CLEQUATINF

+ PRED  
/ XVV

A5.68

In fact I'm hesitant really to be  
too critical of this now looking  
back at it.

B2.58

This has been demonstrated to be  
the most effective way of learning  
it.

SASE A + B

CLAUSE FORMS

II to define PART

a) CLBASPART → PRED

XVI ing  
XVII ing  
XVIII ing  
XVIV ing

b) CLEQUATPART → PRED

XVV ing (being)

c) CLPASSPART → PRED

being XVIII ed.

SASE A + B

II (a) CLBASPART

- |                  |        |  |
|------------------|--------|--|
| + PRED<br>/ XVI  | A1.21  | On the other hand, we have tests for those <u>learning French.</u>                                     |
| +PRED<br>/XVII   | B3.108 | Most English-speaking people have been accustomed (over the years) to <u>listening to bad English.</u> |
| +PRED<br>/XVIII  | A1.47  | And that is that it's a sort of physical share of <u>not succeeding.</u>                               |
| + PRED<br>/ XVIV | A3.69  | Do you think, Miss Churchra, that the idea of <u>teaching French to everyone</u> is a good one?        |

SASE A + B

II (b) CLEQUATPART

B5.98 But it might (at least) keep one  
from becoming too rusty during  
the periods between courses.

B3.67 Perhaps, there are many Anglophones  
who are not motivated towards becom-  
ing bilingual.

SASE A B

II (c) CLPASSPART

A1.43 But the one fear that is bound to dominate the thinking of a young employee is the threat of him being removed from his own cultural context and forcibly inserted into a strange one.



SASE A+B  
CLAUSE FORMS

FORMAL/INFORMAL DISCUSSION

WH clauses filling Level 3 functions

I +CLNUC

II Nuclear Tagmemes: a) +S  
b) +OD  
c) +PREDNOM

III Non-Nuclear Tagmemes: a) +CPREDADJ  
b) +CPREDNOM  
c) +SPECREDNOM

BEST COPY AVAILABLE

SASE A+B

I +CLNUC

- 1) +CLNUC  
/CLBASWH B6.22 Well, I think it would be an excellent opportunity to learn... if you had...
- 2) B2.71 This was quite clear that he expected you (while you were on French) to carry on...
- 3) A2.66 But I don't know whether it was of any assistance to him or not because...
- 4) +CLNUC  
/CLEQUATWH B6.19 I would think while this may be a fact, that this would be too bad.
- 5) B2.12 Because I think a few people are discouraged in the sense that...
- 6) +CLNUM  
/CLPASSWH A3.68 I think I am scheduled to take nine weeks of this starting...

SASE A+B

IIa) +S

- 1) +S /CLBASWH A4.64 But <sup>oo</sup> what I would say is that his English language training has been effective.
- 2) +S /CLBASWH B5.6 It doesn't matter <sup>COMPL</sup> if we say the same things over again.
- 3) +S /CLBASWH B5.111 It seems to me <sup>COMPL</sup> that I've had some French element in my staffs for the last twenty years.
- 4) +S /CLEQUATWH B1.54 Now maybe it's felt this is too much of a crutch.
- 5) +S /CLPASSWH B1.14 It's amazing <sup>s</sup> what is learned during the period on course

SASE A+B

IIb) +OD

- 1) +OD /CLBASWH A4.89 I think it helps a little bit.
- 2) +OD /CLEQUATWH B2.6 Others find <sup>COMPL</sup> that it's a bit of a drag.
- 3) +OD /CLELLWH A5.16 I would say pretty much the same for English
- 4) +OD /CLPASSWH B3.12 You're suggesting <sup>COMPL</sup> that it was intentionally designed.
- 5) +OD /CLIMPERSWH B2.56 I think it's just a simple matter of the learning process

SASE A+B

IIc) +PREDNOM

- 1) +PREDNOM /CLBASWH B4:56...going through the first degree is <sup>COMPL</sup> that you sort of learn by memory
- 2) +PREDNOM /CLBASWH A3.78 It's rather, <sup>oo</sup> how much do you get...
- 3) +PREDNOM /CLEQUATWH A4.64 ...what I would say is <sup>COMPL</sup> that his English language training has been effective
- 4) +PREDNOM /CLEQUATWH B3.116 At least this is <sup>s</sup> what is now apparent
- 5) +PREDNOM /CLPASSWH A2.53 The only result, (profitable result) from it would be <sup>COMPL</sup> that their fluency would be increased

SASE A+B

IIIa) +CPREDADJ

- 1) +CPREDADJ  
/CLBASWII      A2:21 I'm sure in our courses we've had French  
Canadians taking the English course
- 2) +CPREDADJ  
/CLQUATWII      B3.65 I'm not sure <sup>COMPL</sup> that the environment is ideal
- 3)                      B3.16 I have become convinced through my own  
experience that aptitude is paramount.
- 4) +CPREDADJ  
/CLIMPERSWH      B6.23 I'm sure there would be places in the  
civil service where that would be feasible.
- 5)                      A4.83 I'm afraid there are probably still some  
freeloaders...

SASE A+B

IIIb) +CPREDNOM

1) +CPREDNOM  
/CIEQUATWH

B1.2 ...being a question of habituating students  
to say things in a certain way <sup>s</sup>which is basically  
what I understand by Skinner's theory

SASE A+B

IIIc) +SPECREDNOM

- 1) +SPECREDNOM B6:21 My objectives are so, that I would be  
CLEQUATWH able to enter into a discussion...  
p. 241



APPENDIX 6

SAWE - A

ADMINISTRATIVE WRITING

Sentence Forms (level 1 forms defined by level 2 functions - Nuclear tagmemes only)

I. SENSIM → +CLIND ± CLINDPAREN  
(1, 4)

II. SENCOMPOUND → +CLIND CLIND ± CLIND ± CLINDPAREN  
(1, 2, 3)

III. SENCOMPLEX → +CLNUC +CLDEP ± CLNUC ± CLDEP  
(1, 2, 3, 5) ± CLINDPAREN

IV. SENCOMPOUNDCOMPLEX → +CLIND +CLNUC +CLDEP  
(1, 2, 6) ± CLNUC ± CLDEP ± CLIND

NON-NUCLEAR TAGMEMES

1. ELTRANS
2. CORR
3. CV
4. INTERJEC
5. SPECCLDEP
6. SPECCLIND,-NUC

Note: order of clauses not represented.

BEST COPY AVAILABLE

SAWE - A

I.      SENSIM →      + CLIND      ± CLINDPAREN

eg.      + CLIND

A9.20    I agreed to extend the contract date to August 1st.

A13.13   He indicated that the total cost would approximate \$350.

+ CLIND      + CLINDPAREN

A6.37    For the time being, we have, I believe, established an effective modus vivendi.

+ INTERJEC    + CLIND

A17.10   Of course, in some of the larger parks, these visitor services centers, or town-sites, are located within the parks.

+ ELTRANS    + CLIND

A6.23    Also, I would appreciate your keeping me advised of any action you may take.

BEST COPY AVAILABLE

SAWE - A

II. SENCOMPOUND → +CLIND +CLIND +CLIND +CLINDPAREN

eg. +CLIND +CLIND

A14.47 I am pleased to hear that you can correct "the ravages of time"; I am sure I can live with what you produce.

+CLIND +CORR +CLIND +CLINDPAREN

A3.26 Our intention therefore is to add a second set to your region a year from now, and, this set, we anticipate, will be an improvement over that being delivered in May 1970.

+CVSIT +CLIND +CORR +CLIND

A15.11 In response to your memorandum of April 6, I have contacted Alberta and British Columbia regions and informed them of Mr. Honey's visit.

+ELTRANS +CLIND +CORR +CLIND

A17.5 However, the parks are for people and therefore it is necessary to ensure that visitors can derive enjoyment from them.

SAWE - A

- III. SENCOMPLEX → + CLNUC + CLDEP ± CLNUC ± CLDEP  
 ± CLINDPAREN
- eg. + CLDEP + CLNUC
- A17.11 In order to provide these services to the public, both residential and commercial leases are required.
- + CLNUC + SPECCLDEP + CLDEP
- A7.15 Expenses for entertainment and hospitality are authorized only where expenses are of direct, immediate, and measurable benefit to the Board.
- + CLDEP + CORR + CLDEP + CLNUC
- A6.41 As I am receiving two daily market reports from you and only need one, would you kindly adjust your mailing list.
- + CLNUC + CLDEP + CLDEP + CLNUC
- A13.35 Please discuss if you have objections to this proposal; if not, please arrange in consultation with Marcel Martin.
- + ELTRANS + CLNUC + CLDEP
- A17.22 In addition, a public hearing program has been initiated so that all interested groups and individuals may have an opportunity to review the proposed development plan for the park and suggest changes.
- + CLINDPAREN + CLNUC + CLDEP
- A20.19 As you point out, the Canada Labour Relations Board has seen fit to reject, on two occasions, an application for certification on the grounds that foremen are not considered as employees within the meaning of the Industrial Relations and Disputes Investigation Act.

BEST COPY AVAILABLE

+CVSIT    +CLDEP    +CLNUC

AJ.30    Reference "G" of your memorandum, if you should require a signing authority on a Treasury Board submission, I would be pleased to assist in either signing the submission or as required in obtaining the Deputy Minister's approval.

BEST COPY AVAILABLE

SAWE - A

IV. SENCOMPOUNDCOMPLEX → +CLIND +CLNUC +CLDEP ±CLIND  
±CLNUC ±CLDEP

eg. +CLIND +CLNUC +CLDEP

A20.8 I have indicated my suggested corrections in pencil; please feel free not to accept if you disagree with them.

+CLIND +CORR +CLDEP +CLNUC CLDEP

A9.49 Your application has been recorded, and when our field officers are in this vicinity, they will make an examination to ascertain the conditions for the cultivation of oysters.

+SPECCLIND +CLIND +SPECCLIND +CLIND +SPECCLNUC  
+CLDEP +CLNUC

A11.35 Firstly, our operational men are giving the tax guide material close scrutiny; secondly, the tax administration policy changes are not very extensive; thirdly if we bounce the material off the field officers before release to the taxpayers, I fear that we may settle down to a lengthy period of nitpicking while the taxpayer waits.

+ELTRANS +CLNUC +CLDEP +CORR +CLIND

A19.7 Rather, our regulations will supplant the provincial requirements where there are comparable exactments and secondly our regulations may deal with matters not covered L provincial regulations.

SAWE - A

ADMINISTRATIVE WRITING

LEVEL 2

CLAUSE FUNCTIONS

FORMAL DESCRIPTIVE DEFINITIONS  
(level 2 functions defined by level 2 forms - Nuclear Tagemes only)

I. CLIND →

/CL BAS  
EQUAT  
IMPERS  
PASS  
MONO  
ELL  
COMPLEX

\*cannot have COMPL or SUB

SAWE - A

1) + CLIND  
/CLBAS

A3.23 We expect delivery about the 15 - 20th May.

A5.8 In due course, Mr. Curry should return it to me.

A18.6 I am asking that you two share that responsibility.



SAWE - A

2) + CLIND  
/CLEQUAT

A5.6 Our base for this is our 1970-71 estimates.

A4.7 The best approach would be a joint proposal from both laboratories.

A17.32 Classification and recruitment for the increased program is now underway.

SAWE - A

- 3) + CLIND  
/CLIMPERS
- A4.48 It is my understanding that you will forward this material to the appropriate office.
- A7.7 There is no money available to hire casuals.
- A8.6 It would be appreciated if these documents could be placed in the departmental vault for safekeeping.

SAWE - A

- 4) + CLIND  
/CLPASS
- A3.22 The following items have been ordered for each region.
- A4.11 This inspection was made on January 27, 1969.
- A3.35 The copy of the decision should be corrected accordingly.

SAVE - A

5) + CLIND  
/CLMONO

A13.36 Thank you. . .

A14.48 Thanks.

SAWE - A

6) + CLIND A18.16 The following air mail from Creighton Douglas  
/CLELL (2) today.

A18.22 Not bloody likely .

SAWE - A

7) +CLIND            A19.42  
   /CLCOMPLEX (2)

Films which set out to present a stage work on film for public viewing are very frequently misleading: Either they magnify the dynamic range of the work and distort it in other ways to make it "more effective" or they diminish it and flatten it out until it is a pale carbon copy of the original.

SAWE - A

CLAUSE FUNCTIONS

II      CLNUC →      /CLBAS  
                                 EQUAT  
                                 IMPERS  
                                 PASS  
                                 ELL  
                                 COMPLEX

SAWE - A

- 1) +CLNUC  
/CLBAS
- A12.49 If I can find the relevant newspaper clippings at home I will bring them into the office.
- A16.44 After you have had an opportunity to think over the matter, will you please drop us a note?
- A18.44 This applies to all types of leave as laid out in the various group agreements.



SAVE - A

2) +CLNUC  
/CLEQUAT

A5.29

As previously stated this is no longer in existence.

A6.12

The cells and pools are reinforced concrete, the cells being of high density material.

A5.27

As this is a fairly recent change from the previous system, brochures are not yet available describing the latest system.

BEST COPY AVAILABLE

SAWE - A

3)

+CLNUC  
/CLIMPERS

A20.41

Since a delegation of this size will not permit full coverage of all the agenda items, it is necessary for us to make a choice.

A12.29

If the enclosed orders satisfy requirements as to form and draftsmanship, it would be appreciated if you could provide us with early clearance.

A19.50

It might be useful to send it (if you have one to spare) and also to keep us advised about future public appearances either in Toronto or elsewhere.

SAWE - A

- 4) +CLNUC  
/CLPASS
- A13.38 These outlets are required for use of drafting lamps, electrical crasing machines and other electrical drafting equipment thus avoiding dangerous over-loading of wall plugs.
- A18.45 When certified sick leave, special leave or leave without pay is taken, an explanation must be given.
- A1.21 As we have received a number of grievances on this matter, your early decision would be most appreciated.

SAWE - A

5) +CLNUC            A4.4            The more direct the involvement  
      /CLELL            (1)            the better.

SAWE - A

6) + CLNUC A14.2  
/ CLCOMPLEX  
(3)

Nor would the designers be excused from modifying the existing design if conditions were identified as being unsafe even though these conditions were not at variance with the earlier code.

A9.50

If conditions are found to be satisfactory, a survey will be carried out to determine the boundaries, and a lease will then be sent to you to be signed.

SAWE - A

CLAUSE FUNCTIONS

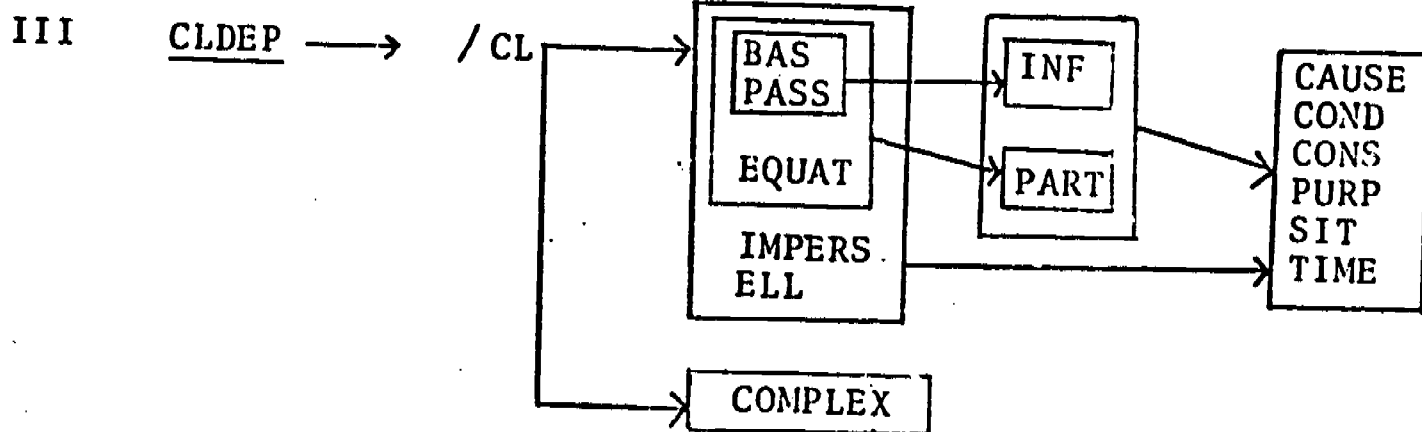

(can have COMPL or SUB)

SAWE - A

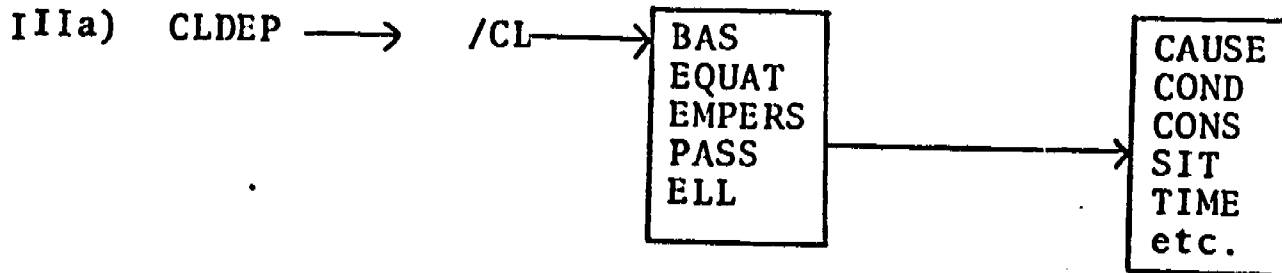

- 1) +CLDEP            A12.49    If I can find the relevant newspaper  
   /CLBASCOND                            clippings at home I will bring them  
   into the office.
  
- 2) +CLDEP            A1.21     As we have received a number of  
   /CLBASCAUSE                           grievances on this matter, your  
   early decision would be most ap-  
   preciated.
  
- 3) +CLDEP            A16.44    After you have had an opportunity  
   /CLBASTIME                           to think over the matter, will you  
   please drop us a note?

- 4) +CLDEP A5.27  
/CLEQUATCAUSE As this is a fairly recent change from the previous system, brochures are not yet available describing the latest system.
- 5) +CLDEP A4.28  
/CLEQUATSIT As the desalting plants get bigger, not only the desalting firms but the nuclear firms will offer their products.
- 6) +CLDEP A12.38  
/CLEQUATCOND We will proceed in accordance with this submission providing it is acceptable to you.



7) +CLDEP A19.22  
/CLIMPERSSIT

Where, of course, there would be a conflict, the federal requirements would have to prevail.

8) +CLDEP A19.24  
/CLIMPERSCOND

If it should happen that in some areas we are unable to make mutually satisfactory arrangements with provincial authorities then we would conduct our own inspection services.

- 9) +CLDEP A4.35 If the date of delivery is not  
/CLPASSCOND yet determined, a brief explana-  
tion is required.
- 10) +CLDEP A5.29 As previously stated this is no  
/CLPASSIT longer in existence.
- 11) +CLDEP A1.25 As soon as it has been published  
/CLPASSTIME I will hasten to forward a copy  
to you.

- 12) +CLDEP A4.4 The more direct the involvement  
/CLELLCONS of industry the better.
- 13) +CLDEP A9.4 Please identify each sample clearly  
/CLELLSIT and supply where possible as much  
information as available on physical  
and chemical properties and specifi-  
cations.

SAWE - A

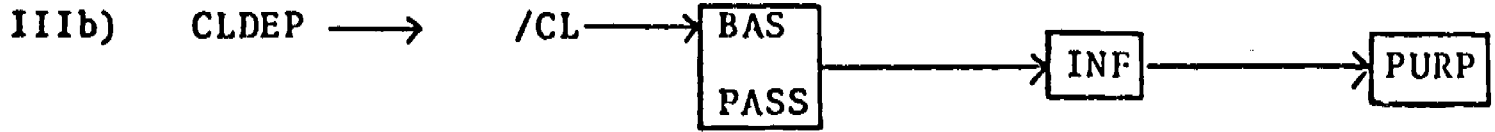

1) +CLDEP A13.9 To arrange the visit we should  
 /CLBASINFPURP contact Graham Ferguson in  
 Hamilton, area code 519, phone  
 623-3740.

A17.11 In order to provide these services  
to the public, both residential  
and commercial leases are required.

2) +CLDEP (1) A9.50 If conditions are found to be  
 /CLPASSINFPURP satisfactory, a survey will be  
 carried out to determine the boun-  
 daries, and a lease will then be  
 sent to you to be signed.

BEST COPY AVAILABLE

SAVE - A



1) +CLDEP A16.5 Mr. Toye will write to Dr. Aiken  
 ✓CLBASPARTPURP before the end of December giving  
Canadian Westinghouse fuel fabri-  
cation prices.

2) +CLDEP A6.12 The cells and pools are reinforced  
 /CLEQUATPARTSIT concrete, the cells being of high  
density material.

3) +CLDEP A12.47 He vomited while being assisted  
 /CLPASSPARTTIME to the police cruiser.

SAWE - A

IIId) CLDEP → CLCOMPLEX

- 1) + CLDEP A5.22 This same principle applies in our  
/ CLCOMPLEX department as a review must be made  
of overall departmental requirements  
to establish priorities etc., relative  
to targets.
- A12.23 As to schistosomiasis (while we agree  
that this condition is not any definite  
problem in Canada insofar as transmis-  
sion of the disease is concerned) a  
medical opinion as to admissability  
to Canada is made in each individual  
case on the circumstances.

SAWE - A

CLAUSE FUNCTIONS

IV CLINDPAREN →

/CL

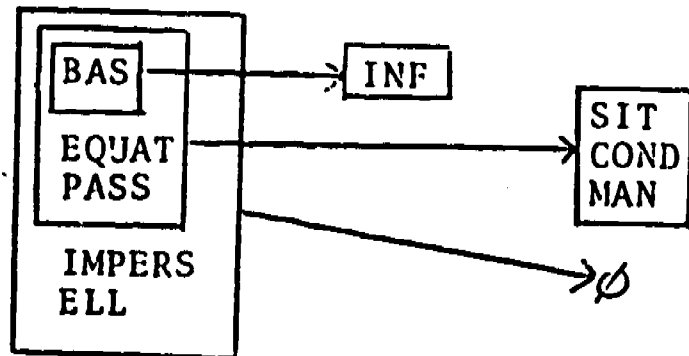

SAWE - A

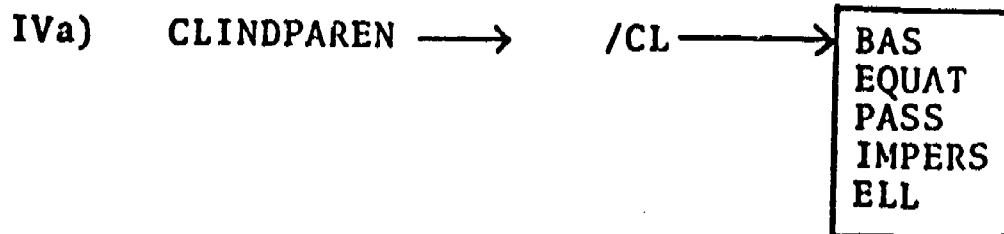

- 1) +CLINDPAREN A6.37 /CLBAS For the time being, we have, I believe, established through our discussions an effective modus vivendi.
- 2) +CLINDPAREN A2.25 /CLEQUAT As you will be aware, A.G.C. has been completing a review... cancelled.
- 3) +CLINDPAREN A16.38 /CLIMPERS This, it is expected, will allow for uniformity in the handling of consumer complaints from the new Department of Consumer and Corporate Affairs.
- 4) +CLINDPAREN A19.45 /CLPASS I am not saying that a fairly exact film equivalent of a dance work cannot be achieved (in a few instances it has been), but merely that it is far more difficult than is generally supposed.
- 5) +CLINDPAREN A3.21 /CLELL Mrs. Grenon called our office on April 15, 1970, and stated she is anxious to give the necessary explanations in order to clear up this matter (her telephone no. 731-6841).



SAWE - A

IVb) CLINDPAREN → /CL → BAS → INF

- 1) †CLINDPAREN A18.40 To summarize, it is the opinion of  
/CLBASINF officials of the department... agrce-  
ment.

SAWE - A

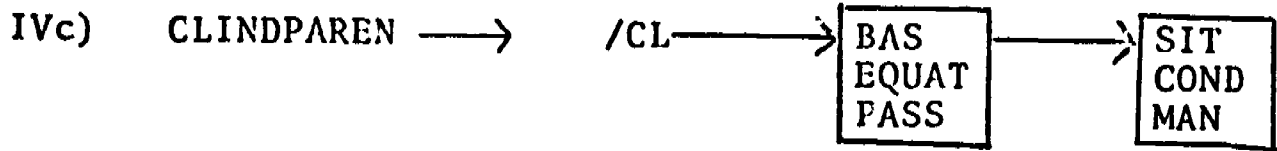

- 1) †CLINDPAREN A16.39 As you know, this company is a large newspaper printer, indeed the largest daily newspaper printer in Canada in the English language.  
/CLBASSIT
- 2) †CLINDPAREN A20.9 On the whole, if you allow me, I may mention that this lexicon is much more than a nuclear directory.  
/CLBASCOND
- 3) †CLINDPAREN A7.45 As you are aware we are actively participating in the work of the O.E.C.D. Pulp and Paper Committee.  
/CLEQUATSIT
- 4) †CLINDPAREN A20.21 As you are aware I will very shortly be recommending to my colleagues introduction of legislation involving complete amendment of the Industrial Relations and Disputes Investigation Act.  
/CLEQUATMAN
- 5) †CLINDPAREN A6.29 Arrangements are in progress to delegate the authorities, as indicated by you.  
/CLPASSMAN

SAWE - A  
CLAUSE FUNCTIONS

ADMINISTRATIVE WRITING  
Level 3 functions defined by Level 3 forms  
(all fill CLCOMPLEX at level 3)

I CLNUC

I a) CLNUC → /CL 

BAS
PASS

- 1) +CLNUC (4) A19.42 Films which set out to present a stage work on film for public viewing are very frequently misleading: either they magnify the dynamic range of the work and distort it in other ways "to make it more effective" or they diminish it and flatten it out until it is a pale carbon copy of the original.
- 2) +CLNUC (2) A9.50 If conditions are found to be satisfactory, a survey will be carried out to determine the boundaries, and a lease will then be sent to you to be signed.

A14.2 Nor would the designers be excused from modifying the existing design if conditions were identified as being unsafe even though these conditions were not at variance with the earlier code.

SAWE - A

1b) CLNUC → /CL BAS → INF

1) †CLNUC  
/CLBASINF

A10.42 All that remains now is to determine firm arrival times so that I can telex B.C. and Alberta regions; and I expect you will advise me of these when you have them.

SAWE - A

Ic) CLNUC → /CL 

BAS
EQUAT

 → PART

1) +CLNUC                    A10.17 This is in response to your letter of  
/CLBASPART                    December 23, 1969, in which you request the  
                                  return of certain documents forwarded to this  
                                  office for the purpose of obtaining information  
                                  to import semen from the United States.

2) +CLNUC                    A12.44 You may have noticed in the local news-  
/CLEQUATPART                    papers the recent case of a man who was charged  
                                  with being impaired while driving but the crown  
                                  lost the case against him because the evidence  
                                  indicated that he had used a de-icer on the in-  
                                  terior of his car's windshield while the car  
                                  was closed.

Id) CLNUC → /CL

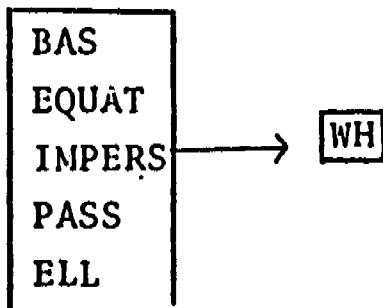

1) +CLNUC  
/CLBASWH

A5.3 What has brought this matter particularly to mind is the December, 1969 revision of the Program Forecast and Estimates Manual which I sent to you to look over.

2) +CLNUC  
/CLEQUATWH

A18.2 I believe that this subject will be of interest to all of the provincial directors who will be present as they are responsible for vast northern areas

3) +CLNUC  
/CLIMPERSWH

A11.48 Frankly, my reaction 's that it is the regions' responsibility to keep on top of information to taxpayers particularly when certain taxpayers must be advised of changes in tax administration policy.

4) +CLNUC  
/CLPASSWH

A6.10 The concrete block walls are faced with precast concrete panels which can be moved to accommodate building expansion.

5) +CLNUC  
/CLELLWH

A14.5 Section VIII did not call for a detailed stress analysis but merely set the wall thickness necessary to keep the basic loop stress below the tabulated allowable stress.

BEST COPY AVAILABLE

SAWE - A

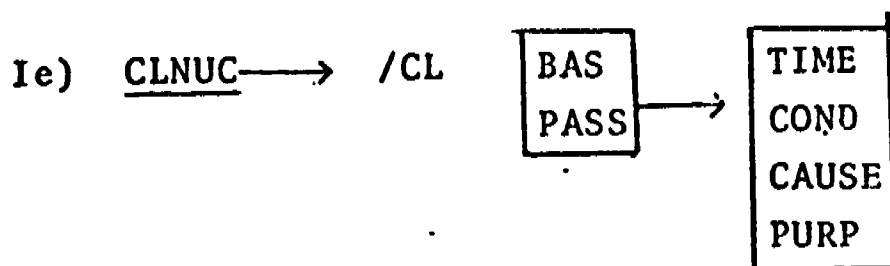

- 1) +CLNUC  
/CLBASTIME  
A19.18 For example, when we might require the services of a provincial Department of Health to carry out some environmental or other special assessment, these services can be arranged through our existing authorities in each province.
  
- 2) +CLNUC  
/CLBASCOND  
A17.30 I would appreciate it if you would amend the establishment records of the Canadian Wildlife Service to reflect these program changes for fiscal 1970-71.
  
- 3) +CLNUC  
/CLBASOPPOS  
A12.23 As to schistosomiasis (while we agree that this condition is not any definite problem in Canada insofar as transmission of the disease is concerned) a medical opinion as to admissibility to Canada is made in each individual case on the circumstances.
  
- 4) +CLNUC  
/CLBASCAUSE  
A11.20 I am afraid you will have to visit Montreal in order to carry out detailed research as you would have to refer to a large variety of sources here to cover the career of McLaren.

5) +CLNUC  
/CLPASSPURP

A16.35 It was decided by senior staff that when consumer complaints originate from the Dept. of Consumer and Corporate Affairs and are sent to the Food and Drug Directorate for investigation, copies of any letters sent to the consumer should be sent to Ottawa, so that one copy can be forwarded to the Dept. of Consumer and Corporate Affairs to complete their files.



SAWE - A

If) CLNUC → /CL BAS → PART → SIT

- 1) +CLNUC            A19.43 People seeing the version, upon going  
/CLBASPARTSIT to see the live company, might well be inclined  
to be disappointed; those seeing the second  
version would avoid going to see the live  
company at all.

SAWE - A

Ig) CLNUC → /CL COMPLEX

1) +CLNUC  
/CLCOMPLEX

(1) A14.31 It is my opinion that when not faced with the problem of the material size of a vessel, i.e., when its construction is not affected by the size or when not under pressure to conserve material for other reasons, the methods of Section VIII will probably be safer than those of Section III with its lower factor because to justify the lower factor the stress analysis must be done properly and this is by no means an achievement that can be relied on.

SAWE - A

CLAUSE FUNCTIONS

Level 3 functions defined by level 3 forms

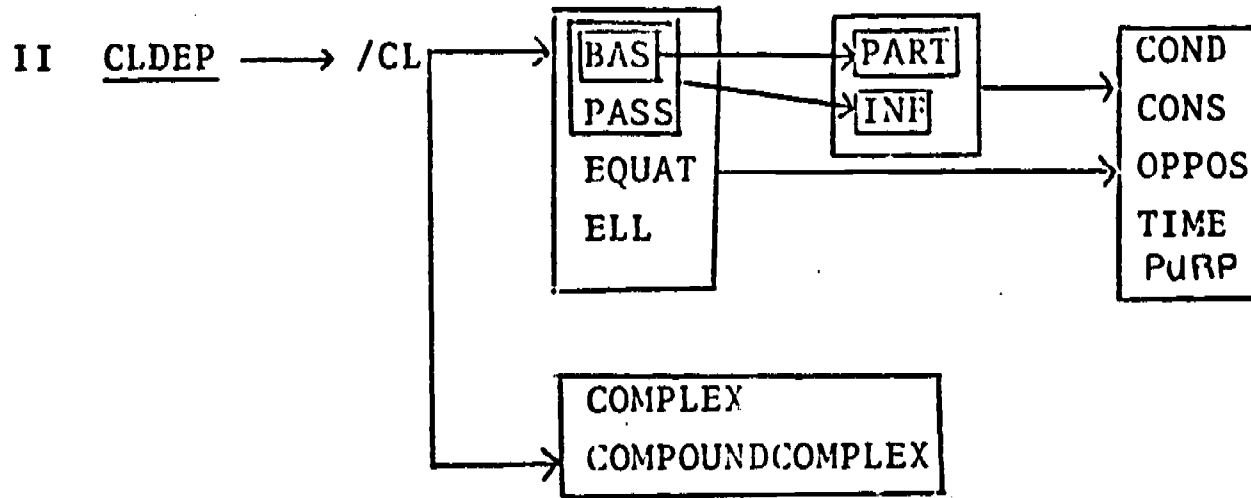

SAWE - A

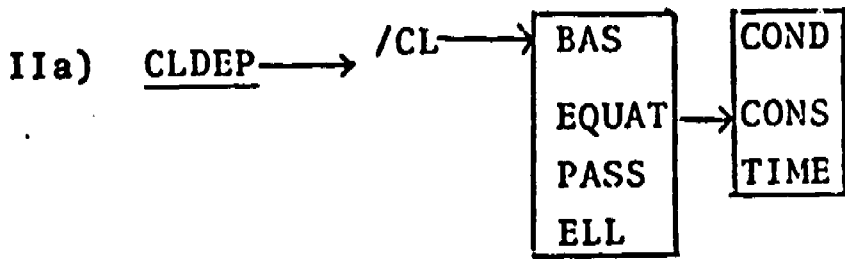

- 1) +CLDEP  
/CLBASCONS  
A11.40 Following the Regional Director's Conference I understand that we received a legal opinion as the result of which we backed off.
- 2) +CLDEP  
/CLEQUATTIME  
A20.3 At that time, it was pointed out that this requirement would cease when the Central Pay Office would be able to provide the required information.
- 3) +CLDEP  
/CLPASSTIME  
(2) A13.20 The company has been informed that although the department will proceed with the processing of this first claim the cheque will be withheld until the following are completed and sent to us.
- 4) +CLDEP  
/CLELLCOND  
A16.47 Please advise whether the draft letter to Dr. Bruckner is appropriate and what changes should be made, if any.

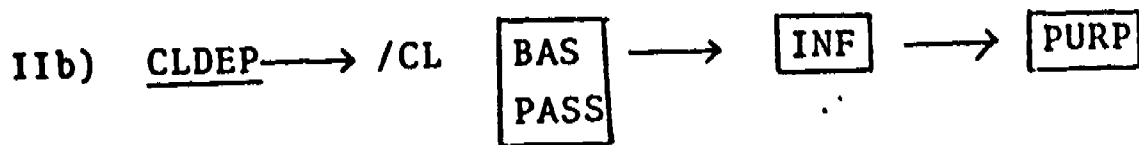
SAWE - A

- 1) +CLDEP      A3.21 Mrs. Grenon called our office on April 15, 1970, and stated she is anxious to give the necessary explanations in order to clear up this matter (her telephone no. 731-6841).  
/CLBASINFPURP
- 2) +CLDEP      A9.50 If conditions are found to be satisfactory a survey will be carried out to determine the boundaries, and a lease will then be sent to you to be signed.  
/CLPASSINFPURPa

SAWE - A

IIc) CLDEP → /CL BAS → PART → OPPOS

1) +CLDEP  
/CLBASPARTOPPOS

A17.20 These are presently being carefully examined and development will take place so as to ensure that the land may be used in the best interests of the people of Canada while at the same time keeping impairment of the natural values to a minimum.

SAWE - A

II d) CLDEP → /CL

COMPLEX COMPOUNDCOMPLEX
----------------------------

1) +CLDEP  
/CLCOMPLEX

A5.21 The Treasury Board indicates in its manual that delays cause them serious problems as budgets cannot be established until all departments have reported.

2) +CLDEP  
/CLCOMPOUNDCOMPLEX

A14.31 It is my opinion that when not faced with the problem of the material size of a vessel, i.e., when its construction is not affected by the size or when not under pressure to conserve material for other reasons, the methods of Section VIII will probably be safer than those of Section III with its lower factor because to justify the lower factor the stress analysis must be done properly and this is by no means an achievement that can be relied on.

SAWE - A

Administrative Writing

CLAUSE FORMS

Level 2 forms defined by Level 3 PRED

FUNCTIONS AND FORMS

I CL BAS

EQUAT

1 PRED

IMPERS

PASS

II ELL

Ellided PRED

III MONO

No PRED

IV COMPLEX

2 or more PRED's

V COMPLEXELL

at least 1 PRED

+ an additional ellided PRED

VI COMPOUNDCOMPLEX

at least 3 PRED's

345



SAWE - A

IA CLBAS → +PRED = S = OD = OI

PRED → /XVI	Direct Object	} Transitive
/XVII	Indirect Object	
/XVIII	No Object	} Intransitive
/XIV	Direct & Indirect Objects	} Ditransitive

(  
/PHV + SAUX + XV  
/XVCOMP + AUX + XV  
+ MODAL  
)

1) +PRED  
/XVI

A 5.1 I believe it is highly desirable to improve our planning and activities relative to the subject noted.

A 3.3 The provisions of Section 13 allow for the granting of Special Leave "where circumstances not directly attributable to the employee prevented his reporting for duty."

2) +PRED  
/XVII

A 1.46 The Canada Shipping Act and all regulations written thereunder apply to all Canadian ships and vessels that are within Canadian waters.

A10.39 There, Mr. Agar should apply directly to that Government for employment in the North.

3) +PRED  
/XVIII

A13.35 Please arrange in consultation with Marcel Martin.

A 9.19 The late date for this project arises because Colbert will be starting on an urgent project for ERCO, and can only work on this report part-time.

4) +PRED  
/XVIV

A 6.22 Please send copies of your early letters to our Dublin office, viz: Commercial Counsellor for Canada, 66 Upper O'Connell Street, Dublin, Ireland.

A11.33 We should release the guide simultaneously to staff and taxpayers.

SAWE - A

IE CLEQUAT → +PRED + 

PREDADJ
PREDNOM

 ± S. ± OI

+PRED → /XVV

(cf /XVCOMP or /PHV containing XVV) ?

1) +PRED  
/XVV

A16.23 The road is sub-standard but with care  
can be traversed by car.

A18.38 I feel certain that you will appreciate  
my views when I say that it would be most  
inappropriate for me to intervene with  
the due process of collective bargaining.

A17.35 While cost reductions have been proposed  
for both vertical and horizontal reactors  
since then, these represent our latest  
available comparisons.

A19.4 I am sure this has been beneficial.

A12.31 It is a well-written document.

A 1.32 M.J. Alton was the union nominee on the  
clerical division board.

SAWE - A

IC CLIMBERS → + PRED ± [PREDNOM  
PREDADJ] ± OI ± S ± AGENT

+ PRED → /PHVIMBERS

1) +PRED  
/PHVIMBERS

A13.37 It is requested that you kindly take the necessary action to have two electrical outlet boxes installed on two drafting tables in Rooms 338 and 340, Hunter Building.

A 1.33 There is one report dealing with both the plant and traffic divisions.

A 3.31 It will be noted that the position taken by the Treasury Board has been upheld.

A 2.41 It is absolutely essential that the floor of this unit be wet-mopped on a daily basis.

A14.26 There appears to me to be no reason why the stress analysis requirement of Section III need be invoked in order to use a lower safety factor.



BEST COPY AVAILABLE

SAWE - A

II CLELL → \*S \* OD \* OI \* [PREDADJ]  
[PREDNOM] \* Non Nuclear Tagmemes  
(\*SUB, \*NEG)

- 1) /CLELL  
+S           A 4.21 On the market side, water requirements  
are increasing much faster than  
electricity demands.
  
- 2) /CLELL  
+OD           A17.33 Thanks for your two memos of November 12th.
  
- 3) /CLELL  
+S+OI+OI       A13.21 Congratulations to you and to those  
associated with you in this splendid  
achievement.
  
- 4) /CLELL  
+PREDADJ       A 1.38 It is recommended for your approval that  
the reports be released as quickly as  
possible.
  
- 5) /CLELL  
+S+PREDNOM     A 3.21 ... Her telephone no. 731-6841.
  
- 6) /CLELLCND  
+SUB+NEG       A 1.50 I trust that this is the information  
you require, but if not please let me  
know.

SAWE - AIII CLMONO → Non-Nuclear Tagmeme INTERJEC (only 3 cases)

- 1) A14.48 Thanks.
- 2) A13.36 Thank you.  
A13.45 Thank you.

SAWE - A

CLAUSE FORMS

I. to define INF

"PRED

- a) CLBASINF → to XVI  
to XVII  
to XVIII  
to XVIV
- b) CLEQUATINF → to be (to XVV)
- c) CLIMPERSINF → PHVIMPERS → PRED → to XVV
- d) CLPASSINF → to XVCOMP  
/ PHV

(XVCOMP or PHV can be filled by XVI, XVII, XVIII)



BEST COPY AVAILABLE

SAWE - A

Ia) CLBASINF

- 1) +PRED  
/XVI A2.18 A few scattered oysters of good quality are present but not in sufficient quantity to warrant consideration.
- 2) +PRED  
/XVII A10.21 Please feel free to write us if we have not included all the reports Mr. Lasater requires.
- 3) +PRED  
/XVIII A11.11 The accepted sub-contractor submits a written request for permission to withdraw stating he is unable to perform work contracted and reasons why.
- 4) +PRED  
/XIV A12.16 If there are any points that you would like expanded, please contact me at extension 6-1062 as I would welcome the opportunity to discuss them with you.

SAWE - A

Ib) CLEQUATINF (3)

† PRED  
/ XVV

A9.11 They also feel the potential market for such units over the next five years is too small to be interesting.

A4.5 To capitalize on the current interest we would like to be able to present your proposals by mid-February.

A3.10 The trustee feels that there is nothing here to be concerned about while Mr. Feller maintains that there are large discrepancies between the amounts collected in the business and those deposited in the bank.

SAWE - A

Ic) CLIMPERSINF (1)

+PRED  
/PHVIMPERS

A12.39

In view of the environment in which the recommendations were developed, I believe it to be entirely possible that the program may experience more redirection as time goes on than is usual in our R & D work.

SAWE - A

Id) CLPASSINF (7)

+PRED  
/XVCOMP  
or /PHV

A10.36 I am sending two "Application for Employment" forms which you may forward to Mr. Agar to be completed and mailed to the addresses on the posters. (XVIII, XVII)

A9.18 They would hope to be considered. (XVIII)

A18.5 I also believe that it would be most appropriate to have this panel re-presented in the chair by the Canadian Wildlife Service. (XVI)

SAWE - A

CLAUSE FORMS

II. to define PART

PRED

- a) CLBASPART → XVI ing  
XVII ing  
XVIII ing  
XIV ing
- b) CLEQUATPART → XVV ing (being)
- c) CLPASSPART → being XVIII ed

SAWE - A

IIa) CLBASPART

- 1) +PRED /XVI A3.12 CCGS "Griffon" placed lighted buoy 75T on April 28th; however buoy report card covering the installation has not yet been received in the office.
- 2) +PRED /XVII A8.20 The commentary indicates that more comprehensive guides relating to particular provisions will be forthcoming.
- 3) +PRED /XVIII A1.19 This, of course, is considerably less than the cost of transferring and paying storage charges for new employees.
- 4) +PRED /XIV A1.19 This, of course, is considerably less than the cost of transferring and paying storage charges for new employees.

SAWE - A

IIb) CLEQUATPART

+PRED  
/XVV

- A12.44 You may have noticed in the local newspapers the recent case of a man who was charged with being impaired while driving but the crown lost the case against him because the evidence indicated that he had used a de-icer on the interior of his car's windshield while the car was closed.
- A14.2 Nor would the designers be excused from modifying the existing design if conditions were identified as being unsafe even though these conditions were not at variance with the earlier ones.
- A13.21 It is noted that the progress claim includes patent costs of \$5,155.00; being recent costs in this connection.

SAWE - A

IIc) CLPASSPART

A.3.26 Our intention therefore is to add a second set to your Region a year from now, and, this set, we anticipate, will be an improvement over that being delivered in May 1970.  
(XVIII)

A12.33 The manual can be kept up-to-date by simply filling-in the bottom portion of the first page so as to ensure being placed on the mailing list for revisions. (XVIII)



SAWE - A

Administrative Writing

CLAUSE FORMS

WH Clauses filling Level 3 functions

I + CLNUC

II Nuclear Tagmemes: a) + S  
b) + OD  
c) + OI  
d) + PREDNOM

III Non-Nuclear Tagmemes: a) + CPREDADJ  
b) + SPECOD

SAWE - A

I + CLNUC

- /CLBASWH      A11.40    Following the Regional Directors' Conference, I understand that we received a legal opinion as the result of which we backed off.
- /CLELLWH      A14.5    Section VIII did not call for a detailed stress analysis but merely set the wall thickness necessary to keep the basic loop stress below the tabulated allowable stress.
- /CLEQUATWH    A18.2    I believe that this subject will be of interest to all of the provincial directors who will be present as they are responsible for vast northern areas.
- /CLIMPERSWH   A11.48   Frankly, it is my reaction that it is the region's responsibility to keep on top of information to taxpayers particularly when certain taxpayers must be advised of changes in tax administration policy.
- /CLPASSWH     A 8.45    In this particular case of the Red Sucker Day School, it would appear that the project was not referred to DPW because your Department had originally estimated the cost at \$239,000 only.

SAWE - A

II a) + S

/CLBASWH      A 5.3 What has brought this matter particularly  
to mind is ...

/CLPASSWH      A 1.17 It is requested that an extension be granted  
until June 1, 1971.

SAWE - A

II b) + OD

- /CLBASWH A 6.57 I ... noticed that a considerable amount of gas ... had leaked on the floor.
- A 4.15 I hope that you have now received them.
- /CLEQUATWH A 3.21 ... stated she is anxious to give the necessary explanations...
- A 8.2 I think it is largely self-explanatory.
- /CLIMPERSWH A 3.19 The trustee feels that there is nothing here to be concerned about.
- A 2.26 He has noted that there are in air services other circular letters which have been issued ...
- /CLPASSWH A 1.40 This is to inform you that Mr. B. Marshall... has been transferred from administrative services.
- A 9.42 You can be assured that the information ... will be treated on a confidential basis ...

SAWE - A

II c) + OI

/CLBASWH

A 4.32 ... please be advised that the Dept.... has no staff ... and has no need for accommodation...

A 5.46 We were advised that the Centre had selected our ... Council ...

A11.5 ... you were informed ... that detailed instructions ... would follow.

/CLEQUATWH

A11.5 ... you were informed ... approval of sub-contractors would become your responsibility...

/CLPASSWH

A 9.42 You can be assured that the information provided ... will be treated on a strictly confidential basis ...

A 5.40 ... we are informed ... that technical and scientific research are being performed ...

SAWE - A

II d) + PREDNOM

/CLBASWH      A11.29    This is how the timetable for the tax  
guide is shaping up.

A 7.11    Your criterion whether travel should take  
place or not is whether the trip relates  
to immediate revenue-producing activities  
or to any critical personnel problems.

/CLEQUATWH    A19.6    ... the situation would not be that our  
regulations would be ... on top of  
provincial requirements.

SAWE - A

III a) + CPREDADJ

- /CLBASWH      A14.47    I am sure I can live with what you produce.
- A12.43    The lady was concerned that the label on  
the can ... contained no warning ...
- A 4.30    I am perfectly sure that the resources  
exist within AECL to start a modest program...
- /CLEQUATWH    A10.45    I am sorry I cannot be of more direct  
assistance to Mr. Agar.
- A13.29    I am sure that this collection will become  
even more valuable ...
- /CLPASSWH     A13.29    I am very glad that this unique  
institution has been created.

BEST COPY AVAILABLE

SAWE - A

III b) + SPECOD

/CLBASWH

A18.15 ... would appreciate it if you will  
keep me informed.

A16.15 They have reiterated the following:  
regional office of DPW should not  
correspond directly with RCMP members ...

A15.47 I would appreciate it if you would  
ensure that the contents of these  
minutes are brought to the attention  
of those members...



APPENDIX 7

I. SEQUENCES OF STRUCTURES IN THE COMPUTER PRINTOUT

I. TERMINOLOGY

(PHASE II)

1) Group

Group refers to the tagmemes of a construction without regard to arrangement. When this term is further qualified as in "function group". it means that reference is being made only to the function labels of the tagmemes.

2) A string is a group of tagmemes representing an actual order of occurrence of those tagmemes.

- EX. 1
- |    |                       |                           |                           |
|----|-----------------------|---------------------------|---------------------------|
| a) | +ELTRANS<br>/ADVTRANS | +CLNUC<br>/CLBAS          | +CLDEP<br>/CLBASPARTCAUSE |
| b) | +ELTRANS<br>/ADVTRANS | +CLDEP<br>/CLBASPARTCAUSE | +CLNUC<br>/CLBAS          |

In EX. 1, a & b are two different strings with the same group of sentence level tagmemes.

When "string" refers specifically to FUNCTION or FORM, only that part of the tagmeme to which it refers is considered.

- EX. 2
- |    |                       |                    |                           |
|----|-----------------------|--------------------|---------------------------|
| a) | +ELTRANS<br>/ADVTRANS | +CLNUC<br>/CLBAS   | +CLDEP<br>/CLBASINFPURP   |
| b) | +ELTRANS<br>/ADVTRANS | +CLNUC<br>/CLEQUAT | +CLDEP<br>/CLBASPARTCAUSE |

When referring specifically to FUNCTION, the strings in EX. 2 are considered identical.

Alphabetic order of strings involves listing strings according to alphabetic sequence of tagmemes, considering FUNCTION first and FORM second.

- |       |    |                         |                           |                           |
|-------|----|-------------------------|---------------------------|---------------------------|
| EX. 3 | 1. | +CLDEP<br>/CLBASINFPURP | +CLNUC<br>/CLBAS          | +CLDEP<br>/CLBASPARTTIME  |
|       | 2. | +CLNUC<br>/CLBAS        | +CLDEP<br>/CLBASPARTCAUSE | +CLDEP<br>/CLBASPARTCAUSE |
|       | 3. | +CLNUC<br>/CLEQUAT      | +CLDEP<br>/CLBASPARTCAUSE | +CLDEP<br>/CLBASPARTCAUSE |

In EX. 3, string 1 is listed before string 2 since the first function label of string 1, +CLDEP, comes alphabetically before the first function label of string 2, +CLNUC. Within a list of identical FUNCTION strings, the alphabetic sequence of FORM labels is considered. Thus string 3 comes after string 2 since /CLEQUAT follows /CLBAS alphabetically.

### 3) Order Deviation

An order deviation is a deviation of the actual order from the following arbitrarily predetermined standard order of Nuclear Tagmeme Functions in Level 3.

+ S, + PRED, + OD, + OI, + PREDADJ, + PREDNOM, + AGENT

These are quantified in terms of how many tagmemes are out of place.

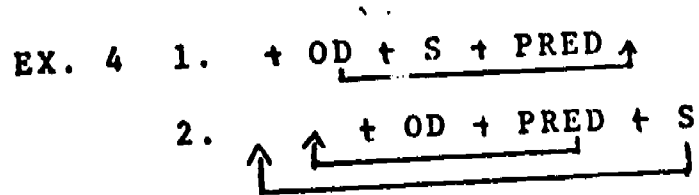

one order deviation  
two order deviations

4. Reference

The reference is the sentence identification number of the portion of text to which it refers.

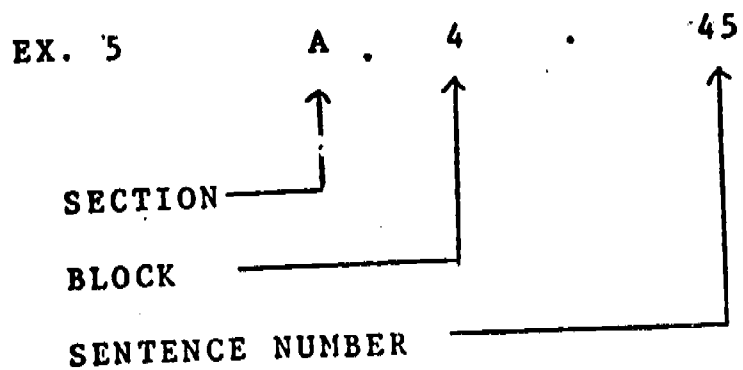

II CRITERIA FOR  
SEQUENCING OF STRUCTURES IN PHASE III PRINTOUT

1. DISCOURSE LEVEL

1. FUNCTION: alphabetic sequence
2. FORM: predetermined sequence.

2. SENTENCE LEVEL )

3. CLAUSE LEVEL )

4. PHRASE LEVEL )

Sequencing is the same except for  
FUNCTION GROUPS

1. TITLE: Level 2 - sentence forms in predefined sequence  
Level 3 - clause forms in alphabetic sequence  
Level 4 - phrase forms in alphabetic sequence
2. FUNCTION: \*see "Criteria for Sequencing of Function groups"
3. DEPTH: ascending maximum relative depth
4. FORM: alphabetic order of entire string
5. DISCONTINUITY: count
6. VALUE OF BRACKETED ELEMENT \*see  
"Variables Associated with Complexity"
7. REFERENCE: numerical order of  
sentence identification  
numbers.

5. EXPRESSION LEVEL

NOTE: Level 5 is primarily a listing by form of all verbs, and expressions consisting of more than one word (eg. XVI, XPREP, XN, XCONJCCORD). Only XVCOMP, XVAUXCOMP and XVSAUXCOMP can be sequenced by FORM and FUNCTION since they are the only tagmemes at this level.

1. TITLE: expression forms in alphabetic sequence except XVCOMP, XVAUXCOMP and XVSAUXCOMP, which are last.
2. FUNCTION: XVCOMP, XVAUXCOMP, XVSAUXCOMP only — alphabetic order of entire string.
3. FORM: XVCOMP, XVAUXCOMP, XVSAUXCOMP only — alphabetic order of entire string.
4. TEXT: alphabetic order  
Sentence identification numbers are included where the number of occurrences is 10 or less.

EX.1. LEVEL 2 SEQUENCING OF STRUCTURES IN PHASE III PRINTOUT  
(theoretical example)

1.1 SENSIM

2.1 CLIND

3.1 DEPTH 1

4.1 + CLIND  
/ CLELL

5.1 1/0

6.1 1/0

7.1 A1.27  
A1.35...

4.2 + CLIND  
/ CLMONO

5.1 1/0

6.1 1/0

7.1 A1.16  
A1.32...

3.2 DEPTH 2

4.1 + CLIND  
/ CLBAS

5.1 1/0

6.1 1/0

7.1 A1.42  
A2. 2...

3.3 DEPTH 3

4.1 + CLIND  
/ CLBAS

5.1 1/0

6.1 1/0

7.1 A2.14  
A2.20...

2.2 ELTRANS CLIND

3.1...

III CRITERIA FOR  
SEQUENCING OF FUNCTION GROUPS

1. DISCOURSE LEVEL

Predefined sequence: SENSIM  
SENCOMPOUND  
SENCOMPLEX  
SENCOMPLEXELL  
SENCOMPOUNDCOMPLEX

2. SENTENCE LEVEL

1. Number of NUCLEAR TAGMEMES
2. Number of NON-NUCLEAR TAGMEMES beginning with CL
3. Alphabetic order of STRINGS of NON-NUCLEAR TAGMEMES beginning with CL
4. Number of OTHER NON-NUCLEAR TAGMEMES
5. Alphabetic order of STRING of OTHER NON-NUCLEAR TAGMEMES
6. Alphabetic order of ENTIRE STRING

3. CLAUSE LEVEL

1. Number of NUCLEAR TAGMEMES
  2. Alphabetic order of ALPHABETIC ARRANGEMENT OF NUCLEAR TAGMEMES
  3. Number of ORDER DEVIATIONS of NUCLEAR TAGMEMES
- \*See "Terminology Associated with Sequencing of Structures"

4. Alphabetic order of STRINGS of NUCLEAR TAGMEMES

5. Number of NON-NUCLEAR TAGMEMES

6. Alphabetic order of ENTIRE STRING

4. PHRASE LEVEL

1. Number of NUCLEAR TAGMEMES

2. Number of NON-NUCLEAR TAGMEMES

3. Alphabetic order of ENTIRE STRING

5. EXPRESSION LEVEL

1. Alphabetic order of ENTIRE STRING

(XVCOMP, XVAUXCOMP, XVS AUXCOMP only)

EX. 2 LEVEL 2 SEQUENCING OF FUNCTION STRUCTURES

(SASE A p. 2)

SENSIM

1.1 NO NUCLEAR TAGMEMES

2.1 One NON-NUCLEAR TAGMEME beginning with CL

3.1 +CLIND

4.1 One OTHER NON-NUCLEAR TAGMEME

5.1 +ELTRANS

6.1 +ELTRANS +CLIND

4.2 Two OTHER NON-NUCLEAR TAGMEMES

5.1 +ELTRANS +ELTRANS

6.1 +ELTRANS +ELTRANS +CLIND



2.2 Two NON-NUCLEAR TAGMEMES beginning with CL

3.1 +CLIND+CLINDPAREN

4.1 One OTHER NON-NUCLEAR TAGMEME

5.1 +ELTRANS

6.1 +ELTRANS+CLIND+CLINDPAREN

3.2 CLINDPAREN CLIND

4.1 One OTHER NON-NUCLEAR TAGMEME

5.1 +ELTRANS

6.1 +ELTRANS+CLINDPAREN+CLIND

2.3 Three NON-NUCLEAR TAGMEMES beginning with CL

3.1 +CLIND+CLINDPAREN+CLINDPAREN

4.1 One OTHER NON-NUCLEAR TAGMEME

5.1 +ELTRANS

6.1 +ELTRANS+CLIND+CLINDPAREN

+CLINDPAREN

COMPLEXITY

I. TERMINOLOGY

1) Level

There are 5 levels of analysis:

- 1) discourse
- 2) sentence
- 3) clause
- 4) phrase
- 5) expression

2) Tagmeme

A tagmeme is a combination of a function and a form at any level.

EX. 1 +CLIND      or   +NUC      or   +PRED  
      /CLBAS      /PHN      /XVI

3) Generation

The constituents of a tagmeme are one generation removed from that tagmeme. Starting with the Discourse Level which is the first generation, its constituents (sentences) are generation removed; thus they are the 2nd generation of tagmemes.

4) Depth Value

The depth value of a tagmeme is the number of generations removed from the discourse level.

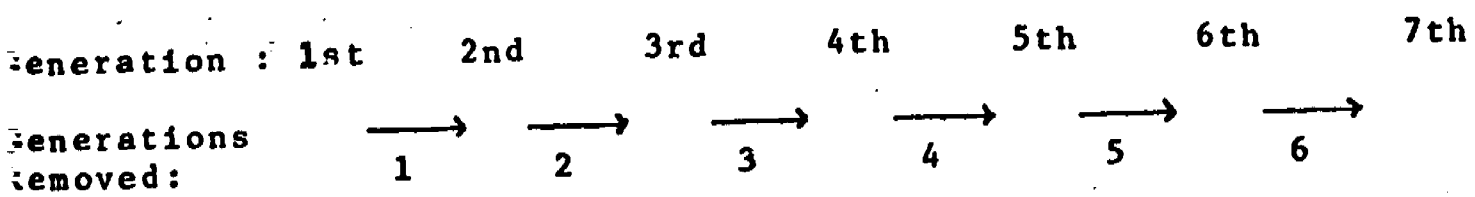
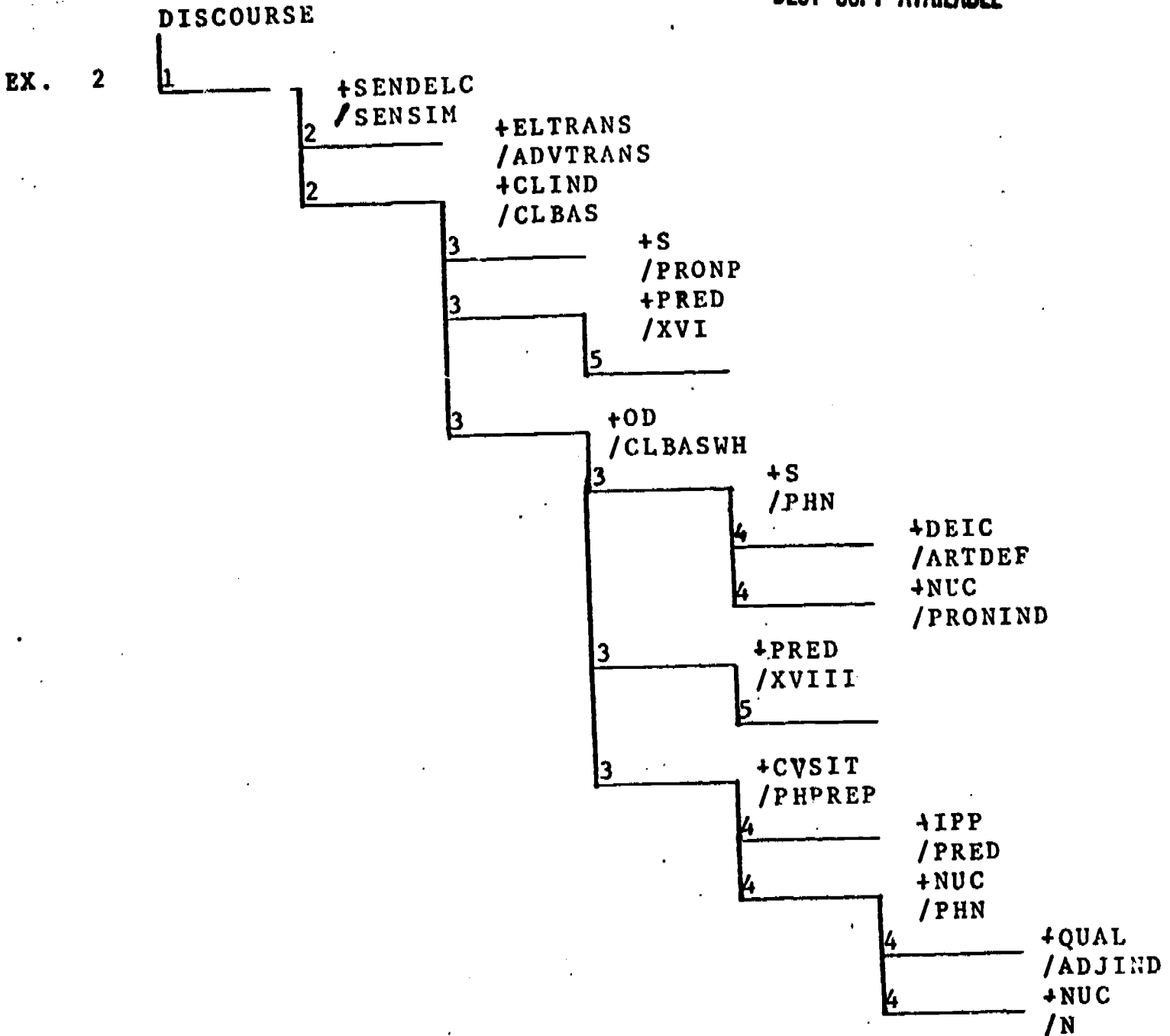

ie The depth value of the tagmeme + QUAL is 6 since it is 6 generation / ADJIND removed from the discourse.





6) Discontinuity

A discontinuity occurs when the consistents of a tagmeme are interrupted by some element which is not a constituent of that tagmeme. This element is called "the bracketted element" and usually has the same constitute as the tagmeme whose constituents are interrupted. It's constitute may, however lie in a previous generation.

The level at which a discontinuity is said to occur is the level at which the bracketted element is a constituent of some tagmeme, not the level at which it interrupts.

Ex. 4 SASE A 3.6 Mr. Buchanan, do (you) feel any effects of French

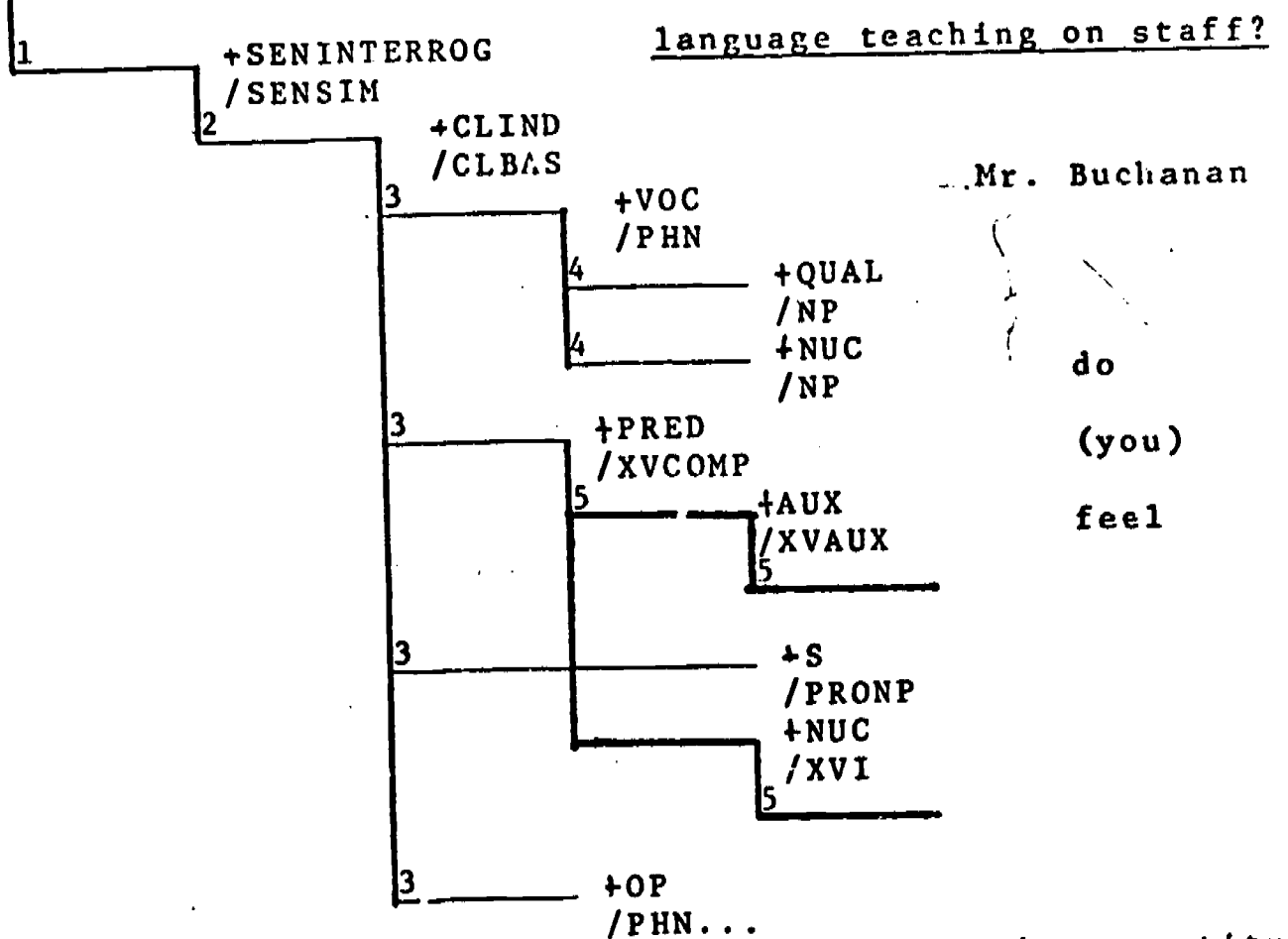

In Ex. 4, +PREP is the discontinuous element since its constituent /IXVCOMP

(+AUX +NUC) (+S / PRONP) are interrupted by /PRONP, the bracketted element.

Note that the bracketted element has the same constitute, +CLIND / CLBAS as the discontinuity element. This is the usual case.

The bracketted element, <sup>+S</sup> /PRONP is said to occur at level 3, since it is the constituent of a clause.

II COMPLEXITY INDEX

To determine the complexity of a structure, the following three variables are considered.

1. Maximum Relative Depth
2. Number of Discontinuities
3. Value of the Bracketted Element within a discontinuity.

First, the depth of each structure is determined, and all structures of the same depth are grouped together. Within each depth category, structures are further grouped and ranked according to the number of discontinuities they contain. Within each discontinuity sub-category, the structures are grouped and ranked according to the value of bracketted element.

INDEXING SYSTEM

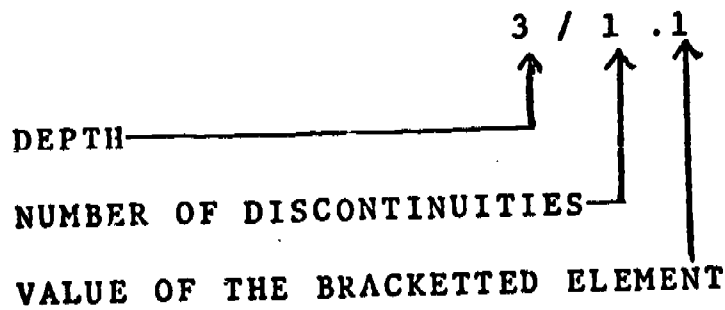

III VARIABLES ASSOCIATED WITH COMPLEXITY

1) Maximum Relative Dept.

The maximum relative depth of a tagmeme is the depth value, relative to that tagmeme, of its furthest removed terminal element (minus 1)

Ex. 5 SASE A 3.3 So, in the working environment it's one thing.

(DISCOURSE)

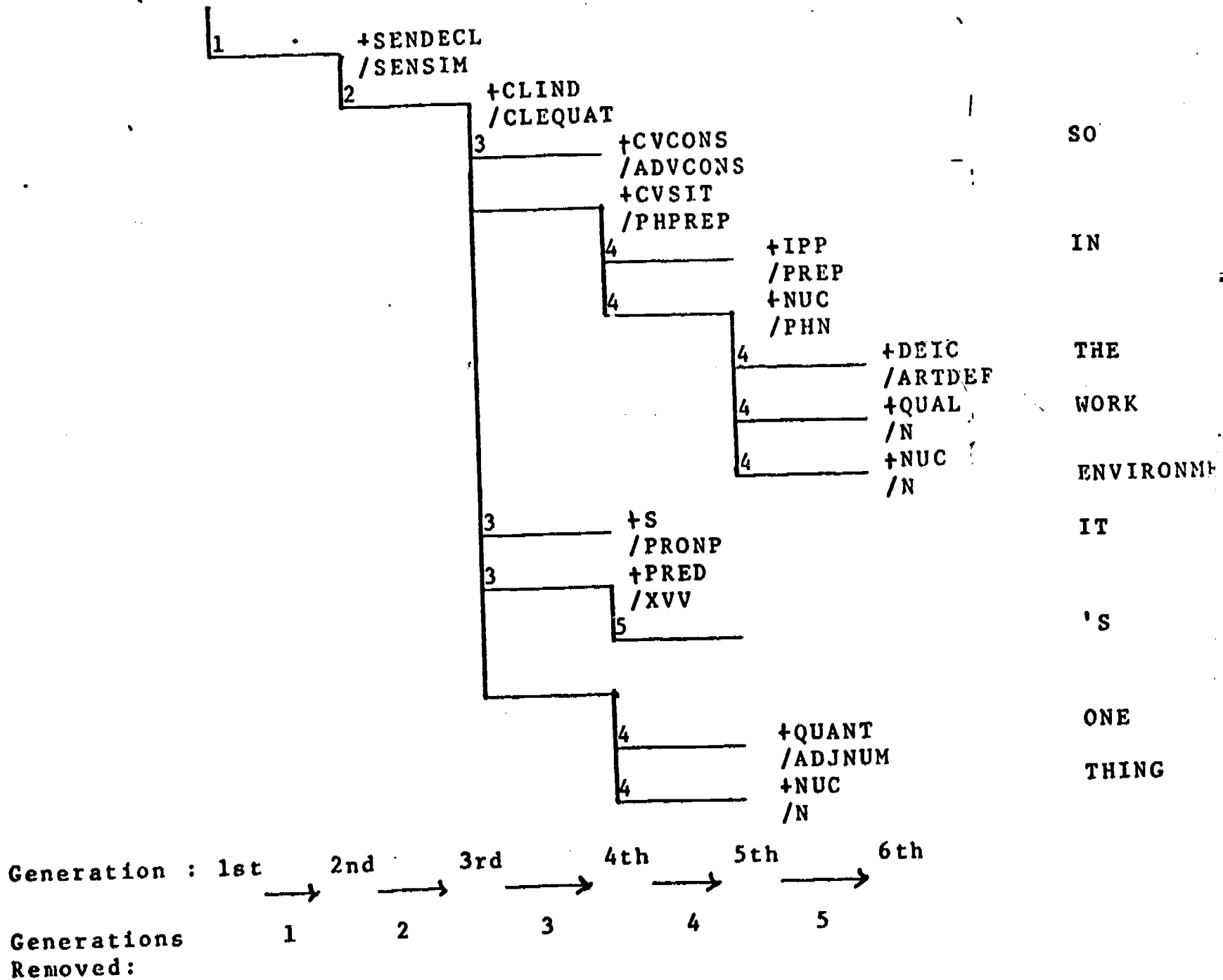



In ex. 5, the three tagmemes enclosed in a box are the terminal elements which are the furthest removed from +SENDECL +CLIND +CVSIT /SENSIM (Level 2), /CLEQUAT (Level 3), /PHPREP (Level 4).

Relative to the sentence, they have a depth value of 4, relative to the clause, a depth value of 3, and relative to the prepositional phrase, a depth of 2. Thus, according to the definition, the sentence has a maximum relative depth of 3, the clause, 2 and the prepositional phrase, 1.

2) Number of Discontinuities

The number of discontinuities within a tagmeme is the number of bracketted elements (not the number of tagmemes within the brackets)

Ex. 6 SASE A 3.77

I suggest that it's (not the age) that makes one incapable of learning.

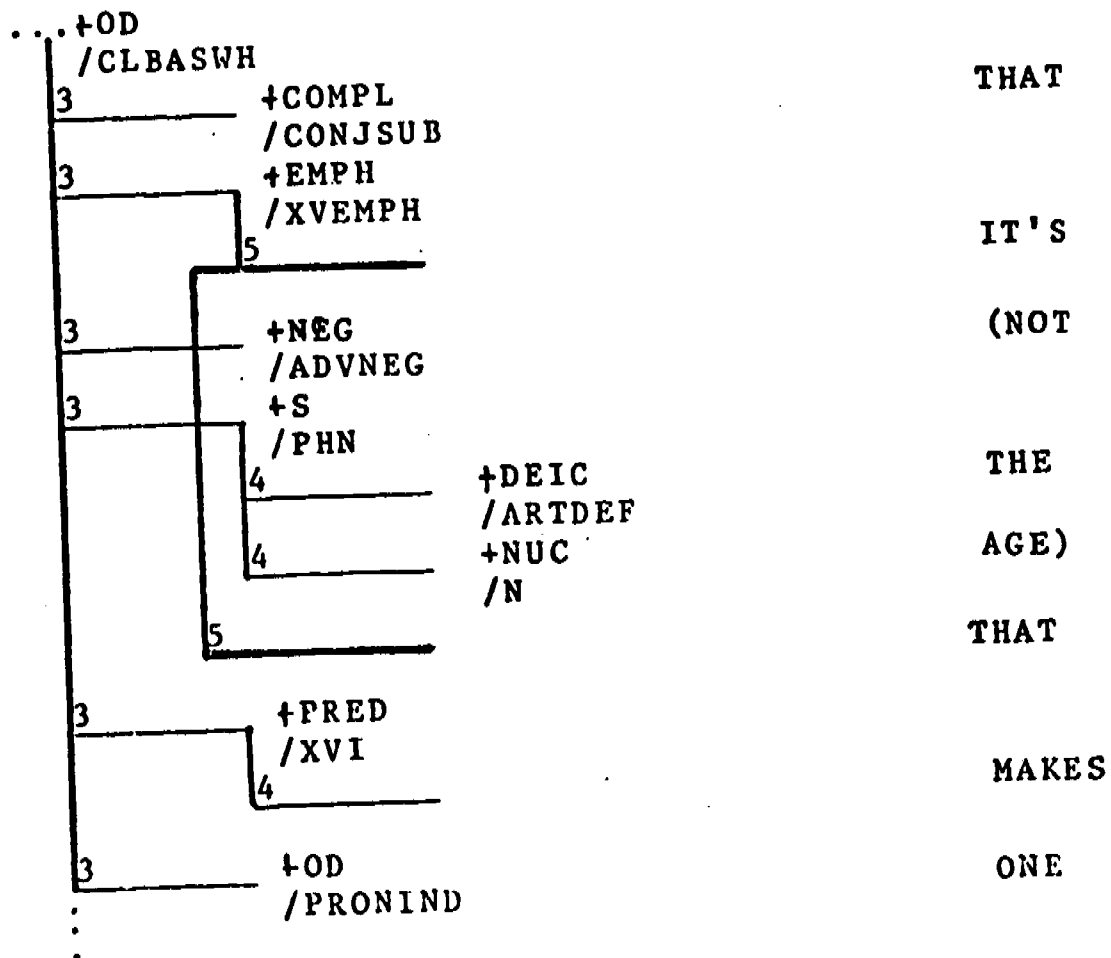

+EMPH

In ex. 6, the only discontinuous element is /XVEMPH. The bracketted element which interrupts this tagmeme is counted as one discontinuity.

3) Value of the bracketted element within a discontinuity

The value generally assigned to the bracketted element within a discontinuity is the total number of tagmemic. Constituents for all generations of that element.

Ex. 7 SASE A 1.82

You become annoyed not only (at yourself), but at the ...

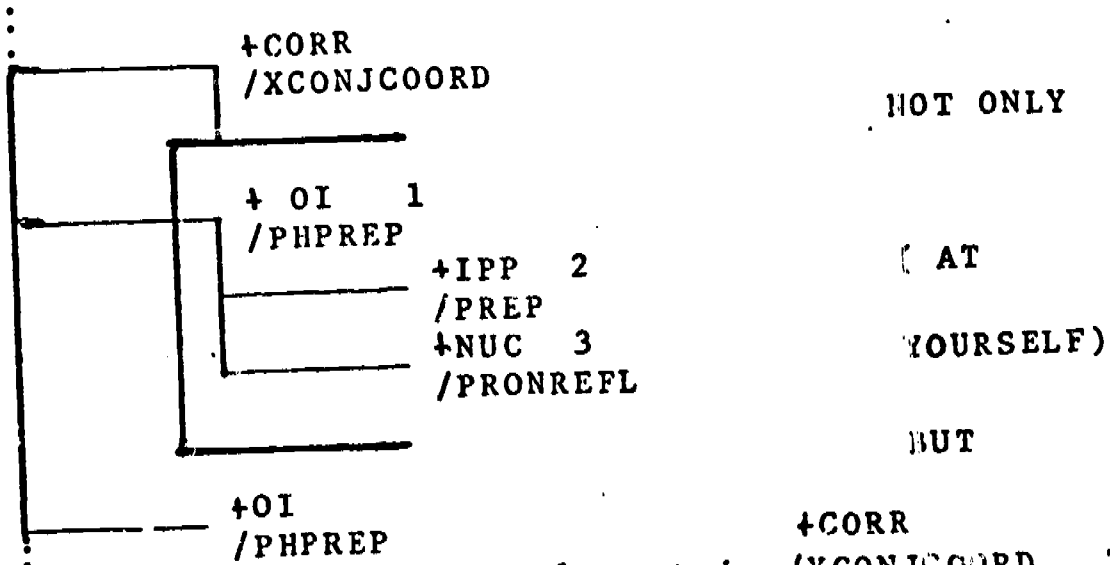

In ex. 7, the discontinuous element is /XCONJCOORD. The value of a bracketted element is 3.

Special Considerations

1. When a terminal element is listed at the expression level, level 5, it is counted twice, once the first time it appears and a second time when it is listed at level 5.





IV COMPLEXITY VS. NUMBER OF CONSTITUENTS

Greater complexity does not necessarily imply greater number of tagmemic constituents or greater number of terminal elements, and vice versa. This is true since the constituents of a tagmeme of any particular generation may be either terminal elements or constituents of further constituents. They may contain a number of discontinuous elements or none at all. Thus, a tagmeme which has several constituents which are very simple tagmemes is not considered to be as complex as one which has fewer constituents, but are more complex in themselves.

Ex. 10 SASE A 2.55

Ex. 11 SASE A 1.15

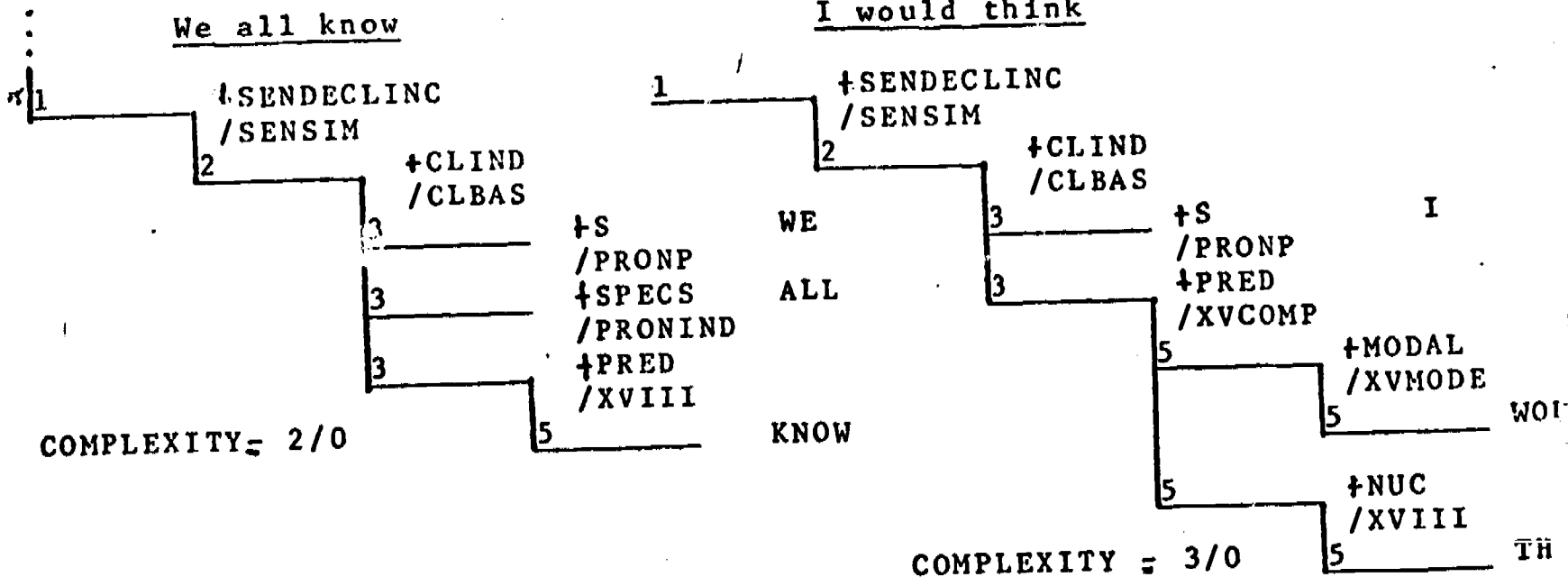

In Ex. 10 and Ex. 11 above, although the number of tagmemes at the sentence level and the number of terminal elements are the same, the sentence Ex. 10 is less complex than sentence Ex. 11. This is true since the sentence in Ex. 10 is made up of a clause tagmeme composed of three terminal elements, whereas that in Ex. 11 is made up of a clause tagmeme, which is a constituent of further constituents.

Ex. 12 SASE A 2.51

But both of them performed their duties in an English environment before they began the course.

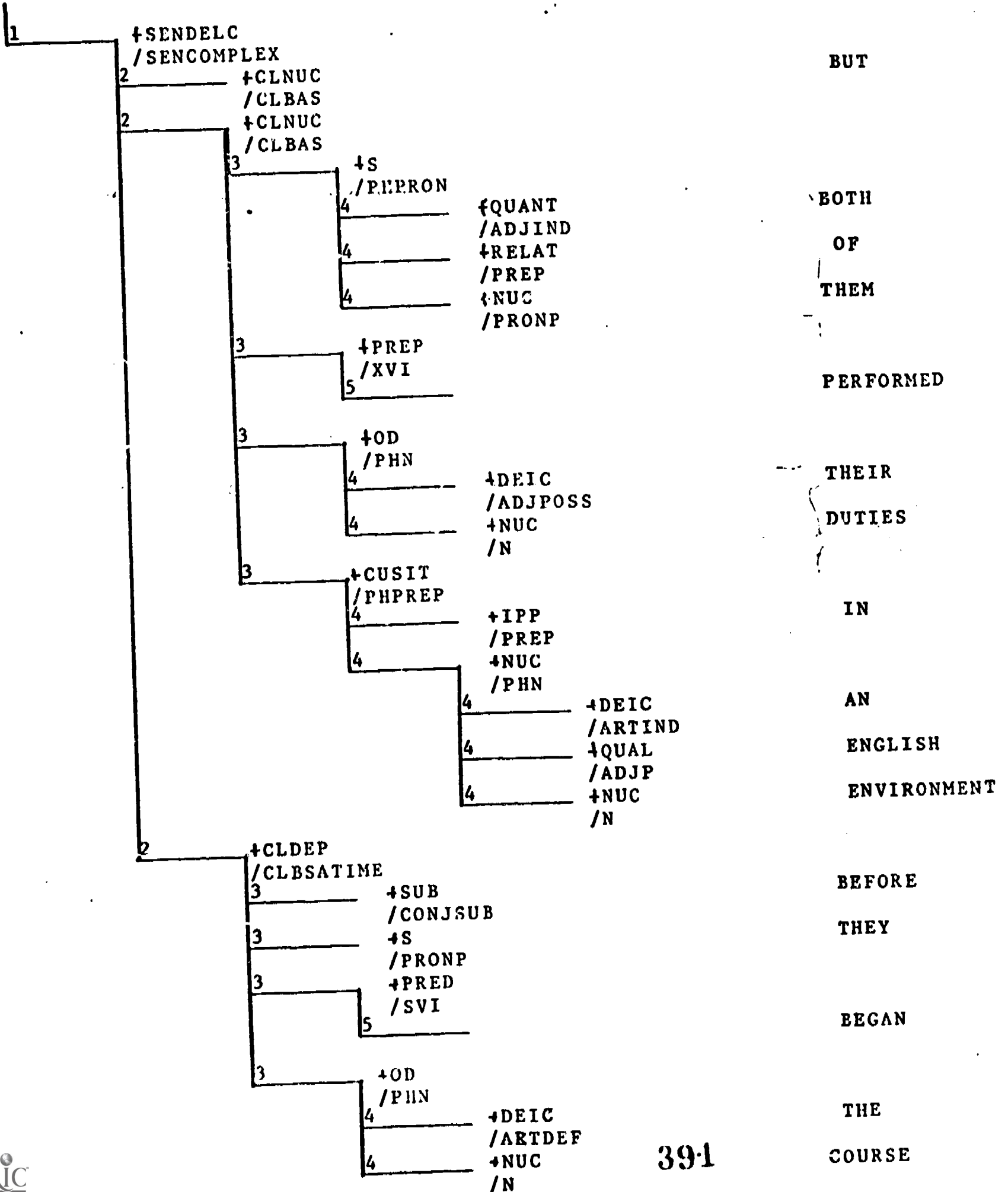

Comparing EX. 11 and EX.12, although the sentence in EX. 12 has more tagmemes at the sentence level as well as more terminal elements than that in EX. 11, these sentences have the same complexity. This is due to the fact that the most complex constitute of the sentence in EX. 11 is of the same complexity as the most complex constitute of the sentence in EX. 12.

#### SEQUENCING OF COMPLEXITY IN THE PHASE III PRINTOUT

It is important to note that complexity is not the only variable involved in the sequency of strings in the phase III printout. Furthermore, as far as the sequencing is concerned complexity is regarded as three separate variables. Thus, the strings are ranked according to depth within all structures having the identical FUNCTION strings, whereas they are ranked according to the number of discontinuities and the value of the bracketted element within the more frequently changing list of FORM strings. Therefore, we cannot expect an index of complexity which ranges from least to greatest throughout the entire printout, but rather one which covers the entire range of complexity within each variation of the string.

EX. 13 Theoretical Example of Complexity Index at Level 2

Depth 3	3/0 +CLIND /CLBAS	1. 2. 3...	} *These numbers represent actual references printed with texts	
	3/1.1	1. 2. 3...		
	3/0 +CLIND /CLEQUAT	1. 2. 3...		
	3/1.1	1. 2. 3...		
	3/1.2	1. 2. 3...		
Depth 4	4/0 +CLIND /CLBAS	1. 2. 3...		
	4/1.1	1. 2. 3...		
	+CLIND /CLEQUAT 4/0	1. 2. 3...		
Depth 3	3/0 +ELTRANS /ADVTRANS	+CLIND /CLBAS		1. 2. 3...
	3/1.1	+CLIND /CLEQUAT		1. 2. 3...
	3/0 +ELTRANS /ADVTRANS	+CLIND /CLEQUAT	1. 2. 3...	
	3/1.1	+CLIND /CLEQUAT	1. 2. 3...	

In EX. 13, the depth varies from 3 to 4 within all structures having the FUNCTION string + CLIND. When the function string



changes to, +ELTRANS +CLIND the depth variable of the complexity index starts over. The other two complexity variables start over with each change of FORM string, for example a change from /CLBAS to /CLEQUAT.

ADMINISTRATIVE CORRESPONDENCE

Level 3

Exhaustive List of Clause Structures (Nuclear Tagmemes, Ordered)

No. of Clauses: 2771  
 No. of Types : 98

ANK	TYPES	Cum. % of TYPE	Freq.	% of Tokens	Cum. % of Tokens
1	S PRED OD	1.02	590	21.29	21.29
2	S PRED	2.04	418	15.08	36.38
3	PRED OD	3.06	384	13.86	50.23
4	PRED	4.08	250	9.02	59.25
5	S PRED PREDADJ	5.10	182	6.57	65.82
6	S PRED OI	6.12	131	4.73	70.55
7	S PRED PREDNOM	7.14	96	3.46	74.01
8	PRED S	8.16	93	3.35	77.37
9	PRED OI	9.18	59	2.09	79.50
0	PRED OD OI	10.20	45	1.62	81.12
1	S PRED OD OD	11.22	37	1.34	82.46
1	PRED AGENT	12.24	37	1.34	83.79
3	PREDADJ	13.27	35	1.26	85.05
4	S PRED OD OI	14.29	33	1.09	86.25
5	PRED PREDADJ S	15.31	30	1.08	87.33
6	OD S PRED	16.33	29	1.05	88.37
7	S PRED AGENT	17.35	26	.94	89.31
8	S PRED OI OD	18.37	23	.83	90.14
9	PRED OD OD	19.39	20	.72	90.86
9	S	20.41	20	.72	91.59
21	PRED S OD	21.43	19	.69	92.27
22	PRED PREDADJ	22.45	18	.65	92.92
23	S PRED PREDADJ OI	23.47	14	.51	93.43
24	PRED OI OD	24.49	12	.43	93.86
25	No Nuclear Tagmemes	25.51	11	.40	94.26
25	PRED PREDNOM S	26.53	11	.40	94.65

NR	TYPE	BEST COPY AVAILABLE	CUMU. % of TYPE	Freq.	% of Tokens	Cum. % of tokens
	S S	PRED	27.55	9	.32	94.98
	S	PRED OI OI	28.57	7	.25	95.23
	PRED	S S	29.59	7	.25	95.48
	S	PRED PREDNOM PREDNOM	30.61	6	.22	95.70
	S S	FRED OD	31.63	6	.22	95.92
	OD S	PRED OI	32.65	5	.18	96.10
	S	PRED OD OD OD	33.67	5	.18	96.28
	OI S	PRED OD	34.69	5	.18	96.46
	S S	PRED PREDADJ	35.71	4	.14	96.60
	PRED	OD OI OI	36.73	3	.11	96.71
	PREDADJ	S PRED	37.76	3	.11	96.82
	PRED	S PREDADJ	38.78	3	.11	96.93
	PRED	OI S	39.80	3	.11	97.04
	OI S	PRED	40.82	3	.11	97.14
	PRED	OI AGENT	41.84	3	.11	97.25
	OD	PRED	42.86	3	.11	97.36
	PRED	S OD OI	43.88	2	.07	97.43
	PRED	OI OD OD	44.90	2	.07	97.50
	PRED	OD OD OD	45.92	2	.07	97.57
	S	PRED AGENT OI	46.94	2	.07	97.65
	S	PRED OD AGENT	47.96	2	.07	97.72
	PREDADJ	PRED S	48.98	2	.07	97.79
	PRED	S OI	50.00	2	.07	97.87
	PRED	OI OI	51.02	2	.07	97.94
	PRED	OD AGENT	52.04	2	.07	98.01
	PRED	PREDNOM	53.06	2	.07	98.08
	OD		54.08	2	.07	98.15
	PRED	S S S	55.10	2	.07	98.22
	S S S	PRED	56.12	2	.07	98.30
	PRED	PREDNOM S S	57.14	2	.07	98.37
	S	PRED PREDADJ PREDADJ	58.16	2	.07	98.44
	S	PRED OD OD OD OD OD	59.18	2	.07	98.52
	PRED	S OI OD	60.20	2	.07	98.59

BEST COPY AVAILABLE

ANK	TYPE	CUM. % OF TYPE	FREQ.	% OF TOKENS	CUM. % OF TOKENS
0	OD S S PRED	61.22	1	.04	98.62
0	PRED OI OI OI	62.24	1	.04	98.66
0	PRED PREDADJ OI S	63.27	1	.04	98.70
0	S S PRED OI	64.29	1	.04	98.73
0	PRED PREDADJ S S	65.31	1	.04	98.77
0	PRED OD OD OD OD	66.33	1	.04	98.80
0	S PRED OD OD OI	67.35	1	.04	98.84
0	S. PRED OD OI OI	68.37	1	.04	98.88
0	S PREDNOM	69.39	1	.04	98.91
0	PRED AGENT OI	70.41	1	.04	98.95
0	PRED AGENT S	71.43	1	.04	98.99
0	PKED S AGENT	72.45	1	.04	99.02
0	OI PRED OD	73.47	1	.04	99.06
0	PRED CD S	74.49	1	.04	99.09
0	OD PRED S	75.51	1	.04	99.13
0	S OI OI	76.53	1	.04	99.16
0	PREDNOM S PRED	77.55	1	.04	99.20
0	PREDNOM PRED S	78.57	1	.04	99.24
0	S PRED S	79.59	1	.04	99.27
0	S S S	80.61	1	.04	99.31
0	S PKED AGENT AGENT	81.63	1	.04	99.35
0	S PRED AGENT OD	82.65	1	.04	99.38
0	OI S PRED AGENT	83.67	1	.04	99.42
0	PRED OD OD OI	84.69	1	.04	99.45
0	OD OI.	85.71	1	.04	99.49
0	PREDNOM OI	86.73	1	.04	99.53
0	PREDADJ S	87.76	1	.04	99.56
0	S S PRED OI OI	88.78	1	.04	99.60
0	PRED PREDADJ OI S S	89.80	1	.04	99.63
0	S S S S PRED	90.82	1	.04	99.67

BEST COPY AVAILABLE

NK	TYPE	CUM. % OF TYPE	FREQ.	% OF TOKENS	CUM. % OF TOKENS
1	S PRED OD OD OD OD	91.84	1	.04	99.71
1	S PRED PREDADJ OI OI OI	92.86	1	.04	99.74
1	S S S S PRED OD OD	93.88	1	.04	99.78
1	S S S S S S PRED	94.90	1	.04	99.81
1	S PRED PREDNOM PREDNOM PREDNOM PREDNOM	95.92	1	.04	99.85
1	PRED OD OD OD OD OD OD OD	96.94	1	.04	99.89
1	S PRED PREDNOM PREDNOM PREDNOM PREDNOM PREDNOM PREDNOM PREDNOM	97.96	1	.04	99.92
1	PRED OI OD OD OD	98.98	1	.04	99.96
1	PRED OI OI OD	100.00	1	.04	100.00
			<u>2771</u>	<u>99.99</u>	

BEST COPY AVAILABLE

FORMAL/ INFORMAL DISCUSSION

LEVEL 3

Exhaustive List of Clause Structures (Nuclear Tagmemes, Ordered)

No. of Clauses: 2,901

No. of Types: 69

ANK	TYPE	Cum. % of type	FREQ.	Rel. % of Tokens	Cum. % of Tokens
	S PRED OD	1.45	842	29.02	29.02
	S PRED	2.9	525	18.09	47.12
	PRED OD	4.35	299	10.3	57.42
	S PRED PREDADJ	5.8	227	7.82	65.25
	S PRED PREDNOM	7.25	165	5.68	70.94
	PRED	8.7	125	4.3	75.24
	PRED S	10.15	114	3.92	79.17
	No Nuclear Tagmemes	11.6	99	3.41	82.59
	OD S PRED	13.05	73	2.51	85.1
	S PRED OI	14.5	69	2.37	87.48
	PRED S OD	15.95	37	1.27	88.76
	S	17.4	34	1.17	89.93
	S PRED OD OD	18.85	32	1.1	91.03
	PRED PREDADJ S	20.3	28	0.96	92
	PRED OI	21.75	26	0.89	92.89
	PRED PREDADJ	23.2	15	0.51	93.41
	S PRED OD OI	24.65	14	0.48	93.89
	PRED OI OD	26.1	10	0.34	94.24
	PRED OD OI	27.55	10	0.34	94.58
	S PRED OI OD	29	9	0.31	94.89

BEST COPY AVAILABLE

NK	TYPE	Cum. % of Type	FREQ.	Rel. % of Tokens	Cum. % of Tokens
.	PRED OD OD	30.45	9	0.31	95.2
1	PREDADJ	31.9	9	0.31	95.51
1	OD PRED S	33.35	8	0.27	95.79
3	PREDNOM	34.8	8	0.27	96.07
3	OD	36.25	8	0.27	96.34
6	OI S PRED	37.7	7	0.24	96.59
7	S PRED PREDADJ PREDADJ	39.15	6	0.2	96.79
7	PRED OI S	40.6	6	0.2	97
9	PRED PREDNOM S	42.05	5	0.17	97.17
9	OD PRED	43.5	5	0.17	97.35
11	S PRED PREDNOM PREDNOM	44.95	4	0.13	97.48
11	S PRED OI OI	46.4	4	0.13	97.62
11	OD S PRED OI	47.85	4	0.13	97.76
31	PREDNOM S PRED	49.3	4	0.13	97.9
31	S PRED AGENT	50.75	4	0.13	98.04
31	PRED PREDNOM	52.2	4	0.13	98.17
37	S PRED OD OI OI	53.65	3	0.1	98.28
37	S S PRED PREDADJ	55.1	3	0.1	98.38
37	PREDADJ S PRED	56.55	3	0.1	98.48
37	PRED AGENT	58	3	0.1	98.59
41	S PRED OD OD OD OD	59.45	2	0.06	98.66
41	S PRED PREDNOM PREDNOM PREDNOM	60.9	2	0.06	98.72
41	S PRED OD OD OD	62.35	2	0.06	98.79

BEST COPY AVAILABLE

ANK	TYPE	Cum. % of type	FREQ.	Rel. % of tokens	Cum. % of Tokens
1	PRED PREDADJ S S	63.8	2	0.06	98.86
1	S PRED PRED OD	65.25	2	0.06	98.93
1	OI S PRED OD	66.7	2	0.06	99
1	OD OD S PRED	68.15	2	0.06	99.07
1	S S PRED	69.6	2	0.06	99.14
1	PRED S PREDADJ	71.05	2	0.06	99.21
1	PRED OD S	72.5	2	0.06	99.28
1	OD PRED PREDADJ	73.95	2	0.06	99.35
1	PREDNOM PREDNOM	75.4	2	0.06	99.41
3	SSSS PRED PREDADJ	76.85	1	0.03	99.45
3	S PRED PREDADJ PREDADJ PREDADJ PREDADJ	78.3	1	0.03	99.48
3	S PRED PREDADJ OI OI	79.75	1	0.03	99.52
3	S PRED OD OD OD AGENT	81.2	1	0.03	99.55
3	PRED PREDADJ PREDADJ S	82.65	1	0.03	99.59
3	S PRED PREDADJ OI	84.1	1	0.03	99.62
3	S S PRED OD	85.55	1	0.03	99.66
3	OD PRED S OI	87	1	0.03	99.69
3	PRED OD OI OI	88.45	1	0.03	99.72
3	PRED OD OD OD	89.9	1	0.03	99.76
3	PRED S S	91.35	1	0.03	99.79
3	PREDNOM PRED S	92.8	1	0.03	99.83
3	PRED PREDNOM PREDNOM	94.25	1	0.03	99.86
3	PREDADJ PRED S	95.7	1	0.03	99.9



BEST COPY AVAILABLE

ANK	TYPE	Cum. % of type	FREQ.	Rel. % of Tokens	Cum. % of Tokens
3	PRED PREDADJ PREDADJ	97.15	1	0.03	99.93
3	PRED OI OI	98.6	1	0.03	99.97
3	S OD	100.05	1	0.03	100

TYPES OF NOUN PHRASE MODIFICATIONIN SAWE-A and SASE A+B

Modification of PHN's was divided into four distinct types according to the environment of the nuclear element: 1) Unmodified 2) Pre-modified 3) Post-modified and 4) Pre-&Post-modified. Only those modifiers which applied to the entire nucleus were considered in the classification. Thus, if the nucleus itself were filled by a PHN, the modification of that PHN was not considered in the classification of its constitute.

EX.1    +NUC            +QUAL  
          /PHN            /PHPREP

SASE A5.8    telephone calls in the French language.

In EX.1, since the entire underlined portion is the nuclear element, this PHN is considered to be post-modified only. The PHN which fills the nucleus, when analysed further, is classed as pre-modified only.

The criteria for classifying PHN's according to their type of modification are as follows:

A. Unmodified

The unmodified category in noun phrase modification includes:

- 1) Nuclear tagmemes with no modification at all, which necessarily implies two or more nuclei.

EX.1    +NUC   +NUC   +CORR   +NUC

SAWE-A8.18    agreements, guidelines and the imple-  
mentation orders.

BEST COPY AVAILABLE

EX.2 +NUC +CORR +NUC

SASE-B2.74 three hours or four hours.

2) Nuclear tagmemes preceded only by a DEIC\*

EX.1 +DEIC +NUC

SAWE-A6.50 that area.

\*CORR and INTERJEC were also not counted as modifiers.

B. Premodified

The premodified category in noun phrase modification includes:

1) Nuclear tagmemes preceded by one or more of the following functions or strings of functions:

EXAMPLES: \* where examples are drawn from only one corpus, they are representative of both corpora.

- (i) +QUAL: SAWE-A 11.12 acceptable proof.
- (ii) +QUANT: SAWE-A 2.28 all cases
- (iii) +SPECNUC: SASE-A 1.40 particularly the younger francophone generation.
- (iv) +REINFDEIC: SAWE-A 12.12 its own advantages  
\*can only occur with DEIC
- (v) +QUAL +RELAT: SAWE-A 14.15 a set of rules
- (vi) +QUANT +RELAT: SAWE-A 19.4 all of us
- (vii) +QUAL +POSS: SAWE-A 17.48 contractor's holdback
- (viii) +REINFQUANT SASE A5.47 no matter how much pressur  
\*only occurs in SASE, only occurs once.

2) All items in No.1 above which are preceded by DEIC.

EX.1 +DEIC +QUAL +NUC

SAWE-A 18.9 this new concern.

EX.2 +DEIC +QUAL +QUANT +NUC

SASE-A 3.45 the last five years.

C. Post-modified

The post-modified category in noun phrase modification includes:

- 1) Nuclear tagmemes followed by one or more of the following functions:

EXAMPLES: \*where examples have been drawn from only one corpus they are representative of both corpora.

- (i) +QUAL: SAWE-A 5.24 brochures describing two programs
- (ii) +QUANT: SAWE-A 4.9 \$15,000  
\*only occurs in SAWE
- (iii) +SPECNUC: SAWE-A 8.35 page 2  
SASE-B 3.115 the cultural aspect first
- (iv) +REINFNUC: SAWE-A 17.9 the park itself
- (v) +APP: SAWE-A 15.12 Mr. Jutras, the Acting Regional Director  
\*only occurs in SAWE
- (vi) +SPECQUAL: SAWE-A 17.2 your concern about the future of this park and indeed your own future as a leaseholder.

405 \*only occurs in SAWE, only 1 example

- (vii) +REINFQUANT: SASE B 3.73 no trouble at all
- (viii) +ELSPEC +SPECNUC: SAWE-A 16.10 a Mexican port  
ie Veracruz

\*only occurs in SAWE

2) All items in No.1 above which are preceded by DEIC

eg. +DEIC +NUC +QUAL

SASE-B 2.85 this question of total immersion

D. Pre & Post modified

The pre & post modified category in noun phrase modification includes:

- 1) Nuclear tagmemes which are both premodified and post-modified by one or more of the functions listed in B + C above.

eg. +QUAL +NUC +QUAL

SASE-A 3.93 chief effect of language training.

- 2) All items in No.1 above which are preceded by DEIC.

eg. +DEIC +QUAL +NUC +QUAL

SAWE-A 9.14 the next phase of development.



BEST COPY AVAILABLE

3. Clause  
Clause forms include all clauses as well as discourse explanations, (DEXPL), which only occur in SAWE

EX. (1) /DEXPL Mammals - Two Man years; see memo-randum dated January 6, 1970, re. Arctic Ecological unit.

4. Elliptical  
Elliptical forms fill understood functions; thus there is no actual representation of the form.

EX. (1) SASE-B 3.34 There might be acknowledgement that I do not have the competence (to learn Hindustani) or the aptitude to learn Hindustani.

In EX.1 the element in brackets does not actually occur in that position in the sentence, but represents an elliptical form filling the qualifier which is understood in the underlined phrase.

BEST COPY AVAILABLE

SAWE-A

NOUN PHRASE MODIFICATION: FORMS FILLING PRE-MODIFIER SLOTS

I. Terminal

\* All expressions (eg. XN, XADJIND, etc) are considered as terminal elements, but examples are not given for all that occur.

1. +QUAL

/ADJ	A11.12	<u>acceptable</u> proof
/ADJIND	A2.31	<u>another</u> branch
/ADJNEG	A11.9	<u>no</u> change
/ADJNUM	A15.23	<u>first</u> (Elliptical NUC)
/ADJP	A4.27	<u>American</u> industry
/ADJPOSS	A2.49	<u>its</u> bids
/N	A2.14	<u>air</u> transportation
/NP	A16.5	<u>Dr.</u> Aiken
/PRONREL	A16.47	<u>what</u> changes
/XADJ	A2.20	<u>good-quality</u> oysters
/XNDATE	A17.27	<u>1970-71</u> fiscal year

2. +QUANT

/ADJIND	A17.3	<u>all</u> Canadians
/ADJNUM	A12.21	<u>eleven</u> years

3. +REINFDEIC

/ADJPOSS	A12.12	<u>its own</u> advantages
----------	--------	---------------------------

4. +SPECNUC

/XADVSPEC	A20.16	<u>for example,</u> computers
/NP	A19.30	<u>Lindane</u> 0.001 PPM.



BEST COPY AVAILABLE

/ADVOPIIN A4.19

probably BWR'S and PWR'S

II. Phrase

1. +QUAL

/PHADJ A15.36

/PHN A19.11

/PHPREP A19.2

better than average progress.  
accident prevention regulation.  
over which jurisdiction

2. +QUANT

/PHADJ A3.14

/PHN A6.7

approximately 6 inches  
15 ton capacity

3. +QUAL +RELAT

/N /PREP A5.38

/ADJIND /PREP A5.47

/PHN /PREP A17.21

modes of transportation  
any of the agreements  
some form of agreement with  
the province

4. +QUANT +RELAT

/ADJIND /PREP SAWE A19.12

/ADJNUM /PREP SAWE A16.42

/N /PREP SAWE A6.5

/PHADJ /PREP SAWE A19.39

/PHN /PREP SAWE A11.49

many of which  
one of the samples  
part of the building  
one or more of your works  
a large segment of taxpayers

5. +QUAL +POSS

/N /PARTPOSS A17.48

/NP /PARTPOSS A16.4

/PHN /PARTPOSS A12.44

/XN /PARTPOSS A1.45

/XNP /PARTPOSS A7.29

contractor's holdback  
AECL's tendering document  
his car's windshield  
to-day's date  
Charlie Law's story on fuel.

III. Clause - only one legitimate example:

+QUAL  
/ADJ

+CORR      +QUAL      +NUC  
/CONJCOORD/CLPASSWH /N

A15.38 signed and expected  
to be signed con-  
tracts.

BEST COPY AVAILABLE

SAWE A

NOUN PHRASE MODIFICATION: FORMS FILLING POST-MODIFIER SLOTS

I. Terminal

1. +AP2

/XNP A8.47

vote 1, Departmental Administration

/N A19.32

parts per million, PPM

2. +QUANT

/ADJNUM A4.9

\$15,000

3. +SPECNUC

/N A14.18

class A

/NP A9.22

Belleville, Ontario

/XN A12.16

extension 6-1062

/XNP A4.40

Chief, Financial Services Division

/XNADDRESS A9.26

National and Historic Parks  
Branch, Room 1201, 400

Laurier Avenue West, Ottawa 4  
Ontario.

4. +REINFNUC

/PRONREFL A17.9

the park itself

5. +SPECQUAL

/ADVEMPH A17.2

Your concern about the future  
of this park and indeed your  
own future as a leaseholder

6. +REINFQUANT

/XADVDEG A7.22

any inconvenience whatsoever

BEST COPY AVAILABLE

II. Phrase

1. +QUAL

/PHPREP A12.23

admissibility to Canada

2. +QUANT

/PHADJ A1.18

\$130.53 monthly

3. +SPECNUC

/PHN A15.49

General Manager, Product Development H.J. Heinz Company of Canada, LTD

/PHPREP A2.48

my memorandum of January 9, 19

4. +APP

/PHN A15.12

Mr, Jutras, the Acting Regional Director

5. +ELSPEC +SPECNUC

/XADVSPEC /NP A16.10

a Mexican port ie Veracruz

/ADVSPEC /PHN A2.1

the commodity divisions concerned namely Chemical Specialties Division and the Iron and Steel Division

III. Clause

1. +QUAL

/CLELLWH A11.11

reasons why

/CLBASINF A11.4

permission to change

/CLBASPART A5.24

brochures describing two programs

/CLBASWH A4.22

areas which never expected such changes

/CLEQUATWH A6.27

/CLPASSWH A19.7

/CLCOMPLEX A5.3

2. +SPECNUC

/DEXPL A17.50

proof that it is his respon-  
sibility now rather than  
yours

matters not covered by pro-  
vincial regulations

the program forecast and  
estimates manual which I sent  
to you to look over

Mammals - Two Man-Years; see  
memorandum dated December 18,  
1969, with Deputy Minister  
approval on it.

BEST COPY AVAILABLE

SASE A+B

NOUN PHRASE MODIFICATION: FORMS FILLING PRE-MODIFIER SLOTS

I. Terminal

\*All expressions (eg. XN, XADJIND, etc) are considered as terminal elements, but not all that occur are included in the examples.

1. +QUAL

/ADJ	B1.5	<u>advanced</u> courses
/ADJIND	B3.44	<u>another</u> country
/ADJINTERROG	B6.3	<u>which</u> aim
/ADJNEG	B1.57	<u>no</u> reason
/ADJNUM	B2.49	<u>first</u> degree
/ADJP	A1.72	<u>English</u> culture
/N	A2.2	<u>language</u> teaching
/NP	A2.21	<u>English</u> course
	A2.57	<u>Miss</u> Churchra

2. +QUANT

/ADJIND	B4.38	<u>some</u> people
/ADJNUM	B1.53	<u>eight</u> hours
/XNMEASURE	B4.66	that <u>six-week</u> period (p.547)

3. +SPECNUC

/ADVSPEC	A1.40	<u>particularly</u> the younger francophone generation
/XADJIND	A1.13	<u>sort of</u> expressions of disappointment

4. +REINFDEIC

/ADJPOSS	A5.2	his <u>own</u> language
----------	------	-------------------------

BEST COPY AVAILABLE

5. +REINQUANT

/ADVDEG A5.47

no matter how much pressure  
(p. 560)

II. Phrase

1. +QUAL

/PHADJ A5.22

about three years

/PHN B2.9

French language training

/PHADVDEG B6.5

enough (French) to be able

to carry on a conversation

and make (myself) understood

and understand what the other

party's saying in the ordinary

sort of discourse one has.

2. +QUANT

/PHADJ A2.99

very little French

/PHPRON B1.5

this many course

3. +SPECNUC

/PHADVDEG A5.16

pretty much the same

4. +QUAL +POSS

/NP /PARTPOSS B4.64

Mac's name

/PRONIND /PARTPOSS B2.110

one's work

/PHN /Ø A1.38

the teachers' point of view

5. +QUAL +RELAT

/N /PREP A3.33

degree of success

/ADJIND /PREP B2.72

some of your French.

/PHN /PREP A5.96

a different kind of course

6. +QUANT +RELAT

/ADJIND /PREP A2.40

/N /PREP B1.71

/ADJNUM /PREP A5.4

/PHADJ /PREP A2.16

/PHN /PREP B5.10

all of the briefings

part of the old traditional  
method

one of these two

too many of our teachers

a certain amount of help

III. Elliptical

1. +QUAL

/Ø

A4.25

— McPherson... (only example p.5)



BEST COPY AVAILABLE

SASE A+B

NOUN PHRASE MODIFICATION: FORMS FILLING POST-MODIFIER SLOTS

I. Terminal

1. +QUAL

/ADJ B5.103

their mouth open (only example p.526)

/ADVLOC B2.113

these people here (P.526,527)

2. +REINFNUC

/PRONP B1.50

the students themselves

3. +SPECNUC

/ADJNUM B3.115

the cultural aspect first

/N B1.149

student A B C D

4. +REINFQUANT

/XADVDEG B5.47

no French at all.

II. Phrase

1. +QUAL

/PHPREP A1.140

competence in English

/PHADJ B4.16

longer than three weeks at

a time (elliptical Nuc - only example p.514)

/PHADVLOC A4.30

the voices out there

2. +SPECNUC

/PHPREP A5.57

my age for one

III. Clause

1. +QUAL

/CLBASINF B3.33

ability to learn the second official language