

DOCUMENT RESUME

ED 099 217

95

SE 018 290

TITLE A Multidisciplinary Process Curriculum in Environmental Education, Grade 2.
INSTITUTION Edmonds School District 15, Lynnwood, Wash.
SPONS AGENCY Office of Education (DHEW), Washington, D.C.
PUB DATE 73
GRANT OEG-0-72-5436
NOTE 147p.

EDRS PRICE MF-\$0.75 HC-\$6.60 PLUS POSTAGE
DESCRIPTORS *Conservation Education; *Curriculum Guides; *Elementary Education; *Environmental Education; Field Trips; Grade 2; Instructional Materials; Learning Activities; Natural Resources; Outdoor Education; *Science Education; Teaching Guides

ABSTRACT

This second grade curriculum guide is based on a multidisciplinary approach to environmental education. The guide includes activities, guidelines for field trip planning, and a resource section. The guide deals with the subjects of plants, soil, and litter. Each subject section includes activities based on the physical characteristics, man's use, and man's misuse of the subject. Activities may be used individually or in sequence, and aim to promote the development of positive attitudes toward the environment. Each activity provides the teacher with objectives, teacher background information, a materials list, a preactivity, the activity, a postactivity, supplemental activities, and illustrations intended for copying. Guidelines for conducting a field trip are included to facilitate the teacher in teaching in the out-of-doors. The guidelines cover pre-field trip, field trip, and post-field trip planning. A resource section includes speakers, films, free and inexpensive materials, pamphlets, and conservation and environmental groups which may be contacted for information on environmental topics. (TK)

U.S. DEPARTMENT OF HEALTH,
EDUCATION & WELFARE
NATIONAL INSTITUTE OF
EDUCATION
THIS DOCUMENT HAS BEEN REPRO-
DUCED EXACTLY AS RECEIVED FROM
THE PERSON OR ORGANIZATION ORIGIN-
ATING IT. POINTS OF VIEW OR OPINIONS
STATED DO NOT NECESSARILY REPRESENT
THE OFFICE OF THE NATIONAL INSTITUTE OF
EDUCATION, POSITION OR POLICY.

BEST COPY AVAILABLE

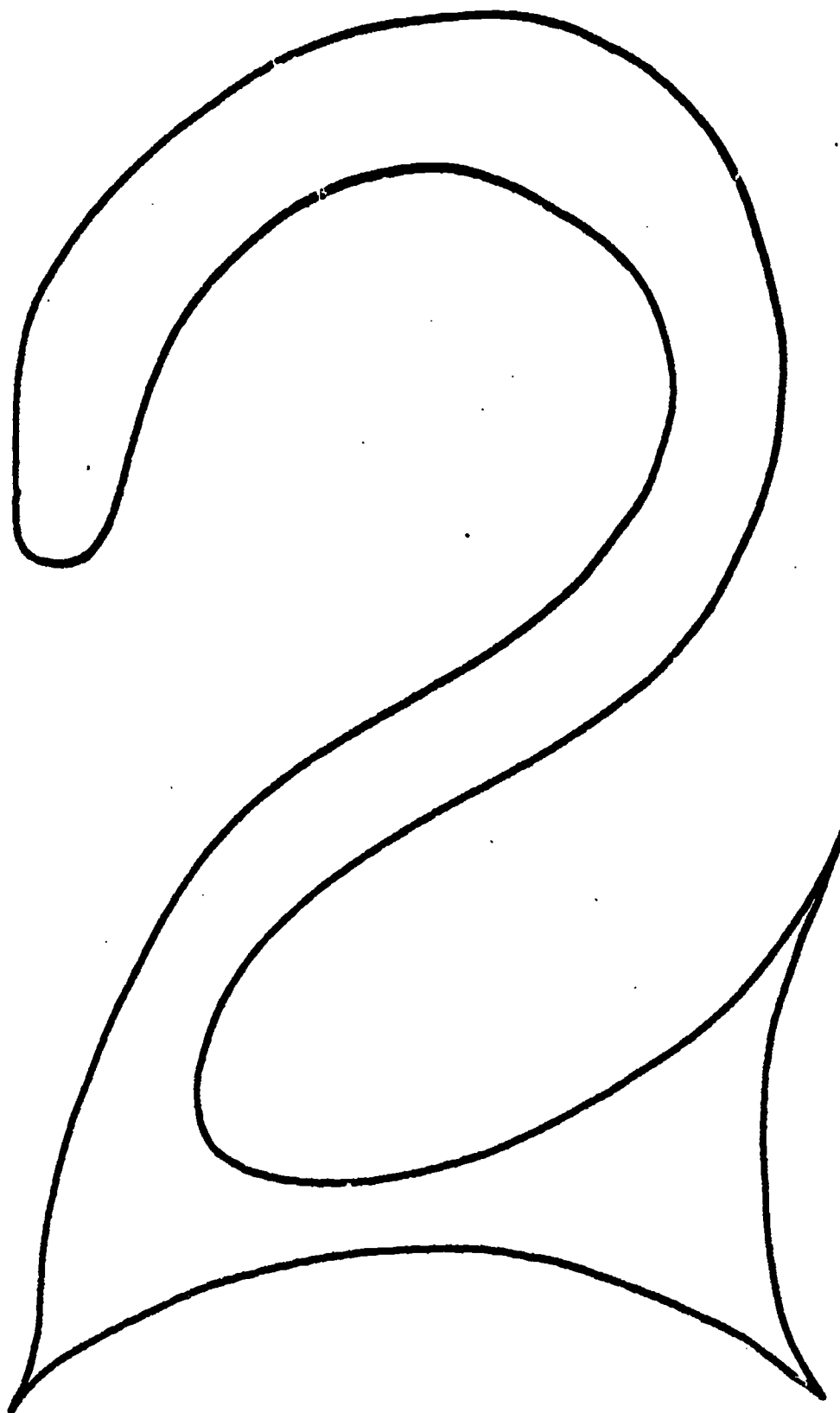

ED 099217

06281035

ED 099217

A MULTIDISCIPLINARY PROCESS
CURRICULUM IN ENVIRONMENTAL EDUCATION

K - 12

Under Provision of Public Law 91-516, Grant No. OEG-0-72-5436

Project No. RO 21178

PROJECT WRITING TEAM

Elementary

Sue Brown
Larry Gidner
Carol Gissberg
Dan Griner
Patricia Meived
Mary Beth Peters
Lynn Severance
Rosanne Walker

Secondary

Steve Burger
Bill Hanlon
Les Kramer
Larry Luke
Lauretta Main
Rod McLeod
Jan Parsons

Staff Artists

Kathy Aukland
Kathy Hildahl

Project Director

Bill Hamilton

Edmonds School District No. 15
Snohomish County
Lynnwood, Washington

1973

PROJECT SUMMARY

This project was designed to provide a working model for the structure and implementation of a multidisciplinary process curriculum in environmental education, grades K-12. This model emphasizes the broadly based socio-ecological approach endorsed by the Edmonds School District Environmental Education Council, as a unifying theme to be incorporated into a comprehensive environmental program. Such an approach seeks to integrate the cultural, historical, and social aspects of man with fundamental sociological principles applicable to all living organisms. It will utilize the school and total community as a field laboratory and as a basis for the investigation of ecological relationships and environmental problems. The design of the model presented here includes five phases which have been sequentially organized into the following areas:

1. To plan for the structure of appropriate training and student activities as designed by two writing teams selected on the basis of defined qualifications. The participating teams represented each grade level, K-6, and each relevant secondary discipline, 7-12. The team consulted with community, local, state, and natural resource personnel and incorporated existing materials into a total program that reflects the objectives established.
2. A plan for implementing the materials written by means of training sessions at the elementary building level and for the specific secondary disciplines and secondary teachers involved. The writing team will form a nucleus for the training of teachers in use of materials and equipment.
3. A plan to evaluate the effectiveness of materials and methods used through formal and informal feedback from students and teachers involved. Students will be evaluated on the cognitive aspects of the curriculum materials written and both teachers and students on the attitudinal aspects.
4. A plan for revision and retraining as necessitated by the analysis of evaluation procedures and results, and from community feedback.
5. A plan to continue the program utilizing district and community funds under the guidance of the Edmonds District No. 15 Environmental Council in cooperation with the District Environmental Consultant.

This project is a "beginning". It was written during four weeks of the summer of 1973. The writing team realizes that they have just scratched the surface of putting together a K-12 multidisciplinary environmental education curriculum. We know that it needs to be tried by teachers, and hope that you will use it while instructing your students. Try it out! Write in it and jot down your notes. Revise, add and delete! Then give us feedback as to how you used it and how you felt about the whole thing so that we can work your ideas into our revision next summer. There are extra lesson outlines in the back to experiment with. Now -- enjoy!

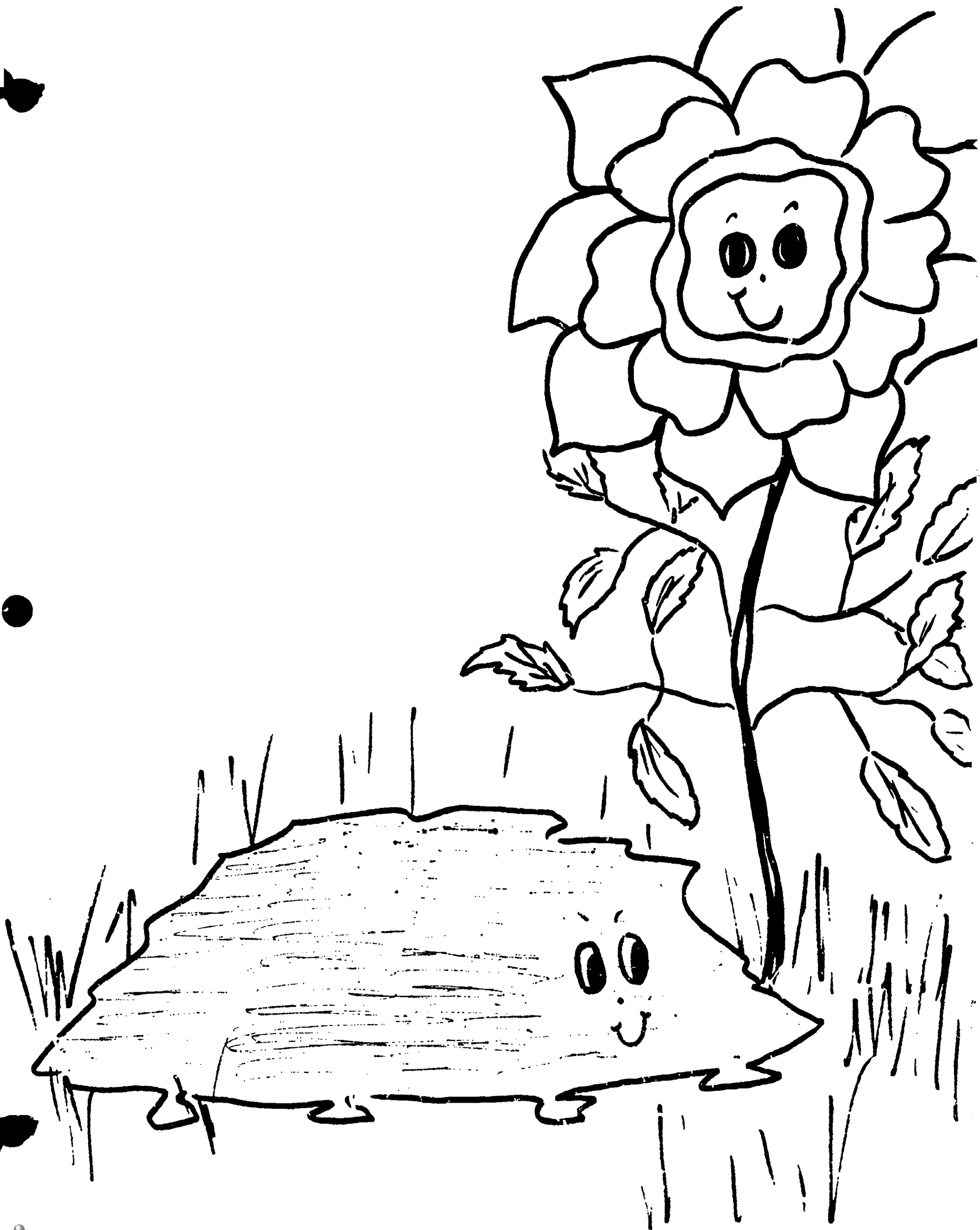

ROSE

PETAL

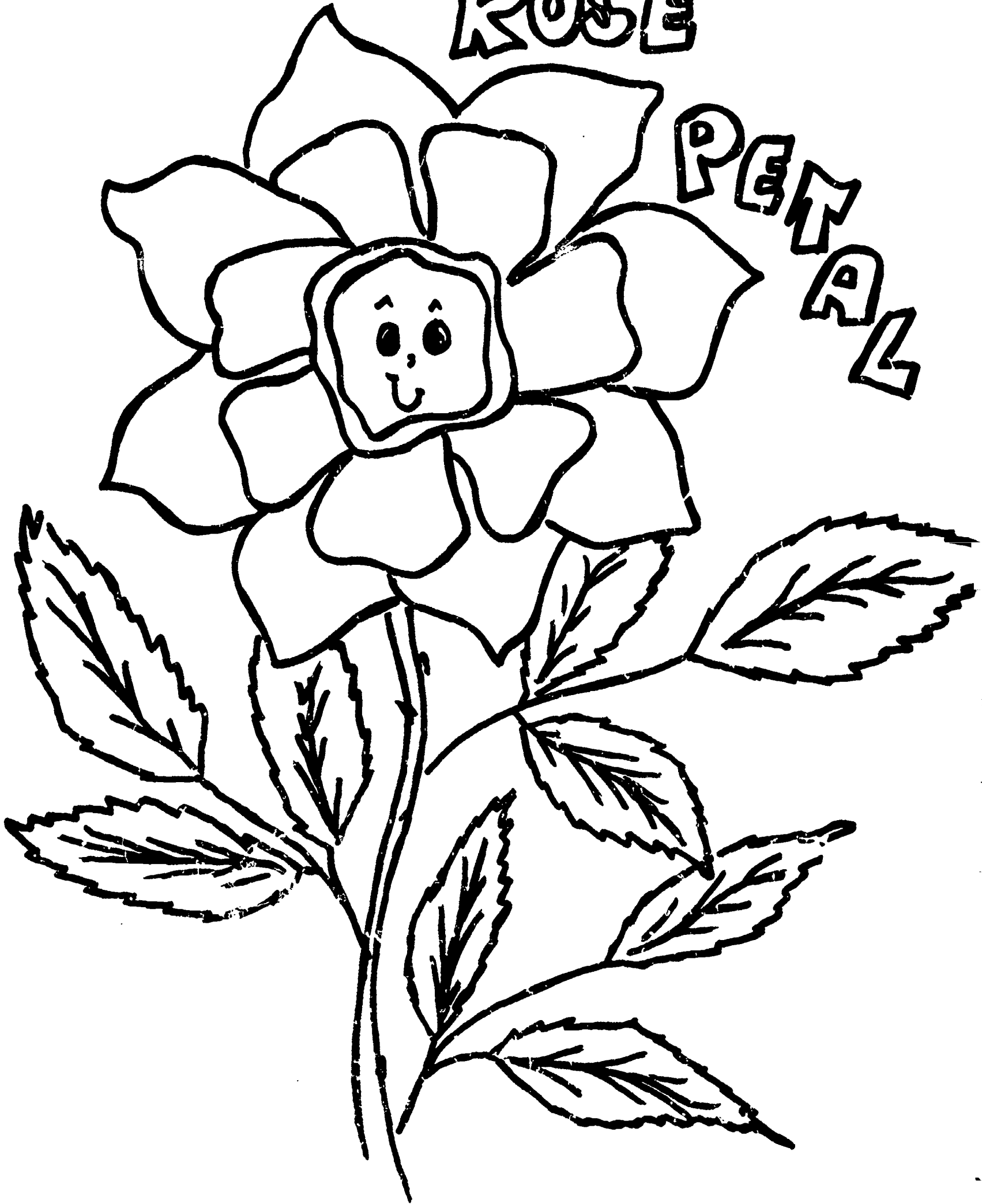

The intent of this unit is to develop awareness of basic deductive and inductive skills stressing scientific methods of study, development of attitudes and perception, and a process approach to learning.

In dealing with our objectives, we are using an activity oriented approach. Each of our subject areas has been divided into three parts, the PHYSICAL CHARACTERISTICS of the subject, MAN'S USE, and MAN'S MISUSE. Each lesson is designed to be complete in itself.

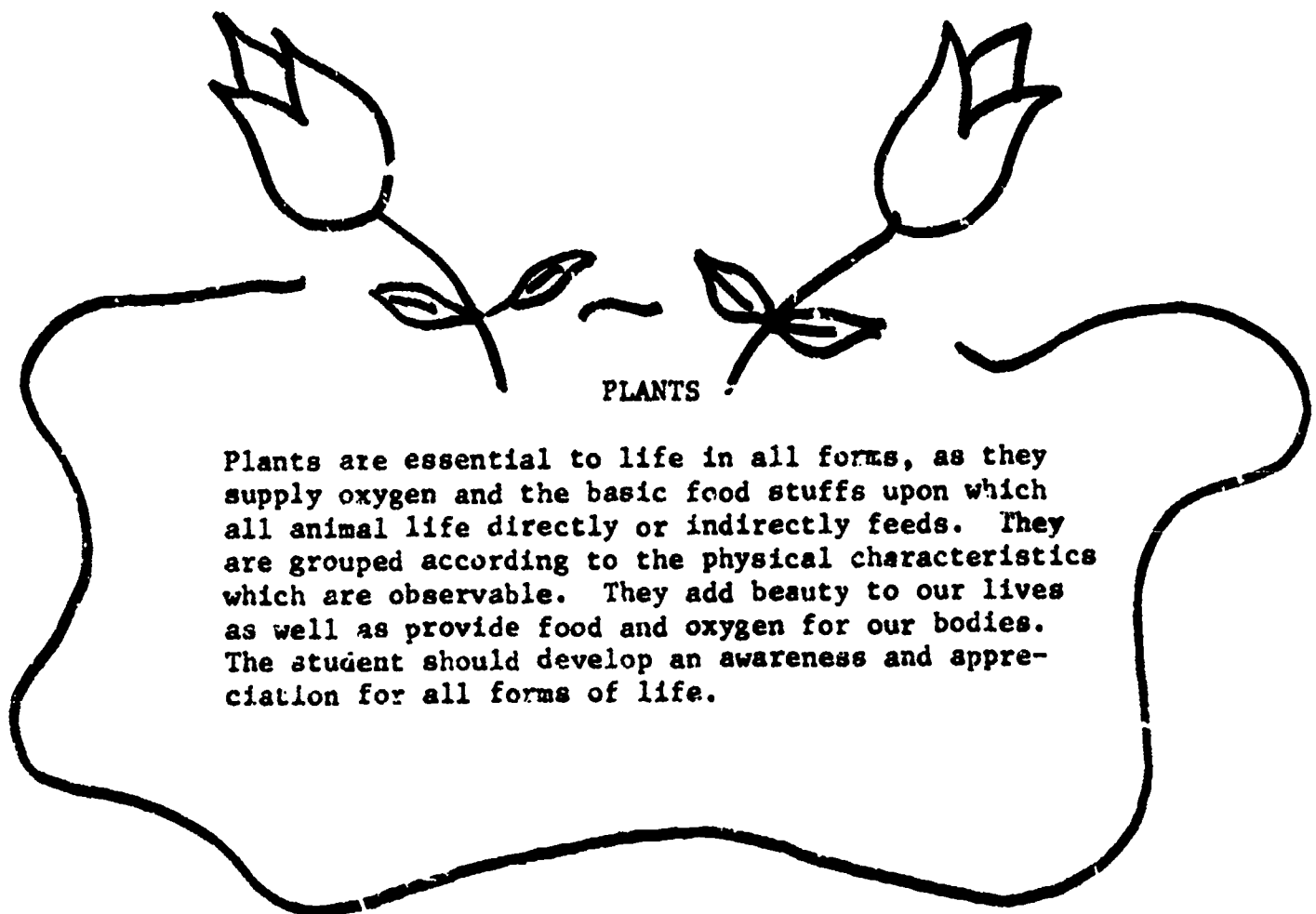

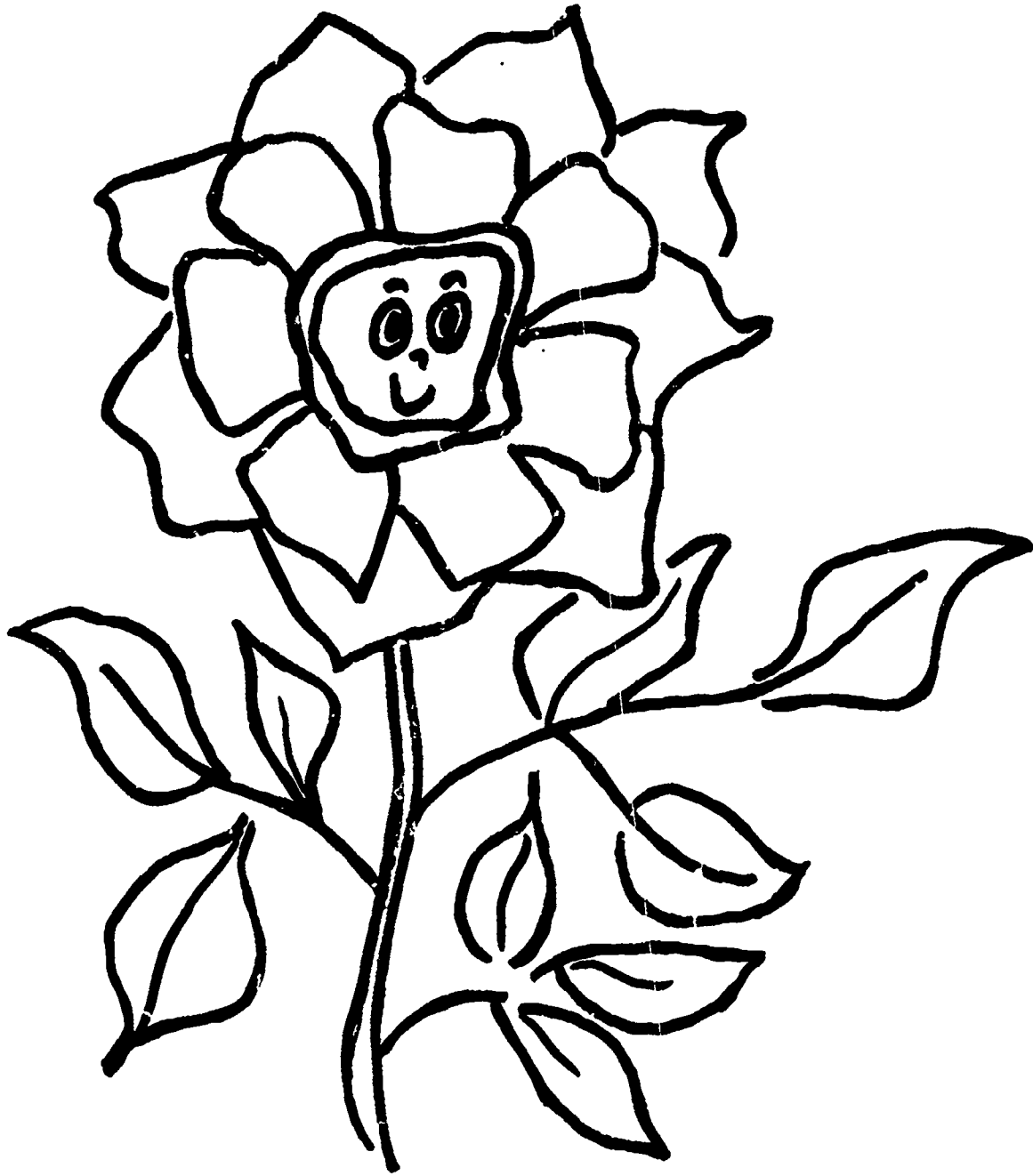

We visualize Rose Petal as a creative character that may help tie in the various activities that follow. She may act as a visual aid in flannel on your flannel board or as a means of introducing lessons, related poems, films, etc. The larger picture of Rose on the next page could be made into a ditto and serve as a cover on a Plant Looklet. You may want to adapt her into a puppet character.

We know you'll have a lot of your own ideas, too. We'll be anxious to have you share them with us during our inservice get togethers and will want to include them in our revision.

ROSE

PETAL

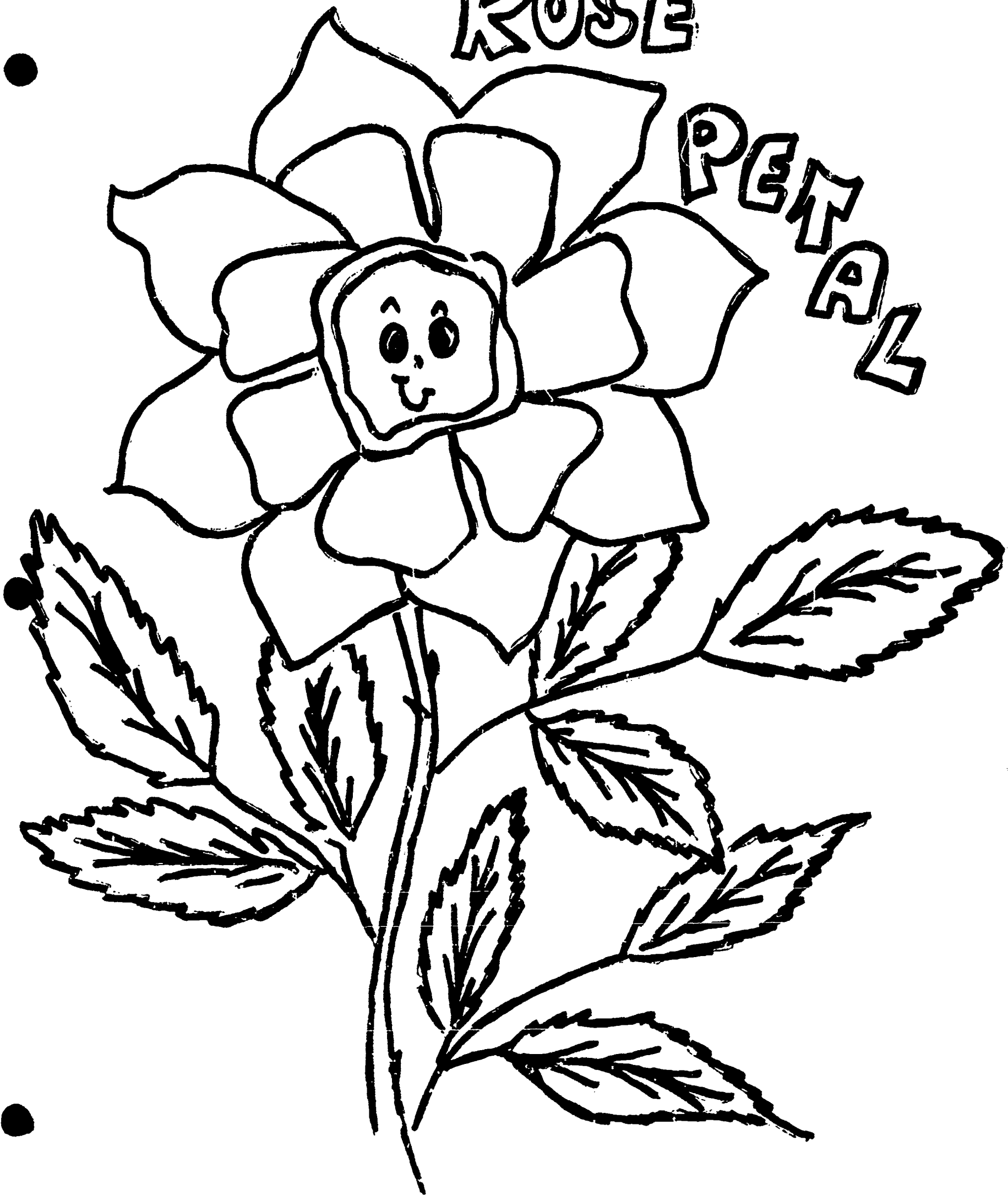

PLANTS

Topic: Plant Classification
Grade: 2
Estimated Time:
Subject Areas: Science

LEVEL V OBJECTIVE:

STUDENTS WILL KNOW THE CLASSIFICATION SYSTEMS OF THE VARIOUS FORMS OF PLANT AND ANIMAL LIFE.

LEVEL VI OBJECTIVE:

THE STUDENT WILL BE ABLE TO IDENTIFY THE VARIOUS PARTS OF PLANTS SUCH AS ROOT, STEM, LEAF, AND FRUIT.

GETTING IT TOGETHER

MATERIALS

Paper, scissors, pencil, glue, the attached worksheet.

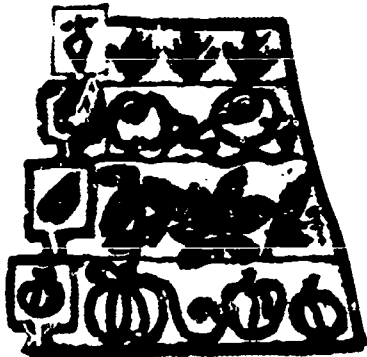

TEACHER BACKGROUND INFORMATION

In order to become aware of the great variety of plant life, children should have the opportunity to observe and handle as many kinds as possible. Furthermore, it is important that children understand that the process of classifying or grouping plants into definite categories is simply a means of making a great deal of information more useful. For example, it is much easier to speak of evergreens than to have to explain each time such plants are discussed, that we mean plants that remain green during each season of the year because they do not lose their leaves all at once - or that conifer refers to an ever-green plant with needle-shaped leaves and with seeds borne on structures called cones. Botanists have worked out specific methods for placing all known plants into particular groups following rules based upon similarities and differences in structure. The same approach can

Teacher Background (cont.)



be used here by permitting each child or small groups of children to decide which plants can be grouped in many ways, such as green and non-green, seed plants or non-seed plants, needle leaves or broad leaves. Green plants may be broken down further into cone-bearing and flower bearing divisions and so forth.

There are two major groups of seed producing plants - those that produce seeds in cones without protective coating (gymnosperms), and those that produce seeds by means of flowers enveloped in a protective fruit (angiosperms). Gymnosperms include the evergreens, whose foliage is inedible by all but a few organisms but the seeds are eaten by many plants and mammals. The angiosperms make up the deciduous forests and provide much of the underbrush and ground cover in areas that may or may not be dominated by gymnosperms. The angiosperms are also the major source of man's immediate food supply in providing cereals, vegetables, fruits, nuts and berries.



The role of green plants in transforming light energy into the chemical energy stored as edible foods through the process of photosynthesis is a difficult one to demonstrate. Yet, the fact that only green plants are able to transform light energy into a form that living things can utilize for all life functions, and in the process release oxygen as a waste product, makes photosynthesis absolutely necessary for the survival of life on the planet earth. The success of any biotic community really depends upon the amount of photosynthesis that can occur. Plants that lack chlorophyll can not photosynthesize and must take their food from their environment as do animals.

Teacher Background (cont.)

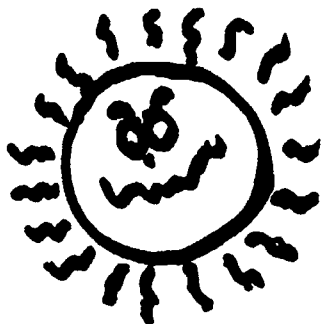

The main idea in the "discovery approach" is that the learner asks himself, as he stands before the unknown specimen, "What do I want to remember about this tree in order to be able to recognize others like it?" As each student gathers notes in the field for his own personal Clue Chart for Trees, he may come up with something on the order of the attached chart.



Finding sufficient evidence to fill in each column of the Clue Chart may require many observations over several seasons. For example, an observer's flower column may be incomplete until he discovers the tree in its flowering stage. Once having completed a Clue Chart, however, the learner will have more first-hand knowledge of the trees which he has studied than the person who has gained his information from books alone. Quite often, one distinctive characteristic is sufficient to identify a particular tree. Once having developed a Clue Chart, the student will readily recognize, even in winter without its leaves, a tree which has opposite budding and branching and whose twigs are square to the touch rather than round, as a blue ash. Even the beginning observer of nature soon learns to recognize the honey locust solely by its distinctive clusters of long thorns.

PRE-ACTIVITY

Discuss terms with students: Roots, stems, leaves, fruit.

ACTIVITY

Pass out activity sheet (attached) and supplies.

POST-ACTIVITY

Take nature walk and identify parts of plants you see.

WHY NOT
TRY
THESE?

SUGGESTED ADDITIONAL ACTIVITIES

1. Find pictures for each group.
2. Vary worksheet approach using shrubs and trees (attached).
3. Vary worksheet by crossing out pictures that don't belong to a particular group and color the others.
4. Play a food game. If you were going to prepare a stew using roots only, what would you use? If you were going to prepare a salad just using leaves, what would you use?

RESOURCES

STUDENT

See attached Bibliography















TEACHER

"Seeds Grow into Plants" - EF 7

"Life Story of a Plant" - EF 353

Edmonds Curriculum Bulletin EE 1
"Marshall Outdoor Laboratory"

TEACHING IN THE OUTDOORS, Hammermen

SHAPE	LEAVES	BUDS	BARK	FLOWER	FRUIT	DISTINCTIVE CHARACTERISTICS	NAME
 LARGE & SPREADING			PEELING WITH MARKS	SMALL GREENISH HANG IN CLUSTERS	 TWISTY BEAN 10" 18" LONG	LARGE THORUS GROWING IN CLUSTERS	HONEY LOCUST
LIMBS SNAILED & TWISTED	 HINGED WAIST	IN A CLUSTER & ROUND 	DEEPLY RIDGED			ACORN CAP WITH RIDGE	BUR
 LIMBS BREAK UPWARD	 POINTED TIPS	IN A CLUSTER & POINTED 	VERTICAL LIGHT & DARK STRIPING	LONG DROOPING CATTAILS 	ACORN 	SHALLOW ACORN CAP LIGHTISH NUT	RED OAK
		LARGE EGG SHAPED 	PEELING SCALY		 NUT	SMOOTH BARK	SHAG BARK HICKORY

Source for chart above and
Teacher Background Information:

TEACHING IN THE OUTDOORS,
Hammermen, copyright 1964,
Burgess Pub. Co.

Color Roots-brown, Leaves-green,

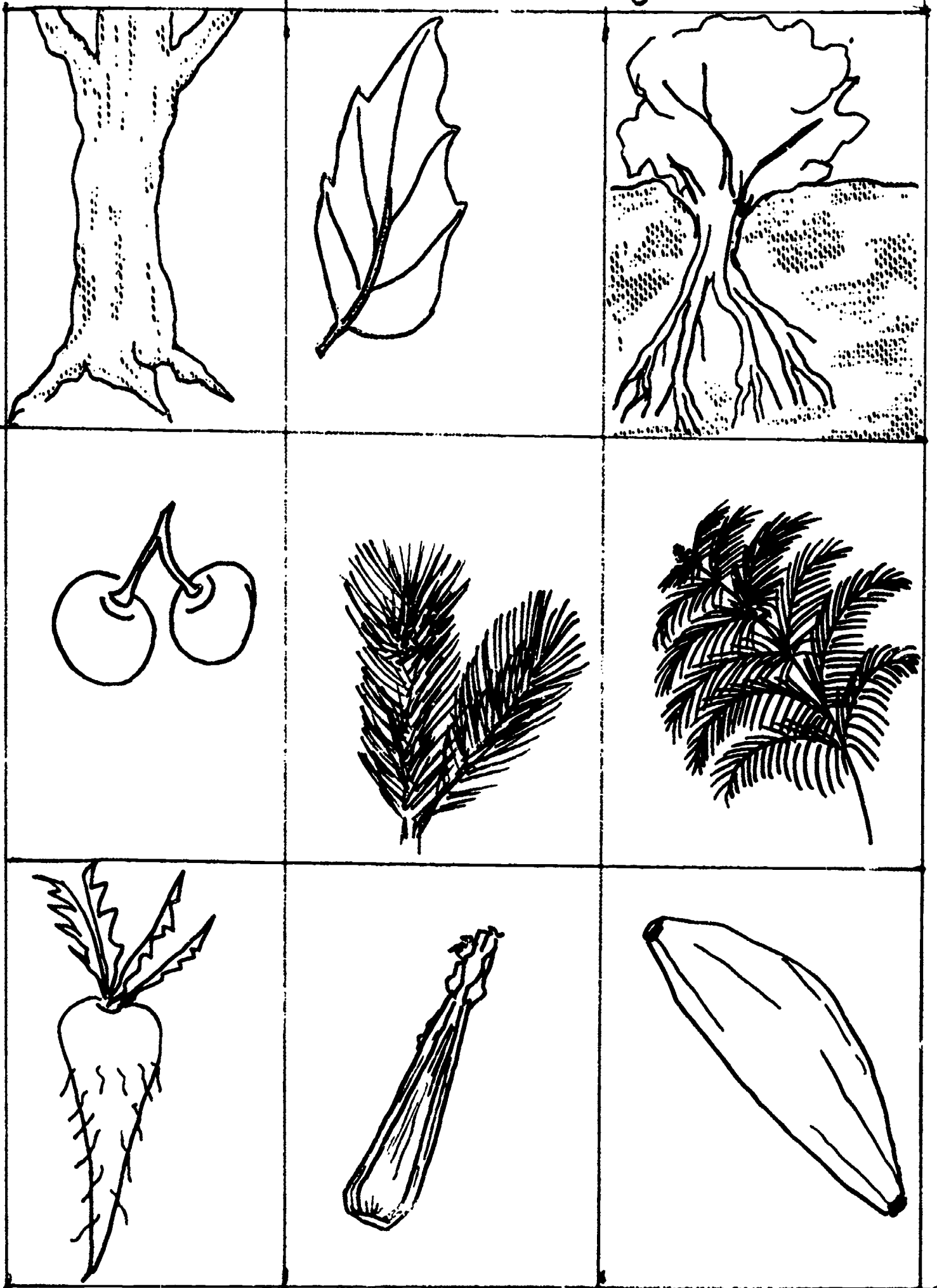

Stems- yellow, Fruit orange

Color Roots-brown, Leaves-green

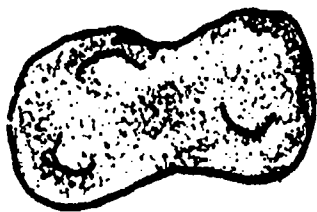

Potato



carrot



lettuce

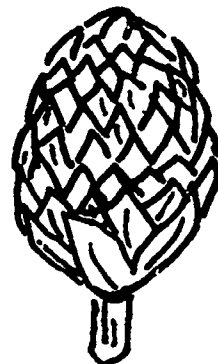

artichoke



Spinach

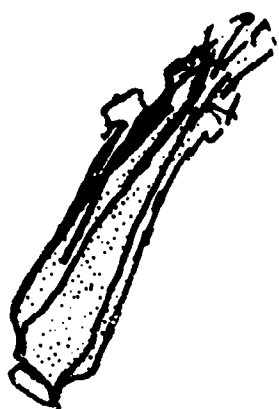

celery

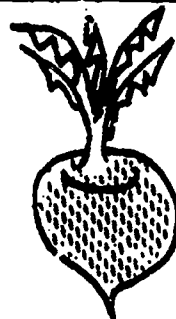

beet



corn

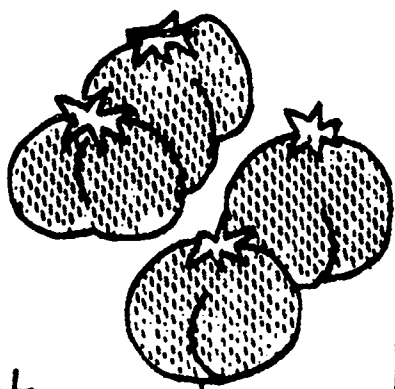

tomato

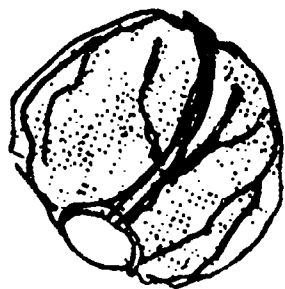

cabbage



peas

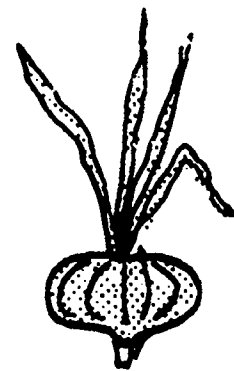

onion

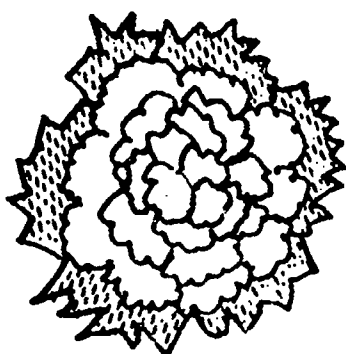

califlower



pumpkin



peanut



asparagus

Stems - yellow, Fruit - orange

EXAMPLES OF SEED DISPERSAL MECHANISMS

Seeds Carried by Parachutes

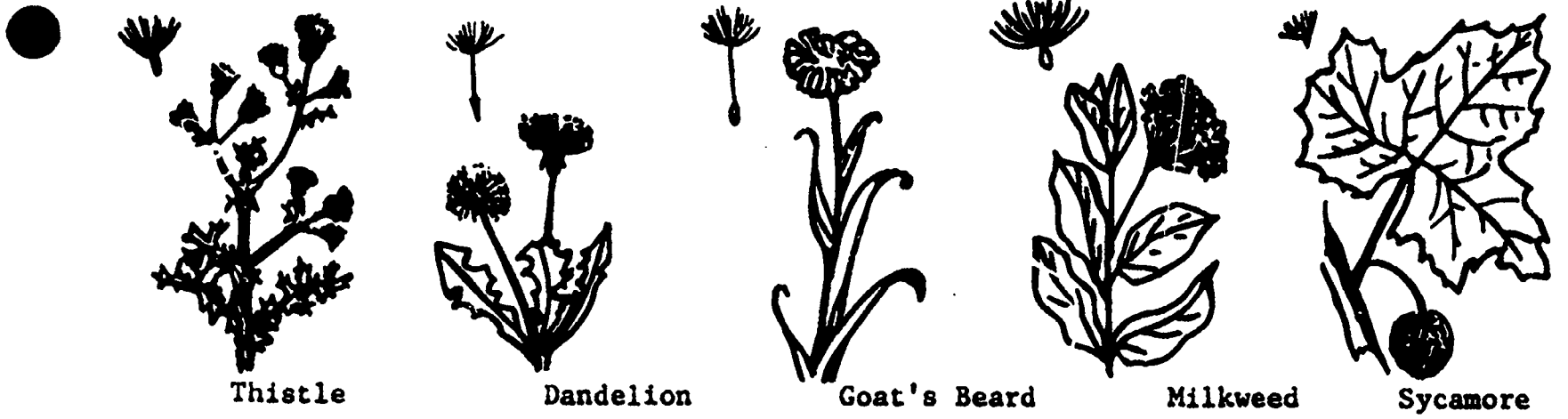

Seeds Carried by Wings

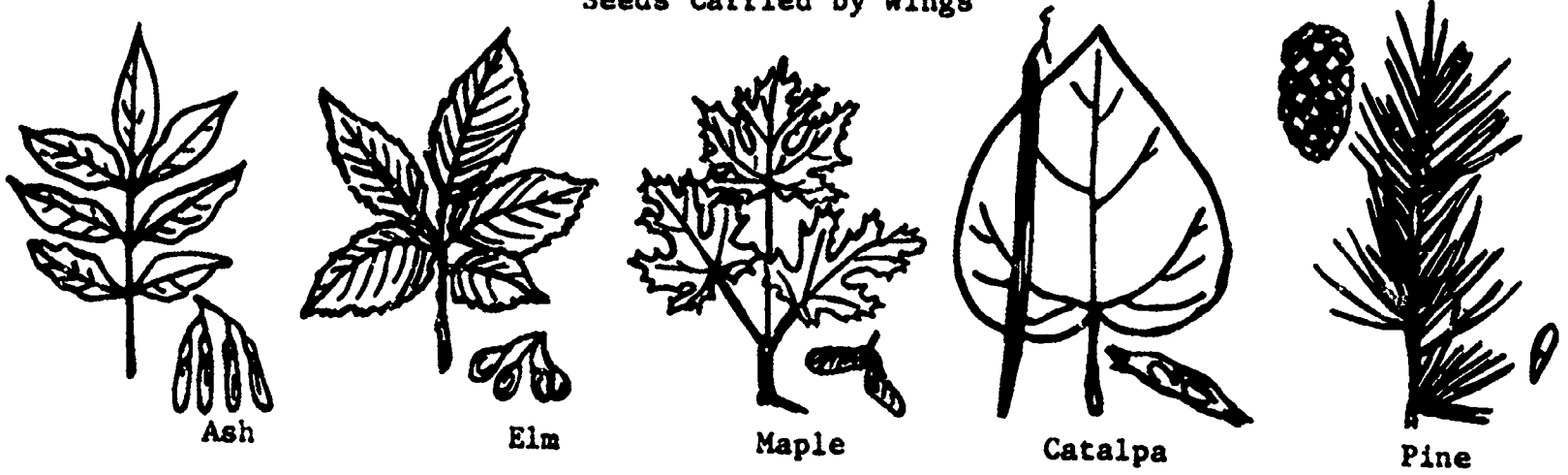

Seedcases with Hooks

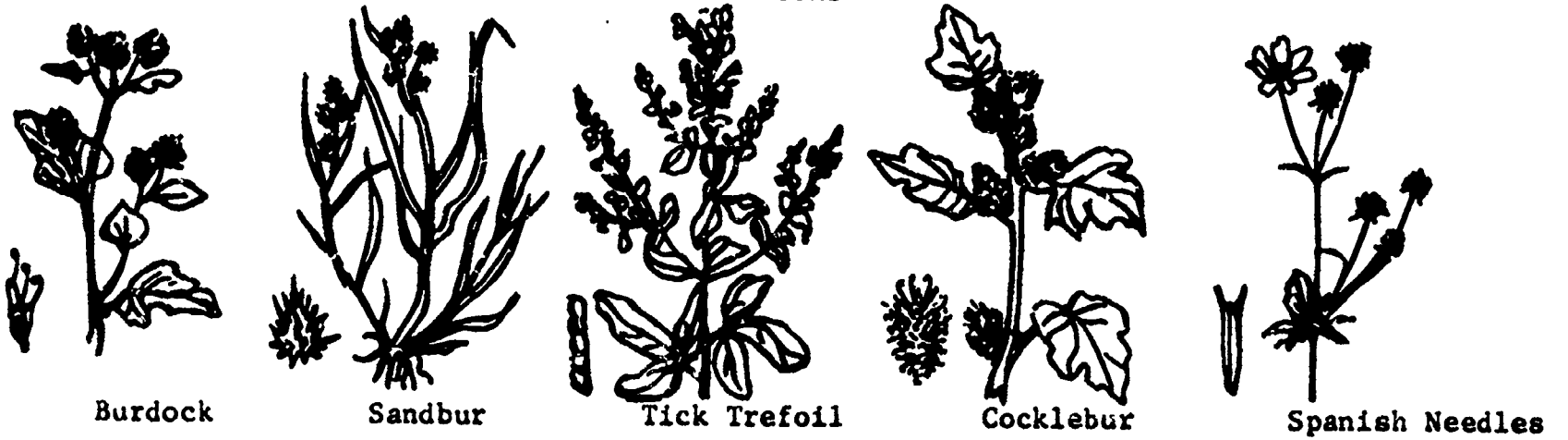

Seeds without Parachutes, Wings, or Hooks

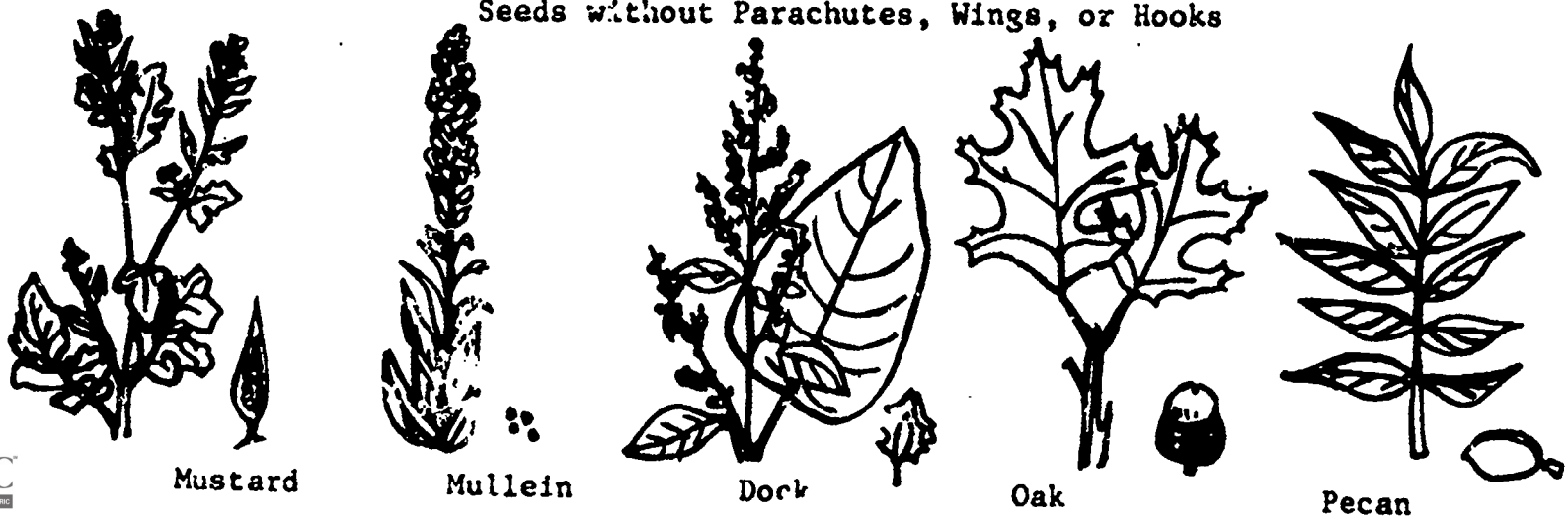

Cut out the flower pieces. Paste the circle on a sheet of paper. If you can write an addition or subtraction combination equal to 6 on a petal, you can paste the petal on the flower.

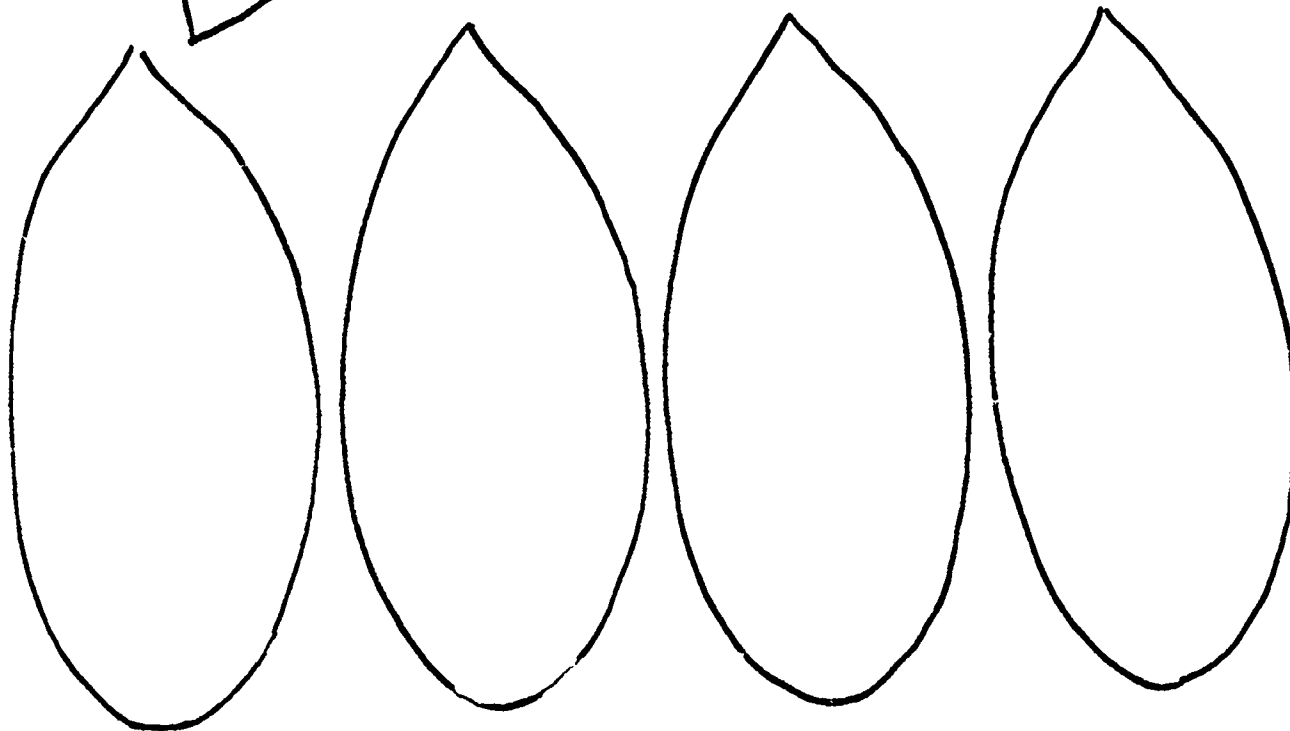
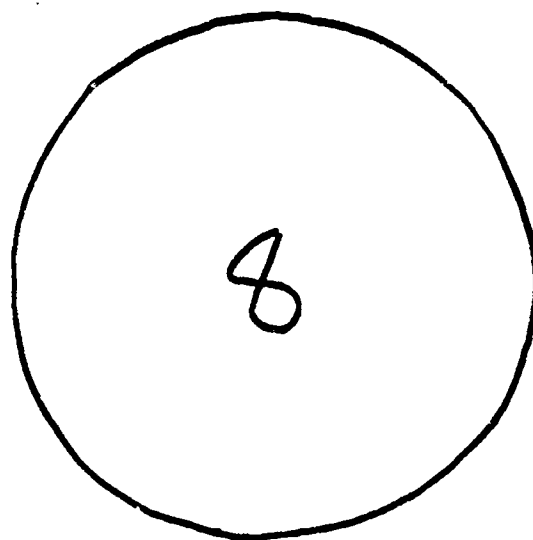
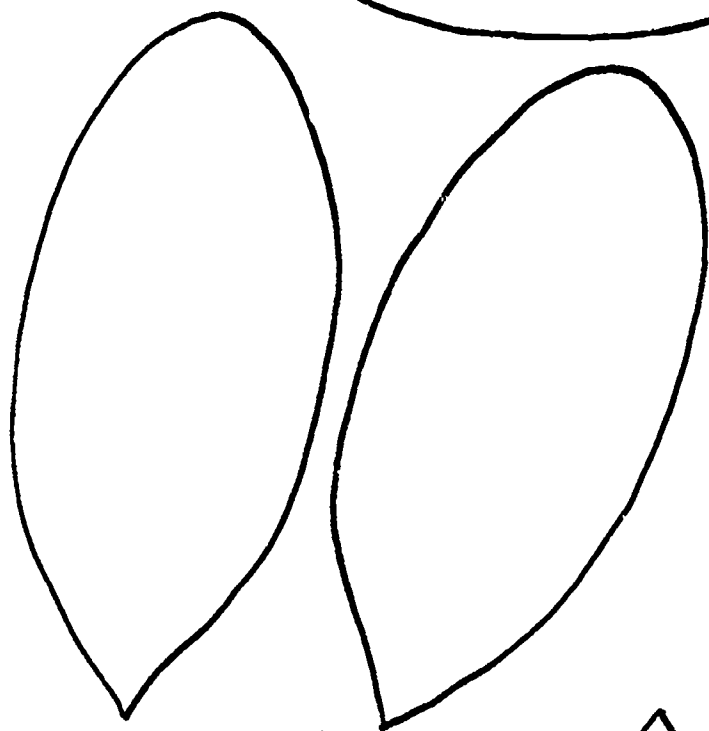
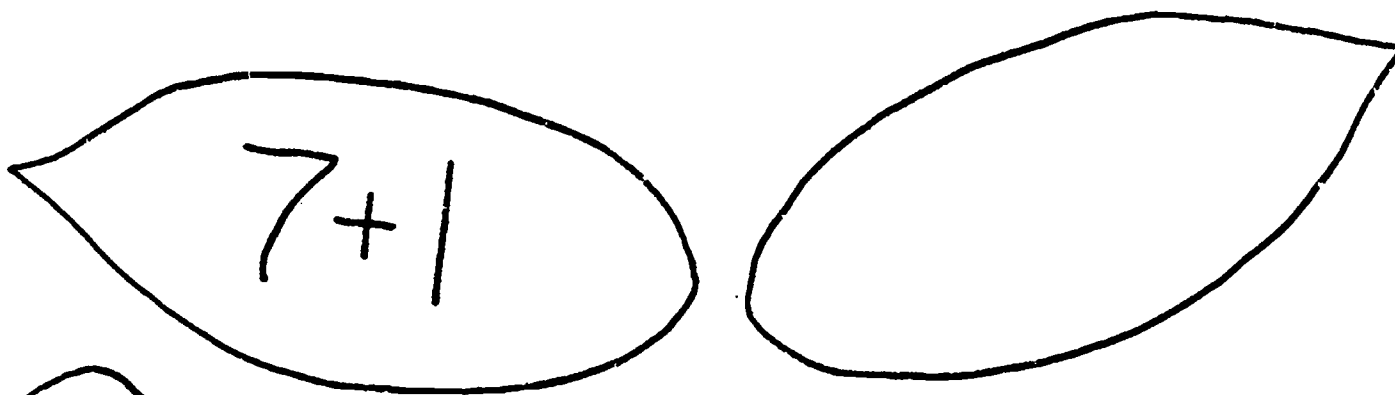

PLANTS

Topic: Plant Classification

Grade: 2

Estimated Time:

Subject Areas: Science, Art, Soc.
Studies, Lang. Arts

LEVEL V OBJECTIVE:

STUDENTS WILL KNOW THE CLASSIFICATION SYSTEMS OF THE VARIOUS FORMS OF PLANT AND ANIMAL LIFE.

THE STUDENT WILL BE ABLE TO IDENTIFY PLANTS AND ANIMALS OF HIS LOCAL ENVIRONMENT.

LEVEL VI OBJECTIVE:

THE STUDENT WILL BE ABLE TO CLASSIFY PLANTS INTO TWO GROUPS; SEED AND NON-SEED.

GETTING IT TOGETHER

MATERIALS

Plastic bags;
assortment of tag-
board plants (attached
sheet); scissors, crayons.
Many drawings are already
in BIOLOGY OF THE NW
guide

TEACHER BACKGROUND INFORMATION

Plant classification chart. Refer to
Lesson #1 for additional information.

PRE-ACTIVITY

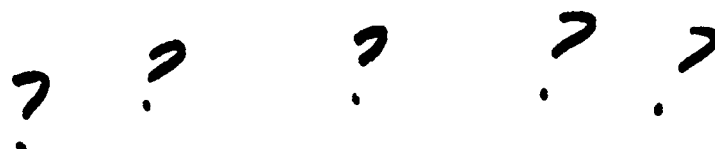
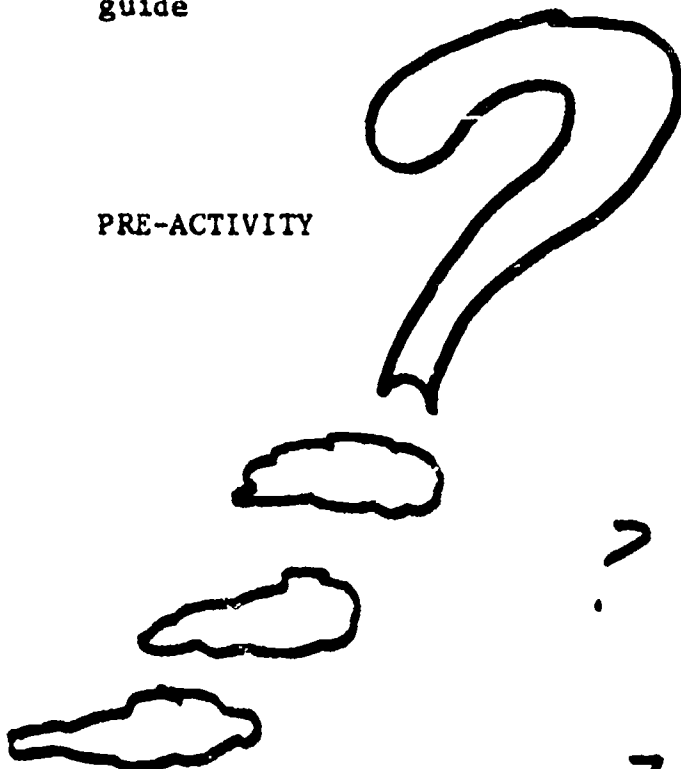

Discuss the following questions with
the class:

1. If you were given the job of taking care of a large number of small objects so that any one thing could easily be found, and they were given to you all mixed up in a big sack, what is the first thing you would do? (Put them in separate groups)
2. How would you decide, if you didn't know the names of any of the objects, how to group them? (Color, size, use, material made from, etc.)

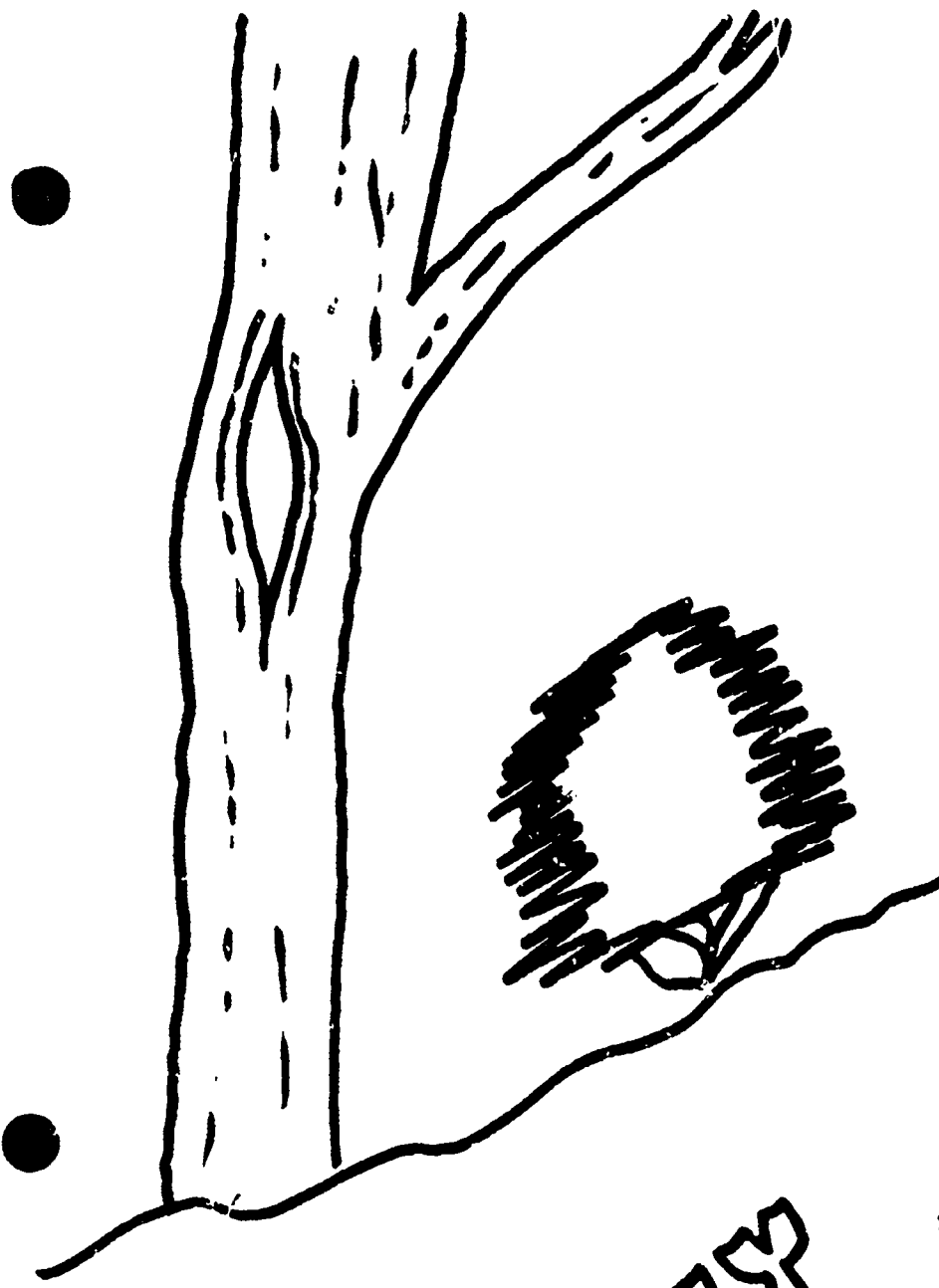

ACTIVITY

Pre-Activity (cont.)

3. How many situations can you think of where grouping objects or information is done as a matter of convenience? (Libraries, grocery stores, kitchen cupboards, encyclopedias, dictionaries, etc.)
4. Explain that biologists have also found it convenient to place plants and animals into particular groups. Groups are based upon how much alike the organisms in the groups are and how they differ from other groups. Such a method of grouping is called a classification system and it helps us to understand which living things are most closely related. Biological classification is based on structural characteristics.

Divide the class into groups of four to six students and have each section take a plastic bag containing an assortment of the following plants (If possible, include a portion of the root, stem, leaf, flower, or seed in those plants that have such structures. Try to attach a cone to any conifers included):

Moss	Wild Rose
Grass	Fern
Mushroom	Willow
Lichen	Elderberry
Dandelion	Seaweeds
Clover	Pond Algae
Fir	Molds
Hemlock	Cedar

1. Have the students separate the plants into two groups based on whether the plants reproduce by seeds or spores. Allow about ten minutes to make their decisions and then pass out copies of the classification sheet and ask them to check their plant groups with the descriptions on the sheet.

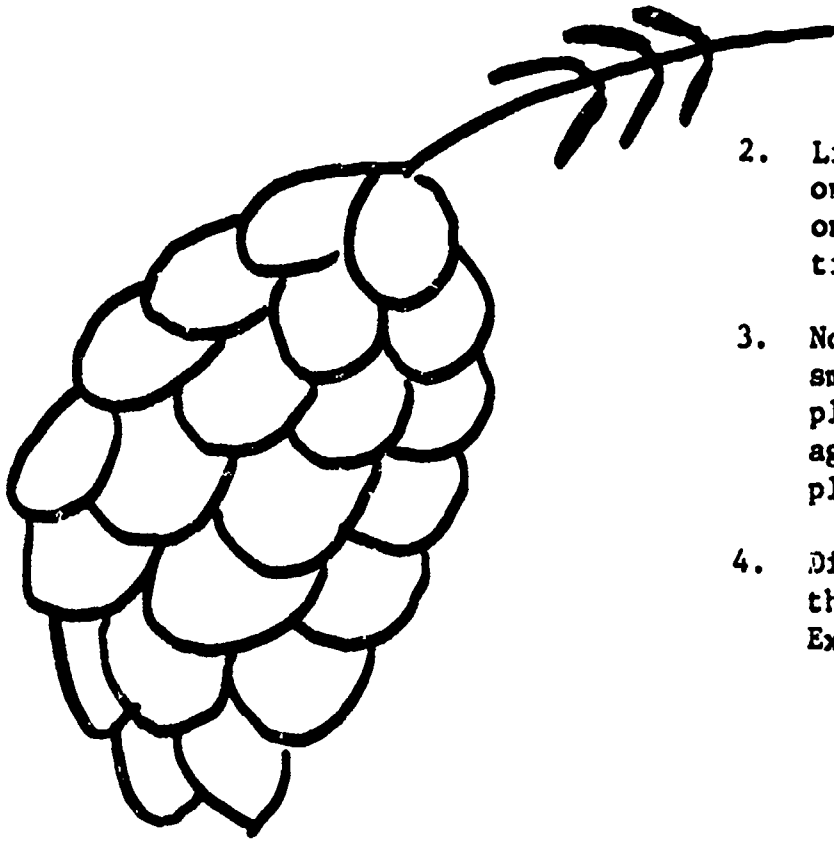

2. List the seed and non-seed plants on the board to be sure that everyone agrees and discuss any uncertainties.
3. Now divide the seed plants into two smaller groups and the non-seed plants into five smaller groups, again checking decisions with the plant classification sheet.
4. Discuss the structural basis for the classification of each group.
Example: How do fungi differ from all of the other plants?

How can we tell whether or not a plant belongs to the moss group?

POST-ACTIVITY

1. Construct a classification key using just one subgroup of plants such as the flowering plants, conifers, mosses or fungi.
2. Use the animal classification chart and pictures of various animals in the same manner as plants.

RESOURCES

STUDENTS

See attached Bibliography

TEACHER

See attached Bibliography

CREDIT

Edmonds Curriculum Bulletin EE 4
"Field Study Manual"

PLANT CLASSIFICATION

PLANT KINGDOM

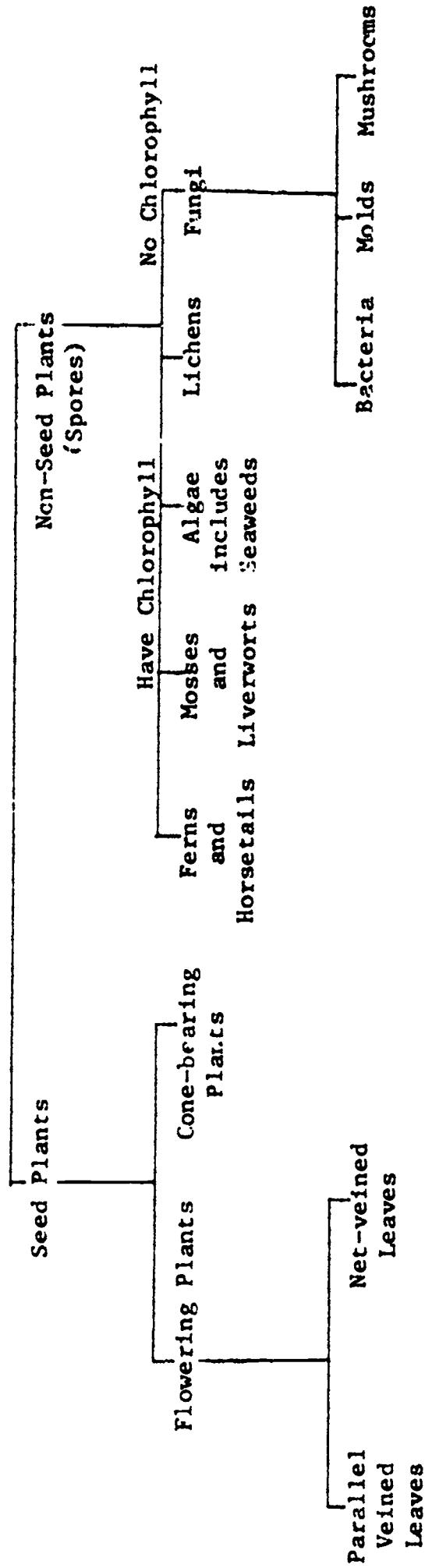

PLANTS

Topic: Plants
Grade: 2
Estimated Time:
Subject Areas: Science

LEVEL V OBJECTIVE: THE STUDENT WILL KNOW THE CLASSIFICATION SYSTEMS OF VARIOUS FORMS OF PLANT AND ANIMAL LIFE.

LEVEL VI OBJECTIVE: THE STUDENT WILL BE ABLE TO DESCRIBE THE DIFFERENCES IN SHAPE OF TWO TREES, ONE EVERGREEN AND THE OTHER DECIDUOUS.

GETTING

IT TOGETHER

MATERIALS

TEACHER BACKGROUND INFORMATION

Refer to lesson #1.

PRE-ACTIVITY

- A. Discuss terms "evergreen" and "deciduous."
- B. Find two trees with different shapes - one evergreen and one deciduous.

ACTIVITY

1. Look at a tree from a distance.
2. With your finger, "trace" (in the air) the shape of the tree (do this from the ground up to the top and from the top down to the ground.).
3. Describe the shape of the tree.
4. Make a "telescope" with your hands. Look through this telescope at your tree from a distance.

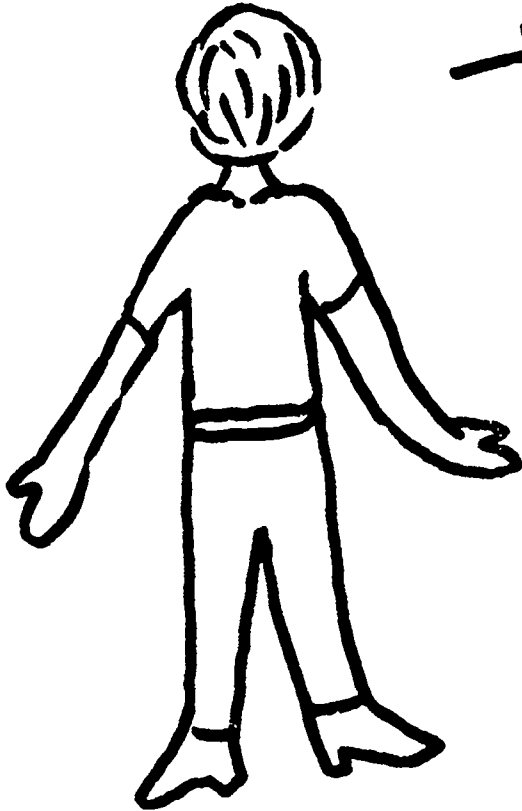

5. Describe how the branches go out from the trunk (up? out? down?).
6. Hold out your arms to show how the branches grow out from the tree trunk.
7. Go closer to the tree. What else do you notice about it?
8. Get close to the trunk of the tree. Look up into the tree. What do you see?
9. Go to a comfortable place where you can see your tree. Sketch it with the crayon you brought.
10. Repeat for a second tree.
11. Add some of nature's color to your sketch. Pick some grass. Use it as a crayon. Rub it around on the paper to show where the green is on your tree.

Pick a yellow dandelion blossom. Use it as a crayon somewhere on your sketch.

POST-ACTIVITY

Draw same trees at a different season.

RESOURCES

STUDENT

See attached Bibliography

TEACHER

- "Plants Through the Season" EF 348
"The Tree" EF 186
"Tree is a Living Thing" EF 361

PLANTS

Topic: Plants
Grade: 2
Estimated Time:
Subject Areas: Math

LEVEL V OBJECTIVE:

THE STUDENT WILL BE ABLE TO IDENTIFY PLANTS AND ANIMALS OF HIS LOCAL ENVIRONMENT.

LEVEL VI OBJECTIVE:

THE STUDENT WILL BE ABLE TO USE HIS MATHEMATICAL BACKGROUND TO SOLVE STORY PROBLEMS WITH PLANT LIFE AS SUBJECT MATTER.

GETTING IT TOGETHER

MATERIALS

Paper, paste, pencil

TEACHER BACKGROUND INFORMATION

Refer to Lesson #1

PRE-ACTIVITY

1. Discuss the terms odd and even.
2. Work with numbers that are even.
3. Work with odd numbers.
4. Relate the number activity to leaves of plants.

ACTIVITY

Do attached worksheet identifying as many leaves as they can.



Sam needs 28 beets.

I Sam has 21 beets.

Sam needs to pull _____ beets.

Sam needs 53 potatoes.

Sam has 49 potatoes.

Sam needs to dig _____ potatoes.



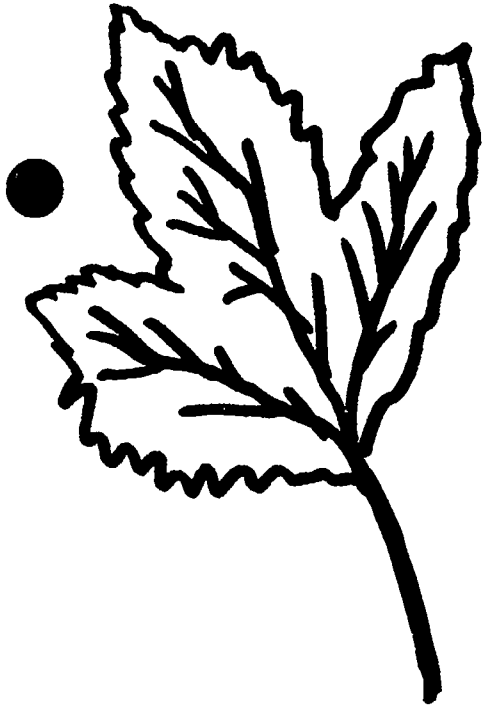

Lynn started to school with 20 maple leaves.
She lost 5 maple leaves.
She had _____ maple leaves left.



Karen started to school with 14 oak leaves.
On the way she gave 5 oak leaves to Ben.
Karen had _____ oak leaves left.

Mother's rosebush had 41 buds.
6 buds opened today.
How many buds are left?

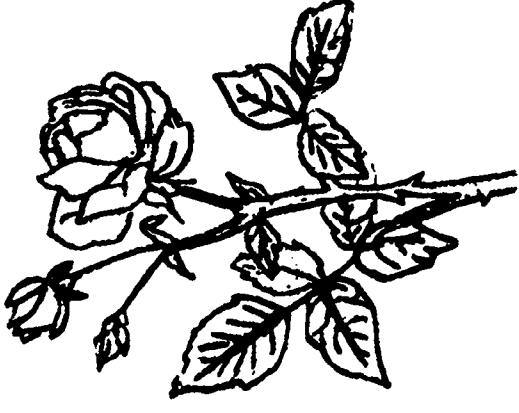

Betty's violet plants had 51
blossoms.
Betty picked 5 blossoms?
How many blossoms were left?

Tom's tulip plants had 32 blossoms.
Tom picked 4 blossoms.
How many blossoms were left?

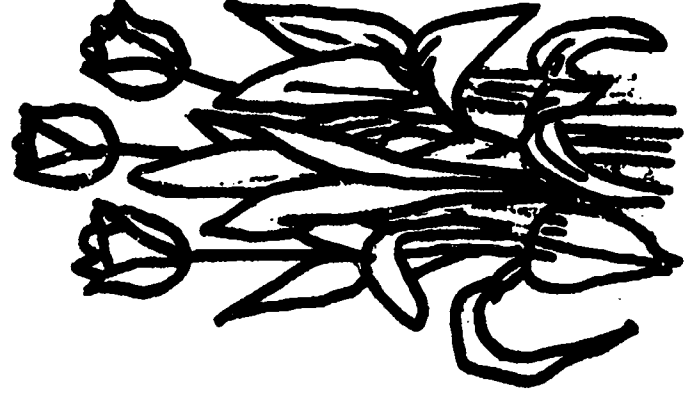



Tom and Ann want 13 boxes of raspberries.
They have 9 boxes of raspberries.
They need to pick _____ boxes of raspberries.



Tom and Ann want 41 boxes of strawberries.
They have 33 boxes of strawberries.
They need to pick _____ boxes of strawberries.

Tom and Ann want 21 boxes of grapes.
They have 18 boxes of grapes.
They need to pick _____ boxes of grapes.

PLANTS

Topic: Plants - Identification
Grade: 2
Estimated Time:
Subject Areas: Art and Science

LEVEL V OBJECTIVE:

STUDENTS WILL BE ABLE TO IDENTIFY PLANTS AND ANIMALS OF HIS LOCAL ENVIRONMENT.

LEVEL VI OBJECTIVE:

THE STUDENT WILL UNDERSTAND THAT LEAVES ARE GROUPED ACCORDING TO PATTERNS, SUCH AS OPPOSITE, ALTERNATE, PARALLEL, AND WHORLED.

GETTING IT TOGETHER

MATERIALS

Pictures of different plants, chart

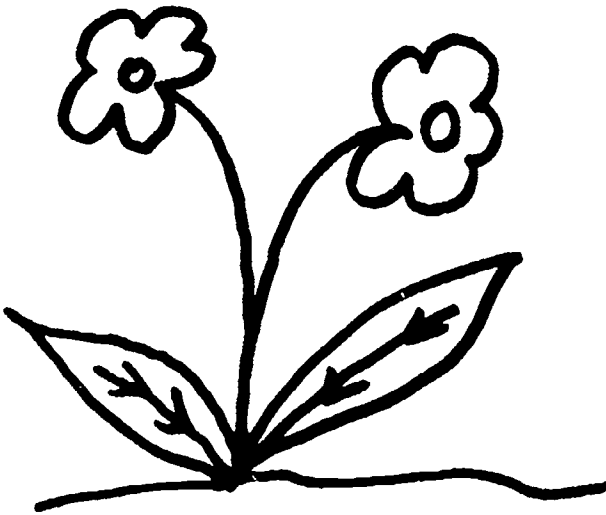

PRE-ACTIVITY

TEACHER BACKGROUND INFORMATION

Branch patterns - leaf vein patterns.

Opposite-



Alternate-

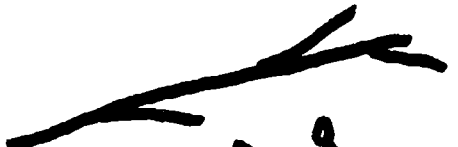

Parallel-

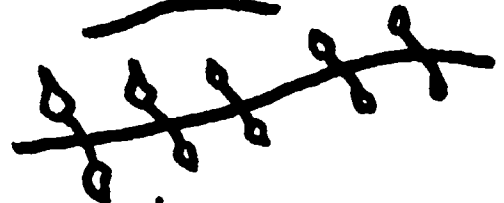

Whorled-



Discussion: Four Ways Plants Branch
Out from the Stem.

Time: 10 minutes

1. Diagram 4 patterns on board.
2. Have children suggest own names for patterns.
3. Introduce scientific names.

ACTIVITY

1. Gather or draw pictures of different plants.
2. Group according to branch patterns.

POST-ACTIVITY

Repeat lesson using leaf vein patterns instead of branch patterns.

Go on a nature walk. Identify plants by using branch and leaf patterns.

WHY NOT
TRY
THESE?

SUGGESTED ADDITIONAL ACTIVITIES

Develop worksheets for follow-up activities.

Draw pictures of examples from local environment.

Use tennis shoes and see if children can create the patterns in the laces.

RESOURCES

STUDENT

See attached Bibliography

TEACHER

Films:

- "Discovering Creative Patterns" EF 1170
- "Discovering Harmon. in Art" EF 1477
- "Discovering Ideas for Art" EF 1476

(You may want to adapt these films down for your students)

PLANTS

Topic: Plants - Life Cycles
Grade: 2
Estimated Time:
Subject Areas: Art, Lang. Art, Science

LEVEL V OBJECTIVE:

STUDENTS WILL UNDERSTAND HOW THE STRUCTURAL AND BEHAVIORAL CHANGE OF PLANTS AND ANIMALS TAKES PLACE.

LEVEL VI OBJECTIVE:

THE STUDENT WILL BE ABLE TO IDENTIFY FACTORS IN THE LIFE CYCLE OF A FOREST IN THE LOCAL ENVIRONMENT.

GETTING IT TOGETHER

MATERIALS

Rotten log, Task Sheet (attached)

TEACHER BACKGROUND INFORMATION

The concept of a constantly changing environment, both natural or man-induced, is fairly easy for children to understand since most are aware that conditions and living things have changed over geological time and dinosaurs and giant ferns no longer dominate our planet. Seasonal changes are obvious as well as changes due to logging, dams, highways, and housing projects. The actual mechanics of the natural process of biological succession, however, are usually subtle and proceed so slowly that recognizable changes may not be observed during the life span of a few generations of humans, in an area where the effects of fire, flood, erosion, or man are negligible. The life, death, and decay of living organisms in any particular environmental situation slowly change existing physical and biotic conditions so that new organisms become established and other populations die out. Various stages in succession may last for hundreds of years and each stage is typically

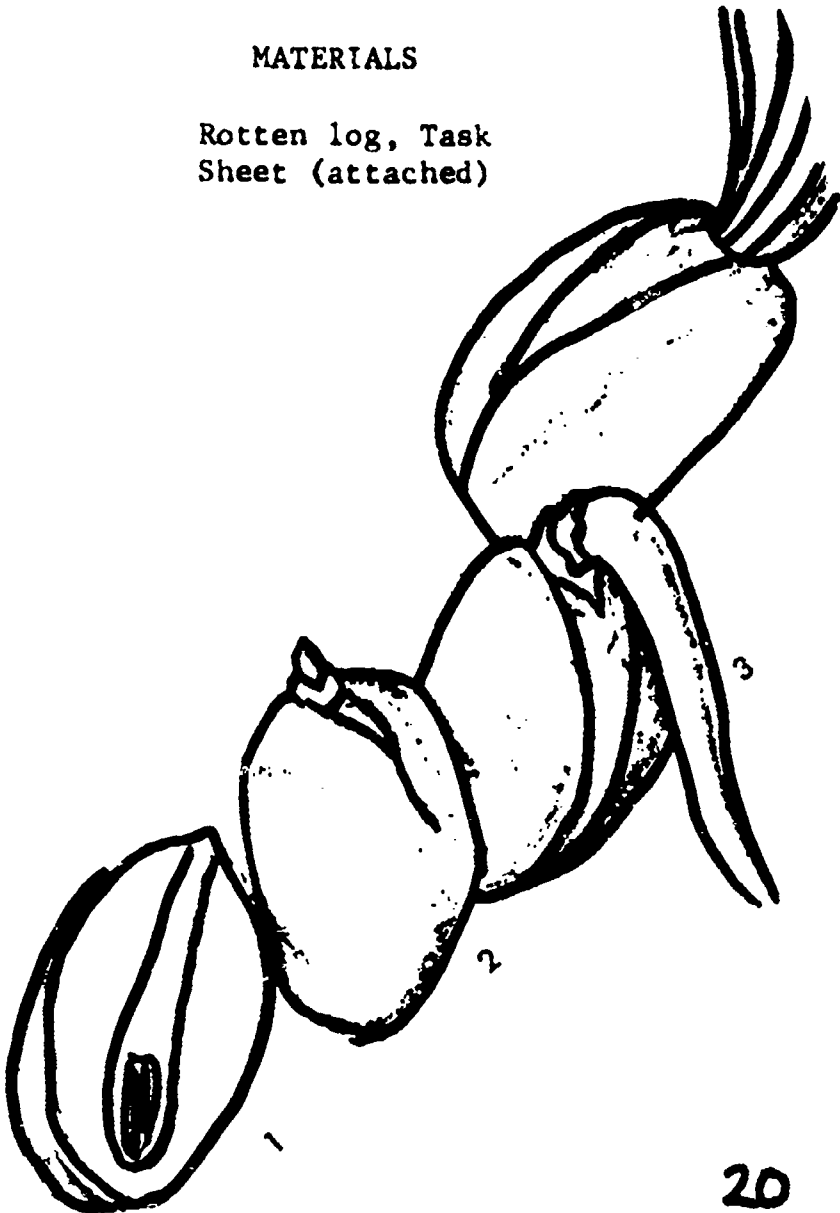



Teacher Background (cont.)

characterized by dominate plant and animal forms. Eventually, barring man's influence and in spite of catastrophic interruptions such as fire, climax conditions stablize the community. Climax vegetation perpetuates itself indefinetly as do the dependent animal populations. Changes now are even more subtle and more closely related to seasonal birth and death. Some populations display not only seasonal fluctuations but also regular changes over longer periods of time as the result of closely interwoven ecological factors. Familiar examples are found in the lemming and snowy owl populations of the far north and the recurrent tent caterpillar "epidemics" is our own areas. All biotic communities undergo succession but the kind of succession that can occur on any given part of the earth depends entirely on the prevailing physical factors - altitude, latitude, topography, climate, and mineral content of the parent rock. Thus lakes, sand dunes and bare rock may eventually become forests or grasslands.

PRE-ACTIVITY

In a discussion, ask what causes trees to fall (man, wind, erosion)? What happens to the tree when left on the ground (decomposition, regrowth)?

ACTIVITY

Observations

1. Go on a walk. Find a felled tree. List things that have changed and are changing about the tree.
2. Fill out task sheet.

POST-ACTIVITY

List factors. Order them in way you think they happened.

Discuss differences.

WHY NOT
TRY
THESE?

SUGGESTED ADDITIONAL ACTIVITIES

Art: Draw a tree in different stages.

Writing: Pretend you are an old, old tree. What will happen to you?

RESOURCES

STUDENT

See attached Bibliography

TEACHER

"Tree is a Living Thing" EF 361

"The Tree" EF 186

CREDIT

Edmonds Curriculum Guide, EE 1
"Marshall Outdoor Laboratory"

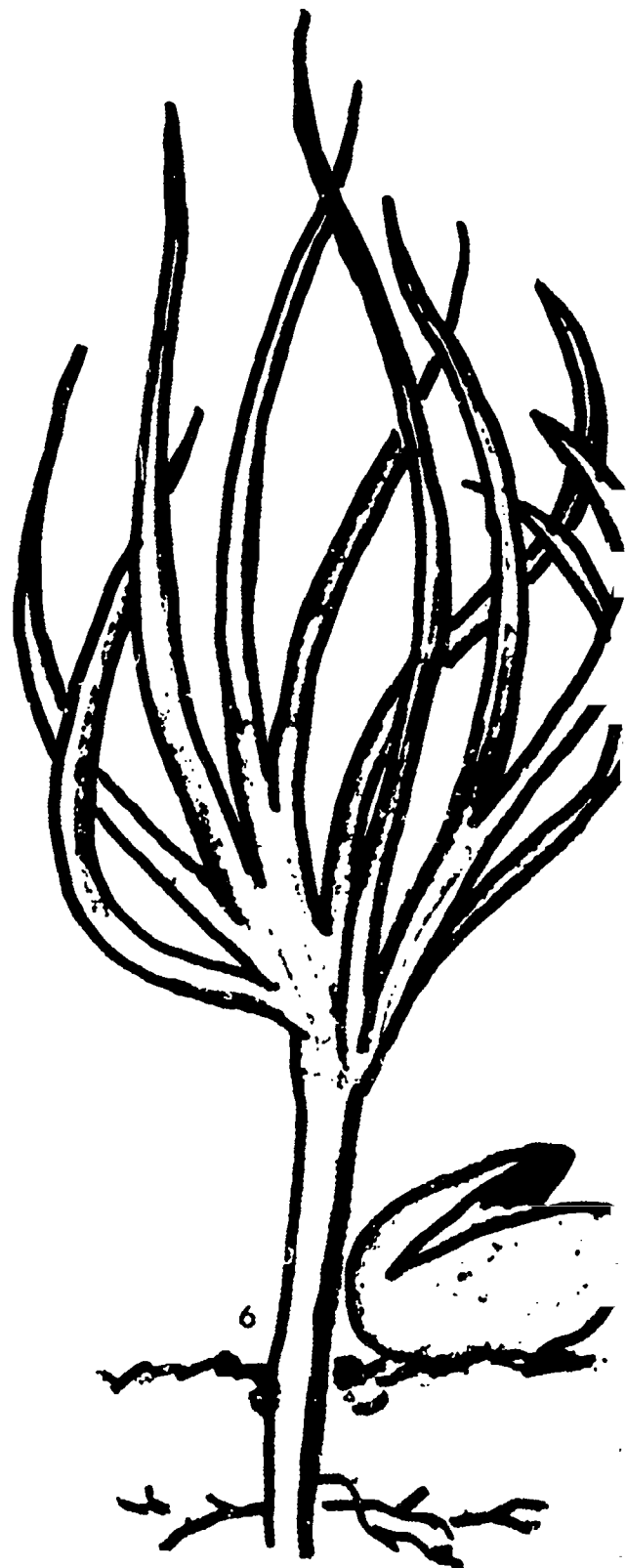

PLANTS

Topic: Plant Adaptation
Grade: 2
Estimated Time:
Subject Areas: Speech, Science,
Soc. Studies, Lang. Arts

LEVEL V OBJECTIVE:

STUDENTS WILL UNDERSTAND HOW THE STRUCTURAL AND BEHAVIORAL CHANGES OF PLANTS AND ANIMALS TAKE PLACE.

LEVEL VI OBJECTIVE:

THE STUDENT WILL BE ABLE TO IDENTIFY FACTORS IN THE LIFE CYCLE OF A FOREST IN A LOCAL ENVIRONMENT.

GETTING IT TOGETHER

MATERIALS

Pictures of plants or real plants in different environments, desert, intermediate and tropical; 3 tables or observation areas; Task Sheet (attached); pencils

TEACHER BACKGROUND INFORMATION

Refer to Lesson #6

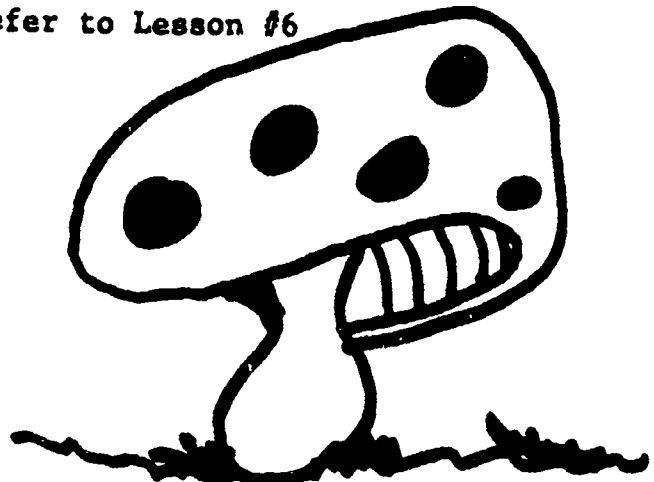

PRE-ACTIVITY

Divide group into a workable size for observation and writing on the Task Sheet. Instruct them as to what they are looking for and how to fill out the sheet.

ACTIVITY

Let students observe and fill out Task Sheet.

POST-ACTIVITY

WHY NOT

TRY

THESE ?

Choose speaker from each group to make a report to the total group. Compare and discuss findings.

SUGGESTED ADDITIONAL ACTIVITIES

Lang. Arts: Show a film about plants in different environments.

Find pictures of plants in each environment.

Soc. Studies: Discuss the people and how they live in the different environments.

Take a field trip to a nursery.

RESOURCES

STUDENT

See attached Bibliography

TEACHER

"Living Things Depend on Each Other"
EF 1579

TASK SHEET A

1. How big do you think this tree used to be? What tells you it might have been big?
2. What color is the tree? Might it be a different color at some other time?
3. What has happened to the tree since it was killed?
4. What could have killed this tree? What position is it in?
5. What do you see growing on the tree? How could they live?
7. Can you find trees that you think might be the same kind? Why do you think it might be similar?
8. What could we do with this stump?

Task Sheet - Page 2

9. What has happened to the wood? Is it like live wood? What makes it different?

10. How has this stump affected the surrounding plants or animals?

PLANTS

Topic: Plants - Man's Use (Food)
Grade: 2
Estimated Time:
Subject Areas: Science, Lang.Arts

LEVEL V OBJECTIVE:

STUDENTS WILL UNDERSTAND HOW THE STRUCTURAL AND BEHAVIORAL CHANGES OF PLANTS AND ANIMALS TAKES PLACE.

LEVEL VI OBJECTIVE:

THE STUDENT WILL BE ABLE TO IDENTIFY CHANGES IN THE LIFE CYCLE OF A PLANT.

GETTING IT TOGETHER

MATERIALS

Films:
"Life Story of a Plant"
EF 353
"Seeds Grow into Plants"
EF 7

PRE-ACTIVITY

Order films.

To find out what students already know, discuss with them how seeds grow, what they need for growth, and how seeds might travel from one place to another.

View film.

ACTIVITY

POST-ACTIVITY

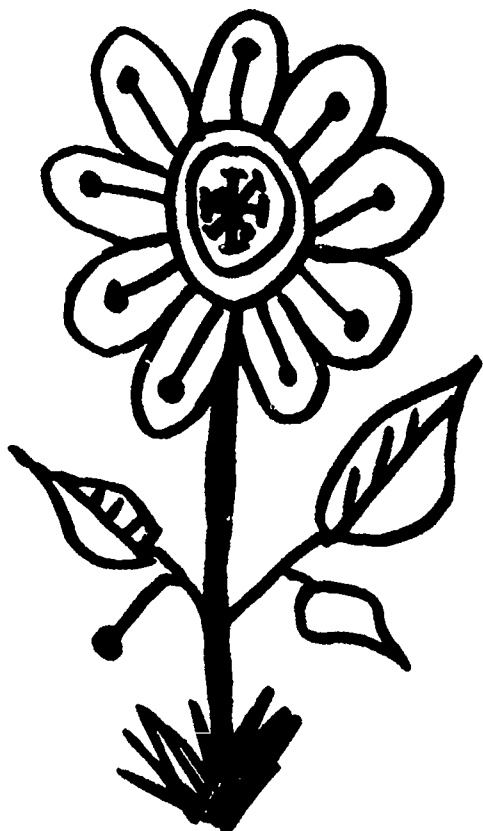

Discuss again including new information and correcting any ideas that may have been incorrect.

Do the following activity:

HOW A SEED GROWS INTO A PLANT

Materials: lima beans; kernels of corn; box of rich soil.

- Directions:
1. Divide a box of soil into two equal halves by placing a string down the middle.
 2. Plant some lima beans on one side of the string and kernels of corn on the other side.
 3. Water them daily.
 4. Dig up one or two seeds of each kind every day and notice how each one develops underground.
 5. Notice how each one finally breaks through the surface of the soil. What appeared above the soil first?
 6. Draw a sketch of what happened in your note book.

WHY NOT

TRY
THESE ?

SUGGESTED ADDITIONAL ACTIVITIES

1. Adopt a tree for the school year. Watch it grow and change during the different seasons.
2. Cut open a pumpkin and give each of your children a chance to scrutinize the insides.



Suggested Activities (cont.)

3. Use the pumpkin seeds to demonstrate set theory in Math.
4. Make seed mosaics. Have each child do an outline drawing of a canoe, boat, turkey, whatever. Provide seeds that they can glue onto their pictures.
5. Use seeds to make jewelry.

RESOURCES

STUDENT

See attached Bibliography

TEACHER

See attached Bibliography

PLANTS

Topic: Plants
Grade: 2
Estimated Time:
Subject Areas: Art, Math, Science

LEVEL V OBJECTIVE:

STUDENT WILL PERCEIVE HIMSELF AS A PART OF NATURE AND WILL DESIRE TO LIVE IN HARMONY (DYNAMIC BALANCE) WITH THE REST OF NATURE.

LEVEL VI OBJECTIVE:

THE STUDENT WILL BE ABLE TO SKETCH PICTURES OF OBJECTS WHICH ARE PROPORTIONAL TO THEIR TRUE SIZE.

GETTING IT TOGETHER

MATERIALS

1 long, soft lead pencil; 1 eraser; 1 hard surface that is portable; something to sit on (newspaper); manila sketching paper. One of each per student.

TEACHER BACKGROUND INFORMATION

This is an exercise in proportional and perceptual drawing.

PRE-ACTIVITY

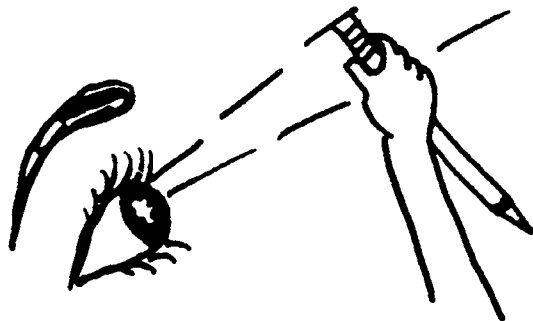

1. Select an object such as a window, door frame, case.
2. Use drawing materials listed above.
3. Hold pencil at arms length, grasping pencil upright.
4. Sight the object to be drawn with the pencil as a comparing tool, lining the top of the pencil up with one side to be drawn and using the thumb of the hand grasping to mark the other edge.



ACTIVITY

5. Lay the pencil along the paper marking the top and the other point determined. Taking the measure across and up and down, you should establish the arc for the proportional drawing on your paper.
6. Finish the drawing section by section.

Go Outdoors

Choose a view with a lawn, meadow or road in front of it. Draw a baseline on the paper. Use the pencil to measure height and width of trees, shrubs above the baseline by lining up the top of the pencil with the top of the tree and using the thumb of the hand grasping the pencil to mark the point at which the trunk meets the baseline. Work can be finished by using this method to measure widths of trees and shrubs alike.

When the tip and base points have been established, sketch the tree and branches as they would grow from the base upward and from the trunk section outward.

POST-ACTIVITY

Construction of a bulletin board to display the artwork.

RESOURCES

STUDENT

See attached Bibliography

TEACHER

See attached Bibliography

CREDIT

"Field Study Manual" EE 4

PLANTS

Topic: Plants - Aesthetic
Grade: 2
Estimated Time:
Subject Areas: Art

LEVEL V OBJECTIVE:

STUDENT WILL PERCEIVE HIMSELF AS A PART OF NATURE AND WILL DESIRE TO LIVE IN HARMONY (DYNAMIC BALANCE) WITH THE REST OF NATURE.

LEVEL VI OBJECTIVE:

THE STUDENT WILL BE ABLE TO UNDERSTAND HOW PLANTS FROM THE LOCAL ENVIRONMENT CAN BE USED TO PROVIDE COLORS FOR A PICTURE.

GETTING IT TOGETHER

MATERIALS

Bags for collecting material, paper

TEACHING BACKGROUND INFORMATION

Sample materials, elderberry, dandelion, charcoal, mullein leaves, grass.

PRE-ACTIVITY

Gather materials and prepare students. Take a walk through the woods. Gather stems, berries, rotten wood, leaves, flowers.

ACTIVITY

Make a color chart using the materials gathered.

POST-ACTIVITY

Using the color chart as a guide,
have the students create their own
pictures using natural colors.

SUGGESTED ADDITIONAL ACTIVITIES

Lang. Arts: Color Images (attached)

Diamante Poetry (attached)

RESOURCES

STUDENT

See attached Bibliography

TEACHER

See attached Bibliography



COLOR IMAGES

What is Green?

Develop your own color images from the outdoor environment.

Green things you can see.

What are the sounds of green?

How does green feel?

What are the tastes of green?

How does green smell?

Green is the feeling of...

DIAMANTE POETRY

Diamante is a seven lined contrast poem developed by Iris Tiedt of the University of Santa Clara. She was interested in developing a simple type of poem which could be used with children to express their observations and feelings. The lines of the poem form a diamond shape.

- Reflecting #1 { Line 1 - One word subject noun
Line 2 - Two words, adjectives
Line 3 - Three words, participles (ing or ed, but not a mixture)
- Line 4 - Four words, nouns related to subjects which reflect a transition
- Reflecting #7 { Line 5 - Three words, participles (ing or ed, but not a mixture)
Line 6 - Two words, adjectives
Line 7 - One word subject noun (opposite of line 1)

Select two opposite ideas, such as spring and fall, or sky and ground. Write one on line 1 and one on line 7. Then develop from line 2 through line 6. Line 4 is a transition line. The first two words should reflect line 1, while the last two words should reflect line 7.

Example of Form

MOSS

SMALL GREEN

SPREADING, FEEDING, COVERING

SYMBIOSIS, BARK, FOOD, LIFE

GROWING, INTERACTING, LIFTING

LARGE GREEN

TREE

PLANTS

Topic: Plants - Misuse

Grade: 2

Estimated Time:

Subject Areas: Science, Math, Lang. Arts

LEVEL V OBJECTIVE:

EACH STUDENT SHALL RECOGNIZE VARIOUS POLLUTION PROBLEMS, THEIR CAUSES AND EFFECTS.

LEVEL VI OBJECTIVE:

THE STUDENT WILL KNOW THE EFFECT OF WATER POLLUTED BY DETERGENTS ON PLANT LIFE.

GETTING IT TOGETHER

MATERIALS

Two plants; detergent

PRE-ACTIVITY

Gather materials.

1. Discuss what plants need to grow.
2. How might plants be affected in a negative way by their surroundings?

ACTIVITY

1. Combine some detergent with water and use this solution to water one of the plants. Use other plant as a control, watering it in normal manner. Observe what happens.

POST-ACTIVITY

Discuss what effects the detergent has on the plant. Extend these observations to the possible effects on the larger environment.

**WHY NOT
TRY
THESE?**

SUGGESTED ADDITIONAL ACTIVITIES

1. Children bring in samples of plants that are unhealthy-looking or discolored. Make guesses about damage.
2. Place potted flowers such as petunias, snapdragons, zinnias or pansies outside in the polluted air and observe the affects on them in a few weeks. For example: Give plants a blast of car exhaust each day.

RESOURCES

STUDENT

See attached Bibliography

TEACHER

"Let's Watch Plants Grow" EF 265

"What Plants Need for Growth" EF 1183

PLANTS

Topic: Plants - Misuse
Grade: 2
Estimated Time:
Subject Areas: Science

LEVEL V OBJECTIVE:

STUDENTS SHALL RECOGNIZE VARIOUS POLLUTION PROBLEMS, THEIR CAUSES AND EFFECTS.

LEVEL VI OBJECTIVE:

THE STUDENT WILL KNOW THE EFFECT OF CAR EXHAUST FUMES ON PLANT GROWTH.

GETTING IT TOGETHER

MATERIALS

2 plants, car
cellophane bag

PRE-ACTIVITY

With a few children, go to the school parking lot. Place a cellophane bag over an exhaust pipe. Start the car. Collect a bag full of exhaust.

ACTIVITY

Put the bag with the exhaust in it over one plant and tighten it around container. Use other plant as a control plant.

POST-ACTIVITY

Observe. Discuss the effects of exhaust on the plant. Extend to speculate what happens to our environment with many cars giving off exhaust fumes.

RESOURCES

STUDENT

See attached Bibliography

TEACHER

See attached Bibliography

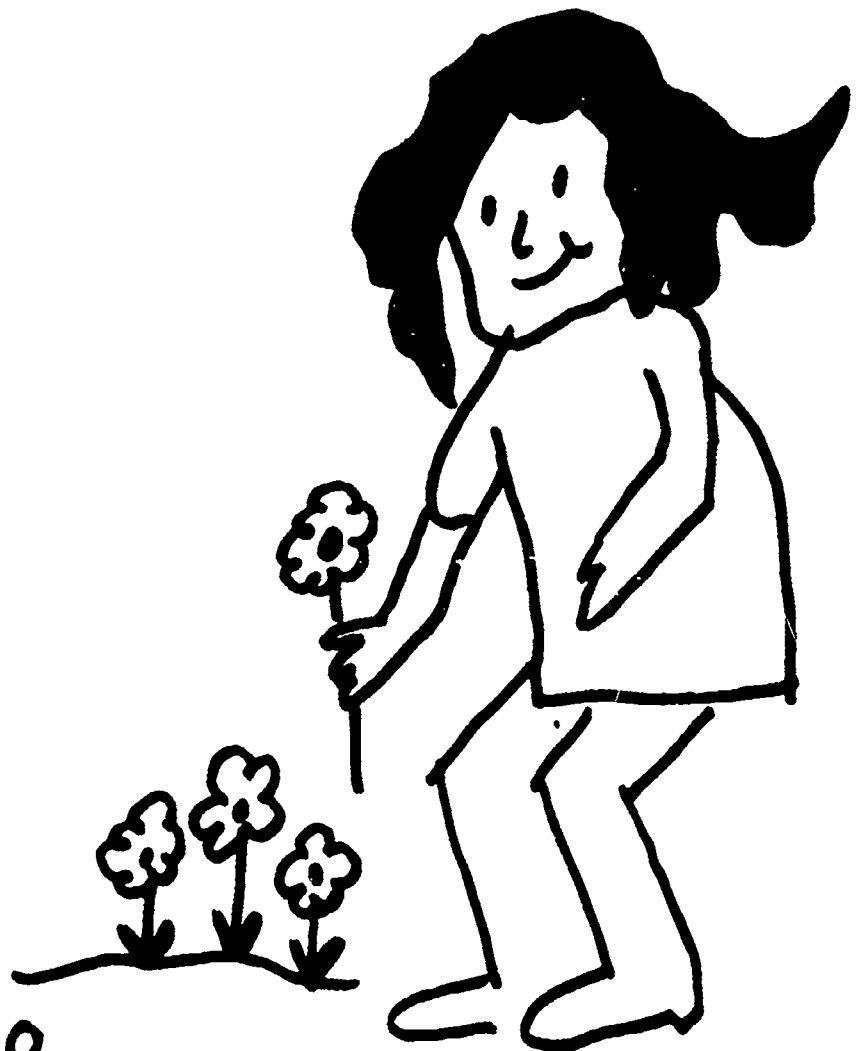

SUPPLEMENTARY PLANT ACTIVITIES

1. Make into Job Cards

Grow a mold garden!

Stuff:

Oranges

Apples

Bread

Foodscrapes

Microscops and slides

Plot the life story of a
forest fire.

Explore:

What control was used?

What could have been done?

2. Activity: Observation

Objective: Each child will tell the similarities and differences between a wheat plant and an oat or grass plant.

Materials: A flowering grass plant or an oat plant (these can usually be found in a field).

A diagram of a wheat plant.

Procedure: Give each child a plant. Discuss the different parts that are found on the plant. Take a look at the diagram of the wheat plant. What similarities can you discover?

3. Take the group outdoors to observe:

Leafage and buds on trees and bushes

Pussy willows

Forsythia blossoms

Blossoms on fruit trees

Talk about:

The trunk of the tree

The branches

The leaves growing on the branches

The roots that can be seen

If branches of forsythia and pussy willows are brought in to the room and put in water, children may note that when the blossoms fall, leaves begin to appear. Let them observe the roots that begin to grow.

4. Make a bulletin board of pretty flowers. Have each child "Pick a Pretty Flower." Soon there are few left. Relate this to what happens to things in nature.

5. Discuss reasons people should use sidewalks.

6. Examine a cotton ball. Discuss types of cotton clothing being worn by children in the class and other types of cotton cloth.

7. Plant a strawberry plant, ajuga or clover in a flower pot. It will send out runners to show how new plants are developed (runner-type reproduction).

8. Plants need air. Cover the soil around the stem of a plant with paper. Place a jar over the plant. Set the plant in the sun and observe how the plant begins to droop due to lack of air.
9. Math - Use number and size concepts on the playground. Have each child count the number of main leaf veins in a leaf of a certain kind of tree. Compare these figures. Compare the number of veins of various kinds of trees.
10. Splatter Print - Place newspaper over work area. Lay paper to be splattered on cardboard, and pin leaf flat to this, pins upright. (Leaf prints will be more successful if the leaf has been pressed for an hour or two). Prepare poster paint the consistency of thin cream; dip an old toothbrush into the mixture, and press against the side of the can to remove excess paint. Rub toothbrush towards you on a small piece of clean window screening held over the leaf. Spatter paint onto the paper all around the leaf. When dry, remove the leaf.
11. Crayon Prints - Place a section of newspaper on the work area to give a soft surface. Lay the leaf on this with the vein side up. Place a sheet of ditto paper over this, hold carefully and color in the same direction over the leaf area using the tip or the side of the crayon. You may want to cut out along the leaf outline.
12. An Alphabet Scavenger Hunt - Each child or group is to find a series of nature objects chosen so that for each letter of the alphabet there will be an object whose name (or some part of it) begins with that letter. The alphabet could be broken into sections giving each group 5-10 letters, if you wish.
13. Music: Making Instruments - Many natural objects can be used directly or adapted for use as rhythm instruments or other musical instruments. Pebbles, sticks, black locust seed pods, gourds, acorn caps, rock, dried grasses, hollow reeds, and tree branches bearing dried leaves are among the objects that can be collected in preparation for making instruments for the rhythm or musical "band."
14. Playing a Game of Categories - Near the close of an outdoor educational experience, practice organizing information by using a game. Divide the class into groups, each of which chooses something - an animal, bird, tree, or living thing from some other category, depending on the emphasis of the experience. One group tells the class of the object that they chose. One of the groups tries to guess the name of the object by asking questions that can be answered by yes or no. A no answer gives the turn to ask questions of another group. The group that guesses the object correctly may choose the next object. Any group that has to say, "We don't know" instead of yes or no to more than three questions, must tell the name of it's object.

15. Gardens

- Give the children the opportunities to tell about gardening activities at their homes
16. Show and discuss pictures of people working in gardens
17. Talk about basic plant structure
18. Provide firsthand experiences with seeds, planting, and care of growing things
19. Through firsthand experiences children should learn that plants need:
Air, water, light, warmth, food
20. Note to the teacher:
Plants make their food in the green leaves
Water and the dissolved minerals come from the soil
21. Take the group for walks in the neighborhood to see plant growth:
In the gardens
In fields
In parks
22. Adventures of Peter Pine - dramatized episodes in the life of a pine tree from seedling to saw. Timber size and through its harvest and utilization as wood products.
- Preparing the soil:
Spading, hoeing, raking
Planting:
Flower seeds, bulbs, small plants, vegetable seeds
Caring for the garden:
Weeding, watering, hoeing
Parts of plant:
Leaves, stems, roots
If outdoor space is not available, planting may be done:
In flats
In other low wooden boxes
In cans
In flower pots
In heavy paper cups
Grass seed, bird seed, or flax seed may be planted on a wet sponge or wet cotton
Carrot or turnip tops or a sweet potato may be placed in a jar of water so children can watch growth of roots, stems and leaves
Moistened blotter paper may be placed to fit the inside of a glass. If lima beans are placed between the paper and the glass, children can watch them develop. Beans grow quickly and are interesting to watch. Seeds saved from a Halloween pumpkin may be planted.

- T 592 Farmer Simmons Discovers Green Gold
T 593 Mr. Boxlar's Advice
T 594 Paper Making - Tiny Fibers from Tree Trunks
T 595 The Wise Landlord

23. Have you any idea how many living things are spending the winter under ground? You can get a good idea by making a WAKE-UP GARDEN. After a winter thaw, dig up some soil from the top of the ground, about one foot square and about two inches deep, and place in a terrarium. (Make the terrarium from two pieces of window glass 10" x 8" for the ends; two pieces 10" x 16" for the sides and one piece 17" x 9" for the top. Tape the end and side pieces together into a glass rectangle 16" x 8" x 10" high. Now shellac the taped corners to make them water-proof. Spread freshly mixed plaster of Paris over the bottom of a shallow pan measuring about 17" x 9" x 1" high. Set the glass rectangle onto the pan, pressing it down gently but firmly into the wet plaster of Paris. As the plaster hardens, it will hold the glass securely in place. Keep the top separate so that it may be taken on and off easily.)

Put the soil you have dug up in the terrarium, place the glass cover on top and set in a good light. As the soil warms up, lots of little creatures that have been spending the winter under ground will begin to move about. Also, you'll see many little plants sprouting up from seeds that have been buried in the soil. Empty the "garden" on some large sheets of newspaper and see how many little plants and animals you can count that were living in this one square foot of soil. Using the size of the "garden" as a gauge, try to estimate the number there are in the whole area you are exploring. Don't be surprized if the answer comes out in the millions.

24. Sealed Terrariums

1. Getting the dirt into the bottle:

Round gallon bottles with a lot of growing space at the bottom are best. Wash and dry bottles thoroughly. Select small plants. Soak a commercial houseplant planting mixture in water until it is completely wet. Fashion a tagboard tube. Put in bottle until 2" from bottom. Tape bottle neck to tube so no dirt hits the inside walls of the bottle.

Squeeze water from plant mixture. Use a wooden dowel to poke it down the tube. Use split shingle to spread mixture evenly.

2. Getting plant into the bottle:

Take plant from container; wash under cold water until all dirt is removed. Drip through neck of bottle. Once plant is on the bottom, cover roots with plant mixture.

3. Taking care:

Seal bottle and place in indirect lighting near window. The plant will give off water vapor which condenses and runs down sides of bottle. No watering needed.

LITTLE BITTY RAINDROP

Once upon a time Little Bitty Raindrop with his father and mother and his forty-four brothers and fifty-five sisters lived on a big white cloud high up in the blue, blue sky.

One day when the thunder roared, his father and mother and his forty-four brothers and fifty-five sisters jumped off the cloud and parachuted to earth. But Little Bitty Raindrop was sleeping soundly. He did not hear the thunder. When he awoke, he was alone on the big white cloud.

But he didn't mind one bit.

He lay in the warm sun. He bounced up and down on the soft cloud. He put his little hand out to touch other clouds that sailed past.

It was a pleasant life indeed.

After awhile, Little Bitty Raindrop began to wonder what was down under the cloud. He leaned over, then a little farther, and a little farther, and WHOOPS----

He fell right off the big white cloud. And he didn't have his parachute. He shut his eyes tight and held his tummy with both hands. He fell--and he fell. Then finally he landed with a plop.

Little Bitty Raindrop slowly opened one eye, and then the other. Where was he? He was sitting on a leaf in the very top of a big tree that stood in the meadow.

"Oh dear. You almost knocked the breath out of me," groaned the leaf.

"I'm sorry," said Little Bitty Raindrop, "But I forgot my parachute."

"Oh, that's why you landed so hard. Where are you going now?" the leaf asked.

"Why I ----" began the tiny raindrop.

But just then the wind gave a big sneeze. The leaf shivered. Little Bitty Raindrop slipped off and landed on the head of a brindle cow that stood under the tree.

"Oh, I beg your pardon," said the raindrop.

"Not at all," said the cow. "You make my head feel cool. It certainly is hot in the sun. I stepped over here in the shade of the tree to finish my lunch."

Little Bitty (cont.)

"What will you do after lunch?" asked little Bitty Raindrop.

"Oh, by the time I chew my cud for lunch, it will be time to start eating dinner," the cow said gently. "Just one meal after another all day long."

When the brindle cow leaned down to bite off a juicy bit of grass, Little Bitty Raindrop rolled down her nose and off--.

He would have fallen to the ground but a butterfly caught him on her back.

"Thank you, pretty butterfly," the tiny raindrop cried. "Thank you very much."

"That's all right," said the butterfly. "Where can I take you?"

"I would like to rest for a few minutes. I've been falling all day," said Little Bitty Raindrop.

"I know just the spot for you," the butterfly said.

They circled over a stream, and the butterfly glided down to a bed of water lilies. Little Bitty Raindrop slid down on top of a petal.

"You'll have a quiet rest on that water lily. Good-bye," the butterfly called as she fluttered away.

"Good-bye," Little Bitty Raindrop answered and waved after her.

The small raindrop was stretching out on the petal for a nap when the Water Lily cried, "Look out, Little Bitty Raindrop, look out!"

But the water lily called too late. A big green bullfrog landed kersplash on top of the water lily.

Poor Little Bitty Raindrop blew into the air with a whirl. When he came down again, he landed on a small brown branch that was floating down the stream.

"Do you mind if I go with you?" the raindrop asked the branch.

"Come along," said the small branch. "I'm on my way to the ocean to watch the sea gulls play."

"Oh, that'll be fun," cried the raindrop.

So the little raindrop curled up on the branch and fell sound asleep. On and on he went down the stream toward the ocean.

Later he woke with a start to hear the branch shouting, "Wake up! This is the ocean. Wake up!"

Little Bitty (cont.)

Little Bitty Raindrop opened his eyes. A huge wave wearing a foamy white cap was rushing toward him and the little brown branch. Little Bitty Raindrop shut his eyes tight and tried to hold on to the branch, but the big wave swept him right off into the water. How frightened he was!

Just then he heard a familiar voice say, laughingly, "Why it's Little Bitty Raindrop. Where have you been?"

When he opened his eyes, he shouted for joy. His father and mother and his forty-four brothers and fifty-five sisters were swimming around him. His grandfathers, his grandmothers, his uncles, his cousins and his aunts were there, too.

"Oh!" cried Little Bitty Raindrop, "It's wonderful to be back with everyone again. Now if I could only climb back to our cloud home!"

Little Bitty Raindrop hugged his mother and father and every one of his brothers and sisters.

The sun in the sky heard his wish and sent down sunbeams to the raindrop family. Then how they scampered!

Little Bitty Raindrop and his father and mother and his forty-four brothers and his fifty-five sisters and grandfathers and grandmothers with all the aunts and uncles and cousins, climbed up the sunbeam's ladder to their cloud home in the sky.

"Now we'll all live happily," said Little Bitty Raindrop. "And I'll remember to take my parachute with me when I travel to earth again."

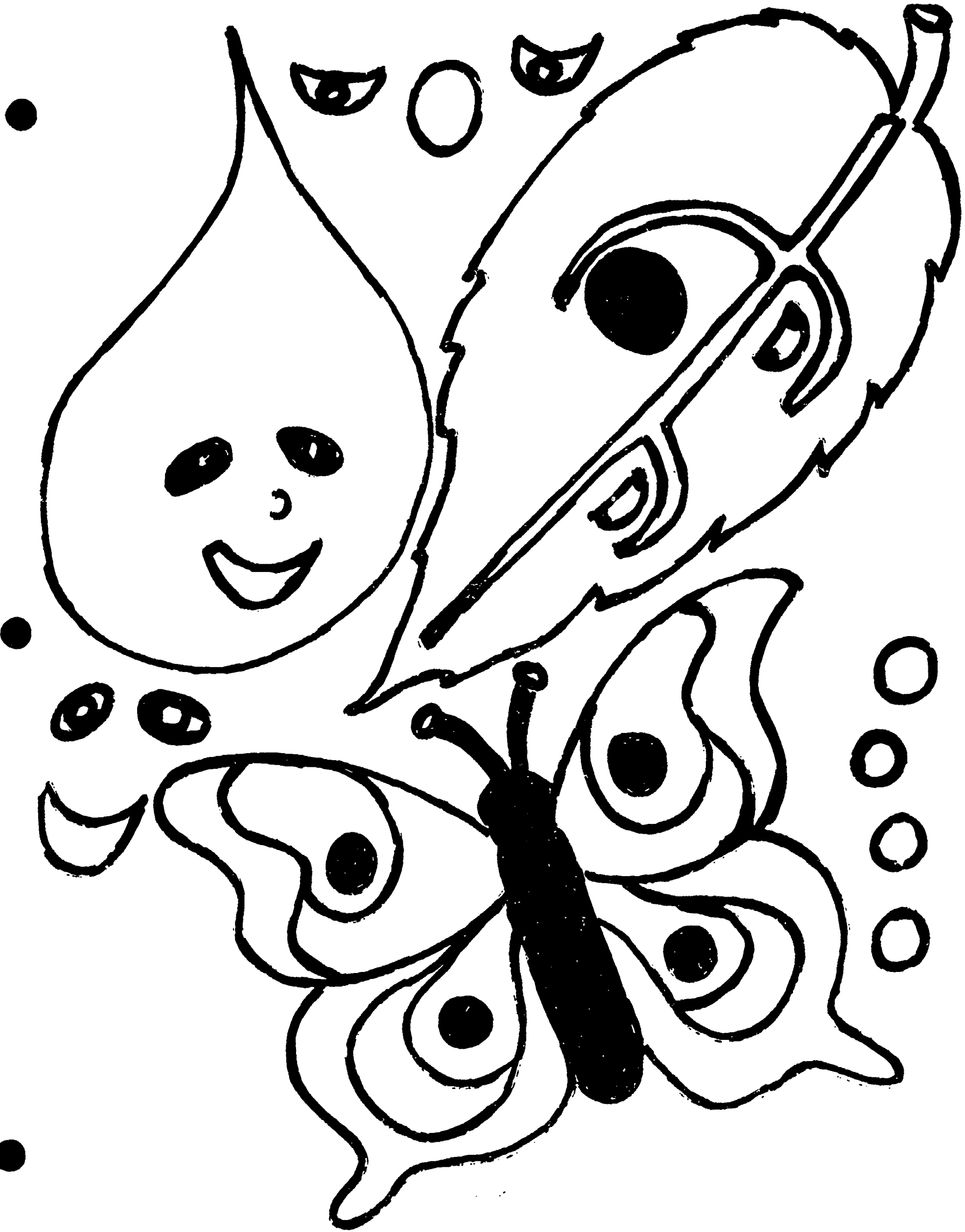

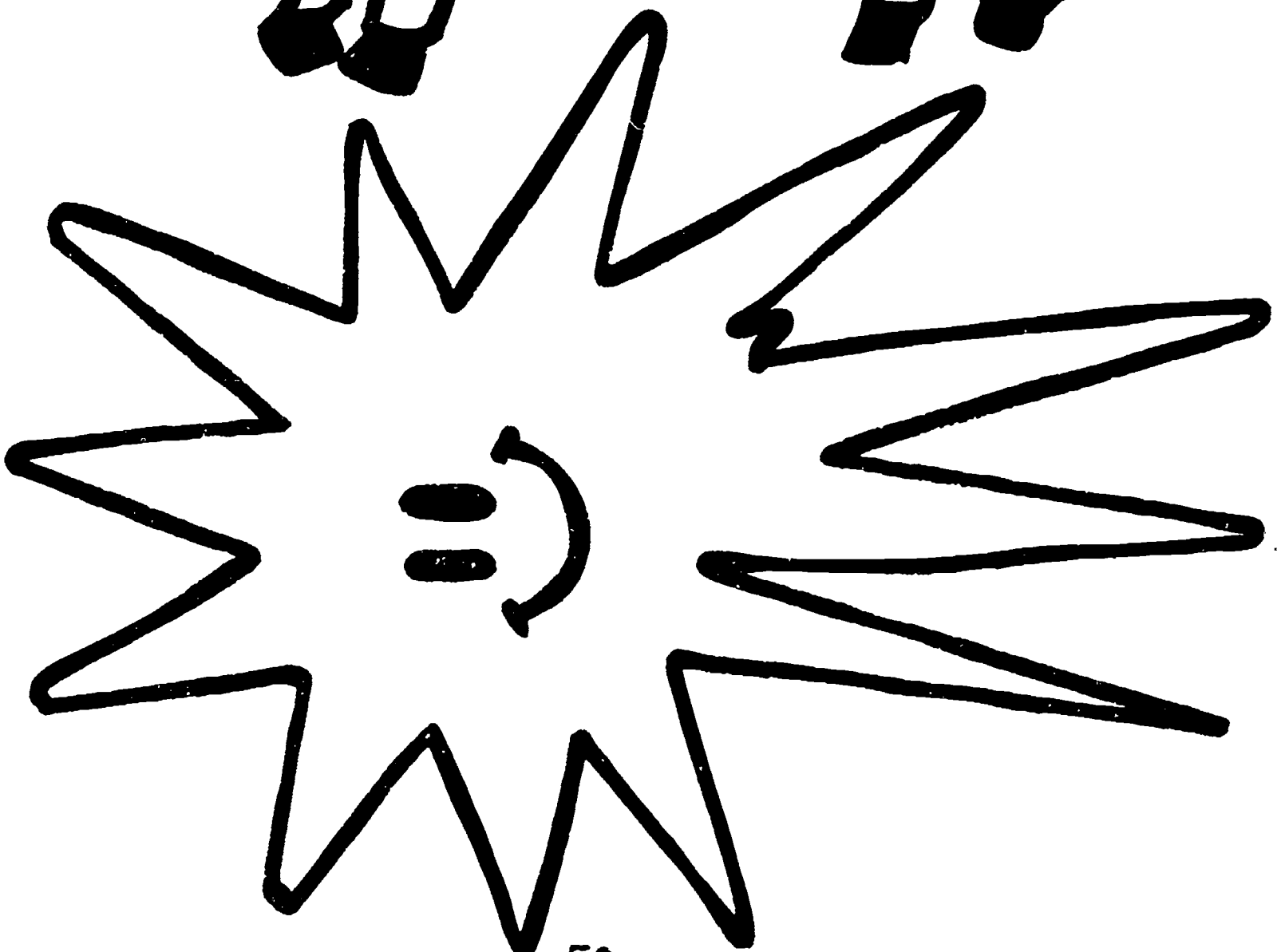
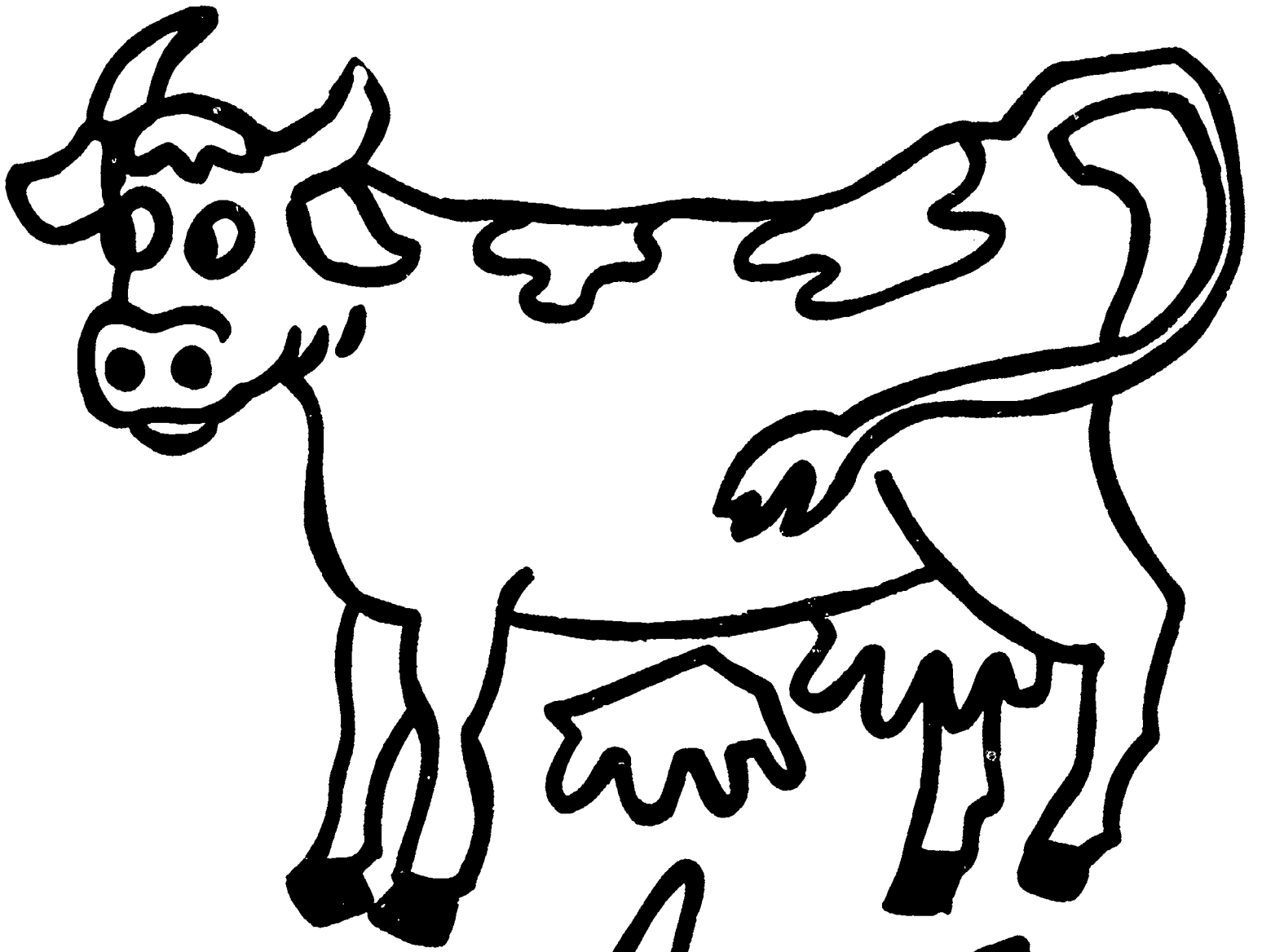

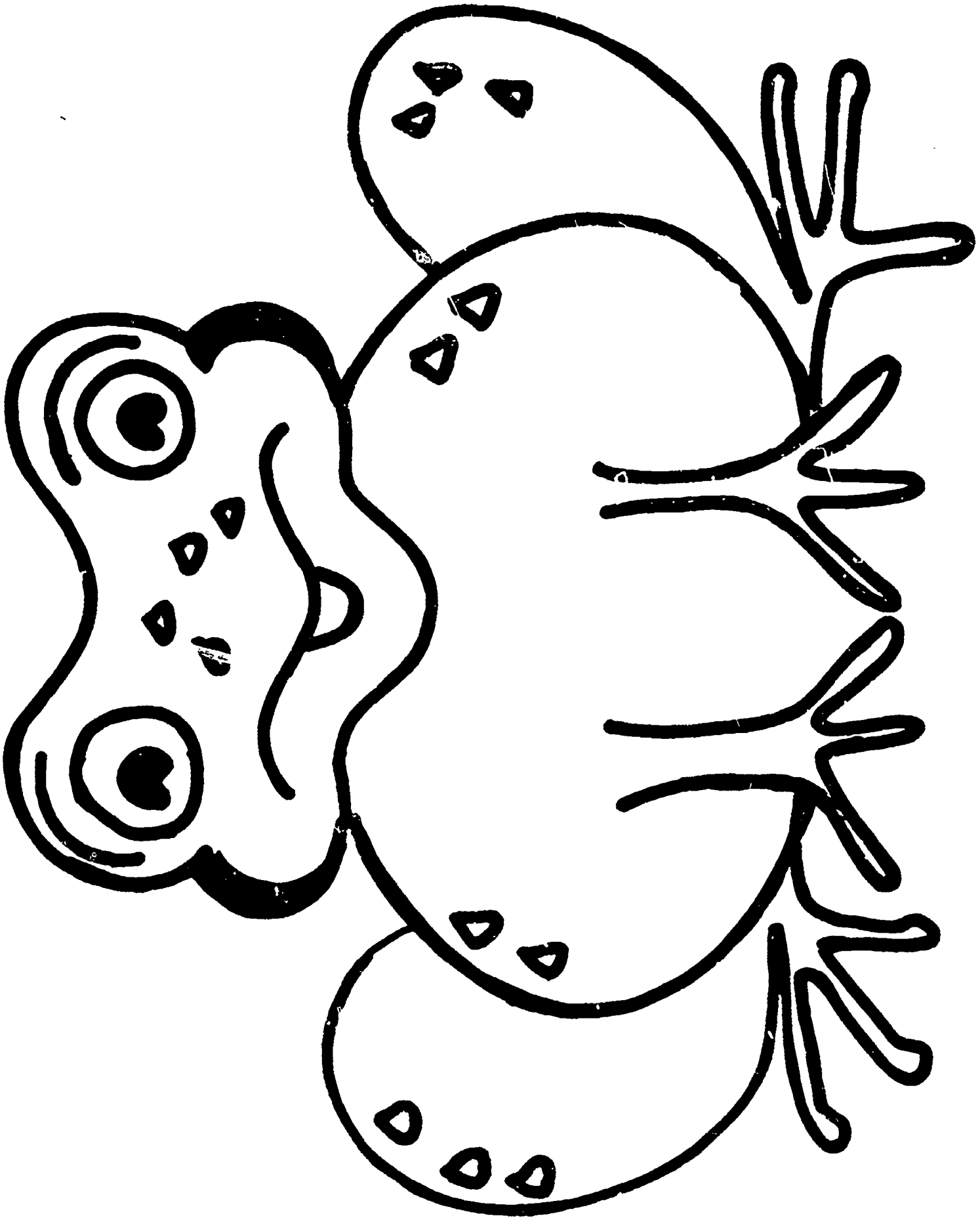

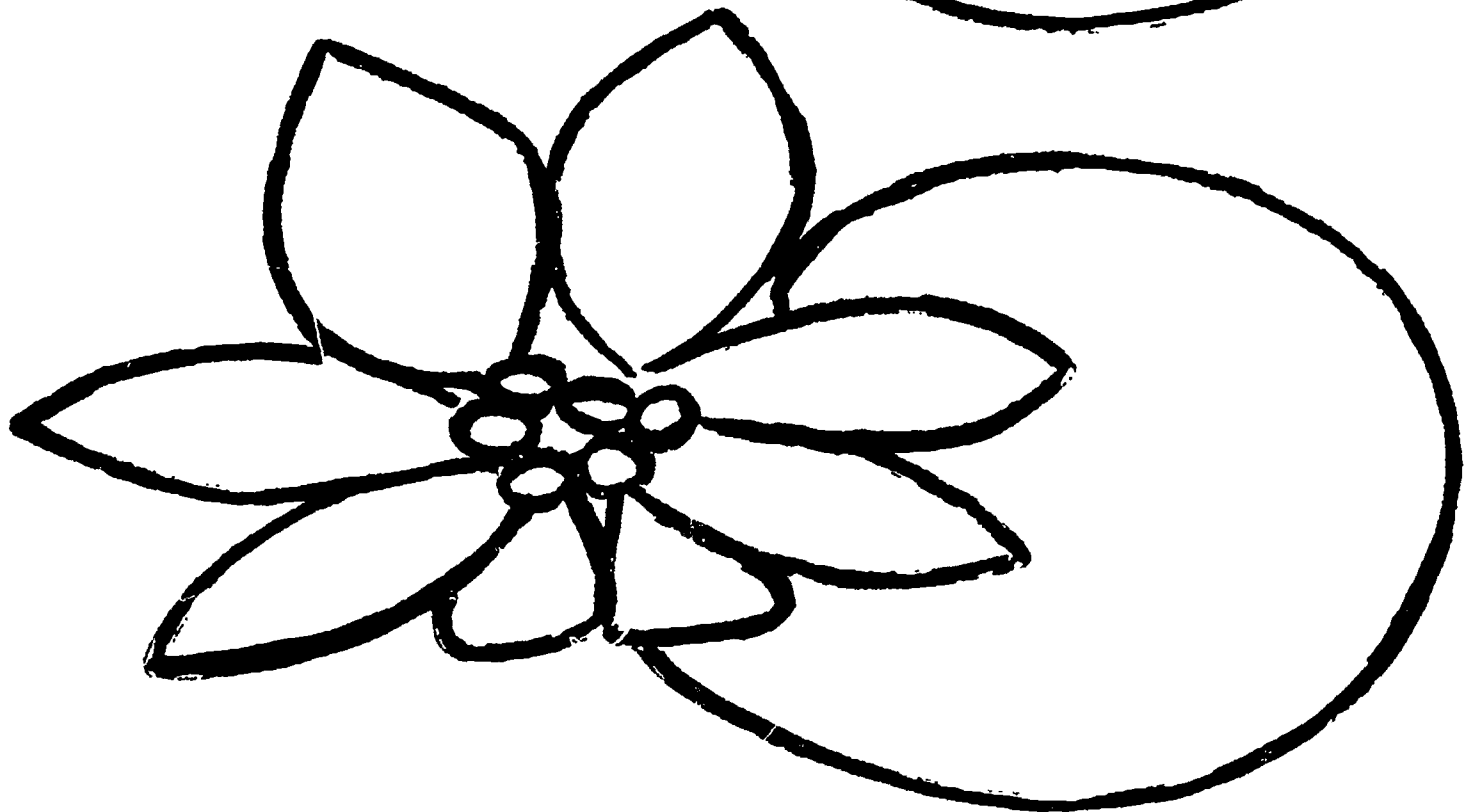
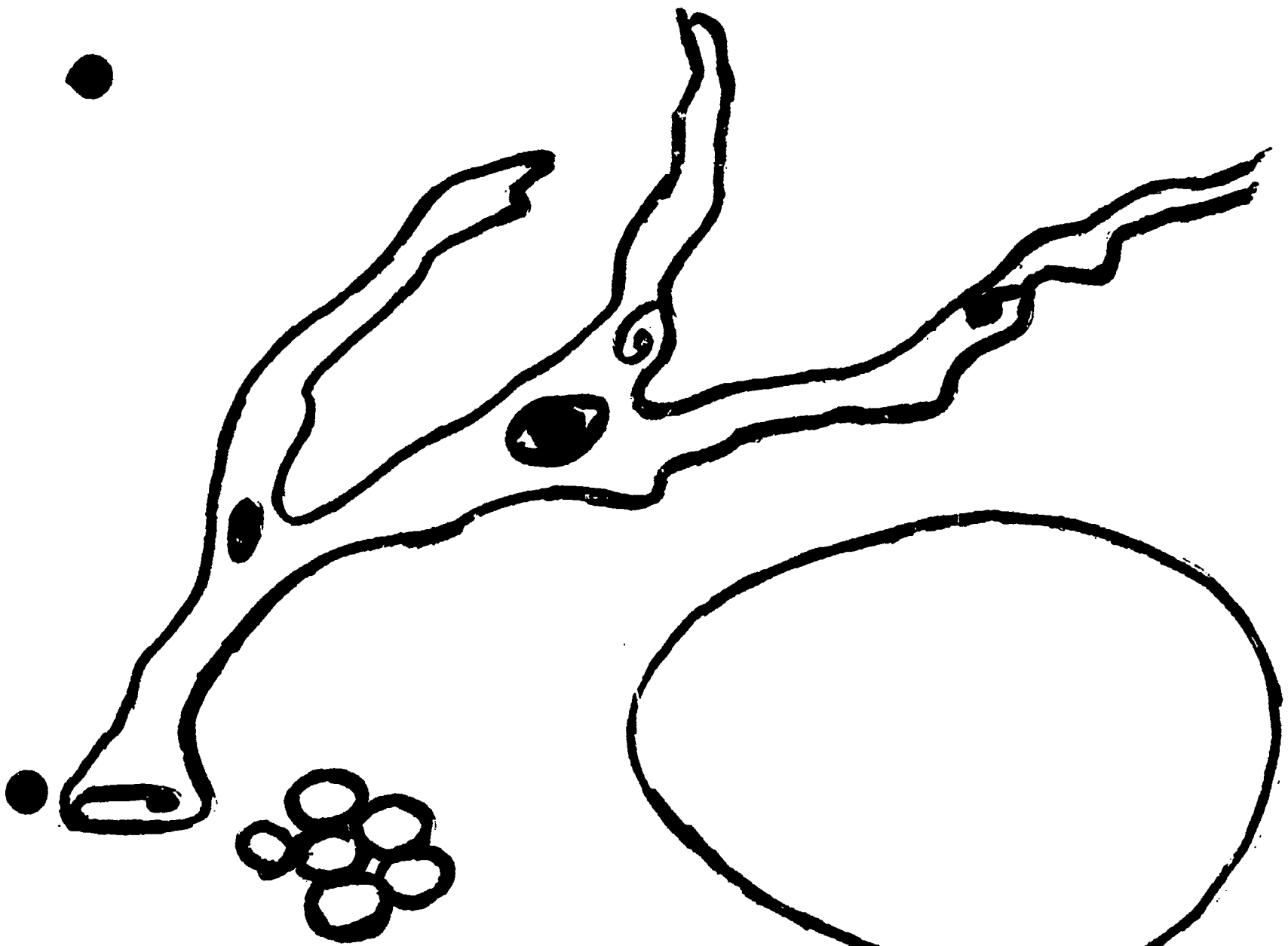

FOOD CHAIN

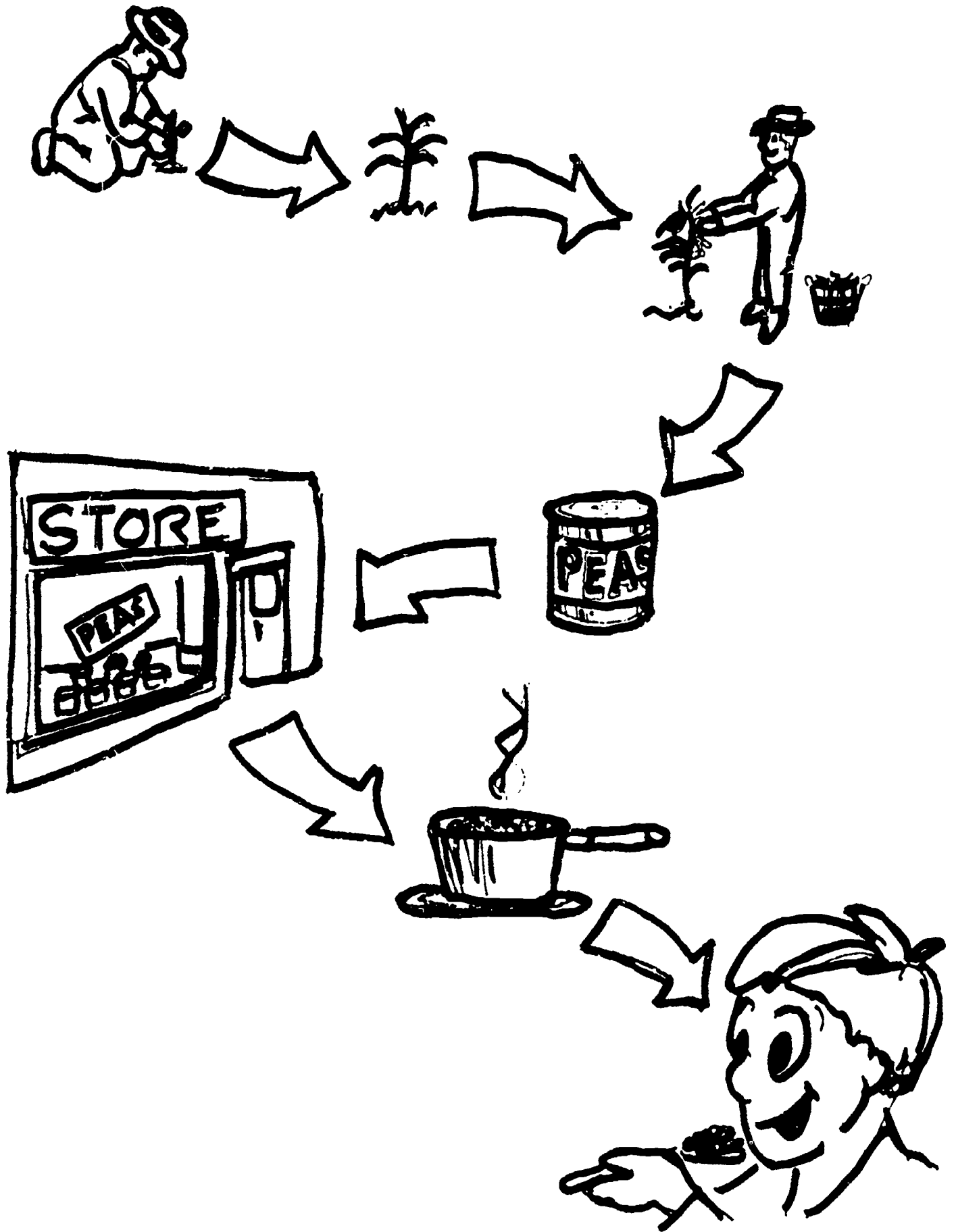

ENVIRONMENTAL BIBLIOGRAPHY

STUDENTS

- | | |
|-------------------------------------------------------|-------------------------------------------|
| SS LEAVES
PARKER | PB A TREE IS NICE
MARSIMNOT |
| SS A TREE IS A PLANT
BULLA | SS JOHNNY MAPLELEAF
TRESSELT |
| SS WHAT IS A TREE?
DARBY | SS HOW A SEED GROWS
HELENE JORDAN |
| M TWO BOYS IN A TREE
GATES | SS HOW PLANTS GROW
MEURATH |
| SS SEEDS ARE WONDERFUL
FOSTER | SS GREEN IS FOR GROWING
LUBELL |
| M PLEASE PASS THE GRASS
LEONE ADELSON 1960 | HS A TREE THIS TALL
INEZ RICE |
| M THE STORY OF JOHNNY APPLESEED
ALIKI 1963 | SS THE LITTLE CIRCLE
ANN ATWOOD |
| M THE POPPY SEEDS
CLYDE ROBERT BULLA | SS ONCE THERE WAS A TREE
PHYLLIS BUSCH |
| CH DANNY ON THE LOOKOUT
LEONARD SHORTALL | SS FROM FIELD TO FOREST
PRINGLE |
| H ARBOR DAY
AILEEN FISHER | SS LIVING SCIENCE: PLANTS
SULLIVAN |
| SS THE TRUE BOOK OF PLANT
EXPERIMENTS
PODENDORF | SS A MAPLE BEGINS
WATSON |
| PB THE CARROT SEED
RUTH KRAUSE AND CROCKET JOHNSON | SS ONE DAY IN THE GARDEN
VASILIEI |
| SS HOW TO BE A NATURE DETECTIVE
SELSAM | SS TRAVELERS ALL
WEBER |

TEACHER

- | | |
|-------------------------------------|-----------------------------------------------|
| E DESERT BOY
HAMBLY | 582 C HOW AND WHY WONDER BOOK OF TREES
COE |
| 918 LIFE IN THE TROPICS
HOLSAERT | 580 S PLANTS OF WOODLAND AND WAYSIDE
SWAIN |

PLANTS
54

- | | | | |
|-------|-----------------------------------------------------------------|-----|----------------------------------------------------------|
| 574 P | THE WEB OF NATURE
PETTIT | 630 | LOOK OUT FOR THE FOREST
BLOUGH |
| 630 B | THE INDOOR AND OUTDOOR
GROW IT BOOK
BAKER | 740 | HOW TO DRAW FLOWERS, FRUITS,
VEGETABLES
ZAIDENBERG |
| 574 | PLANT AND ANIMAL PARTNERSHIPS
PARKER | 630 | TREE PRODUCTS
ADLER |
| 580 | HOW AND WHY WONDER BOOKS
OF WILDFLOWERS | 364 | BOY SCOUTS OF AMERICA
(BOTANY, NATURE) |
| 580 H | THE BEGINNING KNOWLEDGE BOOK
OF BACKYARD FLOWERS
HATHAWAY | 300 | THE FIRST BOOK OF CONSERVATION
SMITH |
| 582 | BACKYARD TREES
RUSH | 300 | CONSERVATION OF NATURE
DUFFEY |
| 580 | SEEDS AND SEED TRAVELS
PARKER | 580 | THE FIRST BOOK OF PLANTS
DICKINSON |
| 630 | GARDENS INDOORS
PARKER | 580 | THE PLANTS WE EAT
SELSAM |
| 630 | THE GOLDEN BOOK OF GARDENING
GLANNONI | 582 | THIS IS A TREE
HUTCHINS |

AUDIO-VISUAL

- | | | | |
|---------|--------------------------|---------|----------------------------------------|
| EF 225 | LEARNING ABOUT FLOWERS | EF 361 | TREE IS A LIVING THING |
| EF 1185 | LEARNING ABOUT SEEDS | EF 1183 | WHAT PLANTS NEED FOR GROWTH |
| EF 265 | LET'S WATCH PLANTS GROW | EF 363 | WE GET FOOD FROM PLANTS
AND ANIMALS |
| EF 353 | LIFE STORY OF A PLANT | EF 1406 | FOOD FOR THE CITY: PRODUCE |
| EF 348 | PLANT THROUGH THE SEASON | EF 351 | FOOD FROM THE SUN |
| EF 7 | SEEDS GROW INTO PLANTS | EF 182 | FROZEN FOODS |
| EF 186 | TREES, THE | | |

ROCKY



The intent of this unit is to develop awareness of basic deductive and inductive skills stressing scientific methods of study, development of attitudes and perceptions, and a process approach to learning.

In dealing with our objectives, we are using an activity oriented approach. Each of our subject areas has been divided into three parts, the PHYSICAL CHARACTERISTICS of the subject, MAN'S USE, and an awareness activity focusing on MAN'S MISUSE. Each lesson is designed to be complete in itself.

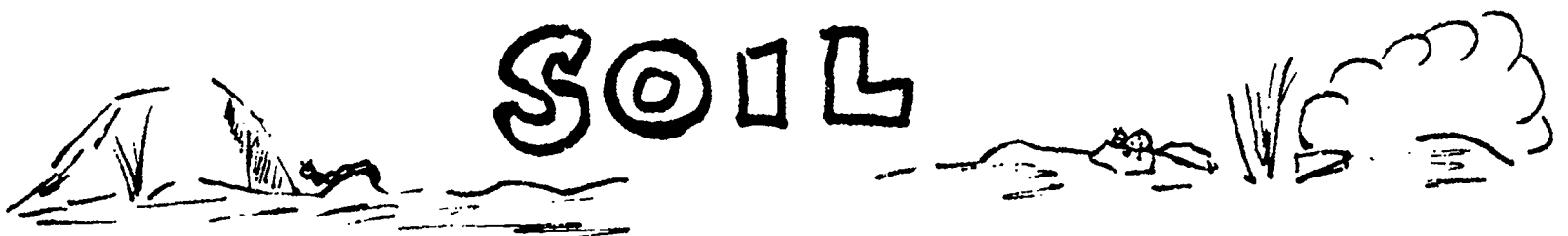

Soil covers much of our land. It is in a constant state of change. Soil has a definite value for man, but he in turn must learn to use it properly. In order for this to be accomplished, the student needs to understand composition of soil and how it supplies the raw materials needed for life to exist on our planet.

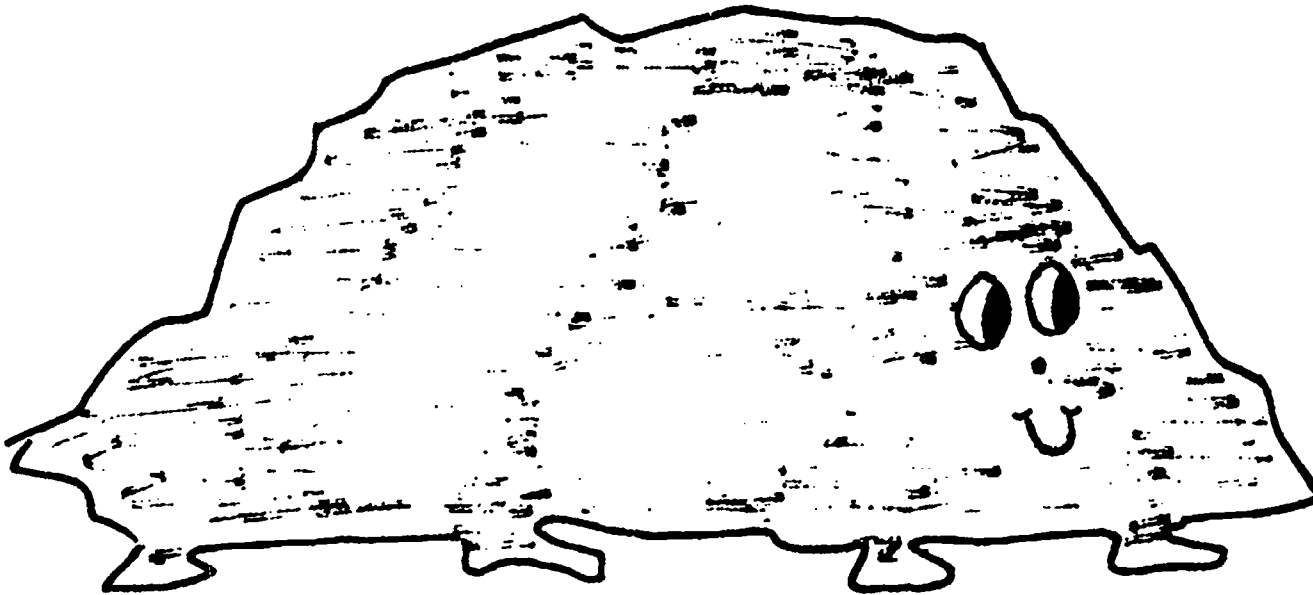

We visualize Rocky as a creative character that may help tie in the various activities that follow. He may act as a visual aid in flannel on your flannel board or as a means of introducing lessons, related poems, films, etc. The larger picture of Rocky on the next page could be made into a ditto and serve as a cover on a soil booklet for each student. You may want to adapt him into a puppet character.

We know you'll have a lot of your own good ideas too. We'll be anxious to have you share them with us during our inservice get togethers and will want to include them in our revision.

ROCK ↘

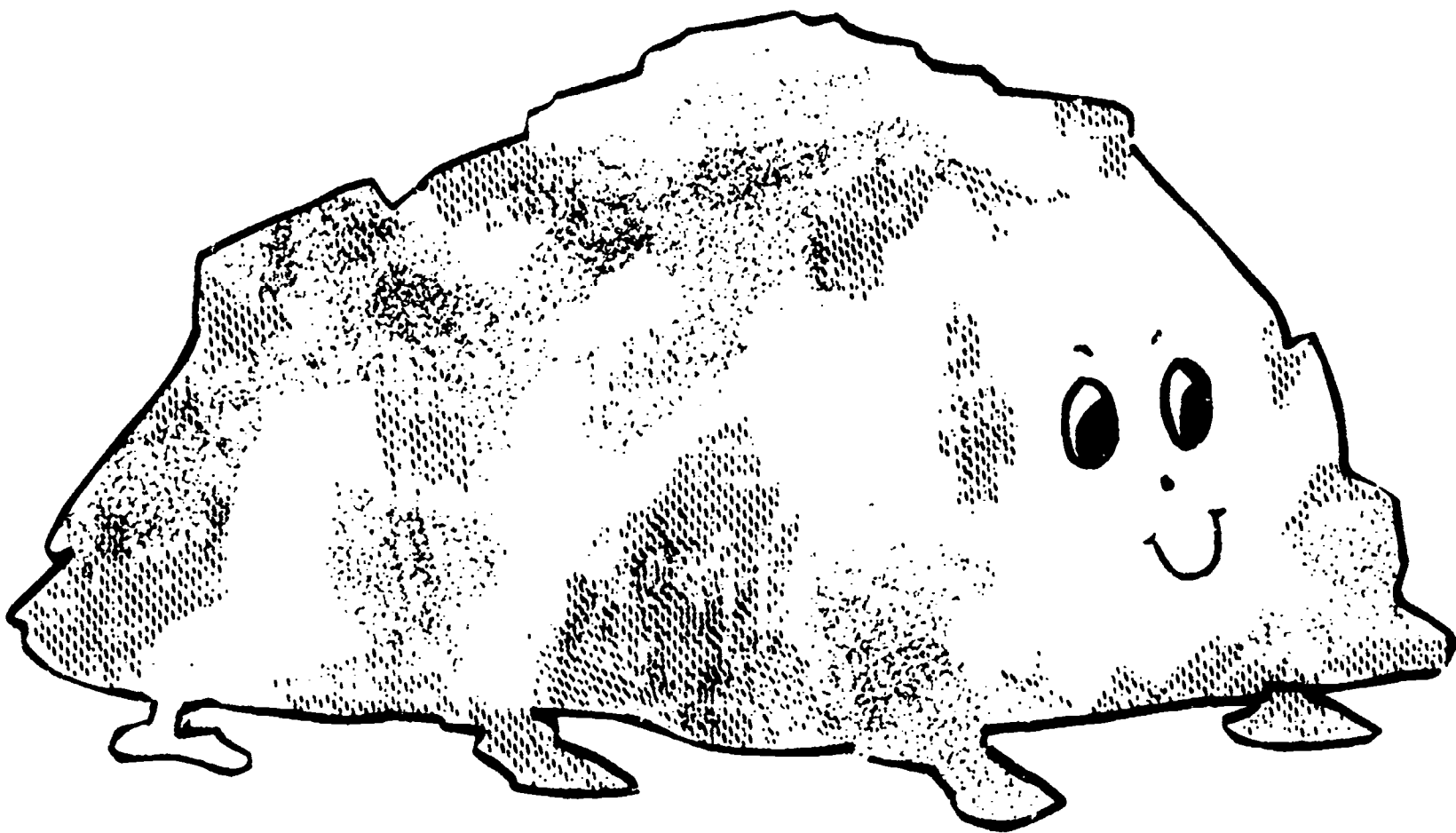

SOIL

Topic: Soil
Grade: Two
Estimated time:
Subject Areas: Science

LEVEL V OBJECTIVE:

THE STUDENT WILL UNDERSTAND THE COMPOSITION OF SOIL.

LEVEL VI OBJECTIVE:

THE STUDENT WILL RECOGNIZE THAT THERE ARE VARIOUS TYPES OF SOIL SUCH AS CLAY, SAND, GRAVEL, LOAM, AND HUMUS.

GETTING IT TOGETHER

MATERIALS

Shovel, something to put soil sample in.

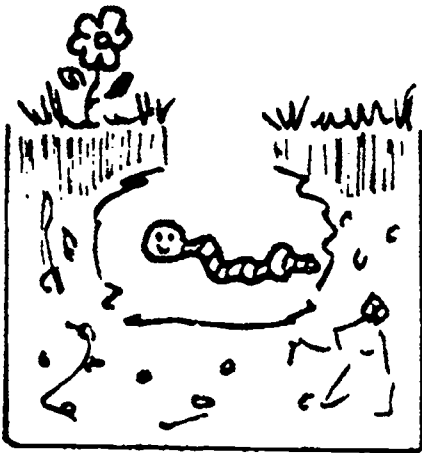

TEACHER BACKGROUND INFORMATION

Soil is a covering for much of the land on the earth. Soil is made from broken rock, dead plants, and dead animals. There are many kinds of soil. The basic soil compositions that you will need to be familiar with are:

Clay soil: fine, light in color.

Sandy soil: gritty

Gravel soil: coarse and pebbly

Loamy soil: Mixture of sand, clay, and organic material

Humus: organic components of soil

PRE-ACTIVITY

Discussion (Time: 5 minutes)

Have children discuss what soil is made of.

ACTIVITY

Go outdoors and collect samples of soil from different areas (i.e. rocky, loamy, from under trees, from beaten path, from garden.

POST-ACTIVITY

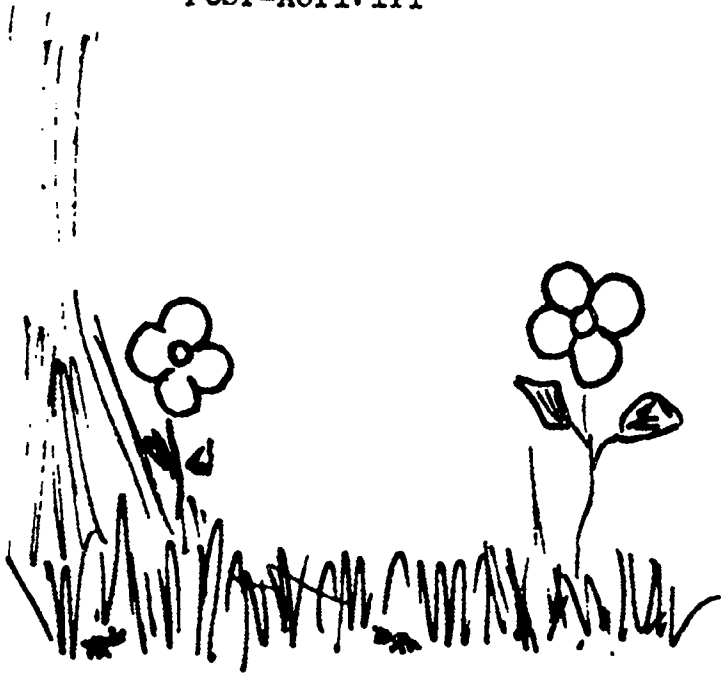

List the various things found in soil: dirt, rocks, dead plant material, garbage, animal life.

Discuss

1. Compare materials found in different areas - which would be best for growing things?
2. How animals in the soil help it to breathe, absorb water.
3. What soil in your garden would need.

SUGGESTED ADDITIONAL ACTIVITIES

Compare through pictures, different types of soils in different types of environments (i.e., desert, tropical, etc.)

Show the film below.

RESOURCES

Student

See attached bibliography

Teacher

Film: Soil: What it is and what it does
EF 469

SOIL

Topic: Soil Composition
Grade: Two
Estimated Time:
Subject Areas: Science, Art

LEVEL V OBJECTIVE:

STUDENTS WILL UNDERSTAND THE COMPOSITION OF SOIL.

LEVEL VI OBJECTIVE:

THE STUDENT WILL BE ABLE TO RECOGNIZE THAT THE COMPOSITION OF SOILS SUCH AS CLAY, SAND, LOAM, HAVE AN EFFECT ON PLANT GROWTH.

GETTING IT TOGETHER

MATERIALS

Different types of soil (sand, loam, dirt from under a tree), seeds, water, nutrients (commercial fertilizer).

TEACHER BACKGROUND INFORMATION

PRE-ACTIVITY

In what ways do we depend on soil for food?

In what ways do animals depend on soil for food?

Why is soil quality important?



ACTIVITY

Mix water with different kinds of soil to see how they differ. Try to grow a variety of seeds in various soils. Add various nutrients and observe the effects.

POST-ACTIVITY

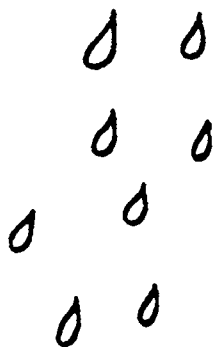
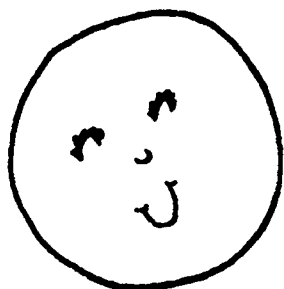

List the needs of plants as observed.

Draw pictures of various results.

SUGGESTED ADDITIONAL ACTIVITIES

Obtain a pH kit and take an acidity-alkaline reading for the various soils. Relate this to its productive ability.



RESOURCES

Student

See attached bibliography

Teacher

See attached bibliography

SOIL

Topic: Soil
Grade: Two
Estimated Time:
Subject Area: Science

LEVEL V OBJECTIVE:

STUDENT WILL UNDERSTAND THE COMPOSITION OF SOIL.

LEVEL VI OBJECTIVE:

THE STUDENT WILL BE ABLE TO RECOGNIZE THE EFFECT OF WATER EROSION ON SOIL WITH AND WITHOUT A GRASS COVERING.

GETTING IT TOGETHER

MATERIALS

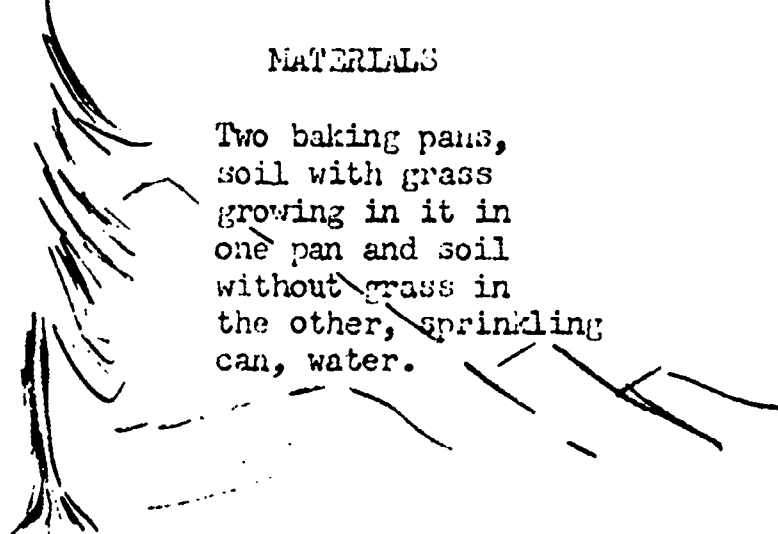

Two baking pans, soil with grass growing in it in one pan and soil without grass in the other, sprinkling can, water.

TEACHER BACKGROUND INFORMATION

PRE-ACTIVITY



Ask students if they have ever noticed differences in the shape of soil. Is it always evenly distributed or does it differ? How might this happen?

ACTIVITY

Gather students around two baking pans. Let students participate in experiment. Tilt baking pans so they look like hills. Sprinkle water on soil in both pans. Observe what happens.

P. ST-ACTIVITY

Discuss:

What do we need to keep the soil from being washed away?

Can you think of anything else that will hold the soil in place?

What does conservation mean?



SUGGESTED ADDITIONAL ACTIVITIES

1. Go out and find examples of wash-out erosion in the environment - gullies, etc.
2. Find examples of "people" erosion - where kids have worn paths. Look for examples of water erosion down the people paths.

RESOURCES

Student

See attached bibliography

Teacher

See attached bibliography

SOIL

Topic: Soil (Use)
Grade: Two
Estimated Time:
Subject Area: Science

LEVEL V OBJECTIVE:

STUDENT WILL UNDERSTAND THE COMPOSITION OF SOIL.

LEVEL VI OBJECTIVE:

THE STUDENT WILL KNOW WHAT EFFECT VARIOUS MATERIAL SUCH AS SAND, WATER, LOAM, AND TOPSOIL HAVE ON PLANT GROWTH.

GETTING IT TOGETHER

MATERIALS

Radish seeds, carrot seeds, bean seeds, containers sand, loam, water, topsoil

TEACHER BACKGROUND INFORMATION

PRE-ACTIVITY

1. Discuss how soil is of value in food production.
2. Ask: Do all types of soil have the same effect on plants? Make some predictions.

ACTIVITY

1. Plant seeds in the four types of media.
2. Observe the effects of each type of soil on the seeds.

POST-ACTIVITY

Discuss the affects of each kind of soil on the seeds.

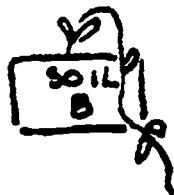
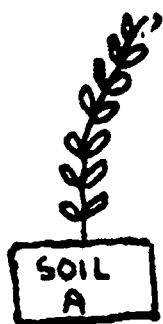

SUGGESTED ADDITIONAL ACTIVITIES

1. Find out what types of plants will grow in different types of soil (seaweed in water, cactus in sand).
2. Film: Terrarium, the Classroom Science EF 1400

RESOURCES

Student

See attached bibliography

Teacher

Film: Terrarium, the Classroom Science
EF 1400

SOIL

Topic: Soil
Grade: Two
Estimated Time:
Subject Areas: Science, Math

LEVEL V OBJECTIVE:

STUDENTS WILL UNDERSTAND THE COMPOSITION OF SOIL.

LEVEL VI OBJECTIVE:

THE STUDENT WILL BE ABLE TO RECOGNIZE THE DIFFERENCES IN WATER ABSORPTION IN SOIL COVERED SOIL, BARE GROUND, SAND, CLAY, HUMUS, AND LOAM.

GETTING IT TOGETHER

MATERIALS

Soup cans or cans of the same size, can opener, various soil types.

TEACHER BACKGROUND INFORMATION

PRE-ACTIVITY



Remove both ends of cans. Place cans so that one end is forced 1/2" below the soil surface in a variety of soil types and conditions: sod-covered soil, bare ground, sand, clay, etc.

ACTIVITY

Fill each can with water and using a watch to time the action, note how long it takes for the water to be absorbed into the particular kind of soil.

POST-ACTIVITY

Draw Conclusions.

1. In general, the soil with the most humus will absorb water the most rapidly.
2. The water in the soil, of course, is the amount of water available to plants.

RESOURCES

Student

See attached bibliography

Teacher

See attached bibliography

SOIL

Topic: Soil
Grade: Two
Estimated Time:
Subject Areas: (Litter- Solid Waste), Science, Lang. Arts

LEVEL V OBJECTIVE:

STUDENTS SHALL RECOGNIZE VARIOUS POLLUTION PROBLEMS, THEIR CAUSES AND EFFECTS.

LEVEL VI OBJECTIVE:

THE STUDENT WILL BE ABLE TO UNDERSTAND THAT PAPER LITTER IS AN EYE SORE IN A CLEAN ROOM.

GETTING IT TOGETHER

MATERIALS

Papers to throw on floor (optional)
mask of a litterbug,
or a litterbag.

TEACHER BACKGROUND INFORMATION

PRE-ACTIVITY

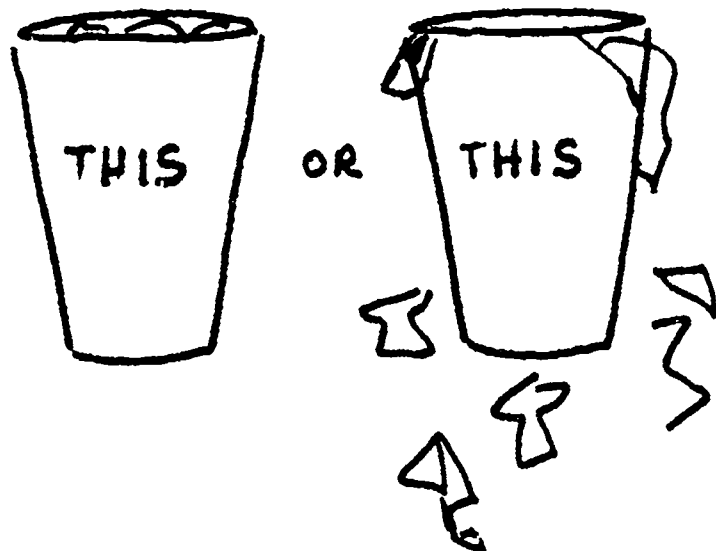

1. A brief description on cleanliness of room.
2. How can we keep the room neat?
3. What things do we need in the in the room to keep it neat?

Role Playing

1. The teacher will choose two individuals or groups, one called the Litterbugs and the other the Litterbags.
2. Examples
 - A. She may ask a Litterbug to eat a piece of candy and drop the paper on the floor. Litterbags will be asked to pick it up.
 - B. She may give a Litterbug many papers to carry from one place to another. Again Litterbags will pick it up.

ACTIVITY

POST-ACTIVITY

Following the role playing, the teacher should ask the group to suggest or think about some of the whys for behavior of litterbugs and how to overcome them.



WHY NOT TRY THESE?

SUGGESTED ADDITIONAL ACTIVITIES

1. Make anti-litter posters to be put up as reminders around the school room.
2. Write and produce a litter play to be presented to other classes.
3. Decorate waste containers for school use.
4. Do a litter diorama.
5. Write and produce a litter puppet show.

RESOURCES

Student

See attached bibliography

Teacher

See attached bibliography

SOIL

Topic: Soil
Grade: Two
Estimated Time:
Subject Areas: Science, Social
Studies

LEVEL V OBJECTIVE:

STUDENTS SHALL RECOGNIZE VARIOUS POLLUTION PROBLEMS,
THEIR CAUSES AND EFFECTS.

LEVEL VI OBJECTIVE:

THE STUDENT WILL RECOGNIZE THAT LITTER CAN BE A PROBLEM
IN HIS CLASSROOM.

GETTING IT TOGETHER

MATERIALS

Paper and pencil.

TEACHER BACKGROUND INFORMATION

PRE-ACTIVITY

Lead children into a discussion in which they will form the hypothesis - "Litter is a problem in the school".

ACTIVITY

Game - Divide the group into three sections of "Detectives."

- A. One group will go to the principal and janitor in an effort to find out if these people feel that littering is a problem for the school.



Activity (con't)

- B. The second group will visit 3-4 classrooms to find out if they have litter problems.
- C. The third group will remain in the classroom and pick up litter, noting where most is found.

The three groups will meet and report on their findings. They will also discuss ways to improve the areas.

SUGGESTED ADDITIONAL ACTIVITIES

1. Litter Bulletin Board, based on Less Litter (see attached sheet).
2. Write stories about Less.

RESOURCES

Student

See attached bibliography

Teacher

See attached bibliography

Hi!

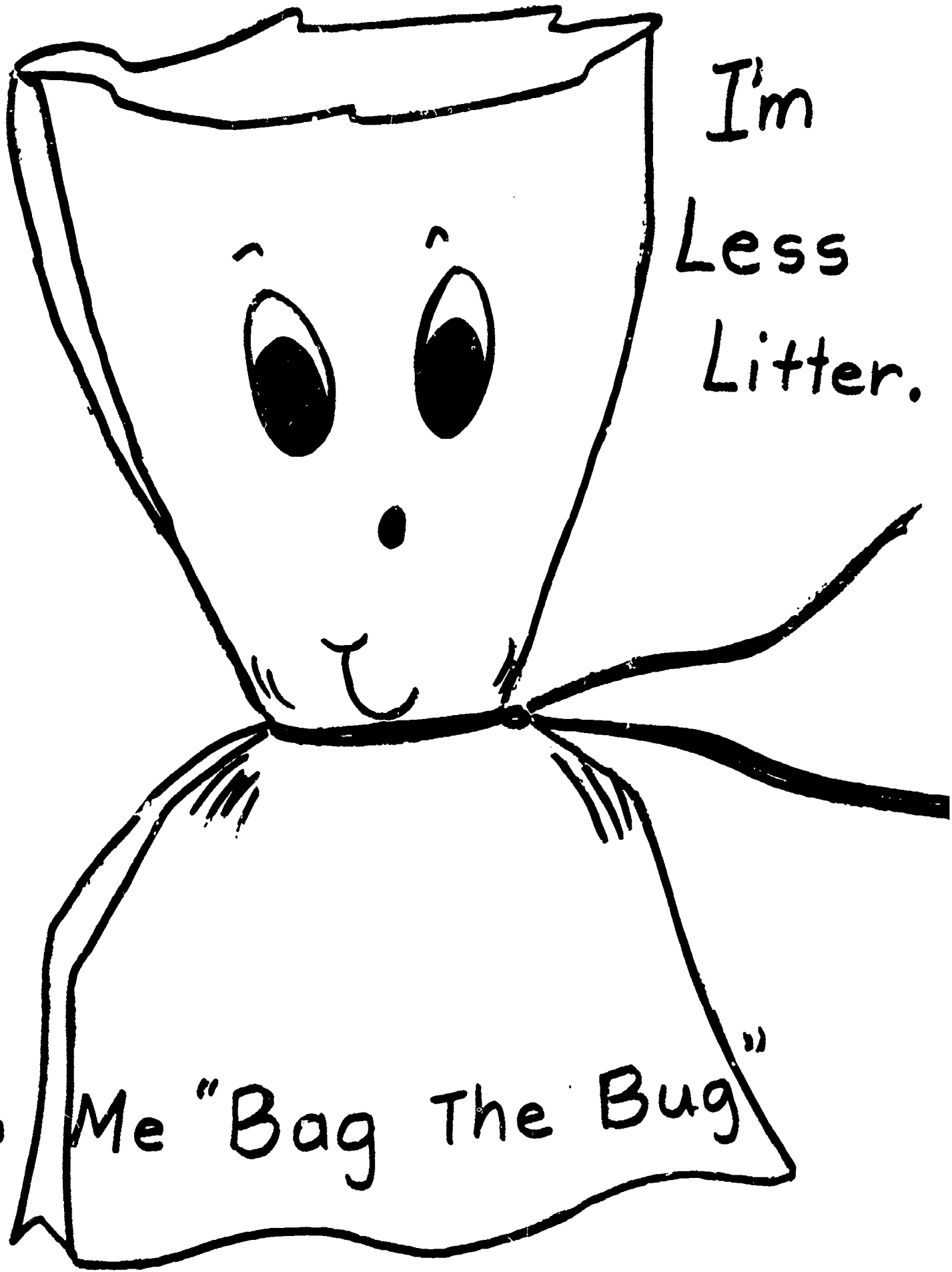

I'm
Less
Litter.

Help Me "Bag The Bug"

SOIL

Topic: Soil
Grade: Two
Estimated Time:
Subject Areas: Science, Art,
Music

LEVEL V OBJECTIVE:

STUDENTS SHALL RECOGNIZE VARIOUS POLLUTION PROBLEMS,
THEIR CAUSES AND EFFECTS.

LEVEL VI OBJECTIVE:

THE STUDENT WILL RECOGNIZE THAT SOLID WASTE SUCH AS REFUSE,
TRASH, AND GARBAGE CAUSE DISPOSAL PROBLEMS.

GETTING IT TOGETHER

MATERIALS

Pictures of different
types of solid waste,
paper, pencil, crayons

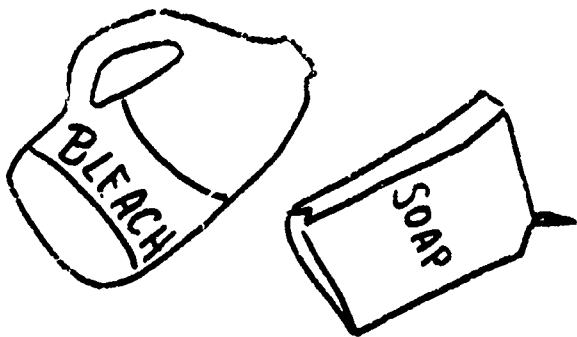

TEACHER BACKGROUND INFORMATION

Taken from: "Solid Waste Disposal,"
Clifford Knapp, INSTRUCTOR MAGAZINE,
August/September 1970.

We are up to our ears in solid waste and the problem may become worse in the future. The question is - What to do with all the material we throw away? Every person in this country is responsible for an average of five pounds of waste everyday. Some estimate that by 1980, this figure will increase to about eight pounds daily. Where does it all come from?

Solid waste (refuse or trash) includes garbage, rubbish, and ashes. Garbage results from handling (preparation and packaging), selling, eating foods, and other necessities of living. Rubbish is either burnable or non-burnable. Metal, dirt, and glass usually don't burn.

Teacher Background (cont.)

Cities gather trash when they clean streets and parks or pick up refuse from hospitals, schools, and churches. Stores, offices, markets, movie theaters, factories, and other industries add to the problem. Where else can you find solid wastes?

Fire and Smoke

Common ways to dispose of solid wastes are by burning or dumping them on the ground or into the water. We never really get rid of waste. We just move it from place to place and change it so that it takes up less space. When waste is burned in an incinerator or at a dump, smoke and poisonous gases escape into the air. These can affect people's health and damage property. Dumps near buildings can be hazardous. If trash accidentally catches fire, life and property can be destroyed.

Odors

Dumped garbage often creates distasteful odors as it decays. Not many people want to live near a smelly dump. Land values may go down and the community may decay along with the garbage.

Water Pollution

When it rains over an open dump, water drains through the solid waste and often enters our ground water supply (also rivers and streams). Harmful chemicals in the drainage can enter and pollute it. This can cause death to fish and ruin outdoor recreation sites.

Animal Nuisances

Dumps attract and offer food and shelter to rats and mice. They thrive in this kind of environment. Rodents may carry disease and are sometimes a threat to human health.

Dumps provide breeding places for insects. These pests also carry diseases harmful to other animals and man.

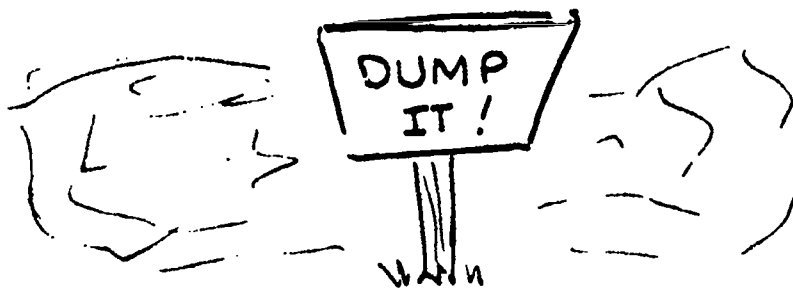

Wetlands and Shoreline Changes

For years man has used wetlands, shorelines and stream valleys to dump his refuse in. San Francisco Bay has been much reduced in size by this continuous dumping.

Most wetlands are valuable for supporting a variety of wildlife and provide areas for people to enjoy and study nature. They can be important for emergency use in time of drought, for fire protection, and in maintaining the area's water-table level. In time of flood, wetlands can serve as reservoirs. But once they become filled with refuse, they are usually gone forever.

Disposal Methods

What are some alternatives to open burning in dumps? If land area is available, a practical method is called "sanitary landfill." This involves digging a large hole or trench, compacting solid waste, and burying it every day. If done correctly it eliminates most of the problems in the accompanying pictures.

Using very high-temperature incinerators is another method. Usually, ordinary ones are not hot enough to eliminate the smoke problem. Temperatures of over 2500 degrees Fahrenheit do a good job of disposing of waste and smoke, but they are expensive to install.

Some communities have considered separating their garbage from the other solid wastes, composting it, and selling the compost as fertilizer for soil.

A few machines are able to crush metal into blocks to be used in foundations of buildings and highways. Crushed glass has even been tested for use with materials for construction, insulation, and floor tiles.

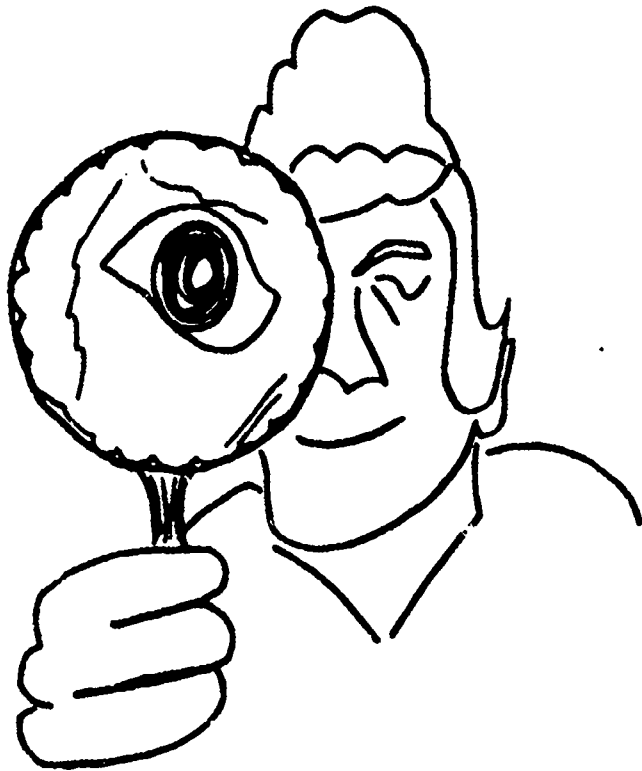

LET'S
FIND
A
WAY!

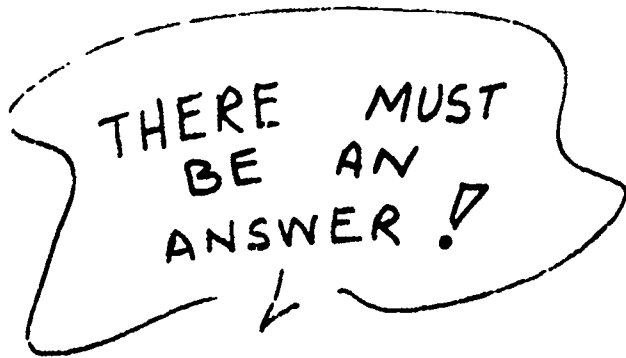

Teacher Background (cont.)

Man is tackling the refuse problem another way by attempting to invent a glass bottle that will dissolve after it is broken. Today we have paper products that dissolve in water.

Reuse and recycling through using returnable bottles are another means of reducing waste. Reusing old aluminum in new products also reduces the solid waste problem.

Scientists are finding ways to obtain gas from refuse for use as an energy source, and to convert some wastes into high-protein animal food. Research continues to seek new ways. What other suggestions can your class make?

PRE-ACTIVITY

Prepare group for discussion.

ACTIVITY

Show pictures. Discuss problems. How is man dealing with pollution? How can we be part of a solution?

POST-ACTIVITY

Draw pictures as result of your discussion.



SUGGESTED ADDITIONAL ACTIVITIES

Using a familiar tune, create your own "Pollution" or environmental problems.

RESOURCES

Student

See attached bibliography

Teacher

See attached bibliography

SUPPLEMENTAL SOIL ACTIVITIES

1. Find soil from various places (school yard, garden, road). Put each kind in a jar. Compare colors. Look through a hand lens and see what particles compose the soil (pebbles, roots, leaves, sand, etc.).
2. Smell the soil to see if it has an odor. Feel ground in different places and discuss differences (cool, warm, sandy, sticky).
3. "Make" soil by rubbing 2 rocks together. Try "making" soil by breaking up crumbly rock. Put cloth around the rock while breaking it to avoid injury. Plant some seeds in these and other soils and compare results.
4. Get some topsoil and put it in a large jar. Go outside (after a rain is a good time) and collect some earthworms to put in the jar. Put the jar in a dark place and leave it for a day or two. Discover the worms making tunnels. Then put some water into the soil. Observe the worms.

Source:

Outdoor Education Primary Resource
Guide, Grade 1-3
U.S. Dept. of H.E.W., Office of Education

WHY NOT

TRY

THESE?

TEST SOIL WATER-HOLDING CAPACITY

Physical
Properties

Paraphernalia:
Cheesecloth
Jar
Glass Chimney
or bottle with
bottom removed
Water
Beaker
String



Quantitate
Try different soils



Spoon
Shovel
Glass Container

Predict Results

Let it Set

Time it

What happened?

Try other soil

Or: Make a soil
layer cake
with sieves or
screen

Measure how much water
the soil will hold.

Try different types of soil.

SOIL

ENVIRONMENTAL BIBLIOGRAPHY

STUDENT

SS WHAT IS A ROCK?
SYROCKI

SS ROCKS AND HOW WE USE THEM
PINE AND LEVINE

PA THE DIRT ROAD
CARRICK

TEACHER

630 WHAT IS SOIL?
SYROCKI

550 HOW AND WHY BOOK OF ROCKS
AND MINERALS
HYLER

364 BOY SCOUTS OF AMERICA
(SOIL AND CONSERVATION BOOKS)

300 THE FIRST BOOK OF CONSERVATION
SMITH

AUDIO-VISUAL

EF 1469 SOIL: WHAT IT IS AND WHAT IT DOES

EF 1100 TERRARIUM, THE CLASSROOM SCIENCE

EF 1183 WHAT PLANTS NEED FOR GROWTH

Hi!

I'm
Less
Litter

Help Me "Bag The Bug"



LITTER

Topic: Environmental Awareness
Activities

Grade: 1 and 2

Subject Areas: Art, Soc. Studies
Language Art

LEVEL V OBJECTIVE: The student will perceive himself as part of nature and will desire to live in harmony (dynamic balance) with the rest of nature.

LEVEL VI OBJECTIVE: The student will know various litter pollutants in the local environment such as bottles, cans, and paper.

MATERIALS

Various materials-check out the individual activities.



ACTIVITIES

1. Introduce "Less Litter" (see worksheet #1).
2. What's wrong with these pictures? (See worksheet #2).
3. Distribute and talk about "Earth" coloring book. (See attached master copy).
4. **Recycling Activity:**
Collect bottles and other glass containers. Plan a field trip to a recycling center where youngster can view the containers being weighed and dumped into bins before they are crushed and melted down for reuse.
5. Encourage students to recycle their lunch sacks instead of throwing them away each day.
6. Encourage reuse of wrapping paper for gifts.

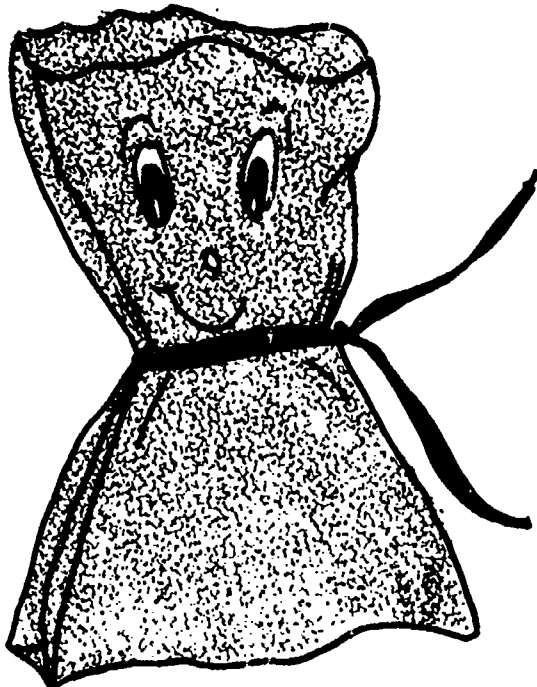

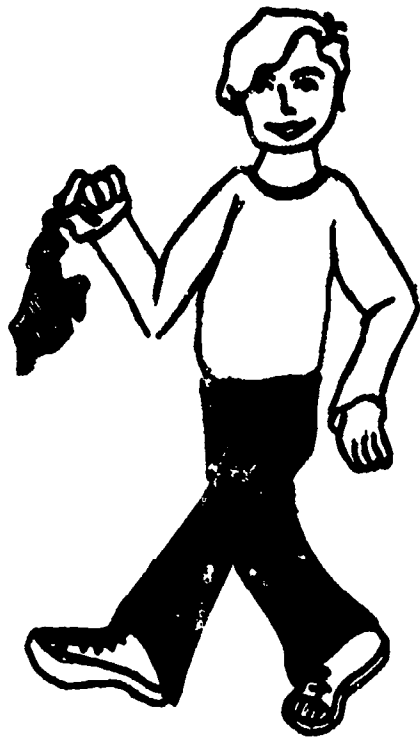

7. Set up "Paper Recycling" corner in the room. Encourage conservation by a conservative use of paper. In the recycling corner, paper can be stacked for use as scratch paper, drill work, art projects, etc. Teacher can consider using backs of ditto sheets.
8. How can a newspaper be used? Most people read the paper and throw it away. Are there any alternatives?
9. In what ways do we waste paper through the use of paper napkins, tissues, paper plates and paper cups?
10. Collect and compare pictures of attractive yards and cluttered yards. How do we personally affect land use?
11. Introduce your students to WOODSY, the Forest Service Owl. He is a new character whose main role is to remind people to take care of the environment. You'll find him on posters and in the newspaper along side of his slogan, "GIVE A HOOT! DON'T POLLUTE!" Many activities can be done relating back to Woodsy. Create posters showing how you can give a hoot. Learn a song about Woodsy. (See attached sheet #4).



12. Litterbug Game: Each child finds something in his desk he no longer wants. One child will drop his litter either inside or outside. Have a few more do the same. Discuss the change that took place. Next step-Clean up. Put the litter in trash cans. (Encourage high school ag or art classes to design attractive litter containers).



13. Litter Bug Bulletin Board: Draw the outline of a huge bug. Children go on a "pick-up litter" walk. When they come back, glue the litter found to the "Litter Bug".
14. Make individual litter bags with slogans in art class. Use them for pick-up at school or the family car.
15. Role Playing-the teacher will choose two individuals or groups. One will be called the LITTERBAGS and the other the LITTERBUGS. She may ask a Litterbug to eat a piece of candy and drop the paper on the floor. Litterbags will be asked to pick it up. Then change roles. Have the groups talk about their behavior and how they felt about their role.
16. Litter game-Divide the group into three sections of DETECTIVES. One group will go to the principal and janitor in an effort to find out if these people feel that littering inside the school is a problem. The second group will visit 3-4 classrooms to find out if they have litter problems. The third group will remain in the classroom and pick up the litter, noting where most is found. The three groups will meet and report their findings.
17. Read about "Smokey, the Bear." Let student draw his picture and write a story.
18. Channel 9 is broadcasting a television series, weekly, for grades 1 and 2 called WORKING TOGETHER. It emphasizes many environmental concerns while exploring different jobs that people do in various parts of the state of Washington.

19. Forest Fires: Draw what someone did that started a forest fire: matches, unattended fire, cigarettes, etc. Draw trees burning. Draw the results: blackened stumps, wildlife looking for new homes, etc. Children can also color and discuss #5 and #6 worksheets.
20. The following picture of WOODSY could be used for a bulletin board idea.



#1

Hi!

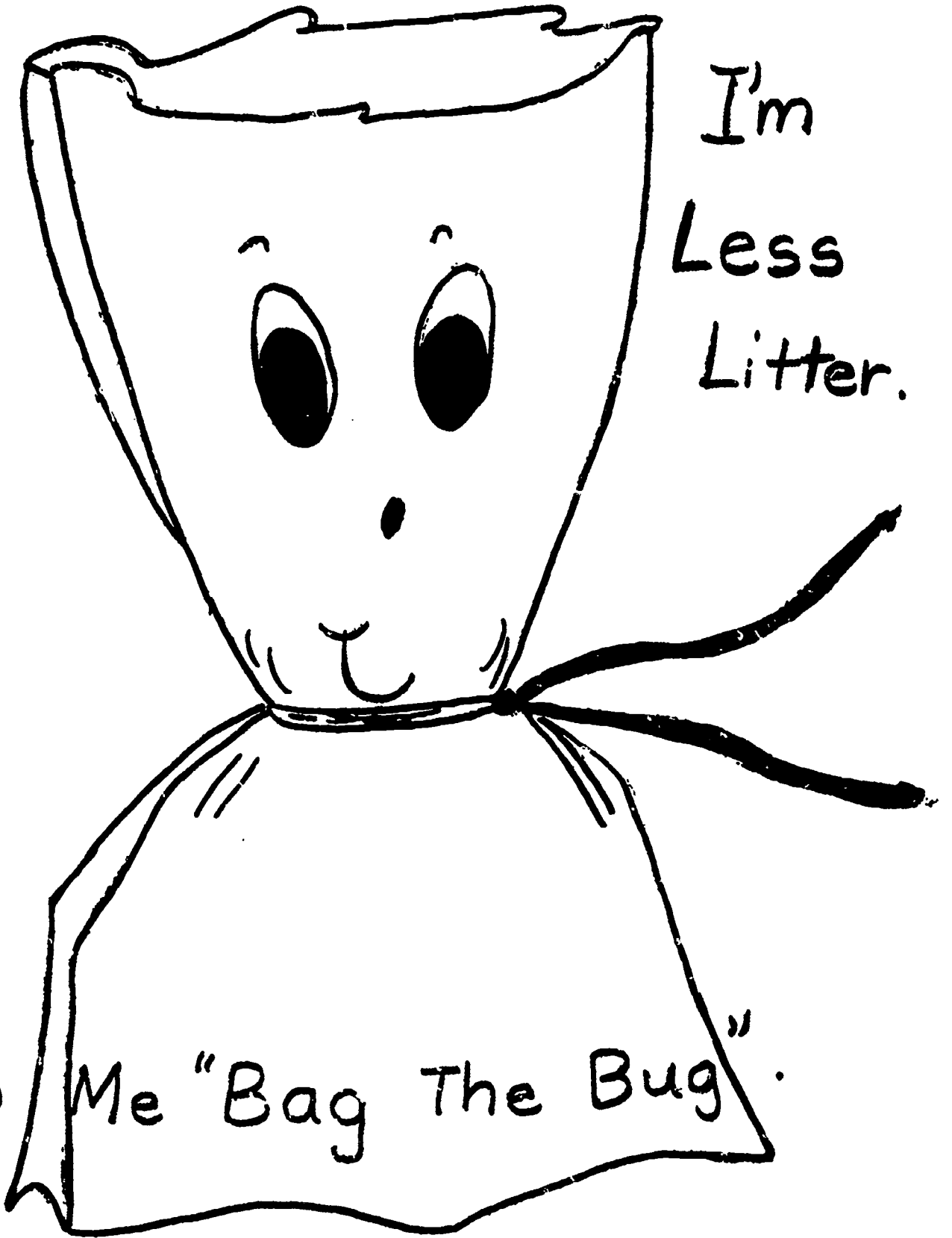

I'm
Less
Litter.

Help Me "Bag The Bug".

2

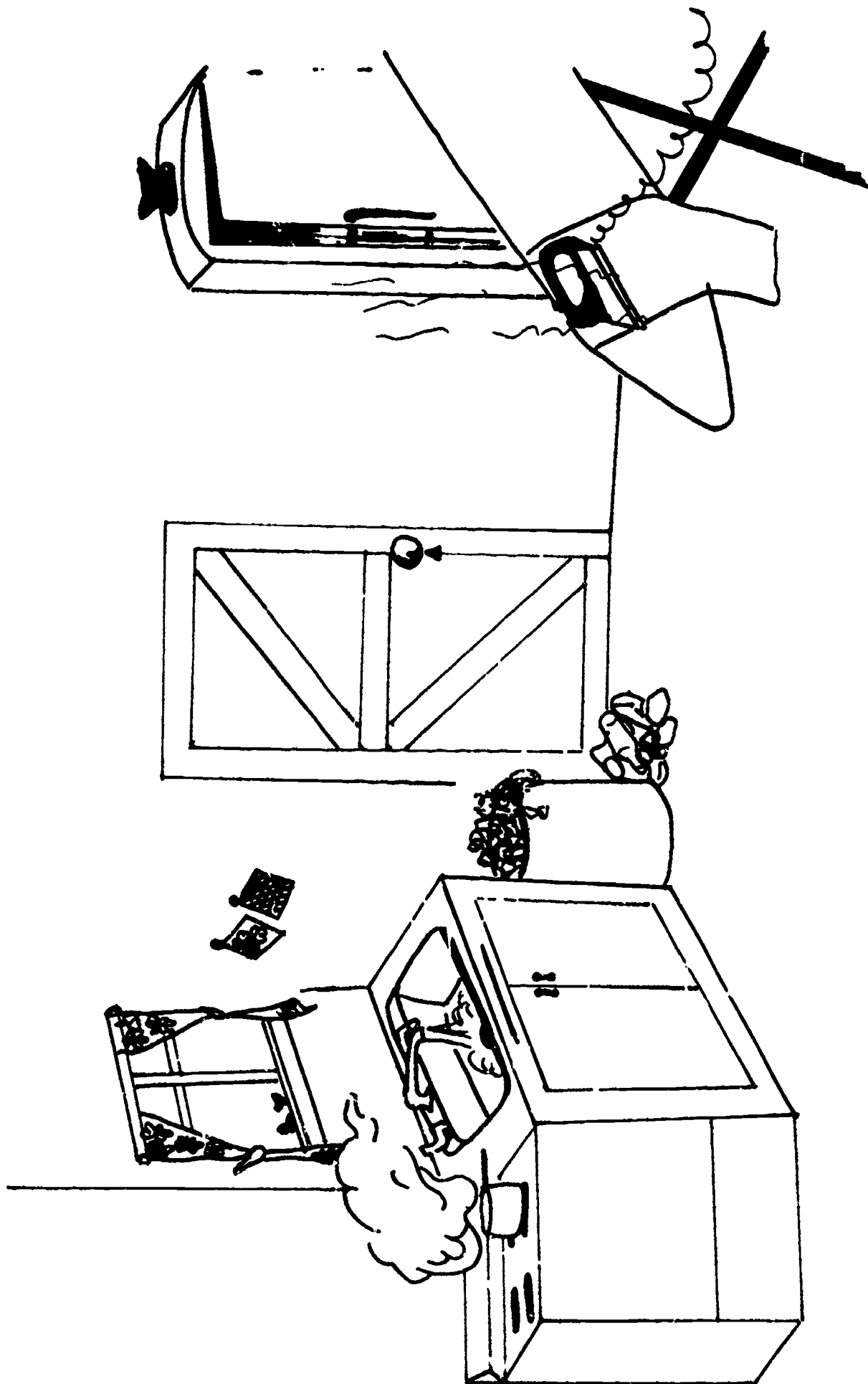

#2 a

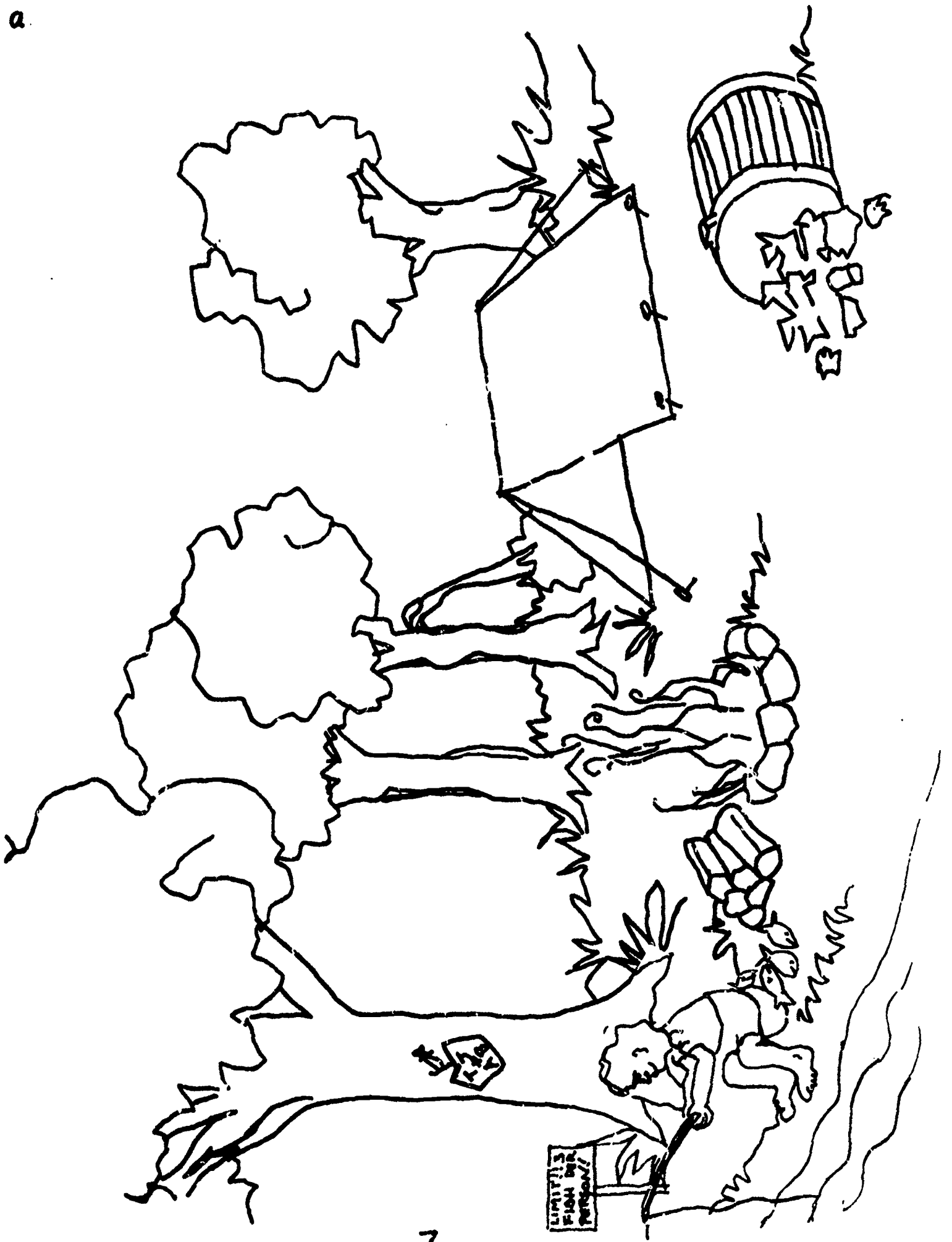

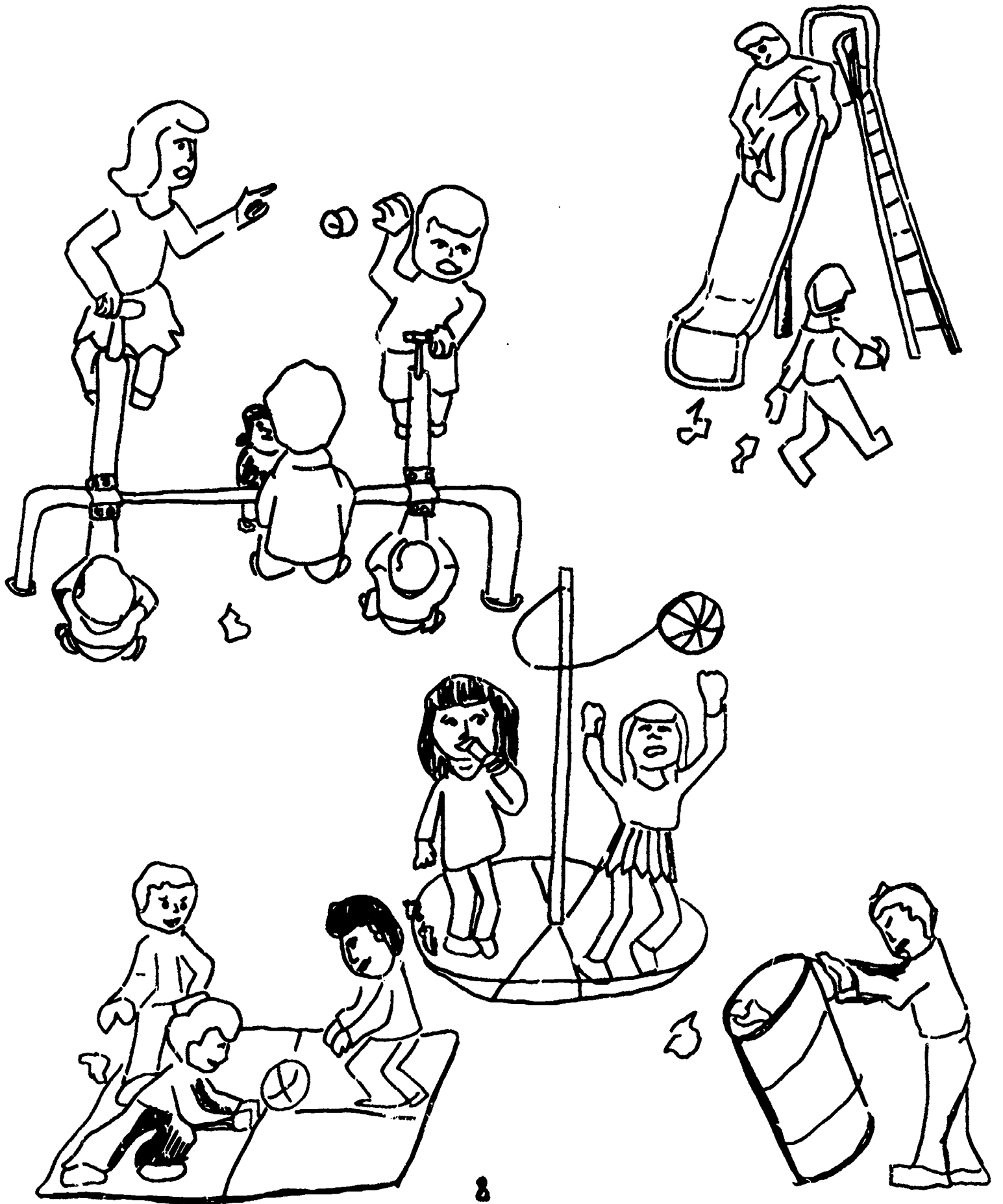

#3 The

EARTH



"We Live Here"

RECYCLED PAPER



Littering



Buried in Litter

||

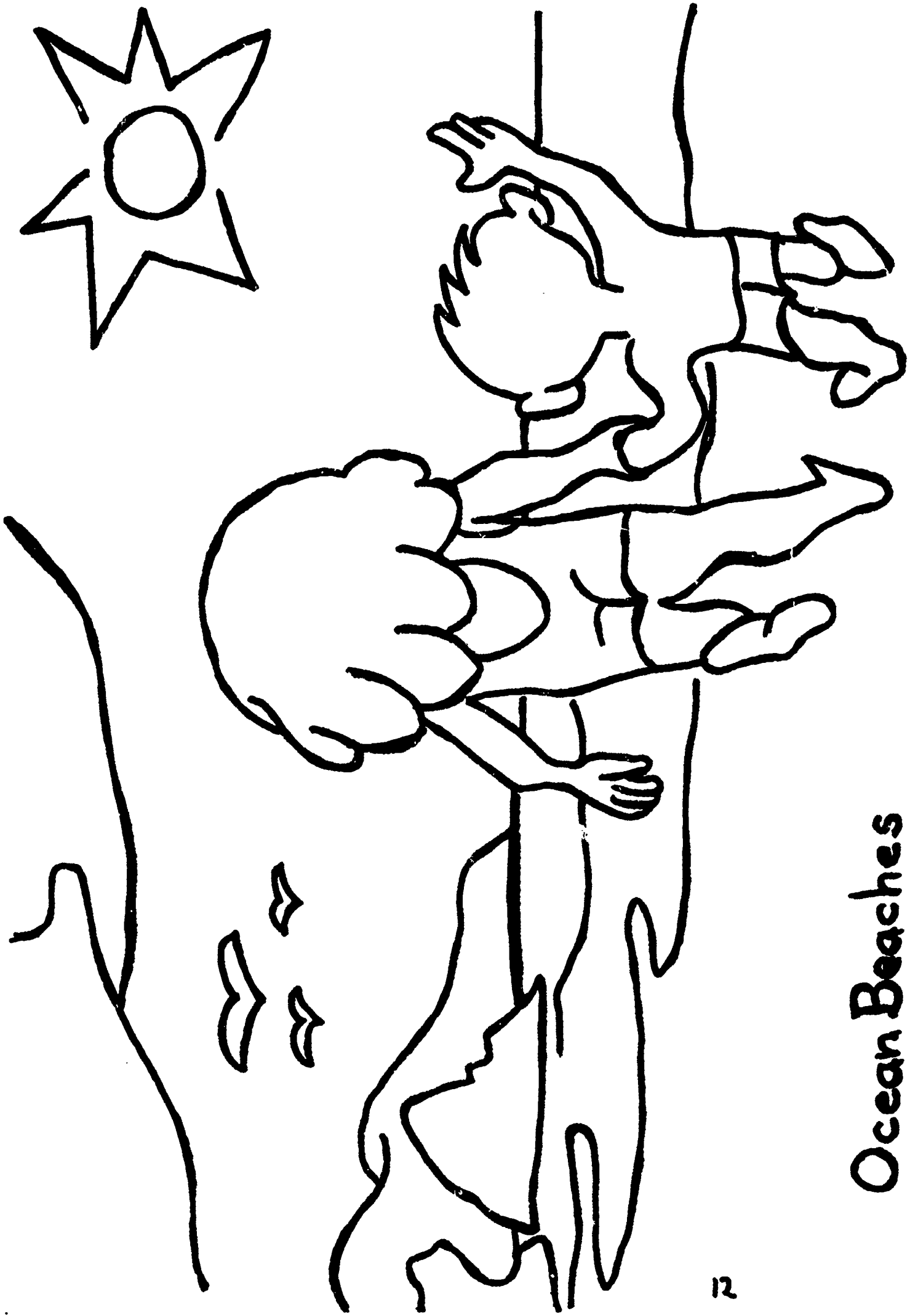

Ocean Beaches



Oil Spill Victims



Logging

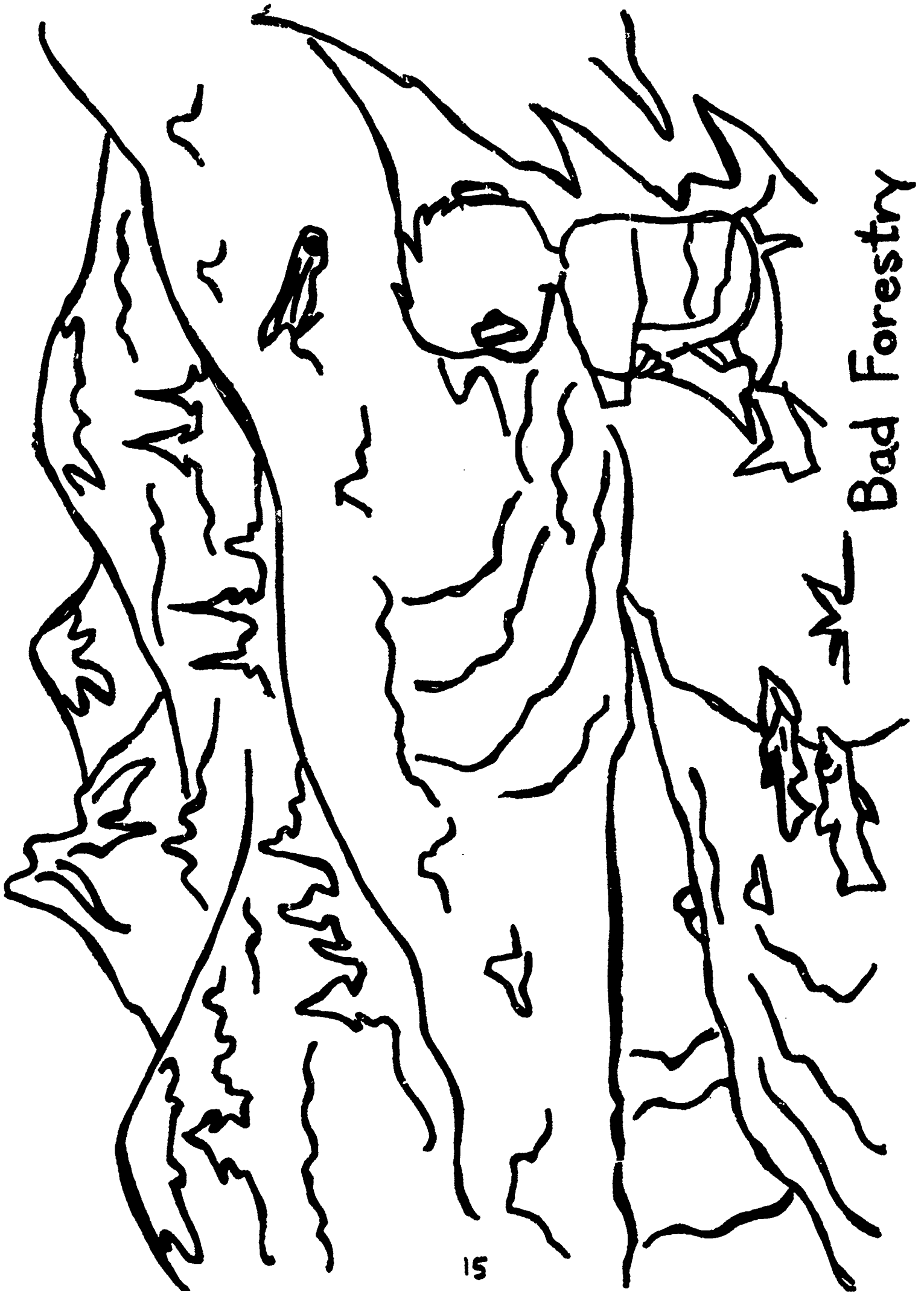

Bad Forestry

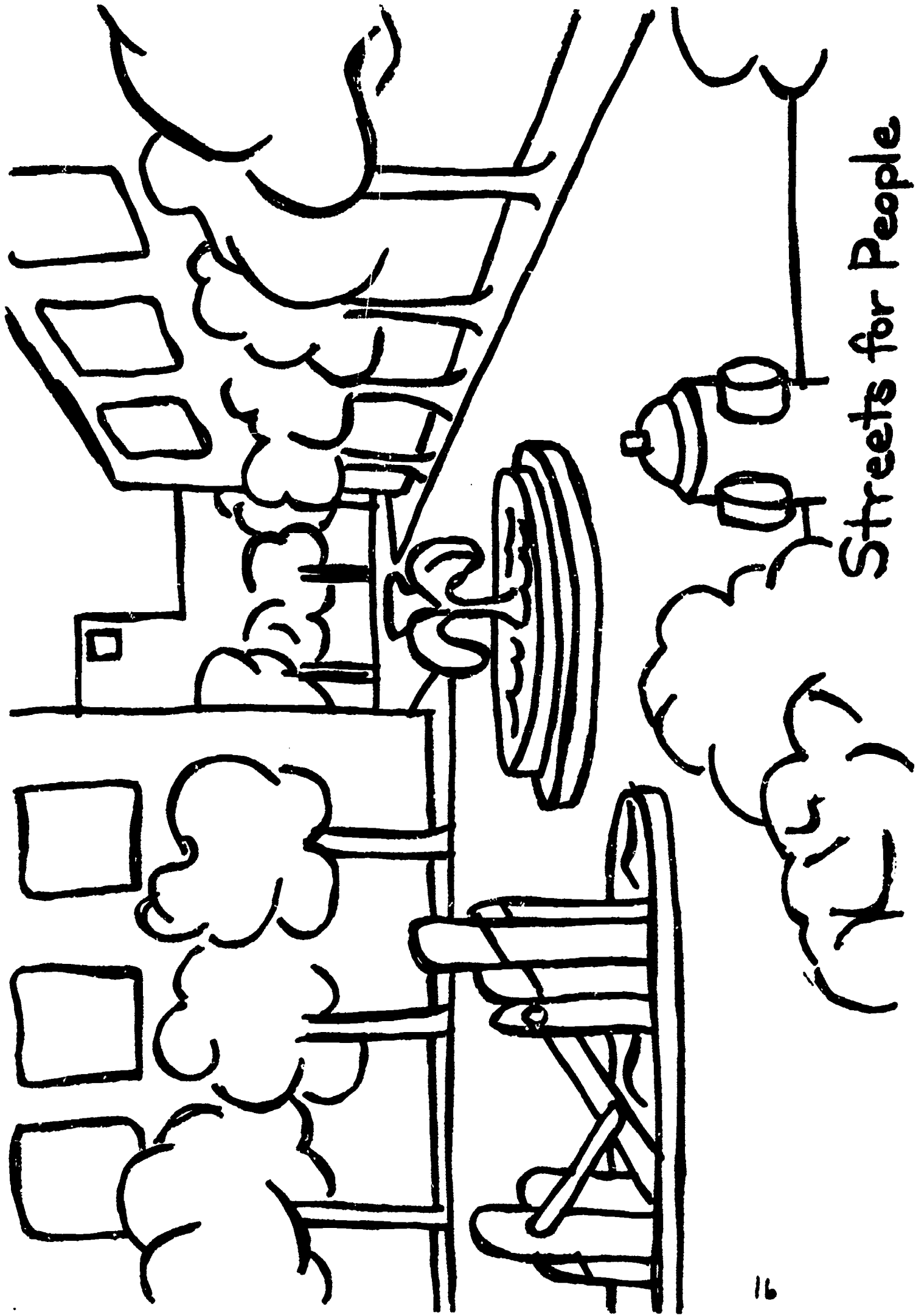

Streets for People

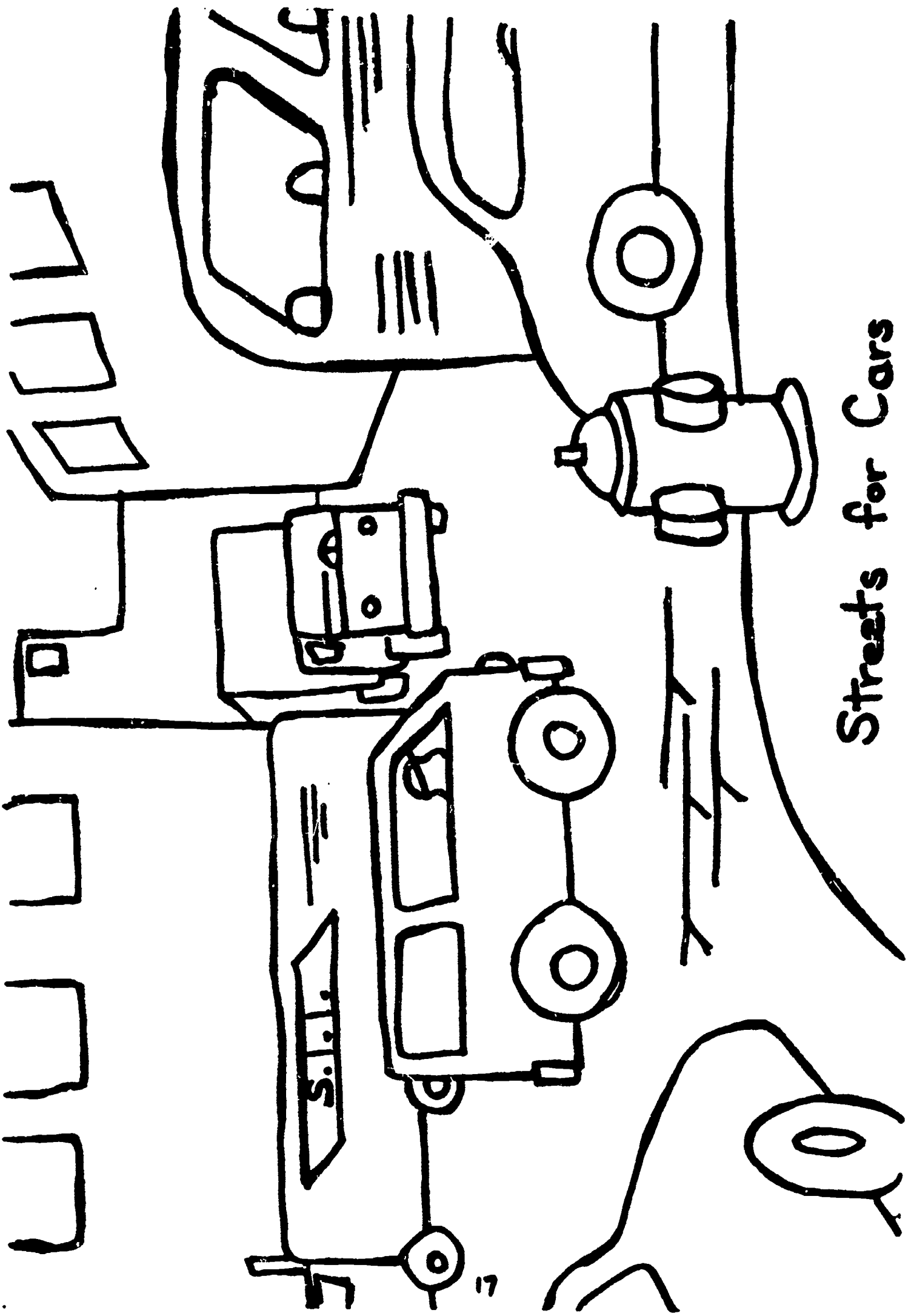

Streets for Cars

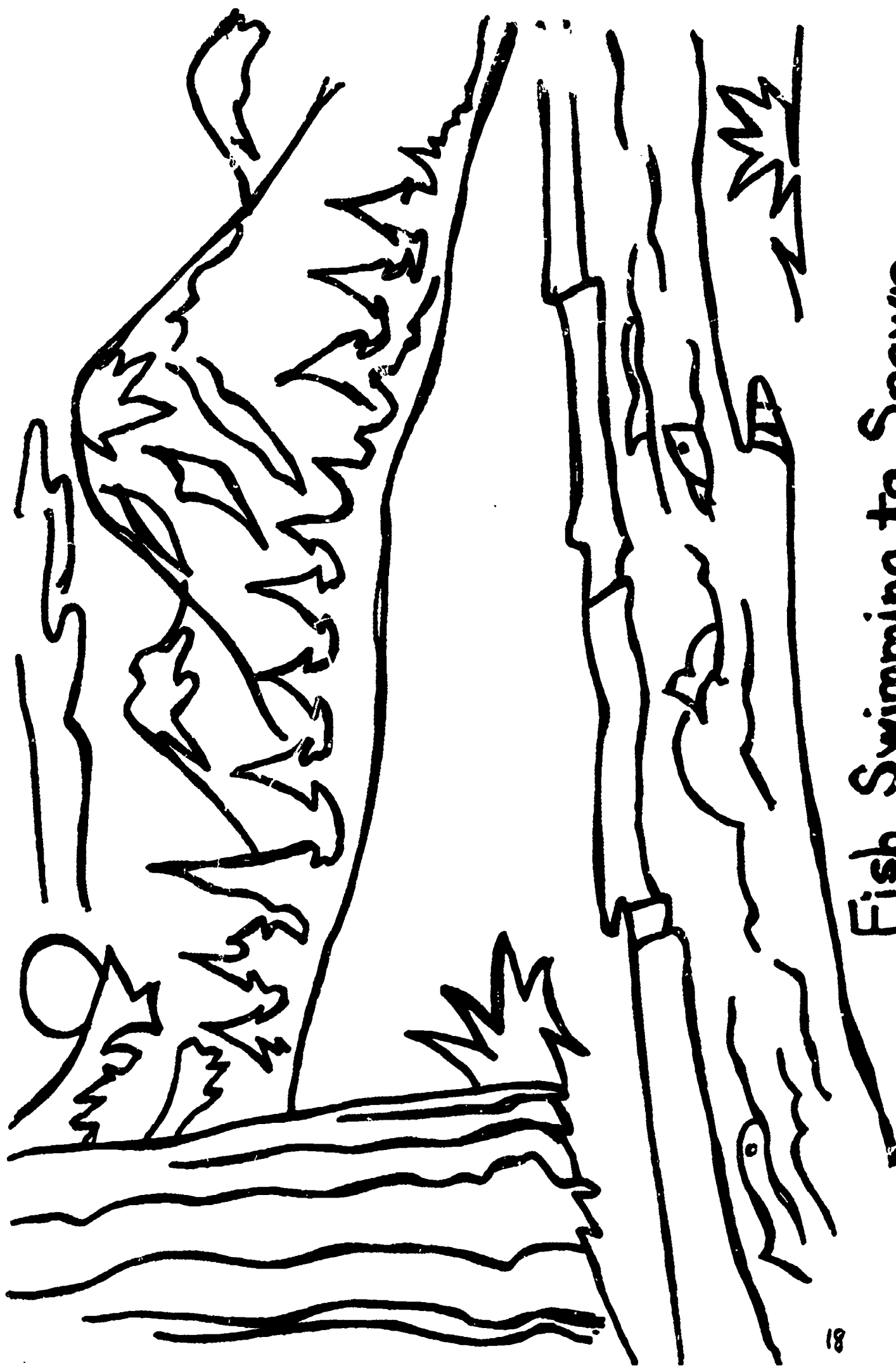

Fish Swimming to Spawn



Stopping the Fish

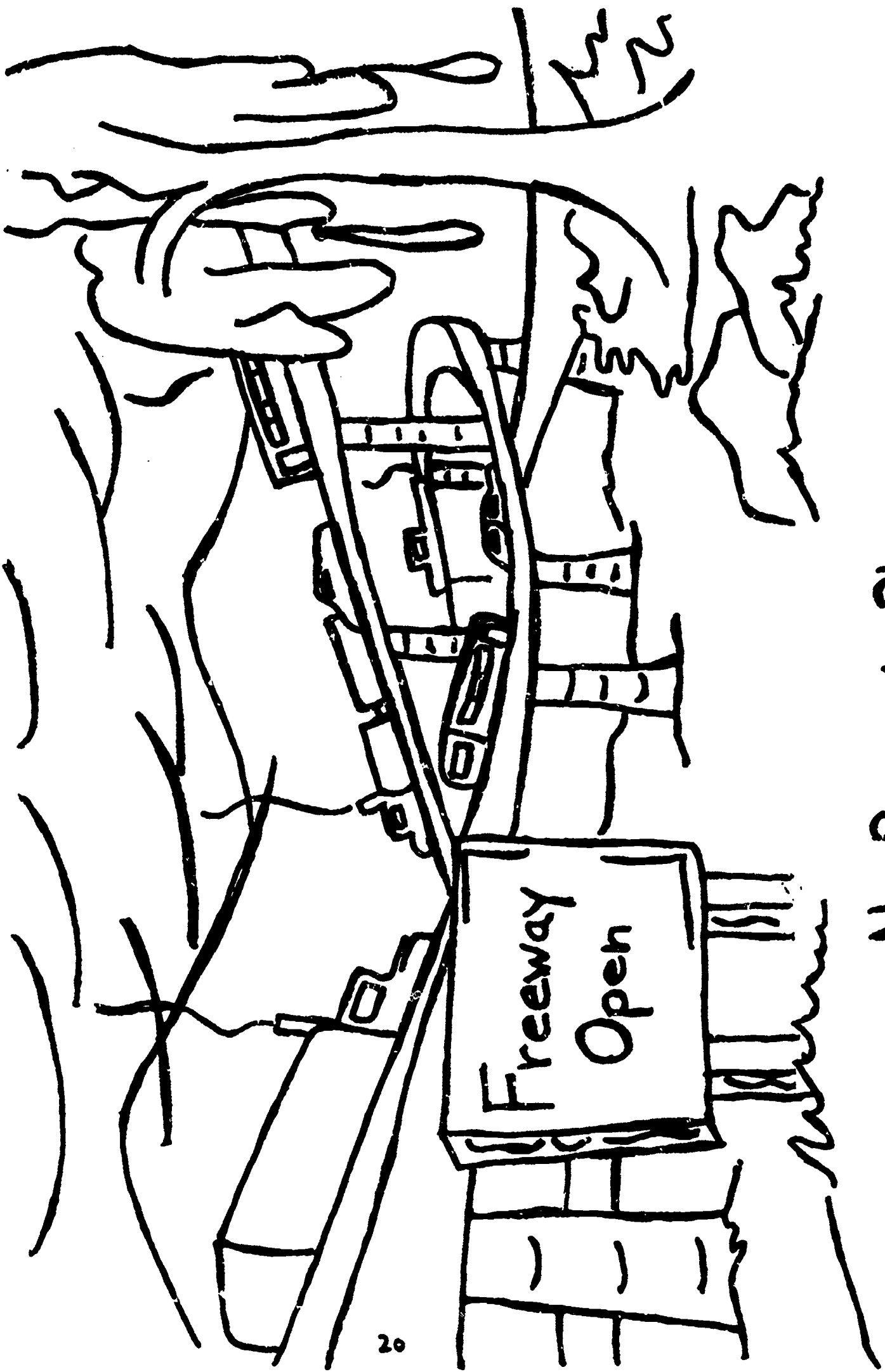

No Room to Play



drawings by
GREG WORTHING

coordinated by
BOB SWANSON and
CLAUDIA ANDERSON

THE EARTH - "We Live Here" is a public service project of the
Environmental Affairs Agency and the Political Education
Commission of the University of Washington (543-8700).
Distributed through the cooperation of the Washington State Department
of Ecology.

Printed on 100% recycled/recyclable paper

#4

GIVE A HOOT! DON'T POLLUTE

(Tune: Old MacDonald Words: Nancy Wells, Lynn Severance)

Woodsy is a forest owl.
(Rooty, toot, rooty toot, toot, toot, toot).....use a kazoo or a kazoo sound
There's just one thing that makes him scowl.
(Rooty toot, rooty toot, toot, toot, toot)
A litter bit here,
A litter bit there,
Here a bit, there a bit, everywhere a litter bit,
If you want to make him smile
(Rooty toot, rooty toot, toot, toot, toot)
GIVE A HOOT! DON'T POLLUTE! (SHOUT)

Through the forest you may roam
(Rooty toot, rooty toot, toot, toot, toot)
But don't forget it's not your home
(Rooty toot, rooty toot, toot, toot, toot)
There's a chipmunk here
A nest of birds there,
Here a deer, there a bear, look around everywhere
If you want to help them stay,
(Rooty toot, rooty toot, toot, toot, toot)
GIVE A HOOT! DON'T POLLUTE!

Look upon this forest scene
(Rooty toot, rooty toot, toot, toot, toot)
Don't you want to keep it green
(Rooty toot, rooty toot, toot, toot, toot)
If I do my part
And you do your part
Some of these problems will never start
Join with Woodsy and you'll shout
(Rooty toot, rooty toot, toot, toot, toot)
GIVE A HOOT! DON'T POLLUTE!



8



● #5 Forest fires burn more than trees!



ENVIRONMENT AWARENESS

BIBLIOGRAPHY

STUDENT

- CH A Walk in the City, Dawson.
HS How People Live in the Big City, Stanek and Johnson.
SS The Little Circle, Atwood
M How the West Got Its Name, Koch.
SS How to Be a Nature Detective, Selsam.
M If Everybody Did, Stober
M Glimmer Glinner Glumpkin, Olsson.

TEACHER RESOURCE

- 300 Nature Sleuths, McCoy.
300 Man and His Resources in Today's World, Mattison
364 Boy Scouts of America, Nature.
500 Research Ideas for Young Scientists, Barr.
500 The Only Earth We Have, Pringle.
580 The Life of a Forest, McCormick.
574 A Guide to Nature Projects, Pettit.

AUDIO-VISUAL

- Garbage, CEBA 9 Agency.
Litterbug, Avis, BAVI.
The Litterbug, Walt Disney.
Forests, Gateway, BAVI.
Save It or Destroy It, BAVI.
Environmental Awareness, EF 550.
Good Citizens, EF 189.
I'M No Fool With Fire, EF 236.
Hunter and the Forest, Ef 296.

COMMUNITY

- Forest Ranger
Janitor
Nursery or Greenhouse

TEACHING CHILDREN OUTDOORS

Guidelines for Conducting a Field Trip

I. PRE-TRIP

A. LOGISTICS

PREPARING TO USE AN ENVIRONMENTAL STUDY AREA

Visit the site yourself first in order to have the best control of the situation and anticipate some of the difficulties or logistics questions that could arise. Examine the area carefully and know your trails. This one step can make the difference between a successful and a chaotic trip.

Is there room for your thirty active children? Are there problems of access? Will the children be able to see? You should obtain permission in advance if you plan to bring your class into a private area.

Organization and planning is essential. How far is it? How long will it take? What is needed (water, lunch, other equipment)?

RULES AND RESPONSIBILITIES

Before the trip, have the children join you in deciding on a set of rules and conduct based on the suggestions listed under the Activity Section. Try to keep the rules "do" rather than "do not." They should include most of the following:

1. Always keep the teacher within sight and sound.

2. Stay behind the leader and at a sufficiently safe distance from one another and dangerous areas. (Proper distance can be measured safely and conveniently by the students in terms of "body length.")
3. Always watch and listen for the teacher's signal to pay attention and gather together.
4. Try to leave the place in as good, or better condition, than you found it. Replace everything you move. Avoid stepping on plants and animals whenever possible.

PREPARE FOR EMERGENCIES

1. What are the health and safety hazards? Include a First Aid Kit and water, if necessary.
2. Remind students to dress properly for the weather and type of activity planned (e.g. hats, raincoats, wading boots, etc.)
3. Children should be warned that they are to avoid picking up any plant or animal about which they are in doubt (see guidelines for collecting specimens). Students should not taste or eat anything without first checking with the leader.
4. If you teach in an area where there are poisonous plants, snakes or insects, be sure that you and the children recognize the poisonous

4. (continued)
species. Then they should also know poison ivy, poison oak and poison sumac and avoid them.

4. Docent Aide Programs of Community Organizations:
For further information, contact your school district's Coordinator of Community Volunteers.

USE OF ASSISTANTS OR
PARAPROFESSIONAL AIDES

1. High School Teachers' Aides:
If you have a high school teacher aide, why not divide your class in half and plan together to let him/her help in certain phases of teaching outdoors (within sight and sound of your supervision).

More information about the availability and assignment of high school student teachers' aides for classwork and or field trips may be obtained from the high school Counseling Office in each high school.

2. Intermediate and Junior High School Students: Depending on the time and difficulty of your particular outdoor activity, you can depend upon junior high and even intermediate students to conduct simple 10-15 minute exercises outdoors with small groups of younger students. It is mutually beneficial if properly planned and supervised. Contact the Counseling Office in each school for aides.
3. Parents: Find a parent who is willing to assume an active role in assisting you with learning activities outdoors.

Also, why not organize parent work parties after school to improve outdoor laboratories for learning on or near elementary school sites?

B. LESSON PLANNING**AREAS AVAILABLE FOR USE**

- A. School Site: Your own school site is rich in opportunities for environmental observation, learning, beautification, and improvement.

When you have seen your own school site, why not schedule a field trip to another school site?

- B. Neighborhood Parks: Check your city map and plan a hike to the nearest park or public natural area. What are its unique characteristics and experiences for learning?

- C. Special Attractions: Included here are areas such as Marshall Outdoor Laboratory, Chase Lake Bog, State and National Parks and Forests and other public or private areas permitting your use for education.

PREPARE THE GROUP IN ADVANCE**Where to Go**

The first prerequisite for a site is that it provide what you want the children to see or do. The closer it is and the easier it is to get to, the better.

First, the teacher must become acquainted with the descriptive features of the area and with its significance. But you should go beyond merely identifying the flora and fauna or the outstanding physical features of the facility. You should take a close, analytical look around the site and decide which of its characteristics are relevant to people and environmental education in terms

of your subject or discipline.

When you find something interesting, tie a piece of yarn near to it to help you find it when you want to show it to the rest of the class.

- A. Motivation: Discuss the purpose of the trip with the class beforehand. If the children don't know what to look for, they will become bored and restless quickly. If they are absorbed in a problem, they may maintain interest for a long time. You should know what you want the children to look for before you start out, even if it is stated in only the most general terms.

Be prepared to cover at least some of the field trip objectives given to you by your group during your planning sessions.

- B. Materials: Take as little as possible with you; the less equipment, the better. What you decide to take depends on the purpose of the trip. You may want the children to have pencils and notepads. Pieces of yarn can serve as markers for interesting discoveries made by the children. Magnifiers, maps or compasses may be very useful, but you risk loss or damage.

If you want to have them along, take as few as you can and put each one in the specific care of a responsible child.

If you intend to collect specimens, you will need appropriate equipment such as plastic bags, etc. You may also want to carry a camera. Collecting on the site is done only with special permission and is generally discouraged; therefore, bottles, nets, traps,

or other cumbersome and often dangerous paraphernalia should be left at home. Students saddled with the responsibility of comprehensive notetaking or with long checklists of things to observe, are often so busy recording and searching for specifics that they rarely get the big environmental picture.

Reference materials to aid in identification are handy, but not so essential that the expedition be weighted down with them.

The on-site experience should be primarily observational. Work best accomplished in the classroom, such as research, calculations, and more academic studies, should not be attempted at the environmental study area, but rather left to the post-site lessons back in the classroom.

The best guides as to what to take along are the activities most suited to the site and the subjects to be studied there.

1) If the on-site experience is to include identification of objects, the pre-site studies should include enough information so that the students know what to look for. 2) If, on the other hand, the on-site experience is to allow the students the excitement of making discoveries, there should be enough guidance - in the form of pertinent questions - to direct their observations toward the given goal. 3) When the environment is to be used as a vehicle for discussion, as in a social science field study, there should be a predetermined understanding of what environmental on-site observations will best motivate the students.

4) A research trip, though open-ended and allowing students a great deal of freedom, should have specific learning objectives.

II. ACTIVITY

A. LOGISTICS

1. Review your student-made rules and define your boundaries with easily recognized landmarks.
2. Explain that this is an outdoor classroom, and that the students should act like students.
3. Ask students to go to the restrooms and get a drink of water before the trip starts.
4. Explain that you will raise your hand to get the group's attention while on the trail. This should serve as an automatic signal for them to stop where they are and remain quiet.
5. When students see or hear the established signal, they should immediately gather around the teacher or in a semi-circle around a point of interest.
6. Whistles are disturbing to children, other groups, and wildlife and should not be used except in an emergency when everyone is called to assemble and return to the school at once. In such a case, the children should be taught to recognize one internationally accepted signal for distress, which is three short blasts on a whistle.
7. There are occasions, depending on the nature of the trip, when the "Buddy System" works just as well on field trips as at the waterfront.
8. Before leaving, have students count off. Before returning from the field, count off again.
9. The teacher or another adult who is familiar with the area should lead the group. Any other arrangement must remain in control (sight and sound) of the adult leader at all times.
10. It is most essential to have a responsible person at the rear at all times.
11. Have students play follow the leader, in single file, when you want to arrange them in a semi-circle around a particular point of interest.
12. Be quiet and move slowly so that you do not disturb the creatures that live there.
13. Watch the length of the line. Don't make the trip a marathon. Move out rapidly at first, and then proceed according to the group's ability. Pace is determined by the slowest walker. Don't make walking a chore. Change the speed of your pace occasionally. It helps to maintain interest.
14. Always remember to stay on the trail, watch your feet, display good outdoor manners and practice good conservation.
15. Keep stops short. When choosing resting places, try to find an interesting site to accommodate the group: A hilltop or hillside with a panoramic view; a stream or lake side; beside a gravel pit; at the dooryard of an abandoned farm;

15. (continued)
at the edge of a forest.
Avoid poisonous plants. While resting, check on the condition of your students, as well as cameras, compasses, sketch pads, and exchange of information.
16. Try a different route if a return trip to the starting point is necessary. It helps to keep up interest.
17. Conclude the trip on an interesting note.

B. LESSON PLANNING**TEACHING TECHNIQUES**

1. Involve the group actively during the trip as much as possible. Emphasis should be placed on doing. Look for things you have talked about. Emphasize self discovery. Allow time for free exploration. Encourage individual curiosity, investigation and sharing of discoveries with the rest of the group. Encourage use of all five senses whenever possible. Encourage the children to taste, smell, hear and see.
2. Avoid talking about something while on the trail until the entire group has caught up and you have their attention. If possible, try to get the group around you before you start talking.
3. Project your voice. Lift chin up and talk up and over those in front, when the group cannot gather around you but is strung out in a long line. Direct your voice to the last person in the line.
4. Watch your vocabulary, especially natural history and conservation jargon which may be new to the children.
5. Avoid identification for its own sake. Identification and uses of plants and materials helps, but it is not necessary to be a walking encyclopedia. Even Indians did not know all of the oaks, but they knew which acorns were good to eat.
6. Repeat out loud questions directed to you from the group so that everyone hears the question.
7. Talk conversationally. Lecture as little as possible. Ask leading questions to stimulate participation. Answer a child's question with a question which will guide him toward giving the correct answer himself. Don't, however, belabor this technique. Don't bluff. If you can't answer the question, say so, then suggest that the student investigate the resources for an answer.
8. Make it exciting. Be enthusiastic even over something you have noticed before. Remember, to the group it is new. Maintain a feeling of adventuring. Remember that there can be a significant difference between excitement and learning. Excitement should be delicately channeled toward interest. If you become the eyes and ears of your inexperienced charges, you will soon find that your sensitized students will serve as additional eyes and ears for you. They will call to your attention things that you would ordinarily overlook.
9. Prepare for surprises. Take advantage of teachable moments! If a child discovers something exciting, stop what you are doing, if possible, even if what the child wants to share with the group has little or nothing to do with whatever subject you are covering, and allow him to talk about his discovery. You can direct the group's attention back to your subject later. Use tact in keeping the students' facts straight to avoid discouraging self-expression. Avoid getting off on a tangent for very long, unless you all agree that a new study area is more important than the original purpose of the trip.

9. (continued)

So many things that can initiate learning out-of-doors are sometimes overlooked - buds on twigs, a bird with something in its beak, an ant dragging a caterpillar along the ground, the direction in which dandelion fluff is blowing, the position and phase of the daytime moon.

Any single observation can be the beginning of exciting exploration and lead to the joy of further discovery.

Every observation leads to a question: What is inside buds? Why doesn't the bird swallow the worm in its beak? Where is the ant going with the caterpillar? What happens to the dandelion seeds after they blow away?

The most interesting questions are questions that do not have neat, precise answers, but this should not prevent your investigating them anyway. The out-of-doors is so full of interacting things, that answers are always new and interesting and different.

10. Collecting Specimens: The field trip may lay the groundwork for activities you will want to do in the classroom. Collect only those things as are absolutely necessary for such follow-up, because it is important that the children learn good conservation habits.

The basic rule is to leave a natural habitat undisturbed. Replace anything you move. Avoid stepping on plants or animals whenever possible. If an animal is caught and observed, it should be put back where it was found - allowed to "go home."

The field trip should be distinguished from a collecting expedition, which would be better carried out by you alone or with a few selected students.

Make all collections in accordance with the law or other prescribed regulations, and try to leave the place in as good, or better, condition than you found it.

III. POST-ACTIVITY

AFTER THE TRIP - LET THE MEMORY LINGER ON

Some leaders like to have group evaluations before a trip is concluded, or at a later time. In some instances, an evaluation is not necessary.

CREDITS

LEADING CHILDREN IN THE FIELD,
U.S. Forest Service, R-6,
Portland, Oregon. PUTTING
CONSERVATION TO WORK, Teaching
A/J #4, August 1965.

MAN AND HIS ENVIRONMENT
"Preparing to Use the Environ-
mental Study Area," pps. 16-20,
National Education Association,
1970.

LIVING THINGS IN FIELD AND CLASS-
ROOM, "Planning Any Type of
Trip," pps. 97-99, Minnesota
Math and Science Teaching Pro-
ject, University of Minnesota,
copyright 1969.

SUGGESTIONS FOR OUTDOOR FIELD TRIPS
Ernest V. Blohm, Executive Sec-
retary, Michigan Interagency
Council for Recreation, Lansing
Michigan, April 19, 1966.

TIPS FOR TRAIL LEADERS
Charles Holtzer, Consultant,
Conservation and Outdoor Education,
Colorado Dept. of Education,
September 1968.

**RESOURCES, BACKGROUND INFORMATION,
AND SPEAKERS**

DEPARTMENT OF ENVIRONMENTAL HEALTH
University of Washington (543-3620)
Tours of facilities for all grade levels.

U.S FOREST SERVICE
Pacific N.W. Region (R-6)
Motion picture films available in Region 6 library, available on
loan for educational purposes to schools, civic groups, churches.
Write to: WASHINGTON STATE FILM LIBRARY
Olympia, Wash. 98504 (206-753-3390)

DEPARTMENT OF CIVIL ENGINEERING: Air and Waste Quality Control
University of Washington
Tours and information.

EDMONDS RECREATION AND PARKS
Subject: Park Acquisition and/or Development
Rod Garretson, Dept. Director
Subject: Park Management
Rod Garretson or Don Burton, Park Superintendent
Subject: Recreation Program - Correct Park Usage, etc.
Doug Schafer, Recreation Supervisor

SNOHOMISH COUNTY PUD
Subject: Energy
Dick Downie, Environmental Coordinator
Don Rider, Public Relations

SNOHOMISH COUNTY HEALTH DEPARTMENT
Subject: Nursing
Ann Wilson, Kathy Carrol (259-9386)
Subject: Environmental Health
Sewage - Charles Mangum (259-9473)
Food Programs - includes restaurants, bakeries, itinerant
food (circuses, carnivals, etc.), meat markets.
School, Solid Waste, Camping Areas, Mobile Home Courts,
Chemical and Physical Health Hazards Unit, Rodent Control -
Byron Robertson (259-9499)
Water and Noise - Gary Fraser (259-9499)
Epidemiology Unit - Dr. Luke (259-9473)
V.D. Section

THE INSTRUCTOR PUBLICATIONS, INC.
Subject: Ecology Posters #750
Dansville, NY 14437

WASHINGTON LUNG ASSOCIATION
216 Broadway East
Seattle, WA 98102

Contact: Mr. David L. Chivers, Regional Program Director
For: "Our Polluted Air" Mobile Workshop (one month in advance),
various air pollution pamphlets and health information, films
also available on request.

EDUCATIONAL SERVICES CENTER
Bill Hamilton (778-8965) or John McAdam (778-8658)
Information and resources

SEATTLE AUDUBON SOCIETY
712 Joshua Green Bldg.
Seattle, WA 98101 (622-6695)

FILMS

Numbers in parentheses immediately following titles indicate lengths of film in minutes. C for color; BW for black and white.

Conservation

A MATTER OF TIME	Conservation Foundation 30 East 40th Street New York, N.Y.
PARADISE POLLUTED	Roy Wilcox Productions 301 Allen Hill Meriden, Conn.
THE PERSISTENT SEED	National Film Board of Canada Canadian Embassy 1746 Mass. Ave. NW Washington, D.C. 20036
WITH EACH BREATH	New York State Air Pollution Control Board 84 Holland Avenue Albany, N.Y.

CONSERVATION AND BALANCE IN NATURE	International Film Bureau 332 South Michigan Avenue Chicago, Ill. 60604
OUR CHANGING ENVIRONMENT	Encyclopedia Britannica Films, Inc. 1150 Wilmett Avenue Wilmett, Ill.
SO LITTLE TIME	USDI Sport Fisheries and Wildlife 710 N.E. Holladay Portland, Oregon
TOWARDS TOMORROW	BBC through British Embassy Washington, D.C.
3 YOUNG AMERICANS IN SEARCH OF SURVIVAL	3M Company Television Production
WILD RIVERS (28)	Modern Talking Picture Service 1212 Avenue of the Americas New York, N.Y. 10036
CLEAN WATERS (20) Free	U.S. Public Health Service Audiovisual Facility Chamblee, Georgia 30005
NATURE'S PLAN (14) \$6.00	Encyclopedia Britannica Films 202 East 44th Street New York, N.Y. 10017
IT'S YOUR DECISION - CLEAN WATER (14 1/2)	Association Films 600 Grand Avenue Ridgfield, N.J. 07657
THE RIVER MUST LIVE (21) Free	Shell Oil Company, Film Library 450 North Meridan Indianapolis, Ind. 46204
TROUBLED WATERS (28) Free	U.S. Senate Public Works Committee Room 4204, New Senate Office Bldg. Washington, D.C. 20510
GREAT LAKES INVADER, THE SEA LAMPREY (13 1/2) Free	Bureau of Sport Fisheries and Wildlife 1002 N.E. Holladay Street Portland, Oregon
THE WHOOPING CRANE (14) Free	Bureau of Sport Fisheries and Wildlife

NATIONAL PARKS, OUR AMERICAN HERITAGE (17-c)	Seattle Public Library 4th and Madison Seattle, Wash. 98104
RETURN OF THE BUFFALO (10-BW)	Seattle Public Library
WOODLAND MANNERS (19-C)	Seattle Public Library
LIFE ON THE WESTERN MARSHES (15-C)	Seattle Public Library
LET'S KEEP AMERICA BEAUTIFUL (18-C) \$1.50	Richfield Oil Company P.O. Box 75007 Sanford Station, Los Angeles, Calif.
WINGS OVER BLITZEN (39-C)	Bureau of Sport Fisheries and Wildlife 730 N.E. Pacific Street Portland, Oregon 97208

Most of the following films on conservation are available to teachers through their school district, or to anyone through Rarig's Inc., Audio-Visual Sales and Service, 2100 North 45th, Seattle, Wash.

CONSERVATION (10-BW)	WHAT MAKES RAIN? (10-BW)
TOPSOIL (10-C)	CONSERVING OUR NATURAL RESOURCES (18-C)
CASCADE MOUNTAINS (20-C)	UNTOUCHED LAND (30-C)
WATER-FOUNTAIN OF LIFE (30-C)	LITTERBUG (8)
WATER CONSERVATION (11-BW)	CITIES AND SUBURBS: METROPOLITAN (9-C)

Ecology and Enjoyment of Nature

The following films are free of charge. Write Conservation Film Center, P.O. Box 9163, Seattle, Wash. 98119

LIVING RIVER - GRAND CANYON (29-C)	THE MYTHS AND THE PARALLELS (27-BW)
WILDERNESS ALPS OF STEHEKIN (30-C)	BEACH HIKE (17-C)
GLACIER PEAK HOLIDAY (30-C)	TWO YOSEMITES (10-C)
BULLDOZED AMERICA (27-BW)	GLEN CANYON (28-C)
NORTH CASCADES (35 mm slide show with script)	WASTED WOODS (15-C)
THE REDWOODS (20-C)	HELLS CANYON (33 mm slide show with script)

Most of the following films on ecology and enjoyment of nature are available to teachers through their school district or to anyone through Rarig's Inc., Audio-Visual Sales and Service, 2100 North 45th, Seattle, Wash.

- | | |
|---------------------------------------------------------------------------------------------------------------------------------|-------------------------------------------------------------------------------------------------------------------------------------|
| THE SEA (26-C) | YELLOWSTONE: OUR FIRST NATIONAL PARK (15-C) |
| WORLDS OF DR. VISHNIAC (C) | GRASS BLADE JUNGLE (11-C) |
| COLUMBIA FRONTIER (27-C) | HERITAGE OF SPLENDOR (16-C) |
| WORLD OF LITTLE THINGS (C) | AROUND THE BIG LAKE (17-C) |
| BALANCE OF NATURE (17-C) | TRAIL RIDE (20-C) |
| WHAT PLANTS NEED FOR GROWTH (10-C) | LIFE IN THE OCEAN (11-C) |
| ECOLOGY (24-C) | SPRING (9-C) |
| LIFE STORY OF THE OYSTER (11-C) | LIFE ON A DEAD TREE (11-C) |
| DISTRIBUTION OF PLANTS AND ANIMALS (16-C) | CONSERVATION: JOBS FOR YOUNG AMERICA (19-C) |
| PLANKTON, PASTURES OF THE OCEAN (10-C) | LIFE IN THE OCEAN (11-C) |
| ANIMAL WAR-ANIMAL PEACE (27-C) | ANIMALS THAT LIVE IN THE SURF (11-C) |
| OUR MISTER SUN (60-C) | MARSH COMMUNITY (11-C) |
| FATHER OCEAN (10-C) | THE DESERT (10-C) |
| WHY PLANTS GROW WHERE THEY DO (11-C) | ANIMAL LIFE AT LOW TIDE (11-C) |
| CANOEING THE BIG COUNTRY (14-C) | SPRING COMES TO A POND (13-C) |
| DESERT COMMUNITY (12-C) | CAVE COMMUNITY (13-C) |
|
 | |
| WAY OF LIFE
(Illustrates predatory tendencies of nearly all animals) | Wash. State Game Dept.
600 N. Capital Way
Olympia, Wash. 98501 |
|
 | |
| WILDERNESS TRAIL (14-C) | U.S. Forest Service Regional Office
P.O. Box 4137
Portland, Oregon |
|
 | |
| WILDERNESS ENCAMPMENT (27-C) | U.S. Forest Service Regional Office |
|
 | |
| NATURE NEXT DOOR (28-C) | Sierra Club
1050 Mills Tower
San Francisco, Calif. |
|
 | |
| AN ISLAND IN TIME (28-C) | Sierra Club |
|
 | |
| THE GREAT SWAMP (30-C)
(Documentary of a national wildlife refuge) | Bureau of Sport Fisheries and Wildlife
Office of Regional Director
730 N.E. Pacific Street, P.O. Box 3737
Portland, Oregon |
|
 | |
| PATTERNS OF THE WILD (27 1/2-C)
(Shows that the wildlife of a forest does not merely live in a forest, but as a part of it.) | Bureau of Sports Fisheries and Wildlife |
|
 | |
| BIRDS AND THEIR MIGRATION (18-C) | Bureau of Sports Fisheries and Wildlife |

FOR THE PEOPLE - WILDLIFE REFUGE (22 1/2-C)	Bureau of Sport Fisheries and Wildlife
GREAT BLUE HERON AND THE SNOWY WHITE EGRET (15-C)	Bureau of Sport Fisheries and Wildlife
KNOW THE HAWKS (10 1/4-C)	Bureau of Sport Fisheries and Wildlife
OUR MAGIC LAND (12 1/2-C) (For primary)	Bureau of Sport Fisheries and Wildlife
WATER BIRDS (22 1/2-C) Walt Disney	Bureau of Sport Fisheries and Wildlife

The following films can be rented from National Audubon Society, 1130 Fifth Avenue, New York, N.Y. 10028. Prices range from \$5.00 to \$11.00. All are 16 mm sound films.

THE BALD EAGLE, OUR NATIONAL BIRD (35-C)	THE LOON'S NECKLACE (11-C)
BEAVER VALLEY (32-C)	NATURE'S HALF ACRE (33-C)
BIRDS OF THE COUNTRYSIDE (11-C)	POISONS, PESTS AND PEOPLE (55-BW)
BIRDS OF THE DOORYARD (11-C)	THE TOUCH OF NATURE (54-C)
THE GOONEY BIRD (20-C)	THE WINDOW (17-C)
ISLAND IN DANGER (25-C)	THE WOOD DUCKS WORLD (30-C)
ISLANDS OF GREEN (24-C)	YOUR LIVING HERITAGE (12-C)
KENTUCKY'S FEATHERED RAINBOW (28-C)	VILLAGE BENEATH THE SEA (90-C) (\$50.00)
LOOK DOWN (55-C)	
A James W. Wilkie Film	

The following 16 mm films must be used in a sound projector. Massachusetts Audubon Society, South Great Road, Lincoln, Mass. 01773.

BEARGRASS GREEK (20-C)	OUR WILDLIFE HERITAGE (30-C)
BEAVER DAM (16-C)	POPULATION ECOLOGY (19-C)
GREEN CITY (30-C)	SILENT SPRING OF RACHEL CARSON (57-BW)
LAND OF THE PRAIRIE DUCK (25-C)	THEIR HERITAGE (20-C)
LIFE IN A TROUT STREAM (10-C)	Free
LIFE IN THE WOODLOT (17-C)	WORLD IN A MARSH (23-C)
MARSHLAND IS NOT WASTELAND (14-C)	YOURS FOR A SONG (14-C)

The following films are available from the Seattle Public Library, Main Branch; free upon request.

AMERICA'S LAST FRONTIER (13-C)	FAMILY AFOOT IN THE YUKON (22-C)
LAND OF THE RED GOAT	MT. RAINIER NATIONAL PARK (20-C)
OLYMPIC RAIN FOREST (10-C)	ANIMALS OF ALASKA (11-C)
BETWEEN THE TIDES (20-C)	MARINE ANIMALS OF THE OPEN COAST (22-C)
ALPINE WILDFLOWERS (11-C)	CONIFER TREES OF THE PACIFIC N.W. (16-C)
EDIBLE PLANTS OF FIELD AND FOREST (24-C)	

FREE AND INEXPENSIVE MATERIALS

The following are good sources for free or low cost informational materials on Population, Conservation and Ecology. Write for information about available materials.

AMERICAN ASSOCIATION OF UNIVERSITY WOMEN

2401 Virginia Avenue, N.W.
Washington D.C. 20037

Resource directory on pollution control - 75¢.
Anti-pollution pamphlets and study guide - 75¢.

AMERICAN FORESTRY ASSOCIATION

919 17th Street N.W.
Washington, D.C. 20006

Pamphlets and bulletins. "You Can Be a Conservationist" by O.E. Randall.

CLEAN WATER

Washington, D.C. 20242

Suggestions about what communities can do to combat water pollution.
Free.

CONSERVATION FOUNDATION

1250 Connecticut Avenue N.W.
Washington, D.C. 20036

Variety of pamphlets and articles dealing with the many aspects of ecology.

ENVIRONMENT MAGAZINE

438 North Skinker
St. Louis, Missouri 63130

Monthly publication dealing with effects of technology on the environment, published by Committee for Environmental Information. Student subscription - \$5.00 per year.

INTERSTATE PRINTERS AND PUBLISHERS

Danville, Illinois 61832

Bibliography of books and other teaching materials in conservation field.

ISAAC WALTON LEAGUE OF AMERICA

1326 Waukegan Road
Glenview, Illinois 60025

"Clean Water - It's Up to You," excellent pamphlet on what local citizens can do about water pollution. Free. Monthly conservation newsletter.

LOCAL TUBERCULOSIS AND RESPIRATORY DISEASE ASSOCIATIONS

"Air Pollution Primer"

NATIONAL PARKS ASSOCIATION

1701 18th Street N.W.
Washington, D.C. 20036

Free or low-cost pamphlets and articles on thermal pollution, noise pollution, pesticides, and basic ecology. Excellent.

NATIONAL WILDLIFE FEDERATION

1412 16th Street N.W.
Washington, D.C. 20036

Conservation Directory - a guide to all state and national sources of conservation and environment information. \$1.50. Informational packets on ecology and pollution - special packets from elementary to adult level. Excellent. Monthly newsletter.

PLANNED PARENTHOOD, WORLD POPULATION

515 Madison Avenue
New York, N.Y. 10022

Bibliography, film guide and following reprints: "Eco-Catastrophe," by P. Ehrlich; "300 Million Americans Would be Wrong," by D. Lillienthal; "The Human Race Has Maybe 35 Years Left,": by D. Lyle.

POPULATION REFERENCE BUREAU

1955 Massachusetts Avenue N.W.
Washington, D.C. 20036

Good bibliography, source list, and film guide on population. Minimal cost.

PORTLAND CENTER FOR CONTINUING EDUCATION

P.O. Box 1491
Portland, Oregon 97207
Attn: Mr. Lawless

"Observing our Environment, " - \$3.00, relating elementary students to our environment.

PROJECT MAN'S ENVIRONMENT

National Education Association
1201 16th Street N.W.
Washington, D.C. 20036

Information on curriculum (K thru 12) environmental study areas.

PUBLIC AFFAIRS INFORMATION SERVICE

U.S. Government Printing Office
Washington, D.C. 20401

PUBLIC AFFAIRS PAMPHLETS

381 Park Avenue South

New York, N.Y. 10016

Pamphlet #421 - "An Environment Fit for People" - 25¢

#403 - "The Battle for Clean Air" - 25¢

SIERRA CLUB

Mills Tower

San Francisco, Calif. 94104

List of publications, pollution, population information, protection of scenic areas.

SUPERINTENDENT OF DOCUMENTS

Government Printing Office

Washington, D.C. 20402

"No Laughing Matter" - book of syndicated cartoons on air and water pollution (70¢). "Primer on Waste Water Treatment" - current and possible future methods of treating sewage and industrial waste (55¢). "Showdown" - picture pamphlet discussing "showdown" for water quality (65¢). "From Sea to Shining Sea" - presentation of environmental situation of U.S. with good bibliography, film list, and resource guide (\$2.50).

U.S. DEPARTMENT OF HEALTH, EDUCATION AND WELFARE

Public Health Service

Bureau of Disease Prevention and Environmental Control

Washington, D.C. 20201

U.S. GOVERNMENT PRINTING OFFICE

Washington, D.C. 20401

Bureau of Census; Bureau of Indian Affairs; Bureau of Land Management; Bureau of Reclamation; Department of Agriculture; Department of Health, Education and Welfare; Department of the Interior; Forest Service; National Park Service; Office of Education; Soil Conservation Service.

WILDERNESS SOCIETY

729 15th Street N.W.

Washington, D.C. 20005

Reports, pamphlets, reprints on preservation and use of our natural heritage.

ZERO POPULATION GROWTH

367 State Street N.W.

Los Altos, Calif. 94022

Newsletters, brochures, ecology leaflets, reprints.

You may also write to your local:

Chamber of Commerce
 Historical Societies
 Preservation Societies
 State Offices
 State Office of Public Instruction
 State Offices:

Agencies of Pollution, Bureau of Fisheries, Fish and Wildlife
 Service, Wildlife Commission.

PAMPHLETS AND OTHER PUBLICATIONS

A CONSERVATION HANDBOOK - 50¢ Ordway, Samuel H., Jr.	The Conservation Foundation, 1949 New York
OBJECTIVES AND CONTENT OF CONSER- VATION EDUCATION FOR AMERICAN YOUTH - 50¢	U. Press, Ohio State University, 1950, Columbus Ohio
MATERIALS FOR TEACHING CONSER- VATION AND RESOURCE USE - 35¢	National Assoc. Biology Teachers, Interstate Printers and Pub., Danville Illinois.
RESOURCES FOR A GROWING POPUL- TION, Seaton, Fred - 25¢	Supt. of Documents, U.S. Govt. Printing Office, Washington, D.C.
THE GLORY TRAIL - One copy free Swift, Ernest	The National Wildlife Federation 1412 16th St. N.W. Washington, D.C. 20036
THE PACIFIC NORTHWEST - \$1 Zim, Herbert S.	Golden Press, New York
THE CONSERVATION OF OUR NATURAL RESOURCES, Seaton, Fred - 20¢	Conservation Bulletin 3-9, Supt. of Documents, above
CAREERS FOR WOMEN IN CONSER- VATION - Free	U.S. Dept. of Labor, Leaflet 50, Women's Bureau, Washington, D.C.
WATER AND OUR FORESTS AIB-71 - 10¢	U.S. Dept. of Agriculture Forest Service, Washington, D.C.
FORESTS AND THE NATURAL WATER CYCLE K-1 - Free	U.S. Dept. of Agriculture
FOREST AND WATER 0-28 - Free	U.S. Dept. of Agriculture
HOW A TREE GROWS (16 x 12 poster) - 10¢	U.S. Dept. of Agriculture

FOREST REGIONS OF THE U.S.	U.S. Dept. of Agriculture
BIRDS, CN-1 - Free (There is a series of conservation notes number CN-1 through CN-21 available for education.)	Bureau of Sport Fisheries and Wildlife Dept. of Interior Washington, D.C. 20240
ENDANGERED WILDLIFE SERIES - Free (Numbered EWS-1 through EWS-5)	Bureau of Sport Fisheries and Wildlife
SOMETHING ABOUT HAWKS, SA-2 - Free	Bureau of Sport Fisheries and Wildlife
TREES OF WASHINGTON - Free (Extension Bulletin #440)	Cooperative Extension Service College of Agriculture Washington State University Pullman, Wash.
OFF ON THE RIGHT FOOT (A guide to proper wilderness use)	The Wilderness Society 729 15th Street N.W. Washington, D.C. 20005
ACTION FOR CLEAN WATER	The Wilderness Society
THE NEW CONSERVATION	The Wilderness Society
NEW CHALLENGES FOR WILDERNESS CONSERVATIONISTS	The Wilderness Society
A NEW LOOK AT OUR CROWDED WORLD Stewart, Maxwell, #393 - 30¢	Public Affairs Supt. of Documents U.S. Government Printing Office Washington, D.C.
PROGRESS IN THE PREVENTION AND CONTROL OF AIR POLLUTION - 30¢	Public Affairs
VEGETATION OF OREGON AND WASHINGTON (PNW Circular #80) - Free	Pacific N.W. Forest and Range Experimental Station P.O. Box 3141 Portland, Oregon 97208

LOCAL CONTACTS

Local decision-makers responsible for environmental quality:

CITY COUNCILMEN

Cities of Lynnwood, Edmonds and Mountlake Terrace

CITY PLANNING COMMISSIONS

SOUTH SNOHOMISH CHAMBER OF COMMERCE

How do present and future business needs affect planning for a quality environment? Will there have to be changes in business activity in order to solve environmental problems?

SNOHOMISH COUNTY PLANNING DEPARTMENT

What are comprehensive land use plans? How closely are these followed? Who is responsible to see that land use plans are complied with?

SNOHOMISH COUNTY PLANNING COMMISSION

How are Planning Commission members selected? What is their responsibility? How does their work relate to that of the Snohomish County Planning Department? Why is there a Planning Commission and not just a Planning Department? Why are there rezones and other exceptions to land use plans? How are these exceptions obtained?

SNOHOMISH COUNTY HEALTH DEPARTMENT

Environmental Health Division

What does the department have to do with problems of sewage disposal, water supplies (Spada Lake), food establishments, schools, tourist facilities, rodent and insect control, swimming pool and bathing beaches, refuse disposal?

SNOHOMISH COUNTY ENGINEER

What is the role of the County Engineer in making decisions on roads, transportation and other capital improvements in Snohomish County?

CITY DEPARTMENTS OF CITIES OF LYNNWOOD, EDMONDS AND MOUNTLAKE TERRACE

Building Department - What is the purpose of building codes? How are codes enforced? Are there exceptions? Why? How are decisions on exceptions made? What about conflicts between creating and enforcing of codes on the one hand, and protecting property rights on the other? Are there basic principles for resolving such conflicts?

Planning Department - What is the current city comprehensive plan? Where should businesses go? Apartments? Other multiple residences? What about lot sizes, etc.? What power does the Planning Department have? How are exceptions to the comprehensive plan decided? How does a city comprehensive plan relate to the county comprehensive plan? Is there some relating of local to regional planning?

Recreation and Parks Department

SNOHOMISH COUNTY ECONOMIC DEVELOPMENT COUNCIL

This organization is comprised of business and other organizations representatives to study and suggest to local land use decision-makers how area-wide comprehensive planning could take place for economic development of areas like Snohomish Valley.

Contact: Mr. Lloyd Repman, Chairman (Al 2-6236)
Monte Cristo Hotel
Everett, Washington

CITY OF EDMONDS

250 5th West

Edmonds, Wash. 98020

City Engineer, Planning Department, Recreation and Parks, Police Department, Water Department (200 Dayton, Edmonds, Wash. 98020)

ALDERWOOD WATER DISTRICT

City Center

Alderwood Manor, Washington 98036

CITY OF BRIER

City Hall

23303 Brier Rd.

Brier, Washington 98036

CITY OF LYNNWOOD

19100 44th Ave. West

Lynnwood, Washington 98036

CITY OF MOUNTLAKE TERRACE

Mountlake Terrace, Washington 98043

TOWN OF WOODWAY

11422 238th S.W.

Edmonds, Washington 98020

LYNNDALE GARDEN CLUB

LOUISE MARSHALL

16812 36th Ave. West

Lynnwood, Washington 98036

Author and editor of environmental and recreational materials.

SOUTH SNOHOMISH COUNTY COUNCIL ON HUMAN RELATIONS

PORT OF EDMONDS
456 Admiral Way
Edmonds, Washington 98020

SOUTH COUNTY SENIOR CITIZENS CENTER, INC.
220 Railroad Avenue
Edmonds, Washington 98020

MARIAN KOHN
1023 241st Place S.W.
Edmonds, Washington 98020
Parent and Research Associate, Zoology Department, University of
Washington.

SNOHOMISH COUNTY HEALTH DEPARTMENT
South County Office
19701 Scriber Lake Road
Lynnwood, Washington 98036

SNOHOMISH COUNTY PARKS DEPARTMENT
Everett Courthouse (259-9317)
Everett, Washington

SNOHOMISH COUNTY PLANNING DEPARTMENT
Everett Courthouse (259-9311)
Everett, Washington

SUPERINTENDENT OF SCHOOLS
ISD 109
Everett Courthouse (259-0621)
Everett, Washington

SNOHOMISH COUNTY P.U.D. #1
21018 Highway 99
Lynnwood, Washington 98036

BOY SCOUTS OF AMERICA
Evergreen Council, Inc.
1615 1/2 Hewitt Avenue
Everett, Washington

SNOHOMISH COUNTY ENVIRONMENTAL COUNCIL

ADDRESSES FOR AGENCIES LISTED IN THE FILM LISTS

Aetna

Aetna Life & Casualty
Audio Visual Services
151 Farmington Ave.
Hartford, Conn. 06115

A -S

Association-Sterling Films
866 3rd Ave.
New York, N.Y. 10022

Common

Commonwealth Film Distributors
1440 S. State College Blvd.
Bldg 6-K
Anaheim, Calif. 92806

EBEC

Encyclopedia Britannica Educational Corp.
425 N. Michigan Ave.
Chicago, Ill. 60611

Ethyl

Ethyl Corp.
Corporate Public Relations Dept.
330 S. 4th St.
Richmond, Va. 23219

FAA

Federal Aviation Administration
Film Library AC-44.5
P.O. Box 25082
Oklahoma City, Oklahoma 73125

GASP

Group Against Smog And Pollution
P.O. Box 2850
Pittsburg, Pa. 15230

JF

Journal Films, Inc.
909 W. Diversey Pkwy
Chicago, Ill. 60614

Motor

Motor Vehicle Mfg Assn, Inc.
320 New Center Bldg
Detroit, Mich. 48202

MTPS

Modern Talking Picture Service
2323 New Hyde Park Rd.
New Hyde Park, N.Y. 11040

MUE

Media For Urban Environment
75 Frost St.
Brooklyn, N.Y.

NAC

General Services Admin.
National Archives And Records Service
National Audiovisual Center
Washington, D.C. 20409

NBC

NBC Educational Enterprises
30 Rockefeller Center
New York, N.Y. 10020

NFBC

National Film Board of Canada
680 5th Avenue
New York, N.Y. 10019

Shell

Shell Film Library
450 N. Meridian St.
Indianapolis, Ind. 46204

LESSON OUTLINE

TOPIC: _____
LEVEL: _____
EST. TIME: _____
SUBJECTS: _____

I. LEVEL V OBJECTIVE

II. LEVEL VI OBJECTIVE

III. TEACHER BACKGROUND INFORMATION

IV. MATERIALS NEEDED

V. ACTIVITY

A. PRE-ACTIVITY _____ Time: _____

B. ACTIVITY _____ Time: _____

C. POST-ACTIVITY _____ Time: _____

VI. RESOURCES

VII. SUGGESTED ADDITIONAL ACTIVITIES