

DOCUMENT RESUME

ED 095 705

95

FL 006 165

TITLE Beginning English for Adults. Vol. 3, Asian Project.

INSTITUTION Los Angeles City Schools, Calif. Div. of Career and Continuing Education.

SPONS AGENCY Office of Education (DHEW), Washington, D.C.

PUB DATE 73

GRANT OEG-71-4409

NOTE 285p.; For related documents, see FL 006 163-170

EDRS PRICE MF-\$0.75 HC-\$13.80 PLUS POSTAGE

DESCRIPTORS Adult Education; \*Adult Students; \*Asian Americans; Chinese Americans; Curriculum Guides; \*English (Second Language); Filipino Americans; \*Instructional Materials; Japanese Americans; Korean Americans; Language Instruction; \*Second Language Learning; \*Visual Aids

ABSTRACT

This volume of visual aids is designed to accompany volumes 1 and 2 of the Asian Project series for the teaching of English as a second language to adults. The drill pictures presented here are coordinated with the dialogues and exercises in each lesson. They are in black and white and 8 1/2 by 11 inches in size. (PF)



BEST COPY AVAILABLE



# ASIAN PROJECT

# Beginning English for Adults

Volume Three

FL 006165

ED 095705

"BRIDGING THE ASIAN LANGUAGE AND CULTURAL GAP"

# BEGINNING ENGLISH FOR ADULTS

VOLUME III.

U.S. DEPARTMENT OF HEALTH  
EDUCATION & WELFARE  
NATIONAL INSTITUTE OF  
EDUCATION

... ..  
... ..  
... ..  
... ..  
... ..  
... ..  
... ..  
... ..

Office of Education Grant No. OEG-71-4409

The project reported herein was supported by a grant under Section 309(b), Title III, P.L. 91-230, Adult Education Act, from the Office of Education, Department of Health, Education and Welfare. The opinions expressed in this publication do not necessarily reflect the position or policy of the Office of Education, and no official endorsement by the Office of Education should be inferred.

DIVISION OF CAREER AND CONTINUING EDUCATION

ADULT BASIC EDUCATION PROGRAM

LOS ANGELES UNIFIED SCHOOL DISTRICT

1971-73

Los Angeles Unified School District

BEGINNING ENGLISH FOR ADULTS

(In Four Volumes)

VOLUME I. FOREWORD

DESIGN OF LESSONS

LESSONS 1 - 20

Components of each lesson: Lesson Guide  
Student Leaflet  
Evaluation Lesson Guide  
Evaluation Student Leaflet  
Chinese Supplement

VOLUME II. LESSONS 21 - 40

\*VOLUME III. DRILL PICTURES P1 - P283

VOLUME IV. TRANSPARENCY MASTERS T1 - T159

## DRILL PICTURES

Lesson	P#	Title	Lesson	P#	Title
(1)	P1--	Dialogue (How are you?)	(6)	P44--	a penny
	P2--	Dialogue (What's your name?)		P45--	a nickel
(2)	P3--	Dialogue (What's your address?)		P46--	a dime
	P4--	Dialogue (Good evening)		P47--	a quarter
(3)	P5--	a doctor		P48--	a half dollar
	P6--	a nurse		P49--	a hamburger 50¢
	P7--	a waiter		P50--	a hot dog 20¢
	P8--	a cook		P51--	a soft drink 15¢
	P9--	a housewife		P52--	a doughnut 15¢
	P10--	a gardener		P53--	Dialogue (The Vending Truck)
	P11--	a secretary		P54--	Facial diagram: /ʒ/ and /d/
	P12--	a saleslady		P55--	a cup of coffee and a cup of tea
	P13--	a salesman		P56--	Dialogue (Coffee or tea?)
	P14--	Dialogue (He's a doctor)	(7)	P57--	an apple
	P15--	Pronunciation: Sue		P58--	an orange
	P16--	Pronunciation: a shoe		P59--	an onion
	P17--	Facial diagram: /s/ and /s̃/		P60--	a lemon
	P18--	Ben		P61--	a pepper (green)
(4)	P19--	a dentist		P62--	a grapefruit
	P20--	a baker		P63--	Dialogue (It's a lemon)
	P21--	a barber		P64--	lemons
	P22--	a lawyer		P65--	apples
	P23--	a busboy		P66--	oranges
	P24--	a teacher		P67--	onions
	P25--	a student		P68--	peppers
	P26--	dentists		P69--	a cabbage and cabbages
	P27--	bakers		P70--	a carrot and carrots
	P28--	barbers		P71--	Dialogue (Are these carrots?)
	P29--	lawyers	(8)	P72--	at the bank
	P30--	waiters		P73--	at the post office
	P31--	busboys		P74--	at the department store
	P32--	teachers		P75--	at the beauty shop
	P33--	students		P76--	at the laundromat
	P34--	cooks		P77--	at the airport
	P35--	doctors		P78--	at the market
	P36--	Dialogue (We're teachers)		P79--	at the hospital
	P37--	Facial diagram: /s/		P80--	a map
	P38--	Facial diagram: /z/		P81--	a mop
	P39--	Dialogue (Where are you from?)		P82--	Facial diagram: /æ/ and /a/
(5)	P40--	Pronunciation: She's sewing a dress	(9)	P83--	a wallet and <u>in</u> the purse
	P41--	Pronunciation: He's sipping it.		P84--	<u>on</u> the table
	P42--	Pronunciation: He's zipping it.		P85--	<u>under</u> the table
	P43--	Dialogue (What day is it?)		P86--	a bedroom

- (9) P87--Dialogue (Where are my shoes?) (14) P133--I'm thirsty  
P88--Facial diagram: /æ/ and /ɛ/ P134--Facial diagram: /ɔ/ and /ow/  
P89--a kitchen
- (10) P90--The Kim family (15) P135--American food  
P91--husband and wife P136--Chinese food  
P92--father and son P137--Japanese food  
P93--mother and daughter P138--Mexican food  
P94--brother and sister P139--Dialogue (He likes Japanese food)  
P95--Dialogue (This is my wife)  
P96--Dialogue (Is your husband at home?) (16) P140--a short dress  
P97--at home P141--a long skirt  
P142--a new suit  
P143--an old shirt  
P144--a light jacket  
P145--a heavy coat  
P146--Reading (Ann likes pretty dresses)
- (11) P98--a headache (17) P147--Reading (It's Saturday morning)  
P99--a toothache P148--Pronunciation: ties  
P100--a backache P149--Facial diagram: /t/ and /θ/  
P101--a stomach ache P150--a waitress  
P102--Dialogue (I have a headache) P151--a florist  
P103--a sore arm  
P104--a sore shoulder (18) P152--Reading (He's parking the car now)  
P105--a sore elbow P153--Pronunciation: put it into the hole  
P106--a sore leg P154--Pronunciation: putt it into the hole  
P107--a sore knee P155--Facial diagram: /ʊ/ and /ɔ/  
P108--a sore ankle P156--Reading (He's learning to dive)  
P109--a telephone  
P110--Dialogue (Do you have a fever?)
- (12) P111--a room (19) P157--an 8-cent stamp  
P112--an apartment P158--an 11-cent airmail stamp  
P113--a house P159--a 17-cent airmail stamp  
P114--Dialogue (I want a house) P160--a 21-cent airmail stamp (overseas)  
P115--2 sons P161--an air letter (aeogram)  
P116--2 daughters P162--a post card  
P117--Pronunciation: a lick P163--Pronunciation: a puppy  
P118--Pronunciation: a leak P164--Pronunciation: a poppy  
P119--Facial diagram: /i/ and /iy/ P165--Facial diagram: /ə/ and /a/  
P166--a calendar
- (13) P120--a living room (20) P167--Dialogue (I'm shaving)  
P121--a dining room  
P122--a bathroom  
P123--a closet  
P124--Pronunciation: a pin  
P125--Facial diagram: /i/ and /ey/
- (14) P126--a chicken  
P127--wings  
P128--breasts  
P129--drumsticks  
P130--thighs  
P131--Dialogue (He wants drumsticks)  
P132--I'm hungry

- (21) P168--He sleeps  
 P169--She cleans the house  
 P170--Facial diagram: /s/ and /θ/  
 P171--They go to the movies  
 P172--They go to the beach  
 P173--They visit friends  
 P174--They go to a restaurant
- (22) P175--a light breakfast  
 P176--a heavy breakfast  
 P177--a light lunch  
 P178--a heavy lunch  
 P179--a light dinner  
 P180--a heavy dinner  
 P181--a snack  
 P182--Facial diagram: /I/ and /E/
- (23) P183--Dialogue (Does this bus go  
 downtown?)  
 P184--Facial diagram: /p/ and /b/  
 P185--Facial diagram: /f/ and /v/  
 P186--Pronunciation: a pan and a fan
- (24) P187--I'm cold  
 P188--I'm warm  
 P189--I'm homesick  
 P190--Dialogue (I want to get a letter)  
 P191--Pronunciation: a curb and a  
 curve
- (25) P192--Dialogue (I need to get some  
 medicine)
- (26) P193--He played cards  
 P194--He played ping pong
- (27) P195--an auto mechanic (repairing a  
 car)  
 P196--a seamstress (using a power  
 machine)  
 P197--a plumber (fixing a faucet)  
 P198--an electrician (fixing the  
 lights)  
 P199--an artist (painting a picture)
- (28) P200--at the art museum  
 P201--at the baseball stadium  
 P202--at the racetrack  
 P203--at the zoo  
 P204--Dialogue (We went to the circus)  
 P205--Facial diagram: /r/  
 P206--dogs and parrot
- (28) P207--cats and goldfish  
 P208--Extension dialogue (Our dog  
 had puppies)
- (29) P209--a 2-door car  
 P210--a 4-door car  
 P211--a compact  
 P212--a station wagon  
 P213--a van  
 P214--a camper  
 P215--Dialogue (That's a good-  
 looking sports car)  
 P216--too small, too big (sweater)  
 P217--too short, too long (pants)
- (30) P218--The White House  
 P219--Yosemite  
 P220--The Grand Canyon  
 P221--Las Vegas  
 P222--Niagara Falls  
 P223--Dialogue (We went to San  
 Francisco)
- (31) P224--It was sunny  
 P225--It was cloudy  
 P226--It was windy  
 P227--It was foggy  
 P228--It was rainy  
 P229--Dialogue (I was in the  
 mountains)  
 P230--Pronunciation: a rock and a  
 lock  
 P231--Facial diagram: /r/ and /l/
- (32) P232--a jewelry box  
 P233--a sewing box  
 P234--a record album  
 P235--a photo album  
 P236--a pen and pencil set  
 P237--a chess set  
 P238--Reading (A Surprise Party)  
 P239--a moustache and a goatee  
 P240--a beard and sideburns  
 P241--Dialogue (Give me a haircut,  
 please)
- (33) P242--a leaking faucet, toilet,  
 shower, pipe, and roof  
 P243--a broken window and a  
 broken doorknob  
 P244--He begins work/He gets off  
 work

- (33) P245--Facial diagram: /ts/  
P246--Facial diagram: /-ts/
- (34) P247--Dialogue (We're all sold out)  
P248--Facial diagram: /ts/ and /dz/
- (35) P249--a toaster and a coffee maker  
P250--an iron and a fan  
P251--a refrigerator and a stove  
P252--a washing machine and a dryer  
P253--Dialogue (The washing machine  
doesn't work)
- (36) P254--an unfurnished apartment  
P255--dress shoes  
P256--work shoes  
P257--tennis shoes  
P258--Dialogue (They feel a little  
tight)
- (37) P259--Listening (They're going to  
move on Monday)  
P260--Pronunciation: grass and glass  
P261--Dialogue (Can you send our  
mail . . . ?)
- (38) P262--Listening (Maria lost her wallet)  
P263--a driver's license  
P264--a temporary driver's license  
P265--Dialogue (I lost my driver's  
license)  
P266--a social security card  
P267--Pronunciation: a bat and a back  
P268--Facial diagram: /-t/ and /-k/  
P269--a garage on fire  
P270--a thief in the house  
P271--Dialogue (I need an ambulance)
- (39) P272--pedestrians, a traffic signal,  
and an ambulance  
P273--Dialogue (Your license, please)  
P274--traffic signs: No Left Turn,  
No Right turn, No U Turn  
P275--Pronunciation: a mask  
P276--Pronunciation: a mast  
P277--a gas gauge  
P278--a dead battery  
P279--a dirty windshield  
P280--a boiling radiator  
P281--a flat tire  
P282--Dialogue (I have a flat tire)
- (40) P283--Dialogue (I'm looking for a  
part-time job)

BEST COPY AVAILABLE



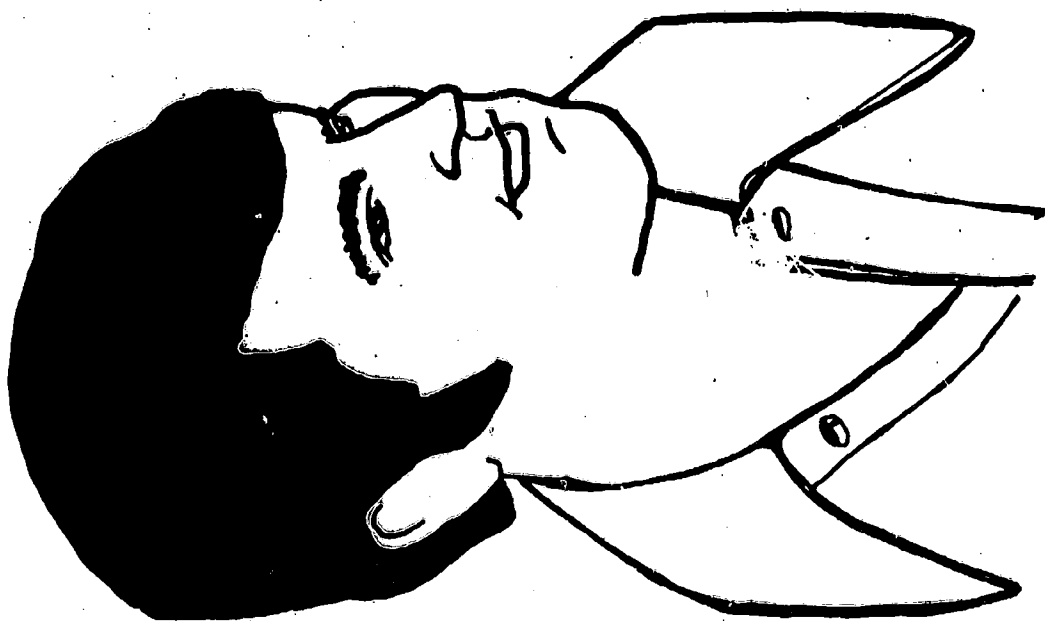
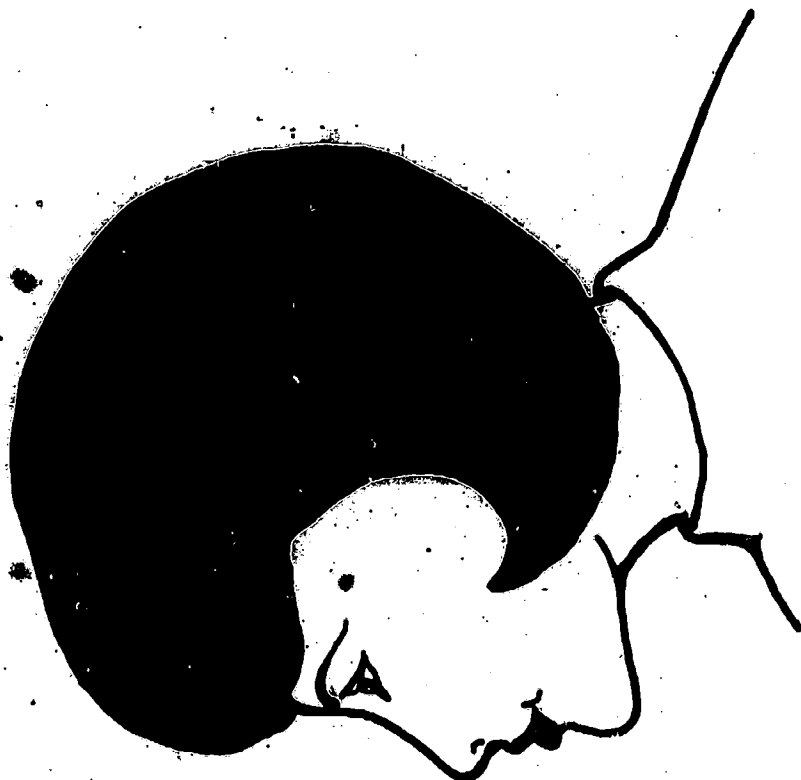

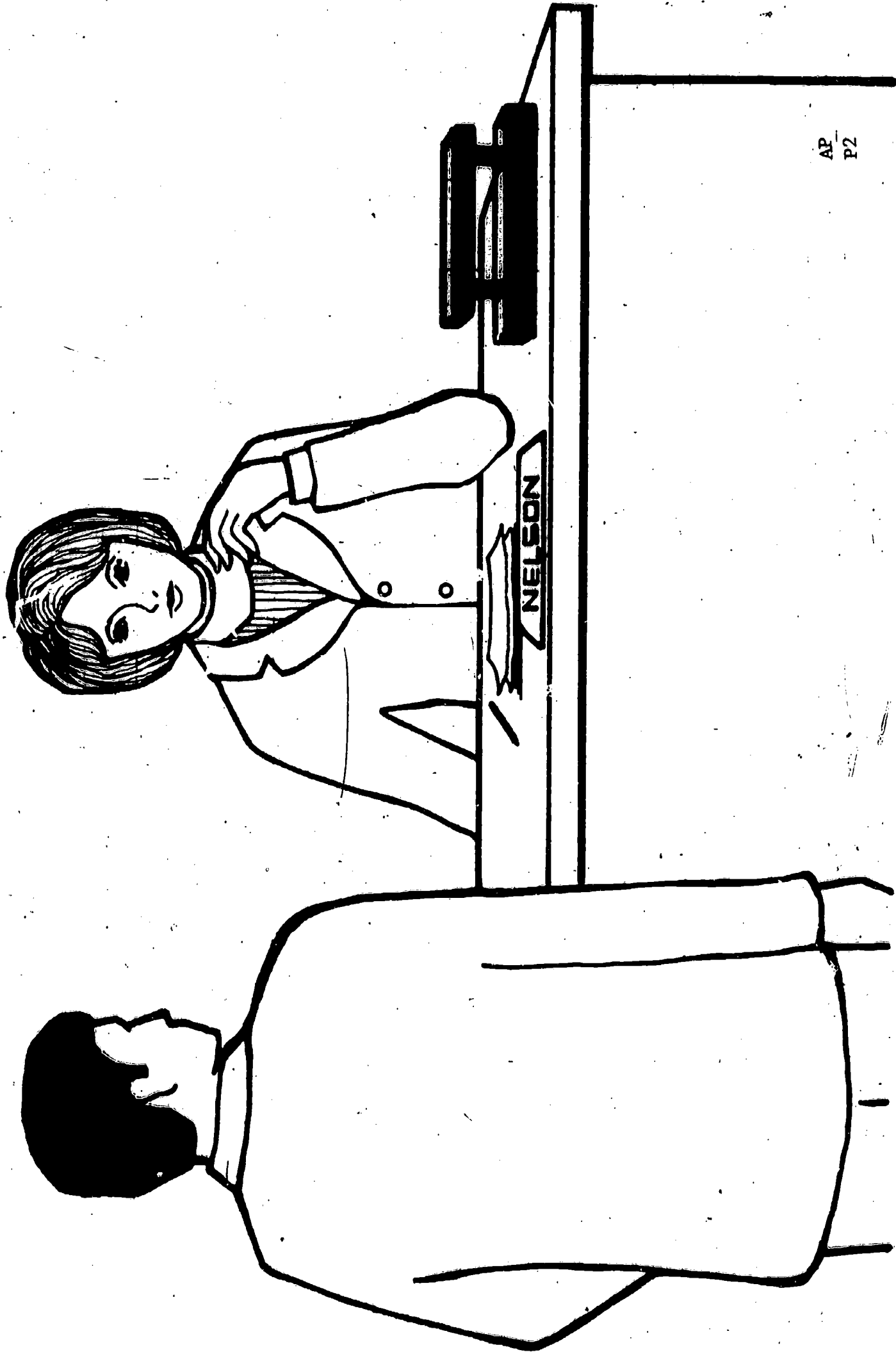

BEST COPY AVAILABLE

AP  
P3

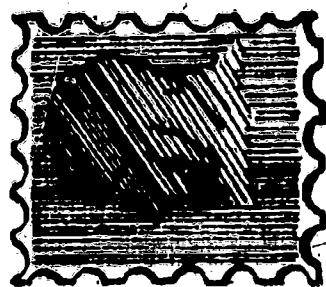

MISS WILSON  
MISS WILSON  
MISS WILSON 91107

MR. BILL  
104 FAY AVENUE  
LOS ANGELES,

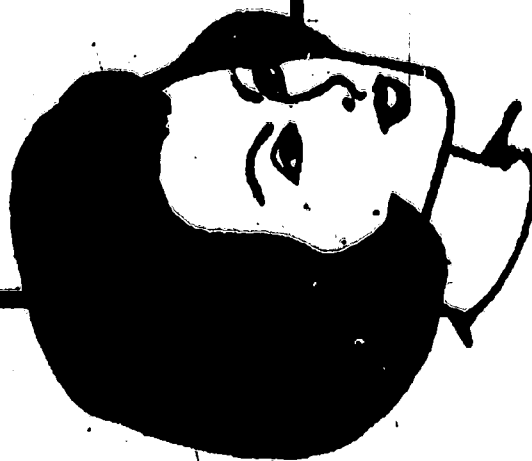

BEST COPY AVAILABLE

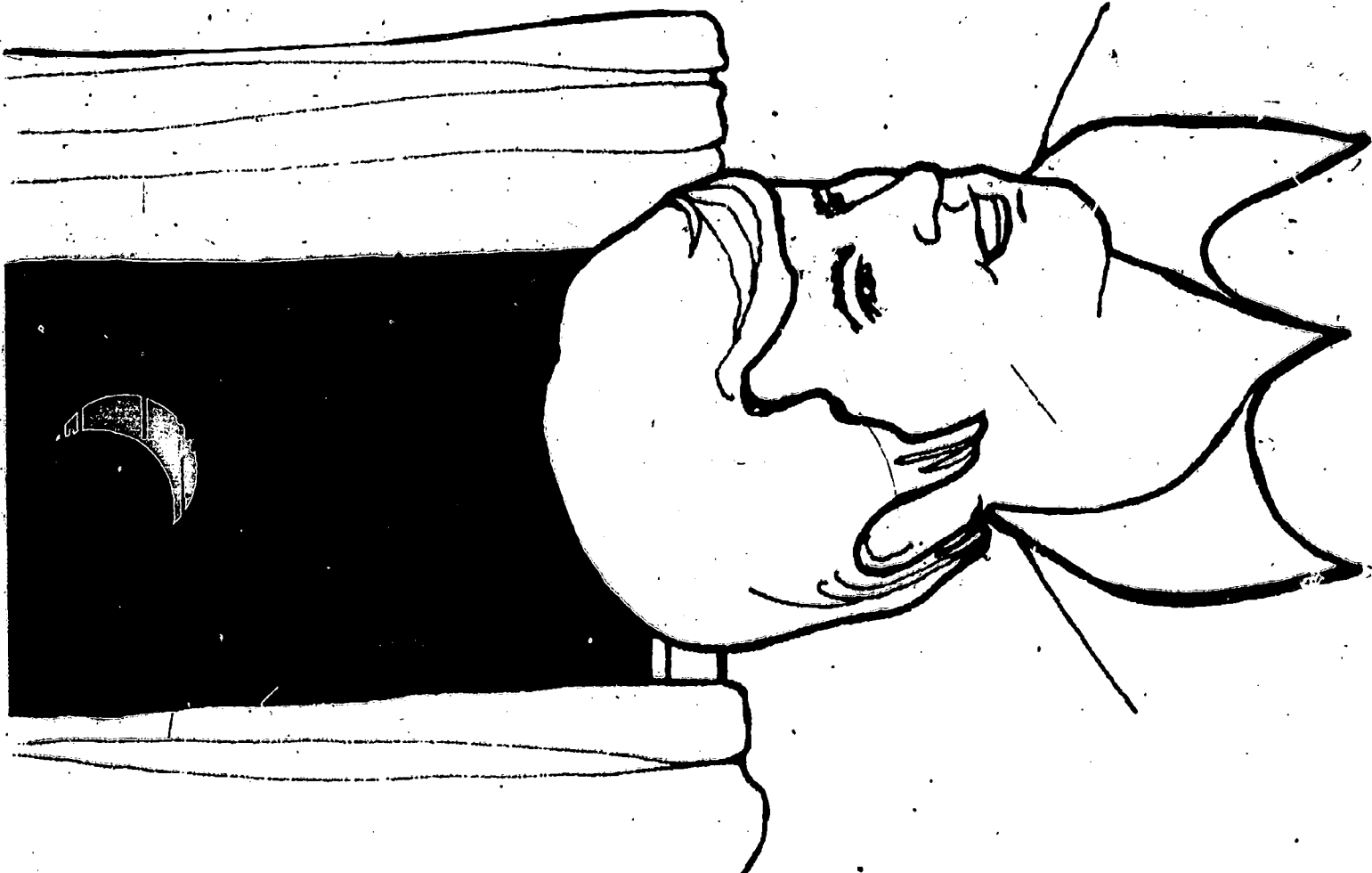
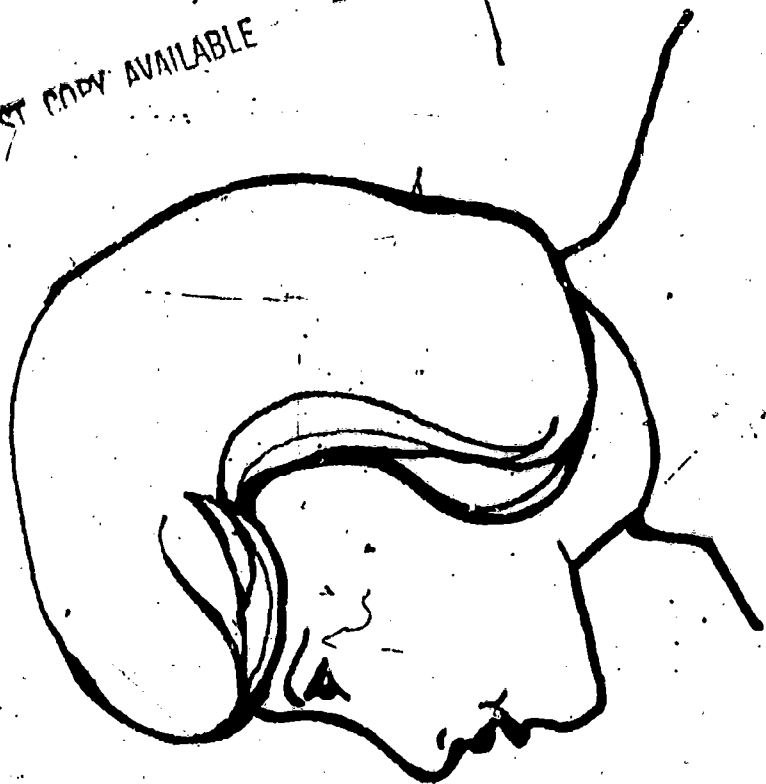
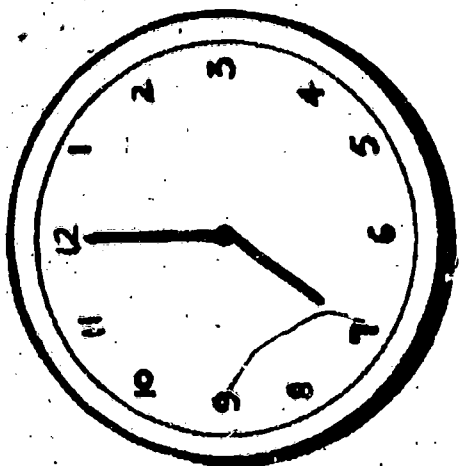





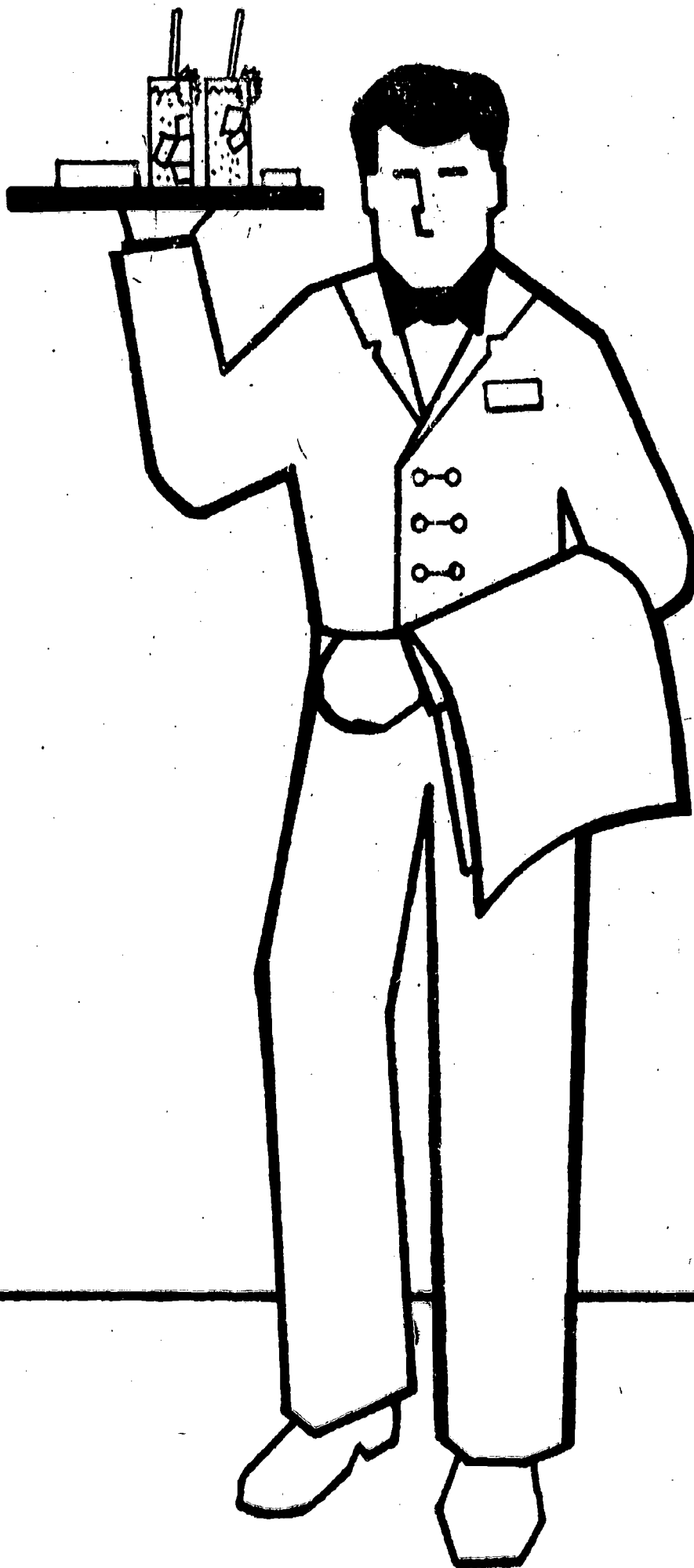





BEST COPY AVAILABLE

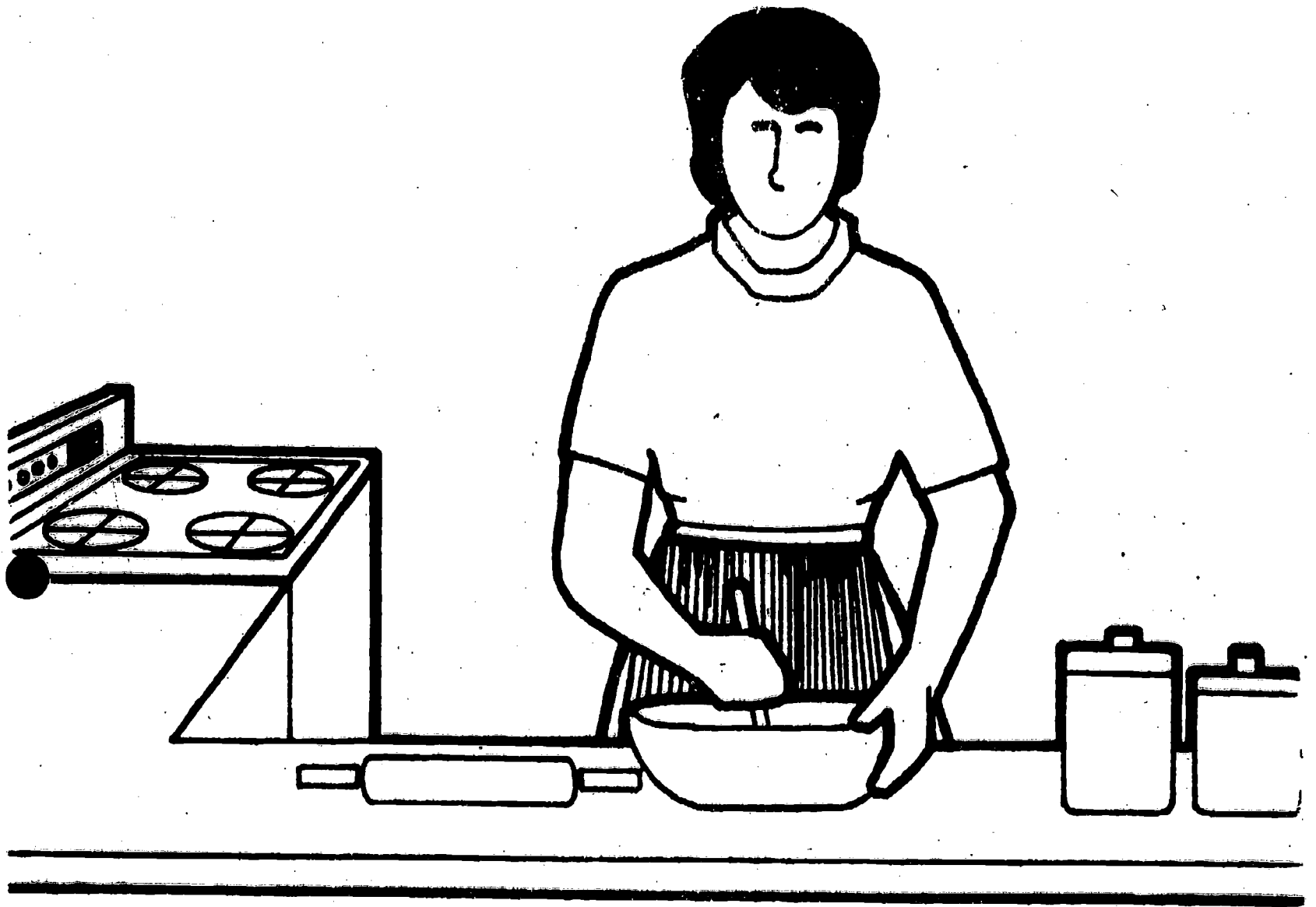

BEST COPY AVAILABLE

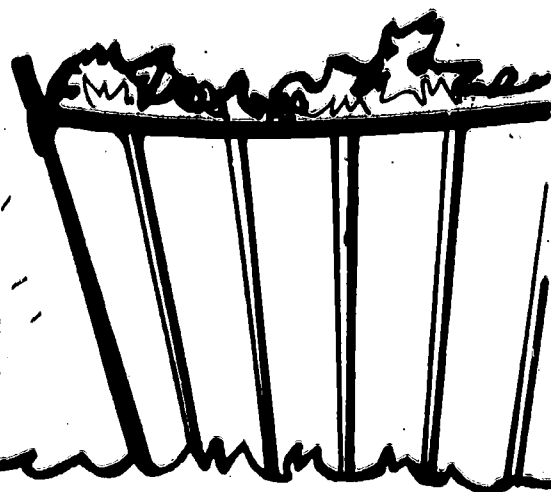
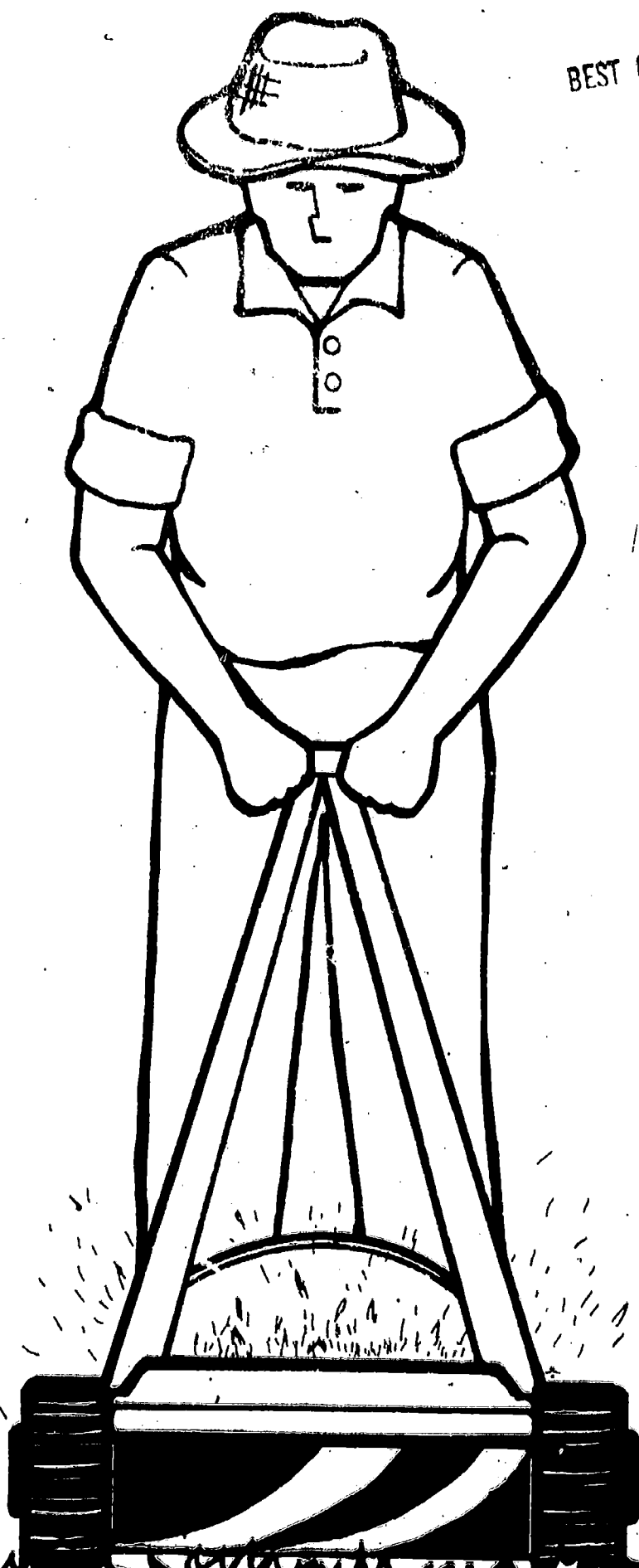

AP  
P10

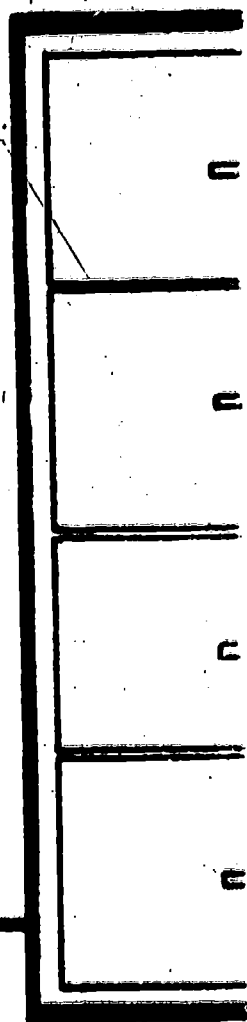
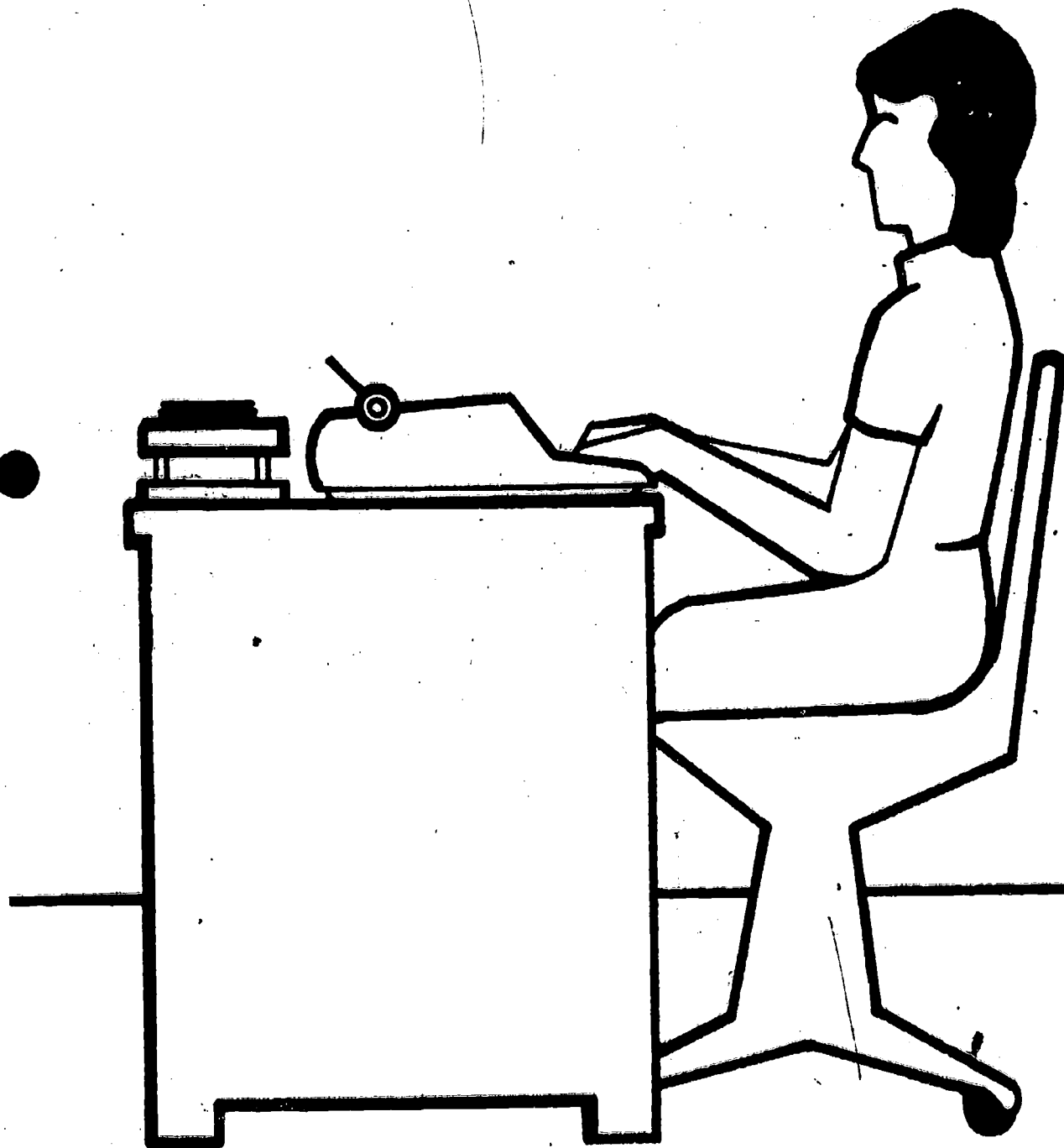
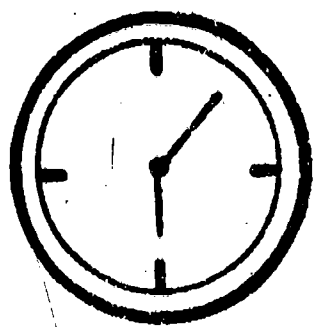

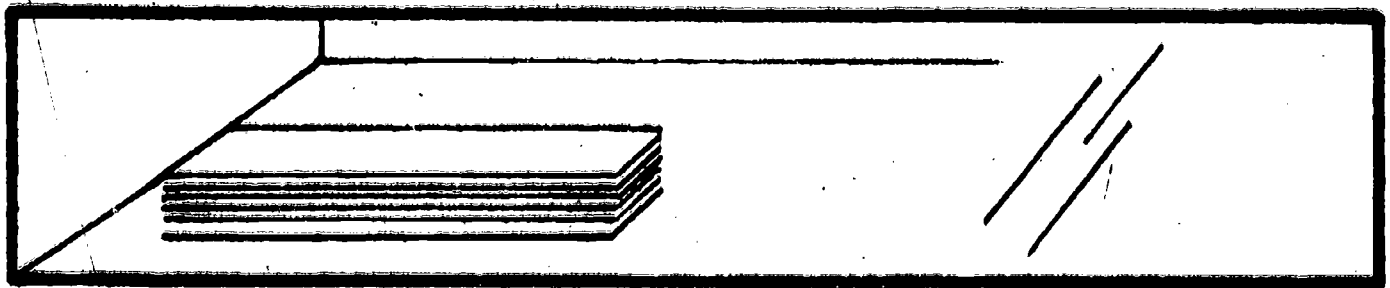
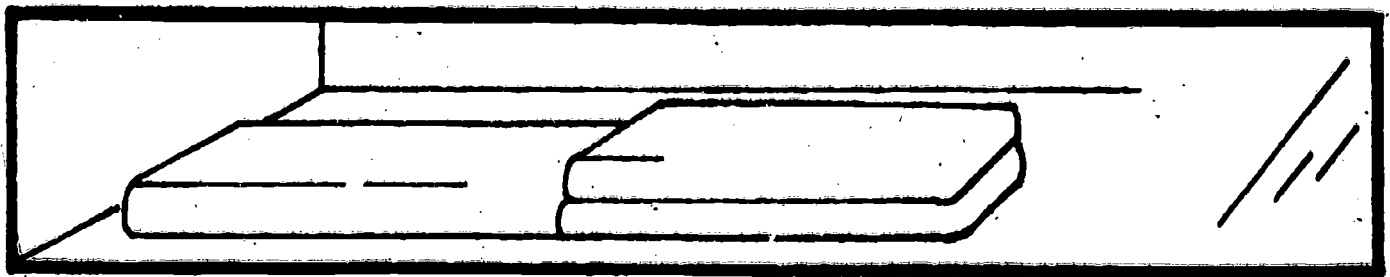
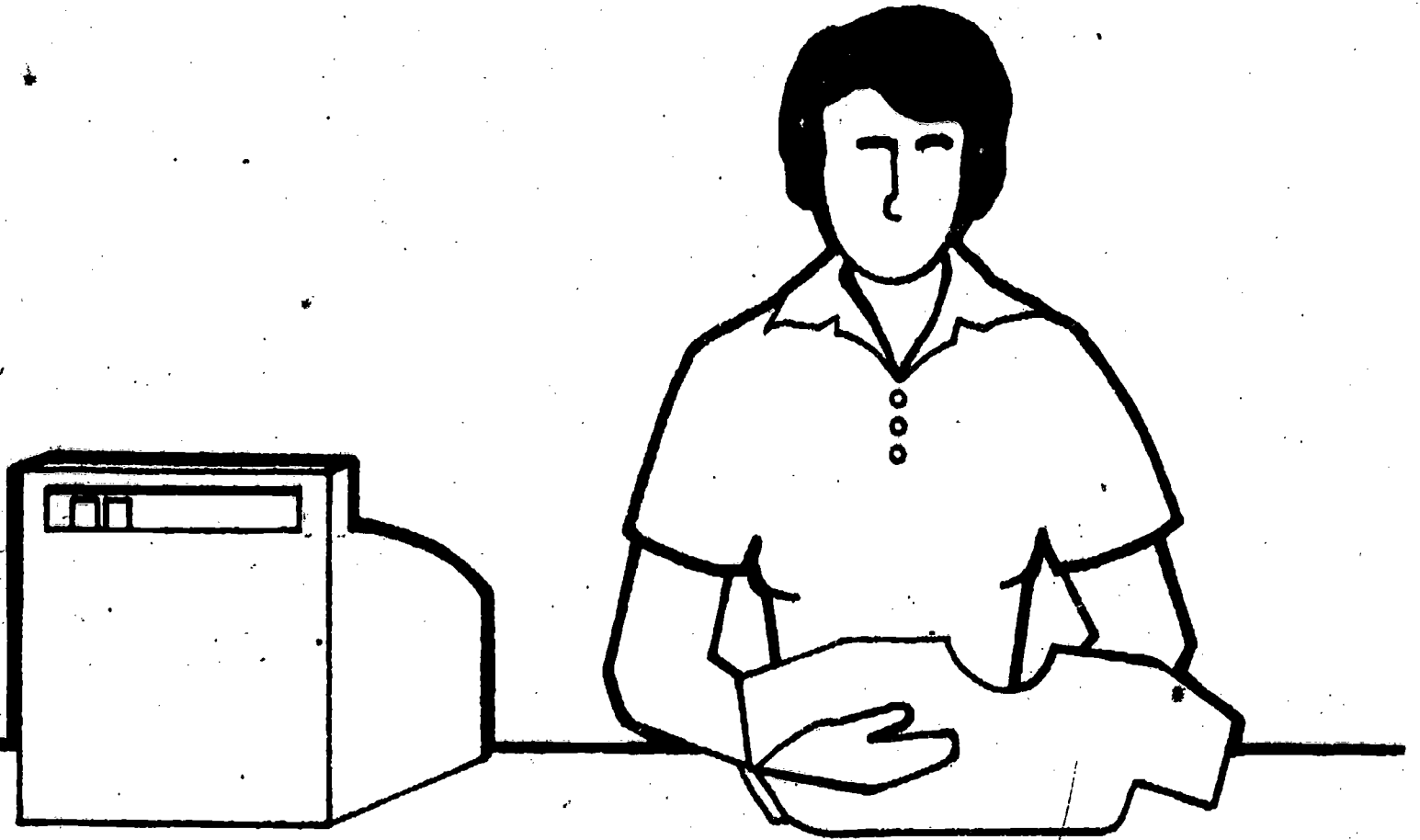

BEST COPY AVAILABLE

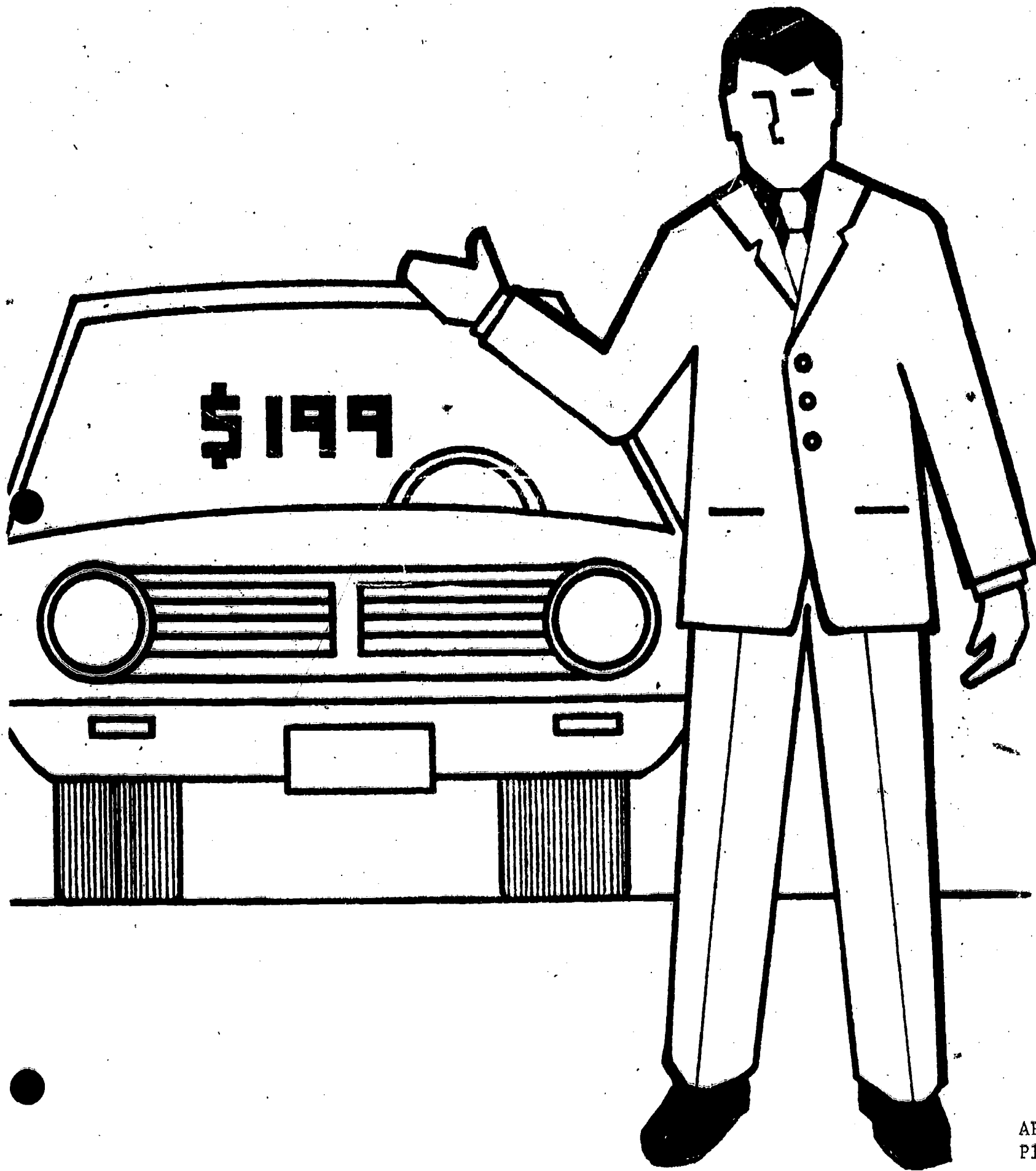

AP  
P13





AP  
P15

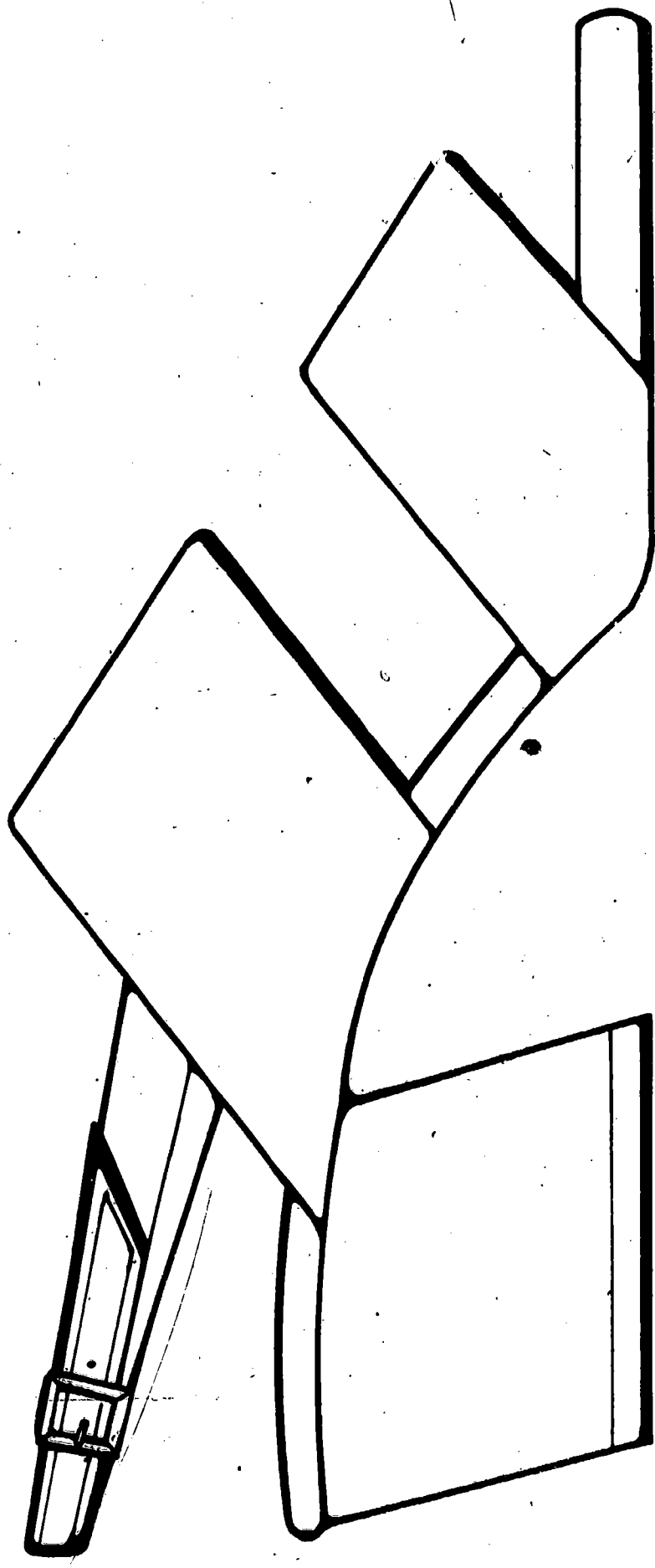



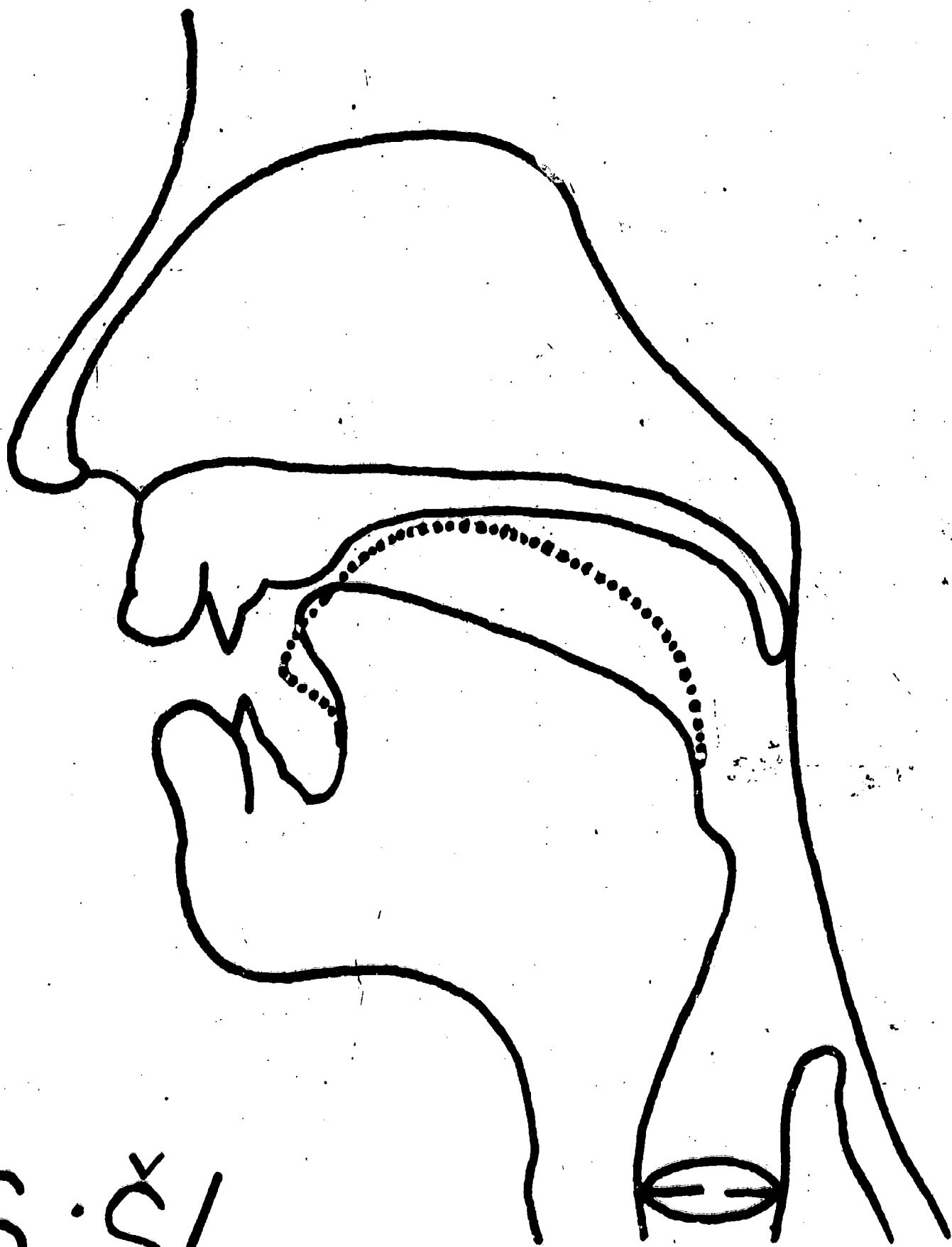

/s : š/

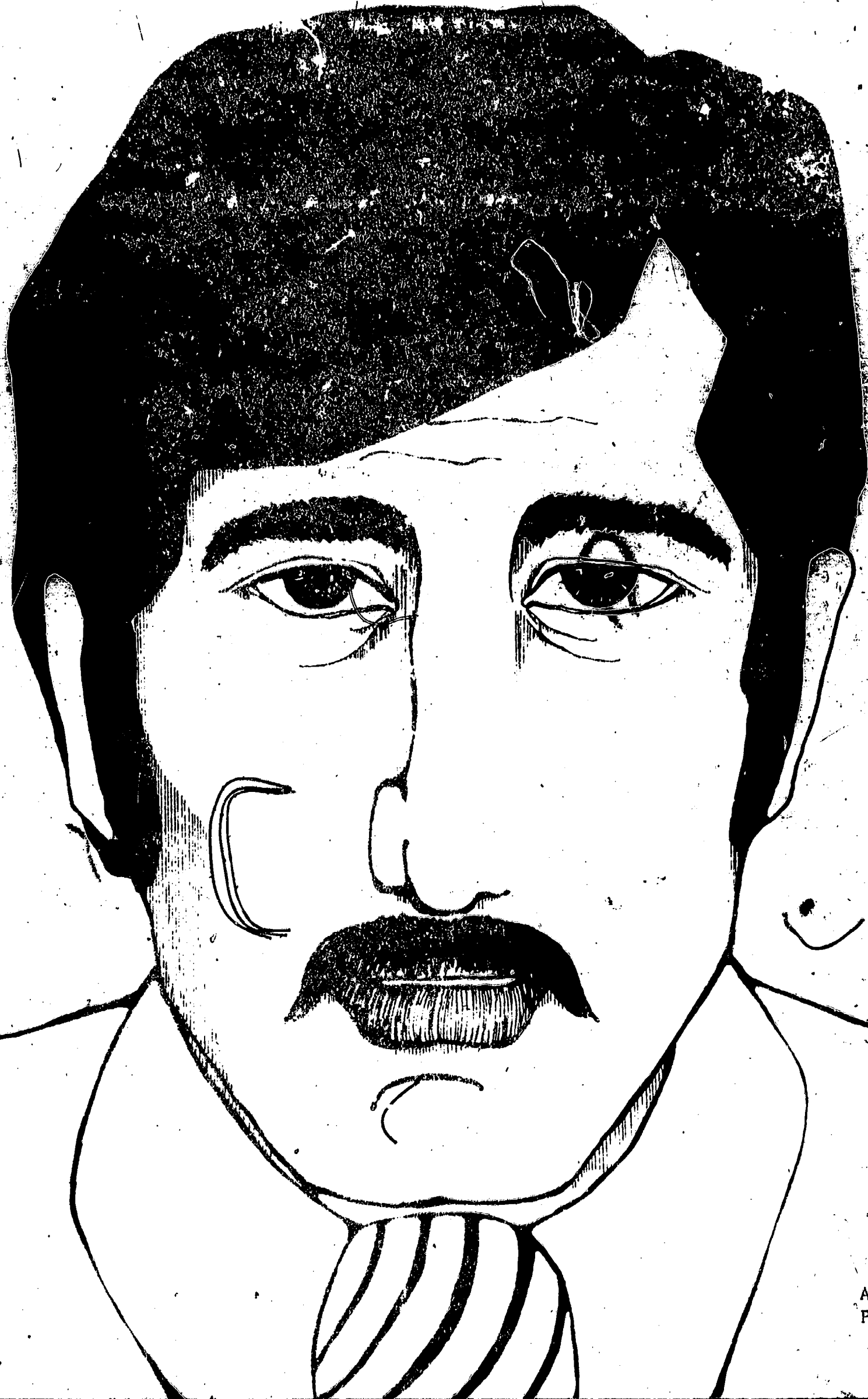

AP  
P18

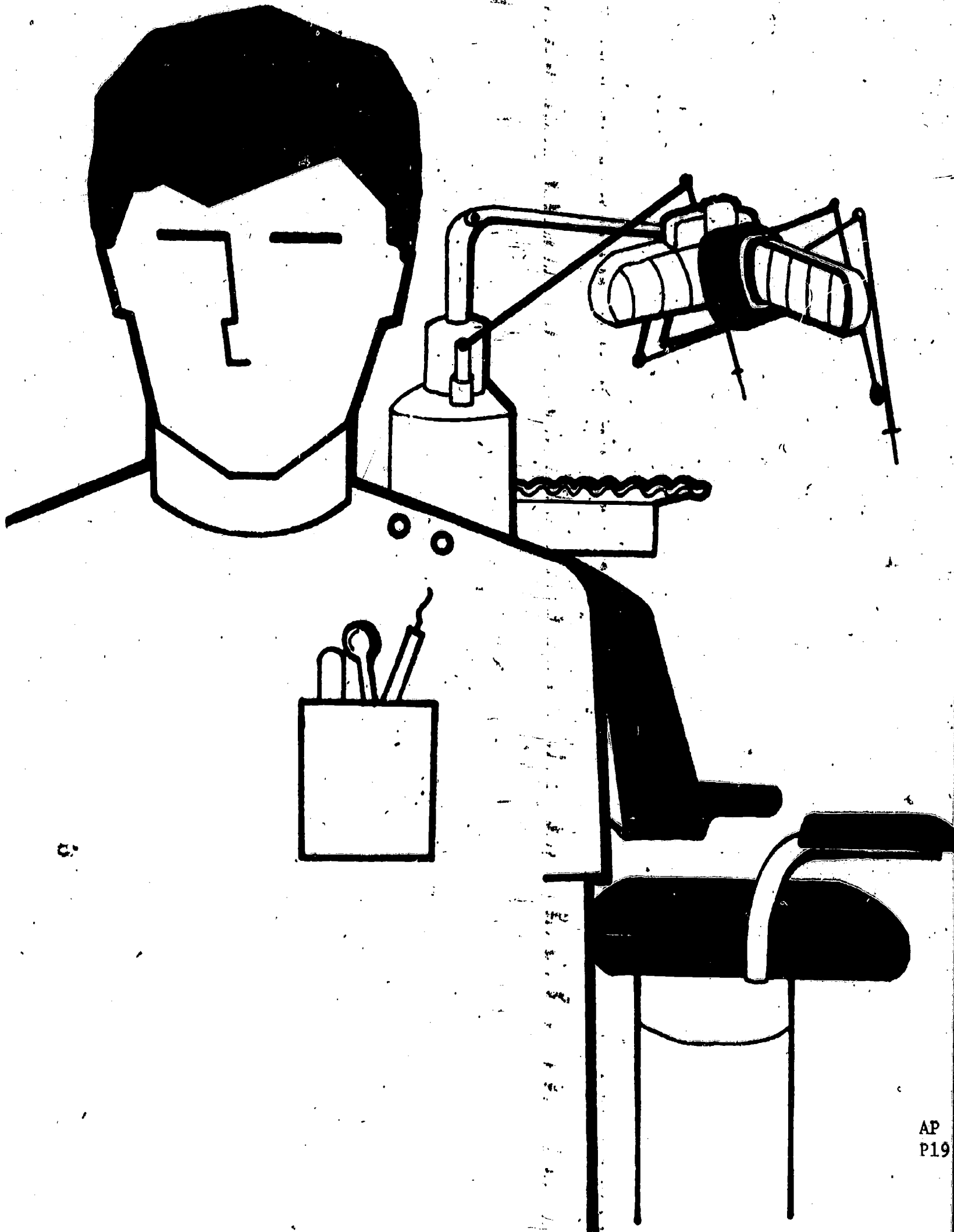



AP  
P20

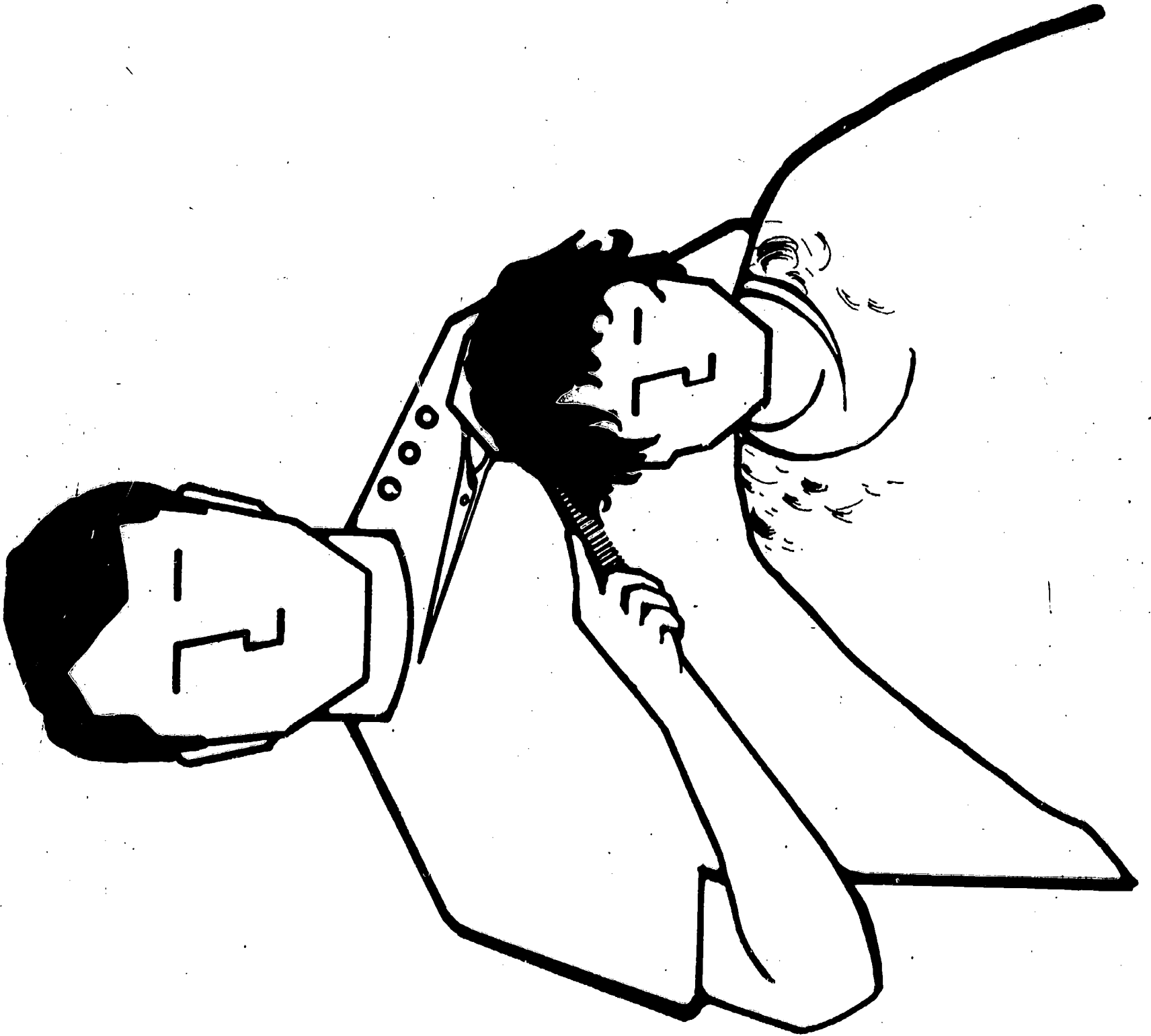

BEST COPY AVAILABLE

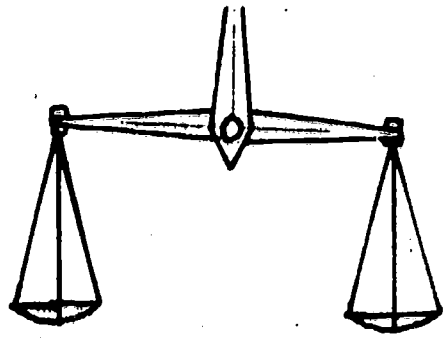

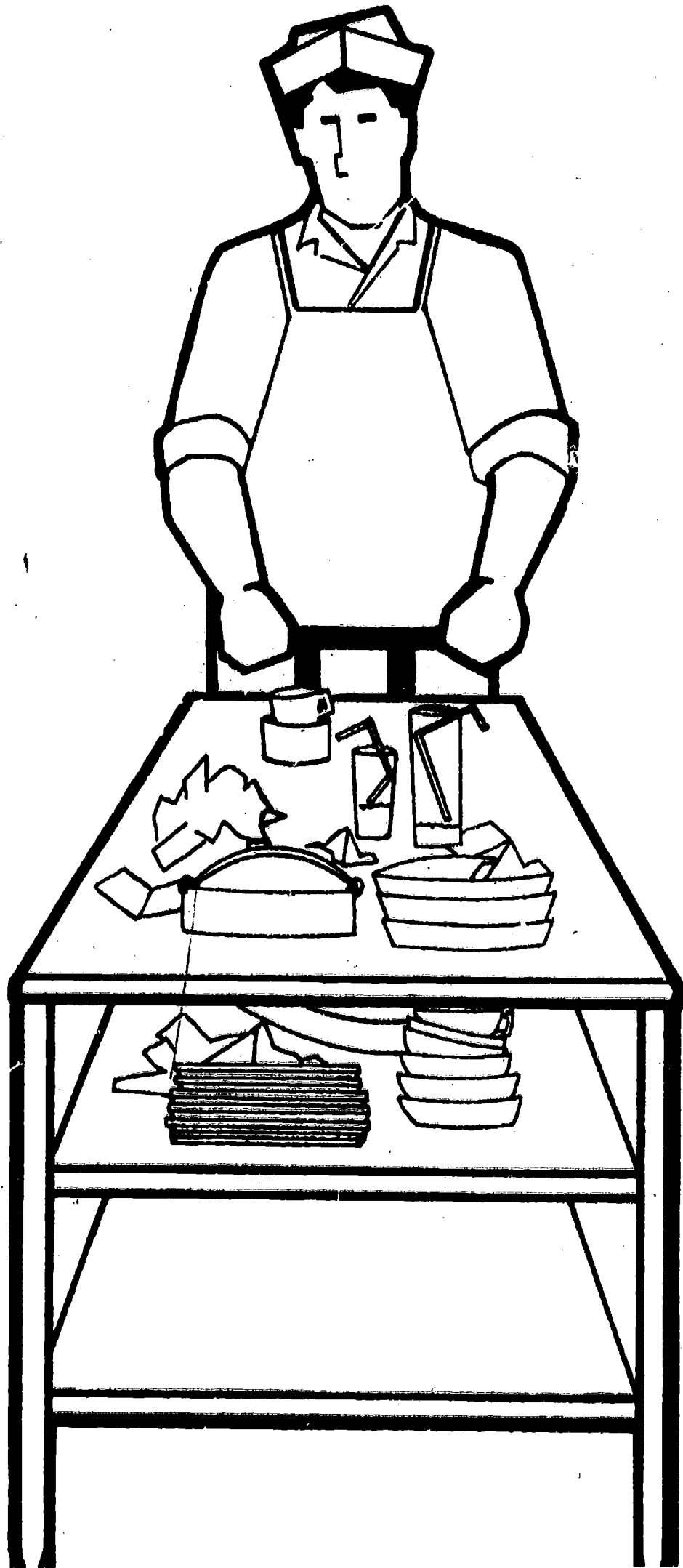

pen  
book  
chair

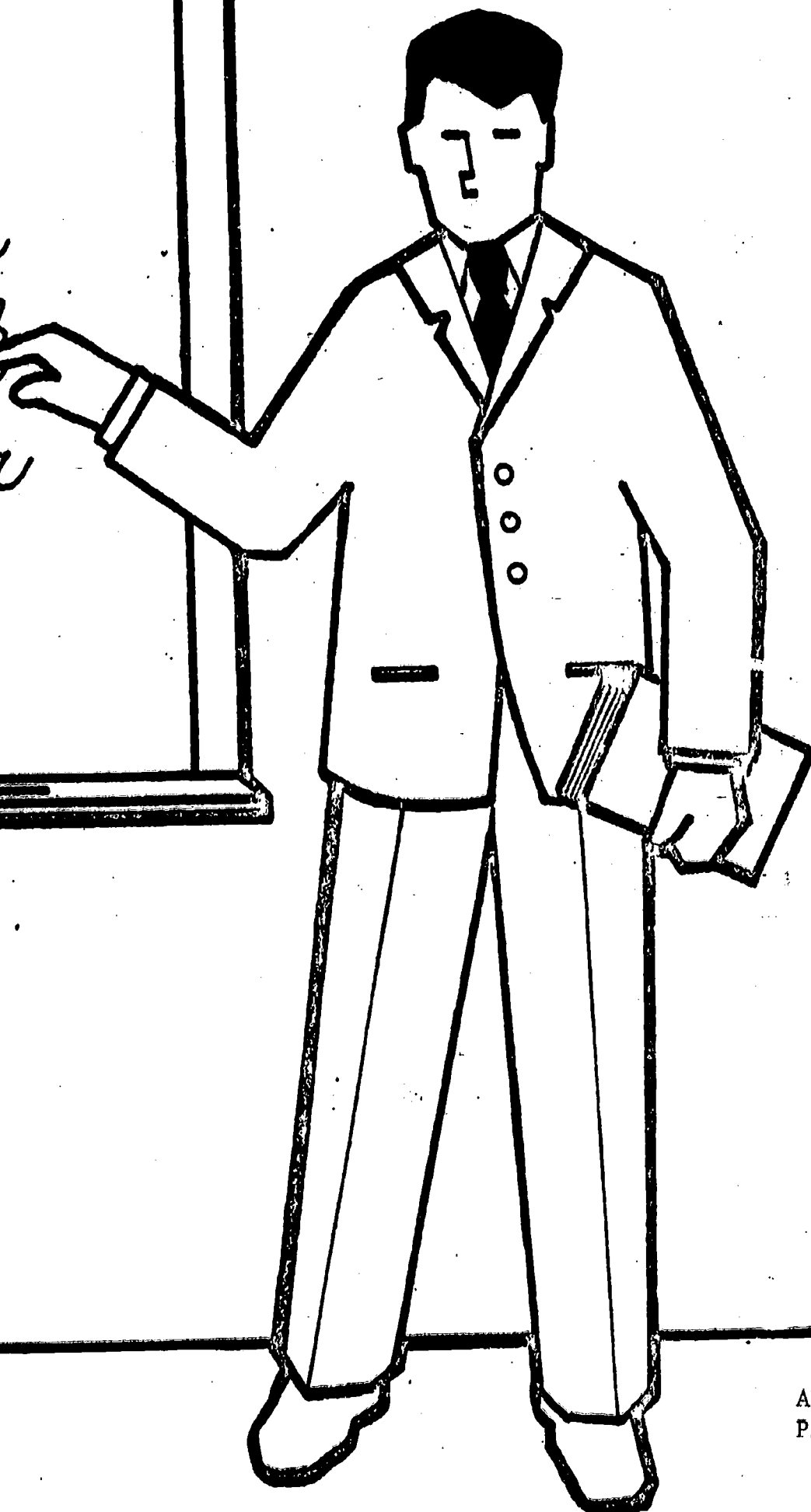



pen  
book  
chair

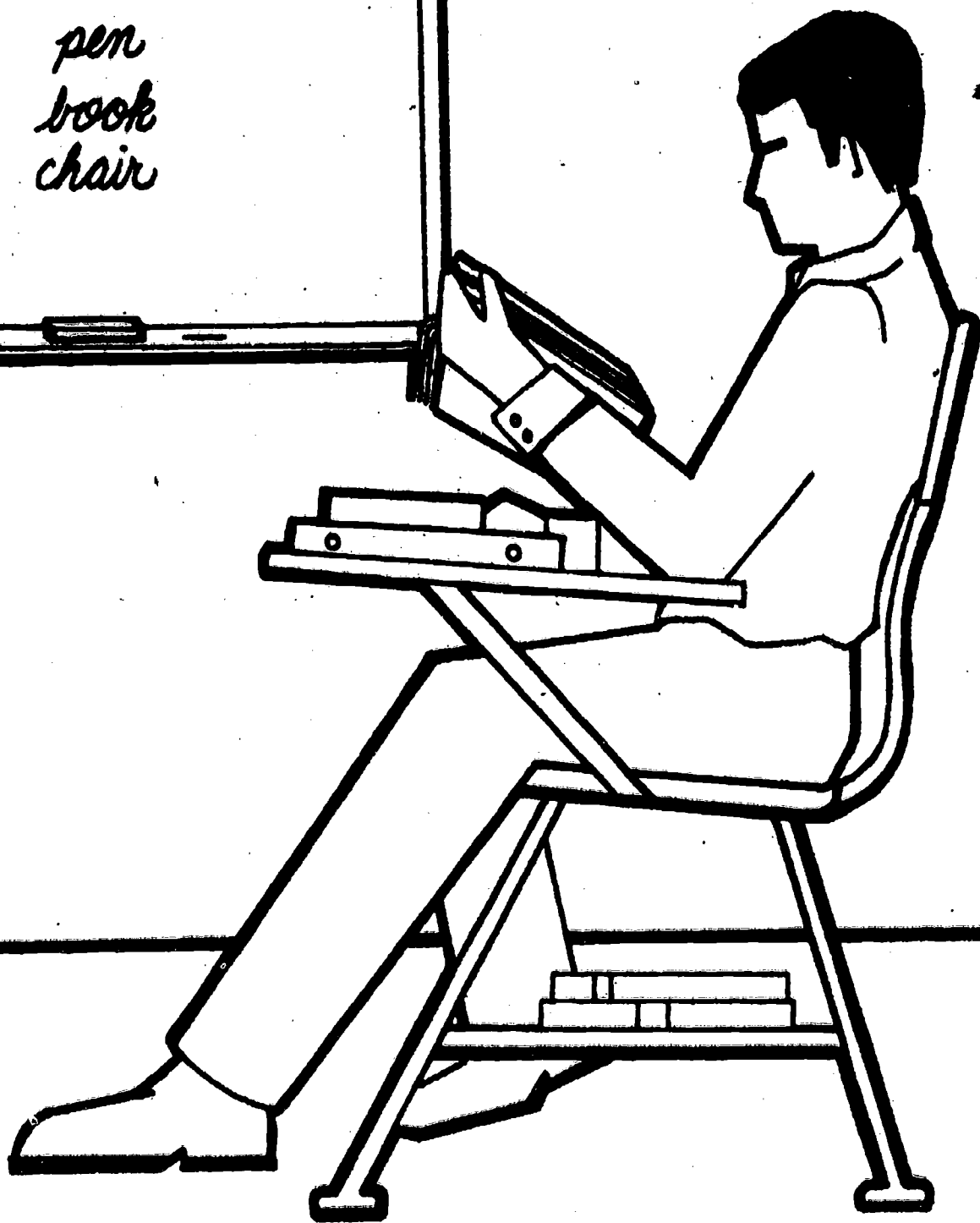

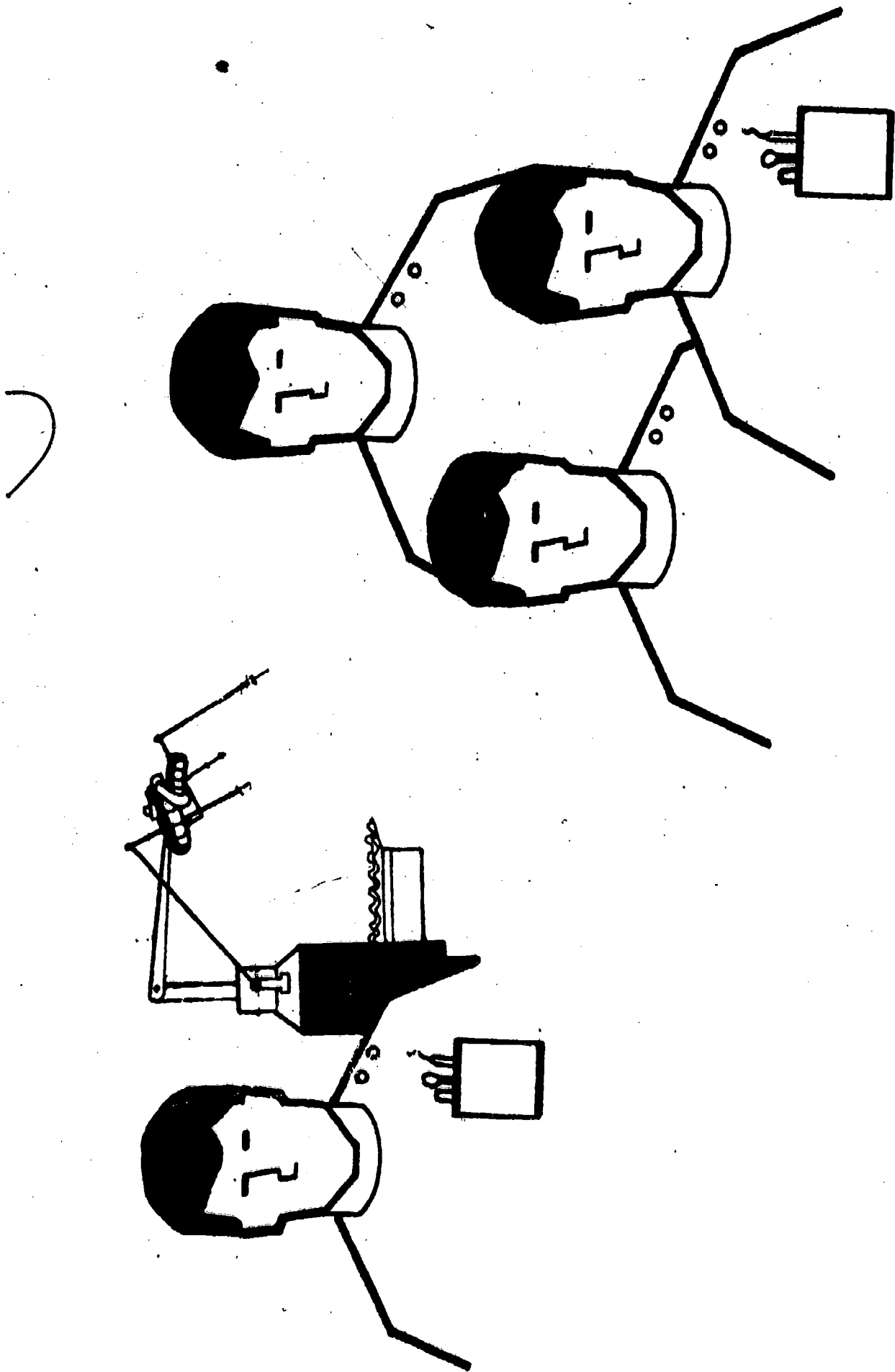

BEST COPY AVAILABLE

AP  
P27

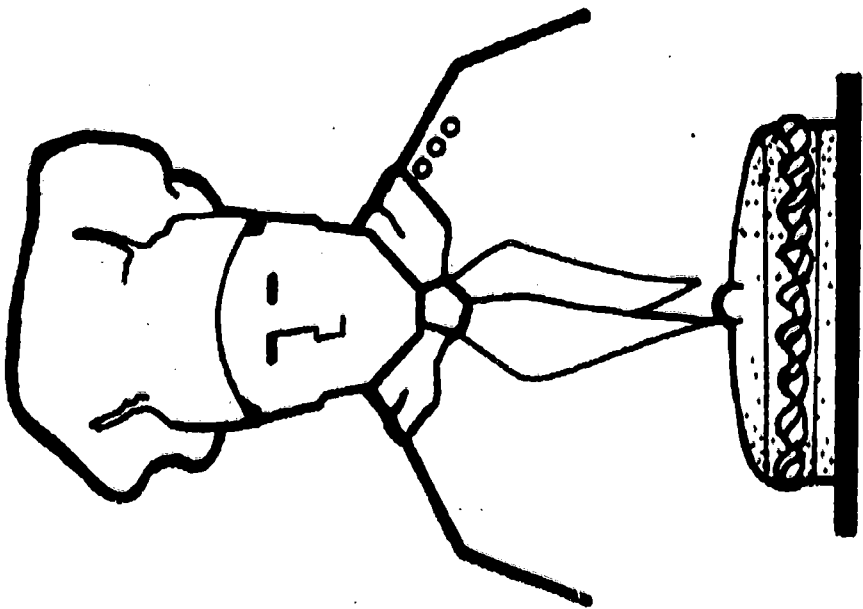
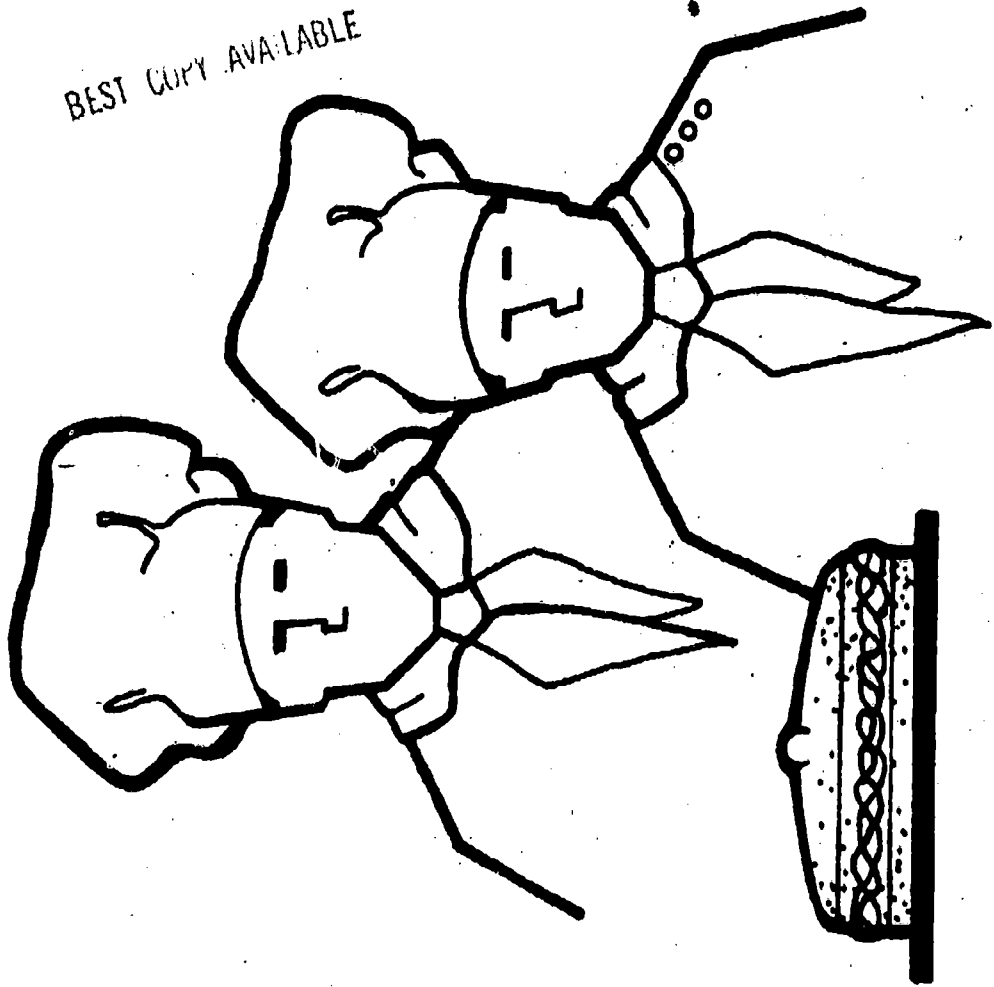

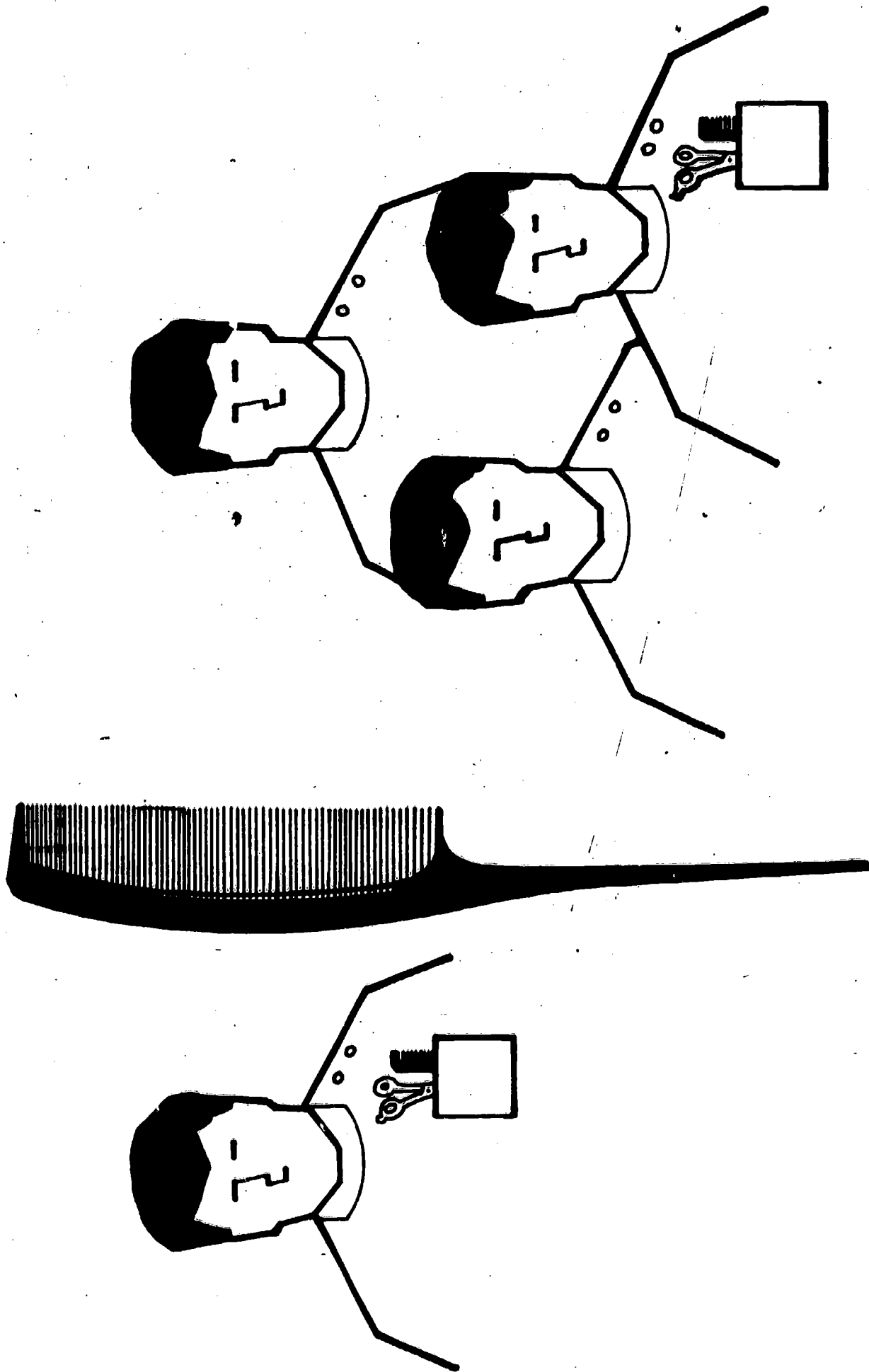

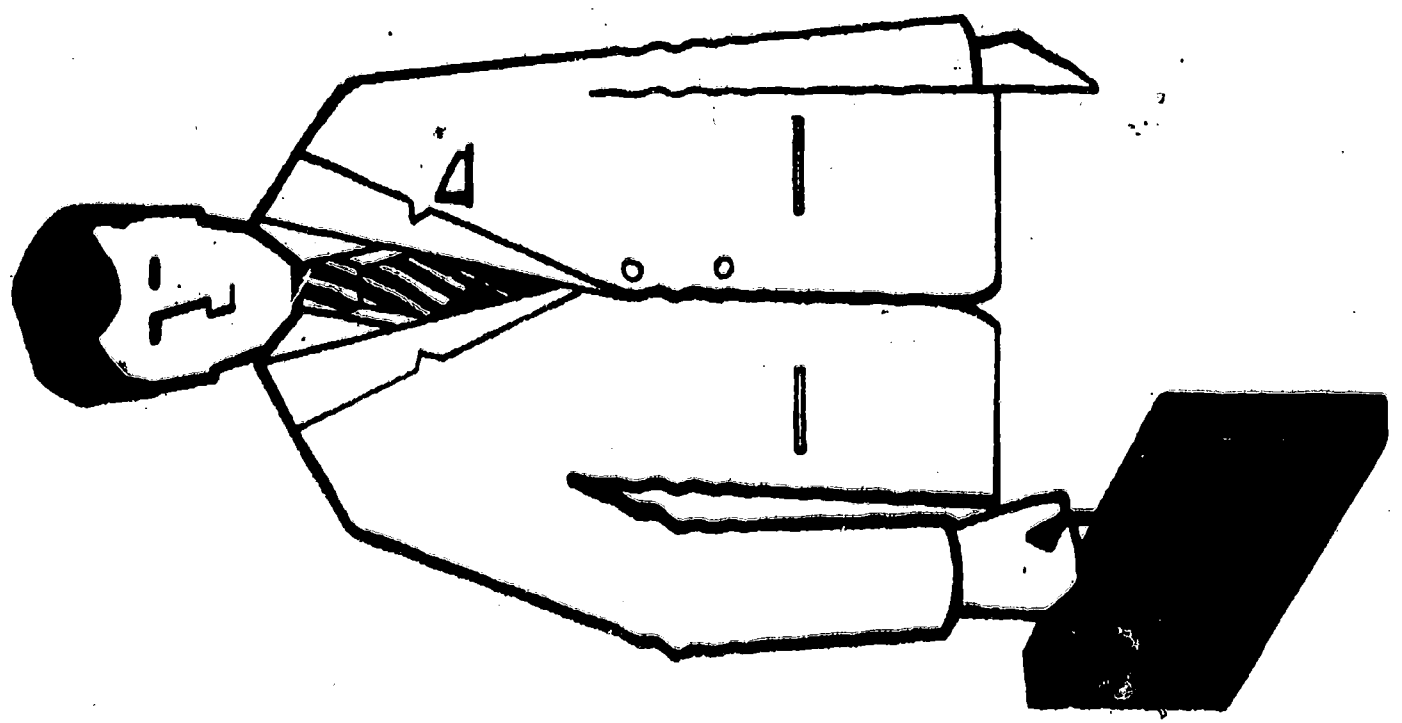
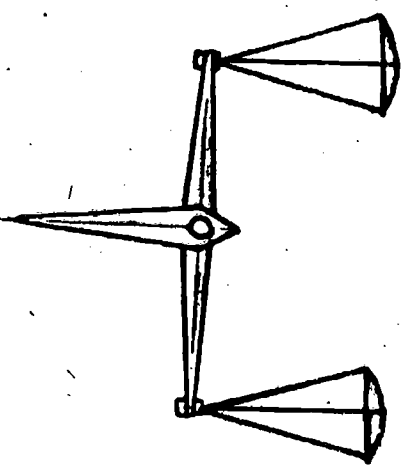
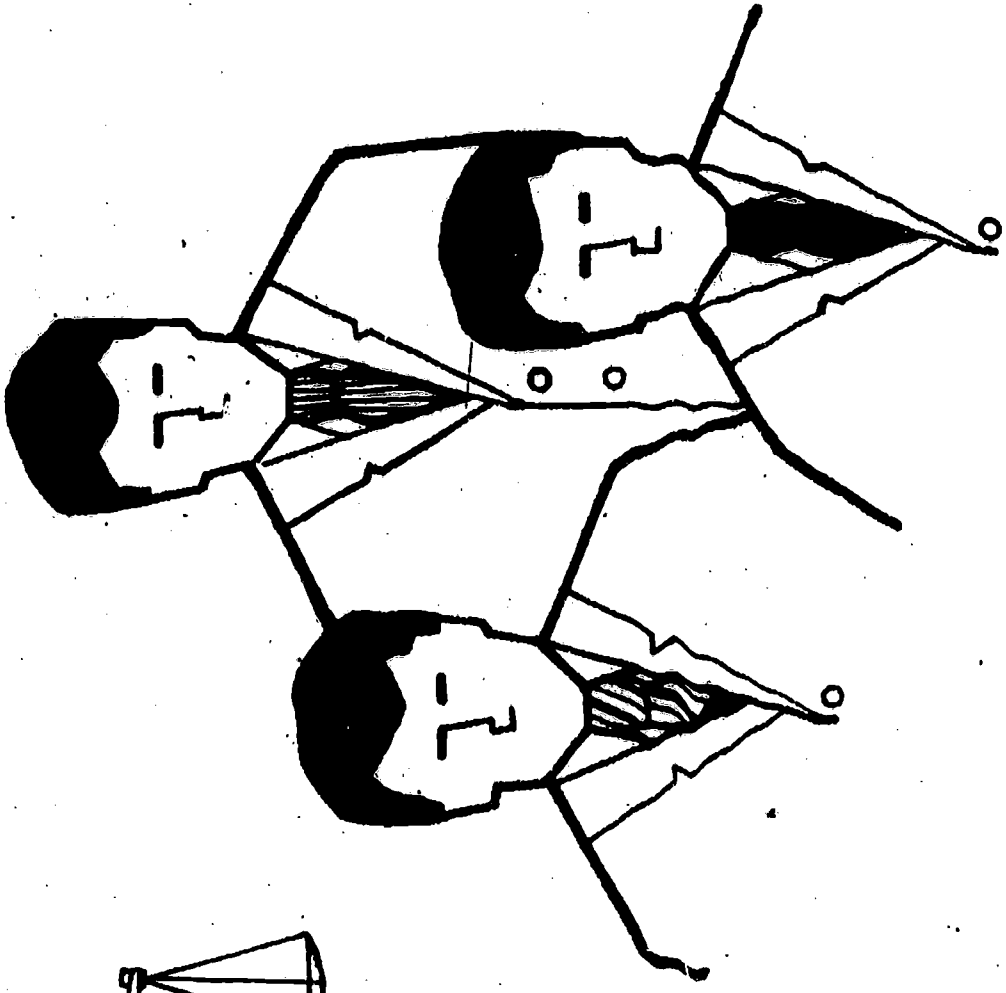

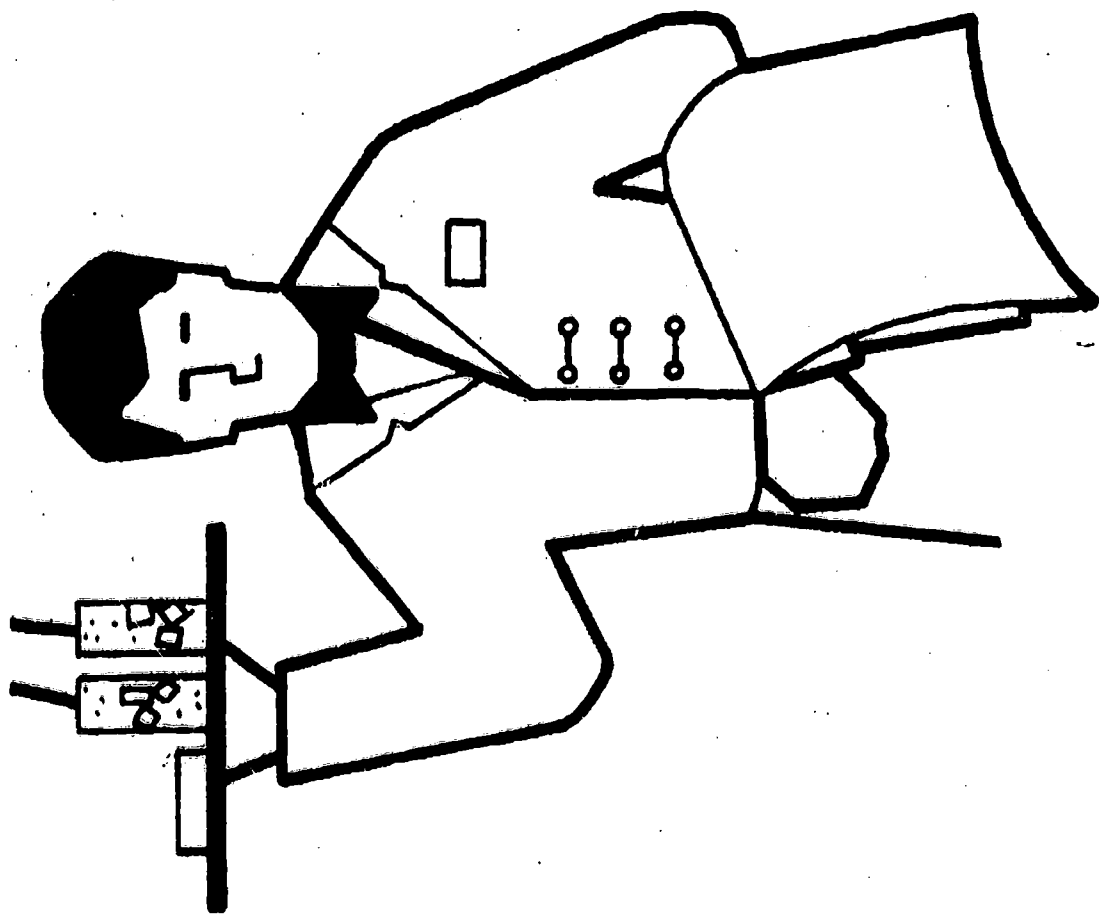
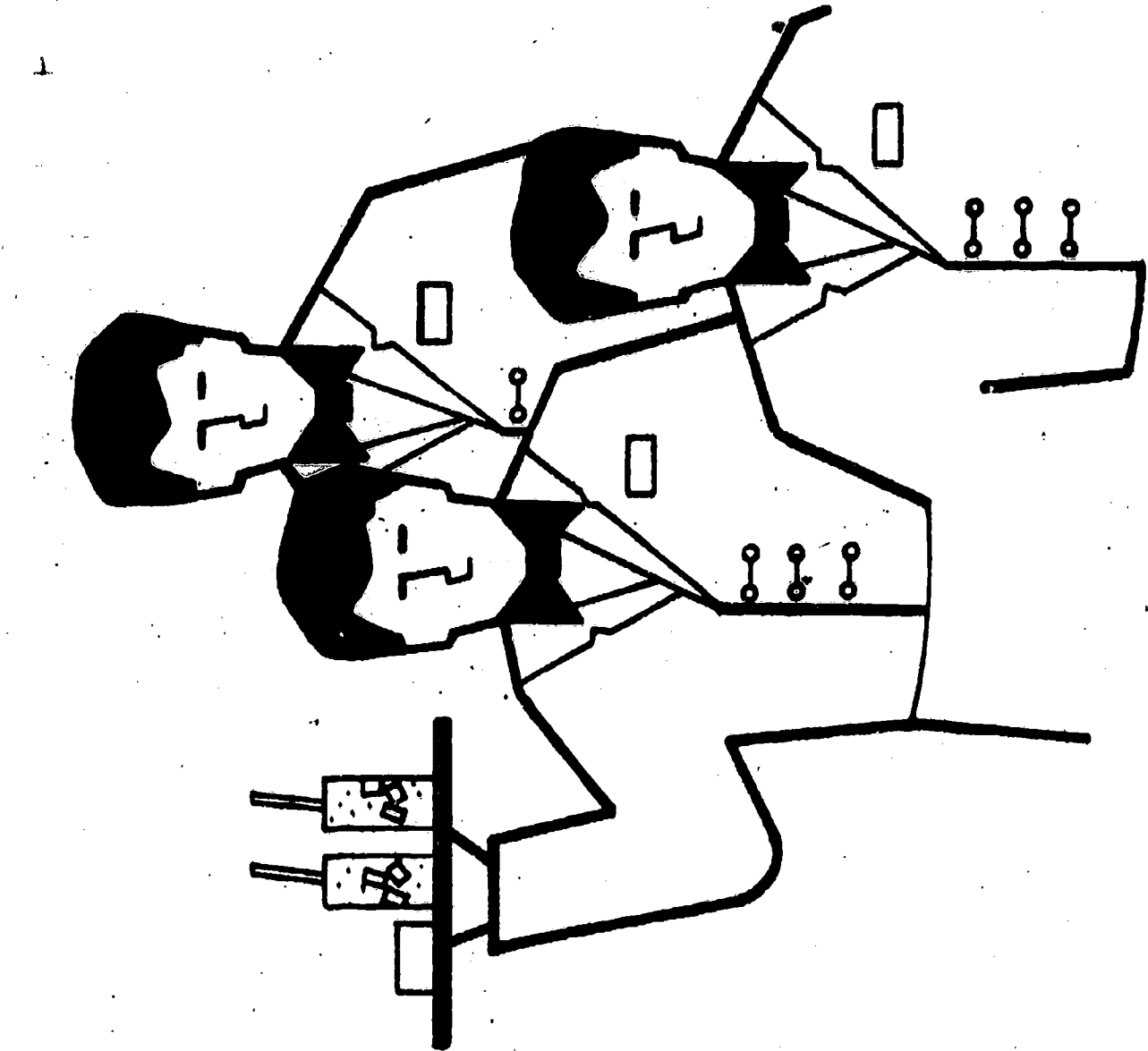

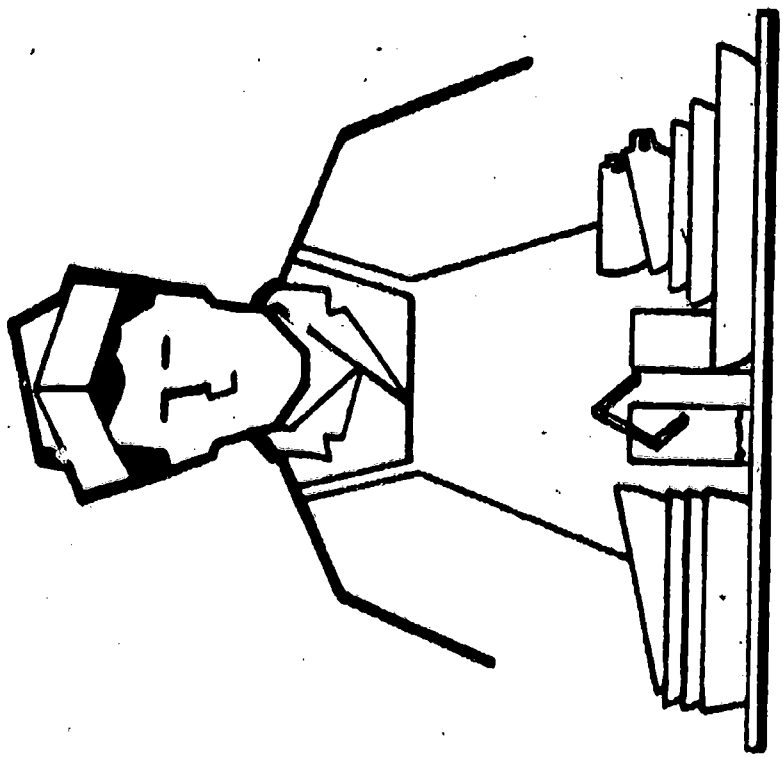
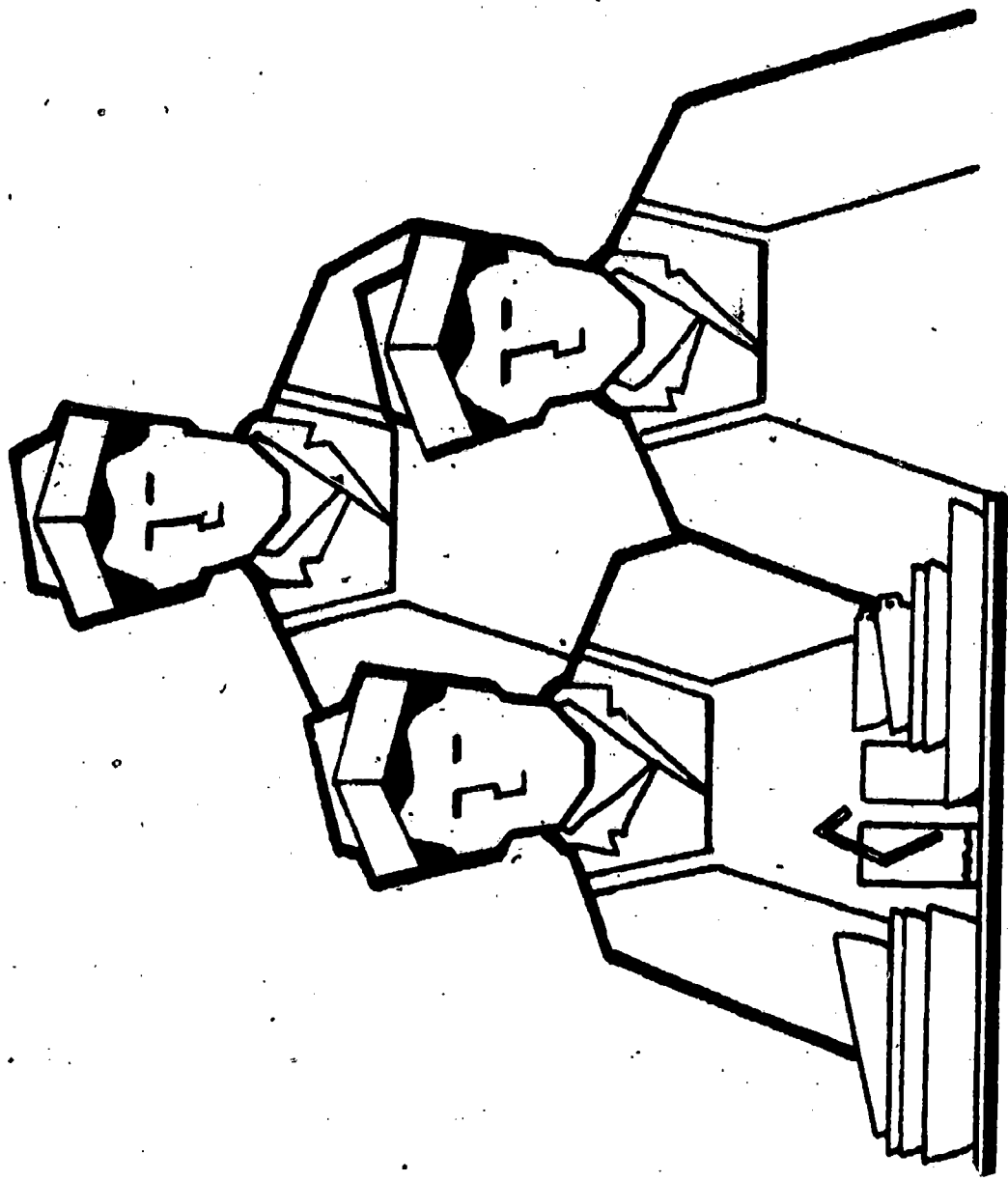

U

pen  
book  
chair

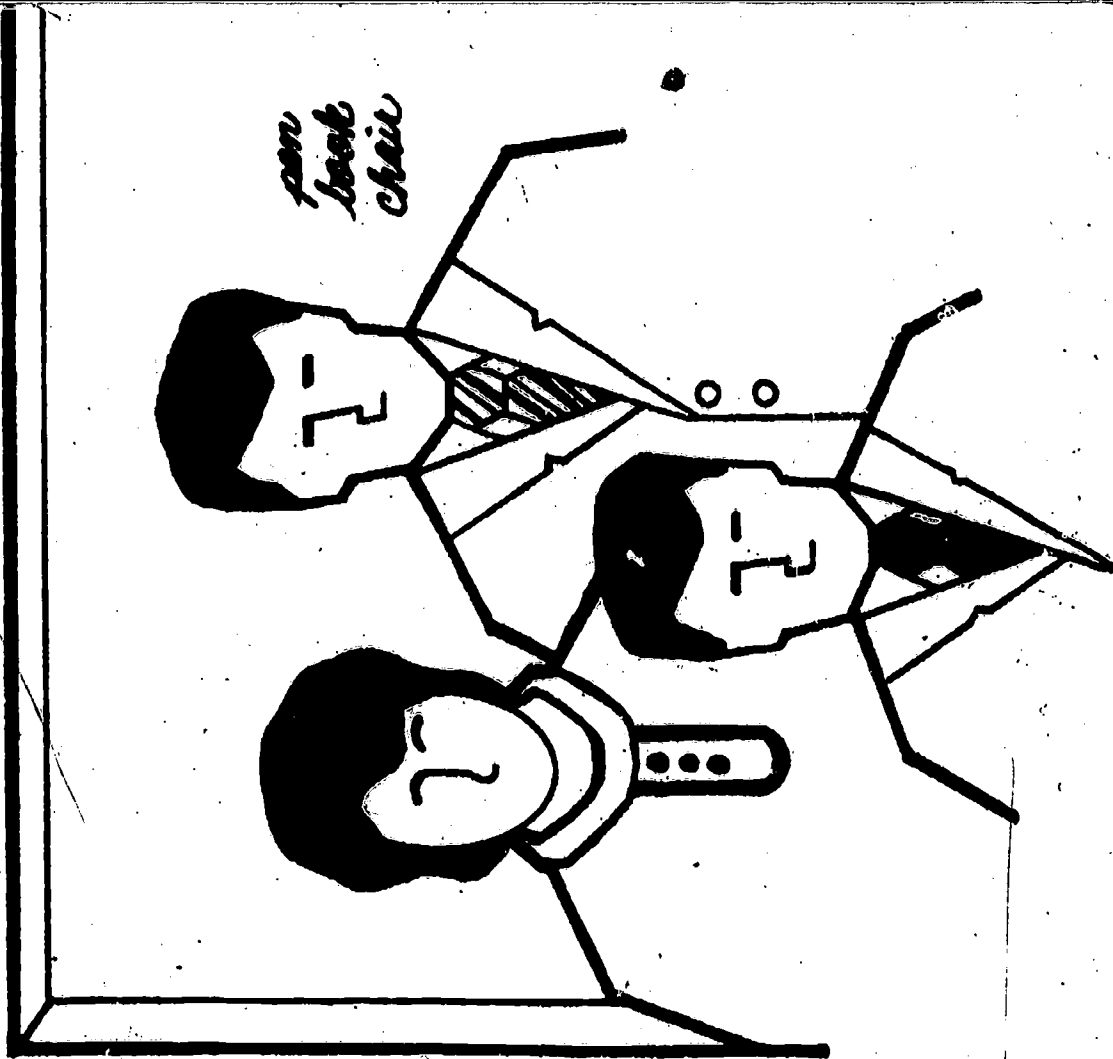

pen  
book  
chair

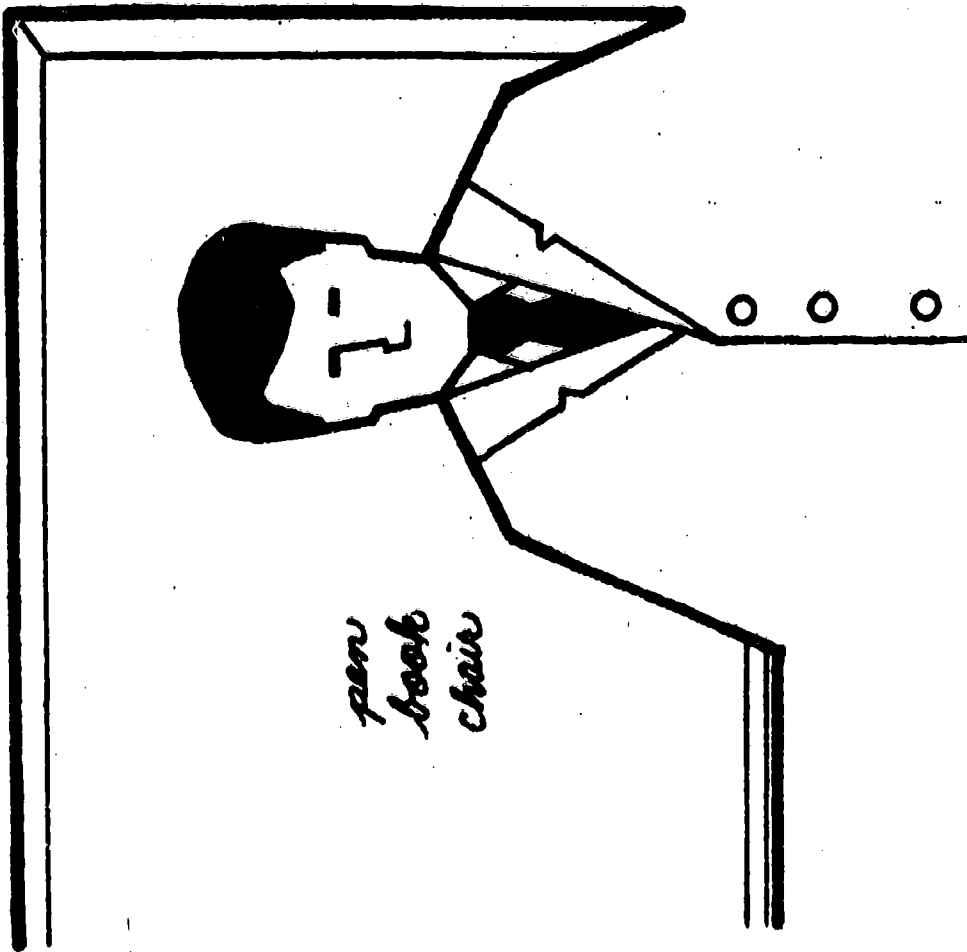



*pen*  
*book*  
*chair*



AP  
P33

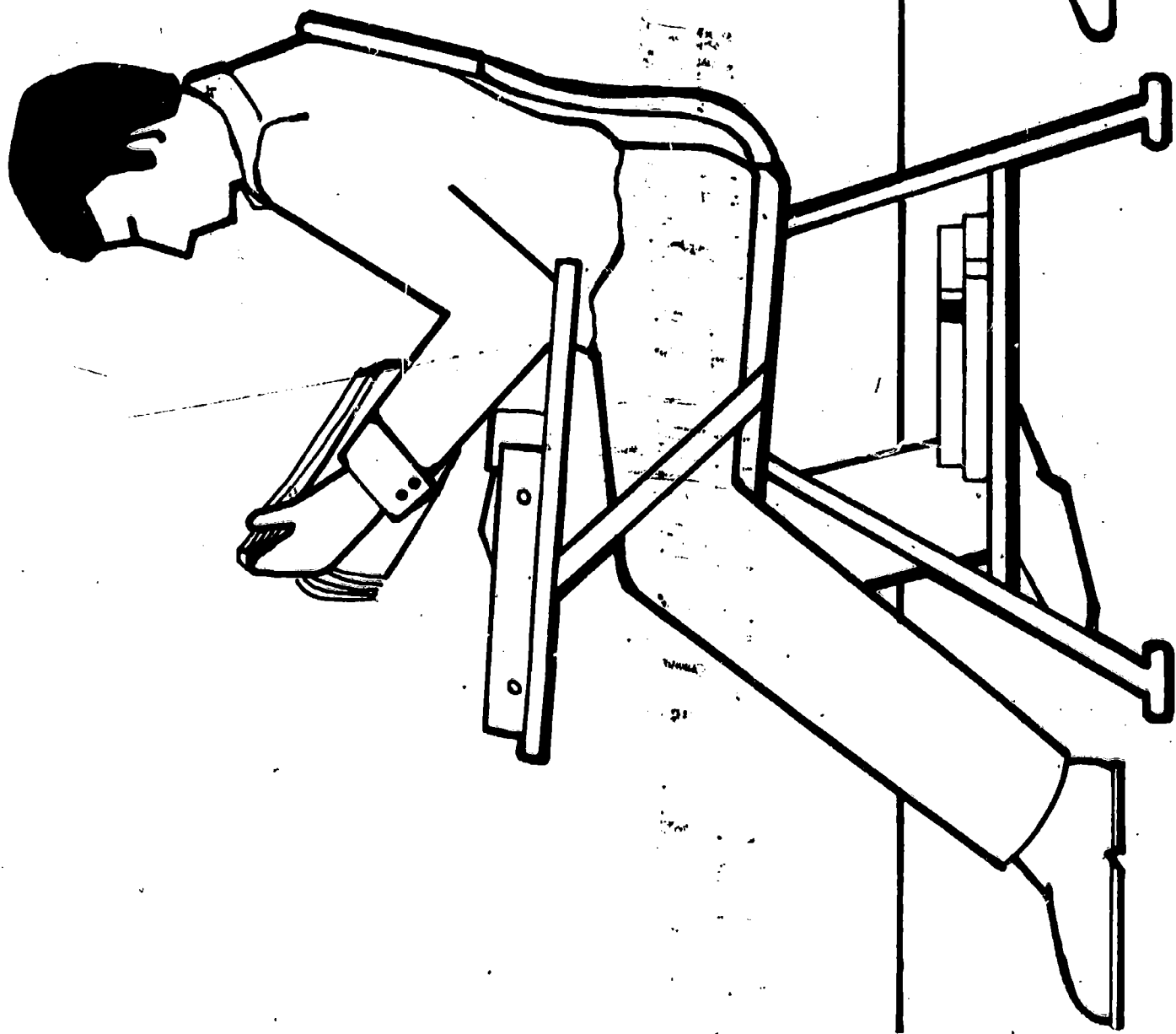

BEST COPY AVAILABLE

AP  
P34

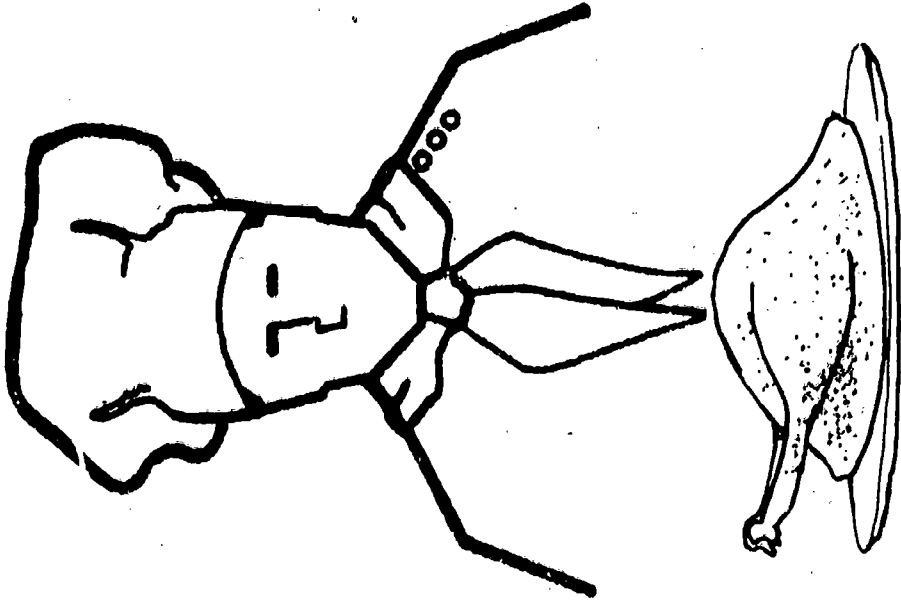
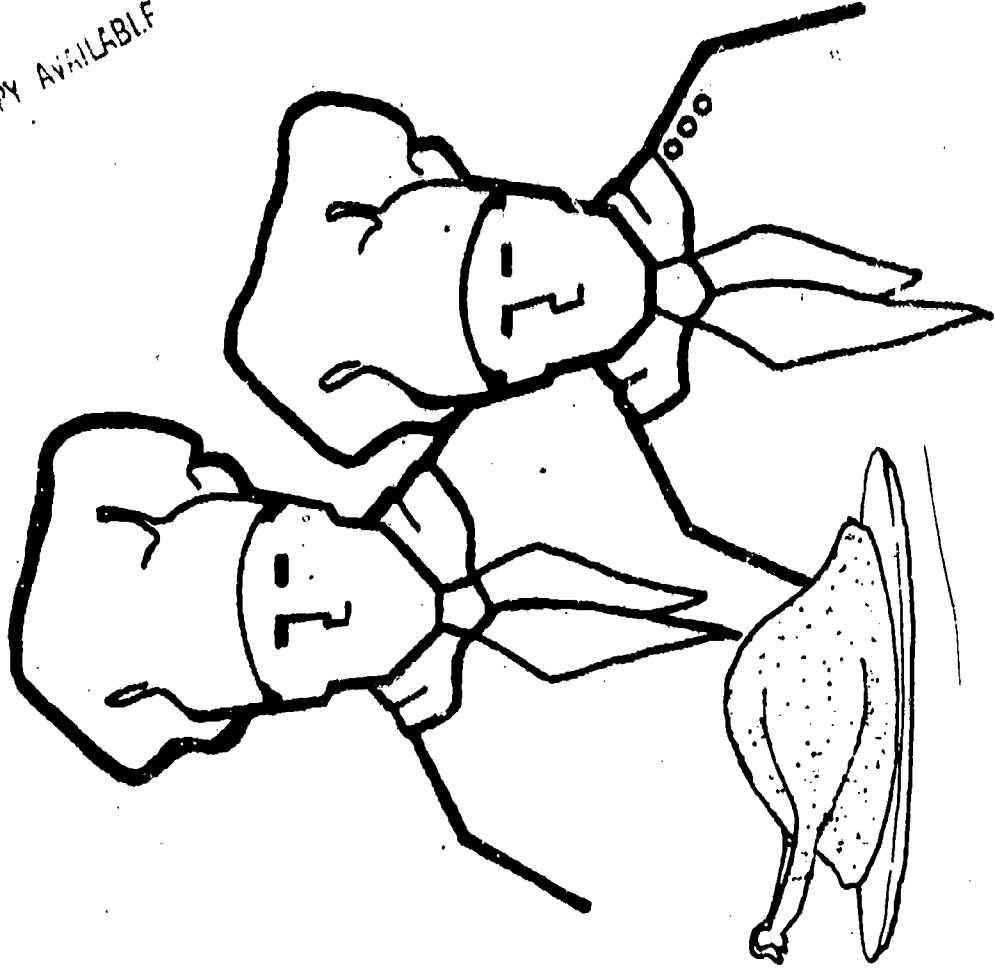

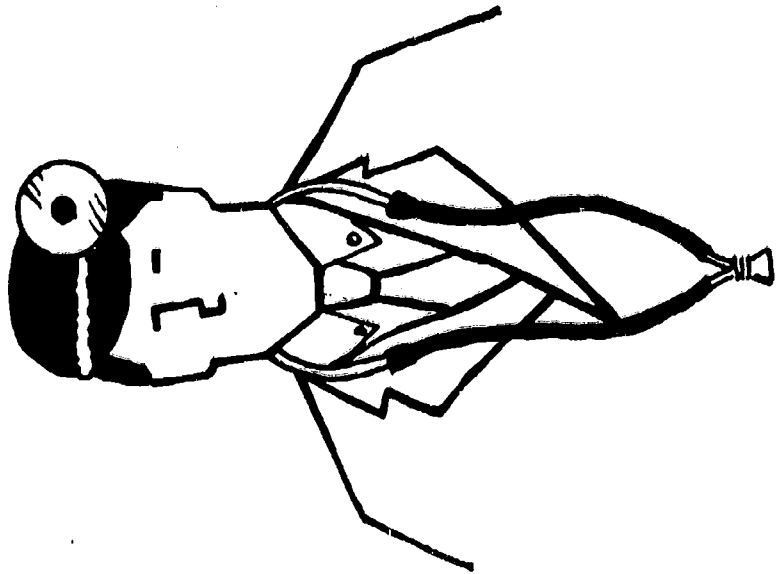
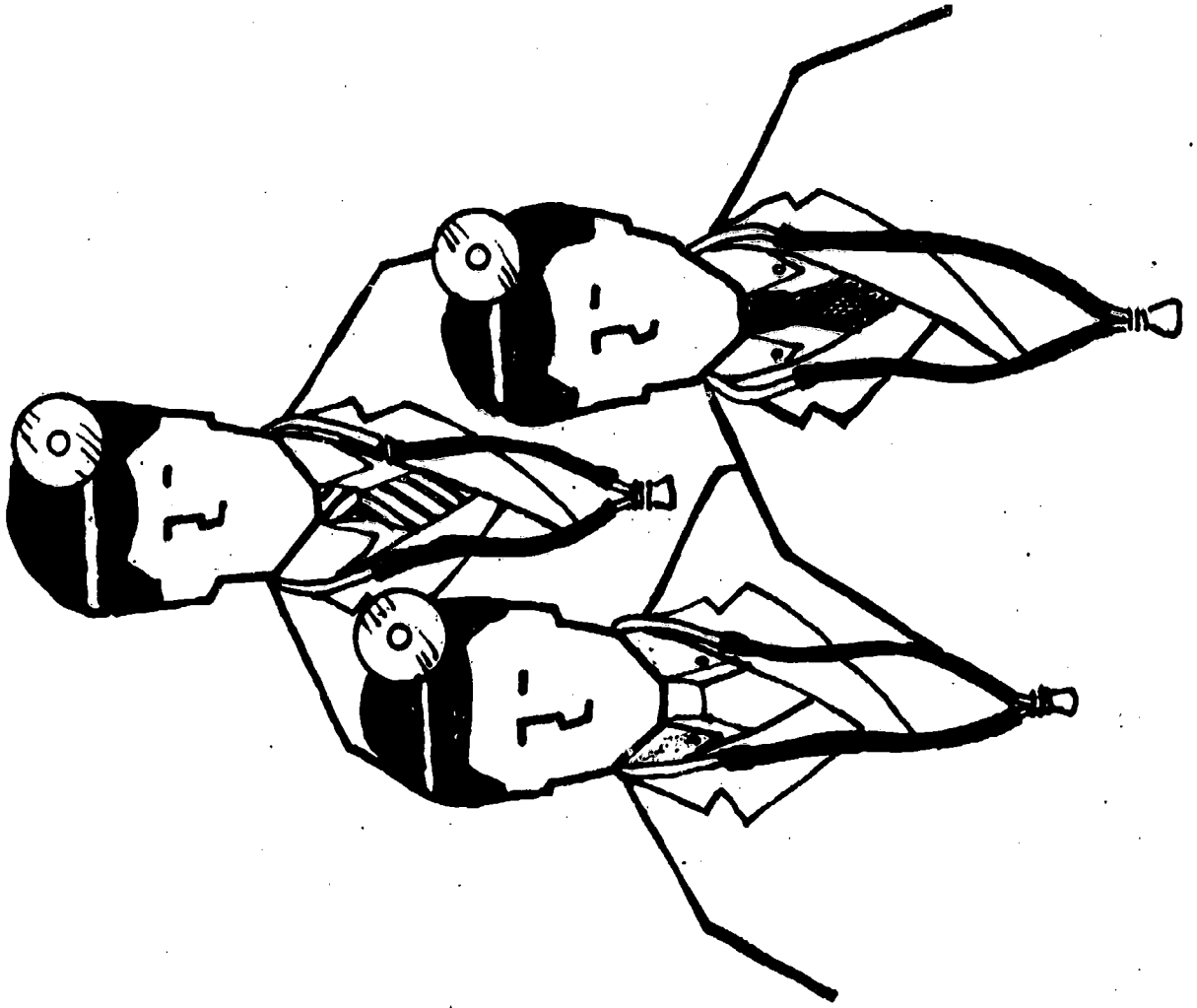

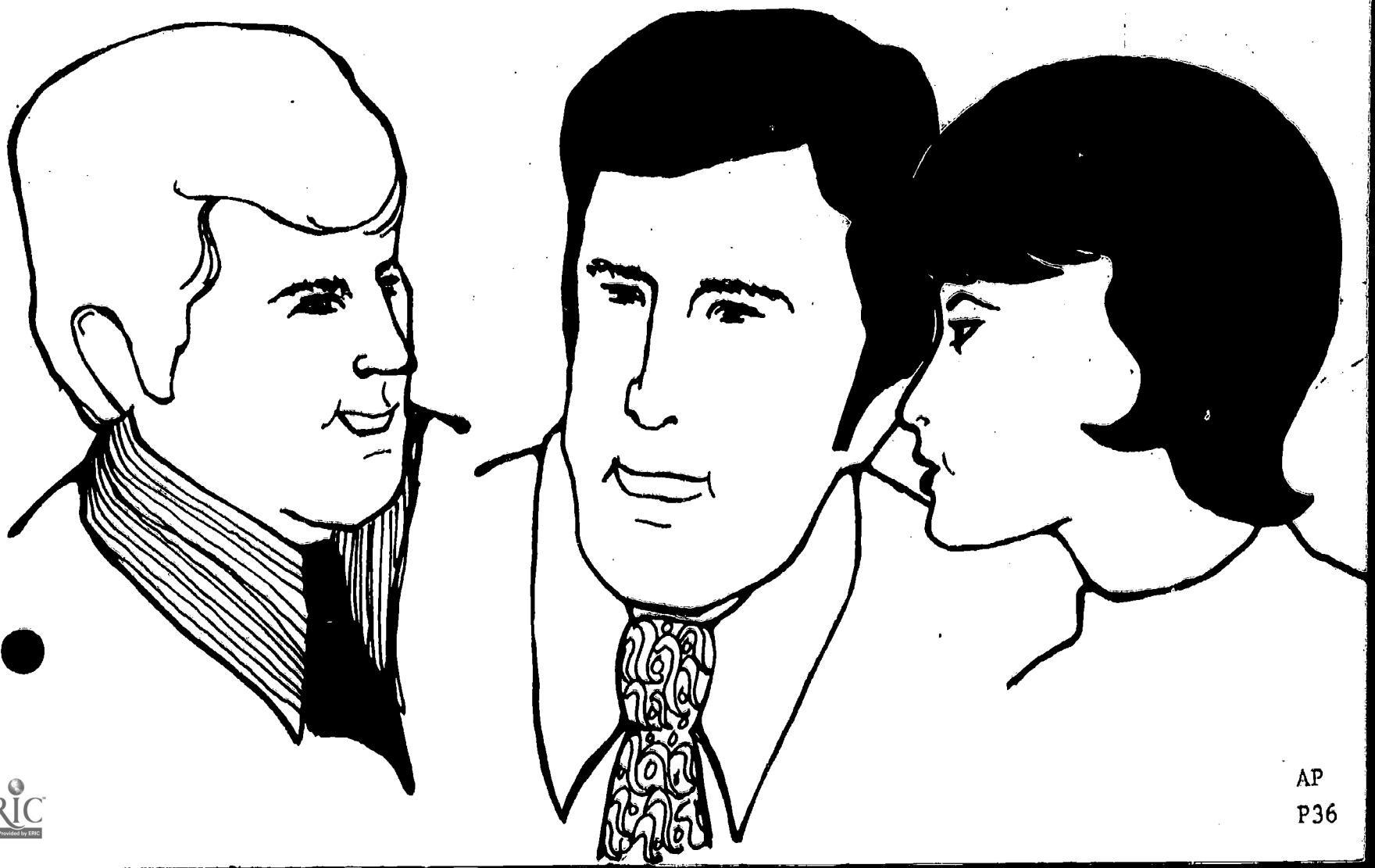
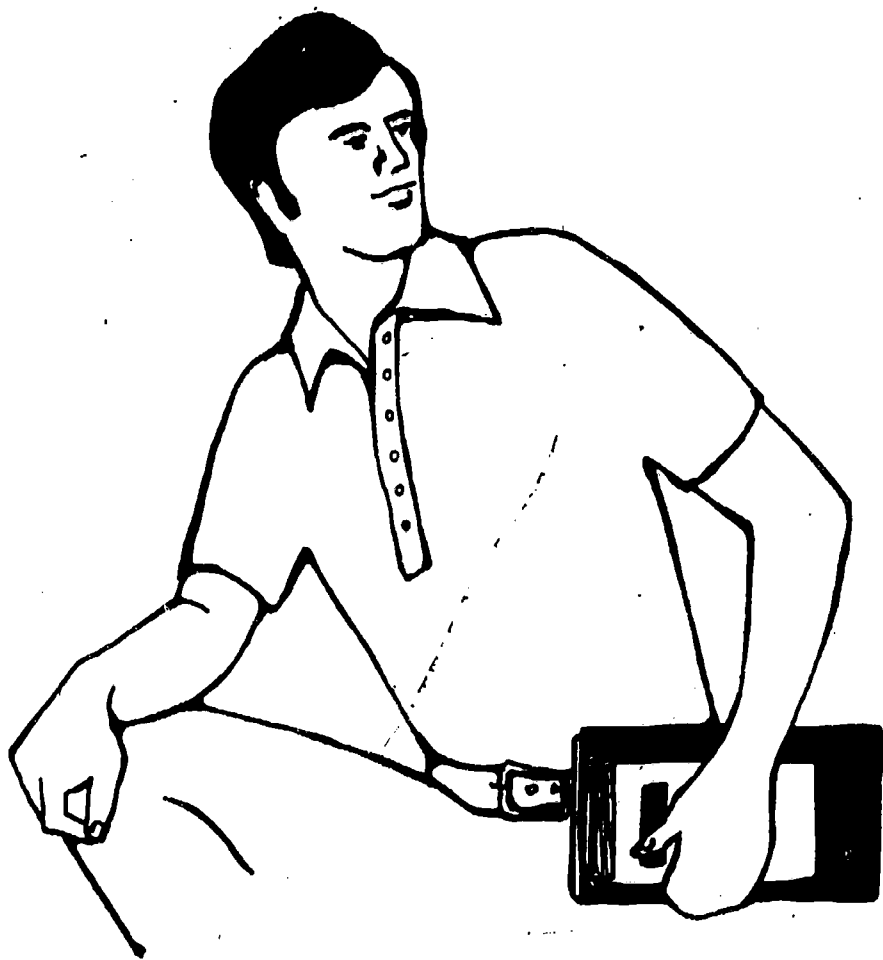

BEST COPY AVAILABLE

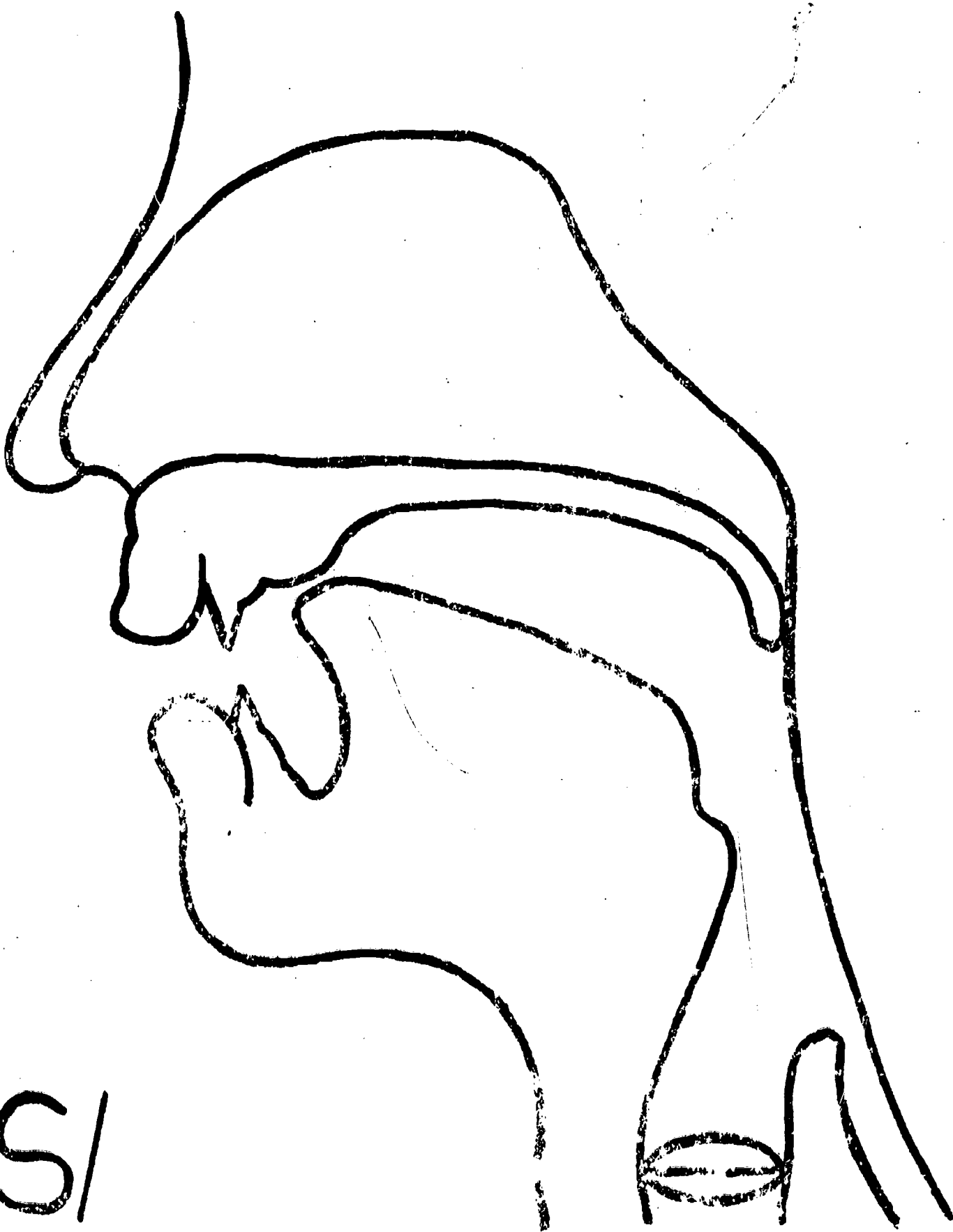

/S/

AP  
P37

BEST COPY AVAILABLE

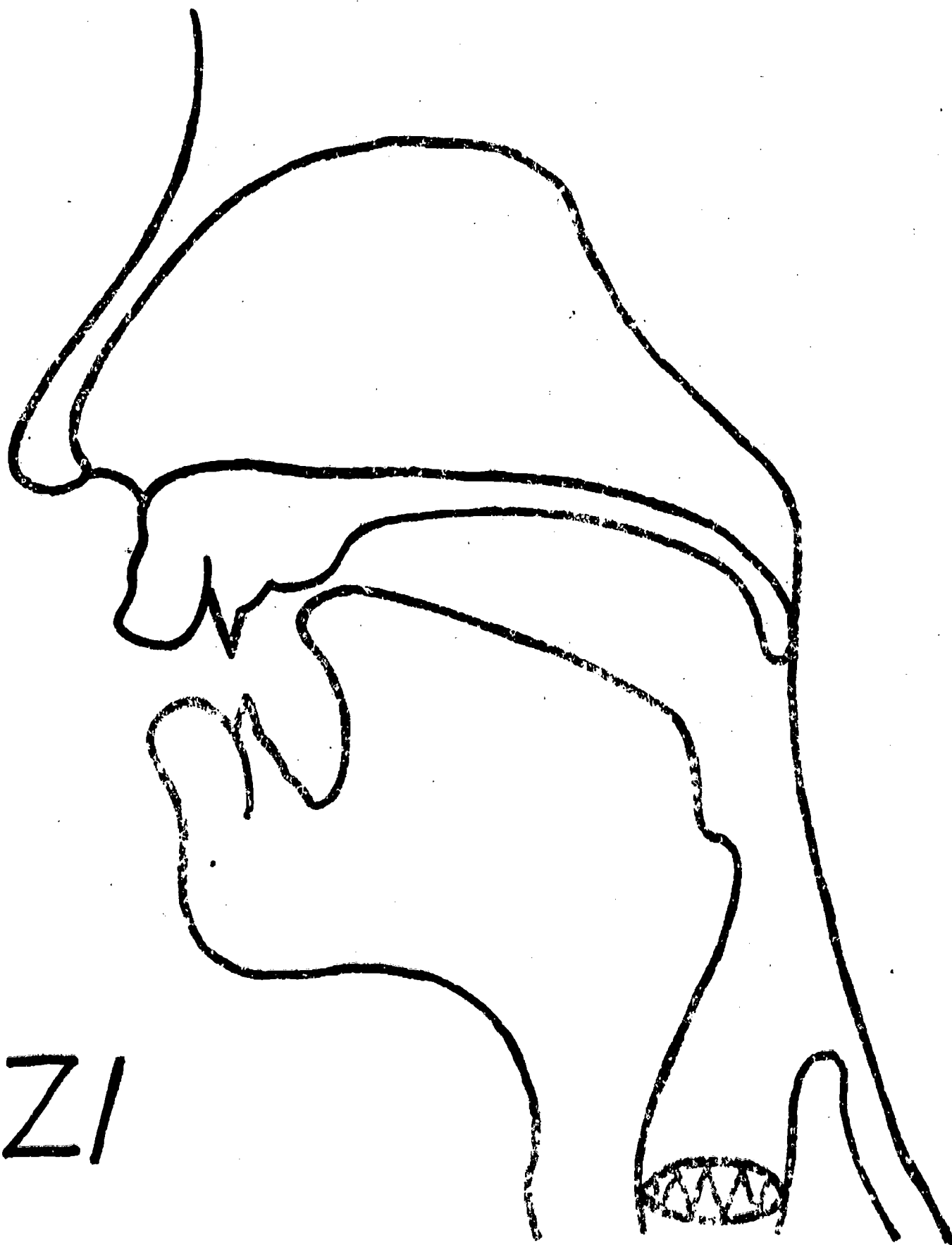

IZI

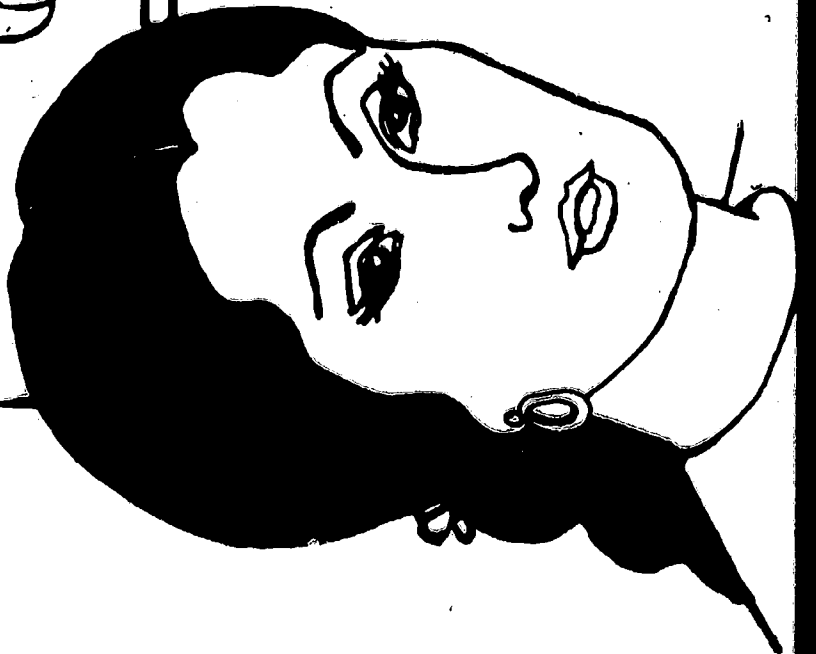

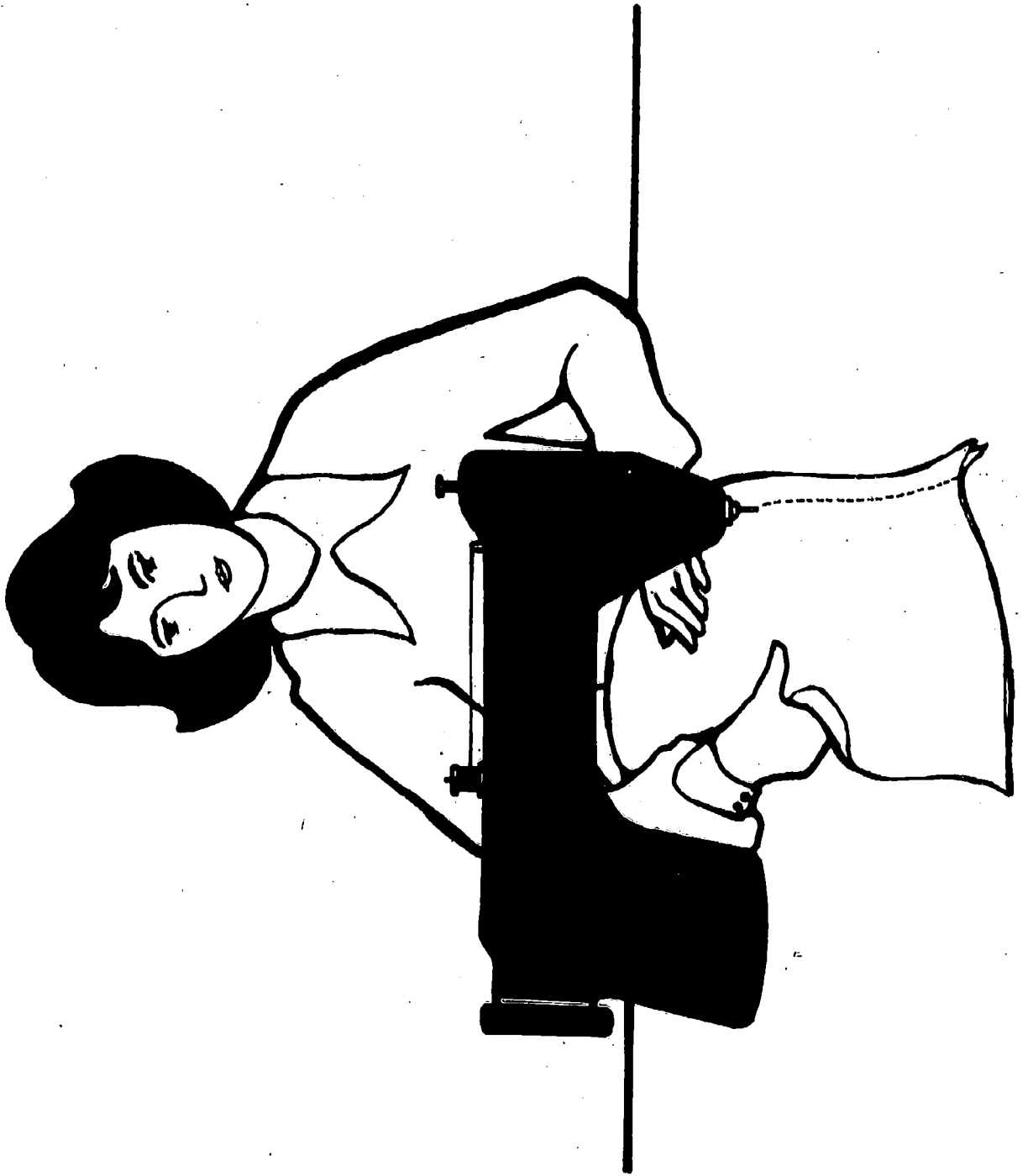



BEST COPY AVAILABLE

AP  
P41

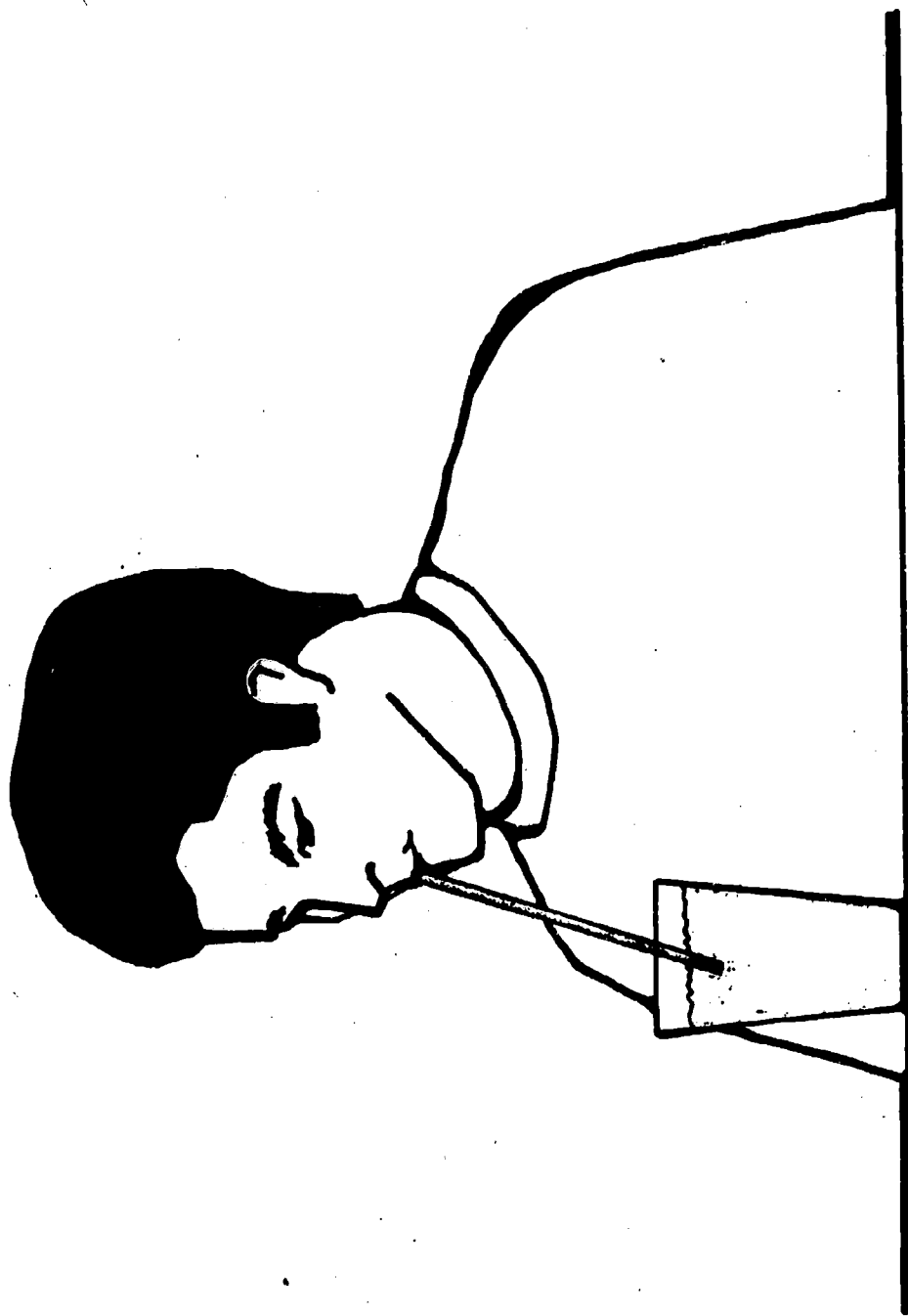

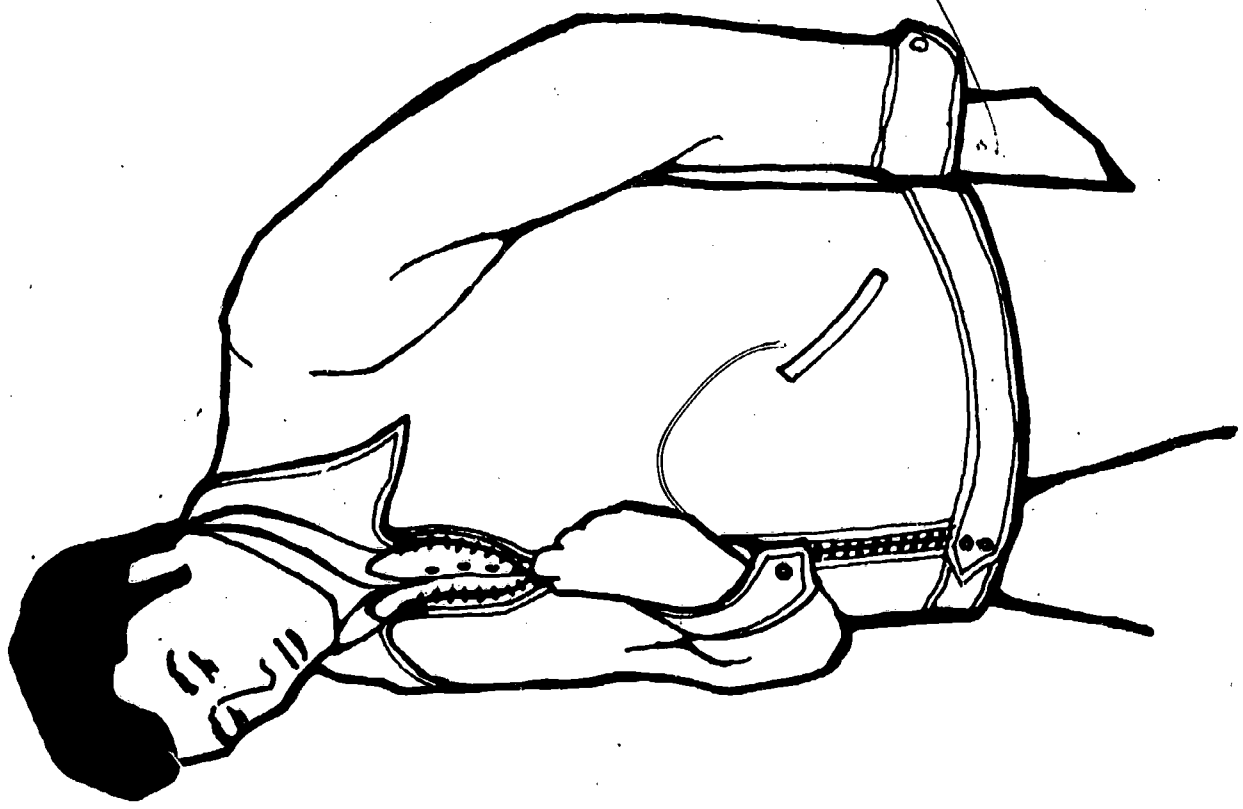

# SEPTEMBER

SUN.	MON.	TUES.	WED.	THUR.	FRI.	SAT.
	1	2	3	4	5	6
7	8	9	10	11		13
14	15	16	17	18		20
21	22	23	24	25		27
	29	30				

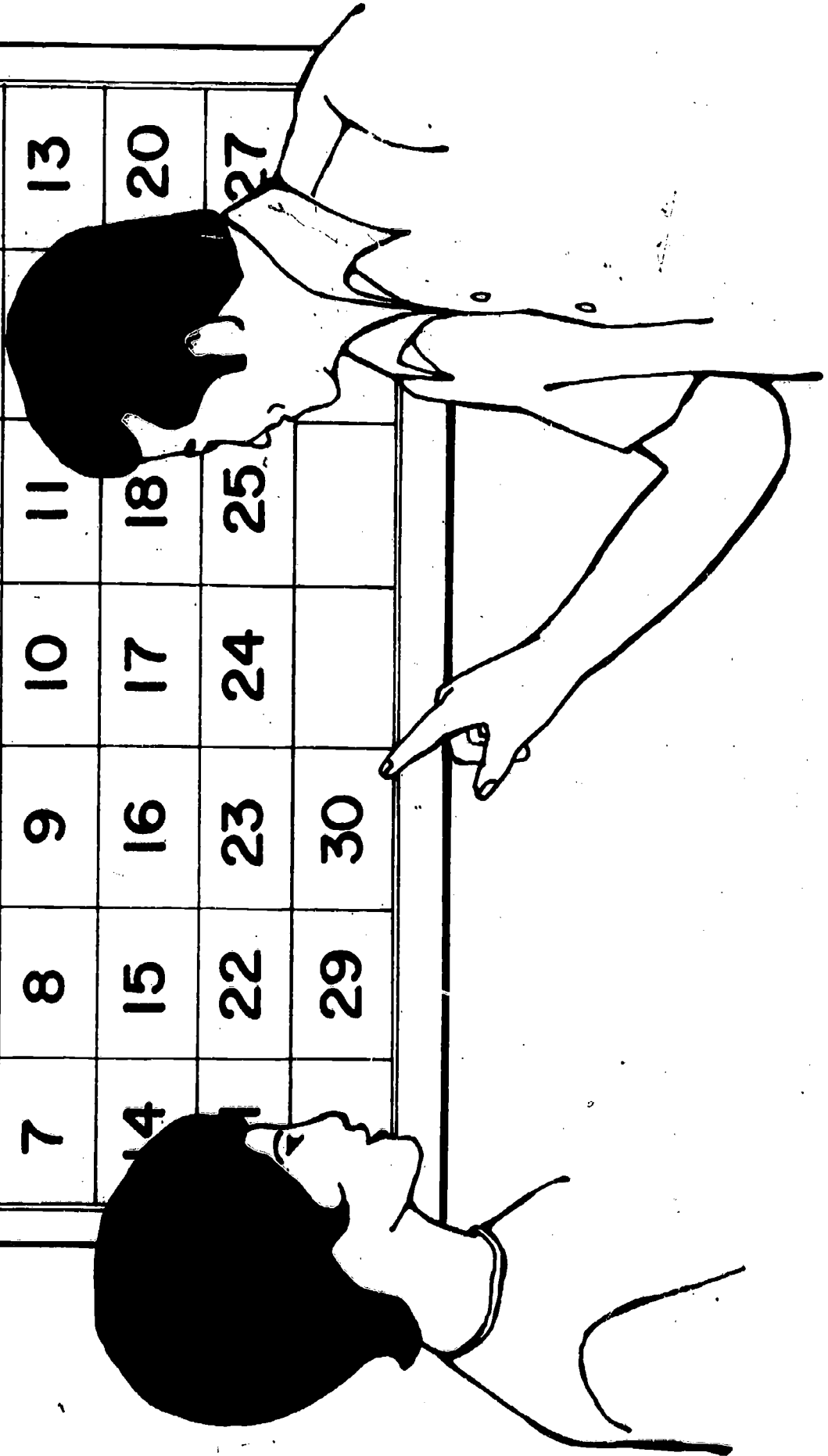



1¢

AP  
P44

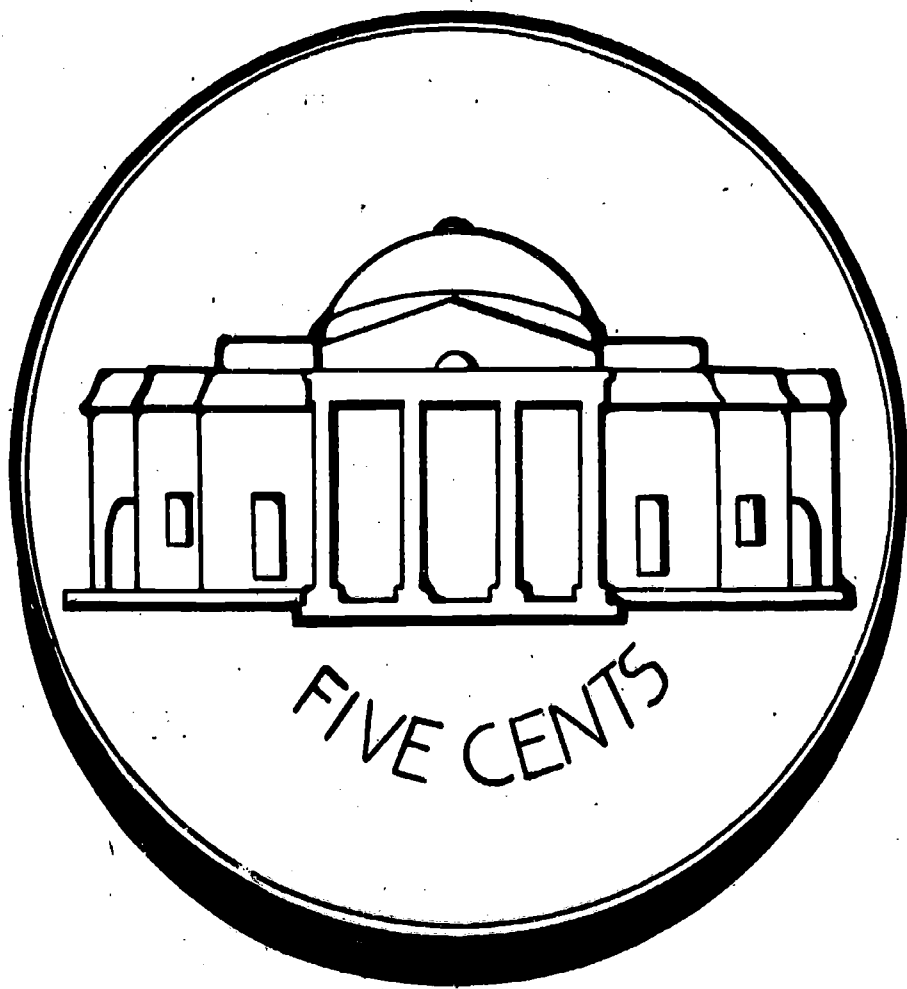

5¢

AP  
P45



10¢

AP  
P46

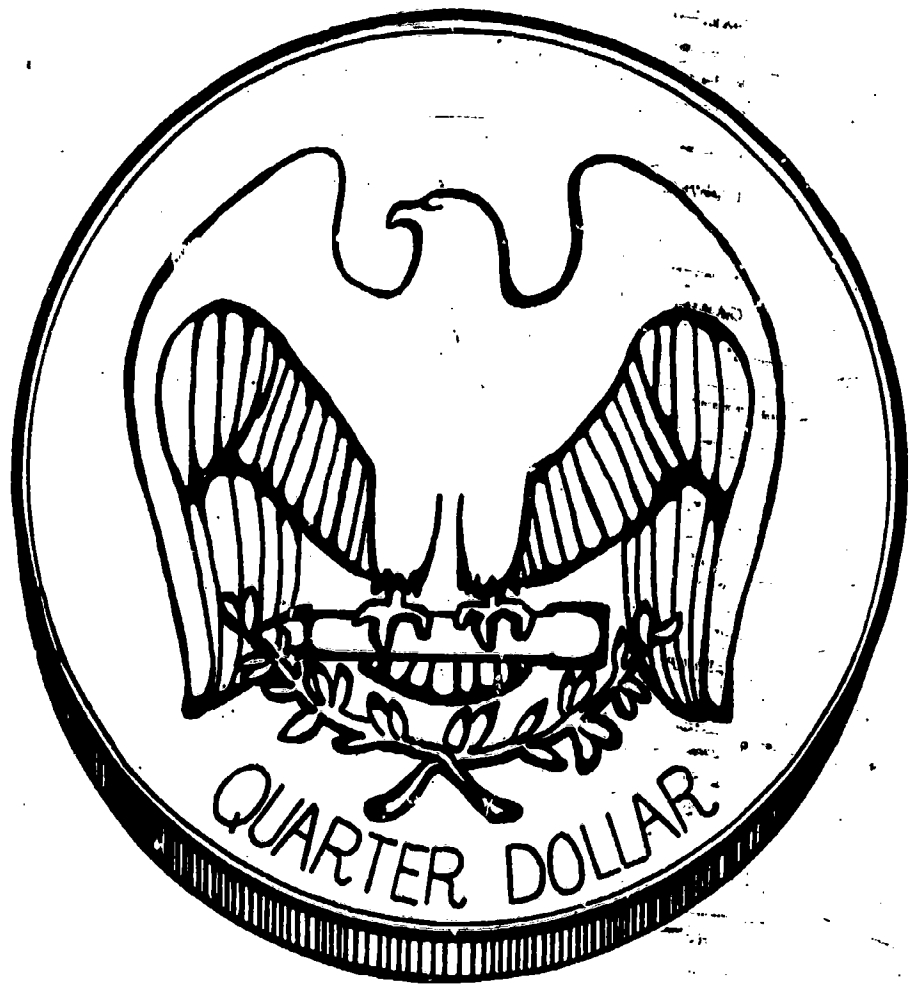

25 ¢



50¢

AP  
P48



REF 500

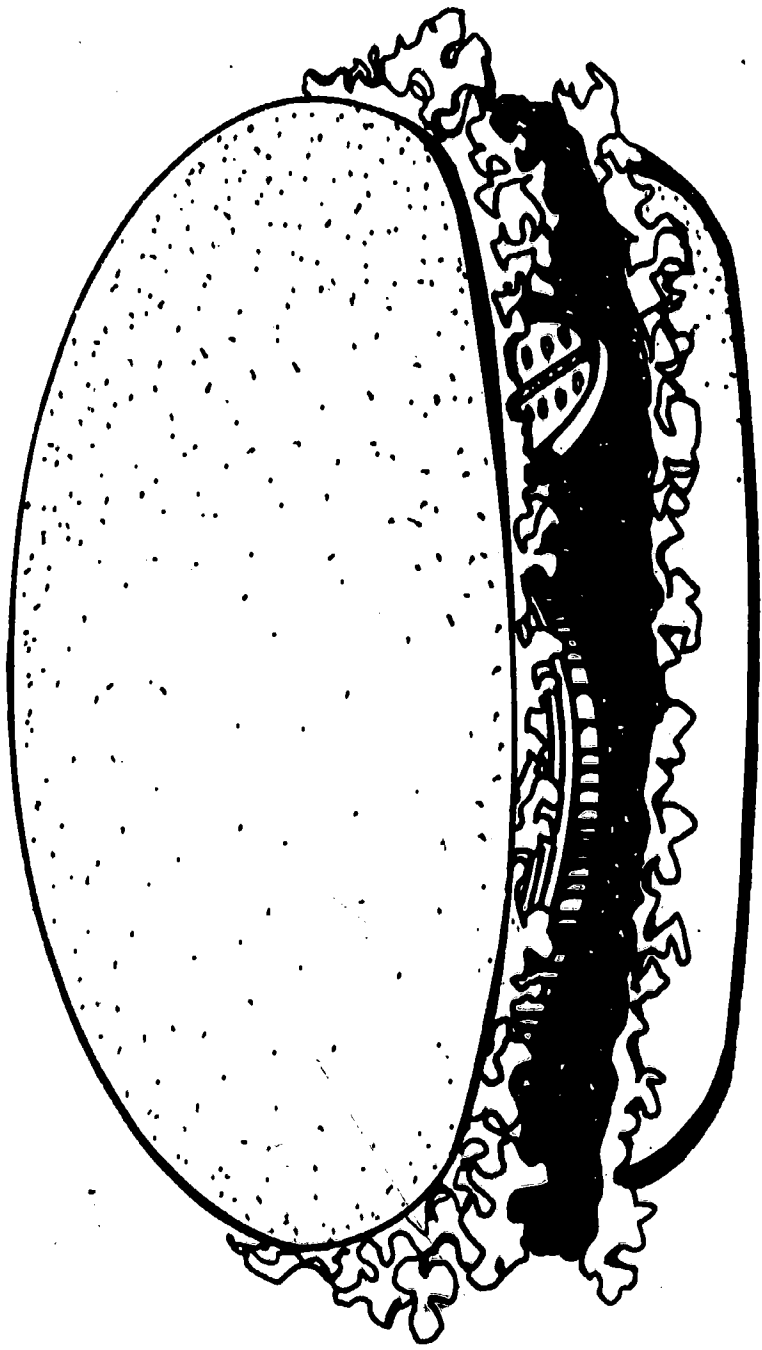

50¢

AP  
P49

BEST COPY AVAILABLE

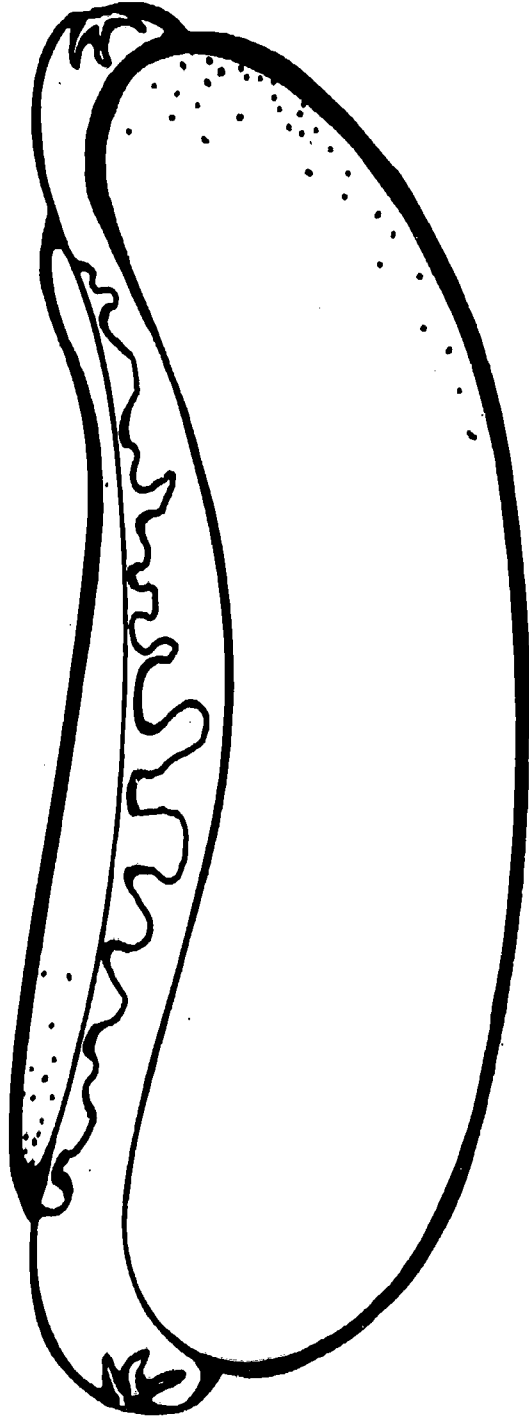

300

AP  
P50



AP  
P51

15¢

BEST COPY AVAILABLE

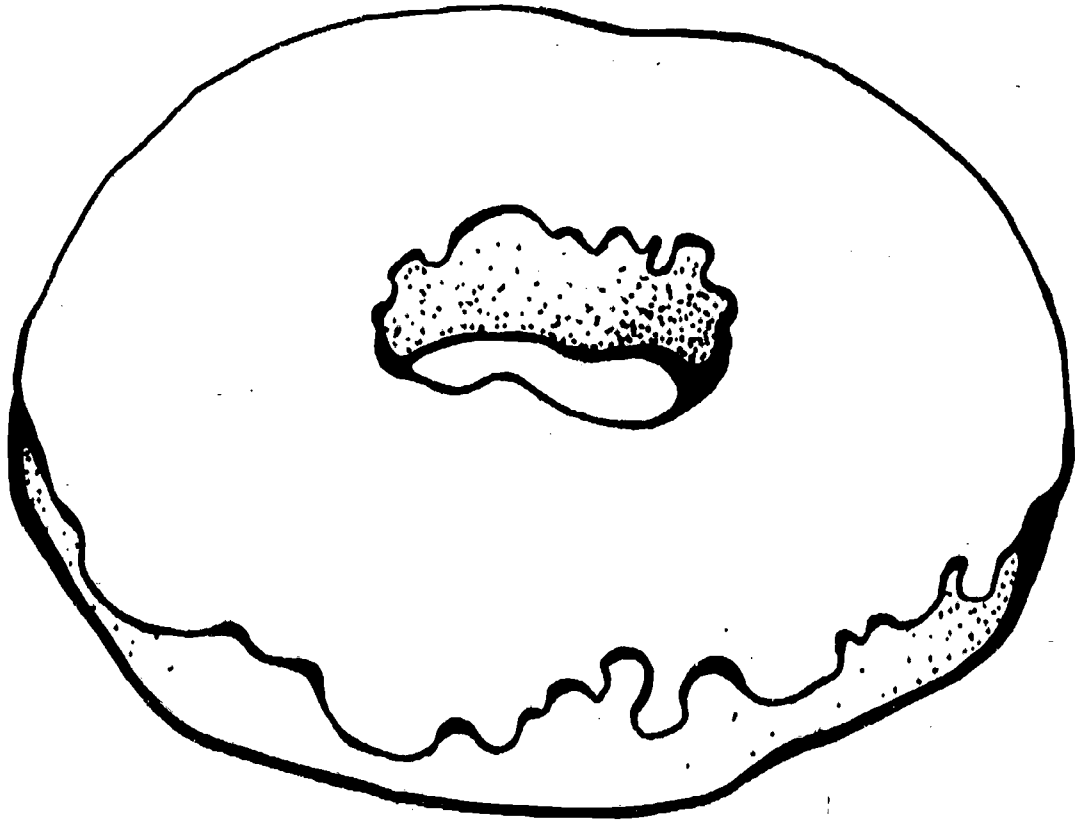

AP  
P52

15¢

BEST COPY AVAILABLE

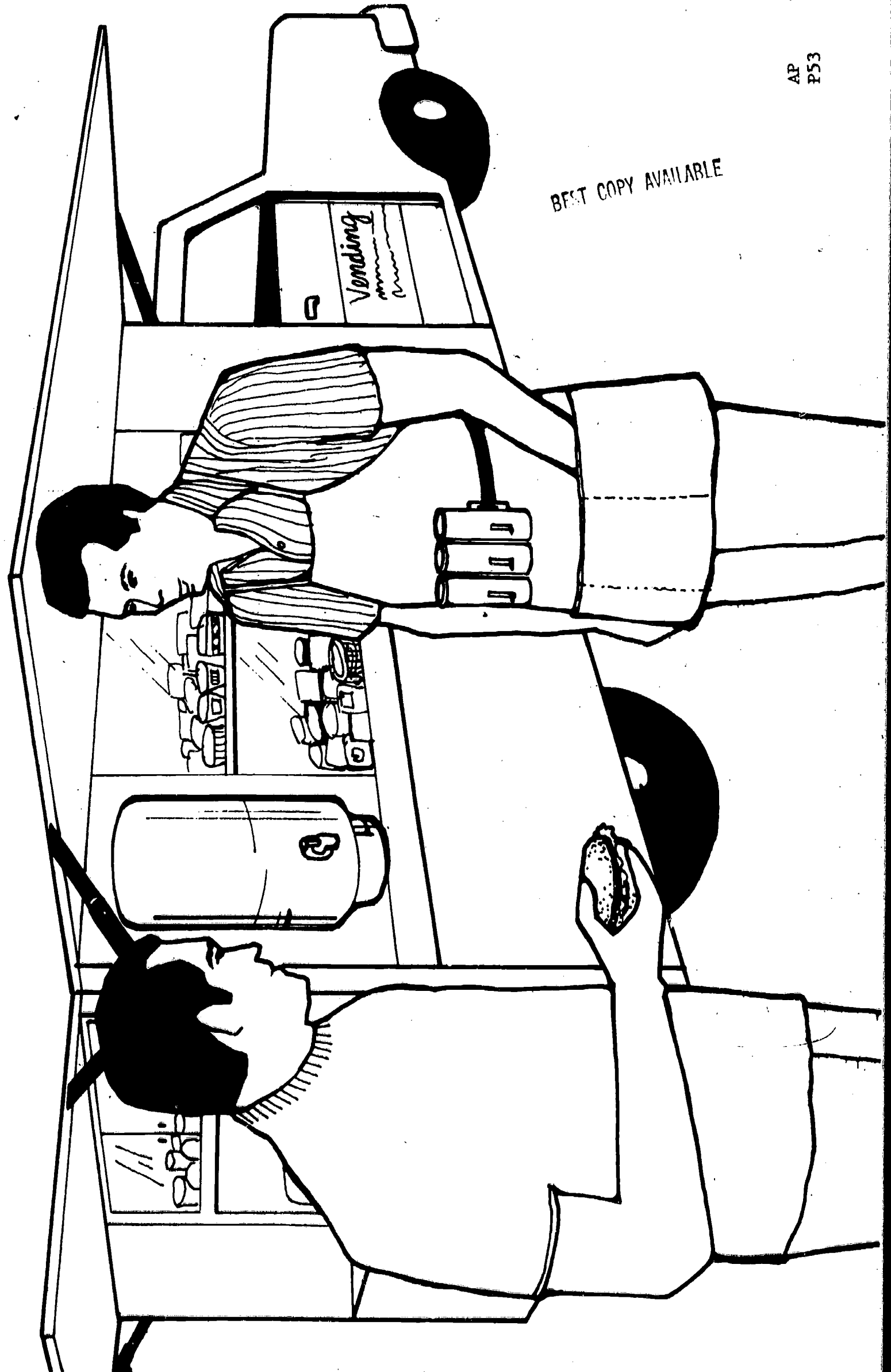

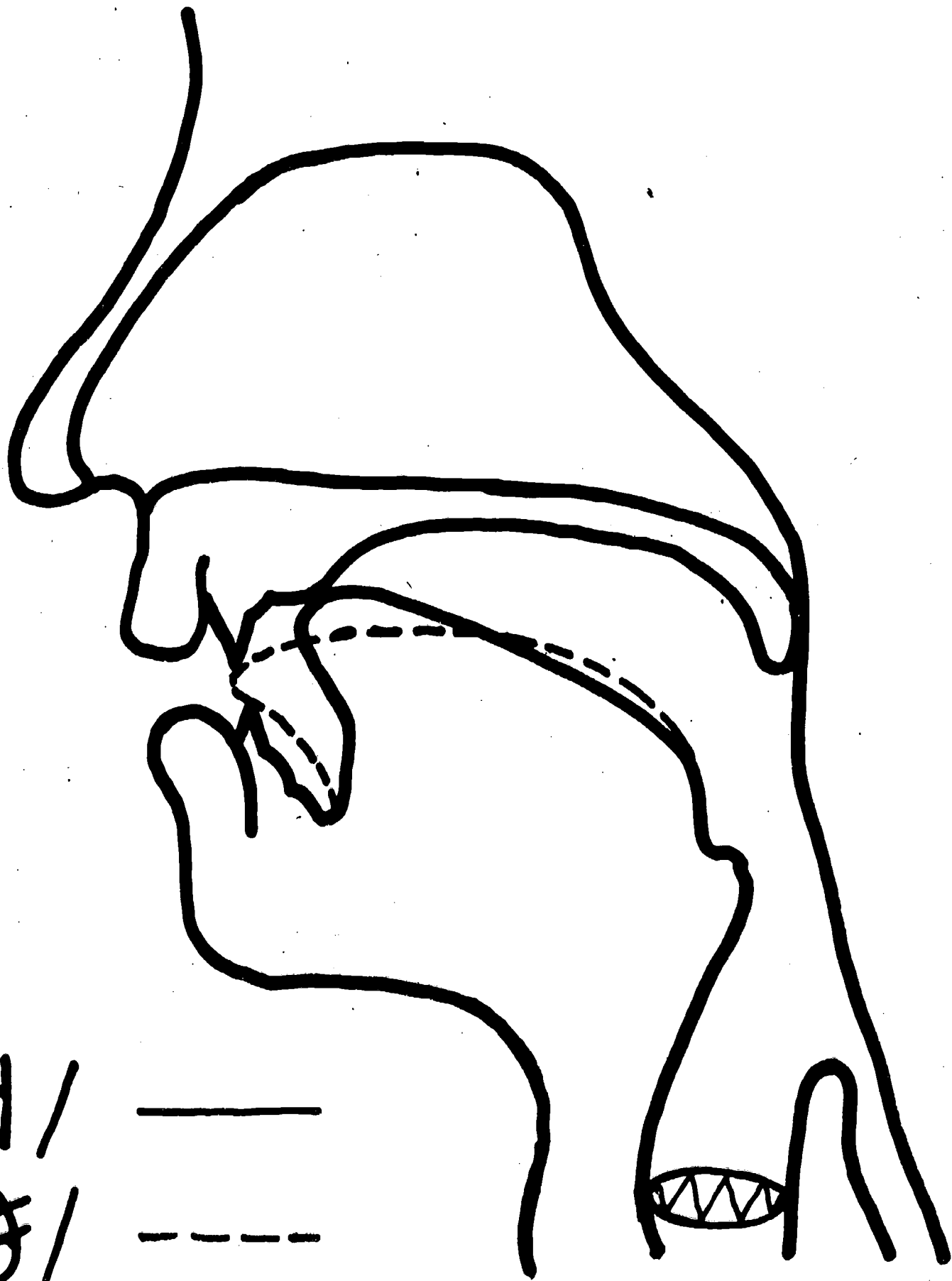

/d/

—

/ð/

- - -

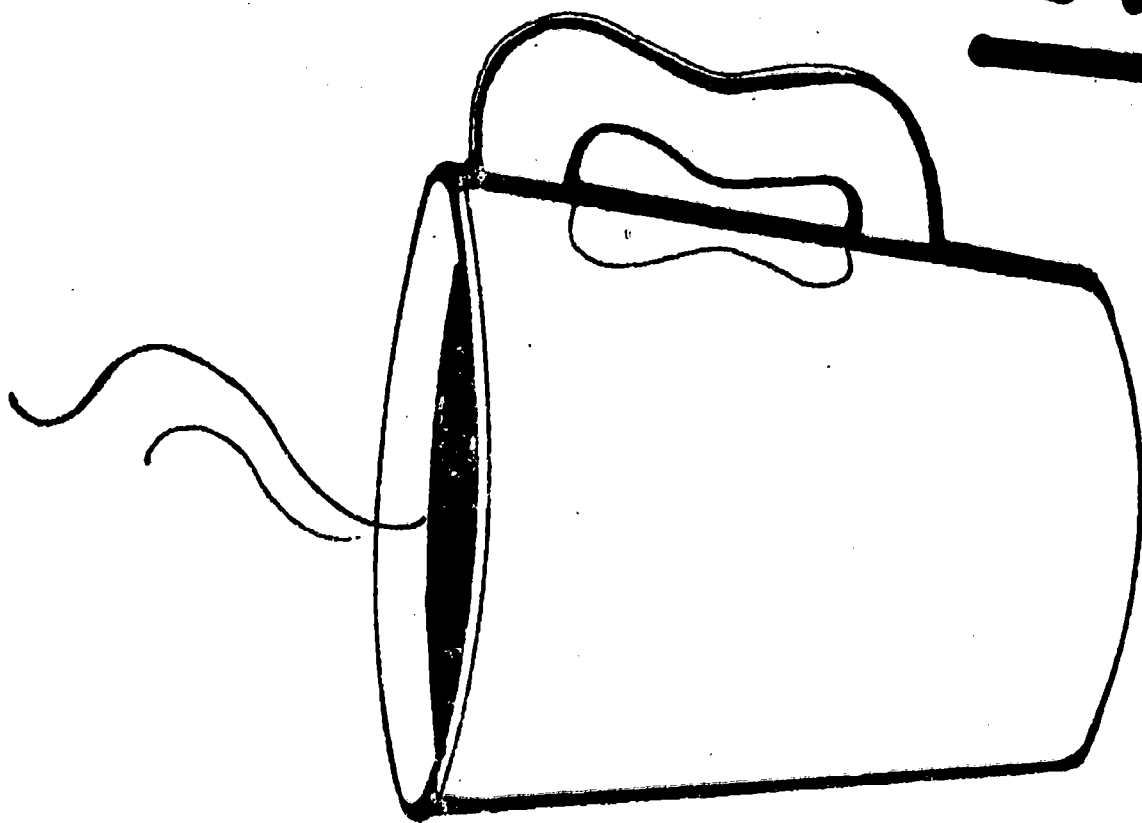
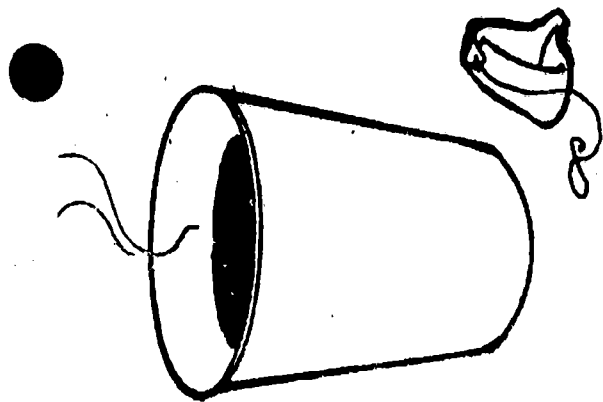

15¢

BEST COPY AVAILABLE





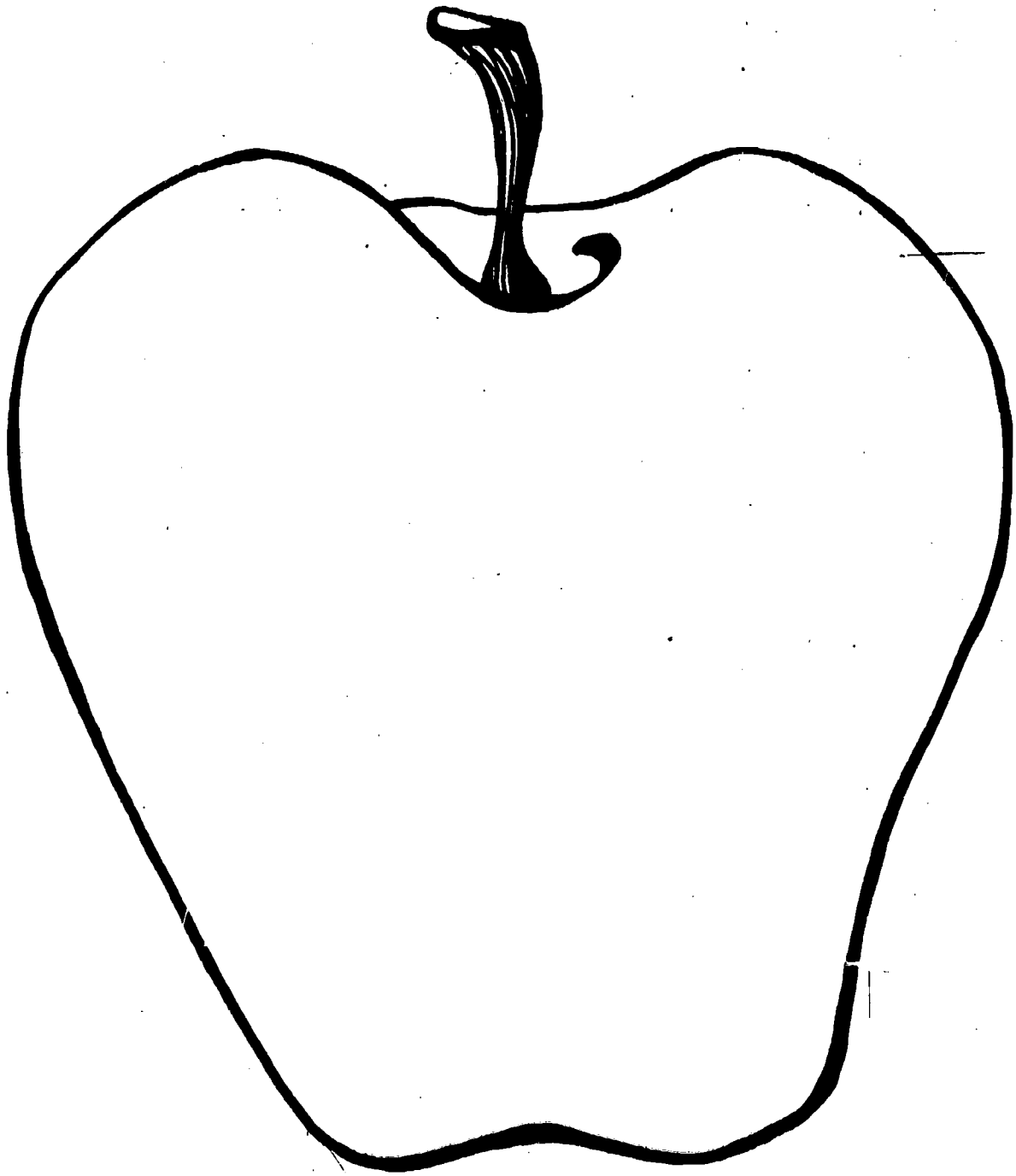

20¢

AP  
P57

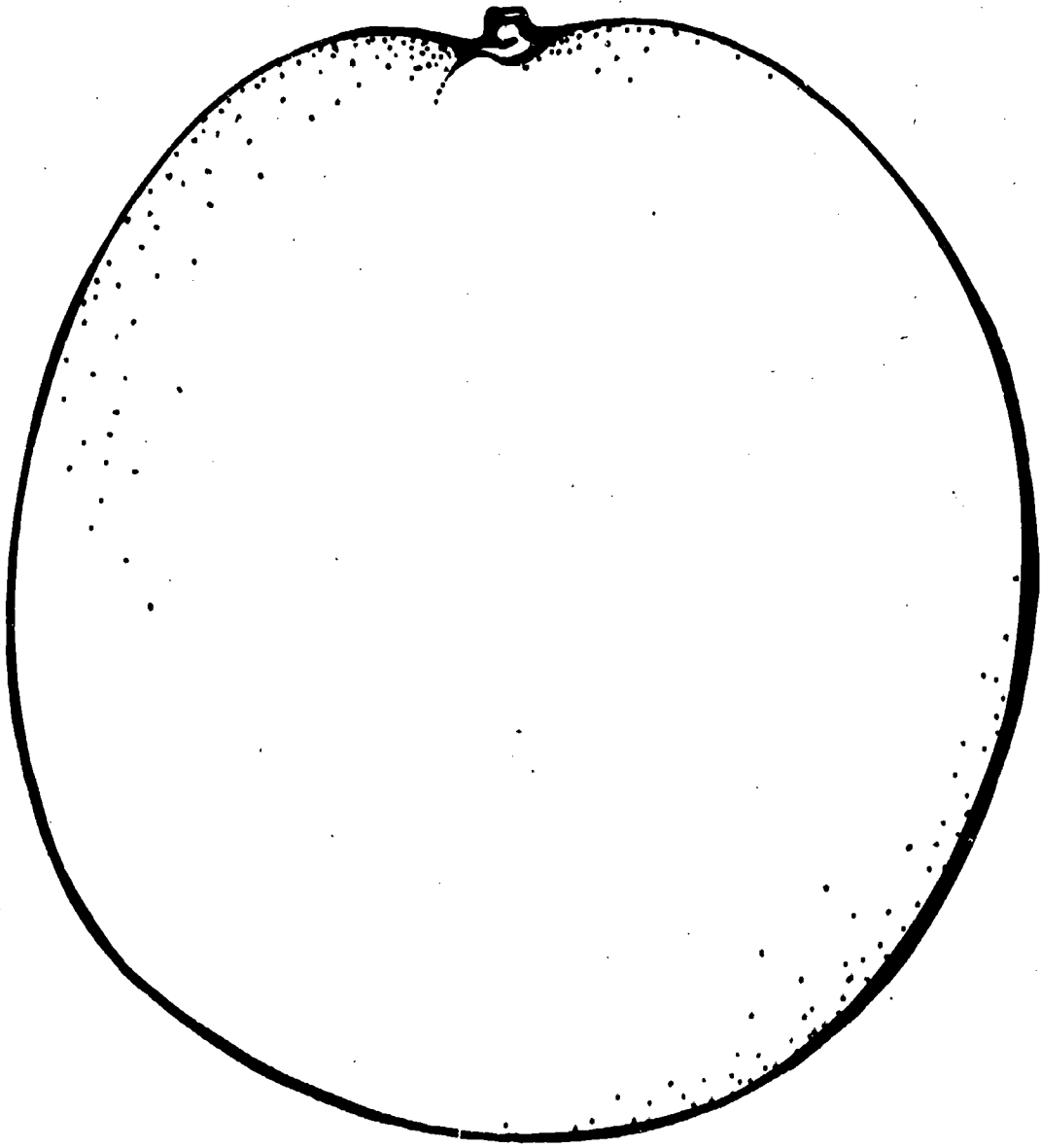

20¢

AP  
P58

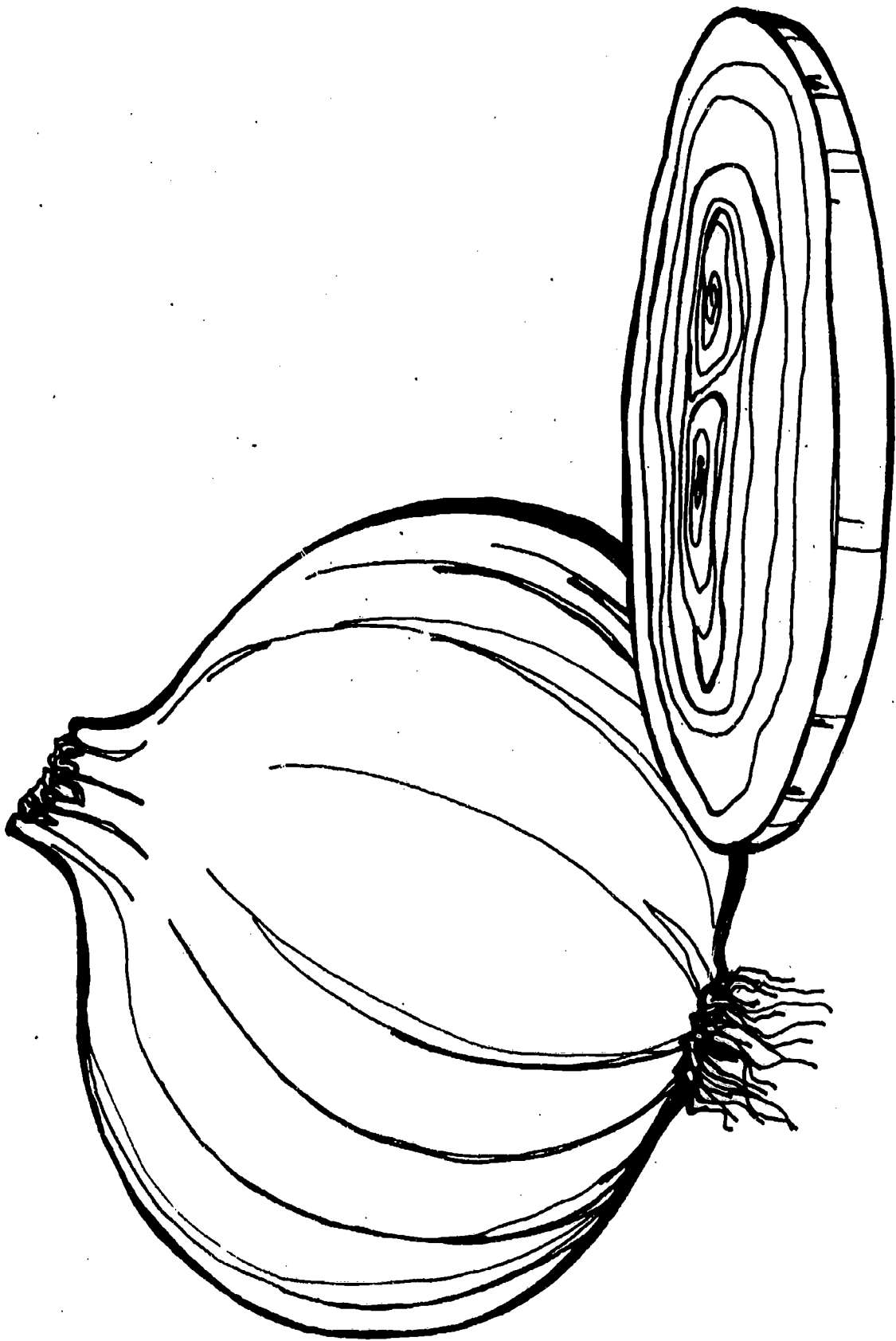

REST COPY AVAILABLE

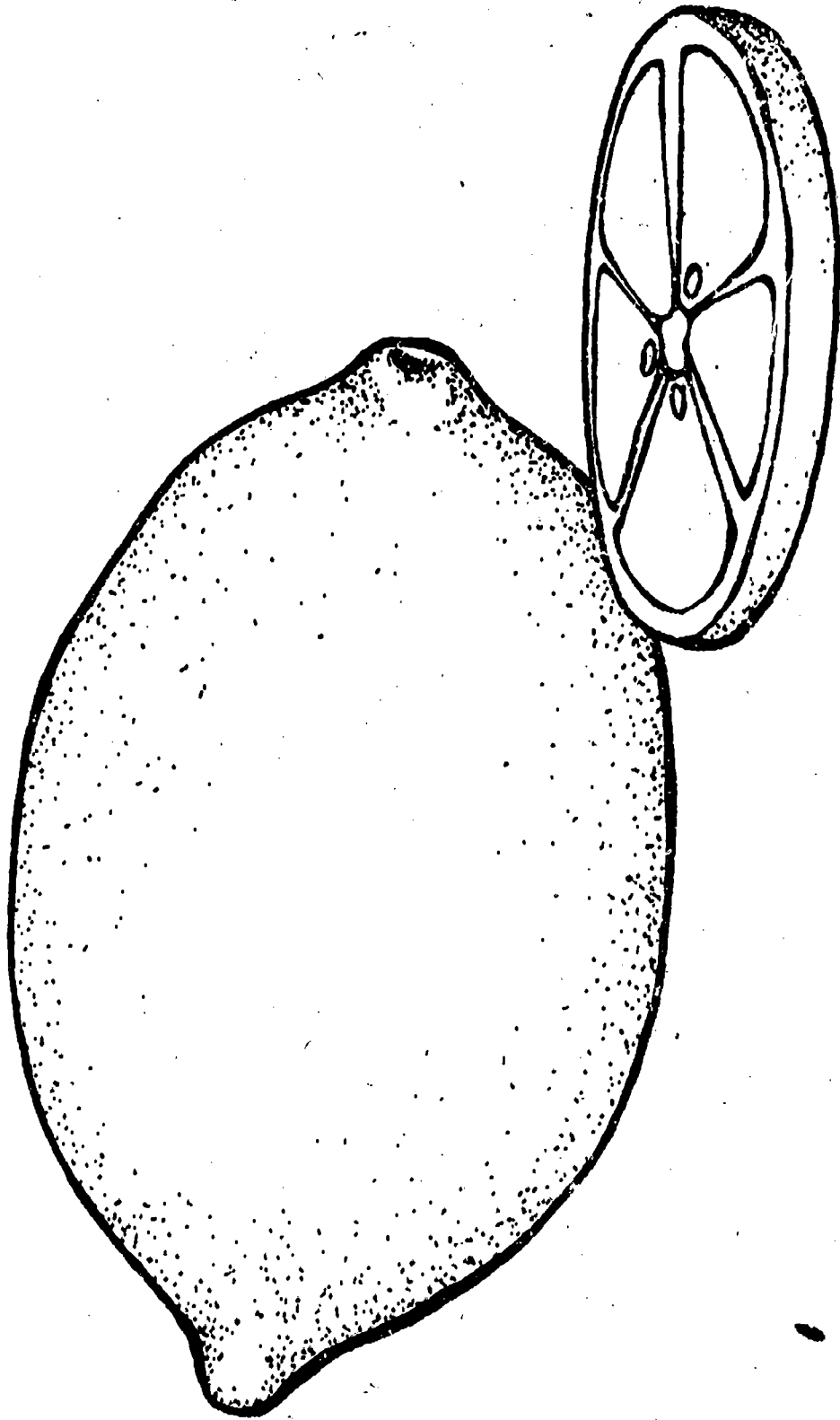

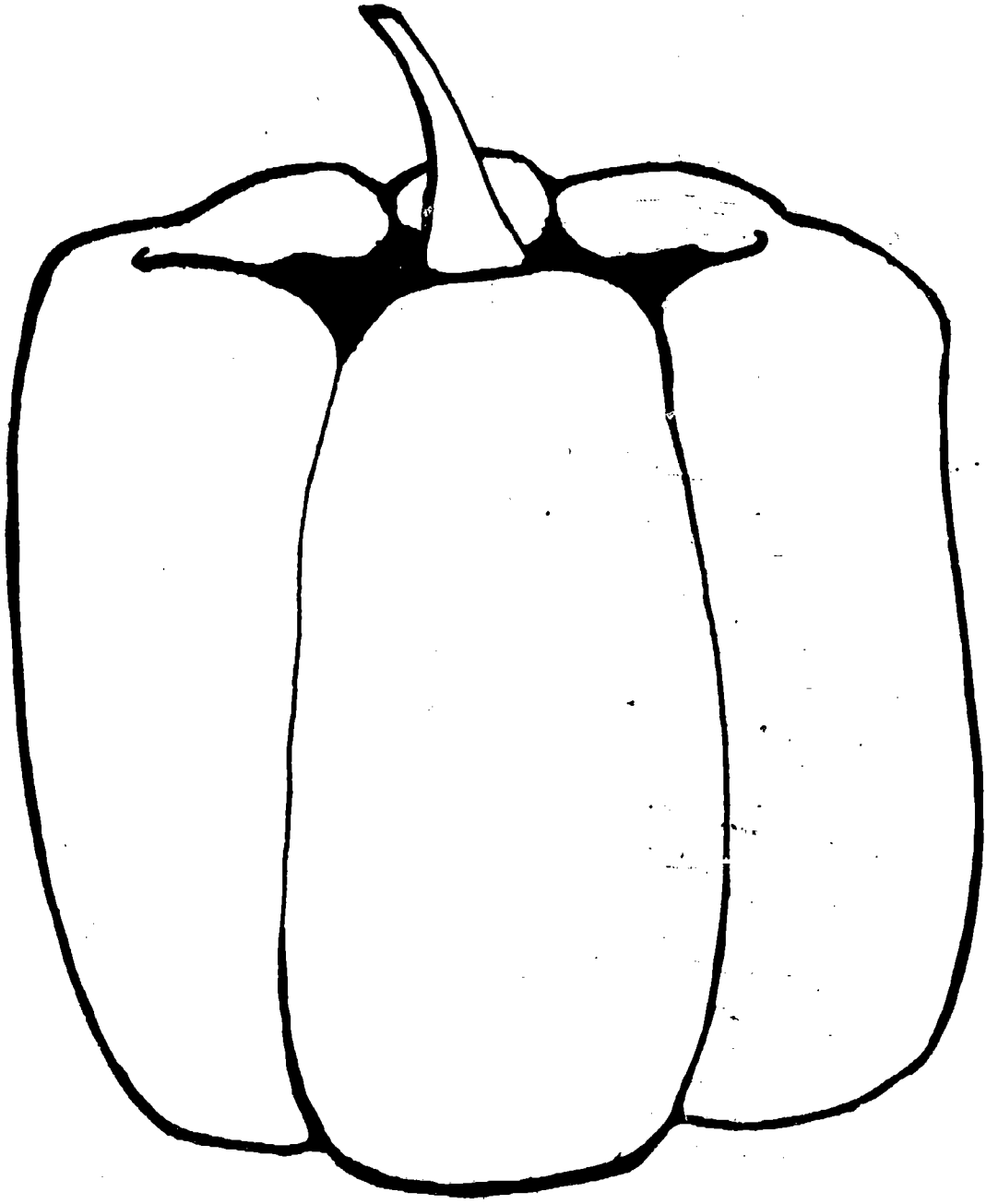

AP  
P61

BEST COPY AVAILABLE

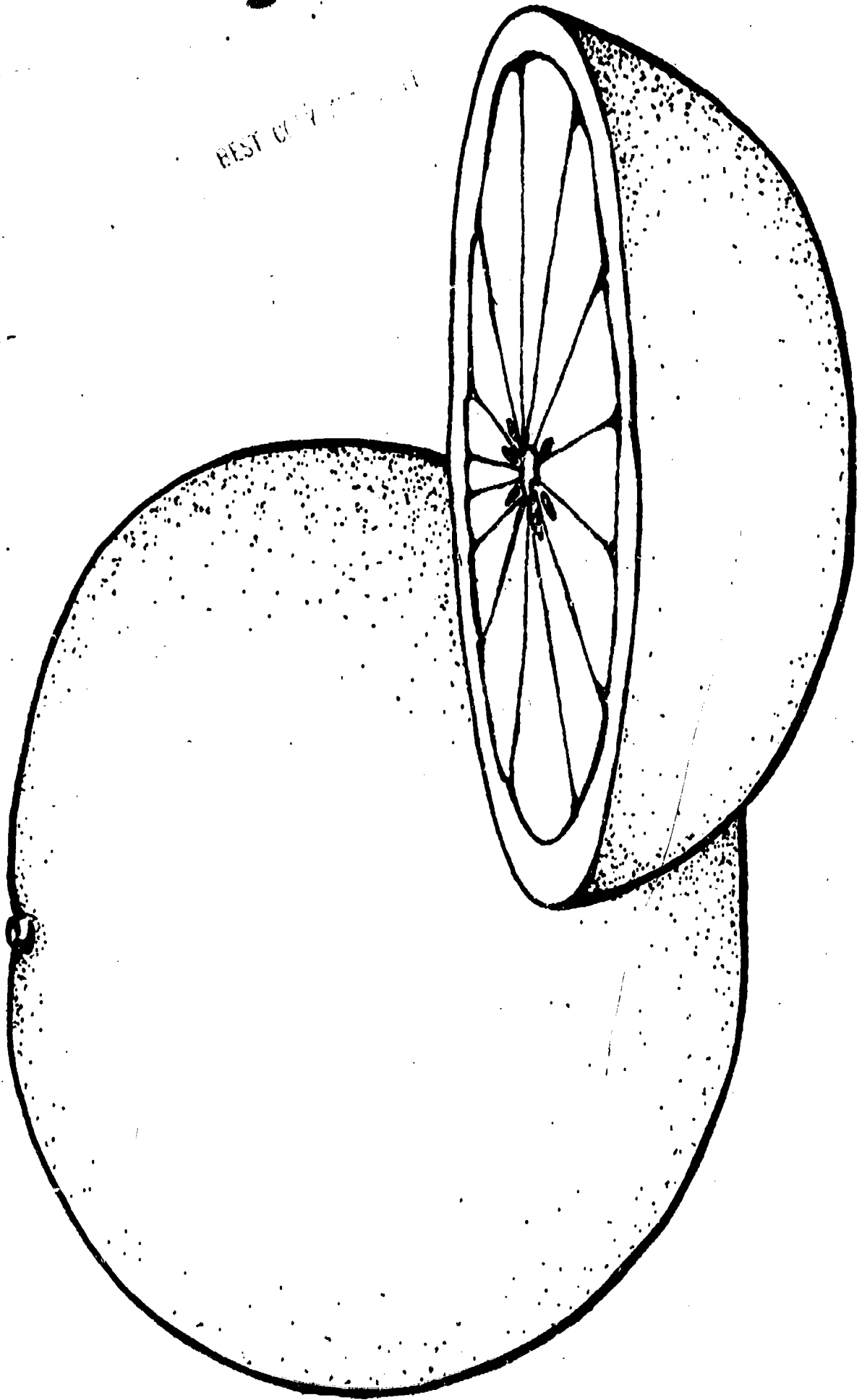

BEST COPY AVAILABLE

AP  
P63

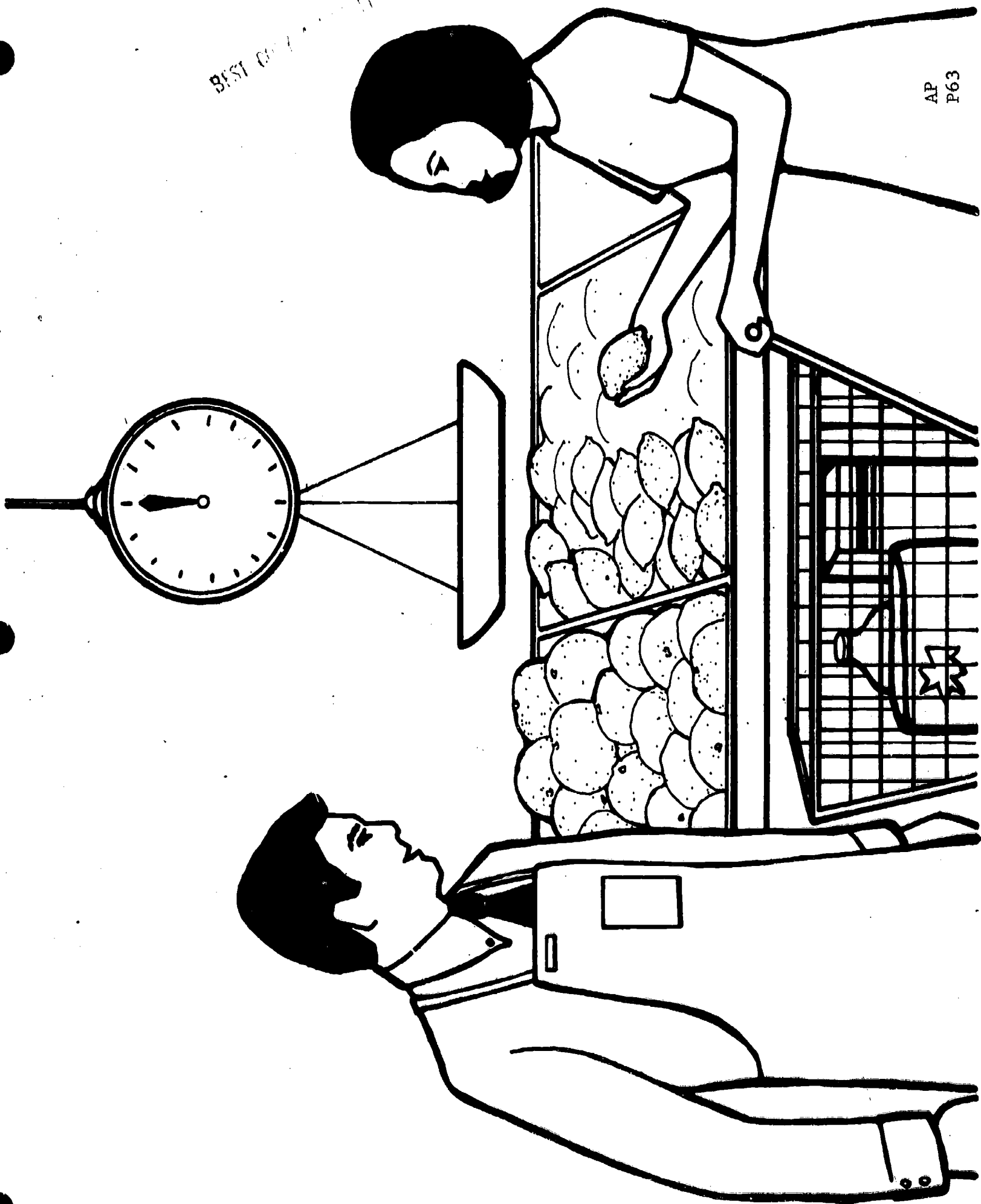

BEST COPY AVAILABLE

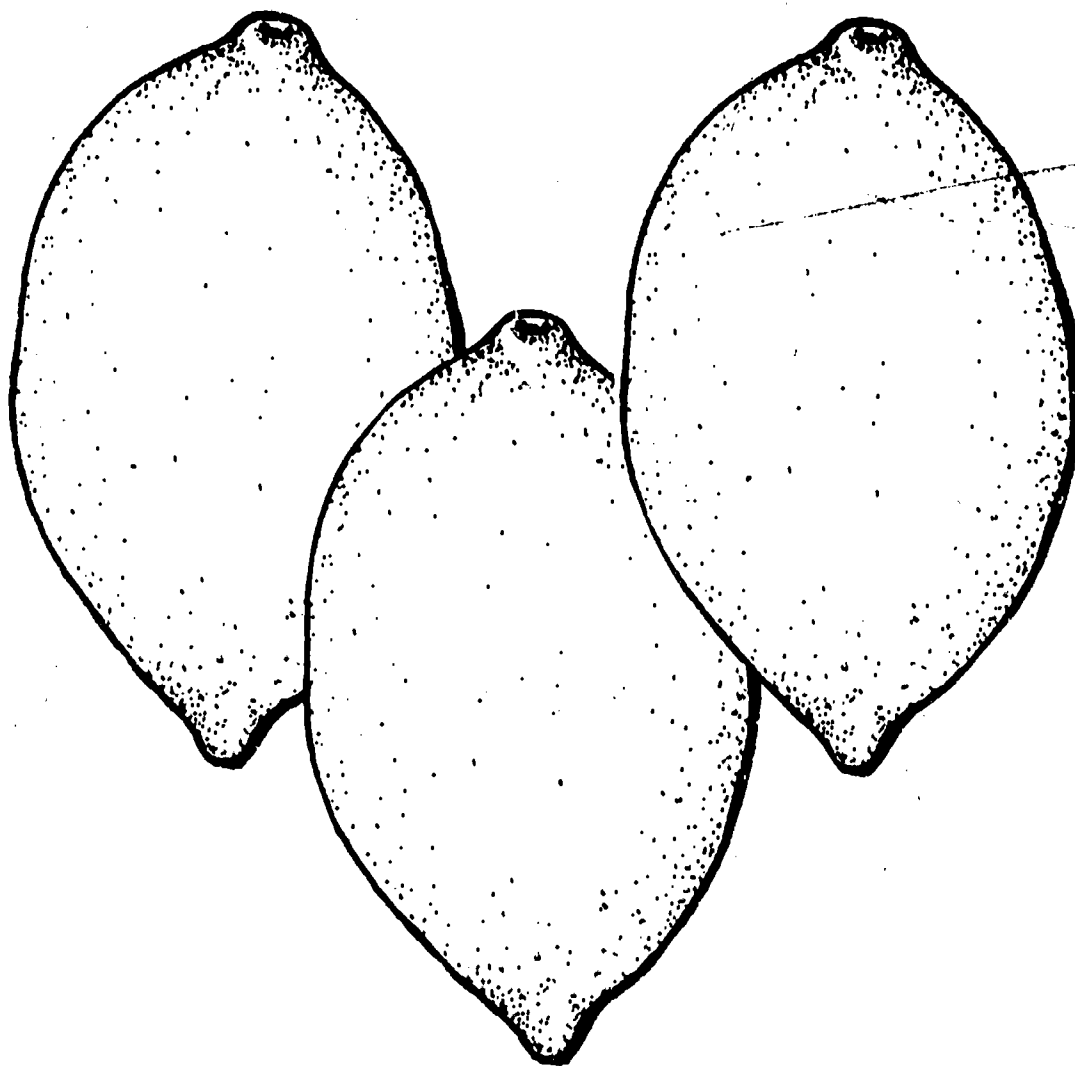



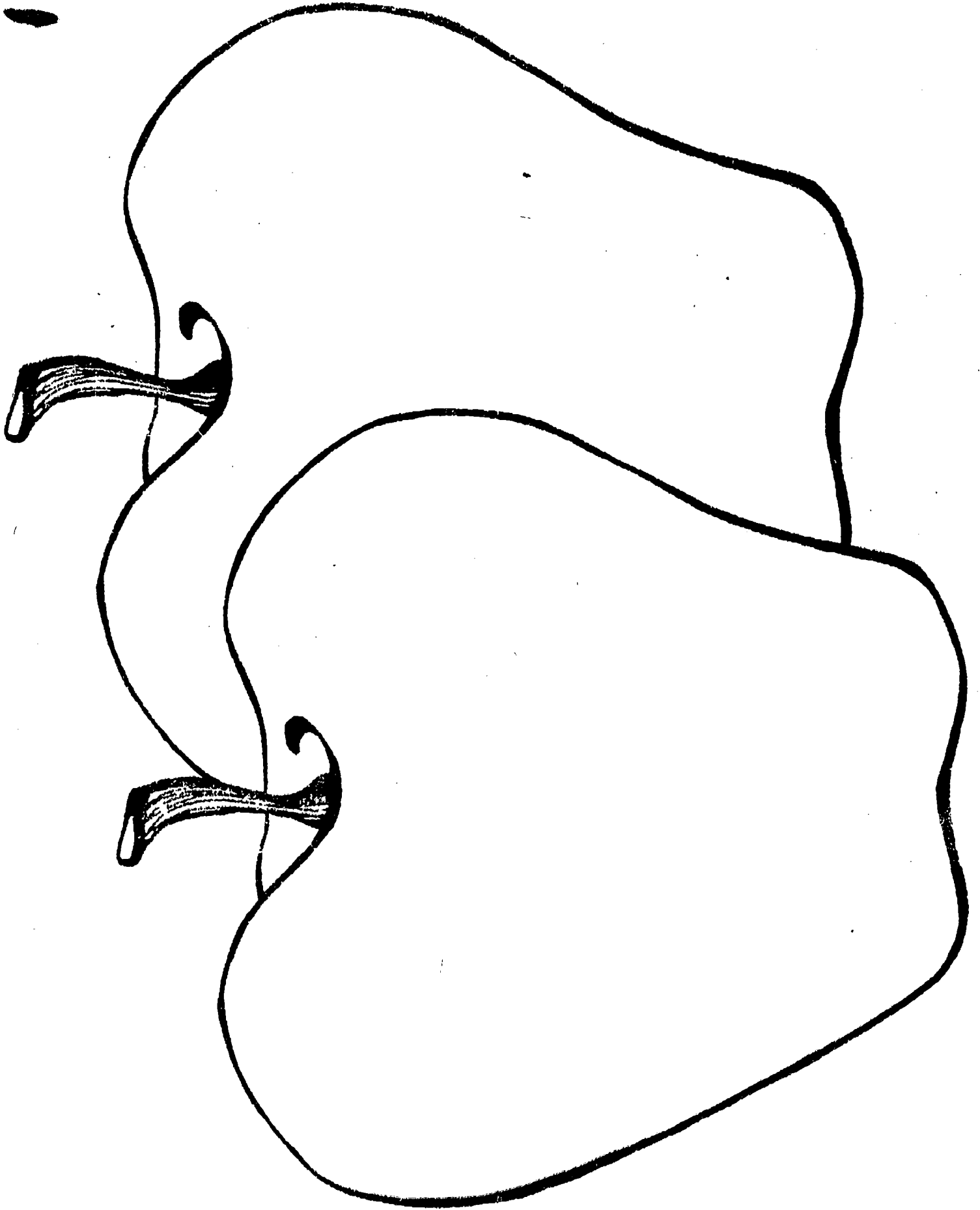

NOT FULLY AVAILABLE

AP  
P66

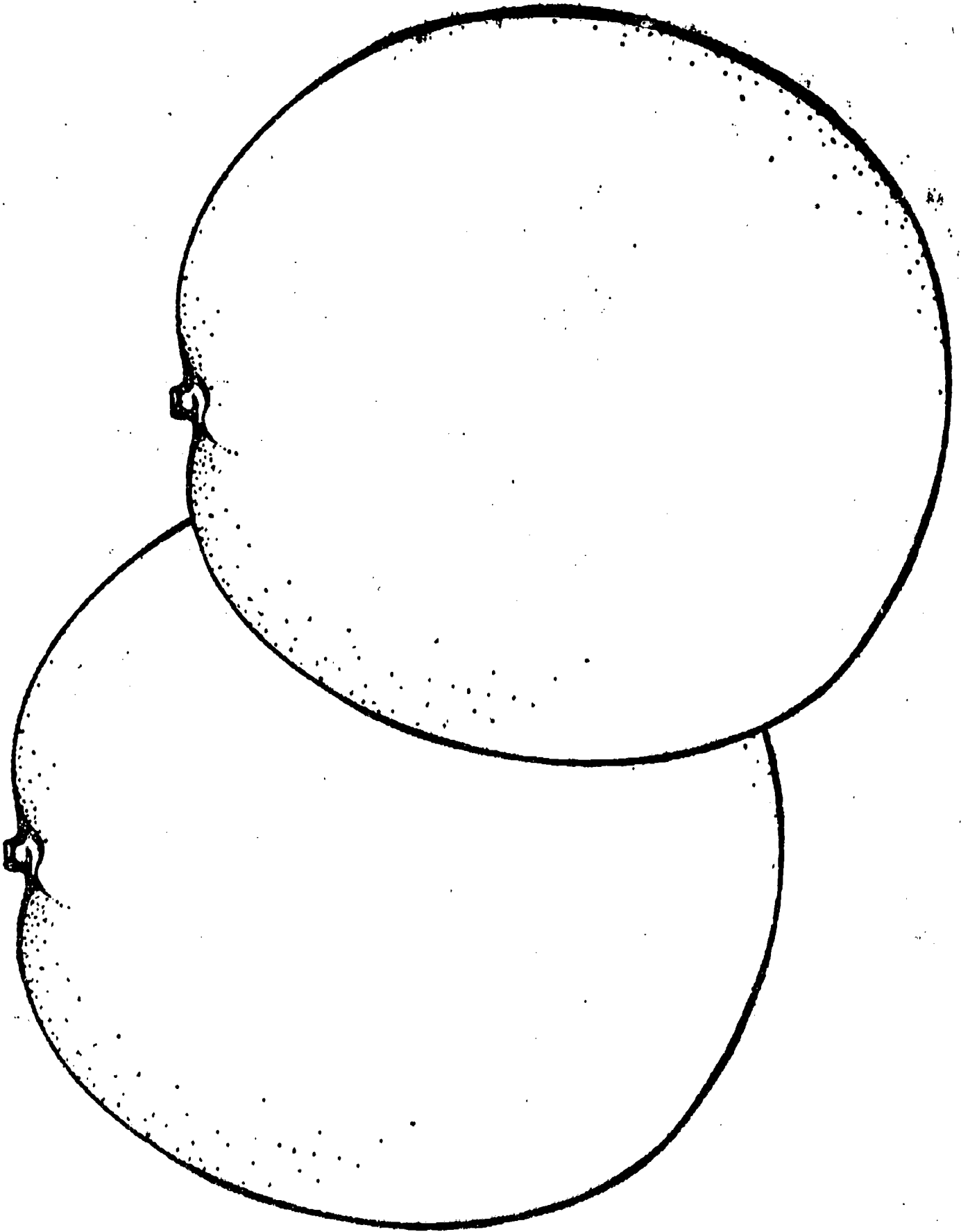

BEST COPY AVAILABLE

AP  
P67

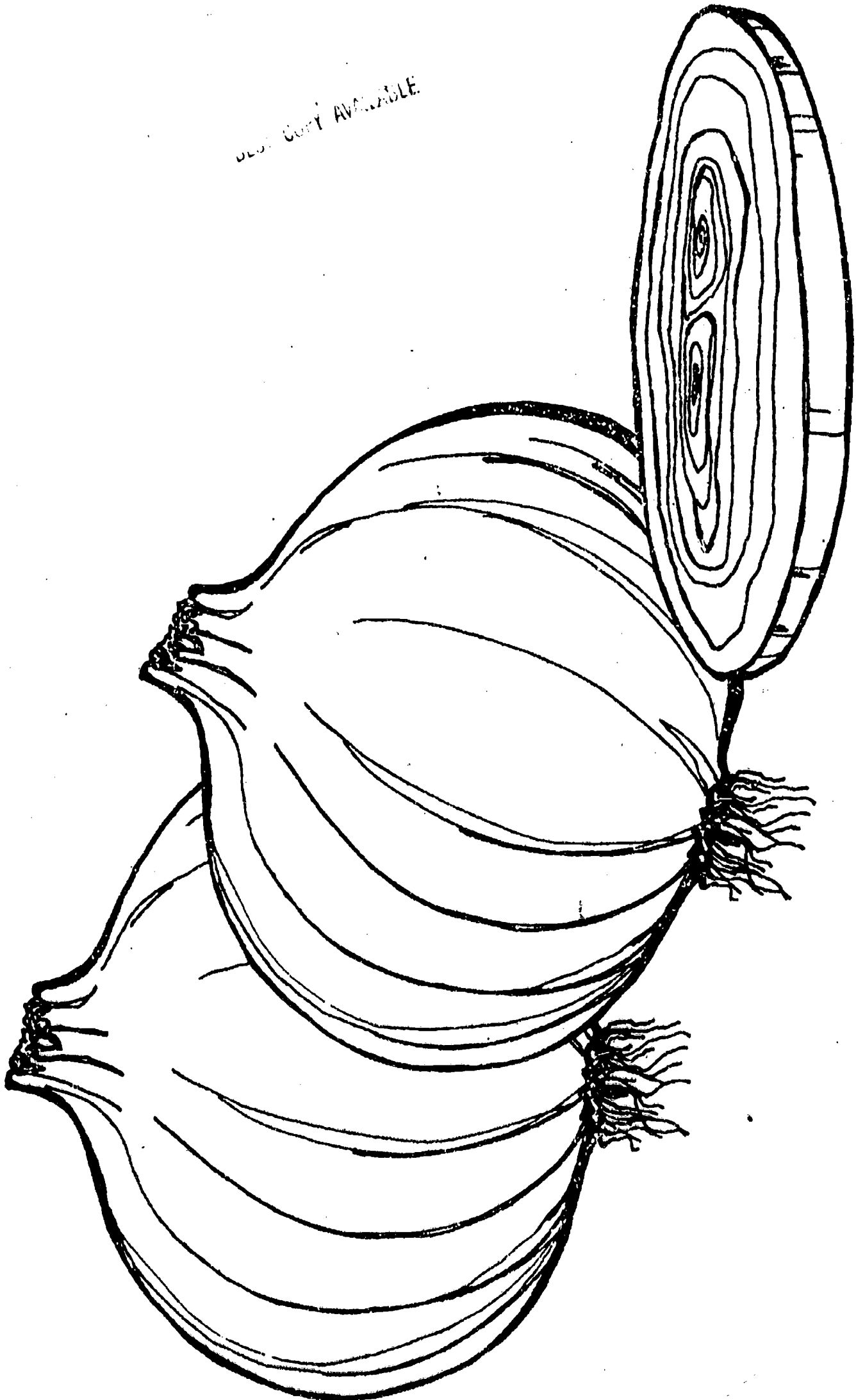

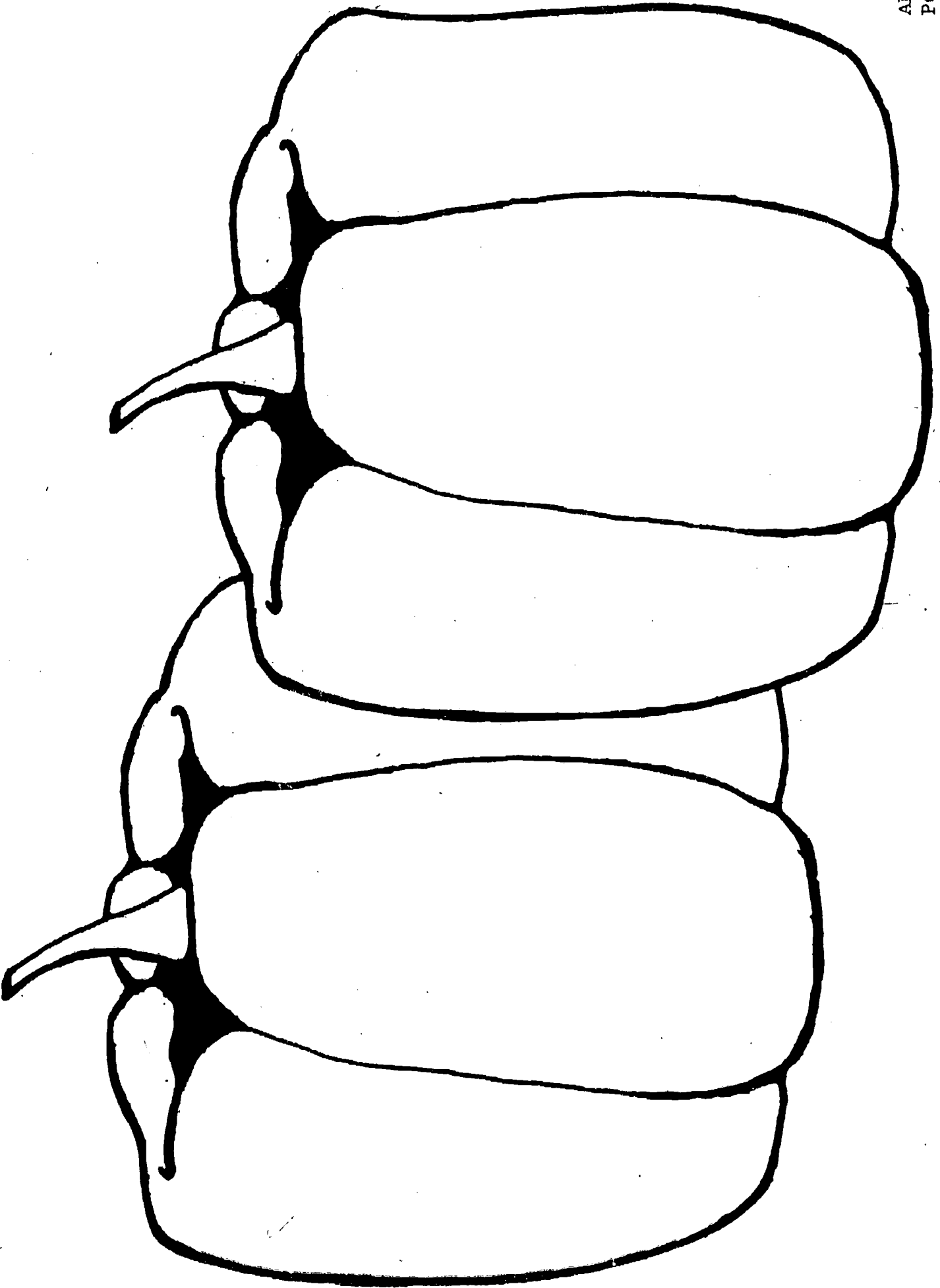

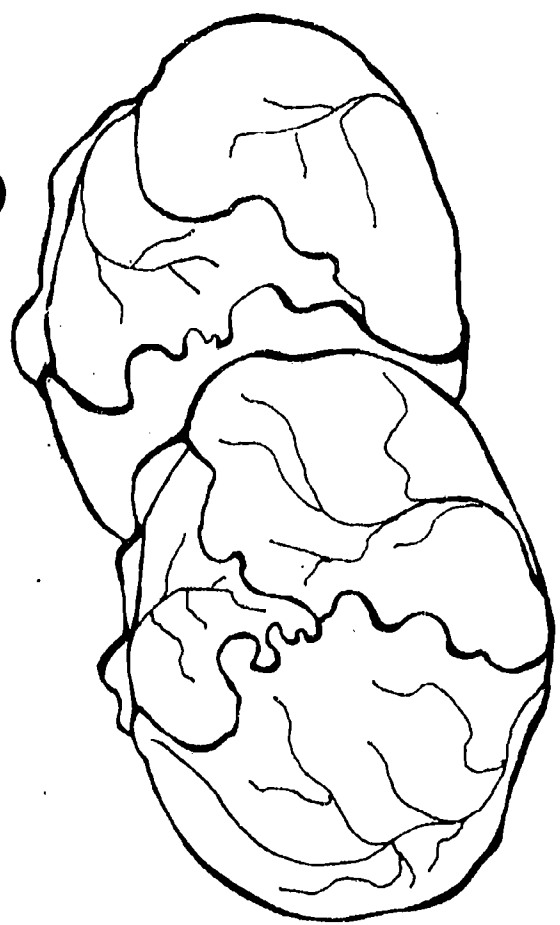

BEST COPY AVAILABLE

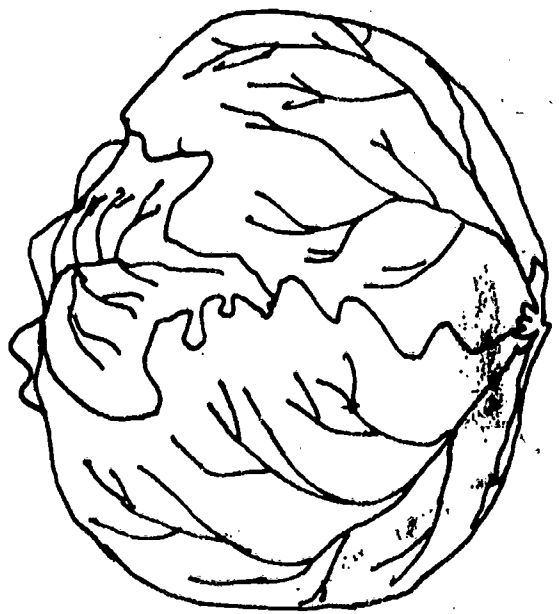

BEST COPY AVAILABLE

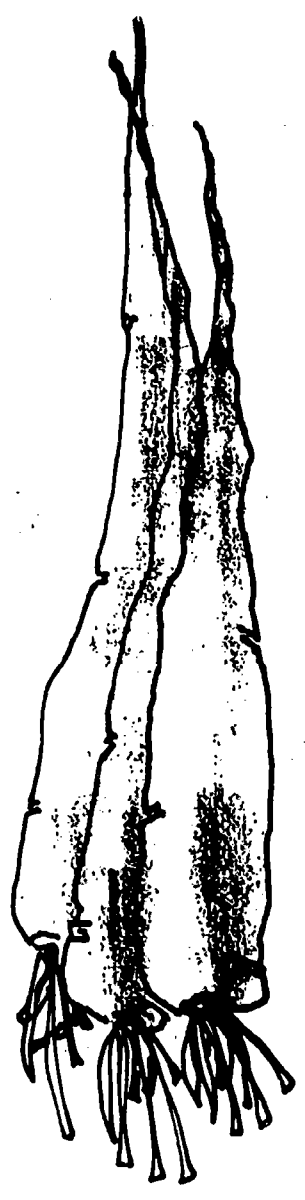

BEST COPY AVAILABLE

AP  
P71

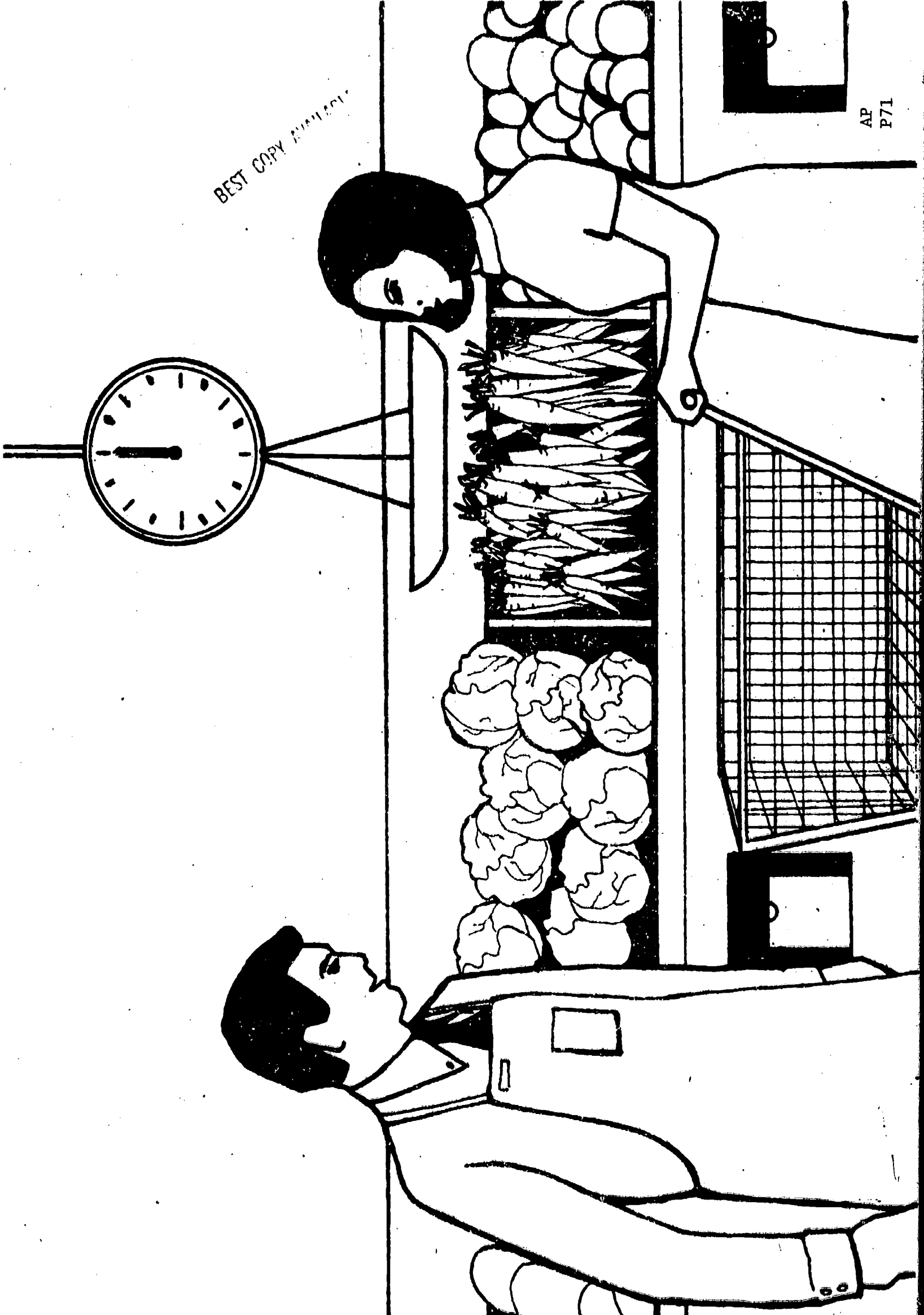

*Y bank*

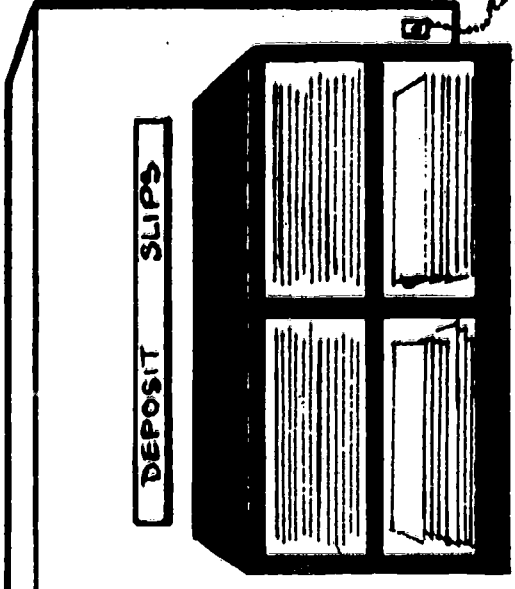
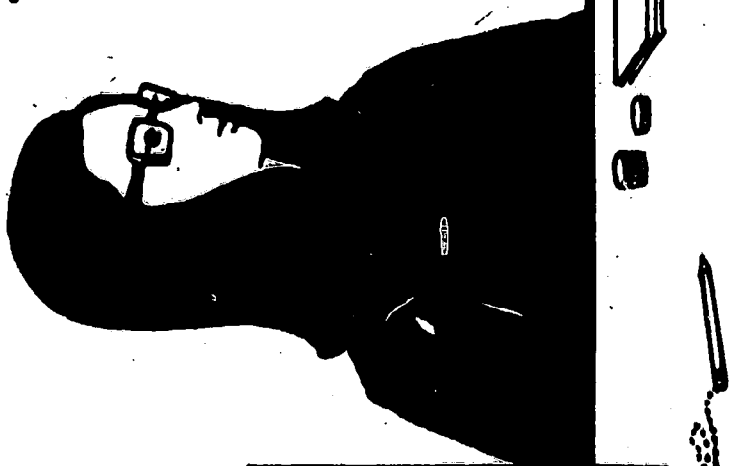
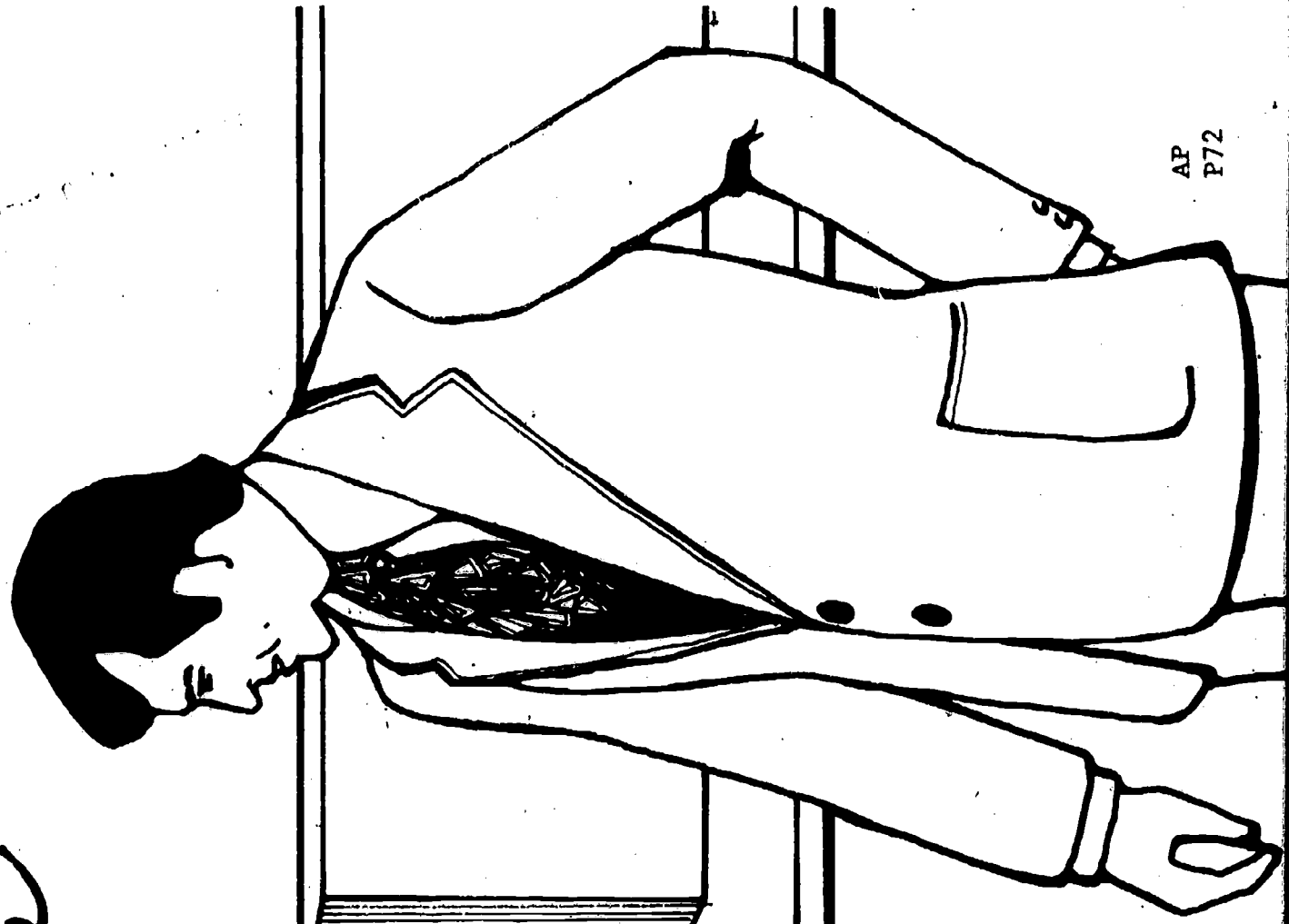



AIR MAIL

LOCAL

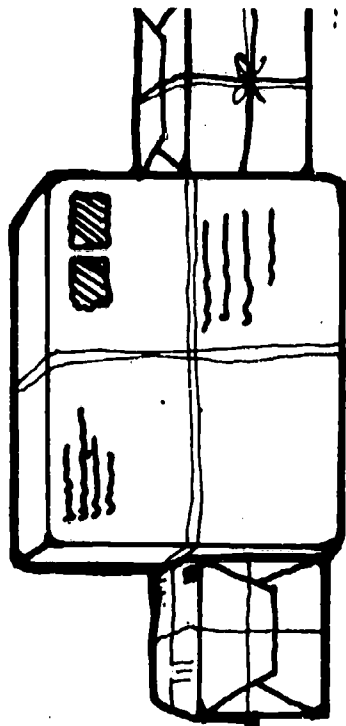
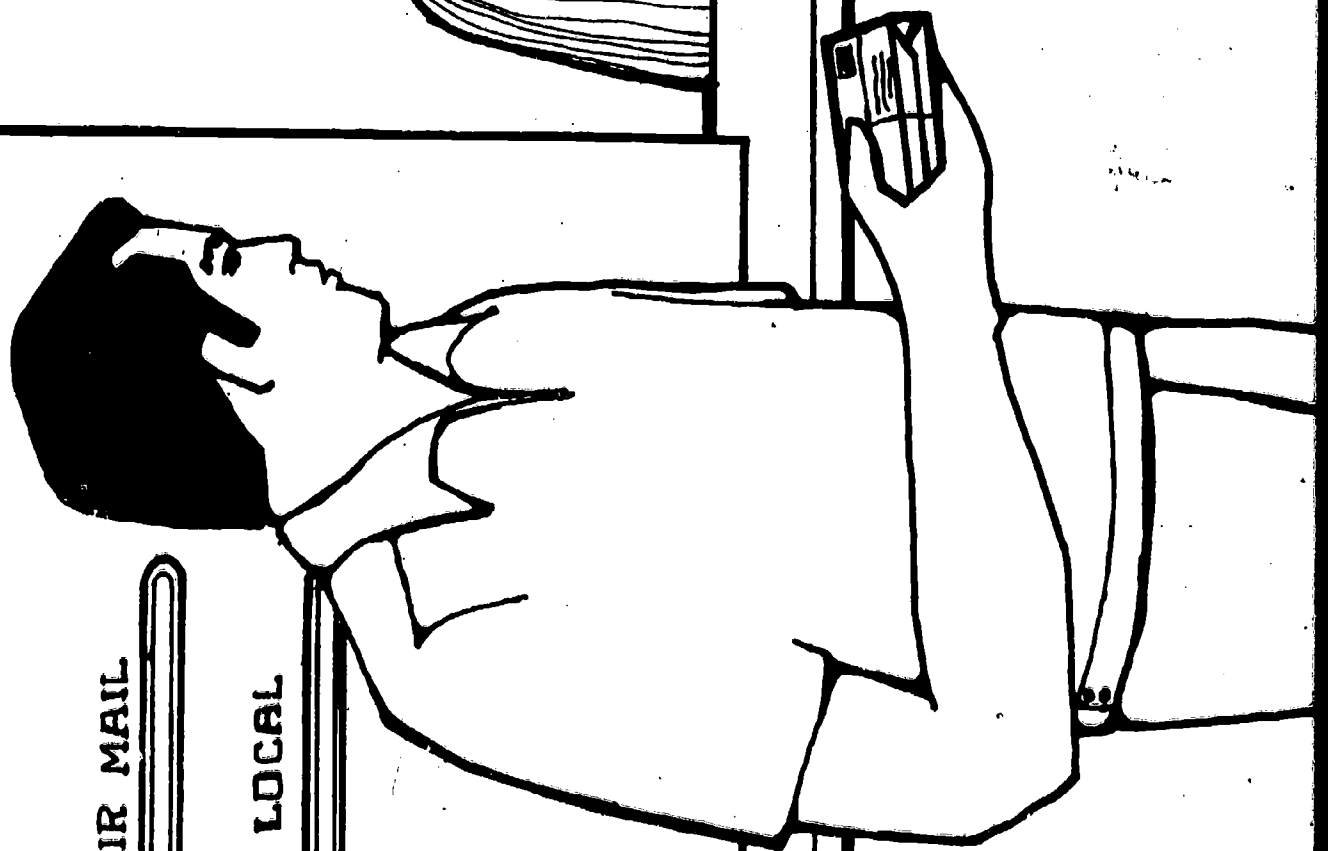

BEST COPY AVAILABLE

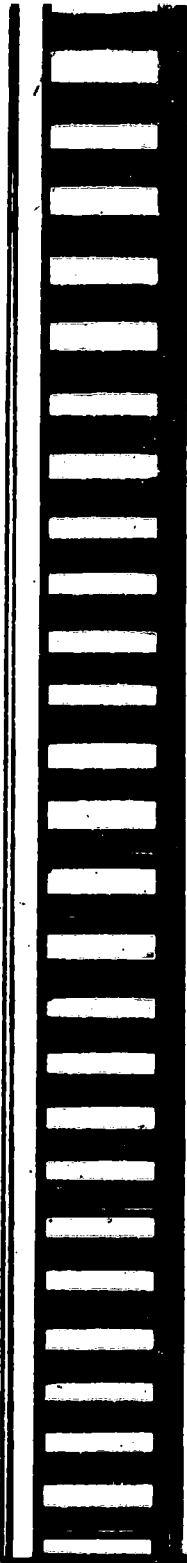

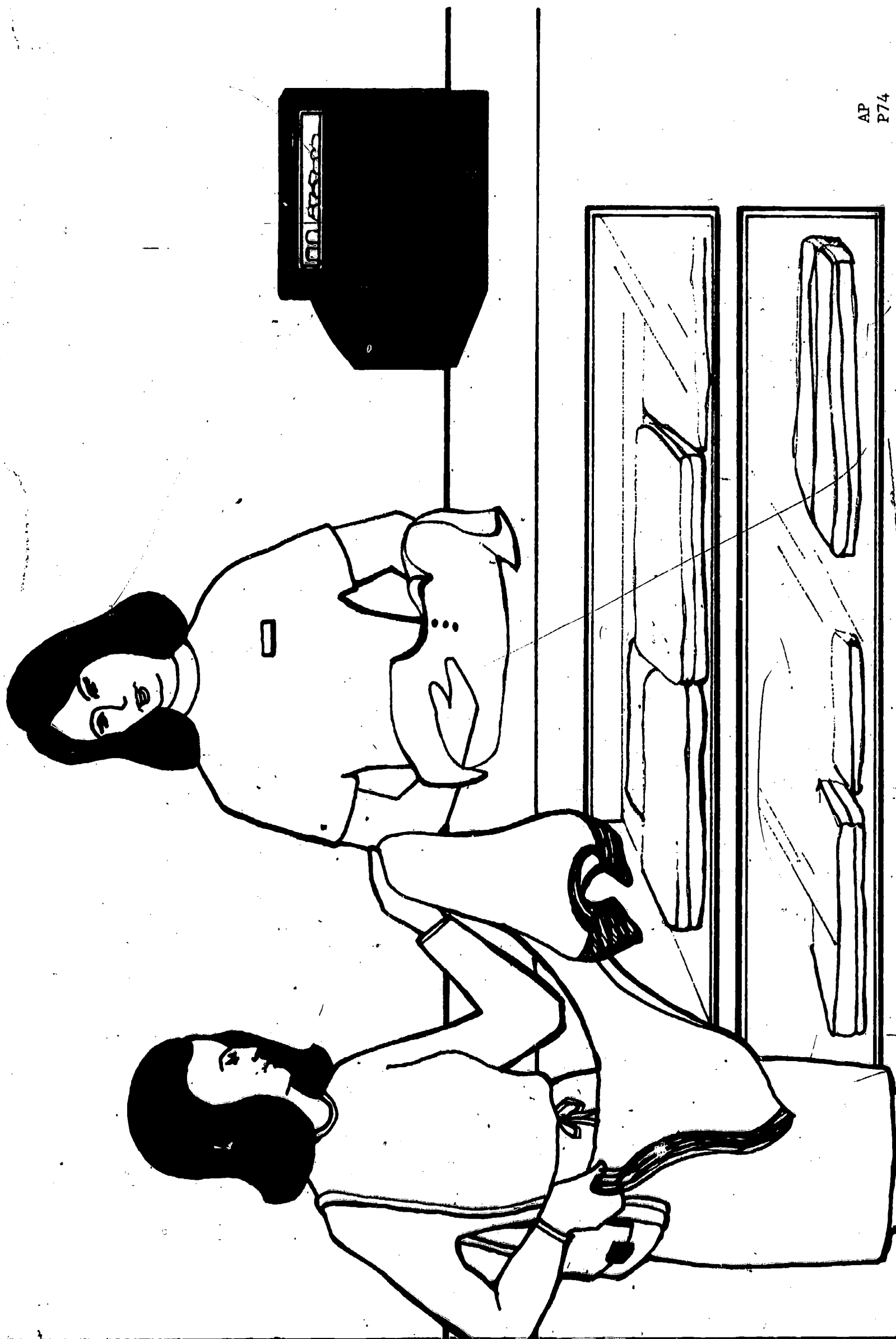

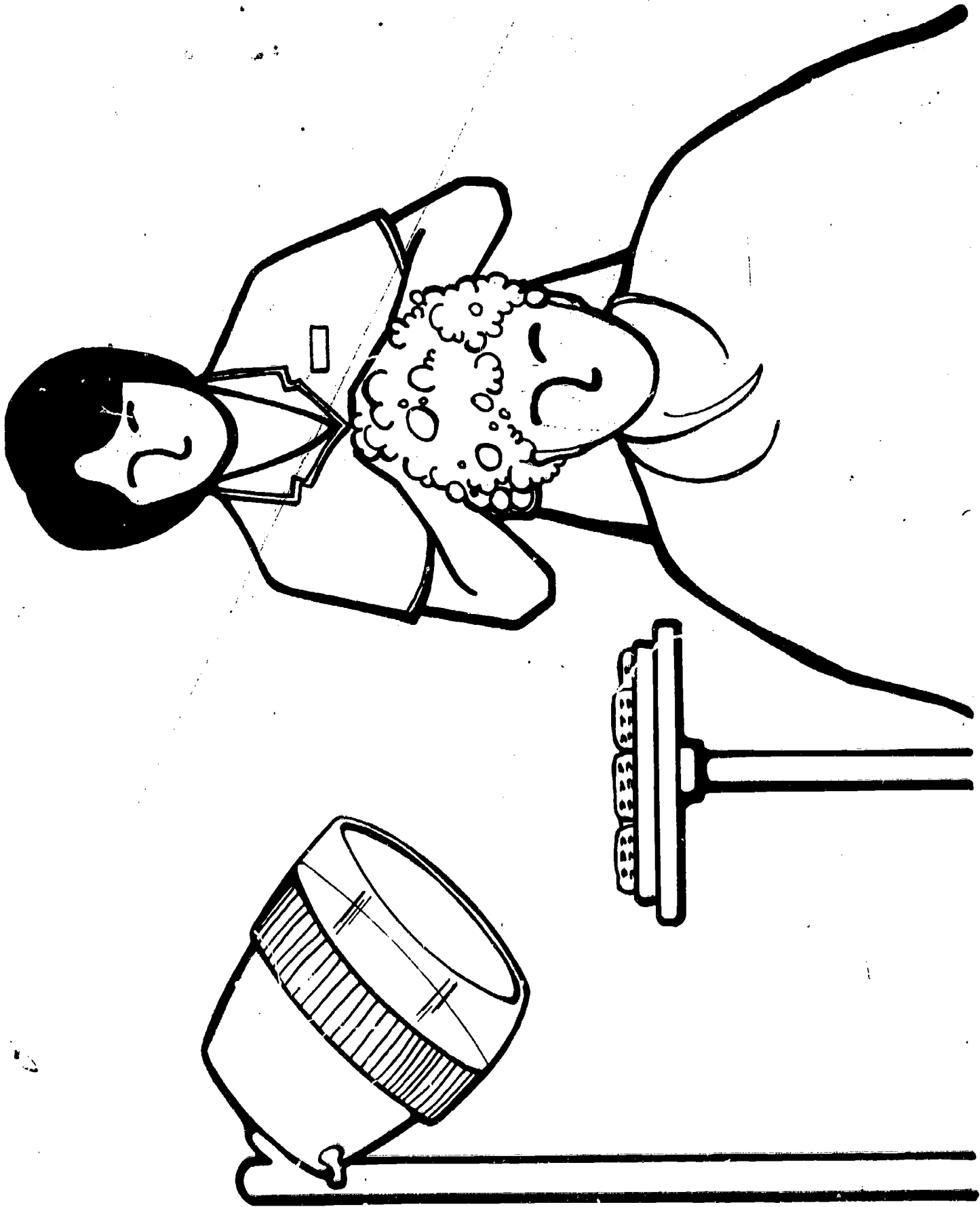

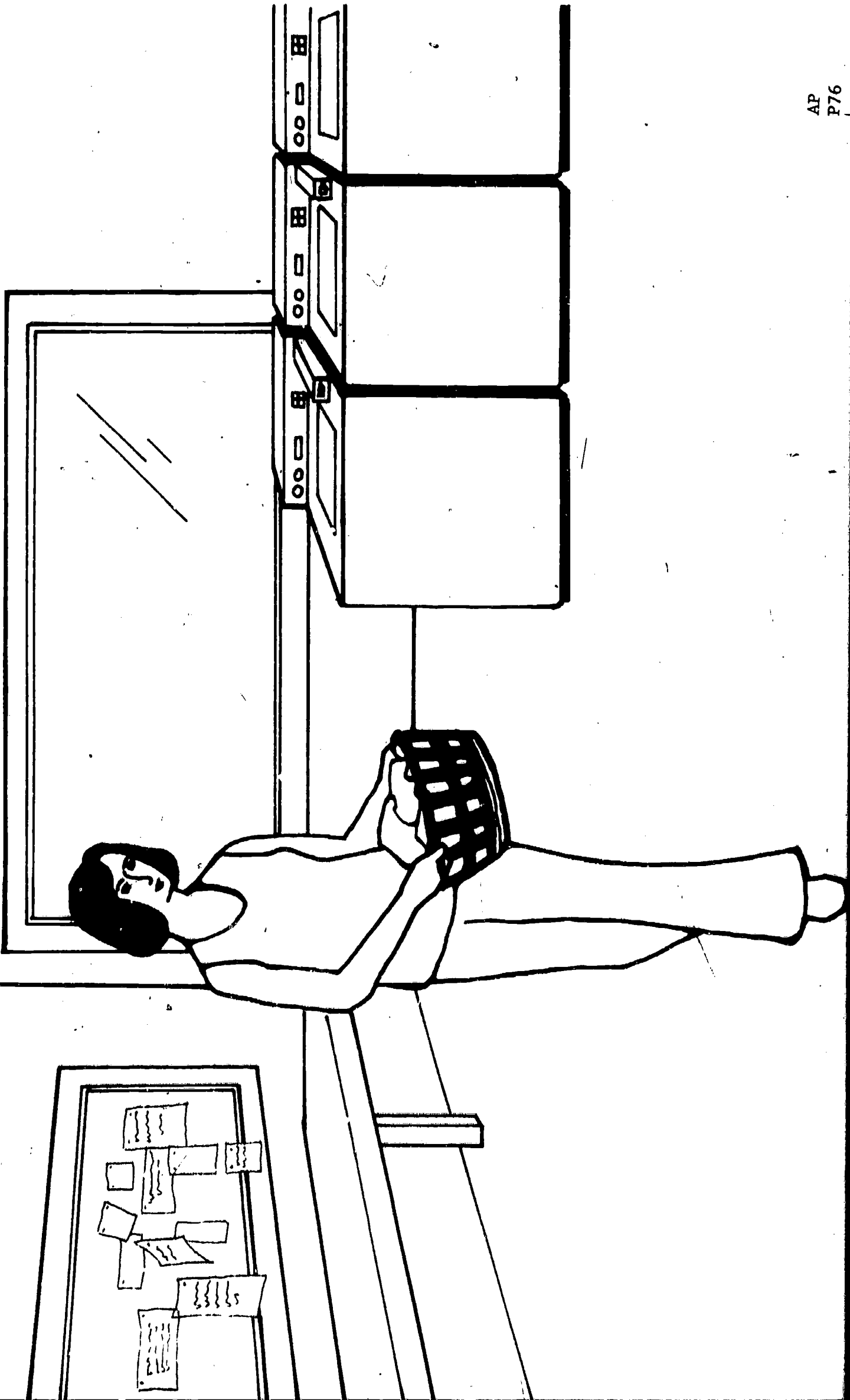

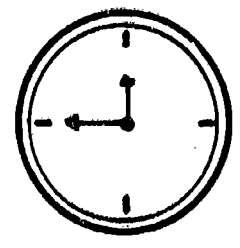
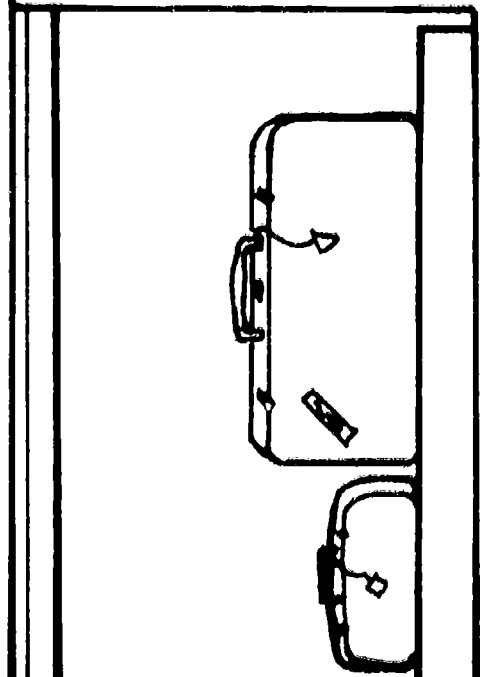
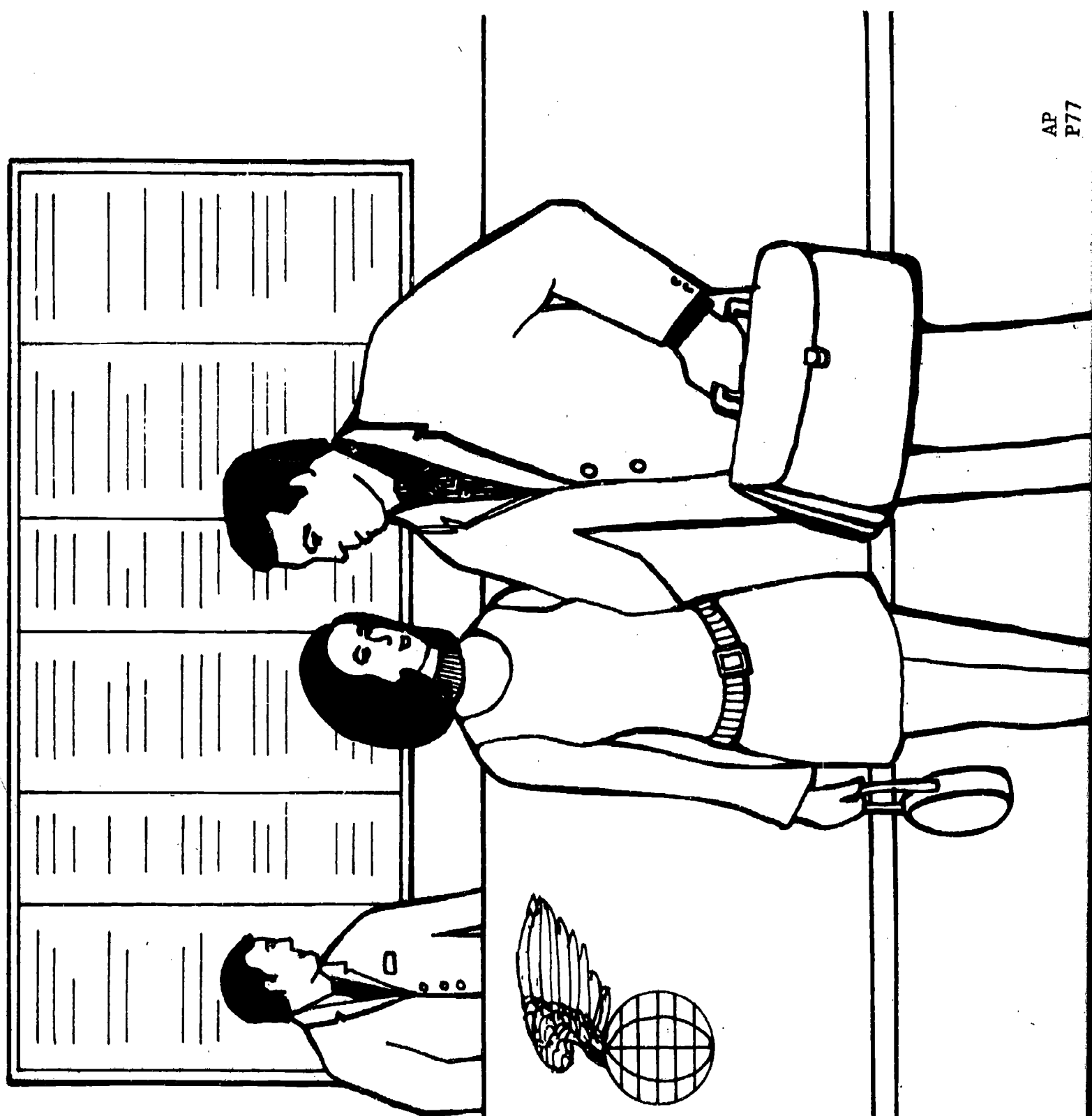

3/1

BEST NEW ALPHABET



AP P78

45¢/lb.

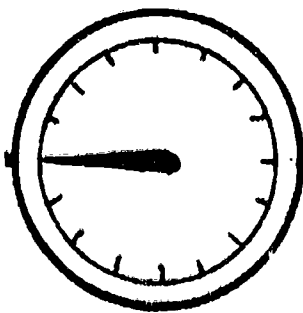
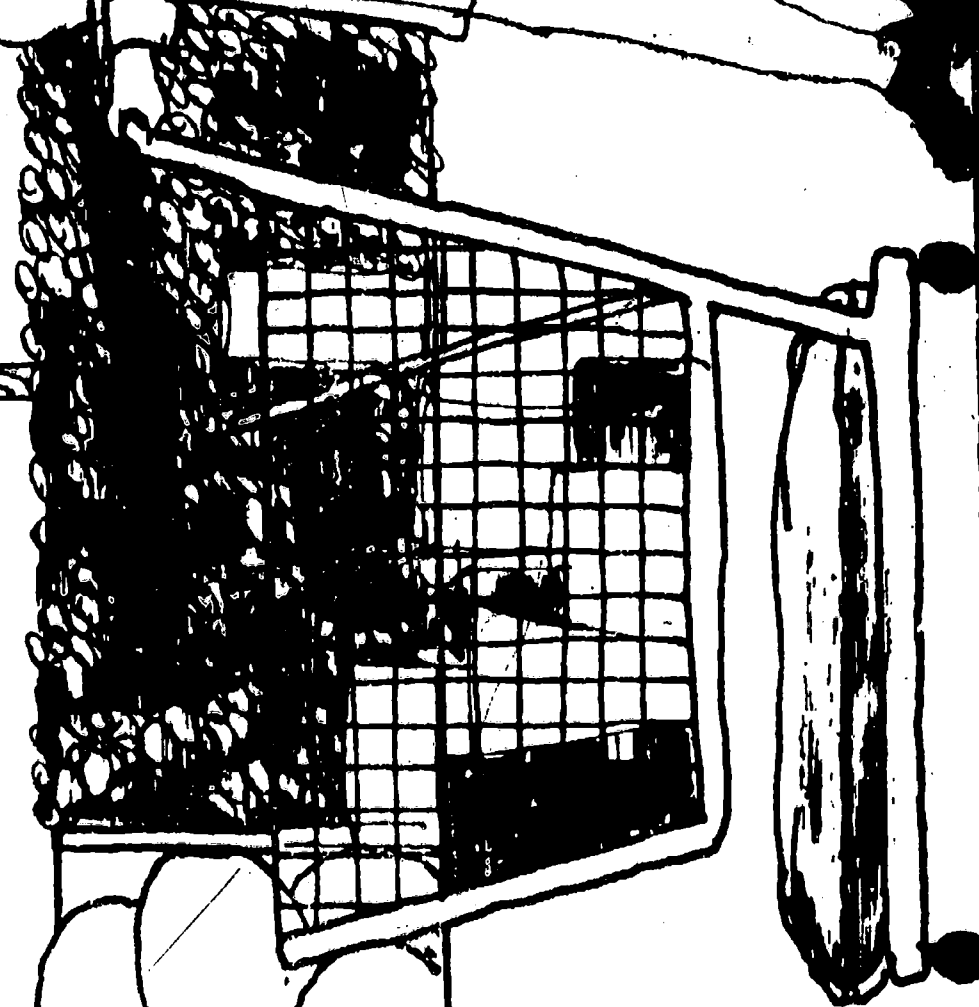

ea.



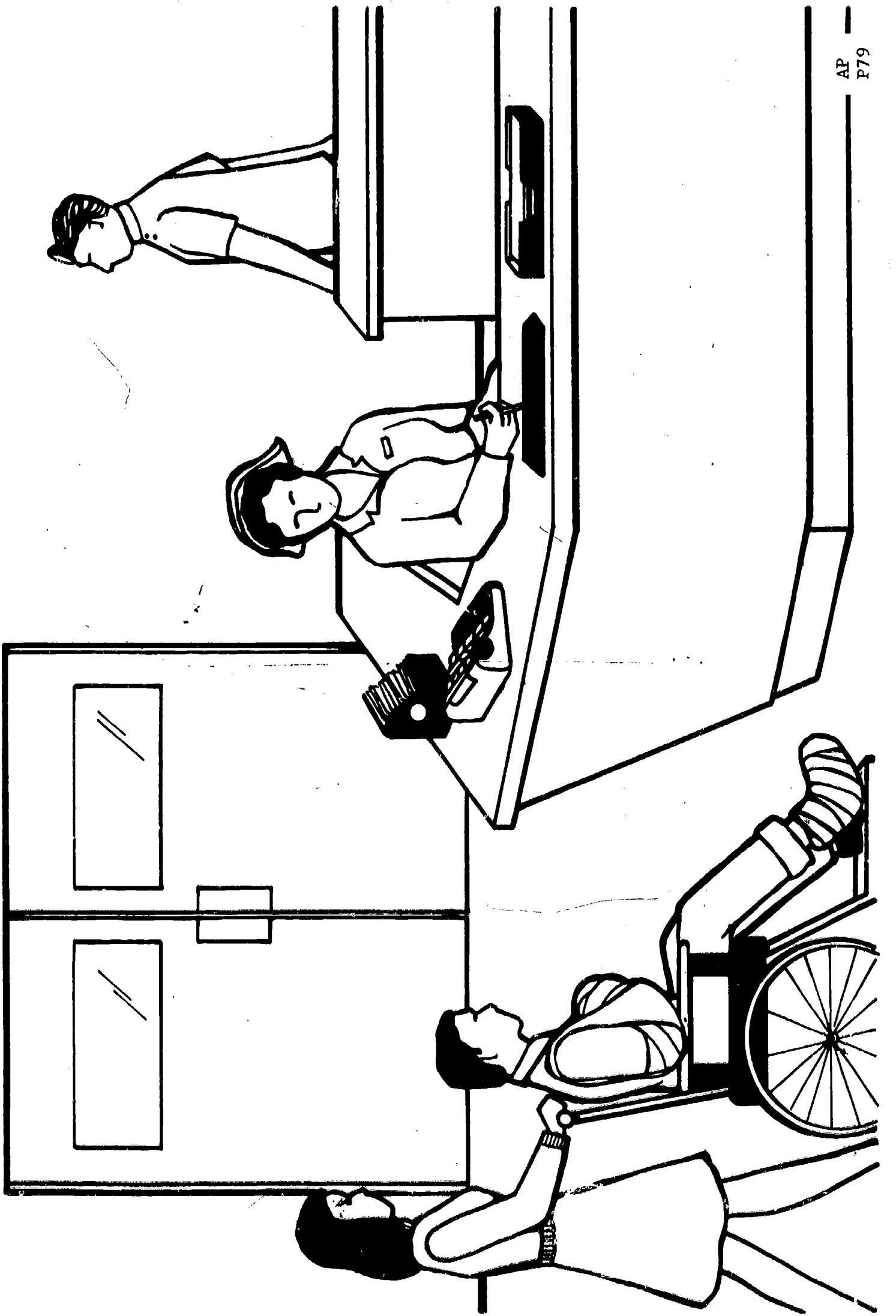

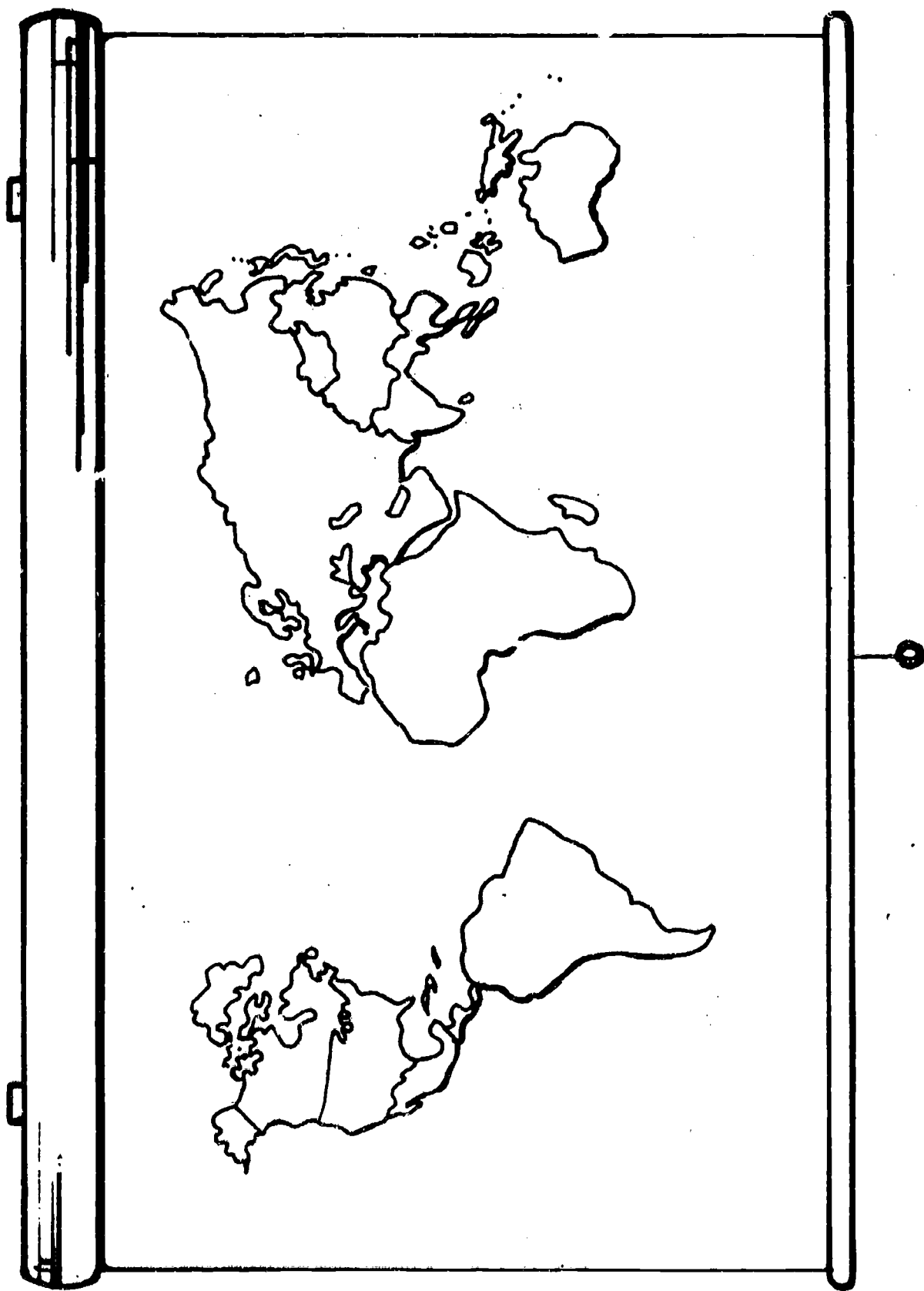



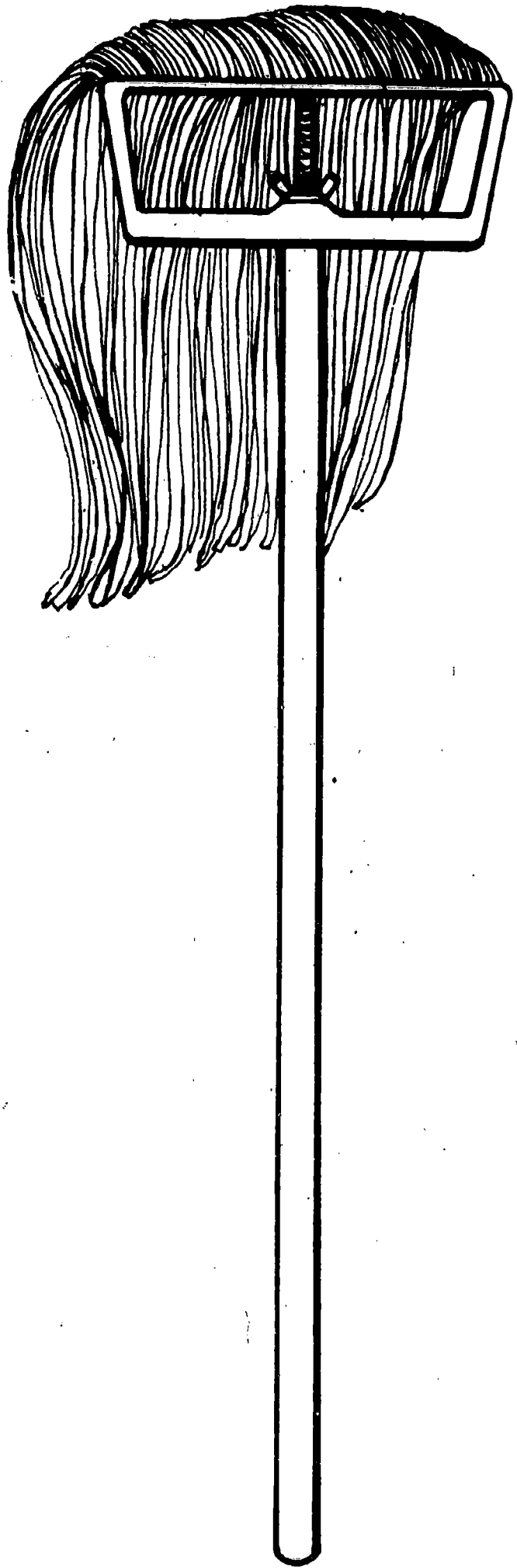

AP  
P81

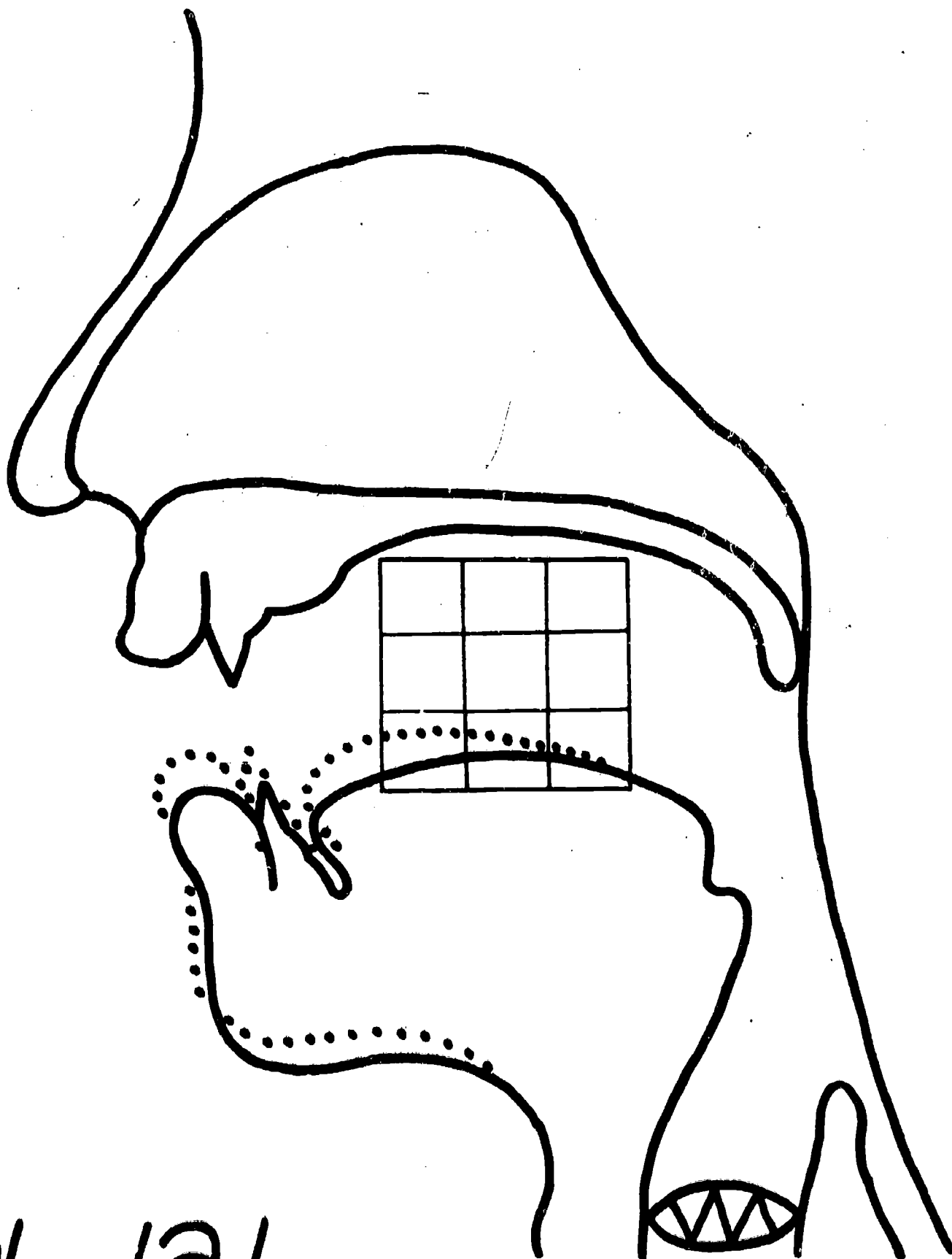

• |a|... |a| —

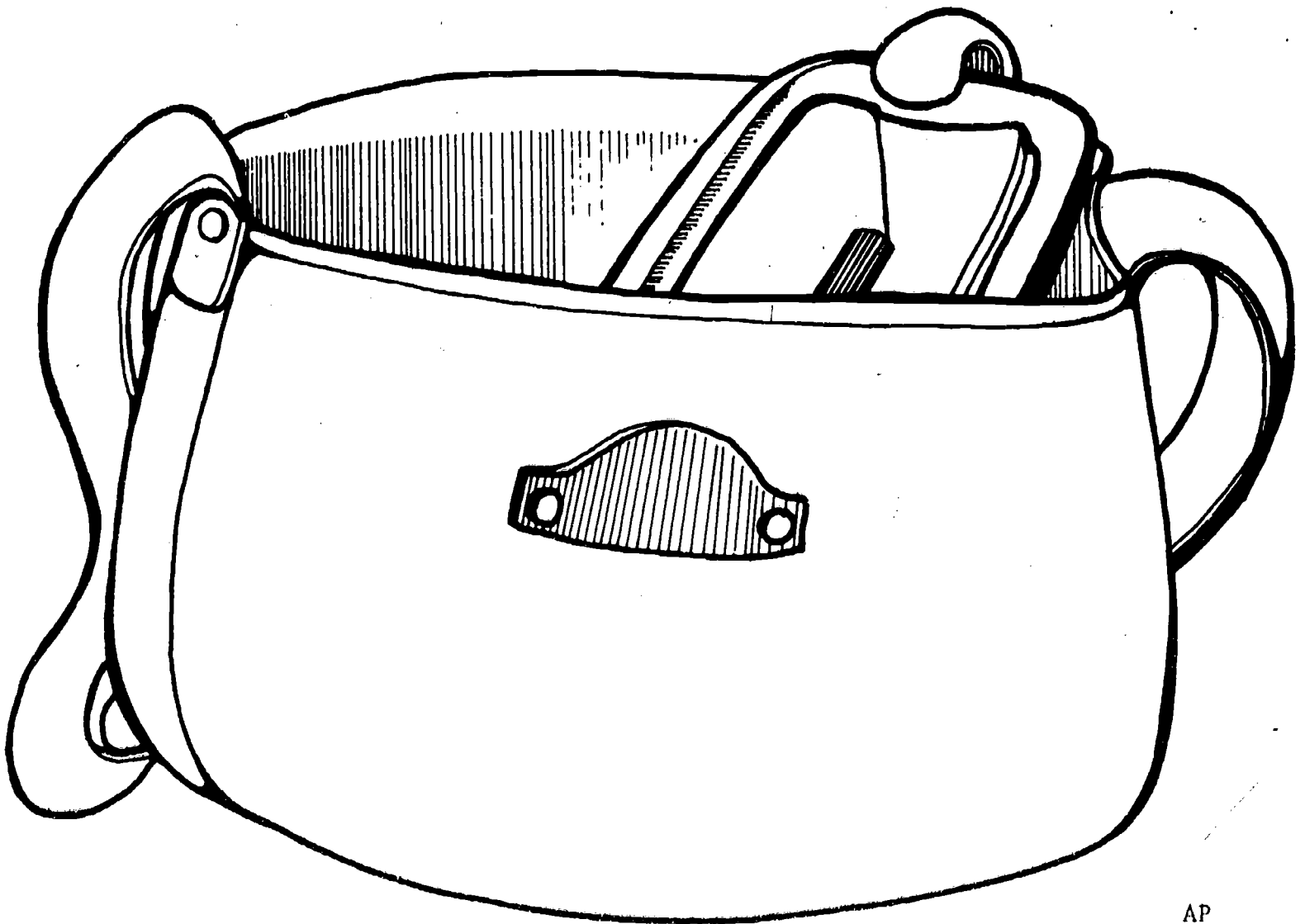
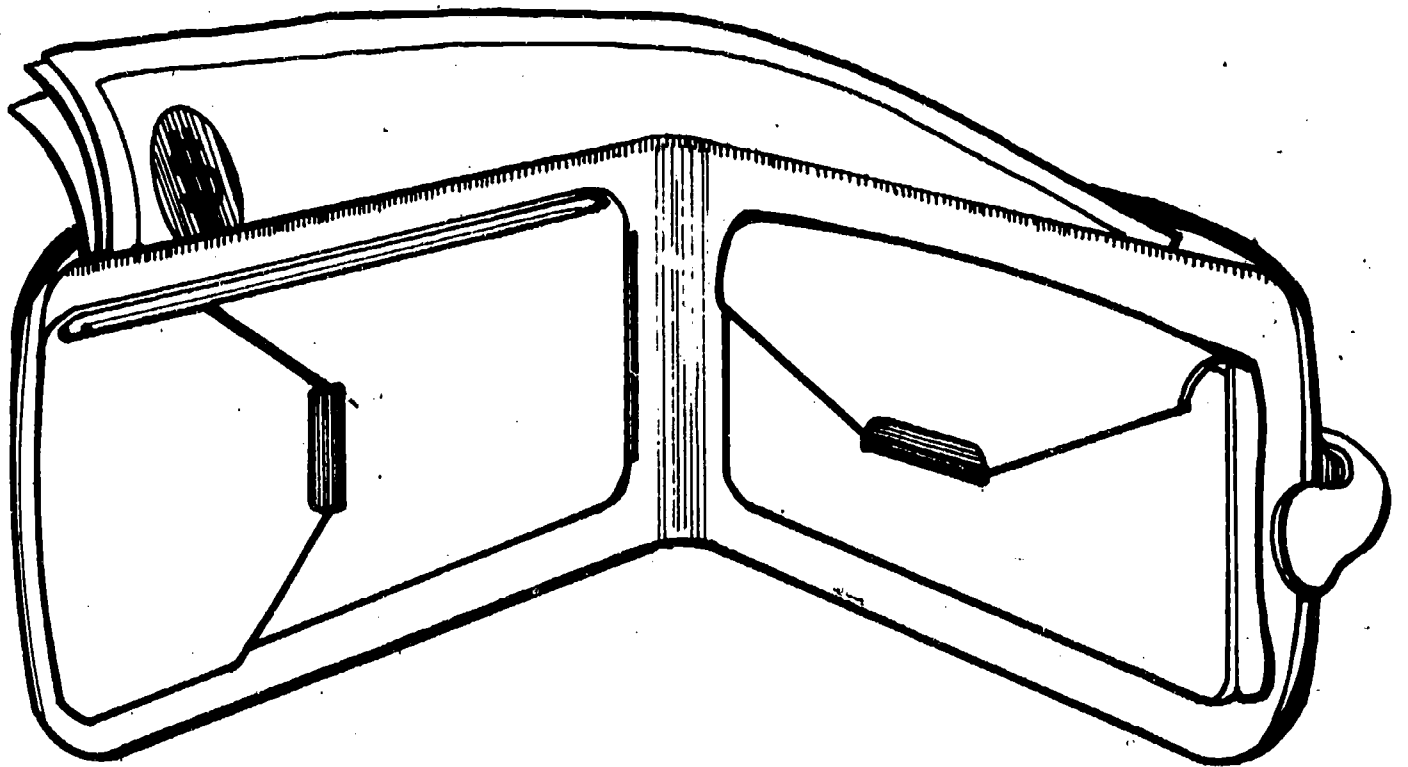

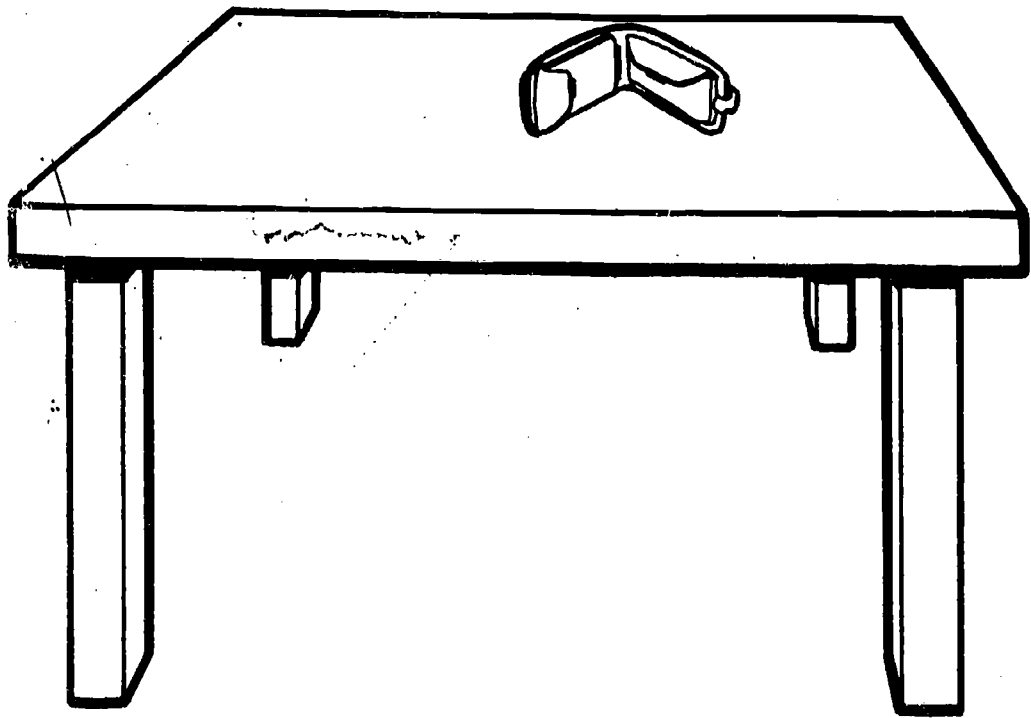

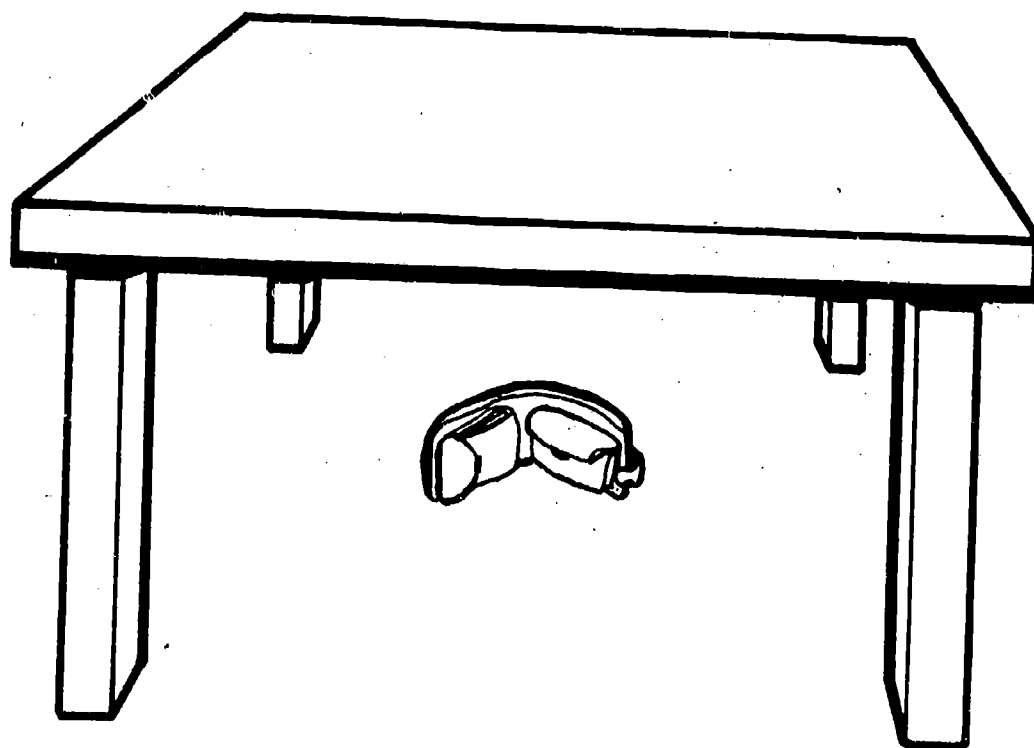

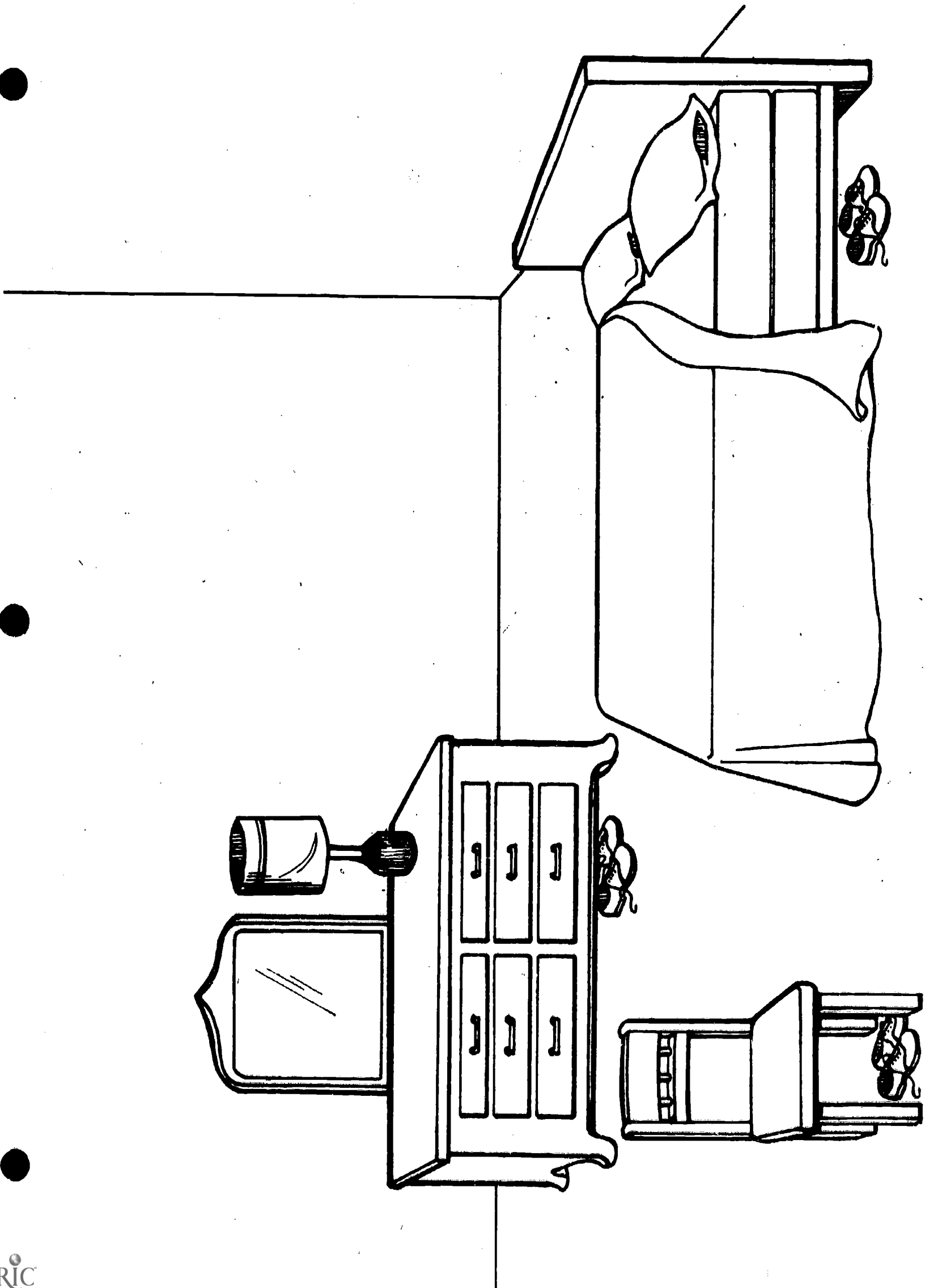

BEST COPY AVAILABLE

AP  
P87

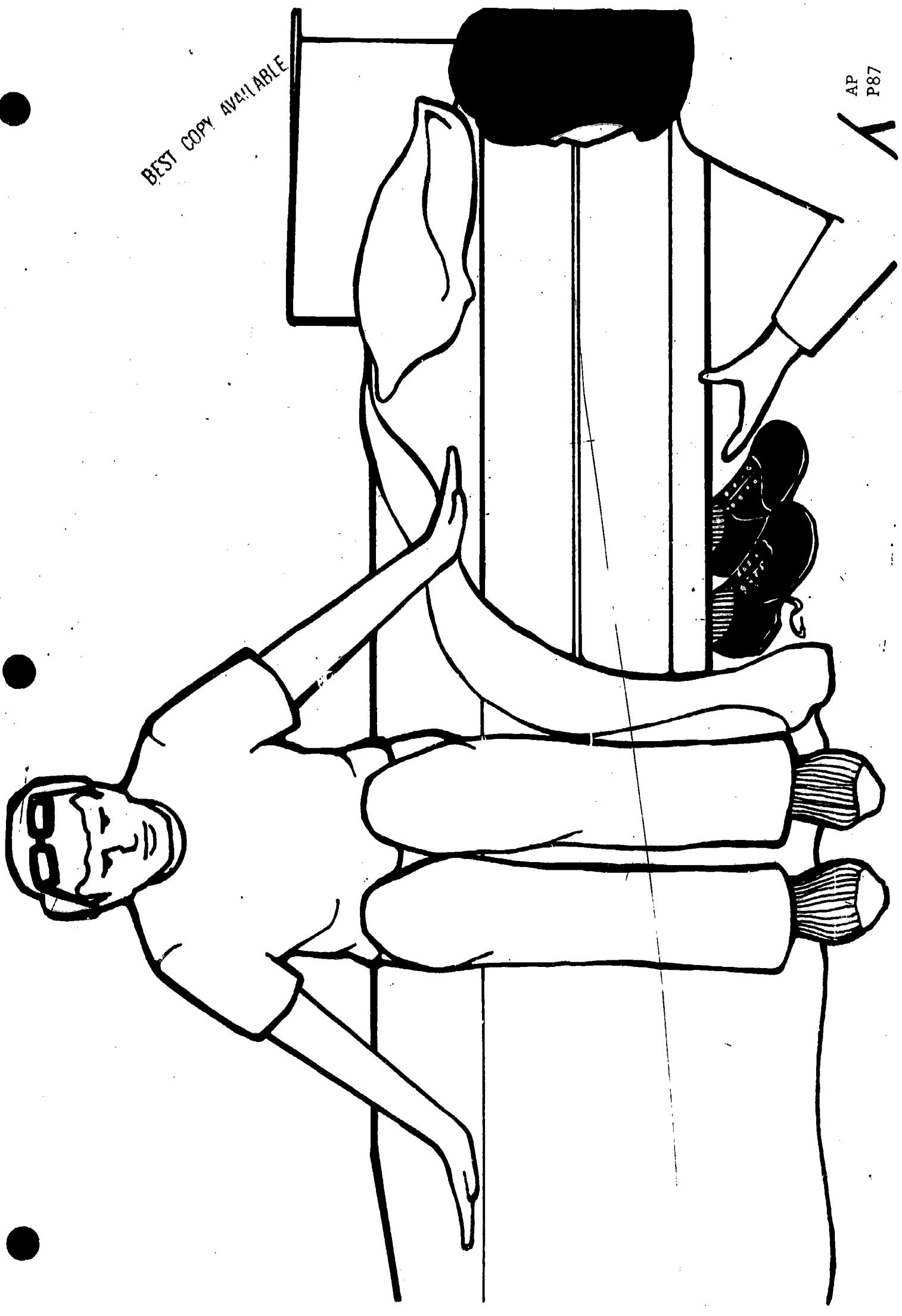

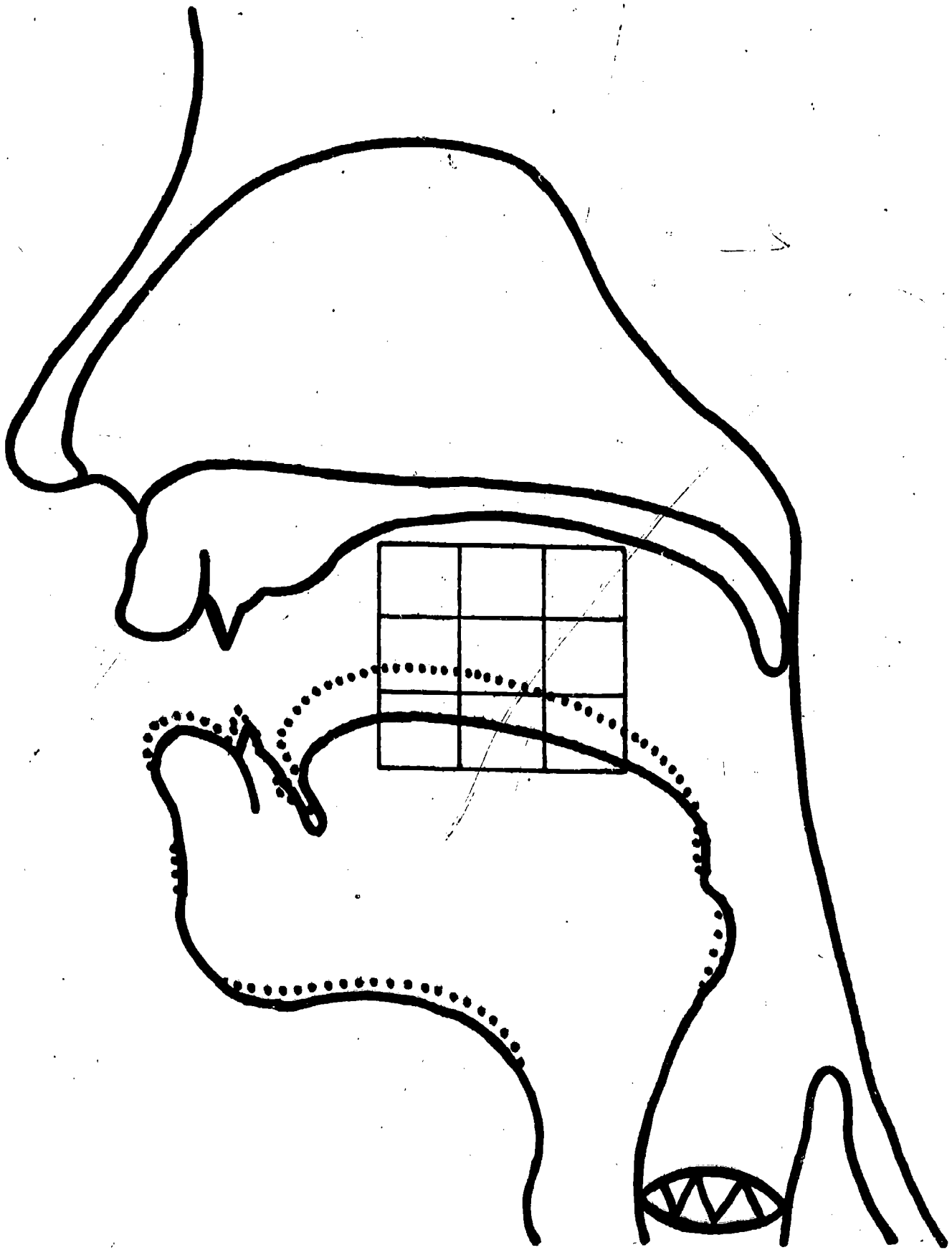

• /æ/ — /ɛ/ ...



BEST COPY AVAILABLE

AP  
P89



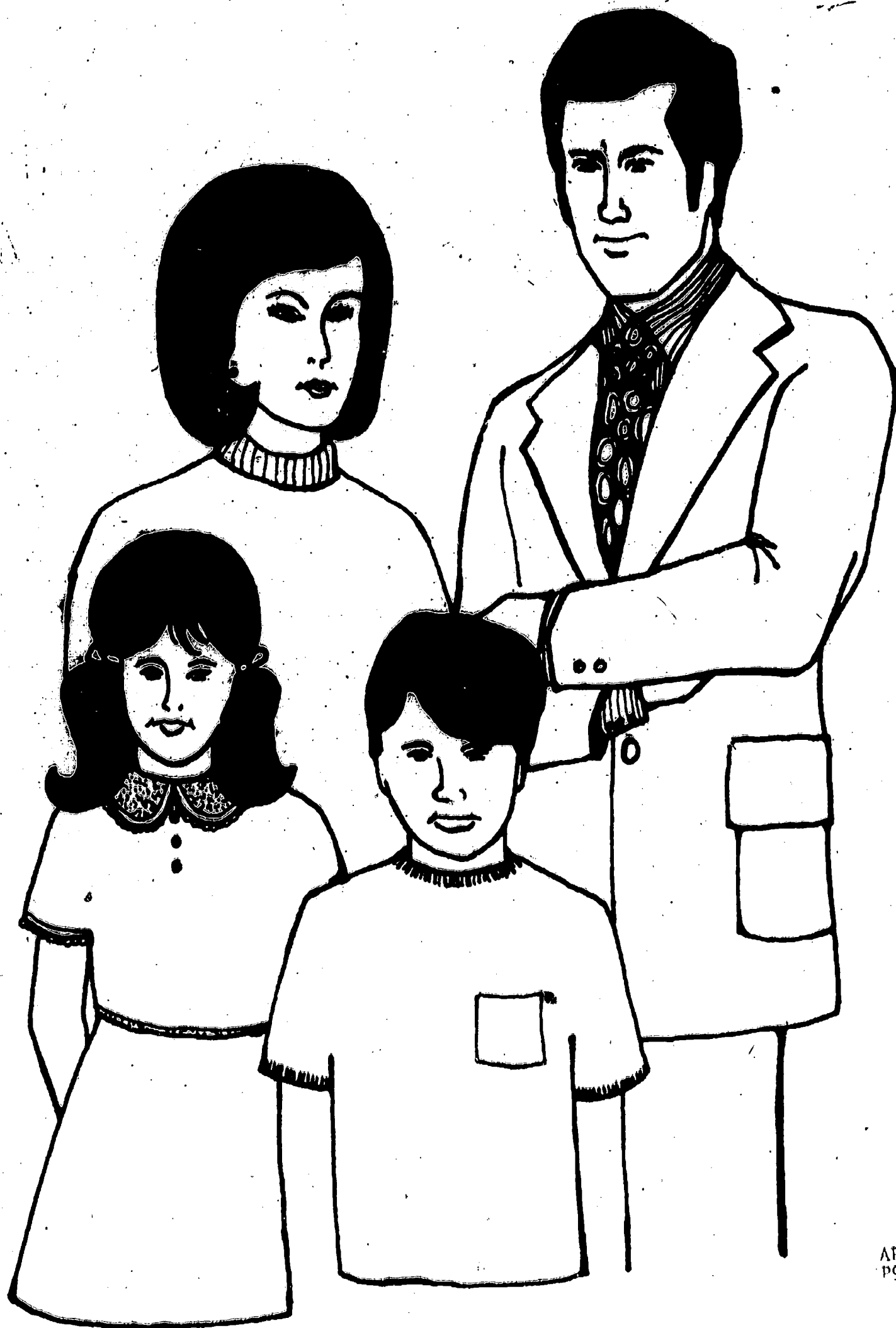









BEST COPY AVAILABLE

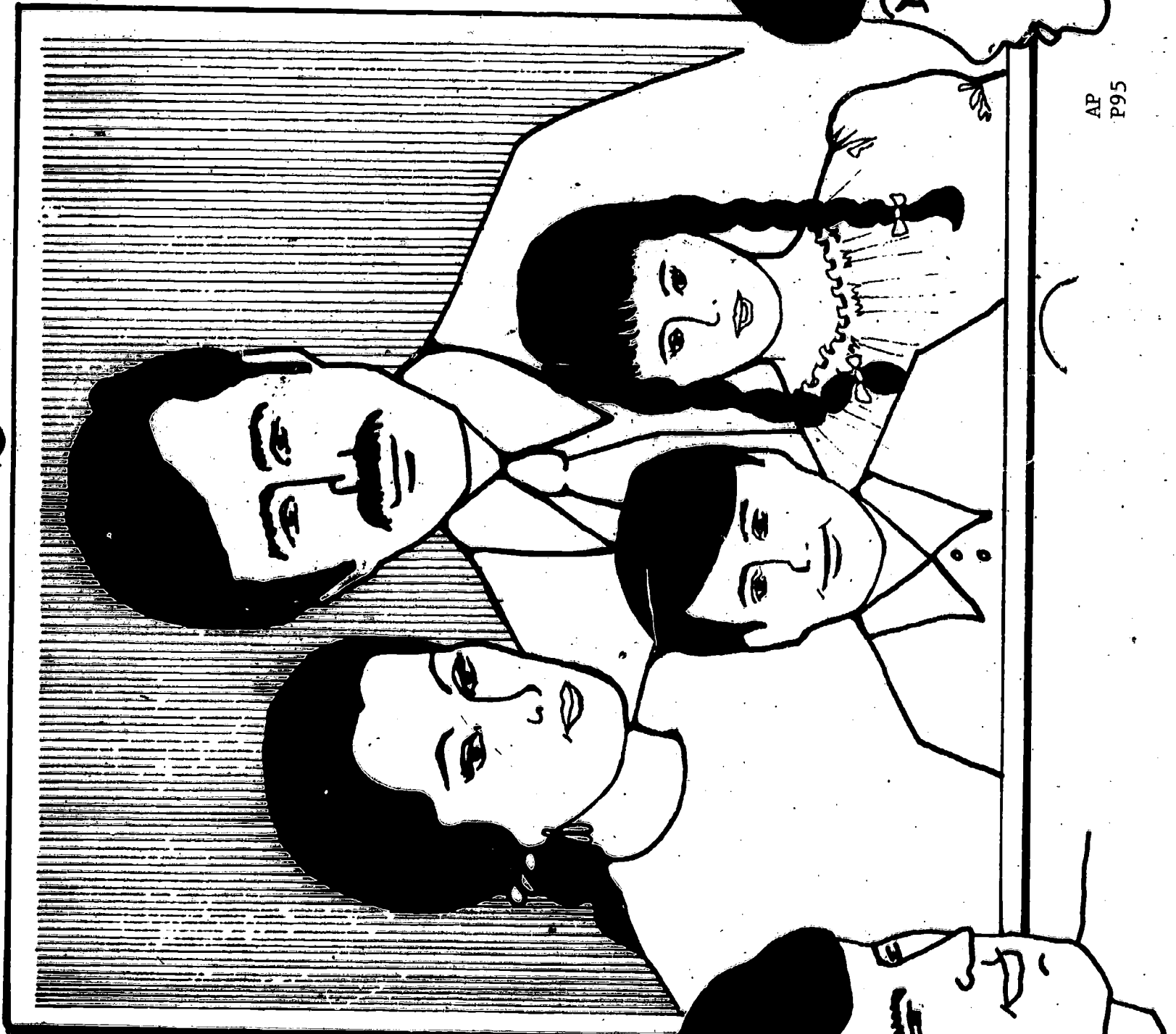

AP  
P95

BEST COPY AVAILABLE

AP  
P96





BEST COPY AVAILABLE

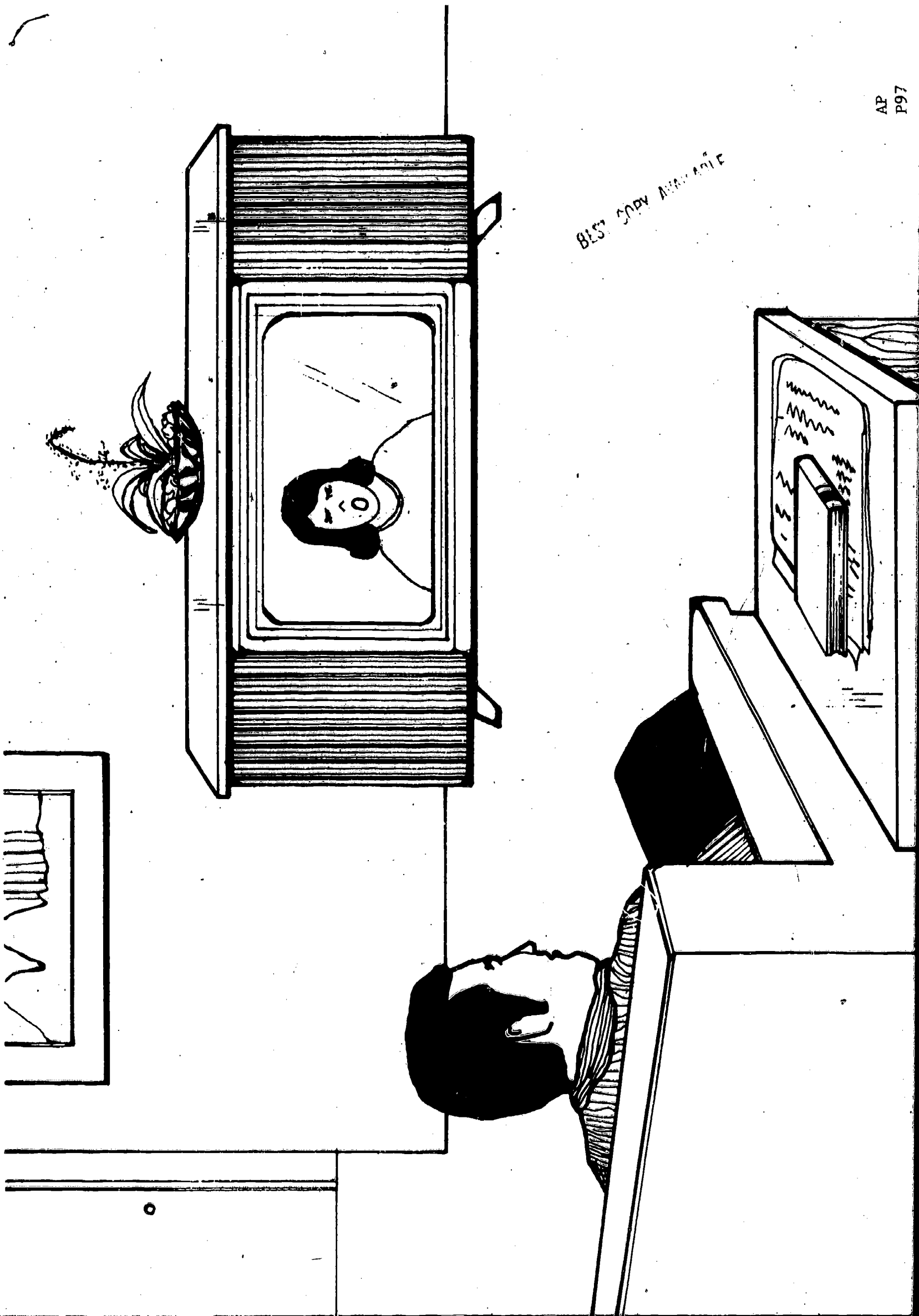



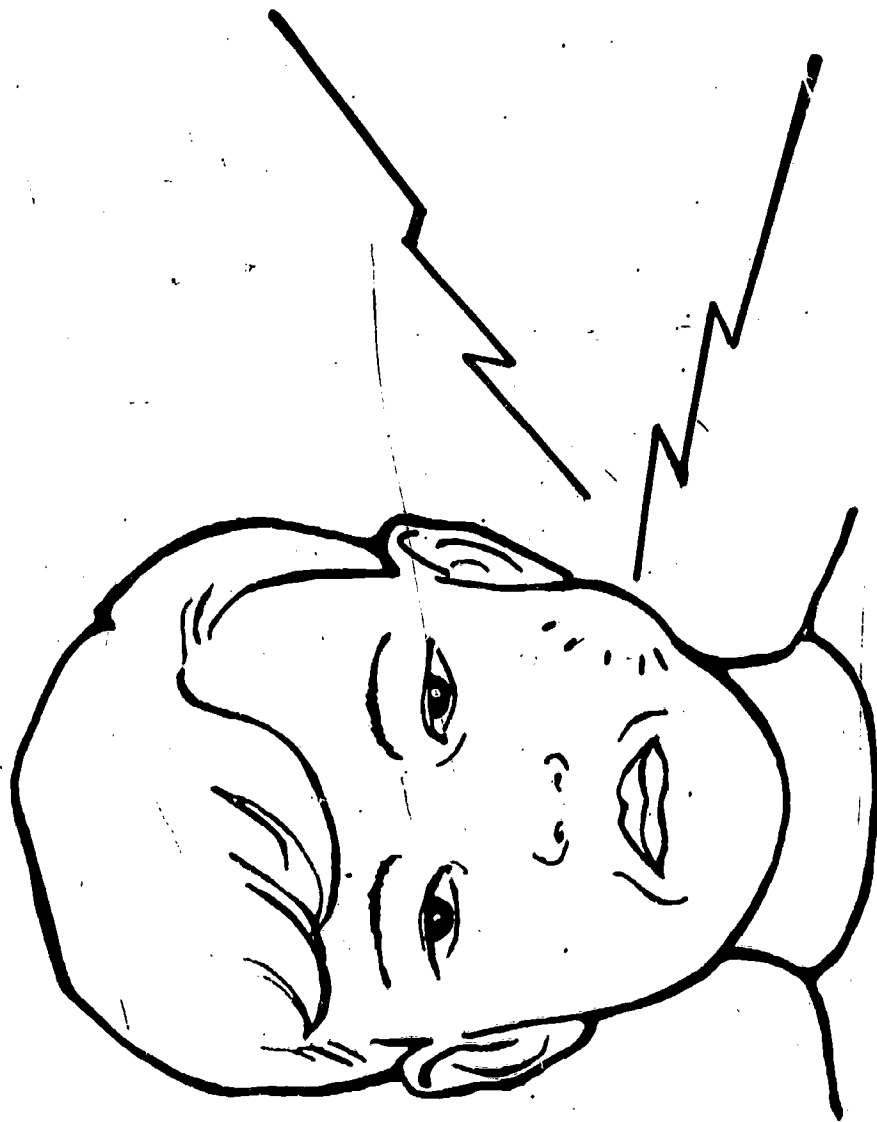



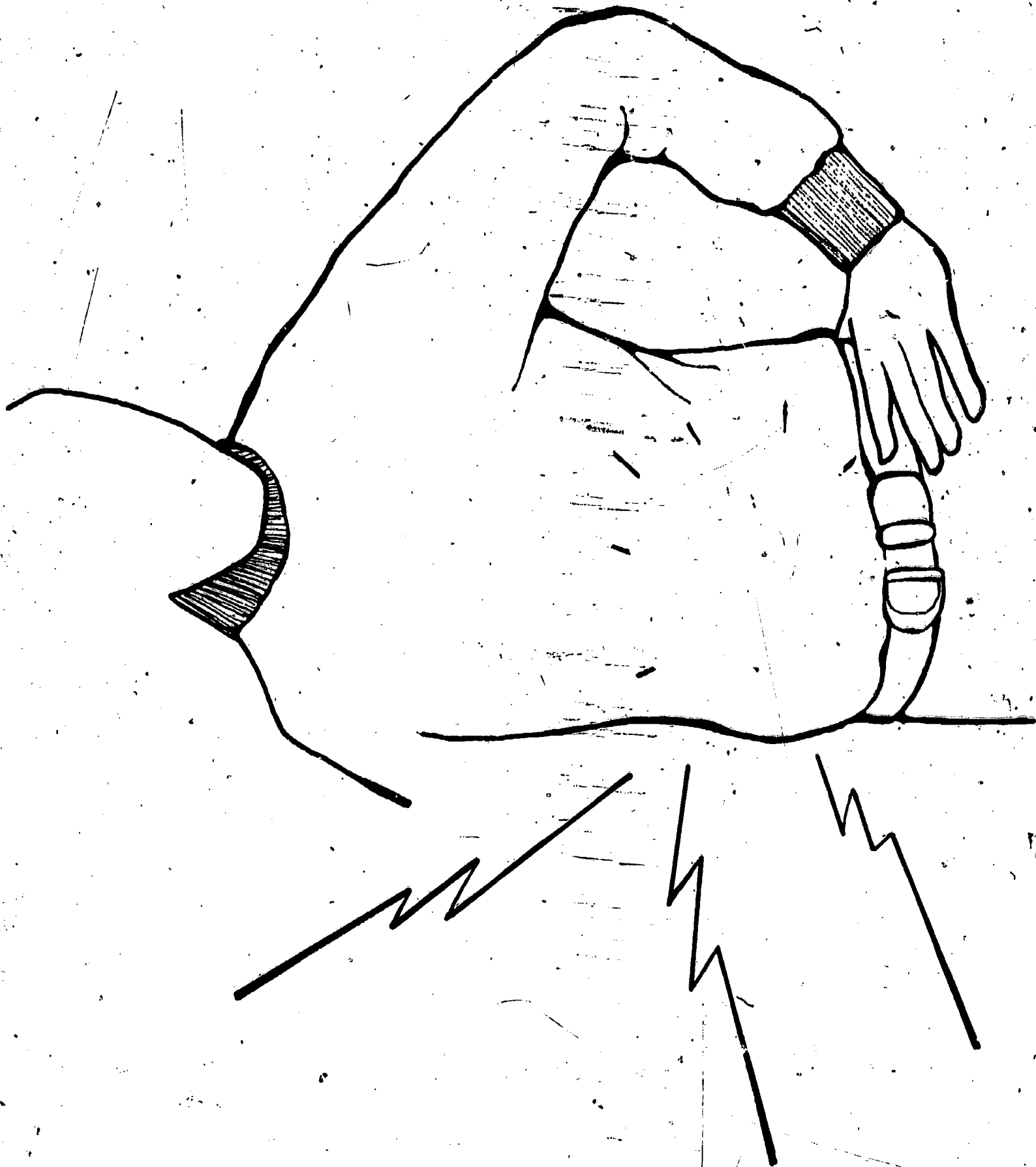

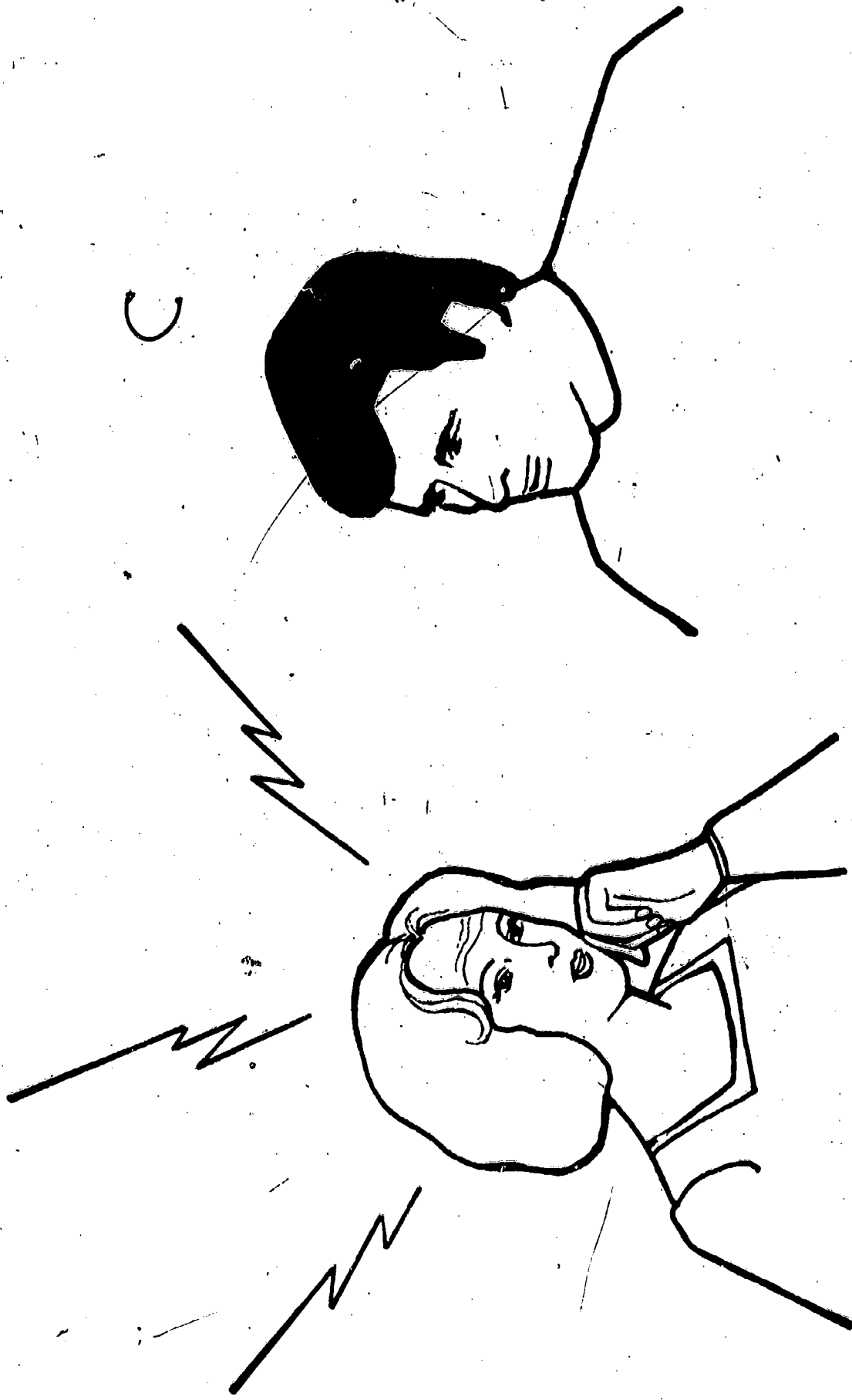

2

AP  
P103



AP  
PI04

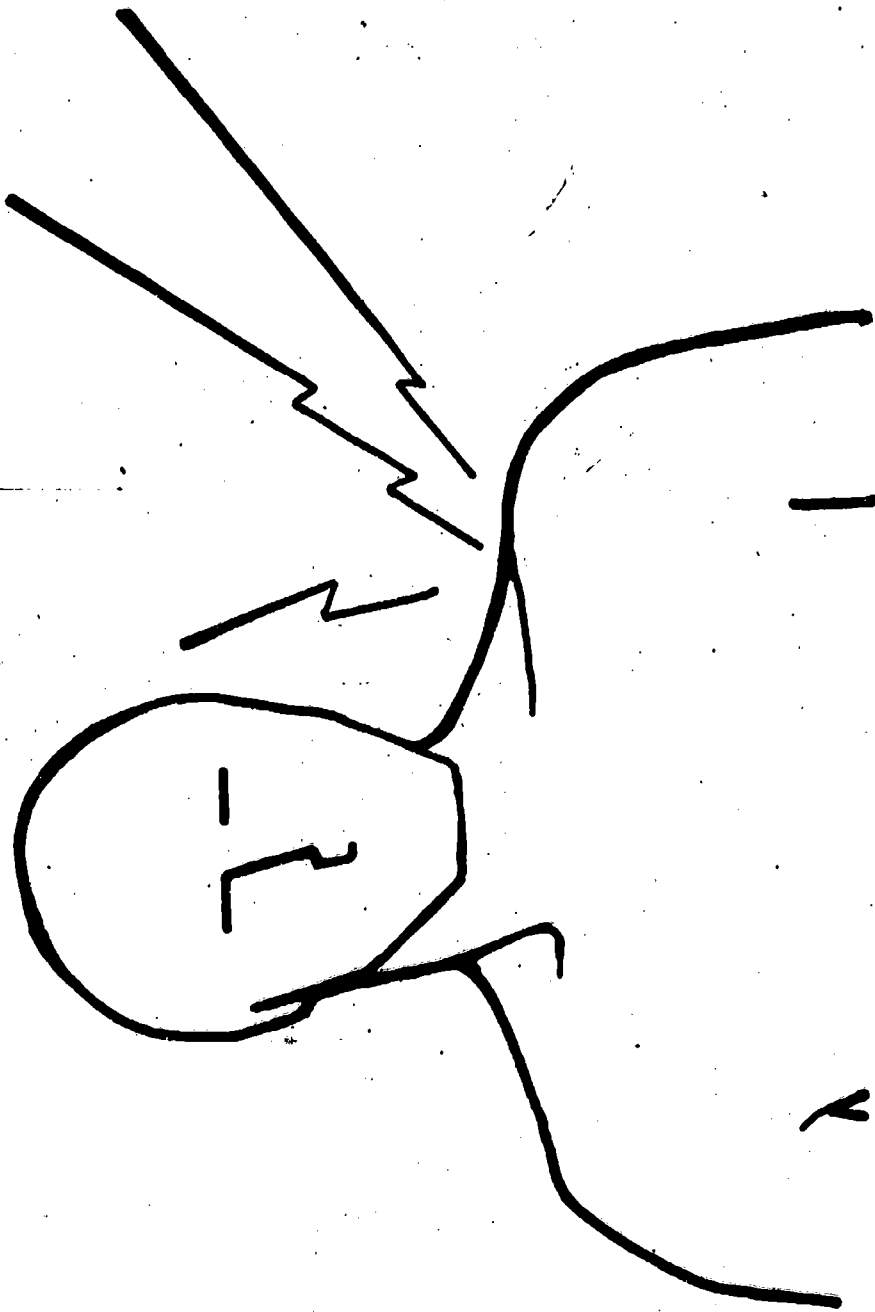



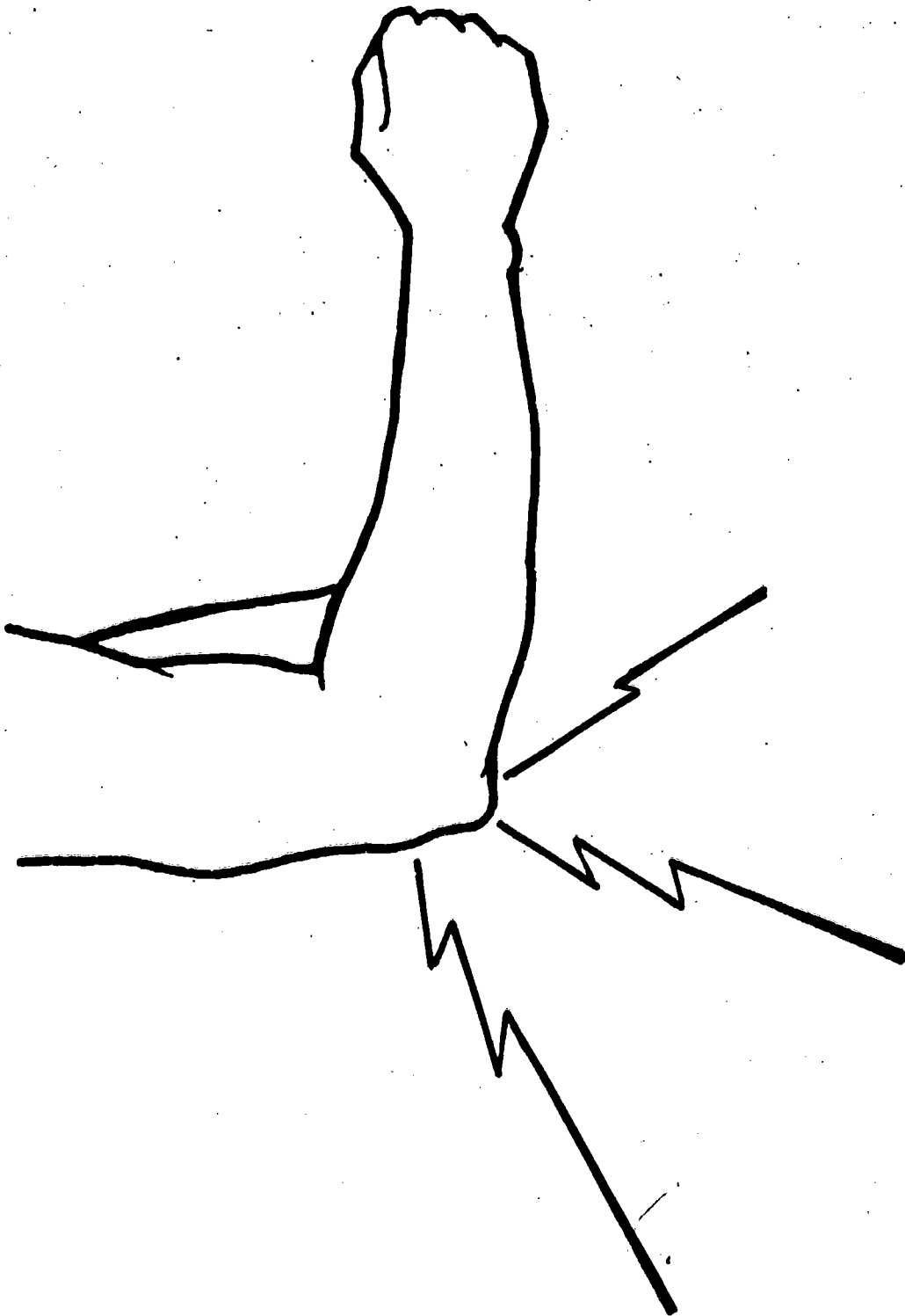

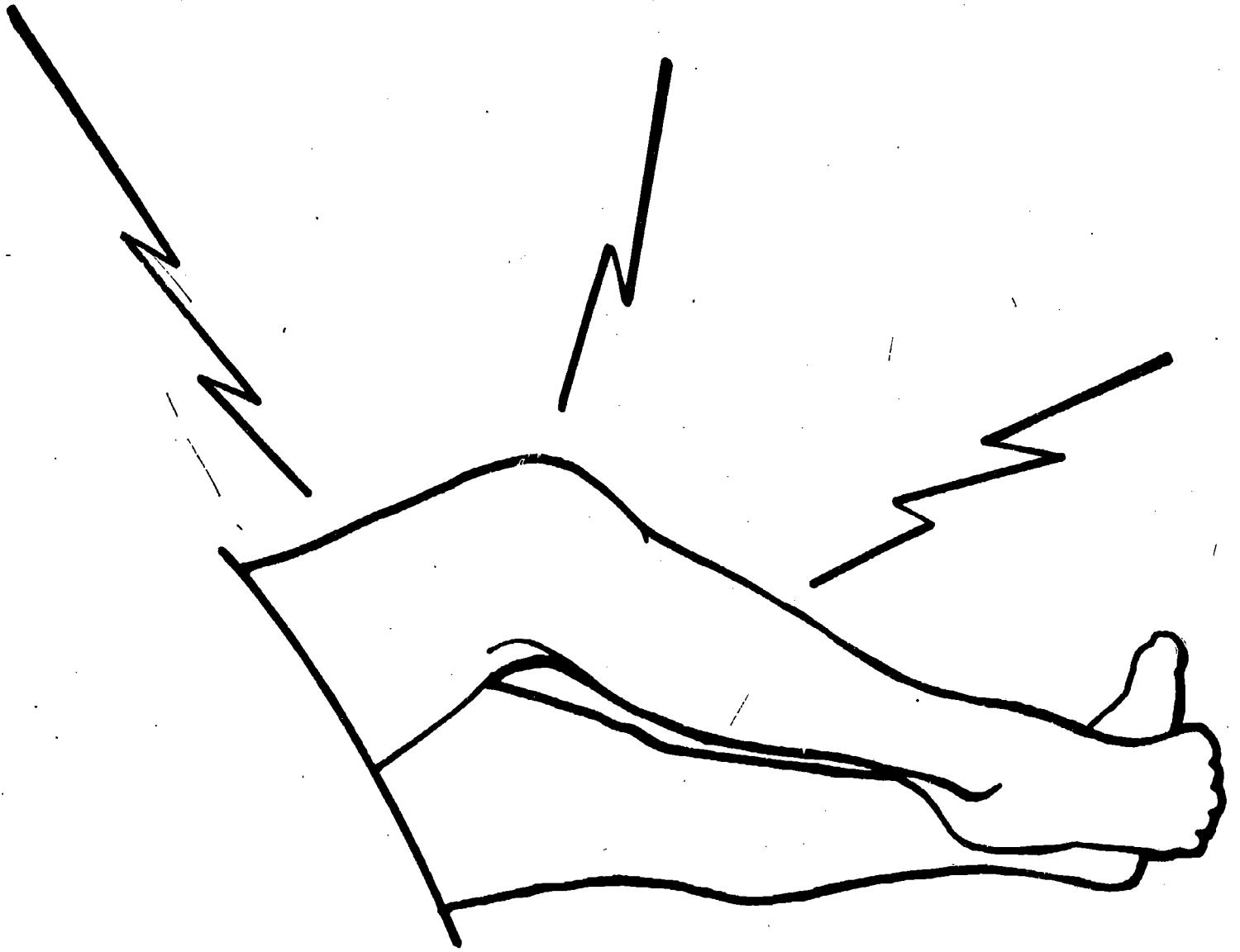

AP  
PI07

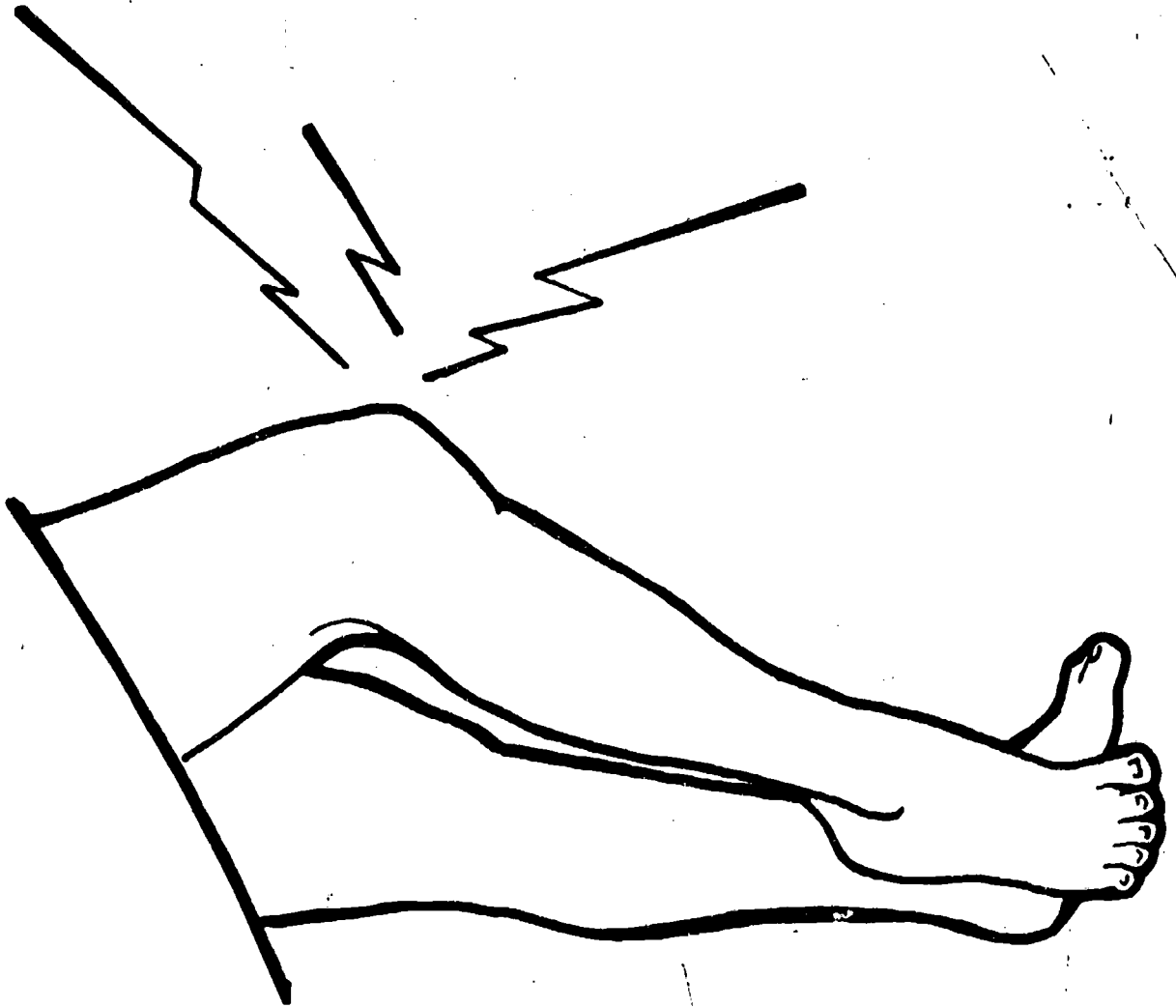

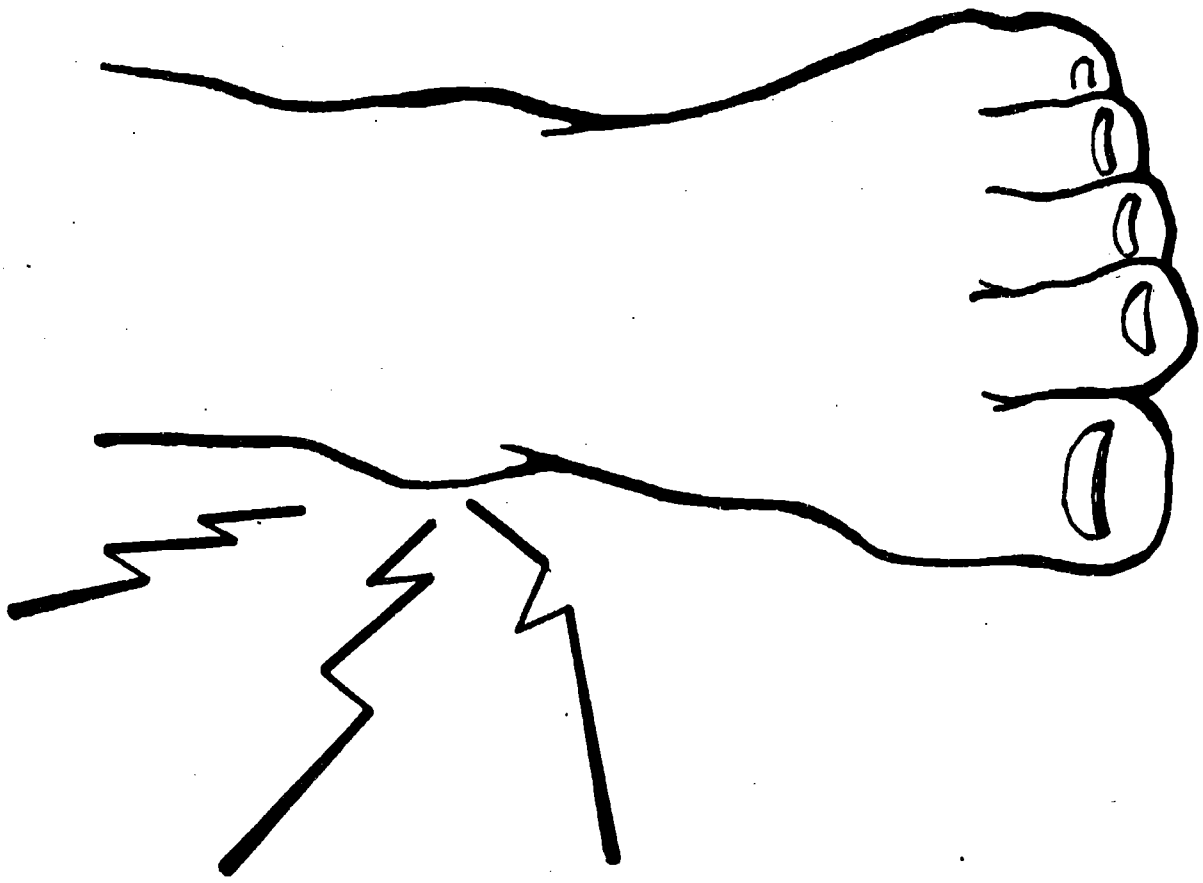

AP  
P109

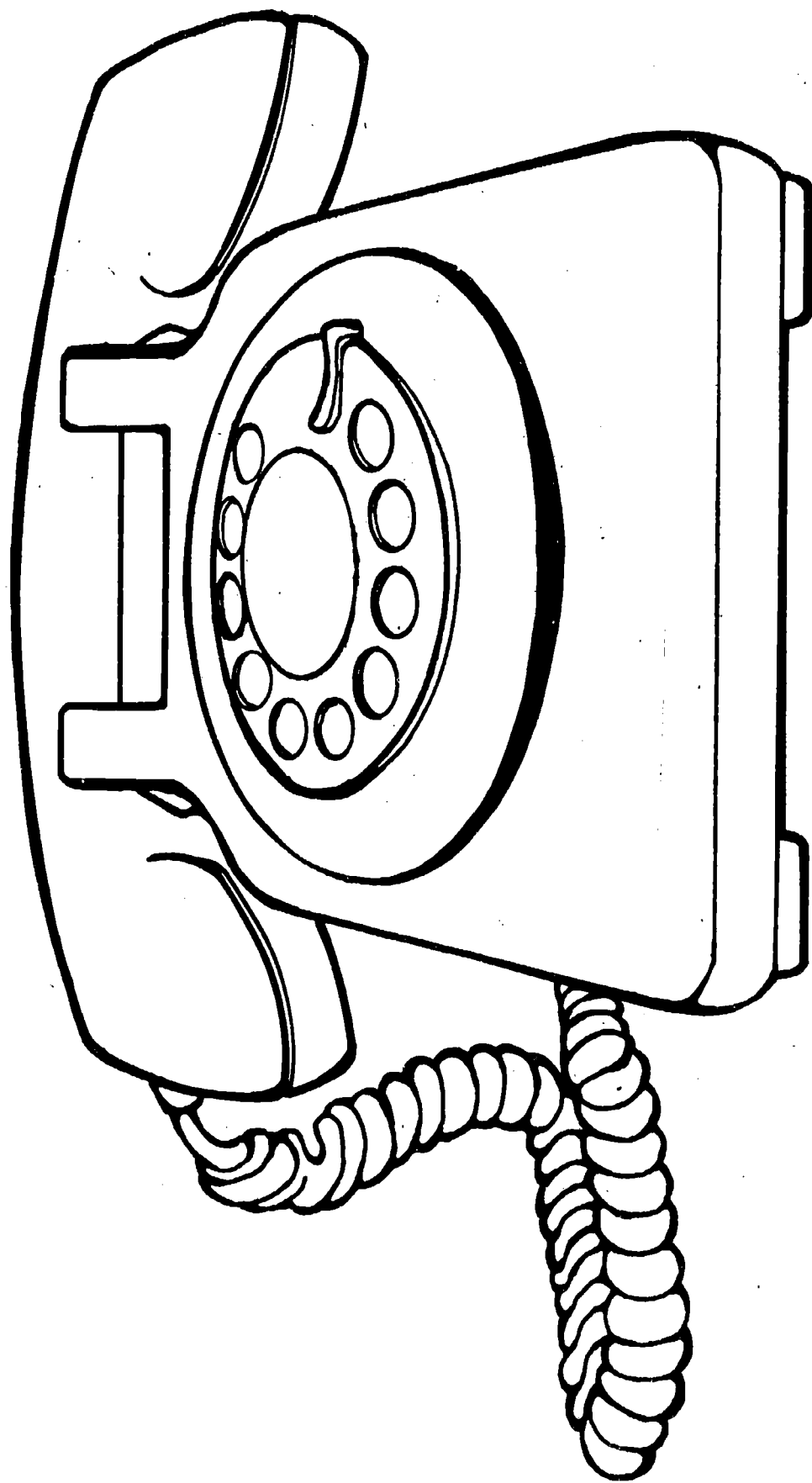

AP  
P110

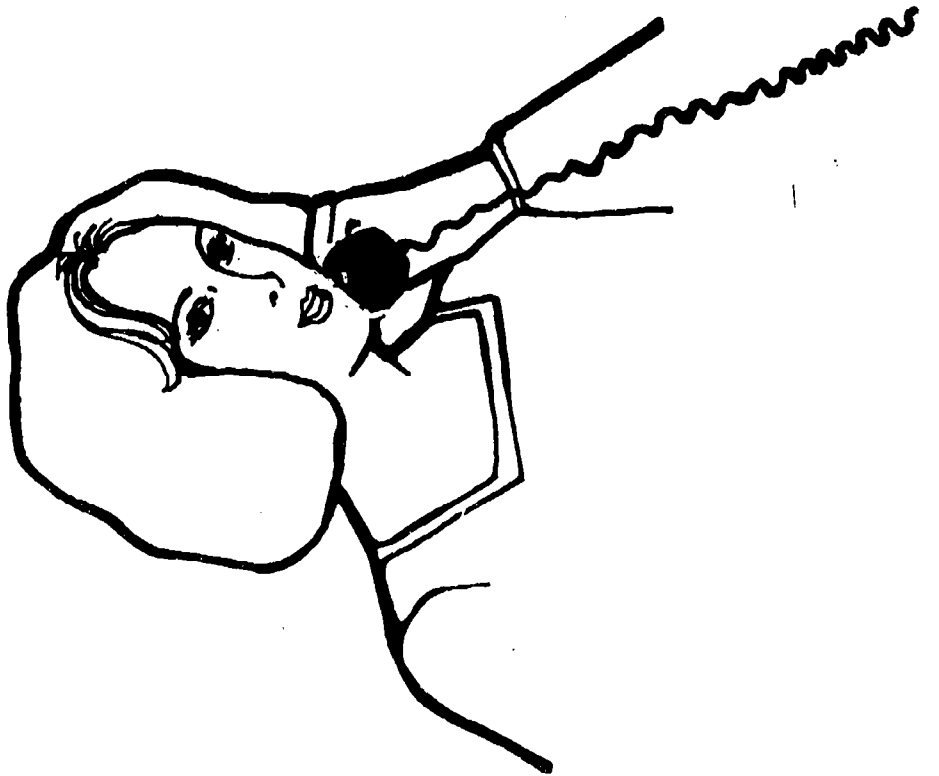
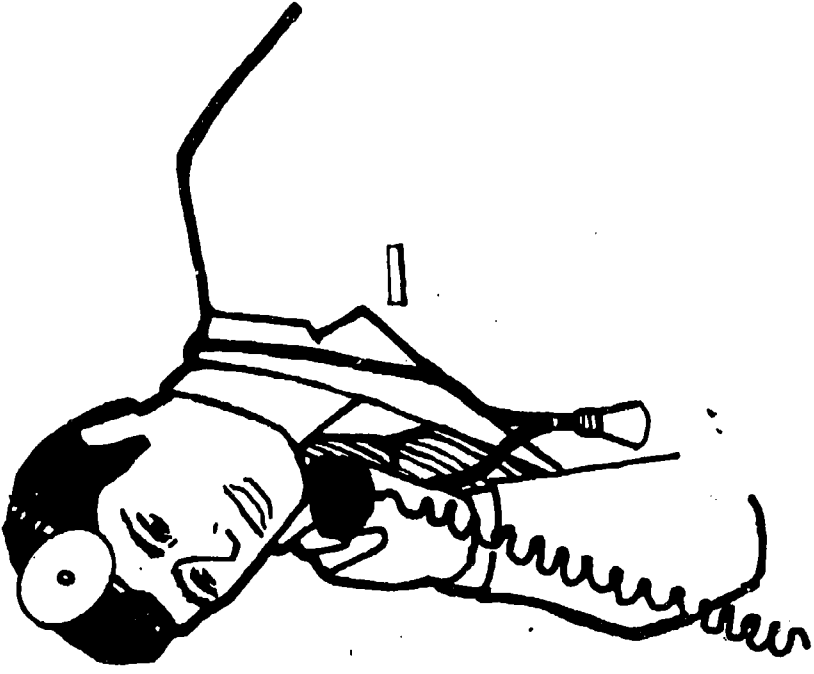

BEST COPY AVAILABLE

AP  
P111

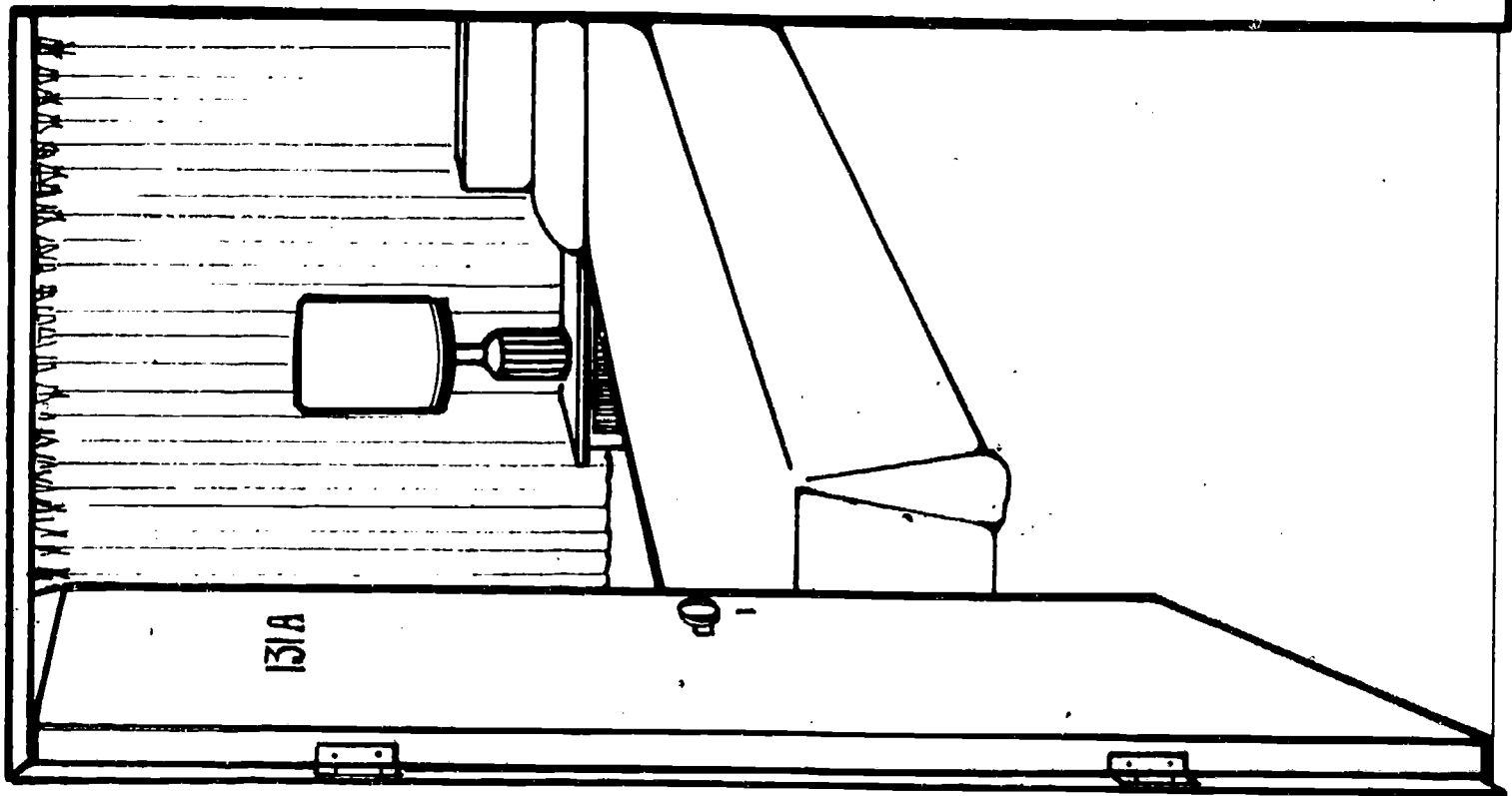

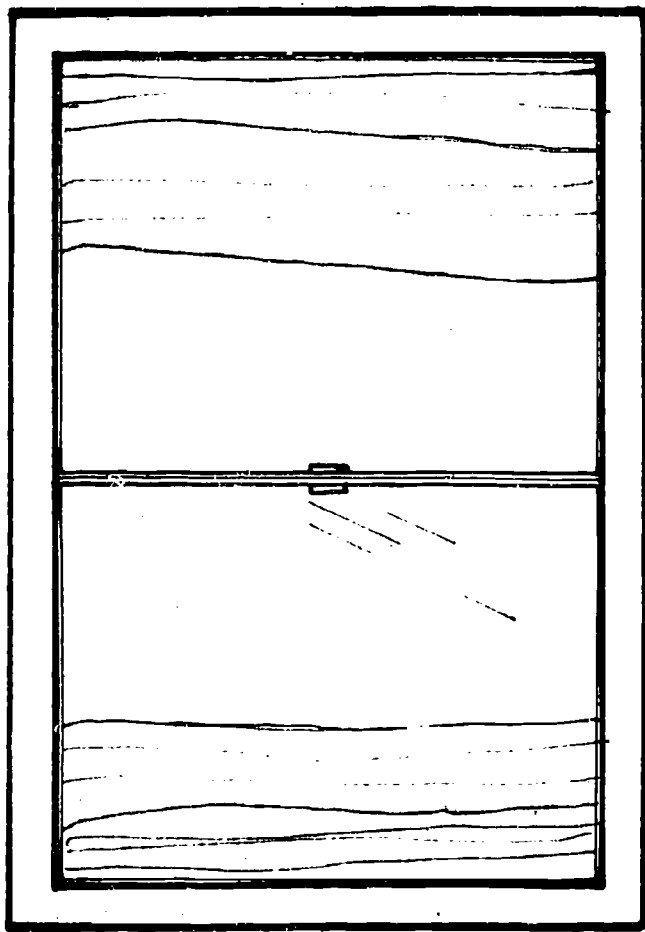

2000-0000-0000

AP  
P112

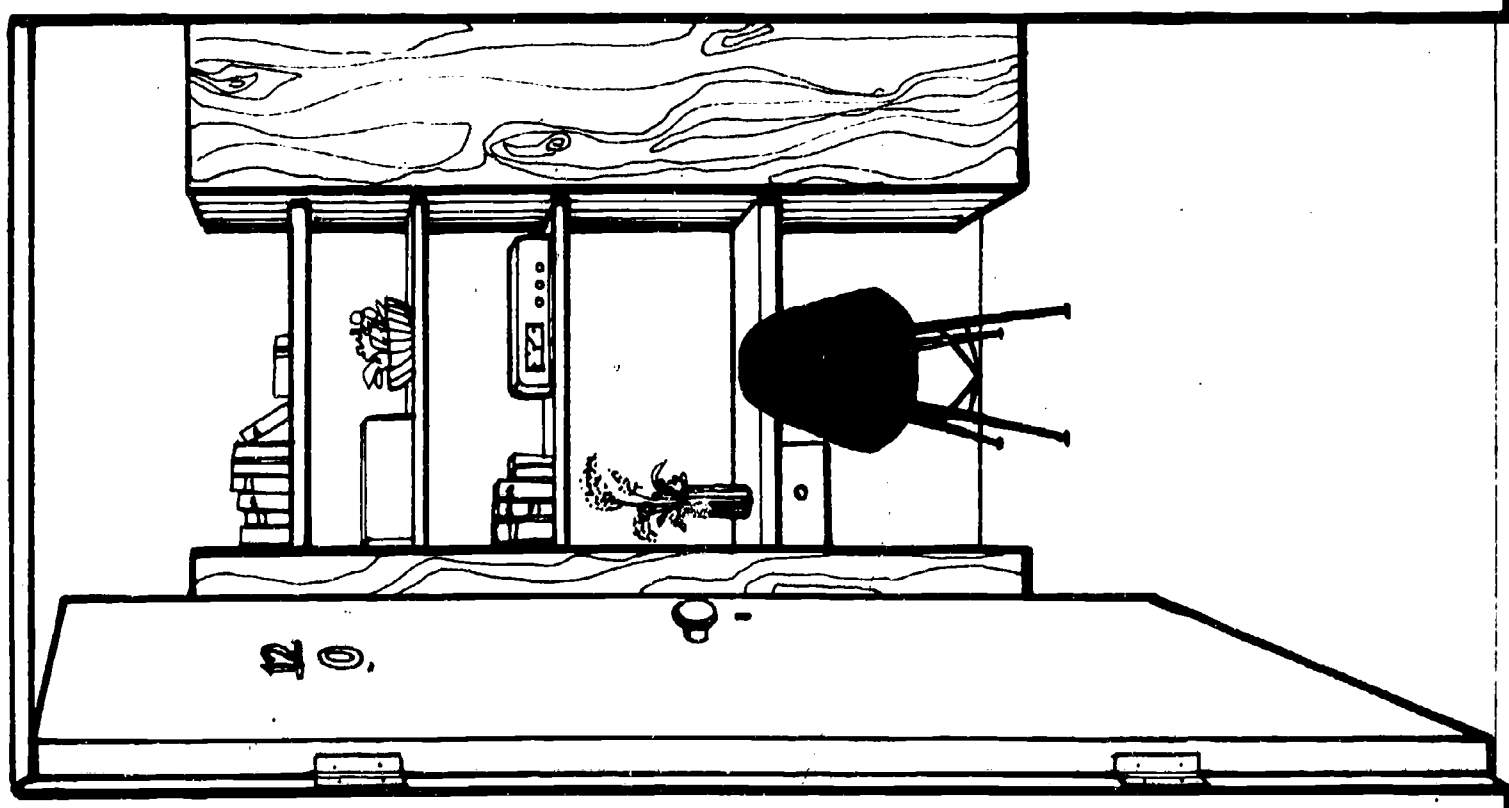



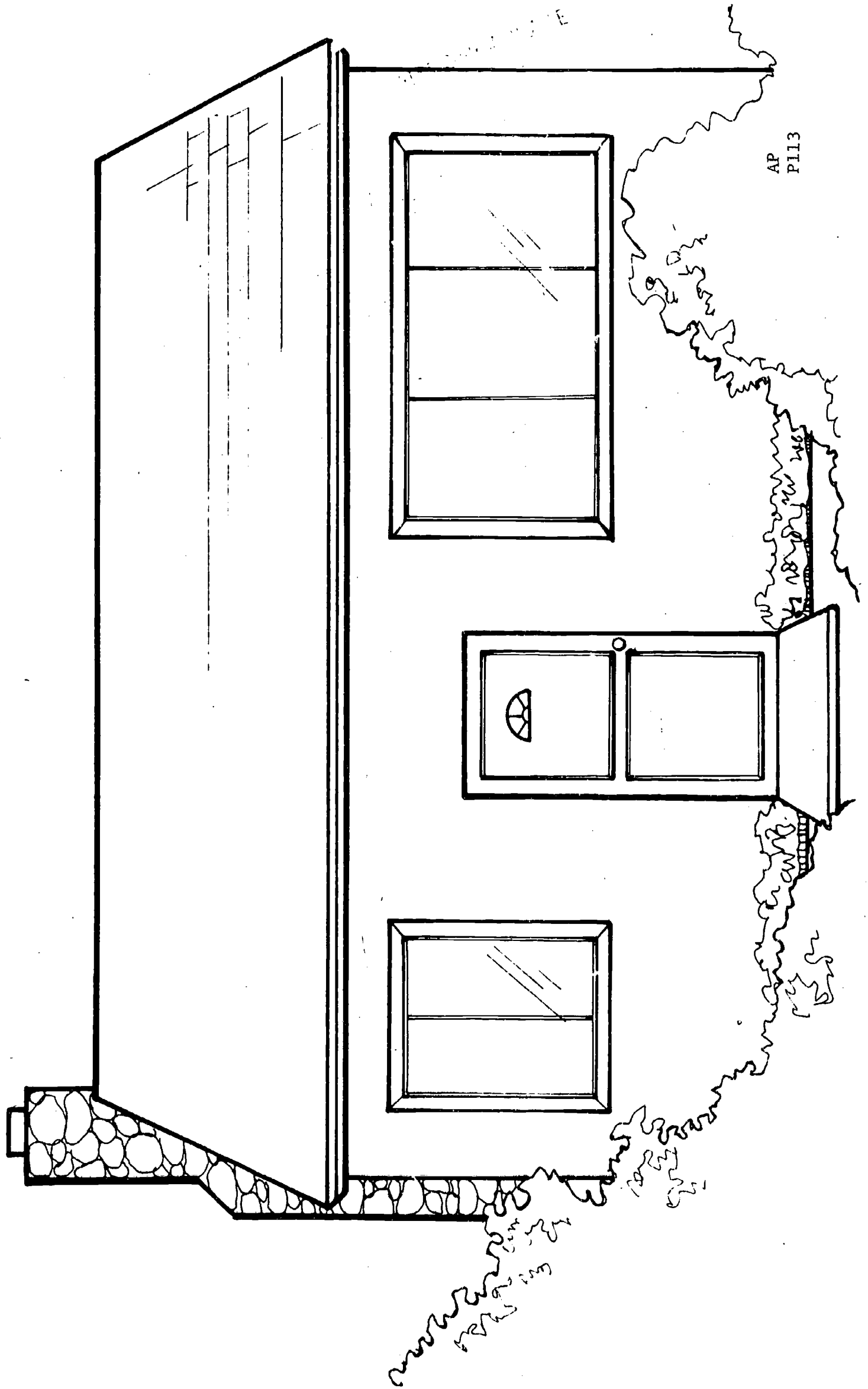

AP  
P113

COPY COPY

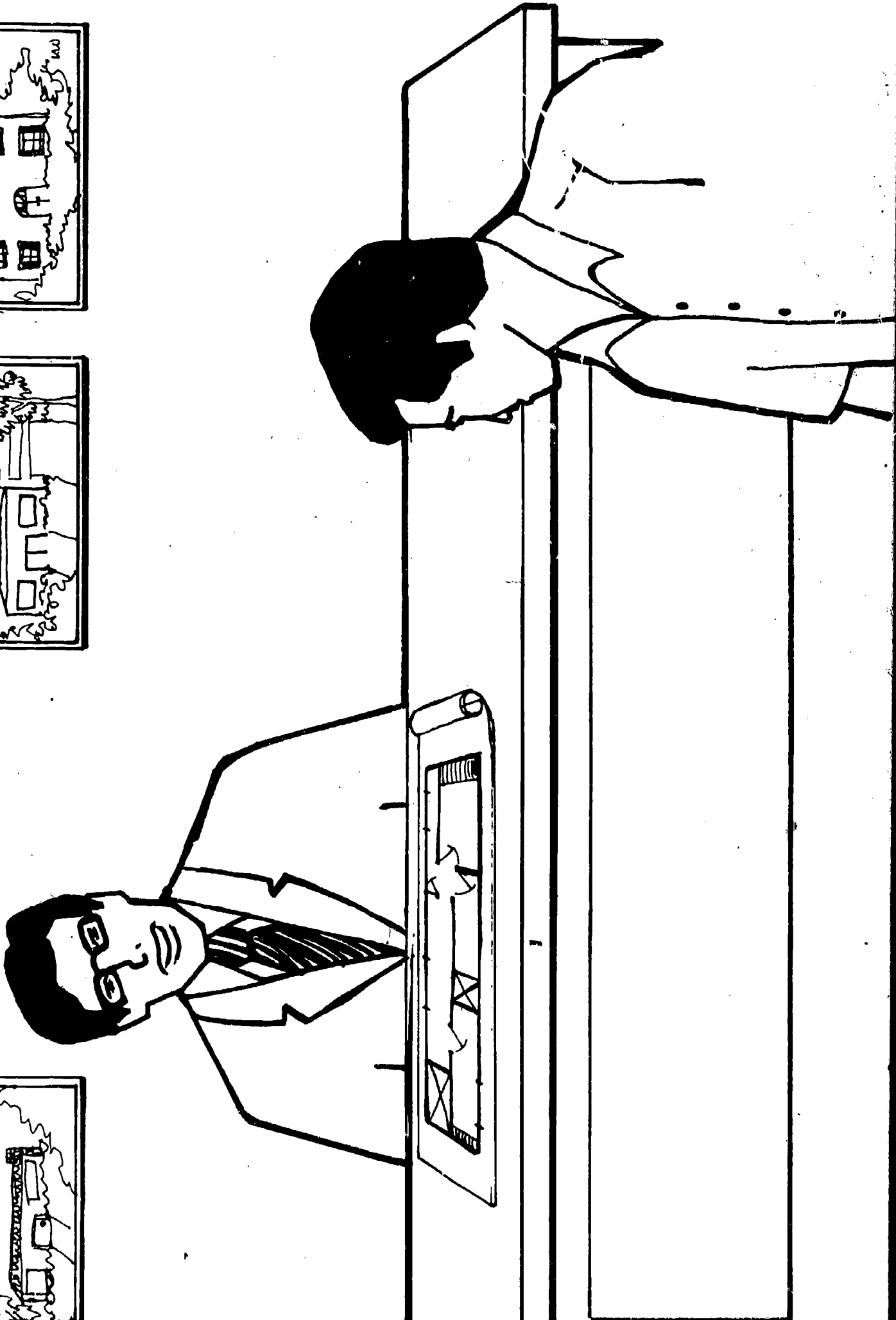
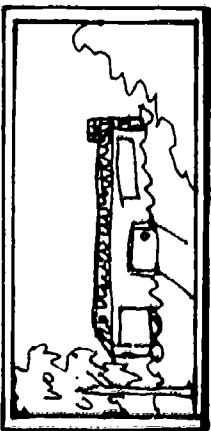
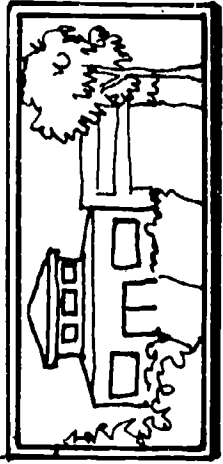
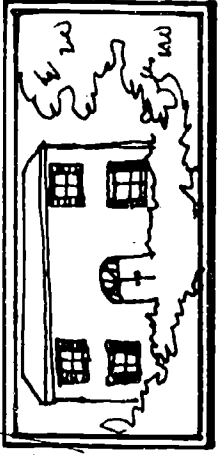

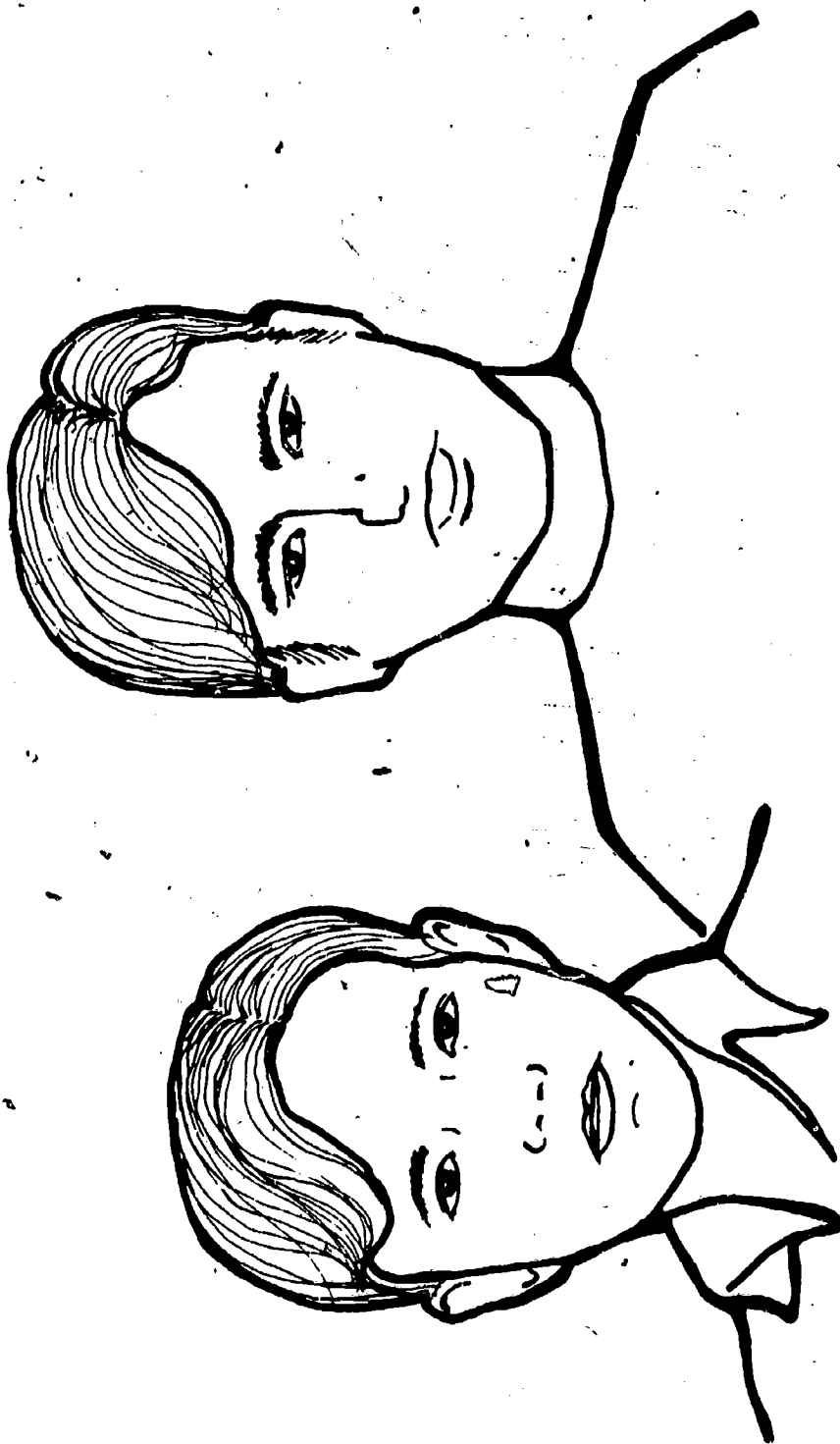

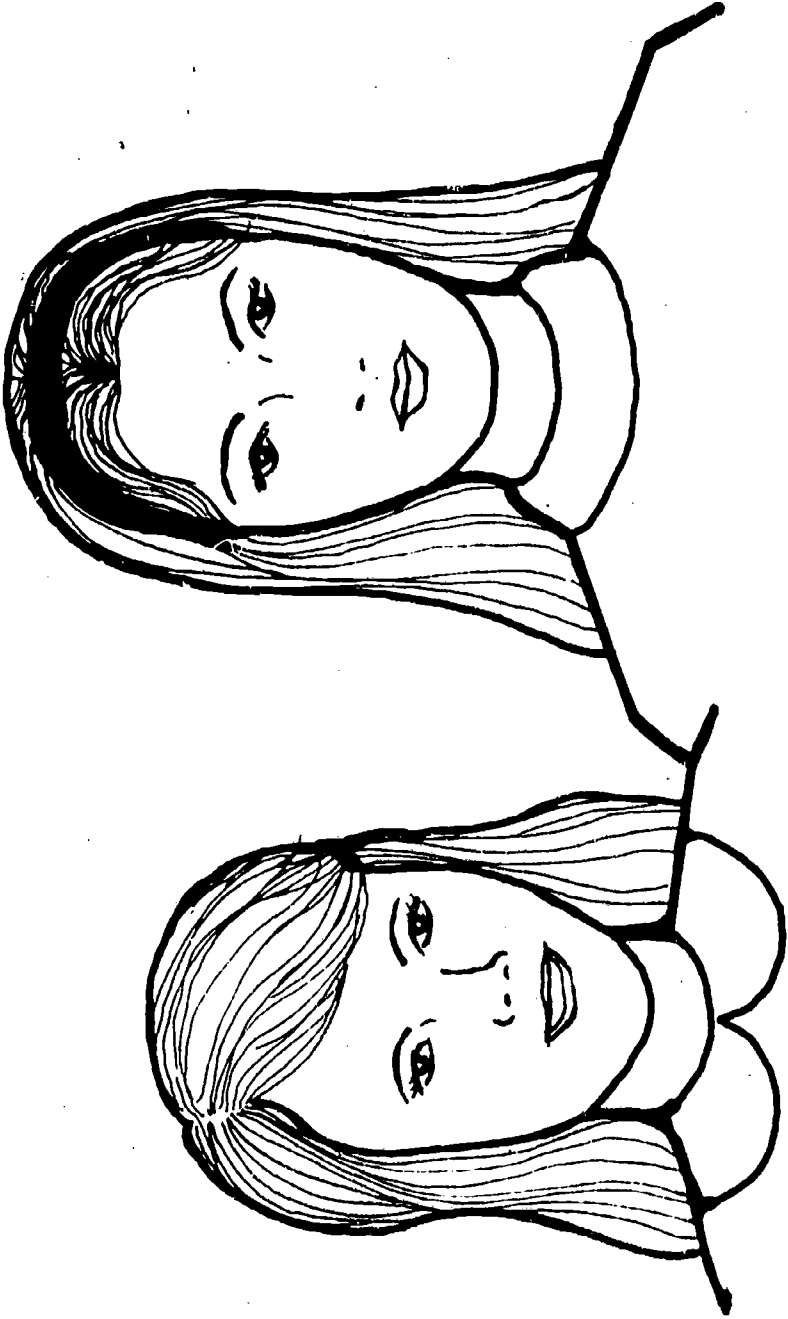

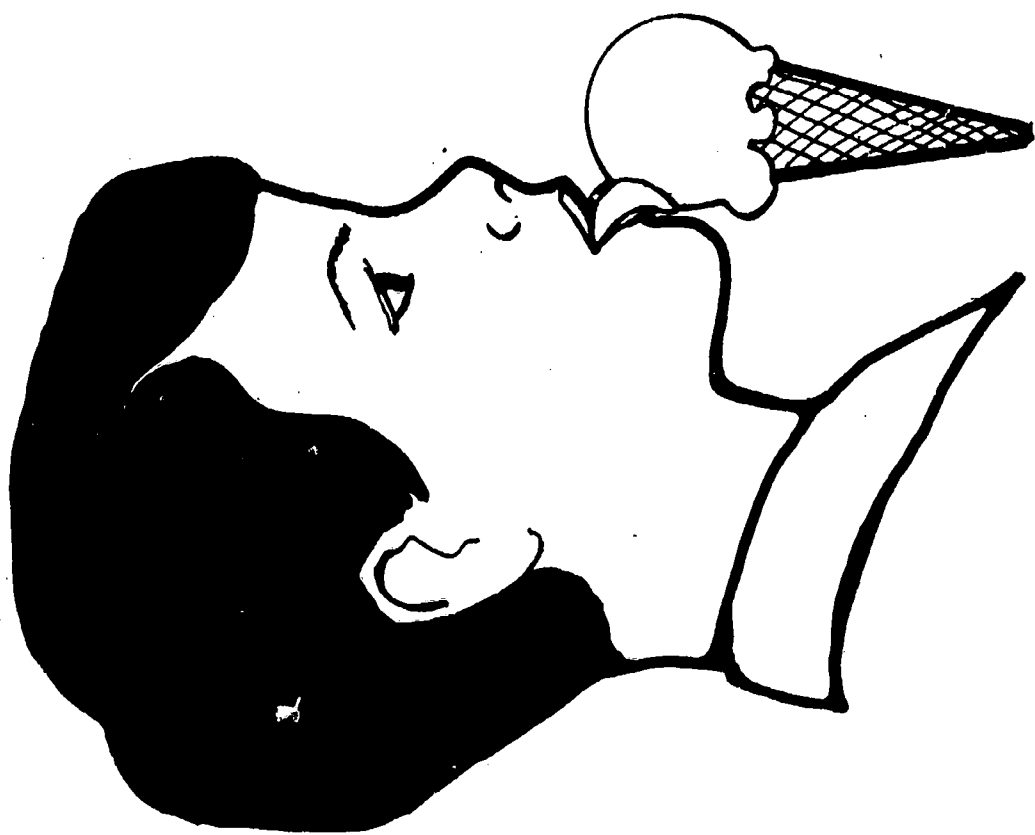

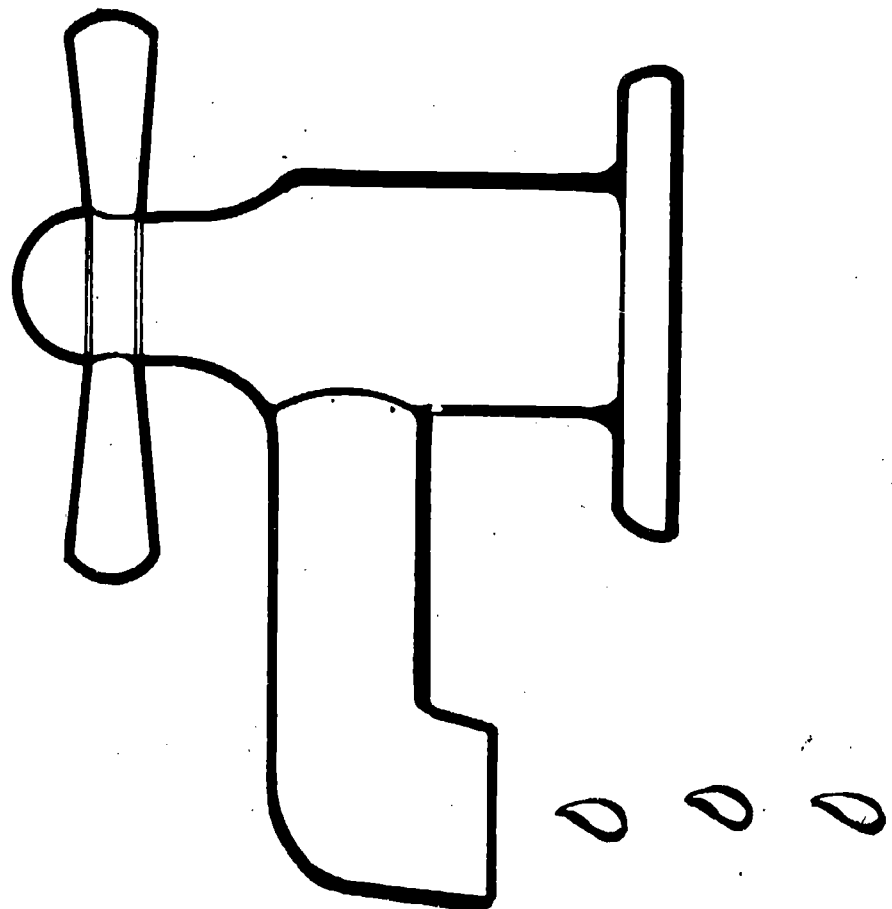

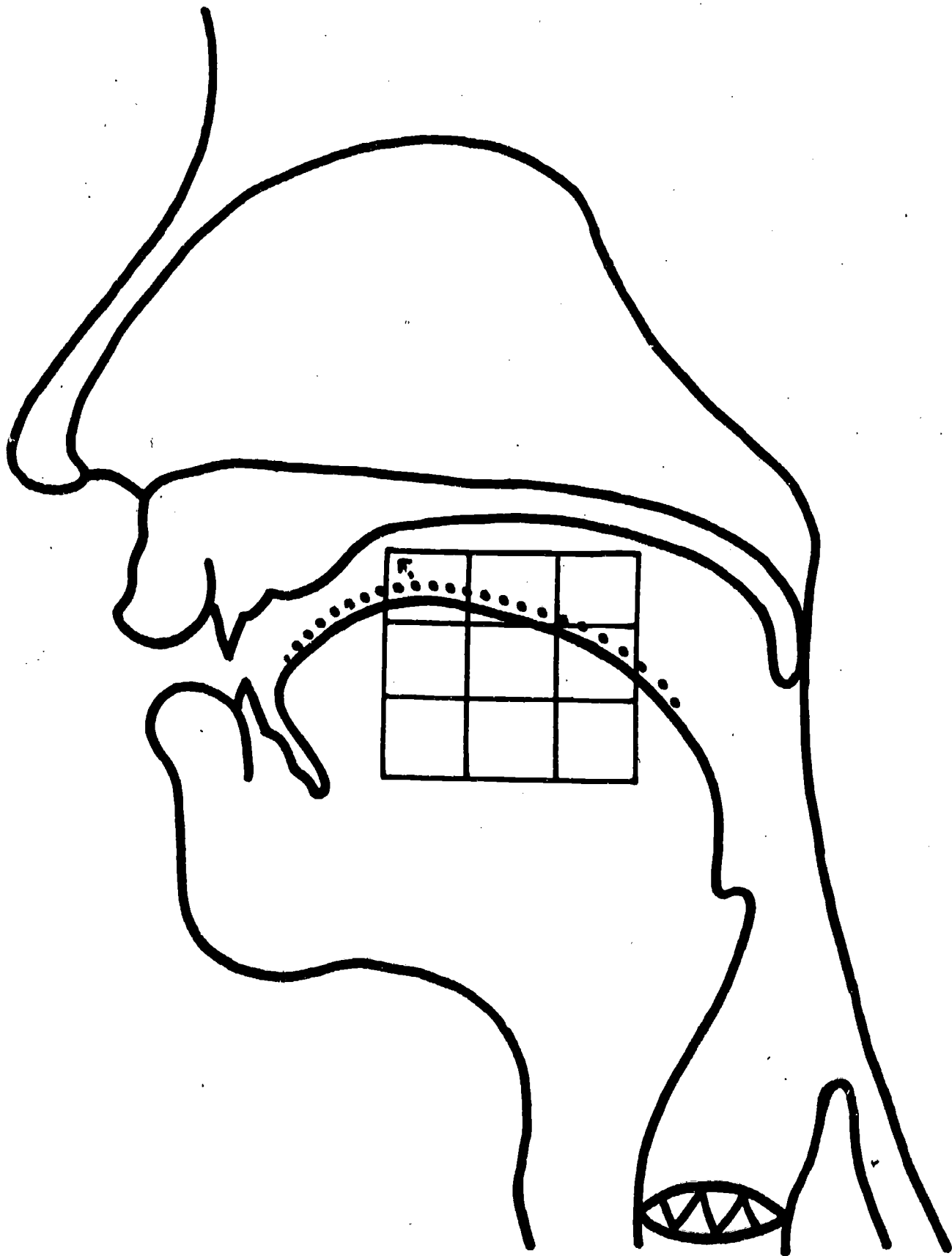

/r/ - /iy/....

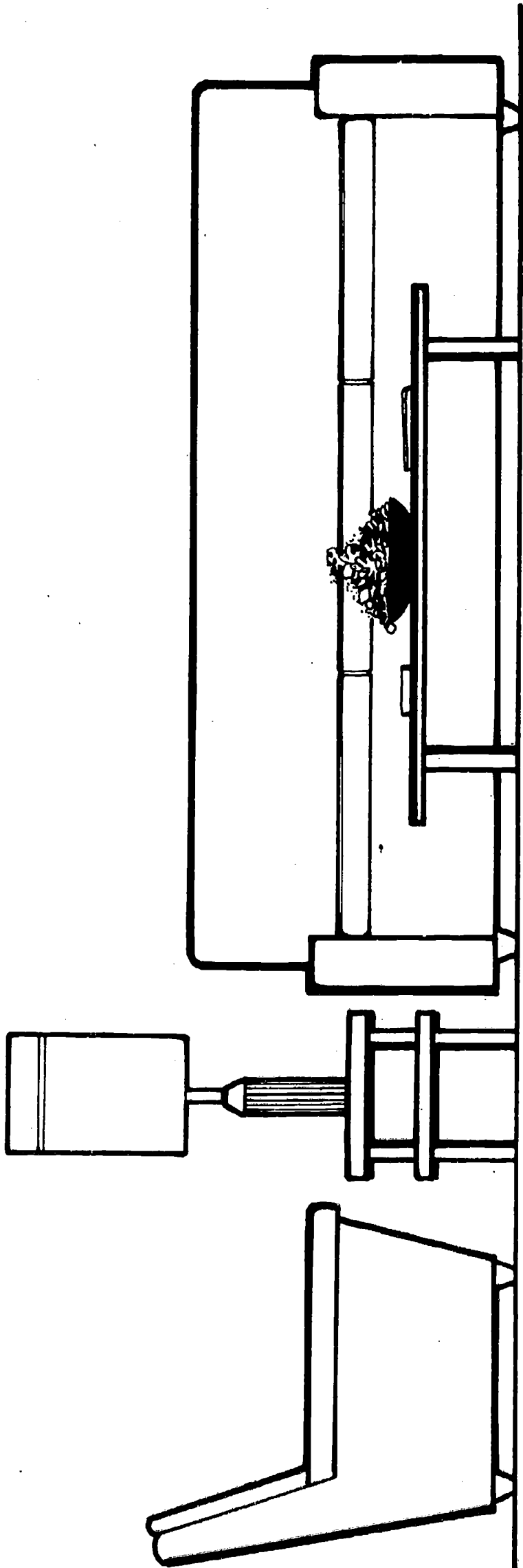



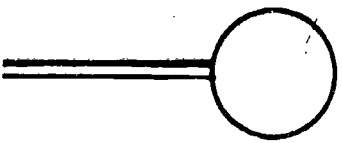
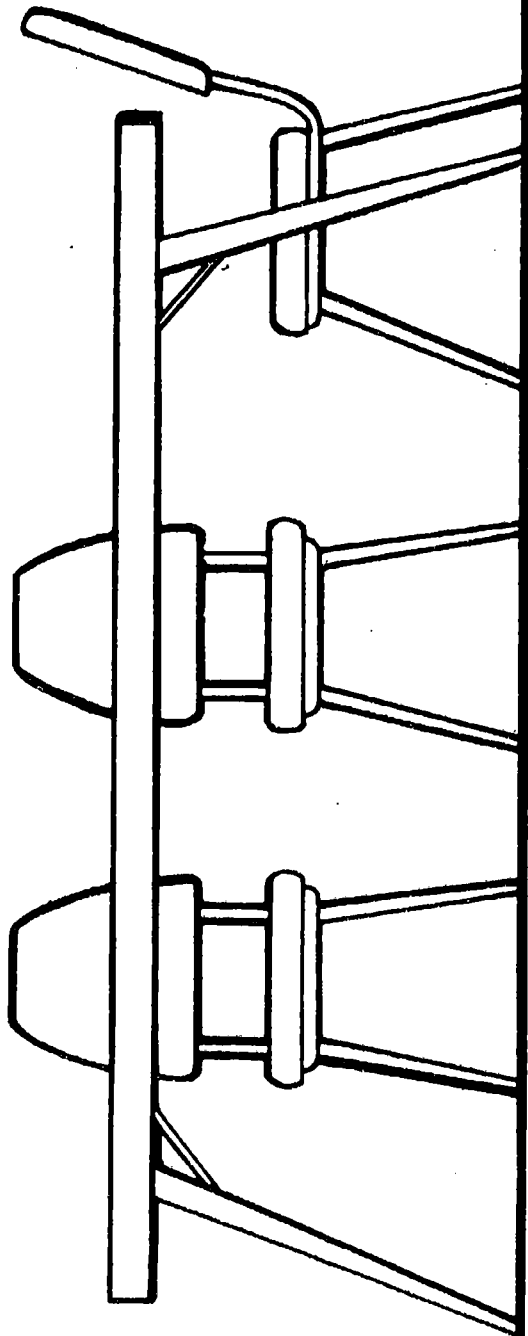
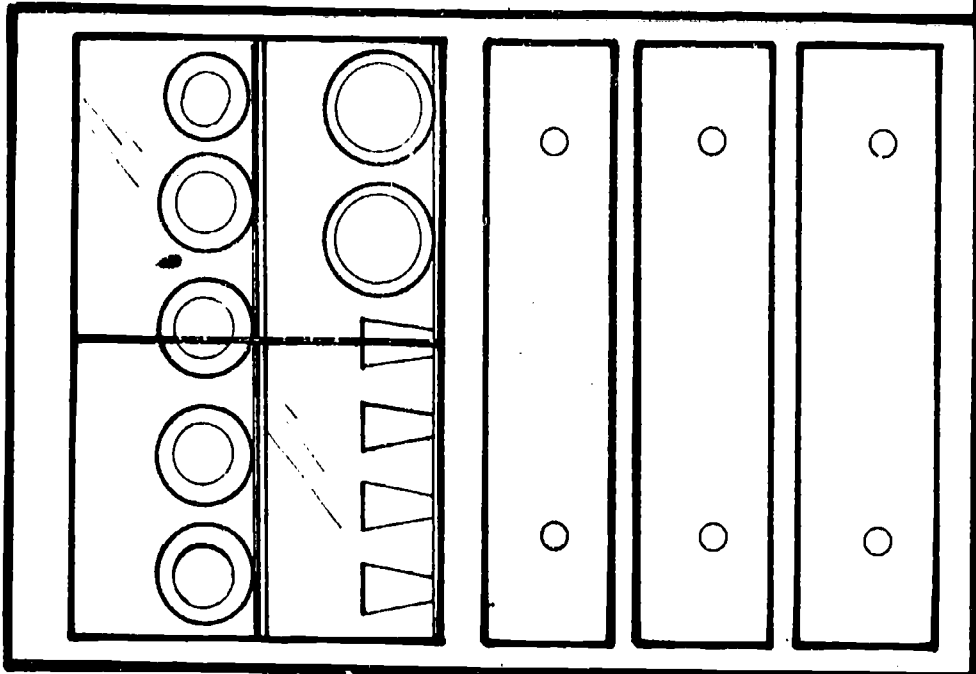

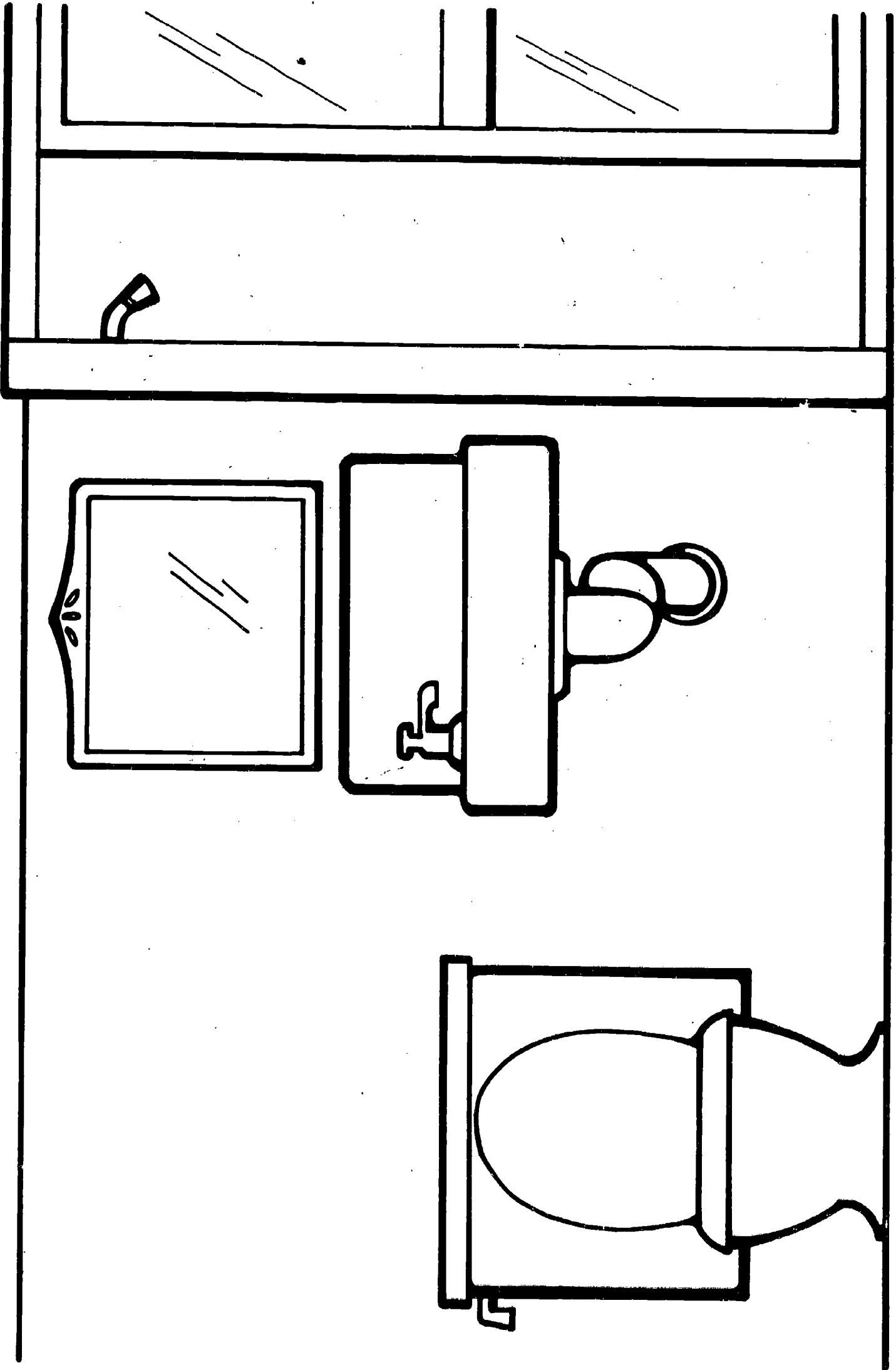

AP  
P122

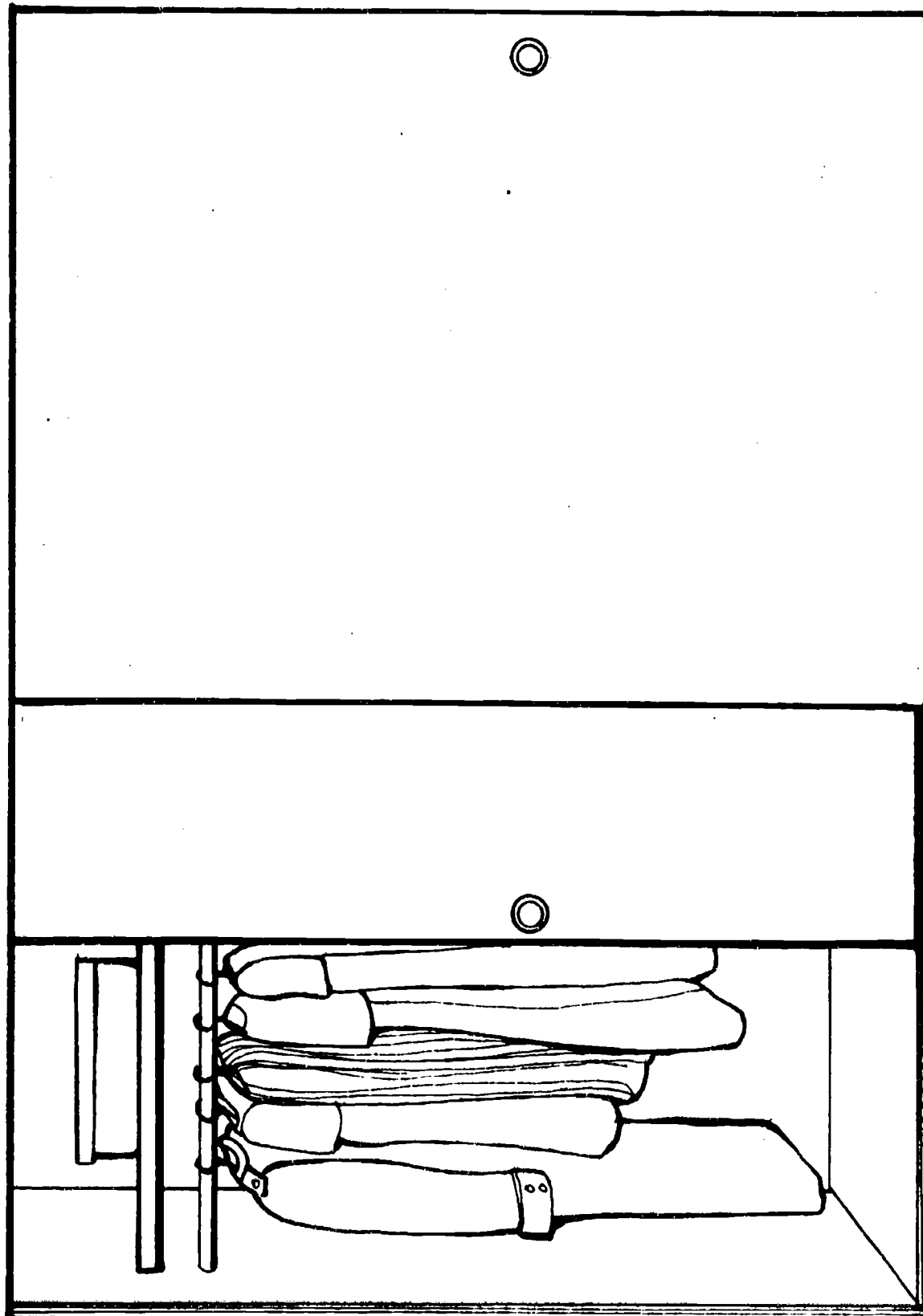

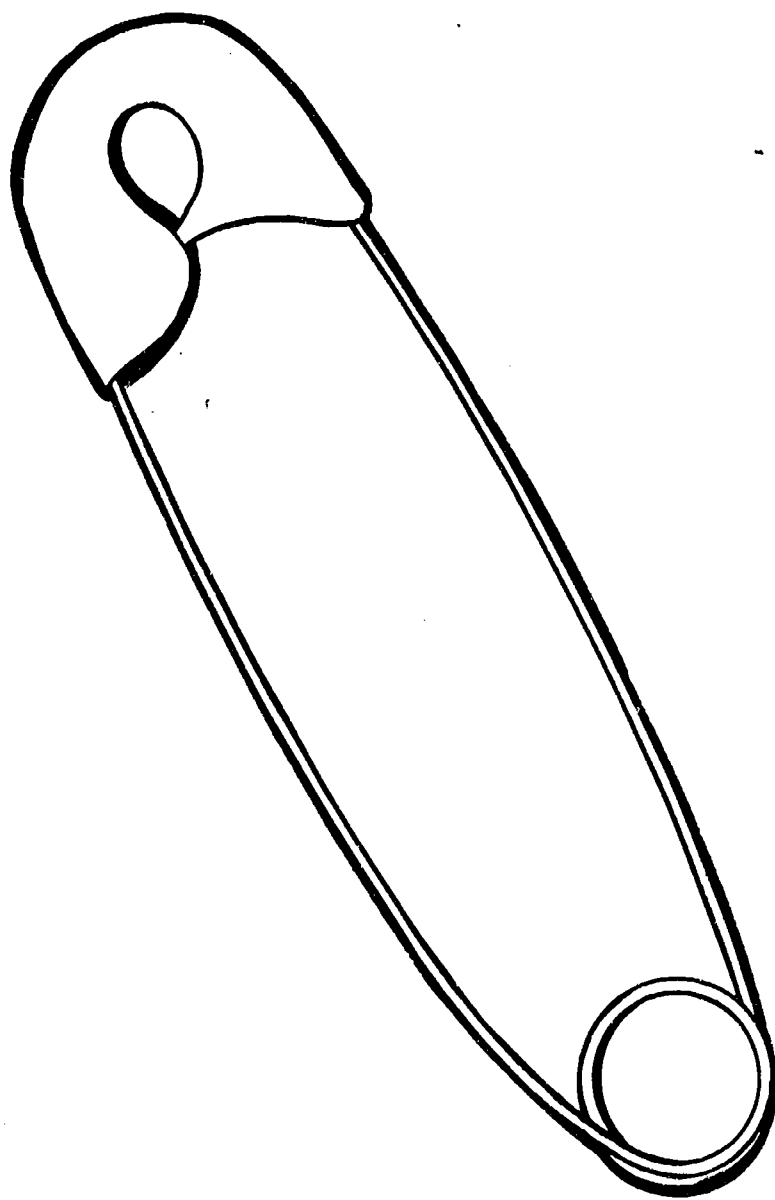



BREAST

DRUMSTICK

WING

BACK

THIGH

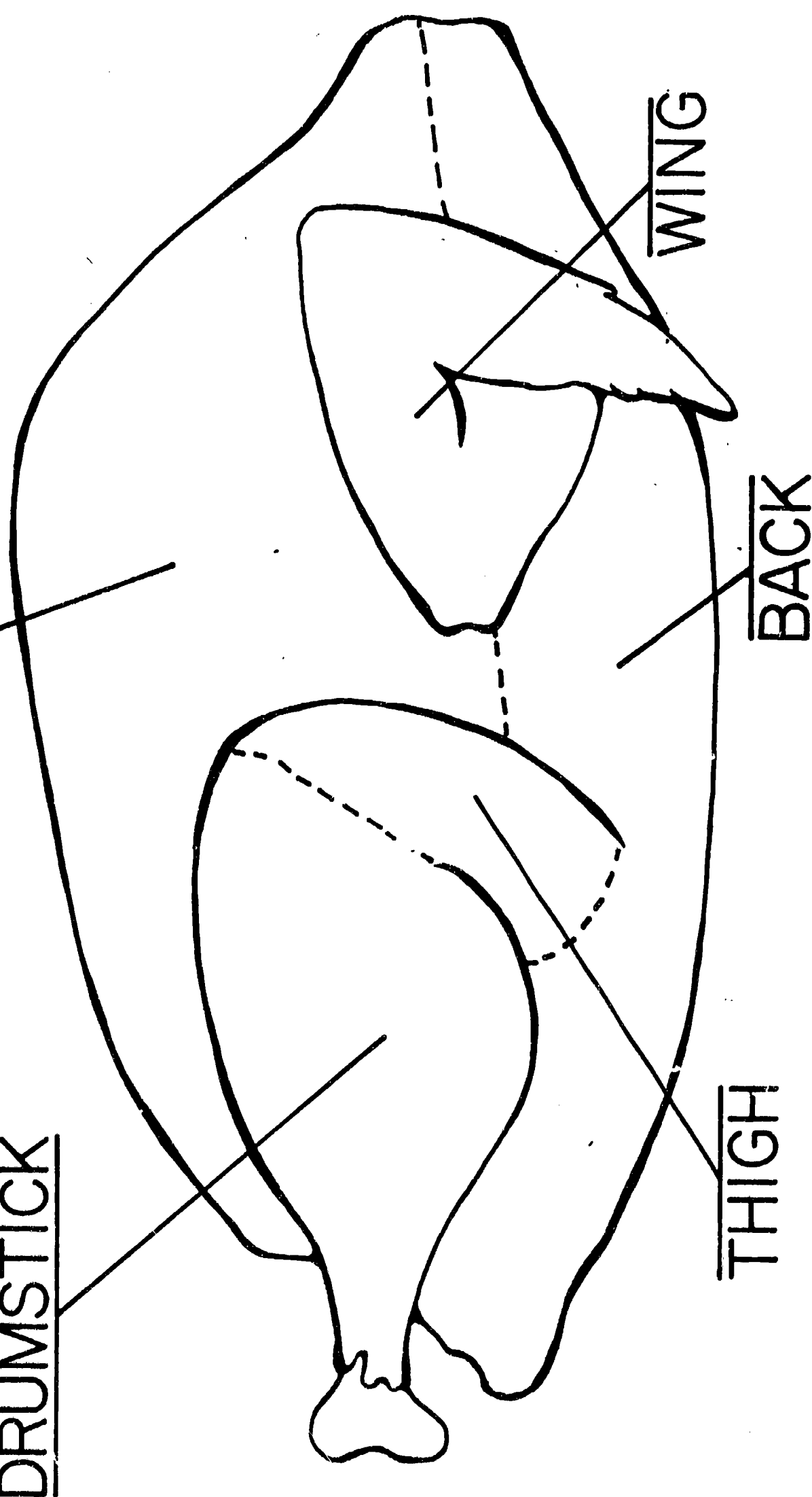

BEST COPY AVAILABLE

AP  
P127

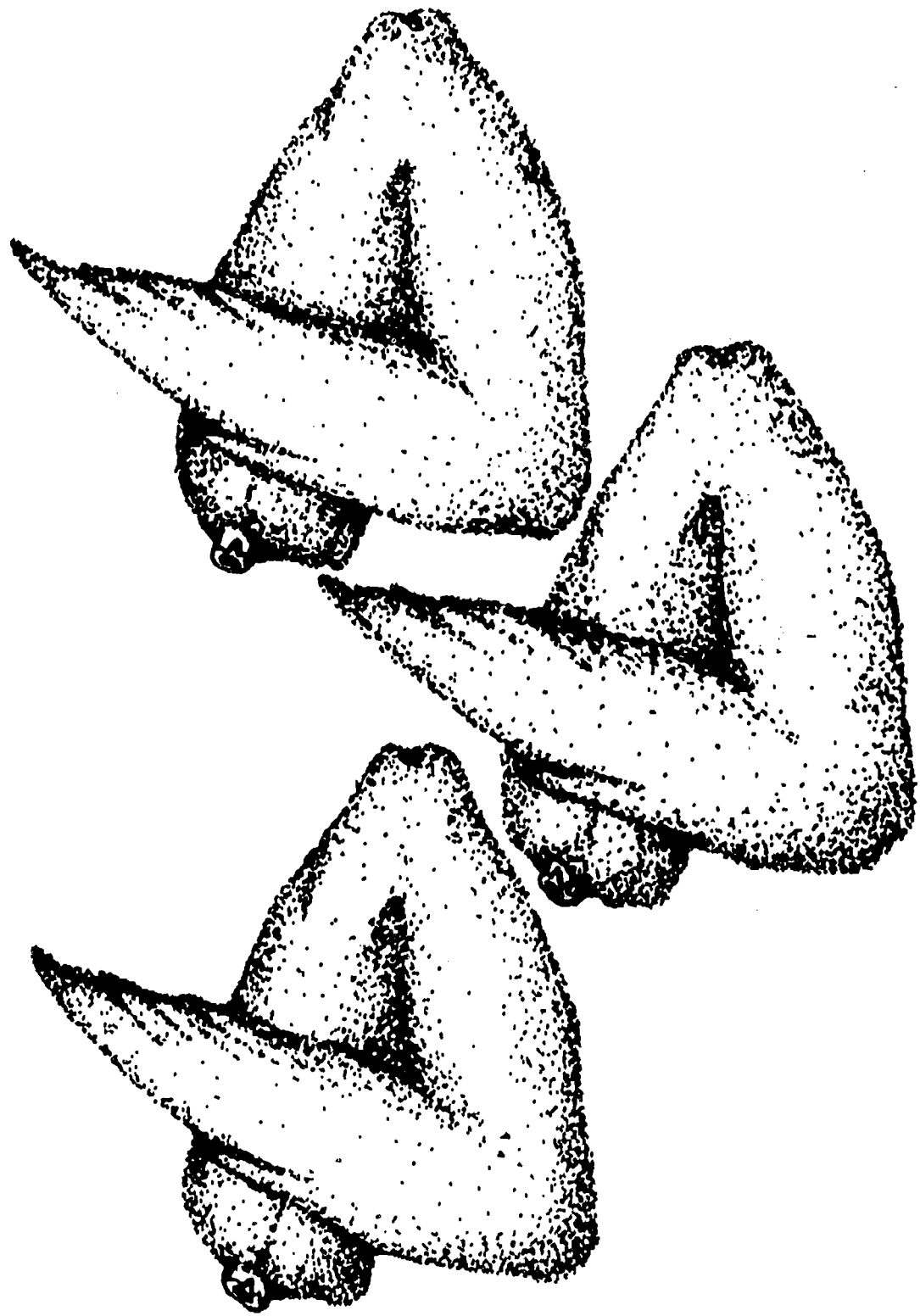

Best Copy Available

AP  
P128

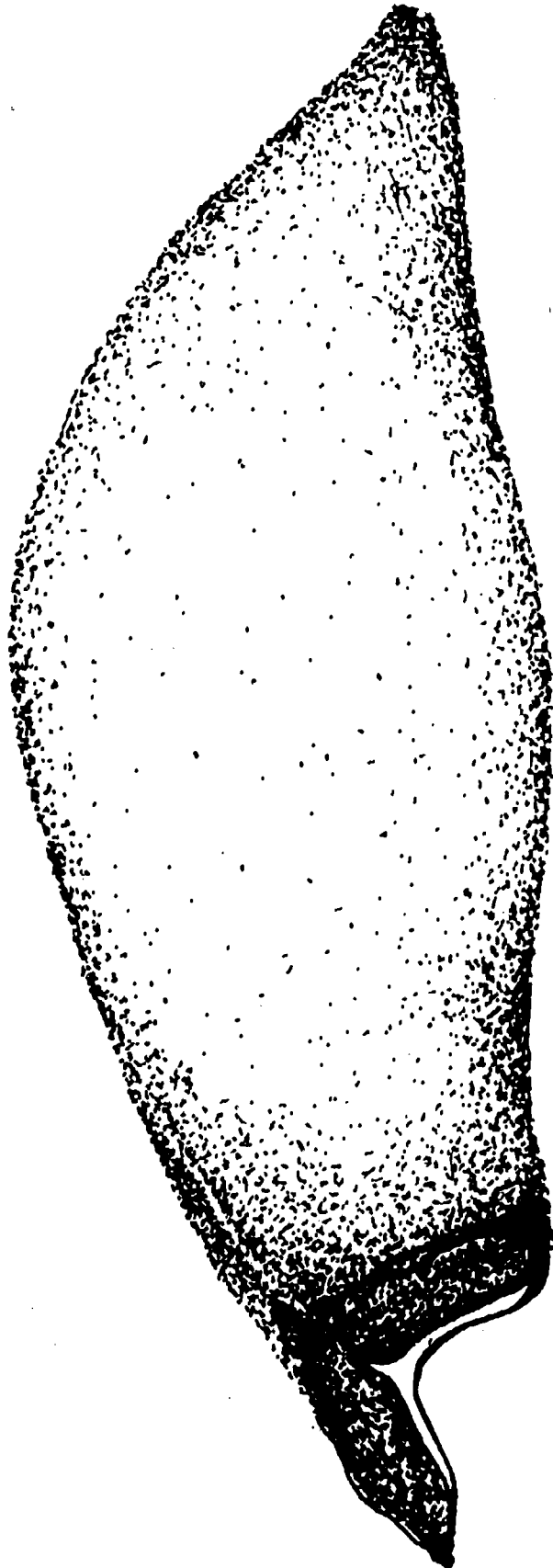
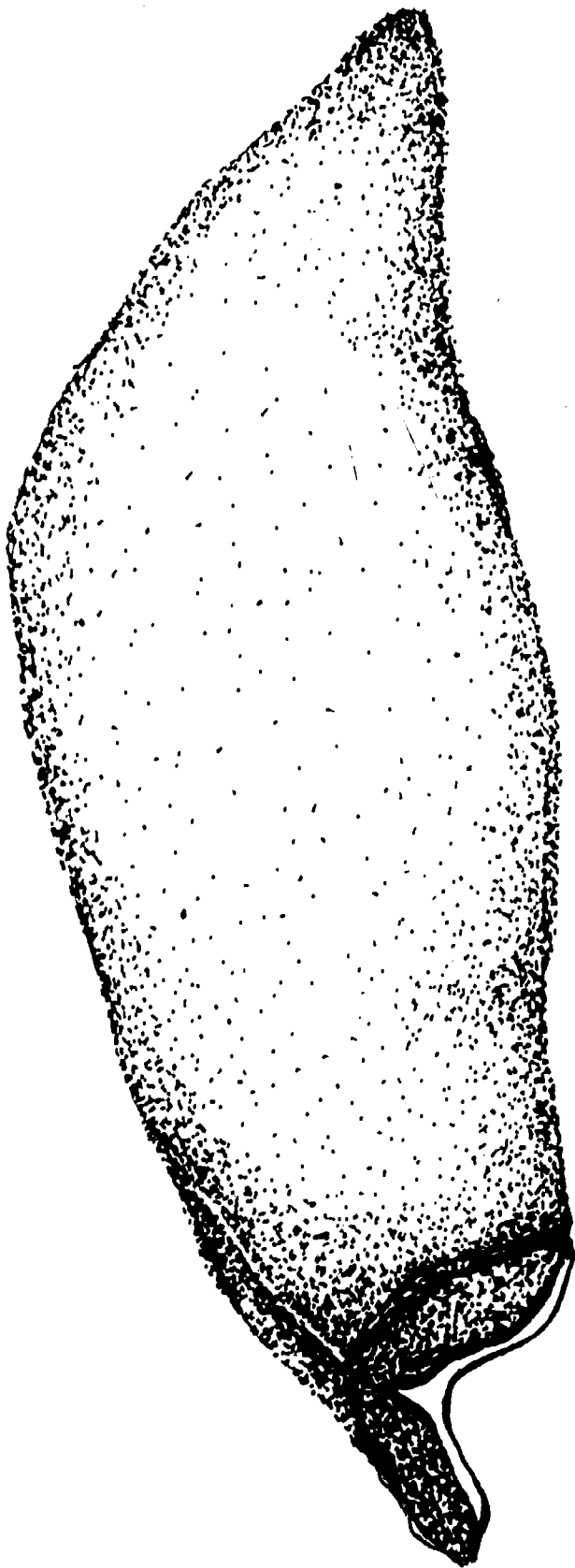



BEST COPY AVAILABLE

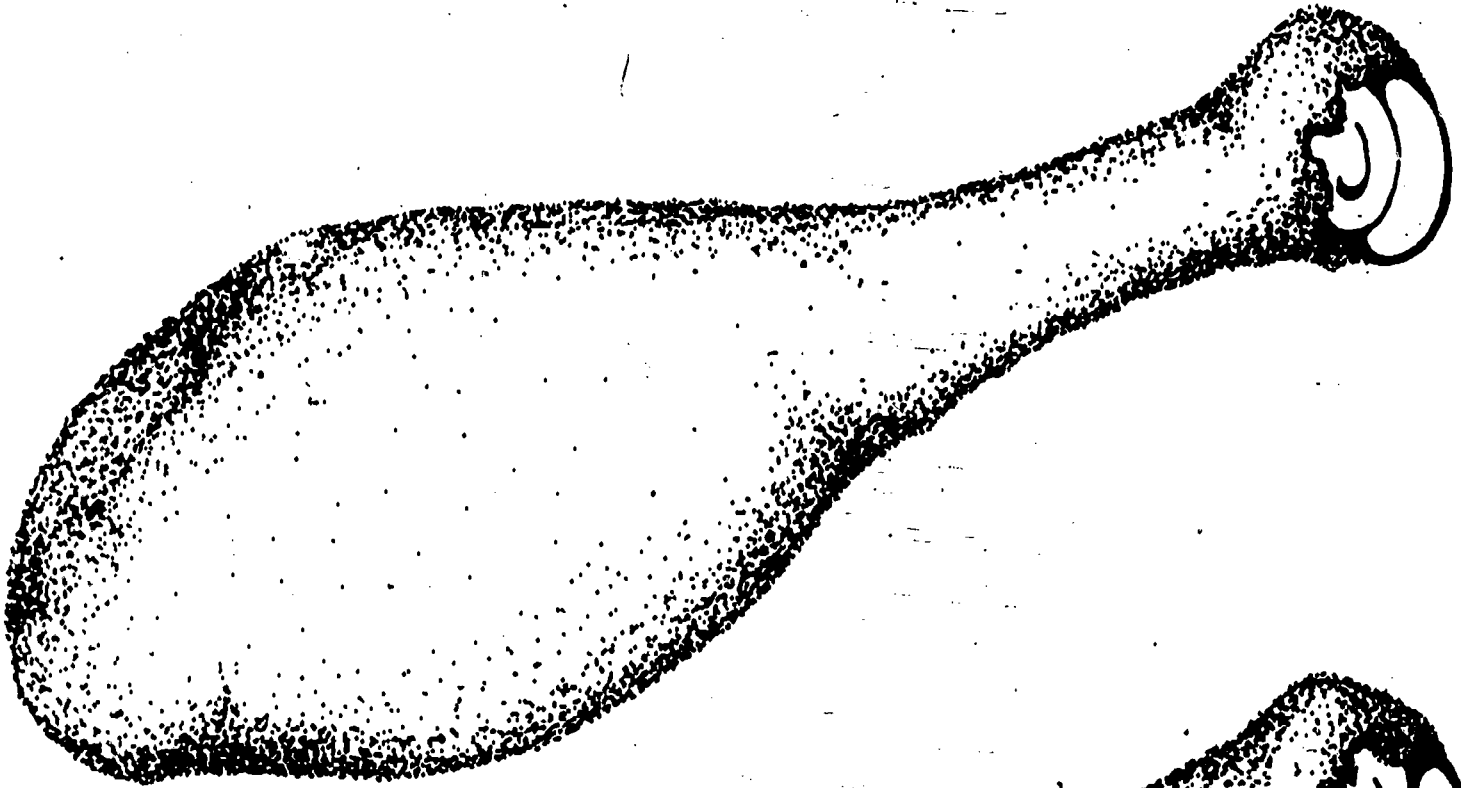

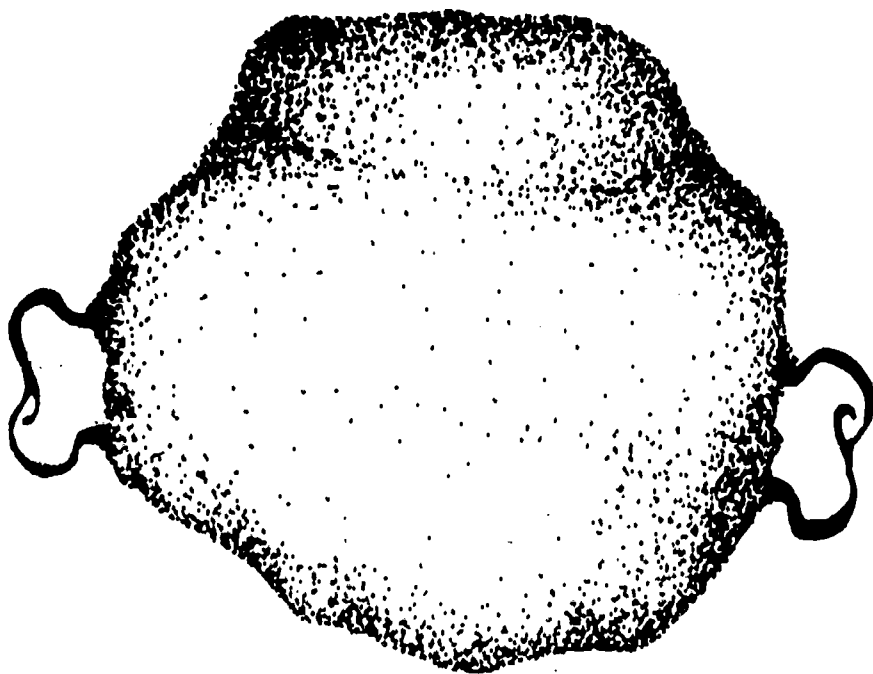
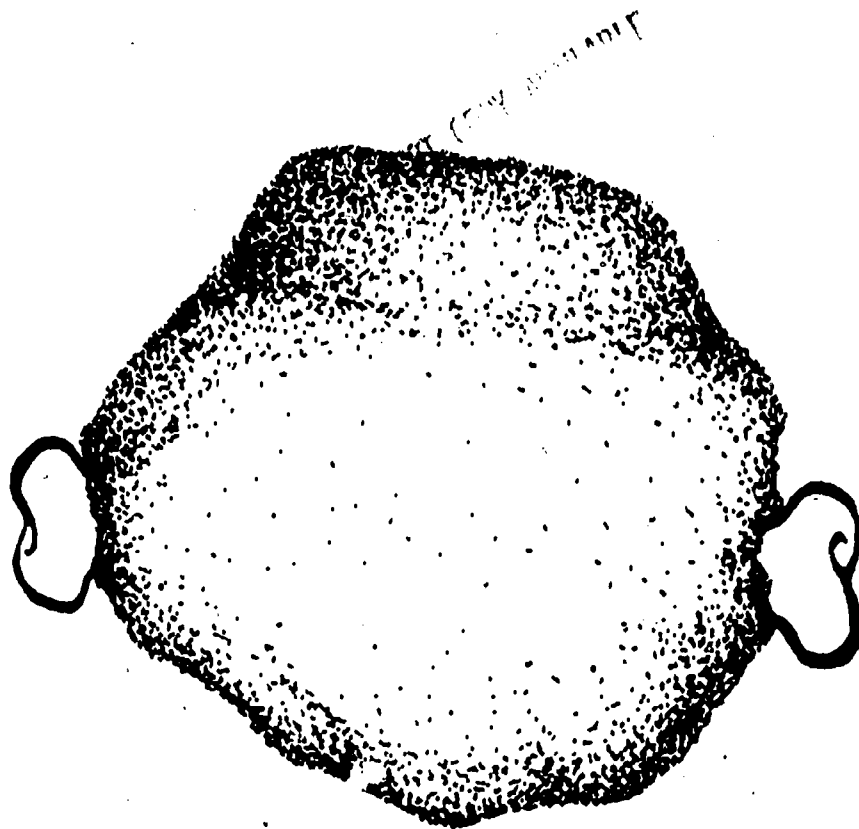

- Breasts
- Backs

- Thighs
- Wings
- Drumsticks

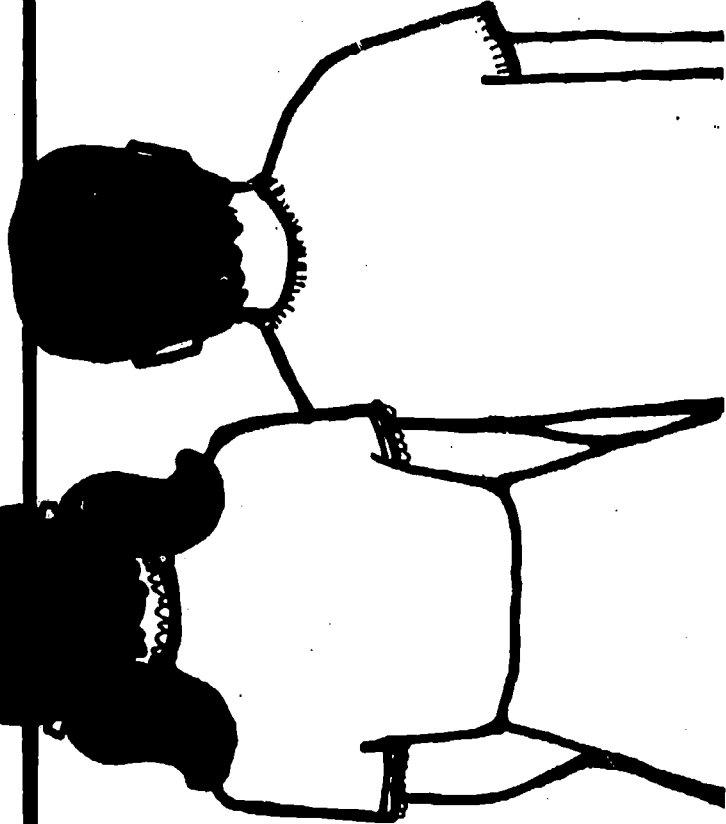
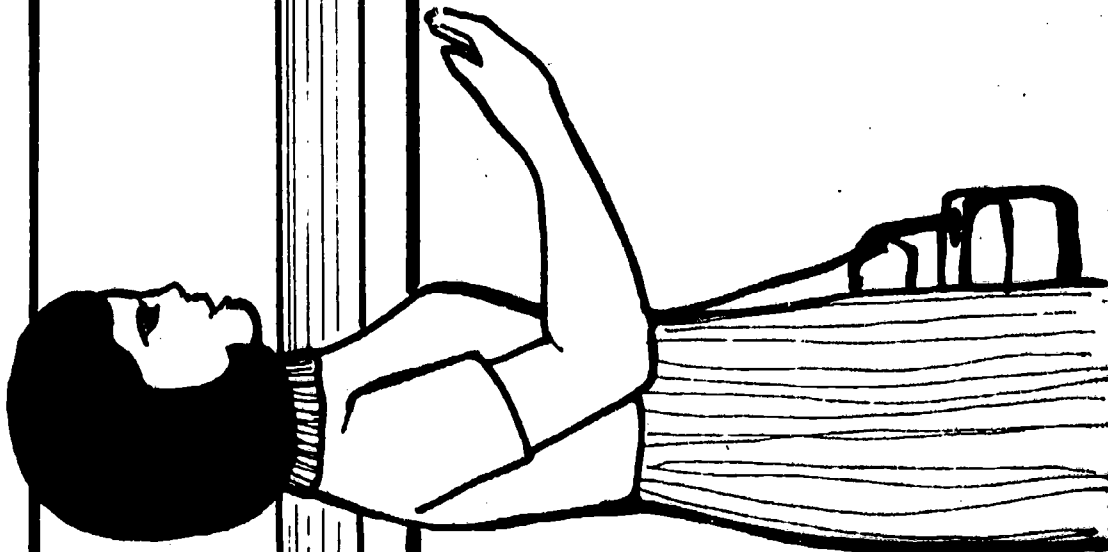
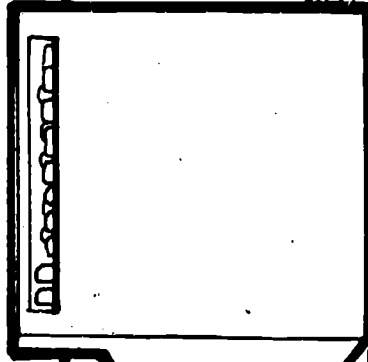
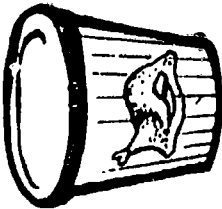
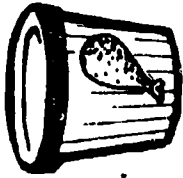

BEST COPY AVAILABLE

AP  
P131

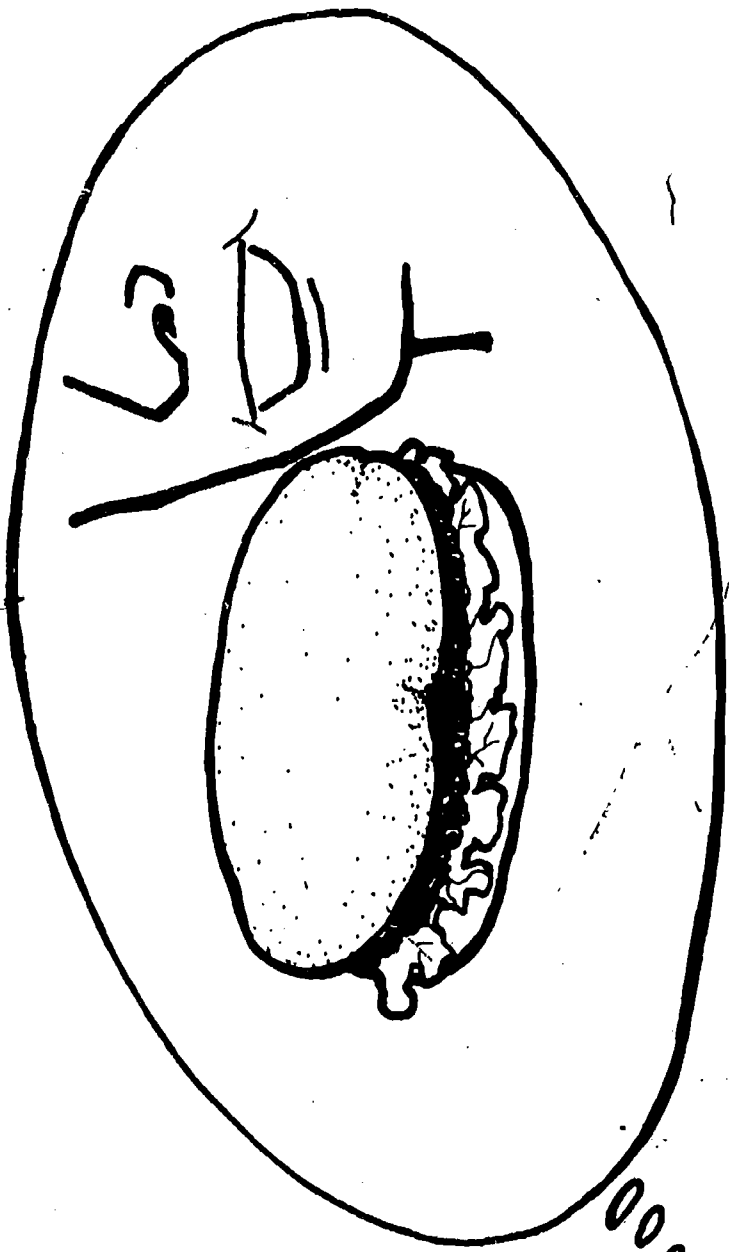

BEST COPY AVAILABLE

AP  
P132

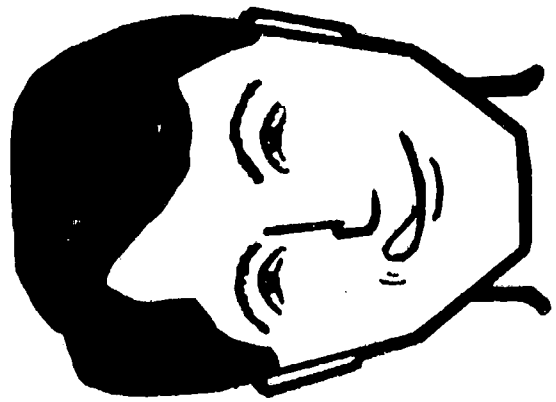

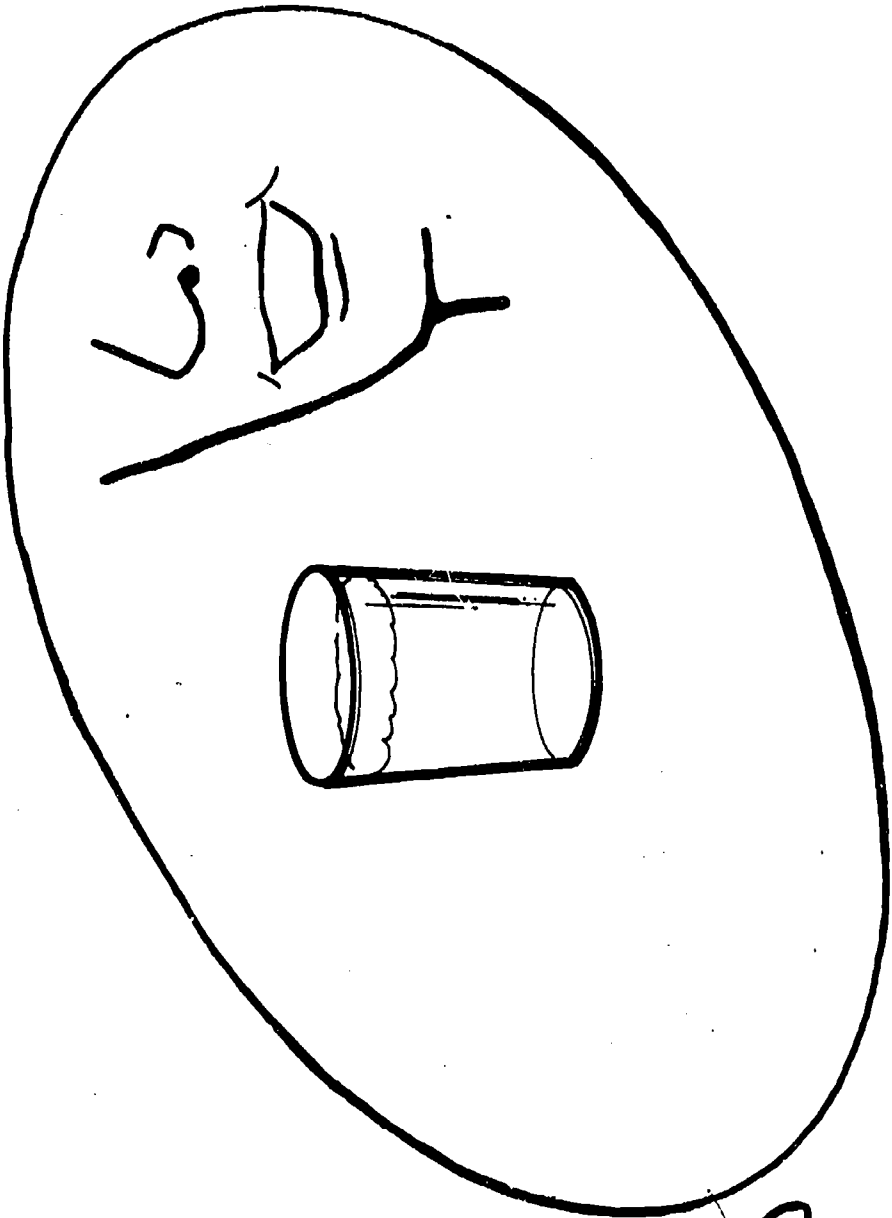

00000

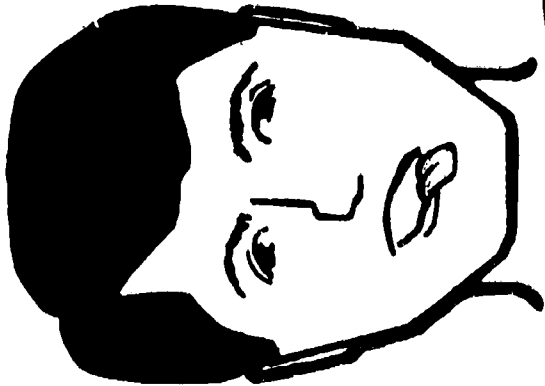

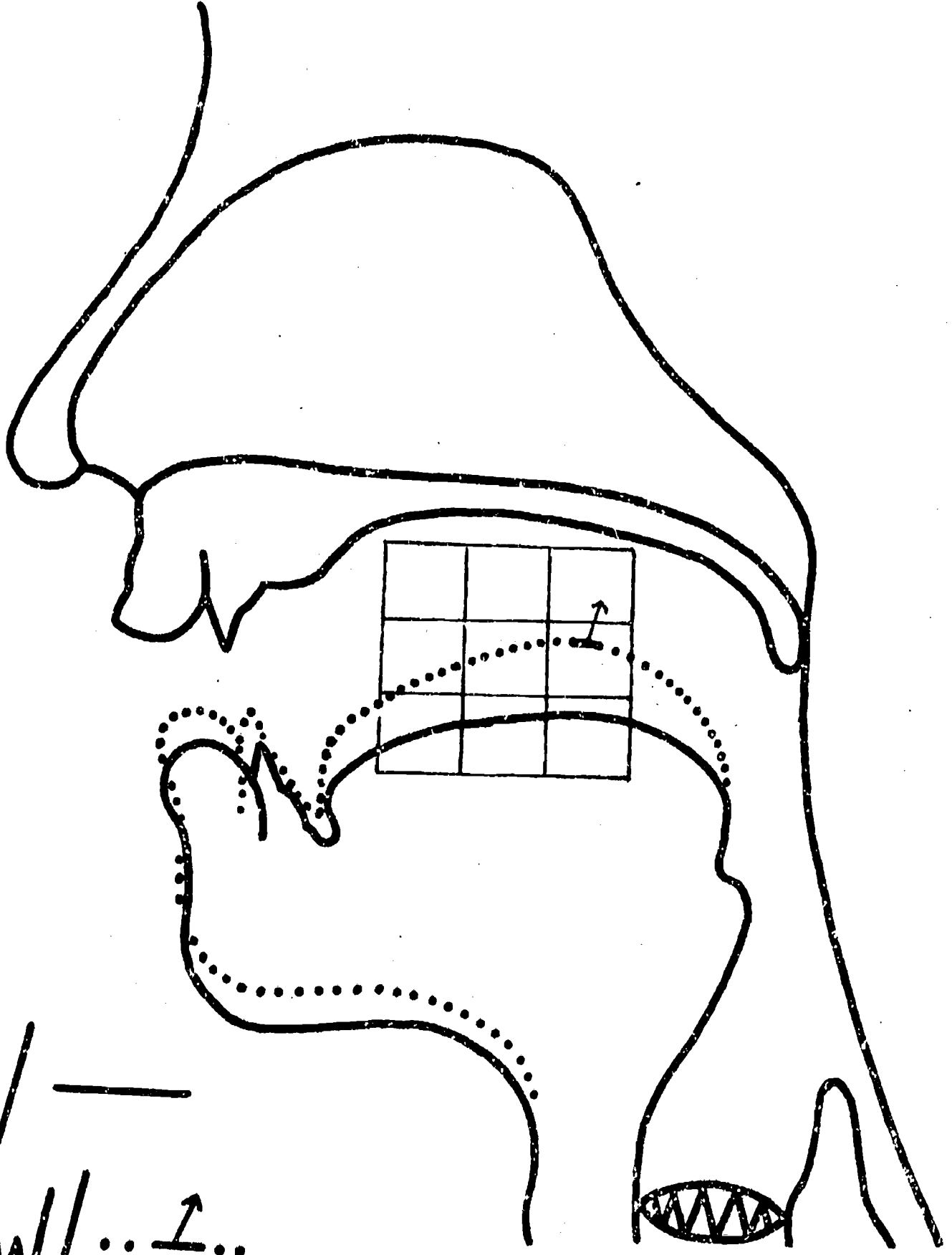

/O/ —  
/OW/ ... 1 ...

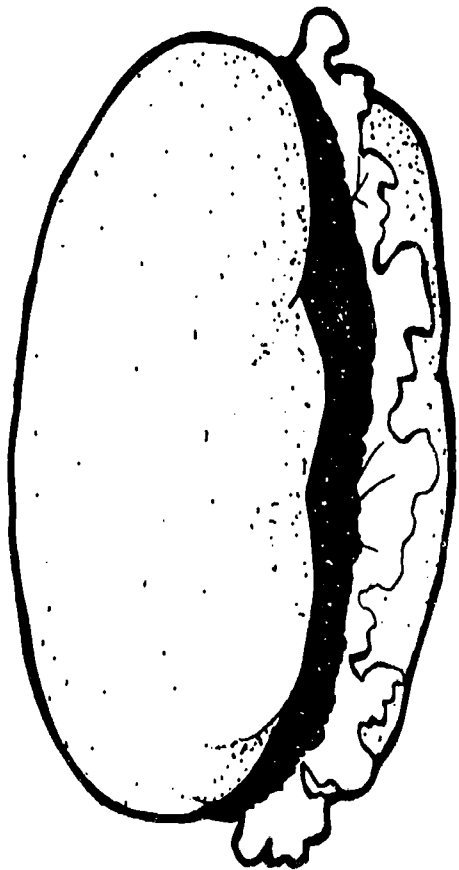
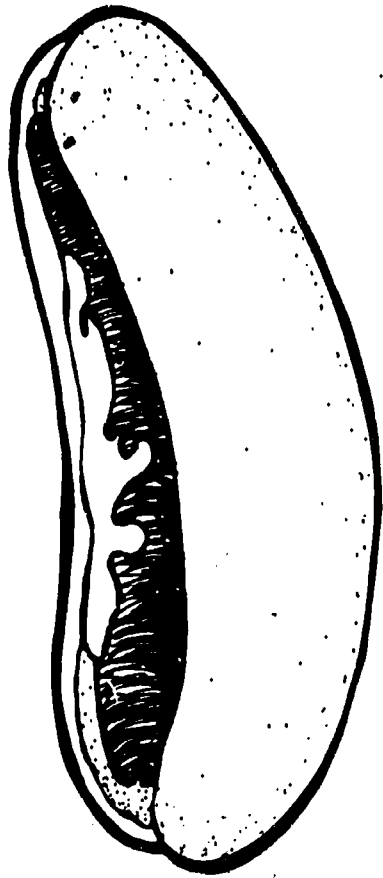
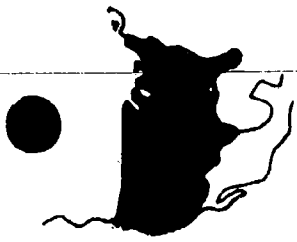

# AMERICAN FOOD

# CHINESE FOOD

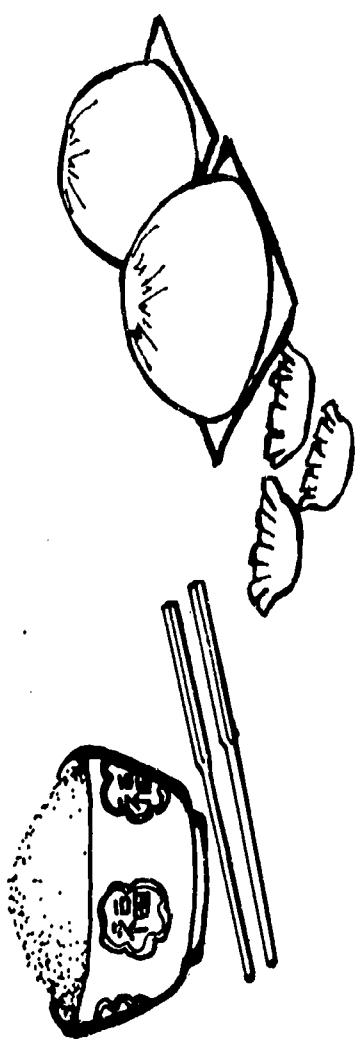
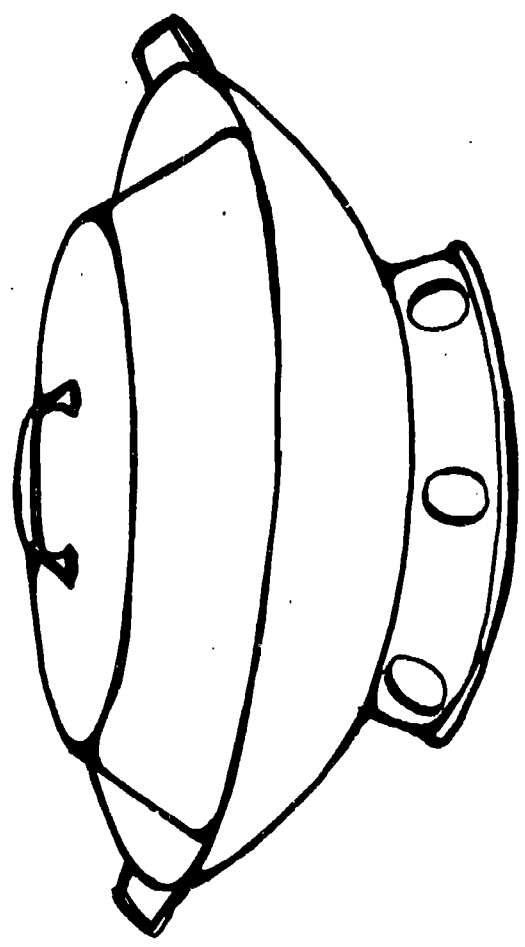
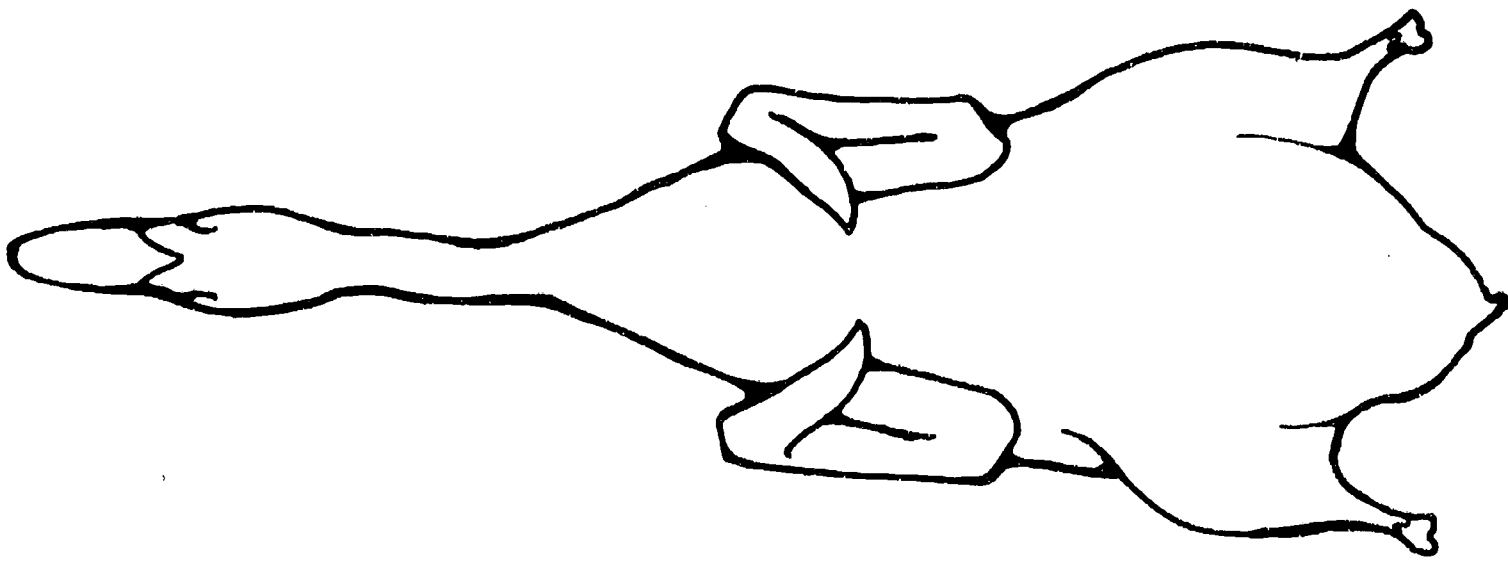



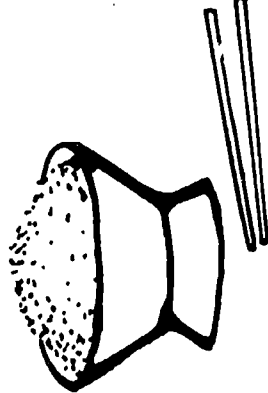
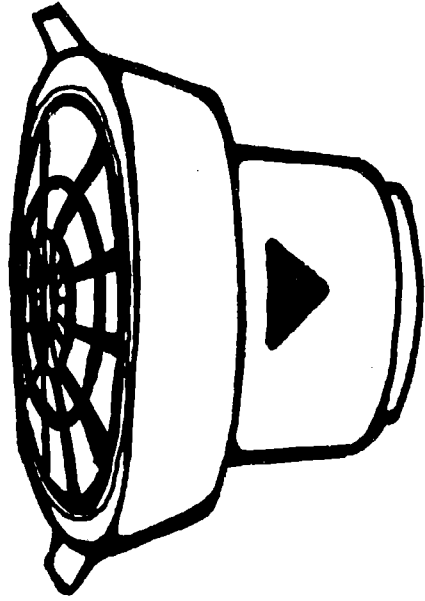

# JAPANESE FOOD

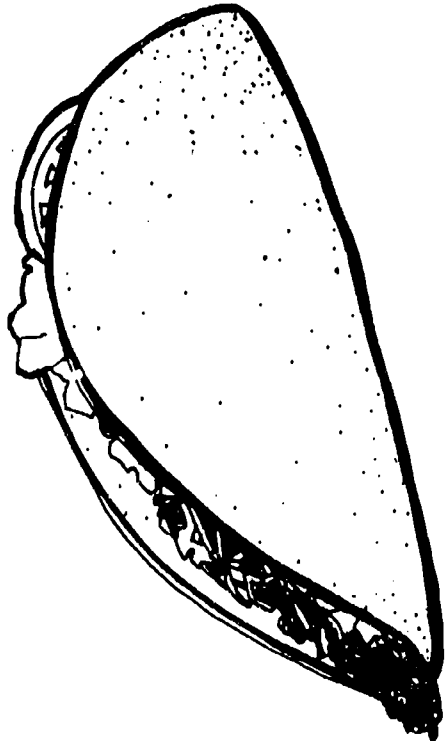
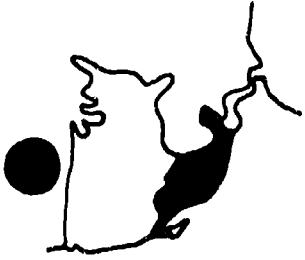

BEST COPY AVAILABLE

# MEXICAN FOOD

AP  
P138

1970

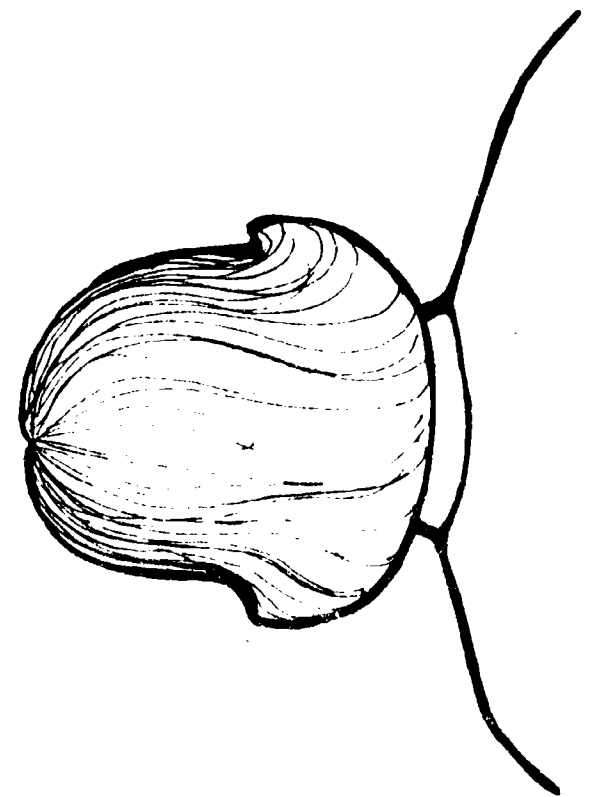
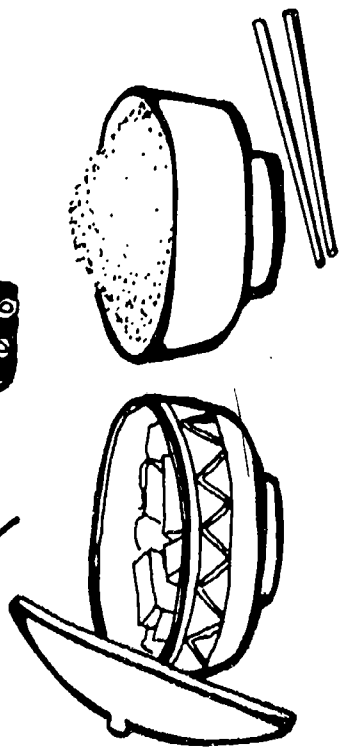
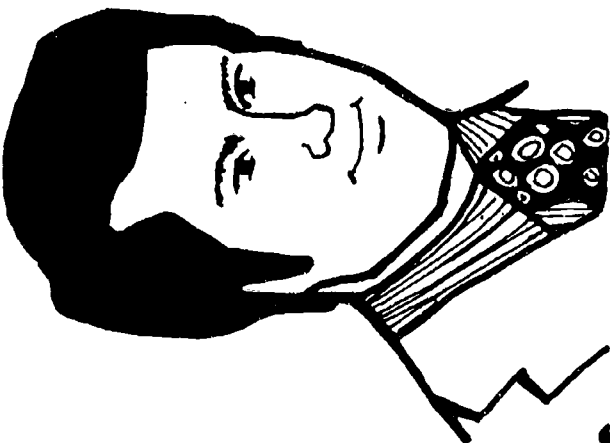
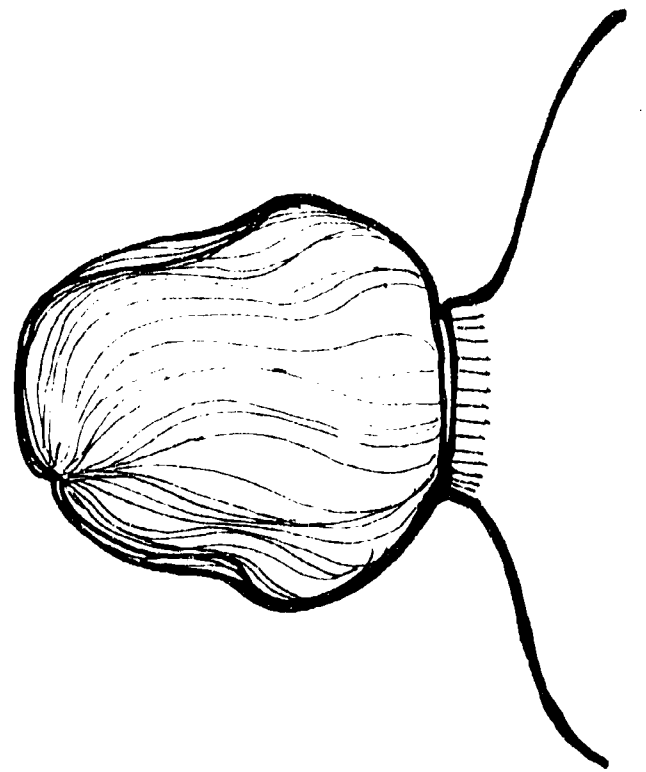
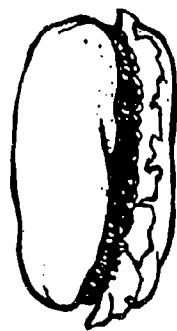
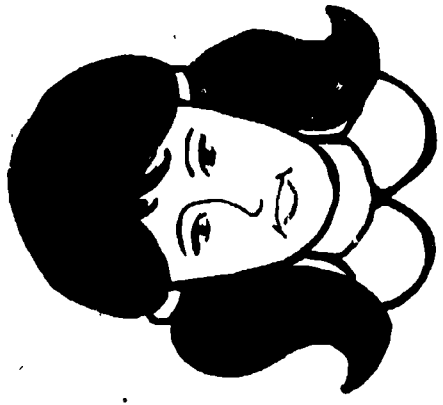
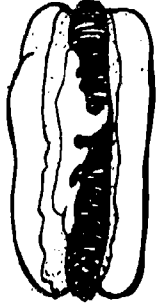

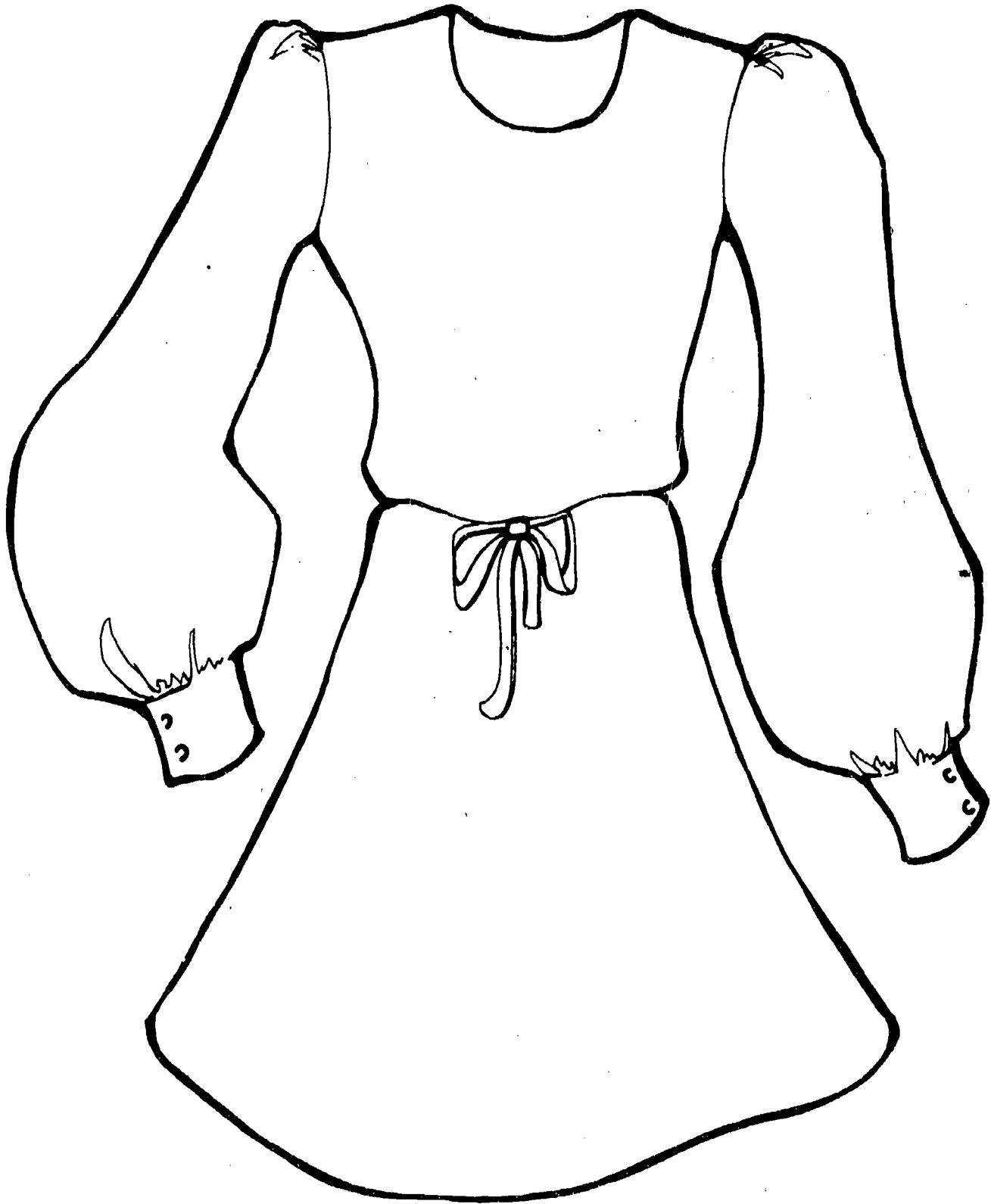

AP  
P140



AP  
P141

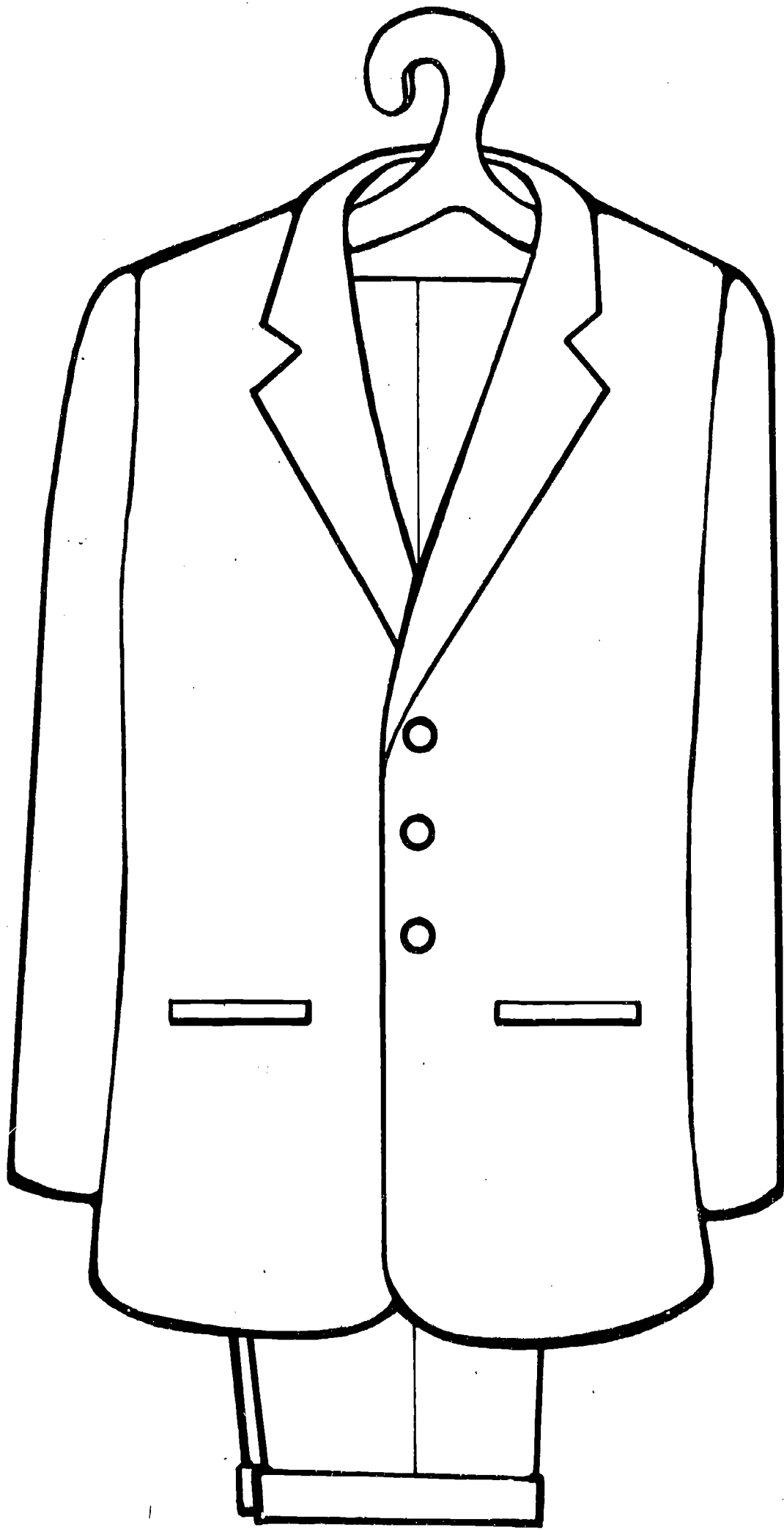

M  
P14.



AI  
P113



AP  
P144



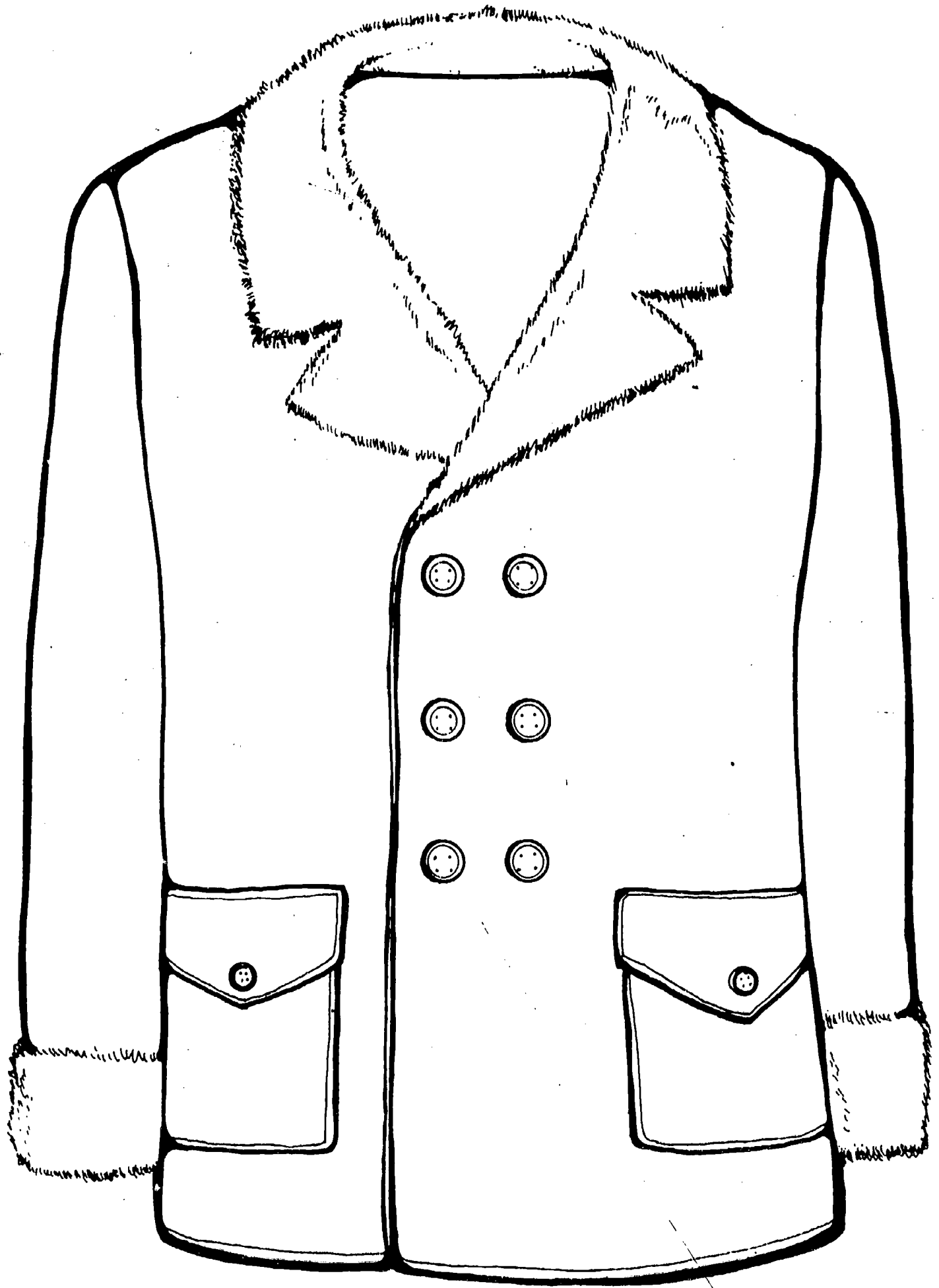

AP  
P145

BEST COPY AVAILABLE

AP  
P-1-6

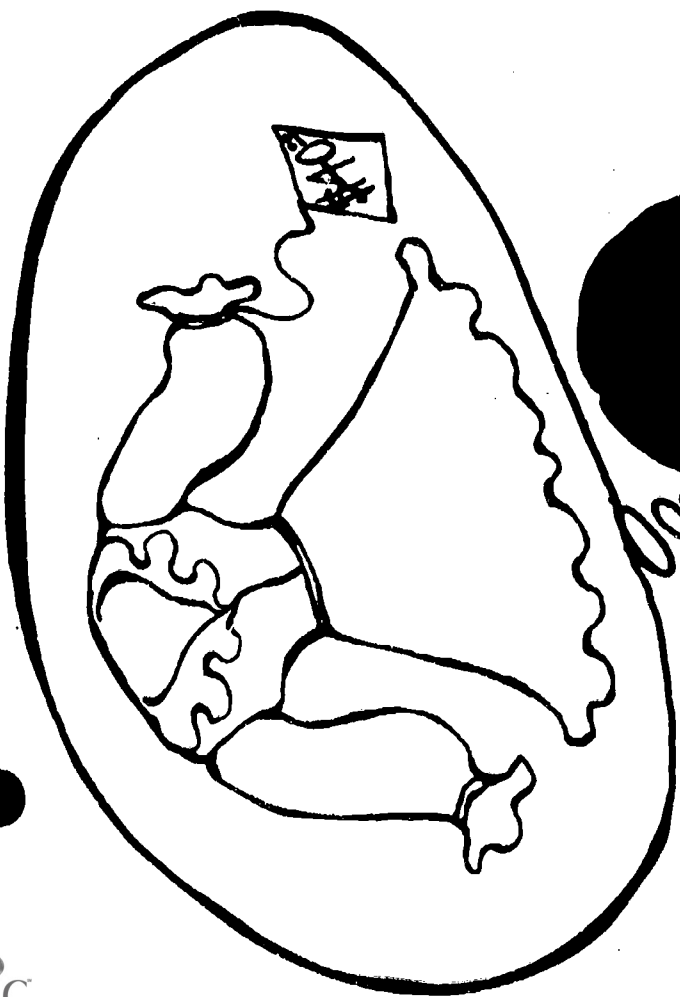
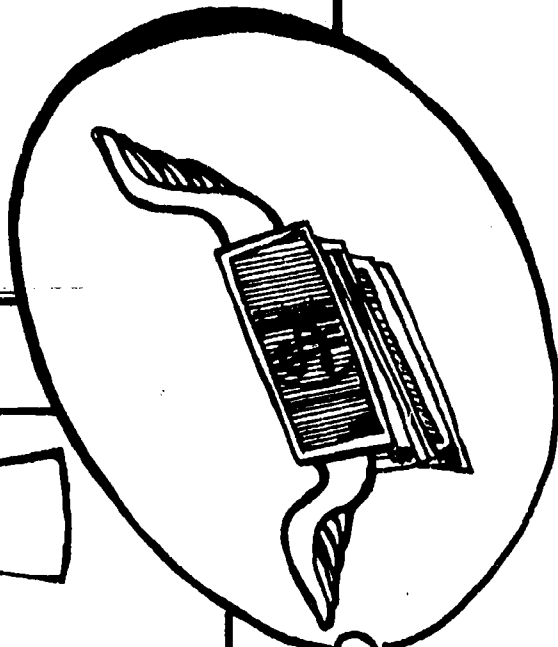
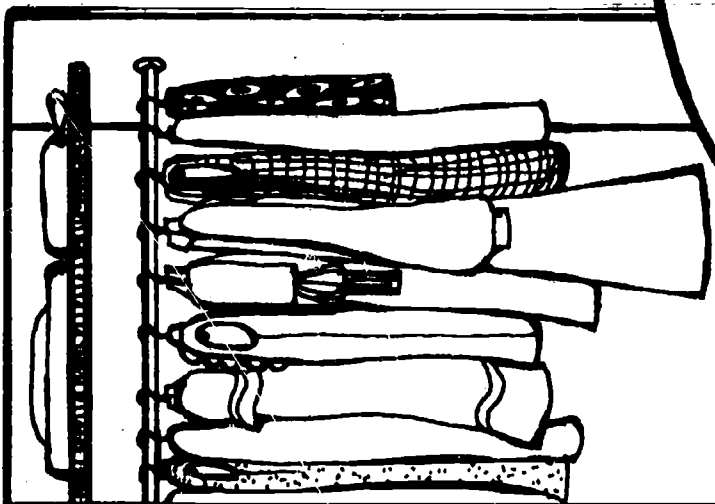

BEST COPY AVAILABLE

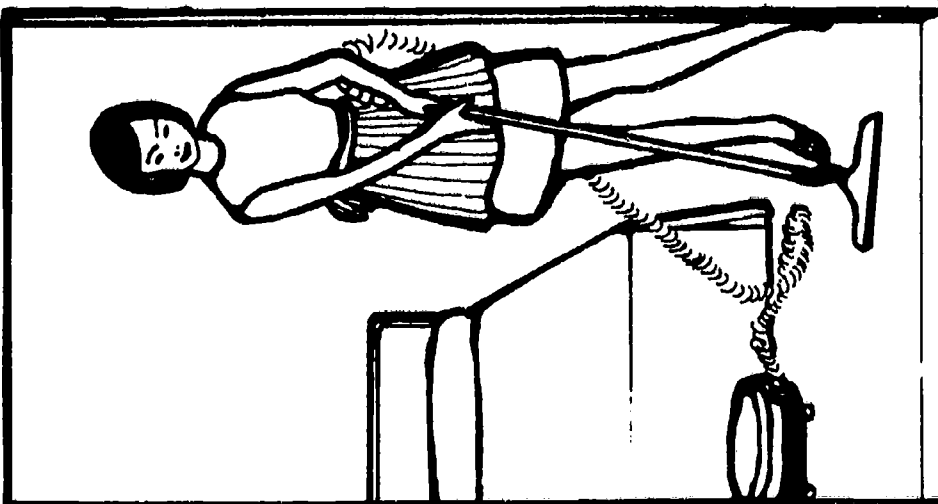
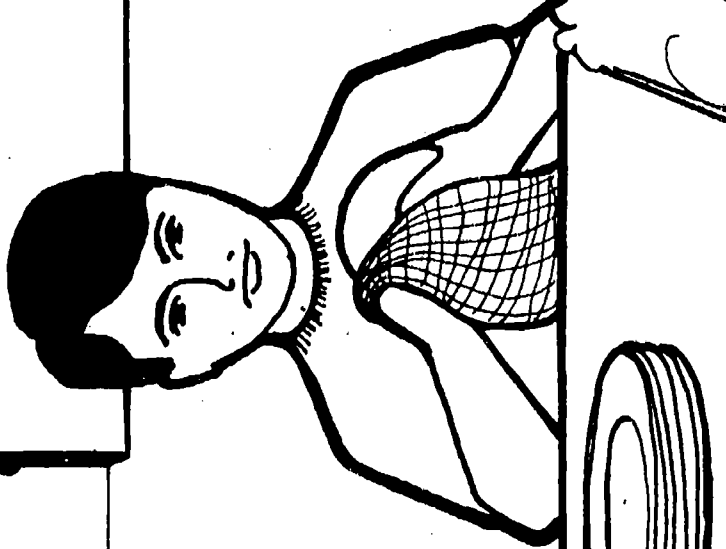
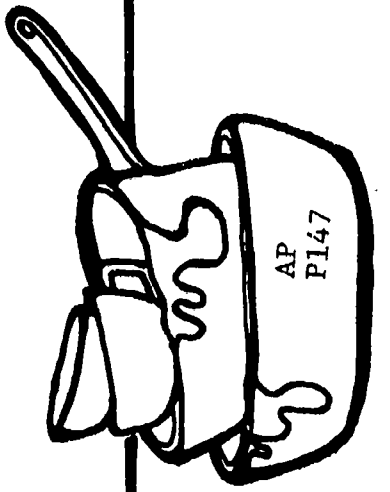

CELLULOSE

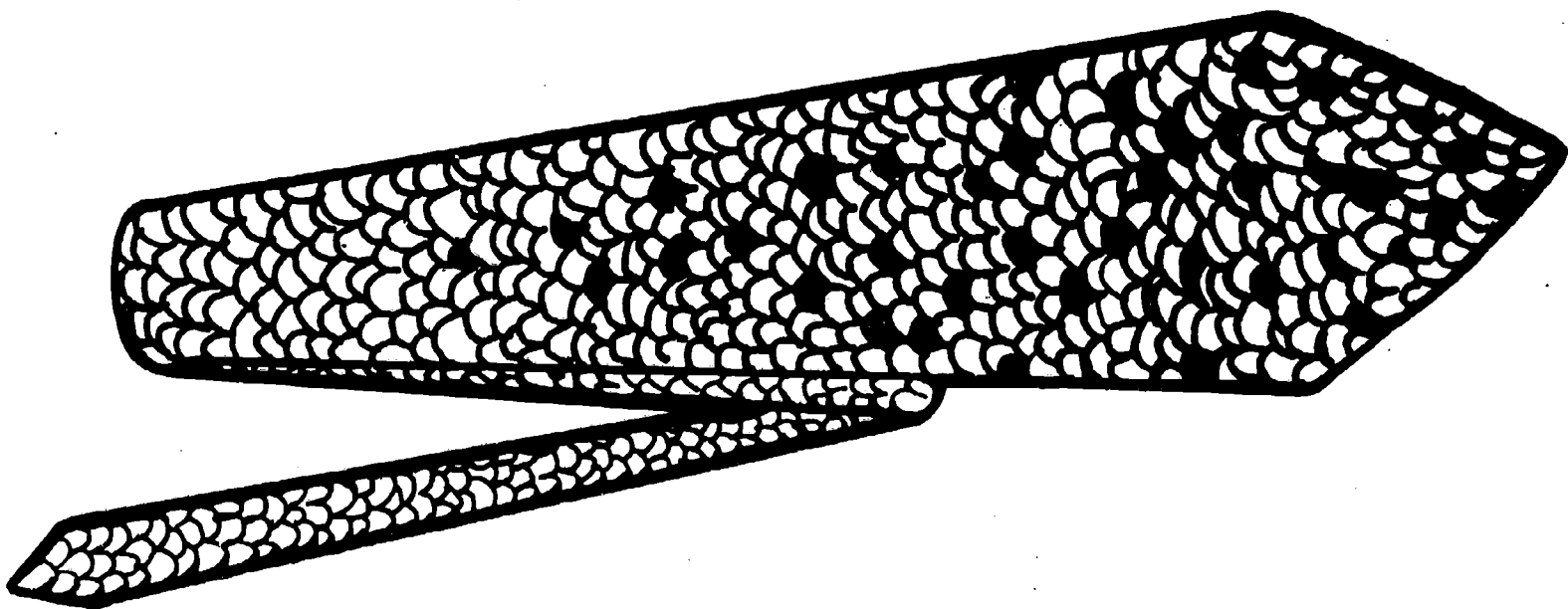
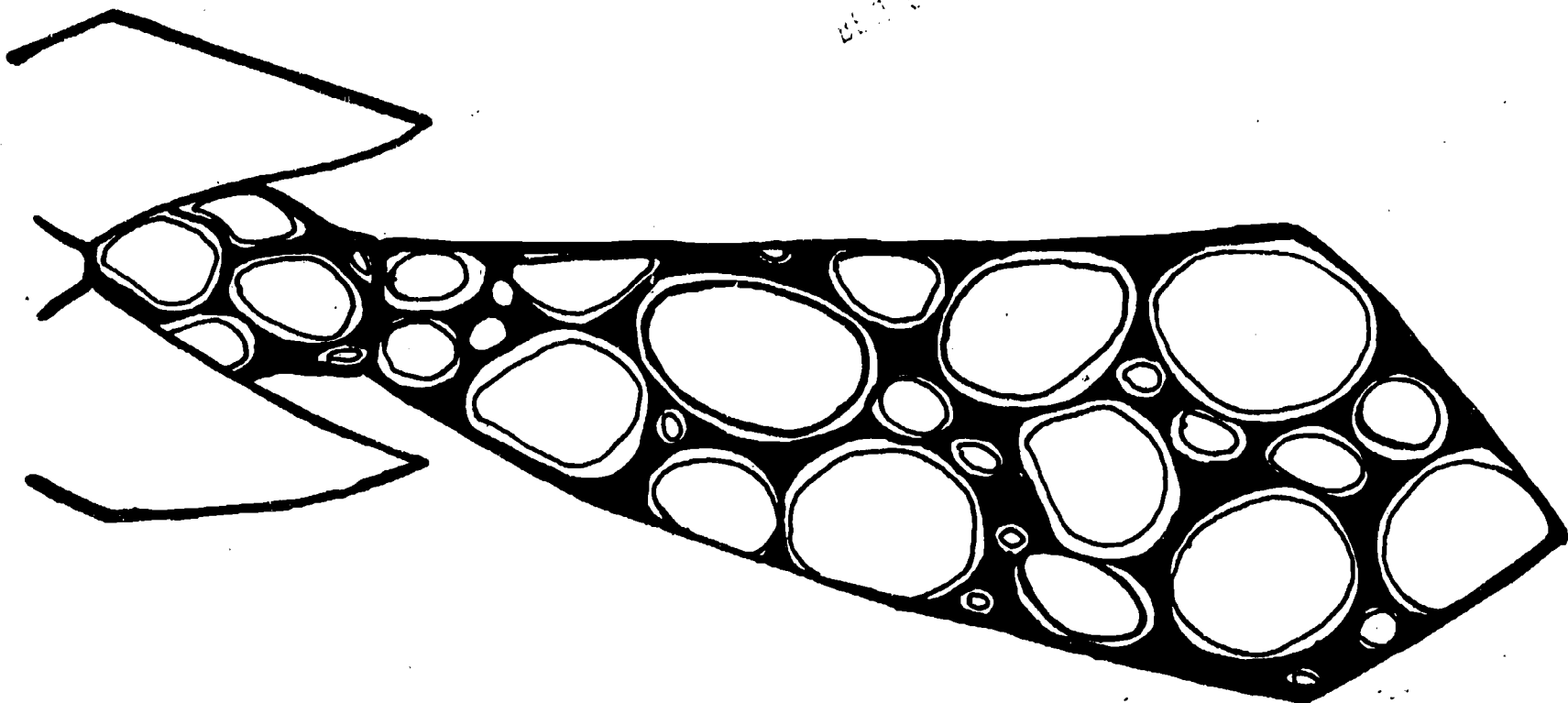

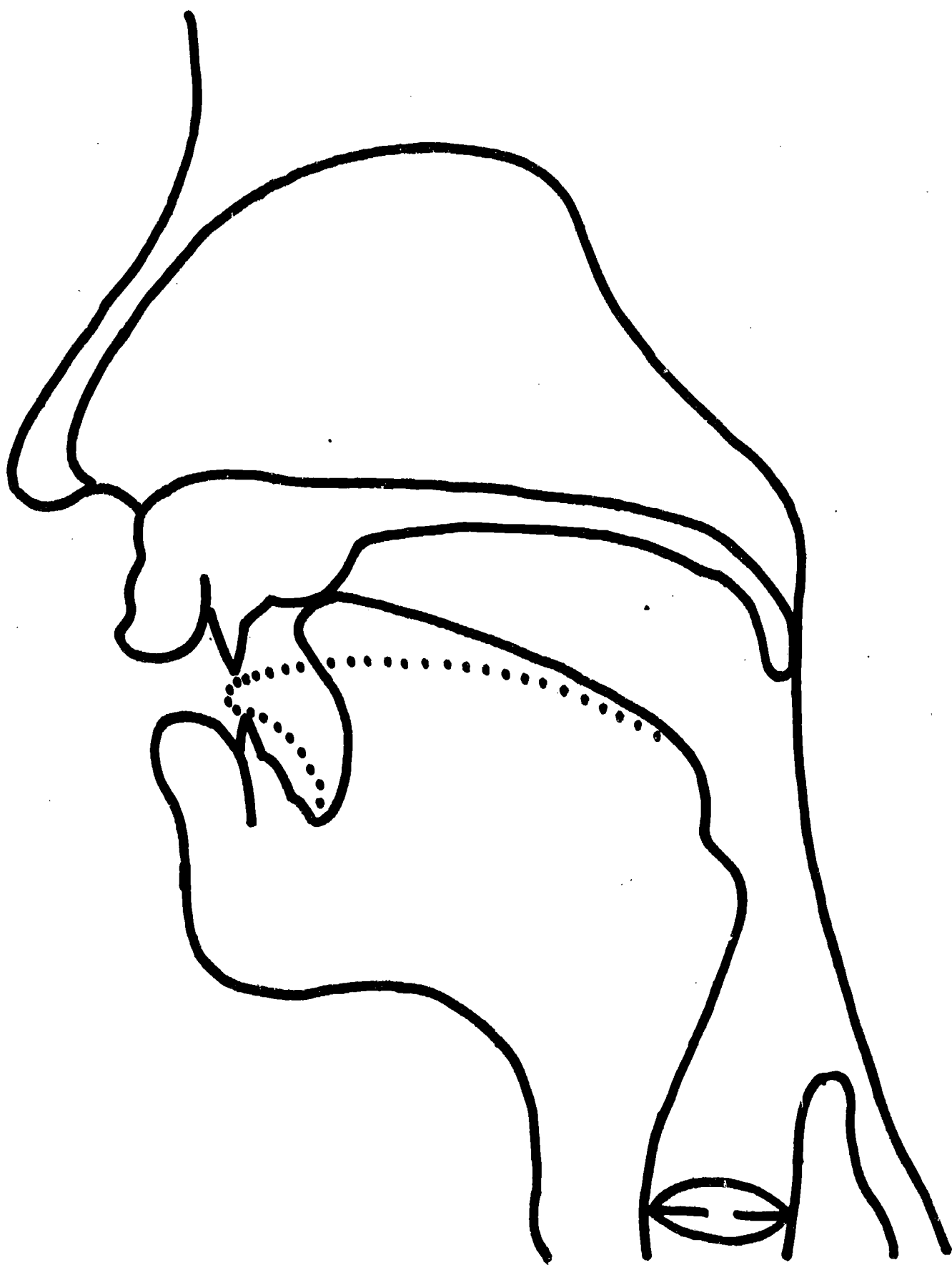

• /t/ — /θ/.....

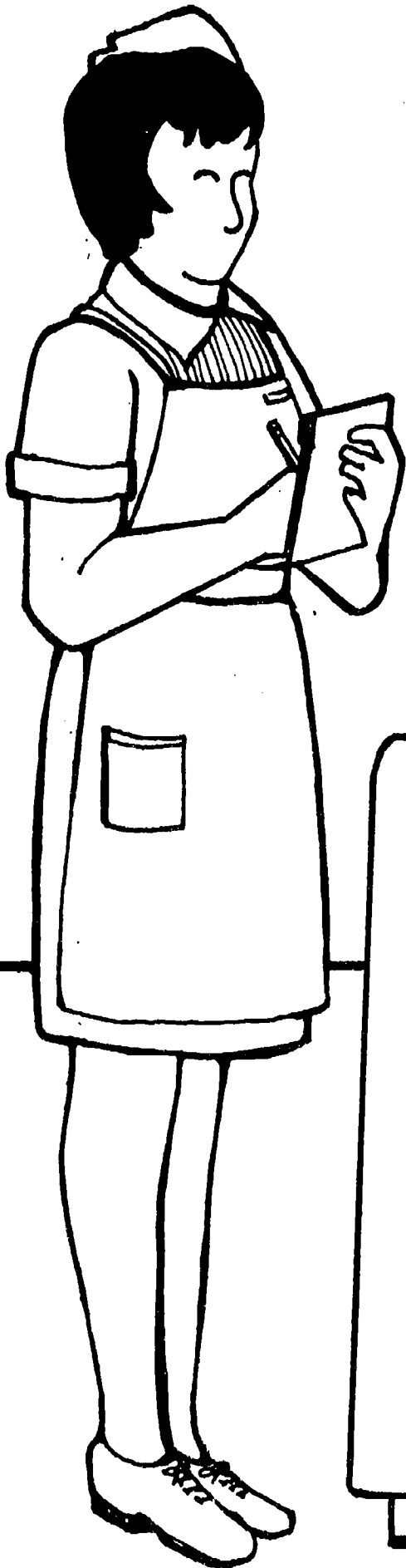

AP  
P150

BEST COPY AVAILABLE

AP  
P151

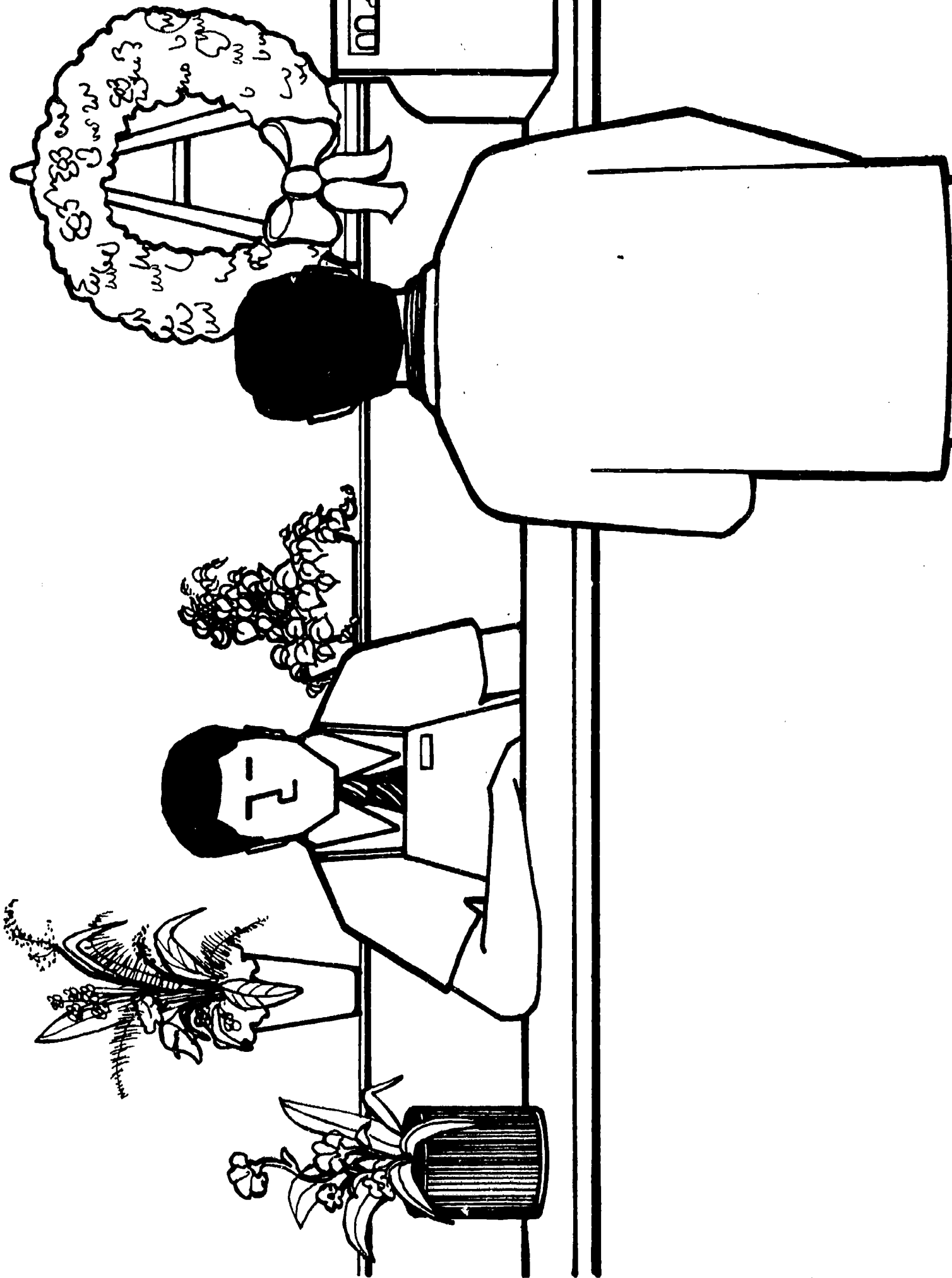

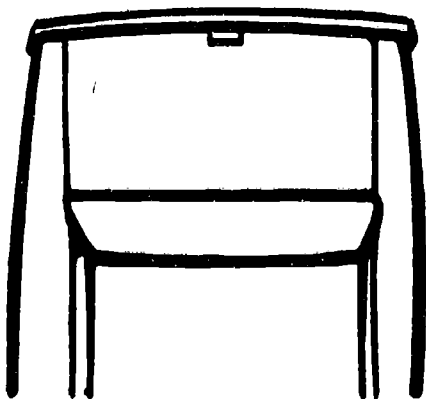
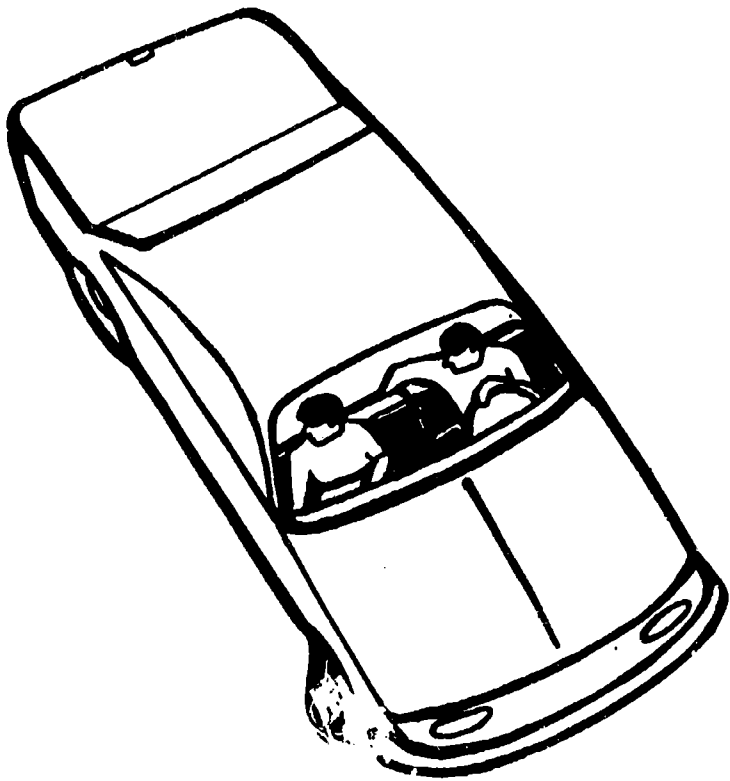
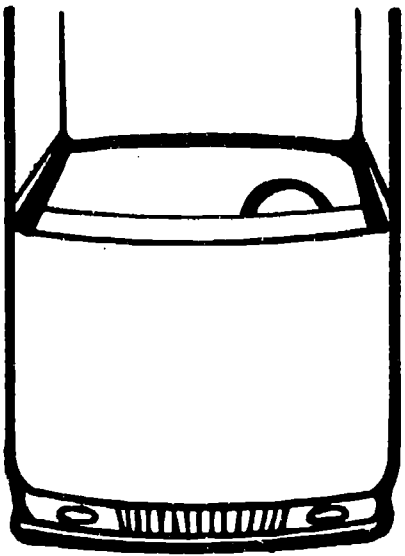

AP  
P152



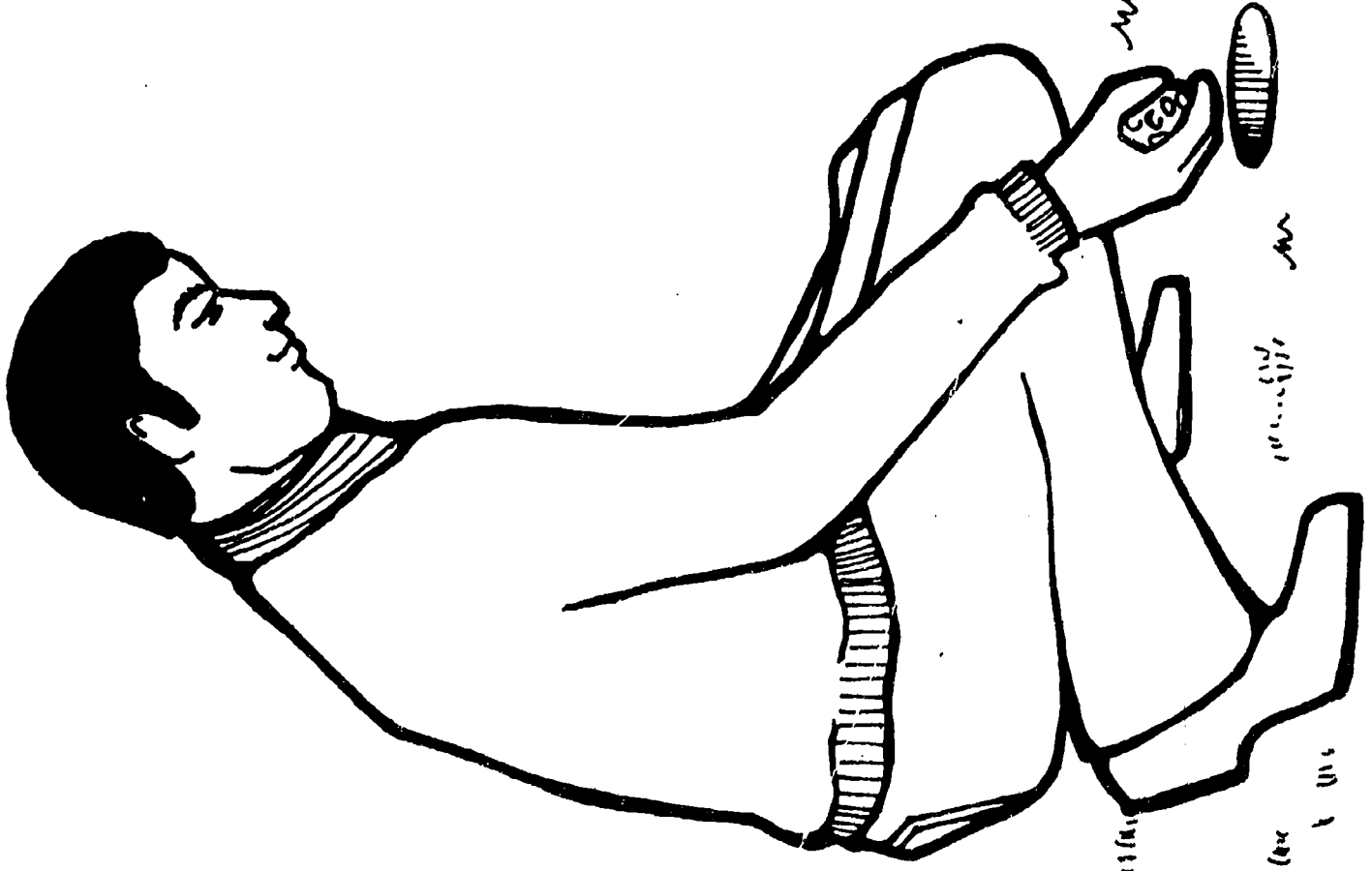

Handwritten notes and scribbles, including the number '411' and some illegible cursive text.

BEST COPY AVAILABLE

AP  
P154

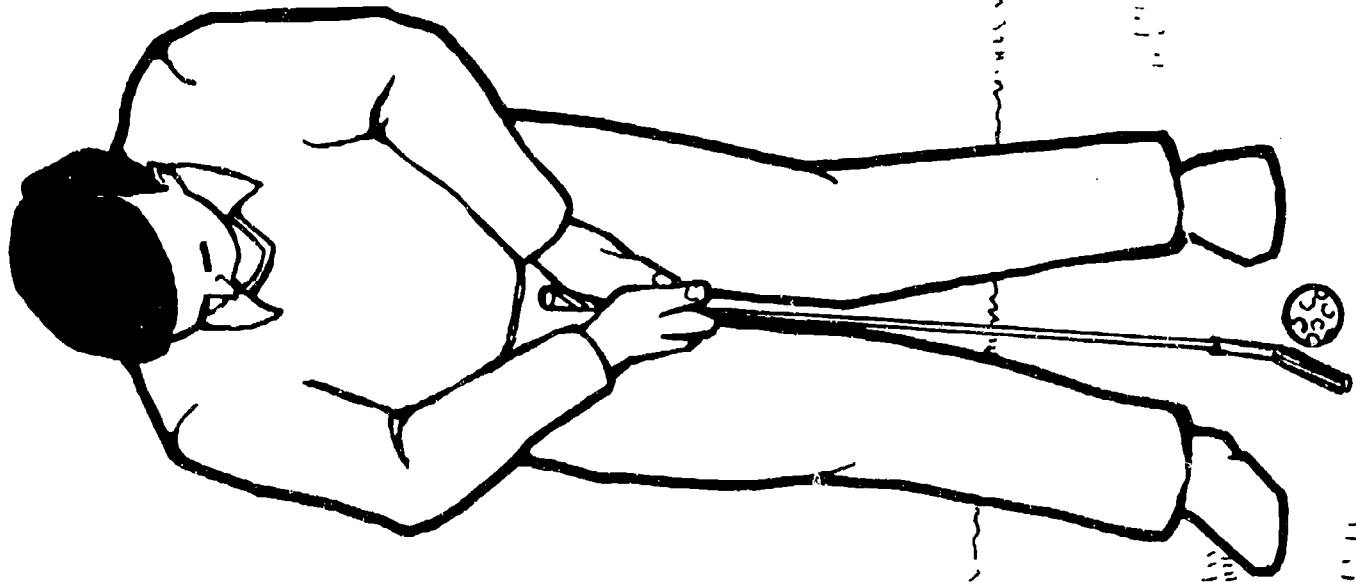

Handwritten notes and scribbles, including a circular stamp with the number '33' and various illegible markings.

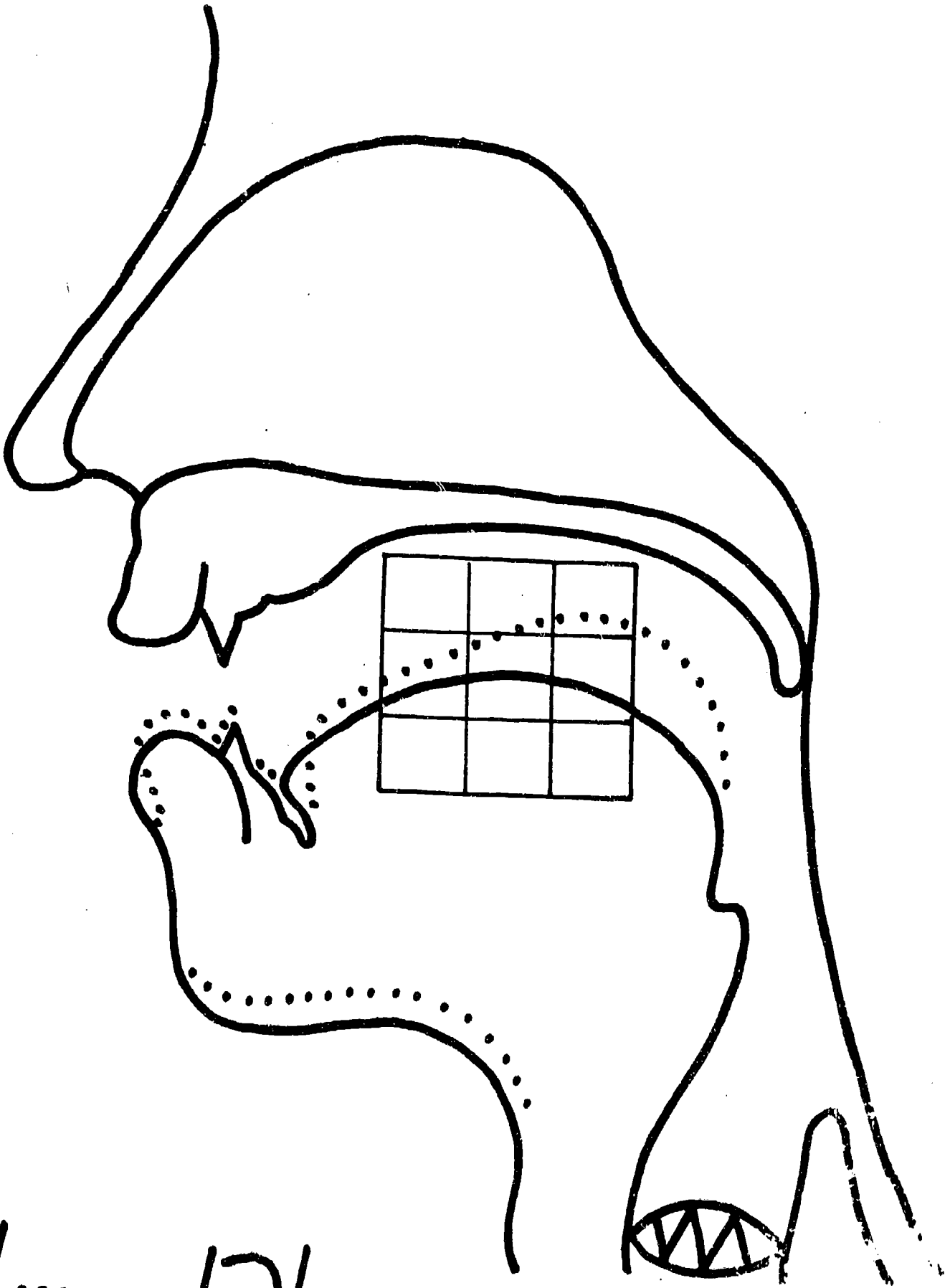

— /r/ — /n/

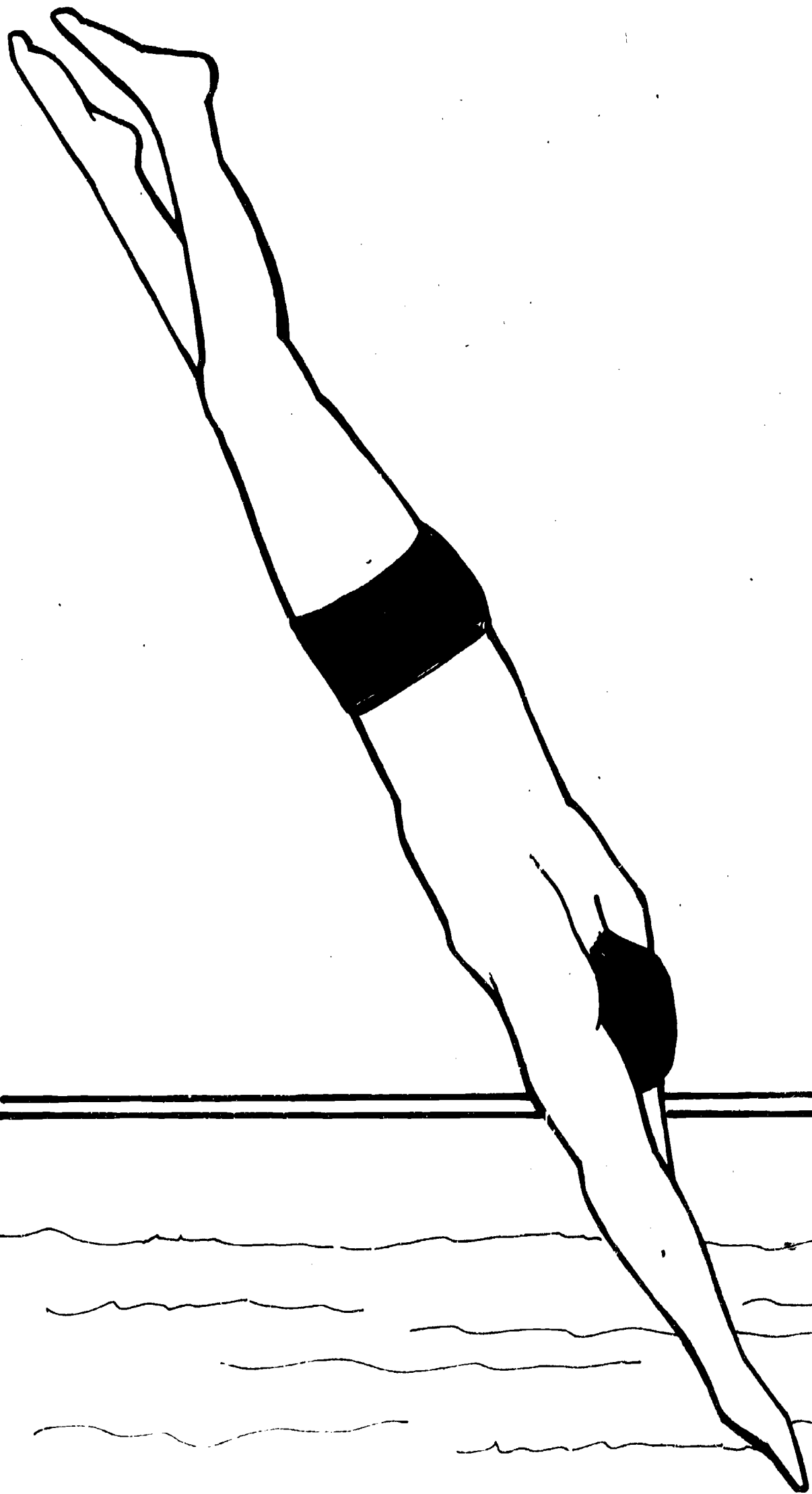

AP  
P156

BEST COPY AVAILABLE

AP  
P157

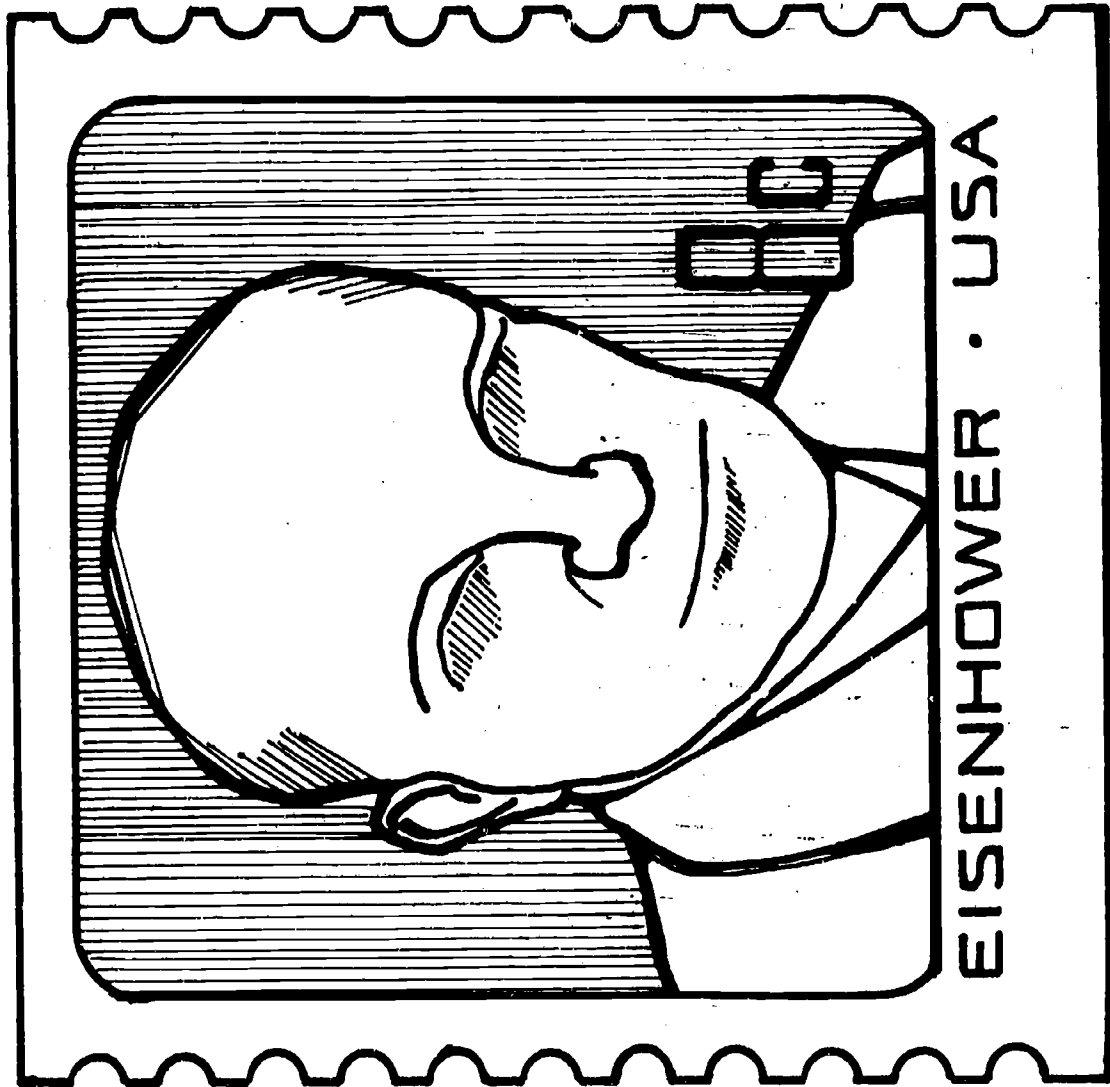

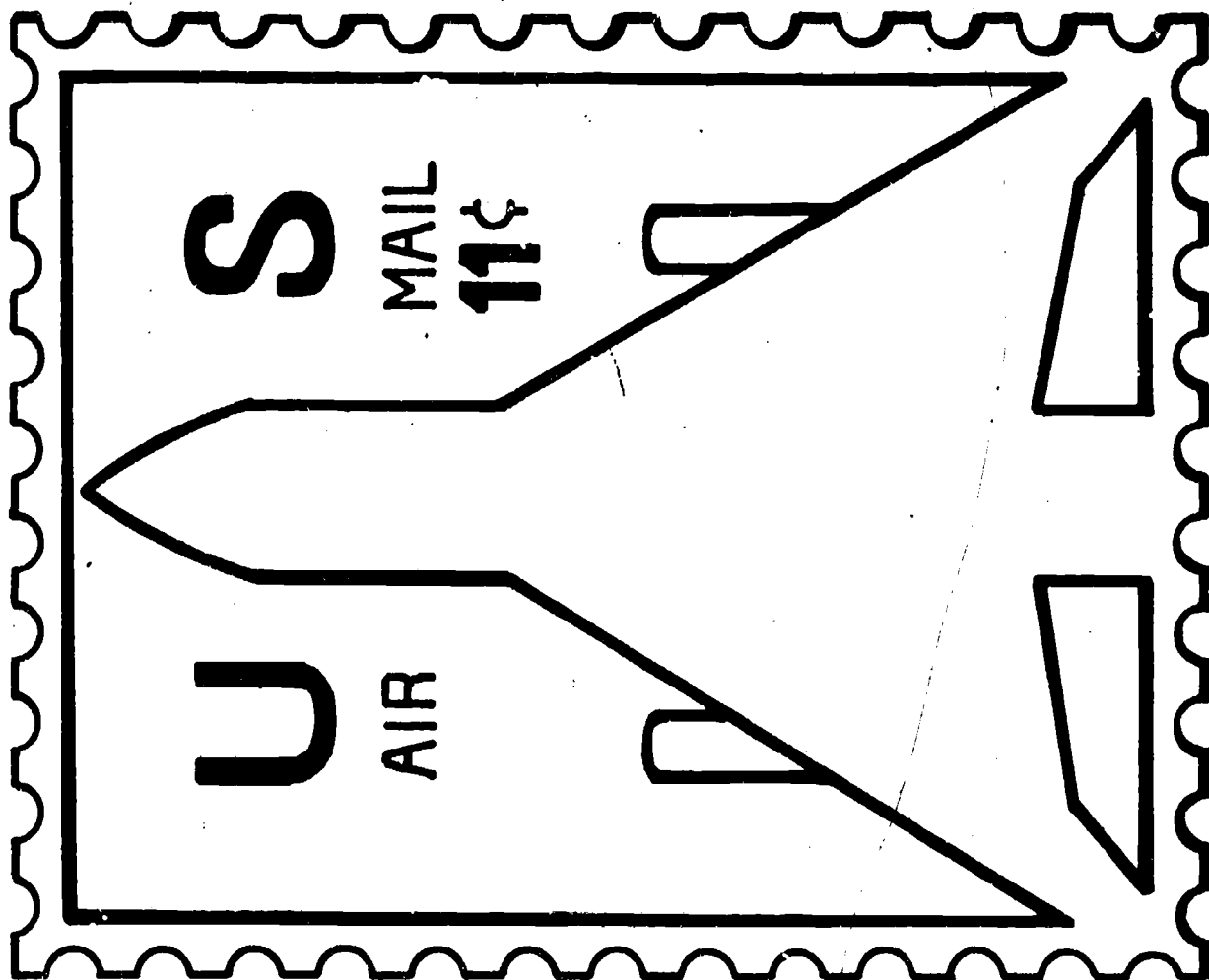

BEST COPY AVAILABLE

AP  
P159





AP  
P160





**USA**  
postage 15c

BEST COPY AVAILABLE

AP  
P162

PLACE  
STAMP  
HERE  
3901096

Burton Culumbay  
billie li of ul mesh with silboudp of tulpeu  
mpoul leup ulumb on lper callin

—burton culumbay burton ul 11061

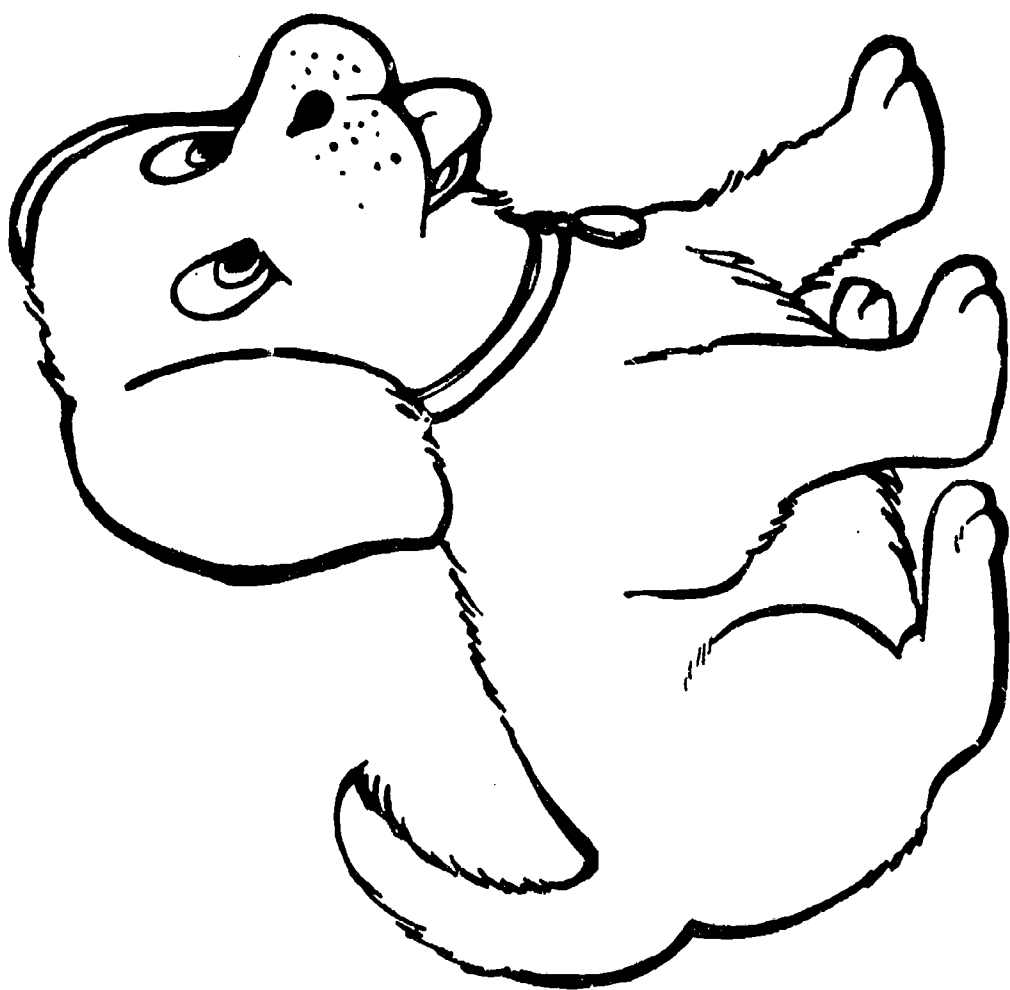

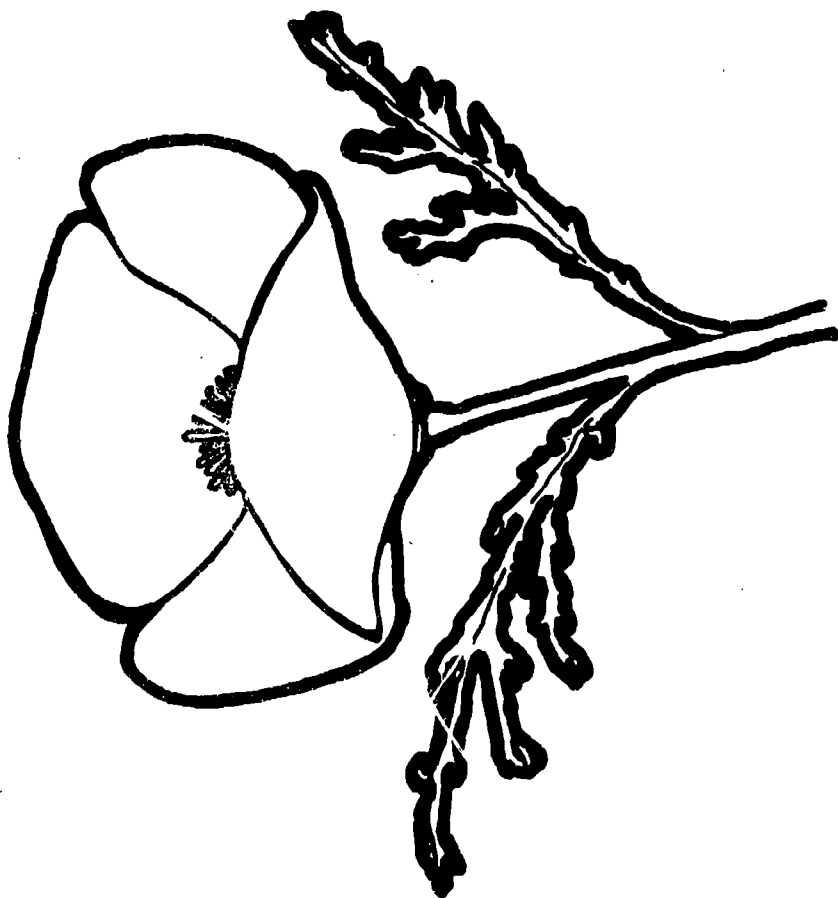

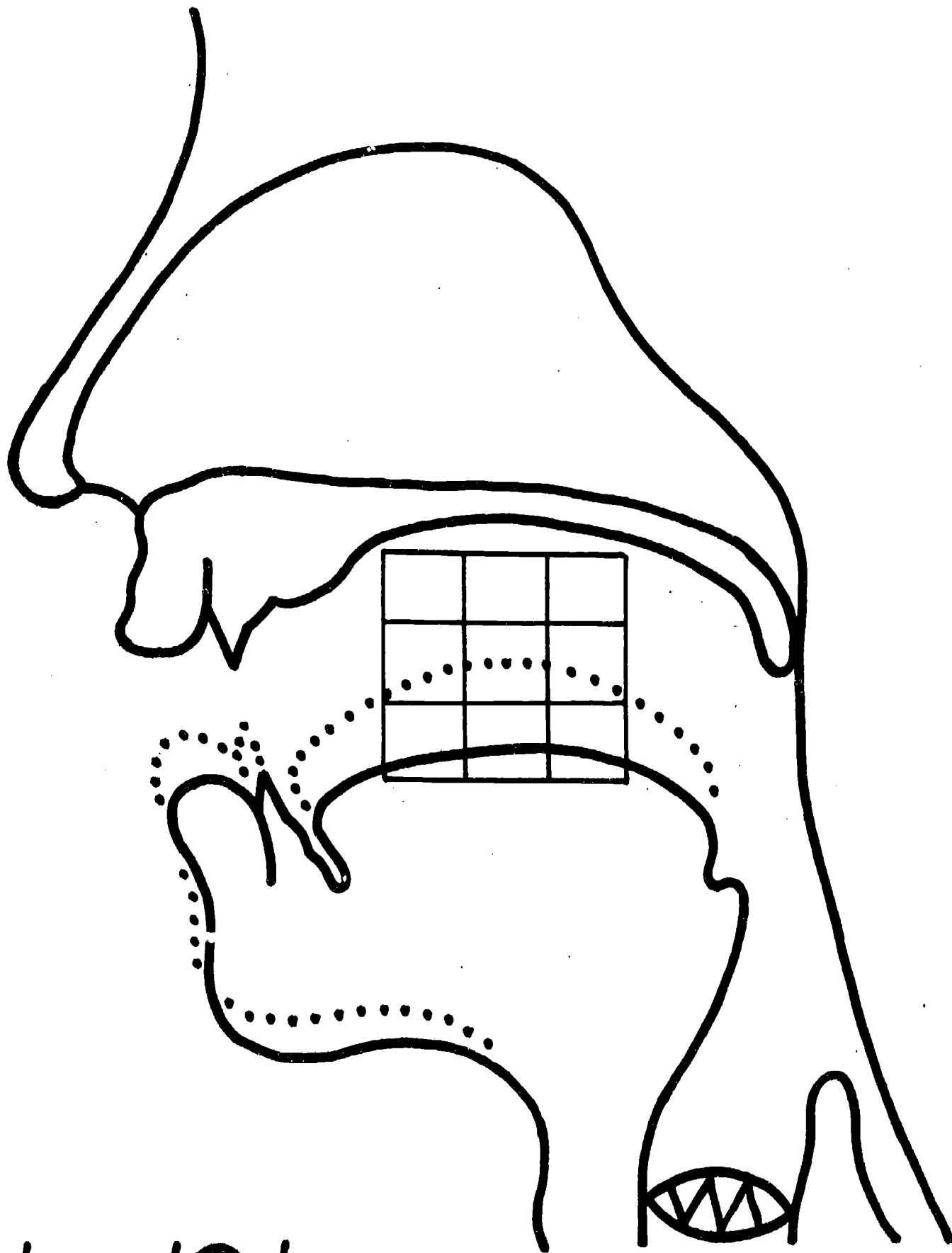

• /a/ ..... /a/ —

# FEBRUARY

S	M	T	W	T	F	S
	1	2	3	4	5	6
7	8	9	10	11	12	13
14	15	16	17	18	19	20
21	22	23	24	25	26	27
28						AP P166

BEST COPY AVAILABLE

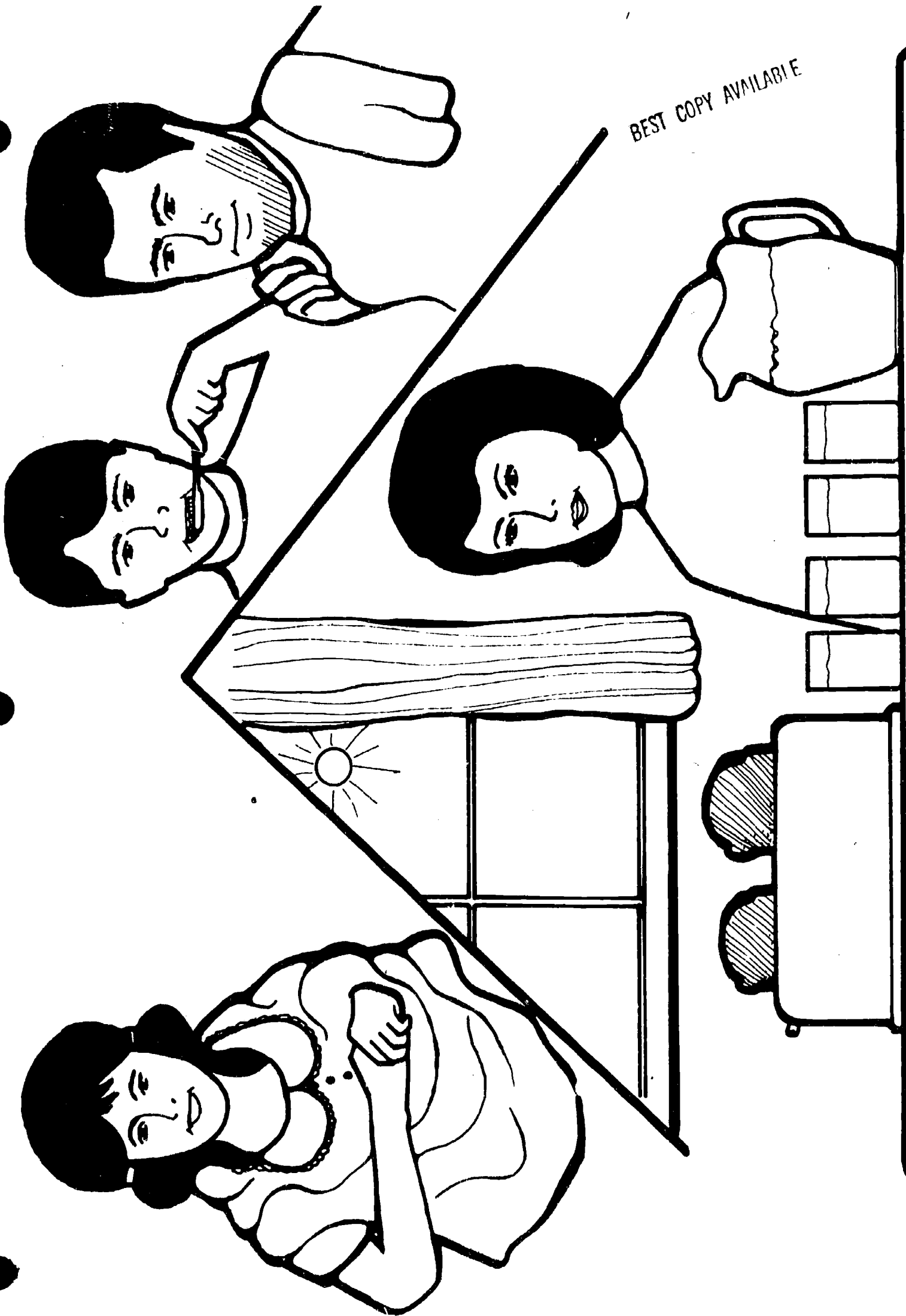

AP  
P167

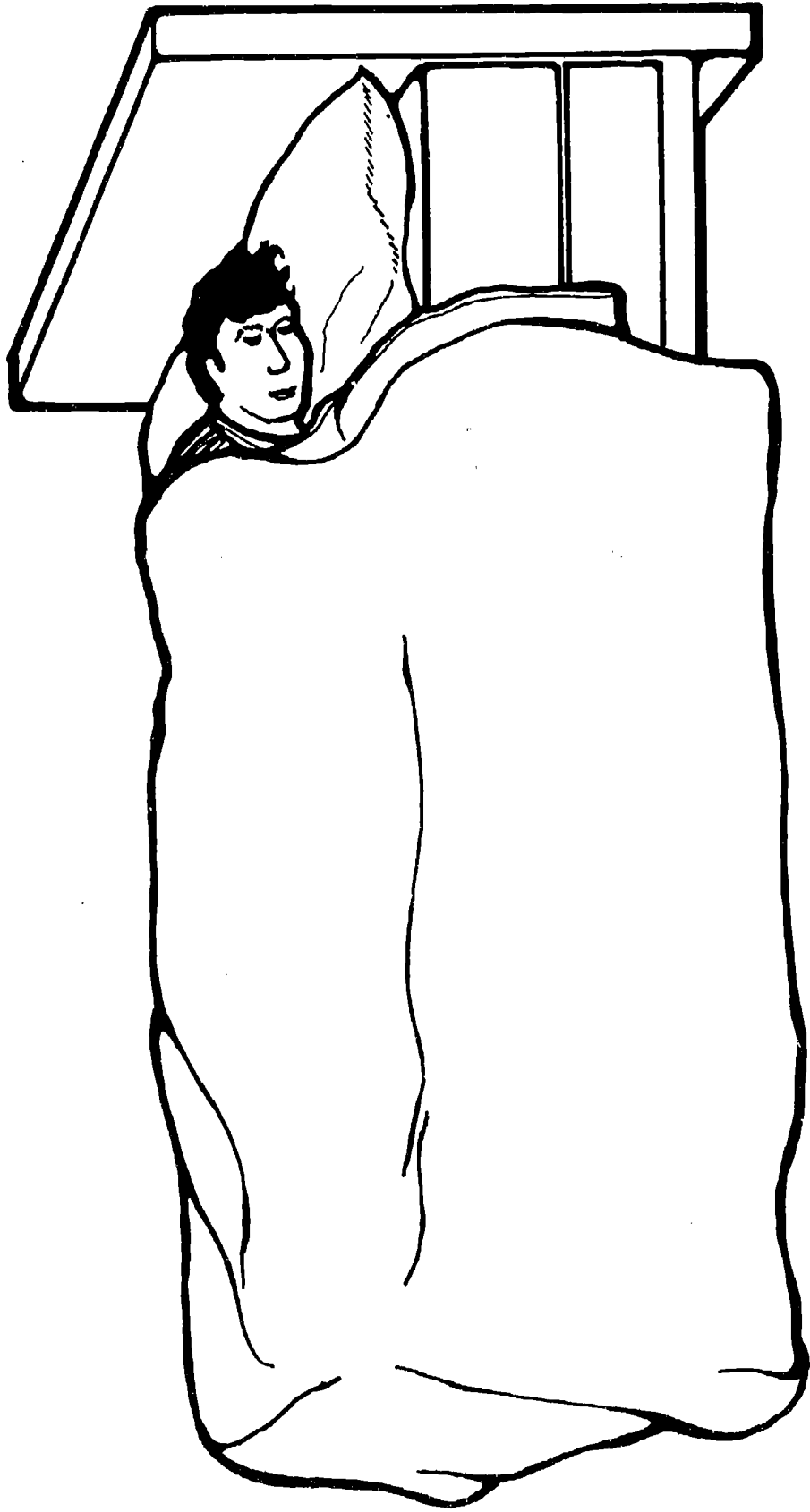



BEST COPY AVAILABLE

AP  
P169

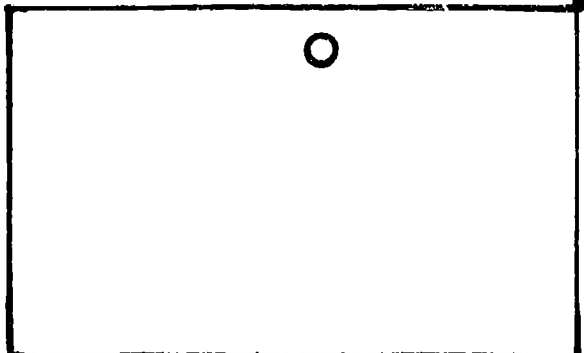
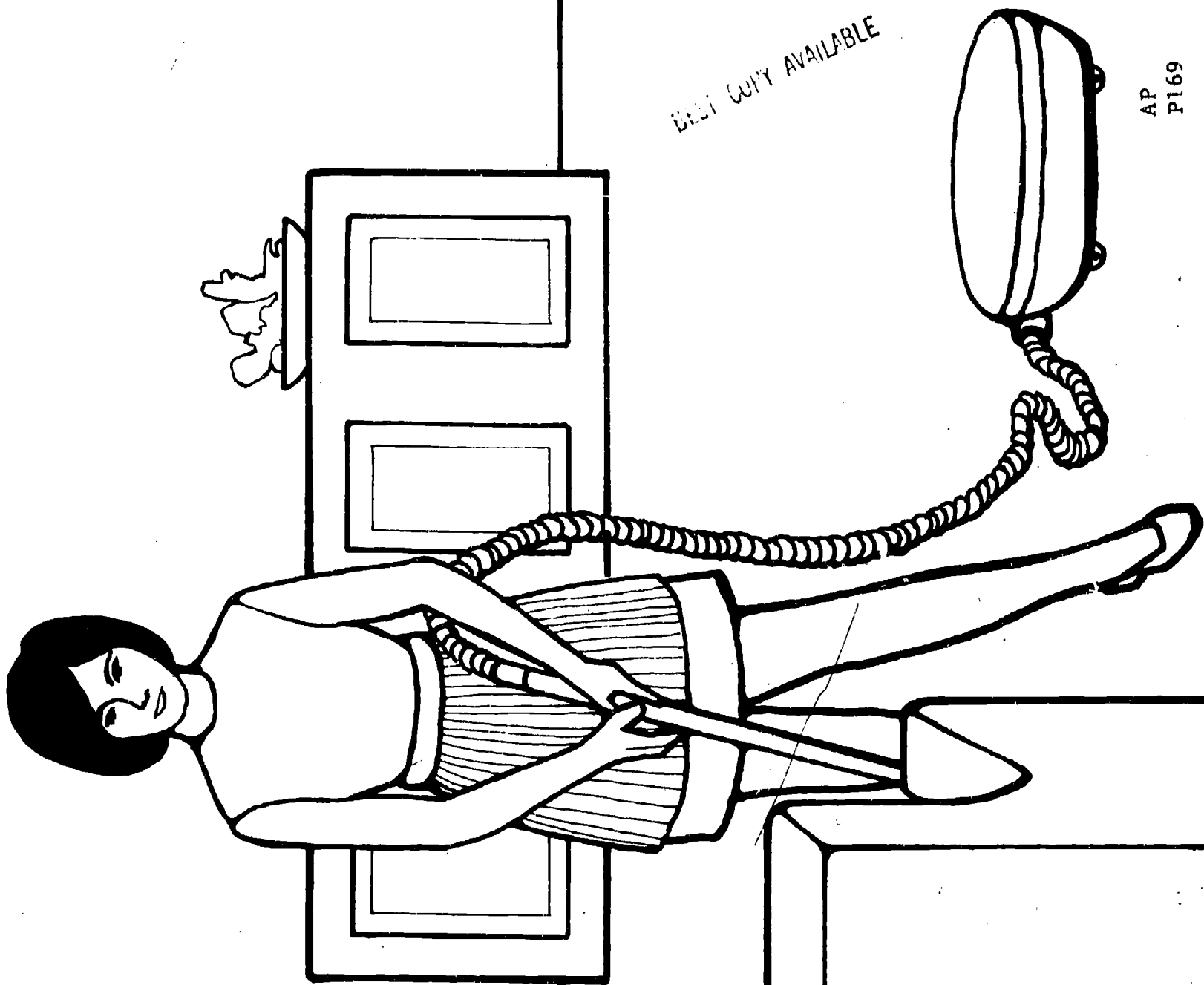

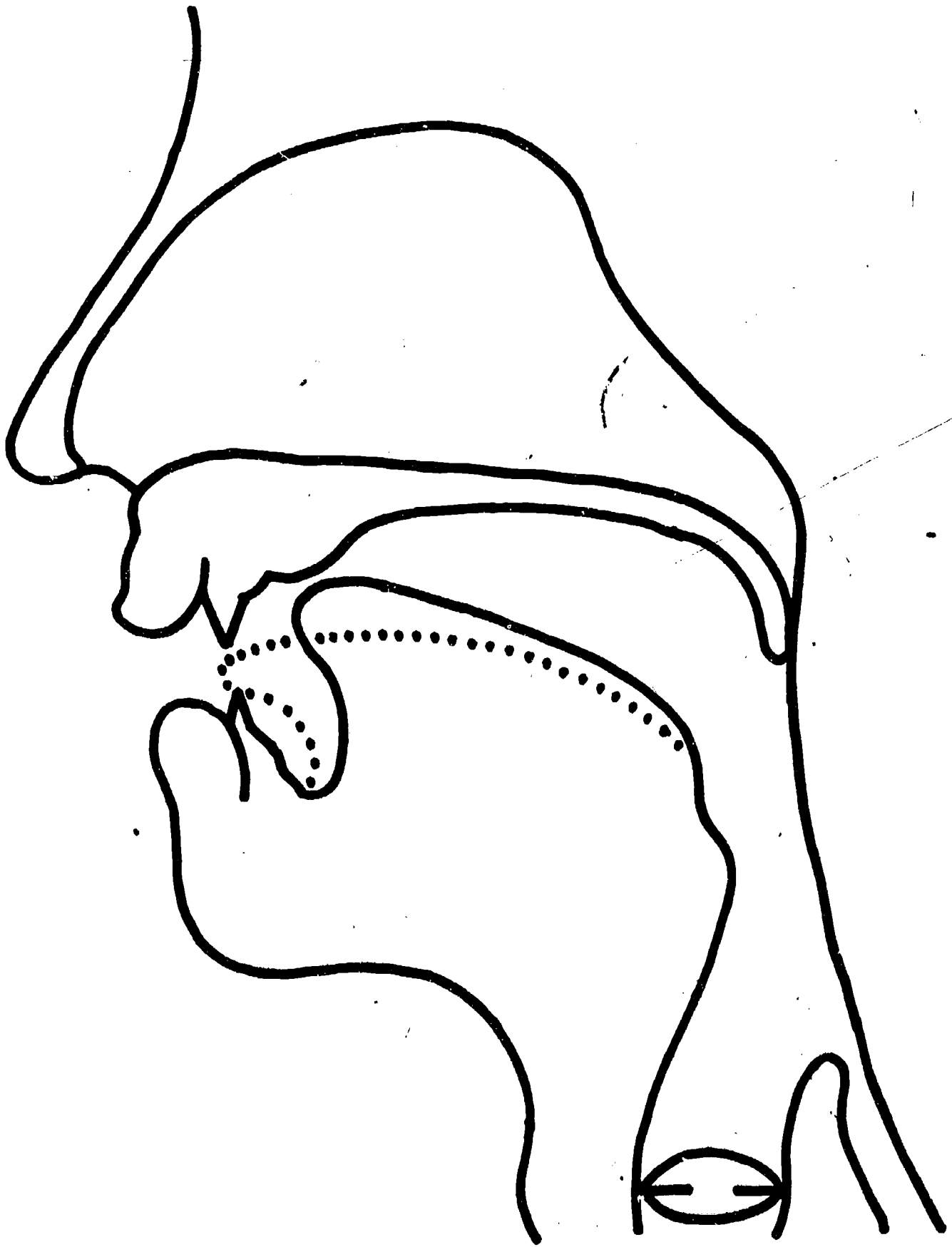

ʔs/ - /θ/.....

AP  
P170

AP  
P171

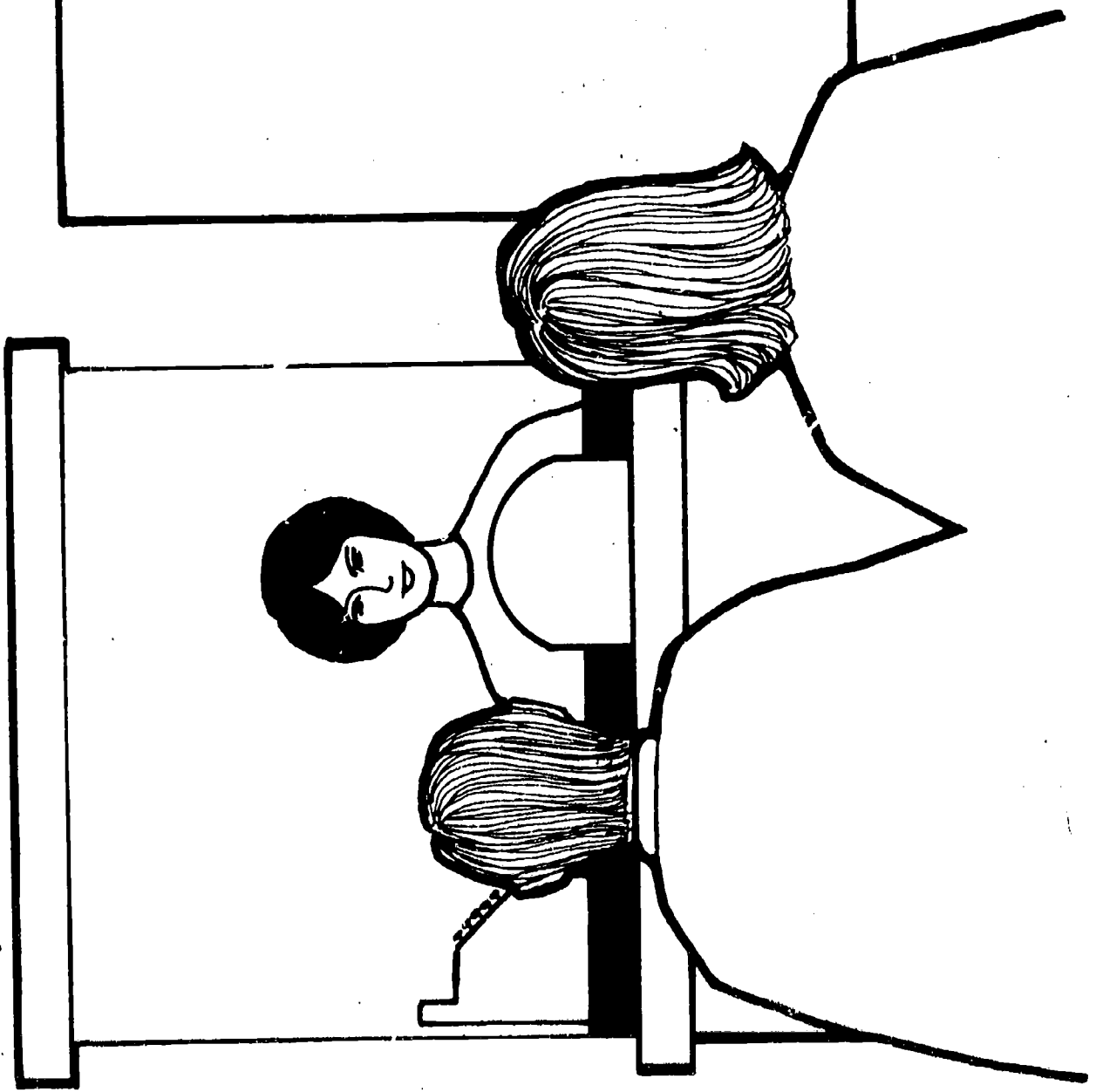
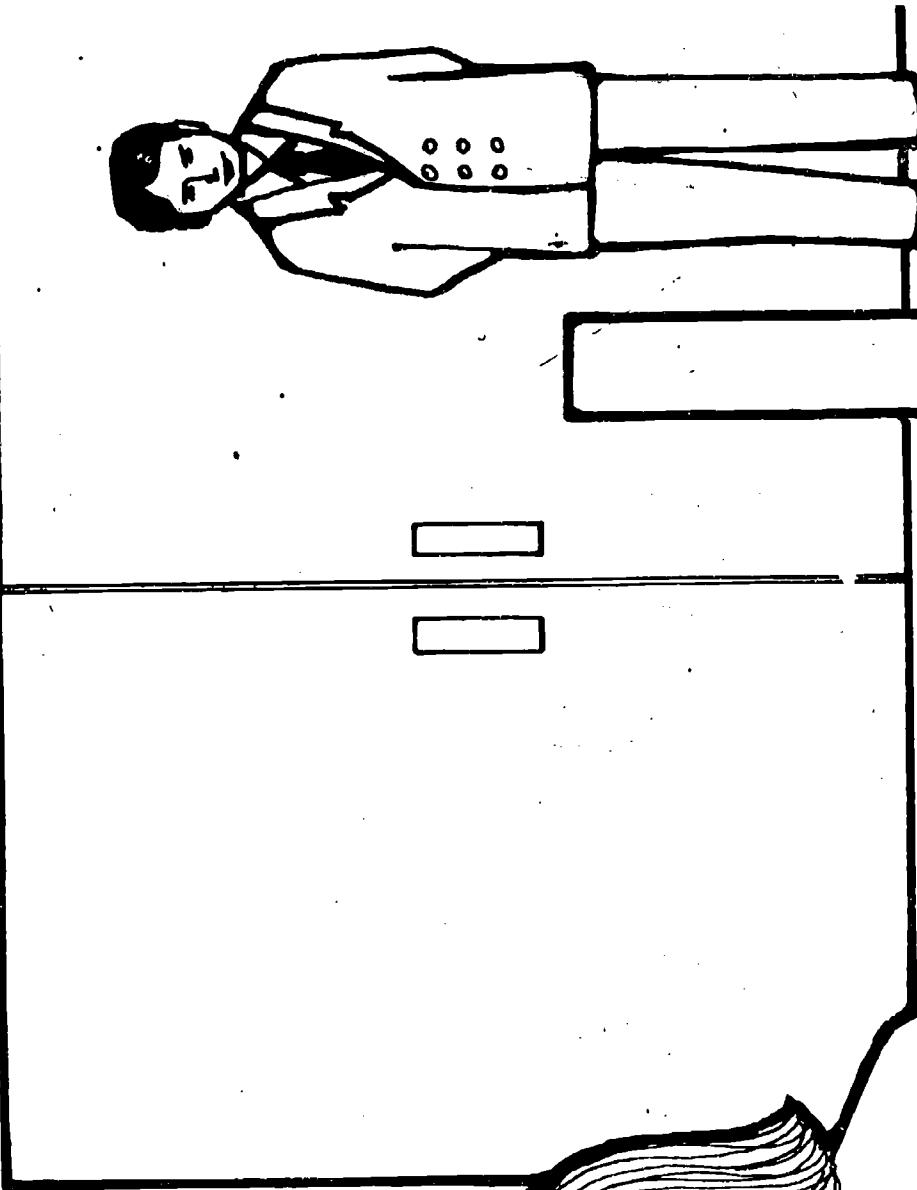
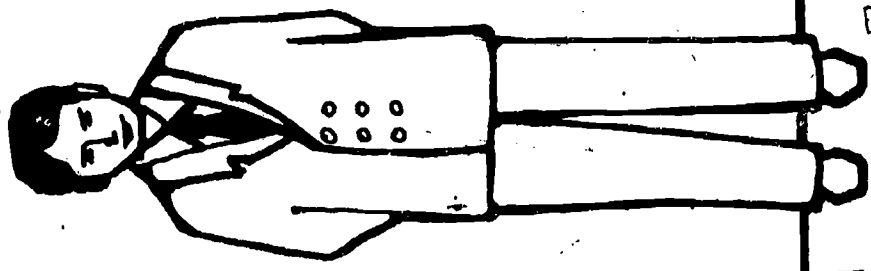

NEW SHIRTS!



BEST COPY AVAILABLE

AP  
P172

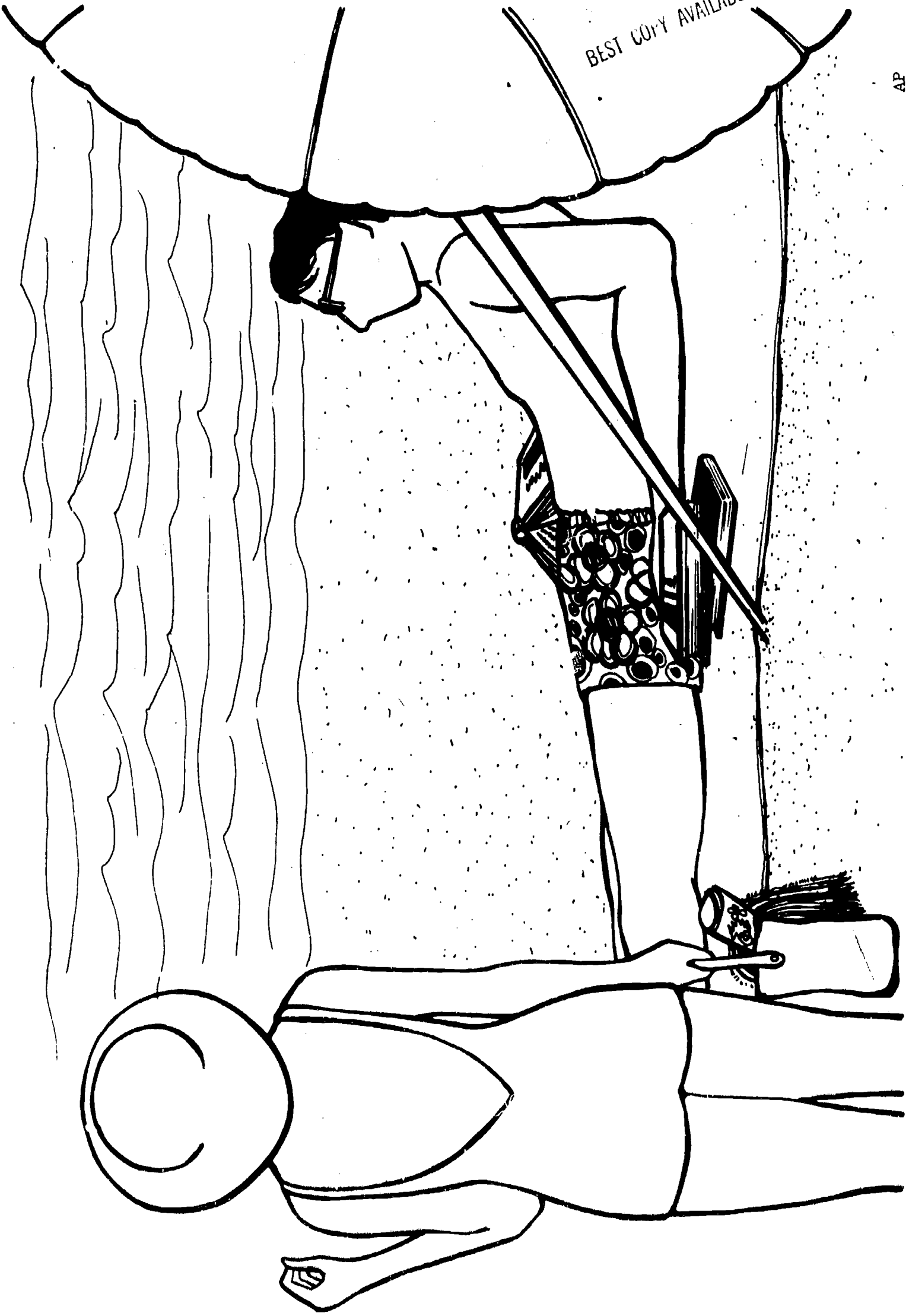

REF. COPY AVAILABLE

AP  
PI73

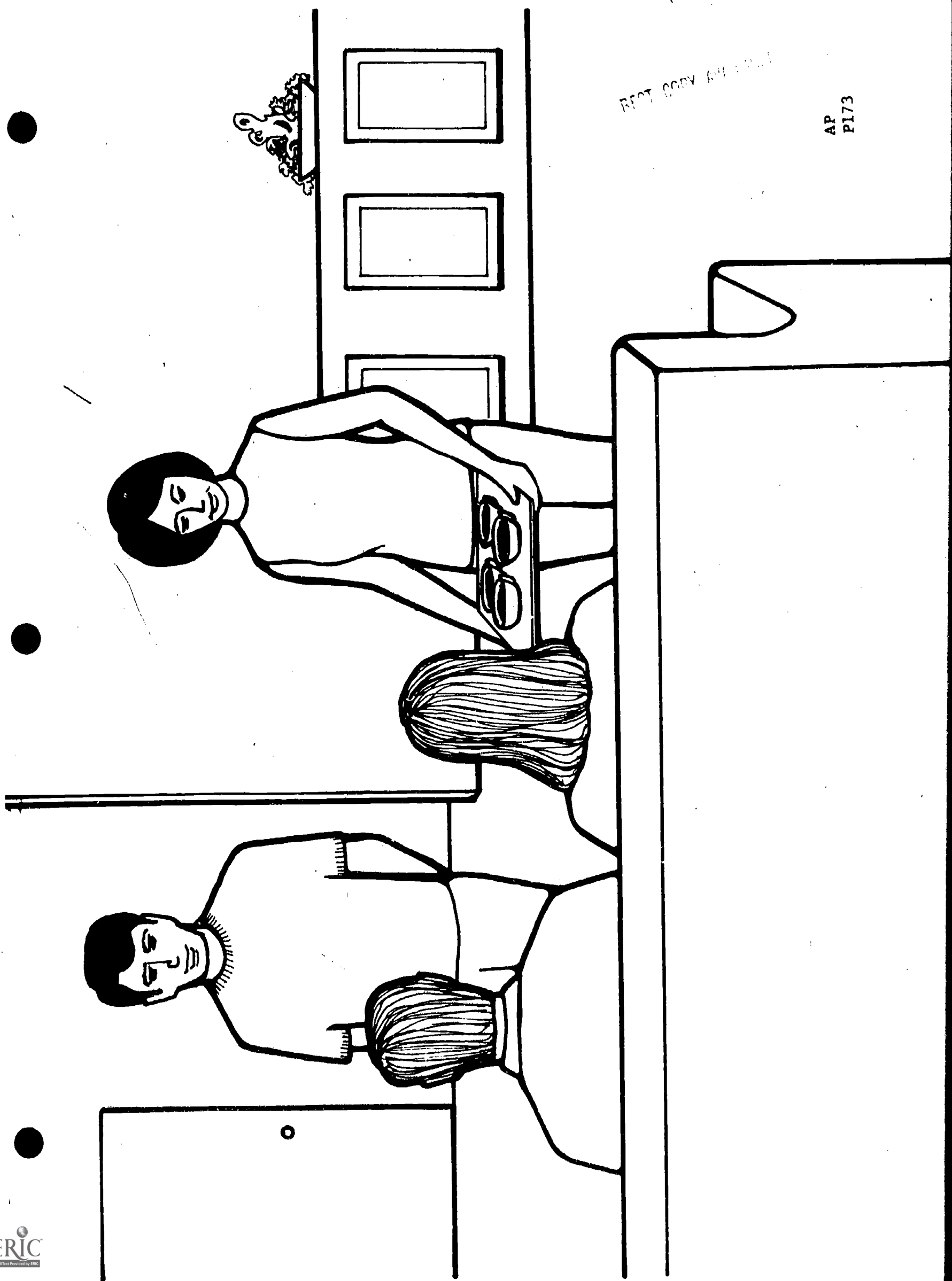

BEST COPY AVAILABLE

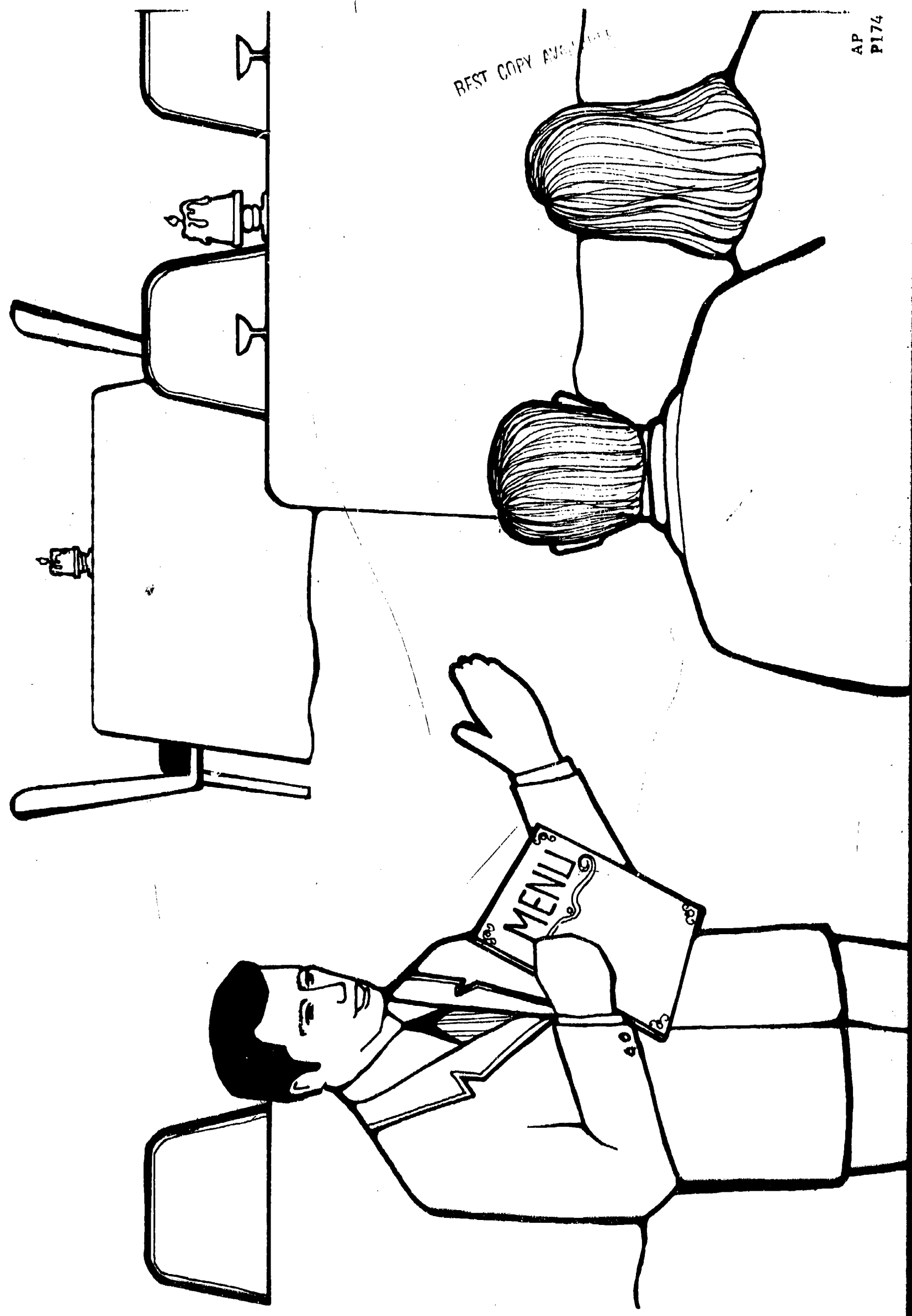

BEST COPY AVAILABLE

AP  
P175

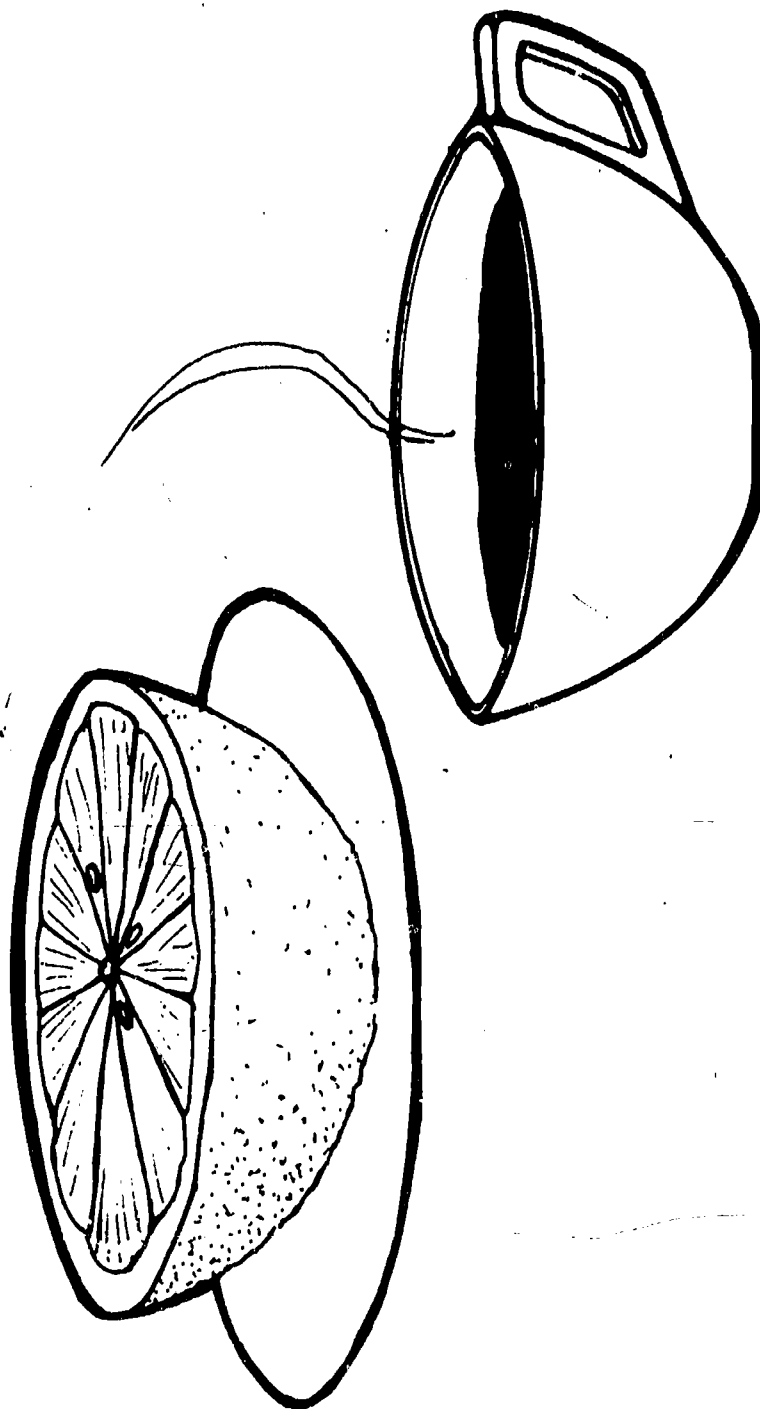

BEST COPY AVAILABLE

AP  
P176

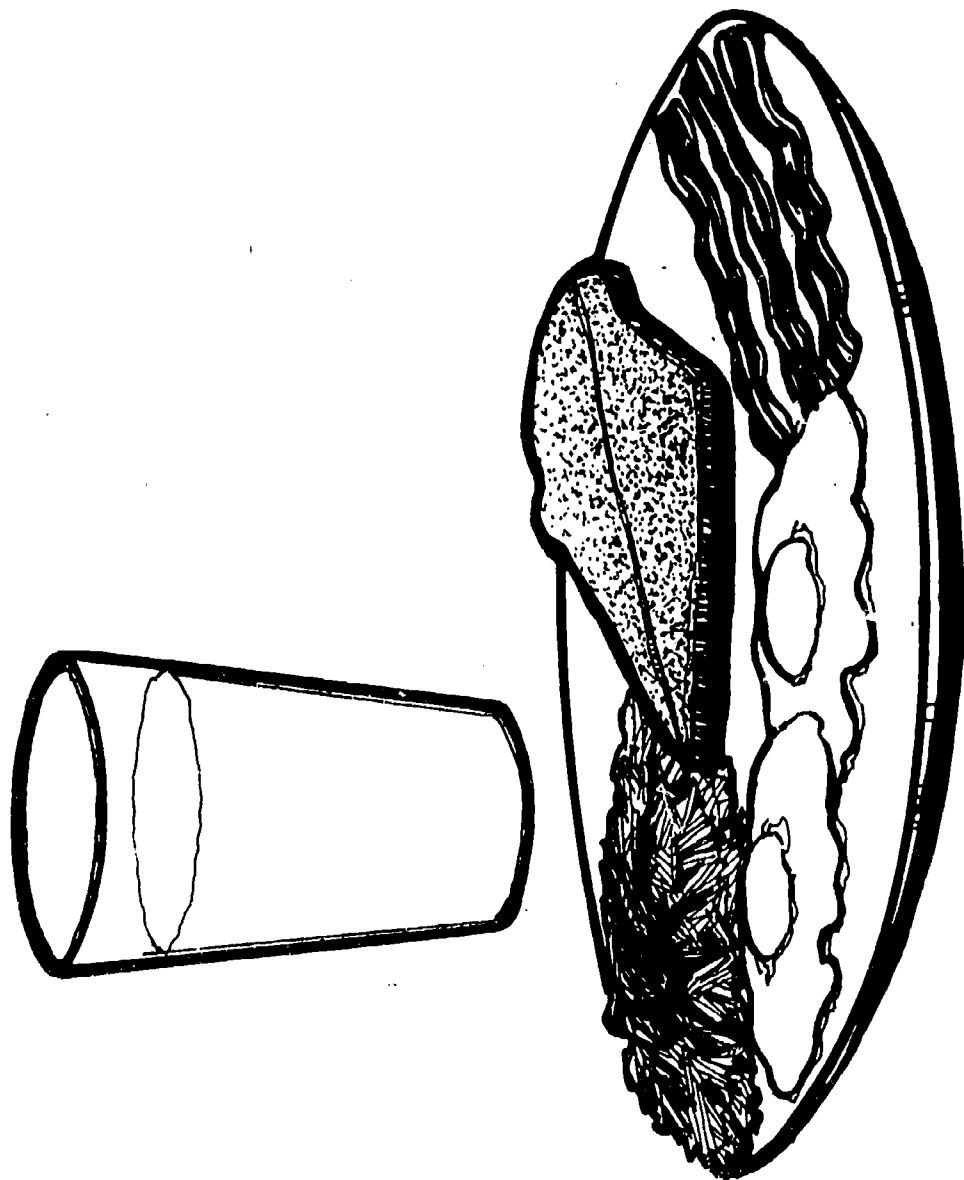



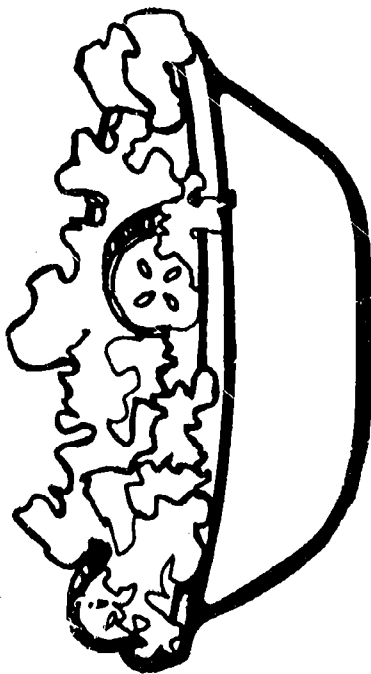

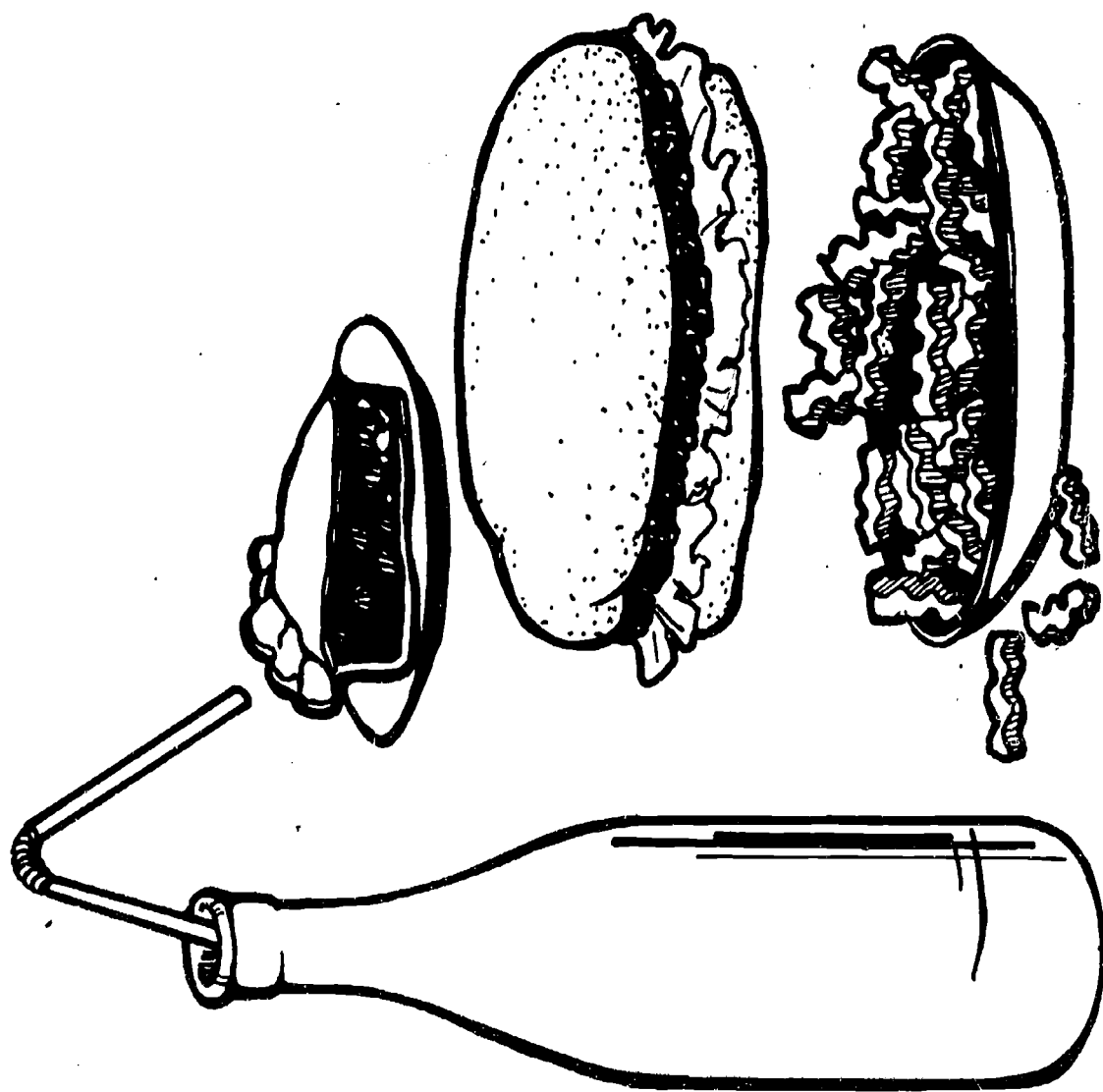

BEST COPY AVAILABLE

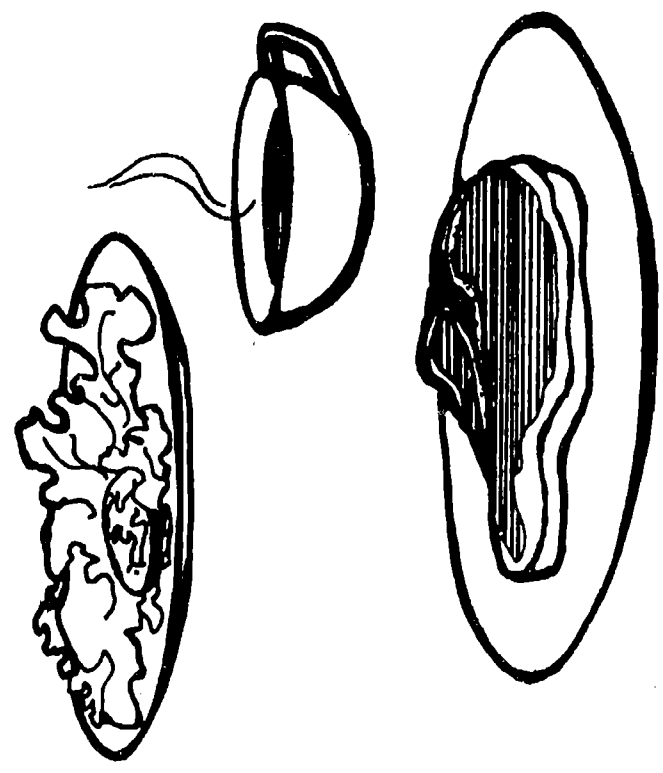

1957 COPY

AP  
P180

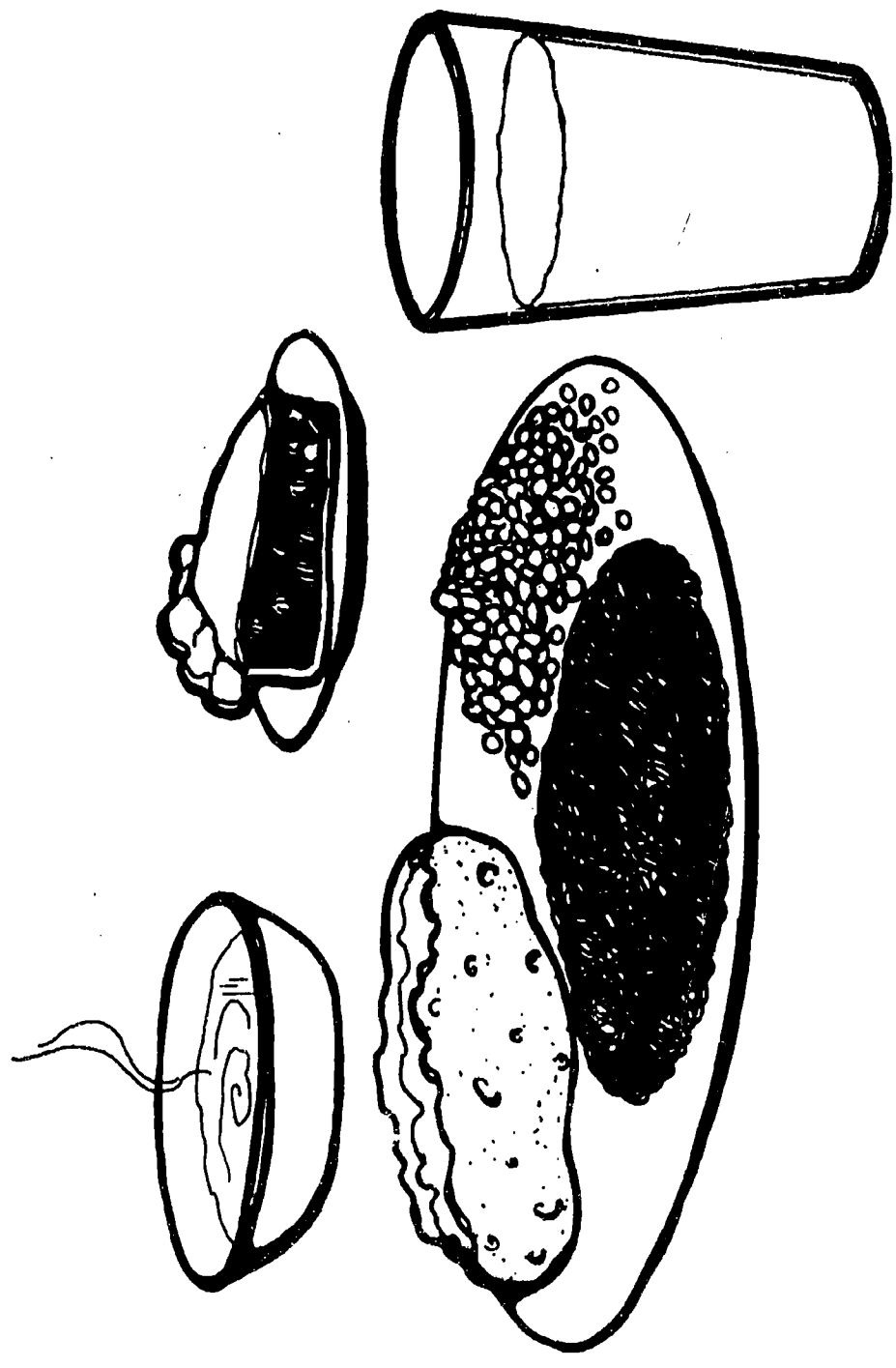

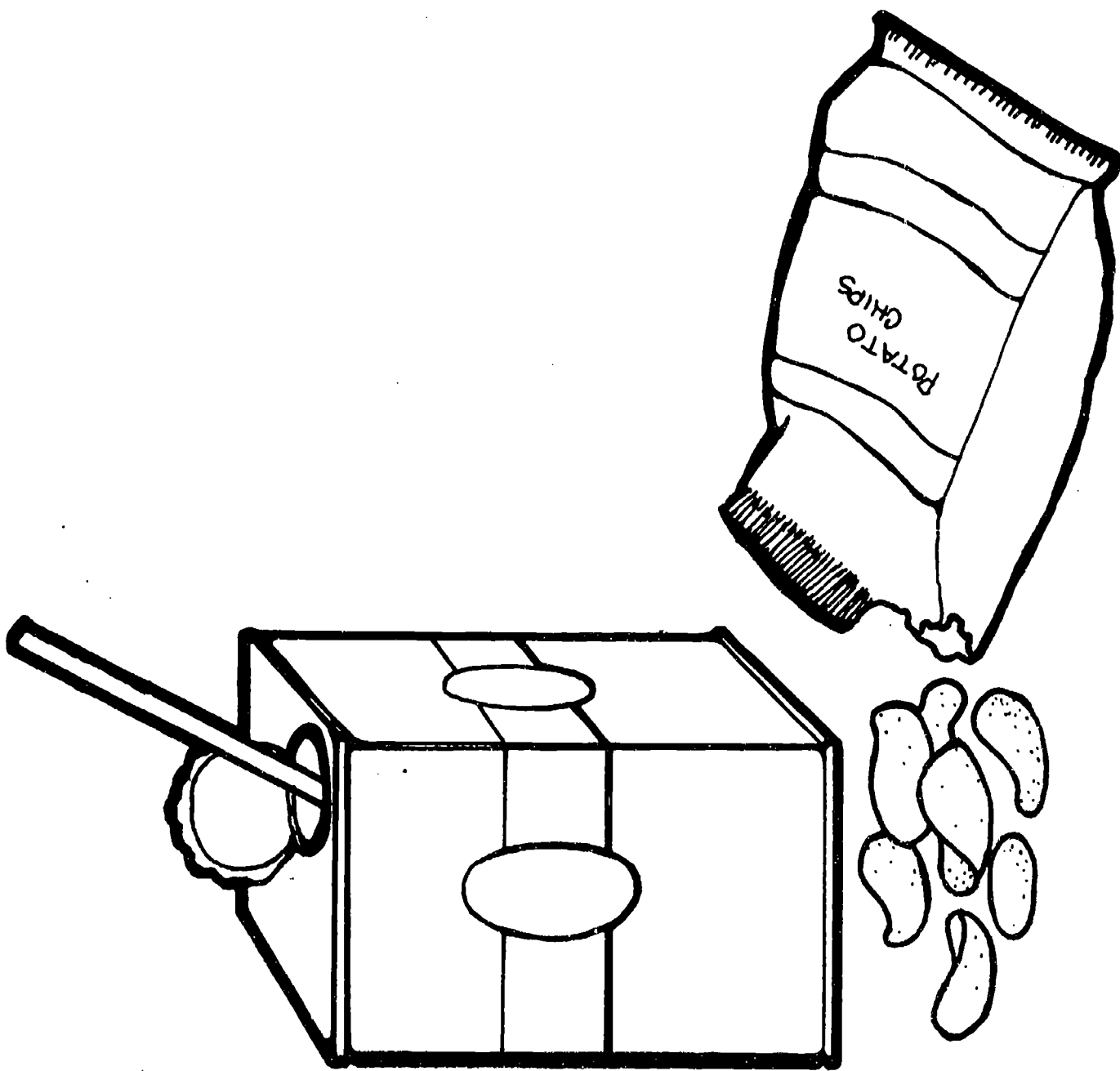

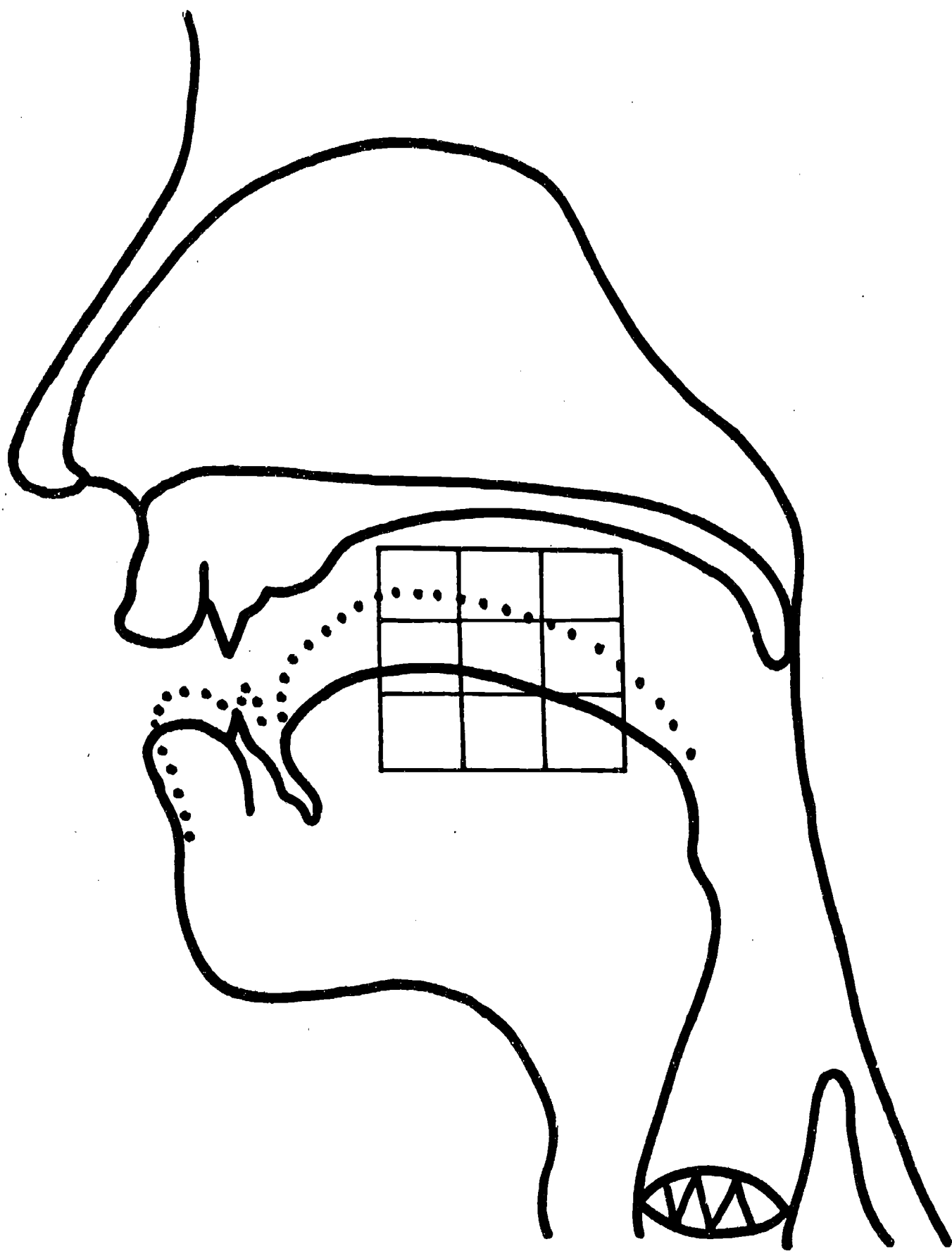

• /I/..... /E/ -

AP  
P182

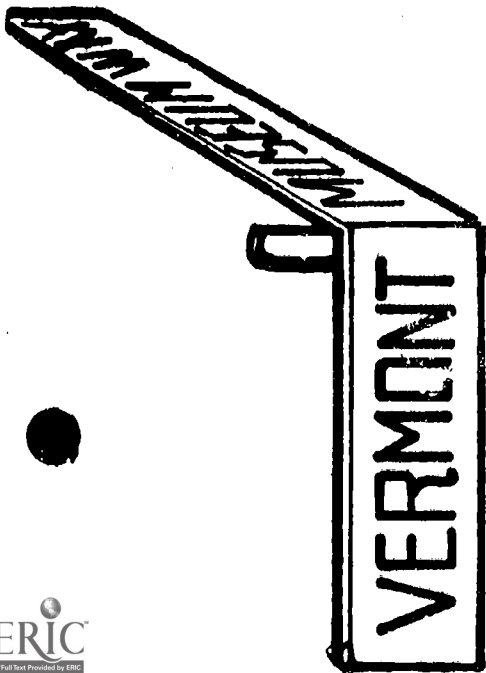
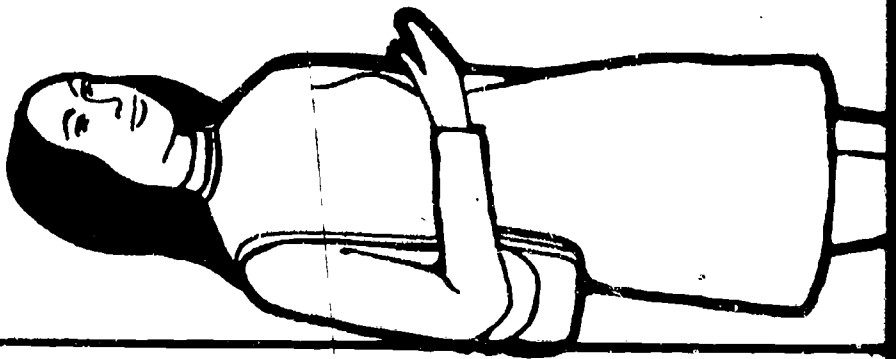

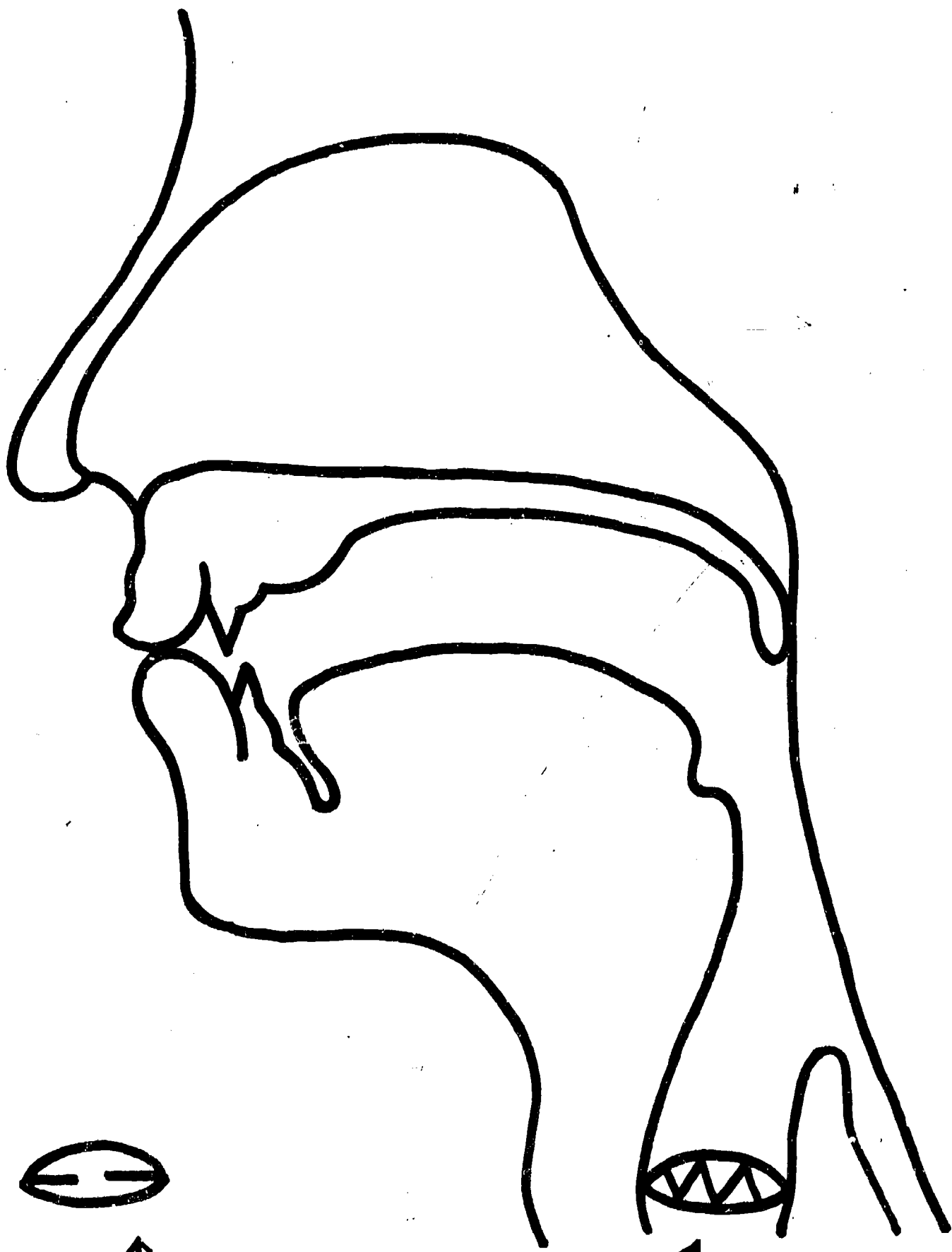

/p/ /b/



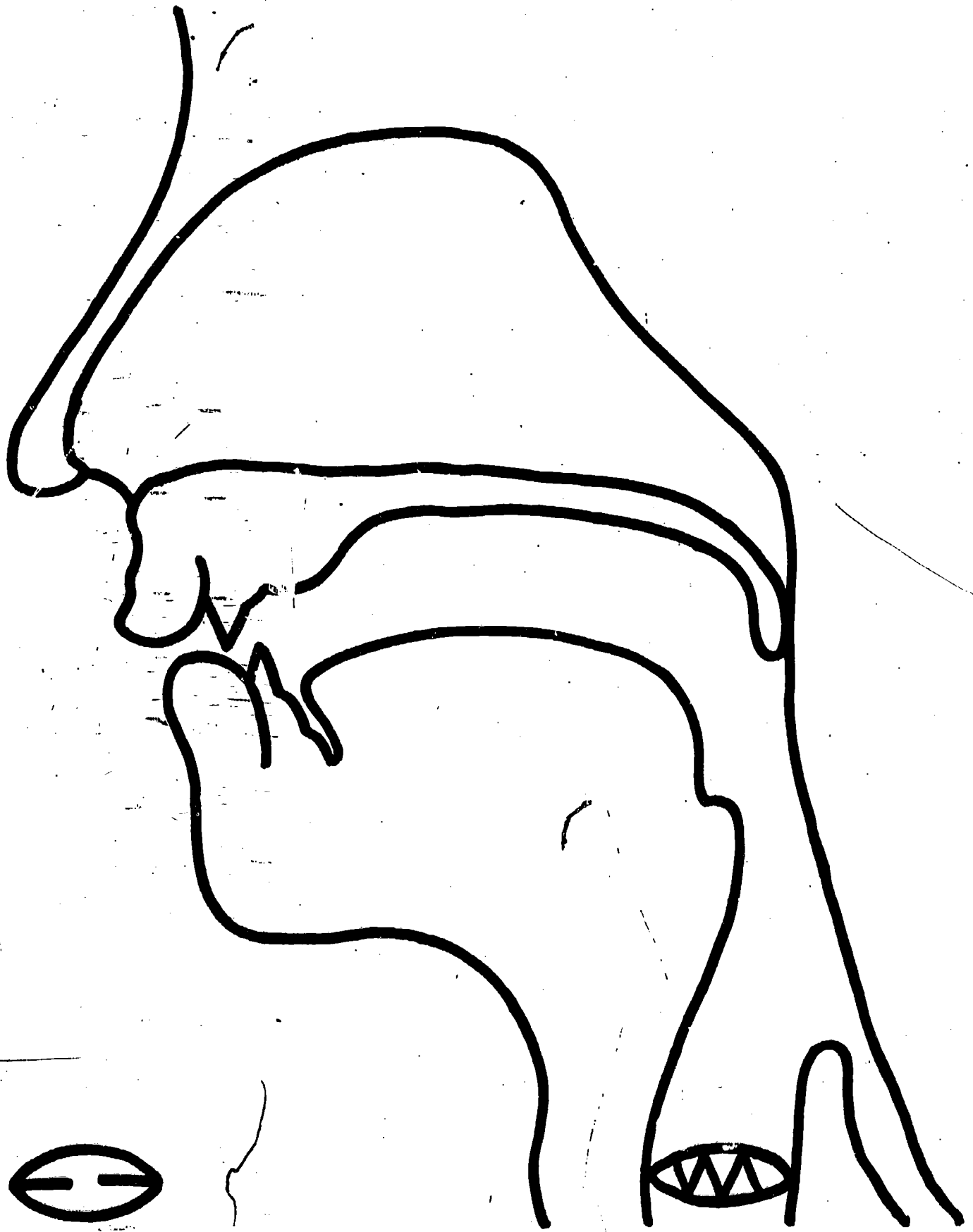

/f/ /v/

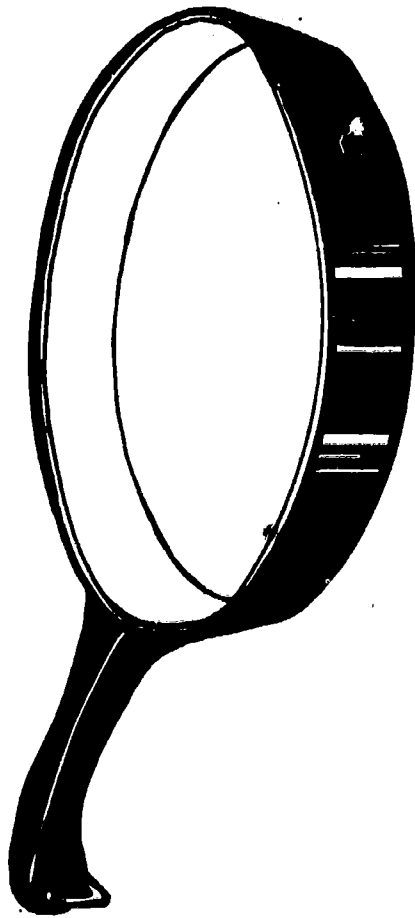
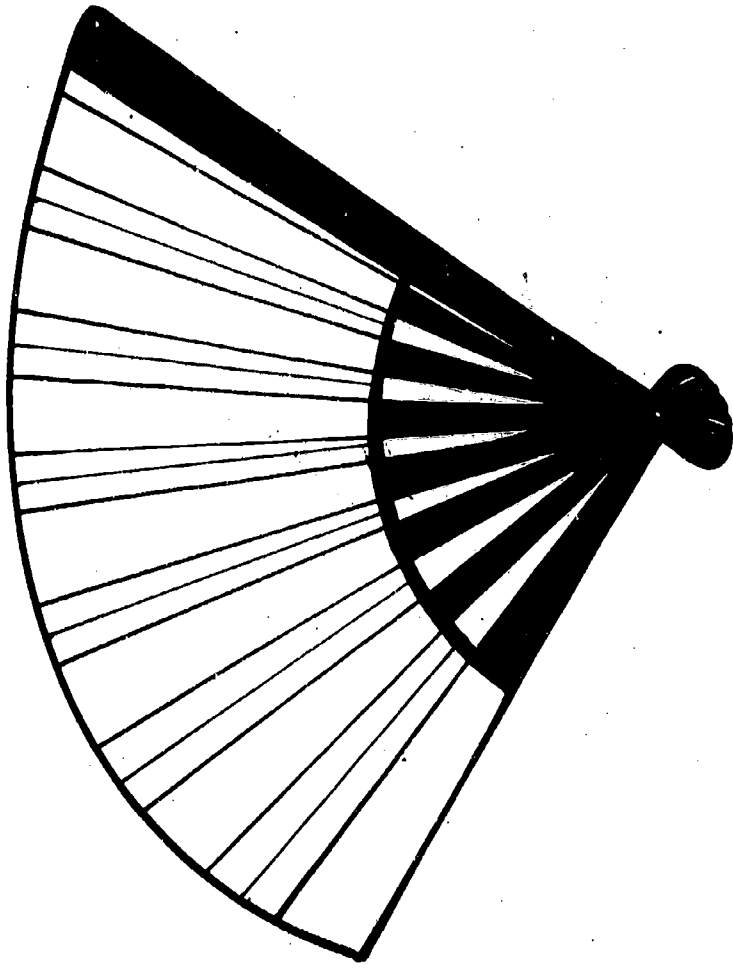



000

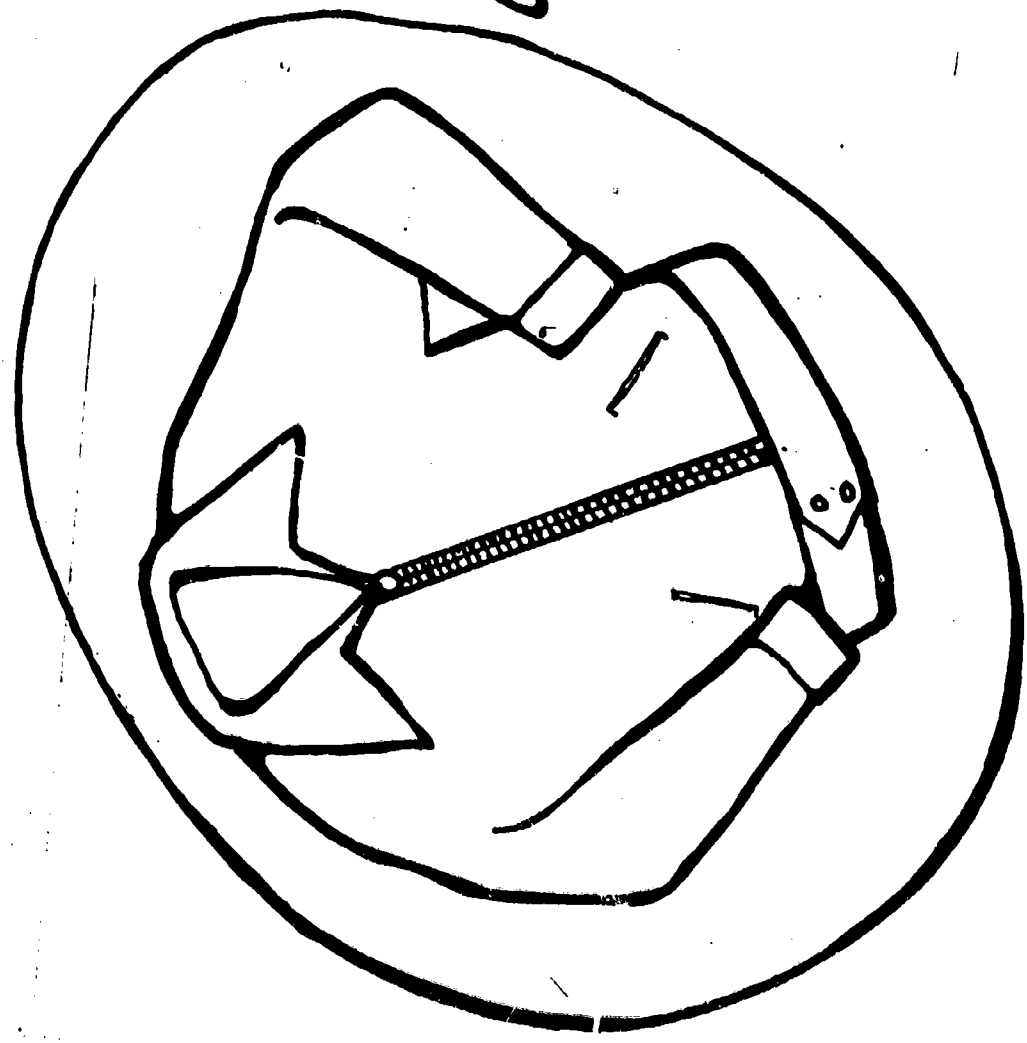

AP  
P188



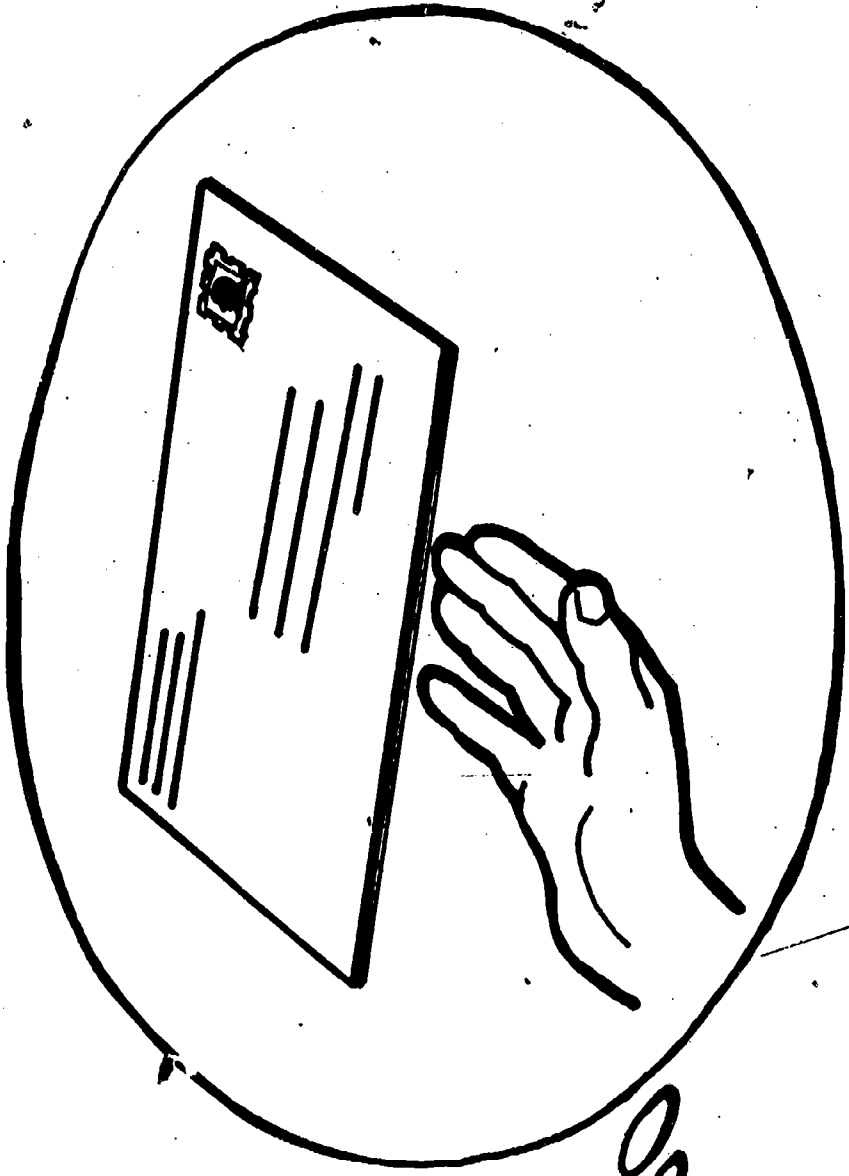

000.

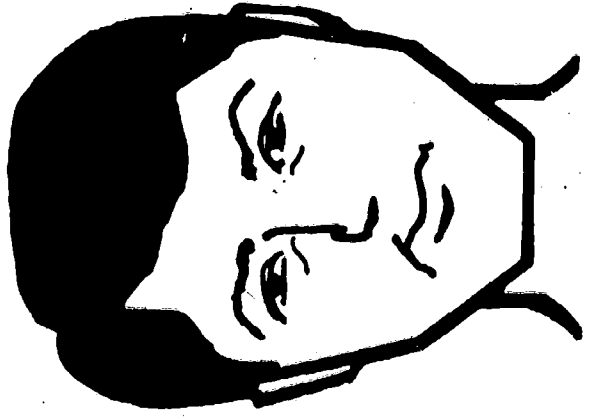

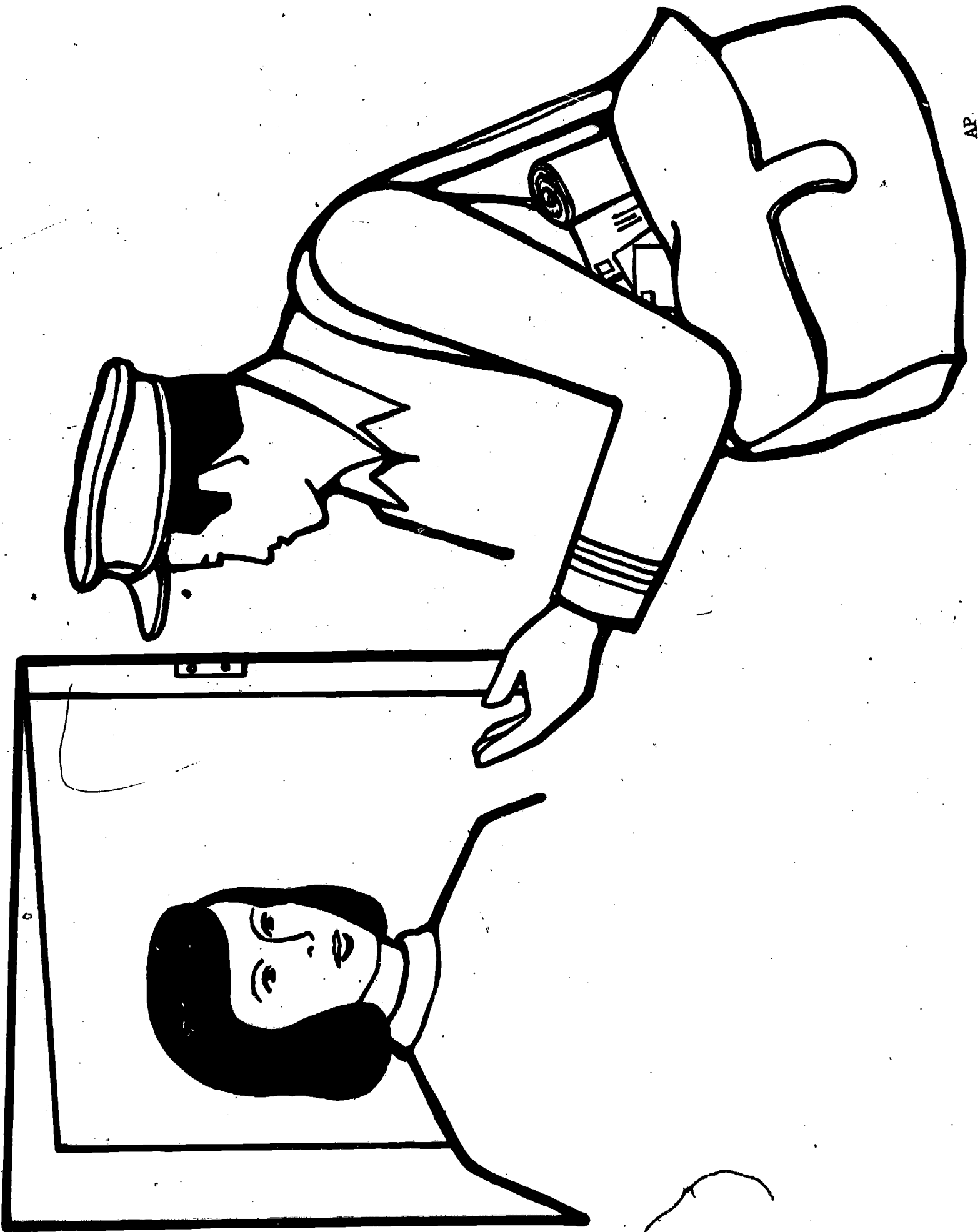

BEST COPY AVAILABLE

AP  
P191

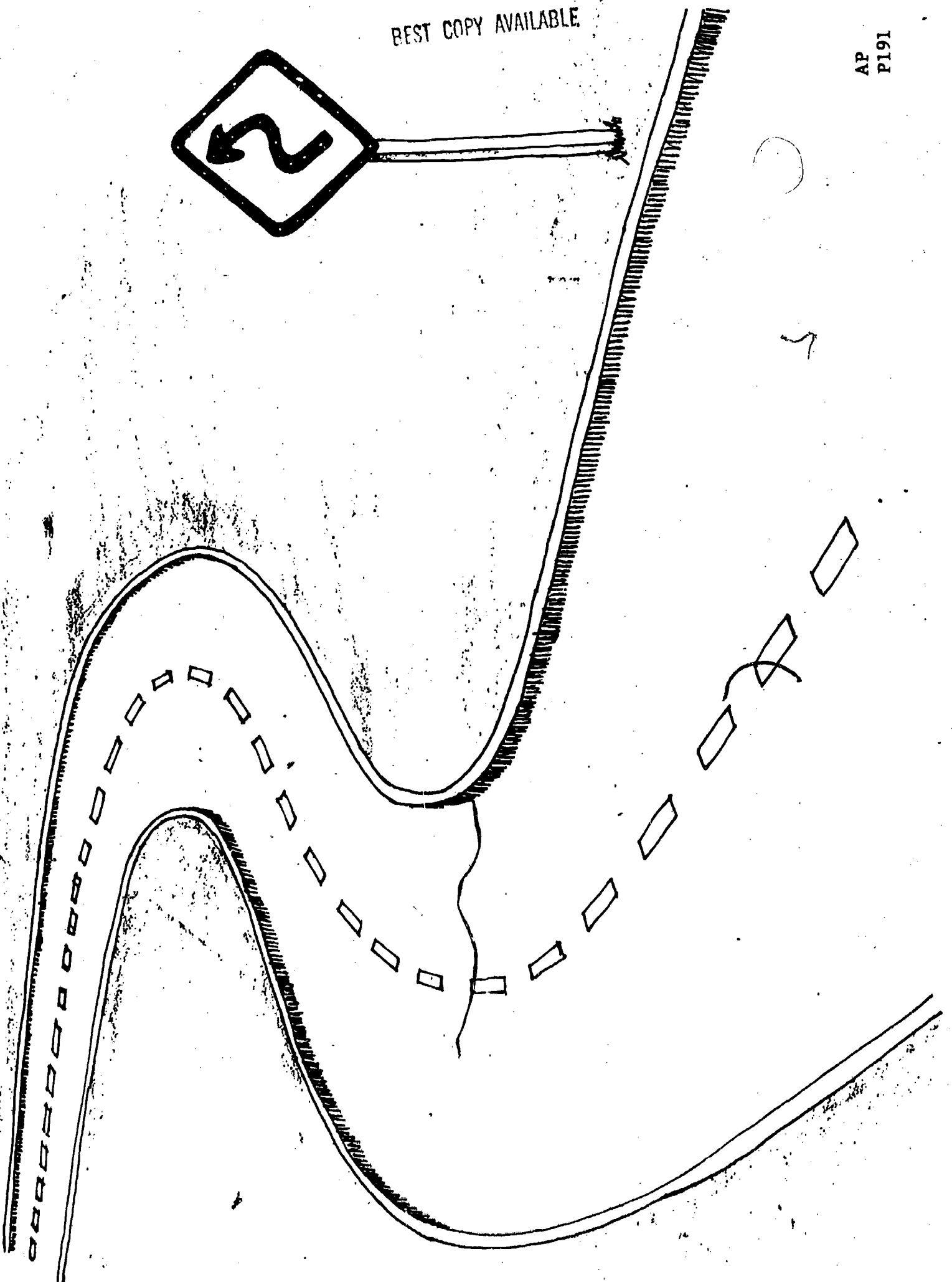
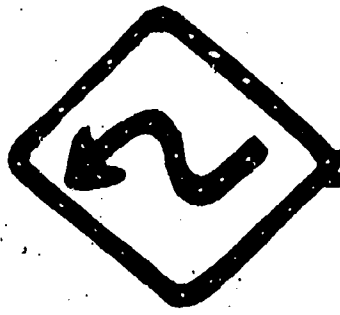

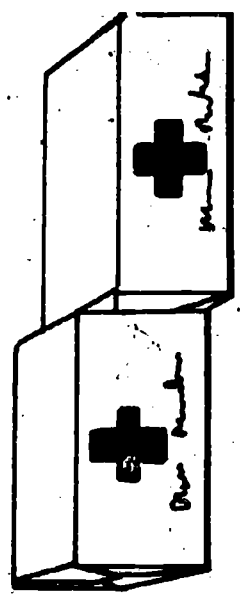
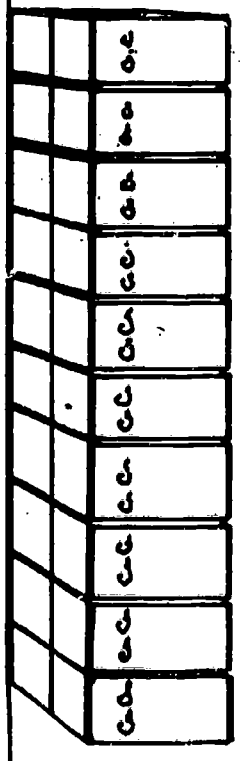
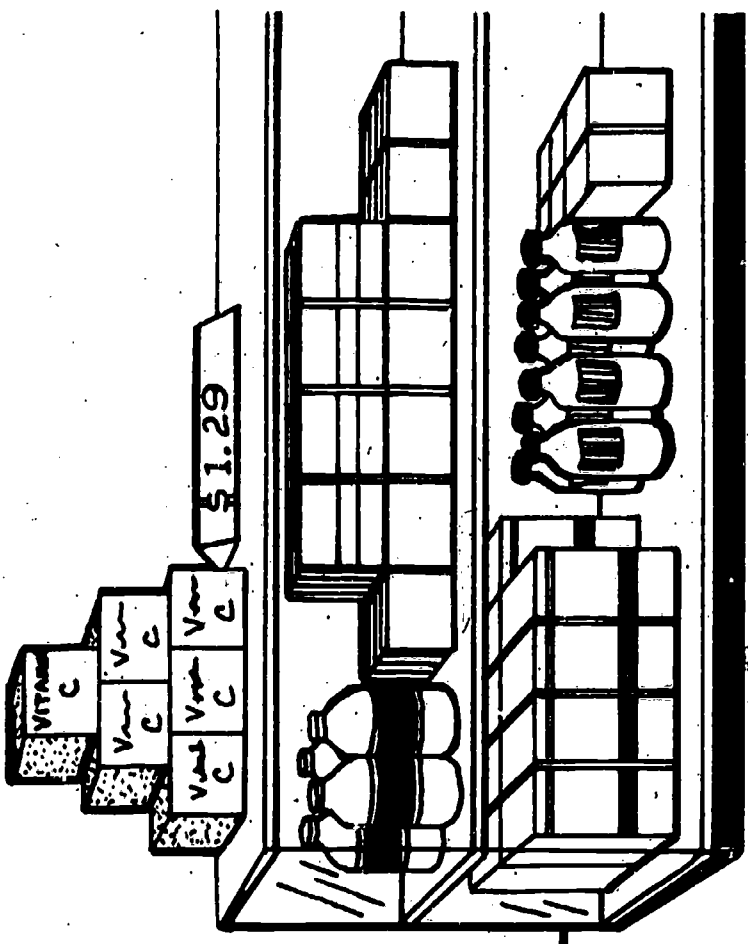
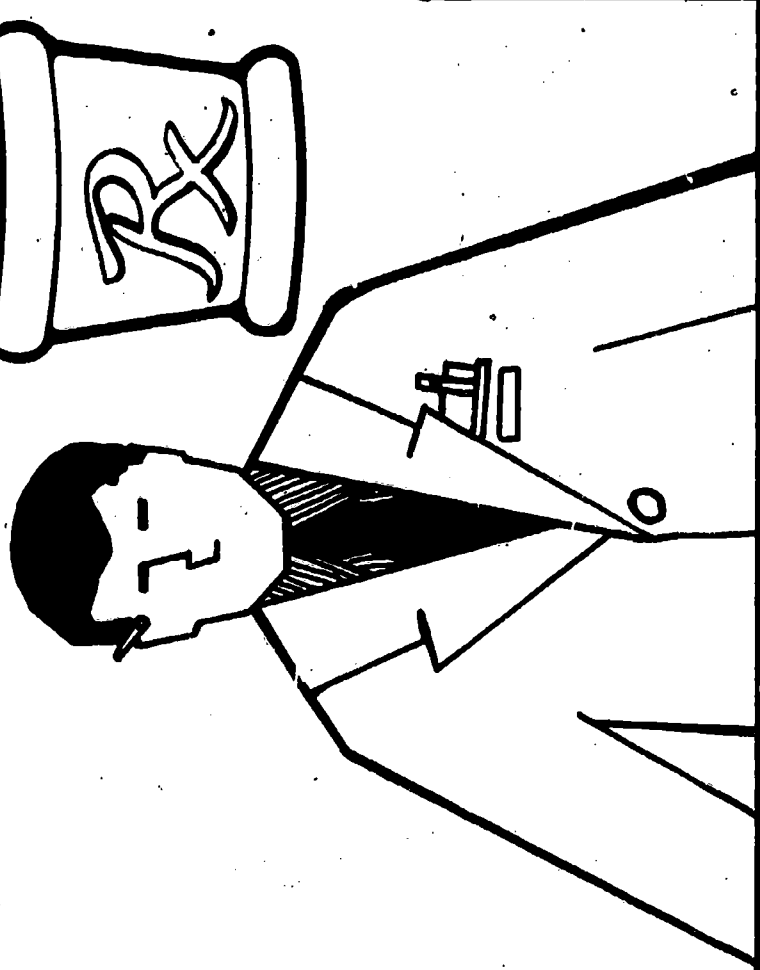

REST COPY AVAILABLE AP P192



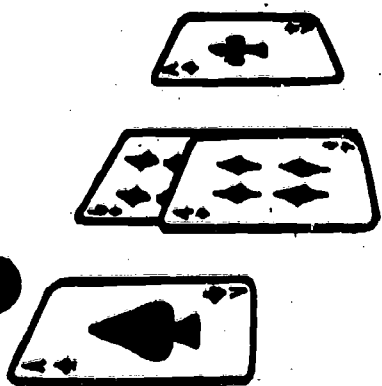
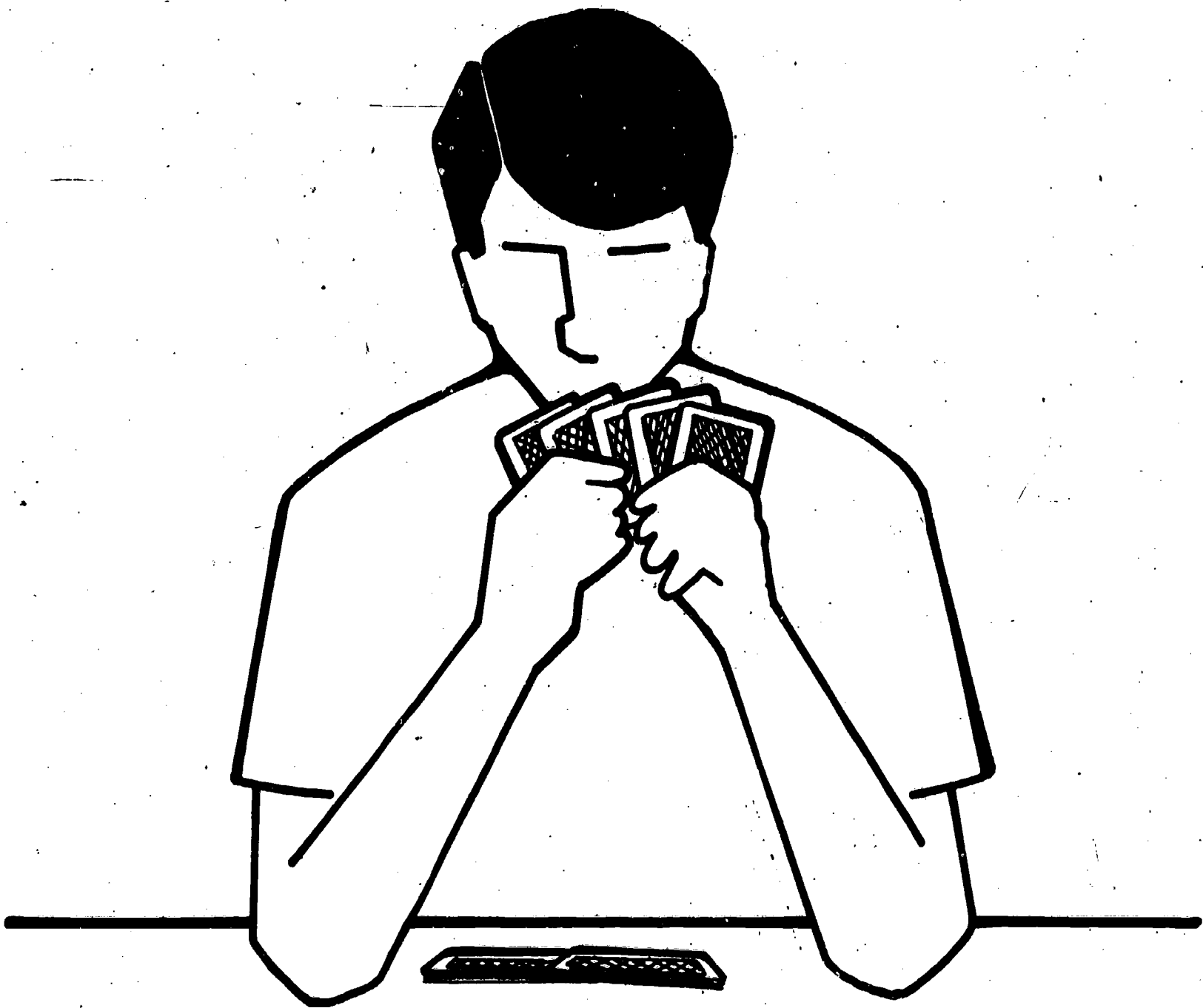

BEST COPY AVAILABLE

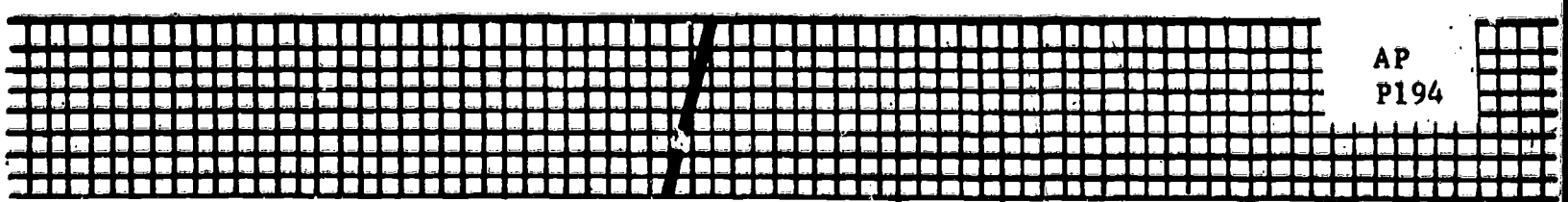
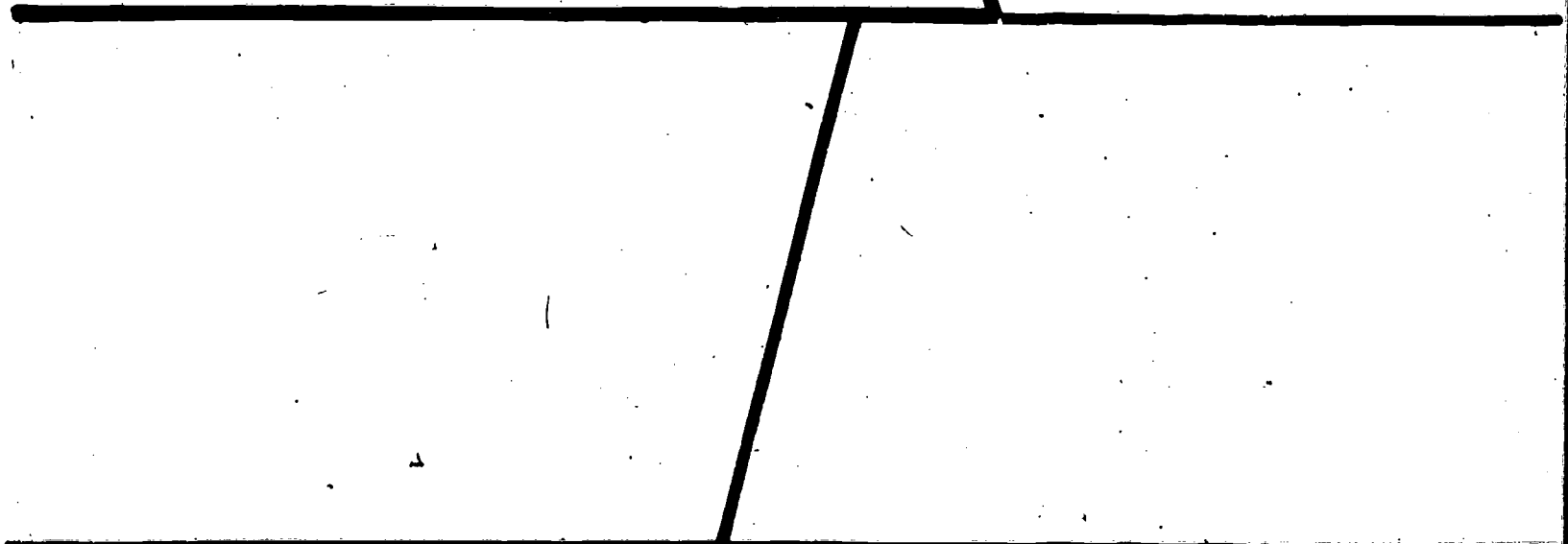
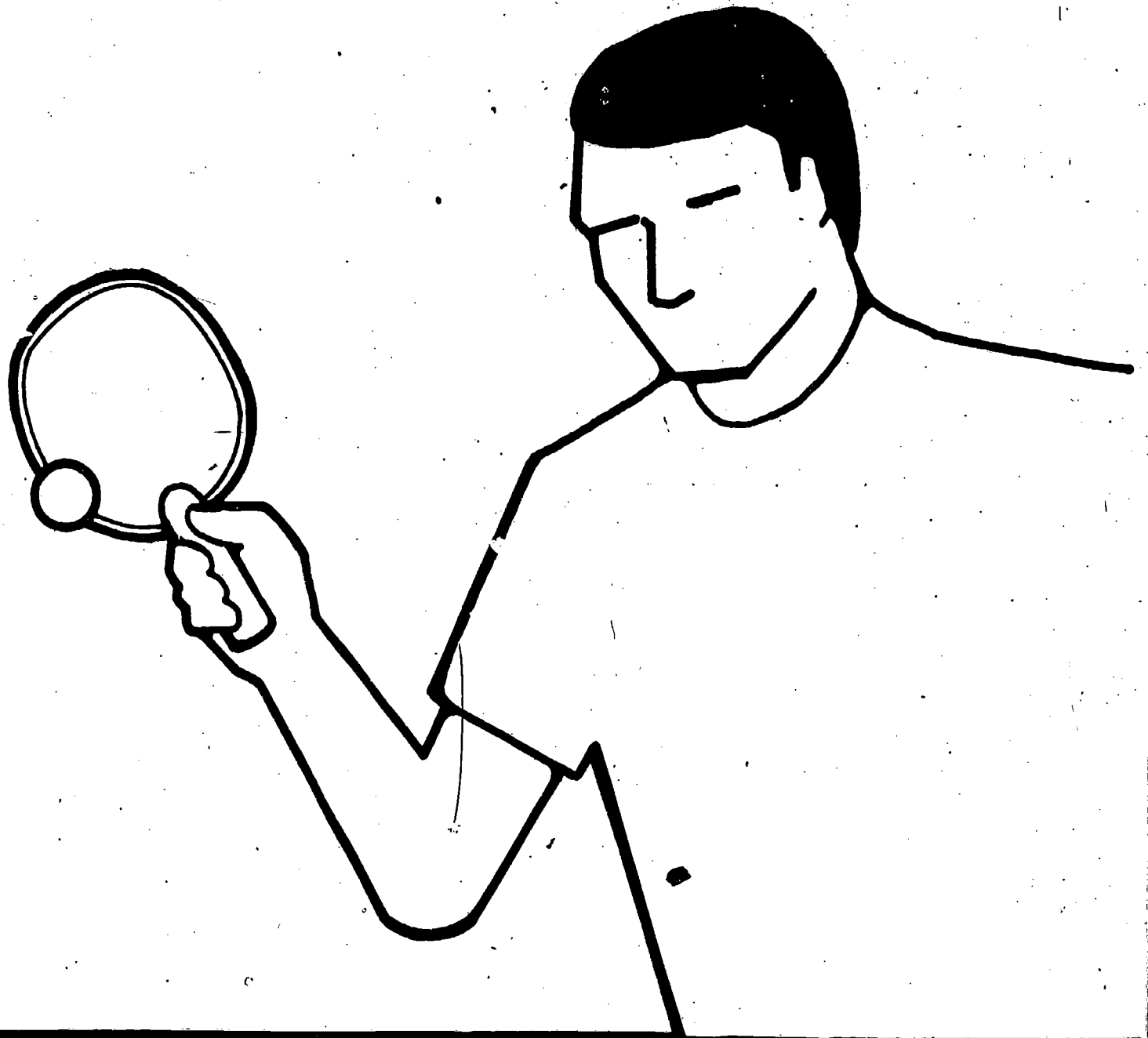

AP  
P194

BEST COPY AVAILABLE

AP  
P195

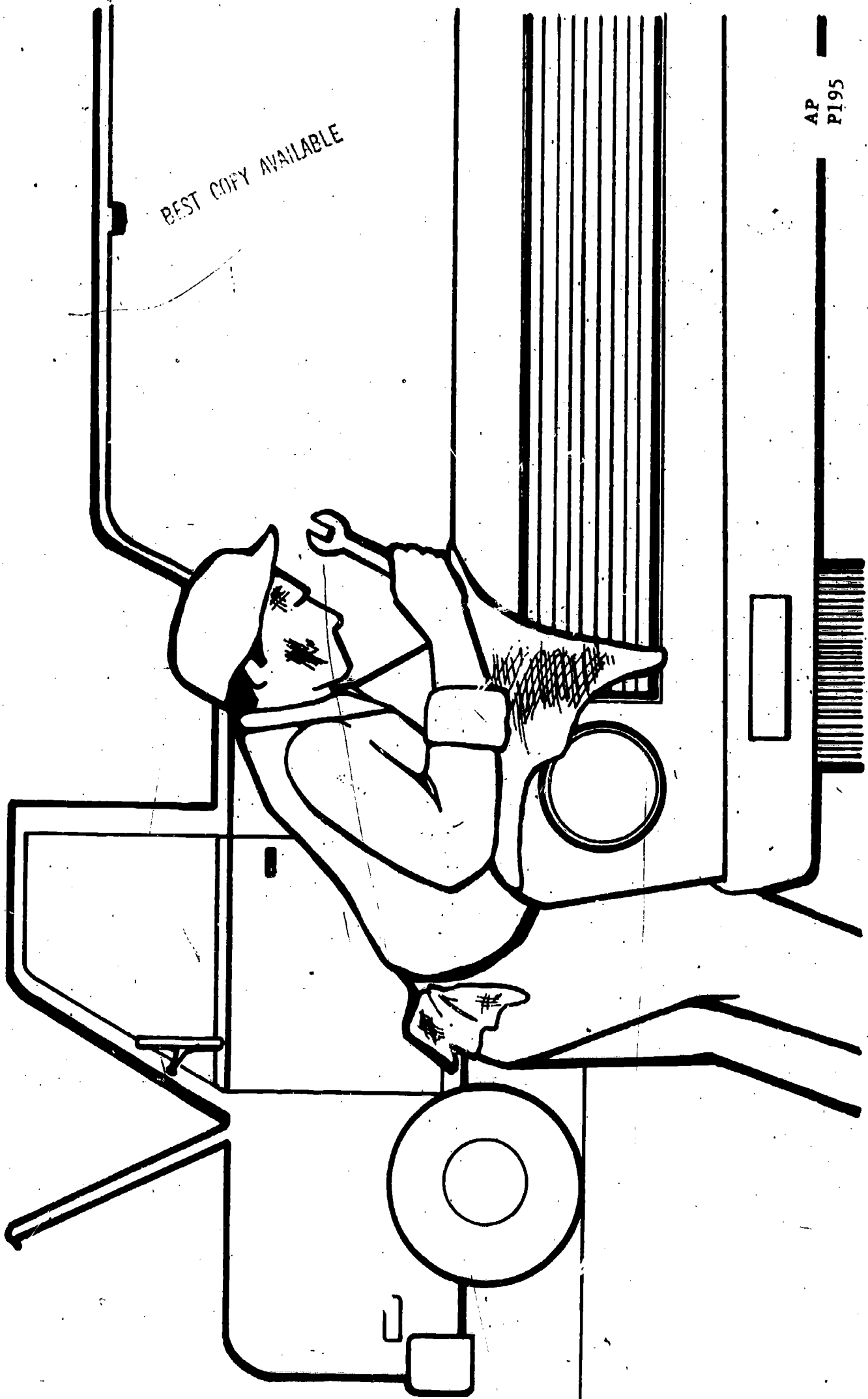



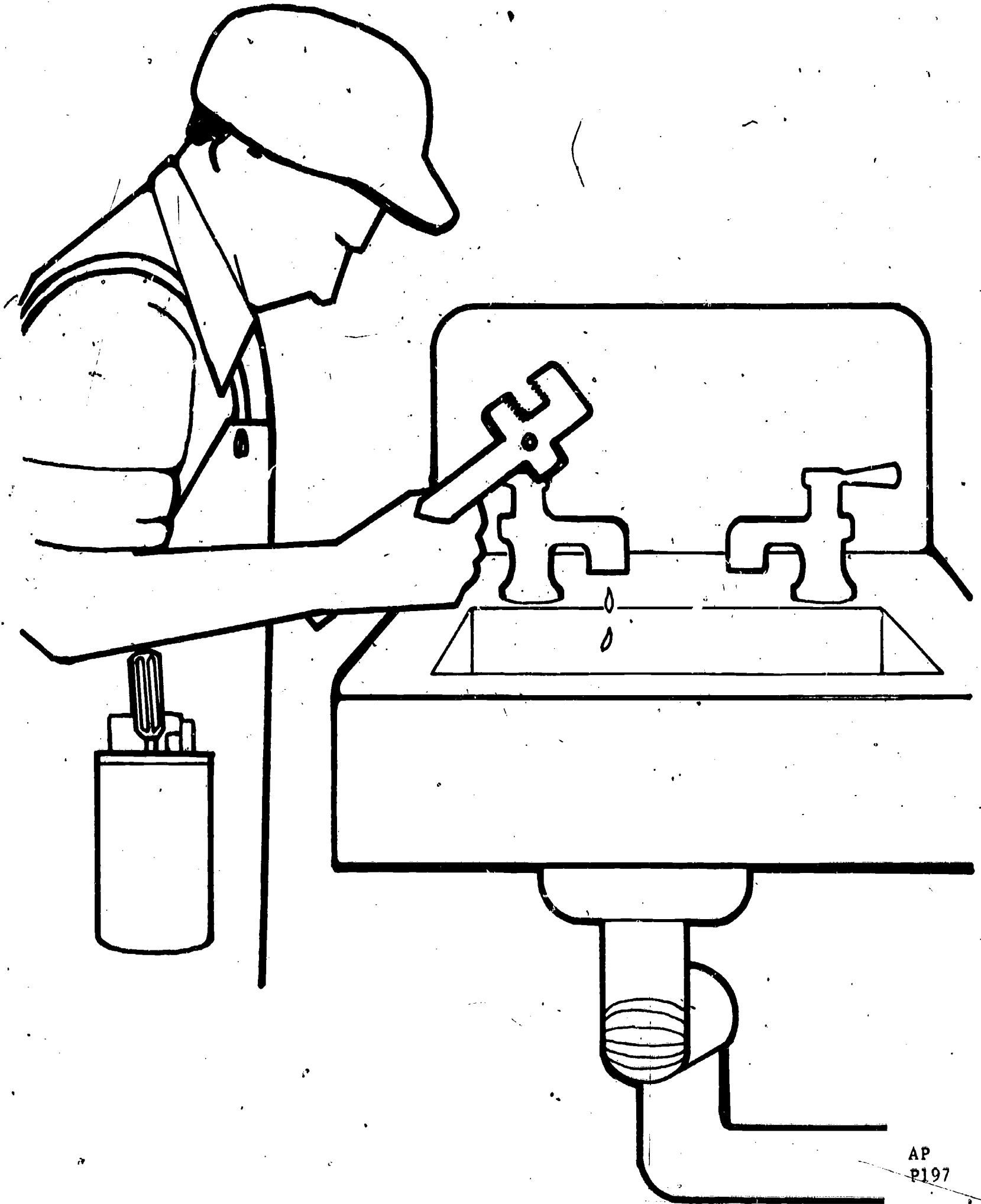

AP  
P197

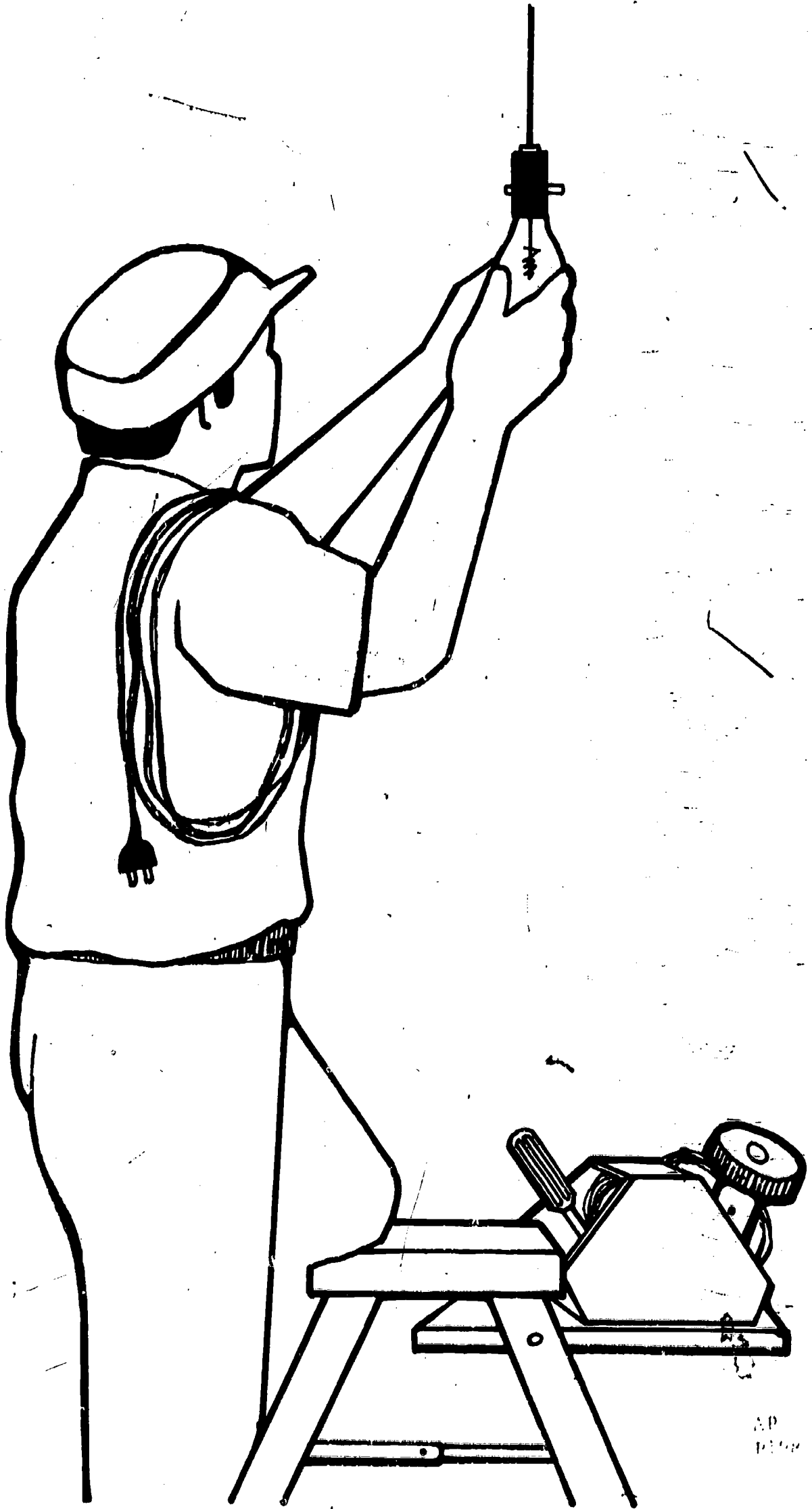

AP  
P. 108

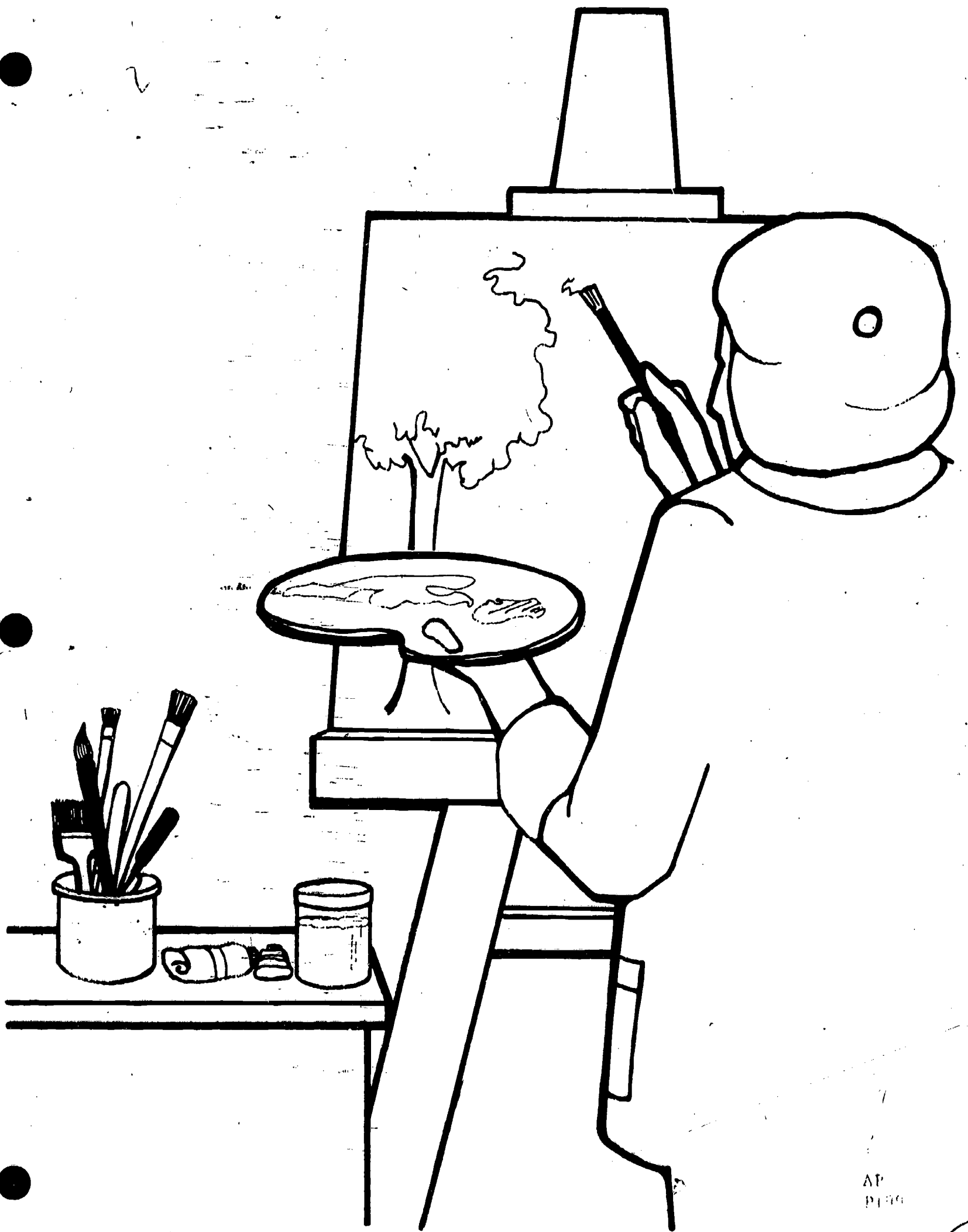

AP  
P199

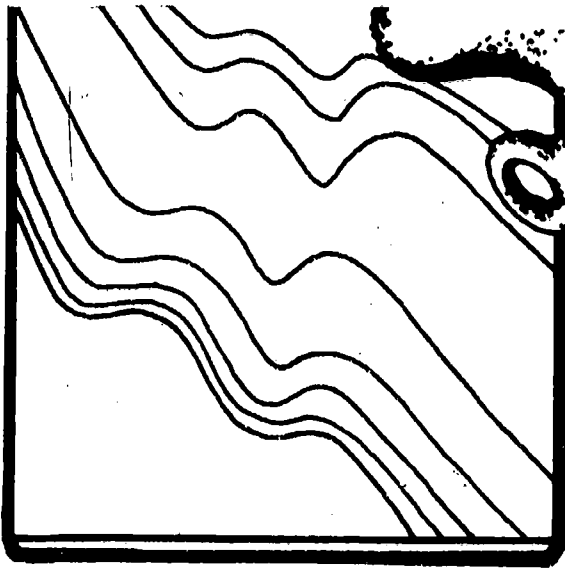

Handwritten scribbles in a small rectangular box.

AP  
P200

BEST COPY AVAILABLE

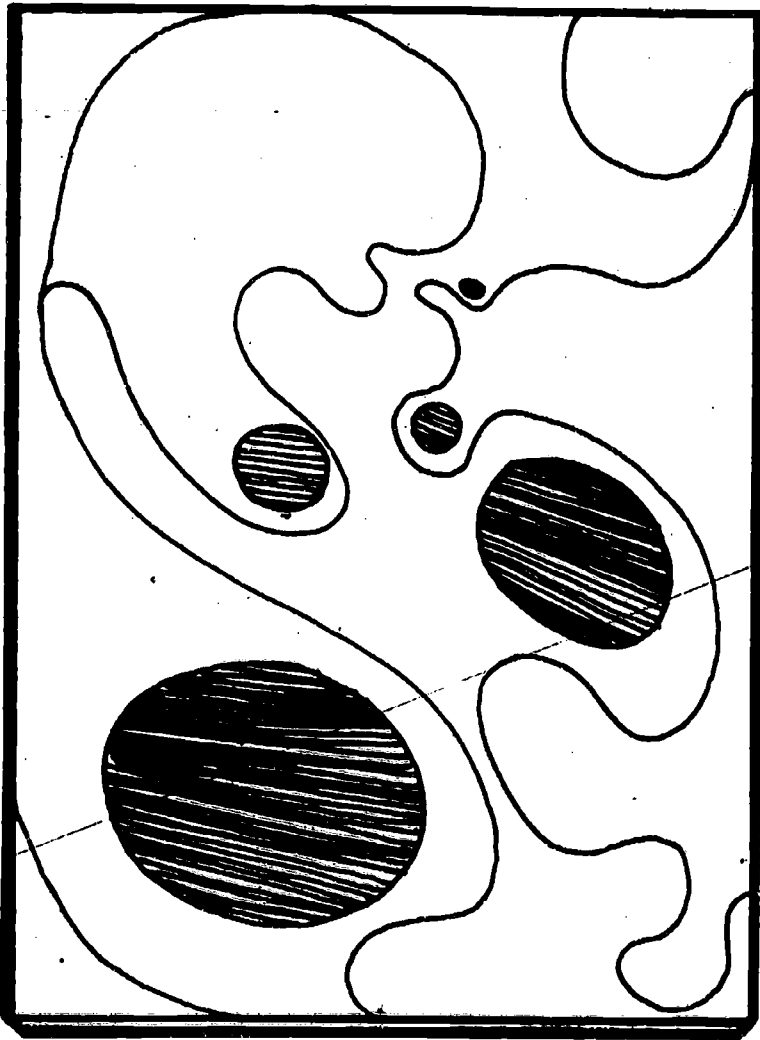

Handwritten scribbles in a small rectangular box.

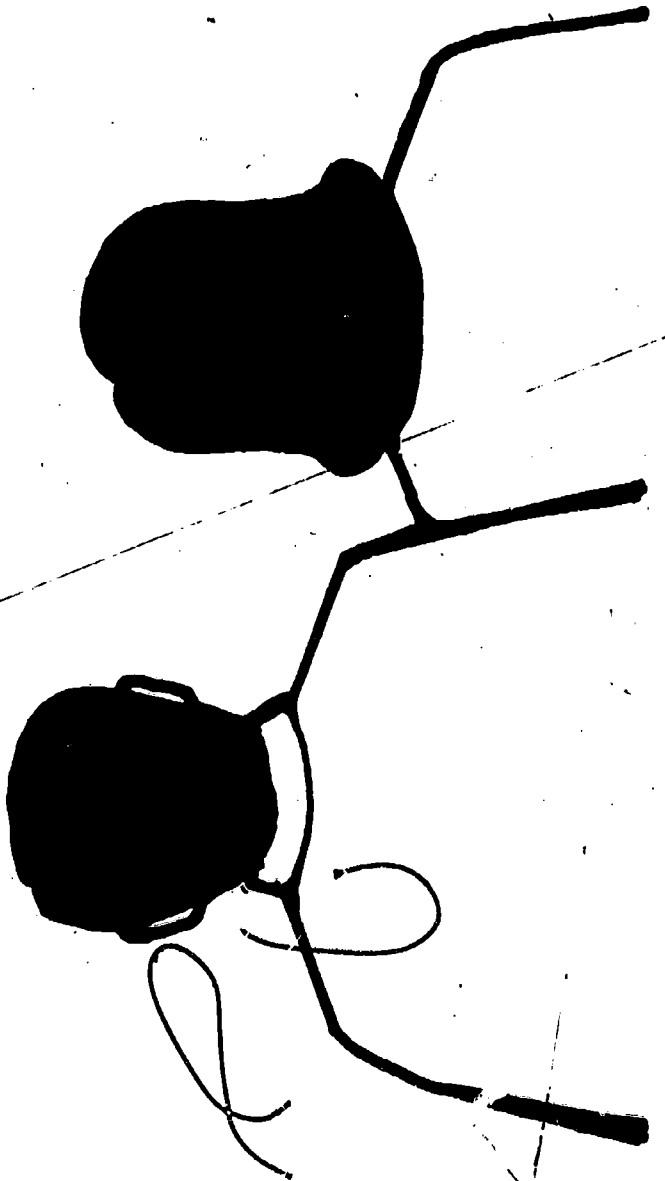

Handwritten scribbles in a rectangular box at the bottom of the page.



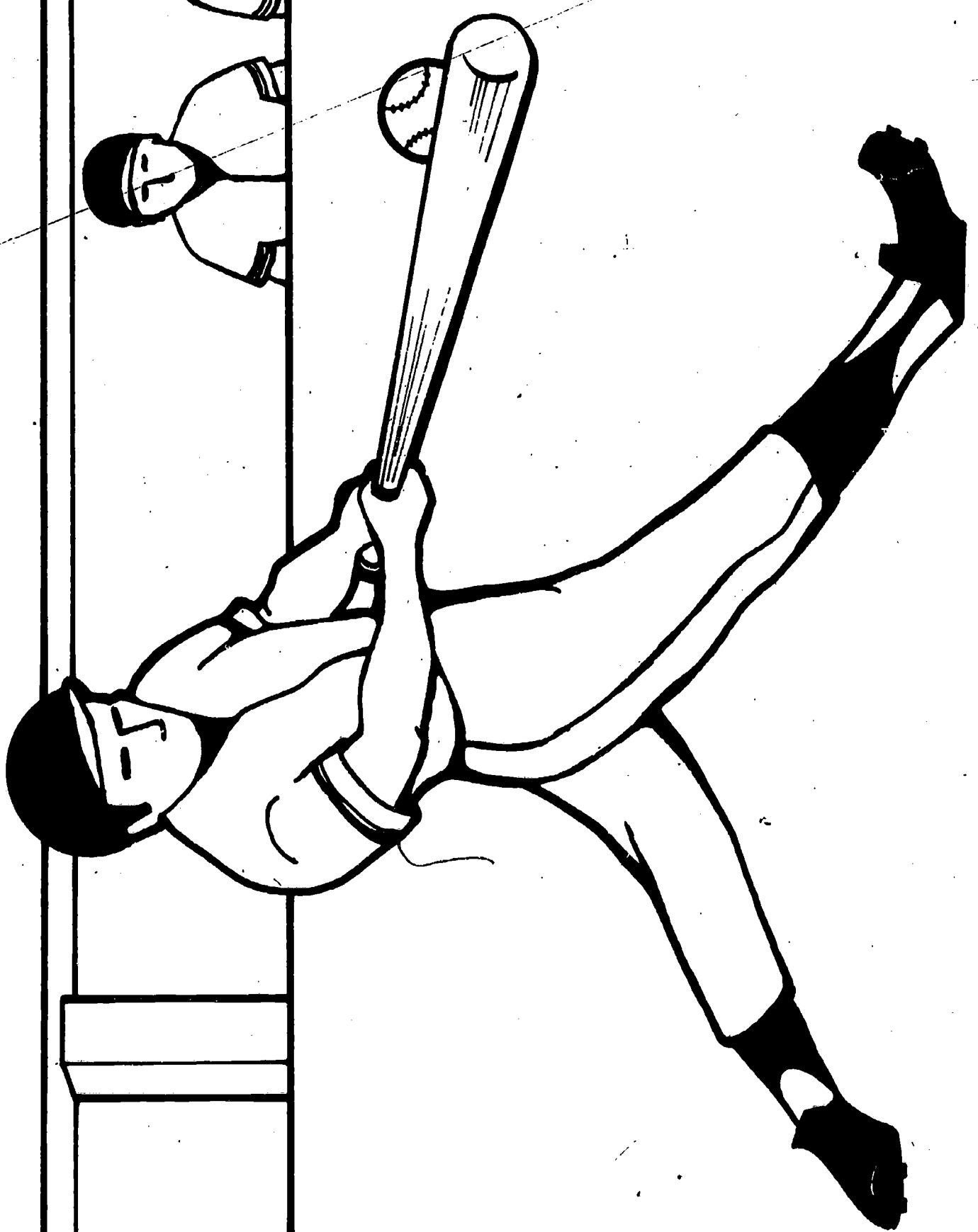

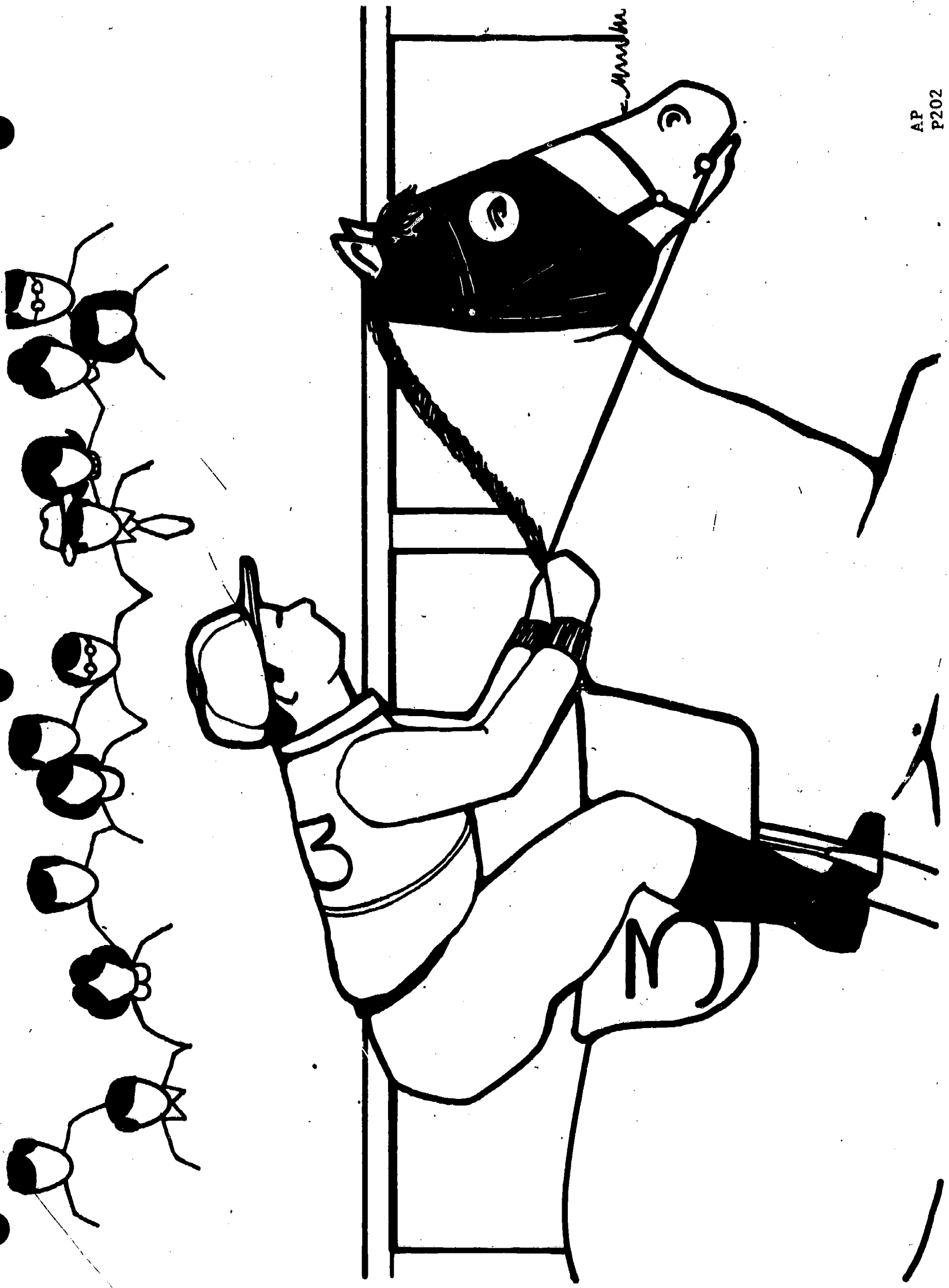

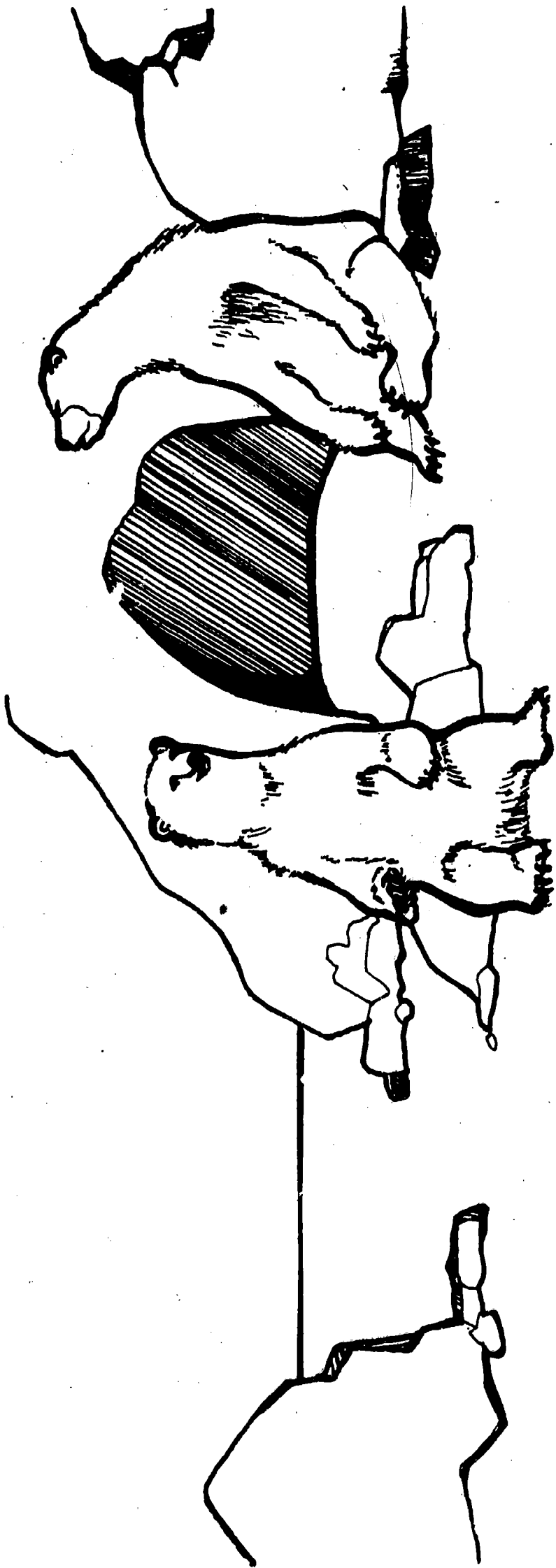

ART 1001 ANNUALE

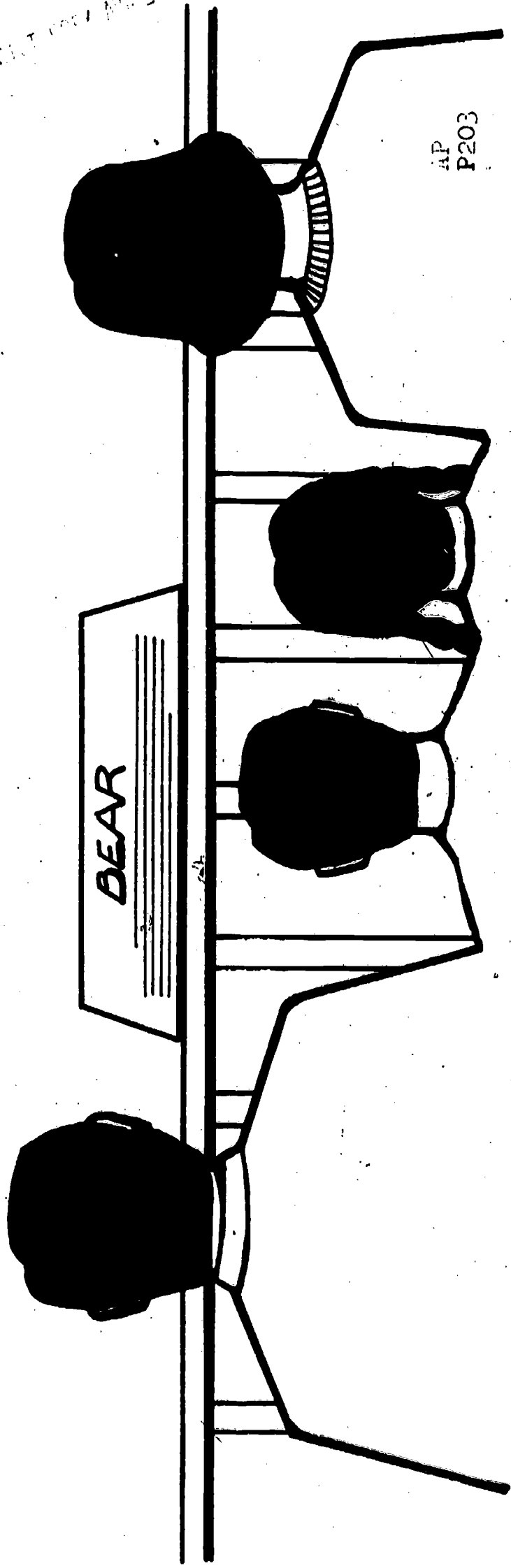

AP  
P203

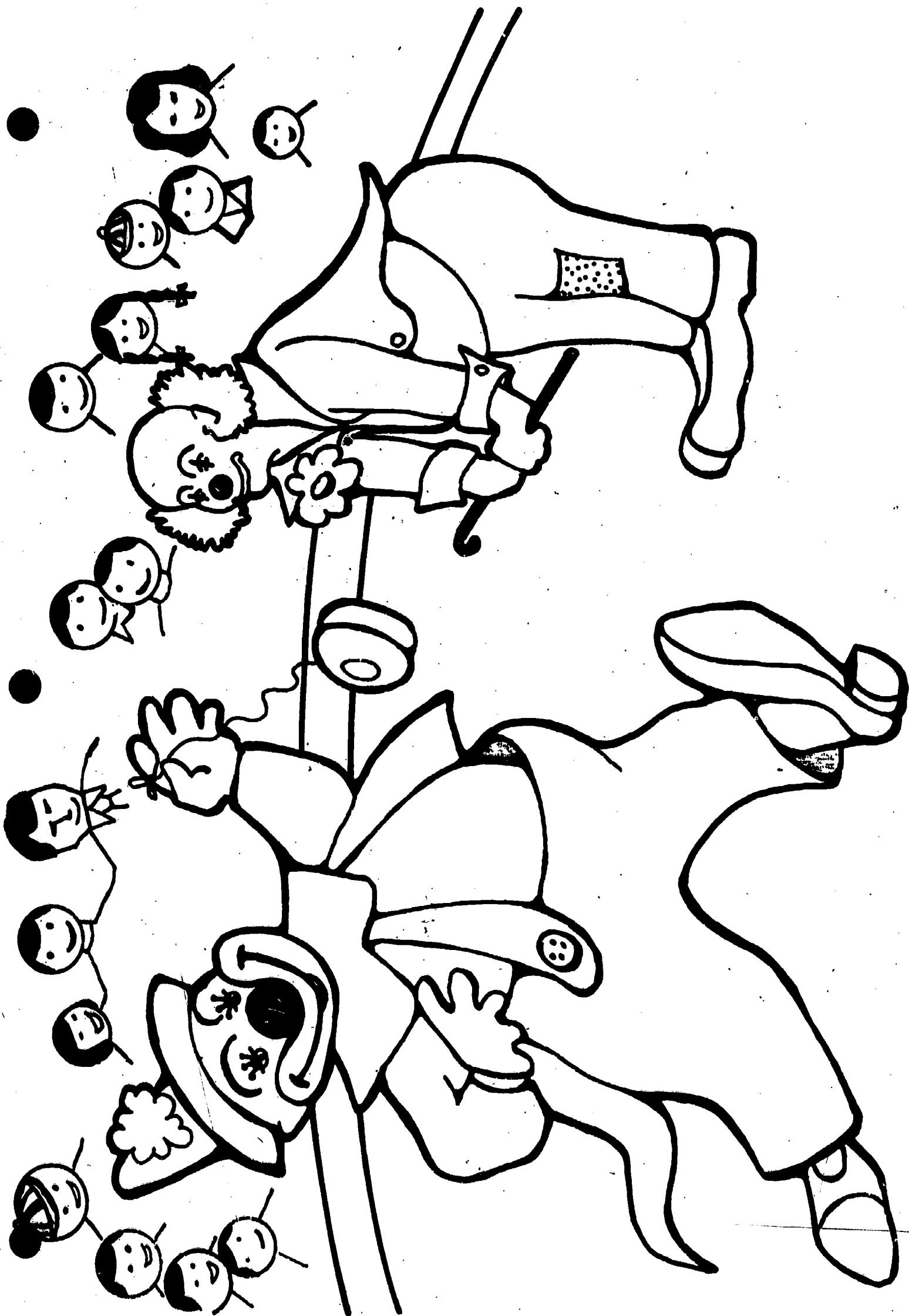



4/21

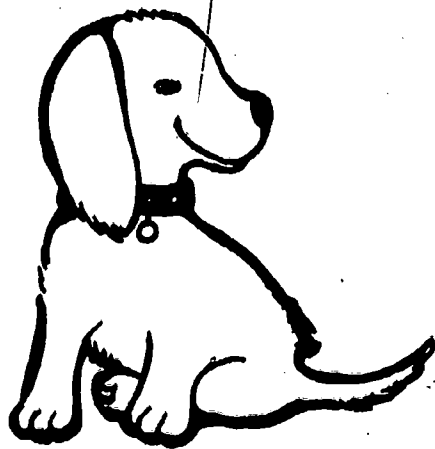
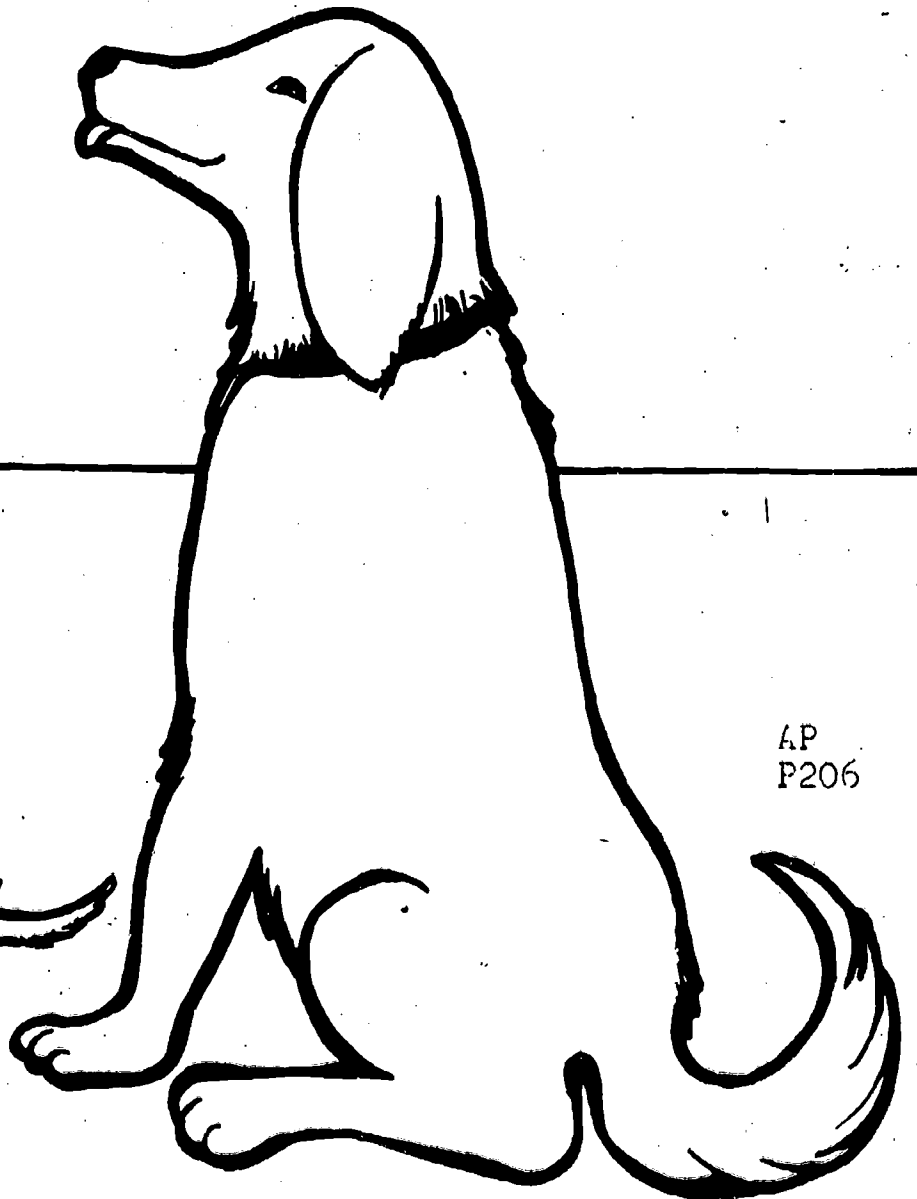
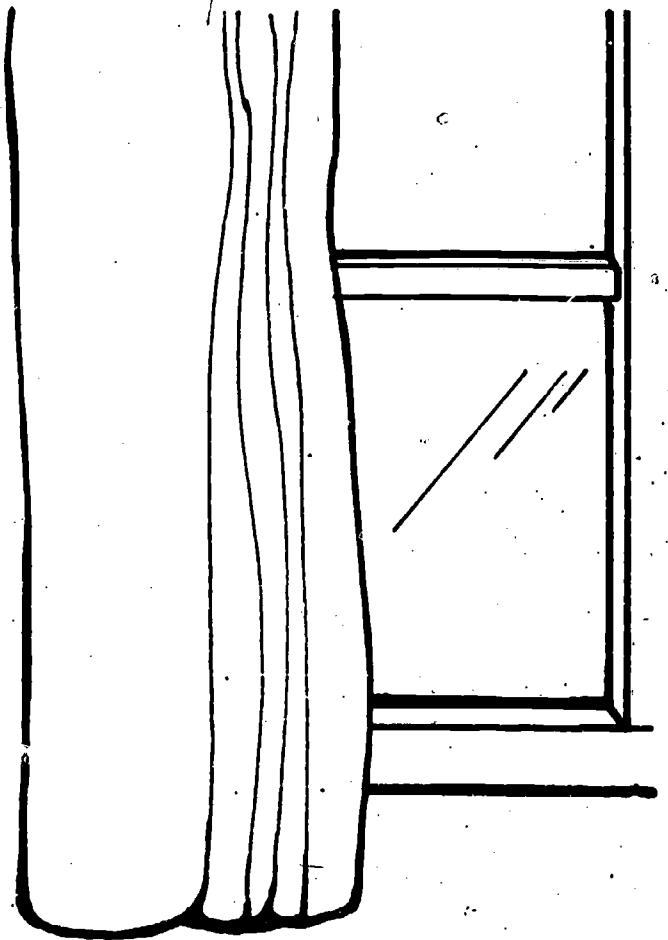
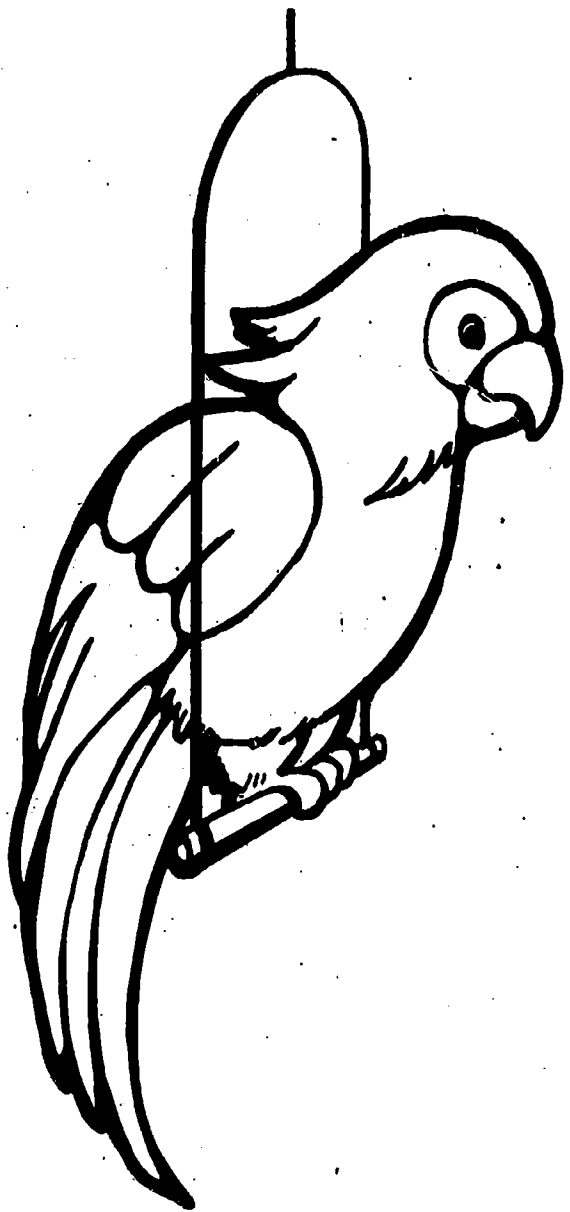

AP  
P206

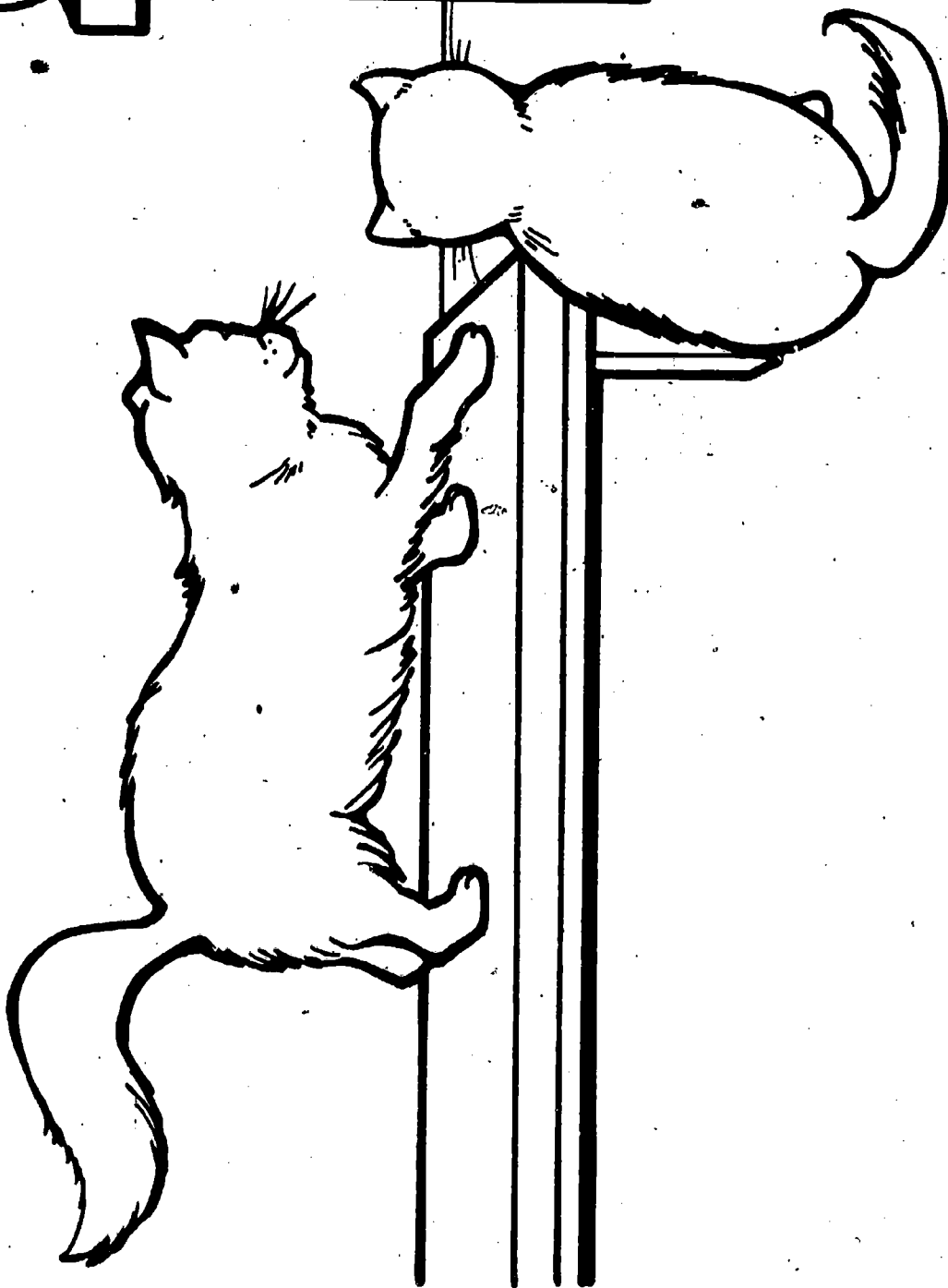
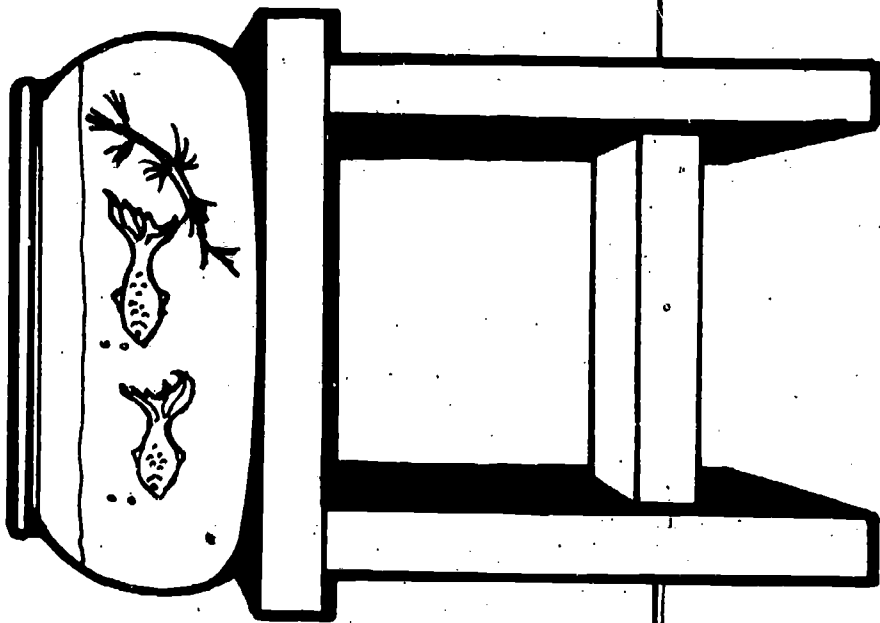

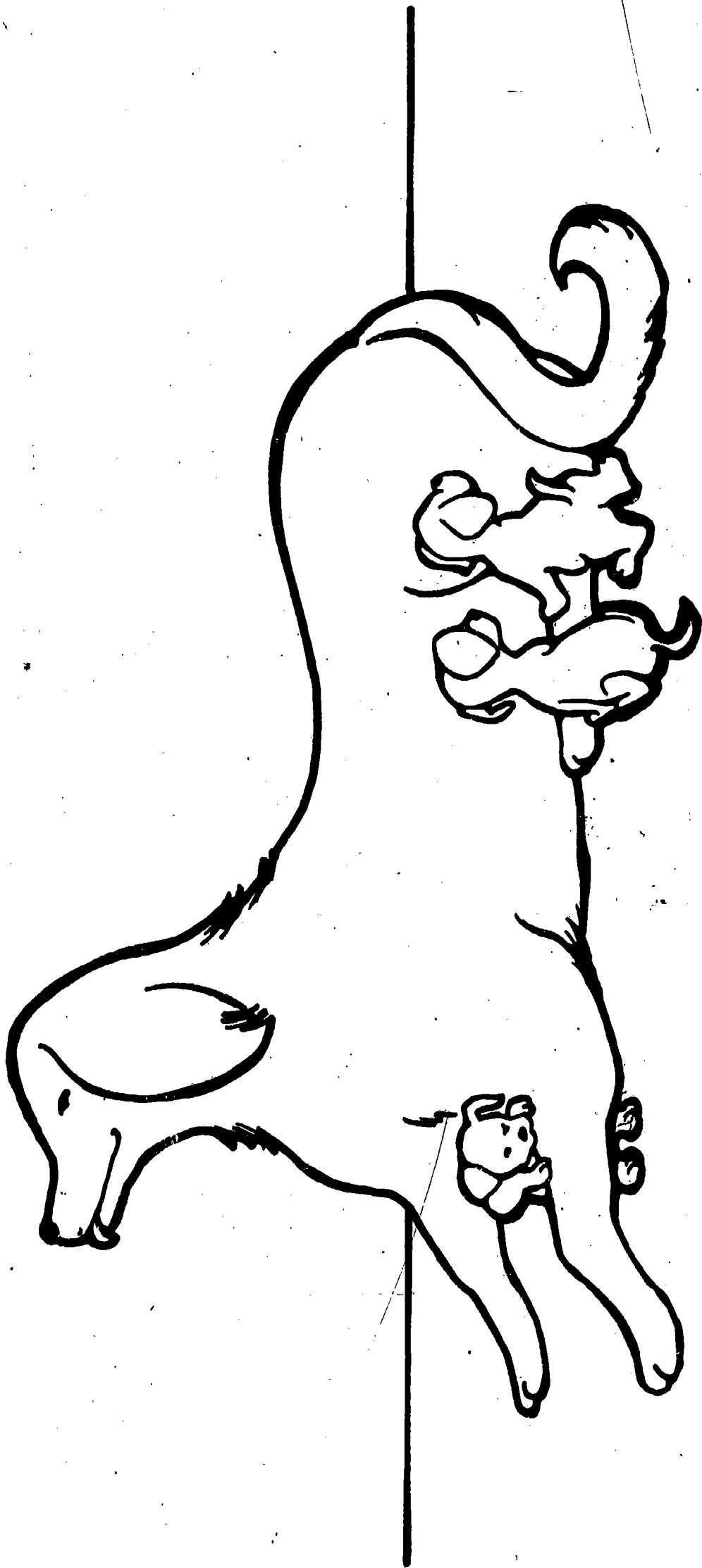



AI  
P209

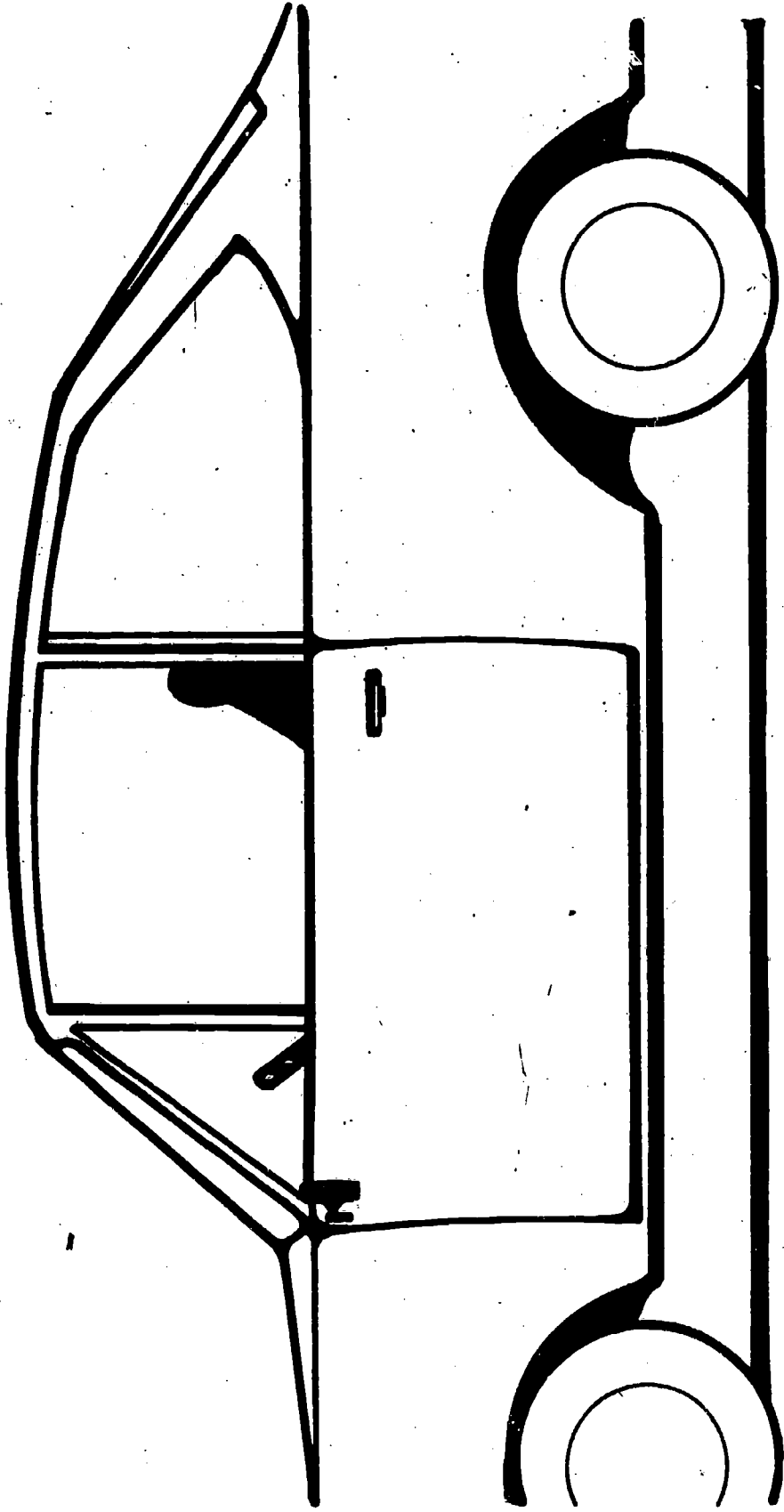

AP  
P219

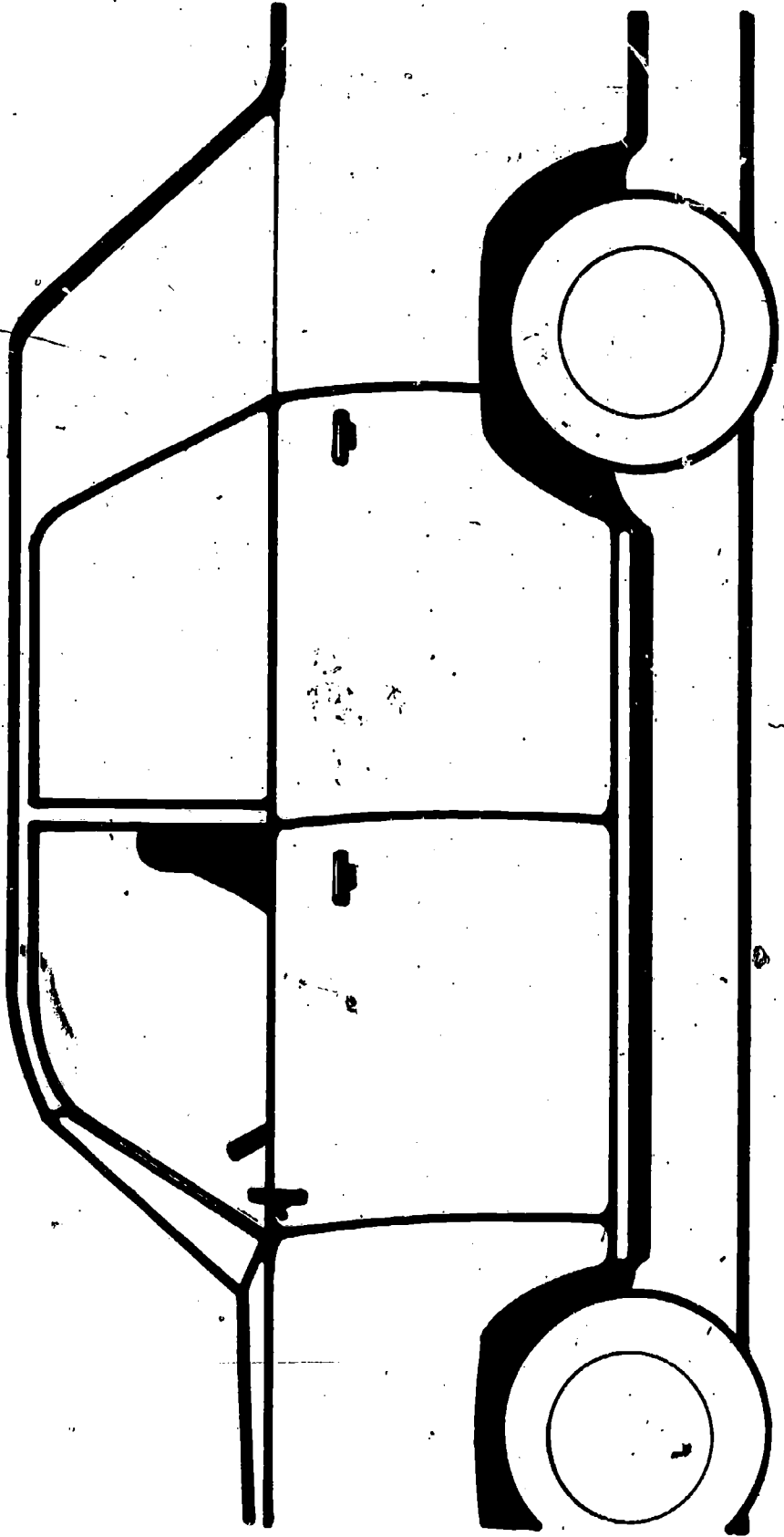

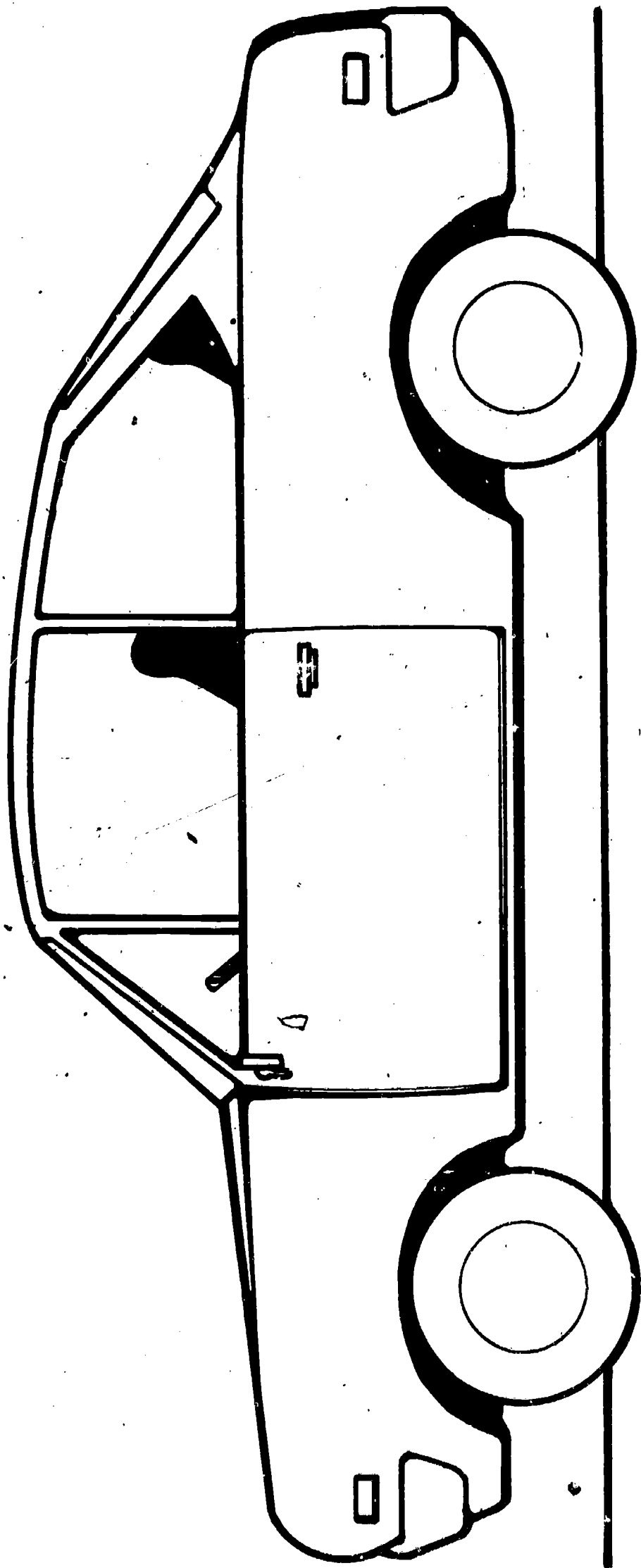

AP P211

AP  
P212

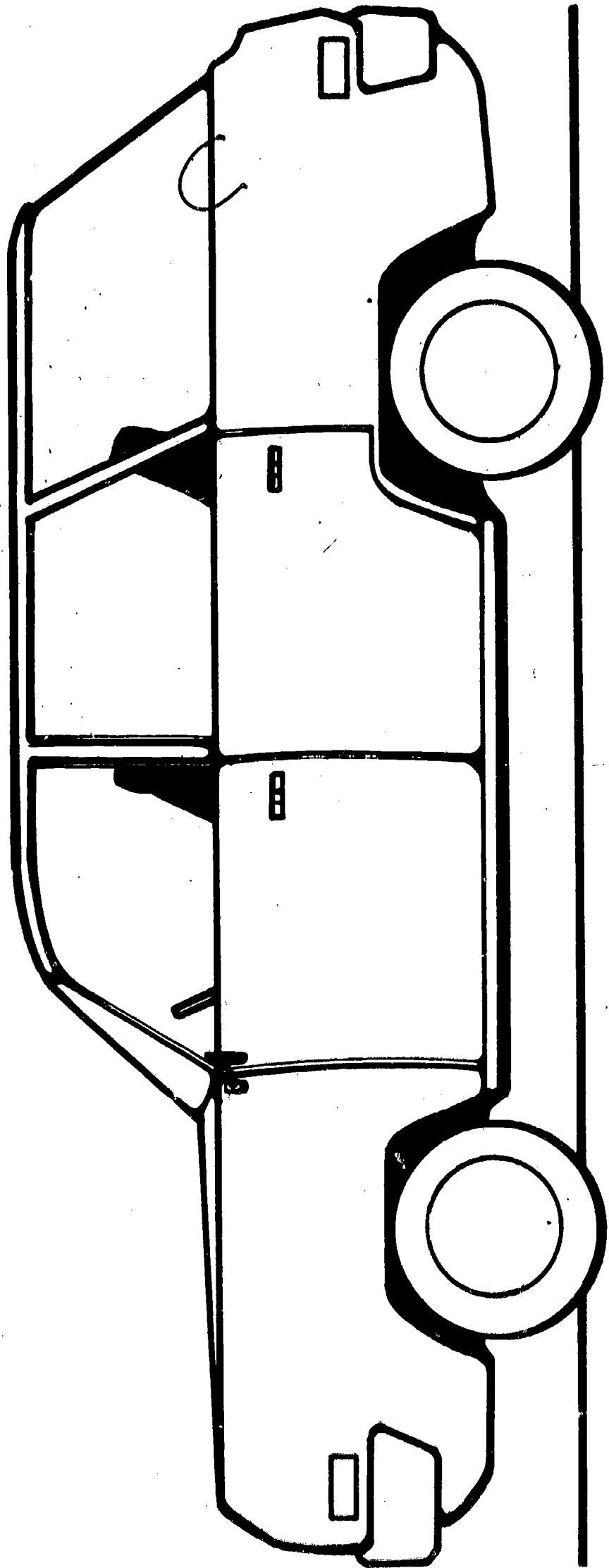

AP  
P213

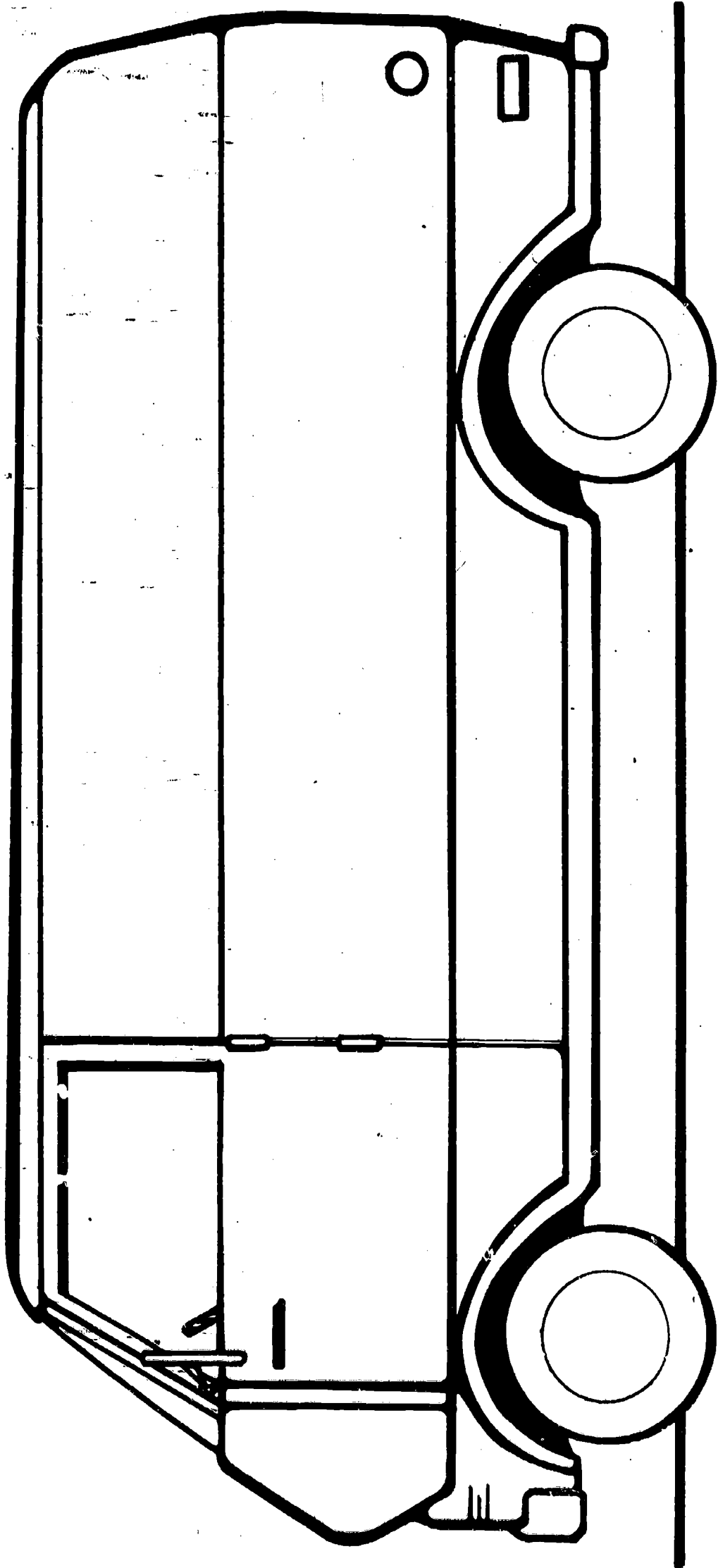

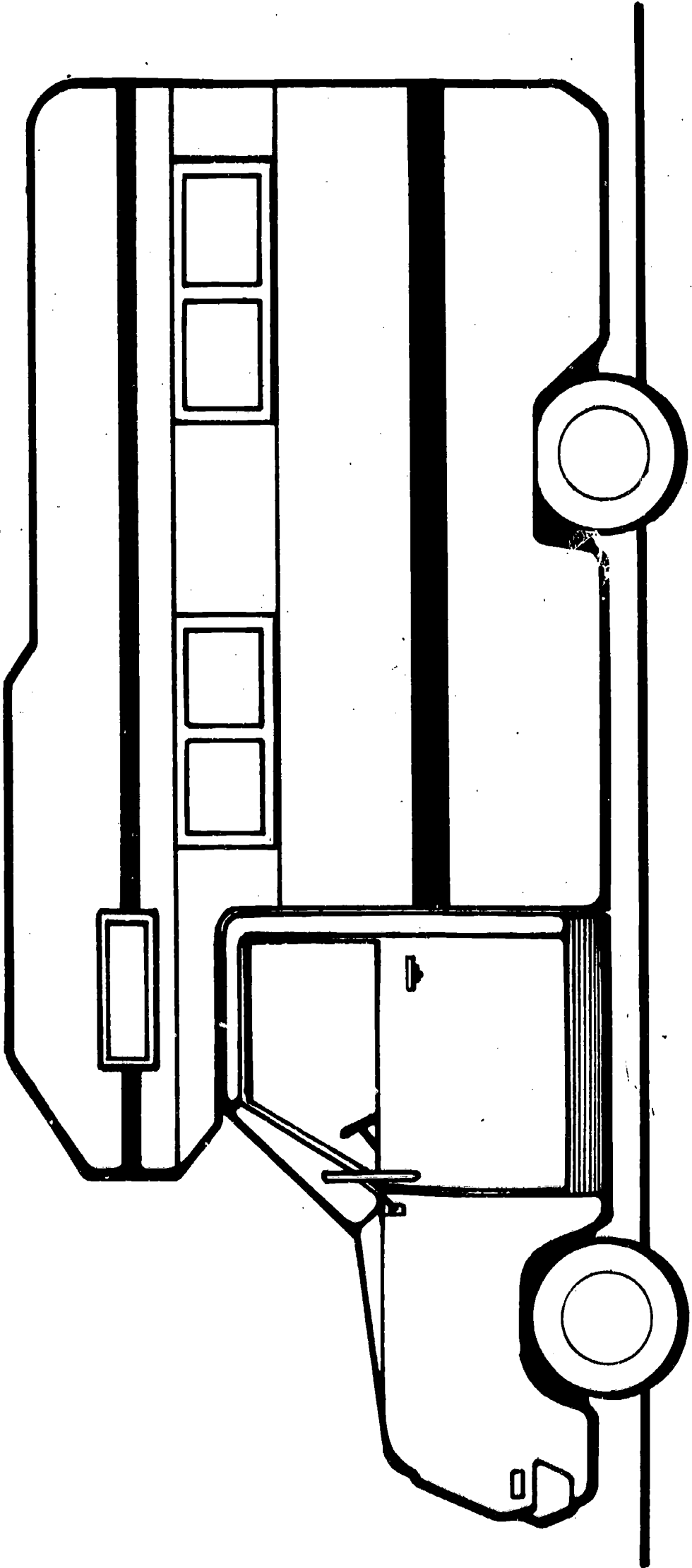

AP  
P215

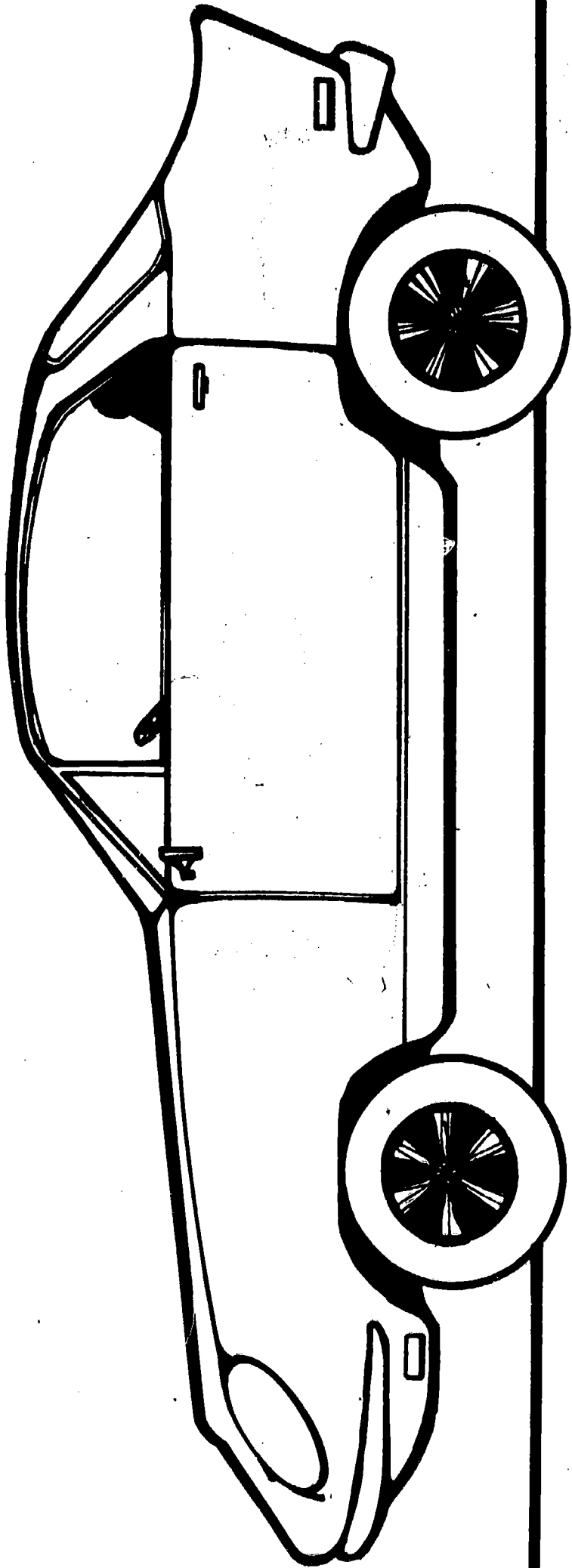

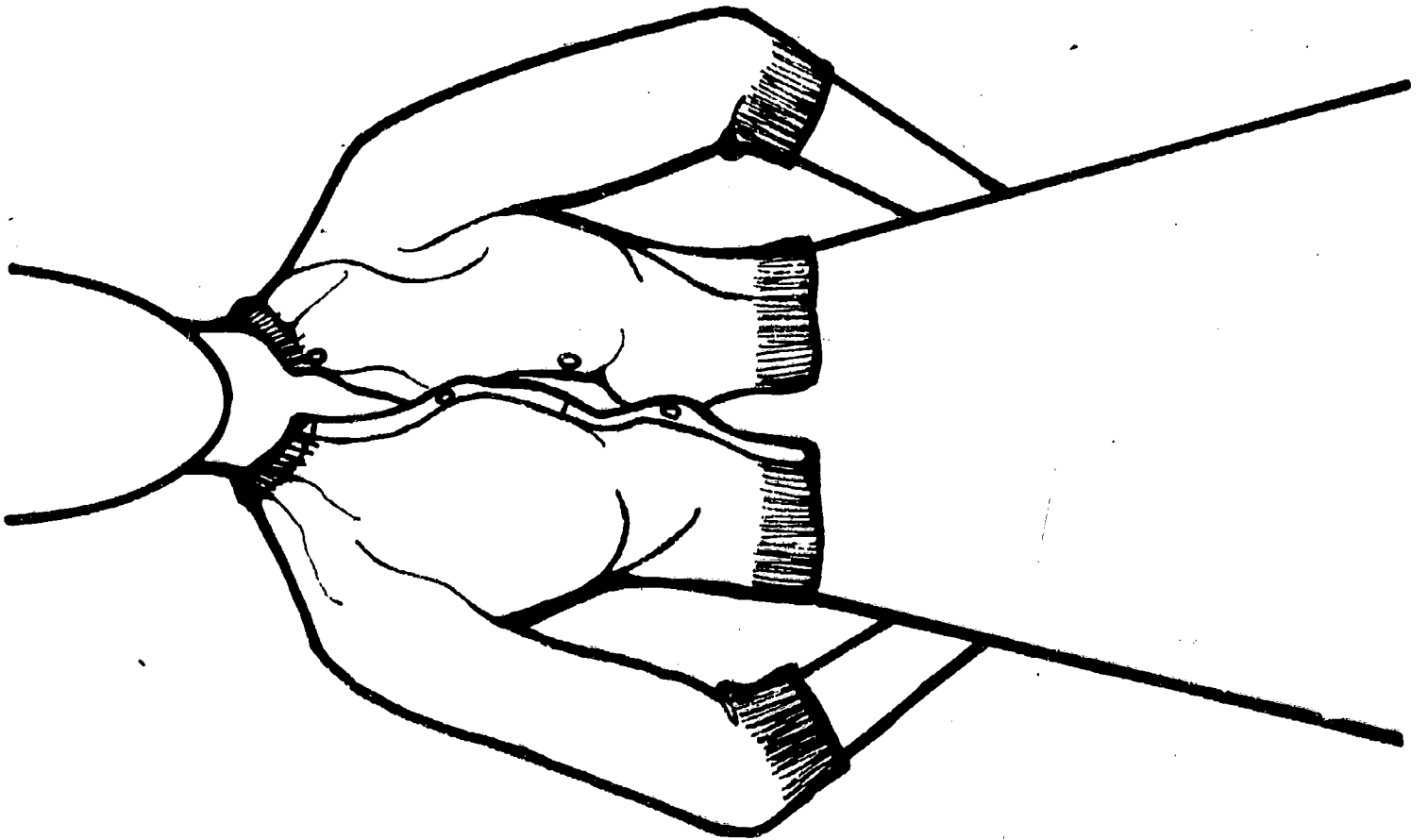
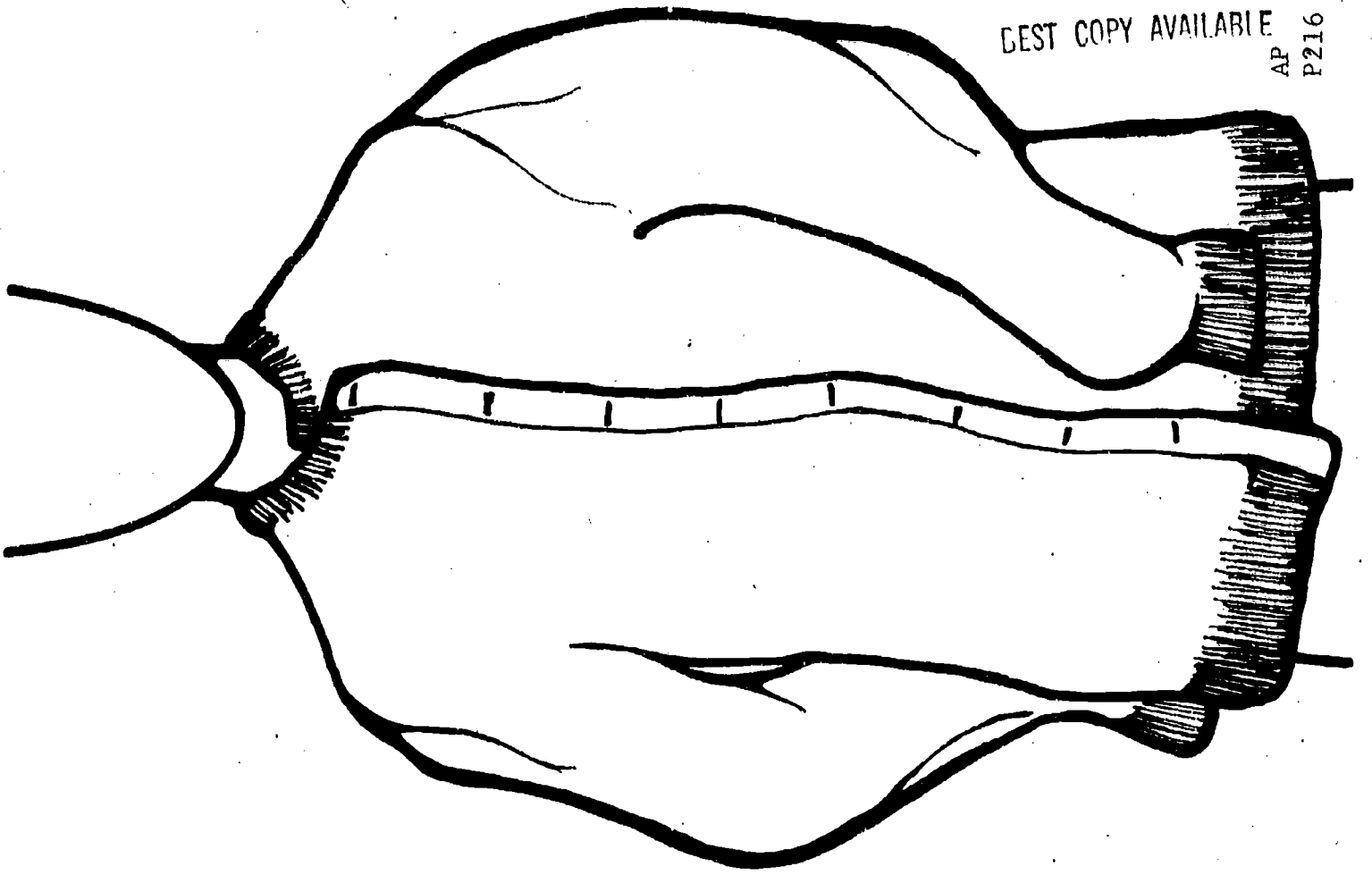



BEST COPY AVAILABLE

AP  
P217

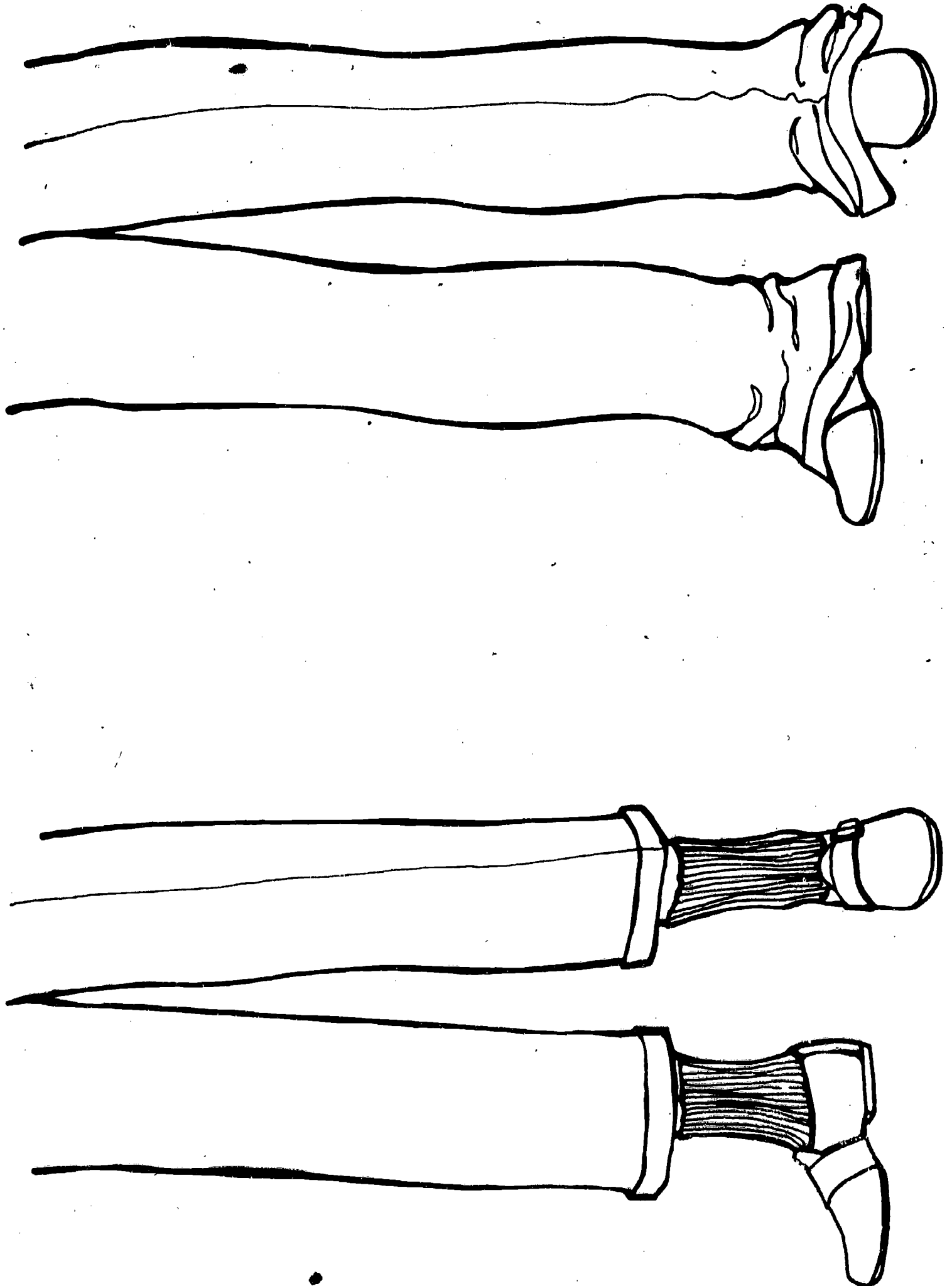

BEST COPY AVAILABLE

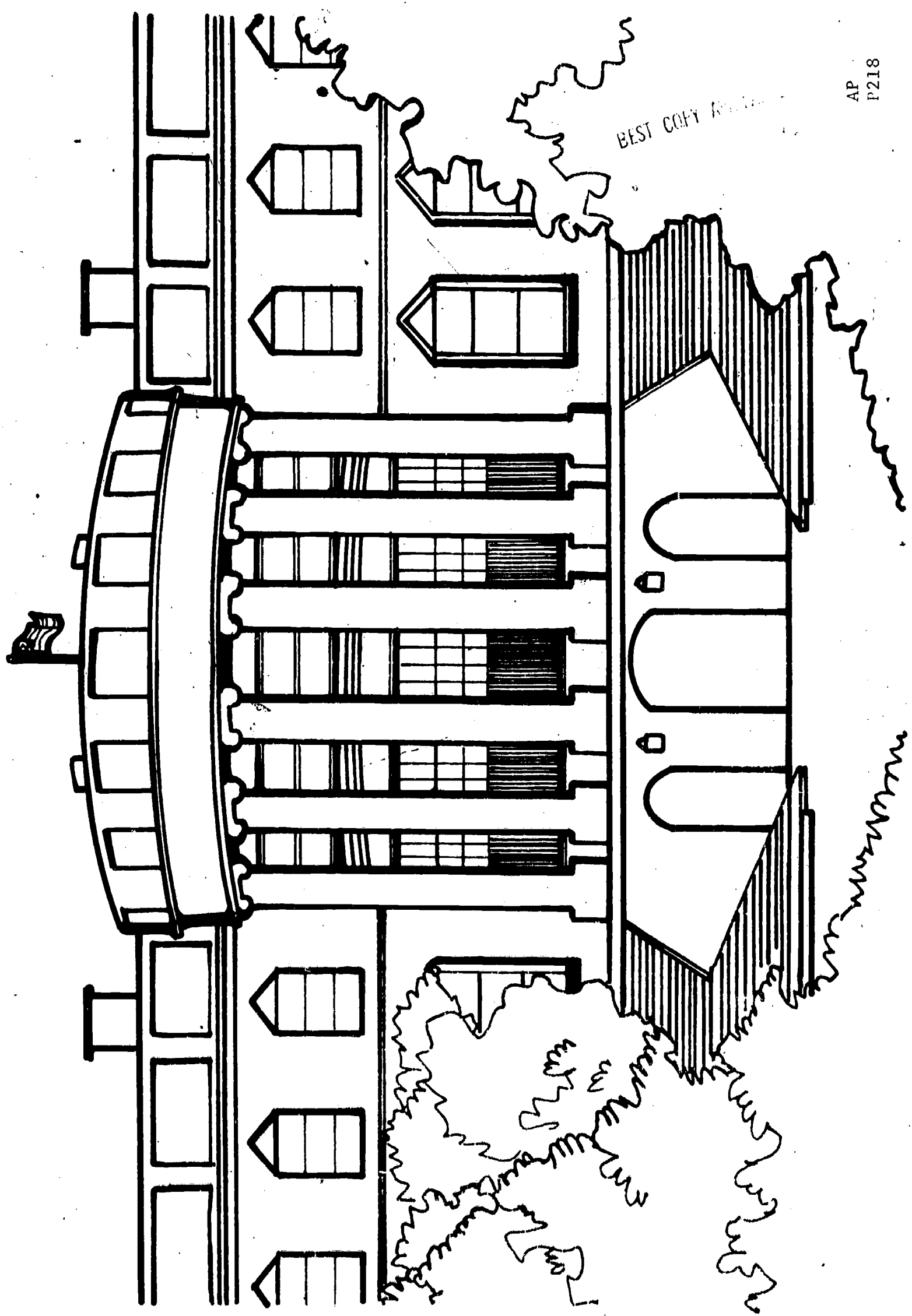

BEST COPY AVAILABLE

AP  
P219

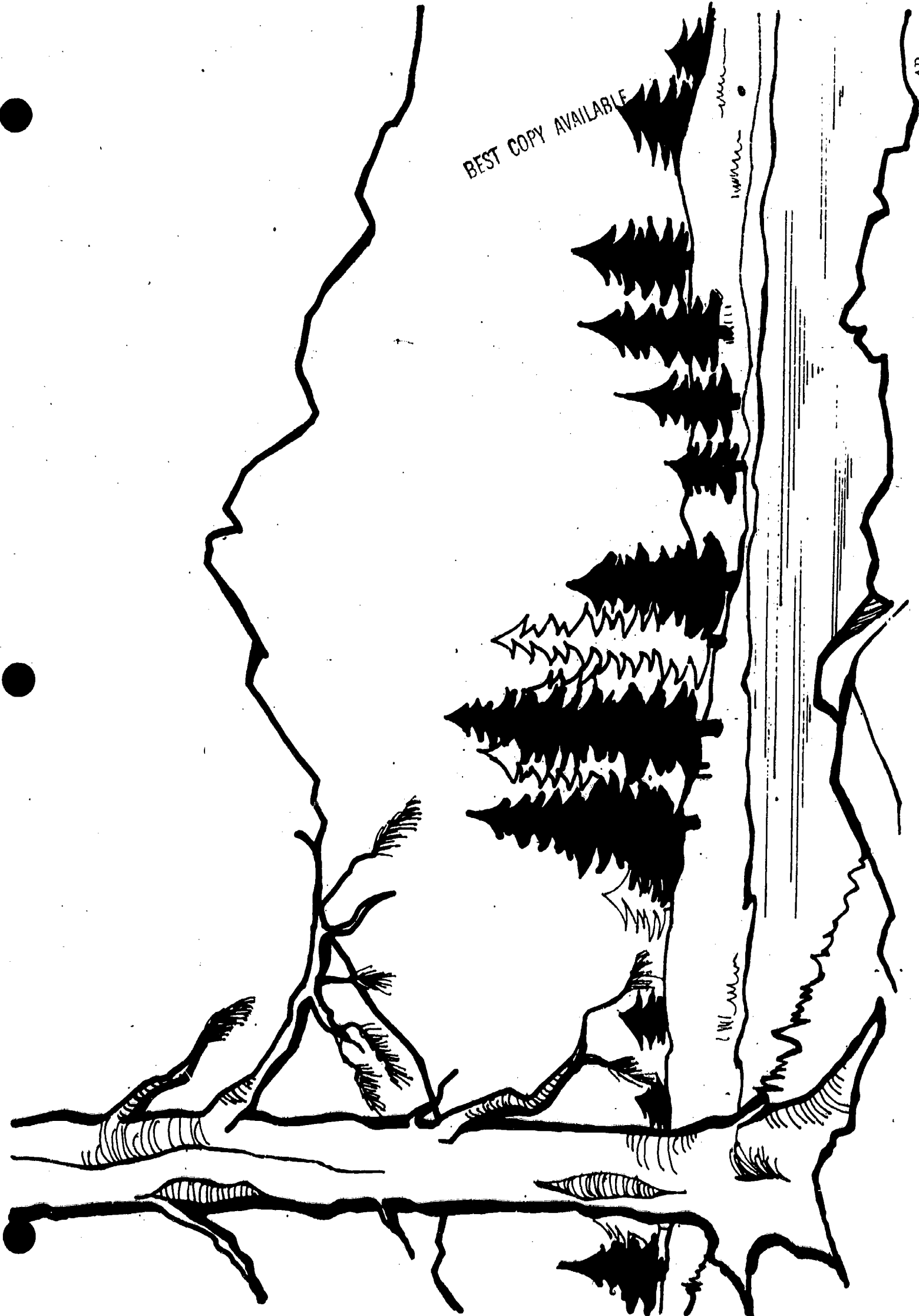

BEST COPY AVAILABLE

AP P220



Mountain  
 range  
 and  
 water  
 level  
 of  
 the  
 river

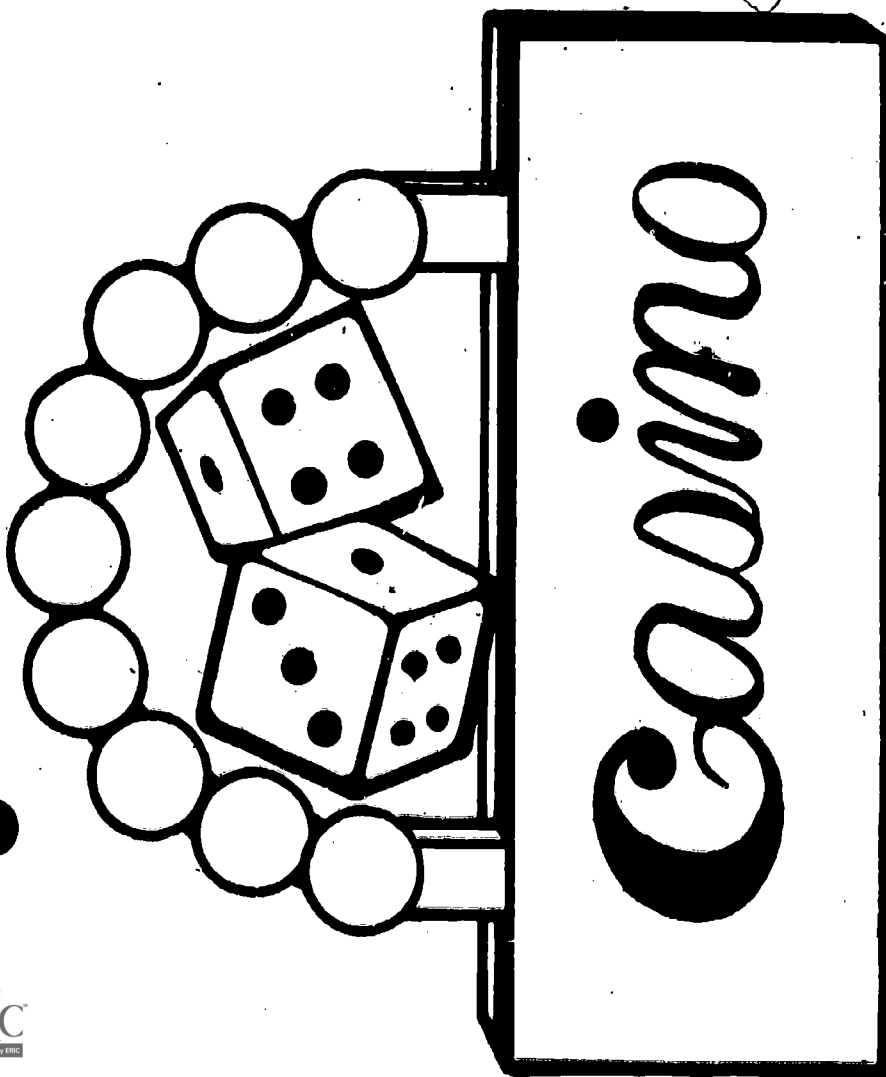
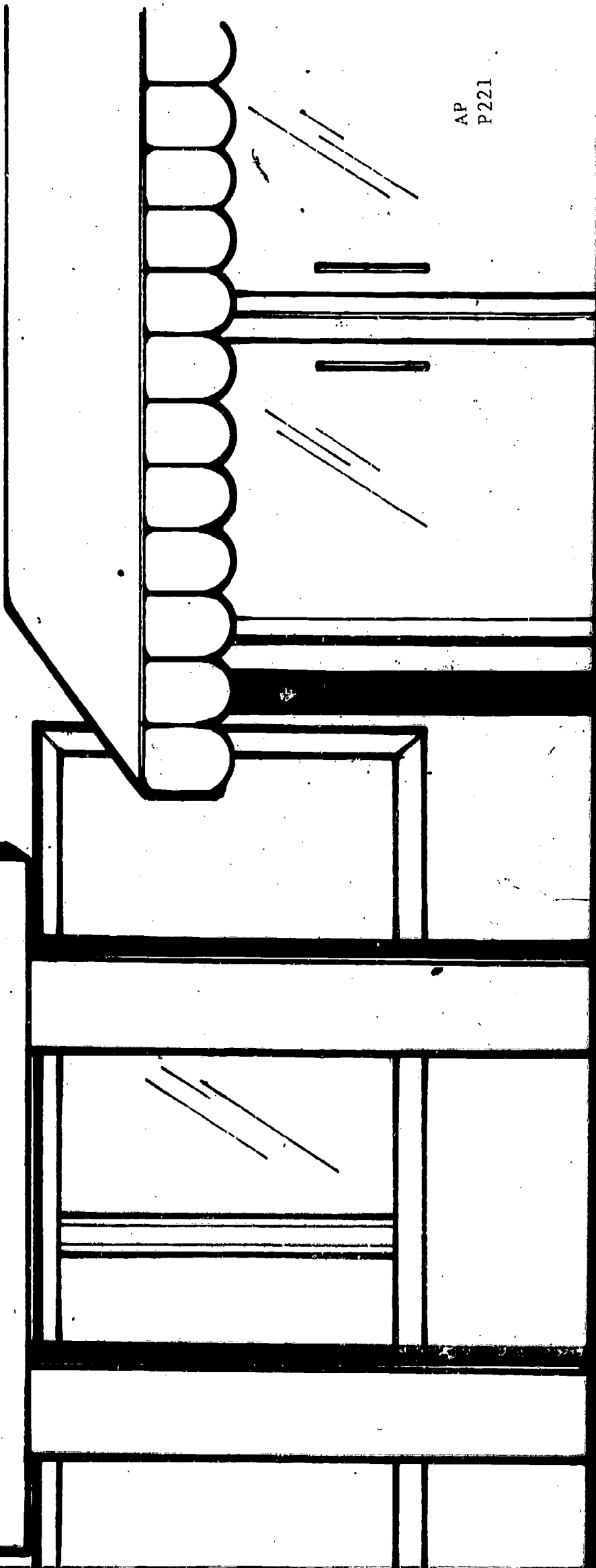

BEST COPY AVAILABLE

AP  
P222

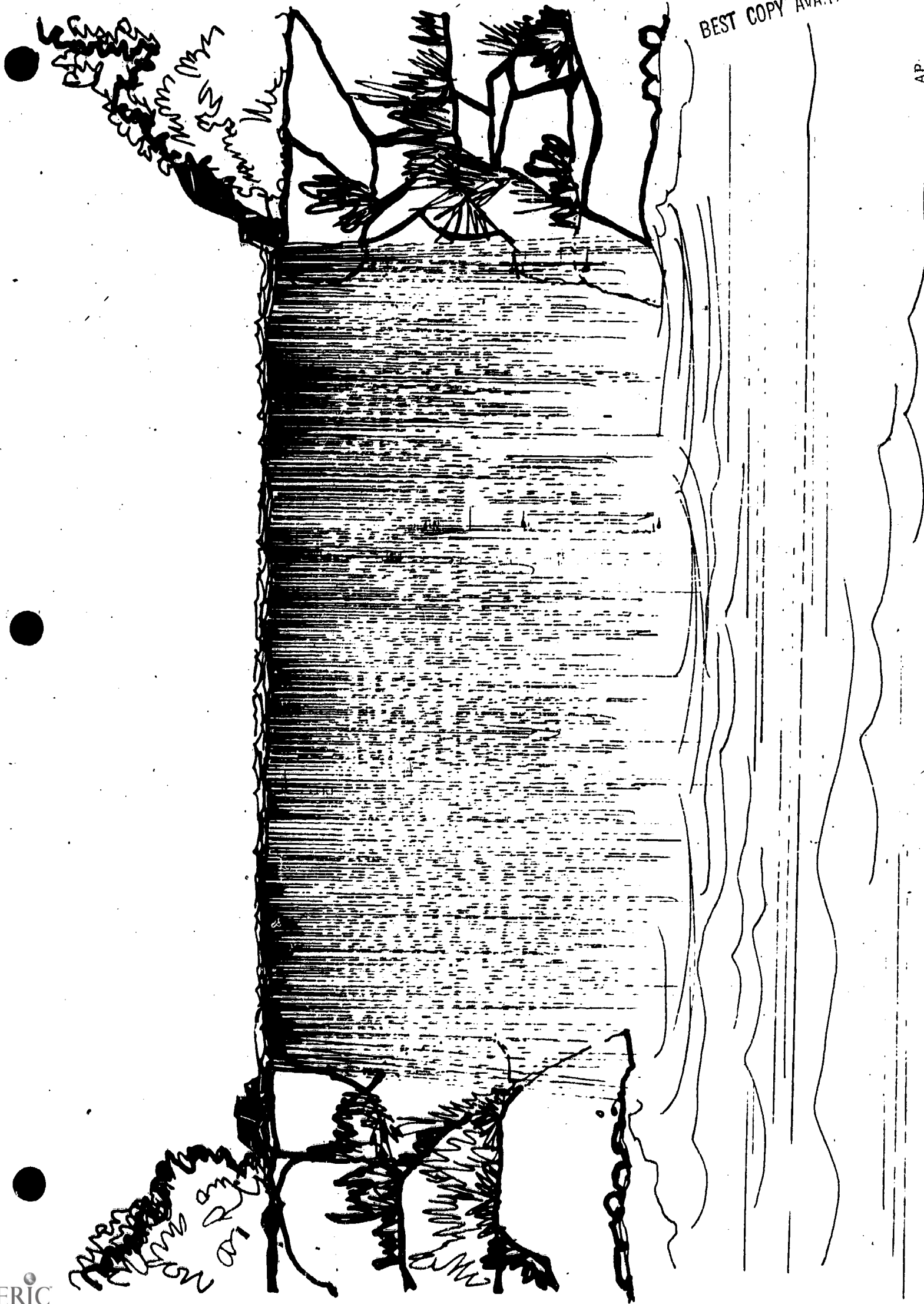

BEST COPY AVAILABLE

AP  
P223

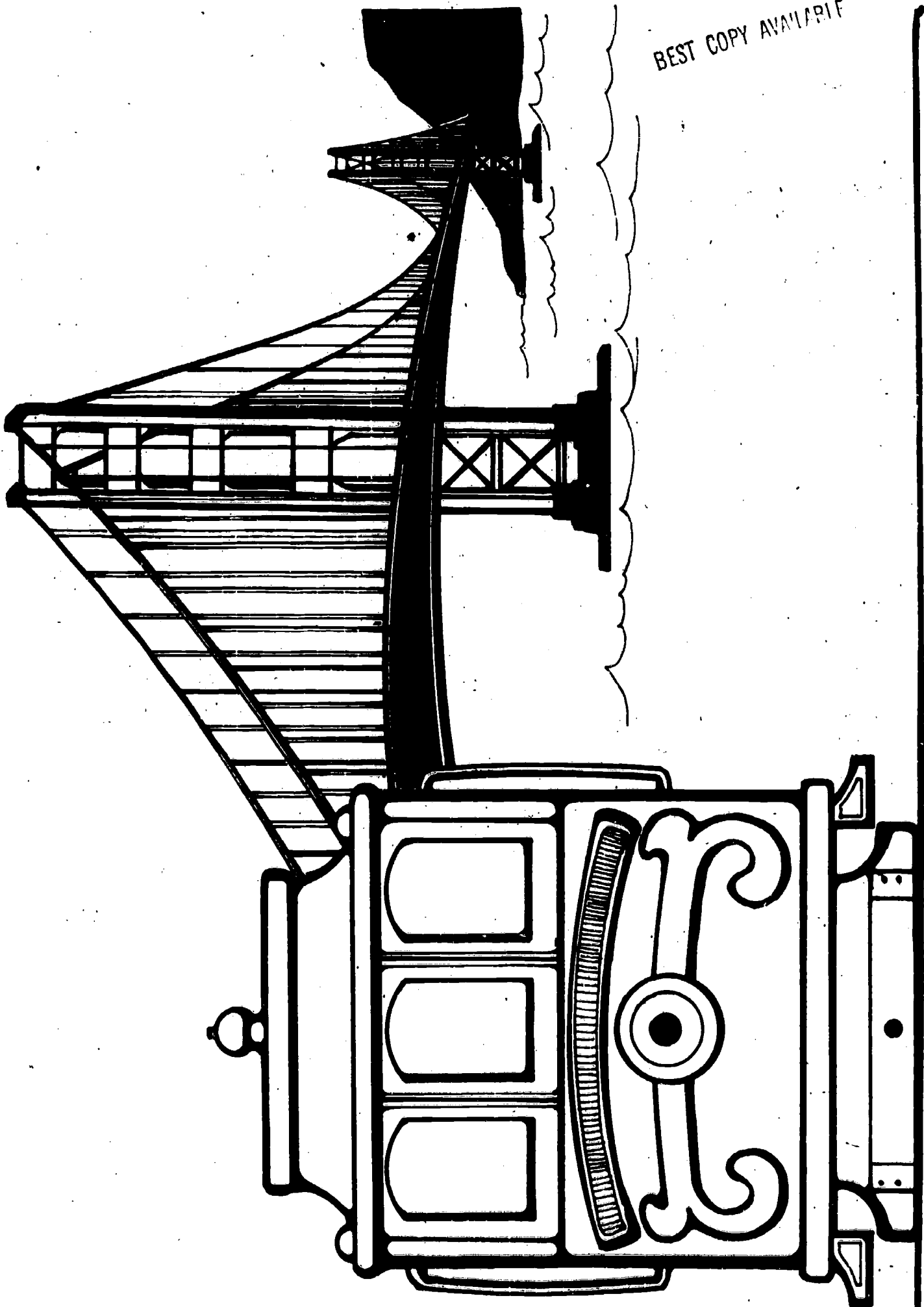

BEST COPY AVAILABLE

AP  
P224

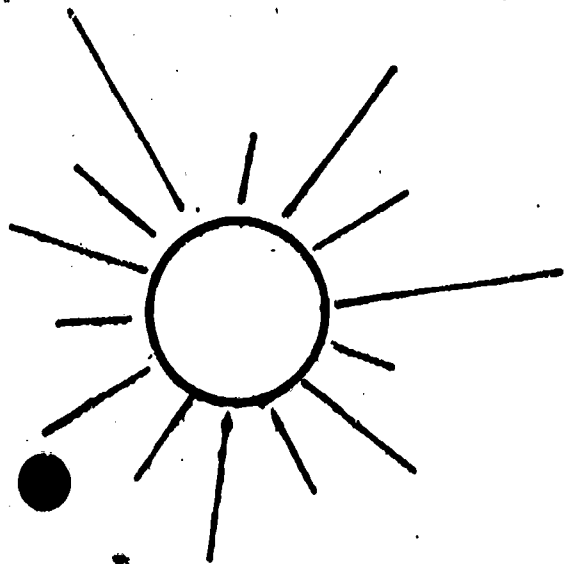
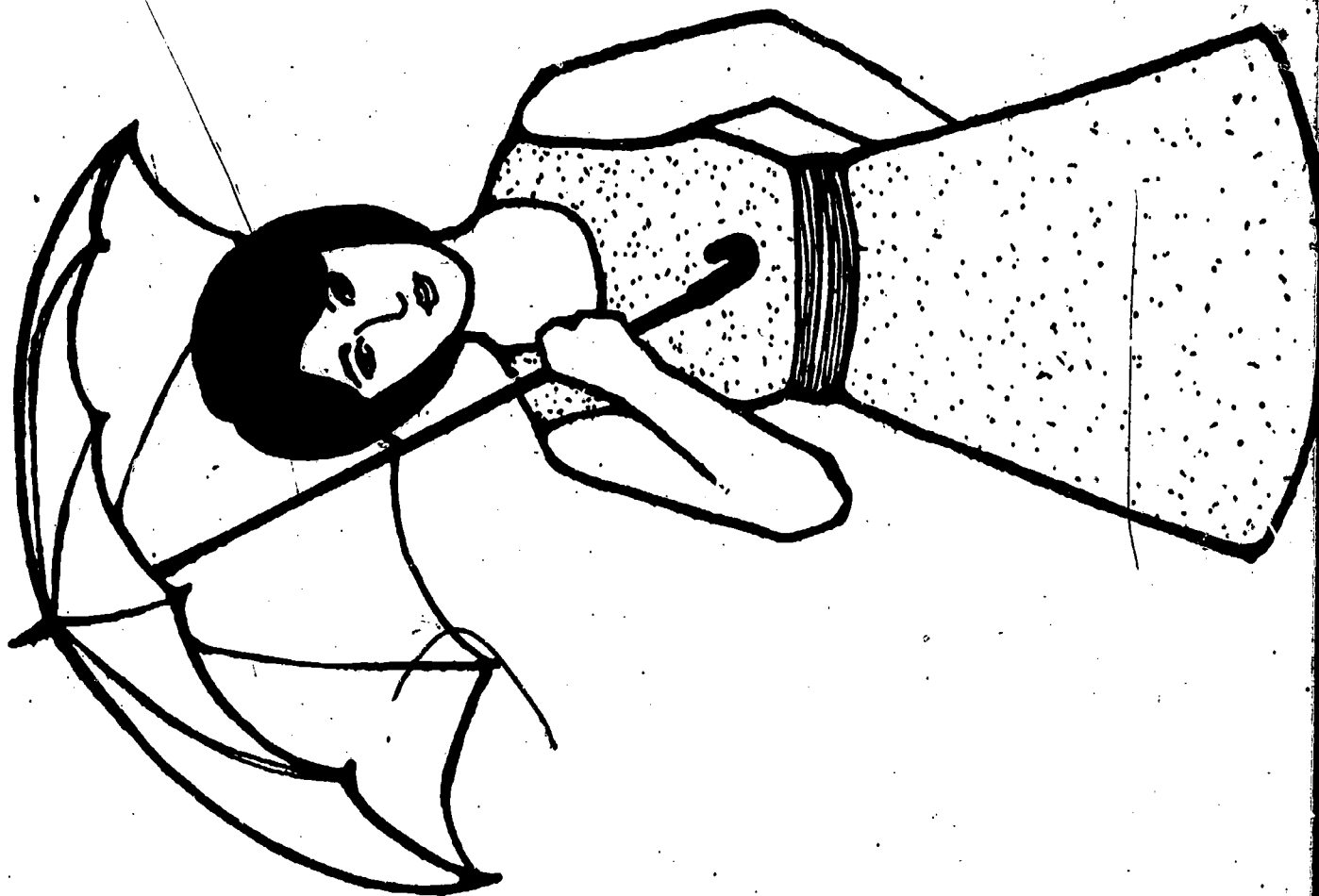



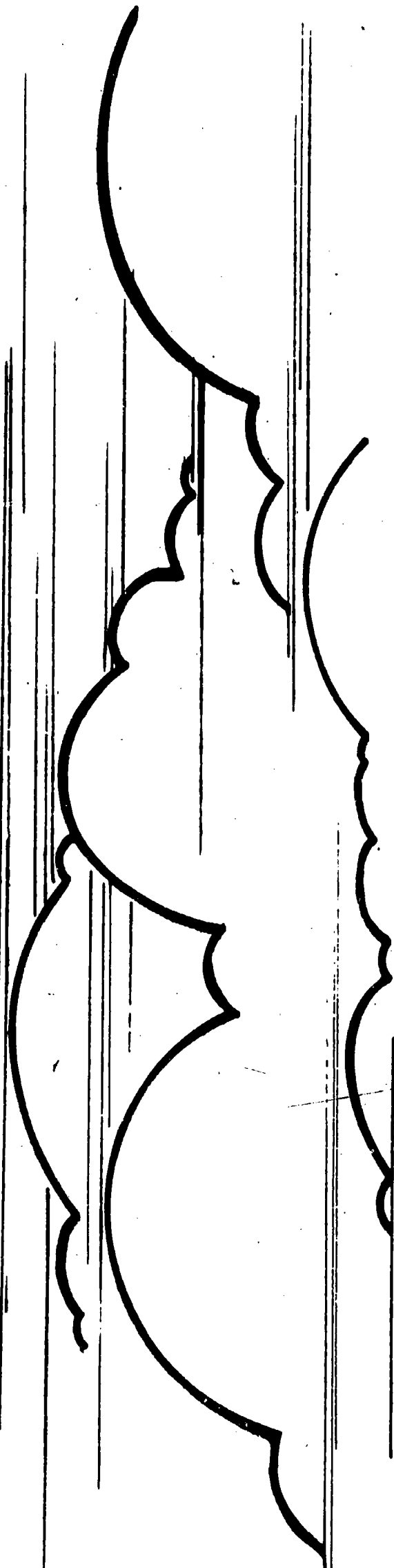

Handwritten text in cursive script, possibly a signature or a name, located at the bottom of the page. The text is written on a set of horizontal lines. The signature appears to be "John M. [unclear]".

BEST COPY AVAILABLE

AP  
P226

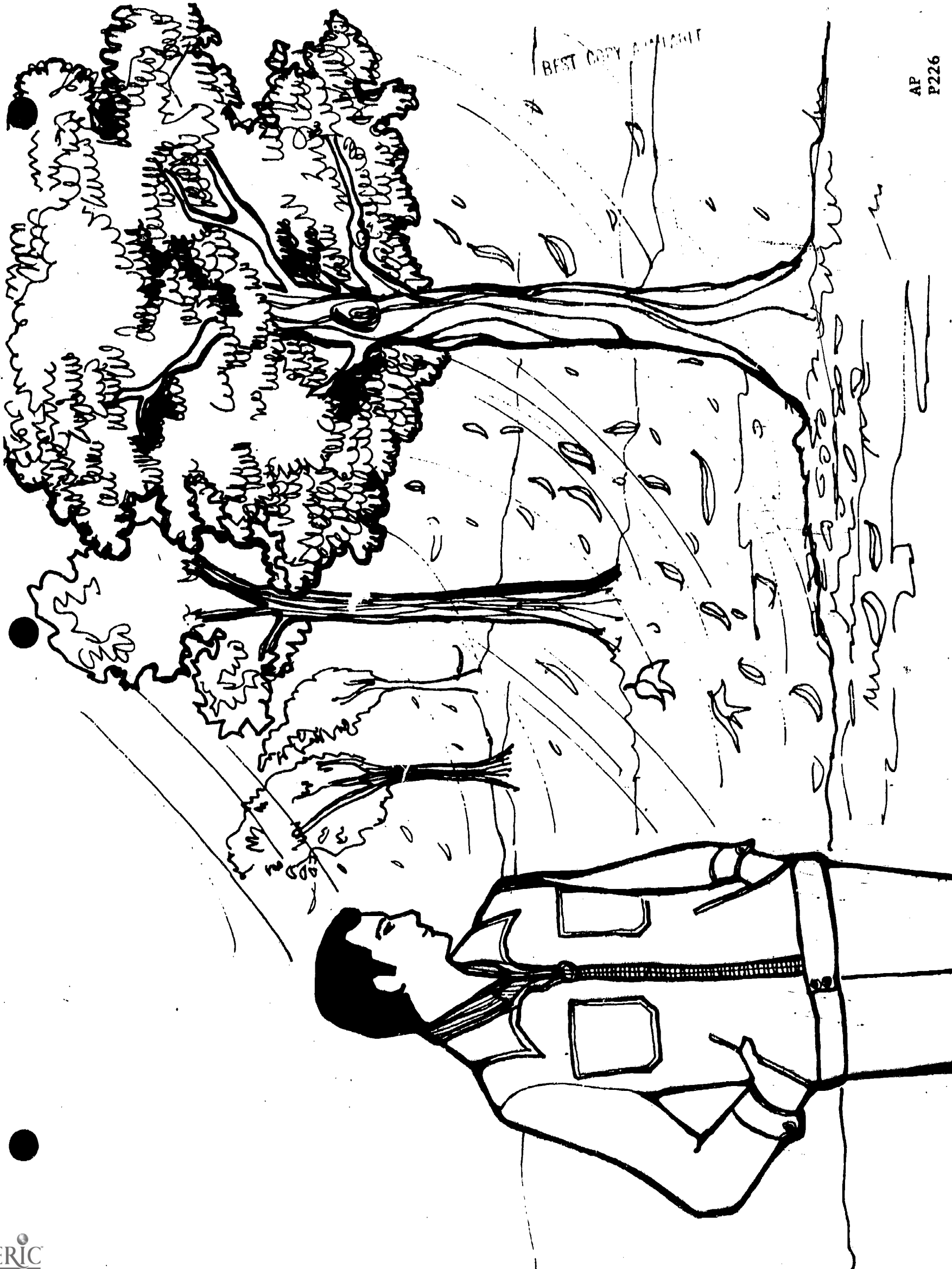

REF. COPY AVAILABLE

AP  
P227

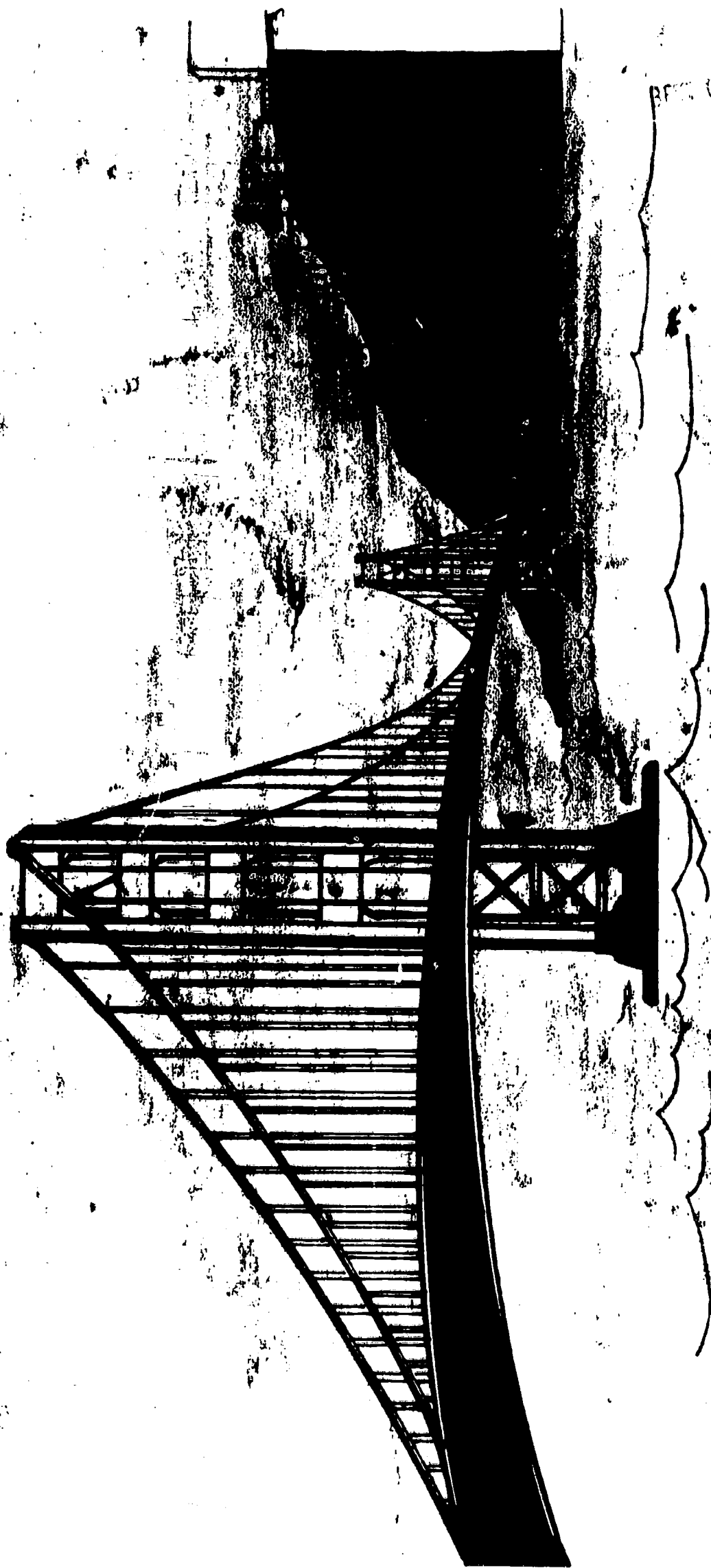

BEST COPY AVAILABLE

AP  
P228

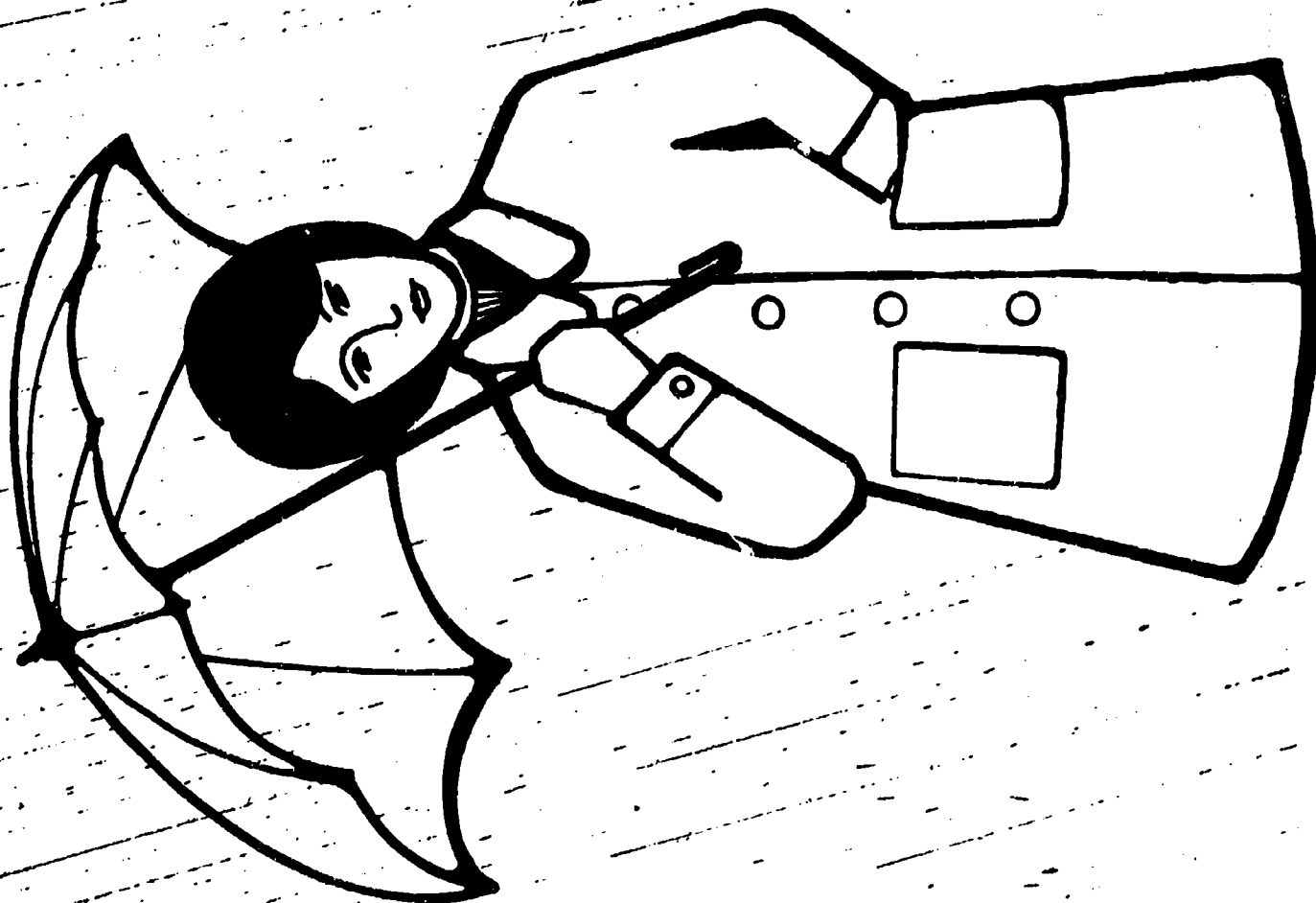

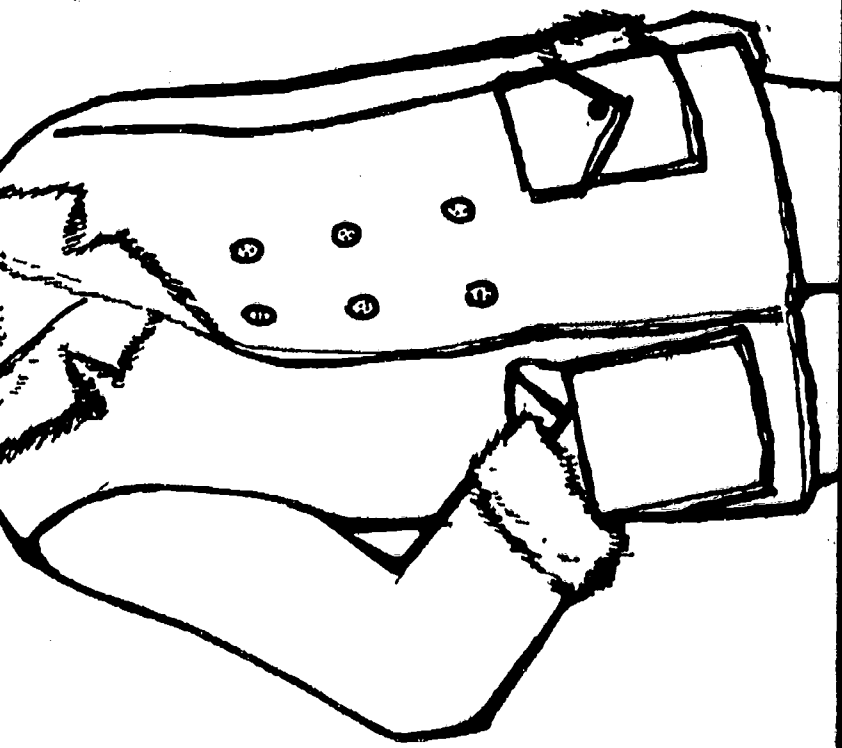
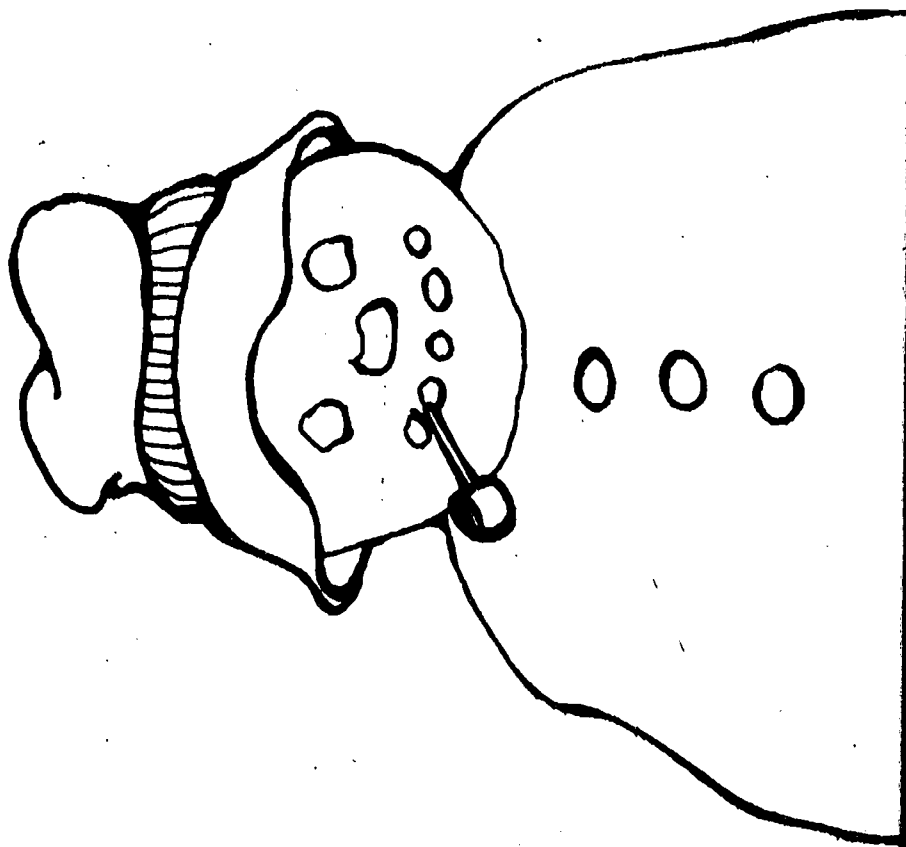

BEST COPY AVAILABLE

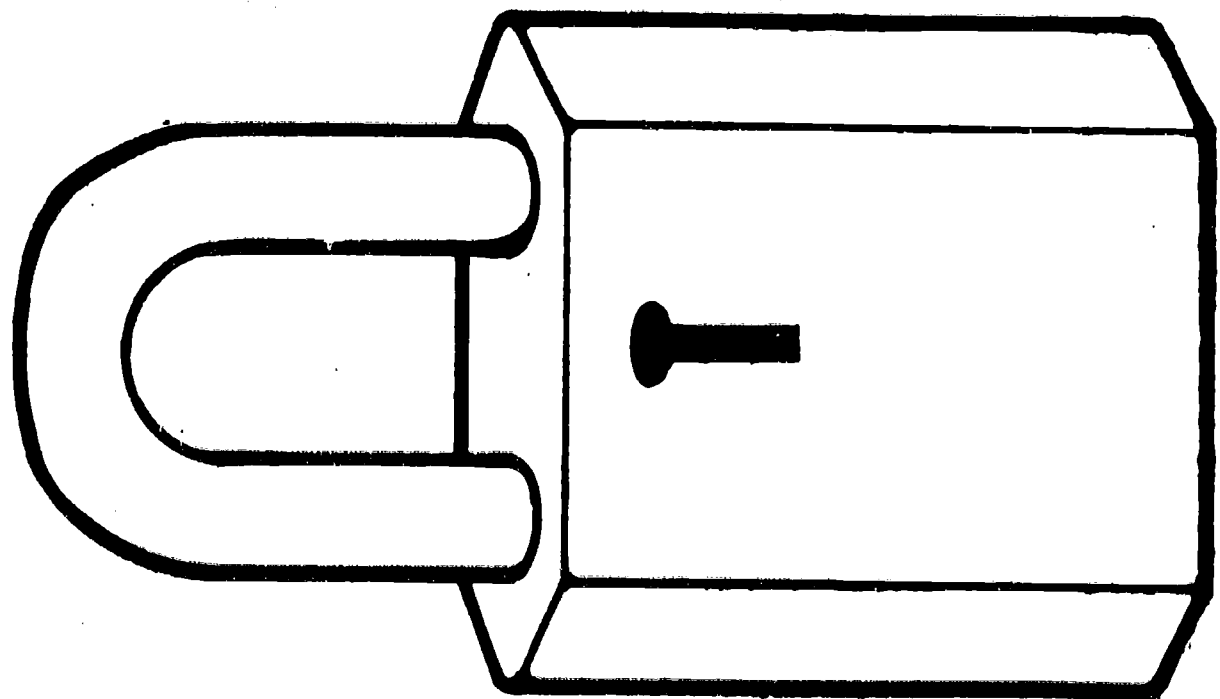
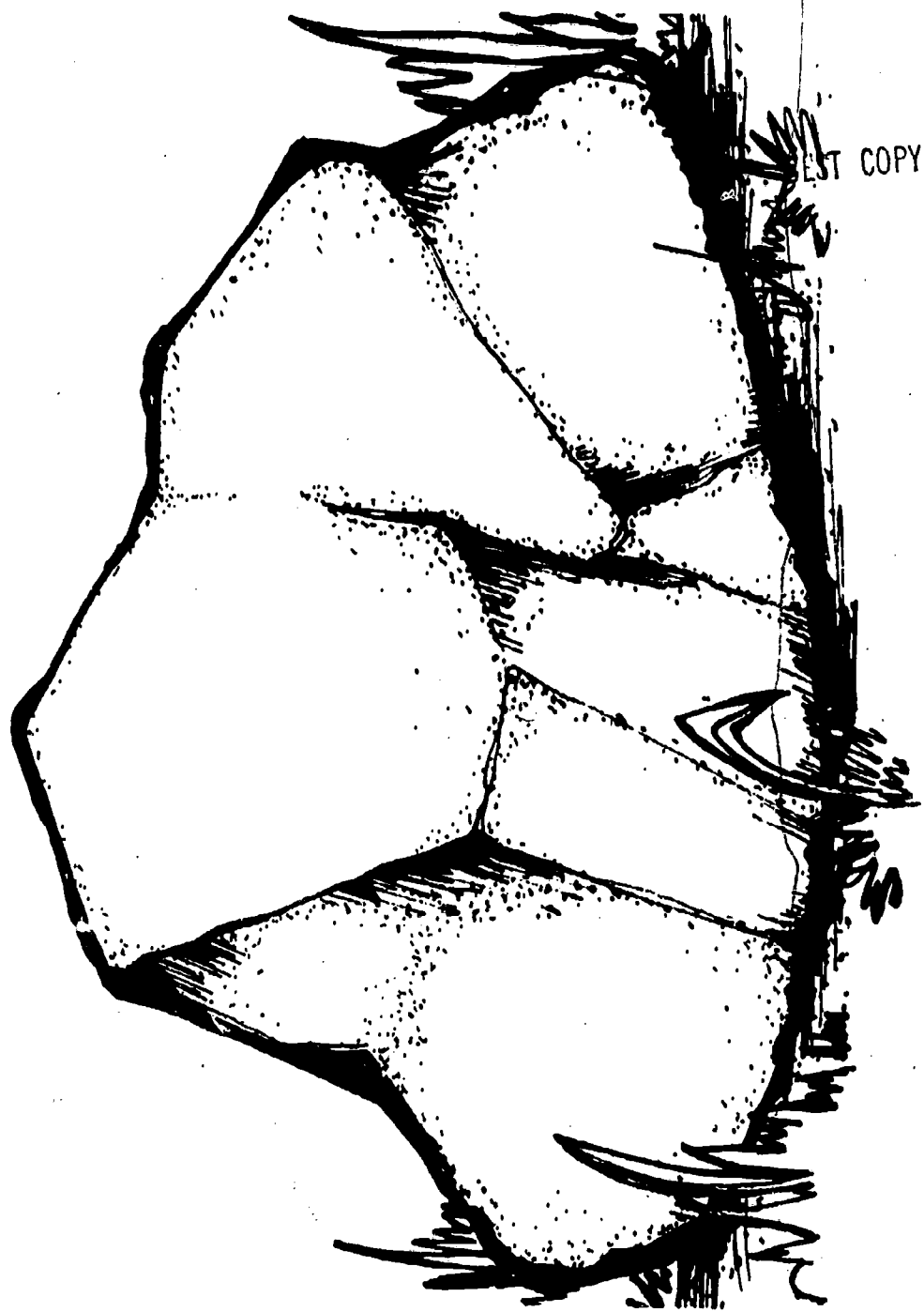

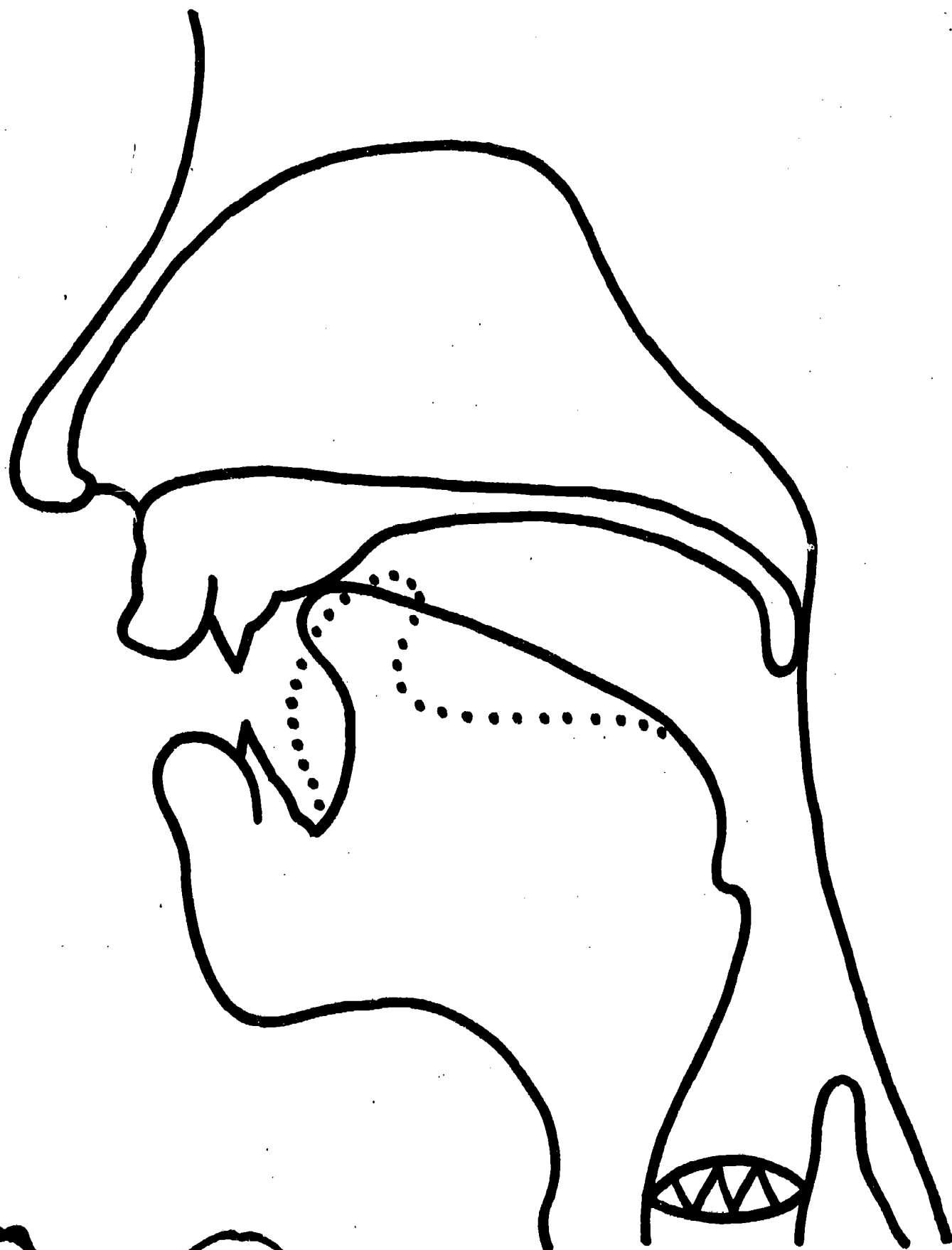

• /r/ — /l/.....

BEST COPY AVAILABLE

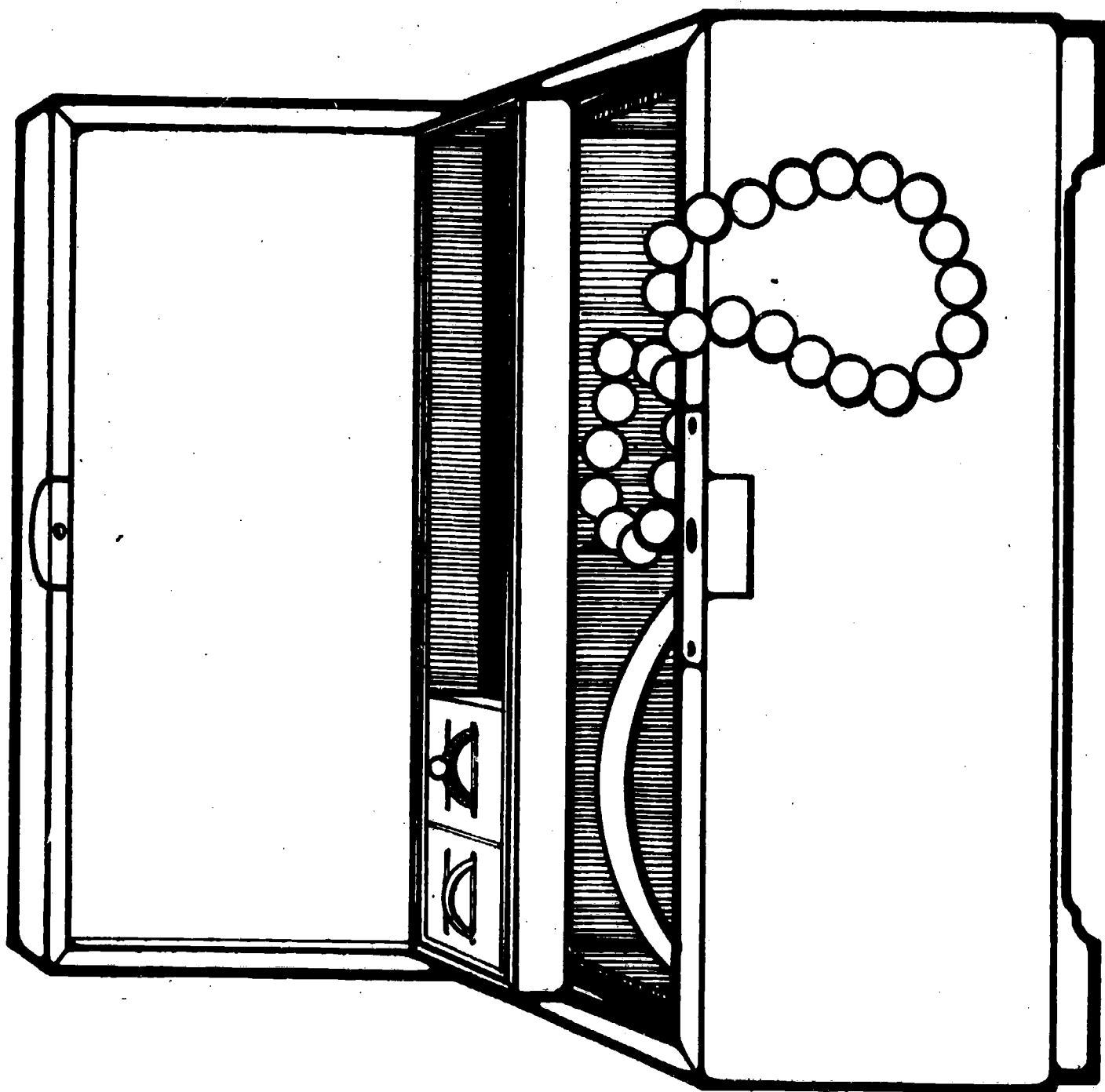



BEST COPY AVAILABLE

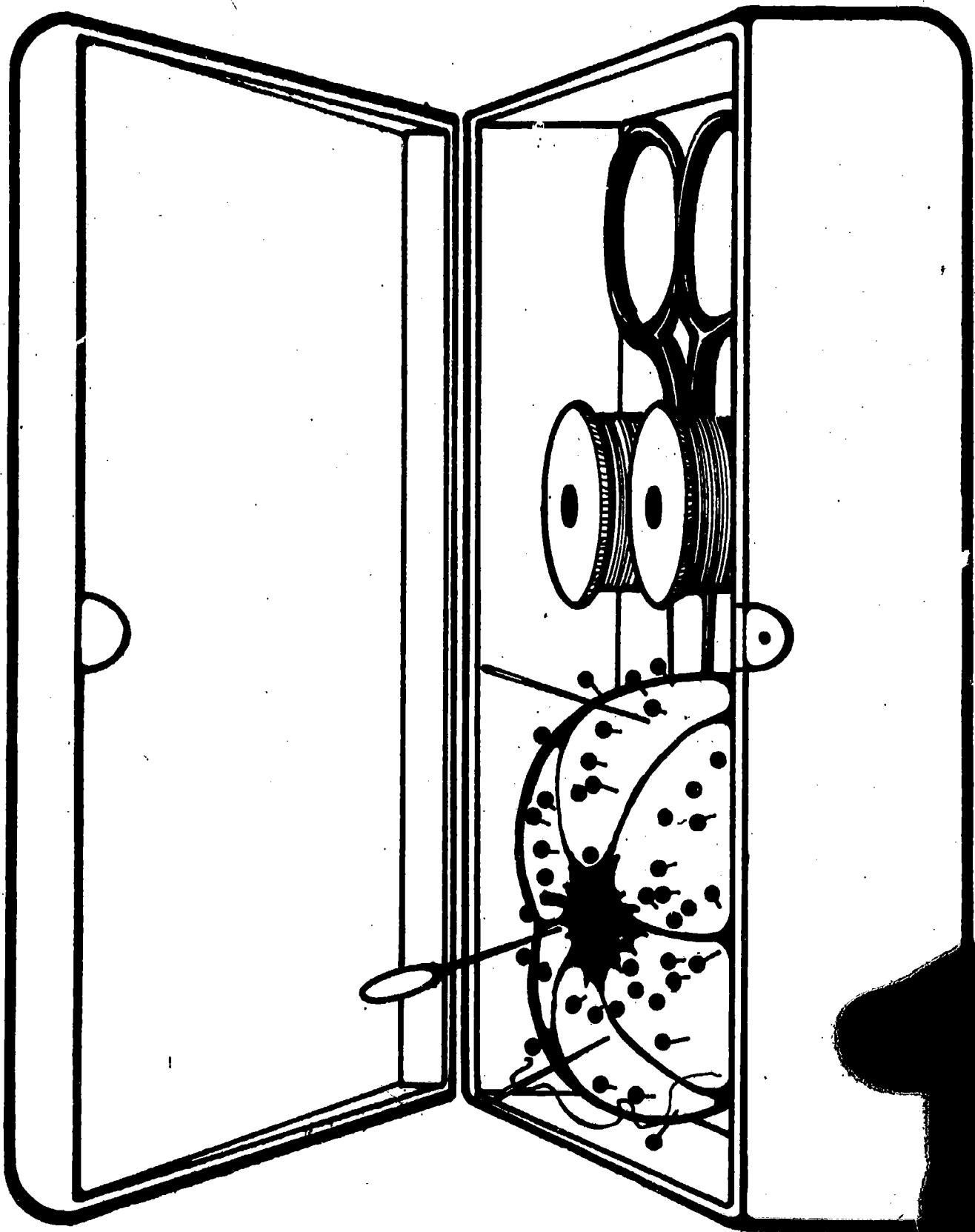

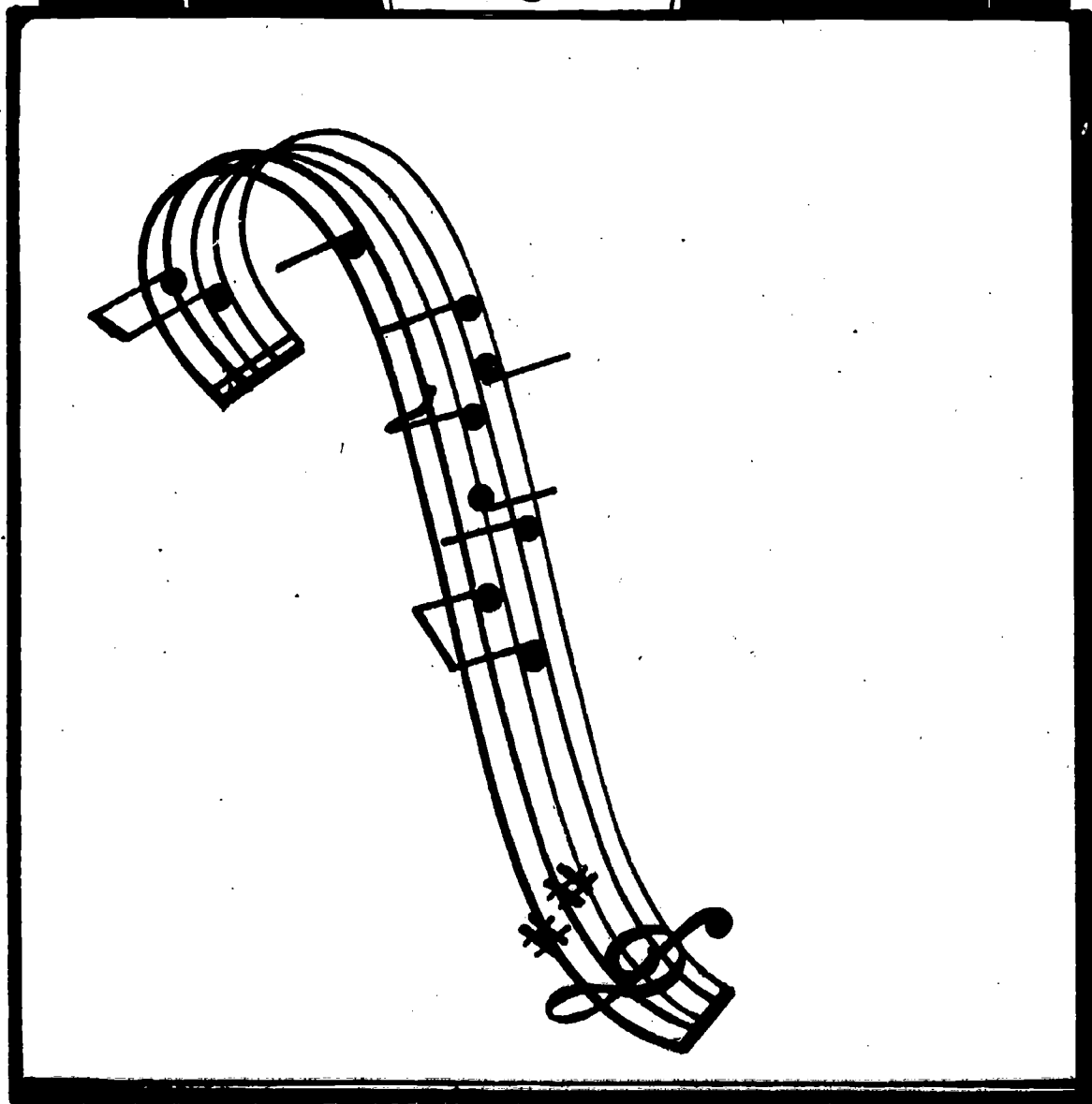

BEST COPY AVAILABLE

AP  
P235

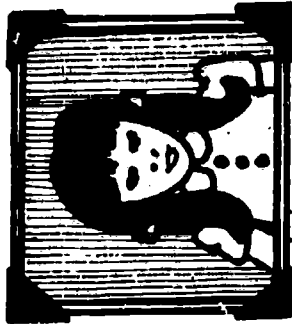
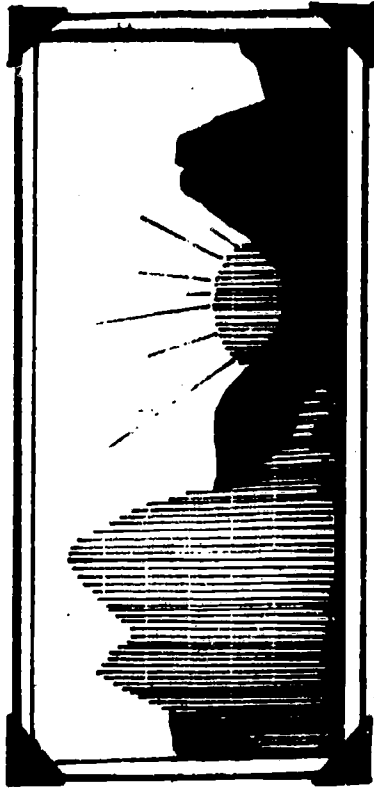

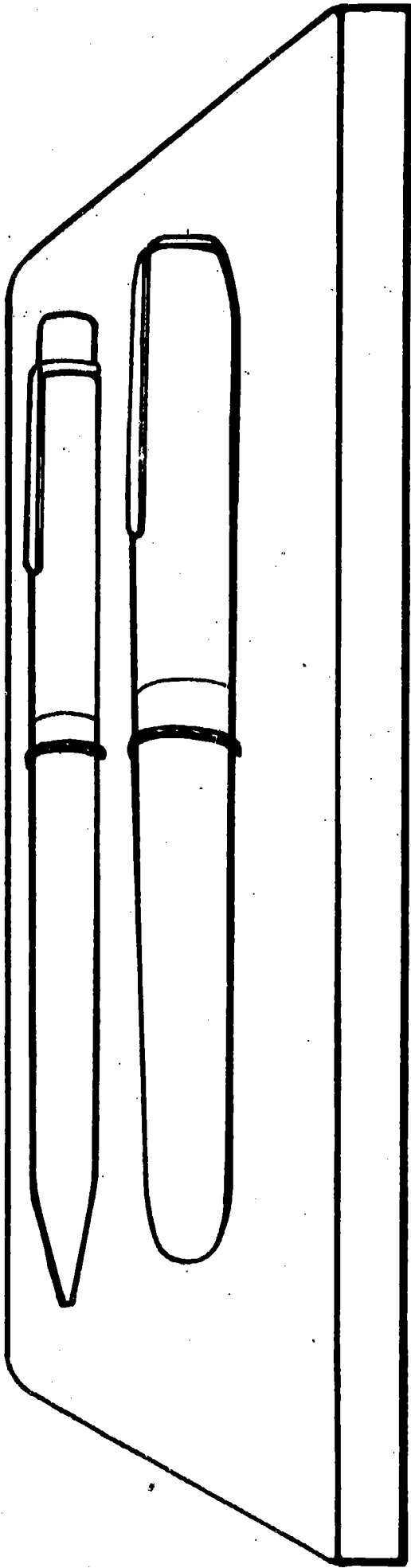

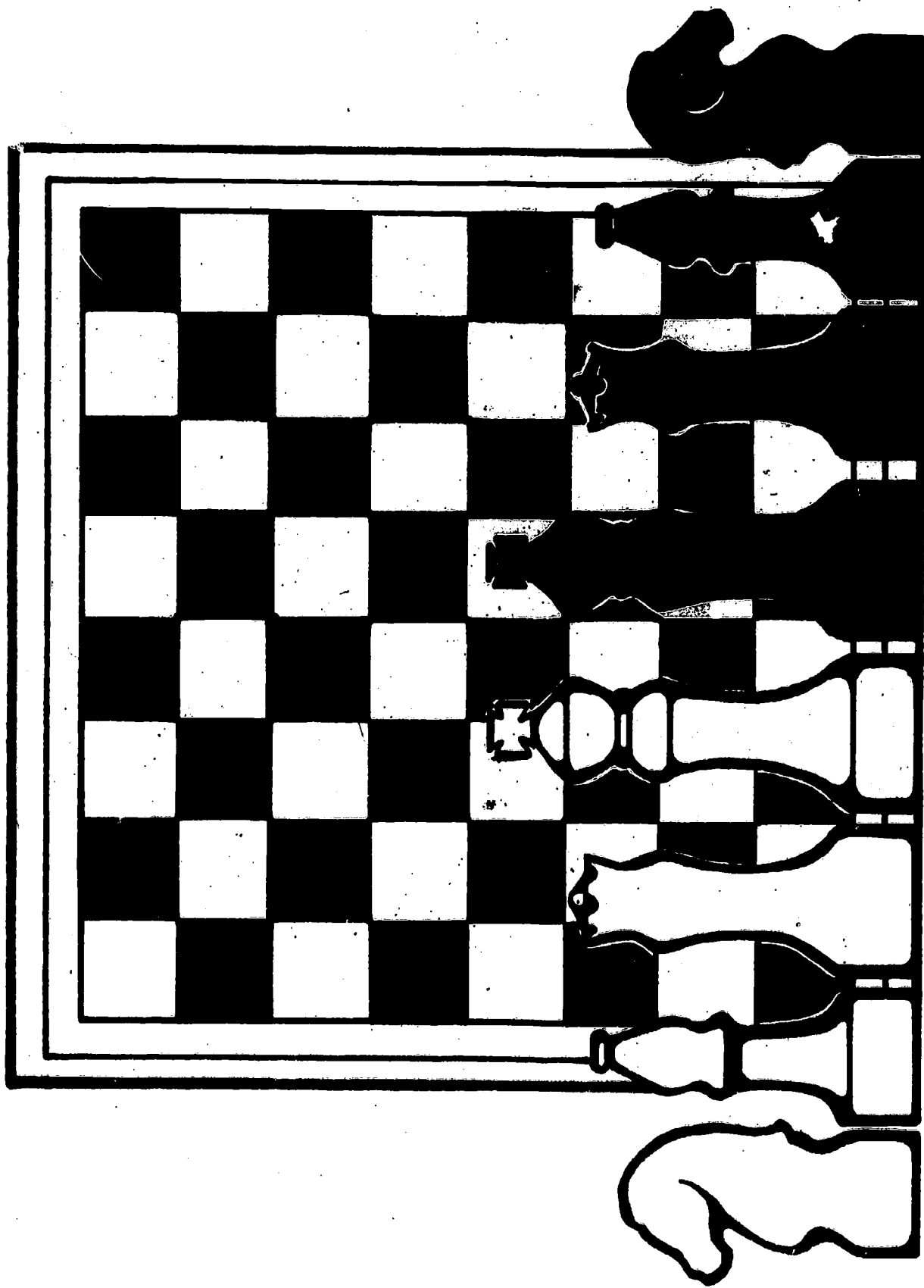

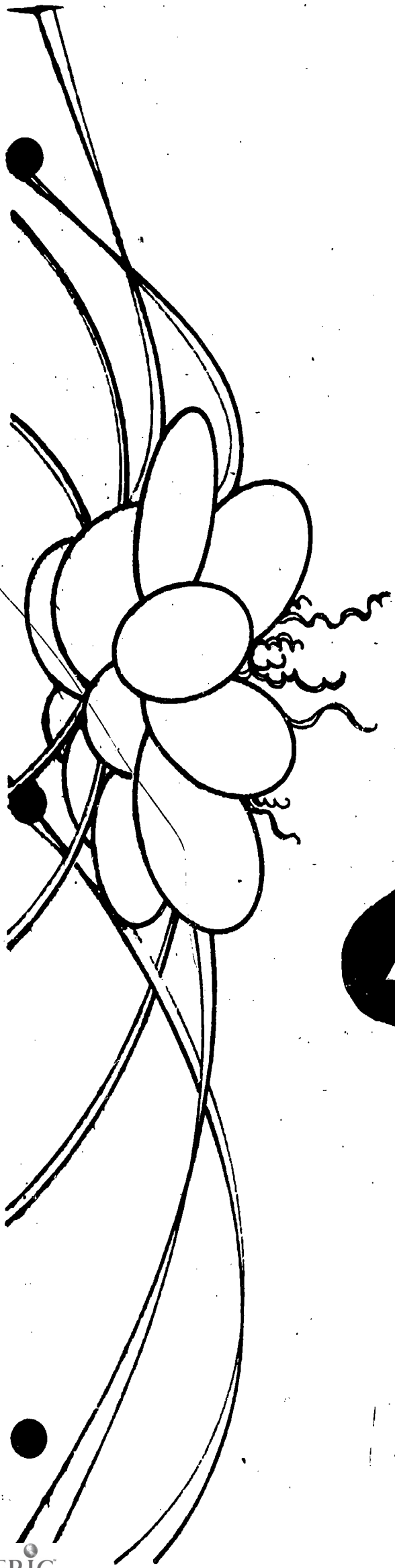
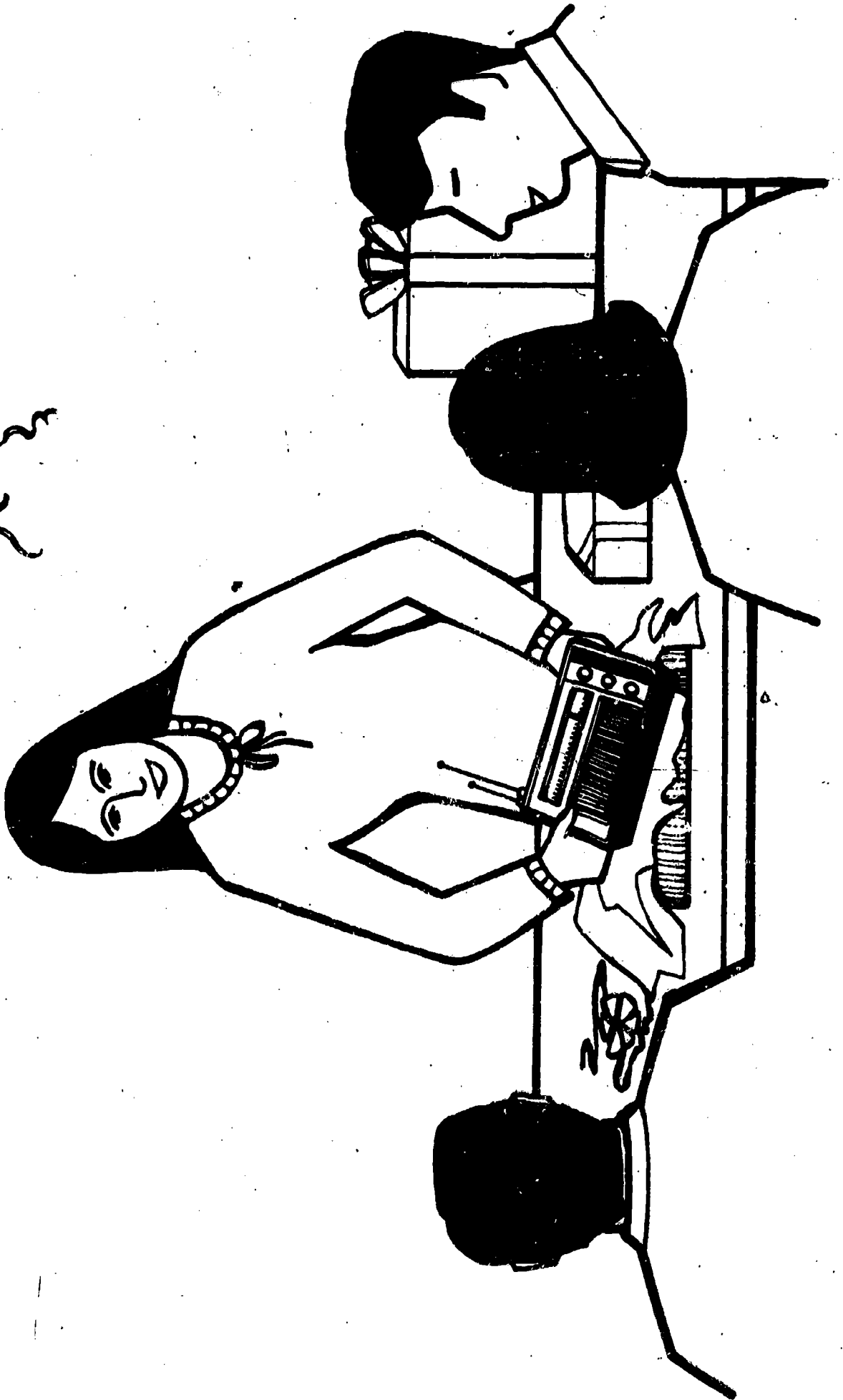

BEST COPY AVAILABLE

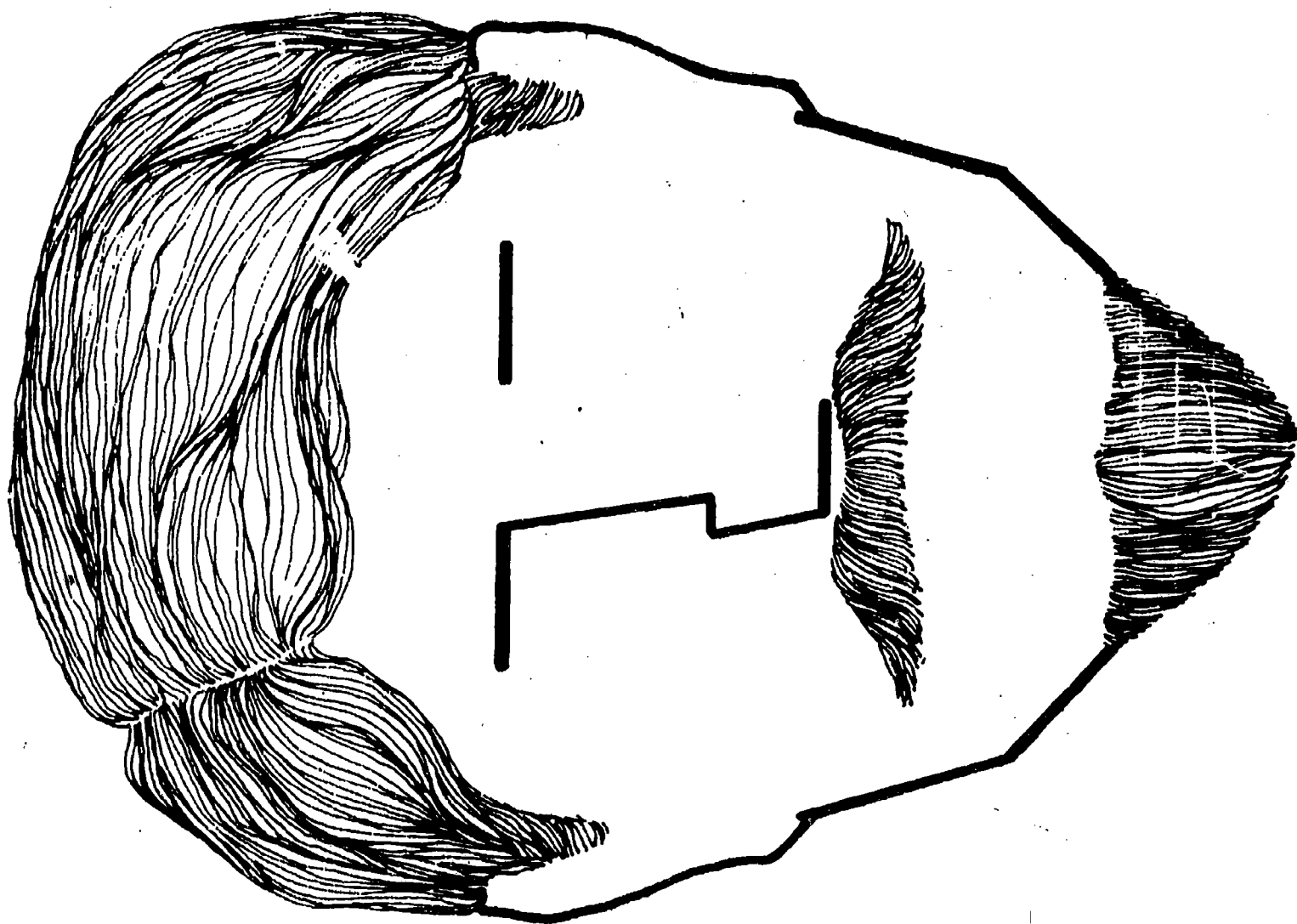

BEST COPY AVAILABLE

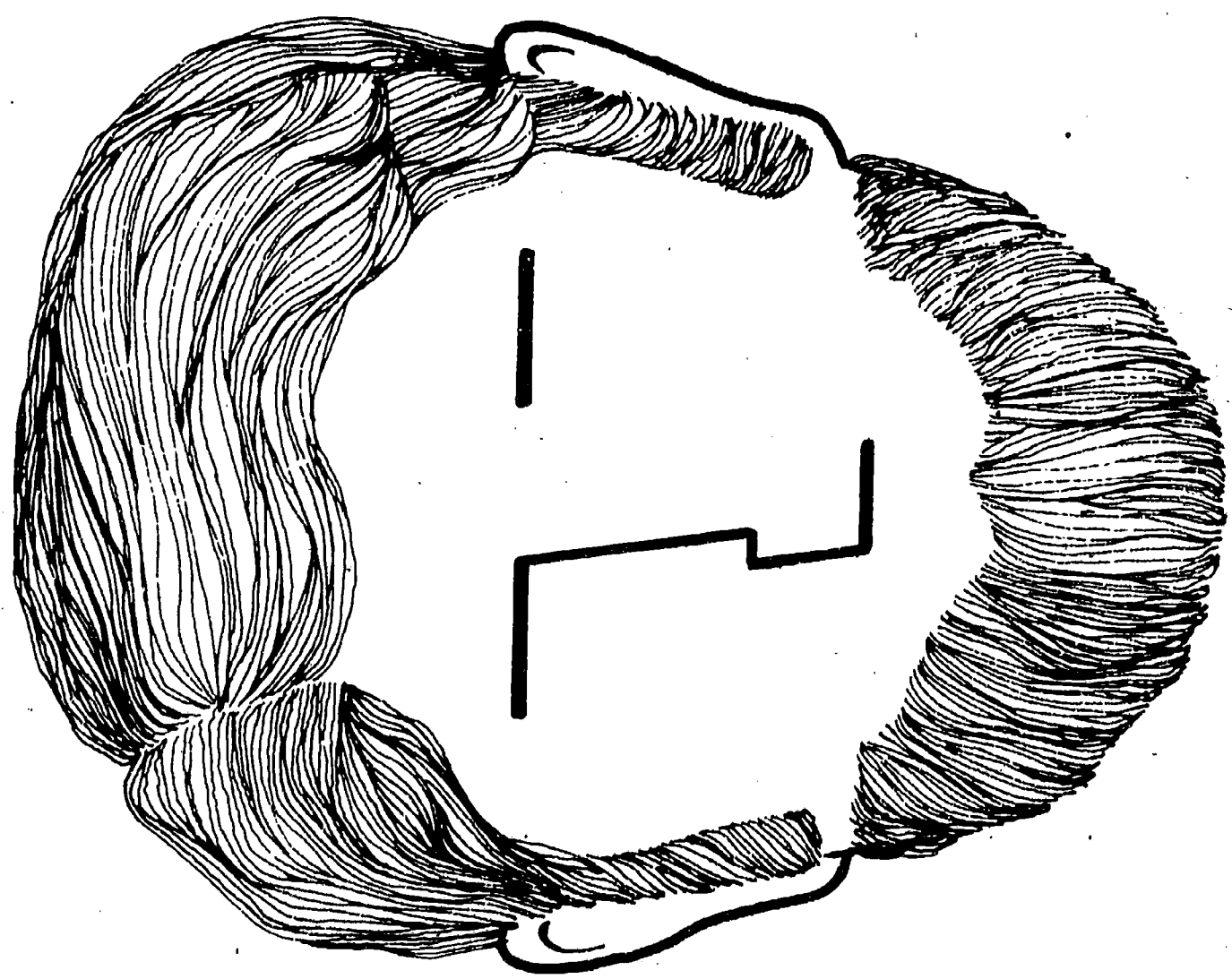



BEST COPY AVAILABLE

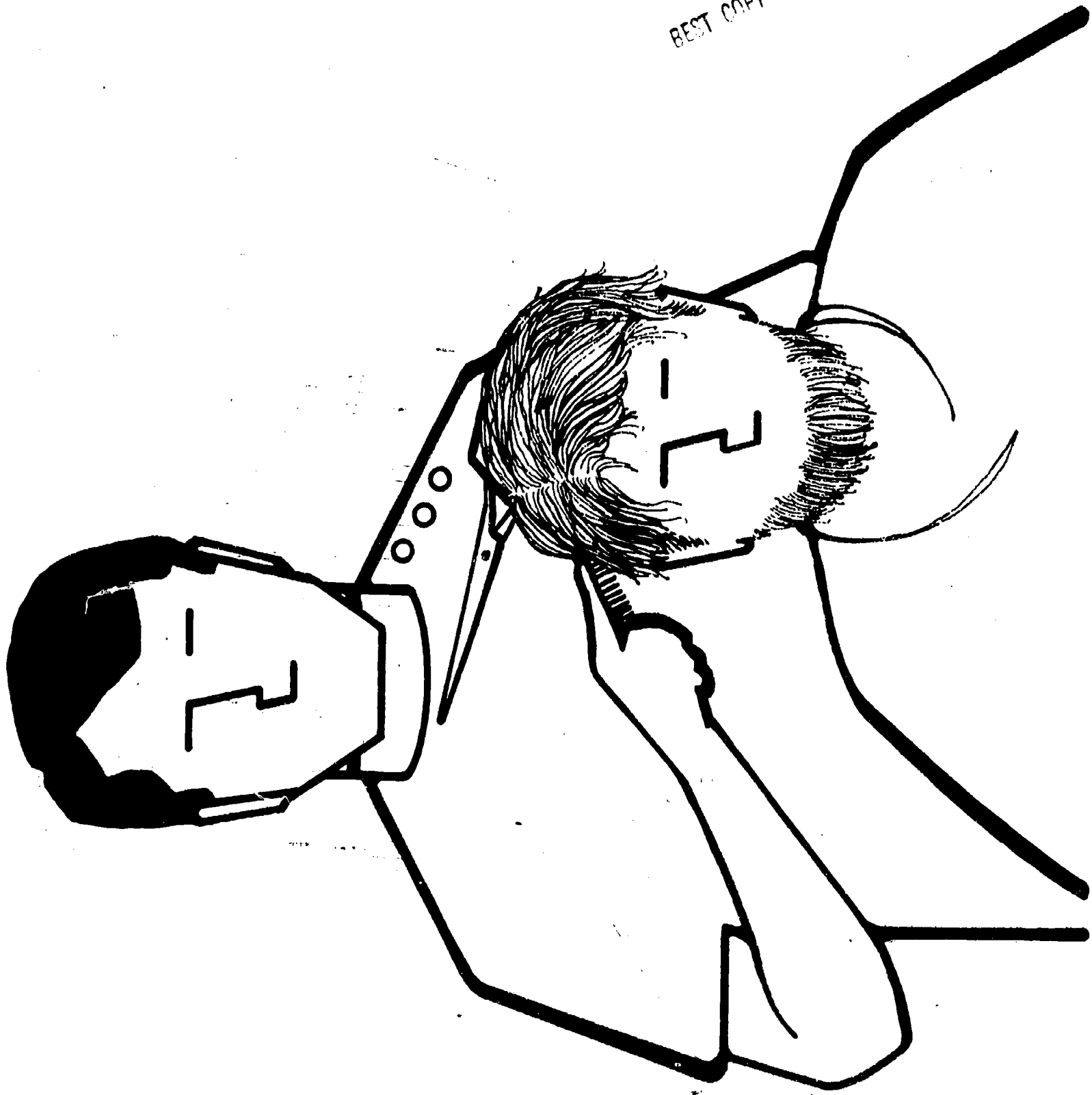

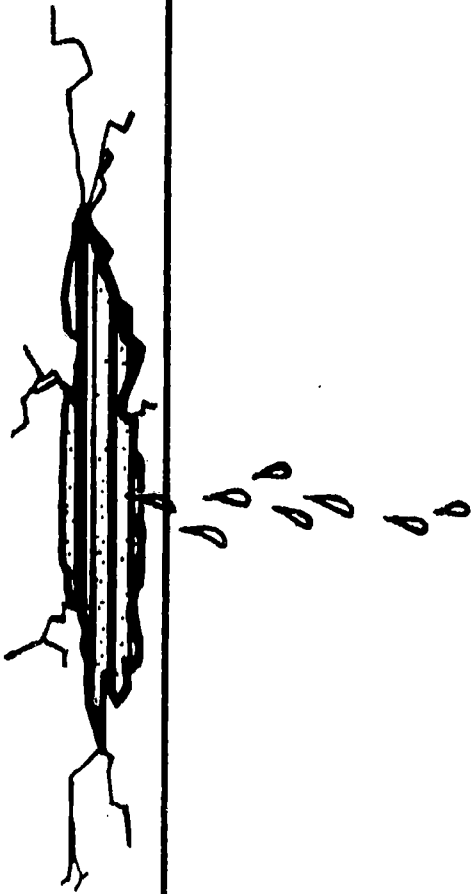
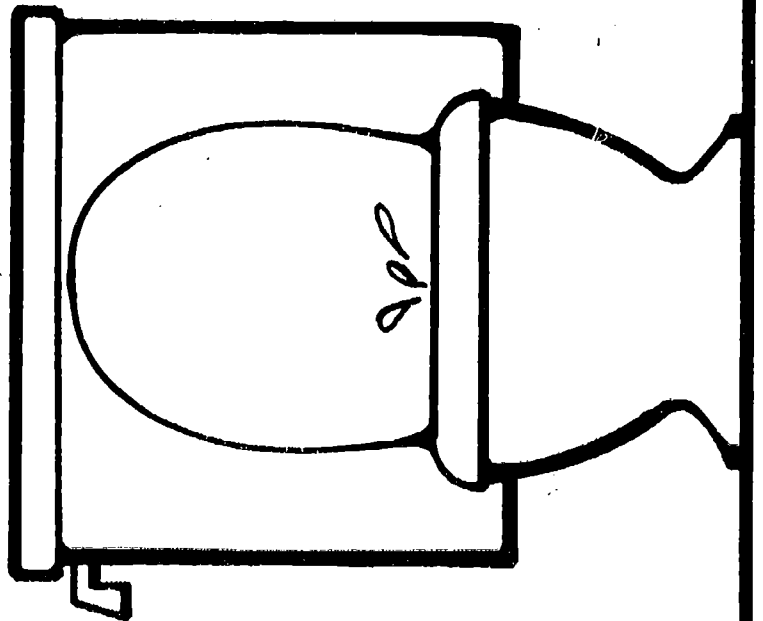
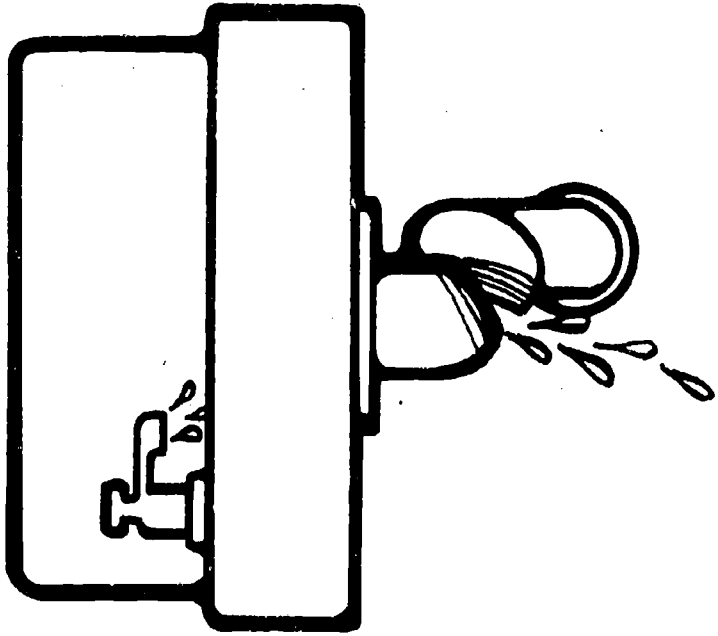
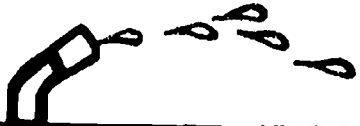

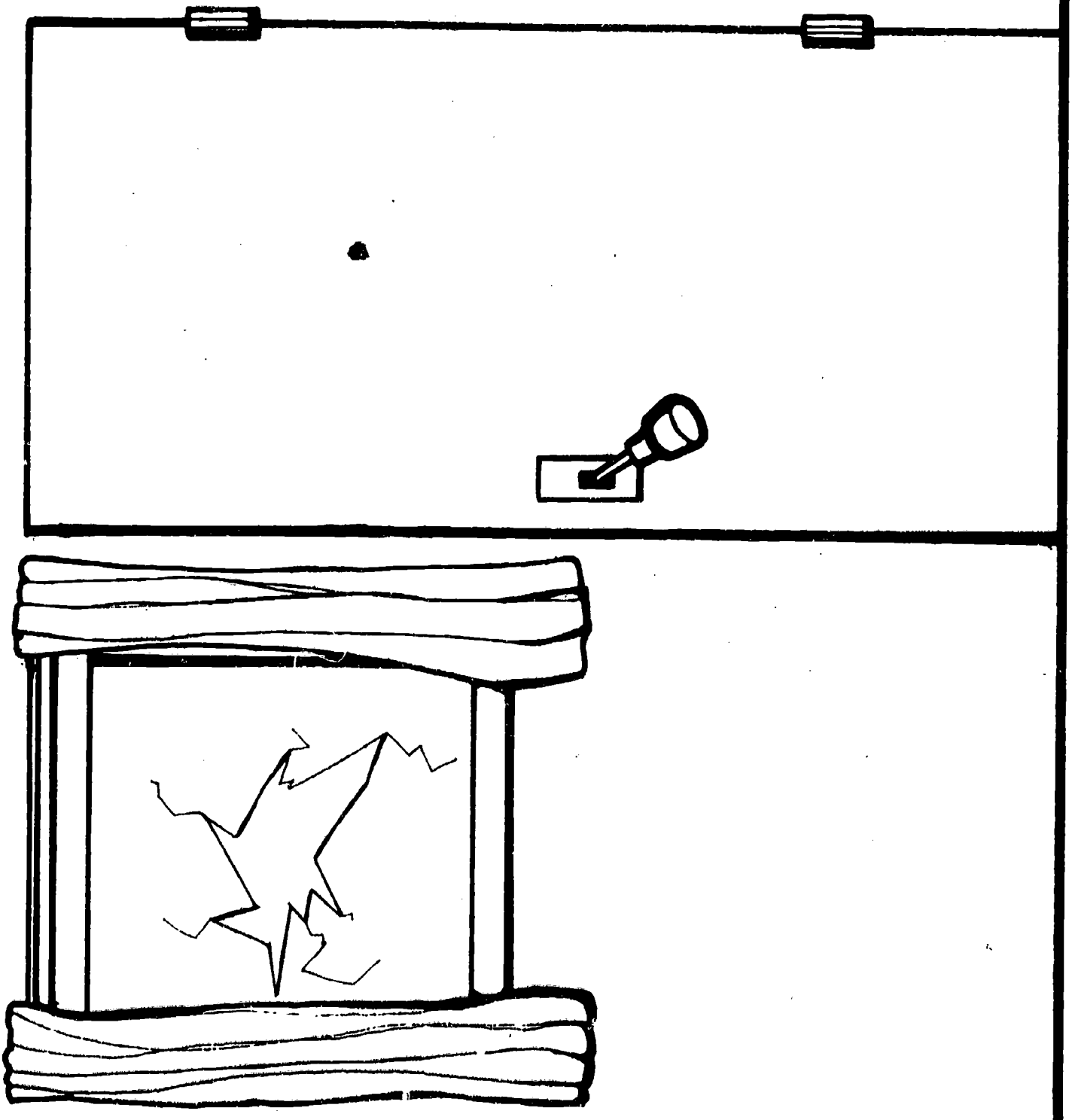
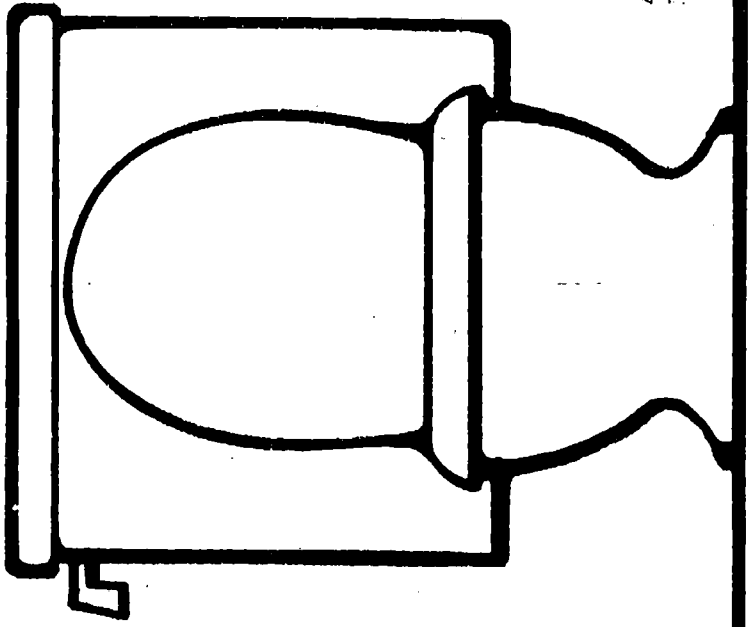



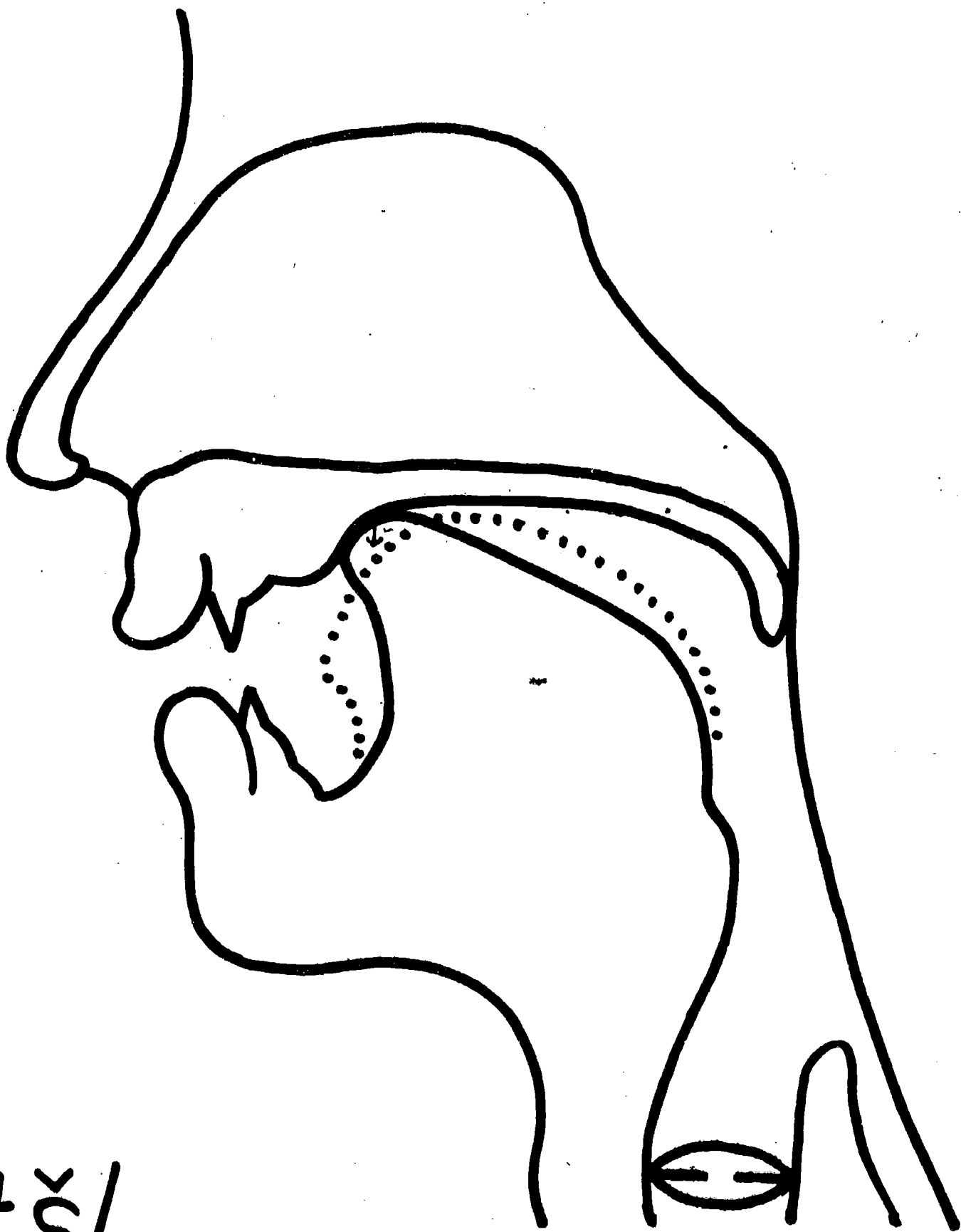

/tʃ/

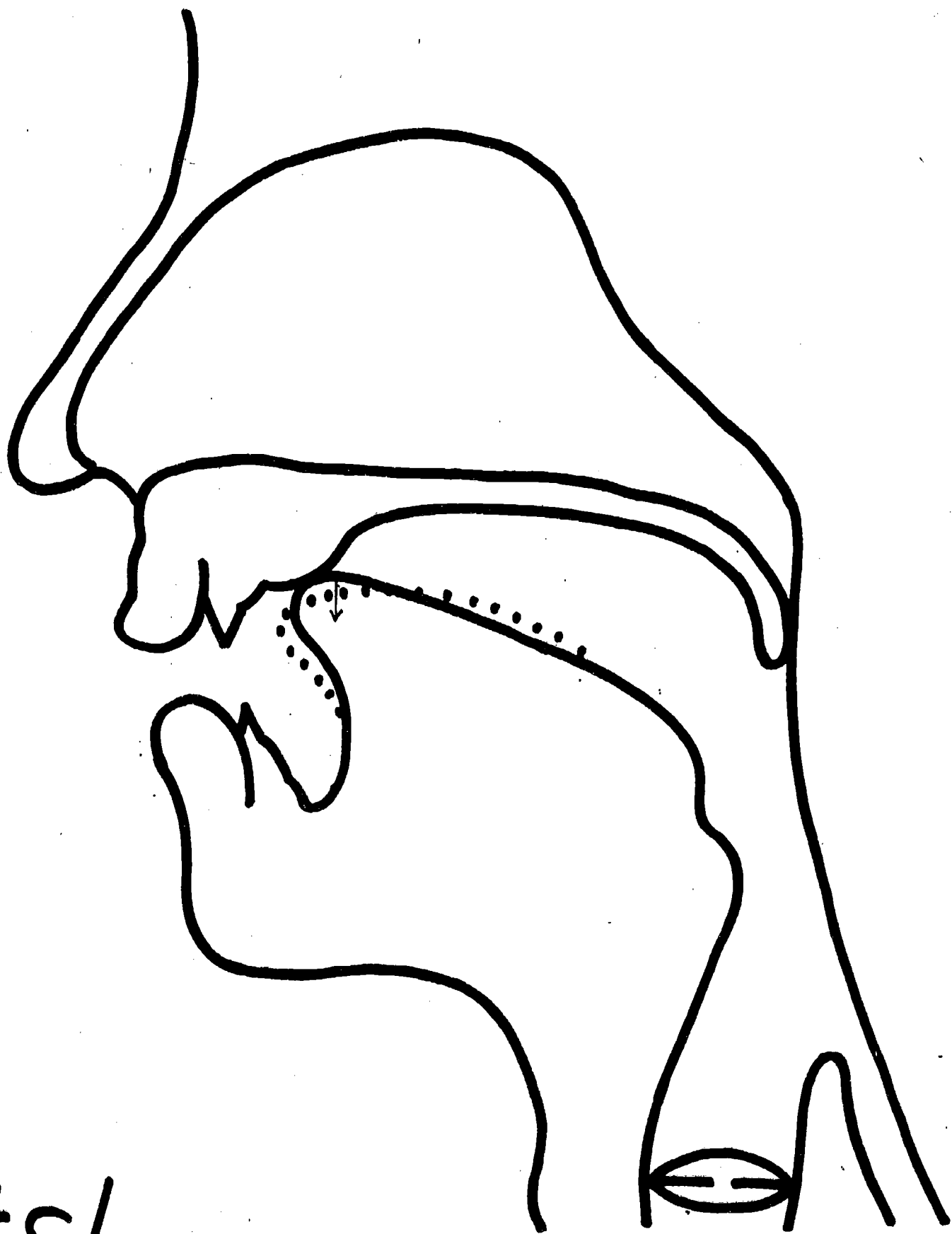

● /ts/

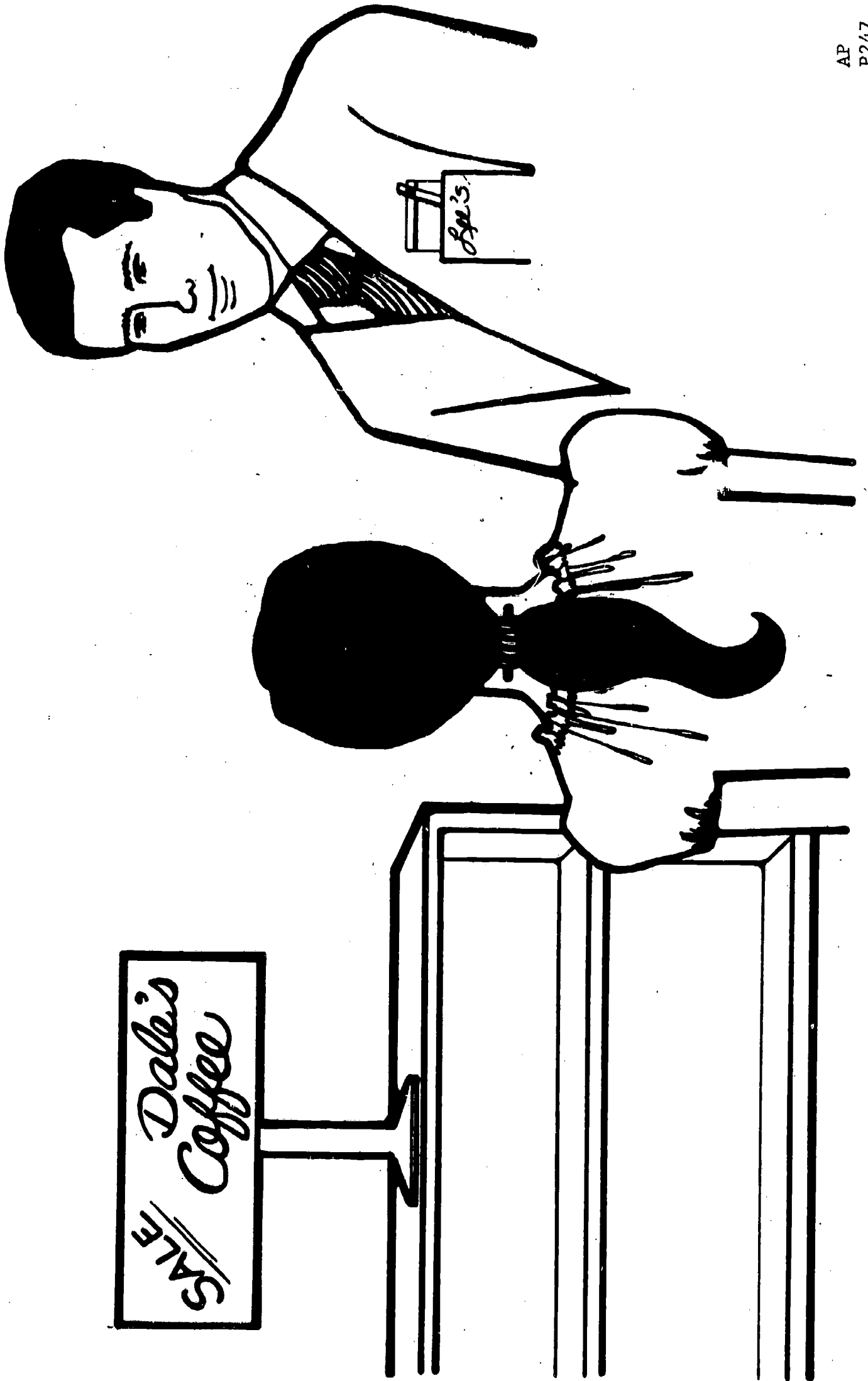

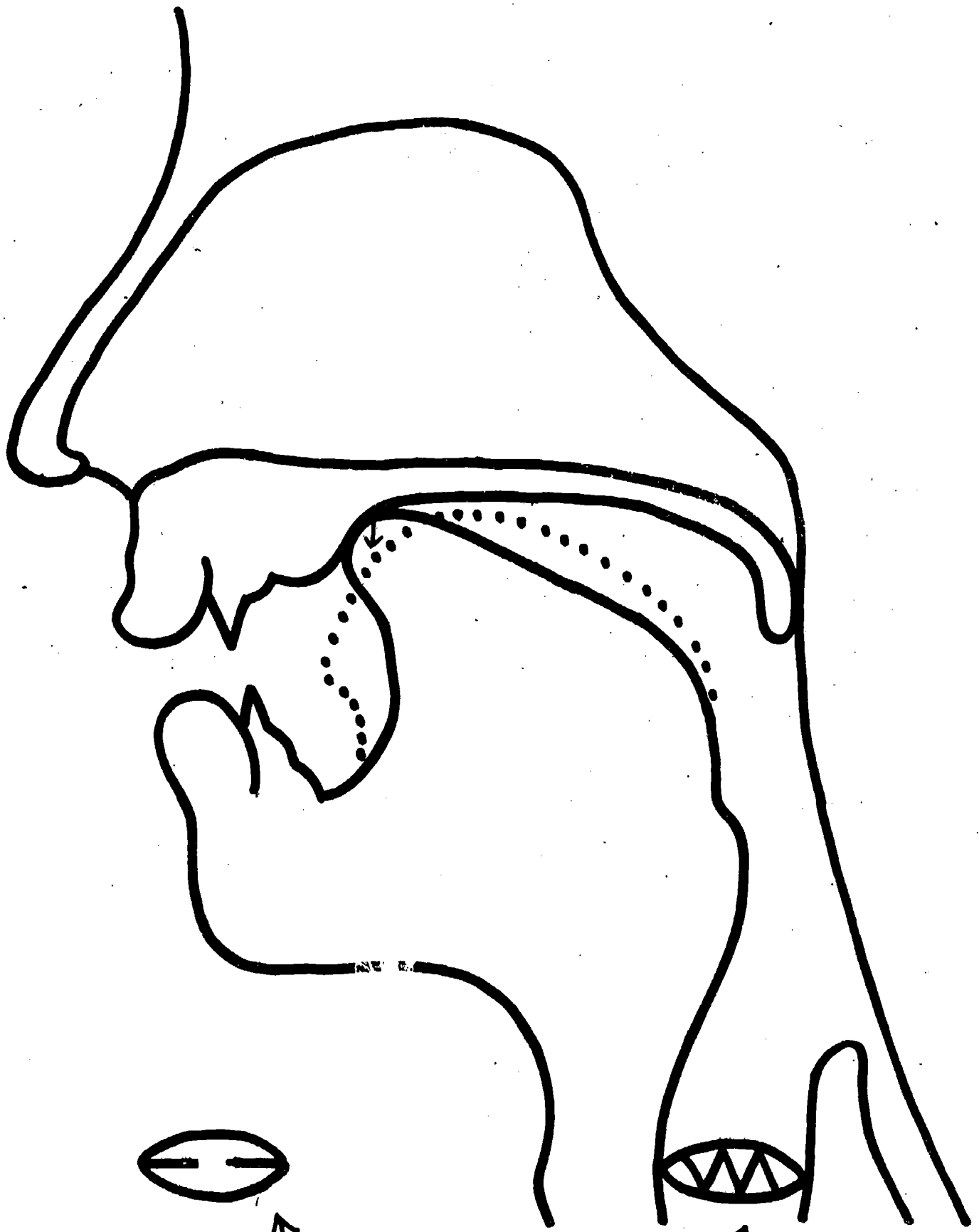

/tš/ /dž/

AF  
F 248



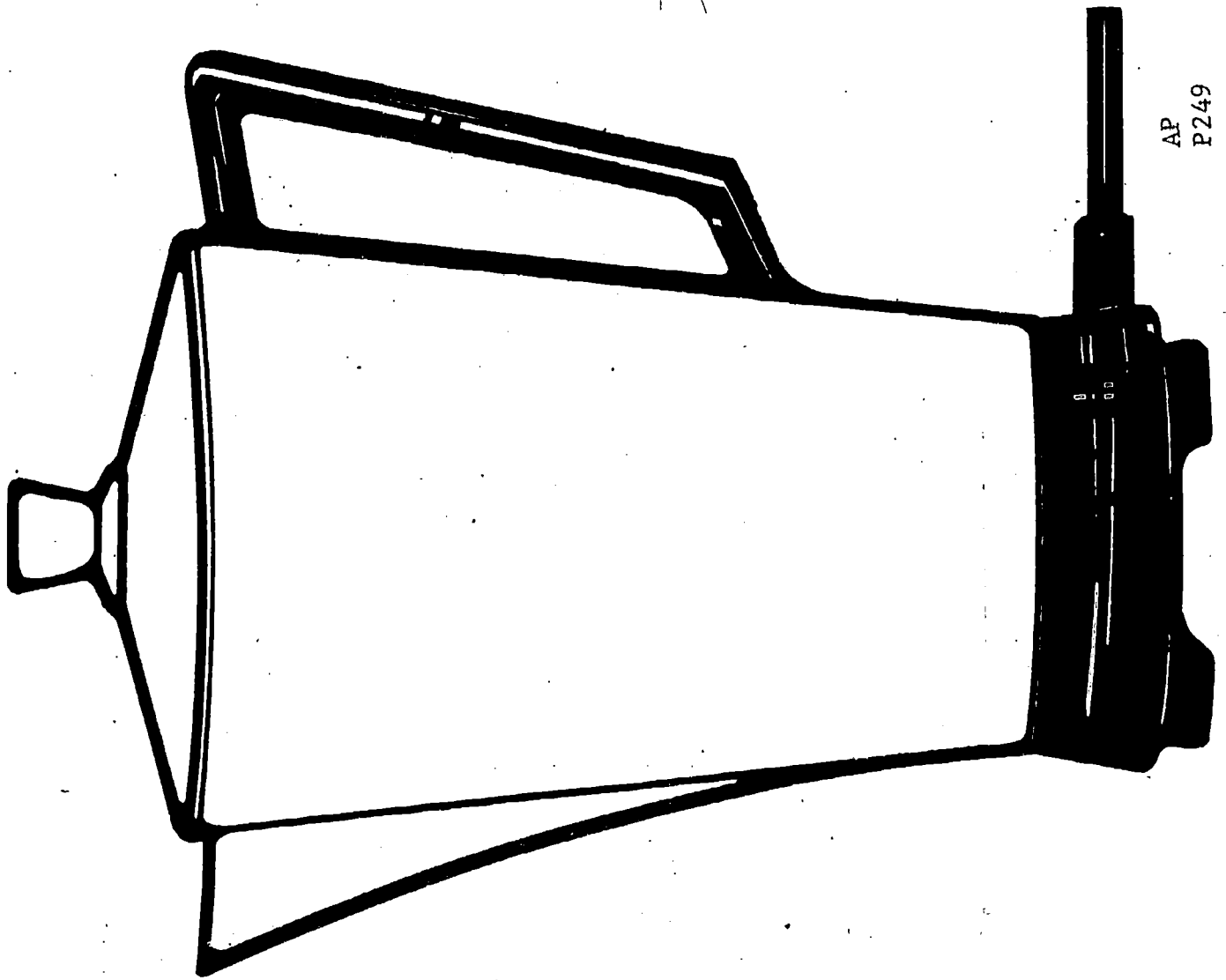

AP  
P249

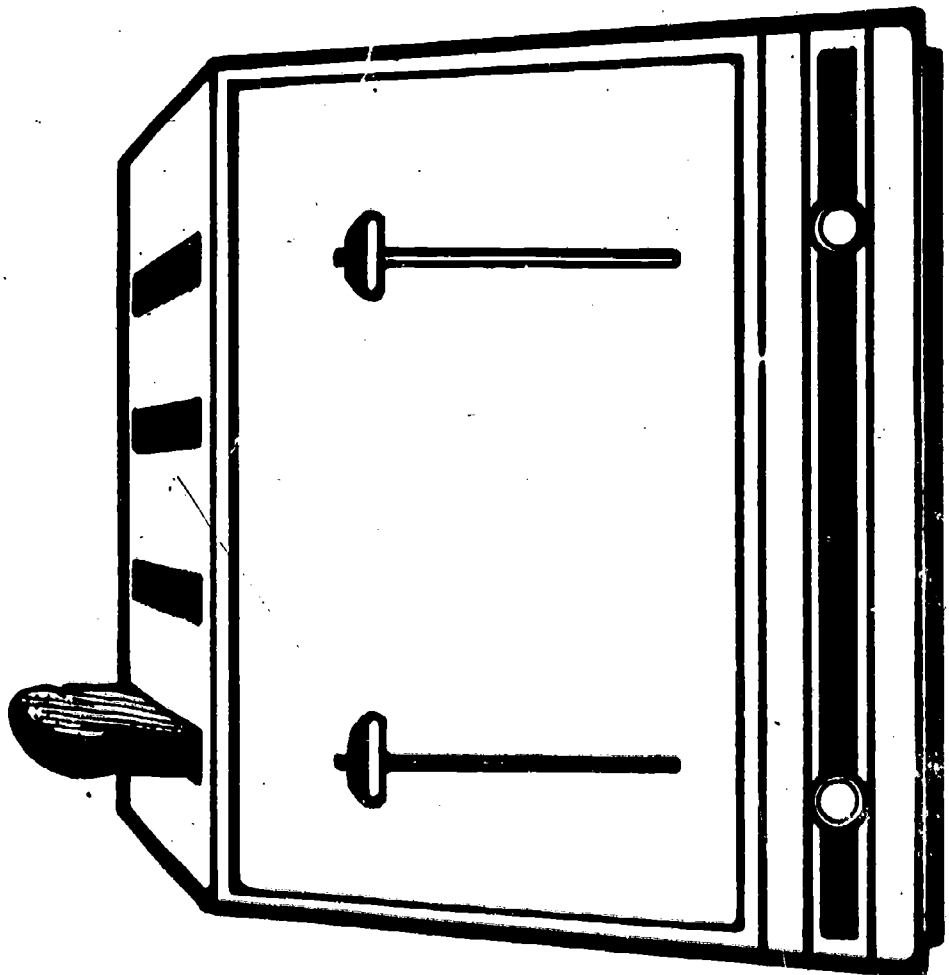

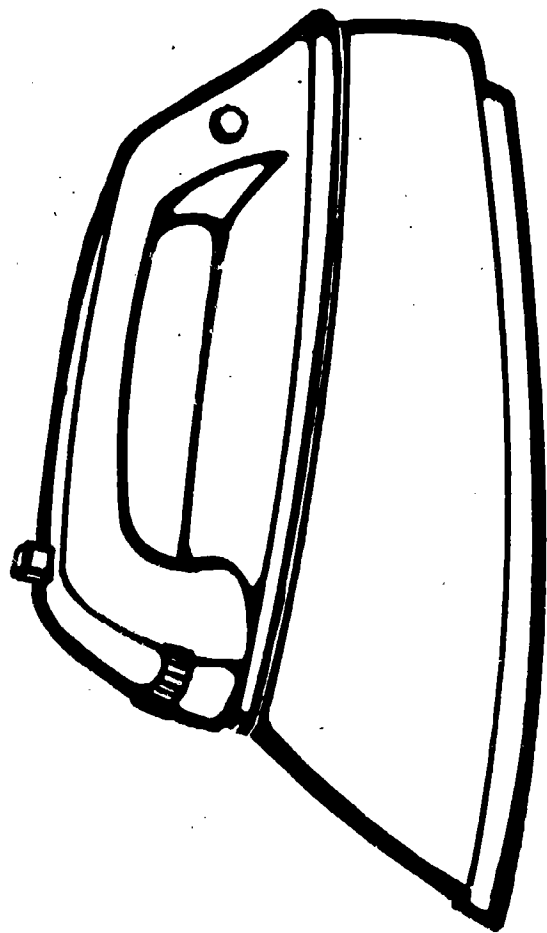
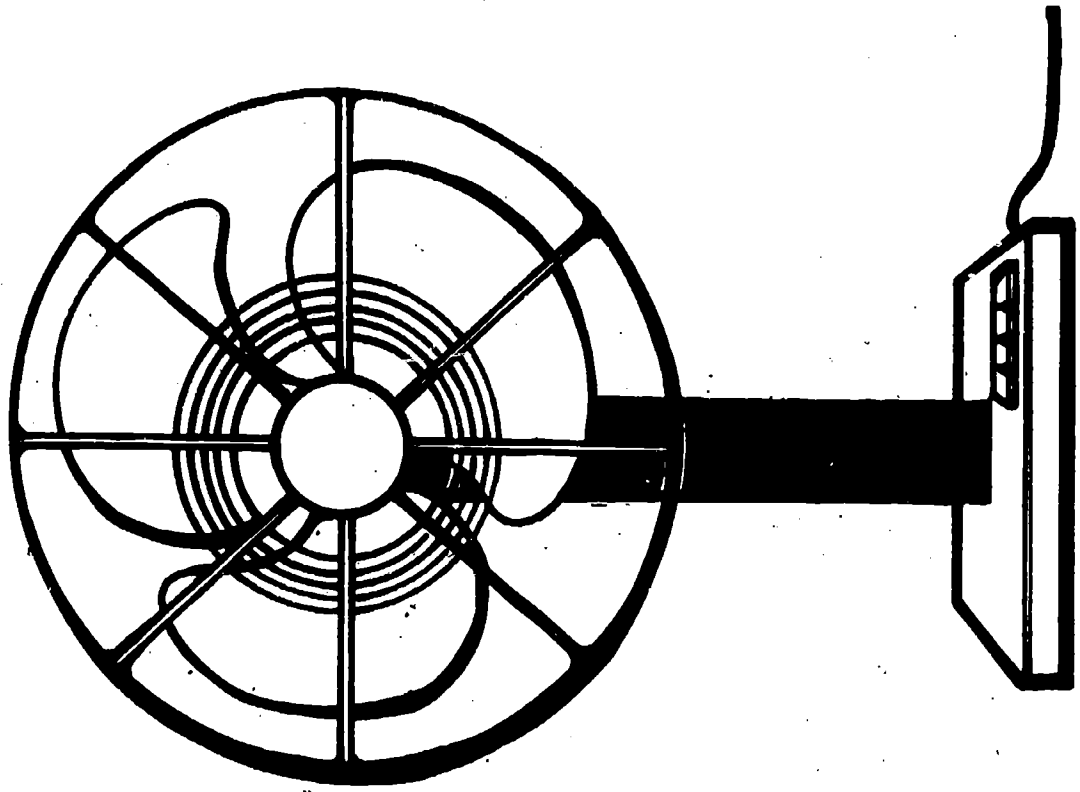

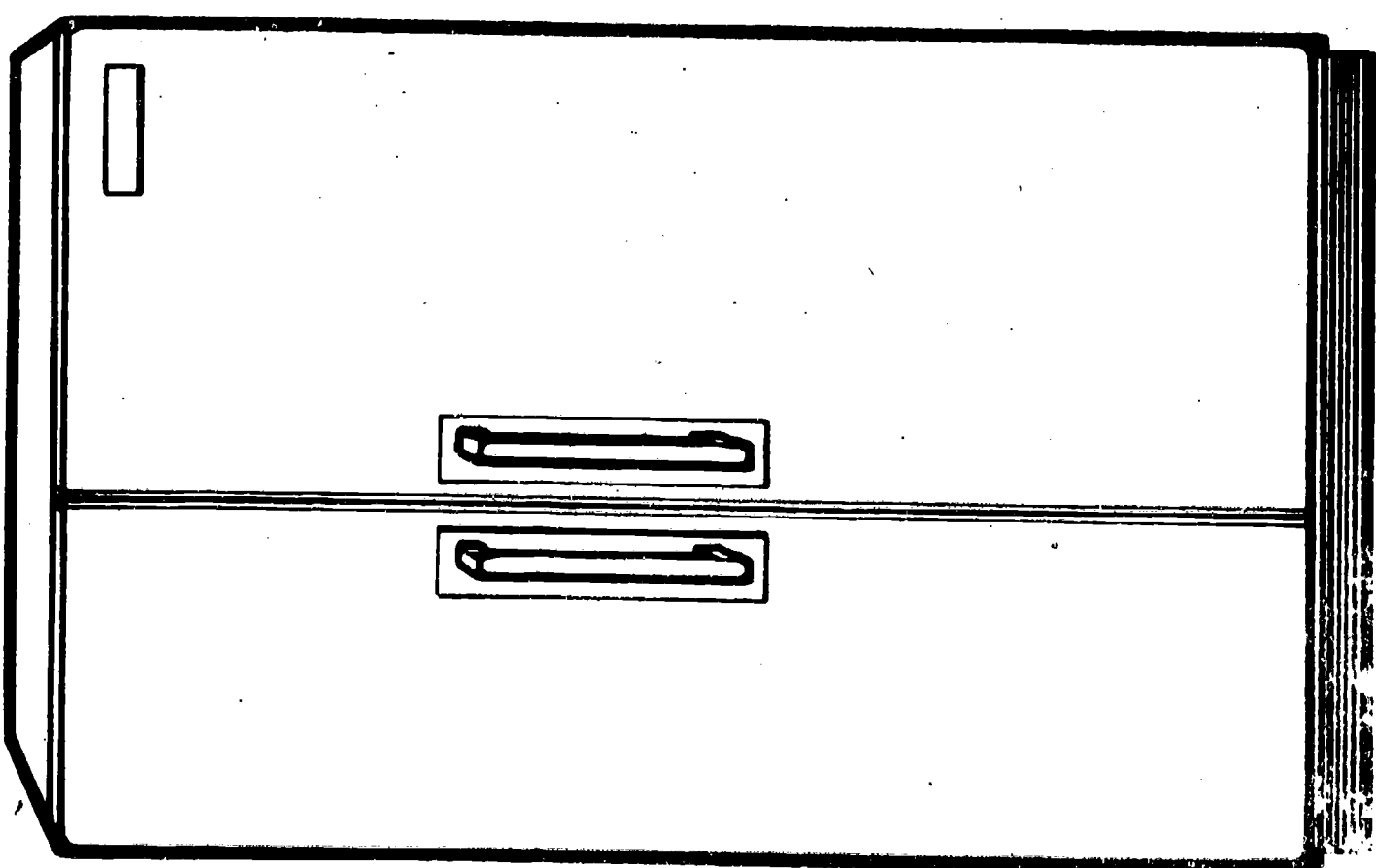
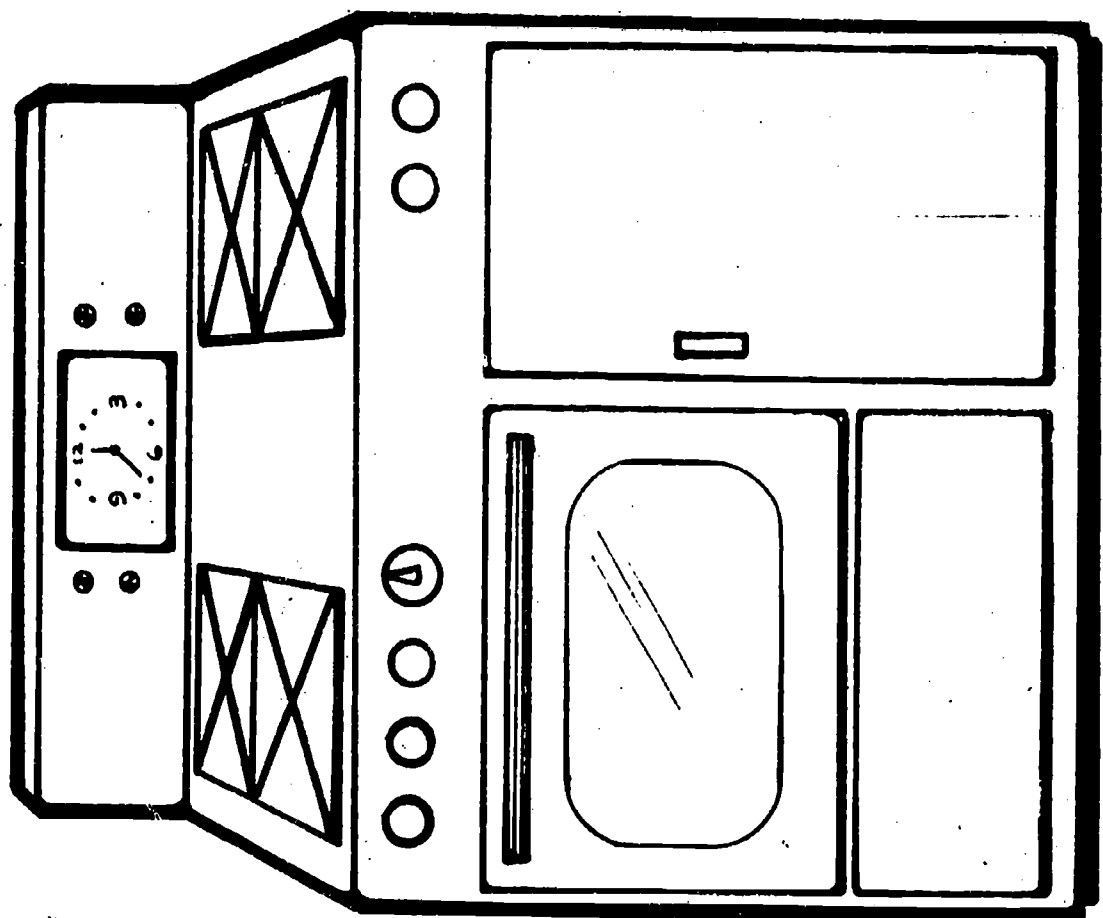

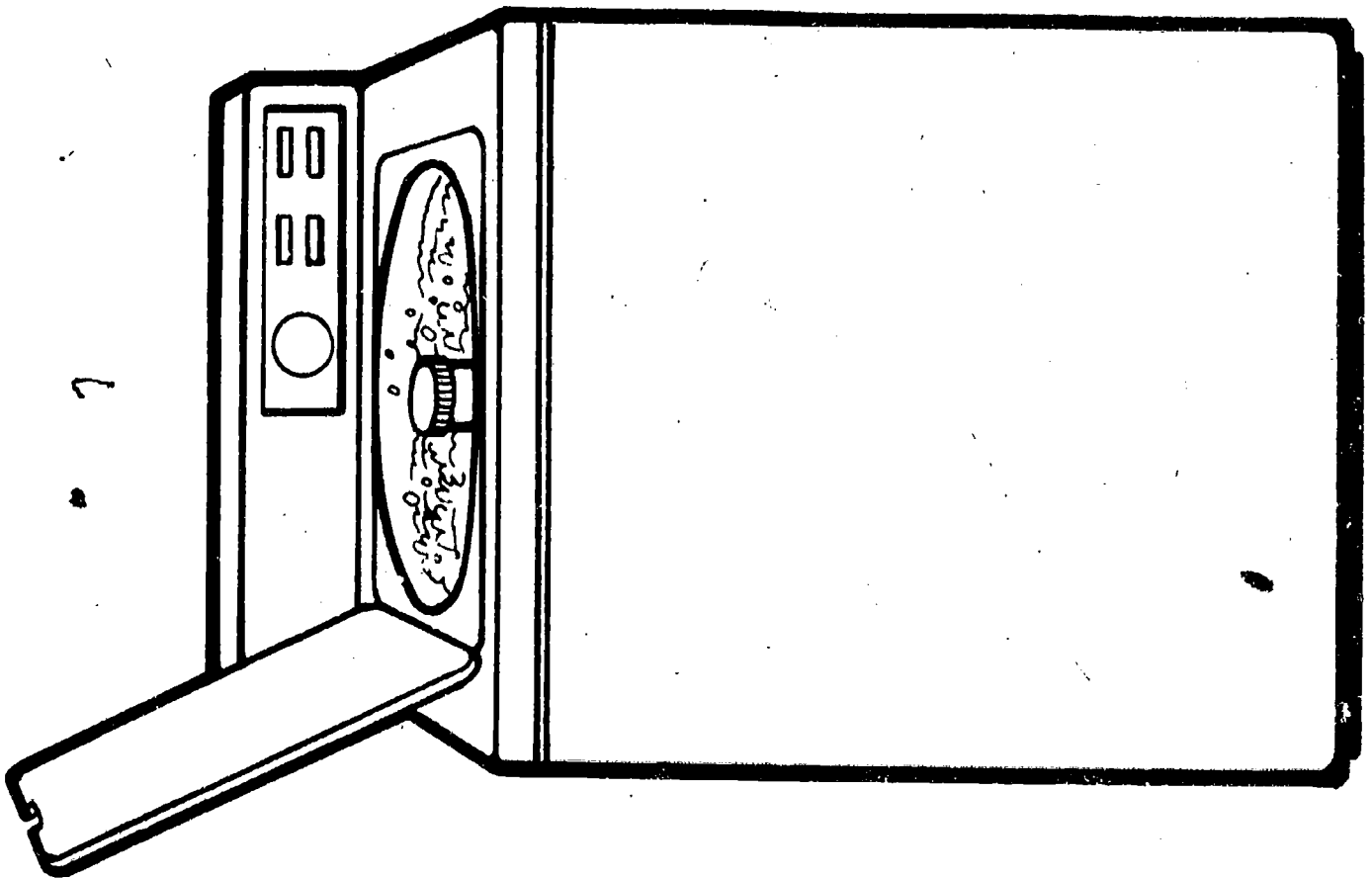
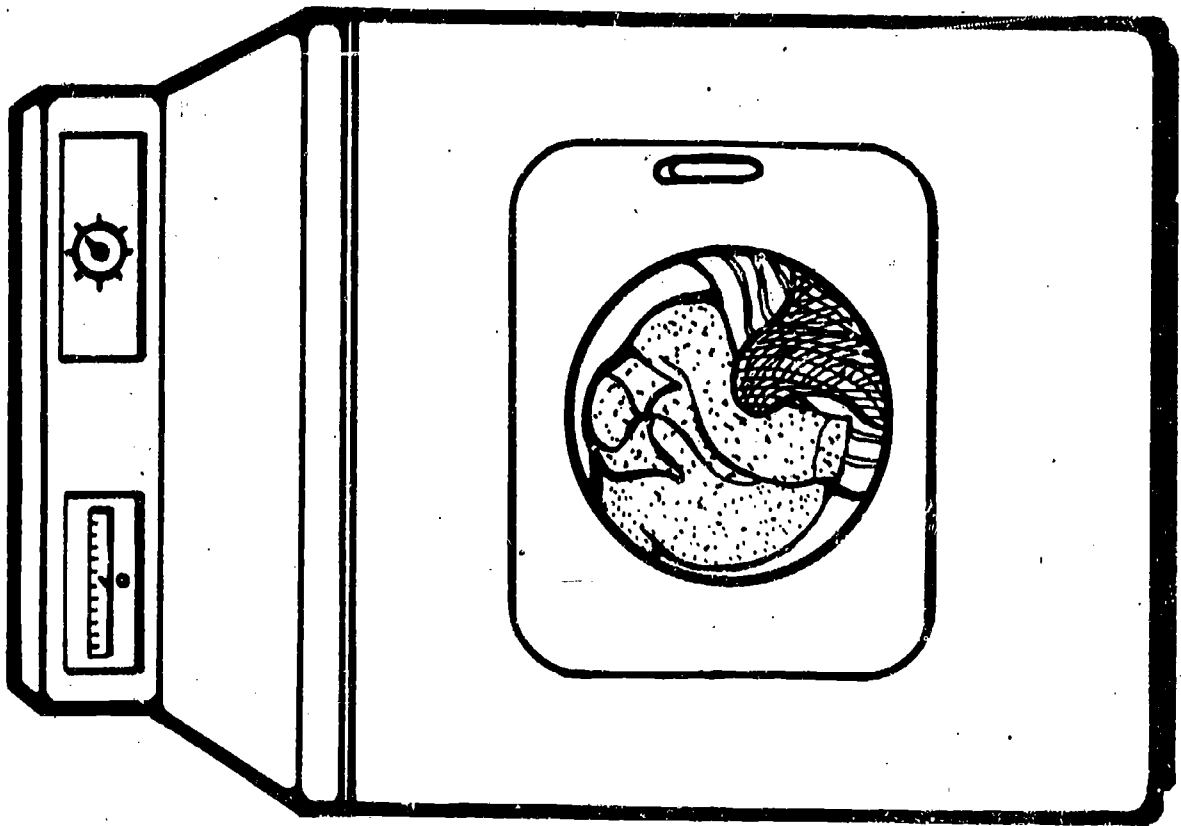

7

BEST COPY AVAILABLE

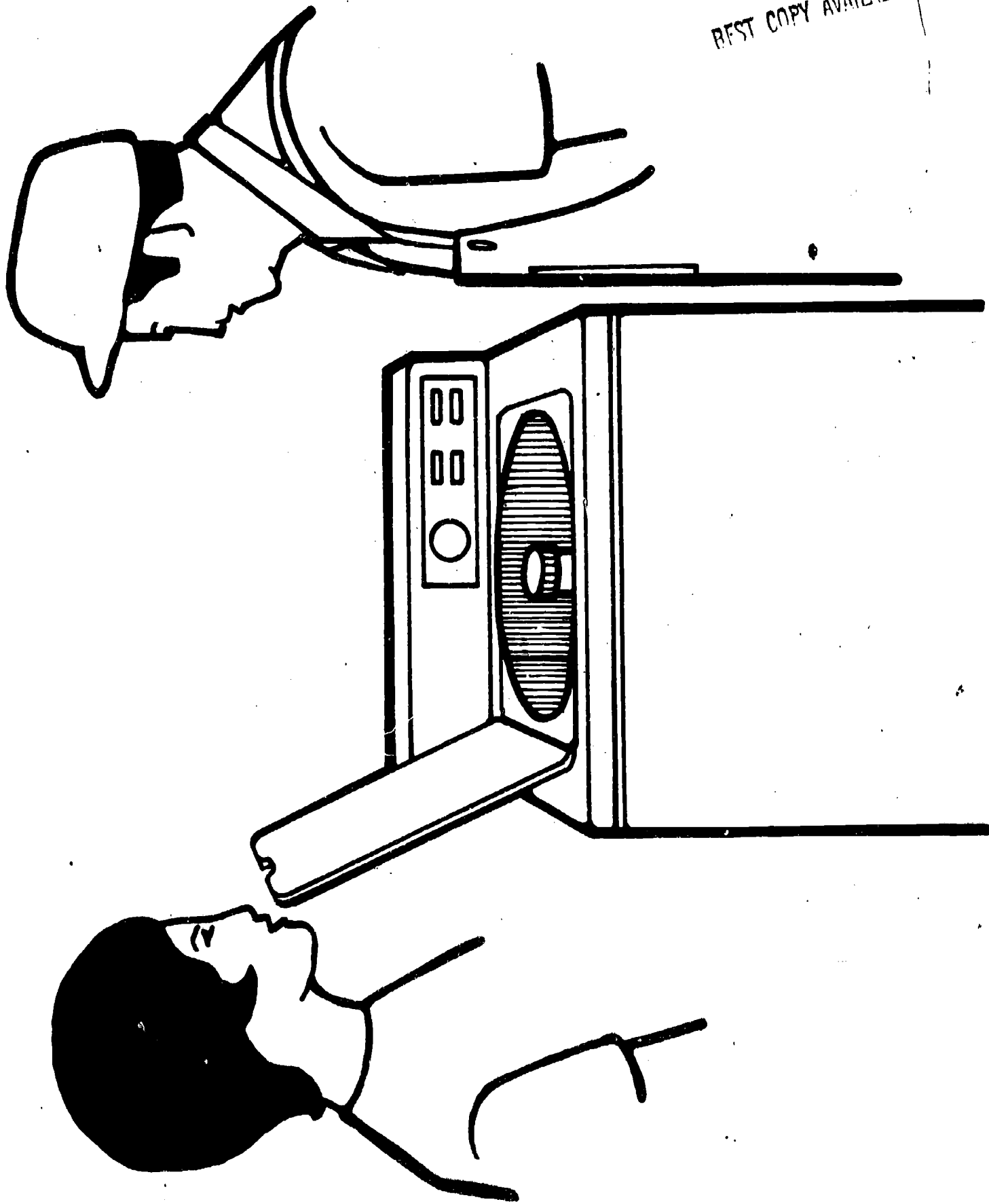

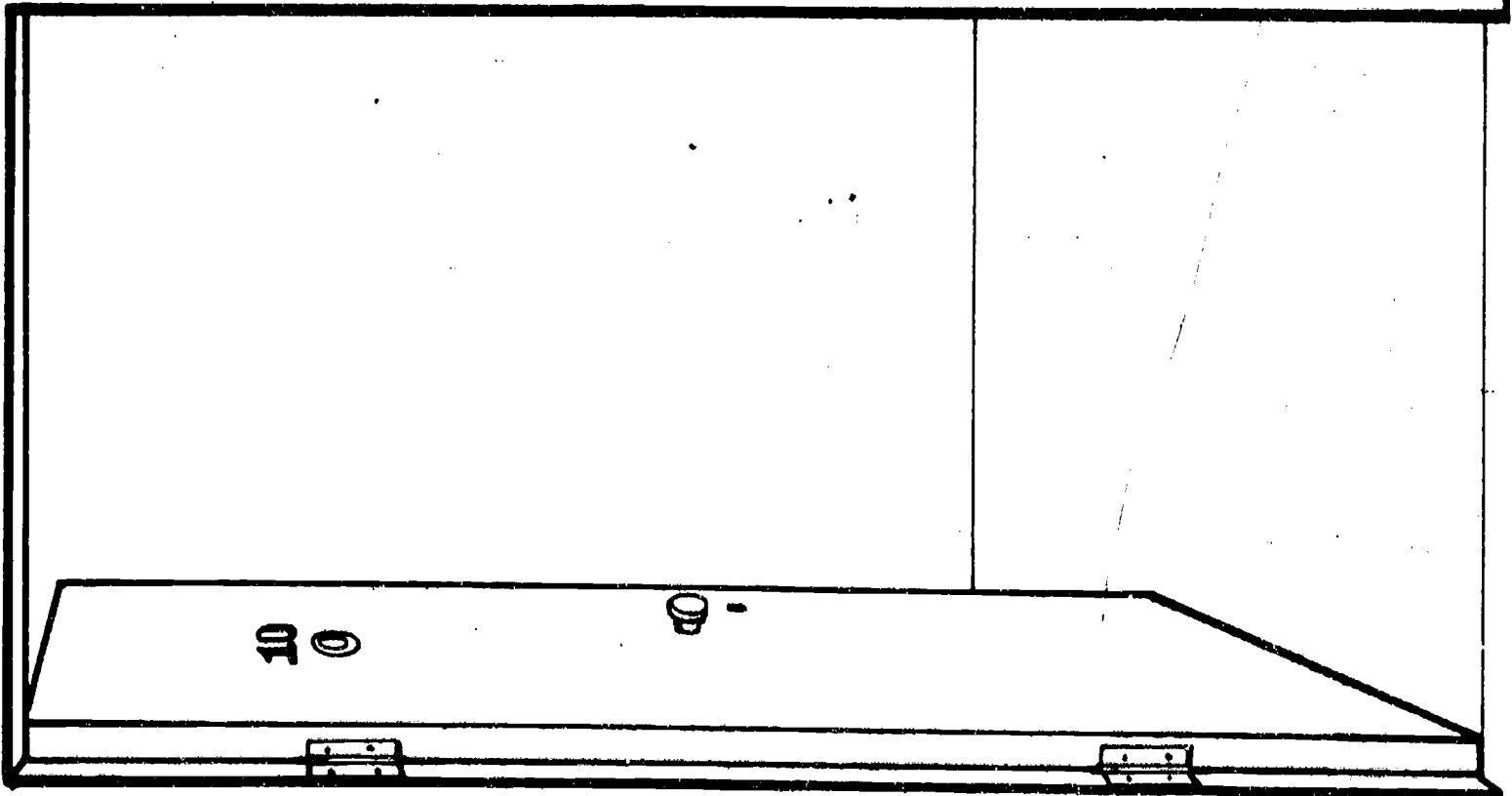
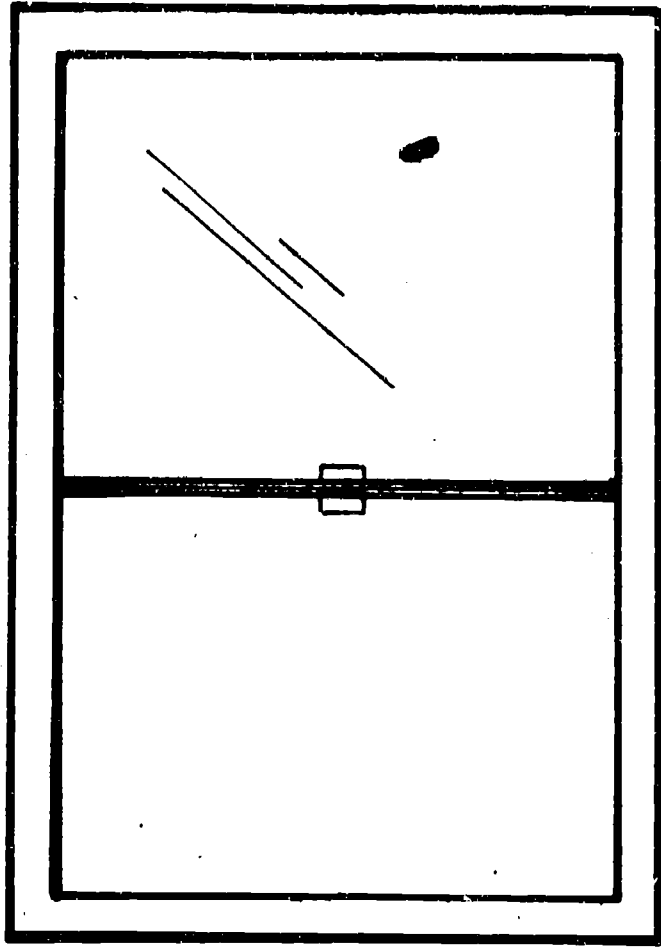

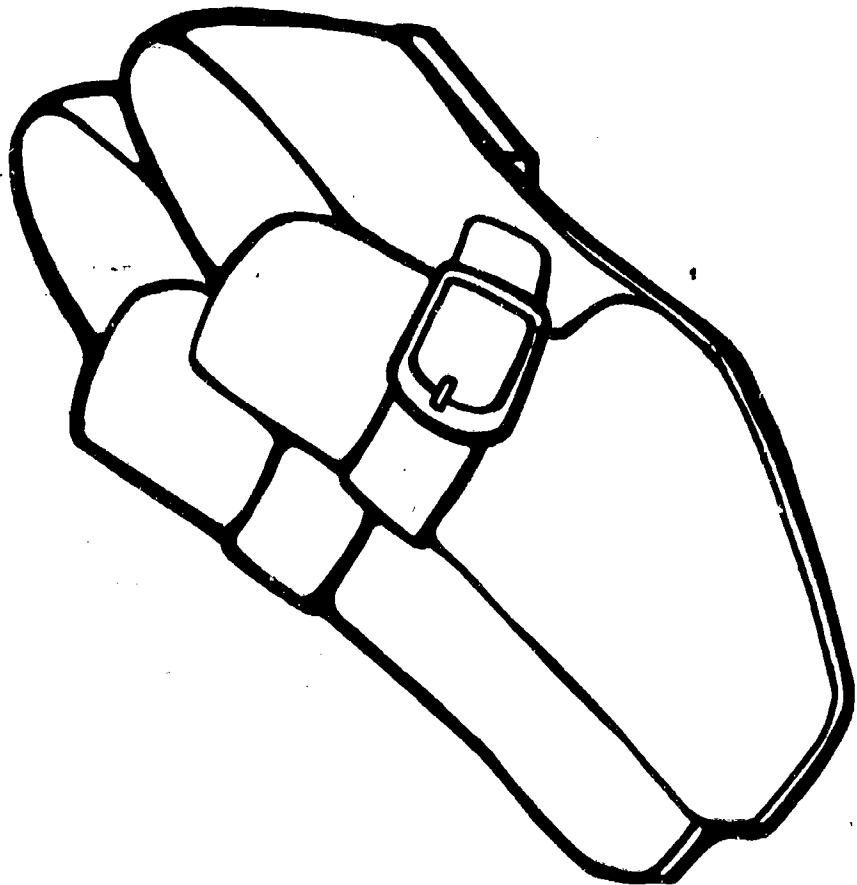
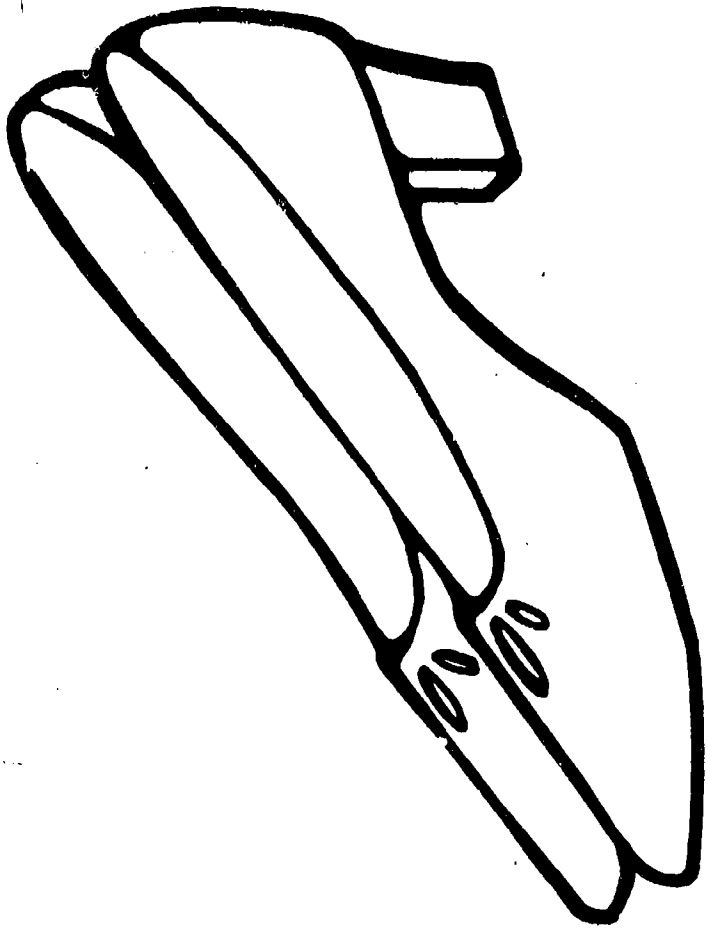

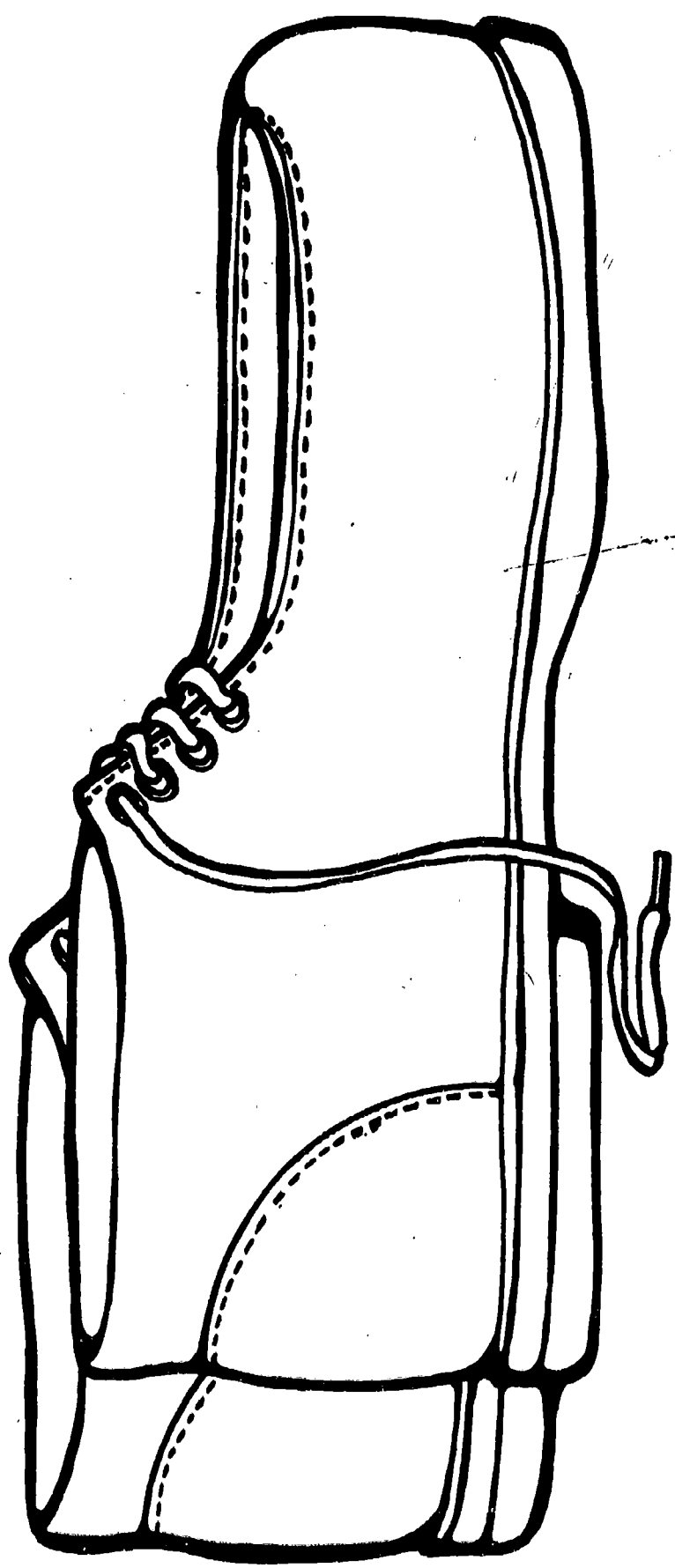



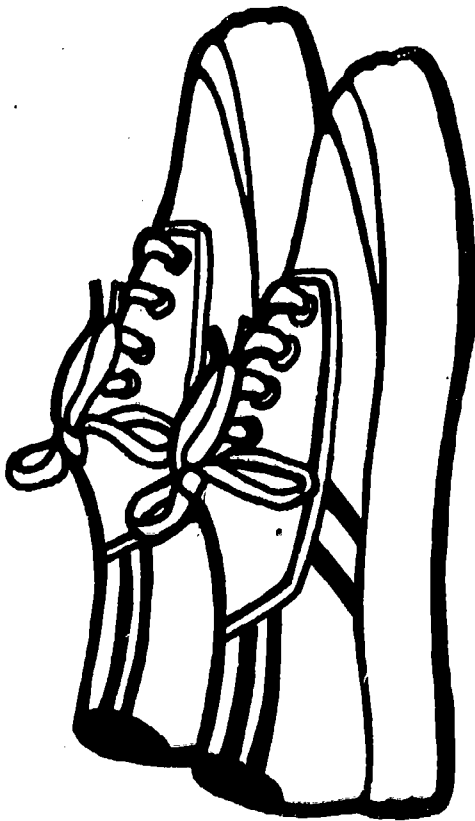
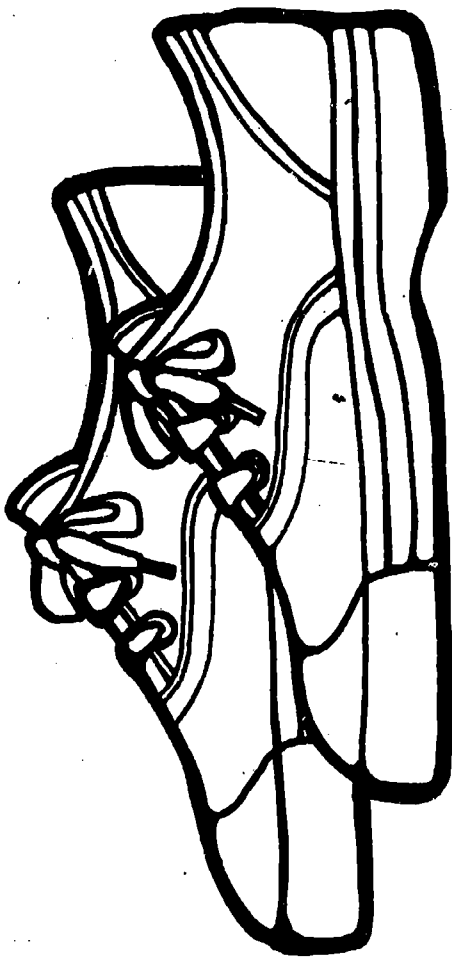

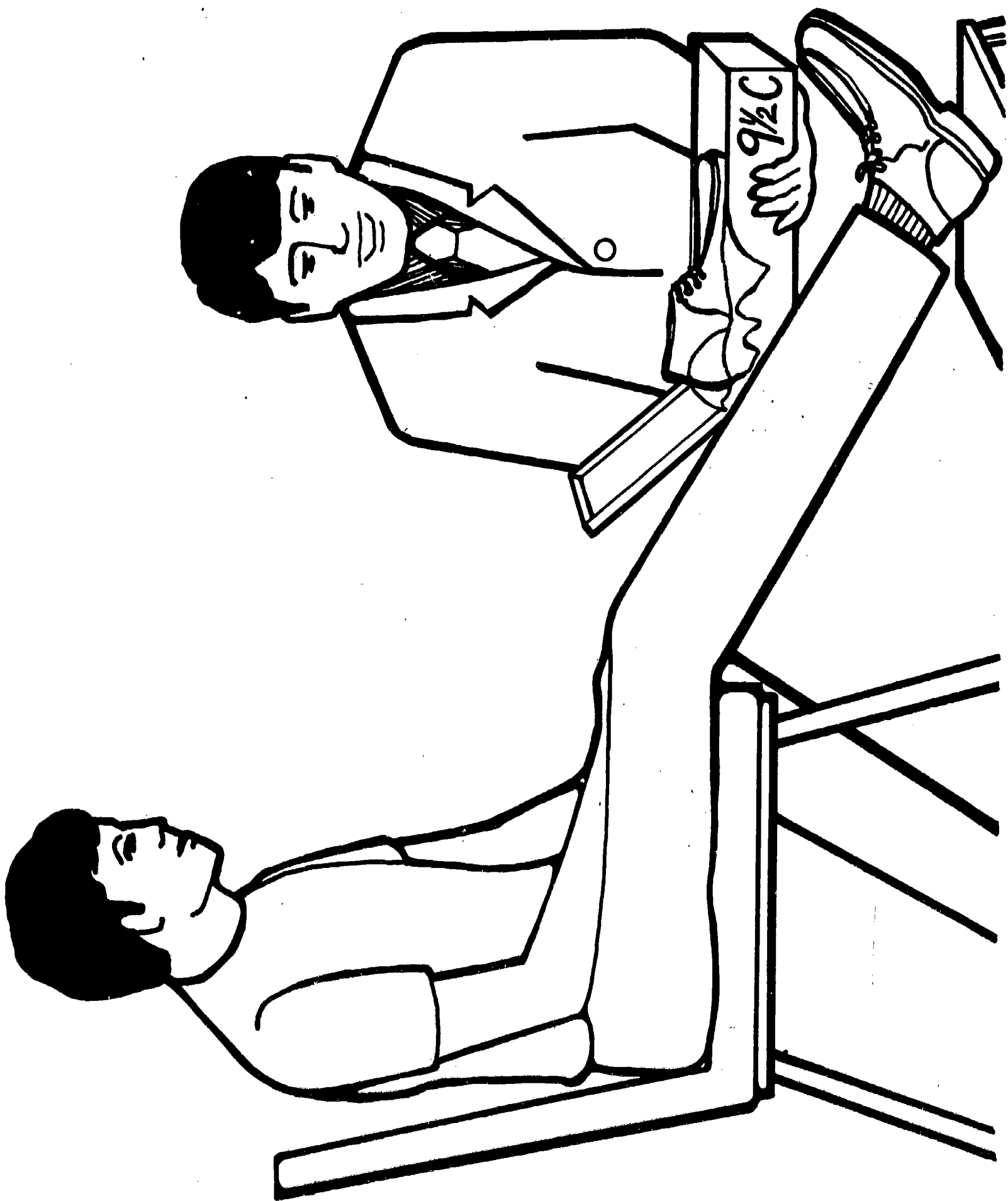

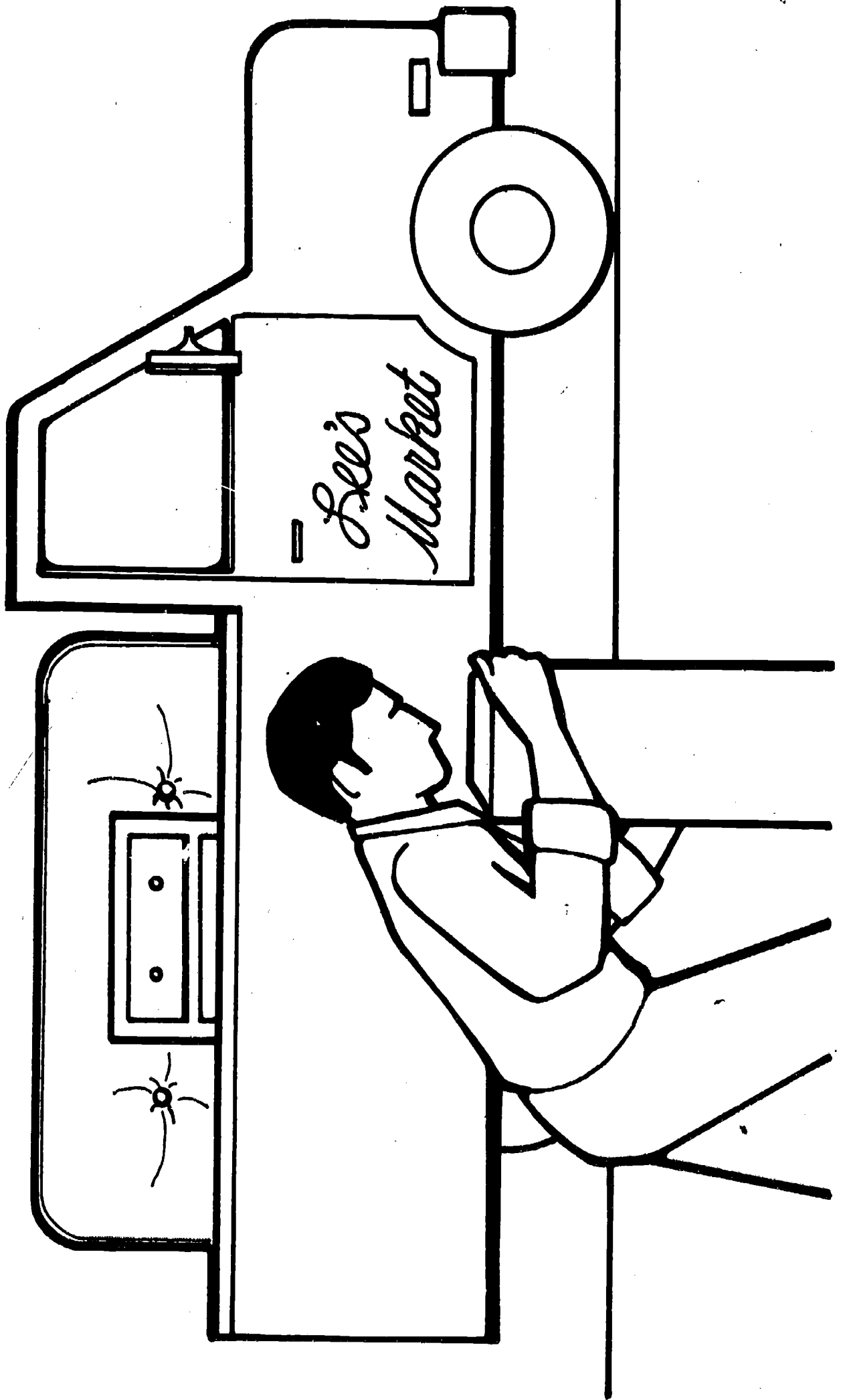

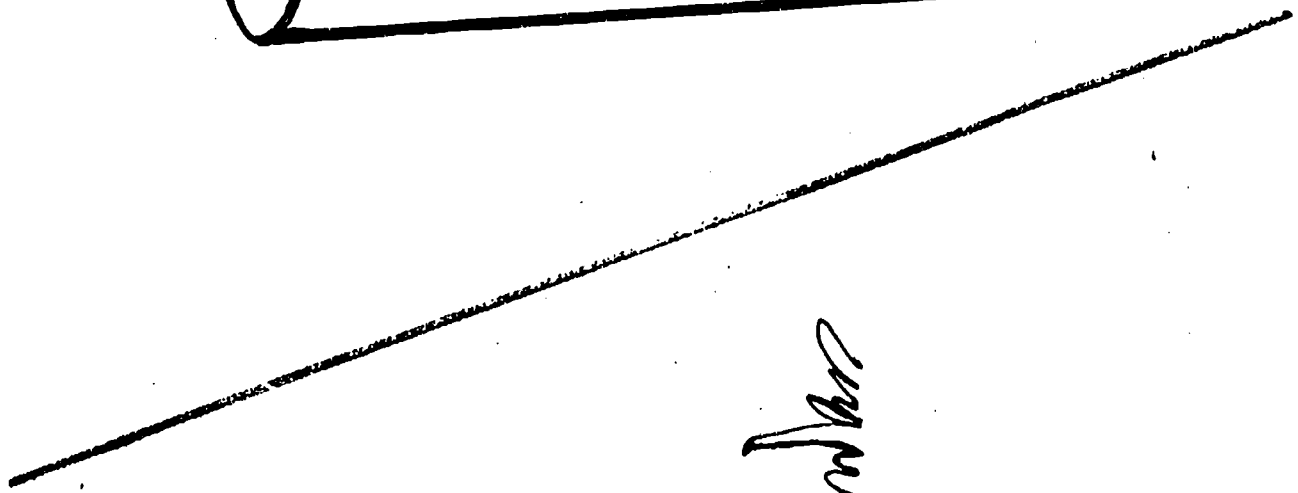
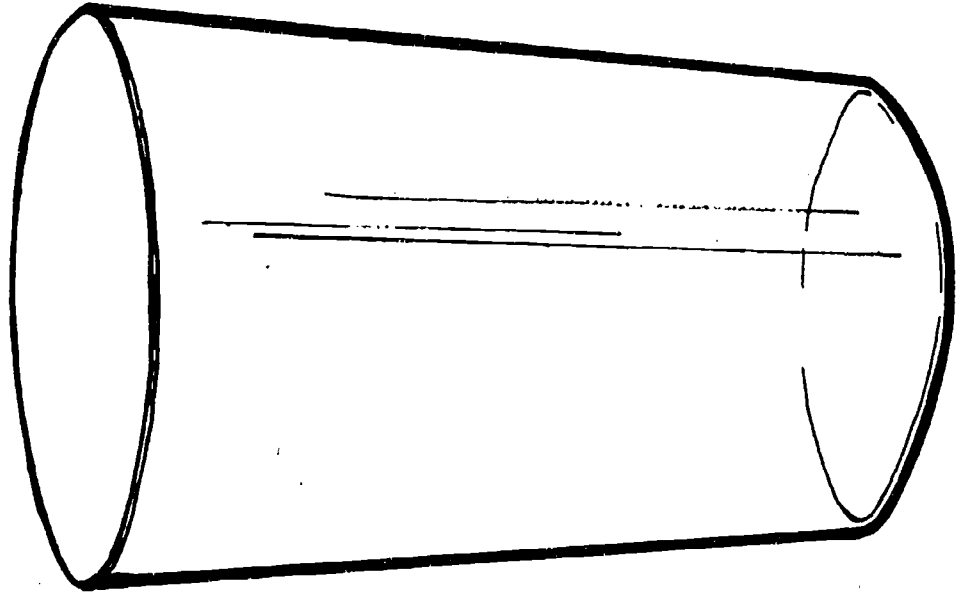

*Handwritten signature or text, possibly reading "Handwritten Signature" or similar.*

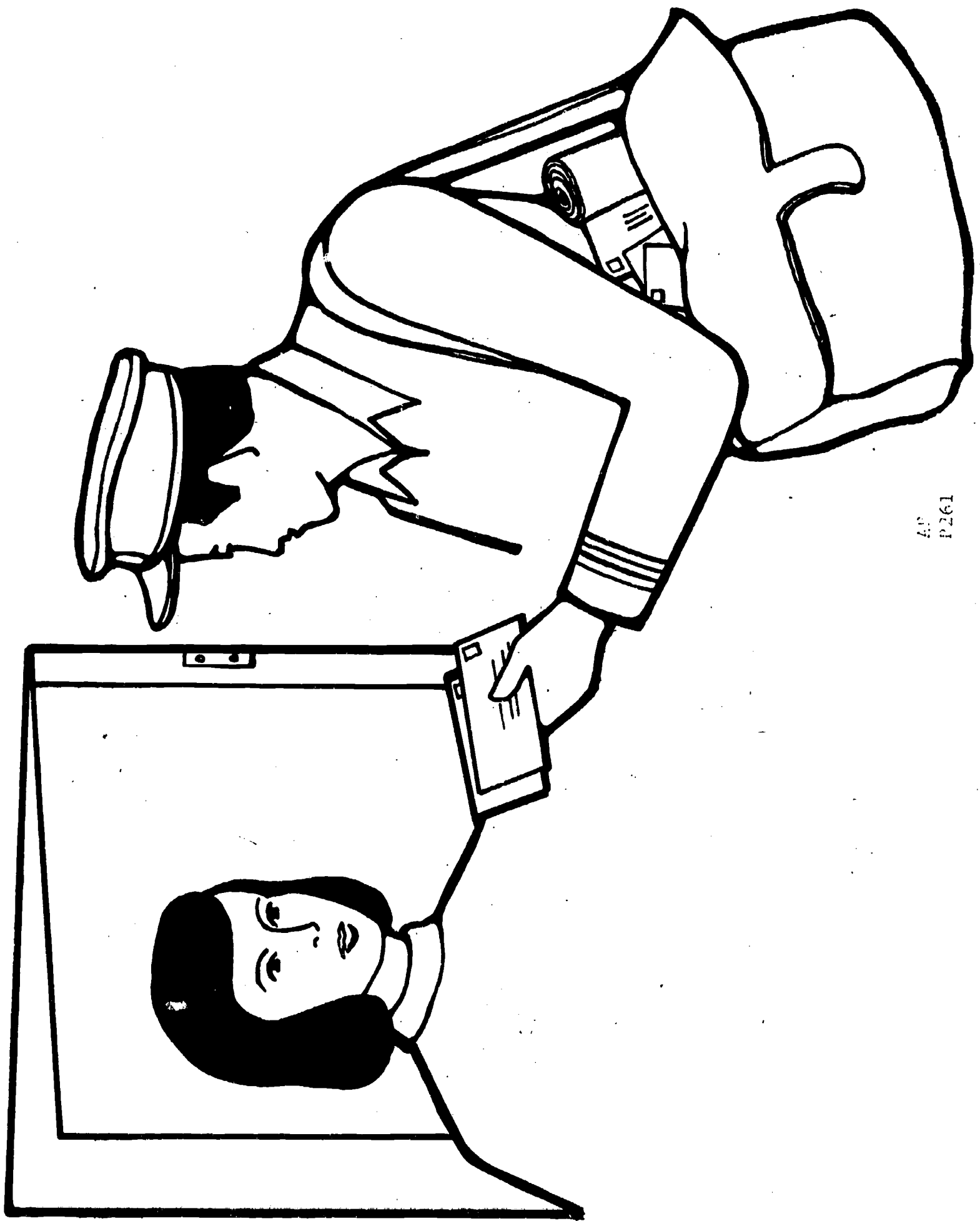

AP  
P261

BEST COPY AVAILABLE

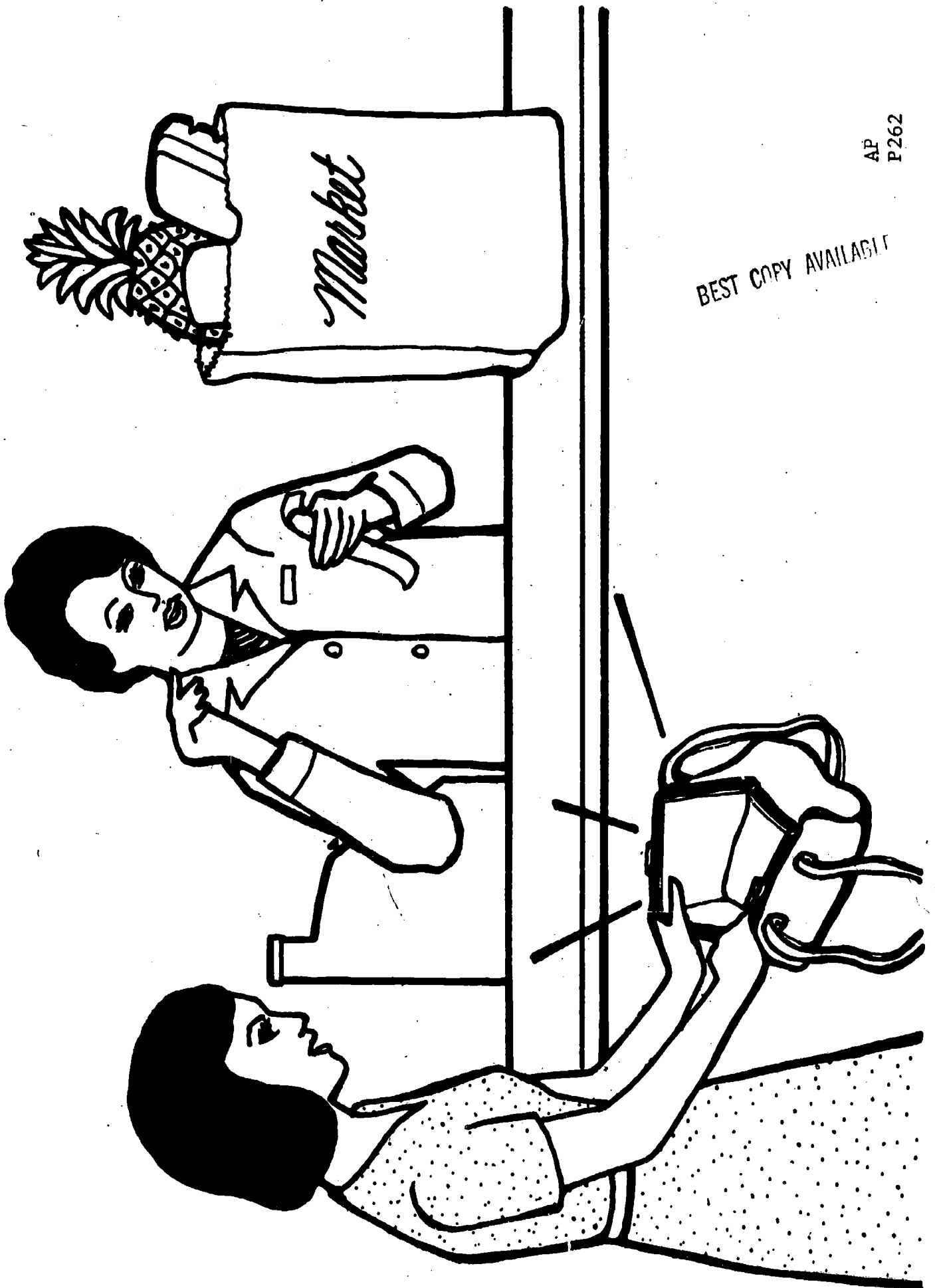

# CALIFORNIA DRIVER LICENSE

EXPIRES ON  
BIRTHDAY IN

197—

A101010

- Maria Gomez
- 123 Oak Street
- Los Angeles, Calif. 90000



BEST COPY AVAILABLE

x *Maria Gomez*

STATE OF CALIFORNIA  
DEPARTMENT OF MOTOR VEHICLES

INTERIM DRIVERS  
LICENSE (TEMPORARY)

VALID FOR 60 DAYS FROM  
JULY 10, 197-

A101010

Maria Gomez

123 Oak Street

Los Angeles, Calif. 90000

x Maria Gomez

CU 311513





BEST COPY AVAILABLE

AP  
P265

**SOCIAL**

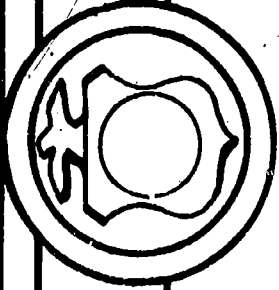

**SECURITY**

555-66-5555

MARIA GOMEZ

SIGNATURE

*Maria Gomez*

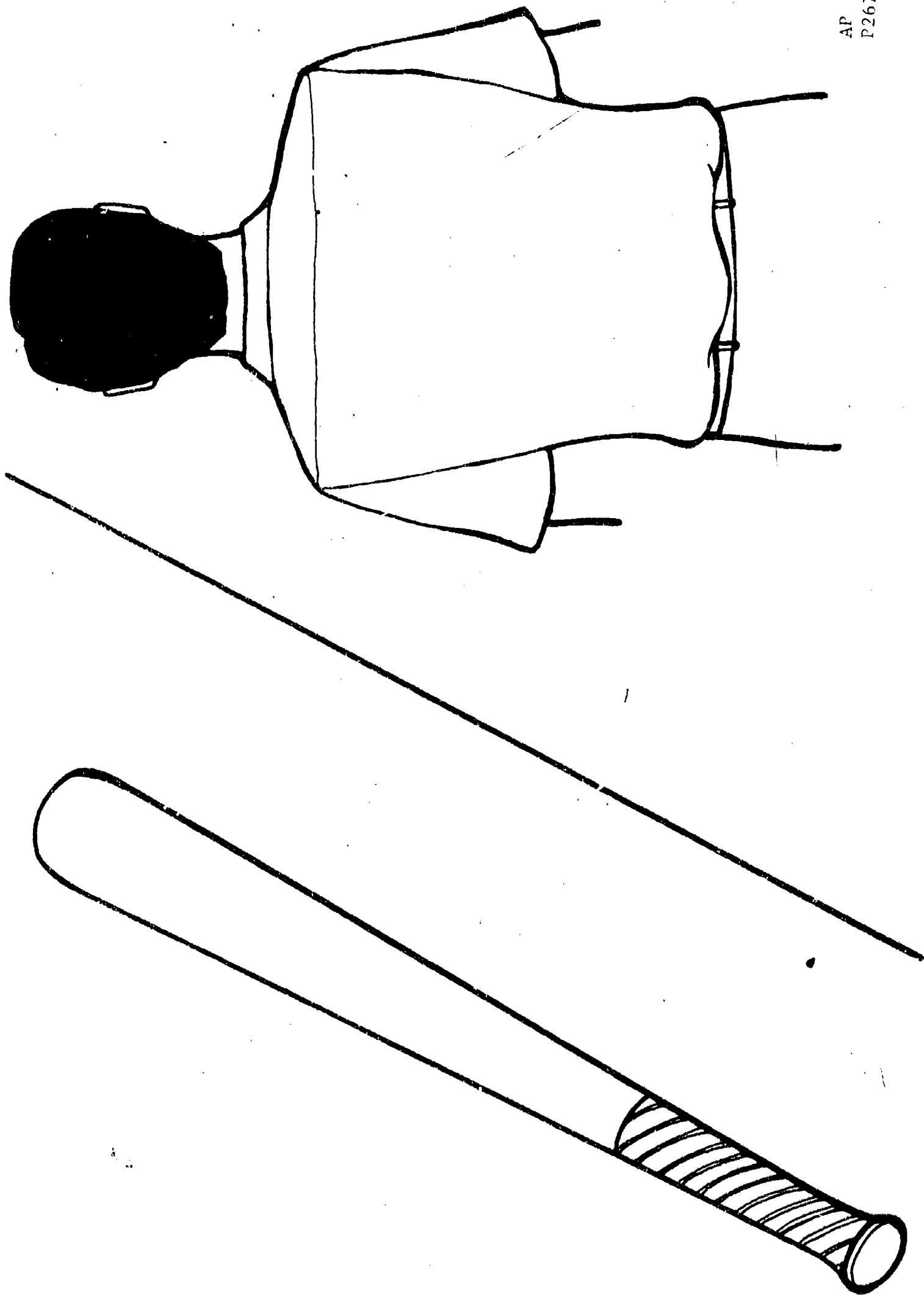

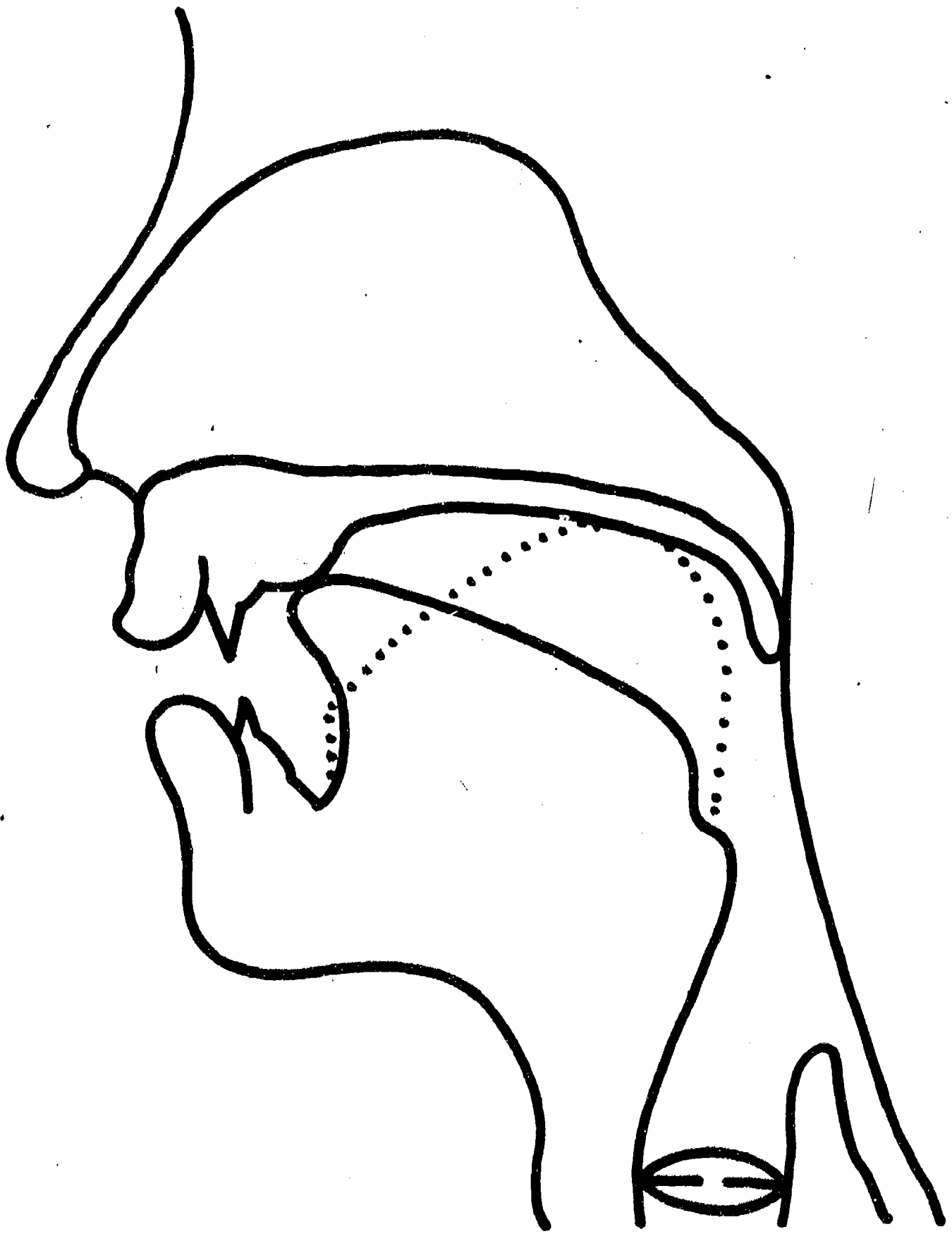

● /t/ - /k/.....

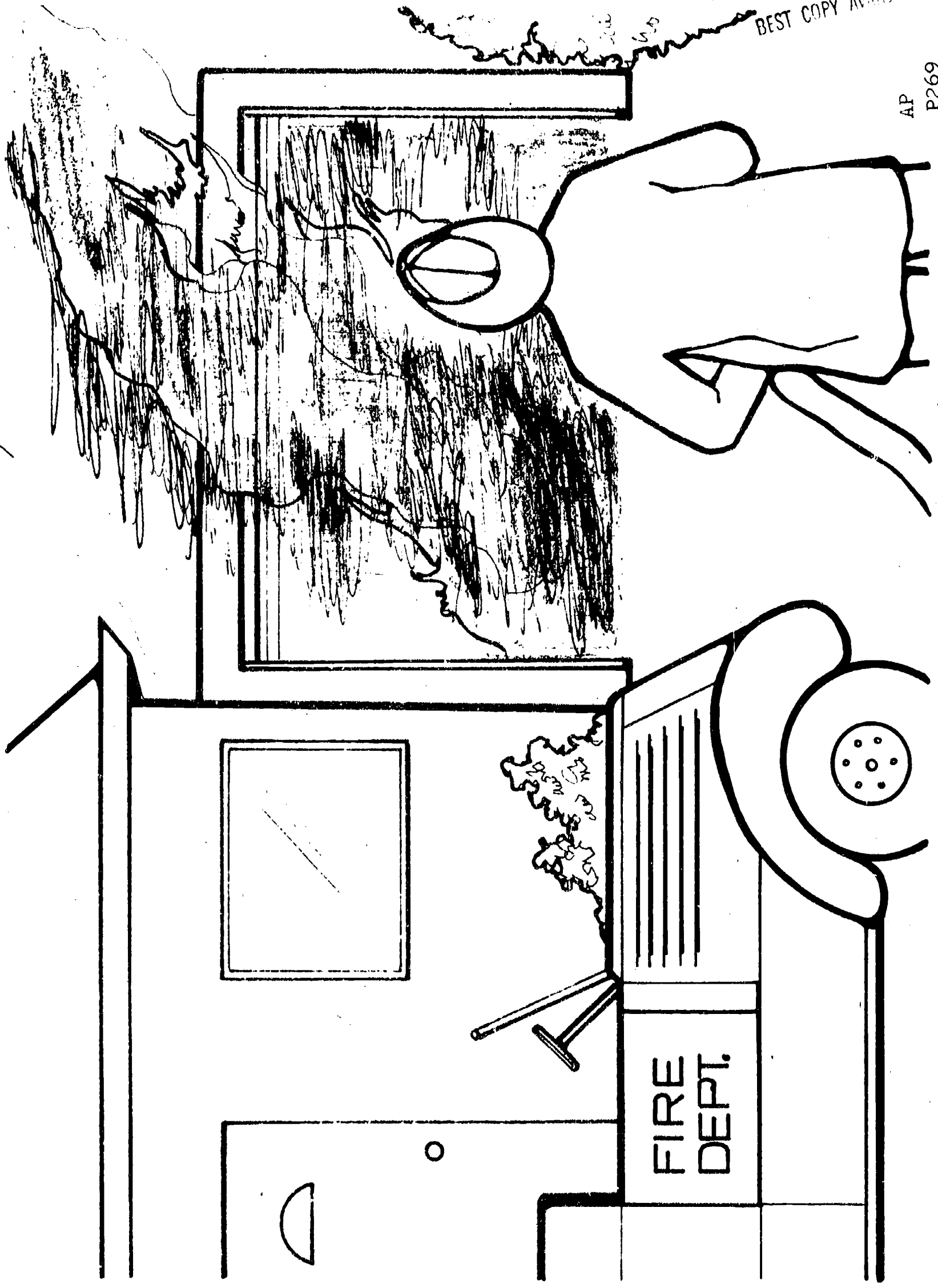

BEST COPY AVAILABLE

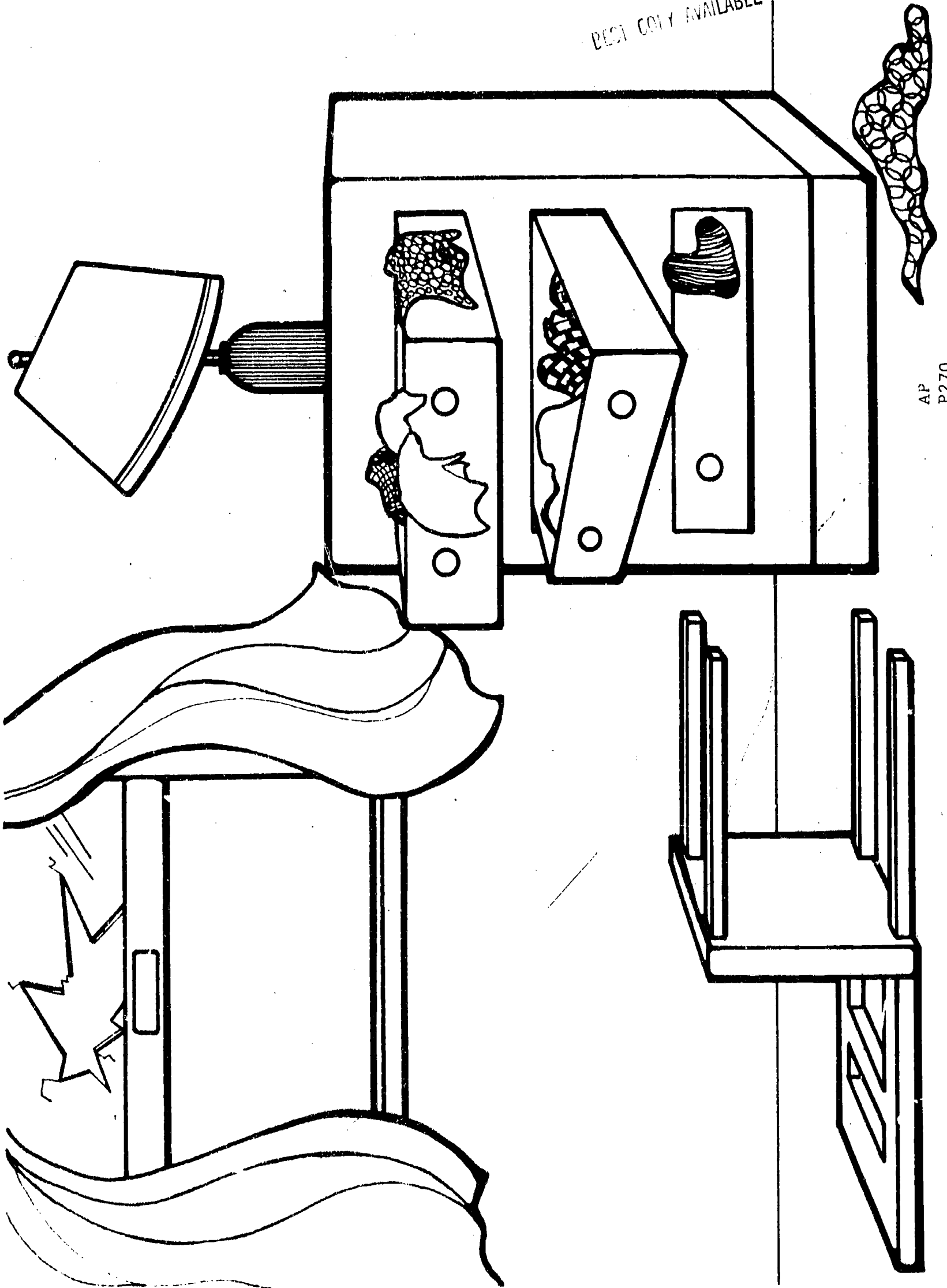

AP  
P270

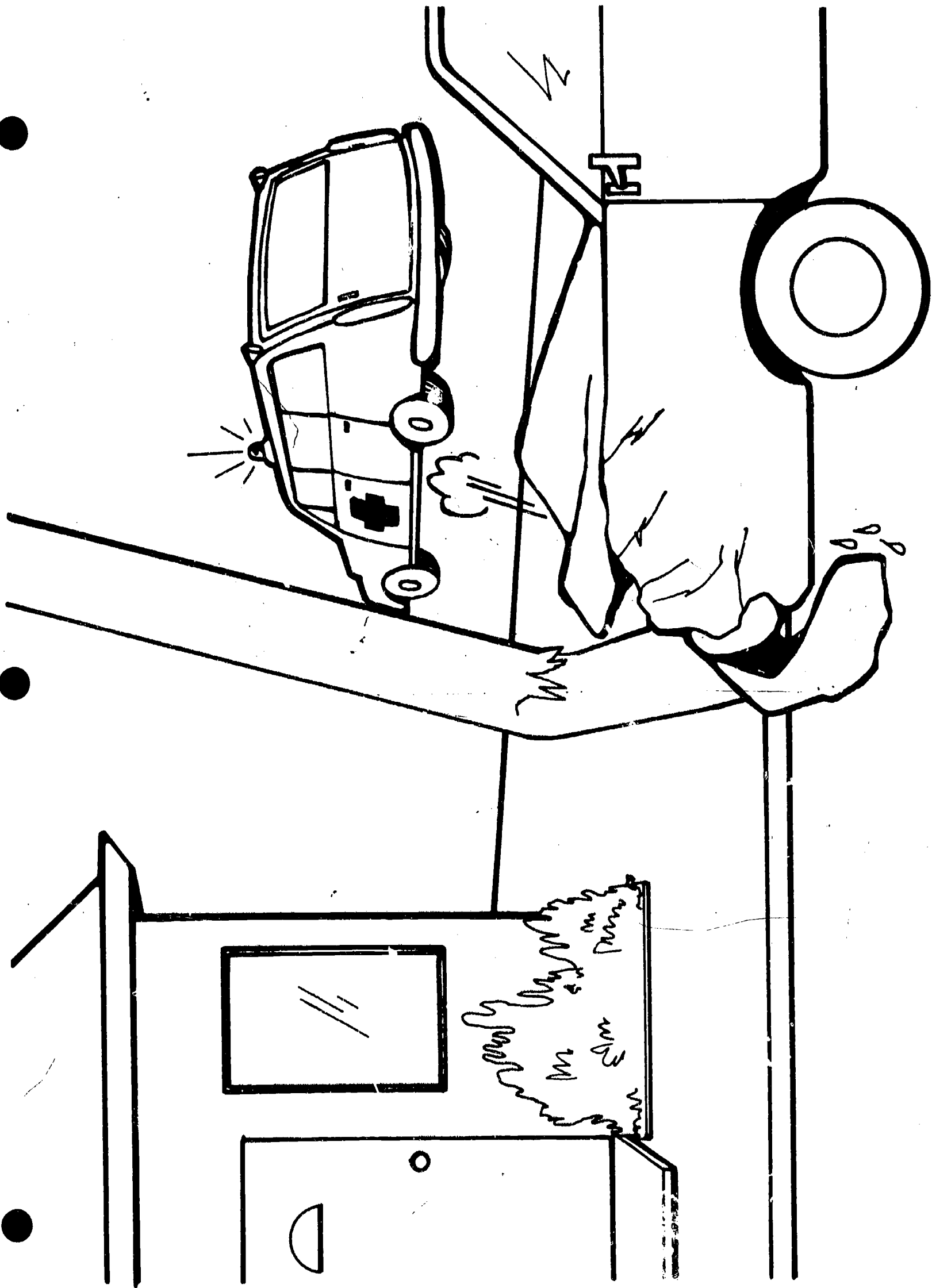

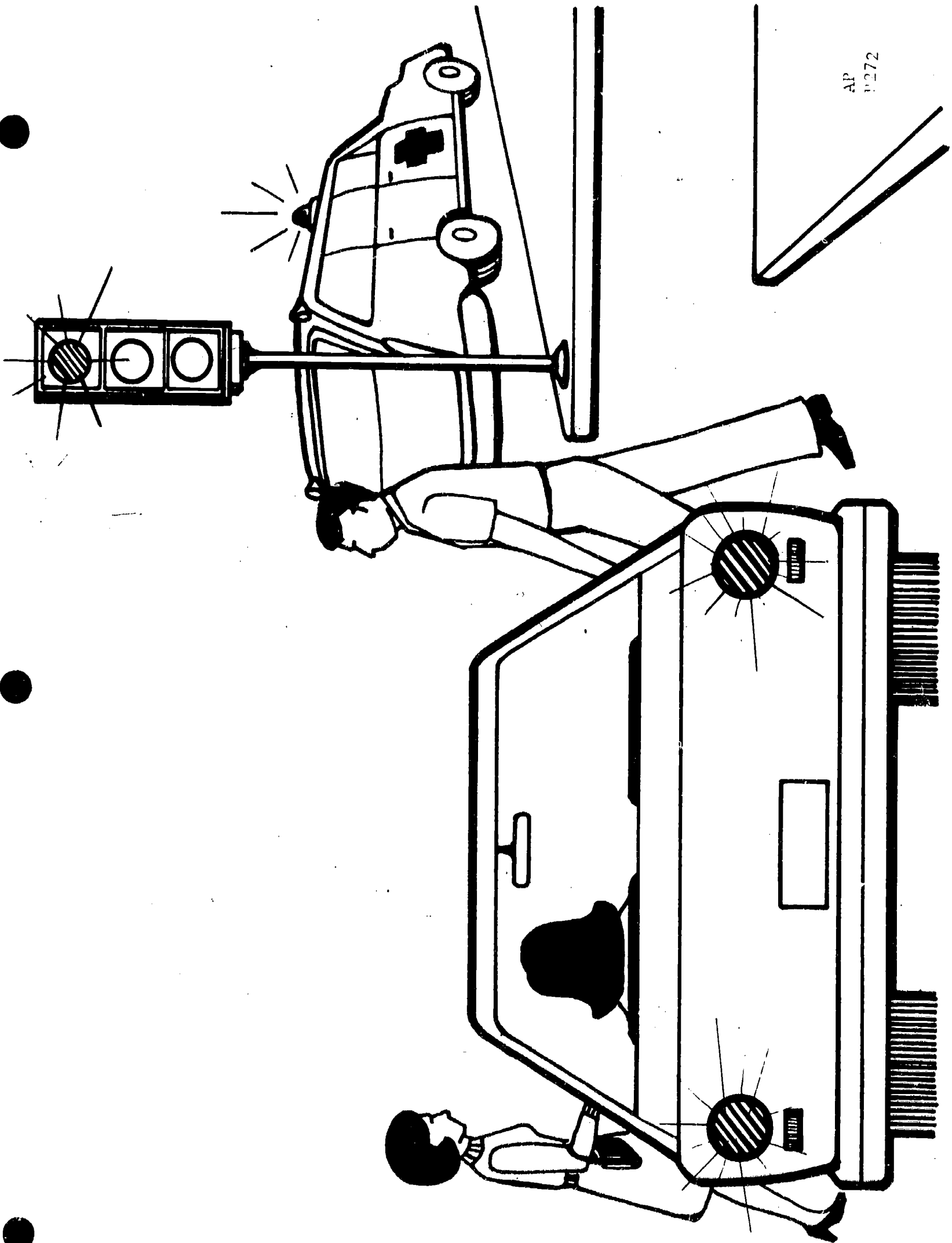



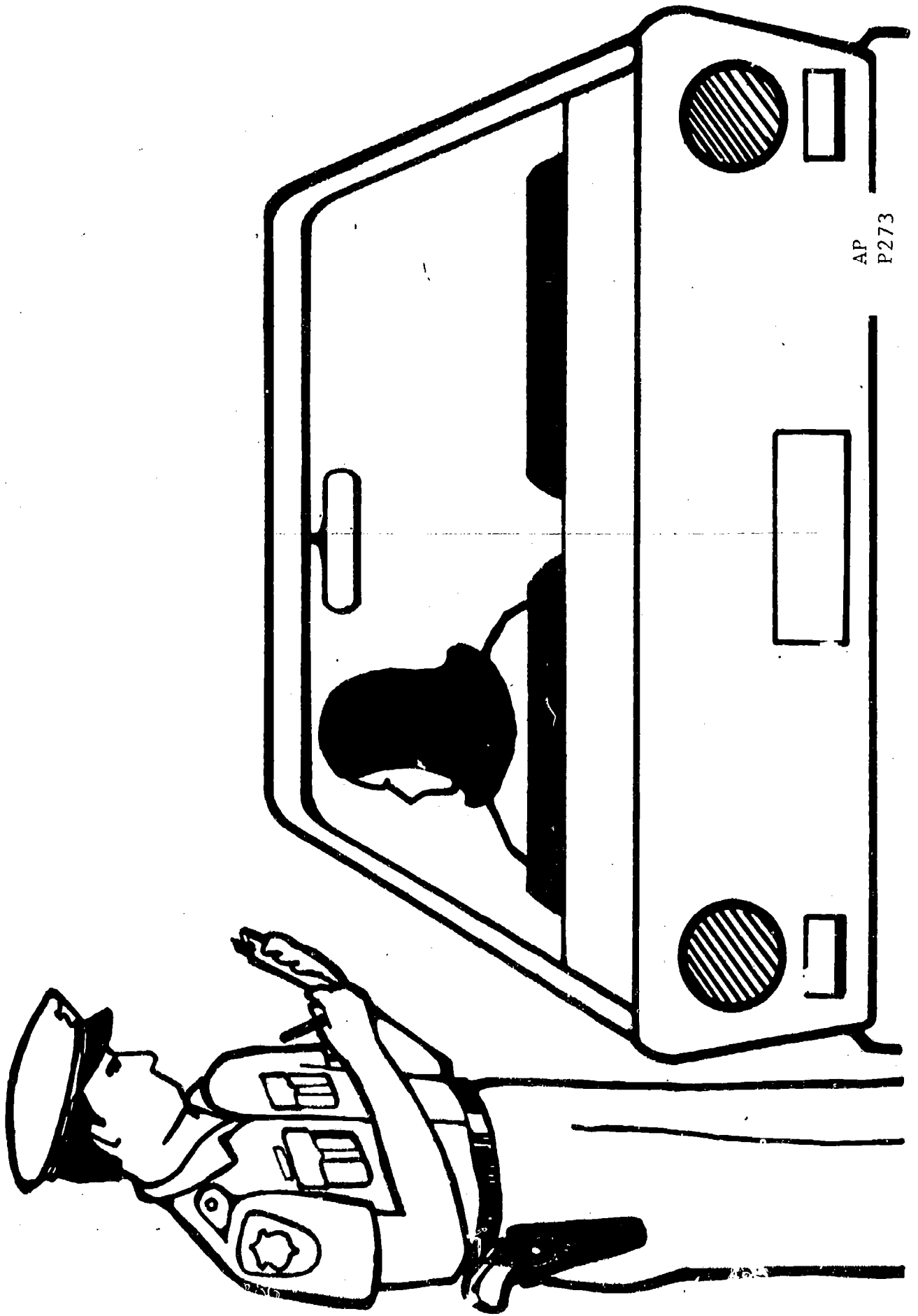

AP  
P273

AP  
P274

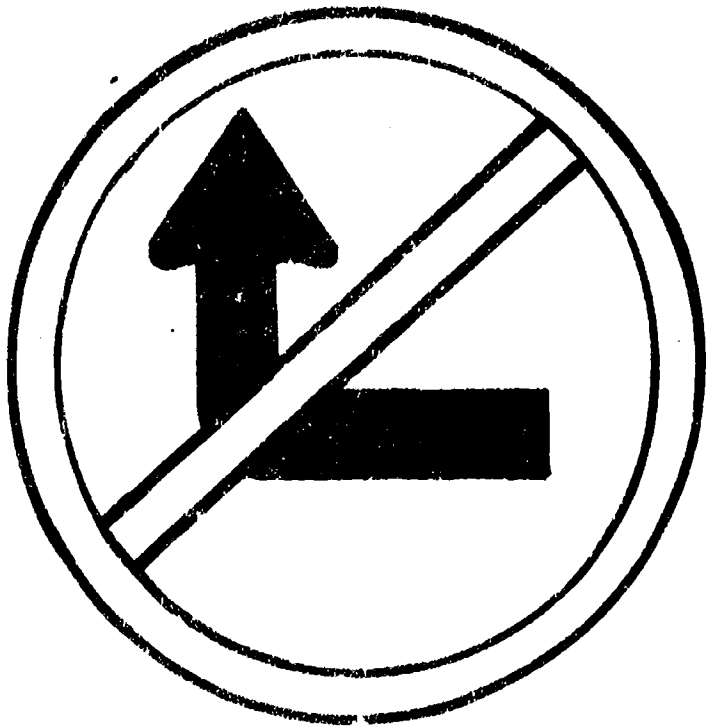
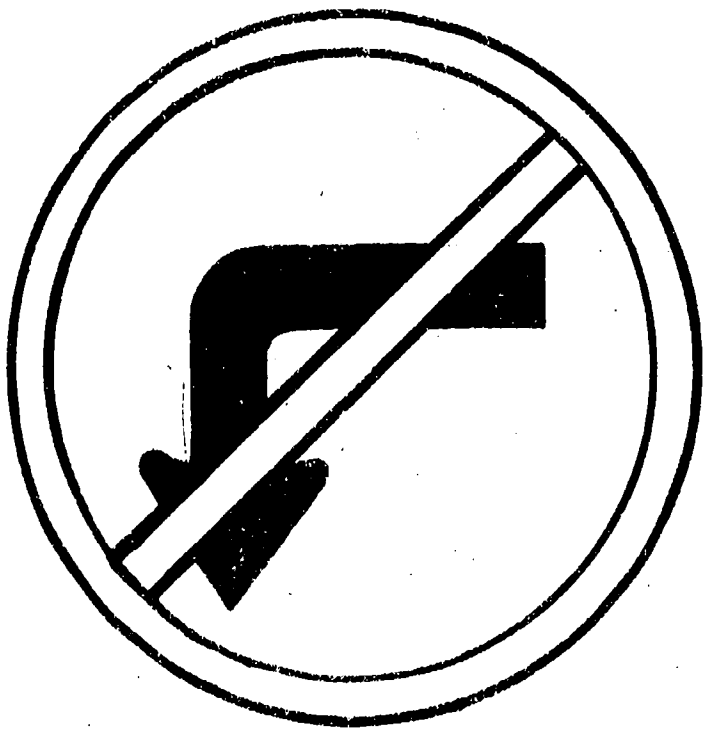

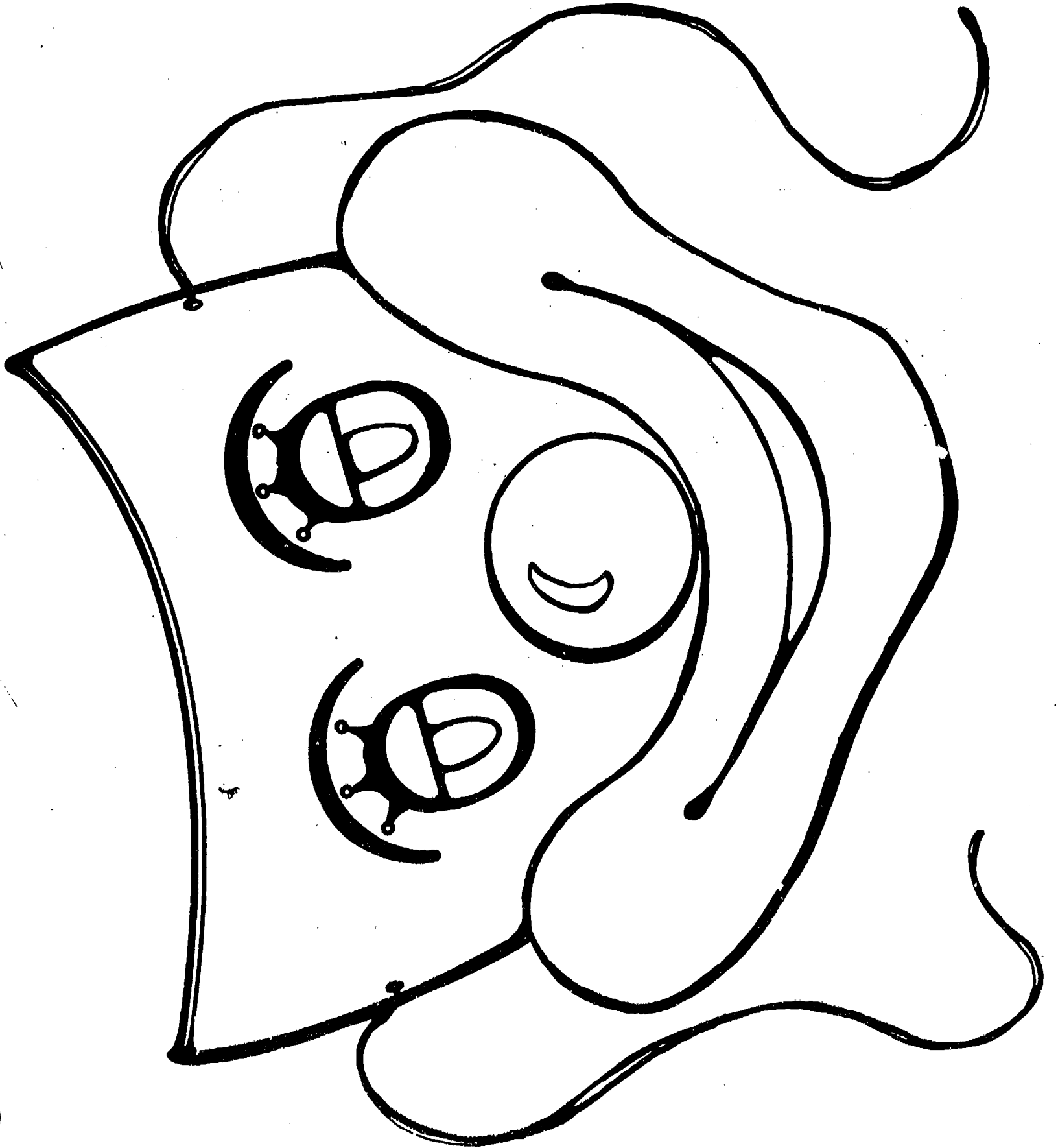

AP  
P276

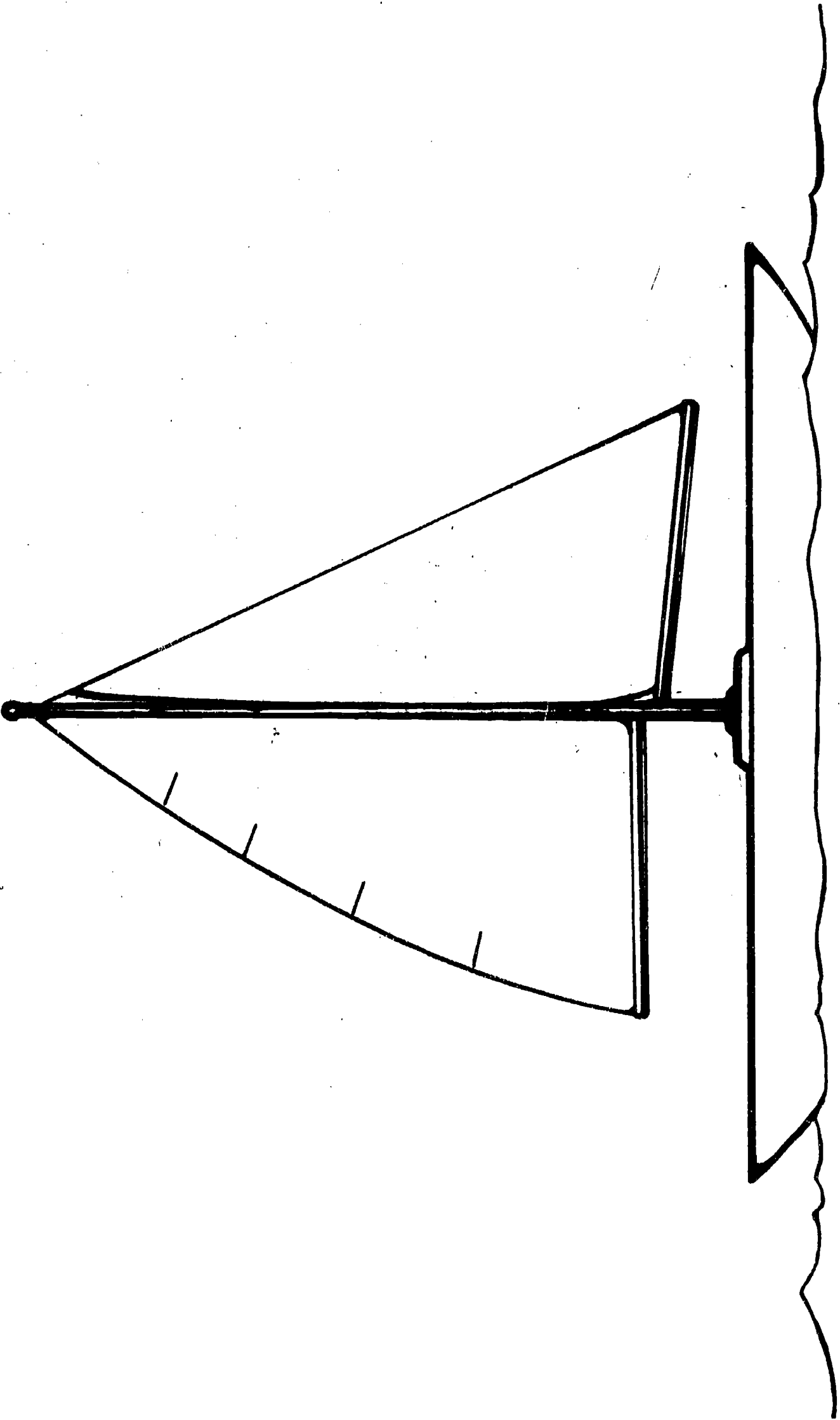

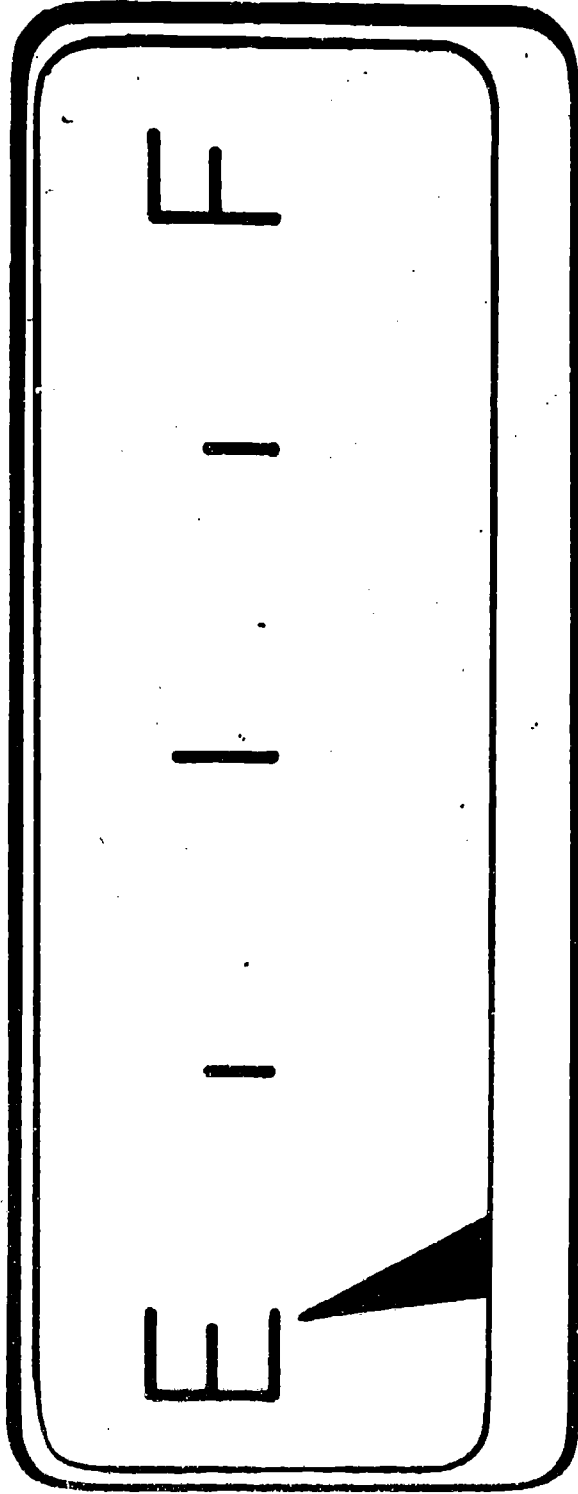

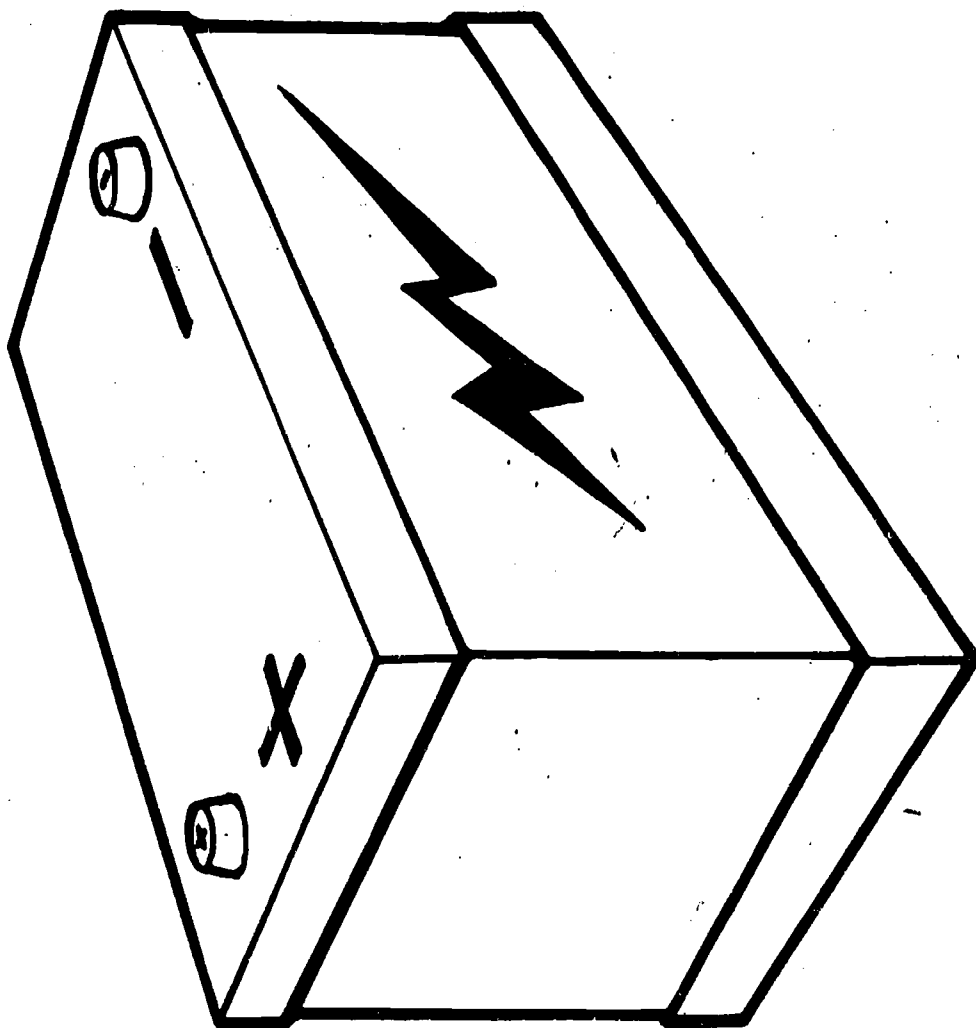

AP  
P279

BEST COPY AVAILABLE

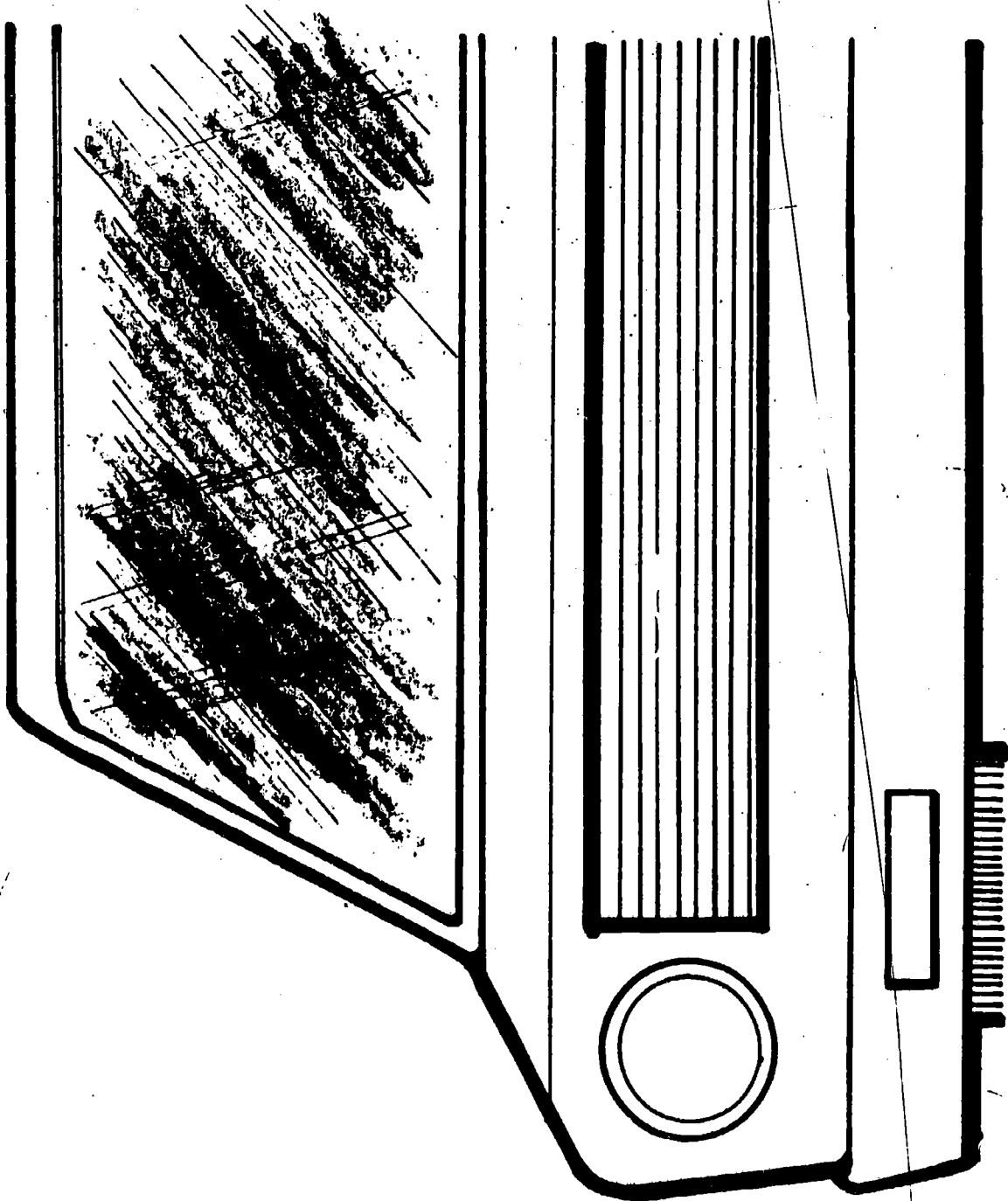

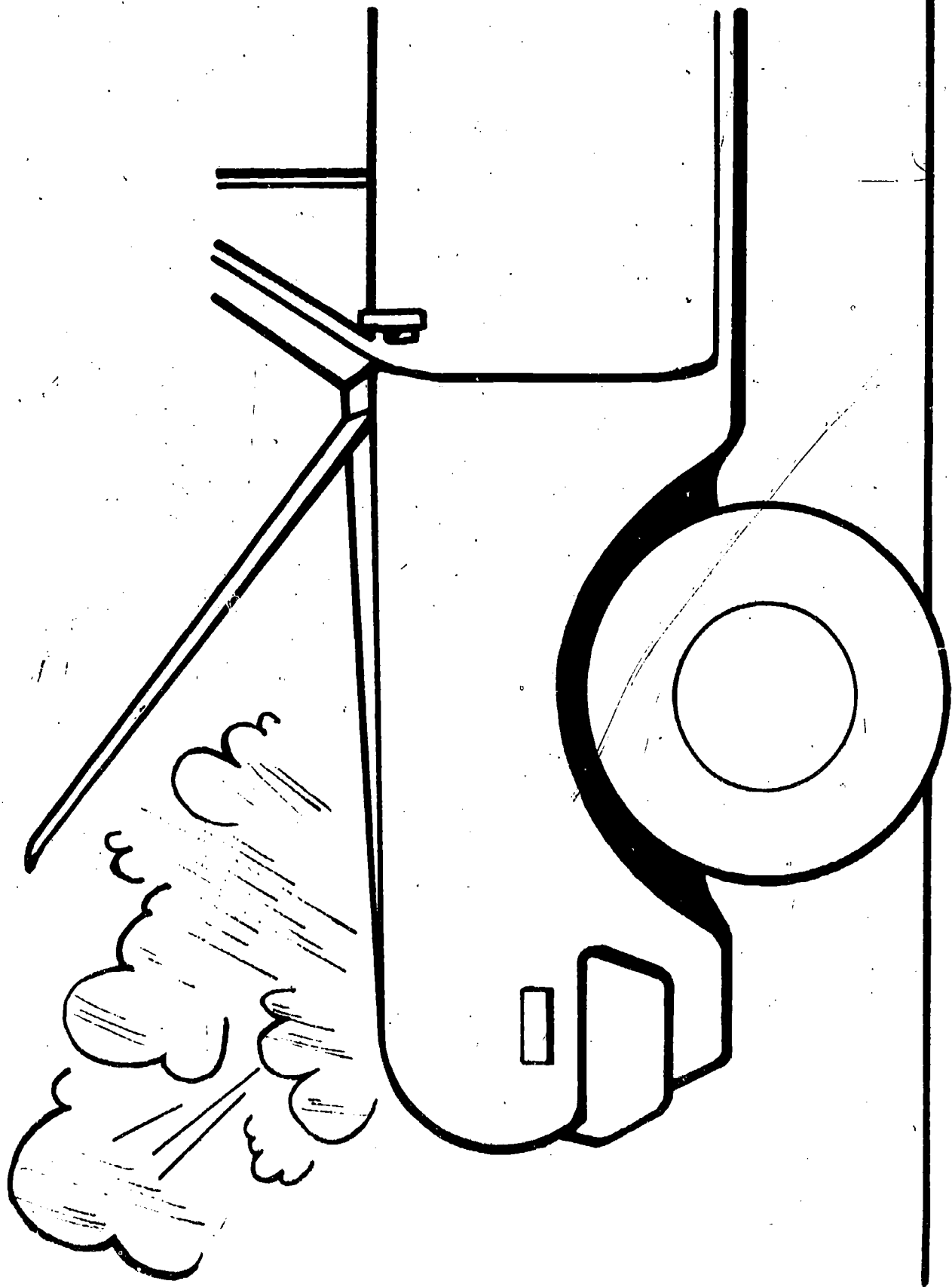

AP  
P280



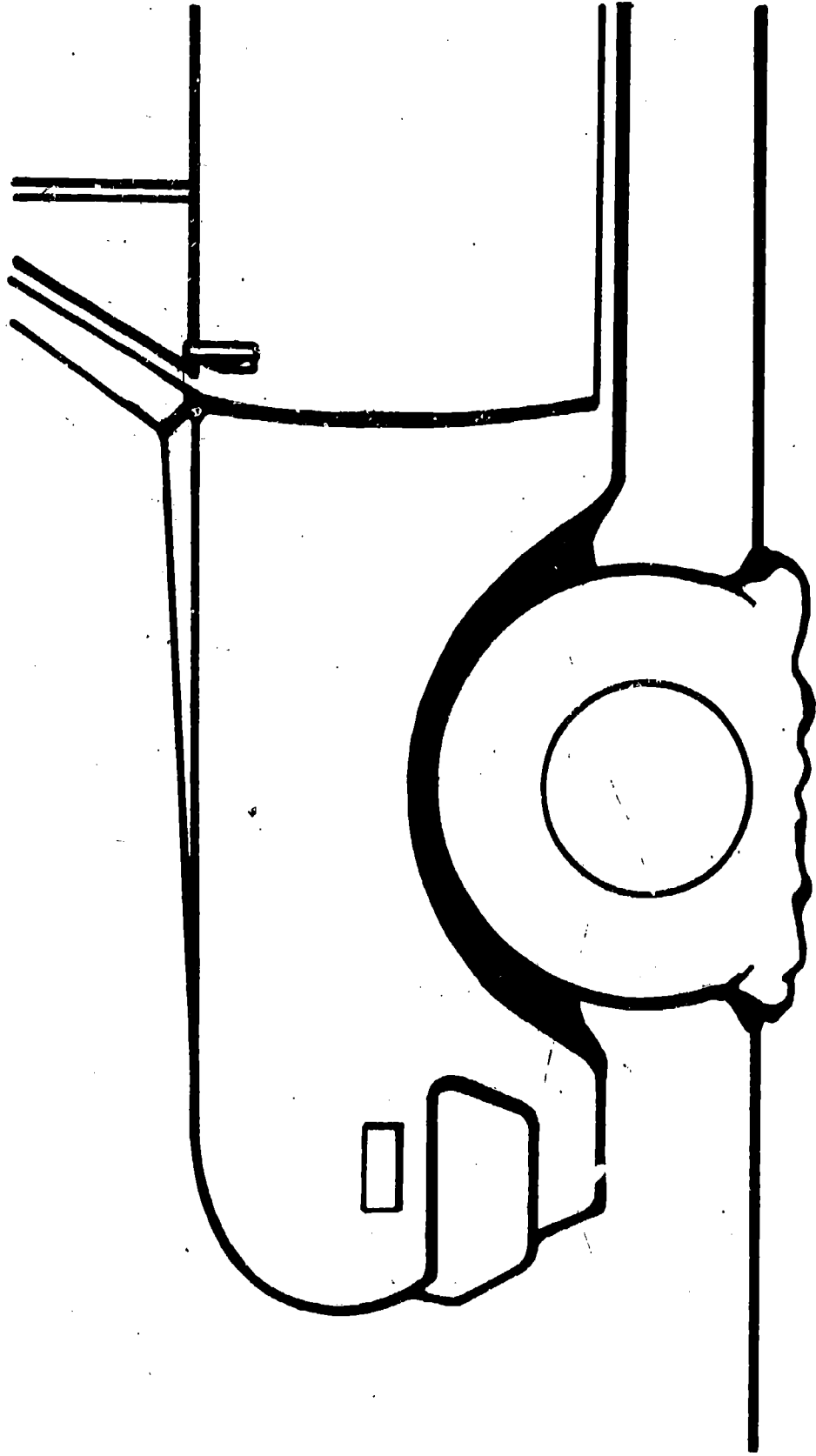

AP  
P281

