

DOCUMENT RESUME

ED 094 986

SE 017 526

AUTHOR Reed, Betty Jane, Ed.; Wood, John, Ed.
TITLE Mathematics for the Elementary School, Unit 5, Map Reading.
INSTITUTION Minnesota Univ., Minneapolis. Minnesota School Mathematics and Science Center.
SPONS AGENCY National Science Foundation, Washington, D.C.
PUB DATE 65
NOTE 77p.
EDRS PRICE MF-\$0.75 HC-\$4.20 PLUS POSTAGE
DESCRIPTORS Activity Learning; *Curriculum; *Elementary School Mathematics; Instruction; *Instructional Materials; *Number Concepts; *Teaching Guides; Units of Study (Subject Fields); Worksheets
IDENTIFIERS Map Reading; MINNEMAST; *Minnesota Mathematics and Science Teaching Project

ABSTRACT

The Minnesota School Mathematics and Science Teaching (MINNEMAST) Project is characterized by its emphasis on the coordination of mathematics and science in the elementary school curriculum. Units are planned to provide children with activities in which they learn various concepts from both subject areas. Each subject is used to support and reinforce the other where appropriate, with common techniques and concepts being sought and exploited. Content is presented in story fashion. The stories serve to introduce concepts and lead to activities. Imbedded in the pictures that accompany the stories are examples of the concepts presented. This booklet presents a unit on map reading and ordinal numbers. The activities include placing objects in specified orders and describing the location of an object by its ordinal position among a set of objects laid out in a row. Mapping activities include describing paths on a grid using north, east, west and south to indicate the direction of movement. Worksheets and commentaries to the teacher are provided and additional activities are suggested. (JP)

ED 094986

MINNE

Math

And

Science

Teaching project

U.S. DEPARTMENT OF HEALTH,
EDUCATION & WELFARE
NATIONAL INSTITUTE OF
EDUCATION

THIS DOCUMENT HAS BEEN REPRO-
DUCED EXACTLY AS RECEIVED FROM
THE PERSON OR ORGANIZATION ORIGIN-
ATING IT. POINTS OF VIEW OR OPINIONS
STATED DO NOT NECESSARILY REPRESENT
OFFICIAL NATIONAL INSTITUTE OF
EDUCATION POSITION OR POLICY

"PERMISSION TO REPRODUCE THIS COPY-
RIGHTED MATERIAL HAS BEEN GRANTED BY"

Alan Humphreys

TO ERIC AND ORGANIZATIONS OPERATING
UNDER AGREEMENTS WITH THE NATIONAL IN-
STITUTE OF EDUCATION. FURTHER REPRO-
DUCTION OUTSIDE THE ERIC SYSTEM RE-
QUIRES PERMISSION OF THE COPYRIGHT
OWNER."

UNIT V MAP READING

5 017 526



Full Text Provided by ERIC

MATHEMATICS
FOR THE
ELEMENTARY SCHOOL

Unit V
Map Reading

The Minnesota School Mathematics and Science Teaching Project
produced these materials under a grant from the
National Science Foundation

second printing
1965

MINNESOTA MATHEMATICS AND SCIENCE TEACHING PROJECT

JAMES H. WERTZ, JR.
Associate Professor of Physics
University of Minnesota
Project Director

PAUL C. ROSENBLOOM
Professor of Mathematics
Teachers College, Columbia University
Mathematics Director

BETTY JANE REED
First grade teacher
Minneapolis

UNIT EDITOR and AUTHOR
'A Scary Halloween',
'Halloween'

JOHN WOOD
Minnemath Center
University of Minnesota

CONTENT EDITOR

NAOMI EISEMANN
Kindergarten teacher
Minneapolis

AUTHOR
'Welcome Home Kathy'

DAVID RATNER
Assistant Professor of Art
Boston University

ARTIST

MARJORY LUCE
Upper elementary teacher
Edina, Minnesota

LORNA MAHONEY
Undergraduate assistant
University of Minnesota

We are deeply indebted to the many teachers who
used earlier versions of this material
and provided suggestions for
this revision

CONTENTS

	Page
Purpose	1
Map Reading	
Story: "A Scary Halloween"	
Song: "Halloween"	
Activities	3
Worksheets 1-3	6
Activities involving North, South, East, West Worksheets 4,5	9
Ordinal Numbers	
Teacher Background	19
Activities	20
Worksheet 6	23
Story: "Welcome Home, Kathy"	
Worksheets 7-11	25
Activity	37

UNIT V MAP READING

Purpose of the Unit

To help the children learn:

1. the use of a map.
2. to differentiate between left and right.
3. the compass points north, south, east and west.
4. the meaning of ordinal numbers.

To give them experience in:

1. locating positions on a simple map.
2. using terms left, right, north, south, east, west through meaningful activities.
3. using ordinals through ten.

Read the story A Scary Halloween, which is designed to highlight the importance of knowing one's address. This story is prepared in booklet form so that the children will each have a copy to follow. Even if the children cannot read at this time, it is desirable for each of them to have his own copy to take home for his mathematics library.



**A
SCARY
HALLOWEEN**

"A SCARY HALLOWEEN"



It was dinner time at Jimmy's house.

Jimmy was so excited!

He was all dressed up as Peter Rabbit.

"Hurry, Mother. Hurry!" said Jimmy.

"Now, Jimmy, you must not eat so fast," said
Father. "It isn't good for you."

Just then the doorbell rang.

"I'll get it.
I'll get it."

Jimmy jumped down
from his chair and
ran to the door.

There he saw
a clown.

"Hello, Jimmy,"
said the clown.
"Are you coming?"

"Is that you,
Tom?" asked Jimmy.

"Yes," laughed
the clown. "Who did
you think it was?"

The children
laughed.

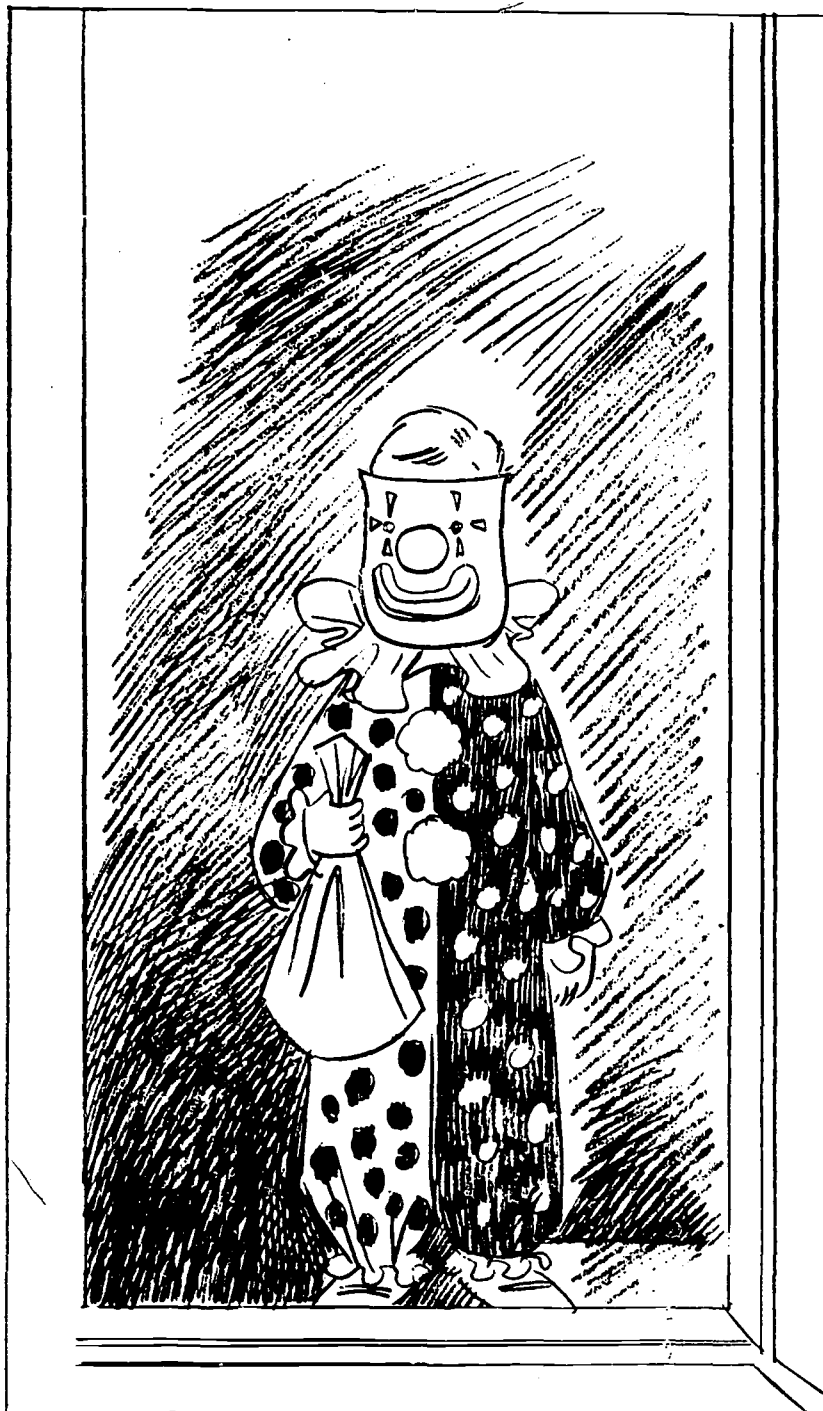

A SCARY HALLOWEEN

Then Jimmy ran to his mother.

"Tom's here, Mother. May I go now?"

"I guess so," said Mother. "But you didn't eat very well."

"Me go too?" asked little Sally.

"You are too little, Sally," said Jimmy. "You can't go. You have to be big like me!"

"I want to go." Sally started to cry.

Mother said, "Don't cry, Sally. Mother will take you out for tricks and treats in a little while."

A SCARY HALLOWEEN



"A SCARY HALLOWEEN"

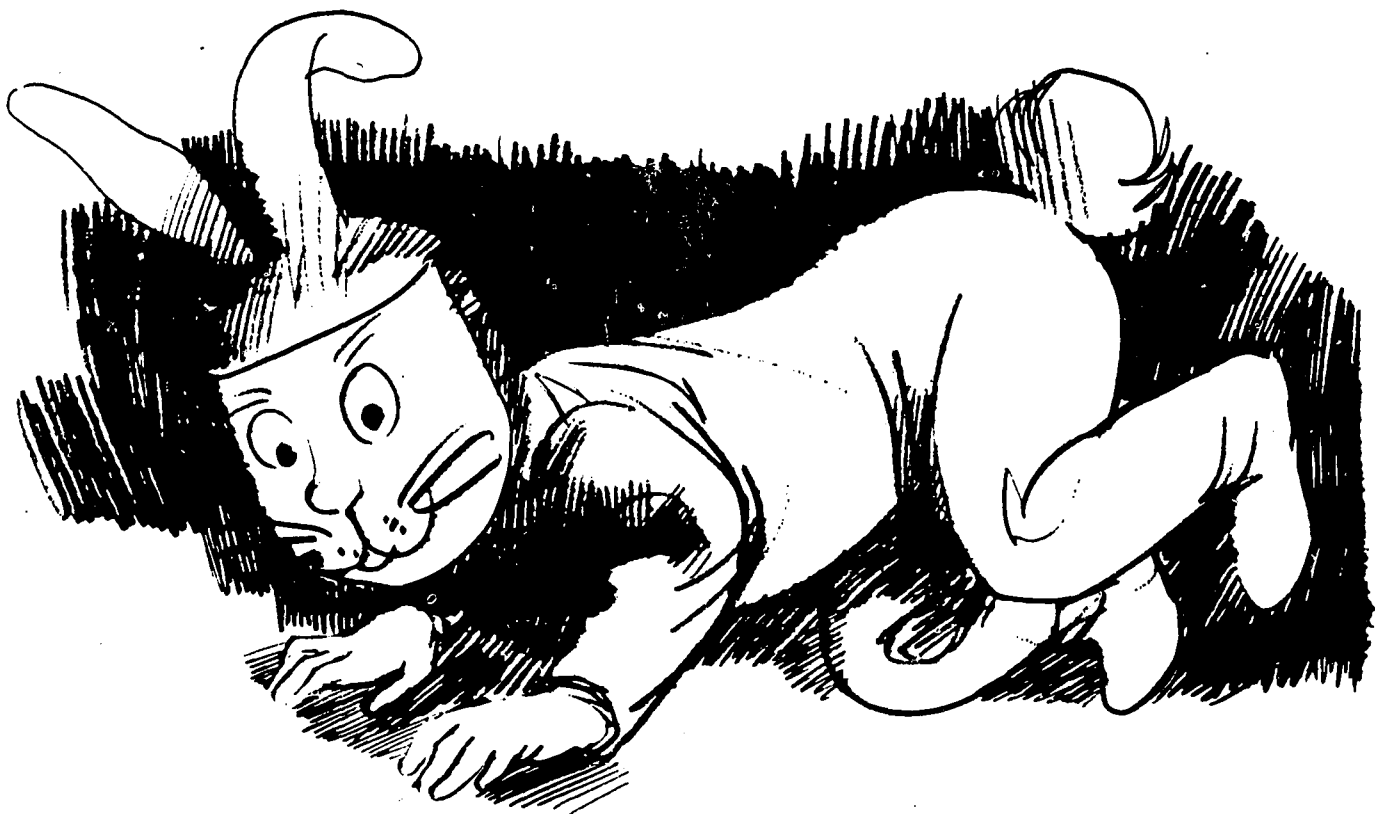

So Sally stopped crying and the two boys took their bags, put on their masks and went out to have fun.

They went from house to house saying, "Tricks or treats -- money or eats."

At some houses people gave them candy or nuts to put in their bags.

Some people made them do tricks to get their treats.

A SCARY HALLOWEEN



Jimmy and Tom had fun!

Soon there were many children. They were dressed as ghosts, witches, clowns, animals and everything you can think of.

They all wore masks.

A SCARY HALLOWEEN

All at once Jimmy looked around.

Where was Tom?

"Tom, Tom. Where are you?" called Jimmy.

There was no answer.

Jimmy was all alone.

He looked around, but he didn't know where he was. All the houses were new to Jimmy.

He tried to remember the way he and Tom had walked. Was it two blocks left and one block right?

Jimmy went that way, but he could not find his house.

A SCARY HALLOWEEN

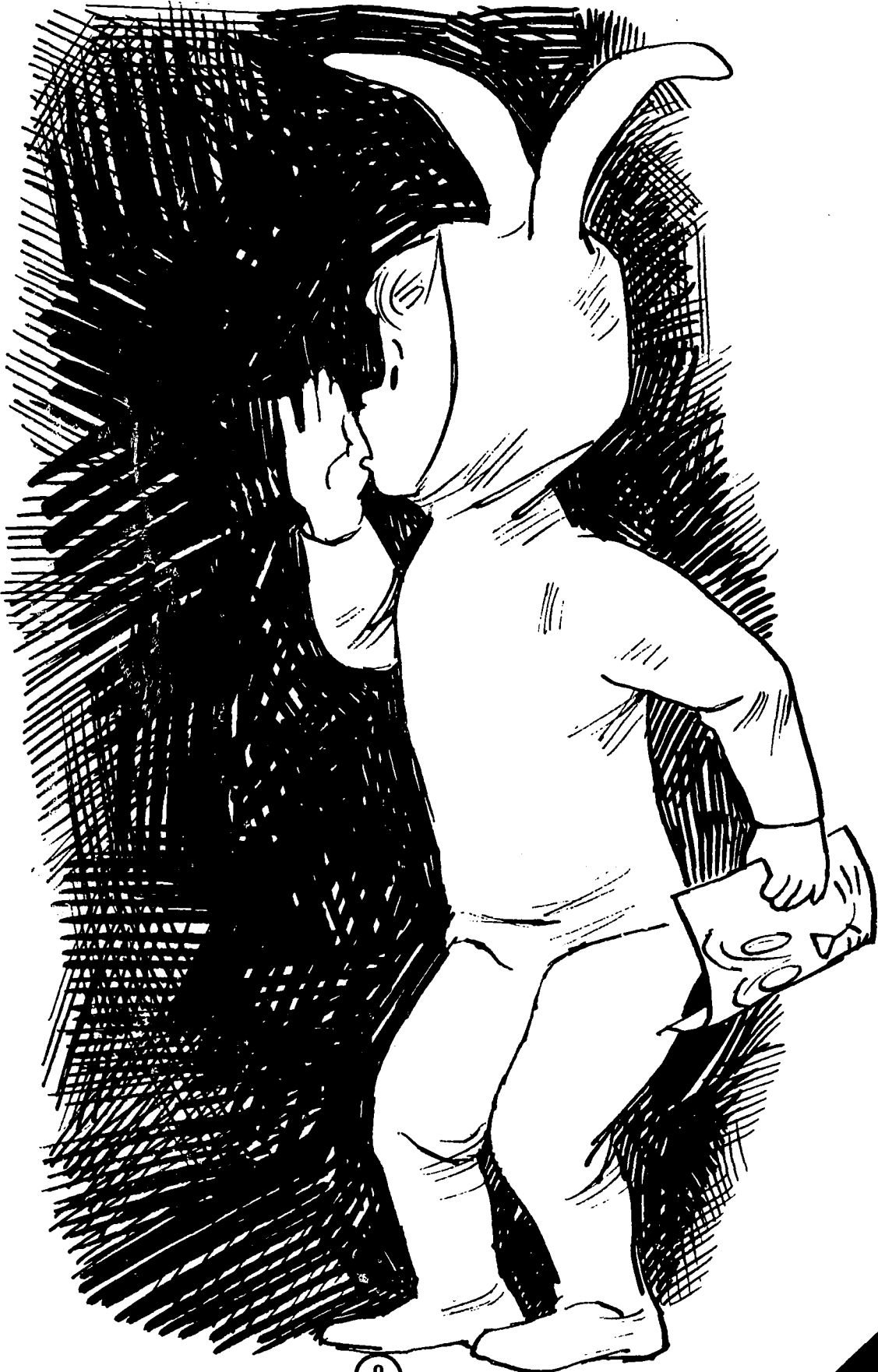

A SCARY HALLOWEEN

The sky was dark and the wind was blowing.

Jimmy began to get scared.

The wind made spooky sounds in the trees.

Jimmy's lost -- Jimmy's lost!
He's a scared little bunny.
Jimmy's lost -- Jimmy's lost!
It isn't very funny.

A dog barked far away. It was a lonesome sound.

Jimmy's lost -- Jimmy's lost!
He's standing all alone.
Jimmy's lost -- Jimmy's lost!
He just can't find his home.

A SCARY HALLOWEEN



A SCARY HALLOWEEN

Jimmy felt little and lost and all alone. He was trying hard not to cry.

Just then a deep friendly voice said, "Hello there, Peter Rabbit. Are you lost?"

Jimmy looked up and saw a policeman.

"No, I'm not lost," he said. "But my house is. I turned right and left and left and right and now I don't know where it is."

A SCARY HALLOWEEN



A SCARY HALLOWEEN

"Let's go and find your lost house, Peter," said the policeman, taking Jimmy's hand.

"My name's not Peter," laughed Jimmy. "I'm just dressed this way for Halloween. My name is Jimmy."

"Well, Jimmy, I am Officer Bill. What's your last name?" asked the policeman.

"It's Johnson. I'm Jimmy Johnson."

"What's your address, Jimmy?" asked Officer Bill.

A SCARY HALLOWEEN

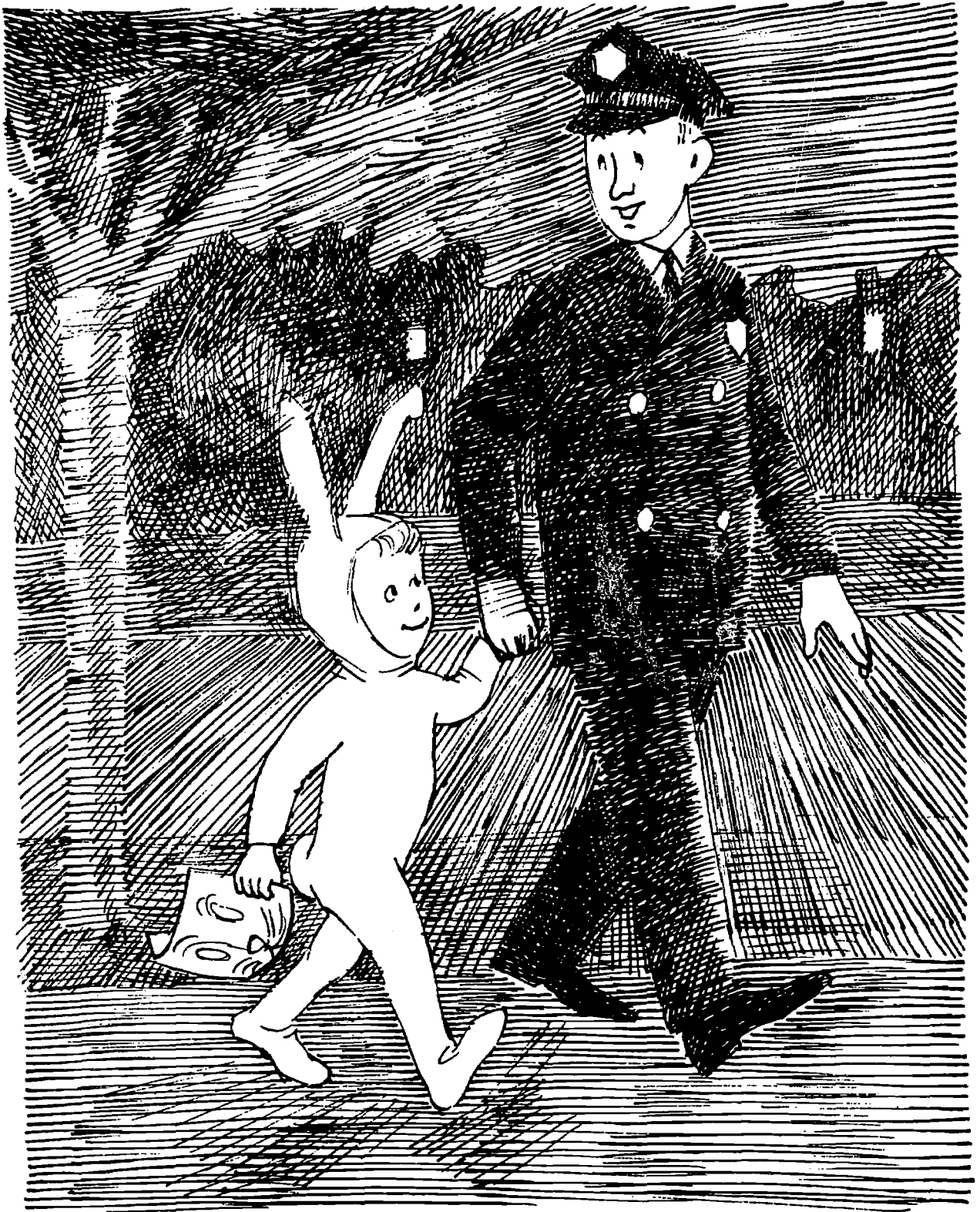

A SCARY HALLOWEEN

"I don't know it," said Jimmy. "But my house is white with a lot of green grass all around it."

"Jimmy, you should know your address. Do you know that I can take you north, south, east, or west and we can find dozens of white houses with a lot of green grass around them? If you don't know the number of your house and the name of your street, I can't find your lost house for you."

Jimmy looked very sad.

A SCARY HALLOWEEN

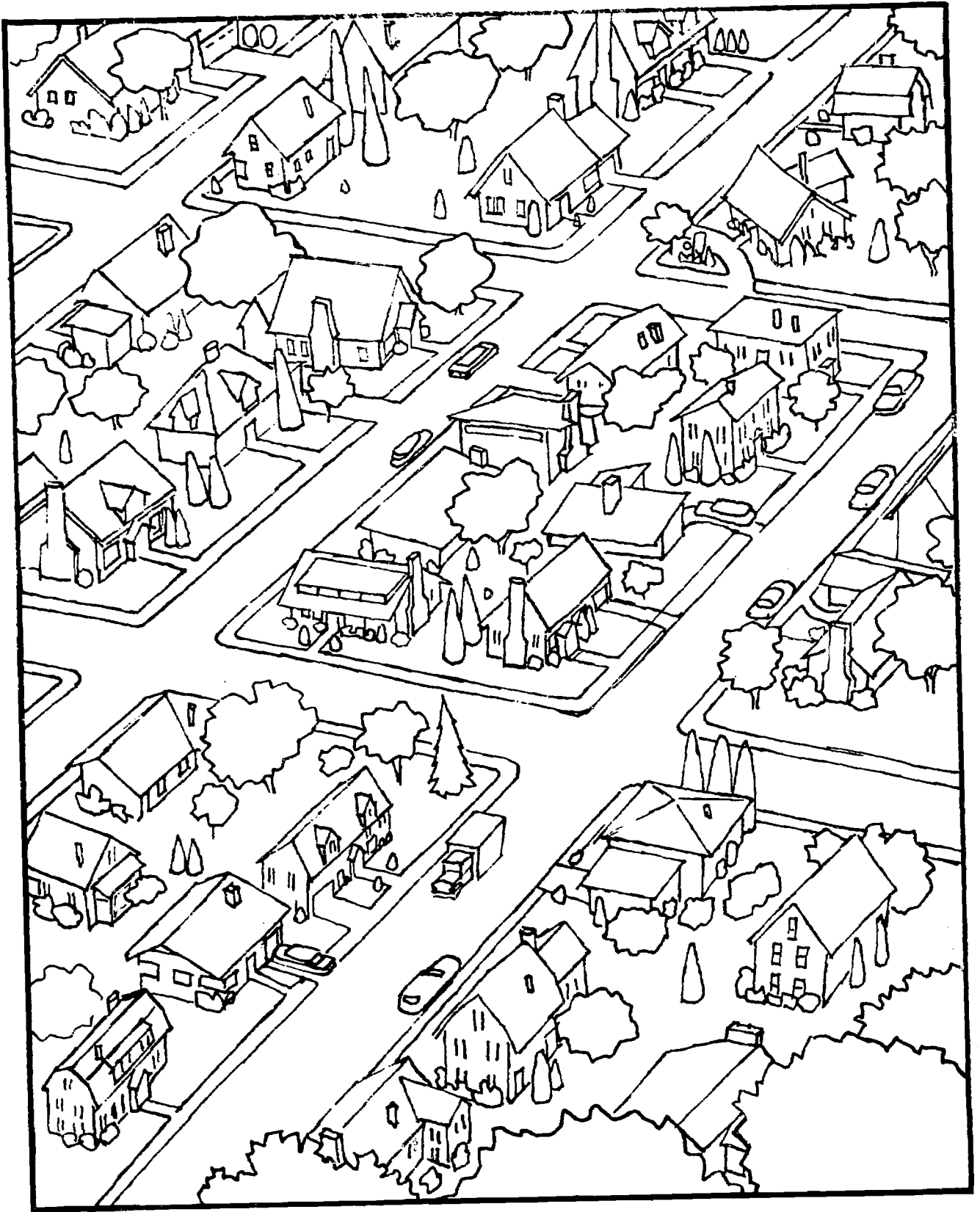

A SCARY HALLOWEEN

Jimmy does not know
The number of his house.
Jimmy's just as home-less
As a little gray mouse.

There are many white houses
Right and left on every street
But Jimmy wants his own house
To rest his weary feet.

His rabbit ears are drooping down,
His face looks very sad.

Then suddenly he hears a voice
That sounds just like his Dad's.

"Jimmy! Hey, Jimmy!" called a voice
from a big blue car.

A SCARY HALLOWEEN

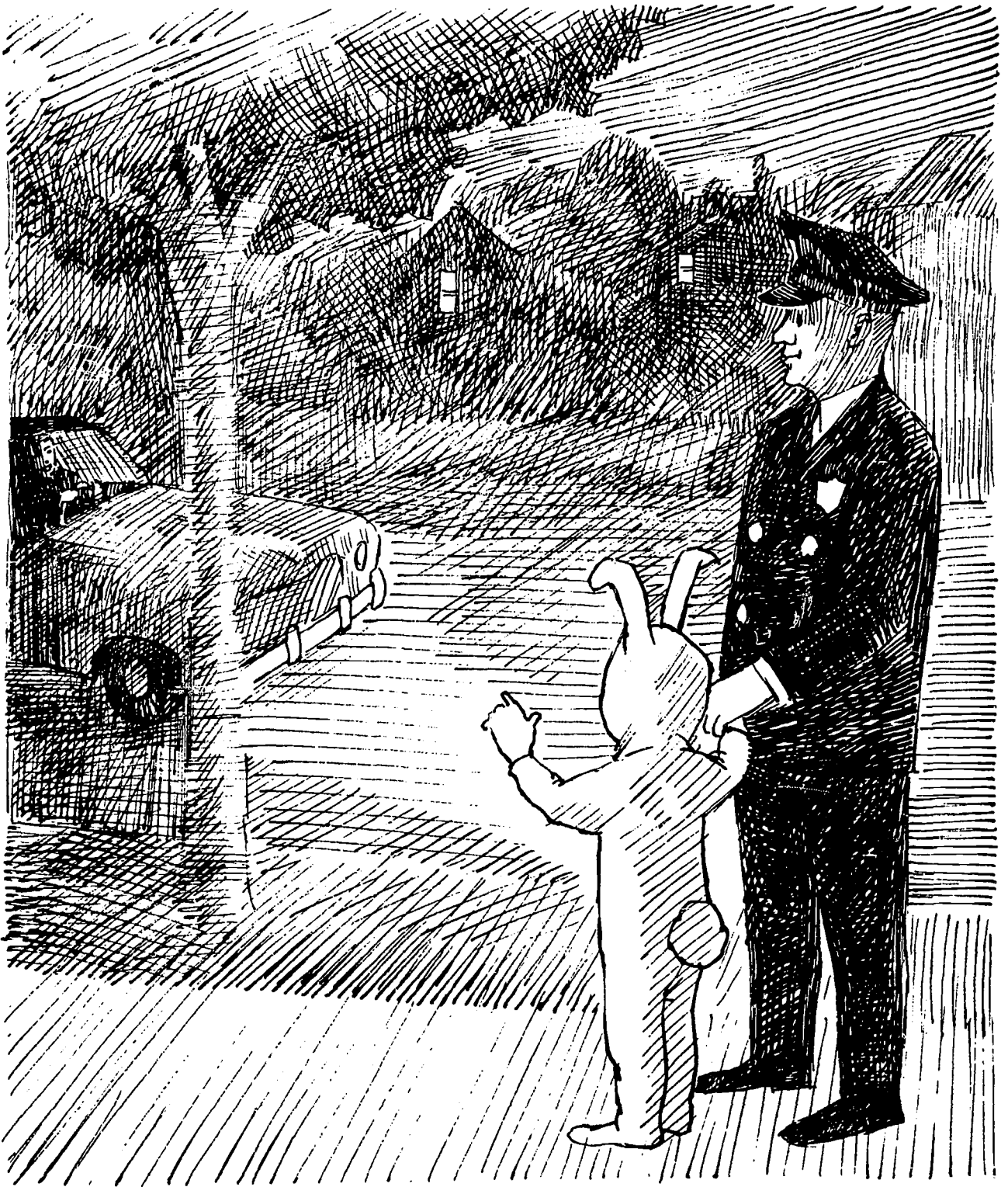

A SCARY HALLOWEEN

"Oh, Daddy," cried Jimmy as he ran to the car. "We can't find our house. It's lost."

"Well, Jimmy, I can find our house. Hop into the car. Mother is worried about you."

"He's a big boy," said Officer Bill. "He didn't cry at all. In fact, he's such a big boy he should learn his address and phone number. I could have found his lost house if he had known his address."

"I'll learn it right away, Officer Bill," promised Jimmy.

"Good for you, Peter Rabbit. Well, good-by now. You'd better go and find your lost house."

"Good-by. Maybe I'll see you again some time."

As Jimmy and his daddy started for home, the wind blew in the trees, but the night was not dark and lonely any more.

A SCARY HALLOWEEN



A SCARY HALLOWEEN

Here are two songs to use at the end of the story.

1. Sing as a round to the tune of Frere Jacques
(Are You Sleeping?)

Where is Jimmy? Where is Jimmy?
He is lost! He is lost!
Tell us where your house is.
What's your street and number?
We will help you
To get home.

2.

HALLOWEEN

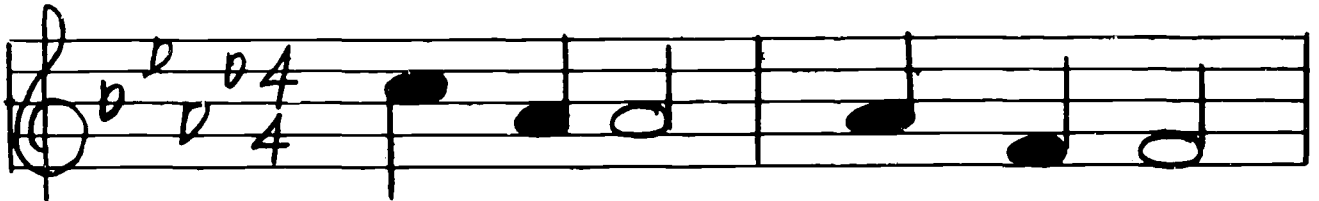

Hall - o - ween !

Hall - o - ween !

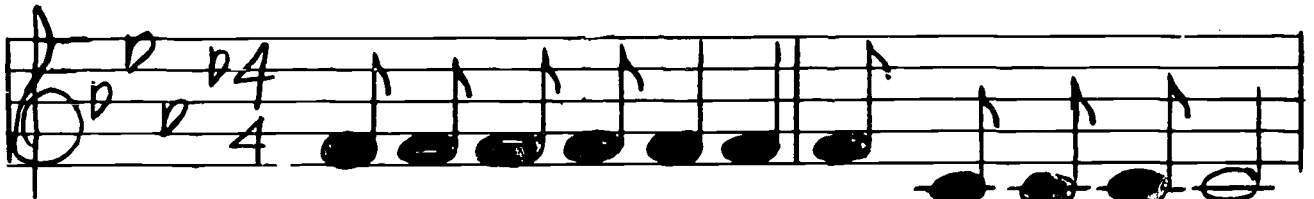

Rab-bits, wit-ches, ghosts and gob-lins can be seen.



Jim - my

got lost on

Hall-o-ween

night.

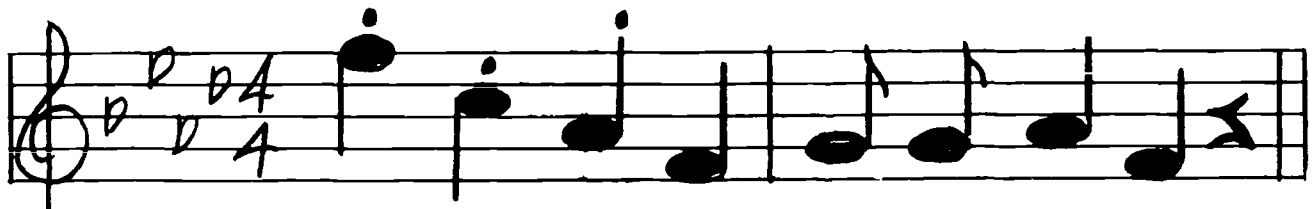

Oh!

He

had

a

terr-i-ble

fright!

Suggested Activities

1. Follow this story with a discussion of the importance of knowing names, addresses, and phone numbers.
2. Have each child tell his name, address, and phone number to the class. As they are able to do this, let them print their names on a large sheet of paper. Head the paper with this poem:

I know my name and address,
And phone number, too,
So I can print my name here.
What about you?

3. Read to the class the story called The Boy Who Would Not Say His Name by Elizabeth Vreeken, Follett Publishing Company.
4. Draw a map of the classroom approximately 2' x 3' in size. (Adjust measurements according to the size and shape of your classroom.)
First draw in the doors and windows. Call on children to show you where to put the teacher's desk, etc. until the map is complete. Tell the children to pretend that they are looking down from the ceiling as the map is being constructed, so that they can get a better over all view.
5. Discuss with the class various places in the room that could be considered danger spots if the children are careless, such as radiators, cloakroom hooks, doors, windows, chairs, desks, etc.
Then have the children make little red flags and paste them at the danger spots on the room map.
6. Have each child (with teacher guidance) make his own map of the classroom similar to the class map. Use 12" x 18" manila paper.

7. Use the following suggested activity or game to help the children understand and use maps.

Where's Your Face

- a. On large brown wrapping paper, teacher makes a map showing seats in the classroom.

Example:

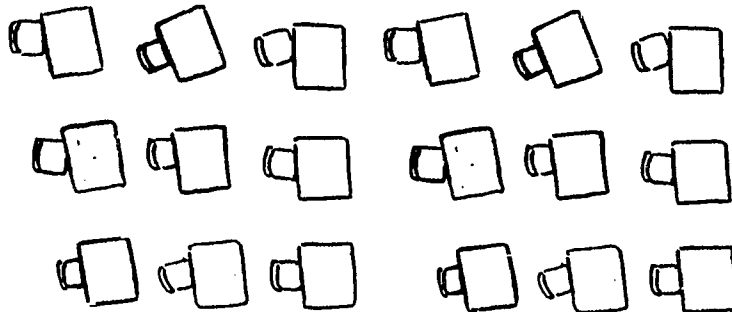

- b. Each child draws a small picture of his own face on light paper sized to fit onto the picture of the desk made on the map by the teacher.
- c. The teacher begins the game when all children have drawn and cut out their faces. She begins by saying to one child as she stands by his desk--
- "What is your name?"
 (Child replies.)
- "Where is your face?"
 (Child picks up picture he has made and show it to her.)
- "Now you may go and put it in your place."
 (Child then goes to map of seats and pastes the picture of his face on the part of the map that represents his own desk.)
- d. That child then becomes the leader and stands by another child and repeats--
- "What is your name?", etc.

- e. To keep the children's interest alive, start a second child as soon as the other children understand what to do. Then two people can be finding their places at the same time. (Since part of the "Fun" of the game lies in hearing the poem repeated, instruct the children to be sure that only one person is giving instruction at one time.)
8. For homework have each child make a map of his own room at home and bring it to school. Have class discussion time when children can explain their maps to others. (It is helpful for the teacher to draw a map on the board showing her own bedroom as an example. Again stress the idea of looking down from the ceiling.)
When the children are explaining their maps to the class, have them show how they get to different places in the room from their door, etc. Encourage use of the terms "left" and "right".
9. In social studies, when studying the school, draw a simplified map of the floor your room is on. Make a flag that says "You are here" and put it by your own room. Have the children take imaginary trips on the map to take messages to other rooms on that floor (i.e., principal, clerk, nurse...).
10. Give children worksheets 1, 2 and 3. These are designed to be used with teacher and children working together.
11. For homework have children ask their parents to help them make a map of a floor of their home. It will help if the teacher draws a map of her own first floor on the board. Omit furniture; just show the different rooms. (Don't require 100% response. Accept those that are brought in but don't pressure for others.)

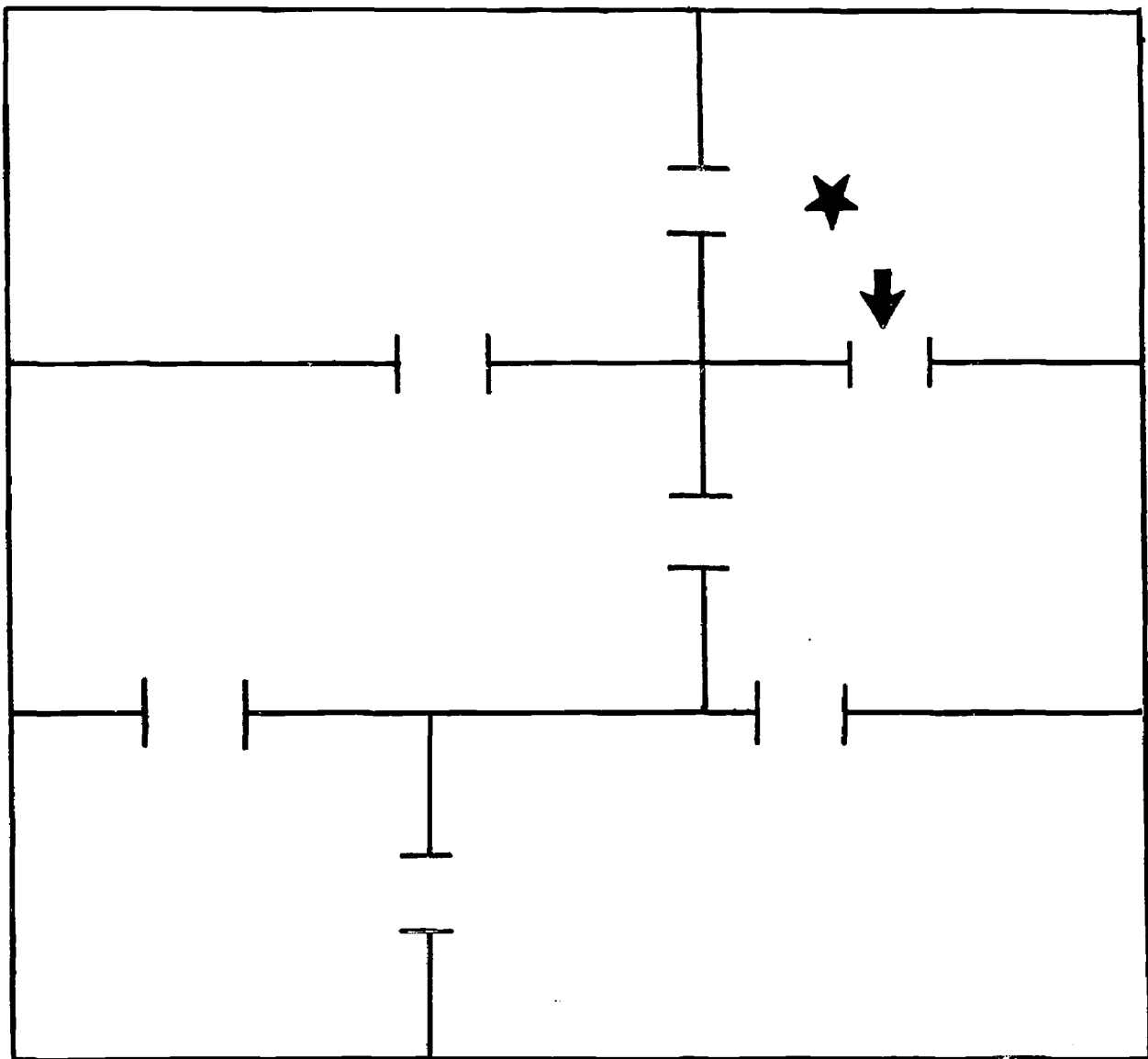

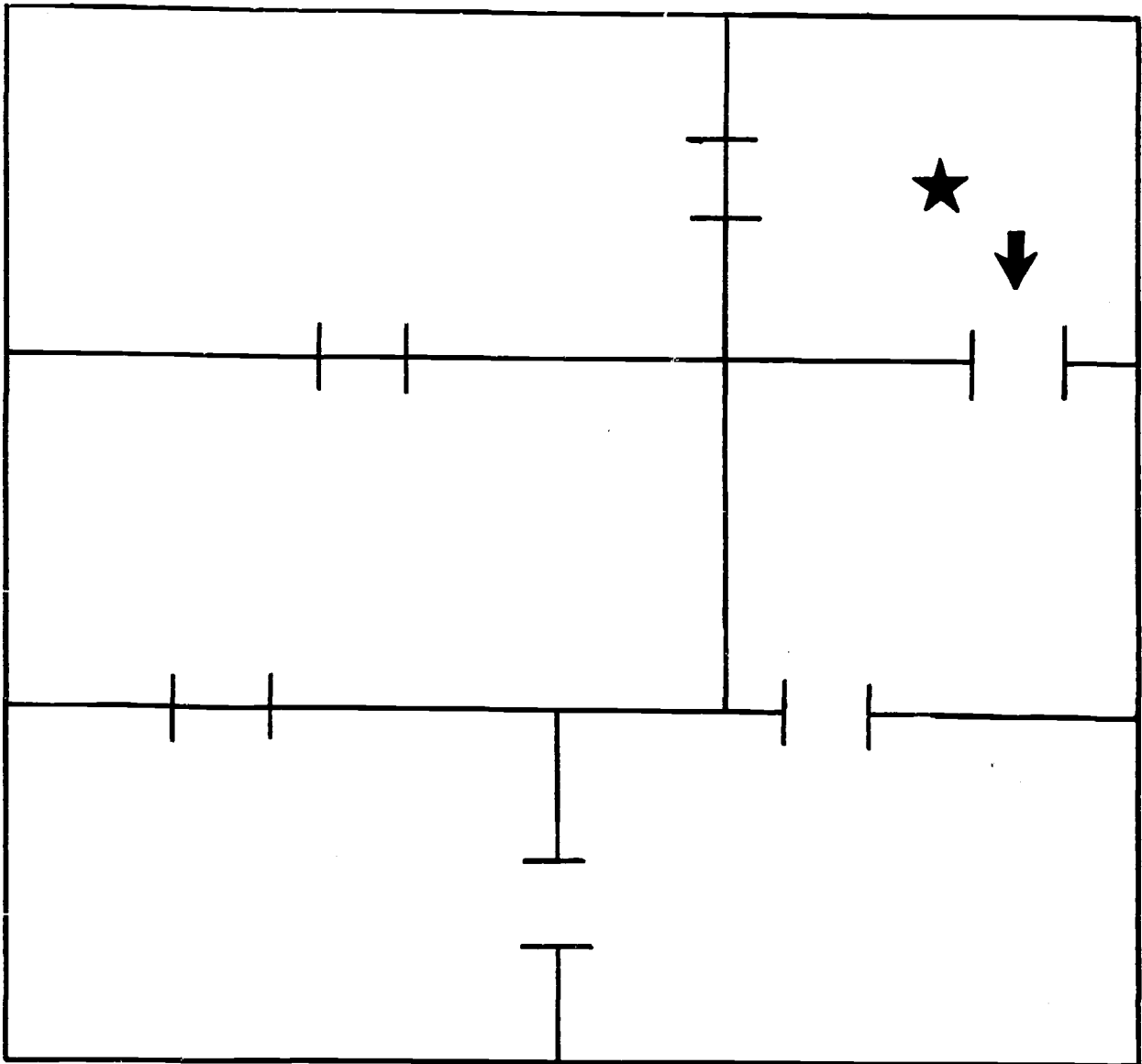

1. Take a crayon.
2. Start at the star and go in the direction the arrow points.
3. Try to go through each room only once, through the open doors, and get back to the star.
4. Can you do it? _____ Yes _____ No

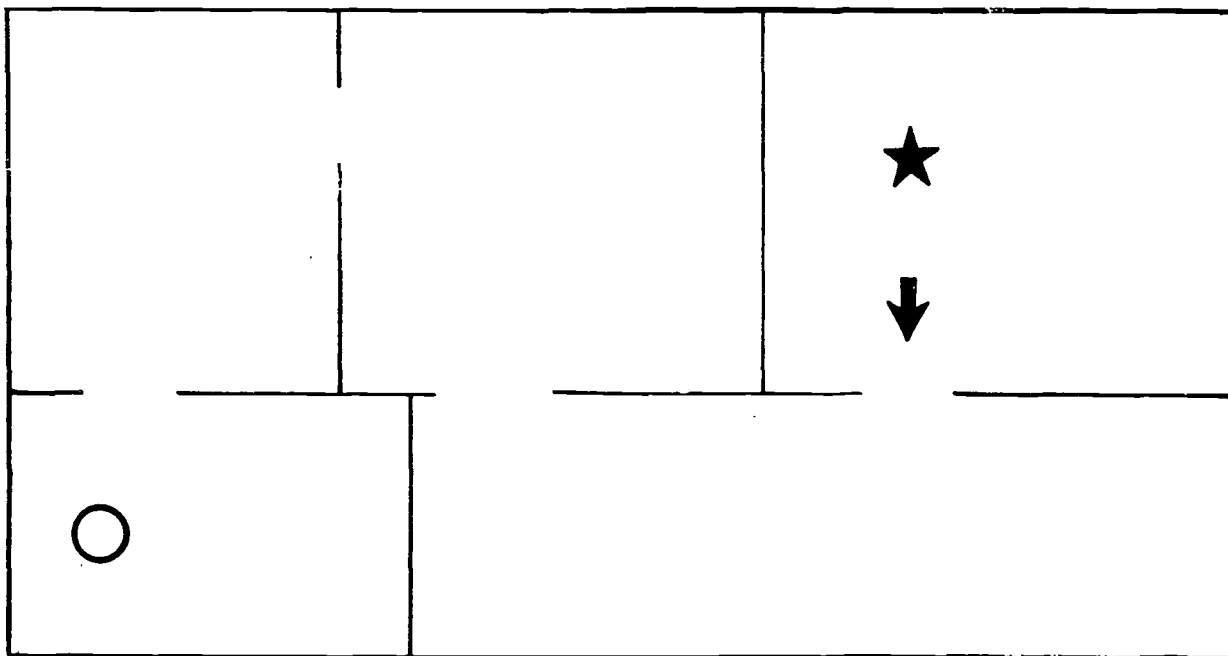

1. Take a crayon
2. Start at the star and go in the direction the arrow points.
3. See how many rooms you can go through, using each open door only once.
4. How many rooms were you in? _____



1. With your crayon, draw a line from the  to the .
2. Were you in every room? _____ yes _____ no

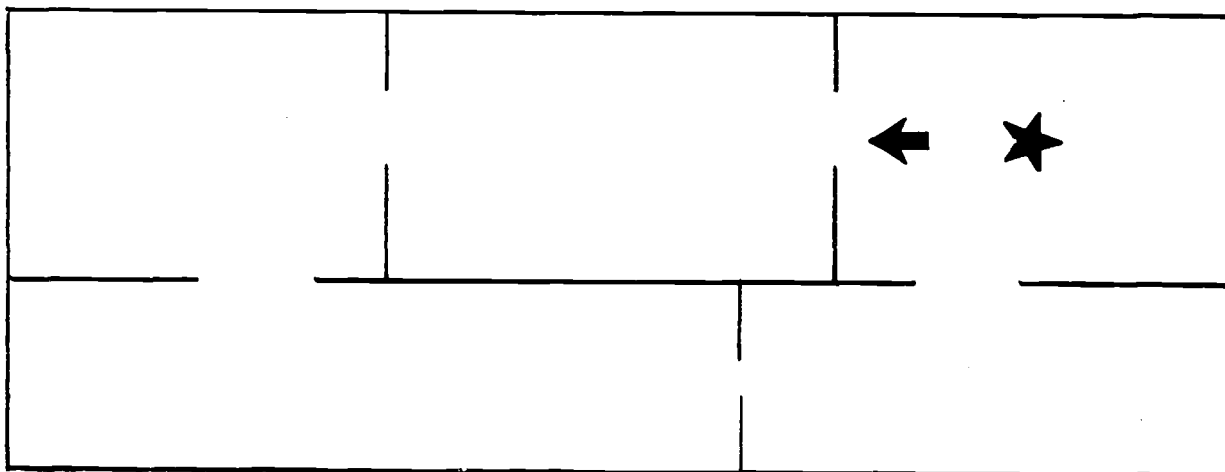

1. With your crayon, draw a line from the star in the direction the arrow points. Go through each open door only once and get back to your starting point.
2. How many rooms were you in? _____

Activities Involving North, East, South, West

1. A safety lesson to develop understanding of maps. At the beginning of the school year, each child should be encouraged to learn his name, address, and phone number. When most of the children know their addresses, the teacher should draw a large map of the school district. (See example.) It should provide blocks large enough for the inclusion of several houses the children make from sheets of colored paper cut to 2" x 2". (Explain that maps are usually prepared with North at the top, South at the bottom, etc. even though North is not really "up".)

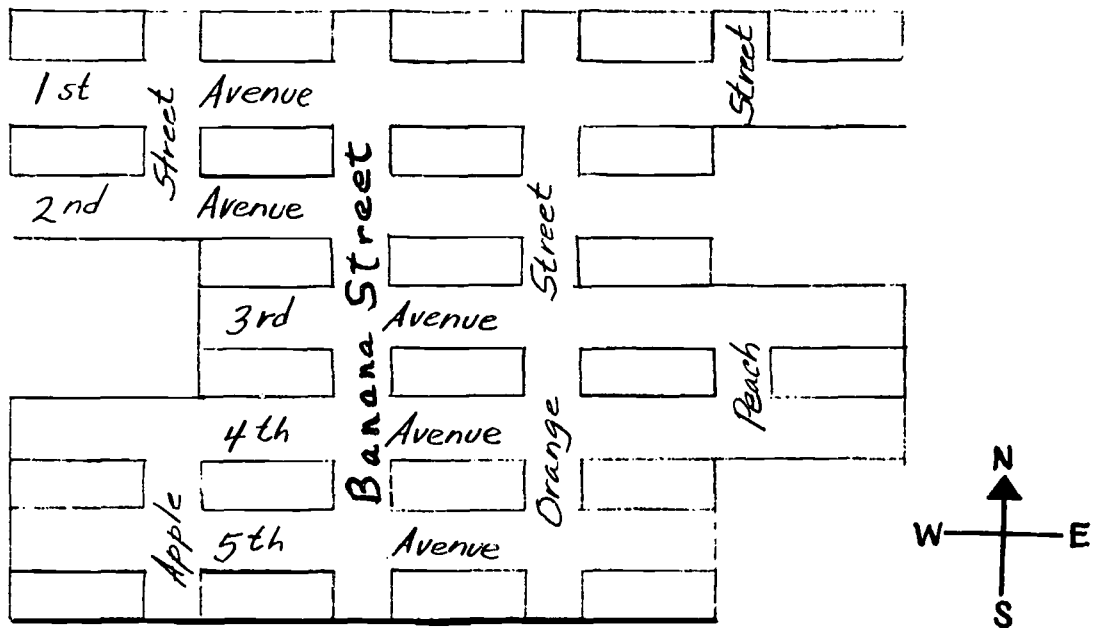

Have someone make a drawing of the school and paste it where it belongs on the map.

Then have each child draw and cut out his own house on the 2" x 2" paper. With teacher help, let each child find the place on the map that shows where he lives and paste his house there. (Be sure to check addresses before the houses are pasted.)

2. When all the houses are in place, an activity for the next day is to determine where stop signs, traffic lights, policemen and patrols are stationed. They should be drawn, cut out, and pasted at appropriate intersections.

When the group is ready to apply safety learnings, children should take turns going to the map and outlining the way they go to and from school. It will take several days for each child to have a turn. Children's interest in watching each other will be sustained if the number of children doing it each day is not too large. You will find that some children detour through alleys or cross where they have no help. This is the time for them to discover a safer route to school and home again.

3. See film "Which Way." (Useful for directions, shadows and sun, use of compass, use of maps. Produced and distributed by Audio-Visual Center, University of Indiana, Bloomington, Indiana.)
4. Remind children that most maps are set up this way for



convenience in reading. Use a compass to show them that "north" is not necessarily in the direction of north on the map.

5. Play the game "A Trip To The Zoo" on Worksheet 4. First play it on the chalkboard to establish an understanding of the rules. Be sure to explain that a diagonal move is not permitted. The moves must be directly North, South, East or West. Use a pack of cards that read "Go 1 block north," "Go 1 block south," "Go 1 block east," "Go 1 block west," "Go 2 blocks north," etc. There is a card for each direction going from zero to 5. There should also be optional cards reading "Go 1 block in any direction," etc. using 0 through 5. Have everyone color the starting block black. A child should then go to the front of the room and take any one of the cards. (If he can't read it, the teacher should.) Let's suppose he takes a card that says "Go 2

blocks east." Tell the children to take a green crayon and color the 2 blocks east of the starting block. Then another child takes a card. (Use a different color crayon this time.) If the card sends them off the chart, they wait for a card directing them on again. The winner is the child who reaches the zoo first. As a card is used it should be returned to the pack and mixed in with the other cards. If a child has traveled 3 blocks north, he has colored in the squares in this manner:

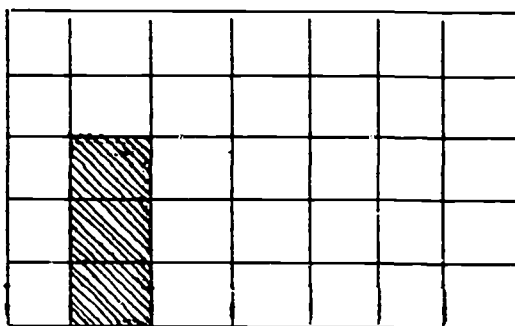

Start

If the next card, or any succeeding cards, should send him back to those squares that are colored in, he cannot move. (i.e. If the next card says "Go 1 block south, he cannot move.) He can go only north, east or west. In other words, the squares become a wall once they are colored, and cannot be used again, or crossed over. If the next card reads "Go 2 blocks east" be sure the children realize that they start with an empty block next to the last one filled.

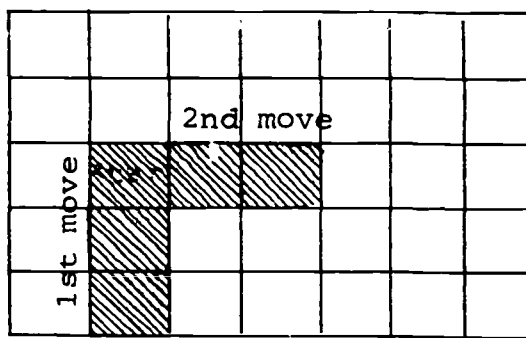

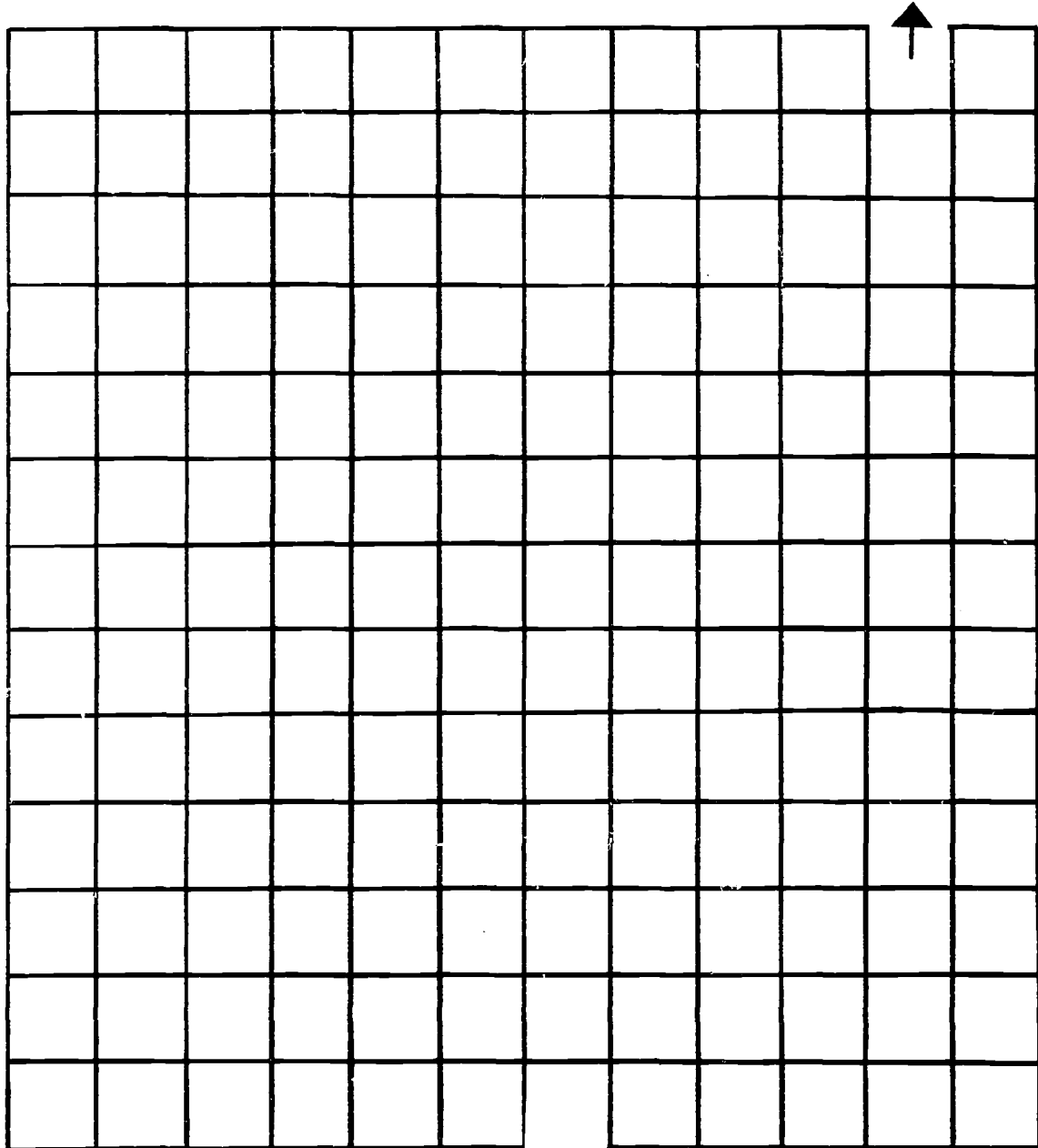
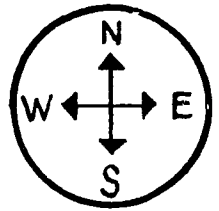
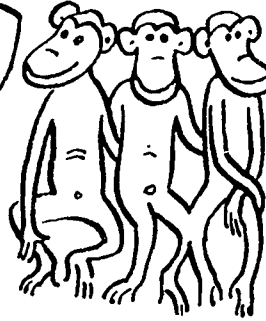
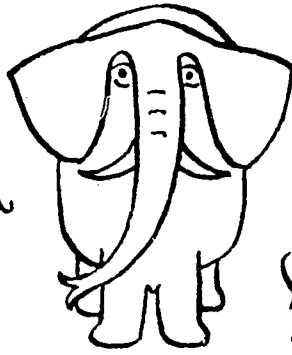
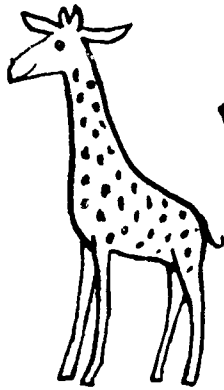

6. Teach the song, "In and Out the Window".*
7. After children are familiar with the song play the game "Song Maze".

Desks and children should be set up for a maze with passages that can be closed by children joining hands or by "official" barricades to avoid indiscriminate road blocks.

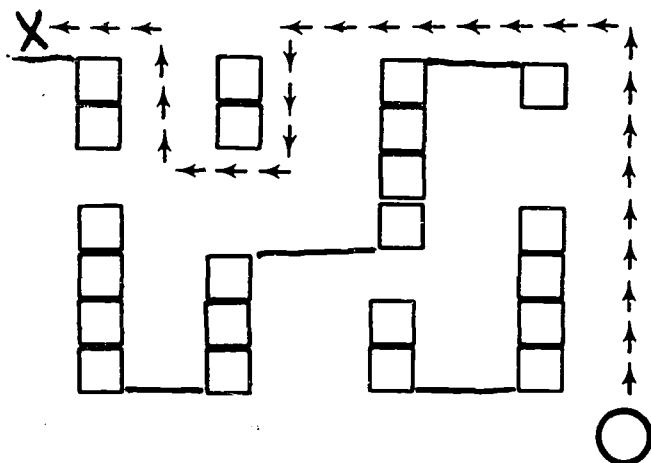

Children take turns (or in two's) to try to reach the treasure (X) by the time the song "In and Out the Window" is finished. Show the class a map of the maze on the board to help them find the treasure in time. Then play the game again. The road blocks will have to change position from time to time because like white mice children soon learn the maze.

* Ohanian, Phyllis, ed., Favorite Nursery Songs, Random House, 1956.

Bley, Edgar S., Best Song Games for Children of All Ages, Sterling Publishing Company, New York.

8. Follow "A Trip To The Zoo" with the following team game. Call it "We Go To Disneyland." (Use Worksheet 5.)

Divide the class into 4 teams. Have them sit at desks so that they can mark their worksheets. Let the children choose names for the teams. The class should be as evenly divided as possible.

Use the same directional cards as for Worksheet 1.

Have the first person on Team 1 choose any card and read it. Everyone on that team takes a green crayon and colors the indicated number of blocks in the direction given on the card. The card is then returned to the pack and mixed in with the others.

Then the first person on the next team chooses a card and the members of that team mark their sheets also with green. And so on, using a different color crayon for each turn. (In other words, each team will use green for the first turn, red for the second, etc.)

The game ends when one team reaches Disneyland or when everyone has had a turn. (If teams are uneven, the first person on any team that is short a member will take a second turn so everyone has at least one turn.)

The team getting to Disneyland first wins the game. They can enter on any number (i.e. if the team is one block from the entrance to Disneyland, they may enter on any number 1, 2, 3, 4, 5 that has the correct direction on it).

If no team has reached Disneyland when everyone has had a turn, then the team that is closest wins. (Sometimes the children might want to save the sheet and continue the game at the next mathematics session so that some team actually gets to Disneyland.)

Worksheet 5

"We Go To Disneyland"

Maps

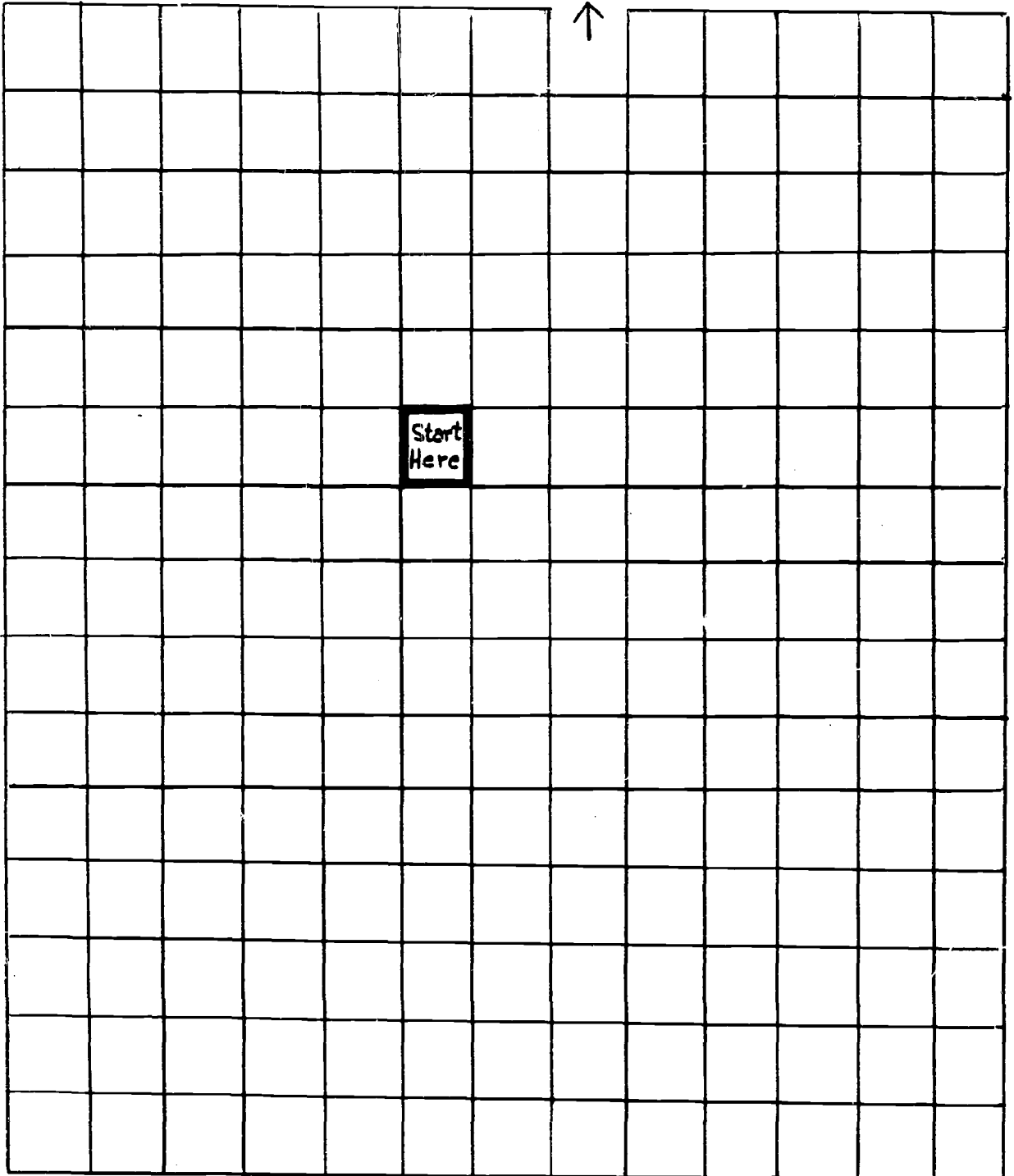
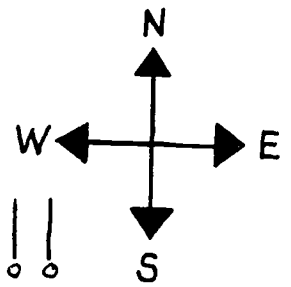

Additional Activities

9. Plan additional game experiences similar to Worksheet 4 and 5, if you wish.
10. If the game "Let's Go" is available place it on the mathematics table for small group activity. Copies of Worksheets 4 and 5 plus the necessary equipment (cards, etc.) should also be made available for independent activity time.
11. Read to the class the book, Harold and the Purple Crayon by Crockett Johnson, published by Harper and Brothers, 1955.
Let a creative youngster make up a trip the same way Harold did, drawing his own map on the chalkboard as he goes along.
12. See film "How Far." (It's helpful in discussing maps and distances. Produced and distributed by Audio-Visual Center, Indiana University, Bloomington, Indiana.)
13. Provide various compass experiences for the class, helping them to find North and to show where South, East and West are in relation to it.
14. Play this game "Treasure Hunt."

Treasure Hunt

Hold the compass up in the front of the room and have one of the children help determine which direction is North. Then draw a large circle on the board and place the directions (North, South, East, and West) on the circle as the compass shows them. Do the same on a piece of brown wrapping paper and tape it to the floor. Put an X in the middle of the circle on the floor. (Be sure to use "magnetic" north, not north as it would appear on a map.)

Choose two children to be "treasure hunters" and have them leave the room. Then choose two more children; one to

be measurer and one to be recorder. Let the class choose an object as a "treasure."

The measurer will then start at the X on the floor compass and will count how many steps and in which direction he must go to get to the "treasure." The class can help him count and can also determine which direction he is moving with the aid of the compasses on the board and on the floor. As the steps are counted, the recorder will draw a map on the chalkboard:

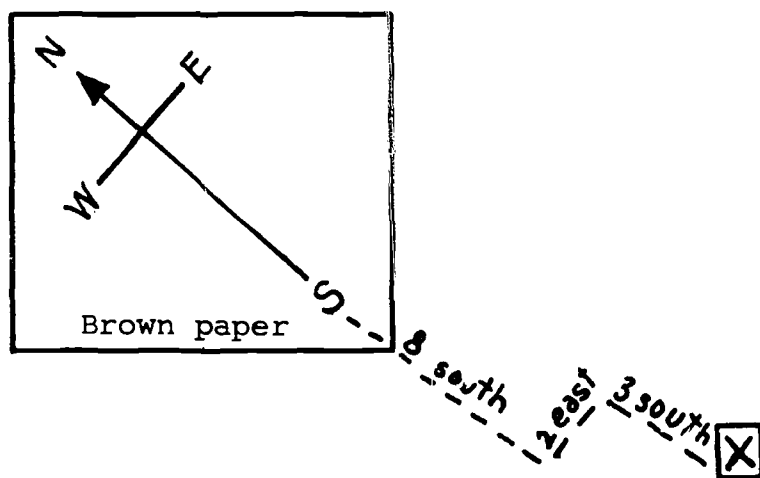

When the first map is finished, label it map 1 and choose another "treasure." (The second one should be in a different part of the room.) Again measure its distance and direction from X and draw another map which will be labeled map 2.

At this point the two "treasure hunters" are called into the room. One of them is instructed to follow map 1, and the other one must follow map 2.

The two "treasure hunters" start at the same time from X. When both of them have found and named their treasure, they choose two new treasure partners.

After the game has been played awhile, it may be possible to merely give the directions and step numbers. Recorder writes 8 east, 2 south, 2 east.

Ordinal Numbers

Teacher Background

The way we have been using numbers up to this time is in the cardinal sense. First grade children should also become acquainted with ordinal numbers through ten.

When we speak of cardinal numbers, we say one, two, three, etc.





















When we speak of ordinal numbers, we say first, second, third, etc.

All first graders should learn the ordinal words through tenth, but many will learn more because of daily exposure, for example, to the calendar where they meet ordinals through the thirty-first.

Be sure to take advantage of any opportunity that arises in the classroom where ordinals might be used.

Note: It is the practice in most classrooms to refer to "rows" of desks. Mathematicians have generally agreed that rows correspond with the x axis and extend, therefore, from left to right. What we generally refer to as "rows" in the classroom should be called "columns" because they correspond to the y axis. If children learn to recognize rows and columns in this manner from the beginning, they will not have to re-orient their interpretation of the words in later mathematics.

Example:

Row 4					
Row 3					
Row 2					
Row 1					
	Column 1	Column 2	Column 3	Column 4	Column 5

Teacher

Note: Somewhere on the chalkboard should be placed 5 pictures. Under these pictures place 1st, 2nd, 3rd, 4th, 5th, so that children will associate the printed ordinal with the spoken as this material is used. (Use "1st" instead of "first," at this time, since children will recognize the numerals but will not be able to read the ordinal words.)

Suggested Activities

1. Play the following game.

Before playing have the children make the columns of desks very straight. Have the children in column one raise their hands. Then the children in column two, etc. Explain that the seat at the front of each column will be the first seat, the next seat will be the second, the next.... Give the ordinals for each seat in the column. To be sure all of the children understand, ask who is sitting in column three, the second seat. Then column two, in the fifth seat.

For our game we will need to say "column two, fifth seat" very quickly. Can anyone think of a different way of saying this? (Lead children to suggest the use of ordinals for columns as well as seats - "second column" instead of "column two.") Explain that when we say you will be in second grade next year, we mean that you will be in grade two. What word do you think we would use in place of the word "one"? What grade are you in when you are in grade one? (First)-Grade three? (Third)-Grade four? (Fourth)-Grade five? (Fifth)-Grade six? (Sixth)-Grade seven? (Seventh)-Grade eight? (Eighth)-Grade nine? (Ninth)-Grade ten? (Tenth). Do this with the whole class, then call on individuals for the answers. Ask who can count to ten using the ordinals. Let several children do this.

Say to the class, "If I were to say 'third column, sixth seat', who would I mean? (Billy) Yes, that's right."

Then go on with the game.

Divide the class into two teams. (Divide the class in half according to seat locations.) All of those on one side of the room will be on one team and those on the other side of the room will be on one team.

Designate a particular aisle to be the dividing line. The children may want to name their teams. For example, the "Tigers", or the "Lions."

Ask who would like to start the game. Choose one of the children and then explain:

"Since Billy is a member of the Tiger's team, he must call on someone from the Lion's team. Whoever he calls on must stand up quickly and call on someone from the Tiger's team before I can count to five slowly."

"There's another rule to this game. When we call on a member from the other team we cannot call his name, we must call his location. In other words, if Billy were going to call on Jim, he would have to say "second column, fifth seat." Then Jim would have to stand up quickly and say the location of someone from the other team such as "third column, second seat." Then Nancy would be the next to stand."

If the person whose location is called doesn't answer in time, the other team will get a point. (Designate an amount of time, such as 10 minutes, for the game to last.) Before starting the game, tell the children to figure out their locations so that they will be ready when they are called.

Another day have the children change seats and play the game. Then they will have a different location.

2. Variation: Locate students by columns and rows, e.g. "Who is in the fifth column, second row?" (Children should learn that the person who is in the fifth column, second row, is different from the person in the second column, fifth row.)
3. Distribute worksheet 6.
4. Read the story "Welcome Home, Kathy" to provide additional contact with the use of ordinals.
5. After the story, distribute worksheets 7-11.

Note: As these worksheets are being used, continue working with concrete objects to help develop an understanding of ordinal position. Use the ordinals in class frequently. For example, "The 3rd person in each set may pass these papers." "Will the 5th person in each set come and tell me how many papers his set needs, etc."

Put a red X on the 3rd (third) horse.

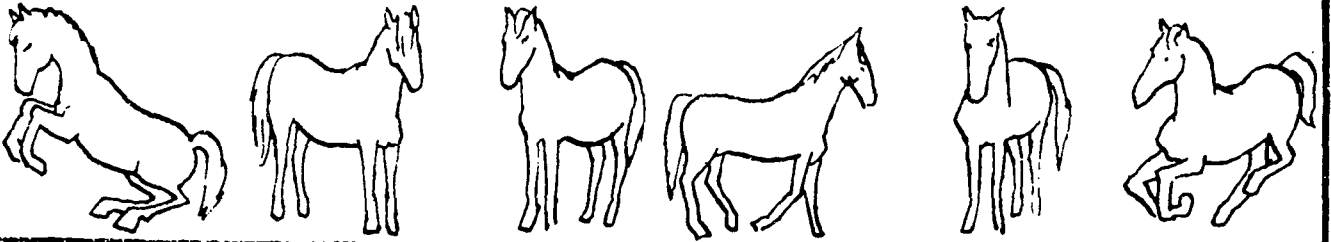

Put a green O on the 1st (first) house.

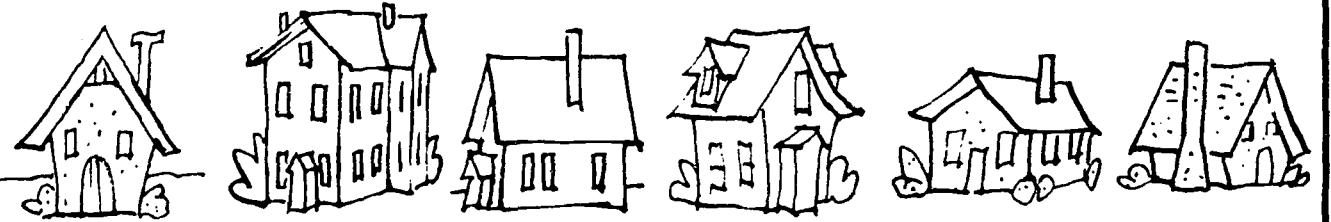

Put a blue X on the 2nd (second) tree.

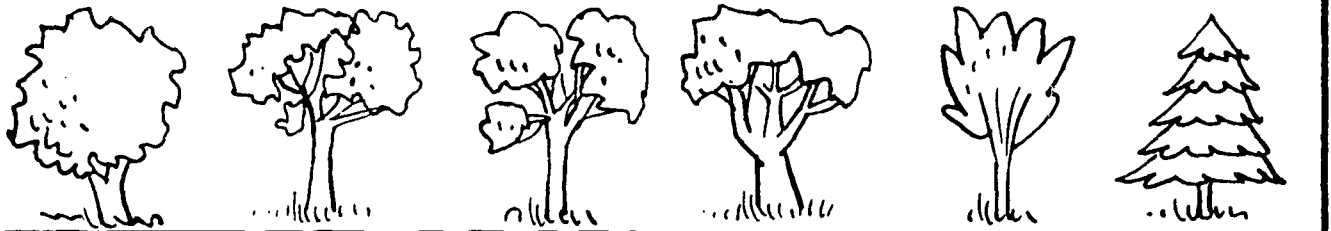

Put an orange O on the 4th (fourth) boy.

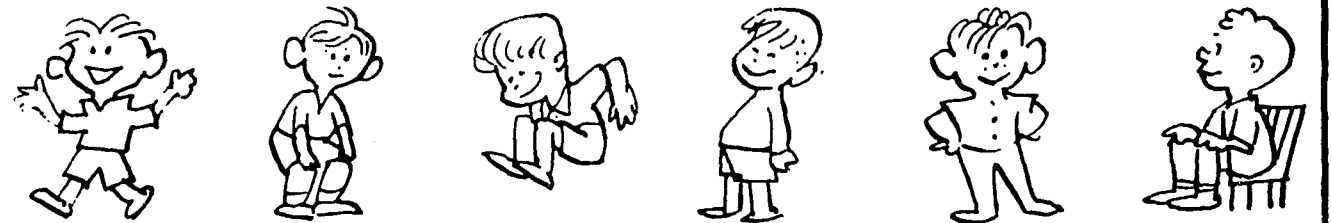

Put a purple X on the 5th (fifth) ball.

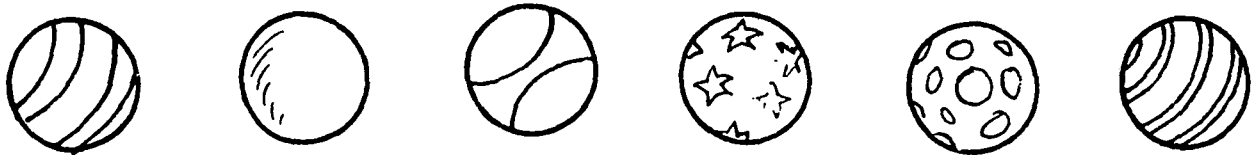

Welcome Home, Kathy

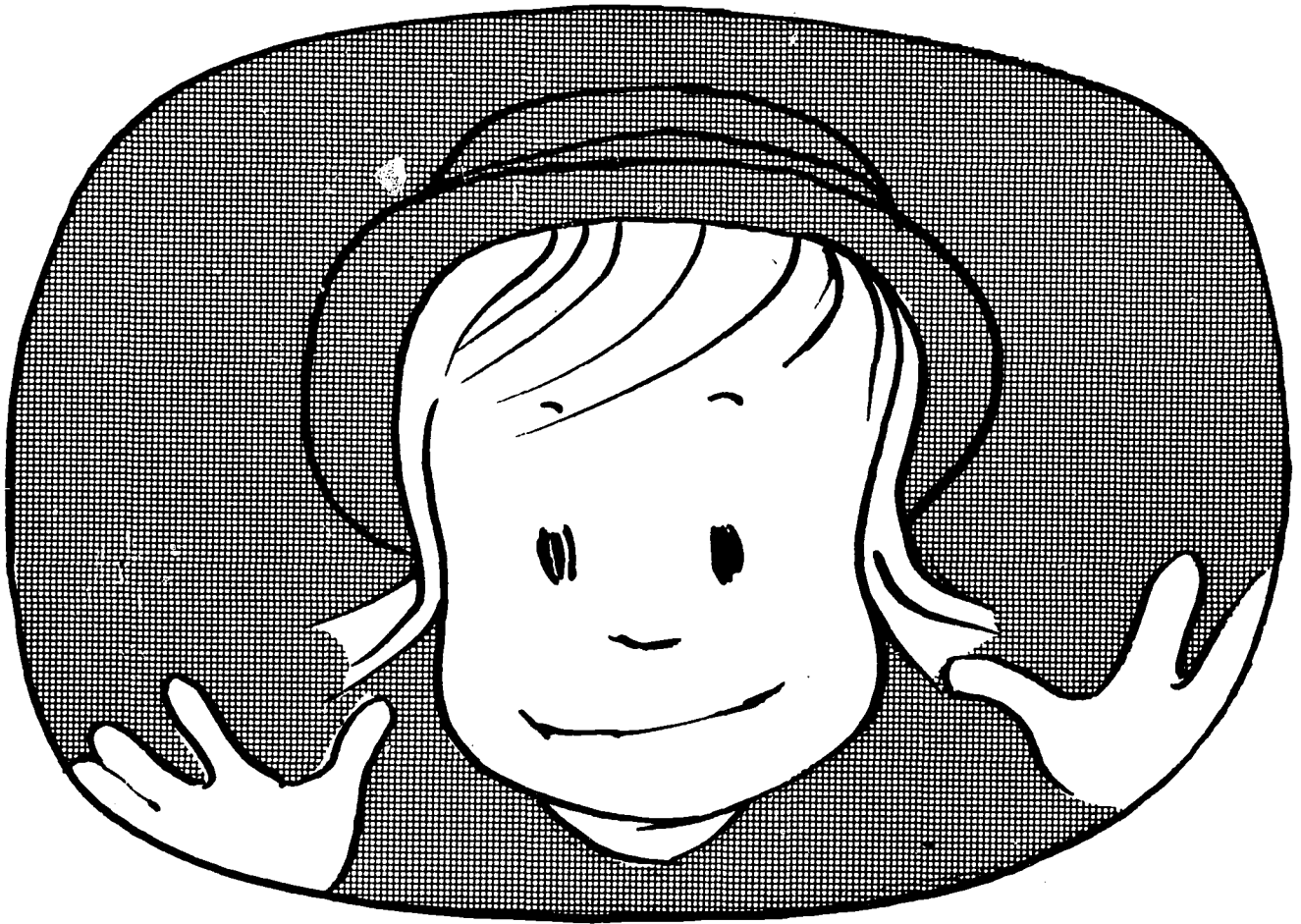

WELCOME HOME, KATHY

Delicious smells are drifting through the kitchen windows, out into the garden, where David and his friends are busy setting the table with the nicest tablecloth, and the prettiest paper cups and plates they could buy. There are blue forget-me-not flowers in a vase. Written in pink icing on a white cake are the words "Welcome Home Kathy." There is a scurrying and a hurrying, a bustling and a hustling. Don't you just wonder what is going on?

Everyone is so busy doing something, that no one has noticed that a taxi-cab has pulled up in front of the house. Out of the taxi-cab now step Grandmother and Grandfather Wright, and a young girl who runs to the door of the house. She rings the bell impatiently, she calls, "Mother, Mother, I'm home. It's me, Kathy. I'm home!"

Mrs. Wright hurries to the door, opens it, and sweeps Kathy into her arms. "Darling, Kathy, how are you? Did you have a good time? How do you feel? Don't cry!"

"I'm not crying," says Kathy, sniffing a little. "It's just that I missed you and Daddy

WELCOME HOME, KATHY



and Ruth Ann and David and Kenny so much. Oh, I love you so Mother!"

"I love you too, darling," says Mother, still hugging her daughter.

It seems as though others love Kathy too. Tookie, who has seen Kathy running to the house, and has followed her, now stands close to her wagging his tail. Fluffpuss rubs her furry coat against Kathy's legs. Kenny nearly knocks her down. He says over and over again, "Kathy has come back! My sister is back!" David comes rushing in and yells, "Hi! Kathy! We're making a surprise party for you, and Ruth Ann baked some cookies, and"

"Oh! Mother," says Kathy excitedly, "Grandma and Grandpa gave me ever so many new toys, and they took me to Niagara Falls. There was so much noise and rumbling as the water from Lake Erie rushed over the cliffs to tumble into the Niagara River that I was quite scared at first. We even had to shout to each other when we talked because the Falls made so much noise. It was so beautiful that we just stood and watched and

WELCOME HOME, KATHY

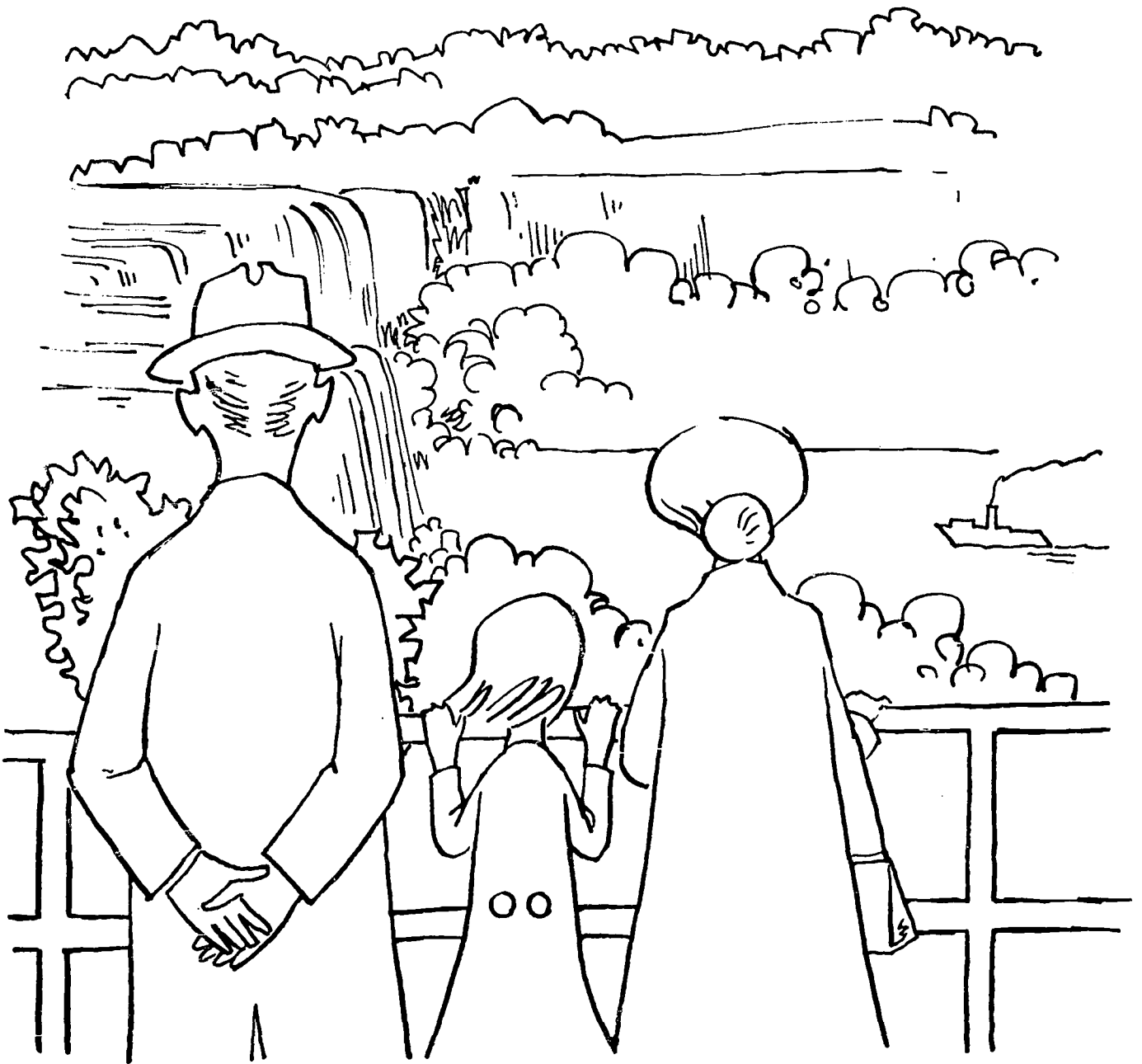

watched. Grandpa Wright says Niagara Falls is so powerful, it produces electricity. I don't quite understand how you get electricity from a rushing waterfall, but if Grandpa says so, it must be true. Oh, Mother! Grandma and Grandpa were so nice to me!"

"Well, I'm glad to hear that," laughs Grandpa Wright, walking into the house with Grandma.

"Kathy was a good girl. We had a lot of fun with her."

"She remembered her manners, and we got along just fine," smiles Grandma giving Kathy a hug.

"I'm proud of you, Kathy," says Mrs. Wright. "And you look so well! I do believe you've grown a bit taller, and have gained a little weight."

"She certainly ate everything on her plate and fell asleep almost as soon as she was in bed..... I'm not surprised she looks healthy," says Grandma.

"I wish I had been at Niagara Falls with you," says David in a sad voice to his grandfather.

"Why did I have to get the measles just as Kathy and I were planning to go with you to Canada? Why couldn't I get the measles another time?"

"Well," smiled Grandfather, "we can't choose

WELCOME HOME, KATHY

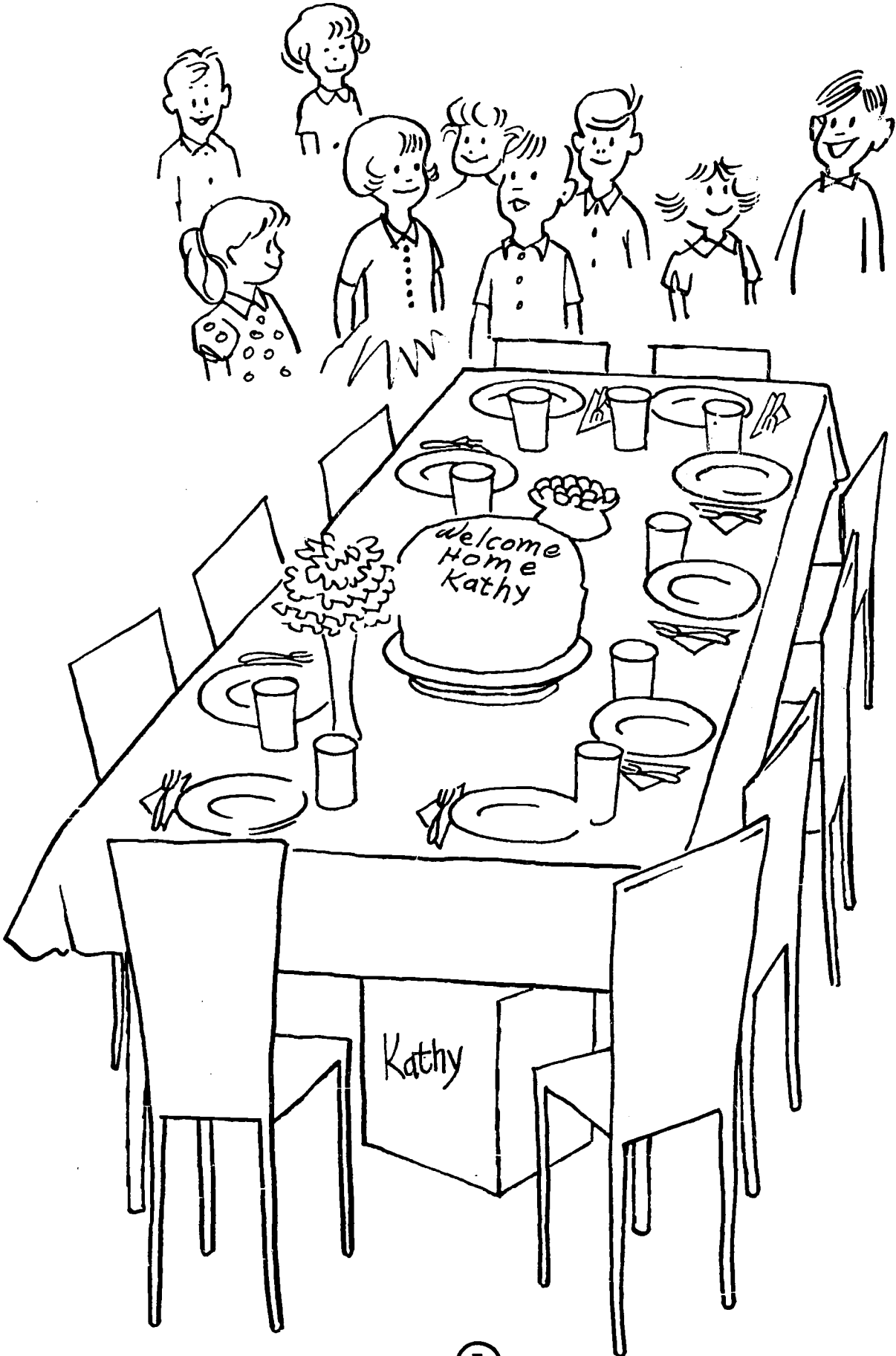

when to become sick. When we're sick, we're sick, and we just have to make the best of it!" He draws David to him, pats his head, and says, "Never mind, David, when you visit us next summer Grandmother Wright and I will make it up to you. We'll take you to Niagara Falls, and to many other places too. Do you suppose that a baseball, a bat, and a mitt will make you happy now? That's what we brought for you. As soon as we unpack you can have them."

David feels happier already and smiles as he says, "Oh, boy! Thanks a lot." He loves playing baseball with his friends. Suddenly he remembers that his friends are in the garden.

"Look! Kathy's back! Everyone look! My sister is back," he yells through the window. "Is the surprise ready for her yet?"

"Yes it is!"

"Kathy, you may come out now....Come on Kathy."

"Come into the garden," ring the voices of her friends.

Kathy walks outside the house and goes to the table. She sees the lovely cake that says "Welcome Home Kathy."

WELCOME HOME, KATHY



"It's beautiful! What a lovely surprise! Thank you very much for planning a surprise party for me..."

"This isn't the only surprise," says Ruth Ann. "We have another surprise ready for you!"

"Another surprise? A second surprise? Two surprises? Where is it? What is it?" Kathy is so excited... Under the table there is a big carton with the name "Kathy" written on it. Don't you just wonder what is in it?

So does Kathy, as she quickly opens the carton and takes out all the packages. She looks at them and then opens the one marked "First Surprise." One big lovely ball comes bouncing out. Then Kathy opens the second package marked "Second Surprise" and finds two pretty aprons. When Kathy opens the package marked "Third Surprise," she finds three stuffed bears - Mama Bear, Papa Bear and Baby Bear.

WELCOME HOME, KATHY

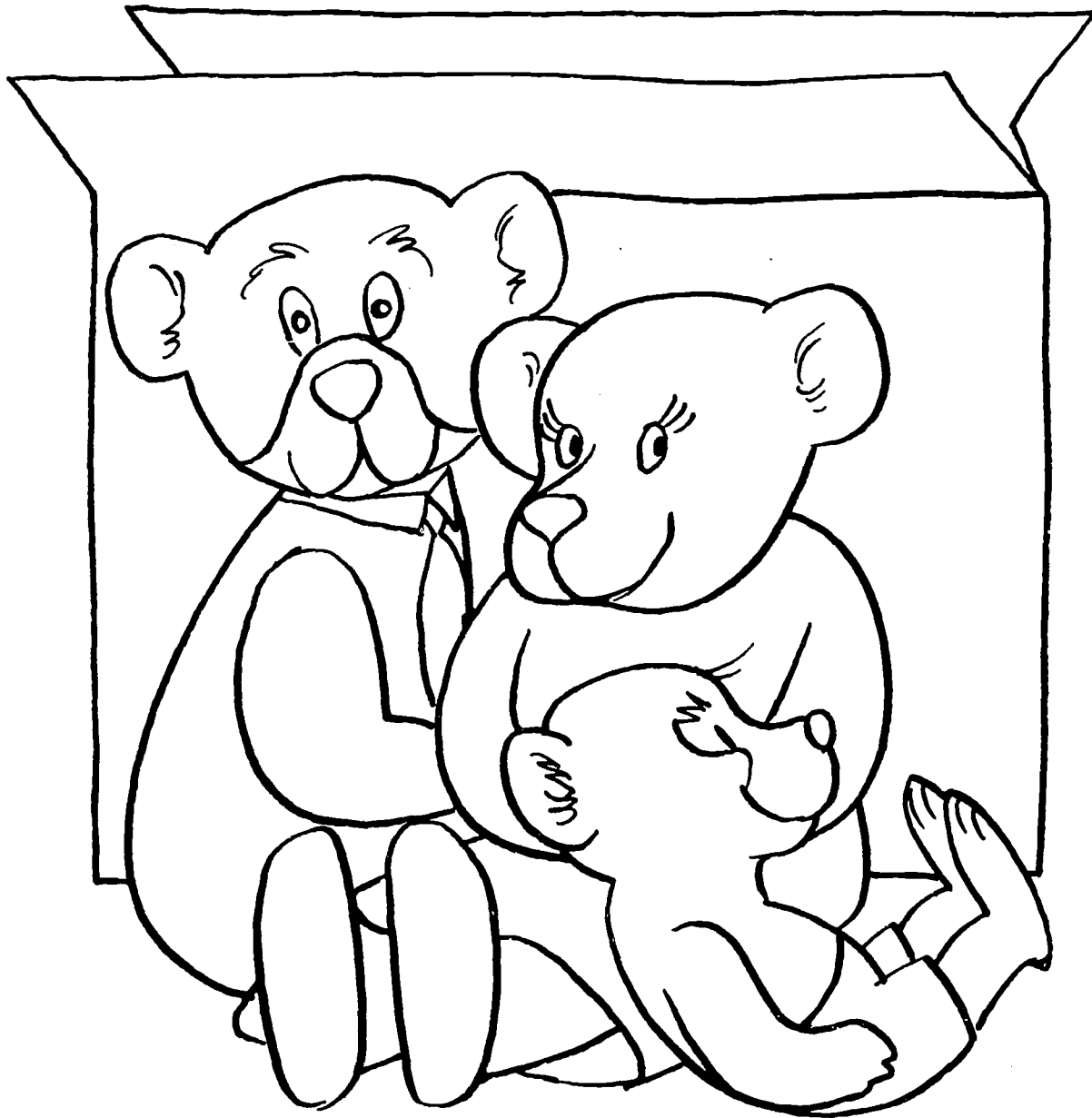

Do you think there are any more surprises for Kathy? There are! There is one package from each friend. There are nine friends at the party.

Next Kathy opens the package marked "Fourth Surprise" and finds four shiny hair ribbons. In the package marked "Fifth Surprise" are five pretty handkerchiefs. Kathy is so excited with all these surprises that she almost opens the one marked "Seventh Surprise," but Ruth Ann who has been helping her says, "After five comes six, so after fifth, comes sixth..."

So Kathy opens the "Sixth Surprise" and six little books fall out. She loves to read.

"Do I open the "Seventh Surprise now?" asks Kathy.

"Yes," says Ruth Ann, smiling at her sister.

In the seventh package, Kathy finds seven paper doll cutouts.

"Now the eighth?"

"That's right...."

"WELCOME HOME, KATHY"



WELCOME HOME, KATHY

In the eighth package Kathy finds a bracelet with eight charms on it. "Now the ninth package! I open the last one now!"

Were there nine books in the ninth package? No. Were there nine marbles? No. What do you suppose Kathy finds in the ninth package? In the ninth package, she finds a photograph of each of her friends..she finds nine photographs, and one big letter that says "Welcome home, Kathy. We missed you. You are a good friend."

Kathy is so happy she doesn't quite know what to say. What would you say? Thank you? That's exactly what Kathy says, "Thank you" to every one of her nine friends.

Then they all sat down to eat the cake.

WELCOME HOME, KATHY

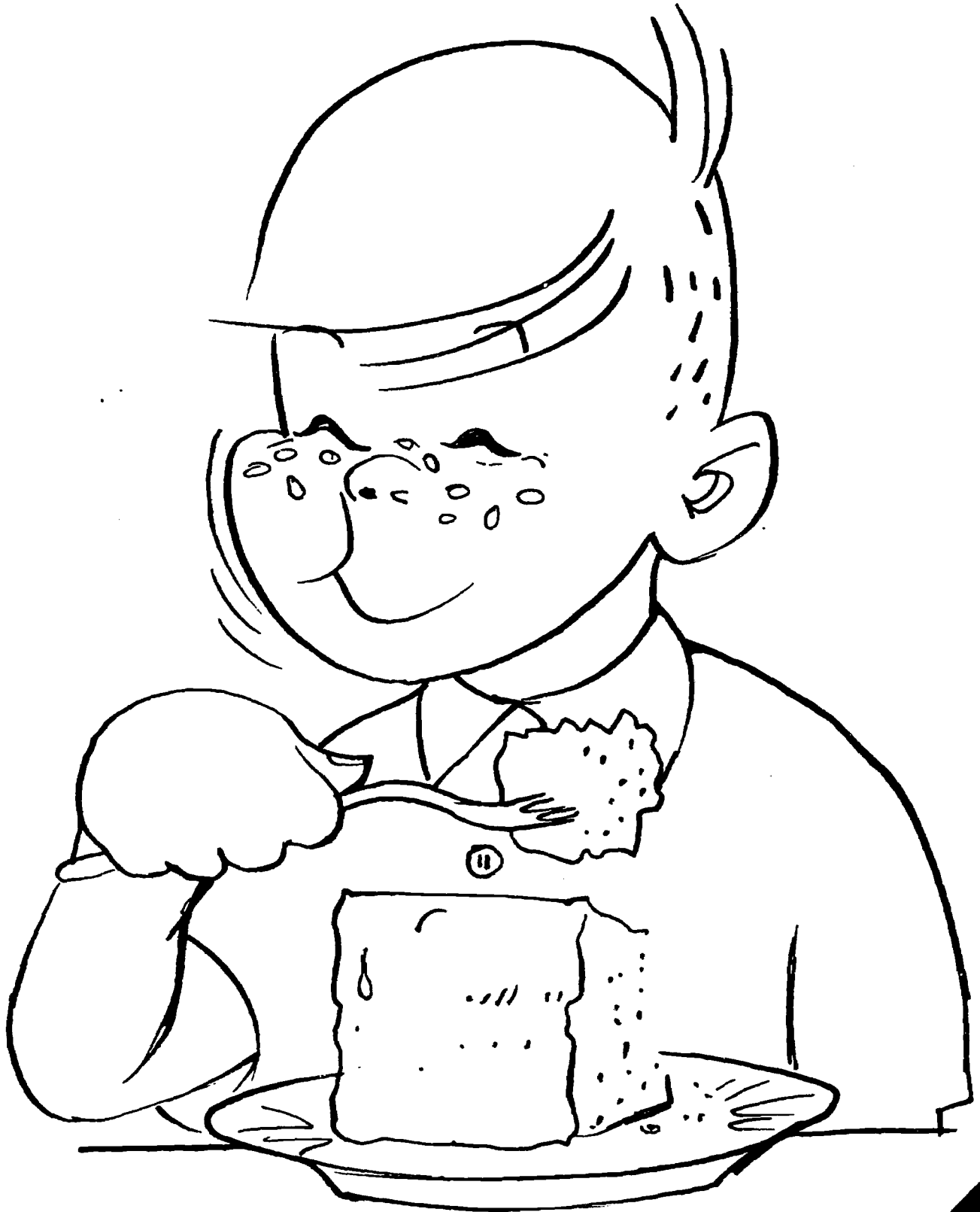

Commentary for Worksheets 7 and 8

Distribute worksheet 7 and the cut-outs for it. (The cut-outs are on the page following the worksheet.) Teacher should be available to help as needed.

Distribute worksheet 8 and the cut-outs for it. This worksheet will need to be carefully guided, with teacher's help available as children need it.

The cut-outs for this worksheet are on the following page. Cut them out and paste the boxes in order. Put the 1st (first) in the number 1 box.

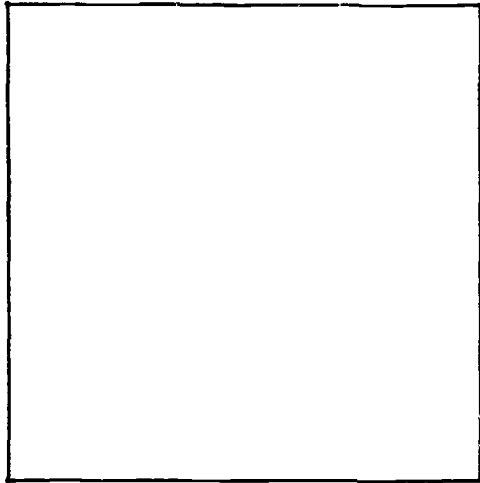

1

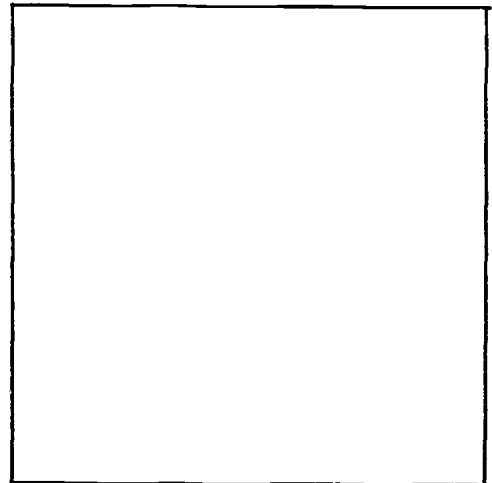

2

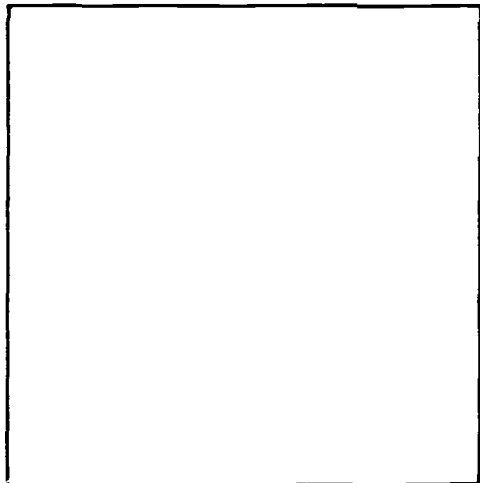

3

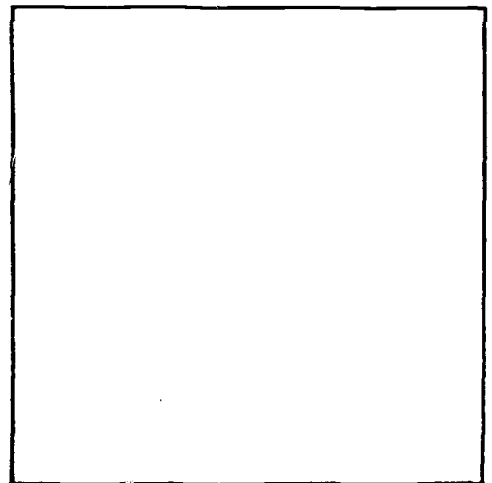

4

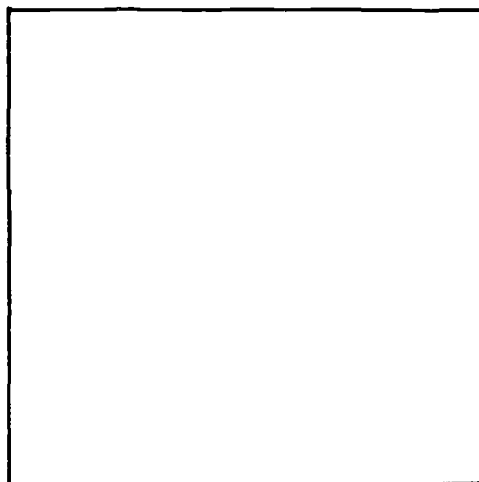

5

Cut-outs for Worksheet 7

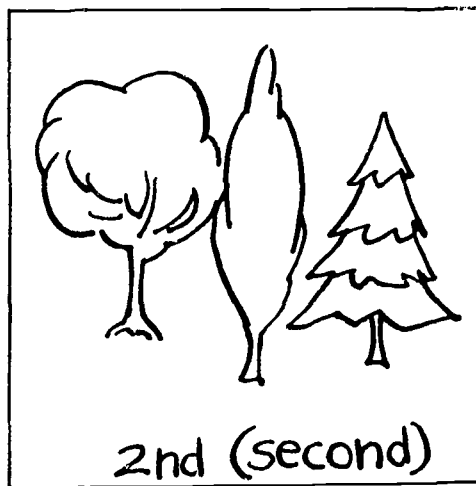
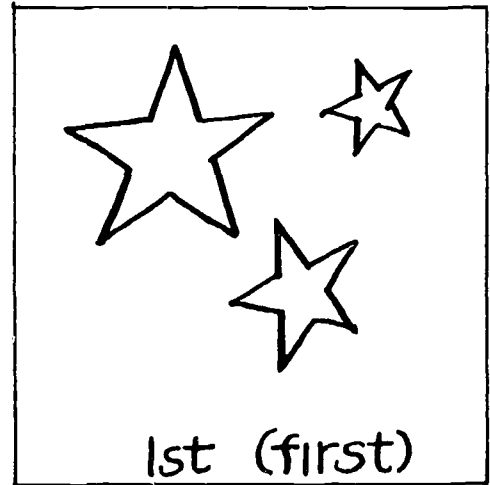
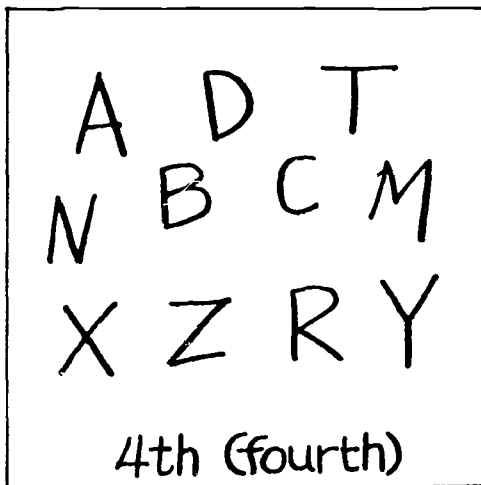
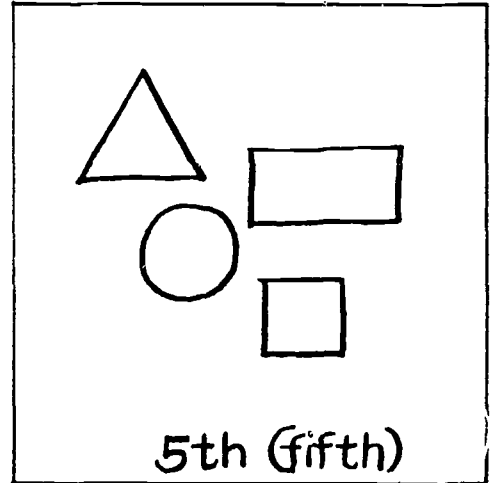
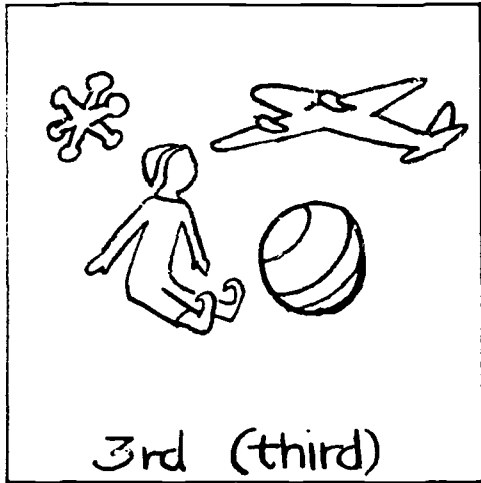

Row 2

Box 1	Box 2	Box 3	Box 4	Box 5
-------	-------	-------	-------	-------

Row 1

Box 1	Box 2	Box 3	Box 4	Box 5
-------	-------	-------	-------	-------

Cut out the boxes from Set A, on the next page. Paste them in Row 1. Start by pasting "1st" (first) in box 1. Paste them

Set A contains cut-outs for Row 1, Worksheet 8.

Set A

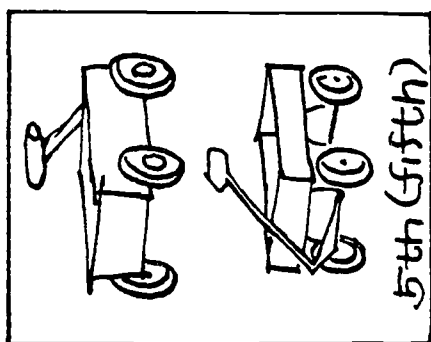
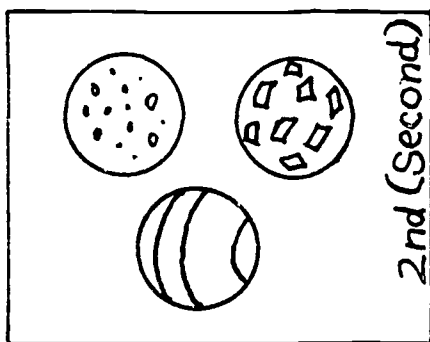
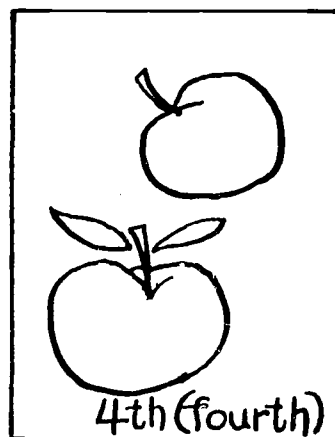
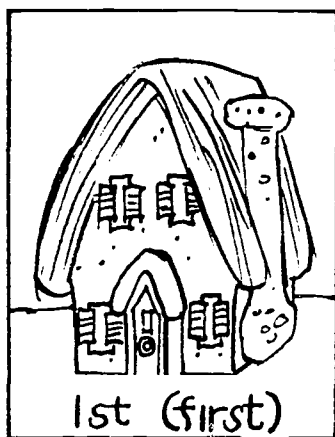
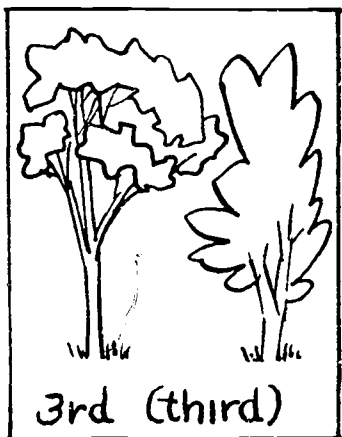

Set B contains cut-outs for Row 2, Worksheet 8.

Set B

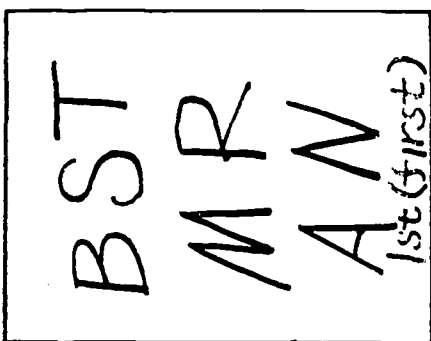
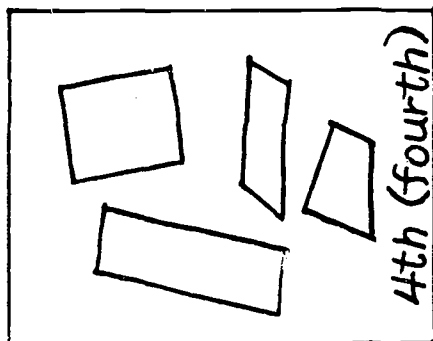
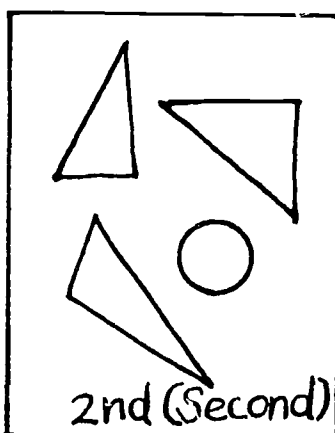
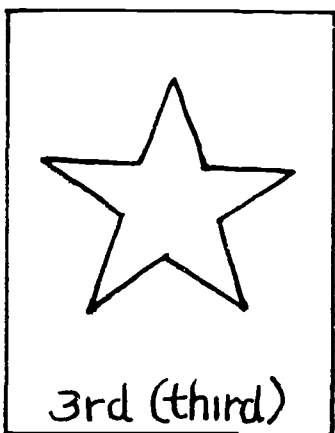
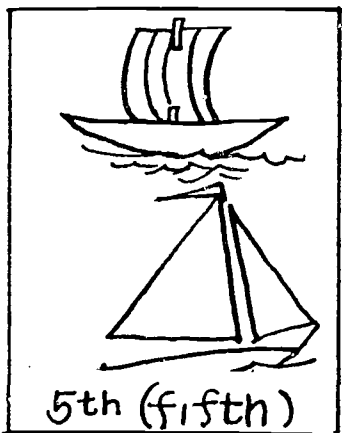

Commentary for Worksheet 9

Worksheet 9 contains 5 rows of assorted objects, Above each row is a sentence which needs completion by the insertion of the proper ordinal number. Have each member of the class cut out the boxes of ordinal numerals at the bottom of the page and paste them in the appropriate blanks in order to complete each sentence correctly. For example, in the first row of objects the ball appears in the fourth place. In order to complete the sentence correctly the child must paste the box containing the 4th on the blank. In this way the sentence will then read: "The ball is the 4th object."

The ball is the _____ Object

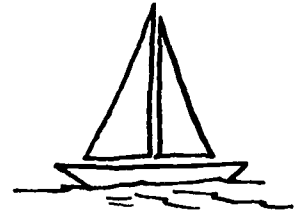
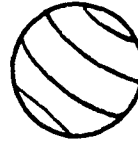
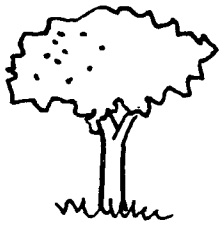

The clown is the _____ Object

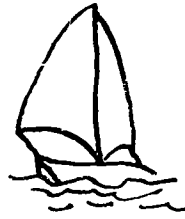
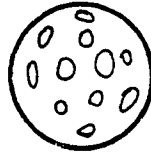

The boy is the _____ Object

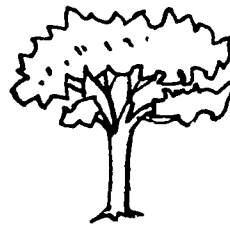
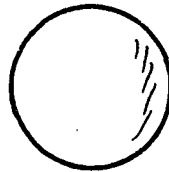
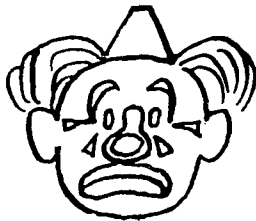

The house is the _____ Object

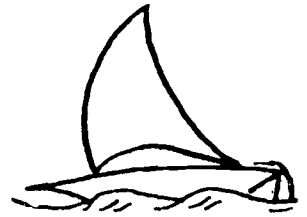
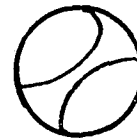

The tree is the _____ Object

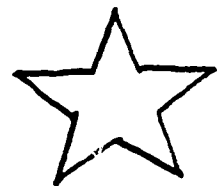
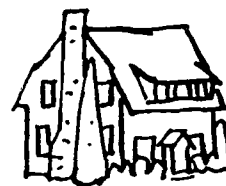

1st

2nd

3rd

4th

5th

Commentary for Worksheets 10 and 11

Worksheets 10 and 11 each contain two sets of empty boxes placed in two rows. Cut outs for these worksheets are on the pages following them.

For Worksheet 10 instruct the children to cut out the boxes of objects in Set A and paste them, in any order they wish, into the empty boxes in Row 1 on Worksheet 10. (Be sure they understand that the pictures in Set A are for Row 1 and the pictures in Set B are for Row 2.)

Then the boxes containing the ordinals are to be pasted in order under the boxes that have been pasted on Worksheet 10. (Call attention to the fact that they will start at the empty box on the left with the first.)

Following the completion of Worksheet 10 discuss the different positions that each child has selected for specific boxes. (e.g., "Who placed the box with the dog in it in the first position in Row 1?" or "In which position in Row 2 have you placed the clown, Mary?")

List on the chalkboard the ordering chosen by one child in Row 1. For example:

	First	second	third	fourth	fifth
Jack	tree	house	boat	bicycle	dog

Then ask, "In Jack's ordering what rank (1st, 2nd, etc.) is your first one, Jim?" etc. Use many children and both rows.

Follow the same procedure for Worksheet 11. This Worksheet may be omitted if the reinforcement is not needed.

Here are 2 sets of empty boxes - Row 1 and Row 2. Cut out the boxes of objects in Set A. Paste them in Row 1, in any order. Then cut out the ordinals. Paste them in the right order beginning with "1st".

Row 1

--	--	--	--	--

In Row 2 paste the cut-outs from Set B, in any order. Add the ordinals.

Row 2

--	--	--	--	--

Set A contains cut-outs for Row 1, Worksheet 10.

Set A

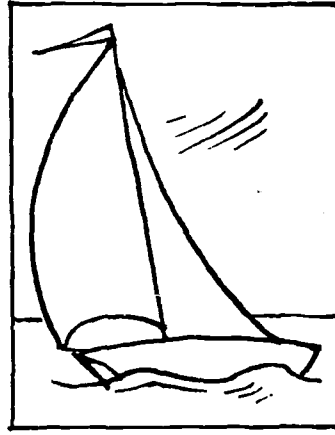
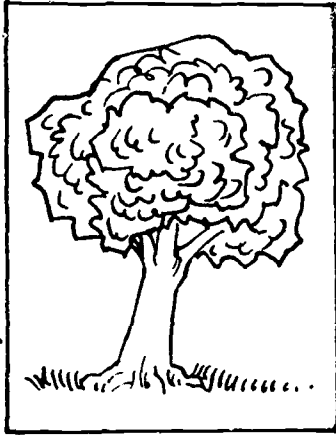

3rd

5th

Set A

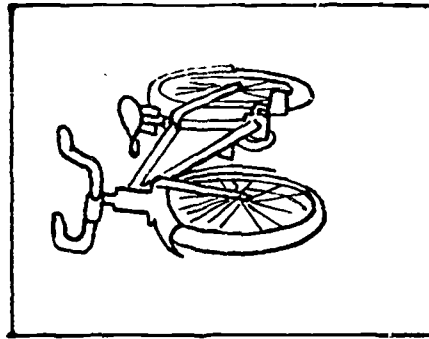
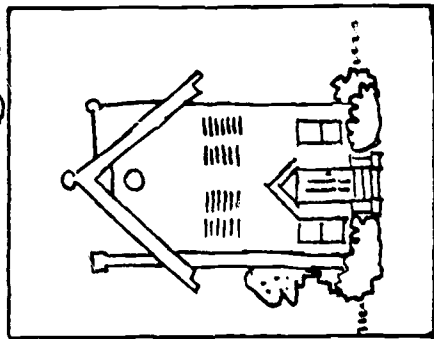

1st

4th

2nd

Set B

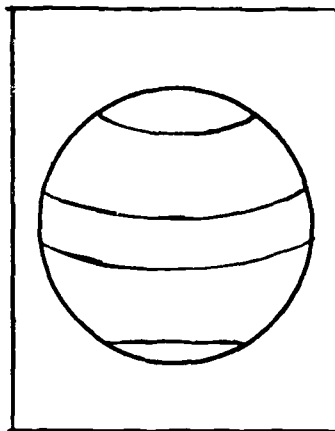
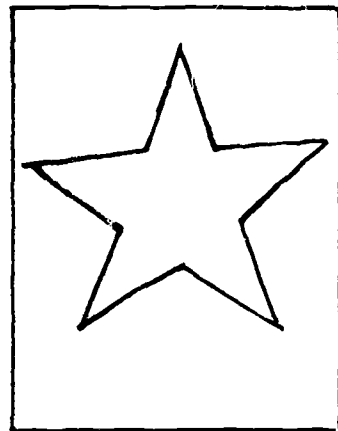

2nd

1st

Set B

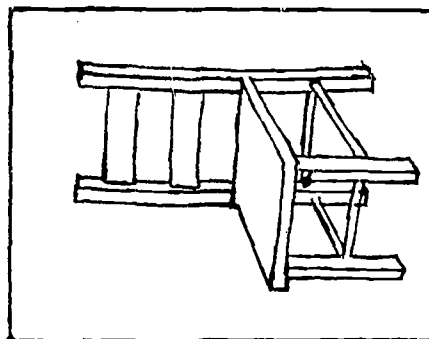
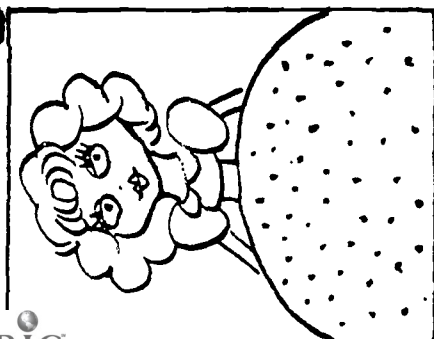

5th

3rd

4th

Set B contains cut-outs for Row 2, Worksheet 10.

Row 2

--	--	--	--	--	--

Row 1

--	--	--	--	--	--

Here are 2 sets of empty boxes - Row 1 and Row 2. Cut out the boxes of objects in Set A. Paste them in Row 1, in any order you wish. Then cut out the ordinals. Paste them in the right order beginning with "1st".

Set A contains cut-outs for Row 1, Worksheet 11.

Set A

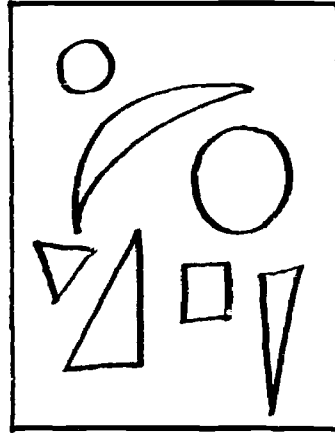
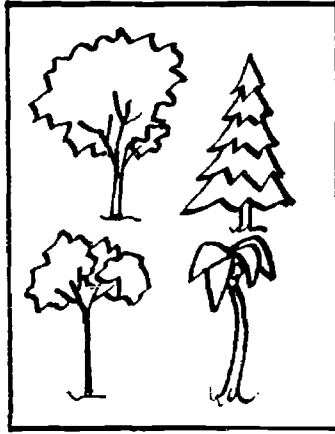
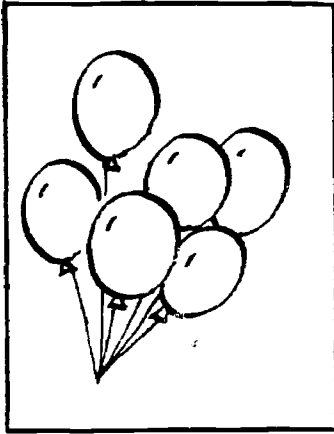

1st

3rd

Set A

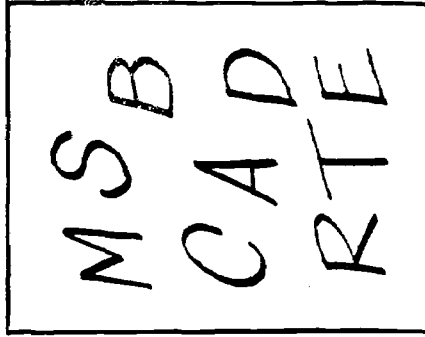
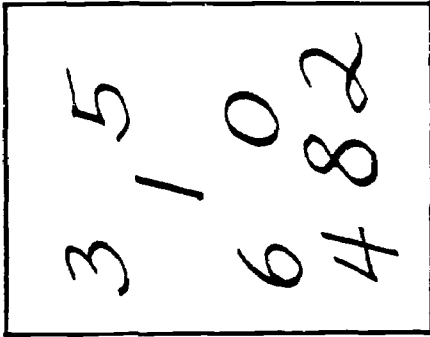

5th

4th

2nd

Set B

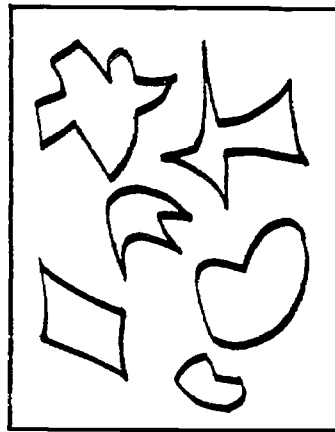
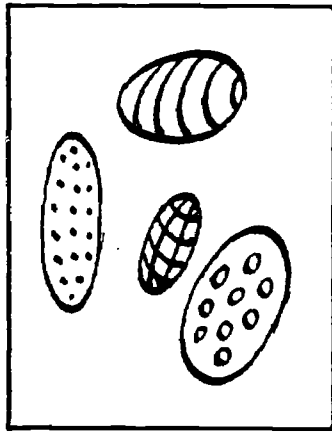
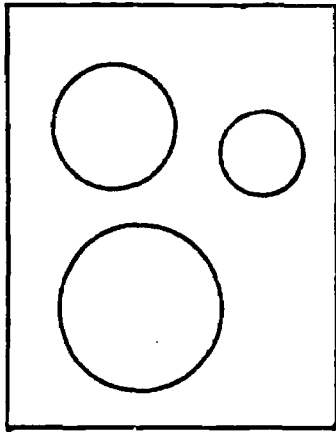

5th

2nd

Set B

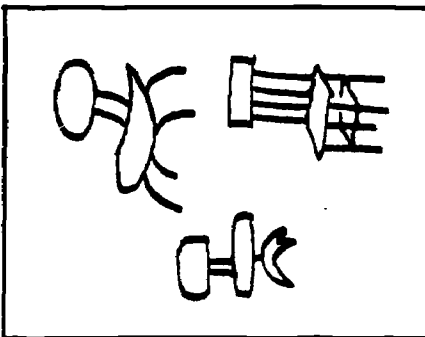
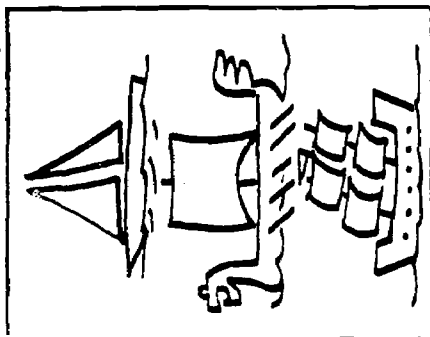

1st

3rd

4th

Set B contains cut-outs for Row 2, Worksheet 11.

Suggested Activity

In order to illustrate to the children that the same set can be ordered in different ways depending upon its different characteristics, the following exercise may be used.

Select five or six children from the class all of whom have last names beginning with different consecutive letters in the alphabet. For example: Anderson, Brown, Campbell, Davis, and Edwards. If there are not children with these letters, start at another point in the alphabet such as J, K, L, M, and N to try to get children with last names that fall in consecutive order.

Next, line these children up in front of the room in alphabetical order and designate their order by telling the class which child is 1st, which is 2nd, 3rd, 4th, and 5th. Now reorder the children according to their comparative heights, placing the tallest child in the 1st position and the shortest child in the 5th position. The class may be asked questions such as:

Do we still have the same set of children?[yes] Is the same child in the 1st position? 2nd? etc. Do the members of a set always have to be in the same order? [no]