

DOCUMENT RESUME

ED 094 954

SE 016 279

TITLE Course Manual for X-Ray Applications.
INSTITUTION Food and Drug Administration (DHEW), Rockville, Md.
Bureau of Radiological Health.; Oregon State Univ.,
Corvallis. Dept. of General Science.
REPORT NO DHEW-FDA-73-8028
PUB DATE Jan 73
NOTE 155p.; Related documents are SE 016 277 and 278
AVAILABLE FROM Superintendent of Documents, U.S. Government Printing
Office, Washington, D.C. 20402

EDRS PRICE MF-\$0.75 HC-\$7.80 PLUS POSTAGE
DESCRIPTORS *Course Content; Curriculum; *Curriculum Guides;
Engineering Education; *Instructional Materials; Post
Secondary Education; *Professional Education;
Professional Training; *Radiation; Radiation
Effects

ABSTRACT

This publication is the third of three sequential course manuals for instructors in x-ray science and engineering. This course manual has been tested by introducing it into the Oregon State University curriculum. The publication is prepared for the purpose of improving the qualifications of x-ray users and to reduce the ionizing radiation exposure of workers and patients. The course manual contains lecture outlines, laboratory exercises, and examinations. References, required equipment, and materials are listed. The purposes, teaching aids, materials, time recommended, and reference materials are suggested for each lecture and laboratory exercise. The equipment listed has been identified by model and manufacturer, but a substitute model of equipment is possible with alterations in the course content whenever required. Some of the lecture and laboratory exercises are x-ray film, x-ray screen, medical radiography, dental radiography, research application of x-rays, x-ray therapy, x-ray film development, and sensitometric properties of medical x-ray film. Three examinations are included.
(PS)

PHS

SE

ED 094954

U.S. DEPARTMENT OF HEALTH,
EDUCATION & WELFARE
NATIONAL INSTITUTE OF
EDUCATION

THIS DOCUMENT HAS BEEN REPRODUCED EXACTLY AS RECEIVED FROM THE PERSON OR ORGANIZATION ORIGINATING IT. POINTS OF VIEW OR OPINIONS STATED DO NOT NECESSARILY REPRESENT OFFICIAL NATIONAL INSTITUTE OF EDUCATION POSITION OR POLICY.

COURSE MANUAL for X-RAY APPLICATIONS

BEST COPY AVAILABLE

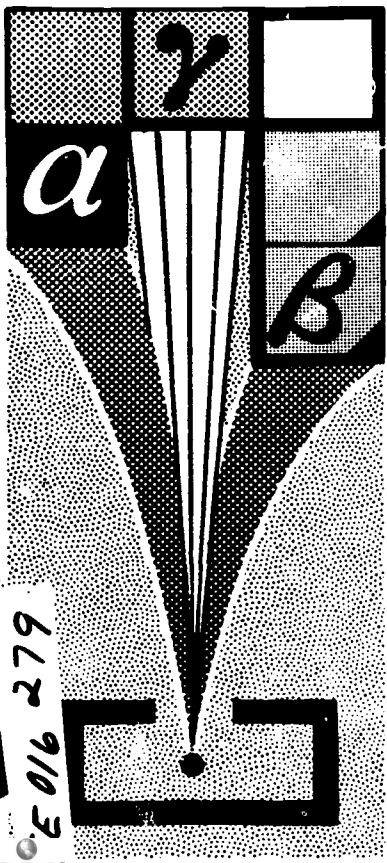
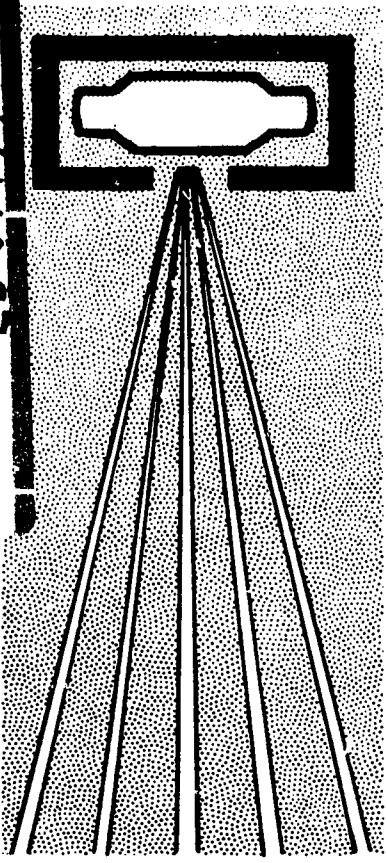

ED 016 279

U.S. DEPARTMENT OF HEALTH, EDUCATION, AND WELFARE
Public Health Service
FOOD AND DRUG ADMINISTRATION

ERIC
Full Text Provided by ERIC

TECHNICAL REPORTS

Technical reports of the Division of Medical Radiation Exposure, Bureau of Radiological Health, are available from the National Technical Information Service, Springfield, Va. 22151, when a PB number is indicated after the title. Microfiche copies are \$0.95; prices for paper copies are indicated after the PB number. Bulk order prices are available from NTIS. The PB number should be cited when ordering. Some reports are also available from the Superintendent of Documents, U.S. Government Printing Office, Washington, D.C. 20402, as indicated after the title.

PHS 1559	Physical Survey Manual Dental X-ray (PB 183 019 \$6)
PHS 1582	Radiation Protection Survey Report Manual (PB 183 018 \$6)
PHS 1663	KWIC Index to the Journal of the Health Physics Society (1958-1966) (PB 176 092 \$6)
PHS 1831	KWIC Index to the Journal of Nuclear Medicine (1960-1967) (PB 179 074 \$6)
PHS 999-RH-29	Tritium Contamination in Particle Accelerator Operation (PB 189 362 - \$6)
PHS 999-RH-30	Reduction of Radiation Exposure in Nuclear Medicine (PB 178 129 \$6)
PHS 999-RH-34	Georgia Radium Management Project (PB 189 359 \$6)
MORP 67-1	X-ray Emission from Shunt Regulator Tubes for Color Television Receivers (PB 184 546 - \$6)
MORP 67-2	Radium Disposal Project (PB 184 096 - \$6)
MORP 67-3	Radium Source Integrity Testing Progress Report (PB 184 095 - \$6)
MORP 67-4	Design of Interlocked Radium Shipping Container (Being revised)
MORP 67-5	A Summary Report on X-ray Diffraction Equipment (PB 183 333 - \$6)
MORP 67-6	Georgia Radium Management Project. . .Phase II (See PHS 999-RH-34)
MORP 67-7	Decontamination Study of a Family Dwelling Formerly Used for Radium Processing (Preliminary Copy) (Being revised)
MORP 68-1	A Collection of Radium Leak Test Articles (PB 178 479 - \$6)
MORP 68-2	Recommendations for the Safe Operation of Particle Accelerators (PB 182 855 - \$6)
MORP 68-3	A System for the Registration of Radiation Sources (PB 178 465 - \$6)
MORP 68-4	Medical Surpak Summary Report (PB 180 525 - \$6)
MORP 68-5	The Use of Radium in Consumer Products (Supt. of Doc., GPO-40c) (PB 182 717 - microfiche only)
MORP 68-6	Preliminary Results of 5263 X-ray Protection Surveys of Facilities with Medical X-ray Equipment (1962-1967) (PB 180 526 - \$6)
MORP 68-7	A Review and Analysis of Radium Incidents (PB 180 527 - \$6)
MORP 68-8	Dental X-ray Teaching and Training Replica (PB 182 854 - \$6)
MORP 68-9	Development and Evaluation of an Automatic Collimator for Medical Diagnostic X-ray Machines (PB 180 528 - \$6)
MORP 68-10	Survey of the Use of Radionuclides in Medicine: Preliminary Report (Superseded by BRH/DMRE 70-1)

(continued on inside of back cover)

ED 094954

COURSE MANUAL for X-RAY APPLICATIONS

(U. S. U. Course GS-463)

Prepared by

The X-Ray Science and Engineering Laboratory
Oregon State University

under

Contract No. PH 86-65-92

Project Director:

E. Dale Trout, Director
X-Ray Science and Engineering Laboratory

Project Officer:

Arve H. Dahl, Acting Director
Division of Medical Radiation Exposure

JANUARY 1973

U.S. DEPARTMENT OF HEALTH, EDUCATION, AND WELFARE
Public Health Service
FOOD AND DRUG ADMINISTRATION
Bureau of Radiological Health
Rockville, Maryland 20852

FOREWORD

The Bureau of Radiological Health implements a national program designed to reduce the exposure of man to hazardous ionizing and non-ionizing radiation.

Within the Bureau, the Division of Medical Radiation Exposure deals with 1) the reduction of unproductive ionizing radiation exposure of patients, workers and others exposed by the use of x rays and other machine-produced ionizing radiation, radioactive materials and radio-pharmaceuticals, and 2) the improvement of radiological "systems" and methodology in the healing arts. A number of projects and studies are aimed at assessing and minimizing radiation exposure in the healing arts and increasing efficiency in the use of radiation in clinical practice. Several projects are directed toward assessing and improving the qualifications of x-ray users in the healing arts.

Results of intramural and contractor projects of general interest are published as technical reports by the Division of Medical Radiation Exposure and distributed to State and local radiological health program personnel, Bureau technical staff and advisory committee members, university radiation safety officers, libraries and information services, industry, hospitals, laboratories, schools, the press and other interested individuals.

Contract reports on highly specialized topics are printed and distributed without editorial revision. Copies of both general interest and limited distribution reports may be purchased from the National Technical Information Service.

I encourage the readers of these reports to inform the Bureau of any omissions or errors. Your additional comments or requests for further information are also solicited.

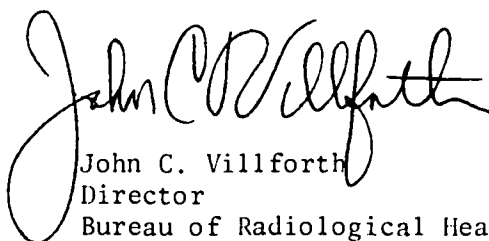
John C. Villforth
Director
Bureau of Radiological Health

PREFACE

Since June 1965, Oregon State University's Department of General Science has been supported by the Bureau of Radiological Health through Contract No. PH 86-65-92 to organize, develop, and conduct a teaching and training program in x-ray science and engineering; and conduct related research, evaluation, and development activities. The project was made possible by the presence of the internationally recognized x-ray expert Dr. E. Dale Trout, Professor of Radiological Physics, who serves as the Project Director. The Assistant Project Director, John P. Kelley, Associate Professor, Department of General Science, is also a nationally recognized expert in the fundamentals and use of x-radiation.

This document, one of three instructor course manuals in x-ray science and engineering, is one of the project's significant contributions to radiological health. The three manuals have been tested in courses introduced into the university curriculum. They are presented in such form that they can be used as models for similar programs in other institutions.

It is appropriate to acknowledge other accomplishments of the project. The project has provided the following staff of the Bureau of Radiological Health with training and supervision in research, evaluation, and developmental work in x-ray science and engineering: Robert L. Elder, Sc.D.; Gregory J. Barone, Ph.D.; Bruce M. Burnett, M.S.; William S. Properzio, M.S.; Kenneth R. Envall, M.S.; Kenneth E. Weaver, M.S.; and Richard E. Gross, M.S.

Reports have been presented at professional meetings and published in the open scientific literature on evaluations of instruments used in x-ray measurements, methodology devised for evaluation of x-ray protective devices and materials, and methodology and instrumentation developed for measurement of x radiation. The project staff has also analyzed and reported to the Bureau regularly on related developments presented at annual meetings of the American College of Radiology, Radiological Society of North America, American Roentgen Ray Society, American Association of Physicists in Medicine, Health Physics Society, and the American Society of Radiologic Technologists.

A model complete x-ray instructional facility known as the X-Ray Science and Engineering Laboratory has been developed containing modern x-ray equipment, electronic and mechanical shops, classroom, office and support space.

Special acknowledgement is also made of the contract support provided to the project during the last 2 years by the National Institute for Occupational Safety and Health because of their need for research and development assistance on production of better quality radiographs for the coal miner pneumoconiosis control program. Acknowledgement is also made of past contributions in development of this project by Dr. Donald R. Chadwick, Mr. James G. Terrill, Jr., and Dr. Russell I. Pierce for the Bureau and by Dr. James H. Jensen, President of Oregon State University at the time the project was started, and Milosh Popovich, Dean of Administration for the University.



Arve H. Dahl, Project Officer

Acting Director
Division of Medical Radiation Exposure
Bureau of Radiological Health

CONTENTS

	Page
FOREWORD	ii
PREFACE	iii
INTRODUCTION	vi
 <u>SECTION I - LECTURES</u>	
1. X-Ray Film	1
2. Latent Image Formation	7
3. X-Ray Film Processing	12
4. Sensitometric Properties of X-Ray Film	20
Problem Set No. 1	28
5. X-Ray Screens	34
6. Radiographic Definition	41
7. X-Ray Grids	47
8. Medical Radiography	53
9. Dental Radiography	57
10. Industrial Radiography	62
11. Research Application of X Rays	66
12. Analytical and Special Industrial Uses of X Rays	68
13. X-Ray Therapy	72
 <u>SECTION II - LABORATORY EXERCISES</u>	
1. X-Ray Film Development	74
2. Sensitometric Properties of Direct Exposure X-Ray Film	84
3. Sensitometric Properties of Medical X-Ray Film	90
4. Introduction of Radiography	102
5. Medical and Dental Radiography	108
6. Industrial Radiography	113
 <u>SECTION III - EXAMINATIONS</u>	
Test No. 1	117
Test No. 2	126
Final Examination	130
 <u>APPENDICES</u>	
A. Materials List	131
B. References	133
C. Sensitometer	136

INTRODUCTION

There are three course manuals in this set. They are used by instructors in the Department of General Science at Oregon State University for planning and presenting a three-course sequence in x-ray science and engineering. The courses, which are offered each year, are open to both undergraduate and graduate students and must be taken in sequence. They are:

GS-461 Machine Sources of X Rays - Fall Term

GS-462 X-Ray Measurements - Winter Term

GS-463 X-Ray Applications - Spring Term

Each is a 3-credit-hour course and consists of two 1-hour lectures and one 3-hour laboratory each week. In the 6 years the course manuals have been used, classes have included students from programs in pre-dentistry, pre-medicine, pre-veterinary medicine, biology, oceanography, physics, engineering, chemistry, education, geology, pharmacy, physiology and agriculture. It is assumed that students will have no x-ray experience but that they will have had at least 1 year's work in college level physics and mathematics.

The course manuals contain lecture outlines, laboratory exercises, and examinations. References, required equipment, and materials are listed. Each lecture and each laboratory exercise is essentially self-contained to permit other schools to select material on the basis of available time and equipment and the objectives of their instructional program. In presenting the subject matter in as uncomplicated a form as possible,

some concepts may have suffered from oversimplification, but the instructor can easily increase the degree of sophistication to the limit of student understanding. It is our belief that full appreciation and understanding of the subjects presented requires laboratory experience. Nonetheless, we are sure that the lecture material alone could be presented as review material or as indoctrination material to a group where x rays might be of peripheral interest. Selected sections from the course manuals have been used as source material for a one-quarter course in Continuing Education and for 2-day working topical seminars.

One of the most frustrating aspects of preparing teaching material is the ever-changing situation in regard to references. New books and technical papers make any list of references obsolete before it appears in print. The instructor must add references as they become available. The references cited must always reflect the experience, interests, and objectives of the instructor, the institution, and the students.

Equipment has been identified by model and manufacturer; instructors may substitute equivalent equipment or alter course content to make use of available equipment. This method of identification does not constitute a recommendation of particular equipment by either Oregon State University or the Bureau of Radiological Health, United States Department of Health, Education, and Welfare.



E. Dale Trout, D.Sc., Project Director

Director
X-Ray Science and Engineering Laboratory
Oregon State University

GS-463 X-RAY APPLICATIONS

SECTION I

LECTURES

LECTURE NO. 1

TITLE: X-Ray Film

PURPOSE: To outline the history of photographic and radiographic film and discuss the composition and manufacture of x-ray film

TIME: One hour

VISUAL AIDS: Blackboard

HANDOUTS: None

REFERENCES: Attix, Roesch and Tuchilin
Radiation Dosimetry

Eastman Kodak Company
Medical Radiography and Photography
Vol. 46, No. 3, 1970

Mees and James
The Theory of the Photographic Process

X-RAY FILM

I. History

A. Early history of photographic film

1. 1802 - silhouettes on glass recorded by contact printing on paper coated with silver chloride. Images were transient
2. 1816 - film used in camera produced transient negative image
3. 1839 - basis for chemical development of photo sensitive materials established
4. 1840 - negative positive photography established
5. 1847 - paper negatives used until 1847. Glass plates coated with albumen emulsion introduced
6. 1851 - wet collodion glass plates
7. 1871 - dry gelatin glass plates
8. 1879 - mechanically coated gelatin glass plates
9. 1885 - stripping film with paper emulsion support
10. 1889 - cellulose nitrate emulsion support
11. 1890 - science of photographic sensitometry by Hurter and Driffield

B. Radiographic film

1. 1895 - photographic glass plates
2. 1914 - single coated cellulose nitrate films
3. 1918 - duplitized film
4. 1924 - cellulose acetate film base
5. 1933 - tinted film base to enhance contrast
6. 1936 - direct exposure film
7. 1940 film suitable for both direct and indirect exposure
8. 1958 - fast light sensitive film
9. 1960's - polyester base and films for rapid processing

II. X-ray Film (Fig. 463-1)

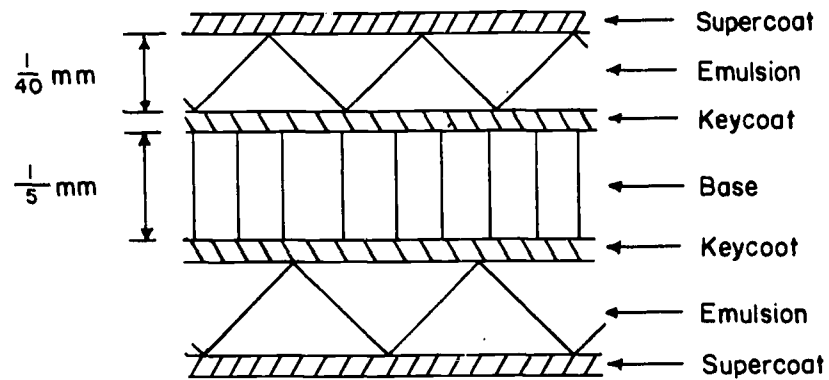

Figure 463-1. Composition of x-ray film

- A. Supercoat (T-coat, anti-stress layer, anti-abrasion layer)
 1. Thin layers of clear gelatin
 2. Normally 0.1 - 0.5 micron thick
 3. Protects underlying emulsion
- B. Emulsion
 1. Layer of gelatin in which grains of silver bromide are suspended
 2. Each grain about 1 micron in diameter (Fig. 463-2)



Figure 463-2. Silver bromide grain

3. One grain has $10^9 - 10^{10}$ atoms
Approximately 10^9 grains/cm³
4. Can be a few microns to several thousand microns thick
5. Speed of film depends on grain size
 - a. Speed: exposure required to obtain a certain density
 - b. Large grain - fast film
 - c. Small grain - slow film
- C. Key coat (subbing layer)
 1. Gelatin and solvent
 2. Serves as bond between emulsion and base

- D. Base
 - 1. Transparent plastic
 - a. Presently polyester
 - b. Formerly cellulose triacetate
 - 2. Supports fragile emulsion layers

III. X-ray Film Manufacture

- A. Gelatin - transparent organic material
 - 1. Preparation
 - a. Use calve's hide
 - b. Lime wash to remove fat and hair
 - c. Acid wash to remove lime
 - d. Gelatin extracted by pressure cooking
 - e. Gelatin concentrated
 - 2. Properties
 - a. Soluble in hot water
 - b. Insoluble in cold water
 - c. Insoluble at normal developing temperatures
 - d. Swells and absorbs liquid without dissolving
 - e. Can be shrunk and hardened into solid state
- B. Silver salt (AgBr)
 - 1. Suspended in gelatin. Portion of film that produces the image
 - 2. Preparation
 - a. Pure Ag and HNO_3 yield AgNO_3
 - b. AgBr formed by mixing KBr solution and AgNO_3 solution

c. AgBr crystals are cubic (Fig. 463-3)

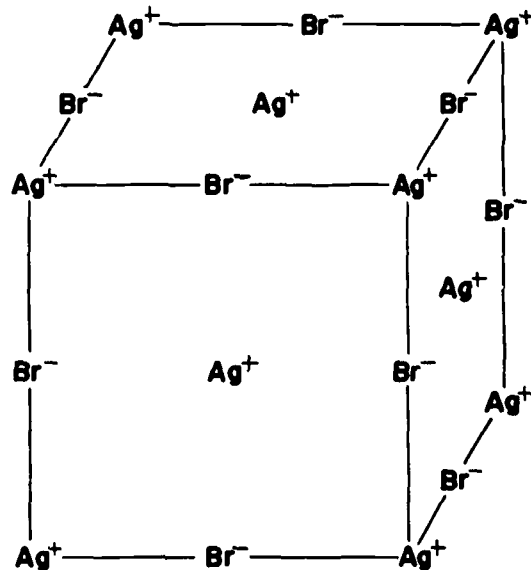

Figure 463-3. Silver bromide crystal

C. Sensitizing agents

1. Make emulsion react to low-energy photons
 - a. Forms sensitive sites
 - b. Focal points of reaction
2. Sensitizer
 - a. "Mustard oil"
 - b. Few drops per ton of emulsion
 - c. Mustard oil treated with alkali and reacts with
— AgBr to form sensitive sites

D. Emulsion

1. AgBr and gelatin mixed to form suspension. Total darkness
2. Suspension coated on base
3. Grain size controlled by rate and temperature of mixing
 - a. Rapid mix, low temperature, fine grain
 - b. Slow mix, higher temperature, larger grains
 - c. Ripening process
4. Typical emulsion 50 grains deep

5. Typical grains triangular or hexagonal with thickness $1/5$ diameter
 6. Washing
Ripened emulsion cooled, shredded, washed
 7. Digestion
 - a. Emulsion re-melted, held at constant temperature for about 1 hour
 - b. Sensitizing (sulfer) agents added
- E. Film coating
1. Dust free, total darkness
 2. Temperature and humidity controlled
 3. Coated on both sides
 4. Film sheets (40" wide, 1000' long)
 - a. Cooled and cut to size
 - b. Packaged

LECTURE NO. 2

- TITLE: Latent Image Formation
- PURPOSE: To discuss the nature and mechanism of formation of the photographic latent image
- TIME: One hour
- VISUAL AIDS: Blackboard
- HANDOUTS: None
- REFERENCES: Eastman Kodak Company
Medical Radiography and Photography
Vol. 46, No. 3 1970
- General Aniline & Film Corporation
Radiography, a Tool of Medical Science
- Gevaert
Medical X-Ray Films
- Mees and James
The Theory of the Photographic Process

LATENT IMAGE FORMATION

I. Formation

- A. Radiation induces change in an AgBr grain
- B. Renders grain susceptible to the action of a developer
- C. Evidence that latent image is silver
 1. Chemically analyzed and found to be silver
 2. Chemical reactions which oxidize silver also destroy latent image

II. Gurner - Mott Theory (1938)

- A. Crystal of silver bromide consists of orderly array of silver and bromine in cubical structure (Fig. 463-4)

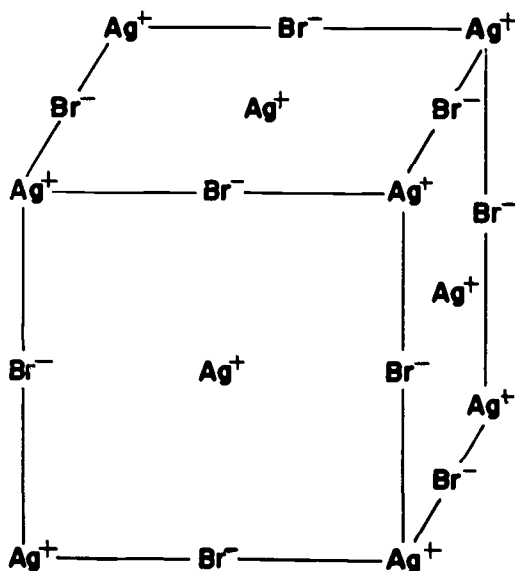
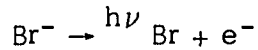

Figure 463-4. Silver bromide crystal

1. Perfect crystal of no value photographically
2. Sensitizer (sulfur compound) produces region on surface of grain called sensitivity speck
3. This region has the ability to trap electrons

- B. Light exposure (x-ray exposure with intensifying screens)
1. Bromine ion absorbs light photon and loses its valence electron



2. Energy level diagram (Fig. 463-5)

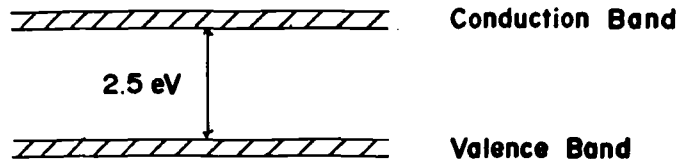

Figure 463-5. Energy level diagram

Most sensitive to green light of 5000 Å

3. Valence electron trapped at sensitivity speck
4. Interstitial silver ion (ion lying within crystal lattice) moves to electron trap site and combines with the electron

$$\text{Ag}^+ + \text{e}^- \rightarrow \text{Ag}$$
5. Silver atom unstable until process repeated several times building up accumulation of silver atoms at site
 - a. Exact number of silver atoms required to make developable latent image not known
 - b. Probably between 10 and 100
6. Neutral bromine ions formed leave crystal and move to the surrounding gelatin
7. If only one light photon interacts with crystal only one silver atom is formed
 - a. Atom will decay unless more silver atoms are formed
 - b. Therefore rate dependence exists
8. Reciprocity law
 - a. States that response of film, eg photographic density, to a given total exposure of a given type of

radiation is independent of the rate at which the exposure was administered

- b. Depends only upon intensity (I) of light and time (t) of exposure
- c. Deviation from reciprocity law is termed "reciprocity law failure"
- d. Reciprocity law holds for films exposed directly to x rays but fails for films exposed to light (Fig. 463-6)

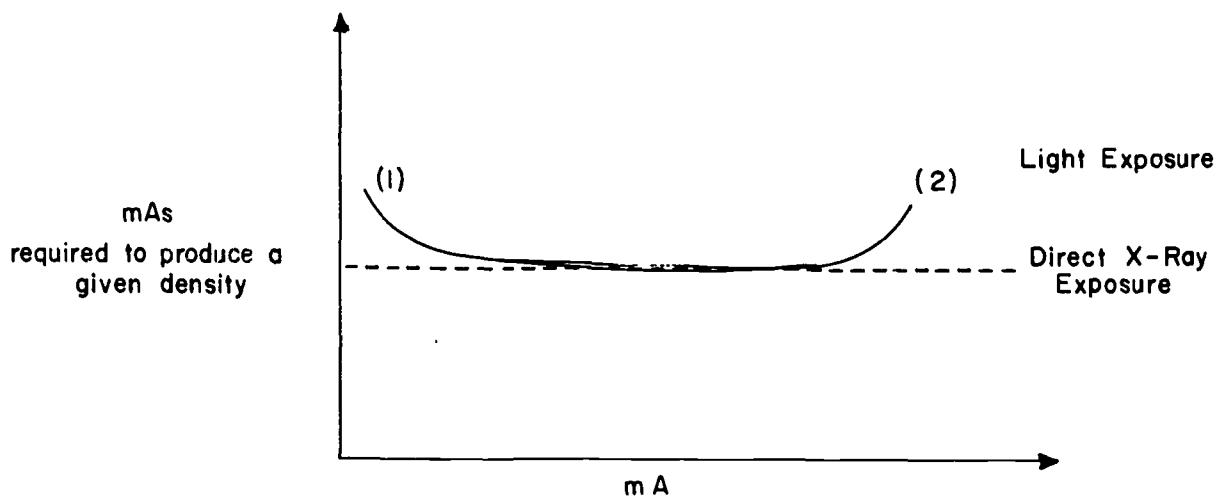

Figure 463-6. Reciprocity law failure

- 1) Low mA, long time; some Ag atoms will decay before stable image is formed
- 2) High mA, short time; electrons released at high rate
 - a) Migrate to sensitivity speck more rapidly than silver ions
 - b) Electron potential created at speck unless Ag^+ added at same rate as e^-
 - c) Only one e^- required to start reaction
 - d) Results in repelling action between electrons and some will be lost and not contribute to latent image production

- e) Such extremes in exposure rate are required to produce reciprocity law failure that it is not of significance in normal radiography
- 3) Reciprocity law failure may make it appear that the inverse square law is not valid

C. Direct x-ray exposure

1. X-ray photon interacts somewhere within emulsion producing photoelectron
2. High-energy electron passes through one or more grains and produces latent image
3. Secondary electrons produced within grain may number up to 1000
 - a. Migrate to speck
 - b. "Single hit" phenomenon
4. Reciprocity law holds

LECTURE NO. 3

- TITLE: X-Ray Film Processing
- PURPOSE: To discuss the chemical actions and procedures used in processing exposed x-ray film
- TIME: Two hours
- VISUAL AIDS: Blackboard
- HANDOUTS: None
- REFERENCES: Eastman Kodak Company
Principles of the Kodak X-OMAT Processing System
- Ilford, Ltd.
X-ray Processing
- Mees and James
The Theory of the Photographic Process

X-RAY FILM PROCESSING

I. Basic Process

- A. Development of latent image
- B. Fixation of latent image
- C. Rinsing away of processing chemicals
- D. Drying the film

II. Theory of Development

- A. Developer converts silver bromide grains with latent image to metallic silver without effecting grains not containing latent image

1. Developing solution provides electrons and reduces AgBr to Ag

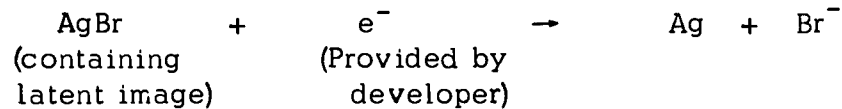

2. Bromine ion taken up in gelatin and eventually in the developing solution

- B. Exterior of AgBr grain has negative barrier due to bromine ions at the surface and absorbed bromine from developer (Fig. 463-7)



Figure 463-7. AgBr grain without latent image

1. Attempt of developer to donate e^- is opposed by this barrier

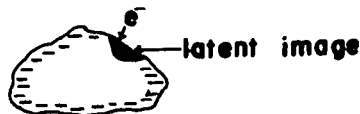

Figure 463-8. AgBr grain with latent image

2. Formation of latent image causes break in barrier (Fig. 463-8)
 - a. Electrons from developer can penetrate grain
 - b. Converts AgBr grain to metallic silver

III. Developing Solution

A. Four basic ingredients

1. Developing agents (electron donors)
 - a. Reduces Ag^+ to metallic Ag
 - b. Combination of hydroquinone and elon or phenidone
2. Alkali
 - a. Activates developing agents
 - b. Sodium carbonate or sodium borate
 - c. Softens and opens up gelatin for developer
 - d. Speed of developer partially dependent on degree of alkalinity
3. Preservative
 - a. Used to prevent oxidation at surface of solution by contact with air and subsequent staining of the gelatin
 - b. Sodium sulfite
4. Restrainer (bromine ions)
 - a. Minimizes development of unexposed grains
 - b. Number of bromine ions increases as films are developed and developing agent becomes depleted
 - c. Necessary to replenish solution with fresh chemicals (or extend developing time)

B. Replenishment

1. Purpose is to renew concentration of developing solution to original strength
2. Accomplished by adding concentrated solution to original developer solution
3. Generally recommend not to replenish more than 3 - 4 times

IV. Stop Bath

- A. Stops activity of developer
- B. 3 1/2% acetic acid

V. Fixing Solution

- A. After development emulsion contains exposed, developed AgBr grains and undeveloped AgBr grains. Gelatin is spongy and saturated with developing agents, alkali, sodium sulfite, bromine ions and development products
- B. Purpose of fixer
 - 1. Stop development process
 - 2. Dissolve unexposed AgBr grains
 - 3. Harden gelatin
- C. Ingredients
 - 1. Clearing agent
 - a. Ammonium thiosulfate ("hypo")
 - b. Dissolves and removes undeveloped AgBr from emulsion
 - c. Clearing time
 - 1) Adequate fix = 2 times clearing time
 - 2) Also allow for hardening of gelatin
 - 2. Acidifier
 - a. Acetic acid
 - b. Neutralizes any developer that may have been carried over
 - c. Necessary for correct action of other chemicals
 - 3. Hardener
 - a. Salts of aluminum
 - b. Toughens gelatin
 - c. Shrinks gelatin to prevent swelling by water absorption in final wash
 - 4. Preservative
 - a. Sodium sulfate
 - b. Prevents decomposition of fixer due to air oxidation
- D. Replenishment
 - 1. To keep fixer solution at peak strength

2. Maintains minimum fixing time
3. Concentrated fixer solution
4. Replenish when clearing time twice that of fresh solutions

VI. Wash and Dry

VII. Manual (Hand) Processing

A. Film handling

1. Use dry hands
2. Hold film by edges
3. Work using safelite or in total darkness
4. Avoid bending or scratching film

B. Time and temperature

1. Light sensitive film, 5 minutes at 68° F
2. Direct exposure film (has thicker emulsion), 5 to 8 minutes at 68°F following manufacturer's instructions
3. Typical recommended times and temperatures

<u>Time - minutes</u>	<u>Temperature - °F</u>
2	85
2 1/2	80
3 1/4	75
3 3/4	72
4 1/2	70
5	68
6 1/4	65

4. In all cases follow manufacturer's instructions

C. Film processing technique

1. Development

- a. Stir developer and fixer
- b. Determine temperature
- c. Set timer for recommended development time

- d. Immerse film in developer
 - 1) Agitate periodically
 - 2) Dislodges air bubbles and keeps fresh solution in contact with film
- 2. Rinse
 - a. Running water 10 - 20 seconds
 - b. Does not stop development process fast
 - c. Stop bath - if available
 - 1) Mild acid
 - 2) 10 seconds
- 3. Fix
 - a. Agitate periodically
 - b. Fix twice clearing time
 - c. Follow manufacturer's instructions
- 4. Wash
 - a. Removes chemicals
 - b. In running water
 - 1) 30 minutes in water flowing at 3 - 4 volume changes per hour
 - 2) Direct exposure film requires longer (2 times) wash than light sensitive film
- 5. Wetting agent - prevents spotting and streaking. Immerse 2 - 3 minutes
- 6. Dry - 10 to 45 minutes in warm circulating air dryer

VIII. Automatic Processing (Kodak M-5 X-Omat)

- A. Use same film handling precautions as for manual processing
- B. Film processing
 - 1. The processor automatically controls time, temperature and replenishment

2. The film is automatically transported from the entrance tray through the developer, fixer, wash and dryer to the exit film bin (Fig. 463-9)

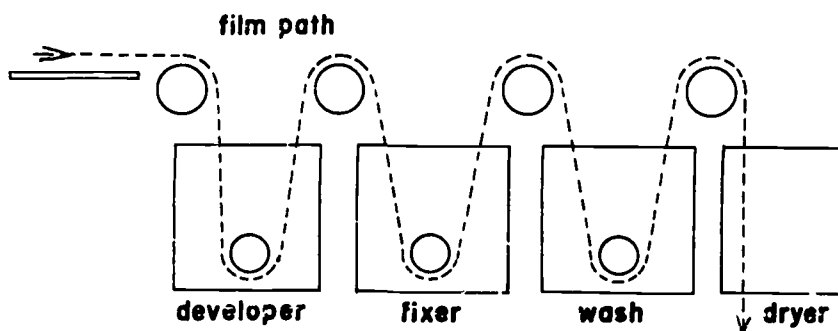

Figure 463-9. X-Omat transport system

- a. Determine that developer temperature is correct (81°F)
- b. Determine that dryer temperature is correct (110°F)
- c. Determine that incoming wash water temperature is correct (76°F)
- d. Set film transport speed control for film type to be processed
 - 1) For light exposure films set control for high speed (approximately 7 minutes processing time)
 - 2) For direct exposure film set control for low speed (approximately 25 minutes processing time)
- e. Place film on entrance tray and slide film forward until it engages with the first set of rollers
 - 1) Follow manufacturer's instructions for film orientation and number of films of a given size that can be processed together
 - 2) Bell in processor will ring when film is in processor and another film can be started into processor
- f. Processor automatically transports film and provides proper replenishment

C. Chemistry

1. Special developer and fixer used
 - a. Hand processing chemicals soften and swell emulsion
 - b. In roller-transport X-Omat this would cause films to "jam" or stick to rollers
 - c. X-Omat chemicals control film swelling
 - d. Roller system forces chemicals into film emulsion
2. Temperature
High developer temperature used to rapidly soften emulsion

D. Other systems

1. Modern automatic film processors all work on roller transport principle
2. Special film for automatic processors is available which, with special chemicals, permits complete processing to be accomplished in 90 seconds

LECTURE NO. 4

- TITLE: Sensitometric Properties of X-Ray Film
- PURPOSE: To discuss the relationship of exposure and processing to x-ray film response
- TIME: Two hours
- VISUAL AIDS: Blackboard
- HANDOUTS: Eastman Kodak and Gevaert reference
- REFERENCES: Eastman Kodak Company
Sensitometric Properties of X-Ray Films
- Gevaert
Sensitometry
- Mees and James
The Theory of the Photographic Process
- Ter-Pogossian
Physical Aspects of Diagnostic Radiology

SENSITOMETRIC PROPERTIES OF X-RAY FILM

I. Introduction

Sensitometry is the study of film response to exposure and/or processing. Factors included in film response are:

1. Contrast
2. Latitude
3. Speed

II. Types of Films

A. Screen-type film (medical film, light sensitive film)

1. Used between two CaWO_4 screens
2. Sensitive to light emitted by screens when screens excited by x rays
3. Small portion of film density due to x rays interacting in film emulsion

B. Non-screen type film (industrial film, direct sensitive film)

1. Density dependent entirely on x-ray interactions in emulsion
2. Less sensitive than screen-type film-slower

III. Characteristic Curve

A. Represents response of film (density) as a function of exposure to light or x rays. Sometimes referred to as sensitometric curve or H. and D. curve after Hurter and Driffield (Fig. 463-10)

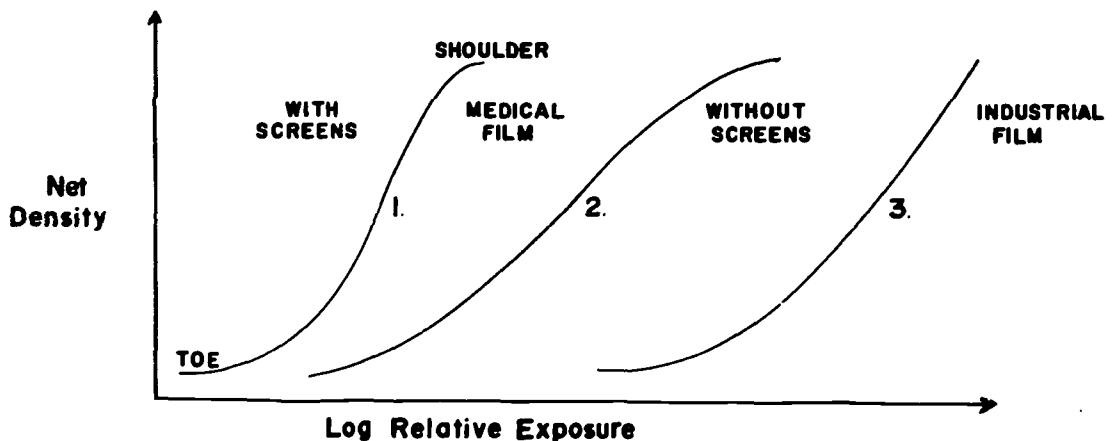

Figure 463-10. Sensitometric curves

1. Screen film exposed with CaWO_4 screens
 2. Screen film exposed without screens
 - a. Broader shoulder
 - b. Greater latitude
 3. Direct exposure film. No shoulder in useful density range
- B. Shape of curve
1. Depend on:
 - a. Type of film
 - b. Processing
 - c. Type of screens
 2. Does not depend on x-ray energy (Fig. 463-11)

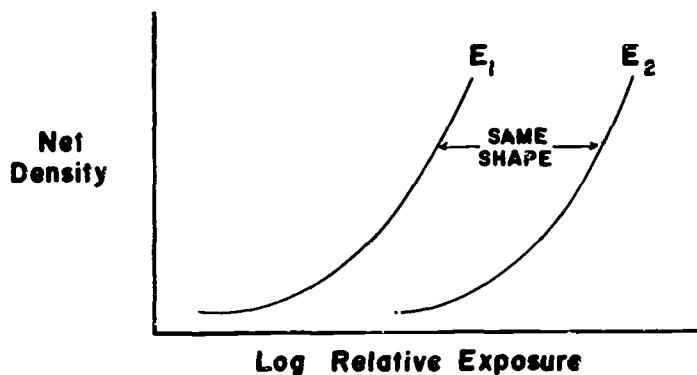

Figure 463-11. Curve shape for two energies

- a. For direct exposure films, displacement of curve depends upon mass absorption coefficient of AgBr
- b. For screen films, displacement depends upon mass absorption coefficient of CaWO_4
- c. As μ/ρ decreases the curve will shift to the right

C. Average gradient - \bar{G}

1. Slope of straight line joining the two points of specified density on the characteristic curve (Fig. 463-12)

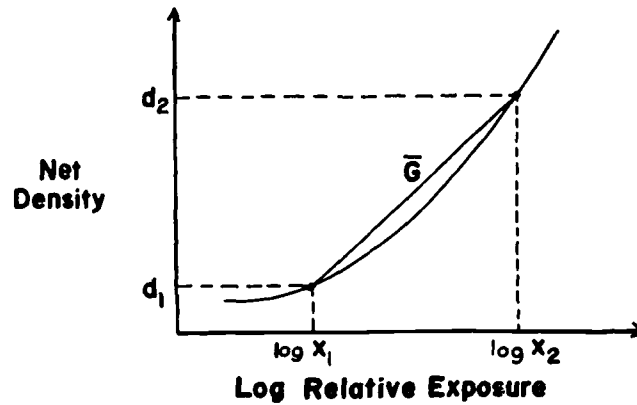

Figure 463-12. Average gradient

$$2. \bar{G} = \frac{d}{\log_{10} X} = \frac{d_2 - d_1}{\log_{10} X_2 - \log_{10} X_1} = \frac{d_2 - d_1}{\log_{10} \frac{X_2}{X_1}}$$

3. Density range (Δd) used in determining average gradient
 - a. Medical film, $\Delta d = 0.5 - 2.0$
 - b. Industrial film, $\Delta d = 0.5 - 2.5$
4. Average gradient is indicator for film contrast
5. Gamma
 - a. Tangent of angle (θ) representing slope of curve at one selected point on curve
 - b. Represents contrast properties of film for straight-line portion of curve (Fig. 463-13)

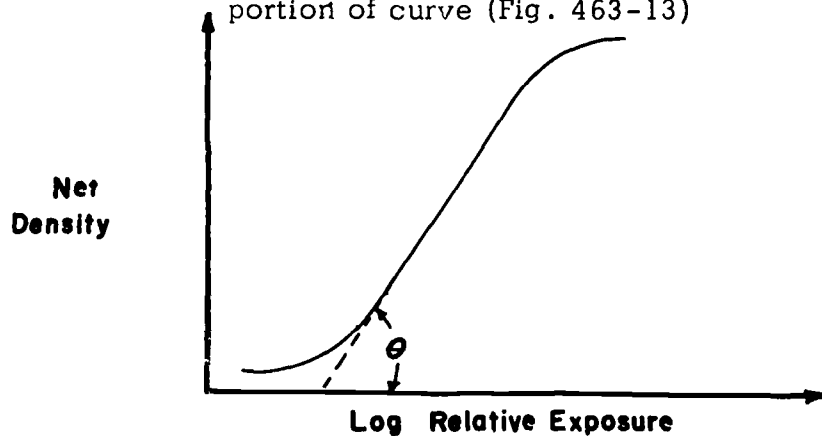

Figure 463-13. Gamma

IV. Film Speed (Sensitivity)

- A. Reciprocal of exposure required to produce a given density
- B. Relative speed (Fig. 463-14)
 1. Specified film or film-screen combination taken as standard and others compared to it
 - a. Medium speed film or film-screen combination usually taken as standard
 - b. Standard assigned a relative speed of 100

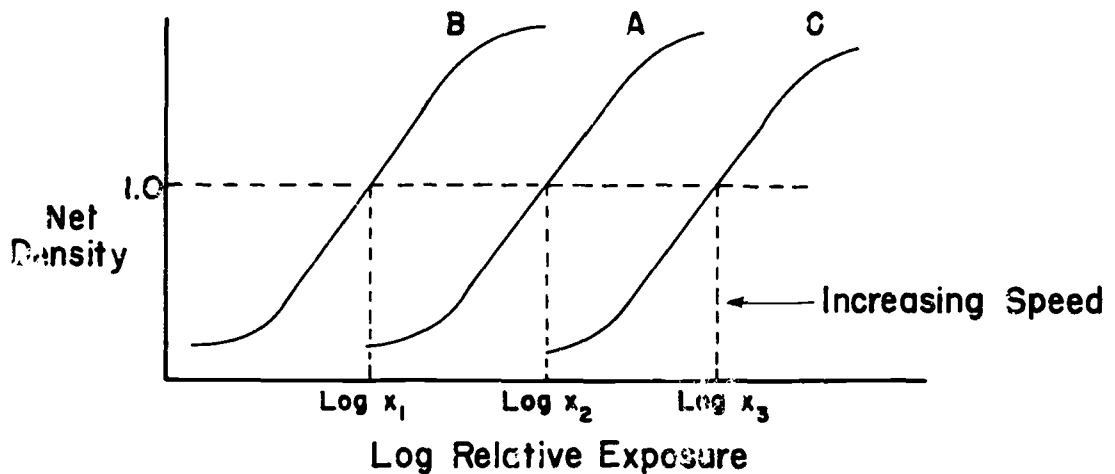

Figure 463-14. Relative speed

- c. If A is standard and $X_1 = 5$, $X_2 = 10$, $X_3 = 20$ then:
 - 1) Relative speed of film A = 100
 - 2) Relative speed of film B = 200
 - 3) Relative speed of film C = 50
- C. Density used in determining speed
 1. Can be at any selected density
 2. For medical film normally net density 1.0
 3. For industrial film normally net density 1.5
- D. Factors influencing film speed
 1. Film type
 2. Processing
 3. Screen type
 4. X-ray energy

E. Relative exposure

1. More useful in determining exposure required than relative speed
2. Ratio of exposure required to produce given density
3. Standard assigned relative exposure of 1.0
4. In example used for relative speed, the relative exposure would be:
 - a. Relative exposure of film A = 1.0
 - b. Relative exposure of film B = 0.5
 - c. Relative exposure of film C = 2.0

V. Radiographic Contrast

- A. The contrast between points on a radiograph is equal to the difference in the densities (d_1 and d_2) at these points. $C = d_2 - d_1$
- B. The minimum contrast visually detected is about 0.02
- C. Subject contrast
 1. Results from differences in absorption of radiation by part under examination (Fig. 463-15)

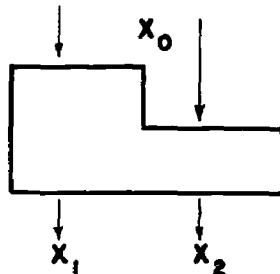

Figure 463-15. Subject contrast

2. The greater the ratio of X_2/X_1 the greater the contrast
3. The ratio of X_2/X_1 depends upon:
 - a. Nature of subject
 - 1) Greater the thickness difference the greater will be X_2/X_1 and contrast will increase
 - 2) Greater the difference in mass absorption coefficients the greater X_2/X_1 will be and contrast will increase

b. X-ray energy

- 1) The greater the x-ray beam energy the smaller will be X_2/X_1 and contrast will decrease

c. Scatter

- 1) Scattered radiation tends to reduce X_2/X_1 and therefore reduce contrast
- 2)
$$\frac{X_2 + X_s}{X_1 + X_s} < \frac{X_2}{X_1}$$
- 3) Scatter can be reduced by using a small field size and a grid

D. Film contrast (Fig. 463-16)

1. Characteristic of film and developing process. Dependent upon slope of characteristic curve

2. For given object and beam energy the subject contrast is constant. If exposure is increased from X_0 to X'_0

$$\log \frac{X_2}{X_1} = \log \frac{X'_2}{X'_1}$$

3. Increasing exposure moves one to different location on characteristic curve. If slope of curve is different, Δd will change causing change in contrast

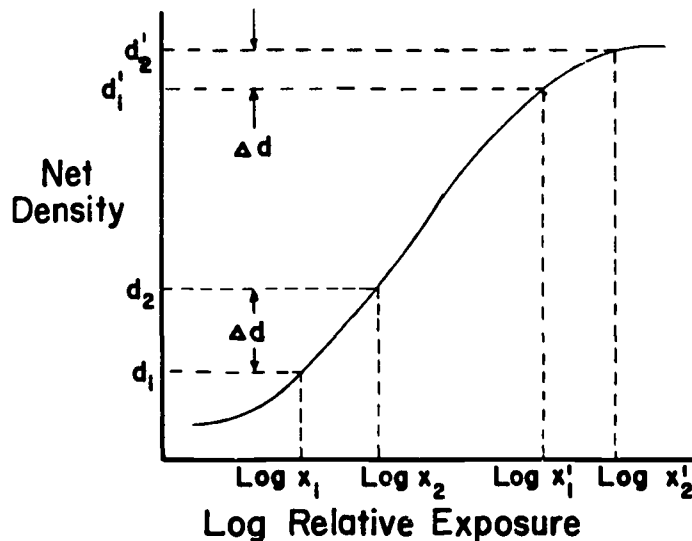

Figure 463-16. Film contrast

4. Film contrast depends upon:
 - a. Film type
 - b. Processing
 - c. Screen type
 - d. Density level
5. Film contrast does not depend upon beam energy

VI. Latitude (Fig. 463-17)

- A. Latitude is the range of exposures over specified density range that is considered useful
- B. Latitude is the reciprocal of contrast. Increasing film latitude decreases contrast

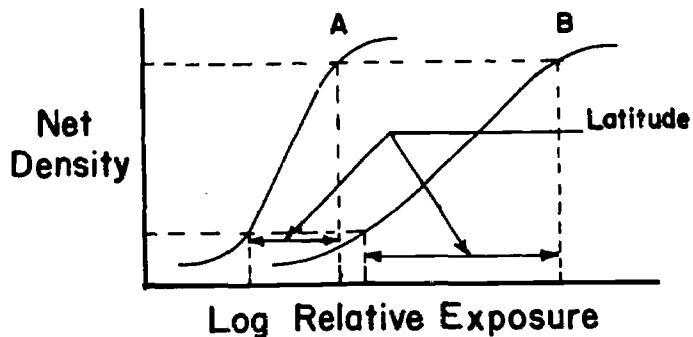

Figure 463-17. Latitude

- C. Film A has greater contrast than film B
Use high contrast film when radiographing uniform areas
- D. Film B has greater latitude than film A
Use low contrast film when radiographing objects with high degree of non-uniformity
- E. Advantage of wide latitude - exposure requirements not as precise
- F. Disadvantage of wide latitude - loss in amplification of subject contrast
- G. Usable density range
 1. Medical film - to onset of shoulder
 2. Industrial film - usually limited by brightness of available illuminator

GS-463
X-Ray Applications

Problem Set No. 1

Sensitometry. Refer to the booklet "Sensitometric Properties of X-Ray Films" by the Eastman Kodak Company in answering the questions.

A. The data shown below were obtained when three different x-ray films were exposed using a "sensitometer".

Film A		Film B		Film C	
<u>Exposure-mAs</u>	<u>Density</u>	<u>Exposure-mAs</u>	<u>Density</u>	<u>Exposure-mAs</u>	<u>Density</u>
3	0.28	15	0.20	30	0.28
4	0.36	20	0.26	40	0.35
5	0.46	25	0.35	50	0.43
5.5	0.55	30	0.46	60	0.53
6	0.70	35	0.58	80	0.72
6.5	0.95	40	0.71	100	0.91
7	1.26	45	0.85	150	1.31
8	1.92	50	1.00	200	1.65
9	2.55	60	1.33	300	2.20
9.5	2.85	70	1.63	400	2.64
10	3.00	85	2.07	500	2.91
12	3.24	100	2.45	600	3.08
15	3.37	125	2.95	750	3.23
20	3.45	150	3.36	1000	3.31
Fog	0.20	Fog	0.10	Fog	0.20

1. Determine and plot net density as a function of log exposure.
2. Assuming a useful net density range of 0.5-2.0, which film has the highest contrast? Explain.
3. Assume film B has a relative speed of 100 at density 1.00. What are the relative speeds of films A and C at net density 1.00?
4. Assume film B has a relative exposure of 1.0 at density 1.50. What are the relative exposures of films A and C at net density 1.50?
5. What is the average gradient for each film for a net density range of 0.5-2.0?
6. What is the gradient for each film at density 1.25?
7. Which film has the greatest latitude and which film has the least latitude? Explain.
8. Which of the films would you expect to be "screen" exposure films and which would you expect to be "direct" exposure films? Explain.

B. Define the following terms:

1. Radiographic contrast
2. Subject contrast
3. Film contrast
4. Gradient
5. Average gradient
6. Gamma
7. Relative speed
8. Reciprocity law

GS-463

Problem Set No. 1

Answers

Part A. 1. Net density vs exposure

Film A		Film B		Film C	
Exposure-mAs	Net Density	Exposure-mAs	Net Density	Exposure-mAs	Net Density
3	0.08	15	0.10	30	0.08
4	0.16	20	0.16	40	0.15
5	0.26	25	0.25	50	0.23
5.5	0.35	30	0.36	60	0.33
6	0.50	35	0.48	80	0.52
6.5	0.75	40	0.61	100	0.71
7	1.06	45	0.75	150	1.11
8	1.72	50	0.90	200	1.45
9	2.35	60	1.23	300	2.00
9.5	2.65	70	1.53	400	2.44
10	2.80	85	1.97	500	2.71
12	3.04	100	2.35	600	2.88
15	3.17	125	2.85	750	3.03
20	3.25	150	3.26	1000	3.11

2. Film A has the highest contrast since it has the highest average gradient (see 5 following). Along the body of the sensitometric curve, a given percentage change in exposure will produce a greater change in density than for films B or C.

$$3. \quad \text{Relative speed} = \frac{(X_B)(100)}{X}$$

$$\text{Film A R.S.} = \frac{(52)(100)}{6.9} = 753$$

$$\text{Film B R.S.} = \frac{(52)(100)}{52} = 100$$

$$\text{Film C R.S.} = \frac{(52)(100)}{133} = 39$$

$$4. \quad \text{Relative exposure} = \frac{(X) (1)}{X_B}$$

$$\text{Film A R.X.} = \frac{(7.7) (1)}{69} = 0.11$$

$$\text{Film B R.X.} = \frac{(69) (1)}{69} = 1.0$$

$$\text{Film C R.X.} = \frac{(205) (1)}{69} = 2.98$$

$$5. \quad \bar{G} = \frac{\Delta d}{\log X_2/X_1} = \frac{2.0-0.5}{\log X_2/X_1} = \frac{1.5}{\log X_2/X_1}$$

$$\text{Film A } \bar{G} = \frac{1.5}{\log 87/35} = \frac{1.5}{0.147} = 10.2$$

$$\text{Film B } \bar{G} = \frac{1.5}{\log 87/35} = \frac{1.5}{0.396} = 3.79$$

$$\text{Film C } \bar{G} = \frac{1.5}{\log 300/76} = \frac{1.5}{0.598} = 2.51$$

$$6. \quad \text{Gradient} = \text{slope of curve at density 1.25}$$

$$= \frac{\Delta d}{\Delta \log X}$$

$$\text{Film A } G = \frac{1.5}{\log 8.8/6.2} = \frac{1.5}{0.154} = 9.75$$

$$\text{Film B } G = \frac{1.5}{\log 91/41} = \frac{1.5}{0.347} = 4.32$$

$$\text{Film C } G = \frac{1.5}{\log 320/88} = \frac{1.5}{0.562} = 2.67$$

7. Film C has the greatest latitude and film A has the least latitude. Film C will cover a much wider range of exposures for a given density range than will film A and B i.e. film B has the greatest latitude.

8. Film A is a light sensitive film exposed using screens. It has a relatively abrupt toe and shoulder and the highest speed. Film B has no shoulder evident and is, therefore, a direct exposure film.

Film C has a broader toe and shoulder so it is a light sensitive film exposed without screens.

- Part B.
1. Radiographic contrast - the difference in density between two areas on a radiograph.
 2. Subject contrast - the ratio of x-ray intensities transmitted by two selected portions of a subject.
 3. Film contrast - slope (steepness) of the characteristic curve of the film.
 4. Gradient - the slope of straight line drawn tangent to the characteristic curve at some point on the curve.
 5. Average gradient - the slope of a straight line joining two points of specified densities on the characteristic curve.
 6. Gamma - the slope of the straight line portion of the characteristic curve.
 7. Relative speed - the speed of one film in relation to another arbitrarily assigned a speed of 100. Relative speed is equal to the exposure required to produce a specified density using the arbitrarily assigned standard film, times 100, divided by the exposure required for the other film to produce the same density, i.e. relative speed = $\frac{X \text{ standard times } 100}{X \text{ unknown}}$
 8. Reciprocity law - the film response (density) is dependent only on the product of intensity and time and is independent of the absolute values of either quantity.

GS - 463
Problem Set No.1, Part A.1
Net Density vs Exposure

Film A

Film B

Film C

Net Density

Exposure - mAs

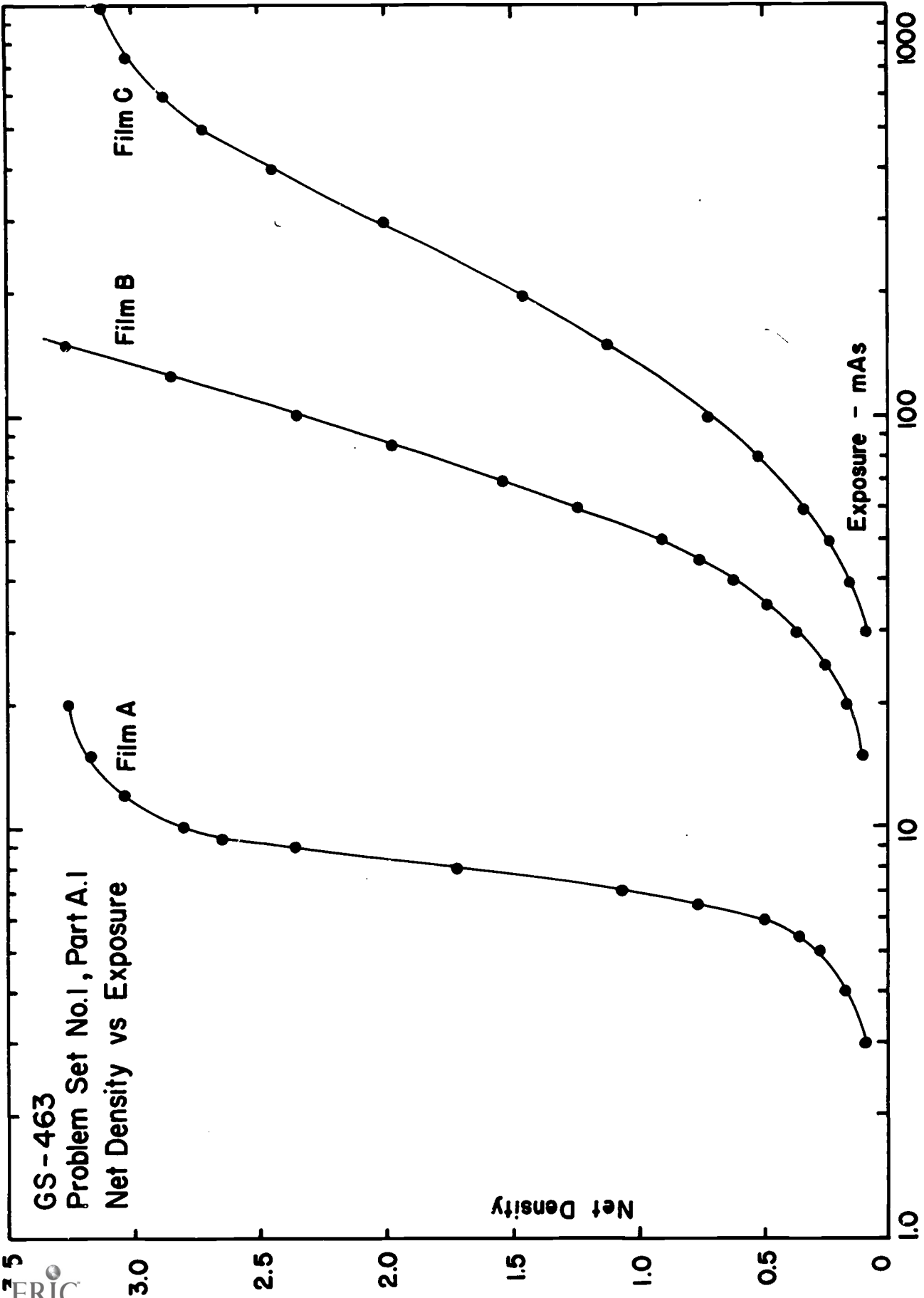

LECTURE NO. 5

TITLE: X-Ray Screens

PURPOSE: To discuss the construction, characteristics and applications of x-ray screens

TIME: Two hours

VISUAL AIDS: Blackboard
Cassette with intensifying screens

HANDOUTS: DuPont and Radelin references

REFERENCES: Curie
Luminescence in Crystals

E. I. DuPont de Nemours & Company
The Care and Use of Cronex Xtra
Life Intensifying Screens

Privgsheim and Vogel
Luminescence of Liquids and Solids

Radelin Division of U. S. Radium Corporation
Application, Construction, Characteristics
and Care of X-Ray Screens

Ter-Pogossian
Physical Aspects of Diagnostic Radiology

X-RAY INTENSIFYING SCREENS

I. Introduction

- A. Radiographic process is very inefficient
1. Efficiency of x-ray production $< 1\%$
 2. Photons reaching object $< 1\%$
 3. Photons transmitted through subject $< 1\%$
 4. Photons absorbed by film $< 1\%$
- B. Intensifying screens
1. Improve efficiency of radiographic process reducing object exposure
 2. Reduce motion by permitting shorter exposure time
- C. Used extensively in medical radiography
- Exceptions are:
1. Extremities
 - a. Easily immobilized
 - b. Low attenuation
 - c. Fine detail often required
 2. Some special procedures such as mammography.

II. Screen Construction

- A. Intensifying screens are mounted in a device called a cassette (Fig. 463-18)
1. Screens mounted to top and bottom of cassette
 2. Film placed between screens

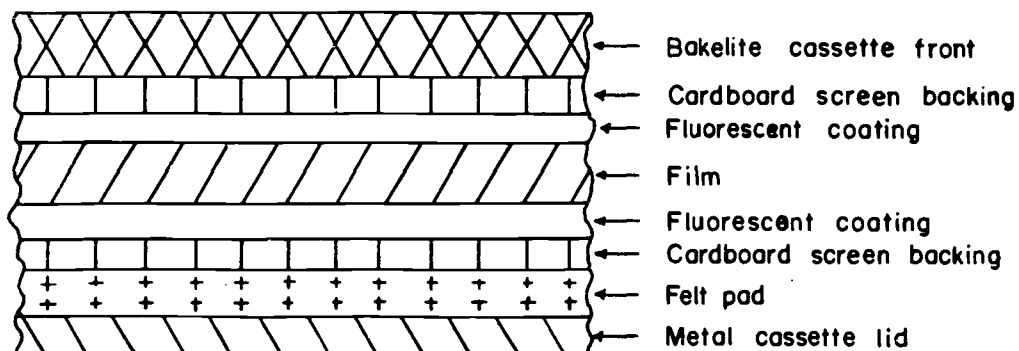

Figure 463-18, Cross-section of cassette with intensifying screens.

B. Requirements

1. Emission in desired color band
2. Good x-ray response
3. Stable
4. Uniform quality
5. No afterglow

C. Structure (Fig. 463-19)

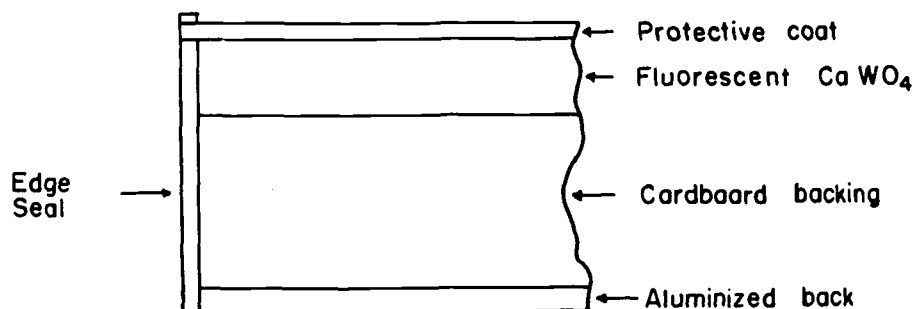

Figure 463-19. Cross-section of typical intensifying screen

III. Screen Characteristics

- A. Phosphors used have ability of absorbing energy from x-ray beam and emitting energy as visible light
- B. Phosphor
 1. Normally calcium tungstate (CaWO_4)
 2. Emits light in blue-violet region matching maximum film sensitivity (Fig. 463-20)

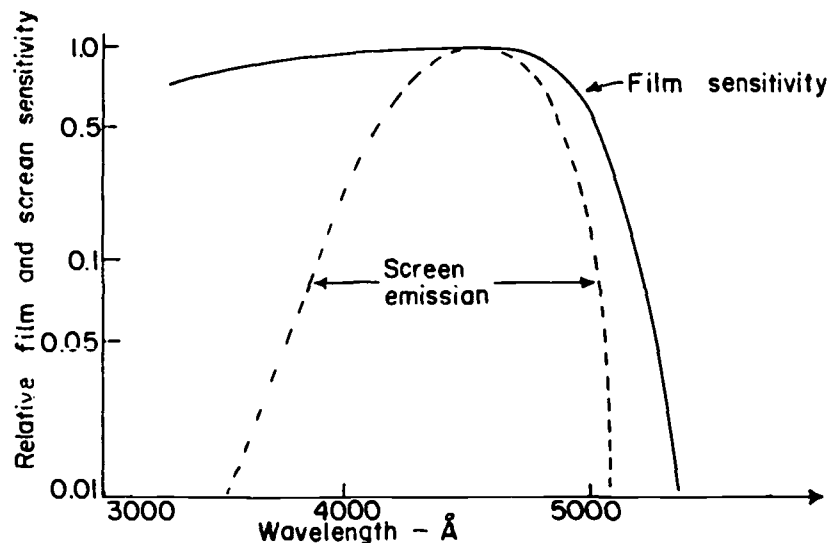

Figure 463-20. Relative sensitivity of films and screens

C. CaWO_4 first used by Edison in 1896

1. From January to March 1896 he investigated over 8000 materials
2. Found 1800 that would fluoresce but CaSO_4 was best
3. Even tried this as light source

IV. Speed of Intensifying Screens

A. Speed depends upon:

1. Thickness of phosphor layer--the thicker the layer the more energy will be absorbed from the x-ray beam
 - a. $\text{Speed} \propto \text{thickness}$ (Fig. 463-21)

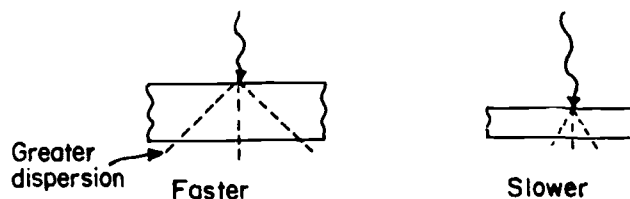

Figure 463-21. Speed vs thickness of intensifying screen.

- b. Greater the thickness the greater the light dispersion, therefore decreased resolution
2. Particle size
 - a. $\text{Speed} \propto \text{CaSO}_4$ particle size
 - b. The larger the size the greater the light dispersion therefore decreased resolution

B. Factors related to screen speed

1. Intensification factor (I.F.)
 - a. Ratio of exposure without screens to exposure with screens to achieve same density

- b. I.F. is function of kVp due to changing μ/ρ for AgBr and CaWO_4 (Fig. 463-22)

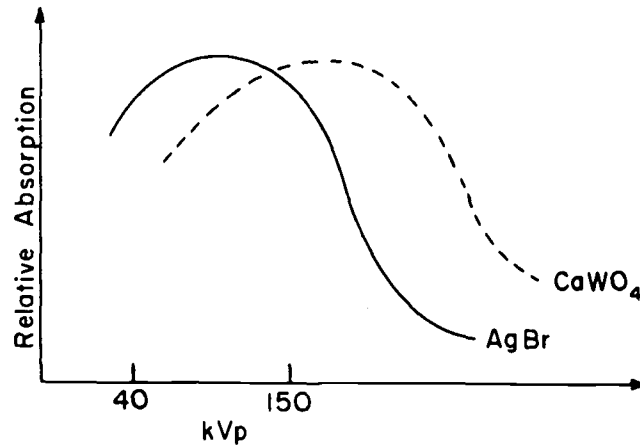

Figure 463-22. Relative absorption of films and screens vs energy.

- c. For ballpark number medium speed screens in diagnostic kVp range have I.F. of 30 - 50
2. Relative exposure factor (REF)
- a. Medium speed assigned REF = 1
- b. REF for another screen y

$$(\text{REF})_y = (\text{REF})_{\text{med}} \left[\frac{X_y}{X_{\text{med}}} \right]$$

- 1) Same density for each exposure
- 2) Same film type
- c. If $(\text{REF})_y = 0.5$ then screen y is faster
- d. REF depends on beam energy and film type

C. Resolving power of screens

1. Ability to record structural detail
2. Expressed as number of lines/mm clearly recorded and can be seen on film
3. If screen can resolve 10 lines/mm, each visibly distinct line would be 0.05 mm wide

D. Classifications of screens

1. Medium-speed
 - a. Provide best balance between speed and detail
 - b. Typical names: Par, standard, universal, mid-speed, etc.
 - c. REF = 1.0
 - d. Resolving power 12 lines/mm
2. High-speed
 - a. Typical names: Hi-speed, fast, etc.
 - b. "Super high-speed" screens (ultra high-speed) available
 - c. Standard high-speed REF = 0.5 and resolving power 10 lines/mm
 - d. "Super high-speed" REF \approx 0.35 and resolving power 8 lines/mm
3. Slow-speed
 - a. Provide increased detail often needed for bone radiography
 - b. Typical names: Detail, fine grain, high definition, etc.
 - c. REF = 4
 - d. Resolving power 14 lines/mm

V. Factors Affecting Screen Performance

- A. Film-screen contact
 1. Warping of cassette front
 2. Wrinkled screens
 3. Foreign bodies (dust, lint, etc.)
 4. Cracked cassette
 5. Worn felt
 6. Contact can be checked by radiographing 1/4" - 1/8" brass or copper mesh

B. Temperature

1. Luminescence decreases with increasing temperature
 - a. At 110° F increase exposure 20%
 - b. At 14° F decrease exposure 30%

C. Static marks and artifacts

1. Caused by:
 - a. Sliding or shuffling dry films over flat surface
 - b. Piling cassettes

LECTURE NO. 6

TITLE: Radiographic Definition

PURPOSE: To discuss the factors which affect radiographic definition

TIME: One hour

VISUAL AIDS: None

HANDOUTS: Eastman Kodak reference

REFERENCES: Bloom, Hollenbach and Morgan
Medical Radiographic Technic

Eastman Kodak Company
The Fundamentals of Radiography

Gevaert
Sensitometry

Johns and Cunningham
The Physics of Radiology

Mees and James
The Theory of the Photographic Process

RADIOGRAPHIC DEFINITION

I. Sharpness (Radiographic Definition)

- A. The more rapid the density change between adjacent areas on a radiograph the greater will be the radiographic definition or sharpness (Fig. 463-23)

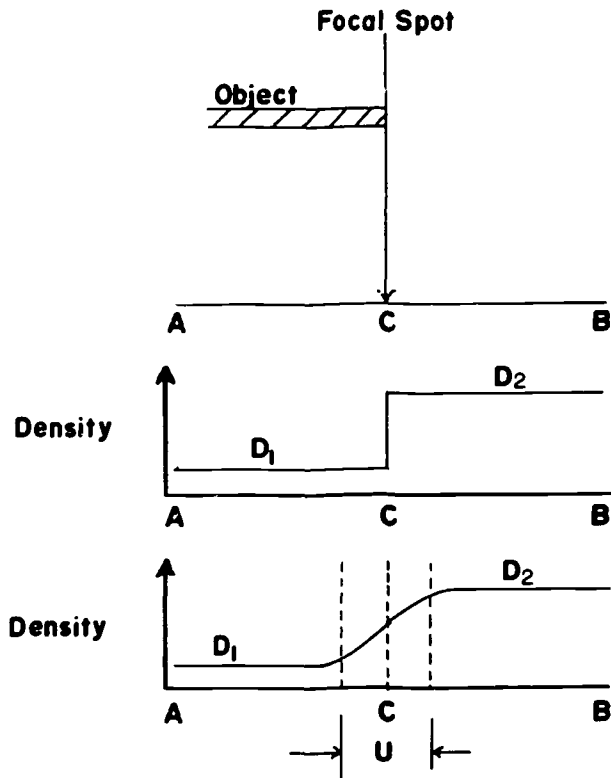

Figure 463-23. Illustration of "sharpness"

- B. Radiographic definition influenced by:
1. Geometric factors
 2. Graininess and mottle of the recording media

II. Geometric Factors

A. Focal spot size (Fig. 463-24)

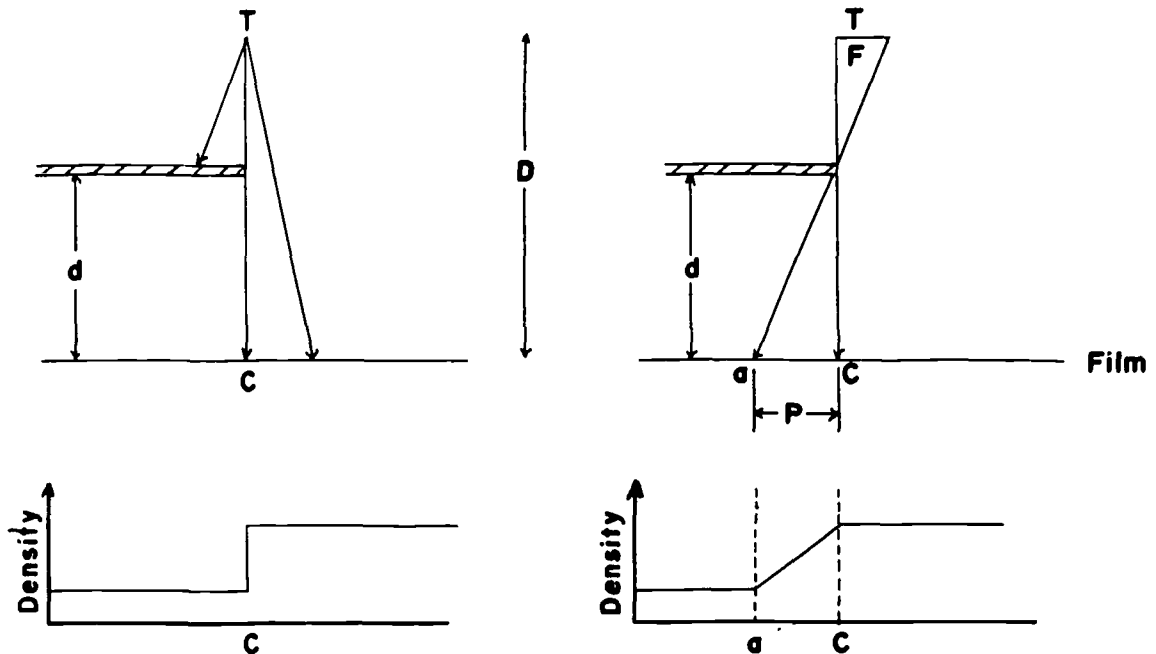

Figure 463-24. Effect of focal spot size on radiographic definition

1. The smaller the focal spot the sharper the image
2. A finite focal spot will produce penumbra. Penumbra reduces definition by reducing density gradient
3. Penumbra width (P) is given by:

$$P = F \left[\frac{d}{D - d} \right]$$

B. Source-film distance (D)

The greater the SFD the less the penumbra

C. Object-film distance (d)

1. To minimize penumbra and increase sharpness
 - a. Use small focal spot
 - b. Use long source-film distance
 - c. Use short object-film distance

D. Film-screen contact

1. Light emitted from intensifying screens is divergent

2. Poor film-screen contact will blur image due to greater light diffusion

E. Motion of object or tube or film relative to other two during exposure will blur image

III. Graininess and Mottle

A. Radiographic mottle. Refers to mottled appearance of radiographs made at very low x-ray exposures e.g. fast film-screen combinations

1. Screen mottle

a. Structure mottle results from structure irregularities of the screen

b. Quantum mottle results from statistical fluctuations in spatial distribution of photons in x-ray image

1) As analogy, consider long sidewalk on a rainy day. Sidewalk corresponds to film-screen combination and the raindrops as the x-ray photons

a) Consider a downpour (slow film-screen combination) where an average of 10^4 drops land on each sidewalk square. This is random process so each square would not receive precisely 10^4 drops. Some more, some less. The difference between the actual and average can be estimated statistically (Poisson Distribution). If a large number of blocks are involved, the actual number of raindrops on 68% of the blocks will differ from the average by no more than σ , the standard deviation

$$\sigma = \sqrt{\bar{N}}$$

$$\bar{N} = 10^4 \text{ raindrops/square}$$

$$\sigma = 10^2 = 100$$

$$N = 10,000 \pm 100 \text{ raindrops/square}$$

$$\% \text{ variation} = \frac{\sigma}{\bar{N}} \times 100 = 1\%$$

Only remaining 32% of squares will differ by more than this number. Thus, difference in "wetness" from one square to another will be small and, likely, unnoticeable.

- b) Consider same sidewalk in light rain with average number of drops per square = 100

$$\bar{N} = 100$$

$$\sigma = 10$$

$$N = 100 \pm 10 \text{ raindrops/square}$$

$$\% \text{ variation} = 10\%$$

Thus, difference in "wetness" from one square to another will be much more noticeable in a light shower (10%) than in a downpour (1%)

- c. Consider raindrops as x-ray photons

- 1) With slow film-screen combination 10,000 photons absorbed may be necessary to produce certain density
- 2) With fast film-screen combination may be 100 photons for same density
- 3) This will lead to mottled effect

B. Film graininess--results from clumping of developed grains and is independent of the screen

C. In conventional radiography, structure mottle and film graininess are considerably finer than quantum mottle and overshadowed by latter.

- D. Greater speed--more mottle
- E. Possible to have less apparant mottle with a fast screen, slow film combination than with a slow screen, fast film combination since greater fast screen thickness tends to diffuse light and reduce apparant mottle.

.....

LECTURE NO. 7

- TITLE: X-Ray Grids
- PURPOSE: To discuss the design, construction and use of x-ray grids
- TIME: One hour
- VISUAL AIDS: Blackboard
Cross-sections of grids
Radiographs made using no grid, 8:1, 12:1 and 16:1 grids
- HANDOUTS: Liebel-Flarsheim reference
- REFERENCES: Hondium Bolding
Quality and Choice of Potter-Bucky Grids
- ICRU Report 10f
- Johns and Cunningham
The Physics of Radiology
- Liebel-Flarsheim Company
Characteristics and Applications of X-Ray Grids

X-RAY GRIDS

I. Scattered X Rays

- A. When an x-ray beam passes through a patient the beam is transmitted, absorbed and scattered
 - 1. The useful radiographic image is produced by the unattenuated primary beam
 - 2. Scattered radiation will mask the primary beam and reduce contrast
 - 3. Reduced contrast results in decreased visibility of resolution
- B. Intensity of scatter depends upon:
 - 1. Density and atomic number of object
 - 2. Volume exposed
 - 3. Photon energy
- C. Quantity of scatter reaching the film can be reduced by:
 - 1. Limiting beam to area of interest (reduce volume exposed)
 - 2. Decreasing kilovoltage with appropriate increase in exposure time
 - 3. Use a grid between patient and film to absorb scattered radiation

II. Grid Design

- A. Dr. Gustar Bucky (1913) built first grid

B. Construction (Fig. 463-25)

1. Alternate strips of lead and low density material (pressed paper, balsa wood, plastic, aluminum, magnesium)

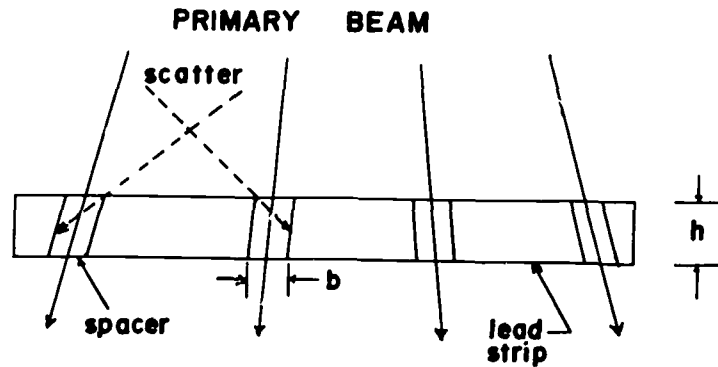

Figure 463-25. X-ray grid construction

2. Thin lead strips in grid (only a few shown in Figure 463-25) remove oblique scattered radiation. Primary beam is parallel to the slots (spacers) and transmitted

C. Grid ratio (h/b)

1. Ratio of height to width of spacers between lead strips
2. Grid ratio range 4:1 to 16:1
3. For constant lead strip thickness, the greater the grid ratio the more effective the grid is in removing scatter

D. Grid fineness

1. The number of grid lines (lead strips) per inch
2. Common range 50 - 150 lines per inch
3. The more fine the less visible will be the lines on the radiograph but more primary absorption
4. If lead strips are too thin:
 - a. Lose support
 - b. No longer effective in stopping scatter

E. Grid types

1. Parallel grid (Fig. 463-26)

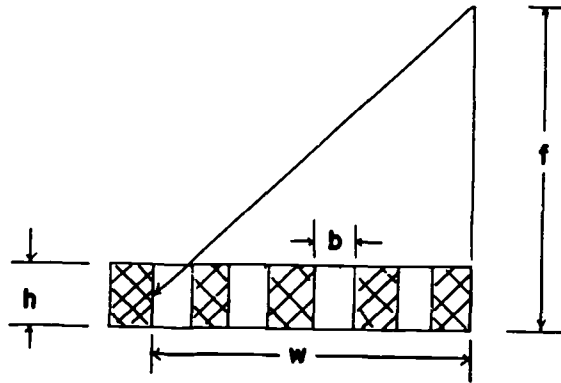

Figure 463-26. Parallel grid

- a. Cut-off of beam will occur as you move away from field center

$$\frac{w}{f} = \frac{b}{h} , \quad w = f \times \frac{b}{h} = \frac{f}{\text{grid ratio}}$$

- b. This will cause gradual reduction in film density on both sides of central beam as cut-off point is reached

2. Focused grid (Fig. 463-27)

- a. Sections of grid about 1" wide are made
- b. Each section positioned at angle pointing toward x-ray tube focal spot

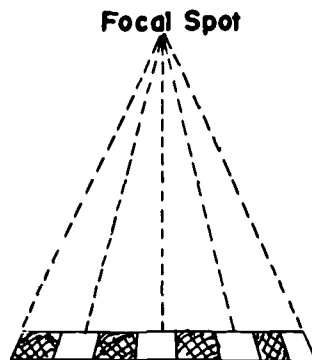

Figure 463-27. Focused grid

- c. No cut-off provided focal spot is at focus of grid
 - d. Most grids permit some latitude in use but as grid ratio increases, latitude decreases
3. Cross grid (Fig. 463-28)
- a. Two linear grids placed on top of each other and at right angles

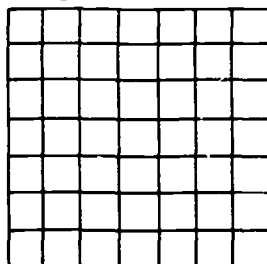

Figure 463-28. Crossed grid

- b. An 8:1 crossed grid gives a 16:1 grid ratio
 - c. Cannot be used with tilting table technics
- F. Moving grids
- 1. When stationary grid is used each lead strip shows up as fine line on radiograph
 - 2. Movement of grid during exposure blurs image of grid lines
 - 3. Moving grid technic developed by Dr. Hollis Potter in 1920. Called Potter-Bucky Diaphragm
 - 4. Potter devised single stroke system
 - a. Superseded ~ 1946 by reciprocating Bucky having a fast and slow stroke for use for short exposures
 - b. Followed ~ 1960 by vibrating continuous motion Bucky
 - 5. Employed in most conventional medical radiographic tables
- G. Focused linear grid best for general purpose radiography

H. As grid ratio increases, three factors become increasingly important

1. Distance
2. Leveling
3. Centering

I. Current use

1. Vibrating grids in radiographic tables
2. Stationary focused grids in grid-front cassettes
3. Stationary fine-line unfocused grids for high voltage chest radiography and special procedures

LECTURE NO. 8

- TITLE: Medical Radiography
- PURPOSE: To discuss the applications of x rays in medical diagnosis
- TIME: One hour
- VISUAL AIDS: Blackboard
Selected radiographs
- HANDOUTS: How to Prepare an X-Ray Technic Chart--General Electric
A Guide to Radiological Anatomy--General Electric
- REFERENCES: Bloom, Hollenbach and Morgan
Medical Radiographic Technic
- Clark, K.C.
Positioning in Radiography

MEDICAL RADIOGRAPHY

I. Factors Affecting Radiographic Detail

- A. Radiographic contrast
 - 1. Subject contrast
 - 2. Film contrast
- B. Radiographic definition
 - 1. Geometric factors
 - 2. Mottle

II. Medical Radiographic Technique

- A. Factors to consider
 - 1. Film type
 - a. Relative speed
 - b. Contrast and latitude
 - 2. Screen type
 - a. Non-screen (cardboard holders)
 - b. Slow
 - c. Medium
 - d. Fast
 - 3. Grids
 - a. No grid
 - b. Grid mAs and kVp conversions
 - 4. Collimation
 - a. Field size
 - b. kVp or mAs change
 - 5. Distance

$$\frac{(\text{mAs})_1}{(\text{mAs})_2} = \left[\frac{D_1}{D_2} \right]^2$$
 - 6. Contrast -- kVp, mAs relation
- B. Variable kilovoltage technic
 - 1. Hold mAs constant

2. Hold distance constant
3. Vary mAs with part thickness

III. Special Radiographic Procedures

A. Stereoradiography (Fig. 463-29)

1. Three-dimensional radiography
2. Two radiographs made, one at position of each eye
3. For viewing distance of 25", the correct tube shift is 1/10 the SFD

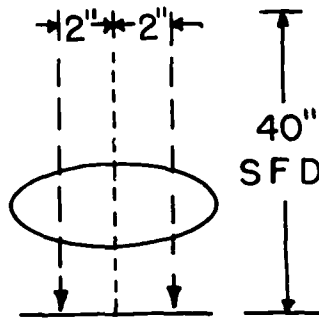

Figure 463-29. Shift for stereoradiography

B. Photofluorography

1. Image from fluoroscopic screen photographed
2. Used in mass chest radiography

C. Cinefluorography -- movies of dynamic system through image intensifier

D. Tomography -- body section radiography. Movement of x-ray tube and film provides radiograph of selected plane through body

E. Rapid Serial Radiograph -- multiple exposure of film to chart progress of radiopaque substance

3

F. Foreign body localization (Fig. 463-30)

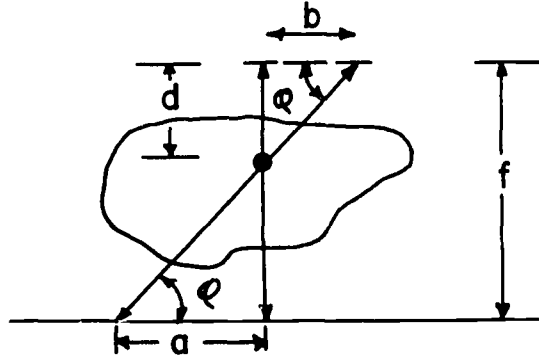

Figure 463-30. Foreign body localization

$$\tan \phi = \frac{f - d}{a} \quad d = \frac{bf}{a+b}$$

G. Contrast studies, angiography, arteriography, cardiac catheterization

LECTURE NO. 9

TITLE: Dental Radiography

PURPOSE: To discuss the uses of x rays in dentistry

TIME: One hour

VISUAL AIDS: Blackboard
Selected dental radiographs

HANDOUTS: None

REFERENCES: Eastman Kodak Company
X-Rays in Dentistry

Clark, K. C.
Positioning in Radiography

Wuehrmann and Manson-Hing
Dental Radiology

DENTAL RADIOGRAPHY

I. Introduction

- A. Use of x rays in dentistry generally accepted as effective means of supplementing physical examination
- B. Two general types of radiographic (radiodontic) examinations
 - 1. Intra-oral
 - 2. Extra-oral

II. Intra-oral Examination

- A. Periapical
 - 1. Entire tooth and surrounding alveolar tissue
 - 2. Film packets
 - a. 1 or 2 films/packet
 - b. Standard size 1 1/4" x 1 5/8"
 - 3. Regions of examinations
 - a. Maxillary
 - 1) Central incisor
 - 2) Lateral incisor (L & R)
 - 3) Cuspid (L & R)
 - 4) Bicuspid (L & R)
 - 5) Molar (L & R)
 - b. Mandibular
 - 1) Incisor
 - 2) Cuspid (L & R)
 - 3) Bicuspid (L & R)
 - 4) Molar (L & R)
 - 4. Film packets for basic adult examination
 - a. 9 maxillary
 - b. 7 mandibular
- B. Interproximal (bite-wing)
 - 1. Detect cavities involving approximal tooth surfaces or defects of coronal and cervical regions and interproximal crests

2. Film packets
 - a. 1 film/packet
 - b. Sizes, from 7/8" x 1 3/8" to 1 1/16" x 2 1/8" depending on location
3. Regions of examinations
 - a. Maxillary and mandibular
 - 1) Central incisor
 - 2) Lateral incisor and cuspid (L & R)
 - 3) Bicuspid and molar (L & R)
4. Film packets for basic adult examination
 - a. Average vault 1 - 5 films
 - b. Narrow vault 1 - 7 films

C. Occlusal

1. Large areas of maxillae or mandible
2. Film packets
 - a. 1 or 2 films/packet
 - b. Size 2 1/4 x 3 inches
3. Regions of examinations
 - a. Maxillary
 - 1) Incisor
 - 2) Cuspid-molar (L & R)
 - b. Mandibular
 - 1) Incisor
 - 2) Cuspid-molar (L & R)
 - 3) Entire mandibular denture
4. Film packets for basic adult examination
 - a. 3 maxillary
 - b. 4 mandibular

D. Exposure factors

1. 65 - 100 kVp
2. 8 - 16 inch SSD

3. 10 - 15 mA
4. 1/60 - 1 1/2 seconds

III. Extra-oral Examination

- A. Not routine
 1. Provide supplementary information
 2. Of value in specific cases
- B. Types of examinations
 1. Mandible and maxillae
 - a. Lateral
 - b. Posteroanterior
 2. Temporomandibular articulation
 3. Facial profile
- C. Film
 1. Size
 - a. 5" x 7"
 - b. 6 1/2" x 8 1/2"
 - c. 8" x 10"
 2. Type
 - a. No-screen
 - b. Medium speed
 - c. High speed
- D. Exposure factors
 1. 65 - 100 kVp
 2. 15 - 72" SFD
 3. 10 - 15 mA
 4. 1/20 - 1 1/4 sec.

IV. Special Equipment

- A. Panoramic
 1. Extra-oral technic
 2. Tube and film move around head
 3. Provides complete dental radiograph on single film

4. Similar to medical tomography
- B. Intra-oral
1. Grounded tube anode placed in oral cavity
 2. Film wrapped around face

LECTURE NO. 10

- TITLE:** Industrial radiography
- PURPOSE:** To discuss the use of x rays in industrial non-destructive testing
- TIME:** Two hours
- VISUAL AIDS:** Blackboard
Selected radiographs
Selected industrial penetrameters
Slide projector and slides of typical industrial installations and radiographs
- HANDOUTS:** None
- REFERENCES:** Eastman Kodak Company
Radiography in Modern Industry

Halmshaw
Physics of Industrial Radiology

INDUSTRIAL RADIOGRAPHY

I. Introduction

- A. Non-destructive testing method
- B. Examination of single pieces to continuous production line work

II. The Industrial Radiograph

- A. Distinction between radiographic quality and sensitivity
 - 1. Radiographic quality
 - a. Depends on total radiograph
 - b. If inspection is of irregular thickness castings then also need to consider thickness latitude as well as sensitivity
 - c. If inspection is to determine orientation of components, sensitivity may be minor factor in radiographic quality
 - 2. Radiographic sensitivity
 - a. Depends on limits to dimensions of defects which can be revealed
- B. Sensitivity
 - 1. Thickness sensitivity

S_T = thickness of thinnest visible plate placed on top of part divided by thickness of part x 100%.
 - 2. Detail (hole) sensitivity

S_N = thickness (diameter) of smallest hole in plate divided by thickness of object x 100%.

III. Penetrameters

- A. Used to measure sensitivity
 - 1. Purpose
 - a. Specify radiographic technic by quoting a value of penetrameter sensitivity for the radiograph to be acceptable

- b. Evaluate sensitivity in different parts of radiograph
 - c. Evaluate unexpected or unpredicted variations which affect radiographic quality
2. Desirable characteristics
- a. Sensitive in readings to changes in radiographic technic
 - b. Easy and simple to read
 - c. Easy to use
 - d. Small, so as not to obscure parts but not so small as to be mistaken for object defect
 - e. Economical
 - f. Identification of size
3. Designs of penetrameters have been based on wires, holes, balls, grooves, slits, etc.
- B. Step penetrameters
- 1. 1/2" square steps
 - 2. Holes centered in steps
- C. Plaque penetrameters
- 1. Plate of uniform thickness
 - 2. 3 holes of different diameters in plate
 - 3. Lead identification numbers
- D. Penetrameter codes
- 1. Essentially the same type of penetrameter is mandatory for all
 - 2. AS ME (boiler code), ASTM, Military standards
 - 3. Equivalent sensitivity assigned on assumption that a 2T (T = plaque thickness) hole in a 2% plaque is described as 2% penetrameter sensitivity
 - 4. Penetrameters of thickness T with 3 holes, 1T, 2T, 4T
 - 5. Levels of sensitivity are listed as 2 - 2T meaning a 2T hole is perceptible in a 2% plaque (2% equivalent sensitivity)

IV. Applications

- A. Foundry practices--development of casting technics and evaluation of castings
- B. Weldment inspection--flat plates, tubes, pressure vessels
- C. Food inspection and processing

V. Industrial X-Ray Sources

- A. Thin metal sections
 - 1. 50 kVp
 - 2. No screens
- B. Light alloys (5" aluminum to 1" steel)
 - 1. 150 kVp
 - 2. No screen or lead foil screens
- C. Steel
 - 1. 1 1/2", 150 kVp, no screen
 - 2. 2", 250 kVp, lead foil screens
 - 3. 3", 400 kVp, lead foil screens
 - 4. 4", 400 kVp, fluorescent screens
 - 5. 5", 1000 kVp, lead foil screens
 - 6. 8", 1000 kVp, fluorescent screens
 - 7. 8", 2000 kVp, lead foil screens
 - 8. 16", 15 - 24 Mev, lead foil screens
 - 9. 20", 15 - 24 Mev, fluorescent screens

LECTURE NO. 11

TITLE: Research Applications of X Rays

PURPOSE: To discuss the uses of x rays in the field of research

TIME: One hour

VISUAL AIDS: Blackboard
Slide projector and slides of research installations and procedures

HANDOUTS: None

REFERENCES: Radiation Research

RESEARCH APPLICATIONS OF X RAY

I. Introduction

X ray is used extensively in the fields of chemistry, biology, medicine, physics, etc. for basic and applied research.

II. Applications

- A. Inducing chemical changes through ionization processes in chemical solutions and compounds
- B. Studying cell action after exposure to varying levels and rates of exposure
- C. Studying animal growth and structure after various insults
- D. Studying fibrous substances
- E. Geological studies
- F. Medical radiology

LECTURE NO. 12

TITLE: Analytical and Special Industrial Uses of X Rays

PURPOSE: To discuss special industrial uses of x rays

TIME: One hour

VISUAL AIDS: Blackboard
Slide projector for selected slides of installations and processes

HANDOUTS: None

REFERENCES: Halmslaw
Physics of Industrial Radiology

ANALYTICAL AND SPECIAL INDUSTRIAL USES OF X RAY

I. Introduction

X rays are used for numerous analytical applications.

These include:

- 1) Equipment for element analysis
- 2) Equipment for thickness gauging
- 3) Equipment for controlling mixes
- 4) Equipment for height of fill determinations

II. X-Ray Diffraction and Emission

- A. Crystal structure of elements produces distinctive x-ray diffraction patterns
- B. Characteristic x-ray emission from elements can be detected
- C. Analytical equipment permits determination of elements present in compound without destroying compound

III. Thickness Gauges

- A. Exposure rate transmitted through a given material is exponential function of material thickness (Fig. 463-31)

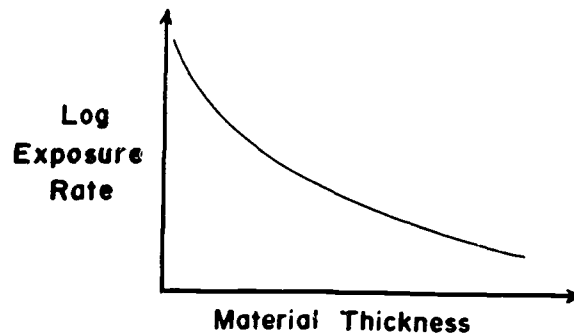

Figure 463-31. Radiation transmission through material

- B. Transmitted exposure rate can be detected and signal used to control final step in rolling process
 1. Metal-steel, aluminum, etc.
 2. Paper

- C. Thickness gauge therefore part of system
- D. Photon energy determined by thickness and type of material

IV. Mixes

- A. Combinations of elements or compounds being mixed, eg. cement, can be determined by x-ray analysis during mix
- B. Detector signal used to control quantity of each component going into mix
- C. Assures consistant product

V. Height of Fill Systems

- A. Liquid level in containers must be accurately controlled
 - 1. Under or over filling can cause deterioration of contents or rupture of container
 - 2. Regulations require that content, usually by weight, be as stated on container
- B. Glass container liquid level can be determined by light beam transmission through container
 - 1. Small light beam with photo-detector can determine over, normal and under fill conditions
 - 2. Light cannot be used when container is opaque, such as metal can
- C. X-ray system
 - 1. Small, 1/64", x-ray beam directed across can line at liquid level corresponding to proper fill height
 - 2. Transmitted x-ray beam exposure rate will be:
 - a. "High" if can underfilled--no liquid attenuation
 - b. "Normal" if can properly filled--part of beam attenuated by liquid
 - c. "Low" if can overfilled--entire x-ray beam attenuated by liquid
 - 3. Two x-ray beams often used
 - a. One detector beam

- b. Second is unattenuated and used as reference source
 - 1) Detector beam referenced to unattenuated beam
 - 2) Automatically compensates for any fluctuations in x-ray output
- 4. Used extensively in canned beverage industry and petroleum industry

VI. Other Applications

- A. Radiography of "works of art"
- B. Radiography of stamps, coins, etc.
- C. Sterilization of instruments--electron beam
- D. Plastics--electron beam
- E. Veterinary radiology

LECTURE NO . 13

TITLE: X-Ray Therapy

PURPOSE: To discuss the use of x rays in the treatment of malignancies

TIME: One hour

VISUAL AIDS: Blackboard
Slide projector for selected slides of installations,
isodose curves and dose distribution patterns

HANDOUTS: None

REFERENCES: Johns and Cunningham
The Physics of Radiology

X-RAY THERAPY

I. Purpose

Produce desired clinical result without objectionable damage to normal tissue

II. Classifications

A. Superficial

1. Conditions at or near body surface
 - a. 10 - 150 kVp
 - b. Contact to 50 cm SSD
 - c. 0 - 1/4 mm Cu total filter

B. Deep

1. Conditions down to body midline
 - a. 150 - 400 kVp
 - b. 30 - 100 cm SSD
 - c. 1/4 - 5 mm Cu total filter

C. Megavoltage

1. Conditions down to body midline
 - a. 1 Mev and up
 - 1) 10 - 24 Mev normal maximum
 - b. 100 cm SSD
 - c. 3 mm Pb at 1 Mev, 6 mm Pb at 2 Mev

III. Technics

A. Dose distribution vs energy

1. Backscatter
2. Depth dose
3. Isodose curves
4. Integral dose
5. Phantoms

B. Fields

1. Single
2. Multiple
3. Rotation

GS-463 X-RAY APPLICATIONS

SECTION II

LABORATORY EXERCISES

LABORATORY NO. 1

TITLE: X-Ray Film Development

PURPOSE: To study the effects of development time on the finished radiograph.

TIME: Three hours

MATERIALS FOR EACH STUDENT GROUP:

One Teaching X-Ray Unit
One manual x-ray film processing station
One sensitometer
Five sheets of 5" x 7" Kodak Royal Blue X-Ray Film
Five cardboard exposure holders (5" x 7")
Five film hangers (5" x 7")
One MacBeth model TD-102 densitometer
One set of lead letters
One sheet of 3-cycle semilog graph paper (K&E 46 5493 or equivalent)
Three sheets of linear graph paper (K&E 46 0703 or equivalent)
One ships curve (K&E 1685-48 or equivalent)

REFERENCES:

Eastman Kodak Company
Sensitometric Properties of X-Ray Films

Meredith
Fundamental Physics of Radiology

Ter-Pogossian
The Physical Aspects of Diagnostic Radiology

Laboratory No. 1

X-RAY FILM DEVELOPMENT

I. INTRODUCTION

The purpose of this laboratory exercise is to study the effects of development time on the finished radiograph.

Factors which will be investigated include base fog, relative speed, and average gradient. Base fog is caused by the development of silver bromide crystals that have not been exposed. Radiographic speed is defined as the reciprocal of the exposure necessary to produce a given density. Relative speed is the speed of different films expressed in terms of the speed of one particular film. The average gradient is the slope of the straight line connecting two points on the density versus log exposure curve.

II. EQUIPMENT

- A. Teaching X-Ray Unit
- B. X-Ray Film (5" x 7") Kodak Royal[™]Blue
- C. Sensitometer
- D. MacBeth model TD-102 densitometer
- E. Manual x-ray film processing station
- F. Cardboard exposure holders
- G. Lead letters

III. PROCEDURE

- A. Load five cardboard holders with Kodak Royal Blue film leaving the protective paper on the film.
- B. Expose each of the films in the sensitometer using the exposure factors given below. On the sixth strip place lead letters to identify your film and the development time to be used.

60 kVp

1 mA

2 mm Al added absorber

55 cm source-film distance

<u>Strip No.</u>	<u>Exposure Time (sec)</u>
1	1/2
2	1
3	2
4	3
5	5
6	8
7	13
8	20
9	30
10	45
11	60
12	80

C. Processing

1. Load films onto hangers
2. Develop one film each for:
 - a. One minute
 - b. Three minutes
 - c. Five minutes
 - d. Seven minutes
 - e. Twenty-five minutes
3. Rinse all films one minute
4. Fix all films five minutes

5. Wash all films 15 minutes
6. Dry all films 20 minutes

IV. RESULTS

- A. Read and record the density of each strip of each film and the unexposed (base fog) portion of each film.
- B. Plot density versus mAs for each development time on the same sheet of semi-log graph paper.
- C. Plot base fog density as a function of development time on linear graph paper.
- D. Effect of development time on speed.
 1. Calculate relative speeds at $d = 1.5$ assigning a relative speed of 100 for five minutes development time.
 2. Relative speed = $\frac{\text{Exposure at five minutes development}}{\text{Exposure at X minutes development}}$
 3. Plot relative speed ($d = 1.5$) versus development time on linear graph paper.
- E. Effect of development time on average gradient
 1. Determine the average gradients between $d = 1.5$ and $d = 2.5$.
 2. Average gradient = $\frac{\Delta \text{ density}}{\Delta \log \text{ exposure (mAs)}} = \frac{\Delta d}{\log \frac{X_2}{X_1}}$
 3. Plot average gradient versus development time on linear graph paper.
- F. Keep a record of the data obtained for the five minute development time as this will be used in a later laboratory.

Laboratory No. 1

TYPICAL DATA

Part IV. Results

A. Density vs exposure and development time 60 kVp, 1 mA, 2 mmAl added filtration

<u>Strip No.</u>	<u>mAs</u>	<u>Development Time - minutes</u>				
		<u>1</u>	<u>3</u>	<u>5</u>	<u>7</u>	<u>25</u>
		<u>Density</u>				
1	0.5	0.34	0.35	0.36	0.38	0.46
2	1	0.46	0.47	0.48	0.49	0.59
3	2	0.66	0.67	0.69	0.71	0.81
4	3	0.83	0.85	0.87	0.89	1.00
5	5	1.11	1.15	1.21	1.25	1.36
6	8	1.36	1.50	1.59	1.62	1.78
7	13	1.65	1.95	2.04	2.06	2.22
8	20	1.90	2.31	2.40	2.44	2.58
9	30	2.14	2.61	2.70	2.76	2.87
10	45	2.32	2.86	2.94	3.00	3.08
11	60	2.46	2.98	3.06	3.11	3.16
12	80	2.56	3.06	3.15	3.20	3.23
Fog	--	0.26	0.27	0.28	0.29	0.36

D. Effect of development time on speed at $d = 1.50$ assigning a relative speed of 100 for 5 minutes development time

1. One minute development
Relative speed = $\frac{(7.1) (100)}{10} = 71$
2. Three minute development
Relative speed = $\frac{(7.1) (100)}{8.0} = 89$
3. Five minute development
Relative speed = $\frac{(7.1) (100)}{7.1} = 100$
4. Seven minute development
Relative speed = $\frac{(7.1) (100)}{6.9} = 103$
5. Twenty-five minute development
Relative speed = $\frac{(7.1) (100)}{5.8} = 123$

E. Effect of development time on average gradient for density range 1.5 to 2.5

1. One minute development
Average gradient = $\frac{2.5 - 1.5}{\log 67/10} = 1.21$
2. Three minute development
Average gradient = $\frac{2.5 - 1.5}{\log 25.6/8.0} = 1.98$
3. Five minute development
Average gradient = $\frac{2.5 - 1.5}{\log 22.8/7.15} = 1.99$
4. Seven minute development
Average gradient = $\frac{2.5 - 1.5}{\log 21.5/6.8} = 2.00$
5. Twenty-five minute development
Average gradient = $\frac{2.5 - 1.5}{\log 18/5.8} = 2.03$

Laboratory No 1, Part IV, A
Density vs Exposure
For Development Times Of
1, 3, 5, 7, And 25 Minutes

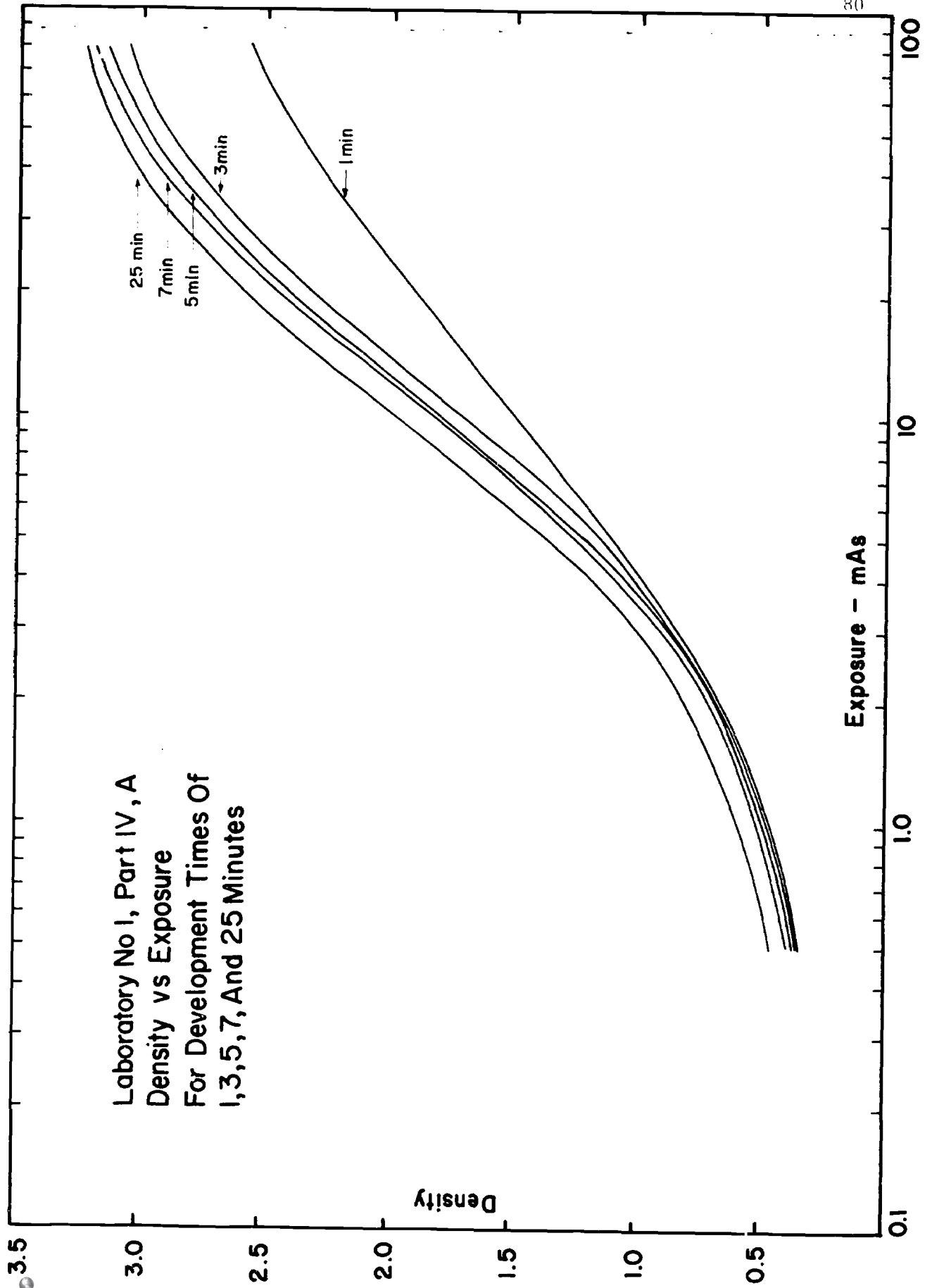

Laboratory No 1, Part IV, C
Base Fog - Density vs Development Time

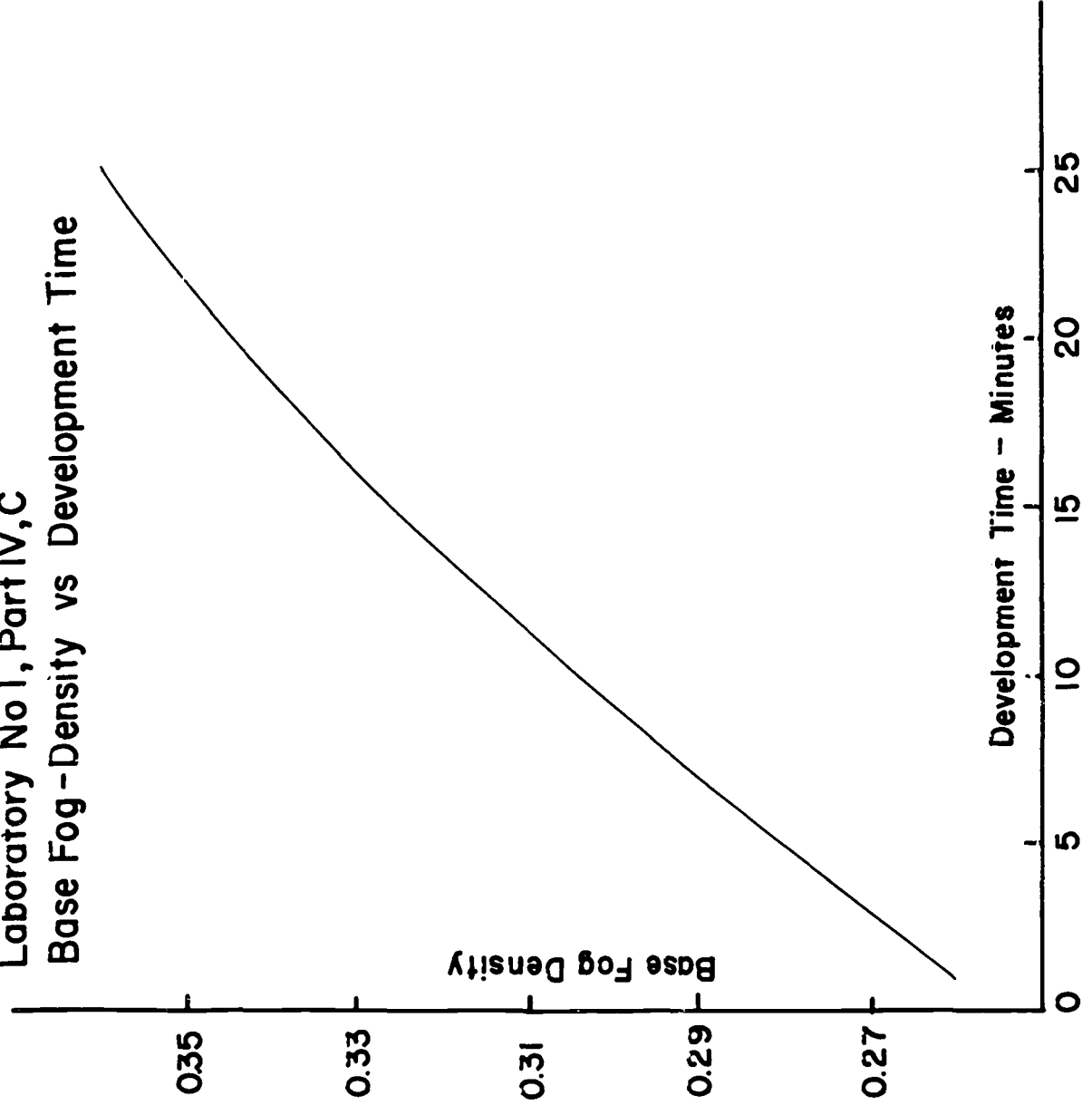

Laboratory No 1, Part IV, D

Relative Speed vs Development Time

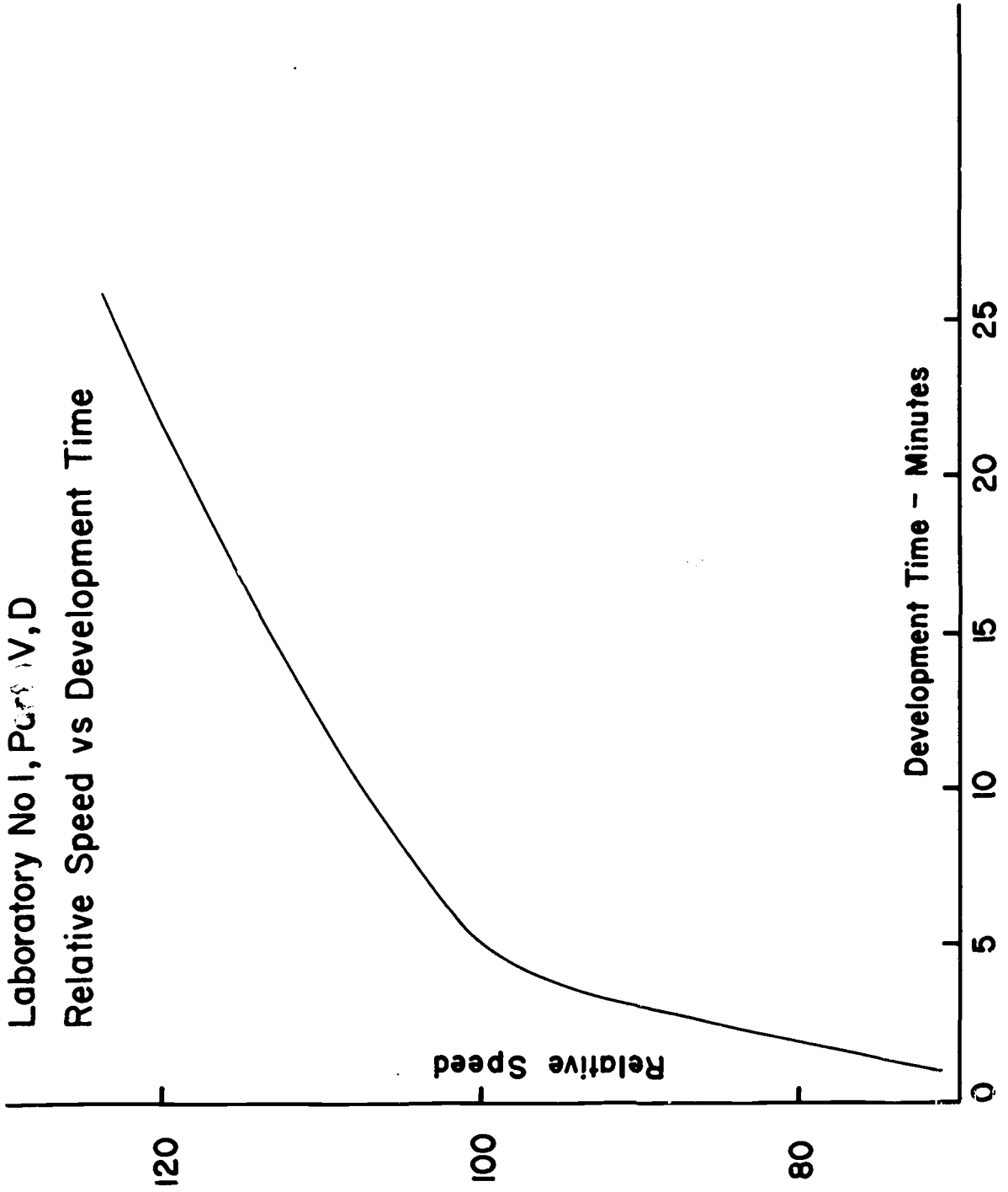

Laboratory No I, Part IV, E
Average Gradient vs Development Time

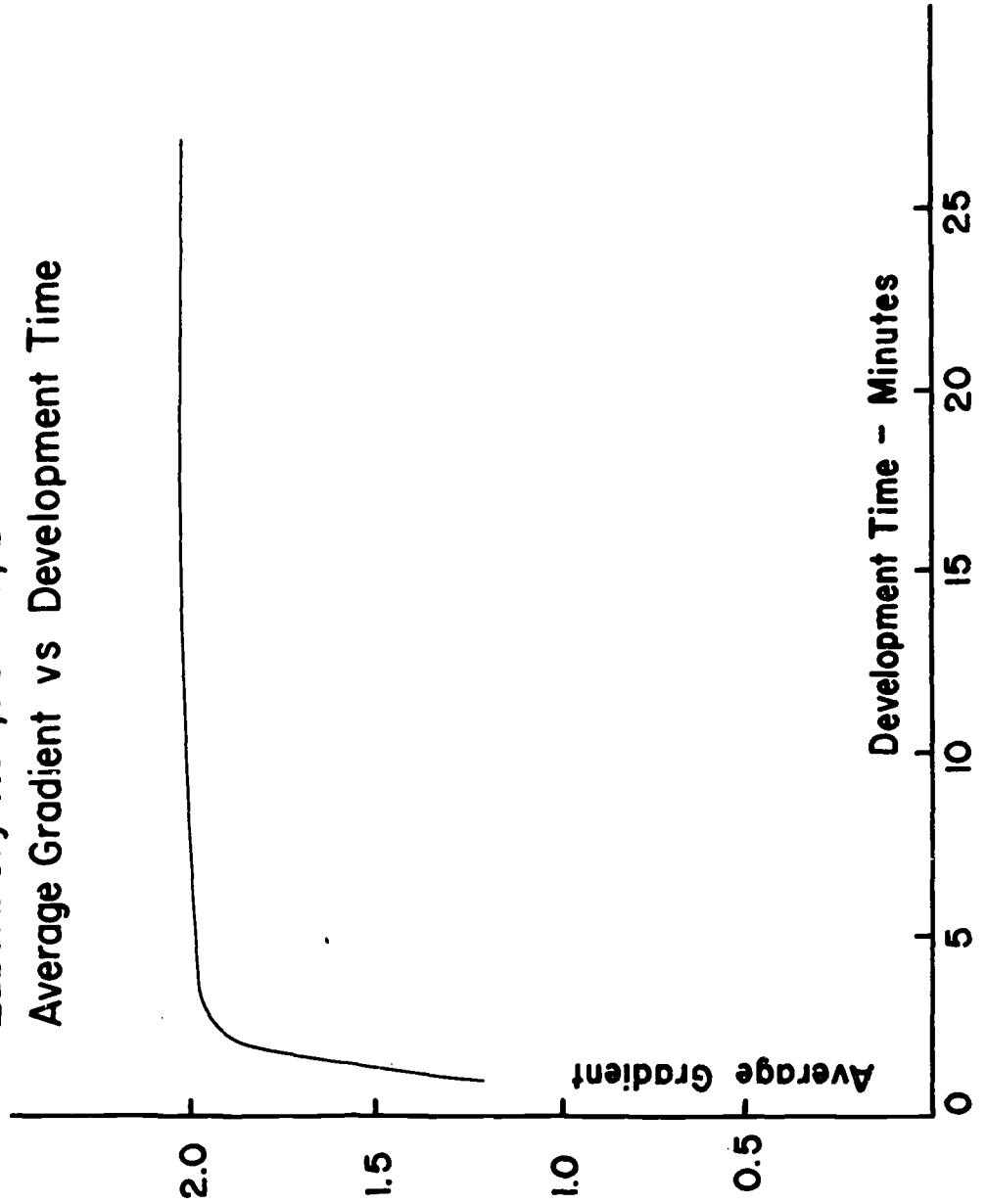

LABORATORY NO. 2

TITLE: Sensitometric Properties of Direct Exposure X-Ray Film

PURPOSE: To construct and study characteristic curves of various direct-exposure x-ray films.

TIME: Three hours

MATERIALS FOR EACH STUDENT GROUP:

One Teaching X-Ray Unit
 One Sensitometer
 One manual x-ray film processing station
 One 5" x 7" sheet of each type of film to be studied:
 Kodak Type M
 Kodak Type AA
 Kodak No Screen
 Three cardboard exposure holders (5" x 7")
 Three film hangers (5" x 7")
 One MacBeth model TD-102 densitometer
 Lead letters
 One sheet four cycle semi-log paper (K&E 46 6013 or equivalent)
 One ships curve (K&E 1685-48 or equivalent)

REFERENCES:

Lastman Kodak Company
Industrial Radiography

Lastman Kodak Company
Sensitometric Properties of X-Ray Film

Meredith
Fundamental Physics of Radiology

Ter-Pogossian
The Physical Aspects of Diagnostic Radiology

Laboratory No. 2

SENSITOMETRIC PROPERTIES OF DIRECT EXPOSURE X-RAY FILMS

I. INTRODUCTION

The purpose of this laboratory exercise is to develop and study the characteristic curves of various direct exposure x-ray films.

II. EQUIPMENT

- A. Teaching X-Ray Unit
- B. X-ray film (5" x 7")
 - 1. Kodak Type M
 - 2. Kodak Type AA
 - 3. Kodak No Screen (Medical)
- C. MacBeth model TD-102 densitometer
- D. Sensitometer
- E. Cardboard exposure holders
- F. Manual x-ray film processing station
- G. Set of lead identifying letters

III. PROCEDURE

- A. Load one cardboard holder for each film type leaving the protective paper on the film.
- B. Expose each of the films in the sensitometer using the exposure factors given below. On the sixth strip place lead letters to identify your film and the film type.

60 kVp

1 mA

2 mm Al added absorber

55 cm source-film distance

<u>Strip No.</u>	Exposure Time (Seconds)		
	<u>Type AA</u>	<u>Type M</u>	<u>No-Screen</u>
1	1	6	1/5
2	2	10	7/20
3	4	14	1/2
4	6	20	4/5
5	10	30	1 1/4
6	14	40	2
7	20	50	3
8	25	70	4
9	35	90	5
10	45	120	6
11	55	150	8
12	65	200	10

C. Processing

1. Develop for 5 minutes (agitate)
2. Rinse for 1 minute
3. Fix for 5 minutes (agitate)
4. Wash for 15 minutes
5. Dry for 20 minutes

D. Read and record the density of each strip and the unexposed portion of the film.

E. Plot net density versus mAs for each film type on the same sheet of semi-log graph paper.

IV. PROBLEMS (Show all calculations)

- A. Find the average gradient of each film for the density range 0.5-2.5.
- B. Find the relative speed of each film at $d = 1.5$ assuming Type AA has a relative speed of 100 at $d = 1.5$.

Laboratory No. 2
TYPICAL DATA

Part III. D. Density vs exposure

Strip No.	Type AA			Type M			No Screen		
	mAs	<u>Gross Density</u>	<u>Net</u>	mAs	<u>Gross Density</u>	<u>Net</u>	mAs	<u>Gross Density</u>	<u>Net</u>
1	1	.22	.05	6	.25	.09	.167	.31	.05
2	2	.30	.13	10	.34	.18	.35	.39	.13
3	4	.42	.25	14	.43	.27	.5	.46	.20
4	6	.55	.38	20	.57	.41	.8	.63	.37
5	10	.81	.64	30	.79	.63	1.25	.86	.60
6	14	1.07	.90	40	.98	.82	2.00	1.24	.98
7	20	1.46	1.29	50	1.17	1.01	3.00	1.66	1.40
8	25	1.79	1.62	70	1.56	1.40	4.00	2.14	1.88
9	35	2.35	2.18	90	2.00	1.84	5.00	2.54	2.28
10	45	2.85	2.58	120	2.63	2.47	6.00	2.74	2.48
11	55	3.36	3.19	150	3.12	2.96	8.00	3.46	3.20
12	55	3.78	3.61	200	3.90	3.74	10.00	>4.00	--
Fog	--	0.17	--	--	0.16	--	--	0.26	--

Part IV. Problems

A. Average gradient for $d = 0.5 - 2.5$

$$1. \text{ No screen } \quad \bar{G} = \frac{2.5 - 0.5}{\log 5.7/1.1} = \frac{2.0}{.714} = 2.80$$

$$2. \text{ Type AA } \quad \bar{G} = \frac{2.5 - 0.5}{\log 40.6/7.9} = \frac{2.0}{.712} = 2.81$$

$$3. \text{ Type M } \quad \bar{G} = \frac{2.5 - 0.5}{\log 123/24.5} = \frac{2.0}{.702} = 2.85$$

B. Relative speed at $d = 1.5$ assuming AA has a relative speed of 100 at $d = 1.5$

$$1. \text{ No Screen relative speed } = \frac{(23.3)(100)}{3.15} = 740$$

$$2. \text{ Type AA relative speed } = \frac{(23.3)(100)}{23.3} = 100$$

$$3. \text{ Type M relative speed } = \frac{(23.3)(100)}{74} = 31.5$$

Laboratory No. 2, Part III, E
Net Density vs Exposure

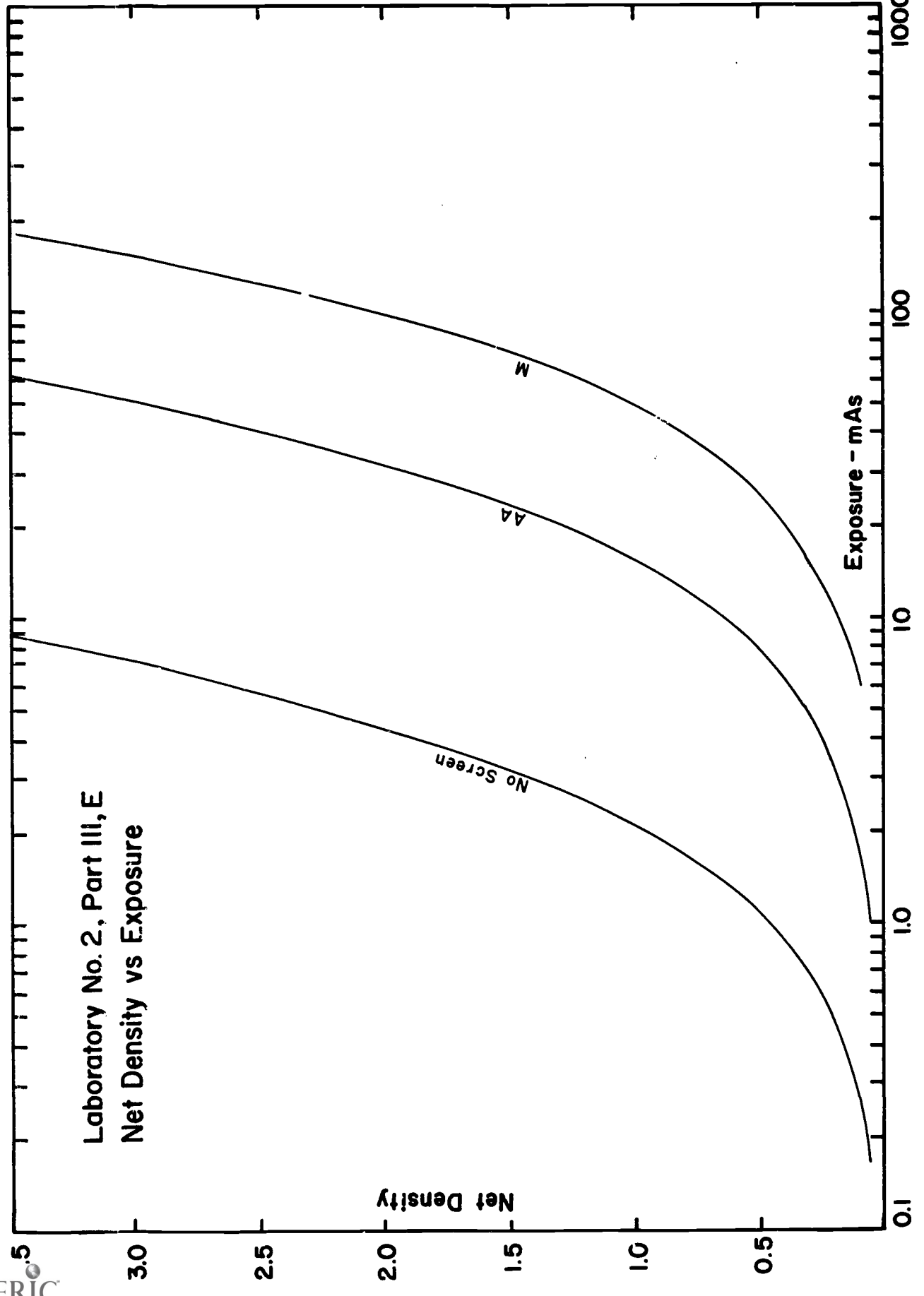

LABORATORY NO. 3

TITLE: Sensitometric Properties of Medical X-Ray Film

PURPOSE: To plot and study characteristic curves of various medical x-ray film-screen combinations.

TIME: Three hours

MATERIALS FOR EACH STUDENT GROUP:

One Teaching X-Ray Unit
One Sensitometer
Four 5" x 7" sheets of each type of film to be studied:
 Kodak Royal Blue
 Kodak Blue Brand
Two 5" x 7" cardboard film holders
Two of each of the following 5" x 7" screen-type film cassettes:
 High Speed
 Par Speed
 Detail
One set lead letters
One Kodak X-OMAT automatic x-ray film processor
One MacBeth model TD-102 densitometer
Two sheets of three cycle semi-log paper (K&E 46 5493 or equivalent)
One ships curve (K&E 1685-48 or equivalent)

REFERENCES:

Dupont Company
 The Care and Use of Cronex Xtra Life Intensifying Screens

Eastman Kodak Company
 Sensitometric Properties of X-Ray Films

Laboratory No. 3
SENSITOMETRIC PROPERTIES OF MEDICAL X-RAY FILM

I. INTRODUCTION

The purpose of this laboratory exercise is to plot and study the characteristic curves of various medical x-ray film-screen combinations.

II. EQUIPMENT

- A. X-ray film (5" x 7")
 - 1. Kodak Royal Blue
 - 2. Kodak Blue Brand
- B. Teaching X-Ray Unit with sensitometer
- C. Film cassettes (5" x 7")
 - 1. High speed
 - 2. Par speed
 - 3. Detail
 - 4. Cardboard
- D. MacBeth model TD-102 densitometer
- E. Kodak X-OMAT automatic x-ray film processor
- F. Lead letters

III. PROCEDURE

- A. Load one cassette for each film-screen combination to be studied.

B. Expose each of the films in the sensitometer using the exposure factors given below. Use the lead letters to identify your films.

1. X-Ray Machine settings for film-screen combinations:

60 kVp

1 mA

0.5 mm Cu Added Absorber

55 cm Source-Film Distance

<u>Strip No.</u>	<u>Exposure Time (Sec.)</u>					
	<u>Blue Brand</u>			<u>Royal Blue</u>		
	<u>Hi</u>	<u>Par</u>	<u>Detail</u>	<u>Hi</u>	<u>Par</u>	<u>Detail</u>
1	2/5	1/2	1 1/2	1/4	3/10	1
2	3/5	4/5	2 1/2	2/5	1/2	1 1/2
3	1	1	4	3/5	4/5	2
4	1 1/2	1 1/2	6	4/5	1	3
5	2	2	9	1 1/4	1 1/2	6
6	3	3	12	2	2	10
7	4	4	15	3	3	15
8	6	6	25	4	4	20
9	10	9	35	6	6	30
10	15	12	50	10	10	50
11	20	20	70	15	15	70
12	30	40	100	25	25	100

2. X-Ray Machine settings for medical films with no screens:

60 kVp

1 mA

2 mm Al Added Absorber

55 cm Source-Film Distance

<u>Strip No.</u>	<u>Exposure Time (Sec.)</u>	
	<u>Royal Blue</u>	<u>Blue Brand</u>
1	1/2	1
2	1	2
3	2	3
4	3	5
5	5	8
6	8	13
7	13	20
8	20	30
9	30	40
10	45	55
11	60	70
12	80	90

- C. Process the films using the automatic processor. Three 5" x 7" film can be processed together.
- D. Read the density of each strip and the unexposed portion of the film.
- E. Plot net density versus mAs for each film-screen combination on the same sheet of semi-log graph paper. On a second sheet of semi-log graph paper plot net density versus mAs for the two films exposed without screens.

IV. PROBLEMS (Show all calculations)

- A. Find the average gradient of each film-screen combination and each direct exposure film for the density range 0.5 - 2.0.
- B. Find the relative speed of each film-screen combination at density 1.0 assuming the Blue Brand-Par Speed combination has a relative speed of 100 at a density of 1.0.
- C. Find the relative speed of the films which were exposed directly to x rays at density 1.5 assuming Type AA has a relative speed of 100 at a density of 1.5 (use the results from Laboratory No. 2).

Laboratory No. 3
TYPICAL DATA

Part III. B . Density vs exposure, film-screen combinations

1. Blue Brand film

<u>Strip No.</u>	<u>Hi Speed</u>			<u>Par Speed</u>			<u>Detail</u>		
	<u>mAs</u>	<u>Gross Density</u>	<u>Net</u>	<u>mAs</u>	<u>Gross Density</u>	<u>Net</u>	<u>mAs</u>	<u>Gross Density</u>	<u>Net</u>
1	0.4	.24	.04	0.5	.22	.02	1.5	.22	.02
2	0.6	.30	.10	0.8	.30	.10	2.5	.26	.06
3	1.0	.54	.34	1.0	.38	.18	4.0	.36	.16
4	1.5	.87	.67	1.25	.61	.41	6.0	.52	.32
5	2.0	1.18	.98	2.0	.90	.70	9.0	.80	.60
6	3.0	1.68	1.48	3.0	1.31	1.11	12.0	1.10	.90
7	4.0	2.16	1.96	4.0	1.68	1.48	15.0	1.36	1.16
8	6.0	2.62	2.42	6.0	2.17	1.97	25.0	1.98	1.78
9	10.0	3.04	2.84	9.0	2.58	2.38	35.0	2.37	2.17
10	15.0	3.22	3.02	12.0	2.83	2.63	50.0	2.67	2.47
11	20.0	3.29	3.09	20.0	3.13	2.93	70.0	2.90	2.70
12	30.0	3.37	3.17	40.0	3.34	3.14	100.0	3.07	2.87
Fog	--	0.20		--	0.20	--	--	0.20	--

2. Royal Blue film

<u>Strip No.</u>	<u>Hi Speed</u>			<u>Par Speed</u>			<u>Detail</u>		
	<u>mAs</u>	<u>Gross Density</u>	<u>Net</u>	<u>mAs</u>	<u>Gross Density</u>	<u>Net</u>	<u>mAs</u>	<u>Gross Density</u>	<u>Net</u>
1	.25	.30	.07	.3	.27	.04	1.0	.26	.03
2	.4	.43	.20	.5	.40	.17	1.5	.32	.09
3	.6	.72	.49	.8	.74	.51	2.0	.40	.17
4	.8	.98	.75	1.0	.93	.70	3.0	.58	.35
5	1.25	1.52	1.29	1.5	1.37	1.14	6.0	1.13	.90
6	2.0	2.05	1.82	2.0	1.74	1.51	10.0	1.71	1.48
7	3.0	2.49	2.26	3.0	2.21	1.98	15.0	2.20	1.97
8	4.0	2.74	2.51	4.0	2.52	2.29	20.0	2.48	2.25
9	6.0	3.03	2.80	6.0	2.85	2.62	30.0	2.77	2.54
10	10.0	3.24	3.01	10.0	3.12	2.89	50.0	3.04	2.81
11	15.0	3.34	3.11	15.0	3.26	3.03	70.0	3.18	2.95
12	25.0	3.46	3.23	25.0	3.34	3.11	100.0	3.30	3.07
Fog	--	0.23	--	--	0.23	--	--	0.23	--

)

Part III. B. Density vs exposure, direct exposures

Strip No.	Blue Brand			Royal Blue		
	mAs	Gross Density	Net	mAs	Gross Density	Net
1	1	.34	.09	0.5	.36	.08
2	2	.47	.22	1.0	.45	.17
3	3	.60	.35	2.0	.67	.39
4	5	.83	.58	3.0	.85	.57
5	8	1.11	.86	5.0	1.16	.88
6	13	1.47	1.22	8.0	1.54	1.26
7	20	1.91	1.66	13.0	2.01	1.73
8	30	2.36	2.11	20.0	2.40	2.12
9	40	2.64	2.39	30.0	2.76	2.48
10	55	2.94	2.69	45.0	3.07	2.79
11	70	3.11	2.86	60.0	3.21	2.93
12	90	3.26	3.01	80.0	3.30	3.02
Fog	--	0.25	--	--	0.28	--

Part IV. Problems

A. Average gradient for $d = 0.5 - 2.0$

1. Blue Brand film, Hi Speed screens

$$\bar{G} = \frac{2.0 - 0.5}{\log 4.2/1.25} = \frac{1.5}{.527} = 2.84$$
2. Blue Brand film, Par Speed screens

$$\bar{G} = \frac{2.0 - 0.5}{\log 6.15/1.65} = \frac{1.5}{.572} = 2.62$$
3. Blue Brand film, Detail screens

$$\bar{G} = \frac{2.0 - 0.5}{\log 30/7.9} = \frac{1.5}{.58} = 2.59$$
4. Royal Blue film, Hi Speed screens

$$\bar{G} = \frac{2.0 - 0.5}{\log 2.3/0.63} = \frac{1.5}{.563} = 2.67$$
5. Royal Blue film, Par Speed screens

$$\bar{G} = \frac{2.0 - 0.5}{\log 3.05/0.81} = \frac{1.5}{.577} = 2.60$$
6. Royal Blue film, Detail screens

$$\bar{G} = \frac{2.0 - 0.5}{\log 15.5/3.7} = \frac{1.5}{.617} = 2.43$$
7. Blue Brand film, cardboard holder

$$\bar{G} = \frac{2.0 - 0.5}{\log 27.5/4.25} = \frac{1.5}{.811} = 1.85$$
8. Royal Blue film, cardboard holder

$$\bar{G} = \frac{2.0 - 0.5}{\log 17.1/2.55} = \frac{1.5}{.828} = 1.81$$

B. Relative speed of film-screen combinations at $d = 1.0$ assuming the Blue Brand film, Par Speed screen combination relative speed = 100 at $d = 1.00$

1. Blue Brand film, Hi Speed screens
Relative speed = $\frac{(2.68) (100)}{2.05} = 131$
2. Blue Brand film, Par Speed screens
Relative speed = $\frac{(2.68) (100)}{2.68} = 100$
3. Blue Brand film, Detail screens
Relative speed = $\frac{(2.68) (100)}{13.2} = 20.3$
4. Royal Blue film, Hi Speed screens
Relative speed = $\frac{(2.68) (100)}{1.0} = 268$
5. Royal Blue film, Par Speed screens
Relative speed = $\frac{(2.68) (100)}{1.31} = 205$
6. Royal Blue film, Detail screens
Relative speed = $\frac{(2.68) (100)}{6.6} = 40.6$

C. Relative speed of direct exposures at $d = 1.5$ using type AA (Laboratory No. 2) relative speed = 100 at $d = 1.5$

1. Blue Brand film
Relative speed = $\frac{(23.3) (100)}{17.0} = 137$
2. Royal Blue film
Relative speed = $\frac{(23.3) (100)}{10.2} = 228$

Laboratory No. 3, Part III, E
Density vs Exposure
Film - Screen Combinations

Net Density

Exposure - mAs

Blue Brand - Detail

Royal Blue - Detail

Blue Brand - Par

Blue Brand - HI

Royal Blue - Par

Royal Blue - HI

Laboratory No. 3, Part III, E
Density vs Exposure
Direct Exposure

Net Density

Exposure - mAs

Blue Brand - Cardboard
Royal Blue - Cardboard

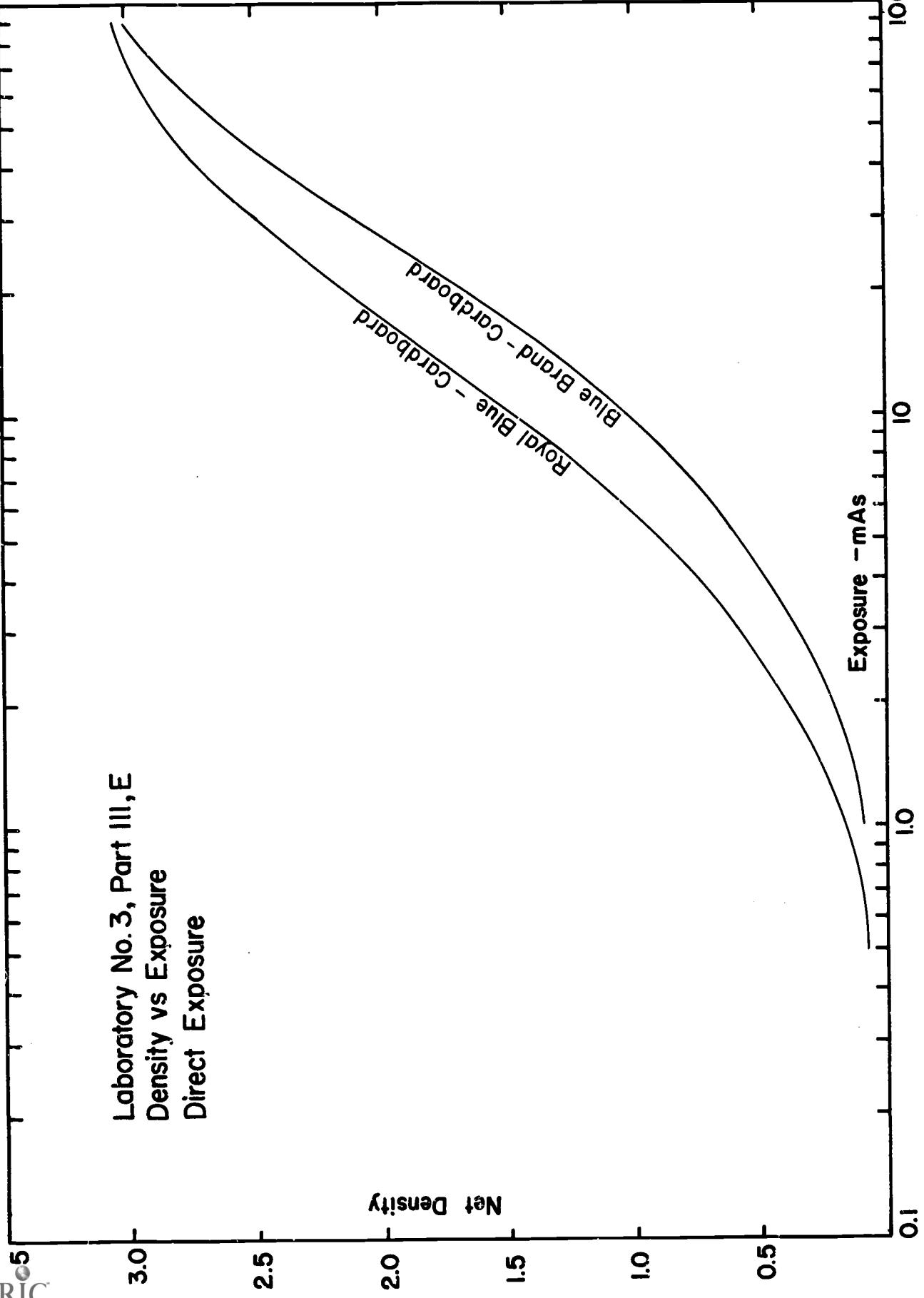

LABORATORY NO. 4

TITLE: Introduction to Radiography

PURPOSE: The purpose of this laboratory exercise is to introduce the student to the principles of medical radiography.

TIME: Three hours

MATERIALS FOR EACH STUDENT GROUP:

One Teaching X-Ray Unit
One Radiographic Test Block
Three 5" x 7" cardboard film holders
Two 5" x 7" Par Speed screen cassettes
Three sheets 5" x 7" Kodak Type M x-ray film
Two sheets 5" x 7" Kodak Blue Brand x-ray film
One set lead numbers and letters
One Kodak M-5 dual speed x-ray film processor
One 14" x 17" illuminator
One MacBeth model TD-102 densitometer

REFERENCES:

Bloom, Hollenbach and Morgan
Medical Radiographic Technic

Trout
Teaching X-Ray Unit

Laboratory No. 4

I. INTRODUCTION

The purpose of this laboratory exercise is to study the effect of kilovoltage, x-ray film type and intensifying screens on film contrast, latitude and definition. The Radiographic Test Block used contains a tooth (with filling), bone, water, fat and air enclosed in a 3/4" thick Plexiglas block and represents the range of material densities normally found in the human body.

II. EQUIPMENT

- A. Teaching X-Ray Unit
- B. Radiographic Test Block
- C. Cardboard film holders
- D. Par Speed screen cassettes
- E. Kodak type M x-ray film
- F. Kodak Blue Brand x-ray film
- G. Lead letters and numbers
- H. Kodak M-5 dual speed X-OMAT
- I. Illuminator
- J. MacBeth model TD-102 densitometer

III. PROCEDURE

- A. Preparations
 - 1. Load three 5" x 7" cardboard film holders with 5" x 7" Kodak Type M x-ray film.
 - 2. Load two 5" x 7" Par Speed screen cassettes with 5" x 7" Kodak Blue Brand x-ray film.
- B. Radiography, Blue Brand film, Par Speed screen cassette, 40 kVp.
 - 1. Set up the x-ray machine as follows:

- a. kVp 40
 - b. mA 1.0
 - c. Added filter None
 - d. Added diaphragm None
2. Center a 5" x 7" Par Speed acreen cassette on the floor of the enclosure with the seven inch dimension front to back in the enclosure. Center the Radiographic Test Block on the cassette with the section containing the tooth to the front. Place a small (1" x 1") lead beam-blocker on the cassette and lead letters and numbers to identify the radiograph.
 3. Make an exposure totalling $7/10$ second (36 impulses plus 6 impulses).
 4. Remove the cassette from the enclosure.
- C. Radiography, Blue Brand film, Par Speed screen cassette, 100 kVp.
1. Set up the x-ray machine as follows:
 - a. kVp 100
 - b. mA 1.0
 - c. Added filter 1.5 mm Al
 - d. Added diaphragm None
 2. Using the second Par Speed screen cassette, position and identify the film as in III. B.
 3. Make a $2/15$ second (8 impluses) exposure.
 4. Remove the cassette from the enclosure.
- D. Film processing.
1. Process the films in the automatic film processor.
 2. Use the high speed processor setting.
 3. Proceed with the Kodak type M film exposures while the Blue Brand films are being processed.

- E. Radiography, Type M film, cardboard film holder, 40 kVp.
1. Set up the x-ray machine as follows:
 - a. kVp 40
 - b. mA 1.0
 - c. Added filter None
 - d. Added diaphragm None
 2. Center a 5" x 7" cardboard film holder on the floor of the enclosure with the seven inch dimension front to back in the enclosure. Center the Radiographic Test Block on the film holder with the section containing the tooth to the front. Place the lead beam blocker and lead letters and numbers on the film holder to identify your radiograph.
 3. Make a 90 second exposure.
 4. Remove the cardboard film holder from the enclosure.
- F. Radiography, Type M film, cardboard film holder, 100 kVp.
1. Set up the x-ray machine as follows:
 - a. kVp 100
 - b. mA 1.0
 - c. Added filter None
 - d. Added diaphragm None
 2. Using a second cardboard film holder position the film holder and Radiographic Test Block and use the beam blocker and lead letters as in III. E.
 3. Make a nine second exposure.
 4. Remove the film holder from the enclosure.
- G. Effect of part-film distance.
1. Set up the x-ray machine as follows:
 - a. kVp 40
 - b. mA 1.0
 - c. Added filter None
 - d. Added diaphragm None

2. Center the third cardboard film holder with Type M film on the floor of the enclosure as before.
 3. Place the Radiographic Test Block on its aluminum support frame. Center the frame on the cassette and make a 90 second exposure.
 4. Remove the film holder from the enclosure.
- H. Film processing.
1. Process the films in the automatic processor.
 2. Three 5" x 7" films can be processed at one time.
 3. Use the low speed processor setting.

IV. FILM DENSITY MEASUREMENTS

- A. Measure and record the section densities for the four films in Parts III. B, C, E and F.
- B. Measure and record the base fog densities (film area under the lead beam blocker) for the four films in Parts III. B, C, E and F.
- C. The section densities should be measured in the center of the tooth and bone and in the center of the other sections.
- D. Determine and record the net density for each section.

V. QUESTIONS

- A. How does kilovoltage effect film density and latitude? Describe in detail referring to the data in Part IV.
- B. What is the effect of film and film-screen combinations on detail? Describe, referring to the films in Parts III. B, C, E and F.
- C. What is the effect of object-film distance on magnification and detail? Describe, referring to the films in Parts III. E and G.

Laboratory No. 4
TYPICAL DATA

Part IV. Film density measurements

<u>kVp</u>	<u>Film</u>	<u>Holder</u>	<u>Part</u>				
			<u>Air</u>	<u>Fat</u> Gross	<u>Water</u> Density	<u>Bone</u>	<u>Tooth</u>
40	Blue Brand	Screen	1.95	1.45	1.14	0.91	0.28
100	Blue Brand	Screen	1.79	1.43	1.34	1.27	0.55
40	Type M	Cardboard	1.98	1.33	1.03	0.87	0.32
100	Type M	Cardboard	1.67	1.33	1.19	1.11	0.54

Base fog: Blue Brand 0.25
Type M 0.17

Part V. Questions

- A. Increasing kilovoltage decreases radiographic contrast and increases latitude. For a constant density at the section containing the water, the density at the air and fat sections decrease as kilovoltage increases and the densities at the bone and tooth sections increase as kilovoltage increases.
- B. There is a loss of detail with the film-screen combination as compared to the direct exposure. This is evident, in particular, in the fine structures of the bone and is due to the coarser film grain and screen mottle with the film-screen combination.
- C. Increasing object-film distance increases magnification and decreases sharpness (due to increased penumbra).

LABORATORY NO. 5

TITLE: Medical and Dental Radiography

PURPOSE: To radiograph various body phantom parts

TIME: Six hours

MATERIALS FOR EACH STUDENT GROUP:

One GE DXS-350 X-Ray Unit
One GE Mobile 100 X-Ray Unit
One GE - 100 Dental X-Ray Unit
One manual x-ray film processing station
One Kodak X-OMAT automatic film processor
8 x 10 inch cardboard exposure holders as required
Par Speed cassettes as required:
 8 x 10 inch
 14 x 17 inch
Kodak Blue Brand medical x-ray film as required:
 8 x 10 inch
 14 x 17 inch
One 3 M human phantom
Kodak Radiatized and Ultra-Speed dental x-ray film as required
One set lead letters and numbers

REFERENCES: Bloom, Hollenbach and Morgan
Medical Radiographic Technic

General Electric
How to Prepare a Technic Chart

Laboratory No. 5
MEDICAL AND DENTAL RADIOGRAPHY

I. INTRODUCTION

The purpose of this laboratory exercise is to radiograph various body phantom parts.

II. EQUIPMENT

- A. X-Ray machines
 - 1. GE DXS-350
 - 2. GE Experimental X-Ray Unit
 - 3. GE-100 Dental
- B. Kodak X-OMAT automatic x-ray film processor
- C. Manual x-ray film processing station
- D. Kodak Blue Brand, No Screen and dental x-ray film
- E. Cardboard exposure holders
- F. Cassettes with Par Speed screens
- G. 3M human phantom
- H. Lead letters and numbers
- I. Vertical cassette holder

III. PROCEDURE

Make radiographs using the suggested exposure values and use the small focal spot for all exposures. Use lead letters to identify your film and the radiographic technic. View each radiograph with the instructor. If the radiograph is not of the correct density, revise the exposure (mAs) using the sensitometric curves for the film or film-screen combination (data from Laboratories 2 and 3) and make another radiograph. If the part is not positioned properly for the radiographic view, reposition the part and make another radiograph. A book on positioning will be supplied by the instructor.

A. Suggested exposure values

<u>View/Part</u>	<u>kVp</u>	<u>SFD-in</u>	<u>Film</u>	<u>Grid</u>	<u>mAs</u>	
					<u>No Screens</u>	<u>Screens</u>
P.A. Hand	60	40	No Screen/Blue Brand	No	12.5	1.25
A.P. Foot	60	40	" "	No	25	3.33
A.P. Ankle	60	40	" "	No	50	5
Lateral Ankle	60	40	" "	No	40	5
A.P. Pelvis	70	40	Blue Brand	12:1	-	100
Lateral Lumbar Spine	86	40	"	12:1	-	200
Lateral Lumbar Spine	66	40	"	12:1	-	1000
A.P. Dorsal Spine	70	40	"	12:1	-	80
Lateral Dorsal Spine	86	40	"	12:1	-	25
Lateral Skull	86	40	"	12:1	-	20
Lateral Mastoid	86	40	"	12:1	-	30
P.A. Skull	86	40	"	12:1	-	60
P.A. Chest	80	72	"	No	-	10
First Molar	90	8	Radia-Tized	No	9	-
First Molar	65	8	Radia-Tized	No	27.5	-
First Molar	90	8	Ultra-Speed	No	1.5	-
First Molar	65	8	Ultra-Speed	No	5	-

B. Extremities

1. Use 8 x 10 inch film
 - a. No Screen film with cardboard exposure holder
 - b. Blue Brand film with Par Speed screen cassette
2. Use the Experimental X-Ray Unit
3. Positioning
 - a. P.A. hand: center distal end of third metacarpal bone over center of film holder and at central beam
 - b. A.P. foot: center proximal end of second metatarsal on film. Tilt tube 15° toward patient's head and 15° toward medial side of foot.

- c. A.P. ankle: center midway between malleoli
- d. Lateral ankle: center at internal malleolus

C. Trunk

1. Use 14 x 17 inch Blue Brand film with a Par Speed screen cassette
2. Use the DXS-350
3. Positioning
 - a. A.P. pelvis: center on median line halfway between superior margin of pubic symphysis and line drawn through anterior superior iliac spines
 - b. Lateral lumbar spine: center on line drawn between first lumbar and junction of fifth lumbar and sacrum with central beam perpendicular to this line.
 - c. A.P. dorsal spine: use table in vertical position. Center on median line halfway between superior border of manubrium and inferior tip of xyphoid process.
 - d. Lateral dorsal spine: use table in vertical position. Center on point halfway between superior border of the manubrium and inferior tip of xyphoid process.
 - e. P.A. chest: use the vertical cassette holder. Locate acromiion processes 2-3 inches below upper corner of cassette. Center central beam at center of cassette.

D. Skull

1. Use 10 x 12 inch Blue Brand film with a Par Speed screen cassette
2. Use the DXS-350
3. Positioning
 - a. Lateral skull: center at midpoint between glabella and occipital protuberance

- b. P.A. skull: position skull on forehead and nose with line between outer canthus of eye and external auditory meatus perpendicular to table top. Center film laterally to outer canthus of eye and central beam to center of film
- c. Lateral mastoid (right): place right external auditory meatus at center of film. Tilt tube 15° toward neck with central beam directed at center of film. Use a field size at the film of 4 x 4 inches

E. Dental

1. Use periapical film, Radiatized and Ultra-Speed
2. Use the Dental 100
3. Positioning
 - a. Place the film in the oral cavity and hold in place using the spring-loaded film holder attached to the phantom base
 - b. Center the x-ray beam on the film with the central beam perpendicular to the film

IV. RESULTS

- A. Prepare a table listing the exposure factors used to obtain your final radiographs
- B. Turn in to the instructor your final radiographs along with the exposure factor table.

LABORATORY NO. 6

TITLE: Industrial Radiography

PURPOSE: To develop techniques for radiography of selected industrial specimens.

TIME: Three hours

MATERIALS FOR EACH STUDENT GROUP:

One Teaching X-Ray Unit
One GE Maxitron 300 X-Ray Unit
One Kodak X-OMAT film processor
Kodak Industrial X-Ray Film 5" x 7", as required
One lead screen cassette, 5" x 7"
Cardboard film holders, 5" x 7", as required
One MacBeth model TD-102 densitometer
One 14" x 17" illuminator
One high intensity illuminator
Selected industrial specimens (magnesium, aluminum,
steel castings and welded plates)
Selected industrial penetrameters
Set lead letters and numbers

REFERENCES: Eastman Kodak Company
Radiography in Modern Industry

Halmshaw
Physics of Industrial Radiology

LABORATORY NO. 6
INDUSTRIAL RADIOGRAPHY

I. INTRODUCTION

The purpose of this laboratory exercise is to develop a technique chart for the radiography of selected industrial specimens.

II. MATERIALS AND EQUIPMENT

- A. Maxitron 300
- B. Teaching X-Ray Unit
- C. Kodak M-5 dual-speed X-OMAT
- D. Kodak industrial film, 5" x 7"
- E. Cardboard film holders, 5" x 7"
- F. Lead screen cassette, 5" x 7"
- G. MacBeth model TD-102 densitometer
- H. Illuminators
- I. Selected industrial specimens
- J. Industrial penetrometers
- K. Lead letters and numbers

III. PROCEDURE

- A. Selection of film type
 - 1. Magnesium
 - a. 0 - 1/2 inch thick, 50 - 100 kVp, Type M
 - b. 1/2 - 1 inch thick, 50 - 80 kVp, Types M or AA
 - c. 1/2 - 1 inch thick, 80 - 100 kVp, Type AA
 - 2. Aluminum
 - a. 0 - 1/4 inch thick, 50 - 80 kVp, Type M
 - b. 0 - 1/4 inch thick, 80 - 100 kVp, Type M
 - c. 1/4 - 1/2 inch thick, 50 - 80 kVp, Type AA
 - d. 1/4 - 1/2 inch thick, 80 - 100 kVp, Type M
 - e. 1/2 - 1 inch thick, 50 - 80 kVp, Type AA

- f. 1/2 - 1 inch thick, 80 - 100 kVp, Type M
3. Steel
 - a. 0 - 1/4 inch thick, 80 - 100 kVp, Type AA
 - b. 1/4 - 1/2 inch thick, 80 - 100 kVp, Type AA
- B. Radiography of flat-welded plate
 1. Obtain two welded plates, one steel and one aluminum, from your instructor.
 2. Select required films:
 - a. Based on thickness and material of specimen
 - b. Based on kVp range
 3. Select proper penetrameter.
 4. Make exposures (see III. D. below)
 - a. Adjust kVp and mAs to give required sensitivity.
 - b. Expose at least three films of each plate at different technics to show that selected factors give maximum sensitivity.
- C. Radiography of castings
 1. Obtain one aluminum casting from your instructor.
 2. Select required film:
 - a. Based on thickness and material of specimen
 - b. Based on kVp range
 3. Make exposure (see III. D. below)
 - a. Adjust exposure factors to give a "high quality" radiograph.
 - b. Expose at least three films at different technics to illustrate why chosen technic is preferred.
- D. Suggested starting exposures
 1. Welded steel plate
 - a. Maxitron 300, no added filter
 - b. Type M film

- c. 140 kVp, 700 mAs, 36" SFD, cardboard film holder
 - d. 140 kVp, 500 mAs, 36" SFD, lead screen cassette
 - e. No. 25 penetrometer.
2. Welded aluminum plate
- a. Teaching X-Ray Unit
 - b. Type M film
 - c. Cardboard film holder
 - d. 80 kVp, 1.0 mA, 30 sec.
 - e. No. 25 penetrometer
3. Aluminum casting No. 1
- a. Teaching X-Ray Unit
 - b. Type M film
 - c. Cardboard film holder
 - d. 100 kVp, 1.0 mA, 150 sec.
4. Aluminum casting No. 1
- a. Maxitron 300, no added filter
 - b. Type M film
 - c. Cardboard film holder
 - d. 100 kVp, 1000 mAs, 36" SFD
5. Aluminum casting No. 2
- a. Teaching X-Ray Unit
 - b. Type M film
 - c. Cardboard film holder
 - d. 80 kVp, 1.0 mA, 60 sec.

IV. RESULTS

- A. View all radiographs.
- B. Identify preferred radiographs and explain preference.

GS-463 X-RAY APPLICATIONS

SECTION III

EXAMINATIONS

Name _____

GS 463
Test No. 1

Part 1. Multiple choice. Circle the letter preceding the answer that correctly completes the statement or answers the question. Grade value 5 points each.

1. Radiographic contrast is independent of:
 - a. the type of film used.
 - b. the x-ray tube kilovoltage.
 - c. the processing procedure used.
 - d. the radiographic density.
 - e. none of the above.

2. Which of the following film exposure techniques has the greatest potential for showing sharpness of structural detail?
 - a. Medical film exposed in a cardboard holder
 - b. Medical film exposed using detail screens
 - c. Direct exposure film in a cardboard holder
 - d. Medical film exposed using high speed screens

3. Which of the following does not influence radiographic definition?
 - a. Film-screen contact
 - b. Screen speed
 - c. Subject contrast
 - d. Source-film distance
 - e. None of the above

4. Radiographic unsharpness due to penumbra will increase as:
- a. source-film distance decreases
 - b. subject-film distance increases
 - c. focal spot size increases
 - d. all of the above
 - e. none of the above
5. Quantum mottle will be affected or influenced by:
- a. exposure time
 - b. screen speed
 - c. film speed
 - d. photon intensity
 - e. all of the above
6. At a given kilovoltage which of the following radiographic exposures would produce the least scattered radiation?
- a. lateral lumbar spine
 - b. A P pelvis
 - c. P A hand
 - d. dorsal spine
 - e. all about the same

7. The shape of the characteristic curve of an x-ray film does not depend upon:
- a. x-ray energy
 - b. film type
 - c. developing time
 - d. screen type
 - e. developing temperature
8. Film A has a relative speed twice that of film B. If film A requires an exposure of 100mAs to produce a density of 1.00, the exposure for film B to produce a density of 1.00 would be
- a. 200mAs
 - b. 50mAs
 - c. 100mAs
 - d. 20mAs
 - e. 5mAs
9. In order to radiograph on a single film an object containing parts of widely different atomic number and thickness, you should:
- a. use a film with high contrast
 - b. use a high kilovoltage
 - c. use a low kilovoltage
 - d. use a long source-film distance
 - e. use high speed intensifying screens

10. In x-ray film sensitometry, average gradient refers to:
- a. the slope of the straight-line portion of the characteristic curve
 - b. the slope of a straight line drawn tangent to the characteristic curve at some point on the curve.
 - c. the slope of a straight line connecting two points of specified densities on the characteristic curve.
 - d. the ratio of exposures required to produce two specified densities
 - e. none of the above

Part II. True-false. If the statement is true, mark T on the line preceding the statement. If false, mark F. Grade value 3 points each.

- T 1. A film with a large average gradient indicates that the film has high contrast.
- T 2. Short exposure times are more important in medical radiography than in industrial radiography
- F 3. Penumbra refers to the mottled appearance of a radiograph
- F 4. A film with high contrast will also have high latitude
- F 5. Reciprocity law failure is more likely to occur with direct exposure film than with film exposed using intensifying screens.
- F 6. The "single hit phenomenon" refers to single photon interaction in an intensifying screen producing a single flash of light.
- F 7. Maximum spectral sensitivity of a typical screen-type film is at 6000 angstroms.

- T 8. The action of the developer in film processing is to convert AgBr grains with a latent image to metallic silver.
- F 9. Developer replenishment dissolves the excess silver in the developer solution
- T 10. One purpose of the fixing solution is to remove unexposed AgBr grains from the film emulsion

Part III. Answer all questions. Grade values shown in parenthesis for each question.

- (10) 1. Sketch a typical sensitometric curve for a light sensitive film exposed using intensifying screens. Label the axis and identify the toe, shoulder and average gradient of the film.

Ans.

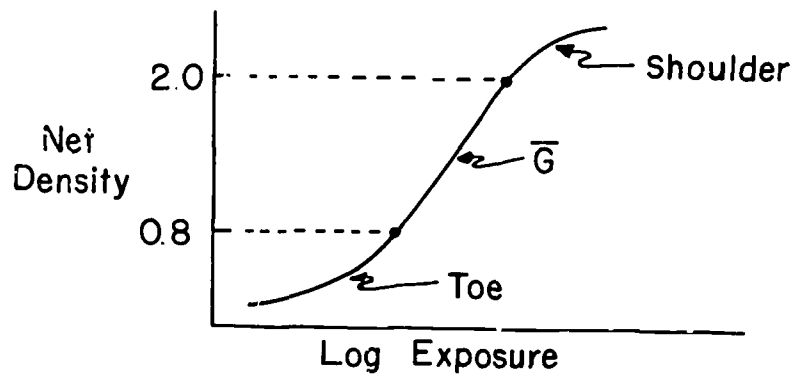

- (6) 2. List the information that can be derived from sensitometric curves?

- Ans.
1. Contrast
 2. Latitude
 3. Speed

(5) 3. In not to exceed 5 lines:

a) give your concept of radiographic contrast.

Ans. Radiographic contrast is the difference in density between two selected locations on a radiograph. $C = d_2 - d_1$

b) what is the difference between detail and contrast?

Ans. Detail is the fineness of the image recorded on the film. Contrast is the density difference and what makes detail visible.

c) how is resolution related to film-screen speed?

Ans. As speed increases, resolution decreases.

(Questions 4-7 refer to the attached curves)

(5) 4. For a net density range between 0.50 and 2.00, which of the three films has the highest contrast?

Ans. A

(5) 5. Assume film B has a relative exposure of 1.0. What is the relative exposures for films A and C relative to B at net density 1.00?

Ans. A. $\frac{53}{1} = \frac{7}{x}$ Rx of A = 0.145
 C. $\frac{53}{1} = \frac{134}{x}$ Rx of C = 2.53

(5) 6. Which film has:

a. the greatest latitude?

Ans. C

b. the least latitude?

Ans. A

(5) 7. Which of the film types would you expect to be:

a. screen films?

Ans. A, C

b. direct exposure films?

Ans. B

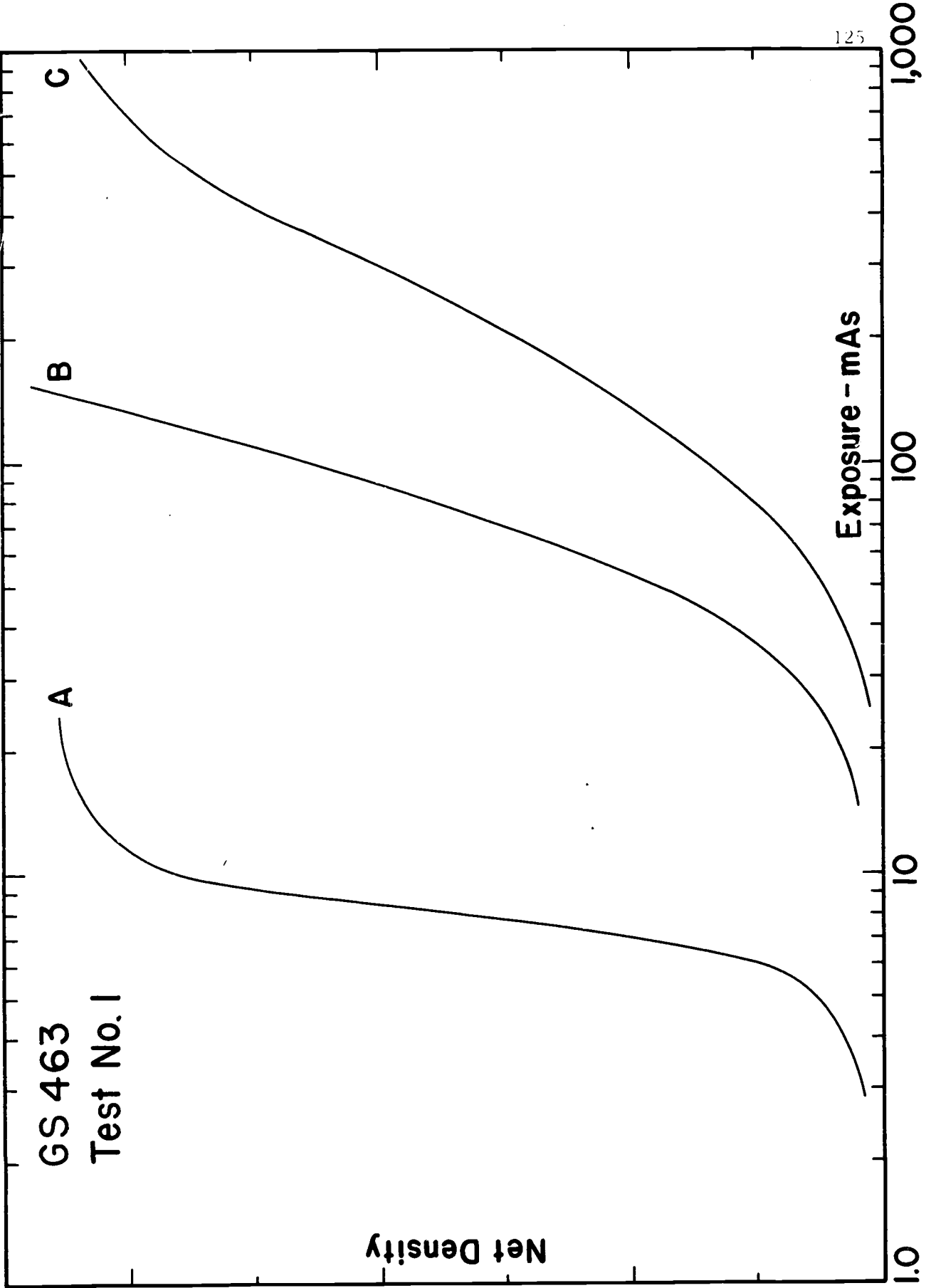

Name _____

GS-463
Test No. 2

Part I - Multiple Choice. Circle the letter preceding the phrase that correctly completes the statement or answers the question. Grade value, 4 points each.

1. Inherent emulsion (film) contrast is independent of:
 - a. film type
 - b. film density
 - c. processing conditions
 - d. kilovoltage
 - e. none of the above

2. Use of a 2.0 mm focal spot rather than a 0.5 mm focal spot (all other exposure factors and geometry constant) will change the radiograph by:
 - a. increasing density
 - b. decreasing density
 - c. improving sharpness
 - d. decreasing sharpness
 - e. it will have no effect

3. An increase in object-film distance will:
 - a. increase sharpness
 - b. decrease sharpness
 - c. increase contrast
 - d. decrease contrast
 - e. decrease magnification

4. Radiographic detail depends upon:
 - a. source-film distance
 - b. object-film distance
 - c. subject contrast
 - d. film contrast
 - e. all of the above

5. Grid ratio refers to:
- the speed of movement of a reciprocating grid
 - the ratio of the height to width of the lead in the grid
 - the ratio of the height to the width of the spacers between the lead strips
 - the ratio of the length to width of the grid
 - none of the above
6. Use of intensifying screens in radiography results in:
- decreased exposure time
 - decreased x-ray tube loading
 - decreased sharpness
 - increased mottle
 - all of the above

Part II. True-false. If the statement is true, mark a T on the line in front of the statement. If false, mark an F. Grade value, 2 points each.

- T 1. In industrial radiography, a 2% penetrameter means the penetrameter thickness is 2% of the object thickness.
- F 2. The wavelength of light emitted from intensifying screens matches the maximum sensitivity of the eye.
- F 3. While maintaining the same density at a small area on a radiograph, increasing the kilovoltage will cause an increase in contrast about this area.
- F 4. An AgBr grain with latent image can be only partially developed.
- F 5. A linear unfocused grid is routinely used in Potter-Bucky diaphragms.
- T 6. Tomography is another name for body-section radiography.
- F 7. Mammography is normally performed using medium speed film and intensifying screens.
- T 8. The clearing agent in the fixer solution removes unexposed AgBr grains from the film.
- T 9. A sulfur compound is used to produce "sensitivity specks" on the surface of AgBr grains.
- F 10. Film contrast results from differences in absorption of the radiation in the part under examination.

Part III. Problems/discussion. Grade value shown in parenthesis for each question.

- (8) 1. The table below lists the exposures required for three different film-screen combinations to produce a density of 1.0.

<u>Combination</u>	<u>Exposure-mAs</u>
A	12
B	3
C	1.5

- a. What are the relative speeds of combinations A and C in relation to combination B?

$$\text{Ans. } RS_A = \frac{3 \times 100}{12} = 25$$

$$RS_B = \frac{3 \times 100}{1.5} = 200$$

- b. What are the relative exposures for combinations A and C in relation to B?

$$\text{Ans. } RX_A = \frac{12 \times 1}{3} = 25$$

$$RX_C = \frac{1.5 \times 1}{3} = 0.5$$

- (7) 2. List three applications of x ray in industry.

Ans. Radiography Gauging
 Fluoroscopy Analytical

- (9) 3. In not to exceed three lines, define the following:

- a. Average gradient

Ans. Slope of straight line connecting two points of specified density on the characteristic curve

- b. Radiographic contrast

Ans. $C = d_2 - d_1$ or density difference between two small areas on a radiograph

- c. Latent image

Ans. Radiation induced change in AgBr that makes it susceptible to the action of a developer

(8) 4. List four major factors which influence radiographic detail.

Ans. Subject contrast
Film (emulsion)
Geometric factors
Grain and mottle

(8) 5. List three modifying factors that can be used to reduce the quantity of scattered radiation reaching the film in medical radiography.

Ans. Reduce kVp
Reduce field size
Use a grid

(8) 6. In not to exceed five lines, what is reciprocity law failure and is it significant in medical radiography?

Ans. Reciprocity law failure is the failure of light exposed film to have the same density for a constant exposure received for a wide range of exposure rates and exposure times. It is not significant in normal medical radiography.

(8) 7. Explain, in not to exceed five lines, why fine grain film requires a higher exposure to produce a given density than does a coarse grain film.

Ans. Since each grain with latent image is completely developed, a coarse grain will produce a greater degree of film darkening than a fine grain therefore more fine grains must be exposed to produce a given density.

GS-463
Final Exam
Spring Term 1971

Prepare a 15 minute talk on one of the subjects, or parts thereof, to be drawn by lot from the list shown below. After your presentation there will be a question and answer period for students and staff. Your grade will be based on relevance, thoroughness, and effectiveness of your presentation and your ability demonstrated in dealing with questions and discussions.

- I. Construction of x-ray film
- II. Latent image formation
- III. X-ray film processing
- IV. Sensitometric properties of x-ray film
- V. X-ray intensifying screens
- VI. Radiographic definition
- VII. Medical radiography
- VIII. Dental radiography
- IX. Industrial radiography
- X. Analytical uses of x ray
- XI. X-ray therapy

APPENDIX A
Materials List

The following is a list of materials needed for each student laboratory group. Major expense items would, of course, be used by all laboratory groups. Material items fabricated in this facility are detailed at the end of this appendix.

<u>Number Required</u>	<u>Item</u>
1	Teaching X-Ray Unit
1	General Electric Experimental X-Ray Unit (150 kVp, 200 mA, single-phase, full-wave rectified unit with continuously variable kVp and mA control)
1	General Electric Horizontal Radiographic Table
1	General Electric DXS-350 X-Ray Unit
1	General Electric Monarch Radiographic Table
1	General Electric Maxitron 300 X-Ray Unit
1	Vertical Cassette Holder
1	General Electric Dental--100 X-Ray Unit
1	Kodak M-5 X-OMAT automatic x-ray film processor
1	Manual x-ray film processing station (see GS-462 materials list)
1	MacBeth Model TD-102 densitometer
1	14 x 17 inch radiographic illuminator
1	High intensity illuminator
1	Set selected industrial specimens
1	Set selected industrial penetrameters
1	3M Company human phantom
1	Set lead letters and numbers
1	Radiographic Test Block (see USPHS Publication No. 1859)
as required *	5 x 7 inch and 8 x 10 inch cardboard film holders

as required *	5 x 7 inch, 8 x 10 inch, 10 x 12 inch and 14 x 17 inch Par Speed screen cassettes
as required *	5 x 7 inch lead screen (0.005 inch) cassettes
as required *	5 x 7 inch Hi Speed and Detail cassettes
as required *	Kodak Blue Brand Medical X-Ray Film, 5 x 7 inch, 8 x 10 inch, 10 x 10 inch and 14 x 17 inch
as required *	Kodak 5 x 7 inch and 8 x 10 inch No Screen film
as required *	Kodak 5 x 7 inch Industrial X-ray film, type M and type AA
as required *	Kodak 5 x 7 inch Royal Blue Medical X-Ray Film
as required *	5 x 7 inch and 8 x 10 inch x-ray film processing hangers
as required *	Kodak Periapical Radia-Tized and Ultra-Speed dental film
as required *	X-ray equipment, film, cardboard holders and cassettes, film processing facilities, etc. for Special Project
1	Sensitometer (see Appendix C)

* See laboratory exercises

Appendix B

REFERENCES

1. American Standards Association, 10 East 40th Street, New York, New York 10016.
 - a. American Standard Method for the Sensitometry of Medical X-Ray Films.
 - b. American Standard Method for the Sensitometry of Industrial X-Ray Films for energies up to 2 Million Electron Volts.
2. Attix, F. H., W. C. Roesch and E. Tochilin, Radiation Dosimetry, Vol. II, Academic Press, 1966.
3. Bloom, W., J. Hollenbach and J. Morgan, Medical Radiographic Technic, third edition, Charles C. Thomas, Publisher, 1965.
4. Bruwer, A. J., Classic Descriptions in Diagnostic Roentgenology, Vol. I, Charles C. Thomas, Publisher, 1964.
5. Clark, G. L., Applied X-Rays, McGraw Hill Co., Publisher, 1927.
6. Clark, K. C., Positioning in Radiography, Intercontinental Medical Book Corporation, 1964.
7. Curie, D., Luminescence in Crystals, John Wiley and Sons, 1963.
8. Eastman Kodak Company, Rochester, New York.
 - a. The Fundamentals of Radiography, 1960.
 - b. Radiography in Modern Industry, 1957.
 - c. Sensitometric Properties of X-Ray Films.
 - d. X-Rays in Dentistry.
 - e. Principles of the Kodak X-OMAT Processing System, 1963.
 - f. Industrial Radiography.
9. E. I. duPont de Nemours and Company, Inc., Willmington, Delaware, The Care and Use of Cronex X-tra Life Intensifying Screens.
10. Fuji Photo Film Co., Ltd. (Japan), New York City, New York, Handling of Medical X-Ray Film.
11. General Aniline and Film Corporation, New York City, New York, Radiography, a Tool of Medical Science, 1965.
12. General Electric Company, X-Ray Department, Milwaukee, Wisconsin, How to Prepare a Technic Chart.

13. Gevaert (Belgium), Low X-Ray Corporation, New York City, New York.
 - a. Industrial Radiography.
 - b. Elementary Principles and Terminology of Sensitometry.
14. Halmshaw, R., Physics of Industrial Radiology, American Elsevier Publishing Company, Inc., 1966.
15. Herz, R. H., The Photographic Action of Ionizing Radiations, John Wiley and Sons, Inc., Publisher, 1969.
16. Hondium Boldingh, Quality and Choice of Potter-Bucky Grids, Acta Radiologica, 55, 1961.
17. Hurst, G. S. and J. E. Turner, Elementary Radiation Physics, John Wiley and Sons, Inc., Publisher, 1970.
18. International Commission on Radiation Units and Measurements, ICRU Report 10f (NBS Handbook 89), Methods of Evaluating Radiological Equipment and Materials, 1962.
19. Ilford Limited (England), New York City, New York.
 - a. Medical X-Ray Films and Chemicals.
 - b. X-Ray Processing.
20. Johns, H. E. and J. R. Cunningham, The Physics of Radiology, third edition, Charles C. Thomas, Publisher, 1969.
21. Liebel-Flarsheim Company, Cincinnati, Ohio, Characteristics and Applications of X-Ray Grids, 1968.
22. Mees, K., From Dry Plates to Ektachrome Film, Ziff-Davis Publishing Company, 1961.
23. Mees, K. and T. James, Theory of the Photographic Process, MacMillan Company, Publisher, 1966.
24. Meredith, W. J. and J. B. Massey, Fundamental Physics of Radiology, Williams and Wilkins Company, Publisher, 1968.
25. Morgan, J. A., The Art and Science of Medical Radiography, 2nd edition, The Catholic Hospital Association.
26. National Council on Radiation Protection and Measurement Reports, NCRP Publications, Washington, D. C.
 - a. Report No. 32, Radiation Protection in Educational Institutions, 1966.

- b. Report No. 33, Medical X-Ray and Gamma-Ray Protection for Energies up to 10 MeV, Equipment Design and Use, 1968.
 - c. Report No. 34, Medical X-Ray and Gamma-Ray Protection for Energies up to 10 MeV, Structural Shielding Design and Evaluation, 1970.
 - d. Report No. 36, Dental X-Ray Protection, 1970.
- 27. Newhall, B., The Latent Image, Double Day and Co., 1967.
 - 28. Pringsheim, P. and M. Vogel, Luminescence of Liquids and Solids, Interscience Publishers, 1943.
 - 29. Ridgway, A. and W. Thumm, The Physics of Medical Radiography, Addison-Wesley, Publishers, 1968.
 - 30. Seemann, H. E., Physical and Photographic Principles of Medical Radiography, John Wiley and Sons, 1968.
 - 31. Siple, L. W., Photography's Great Inventors, American Museum of Photography, 1965.
 - 32. Stanton, L., Basic Medical Radiation Physics, Appleton-Centruy-Crafts, Publisher, 1969.
 - 33. Ter-Pogossian (editor), The Physical Aspects of Diagnostic Radiology, Harper and Row, Publishers, 1967.
 - 34. Trout, E. D., A Teaching X-Ray Unit, U. S. Public Health Service Publication No. 1859, 1968.
 - 35. U. S. Radium Corporation, Radelin Division, Morristown, New Jersey, Application, Construction, Characteristics and Care of X-Ray Screens.

Appendix C

SENSITOMETER

The following drawings show the basic parts of the sensitometer used to construct the x-ray film characteristic curves. The sensitometer consists of:

1. A base assembly made of $3/4$ " plywood.
2. A wood frame to position 5 " x 7 " cardboard film holders in the base assembly.
3. A slide assembly made of $1/8$ " thick lead bonded to $1/2$ " plywood.
4. A shield assembly made of $1/8$ " thick lead bonded to $1/2$ " plywood.

The sensitometer was designed for use with our Teaching X-Ray Units but its use is not limited to these units. It can and has been used with other x-ray sources in our Laboratory including our medical radiographic installations.

Construction

1. Base Assembly

The base assembly is constructed of $3/4$ " thick plywood. The main portion of the base is $11\ 7/8$ " x $14\ 3/4$ " with a $6\ 1/8$ " x $8\ 1/8$ " hole located as shown. A 5 " x 7 " cassette will fit in this hole. A series of $3/16$ " diameter holes are drilled in the base at $1/2$ " intervals as shown. These holes align with a hole in the slide assembly (see following) and are used to position the slide in relation to the x-ray film. Two $3/4$ " x $1\ 3/4$ " x $14\ 1/4$ " wood strips are attached to the top of the base to act as guides for the slide assembly. Scale markings are hand printed on one guide strip and used to establish alignment between the locating hole in the slide assembly and the locating holes in the base. The only critical dimensions in the base assembly are the hole size for the cassette, the space between the two guide strips and the positions of the locating holes.

2. Frame

The frame is used with 5" x 7" cardboard film holders since the overall dimensions of cardboard holders are less than those of cassettes. The frame is constructed of wood strips glued together as shown. The frame fits in the cassette hole in the base assembly.

3. Slide Assembly

The slide assembly is constructed of 1/8" thick lead bonded to 1/2" plywood. A 3 1/8" x 1/2" hole is centered in the assembly and the 3/16" diameter locating hole positioned as shown. A slot is cut out of the wood above the lead at each end of the slide for insertion of the lead baffle strip on the shield assembly (see following). The critical dimensions are the 1/2" dimension of the hole and the location of the hole, the width of the assembly (close fit between guide strips on base assembly) and the positioning of the 3/16" diameter locating hole. The metal pointer (brass or aluminum) can be attached after assembly to align with the proper scale markings on the base. The metal locating pin, inserted through the hole in the slide and into the hole in the base, can be a 1/8" - 5/32" diameter nail.

4. Shield assembly

The shield assembly is constructed of 1/8" thick lead bonded to 1/2" plywood. A 1/8" thick strip of lead is attached at one end immediately above the lead on the plywood as shown to provide baffling between the shield and slide assemblies. The critical dimensions are the overall dimensions of the shield. This shield is required due to the limited space in the Teaching X-Ray Unit enclosure. If the sensitometer were used where

space is not limited, such as on a radiographic table top, the "shield" could be made a permanent part of the slide assembly (the length of the slide increased).

Use (with Teaching X-Ray Unit)

1. Center the base assembly on the bottom of the enclosure (center of x-ray field).
2. Place the 5" x 7" cassette (or frame with 5" x 7" cardboard film holder) in the base.
3. Place the slide on the base between the guide strips. Align the pointer with scale position number 1. Insert the locating pin through the hole in the slide and into the hole in the base.
4. Place the shield on the base at the front between the guides on the base and with the lead baffle strip toward the slide. Mate the shield and slide.
5. Make the x-ray exposure.
6. Remove the locating pin, move the slide and shield to position 2, insert the locating pin, make the x-ray exposure.
7. Repeat this procedure through position 6.
8. At position 7 move the shield from the front to the back of the slide and proceed with the exposures.

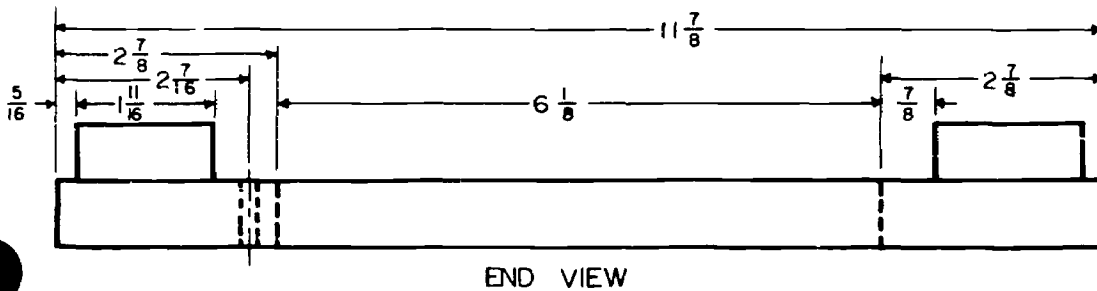
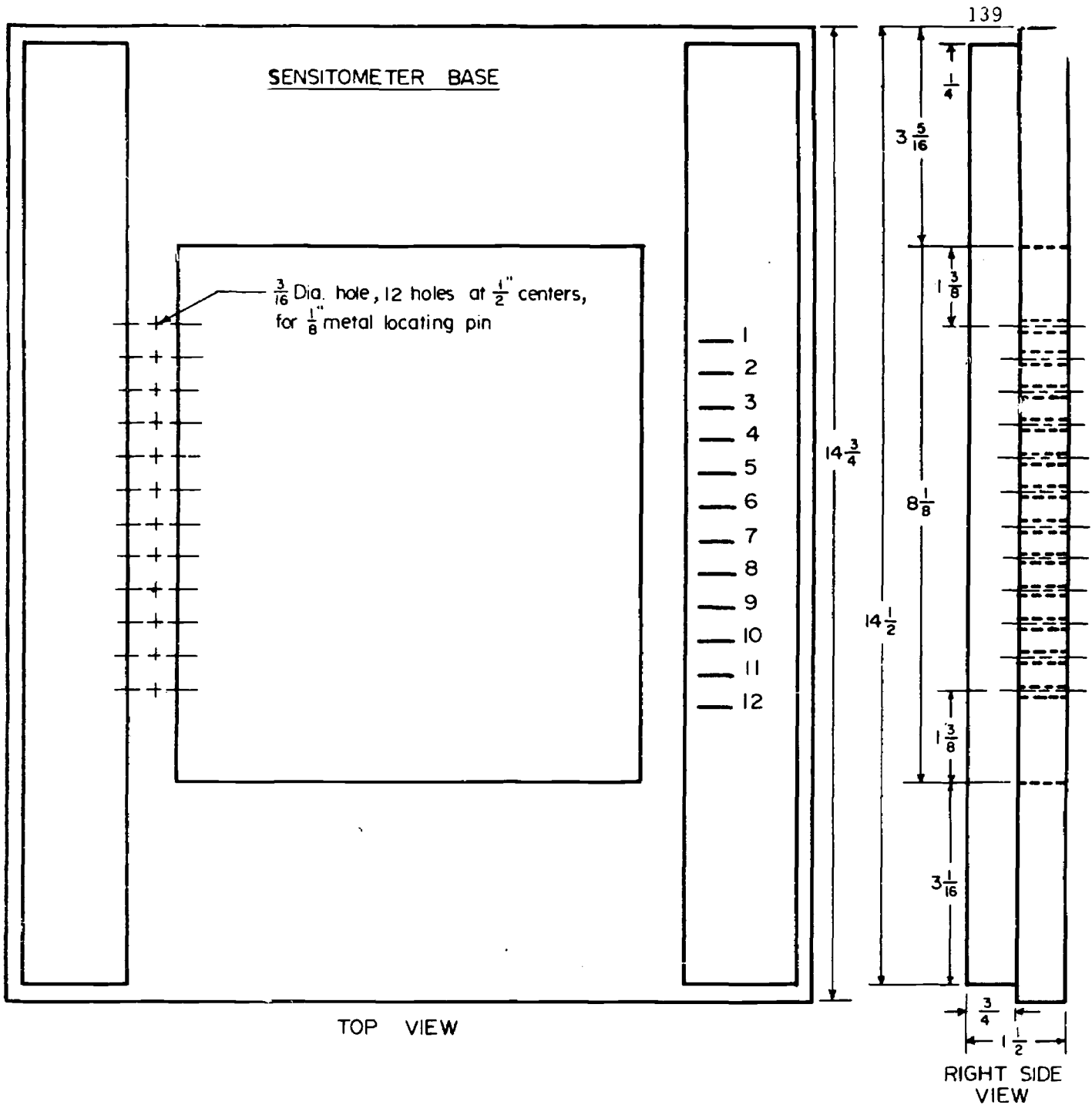

MAT'L: $\frac{3}{4}$ " PLYWOOD

SCALE: $\frac{1}{2}$ " = 1"

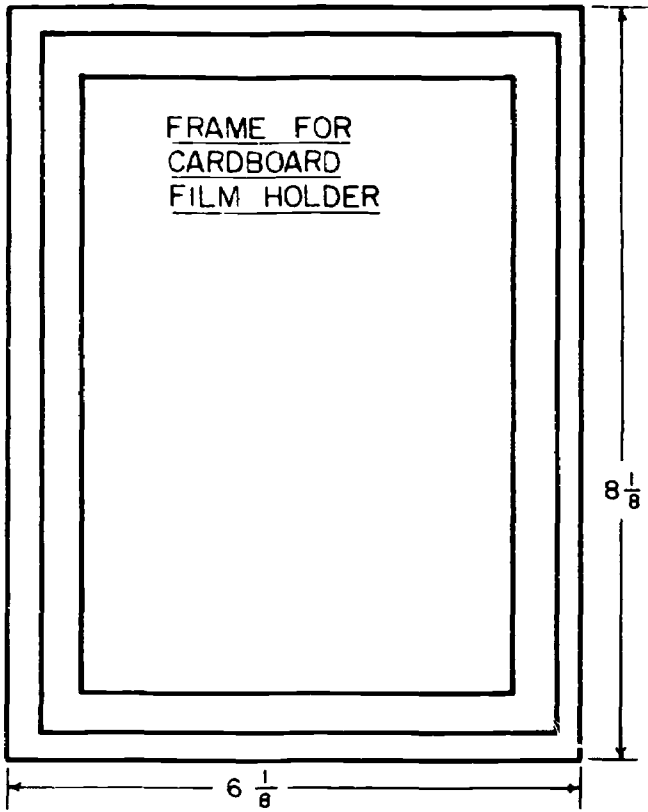

TOP VIEW

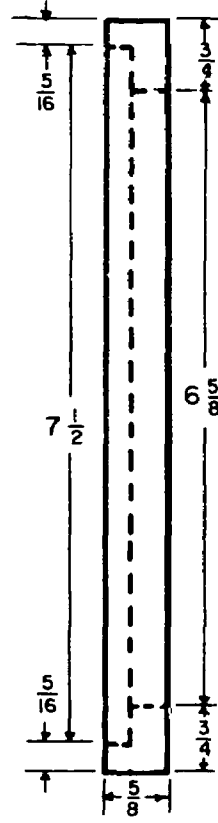

RIGHT SIDE VIEW

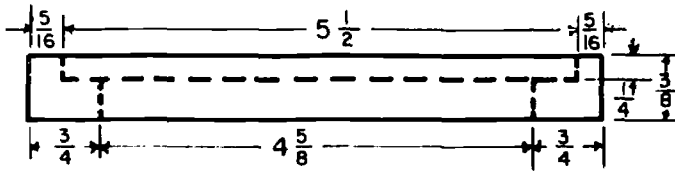

END VIEW

MAT'L : WOOD STRIPS

SCALE : $\frac{1}{2}'' = 1''$

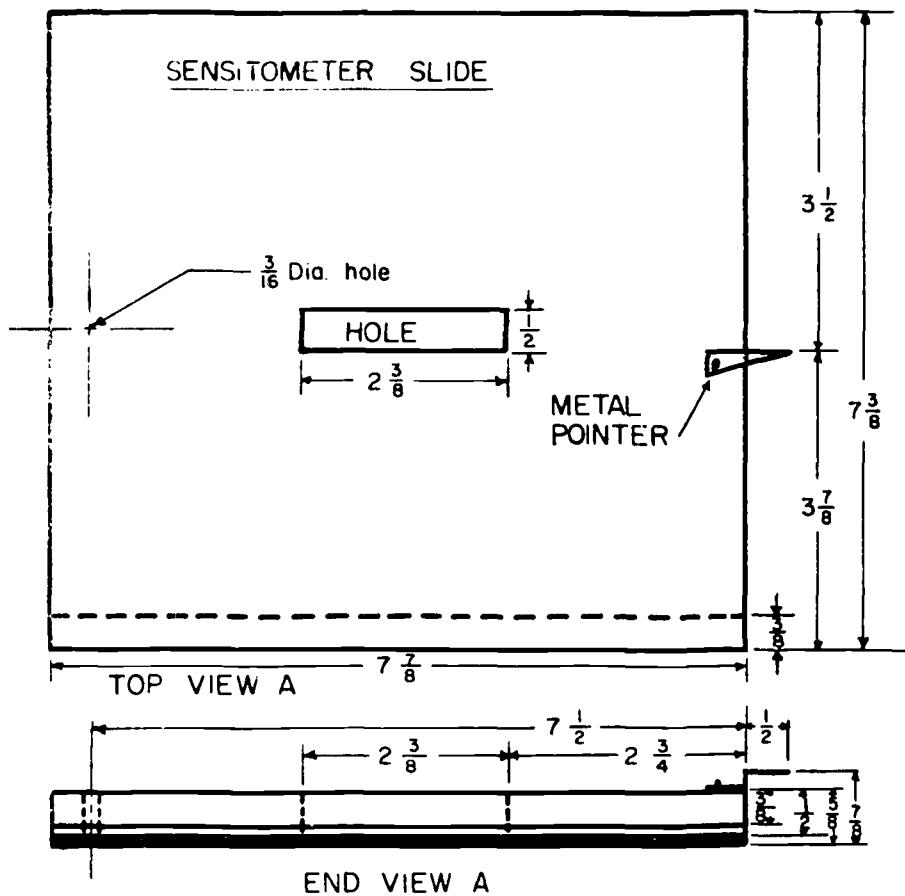

MAT'L: 1/8" LEAD BONDED TO
1/2" PLYWOOD

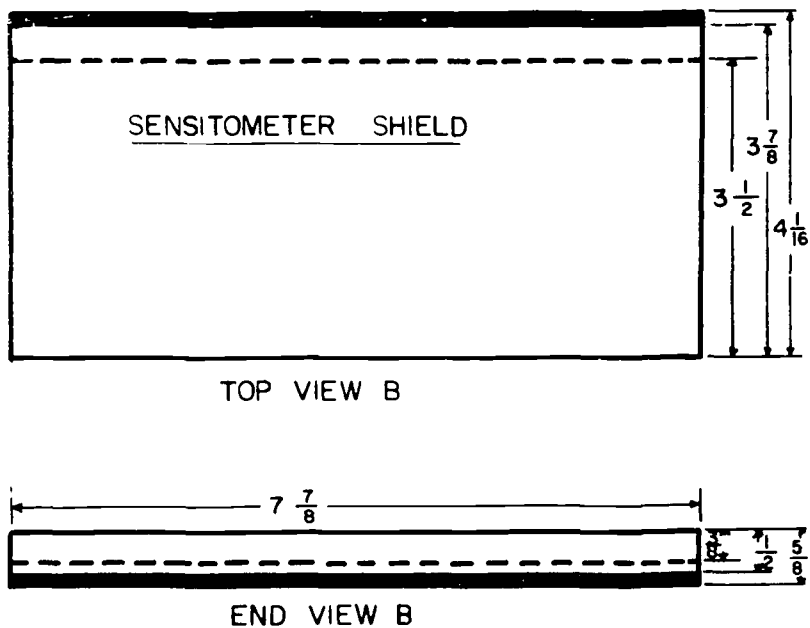

SCALE: 1/2" = 1"

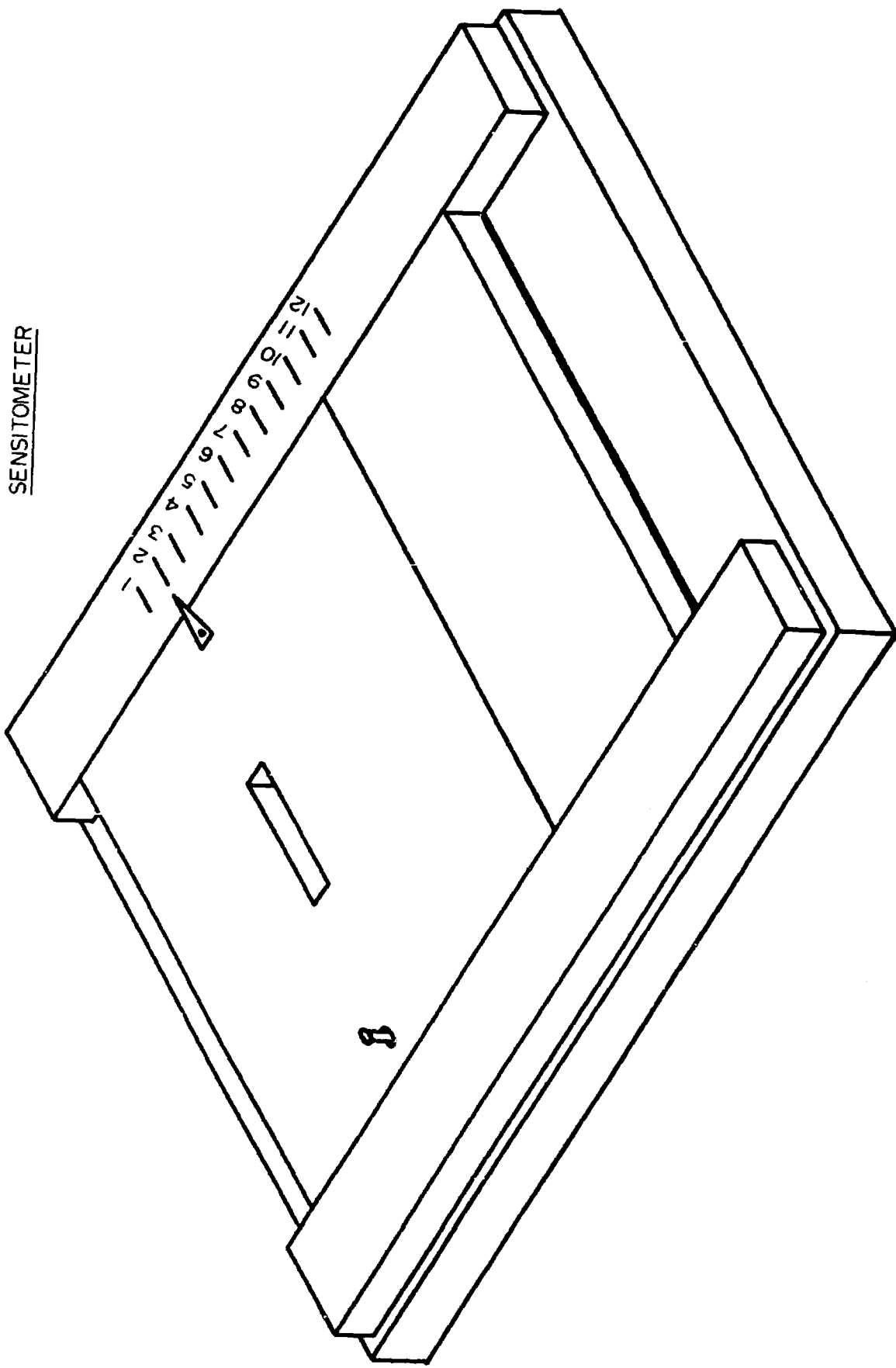

TECHNICAL REPORTS
(continued from inside of front cover)

- MORP 68-11 Dental X-ray Summary Report (PB 184 356 - \$6)
- MORP 68-12 Article: Accelerator Safety Manual (Supt. of Doc., GPO-\$1.25)
(PB 178 32) - microfiche only)
- MORP 68-13 PBS Film Badge Program (In preparation)
- MORP 68-14 Radiation Safety Recommendations for X-ray Diffraction and
Spectroscopic Equipment (PB 182 558 - \$6)
- DMRE 69-1 Report of the Task Force on X-ray Image Analysis and Systems
Development (PB 184 130 - \$6)
- DMRE 69-2 Symposium on Past, Present, and Future State X-ray Programs
(PB 184 481 - \$6)
- DMRE 69-3 Medical Radiation Information for Litigation (PB 187 697 - \$6)
- BRH/DMRE 70-1 Survey of the Use of Radioisotopes in Medicine (PB 188 619 - \$6)
- BRH/DMRE 70-2 Automatic Data Processing System Study for Massachusetts General
Hospital Diagnostic Radiology Department (PB 193 937 - \$6)
- BRH/DMRE 70-3 A Training Manual for Nuclear Medicine Technologists (Supt. of
Doc., GPO-\$1.75, stock no. 1715-0092) (PB 196 441 -
microfiche only)
- BRH/DMRE 70-4 Isotopes in Production of ^{211}Bi - an Evaluation of the Nuclear
Reactions Which Produce This Isotope (PB 196 162 - \$6)
- BRH/DMRE 70-5 The Use of Radioactive Materials in Gas Chromatography
(PB 195 979 - \$6)
- BRH/DMRE 71-1 Summary of Federal Regulations for Packaging and Transportation
of Radioactive Materials (Supt. of Doc., GPO-\$0.50, stock
no. 1715-0086) (PB 197 698 - microfiche only)
- BRH/DMRE 71-2 X-ray Fluorescence Forensics - History, Crystal Kinetics,
Preliminary Report on "Arine" (Supt. of Doc., GPO-\$0.60,
stock no. 1715-0009) (PB 198 239 - microfiche only)
- BRH/DMRE 71-3 Storage and Handling Devices for Radium (Supt. of Doc., GPO-
\$0.39, stock no. 1715-0019) (PB 202 112 - microfiche only)
- BRH/DMRE 71-4 State and Federal Control of Health Hazards from Radioactive
Materials other than Materials Regulated under the Atomic
Energy Act of 1954 (Supt. of Doc., GPO-\$1, stock no. 1715-
0021) (PB 202 810 - microfiche only)
- BRH/DMRE 71-5 Nuclear Medical Technology Training (Supt. of Doc., GPO-\$0.75,
stock no. 1715-0022) (PB 202 814 - microfiche only)
- BRH/DMRE 72-1 Training Needs for Teachers of Dental Radiology in Auxiliary
Training Schools (Supt. of Doc., GPO-\$0.35, stock no. 1712-
0130) (PB 203 745 - microfiche only)
- BRH/DMRE 72-2 National Conference on College Affiliated Educational Programs
in Radiologic Technology (Supt. of Doc., GPO-\$2.25, stock
no. 1715-0026) (PB 203 090 - microfiche only)
- BRH/DMRE 72-3 Design and Evaluation of an Electronic Radiography System
(Supt. of Doc., GPO-\$0.75, stock no. 1715-0030)
(PB 204 930 - microfiche only)
- BRH/DMRE 72-4 Afterloading in Radiotherapy -- Proceedings of a Conference
held in New York City, May 6-8, 1971 (Supt. of Doc.,
GPO-\$3.75, stock no. 1715-0034) (PB 207 706 - microfiche only)
- BRH/DMRE 72-5 The Training of Radiologic Administrators -- Proceedings of a
Symposium held in Cincinnati, Ohio, May 22, 1970 (PB 209 054 - \$3)
- BRH/DMRE 73-1 Reduction of Radiation Dose in Diagnostic X-ray Procedures --
Proceedings of a Symposium held in Houston, Texas, July 8, 1971
(PB 212 491 - \$3)