

DOCUMENT RESUME

ED 091 598

CE 001 383

AUTHOR Leland, Lyle L.
TITLE A Systems Approach to Residential, Family Based Career Education.
PUB DATE Mar 74
NOTE 32p.; Paper presented at the Annual Meeting of the American Educational Research Association (59th, Chicago, Illinois, April 1974)

EDRS PRICE MF-\$0.75 HC-\$1.85 PLUS POSTAGE
DESCRIPTORS *Career Education; Curriculum Evaluation; *Disadvantaged Groups; Formative Evaluation; Job Training; Performance Factors; Program Development; Program Evaluation; *Residential Programs; *Rural Family; *Systems Approach
IDENTIFIERS *Career Awareness; Career Exploration; Residential Based Career Education

ABSTRACT

A systems approach is applied to the assessment of the Model 4 project (administered by Mountain-Plains Education and Economic Development Program, Inc.), a residential career education program for rural, multiproblem families in the States of Idaho, Montana, Nebraska, North Dakota, South Dakota, and Wyoming. The program involves three phases of career education (awareness of various career opportunities, exploration of the universe of career opportunities, and actual career or occupational preparation) and the acquisition of the competencies of: job-getting, job-holding, and job progression; effective interaction with economic and related social aspects of society; effective family management; satisfaction with job and life. The curriculum system is a production process cycle producing changes in students intended to correspond with desired competencies; it is individualized, competency-based, and applicable to rural disadvantaged. Five phases of Model 4 correspond generally to the five years of funding: conceptualization, feasibility testing, program development; program evaluation, replication/diffusion. To determine the status of Model 4 nationally, a study of six family-residential education programs revealed Mountain Plains representing the most advanced stage of evaluation of the family residential educational approach and Model 4 having the most comprehensive innovative form. (EA)

ED 091598

A SYSTEMS APPROACH TO RESIDENTIAL,
FAMILY BASED CAREER EDUCATION

Prepared by: Lyle L. Leland

March 1974

U S DEPARTMENT OF HEALTH,
EDUCATION & WELFARE
NATIONAL INSTITUTE OF
EDUCATION

THIS DOCUMENT HAS BEEN REPRO-
DUCED EXACTLY AS RECEIVED FROM
THE PERSON OR ORGANIZATION ORIGIN-
ATING IT. POINTS OF VIEW OR OPINIONS
STATED DO NOT NECESSARILY REPRESENT
OFFICIAL NATIONAL INSTITUTE OF
EDUCATION POSITION OR POLICY

The project presented or reported herein was performed pursuant to a contract with the National Institute of Education, Department of Health, Education, and Welfare. However, the opinions expressed herein do not necessarily reflect the position or policy of the National Institute of Education, and no official endorsement by the National Institute of Education should be inferred.

001383



MOUNTAIN-PLAINS: INTRODUCTION AND BACKGROUND

Mountain-Plains Education and Economic Development Program, Inc. (MPEEDP) is a private non-profit corporation chartered in Montana. The primary purpose of the Corporation is to concern itself with the educational and closely related socio-economic problems which are peculiar to the essentially rural regions in the states of Idaho, Montana, Nebraska, North Dakota, South Dakota, and Wyoming. In fulfillment of its primary purpose, the corporation is committed to the administration of grants from and contracts with the National Institute of Education (Department of Health, Education and Welfare), over a five year period, commencing May 1, 1971, to develop and test the designated Fourth National Education Research and Development Model (Model IV).

The Model IV program being administered by MPEEDP is a residential career education program for rural, multi-problem families of the six state region.

The basic premise underlying the program is that family oriented career education in a residential setting represents an effective way to improve the employability, standard of living, participation in community involvement, and life satisfaction of the rural disadvantaged.

In the broad sense, the program has goals in four major areas:

- 1) Development - the design and development of the model;
- 2) Research - to perform research and evaluation of the effects of the model;
- 3) Production - to provide guides, methods, procedures, research reports, cost analysis and learning activity packages to permit replicability of the model;
- 4) People - to provide career education to a significant number of rural disadvantaged within the six state region

Headquarters for the program are at Glasgow Air Force Base, Glasgow, Montana. The site provides a unique setting with total community services and educational facilities. Families chosen to participate in the program come from the six states involved in the program.

The Corporation has a Board of Directors consisting of thirteen voting members and one non-voting member. The voting members of the Board are selected on the basis of two from each of the participating states of Montana, North Dakota, South Dakota, Nebraska, Wyoming and Idaho. The members represent a variety of interests and include representatives from:

The Governors' Offices
State Superintendents of Schools
State Vocational-Education Directors
Principal Indian Tribes or Tribal Unions
Regional Federal Councils (Non-voting)
Valley County (Glasgow, Montana)

MPEEDP has staffed an office in each of the state capitol cities to coordinate recruitment, placement and job development for the student families. MPEEDP students are recruited from a variety of sources. New families arrive and depart weekly on an open entry-open exit basis. Selection criteria, based largely on terminal performance desired and program capability, has been established to aid in the selection of suitable students.

Each head-of-household is expected to participate a designated minimum number of hours per week in the program. The spouse has a designated minimum number of hours in the program.

Program areas that student families may become involved in are: counseling, home management, health education, leisure skills, early childhood education, career guidance, foundation education, and occupational preparation. Occupational preparation provides a variety of choices in several skill development areas such as building trades and services, lodging and food services, mobility and transportation, office education, and marketing and distribution.

The program is woven into three phases of career education defined as:

- 1) Awareness of various career opportunities;
- 2) Exploration of the universe of career opportunities;
- 3) Actual career or occupational preparation.

Participant choice in the program is based upon exposure to career clusters, major occupational groups, major job families, and the relating of these experiences to individual potential abilities, aptitudes, interests, responsibilities and job availability.

The instructional approach in the program is performance based and individualized.

The emphasis is on career objectives rather than on immediate placement, although immediate placement is the culminating process when a student completes a program. The state office staff is responsible for placement activities and will have two follow-up activities. The first follow-up responsibility involves social maintenance and/or counseling. This follow-up is intended to solve problems that may arise in the adjustment of the student to his new community or new employment situation. The second type of follow-up is for purposes of data collection. While the actual data collection is conducted again by field staff personnel, it is accomplished in accordance with the procedures and formats of the program research design and the program Center staff at Glasgow.

Out-patient medical services are available to students through a Comprehensive Health Center located on base.

MPEEDP provides program support such as personnel, purchasing, accounting, and maintenance. This includes the responsibility of providing and furnishing housing to students and a system of bus transportation for students on Center and to and from the city of Glasgow. The Counseling Staff is available on a 24-hour basis to students for growth as well as crisis intervention.

MPEEDP's key concepts are:

- 1) A residential and family centered program;
- 2) A comprehensive program;
- 3) Incorporates individualization into evaluation, instruction and operations.

The major research question addressed by Model IV is "What is the value of a comprehensive career education program for improving the economic and human viability of rural, multi-problem families?" /1/2/ *

* The number refers to the resource from which the information was reported.

TABLE OF CONTENTS

A. MOUNTAIN-PLAINS: INTRODUCTION AND BACKGROUND. ii

B. GENERAL SYSTEMS APPROACH 1

C. CURRICULUM SYSTEM. 5

D. CURRICULUM PRODUCTS. 8

E. EVALUATION 13

F. REPLICATION AND DIFFUSION. 16

G. PRESENT STATUS 18

H. BIBLIOGRAPHY 19

I. FIGURES ANNEX. 20

GENERAL SYSTEMS APPROACH

A systems approach applied to education is like systems thinking in other applications. In systems thinking the educational system is viewed as a whole in terms of the existing purpose or product. /3/ * Admittedly educational systems are usually complex. For our purpose then, to concisely relate a curriculum subsystem to the Model IV system, a general set of descriptions and illustrations will be used. Figure 1 represents the general systems model for the approach to the residential, family based career education program at Mountain-Plains.

FIGURE 1. HERE

In this presentation it is intended that only enough of an explanation be given to clarify any illustrations or descriptions and provide background about the project that emphasizes the systems approach employed. To begin then, the problem, identified in Figure 1 as 1.1, is given in the underlined portion of the Model IV mission statement.

The mission of the fourth national research model in career education (Model IV) is to develop, test and report the potential of a residential career education program to improve the economic and human viability of rural multi-problem families chosen from a Western six-state region. /4/

With the problem or purpose of the existing system identified the next step is to identify what needs to be done to alleviate the need, identified

* The number refers to the resource from which the information was reported.

as 1.2 in the General Systems Model. Mountain-Plains determined that successful solution of the problem would be the acquisition of the following competencies:

- a. Job-getting, job-holding, and job progression;
- b. Effective interaction with economic and related social aspects of society;
- c. Effective family management; and
- d. Satisfaction with job and life. /4/

To acquire the stated competencies requires identification of experiences that will bring about the desired changes in the people. This experience identification, the process for producing the changes in people (the Production Process), and the process for obtaining and allocating resources like personnel, students, materials, and facilities (the Support Process) are represented as 1.3 in Figure 1.

It should be emphasized that the competencies stated above are in terms of the "real world". In an educational setting it is often necessary to accept or develop competencies or skills that fall short of the "real world" requirements. Consider a "real world" competency like -- providing desired care for an invalid or disabled family member. It would be hoped that any educational preparation process would allow development of that competency by substituting other than family members, using simulation and/or identifying or describing the desired care process. In the system it is important to distinguish between the "real world" competency (external product) and the competency resulting from the educational production process (internal product). The external and internal product may be the same under the appropriate circumstances, namely when the

"real world" is part of, or is replicated in, the educational environment. The external product is represented in Figure 1 by 1.2 and the internal product by 1.6.1.

When the production and support processes represented by 1.3 are implemented, an existing program (1.6) results. If the systems model is to be applied to any existing program the portion ("For Initial Start-Up") outlined with the dotted line, would not need to be developed. Once an Existing Program (1.6) is functioning a formative evaluation process (1.4) identifies changes to be made in the program product (1.6). This change identification is accomplished by comparing the actual program product (1.6.1) with the desired system product (1.2). Achieving a program product change requires determining how to modify (1.5) the production process (1.6.2). Adjustments in the support process (1.6.3) may be required to implement the new production process (1.6.2).

Both internal and external program analysis is used in formative evaluation (1.4). The internal assessment of program product is intended to determine if the process is preparing what is intended. An actual example--internal assessment of the Mountain-Plains student scheduling, class attendance, and overall class loadings resulted in a much more highly visible student progress profile, and permitted earlier and more positive identification of student problems. This led to revision of the procedures dealing with individual student problems, and resulted in a capability of responding with remedial action much earlier. Mountain-Plains is confident that this earlier intervention is a significant factor in the increasing ratio of program completers to resigners. Earlier intervention also results in a reduction of nonproductive time and a higher level of cost effectiveness. /5/

The intent of the external assessment is to determine if the program product alleviates the problem and serves the purpose of the system. One example of this external checking grew out of the observed experiences of students and resulted in the decision to add certain specific curricula to meet perceived deficiencies. It was found, for example, that student difficulties in effective utilization of the stipend received was intensified by a lack of awareness of legal responsibilities and rights of citizens, particularly those devolving on contract law, interest rates, and installment credit. After reviewing the data and conclusions presented by financial counseling staff, Management authorized the specific development of curricula to provide desired skills in family budgeting and the legal rights and responsibilities of citizens. /5/

After the existence of a program (1.6) it may be summarized that in the general systems model there are three gross activities functioning in an on-going manner. One is the on-going conceptualization of societal needs (1.1) and what should be done to alleviate them (1.2). The second is the operational program (1.6). A third is an evaluative (1.4) and modification (1.5) function.

CURRICULUM SYSTEM

Model IV Project Curriculum is designed to support the mission and be compatible with the total Project system. This curriculum system intends to provide education by objectives and results. Externally the influence of society and the success of completing students confirms the curriculum system results. Internally objectives are developed from an initial theoretical analysis and then modified by real inputs from both internal and external assessments.

An expansion of the general system model, Figure 2, is intended to assist in describing the existing program. One way to examine the curriculum system is to follow the process on a learner.

FIGURE 2. HERE

The learner, recruited from society, upon arrival on Center, has contact with the counseling staff from intake to exit. Through learner orientation and assessment activities (2.1) deficiencies are identified and one or more of the following treatments (2.3) are prescribed and scheduled (2.2):

- Personal Counseling
- Family Counseling
- Cognitive Life Skills Development
- Community Development /6/

An assessment loop for the student is shown in Figure 2 between the learning environment (2.3) and the deficiency identification process (2.1). The assessment, prescription, and learning cycle (2.1, 2.2, 2.3) continues until deficiencies no longer are identified for a learner based on his or

her development plan. At this time the student has validated with those competencies for return to society and job placement.

Career guidance activities are initiated early during the learner's on Center program. These career guidance activities (2.3) assist the student gain knowledge about occupational requirements, their own self structure, and integrate them into a career choice. An individualized educational plan is also developed that focuses on the skills that assist the student in obtaining and maintaining employment. /7/

The educational plan may include acquisition of: Family core skills, foundation education skills (like mathematics and/or communication arts), and certainly some occupational preparation skills. Curriculum prescribed (2.2) for the educational plan and the career guidance activities is identified as part of the existing program's learning environment (2.3).

Another way to examine the curriculum system is to follow the curriculum products development process. This process is illustrated in Figure 2 beginning with the intended system's product (1.2), then the identification of competencies to be developed (2.5), followed by curriculum product (2.6) selection and development. Feedback from assessment (2.1) provides direction for modification of curriculum product (2.6) selection and development. This type of feedback results from a comparison of the student success with the curriculum and the expected competencies on Center.

The expected competencies on Center are derived from the previously mentioned set of external competencies needed to successfully solve the problem for which the system exists. Derivation of these expected internal competencies was accomplished by first developing the set of skill categories Figure 3.

FIGURE 3. HERE

The four major categories and sub-categories of skills in Figure 3 were analyzed and translated into student terminal performance objectives. These performance objectives are key to the development of curriculum products discussed in the following section.

The development of curriculum within Model IV is based generally on the following sequence:

1. Analyze the requirements within the career, home life, or societal area with which a Production Component* is concerned.
2. Separate requirements into functional categories by type of skill required (occupational, academic, personal).
3. Choose the functional category to be considered.
4. Analyze the functional category to determine the knowledges and skills and hence learning units required.
5. Prepare learning units using a logical structure (general to specific).
6. Test learning units existing at such a level of specificity that they interface with students. /4/

It should be noted, in summary, that the curriculum system, as a production process cycle (2.1, 2.2, 2.3), produces changes in students that are intended to correspond with the desired competencies. The curriculum is identified by performance objectives that define competencies that in turn are expected to meet the societal need and purpose of the existing program.

* A part of the Mountain-Plains system whose functions directly result in a product that is part of the systems product and contributes to satisfy the purpose for which the system exists.

CURRICULUM PRODUCTS

A curriculum system, in a functioning program, is supported by curriculum products. An expansion of the existing program, illustrated in Figure 4, represents the development for curriculum products preparation.

FIGURE 4. HERE

Curriculum criteria (4.1) are established that comprise three categories. One category, the key one, includes the characteristics of the objectives that describe the desired competencies (4.1.1). The present criteria are that they:

1. State what the learner will be doing as terminal behavior.
2. State the important conditions under which the terminal behavior occurs.
3. Specify the criteria of acceptable performance.
4. Specify what measurement devices will be used to make this determination. /8/

Another curriculum criteria category involves determination of appropriate learning processes (4.1.2). It is intended, when feasible, to have alternatives. Any alternative must allow for open entrance and exit* of students and allow for various rates of progress by the individual students. After establishing the curriculum criteria for the above two categories the criteria for curriculum product structure is determined. (4.1.3).

A curriculum product structure hierarchy evolved that had essentially four levels. The levels beginning with the lowest are:

* Students are able to begin and end at any time and at any point in each curriculum sequence.

1. Performance activities.
2. Units - each of which represents a logical grouping of performance activities.
3. Courses - each representing a logical collection of units.
4. Curriculum Area - a group of related courses. /8/

The materials/products in which planned curriculum is recorded and the materials and equipment that are used directly in providing learning experience are referred to as the curriculum products. These curriculum products are then classified into the following groups:

1. Guide - designed to give the reader a summary of the content for each Curriculum Area, Course, and Unit.
2. Plan - designed to direct the learner's performance activity.
3. Test - designed to measure the learner's achievement of objectives.
4. Records - designed to facilitate the curriculum information flow and document student and staff progress with curriculum.
5. Resources - those developed or selected materials used to directly provide learning experience. /8/

Formats for the curriculum products are determined and guidelines stated to facilitate comprehension of their structure.

A test development procedure begins with the rationale that the Mountain-Plains project is essentially concerned with two areas of human development. One is the cognitive and performance area which involves the imparting of job preparation and family life. The other, an affective area, involves the changing of attitudes about such things as child raising, home management, and the desirability of maintaining steady employment. /9/

A cognitive testing program originates with the development of item pools at the performance activity level. The item pools consist of objective multiple choice items with four distractors each. The reasons for using objective terms are:

1. That they guarantee high inter-score reliability.
2. A wider range of material can be sampled with them.
3. Objective tests are generally more reliable than others.
4. They fit the domain-sampling model much more readily than other types of items.

Development of item pools to measure specific behavioral objectives is done so that tests may be constructed by randomly sampling items and also to facilitate the construction of alternate test forms.

The unit test is developed by taking a random sample of items from the activity level item pools, and by the development of an item pool to measure behavioral objectives formulated at the Unit level. At the Unit level, the cognitive test is matched with a performance test. The performance test is constructed to measure job skills under simulated or actual job conditions.

In cognitive areas where it is difficult, if not impossible, to develop satisfactory performance tests, attitude scales will be administered before and after the cognitive activity.

A comprehensive test is developed, by sampling items from both the Activity level and the Unit level item pools. This test is used as a pre and post test and will be diagnostic. However, the comprehensive performance test is the ultimate measure of student validation.

Tests for an affective area testing program are developed using the following steps:

1. Identify the behavior desired.
2. Develop a construct to explain the behavior.
3. Identify the components of the construct.
4. Develop statements that represent the components.
5. Determine what is a desirable response using a six-point scale for measuring agreement or disagreement with the statements. /9/

Determining the procedures for curriculum development (4.2) follows establishment of curriculum criteria. The general procedures used are outlined below:

1. Curriculum Area

- a. Identify Courses
- b. Identify Units

A curriculum worksheet* should be submitted to the Curriculum Department after identification of courses and units.

2. Performance Activities (PAs) (stated as objectives)

- a. Identify them
- b. Group them by Units

When the PAs for a course have been identified and assigned to units, submit a complete list of those PAs to the Curriculum Department.

3. Evaluation Techniques

At this point, construction evaluation procedures to measure the degree of success in meeting the performance activity objective.

* A curriculum worksheet lists the curriculum area courses and units. Within occupational preparational areas the worksheet also relates courses and units to job titles.

4. Construct a plan or plans for each Performance Activity

An activity plan worksheet that would be used when possible, for drafts submitted to the Curriculum Department.

5. Prepare Guides for Units

There is a Guide Worksheet to be used when possible for drafts.

6. Prepare Guides for Courses

7. Prepare Guide for Curriculum Area /8/

A curriculum products development routing procedure was prepared and a developmental change procedure described for curriculum products. Existing resources are reviewed for potential use. If they cannot be used or adapted, then on-Center development takes place.

In summary, the curriculum products are prepared (4.3) using procedures for their development (4.2) that are based upon established criteria (4.1) generated from competencies identified as necessary to insure student success in society (2.5).

EVALUATION

A. Mission Assessment

Success of the mission, reported in the description of Model IV, will be measured from both the view-point of society and of the family.

From the view-point of society, the criterion of success will be economic payback to society as measured through cost-benefit analysis or economic return on investment.

From the view-point of the family, success will be in terms of increased family economic viability and satisfaction with job and life. Family economic viability is defined as family economic growth and development. Indicators of success to be measured are:

- a. Job-getting, job-holding, and job-progression.
- b. Effective interaction with economic and related social aspects of society.
- c. Effective family management. /4/

B. Research Design

The basic research design is pre-post measurement with a randomly-chosen control group as illustrated below. Measurement is through the collection of data on indicators of success and the comparison with identical data for the control group.

EXPERIMENTAL PARADIGM

<u>Group</u>	<u>Pre-Test</u>	<u>Treatment</u>	<u>Post-Test</u>
Experimental	0	X	0
Control	0		0 /4/

C. Curriculum

Curriculum within Model IV must meet the tests of being individualized, competency-based, and applicable to the rural disadvantaged. It must be in such form that it can be used by another professional, along with procedural guides, to replicate the Component. Both the curriculum collected and developed will be evaluated by the same process. /4/

Within the curriculum development sequence there are three points at which curriculum is evaluated:

<u>Point</u>	<u>Step*</u>	<u>Test</u>	<u>Result</u>
1.	4. Learning Unit Determination	Review of analysis in steps 1-4.	Established face validity.**
2.	5. Learning Unit Preparation	Quality Control Review**	Ensures required level of quality.
3.	6. Learning Unit Testing	Try interfacing Units with Subjects	Establishes required performance level.

The adequacy of a curriculum sequence is tested by the capability of the sequence to bring participants to a required student terminal performance objective level. /4/

A specific curriculum learning unit interfacing directly with students will be defined as tested and validated if:

1. Anytime after it has been successfully completed (post-test success) on one trial by one student whose curriculum sequence required the unit, five consecutive students requiring the learning unit complete it successfully on one trial.

* Steps referred to are those listed in the second paragraph following Figure 3 in the Curriculum System section.

**Face validity test and quality control review are accomplished by both the direct supervisor of the person writing the learning unit and a Curriculum Specialist.

2. The average time in hours to complete the learning unit as reported by the five students does not exceed a standard set by the instructor prior to testing the learning unit.
3. The instructor expresses his satisfaction that the necessary points are covered in the learning unit, i.e., there are no supplemental areas of information related to the learning unit which the instructor has consistently been required to provide as mandated by student questions. /4/

The failure of two successive revisions of a learning unit to meet the above criteria will indicate the need to devise an alternate approach for the learning unit. This learning unit form has the same performance objectives but utilizes another mode of communication. /4/

Ultimately, curriculum will be validated externally. That is, once it can be demonstrated that curriculum objectives are externally achievable and have face validity, and correlate, through statistical analysis of written comprehensive post tests and performance post tests, with the body of defined desired external competencies, the external competencies themselves, as exemplified by completed comprehensive performance post tests, will be submitted to third party bodies for validation. For example, assuming the above correlations have been achieved, the body of external competencies exemplified in the Drafting area comprehensive performance post-test will be reviewed by the Association of American Draftsmen in terms of their comprehensiveness, level of quality, and possible deficiencies, as they relate to the generally recognized body of skills required by an entry level draftsman.

REPLICATION AND DIFFUSION

Replication and diffusion are two separate but related topics. These involve testing the developed Components, Processes, and curricula as to their replicability, and the diffusion of these Components, Processes, and curricula into American education. /4/

The replication may be approached in either of two ways. One approach is to actually reproduce a Component or Process or use curricula in another location with another target population and to test the success of this use.

The second possible approach to the replication question is to do a conceptual and computational study. It would answer questions as to whether Components, Processes, and curricula would seem to be replicable in other situations. /4/

The diffusion will be a by-product of the replication effort but with specific techniques applied. The techniques to be applied relate to diffusion theory. Following such theory the steps to be taken are:

1. Arranging those aspects of Model IV that are highly recommended by competent and well-known educational authorities.
2. Informing the educational community of the existence of Model IV innovations.
3. Targeting on educational groups and institutions for which the aspects of Model IV are of central importance.
4. Showing that the aspects of Model IV are innovations but are essentially modifications of educational aspects with which American education has had considerable experience.
5. Showing that the innovations of Model IV serve better than their predecessors.
6. Showing that the innovations can be accepted in installments.

7. Identifying early adopters and cultivating and supporting their interest in and use of the innovations.
8. Assisting these early adopters or innovations in influencing others. /4/

Related to Model IV replication and diffusion is the subject of a marketing feasibility study. A conceptual paper has been prepared on product marketability by a third party. In the paper an overview of possible products was listed. The major product categories and the number of possible products listed under each is shown below.

1. Administrative designs and procedures: 9 products.
2. Guidance procedures and programs: 4 products.
3. Counseling procedures and programs: 9 products.
4. Curriculum development procedures and programs: 8 products.
5. Curriculum Materials: 92 Courses
609 Units
3690 Activities plans /10/

PRESENT STATUS

In terms of research, five phases are planned for Model IV. The five phases correspond generally to the five fiscal years of funding that was committed to the project. These phases are:

<u>PHASE</u>	<u>FISCAL YEAR</u>
I Conceptualization	1971-72
II Feasibility Testing	1972-73
III Program Development	1973-74
IV Program Evaluation	1974-75
V Replication and Diffusion	1975-76

To determine the status of Model IV nationally, a study of six family-residential educational programs were conducted. These programs were compared and the conclusions reached were that:

1. Mountain-Plains represents the most advanced stage of evolution of the family residential educational approach.
2. Model IV has the most comprehensive and innovative form. /11/

In terms of curriculum development, Mountain-Plains has essentially completed the first edition of curriculum products.

In terms of the student family throughput, Figure 5 describes the past, current status and projected conditions.

FIGURE 5. HERE

Currently just over 220 families are on Center. This number represents essentially the maximum in housing available within the budget. It is planned that up to 210 families will be on Center in program treatment until project phase out begins.

BIBLIOGRAPHY OF RESOURCES PREPARED BY MOUNTAIN-PLAINS EDUCATION AND ECONOMIC DEVELOPMENT PROGRAM, INC., Post Office Box 3078, Glasgow Air Force Base, Montana 59231.

- /1/ WHAT IS MOUNTAIN-PLAINS?, A Descriptive Flyer, pp. 2.
- /2/ PROPOSAL FOR GRANT CONTINUANCE VOLUME I OF IV LONG RANGE OVERVIEW 1971-1976, Revised November 15, 1973, pp. 36.
- /3/ MODEL FOR IMPLEMENTATION OF A SYSTEMATIC EVALUATION SUBSYSTEM WITHIN CAREER EDUCATION MODEL IV, October 20, 1972, pp. 17.
- /4/ PROPOSAL FOR GRANT CONTINUANCE VOLUME II OF IV RESEARCH DESIGN, Revised November 15, 1973, pp. 108.
- /5/ A SPECIFIC RESPONSE TO THE NATIONAL INSTITUTE OF EDUCATION UNDER THE REQUIREMENTS AS SET FORTH WITH THEIR DOCUMENT ENTITLED: "SCOPE OF WORK", Responding to: "By December 1, Mountain-Plains will provide NIE with a detailed evaluation report for internal evaluation...", December 1, 1973, pp. 81.
- /6/ COUNSELING PROGRAM DEVELOPMENT AND RATIONALE Counseling Services Report No. 10, December 1973, pp. 27.
- /7/ NATIONAL MODEL IV, "A CAREER GUIDANCE OFFERS STUDENTS NEW INSIGHTS", March 1974, Newsletter.
- /8/ CURRICULUM GUIDELINES, Looseleaf Edition, November 1973.
- /9/ DESIGN FOR RELIABILITY AND VALIDITY TESTING OF ASSESSMENT INSTRUMENTS - PHASE II, December 31, 1973, pp. 7.
- /10/ MARKETING FEASIBILITY STUDY DESIGN: "SCOPE OF WORK", Responding to: By January 1, 1974, Mountain-Plains will submit to NIE a conceptual paper on product marketing..., Prepared by: Pathway Research Inc., January 1974, Part I: pp. 290 and Part II: pp. 93.
- /11/ A SPECIFIC RESPONSE TO THE NIE UNDER THE REQUIREMENTS AS SET FORTH WITHIN THEIR DOCUMENT ENTITLED: "SCOPE OF WORK", Responding to: Research and Development: A review and analysis of existing residential approaches with emphasis on approaches accepted and rejected by Mountain-Plains with implications for improving Mountain-Plains approach, February 28, 1973, pp. 94.

FIGURES ANNEX

GENERAL SYSTEMS MODEL FOR THE APPROACH TO RESIDENTIAL,
FAMILY BASED CAREER EDUCATION

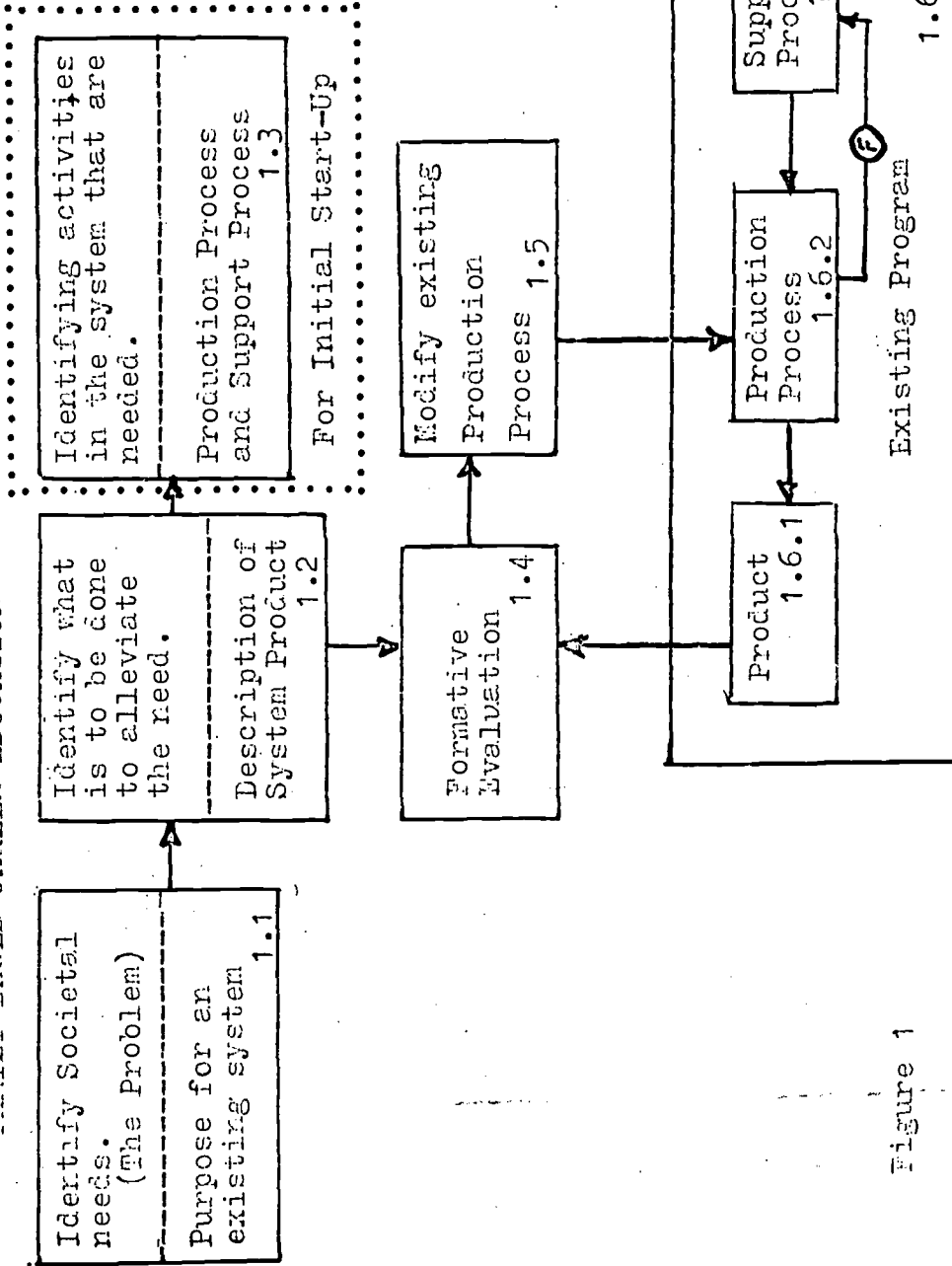

Figure 1

EXPANSION OF GENERAL SYSTEMS MODEL: DESCRIPTION OF EXISTING PROGRAM

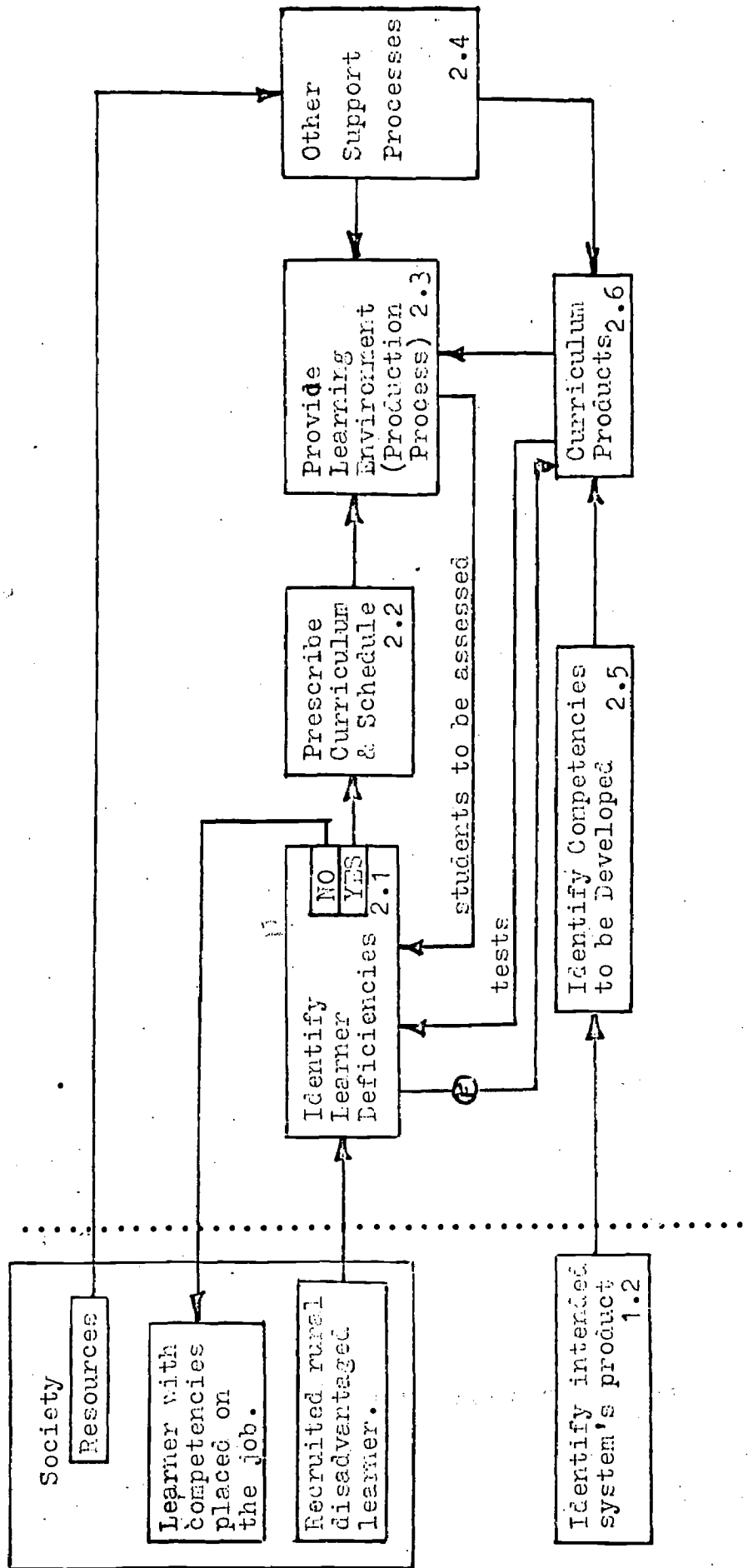

Figure 2

SKILL CATEGORIES FOR PERFORMANCE OBJECTIVES

1.1 Employability Skills

- 1.1.1 World of Work
- 1.1.2 Work Attitudes
- 1.1.3 Academic Skills
- 1.1.4 Functional Job Skills

1.2 Home Life Skills

- 1.2.1 Family Relations
- 1.2.2 Health
- 1.2.3 Home and Consumer Management
- 1.2.4 Leisure Time Skills

1.3 Social Involvement Skills

- 1.3.1 Environment Adjustment
- 1.3.2 Interpersonal Relations

1.4 Personal Improvement Skills

- 1.4.1 Academic Personal Improvement
- 1.4.2 Problem Solving
- 1.4.3 Development and Implementation of Plans
- 1.4.4 Self-recognition Skills

/4/

Figure 3

EXPANSION OF EXISTING PROGRAM: CURRICULUM PRODUCTS

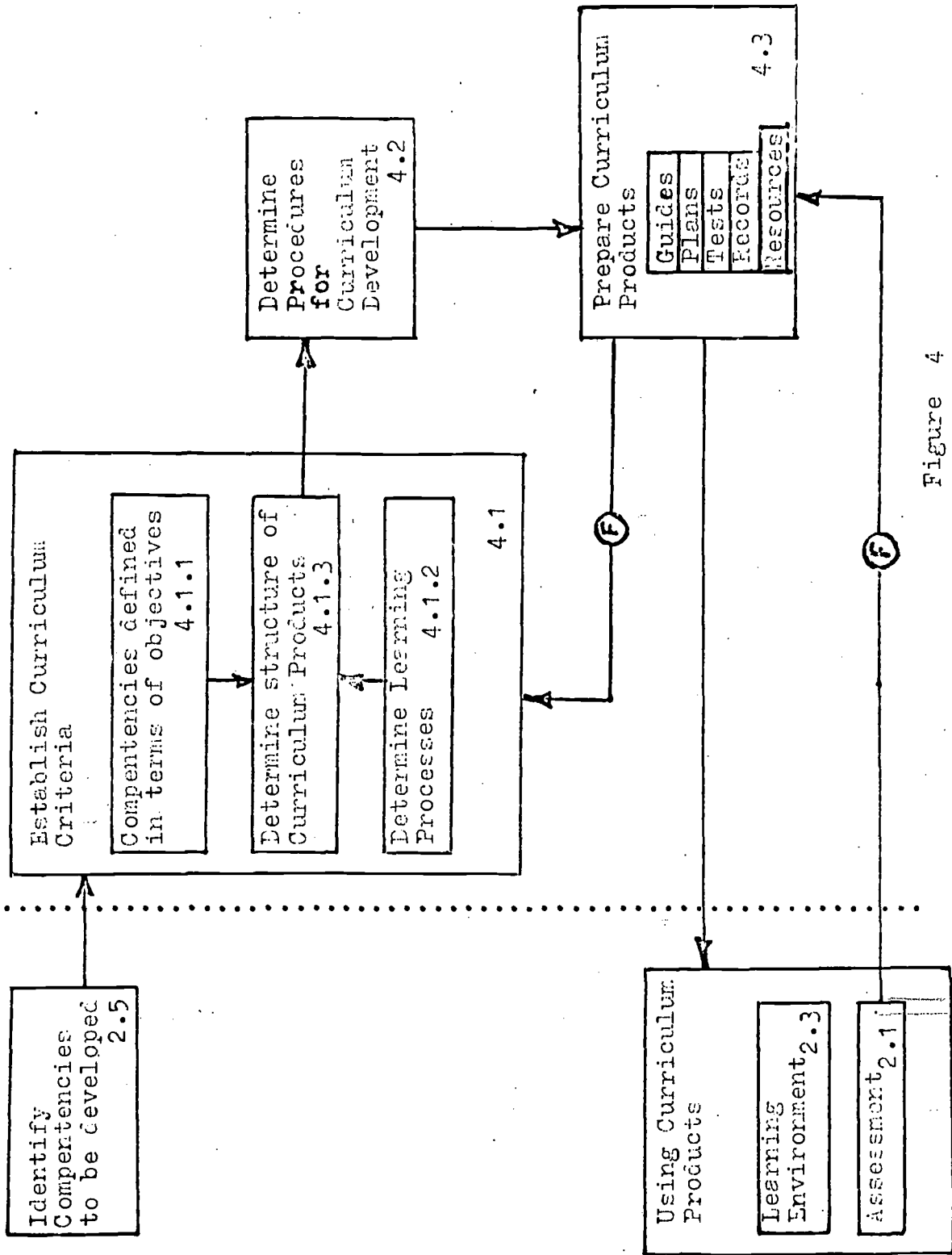

Figure 4

STUDENT FAMILY THROUGHPUT ESTIMATES AND DATA AVAILABILITY PROFILES

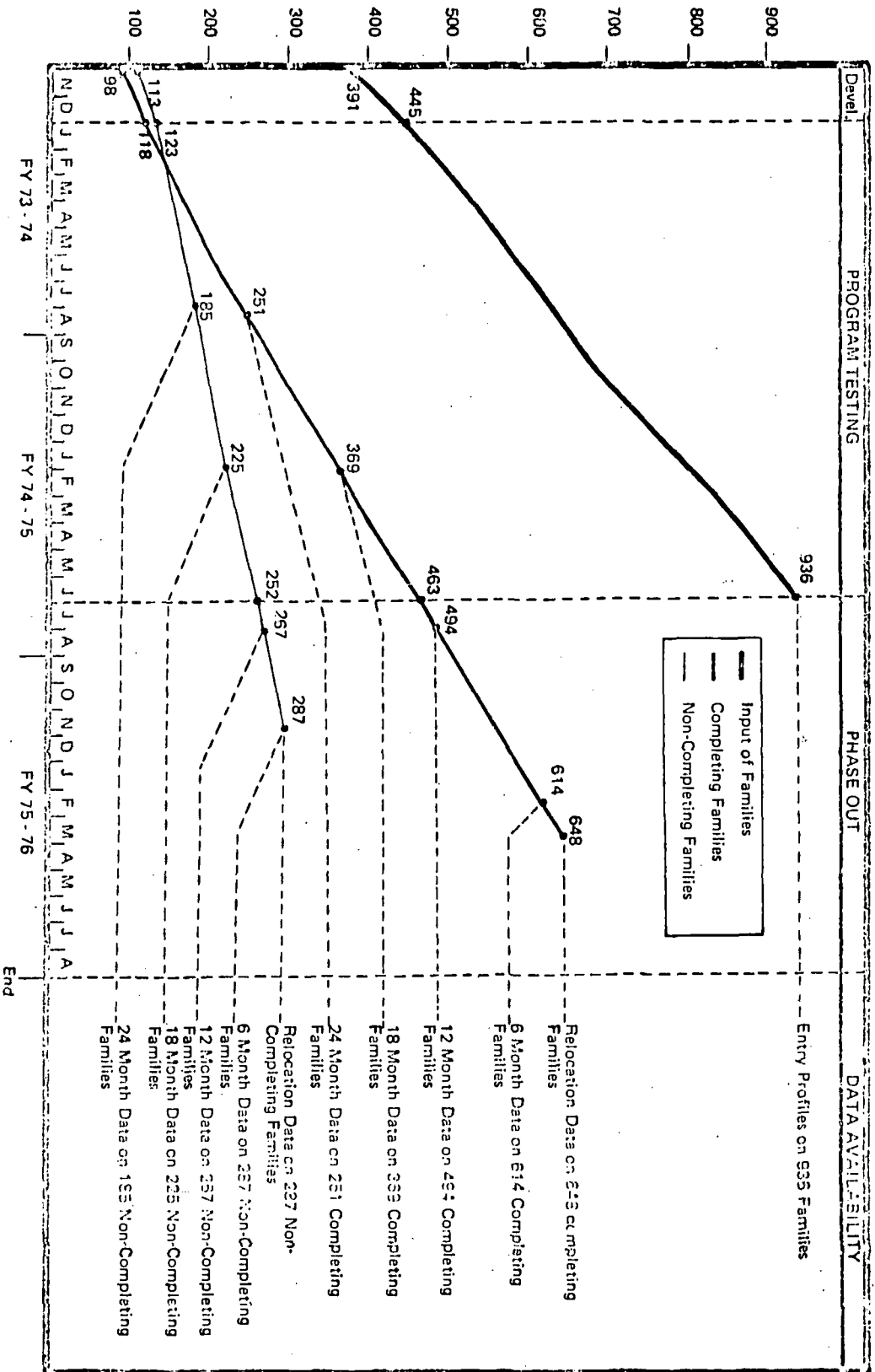

Figure 5