

DOCUMENT RESUME

ED 089 780

IR 000 505

AUTHOR Middleton, Morris G.; And Others
TITLE Computer Managed Instruction in Navy Training.
INSTITUTION Naval Training Equipment Center, Orlando, Fla.
Training Analysis and Evaluation Group.
REPORT NO NAVTRADQUIFCEN-TAEG-14
PUB DATE Mar 74
NOTE 107p.

EDRS PRICE MF-\$0.75 HC-\$5.40 PLUS POSTAGE
DESCRIPTORS *Computer Assisted Instruction; Computers; Cost Effectiveness; Costs; *Educational Programs; *Feasibility Studies; Individualized Instruction; *Management; *Military Training; Pacing; Programming Languages; State of the Art Reviews

IDENTIFIERS CMI; *Computer Managed Instruction; Minicomputers; Shipboard Computers; United States Navy

ABSTRACT

An investigation was made of the feasibility of computer-managed instruction (CMI) for the Navy. Possibilities were examined regarding a centralized computer system for all Navy training, minicomputers for remote classes, and shipboard computers for on-board training. The general state of the art and feasibility of CMI were reviewed, alternative computer languages and terminals studied, and criteria developed for selecting courses for CMI. Literature reviews, site visits, and a questionnaire survey were conducted. Results indicated that despite its high costs, CMI was necessary if a significant number of the more than 4000 Navy training courses were to become individualized and self-paced. It was concluded that the cost of implementing a large-scale centralized computer system for all training courses was prohibitive, but that the use of minicomputers for particular courses and for small, remote classes was feasible. It was also concluded that the use of shipboard computers for training was both desirable and technically feasible, but that this would require the acquisition of additional minicomputers for educational purposes since the existing shipboard equipment was both expensive to convert and already heavily used for other purposes. (Author/PB)

T A E G

TRAINING
ANALYSIS
AND
EVALUATION
GROUP

T A E G R E P O R T
N O . 1 4

C O M P U T E R M A N A G E D I N S T R U C T I O N
I N N A V Y T R A I N I N G

ED 089780

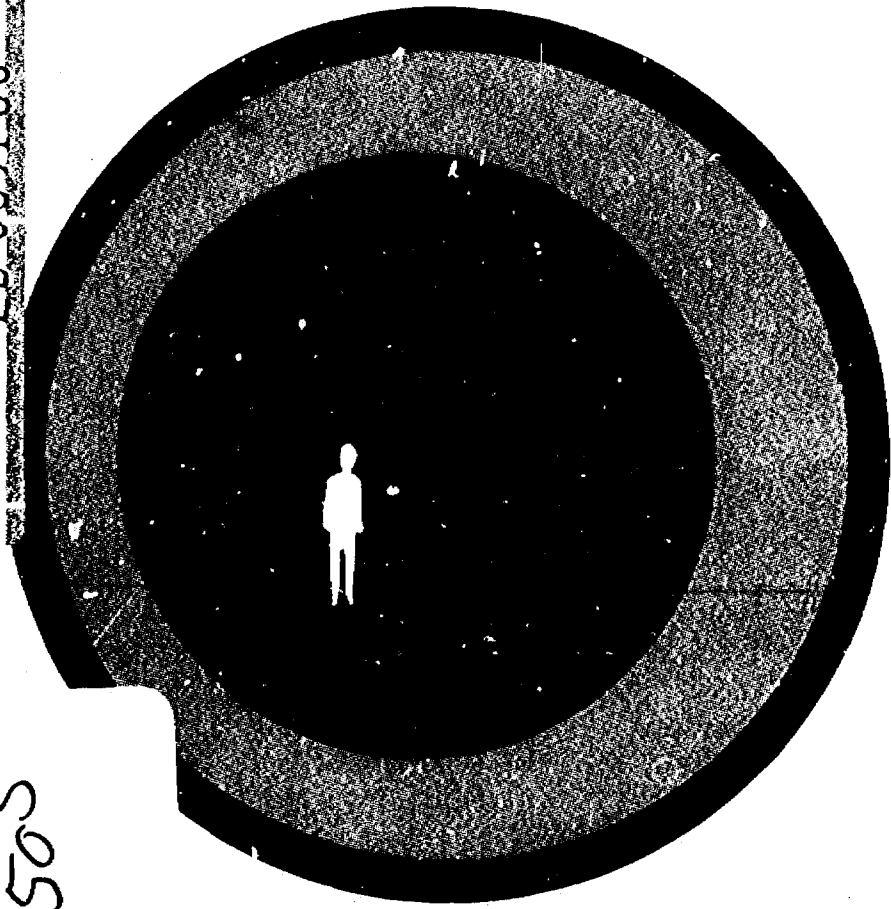

F O C U S
O N
T H E
T R A I N E D
M A N

R P U B L I C R E L E A S E ;
I S U N L I M I T E D .

M A R C H 1 9 7 4

N A V A L T R A I N I N G E Q U I P M E N T C E N T E R
O R L A N D O , F L O R I D A 3 2 8 1 3

I R 000505

TECHNICAL REPORT: TAEG REPORT NO. 14
COMPUTER MANAGED INSTRUCTION IN NAVY TRAINING

ABSTRACT

This report presents the findings of a six-month study undertaken to investigate the feasibility of Computer Managed Instruction (CMI) for the Navy in three areas: (a) large-scale centralized computer system for all formalized Navy training, (b) minicomputers for small, remote classes, and (c) use of shipboard computers for managing individual training aboard ships. Specifically, the report encompasses:

- . An overview of CMI.
- . The state-of-the-art of CMI in the military, government, industry, and education.
- . The feasibility of minicomputers for CMI.
- . The feasibility of shipboard computers for CMI.
- . The feasibility of a centralized computer center for CMI.
- . An overview of computer languages for CMI.
- . Rationale and criteria for selecting Navy courses for CMI.
- . An overview of instructional terminals for CMI.

GOVERNMENT RIGHTS IN DATA STATEMENT

Reproduction of this publication in whole or in part is permitted for any purpose of the United States Government.

ED 089780

COMPUTER MANAGED INSTRUCTION IN NAVY TRAINING

Morris G. Middleton
Clarence J. Papetti
Gene S. Micheli, Ph.D.

Training Analysis and Evaluation Group

March 1974

U.S. DEPARTMENT OF HEALTH,
EDUCATION & WELFARE
NATIONAL INSTITUTE OF
EDUCATION

THIS DOCUMENT HAS BEEN REPRO-
DUCED EXACTLY AS RECEIVED FROM
THE PERSON OR ORGANIZATION ORIGIN-
ATING IT. POINTS OF VIEW OR OPINIONS
STATED DO NOT NECESSARILY REPRESENT
OFFICIAL NATIONAL INSTITUTE OF
EDUCATION POSITION OR POLICY.



H. C. OKRASKI, Acting Director
Training Analysis and Evaluation Group

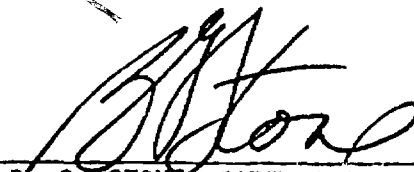

B. G. STONE, CAPT, USN
Head, Program Development Division
Chief of Naval Education and Training

ACKNOWLEDGEMENTS

The authors express their appreciation to Dr. John Ford and Dr. H. Dewey Kribs of the Navy Personnel Research and Development Center, San Diego, California, for their review of this manuscript and their cogent comments.

Particular gratitude is expressed to Dr. David J. Chesler, also of the Navy Personnel Research and Development Center for his thorough technical editing of the manuscript and his constructive critique.

TABLE OF CONTENTS

<u>Section</u>	<u>Page</u>
I INTRODUCTION	1
Purpose.	2
Scope and Constraints.	3
Definitions of Computer Managed Instruction.	3
II APPROACH AND PROCEDURES.	9
Visits and Interviews.	9
Questionnaire.	9
Existing Training Records.	9
III ANALYSIS AND DISCUSSION.	11
Features of Current Computer Managed Instruction Systems . .	11
Use of Minicomputers for Computer Managed Instruction. . .	14
Shipboard Use.	16
Landbased (Remote) Use	20
Subsurface Use	24
Centralized Computer System for Computer Managed Instruction	24
Use of Shipboard Computers for Computer Managed Instruction.	30
Overview of Instructional Terminals	34
Overview of Computer Assisted Instruction Computer	
Languages Used by the Navy.	39
Rationale and Criteria for Computer Managed Instruction	
Course Selection.	42
Cost of Computer Managed Instruction	48
Course Density	51
Course Preparation: Contractor or Local Effort.	51
Computerization of Programmed Instruction.	52
Course Material That Can Be Taught by Computer Managed	
Instruction	54
Effect of Self Pacing on Student Progression	55
Design for Media, Branching and Queuing in Computer	
Managed Instruction	56
Effect of Computerized Instruction on Attrition and	
Achievement	56
Grading Computer Managed Instruction	57
The New (CMI) Instructor	59
The New (CMI) Student.	59
Student Procrastination as a Factor in Computer Managed	
Instruction	60
Computer Managed Instruction and the Personnel	
Qualification Standards	61

TABLE OF CONTENTS (Cont'd)

<u>Section</u>	<u>Page</u>
IV CONCLUSIONS.	63
BIBLIOGRAPHY	67
APPENDIX A Questionnaire.	73
APPENDIX B Navy Formal Schools Catalogs	75
APPENDIX C Abstracts of CMI Systems Visited or Contacted.	77
APPENDIX D Minicomputer and Large System Computer Configuration Hardware Costs.	91
APPENDIX E Shipboard Computer Systems	93
APPENDIX F Potential CMI Courses.	97
APPENDIX G Course Density	99
APPENDIX H Sites Visited.	101
APPENDIX I Contacts for Computer Managed Instruction.	103

LIST OF TABLES

<u>Table</u>		<u>Page</u>
1	Features of Current Computer Managed Instruction Systems . . .	12

LIST OF ILLUSTRATIONS

<u>Figure</u>		<u>Page</u>
1	Computer Managed Instruction Overview.	6
2	Computer Managed Instruction System Characteristics.	7
3	Minicomputer Configuration of USS DAHLGREN	17
4	Typical Shorebased Minicomputer Configuration.	22
5	Area Computer System Concept	29
6	Typical Shipboard Computer Managed Instruction System.	35

SECTION I

Intro A

SECTION I

INTRODUCTION

Individuals come to training situations at different levels of competence, they learn at different rates, they perform differently in the training situation depending on their aptitudes, interests, personalities and learning styles, and they respond differently to various training methods. Consideration of such individualization is perhaps the most talked about issue in educational technology circles today.

"Individualized instruction now is understood to include, when fully functioning: a. freedom for the student to register and commence the program at any time of any day, b. freedom for the student to enter the program learning sequences at a point determined by his measured entry skill level, c. freedom for the student to proceed through the program at a pace determined only by his capability and determination, d. freedom for the student to be measured for achievement of objectives at any time he considers himself ready, e. freedom for the student to select from amongst a set of instructional media and methods, and f. freedom for the student to complete the program whenever he can demonstrate mastery of the objectives" (Scanland, 1973a).

"Such individualization of instruction introduces so many factors and variables into the process that ... manual management of each student's progress through the program becomes a controlling influence on the efficacy of the individualization. At this point management, or at least some part of it, should become automated. Such automation is called CMI" (Computer Managed Instruction) (Scanland, 1973b).

"It is the position of the CNET that CMI has an essential contribution to make to Navy training, that the need will increase in direct proportion to the individualization of training and instruction, and that the Command will continue to support the advancement of empirical knowledge concerning the optimum applications of CMI until it is a well understood and established management tool of training" (Scanland, 1973b).

Accordingly, the Chief of Naval Education and Training (CNET) tasked the Training Analysis and Evaluation Group (TAEG) of the Naval Training Equipment Center (NAVTRAEQUIPCEN) to investigate the feasibility of CMI.

PURPOSE

The purpose of this study was to investigate the feasibility of CMI for the Navy in three areas: (1) a large-scale centralized computer system for all formalized Navy training, (2) minicomputers for small, remote classes, and (3) use of existing shipboard computers for managing individual training aboard ships. A preliminary effort was started in October 1972 to identify the number of formalized courses offered by the Navy and the location of all courses. Over 4,000 courses were identified in over 100 locations. However, because of reorganization and reassignment of personnel, the major portion of the study did not get under way until April 1973.

This report presents the results of this investigation of CMI feasibility. Specifically, this report encompasses:

- o An overview of CMI.
- o The state-of-the-art of CMI in the military, government, industry, and education.
- o The feasibility of minicomputers for CMI.
- o The feasibility of shipboard computers for CMI.

- o The feasibility of a centralized computer center for CMI.
- o An overview of computer languages for CMI.
- o An overview of instructional terminals for CMI.
- o Rationale and criteria for selecting Navy courses for CMI.

SCOPE AND CONSTRAINTS

This study encompassed a review of most of the available literature, a review of the 13 Navy Formal Schools Catalogs, a Defense Documentation Center (DDC) search, an analysis of the Master Course Reference File (MCRF) Automatic Data Processing (ADP) printout, visits to Army, Navy, Marine, Air Force and NASA installations, visits to a representative cross section of industry and the academic sector, and the development of a questionnaire to obtain information on courses.

An interdisciplinary project team from TAEG performed the study during the period April - September 1973. Beyond the constraints of people, time, and money was the problem of investigating a revolutionary concept of education in its embryonic stage.

DEFINITIONS OF COMPUTER MANAGED INSTRUCTION

The definition of what constitutes a CMI system and what it should contain is a controversial topic. There is no operational system that encompasses all the aspects of a CMI system. Almost all of the definitions of CMI in the documents reviewed differed at least slightly from each other. All definitions share the common factors of record keeping and scheduling and some include other factors such as testing, media branching, diagnostics and prescriptives. A representative definition from government, industry and academia is discussed in the following paragraphs.

Florida State University (FSU) has conducted research of Computer Assisted Instruction (CAI) and CMI systems and is considered a leader in the field. Hansen (1970) lists five functions which characterize an ideal CMI system: (1) providing diagnostic evaluations with learning prescriptions, (2) counselling students about adaptive learning strategies and appropriate career development, (3) developing an optimal scheduling system to match students with learning resources, (4) maintaining an appropriate student instructional record system, and (5) the limited use of CAI for drill and practice.

The Navy definition of CMI is found in OPNAVINST 1500.39: "A system in which a computer is used to route a trainee through a series of instructional materials, presented by various media, so as to be best suited to his particular needs and abilities." The instruction also defines key words and terms such as "trainee," "instructional material," etc., such that the complete definition is contained within the instruction.

A CMI definition that reflects the consensus of industry is that given by International Business Machines (IBM) Corporation during a CAI/CMI seminar in 1971 (IBM, 1971). International Business Machines Corporation functionally groups CMI into five major categories: methodology, method of instruction, activities, testing and measuring, and record keeping. These major categories are further divided as follows:

Methodology - Lecture, small group, individual.

Method of Instruction - Programmed instruction, slides, motion pictures, etc.

Activities - Problem solving, study packets, books, etc.

Testing and Measurement - Pretest, post test, prescription, diagnosis.

Record Keeping - Monitoring, scheduling, attendance.

Figure 1 presents the CMI schema in chart format.

During the course of this study it became evident that a CMI system should contain basic building blocks which derive from the above definitions. Such a system is depicted in figure 2. This system provides: (1) the feature of self pacing, (2) individualized instruction, (3) a data base of student records, instructor records, inventory records, curriculum records, and student and course analysis records, (4) optimal scheduling of physical facilities, students, instructors, equipment and instructional material, (5) testing and measuring for diagnostic evaluation and learning prescription, and (6) a model for predicting future needs of the CMI system.

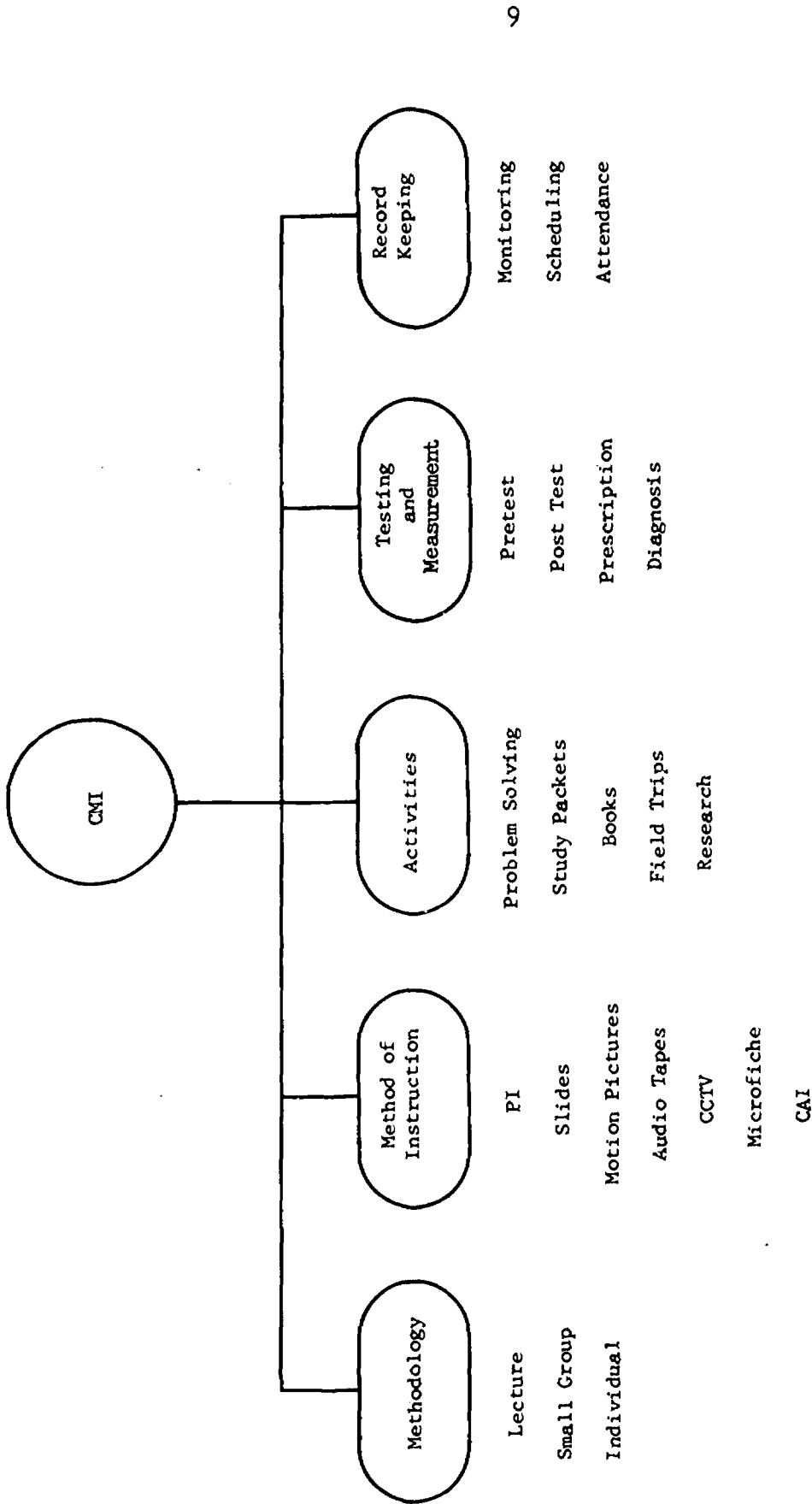

Figure 1. Computer Managed Instruction Overview (IBM, 1971)

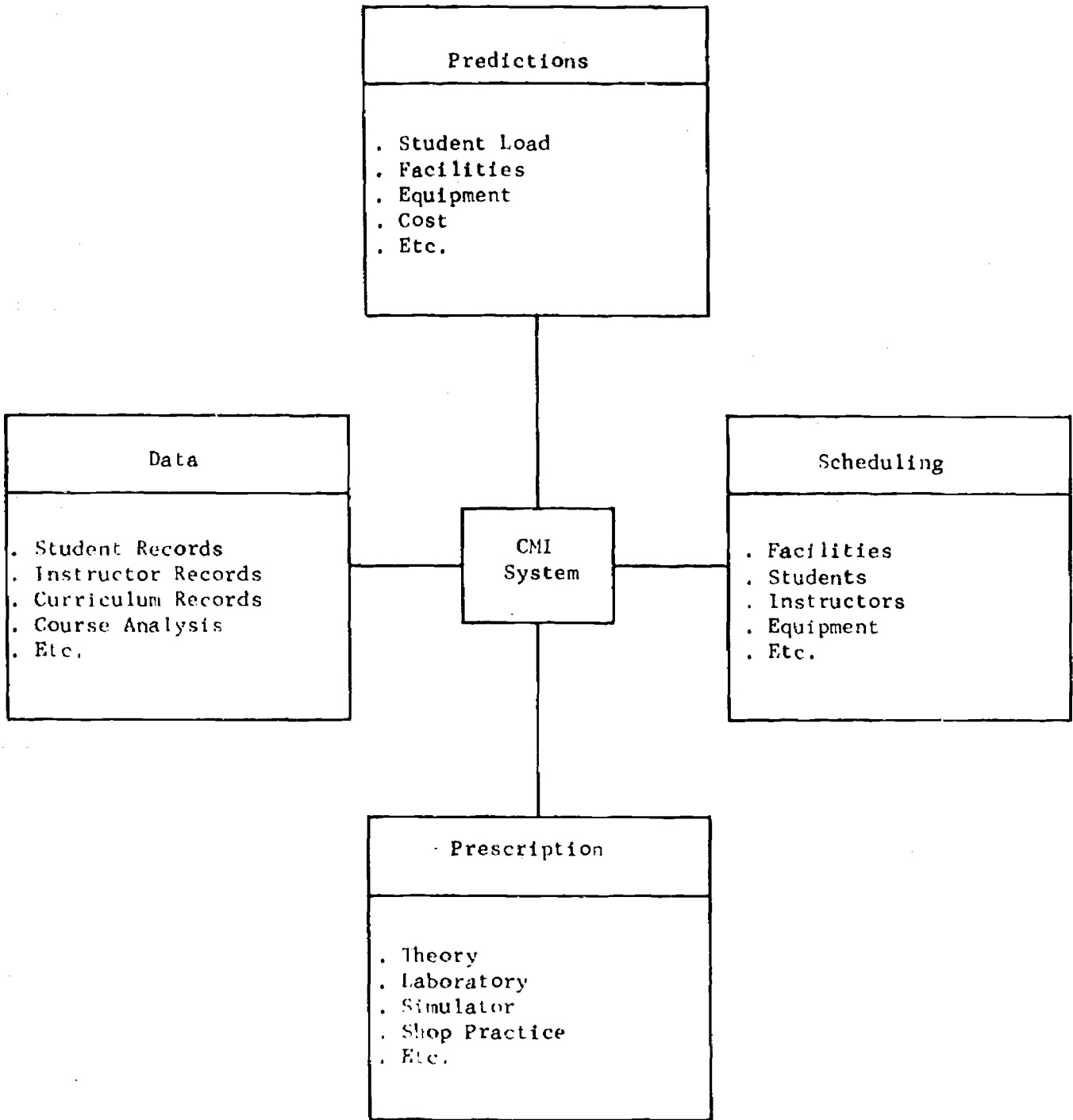

Figure 2. CMI System Characteristics

SECTION II

9A

SECTION II

APPROACH AND PROCEDURES

VISITS AND INTERVIEWS

Navy, Marine Corps, Army, industrial, academic and government CMI activities were visited by an interdisciplinary study team consisting of a psychologist, an engineer, and an education specialist. Appendix H contains a list of all the sites visited; appendix C gives an abstract of each site visit. Interviews with those persons knowledgeable in CMI/CAI, observations of current computerized training activity, and discussions of past programs were accomplished at each site.

QUESTIONNAIRE

To assist in determining the potential application of CMI to each Navy course, a questionnaire (appendix A) was developed. However, due to constraints of time, funds and ADP priorities this questionnaire was not used. The objective of this questionnaire was to obtain data to assess the CMI potential of the approximately 4,000 formal Navy courses. When time and funds become available, this questionnaire can be used.

EXISTING TRAINING RECORDS

Appendix B lists the 13 Navy Formal Schools Catalogs. These catalogs give an abstract of each course, its location, length, skill identifier, Navy Enlisted Classification (NEC), purpose, scope, prerequisites, quota control, funding and course identifying number. These catalogs served as a base line for the present study. All other Navy courses were either too informal or not well established. All formal courses report periodically under the Formal Training Data System (FTDS), and the training data are

compiled on the MCRF and the Student Master File (SMF). The Training Data (TRAD) Report was also used in this study; it lists student records and includes cumulative reports, outputs, and other student course data.

SECTION III

ANALYSIS AND DISCUSSION

This section is based upon analyses performed on information obtained from visits to the activities identified in appendix C, review of available literature, and review of Navy records.

FEATURES OF CURRENT COMPUTER MANAGED INSTRUCTION SYSTEMS

As stated earlier in this report, most CMI systems today do not meet all the requirements which would classify them as complete CMI systems. A comparative analysis of representative systems investigated during this study is shown in table 1. The analysis includes systems currently operating or scheduled for contractual development. The systems that include most CMI features are the Advanced Instructional System (AIS) being developed for the Air Force by McDonnell Douglas Corporation, the Computerized Training System (CTS) being developed by the Army, and the proposed systems for the National Aeronautics and Space Administration (NASA) and Pepperdine University. The other systems have several aspects of a complete CMI system and could be expanded to full CMI systems by using additional software and hardware.

Table 1 indicates that scheduling of students and resources is performed by eight out of 10 systems. Subroutines to accomplish this task for the remaining systems could be added. As more courses are added to the Navy Technical Training Command (NTTC), Memphis, complex, subroutines will be needed to improve the cost effectiveness of the system. The scheduling of students for the USS DAHLGREN project is not included since scheduling in the at-sea environment must be extremely flexible. However, queuing may be required for scheduling the input/output (I/O) terminal

TABLE 1. FEATURES OF CURRENT COMPUTER MANAGED INSTRUCTION SYSTEMS

LOCATION	CLASS/STUDENT SCHEDULING BY COMPUTER	RECORD KEEPING BY COMPUTER	STUDENT PRESCRIPTION OF MEDIA BY COMPUTER	PREDICTION OF FUTURE REQMTS BY COMPUTER	REPORT GENERATION BY COMPUTER	DIAGNOSTIC PRETESTING: ON LINE OR OFF LINE	DIAGNOSTIC TESTING DURING COURSE: ON LINE OR OFF LINE	ANALYSIS OF TEST QUESTIONS BY COMPUTER	COURSE SELF PACED	"PASS-FAIL" OR NUMBER GRADED STUDENTS	NAME AND TELEPHONE NUMBER OF PROGRAM CONTACT	PROJECT OR COURSE TITLE
NTTC, Memphis, TN	No	Partial	No	Yes	Yes	No	Both	No	Yes	Both	Dr. K. Johnson AV 966-5291	(CMI) AFAM, AMFU BE/E
NAS, Lemoore, CA VA-122	Yes	Yes	No	Yes	Yes	Both	Both	No	No	NBR	R. J. Reynolds 209-998-3278	(PMS [Personnel Management System]) A7/AE/AB
NAS, Miramar, CA VF-124	Yes	Yes	No	No	Yes	No	Both	No	No	NBR	CDR R. Martin 714-271-1900	(CMI) F14 Aircraft FRAMP/Air Crew
N.Y. Inst of Technology, Old Westbury, N. Y.	Yes	Yes	No	Yes	Yes	On line	On line	Yes	Yes	NBR	H. Pollack 516-626-3400	(AIS)
Lowry AFB, Denver, Colorado*	Yes	Yes	Yes	Yes	Yes	On Line	On Line	Yes	Yes	NBR	J. Yasutake 303-394-4385	(CTS) Project ABACUS
USASCS, Ft. Monmouth, N. J.*	Yes	Yes	Yes	Yes	Yes	On Line	On Line	Yes	Yes	NBR	F. Giuntti AV 992-4408	(CMI)TTP for MACCS **
MCAS, Twentymine Palms, CA*	Yes	Yes	Yes Limited	Yes	Yes	Both	Both	Yes	No	NBR	Capt W.M. Kemple AV 727-1500 X6427	(CMI) Damage Control, USS DAHLGREN
USS DAHLGREN*	NA	Yes	NA	Yes	Yes	Both	Both	Yes	Yes	NBR	Dr. D. J. Chesler 714-225-7121	(CMI) Space Shuttle
NASA, Houston, TX*	Yes	Yes	Yes	Yes	Yes	Both	Both	Yes	Yes	NBR	D. Smith 713-483-5169	(CPI) School of Business
Pepperdine U. Los Angeles, CA	Yes	Yes	Yes	Yes	Yes	On Line	On Line	Yes	Yes	NBR	Dr. T. Dudley 213-752-6022	

*Predictions
**Primarily Traditional Instruction

to obtain optimum utilization during the evaluation of this system since the system will also be used for training in administration functions and for certain non-training (e.g. supply issue). All systems reviewed have a record keeping capability. Some organizations maintain a more elaborate set of records than others; thus a wide disparity exists in the number and detail of records maintained for present and future use. The capability for prescriptives is available in only 50 percent of the systems. On-line drill by New York Institute of Technology (NYIT) could be classified as branching, since a student who fails a test is prohibited from proceeding with drills in other areas until he reports to his instructors for a procedural decision.

All systems but one have models for predicting additional variables. The most common variable desired by management is the projected completion date of a course based upon past performance of the student. Some of the systems have models for predicting future student load and cost per hour of terminal time. All systems have the capability to generate reports. The data elements in these reports are as varied as the organizations that utilize the systems. The most common report is a personnel record of the student.

Diagnostic pretesting and testing during the course are performed either on line or off line with three organizations using both techniques. An on line testing technique (NYIT, 1973) that saves storage (core, disk, tape, etc.) has been devised, whereby the computer displays on the Cathode Ray Tube (CRT) an item number and a key word. The key word may be a single word, a number, a phrase, a mathematical expression, an equation, or any combination of these. Using a question booklet containing 150

questions, the student finds the item number presented on the CRT. He then types the number of the word, phrase, equation, etc., that most closely corresponds to the key word. An additional feature of this system is the level-of-difficulty rating assigned to each question. Based upon the scoring strategy, weighted or unweighted scoring techniques may be employed.

Seven of the 10 systems observed have the capability to perform test item analysis. The NTTC, Memphis, plans to add this capability in the future. The courses are self paced for seven out of the 10 systems. The exceptions are those that are using CMI for scheduling and record keeping only, namely, Attack Squadron 122 (VA-122), Naval Air Station (NAS), Lemoore; Fighter Squadron 124 (VF-124), NAS, Miramar; and Marine Aircraft Control Squadron, Twentynine Palms.

A system that has all the features of CMI is the AIS system being developed for the Air Force. The system is expensive, i.e., \$9.5 million for three courses. However, it will be cost effective since the courses have ideal characteristics for CMI, namely, throughput, stability and optimum length. The above cost includes system engineering, software development and procedure development for educational strategies which will not require duplication for future courses using the same or a similar concept. The Navy should monitor the AIS program throughout its development.

USE OF MINICOMPUTERS FOR COMPUTER MANAGED INSTRUCTION

The definition of a minicomputer varies within the computer industry. For this study a minicomputer is defined as one that costs less than \$20,000, has a 16 bit word length and uses integrated circuits. Typical characteristics are: weight is less than 50 lbs., consumes less than

500 watts. Using standard 115-volt power, its cabinet is compact for table-top or standard 19-inch rack mounting, has magnetic core storage of 4,096 to 32,768 words and has a cycle time of 0.8 to 1.5 microseconds. A minicomputer system can be configured to perform a number of general functions and at the same time be customized to perform specific functions.

As of this writing, there are 48 different companies producing 107 types of minicomputers. The price of a basic system with 4,000 words of core ranges from \$989 to \$20,000. Depending upon the machine selected, a full line of peripheral equipment is available as well as compilers for FORTRAN, BASIC, ALGOL, and COBOL. The application of minicomputers is extremely varied. For example, the question whether minicomputers can be used aboard ship and/or in remote locations for CMI, can be answered "yes" but with several reservations. Minicomputers are not designed to replace large computer systems, but they can perform, at a lower cost, some of the tasks that are presently being accomplished by large computer systems. Each computer system can be configured for optimum utilization; the problem is to accomplish the proper trade-off analysis to determine the most cost effective system. Minicomputers by themselves are not the answer to any CMI system. The hardware is extremely cheap by large computer standards. However, the costs associated with automatic data processing extend far beyond hardware costs. Consideration must be given to the initial programming requirements, updating and maintenance of existing programs for compatibility, language compatibility, training of programmers to use small machines, compiler compatibility, etc. The following presents additional qualifying discussion of using minicomputers aboard ship and at remote locations.

SHIPBOARD USE. The USS DAHLGREN is presently conducting tests to ascertain if minicomputers can be utilized as an ADP command/management system. Concurrently with this test, the Navy Personnel Research and Development Center (NPRDC) will conduct a parallel investigation to ascertain if the DAHLGREN minicomputer system can be utilized to teach General Damage Control via CMI and to accomplish the shipboard training administration function. This computer configuration and its peripherals are shown in figure 3. The minicomputer for this pilot investigation is the Nova 1200. The cost of such a system is approximately \$78,000 plus shipboard installation. This cost does not include course development, lessonware, off-line instructional media and programming required. The cost of the system may seem excessive unless the proper perspective is taken. The DAHLGREN system has been leased to test and evaluate a prototype ADP command/management system and for training application.

Development of the two training applications for the USS DAHLGREN is expected to commence soon with shipboard installation planned for one year later. Test/evaluation under deployed conditions is planned for completion by June 1975. Regardless of the outcome of this investigation, it is the opinion of the writers that within the next decade minicomputers will be utilized aboard ships not only for training but for functions now being performed by the larger computers. The state of the art continues to advance at such a pace that the physical size of a machine to replace the AN/USQ-20 or the Univac 1219 within the next 10 years will approximate today's minicomputers. The cost of a minicomputer system continues to decrease as its versatility increases.

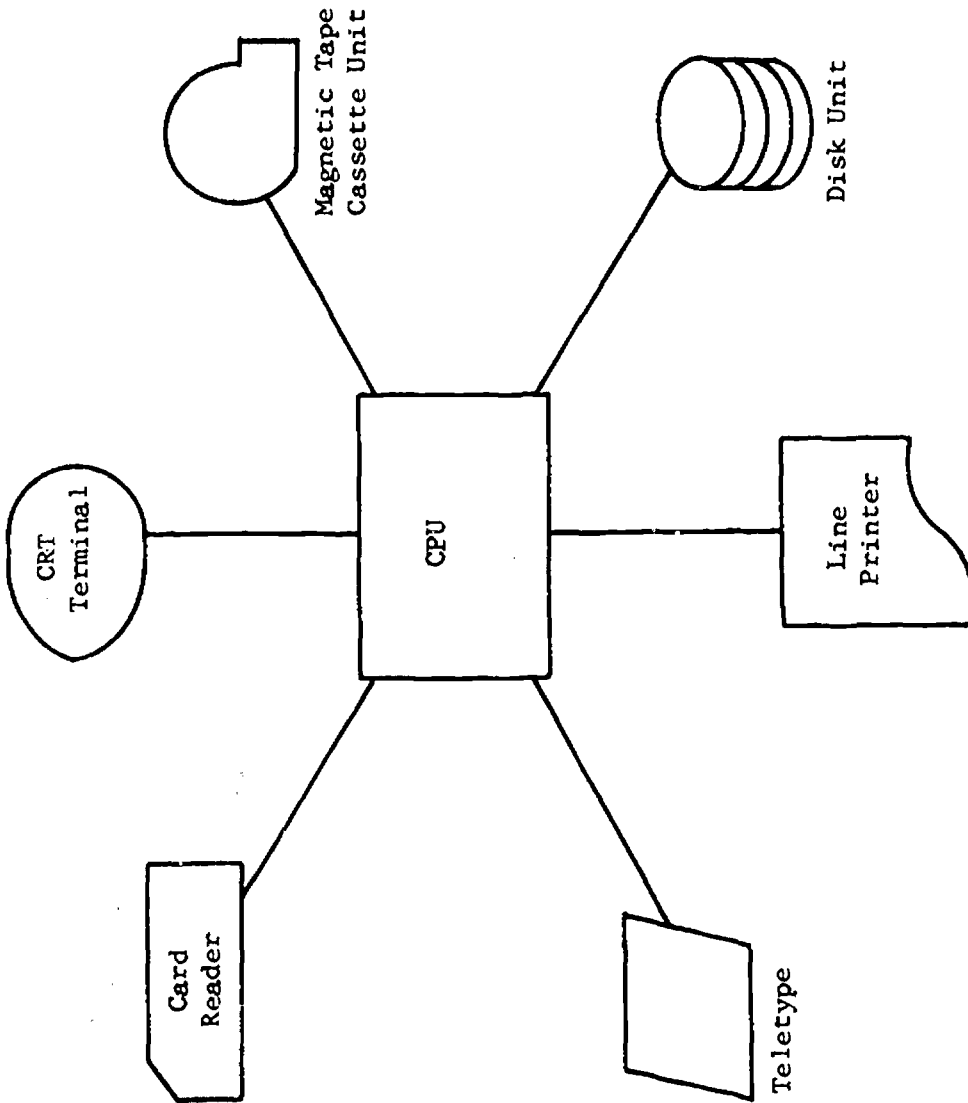

Figure 3. Minicomputer Configuration of USS DAHLGREN

TAEG REPORT NO. 14

Certain problems are encountered when minicomputers are installed aboard ship. Some of the obvious problems are system size and weight, space required for operating the system, maintenance, spare parts and logistics, and trained personnel to operate the system. A typical CMI system for shipboard use, with typical size and weight requirements, would consist of the following:

<u>Component</u>	<u>Dimensions (In Inches)</u>	<u>Weight</u>
Computer	7 x 19 x 23	50 lbs
AN-CRT	12 x 21 x 27	75 lbs
Paper Tape Reader	7 x 9 x 12	20 lbs
Disc	40 x 30 x 24	250 lbs
ASR/KSR-33	33 x 22 x 19	56 lbs

The space required will depend upon the number and configuration of study carrels and the number and type of off-line instructional media. The maintenance of a minicomputer does not impose a major problem since most are designed and constructed on a modular basis. Typical mean time between failure (MTBF) for minicomputers is 7,000 hours and current design offers software to aid in trouble shooting faults to card and often component level. Spare parts and logistics pose a minimum problem since a variety of minicomputers are now being used throughout the Navy in training devices and other uses and have been provisioned by Electronics Supply Office. The training of operational and maintenance personnel can be accomplished by existing training centers.

The above is a minimal system; additional equipment would offer advantages to students and instructors that would not be found in a less

austere environment. The exact configuration of equipment for shipboard use is extremely flexible, depending upon the requirements of the system, the design concept, and time frame of implementation.

A relatively new computer I/O technique that offers great potential as a space and weight saver for CMI shipboard operation is cassettes. The recording/storage of data on cassettes is gaining wide usage in industry. Most cassettes have the storage capability of 100,000 to 150,000 bytes per cassette. Cassettes can be used as a method of distributing CMI courses. A library of CMI courses can be stored on cassettes. When a student aboard ship registers for a course (advancement in rating, high school or college courses, etc.), a set of CMI cassettes would be provided to him along with textbooks and other off-line media. The cassettes would serve two purposes: provide the computer with data to direct the student through various stages of the course, provide tests, prescriptions, etc., and serve as a storage device for recording student data, test scores, etc. At a designated frequency or at the conclusion of a course, the student would return the course cassettes as well as the student's data cassette to the "library" for storage on the computer and subsequently data could be forwarded to interested organizations such as Naval Training Information System (NAVVIS).

A review of existing minicomputer documentation reveals that none are ruggedized. Thus, a conclusive statement cannot be made about the ability of off-the-shelf minicomputers to withstand the at-sea environment of shipboard use. Based upon a preliminary review of reliability data as compiled by various manufactureres of minicomputers, it is the opinion

of the writers that relatively few problems will be encountered in using off-the-shelf machines under normal operating conditions. As stated above, MTBF of 7,000 hours is not uncommon among off-the-shelf machines. This is achieved by the use of large and medium scale integrated circuits, design of printed circuit subassembly boards, modular construction, mechanical design, etc. In summary, it is the opinion of the writers that off-the-shelf minicomputers and their associated peripherals will prove feasible for CMI training aboard ship. The USS DAHLGREN experience will provide data to support or negate this opinion.

LANDBASED (REMOTE) USE. The use of a minicomputer in a remote location for CMI is feasible, provided sufficient floor space and power are available. The power requirements for a typical CMI configuration are 115 volts AC \pm 10 percent, 60 \pm 10 percent Hertz and less than 50 amps. The floor space requirement is extremely flexible (150 square feet and up) depending upon the equipment configuration and number of student carrels.

Providing remote sites with a CMI capability can be accomplished by either of two methods: providing a complete CMI suite at the remote site or locating the CMI hardware system elsewhere and transmitting the required information via land lines, microwave or satellite to a CMI terminal. Each method has its pros and cons. If the entire system is located at a remote site, provisions must be made for spares, equipment maintenance, and training material. If the system is located away from the remote site, CMI capabilities can be provided to other locations on a time-shared basis and some of the logistics problems will be alleviated. However, the concept of a local site will require the purchase of equipment for transmitting and receiving data from the remote site. The cost of leasing land lines is given on page

26. The decision of which method to employ should be based upon a detailed analysis including recurring yearly costs and life cycle costing.

Attack Squadron 122 is in the initial phase of using a minicomputer for CMI for A-7 aircraft crews. The initial phase (presently in final checkout) will be used for non-instructional purposes, i.e., personnel management, determining and scheduling replacement personnel, and predicting training required for replacement personnel. Although not providing instruction during this initial phase, future plans include capabilities for prescription and branching and expansion to 32 alphanumeric terminals. The minicomputer for this system is the Digital Equipment Corporation (DEC) PDP-11/45. Peripheral equipments include DEC tape, alphanumeric display, and high speed line printer.

As described in appendix C, the Army Signal Center and School at Fort Monmouth, New Jersey, is procuring a multi-minicomputer training system. The initial system purchase will consist of one or more minicomputers with 32 alphanumeric terminals and have the capability of expansion to 1,000 alphanumeric terminals. The above examples reinforce the conclusion of this investigation that CMI remote training is feasible. The above two systems though not called CMI, but rather CTS by Fort Monmouth, and Personnel Management System (PMS) by NAS Lemoore, are indeed CMI systems.

Figure 4 presents the major components of a typical minicomputer configuration for a shorebased CMI system. The number of terminals that can be driven by the minicomputer depends upon the exact configuration of the computer and the peripheral equipment of the system. In a multi-minicomputer configuration, a large number of terminals may be driven. The optical scanner allows the student to take tests off line and feed the results to

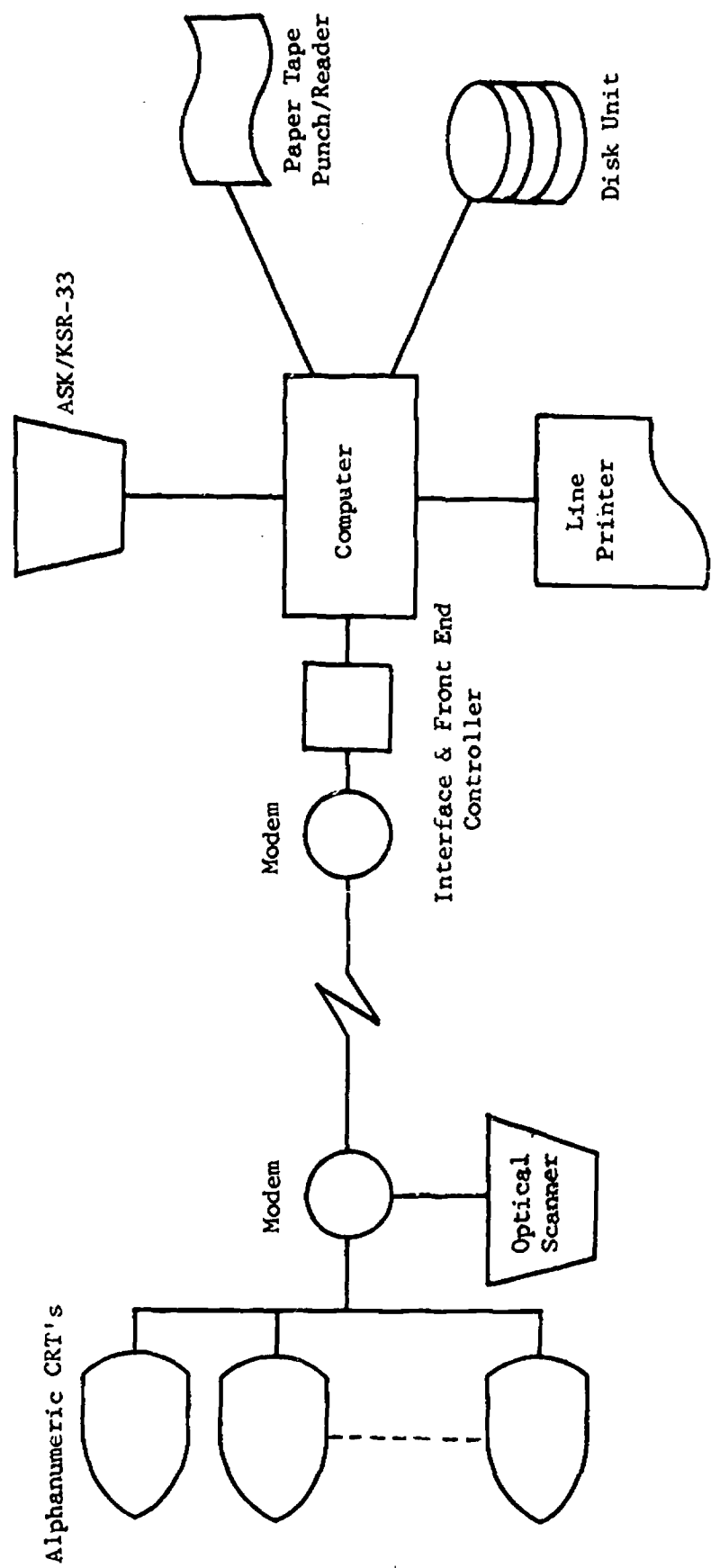

Figure 4. Typical Shorebased Minicomputer Configuration

the computer when economic constraints dictate fewer CRT terminals. The modem in this configuration is to enable the terminals and optical scanner to be remotely located from the remainder of the system. If the system and terminals are remotely located, two modems will be required, one at the computer site and the other at the terminal site. The front end controller ensures the expeditious transfer of data from the computer to the terminals and vice-versa. Also included in figure 4 is the required interface between the computer and the terminals for signal level, conversion, logic, etc. In many cases, a single minicomputer with appropriate peripheral equipment will satisfy the requirements for CMI. However, for locations that have large throughput of students, a multi-minicomputer configuration may be required. The peripheral equipment selected for this typical system includes a paper tape reader/punch, disk and a line printer. The hypothesis for this system is that programming, debugging, lessonware and other items required to produce the CMI course will have taken place earlier at another location that has all the necessary personnel, equipment and material. The paper tape reader/punch will be utilized to load the computer program into the computer and can be used to make minor changes to the program. The disk unit is utilized for mass storage thus freeing the computer from this requirement. Estimated cost for the above typical system is delineated in appendix D.

The above example can be reconfigured in several ways. Instead of an alphanumeric CRT, a teletype unit and optical scanner can be used for the student/instructor I/O. Line drivers can replace modems. The interface can be internal or external to the computer. The computer itself can be configured in almost any desired manner. The mass storage device can be

magnetic tape units, cassettes, or computer core. The paper tape punch/reader can be replaced by cassettes or a card reader/punch. A detailed system analysis must be accomplished to specify the optimum cost effective minicomputer system to meet the specific objectives desired in the computing system.

SUBSURFACE USE. The comments for surface ship and remote CMI training apply to minicomputers for subsurface CMI training. The space for CMI aboard submarines is even more restricted. However, the crew quarters or messing area can be utilized for student carrels. The location of the computer and other equipment for CMI aboard submarines will require a detailed analysis for each class submarine.

CENTRALIZED COMPUTER SYSTEM FOR COMPUTER MANAGED INSTRUCTION

The concept of one centralized computer complex for all formalized Navy training is colossal but not impossible. This concept in the civilian sector has produced a variety of results. The most widely known system in the academic sector for CAI is the Programmed Logic for Automatic Teaching Operation (PLATO) IV system of the University of Illinois at Urbana. This system was started in the late 1950's and began operation with one terminal in June 1960. Since that time, the system has expanded greatly.

The PLATO IV is controlled by a CDC 6400 computer system, a large scale general purpose computer containing one very fast central processing unit and 10 independent peripheral processing units (Stifle, et al., 1972). The central memory is augmented by an extended core storage system which provides an additional storage capacity of two million words. Additional mass storage is provided by three disk pack drives with 32 million characters each and one 75 million character disk. The system is designed to service

1,024 terminals. However, transmission limitations reduce this number to 1,008 terminals. Most of the terminals are grouped into classroom sites of up to 32 terminals each. In late 1972, 250 terminals were in operation at approximately 40 locations (15 on the University of Illinois campus and about 25 off campus). The PLATO IV system is in the process of being updated and expanded. Discussions with University of Illinois officials reveal that when the system is fully operational (all terminals on line) in December 1975, the system will have two central processor units (CDC 6500's) and eight disk drives that will greatly increase the present capability.

A large central computer center has positive and negative aspects. Due to lack of funds to support programming personnel and computers at all training activities, the CNET has recently consolidated personnel for the Naval Training Command Data Service Center (TRA NAVY, Mar 1973). One extremely important consideration in centralization versus decentralization of a system is the number of personnel required to run the system. There is no doubt that centralization tends to consolidate common job functions. However, in a CMI environment, the programmers and/or course writers need not be permanent staff once the CMI courses are developed. The personnel required in the operational environment are technicians to operate the computer. Whenever revisions or updating of courses are required, the course writers and programmers can be called upon. The required hardware for a CMI system comparable to the PLATO IV system is estimated at \$900,000 in yearly rental.

The largest life cycle cost item excluding personnel, to operate the equipment is the recurring cost of leasing the communication network. This cost alone is the major shortcoming of a centralized computer complex. The

Bell Telephone System offers a wide variety of transmission channels and equipment that meet data communication requirements for any centralized system. A single voice-grade channel can easily handle data rates of 1,200 baud, and wideband service offering the equivalent of up to 240 or more voice-grade channels is available in a single package. The interstate tariffs for leased voice-grade lines vary depending upon single or multiple channels and geographical location. The commercial rates for type 3002 leased lines with Class C2 channel conditioning, point to point, full duplex are as follows:

<u>Distance</u>	<u>Rate</u>	<u>Dollars/Month</u>
miles	\$3.30/miles/month	82.50
Next 100 miles	2.30/miles/month	172.50
Next 150 miles	1.65/miles/month	247.50
Next 250 miles	1.15/miles/month	287.50
Next 500 miles and above	.83/miles/month	415.00

Thus a network of terminals connected to a centralized computer system will have a high recurring cost, depending upon the number of terminals and their distances from the computer. A single dedicated line from San Diego, California, to Pensacola, Florida, based upon the above quotations, would cost \$2,034 monthly. Dedicated lines to most or all Navy training sites are apparently prohibitive. Alternate methods of reducing the expense of dedicated lines have their shortcomings. If a multipoint dedicated line is used, one user does not know when the line is in use or when it will be available. Inward Wide Area Telecommunications Service (WATS) with Zone 6 coverage (all states within continental U.S.) is perhaps the most economical method with a centralized computer complex. This service

costs \$1,940 per line per month. With WATS, a time-sharing system utilizing the time differential for various parts of the country could be developed for optimum number of lines. However, this method is still very costly (\$230,800 per year for 10 lines) considering the life cycle costing of the system. Continuous use of the Automatic Voice Network (AUTOVON) is unsatisfactory for transmission of data because of the heavy usage of its present customers. The cost of telecommunications equipment is relatively low. Modem and other standard peripheral equipments are available and can either be purchased or leased.

The recurring cost of leased communication lines has prompted the University of Illinois to investigate other methods of transmitting data to remote sites. The lowest cost offered by the Bell System is 60 cents/mile/month, using 240 channels. Stifle, Bitzer and Johnson (1972) state that "the communication cost for a system of the size of PLATO IV becomes prohibitive, especially over long distances." They propose educational television (ETV) channels as an alternate to land line communication. The quoted tariffs in 1972 for an ETV channel range from \$30 to approximately \$55/mile/month or less depending upon the number of channels leased and distance involved. If their system had its maximum number of users (1,800), the cost would be 5.5 cents/mile/month. This concept hypothesizes only one terminal per user, which is not the case. However, to demonstrate the feasibility of the ETV transmission technique, a digital television receiver and distributor was developed. The prototype system has been field tested using 180 mile loop with the assistance of the Illinois Bell Telephone Company and shows promising results. The University of Illinois is presently conducting experiments to ascertain the validity of using microwave

transmitters/receivers in areas with a high density of PLATO IV terminals in an attempt to further reduce cost. The rationale developed by Stifle, Bitzer and Johnson is excellent if a large number of users share the cost. Unfortunately, if the centralized computer concept is adopted by the Navy, only one customer pays the bill and the recurring cost of either method of transmitting data is high.

A system which supplies management with various reports concerning the status of students can be best accomplished by a combination of a central computer containing high level information and several small computer systems throughout the country that perform the tasks which do not exploit the system's capability. The cost of high data transmission can be alleviated by using the AUTOVON network and a polling technique during non-working hours to update both computer systems. Data can be transferred between the central data bank computer and the area computers on a daily, weekly or monthly basis, on an automatic or prearranged manual basis. The storing of high level student information can be an adjunct function of the NAVTIS system. When NAVTIS comes on line, the data transmission technique procured as part of this system can be used to communicate between the area computer and the large central system to supplement the use of the AUTOVON network. Under the area concept, one CMI complex in the San Diego area can provide training for North Island, Miramar, Fleet Training Center, Naval Training Center, Anti-Submarine Warfare School, etc., as depicted in figure 5. The physical location of the computer system would be optimized for cost effectiveness considering distances, locations of other ADP systems, personnel, etc. It is assumed that ADP systems exist in these areas and personnel already on board would be supplemented where

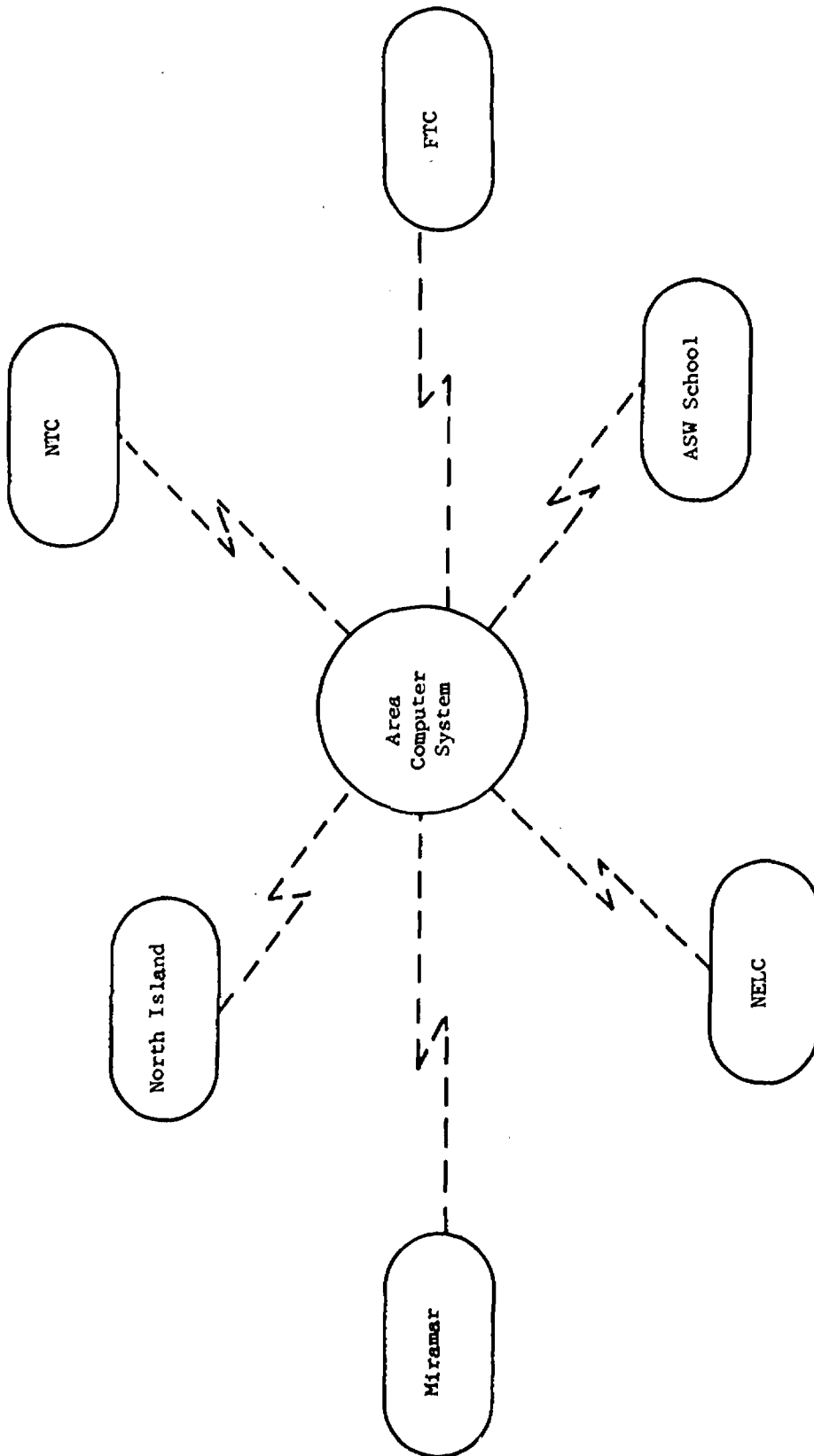

Figure 5. Area Computer System Concept

required. The terminals at each location will be connected to the area's computer via land lines. The same area concept could be employed at San Francisco, Norfolk, New London, etc., thus reducing the number of area computer sites required while minimizing the recurring cost.

Curriculum, lessonware design and programming will probably be the most expensive items of the CMI system. Two widely divergent approaches are used today for the above task. One approach is to have the course author prepare the entire course which includes curriculum design, lesson writing, programming, debug of program and running of the program. The other approach is to have a team of highly trained specialists who contribute their expertise toward the end product. Whatever the computer configuration (large central system, small remote site, combinations of large and small), it is more economical to develop and program the courses at a central location and send them to the using sites.

In summary, the concept of one large centralized computer center is feasible. However, the high cost of data transmission makes this concept a poor choice for a Navy CMI system. Therefore, the utilization of minicomputers to provide CMI on an area basis and feeding the higher level information to a large centrally located computer is recommended.

USE OF SHIPBOARD COMPUTERS FOR COMPUTER MANAGED INSTRUCTION

The use of shipboard tactical and weapon system computers for training has long been the desire of the Navy training community. However, numerous technical problems, logistical problems, and priorities, placed upon the use of the shipboard computer by higher authorities, have allowed only a small amount of training capability via computer systems to be realized aboard ship. The Naval Tactical Data System (NTDS) ships have a simulation

capability which permits simulation of the operational environment for the purpose of Combat Information Center (CIC) team training. This training is restricted to the operators of the system of concern, viz., NTDS operators, but the concept is extremely important. These computer systems have not yet been utilized as host computers for training a wide variety of knowledges and skills. Unfortunately, current weapon system computers are not configured for training personnel other than their own operators.

UNIVAC Corporation (1969), Federal Systems Division, completed a study for the Navy to determine the feasibility of using computers and their related hardware presently installed on board ships for instructional, training management, and administrative purposes. Specifically, this study was performed to determine:

- . The applicability of existing shipboard computer instructional or training management functions,
- . The modifications that would be necessary in computer hardware and/or software to make present and future installations capable of supporting shipboard training programs,
- . The operational and technical characteristics of planned future shipboard computer installations which would permit ancillary use of these systems for instructional and training administration purposes.

Although the objective of the UNIVAC study was to ascertain the feasibility of using on board computers for CAI, the findings are equally or perhaps more applicable to CMI, since most of the learning would take place

off line. The results of the UNIVAC study are contained in three volumes. Volume 1 of the study presents the findings of the data gathering phase and includes a survey of existing shipboard computer systems. Volume 2 provides an engineering plan for a system analysis approach to a computer-based training management program. It also provides an analysis of the problems associated with automatic record keeping and management of shipboard training programs. Volume 3 identifies and discusses operational and technical considerations for future Navy shipboard CAI systems. Included in Volume 3 is a section on trends in computer hardware, software, and system configuration and their possible impact on shipboard training.

The UNIVAC report presents a list (grouped by NTDS, Junior Participating Data System (JPDS), etc.) of significant computer-based systems that were aboard ships at the time of the study. Appendix E of this study updates the UNIVAC listing. The following is a composite list of the significant computer systems aboard ships as of 30 May 1973, based upon the summary activity report of the Naval Command Systems Support Activity (NAVCOSSACT) and various other documents:

- . AN/UYK-7 - 4 Ships
- . AN/UYK-5(V) -54 Ships
- . AN/USQ-1 - 3 Ships
- . AN/USQ-20 -60 Ships
- . UNIVAC 1004 - 4 Ships
- . AN/SSQ-59) - 1 Ship
- . AN/SQQ-64)

The AN/USQ-20 computer is predominately used for NTDS, while the AN/UYK-5 computer is predominately utilized for management, maintenance and

material (3M) information systems and for the supply and accounts system. Construction of DD 963, LHA, and DLGN 38 class ships will, by 1980, add an additional 24 ships to the fleet equipped with tactical computer systems. These ships, as well as the SSN 688 class submarines, will utilize the AN/UYK-7 computer. Other programs are under way to retrofit other ships with computer systems.

The application of computer systems for shipboard training is hampered by the procedures that have been established to ensure best management of each system. Additionally, current equipment configurations, space allocation, incompatibility of systems, and personal attitudes toward training and training procedures pose significant constraints upon implementation of a CMI system aboard ship. Since current operational computer equipments are not designed for CMI, their capability for CMI is very questionable. For example, a cursory analysis of the AN/UYA-4 data display console of the NTDS might lead one to believe that this console is suitable for CMI I/O. However, the AN/UYA-4 alphanumeric cathode tube has a high persistence phosphorous coating that decays slowly after the electron beam used for painting of characters is removed. Several AN/UYA-4 consoles were observed during this study to ascertain the distraction that would be encountered if the console was used for an I/O console. A number of runs were made on each console by writing a full screen and rewriting over the line and/or character that had just been removed. The decay feature is distracting, and one would not use these consoles unless nothing else was available. Other operational equipment likewise have shortcomings and would not be used.

The fundamental units that compose a CMI system are shown in figure 6. A comparison of this figure and available on board equipment reveals that there are three basic units plus lessonware that must be added to each ship to incorporate CMI. The units needed are I/O consoles (either alphanumeric or keyboards), interface between the I/O and the computer, and a mass storage unit. Although mass storage units exist aboard most ships they do not have the reserve storage that will be required if CMI is implemented. Implementation of the concept of utilizing operational computers for CMI will require additional peripheral equipment, program changes, changes to documentation, instructions, regulations, etc. The number and magnitude of changes that must be made to the operational equipment and computers to incorporate CMI is economically questioned. Technically the concept is feasible. However, the cost to retrofit operational equipment and the amount of time that could be allocated for operational equipment to be utilized for CMI without interfering with operational commitments will make the cost per student hour of training high and is not recommended.

OVERVIEW OF INSTRUCTIONAL TERMINALS

The computer utilized for CMI is of little value without an adequate I/O device for instructors and students to communicate with the computer. With the proper I/O device the computer system can diagnose, evaluate, prescribe and record training information. Unless CAI is included as an instructional media, the actual learning does not occur at the computer terminal; all or most of it is therefore conducted off line via various instructional media. The I/O device may direct the student to the instructional material. There are two basic methods by which a student is directed: batched processing and terminal oriented. In the batch processing system,

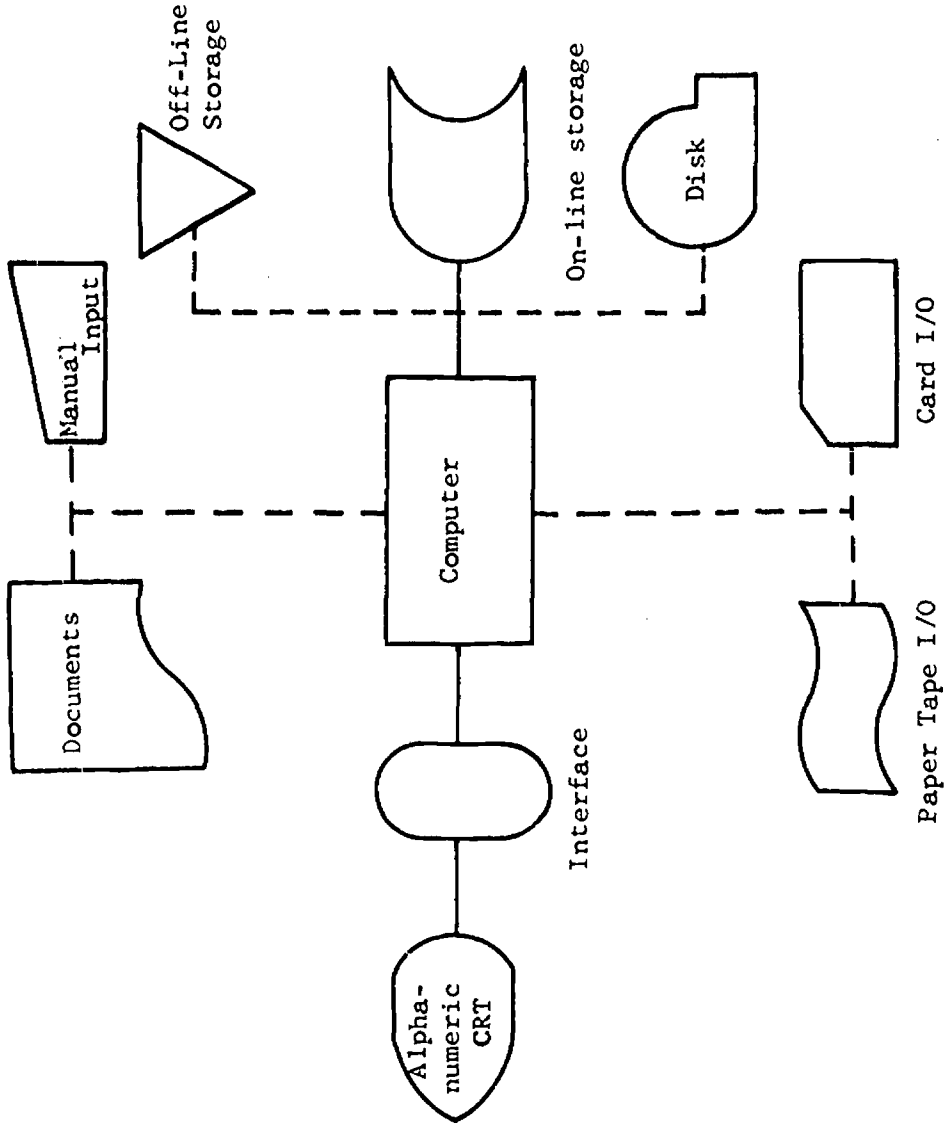

Figure 6. Typical Shipboard Computer Managed Instruction System

students are directed to learning materials based on progress information supplied by the computer to their instructor. Testing is performed in a conventional paper and pencil manner. Test answer sheets are read by optical scanners and the responses are transferred to the computer for analysis and reporting. Reports are presented to the instructor/student for evaluation. This method, which is employed by several groups including NTTC, Memphis, has its pros and cons. Positive features for this mode are cost effectiveness, the computer need not be continually on line for CMI, less storage is needed and fewer terminals are required. Negative features are length of time from submission of card until the instructor receives report (as high as 1-2 days [Brown, Hannum, and Dick, 1971]). Further, diagnostic evaluation and learning prescriptions do not take place in real time. However, the long turn around time experienced by Brown, Hannum and Dick can be reduced to minutes as will be the case in the AIS system. Terminal-oriented systems are used for real time applications and should be used where on-line testing is desirable or where enough media alternates are on line to require terminals.

Review of current literature (Brown, Hannum and Dick, 1971; Anastasio and Morgan, 1972) and discussions with representatives of industry, educators and Department of Defense (DOD) personnel indicate that the terminal-oriented systems are preferred to the batch processing system. Terminal-oriented systems are divided into two categories: CRT's and teletypes (TTY's). A basic CRT terminal includes a keyboard for data input and a display for output. Aside from the CRT itself, the primary components of the CRT terminal are a memory, a character generator, and a communications interface. The memory of a CRT is usually large enough to store one "page"

or full screen of data. The character generator accepts coded characters from the computer and keyboard and converts them to a number of dots or strokes so that the form of the character can be "printed" on the display. The most common character generator can produce 64 characters consisting of upper-case alphabets, numbers and a few special symbols. Extended character generators can produce up to 96 characters which can include any combination of special characters. The communication interface enables communications between the terminal and the computer. The CRT terminals offer a wide variety of useful features and capabilities. No one terminal has them all and some stripped-down economy ones offer very few of them. A survey of the CRT industry made as a subset of this study reveals that 98 companies in the U.S. produce CRT's. The prices start at approximately \$2,000. A typical unit to be utilized for CMI would cost approximately \$4,500 (based on January 1973 prices). Many commercially available CRT's provide adequate I/O for CMI. The major disadvantage of the CRT for CMI is that no hard copy is provided. However, this capability can be added if necessary.

Teletype as an I/O device is a misnomer since it is a trade name for a company. However, the name has been used so frequently and widely that the data processing vocabulary has adopted the word "teletype." A TTY looks and operates much like a typewriter and numerous features, e.g., RD (printer only), KSR (keyboard/printer), ASR (keyboard/printer/paper tape panel), magnetic tape, tape reader, etc., can be procured. The TTY has a standard 4-row typewriter-like keyboard for transmitting data to a computer, and, depending upon the model and type, any of the 128 characters including upper

and lower case alphabets, numerics, special symbols and control codes can be purchased. The majority of printers of typical TTY's have a printing range of 10-20 characters per second. Price range for a typical TTY-KSR varies from \$1,000 to \$6,800. The major disadvantage of TTY's for CMI is noise, and some experience relatively short MTBF. In 1970 the noise problem was overcome by at least one manufacturer, and others are pursuing the problem at the present.

Brown, Hannum and Dick (1971) examined the effect of two different terminal devices (CRT and TTY) on both performance and time required to complete a graduate course offered via interactive CMI. Primary indices of student performance were: (a) student scores on a criterion-referenced test of the major objectives involved in the course, (b) instructor rating of student progress, and (c) time spent at the CMI terminal. Subjects were randomly assigned to either CRT or TTY terminals. The study states, "Both groups performed equally well on the test over the concepts involved in the course. The CRT group had superior scores on the course project and spent less time actually working at a terminal."

In addition to the primary indices, several others were used in the course of the investigation. The more important ones were performance error rate on the terminal, the number of objectives in which criterion performance was not initially reached, and computer cost per student. There were no significant differences between the two groups for test errors and tasks on which criterion performance was not reached on first attempt. However, the computer cost per student was \$14.48 for the CRT group versus \$19.58 for the TTY group, a substantial differential.

Although the authors do not unequivocally state a preference for one terminal over the other, certain points are worth noting. The CMI courses that are project oriented have superior results in student scores and require less time. Since less time is required, computer cost is reduced, more students could finish a course in less time and with fewer CRT's than could be accomplished by using TTY's. Educators believe students prefer CRT's. It is recommended that CRT's be utilized as the terminal I/O device for Navy CMI courses whenever throughput of students makes it economically feasible.

OVERVIEW OF COMPUTER ASSISTED INSTRUCTION COMPUTER LANGUAGES USED BY THE NAVY

Computer programming languages for CAI are discussed in this report because CAI is a subset of CMI and because of the similarity of CMI and CAI with respect to on-line testing, diagnostics, prescription and record keeping. Computer programming languages for CAI traditionally have been divided into four basic categories. Various authors use different names for each type. Zinn (1969) classified the languages according to a mixture of author and student point of view: (a) presentation of successive frames or items, (b) conversation within a limited context, (c) presentation of a curriculum file by standard procedure, and (d) data analysis and revision of material. Walker (1970) used four categories: (a) general purpose languages, (b) extended existing problem languages, (c) interactive terminal problem languages, and (d) author-student problem-oriented languages. Frye (1968) classified languages from an operational point of view as follows: (a) conventional compiler languages, (b) adapted conventional compiler,

(c) interactive computing and display, and (d) author languages. Each of the above authors' subgroupings depicted the computer language according to their particular definition. However, an analysis of the languages contained within each category strongly suggests that regardless of the category titles used, each author used the same basic premises for language grouping. This points out the difficulties encountered in comparative studies of programming languages.

There are more than 65 different computer languages used for CAI. Each of these was designed to make it easy for the instructor/writer to program curricula. This caused a proliferation of languages by computer manufacturers and software houses. A general-purpose programming language that would incorporate all the features desired in a CAI system has been the dream of several authors. However, other authors, e.g., Anastasio and Morgan (1972) state that the emphasis placed on the development of "better" author languages is decreasing. The team approach, using subject matter specialists and experienced programmers, is favored over a better language because it gives the course designer much more flexibility with instructional strategy and techniques. A study conducted by Anastasio and Morgan (1972) reveals that educators and hardware/software specialists consider a new and more appropriate CAI programming language relatively unimportant.

A fundamental problem of CAI and CMI is the choice of computer language. A standardized computer language for CMI is needed. The Navy cannot afford round after round of development of computer languages. Kopstein and Seidel (1967) estimated that the development of one generation of CAI language required an effort of 20 man-years. Based upon current rates, the cost of

developing a CMI language would exceed \$800,000. Sufficient languages are now available for CMI. What is needed are performance and capability standards for these languages. The Programming Language Summary Listing IL-1 (NAVCOSSACT, 1972) reveals that 23 separate languages are used throughout the Navy. These languages are listed below with the number of activities that use them for either their primary or secondary language.

	<u>PRIMARY</u>	<u>SECONDARY</u>
ALGOL	3	3
COBOL	150	85
FORTTRAN	155	147
NELIAC	21	22
JOVIAL	5	1
PL/1	1	5
APL	2	0
BASIC	12	10
CONVER-FORTRAN	0	2
INTERACT LANG	1	4
CS-1	74	15
CMS-2	11	24
APT	0	1
SPECIAL PURPOSE LANG	27	20
REALCOM	0	2
NTPS	3	0
RPG	26	8
STND ASSEMBLER	300	101
SPEC ASSEMBLER	18	7
ASSEMBLER ON SGD	78	21
WRD-PLGBD-PROG	36	0
MACHINE CODE	48	39
PROG TRAINING	17	3

A survey of several activities involved with CMI was made in the data gathering phase of this study. The following is a list of languages in use:

<u>LOCATION</u>	<u>LANGUAGE</u>
VF 124, NAS Miramar, CA	COBOL (80 percent) and AFLD (20 percent)
VA 122, NAS Lemoore, CA	BASIC
NTIC, NAS Memphis, TN	COBOL
NYIT, Old Westbury, NY	BASIC
USAF, Denver, CO	CAMIL
U.S. Army, Fort Monmouth, NJ	Class I

Numerous languages will not run on a computer unless a compiler is part of the system. An example of two programs essentially performing the same function but using different languages without deriving the benefits of the other are the VA-122 and VF-124 squadrons. Each of these organizations seeks the same management results in scheduling and data collection, yet, for various reasons, e.g. available computers and time, each has gone its separate way writing expensive programs that are of no use to the other. Fighter Squadron 124 and its contractor did take advantage of existing programs developed by the Air Force thus saving at least 20 percent of the cost.

It is recommended that a committee be established to analyze the available languages and to determine standards for Navy use. An analysis of the major computer manufacturers reveals all have COBOL and FORTRAN compilers and at least 90 percent of them have BASIC compilers. It is suggested that a desk be established to ensure that the chosen languages are used throughout the Navy.

RATIONALE AND CRITERIA FOR COMPUTER MANAGED INSTRUCTION COURSE SELECTION

The 13 Navy Formal Schools catalogs (A-N) list over 4,000 formal courses that are conducted by the Navy in the continental U.S. and Hawaii. The length of these courses varies from four hours (Night Vision Equipment Familiarization) to 52 weeks (Advanced ASW System Technology); the convening dates vary from once each week to once per year; and the number of students attending varies from 10 to over 7,000. Realizing that it is neither desired nor economically feasible to convert all courses to CMI, a set of criteria was developed to select course candidates for CMI as follows:

- a. Student throughput
- b. Size of class
- c. Frequency of course
- d. Length of course
- e. Subject matter
- f. Mental group of students (category I, II, III or IV)
- g. Stability of training material
- h. Scheduling of subsequent courses
- i. Number of courses at a school/location
- j. Previous knowledge/training of student
- k. Level of training -- basic, advanced or refresher

Each of the above criteria was analyzed to ascertain if the item should be considered as a selection criterion for potential CMI courses.

The throughput of students is extremely important in considering cost of student per hour per day. One of the major benefits of CMI is the management of large numbers of students in a more efficient manner. The smaller the throughput, the less efficient is CMI.

Size of class relates to throughput but can be considered as an independent variable. Size of class affects queuing of students to equipment and the number of instructors that must be available for monitoring and assistance. Size of class is important for "fine tuning" of a CMI course but is not considered essential.

Frequency of a course contributes to the overall throughput but functions independently. The length of a course is important for several aspects. The CMI systems presently being procured at Fort Monmouth and Lowry are expected to produce a 25 percent reduction in training time; other

predictions for reduction in training time range from 33 to 50 percent. Using a conservative estimate of 33 percent reduction, a three week course can be reduced to two weeks. If travel from duty station to course location is involved, a student can travel on weekends without a break in the work week. A review of the Naval Technical Training Command Basic Level Training Data reveals that fewer than 10 percent of the courses conducted by the Navy are less than three weeks in length. Thus, for this study, courses of less than three weeks were not considered.

In considering CMI for a course, the subject matter plays a minor role. It is true that certain courses are more readily adaptable to CMI than others, i.e., basic electronics has been chosen by the Army, Navy, Air Force and the Marine Corps as the prototype course for CAI and now is being used for CMI. However, Ford and Chesler (1973) have chosen Damage Control as the prototype course for CMI, utilizing a minicomputer system aboard the USS DAHLGREN. Although some subjects are easier to place in CMI format, it is safe to say that if a course is given by a conventional lecture, it can be converted to CMI. Thus subject matter is not an initial item of concern.

The mental group of students definitely is a factor in any class. For the purpose of this analysis it was hypothesized that all courses would have a range of mental groups and that different media would be available and selected on an individual basis for each student. This means all courses would require management (direction) of students through the course. Irrespective of mental grouping, CMI can be used for scheduling, data keeping and prediction of course completion. Thus mental group was not considered as an essential criterion for selection of courses for CMI.

The stability of the training material is important to a CMI system. If course content changes frequently or substantially, the course becomes obsolete in a short time and should not be considered for CMI. All courses change, yet the courses that are taught in the Navy schools are reasonably stable (content change is less than 10-12 percent per year). It would seem, therefore, that all courses in the Navy Formal Schools Catalogs are CMI candidates.

Some students attend two or more courses in sequence to obtain a set of related skills. In the lock-step method everyone graduates at the same time. In the individualized self-paced modes of Programmed Instruction (PI), CAI and CMI, an individual is sometimes penalized for completing a course early. Since orders are not flexible or ready, the student in many cases is forced to do odd jobs (clean-up detail, etc) while awaiting orders. The CMI system must encompass scheduling and assignments so that such negative reinforcement is minimized. Scheduling of subsequent courses is important if the system is being implemented but is not important to this study.

The number of courses at a school or particular geographic location is important in considering the optimal hardware configuration. Courses that would not be economically feasible for CMI by themselves may be feasible as a group of courses. A grouping of courses by geographical location is presented in appendix G of this report. Since the majority of the courses offered by the Navy are offered in less than 10 locations, consideration for number of courses can be eliminated as an initial criterion.

Prior knowledge or training can impede or accelerate the completion

of a course. With self-paced individualized techniques of CMI, both the student and the Navy will benefit. Utilizing pretest and branching procedures, it is anticipated that only a small percentage of students will proceed directly from pretest to final testing. Students lacking previous knowledge or training on course material will not be penalized by CMI but will proceed at their own pace. It is believed, therefore, that prior knowledge or training is not an important criterion for converting a course to CMI.

Level of training was considered from three aspects: basic, advanced and refresher. To date, CMI has been associated primarily with basic training. However, the scheduling, data collection and retention characteristics of CMI are now being utilized for advanced and refresher training. Thus it would seem that level of training is not a critical criterion for CMI conversion.

All factors in the foregoing paragraphs are important when deciding if a course should be converted to CMI. The minimum essential criteria for converting a course to CMI in the opinion of the writers are student throughput, frequency of course, and length of course. Limits established for these criteria were throughput ≥ 200 students per year, frequency of course convening ≥ 12 times per year, and course length \geq three weeks. A sample survey of 100 Navy courses indicates an average class size of 16.6 students per class. An analysis of over 1,000 courses reveals that more than 92 percent of the courses convene 12 times or more each year. Thus class size (16.6) multiplied by 12 starts per year equals a throughput of approximately 200 students per year. As stated previously less than 10 percent of Navy courses are less than three weeks in length. Therefore, for this study courses greater than or equal to three weeks in length were chosen as a base line.

Appendix F lists those courses from the Navy Formal Schools Catalogs that have a throughput greater than 1,000 but less than 2,000 and greater than 2,000 and meet the other minimum criteria. As can be seen from this list, only 18 courses have a throughput greater than 2,000 students per year. Based upon cost per student hour, these courses offer the greatest potential savings. The section of appendix F that lists throughput $\geq 2,000$ identifies three of the seven courses that the NTTC has selected for conversion to CMI during FY's 74, 75 and 76. The other four NTTC courses are in the category of 200-1000 throughput.

A review of the descriptions in the Navy Formal Schools Catalogs for courses with a throughput greater than 2,000 was made. The two Basic Electricity and Electronics courses are self-paced but could benefit from CMI for record keeping, scheduling, and testing. Three courses, Avionics Technician, Aviation Machinists Mate, and Aviation Structural Mechanic, are scheduled for conversion to CMI by NTTC. Based upon the minimum essential criteria, the Boiler Technician Class A, Machinists Mate Class A, Nuclear Power, and Basic Enlisted Submarine Courses offer the greatest potential for pilot CMI conversion.

A similar review was made of courses with a throughput of 1,000 to 2,000 students. The Aviation Structural Mechanic (H) course has been selected by NTTC for conversion to CMI in FY 75. The Damage Control Courses at Treasure Island and Philadelphia will benefit from the CMI work to be conducted on the USS DAHLGREN. It should be very easy to convert from a shipboard General Damage Control CMI course to a shorebased course. The remaining courses that seem appropriate for CMI conversion are Electronics

Technician A1 and A2, Fire Control Technician, Interior Communications Electrician, Electricians Mate, and Enlisted Submarine Indoctrination. The Electronics Technician and Electricians Mate courses are excellent pilot program CMI candidates since their combined location throughput is high and the material developed can be used at two sites.

COST OF COMPUTER MANAGED INSTRUCTION

The cost estimating for a CMI system encompasses five areas: (a) purchase or rental of the computer hardware and peripherals, (b) maintenance and spare parts, (c) software (all CMI-related computer programming), (d) curriculum design, and (e) administrative overhead cost. The cost per student hour for a CMI course is the summation of the above costs divided by the number of students enrolled in the course. An outstanding feature of CMI is that once the course has been developed, the recurring costs are maintenance, spare parts, updating lessonware, and the administrative cost of keeping the system on line plus periodic update of the programs.

The analysis of hardware cost is complex. What hardware costs should be considered? Should the analysis include only those equipments on the market today, the near future or the distant future? The state of the art is advancing so rapidly that it is difficult to predict what will be available two years hence. In the past few years, medium and large scale integrated (MSI and LSI) circuits have completely revolutionized the computer industry. Even as this study was being conducted microcomputers were handling tasks formerly conducted by larger machines. The cycle time and data grabbing power of the IBM 360/30 will be duplicated by the end of 1973 by a microcomputer that is smaller than a sugar cube, and has the market capability by 1975 to be available for \$100 (Wiener, 1973).

Forecasts indicate that by the end of 1973, 100,000 minicomputers will be in use. In 1973 alone over 45,000 were shipped to customers (National Electronics Conference, Sep 1973). Thus to predict the cost and state of the art of future systems is beyond the scope of this study.

Utilizing machines available today, CMI hardware costs can be divided into three major categories: data storage, central processing unit (CPU) and communications equipment. The data storage hardware includes disks, drums, tapes and other means for storing information. The CPU and its executive program receives and transmits new information to storage or a terminal. Communications equipment is that equipment required for the student or operator personnel to communicate with the computer. If data are transmitted at appreciable distances, a data transmission fee should be included in hardware cost. The cost of data transmission was presented previously on page 26 of this section. The cost of a representative minicomputer configuration and a large system configuration is presented in appendix D. These costs are only for the equipment described. It should be noted that the price includes only one alphanumeric terminal and that the system is a minimum configuration. The costs of the equipment in this price list are typical and the published rates do not include Original Equipment Manufacture (OEM) or other discounts that may be available. The prices that other manufacturers offer may be higher or lower.

The maintenance and spare parts costs of different systems are extremely varied. Some manufacturers include maintenance courses for procuring activity, on-call field engineering services and initial spare parts as part of the system cost. Other manufacturers price out each task or item as an end product.

The cost of computer programming may be considered from two points of view. First, if an existing computer language is used, a revision or expansion of the high level language chosen may be required. If an existing language is not used, the cost of developing a new language will be approximately \$800,000 as discussed previously on page 41 of this report. Second is the type of computer programming cost associated with the cost of actual course programming. The estimated cost of computer programming can be based upon the number of computer instructions required for a task. An accepted rule of thumb is one instruction per hour when writing an executive program. Programs involving use of data or tables are faster to complete, and a rate of 4-10 instructions per hour is considered normal. This estimate includes all related functions from the initial effort through debug and running of the program plus required documentation. The cost per hour for commercial programming is estimated to be \$21 per hour. This cost represents a base salary of \$8.25 per hour, an overhead rate of 100 percent, general and administrative costs of 15 percent, and a profit of 10 percent. Another method of cost estimating is that used at Fort Monmouth based upon their experience with their CAI system. Using the individualized approach, they estimate it takes 250 hours of development for each hour of CRT instruction. The initial 250 hours decreases to approximately 150 hours per instruction hour after the course designer becomes proficient.

The administrative cost can be considered to be that cost associated with the management of formulating an entire CMI course or the cost of incorporating only administrative data into the CMI system. The administrative cost of an entire CMI system can be extremely costly for a large system. However the cost of inserting administrative data requirements

is small when compared to the overall cost of a CMI system. As with all costs associated with a CMI system, administrative cost has a linear relationship to the length and complexity of the course(s).

COURSE DENSITY

An analysis of the number of courses offered at various military bases is presented in appendix G. Areas in close proximity were grouped (e.g. Miramar and North Island under San Diego and Oceana and Little Creek under Norfolk) for several reasons: some NEC's require completion of a sequence of courses; several courses can time share one computer; lowest recurring cost for data transmission; and flexibility for user to make minor course content changes. The areas having the greatest concentration of courses are San Diego, Norfolk, New London, and San Francisco. These locations all have a wide range of schools (A, B, and C) and are excellent candidates for a pilot program. Several courses conducted for the Navy by other services are included in the overall list. The total number of courses listed in appendix G is 3,225. The disparity between this number and the 4,000 plus courses offered by the Navy is due to the time constraint of this study, during which all course locations could not be determined.

COURSE PREPARATION: CONTRACTOR OR LOCAL EFFORT

The AIS to be installed at Lowry AFB, Colorado (appendix C), is now under contract and is possibly the most extensive and costly computerized training effort in the world. The contractor (McDonnell Douglas) will develop a complete training package. The Marine Corps has awarded a contract to Philco-Ford to develop complete training packages for 30 courses at Twentynine Palms. It is estimated that at least 87 percent of this effort will be conventional classroom lecture/demonstration. The remainder

of the courses may include CAI but not CMI. The cost of a complete CMI package as compared to the cost of conventional instruction is apparent in these two contracts. The Air Force's CMI venture will cost approximately \$9.5 million for three courses. The Marine Corps' venture will cost approximately \$3.5 million for their 30 courses. Contractor curriculum development efforts for CAI, Conventional Instruction (CI), and CMI have not always met with great success. At NAS Miramar, the courses originally prepared by a contractor had to be scrapped and rewritten by Navy personnel using a new task analysis. At Fort Monmouth, after the initial start by the contractor, the CAI courses were prepared by military subject matter experts. The six-week CAI Radio Fundamentals Course at Twentynine Palms is being prepared by military personnel after attending a two-week programming course given by a contractor. The contractor is retained as a service technician for the computer programming. It will be of interest to compare the Marine Corps training improvement plan effort with the Air Force AIS effort, upon completion of both programs, for training and cost effectiveness.

COMPUTERIZATION OF PROGRAMMED INSTRUCTION

If a course is already self-paced, non-computerized PI, computerization of the course may not be worth the additional expense. The U.S. Naval Academy's (1972) Final Report on the Naval Academy's CAI Research Project states, "The use of a dedicated computer system similar to the IBM 1500 for noncomputational techniques (e.g., tutorial, drill, testing) is extremely expensive and with the present state of the art of CAI, it is evident that there are many alternative ways of providing the same teaching effectiveness at a lower operational cost, such as special PI (Programmed Instruction) texts."

This report recommends that if CAI is used, "the system must be capable not only of providing instruction, but of managing data on student performance."

It has been estimated that the Basic Electricity and Electronics Course at San Diego required 14 man-years to convert from traditional instruction (TI) to PI (now called instructor managed instruction (IMI)) and involves no computerization. Since this course is self-paced and is shorter, additional costs for converting to CMI may not be warranted. A very careful cost analysis should precede conversion of a PI course to CMI.

It may or may not be pedagogically advantageous to convert from PI to CAI but conversion from PI to CMI for diagnostics, testing, prescriptives and record keeping is both pedagogically and economically advantageous. A further look at the self-paced Basic Electricity and Electronics School, San Diego, indicates that course length is reduced by an average of one-third and an instructor can monitor five students per week versus approximately three and one-half for conventional instruction. Earlier graduation saves money and hastens the student's arrival to his fleet job.

A cost study at the IBM Training Center, Lexington, Kentucky, (Wong 1973), could not justify the cost of computerization of a machine maintenance course that was originally a traditional course. The course was self-paced due to anticipated growth in equipment and its accompanying increase in maintenance personnel. Previously, the course was centralized at Lexington, but the staff would have been too big under TI to centralize the expansion so a PI package was developed for use at Lexington as well as being sent to the field to save on student travel and administration. Even if PI costs as much as the traditional course, the money

was considered by IBM to be well spent since the PI is measurable, available in the field, and modular for easy revision. The original course was shortened 10 to 20 percent by PI and although the number of instructors remained the same, they required less training in teaching skills and acted more as monitors for the students. The monitors require no formal instructor training in the traditional sense, but are taught necessary monitoring skills by a PI package developed for that purpose. The PI course at IBM is an excellent example of a systems engineered, non-computerized course, using excellent textbooks, carefully illustrated, synchronized with audio and routinely updated.

The lesson suggested by this IBM PI course was reinforced at other activities: if a course has already effectively been put under PI, further cost savings may not always be gained by converting to CAI or CMI. For a profit motivated activity this is a key factor; for a military activity other factors may have more weight than profit.

COURSE MATERIAL THAT CAN BE TAUGHT BY COMPUTER MANAGED INSTRUCTION

The trend in the military for both CMI and CAI has been to begin with basic programs that are comparatively less complex and have a large throughput, e.g., Basic Electronics at Fort Monmouth (CAI), Aviation Fundamentals at NATTC, Memphis (CMI), and Basic Radio at Twentynine Palms (CAI). This appears to be a logical way for administrators to break into something new and difficult. Once prototype courses are proven, expansion moves to broader subject areas, e.g., all 30 courses at Twentynine Palms (modified) CMI; Damage Control aboard the USS DAHLGREN (CMI); Precision Measuring Equipment at Lowry AFB (CMI); Space and Shuttle Technology at NASA (CMI). Academic institutions have computerized both simple and complex knowledge

and skills areas. The amount of money available to start the program, the administrators who make the course selection, the salesmanship of contractors, and the division of effort between contractor and local personnel all have an effect on the course matter selected.

EFFECT OF SELF PACING ON STUDENT PROGRESSION

All so-called military CMI programs have the potential for student self pacing, but few have actually accomplished it to the extent that a student can truly progress, move rapidly on to the next course or unit instruction, and eventually progress to his job assignment. For a student to complete a course ahead of his fellow students and then be rewarded by assignment to kitchen police or other details, is not an incentive. This undesirable situation may be unavoidable during development of a CMI program, unless all successive units of instruction and follow-on courses are implemented en masse, which isn't likely. For example, Twenty-nine Palms is computerizing the last week of the six week (CAI) course first so that the fast student can progress to later instruction without waiting; but the fast student still has to wait for the slow ones during the early weeks.

The administrative problems in the Navy of allowing students to pace themselves and to leave the activity at individual times are tremendous and could only be handled by a complete revamping of all scheduling, courses, records, exams, and assignments plus the preparation of the computer programs. Even then, the F-14 program at NAS Miramar, where extensive computerized record keeping and scheduling is the goal, has made no effort as yet to self-pace instruction. Since it is not self paced and prescriptive, it is not

truly CMI. Diagnostic tests at a NAS Miramar computer course identify a student with poor digital subject matter fundamentals and allow him to select a special self-study carrel on the side. This does not delay his regular course nor shorten its length and is not truly self paced or CMI.

The Damage Control CMI Course to be developed for the USS DAHLGREN is self paced and will average about 25 hours of off-line instruction.

Self-paced learning is advantageous to the Navy in that average course length is shortened, the number of failures is reduced, fewer instructors are needed, and the maximum pipeline to the Fleet is shortened. Each of these reductions cuts costs. To the students, self pacing means a greater personal satisfaction with the training process and fewer failures.

DESIGN FOR MEDIA, BRANCHING AND QUEUING IN COMPUTER MANAGED INSTRUCTION

In CMI, the prescription of learning media can become complicated if the media are not available in sufficient quantities. The number of media units needed is determined by many factors such as class size, branching technique, intelligence level of students, and attrition rate. Some work is being done in media selection. Wildberger's (undated) approach predicts probability of media availability using the variables of class size, mental level, alternate media, and past performance. Wildberger's work involves a computer simulation of self-paced instruction in parallel with a real-life course as a management tool used to generate feasibility schedules, bounds of operability, estimated module completion times, and student throughputs. The simulation aids in the future planning and design of individualized instruction courses.

EFFECT OF COMPUTERIZED INSTRUCTION ON ATTRITION AND ACHIEVEMENT

No evidence was obtained specifically concerning the effect of CMI on

attrition. But, if CAI is any indication, one Fort Monmouth study (Longo, 1972) indicates that in a CAI course there was no significant difference in the attrition rate of students when compared to a traditional class. However, the CAI failures were identified earlier and those that were salvageable could presumably start the retraining process earlier. The implication is that a given student who might have failed the traditional course due to lack of early detection, can now be more often saved by retraining. The assumption is that early detection is an aid in salvaging failures. Intuitively, it is possible that failures are identified early due (in part) to the poor students being affected or frightened by the computer gadgetry, but more likely show up due to the close monitoring by the instructor of students in trouble, a feature of the system.

There is also evidence (Longo, 1972) that in CAI, student achievement is not better, it is just achieved more readily than with TI. This is possibly true for CMI also and conversely this means greater achievement in the same training time.

The NATTC, Memphis, CMI courses (AFAM/AMFU) yield a computer run-off of students in trouble and also allow early detection of failures with the potential of starting retraining sooner.

GRADING COMPUTER MANAGED INSTRUCTION

Problems of grading are inherent in self-paced instruction. How is rank (class standing) determined when some students achieve a high score on the first test and some require three retests, plus special instructor assistance, and more time to achieve the same high score? If a student's grade is a factor in determining his next assignment, then the time it took to complete the course should be a factor in final grading. Otherwise, what is the reward for the bright student who finished first?

The student who has been exposed to the subject matter prior to the course, may be more proficient than the student who is exposed for the first time, and will complete the course more rapidly. In this case, if a pre-test does not identify the informed student, he competes unfairly against the others. Pretesting should always be included in a CMI design.

A common grading method in academic institutions using CMI/CAI or PI is to grade A, B, or fail. The instructor identifies the failing or B student early in the course and devotes more attention to him. By comparison with the old TI course, a student who might have been satisfied with a C or a D grade is now picked up by his CMI/PI instructor early enough to be helped to a B.

An elaborate system of computerizing examinations is in operation at Pepperdine University, California (Dudley, 1973). It maintains records of the number of times a student takes a test or asks for help, and it accumulates data for item analyses. In the Ohio State University CMI Model (Ohio State University, undated), grades would not be assigned at all if the administrative requirements of the institution could be disregarded. This model allows a student to pick his own grade; that is, he may settle for a C or work for a B or A. For example, if he correctly answers the C level test items or the B level test items, he is given the appropriate grade. The final recorded transcript shows only grades, not how many hours of instruction were required. Several institutions have experimented with the non-grade course, and the Navy certainly has subject matter areas where pass/fail only is required. Memphis does not show class standing of graduates in the CMI effort, but they are graded for the permanent record.

THE NEW (CMI) INSTRUCTOR

Most instructors in military CMI/CAI programs are graduates of various instructor training schools. Is formal instructor training as we now know it necessary for a CMI instructor? Probably not. The instructor training school, which emphasizes platform instruction, may eliminate men excellently suited for CMI teaching. Everyone remembers the Navy instructor who "really knew the subject" but "couldn't teach it." These persons may be excellent for monitoring (managing, administering) self-paced instruction. Only a relatively short indoctrination is needed and they can oversee numerous subordinates in the field using a packaged course and standing by as the expert technician when the branching directs the student to the instructor/monitor.

Instructor training schools will be around as long as there is classroom instruction, but CMI monitors will make inroads to match the pace of CMI/CAI implementation.

Any technically competent person can become a CMI instructor. The instructor/monitor will continue to play an important role as instruction progresses toward CMI -- especially for the slower students.

THE NEW (CMI) STUDENT

Just as the instructor role will change in a CMI environment, so will the student role. The training institution of hundreds of students lock-stepped in classroom lecture situations may change -- very gradually -- to busy shops with students alternately working on equipment, sitting at computer terminals, operating sound slide projectors, reading printed texts, and discussing problems individually or in groups with the class monitor. The monitor will still assemble groups to explain things of general interest, but

the student will not feel in a panic in a truly self paced CMI situation. He will often go to his monitor for guidance willingly and with a real motivation.

This, in turn, will call for instructor supervisors with a different orientation. If the instructor and student roles change so drastically, the supervisor must change also. He can no longer sit at the back of a classroom and observe a lecture/demonstration in order to evaluate the instructor; he will mingle with the students.

STUDENT PROCRASTINATION AS A FACTOR IN COMPUTER MANAGED INSTRUCTION

There is some evidence that if a computerized course is designed with too much freedom in self pacing and with too much time allowed to complete the course without penalty, the students tend to procrastinate. However, with CMI the instructor is more aware of procrastinators. Realistic goals and time limits must be engineered into a CMI course and provisions made to adjust the time limits to suit the student variations (Matson, 1973).

In Navy schools, the shortage of students for given specialties will influence allowable time limits for CMI courses. With a high enlistment rate, there may be less need to salvage failing students. Yet, this salvaging of the slow student is one of the prime benefits of self pacing. The top student will pass almost any kind of course with almost any kind of instructor.

Navy CMI programs will require flexibility of design to allow for the procrastination loophole inherent in self pacing and for changing student quotas and rate requirements. Shipboard courses can afford greater leniency since *follow-on* courses are not waiting for student enrollment. If, for example, the shipboard CMI course is one that all are required to pass, more leniency could be allowed if it took a month instead of a week to complete it.

COMPUTER MANAGED INSTRUCTION AND THE PERSONNEL QUALIFICATION STANDARDS

If the Personnel Qualification Standards (PQS) become established in the Navy as an advancement in rating requirement, the adaptability of PQS to computer management becomes more attractive. The PQS is in essence a detailed task description. Its format lends itself to computer storage and recording of the trainees programs, recording of performance on each phase, and direction to appropriate off-line texts, references, media, and equipment. Since the PQS is the Navy-wide basis for a given rate advancement (based on NAVPERS 18068C Manual of Qualifications for Advancement) the CMI program tied to PQS will be eventually adopted -- whenever those charged with the administration of PQS recognize its tie-in advantages.

The PQS concept is inherently a self-paced concept, or as NAVPERS 94100A-2, Handbook on Personnel Qualification Standards, Implementation Procedures Aboard Ships, states, "It (PQS) individualizes learning so that each man will be able to proceed at his own pace. It places the responsibility for learning squarely on the shoulders of the learner, and encourages self-achievement. By providing a convenient record of accomplishment, it provides a means whereby his supervisors can check his speed and the manner of performance." This is an excellent statement of a self-paced course. It is self paced, but not programmed. If the PQS has already been written on a subject, CMI can conceivably pick up the record keeping; if not written, it can be written and tied to CMI in all aspects of branching, direction to media, and record keeping.

The use of CMI to manage PQS is highly speculative, but is an attractive concept. It should be studied further.

SECTION IV

63A

SECTION IV

CONCLUSIONS

CMI is expensive. Whether it is cost effective or not - and it may not be vis-a-vis traditional instruction - there is no alternative for the Navy but to go to CMI if any significant number of its over 4,000 courses are to become self paced and individualized (which is the trend of current educational technology).

The objective of this investigation was to investigate the feasibility of CMI in three areas: namely, (a) a large-scale centralized computer system for all formalized Navy training, (b) minicomputers for small, remote classes, and (c) use of shipboard computers for managing individual training on ships.

The concept of a large-scale centralized computer system for formalized Navy training is colossal. A review of the Navy Formal Schools Catalogs reveals that in excess of 4,000 courses are conducted by the Navy. It is impractical to consider managing many of these courses without the aid of computers. There are only 18 courses that have a throughput of over 2,000 students per year and only 174 courses that have a throughput of over 200 students per year. Information obtained during this study reveals that the Air Force is converting three courses to CMI at a cost of approximately \$9.5 million. It is apparent that some formal Navy courses cannot be converted to CMI because of economic constraints. A large-scale centralized computer system for a selected number of Navy courses will be extremely expensive to acquire and maintain. Preliminary trade off analyses made during this investigation reveal that a combination of minicomputers (strategically located to perform the routine tasks of CMI) and a central

computer system (for high level management information processing) is more cost effective than a single large-scale centralized computer system. The central computer in this concept will be updated daily or weekly by the minicomputers via leased line networks, i.e., AUTOVON, NAVTIS, etc.

Using the combination system, a geographical area can operate independently or interact with other areas. A minicomputer for CMI on an area basis can be linked to the central computer or operate in an independent mode. If funds are not available for a Navy-wide CMI system, this concept allows for a modular addition of courses and other geographical areas as funds become available.

A minicomputer for small, remote classes is feasible. The hardware cost of a system to perform this task is less than \$75,000. The cost of course development varies depending upon the wide variety of subject matter. Although a minicomputer is feasible for this task, the utilization of the equipment by one remote site is not practical. It is proposed that CMI training in remote sites be linked together via land lines. In this concept, a greater number of managers and students can utilize the capabilities of CMI and have a more cost effective system.

The use of shipboard tactical computers for managing individual training has long been desired by the training community. However, numerous technical and logistical problems, as well as priorities placed upon the use of shipboard computers by higher authorities, have allowed relatively little training via operational computers aboard ships. To implement the on-board computer systems for individual training will require additional computer peripheral equipment, computer program changes, changes to documents, instructions, regulations, etc.

The number, complexity, and magnitude of changes that must be made to the operational equipment and computers to incorporate CMI are economically impractical. Technically the concept is feasible. However, the cost of retrofitting operational equipment and the amount of time that could be (or would be) allocated for the operational equipment to be utilized for CMI without interfering with operational commitments will make the cost per student hour of training high. The installation cost of the mini-computer system aboard the USS DAHLGREN was over \$40,000. This installation required minimum changes to the existing ship's systems. The state-of-the-art is advancing at such a pace in the mini and microcomputer field that in the near future the market price for these systems will be such that it will be economically more advantageous for ships to have a dedicated system for education, rather than implementing a retrofit program to use operational equipment and computers for CMI.

BIBLIOGRAPHY

- Air Force Human Resources Laboratory. Advanced Instructional System (AIS) Specification. 17 Apr 1972. Technical Training Division (AFSC), Lowry Air Force Base, CO.
- Anastasio, E. J. and Morgan, J. S. Factors Inhibiting the Use of Computers in Instruction. 1972. EDUCOM, Interuniversity Communications Council, Inc., Princeton, NJ.
- Anastasio, E. J. and Morgan, J. S. Studies that Have Inhibited a More Widespread Use of Computers in the Instructional Process. 1972. EDUCOM, Interuniversity Communications Council, Inc., Princeton, NJ.
- Brown, B. R., Hannum, W. H. and Dick, W. An Investigation of the Effects of Two Types of Instructional Terminals in Computer Managed Instruction. Tech Memo No. 36. 1971. Florida State University, CAI Center, Tallahassee, FL.
- Brown, B. R. and O'Neil, H. F. Computer Terminal Selection: Some Instructional and Psychological Implications. Tech Memo No. 37. 1971. Florida State University, CAI Center, Tallahassee, FL.
- Chief of Naval Education and Training. "Twenty-four Hour Service -- From a Modern Computer Network." TRA NAVY. March 1973. Pensacola, FL. p. 2-5.
- Chief of Naval Technical Training. Navy Integrated Training and Resources Administration System. (undated). Memphis, TN.
- "Colleges Plug in the Teaching Computer." Business Week. Apr 7, 1973.
- Computer Curriculum Corporation. Guide to the GED Curriculum. GEG B 72. (undated). Palo Alto, CA
- Cushman, Robert H. "Communication Circuits: Putting Data on the Telephone Network," EDN Magazine. June 1973. 18. 11.
- Dick, W. An Overview of Computer Assisted Instruction for Adult Educators Tech Memo No. 9, 1969. Florida State University, CAI Center, Tallahassee, FL.
- Dick, W. and Gallagher, P. Systems Concepts and Computer-Managed Instruction: An Implementation and Validation Study. Tech Memo No. 32, 1971. Florida State University, CAI Center, Tallahassee, FL.
- Dudley, T. J. "How the Computer Assists in Pacing and Testing Students' Progress." Educational Technology. March 1973. 13, 3. p. 21-22.

- Dunn, T. G. The Effects of Various Review Paradigms on Performance in an Individualized Computer-Managed Undergraduate Course, Tech Report No. 22. 1971. Florida State University, CAI Center, Tallahassee, FL.
- Durall, E. P. A Feasibility Study: Remediation by Computer Within a Computer-Managed Instruction Course in Junior High School Mathematics Tech Report No. 25. 1972. Florida State University, CAI Center, Tallahassee, FL.
- Education/Research Inc. Study to Determine Viable Approaches to Computer-User Education at NASA. Final Report NASA CR 114488. (undated). Berkeley, CA.
- ENTELEK Inc. ONR Conference on CAI Languages. 2-3 March 1966. Cambridge, MA.
- ENTELEK Inc. ENTELEK Information Exchange, Newburyport, MA.
- Finch, J. M. "An Overview of Computer Managed Instruction." Educational Technology, July 1972. 12, 7. p. 46-47.
- Forbes, B. E. and Green, M. A. "An Economical Full-Scale Multi-purpose Computer System." Hewlett Packard Journal. January 1973, 24, 5. Palo Alto, CA.
- Ford, J. and Chesler, D. J. Personal Communications. 1973. Navy Personnel Research and Development Center, San Diego, CA.
- Frye, C. H. "CAI Languages: Capabilities and Applications." Datamation. Sep 1968. 14, 9. p. 34-37.
- Gallagher, P. D. An Investigation of Instructional Treatments and Learner Characteristics in a Computer-Managed Instruction Course. Tech Report No. 12. 1970. Florida State University, CAI Center, Tallahassee, FL.
- Hagerty, N. K. Development and Implementation of a Computer-Managed Instruction System in Graduate Training. Tech Report No. 11. 1970. Florida State University, CAI Center, Tallahassee, FL.
- Hansen, D. N. The Role of Computers in Education During the 70's. Tech Memo No. 15. 1970. Florida State University, CAI Center, Tallahassee, FL.
- Hansen, D. N. et al. Annual Progress Report--1 January 1972 through 31 December 1972. Florida State University, CAI Center, Tallahassee, FL.
- Hansen, D. N. et al. A Guide to Computer Simulations of Three Adaptive Instructional Models for the Advanced Instructional System. Phases II and III. (undated). Florida State University, CAI Center, Tallahassee, FL.

- Hansen, D. N. et al. The Analysis and Development of an Adaptive Instructional Model(s) for Individualized Technical Training, Phase I (undated). Florida State University, CAI Center, Tallahassee, FL.
- Headquarters, Marine Corps Communication-Electronics School. Computer Aided Instruction Report. (undated). Twentynine Palms, CA.
- Hobson, E. N. Empirical Development of a Computer Managed Instruction System for the Florida State University Model for the Preparation of Elementary School Teachers. Tech Report 8. 1970. Florida State University, CAI Center, Tallahassee, FL.
- International Business Machines Corp. Guide to IBM Education. Education Information Bulletin.
- Koerner, J. "Educational Technology - Does it Have a Future in the Classroom?" Saturday Review Supplement. 1973.
- Kopstein, F. F. and Seidel, J. Computer-Administered Instruction Versus Traditionally Administered Instruction: Economics. Professional Paper 31-67. 1967. The George Washington University, Human Resources Research Office. Alexandria, VA.
- Kribs, H. D. New Aptitudes for Adaptive Instruction: A Computer Simulation of a Learning Environment Individualized by Human Information Processes and Reinforcement Contingencies. 1973. Florida State University, Tallahassee, FL.
- Lawler, R. M. An Investigation of Selected Instructional Strategies in an Undergraduate Computer-Managed Instruction Course. Tech Report No. 19. 1971. Florida State University, CAI Center, Tallahassee, FL.
- Lekan, Helen A. Index to Computer Assisted Instruction. 1971. Instructional Media Laboratory, University of Wisconsin, Milwaukee, Wisconsin.
- Longo, A. A. A Summative Evaluation of Computer Assisted Instruction in US Army Basic Electronics Training. Tech Report 72-1. 1972. US Army Signal Center and School, Fort Monmouth, NJ.
- Matson, R. C. "Coordinating Lecture and Laboratory Using Self-Paced Instruction." IEEE Transactions on Education. Aug 1973. E-16, 3. p. 166-168.
- McCombs, B. L. et al. "An Adaptive Model for Utilizing Learner Characteristics in Computer Based Instructional Systems." Educational Technology, Apr 1973. 13, 4. p. 47-51.
- McGuire, D. (ed) Proceedings of the 14th Annual Institute in Technical and Industrial Communication, July 1971. Colorado State University, Fort Collins, CO.

- Merrill, P. F., and Towle, N. J. The Effects of the Availability of Objectives on Performance in a Computer-Managed Graduate Course. Tech Memo No. 47. 1972. Florida State University, CAI Center, Tallahassee, FL.
- Motley, D. An On-Line-Computer Managed Introduction to Indexing: An Individualized Multimedia Instructional Package Compared to the Traditional Method, Nine Hours of Teacher-Group Contact. Tech Report No. 26. 1972. Florida State University, CAI Center, Tallahassee, FL.
- National Electronics Conference. Mini/Micro Computer Institute, Oak Brook, IL. Sep 1973.
- Naval Command System Support Activity. Programming Language Summary Listing IL-1. 29 Dec 1972. Washington, D. C.
- New York Institute of Technology. An Overview of the System. 1973. Educational Management Information, Old Westbury, NY.
- New York Institute of Technology. Computerized Instruction Support System for the Mineola School District Learner--Centered Mathematics Program. (undated). CISS User Manual, Old Westbury, NY.
- Ohio State University. A Model for the Computer Management of Modular, Individualized Instruction. (undated). Columbus, OH.
- OPNAVINST 1500.39. Glossary of Navy Education and Training Terminology. Government Printing Office, Washington, D. C.
- Philco-Ford Corporation. MACCS Training Improvement Program, Post-Award Meeting Presentation. (undated). Western Development Laboratories Division.
- Scanland, W. Individualized Learning. CNT Point Paper 35-1. 31 Jan 1973(a). Chief of Naval Education and Training, Pensacola, FL.
- Scanland, W. Computer Managed Instruction (CMI). CNT Point Paper 35-7. 19 Jan 1973(b). Chief of Naval Education and Training, Pensacola, FL.
- Stifle, J., Bitzer, D. and Johnson, M. Digital Data Transmission Via CATV. 1971 (revised 1972) CERL. University of Illinois at Urbana, IL.
- Stifle, J. The Plato IV Architecture. CERL Report X-20. 1972. University of Illinois at Urbana, IL.
- Torr, D. V. et al. A Plan for the Establishment of a Computer-Aided Instruction Research and Development Center. 1967. Office of Naval Research, Personnel and Training Branch, Psychological Sciences Division Contract N00014-67-C-0219. Washington, D. C.
- Texas Instruments. Training and Education Via Electronic Media for Improved People Effectiveness. 1973. Dallas, TX.

- Tucker, P. T. "A Large Scale Computer Terminal Output Controller." 1971. CERL, University of Illinois at Urbana, IL.
- UNIVAC Division, Sperry Rand. Use of Shipboard Computer Systems in Support of Training. 1969. BUPERS Contract Number N00022-69-C-0119. Virginia Beach, VA.
- US Army Signal Center and School. Concept Plan, Booklet B Specification No. S-125-72, April 1973. Computerized Training System Project. Fort Monmouth, NJ.
- US Army Signal Center and School. Multi-Minicomputer Training System. CTS Specification No. S-125-72, 16 March 1973. Fort Monmouth, NJ.
- US Army Signal Center and School. Task Group Report Computer Assisted Instruction, Vols, I, II, III. April 1972. Fort Monmouth, NJ.
- US Naval Academy. Final Report on the Naval Academy's Project PR-0571-43, 1972. Educational Systems Center. Annapolis, MD.
- Walker, G. S. and Gardner, E. M. Application of Computers in Educational and Training Systems: A Survey of Computer Assisted Instructional Centers: HRL TR 70-24. 1970. Air Force Systems Command, Technical Training Division, Lowry Air Force Base, CO.
- Wetzel, W. R., "Minisystem Mixes Real-Time, Batch." Computer Decisions. June 1973. p. 8-12.
- Wiener, H. "Computers That Fit in Your Pocket." Computer Decisions. Aug 1973. p. 8-13.
- Wildberger, A. M. The Use of a Concurrent Simulation in the Management of Individualized Instruction. (undated). Naval Ordnance Laboratory, Silver Spring, MD.
- Wong, W. Personal Communication. 1973. International Business Machines Corporation, Lexington, KY.
- Zinn, K. L. Comparative Study of Languages for Programming Interactive Use of Computers in Instruction. RM 1469. 1969. University of Michigan, Ann Arbor, MI. AD 692 506.

TAEG REPORT NO. 14

APPENDIX A
QUESTIONNAIRE *

CMI (COMPUTER MANAGED INSTRUCTION) POTENTIAL

INSTRUCTIONS. A separate form is to be prepared for each course at the addressed activity listed in the appropriate Navy Formal Schools Catalogs (A-N). Do not group courses. Estimates and averages may be used where appropriate. The data gathered is to assist in determining the potential of each course for future consideration of CMI, and will have no immediate effect on the existing courses.

NOTE: Data previously gathered for the FTDS (Formal Training Data System) and SMF (Student Master File) or other FTDS reports may be used, if appropriate.

SUBJECT	ANSWERS
1. ACTIVITY (Short Name)	_____
2. ACTIVITY IDENTIFICATION CODE	_____
3. COURSE TITLE	_____
4. COURSE IDENTIFICATION NUMBER	_____
5. LENGTH OF COURSE (Weeks)	_____
6. FREQUENCY OF COURSE (Average Starts Per Year Based on Future Estimate)	_____
7. THROUGHPUT (Number of Students Completing Course). ANNUAL TOTAL	_____
8. TOTAL INSTRUCTOR PERSONNEL ON BOARD (Per Course)	_____
9. TOTAL INSTRUCTOR PERSONNEL AUTHORIZED (Per Course)	_____
10. STABILITY OF COURSE: Percent of Subject Matter Revised Per Year (estimate)	_____
11. PERCENT OF COURSE CURRENTLY SELF-PACED (Allowing student to advance or complete course at his own rate), BUT NOT COMPUTERIZED	_____
12. PERCENT OF COURSE UNDER PI (PROGRAMMED INSTRUCTION), BUT NOT COMPUTERIZED	_____
13. PERCENT OF COURSE COMPUTERIZED UNDER CAI (Computer Assisted Instruction). (CAI defined as student doing majority of work on the computer terminal.)	_____
14. PERCENT OF COURSE COMPUTERIZED UNDER CMI (Computer Managed Instruction). (CMI defined as student doing majority of work off the terminal with computer directing his choice of media and pace.)	_____
15. STUDENT EQUIPMENT RATIO. Do students usually SHARE equipment or is it available one per student? Answer SHARE or 1:1, Etc.	_____
16. HAS COURSE BEEN SYSTEMS ENGINEERED (e.g., is course based on a formal Job Task/Training Analysis?) Answer YES or NO.	_____
17. DOES COURSE AWARD AN NEC OR IS IT PART OF SERIES OF COURSES THAT DOES? Answer YES or NO.	_____
18. IF PART OF A SERIES, IDENTIFY ADDITIONAL COURSES REQUIRED	_____
19. DOES COURSE REQUIRE MAJORITY OF STUDENTS TO TRAVEL AND OBTAIN PER DIEM TO ATTEND? Answer YES or NO	_____
20. STUDENT FAILURE RATE OF COURSE (Average percent Per Year)	_____
21. PERCENT OF STUDENTS TAKING LONGER THAN REGULAR COURSE LENGTH TO COMPLETE	_____

*The administration and analysis of this questionnaire was not possible within the time frame of this project.

APPENDIX B

*NAVY FORMAL SCHOOLS CATALOGS

- **A Chief of Naval Training (formerly Bureau of Naval Personnel)
- B Chief, Bureau of Medicine and Surgery
- **C Chief of Naval Training (formerly CNATRA)
- D Commander, Naval Air Force, U. S. Atlantic Fleet
- E Commander, Naval Air Force, U. S. Pacific Fleet
- F Commander, Submarine Force, U. S. Atlantic Fleet
- G Commander, Amphibious Operations Support Command, U. S. Atlantic Fleet
- H Commander, Amphibious Operations Support Command, U.S. Pacific Fleet
- J Commander, Training Command, U. S. Atlantic Fleet
- K Commander, Training Command, U. S. Pacific Fleet
- L Commander, Submarine Force, U. S. Pacific Fleet
- M Commanding Officer, Naval Air Systems Command Representative, U. S. Atlantic Fleet
- N Commanding Officer, Naval Air Systems Command Representative, U. S. Pacific Fleet
- * BUPERSINST 1510.108C
- ** Consolidated

APPENDIX C

ABSTRACTS OF CMI SYSTEMS VISITED OR CONTACTED

A. Navy

1. Aviation Fundamentals Course (Class P), Naval Air Technical Training Center, Memphis, Tennessee, is developing a limited CMI system with a course length of two weeks. Estimates are to reduce instructor requirements by 20 percent and the course to one week. An individualized instruction plan is used wherein each trainee advances as directed by the computer. The computer is programmed to make a decision as to which of the available units of instruction is best suited to further the learning of each trainee. The trainee receives the instruction prescribed by the computer at individualized instruction stations (carrels) from programmed booklets and devices that are not controlled by the computer. The carrels contain visual displays, audio tapes, audio tape slides, sound motion films, and other pertinent equipment. The computer is located at nearby Memphis State University and student interaction and response is affected by computer availability and downtime.

2. Aviation Mechanical Fundamentals Course (Class A) at Naval Air Technical Training Center, Memphis, Tennessee, has a weekly input of approximately 175 trainees. The course length of three weeks is expected to be cut to two. This CMI course is run concurrently with the previously described Aviation Fundamentals Course and is of similar CMI design.

3. F-14 Aircraft CMI (or Computer Managed Training (CMT)) program for Fleet Replacement Aviation Maintenance (FRAMP) and Replacement Air Group (RAG) personnel at NAS Miramar is under development by Hughes Aircraft Corporation. A Burroughs computer located in Los Angeles is linked via land

lines to NAS Miramar. Personnel at Miramar can select a series of events to be taught on an individual basis and rearrange events to suit the student. The aircrew students' sequence of events is accomplished by the staff screening students records and tailoring a curriculum for each student; FRAMP is totally CMT (CMI) with 14 courses and two classes per course. The CMI configuration at Miramar consists of a minicomputer which receives data from the Burroughs 3500 and Hazeltine 2000 alphanumeric terminals. The system is capable of expansion to handle 200 students.

The Miramar courses are not true CMI as defined for this study. The major use is for scheduling classes and record keeping and the name was changed from CMI to CMT. Miramar also uses the computer system to enter grades, class roster, completion summary, class standing, locate student by class/phase, count students, identify number of students by class/rate/totals, etc. The interaction of students to computer is almost zero and courses are not truly self paced. CAI is used as just another medium of instruction and the ultimate goal is to fulfill all squadron record keeping and scheduling for student and staff. No effort is made to self pace since none are basic courses but are systems courses. The program should peak at 800 students per year for four years. After squadrons are trained, the replacement program will go into effect with the same inputs. It is estimated that FRAMP will require fewer aircraft per man due to more efficient computer scheduling. Twelve self-study carrels are used with FRAMP; Academics for Organizational Maintenance uses eight and Aircrew Training Academic Centers use 12. Plans are for other activities to use Miramar developed software in the future.

4. The A-7E Aircraft Maintenance Technician Fleet Operational Program Personnel Management System (PMS) at NAS Lemoore is being programmed under contract with Vought Aeronautics (Division of Ling-Temco Vought (LTV)) and is funded by NAVAIR. The programs developed are associated with normal FRAMP student I/O requirements and are being programmed to ultimately maintain student record files and program student schedules. A PDP 11/40 DEC (24K memory) computer is being used. Expansion to 2 million word disk will be provided by Cecil Field.

The NATTC Memphis is writing CMI programs for the ADJ, AM, Plane Captain Courses, and A7E-FRAMP for evaluation in 1974.

5. Shipboard. A CMI (CII) program, project ADO-43-03X-P14 is planned aboard the USS DAHLGREN, DLG-12. A minicomputer (Nova 1200) is already aboard for a management information project and the CII project will share its use. It is probably the only minicomputer aboard any ship.

The CMI project (called CII in this program) will cover damage control (applies to approximately 300 men). This program is under the guidance of NPRDC, San Diego, where it is believed that if the CMI can be successful aboard ship with all the shipboard constraints, it can certainly be done on shore. USS DAHLGREN ships personnel will program the computer and the contractor will develop software. The NPRDC will assist in course writing. The initial program will be developed and debugged on shore and then installed and tested aboard.

Personnel at NPRDC state that shipboard personnel in general seem to be eager to take on computer control of administration, military requirements, security, 3M, etc., but hesitate to tackle training by computer.

Any shipboard subject matter is potentially a CMI possibility.

Items that could conceivably be computerized for shipboard use include:

Weekly Training Status	Leadership Training
Self Study	Division Instruction
Practical Factors	Competitive Exercises
Schools Requirement	Officer Assignments
Advancement in Rate	Drill Records
Basic Training Records	Battle Station Qualifications
Equipment Qualifications	

B. Marine Corps

Communication-Electronics School (C and E School), Twentynine Palms, California. In addition to the CAI program being implemented for the Basic Radio Course (six weeks) the USMC recently awarded a contract to completely redesign the 30 courses that essentially cover the entire school's curriculum. It is known as the Training Improvement Plan for Marine Air Control Squadron (TIP for MACCS). Although this massive effort is not CMI, it would be possible to convert this effort (through renegotiation) to a CMI effort in at least some of the courses during the progress of the contract, though this is not planned.

As the contract now exists, the 30 courses will be completely redesigned by the contractor starting with a new task analysis and Program of Instruction (POI) for each course. The contractor will teach each new course one time and train the Marine instructor. The contractor is free to recommend any media (CAI, audio visual, PI, etc), but it is predicted 87 percent of the courses will be Conventional Instruction (CI).

The contractor will develop complete packages of course materials plus an on-the-job training (OJT) package and will conduct a 14 month evaluation of each course taught.

The TIP for MACCS is designed to improve the quality of instruction, and the contractor is free to consider also using and/or improving the program formerly known as Auto Testing Attrition Control (ATAC) which is a system used to completely keep track of the student from day one to graduation in areas of grades, tests, test item analysis, etc.

The NPRDC is advisor to the TIP for MACCS program.

C. Army

U. S. Army Signal Center and School, Fort Monmouth, N. J. The Army has no large-scale program underway devoted predominantly to CMI. However, as a result of the success of a demonstration CAI project at Fort Monmouth, using a large block of basic electronics instruction, the Army will soon develop an extensive combination CAI/CMI project (under contract) known as CTS under Project ABACUS.

The scope of the CTS project includes the design, development, implementation, operation, and evaluation of the integrated prototype CTS covering a four-year period beginning late 1972 and ending late 1976. Outcomes of the prototype CTS are expected to be a suitable low cost, viable, and effective hardware system, and a newly developed language that will facilitate course materials development and enable maximum flexibility in the use of these hardware systems and course materials among Army training centers.

The Army is responsible for development of the course material for implementation of the prototype CTS. The personnel at Fort Monmouth

have a head start on this phase in that student terminals connected to the PLATO IV System at the University of Illinois will be used to train personnel as instructional programmers and for initial development of the course material designated for the prototype CTS. The prototype system will operate a minimum of one year prior to procurement of operational systems.

The goal of the prototype Army CTS is to assemble and test a computer system which will support several hundred CAI terminals. Each terminal will consist of a student display capable of illustrating text and graphics, a keyboard and pointing device for computer input, and a rear projection device capable of selecting and presenting color and black and white slides (from microfilm) under computer control. The system will support a number of CAI modes of instruction for individual self-paced lessons at each student terminal and management of each student's progress both on line and off.

D. Air Force

The AIS now under contract for the Air Force at Lowry Air Force Base, Colorado, is the most costly single computerized training effort in the military services and possibly the most costly effort in the world. The following AIS description is abstracted from the AIS contract specification (dated 17 Apr 1972):

This system incorporates methods for integrating the latest advances in individualized instruction, including instructional techniques and media, instructional management, and computer hardware and software, to improve the cost/training effectiveness of Air Force technical training and education. The AIS constitutes a prototype individualized multi-

media training system as well as training research facility to allow the systematic evaluation of innovations in instructional technology. The technical development of the AIS will take place over a 48-month period.

The initial design efforts will be directed toward the instructional and computer supported management requirements of three AIS courses: the Precision Measuring Equipment (PME) Specialist Course, the Weapons Mechanic (WM) Course Component, and the Inventory Management (IM) Course. Development of the CMI functions will be the emphasis during initial stages with CAI being used where appropriate to augment off-line media. The three courses are currently operational, well structured, and have clearly stated behavioral objectives and course content.

Course materials, computer support software and hardware, and media support for the three courses will be prepared.

The AIS will be designed, developed, delivered, implemented, evaluated, and initially operated by the contractor as an integrated system comprised of seven interrelated subsystems. These subsystems are as follows: (a) Instructional Materials Subsystem, (b) Instructional Strategy Subsystem, (c) Media Subsystem, (d) Software Subsystem, (e) Computer Hardware Subsystem, (f) Personnel and Training Subsystem, and (g) Related Subsystem.

At the conclusion of the contract, the AIS will operate as a totally integrated computer-based system which is capable of training and managing all students (approximately 2100) in all three shifts of each of the three designated courses with an average of at least 25 percent reduction in training time with equal or better training performance. More specifically, all learning materials, media, supporting hardware/software,

procedures and processes will be of such quality and quantity so as to enable all students in all three shifts of each of the three courses to achieve each criterion objective with an average of at least 25 percent reduction in total training time without exceeding current student elimination or washback rates. An additional goal will be to reduce current academic elimination and washback rates. Average training time will be calculated on the basis of the total number of student classroom hours divided by the total number of students. The resultant average time of the revised course (with common content) will be 25 percent less than the average length of conventional training.

The contractor will include in the design of each course a training analysis, derived learning objectives, prescribed individualized instructional strategies, and evaluation and revision procedures.

E. Industry

1. Mitre Corporation

The TICGIT (Time-Share, Interactive, Computer-Controlled Information Television) System is an example of a government sponsored industry program for public/academic use that is CAI but which could well expand to CMI. It is a new use of cable TV to promote instruction, information, companionship and entertainment on demand in the home (or school). It is a CAI program sponsored at Mitre by the National Science Foundation and has yielded experimental results which may lead to mass education for less cost than traditional books.

To demonstrate computerized instruction further, Mitre's TICGIT program will use two community colleges and 128 terminals on a developmental basis during the 1973/74 academic year. The project cost per

student will be less than one dollar (only one-third of the traditional cost). Here, again, although CAI, the implication for CMI is unlimited.

Brigham Young University is developing the course materials for the Mitre TICCIT program at Northern Virginia Community College, Virginia, and Maricopa County Junior College, Arizona.

2. IBM

The IBM Training Center, Lexington, Kentucky, has an excellent course in IBM machine maintenance that is completely self paced and PI but is not computerized in any way. However, the very fact that IBM, a leader in the field of computerized instruction, developed this up-to-date non-computerized course leads to its being mentioned here and on page 53 of section III because of the logic used in the decision not to computerize the course.

3. Texas Instruments (TI) Incorporated

At the TI Learning Center, employees use a combination of video tape and other media with CAI. Texas Instruments also has a contract with a Phoenix hospital to store all records and teach certain items by computer. Texas Instruments Incorporated retails a video tape packaged course in semi-conductors that condenses a 50-hour classroom course to 12 hours. It is not computerized but would serve as an excellent medium for a CMI-directed program. TI Incorporated will prepare video-taped courses for \$4,500 per hour, including preparation of manuscript, all salaries, all art work, writing, development, tapes, and telecomputers which are ready to add to a CMI program.

4. Jet Propulsion Labs (JPL), Pasadena, California

The JPL conducts most of its computerized training off line using TV tapes, sound-slides, and textbooks. Nearly all employees in scientific

positions have AN-CRT terminals available and can be connected on a time-shared basis with one of several computers at JPL, Cal Tech, etc.

5. Computer Curriculum Corporation

One such effort of modified CMI using off-line materials as well as on-line testing and materials is the General Education Development (GED) curriculum package available from the Computer Curriculum Corporation. For the large number of Navy personnel without a high school education, this GED package seems to be worth looking into for Navy use. Presently it is running successfully in the Los Angeles public school system and has recently been installed in Cincinnati and San Francisco and in Riker's Island Prison in New York.

This GED package can be run on virtually any time-shared computer already installed or as a dedicated self-contained hardware/software package. In the latter case, one can rent the computer with eight terminals for approximately \$2,100 per month including maintenance. No computer operator is required.

It is estimated that three or four months would be the average time to prepare a recruit to take the GED exam successfully, assuming he is at the terminal one hour a day, five days a week. In a 10-hour day, each terminal would accommodate 10 students so that at any given time the system could handle 80 students. Computer Curriculum Corporation has designed a comprehensive curriculum to prepare students for all parts of the GED examination. The GED curriculum contains five courses, one for each test in the exam: English, Social Science, Natural Science, Literature, and Mathematics. The student takes as many courses as needed and each course is self-contained and needs no supplementary textbooks or workbooks.

6. Ling-Temco Vought

See page 79, item A4.

F. Academic

Colleges, universities, and secondary schools have numerous examples of computerized instruction programs, either experimental or in operation. However, as is the case in the military and in industry, CMI (as distinguished from CAI) efforts are rare.

1. Florida State University

Florida State University has been conducting extensive work in computerized education under contract with the Office of Naval Research as well as under federal and state projects and university-sponsored projects. Florida State University's most extensive CMI project deals with the undergraduate health education course. An ample subject pool provided excellent resources for investigations of optimal training strategies within CMI. Research centered upon performance-enhancing learner strategies which optimized CMI instruction. Basically, investigative efforts were comprised of a series of programmatic studies in optimal course revision strategies and alternative prescriptive-remediation techniques within the CMI model. Specifically, investigations dealt with effects of selected instructional strategies on student confidence, study time, terminal time, studying strategies, mastery of objectives, curiosity, attitudes, and performance, particularly in terms of remediation/success criteria.

Out of a total of 369 students in Health Education, 319 were provided an on-going CMI program through the facilities provided by the CAI Center during the calendar year 1972.

An earlier (Dick and Gallaher, 1971) evaluation of CMI by FSU makes a cost comparison of the CMI method with the traditional lecture method and indicates that the CMI approach is less expensive to operate than conventional instruction at FSU. Conservatively (the study relates) the cost of conducting the course via CMI is one-half to one-third the cost of conventional graduate instruction at FSU. Comparison of CMI costs with those of traditional instruction are quite favorable and numerous CMI courses (at FSU) could be implemented at the same cost as a single CAI course. The study details the developmental and implementation costs to support the conclusions.

2. Pepperdine University

Pepperdine University is using computer paced instruction in its school of Business and Management. One phase is the computerized testing program which stores student information as he progresses through the course. The computer can prepare a test on a random basis on demand, grade it, and keep statistics on the results. The student can progress with the course whenever he receives the specified score for each phase.

C. Government

National Aeronautics and Space Administration (NASA), Houston, Texas.

The training for support personnel of all past space missions has been the traditional type, such as lecture, demonstration, and OJT, with self pacing being used to the maximum possible extent. The self pacing of personnel was a necessity due to work loads, availability of subject experts, working hours of personnel, etc. However, this self pacing presented a problem to management inasmuch as it was almost impossible to ascertain the

training proficiency of personnel associated with launches. During the forthcoming Space Shuttle program, the Support Training Department of NASA has been assigned the responsibility of computerizing to the maximum extent the training of all support personnel. This task will encompass the computerization of approximately 24 major courses which includes aerodynamics, structures, propulsion, electrical power, crew stations, avionics, etc.

To implement its computerized training, the NASA Training Support Division will have at its disposal the large computer system presently being used for the Sky Lab program. The NASA is now developing the training requirements and implementation plan. Schedules require NASA to have its system in operation and personnel attending classes by late 1974. The final decision on the percentage of courses that will be under CAI has not been made to date, but the CMI aspect of training for NASA is a necessity to insure success of the Shuttle Program.

Once the requirements and implementation plan have been developed by NASA personnel, the computerization of their courses will be accomplished by a contractor. The throughput of students, approximately 200, is not large enough to achieve the low cost per student hour that universities and other government agencies achieve. However, the cost of computerization is a necessity to accomplish the task.

APPENDIX D

MINICOMPUTER AND LARGE SYSTEM COMPUTER CONFIGURATION HARDWARE COST

<u>Unit</u>	<u>Minicomputer</u>	<u>Price</u>
Computer: Nova 1200 (32K Memory)		\$20,050
Line Printer (356 lpm)		11,500
Line Printer Controller		1,600
Card Reader (1000 cpm)		5,000
Card Reader Controller		1,050
Disk Drive (12,288 million 16 bit words)		12,000
Disk Controller		12,000
Alphanumeric CRT (Hazeltine 2000)		3,000
Miscellaneous		<u>2,000</u>
		\$68,200

Large System Computer

<u>Unit</u>	<u>Price</u>
Computer: Control Data Cyber 72 (65K Memory)	\$1,025,000
Line Printer (1000 lpm)	27,000
Line Printer Controller	17,000
Card Reader (1000 cpm)	24,900
Card Reader Controller	12,700
Disk Drive (120 million 6 bit characters)	28,000
Disk Controller	90,000
Alphanumeric CRT (Hazeltine 2000)	3,000
Miscellaneous	<u>2,000</u>
	\$1,229,600

APPENDIX E

SHIPBOARD COMPUTER SYSTEMS

<u>Ship and Class</u>	<u>Electronic Data Processing Equipment</u>
USS Franklin D. Roosevelt (CVA 42)	AN/UYK-5(V)
USS Forrestal (CVA 59)	AN/USQ20
USS Saratoga (CVA 60)	AN/USQ1, AN/USQ20, AN/UYK-5(V)
USS Independence (CV 62)	AN/USQ1, AN/USQ20, ANUYK-5(V)
USS America (CVA 66)	AN/USQ1, AN/USQ20, ANUYK-5(V)
USS John F. Kennedy (CVA 67)	AN/USQ20, AN/UYK-5(V)
USS Fulton (AS 11)	AN/UYK-5(V)
USS Howard W. Gilmore (AS 16)	AN/UYK-5(V)
USS Orion (AS 18)	AN/UYK-5(V)
USS Cascade (AD 16)	AN/UYK-5(V)
USS Sierra (AD 18)	AN/UYK-5(V)
USS Yosemite (AD 19)	AN/UYK-5(V)
USS Shenandoah (AD 26)	AN/UYK-5(V)
USS Yellowstone (AD 27)	AN/UYK-5(V)
USS Grand Canyon (AR 28)	AN/UYK-5(V)
USS Hunley (AS 31)	AN/UYK-5(V), Univac 1004
USS Holland (AS 32)	AN/UYK-5(V), Univac 1004
USS Simon Lake (AS 33)	AN/UYK-5(V), Univac 1004
USS Canopus (AS 34)	AN/UYK-5(V), Univac 1004
USS Concord (AFS 5)	AN/UYK-5(V)
USS Puget Sound (AD 38)	AN/UYK-5(V)
USS L. Y. Spear (AS 36)	AN/UYK-5(V)
USS Guam (LPH 9)	AN/UYK-5(V)
USS Iwo Jima (LPH 2)	AN/UYK-5(V)
USS Guadalcanal (LPH 7)	AN/UYK-5(V)
USS Vulcan (AR 5)	AN/UYK-5(V)
USS Mount Whitney (LCC 20)	AN/SSQ59, AN/SSQ64, ASIS
USS Inchon (LPH 12)	AN/UYK-5(V)
USS Sylvania (AFS 2)	AN/UYK-5(V)
USS Dixon (AS 37)	AN/UYK-5(V)
USS San Jose (AFS 7)	AN/UYK-5(V)
USS Jason (AR 8)	AN/UYK-5(V)
USS Hector (AR 7)	AN/UYK-5(V)
USS Ajax (AR 6)	AN/UYK-5(V)
USS Okinawa (LPH 3)	AN/UYK-5(V)
USS New Orleans (LPH 11)	AN/UYK-5(V)
USS Tripoli (LPH 10)	AN/UYK-5(V)
USS Bryce Canyon (AD 36)	AN/UYK-5(V)
USS Oriskany (CVA 34)	AN/UYK-5(V)
USS Midway (CVA 41)	AN/UYK-5(V)
USS Coral Sea (CVA 43)	AN/UYK-5(V)
USS Ranger (CVA 61)	AN/UYK-5(V)
USS Kitty Hawk (CVA 63)	AN/UYK-5(V)

SHIPBOARD COMPUTER SYSTEMS (CONT'D)

<u>Ship and Class</u>	<u>Electronic Data Processing Equipment</u>
USS Constellation (CVA 64)	AN/UYK-5(V)
USS Enterprise (CVAN 65)	AN/UYK-5(V)
USS Dixie (AD 14)	AN/UYK-5(V)
USS Prairie (AD 15)	AN/UYK-5(V)
USS Sperry (AS 12)	AN/UYK-5(V)
USS Nereus (AS 17)	AN/UYK-5(V)
USS Proteus (AS 19)	AN/UYK-5(V)
USS Piedmont (AD 17)	AN/UYK-5(V)
USS Samuel Gompers (AD 37)	AN/UYK-5(V)
USS Hunley (AS 31)	AN/UYK-5(V)
USS Mars (AFS 1)	AN/UYK-5(V)
USS Niagara Falls (AFS 3)	AN/UYK-5(V)
USS White Plains (AFS 4)	AN/UYK-5(V)

NOTE:

The AN/UYK-5 (U-1500) Management Information System consists of the following components:

CP-789/UYK-5(V) (Modified 1218) Computer
 RD-302/UYK-5(V) (Univac 1569) Line Printer
 RD-293/UYK-5(V) (Univac 1249) Card Reader-Punch-Interpreter
 TT-515/UYK-5(V) (Univac 1533) Page Printer and Keyboard
 RD-270/UYK-5(V) (Univac 1240) Tape Unit

NTDS EQUIPPED SHIPS

<u>Ship and Class</u>	<u>Electronic Data Processing Equipment</u>
USS Farragut (DLG 6)	AN/USQ 20
USS Luce (DLG 7)	AN/USQ 20
USS MacDonough (DLG 8)	AN/USQ 20
USS Coontz (DLG 9)	AN/USQ 20
USS King (DLG 10)	AN/USQ 20
USS Mahan (DLG 11)	AN/USQ 20
USS Dahlgren (DLG 12)	AN/USQ 20
USS William V. Pratt (DLG 13)	AN/USQ 20
USS Dewey (DLG 14)	AN/USQ 20
USS Preble (DLG 15)	AN/USQ 20
USS Leahy (DLG 16)	AN/USQ 20
USS Harry E. Yarnell (DLG 17)	AN/USQ 20
USS Worden (DLG 18)	AN/USQ 20
USS Dale (DLG 19)	AN/USQ 20
USS Richmond K. Turner (DLG 20)	AN/USQ 20
USS Gridley (DLG 21)	AN/USQ 20
USS England (DLG 22)	AN/USQ 20
USS Halsey (DLG 23)	AN/USQ 20
USS Reeves (DLG 24)	AN/USQ 20
USS Belknap (DLG 26)	AN/USQ 20
USS Josephus Daniels (DLG 27)	AN/USQ 20
USS Wainwright (DLG 28)	AN/USQ 20
USS Jouett (DLG 29)	AN/USQ 20
USS Horne (DLG 30)	AN/USQ 20
USS Sterett (DLG 31)	AN/USQ 20
USS William H. Standley (DLG 32)	AN/USQ 20
USS Fox (DLG 33)	AN/USQ 20
USS Biddle (DLG 34)	AN/USQ 20
USS Truxtun (DLGN 35)	AN/USQ 20
USS Norton Sound (AVN 1)	AN/USQ 20
USS Albany (CG 10)	AN/USQ 20
USS Chicago (CG 11)	AN/USQ 20
USS Voge (DE 1047)	AN/USQ 20
USS Koelsch (DE 1049)	AN/USQ 20
USS Blue Ridge (LCC 19)	AN/USQ 20
USS Mount Whitney (LCC 20)	AN/USQ 20
USS Bainbridge (DLGN 25)	AN/USQ 20
USS California (DLGN-36)	AN/USQ 20
USS South Carolina (DLGN-37)	AN/USQ 20
USS Towers (DDG 9)	AN/UYK7
USS Robison (DDG 12)	AN/UYK7
USS Berkeley (DDG 15)	AN/UYK7
USS Cochrane (DDG 21)	AN/UYK7
USS Orkiskany (CVA 34)	AN/UYK20
USS Midway (CVA 41)	AN/UYK20
USS Coral Sea (CVA 43)	AN/UYK20
USS Forrestal (CVA 59)	AN/USQ- 20

NTDS Equipped Ships (CONT'D)

<u>Ship and Class</u>	<u>Electronic Data Processing Equipment</u>
USS Saratoga (CV 60)	AN/USQ20
USS Ranger (CVA 61)	AN/USQ20
USS Independence (CV 62)	AN/USQ20
USS Kitty Hawk (CVA 63)	AN/USQ20
USS Constellation (CVA 64)	AN/USQ20
USS Enterprise (CVAN 65)	AN/USQ20
USS America (CVA 66)	AN/USQ20
USS John F. Kennedy (CVA 67)	AN/USQ20
USS Nimitz (CVAN 68)	AN/USQ20

APPENDIX F

POTENTIAL CMI COURSES

1000 ≤ THROUGHPUT ≤ 2000

<u>Course Number</u>	<u>Title</u>	<u>Frequency Per Year</u>	<u>Length (Weeks)</u>	<u>Through- Put</u>
A-00-0044	Reserve Officer Candidate	8	15	1540
A-012-0011(GL)	Instructor Basic	1	4	1225
A-012-0012(SD)	Instructor Basic	1	4	1470
A-012-0013(NORVA)	Instructor Basic	1	4	1500
A-041-0010	Gunners Mate Ph A-1	1	16	1250
*A-100-0012(TI)	Electronic Technician A-1	1	13	1903
*A-100-0013(GL)	Electronic Technician A-1	1	13	1951
*A-100-0014(TI)	Electronic Technician A-2	1	15	1534
*A-100-0015(GL)	Electronic Technician A-2	1	15	1631
*A-113-0010	Fire Control Technician Ph A-1	1	13	1402
*A-500-0026	Personnelman Class A	2	8	1375
A-500-0012	Career Information & Counseling	1	5	1470
A-510-0013	Yeoman Class A	2	7	1039
A-551-0014	Storekeeper Class A	1	8	1135
*A-623-0012	Interior Communication Elec	1	13	1158
A-652-0018	Engineman Class A	1	10	1750
*A-662-0015(SD)	Electricians Mate	1	14	1039
*A-662-0016(GL)	Electricians Mate	1	14	1436
A-700-0010	Shipfitter Class A	2	12	1514
A-780-0035 (Ph1)	Damage Controlmen Class A	1	7	1376
A-780-0036 (TI)	Damage Controlmen Class A	1	7	1411
C-100-2010	Advanced Avionics	1	26	1200
C-210-2010	Aviation ASW Operator	1	11	1115
C-602-2017	Aviation Structural Mech	1	7	1670
C-646-2010	Aviation Ordnance	1	12	1720
*A-060-0012	Enlisted Submarine Introduction	8	4	1865
8-EAA-8888		4	4	1200
8-BCA-8888		4	4	1075
8-BEA-8888		4	4	1230
8-EAA-8888		4	4	1650
8-FCA-8888		4	4	1800

* - Excellent Potential

POTENTIAL CMI COURSES (CONT'D)

THROUGHPUT \geq 2000

<u>Course Number</u>	<u>Title</u>	<u>Frequency Per Year</u>	<u>Length (Weeks)</u>	<u>Through- Put</u>
A-100-0011	Basic Electricity & Electronics	1	4	7795
A-100-0010	Basic Electricity & Electronics	1	4	7237
A-201-0013	Radioman Class A	1	14	2212
A-201-0014	Radioman Class A	1	14	2207
A-221-0011	Radioman Class A	1	15	2774
*A-651-0010	Boiler Technician Class A	1	10	3000
*A-651-0015	Machinists Mate Class A	1	12	6250
*A-651-0035	Machinists Mate Class A (NP)	1	3	5173
A-800-0013	Commissarymen/Steward Class A	1	8	2371
*A-060-0011	Basic Enlisted Submarine	2	6	4611
#C-100-2013	Avionics Technician	1	20	2436
C-602-2012		1	21.8	2895
#C-601-2010	Aviation Machinists Mate	1	7	3688
#C-603-2010	Aviation Structural Mechanic	1	8	2070
8-DBR-8880	Group FBM-W Course	4	4	2184
8-FBA-8888	Group EAT-D Course	4	4	3900
8-950-8888	Group FNAT Course	4	4	2888
8888888888	Group Flt Course	4	4	8000

*- Excellent Potential

- Programmed by Memphis for CMI

APPENDIX G

COURSE DENSITY

<u>Location</u>	<u>No. of Courses</u>	<u>Location</u>	<u>No. of Courses</u>
San Diego, CA	486	Idaho Falls, ID	24
Port Hueneme, CA	43	Schenectady, NY	16
Washington, DC	41	Windsor, CT	8
San Francisco, CA	351	Orlando, FL	30
Jacksonville, FL	141	Sonana, CA	2
Brunswick, GA	22	New London, CT	323
Charleston, SC	55	Athens, GA	9
Pearl Harbor, HI	108	Denver, CO	3
Albany, GA	46	Whidbey Island, WA	95
Beauford, SC	50		
Oceanside, CA	24		
Cherry Point, NC	67		
El Toro, CA	166		
Imperial Beach, CA	33		
Corpus Christi, TX	21		
Lakehurst, NJ	32		
Lemoore, CA	77		
Meridian, MS	4		
New River, VA	18		
Norfolk, VA	345		
Patuxent River, MD	83		
Pensacola, FL	41		
Quonset Point, RI	54		
Rochester, NY	1		
Wichita Falls, TX	1		
Long Beach, CA	5		
Newport, RI	84		
Portsmouth, NH	3		
Ft. Monmouth, NJ	10		
Philadelphia, PA	31		
Ft. McClellan, AL	1		
Ft. Devens, MA	6		
Biloxi, MS	9		
San Angelo, TX	24		
Indianapolis, IN	7		
Indian Head, MD	19		
Key West, FL	36		
Great Lakes, IL	104		
Albuquerque, NM	9		
Memphis, TN	33		
Ft. Mead, MD	11		
Cocoa Beach, FL	2		
Ft. Belvoir, VA	5		
Bainbridge, MD	6		

APPENDIX H

SITES VISITED

MILITARY

Navy

Naval Technical Training Center Memphis, Millington, TN
AVFUND (P) School, AVMECHFUND (A) School
Naval Air Station, Miramar, San Diego, CA
F14 Squadron
Chief of Naval Education and Training, NAS, Pensacola, FL
Chief of Naval Personnel (B2243) Washington, DC
Naval Electronics Laboratory Center, San Diego, CA
Navy Personnel Research and Development Center (NPRDC), San Diego, CA

Marine Corps

Communication-Electronics School (CE), Marine Corps Air Station,
Twentynine Palms, CA

Army

U.S. Army Signal Center and School (USASCS), Ft. Monmouth, N.J.

INDUSTRIAL

Mitre Corporation, McLean, VA
IBM Corporation, Cape Canaveral, FL
IBM Training Center, Lexington, KY
IBM Corporation, New York City (Madison Ave), NY
MCA - Disco-Vision, Inc., Universal City, CA
UNIVAC Division (Sperry Rand), St. Paul, MN
Honeywell Systems Research Div., Minneapolis, MN
McDonnell Douglas Astronautics, St. Louis, MO
Hewlett Packard, San Francisco, CA
Hughes Aircraft, Los Angeles, CA
Ling-Temco Vought, Dallas, TX
Grumman Aircraft, Bethpage, NY
Jet Propulsion Laboratories, San Francisco, CA

GOVERNMENT (Non-Military)

NASA-Ames, San Francisco, CA
NASA-Houston, TX (Support Training Dept.)

ACADEMIC

Columbia University, New York City, NY
New York Institute of Technology, (CAI Center), Old Westbury, NY
Florida State University, Tallahassee, FL
Educational Testing Service, Princeton, NJ

APPENDIX I

CONTACTS FOR COMPUTER MANAGED INSTRUCTION

Dr. Michael W. Allen
Ohio State University
Office of Academic Affairs
1080 Carmack Road
Columbus, OH 43210 PH 614-422-9821

John A. Anderson
UNIVAC
UNIVAC Park
St. Paul, MN 55165 PH 612-331-4141

Dr. F.J. Blaisdell
UNIVAC
1333 Camino Del Rio S.
San Diego, CA 92108 PH 714-291-4211

Dr. William T. Blessum
Biometrics Laboratory
California College of Medicine
University of California
Irvine, CA 92664 PH 714-833-7418

Charles R. Bowen
IBM
Astor's Lane
Sands Point, Point Washington, NY
11150 PH 516-883-5400

Patrick M. Casey
Systems Maintainability and Systems
Prog., UNIVAC
St. Paul, MN 55165 PH 612-645-8511

Dr. David J. Chesler
Navy Personnel Research and Develop-
ment Center
San Diego, CA 92152 PH 714-225-7121

Dr. G. Ronald Christiansen
Ohio State University
Bevis Hall
Columbus, OH 43210 PH 614-422-9821

Dr. Perrin S. Cohen
Psychology Department
Florida State University
Tallahassee, FL 32306 PH 904-599-2008

Dr. B. Ward Deutschman
Learning Management and Resources
Center
New York Institute of Technology
Old Westbury, NY 11568

Dr. Walter Dick
Florida State University
CAI Center
Tallahassee, FL 32306 PH 904-599-4775

James B. Dolkas
NASA-AMES Research Center
Moffett Field, CA 94035
PH 415

Dr. Warren D. Dolphin
Biology Program
201 Bessey Hall
Iowa State University
Ames, IA 50010 PH 555-294-8451

Dr. Thomas Dudley
Pepperdine University
1121 W. 79th Street
Los Angeles, CA 90044 PH 213-752-4022

Gordon Ferguson
NASA Manned Space Flight Center
Houston, TX 77058 PH 713-483-5169

Dr. John Ford
Navy Personnel Research and Develop-
ment Center
San Diego, CA 92152 PH 714-225-7121

Thomas Gillespie
U.S. Army and Training Doctrine
Command
Fort Monroe, VA 23351 PH AV 680-1110

Frank Guinti
U.S. Army Signal Center and School
Ft. Monmouth, NJ 07703 PH 201-532-4408/
3115

CONTACTS FOR COMPUTER MANAGED INSTRUCTION (CONT'D)

Harry Hammerdinger Vought Aeronautics (LTV) Arlington, TX PH 214-266-2011	Capt. William G. Kemple, USMC U.S. Marine Corps Communication-Electronics School Twentynine Palms, CA 92278 PH 714-367-9111 X 6674/6477
Dr. Duncan N. Hansen Memphis State University Memphis TN 38152 PH 901-321-1406	Lt. R. Kluckhohn, USN Naval Air Station, Moffett Field Sunnyvale, CA 94035 PH 415-966-5082
Dr. Larry Harding Human Resources Lab. Lowry AFB, CO 80230 PH 303 +4385	Dr. H. Dewey Kribs Navy Personnel Research and Development Center San Diego, CA 92152 PH 714-225-7121
Dr. Albert Hickey ENTELEX, Inc. Newburyport, MA 01950 PH 617-465-3000	John F. Kropf Hewlett-Packard 11000 Wolfe Road Cupertino, CA 95014 PH 408-257-7000
Col. G.B. Howard, USA U.S. Army Signal Center and School Ft Monmouth, NJ 07703 PH 201-532-3380	A.A. Longo U.S. Army Signal Center and School Ft. Monmouth, NJ 07703 PH 201-532-4328
Dr. Richard Hurlock Navy Personnel Research and Development Center San Diego, CA 92152 PH 714-225-7121	CDR. Richard Martin, USN VF 2 Naval Air Station, Miramar San Diego, CA 92145 PH 714-271-2152
Dr. Kirk Johnson CMI Project Naval Air Station Memphis, TN 38054 PH 901-872-5289	Lt.Col. Robert Mason, USMC U.S. Marine Corps Communication-Electronics School Twentynine Palms, CA 92278 PH 714-367-9111
Dr. Edward Jones McDonnell Douglas Astronautics Corporation Lambert Airport St. Louis, MO 63166 PH 314-232-6681	Dr. Barbara McCombs McDonnell Douglas Astronautics Corp. Bldg 107, Level I, Box 516 St. Louis, MO 63166 PH 314-232-6743
Bill F. Judis VF 124 FRAMP Naval Air Station, Miramar San Diego, CA 92145 PH 714-271-2239	Dr. Gene Micheli Naval Training Equipment Center Code N-00T Orlando, FL 32813 PH 305-646-5198
Dr. Milton Katz Mitre Corporation 1820 Dolly Madison Boulevard McLean, VA 22101 PH 703-893-3500	

CONTACTS FOR COMPUTER MANAGED INSTRUCTION (CONT'D)

Morris G. Middleton Naval Training Equipment Center Code N-00T Orlando, FL 32813 PH 305-646-4367	Harvey Pollack Learning Management and Resources Center New York Institute of Technology Old Westbury, NY 11568 PH 516-626-3400
Edward G. Morrett Texas Instruments, Inc. P.O. Box 5012, M/S 84 Dallas, TX 75222 PH 214-238-3741	WO R. J. Rezabek, USN VA 122 Naval Air Station, Lemoore Lemoore, CA 93245 PH 209-998-3278
Walter G. Nagel Systems Maintainability and Systems Prog., UNIVAC 1287 Lawrence Station Road Sunnyvale, CA 94086 PH 408-734-4780	Dr. F. Worth Scanland Training Implementation Division Chief of Naval Education and Training (Code 352) Pensacola, FL 32508 PH 904-452-2344
Jacques Navaux Hughes Aircraft Corporation P.O. Box 90515 Los Angeles, CA 90009 PH 213-670-1515	William Stobie McDonnell Douglas Astronautics Corp. Lambert Airport St. Louis, MO 62166 PH 314-232-6743
LCDR T. L. Nelson, USN VA 122 Naval Air Station, Lemoore Lemoore, CA 93245 PH 209-998-3132	Dr. Dewey Slough Navy Personnel Research and Develop- ment Center San Diego, CA 92152 PH 714-225-7121
Dr. Harold F. O'Neil University of Texas Austin, TX 20012	Donald Smith NASA Manned Space Flight Center Houston, TX 77058 PH 713-483-5169
Dr. Robert P. O'Reilly Bureau of School and Cultural Research New York State Education Department Room 481, Annex Washington Avenue Albany, NY 12225 PH 518-474-2121	Gordon A. Smith Jet Propulsion Laboratory 4800 Oak Grove Drive M/S 125-143 Pasadena, CA 91103 PH 213-354-5429
Thomas O'Sullivan Raytheon Corporation 1847 Westmain Road Portsmouth, NH 03801 PH 617-449-9521	Jan Smith UNIVAC 28035 N. Stanford P.O. Box 5520 Valencia, CA 91355
Clarence Papetti Naval Training Equipment Center Code N-00T Orlando, FL 32813 PH 305-646-4367	Dr. Roulette W. Smith Departments of Psychology and Education University of California Santa Barbara, CA 93106 PH 805-961-4078

CONTACTS FOR COMPUTER MANAGED INSTRUCTION (CONT'D)

Dr. Patrick Suppes
Stanford University
Stanford, CA 94305 PH 415-321-2300
X 3111

E. A. (AL) Thompson
Hughes Aircraft Corporation
P.O. Box 90515
Los Angeles, CA 90009 PH 213-670-1515
X 6415

Charles M. Tilley
CMI Project
Naval Air Station
Memphis, TN 38054

Gerald O. White
UNIVAC Division
3500 Virginia Beach Blvd.
Virginia Beach, VA 23452
PH 804-486-3545

A. J. Whitehurst
Aerospace Group
Hughes Aircraft Company
P.O. Box 90515
Los Angeles, CA 90009 PH 213-670-1515
X 6382

Dr. Wilson Wong
IBM Corporation
Lexington, KY 40507 PH 606-233-2000

Joseph Y. Yasutake
Human Resources Laboratory
Lowry AFB, CO 80230 PH 303-394-4385

DOCUMENT CONTROL DATA - R & D

(Security classification of title, body of abstract and indexing annotation must be entered when the overall report is classified)

1. ORIGINATING ACTIVITY (Corporate author) Naval Training Equipment Center Training Analysis and Evaluation Group Orlando, Florida 32813	2a. REPORT SECURITY CLASSIFICATION Unclassified
	2b. GROUP

3. REPORT TITLE
Computer Managed Instruction in Navy Training

4. DESCRIPTIVE NOTES (7) (e of report and inclusive dates)
Final Report

5. AUTHOR(S) (First name, middle initial, last name)
Morris G. Middleton; Clarence J. Papetti and Gene S. Micheli, Ph.D.

6. REPORT DATE March 1974	7a. TOTAL NO. OF PAGES 106	7b. NO. OF REFS 67
-------------------------------------	--------------------------------------	------------------------------

8a. CONTRACT OR GRANT NO.	9a. ORIGINATOR'S REPORT NUMBER(S) TAEG Report No. 14
b. PROJECT NO.	
c. Work Assignment No. 1083	
d.	
9b. OTHER REPORT NO(S) (Any other numbers that may be assigned this report)	

10. DISTRIBUTION STATEMENT
Approved for public release; distribution is unlimited.

11. SUPPLEMENTARY NOTES	12. SPONSORING MILITARY ACTIVITY
-------------------------	----------------------------------

13. ABSTRACT

This report presents the findings of a six-month study undertaken to investigate the feasibility of Computer Managed Instruction (CMI) for the Navy in three areas: (a) large-scale centralized computer system for all formalized Navy training, (b) minicomputers for small, remote classes, and (c) use of shipboard computers for managing individual training aboard ships. Specifically, the report encompasses:

- . An overview of CMI.
- . The state-of-the-art of CMI in the military, government, industry, and education.
- . The feasibility of minicomputers for CMI.
- . The feasibility of shipboard computers for CMI.
- . The feasibility of a centralized computer center for CMI.
- . An overview of computer languages for CMI.
- . Rationale and criteria for selecting Navy courses for CMI.
- . An overview of instructional terminals for CMI.



14

KEY WORDS

LINK A

LINK B

LINK C

ROLE

WT

ROLE

WT

ROLE

WT

Computer Managed Instruction
Training
Computers
Individualized Instruction
Management Systems

DISTRIBUTION LIST

UNIVAC (John A. Anderson, Dr. F.J. Blaisdell, Patrick M. Casey, Walter G. Nagel, Jan Smith, Gerald O. White)	Hughes Aircraft Corporation (Jacques Navaux, E.A. Thompson)
University of California (Dr. William T. Blessum, Dr. Roulette W. Smith)	VA 122 (LCDR T.L. Nelson, USN, WO Rezabek, USN)
IBM Corporation (Charles R. Bowen, Dr. Wilson Wong)	NASA Manned Space Flight Center (Gordon Ferguson, Donald Smith)
Ohio State University (Dr. G. Ronald Christiansen, Dr. Michael W. Allen)	NASA-AMES Research Center (James B. Dolkas)
Navy Personnel Research and Development Center (Dr. David J. Chesler, Dr. Richard Hurlock, Dr. H. Dewey Kribs, Dr. Dewey Slough, Dr. J. Ford)	Iowa State University (Dr. Warren E. Dolphin)
Florida State University (Dr. Perrin S. Cohen, Dr. Walter Dick)	Pepperdine University (Dr. Thomas Dudley)
U.S. Army Signal Center and School (Frank Guinti, A.A. Longo, Col. G.B. Howard, USA)	Vought Aeronautics (LTV) (Harry Hammerdinger)
New York Institute of Technology (Dr. B. Ward Deutschman, Harvey Pollack)	Memphis State University (Dr. Duncan N.Hansen)
Lowry AFB (Joseph Y. Yasutake, Dr. Larry Harding)	ENTELEX, Inc. (Dr. Albert Hickey)
Naval Air Station, Memphis (Dr. Kirk Johnson, Charles M. Tilley)	VF 124 FRAMP (W.F. Judis)
McDonnell Douglas Astronautics Corp. (Dr. Edward Jones, Dr. Barbara McCombs, William Stobie)	Mitre Corporation (Dr. Milton Katz)
Communication-Electronics School, Twentynine Palms (Capt. William G. Kemple, USMC, Lt.Col. Robert Mason, USMC)	Naval Air Station, Moffett Field (LT R. Kluckhohn, USN)
	Hewlett-Packard (John F. Kropf)
	VF 2 (CDR Richard Martin, USN)
	Defense Documentation Center (12 cys)
	NWL (B. Duren)
	Texas Instruments, Inc. (Edward G. Morrett)

University of Texas (Dr. Harold F.
O'Neil)

New York State Education Department
(Dr. Robert P. O'Reilly)

Raytheon Corporation (Thomas
O'Sullivan)

Chief of Naval Education and Training
(Dr. F. Worth Scanland)

Jet Propulsion Laboratory (Gordon A.
Smith)

Stanford University (Dr. Patrick
Suppes)

U.S. Army and Training Doctrine
Command (T. Gillespie)

Industrial College of Armed Forces
(LtCol Gene Sherron)

National Defense Headquarters Ottawa
(Commander J. L. Belyea)

CNETS (Dr. Alfred R. Fregly, LCDR R. J.
Biersner)

CNET (CDR Curt English)

CO Naval Education and Training
Support Center, NORVA

Chief of Naval Reserve (Code O2)

Commander, Naval Ship Systems Command
(James R. Curtin, SHIP 0470)

Navy Personnel Research and Development
Center (Dr. James J. Regan)

COMPUTER MANAGED INSTRUCTION IN NAVY TRAINING
FINAL REPORT. 1974, 106p., 9 illus., 1 table, 67
refs.

This report presents the findings of a six-month study undertaken to investigate the feasibility of Computer Managed Instruction (CMI) for the Navy in three areas: (a) large-scale centralized computer system for all formalized Navy training, (b) mini-computers for small, remote classes, and (c) use of shipboard computers for managing individual training aboard ships. Specifically, the report encompasses:

• An overview of CMI.

KEY WORDS

Computer Managed Instruction
Training
Computers
Individualized Instruction
Management Systems

Naval Training Equipment Center
Middleton, M.C.; Papetti, C.J.;
and Micheli, G.S.
NAVTRAEQUIPCEN
Work Assignment no. 1083

COMPUTER MANAGED INSTRUCTION IN NAVY TRAINING
FINAL REPORT. 1974, 106p., 9 illus., 1 table, 67
refs.

This report presents the findings of a six-month study undertaken to investigate the feasibility of Computer Managed Instruction (CMI) for the Navy in three areas: (a) large-scale centralized computer system for all formalized Navy training, (b) mini-computers for small, remote classes, and (c) use of shipboard computers for managing individual training aboard ships. Specifically, the report encompasses:

• An overview of CMI.

KEY WORDS

Computer Managed Instruction
Training
Computers
Individualized Instruction
Management Systems

Naval Training Equipment Center
Middleton, M.C.; Papetti, C.J.;
and Micheli, G.S.
NAVTRAEQUIPCEN
Work Assignment No. 1083

- The state-of-the art of CMI in the military, government, industry, and education.
- The feasibility of minicomputers for CMI.
- The feasibility of shipboard computers for CMI.
- An overview of computer languages for CMI.
- Rationale and criteria for selecting Navy courses for CMI.
- An overview of instructional terminals for CMI.

- The state-of-the art of CMI in the military, government, industry, and education.
- The feasibility of minicomputers for CMI.
- The feasibility of shipboard computers for CMI.
- An overview of computer languages for CMI.
- Rationale and criteria for selecting Navy courses for CMI.
- An overview of instructional terminals for CMI.

Learning Equipment Center, Orlando, FL
Report 14

UNCLASSIFIED
AD

COMPUTER MANAGED INSTRUCTION IN NAVY TRAINING
FINAL REPORT. 1974, 106p., 9 illus., 1 table, 67
refs.

This report presents the findings of a six-month study undertaken to investigate the feasibility of Computer Managed Instruction (CMI) for the Navy in three areas: (a) large-scale centralized computer systems for all formalized Navy training, (b) mini-computers for small, remote classes, and (c) use of shipboard computers for managing individual training aboard ships. Specifically, the report encompasses:

An overview of CMI.

KEY WORDS
Computer Managed Instruction
Training
Computers
Individualized Instruction
Management Systems

UNCLASSIFIED
AD

COMPUTER MANAGED INSTRUCTION IN NAVY TRAINING
FINAL REPORT. 1974, 106p., 6 illus., 1 table, 67
refs.

This report presents the findings of a six-month study undertaken to investigate the feasibility of Computer Managed Instruction (CMI) for the Navy in three areas: (a) large-scale centralized computer systems for all formalized Navy training, (b) mini-computers for small, remote classes, and (c) use of shipboard computers for managing individual training aboard ships. Specifically, the report encompasses:

An overview of CMI.

Naval Training Equipment Center, Orlando, FL
TR TAEG Report 14

UNCLASSIFIED
AD

COMPUTER MANAGED INSTRUCTION IN NAVY TRAINING
FINAL REPORT. 1974, 106p., 6 illus., 1 table, 67
refs.

This report presents the findings of a six-month study undertaken to investigate the feasibility of Computer Managed Instruction (CMI) for the Navy in three areas: (a) large-scale centralized computer systems for all formalized Navy training, (b) mini-computers for small, remote classes, and (c) use of shipboard computers for managing individual training aboard ships. Specifically, the report encompasses:

An overview of CMI.

KEY WORDS
Computer Managed Instruction
Training
Computers
Individualized Instruction
Management Systems

UNCLASSIFIED
AD

COMPUTER MANAGED INSTRUCTION IN NAVY TRAINING
FINAL REPORT. 1974, 106p., 6 illus., 1 table, 67
refs.

This report presents the findings of a six-month study undertaken to investigate the feasibility of Computer Managed Instruction (CMI) for the Navy in three areas: (a) large-scale centralized computer systems for all formalized Navy training, (b) mini-computers for small, remote classes, and (c) use of shipboard computers for managing individual training aboard ships. Specifically, the report encompasses:

An overview of CMI.

- An overview of instructional terminals for CMI.
- Rationale and criteria for selecting Navy courses for CMI.
- An overview of computer languages for CMI.
- The feasibility of shipboard computers for CMI.
- The feasibility of minicomputers for CMI.
- The state-of-the art of CMI in the military, government, industry, and education.

- An overview of instructional terminals for CMI.
- Rationale and criteria for selecting Navy courses for CMI.
- An overview of computer languages for CMI.
- The feasibility of shipboard computers for CMI.
- The feasibility of minicomputers for CMI.
- The state-of-the art of CMI in the military, government, industry, and education.