

DOCUMENT RESUME

ED 089 103

CE 001 159

TITLE Speeches Presented at the Annual National Leadership Development Seminar for State Directors of Vocational Education, (6th, Nashville, Tennessee, September 18-21, 1973).

INSTITUTION Ohio State Univ., Columbus. Center for Vocational and Technical Education.

PUB DATE Sep 73

NOTE 293p.

EDRS PRICE MF-\$0.75 HC-\$13.80 PLUS POSTAGE

DESCRIPTORS Career Education; Decision Making; *Educational Administration; *Leadership; Management; Management Information Systems; Management Systems; Performance Specifications; Program Evaluation; Seminars; Speeches; *State Agencies; State Boards of Education; State Departments of Education; Statewide Planning; *Vocational Education

IDENTIFIERS Fiedler (F E)

ABSTRACT

Following a welcoming address by the Governor of Tennessee, fifteen speeches were presented at the seminar. W. H. Pierce examined approaches to educational governance at the State level. Management, its efficiency, effectiveness, and organization, was the topic of several speeches (J. D. Mills, D. K. Gentry and C. F. Lamar). The development of performance based objectives was discussed by O. C. Behling, and the use of performance based objectives in statewide planning was the emphasis of D. L. Parks' presentation. Program evaluation was the topic of concern in speeches by R. S. Schendorf and by N. McCaslin. Aspects of career education were the focal point in both Wm. L. Smith's "The Greening of Career Education" and W. N. Suzuki's "A System for Upgrading Career Guidance Programs". The "Tennessee Management Information System" by Wm. M. Harrison and a discussion of a systems approach to management by C. H. Johnson, Jr., provided additional material. Iowa's approach to vocational education administration was described by Wm. O. Schuermann. A speech reviewing F. E. Fiedler's Contingency Model of leadership effectiveness presented by T. R. Mitchell and an analysis of techniques for administrative decision-making by D. E. Koble also contributed to the seminar. (AG)

ED 089103

U.S. DEPARTMENT OF HEALTH,
EDUCATION & WELFARE
NATIONAL INSTITUTE OF
EDUCATION

THIS DOCUMENT HAS BEEN REPRO-
DUCED EXACTLY AS RECEIVED FROM
THE PERSON OR ORGANIZATION ORIGIN-
ATING IT. POINTS OF VIEW OR OPINIONS
STATED DO NOT NECESSARILY REPRESENT OFFICIAL NATIONAL INSTITUTE OF
EDUCATION POSITION OR POLICY.

Speeches Presented at the Sixth Annual National Leadership Development
Seminar for State Directors of Vocational Education

September 18-21, 1973
Sheraton Nashville Hotel, Nashville, Tennessee

E 001 159

Governor Winfield Dunn
Sixth Annual National Leadership
Development Seminar
National Association of State
Directors of Vocational Education
Nashville, Tennessee
September 18, 1973 9:30 a.m.

Mr. Orr, Commissioner Smith, Commissioner Carmichael, Bill Harrison,
State Vocational Education Directors, Ladies and Gentlemen:

It is my great pleasure to welcome each of you to Nashville for the Sixth Annual National Leadership Development Seminar for State Directors of Vocational Education. I applaud The Center for Vocational and Technical Education for sponsoring this annual conference, and especially for the decision to convene this year in the great state of Tennessee. I extend you our hospitality and any knowledge we may possess, and I know Tennessee will benefit from the thoughts that will be shared in this seminar.

In thinking about the subject of vocational education, I am reminded of a relatively unknown chapter of Tennessee history. I doubt that many of you are aware of the small community of Rugby, Tennessee, in the Cumberland Mountains some 125 miles east of here. It is, however, listed on the National Register of Historic Sites in recognition of its national significance.

In 1880, Thomas Hughes, the English statesman, novelist, and philanthropist, established the Rugby colony for certain sons of the aristocracy. These lads were brought to Tennessee because their society denied them a basic right, the right to pursue the vocation of their choice. These young men wanted to learn manual trades, endeavors which were not considered "respectable," at a time when the English educational system had nothing to offer but preparation for the "learned professions" of medicine, law, and the clergy.

Unfortunately, some sectors of our society still regard the trades as less than respectable. No one has more forcefully indicted this attitude than U. S. Assistant Secretary of Education Sidney Marland. In a recent speech, he noted that "Education that is class-conscious, separating collars by color, cannot be a source of equality but of divisiveness, inevitably weakening and blurring the mutual respect and understanding upon which American Society is intended to stand." Secretary Marland is, as you know, the foremost advocate of a concept called "Career Education" as the remedy to this divisive dichotomy of our educational system. For a few moments, I would like to relate our efforts to interpret and implement this concept in Tennessee.

Many educators and public officials have tried to define the concept of Career Education. I prefer to think of it simply: Career Education is the common sense idea that all our citizens should receive the type of education which will enable them to have satisfying and productive lives.

Career Education, itself, is not a program. In fact, one aspect of this concept is the realization that all education is Career Education, but not all our education is good Career Education. The emphasis on this concept is an attempt to increase the value of our instructional efforts to our citizens and their lifework.

The essence of Career Education is that all educational activities should be aimed at assisting the individual to analyze his abilities and interests and provide him the necessary information, guidance, and skill development to help him achieve a self-determined career objective. In addition, education must give the student the opportunity -- and the knowledge to take advantage of it -- to leave the system at any of several appropriate points fully prepared for the occupation he or she has chosen.

The alternatives, either dropping out without sufficient skills or becoming overqualified for the chosen career, are proven plagues to our economy and society.

One example of the efforts of this administration is the million dollar special industry training program begun last year to provide workers trained to meet specific needs of Tennessee industries. But most important is the current planning of the Department of Education designed to provide vocational education opportunities for all high school students by 1977, serving at least 50 percent in each county, as well as prevocational instruction in junior high.

The Department of Education will present a comprehensive vocational education plan to the next session of the General Assembly. The funds available for this purpose will then be applied to this plan in order to progress toward the 1977 goal. Of course, a primary emphasis will be placed on the best utilization of the existing comprehensive high schools and area vocational-technical schools in developing a coordinated system of comprehensive vocational education.

We lose sight of the reason for this program unless we weigh its impact in human terms. For example, we know that more than a quarter of Tennessee's 9th grade students never reach high school graduation. This dropout rate is tragic in a society of increasing specialization and reliance on formal training.

What does a high school dropout have to look forward to? Fifty years ago, his prospects were not bad, because he was often competing with individuals with a similar lack of formal education.

But in 1973, a high school dropout is often doomed to a life of

drifting from one minimum wage job to another, with periods of unemployment in between. All because of the competitive disadvantage of not possessing a diploma.

In comparison, what can a student in one of the new comprehensive vocational education programs expect when he or she leaves school? He can expect to enter a labor market where his skill will be rewarded by a meaningful wage. Perhaps even more important, he will possess a skill which industry wants and needs and which gives him the flexibility to find a self-supporting and self-fulfilling job, he will be, in short, a productive member of society.

It is with this prospect of investing in persons who will build a better Tennessee and a better nation that I look upon our planning efforts for comprehensive vocational education. Even more satisfying is the knowledge that we as Tennesseans are giving other Tennesseans the opportunity to develop their potentials and their self-esteem.

Each state represented here is engaged in varying degrees and in various ways in the effort to make our educational system better serve the needs of students and society. In my opinion, there is no more important endeavor. I applaud each of you for taking the time to multiply our progress through sharing and cooperation. There are more than 50 million good reasons -- the school age children of this nation -- why your time will be well-spent.

Thank you.

TIME FOR THE EDUCATIONAL SUPERBOARD?

INTRODUCTION

Most studies of state educational agencies deal with the state department of education serving elementary-secondary education or with the coordinating or governing boards serving postsecondary education. At the elementary-secondary level, Dr. Roald Campbell is in the midst of a study of educational governance in the states, focusing on state agencies. At the same time, the Education Commission of the States has a major task force studying coordination, governance and structure of postsecondary education. But is anyone taking an overall look at governance for all levels of education at the same time? Can we afford to let each level of education continue an almost independent quest for state support? Or shouldn't we be searching now for a cohesive approach to governance and funding for all education?

As the states strengthen their leadership role in education, backed up by the recent Supreme Court decision on the Rodriguez school finance case, general and special revenue sharing before the Congress, the "new federalism" philosophy of the current federal administration, the emphasis in the 1972 amendments to the Higher Education Act and in particular the state coordinating commissions in section 1202 of that legislation, we must seriously rethink state governance patterns for education at all levels. This task is complicated by the diversity of the states, their unique problems, and therefore our inability to establish a single pattern or even guidelines for a pattern that will assure effective operation of state agencies.

In considering the diverse approaches taken by states, it might be useful to schematize the major structures at this time. States provide overall direction and guidance to education through agencies, departments, or boards organized in a variety of ways. Some of these may be virtually autonomous. In some states the administrators or board members are appointed by the governor; in others they are elected by the people. While some states have one board for all education agencies, others have separate agencies for each level and sometimes for the several institutions on one level or another. The following are examples of how the states have organized their various education divisions.

A few States have:

One Agency for All Levels of Education

Examples: New York, Rhode Island, Pennsylvania

Several States have:

An Agency for Elementary and Secondary Schools Including Vocational Education

-and-

A Legal State Coordinating or Governing Agency for Higher Education

Examples: Georgia, Connecticut, California

Some States have:

An Agency for Elementary and Secondary Schools

-and-

An Agency for Vocational Education

-and-

A Legal State Coordinating or Governing Agency for Higher Education

Examples: Colorado, Oklahoma, Washington

Still others have:

An Agency for Elementary and Secondary Schools Including Vocational Education	-and-	Governing Boards for Individual Institutions but No Legal Statewide Agency for Higher Education
---	-------	---

Examples: Delaware, Nebraska, Vermont

Obviously, there are a variety of ways in which a state can organize its educational governance. No evidence exists supporting any particular plan for a given state, nor is it possible under most conditions to copy one state's plan in another state. While there are problems and recommendations expressed by scholars in this area, there seems to be little hard evidence of the effectiveness and efficiency of one approach or another. Though some states have enjoyed a stable governing structure for a number of years, most states have this issue under study by legislative committees and education organizations continuously, the only consistency being that they want a change. But in many cases change is not simple because of constitutional limitations, deep-seated commitments to certain principles of structure, and political considerations inhibiting change.

State Departments of Education (Primarily Elementary-Secondary)

Of the 50 states and the territories, only Wisconsin is without a state board of education for the state elementary-secondary system. Forty-six of the other 55 state boards of education serve also in the capacity of the state board for vocational education. Eight states (Colorado, Illinois, Indiana, Oklahoma, Washington, Wisconsin, Puerto Rico, the Virgin Islands) and the District of Columbia have a separate board for vocational education. The state board responsible for vocational education

is the state board of education in 46 states, the state board of vocational education in 9 states, and the board of regents of the state university in 1 state. Board members secure positions by election by the people or representatives of the people, appointment by the governor, or automatically by virtue of the position title held.

Chief State School Officers are elected by popular vote in 19 states. In 28 states, they are appointed by the state board of education. In 9 states the Chief is appointed by the governor.

Since 1812, when New York first provided state supervision for education, state agencies have evolved through three stages. First, they were primarily designed for gathering statistics. Then they went through the inspector stage, and finally have assumed the role of providing leadership, planning and technical assistance to improve education. This latter role received great impetus by the passing of the Elementary and Secondary Education Act of 1965, and in particular through Title V, which permitted expansion of staff and redefinition of function. Progress has been marked since that date. However, there are indications that where federal funds were limited to categorical program administration, serious imbalances in staffing of state agencies occurred and gaps in needed services existed.

As state agencies developed functions to assist in providing leadership to local school systems, the following became significant roles for the agencies: 1) establishing goals, 2) developing policies, 3) planning needed changes, 4) determining priorities, 5) devising specific steps, procedures and strategies for attaining goals, and 6) developing and implementing appropriate procedures for continuous evaluation of programs.¹

¹ Dochterman, Clifford L. and Beshoar, Barron B., Directions to Better Education, Project on Improving State Leadership in Education, Denver, Colorado, 1970, pp. 13-14.

Coordinating and Governing Agencies for Postsecondary Education

The last seven years have seen the rapid establishment of either coordinating or governing boards to deal with the administration of postsecondary education. Currently 27 states have a statewide coordinating agency, 20 have governing boards and 3 either have no agency or a voluntary agency. Statistics about the establishment of these agencies at the higher education level fail to reflect the complexity of the governance of postsecondary education. In states where there are councils for coordinating higher education, there are quite frequently many governing boards representing different institutions, or classes of institutions and, in some cases, at least for the planning aspect, representing private and proprietary as well as public institutions. Oregon and New York are illustrations of this over-arching responsibility.

It should be stressed again that state agencies operating either as coordinating or governing boards at the state level are of recent origin. In most states their structure and functions are under continual legislative scrutiny. In many states little coordination is exercised between postsecondary and elementary-secondary state agencies. In some states, educational functions fall between the cracks of the operations of these various boards; or where the functions overlap there is little coordination.

Vocational/technical education and, in its broad aspects, career education, have suffered from this confusion. Congress attacked this problem by providing for designation or creation of state postsecondary education commissions in section 1202 of the Education Amendments of 1972. These commissions were to be charged with responsibility for comprehensive planning for postsecondary education including some articulation in

occupational education with elementary-secondary education. However, through withholding of guidelines no effective leadership has come from the federal government in implementing the commissions. In addition, these coordinating commissions and superboards are quite frequently feared by educators at the various levels because of the danger of loss of immediate control. For many years education was treated as a fourth form of government independent of local, state and federal general government. Educators abhorred an interrelationship with or controls by general government and they were fearful of any relationships with politicians. They said "Give us the money and we will determine how to educate your children." But Sputnik and federal aid in the sixties changed all that. Education became one of the major domestic issues. Politicians found that positions on educational issues gave them political mileage.

As the cost of education mounted and its visibility continued to increase, the general public became disenchanted with the idea that more money meant better education. Surveys found the public uncertain about the ability of the educational structure to offer the quality and diversity of education necessary to meet future needs.

Since in many states education accounted for 50% or more of the state's expenditures, governors expressed the desire for closer control over this activity. With the support of legislatures, state governments were reorganized to establish a secretary of education responsible for all education or some similar title appointed by the governor operating as a cabinet member. Massachusetts, Pennsylvania, South Dakota and Virginia have followed this pattern, but it is still too new to offer any evaluation of its effectiveness.

Strengths and Weaknesses of State Agencies

As stated previously, the most serious problem faced by political and educational leaders involved in the restructuring of the governance of education is the lack of hard data on the effectiveness of existing operations. Because of the uniquenesses of state structures, criteria for evaluation must be developed state by state to be responsive to their unique evolutionary processes.

Identifiable strengths and weaknesses in any governing structure are interpreted variously, dependent upon the position of the viewer in that structure and his concept of what it should accomplish. State officials quite frequently can be pleased with a given function because of its preciseness, supportive data, etc., but educators may be disturbed because of its failure to meet the diverse educational needs of the state. In fact, I do not know anyone who has sufficient grasp of the overall governing structure in the various states to give quantitative evaluation of strengths and weaknesses. This certainly is an area for further research. However, a couple of weaknesses can be identified and will be recorded later in this paper.

CHANGE IN THE GOVERNANCE OF EDUCATION

During the 1960's, both educators and politicians had hoped that the federal government would furnish the impetus and resources for sweeping changes in education. The Elementary and Secondary Education Act, the Vocational Education Act of 1963 and the Amendments of 1968, and the Higher Education Act of 1965 all seemed to open new vistas for the solution of educational problems. In fact, all made major contributions to our thinking

today. They helped sharpen our focus, identify our problems, and give a realism to our priorities. But by the late '60's and certainly into the early '70's we became aware that the federal government was not going to maintain this leadership role, and as I noted before, the state responsibility for education was re-emphasized.

Now aid from the federal government for education is moving away from categorical to larger block grants, general aid, or aid to the student rather than the institution. Another trend is the move toward the free marketplace for tax dollars to students so they can buy the kind of education they wish. Public education or education in general is under attack. The public has begun to question the dollars it takes to educate our children and youth. The notion of education for education's sake is gradually passing, and preparation for a career is becoming the goal of youth. The reordering of students' interests is shaking the very foundations of education. The status quo is not good enough. Change is a requirement and diversity in education is the "in" word. Parents and youth are concerned about what they get from education, what it permits them to do, what kind of a life it leads to. And so accountability, while all too frequently applied only to the teacher or the professor, now is sifting back through the structure and is being applied to the superintendent, president, state educational executives, the legislator and the governor. All this means that the states must look at their education governance structure to find ways to overcome each duplication, and to promote articulation in answering the question of how effective and efficient this structure operates.

These are some of the conditions and problems that educational governance must cope with:

- (a) Fragmentation among state agencies and the resulting competition, duplication, and dissipation of resources.
- (b) Competing priorities within education, and between education and other public agencies, for state funds.
- (c) Growing insistence by legislators, executives, and the general public for education accountability.
- (d) Increased congressional support for grant and program consolidation for special education revenue sharing in elementary-secondary education -- although this is not extended by the Administration to postsecondary education.
- (e) Clearer recognition on the part of state and federal governments of the need for continuity in career education.
- (f) Shifting emphasis federally (at least on the part of the Administration) to aid students rather than institutions in postsecondary education and to support a "free-market" concept at a time when competition for enrollments is escalating.
- (g) Increased emphasis on the need for encompassing the range of postsecondary education -- public, private, and proprietary -- in any planning or funding effort.
- (h) Continued dissatisfaction with the effectiveness of education at the various levels of education, along with concern for evaluations based more on output than on input.
- (i) Ferment within both elementary-secondary and postsecondary education in relation to innovation and change.
- (j) Demographic changes, including dropping birthrates and decreasing school populations for the foreseeable future.

- (k) Increased concern for lifelong learning and the opening of educational opportunities to people of all ages.

While some of these changes will require precipitous action, most can be dealt with over time. The only danger is that procrastination and unwillingness to act will result in a continuous stream of precipitous actions in systems of governance and structures not geared to the needs of tomorrow. The challenge is then to direct our complex decision making process of federal, state, local and institutional levels to meeting the needs of next generation's youth and adults.

THE FUTURE IN STATE GOVERNANCE OF EDUCATION

Most educators are inclined to think that the major politics affecting education and structures established for the governance of education should be their prerogative. If they don't think those matters are their prerogative, then they are convinced that the people who make the decisions should have the result of their wisdom. In recent years it has become apparent to me that the major decisions affecting education are made in the political arena. The methods of governance in the various states will be determined by the legislatures of those states. Educators can have an input if they recognize that change is inevitable and are willing to participate constructively in this change process.

It behooves us to think through the kind of structure we wish, why we support it, and to accumulate the evidence necessary to interpret it. No single form of governance is best for all states. Each state must make its adaptations based upon its own evolution of governance. In addition,

they must keep in mind the constitutional limitations and legislative restrictions, since it frequently takes time to create an atmosphere for change. Systematic processes should be developed to re-align the functions to be performed by the governance system, to clarify functions to be performed at the state level, at the state and local levels, or, in the case of elementary-secondary education, by any intermediate governance units established. Consideration should also be given to uniquenesses that may exist between various sections of a state or various institutions of a state. As an illustration, states with rural areas and heavily populated metropolitan areas may wish to establish intermediate units in the sparse areas to make certain that equitable services are available to all children and youth.

This is the era of involvement. The diverse groups encompassing the citizenry of a state must have access to and, frequently, representation on the policy making groups governing our schools. The details of appointment versus election to various boards must meet the political test within each state, but some way must be found not only for involvement of citizens but for prestige to be assigned to such boards.

Because of the growing interrelationship between elementary-secondary and postsecondary education with the total range of education, including continuing education, meeting the test of diversity will necessitate either a "superboard" or overall board, such as found in New York, Oregon, Pennsylvania and Rhode Island, or some other mechanism such as a joint planning coordinating commission which makes it possible to develop comprehensive educational plans throughout the range of education. Boards

such as these, which have prestige and overall responsibility, must establish mechanisms so that the special service needs of vocational/technical, handicapped and early childhood education are met.

The mantle of leadership in education has been placed on the states. As governance is restructured, functions that are to be performed must be redefined. States must be in a position to carry out comprehensive planning, to establish priorities, to assess results, to fix accountability, and to offer the necessary technical assistance. As I look to the future, I see a responsive structure which meets the needs of overall education, with management and planning capabilities, and access to experts so that institutions and local school districts can function effectively.

The future educational governance structure at the state level must meet the following guidelines. It must be able to:

1. Furnish leadership for education across the board.
2. Establish priorities for the state, but be responsive to national needs.
3. Be sensitive and responsive to the political leadership of the state at the executive and legislative level.
4. Adjust to changing needs for leadership.
5. Plan, innovate and evaluate programs.
6. Bring about effective articulation between the levels of education.
7. Plan allocation of funds between the levels and by programs to best meet the education needs of the state.
8. Define functions to be performed by local school districts or, in the case of postsecondary education institutions, define functions performed by those institutions in contrast to state functions.

9. Adjust the structure within the state to meet unique needs such as sparsity or urban concentration.
10. Be structured so the diverse constituency within the state will have adequate representation and involvement.
11. Effectively manage its own personnel and functions.
12. Offer technical assistance to local districts and institutions.
13. Render service to its constituency, including the political decision makers.
14. Interpret the financial needs of education in competition with other human resource needs.
15. Make continual adjustment of the goals of education in keeping with societal needs.
16. Assess the outputs of education in relation to the state's goals for this most important state function.

This is my first attempt to set down my view of governance for all levels of education in light of the dominant state role. Much that I have said is based on observation; thus it does not have a sound research base. We need much more basic research into the structure and functions of state agencies to assist the decision makers as they restructure governance at the state levels. These activities all point to more effective leadership through better education for our citizens.

TENNESSEE MANAGEMENT INFORMATION SYSTEM

By

William M. Harrison
Assistant Commissioner
Vocational-Technical Education

The Center for Vocational and Technical Education
The Ohio State University

Presented At The

Sixth Annual National Leadership Development Seminar
For State Directors of Vocational Education

September 18-21, 1973

The Sheraton Nashville Hotel, Nashville, Tennessee

THE CENTER FOR VOCATIONAL
AND TECHNICAL EDUCATION

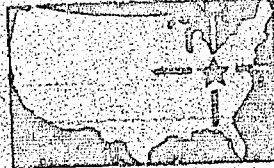

THE OHIO STATE UNIVERSITY
1630 Kenny Rd. Columbus, Ohio 43210

Tennessee Management Information System

INTRODUCTION

Wise decisions are based on careful considerations of all available information. Decisions that must be made without adequate information because such information does not exist, are not unwise, but are unfortunate.

Administration of educational programs whether on the federal, state, or local level is primarily a decision-making activity. Some decisions are relatively easy to make, the information needed is available and reliable, and the consequences of the decision are relatively minor. On the other hand, some decisions are quite difficult to make because available information is sketchy or questionable, with the consequences of such decisions having a major impact on programs and program development. Relevant, specific, and up-to-date information can have a significant effect on the general quality of educational decision-making. Good information helps to make all decision-making easier.

Making sure that appropriate information reaches the right decision-making levels at the right time is a tremendously important task and, I believe, a vital function of a state division of vocational-technical education. The Tennessee Management Information System for Vocational Education was created to meet that need.

We are not naive enough to think that any single system can collect, file, make available, and retrieve all of the minute objective, and sometimes subjective, information that has an impact on decision-making in vocational-technical education. However, there are some major types of important data that can be obtained, filed, and retrieved through a coordinated management information system.

GENERAL DESCRIPTION OF T.M.I.S.

The primary purpose of the Tennessee Management Information System at the present time is to provide information relative to program planning and evaluation. Our Management Information

System can be described as a cooperative effort of more than 150 autonomous local education agencies in the state that conduct vocational education programs. The Management Information System is the data based portion of the total information services program of the Tennessee Research Coordinating Unit for Vocational Education.

The Management Information System is a computer-oriented system that makes use of up-to-date electronic data processing technology and techniques. In this way it brings to public education in Tennessee some of the benefits that have long been in use by business and industry. This system makes possible the collection, filing, and retrieval of vast quantities of data that heretofore have been entirely unfeasible for public education administrators.

The total Management Information System envisioned for the Division of Vocational-Technical Education includes the following data files: (1) student information, (2) teacher, supervisor, and administrator information, (3) program evaluation information, (4) program cost information, (5) manpower needs information, and (6) census and related demographic information.

Currently, three of these data files are operating, with at least one to be added this year and others to be added as rapidly as possible. Our system has in operation the student file, the teacher, supervisor, and administrator file, and the census and demographic data files. This system utilizes primary and secondary data sources for input. A subsystem for compiling and analyzing appropriate data and an output subsystem that disseminates information and related data to appropriate decision-makers.

M.I.S. OBJECTIVES

The major objectives of our system can be summarized by the following five statements:

1. To collect and store as much data relevant to public vocational education programs as practical consideration will allow
2. To maintain the greatest flexibility by gathering and storing data on the smallest possible reporting unit (a single student)
3. To provide data tabulations for use at the state level as a whole and to smaller administrative units for their use
4. To disseminate to local educational agencies standard data on their own school system
5. To increase the use of stored data and special analyses to help solve specific problems.

SYSTEM COMPONENTS

As indicated earlier there are several data files currently operational in our system as well as several in the planning stages. The data base currently maintained is described below:

Student Accounting Subsystem

The student enrollment file contains individual records for each student enrolled in the public vocational technical education program in the state of Tennessee. The secondary school file contains records on approximately 102,000 students, 20,000 adult students enrolled in adult contract programs in local school systems, and approximately 25,000 students who are enrolled in area vocational-technical schools and their post-secondary and adult programs. Individual students enrolled in more than one program at any given time appear in multiple enrollment records, allowing tabulations of both duplicate and unduplicated student totals. Enrollment information currently collected and stored on each student includes:

- Name
- Address
- Sex
- Race
- Birthdate
- Marital status
- Veteran status
- Whether "Regular, Disadvantaged, or Handicapped" (determined by the teacher)
- Date enrolled in program
- U.S.O.E. occupational code for program
- Type program
- Grade level or adult classification
- Whether enrolled in another class
- U.S.O.E. code of other class (if applicable)
- Type school
- Type and number of vocational courses already completed
- Plans for additional vocational training
- Plans to remain in or leave county after training
- Parent's occupation
- Years parent has lived in county
- County, district, and school of enrollment
- Teacher social security number

Student information is collected on mark sense forms filled out by the student under the direction of the teacher who reads the process from a step-by-step script. The form consists of one sheet printed on both sides. Students are initially enrolled in September, with teacher verification of records and additional student updating occurring in January and May of each year.

Student Follow-Up Subsystem

Having all secondary students enrolled in vocational technical education in public schools in the student accounting subsystem, program completion and job placement information is much easier to handle. Follow-up information is also collected on mark sense forms. This system uses the teacher as a basis for the input. Currently, secondary student follow-up input information is verified on a sample basis with direct mail out and contact with the student. In other words, most of the information comes from the teacher and not from the student. Post-secondary follow-up information is obtained directly from the student with a follow-up being mailed to the student on his birthday. This provides for a continual year-round process of follow-up.

Personnel Information Subsystem

This file includes personnel records on all persons whose assignments are connected with vocational-technical education at the secondary or adult level. Approximately 2,400 personnel records are on file, including duplicate records of personnel assigned to secondary and adult programs.

Personnel information is also collected on a single-sheet, optical scan form printed on both sides. Step-by-step instructions are made available to all personnel filling out these forms.

Census and Demographic Data Subsystem

Working with the University of Tennessee Center for Business and Economic Research, we have access to all 1970 Census data. These data are available upon request and can be programmed to provide information and formats needed for planning at the state and local levels.

SYSTEM OUTPUTS

Currently, the system has several valuable outputs. Some are used extensively, while other outputs are not used much because not all of our local decision-makers are yet trained to use them.

The development of the system began in response to the need to complete U.S.O.E. statistical report forms. Consequently some of the system outputs are geared to that need. More specifically, our output includes:

1. All statistical data needed to complete U.S.O.E. Form No. . (Student enrollments)
2. All statistical data needed to complete U.S.O.E. Form No. . (Student follow-up)
3. Class rosters by teacher
4. Program summaries by school, district, county, region, development district, congressional district, etc.
5. Follow-up report by teacher, program, school, district, county, region, etc.
6. Mailing and address labels of students, teachers, and other personnel
7. Directories of personnel (Listed by subject area and/or school, district, etc.)

STRENGTHS AND WEAKNESSES OF THE M.I.S.

As is true with the development of any new system, many strong parts and problem areas will be present, and we feel that our system has both. Let me start with one problem area.

Weaknesses in the M.I.S.

Since we are dealing with many independent school systems, there are times when we have trouble gaining the cooperation of all school superintendents, principals, and teachers. We have, at present, no way of demanding the cooperation of local personnel to get accurate input data. In other words, we just cannot require that they have students fill out our optical scan forms.

For our secondary student follow-up system, we presently rely upon the teacher for the follow-up input data. Some people look at this as a severe limitation. But, to date, our validity checks have shown that we can trust the teacher. The biggest problem we see here is that there are some specific kinds of data that would be valuable to us that we cannot get from the teacher. For example, we can ask the teacher which former students are employed, unemployed, in school, etc., but we cannot ask him to give us the former student's salary or wages. We would have to go directly to the student for that.

A third problem that we see, and this would be characteristic of any new major development, is that local administrators, teachers, and other users of the system output are not fully able to utilize the output for management of their programs. The system in itself has not provided for professional development of its users. Another way of saying this is that the technology frightens some people.

A fourth weakness that we see is one related to short-term adult courses. Adults, again, are not as familiar with optical scanning forms (the new technology) and are not as accurate in completing the forms. This, then, causes an inherent weakness in the adult follow-up phase.

Strengths of Tennessee's M.I.S.

I hope I haven't left you with the impression that we have just a bundle of problems. We feel that our system does have some important strengths. Briefly, some of those strengths are:

1. Low cost per student. Total costs for all input and output is running in the neighborhood of 45-cent per student for the secondary system.
2. We have information on a very small reporting unit, the teacher, and with just a little computer programming time, we can produce about any type of analysis or cross tabulation that may be needed.

3. The error rate on the input side is between .1 and .2 per cent of all records.
4. For operation, only clerical staff with periodic support from technical staff is needed. (Development of new components, files, etc., required more professional staff)
5. Although we are not yet using on-line access, our system is set up so we can enter the system at any point to add, delete, or change any single record or piece of information within a record.
6. Attributable to our feedback system, local people are beginning to learn how to use current data and information for local program planning, implementation, and evaluation.
7. And, finally, we are able to produce accurate statistical data for completing U.S.O.E. reports directly from the computer.

Obviously, there are several other strengths and weaknesses that could be discussed, but I think I have hit the major ones here.

SUMMARY

It is difficult to summarize our total M.I.S. because what I have given you to this point is basically a summary. Let me close by putting it this way:

1. We use the individual student and teacher record as a base.
2. We use mark sense forms rather than key-punching.
3. Output from the system is used for planning, management, and administrative purposes.
4. The system is relatively fast, accurate, and low cost.
5. We have a few problems, but within a year we hope to have these moved over to the strength side of the ledger.

LEGISLATION FOR PROVIDING COMPREHENSIVE VOCATIONAL-TECHNICAL EDUCATION IN TENNESSEE

The Eighty-Seventh General Assembly of the state of Tennessee meeting in 1971 and 1972, passed House Joint Resolution No. 190. This resolution directed the Legislative Council Committee to study vocational education programs in grades 7-12. It stated, in part: "Be it resolved by the House of Representatives of the Eighty-Seventh General Assembly, the Senate concurring, that the Legislative Council Committee is directed to make a study concerning the desirability, feasibility, and cost of expanding the vocational programs in the public schools of Tennessee, grades 7-12." The Legislative Council Committee was to report its findings to the Eighty-Eighth General Assembly meeting in 1973.

A subcommittee on educational studies was appointed to complete the study. The study resulted in "Report of the Subcommittee on the Study of Vocational Education Programs in Grades 7-12 to the Legislative Committee, 1973." This committee, using the completed study as a basis of recommendation, conducted a series of meetings as a committee and with Commissioner Benjamin E. Carmichael and Assistant Commissioner William M. Harrison to formulate final recommendations to present to the Eighty-Eighth General Assembly on which they would base suitable legislation. The recommendations of the subcommittee are summarized as follows:

1. Introduce career exploration in the elementary grades.
2. Initiate at the seventh and eighth grade levels: (a) prevocational information and exploratory activities, and (b) counseling at the ratio of one counselor with special competence in vocational guidance for each 200 students.
3. Provide at the high school level (grades 9-12): (a) access to comprehensive vocational training to every student of each county of the state and (b) counseling at the ratio of one counselor to 200 students.
4. Draw upon business and industry to determine skill needs, to acquaint students with the "world of work," and to develop desirable work attitudes and habits.
5. Increase student aspirations for noncollege preparatory occupations.

Let us digress at this point long enough to look at the most important finding of the study conducted by the Legislative Committee. The committee indicates that by 1980 only 20 per cent of all jobs will require a college degree, while 80 per cent of high school students are taking the curricula geared to college preparation. College graduates are having difficulty in finding jobs, with industry and business being unable to find enough skilled workers for their operations.

The final report of the study conducted by the Legislative Committee and the recommendations of the educational subcommittee were presented to the Eighty-Eighth General Assembly in early 1973. The legislature was quick to act in providing legislation that would provide suitable and meaningful training for the 80 per cent of the students in Tennessee who will earn their livelihood without the benefit of a baccalaureate degree. This action was taken in the form of an act to amend the present laws covering vocational education and was passed as House Bill 1203 and Senate Bill 1091. The salient features of this act are as follows:

1. It is the legislative intent of the General Assembly of the state of Tennessee that comprehensive vocational and technical education be made available by the state and local educational agencies in grades 9-12.
2. The act provided that the State Department of Education during the 1973-74 school year would survey each county, including the city and special school districts within, ~~to determine the needed expansion of vocational and technical education programs~~ for the students of high school and post-high school ages and the most feasible method of meeting this need. It also specified that such programs would be made accessible to all high school students and planned to serve at least 50 per cent of the students in grades 9-12, beginning with the school year 1973 and being completed by the school year beginning in September 1977.
3. The act provided that all capital costs and operating costs of the programs developed under this legislation would be borne by the state and that the operation of the facilities would be by local boards of education or as joint facilities by two or more local systems.
4. Included also was a requirement for counseling and prevocational courses to be made available by 1975 in grades 7 and 8 and that the counselors would be in the ratio of one for each 200 students, with the counselor having special competence in vocational guidance, including some practical experience.

5. The act provided that after the surveys of the 95 counties were completed, county plans for expansion would be in accordance with one of the following alternatives:

(a) Comprehensive High Schools. Facilities will be utilized and/or expanded in school systems where schools have been consolidated sufficiently to provide comprehensive high schools for a minimum of about 1,500 students.

(b) Area Vocational-Technical Schools. Facilities will be utilized and/or expanded in area vocational-technical schools, where properly located, to provide comprehensive high school vocational training.

(c) Vocational Training Centers. In counties, including city and special school districts, with two or more high schools, where students cannot be served under the provisions of item (a) or item (b) of this section, a vocational training center will be established separate from any existing school.

(d) Joint Facilities. Where practicable, and where school systems may not be served adequately by either of the above alternatives, joint facilities may be established and operated to serve two or more counties and/or school systems.

The act also provided that planning and implementation would include vocational training for post-high school students who would have access to all programs of any facility. All county plans for expansion will be acted on by the State Board for Vocational Education upon the recommendation of its executive officer.

STAFF ORGANIZATION FOR EFFECTIVE MANAGEMENT

By

**Joe D. Mills, State Director
Division of Vocational, Technical and Adult Education
Tallahassee, Florida**

Presented at the

**Sixth Annual National Leadership Development Seminar
for State Directors of Vocational Education**

September 18-21, 1973

The Sheraton-Nashville Hotel, Nashville, Tennessee

**THE CENTER FOR VOCATIONAL
AND TECHNICAL EDUCATION**



**THE OHIO STATE UNIVERSITY
1880 Kenny Rd., Columbus, Ohio 43210**

DEPARTMENT OF EDUCATION
Division of Vocational, Technical and Adult Education
Tallahassee, Florida

STAFF ORGANIZATION FOR EFFECTIVE MANAGEMENT

The Tenth Amendment of the United States Constitution assigns to the States those powers which are neither reserved to the federal government nor denied to the States. Among these is education.

I. Philosophy and Objectives Underlying the Organizational Structure

In Florida, public education, at all levels, is clearly a State responsibility.

Both the Commissioner of Education and the State Board of Education are charged by the Constitution of the State with the supervision of the system of public education as provided by law.

In line with the broad responsibility the Commissioner has been charged by the Florida Legislature to:

- A. expand the capability of the Department of Education in planning the State's strategy for effecting constructive change and providing and coordinating creative services necessary to achieve greater quality in education and
- B. utilize all appropriate modern management tools, techniques and practices which will cause the State's educational program to be more effective and provide the greatest economics in the management and operation of the State's system of education.

To aid the Commissioner and State Board, the State Legislature authorized staff for them and established by statute, four operating divisions within the Department of Education:

- A. Division of Elementary and Secondary Education
- B. Division of Vocational Education
- C. Division of Community Colleges
- D. Division of Universities

Each Division is organized to fulfill its mission in terms of the State system of education in coordination with the other divisions as well as the specific programs, services and activities for which each has primary responsibility.

More specifically the Division of Vocational Education is:

- A. Program oriented rather than institutionally oriented being organized to serve programs at all levels and in all types of institutions.
- B. Organized in accordance with major functions with due regard for span of control, i.e., Planning, Program Supervision, Program Services, Research and Evaluation, General Administration and State Advisory Council.
- C. Organized to maintain the integrity and expertise of the staff of major programs, such as, Agriculture, Business and Distribution, with coordination provided at the bureau chiefs level, within bureaus and within regional offices to accomplish a total program of vocational education and adult general education.
- D. Organized to provide consultative services immediately available to local educational agencies by decentralizing division services into five regions.
- E. Arranged so that each regional office serves a major labor market area and is in a position to coordinate program development by school districts and community colleges to meet total labor market needs.
- F. Arranged so that each regional office is in close proximity to one or more approved teacher education institutions.
- G. Organized so that there are means to identify improved practices and ways to disseminate and diffuse them.

II. Present Programs, Organization and Staffing

A. PROGRAMS

The Division of Vocational, Technical and Adult Education is responsible for the following programs conducted primarily by 67 school boards and 28 junior college boards of trustees as well as the ancillary services in support of them:

1. Comprehensive Vocational Education Program for Career Development consisting of offerings in:
 - a. Orientation to the World of Work
 - b. Pre-vocational Education
 - c. Pre-technical Education
 - d. Agricultural Education
 - e. Business Education

- f. Distributive Education
- g. Diversified Occupations Education
- h. Health Occupations Education
- i. Home Economics Education
- j. Industrial Arts Education
- k. Industrial Education
- l. Related Instruction for Apprentices
- m. Technical Education
- n. Vocational Education Youth Organizations

These offerings are organized into instructional components, the major ones being:

- a. Introduction to the World of Work, Grades 1-6
 - b. Occupational Exploration, Grades 7-9
 - c. Job Preparatory Training
 - Secondary, Grades 7-12
 - Post Secondary
 - Adult
 - d. Supplemental Training
2. Manpower Development Training, P.L. 87-415, consisting of:
- a. Institutional Training
 - b. Individual Referrals
3. Adult General Education consisting of:
- a. ~~Elementary Education for Adults~~
 - b. ~~Secondary Education for Adults~~
 - c. Community Service Education for Adults
 - d. Adult Basic Education (Federal)
 - e. Civil Defense Education (Federal)
 - High School
 - Adult
 - f. Adult Migrant and Seasonal Farm Worker Education (Federal)
4. Ancillary and Support Services including:
- a. Development of Area Vocational-Technical Centers and Area Vocational Education Schools
 - b. High School Equivalency Testing Program
 - c. Occupational Specialist Training Programs
 - d. Research Coordinating Unit
 - e. State Approval Agency for Veteran Education and Training
 - f. Vocational Improvement Fund

Programs and services are provided for students at the following levels: elementary, middle and junior high school, senior high school, post-secondary and adult.

Target groups served include regular, disadvantaged and handicapped students.

B. ORGANIZATION

The State Board of Education is the chief policy-making and coordinating body of public education in Florida (Section 229.053, F.S.). Section 229.061, F.S., authorizes the State Board of Education to constitute the State Board for Vocational Education with responsibility for administering all state and federal laws for the promotion of vocational education and articulating it with other state educational programs. The State Board is also authorized to approve plans for cooperating with the federal government, accept funds, create subordinate units and provide necessary administration required by any federal programs.

Through the Department of Education organizational structure adopted by the State Board of Education on August 19, 1969 the Division of Vocational Education was designated as one of four operating divisions of the department consistent with the Government Reorganization Act of 1969.

The Florida State Plan for the Administration of Vocational Education approved annually by the Florida State Board for Vocational Education, further establishes the Division as the State Board staff responsible for the provision of "leadership in the planning, coordination and general administration of the statewide program of vocational education with the local educational agency being responsible for local program operation."

As the result of the breadth of responsibilities assigned to it, the Division of Vocational, Technical and Adult Education is "program oriented" rather than "institutionally oriented" because it is concerned with the promotion, development, implementation and evaluation of quality vocational, technical and adult education rather than the institutional arrangement which provides the services at the district level. It is within this context that the Director of the Division with qualified professional assistants discharge their leadership roles.

The Division is organized into six major functions for operating purposes:

1. Division Administration
2. Bureau of Vocational Planning
3. Bureau of Vocational and Adult Programs
4. Bureau of Vocational Research and Evaluation
5. Bureau of Vocational Program Services
6. State Advisory Council for Vocational and Technical Education

The responsibilities of each are:

1. Division Administration

This function comprises the major administrative office of the Division.

2. Bureau of Vocational Planning

The responsibilities of this bureau are concerned with:

- a. directing major planning activities within the Division, including PPBS and coordinating Division planning with other divisions of the Department of Education and State Government;
- b. planning, development and construction of area vocational-technical center and area vocational education school facilities; and
- c. coordinating with the Division of Elementary and Secondary Education staff assistance to School Districts in Comprehensive Educational Planning.

3. Bureau of Vocational and Adult Programs

The principal responsibility of this bureau is that of effecting a coordinated and inter-related statewide program of Vocational, Technical and Adult Education including program articulation at all instructional levels involving all types of public educational institutions. Within this bureau fall the Sections and Area Offices which deal with the administration of programs and the provision of program consultative services to Districts.

4. Bureau of Vocational Research and Evaluation

This bureau is concerned with:

- a. the promotion and coordination of vocational research and related activities at all instructional levels conducted primarily by local educational agencies, universities and other public agencies and institutions, and
- b. the evaluation of the statewide program of vocational and adult education.

Within this bureau fall the design and evaluation of exemplary projects, projects related to career education and the Research Coordinating Unit.

5. Bureau of Vocational Program Services

This bureau is responsible for services supportive to the instructional, supervisory and administrative functions of the Program Sections, Bureaus and General Administration of the Division. Included are: statistical services, information systems, teacher education, staff development, vocational guidance, occupational specialist training, materials development, preparation of reports, development and revision of the State Plan and other special services as may be assigned.

6. State Advisory Council for Vocational and Technical Education

This Function is responsible for:

- a. advising the State Board for Vocational Education on the development of the State Plan for Vocational Education and policy matters arising in its administration,
- b. advising the State Board for Vocational Education on the preparation of long-range and annual program plans,
- c. evaluating annually the statewide vocational and technical education programs,
- d. preparing and submitting through the State Board for Vocational Education to the U. S. Commissioner of Education and the National Advisory Council an annual evaluation report.

The organization of the Division emphasizes effective and efficient services to local districts through the decentralization of supervisory services.

Although the Division Headquarters is located in Tallahassee, the State is divided into five regions approximating major labor market areas with area offices in Tallahassee, Gainesville, Orlando, Tampa and Boca Raton. Each Program Operating Section of the Division has area supervisors assigned to these offices under the direction of an Area Program Coordinator. By living in the region, and working out of the area office, a supervisor can provide more effective, efficient and rapid consultative services either as an individual or member of a team to the educational leaders in local districts.

The next three pages contain the following:

1. Chart of the Relationship of the Division of Vocational, Technical and Adult Education to other Units of the Department of Education and other governmental agencies.
2. Chart of the Organization of the Division of Vocational, Technical and Adult Education showing relationship of functions, bureaus and area offices.
3. Map of Florida outlining the five areas of Florida with the location of area offices.

RELATIONSHIP OF THE DIVISION OF VTAE
TO OTHER PUBLIC AGENCIES

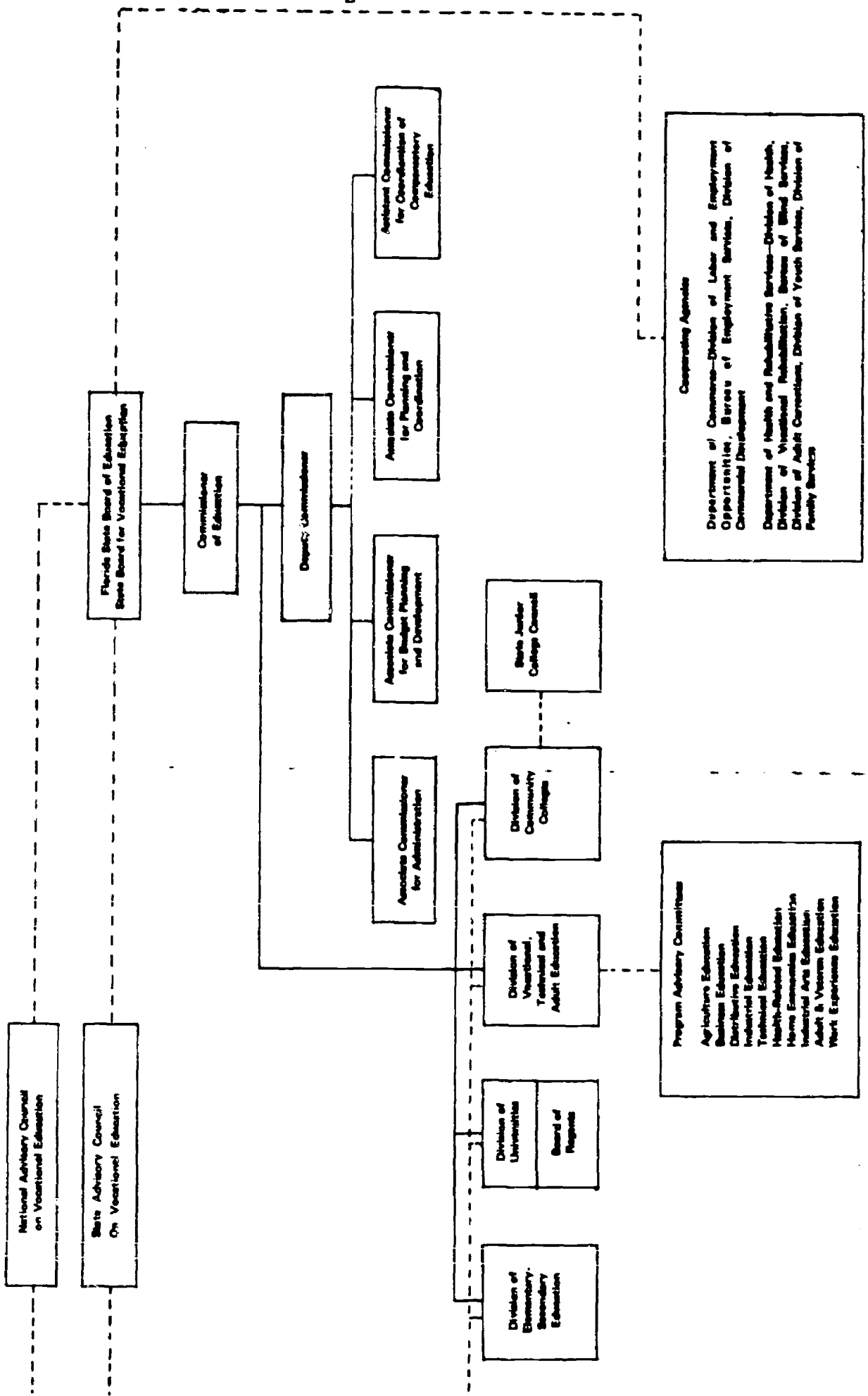

DIVISION OF
VOCATIONAL, TECHNICAL AND
ADULT EDUCATION

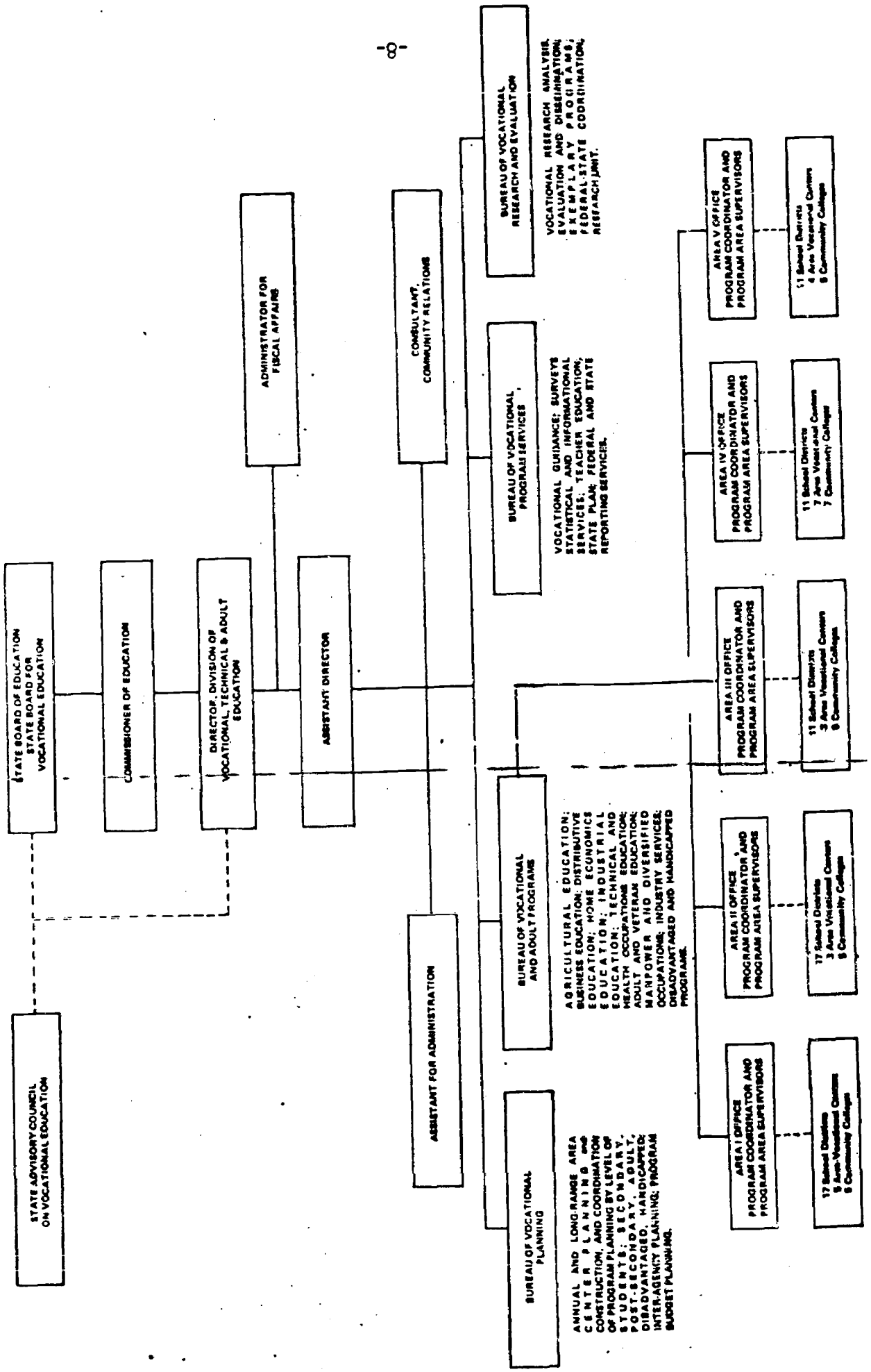

STATE ADVISORY COUNCIL
ON VOCATIONAL EDUCATION

STATE BOARD OF EDUCATION
STATE BOARD FOR
VOCATIONAL EDUCATION

COMMISSIONER OF EDUCATION

DIRECTOR, DIVISION OF
VOCATIONAL, TECHNICAL & ADULT
EDUCATION

ADMINISTRATOR FOR
FISCAL AFFAIRS

ASSISTANT DIRECTOR

ASSISTANT FOR ADMINISTRATION

CONSULTANT,
COMMUNITY RELATIONS

BUREAU OF VOCATIONAL
PLANNING

ANNUAL AND LONG-RANGE AREA
CENTER PLANNING AND
CONSTRUCTION, AND COORDINATION
OF PROGRAM PLANNING BY LEVEL OF
STUDENTS: SECONDARY, ADULT,
POST-SECONDARY, HANDICAPPED,
DISADVANTAGED, HANDICAPPED,
INTER-AGENCY PLANNING; PROGRAM
BUDGET PLANNING.

BUREAU OF VOCATIONAL
AND ADULT PROGRAMS

AGRICULTURAL EDUCATION;
BUSINESS EDUCATION; DISTRIBUTIVE
EDUCATION; HOME ECONOMICS
EDUCATION; INDUSTRIAL AND
EDUCATION; TECHNICAL AND
HEALTH OCCUPATIONS EDUCATION;
ADULT AND VETERAN EDUCATION;
MANPOWER AND DIVERSIFIED
OCCUPATIONS, INDUSTRY SERVICES,
DISADVANTAGED AND HANDICAPPED
PROGRAMS.

BUREAU OF VOCATIONAL
PROGRAM SERVICES

VOCATIONAL GUIDANCE; SURVEYS
STATISTICAL AND INFORMATIONAL
SERVICES; TEACHER EDUCATION,
STATE PLAN; FEDERAL AND STATE
REPORTING SERVICES.

BUREAU OF VOCATIONAL
RESEARCH AND EVALUATION

VOCATIONAL RESEARCH ANALYSIS,
EVALUATION AND DISSEMINATION;
EMPLOYMENT PROGRAMS;
FEDERAL-STATE COORDINATION;
RESEARCH UNIT.

AREA I OFFICE
PROGRAM COORDINATOR AND
PROGRAM AREA SUPERVISORS

17 School Districts
3 Area Vocational Centers
8 Community Colleges

AREA II OFFICE
PROGRAM COORDINATOR AND
PROGRAM AREA SUPERVISORS

17 School Districts
3 Area Vocational Centers
8 Community Colleges

AREA III OFFICE
PROGRAM COORDINATOR AND
PROGRAM AREA SUPERVISORS

11 School Districts
3 Area Vocational Centers
8 Community Colleges

AREA IV OFFICE
PROGRAM COORDINATOR AND
PROGRAM AREA SUPERVISORS

11 School Districts
7 Area Vocational Centers
7 Community Colleges

AREA V OFFICE
PROGRAM COORDINATOR AND
PROGRAM AREA SUPERVISORS

51 School Districts
4 Area Vocational Centers
8 Community Colleges

FIVE GEOGRAPHICAL AREAS

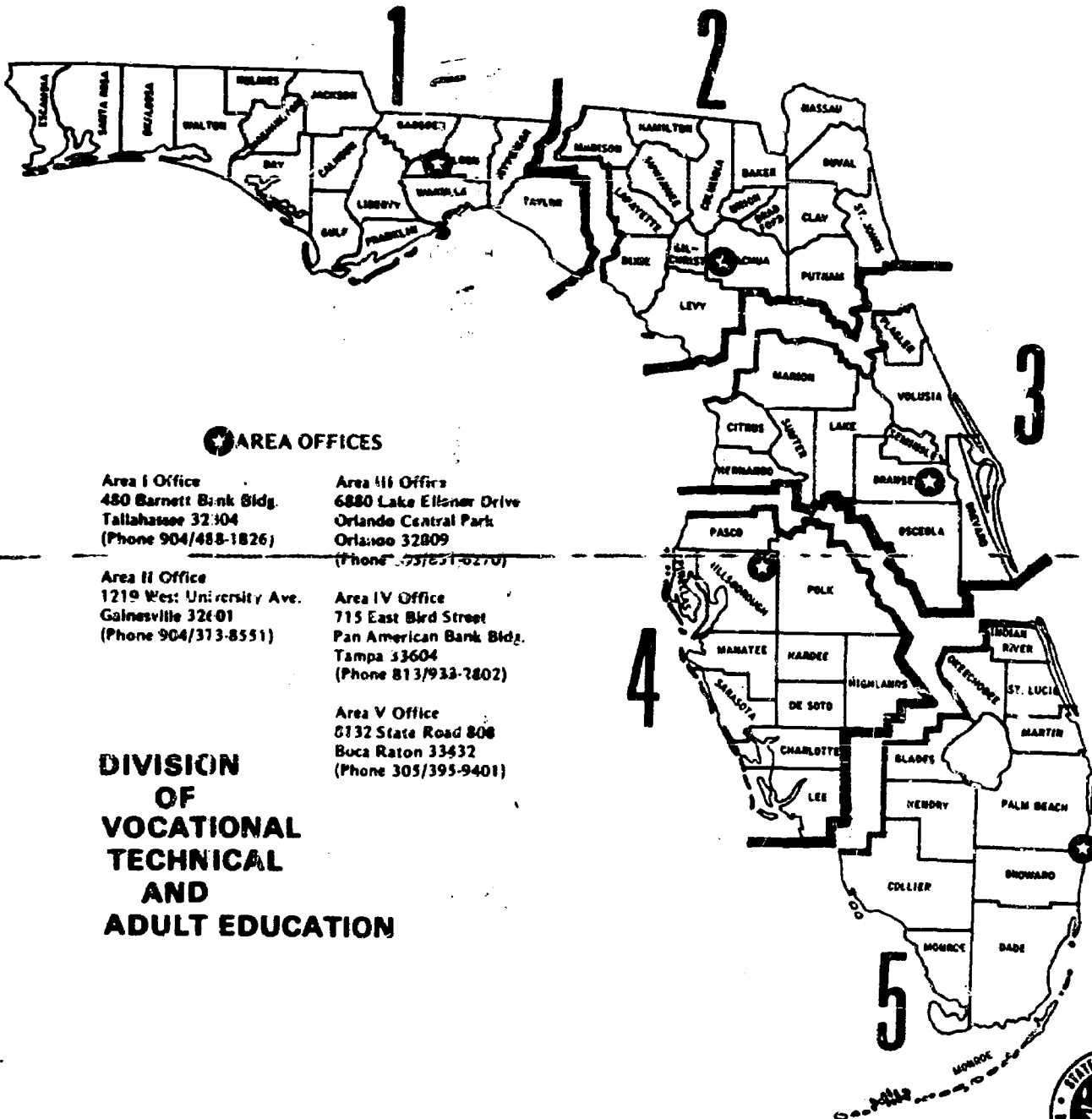

AREA OFFICES

Area I Office
 480 Barnett Bank Bldg.
 Tallahassee 32304
 (Phone 904/488-1826)

Area III Office
 6880 Lake Ellsner Drive
 Orlando Central Park
 Orlando 32809
 (Phone 352/51-0270)

Area II Office
 1219 West University Ave.
 Gainesville 32601
 (Phone 904/373-8551)

Area IV Office
 715 East Bird Street
 Pan American Bank Bldg.
 Tampa 33604
 (Phone 813/933-2802)

Area V Office
 6132 State Road 808
 Boca Raton 33432
 (Phone 305/395-9401)

**DIVISION
 OF
 VOCATIONAL
 TECHNICAL
 AND
 ADULT EDUCATION**



DEPARTMENT OF EDUCATION
 TALLAHASSEE • FLORIDA
FLOYD T. CHRISTIAN • COMMISSIONER

C. STAFFING

Part II-A of this memorandum lists the variety of programs and services for which the Division of Vocational, Technical and Adult Education is responsible. The following assignment of authorized FTE positions is in support of them:

<u>Organizational Unit</u>	<u>No. of FTE Positions</u>		
	<u>Staff</u>	<u>Clerical</u>	<u>Total</u>
1. Division Administration	7	10	17
2. Bureau of Vocational Planning	4	2	6
3. Bureau of Vocational and Adult Programs			
a. Office of Bureau Chief	4	3	7
b. Adult and Veteran Education	20	10.5	30.5
c. Agricultural Education	8	3	11
d. Business Education	6	2	8
e. Distributive Education	5	2	7
f. Home Economics Education	10	5	15
g. Industrial Education	16	6	22
h. Manpower Development Training	8	8	16
i. Diversified Occupations	4	2	6
j. Technical and Health Occupations Education	11	3	14
k. Area Offices*			
Area I	1	2	3
Area II	1	1	2
Area III	1	2	3
Area IV	1	2	3
Area V	1	3	4
Total of Bureau	<u>97</u>	<u>54.5</u>	<u>151.5*</u>
4. Bureau of Vocational Research and Evaluation	3	3	6
5. Bureau of Vocational Program Services	6	5	11
6. State Advisory Council for Vocational and Technical Education	<u>2</u>	<u>1</u>	<u>3</u>
DIVISION TOTAL	<u>119</u>	<u>75.5</u>	<u>194.5</u>

*NOTE: The figures for each area office represents the Area Program Coordinator and Secretarial assistance. In addition, representatives from each Program are assigned to these offices. Of the 151.5 FTE positions (97 staff and 54.5 clerical) in the Bureau of Vocational and Adult Programs 59 FTE positions (49 staff and 10 clerical) are assigned to area offices.

III. Changes in the Organizational Structure within the Past 10 Years

Rapid program growth, a changing role of the Department of Education, and acknowledgment by the State Legislature of the Division of Vocational Education as one of four operating divisions of the Department, dictated a need for a continuing study of the division organization.

During the past 10 years the organization of the division changed from one in which the emphasis was upon individual program sections with all administrators reporting to the Division Director to the present organization based upon functions and corresponding bureaus and offices.

A series of changes took place in an orderly fashion with the involvement of the total staff of the Division.

A significant contribution to this effort came from a study conducted by the Oregon Center for Research and Development in State Leadership.

During the Fall of 1968, Florida was accepted as one of five pilot states to engage in a study of the structure at state level for Vocational Education and in the capability of such a structure to meet the demands for change in this important field of Education resulting from the Vocational Education Amendments of 1968 and other federal legislation. These studies were conducted by the Center for Research and Development in State Education Leadership, Teaching Research Division, Oregon State System of Higher Education, Monmouth, Oregon through contract with the U. S. Office of Education. The study began December 16, 1968.

In brief, the study involved a self analysis by the total Division staff following criteria furnished by the Oregon Center. On April 23, 24, and 25, 1969, a team selected by the Center visited the Division of Vocational, Technical and Adult Education to study first hand its organization and operation.

The recommendations of the Oregon Center for Research and Development in State Leadership have provided the Division with significant guidelines in its reorganization.

IV. Projected Changes Foreseen in the Organization of the State Vocational Education Agency Over the Next Ten Years

The role of the Florida Department of Education is changing from a regulatory function to one in support of educational renewal.

Under these conditions the Department of Education and the Division of Vocational Education will become:

- A. More responsive to and responsible for improved policy at the federal, state and local levels, and
- B. More involved in educational renewal, the process whereby the goals and objectives of education are continually modified to meet the changing needs of its clients and educational programs are continually modified to facilitate the attainment of those objectives.

Although staffing patterns may change, it is believed that the present organization based upon the mission of the Division and its major functions will continue to be viable and will adapt to changing emphases as Florida moves into and through the next decade.

**STATE PROGRAM PLANNING VIA
PERFORMANCE BASED OBJECTIVES**

By

**Darrell L. Parks
Administrative Specialist
Instructional Program Management
Great Oaks Joint Vocational School District
Cincinnati, Ohio**

Presented at the

**Sixth Annual National Leadership Development Seminar
for State Directors of Vocational Education**

September 18-21, 1973

The Sheraton-Nashville Hotel, Nashville, Tennessee

**THE CENTER FOR VOCATIONAL
AND TECHNICAL EDUCATION**



**THE OHIO STATE UNIVERSITY
1960 Kenny Rd. Columbus, Ohio 43210**

STATE PROGRAM PLANNING VIA
PERFORMANCE BASED OBJECTIVES

A Paper Prepared by

Darrell L. Parks
Administrative Specialist
Instructional Program Management
Great Oaks Joint Vocational School District
Cincinnati, Ohio

and Presented at

The Sixth National Leadership Development Seminar
for State Directors of Vocational Education

September 17-21, 1973
The Sheraton-Nashville Hotel
Nashville, Tennessee

STATE PROGRAM PLANNING VIA PERFORMANCE BASED OBJECTIVES

The foremost challenge confronting vocational education in the seventies is to maximize its productivity. To this end, an educational management structure must be fashioned that will make education and training more meaningful, more rewarding, more available, more relevant and more productive in terms of human resources and financial investment.

Most professional educators would not quarrel with the preceding statement. The general public's hue and cry for more accountability and an increased measure of confidence on the part of the educational institution at all levels have made educators sensitive to providing a more effective and responsible delivery mechanism.

Thus, the point in question is not "what should education be about" but one of "how should education go about it;" that is, what management tool or technique should be employed to bring about the desired change?

At a time when a more sophisticated concept of educational management and decision-making is coming of age, a systems approach to such management and decision-making processes, centering around performance based objectives, is rapidly gaining impetus. It is with regards to this systems approach as it relates to state program planning in vocational education that the remainder of this paper will address itself.

A RATIONALE FOR PERFORMANCE BASED OBJECTIVES IN STATE PROGRAM PLANNING

Although the concept of performance based objectives is not necessarily new in the business and industry management arenas, its application in educational planning is relatively untested. In the context of this presentation let it suffice to define a performance based objective as follows: A statement that precisely indicates what is to happen and to what extent it is to happen within a specified time frame.

In applying such a definition to state educational program planning endeavors, it can and does facilitate the planning process and offers a mechanism for further decision-making tasks.

Essentially, a planning process built upon performance based objectives offers the following advantages:

1. It provides specific direction with regards to what the State Educational Agency is about concerning its program management and responsibilities. For example, a properly stated performance based objective that indicates that fifty new vocationally oriented auto mechanics programs will be implemented across the state during the 1973-74 school year forces a management agency to address itself to specific ways and means to bring about such an outcome. Activities which cannot be directly related to the stated objective must be seriously questioned as to their legitimacy. Thus, such an approach to planning forces those who are doing the planning to think and act from a standpoint of productivity.

2. It incorporates a philosophy of participatory management. In the process of identifying and stating performance based objectives, careful and analytical thinking from numerous sources is paramount. Without the involvement and assistance of those who are charged with the responsibility of accomplishing such objectives, such a process is doomed to failure. Performance based objectives must be realistically stated and universally accepted on the part of the management staff if they are to be met. Such can only be assured through the involvement of those to whom the objectives relate.

3. It facilitates budgeting and priority ranking processes. As mentioned previously, the concise and time-referenced statement of anticipated outcomes aids in determining the appropriate and necessary activities for bringing about such desired change. Once such activities are identified, it becomes a mechanical process to cost out such activities and match those costs with available or anticipated budget allotments. In the event of limited financial resources, a rank ordering of objectives can be made with regard to importance and/or preference, thus providing valuable insight concerning budget management decisions.

4. It offers a mechanism for matching job requirements with personnel talents and interests. The identification of specifically designed activities which are essential for attaining the objectives set forth previously will give rise to position guides or job descriptions for existing and/or anticipated staff personnel. Pursuant to the development of

such position guides, it once again becomes a somewhat mechanical process of aligning existing staff talents and interests with the respective tasks. Such guides also provide the basis for the recruitment and selection of additional and replacement personnel.

5. It provides the basic criteria for program and personnel appraisal. Perhaps one of the foremost advantages of a performance based objective planning concept is that it forces the early and objective statement of success criteria. Such success criteria, quantified over time, provide the basis for an objective appraisal of program outcomes in terms of whether or not performance standards have been realized. Not only does the concept lend itself to terminal appraisal, but it provides a benchmark against which periodic progress readings can be made.

Furthermore, such a planning concept provides the foundation for appraising the effectiveness of staff personnel. Such appraisal should focus upon the extent to which objectives relate to the assigned tasks and responsibilities of each respective staff person. Thus, appraisal is based upon product rather than process criteria and affords optimum flexibility, innovativeness and creativity on the part of staff personnel in achieving the end result. It provides all parties concerned with a decision-making and managerial job.

6. It is applicable at any management level. Educational management employing the performance based objective

planning concept may be applied at any managerial level within the management structure. Admittedly, it must be used advisedly when such a management technique must link up with other managerial styles but still, at levels where independent management decision-making occurs, such a system can stand alone and operate effectively.

THE DEVELOPMENT OF A PERFORMANCE BASED OBJECTIVE PLANNING AND MANAGEMENT SYSTEM

As has been alluded to in numerous preceding statements, management via performance based objectives is a systems approach to management. Not only does this mean that such a system, when fully operative, flows in a logical, sequential fashion, but it also implies that in the process of adopting the system itself, there is a logically sequenced procedure. An illustration of such a procedure is shown in the paradigm on page 6.

A closer scrutiny of this model suggests that the initial point of departure in implementing a performance based objectives management concept is an objective and factual assessment of immediate and anticipated needs to which the respective educational program must relate. Such needs must be derived from a carefully designed and reliable data gathering system and, furthermore, must be expressed in terms of actual numbers of individuals to be served within various population groupings or age levels. An expression of such needs should be substantiated from available facts and information with respect to enrollment data, employment

**A PROCESS FOR THE DEVELOPMENT AND IMPLEMENTATION
OF PERFORMANCE BASED OBJECTIVES IN
STATE PROGRAM PLANNING**

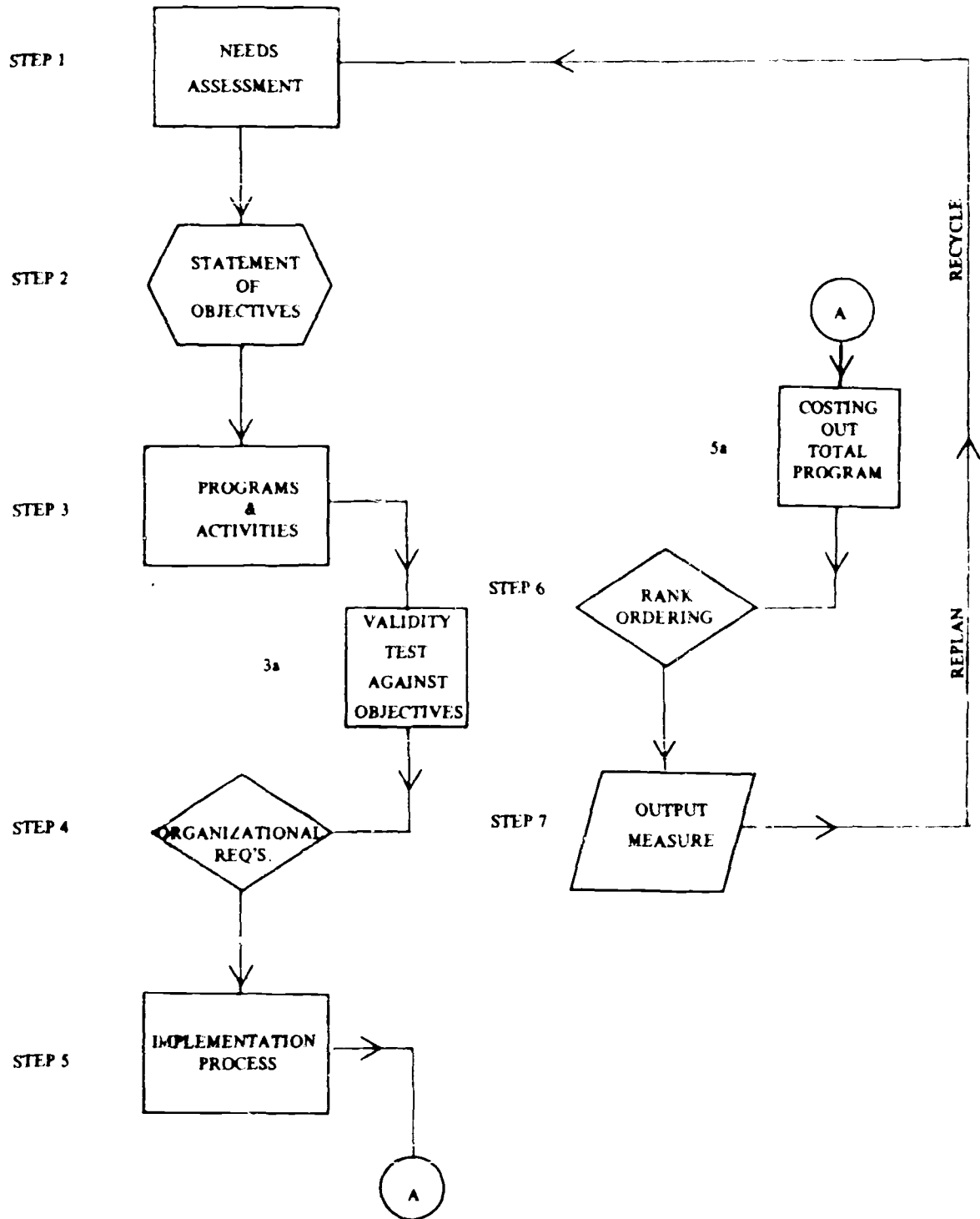

needs and patterns, program availability and any other demographic and/or economic information deemed appropriate.

The degree of accuracy with which such needs are determined is directly related to the ultimate success of a performance based management structure. Insufficient or inaccurate initial information will give rise to a management structure that must function, in large part, on intuition and subjectivity which can only parallel a practice of management which has for too many years been an integral part of the educational process.

Pursuant to the needs assessment phase, a statement of performance based objectives becomes the next activity. As previously mentioned, such a statement of objectives must incorporate three essential components in order to be a valid statement: what is to be accomplished, to what extent is the accomplishment to be realized, and by what specific point in time is such an accomplishment to be fulfilled. Input into the formulation of a statement of objectives should be solicited from each respective staff member and general concurrence regarding the final draft of such a statement is desirable. The statement of objectives is, in actuality, a statement of success criteria or performance standards, thus such a statement should provide a basis for all ensuing activities in the initiation and adoption of a performance based management structure.

The remaining steps, namely three through seven as illustrated in the model, evolve around the statement of

objectives set forth in step two. Programs and activities should address themselves to the fulfillment of the stated objectives. If no relationship can be made between any given program or activity and one or more of the stated objectives, serious questions must be raised concerning such a program or activity's legitimacy in the management structure and whether or not it should be retained.

The modification or redesign of an organizational structure may be dictated by the programs and activities identified in step three. By making a task analysis of what needs to be done, the resultant product should be an organizational format that will enhance the efficient and effective realization of the desired outcomes. Again, let it be emphasized that any organizational format, irregardless of its design, must be oriented to productivity and not process in a performance based management structure. The determination of an acceptable organizational structure also provides impetus for the development of individual professional and paraprofessional position guides and job descriptions.

The implementation process, step five, is included as a means of providing the direction for flowing the performance based management structure into a currently operating management system. Such a change-over may require additional personnel, modified physical facilities, equipment, and supportive services, all important budgetary considerations.

Costing out the implementation process provides a financial perspective of the entire concept and gives rise to

**THIS PAGE WAS MISSING FROM THE DOCUMENT THAT WAS
SUBMITTED TO ERIC DOCUMENT REPRODUCTION SERVICE.**

significance. Such results tend to reduce credibility gaps and increase levels of confidence on the part of educational managers regarding their ability to produce.

Conversely, if the stated objectives were not fully realized, evidences should readily indicate why they were not realized and further analysis might dictate corrective measures which should be enacted.

SUMMARY AND CONCLUSIONS

A management structure built upon performance based objectives offers educational managers a potent vehicle to affect change. It is built upon the concept of productivity and if properly and consistently administered, it can positively enhance both the efficiency and effectiveness of an educational entity.

In state program planning the adoption of a management process founded upon performance based objectives provides educational managers many distinct advantages.

1. Such a process places the educational manager in a truly leadership role in that he is plotting a course of action based upon carefully defined and documented societal and economic needs.
2. It provides a mechanism for seeking, obtaining and justifying budget appropriations because budget control agencies can readily see what their investment is buying. If a stated need is not met due to inadequate funding levels, then the fault is

not that of the educational component but becomes a state finance agency concern. A performance based management concept is an offensive rather than a defensive management tool.

3. It provides a means for optimizing staff talents and abilities.
4. It offers a built-in mechanism for periodically appraising the program effectiveness as a whole and/or any specific part thereof.
5. It demands commitment in that an agency has, in essence, contracted with "John Q. Public" regarding what it will deliver within an expressed time frame.

In employing such a management tool as the performance based objectives concept, certain essential ingredients must be assured.

Such an approach to management if it is to be attempted, should enjoy the support of the total staff, especially the top decision maker. If such a management concept enjoys less than the most enthusiastic support of the chief administrator, the chances of such a concept being successful are minimal.

Another essential ingredient is a commitment of the necessary time and resources to bring about such a management concept. A performance based management system doesn't just happen; it takes a lot of time and hard work on the part of each individual involved. An important point to emphasize, however, is that it takes an initial investment of time to

save time.

Finally, there is no short cut to adopting a performance based management concept. A consultant agency cannot do it effectively for another agency, a university grant or contract cannot accomplish it, nor can a specialist on a staff be expected to fulfill such an assignment alone. Each respective staff member must experience the discouragement and frustration which normally accompanies the adoption of such a concept. Ultimately, however, such discouragement and frustration should lead to a more totally informed and deeply committed staff with regards to the realization of the goals which they have set forth.

Management by performance based objectives is a tool, which if properly employed, could move educational management at all existing levels into new dimensions of leadership and respectability through the assurance that it is systematically addressing the immediate and critical needs of society which will eventually enhance the welfare of mankind.

BIBLIOGRAPHY

- Armstrong, Robert J., et al. The Development and Evaluation of Behavioral Objectives. Worthington: Charles A. Jones Publishing Company, 1970.
- Byers, Edward E. "Accountability's Offspring," American Vocational Journal. Vol. 48, No. 4, April, 1973, pp. 24-25.
- Elias, John E. and Barry L. Reece. "Accountability Means Product," American Vocational Journal. Vol. 48, No. 3, March, 1973. pp. 40-43.
- Hartley, Harry J. Educational Planning - Programming - Budgeting, A Systems Approach. Englewood Cliffs, New Jersey: Prentice-Hall, Inc., 1968.
- Huffman, Harry. "A Model for Generating Performance Goals," American Vocational Journal. Vol. 48, No. 4, April, 1973. pp. 26-30.
- Koontz, Harold and Cyril O'Donnell. Principles Of Management. New York: McGraw-Hill, Inc., 1968.
- Likert, Rensis. New Patterns of Management. New York: McGraw-Hill, Inc., 1961.
- Parks, Darrell L., editor. Management By Objectives. Unpublished Workshop Report. Columbus: Ohio Department of Education, Division of Vocational Education, 1970.
- Morrison, Edward J. "How to Test Performance," American Vocational Journal. Vol. 48, No. 4, April, 1973. pp. 38-39.
- Odiorne, George S. Management By Objectives. New York: Pitman Publishing Corp., 1965.
- O'Grady, James P., Jr. "New Movement Underway?," American Vocational Journal. Vol. 48, No. 4, April, 1973. pp. 80-81.
- Schleh, Edward C. Management By Results. New York: McGraw-Hill, Inc., 1961.
- Tanner, C. K. Educational Management by Objectives. Paper presented at the Tennessee MBO Conference, Montgomery Bell State Park, November 8-11, 1971.

THE GREENING OF CAREER EDUCATION

By

William L. Smith
Acting Deputy Commissioner for Development
U. S. Office of Education

The Center for Vocational and Technical Education
The Ohio State University

Presented At The

Sixth Annual National Leadership Development Seminar
For State Directors of Vocational Education

September 18-21, 1973

The Sheraton Nashville Hotel, Nashville, Tennessee

THE CENTER FOR VOCATIONAL
AND TECHNICAL EDUCATION



THE OHIO STATE UNIVERSITY
1850 Kenny Rd. Columbus Ohio 43210

THE GREENING OF CAREER EDUCATION *

Jonathan Swift, the satirist, wrote some time ago about imaginary people who fought bloody wars among themselves over such esoteric considerations as whether an egg should be opened from the big end or the little end. Over the years, the education world has had its share of big-endiens and little-endiens. In the course of their tribal battles, some deep and painful wounds were inflicted on both the institutions responsible for the education process and the people concerned with teaching and learning.

The historical schism between the vocational education camp and the so-called academic camp is a case in point. The labels, the snobbery, the reverse snobbery, and the "We-They" syndrome that marked the continuing conflict played havoc with human relationships among educational personnel -- and more importantly, with the learning opportunities and developing life styles of young people in the classroom.

Though the educational battleground may never be overgrown with roses, I think we have reached a kind of maturity in the education community -- a level of sophistication that permits us to view education not as a

*Prepared for delivery before National Leadership Development Seminar for State Directors of Vocational Education, Nashville, Tenn, Sept. 18, 1973.

series of separate enterprises but as a collaborative independent venture made up of the sum of all of its parts. With this maturity has also come the ability -- and the desire -- to sort out the big issues from the paltry ones. In short, we are no longer willing to dissipate our energies and resources in determining from which end the egg should be opened.

Let me cite just two examples of this collaborative movement which, I might add, the Federal government has had a hand in promoting:

We see it in the new alliances formed in the area of teacher training. Where colleges once prepared teachers in isolation from the school systems that employed them, the State agencies that accredited them, and the communities they served, there is now a deliberate movement toward mutual and collaborative training programs -- toward a sharing of responsibility and resources. Efforts such as the Teacher Corps, the Career Opportunities Program, training in special education for the regular classroom teacher, and others have helped move teacher training out of the make-believe into the real world. Not too long ago that was considered a task as impossible as moving Lake Michigan to Arizona.

We also see a new camaraderie between Federal and State education agencies. Where once there was scant communication and token cooperation, we now have a variety of new alliances and partnerships. Much of the improved relationship can be traced to Title V of ESEA, a variety of formula grants under other legislation, and efforts to make effective use of discretionary funds. I can remember the time when expecting State and Federal agencies to sit together in any meaningful joint venture was like expecting the Republicans and Democrats to hold a joint convention.

The collaborative efforts, the pooling of talent in these areas predictably led to a cooling of animosities. I would venture a guess that much the same thing is destined to occur among the disciplines that make up the components of Career Education. For Career Education introduces a new set of values and requires a new climate -- one in which there is no room for self serving dichotomies.

It demands that the vocational educators and the academicians come together on a parity basis to blend their expertise. Not that there isn't room for a healthy back and forth, but developing the Career Education concept with any integrity means that all concerned must work side by side in mutual respect, not only for one another but for a movement which implies a whole new concept of what education ought to be. And that concept is designed to restructure the educational system to the extent that it is no longer locked into a two-belt conveyor system -- one geared to producing "winners" and the other adjusted to turning out "losers."

Unfortunately, Career Education does not readily lend itself to a one-sentence definition. It has lent itself to a myriad of disparate definitions. The disparity was probably due to the fact that the term was thrust upon us with some abruptness and people developed their own "intuitive" -- and sometimes self-serving -- notions of what it meant. Here was a perfect breeding ground for perpetuating the "We-They" struggle -- for taking myths and hardening them into dogma. If we in OE do have a mission, it is to see that this does not continue to happen.

The one thing most current definitions have in common is that the purpose of Career Education is to establish a relationship between education and work. Beyond that, the goal is to make work -- whether it is for the purpose of earning a living, whether it is in service to one's home, one's family, one's community, or one's self -- become possible, meaningful, and satisfying to each individual.

It is also generally agreed that Career Education takes place at all levels of education, starting with career awareness and progressing through an exploration of the world of work, decision making relative to educational needs, and finally preparation for career proficiency. It allows for decisions at various stages, including new decisions in early or mid-career. It also provides for an understanding of the relationship between a career and one's life style.

Yet, it seems to me that the consensus toward which we are moving in definitions and in rhetoric is sometimes at odds with the reality of what is happening out in the field. It is part of my mission to prevent this from continuing.

In recent months, I have talked with numbers of people concerned with Career Education -- chief State school officers, some State and local vocational education directors, researchers, a host of concerned individuals in academic quarters, and people influential in vocational education organizations.

What I have learned is that there is great concern that Career Education is being viewed by many in the education community as simply a rehashed working of vocational education -- an effort to enhance it and legitimize it. Well, implicit in Career Education is an effort to enhance vocational education, but as a discipline in its own right which has a sizable contribution to make to the larger concept of Career Education. The advice I have received is to make sure that Career Ed is not vocational education by another name -- that vocational education is recognized as a discipline within Career Education just as are math, science, English, and the social sciences. Frankly, it is an important part of my mission to see that vocational education does not dominate, control, or unduly influence the Career Education concept.

There are other things I have learned. One is that some folk in the academic world look askance at the whole movement. They see it as a rejection of the liberal, humanistic tradition of education in favor of a strictly pragmatic approach focusing on employment and income and meeting manpower needs. This attitude, I think, indicates either a failure to do one's homework or that some highly credentialed practitioners are educated beyond their capacity to learn.

As I see it, if Career Education is to serve its purpose, it must be recognized that many components contribute to a meaningful career and all of the rewards that accompany it. An individual, no matter at what level he enters the job market, if he is to enjoy the higher quality of life requires skills in communication and computing, an attitude compatible with good mental and physical health, and skills in human interactions. To pursue satisfying work at any level requires a familiarity with science and technology, the ability and knowledge necessary to function as a citizen, exposure to art forms and an appreciation of beauty, and an element of self awareness. This is far from rejection of the human tradition. On the contrary, it supports it and carries it further by saying that intelligent career choices enhance an individual's opportunities to pursue a meaningful life.

There is nothing to rule out the study of history or English or biology or philosophy for their own sake -- for the simple reason that one is desirous of learning them. And the student with a deep and abiding interest in any subject area has a disservice perpetrated upon him if he does not have the added advantage of exploring related career opportunities.

No, Career Education, when properly articulated, understood and implemented, does not stifle academic or intellectual achievement. A significant part of my mission has to do with reeducating those academicians who have been reluctant to take a hard look at the world around them so that they can relate their work to it.

I have also learned -- and this, as you might suspect, I learned early in the game -- that most minority groups, especially the poor, are suspicious of Career Education. They fear it is a design to feed them into service occupations while middle-and upper-class majority groups are directed into colleges where they can prepare for well-paying jobs. It seems to me that exposure to alternatives in the world of work, opportunities to get "hands on" experience from real-world situations, or the chance to explore intellectually demanding careers brings a new dimension to the minority experience.

Properly applied, Career Education will become a vehicle for directing more young people from minority groups into the work world or into our colleges. It will do this by preparing them at an early age -- by introducing them to the opportunities open to them. Many of the young people for whom Career Education can open new worlds are the very same youth who are presently dropping out of high school or graduating without a marketable skill or a career goal.

If the purpose and function of Career Education is not understood or is deliberately ignored, there is a real danger that the fears expressed by minority groups will be realized. It is my mission to make certain that these fears are not realized.

I have also learned that some people see Career Education as a scheme to force early career decisions. On the contrary, it is an effort to expose people at a very early age to the vast variety of opportunities open to them. As someone recently said: Failure to teach decision-making in relation to work situations is like forbidding a youth to date until he is 21. The intention is to keep options open, but the result is often the opposite -- a liaison with the first person available after the bars are let down.

These are some of the doubts I have encountered. And they are not ill-founded or foolish as long as misinformed or ill-informed school and non-school people continue to flounder with an ill-defined concept. The floundering is, in a way, understandable because during the early growth of the Career Education movement the Office of Education sought to avoid a prescriptive and premature definition which might stifle creativity and diversity.

But the time has come for us to assume a national leadership role and to set down some ground rules, for we have found that in some cases creativity often meant doing a cosmetic job on old existing programs and masquerading them as career education.

And diversity sometimes became debauchery -- with a few people rushing into something that exhibited little commitment to anything beyond the acquisition of Federal or State dollars.

Of course, it is not my intent to imply that deception was the name of the game. Far from it. Most people who either developed new programs or revamped old ones made an honest effort to fit into a range of activities. aimed at giving young people the tools to make better choices about their career. As you know, some of the States and some local school systems developed highly sophisticated programs. And many of these we think will hold up under criteria currently being developed.

In spite of these and other encouraging events, we are still handicapped by a fact I mentioned earlier -- that over the past few years Career Education has come to mean different things to different people. Everyone seems to be doing his own thing.

From the Federal perspective, the new Center for Career Education (CCE) is faced with the problem of supporting activities designed to bring a greater measure of order to the Career Education movement. This is primarily because:

Career Education is receiving wide attention, and a wide variety of programmatic efforts to incorporate Career Education in the schools and colleges is being made. This situation poses a problem for Federal policy-making. On the one hand, any effort to construct a single definition runs the risk of stifling the creativity which is so important a part of educational reform. On the other hand, without some common understanding as to the meaning and purpose of Career Education, confusion and fragmentation of effort will result.

Consequently, a concise operational effort will be undertaken, thereby assuring a more effective leadership role for the Federal government. That effort will facilitate discussion and sharpen both the issues and the operational positions. The process will further refine the Career Education concept through a synthesis and exploration of major variants, and in so doing build constituent support and clarify the major issues to be addressed during major installational activities.

At the same time that this conceptual analysis and site diagnosis effort is taking place, pre-installation activities will be undertaken. These will involve a needs assessment by each State education agency, the development of networks of two-year and four-year post-secondary institutions in Career Education, the initiation of teacher training and staff development activities in IHE and LEA consortia, and the development of an information system which will enable the Office of Education to provide assistance to States, schools, and colleges interested in beginning or enhancing Career Education initiatives.

The purpose of these activities is to begin the development of a support system in preparation for installation of comprehensive Career Education efforts on a national scale based upon the data developed from this diagnostic analysis. States will be able to determine their needs and assess their capacity not only for participation in the national installation program but also to increase or begin initiatives of their own. Postsecondary institutions are in a wide range of postures

vis-a-vis Career Education and must be encouraged to begin an exchange of information on an organized basis and to seek effective ways to coordinate their efforts with school systems. Since staff is the key to any program initiative in Career Education, efforts must be encouraged to devise staff training programs and the materials needed for training, and to do so by supporting consortia arrangements among school systems and universities and colleges. And information containing comprehensive illustrations of successful Career Education practices and processes must be made available to the field as a major form of OE developmental assistance. We firmly believe in the journal of negative finding-knowing what not to do can be as helpful as knowing what to do.

Please remember that particular attention to a coordinated, carefully defined and focused effort in Career Education was first made possible with the creation of the Bureau of Occupational and Adult Education in the Office of Education.. The Bureau was established under authority of the Education Amendments of 1972. It officially came into being on May 17, 1973.

At the same time, the Center for Career Education was established within the new Bureau. The Center has been given responsibility to -- according to the Federal Register -- "plan, develop, and coordinate all Career Education programs within the Office of Education." The present planning activities require the Center staff, to develop a set of criteria to be used in identifying Career Education activities -- first in OE and then in the field.

We are doing this in concert with all of the Deputyships that have an interest or investment in Career Education, with the staff of the Assistant Secretary for Education, Sidney P. Marland, and with the Career Education Task Force of the National Institute of Education.

It is safe to say that no effort in OE over the last two years has had so many units within the Office feeling a sense of ownership as has the Career Education notion. I am sure that much the same thing is happening in the field -- everybody seems to own or want a piece of the action. This situation has its good points and its bad points, but from an administrative view, it demands rigorous coordinating efforts. The criteria to which I referred represent a first but important step in "getting it all together in the Office of Education."

While the criteria are not finalized, I think they can give you a clear notion of the direction in which we are moving. Let me paraphrase from the official document setting forth the criteria:

In accordance with the agreement reached among OE, NIE, and the Office of the Assistant Secretary for Education, Career Education is a major Education Division theme for making education consistent with the needs of society and its members. (The Education Division includes OE, NIE and the Fund for the Improvement of Postsecondary Education) These major objectives of Career Education have been agreed upon:

1. To improve the quality of career choice.
2. To improve individual opportunities for career entry.
3. To improve individual opportunities for career progression.

All of these goals, especially the third, require the involvement of other segments of society in addition to the education sector. Nevertheless, the education sector has specific responsibilities in insuring attention to the qualitative aspects of career choices. It is also responsible for preparing students for career entry and enabling them to make and prepare for subsequent choices and progress in careers. Accordingly, the following criteria are considered instrumental to the fulfillment of OE's contribution to the goals of Career Education. They will be used to identify OE Career Education initiatives:

There are three types of projects. The first will be designated a "Comprehensive Career Education Project." It must contain all of the following objectives:

1. To develop and expand the career awareness of all students in the educational levels served.
2. To provide all students in the educational levels served with opportunities for detailed exploration and/or specific and general knowledge and skill attainment in a career of their choice through in-school and out-of-school activities.
3. To provide career oriented guidance and counseling to all students in the educational levels served.
4. To provide career placement services to students leaving educational programs at any level to insure that each such student enters or returns to either a job, further formal education, or a specific alternative life experience designed in terms of the individual's career development.

5. To improve the cognitive and affective performance of all students in the educational levels served by restructuring the curriculum to focus all subjects around a career development theme.
6. To provide training for educational personnel to improve their capability to design, operate, and/or evaluate those aspects of educational programs which meet the preceding objectives.

A second type of project will be designated a "Career Education Support System Project" if it contains one or more of the following as its only objective or objectives:

1. To provide training for educational personnel to improve their capability to design, operate, and/or evaluate those aspects of educational programs and experiences which meet one or more of the objectives enumerated in the "Comprehensive Career Education Project" design.
2. To design, develop, test, demonstrate, or disseminate curriculum materials the specific purpose of which is to enhance those aspects of educational programs and experiences which meet one or more of the objectives in the "Comprehensive" design.
3. To design, develop, test, demonstrate, or disseminate management materials the specific purpose of which is to enhance those aspects of educational programs and experiences which meet one or more of the objectives in the "Comprehensive" design.

A third type of project will be "Career Education Related" and will have more limited goals. It will be so designated if:

1. It contains one or more, but not all, of the objectives in the "Comprehensive" design or
2. It contains one or more of the "Comprehensive" objectives but attempts to serve only some students in the educational levels served. (E.G. a school English department attempts to make its curriculum career oriented although the other academic departments in the school do not; or a specific vocational program adds a career development dimension to its courses while the remainder of the school maintains the traditional academic-vocational split.)
3. It contains, as only a portion of its objectives, one or more of the objectives in the second design -- the "Support System" group of projects.

Running through the criteria I have just read is a recurrent phrase -- "students at all educational levels." That should tell you that we are not restricting our concerns to elementary and secondary schools. A great deal needs to be done at the college and university level and certainly within the two-year colleges. Pressure for career oriented curriculums is coming as much from students in postsecondary institutions as from anyone else. They have a heavy investment in their college educations and they want them relevant, they want them to pay off in terms of a worthwhile career and satisfying lifestyle. Institutions of higher education also will certainly be involved in the training and retraining of educational personnel.

Obviously, I am attempting to cover a lot of ground here, and I think I have described the Office of Education's stance to date on Career Education as best I can. I have shared with you certain decisions though they have not been completely finalized. Now I would like to touch upon the role of vocational educators.

Over a period of time, I have worked with many vocational educators, especially those involved in personnel development activities under Part F of the Education Professions Development Act. One of the most important things I found out is that the concerned vocational educator is perpetually involved in efforts to improve his discipline. And that, it seems to me, is one of the most significant contributions the vocational educator can make to developing the Career Education concept. At the State level, I would say that you must assume leadership in problem areas where you have both authority and expertise.

For instance:

- How do you provide for effective linkages and articulation with trade schools, apprenticeship arrangements, manpower development and training efforts, adult and continuing education programs, especially for minority groups and the poor?
- In view of oversized classes in most voc-ed facilities, how do you provide for optimum utilization of equipment and space?
- What progress are you making with cooperative education?
- What are you doing to reach out into business and industry to ascertain that training is appropriate? Are advisory committees being used effectively?

- How are you evaluating placement efforts? What kind of follow-up activities are you conducting, including follow-up on upward mobility?
- What influence do you use to determine the location of voc-ed schools? I know of a number of schools that have been constructed at the city-suburban border, making it difficult for the inner-city poor to get there.
- How many students are still being trained for a single career -- a lifetime occupational role, in spite of evidence that increasing numbers of workers feel "locked in" and desire early and mid-career changes?
- Are women, minority people, or the poor, led into stereotyped roles and prepared for stereotyped jobs?

These are some of the questions facing Career Education, and certainly you know them well. Yet these are examples of areas in which your discipline -- and in some cases related disciplines-- have serious obligations. These are areas that have much to do with the success of all of Career Education.

While you examine your discipline, let me assure you, at the Office of Education we also are examining ours. We call ours "bureaucracy," and it, as you well know, is closely related to another discipline -- economics. Or, to be more precise, finances. Let me tell you where we stand.

As you know, most of what is called Career Education now is funded in either NIE and OE. In OE the major emphasis has been through Parts C and D and I of the Vocational Education Amendments of 1968. These are administered through the Division of Vocational Research in the Bureau of Occupational and Adult Education. And this has been a thorn in the side of some vocational educators. In Fiscal Year 1974, and thereafter, the vocational education

money will be used for strictly vocational education projects, though these projects, if they meet certain criteria, could become an important component of the Career Education design either in support systems or CE related categories.

I should hasten to add that Career Education projects currently funded under Part D will continue to be supported under the same authority for the agreed upon term. And the Commissioner's share of Part C -- the OE discretionary part -- will be used for applied studies in vocational education.

Federal options for Career Education expenditures for Fiscal Year 1974 and after are affected by a number of constraints beyond the control of the Center for Career Education and the Office of Education. The most salient of these is appropriations. The FY 74 estimates included a Career Education line item of \$14 million under authority of the Cooperative Research Act. The House appropriation bill did not include this item. Although there is reason to hope that the Senate may act to restore at least part of this appropriation, the final figure coming out of a House-Senate conference committee is likely to be considerably less than originally expected. Whatever money is appropriated probably will not be available to us before November or December.

In any case, we are going ahead with our planning, and I would like to share with you some of our ideas as to the general direction in which we hope to move.

As I explained earlier, we are setting up certain criteria for determining what legitimately can be supported as Career Education. In conjunction with the National Institute of Education, the Center for Career Education initially will use its limited resources to provide the developmental impetus and cross-boundary perspective necessary to advance the implementation of the Career Education effort.

Obviously, funds available in FY 74 and 75 will allow direct funding of a very small number of State, regional, and local programs. That support will be limited to pre-installation activities. And, as I have already indicated, much of our energy will be devoted to surveying and evaluating what has already been developed over the past two years. To put it another way, the bulk of FY 74 funds earmarked specifically for Career Education will be spent on trying to identify various approaches that have been developed, on getting people together to examine these approaches, and on determining what facilities should be funded in FY 75. During this entire period, we will be working closely with practitioners in the field, seeking their comments, their advice, and their expertise.

One thing of which I am certain is that Career Education, by its very nature, is one of the most difficult challenges OE has had to face. Yet, it clearly addresses itself to a pressing need -- one which more and more young people are identifying as a need.

The invitation to speak here specifically asked that I suggest some administrative and organizational strategies which State education agencies could adopt in order to implement Career Education programs.

I think I have implied one strategy when I said that Career Education is of an inter-disciplinary nature and vocational education is a contributing discipline. At the risk of putting some noses out of joint, I would recommend that the State person coordinating Career Education efforts be an individual with a multi-disciplinary background and approach. Ideally, he or she should be a person designated to work out of the office of the superintendent or be his assistant for Curriculum, Instruction, or Elementary, Secondary, or Postsecondary Education. It is my firm conviction that Career Education cannot and will not become the private domain of vocational education or any other single discipline if we expect it to succeed.

Certainly, the experience and knowledge of vocational educators will contribute greatly to the development and operation of the concept, but the very essence of Career Education is that it touches and reaches into all areas of learning.

Now, you must decide in your own mind whether this threatens or enhances vocational education or vocational educators. I see opportunities for enhancement -- opportunities for contributing to the mainstream of every State department on a parity basis with every other segment of the Department.

Other administrative and organizational strategies?

- Those that are necessary to move us into an open entrance-exit system-- permitting an in-and-out movement for students starting, perhaps, in junior high school and extending through adult education.

- Those changes necessary to permit students to combine school with work.

- Those that introduce performance based criteria for evaluating students, teachers, counselors, supervisors, administrators -- and, yes, superintendents.
- Strategies necessary to include students, teachers, parents, and the community in educational planning and decision making -- whether it is at the elementary level or at the adult education level.

I could go further. State departments and local education agencies need to work out additional cooperative arrangements with institutions that train educational personnel. The goal is to be the master of your own fate -- and that can't happen unless all have a say in how all personnel are either trained or retrained in in-service programs.

Lastly, there is a need for strategies that will guarantee a commitment to the Career Education concept, a willingness to contribute to its further development. While the Office of Education can provide a certain impetus we know that the real development will be at the State and local levels. That's where the decisions that affect the everyday life of teachers and students are really made.

It is relatively easy for me to talk about necessary power rearrangement and changes. Some of them are difficult to make. Certainly changes do not come more easily at the Federal level than they do at the State level. Yet we have been able to do some of the things that I am suggesting you undertake. For one thing, those of us specifically involved with Career Education have established an excellent relationship with other units within the Bureau of Occupational and Adult Education. And we have had immeasurable assistance from the people who administer Parts C, D, and I of the Vocational Education

Amendments. Yet it is clearly understood in OE that vocational education is but one component of Career Education. I think that each unit has a respect for its own discipline and for the other fellow's discipline. This kind of understanding and respect enables us to work together on a parity basis and move ahead in harmony.

I am certain that the same kind of harmony can extend to our relationships with the State education agencies, and especially the vocational education family, for SEAs must be directly involved, particularly in determining their own needs and in building their own capacity for exerting leadership in the Career Education movement.

This has been a lengthy presentation -- but if I have been lengthy I hope I have also been enlightening.

IMPROVING ADMINISTRATIVE ACTIVITIES
OF STATE VOCATIONAL EDUCATIONAL AGENCIES
OR
IOWA VOCATIONAL EDUCATION

By
William O. Schwesinger
Director of Career Education
Iowa Department of Public Instruction
Des Moines, Iowa

Presented at the

Sixth Annual National Leadership Development Seminar
For State Directors of Vocational Education

September 18-21, 1973

The Sheraton-Nashville Hotel, Nashville, Tennessee



IMPROVING ADMINISTRATIVE ACTIVITIES
OF STATE VOCATIONAL EDUCATIONAL AGENCIES
OR
IOWA VOCATIONAL EDUCATION

The presentation in the next twelve minutes will cover a period of time starting with the Smith-Hughes Act to the present. In fact to relate the actions taken over this period of time relates quite well the development of the administrative activities to provide a manageable means of state administration of the vocational educational effort in the state of Iowa. This presentation could be expanded and developed into a three hour graduate course offered by a state university. What I will present today is a brief overview.

In reviewing the state vocational administrative structure ten years ago, it well met and reflected the Smith-Hughes Act. We implemented very well the intent and purpose of that time. At that point in time we believed the purpose was to supervise and monitor vocational education programs. Our division staff was identified with the typical categorical funding pattern-- agriculture, home economics, trade and industry, office education and distributive education. During this time vocational education was aimed toward program development separate and apart from the rest of education. Smith-Hughes type of federal legislation greatly contributed to the chasm that occurred in attempting to educate the whole person in total education.

In 1962 the Manpower Development Training Act was passed and for the first time legislation became available which directed vocational education training to be people oriented rather than program oriented. Most vocational educators felt that MDTA (sometimes referred to as "More Damn Trouble Ahead") was no more than a "band-aid" vocational program and in two or three years

would disappear. Under MDTA training it was immediately recognized that the student required more than just skill training in order to be acceptable at the job entry level.

The Vocational Act of 1963 was passed by Congress and implied many changes should be taken - five years later the Amendments of 1968 mandated a change to be made from program needs to individual or student needs. The 1968 Amendments also eliminated categorical funding for special occupational groups.

In 1965 the State Legislature of Iowa passed legislation that created not less than four or more than twenty postsecondary area schools in our state. Since Iowa had no vocational postsecondary schools the action within the state to create area schools moved quickly and created what we now have as fifteen postsecondary or area schools. The state also at this time had a number of postsecondary junior colleges and by law these were linked with the area vocational schools to create in our state the first comprehensive community colleges.

All of the before mentioned circumstances contributed to and influenced the restructuring of the Vocational Education Division of the Department of Public Instruction. In Iowa the State Board of Public Instruction acts as the State Board of Vocational Education and Area Schools as well as elementary and secondary public education.

In 1968 the state superintendent requested that the Vocational Education Division evaluate its operation and recommend changes that we felt would better meet the needs of the 1968 Amendments and would also assist our division staff in providing leadership and consultative services to the public schools at the elementary-secondary and postsecondary levels. Since we were vocational educators, we set up a task force within our division made up of the head supervisors of the occupational units and approached the effort in

a problem solving manner.

1. Define the function or purpose
2. Develop ideal solution
3. Develop practical solution
4. Do it that way

At this point it was very difficult to apply to ourselves what we were recommending all others in vocational education use as a system of problem solving. A practical solution was agreed upon and the restructuring of our division was made. (See Appendix I and II) At this time the Vocational Education Division was renamed the Career Education Division to add thrust and assist the Department in the Career Education movement. This allowed us to implement the Amendments of 1968 in its broadest concept which we in Iowa felt was the intent of Congress and HEW. The renaming of the division also caused confusion in the field since our division continued to conduct all vocational education offerings as well as promote the career development concept to all educational efforts at all educational levels.

Additional services such as Special Needs, Guidance, Certification and Approval, etc., (See Appendix III), are performed by consultants attached to the other branches (See Appendix IV).

We feel that the present organizational structure outlined has operated quite well over the past four years. As we all know the persons performing the tasks indicated in the operational chart is the key to success of the operation. The consultants assigned to the operational services or units are vocational educators with specialities in various occupations. This expertise is interchanged in an assistive manner between services of the division and department. We also determined the need for division management, planning and review. This is accomplished by having weekly management staff

meetings of the chiefs of the division services and chiefs of periphery support services such as fiscal control, special needs, guidance, supplementary (adult) education, and data processing. We also, on occasion, as the problem under consideration dictates expand the management staff meetings to include other personnel in the department.

MERGED AREA SCHOOLS

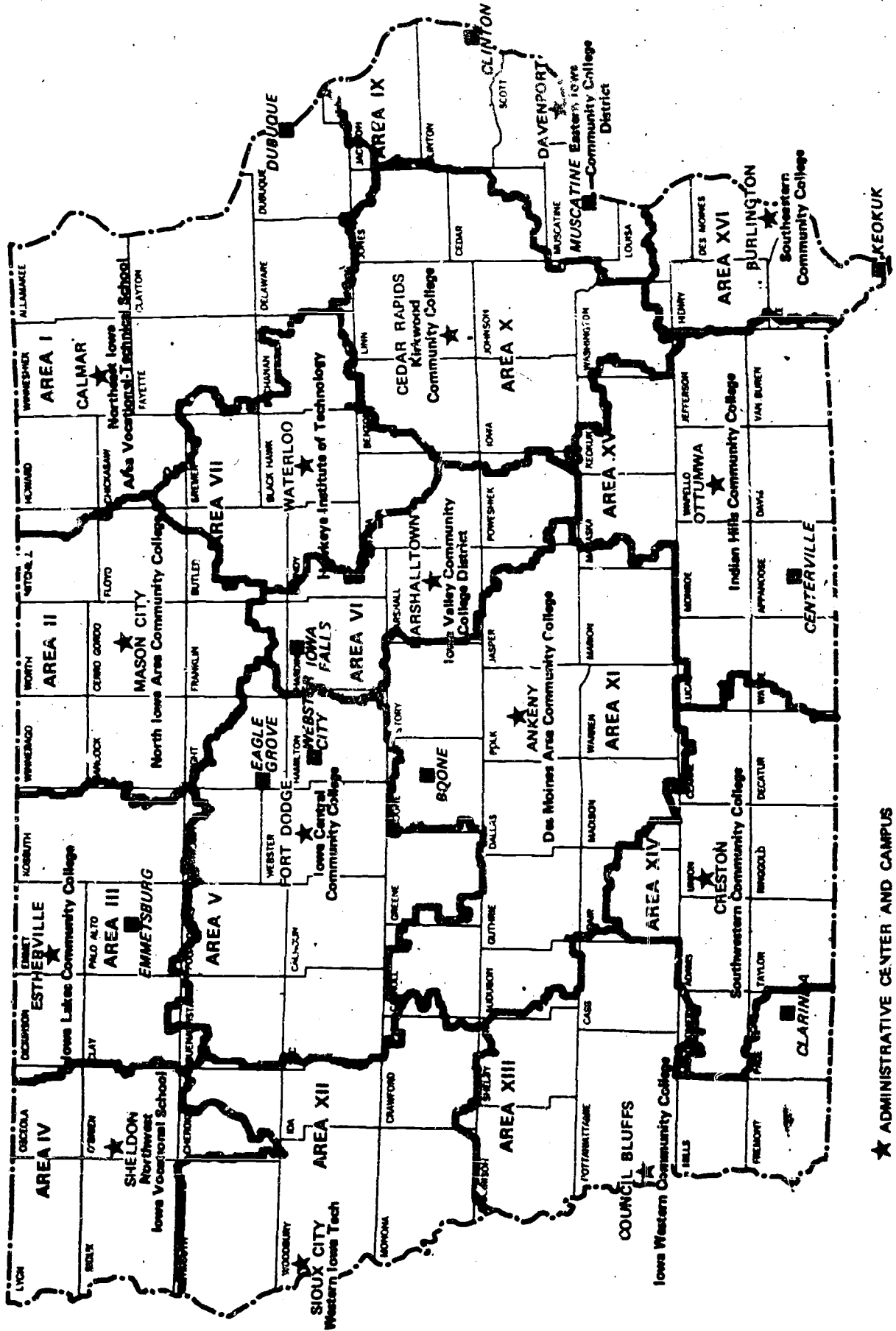

★ ADMINISTRATIVE CENTER AND CAMPUS
 ■ OTHER CAMPUS (AREA SCHOOLS WITH MORE THAN ONE MAJOR CAMPUS)

AREA SCHOOLS AND CAREER EDUCATION BRANCH

ORGANIZATION CHART VERIFIED 10-1-70

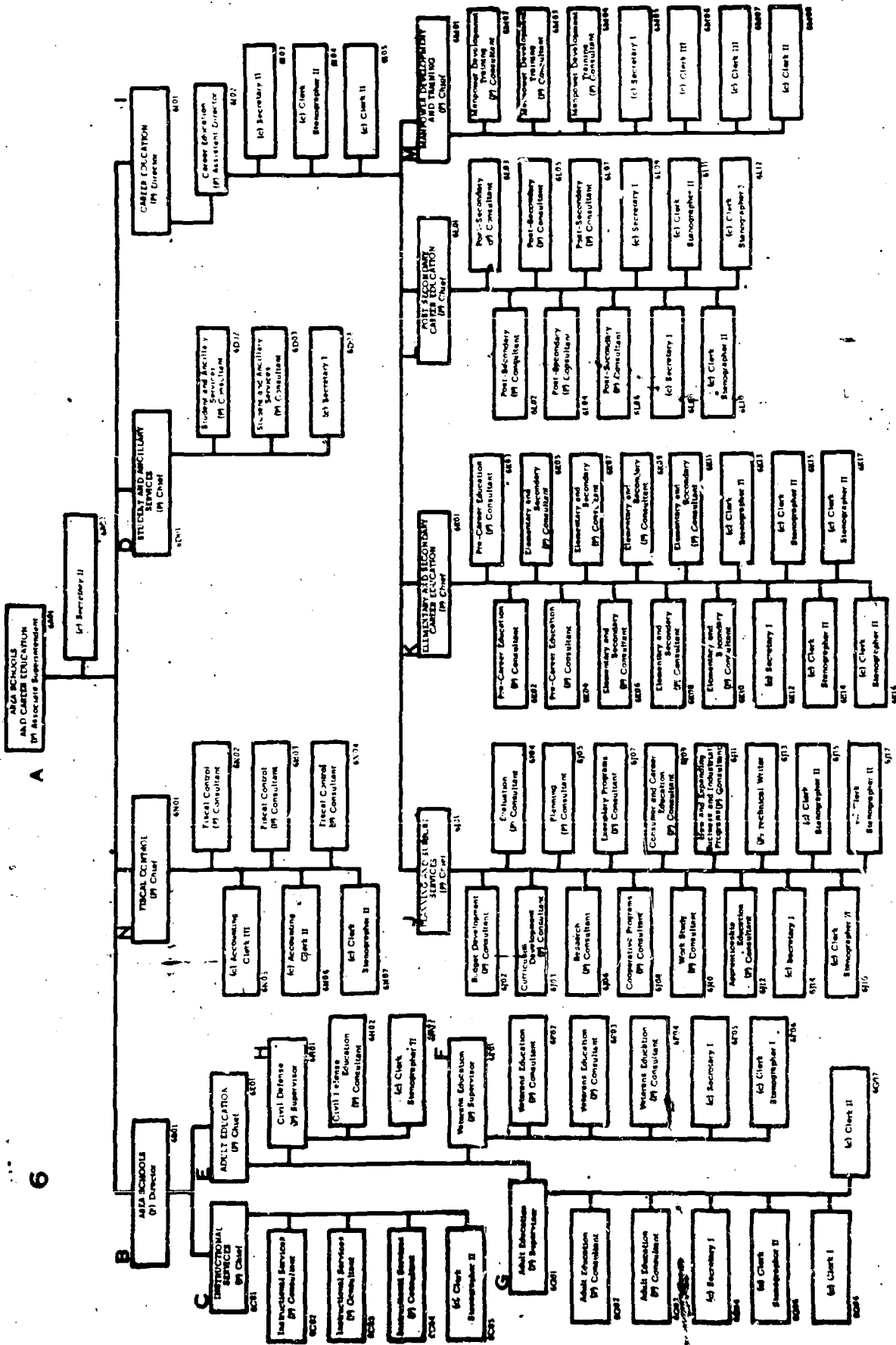

6

ADDITIONS TO ORGANIZATIONAL CHART

1. Special Needs - Special Needs activities pertaining to the disadvantaged and handicapped under the Act are being served by a Special Needs Section in the Pupil Personnel Services Branch (5F). Currently the staff consists of three professional persons.
2. Guidance - Career Guidance activities are being coordinated by a professional staff member of the Guidance Services Section in the Pupil Personnel Services Branch (5E).
3. Certification and Approval - Activities relative to this area are assigned to a professional staff member of the Education Professional Development Section of the Instruction and Professional Education Branch (4D).
4. Plant and Facilities - Activities in this area are coordinated by a professional staff member who is assigned to the School Plant Facilities Section of the Administration Branch (2L).
5. Fiscal Affairs - Fiscal matters pertaining to secondary and postsecondary career education programs, services, and activities are handled by personnel in the Fiscal Control Section of the Area Schools and Career Education Branch (6N).
6. Health Occupations - Provision has been made for the employment of a health consultant who will be a member of the Postsecondary Career Education Section of the Area Schools and Career Education Branch (6L). This state consultant will coordinate the work of the Career Education Division relative to health occupations with the health occupations unit of the University of Iowa, under a contract with the Career Education Division.

RESPONSIBILITIES AND RELATIONSHIPS
IN
CAREER EDUCATION SERVICES

CODE

- R - Responsible
- I - Implement
- A - Assist

	Planning	Support Service	Post Sec.	Elem. Sec.	Fiscal	Adult Educ.	College Parallel	Student & Ancillary Service
<u>Budget Development</u>								
1. Develop program cost guidelines relative to career education.	R/I	A	A	A	A	A		
2. Consult with L.E.A.'s in the preparation of budgets.	A	R/I	R/I	R/I	A	R/I		
3. Receive and review budget submitted by L.E.A.'s.	R/I	A	A	A	A	A		
4. Recommend career program budgets.	R/I							
5. Develop and recommend Career Education Division budget (in office)	R/I	A	A	A	A	A		
6. Recommend allocation of funds.	R/I	A	A	A	A	A		
<u>Planning</u>								
1. Identify and project needs of employers and individuals.	R/I	A	A	A		A		
2. Maintain Career Education Division goals/objectives	R/I	A	A	A		A		
3. Up-date state plans.	R/I	A	A	A		A		
4. Disseminate planning information.	R/I	I	I	I		I		
5. Coordinate career education planning with over-all departmental planning and development section and other agencies, institutions and organizations.	R/I	A	A	A		A		
6. Receive, review and recommend programs.								

L.E.A.'s - Local education agencies

	Planning	Support Service	Post Sec.	Elem. Sec.	Fiscal	Adult Educ.	College Parallel	Student Ancilla Service
<u>Evaluation</u>								
1. Design follow-up of program operation and effectiveness.	R/I	A	A	A		A		
2. Assess attrition in career programs.	R/I	A	A	A		A		
3. Ascertain program effectiveness in meeting needs of individuals and employers.	R/I	A	A	A		A		
4. Make recommendations based on evaluation findings.	R/I							
5. Develop evaluation procedures and techniques.	R/I	A	A	A		A		
6. Assist L.E.A.'s in measuring program effectiveness.	A	R/I	R/I	R/I		R/I		
<u>Research</u>								
1. Stimulate and encourage research.	R/I	A	A	A		A		
2. Identify potential research problems.	R/I	A	A	A		A		
3. Collect and disseminate research information.	R/I							
4. Coordinate development and dissemination of career education information.	A	R/I	A	A		A		
5. Coordinate research activities with other agencies, institutions, and organizations.	R/I							
6. Provide consultative services in regard to preparation of research proposals and research methodology.	R/I							
7. Conduct intra-organization research.	R/I	A	A	A		A		
8. Review and recommend action for funding of research proposals.	R/I							

	Planning	Support Service	Post Sec.	Elem. Sec.	Fiscal	Adult Educ.	College Parallel	Student & Ancillary Service
<u>Curriculum</u>								
1. Develop "basic", "suggested" state-wide curriculum guidelines for existing, new and emerging programs.	R/I	A	A	A		A		
2. Coordinate curriculum activities for career education with other resources.	R/I	A	A	A		A		
3. Consult with L.E.A.'s on curriculum, equipment, and facilities.	A	R/I	R/I	R/I		R/I		
4. Collect and disseminate curriculum research and materials.	R/I	A/I	A/I	A/I		A/I		
5. Consult with L.E.A.'s on youth organizations.	A		R/I	R/I				
<u>Reporting</u>								
1. Establish data collection system.	A				R/I			
2. Collect data.					R/I			
3. Formulate reports.	R/I	A	A	A	A	A		
4. Disseminate reports.	R/I							

	Planning	Support Service	Post Sec.	Elem. Sec.	Fiscal	Adult Educ.	College Parallel	Student & Ancillary Service
<u>Teacher Education</u>								
1. Consult with L.E.A.'s on teaching techniques.		A/R/I	R/I	R/I		R/I		
2. Contract for teacher education services.	A	R/I	A	A		A		
3. Organize conferences, workshops, etc.	A	A/R/I	R/I	K/I		R/I		
4. Consult with L.E.A.'s on teacher recruitment and staffing.		A/R/I	R/I	R/I		R/I		
5. Certify and approve teachers.		A/R/I	A	A		A/I		
<u>Plant Facilities</u>								
1. Analysis of school sites and plants.	A	R/I	A	A		A		
2. Review and recommend plans and specifications for facilities.		R/I	A	A		A		
3. Conduct school plant surveys.	A	R/I	A	A		A		
4. Project needs.	A	R/I	A	A		A		

Guidance

1. Assist L.E.A. in providing a comprehensive program of guidance services which emphasizes career education as a meaningful choice.
2. Assist L.E.A. in providing a program of guidance services which assures assistance to youth and adults participating in career education.
3. Develop and disseminate career education information.
4. Consult with guidance personnel concerning effective use of career education information.
5. Assist L.E.A. in assessing from pupils and community the interests, expectations, and needs for career education programs.
6. Consult with institutions in the continued development of programs for the preparation of guidance personnel.
7. Assist in evaluation of counselor education programs as they are considered for approval to prepare school counselors.
8. Coordinate the direction and efforts of the Statewide Guidance Advisory Committee.

	Planning	Support Service	Post Sec.	Elem. Sec.	Fiscal	Adult Educ.	College Parallel	Student & Ancillary Service
	A	A/R/I	A	A		A	A	A/R/I
	A	A/R/I		A		A	A	A/R/I
	A/I	A/R/I	A/I	A/I		A/I	A/I	A/R/I
		A/R/I	A	A		A	A	A/R/I
	A	A/R/I	A	A		A	A	A/R/I
		A/R/I						R/I
	A	A/R/I						R/I
		R/I						R/I

SUPPORT SERVICES SECTION

<u>Function</u>	<u>Responsibility</u>	<u>Procedure</u>
Budget Development	Develop program cost guidelines relative to career education.	Analyze costs of personnel, equipment facilities, supplies and materials and other program related costs to guide budgetary decisions. Use the expertise of career consultants personnel, advisory committees, post fiscal records and program projections in such analysis.
	Assist in consulting with L.E.A.'s in the preparation of budgets.	Make available to consultants, resource materials for use in assisting L.E.A.'s in budget preparation.
	Receive and review budget submitted by L.E.A.'s.	Review budgets in terms of program cost guidelines. Maintain a log of budget requests. Receive budget proposals directly from L.E.A. administration.
	Recommend career program budgets.	Formulate and submit budget recommendation with backup materials to Director of Career Education for action.
	Developing and recommending Career Education Division budget (in office)	Use projected plan of activities in developing Career Education Division budget. Solicit budget needs from services within Division. Work in conjunction with Administrative Services. Submit recommendations with backup material to Director of Career Education.
	Recommend allocation of funds	Review total program budgets and funds available for allocation as a base for recommendations to be submitted to Director of Career Education.
Planning	Identifying and projecting needs of employers and individuals.	Establish and maintain working relationships with other agencies, institutions and organizations for the purpose of obtaining information relative to needs. Develop procedures and format to institute these activities.
	Maintaining Career Education Division goals/objectives	Evaluate and revise current goals/objectives in light of new legislation and changing needs of society.

SUPPORT SERVICES SECTION (cont)

<u>Function</u>	<u>Responsibility</u>	<u>Procedure</u>
Planning (Cont)	Up-dating state plans.	Periodically give attention to revising the plans for career education that have been adopted by the state board. Solicit suggestions from sources that will aid in up-dating the plan.
	Disseminating planning information.	Establish channels through which planning information should be directed. Organize materials for users. Direct materials to prospective users.
	Coordinate career education planning with overall departmental planning and development section and the state office for planning and programming.	Develop working relationships. Utilize data from these sources. Participate in joint-planning activities. Provide information to others.
Evaluation.	Design follow-up of program operation and effectiveness.	Establish criteria for follow-up. Stimulate the preparation of forms guides and procedures for follow-up. Determine reliability and validity of follow-up results.
	Assess attrition in career programs.	Establish procedure for identifying dropouts. Collect and analyze information about dropouts.
	Ascertain program effectiveness in meeting needs of individuals and employers.	Determine the degree to which a program is meeting its objectives and goals (see item 5 below). Survey employers for success of graduates. Follow-up of graduates.
	Make recommendations based on evaluation findings.	Formulate and submit recommendations to Director of Career Education for action.

SUPPORT SERVICES SECTION (cont.)

<u>Function</u>	<u>Responsibility</u>	<u>Procedure</u>
Evaluation (Cont)	Develop evaluation procedures and techniques.	Determine purpose of evaluation. Develop criteria for program evaluation. Collect information relative to evaluation from other agencies, institutions and organizations. Develop instruments to be used in evaluation.
	Assist L.E.A.'s in measuring program effectiveness.	Provide feedback information gained through follow-up and evaluation efforts.
Research	Stimulate and encourage research.	Involve appropriate personnel in institutions, organizations and agencies in research activities. Cite research needs.
	Identify potential research problems	Maintain contacts with business, industry and educational institutions. Develop potential list of research problems. Establish priorities.
	Collect and disseminate research information	Develop techniques and procedures for collection, classification, summarization, tabulation, storage, retrieval and dissemination of information on employment opportunities, human resources and training. Maintain continuous inventory of available data.
	Coordinate development of career education information.	Work with other agencies, institutions, and organizations. Develop criteria and evaluate appropriateness of information. Establish dissemination network.
	Coordinate research activities with other agencies, institutions, and organizations.	Participate in inter-group planning. Participate in cooperative research. Maintain avenues for exchange of information.
	Provide consultative services in regard to preparation of research proposals and research methodology.	Provide guidelines for preparation of research proposals. Provide information regarding related studies and resource materials.

SUPPORT SERVICES SECTION (cont.)

<u>Function</u>	<u>Responsibility</u>	<u>Procedure</u>
Research (Cont)	Conduct intra-organizational research	Establish methods for conducting research. Identify research problems.
	Review and recommend action for funding of research proposals.	As stated in State Plan.
Curriculum	Develop "basic," "suggested" statewide curriculum guidelines for existing, new and emerging programs.	Make analyses of occupations. Work with instructional personnel, consultants, and advisory committees. Develop suggested objectives, curriculum content, and resource units. Print and disseminate guidelines.
	Coordinate curriculum activities for career education with other resources.	Organize meetings, task force assignments, and the like between educators and persons knowledgeable about content that should be included in career programs. Maintain contact with institutions, organizations, and agencies concerned with curricula. Keep abreast of other curriculum activities within the Department of Public Instruction.
	Assist in consulting with L.E.A.'s on curriculum, equipment, and facilities.	Provide appropriate materials and information for use by consultants when working with L.E.A.'s.
	Collect and disseminate curriculum research and materials.	Collect curriculum and related materials from in-state and out-of-state sources. Develop techniques and procedures for the collection, classification, summarization or tabulation, storage, retrieval, and dissemination of curriculum research and materials. Conduct a continuous inventory of available data and research on curriculum from institution, agencies, and organizations. Establish a network of users.
	Consult with L.E.A.'s on youth organizations.	Assist in collecting and disseminating instructional content, evaluating operation of program, and developing policy relating to state administrator of youth organizations.

SUPPORT SERVICES SECTION (cont.)

<u>Function</u>	<u>Responsibility</u>	<u>Procedure</u>
Reporting	Assist in establishing data collection system.	Provide expertise for design of data collection systems to insure compatibility between information collected and the formulation of state and federal career education reports.
	Formulate reports	Obtain and interpret information from administrative service and other sources to complete required state and federal career education reports and special reports as needed.
	Disseminate reports.	Establish channels through which information should be directed. Direct materials to prospective users.
Teacher education	Assist in contracting for teacher education services.	Provide budgetary, curriculum, research, and evaluation information and services.
	Assist in organizing conferences, workshops, etc.	Provide timetable information to coordinate these activities. Provide resource information regarding curriculum, research, and evaluation.
Plant Facilities	Assist in analysis of school sites and plants.	Assist in developing criteria and procedures to be used in this analysis.
	Assist in conducting school surveys	Provide information relative to program expansions or reductions based on annual and five year plans.
	Assist in projecting needs	Provide information relative to program expansions or reductions based on annual and five year plans.

ELEMENTARY-SECONDARY SECTION

<u>Function</u>	<u>Responsibilities</u>	<u>Procedures</u>
Budget Development	Assist planning in developing program cost guidelines relative to career education.	Collect program cost information. Make judgements regarding relevance of equipment, facilities, etc. to program objectives and costs.
	Consult with L.E.A.'s in the preparation of budgets.	Contact administrative and instructional personnel relative to those items to be included in the budget. Make available resource materials to guide development of budgets.
	Assist planning in reviewing budget submitted by L.E.A.'s.	When requested, participate in review of budgets.
	Assist planning in recommending Career Education Division budget (in office).	Prepare, on the basis of past experiences and projected activities, the budget needs as perceived by members of this staff.
	Assist planning in recommending allocation of funds.	Prepare back-up material for suggesting allocation of funds.
Planning	Assist planning in identifying and projecting needs of employers and individuals.	Meet with employers, school personnel and other groups to ascertain educational needs. Submit findings and information to planning.
	Assist planning in maintaining Career Education Division goals/objectives.	Interpret changing needs of business, industry, etc. to the planning group.
	Assist planning in updating state plans.	Be alert to gathering information which has implications for needed plan changes. Aid through discussions and committee work to formulate new plans.
	Assist planning in disseminating planning information.	Assist in development of dissemination channels. Consult with users relative to the adaptation of planning information to their needs.
		When requested, participate in review of budgets.
Evaluation	Assist planning in follow-up of program operation and effectiveness.	Provide consultative assistance when called upon.

ELEMENTARY-SECONDARY (Cont)

<u>Function</u>	<u>Responsibilities</u>	<u>Procedures</u>
Evaluation (Cont)	Assist planning in attrition in career programs.	Aid in analysis of attrition.
	Assist planning in ascertaining program effectiveness in meeting needs of individuals and employers.	Make individual and employer contacts. Contribute to evaluation through observation of day-to-day operation. Work with local advisory committees.
	Develop evaluation procedures and techniques.	Provide assistance as needed.
	Assist L.E.A.'s in measuring program effectiveness.	Work with local advisory committees. Interpret forms and procedures to L.E.A.'s.
Research	Assist in stimulating and encouraging research.	Perform assistance roles similar to planning services.
	Assist in identifying potential research problems.	Suggest and recommend areas for research based on field observations and experiences.
	Assist in coordinating development of career education information.	Assist in development of evaluative criteria. Assist in dissemination through appropriate media.
	Assist in conducting intra-organization research.	Identify research problems. Assist in contacting population included in the research.
Curriculum	Assist in developing "basic," "suggested" state-wide curriculum guidelines for existing, new and emerging programs.	Act as resource for identifying personnel qualified to consult on this activity. Provide expertise when staff member's background qualifies. Assist planning in organizing and conducting activities relating to this task.
	Assist in coordinating curriculum activities for career education with other resources.	Assist planning group as needed.
	Consult with L.E.A.'s on curriculum, equipment, and facilities.	Through visitations, comment and provide assistance on appropriateness of curriculum content relative to occupation, objectives established, and need. Observe kinds and condition of equipment and facilities. Make recommendations whenever

ELEMENTARY-SECONDARY (Cont)

<u>Function</u>	<u>Responsibilities</u>	<u>Procedures</u>
Curriculum (Cont)	<p>Collect and disseminate curriculum research and materials.</p> <p>Consult with L.E.A.'s on youth organizations.</p>	<p>appropriate. Maintain communication in office and prepare follow-up reports to L.E.A.'s.</p> <p>Serve as communication link between L.E.A.'s and the Division regarding curriculum, equipment, and facilities.</p> <p>Consult with L.E.A.'s relative to: developing program of work which carries out the purposes of the organization, providing leadership training, and planning and coordinating conferences. Disseminate state and national information.</p>
Reporting	Assist in formulating reports.	Provide information as needed and verify information in reports.
Teacher education	<p>Consult with L.E.A.'s on teaching techniques.</p> <p>Assist in contracting for teacher education services.</p> <p>Organize conferences, workshops, etc.</p> <p>Consult with L.E.A.'s on teacher recruitment and staffing.</p> <p>Assist in certifying and approving teachers</p>	<p>Through visitations, observe, comment, and provide assistance on techniques being used by instructional staff. Make recommendations relative to in-service education. Provide information on instructional aids and innovations.</p> <p>Provide information pertinent to the supply and demand for career educational personnel. Recommend needed in-service education.</p> <p>With assistance of advisory committees, provide for preservice and in-service teacher education activities. Maintain contact with teacher educators on matters relating to this service.</p> <p>Maintain and disseminate rosters of educational personnel employed in career education programs in the state. (Maintained by institution, geographical area, and instructional area.) Be knowledgeable as to individuals available for employment. (In-state and out-of-state institutions and organizations.)</p> <p>Serve on committees to aid in analyzing qualifications of applicants for certificates and career education subject approval.</p>

ELEMENTARY-SECONDARY

<u>Function</u>	<u>Responsibility</u>	<u>Procedures</u>
Plant facilities	Assist in analysis of school sites and plants.	Assist in developing criteria and procedure to be used in this analysis.
	Assist in reviewing and recommending plans and specifications for facilities.	Provide technical information to assist plant facilities group in formulating recommendations.
	Assist in conducting school plant surveys.	Upon request, observe and report findings.
	Assist in projecting needs.	Provide information relative to program expansions or reductions.

POSTSECONDARY SERVICES SECTION

<u>Function</u>	<u>Responsibilities</u>	<u>Procedures</u>
Budget Development	Assist planning in developing program cost guidelines relative to career education.	Collect program cost information. Make judgements regarding relevance of equipment, facilities, etc. to program objectives and costs.
	Consult with L.E.A.'s in the preparation of budgets.	Contact administrative and instructional personnel relative to those items to be included in the budget. Make available resource materials to guide development of budgets.
	Assist planning in reviewing budget submitted by L.E.A.'s.	When requested, participate in review of budgets.
	Assist planning in recommending Career Education Division budget (in office).	Prepare, on the basis of past experiences and projected activities, the budget needs as perceived by members of this staff.
	Assist planning in recommending allocation of funds.	Prepare back-up material for suggesting allocation of funds.
Planning	Assist planning in identifying and projecting needs of employers and individuals.	Meet with employers, school personnel and other groups to ascertain educational needs. Submit findings and information to planning.
	Assist planning in maintaining Career Education Division goals/objectives.	Interpret changing needs of business, industry, etc. to the planning group.
	Assist planning in updating state plans.	Be alert to gathering information which has implications for needed plan changes. Aid through discussions and committee work to formulate new plans.
	Assist planning in disseminating planning information.	Assist in development of dissemination channels. Consult with users relative to the adaptation of planning information to their needs.
		When requested, participate in review of budgets.
Evaluation	Assist planning in follow-up of program operation and effectiveness.	Provide consultative assistance when called upon.

POSTSECONDARY (cont)

<u>Function</u>	<u>Responsibilities</u>	<u>Procedures</u>
Evaluation (Cont)	Assist planning in attrition in career programs.	Aid in analysis of attrition.
	Assist planning in ascertaining program effectiveness in meeting needs of individuals and employers.	Make individual and employer contacts. Contribute to evaluation through observation of day-to-day operation. Work with local advisory committees.
	Develop evaluation procedures and techniques.	Provide assistance as needed.
	Assist L.E.A.'s in measuring program effectiveness.	Work with local advisory committees. Interpret forms and procedures to L.E.A.'s
Research	Assist in stimulating and encouraging research.	Perform assistance roles similar to planning services.
	Assist in identifying potential research problems.	Suggest and recommend areas for research based on field observations and experiences.
	Assist in coordinating development of career education information.	Assist in development of evaluative criteria. Assist in dissemination through appropriate media.
	Assist in conducting intra-organization research.	Identify research problems. Assist in contacting population included in the research.
Curriculum	Assist in developing "basic," "suggested" state-wide curriculum guidelines for existing, new and emerging programs.	Act as resource for identifying personnel qualified to consult on this activity. Provide expertise when staff member's background qualifies. Assist planning in organizing and conducting activities relating to this task.
	Assist in coordinating curriculum activities for career education with other resources.	Assist planning group as needed.
	Consult with L.E.A.'s on curriculum, equipment, and facilities.	Through visitations, comment and provide assistance on appropriateness of curriculum content relative to occupations, objectives established, and need. Observe kinds and condition

POSTSECONDARY (cont)

Function

Responsibilities

Procedures

Curriculum
(Cont)

of equipment and facilities. Make recommendations whenever appropriate. Maintain communication in office and prepare follow-up reports to L.E.A.'s.

Collect and disseminate curriculum research and materials.

Serve as communication link between L.E.A.'s and the Branch regarding curriculum, equipment, and facilities.

Consult with L.E.A.'s on youth organizations.

Consult with L.E.A.'s relative to: developing program of work which carries out the purposes of the organization, providing leadership training, and planning and coordinating conferences. Disseminate state and national information.

Reporting

Assist in formulating reports.

Provide information as needed and verify information in reports.

Teacher
education

Consult with L.E.A.'s on teaching techniques.

Through visitations, observe, comment, and provide assistance on techniques being used by instructional staff. Make recommendations relative to in-service education. Provide information on instructional aids and innovations.

Assist in contracting for teacher education services.

Provide information pertinent to the supply and demand for career educational personnel. Recommend needed in-service education.

Organize conferences, workshops, etc.

With assistance of advisory committees, provide for preservice and in-service teacher education activities. Maintain contact with teacher educators on matters relating to this service.

Consult with L.E.A.'s on teacher recruitment and staffing.

Maintain and disseminate rosters of educational personnel employed in career education programs in the state. (Maintained by institution, geographical area, and instructional area.) Be knowledgeable as to individuals available for employment. (In-state and out-of-state institutions and organizations.)

POSTSECONDARY (cont)

<u>Function</u>	<u>Responsibilities</u>	<u>Procedures</u>
Teacher education (Cont)	Assist in certifying and approving teachers.	Serve on committees to aid in analyzing qualifications of applicants for certificates and career education subject approval.
Plant facilities	Assist in analysis of school sites and plants.	Assist in developing criteria and procedure to be used in this analysis.
	Assist in reviewing and recommending plans and specifications for facilities.	Provide technical information to assist plant facilities group in formulating recommendations.
	Assist in conducting school plant surveys.	Upon request, observe and report findings.
	Assist in projecting needs.	Provide information relative to program expansions or reductions.

MDTA - This service shall have the responsibility for the direct administration, including fiscal control, planning, approval, and evaluation of federally funded MDTA programs and other federally funded Department of Labor and OEO programs which may be implemented in the future. The Chief of this service shall report directly to the Director of the Career Education Division. This service performs an independent contracting service but it is coordinated with the Career Education Division since these services are largely implemented through area schools.

ANCILLARY SERVICES

SPECIAL NEEDS

<u>Function</u>	<u>Responsibilities</u>	<u>Procedures</u>
Budget Development	Assist planning in the development of programs cost guidelines.	Interpret costs, etc. in regard to special needs during the preparation of program cost guidelines for all career programs.
	Assist in the review of program budgets.	Determine appropriateness of budget requests in terms of special needs students and projects.
	Consult with LEA's in the preparation of budget.	Make available to LEA's, resource material related to special needs budgets. Consult with administrative and instructional personnel relative to budget items for special needs.
Planning	Assist planning in identifying needs of individuals.	Identify objectives and goals of special needs programs, the special needs population and maintain working relationships with other agencies in providing services and programs direction for special needs projects.
	Assist planning in the review of program proposals.	Participate in the review of proposals and make recommendations as related to special needs.
	Assist planning in maintaining Career Education Division goals/objectives.	Interpret information into the planning process to assure the needs of the special needs population of the state are being provided for.
Evaluation	Assist planning in ascertaining program effectiveness in terms of meeting needs of individuals.	Develop criteria to be used in measuring program effectiveness in terms of the special needs population.
	Assist LEA's in measuring program effectiveness.	Consult with LEA/s regarding program evaluation as related to special needs.
Research	Identify potential research problems.	Interpret needs for research dealing with special needs to the planning and others.
	Stimulate and encourage research	Assist LEA's in conducting or participating in research related to special needs.

SPECIAL NEEDS (cont)

<u>Function</u>	<u>Responsibilities</u>	<u>Procedures</u>
Curriculum	<p>Assist planning in the development of curriculum guidelines for existing, new and emerging programs.</p> <p>Consult with LEA's on curriculum, equipment and facilities.</p>	<p>Interpret the needs of the special needs population in terms of curriculum, equipment and facilities.</p> <p>Assist LEA's in adapting guidelines to special populations and programs.</p>

GUIDANCE

<u>Function</u>	<u>Responsibility</u>	<u>Procedures</u>
Budget Development	Assist planning in the development of program cost guidelines relative to guidance services for career education.	Provide information regarding costs, etc., relative to guidance programs.
	Consult with L.E.A.'s regarding the preparation of guidance budgets.	Conduct visitations, workshops and seminars to assist in budget preparation.
	Assist planning in the review of program budgets.	Provide information relative to guidance needs of students.
	Assist planning in the development of the Career Education Division budget.	Convey budget needs for administration of state career guidance activities.
Planning	Assist planning in recommending allocation of funds.	Provide information to planning to be used in developing recommendations for the allocation of funds to support career guidance programs.
	Assist planning in the identifying and projecting the needs of individuals.	Assist L.E.A.'s in assessing from students and the community the interests, expectations and needs of individuals for career education programs.
	Assist planning in maintaining Career Education Division goals/objectives.	Review and suggest how to update those provisions of the State Plan regarding vocational guidance.
	Implement activities or efforts which will convey information relating to guidance programs.	Disseminate planning information through workshops, seminars, etc.
Evaluation	Assist planning in the processing of career guidance program proposals.	Provide judgements regarding feasibility of proposed effort in relation to identified staff and other resources.
	Assist planning in the design of follow-up of program operation and effectiveness. Assist planning in assessing attrition in career programs.	Provide student data relating to program operation and effectiveness. Develop criteria to be used in measuring program effectiveness in terms of career guidance programs.

GUIDANCE

<u>Function</u>	<u>Responsibility</u>	<u>Procedures</u>
Evaluation (Cont)	Assist planning to ascertain program effectiveness in meeting needs of individuals.	(same as above)
	Conduct evaluations regarding career guidance programs.	(Same as above)
	Assist planning to develop evaluative procedures and techniques.	(Same as above)
Research	Assist planning to implement activities which stimulate and encourage research.	Convey researchable ideas and research outcomes to guidance personnel.
	Assist planning in the identification of research problems.	Convey "guidance needs" type research ideas to planning.
	Assist planning in the coordination of career education information.	Career education information will be developed through the utilization of all resources available through this and/or other agencies, institutions, and firms of contract or agreement.
	Develop and disseminate career education information.	(Same as above) Career education information will be disseminated to all guidance personnel involved in providing guidance services to youth and adults.
	Consult with guidance personnel concerning the effective use of career education information.	Implement workshops, seminars, visitations, etc., regarding use of career information.
	Assist planning in conducting intra-organization research.	Convey all appropriate guidance information available.
Curriculum	Assist planning in the development of "basic," "suggested" state-wide curriculum guidelines for existing, new and/or emerging programs.	Work with planning to review existing policies, guidelines and handbook information relating to guidance programs and cooperate in the development of specific efforts when needed.

GUIDANCE (Cont)

<u>Function</u>	<u>Responsibility</u>	<u>Procedures</u>
Curriculum (Cont)	Consult with L.E.A.'s on curriculum, equipment and facilities for career guidance programs.	Consultative services provided through visitations, workshops, seminars, etc.
	Assist in the collection and dissemination of curriculum research and materials for career guidance programs.	Consultative services provided through visitations, workshops, seminars, etc.
Reporting	Assist planning in the formulation of reports.	Provide to planning the student and program information required in reporting career guidance activities.

In addition to the above, the following are listed to delineate the identifiable support services of the Guidance Services:

Assist LEA in providing a comprehensive program of guidance services which emphasizes career education as a meaningful choice.

Assist LEA in providing a program of guidance services which assures assistance to youth and adults participating in career education.

Assist LEA in assessing from pupils and community the interests, expectations, and needs for career education programs.

Consult with institutions in the continued development of programs for the preparation of guidance personnel.

Assist in evaluation of counselor education programs as they are considered for approval to prepare school counselors.

Coordinate the direction and efforts of the Statewide Guidance Advisory Committee.

ANCILLARY SERVICES

DATA PROCESSING

<u>Function</u>	<u>Responsibility</u>	<u>Procedure</u>
Budget Development	Assist in development of program cost guidelines relative to career education.	Assist by providing (1) historical factors on programs and (2) designing computer program keyed to guidelines and (3) accounting services.
Planning	Assist in identification and projection of needs of employers and individuals.	Assist by taking most recent research findings and updating data bank of need information utilizing common coding numbers. Provide data print-outs by common code numbers for area and state wide districts needs, by job classifications.
Planning	Assist in the review of budgets submitted L.E.A.'s.	Provide up-to-date data of needs of industry for purpose of updating State Plan.
Evaluation	Assist in development of evaluation procedures and techniques.	Provide information and expertise needed to utilize E.D.P. in the development of evaluation procedure and technique.
Research	Assist in the collection and dissemination of research information.	Assist in the development of a state-wide computer-based system of career education information.
Curriculum	Assist in the collection and dissemination of curriculum research and materials.	Assist by establishing data bank of curriculum and materials information.
Reporting	Assist in the establishment of data collection system.	Advise "Fiscal" on establishment of data collection system compatible with equipment available and abilities of personnel.
Reporting	Assist in the formulation of reports.	Provide programs and services which will assimilate input information compatible with required reports.

DATA PROCESSING (cont)

<u>Function</u>	<u>Responsibility</u>	<u>Procedures</u>
Plant facilities	Analysis of school sites and plants.	Develop criteria and procedures to be used in this analysis. Provide on-site consultation when requested by L.E.A. Board and/or administrative personnel.
	Review and recommend plans and specifications for facilities.	On basis of established criteria discussions with L.E.A. Board and/or administration personnel, and Career Education consultants, evaluate materials and information supplied by L.E.A. Convey recommendations to Director, Career Education.
	Conduct school plant surveys.	Survey present facilities to determine adequacy or need for additional facilities to meet program needs.
	Project needs.	Make recommendations based on annual and five-year plans pertaining to program expansions or reductions.
Teacher Education	Consult with L.E.A.'s on teaching techniques.	Provide information on instructional aids and innovations. Coordination with other division and departmental personnel to aid in providing for services connected with teaching methods/techniques. Through visitation, observe, comment, and provide assistance on techniques being used by instructional staff. Make recommendations relative to in-service education.
	Contract for teacher education services.	Work with personnel at public institutions and Division consultants to make contractual arrangements for preservice and in-service education of career education instructors and administrators. Maintain records that indicate costs of career education programs and number of instructors being served.
	Organize conferences, workshops, etc.	With assistance of advisory committees, provide for preservice and in-service teacher education activities. Maintain contacts with teacher educators on matters relating to this service.

DATA PROCESSING (Cont)

<u>Function</u>	<u>Responsibility</u>	<u>Procedure</u>
	Consult with L.E.A.'s on teacher recruitment and staffing.	Provide information pertinent to demands for career education personnel in specialized areas--guidance, handicapped, and disadvantaged.
		Maintain and disseminate rosters of educational personnel employed in career education programs in the state. (Maintained by institution, geographical area, and instructional area.) Be knowledgeable as to individuals available for employment. (In-state and out-of-state institutions and organizations.)
	Certify and approve teachers.	Provide pertinent information relative to qualifications of career education personnel in specialized areas--guidance, special needs and instructional resources.
		Aid personnel in the Instruction and Professional Education Branch with correspondence and processing of applications of career education instructors and administrators. Maintain records of instructors who are currently employed in programs.

ADMINISTRATION AND FINANCE - The state comptroller will receive direction from the Administration and Finance Division of the Department of Public Instruction. This request will be developed from data collected by the Administration Service of the Area Schools Division.

Services from the Word Process Center will be coordinated with the Administration and Finance Division for contracted services.

DIRECTOR OF CAREER EDUCATION

FunctionsResponsibilitiesProcedure

Recommend programs to the Associate Superintendent, Career Education

Review all recommendations prior to submission. Determine all recommendations have followed proper procedures. Review all appeals concerning recommendations.

Recommendations concerning programs for approval or disapproval of career education in both Elementary-Secondary/Postsecondary shall be reviewed by this office prior to submission to the Associate Superintendent. These recommendations are initiated by the Career Education Division Support Services Section.

Coordination of Career Education Services

Give direction and supervision to the Chiefs of Services: Support Services, Elementary-Secondary, Postsecondary, and career education adult programs from DHEW directors, State Plan, State Standards, and laws, both Federal and State.

Assist chiefs of Career Education Services (Sections) in direction for planning and consultation services. Participate in total Area Schools and Career Education Branch planning consisting of Associate Superintendent, Director of Career Education, Director of Area Schools Division, Assistant Director of Career Education, the chiefs of the career education sections: Elementary-Secondary, Postsecondary, Support, Administrative Service, Adult Education, College Parallel, Ancillary Services, Manpower Development and Training.

Coordination of Career Education in the Area Schools and Career Education Branch

Become knowledgeable about total programs offered in the Area Schools.

Develop an annual review procedure in conjunction with the Director of Area Schools Division.

OCCUPATION EDUCATION PROGRAM EVALUATION

IN NEW YORK STATE

By

**Robert S. Seckendorf
Assistant Commissioner for Occupational Education
New York**

Presented at the

**Sixth Annual National Leadership Development Seminar
For State Directors of Vocational Education**

September 18-21, 1973

The Sheraton Nashville Hotel, Nashville, Tennessee

**THE CENTER FOR VOCATIONAL
AND TECHNICAL EDUCATION**



**THE OHIO STATE UNIVERSITY
1000 Kenny Rd., Columbus, Ohio 43210**

OCCUPATIONAL EDUCATION PROGRAM EVALUATION IN NEW YORK STATE

If one considers the root purpose of evaluation, bringing it down to its most elementary level, evaluation should be the basis for decision making with respect to the delivery of quality educational services to clients (students at whatever level one wishes to consider). Delivery of services is a cost to taxpayers, and our responsibility should concern itself with the wisest and most effective expenditure of public funds for the public good.

Every state director at some time in his annual work cycle must prepare and defend an administrative budget and some must also do the same with requested local assistance expenditures. How many times have you been asked to spell out the effectiveness of specific expenditures, to defend maintaining certain staff positions, to provide explicit information relative to results obtained by expenditures directed to local programs? And how many times did you wish that you had definitive data to demonstrate continued need? How many times have you been confronted with a fixed level of appropriation and the need to reduce proposed expenditures to meet an externally imposed ceiling? And how many times did you make a "seat of the pants" judgement based on some subjective feelings as opposed to clear analysis of alternative solutions? How many times have you asked a question about a proposed expenditure and the justification given was "we have a big job ahead and we need the money to do it."?

The climate at every level indicates that the days of free spending and unlimited supplies of tax dollars are fast coming to an end. Legislators and taxpayers are asking public officials for hard justification for every proposed expenditure including funds to continue and maintain existing activities.

Now it may be that this viewpoint on the need for systematic, organized, timely evaluation may be blown all out of proportion, even running counter to what an educator may believe with respect to the purpose of evaluation. To many of us the purpose of evaluation should be to measure the effectiveness and end results of programs. This point of view would stir little argument until the question is asked, "Results at what cost?"

While evaluation of occupational education programs is essential for accountability and for program development and improvement, it is this State Director's view that decision making in respect to allocation of funds and budget justifications are more critical purposes.

Background

Other states are probably no different than New York when it comes to the form and process of evaluation that presently exists. It is possible to rationalize on the elements of a system, but an analysis will, in all likelihood, reveal a wide variety of evaluation techniques. In some instances, evaluation of a highly structured nature will be devised for a low budget, minor pilot project, while surface judgements are made with respect to the extent to which major program goals are met. In some instances, an end of year report of accomplishments is used as an evaluation of a program, and other times an on-site visit performed by Education Department personnel becomes the evaluation of a fairly extensive program. These are just examples of what can be construed to be "evaluations" being conducted for the purpose of satisfying some legislative or regulatory requirements.

Before one begins to realize what is happening, he is surrounded by a host of processes and systems all purporting to be part of an organized arrangement for evaluating occupational education.

Quite frankly, that is about where New York State finds itself at this moment. Rather than try to describe these partial systems or processes or to relate how weakly the present activities key against budget decisions at all levels, it is the intention of this presentation to describe what New York State is developing now to meet its overall needs and also be able to answer the critical financial questions.

New York State's occupational education program is located in 760 public school districts, 72 secondary level area centers operated by intermediate districts (boards of cooperative educational services), 40 community colleges, 6 state operated agricultural and technical colleges, approximately 300 private occupational schools and a host of less easily identified agencies, such as hospitals and other institutions as well as industry-based apprenticeship programs.

School districts range in size from over a million students to several with less than 600, community colleges have enrollments ranging from under 1,000 to well over 5,000, some private schools have fewer than 50 students while others reach several thousand. Program size ranges from schools offering a single course in shorthand and typing to large diversified facilities with better than 50 occupational choices. Both enrollment in occupational education and total expenditures have doubled in the past six years.

With a statewide program as diversified and as extensive as that described, and with the rapid increases in size and structure, system development outstripped any attempt at the establishment of an orderly evaluation process. The era of "seat of the pants" evaluation with respect to achievement of objectives and measures of effectiveness prevails. Budget decisions and resource allocations are made using "experiential" evaluation.

Initial Planning

Last year it was decided to stop and take stock of what had been accomplished and what the situation looked like. About 80 percent of planned program development was in place. Sufficient quantity was available and it was now time to concentrate on quality. Federal funds have been held at a constant level of appropriations. State and local costs were increasing, sometimes beyond the limits of taxpayer acceptance. Program data were spongy and less than at a reliable level. The evaluation process was unsatisfactory as a tool for program and budget decision making.

It was found that evaluations were primarily subjective. Long-term data were not available. The process lacked clear targeted levels and purposes. In many cases program objectives were not specified in measurable terms and cost information was either totally lacking or limited in relation to program purposes.

No decision maker, faced with evidence of this kind, could draw any other conclusion but that there was a need for an orderly evaluation system.

With the assistance of a private research contractor, the design specifications of an evaluation system for New York State were prepared based on several guiding principles, including:

1. Program evaluation takes place at several levels and should be tailored to the specific objectives to be achieved at each level.
2. An effective program evaluation system, usable by teachers and local administrators, should be built on an individual student record system.
3. Effectiveness of program operation can be measured in terms of ultimate employment and should take into consideration continued education beyond the first level of instruction.
4. Total measures of effectiveness of instructional programs should be based on long term follow up as opposed to analysis of initial employment of program completers.
5. Program evaluation should take into consideration those factors which deal with measures that permit decisions to be made regarding resource allocation and cost effectiveness.

In addition, a set of system objectives were established which included the following:

1. Permit continuous monitoring and evaluation over time.
2. Provide for an open-ended entry of data elements.
3. Be usable at the local, regional, and State levels.
4. Permit an unlimited number of optional evaluation procedures without the requirement for pre-programming.

5. While providing for the maximum in flexibility, the system should not be burdensome to use and it must be cost efficient.
6. The data base for evaluation and monitoring should be usable for other applications including required reporting and analysis of data for planning.

The total evaluation system proposed for New York State was one which would provide all the data necessary for evaluation activity to take place at the State, regional or local level. The system had to contain all data including measurements of instructional accomplishment in order to do all that was desired.

The major elements of the planned reporting, evaluation and monitoring system includes the following:

1. A data base built on individual student records which provides basic information about a student is capable of maintaining information and adding information over a long period of time.
2. A system of predicting manpower needs in regions as well as shifts in those needs and at the same time providing long term follow-up of completers of programs.
3. A system for sorting out and identifying cost and expenditures at each level, attributable to achieving specific objectives.
4. A data bank consisting of behavioral objectives keyed to skills necessary in performing a job for which training is being provided.
5. A curricular design which reduces each program of study for each occupation into short modules of instruction based on measurable achievement.

6. A compendium of skills mastery check lists for various occupations keyed to behavioral objectives and modules of instruction, supported by a criterion-referenced testing scheme to determine the extent of accomplishment on the part of individual students.

Development of the System

During the preliminary developmental stage, several decisions had to be made with regard to priorities in order to meet the ultimate goal of an orderly and systematic evaluation system which would encompass defined principles and meet specified objectives.

In view of the fact that the reporting, evaluation and monitoring system was to be student-based and the initial point at which the system would function related to students in programs, it was decided that the first concentrated effort should be on the development of a reporting and information system capable of generating needed information about programs at the State level, permit the utilization of the same data at a regional level for planning purposes and, at the same time, be useful at the local level for analysis of program accomplishments as well as forming the base on which to build monitoring and evaluation activity.

It was agreed as well that two other activities could be conducted at the same time, since their development was not dependent upon building a data base in the State. These two activities were a bank of behavioral objectives keyed to specific occupations and the modularization of curriculums in all of the occupational areas. Both of these activities are proceeding in an orderly fashion. Presently between 8 and 10,000 behavioral objectives have been classified and are clearly identified with specific occupations and work functions within occupations. The utilization of the behavioral objectives is presently being tested in

several locations across the State at both the secondary and community college level. While use of these behavioral objectives can be made by individual teachers in the course of their instructional programs without the need for a data base or the other elements of the evaluation system, ultimately, this portion of the system will be built into the overall operation.

In the same way modularization of curriculums can be utilized independently of an organized monitoring system. On the other hand, the ultimate design of the evaluation and monitoring system is dependent to a great extent on using a modular approach to instructional units. At this time, most agricultural occupation programs are modularized into three week units each having a specific measurable objective and content which does not require prerequisites. The system of modules has been designed in such a way that entrance into an occupational program can be achieved by a student at any point during the year as opposed to the usual semester or beginning of school year starting times. In conjunction with the development of modules, each of the major occupations within the agriculture field have been analyzed in order to identify the skills required to prepare for entrance into a specific occupation. While it is usual for a student to pursue a specific set of modules in order to achieve preparation for an occupation, it is also possible for a student to move from one occupational area to the other, transferring skills which are basic to another occupation.

It is not important within the framework of this presentation to dwell on the details of the modularization of curriculum. At this time testing in the field of agriculture is complete. A similar analysis of occupations is being initiated in other fields and development of modularization for all other curriculums will begin shortly. Total modularization of all curriculums is projected for three years hence, at which time it will be possible to tailor an instructional program to the specific career goal of an individual student. The completion time for this phase will coincide with a projected Statewide installation date for the total evaluation and monitoring system. While these two activities, classification of behavioral objectives and modularization of curriculum, are being developed independently of the main thrust, a reporting and information system has been developed which will meet state requirements for reporting, regional requirements for analysis and planning, and local requirements for monitoring, accountability, and reporting. As the system was generated, additional applications conceived by local school officials were developed in several test areas.

The Information Component

At this point, it would seem helpful to describe briefly the information system and the way it operates.

The reporting system has as its base an individual student record. This record, generated at the local level, contains basic information about the student and his characteristics including an identifying number (a social security number where it is available, otherwise a unique identifying number can be generated by the system) and, in addition, the record contains a code number for the student's occupational program. The initial set of characteristics and bits of

information maintained in the individual student record are those required for specific reporting to the Education Department. Much of this same information can be used for planning purposes at the regional level as well as for reporting back to local school districts participating in regional programs. Beyond this essential information, a local district, at its option, can add other data elements, including such things as attendance reports, test scores, modules of instruction completed, achievement as it relates to behavioral objectives and any other information deemed necessary or useful by the local agency. Because of the flexibility of the system, data elements beyond those which are required for State use can vary from agency to agency. A student record of this nature is generated for every individual enrolling in an occupational program for the first time. School district, county and zip code for place of residence are also included in the record card.

A highly flexible computer software package, available exclusively to New York State, is utilized to maintain the information on each student in a centralized computer. Input of data from a local agency can be made by shipping copies of the student records to the central facility for input or remote data entry terminals can be used to input information directly over telephone lines. All data are maintained in the computer by the software package in a disaggregated form. An arrangement of this kind permits local, regional or State level agencies to utilize the information for whatever purpose they find necessary and, at the same time, maintain confidentiality with respect to certain data. County A, for example, cannot extract data about students in County B and, at the same time, the State Education Department can only extract from the system information of a basic nature required for its reporting and

planning purposes. In other words, the Education Department will not be able to monitor the test scores or attendance records of individual students or for that matter all students in a particular agency.

Two key design elements permit complete flexibility on the part of the users of this system. The first relates to the computer software package itself. This software system does not require pre-programming to extract any information needed at any particular point in time. The second element relates to the access system itself. The language for accessing information is simple English. Therefore, it is possible for any user, within the constraints of confidentiality, to ask any question about a program without concern that there is a program written for that information. It is a simple task to ask the computer to display, as an example, by regions of the state, the number of disadvantaged students who have completed a carpentry program and have been placed on jobs related to the occupational program in which they participated. In the same way, a local agency can ask for similar information but add an element requesting that for each completer an attendance record be displayed as well.

These illustrations are used in order to demonstrate the complete flexibility of the reporting system and its data base so that later its use can be demonstrated with respect to evaluation and monitoring procedures. This reporting system has been tested in two major locations including New York City and is now being installed for use beginning this month in approximately one third of the agencies in the State. By September of 1974, all agencies offering occupational education programs will be utilizing this data system.

It should be pointed out that because the individual student reporting system is computer maintained and utilizes unique identifying numbers for each student, it is possible for the record to be continued beyond the secondary level by other educational institutions offering occupational education programs, including community colleges and adult programs. When a student appears for enrollment in a community college, it is a simple matter for that institution to access the basic records of a student who has completed a secondary level program and continue to input additional information about that person. The same would hold true for someone continuing in an adult education component of the occupational education program after employment.

Manpower Needs and Follow-Up

Another subsystem in the overall evaluation package relates to decision making with respect to manpower needs as well as establishing a system of long term follow-up of individuals who complete occupational education programs.

A system has been designed which utilizes industrial development information as well as State income tax files for the purpose of determining the extent to which certain occupational areas are maintaining stability within a particular region or are being reduced in need. In addition, information can be generated to tell whether there is an out-migration of trained persons from a region or whether individuals are coming into the region from other locations to seek employment in a particular occupational field. Such information will be helpful in making decisions regarding the extent to which services should be provided in various parts of the State.

A complete description of this system would be time consuming and, therefore, it is sufficient to report that a system has been designed which will permit analysis and assessment of manpower needs and make decisions with respect to expanding, maintaining or phasing out specific occupational programs. The system requires a minor legislative change in order to become operable, but it is anticipated that this issue will be settled in the next legislative session.

One other aspect of the targeting and follow-up system relates to follow-up directly. At this time, follow-up studies are difficult at best, time consuming, and in many ways unreliable because of a lack of responses. As part of the overall evaluation and monitoring system, another subset was developed which will utilize three numbers found both in the student record data system maintained for occupational education and in the State income tax files. These numbers are: social security number, dictionary of occupational titles code number for the occupation of the individual, and the zip code of residence. Utilizing the flexibility of the computer software package, it will be possible to search both the occupational education files and the tax files simultaneously and match social security numbers, DOT numbers, and zip code numbers. Matching numbers permits noiseless, burdenless, follow-up of completers over long periods of time. From an evaluation point of view, long term follow-up (three years - five years - or longer) is more significant than results of a survey of initial employment. The use of zip code numbers permits, as well, mobility studies to be instituted at any time. Studies of this nature can be invaluable in planning programs, assessing the impact of

programs in specific areas as well as becoming part of an overall evaluation process. Until the targeting and follow-up system is operational, there is available a semi-noiseless follow-up system built into the reporting subsystem. Each local or regional educational agency can request of the computer printed mailing labels preceded with some information for use in a mail survey of completers. Hand analysis of returned survey forms need not be performed, but rather data elements are added to each student's file as part of his permanent record. At the close of the survey, specific analyses of the follow-up data can be retrieved in any form required by the local agency or the State.

Cost Evaluation

One of the major portions of the total evaluation system relates to cost data. As indicated earlier, this is an essential element and is required to meet the original rationale presented for evaluation programs. While it is believed that this is one of the most critical elements, the decision was made to leave its development for a later time. A solid data base and follow-up and a monitoring system that can measure achievement in instructional programs is needed first. Adding the cost elements will not be a complicated or time consuming process, again because of the flexibility of the computer software used as the foundation for operating the entire system.

Instructional Monitoring

With this very brief overview of the elements of an evaluation system, a more detailed description of the monitoring activity is in order.

Monitoring in this context is a method for continuous review of accomplishments during the teaching-learning process. It permits managers and instructional personnel to individualize the instructional process so that the most effective delivery system is provided for each student.

Essentially, the process permits periodic (daily if needed) reporting of results of accomplishments on the part of students. In this way, progress of each student can be checked against his own career objective. At the same time, program managers can determine the effectiveness of alternative methods of instruction, assign costs to instructional elements and determine if budget reallocations are required as well as maintaining cost accounting for periodic evaluation of earlier resource decisions.

The process utilizes the bank of behavioral objectives, the modular curriculum units, and skills check lists described earlier. In addition, a key element is the use of criterion-referenced tests based on specific effectiveness measures. In this way, accomplishments on the part of individual students are determined against required skills and knowledge performed on the job, as opposed to other measures such as norm-referenced tests which might report on overall accomplishment as a percentage of all the material covered in a particular course.

Utilizing objective measures of accomplishment permits the teacher to determine specific areas of weakness and make decisions about recycling a student through all or part of a module of instruction, or changing the approach or using some additional resource or alternate means of instruction. Examining results of the same nature for class groups provides the

instructor with information sufficient to analyze his own choice of instructional mode and permits decisions to be made for improvement of the program for future groups.

The basic data system (the student information file) maintains the results of criterion-referenced tests and other means of determining individual student accomplishment. Items such as length of time needed by students to master specific skills, or achieve objectives can be included. Data of this nature permits a variety of analyses to be accomplished simply by instructing the computer to generate the needed data.

The system is usable as well as a guidance tool to assist in determining the abilities of students at any point in time in reference to their employability at specific job levels. In addition, counselors can use the data base and results of skill mastery tests to assist students in making decisions about changing career goals. With the use of modules, it is possible to construct arrangements which indicate those skills mastered that are transferable to another occupation. In a case where a change in occupational goal is made, the student record can be used to construct a new set of modules needed for the new occupational choice, building on what has already been learned.

Summary

When all of the subsystems are in place, New York will have a comprehensive system for evaluation which can be utilized at the State, regional, or local level for whatever applications are needed with respect to evaluation functions at each level.

The system should be cost-efficient based on initial review of the cost of operating a flexible computer based bank of data elements, each usable for a multitude of functional analyses.

Such a system will reduce extensively the need for periodic indepth evaluations of the kind now performed. It will reduce or eliminate entirely costs associated with maintaining records in the present mode.

Data will be available at all times in an up-to-date fashion. New data can be entered at any time to revise information already stored. And, of course, the flexibility of the software package will permit an infinite number of outputs.

The time frame for full implementation of the system still has two years to go. However, the end result will outweigh the early time consuming design and testing phases now being undertaken.

To return to the initial position taken with respect to the ultimate
purpose of evaluation -- determining the cost effectiveness of the occupational education system at every level -- ultimately the system and approach described will be of significant benefit to New York State and the future development and improvement of occupational education. It is only through hard data of the kind obtainable utilizing a total evaluation system that successes can be used to generate continued and increased support. At the same time, the willingness to clearly identify weaknesses and take action to correct deficiencies becomes an additional strategy for gaining the resources necessary to meet long term objectives.

A SYSTEM FOR UPGRADING CAREER GUIDANCE PROGRAMS

By

**Warren N. Suzuki
Research and Development Specialist**

and

**Paul E. Shaltry
Program Assistant
The Center for Vocational and Technical Education
The Ohio State University
Columbus, Ohio**

Presented at the

**Sixth Annual National Leadership Development Seminar
For State Directors of Vocational Education**

September 18-21, 1973

The Sheraton-Nashville Hotel, Nashville, Tennessee

**THE CENTER FOR VOCATIONAL
AND TECHNICAL EDUCATION**



**THE OHIO STATE UNIVERSITY
1960 Kenny Rd. Columbus Ohio 43210**

As technology fosters diversity, that diversity is reflected in our labor force and complex economic system. Tools make jobs and jobs make tools, so to speak. Job specialization is something we all live with today. Certainly, if you will permit me an understatement, a young person looking for a job today is faced with an ever increasingly difficult task. It is hard enough for a high school student to know about the complex job market structure, not to mention being sure he will like a particular job and find it rewarding.

Over recent years several studies have described a high incidence of floundering among recent high school graduates. Floundering is characterized by frequently changing jobs, often into different occupations, and work adjustment problems once on the job. Some youth lack even the know-how to begin looking for work or to understand what special educational requirements there may be for a particular job.

While the overall problem is complex and may be attacked from several perspectives, Operation Guidance deals with career development problems at the high school level.

A national survey of career guidance in 1968 reports that high school career guidance programs appeared to be offering more guidance services than the schools could possibly support with the resources they had. In effect, the national survey and subsequent assessments have found high school guidance programs, for the most part, to be inefficient in helping our youth to cope with post-high school employment or further education.

The 1968 study reported that inadequate delivery systems for career guidance services were a major factor contributing to ineffectiveness. In addition, career guidance programs, by and large, were not equipped to assimilate innovations in career guidance that might improve the effectiveness and efficiency of career guidance programs.

Operation Guidance uses a systems approach to upgrade high school career guidance programs. It does not prescribe program content for any particular high school. Content is determined locally. Rather, Operation Guidance enables faculty, staff, and students to assess career guidance needs of their students, identify resources and determine what methods would work in their local situation. Thus, content is determined locally.

Operation Guidance involves six major tasks: organizing the school to use Operation Guidance; conducting a needs and resource assessment; formulating goals from needs; determining behavioral objectives to meet those goals; selecting, implementing, and testing methods to enable the achievement of these behavioral objectives; and establishing a system to monitor the continued effectiveness and efficiency of the renovated career guidance program.

These tasks are accomplished by following the programmed instructional materials and supplemental information provided in the Operation Guidance package. Only minimal, if any, outside help is needed by the school.

How quickly a school gets through the Operation Guidance tasks depends on the school. The materials allow for self-pacing, but a school can get through the initial cycle at a reasonable speed, within one school year once the product is finalized.

If a high school elects to use and complete Operation Guidance, these results should be achieved:

1. Student career guidance needs will be documented.
2. Goals will be formulated to ameliorate student needs.
3. Behavioral objectives to meet the goals will be derived.
4. Career development units to accomplish the behavioral objectives will be developed.
5. A system will exist to collect, analyze, and report evaluative

information on student achievement of behavioral objectives and on changes in resources or student needs.

Given these results, the career guidance program should have the following characteristics:

- School and community resources will have increased use, if previously under-utilized.
- Career guidance services and counselor activities will be optimally responsive to student needs.

The audiovisual presentation you are about to see serves two purposes. First, it is an explanation of the overall program we now call Operation Guidance and second, it is an entry level basis for discussion for any comprehensive high school that may be interested in adopting the Operation Guidance program.

(Show A/V 1-1)

Traditionally, career guidance has been viewed as only those activities accomplished by counselors. By looking toward other parts of the school and community agencies as sources for career guidance services, the school should increase the resource base for its career guidance program.

Normally, the principal, with the advice of his faculty, chooses to use the program in his school. Before a school should use Operation Guidance, we feel that a majority of the faculty and staff members and students of the school must be willing to participate in the developmental activities if the use of the package is to be successful. It is important that all types of individuals be included so that the unique perspective of each may be considered in the resolution of some critical career guidance problems and the accomplishment of difficult tasks. Furthermore, this widespread involvement

in the development of a career guidance program can facilitate the acceptance by faculty, staff, students, and members of the community of changes to the high school's career guidance program.

In summary, application of Operation Guidance can result in a career development program that is student centered, makes optimal use of resources, has an extended base, includes innovative career guidance methods, is designed for each individual high school, and encourages decisions based on current information from graduates, parents, teachers, counselors, and students.

- Operation Guidance enables schools to derive behavioral objectives that specify what students will be able to do, instead of how students will achieve an objective or what teachers or counselors will do.
- The chances of satisfying student needs should increase if the career guidance services offered are limited to only those that can be adequately supported with available resources.
- A school should consider career guidance as more than an assistance provided to students by counselors and the school. The program should include teachers, administrators, students, and public and private agencies within the community.
- A broad range of career methods and techniques should be considered for inclusions in the program. This requires a purposeful search to increase the probability of identifying and installing the effective innovative career guidance methods.
- Because each community and the high schools within it are unique, each career guidance program will probably be unique also, In view of this, Operation Guidance permits each school to install its own program to meet the needs of its own students, rather than imposing a predetermined standardized program on a school.

—Operation Guidance enables each school to make decisions concerning its own career guidance program based on reliable information that it collects itself.

This has been a brief overview of Operation Guidance. We at The Center for Vocational and Technical Education are currently developing this Operation Guidance package which will enable individual schools to apply the previously mentioned procedures. Six schools and five state departments of education are currently working with us in the development of the Operation Guidance package. These schools are: Agua Fria Union High School in Avondale, Arizona; East Bank Senior High School in Kanawha County, West Virginia; Walter George High School and Booker T. Washington High Schools in Atlanta, Georgia; Jesse H. Jones High School in Houston, Texas; and Sunset High School in Beaverton, Oregon. The development effort is now scheduled to be completed in the Fall of 1974. Then the entire product will be available to many more schools on a national basis.

Operation Guidance's development into an efficient and effective package is made possible only through the support and assistance of the cooperating schools, school districts and state departments of education. In every case, linkage with a school has been and will be made through the assistance of the state director of vocational or career education.

Very little information on Operation Guidance is available for general distribution at this time; however, if you want information as it becomes available, please fill out one of these blanks at the back of the room, or pick up a blank at The Center's booth in the exhibit hall.

STATE AND LOCAL PROGRAM EVALUATION

By

**H. "Mac" McCain
Research and Development Specialist
The Center for Vocational and Technical Education
Columbus, Ohio**

Presented at the

**Sixth Annual National Leadership Development Seminar
for State Directors of Vocational Education**

September 18-21, 1973

The Sheraton-Nashville Hotel, Nashville, Tennessee

**THE CENTER FOR VOCATIONAL
AND TECHNICAL EDUCATION**



**THE OHIO STATE UNIVERSITY
1225 Kenny Rd., Columbus, Ohio 43210**

Program Evaluation: Problems, Pre-requisites, Characteristics and Implementation

Evaluation and accountability are two of the major concerns of educators today. These concerns have emerged as Congress and the public have demanded evidence of the benefits obtained from the expenditures of tax dollars on education. Additionally, other sectors of society are making their demands for tax dollars and, in effect, forcing a prioritization of the activities for which tax funds will be appropriated. Even within the education community, one can envision keener competition for these limited resources. As all of these demands are made and priorities are established, it is essential that the education community have the necessary information for use by decision makers in order that the allocation and appropriation of tax dollars are as equitable as possible.

Program evaluations are one source of information that decision makers need to have available to them. However, information on program evaluations alone is insufficient for improved decision making in education and society. Decision makers are also influenced by their own philosophical values, societal pressures, other options available to them, personality traits, etc. These influences are not subject to control, however. Therefore, evaluation remains the only controllable input that can be used to improve decision making.

The efficacy of evaluation for vocational education programs is generally accepted in principle. However, the implementation of evaluation in vocational education is a difficult and complex process for several reasons. First, vocational education programs are widely

divergent in nature. Second, the present state of the methodology of evaluation is inadequate to serve as the basis for determining program effectiveness. Finally, a common definition of evaluation is not widely accepted. For the purpose of this paper, Harris' (1) definition of evaluation is used. This definition is as follows:

Evaluation is the systematic process of judging the worth, desirability, effectiveness, or adequacy of something according to definite criteria and purposes. The judgment is based upon a careful comparison of observation data with criteria standards. Precise definitions of what is to be appraised, clearly stated purposes, specific standards for the criteria traits, accurate observations and measurements and logical conclusions are hallmarks of valid evaluation.

This paper will discuss the several dimensions of program evaluation in vocational education. These dimensions include: (1) problems with program evaluation, (2) pre-requisites of an evaluation system, (3) desirable characteristics of an evaluation system, and (4) implementing the results of evaluation.

Problems with Program Evaluation

Those individuals who have been involved with program evaluation realize that there are certain problems that seem to be everpresent. It is important that administrators be aware of and understand these problems so that they can more effectively work with evaluation efforts. This section will discuss some of the major problems with evaluation.

Unfortunately, evaluation, all too often, has the connotation of something bad. This bad connotation is partly due to unpleasant experiences that have arisen as the result of previous program evaluations. In many instances, vast differences of opinion have arisen as

a result of evaluations. In other cases, suspicion of those conducting the evaluation by program personnel has been a problem and program personnel have felt threatened by the presence of an evaluator. These attitudes have resulted in less than enthusiastic support of evaluation in practice.

Another problem is that little attention has been given to the philosophical value systems that affect the outcomes of an evaluation. The evaluator, evaluatee and administrator all have certain values and beliefs that enter, either consciously or unconsciously, into the evaluation process. Value conflicts can, and do, occur at many points during the evaluation process. Those individuals responsible for evaluation need to be aware of this problem and alert to ways of minimizing serious potential conflicts.

Failure to specify the use that is to be made of the evaluation reports is another major problem. Administrators need to specify the purpose(s) of the evaluation and how it will be used. There are at least two major ways in which evaluation results can be used in decision making. In the first way, evaluative data are collected once and little use is made of these efforts in improving the program. The major uses that can be made of this type of evaluation are motivation and measuring past performance. This method of evaluation is of particular relevance to programs of short duration and are not likely to be conducted again. The second way evaluation data can be used is in improving programs. This method of evaluation is commonly used on programs that are on-going and will be continued. This type of evaluation is helpful in planning and budgeting future programs. Clearly, the same type of information is not needed for each of these two methods. Historically, evaluation has

been placed at the end of a program or fiscal year of operation. Many times these reports have been available too late for use in influencing programs and budgeting. Failure to distinguish the use that is to be made of the evaluation report has often resulted in the wrong type of information at the wrong time.

Little real incentive for conducting good evaluation has been another problem. Both program personnel and evaluators have indicated that there is little feedback on the use and usefulness of the evaluation report. Information on the consequences of evaluation reports is practically non-existent. Feedback on the result of evaluation could be used to improve future evaluative efforts.

One could include a number of other problems with evaluation efforts. However, the problems expressed should be of sufficient strength and number to indicate the general problems that evaluation efforts have faced.

Pre-requisites of an Effective Evaluation System

Many problems considered in the previous section could have been eliminated or, at least, reduced if certain conditions had been met. The purpose of this section is to provide a list of suggestions that should reduce potential problems.

One of the major pre-requisites for evaluation systems is that the administrator must understand, support, and be committed to the concept of evaluation. Administrators have been known, in some areas, to use evaluation only as "window dressing." In the final analysis, these administrators disregard evaluation results and rely on their own professional judgment in making decisions that affect program operation. In these situations the resources expended for evaluation are wasted.

Once there is commitment to the evaluation concept, another pre-requisite is that the administrator must have a well defined purpose for conducting the evaluation. If the purposes are clearly understood by administrators, then much of the confusion about evaluation can be prevented.

As a result of establishing the purpose for an evaluation, another pre-requisite is the administrator must formulate realistic goals for that effort. After the goals have been established, the administrator must then communicate these goals to evaluation and program personnel. Evaluation and program personnel are then responsible to develop clear, operational objectives to accomplish these goals. This process should insure that the information that is collected and analyzed will be relevant to the original purpose(s) stated by the administrator.

Another pre-requisite is that administrators must provide an effective environment for conducting evaluation. This environment includes: (1) role definition, (2) duties of evaluators, and (3) organizational location of evaluation personnel.

First, the role of the evaluator is a critical issue that needs attention. Evaluators, like anyone else, need to feel important and needed in their job. In this regard, some caution should be taken to insure that evaluators are not just monitors. If they do become monitors, there is an increasing danger that they will find their job less than challenging and therefore, unimportant. Additionally, knowledge that the results of these efforts are useful and being utilized in the decision making process is important. If the evaluation results are not useable to the administrator, evaluators need to be told and the type of information needs should be clarified, or the expertise

of the evaluator should be questioned.

A second pre-requisite that administrators need to consider is that evaluation should be the major, if not only, duty of evaluators. Evaluation personnel should not be viewed as a "catch-all" for other duties and responsibilities that an administrator may need. Additional responsibilities will reduce the amount of time available to the evaluator and lessens the chances that the evaluator will be able to provide information that will be useful in making decisions about program operation. Furthermore, the evaluator's role must be legitimate and not one of being a "yes" person to the administrator. The evaluator must have the freedom to be objective and "tell it like it is." If this is not the case, the resources committed to evaluation are being wasted and should be utilized on other activities.

A third pre-requisite that should be discussed is the organizational location of the evaluation unit. Throughout the United States, evaluation units are typically located (1) within the program to be evaluated, (2) within a separate unit in the vocational education division, or (3) outside of the vocational education division, but within the state department. This author feels that evaluation should not be located within the program to be evaluated. Location within the program to be evaluated will lessen the credibility and objectivity of the results. However, directors of vocational education should have control over the evaluation unit, if these efforts are to be useable in decision making. Therefore, the most desirable location would be within the vocational administrative division.

A final pre-requisite discussed here is the expertise of the

evaluation staff. Evaluators must be knowledgeable about evaluation techniques. They should also be knowledgeable of the program they are to evaluate. However, some provision should be made to provide appropriate consultation when needed. Undoubtedly, funds expended to bring in persons for short periods of time, to bolster any specific weaknesses or inadequacies in existing staff, would be a wise investment.

This section has attempted to alert administrators to some of the pre-requisites for the development of effective evaluation systems. This list is not complete and each state department must adapt these requirements to their own individual situations.

Desirable Characteristics of an Evaluation System

There are a number of different methods that states use to evaluate their vocational education programs. Each of these evaluation systems have certain elements that make it somewhat unique. These systems include such informational elements as, manpower demands, manpower supply, student needs and aspirations, placement and follow-up of graduates, local opinions of their programs, cost data, enrollment data, etc. Regardless of the particular evaluation system, however, certain characteristics are desirable if the system is to be useful and effective. This section will discuss desirable characteristics of an evaluation system.

The first desirable characteristic of an evaluation system is that realistic objectives should be formulated. The formulation of these objectives should be realistic and involve both program and evaluation personnel. If there is basic agreement on these objectives, many misunderstandings can be avoided at a later time. However, it should be

noted that mutual objective setting is not a panacea for avoiding conflict. In a practical sense, program people have to believe in what they are doing; evaluation personnel, on the other hand, have to question what vocational education programs are doing. Both of these points must be reconciled in conducting the evaluation.

Secondly, a sound basis for measuring these objectives must be established. In some cases appropriate measurement techniques may already exist. In other cases, these techniques may require modification to be developed or modified. In still other cases, development of new measurement techniques may be required. A caveat is necessary; there is often a tendency to measure those items that are easy and ignore the more difficult ones. For example, information on the number of students completing a program may be collected, when information on the students job performance after completing a program should be included. The objective to be measured should dictate the type of information to be collected.

A third desirable characteristic of an evaluation system is that of clear and immediate feedback. Feedback, in this instance, is considered a two-step process. First, the administrator needs to inform the evaluator and/or program personnel on the adequacy of the evaluation results to meet his decision making needs. Secondly, the evaluation and program personnel need to provide information to those programs from which the data were collected. All too often, evaluation has been a one-way, upward flow of information. However, a two-way flow of information is necessary. People at all levels of the education community resist filling out forms and providing data. Some procedures must be provided to insure that those who complete the forms understand the

reasons for the collection of and use of the information. For example, local schools should have a summary of the information they submitted returned to them. Perhaps a comparison of their results with the comparable state figure would be helpful. It is also important the information should be summarized in a manner that is easily understood and as brief as possible. If the evaluation feedback is voluminous, chances are it will be ignored. Certainly, all of the information needed by a state will not be the same type of information needed by a local educational agency. Whenever possible, these requirements should supplement one another.

A fourth characteristic is that the information collected by an evaluation system should reflect the original purpose(s) of the evaluation. In this regard planning and budgetary information should be future oriented. Information on performance factors and motivation can be present and/or post oriented. The major problem has been, as specified earlier the administrator did not develop clear purposes for the evaluation initially. This results in information that is not relevant to the administrator's decision making requirements. Given that the evaluation results are relevant, evaluation reports should include the negative, as well as, the positive effects of the programs. Evaluation results should also include suggestions for potential alternative courses of action for decision makers. Additionally, both the advantages and disadvantages of each alternative should be specified by the evaluator. The administrator must realize that both the alternatives and advantages and disadvantages will undoubtedly reflect the biases of the evaluator. Therefore, these must be interpreted in that regard.

Involvement of personnel interested in, and affected by the program

to be evaluated is a fifth characteristic of a desirable evaluation system. Many evaluations have encountered problems due to apparent misunderstandings that have arisen due to the non-involvement of personnel. It is important that program evaluation reflect a consensus of the opinions of these personnel on a number of issues. Weis (2) has stated that if evaluation is to be relevant, these issues should include:

1. The goals of the program,
2. The nature of the program service (and any variants thereof),
3. Measures that indicated the effectiveness of the program in meeting goals,
4. Methods of selection of participants and controls,
5. Allocation of responsibilities for participant selection, data collection, descriptions of program input, etc.,
6. Procedures for resolving disagreements between program and evaluation, and above all,
7. The decisional purposes that evaluation is expected to serve.

Although total agreement on each of these points will not remove all the problems, they should be minimal.

A sixth, and final, characteristic to be discussed in this section is that an effective evaluation system must be reasonable in cost. Administrators need to be aware of on-going evaluation efforts and their cost in order that realistic budgets can be prepared. Typically, evaluation studies range from approximately five to ten percent of the program budgets. As a general rule, the larger the program budget, the smaller the percent that will be required for evaluation. It has not been uncommon for some personnel to think that evaluation can be conducted for as little as one percent or less of total budgets.

Personnel costs alone make it extremely difficult to conduct meaningful evaluations, for most programs, at this rate of funding. Again, anything less than a total effort is a waste of resources.

There are many factors that will affect the cost of conducting program evaluation. Administrators need to examine what the purposes for program evaluations are and then insure that the funds budgeted for this activity are realistic.

Implementing the Results of Evaluation

Within the past few years, there has been an increasing demand for evidence to indicate the relative effectiveness or ineffectiveness of various educational programs. This trend has caused some administrators to develop organizational capacities for conducting evaluation. Other administrators have had, within their organization, capacities for evaluation and have relied upon their services for conducting evaluation. Still other administrators have contracted evaluation to an outside agency or group.

Regardless of the way in which evaluation is conducted, the administrator is then faced with the problem of utilizing the results in future decision making. The purpose of this section is to give direction to those responsible for implementing the results of evaluation studies. At least three major factors seem to have relevance if evaluation results are to be used by administrators in decision making. These factors include: (1) understand the conditions under which the evaluation study was conducted, (2) recognize the limitations of the study, and (3) be certain the conclusions of the study are appropriate.

First, administrators should understand the conditions under which

the evaluation study was conducted. It is not uncommon for busy administrators to read only the summary and/or conclusions of research and evaluation studies. This overview provides the administrator the basic information needed in decision making. This cursory approach, however, has caused problems for those individuals who did not fully understand how the study was conducted and how the conclusions were reached. In some cases, the evaluation report has been so lengthy that individuals directed their interests to the results and disregarded the methodology and procedures. In still other cases, the format of the evaluation reports has not been conducive to easy reading and the methodology sections were ignored.

Some questions that the administrator should ask about the conditions surrounding an evaluation study include, but are not limited to:

1. What criteria were used in the evaluation process?
2. Who conducted the evaluation?
3. How was the information collected?
4. Was a sampling procedure used?
5. What was the response rate?

If an administrator asks questions like these as an evaluation report is reviewed, the decisions made as a result of the report will be more realistic and appropriate.

Recognition of the limitations of the study is a second factor that should be considered if evaluation results are to be utilized in decision making. All evaluation studies should have certain restrictions stated about the generalizability of the results. Anyone examining evaluation reports should seek and/or determine these restrictions prior to making decisions utilizing information presented in the evaluation

report. Furthermore, most evaluations are charged to do more than the limited resources make possible. The reviewer of evaluation reports needs to assess that which was evaluated to determine if realistic priorities were established. Finally, the present methodology of evaluation is often inadequate to provide all of the information required.

Questions administrators might ask that indicate the limitations of the study includes:

1. Were responses obtained from representatives of all those involved in the program?
2. Were the assumptions listed in the study appropriate?
3. Were the objectives of the study within the resources and/or capabilities of the evaluation?
4. Were the measurement techniques appropriate for the stated objectives?

These questions are not meant to be inclusive of all those that an administrator should ask about the limitations of the study. The individual evaluation study itself will, undoubtedly, raise additional questions. As long as administrators determine the limitations of the study, the decisions made as a result of the evaluation should be enhanced.

The third condition that needs attention if evaluation results are to be used in decision making includes the appropriateness of the conclusions. The appropriateness of the conclusions is determined by examining the data that served as the basis for the conclusions that were reached. Any conclusion should be supported by evidence collected during the evaluation study. Although evaluations often contain subjective conclusions, some caution should be demonstrated by the evaluation

reviewer in interpreting these conclusions. Conclusions supported only by subjective information should be viewed with skepticism. Few evaluators are able to plan and conduct evaluation studies with a completely detached attitude, and an administrator needs to question the framework, assumptions, criteria, and data that enable the evaluator to make conclusions. Perhaps evaluation studies need labels similar to cigarette packages that state:

Warning: It has been determined that the results of this study may be dangerous if interpreted incorrectly.

Questions that an administrator might ask about the conclusions include:

1. Why was the study conducted?
2. Are the conclusions consistent with the original objectives?
3. Have the personal biases of the evaluator been minimized?
4. What additional information would have been helpful in making administrative decisions?

Again, this list is intended to be illustrative of the type of questions that administrators should ask about the conclusion. Careful examination of the study will probably suggest additional questions.

For those concerned with improving vocational education programs, evaluation activities seem to promise at least a partial solution. However, application of evaluation findings without (1) understanding the conditions under which the study was made, (2) recognizing the limitations, and (3) being certain the conclusions are appropriate, may be worse than no evaluation activities at all.

BIBLIOGRAPHY

Harris, Wilbur. "The Nature and Function of Educational Evaluation," Peabody Journal of Education, September, 1968.

Weiss, Carol H. "Between the Cup and the Lip..." Evaluation: A Forum for Human Service Decision-Makers, Volume 1, Number 2, 1973.

LEADERSHIP STYLE AND ORGANIZATIONAL EFFECTIVENESS

By

Terence R. Mitchell, Associate Professor
of Management and Organization and of Psychology
University of Washington
Seattle, Washington



Presented at the

Sixth Annual National Leadership Development Seminar
For State Directors of Vocational Education

September 18-21, 1973

The Sheraton-Nashville Hotel, Nashville, Tennessee

THE CENTER FOR VOCATIONAL
AND TECHNICAL EDUCATION



THE OHIO STATE UNIVERSITY
1080 Kenny Rd. Columbus Ohio 43210

LEADERSHIP STYLE AND ORGANIZATIONAL EFFECTIVENESS

Terence R. Mitchell

University of Washington

Abstract

A review of Piedler's Contingency Model of leadership effectiveness is presented. The paper covers the development of the model and recent validation evidence cited by Piedler (1970). Some criticisms of the model are discussed, as well as the practical implications of the model in the areas of leader selection and leadership training.

LEADERSHIP STYLE AND ORGANIZATIONAL EFFECTIVENESS¹

Terence D. Mitchell
University of Washington

Most people would agree that the success or failure of a group is largely determined by the effectiveness of its leader. When a business or a military campaign is successful, it is the top manager or general who receives the credit. When baseball or football teams have a losing season, the manager or coach is the first to go. Most organizations recognize the importance of leadership and have, therefore, devoted a great deal of time and energy to the task of identifying and developing good leaders.

The research in this area has concentrated on two main questions: First, what kinds of people will rise to leadership positions? What makes the man in a leadership position effective?

Review of Past Research

The attempts to find personality traits which can be utilized to differentiate the potential leader from the follower have typically failed (Stogdill, 1948; Gibb, 1954). All folklore and isolated anecdotes to the contrary, there seem to be no distinct leadership traits, although such attributes as higher intelligence, greater physical size, etc., are somewhat more characteristic of leaders than non-leaders. As a result, there are also no effective or practical leadership selection tests. Who becomes a leader depends in part on personality factors, such as intelligence and ability to get along with people. However, in large part, it also depends on economic, political, and social factors, and on the academic background and experience which a man happens to have, and the skills a job happens to require.

A similar problem exists when we try to distinguish by means of personality tests between effective and ineffective leaders. A certain trait may be useful in one situation, but not in another. For example, interpersonal skills might be important in organizations which emphasize tasks that require cooperation and interpersonal contact. These same traits might not be related to performance in organizations which emphasize individual ability or aggressiveness.

Attempts to measure leader behavior have also produced discouraging results. Leadership research has identified two major behavioral styles which leaders use to interact with their group members (Bales, 1958; Stogdill, 1948; Kahn & Katz, 1960). One of these has been identified as a human relations-oriented, considerate, permissive, or non-directive type of leadership. The other is a directive, task-oriented, and structuring type of leadership we associate more commonly with orthodox supervisory and military training. However, the use of these styles to predict effective performance across situations or to help in the prediction of a rise to leadership status has not proven to be fruitful. These styles are helpful in some situations and not in others.

What I am saying is not new. Different situations require different leadership. This means that the same type of leadership style or the same leadership behavior will not be effective in all situations. The question is, what kinds of situations require what kinds of leadership? If we want to predict leadership performance, we must learn how to match a man's leadership style with his leadership situation.

Development of the Contingency Model

An extensive research program by Fiedler since 1951 has resulted in the development of "The Contingency Model of Leadership Effectiveness." This model suggests that an effective leader must match his "style" with the demands of the situation. To provide support for this model it was necessary to define effectiveness, leadership style, and the situational demands. The rest of this paper will describe the model, the data on which it was based, validation evidence, and the implications of using such a model.

Effectiveness

By effective leadership, it is meant that the leader's group has performed well, or that it has succeeded in comparison with other groups. In other words leadership effectiveness, as the term is defined here, is measured on the basis of group performance. An orchestra conductor has to be evaluated on how well his orchestra performs: a general is effective to the extent to which his troops perform well.

Leadership Style

Relationship-oriented versus task-oriented leadership styles are measured by means of the Least Preferred Coworker Scores (LPC). The score is obtained by asking the individual to think of all the people with whom he has ever worked. He then describes his Least-Preferred Coworker (or LPC): that is, the person in his life with whom he has been least able to work well. The items follow the form of Osgood's Semantic Differential (1957). For example,

	Intelligent :	_____ :	_____ :	_____ :	_____ :	_____ :	_____ :	_____ :	_____ :	Not Intelligent
	8	7	6	5	4	3	2	1		
	: _____ : _____ : _____ : _____ : _____ : _____ : _____ : _____ :									
	8	7	6	5	4	3	2	1		Not Friendly

A favorable description of the Least Preferred Coworker indicates a relationship-oriented style; an unfavorable description indicates a task-oriented style of leadership. Since this Least Preferred Coworker does not need to be a member of his task group, the LPC score can be obtained before the leader is assigned to his group.

This leadership style measure, or variants of it, has been used in a wide variety of interacting groups, ranging from high school basketball teams and surveying parties to military combat crews, research and management teams, and boards of directors. The results, however, failed to indicate that one type of leader was consistently better than another. To interpret the results it was necessary to have some sort of assessment of the situation.

Factors Determining Situational Favorableness

Fiedler has argued that the basic component of leadership is influence. That is, leadership is defined as a relationship in which one person tries to influence others in the performance of a common task. Therefore, his situational assessment consists of one underlying dimension: The degree to which the leader can influence his members.

This dimension is composed of three factors. The first and most important is the degree to which the leader is liked and accepted by his members. The better the interpersonal relations, the more influence the leader has.

The second factor is the leader's formal power. The more positive and negative actions that he can use, the more influence he will have. The final factor is defined by the degree to which the task is structured or unstructured. The greater the structure, the easier it is for the leader to tell his men what to do.

These are at least three of the major factors which determine leader influence. These three dimensions lead to a classification of group situations shown in Figure 1. Just as there is no one style of leadership which is effective for all groups, so there is no one type of situation that makes a group effective. Liked leaders do not on the average perform more effectively than do disliked leaders: and powerful leaders do not perform better than leaders with low position power.

Please note that this says nothing about how intrinsically difficult the task itself may be. A structured task, say building an electronic computer, may be much more difficult than an unstructured job of preparing an entertainment program. But the leader's problem of influencing the group will be greater in the volunteer committee than in the task of building a computer. It will obviously be easier to lead if you are the liked and trusted sergeant of a rifle squad (Cell 1) than if you are the informal leader of a recreational basketball team (Cell 2), and it will be very difficult indeed to be the disliked and distrusted leader of a volunteer group which is asked to plan the program of an annual meeting (Cell 8). In other words, we can order the cells on the basis of how favorable or unfavorable the situation will be for the leader.

The Contingency Model

We are now able to ask what kind of leadership styles various situations require. To answer this question, the leadership style score has been correlated with the performance of the leader's group in each of the situations on which there was data (Figure 1).

The correlation between the leadership style score and group performance is shown on the vertical axis of this graph. The difficulty of the situation

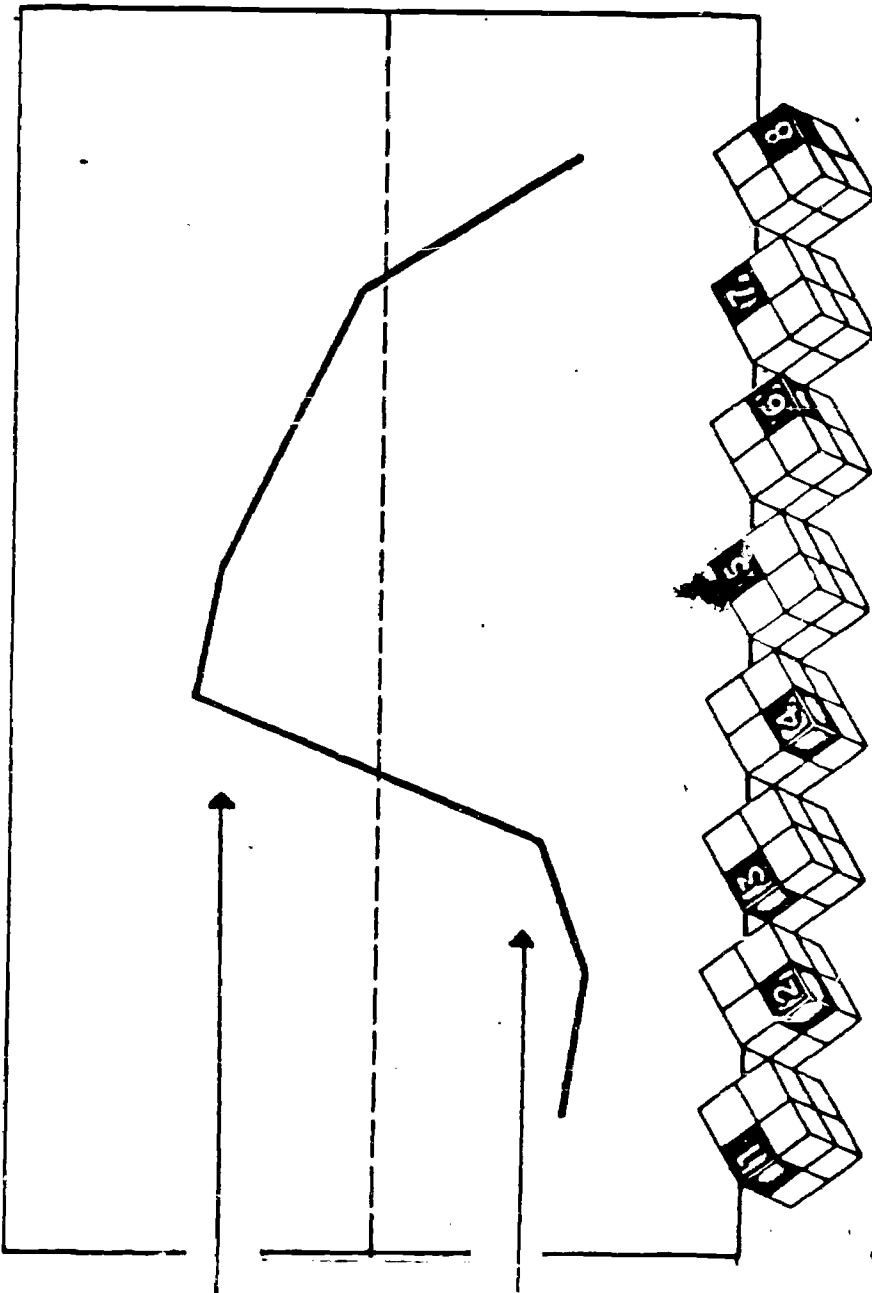

RELATIONSHIP-MOTIVATED LEADERS PERFORM BETTER

TASK-MOTIVATED LEADERS PERFORM BETTER

LEADER-MEMBER RELATIONS	GOOD	GOOD	GOOD	POOR	POOR	POOR	POOR	POOR
TASK STRUCTURE	STRUCTURED		UNSTRUCTURED		STRUCTURED		UNSTRUCTURED	
LEADER POSITION POWER	STRONG	WEAK	STRONG	WEAK	STRONG	WEAK	STRONG	WEAK

Figure 1

is shown on the horizontal axis. There are over 500 different groups represented on this plot.

What does this figure show? Positive correlations; that is, points falling above the midline of the graph, indicate that the relationship-oriented leaders performed better than did task-oriented leaders. Negative correlations, represented by points falling below the midline of the graph, indicate that the task-oriented leaders performed better than did the relationship-oriented leaders.

Taken as a whole, the plot shows that the task-oriented leaders are more effective in situations in which the leader has very much influence as well as in situations in which he has relatively little influence. The relationship-oriented person is most effective in situations which are only moderately favorable for the leader. In effect, these data reconcile the two major viewpoints in leadership theory.

Fiedler argues that in the very easy or very difficult situations, strong task-oriented leadership is needed to be effective. In situations of moderate difficulty, the leader who spends time being concerned about the interpersonal relationships in the group will be most effective.

Validation Evidence

Classification of Studies

A number of studies designed to test the model have been conducted by various independent investigators as well as by Fiedler and his associates. Some of these investigators, by design, and others, by oversight, have not followed the methodology originally described. Different operationalizations of situational favorableness were used in some studies, while others extended the model to co-acting groups (Hunt, 1967; Hill, 1969; Bates, 1969), and some used leadership style measures unrelated to LPC (Shaw

and Blum, 1966). These differences in methodology and divergences from the model are, of course, quite appropriate and desirable. However, studies which do not conform to the explicit methodology of the earlier work cannot be used as exact tests of the model.

Therefore, four independent judges were given information about the methodology of the earlier work and asked to choose from about twenty studies those which conformed to these procedures. Nine studies were selected that at least three of the judges agreed upon.

Table 1 summarizes all the correlations from these acceptable studies and shows that the median correlations for six of the seven octants are in the predicted direction (Octant VI was not predicted). Of these the joint probabilities of the correlations in Octants I, III, and IV are significant below the .05 level. Also, 34 of the 45 correlations are in the predicted direction, a finding significant at the .01 level by binomial test. These results permit the conclusion that we are not dealing with random effects: Group performance appears to be contingent upon leadership style and situational favorableness. A more detailed description of these studies is presented in Fiedler (1970).

A recent set of validation studies has taken a different approach (Fiedler, 1973; Csoka & Fiedler, 1972). The argument is that training and experience could also change the amount of influence attained by a leader and therefore change the favorability of the situation for him. Under these circumstances the model would predict that training would be good for some people and not for others. For example, let's say we had a group of managers working in a situation of moderate favorability. Normally, high LPC interpersonal types would perform best. We proceed to give

extensive behavioral and interpersonal training to this group. If Fiedler is correct, then the situation becomes more favorable for everyone. In terms of performance, however, we have a problem. The high LPC leaders are now in a favorable situation; one which is no longer an optimal match for their style. The low LPC task-oriented types have moved into a situation which is better fit for their leadership style and consequently they perform better. Thus, training is only helpful for some people. Hypotheses such as those above have now been empirically supported in a number of settings. These results also provide predictive validity for the model as well as suggest some interesting questions about traditional training practices. We will return to this point later in the paper.

Brief Critique of the Model

Recently a number of critiques and evaluations of the model have appeared (Fiedler, 1970; Mitchell, Biglan, Oncken, & Fiedler, 1970; Graen, Orris, & Alvares, 1970). A brief summary of the major points of these reviews is presented below.

LPC

Attempts to relate this measure to other personality measures has met with repeated failure (Bass, Fiedler, & Krueger, 1964; Fishbein, Landy, and Hatch, 1969). Only recently have some suggestions gained support. Mitchell (1970) has shown that the LPC variable is related to the leader's ability to make numerous distinctions within his leadership role (cognitive complexity). These data have been reconciled with the model in a paper by Foa, Mitchell, and Fiedler (1970) which suggests that situational favorability may also be related to the complexity of the situation. This interpretation suggests that cognitively simple leaders (low LPC) perform better in simple situations which are composed of all good aspects or all bad aspects. More

complex leaders (High LPC) would perform better in situations of moderate favorability which have some good and some poor aspects.

Favorability Dimension

One of the major problems with the model has been the incomparability of studies. It is difficult to equate studies using different measures of interpersonal relations, task structure, or position power. A recent report by Posthuma (1970) has attempted to provide normative data for the LPC and Group Atmosphere scales. Also, in a study by O'Brien an independent index of influence was generated using Structural Role Theory and groups were placed in three situational categories (high, medium, and low leader influence). The correlations for the high and low situations between leader LPC and performance were negative as was expected. In situations of medium influence, these correlations were positive. These results provided some support for the validity of the favorability dimension.

Methodology

A number of methodological issues will be discussed. First, as can be seen in Table 1, Fiedler has not used the usual tests of statistical significance to test the model. Since the number of cases per octant in any one study tends to be very small, the more lenient criterion of being in the hypothesized direction was used. This results in an alpha level of .50 for a specific correlation. To use this lenient criterion as support for the model, it is necessary to generate almost the entire sampling distribution of correlations in an octant before the null hypothesis can be rejected. The question of whether 500 groups are sufficient is debatable.

TABLE 1

Summary of Field and Laboratory Studies
Testing the Contingency Model

<u>Field Studies</u>	<u>Octants</u>							
	I	II	III	IV	V	VI	VII	VIII
Hunt	-.64 -.51		-.80		.21		.30 -.30	
Hill		-.10	-.29			-.24	.62	
Fiedler, <u>et al.</u>		-.21		.00		.67*		-.51
O'Brien, <u>et al.</u>		-.46		.47		-.45		.14
<hr/>								
<u>Laboratory Experiments</u>								
Belgian Navy	-.72 -.77	.37 .50	-.16 -.54	.08 .13	.16 .03	.07 .14	.26 -.27	-.37 .60
Shima		-.26		.71*				
Mitchell		.24 .17		.43 .38				
Fiedler Exec.		.34		.51				
Skrzypek	-.43	-.32	.10	.35	.28	.13	.08	-.33
<hr/>								
Median, all studies	-.69	.17	-.22	.38	.22	.10	.26	-.35
Median, Field studies	-.59	-.21	-.29	.23	.21	-.24	.30	-.33
Median, Laboratory Experiments	-.72	.24	-.16	.38	.16	.13	.08	-.33
Medians in original studies	-.52	-.58	-.33	.47	.42		.05	-.43
Number of correlations in the expected direction								34 ¹
Number of correlations opposite to expected direction.								9
p by binomial test01

¹ exclusive of Octant VI, for which no prediction had been made.

* p < .05

** Studies not conducted by the writer or his associates.

A final methodological difficulty with the Contingency Model has to do with the partitioning of the situational favorability dimension into homogeneous subsets of groups (Graen, et al., 1970). Fiedler states, "The basic hypothesis of the Contingency Model...is not tied to the definition of the favorableness dimension in terms of group climate, position power, and task structure...The main question is always how to order situations in terms of their favorableness." This implies a research strategy involving partitioning the groups on a number of variables until meaningful results (i.e., supporting the model) are obtained. This type of research strategy has two consequences. First, with continued partitioning, the number of groups within any octant is reduced to a level where meaningful statistical tests cannot be performed. Second, this approach will inevitably lead to a rejection of the null hypothesis over a series of studies. The rejection of the null hypothesis of no systematic relationship would, in this case, be due not to any true relationship, but rather to the systematic treatment of the data (Graen, et al., 1970). Obviously, what is needed are more independent tests of the model.

Implications for Further Research

Individual Characteristics

The use of the LPC scale is not a necessary condition for pursuing the ideas suggested by Fiedler's model. Other individual traits or characteristics may be found which are more systematically related to performance in a given situation. Perhaps the most important question here is "what is the leader doing." That is, given the situation, what behaviors lead to effective performance? If, indeed, motivation is tied to need fulfillment (as

suggested by Maslow, 1954; Herzberg, 1966; or Vroom, 1964), then what needs are being satisfied in these various situations, and how this is accomplished must be discovered.

Situation Characteristics

It was mentioned that only three characteristics were used in Fiedler's model. These factors are certainly not the only factors related to the leader's influence. Factors such as stress or similarity of group members are also important. It is necessary, therefore, to construct a different method of measuring the favorableness of the situation which will incorporate these factors. It is suggested here that the use of structural role theory or some other technique might be better than using the type of division currently demanded by Fiedler's approach. This suggestion is made because the addition of one new variable to Fiedler's model gives you 16 situations; the addition of two variables gives you 32, etc. These partitions would make the model very cumbersome and certainly are not required by its underlying theoretical assumptions.

Implications for Improving Leadership Performance

What are the major implications of the model for understanding leadership and supervision, and what does the model tell us about leadership selection and training and the more general problem of improving group performance?

Leader Selection

Traditionally, psychologists have used a rather simple model of selection. Dunnette points out that "this model has sought to link predictors (that is, various measures of individual differences) directly with so-called criteria (that is, various measures of organizational consequences or job "success) through a simple index or relationship,

the correlation coefficient. This traditional validation model directed that persons on any given job be divided on some global measure (such as sales volume, overall rating of "success," or potential for promotion) into successes and failures and that they be compared on test scores, biographical information, or any other personal measurements available." Such an approach overlooks at least two major considerations. First, numerous behavioral styles might be used to acquire success, some of which would be more in line with the position of company policy. That is, two salesmen might have equally good sales records but one might be diligent, courteous, and highly motivated while the other might practice various forms of deception. A second problem is that certain characteristics might be helpful in most situations but not in all. There are data for example which show that hiring bright people for certain kinds of routine jobs leads to a high level of turnover. Yet, it would be hard to convince an employer to hire the applicant who is not as bright as another, equally qualified candidate. The result of this process is that most selection devices correlate with performance at best in the 20s and low 30s.

What is needed is a thorough analysis of the jobs and the behaviors required to be successful on that job. Various selection techniques can be used to determine what types of people are most likely to display these behaviors. Such a model has been suggested by Dunnette and is presented in Figure 2. Some recent research using this approach has been completed. Dunnette discusses research with managers at Standard Oil, with a small electrical goods company, with district marketing managers and with Farmers Mutual Reinsurance Company. All of these studies showed support for the model. However, it is also true that people and jobs change over time and

people frequently change positions. To match people with positions when both might change has implications for training.

Insert Figure 2 about here

Leadership Training

The second method for improving performance has been through leadership training. In fact when we talk about improving leadership, we immediately think of training. And yet, after all these years we have no convincing evidence that leadership training improves organizational performance.

Let me stress that we are not speaking here of training military leaders or business executives in administrative procedures, in personnel methods, or in the technical aspects of their jobs. Training of this type is obviously important, if not essential, to organizational performance. Our remarks concern the training of leadership ability or leadership behavior per se, and our criterion of effectiveness is organizational performance.

This is clearly a crucial problem. Yet according to Gilmer (1966, p. 245), "A rigorously controlled study of the value of executive training has...never been conducted." More recent studies have not settled the problem. But as we mentioned earlier, the Contingency Model has explained why these results are so poor. Training is good for some managers and not for others.

If the theory is correct, training can be effective only if it teaches the individual first to diagnose the situation correctly and then either to modify his leadership style to fit the situation, or to modify the situation to fit his leadership style.

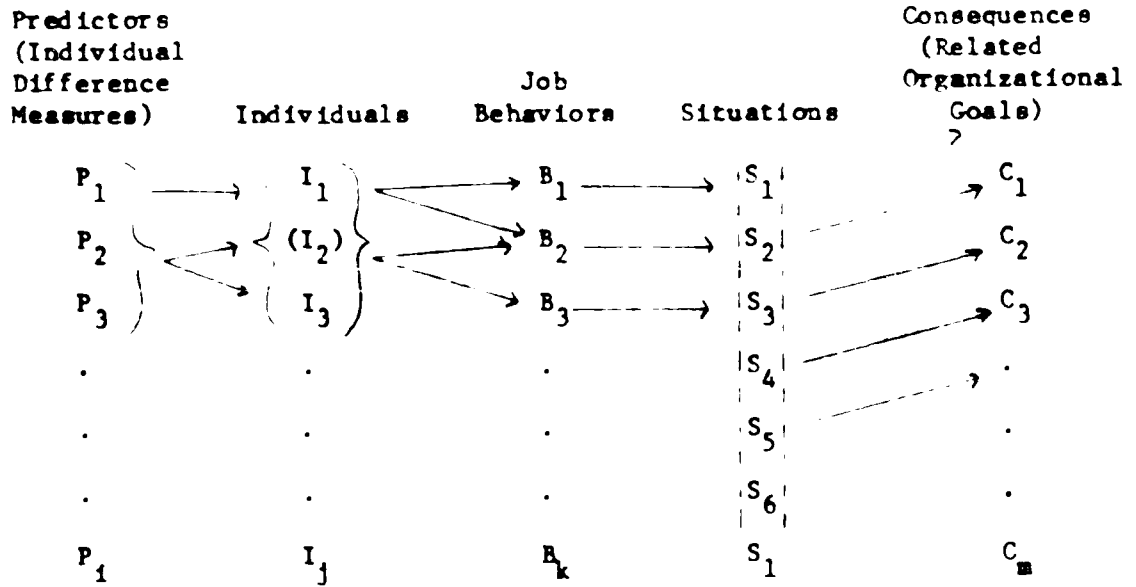

Source: Marvin D. Dummette, (1966; p. 105)

A Model for Test Validation and Selection Research

Figure 2

However, it is very difficult to change leadership style. When we talk about leadership styles we are not dealing with surface behaviors, but with deeply ingrained patterns of relating to others. It seems doubtful that these patterns of relating can be switched on and off at will. Would it not be easier, therefore, to teach the executive to fit his job to his leadership style than to change his personality to fit each of his successive jobs?

How might this be done? Well, we could change a man's power through a variety of procedures. The decision making could be allocated to him alone or to him and his subordinates. Titles can be changed, people of various ranks can be assigned to him, or we can control certain powers that he might have (raises, firing, etc.).

Interpersonal relations are changed by the character of our group members. For example, racial and cultural heterogeneity is related to group cohesiveness. We can assign troublemakers to him, or other types of individuals.

The task structure can be modified in terms of the specificity of instructions, the latitude of decision making, or through other procedures which influence the amounts and kinds of information that the leader has about the job.

These changes in supervisory jobs which we are discussing are relatively small and do not require reorganizing the entire unit. Our research does not suggest something brand new, but rather it hopefully provides a rationale and a better basis for making these organizational engineering decisions.

Finally, we might suggest that a policy of job rotation be adopted. This is a fairly common practice in many organizations both to promote an individual or to familiarize him with other aspects of the organization. In

many cases rotation is an integral part of a long term management development program.

Historically, however, most rotational decisions have been made on an intuitive basis. The Contingency Model may provide an empirical rationale for these decisions. Thus, individuals could be rotated to positions that best matched their style. In this way, the changing dynamics of any situation may be dealt with appropriately. Since situations are constantly changing, if we couple rotation policies with training policies that teach an individual how to manipulate the setting in optimal ways we are better able to maximize the fit between the individual and his job.

In summary, there can be no question that new approaches to leadership are required. We are facing increasing shortages of highly trained, highly intelligent executive manpower. We can no longer afford to discard a highly qualified specialist just because he may not perform effectively in a particular leadership position, nor should we expect that a man will be an outstanding leader no matter what the situation. Rather we need to learn how to engineer the organization to make the leader effective.

References

- Bales, R. F. Task roles and social roles in problem-solving groups. In E. Maccoby, T. Newcomb, & E. Hartley (Eds.), Readings in social psychology. New York: Holt, Rinehart, & Winston, 1958. Pp. 437-447.
- Bass, A. R., Fiedler, F. E., & Krueger, S. Personality correlates of Assumed Similarity (ASo) and related scores. USPHS Technical Report No. 19, Group Effectiveness Research Laboratory, University of Illinois, Urbana, Illinois. March, 1964.
- Csoka, L. S., & Fiedler, F. E. The effect of leadership experience and training in structured military tasks - A test of the Contingency Model, Organizational Behavior and Human Performance, 1972, 8, 395-407.
- Dunnette, M. D. Personnel Selection and Placement, Belmont, California, Wadsworth Publishing Co., 1966, p. 105.
- Fiedler, F. E. Leadership experience and leadership training - some new answers to an old problem, Administrative Science Quarterly, 1972, 17, 453-470.
- Fiedler, R. E. Engineer the job to fit the manager. Harvard Business Review, 1965, 43, 115-122.
- Fiedler, F. E. The effect of leadership and cultural heterogeneity on group performance: A test of the Contingency Model. Journal of Experimental Social Psychology, 1966, 2, 237-264.
- Fiedler, F. E. A theory of leadership effectiveness. New York: McGraw-Hill, 1967.
- Fiedler, F. E. Validation and extension of the Contingency Model of Leadership effectiveness: A review of empirical findings. Psychological Bulletin, in press.

- Fishbein, M., Landy, E., & Hatch, G. Some determinants of an individual's esteem for his least preferred coworker: An attitudinal analysis. Human Relations, 1969, 22, 173-188.
- Flanagan, J. C. Critical requirements: A new approach to employee evaluation. Personnel Psychology, 1949, 2, 419-425.
- Foa, U. G., Mitchell, T. R., & Fiedler, F. E. Differentiation matching. Behavioral Sciences, in press.
- Gibb, C. A. Leadership. In G. Lindzey, Handbook of social psychology, Vol. II. Cambridge, Mass.: Addison-Wesley, 1954.
- Gilmer, B. von H. Industrial psychology: Second edition. New York: McGraw-Hill, 1966.
- Graen, G., Orris, J. B., & Alvares, V. M. The Contingency Model of leadership effectiveness: Some experimental results. Journal of Applied Psychology (in press).
- Herzberg, F. Work and the nature of man. Cleveland and New York: World Publishing Company, 1966.
- Hill, W. The validation and extension of Fiedler's theory of leadership effectiveness. Academy of Management Journal, March 1969, 33-47.
- Hunt, J. G. A test of the leadership contingency model in three organizations. Urbana, Illinois: Group Effectiveness Research Laboratory, University of Illinois, 1967.
- Kahn, R. L., & Katz, D. Leadership practices in relation to productivity and morale. In D. Cartwright and Z. Zander (Eds.), Group Dynamics, Second Edition, Evanston, Ill.: Row-Peterson, 1960. Pp. 554-570.
- Maslow, A. Motivation and personality. New York: Harper and Row, 1954.

- Mitchell, T. R., Biglan, A., Oncken, G. R., Fiedler, F. E. The Contingency Model: Criticisms and suggestions. Academy of Management Journal, 1970, 13 (3), 253-267.
- Newport, M. G. Middle management development in industrial organizations. Unpublished doctoral dissertation, University of Illinois, 1963.
- O'Brien, G. E. Group structure and the measurement of potential leader influence. Australian Journal of Psychology, 1969, 21, 277-289.
- Osgood, C. E., Suci, G. A., & Tannenbaum, P. H. The measurement of meaning. Urbana, Ill.: University of Illinois Press, 1957.
- Posthuma, A. Normative data on the least-preferred coworker scale (LPC) and the group atmosphere questionnaire (GA). TR 70-8, Seattle, Wash.: Organizational Research, University of Washington, 1970.
- Shaw, M. E., & Blum, J. M. Effects of leadership style upon group performance as a function of task structure. Journal of Personality and Social Psychology, 1966, 3 (2), 238-242.
- Stogdill, R. Personal factors associated with leadership: A survey of the literature. Journal of Psychology, 1948, 25, 35-71.
- Vroom, V. H. Work and motivation. New York: John Wiley and Sons, 1964 .
- Warner, W. L., & Abegglen, J. C. Big business leaders in America. New York: Harper, 1955.

Footnotes

¹Research conducted under Office of Naval Research Contract N6-ori-07135, and ARPA Order 454 under Office of Naval Research Contract 177-472, Nonr 1834(36) and Contract DA-49-193-MC-3060 with the Office of the Surgeon General.

²Other items were: confident--not confident; impatient--patient; hardworking--not hardworking; close--distant; lazy--ambitious; warm-cold; productive--not productive; sociable--not sociable; casual--formal; considerate--not considerate; dependable--not dependable; agreeable--not agreeable; creative--not creative; sympathetic--not sympathetic.

INDIANA'S STAFF ORGANIZATION FOR EFFECTIVE MANAGEMENT

By

**Don K. Gentry
State Director of Vocational Education
State Department of Education
Indianapolis, Indiana**

Presented at the

**Sixth Annual National Leadership Development Seminar
for State Directors of Vocational Education**

September 18-21, 1973

The Sheraton Nashville Hotel, Nashville, Tennessee

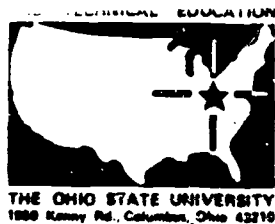

INDIANA'S STAFF ORGANIZATION FOR EFFECTIVE MANAGEMENT

Several major changes have taken place in the administration of vocational education in Indiana during the 1960's and early 70's-- a new State Board of Vocational and Technical Education, a new State supported technical college, a new State Advisory Council, a new Higher Education Commission, and the development of an area vocational school system--just to name a few. The ideas presented in this paper are not intended to be new, but are a combination of good management practices that have worked in Indiana for the past three years.

In the late 1960's, the Division of Vocational Education was inflexible, regulatory in nature, and used a traditional approach to administration of vocational education programs. There was very little contact with other segments of education, and each of the six program areas operated as autonomous divisions within a division. Over 75 report forms were used in asking local educational agencies to report necessary data for program management.

Early in 1970, the administration recognized that a complete service could not be provided until the vocational family was unified. This caused the administration to take a close look at the philosophy, organization, and State administrative structure for providing a service to the local educational agencies.

Indiana has a long history of vocational education programs, getting its first legislative support in 1913. Indiana is the thirteenth largest state. It runs from a very industrialized community to farming operations to large manufacturing businesses. Indiana is approaching a population of 6 million and receives over \$12 million of federal vocational education funds.

During 1973, we are serving over 120,000 high school students in vocational education programs and over 170,000 high school students in industrial arts and non-reimbursable business education programs. Of the 360,000 high school population, more than 200,000 students are being served in occupational related programs. We are serving over 50,000 adults and 10,000 post-secondary vocational students. The restructuring of the administrative system has developed these improved management functions.

Staff Management System known as Indiana's Management by Objective System

State-Wide In-Service Training Program

State-Wide Area School System

State-Wide Post-Secondary Technical System

State VOCED Data System

State System of Career Education Programs

State Self-Evaluation System

Combined Youth Leadership Programs

State Technical Assistance Program

State Staff Professional Development Program

Communications System with other Education Agencies and the State
Legislature

In all, our professional staff of 28 people is providing a service to over 345 local educational agencies. An administrative service plan was developed to coordinate, combine, and review the many different functions to be served by the State Vocational Staff. After staff workshops, training programs, and input from local educational agencies; the basic functions, goals, and objectives of the State vocational system were identified. The principle used in outlining this portion of the system: a good staff management system is dependent upon having clearly defined, measurable goals and objectives at all levels of operation. (Attachment A)

It was acknowledged early in the planning of this new approach to State administration that a total commitment, understanding, and involvement of the staff was essential. It was imperative all people involved in the system have an understanding of the system, be involved in the planning and development of the system, and have a total commitment to its implementation. Using the input of the State Staff and the local educational agencies, the Indiana Management by Objective System was developed. Input from the various segments of vocational education was important, but sometimes trying. As a well-known philosopher said, "The trouble with good advice is that it usually interferes with our plans."

The previous administrative structure, allowing for complete autonomy

of the different program areas, could not be used if a unified system of service was to be implemented. After much discussion, an administrative structure was developed. (See Chart - Attachment B)

The administrative structure called for vocational education to be part of the total educational system of the State. The structure uses input from various agencies involved in planning for vocational education and stresses service versus regulatory functions of the State Vocational Staff. The administrative structure of the State Staff is broken into two major service areas--Program Service Unit and Administrative Service Unit. The functions assigned to each unit are outlined in the organizational table. The structure uses new approaches to providing service in our State. A team service approach and the use of task forces have been initiated to accomplish the common objectives of the Division of Vocational Education.

As the system developed, centralization of statistical, financial information, and other operational procedures became essential for its success. The services of computer experts were utilized to develop a completely automated system of data collection, retrieval, and dissemination. Titles of program supervisors were changed to program consultants. It was also realized changing the names was not necessarily enough; much in-service education, indoctrination, and in some cases some real "head knocking" was required before the system was understood. It was important each staff member develop the philosophy of providing service as opposed to regulatory functions.

Another major administrative decision was staffing the system. With non-expanding resources for the State Administrative Staff, the decision was reached to reduce the program area personnel and expand the overall or total vocational positions with people within the Division. Staff members with broader perspectives than just one program area and who had a total vocational education philosophy were used for the new positions. Job descriptions were developed, and again in-service education for the entire staff was necessary.

(Attachment C) Of paramount importance was the principle of a balance of program specialists and total vocational oriented personnel.

Although this was not developed without problems, I believe the system is stronger because we used our people, who had an interest in providing a more total service to local educational agencies.

The total implementation stage took a commitment and perseverance on the part of the administration. As Franklin D. Roosevelt said, "New ideas cannot be administered successfully by men with old ideas, for the first essential of doing a job well is the wish to see the job done at all." The job has not been easy; easy jobs never last long, the competition is too keen. The administration made a commitment, stuck by that commitment, and the system to provide a service was implemented and has been successful. (Attachment D)

During the planning and development stage, the principle adopted was any good staff management system contains elements of review, evaluation, and renewal. The management system was developed to allow for

continuous updating and revision. Weekly staff meetings were planned for communication purposes and review of activities.

The evaluation segment included weekly, monthly, quarterly, and yearly individual and total staff reports and reviews, allowing for input from all people involved for success of the system. Periodically, the services provided are evaluated by ad hoc committees representing the local educational agencies of vocational education in Indiana.

As earlier stated, the system is a collection of administrative practices and procedures. When coordinated together, they have developed into a staff management system that has worked for three years. At the present time, there are few plans for changing or revising the system. Two areas under consideration are the development of a centralized filing system for the Program Service Unit and a more coordinated centralization of youth activities.

In summary, we were faced with a given amount of resources to provide the most efficient and effective services to local educational agencies. We have met the challenge with a unified staff management system that has proven not only successful but also very rewarding for all.

(Attachment E) Making this change was not easy, but we cannot be afraid of change if we are going to provide the services needed by the various agencies. The five major principles developed and implemented in our staff management system are;

1. A total commitment, understanding, and involvement of the State Staff

2. Centralization of data, fiscal information, and other operational processes
3. Clearly defined, measurable goals and objectives at all levels of the operation
4. A balance of program specialists and total vocational personnel
5. Contains elements of continuous review, communication, evaluation, and renewal

With the above outlined program, our services just seem to multiply.

(Attachment F)

1973-74

DIVISION OF VOCATIONAL EDUCATION

GOALS AND OBJECTIVES FOR PROVIDING SERVICE TO LEA'S

The Goals and Objectives for Providing Service to Local Educational Agencies are available upon request to the State Director of Vocational Education, Room 10.2, State Office Building, Indianapolis, Indiana 46204.

STAFF ORGANIZATION STRUCTURE FOR SERVICE

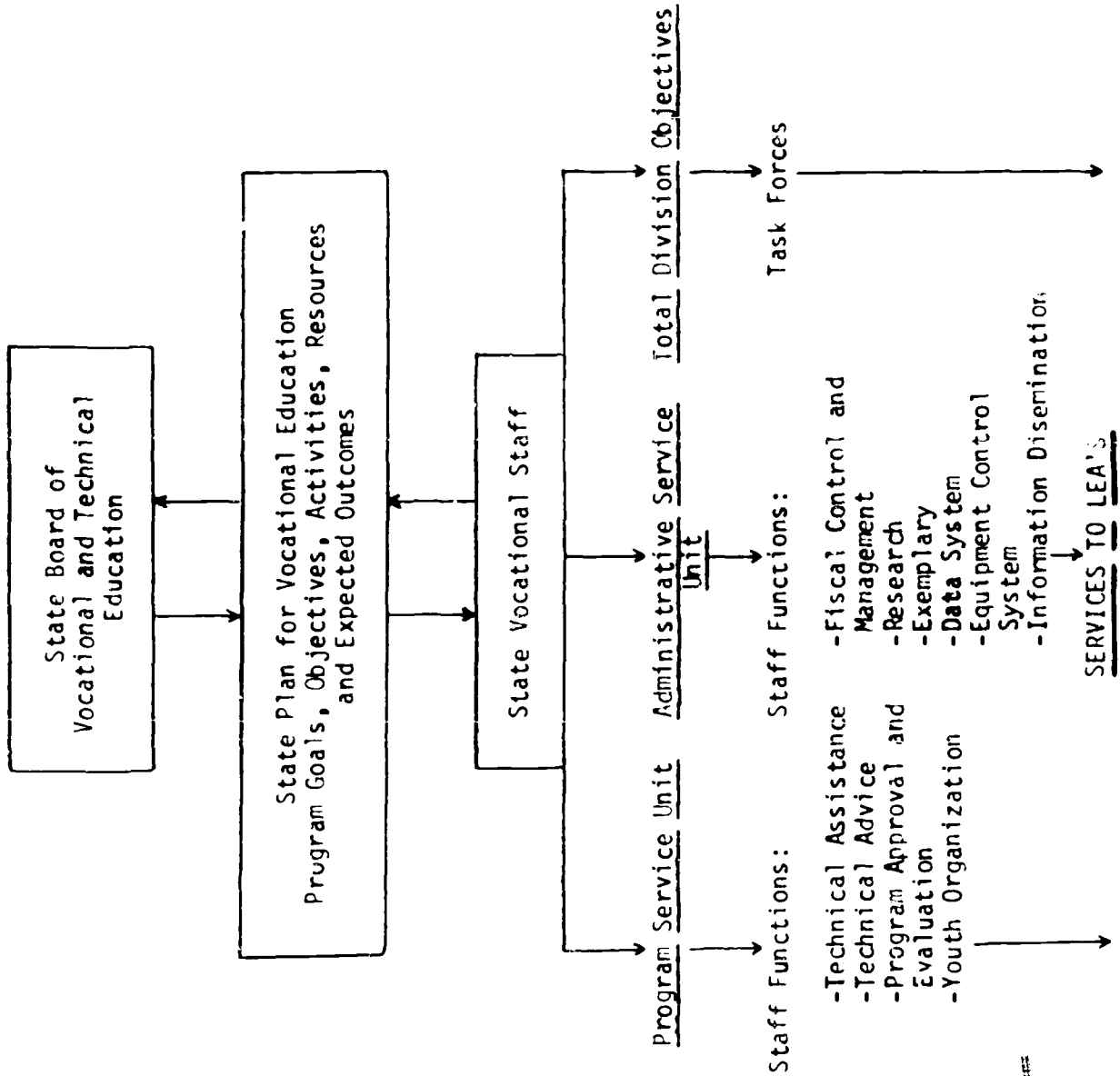

MY JOB

IT'S NOT MY JOB TO RUN THE TRAIN,

THE WHISTLE I CAN'T BLOW,

IT'S NOT FOR ME TO SAY HOW FAR

THE TRAINS ALLOWED TO GO,

I'M NOT ALLOWED TO BLOW OFF STEAM,

NOR EVEN CLANG THE BELL,

BUT LET THE DAMN THING JUMP THE

TRACK AND SEE WHO CATCHES HELL.

EMPLOYMENT
ANNOUNCEMENT
Vocational Director
INDIANA

BE SHARP

LOOK SHARP

STAY SHARP

Must be a man of vision and ambition, after-dinner speaker, before and after dinner guzzler, night owl, able to travel all day and make out reports all night and appear fresh the next day, learn to sleep on the floor and eat two meals a day to economize on traveling expenses so he can entertain friends in the next town.

Must be able to entertain wives, sweethearts, and stenographers without becoming too amorous; date waitresses and at the same time keep out of the local bas-tille; inhale dust; drive through snow ten inches deep at ten below and work all summer without perspiring or acquiring B.O.

Must be a man's man, a ladies' man, a mode? man, a good husband, fatherly father, a good provider, a plutocrat, a democrat, a republican, a new-dealer, an old dealer, and a fast dealer. A technician, a politician, mathematician, an old airplane and engine mechanic, and be an authority on trucks, buses, street-cars, and industrial machinery. A competent steno and typist, able to do 150 words a minute and keep a cigar going full blast. Attend all meetings, conventions, funerals, visit hospitals, and jails, contact and soothe the feelings of every customer in his territory, and take time for missionary work and goodwill work. Drive a company car and be readily able to compute mileage, drift, ground speed, gas consumption per block per minute, wear and tear on the tires and depreciation on the paint job.

Must have unlimited endurance and frequent over-indulgence in wine, women, and wind and gab; wide range of telephone numbers and latest stories. Must be owner of the latest car and attractive home. Must be able to figure his own social security deductions, income tax, luxury tax and liquor tax.

Must be able to stick out his neck by answering questions of customers and pull it back in before it is chopped off. Must be an expert talker, liar, dancer, traveler, bridge player, poker hound, authority on palm-istry, physiology, psychology, cats, dogs, etc., and still make his expense account and voucher stick the first time it is submitted.

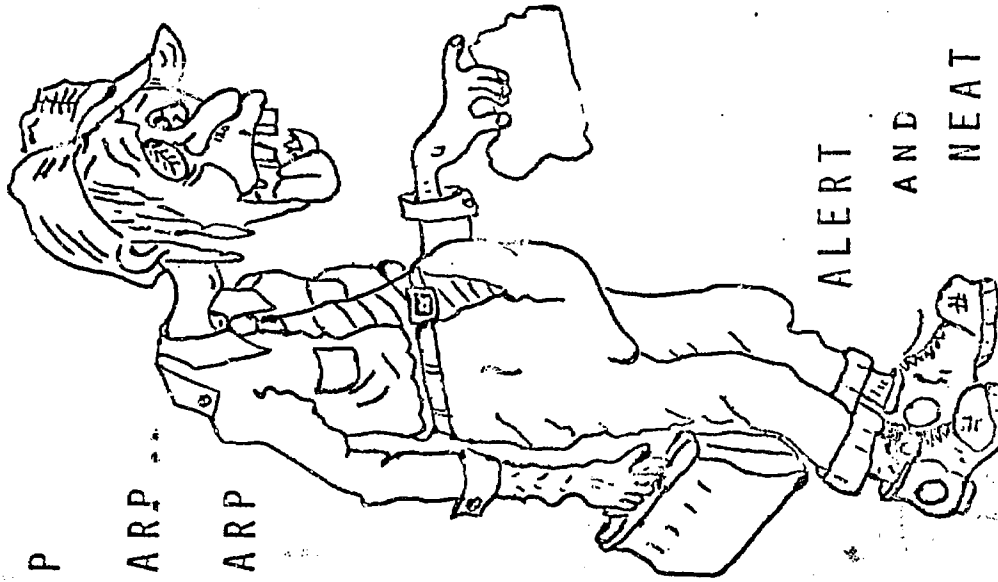

ALERT

AND

NEAT

DO SOMETHING

EITHER LEAD -- FOLLOW

OR

GET THE HELL OUT OF THE WAY

QUINCARD 473

BE KIND AND GOOD NATURED
YOU'LL ALWAYS GET YOUR
REWARD !!





STAFF ORGANIZATION FOR EFFICIENT MANAGEMENT

By

**Carl F. Lamar
Assistant Superintendent
for Vocational Education**

**The Center for Vocational and Technical Education
The Ohio State University**

Presented At The

**Sixth Annual National Leadership Development Seminar
For State Directors of Vocational Education**

September 18-21, 1973

The Sheraton-Nashville Hotel, Nashville, Tennessee

**THE CENTER FOR VOCATIONAL
AND TECHNICAL EDUCATION**



**THE OHIO STATE UNIVERSITY
1960 Kenny Rd., Columbus, Ohio 43210**

STAFF ORGANIZATION FOR EFFICIENT MANAGEMENT

Scope of the Discourse

I have been asked to discuss "Staff Organization for Efficient Management." In attempting to intelligently deal with this topic, it has been necessary to make certain basic assumptions, establish the scope of the presentation, and clearly define the significant terms used. The theme of the overall conference is "Improving Administrative Activities of State Vocational Education Agencies." Thus, our major interest is vocational education. The scope of our concern is improving administrative activities of the state agency which is responsible for vocational education. The significant administrative activities of the state agency are staff organization and management.

Staff organization and management of the state agency must be closely tied to the statewide program of vocational education. There must be a clear understanding regarding its orientation and operation--its underlying philosophy, purpose, goals, and objectives; and the decision-making process involved. Each of these categories should be fully conceptualized with respect to the needs of the people to be served and the people employed to provide the services. My remarks will be centered largely on experiences in my state in the areas of organization and administration. Emphasis shall be given to: (1) the philosophy, purpose, goals, and objectives that have provided the basis for the development of the present organizational structure in Kentucky; (2) the Kentucky organizational chart and principles of operation; (3) changes which have been made in the organizational structure in the past ten years; and (4) projected changes foreseen in the organization of the state vocational education agency over the next ten years.

In a study of the organization and administrative procedures in other states, I have not been able to find any two states with the same structure. All of them operate according to a "State Plan for the Administration of Vocational Education" which follow the same basic guidelines and are structured along a similar pattern, but the details of their operation vary considerably. I have not attempted to compare differences among the states. I have limited my discussion to what has happened in Kentucky and what changes are anticipated for the future.

Organizational Structure for Vocational Education in Kentucky

Kentucky is oriented to a statewide system of vocational education. It has been largely developed as an integral part of the total educational system. The state vocational education agency is located in the State Department of Education. It operates under the management and control of the State Board of Education, which is also the State Board for Vocational Education. The state vocational education agency is called the Bureau of Vocational Education. Its administrative officer is designated as the Assistant Superintendent for Vocational Education. The organizational structure of the Bureau of Vocational Education is shown in Figure 1.

The Bureau of Vocational Education is now divided into six divisions which have been organized largely on the basis of functions to be performed. However, the planning function designed to identify program needs, develop curriculums on the basis of the program needs, and determine the appropriate means of implementing the instructional programs is done primarily on the basis of major occupational areas or categories.

In the planning process, increased attention is being given to the broad scope of occupational clusters in assigning responsibilities for program development. Yet, we realize that considerable research, exemplary

Figure 1

ORGANIZATIONAL CHART -- KENTUCKY BUREAU OF VOCATIONAL EDUCATION

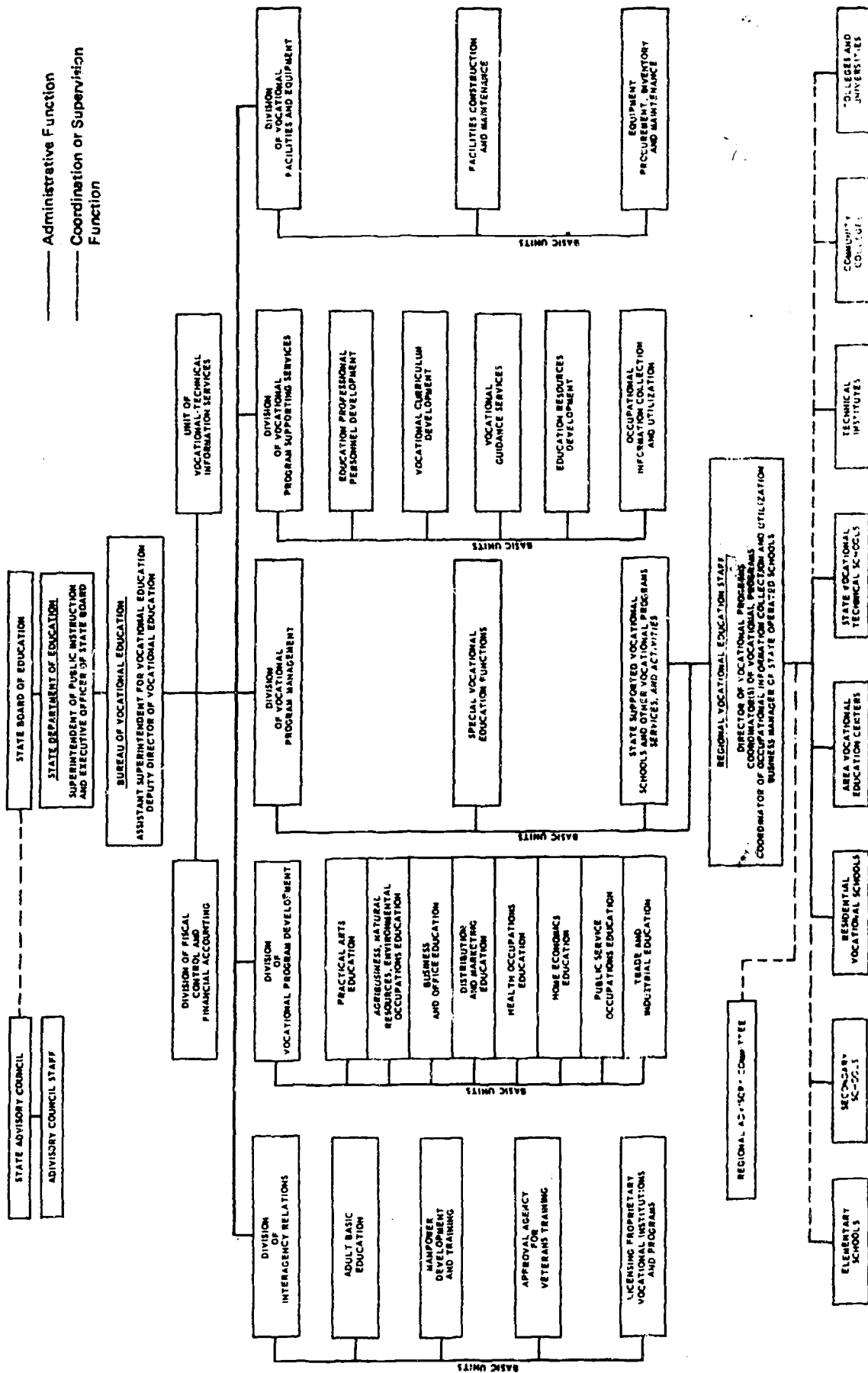

efforts, and program evaluation must be accomplished before we will be fully confident in our approach to determine what pattern of program planning will best serve our needs--what clusters of occupations should be included; what should be emphasized at each level of the educational process; and how the overall curriculum pattern should be structured.

The basic divisions that we now have operating in the Bureau are:

(1) Interagency Relations; (2) Vocational Program Development; (3) Vocational Program Supporting Services; (4) Vocational Facilities Construction and Maintenance; (5) Fiscal Control and Financial Accounting; and (6) Vocational Program Management. Vocational-technical information services are organized as a separate auxiliary unit which operates closely with the State Department of Education's Division of Information and Publications.

The Bureau of Vocational Education in Kentucky relates to institutions of higher education and local educational agencies through contractual arrangements. It secures their assistance in providing certain programs and services through reimbursement contracts. It also has cooperative agreements with other state organizations, institutions, and agencies which have mutual interests in programs pertaining to vocational education, manpower development, economic development, and institutional accreditation.

The Bureau of Vocational Education in Kentucky is responsible for all vocational education programs administered under the Vocational Education Amendments of 1968; Appalachian Redevelopment Act of 1965; Economic Development Act of 1965; Manpower Development and Training Act of 1962; other manpower programs administered through the State Department of Economic Security; and all adult education programs administered under the Adult Education Act of 1966.

The Bureau of Vocational Education serves as the state agency for the approval of institutions that offer training under the Veterans Rehabilitation

Act of 1966. It is responsible to license private proprietary schools offering vocational and technical education programs in the state which are not under the jurisdiction of other state licensing boards.

As shown in Figure 2, the State of Kentucky is divided into seventeen (17) education development districts. They follow the same pattern as the fifteen (15) area development districts which were established by the State Legislature for the organization and development of programs operated by other state agencies. The Bureau of Vocational Education has followed this same pattern in dividing the state into fourteen (14) vocational education regions (same as the area development districts, except that area development districts 8 and 9 are combined to form vocational education region 9).

Each vocational education region has a regional staff which is employed through the Bureau of Vocational Education as state employees. The regional vocational education staffs are directly responsible to the Bureau of Vocational Education in the State Department of Education for the operation of all adult, vocational, and technical education programs offered in the different vocational education regions under the management and control of the State Board of Education.

Kentucky, basically, supports two kinds of organizational arrangements for adult, vocational, and technical education which come under the management and control of the State Board of Education. It has a system of state-operated vocational-technical schools and area vocational education centers. They are directly managed by the Bureau of Vocational Education. The state vocational-technical schools are owned, financed, and operated by the state. They are established primarily to serve postsecondary students and adults. However, they may serve some secondary students during the regular school day. This is the practice where the secondary students do not have ready access to an area vocational education center. We now have

Figure 2
KENTUCKY EDUCATION DEVELOPMENT DISTRICTS

KENTUCKY STATE VOCATIONAL-TECHNICAL SCHOOLS
and AREA VOCATIONAL EDUCATION CENTERS

VOCATIONAL EDUCATION REGION 6 CONTAINS
EDUCATIONAL REGIONS 161 AND 162.

VOCATIONAL EDUCATION REGION 13 CONTAINS
EDUCATIONAL REGIONS 116, 119, AND 117.

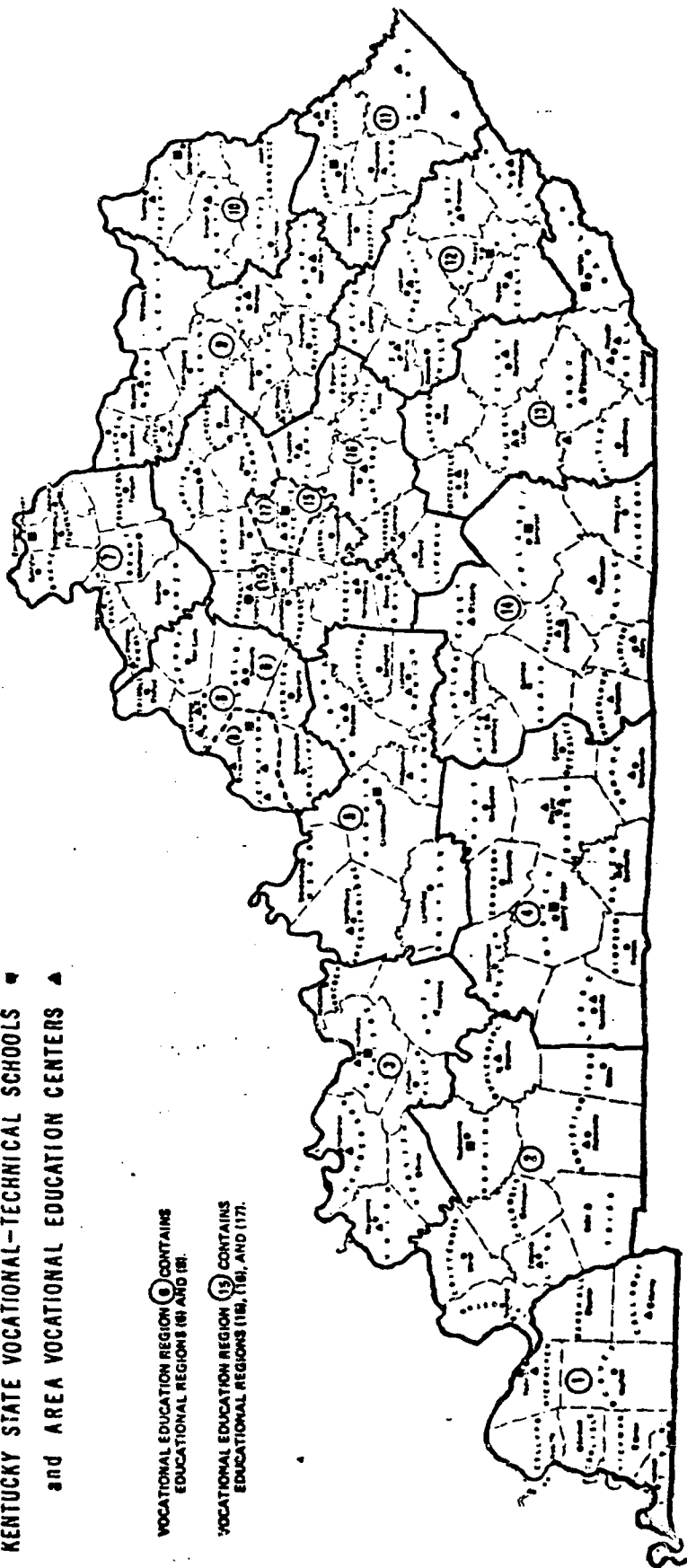

fourteen (14) state vocational-technical schools approved by the State Board of Education. Each area vocational education center is owned by a local school district, but it is financed and operated by the state to serve two or more secondary schools in one or more local school districts. The area vocational education centers are established primarily to serve secondary students during the regular school day. They may serve postsecondary students and adults in the late afternoons and evenings. We now have sixty-four (64) area vocational education centers approved by the State Board of Education. Five of these centers are in correctional institutions.

Kentucky also supports adult, vocational, and technical education programs on a reimbursement basis through a variety of local educational agencies, including 319 secondary schools in 189 local school districts (A single school district may have a vocational education department.); thirteen (13) community colleges in the University of Kentucky System; seven (7) state universities; and one (1) four-year state college. The Bureau of Vocational Education staff, in cooperation with the regional vocational education staffs, provides consultative assistance and supervision for all local educational agencies that operate reimbursed adult, vocational, and technical education programs.

Philosophy of Vocational Education

In the development of a staff organization for efficient program management, our most significant task has been to conceptualize a statewide system of adult, vocational, and technical education; determine how it should be meshed into the total educational program of the state; and determine the other programs or systems with which it needed to cooperate or coordinate its efforts. It is believed that vocational education, same as any other viable system, needs to share its resources with other related systems. These we

call available inputs to the system which need to be organized and handled through a process designed to attain certain desired outputs. The expected outputs are intended to satisfy the purpose, goals, and objectives of the statewide system. Together, the inputs, processes applied to the inputs to produce the desired outputs, and the outputs are intended to produce a dynamic system of vocational education for the benefit of Kentucky.

If one is to assess the viability of a vocational education system in order to improve its performance and the quality of its outputs and to intelligently plan its future course, the relation of its important components must be continuously examined as interacting entities or as a unified whole. The components in such a system constantly interact on each other and dictate any far reaching changes that need to be made to satisfy the ever changing purposes of the system. Decisions should be made to change the staff organization and the system's structure, revise the curriculum and teaching methods, alter facilities and equipment to satisfy the curriculum changes, reassign responsibilities of staff personnel, and adjust educational programs to satisfy the needs of individual students whenever they are justified as a means of improving the effectiveness of the system. Systems analysis may dictate new program purposes, goals, and objectives which call for changes in the basic staff organization and management procedures.

We need to look at the internal components of the state vocational education system to make sure that it is properly organized, staffed, and managed to satisfy the basic purpose for which it was established. However, it must be clearly understood that the general public--the people--supplies the basic resources by which the system is enabled to function. The vocational education system must make a significant contribution to the welfare of society if it can expect to receive the public support which it needs in order to attain its intended purpose. This basic fact requires a careful

examination of the inputs, the process, and the outputs of the system with respect to their external relationship in meeting the needs of the people. An understanding of the relationship of these aspects of the system should reveal the resource limitations that impede the system and the factors that will ultimately determine its productivity in terms of its goals and objectives. This implies that there is a basic need to identify the significant elements that will indicate the probable effectiveness of the system's inputs on the quality of the system's outputs.

It should be clearly understood that the people to be served--the students--represent the primary input of the vocational education system. Their proper development is the educational system's primary reason for existing. Their attitudes about the school and the program in which they are enrolled greatly affect the operation of the system. In the final analysis, the students become the primary output or product of the educational process. It can be assumed that the general public will expect the educational experiences provided by the school to bring about a wholesome change in the lives of the people who have participated. Society has a right to expect the students' educational experiences to develop the knowledge, attitudes, and skills needed which they cannot get elsewhere. The programs offered by the school are expected to make a significant difference in the lives of the students--in their ability to assume productive roles in the "world of work" and in other areas of social responsibility.

It is also important to recognize that, after the students, teachers constitute the largest and most important inputs in the total educational system. Teachers are the most expensive inputs. They play the central role in determining results--the value of the educational experiences. Their cost, as measured by student achievement, demands close analysis and continuing evaluation. An important goal of the educational system should

always be to hold down costs in relation to student achievement so as to maximize learning results. This is the basic challenge to efficient educational management. This is the real reason why "Staff Organization for Efficient Management" deserves constant attention by those responsible for "Improving Administrative Activities of State Vocational Education Agencies."

Vocational education is fundamentally a "teaching-learning process." Teaching is directing the learning process--the activities of the learner--so as to bring about the maximum amount of desired learning and a minimum amount of undesired learning. Learning is a self-active process on the part of each learner. It is a process by which the individual learner through his own activities--through what he does--becomes changed in behavior. Productive behavior or performance of the individual student is the intended output of the experiential process provided by the school.

This experiential process involves and impacts on the cognitive, affective, and psychomotor domains of the human organism. They interact and reinforce each other during the learning process. A soundly conceived and well planned educational program must be based on the significance of these domains to desirable individual achievement in the socioeconomic environment. As we consider "Staff Organization for Efficient Management," our basic goal must be the achievement of success with the "teaching-learning process" in vocational education.

Expansion in the functions of vocational education has led to significant changes in its basic orientation. More attention is now being given to the special problems of individuals and groups who were ignored or neglected during the years before passage of the Vocational Education Act of 1963. Increased emphasis is being focused on the needs of the disadvantaged, handicapped, and gifted. It is becoming increasingly apparent that vocational education needs to be an integral part of a sound comprehensive

educational system that serves a majority of the population. More attention is being focused on problems of the unemployed, underemployed, and underprivileged--those living in poverty, minority groups, and females.

More interest is now being given to the role of vocational education as a part of career education and an integral part of the total educational process. It is becoming accepted by more leaders in education as a vital part of each individual's total life career development which must not be overlooked or neglected. These new horizons for vocational education have placed greater significance on the social and psychological foundations of education as they relate to vocational education and life career development. What the individual wants to do with his life should be determined through a well planned and effectively implemented experiential process--the total educational process. It should purposefully maximize individual development in terms of one's social and economic interests, needs, and capabilities.

A shift in the emphasis of vocational education and a redirection in the programs and practices has resulted in rather extensive changes in organization and management at practically all levels of operation. There has been a significant shift in emphasis from an orientation on specific occupational program areas based on the manpower requirements of the labor force to an orientation toward the development of comprehensive vocational education programs and program supporting services based on the vocational education needs of the people to be served. These shifts in emphasis were made for the expressed purpose of causing leaders in vocational education to recognize and accept the emerging new responsibilities for vocational education at different educational levels and the need for expanding supporting services.

The changes recognized for vocational education have placed increased

stress on the need for a stronger and more dynamic leadership role for the managers of vocational education programs and services.

Purpose of Vocational Education -- The Vocational Education Act of 1963, as amended in 1968, provides an excellent statement of the purposes of vocational education. As quoted from the Act:

"It is the purpose of this [Act] to authorize Federal grants to States to assist them to maintain, extend, and improve existing programs of vocational education, to develop new programs of vocational education, and to provide part-time employment for youths who need the earnings from such employment to continue their vocational training on a full-time basis, so that persons of all ages in all communities of the State--those in high school, those who have completed or discontinued their formal education and are preparing to enter the labor market, those who have already entered the labor market but need to upgrade their skills or learn new ones, those with special educational handicaps, and those in postsecondary schools--will have ready access to vocational training or retraining which is of high quality, which is realistic in the light of actual or anticipated opportunities for gainful employment, and which is suited to their needs, interests, and ability to benefit from such training."

This Act clearly indicates that the purpose of vocational education is to prepare persons of all ages who are preparing to enter the labor market, or who have already entered the labor market for vocational training or retraining which is of high quality, and which is realistic in the light of actual or anticipated opportunities for gainful employment.

Goals and Objectives of Vocational Education -- Basically, the goal of vocational education is the preparation of persons of all ages in all communities of the state for gainful employment so they can attain self-fulfillment as productive individuals in the "world of work" and as responsible citizens in important social endeavors.

It is the objective of the Bureau of Vocational Education in Kentucky that through its leadership, planning, and administration, the statewide system of vocational education will serve the occupational education needs of all the people. It is intended that the people throughout the state will

have ready access to high quality vocational instruction which is realistic in the light of actual or anticipated opportunities for gainful employment. The planning will be done to provide instructional programs and services which are suited to the people's needs, interests, and abilities. Occupational competence of each individual is the expected objective. Promotion of the work ethic through the vocational education system is emphasized to convey to each individual the challenges and opportunities open to him. Provisions will be made for each individual to adequately prepare himself for the occupation or career of his choice. This will be reinforced with provisions for continuing training or retraining as the need arises so that occupational competence may be achieved and maintained. Thus, the significant objectives which have been identified for attainment in vocational education are to:

- 1) Understand the contribution of occupations to the welfare of each individual and to society.
- 2) Understand the variety of career opportunities available to each individual.
- 3) Provide adequate opportunities for acquiring appropriate occupational skills for job entry and maintenance by persons of all ages in all communities of the state.
- 4) Cope with changing occupational requirements and demands on a continuing basis.

Principles of Operation

The basis for planning, developing, and implementing a sound statewide system of vocational education in Kentucky is the sincere belief that there must be mutual understanding, cooperation, coordination, and financial support from the federal, state, and local levels of government if desirable results can be expected. It is believed that vocational education must be a national concern and responsibility expressed by federal leadership, technical assistance, and financial support; a state function and responsibility expressed by state leadership, planning, administration, and financial

support; and a local operation expressed by local financial support, effective program planning, program development, and the implementation of a sound comprehensive instructional program. The program should be based on the needs of the people and the manpower requirements of the labor market and reinforced by the essential program supporting services and the assistance of an active advisory committee composed of lay citizens.

The basis of a sound statewide program of vocational education is a soundly conceived, well planned, and effectively implemented comprehensive vocational education program in each local community throughout the state. Such a program needs leadership, guidance, and technical assistance from the state vocational education agency; institutions of higher education; and other related institutions, organizations, and agencies with mutual interests.

A comprehensive local vocational education program has as its base a sound instructional program which is managed to satisfy current occupational demands for manpower and the vocational education needs of the people. Such a program needs the services of a full-time director and a competent staff which is capable of providing such essential ancillary services as: short-term and long-range program planning; operational research and related activities; curriculum development; vocational guidance services; inservice personnel development; exemplary or innovative program activities; facilities planning and maintenance; personnel recruitment, placement, and follow up; and program evaluation. Such a staff needs to be organized to work as a team in carrying out these functions and to provide viable local leadership in carrying out an effective program.

If a well rounded and competent local vocational education staff is to be produced, the institutions of higher education need to develop comprehensive teacher education programs which will develop in the personnel that they train the competencies needed to properly function in a comprehensive

program at the local level. This challenge is expressed in the Vocational Education Amendments of 1968. It states that:

"The Commissioner shall approve the vocational education leadership development program of an institution of higher education upon finding that -- (1) the institution offers a comprehensive program of vocational education with adequate supporting services and disciplines such as education administration, guidance and counseling, research, and curriculum development; (2) such program is designed to further substantially the objective of improving vocational education through providing opportunities for graduate training of vocational education teachers, supervisors, and administrators, and of university level vocational education teacher educators and researchers...."

Improvement to get a well balanced comprehensive vocational education program implemented at the local level and improvement to get a comprehensive program for vocational education personnel development in institutions of higher education represent the areas where state vocational education agencies now have their greatest challenge. Effective programs at the higher education level are vital to the success of programs offered by local educational agencies. Competent personnel are essential to the success of local vocational education programs. Much of their orientation, basic development, and commitment to professional excellence are acquired in their preservice vocational training which is secured in institutions of higher education.

Changes that have Occurred in the Organizational Structure

The organization of the Bureau of Vocational Education has been gradually changing in its orientation and organizational structure during the past decade. Since passage of the Vocational Education Act of 1963, it has been reorganized three times. The changes have occurred because of a shift in the emphasis of vocational education; addition of new responsibilities assigned to the Bureau; and expanded programs and services assumed by the Bureau.

The initial reorganization was due primarily to the changed emphasis placed on vocational education in the new federal legislation and the new provisions in the State Plan for the Administration of Vocational Education. The change in emphasis from primary attention on specific occupational areas to primary attention on special program functions and expanded support for vocational education to include all publicly acceptable occupations resulted in a complete reorganization of the Bureau of Vocational Education in Kentucky. The second reorganization placed increased emphasis on functions as a means of delivering programs and services to local educational agencies.

The Bureau of Vocational Education was reorganized for a third time in 1972. This was done with the intention of developing a staff organization which would acquire the competencies needed to manage the Bureau on the basis of clearly formulated goals and objectives. The present organizational structure is shown in Figure 1.

Basically, the Bureau of Vocational Education is organized into divisions, and the divisions are organized into units. The units are organized on the basis of specific occupational areas and program functions. To date, we have not been able to conceptualize a delivery system for implementing adult, vocational, and technical education programs and services in local educational agencies which would be more effective than doing it through the occupational program areas; such as, agriculture, business and office, marketing and distribution, health occupations, home economics, industrial occupations, public service occupations, and practical arts. The primary emphasis on practical arts is at the middle school or junior high school level (usually in grades 7, 8, and 9). The practical arts are organized on the basis of occupational clusters. The curriculum emphasis for the practical arts is on: (1) introduction to the economic system and its structure; (2) orientation to the different occupational clusters in the economic

system; and (3) exploration of the occupational clusters which are of interest to the students with appropriate opportunities for hands-on experiences. It is desired that these experiences in the practical arts will lead to special or specific occupational preparation programs.

The occupational program units are located in the program development division. Adult basic education and manpower programs are located in the interagency relations division. The other divisions are organized to assume responsibility for the implementation of the various vocational education functions provided for in the State Plan for the Administration of Vocational Education.

The staff in the Bureau of Vocational Education is organized so that it can relate to the institutions of higher education and, through the regional vocational education staffs, to the local educational agencies on a collegial or pluralistic basis in carrying out their assigned responsibilities. Basically, this is done through the division structure and in terms of functions to be performed.

To properly relate the different program functions to be carried out with the different occupational program areas, we have developed an organizational structure within the Bureau which has all professional personnel assigned to task forces. The task forces have the responsibility for planning and developing the various functions of the state program of vocational education. The functions are largely implemented through the appropriate occupational program areas. The task forces are organized so that personnel from the different divisions in the Bureau and from the different occupational program areas are represented on a given task force so they can help plan and develop the particular function assigned to the task force. It is the responsibility of the task force to determine how the function is to be developed; who is to implement it; and who will be responsible to monitor

the on-going program. The representative from a given occupational program area who is working with a particular task force has the responsibility to keep the personnel in his unit properly informed of actions taken by the task force. He also has the responsibility to assume the leadership role in getting the people in his unit organized to appropriately carry out this particular function as it pertains to this particular occupational area. The pattern for organizing the task forces to plan, develop, and implement the various functions in vocational education is shown in Figure 3.

Projected Changes Anticipated in the Organizational Structure

In Kentucky, we have been experimenting with several exemplary programs and projects during the past decade in an attempt to develop the kind of a vocational education system that would effectively serve the occupational education needs of the people and the manpower requirements of the labor market. We have attempted to organize the vocational education program so that it would be a viable force in improving existing industries and attracting new industries so as to improve the economy of the state and thereby enhance the employment opportunities for the people. The record will show that significant progress has been made in these endeavors.

We have recognized that a sound comprehensive vocational education system must depend upon a sound organizational structure supported by the appropriate administrative tasks which are properly planned, supported, and implemented. Attention has been given to the organization and development of the different administrative tasks into a viable management system with the essential supporting components and services.

Our efforts have included cooperative activities with many other organizations, agencies, and institutions. We are convinced that practically all of these experiences have been highly beneficial to the program of

Figure 3

ORGANIZATIONAL STRUCTURE FOR TASK FORCES
 BUREAU OF VOCATIONAL EDUCATION, STATE DEPARTMENT OF EDUCATION

PROGRAM FUNCTIONS PLANNED BY TASK FORCES	DIVISIONS IN THE BUREAU										COORDINATORS OF THE DIFFERENT TASK FORCES	
	Vocational Program Development		Vocational Interagency Relations		Vocational Program Supporting Services		Vocational Facilities and Equipment		Vocational Fiscal Control and Financial Accounting			Vocational Program Management
	Units		Units		Units		Units		Units		Units	
Secondary Programs	Agriculture		Adult Basic		Curriculum Development		Equipment -- Procurement and Maintenance		Fiscal Control		State Supported Schools	
Postsecondary Programs	Business and Office		Manpower		Occupational Information System		Facilities -- Construction and Maintenance		Financial Accounting		Special Programs	
Adult Programs	Marketing and Distribution		Veterans Approval		Personnel Development							
Disadvantaged	Health		Licensing Proprietary Schools		Resources Development							
Hardicapped	Home Economics				Occupational Information System							
Cooperative Vocational Education	Industrial				Personnel Development							
Work Study	Public Service				Curriculum Development							
Student Organizations	Practical Arts											
Personnel Development	Health											
Curriculum Development	Marketing and Distribution											
Occupational Information System	Business and Office											
Evaluation and Accreditation	Agriculture											
Program Planning												
Dissemination												
Research and Exemplary												
Manpower Programs												
Facilities												
Equipment												
Licensing Proprietary Schools												
Vocational Guidance												

vocational education in Kentucky. We are not completely satisfied with our accomplishments, but we feel confident that we are now at the threshold of pulling things together so we can have an effective and efficient management system for a well organized state program of vocational education.

State government in Kentucky has been studying the feasibility of making certain basic changes in its organizational structure for more than four years. The possible changes would involve the State Department of Education and the Bureau of Vocational Education. The basic purposes of the recommended changes are to consolidate like functions and services so as to improve efficiency and effectiveness of state agencies in providing the essential programs and services to the people. Emphasis is being placed on "management for results." The intention is to eliminate duplication of efforts and waste in providing an effective management by objectives system which will be sound from a cost-benefit point of view--one whereby state government can be held more accountable to the general public for programs and services which it has promised to deliver.

State government is moving to organize all state agencies on the basis of Management by Objectives. To implement this concept, we are now in the process of developing the basic components required to support such a system. The Bureau of Vocational Education in the State Department of Education has been designated as one of the units within the state system to develop a Management by Objectives system for the state program of vocational education. It is expected that some of the components to be developed by the Bureau will also support other bureaus in the State Department of Education and other agencies of state government.

In our efforts to conceptualize, develop, and implement a viable Management by Objectives system which would satisfy the needs of the state-wide system of vocational education, we have sought technical assistance,

financial support, and cooperation from all possible sources where we thought promising exemplary programs were being conducted and expertise would be available to reinforce our efforts. We believed that such assistance would possibly accelerate the full implementation of the system that we have conceptualized.

Stevenson has defined Management by Objectives in terms that explain rather clearly the ideas which we are attempting to conceptualize and implement in Kentucky. He has said:

"Management by Objectives is a system which enables an organization to plan its course of action, to assist individuals with contributing to that course, and to determine progress toward mutually accepted goals. It provides a mechanism whereby an organization may concentrate its efforts upon a set of priorities which have been mutually determined and broadly accepted. This system allows every individual in the organization regardless of level and responsibility to know what is expected of him, where he may look for guidance and assistance, and who he is expected to coordinate with in his work. The system provides for the progress of the organization toward certain goals and keeps disruption due to both outside and inside changes to a minimum."¹

It is believed that a sound Management by Objectives system which is properly implemented will provide for accountability by the state agency; supporting institutions, agencies, and organizations; and individuals in the attainment of organizational goals and objectives.

As we view Management by Objectives, it is a system where managers at all levels of operation assist their subordinates in planning their work, meeting their objectives, and reviewing their performance so they may achieve optimum results from their efforts. In following this practice, they will assist in the accomplishment of the overall goals and objectives of the organization.

¹Management by Objectives, "Foreword" by Dr. William W. Stevenson, State Department of Vocational and Technical Education; Stillwater, Oklahoma; January, 1973.

The Bureau of Vocational Education has been involved in several exemplary projects during the past few years striving to develop the essential components which are needed to support an effective organization for managing the administrative tasks assigned to the Bureau. As we now view it, Management by Objectives is the approach that we want to take in managing the state vocational education agency in Kentucky. It gives each program manager in the agency responsibility for planning on the basis of goals and objectives; administration of programs, services, and activities required to attain his goals and objectives; and leadership in seeing that subordinates are properly oriented, trained, and managed to carry out their assigned functions.

At the core of the total organization are the administrative tasks that must be performed in order to carry out the purpose of the organization. In vocational education, we have identified these tasks to be:

- 1) Effective communications within the Bureau, between the Bureau and the operating units within the statewide system, and between vocational education and other organizations, with which it needs to maintain good working relations.
- 2) Staff personnel development for all personnel in the Bureau, and in all other operating units within the statewide system of vocational education designed to produce appropriate understanding, commitment, and competencies in all employees.
- 3) Curriculum development and instruction for all programs and services to be offered.
- 4) Facilities planning, construction, and maintenance to accommodate the statewide system of vocational education.
- 5) Student personnel services.
- 6) Business management, including program budgeting, financial accounting, and fiscal control.
- 7) Program supporting services; such as, problem definition, operational research, program evaluation, and a management information system.

If Management by Objectives is to facilitate the implementation of a

sound teaching-learning process in vocational education, it is essential that the major administrative tasks be properly planned and implemented. There needs to be developed a reinforcing relationship among the administrative tasks which is well understood and supported by each program manager. The proper organization of the different administrative tasks into operational areas should bring a desired order and cohesiveness to the vocational education system which will prove beneficial to the entire staff through its management capability and to the students enrolled in the program.

At the center of the process of Management by Objectives are people, ideas, and things. They are the basic components of the organization with which the managers must work. People create the need for leadership; ideas create the need for conceptual thinking and planning; and things create the need for administration. The management process involves three basic functions. They are problem identification and analysis, decision making, and communications. However, there are other functions which must be performed in the management process. They are planning, organizing, staffing, directing, coordinating, and budgeting. The manager must strive at all times to sense the pulse of his organization and take appropriate action to keep it dynamic in working toward its goals and objectives. To do this, he needs certain basic management tools at his command. When he has them properly organized and functioning, he has a viable system. He has an efficient staff organization and an effective management process.

In Kentucky, the Bureau of Vocational Education is in the process of developing these components of its management system:

- 1) Education Resources Development Unit which will be responsible for operational research, program planning, exemplary programs, program evaluation, and information dissemination. This unit has the major responsibility for providing the leadership in getting developed the goals and objectives for the Bureau and for the state program of vocational education. This is being

done by involving the entire staff in the process. Basically, the "Delphi Technique" is being used to secure agreement on goals and objectives for the Bureau and the divisions and units within the Bureau, and for other operational subdivisions in the state system.

Each operational unit is being trained in the use of the Program Evaluation Review Technique (PERT) in program planning, allocation of resources, and program implementation.

- 2) Occupational Information Collection and Utilization Unit. This unit has the major responsibility to develop and operate a management information system for the benefit of the Bureau and all local educational agencies that are required to produce an annual and long-range program plan for vocational education. The unit will produce and maintain an up-to-date "Manpower and Occupational Information Handbook" for each county in the state and for the state as a whole. It will include manpower demand; manpower supply; educational resources; and student enrollment, placement, and follow-up information.
- 3) Fiscal Control and Financial Accounting Unit. This unit has the major responsibility to coordinate the development of a program budget for vocational education in the State Department of Education. All divisions and units in the Bureau will be involved in this operation. The Programming, Planning, Budgeting System concept will be followed in producing the annual and biennial vocational education budgets for the state program.
- 4) Education Personnel Development Unit. This unit has the responsibility to provide leadership and coordination in assessing the needs of all personnel employed in vocational education in the state for preservice and inservice training to keep them up to date with the responsibilities of their job. Through the support of the Education Professions Development Act, the Bureau has developed a statewide plan for personnel development.
- 5) Program Development. This function will be largely carried out through the program development, interagency relations, facilities construction and maintenance, program supporting services, and program management divisions. This will require cooperation and coordination by the directors of these divisions to get an effective job done. Each of these divisions has a significant contribution to make to program development. They are expected to maintain a collegial or pluralistic relationship in performing their assigned responsibilities.
- 6) Program Management by Objectives. The Assistant Superintendent for Vocational Education plans to use the directors of all divisions in the Bureau of Vocational Education as a coordinating committee to provide the leadership in organizing and implementing the Management by Objectives system in the Bureau and in all vocational education regions of the state.

It is believed that all activities of management in Kentucky, whether they involve the professional staff, the State Board of Education, the State Advisory Council on Vocational Education, or the general public, should contribute to the attainment of the intended results of the organization. In vocational education, the intended goal is an effective teaching-learning process which will benefit all persons who desire to enroll in the program.

An effective staff organization and efficient management process should accomplish these basic functions:

- 1) Identify and influence the formulation of appropriate policies, goals, and objectives for the organization.
- 2) Stimulate and direct the development of programs and services designed to achieve the purpose, goals, and objectives.
- 3) Organize and coordinate those responsible for planning, developing, and implementing the programs and services which are essential in attaining the goals and objectives of the organization.
- 4) Secure and manage the resources which are needed to support the organization and its programs and services.

DEVELOPING PERFORMANCE BASED OBJECTIVES

By

**Orlando C. Bekking
Professor of Management Science
The Ohio State University
Columbus, Ohio**

Presented at the

**Sixth Annual National Leadership Development Seminar
for State Directors of Vocational Education**

September 18-21, 1973

The Sheraton-Nashville Hotel, Nashville, Tennessee

**THE CENTER FOR VOCATIONAL
AND TECHNICAL EDUCATION**



**THE OHIO STATE UNIVERSITY
1860 Kenny Rd., Columbus, Ohio 43210**

DEVELOPING PERFORMANCE BASED OBJECTIVES

You and I are here for an important reason this afternoon; to help improve the quality of operations of your state vocational education agencies. There are obviously many different aspects of this broad topic area we could discuss, but this afternoon we are going to concentrate on the use of objective-based systems of administration as tools for the improvement of individual and organizational performance. Before the day is done, all of you will have had the chance to work in seminar groups on direct applications of these systems to vocational education, so I am not going to try to cover the same material. Rather, I'd like to make my contribution in terms of giving you the basis for understanding how and why these systems do or do not work and why---though I must caution you to beware of academicians bearing simple solutions to complicated problems ---they appear to be one of the most fruitful approaches to the complicated job of administering organizations.

Let us begin by looking broadly at the things you as an administrator can manipulate as you attempt to improve the vocational education effort in your state. If you are dissatisfied with the performance of a part of the organization you supervise, one possible area in which the search for solutions to the problem can be begun is that of technology. You may ask yourself, "Is there any piece of equipment---a computer, a typewriter, a car, microfilm or you name it that could solve the problem for me?" So far as western society is concerned, indeed, our most frequent response to any social or organizational problem is to assume that a new piece of equipment is the key to solving it.

A second possible source of solutions to the problems of performance in your agencies lies in the area of structure. If this Leadership Development Seminar does nothing else, it will have made a contribution to

the quality of vocational education if it alerts you to the possibility of structural difficulties within your organization and leads you to ask questions such as, "Is the problem in Instructional Services due to failure on my part to provide adequate communication channels or to provide the Supervisor of Instructional Services with the kind of authority he needs to do his job properly?" Again, I cannot downgrade the importance of structure as a possible source of solutions to problems of agency performance, if for no other reason than the fact that I have seen structural solutions work in numerous on-going organizations.

Finally, we come to the area of people as potential sources of solutions to performance problems. We may look at the individuals who make up our organizations and ask, "Can we handle this problem by replacing particular individuals or groups with others or by changing their behavior through education, training or other techniques?" It is with this third area that we are primarily concerned today, not because we feel the others are unimportant, but because it is a topic area in which I have some expertise and one that was assigned to me for the program. Let's begin our discussion by looking at possible sources of individual performance problems in much the same way we looked at organizational performance problems. The framework we'll use is one developed by Porter and Lawler (1964) as part of a broader analysis of individual performance. Though the entire model has some problems of its own, the segment we are using here is a useful tool for taking problems of individual performance apart.

If an individual employee in your agency is not performing well, one source of the problem may be a lack of the traits and abilities necessary to perform well in his assignment. All of us at one time or another have seen organizational problems created by mismatches of people and jobs. The

assignment of individuals to positions for which they lack the necessary skill or personal make-up can create major problems for organizations. They can be solved in three different ways (1) By changing the individual so he better meets the requirements of the job---a task that ranges from the simple to the impossible, (2) By changing the job so it better fits the mix of abilities and personal characteristics of the incumbent or (3) By replacing the individual with someone who better fits the position requirements, something that is easier to do in some organizations than in others.

Problems of individual performance may also stem from lack of effort on the part of the individual employee. All of us are familiar with the underachiever syndrome among employees as well as among school children---the individual who has all the potential in the world, but somehow puts forth only the minimum amount of effort. Here the solution to the problem lies in the nebulous area that we call "employee motivation," a topic we will discuss in a bit more detail in a few moments.

Finally, we have the possibility that poor individual performance may stem from neither lack of traits and abilities necessary for the position, nor substandard effort. It may be that the individual's role perception---his understanding of what is expected of him---is incorrect; that is, he does not see his duties the same way his boss does. He can do the job and he is trying hard, but his priorities are wrong. In such cases we normally start thinking about job descriptions, indoctrination programs and communication programs as ways of dealing with the problem.

Thus far, then, we have established that effective individual performance requires three things: (1) Appropriate traits and abilities, (2) Effort and (3) Accurate role perceptions. At this point it is helpful in our task

of understanding how to deal with employee performance problems to lay out the approaches commonly used by administrators in dealing with them. Given the time limits we're operating under, I'll be able to treat only the extremes of the total range of approaches to such problems. Thus Approach A and Approach B are really more caricatures than actual ways in which administrators deal with problems of individual performance.

Approach A flows from a stream of thought which has pretty well dominated teaching about individual employee performance since the beginning of the study of management as an independent field. Those who follow this way of handling employee performance problems seem to deal with each of the areas we have discussed---abilities and traits, effort and role perceptions ---in a consistent way. Their "knee-jerk" response to problems of traits and abilities is to look for improved selection techniques or to institute various forms of formal training programs. Thus we would expect to see a ~~State Director of Vocational Education concerned with poor performance on~~ the part of his office staff to institute to classes in clerical skills, office procedures and the like and to call upon the State Department of Personnel for improved selection procedures and higher standards in screening applicants. If the problem were limited to a few individuals, he might begin steps to terminate their employment or to get them transferred, a process we refer to as "rotation of the rejects."

Typically followers of this approach deal with problems of low effort through what have been called extrinsic factors. These are things such as pay, promotions, special privileges and awards which are related to but are not actually part of the individual's work itself. Problems of role perception are dealt with through formal job or position descriptions which list in detail the activities the employee is expected to perform.

Followers of Approach B, on the other hand, have their own set of more or less automatic responses to problems of employee performance seen as stemming from the various sources. The problems of traits and abilities are dealt with in much the same manner as under Approach A, with one major exception. Advocates of Approach B normally place far less emphasis on formal training programs than do their Approach A counterparts. Instead they place far greater weight on informal coaching by the employee's superior. Formal programs are frequently seen by these individuals as irrelevant to the day-to-day problems of the organization. Frequently the individuals sent to formal programs by the advocates of this approach are those he can spare, rather than those who have the greatest need for it, from an objective point of view.

Lack of effort is seen as stemming for the most part not from poor use of extrinsic factors, but from the failure to build intrinsic sources of satisfaction---interesting work challenge, achievement, opportunities to earn recognition and the like---into the individual employee's job itself. The administrator deals with problems not primarily through pay and the like, but through job redesign aimed at providing the employee with a meaningful, interesting, challenging job. Performance problems coming from poor role perceptions are typically handled not through listing of activities to be performed in position descriptions, but rather through a process of mutual goal-setting in which employee and boss jointly establish priorities, targets and deadlines. The individual learns what is expected of him indirectly through this process, rather than by having his superior's expectations spelled out for him in a position description.

The evidence is certainly not all in regarding the relative effectiveness of these two approaches. A great deal more research needs to be

done before I can stand up in front of you or any other group of administrators and say, "This approach is the answer to problems of employee performance." Yet, if I were a betting man, I'd have to put my money on Approach B. The results of the studies performed thus far, limited as they are, point in that direction. As Carroll and Tosi point out,

We have...evaluated the research relevant to certain aspects of (Approach B), such as goal setting, feedback on performance, and participation. This research supports the idea that (Approach B) should result in higher levels of performance than those of management approaches that do not involve the establishment of performance goals, the provision of feedback relevant to performance as it relates to such goals, and subordinate participation in the setting of such goals. (Carroll and Tosi, 1973, p. 16)

Further, the B Approach makes considerable conceptual sense as well. So far as the improvement of traits and abilities are concerned, the day-to-day guidance of the boss should provide more directly relevant information for the employee than formally developed classroom procedures. Similarly, there is little question that intrinsic sources of motivation are more potent than their extrinsic counterparts, if for no other reason than the fact that Civil Service regulations and union contracts severely constrain use of extrinsic factors as means of increasing employee effort. Similarly, there is little question that the setting of specific concrete goals with firm deadlines for their accomplishment can clarify an employee's role perception far more completely and clearly than can the vague listing of generalities that the typical position description contains. The mutual goal-setting process advocated in Approach B also makes considerable sense, because it provides both a sense of personal commitment to the goals on the part of the subordinate and also is frequently interpreted as a compliment, reflecting favorably on the respect in which the employee is held by his boss.

Yet, despite the evidence in support of this type of approach to problems of employee performance, there is considerable difficulty on the part of many administrators in making the system work as well as they would like. There are several reasons for this, but in my mind one stands out. Administrators find it difficult to open the direct communication with their subordinates which is necessary for the effective operation of such a program. Specifically, they tend to fall into three traps:

1. They tend to talk primarily in terms of individual traits or characteristics such as reliability, trustworthiness, cooperativeness and the like. These terms, when used in a critical manner, are almost certain to generate defensive reactions that hamper communication. Discussion should be organized about behaviors, rather than traits.
2. They tend to get involved in long-winded debates with the subordinate over what he has or has not done in the past. The administrator should use the past performance of the employee as a springboard for discussion of the future. The typical administrator has no time to waste on discussion of the past. What is done is done and cannot be changed. Only the future is subject to management control.
3. They often take the position of judge, telling the individual employee their verdict, a process which also generates defensive reactions and cuts off free discussion. The superior should take a problem-solving attitude, rather than acting as judge.

Taken together, performance based objectives provide a major advance over more traditional methods of dealing with employee performance problems.

They provide a means through which an individual administrator can more directly and effectively influence the performance of his subordinates.

REFERENCES

Carroll, S. J. and H. L. Tosi, Jr., Management by Objectives: Applications and Research, New York, The Macmillan Company, 1973.

Porter, L. W. and E. E. Lawler, III, Managerial Attitudes and Performance Homewood, Illinois, Richard D. Irwin, 1968.

MANAGEMENT SYSTEMS

By

Cecil H. Johnson, Jr., Program Director
The Center for Vocational and Technical Education
Columbus, Ohio

Presented at the

Sixth Annual National Leadership Development Seminar
for State Directors of Vocational Education

September 18-21, 1973

The Sheraton-Nashville Hotel, Nashville, Tennessee

THE CENTER FOR VOCATIONAL
AND TECHNICAL EDUCATION



THE OHIO STATE UNIVERSITY
1860 Kenny Rd. Columbus, Ohio 43210

Table of Contents

	Page
1. Introduction-----	1
2. The Management Process-----	2
3. System Approach-----	5
4. System Analysis Steps-----	6
5. Information System-----	9
6. MISVE-----	9
System Objectives-----	10
Conceptual Design-----	10
Goals and Objectives-----	13
Resource Allocation Strategies-----	13
Manpower Supply-----	13
Manpower Demand-----	14
Underdeveloped Human Resources-----	14
Student Follow-up-----	14
Resources Inventory-----	14
Program Costs-----	15
Program Characteristics-----	15
Instruments Available Now-----	18
Components Under Development-----	19

Introduction

Critics of American education often appear to believe that the educational system possesses modest aspirations and even more modest achievements. This may be an unjust viewpoint but it serves to point up the fact that the educational system has been provided with ineffectual devices for planning activities and reporting accomplishments to the public. The problem is compounded by a lack of consensus as to what constitutes educational output. With uncertainty surrounding educational productivity, schools have suffered because of problems in designing their programs, assessing their performance, and developing suitable allocative strategies (or means to determine how best to utilize limited human and non-human resources in the learning process).

What is lacking is a general framework for educational planning that is appropriate for educational agencies. Planning is formulating a system-wide philosophy, general goals and objectives; organizing relevant data, determining personnel, space and material requirements; examining alternative procedures and establishing priorities; providing for communications and information retrieval for the system; analyzing financial resources; evaluating how well objectives are being met; looking to the future and reviewing the system continually to ensure that objectives are being reformulated and that the system is dynamic and innovative rather than static and rigid. If properly conducted, systematic planning can provide educators with a more complete basis for rational choice. It is a way of attempting to control the future instead of merely reacting to it. (1)

The Management Process

In his book, Planning and Control Systems: A Framework for Analysis, Robert Anthony views the management process as occurring at essentially three levels of the organization. His definition of these levels is accomplished by stating the general type of management process which occurs there, to wit: strategic planning, management control and operational control. (2)

Strategic planning is defined as "the process of deciding on objectives of the organization, on changes in the objectives and the policies that are to govern the acquisition, use and disposition of resources." This process is obviously and necessarily accomplished at the highest levels within the organization.

Management control is defined as "the process by which managers assure that resources are obtained and used efficiently and effectively in accomplishment of the organizational objectives." Operational control is "the process of assuring that specific tasks are carried out effectively and efficiently."

Every organization, formal or informal, by its own nature of being an organization, will have objectives. It is essential, especially to formal organizations in education that these objectives be firmly established, clearly defined, attainable and communicated throughout the organization. This is not to say that objectives cannot change, but that they must not be vague, undefineable or uncommunicated. This becomes the first step in the management process, establishing objectives. This establishment has the effect of providing a framework in which all management action takes place. It channels planning and is indeed a prerequisite.

The decision-making process cannot effectively operate unless oriented toward objectives.

Objectives are not, however, peculiar only to the organization as a whole. There are several types and levels of objectives. Long-range objectives are, in effect, a statement of where the organization is going, or intends to go. In a means-ends situation, they are the ends. If long-range objectives are the ends, then short-range objectives are the means, the way in which long-range objectives are intended to be met. It follows, therefore, that short-range objectives must support long-range objectives.

Objective breakdown results in a so-called hierarchy of objectives. Once organizational objectives are established, they can be broken into more operable segments and assigned to sub-units of the organization. This breakdown process can be carried out to the lowest level of the organization, the individual. The obvious advantages of this breakdown are to give each sub-unit or individual a definite goal to work toward. Also, it facilitates greatly the control process by providing a framework for progress analysis.

As stated previously, objectives provide a framework for planning. Logically, then, planning is the next step in the management process. Planning, once again, is defined as essentially a process by which future courses of action are defined, evaluated and selected with reference to organizational objectives. As objectives provide a framework for planning, so does planning provide a framework for control.

As there is a hierarchy of objectives, so also must there be a hierarchy of plans. Planning must pervade all levels of the organization,

becoming increasingly more detailed toward the lower management levels. The progress of the organization will increase greatly as more individuals from all levels of the organization become involved in the planning and decision-making process. It only seems natural to state that an individual will become more involved and interested in that in which he has taken part in developing.

The next step in the management process is scheduling which is essentially "putting the plan on a calendar." Current planning and control systems such as PERT and CPM emphasize the condition of a plan, that is the network, without reference to a schedule. It is only after the completion of the network that a schedule of start and completion dates is developed. This does not mean that time is not applicable to plan development. As a plan is divided into its constituent parts, time estimates (duration estimates) are made for each, but start and completion dates are not set. The purpose behind this technique is to avoid biasing time estimates in favor of calendar dates. Once schedules are established and implemented they become an extension of the plan for purposes of control.

Several factors combine to influence scheduling, a few of which will be mentioned here. The availability of resources is probably the single most important factor. Resources in this context include personnel, both quantity and quality (technical ability), money, facilities (to include make-or-buy situations) and time. Time becomes increasingly important when plans have an assigned completion date. An important point in this situation is to maintain independence between time estimates and scheduled (assigned) completion dates. Time estimates should be made and then assigned dates applied. At this point, if it is seen that the

time estimated will result in a time overrun, then replanning must be done, but this has hopefully avoided biasing time estimates in favor of assigned dates.

Other factors influencing scheduling are the desire for efficient utilization of personnel and facilities; that is, reducing idle time , and evaluating time estimates made by other personnel to account for tendencies to either "pad" estimates or to overestimate abilities.

Once a plan is finalized and implemented, management needs some method for determining if progress is as planned. To be effective, this control process must be flexible and dynamic. A plan seldom remains unchanged throughout its implementation. As it changes, the control process must adapt to it. Completion of the control process leads back to the first step in the cycle and sets the stage for another journey through it. (3)

Systems Approach

The study of organizational activities such as planning, controlling and evaluating may be called systems analysis. The term systems analysis has a great number of definitions and should be used carefully. It is part of the new generation of interrelated management procedures that seek to enhance organizational rationality. In education, a system may be defined as "The sum total of separate parts working independently and in interaction to achieve previously specified objectives." (4)

The system approach is a methodological approach to decision-making and is generally described by the term system analysis - "a generalized and logical process for identifying and breaking down, into as many carefully distinguishable parts as possible, the structure, parts and

interactions of a system." (4)

1. Where are we going and how do we know when we have arrived?
2. What are the things that will keep us from where we are going and how do we eliminate them?
3. What are the major milestones along the way to where we are going?
4. What are the "things" that must be done to get to each milestone?
5. Of what specific tasks are the "things" composed?
6. What are the possible ways of getting the "things" done?

In the educators' language these questions may be proposed as the steps in educational system analysis.

1. Determine mission objectives and performance requirements.
2. Determine and reconcile constraints.
3. Determine mission profile.
4. Perform functional analysis.
5. Perform task analysis.
6. Perform methods-means analysis.

In summary, system analysis should yield, in precise form, a collection of data which tells us what is to be done, in what order it must be done, what are the feasible performance requirements at each level and what possible ways are there to get the mission performed. (5)

System Analysis Steps

System analysis, in education, can be reduced to four basic tasks

consisting of:

1. Mission analysis
2. Functional analysis
3. Task analysis
4. Method - means analysis.

Mission analysis consists of defining the overall mission objective and determining mission performance requirements, constraints and profile. The purpose of mission analysis is to define and express in concise, explicit measurable terms the tangible end product to be produced, defining:

1. Product specifications representing terminal success of the mission objective
2. Performance restrictions or limits representing the operational tolerances measuring acceptable final achievement.
3. Performance characteristics and restrictions.

System analysis should not only assist in deriving a concise, operationally stated mission objective and specific performance requirements, it should also determine the "hurdles" which make the production of the end product infeasible. As such, a primary requirement for the system analyst will be to identify constraints which can jeopardize the achievement of the mission objective.

Functional analysis shows what must be done in the order that it must be done. Each top level function may be analyzed into constituent lower level functions and as the analysis moves down the problems and functions are defined and identified in greater and greater detail. Each analysis step results in the determination of additional performance requirements for that level allowing the identification of additional

constraints for that level. Thus, at each level functions are identified and analyzed and each functions performance requirements and constraints are identified. The resulting data is used to determine lower order functions.

Functions are collections of "things" to be done to meet a performance requirement. The analysis continues until all are identified for complete problem definition. This "vertical" analysis continues until further analysis starts to yield units of performance called tasks. Task analysis identifies the units of performance for each function which, when sequenced in the order in which they occur, will "add-up" to the functions which they constitute.

Method-means analysis identifies the total array of methods and means for meeting the performance requirements at successive levels of analysis for each and all functions and tasks. It determines for each performance requirements or family of performance requirements.

1. What is available
2. What are the advantages
3. What are the disadvantages

Method-means analysis provides data to be used in determining the final methods-means decisions during system synthesis. Upon completion of the total checking between the steps of mission analysis, functional analysis and task analysis, the method-means data bank will contain all of the method-means which could meet the total array of performance requirements at each and every level of the system analysis.

In summary, system analysis may be used at each step in system development - any place where logical problem-solving is relevant. System analysis may be used to determine what the final product is to do

and/or look like and/or perform as well as produce the design process for producing the final system product.

Information System

Underlying and permeating the use of system analysis is the development of an information system that provides accurate and sufficient data for defining the problem or mission and evaluating progress or lack of progress toward attaining mission objectives. The best way to identify real problems is to perform a need assessment or obtain data from a valid need assessment. A need assessment will show the discrepancies between what is and what is required. A total array of discrepancies will provide data which will allow the selection of the problems with highest priority. Education will probably never have the resources to deal with all of its problems, so it must derive and apply criteria to select those with the greatest urgency or highest criticality from the total array of needs.

MISVE

The Center, in response to the expressed need of many states for an information system for use both in planning and evaluating vocational education programmatic efforts, and for meeting reporting requirements, is undertaking the development of a transportable management information system for vocational education. This system is expected to be an improvement over systems currently in use by the states because it operationalizes a core set of goals and objectives common to most states' priority planning, evaluating, and reporting concerns, yet provides procedures, guidelines, and software for adding goals, objectives, and data to the system to insure responsiveness to unique state needs and requirements.

SYSTEM OBJECTIVES

The primary objective of the Management Information System for Vocational Education (MISVE) is to provide comprehensive analysis of data essential to education decision-makers in the allocation of resources for vocational programs. The analysis will be designed to (a) assist in identifying those who might benefit from vocational education, (b) identifying programs/training best suited to prepare students for a changing job market, (c) provide an information base for developing a more cost-effective training program mix, and (d) provide a central source of data for encouraging inter-agency based manpower planning efforts. Secondary objectives include, (a) assistance in facilitating the accountability of vocational-technical education to its clientele, advisory groups, and administration boards and, (b) the provision of data required for Office of Education (OE) reporting and for the state plan for vocational and technical education.

CONCEPTUAL DESIGN

The overall thrust of the MISVE design is to integrate a number of data collection and analysis elements to meet the above objectives. Primary users of the system are expected to be state directors of vocational education and their planning and evaluation staffs. Analyses desired include those pertaining to manpower requirements, program effectiveness, cost analyses, student characteristics, student program preferences and post-schooling mobility patterns. It is intended that these analyses be packaged into separate feedback reports to students, teachers, and counselors, schools, school districts, state agencies, employers, and human resource data banks.

The data and analyses anticipated are considered to be comprehensive in the sense that specific kinds of data (e.g., output of trained manpower) will not be limited to the public sector (public vocational education system), but will include data from private schools and industrial situations to the fullest extent practicable. Because such comprehensive data collection will involve new levels of inter-agency cooperation, this in itself is an expected outcome of the project, and necessary to its success.

Conceptually, the system divides into two subsystems (see Figure 1) with the following functions:

The Evaluation Subsystem will collect/process and analyze data useful to program administrators, clients, and potential clients. Although initially categorized and collected within seven data elements, analysis of the data goes beyond the mere aggregation of data within elements to include inter-element analyses.

The Planning Subsystem will provide mechanisms for utilization of information from the Evaluation Subsystem in the identification of goals and objectives of vocational education, and in identification and analysis of alternative strategies for achievement of these objectives.

Data collected for the Evaluation Subsystem are initially categorized into seven information elements: Manpower Supply, Manpower Demand, Under-developed Human Resources, Student Follow-up, Program Cost, Resources Inventory, and Program Characteristics. The information aggregated and/or analyzed in the Evaluation Subsystem, while useful in itself for reporting and accountability purposes, is utilized further in the form of essential inputs to the Planning Subsystem. The total system provides mechanisms for utilizing the evaluative information for setting goals and objectives, and determining alternative resource allocation strategies. Goals and objectives and Resource Allocation Strategies are the two elements of the Planning Subsystem.

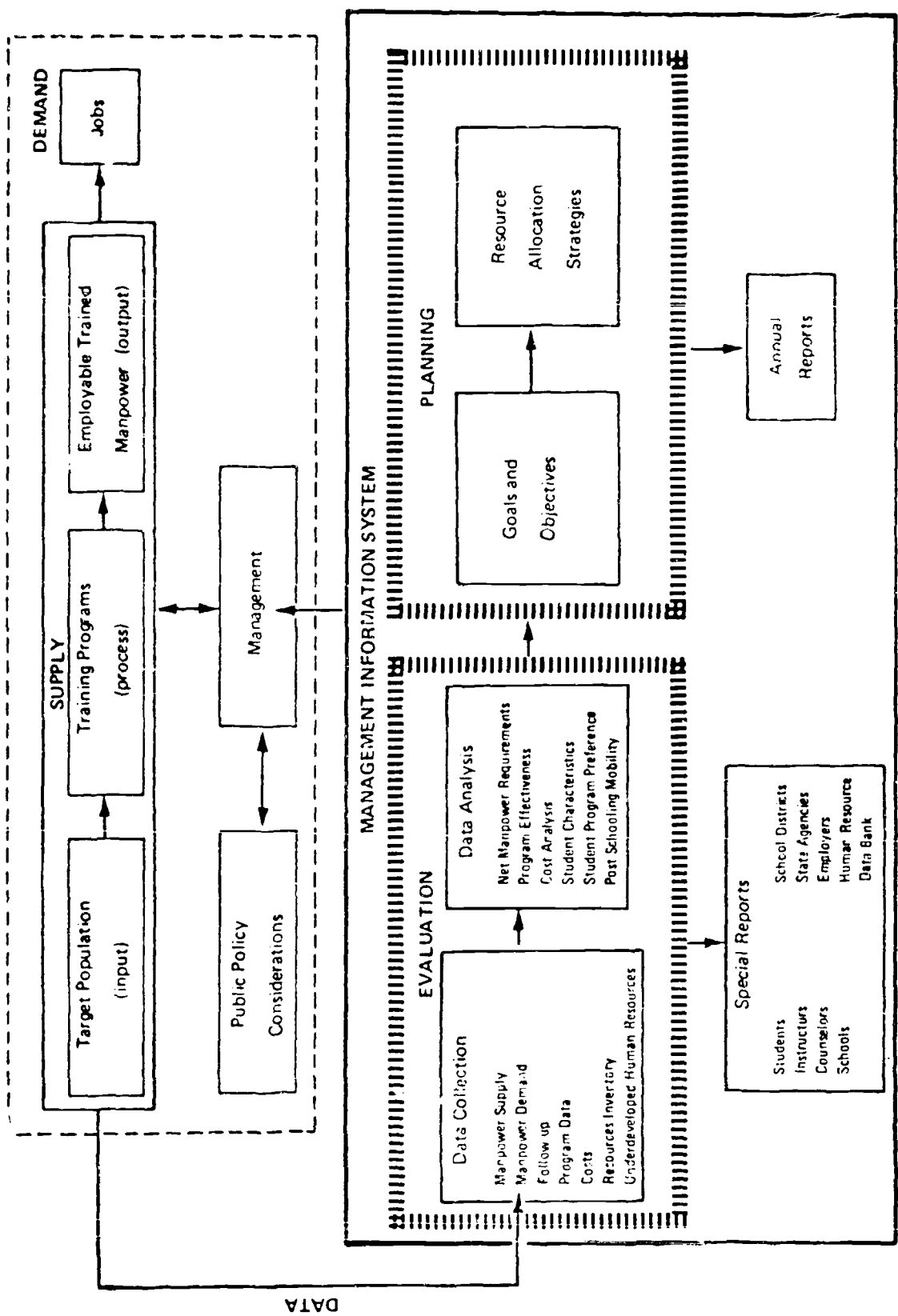

CONCEPTUAL DIAGRAM OF MANAGEMENT INFORMATION SYSTEM FOR VOCATIONAL EDUCATION

Figure 1

Goals and Objectives

The Goals and Objectives element will provide a mechanism by which management and advisory group personnel can identify goals and objectives and weight them as to their relative importance. Goals are considered to reflect the underlying philosophy of the occupational education system, while objectives represent specific measurable benchmarks against which achievement can be appraised. Goals and Objectives are critical to the analysis of program effectiveness and, as weighted, also critical to the selection of alternative resource allocation strategies.

Resource Allocation Strategies

The Resource Allocation Strategies element will provide a set of alternatives consisting of program enrollment and financial outlay structures, each designed to satisfy an alternative set of priorities. The strategies will be designed to implement the objectives, and, hence, will be developed for procedural compatibility. Information required to formulate strategies (e.g., relative efficiencies of alternative vocational education programs, program cost, labor market requirements, and student interest) will be supplied by the Evaluation Subsystem.

Manpower Supply

The Manpower Supply element will collect/analyze and report data pertaining to the projected output from the vocational education system (including private schools), classified by the United States Office of Education (U.S.O.E.) program codes. In addition, other supply data such as apprenticeships will be collected insofar as such is feasible. Exemplary data includes breakdown by geographic area, age, and sex.

Manpower Demand

The Manpower Demand element will collect/analyze and report on current and projected occupational employment. It will rely basically upon three sources of information: The U. S. Department of Labor's new Occupational Employment Statistics program combined with techniques in Tomorrow's Manpower Needs, existing Employment Security Information, and follow-up surveys of graduates and dropouts. It is designed for states that are participating in the Occupational Employment Statistics (OES) program, which is envisioned to eventually include all states.

Underdeveloped Human Resources

The Underdeveloped Human Resources element is intended to collect, analyze, or use data which will identify the training needed of persons who are unemployed, or underemployed. It will also include a model for forecasting the needs for vocational training by the total population within a specified region, by age group, socio-economic background, and geographic location based on census data.

Student Follow-Up

The Follow-up element will collect/analyze and report information on the post-schooling experiences of graduates and dropouts from vocational programs. Data collected will include information of former students' occupations and their relationship to training programs, income, geographic mobility, job satisfaction, and need for retraining.

Resources Inventory

The Resources Inventory element aims at compiling an inventory of all physical and human resources available to decision-makers at local,

regional, and state levels. Included in this inventory would be the kinds of data pertaining to current and potential use of such resources as (a) staff, by age group, sex, education qualifications, work experience, program, and school; (b) buildings; (c) equipment; (d) curricular software; and (e) other non-fiscal resources.

Program Costs

The Cost element will collect/analyze and report the cost base for cost-effectiveness analysis (useful in designing more efficient programs), as well as the data necessary for estimating resources required for program expansions. This element will assess the feasibility of generating, on a continual basis, past and future costs of specific programs (e.g., the cost of a nurse aid program per graduate in a specific institution) rather than the average state cost for aggregations of occupational programs (e.g., health programs).

Program Characteristics

Program Characteristics data will be collected to provide administrators a clear understanding of the general design of their education system. In addition to traditional service area classifications, data will be collected by United States Office of Education program codes on characteristics such as day versus evening classes, institutional versus cooperative modes, and whether the program is modular or not in its format. Included in the program data to be collected, analyzed and reported will be such indicators of program quality as staff qualifications, advisory committee involvement degree to which planning exists, program duration, special and regular needs being served, utilization of facilities, out of class experience provided, utilization of guidance services.

Each element in the evaluation subsystem will yield data which combined with the yield from one or more other elements will result in three levels of data analysis. Figure 2 indicates the anticipated types of yield from the management information system.

Specifically, the anticipated data collection would be:

1. Student enrollment/termination
2. Current Occupational Employment
3. Student follow-up
4. Demographic
5. Disadvantaged needs
6. Program financial data
7. Resources inventory
8. Program characteristics

The level A Analysis expected would include:

1. Manpower supply projections
2. Manpower demand projections
3. Student characteristics
4. Projected needs for vocational education
5. Program effectiveness
6. Program cost analysis
7. Program resource utilization

Level B Analysis would include:

1. Net manpower requirements projections
2. Cost effectiveness of current programs
3. Population to be served (regular and special needs)

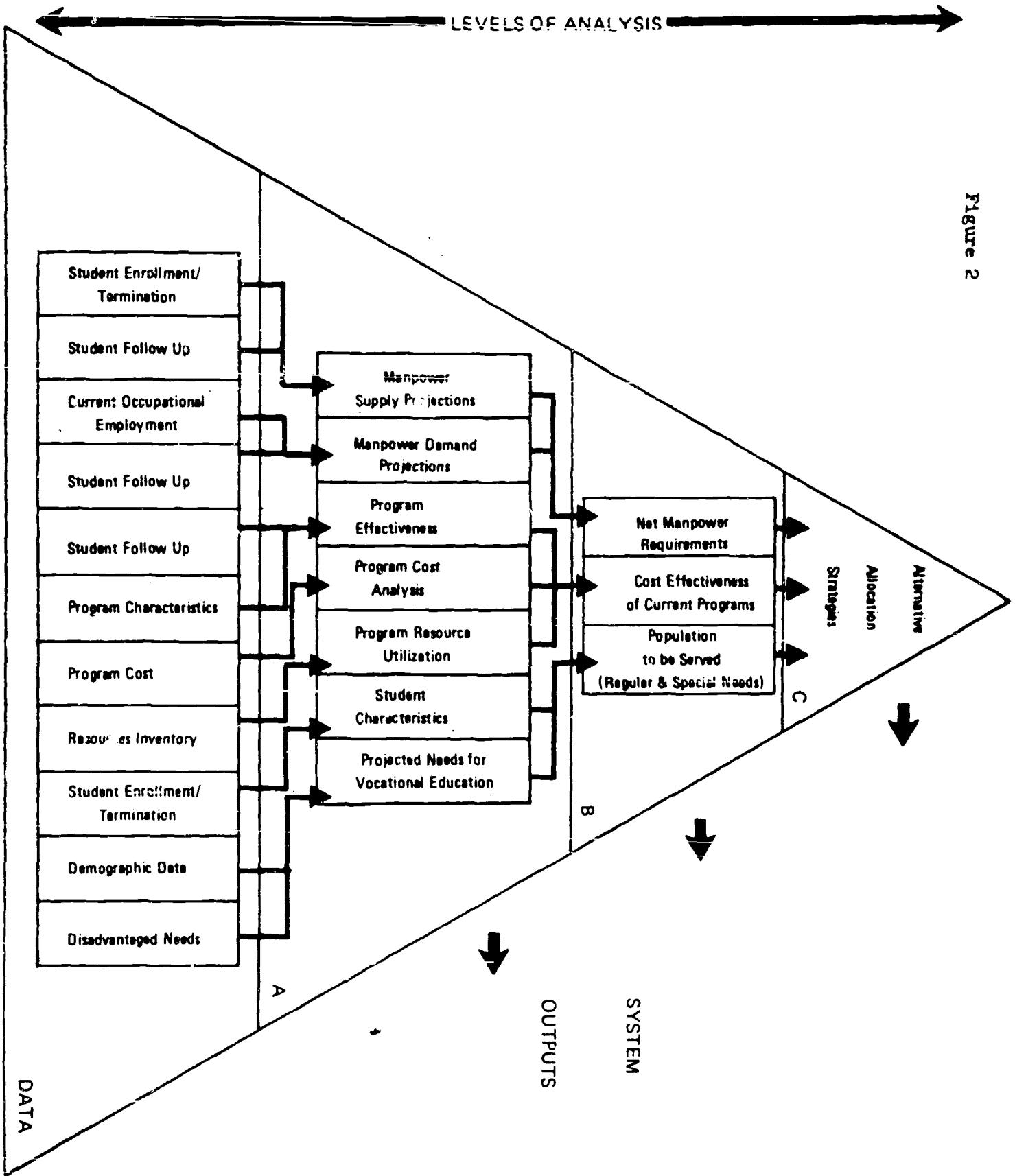

Figure 2

Level C analysis would consist of Alternative Resource Allocation Strategies utilizing A and B level analyses

Instruments Available Now

Means for collecting data for three instruments are available presently. Instrumentation is on the Statewide Evaluation System which will provide limited data on (1) student enrollment/terminations, (2) student follow-up, and (3) program characteristics.

Some of the specific data items provided on student enrollment are:

1. Enrollment by sex and grade level
2. Number of handicapped enrolled in each program
3. Number of socio-economically disadvantaged persons enrolled in each program
4. Number with educational deficiencies enrolled
5. Number of completions/dropouts placed by placement services

A representative sample of the specific data items produced on student follow-up are:

1. Percent of persons who sought full-time employment
2. Percent of persons who sought part-time employment
3. Specific title of first full-time job
4. Relation of training for first full-time job
5. Beginning hourly wage for first full-time job
6. Relation of training to last job.

Program characteristics sample data yield includes:

1. Advisory committee involvement
2. Duration of time in weeks to complete each program

3. Number of courses in each instructional program
4. Types of out-of-class laboratory experiences provided
5. Number of staff vacancies both current and anticipated for total vocational program and each individual program
6. Other agencies involved in each instructional program

Components Under Development

Components currently under development include:

1. Goals and Objectives
2. Resource Allocation Strategies
3. Manpower Demand
4. Underdeveloped Human Resources
5. Resources Inventory
6. Cost
7. Follow-up*
8. Manpower Supply*

Instrumentation and analysis techniques are presently under development in these eight components and should be available for pilot testing during calendar year 1973. Following field testing and revision of these components in 1974 the total management information system should be available.

*Although follow-up and manpower supply are a part of the currently available state-wide Evaluation System, additional instruments will be developed, including instruments designed to collect data on (1) manpower supply from sources other than the public school system and (2) a long-term follow-up of program terminess.

BIBLIOGRAPHY

1. Hartley, Harry J. Educational Planning - Programming - Budgeting. Prentice-Hall, Inc. Englewood Cliffs, New Jersey, 1968 pp 1-3.
2. Anthony, Robert N., Planning and Control Systems: A Framework for Analysis, Division of Research, Graduate School of Business Administration, Harvard University, Boston, 1965.
3. Loeber, Bill and Desmond L. Cook. The Management Process, Operation PEP: A State-wide Project to Prepare Educational Planners for California, 1968. pp 1-6.
4. Miller, Donald R. A System Approach for Solving Educational Problems, Operation PEP: A State-wide Project to Prepare Educational Planners for California, 1967. p 3.
5. Kaufman, Roger A. and Robert E. Corrigan, The Key Steps and Tools of System Analysis as Applied to Education, Operation PEP: A State-wide Project to Prepare Educational Planners for California, 1967. pp 44-45.

THE PRODUCTS OF THE
SYSTEM ANALYSIS PROCESS
WILL BE THE FEASIBLE

"WHAT'S"

FOR PROBLEM SOLUTION

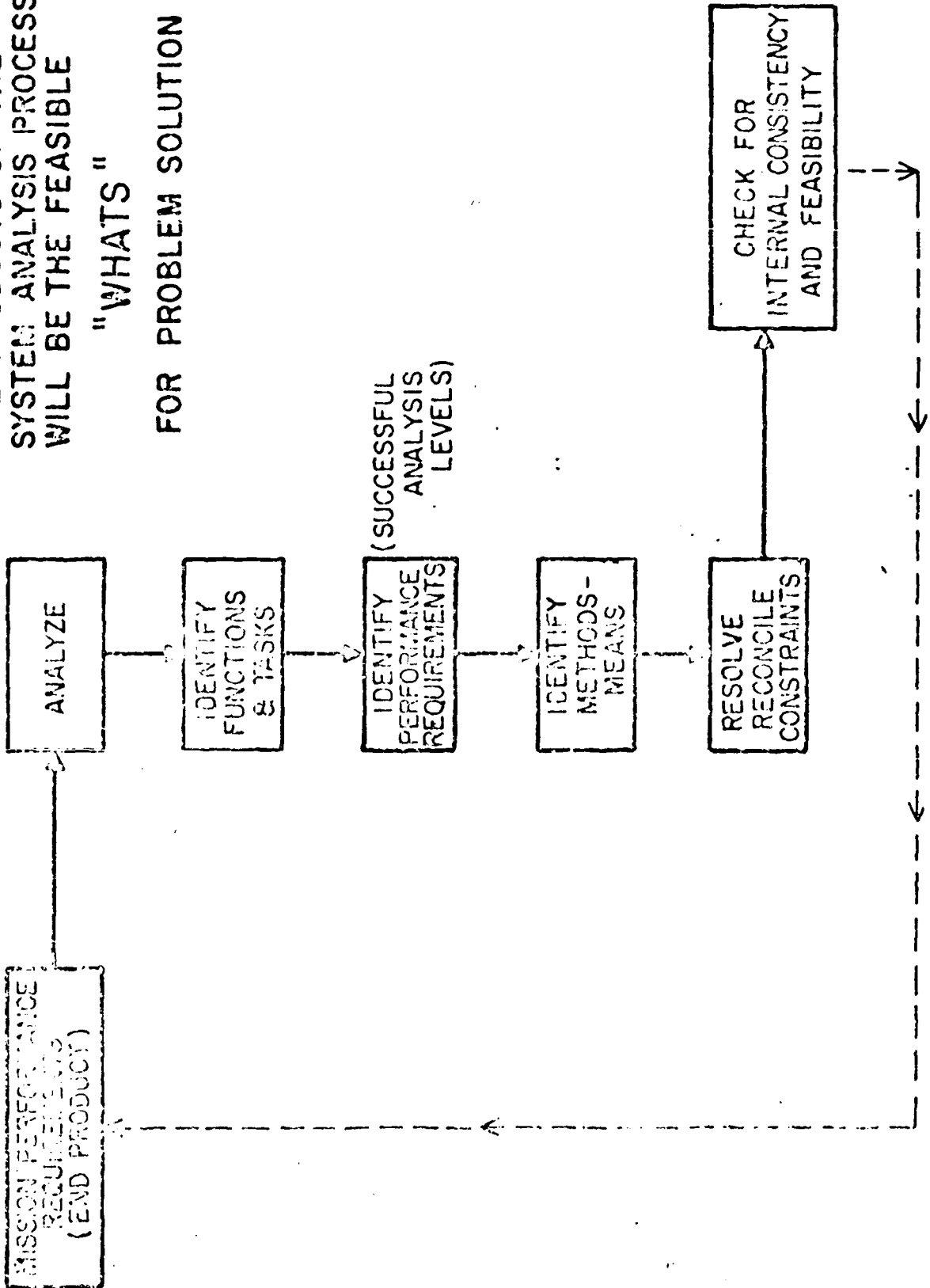

THE STEPS IN AN EDUCATIONAL SYSTEM ANALYSIS

DETERMINE MISSION OBJECTIVES AND PERFORMANCE REQUIREMENTS.
DETERMINE AND RECONCILE CONSTRAINTS.
DETERMINE MISSION PROFILE.
PERFORM FUNCTIONAL ANALYSIS.
PERFORM TASK ANALYSIS.
PERFORM METHODS-MEANS ANALYSIS.

THE QUESTIONS TO BE ANSWERED BY AN EDUCATIONAL SYSTEM ANALYSIS

WHERE ARE WE GOING AND HOW DO WE KNOW WHEN WE'VE ARRIVED?
WHAT ARE THE THINGS THAT WILL KEEP US FROM WHERE WE'RE GOING AND HOW DO WE ELIMINATE THEM?
WHAT ARE THE MAJOR MILESTONES ALONG THE WAY TO WHERE WE'RE GOING?
WHAT ARE THE "THINGS" THAT MUST BE DONE TO GET TO EACH MILESTONE?
OF WHAT SPECIFIC TASKS ARE THE "THINGS" COMPOSED?
WHAT ARE THE POSSIBLE WAYS OF GETTING THE "THINGS" DONE?

IN SUMMARY, THE SYSTEM ANALYSIS PROCESS CONSISTS OF:

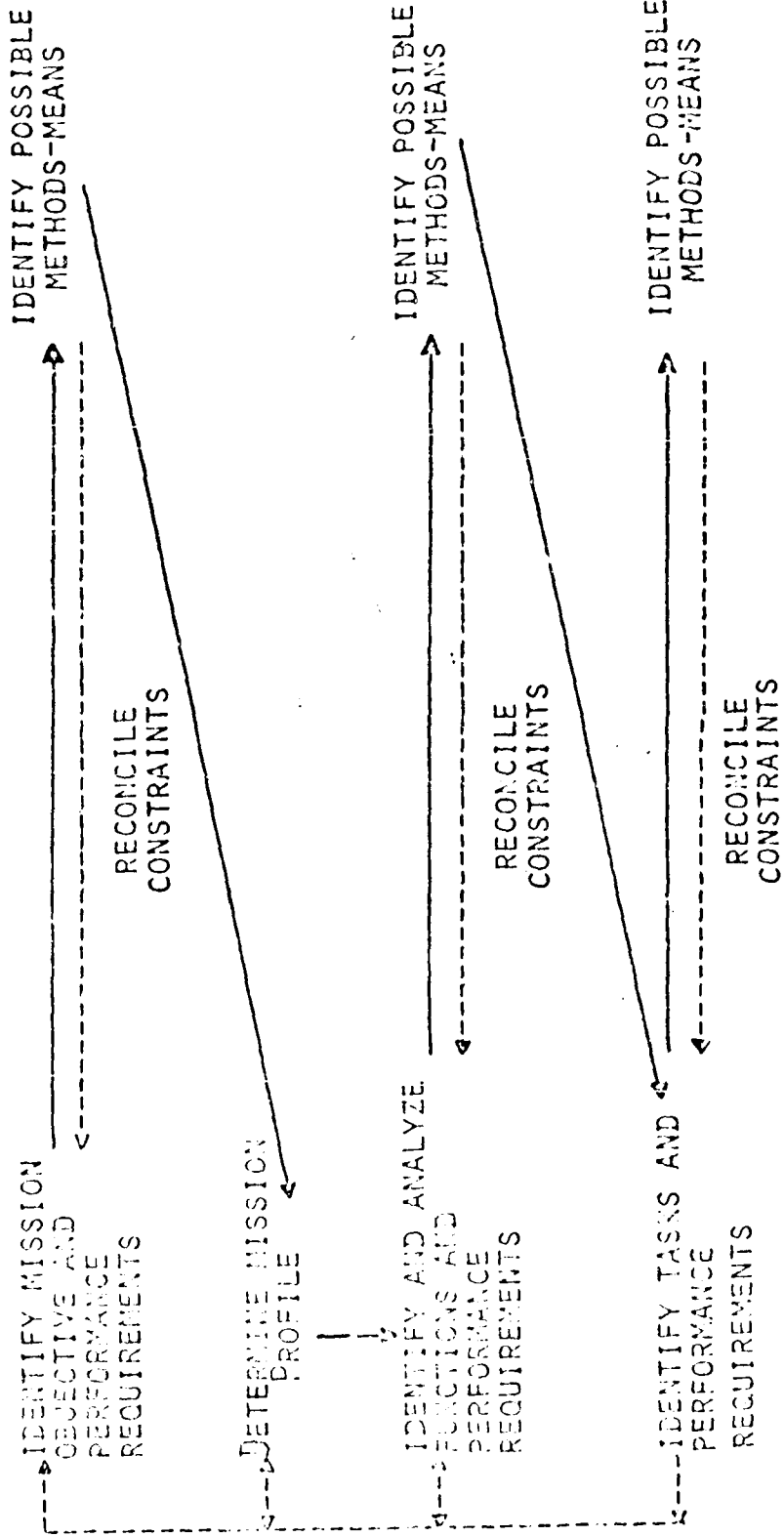

(CHECK FOR CONSISTENCY AND FEASIBILITY AT EACH STEP)

SYSTEM
APPROACH
DEFINITION

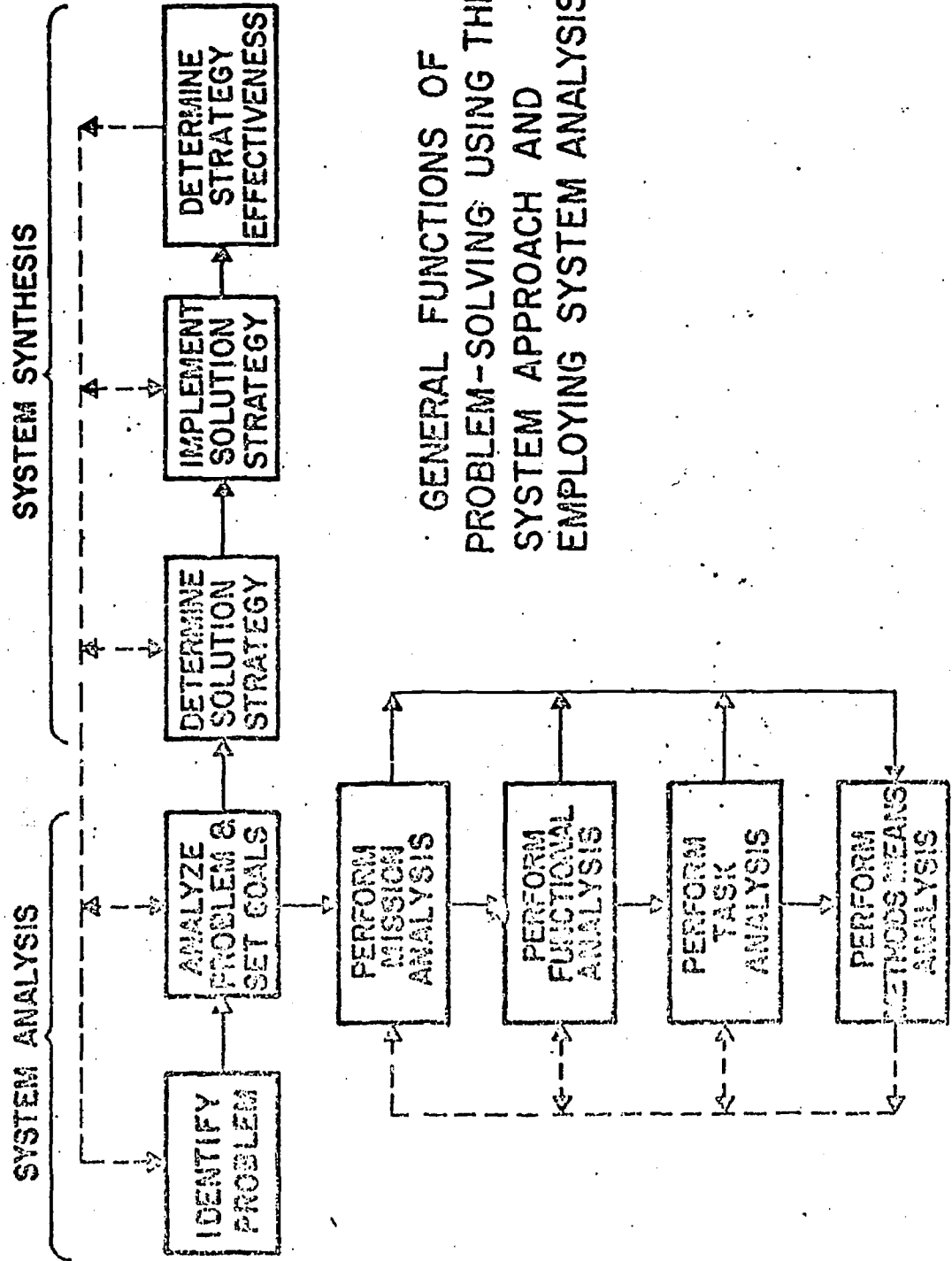

GENERAL FUNCTIONS OF
PROBLEM-SOLVING USING THE
SYSTEM APPROACH AND
EMPLOYING SYSTEM ANALYSIS

GENERAL FUNCTIONS OF PROBLEM-SOLVING USING A SYSTEM APPROACH

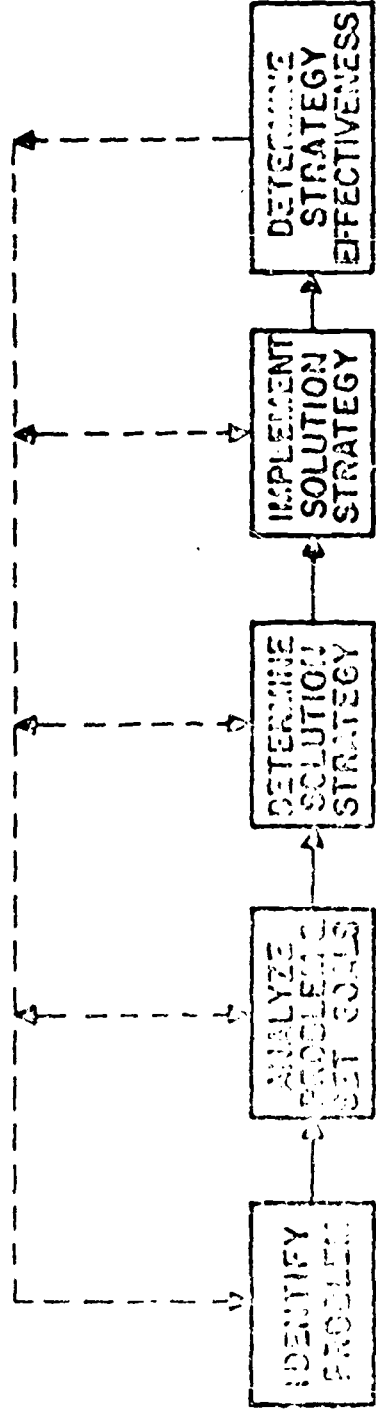

- FORWARD PROGRESSION
- ←--- FEEDBACK FOR REVISION
- SEPARATE FUNCTIONS, OR STEPS.

THE COMPLETE SYSTEM ANALYSIS CYCLE WOULD CONCEPTUALLY LOOK LIKE THIS:

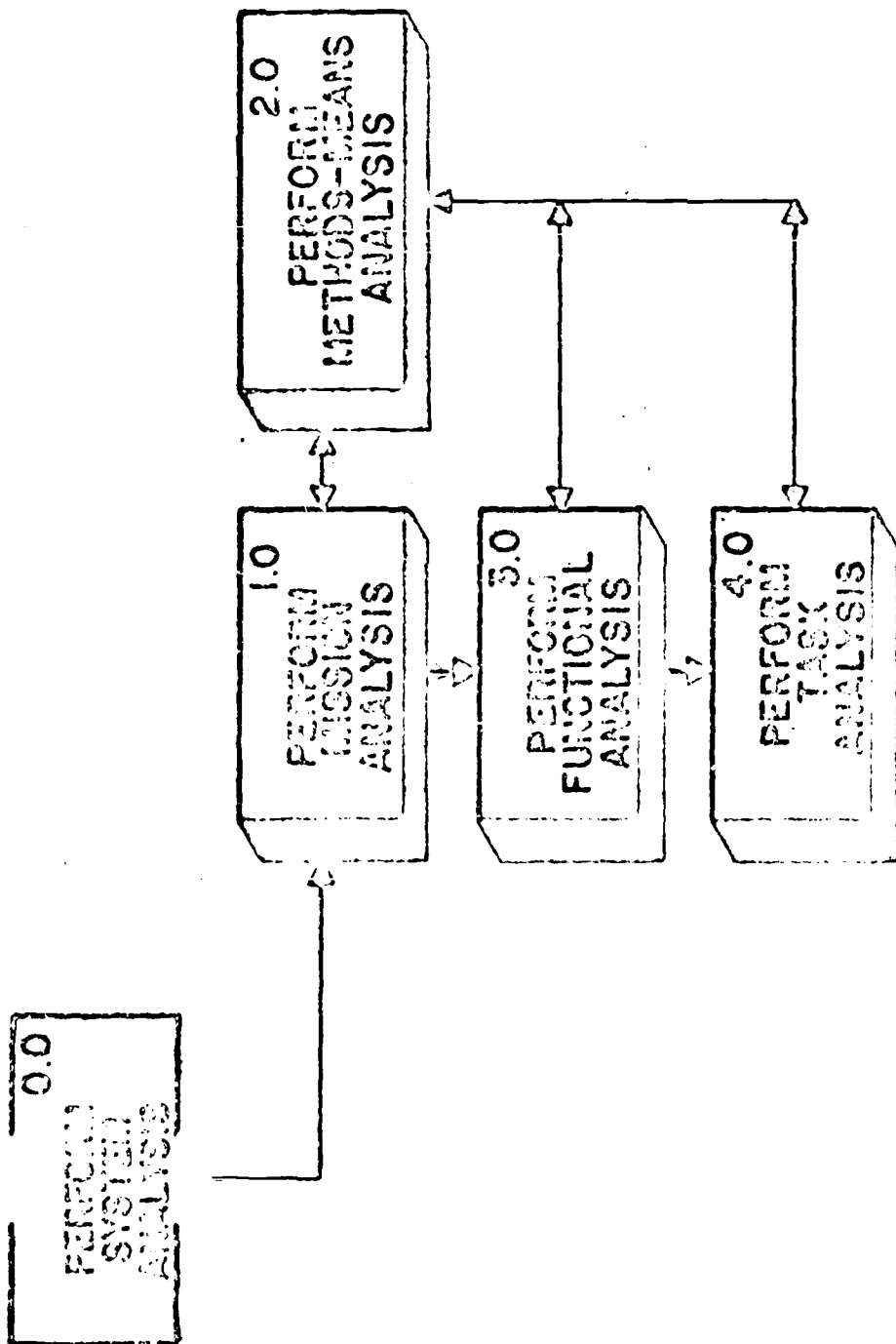

(IT SHOULD BE NOTED THAT AT EACH SYSTEM ANALYSIS STEP, OR LEVEL, ALL CONSTRAINTS MUST BE RECONCILED BEFORE PROCEEDING TO THE NEXT LEVEL OF ANALYSIS.)

TECHNIQUES FOR ADMINISTRATIVE DECISION-MAKING

By

Daniel E. Koble, Jr.
Research and Development Specialist

David C. Gilmore
Graduate Research Associate

The Center for Vocational and Technical Education
The Ohio State University

Presented At The

Sixth Annual National Leadership Development Seminar
For State Directors of Vocational Education

September 18-21, 1973

The Sheraton Nashville Hotel, Nashville, Tennessee

**THE CENTER FOR VOCATIONAL
AND TECHNICAL EDUCATION**



THE OHIO STATE UNIVERSITY
1960 Kenny Rd Columbus, Ohio 43210

TECHNIQUES FOR ADMINISTRATIVE DECISION-MAKING

You carry authority, but are not its source...your authority is confined strictly within a prescribed orbit of occupational actions, and such power as you wield is a borrowed thing..... You are the servant of decision, the assistant of authority, the minion of management. You are closer to management than the wage-workers are, but yours is seldom the last decision.¹

Seminar Group Objectives:

The specific objectives of this seminar group on "techniques for administrative decision-making" are:

1. To provide you with an opportunity to examine your own decision-making behavior internally and objectively.
2. To provide an opportunity for you to become better acquainted with emerging theory and concepts useful in guiding your decision-making behavior.

In order to meet these objectives, it is important to review some of the existing theories related to decision-making and problem-solving in bureaucratic organizations.

A Communication-Influence Model:

Shartle² has developed an interaction model for the making of administrative decisions which can be adapted to the situations found in many state vocational education agencies. The forces, both internal and external, which

¹Mills, C. Wright. White Collar: The American Middle Classes. Oxford University Press, 1953.

²Shartle, Carroll L., "An Interaction Model for Administrative Decisions." Prakseologica (Published in the USSR) ROK 1971.

are acting upon these agencies require organizational adjustments, and therefore, place complex problems before both members and leaders in the organization. "These pressures are often described as 'political' and require responses which are also 'political'." Political in this context relates to all external forces as opposed to partisan politics which is only a part of the external environment. The state director is in a unique role in that he is both a "decision-maker" and a source of decision-making information. His role and limitations in decision-making are defined at a higher level in the organization. Obviously, the scope and power delegated to each agency head varies from state to state, and therefore, it is not always the state director who makes the final decision.

The psychophysiological abilities of the agency head "makes it possible for him to receive and give information, to respond internally, that is to think, and to act with the belief that he has at least limited latitude to choose among alternative strategies."

Shartle classifies alternative strategies in a decision-making situation into three categories:

1. Acts against the force of threat such as denial of charges, verbal attacks on adversaries and expelling or threatening attackers who may be within the organization.
2. No action that appears significant to the threat, except as a tactical delay.
3. Acts of recognizing and yielding to the force, including concessions to those advocating change, and making organizational adjustments to prevent farther difficulties.

Shartle's model suggests that there is communication among at least eight identifiable components or open subsystems in an organization. The intensity and quality of communication will vary according to personal and organizational differences. The subsystems are as follows:

- A. Intimates: Family members, close friends, and intimate colleagues. These are persons with whom the agency head discusses matters in confidence and often in detail.
- B. Superiors: Persons of higher authority in the organization, including boards of control. Discussion of matters is usually more or less guarded depending upon the degree of social distance suggested by the situation.
- C. Subordinates: Persons on the agency head's staff. Decisions of importance usually involve interaction with subordinates to a considerable degree. The intensity and quality of communication is determined by the degree of social distance among communicants.
- D. Colleagues: Persons who are usually in the same organization and with whom the agency head interacts less frequently and less intimately but on the same status level as intimates. These persons are usually of equal status with the agency head but not in a line relationship. This is generally a much lower social distance situation.
- E. Consultants: Paid and unpaid advisors who may perform as individuals or in a group.
- F. Constituents: Persons or groups that the agency head serves or to whom he may have obligations.
- G. Political Bodies: Organizations that have an avowed political mission. Includes both partisan and non-partisan groups.
- H. Mass Media: Television, radio, movies, newspapers, periodicals and books.

These subsystems interact and function in patterns that relate to the nature of the problem. In attempting to predict or to influence administrative decisions of high importance the agency head must have a knowledge of the organizational power structure and communication network in order to obtain information for the ultimate decision-maker. The agency head must also be knowledgeable about other variables in each subsystem, including information about the goals of the group or individual, their economic or political strength, their public image, and their value orientations.

The successful state director of vocational education should develop a similar communication-influence model for his own situation. Once these agents of influence and channels of communication have been identified, he can concentrate on establishing a desirable relationship with them. It is important that a feeling of mutual understanding and respect be established before a problem situation arises.

The development and maintenance of this communication-influence network is probably one of the greatest challenges faced by the agency head. Organizations ultimately feel the impact of the environments which they have helped to create. Vocational education agencies are striving to produce changes and improvements in the social and economic lives of people that will ultimately result in closer involvement of these individuals in the decision-making process.

Organizing For Decision-Making:

The basis of a successful and sound system for decision-making is the development of an organization which encourages and facilitates collaborative and creative problem solving. Several constraints may limit an agency head's freedom to organize in a fashion which is completely acceptable to him. Some of these are:

1. Restrictive policies and procedures of the parent organization (State Education Agency).
2. Limitations in the capabilities of existing staff personnel.

A great deal of emphasis today is placed on participatory or collaborative decision-making; the involvement of others, including subordinates and constituents, in the solving of problems is often advantageous for both the individual and the organization.

Schmuck³ claims that by changing organizational patterns to increase reliance upon participatory decision-making, many sources of conflict, both external and internal, can be uncovered before severe hostilities develop. He further states "...organizational structures can be built through which these groups can communicate effectively with one another, and skills and norms can be established within and among these groups for joint problem-solving and decision-making." One of the goals in organizing for participatory management should be to bring administrators, supporting staff and subordinate staff members into the same cycle of decision-making. Schmuck does not believe that every staff member should participate in every decision. Instead, he suggests "one of the important tasks (of the agency head) is ascertaining criteria for assigning some decisions to particular staff members." Thus, the agency head can either make a decision himself, delegate it to a subordinate, or assemble a group of individuals who will collectively solve the problem.

A number of new and variations of old methods are currently being advocated for implementing programs of participatory management. One such idea is called the "Panel Consensus Technique".⁴ This technique for instance, could be applied in state vocational education agencies in the selection of funding priorities or the choosing of problems to be challenged in a particular year.

³Schmuck, Richard A. "New Procedures for Collaborative Decision-Making" R and D Perspectives, The Center for the Advanced Study of Educational Administration, University of Oregon, Eugene, Spring 1973.

⁴Taylor, Charles W. "Panel Consensus Technique: A New Approach To Decision-Making" Journal of Creative Behavior, Vol. 6, No. 3, Third Quarter, 1972, pp. 187-198.

The Panel Consensus Technique contains five distinct action levels:

1. Ideate level - "At the ideate level, individuals with knowledge of the problem subject supply ideas for solving the problem."
2. Screen level - "The screen level is the first review level....the task of the screen panels is to begin the process of narrowing down or shrinking the number of ideas, by repeated review and assignment of weighted values, to obtain a predetermined number of the best ideas submitted."
3. Select level - "The select action level is made up of three panels, each with five action members and a monitor....the task at the select action level is for each panel to select five (for example) of the preferred good ideas passed on to it from the screen level."
4. Refine level - "The refine level, the first level of executive decision-making, is staffed with five action members and a monitor....the task of the refine panel is to select the five (for example) best ideas from the fifteen preferred ideas of the select panels."
5. Decide level - "The actual decision as to which idea will be implemented is made at the decide action level. The decide panel, like all others consists of five action members and a monitor. It is staffed with the top managers of the organization and, if broad perspective is desired, could include individuals of equal position from outside

the organization....the decide panel is not bound to accept any of the ideas and may return them to the controller for reconsideration by appropriate panels."

It is obvious that one of the limiting factors associated with using this method is the amount of turn-around time involved. Taylor states, "Under optimum conditions the final selection of ideas can be completed in a week's time." This limits its use to those decisions about matters which can be anticipated and which are of sufficient importance and scope to involve a great deal of staff time and effort.

To understand how decisions are actually made, we need knowledge about environments in which decision-makers work, about individuals and groups as decision-makers, and about the complexities of interpersonal and intergroup relations in decision-making.⁵

The organizational environment or the features of environments in which decision-makers work consists of the following characteristics:

- A. Problems which are presented for solving are ambiguous and not clearly defined by the external environment which presents them for solving. Both agenda-building and search activities may have greater effects on the future of an organization than the actual choice.
- B. Organizational environments are factorable. Most environments provide strong cues that help organizations build simplified models of what their environments demand and what the outcomes will be. These cues are:
 1. The source of environmental inputs.
 2. The manner by which the inputs are transmitted to the organization.

⁵Adapted from Dill, William R. "Decision-Making" in Behavioral Science and Educational Administration. Ed. Daniel E. Griffiths, Sixty-third yearbook of the NSSE (Part II) University of Chicago Press, Chicago, Illinois 1964, pp. 199-222.

3. The clarity of the information and the frequency with which it is repeated to the organization.
- C. Organizational environments are heterogeneous in that they present a set of overlapping environments. It, therefore, matters who discovers that a decision needs to be made.
 - D. The environment's long-run impact on the people who make up an organization and on their approach to decision-making can be significant.

Problems which require decisions in vocational education organizations are generally of three types:

1. Operational problems: Those dealing with the management, operation or structure of the working body (finance, personnel, etc.).
2. Specific problems: A content area or field relating to an individual discipline.
3. General problems: Curriculum, special needs, etc.

Once a pattern of organization has been determined and established to deal with these problems in the state vocational education agency, it is necessary to implement practices for the maintenance of organizational effectiveness and efficiency. These practices may very simply be broken down into two classifications: individual and group involvement. Each of these classifications will be discussed separately.

The Individual In Decision-Making

The prime function of state level leadership in vocational education is decision-making which leads to policy setting and program implementation. Man is distinguished from lower forms of animal life in his abilities to reason, to make considered and intelligent decisions and to communicate

those decisions to his fellow man. Thus, as Miller and Starr claim "the executive is a decider and not a doer."⁶ Griffiths, also perceives of administrative decision-making as an important function.

.....the central function of administration is directing and controlling the decision-making process. It is not only central in the sense that it is more important than other functions....but it is central in that all other functions of administration can best be interpreted in terms of the decision-making process.

Most managers who make informed individual decisions go through the following five stages of activity:

1. Agenda-building phase (intelligence activity) - covers the activities of the administrator in defining goals and assigning priorities for their completion.
2. Search phase (design activity) - encompasses efforts to find or invent alternative courses of action and to find information that can be used to evaluate them.
3. Commitment phase (choice activity) - involves testing proposed alternatives to choose one for adoption or, as is often appropriate, to postpone making the choice.
4. Implementation phase includes clarifying the meaning of a decision for those who are to carry it out, elaborating new tasks or decision problems that the commitment leads to, and motivating people to put the commitment into effect.
5. Evaluation phase - involves examining the results of previous commitments and actions in order to find problem

⁶Griffiths, Daniel E., Administrative Theory. New York: Appleton-Century-Crafts, Inc., 1959.

areas for the agenda and to help the organization learn how to make decisions more effectively.⁸

In order to make adequate decisions the administrator should carefully think about the answers to the following questions:

1. How are decisions made?
2. Who should make decisions?
3. How can I make better decisions?

Individual decision-makers in a bureaucracy generally have the following three common properties:

1. They make most decisions in a way which is satisfactory for the present, rather than "optimizing" for the long-range, future effect. (The immediate effect is of greatest concern.)
2. Overall, an individual's decision-making behavior can be described effectively in terms of strategies or programs for action. That is, we can predict what an individual's response will be, if all the facts are available. (Decision-making activities are predictable.)
3. The decision process is a sequence of fairly simple elements; the thought processes of skilled and less skilled decision makers are not necessarily dissimilar. The difference between them lies in how basic strategies are combined to change goals, how they interpret the environment, and how they develop and evaluate alternative courses of action.

⁸ Dill, William R. "Administrative Decision-Making," in Concepts and Issues In Administrative Behavior, pp. 29-48. Edited by Sidney Mallick and Edward H. Van Ness. Englewood Cliffs, New Jersey: Prentice-Hall, Inc. 1962.

(Skilled and less skilled decision-makers vary greatest in the way they organize for and gather information for making decisions.)

Group Decision-Making

The United States has sometimes been referred to as a melting pot because its people originated from a variety of races and cultures. The growth of the country has been assisted because groups worked together toward common goals.

State Vocational Education Agencies need such working together too. Each professional employee has special talents and abilities. It is management's role to identify the capabilities and abilities of each individual, and to provide uses for them.

Individuals, who have discovered and developed their individual talents, can work together cooperatively toward a common goal. With so many kinds of abilities existing within the organization, each member contributes unique insight and commitment to the other members of a problem-solving group. One result of using the special talents and abilities of individuals in a group decision-making situation is a continual growth and understanding of the agency and its purposes.

In a group situation each individual may provide a unique contribution, yet each remains incomplete without the other. Each employee needs to fulfill his own duties, but they need at the same time, to help other members of the agency in the full use of their talents. To this end they need to reflect on the purposes of the organization and to evaluate their tasks in this context.

Group education experiences can take the form of encounter groups, sensitivity groups, T-groups (training groups) and others. Sociologists, psychologists and psychiatrists have on occasion, been rather critical of these techniques and the individuals who propose them as a means of changing people in organizations. Back⁹ regards encounter groups which are conducted outside the realm of strict social control as potentially dangerous. He implies that so little is known about the conduct of such group experiences and the outcomes of them on certain types of individuals, that it is difficult to justify their use as a training technique for the purpose of changing human behavior.

In the past state leadership personnel have approached the use of group decision-making on an intuitive basis and have "flown by the seat of their pants." Little formal preparation has been offered to them in this area, and even less has been written about the application and techniques in vocational books and periodicals. Nevertheless, successful leaders in vocational education have long recognized the value of certain group staff activities such as staff meetings, task forces, and committees to solve problems or plan retreats, workshops and other unique events.

A study reported by Koile and Draeger¹⁰ dealing with an analysis of T-Group member ratings of leader and self in a human relations laboratory found the following:

⁹Back, Kurt W. "Stimulus/Response" in Psychology Today. Vol. 6, No. 7, December 1972, pp. 28-35.

¹⁰Koile, Earl A. and Draeger, Carolyn, "T-Group Member Ratings of Leader and Self In A Human Relations Laboratory" The Journal of Psychology, Vol. 72, 1972, pp. 11-20.

1. T-Group members and leaders did not rate themselves more nearly alike at the end of the sessions compared to the beginning of the group experience. Therefore, members and their leaders did not become more like each other as the sessions progressed.
2. Members saw their group leaders more positively in the last session than in the first session. However, the shifts in members' perceptions of the leaders from one session to another were not continuously positive.
3. It was found that members came to perceive the leaders more like the leaders perceived themselves by the last sessions.
4. T-Group members saw themselves more positively at the end than at the beginning of the sessions.
5. Group members did not tend to become more similar in their self-ratings after the last session.

A management technique which capitalizes on some of the positive effects of group problem solving is the task force approach. Task force operations can be very effective for an organization, however, many individual managers have said "We tried task forces in the past but they didn't work because the mismanagement of one element of a task force caused its failure."

It is extremely important that someone in the organization be assigned the responsibility for seeing to it that the task force committees function properly. This overseer's job consists of:

- a. Receiving problems to be attacked from top management personnel.

- b. Assigning the most appropriate persons to each task force group.
- c. Briefing each task force group on its mission and function.
- d. Insuring the maintenance of task force records including membership lists, objectives, time lines, milestone achievements, outcomes, etc.

From the standpoint of subordinate members of the organization, it is extremely important that someone in management be responsible for seeing that certain organization members are not overutilized and others underutilized in committee or task force assignments. This individual or task force manager, must have a thorough knowledge of each member's personal capabilities, characteristics and capacities. The task force manager must also be thoroughly schooled in systems design, personnel management, evaluation techniques and modern problem solving methods. It is the basic responsibility of the agency head to select and prepare his task force manager.

The following potential problem situations may occur when task forces are used to make decisions:

1. Involving individuals from outside the immediate organization in task forces.
2. Relying upon the expertise of the "lower" in task force deliberations.
3. Differences of opinions or philosophical differences within the group may be difficult to resolve.
4. The group may be reluctant to reach decisions about possible solutions and a solution may be dictated by other people.

5. Members may disagree in their solutions and reach an impasse leading to confusion and frustration.
6. Solutions may become so complex and involved so as to be impractical to implement.

The potential strengths of using the task force approach in solving problems are:

1. Provides input from several disciplines, content areas, philosophies, viewpoints, etc.
2. Spreads the burden of advisement to several individuals.
3. Increases the acceptance of decisions by involving more individuals in the decision-making process.

The agency head must insure that the following critical requirements of task force management are met:

1. Identification of problems to be studied by task forces.
2. Selection and preparation of the task force manager.
3. Assignment of the task force manager to an advantageous position in the organizational hierarchy.
4. Selection and preparation of task force leaders and members.
5. Keeping task force on schedule.
6. Evaluating the work of task forces.

In so far as is possible, the people who are affected by decisions should be involved more fully in the process of defining the problems, developing alternatives and the making of choices. This insures more cooperation in implementing the decisions as well as gives better quality decisions. These participative methods can also lead to greater production, increased efficiency and higher morale.

If participatory management is to be used, the organization environment must be adaptable. There cannot be conflicting elements in the environment which neutralize or interfere with the effects participation is to produce. For example, the decision to use participatory management cannot be nonparticipative. This in effect becomes a democratic-dictatorship. "You will participate regardless of whether you want to or not." The bulk of needed advice should come from sources internal to the organization with only a minimum amount coming from external sources, and then only as matter of supplementing inadequate internal sources.

Some negative aspects of participatory methods are:

1. Managers sometimes make decisions, and consult with staff members under the pretense of seeking help in making a decision which has already been made. This, in effect, becomes brain-washing or the seeking of reinforcement. It is often interesting to observe the reaction of managers who are confronted with invited participants who refuse to support a decision which has already been made.
2. Managers sometimes only consult with their staff about impossible or highly difficult situations. A favorite ploy of an autocratic manager is to pass the very difficult or almost impossible decisions to the lowest level of the organization. The logic behind such action is that if things don't work out well, the blame will be placed at a lower level.
3. Participative management techniques should not be used by all managers. For example, a manager who is easily threatened or who needs constant reinforcement may feel uncon-

fortable since this form of decision-making elicits open and frank criticism and evaluation by subordinate staff. In other words, the manager and anyone who participates must be able to take criticism.

In deciding upon the strategy to use in solving a particular problem an administrator should always consider the fact that inviting wider involvement in making decisions does not always bring positive results.

It should be kept in mind that the decision-making process can produce many side benefits, some desirable and some undesirable. Participative decision-making can be used as an in-service development program for strengthening and improving staff. It can also be used as a technique for observing an individual's readiness for promotions or assignments requiring increased responsibility. In these situations, the superordinate may not relinquish his responsibility for the final decision, but rather becomes a filter through which the decisions his subordinates make are passed and evaluated. This process must be so structured that the subordinate does not perceive it to be simply a simulated procedure.

Some people are not interested in participating in the making of decisions. In fact, some people are not interested in taking any responsibility. Many studies show employees are willing to let employers make decisions for them.

What are the reasons for this condition?

1. Employees are conditioned to having someone else make their decisions for them.
2. Their personality characteristics are not conducive to making decisions.
3. They do not trust or respect their superiors.

4. They perceive their role as being one where they do not make decisions.

Perhaps the time is at hand for experimentation, demonstration and learning about some of the following unanswered questions underlying the use of group problem-solving.

- What are some of the successful methods and techniques which can be applied to using groups to bring about desired changes in state divisions of vocational education?
- What are the roles of the group leader and followers in these group experiences?
- Under what situations should groups be used and when will they be less than successful?
- What methods should be used in selecting group members?
- How should groups be structured for most effective operation?

The main question is "Should the principles of sensitivity training techniques be categorically ignored by the leadership in vocational education or are there useful aspects which can be adapted and used to bring about desired changes?"

One of the areas state directors of vocational education frequently are called upon to make decisions about is "personnel management". The following is a short attitude assessment exercise concerning your opinions about personnel administration which will be useful later.

Opinions About Personnel Administration¹¹

Please indicate if you agree with, disagree with or are undecided about the following:

	Agree A	Undecided U	Disagree D
1. Staff personnel policy and practices should seek to enhance the dignity, integrity, and self-respect of the state supervisory staff.			
2. Staff personnel policy and practices should generally encourage the creativity, individuality, and self-realization of the supervisory staff.			
3. If one must decide between equal treatment of state supervisors of permitting variations in personnel practices to accommodate individual differences among state supervisors, the state director of vocational education should generally favor the former.			
4. If a serious conflict arises between two state supervisors, it is usually a good idea for the state director of vocational education to moderate a discussion between the two in an effort to reduce the conflict.			

The following are simulated situations requiring decisions about personnel management. Please review each situation and determine how you would resolve it.¹²

¹¹Adapted from: Wynn, Richard, Simulation Materials on Decision-Making in Elementary School Administration. The University Council for Education Administration, Columbus, Ohio, January, 1966.

¹²ibid. Wynn, Richard

SITUATION 1

TO: All Division Directors

FROM: James Long, State Superintendent

DATE: January 3, 1973

SUBJECT: Sick leave provisions

As you know, the Personnel Committee of the State Board of Education is reviewing certain aspects of our personnel policies. Presently under consideration is our provision for up to five days absence annually, cumulative up to thirty days after six years, for absence with pay because of illness. There is good reason to believe that a few state supervisors are taking advantage of this generous provision by claiming illness while absent for other reasons.

Please indicate below how you would feel about our requiring a doctor's certificate certifying illness for all such absences of two or more consecutive days duration.

_____ I favor the requirement of a doctor's certificate.

_____ I disfavor the requirement of a doctor's certificate.

SITUATION 2

TO: All Division Directors

FROM: James Long, State Superintendent

DATE: January 4, 1973

SUBJECT: Reconsideration of retirement policy

I tend to favor division directors having a major responsibility in determining the proper time for the retirement of state supervisors. If the board were to delegate this authority to division directors, would you generally favor

_____ the automatic retirement of all state supervisors at a predetermined compulsory retirement age for all?

_____ the retirement of state supervisors at various ages beyond, say 65, as determined by the merits of the individual case?

Please check your preference and return it to me. There will, of course, be opportunity for further discussion before any change of policy is undertaken, if consideration of such change seems appropriate from your responses.

SITUATION 3

In September, you receive these three items in your mail.

#1

TO: All Division Directors
 FROM: James Long, State Superintendent
 SUBJECT: Membership in professional associations

For the past eleven years, our state education agency has taken pride in the 100 percent membership of our staff in NEA and LSEA. We regard membership in education associations as the hallmark of the truly professional person. I hope that division directors will initiate appropriate action among their supervisors to encourage our continued perfect membership in these important associations.

* * * * *

#2

September 20, 1973

Dear Fran:

As you know, we've had 100 percent membership of our supervisory staff in our professional associations. But this year, five supervisors on your staff (Davis, James, Rubin, Jeffco, and White) have failed to submit their applications for membership despite some nudging from our state membership committee.

Would you take a moment at your next staff meeting to speak of the benefits which derive to us and of the prestige to our state education agency membership in our professional associations? Perhaps you will want to speak to these supervisors individually.

Bill Dodridge, President
 Limbo State Agency
 Education Association

* * * * *

#3

Dear Fran:

Several of us are interested in the possibility of establishing a state education agency affiliate of the United Federation of State Employees (UFSE). Could you make conference room #2 of the John Dewey building available to us for a meeting on October 1, 1973 at 8:00 p.m., to explore this possibility further? Since we'd like to get out the notices soon, could you give my secretary your reply before the end of the day please?

Yours truly,
Chuck Radosovitch

I WOULD

SITUATION 4

You are the state director of vocational education for the State of Limbo and you are due in a state superintendent's cabinet meeting in fifteen minutes. You find two telephone memos from your secretary in your in-basket on your desk upon returning from a meeting of the State Apprenticeship Council. You have time to deal with only one of them before leaving for the meeting. Place an "X" in the space before the one matter which you would attempt to handle before your departure.

- _____ 1. A telephone call from the chairman of the state advisory council on vocational education asking that you return his call.

- _____ 2. A telephone call from your state supervisor of home economics education requesting to see you and telling you she had a matter which she wished to discuss with you.

SITUATION 5

Mr. Kunkle, your state supervisor of vocational agriculture, sent you this note yesterday:

While visiting in the Meadowbrook Consolidated High School today, I discovered that the principal, Mr. Enbright is planning to drop the vocational agriculture program next year. I discussed the matter with Mr. Witty, the teacher of Vocational Agriculture and he and I had it out with Mr. Enbright. I wanted you to know of this in case Mr. Enbright decides to make an issue of the case.

Donald Kunkle

Sure enough, the next morning you get a phone call from Dr. Langdon, Superintendent of Schools in Meadowbrook proclaiming the district's right to drop the agriculture program and protesting Mr. Kunkel's action. He requests you to intercede in the matter.

* * * * *

In such circumstances, when I can't establish the facts for myself, I WOULD

- _____ Support the state supervisor.
- _____ Support the principal and superintendent.
- _____ Ask the state supervisor to apologize to the principal.
- _____ Ask the state supervisor to conduct a thorough study of the situation.
- _____ Take no stand, simply try to pacify both parties.

SITUATION 6

Borough of Homewood
Homewood, Limbo
July 15, 1973

Dear Fran:

I noticed in yesterday's Times Herald that Mr. Jeffco, one of your state supervisors wrote a shameful letter to the editor disparaging the whole equal employment movement in labor unions.

Just when we seem to be making real progress in this state, we get this gratuitous slap in the face from -- of all persons -- a state employee. I hate to think of a man with those views leading our teachers.

Would you point out to Mr. Jeffco how a letter like that from a man in his position weakens our hard won progress and try to discourage him from any more public pronouncements of this sort? Could you follow up appropriately and let me know how you make out? Thanks.

We missed you at bowling on Tuesday.

Sincerely yours,

Jack Powers, Chairman
The Governor's Labor
Relation Council

* * * * *

I WOULD

SITUATION 7

In looking at your calendar for this afternoon, you note that you should be doing three things at the same time and that you are tied up in other meetings late afternoon and during the evening.

1. An ad hoc committee of state instructional supervisors wants you to meet with them to hear some complaints from local educational agencies about insufficient funds for conducting needed vocational education programs and to help them plan for conducting public hearings on vocational education prior to the next session of the state legislature.
2. State superintendent Long has called a meeting of division directors to plan programs for National Education Week next month.
3. You have a reminder to yourself to write an article for the American Vocational Journal on the need for improved personnel development programs in vocational education.

* * * * *

Since I can handle only one of these in the time remaining this afternoon, I WOULD undertake # _____ this afternoon and deal with the other two in the following ways:

SITUATION 8

TO: All Division Directors
 FROM: James Long, State Superintendent
 DATE: August 15, 1973
 SUBJECT: Volunteers for Committees

I wish to appoint three ad hoc committees this year to study some special problems and to report their recommendations to the Administrative Council later. I want to have representation from our division directors on each of the committees and prefer to have you working on committees whose assignments interest you most. Would you please indicate which one of the following committees you'd prefer to work with?

1. Committee to study the feasibility of automatic data processing equipment for use in handling personnel records, financial accounting, enrollment projections and other tasks.
2. Committee to prepare a position paper on our relations with the State Board of Education and revise outdated sections of the Policies and Procedures Handbook.
3. Committee to study the task force plan of organization and consider its appropriateness for our state agency before we get too far along in our plans for a new office building.

* * * * *

I WOULD PREFER to serve on committee # _____ for the following reasons:

Discussion of Problem Situations

In reflecting upon your responses to the previous situations, you may consider the following:

1. Situation 1 and Situation 2 - In looking back on your responses you may wish to reconcile your choices of alternatives with your preferred values on items 1 and 2 of the exercise "Opinions About Personnel Administration". These two situations illustrate the phenomenon of making decisions based upon administrative convenience rather than upon expressed values.
2. Situation 3 - Again, reconcile your response to this situation in light of your expressed opinions in the earlier survey.
3. Situation 4 and Situation 5 - Situation 4 demonstrates the common disposition of administrators to respond to outsiders rather than to insiders and Situation 5 shows a common failure to back up supervisory staff.
4. Situation 6 - This situation has relevance to personal freedom and the civil liberties of professional employees of state governments. It also relates to the second item in the opinion survey.
5. Situation 7 - This situation requires a choice among (1). Appellate (response to subordinates), (2). Intermediary (response to superiors), (3). Creative (response to self-initiated) stimuli to action. The tendency is for administrators to respond to superiors in preference to subordinates and to neglect creative decisions.
6. Situation 8 - This situation prompts the consideration of decision among (1). Technical concepts (2). Human relations concepts, and (3). Conceptual problems and skills and reveals the administrators' disposition to neglect the latter.

Decision-Making As Conflict Reduction

Administrators should strive for the resolution of conflict through integrative decisions as much as possible, turning to compromise or domination only when integration is impossible. The acid test of administration is its ability to handle conflict. Here are some common sense and humane strategies for handling conflict that make both the experience and the solutions more civilized.¹³

¹³ibid. Wynn, Richard

1. Regard conflict, not as an annoyance to be smoothed over as quickly as possible, but as an opportunity to resolve an issue, to be creative. Most of man's greatest contributions to civilization have been borne out of conflict.
2. Anticipate problems early before positions are fixed.
3. Talk with conflicting parties privately first to assess possibilities of negotiating agreement. Don't bring them together until such possibilities look fairly good.
4. Keep a posture of open-mindedness. Avoid prejudging conflicts. Get all the evidence. Hear all opinions. Ask questions. Listen carefully. Give people plenty of time to talk since often all they want is an opportunity to have their side heard. Try not to put people on the defensive since this often serves only to entrench them in their position.
5. Make sure you know what the issue really is. A person might say "I don't think his plan will work": when he really means "I think he's getting too much power around here." Identify other problems tied in with it, then try to get those involved to deal with them one at a time.
6. Encourage conflicting parties to state others' position. Carl Rogers said: "You are never ready to argue with someone until you are able to state his position to his satisfaction."
7. Avoid being in a hurry to reach solutions to difficult problems. It is often better to postpone a decision than to make a rash uninformed one.
8. A decision that splits the group down the middle may be worse than no decision at all. Avoid the either-or proposition. Try to find an "integrative" decision that includes as much as possible the expectations of both contenders.
9. Don't overlook the possibility of mediation by an outside, disinterested, but knowledgeable person.
10. Don't try to reach a decision when anger is evident -- either your own anger or that of others. When feelings run high, summarize, clarify the issues, take a break, tell a story, or recess the meeting.
11. Make sure the group has all the information it needs before deciding.
12. In dealing with a conflict, keep reviewing areas of agreement. Stress agreement. There are usually large areas of agreement in any conflict that are ignored in preoccupation with smaller areas of disagreement. Keep trying to extend areas of agreement rather than belaboring disagreement, although the disagreement must be clearly defined and understood also.

13. Small groups are usually better than large groups for reaching tough decisions, but avoid triads.
14. Try to disassociate ideas from personalities. Don't say "Mr. Smith has argued that....."but rather say "We have said that.....".
15. Establish grievance procedures and use them when necessary.
16. Satisfaction of the affected people with the decision is more important than getting your own way.
17. George Bernard Shaw said: "The supreme test of a man's breeding is how well he behaves in a quarrel." The supreme test of an administrator may be how well he handles conflict.

A Decision-Making Checklist¹⁴

The following checklist may serve as a helpful guide to making the decision process an organized and cognitive procedure.

BEFORE THE DECISION

- _____ Is there really a problem?
- _____ Is the problem clearly defined?
- _____ Are other problems tied in with it? Can they be factored out?
- _____ What kind of problem is it?
- Policy? Executive? Intermediary? Appellate? Creative?
Human Relations? Technical? Conceptual? Personal?
Organizational?
- _____ Is it one in which I should take action?
- _____ Who should decide?
- _____ If it is me, am I willing to accept responsibility for the decision?
- _____ If I contemplate "passing the buck", do I have justifiable reason?
- _____ What values are involved?
- _____ What do I wish to accomplish through the decision?
- _____

¹⁴ibid. Wynn, Richard

- _____ Are all necessary facts at hand and properly verified?
- _____ Is the environment ready for a decision?
- _____ Have all possible alternative courses of action been carefully weighed?
- _____ Which course of action is most integrative, least coercive or compromising?

AFTER THE DECISION

- _____ Has the decision been communicated clearly to all essential persons?
- _____ Have I provided for implementation and follow-up of the decision?
- _____ Have I arranged for feedback, review, and evaluation of the decision?
- _____ Have I established a process, policy, set of criteria, etc., that can serve me in making other decisions? That is, what have I learned from this decision that will help me in future decisions?

REVIEW

1. The function of administering the decision-making process may be viewed as both the essence and the genius of administration.
2. It is not the function of the administrator to make all important decisions, but rather to create the environment and the procedures which will permit the best possible decisions to emerge from the total organization.
3. Decisions in educational administration should harmonize as much as possible with the values indigenous to a free society and the purposes of an educational system therein.
4. The preeminent consideration in reaching decisions in educational administration is the best interests of the clientele to be served.
5. The effective administrator refuses to back up subordinates in deference to outsiders only when he has very substantial reason.
6. Administrators may need to protect themselves from a natural preoccupation with intermediary decisions at the expense of appellate, and more especially, creative decisions.

7. Administrators may need to protect themselves from a natural preoccupation with technical and human relations problems at the expense of conceptual problems. The latter may often be more fruitful in the long run.
8. There is an emerging theory and science of decision-making which helps to illuminate the problem-solving process and to yield more rational and effective decision-making behavior.

The agency head should provide the leadership for establishing a mechanism in the organization which will allow for a dynamic process of problem-solving and which will produce sound decisions. Included in such a mechanism must be the following provisions:

1. Procedures for the collection and processing of relevant data about the problem under study.
2. Procedures, which include those involved in the decision and those affected by the decision, in the decision-making process.
3. Procedures for holding the decision-makers accountable for their actions.

For Further Study

We have discussed in a limited way the techniques for administrative decision-making. If you wish to study this topic further, the following sources may be helpful.

Alkin, M. C. The Use of Quantitative Methods as an Aid to Decision-Making in Educational Administration. Paper presented at the annual conference of the American Educational Research Association, Los Angeles, California Center for the Study of Evaluation of Instructional Programs, 1969.

Anonymous. Decision-Making and American Values in School Administration, New York: Bureau of Publications, Teachers College, Columbia University, 1954.

Anonymous. National Education Association, Group Development, Washington, D.C. The Association, 1961.

Campbell, Roald F., Corbally, John E., and Ramseyer, John A., Introduction to Educational Administration. Boston: Allyn and Bacon, 1962.

Campbell, Roald F., and Wayson, William W., "Decision-Making in the Elementary Principalship," The National Elementary Principal 41 (January, 1962), pp. 17-22.

Cyert, R. M., Dill, W. R., and March, J. G. "The Role of Expectations in Business Decision-Making", Administrative Science Quarterly, Vol. 3, 1958.

Gold, B. K., "Quantitative Methods for Administrative Decision-Making in Junior Colleges" Unpublished Ed.D. Dissertation, University of California, Graduate School of Education, 1966.

Griffiths, Daniel E., Human Relations in School Administration. New York: Appleton-Century-Crofts, Inc., 1956.

Griffiths, Daniel E., "The Nature and Meaning of Theory" Behavioral Science and Educational Administration. Sixty-third Yearbook of the National Society for the Study of Education, Part 2, Chicago, Illinois: The University of Chicago Press, 1964.

- Hemphill, John K., Griffiths, Daniel E., and Frederiksen, Norman, Administrative Performance and Personality. New York: Bureau of Publications, Teachers College, Columbia University, 1962.
- Hitch, C. J. "Analysis for Air Force Decisions." Analysis of Military Decisions. Edited by E. S. Quade, Chicago, Illinois: Rand McNally, 1964.
- Lindsay, F. A. New Techniques for Management Decision-Making. New York, New York: McGraw-Hill, Inc. 1963.
- Magge, John F., "Decision Trees for Decision-Making." Harvard Business Review. Vol. 42, July - August, 1964.
- Newsome, George L. and Gentry, Harold W., "Values and Educational Decisions," The National Elementary Principal, Vol. 42, November, 1962, pp. 24-29.
- Pfeiffer, John "Decision-Making in Action." Chapter 2. New Look at Education: Systems Analysis in our Schools and Colleges. 1968.
- Rappaport, Donald A. "New Approaches in Public Administration." The Prison-Water-House Review, Winter, 1957.
- Salveson, M. E. "An Analysis of Decisions." Management-Services, Vol. 4, 1958.
- Siegal, S. and Goldstein, A. D. "Decision-Making Behavior in a Free Choice Uncertain Outcome Situation." Journal of Experimental Psychology, Vol. 57, 1959.
- Simon, Herbert A. Administrative Behavior: A Study of Decision-Making Processes in Administrative Organization, New York: MacMillan Co., 1957.
- Simon, Herbert A., The New Science of Management Decision. New York: Harper and Bros., 1960.
- Simon, Herbert A., "Theories of Decision-Making in Economics and Behavioral Science." American Economic Reviews, Vol. 49, 1959.
- Thomas, J.A. "Educational Decision-Making and the School Budget." Administrators Notebook, No. 4, 1963.

Thrall, R. W., Coombs, C. H. and Davis, R. L. eds. Decision Processes.
New York, New York: John Wiley and Sons, 1954.

P. Wasserman and F. S. Silander, Decision-Making: An Annotated Bibliography.
Ithaca, New York: Cornell University Press, 1958.

4.2