

DOCUMENT RESUME

ED 087 880

CE 000 970

AUTHOR Messer, John D.
TITLE Air Conditioning, Heating, and Ventilating: Construction, Supervision, and Inspection. Course of Study.
INSTITUTION California Community Colleges, Sacramento. Office of the Chancellor.; Los Rios Junior Coll. District, Sacramento, Calif.
PUB DATE 73
NOTE 337p.; For related documents, see CE 000 969, CE 000 971

EDRS PRICE MF-\$0.75 HC-\$16.20
DESCRIPTORS *Air Conditioning; Community Colleges; Construction (Process); *Heating; Inspection; Junior Colleges; Performance Specifications; Standards; *Study Guides; Supervision; *Technical Education; *Ventilation
IDENTIFIERS California

ABSTRACT

This course of study on air conditioning, heating, and ventilating is part of a construction, supervision, and inspection series, which provides instructional materials for community or junior college technical courses in the inspection program. Material covered pertains to: piping and piping systems; air movers; boilers; heat exchangers; cooling and heating coils; pumps; refrigeration; temperature control and natural draft venting systems; sound control; insulation; air ducts; ventilation systems; instrumentation. Many charts and diagrams are interspersed throughout the document to assist the reader; the 75-page appendix is made up entirely of charts and diagrams. The course of study may contain more material than can be covered in one semester. (Parts of this document may not reproduce clearly.) (EA)

Course of Study

CONSTRUCTION SUPERVISION AND INSPECTION

AIR CONDITIONING, HEATING, AND VENTILATING

U.S. DEPARTMENT OF HEALTH,
EDUCATION & WELFARE
NATIONAL INSTITUTE OF
EDUCATION

THIS DOCUMENT HAS BEEN REPRODUCED EXACTLY AS RECEIVED FROM THE PERSON OR ORGANIZATION ORIGINATING IT. POINTS OF VIEW OR OPINIONS STATED DO NOT NECESSARILY REPRESENT OFFICIAL NATIONAL INSTITUTE OF EDUCATION POSITION OR POLICY.

CHANCELLOR'S OFFICE
CALIFORNIA COMMUNITY COLLEGES

1973

CE 000 970

Course of Study
CONSTRUCTION
SUPERVISION
AND
INSPECTION

AIR CONDITIONING, HEATING, AND VENTILATING

by

John D. Messer, P.E.

for the

CHANCELLOR'S OFFICE
CALIFORNIA COMMUNITY COLLEGES
SACRAMENTO

1973

This publication was prepared by Cerritos Community College District in cooperation with California Community Colleges pursuant to a funding under the Vocational Education Act of 1968 (Public Law 90-576)

CONSTRUCTION SUPERVISION AND INSPECTION

COURSES OF STUDY

Structural Series No. 1 - 1966
Structural Series No. 2 - 1967
Electrical Series No. 1 - 1972
Air Conditioning, Heating, and Ventilating - 1973
Architectural - 1973 (In Progress)
Plumbing and Piping - 1973 (In Progress)

FOREWORD

As the construction industry becomes more complex, the need for a higher level of competency for construction supervisors and inspectors is apparent. More education is demanded of people entering the field. Upgrading and retraining are required. The success of courses and programs in construction supervision and inspection is largely dependent on the availability of highly qualified instructors and appropriate instructional materials.

This Air Conditioning, Heating, and Ventilating course of study is the fourth to be developed in the Construction Supervision and Inspection series. The series will ultimately have six publications which will cover all aspects of construction inspection. The series should provide the basis of a significant Community College program.

SIDNEY W. BROSSMAN, CHANCELLOR
CALIFORNIA COMMUNITY COLLEGES

PREFACE

This course of study was prepared for the purpose of embodying in a single publication the fundamentals basic to the practice of air conditioning, heating, and ventilating inspection. It is essentially a summary of fundamental inspection procedures and techniques normally covered and obtained by researching several publications. Useful information was assembled to provide the basis for a course in inspection and to provide the inspector a reference to assist him in performing his duties. Hopefully, the material brings some degree of uniformity to a complex subject.

This publication is in draft form and will be refined after it has been used and evaluated by instructors, students and practitioners. Instructors may find that all this material cannot be covered in one semester. We welcome your comments and suggestions.

I wish to express my appreciation to the author, Mr. John D. Messer, to the ad hoc committee that guided him, and to the staff at Cerritos College for their involvement.

LELAND P. BALDWIN
ASSISTANT CHANCELLOR
OCCUPATIONAL EDUCATION
CALIFORNIA COMMUNITY COLLEGES

ACKNOWLEDGEMENTS

The following advisory committee members should be acknowledged for participating in the preparation of this course of study:

Wake Angel
General Superintendent
Kenneth Fraser Company, Inc.
Pasadena, CA

Orlando (Londi) Ciabattoni
Senior Construction Inspector
Office of Architects and Engineers
University of California
Santa Barbara, CA

Richard Cram
Consulting Engineer
Instructor, Los Angeles Trade-
Technical College
Los Angeles, CA

Nick Gatoura
Civil Engineer and Contractor
Fullerton, CA

R. T. Hubbell
Senior Building Inspector
City of Fountain Valley, CA

Kenneth King
Construction Inspector
Chairman, Education Committee,
California Council of Construction
Inspectors Associations
Sacramento, CA

James McKenzie, P.E.
Chief Mechanical Engineer
Archer-Spencer Engineering
Associates, Inc.
Santa Barbara, CA

C. Stuart Perkins
Director of Technical Services
Los Angeles Chapter
Sheetmetal and Air Conditioning
Contractors National Assoc.
Los Angeles, CA

Richard Whiteman
Dean of Vocational Education
Cerritos College
Norwalk, CA

TABLE OF CONTENTS

PAGE

Definitions and abbreviations xiii

Section 1. The Role of the Mechanical Inspector 1

Section 2. Piping 3

 Types of Piping 3

 Pipe Jointing and Fittings 5

 Inspection of Welds 8

 Certification of Welders 15

 ANSI Code for Pressure Piping (Welding Excerpts) 21

 Flanged and Solder Joints 26

 Grooved Pipe Joints 28

 Silver Brazing Methods 31

 Compression Sleeve Joints 36

 Installation of Piping 36

 Pipe Cleaning 43

 Valve Types 44

Section 3. Piping Systems 49

 Steam and Condensate Returns 49

 Hot Water Supply and Return 51

 Piping Check-Points 58

Section 4. Air Movers 60

 Fan Types 60

 Fan Terms 60

 Fan Characteristics 63

 Fan Arrangements 66

 The Air Moving and Conditioning Association 69

 Fan Drives 70

 Capacity Controls 76

 Elimination of Vibration 76

 Vibration Isolators 78

 Fan Duct Connections 82

 Construction Details and Assembly 82

 Fan Testing 90

 Adjustments to Meet Design Conditions 100

 Fan Laws 101

 Fan Check-Points 104

Section 5. Boilers 105

 Pressure Classifications 105

 Ratings 105

 Testing Boiler Output and Efficiency 112

 Operating and Safety Controls and Trim 115

 Safety Valves 115

 Low Water Cutoffs 122

 Controllers 122

 Water Columns 122

 Combustion Supervisor Controls 122

 Boiler Installation 128



Boiler Installation (continued)	
Floor Trenches and Drains	128
Piping	128
ASME Boiler Code Requirements	129
Fuel Piping	131
Boiler Feed	131
Firebox Inspection	133
Boil-out	133
Water Treatment	133
Section 6. Heat Exchangers	154
Construction Details	134
Installation Recommendations	134
Allowable Nozzle Steam Velocity	139
Section 7. Cooling and Heating Coils	141
General Construction	141
Water Coil Connections	141
Cooling Coil Condensate Removal	141
Steam Heating Coils and Connections	142
Coil Rating Standards (Air Conditioning and Refrigeration Institute (ARI)).	142
Coil Check-Points	150
Section 8. Pumps	151
Types and Characteristics	151
Mechanical Features	151
Pump Foundations and Alignment	156
Piping Connections	159
Testing Pump Performance	165
Pump Laws	169
Pump Check-Points	170
Section 9. Refrigeration	171
Basic Compression Cycle	171
Ratings	171
Compressor Types	174
Condensers	174
Evaporators	190
Refrigeration Piping	180
Refrigeration System Cleaning	184
Cooling Towers	188
Refrigeration Check-Points	191
Section 10. Temperature Control Systems	193
Control Air Compressor	193
Controllers	193
Control Terms and Definitions	195
Control Valves	197
Section 11. Natural Draft Venting Systems	201
Section 12. Sound Control in Ventilation Systems	210
Terms and Definitions	210
Ventilation System Internal Noises	211
Ventilation System External Noises	213

Sound Control in Ventilation Systems (continued)	
Noise Detrimental to Health	213
State of California Noise Control Safety Orders	214
Section 13. Insulation	215
Various Materials	215
Vapor Barriers	216
Piping Insulation Pointers	216
Duct Insulation Pointers	217
Section 14. Air Ducts	218
Sheetmetal Ducts	218
Fiber Glass Ducts	219
Duct Fittings and Configurations	219
Duct Leakage Tests	223
Duct Check-Points	229
Section 15. Types of Ventilation Systems	230
Basic Air Conditioning System	230
Multizone System	231
Reheat System	232
Induction System	233
High Pressure Dual Duct	234
Section 16. Testing and Balancing of Ventilation Systems	237
Importance of Balancing	237
Damper Locations	237
Balancing Procedure	239
Instruments, Types and Uses	239
Limitations of Anemometers	242
Hydronic Balancing	242
Section 17. Instrumentation	244
Flow Measuring Devices	244
Thermometers	246
Gages	248

Appendix

Definitions

Boiler horsepower:

The equivalent evaporation of 34.5 lbs of water from and at 212° F, equal to 33,475 btu per hour.

Brake horsepower:

The actual horsepower required to drive a piece of machinery; or the actual horsepower delivered at the shaft of a prime mover.

Air, standard conditions:

Air with a density of 0.075 lb per cu ft. Equivalent to dry air at 70° F and 29.92" Hg, and 50% relative humidity.

Dew Point Temperature:

The temperature at which water vapor begins to condense when a constant mixture of air and water vapor is cooled.

Atmospheric pressure:

The pressure due to the weight of the atmosphere. A standard atmosphere is 14.696 psi or 29.92 in. of mercury at 32° F.

Dehumidification:

The reduction of moisture in a given volume of air.

Heat, latent:

The change of energy involved in a change of state; as steam condensing to water, or water freezing to ice.

Heat, sensible:

The change of energy involved in changing the temperature of a substance, as heating or cooling air or water, etc.

Psychrometer:

Basically, a device that consists of a dry bulb thermometer and a wet bulb thermometer for finding the humidity characteristics of air by means of a psychrometric chart.

Steam tables:

A tabulation of the physical and thermodynamic properties of water and steam at various pressures and temperatures.

Velocity pressure:

The impact pressure of a moving fluid upon a flat surface at 90° to the direction of flow, inches w.c.

Static pressure:

The pressure of a contained fluid upon the sides of the container, inches w.c.

Total pressure:

The sum of the impact and velocity pressure, inches w.c.

Air horsepower:

The horsepower needed to drive a fan.

$$\text{HP} = \frac{\text{cfm} \times .0157 \times \text{total pressure, (inches w.c.)}}{\% \text{ fan efficiency}}$$

Pump horsepower:

$$\frac{(\text{gpm}) \times (8.33) \times (\text{head in feet})}{(33000) \times \% \text{ pump eff.} \times 100}$$

Cold Spring:

An initial separation or spreading of the legs of an expansion U bend from the cold position such that the heated pipe will return the legs to the cold position and beyond. Cold spring generally equals $1/2$ the thermal expansion.

Ordinate:

Vertical, parallel to the Y axis.

Abscissa:

The horizontal ordinate, X axis.

Plenum:

An enclosed space in which the pressure is greater or less than atmospheric pressure.

Abbreviations

psia....lb per sq in. absolute + gage pressure ; (14.7 - at sea level)

psig....lb per sq in. gage

btu.....British thermal unit - the heat required to raise the temperature of one pound of water at 62° F. one degree Fahrenheit.

cfm.....cubic feet per min

cfh.....cubic feet per hour

EDR.....equivalent direct radiation, 1 sq ft EDR = 240 Btu per hour

F.....degrees Fahrenheit

fpm.....feet per minute

fps.....feet per second

in. Hg..inches of mercury

in. wc..inches water column

mbh.....1000 British thermal units per hour

od.....outside diameter

id.....inside diameter

ips.....iron pipe size

NPT.....National pipe thread

rpm.....revolutions per minute

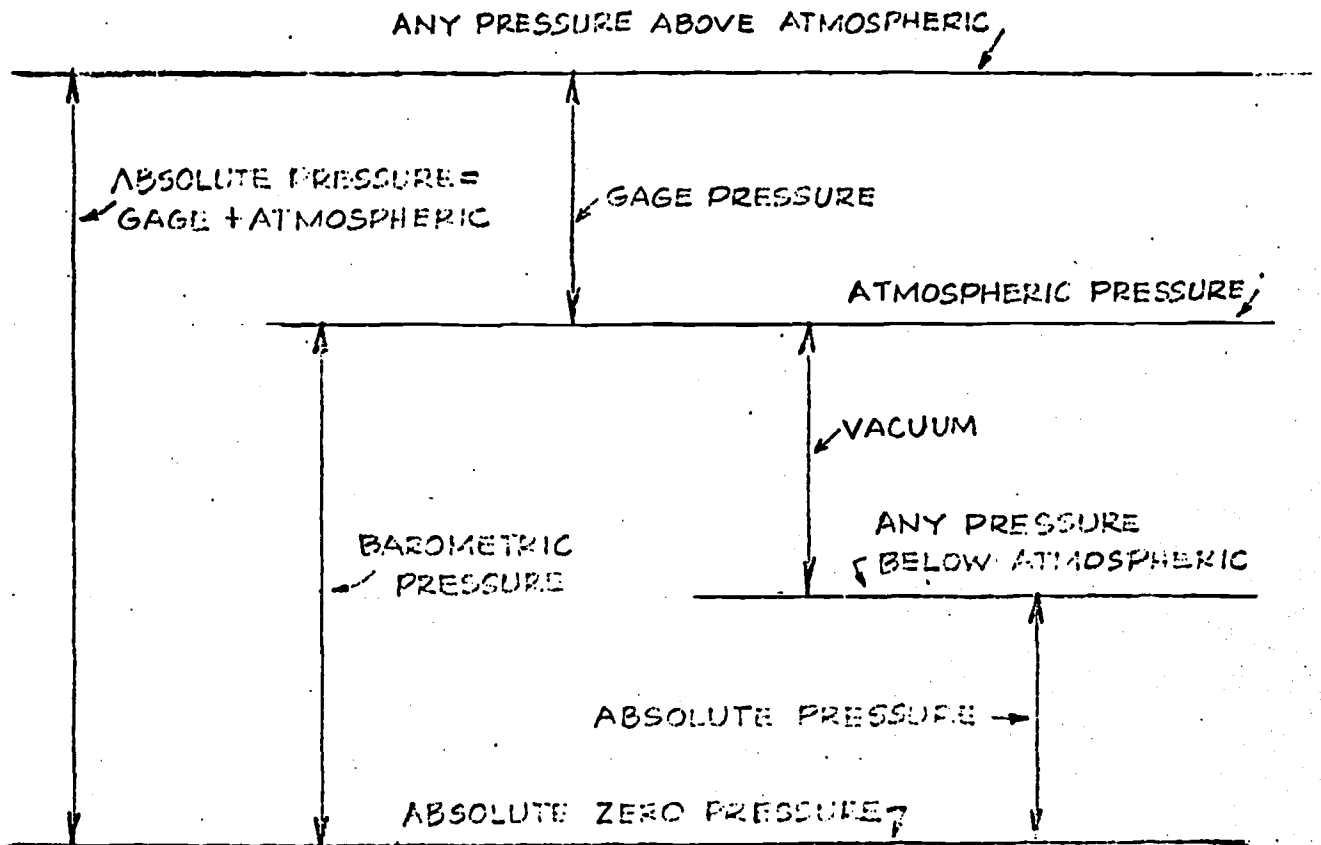
bhp.....brake horsepower

Q.....Quantity, cu ft per minute

v.....velocity, fpm

a.....area, sq ft or sq inch

gpm.....gallons per minute



PRESSURE RELATIONSHIPS

I. THE ROLE OF THE MECHANICAL INSPECTOR.

Responsibility

Like all other inspectors on construction projects, the mechanical inspector is a representative of the Architect and Engineer. The degree of his authority to make field decisions, approve change orders, etc, is controlled by the Architect and Engineer. The responsibility of seeing that the requirements of the contract plans and specifications are followed is the inspector's. He also has a responsibility to the contractor in maintaining a co-operative attitude by acting promptly in getting answers and solutions to everyday problems that arise, being on time to witness tests, and expedite approvals or similar paper work that will cause a delay.

At the start of the job the inspector should meet with the mechanical contractor's representative, (particularly the superintendent and foreman who will be in charge of the work) to review the drawings and specifications. This is the time to explain what will be required and to clear up any questions or discrepancies. Any matters that cannot be resolved at the field level should be referred to the Architect-Engineer by the inspector.

The mechanical work is usually subcontracted by the General Contractor so all directives intended for the mechanical subcontractor must be channeled through the General. Where the mechanical work is a prime contract, take care to keep other contractors advised of any developments that will affect their work.

Guidance Documents

1. Plans and Specifications.

Complete familiarity with all the construction drawings is axiomatic.

2. Approved Submittals.

Material and equipment data sheets should be carefully studied and filed for ready reference. Nameplate data on equipment, dimensions, etc, should be checked on arrival at the job. Check shop drawings of equipment for space requirements, connection locations, etc. Obtain an approval for each piece of equipment to be installed.

3. The manufacturer's installation instructions.

These should be obtained before the start of the job and referred to while the work is in progress.

4. Industry standards adopted by the Specification (such as SMACCNA).
5. Regulatory and Governmental Codes.
 - a. Uniform Mechanical Code (Volume II of the Uniform Building Code). Published by the International Association of Plumbing and Mechanical Officials, 5032 Alhambra Avenue, Los Angeles, Calif. 90032.
 - b. State of California Administrative Code, Title 24, Part 4, Office of Procurement, Document Section, P.O. Box 20191, Sacramento, California 95820
 - c. Code for Pressure Piping (Power) ANSI B31.1.0 American Society of Mechanical Engineers, 345 East 47th Street, New York, New York 10017
 - d. Boiler and Fired Pressure Vessel Safety Orders, State of California, Division of Industrial Safety, P.O. Box 20191, Sacramento, California 95920
 - e. Code for Unfired Pressure Vessels American Society of Mechanical Engineers (same address as (c)).
 - f. National Fire Protection Association 60 Batterymarch Street, Boston, Massachusetts 02110 (see appendix for list of publications)

2. PIPING

Types of piping

The various kinds of piping materials are specified by the American Society of Testing Materials (ASTM). The following grades of carbon-steel are most commonly used in air conditioning and heating work:

ASTM	pipe sizes	service	type weld	tests required, psi
A53	1/8" - 24"	Ordinary (steam, water, gas, etc.)	Seamless, furnace butt welded, electric resistance welded.	2,500 to 3" 2,300 over 3"
A120	1/8" - 24"	"	4" and under, seamless, butt or electric weld. Over 4", seamless or electric weld.	s = 0.60 yield strength
A134	16" O.D. and over, walls to 3/4" thk.	Ordinary Service	Electric fusion (arc) welded	s = 0.60 y.s. 2,300 max.

The following is an excerpt from Table A-1 (in the Appendix) which lists the dimensions and properties of steel pipe.

COMMERCIAL WROUGHT STEEL PIPE DATA

Note: 1: The letters "s", "x", and "xx" in the column of Schedule Numbers indicate Standard, Extra Strong and Double Extra Strong Pipe, respectively.

Note 2: The values shown in square feet for the Transverse Internal Area also represent the volume in cubic feet per foot of pipe length.

Nominal Pipe Size Inches	Outside Diameter (D) Inches	Schedule No. See Note 1	Wall Thickness (t) Inches	Inside Diameter (d) Inches	Area of Metal (a) Sq Inches	Transverse Internal Area See Note 2		Moment of Interior (I) Inches to 4th Power	Weight of Pipe Pounds per Foot	Weight of Water Pounds per Foot of Pipe	External Surface Sq Feet per Foot of Pipe	Section Modulus (1 - 2 - D)
						Square Inches	Square Feet					
1/4	0.405	40s	.065	.269	.0720	.0568	.00040	.00106	.244	.025	.106	.00523
		80x	.095	.215	.0925	.0364	.00025	.00122	.314	.016	.106	.00602
3/8	0.540	40s	.088	.364	.1250	.1041	.00072	.00331	.424	.045	.141	.01227
		80x	.119	.302	.1574	.0716	.00050	.00377	.535	.031	.141	.01395
1/2	0.675	40s	.091	.493	.1670	.1910	.00133	.00729	.567	.083	.178	.02160
		80x	.126	.423	.2173	.1405	.00098	.00662	.738	.061	.178	.02554
3/4	0.840	40s	.109	.622	.2503	.3040	.00211	.01709	.850	.132	.220	.04069
		80x	.147	.546	.3200	.2340	.00163	.02008	1.087	.102	.220	.04750
		160	.187	.466	.3535	.1706	.00118	.02212	1.300	.074	.220	.05267
		xx	.294	.252	.5043	.050	.00035	.0242	1.714	.022	.220	.05762

Pipe is designated by "schedule" numbers, as schedule 40, 80, or 160. Schedule 40 is also known as "standard" weight and schedule 80 as "extra strong". Double extra strong (not too common) generally does not have a schedule designation. Note that for a given nominal pipe size (also called "iron pipe size" or ips), the outside diameter of the pipe is the same for all weight schedules. That is, the thicker the pipe wall, the smaller the inside diameter.

The allowable working pressure of a piece of pipe may be found from the formula:

$$P = \frac{2 \times t \times s \times E}{d}$$

where t = wall thickness, inches

s = allowable fiber stress of the metal, lb per sq. in.

d = outside diameter of the pipe, inches

E = joint efficiency

Allowable fiber stress of the metal can be found in the Code for Pressure Piping or ASME Boiler Code Section VIII. Steel pipe is rarely stressed to the allowable in heating and ventilating work.

Example: Find the stress in a 6" ips schedule 40 A-53 steel pipe filled with 125 psig steam.

$$P = 125 \text{ psig} \quad E = 1.00$$

$$d = 6.625 \text{ inches}$$

$$t = 0.280 \text{ inches}$$

$$s_t = \frac{P \times d}{2 \times t}$$

$$= \frac{(125) (6.625) (1)}{(2) (.280)} = 1,480 \text{ lb per sq in., stress}$$

(The Code allows 5,000 lb per sq in.)

Copper Tubing

ASTM specification B-88 covers the material requirements for copper tubing used in heating and ventilating, types K, L, and M.

Table A-2 (appendix) shows the physical dimensions of types, K, L, and M copper tubing.

The allowable working stress for B-88 copper tubing is 5,000 psi (at 300° F.), and the working pressure can be calculated from:

$$P = \frac{2 \times s \times t}{d} \quad (s, t, \text{ and } d \text{ same as shown above})$$

Example: Find the allowable working pressure of a piece of type K copper tubing with a wall thickness of 0.083", and an outside diameter of 2.125".

$$P = \frac{(2) (0.083) (5,000)}{2.125}$$

= 388 psi, working pressure

However, the working pressure of copper tubing systems using solder joints are governed by the strength of the joints, to be discussed later in this section.

Plastic Piping

Thermoplastic piping is used in chilled water systems and for miscellaneous services as drains, vents and cold water connections in the heating and ventilating plant. The most common type is polyvinyl chloride (PVC) which is available in ip sizes, schedule 40 and 80. Type I is designated as a "normal impact" grade and can be stressed to 2,000 lb per sq in. fiber stress. Type II, "high impact grade" has a design fiber stress of 1,000 to 1600 lb per sq in., depending on the grade. The Type II has a greater resistance to impact stresses, such as surges due to water hammer, but has a lower design fiber stress. Table 2-1 gives the dimensions of PVC pipe and Table 2-2 shows the allowable water (73° F) pressure for threaded PVC. Unthreaded pipe is rated at twice the pressures shown in Table 2-2.

Thermosetting plastic piping is a polyester or epoxy resin base material reinforced with glass or asbestos fibers for strength. Due to its resistance to many corrosive substances and high temperature and pressure rating it is used for steam condensate, which attacks ferrous pipe. This pipe utilizes glued slip-on flanges and couplings for joint make-up and must be done in accordance with the manufacturer's instructions.

Pipe Jointing and Fittings

Threaded joints are cut on a taper as shown in Table 2-5. The dimension L_1 , called the thread engagement is important; if too short the joint will not develop full strength and may leak; if too long the pipe will protrude too far into the fitting preventing it from being tightened and may interfere with the flow. The dimensions of L_1 are shown for various pipe sizes and should be obtained when the pipe is screwed into a fitting hand tight. Threads should be inspected for smooth, clean, sharp cuts, and the inside of the pipe checked for removal of burrs. Some form of thread compound is used to insure a tight joint and provide lubrication when the joint is being made up.

The following compounds have been used with satisfactory results:

Refrigeration and Oil Piping - Litharge and glycerin or Expando, or equal.

Table 2-1

**Commercial Sizes (IPS) and Weights of Polyvinyl Chloride (PVC)
Pipe (Abstracted from ATSM Specification D1785-64T)**

Nominal size, in.	Schedule	Wall thickness, ** in.	OD, in.	ID, in.	Theoretical weight, ° lb/ft	Calculated min bursting pressure, psi	
						Note 1	Note 2
¼	40	0.088	0.540	0.364	0.076	2,490	1,950
	80	0.119	0.540	0.302	0.096	3,620	2,830
½	40	0.109	0.840	0.622	0.153	1,910	1,490
	80	0.147	0.840	0.546	0.195	2,720	2,120
¾	40	0.113	1.050	0.824	0.203	1,540	1,210
	80	0.154	1.050	0.742	0.265	2,200	1,720
1	40	0.133	1.315	1.049	0.305	1,440	1,130
	80	0.179	1.315	0.957	0.385	2,020	1,580
1¼	40	0.140	1.660	1.380	0.409	1,180	920
	80	0.191	1.660	1.278	0.550	1,660	1,300
1½	40	0.145	1.900	1.610	0.489	1,060	830
	80	0.200	1.900	1.500	0.653	1,510	1,180
2	40	0.154	2.375	2.067	0.640	890	690
	80	0.218	2.375	1.939	0.910	1,290	1,010
3	40	0.216	3.500	3.068	1.380	840	660
	80	0.300	3.500	2.900	1.845	1,200	940
4	40	0.237	4.500	4.026	1.965	710	560
	80	0.337	4.500	3.826	2.710	1,040	810

**Water-pressure Ratings at 23 C (73.4 F) for Class T Threaded
PVC Plastic Pipe (Commercial Standard CS256-63)**

Nominal pipe size, in.	Dimension ratio	Pressure ratings ¹ for PVC plastic pipe made from		
		PVC1120 PVC1220, psi	PVC4116, psi	PVC2110, psi
¼	4.15	630	500	315
¼	4.15	630	500	315
¾	4.15	630	500	315
¾	5.0	500	400	250
¾	6.0	400	315	200
1	6.0	400	314	200
1¼	7.3	315	250	160
1½	9.0	250	200	125
2	11.0	200	160	100
2½	11.0	200	160	100
3	13.5	160	125	80
3½	13.5	160	125	80
4	17.0	125	100	63
5	17.0	125	100	63
6	21.0	100	80	50
8	26.0	80	63	NPR ²
10	32.5	63	50	NPR ²
12	41.0	50	NPR	NPR ²

¹ Pressure ratings shown for threaded pipe are one-half those calculated in accordance with

$$\frac{2S}{P} = \text{SDR} - 1 \quad \text{or} \quad \frac{2S}{P} = \frac{\text{OD}}{t} - 1$$

where S = design stress, psi

P = pressure rating, psi

OD = average outside diameter, in.

t = minimum wall thickness, in.

SDR = standard thermoplastic pipe dimension ratio (OD/ t for PVC pipe)

² Thus, pressure ratings for nonthreaded pipe in Class-T dimensions are twice those given in this table.

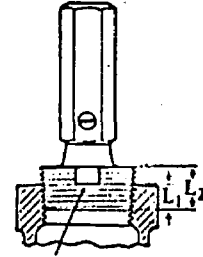
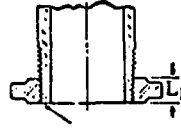
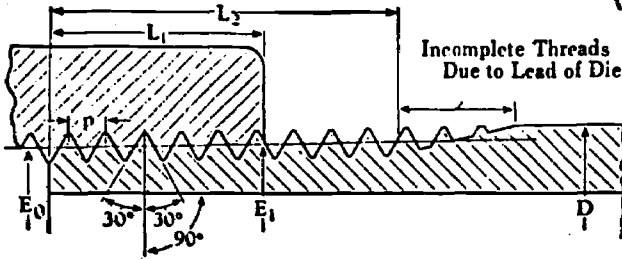
³ NPR = not pressure-rated.

Table 2-2

Tables 2-1 and 2-2 are from "Piping Handbook" by Crocker and King. Copyright 1967, by McGraw-Hill, Inc. Used with permission of McGraw-Hill Book Co.

AMERICAN STANDARD TAPER PIPE THREADS

(NPT)



$$E_0 = D - (0.050D + 1.1)p$$

$$E_1 = E_0 + 0.0625 L_1$$

$$L_1 = (0.80D + 6.8)p$$

p = Pitch
 Depth of thread = 0.80p
 Total Taper 1/4-inch per Foot

Tolerance on Product:
 One turn large or small from notch on plug gauge or face of ring gauge.

Notch flush with face of fitting. If chamfered, notch flush with bottom of chamfer.

Dimensions in Inches

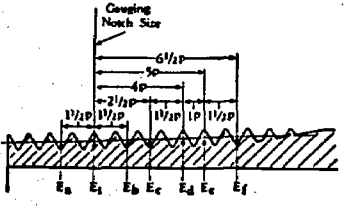
Nominal Pipe Size	D Outside Diameter of Pipe	E_0 Pitch Diameter at End of External Thread	$E_{1\ddagger}$ Pitch Diameter at End of Internal Thread	L_1 Normal Engagement by Hand between External & Internal Threads	L_2 Length of Effective Thread	P Pitch of Thread	Depth of Thread	Number of Threads Per Inch
1/8	0.405	0.36351	0.37476	0.180	0.2639	0.03704	0.02963	27
1/4	0.540	0.47739	0.48989	0.200	0.4018	0.05556	0.04444	18
3/8	0.675	0.61201	0.62701	0.240	0.4078	0.05556	0.04444	18
1/2	0.840	0.75443	0.77843	0.320	0.5337	0.07143	0.05714	14
3/4	1.050	0.96768	0.98887	0.350	0.6457	0.07143	0.05714	14
1	1.315	1.21363	1.23683	0.400	0.6828	0.08896	0.06957	11 1/2
1 1/8	1.660	1.55713	1.58338	0.420	0.7068	0.08896	0.06957	11 1/2
1 1/4	1.900	1.78609	1.82234	0.420	0.7235	0.08896	0.06957	11 1/2
2	2.375	2.28902	2.29627	0.436	0.7565	0.08896	0.06957	11 1/2
2 1/2	2.875	2.71953	2.76216	0.682	1.1375	0.12500	0.10000	8
3	3.500	3.34062	3.38850	0.706	1.2000	0.12500	0.10000	8
3 1/2	4.000	3.83750	3.88881	0.821	1.2500	0.12500	0.10000	8
4	4.500	4.33438	4.38712	0.844	1.3000	0.12500	0.10000	8
5	5.563	5.39073	5.44929	0.937	1.4063	0.12500	0.10000	8
6	6.625	6.44609	6.50597	0.958	1.5125	0.12500	0.10000	8
8	8.625	8.43359	8.50003	1.063	1.7125	0.12500	0.10000	8
10	10.750	10.54531	10.62094	1.210	1.9250	0.12500	0.10000	8
12	12.750	12.53281	12.61781	1.360	2.1250	0.12500	0.10000	8
14 O.D.	16.000	15.77500	15.87282	1.562	2.2500	0.12500	0.10000	8
16 O.D.	18.000	17.76250	17.87575	1.812	2.4500	0.12500	0.10000	8
18 O.D.	18.000	17.75000	17.87500	2.000	2.6500	0.12500	0.10000	8
20 O.D.	20.000	19.73750	19.87031	2.125	2.8500	0.12500	0.10000	8
24 O.D.	24.000	23.71250	23.86094	2.375	3.2500	0.12500	0.10000	8

†Also pitch diameter at gauging notch.

‡Also length of plug gauge.

‡Also length of ring gauge, and length from gauging notch to small end of plug gauge.

AMERICAN STANDARD STRAIGHT PIPE THREADS



*Straight pipe threads in couplings are gauged with American Standard Taper Pipe Thread plug gauges, the notch (P.D. = E_1) to come flush at bottom of chamfer with gauging tolerance of one and one-half turns large or small. While this theoretically provides maximum and minimum pitch diameters as shown, the actual pitch diameters of the tapped hole will be slightly smaller than the values given.

†Mechanical joint straight pipe threads are gauged with straight thread gauges.

Dimensions in Inches

Nominal Pipe Size	Number of Threads per Inch	Pitch of Thread P	Increase in Pitch Diameter per Turn	PITCH DIAMETER									
				Straight Thread Couplings* (Internal Thread) for use with Tapered Thread Pipe for Pressure Tight Joints (NPTC)		Straight Thread (Free Fitting) Mechanical Joints (NPSM)				Straight Thread (Loose Fitting) Mechanical Joints Locknut Connections (NPSL)			
				Min. E_0	Max. E_7	EXTERNAL		INTERNAL		EXTERNAL		INTERNAL	
1/8	27	0.03704	0.00231	0.3713	0.3782	0.3713	0.3746	0.3748	0.3782	0.3805	0.3840	0.3863	0.3898
1/4	18	0.05556	0.00347	0.4847	0.4951	0.4847	0.4899	0.4899	0.4951	0.4986	0.5038	0.5073	0.5125
3/8	18	0.05556	0.00347	0.6218	0.6322	0.6218	0.6270	0.6270	0.6322	0.6357	0.6409	0.6444	0.6496
1/2	14	0.07143	0.00446	0.7717	0.7851	0.7717	0.7784	0.7784	0.7851	0.7896	0.7963	0.8008	0.8075
3/4	14	0.07143	0.00446	0.9822	0.9956	0.9822	0.9889	0.9889	0.9956	1.0000	1.0067	1.0112	1.0179
1	11 1/2	0.08896	0.00543	1.2305	1.2468	1.2305	1.2386	1.2386	1.2468	1.2523	1.2604	1.2658	1.2739
1 1/8	11 1/2	0.08896	0.00543	1.5722	1.5915	1.5722	1.5834	1.5834	1.5915	1.6051	1.6051	1.6100	1.6187
1 1/4	11 1/2	0.08896	0.00543	1.8142	1.8305	1.8142	1.8223	1.8223	1.8305	1.8360	1.8441	1.8495	1.8576
2	8	0.08896	0.00543	2.2881	2.3044	2.2881	2.2963	2.2963	2.3044	2.3099	2.3180	2.3234	2.3315
2 1/2	8	0.12500	0.00781	2.7505	2.7739	2.7505	2.7622	2.7622	2.7739	2.7817	2.7934	2.8012	2.8129
3	8	0.12500	0.00781	3.3768	3.4002	3.3768	3.3885	3.3885	3.4002	3.4081	3.4198	3.4276	3.4393
3 1/2	8	0.12500	0.00781	3.8771	3.9005	3.8771	3.8888	3.8888	3.9005	3.9084	3.9201	3.9279	3.9396
4	8	0.12500	0.00781	4.3754	4.3988	4.3754	4.3871	4.3871	4.3988	4.4067	4.4184	4.4262	4.4379
5	8	0.12500	0.00781	5.4378	5.4493	5.4378	5.4493	5.4493	5.4610	5.4688	5.4805	5.4884	5.5001
6	8	0.12500	0.00781	6.4943	6.5060	6.4943	6.5060	6.5060	6.5177	6.5255	6.5372	6.5450	6.5567
8	8	0.12500	0.00781							8.5196	8.5313	8.5391	8.5508
10	8	0.12500	0.00781							10.6222	10.6222	10.6600	10.6717
12	8	0.12500	0.00781							12.6374	12.6374	12.6569	12.6686

Table 2-3



Plastic Piping - Teflon pipe compound or sealing tape.

Other Services - Armite Joint Seal Compound #250,
Commercial "Thred-Seal",
Baker Oil Tool Teflon "Bakerseal" or equal.

Compound should be smoothed on the male thread and not in the fittings.

Threaded fittings are available in the following materials and pressure ranges:

Cast iron	125 and 250 lb, steam
Malleable iron	150 and 300 lb, steam
Brass and copper	150 and 250 lb, steam
Forged steel	2,000, 3,000, and 6,000 lb, steam

Welded joints and fittings are used for steam, hot water and chilled water piping. The butt weld is used to join pipe ends, pipe to flange, and pipe to fittings. The pipe ends are beveled by grinding or oxygen-flame cut to an angle between 35° to 40°, Fig. 2-1, and to a compound bevel for thicker wall pipes, Fig. 2-2. Backing rings, or chill rings, are sometimes specified for butt welds, Fig. 2-3. These prevent icicles and slag from forming on the inside of the pipe. In the smaller sizes of welded piping the use of socket end welding fittings eliminates this problem. Butt weld fittings are forged steel and are classified by schedule number (20, 40, 60, 80 and 160) and have the same pressure and temperature ratings as seamless steel pipe of the same schedule. Socket weld fittings are available in sizes to 4", 3,000 and 6,000 psi ratings. Forged branch fittings welded directly to the side of a pipe, as the "Weldolet", etc, Fig. 2-5, are sufficiently reinforced to meet the ASME requirements of replacing the metal cut out for the branch opening.

Inspection of welded joints is accomplished visually, by radiographic methods, magnetic particle inspection, by use of dye penetrants, and ultrasonic testing. Some of the defects that can be observed are shown in Figs. 2-6 to 2-8.

Visual Inspection of Welds

The following procedures and visual inspection should be made of welds whether or not a radiographic inspection will be made.

Before Welding

1. Welders qualifications.
2. Inspect base materials for seams, scale or delamination. Check material for proper thickness.

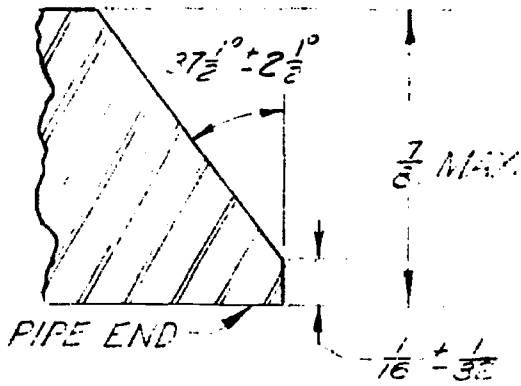


Fig. 2-1

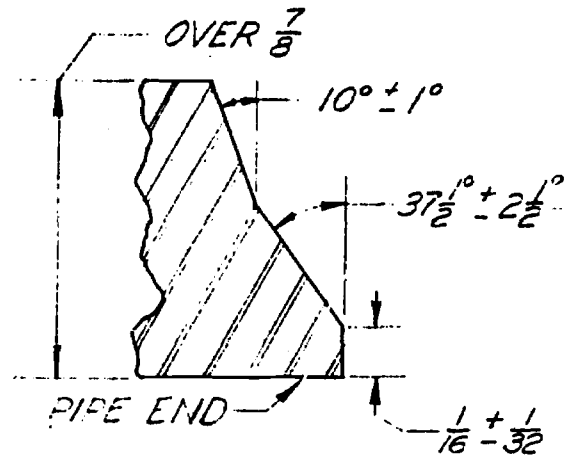
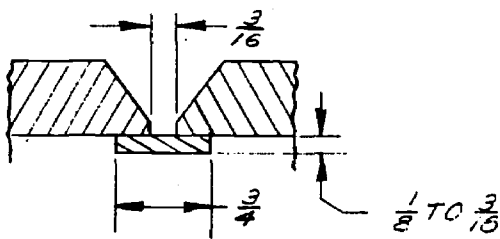


Fig. 2-2

PIPE END BEVEL



BACKING RING

Fig. 2-3

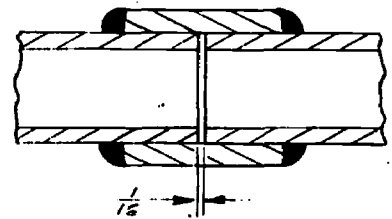
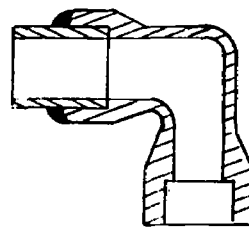
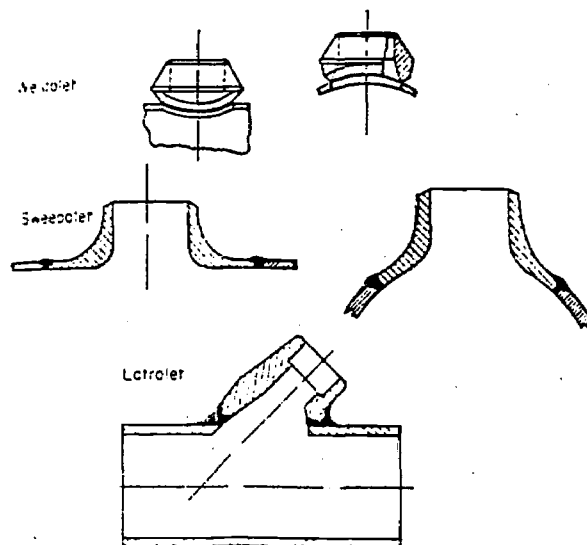


Fig. 2-4

SOCKET END WELDING FITTING



Weldolet; Sweepolet; Latrolet.

Fig. 2-5

From "Piping Handbook" by Crocker and King. Copyright 1967, by McGraw-Hill, Inc. Used with permission of McGraw-Hill Book Co.

3. After parts are assembled for welding, check:
 - a. weld preparation for dimensions and finish.
 - b. clearance dimensions of backing strips, rings or backing filler metal.
 - c. alignment and fit up to the pieces being welded.
 - d. clean metal surfaces.
 - e. electrode specification and storage.

During welding, check:

1. Welding process (welding procedure specification if one exists).
2. Filler metal.
3. Cleaning of welds.
4. Penetration of successive passes.
5. Undercutting.
6. Surface uniformity.
7. Chipping, grinding or gouging.
8. Warpage.

After welding, check for:

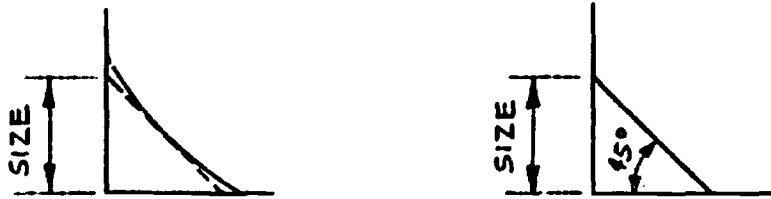
1. Cracks (not acceptable).
2. Undercutting (not to exceed 1/32" in depth).
3. Weld reinforcement; not to exceed the following:

<u>component thickness</u> inches	<u>reinforcement thickness,</u> inches
1/2 and under	1/8
over 1/2 through 1	5/32
over 1	3/16

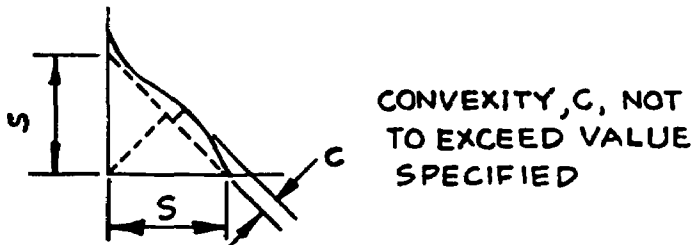
Surface of the weld shall fair into the base metal with no overlap.

4. Fillet weld dimensions (see Fig. 2-11 for acceptable divergences).
5. Acceptability of weld regarding appearance (surface roughness, weld splatter, etc).

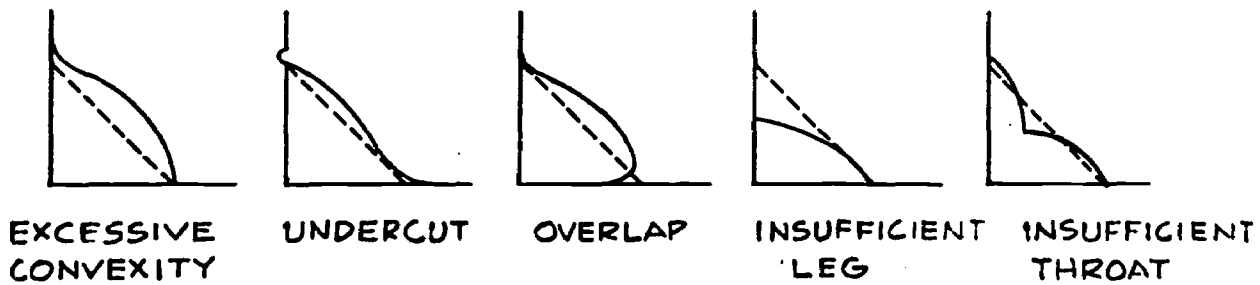
Radiographic methods employing X-ray or radioactive isotopes are used both in shop and the field. Butt welds may be examined by placing the radiation source on one side of the pipe. Some piping Codes require the use of a gage called a "penetrameter" which is placed near the weld being radiographed. The purpose of this gage is to produce a film sufficiently sensitive to show the various holes on the penetrameter, as shown in Fig. 2-9. Magnetic particles will show up surface and sub-surface discontinuities in the path of a magnetic flux in a magnetic field placed around ferro-magnetic metals. Dye penetrants are used to inspect pipe base materials and welds. The highly penetrating



DESIRABLE FILLET WELD PROFILES

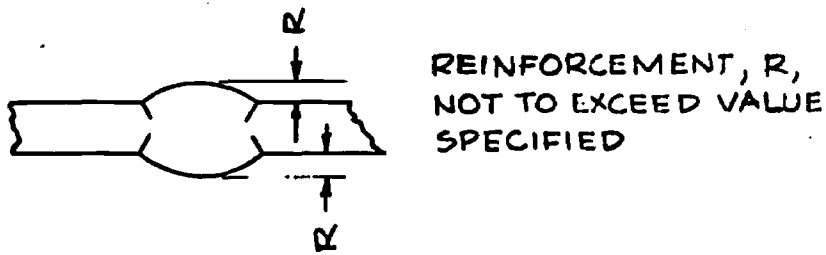


ACCEPTABLE FILLET WELD PROFILE

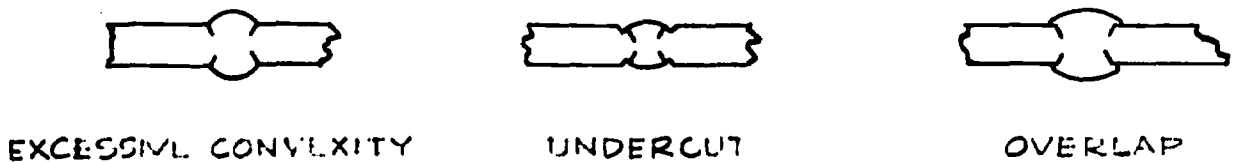


EXCESSIVE CONVEXITY UNDERCUT OVERLAP INSUFFICIENT LEG INSUFFICIENT THROAT

DEFECTIVE FILET WELD PROFILES



ACCEPTABLE BUTT WELD PROFILE

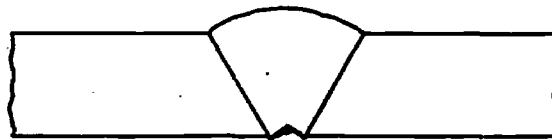


EXCESSIVE CONVEXITY UNDERCUT OVERLAP

DEFECTIVE BUTT WELD PROFILES

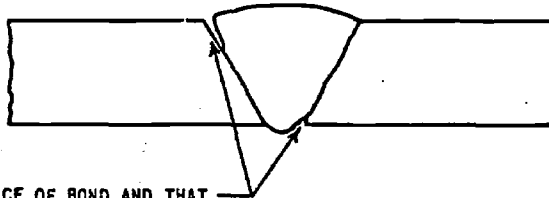
Fig. 2-6

ACCEPTABLE & DEFECTIVE WELD PROFILES



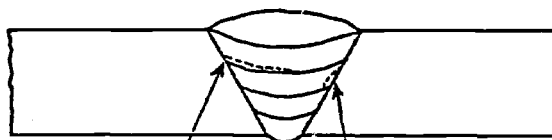
ROOT BEAD FUSED TO BOTH
INSIDE SURFACES BUT CEN-
TER OF ROOT PASS SLIGHTLY
BELOW INSIDE SURFACE OF PIPE

INADEQUATE PENETRATION DUE TO INTERNAL CONCAVITY



NOTE ABSENCE OF BOND AND THAT
DISCONTINUITY IS SURFACE CONNECTED

INCOMPLETE FUSION AT ROOT OF BEAD OR TOP OF THE JOINT



COLD LAP BETWEEN
ADJACENT BEADS

COLD LAP BETWEEN WELD
BEAD AND BASE METAL

NOTE: COLD LAP IS NOT SURFACE CONNECTED

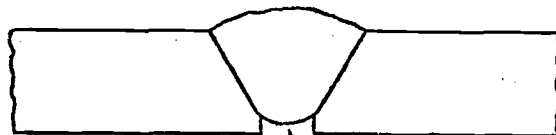
INCOMPLETE FUSION DUE TO COLD LAP

Fig. 2-7

Figs. 2-7, 2-8, and 2-9 used by permis-
sion, Division of Transportation,
American Petroleum Institute from API
Std. 1104, STANDARD FOR WELDING PIPE
LINES AND RELATED FACILITIES, 11th
Edition.

ONE OR BOTH BEVELS
MAY BE INADEQUATELY
FILLED AT INSIDE
SURFACE

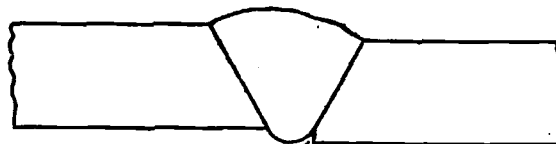
NO HIGH-LOW
AT ROOT



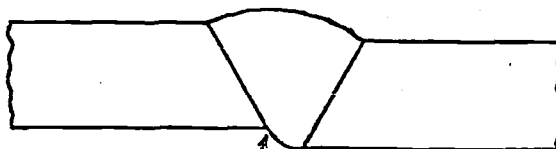
NOTE INCOMPLETE
FILLING AT ROOT

INADEQUATE PENETRATION OF WELD GROOVE

NOTE HIGH-LOW
AT ROOT



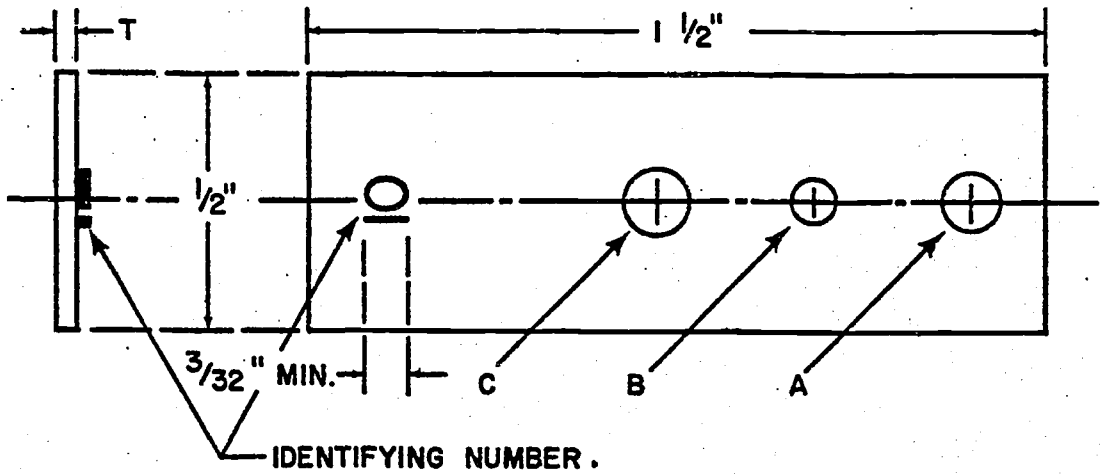
NOTE INCOMPLETE FILLING
AT ROOT ON ONE SIDE ONLY



BOTH SIDES COMPLETELY
TIED-IN BY WELD METAL

INADEQUATE PENETRATION DUE TO HIGH-LOW

Fig. 2-8



T = PENETRATOR THICKNESS

A DIAMETER = 2T

B DIAMETER = 1T

C DIAMETER = 4T

EXCEPT THAT THE SMALLEST HOLE NEED NOT BE LESS THAN 1/16" IN DIAMETER.

HOLES SHALL BE ROUND AND DRILLED PERPENDICULAR TO THE SURFACE. HOLES SHALL BE FREE OF BURRS BUT EDGES SHALL NOT BE CHAMFERED.

EACH PENETRATOR SHALL CARRY A LEAD IDENTIFICATION NUMBER.

Weld Thickness, Inches	Penetrator Thickness Inches	Identifying Number
Up to 1/8 incl.....	0.005	5
Over 1/8 through 1/4.....	0.0075	7
Over 1/4 through 3/8.....	0.010	10
Over 3/8 through 1/2.....	0.0125	12
Over 1/2 through 3/4.....	0.015	15
Over 3/4 through 1.....	0.0175	17
Over 1 through 1 1/4.....	0.020	20
Over 1 1/4 through 1 1/2.....	0.025	25
Over 1 1/2 through 1 3/4.....	0.030	30
Over 1 3/4 through 2.....	0.035	35

STANDARD PENETRATOR

Fig. 2-9

liquid is applied to the metal surface and left for 15 to 30 minutes. The welded area is then wiped clean and sprayed with a fine white powder. Any dye which previously penetrated surface discontinuities will be absorbed by the dried powder and be visible to the eye. The ultrasonic method of inspection transmits mechanical vibrations at ultra-high frequencies through the test specimen with little or no loss of energy if the material is homogeneous throughout. The presence of a defect or flaw in the material will cause a reduction or reflection of this energy, thereby providing a means of detection.

The various piping Codes, ASME, ANSI, etc, allow specific amounts of imperfections, such as slag inclusions, incomplete penetration, and porosity. Fig. 2-10 shows allowable maximum distribution of gas pockets (porosity).

Certification of Welders

All welding of piping installed under the requirements of the Code for Pressure Piping, Power Piping, ANSI B31.1.0, and the ASME Boiler and Pressure Vessel Code (Section IX) require that welders be qualified under the requirements of these Codes. Each employer is responsible for the welding done by the personnel of his organization and shall conduct the required qualification test (or have it done by a certified testing laboratory). The Code for Pressure Piping requirements are the same as the ASME Pressure Vessel Code except that under the former welders qualified by one employer may be accepted by another employer on piping using the same or equivalent procedure where the essential variables are within the limits of Section IX of the ASME Code.¹ The new employer assumes responsibility for the welds. Under both Codes, welders are qualified as competent to weld in one or all of the positions designated as 1G, 2G, etc, all as described in the Section IX of the ASME Code as follows:

- 1G Pipe axis horizontal, weld groove horizontal
- 2G Pipe axis vertical, weld axis horizontal
- 5G Pipe axis horizontal, weld groove vertical

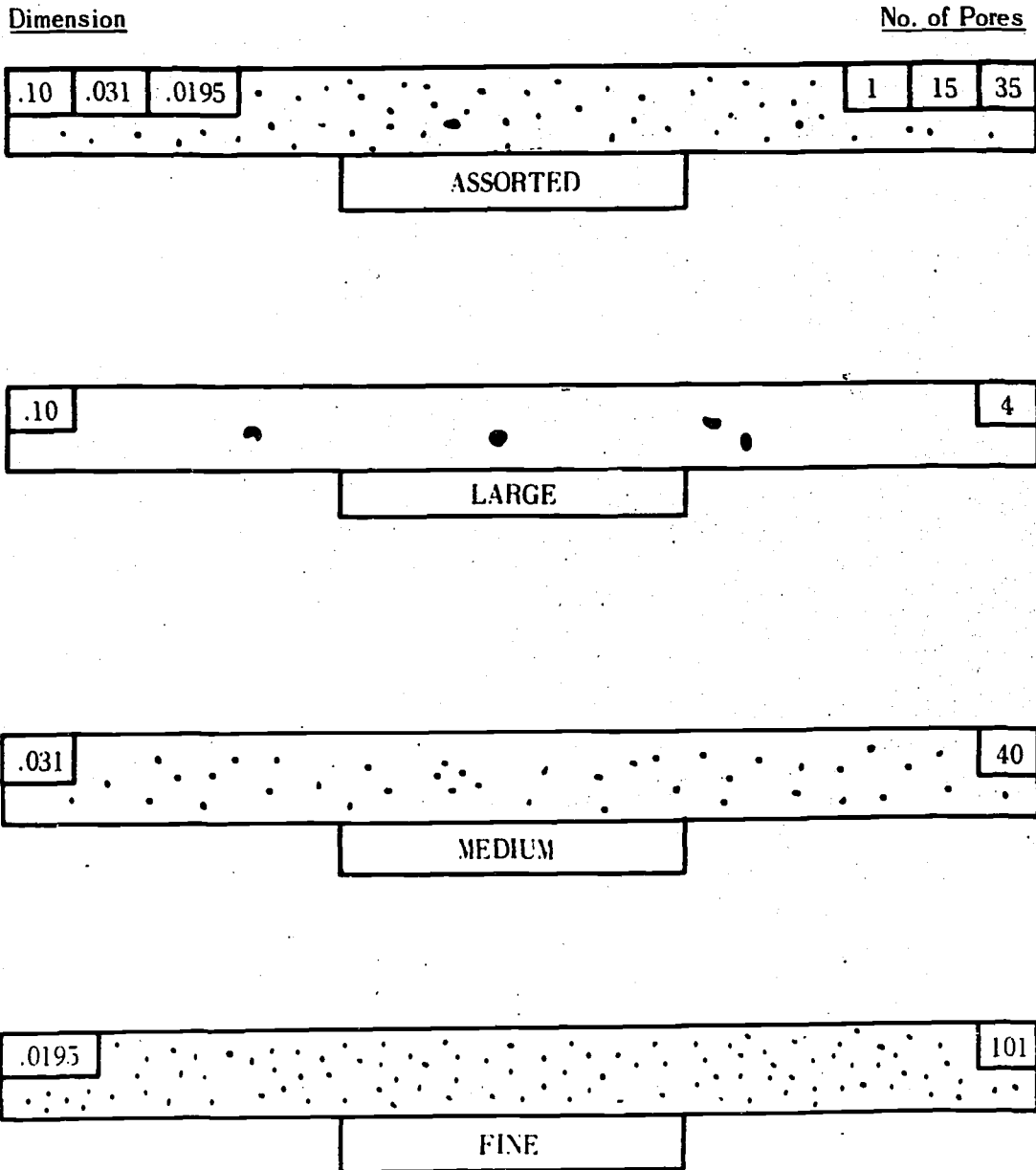
These positions are shown on page (Fig. 127.5.4) of the Pressure Piping Code.² Note that qualification for these positions on pipe also qualify for comparable positions for plate groove and fillet welds.

Coupons are cut from welded sections and subjected to tension and bending tests to determine the tensile strength and degree of soundness and ductility of the weld. ~~The weld is also radio-~~graphed and sectionalized to prove soundness.

The report of the performance qualification test includes the ASTM specification of the material welded, or the P-Number, which various steels are classed in Section IX as follows:

- P-1 Carbon Steels, 40,000 to 75,000 psi min tensile
- P-3 Low alloy steels, not over 2% alloy

Porosity Charts



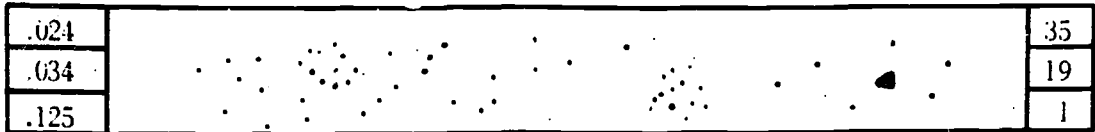
TYPICAL NUMBER AND SIZE PERMITTED
 IN ANY SIX INCH LENGTH OF WELD
 ONE HALF INCH WELD THICKNESS
 TOTAL PORE AREA PERMITTED IS .030 SQ. IN.

Fig. 2-10 (a)¹

Porosity Charts

Dimension

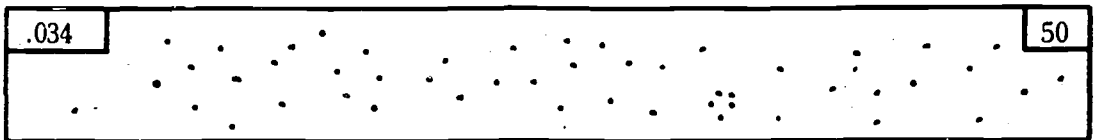
No. of Pores



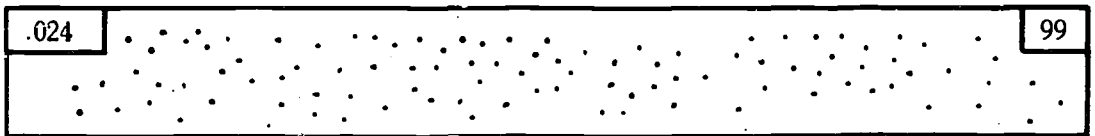
ASSORTED



LARGE



MEDIUM



FINE

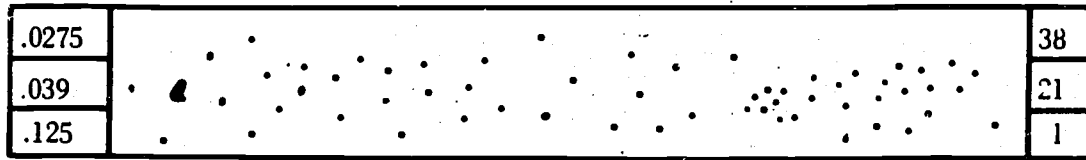
TYPICAL NUMBER AND SIZE PERMITTED
 IN ANY SIX INCH LENGTH OF WELD
 THREE QUARTER INCH WELD THICKNESS
 TOTAL PORE AREA PERMITTED IS .045 SQ. IN.

Fig. 2-10 (b)¹

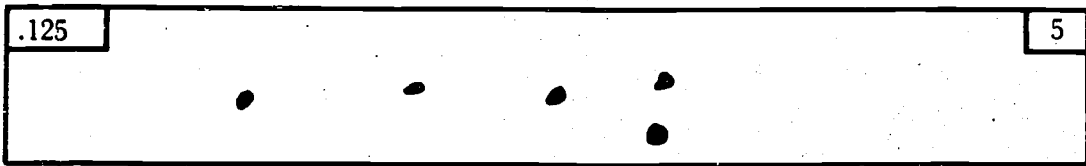
Porosity Charts

Dimension

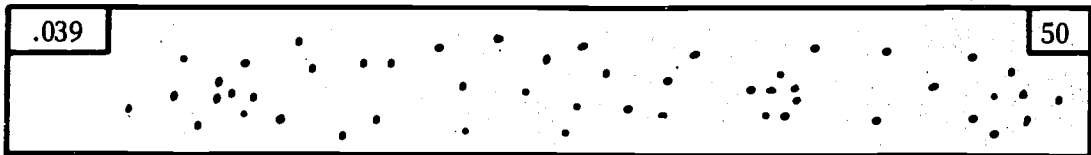
No. of Pores



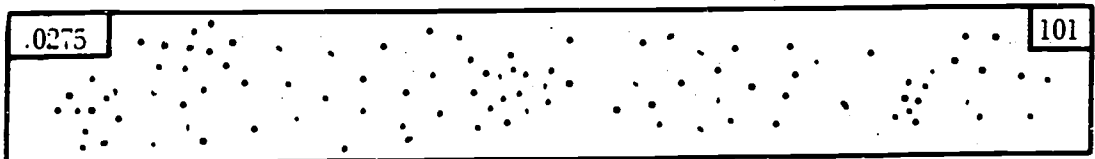
ASSORTED



LARGE



MEDIUM

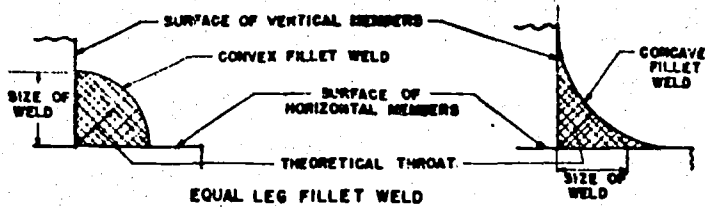


FINE

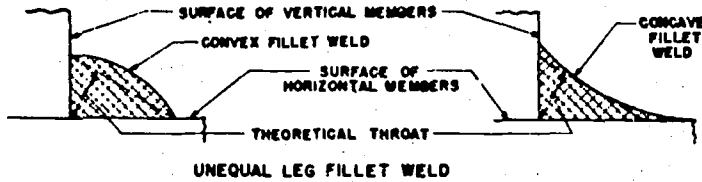
TYPICAL NUMBER AND SIZE PERMITTED
 IN ANY SIX INCH LENGTH OF WELD
 ONE INCH WELD THICKNESS
 TOTAL PORE AREA PERMITTED IS .060 SQ. IN.

Fig. 2-10 (c)¹

USA STANDARD CODE FOR PRESSURE PIPING

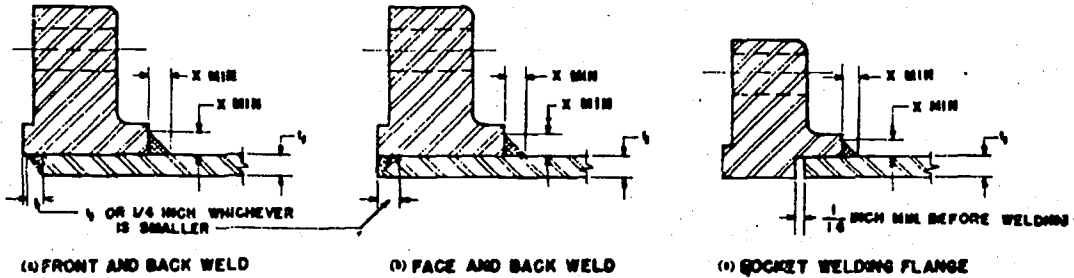


NOTE: THE "SIZE" OF AN EQUAL LEG FILLET WELD IS THE LENGTH OF THE LARGEST INSCRIBED RIGHT ISOSCELES TRIANGLE
THEORETICAL THROAT = $0.7 \times \text{SIZE}$



NOTE: FOR UNEQUAL LEG FILLET WELDS, THE SIZE OF THE WELD IS THE LEG LENGTHS OF THE LARGEST RIGHT TRIANGLE WHICH CAN BE INSCRIBED WITHIN THE FILLET WELD CROSS SECTION

FIG 127.4.A FILLET WELD SIZE



X = NOMINAL PIPE WALL THICKNESS
 $X \text{ MIN} = L_1$, OR THICKNESS OF THE FRB, WHICHEVER IS SMALLER BUT NOT LESS THAN $1/8$ INCH

FIG 127.4.B WELDING DETAILS FOR SLIP-ON AND SOCKET-WELDING FLANGES
SOME ACCEPTABLE TYPES OF FLANGE ATTACHMENT WELDS

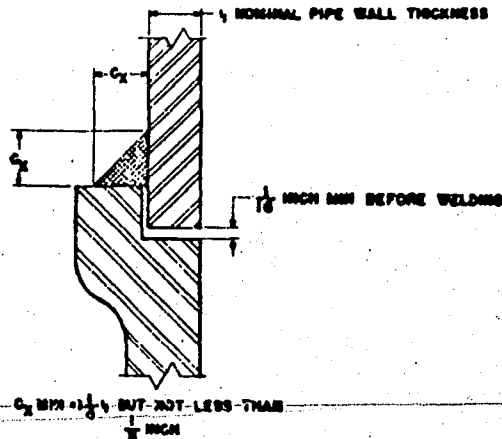


FIG 127.4.C MINIMUM WELDING DIMENSIONS REQUIRED FOR SOCKET WELDING COMPONENTS OTHER THAN FLANGES

RECOMMENDED FORM Q-1 MANUFACTURER'S RECORD OF WELDING PROCEDURE QUALIFICATION TESTS

Specification No. _____ Date _____
 Welding Process _____ Manual or Machine _____
 Material Specification _____ to _____ of P-No. _____ to P-No. _____
 Thickness (if pipe, diameter and wall thickness) _____
 Thickness Range this test qualifies _____
 Filler Metal Group No. F- _____
 Weld Metal Analysis No. A- _____
 Describe Filler Metal if not included in Table Q-11.2 or QN-11.2 _____
 For oxyacetylene welding—State if Filler Metal is silicon or aluminum killed. _____

FLUX OR ATMOSPHERE

Flux Trade Name or Composition _____
 Inert Gas Composition _____
 Trade Name _____ Flow Rate _____
 Is Backing Strip used? _____
 Preheat Temperature Range _____
 Interpass Temperature Range _____
 Postheat Treatment _____

WELDING PROCEDURE

Single or Multiple Pass _____
 Single or Multiple Arc _____
 Position of Groove _____ (See Pars. & Figs. Q-2 & Q-3, or QN-2 & QN-3)
 (Flat, horizontal, vertical, or overhead; if vertical, state whether upward or downward)

FOR INFORMATION ONLY

Filler Wire—Diameter _____
 Trade Name _____
 Type of Backing _____
 Forehand or Backhand _____

WELDING TECHNIQUES

Joint Dimensions Accord with _____
 amps _____ volts _____ inches per min. _____
 Current _____ Polarity _____

REDUCED SECTION TENSILE TEST (Figs. Q-6 and QN-6)

Specimen No.	Dimensions		Area	Ultimate Total Load, lb.	Ultimate Unit Stress, psi	Character of Failure and Location
	Width	Thickness				

GUIDED BEND TESTS (Figs. Q-7.1, Q-7.2, QN-7.1, QN-7.2, QN-7.3)

Type and Figure No.	Result	Type and Figure No.	Result

Results of Filletweld Tests, Fig. Q-9(c) _____
 Welder's Name _____ Clock No. _____ Stamp No. _____
 Who by virtue of these tests meets welder performance requirements.
 Test Conducted by _____ Laboratory—Test No. _____
 per _____

We certify that the statements in this record are correct and that the test welds were prepared, welded and tested in accordance with the requirements of Section IX of the ASME Code.

Signed _____
(Manufacturer)

Date _____ By _____

(Detail of record of tests are illustrative only and may be modified to conform to the type and number of tests required by the Code. Recommended Form Q-1 is available for purchase at ASME Headquarters.)

NOTE: Any essential variables in addition to those above shall be recorded.

Chapter V

FABRICATION, ASSEMBLY AND ERECTION

127 WELDING

127.1 General

The following applies essentially to the welding of ferrous materials. The welding of aluminum, copper, etc., requires different preparations and procedures.

127.2 Material.

127.2.1 Filler Metal.

All filler metal shall comply with the requirements of Section IX, ASME Boiler and Pressure Vessel Code. A new filler metal not yet incorporated in Section IX, and which is necessary for the development of the science of welding, may be used if a procedure qualification test is first successfully made.

127.2.2 Backing Rings.

When backing rings are used they shall be made from material of weldable quality compatible with the base metal or be of a removable type. Backing rings may be of the consumable insert type, removable ceramic type, or solid or split band type. A ferrous backing ring which becomes a permanent part of the weld shall not exceed 0.05 per cent sulphur.

If two abutting surfaces are to be welded to a third member used as a backing ring and one or two of the three members are ferritic and the other member or members are austenitic, the satisfactory use of such materials shall be determined by procedure qualification.

127.3 Preparation.

127.3.1 Butt Welds.

(a) End Preparation.

1. Oxygen or arc cutting is acceptable only if the cut is reasonably smooth and true, and all slag is cleaned from the flame cut surfaces. Discoloration which may remain on the flame cut surface is not considered to be detrimental oxidation.

2. Butt-welding end preparation dimensions contained in USAS B16.25 or any other end preparation which meets the procedure qualification are acceptable.

3. If piping component ends are bored such boring shall not result in the finished wall thickness after welding less than the minimum design thickness. Where necessary, weld metal of the appropriate analysis may be deposited on the

inside of the piping component to provide sufficient material for machining to insure satisfactory fitting of rings.

4. If the piping component ends are upset they may be bored to allow for a completely recessed backing ring, provided the remaining net thickness of the finished ends is not less than the minimum design thickness.

(b) Cleaning.

Surfaces for welding shall be clean and shall be free from paint, oil, rust, scale, or other material which is detrimental to welding.

(c) Alignment.

The ends of piping components to be joined shall be aligned as accurately as is practicable within existing commercial tolerances on diameters, wall thicknesses, and out-of-roundness. Alignment shall be preserved during welding. Where ends are to be joined and the internal misalignment exceeds 1/16 in., it is preferred that the component with the wall extending internally be internally trimmed (see Fig. 127.3.1) so that adjoining internal surfaces are approximately flush. However, this trimming shall not result in a piping component wall thickness less than the minimum design thickness and the change in contour shall not be so abrupt as to cause a stress concentration. Inert gas metal arc welding may require more accurate alignment than specified above.

(d) Spacing.

The root opening of the joint shall be as given in the procedure specifications.

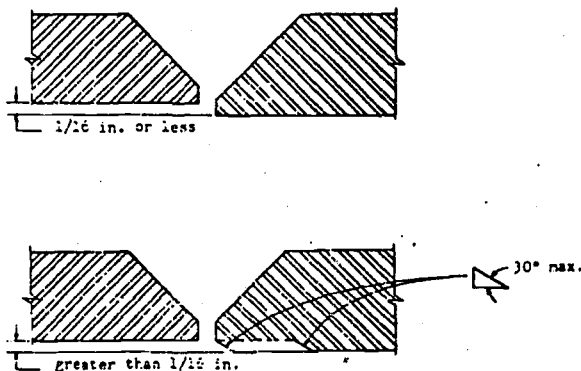


FIG. 127.3.1. BUTT WELDING OF PIPING COMPONENTS WITH INTERNAL MISALIGNMENT.

(From ANSI B31.1.0²)

127.3.2 Fillet Welds.

Piping components which are to be joined in a manner which includes fillet welding shall be prepared in accordance with applicable provisions and requirements of Par. 127.3.1. For typical details see Fig. 127.4.4A, B and C.

127.4 Procedure.**127.4.1 General.**

(a) Qualification of the welding procedures to be used, and of the performance of welders and operators, is required, and shall comply with the requirements of the ASME Boiler and Pressure Vessel Code (Section IX) except as modified by Par. 127.5.

(b) No welding shall be done if there is impingement of rain, snow, sleet or high wind on the weld area.

127.4.2 Girth Butt Welds.

(a) Girth butt welds may be made with a single vee, double vee, or other suitable type of groove, with or without backing rings or consumable inserts.

(b) Tack welds shall be made by a qualified welder. Tack welds made by an unqualified welder shall be removed. Tack welds which are not removed shall be made with an electrode which is the same as or equivalent to the electrode to be used for the first pass. Tack welds which have cracked shall be removed.

(c) When components of different outside diameters are welded together, there shall be a gradual transition in the weld between the two surfaces. If the difference in surfaces exceeds 1/4 in., the outside surface of the component having the larger diameter shall be tapered at an angle not to exceed thirty degrees with the axis of the pipe.

(d) The finished surface of the weld shall merge smoothly into the component surface at the weld toe. The thickness of weld reinforcement shall not exceed the following, considering the thickness of the thinner component being joined.

<u>Component Thickness</u>	<u>Reinforcement Thickness, Max</u>
Up to 1/2 in.	1/16 in.
Over 1/2 to 1 in.	3/32 in.
Over 1 to 2 in.	1/8 in.
Over 2 in.	5/32 in.

This reinforcement need not be removed except in the case where a joint is to be radiographed; then excessive ridges which may interfere with proper interpretation of a radiograph shall be removed.

For double-welded joints, this limitation on

reinforcement shall apply to each surface of the weld separately.

(e) Girth butt welds may be examined by any or all of the methods stated in Table 127.4.6. The types and extent of examination required are specified in Par. 136.5.

Sections of welds that are shown by radiography or other examination to have any of the following types of imperfections shall be judged unacceptable and shall be repaired as provided in Par. 127.4.7.

1. Any type of crack or zone of incomplete fusion or penetration.

2. Any slag inclusion or porosity greater in extent than those specified as acceptable by the radiographic methods of examination set forth in Par. 136.4.3(b) and (c).

3. Undercuts in the external surfaces of butt welds which are more than 1/32 in. deep.

4. Concavity on the root side of full penetration girth butt welds where the resulting weld thickness is less than the minimum pipe wall thickness required by this Code. Weld reinforcement up to a maximum of 1/32 in. thickness may be considered as pipe wall thickness in such cases.

127.4.3 Longitudinal Butt Welds.

Longitudinal butt welds in piping components not made in accordance with the standards and specifications listed in Table 126.1 may be examined by any or all of the methods stated in Table 127.4.6. Imperfections shall not exceed the limits established for girth butt welds except that no undercutting shall be permitted in longitudinal butt welds.

127.4.4 Fillet Welds.

Fillet welds may vary convex to concave. The size of a fillet weld is determined as shown in Fig. 127.4.4A. Typical minimum fillet weld details for slip-on flanges and socket-welding components are shown in Fig. 127.4.4B and 127.4.4C.

The limitations on cracks and undercutting set forth in Par. 127.4.2(e) for girth welds are also applicable to fillet welds.

127.4.5 Seal Welds.

Where seal welding of threaded joints is performed, threads shall be entirely covered by the seal weld. Seal welding shall be done by qualified welders.

The limitations on cracks and undercutting set forth in Par. 127.4.2(e) for girth welds are also applicable to seal welds.

127.4.7 Weld Defect Repairs.

All defects in welds requiring repair shall

(From ANSI B31.1.0²)

Table 127.4.6.

Examination for	Methods of Examination of Welds				
	Visual	Magnetic Particle	Ultrasonic	Radio-graphy	Liquid Penetrant X-Ray
Crack	X	X	X	X	X
Incomplete Penetration			X		
Weld Undercutting	X				X
Weld Reinforcement	X				
Porosity			X	X	X
Slag Inclusions			X	X	X
Lack of Fusion		X	X	X	X

be removed by flame or arc gouging, grinding, chipping, or machining. Repair welds shall be made in accordance with the same procedure used for original welds, recognizing that the cavity to be repaired may differ in contour and dimensions from the original joint. The types, extent and method of examination and limits of imperfections of repair welds shall be the same as for the original weld.

Preheating may be required for flame-gouging or arc-gouging on certain alloy materials of the air hardening type in order to prevent surface checking or cracking adjacent to the flame or arc-gouged surface.

127.4.8 Welded Branch Connections.

(a) Fig. 127.4.8A, 127.4.8B and 127.4.8C show typical details of branch connections with and without added reinforcement. However, no attempt has been made to show all acceptable types of construction and the fact that a certain type of construction is illustrated does not indicate that it is recommended over other types not illustrated.

(b) Fig. 127.4.8D shows basic types of weld attachments used in the fabrication of branch connections. The location and minimum size of these attachment welds shall conform to the requirements of Par. 127.4.8. Welds shall be calculated in accordance with Par. 104.3.1 but shall not be less than the sizes shown in Fig. 127.4.8D.

The notations and symbols used in this paragraph and in Fig. 127.4.8D are as follows:

t_n = nominal thickness of branch wall less corrosion allowance, inches.

t_c = the smaller of 1/4 inch or $0.7 t_n$

t_e = nominal thickness of reinforcing element (ring or saddle), inches. ($t_e = 0$ if there is no added reinforcement).

t_{min} = the smaller of t_n or t_e .

(c) Branch connections (including specially-made integrally reinforced branch connection fittings) which abut the outside surface of the run wall, or which are inserted through an opening cut in the run wall, shall have opening and branch contour to provide a good fit and shall be attached by means of full penetration groove welds. The full penetration groove welds shall be finished with cover fillet welds having a minimum throat dimension not less than t_c . The limitation as to imperfection of these groove welds shall be as set forth in Par. 127.4.2(e) for girth welds.

(d) In branch connections having reinforcement pads or saddles, the reinforcement shall be attached by welds at the outer edge and at the branch periphery as follows:

1. If the weld joining the added reinforcement to the branch is a full penetration groove weld, it shall be finished with a cover fillet weld having a minimum throat dimension not less than t_c ; the weld at the outer edge, joining the added reinforcement to the run, shall be a fillet weld with a minimum throat dimension of $0.5 t_e$.

2. If the weld joining the added reinforcement to the branch is a fillet weld, the throat dimension shall not be less than $0.7 t_{min}$. The weld at the outer edge joining the outer reinforcement to the run shall also be a fillet weld with a minimum throat dimension of $0.5 t_e$.

(e) When rings or saddles are used, a vent hole shall be provided (at the side and not at the crotch) in the ring or saddle to reveal leakage in the weld between branch and main run and to provide venting during welding and heat treating operations. Rings or saddles may be made in more than one piece if the joints between the pieces have strength equivalent to ring or saddle parent metal and if each piece is provided with a vent hole. A good fit shall be provided between reinforcing rings or saddles and the parts to which they are attached.

127.4.9 Heat Treatment.

Heat treatment for welds shall be in accordance with Par. 131.

127.5 Qualification.

127.5.1 General.

Qualification of the welding procedures to be used, and of the performance of welders and welding operators, is required, and shall comply with the requirements of the ASME Boiler and

(From ANSI B31.1.0²)

Pressure Vessel Code (Section IX) except as modified by this Par. 127.5.

127.5.2 Welding Responsibility.

Each employer is responsible for the welding done by personnel of his organization, and shall conduct the required qualification tests to qualify the welding procedures, and the welders or welding operators.

127.5.3 Qualification by Others.

To avoid duplication of qualification tests of welders or welding operators, the welders or welding operators qualified as required above by one employer may be accepted by another employer (subject to the approval of the owner) on piping using the same or an equivalent procedure wherein the essential variables are within the limits established in Section IX, ASME Boiler and Pressure Vessel Code. An employer accepting such qualification tests by another employer shall obtain a copy (from the previous employer) of the performance qualification test record, showing the name of the employer by whom the welders or welding operators were qualified, the dates of such qualification, and the date the welder last welded pressure piping components under such qualification. The employer shall then prepare and sign the record required in Par. 127.6, accepting responsibility for the ability of the welder or welding operator.

127.5.4 Test Joint.

(a) Test joints for both procedure qualification and performance qualification shall be made as groove welds in pipe in one or more of the specified basic qualification test positions.

(b) Both procedure and performance qualification on groove welds in pipe in a given position shall also qualify for groove welds in plate and fillet welds in pipe or plate, for equivalent welding positions as shown in Section IX, ASME Boiler and Pressure Vessel Code, and Fig. 127.5.4.

(c) Qualification in Position 1G qualifies for welds in that position only. Qualification in either Position 2G or 5G qualifies for welds in those respective positions; and also for welds covered by Position 1G. Qualification in both Positions 2G and 5G qualifies for welds to be made in any position regardless of the orientation of the weld or of the pipe axis, and regardless of whether the pipe is rolled.

127.5.6 Performance Requalification.

Renewal of performance qualification is required under either of the following conditions:

(1) A welder has not used the specific process within the essential variables

given in Section IX, ASME Boiler and Pressure Vessel Code, to weld either ferrous or nonferrous pressure piping materials for a period of three months, or

(2) If there is reason to question his ability to make welds that meet the performance qualification requirements.

Renewal of qualification under condition (1) need be made in only a single pipe wall thickness and may be made by either a test weld or a production weld checked on the basis of acceptable radiography.

127.6 Qualification Records.

The employer shall maintain a record, certified by him, and available to the purchaser or his agent and the inspector, of the procedures used and the welders or welding operators employed by him, showing the date and results of procedure and performance qualifications, and the identification symbol assigned to each performance qualification. The identification symbol shall be used to identify the work performed by the welder or welding operator, and after completing a welded joint, he shall identify it as his work by applying his assigned symbol for permanent record in a manner specified by his employer.

128 BRAZING

128.1 Materials.

128.1.1 Filler Metal.

The filler metal used in brazing shall be a nonferrous metal or alloy having a melting point above 800 F and below that of the metal being joined. The filler metal shall melt and flow freely within the desired temperature range and, in conjunction with a suitable flux or controlled atmosphere, shall wet and adhere to the surfaces to be joined.

128.1.2 Flux.

Fluxes that are fluid and chemically active at the brazing temperature shall be used when necessary to prevent oxidation of the filler metal and the surfaces to be joined and to promote free flowing of the filler metal.

128.2 Preparation and Procedure.

128.2.1 Surface Preparation.

The surfaces to be brazed shall be clean and free from grease, oxides, paint, scale, and dirt of any kind. Any suitable chemical or mechanical cleaning method may be used to provide a clean wettable surface for brazing.

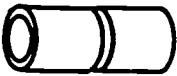


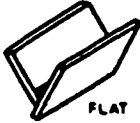




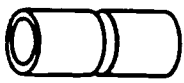

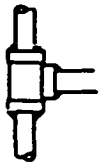






128.2.2 Joint Clearance.

The clearance between surfaces to be joined shall be no larger than is necessary to insure complete capillary distribution of the filler metal.

(From ANSI B31.1.0²)

FIG. 127.5.4. TEST JOINT POSITIONS.

For Qualification of Welding Procedure and Welder Performance

BASIC QUALIFICATION TEST:	ALSO QUALIFIES FOR:		
	GROOVE WELDS IN PIPE	GROOVE WELDS IN PLATE	FILLET WELDS IN
			PIPE
			PLATE
 PIPE - HORIZONTAL ROLLED WELD FLAT	 FLAT	 ROLLED	 FLAT
 PIPE - VERTICAL FIXED WELD - HORIZONTAL	 FLAT	 HORIZONTAL	 FLAT
 PIPE - HORIZONTAL FIXED WELD - FLAT, VERTICAL AND OVERHEAD	 FLAT	 HORIZONTAL, VERTICAL AND OVERHEAD	 VERTICAL
	 OVERHEAD		 FLAT
	 VERTICAL		 HORIZONTAL
			 OVERHEAD

128.2.3 Heating.

The joint shall be brought to brazing temperature in as short a time as possible to minimize oxidation.

128.2.4 Brazing Qualification.

The qualification of the brazing procedure, and of the performance of brazers and brazing operators, shall be in accordance with the requirements of Part C, Section IX, ASME Boiler and Pressure Vessel Code.

129 BENDING AND FORMING

129.1 Bending.

Pipe may be bent by any hot or cold method and to any radius which will result in a bend surface free of cracks, as determined by a method of inspection specified in the design, and substantially free of buckles. Such bends shall meet the design requirements of Par. 102.4.5 and Par. 104.2.1. This shall not prohibit the use of bends designed as creased or corrugated.

129.2 Forming.

Piping components may be formed, (swedging, lapping, or upsetting of pipe ends, extrusion of

necks, etc.), by any suitable hot or cold working method, provided such processes result in formed surfaces which are uniform and free of cracks or other defects, as determined by methods of inspection specified in the design.

129.3 Heat Treatment of Bends and Formed Components.

129.3.1 Carbon steel piping which has been heated to 1650 F or higher for bending or other forming operations shall require no subsequent heat treatment.

129.3.2 Ferritic alloy steel piping which has been heated for bending or other forming operations shall receive a stress relieving treatment, a full anneal, or a normalize and temper treatment, as specified by the design.

129.3.3 Cold bending and forming of carbon steel having a wall thickness of $\frac{3}{4}$ in. and heavier, and all ferritic alloy pipe in nominal pipe sizes of 4 in. and larger, or $\frac{1}{2}$ in. wall thickness or heavier, shall require a stress relieving treatment.

129.3.4 Cold bending of carbon and ferritic alloy steel pipe in sizes and wall thicknesses less than specified in Par. 129.3.3 may be used without a postheat treatment.

(From ANSI B31.1.0²)

P-4 Alloy steels, not over 2 3/4% alloy
P-5 to P-8 alloy steels (not pertinent to this text)

The grouping of materials in this Section of the Code as to "P" numbers is made on the basis of hardenability characteristics to reduce the number of welding procedure qualifications required.

Fig. 2-12 is the recommended form (Q-1) for the manufacturer's record of a welding qualification test. It will be noted that the specification of the metal is to be reported and also the weld position, 1G, 2G or 5G. Similar forms of certifications should contain the same information; namely, weld position, material welded, date certified, etc.

Pages 21 to 25 are from the Code for Pressure Piping regarding welder qualification and should be studied closely.

Flanged Joints

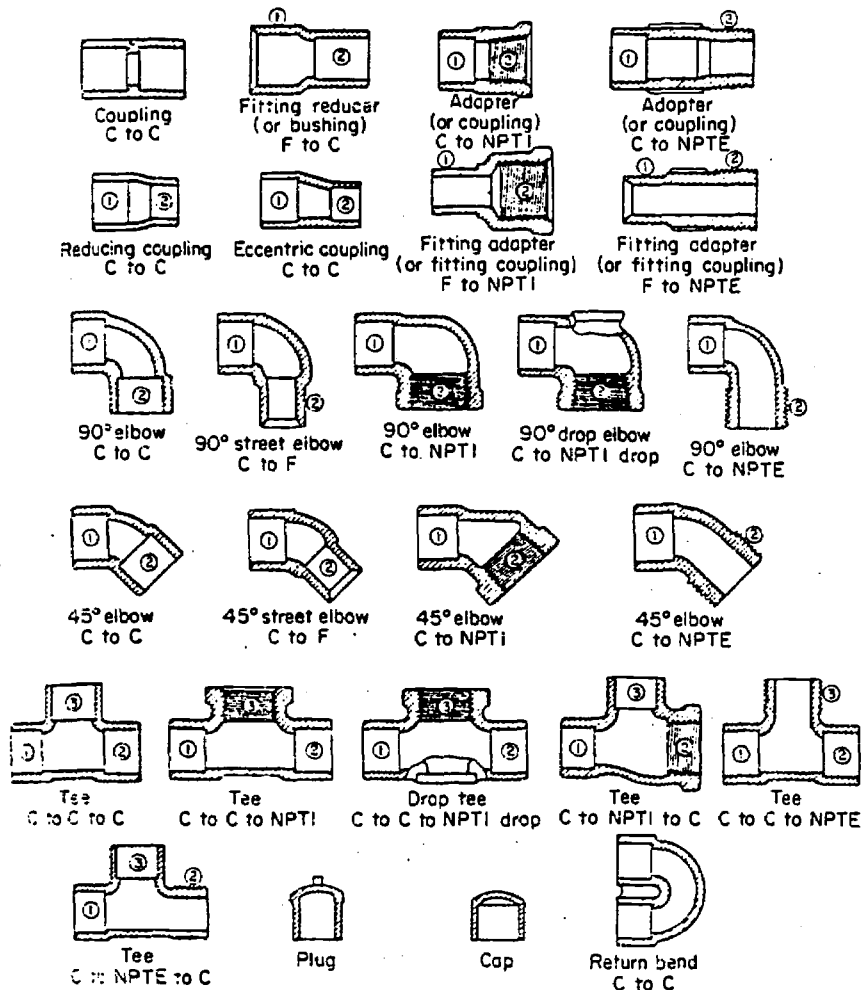
Flanges used in heating and ventilating piping systems are mostly cast iron and forged steel. They are preferred over screwed joints in sizes above 2" ips. They are made in the following pressure standards:

<u>Cast iron</u>	<u>Steel</u>
125 lb	150, 300, 400, 600
250 lb	900, 1500, 2500 lb

Cast iron flanges are tapped for standard pipe threads (when used for steel pipe), and steel flanges are produced for screwed or welded connections. Steel welding flanges are furnished for slip-on and fillet welded, or with a welding neck which is butt welded. The 125 lb cast iron flange has a flat machined face, all others have raised faces. A flat face should never be bolted to a raised face for fear of breaking the former. The outside diameters, bolt circle, number of bolts, etc, for a given pipe size conform to the ANSI Flange Standards, but reducing flanges can be obtained that permit a size reduction from one line to another. Attention should be paid to the bolt and nuts specification. Bolts with higher tensile strength than commercial steel have distinctive markings on the head, as do nuts.

Solder Fittings and Joints

The different styles of solder fittings are shown in Fig. 2-13. Some are soldered at all connections while others have male or female National Pipe thread outlets. The tubing end(s) of fittings go by the O.D. size of copper tubing, not by nominal size. Thus, the nominal size may be 1", but the fitting (and tubing) is designated as 1 1/8" O.D. In Fig. 2-13 the threaded ends are designated "I" for internal and "E" for external. The bore of the soldered end is held to a small clearance between it



Note: Reducing fittings are designated by size in the order ① x ② x ③

Fig. 2-13

Table 14. Pressure Ratings of Solder Joints (ASA B16.18-1963)
Maximum working pressure, psi

Solder used in joints	Working temperatures, F	½-1 in., incl. ¹	1¼-2 in., incl. ¹	2½-4 in., incl. ¹	5-8 in., incl. ¹
50-50, tin-lead ²	100	200	175	150	135
	150	150	125	100	90
	200	100	90	75	70
	250	85	75	50	45
95-5, tin-antimony	100	500	400	300	270
	150	400	350	275	250
	200	300	250	200	180
	250	200	175	150	135
Solders melting at or above 1100 F	350	270	190	155	140

¹ Standard water tube sizes.

² ASTM B32-60aT Alloy Grade 50A.

Table 2-5

Fig. 2-13 and Table 2-5 are from "Piping Handbook" by Crocker and King. Copyright 1967, by McGraw-Hill, Inc. Used with permission of McGraw-Hill Book Co.

and the tubing so that the melted solder is drawn into the socket by capillary action. Some fittings have a pre-inserted ring of silver solder which is melted and flows around the tubing.

Table 2-5 gives the allowable maximum working pressures at different temperatures for various pipe sizes for 50-50 solder, 95-5 and silver solder.

Soldering is a joining process where tube and fitting are bonded together by suitable heating (below 800° F) with a non-ferrous filler metal having a melting temperature below those of the base metals. The steps of the soldering process are shown in Fig. 2-14 for solder with low melting points.

Tin-lead and tin-antimony solders are used for piping systems in heating work. Tin-lead solders come in a variety of tin-to-lead proportions but 50% tin and 50% lead is suitable for joining copper tubing. It is a solid at 361° F and a liquid at 421° F. Tin-lead solder is unsatisfactory for use under sustained loads above 300° F. Tin (95%) - antimony (5%), known as "95-5", has higher strength at moderately higher temperatures. This material is a solid at 452° F and liquid at 464° F. Silver solder, or brazing alloys have the following composition:

	silver %	Copper	Zinc	Other	Melting Point	Flow Point
Easy-Flow 45	45	15	16	24 Cadmium	1125° F	1145° F
Sil-Fos	15	80	0	5 Phosphorus	1185° F	1300° F

Fig. 2-15 shows the procedures for silver soldering fittings with pre-inserted solder, and hand fed solder. Care must be taken to prevent overheating of the pipe, fittings and valves.

Soldering flux is used to remove and exclude oxides and other impurities from the joint. An efficient flux removes tarnish films and oxides and prevents reoxidation of the surfaces when heated.

Grooved Pipe Connections (victaulic, and similar)

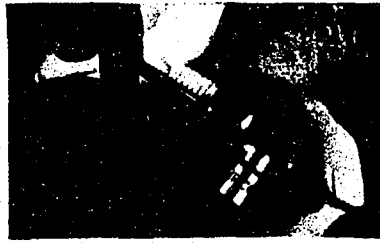
This joint type is used for steel and cast iron pipe in which grooves are cut in the pipe ends (see Fig. 2-16) and held together with a clamp-type coupling that fits into the grooves. A U-shaped gasket prevents leakage. The clearances used permit some angular displacement and movement due to the expansion and contraction. In the case of thin walled pipe, the groove is

COPPER WATER TUBE

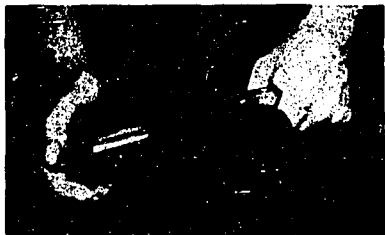
Making a Joint with Solder Type Fittings



1. Remove burrs with file or scraper.



5. Apply a thin, even coat of non-corrosive soldering paste to fitting.



2. Clean pipe well with steel wool. Be sure that all traces of oxidation are removed. Parts should be bright copper color.



6. Slip pipe into fitting until it is tightly seated against stop.



3. Apply a thin, even coat of any good non-corrosive soldering paste to pipe.



7. Apply heat. When flux boils, touch edge of fitting with solder. Feed until solder drips from fitting.

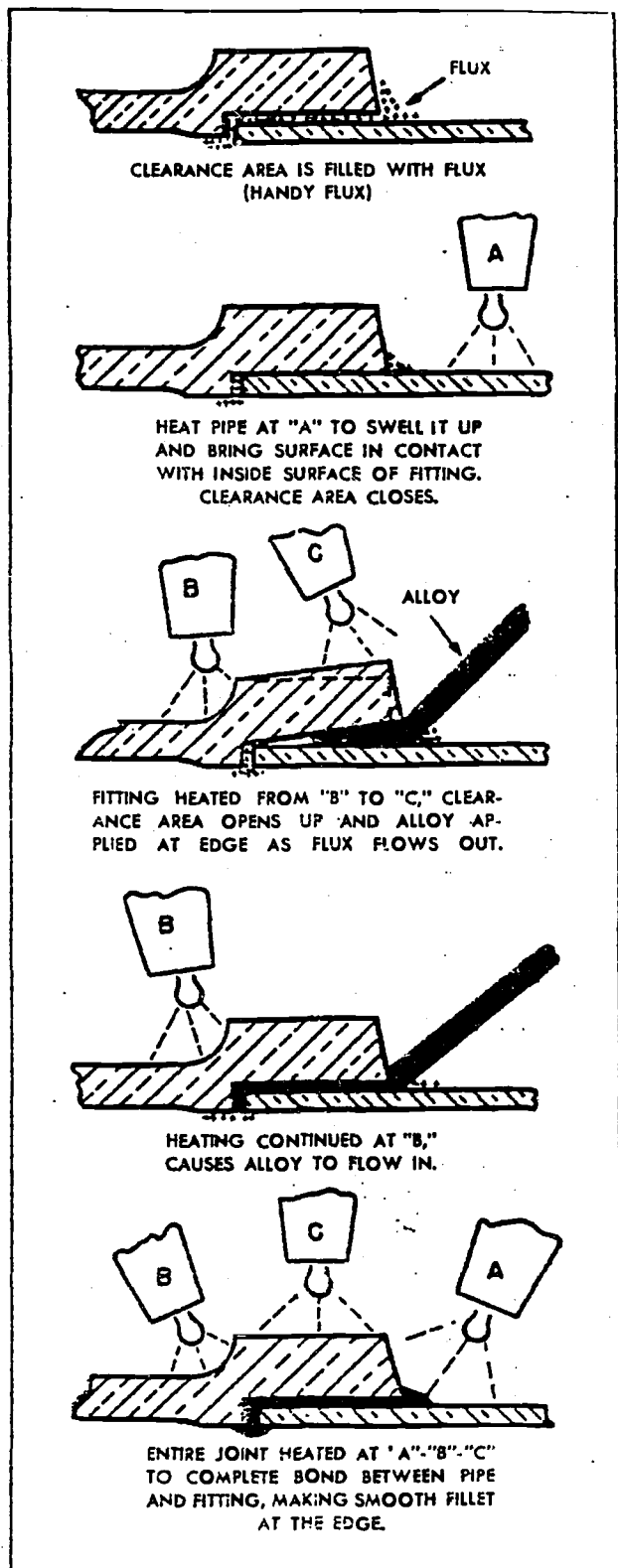
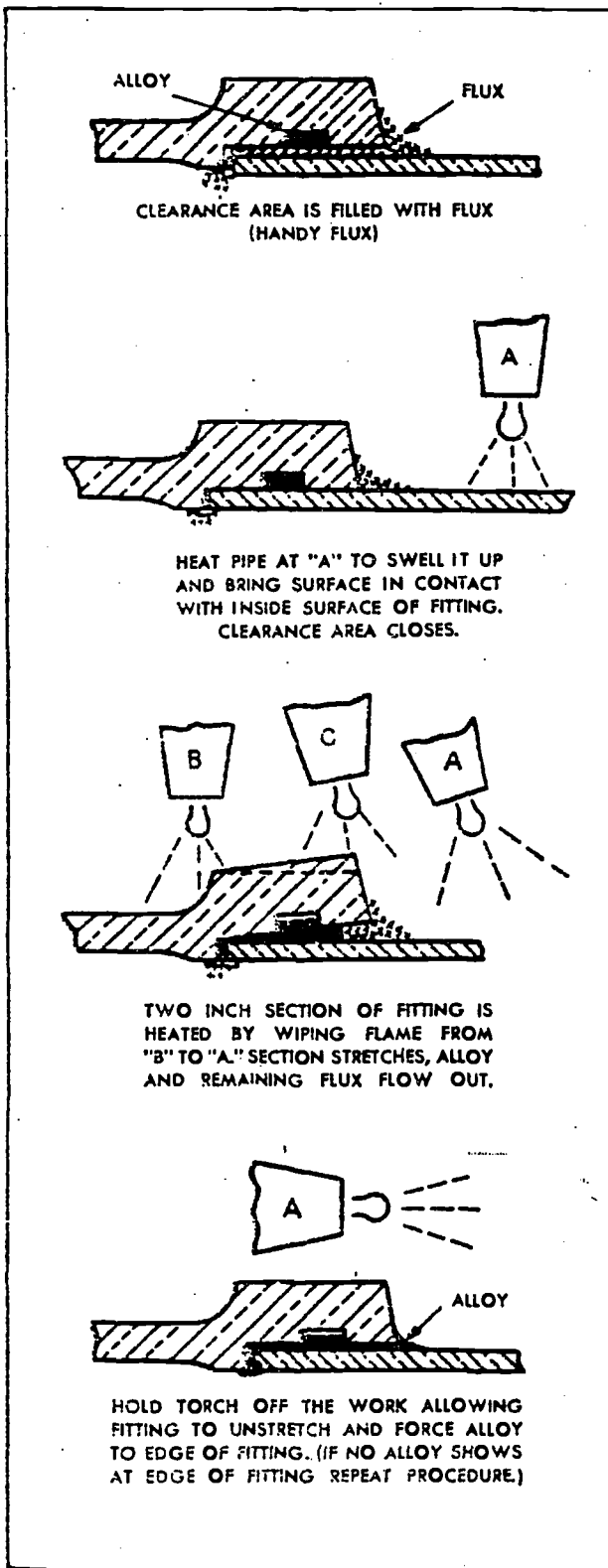


4. Clean fitting with steel wool to remove all traces of oxidation.



8. Wipe joint with rag. Remove discoloration by rubbing with steel wool.

Fig. 2-14



Alloy method of silver brazing.

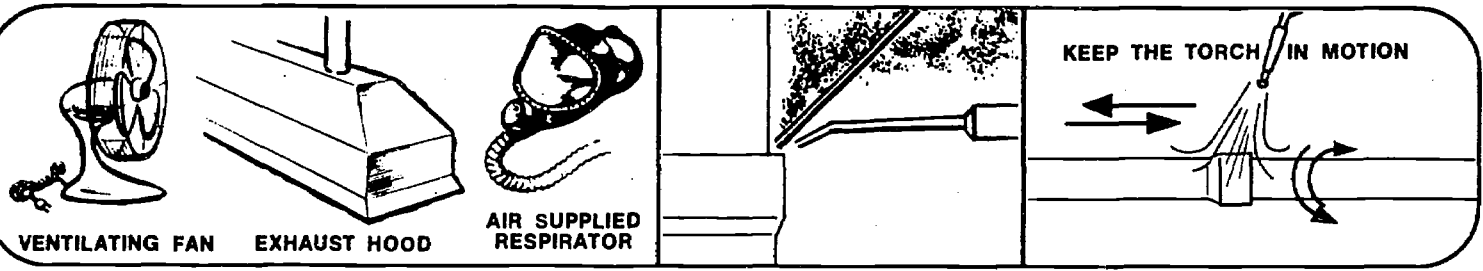
Fig. 2-15

INSTRUCTIONS FOR BRAZING FITTINGS TO PIPE AND TUBING WITH **HH** HANDY & HARMAN BRAZING ALLOYS

For strong, long-lasting, leak-tight, corrosion-resistant, vibration-proof joints on similar and dissimilar metals such as copper, brass, steel, stainless steel, etc.

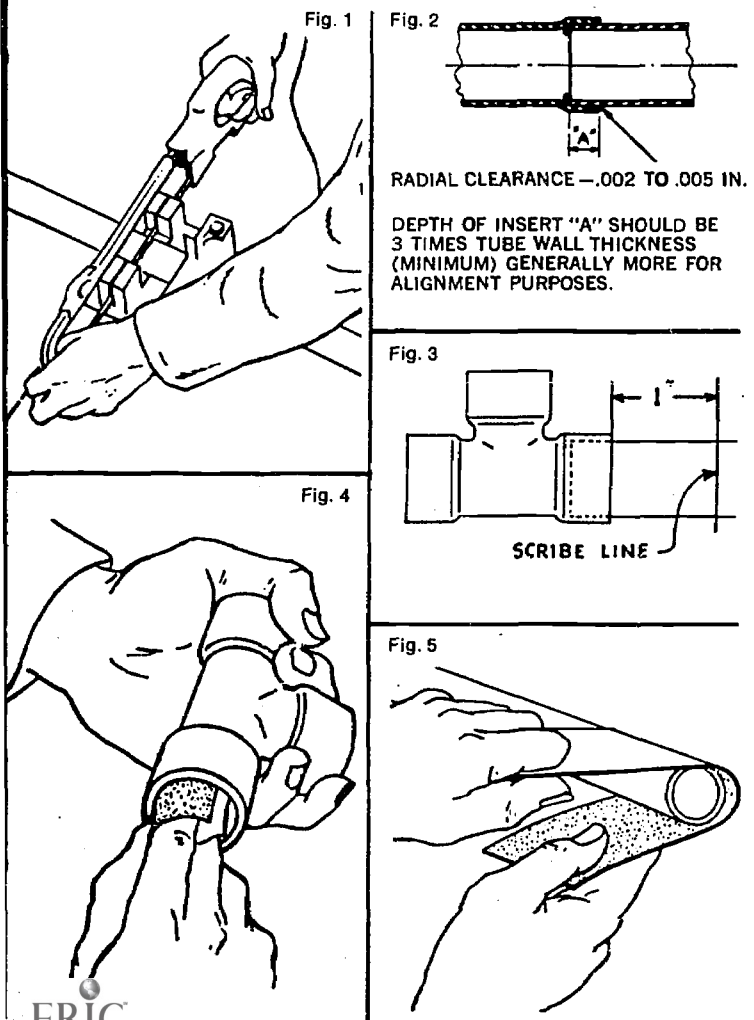
BRAZE SAFELY!

- A USE ADEQUATE VENTILATION** **B DON'T OVERHEAT** **C AVOID HOT SPOTS**



A Welding and brazing fumes may cause sickness and, in some cases, could prove fatal, if not handled properly. Particular care should be exercised with materials containing *cadmium* (cadmium plating should be removed), *beryllium*, *tellurium*, *lead*, *mercury*, *antimony*, *arsenic*, *bismuth* and *their compounds*, and *fluorides*. Vapors from cleaning compounds containing chlorinated hydrocarbons should not be allowed in the brazing area. (See USA Standard Z49.1 *Safety in Welding and Cutting* published by the American Welding Society, 347 E. 47th St., New York, N.Y.). **B** Overheating increases the amount of toxic fumes, particularly from cadmium. Use **HANDY FLUX** as temperature indicator (see "HEATING" below). **C** Localized overheating increases warping and interferes with good brazing. Apply more heat to the better conducting and the heavier of the sections being joined.

SIX STEPS TO EFFICIENT BRAZING



- 1. CUTTING AND FITTING**
 - a. Cut pipe or tubing to length. Make sure ends are cut square. Use of a square-end sawing vise or cutter is recommended, Fig. 1.
 - b. Remove burrs with a reamer or half-round file.
 - c. Try pipe or tubing end in the fitting to be sure it has the proper close fit. Clearance should not be more than .005", Fig. 2, except on large piping where greater clearances are necessary for ease of assembly.
 - d. Clearance should be uniform all around. Where necessary, round out pipe or tubing with a sizing tool.
 - e. On large piping, scribe a line on pipe at a distance from the cut end equal to the depth of fitting socket plus 1". This line serves as a check to make sure pipe is inserted full depth when assembled in the fitting, Fig. 3.
- 2. CLEANING**

Surfaces to be joined must be free of oil, grease, rust or oxides. Clean them as follows:

 - a. Practically all fittings have a coating of oil or grease. The liberal application of an effective solvent with a brush or by dipping of fittings and pipe ends can be used.
 - b. Subsequently, clean socket of fitting and end of pipe thoroughly with emery cloth to remove rust and oxides, Figs. 4 and 5, and remove residue. Grey cast iron fittings require special treatment to remove free surface graphite and sand inclusions.
 - c. Do not handle surfaces after cleaning.

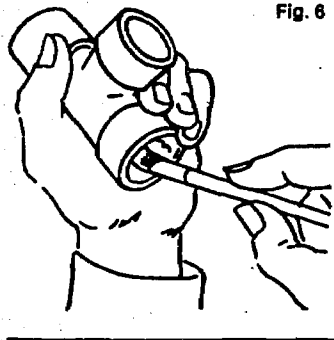


Fig. 6

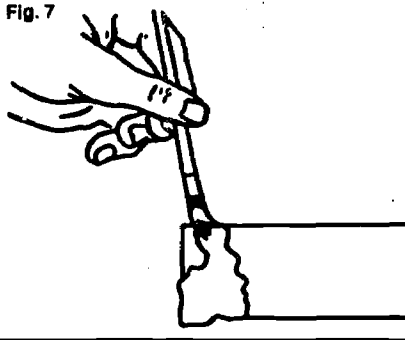


Fig. 7

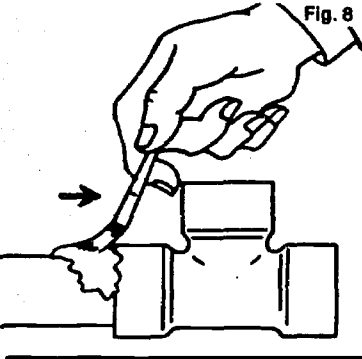


Fig. 8

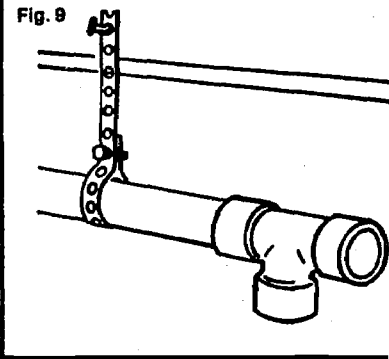


Fig. 9

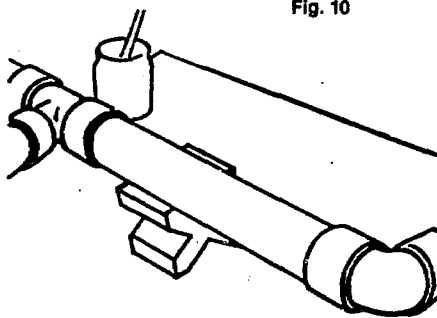


Fig. 10

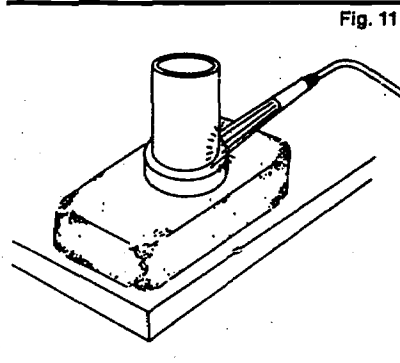


Fig. 11

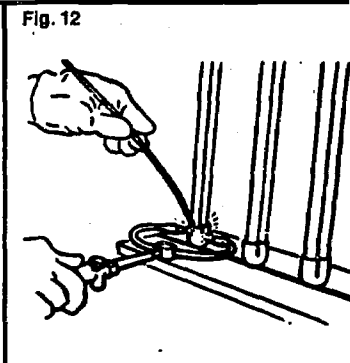


Fig. 12

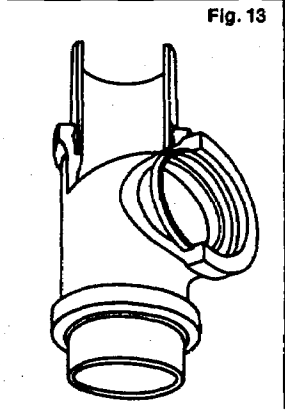


Fig. 13

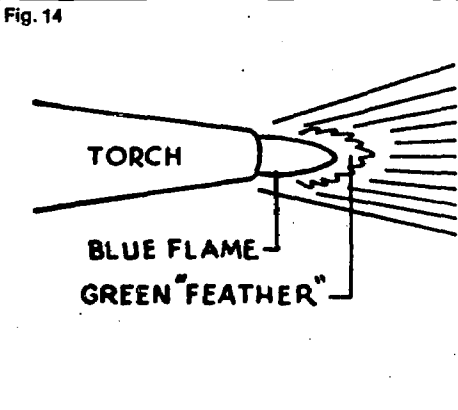


Fig. 14

3. FLUXING

- a. Immediately after cleaning, apply Handy Flux evenly with a brush to each joint surface, Figs. 6 and 7. When using Sil-Fos on copper-to-copper joints, Handy Flux can be omitted, but brass and bronze must have flux. If flux leaves bare spots, metal is dirty and will not join properly.
- b. Avoid leaving flux inside of pipe or fitting. In the case of refrigeration joints, do not flux the inside of the fitting. Just flux the pipe back from the end and push it into the fitting. On $\frac{1}{2}$ " and smaller tubing, flux applied only to the outside of the joint is often adequate. Flux inclusions can be minimized by placing a brazing alloy ring at the bottom of the joint, Fig. 2, so that it will flow outward, pushing the flux out ahead of it. This also insures that a sound joint has been made if the alloy appears uniformly at the socket edge.
- c. Assemble pipe into fitting immediately after fluxing.
- d. Where possible, revolve fitting once or twice on pipe to spread flux uniformly.
- e. Make scribe line check, Fig. 3, to see that pipe is inserted full depth in socket.
- f. Brush flux back over entire end of fitting all around Fig. 8. This prevents oxidation of the end.

4. SUPPORTING THE ASSEMBLY

- a. Before brazing, assembly should be carefully aligned and adequately supported, Figs. 9 and 10.
- b. Arrange supports so that expansion and contraction will not be restricted.
- c. See that no strain is placed on the joints during brazing and cooling.

5. HEATING AND FLOWING THE ALLOY

- Whenever possible, the entire joint should be brazed at once. Use of multiflame heating tips, Fig. 11, and multiple-tipped torches, Fig. 12, help in fast, even heating, particularly with preplaced alloy rings, Fig. 13. Do not heat brazing alloy directly. Watch the Handy Flux: when it turns clear, the parts are at 1100°F .
- a. Use a low velocity bulbous flame of sufficient size to permit rapid and even heating. The flame should be soft enough to wrap itself around the small diameter pipe or fitting, except on ETP copper where a neutral or slightly oxidizing flame should be used.
 - b. Adjust torch for a slightly reducing flame, Fig. 14.
 - c. If possible torch should be fitted with a soft copper extension tube about 10" long, so tip can be bent to direct flame where desired when working in tight quarters.

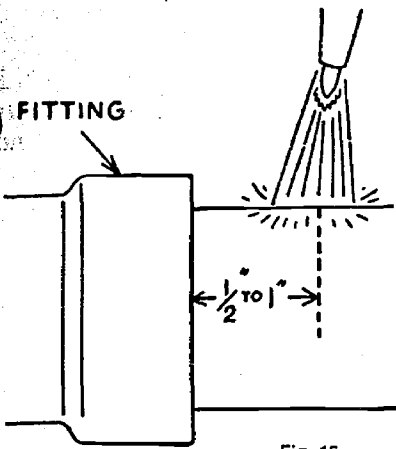


Fig. 15

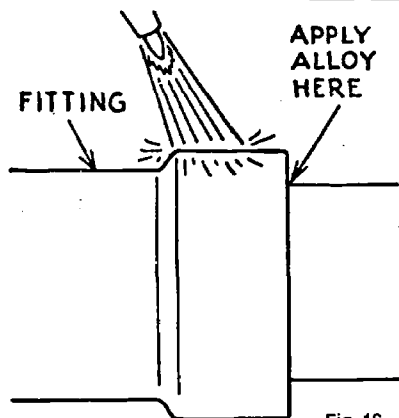


Fig. 16

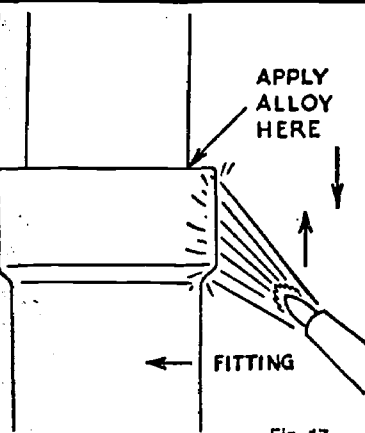


Fig. 17

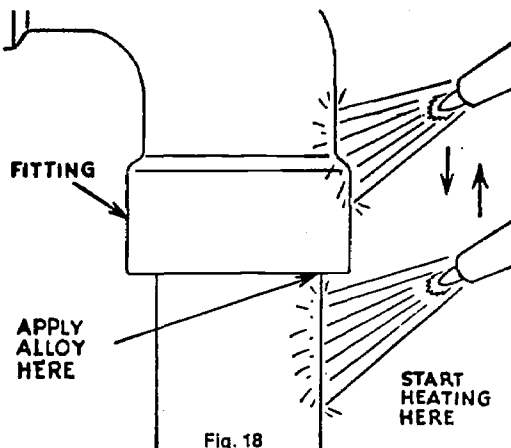


Fig. 18

- d. Start heating pipe or tube about $\frac{1}{2}$ " to 1" away from end of fitting, Fig. 15. Heat evenly all around to get uniform expansion of pipe and to carry the heat uniformly to the end inside the fitting.
- e. When flux on pipe adjacent to joint has melted to a milky liquid, transfer heat to fitting, Fig. 16.
- f. Sweep flame steadily back and forth from fitting to pipe, keeping it pointed toward pipe, Fig. 16. The object is to bring fitting and pipe up to an equal heat together for application of the silver brazing alloy. Avoid holding the flame at one location on the fitting as this can cause localized overheating.
- g. When flux is a clear, fluid liquid on both fitting and pipe, pull flame back a little and apply alloy firmly against pipe at junction between pipe and fitting, Fig. 16. With proper heating, alloy will flow freely into the joint. One final pass with the torch at the base of the joint and, when possible, rotating the fitting while the alloy is molten will help expel entrapped gases and flux.

Making Vertical Down Joints

- a. In joining fittings to $\frac{3}{4}$ " pipe or smaller, the entire joint can be brazed in one simultaneous heating operation as described in the preceding section.
- b. When pipe and fittings are larger than $\frac{3}{4}$ ", sectional heating is necessary. This is done as follows:
 - 1.—Always start with a preliminary heating of pipe and fitting according to section 5d above. Bring pipe and fitting to a black heat only.
 - 2.—After preliminary heating, select a 2" segment and bring pipe and fitting to brazing temperature by wiping flame from back of bead of fitting toward pipe, Fig. 17. When segment is up to temperature, as indicated by clear, very fluid state of flux, apply silver brazing alloy and sweat it in.
 - 3.—Then do an adjacent segment and proceed around the pipe, being sure to overlap the braze from segment to segment.

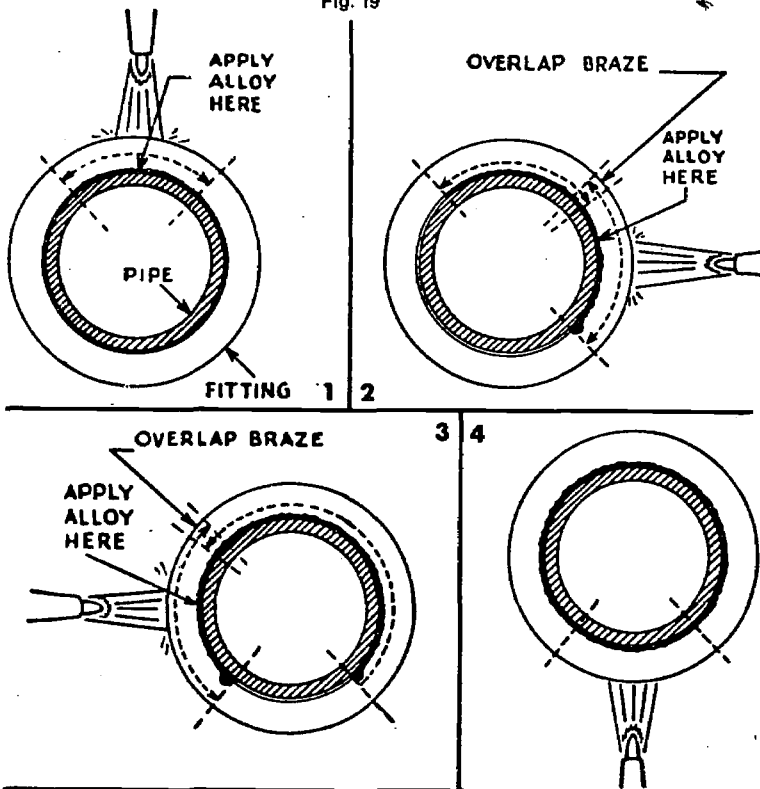
Making Vertical Up Joints

- a. Start with preliminary heating of pipe as before. When flux is liquid and milky, transfer heat to fitting and sweep back and forth from fitting to pipe, Fig. 18. Do this all around. Be careful not to overheat pipe below fitting as this will cause alloy to run down pipe and out of the joint.
- b. When brazing temperature is reached, as indicated by flux, touch alloy to joint with heat aimed on wall of fitting to pull alloy up into the entire joint area.

Making Horizontal Joints

If the entire joint can be made in one operation, apply the alloy at the top of the joint, so it can run down each side of the tube by capillarity and gravity. Apply the torch to the bottom of the fitting to pull the alloy into the joint. Make sure there is alloy showing

Fig. 19



around the fitting; if the top is void, add more alloy. The excess will collect at the bottom.

If the joint is too large to be brazed at one time:

- Start by preheating pipe until it shows a black heat around its entire circumference. Duplicate this procedure on fitting.
- Now, select a segment on top of pipe and bring it up to brazing temperature by sweeping flame back and forth between fitting and pipe. Then apply alloy, Fig. 19 (1), after which, remove heat and allow alloy to set.
- Then do one side starting below center, Fig. 19 (2). Be sure to overlap top segment.
- Next do the other side, Fig. 19 (3), again being sure to overlap top segment.
- When both sides are done there will be a globule of alloy on each side at the bottom of the brazed segment, Fig. 19 (3). Apply heat on bottom of fitting and back of bead and with the usual back and forth motion toward pipe, draw the alloy into the bottom joint segment. Do not be fooled by a large fillet along the bottom. It may have flowed down over relatively cold metal. Always heat bottom of fitting to pull this alloy into the joint.
- Finally, again check the top side of the joint to be sure the brazing alloy did not drain out. If necessary, reheat and touch more alloy to this area to form a slight fillet.

Fig. 20

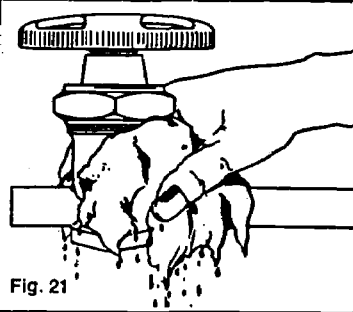
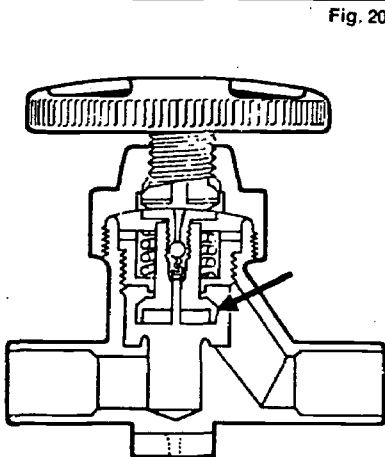


Fig. 21

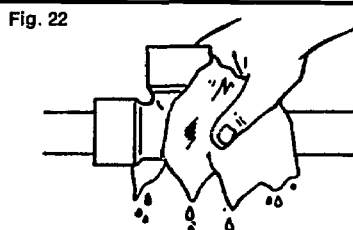


Fig. 22

Joining Valves

Valve packings, seats and diaphragms can be damaged by excessive heat. Packings may have to be removed or water-cooled during brazing. Seats can be protected by suspension inside the valve, Fig. 20, by closing valve 1/4 turn from fully open, and minimizing the heating time. Follow any of the above procedures but point the flame away from the valve body and use a low-melting and free-flowing brazing alloy such as Easy-Flo 45. Apply a wet rag or swab to the valve body immediately after the alloy sets, Fig. 21.

6. CLEANING AFTER BRAZING

- Immediately after brazing alloy has set, apply a wire brush or swab to joint, Fig. 22, to crack and wash out flux. Flux can be removed from inside of pipes by flushing with water, preferably hot. All flux must be removed for inspection and pressure testing. Use wire brush if necessary.

APPROXIMATE AMOUNTS OF SILVER ALLOY FOR BRAZING DIFFERENT SIZES OF PIPE AND TUBING

Pipe & Tube Size	INCHES OF WIRE PER JOINT		
	Easy-Flo alloys for Steel or Brass I.P.S. Fittings		Sil-Fos for Copper & Brass Nominal Fittings
	1/16" Wire	3/32" Wire	.050" x 1/8" x 20"
1/4"	3/4"		3/4"
3/8"	1"		1"
1/2"	2"	1"	1 1/4"
3/4"	3"	1 1/2"	2"
1"	4"	2"	3 1/2"
1 1/4"	5"	2 1/2"	4"
1 1/2"	6"	3 1/2"	4 1/2"
1 3/4"		5 1/2"	6"
2"		6 1/2"	8"
2 1/2"		9 1/2"	12"
3"		14 1/2"	16"
3 1/2"		17"	20"
4"		20"	24"
5"		25"	35"
6"		36"	45"
8"		46"	57"

WARRANTY CLAUSE:

Handy & Harman believes the information contained herein to be reliable. However, the technical information is given by Handy & Harman without charge and the user shall employ such information at its own discretion and risk, and Handy & Harman assumes no responsibility for results obtained or damages incurred from the use of such information in whole or in part.



HANDY & HARMAN 850 THIRD AVENUE NEW YORK, N.Y. 10022

Victaulic

GROOVED PIPING METHOD

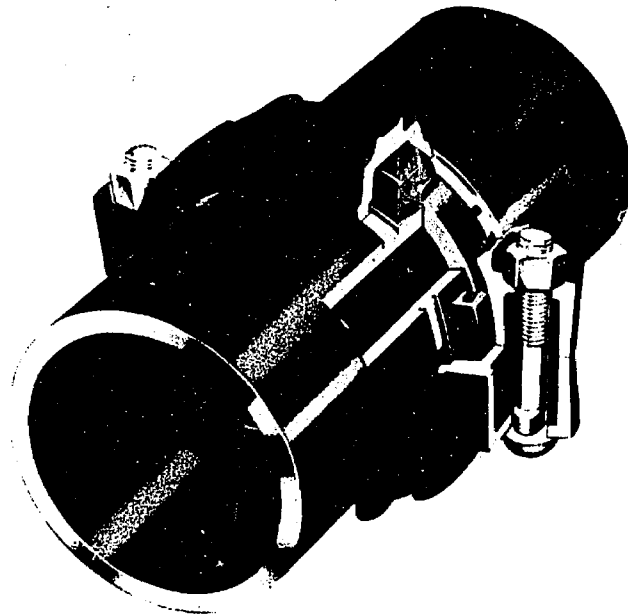
The Victaulic method of joining grooved pipe is the most versatile piping method available. It is five times faster than welding; easier and more reliable than threaded or flanged methods. Assures long life, leak tight security and lower installed cost than competitive methods.

The Victaulic method has the versatility of a piping system which provides expansion, flexibility and vibration reduction with a union at each joint. Victaulic can be applied to black or galvanized steel, stainless, aluminum, wrought iron, plastic—almost any pipe of IPS dimensions. A single coupling size fits most types and wall thickness of pipe in its size. (And Victaulic has couplings for cast iron sizes, too.)

The Victaulic grooved piping line is the most complete available. With a variety of couplings in $\frac{3}{4}$ " through 30" sizes. A complete line of fittings. Butterfly valves. Plus the unique Vic-Flange, Outlet Couplings and other products available only from Victaulic. Portable groovers for on-site grooving. A nation wide stocking distributor organization, backed by eight Victaulic warehouses across the country.

The Victaulic method is simple yet effective. Based on a groove machined in the pipe end, the system is joined by ductile or malleable iron housings which lock into the grooves enclosing a synthetic gasket to create the seal.

- 1—**HOUSING**—The housing segments are precisely cast of ductile or malleable iron. The housing key engages the grooves in the pipe around the entire circumference securely joining the pipes.
- 2—**GASKET**—The gasket is designed to seal under pressure or vacuum. Molded of varied synthetic elastomers, the gasket is designed to provide long life for the intended service.



- 3—**BOLTS/NUTS**—The steel oval neck track bolts seat in the housing slots permitting assembly with a single wrench.
- 4—**GROOVE**—The groove permits joining of the pipes together without clamping. This provides the controlled flexibility and permits rapid assembly. Pipe is available from mills or distributors grooved for Victaulic couplings. A complete line of portable tools adds versatility for easy on-site grooving.

THE METHOD . . . The unique design features of the Victaulic grooved piping method offer many advantages not available with other methods. Victaulic offers the versatility of a wide variety of coupling styles and sizes

plus a complete line of fittings, grooving tools and accessories. Quality and reliability are assured by more than 45 years of experience in grooved pipe joining.



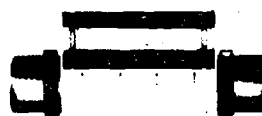
Fast, simple assembly



A permanent joint



Expansion and contraction allowance



Union at each joint



Easy alignment

Fig. 2-16

Working pressures listed are based on hydrostatic tests with no external load using standard weight steel pipe through 20-inch (XS above 20-inch), square cut grooved to Victaulic standard specifications.

Field test pressures shall not exceed $1\frac{1}{2}$ times rated the working pressure including external loads.

To assure the maximum life for a particular service, refer to Victaulic Gasket Selection Guide and always specify gasket grade when ordering.

rolled into the metal. Grooved fittings as shown are used to complete the system, which is used for chilled water and condensing water piping in heating and ventilating work.

Compression-sleeve Couplings (Dresser)

This joint forms a water tight connection between two plain ended pieces of pipe by clamping two rubber gaskets around each piece. There is no provision to keep the pipe ends together, therefore thrust blocks, anchors or other restraints must be used to keep the joint from pulling apart. (Fig. 2-16)

Installation of Piping

Good piping systems don't just happen - - they are planned. The piping drawings usually show a schematic arrangement indicating the general location of the various lines, but it is usually the job of the contractor's layout man to locate them to miss duct work, lighting fixtures and structural obstacles with the minimum amount of labor and fittings.

The following pointers are some of the things that make a good piping system:

1. General Arrangement:

Pipes to be installed parallel to walls, arranged to present a neat appearance as to grouping and workmanship.

No interference of piping with light fixtures, passing over access openings, or blocking passageways.

Sufficient distance between pipes to allow proper installation of insulation and painting.

Pipes installed high enough above passageways to allow 6'-9" clear headroom.

Pressure gages and thermometers installed for easy visibility from the working level.

Sufficient unions or flanges installed to permit disassembly of piping for access to equipment.

2. Pipe Support Systems.

A hanger should be placed within 1 foot of the elbow where there is a change of direction in either the horizontal or vertical plane.

Hangers should be placed near the connections to equipment such as pump, compressors, etc. so that no weight is transmitted to the equipment. A hanger should be placed close to a union especially if it is next to a heavy valve.

Hangers which support moving pipe should have a hinged joint at the point of support from the building, otherwise the rod will fatigue and fail.

Piping subject to surges, water hammer, or pump action require braces at changes of direction.

The following is a good schedule for hanger spacing:

Type of Pipe	3/4" Size or Smaller	1" Thru 1-1/4" Size	1-1/2" Size or Larger
*Steel Pipe	8'-0"	10'-0"	**10'-0"
Copper Tubing	5'-0"	8'-0"	10'-0"
IPS Brass Pipe	8'-0"	8'-0"	10'-0"
Plastic (PVC)	3'-0"	5'-0"	7'-0"
Plastic (Polyethylene)	12 Times Pipe O.D.	8 Times Pipe O.D.	8 Times Pipe O.D.

* Hangers for steel gas lines shall be spaced on centers of 6'-0" for 1/2" sizes, 8'-0" for 3/4" and 1" sizes and 10'-0" for all other larger sizes.

** Spacing may be 16'-0" for sizes 6" and larger (steel pipe only).

Where compression type joints are used, similar to the Dresser coupling, or O-ring joints, thrust anchors must be used at changes of directions. For buried lines, the size of the thrust block depends on the bearing strength of the soil, the pipe diameter, the angle of direction change and the pressure in the pipe. The load on the anchor is found as follows:

Load = internal pressure x internal area of pipe x fitting factor.

Where load = lbs

Internal pressure = lb per sq in.

Internal area = square inches

Fitting factor:

90° ell = 1.41

Caps, plugs, tees = 1.00

45° ell = 0.77

22½° ell = 0.39

11¼° ell = 0.20

The following bearing loads are for horizontal thrusts when the depth of cover over the pipe is 2 feet or greater:

Muck, peat, etc.....	0 lb per sq ft.
Soft clay.....	1,000 lb per sq ft.
Sand.....	2,000 lb per sq ft.
Sand and gravel.....	3,000 lb per sq ft.
Sand and gravel with clay.....	4,000 lb per sq ft.
Hard shale.....	10,000 lb per sq ft.

The anchor block of concrete must be poured up against undisturbed earth, with no form lumber between the two; the bearing area equal to or greater than the amount calculated from the above formulas. See Fig. 2-17 for typical thrust block arrangements.

Allowance must be made for the expansion and contraction of pipe subject to temperature change. Expansion can be provided for by means of "U bends" or offsets fabricated from pipe and welding elbows, by packed slip joints, corrugated bellows, and ball joints. Expansion bends do not require any maintenance but may require more room than is available. Guides are needed to restrain the pipe movement along its axis and to keep the pipe from raising off its supports. The slip joint requires some maintenance and needs guides, as does the bellows type.

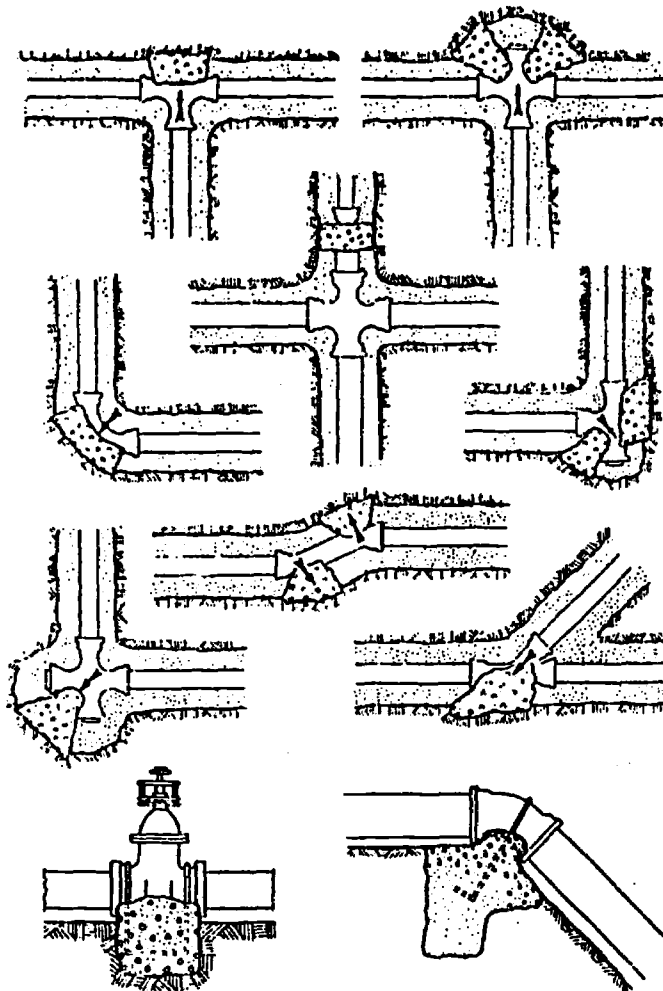
Expansion loops are fabricated from welding fittings and pipe in U shapes (where space permits) for high temperature steam and water. They require anchors and guides to restrain the pipe and keep it from raising or moving sideways off the supports.

Fig. 2-18 shows corrugated bellows; (a) the restrained type for high pressures and (b) suitable for 30 psi. Fig. 2-19 is a typical layout using bellows showing guide and anchor arrangements. This joint cannot be subjected to lateral offset and the pipe must be guided squarely into the joint. Figs. 2-21 and 2-22 show a packed slip joint, anchor and guide layouts for a typical arrangement. Fig. 2-24 is an expansion U bend, and an offset constructed of pipe and welded fittings with the recommended guide locations. "Cold springing" an expansion loop is done to get more flexure from the loop. It can be seen that by spreading the legs apart (before connecting the pipe) an amount equal to 1/2 the expected thermal expansion, the expanded pipe will close the loop together only 1/2 of what it would without cold spring. This permits the use of smaller loops for a given expansion. It is very important that the loop be cold sprung to the figure shown on the design drawings, otherwise the pipe will be overstressed.

See Appendix Table A-4 & Fig. 2-20 for expansion of piping, and copper expansion loops.

LOCATION OF THRUST BLOCKS

The location of thrust blocks depends on direction of thrust and type of fitting as shown below.



If thrusts, due to high pressure, are expected, anchor valves as above (see also page 67).

At vertical bands, anchor to resist outward thrusts—see page 65.

Fig. 2-17
Courtesy, Johns-Manville Transite Pipe Division

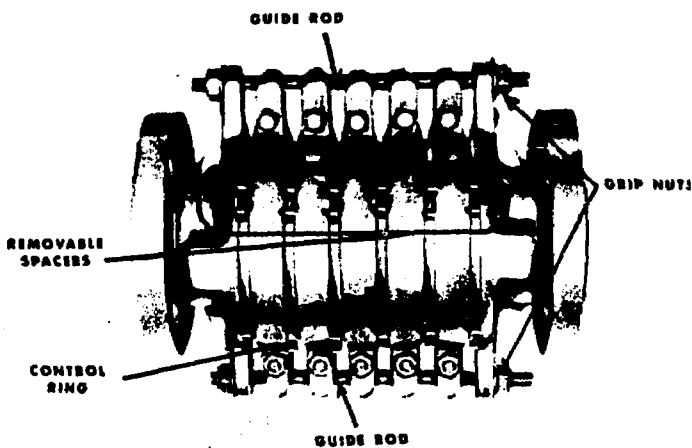
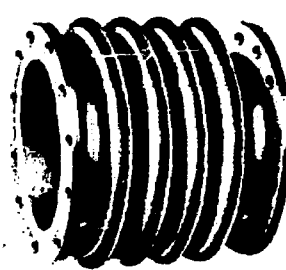
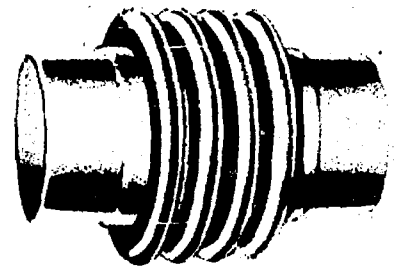


Fig. 2-18 (a)



With Standard Flanges



With Welding Ends

Fig. 2-18 (b)

Typical Installation

CORRUGATED EXPANSION JOINTS

Example of Joint Selection.

A is Main Anchor
B is Intermediate Anchor
C is Guide

EXPANSION CALCULATIONS

EXAMPLE:

DATA—Pressure 75 P.S.I.
Pipe Size—8 in. Steel Pipe
Length of Pipe—175 Feet
Temperature (Operating) 340°F.
Temperature (Installed) 60°F.

EXPANSION TO BE CARED FOR:

Maximum Temperature 340°F.	Expansion per 100 Ft.	2.862"
Installed Temperature 60°F.	Expansion per 100 Ft.	.593"
		2.269"

$$2.269" \times \frac{175'}{100} = 3.97" \text{ Total Expansion}$$

For this installation use Controlled-Flexing Joint with 4 3/8" Traverse.

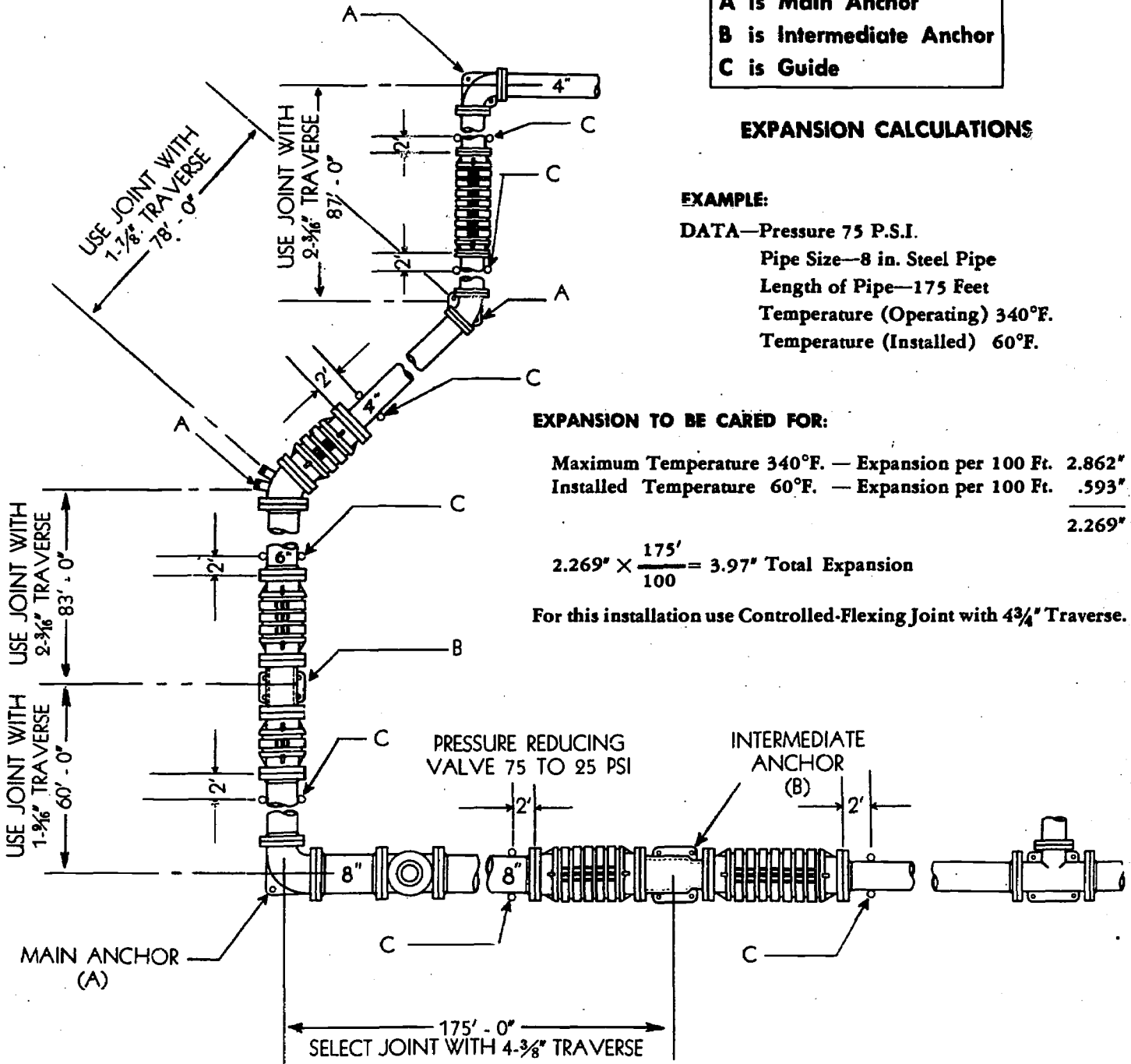


Fig. 2-19

In order to insure the proper functioning of corrugated expansion joints it is highly important that all pipe lines in which expansion joints are located be suitably anchored, guided and supported. Proper anchoring, guiding and supporting will insure a controlled motion of the expansion joint and pipe line, free from lateral stresses.

Whenever possible, the expansion joint should be located near the anchor point, preferably within two feet of the anchor. (Note main anchors at points "A" in diagram.) When it is necessary to install the joint midway between anchors, or at another

point, suitable guides should be provided within two feet of each end of the expansion joint to prevent lateral or huckling force on the joint. (Note intermediate anchors "B" in diagram.)

Where two or more joints are required in a straight run of pipe, place intermediate anchors between them. This insures that each expansion joint will properly absorb its rated share of the total motion involved. (Note intermediate anchors "B" in diagram.)

An expansion joint should be installed with each directional change of the pipe line unless designed for combination motions.

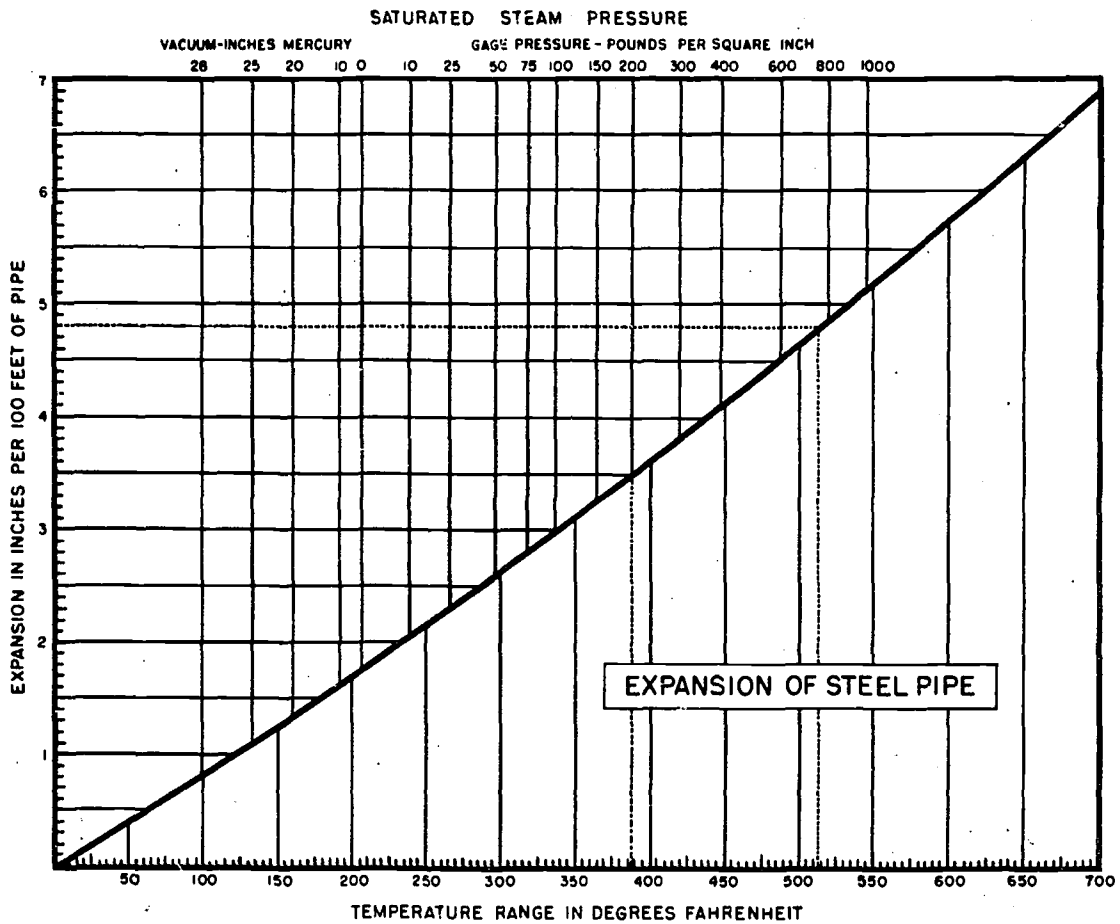


Fig. 2-20

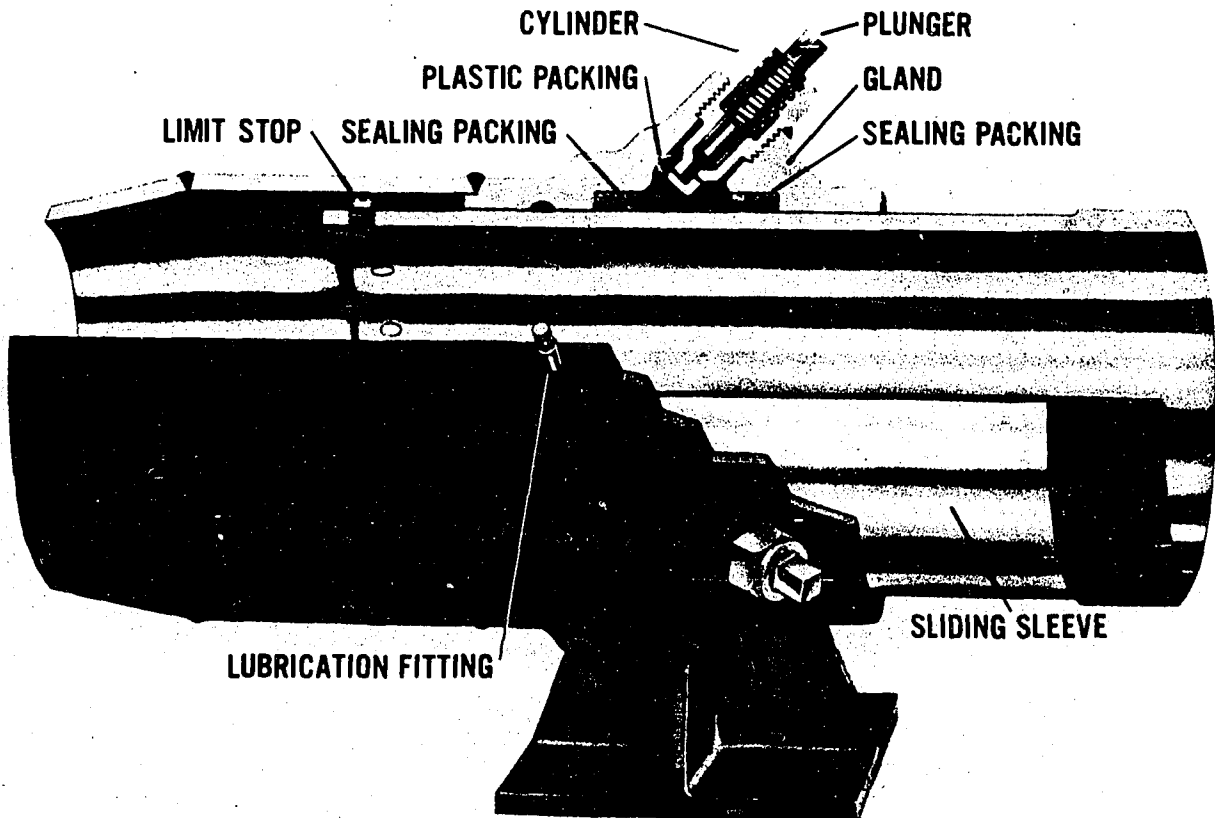


Fig. 2-21
41

Yarway Co.

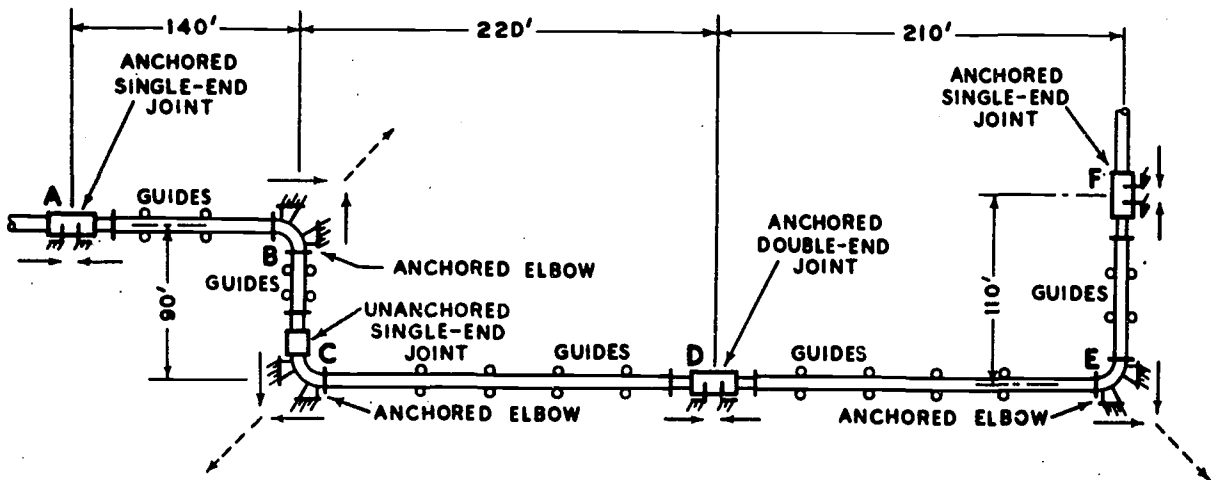


Fig. 2-22

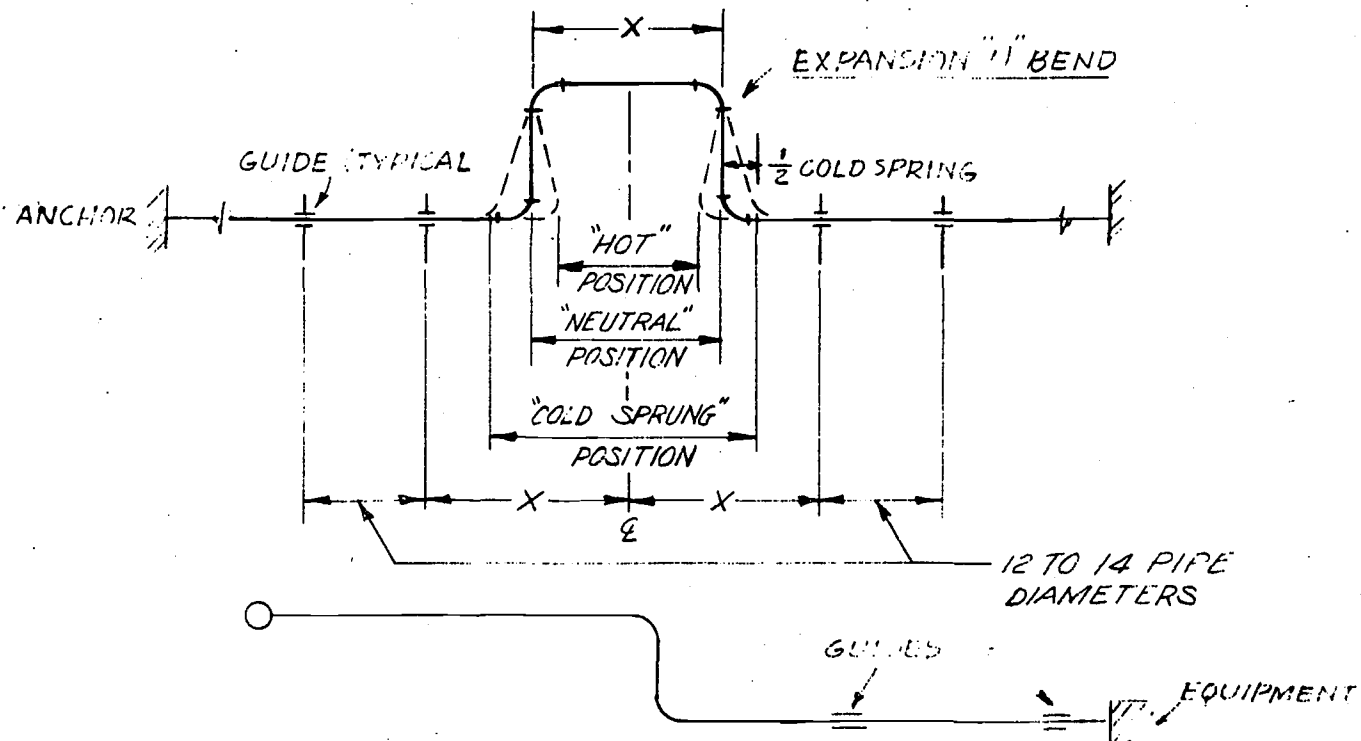
Yarway Co.

RECOMMENDED SPACING FOR GUIDES AND SUPPORTS (Dimensions in feet)

Nominal pipe sizes (inches)		1½	2	2½	3	3½	4	5	6	8	10	12	14	16	18	20	24
Distance between joint and first alignment guide		8	10	11	12	13	14	15	16	18	20	21	22	23	24	25	26
Distance between alignment guides	150 psi	12	16	22	28	30	34	42	51	65	82	94	96	107	116	125	141
	300 psi	12	14	18	22	26	29	36	42	53	66	75	76	84	90	96	107
Maximum distance between pipe supports		8	10	11	12	13	14	15	16	18	20	21	22	23	24	25	26

Fig. 2-23

Yarway Co.



OFF-SET BEND

Fig. 2-24

Provision should be made for venting air from a system which will be hydrostatically tested and also for completely draining it afterwards. Sufficient drains are also needed to completely flush the lines during the cleaning operation.

Pipe and fittings should be inspected for obstructions such as shipping material, rags, construction dirt, etc, prior to closing up, and temporarily capped up when hung in place. Water should not be allowed to stand in open piping.

When pipes pass through floors and walls of buildings there should be a clear space left around the pipe sufficiently large for movement caused by expansion of the pipe and movement of the building from settling or earthquakes. Never grout around a pipe.

Special provision must be made for underground piping passing through subgrade walls to seal off ground water from entering around the pipe opening, without sacrificing flexibility between the pipe and wall.

Piping systems should be tested hydrostatically, the exception being refrigeration piping. The system must be completely filled with water, and completely rid of air. The test pressure is then applied with a positive displacement (plunger) pump, hand or motor driven. When the test pressure has been reached, the pump should be valved off or disconnected, and the gage observed during the test period. A minute leak will cause a large pressure reduction, which is the advantage of the hydrostatic over an air pressure test. If the line is subject to temperature changes, the amount of water bled off and then added to keep the pressure at the prescribed level during a 24-hour test period should be recorded and the net leakage determined, if any. Welds should be carefully inspected during the test for weeps, and repaired as required.

Pipe Cleaning

Some specifications contain requirements for cleaning the piping as follows: "Drain and flush piping to remove grease and foreign matter. Blow out oil, air, vacuum and gas piping with compressed air". To effectively move debris through a pipe by flushing or blowing requires a large volume of water or air, and generously sized drain or blowoffs at all the low points to get rid of the dirt. The results are usually less than satisfactory.

Most construction dirt can be kept out of pipe by storing it on cribs above the ground and keeping it covered. Larger pipes should be swabbed out free of welding slag as the fabrication proceeds. The rust, scale and oils that adhere to the inside of the pipe are best removed by chemical cleaning which is neither expensive or difficult. Trisodium Phosphate (TSP) mixed one pound for each fifty gallons of water in the system, and heated to the operating temperature is a good cleaner. This is circulated for a few hours, then completely drained, and the system refilled with clean water (if a hot or chilled water system). Commercial pipe cleaning firms

are also available to perform this service.

Valve types

The more common valve types and some details of their construction are shown:

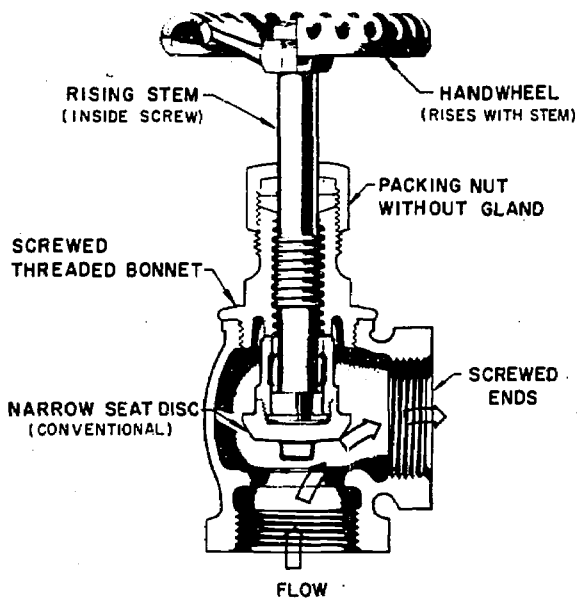


Fig. 2-25 Angle Valve

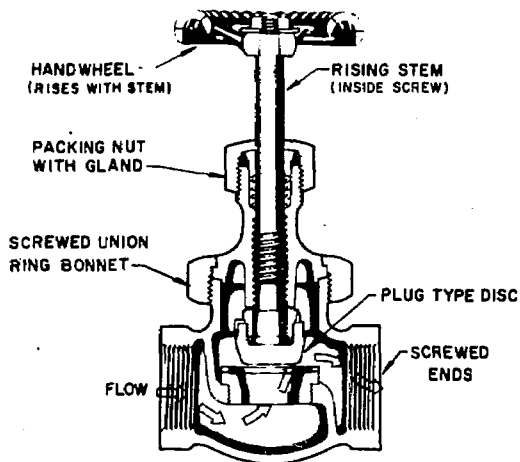


Fig. 2-26 Globe Valve

This angle valve has a rising stem and threaded bonnet, as noted. Angle valves can be used for throttling (adjusting) the flow without seat damage.

The globe valve shown has a rising stem, and a screwed union bonnet, which is a more rugged construction than the threaded bonnet. It is easier to disassemble. A plug type disc is shown, which gives it good throttling characteristics, and allows tight shut-off.

Figs. 2-25 to 2-31 Courtesy of Crane Co.

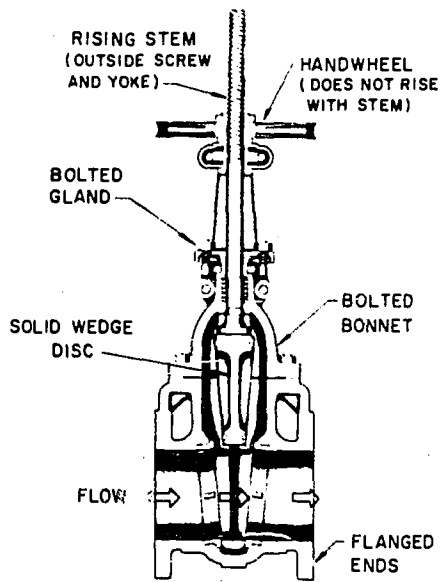


Fig. 2-27 Gate Valve
Rising Stem

The gate valve of Fig. 2-27 has a rising stem (but fixed handwheel) and a bolted bonnet, and is also called an outside screw and yoke (OSY). It requires more room because of the emergent stem, the threads of which are not in contact with the fluid. The position of the stem indicates whether the valve is open or closed. The disc is a solid wedge. All gate valves must be full open or full closed.

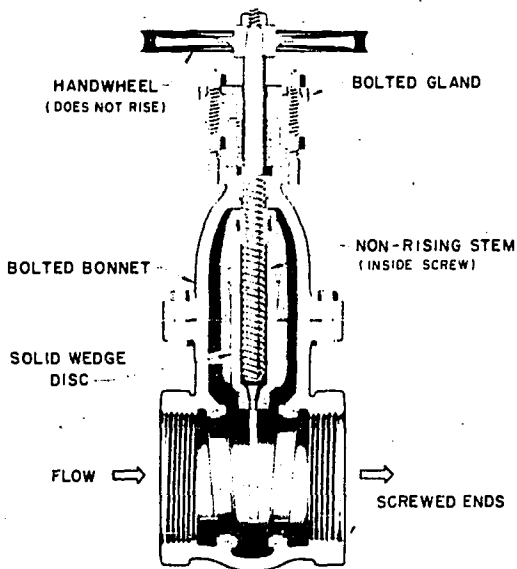


Fig. 2-28 Gate Valve
Non-rising stem

This gate valve has a non-rising stem and handwheel. The screw is inside the bolted bonnet. The disc is a solid wedge. Solid wedges are the most common type of gate valves, but are subject to sticking where there is a change of temperature.

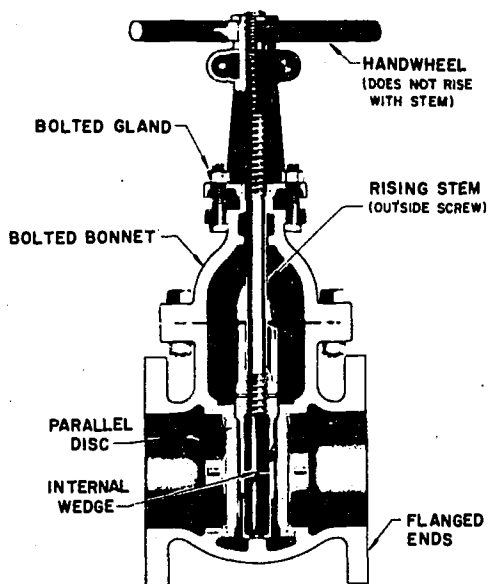


Fig. 2-29
Double Disc Parallel Seat
(Gate Valve)

This style of gate valve (non-rising stem) has a double disc seat and utilizes an internal wedge to force the double discs against the seat. This valve is less likely to stick because of a temperature change.

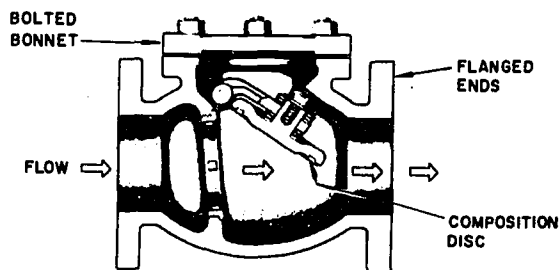


Fig. 2-30
Swing Check Valve

Check valves permit flow in one direction only. The swing check can be installed vertically or horizontally.

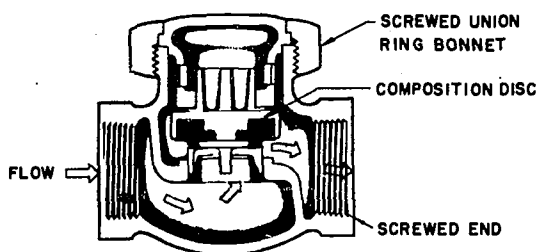
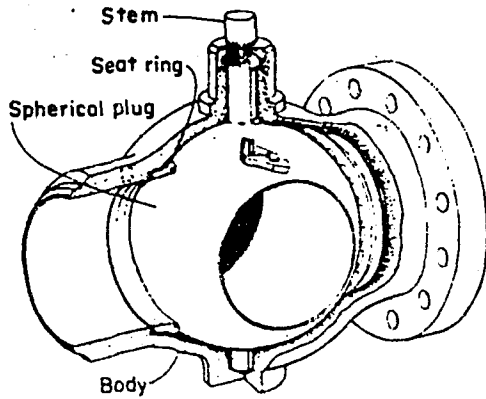


Fig. 2-31
Lift Check Valve

The lift check can be installed in a horizontal position only. Its composition seat will make a tight shut-off.



Ball valve in closed position.

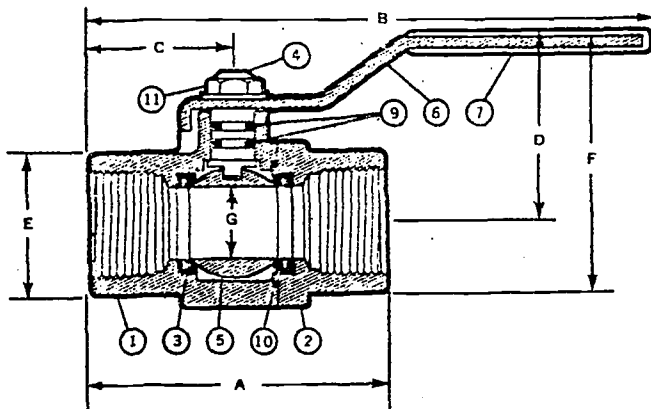
PRESSURE-TEMPERATURE RATINGS

SERVICE	BL-301 BUNA-N	BL-301TF TEFLON
WATER	400 psig @ 100°F	400 psig @ 100°F
OIL OR	300 psig @ 125°F	300 psig @ 200°F
GAS	200 psig @ 150°F	250 psig @ 300°F
	100 psig @ 220°F	200 psig @ 400°F
STEAM		150 psig — Saturated Steam

NOTE: BL-301 with Buna-N trim is Underwriters Laboratories approved for use on Liquefied Petroleum Gas at maximum pressure of 250 psig.

TESTS

Hydrostatic Shell — 600 Lbs. psig
Air under Water — 250 Lbs. psig



MATERIALS

1. BODY. Forged brass. ASTM B 283.
2. CAP. Forged brass. ASTM B 283.
3. SEAT. BL-301: Buna-N, brass insert.
BL-301TF: Teflon.
4. STEM. Naval brass. ASTM B21 Alloy C.
5. BALL. 1/4" thru 1"; Naval brass. ASTM B 21 Alloy C.
1 1/4" thru 2"; Forged brass ASTM B 283.
6. HANDLE. Carbon steel, cadmium plated.
7. GRIP. BL-301: Black vinyl.
BL-301TF: White vinyl.
8. SCREW. Carbon steel, cadmium plated.
9. O-RING. BL-301: Buna-N.
BL-301TF: Viton rubber Teflon.
10. O-RING. BL-301: Buna-N.
BL-301TF: Teflon.
11. SHAKEPROOF NUT: Carbon steel, cadmium plated.

R-P-C Valve Co.

Fig. 2-32. Ball valves turn from full closed to full open in one-quarter turn and can be used for steam and water service. The valve stems are sealed with O-rings.

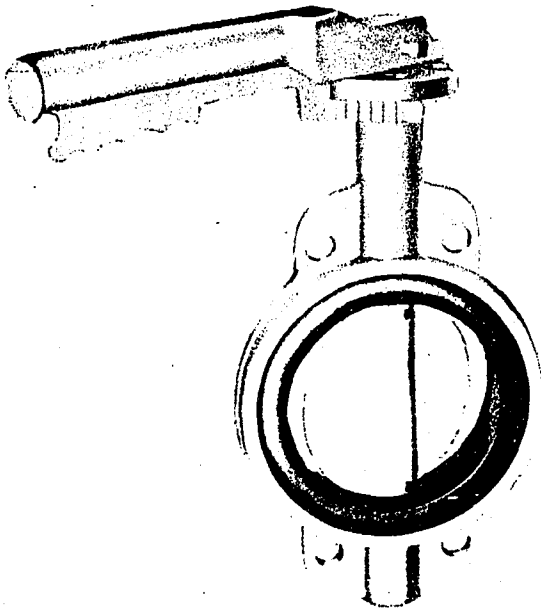


Fig. 2-32A

Butterfly valves are used for tight shut off and throttling liquids and gases. The disc seats against a Buna-N boot for tight closure. The valve is locked in various positions by means of a ratchet as shown. Gear operators are used for the larger sizes. Discs and liners are available in many different materials and should be checked against the specifications.

Valves are usually basically rated in terms of allowable steam pressure, as 125, 150, 200, 300, etc, but also carry a rating for OWG (oil, water, gas, non-shock) of much higher pressures. Thus, a certain 125 lb valve is good for 125 lb steam and 200 lb WOG, etc. The pressure ratings are cast on the body.

Bibliography

Footnote 1. Extracted from the ASME Boiler and Pressure Vessel Code (Section IX), with the permission of the publisher, The American Society of Mechanical Engineers, United Engineering Center, 345 East 47th Street, New York, N.Y., 10017.

Footnote 2. Extracted from the ANSI Standard Code for Pressure Piping, Power Piping, ANSIB 31.1.0 with the permission of the publisher, The American Society of Mechanical Engineers.

3. PIPING SYSTEMS

This section will deal with good piping practices to be observed for the various types of systems used in air conditioning, heating and ventilating plants.

Steam and Condensate Returns

The steam produced by steam heating boilers is usually at the saturation temperature of the boiler pressure (no superheat) and starts to form condensate as soon as it leaves the boiler outlet. The steam mains and branches must be graded "downhill" to pockets or "drip legs" where the condensed steam passes through a steam trap and flows through a drain collecting system and eventually back to the boiler. The steam travels at a high velocity and sweeps the condensate along with it. If the line is not properly graded and kept free of condensate the steam will pick it up and throw it against the end of the main with a tremendous force. The main, and any steam line in which the condensate travels the same direction of the steam, should pitch down $1/2$ " per foot if practicable. The exception to the above is branch connections to heaters (Fig. 3-1-(e)) where the steam flows upwards and the condensate flows counter-currently back to the main. In this case the branch is pitched up 1" in 10' and made one size larger than the riser it services. Steam branches should always be taken off the top of the main, either 90° or 45° .

In connecting a steam supply to a temperature control or similar open-closed device the piping should be arranged so as to prevent an accumulation of condensate against the closed valve. (Fig. 3-2)

The condensate build-up will damage the seat of the temperature control valve in time and also cause erosion of the heat exchange coils or tubes. The "wrong" method could be corrected by installing a steam trap ahead of the control valve.

Drip legs (also called dirt legs) should be the full line size and long enough to keep the line well drained.

Steam traps are automatic devices that discharge condensate from a steam filled space but prevent the steam from leaving. The general types are float, bucket, and thermostatic in heating applications. The float and bucket types are opened and closed by the condensate level in the body. The thermostatic type is opened and closed by the temperature of the steam (or condensate) acting on the heat actuated element. The capacity of a trap is rated in pounds of hour of condensate discharged. (Refer to Appendix page A-5 for trap descriptions and operation)

The capacity is determined by the size of the discharge orifice and the pressure differential available to force the water through the orifice. For example, a bucket trap used to drain a 125 psi steam and discharging into a gravity condensate return system will have over a 100 psi differential pressure and requires a small orifice. On the other hand, the steam pressure inside a heat

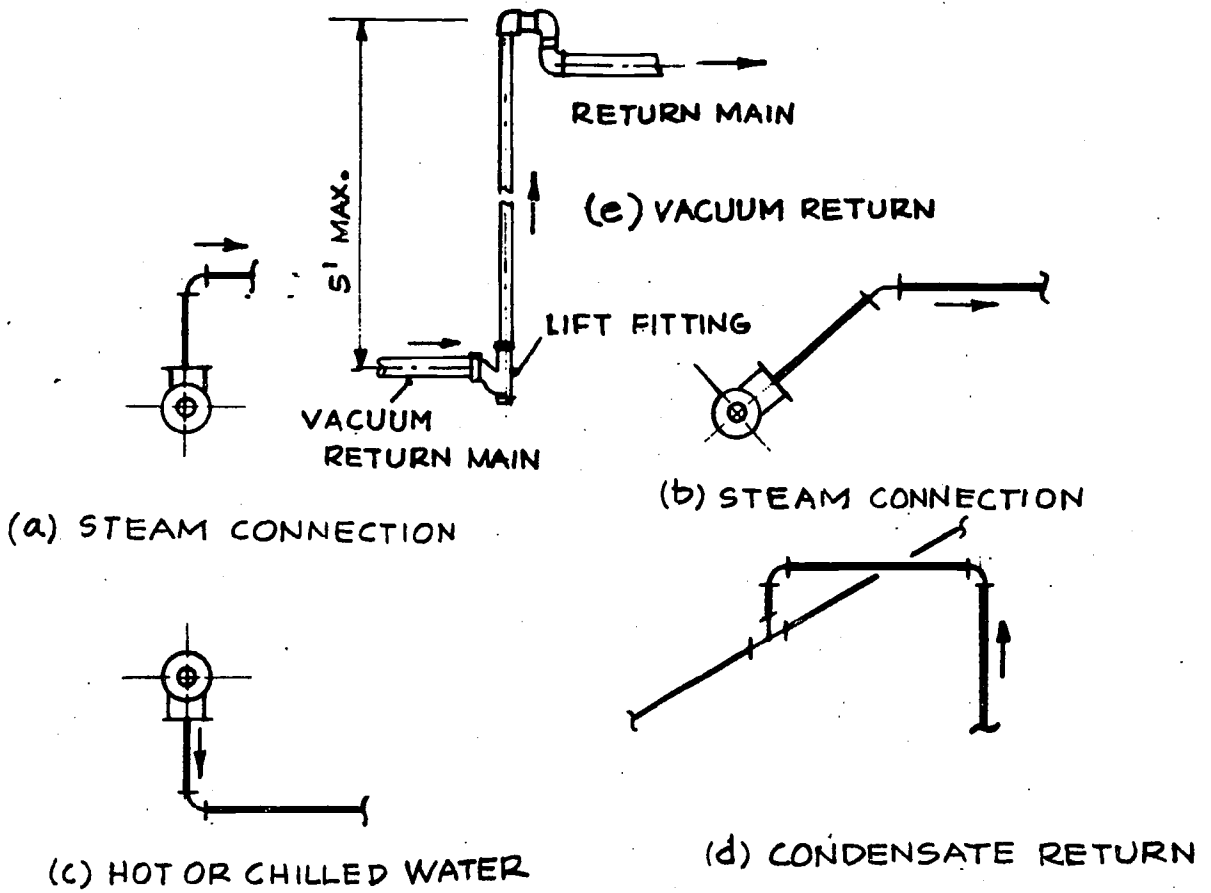


Fig. 3-1

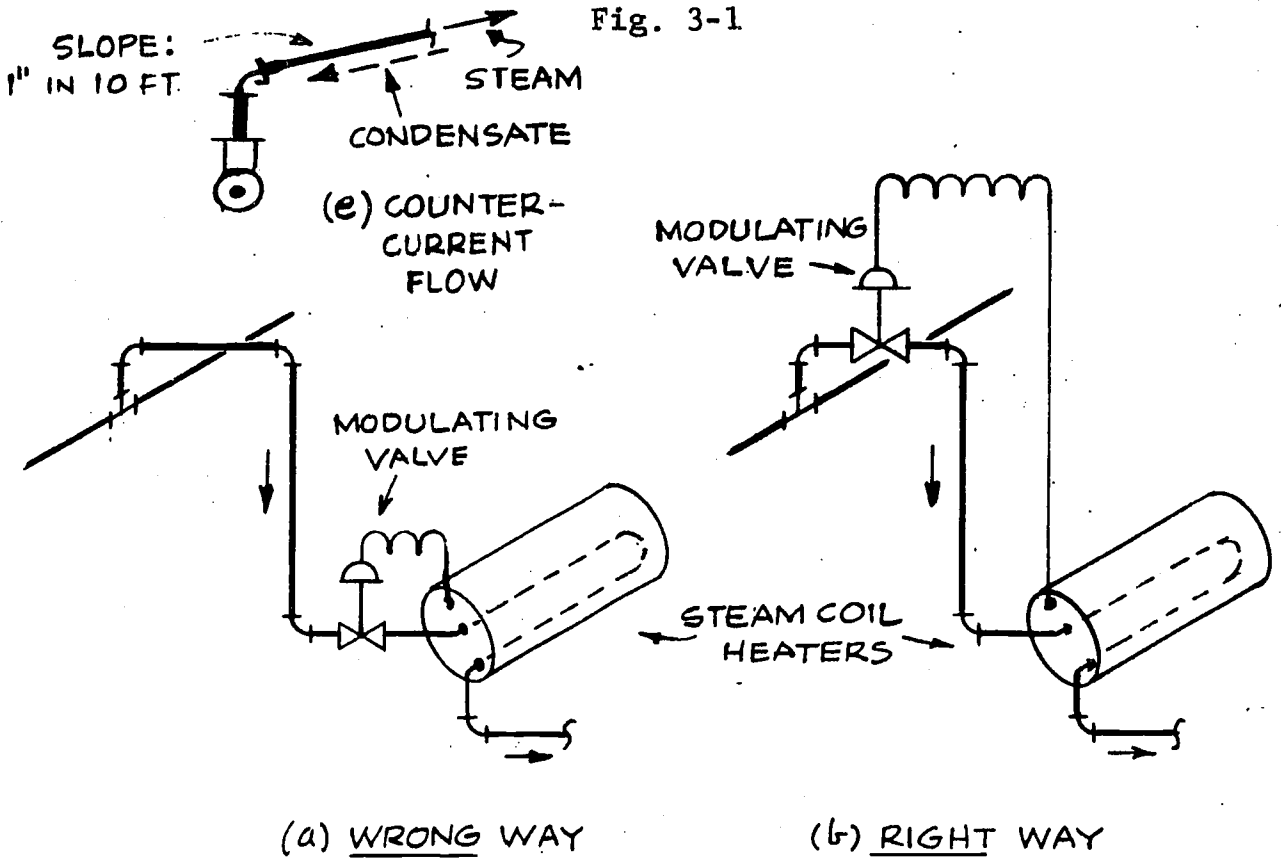


Fig. 3-2

exchanger may be 3 or 4 psi, or even a vacuum at times due to the condensing effect of the steam, and requires a large orificed trap. If condensate is allowed to collect inside the shell of a heat exchanger, the energy given up by incoming steam as it condenses on the water surface will rupture the tubes in time. For this reason it is mandatory that steam traps be generously sized to allow discharge of the condensate, and that the discharge piping always be lower than the lowest point of the heat exchange apparatus. The discharge piping must never rise above the drain outlet. The condensate flows through the "return" system to a condensate return receiver and is pumped back into the boiler feed system. High pressure and low pressure returns (from high and low pressure steam lines) should be run separately to the condensate receiver or considerable water hammer and pipe movement and possibly pipe failure will result.

Vacuum systems have a pump that maintains a vacuum in the return line and returns condensate to the boiler. Lift fittings are used to elevate the condensate as shown in Fig. 3-1 (e). Lift fittings will operate under a vacuum only.

Hot Water Supply and Return

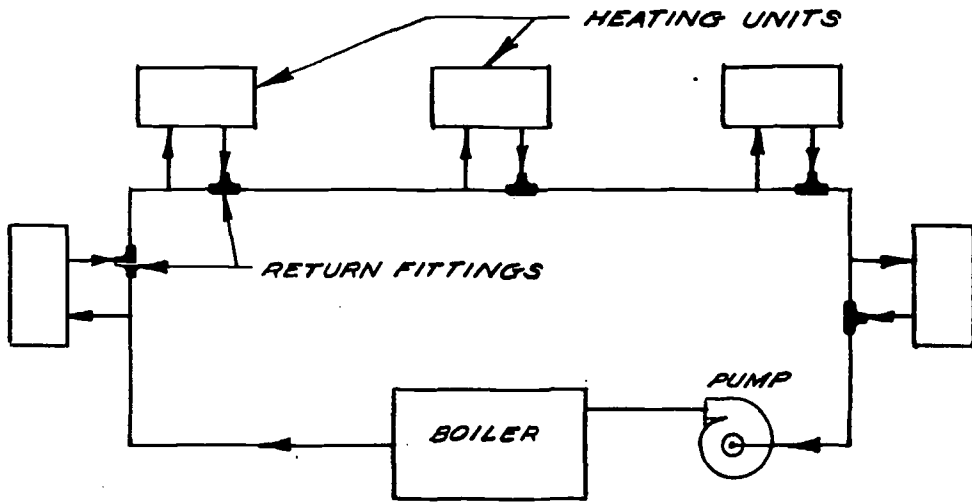
There are three general types of hot water heating piping systems: the one pipe, the 2 pipe direct, and the 2 pipe reverse return (Fig. 3-3). The one pipe has a single main which is the same size throughout and handles the supply and return to and from each heater. A special fitting is used to divert a certain amount of water to each heating unit. In the two pipe direct system, a loop is formed by the supply and return lines, the return from each unit returning directly to the boiler by the most direct route. It can be seen that the first unit nearest the boiler has a greater pressure difference between its supply and return connections than the one at the end of the loop, which make it difficult to obtain an equal flow of water through all heaters. This is overcome by the two pipe reversed arrangement which takes more pipe but is practically self-balancing.

The trapping and elimination of unwanted air in a hot water system is necessary for the system to operate properly. Air will collect at the high points of piping and heating coils and prevent flow of water and heat transfer. Theoretically, a hot water system is closed and completely full of water. However, air does enter with make up water, through automatic air vents (if used) and around pump packed glands. Some of the methods and special fittings to eliminate air problems are listed below.

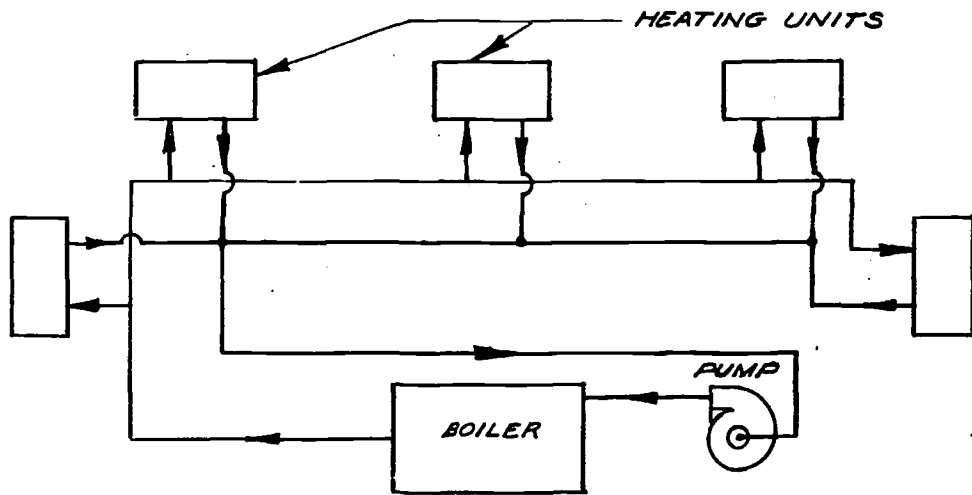
Pipe is graded upwards in the direction of flow at the rate of 1/4" - 10 feet to high point and released by means of manually operated bleed off valves. Any reducers used are eccentric, with the flat side on top.

Manual vents are used instead of automatic (ball float operated) vents, as the latter will open and admit air if the water level should fall.

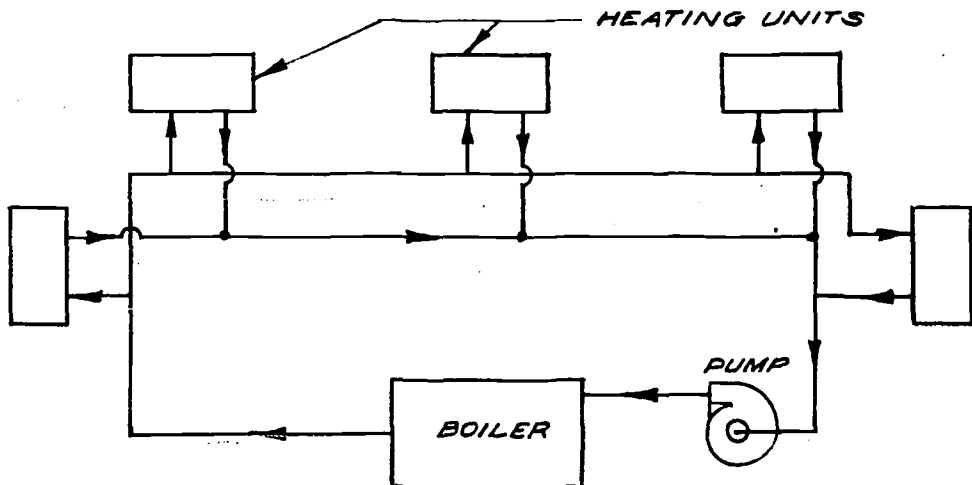
Air collecting fittings are used on the outlets of boilers and in



(a) ONE PIPE SYSTEM



(b) TWO-PIPE DIRECT-RETURN SYSTEM



(c) TWO-PIPE REVERSED-RETURN SYSTEM

the hot water discharge piping from heat exchangers (Fig. 3-4). The air outlets are piped directly from the air collecting devices to the expansion tank, and any horizontal sections are graded up not less than 1" in 5 feet. (Fig. 3-7) An "Airtrol" fitting, or equal, is installed in the bottom of the expansion tank. The air breather tube permits the tank to be quickly drained periodically, which is necessary to replenish the air cushion. The air in an expansion tank is gradually absorbed by the water and the tank is recharged by completely emptying it and refilling. The pressure reducing valve should supply enough pressure to fill the system to the highest point plus a few pounds extra. Any pressure higher than this requirement will reduce the capacity of the expansion tank unnecessarily. In order to be able to drain the tank it will have to be isolated from the rest of the system with a shut-off valve which preferably should be a rising stem type locked open during normal operation. Also note in Fig. 3-7 that the make-up water connection is connected into the side of the vertical riser to the expansion tank, as the pressure at this point is not affected by the pump.

Chilled Water Systems

The same general remarks and precautions discussed above also apply to chilled water supply and return systems.

TYPICAL AIRTROL BOILER FITTING INSTALLATION DETAILS

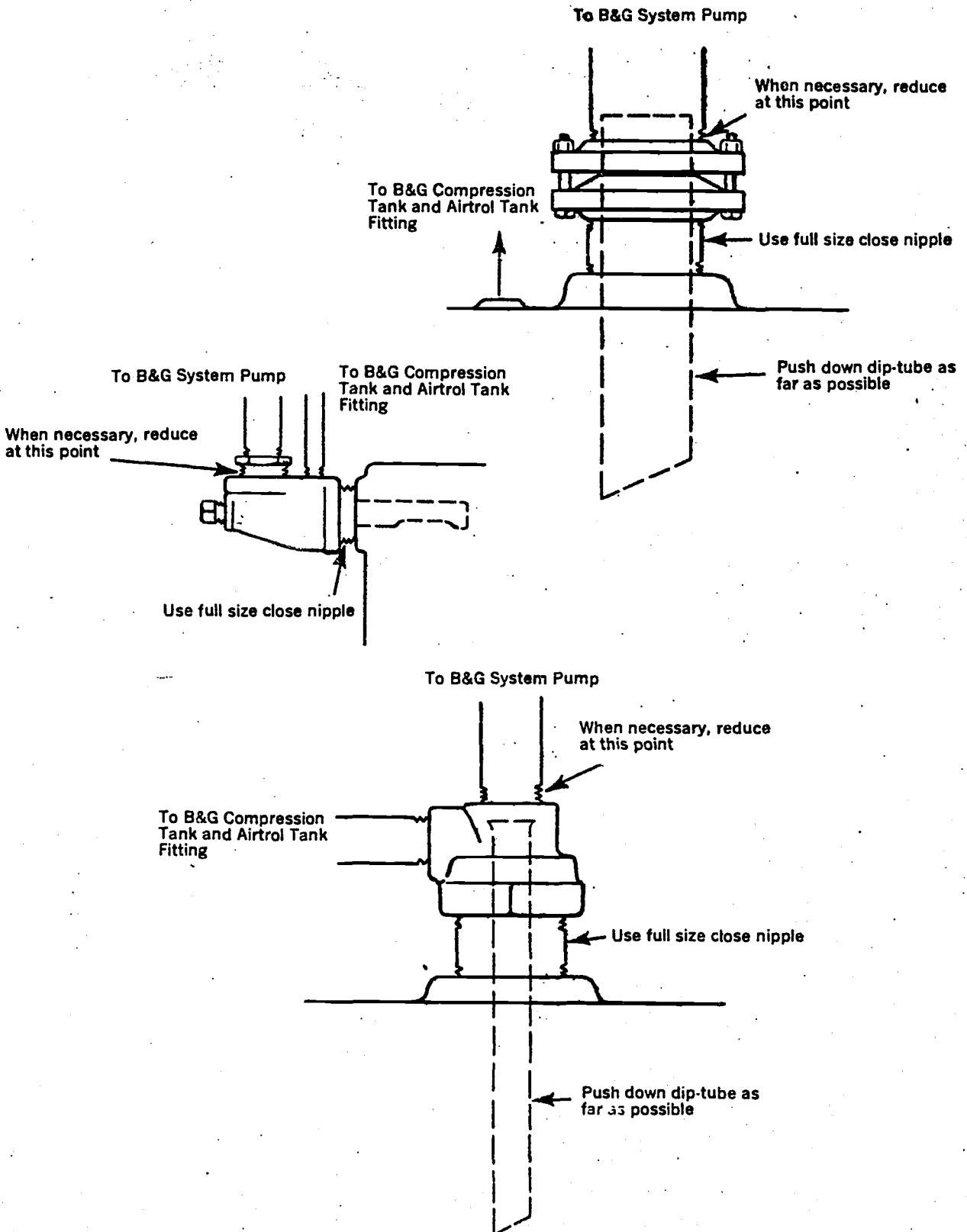


Fig. 3-4

CHAPTER 6

AIR SEPARATORS

BOILER DIP TUBES

The most common and often one of the most effective air separators available to design engineers is the conventional hot water heating boiler. In boilers having large internal water passages, water velocity is usually quite low and free air released in heating can readily rise to a convenient high point. From this collecting point, air can then rise into the compression tank. To prevent free air collected at the top of the boiler from being circulated out into the system and

into the radiation, boiler dip tubes, either top outlet or side outlet, are available. Some boiler manufacturers furnish these dip tubes as standard equipment. B&G offers a complete line of boiler dip tubes for practically all sizes and style of boilers. Figure 14 illustrates some typical piping arrangements where dip tubes can be installed in boilers to create an air separating point. Boiler dip tubes should always be installed so that the dip tube is pushed into the boiler as far as possible, well below the top of a top outlet boiler or well into a side outlet boiler.

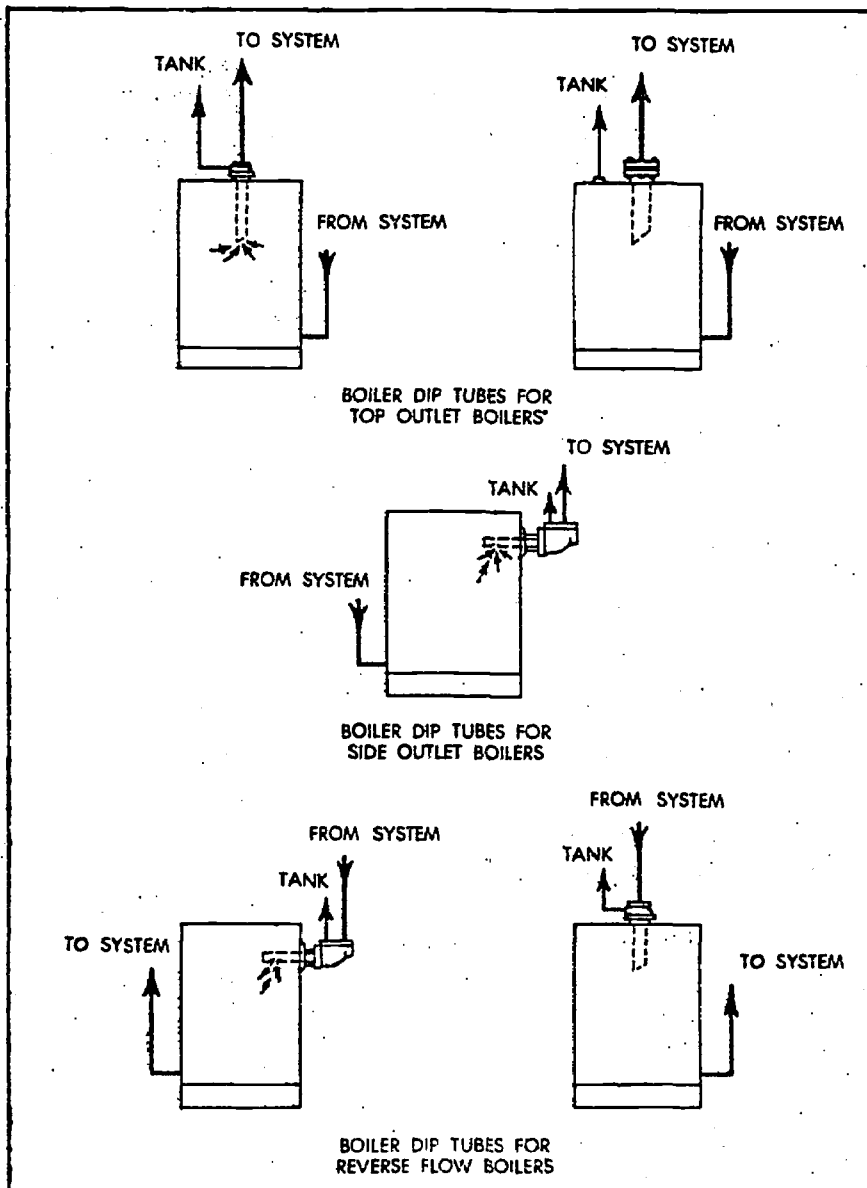
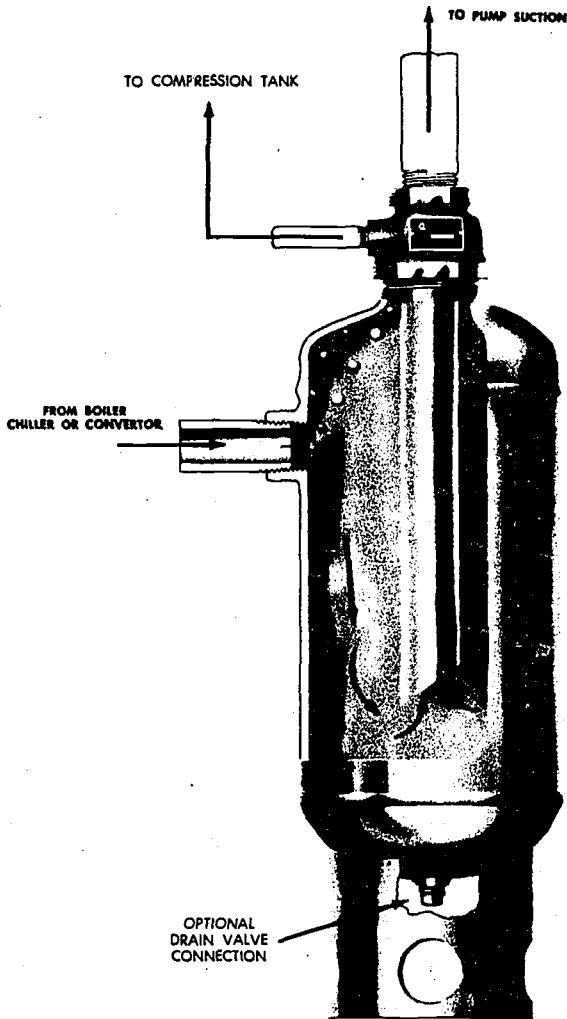


Fig. 3-5

Courtesy, ITT-Bell and Gossett Co.

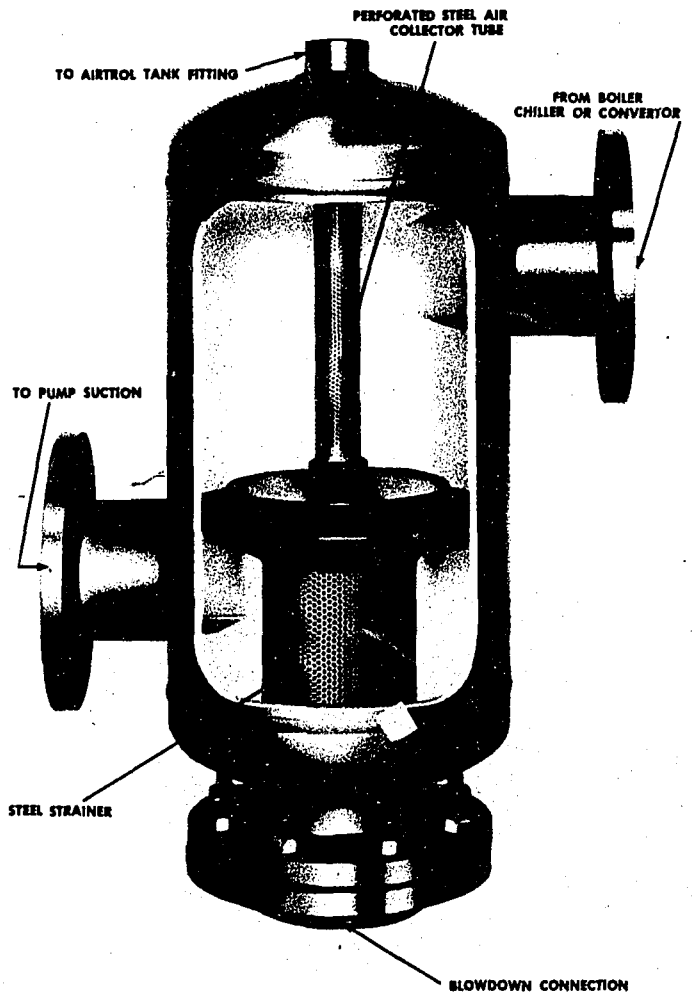


(a) *In-Line Air Separator.*

IAF AIR SEPARATORS

Often, however, a boiler is not available or useable as the point of air separation. Another low velocity area must be provided in the system as the air separating point.

Figure a illustrates an effective low velocity air separating tank which is equipped with a dip tube to create a reversal of flow. Tests have shown that water velocity must be reduced to at least six inches per second for effective separation of free air from a piping circuit. However, a straight-through tank for air separation, even though sized for low water velocity, is apt to develop short circuiting channels or water streams where air bubbles will remain entrained. The vertical distance and velocity of water travel in a separator is directly related to the percentage of free air that will be separated. The dip tube air separator (B&G IAF model) also serves as an effective settling point for sediment and other debris common to new piping systems.



(b) *Rolairtrol air separator with removeable system strainer.*

ROLAIRTROL AIR SEPARATORS

Another effective air separator now available (the B&G Rolairtrol) utilizes a different principle for separation rather than low velocity alone. (See Fig. b) Inlet and outlet openings on the Rolairtrol are installed tangentially. Circulation through the Rolairtrol creates a vortex or whirlpool in the center where entrained air, being lighter, can collect and rise into a compression tank installed above. Instead of relying entirely on low velocity separation, the action of centrifugal force sends heavier air-free water to the outer portion of the tank, allowing lighter air-water mixture to move into the lower velocity center. An air collecting screen located in the vortex aids in developing a low velocity area in the center where air can collect. The Rolairtrol offers the advantage of achieving efficient separation in a much smaller size of tank.

Courtesy, ITT-Bell and Gossett Co.

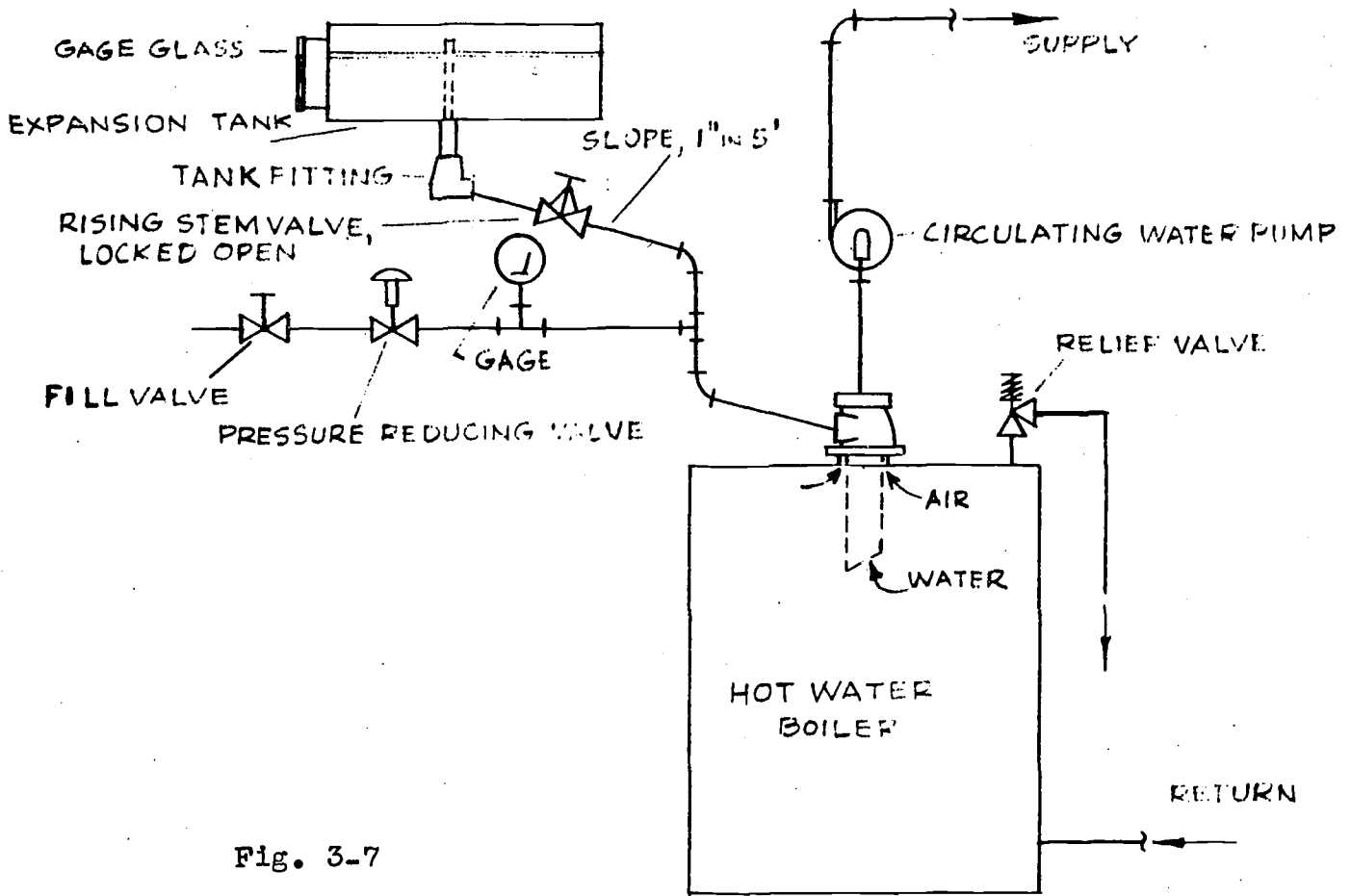


Fig. 3-7

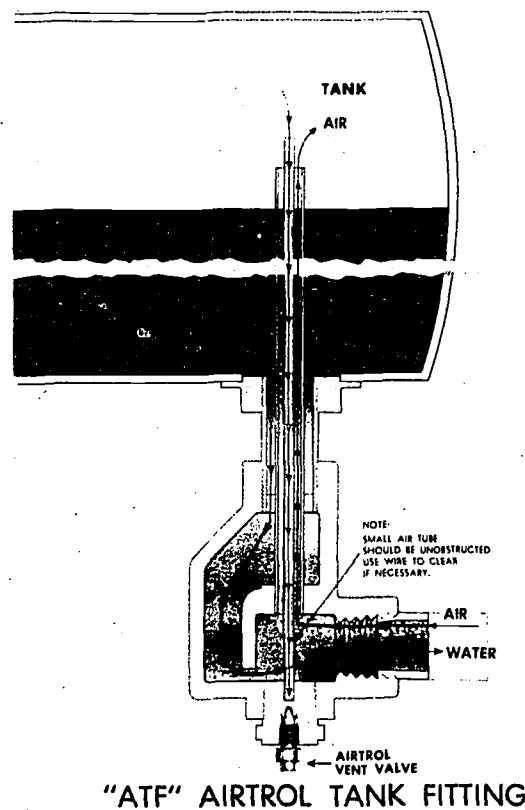


Fig. 3-8

Courtesy, ITT-Bell and Gossett Co.

19. Restrainer bolts are installed on flexible connectors to prevent them from blowing apart when pressurized.
20. Hangers are adjusted for equal load. Clevis hangers bolted to hanger rod with two nuts; above and below upper strap.
21. Steam strainers blow off to a safe place.
22. Strainer baskets can be withdrawn without interference.
23. Strainer blow off valve same size as connection on strainer body.
24. Relief valves discharge to a safe place, and drained in the case of a vertical riser so water will not collect against the top of the seat.
25. Vents from natural gas pressure regulators are piped to a safe place (to a vented firebox, or to atmosphere).
26. Shut-off valves located for easy accessibility.
27. Gas shut-off valve located outside the building.

4. AIR MOVERS

Air movers, popularly called "fans", are the workhorses of ventilating systems. They come in a great variety of shapes and sizes, must be carefully selected for the job they are to do, and need to be installed with near-ideal inlet and outlet conditions to produce the expected performance. The most useful tool in establishing fan output is the fan curve which will be discussed as well as the various types of air movers.

The Air Moving and Conditioning Association (AMCA) has standardized fan types as shown in Fig. 4-1. The familiar propeller fan has a propeller or disc type wheel mounted in a ring or shroud, and is generally used for free delivery, or against a low resistance. The tubeaxial fan consists of an axial flow wheel inside a cylindrical housing, in addition to which the vaneaxial fan uses guide vanes before or after the wheel. The centrifugal fan consists of a fan rotor or wheel within a scroll shaped housing.

The following terms are used in specifying and evaluating fan performance and are as defined by the AMCA:

1. Volume handled by a fan is the number of cubic feet of air per minute expressed at fan outlet conditions (namely, air pressure and temperature).
2. Total pressure of a fan is the rise of pressure from fan inlet to fan outlet, that is, the net pressure produced by the fan.
3. Velocity pressure of a fan is the pressure corresponding to the average velocity determination from the volume of air flow at the fan outlet area.
4. Static pressure of a fan is the total pressure diminished by the fan velocity pressure.
5. Power output of a fan is expressed in horsepower and is based on fan volume and the fan total pressure.
6. Power input to a fan is expressed in horsepower and is measured horsepower delivered to the fan shaft.
7. Mechanical efficiency of a fan is the ratio of power output to power input.
8. Fan outlet area is the inside area of the fan outlet.

Further explanation and application of these terms will be covered later in this section.

Of the four general types of fans described above, the centrifugal fan is most commonly used for ventilating systems and is further classified by type of blades: (1) forward curved, (curved in the direction of rotation), (2) straight radial blades and (3) back-

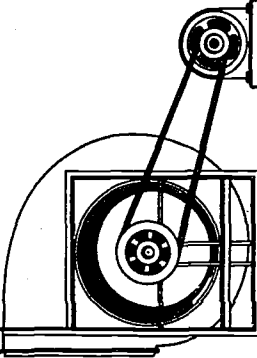
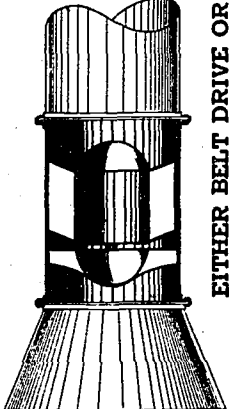
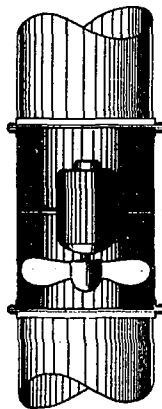
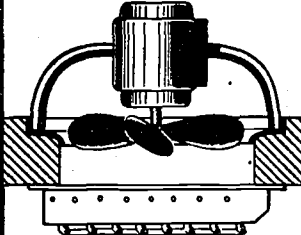
GROUP CLASSIFICATION	DESCRIPTION
<p style="text-align: center;">CENTRIFUGAL FAN</p> <p style="text-align: center;">EITHER BELT DRIVE OR DIRECT CONNECTION</p> 	<p>A Centrifugal Fan consists of a fan rotor or wheel within a scroll type of housing. The Centrifugal Fan is designed to move air or gases over a wide range of volumes and pressures. The fan wheel may be furnished with straight, forward curve, backward curve, or radial tip blades. The fan housing may be constructed of sheet metal or cast metals with or without protective coatings such as rubber, lead, enamel, etc.</p>
<p style="text-align: center;">VANEAXIAL FAN</p> <p style="text-align: center;">EITHER BELT DRIVE OR DIRECT CONNECTION</p> 	<p>A Vaneaxial Fan consists of an axial flow wheel within a cylinder combined with a set of air guide vanes located either before or after the wheel. The Vaneaxial Fan is designed to move air or gases over a wide range of volumes and pressures. It is generally constructed of sheet metal although cast metal fan wheels are sometimes furnished.</p>
<p style="text-align: center;">TUBEAXIAL FAN</p> <p style="text-align: center;">EITHER BELT DRIVE OR DIRECT CONNECTION</p> 	<p>A Tubeaxial Fan consists of an axial flow wheel within a cylinder. The Tubeaxial Fan is designed to move air or gas through a wide range of volumes at medium pressures. Its construction is similar to the Vaneaxial Fan.</p>
<p style="text-align: center;">PROPELLER FAN</p> <p style="text-align: center;">EITHER BELT DRIVE OR DIRECT CONNECTION</p> 	<p>A Propeller Fan consists of a propeller or disc wheel within a mounting ring or plate. The Propeller Fan is designed to move air from one enclosed space to another or from indoors to outdoors or visa versa in a wide range of volumes at low pressure. (The automatic type of shutter illustrated in cut opposite is not a part of the Propeller Fan but is an auxiliary device to protect the fan when not operating by keeping out wind, rain, snow and cold).</p>

Fig. 4-1

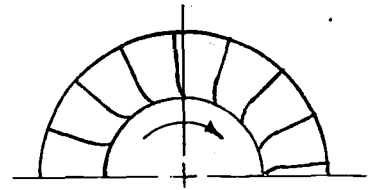
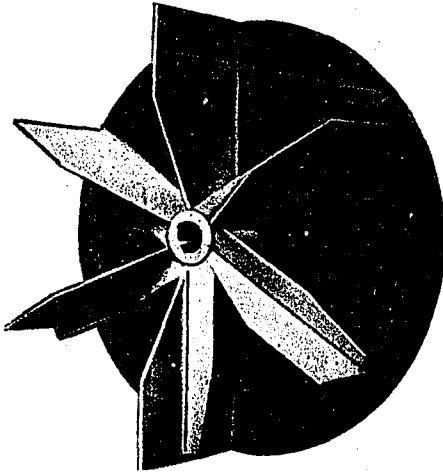


Fig. 4-2

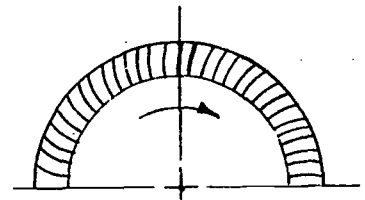
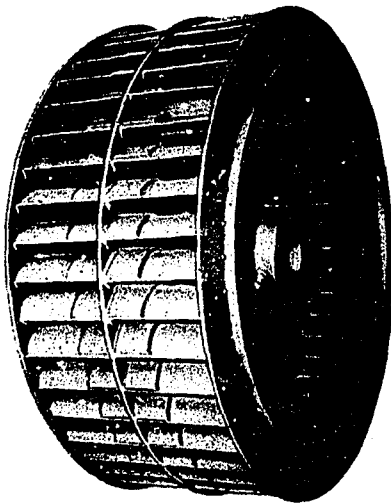


Fig. 4-3

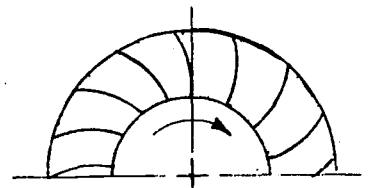
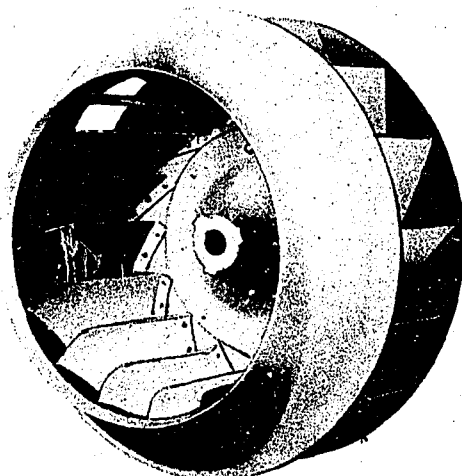
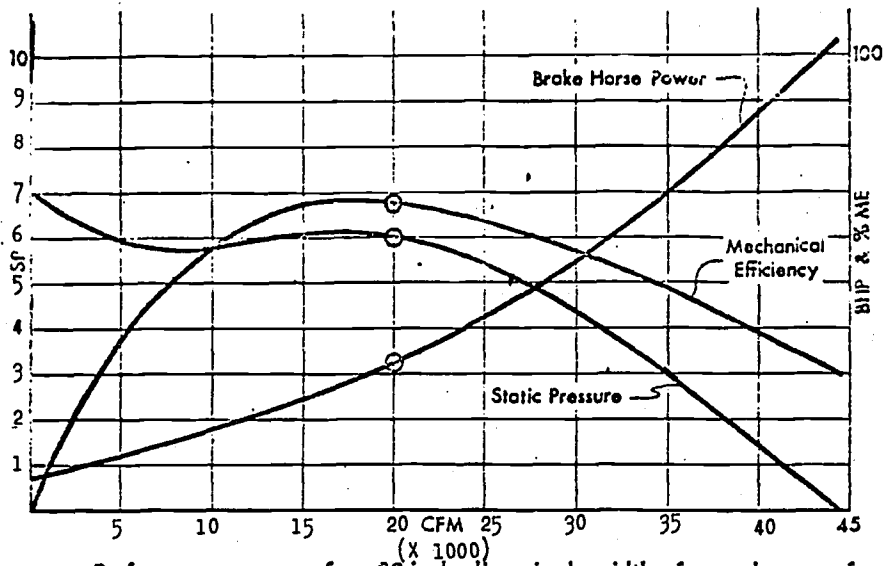


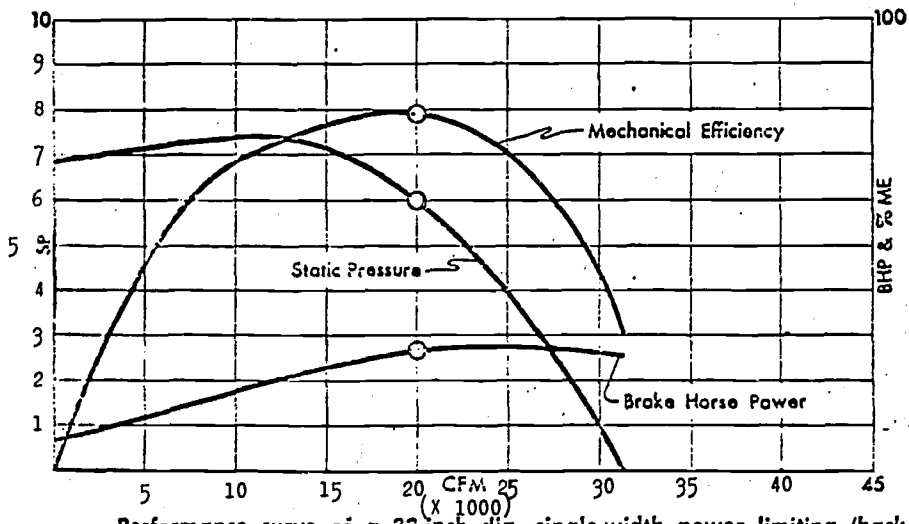
Fig. 4-4

wardly inclined blades. There are many variations of these basic blade types, but all centrifugal fans fall into one of these groups. The radial blade fan (Fig. 4-2) was the first style developed but nowadays is used mostly for pneumatic conveying systems, as sawdust and shavings, and for high pressure blowers. It is not used in ventilating systems. The next fan developed was the forward curved blade design, (Fig. 4-3) which consists of narrow cup shaped blades which rotate in a direction seemingly to scoop up the air, while the backwardly inclined bladed fan (Fig. 4-4) appears to "wipe" the air. The effect of these differently shaped blades on the fan characteristics is shown by the fan curves such as those shown below in Fig. 4-5 and Fig. 4-6.



Performance curve of a 30-inch dia, single-width, forward curve fan, selected for 20,000 cfm at 6 in. SP.

Fig. 4-5



Performance curve of a 33-inch dia, single-width power limiting (backwardly inclined blade) fan, selected for 20,000 cfm at 6 in. SP.

Fig. 4-6

Figs. 4-5 and 4-6 courtesy of New York Blower Co.¹

However, before proceeding with this comparison, we will discuss fan curves in general. Referring to Fig. 4-5, note that there are 3 curves shown, labeled "static pressure", "brake horsepower" and "mechanical efficiency", and that there are values correspondingly marked in graduations on the vertical (ordinate) sides of the graph. "Cfm" is similarly scaled off on the horizontal (abscissa) edge. This particular fan was selected to produce 20,000 cubic feet per minute of air against a static pressure of 6 inches which is what the designer figured he needed to do a certain ventilation job. So, when the fan is connected up to the ventilation system and all dampers have been adjusted, the fan will deliver 20,000 cfm if the static pressure is 6". If the static pressure developed by the fan is, say 5", because of an error in estimating the pressure, the fan will deliver 27,500 cfm. The point is, that the fan delivery depends on what static pressure it works against, and this is called the system resistance.

Referring again to Fig. 4-5, at 6" sp, the brake horsepower is 32, and the mechanical efficiency is 68%.

Fig. 4-6 shows a set of curves for a backwardly inclined blade fan, also selected for 20,000 cfm delivery against a 6" static pressure head. The curves are similar to a degree but closer study shows significant differences in performance. The forward curved fan has a constantly rising horsepower curve, while the backwardly inclined blade fan has a horsepower curve that rises to a maximum and then levels off or decreases slightly with increased cfm. This points out the main disadvantage of the forward curve bladed fan; that is, if the system pressure was calculated too high or the system changed so as to reduce the pressure, the horsepower becomes excessive and overloads the motor. The backwardly inclined blade fan has a self-limiting horsepower curve and cannot be overloaded under any conditions at a given speed. It will be noted that the static pressure - cfm curve of Fig. 4-5 is about 7" at 0 cfm, dips to 5 3/4", then reaches a maximum of 6". The portion of the curve to the left of the 6" peak is an area of unstable operation, and this is another disadvantage of the forward curve fan should a design error result in operation to the left of the peak. The forward curve fan has another disadvantage of being less efficient than its backward inclined blade counterpart, as shown by the mechanical efficiency curves. The advantages of the forward curved fan is that it turns at lower speeds than other types, runs quieter and is smaller than the backwardly inclined fan to produce equal cfm and head. The backwardly inclined blade fan has the advantages of higher efficiency which can save power costs for large continuous operation applications, and a limited horsepower requirement which permits economical motor sizing. Another advantage is its steeper static pressure vs cfm curve, which means that a variation in the system pressure will result in a smaller variation in air delivery than with a forward curved fan.

For example, Fig. 4-5 (forward curve) at 6" static pressure, the delivery is 20,000 cfm. At 5" static pressure, delivery is

27,500 cfm. Fig. 4-6 (backwardly inclined) shows that at 6" static pressure, the output is 20,000 cfm, and at 5" it is 22,000 cfm.

An important variation of the backward inclined fan is the air foil shaped blade (Fig. 4-7) shaped like an airplane wing, and is designed to allow air flow through the wheel with less turbulence than the conventional backward inclined flat blade. The advantage of this is to produce quieter operation, and to operate without surging or pulsation throughout the entire range.

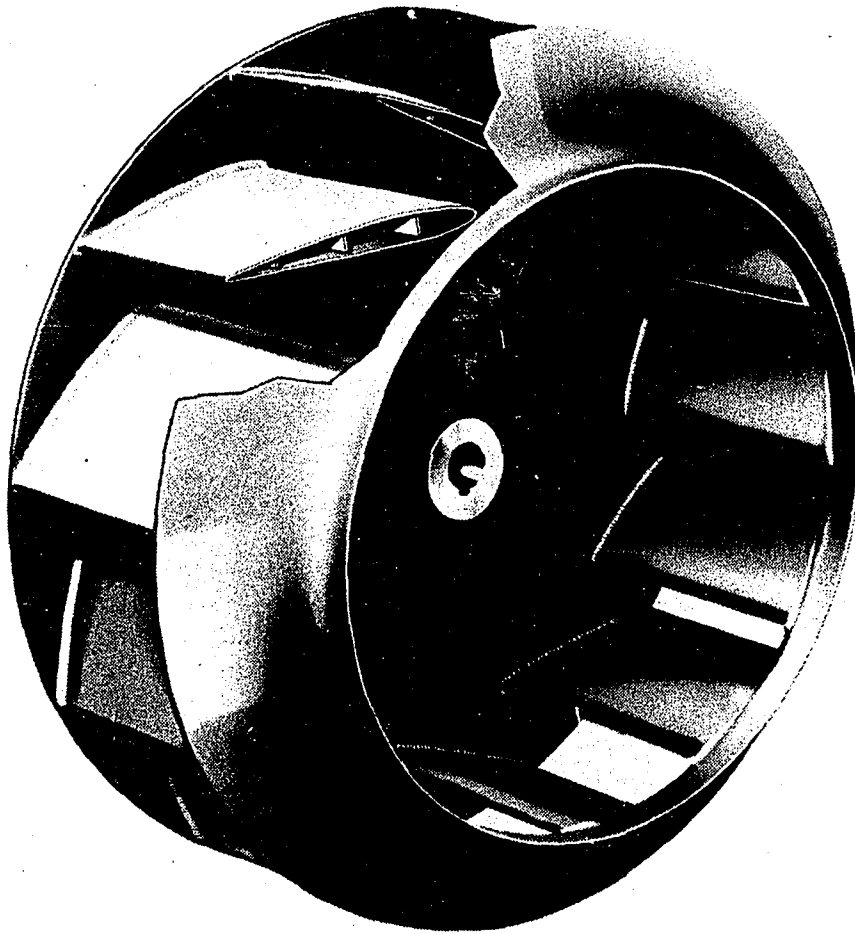
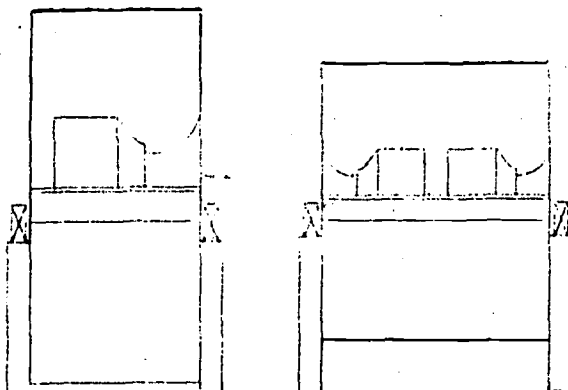


Fig. 4-7 Courtesy, Trane Co.



Comparison of outlines of single- and double-width fans having the same outlet areas and suitable for the same performance.

Fig. 4-8

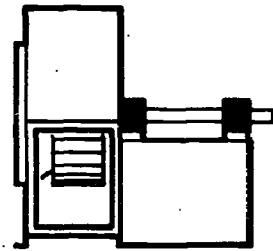
SW - Single Width DW - Double Width
 SI - Single Inlet DI - Double Inlet

Arrangements 1, 3, 7 and 8 are also available with bearings mounted on pedestals or base set independent of the fan housing.

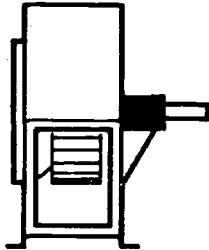
For designation of rotation and discharge, see AS 2406.

For motor position, belt or chain drive, see AS 2407.

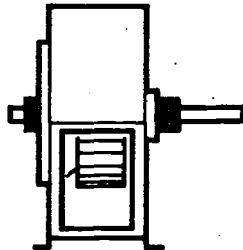
For designation of position of inlet boxes, see AS 2405.



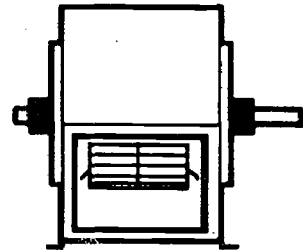
ARR. 1 SWSI For belt drive or direct connection. Impeller overhung. Two bearings on base.



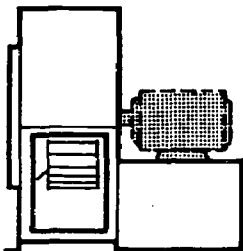
ARR. 2 SWSI For belt drive or direct connection. Impeller overhung. Bearings in bracket supported by fan housing.



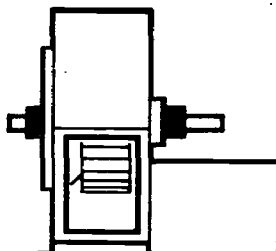
ARR. 3 SWSI For belt drive or direct connection. One bearing on each side and supported by fan housing. Not recommended in sizes 27-inch diameter impeller and smaller.



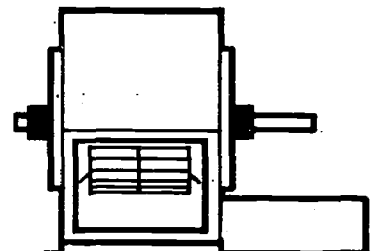
ARR. 3 DWDI For belt drive or direct connection. One bearing on each side and supported by fan housing.



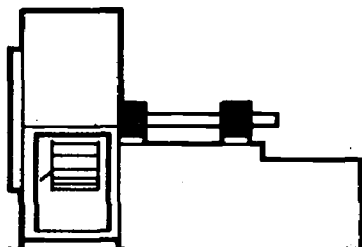
ARR. 4 SWSI For belt drive. Impeller overhung on prime mover shaft. No bearings on fan. Prime mover base mounted or integrally directly connected.



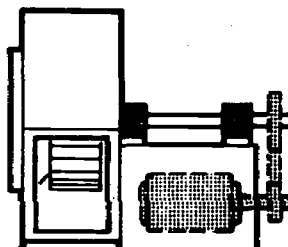
ARR. 7 SWSI For belt drive or direct connection. Arrangement 3 plus base for prime mover. Not recommended in sizes 27-inch diameter impeller and smaller.



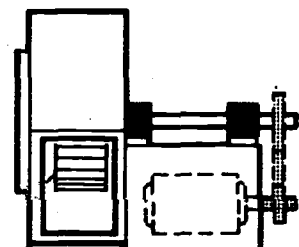
ARR. 7 DWDI For belt drive or direct connection. Arrangement 3 plus base for prime mover.



ARR. 8 SWSI For belt drive or direct connection. Arrangement 1 plus extended base for prime mover.



ARR. 9 SWSI For belt drive. Impeller overhung, two bearings, with prime mover outside base.

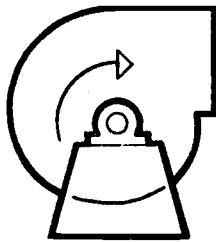


ARR. 10 SWSI For belt drive. Impeller overhung, two bearings, with prime mover inside base.

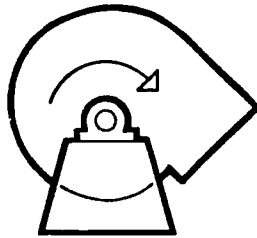
Adopted
4-1-66
Revised
11-20-66

DRIVE ARRANGEMENTS FOR CENTRIFUGAL FANS

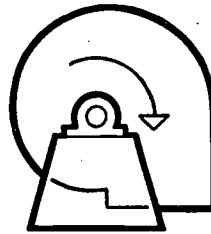
**AMCA STANDARD
2404-66**



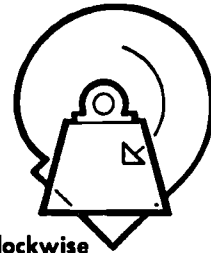
**Clockwise
Top Horizontal**



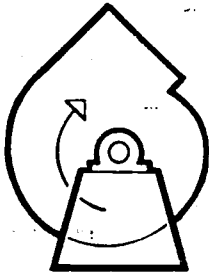
**Clockwise
Top Angular Down**



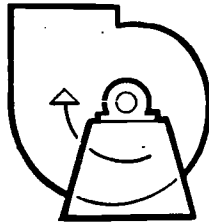
**Clockwise
Down Blast**



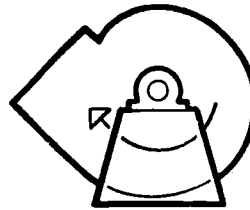
**Clockwise
Bottom Angular Down**



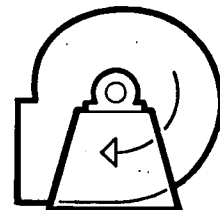
**Clockwise
Top Angular Up**



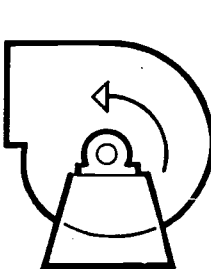
**Clockwise
Up Blast**



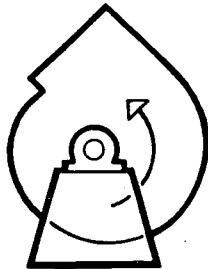
**Clockwise
Bottom Angular Up**



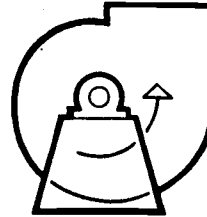
**Clockwise
Bottom Horizontal**



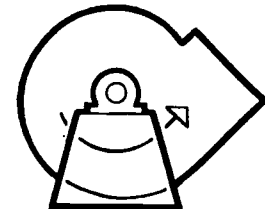
**Counterclockwise
Top Horizontal**



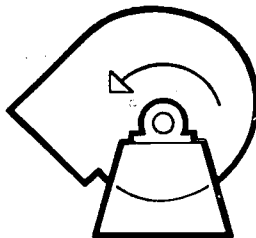
**Counterclockwise
Top Angular Up**



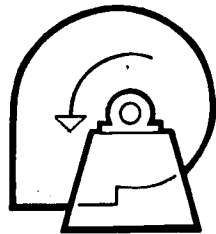
**Counterclockwise
Up Blast**



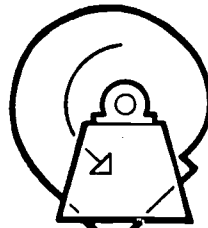
**Counterclockwise
Bottom Angular Up**



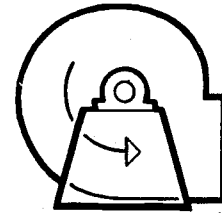
**Counterclockwise
Top Angular Down**



**Counterclockwise
Down Blast**



**Counterclockwise
Bottom Angular Down**



**Counterclockwise
Bottom Horizontal**

Direction of rotation is determined from drive side of fan.

On single inlet fans, drive side is always considered as the side opposite fan inlet.

On double inlet fans with drives on both sides, drive side is that with the higher powered drive unit.

Direction of discharge is determined in accordance with diagrams. Angle of discharge is referred to the horizontal axis of fan and designated in degrees above or below such standard reference axis.

For fan inverted for ceiling suspension, or side wall mounting, direction of rotation and discharge is determined when fan is resting on floor.

Adopted
5-26-60

Revised
1-30-66

DESIGNATIONS FOR ROTATION AND DISCHARGE OF CENTRIFUGAL FANS

AMCA STANDARD

2406-66

Fan Arrangements

Fan arrangements refers to the relation of wheels and bearings, and whether the fan has one wheel (single width, SW) or two wheels (double width, DW) and single inlet (SI) or double inlet (DI).

Fig. 4-8 is an elevation view looking at the discharges of a single width, and a double width fan each having the same outlet area and giving the same performance. The single width is 30% taller, but only 70% as wide as the double width. The single width is best for a duct inlet connection, while the double width is best for installation in a plenum. Cost also governs the choice of single or double width fan. When the fan outlet area is about 8 sq feet, the two cost about the same; below this size, the single width is less expensive and above it the double width is cheaper. First cost and space requirements largely determine which fan arrangement to use.

The various arrangements as designated by AMCA are shown in Fig. 4-9. It will be noted that there are 4 basic bearing arrangements. Arrangement 1 consists of 2 bearings resting on a metal base, supporting the shaft and wheel, independent of the fan housing. Arrangement 2 uses a single bearing housing (containing 2 spaced bearings or a single sleeve) mounted on a bracket supported by the fan housing. Arrangement 3 has one bearing mounted on each side and supported by the fan housing.

Note that this arrangement is not recommended by manufacturers for wheel diameters of 27" and less because the bearing blocks the air passage to the fan inlet. In Arrangement 4, the motor supports the wheel on a long shaft with no bearings on the fan. The balance of the arrangements designate drive arrangements and bases. Arrangement 3 is the most common in ventilation work because of cost and space savings realized without the fan bearing support platform.

Direction of rotation and discharge is designated by the AMCA as shown in Fig. 4-10.

Classes of Fans

Fans are constructed in three strength classes as set by the AMCA for operation in the following pressure ranges:

Class I up through 3 1/4 inches of total water pressure.

Class II up through 6 3/4 inches of total water pressure.

Class III up through 12 1/4 inches of total water pressure.

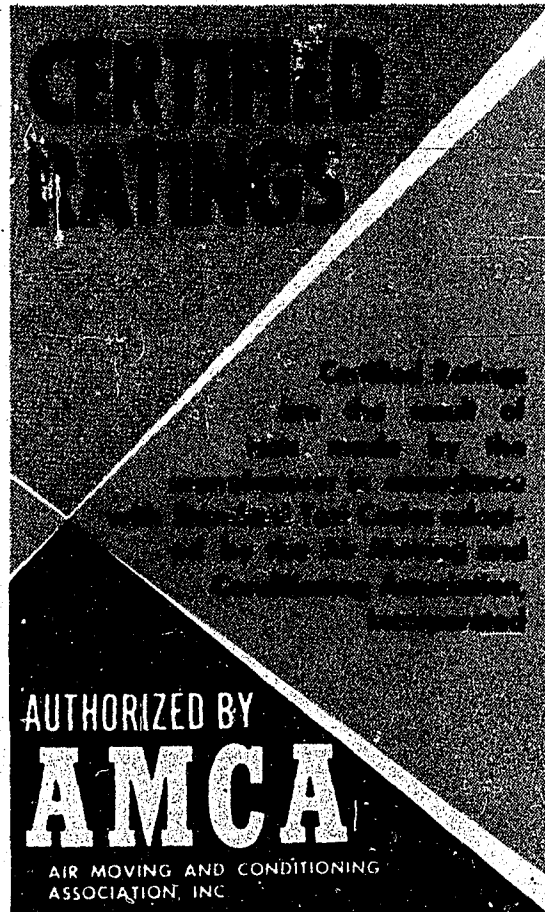
AMCA does not control the metal gages, bracing or design, but specifies that the fans shall be suitable for pressures shown.

The Air Moving and Conditioning Association, Inc.

"The AMCA is a non-profit Association composed of the majority of air moving equipment manufacturers in the United States and Canada. The main technical effort of the Association is aimed at the development of accurate and reliable testing procedures which are adopted as standard test codes and are used as a basis for rating the industry's products.

The AMCA Laboratory is specifically designed to check test the air performance and sound ratings of air moving equipment licensed to use the AMCA Certified Ratings Seal. Each manufacturer participating in the AMCA Certified Ratings Program agrees that the Staff shall, at random intervals, obtain a production sample of each licensed product for the purpose of checking its actual performance against published catalog ratings. Failure to perform within the specified tolerance results in the loss of the license to use the AMCA Seal on the entire product line."

The above is excerpted from a AMCA publication and describes the function of this Association, and the significance of the rating seal. A line of fans (by model number) that have been tested by AMCA are authorized to bear the seal:



Fan Drives

The most common types of fan drives for ventilation applications are v-belts. They require careful selection and installation, and frequently need to be checked for proper application by the mechanical inspector.

V-belts are of rubber, or of synthetic rubber and cotton, reinforced with cord or finely stranded steel cables. They are shaped like a trapezoid, and made in six standard cross-sections; FHP, A, B, C, D and E and to the dimensions shown in Fig. 4-12. V-belts are made in standard lengths, called pitch lengths; the length, and the type (A, B, etc), are imprinted on the outer periphery of the belt. The pitch diameter of a pulley is the outside diameter less twice one half the thickness of the type of v-belt that it is made for, or more simply, the outside diameter less the thickness of the belt. The pitch length of a belt may be calculated as shown in Fig. 4-11.

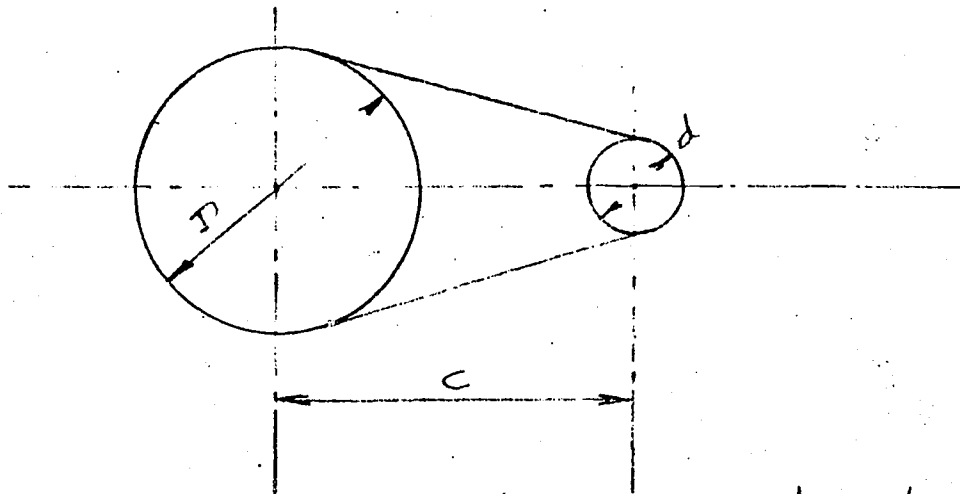
Since the tightness of belts is adjusted by moving the motor closer or away from the driven pulley by means of jacking bolts on the motor base, be sure there is sufficient "slot" length to move the base either way, and also that the belts will not rub against the belt guard.

The load on belts is determined by the following factors:

1. Horsepower of the driver.
2. Service factor of the driver equipment.
3. Belt speed.
4. Angle of contact of the belts with the sheave.

The adequacy of a belt drive system can be checked as follows:

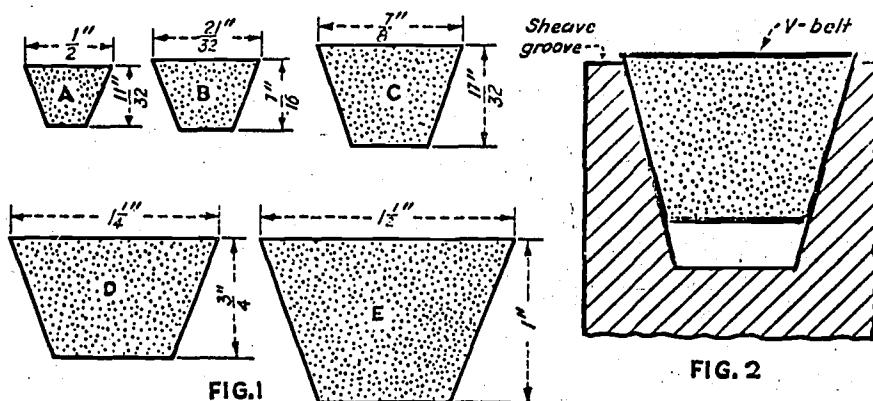
1. Read the motor nameplate horsepower and multiply it by the service factor (from table 4-2) for application and type of motor used.
2. Find the belt speed from:
$$V = 3.14 \times d \text{ (ft)} \times \text{rpm}$$
$$= .262 \times d \text{ (inches)} \times \text{rpm, feet per minute}$$
3. From Table 4-4, find the nominal horsepower rating per belt, knowing the pitch dia. of the section.
4. Find the arc of contact on the small sheave by the formula:



$$L = 2c + 1.57(D+d) + \frac{(D-d)^2}{4c}$$

c = center to center distance
D = pulley pitch diameter
d = sheave pitch diameter

Fig. 4-11



- 1 V-belts are made in five standard cross-sections, designated A, B, C, D and E.
- 2 Sheave grooves are practically same size as belts, but cut about 3/16 in. deeper

Fig. 4-12

Table 4-1 Dimensions of V-Belts and Sheaves

Designation of Cross Section	V-Belt Dimensions, Inches		Sheave Dimensions, Inches				
	Width at Top	Depth or Thickness	Groove Spacing	Min. Recommended Pitch Dia.	Pitch Diameters Available		Add to P.D. to Obtain Outside Diameter
					Stock	Non-Stock	
A	1/2	1 1/32	5/8	2.6	3.0 to 6.4 in 0.2 in. increments; 7.0, 8.2, 9.0, 10.6, 12.0, 15.0, 18.0	3.0 to 36.0 in 1 in. increments; 38.0 and 40.0	3/8
B	2 1/32	7/16	3/4	5.0	5.0 to 7.0 in 0.2 in. increments; 7.4, 8.6, 9.4, 11.0, 11.4, 13.6, 15.4, 16.0, 18.4, 20.0, 25.0, 30.0, 38.0	7.0 to 36.0 in 1 in. increments; 38.0 to 60.0 in 2 in. increments	1/2
C	7/8	1 7/32	1	7.0	9.0 to 10.2 in 0.2 in. increments; 10.6, 13.0, 16.0, 20.0, 24.0, 30.0, 36.0, 44.0, 50.0	11.0 to 36.0 in 1 in. increments and 38.0 to 72.0 in 2 in. increments	3/4
D	1 1/4	3/4	1 1/16	12.0	13.0 to 15.4 in 0.4 in. increments; 18.0, 22.0, 27.0, 33.0, 40.0, 48.0	14.0; 16.0 to 36.0 in 1 in. increments; 38.0 to 96.0 in 2 in. increments	7/8
E	1 1/2	1	1 3/4	20.0	None	20.0 to 36.0 in 1 in. increments; 38.0 to 96.0 in 2 in. increments	1 1/8

Table 4-2 Service Factors for Various V-Belt Applications

Application	Type of Motor								
	Squirrel Cage			Wound Rotor	Synchronous		Single Phase		D.C. Shunt Wound
	Normal Torque Line Start	Normal Torque Compensator Start	High Torque		Normal	High	Repulsion and Split Phase	Capacitor	
Service Factor (Multiplier)									
Centrifugal fan	1.2	1.2	—	1.4	—	—	—	—	1.2
Propeller fan	1.4	1.4	2.0	1.6	—	2.0	—	—	1.4
Induced draft fan	1.2	1.2	—	1.4	—	—	—	—	1.4
Positive blower	1.6	1.6	—	2.0	2.0	2.0	—	—	—
Centrifugal compressor	1.2	1.2	—	1.4	1.4	—	—	—	1.2
Rotary compressor	1.2	1.2	—	1.4	1.4	—	1.2	1.2	1.2
Reciprocating compressor (3 or more cyl.)	1.2	1.2	—	1.4	1.4	—	—	—	1.2
Reciprocating compressor (1 or 2 cyl.)	1.4	1.4	—	1.5	1.5	—	—	—	1.2
Centrifugal pump	1.2	1.2	1.4	1.4	—	—	1.2	1.2	—

Tables on pages 72 and 73 reproduced by permission of the publishers of "Buildings Systems Design," successor to "Heating and Ventilating."

SELECTION OF V-BELT DRIVES

V-Belt Sizes for Various Loads

RPM of Smaller Pulley	Horsepower									
	1/2	1	2	3	5	7 1/2	10	15	20	30
	Section Designation									
4000	A	A	A	A	A	A	A	A	A	B
3500	A	A	A	A	A	AB	AB	AB	AB	B
3000	A	A	A	A	A	AB	AB	AB	AB	B
2500	A	A	A	A	A	AB	AB	AB	AB	BC
2000	A	A	A	A	AB	AB	AB	AB	BC	C
1750	A	A	A	A	AB	AB	AB	BC	BC	CD
1500	A	A	A	AB	AB	AB	AB	BC	BC	CD
1250	A	A	A	AB	AB	AB	AB	BC	BC	CD
1000	A	A	A	AB	AB	AB	BC	BC	C	CD
900	A	A	AB	AB	AB	AB	BC	BC	CD	CD
800	A	A	AB	AB	AB	B	BC	C	CD	CD
700	A	A	AB	AB	AB	BC	BC	C	CD	CD
600	A	AB	AB	AB	B	BC	BC	C	CD	CD
500	A	AB	AB	AB	BC	BC	C	CD	CD	DE

Table 4-3

Nominal Horsepower Ratings per Belt

Belt Velocity, ft. per min.	Section Designation																
	A		B		C		D		E								
	Pitch Diameter, Small Pulley, Inches																
	2.6	3.4	4.2	5.0	5.0	5.8	6.6	7.0	9.0	11.0	12.0	14.0	16.0	21.0	23.0	25.0	27.0
Nominal Horsepower per Belt																	
1000	.5	.8	.9	1.0	1.3	1.5	1.7	2.0	2.8	3.4	4.5	5.6	6.5	8.5	9.4	10.2	10.9
1500	.8	1.1	1.4	1.5	1.8	2.1	2.4	2.9	4.2	5.0	6.5	8.2	9.6	12.5	13.9	15.1	16.1
2000	1.0	1.5	1.8	2.0	2.4	2.8	3.1	3.7	5.5	6.5	8.4	10.7	12.5	16.2	18.1	19.6	21.0
2500	1.1	1.7	2.1	2.4	2.8	3.3	3.7	4.5	6.6	8.0	10.1	12.9	15.1	19.6	21.9	23.9	25.5
3000	—	2.0	2.4	2.7	3.2	3.8	4.3	5.0	7.6	9.2	11.4	14.9	17.5	22.7	25.3	27.6	29.6
3500	—	—	2.7	3.0	3.4	4.1	—	—	8.4	10.3	12.4	16.5	19.5	24.9	28.1	30.8	33.1
4000	—	—	2.8	3.3	3.5	4.4	5.0	—	9.0	11.2	—	17.6	21.0	26.6	30.3	33.4	36.0
4500	—	—	—	3.4	3.5	4.4	5.1	—	—	11.8	—	—	22.1	—	31.7	35.2	38.2
5000	—	—	—	3.4	3.3	4.3	5.1	—	—	12.2	—	—	22.6	—	—	36.2	39.5

Table 4-4

Correction Factor for Shave Arc of Contact

Arc of Contact	180°	170	160	150	140	130	120	110
Multiplier	1.00	.98	.95	.92	.89	.86	.83	.79

Table 4-5

$$\text{Arc of contact} = 180^\circ - \frac{60(D-d)}{C} \text{ degrees}$$

D = pulley dia., inches

d = sheave dia., inches

C = center distance, inches

5. Find the correction factor for the angle of contact from Table 4-5. Any angle less than 180° arc of contact will reduce the horsepower transferred by the factor shown.
6. Multiply horsepower per belt by the factor, which gives the corrected horsepower per belt.
7. Dividing the corrected horsepower, 1st step, by the horsepower rating per belt will give the number of belts required.

Example:

A 1 hp motor 1750 rpm normal torque line start squirrel cage motor drives a centrifugal fan at 400 rpm. There is one A section belt, 97.1 inches long. The motor pulley is 3.4 inches in diameter, the fan pulley diameter is 14.9 inches and center to center distance is 33.7 inches. Find if the single A belt is sufficient to drive the fan.

1. from Table 4-2 the service factor is 1.2

$$1.0 \times 1.2 = 1.2 \text{ hp required}$$

2. belt speed = $.262 \times 3.4 \times 1750$

$$= 1559 \text{ fpm}$$

3. from Table 4-4 hp = 1.1 (for 180° contact)

4. find arc of contact

$$180^\circ - \frac{60(14.9 - 3.4)}{33.7} = 159.5^\circ$$

5. from Table 4-5, correction factor = 0.95

6. corrected hp transmitted = $(1.1)(0.95)$

$$= 1.05 \text{ hp}$$

This is 12.5% less than the required 1.20 hp, so two A section belts should be used.

Table 4-2 lists the nominal horsepower ratings of v-belts generally. For exact solutions, use the manufacturer's rating tables.

Inspect V-belt drives for the following:

1. The sheave, or motor pulley, should not be undersized, otherwise excessive tension will be required to prevent slipping causing undue binding stresses, overheating and breakdown of the belt. The minimum sheave sizes are:

Belt Section	Min. Sheave Pitch dia., inches
FHP	2.0
A	3.0
B	5.0
C	7.0
D	12.0
E	20.0

2. Multiple V-belts for a given drive should be a matched set, otherwise the shorter ones will carry all the load. If it is necessary to replace a belt the whole set should be replaced.
3. Belts should not be operated over 5,000 fpm.
4. Check for sufficient take up. New belts have to be re-tightened after running awhile.
5. Make sure the V-belts and grooves match. Oversize grooves will cause the belts to ride low (they must never ride on the bottom of the groove) and undersized grooves will cause the belt to ride high. The top of the belt should be approximately flush with the top of the groove with approximately 1/8" to 3/16" clearance at the bottom.
6. Check shafts and pulleys for alignment. A straightedge layed along the sides of the pulley and sheave should contact the entire surface of each.
7. Check belts for proper tension. Overtightening causes internal heating of the belt and overloads motor bearings. Undertensioning will cause excessive slippage and dangerous heating of the belts. Follow the manufacturer's instructions for applying proper tension.
8. Do not permit anyone to pry V-belts out or across the sheave face. The driver should be slacked off so that belts can be easily moved.

9. The belt guard should be sufficiently open to permit ventilation around the belts, but must be totally enclosed. (State Safety Orders.) Metal screen with small openings may be used.

Fan Capacity Controls

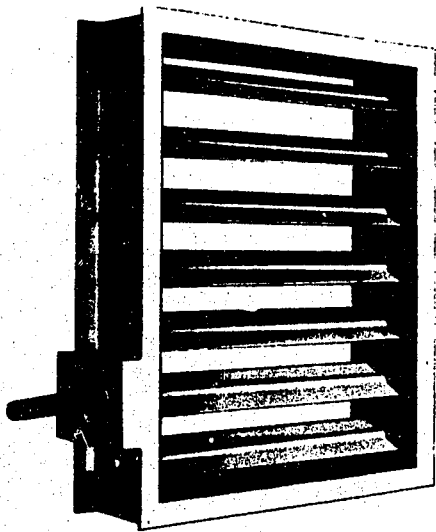
In ventilation work fan capacities are varied by changing the speed, or by use of dampers. In sizes up through 10 or 20 hp, adjustable pitch diameter sheaves are used. Above 20 hp and where more than 2 belts must be used variable pitch sheaves are expensive. If only one speed change needs to be made it may be more economical to install a new sheave. When capacity must be increased or decreased to suit a changing condition inlet or outlet dampers (Figs. 4-13, 4-14, and 4-15) may be used. The variable inlet vane damper reduces the horsepower required as the capacity is reduced and its higher cost is justified if the fan is to operate for long periods at low output. Fig. 4-16 shows the mechanics of an inlet vane damper. If a damper is needed for just short periods, the outlet damper would be a better selection.

Elimination of Vibration

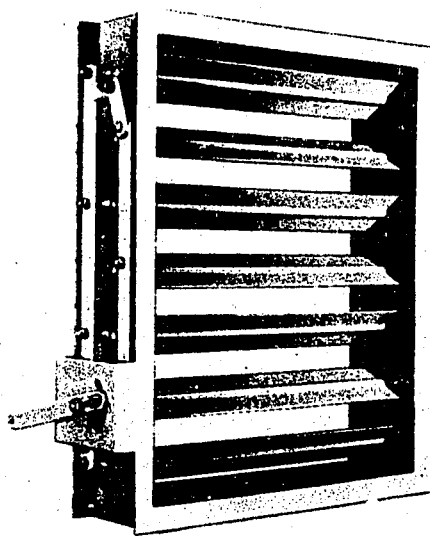
A fan has six rotating parts that can cause vibration: the wheel, shaft, sheave, pulley, belts and motor. The various parts were probably balanced at the factory but the assembled fan and drive vibrates somewhere between "acceptable" to "excessive". Or, vibration can be caused by turbulent air flow into the fan inlet. A fan operated with a throttled discharge may operate on an unstable part of the curve and pulsate and surge. This can be verified by allowing the fan to move more air (by opening a plenum door on the discharge side) and observing if the vibration decreases.

Some of the causes of vibration which can be checked are:

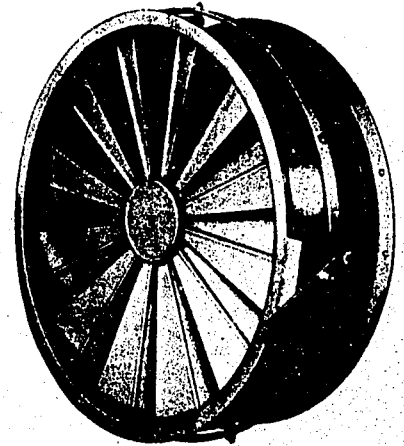
<u>Causes</u>	<u>Check</u>
1. Sprung shaft	Steady-rest a reference point near the pulley face, and also near the outside circumference of the pulley to just touch and observe any movement between the reference point and the pulley.
2. Pulley mis-alignment	Check with a straight edge along the pulley sides.
3. Dirt in pulley grooves	Grooves must be smooth and concentric.
4. Dirt or lumps on V-belt	Defective belts will have rough joint.
5. Dirty fan wheels	



PARALLEL BLADE
OUTLET DAMPER



OPPOSED BLADE
OUTLET DAMPER



INLET DAMPER

Fig. 4-13

Fig. 4-14

Fig. 4-15

Figs. 4-13 to 4-15, New York Blower Co.

PARTS LIST	
Part No.	Part Name
1	Blade
2	Rod
3	Bevel Pinion
4	Outer Bearing
5*	Center Hub
6*	Drive Gear
7	Gear Retainer - Ring - Arr. No. 1, 3, & 7
8	Gear Retainer - Disc. - Arr. No. 1, 2, 4, & 6
9	Operating Rod
10*	Gear Cover Back
11*	Gear Cover Front
12	Operating Lever
13	Operating Bracket
14*	Lever Bracket
15	Control Quadrant
16	Center Stud - Des. No. 1
16A*	Center Shaft - Des. No. 3
16B*	Spacer - Des. No. 3

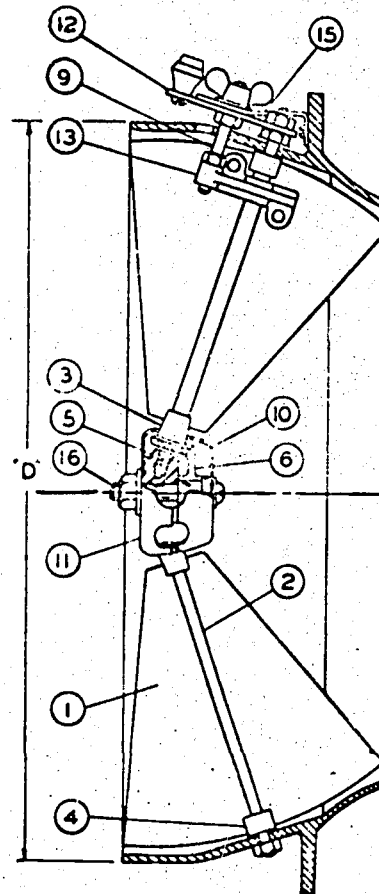


Fig. 4-16 Courtesy, Zurn-Clarage

<u>Causes</u>	<u>Check</u>
6. Unbalanced motor or motor pulleys	Remove V-belt or disconnect coupling and run motor to check for motor vibration.
7. Loose set screws on fan wheel or pulleys	
8. Loose foundation bolts	
9. Loose bearing bolts	
10. Bearings loose on shaft	
11. Damaged wheel	

The vibration produced by a fan can be prevented from effecting the surrounding structure by absorbing it with a massive foundation, such as a block of concrete, 2 or 3 times the weight of the machinery. In severe cases or where extra precautions are necessary, the block is mounted on an isolation base. The isolation elements commonly used are rubber-in-shear, cork and steel springs, and are available in the following forms:

1. Pads of rubber-in-shear with a base plate for bolting to a fixed base, with attached stud for securing the equipment, Fig. 4-17. Pads are also made of rubber and cork sandwiches with ribbed bottoms, Fig. 4-18. The latter are also used for heavy machinery that must not be bolted rigidly because of expansion and contraction.
2. Bases or rails mounted on rubber or springs, Figs. 4-19 and 4-20, to hold the fan and motor in place while isolating them from the floor. This base keeps the motor and fan from drawing together because of belt tension.
3. Reinforced concrete inertia pad set on individual spring mounts, Fig. 4-21. Fig. 4-23 shows a well designed base on spring rails. The snubber nuts are only "finger tight" to permit vertical movement of the assembly.

Springs must be designed and selected by the manufacturer for the load and rotating speed of the equipment and the distribution of the load on the base. A location plan is usually sent with the springs which are color coded. When loaded the springs must not be closed solid but should have at least enough space to insert a calling card between the coils.

Flexible connectors at the fan connections are required to isolate



Fig. 4-17

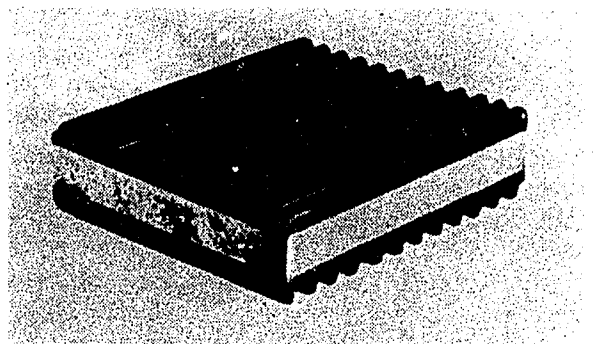


Fig. 4-18

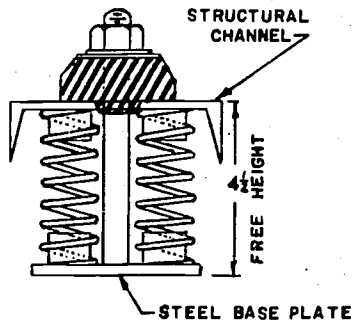
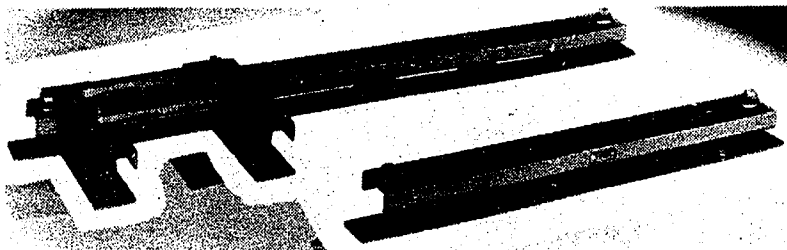


Fig. 4-19

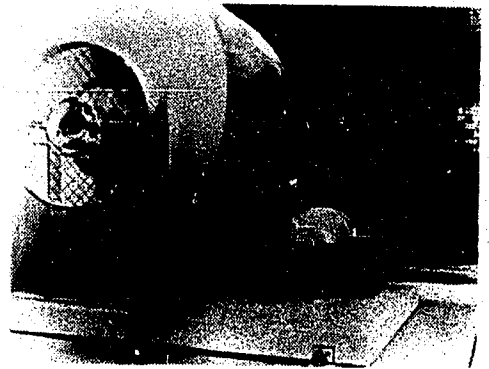


Fig. 4-20

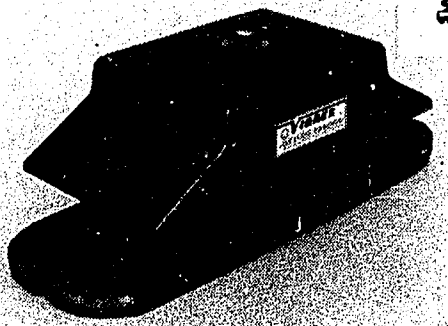
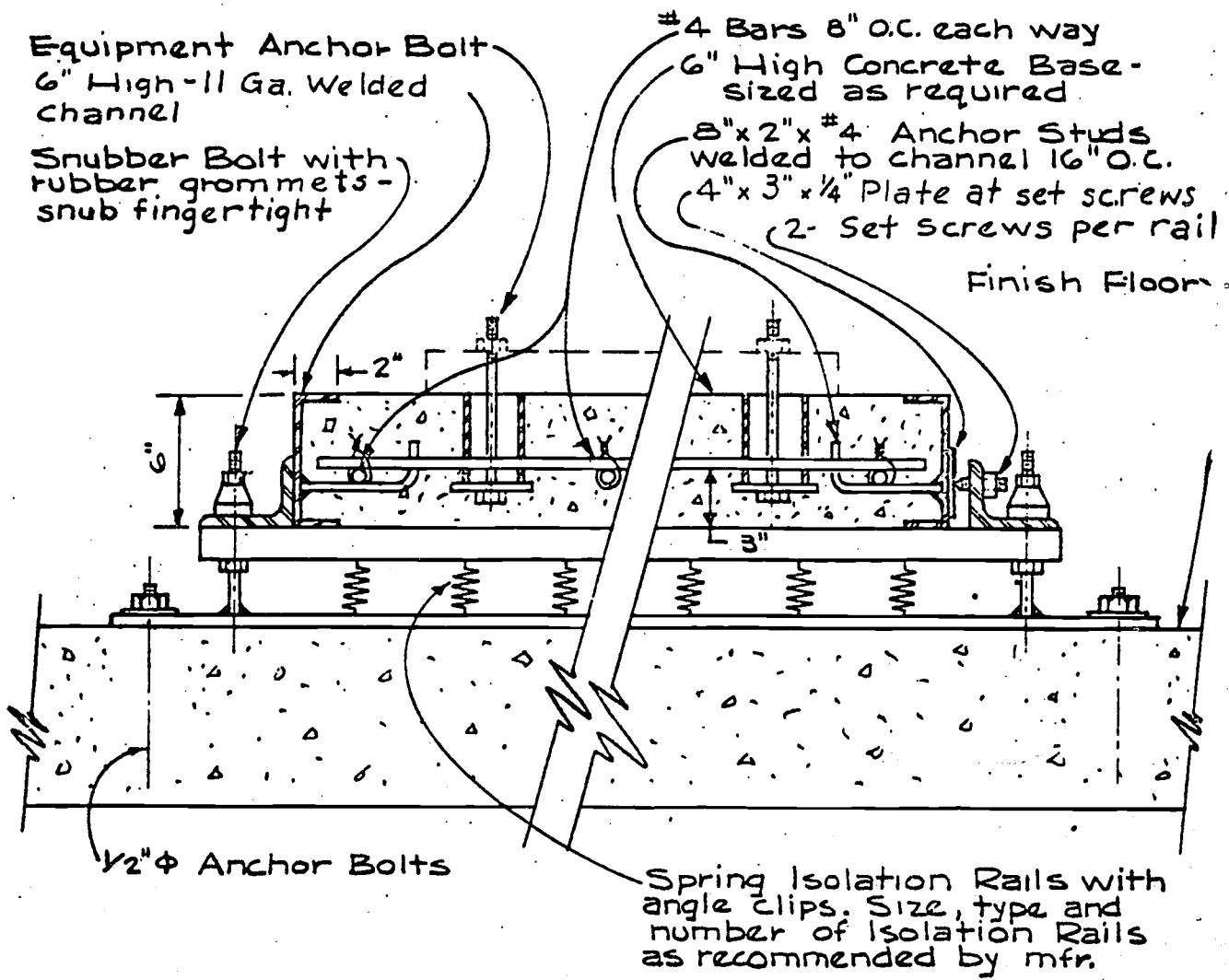


Fig. 4-21



Fig. 4-22



INERTIA ANTI-VIBRATION BASE

Fig. 4-23

any vibration being transferred to the duct work. A neoprene coated glass fabric is generally used and is available rolled into strips with sheetmetal bands on both sides for attachment to the duct. The ducts should be checked at these points for proper support and stiffening so as to not "hang" on the flexible joint and tear it or partially close the fan inlet or outlet. The wiring to the motor should be run in flexible conduit. (See Fig. 4-24)

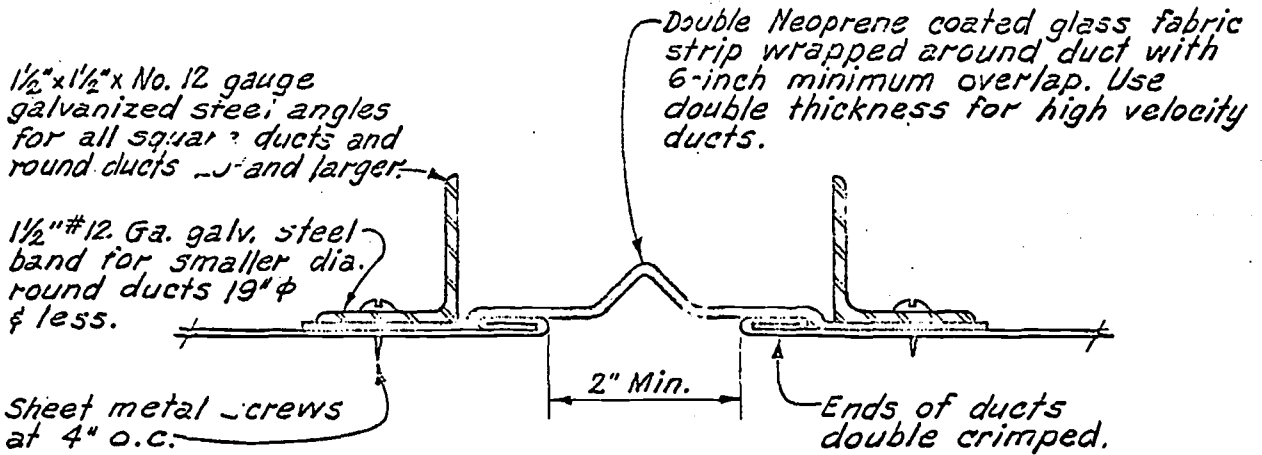
Duct Connections

The manner in which air enters and leaves a fan has a profound effect on its performance. At the inlet the air should fill the eye of the impeller equally without crowding on one side and without turbulence or spin. The outlet discharge duct is not as sensitive as the inlet, but will reduce the fan performance if it does not permit the full development of the fan pressure. When fans are tested in a laboratory with duct connections as a test requirement, the ducts are designed to provide uniform straight flow to the fan inlet, and the outlet connection is equal in area to the fan discharge and straight for at least 10 diameters. These conditions usually cannot be duplicated in the installation due to space limitations, and the performance will be correspondingly reduced. However, avoiding some of the common errors shown below will allow the fan to produce the air quantities needed and cost less to operate. The designer has the prime responsibility to produce the optimum configurations and these should be followed as closely as field conditions permit.

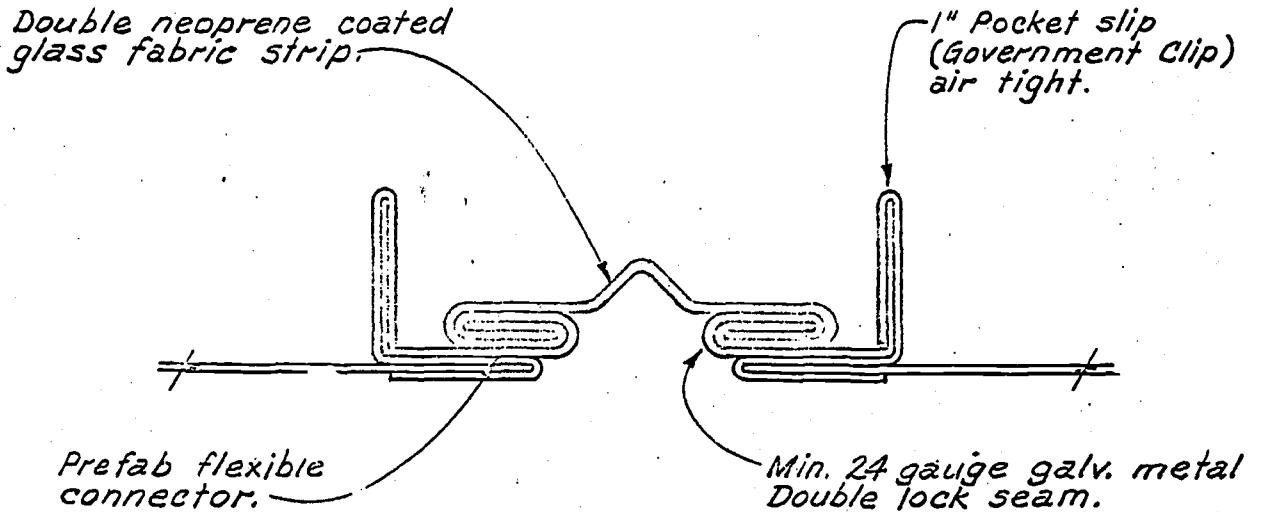
Fig. 4-25 illustrates the air flow with straight duct, and an elbow connection to a fan inlet. On the latter, air is crowded to one side of the impeller suction, and because even flow through the wheel does not occur, the total air flow is reduced by 5 to 10%. Fig. 4-26 illustrates spinning caused by a poorly designed inlet box which can be alleviated by turning vanes, Fig. 4-27. Fig. 4-28 is an all too common method of connecting to exhaust fans with the results, and a method of correcting them in Fig. 4-29. In Fig. 4-30, it would be better to introduce the air straight into the inlet; otherwise, the distance between fan inlet and plenum wall should not be less than one wheel diameter. The remaining figures show poor and preferred methods of connection and recommended corrections where space limitations exist. Figs. 4-31-33 show more examples of "best, good and fair" ways to connect fan discharges, and the proper clearances and contraction angles to be observed for fan inlets.

Construction Details

Fig. 4-33a illustrates the basic parts of a typical arrangement 2 single width fan. The base and drive is not shown. The housing consists of an outer wrapper called the scroll plate, and two side plates. The scroll is in the shape of a volute which converts the velocity pressure developed by the impeller wheel

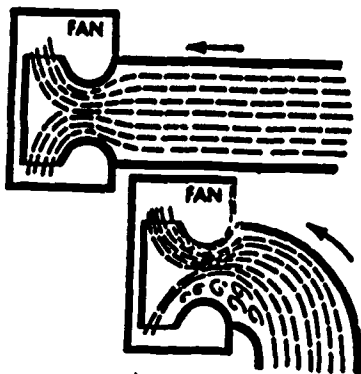


FLEXIBLE DUCT CONNECTION



OPTIONAL PREFAB FLEXIBLE DUCT CONNECTION!

Fig. 4-24



Air load distribution at inlet to the fan.

Fig. 4-25

Spinning caused by a poorly designed inlet box.

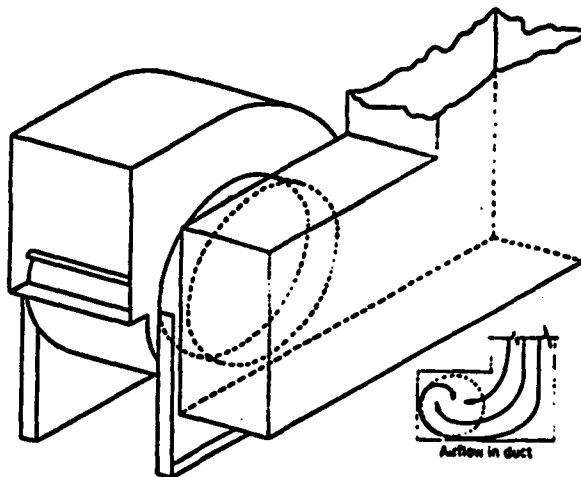


Fig. 4-26

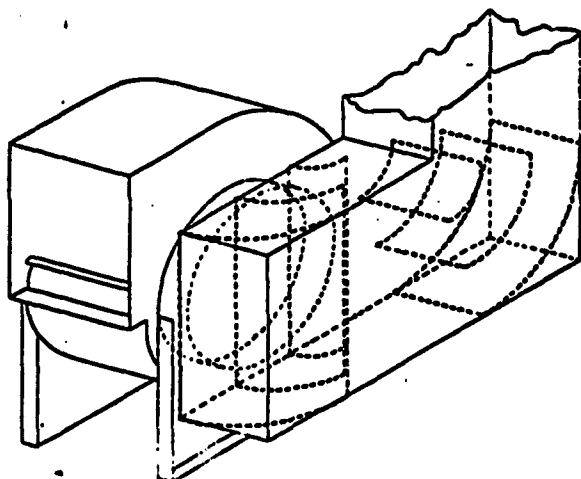
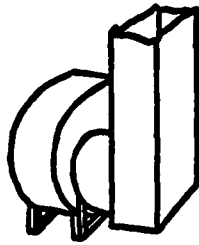


Fig. 4-27

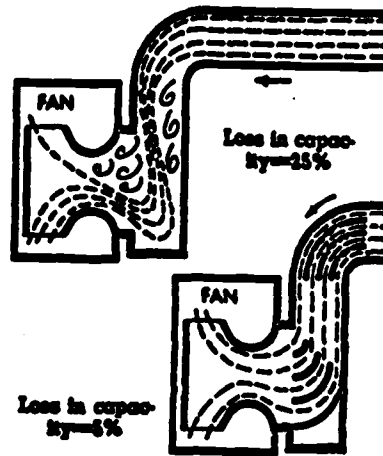
Inlet box without vanes has loss of 40% of CFM; requires 180% extra SP selection to bring fan to desired capacity. With upstream vanes, loss is 17%; SP needs 45% increase. With both sets of vanes, loss is 11%; SP needs 25% increase.

Courtesy, New York Blower Co.¹



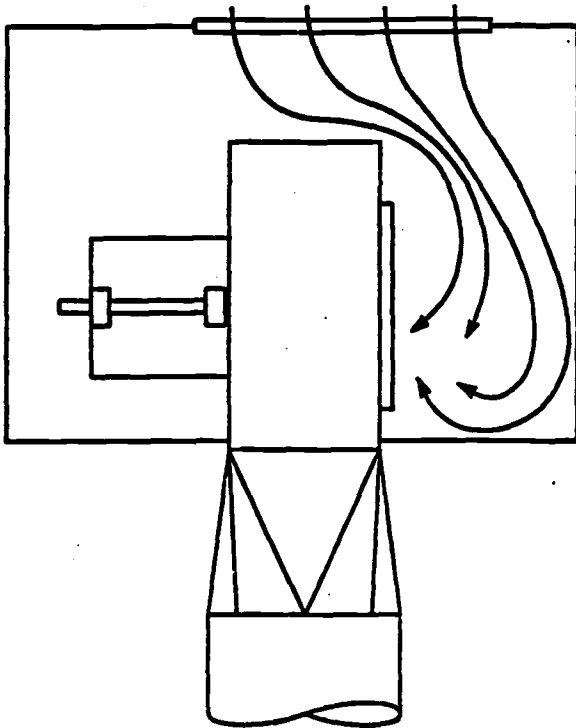
Inlet box causing eccentric flow.

Fig. 4-28



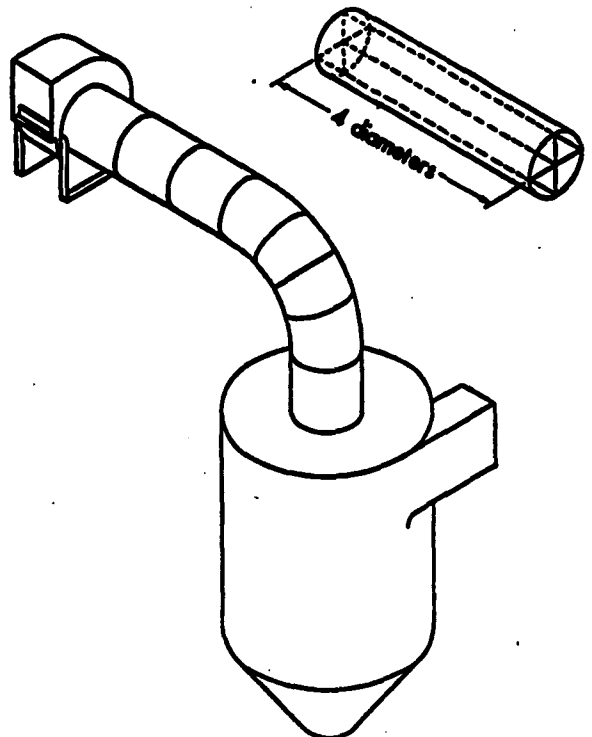
Inlet box causing 25% loss due to eccentric flow, and use of vane to remedy the condition.

Fig. 4-29



Inlet plenum causing eccentric flow.

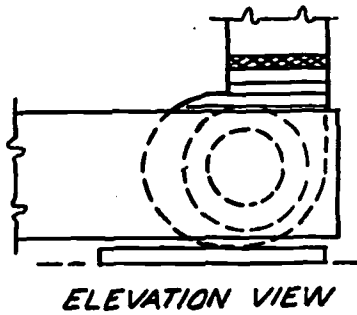
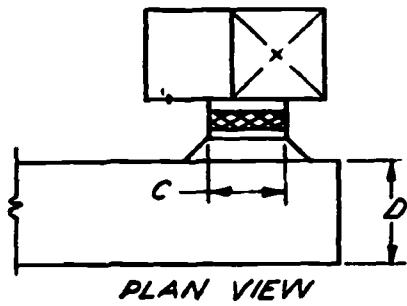
Fig. 4-30



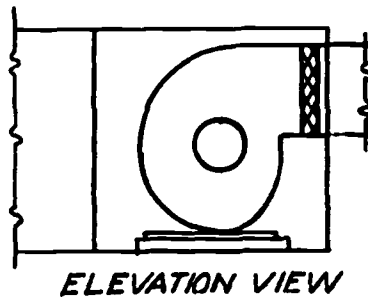
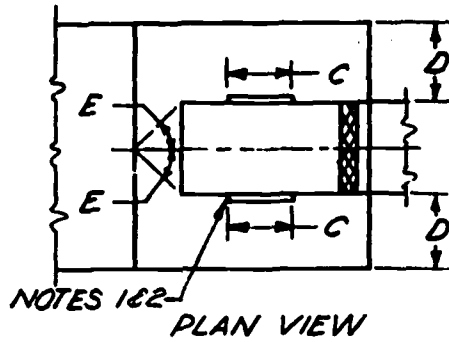
Fan exhausting from cyclone. The loss depends upon the proportion of cyclone and could be as much as 40% of desired CFM. At upper right is simple remedy: an egg-crate straightener is put in the duct.

Fig. 4-31

SINGLE INLET FAN



DOUBLE INLET FAN

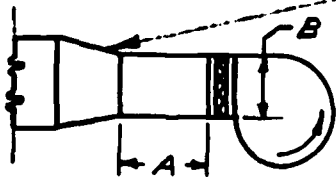


C = DIAMETER OF FAN INLET
 $D = 1\frac{1}{4} \times C$
E = 45° MAXIMUM, 30° PREFERRED

INLET CONNECTIONS

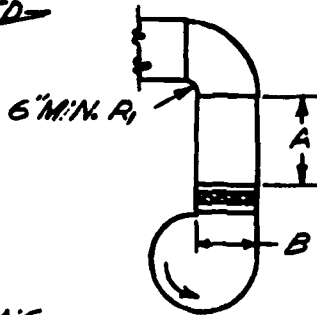
Fig. 4-32

BEST
 TRANSFORMATION 1" IN 7"
 PREFERRED, 1" TO 4" PERMITTED

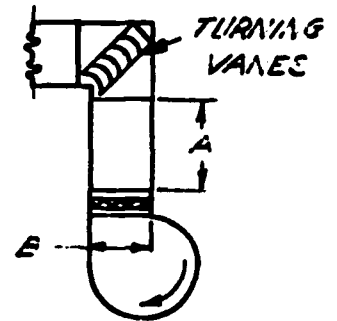


DIMENSIONS:
 $A = 1\frac{1}{2} \times B$ TO $2\frac{1}{2} \times B$
 $B =$ FAN DISCHARGE OPENING,
 LARGEST DIMENSION

GOOD

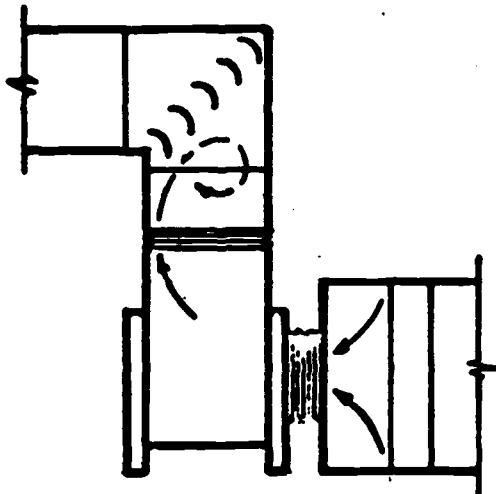


FAIR



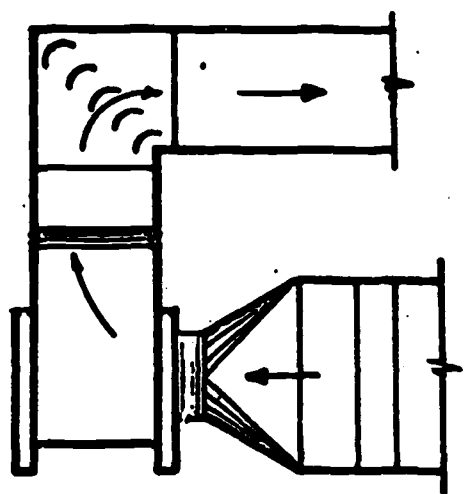
DISCHARGE CONNECTIONS

POOR FAN OUTLET FLOW

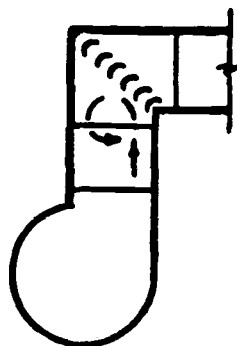


POOR FAN INLET FLOW

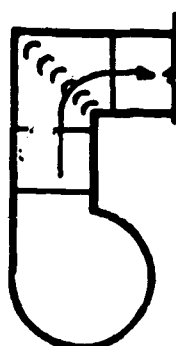
FINE FAN OUTLET FLOW



GOOD FAN INLET FLOW

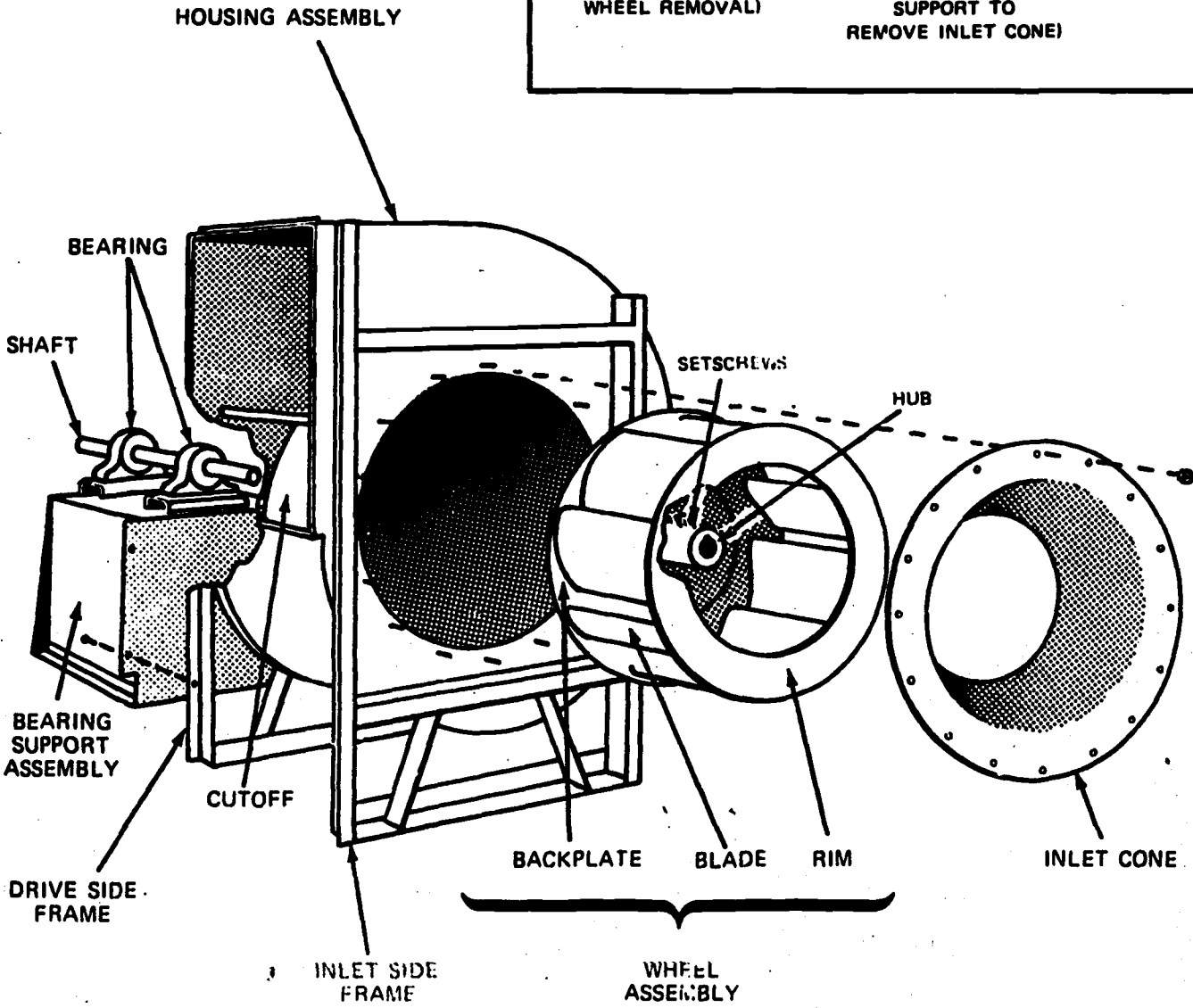
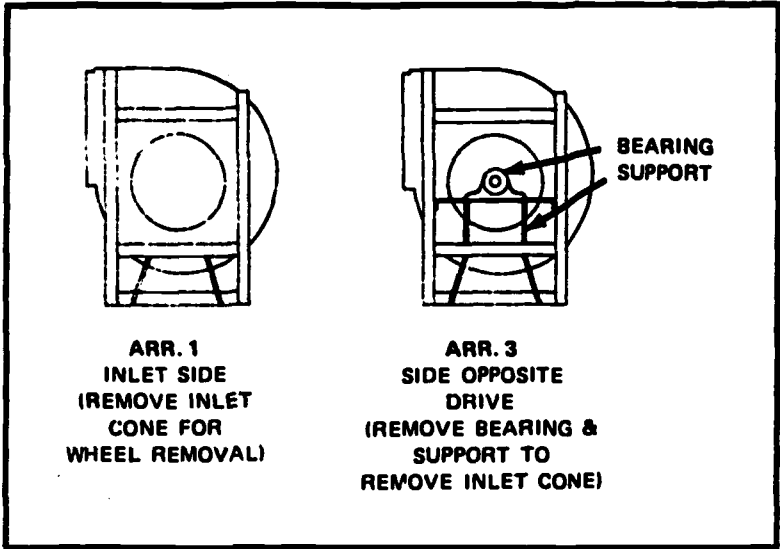


POOR FLOW



GOOD FLOW

Fig. 4-33



ROUND DUCT
CONNECTION
NOT SHOWN

Fig. 4-33 (a)

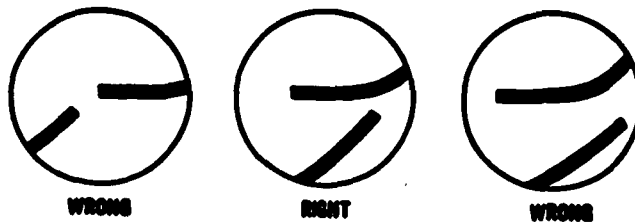
Courtesy, Zurn-Clarage

into static pressure. The lower edge of the scroll terminates with a section called the "cut-off" which is positioned as close to the rotating impeller as is practical. Its purpose is to prevent air in the high pressure area of the discharge from short-circuiting back to the suction side which reduce capacity and waste power. The side plate on the right supports the inlet cone which is faired and shaped with a bell mouth inlet to lead the air into the impeller eye with a minimum of turbulence. Since this is a single inlet fan, all of the air enters through the right side cone, the left side plate being solid except for running clearance around the shaft. The overhung impeller is supported by a pillow block with a bearing at each end, the pillow block being rigidly supported from the fan frame. The position of the impeller with respect to the inlet is very important and should be checked for agreement with the manufacturer's instructions. Double width wheels should be centered between the inlets. Single width wheels are generally designed with an inside diameter slightly larger than the cone outside diameter, in which case the wheel should overlap the cone with a minimum of running clearance. Fig. 4-34 shows the degree of overlap as specified by one manufacturer, and Fig. 4-35 shows various configurations and clearances used by another firm. Here again, the purpose of restricting this space to the minimum is to prevent short circuiting the air from the high pressure area to the suction side of the impeller.

It is not uncommon to find a fan rotating backward and occasionally find a clockwise fan fitted with a counter-clock wise impeller. A simple rule to determine the correct rotation is to think of a particle of air as starting at the cut-off and traveling around the spiral of the scroll to the discharge. This will be the direction of rotation for all impellers regardless of the type of blade. As mentioned previously, the forward curve blade will appear to be "scooping" the air and the backward inclined type will lay back against the air but never scoop it. Radial blades project straight out and may be machined or surfaced on the leading face.

Whether assembled on the job or at the factory, fans should be checked for the following points and in conformance with the manufacturer's installation instructions:

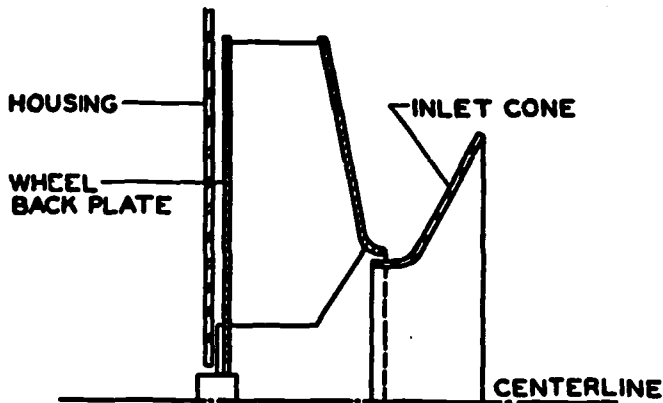
1. On arrival at the job site inspect the housing for dents or any damage to the base or bearing supports. If it is necessary to store it in the weather it should be covered with a rain proof cover and set on timbers. Bearings should be covered and sealed with tape whether inside or out to keep out construction dirt. Shaft should be protected with rust preventive compound. As a safety precaution, the impeller should be restrained from turning by "wind milling" in the wind.
2. After the fan is set on the permanent foundation check the shaft for level. A small deflection of the shaft will occur due to the weight of the impeller. The shaft is



Axial Overlap Between Wheel And Inlet Cone.

Fig. 4-34 Trane Co.

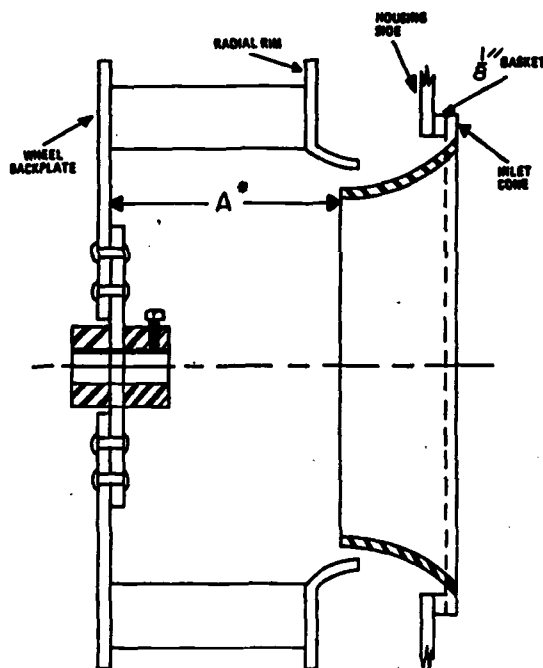
NOTE — Wheel rim should overlap inlet cone. Allow adequate running clearance between wheel back plate and housing.



Type O Single Inlet Fans.

Fig. 4-35 (a)

Zurn-Clarage



FAN SIZE	"A" DIM.
	61000 SERIES
60	4 1/2
66	4 1/8
73	5 7/8

* Dimension "A" should be measured at 4 points approximately 90 degrees apart.

Fig. 4-35 (b) Zurn-Clarage

level when the same amount of slope at each bearing is indicated. The centerline of the shaft at each bearing must be at the same elevation.

3. Check double wheel impellers for being centered between the inlet cones, and single wheels for overlap with the cone.
4. Check impellers for concentricity with the inlet cones, while slowly rotating the impeller.
5. Check shaft size, bearings, motor and drive details against the specifications and approvals for compliance.

Fan Testing

After a fan and the system it serves has been installed the fan should be tested for performance. The value of this test is to determine what the fan produces and where the data gathered falls on the fan curve; and to record the actual power load, speed, and static pressure. Field tests can rarely be made with the accuracy of a laboratory test; however, reasonable accuracy can be attained if care is taken. If it develops that the fan delivers substantially more or less air than anticipated, the data gathered by the test will be used by the designer and the manufacturer in adjustments of the fan speed or system resistance. After such changes are made the test should be repeated.

The data to be gathered are:

1. Static pressure (at inlet and outlet).
2. Cubic feet per minute (determined by multiplying the velocity through the duct connected to the fan discharge by the area of the duct, or

$$Q = a \times v$$

Q = cubic ft of air per min
a = area, sq ft
v = velocity, fpm

3. Fan speed.
4. Power input to the fan.
5. Temperature of the air at the fan inlet.

The instruments used for obtaining the above are simple, uncomplicated and dependable. Similarly, the calculations used in arriving at the test report results involve simple arithmetic.

The devices used for finding static pressure and velocity of the air stream are the manometer and the Pitot tube (pronounced pē - tō). Fig. 4-36 illustrates a manometer, also called a "U" tube, which consists of glass or plastic tubing of uniform bore, formed in a "U" shape and filled with water. With equal pressure

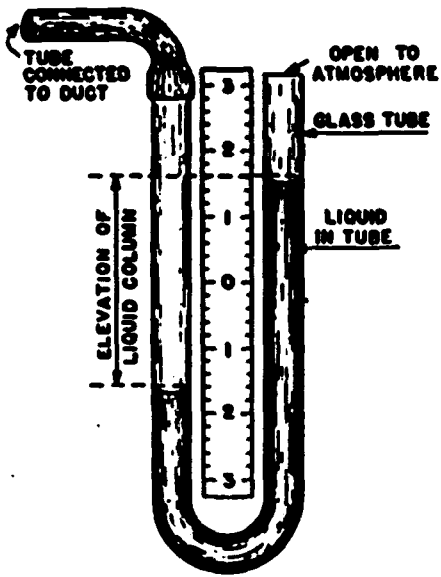


Fig. 4-36

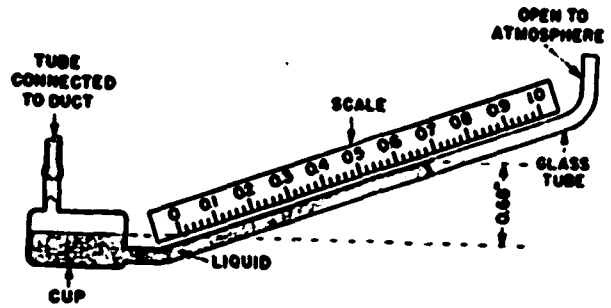


Fig. 4-37

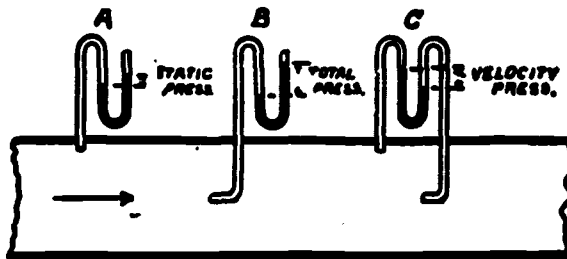
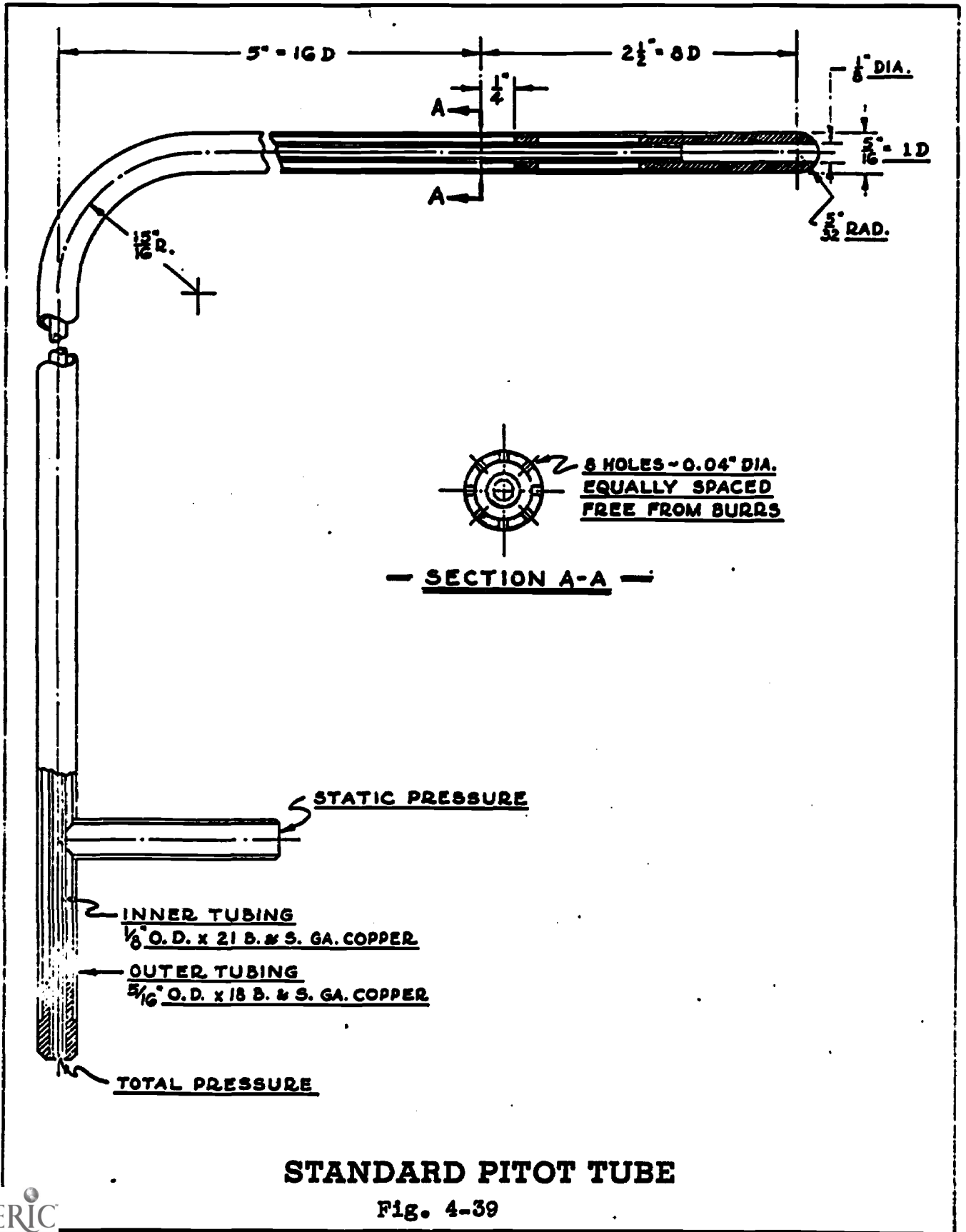


Fig. 4-38



STANDARD PITOT TUBE

Fig. 4-39

on both legs (assume atmospheric) the water in each leg will be at the same level. The scale in the middle is adjusted up or down so that "0" lines up with the liquid levels. When the tube on the left is connected to a pressurized duct the air pressure displaces the liquid until the height of the water on the right exactly balances the duct pressure. Thus, the reading is the measurement between the two liquid levels in inches of water, which is the unit of pressure used in ventilation work. Similarly, if the duct pressure is negative, the atmospheric pressure will force the liquid column down. For reading low air pressures (as 0.1 inch water) an inclined manometer is used (Fig. 4-37) which has the effect of magnifying the vertical movement of the liquid interface. A standard Pitot tube is shown in Fig. 4-38. The horizontal portion is constructed to the standard dimensions shown, but the vertical leg is available in different lengths depending on the width of the duct to be probed. The total pressure in the duct is transmitted through the inner tube, while the static pressure is sensed through the openings around the outer tube (Section A-A) and transmitted to the "static pressure" tap.

The function of the Pitot tube is to measure the velocity of the air, the principle of its action being shown in Fig. 4-39. A, B and C are manometers registering static pressure, total pressure, and velocity pressure.

The reason why the Pitot tube is able to measure velocity pressure from which the flow velocity of the air stream is found can be explained as follows:

Referring to Fig. 4-39, it is obvious that the pressure P_1 must be greater than the pressure P_2 , in order to move the air through the duct. The pressure P_1 imparts a velocity to the air stream, called velocity head; and P_1 also overcomes the friction loss or head caused by the air flowing along the sides of the duct. Not all of the pressure P_1 is used up for velocity and friction heads, and the balance remaining is the static pressure existing in the duct. When moving air strikes or impinges on a surface at right angles to the direction of flow its velocity head is converted to pressure head. Thus, when the moving air impinges on the tip of the tube faced into the air stream (B) the velocity head, or pressure, is registered directly on the manometer. However, the reading obtained at (B) also includes the static pressure in the duct at that point, so the static is subtracted from the total pressure by connecting the left leg of the manometer to the side of the duct. This additional duct tap is not necessary with the Pitot tube as it is constructed with a static pressure connection (Fig. 4-39). After the velocity head has been determined, the velocity of the air stream is calculated from the formula

$$V = 1036.5 \sqrt{\frac{P}{W}}$$

where V = fpm
 P = head, or pressure, inches water
 W = weight of air, lb per cubic foot

For standard air conditions, (at 70° F and 29.92" barometric pressure) $W = 0.0749$ lb per cu ft, and is substituted in the equation, which reduces to

$$V = 4005 \sqrt{p}$$

Thus, if $p = 1$ " velocity pressure,

$$V = 4005 \sqrt{1"} \quad \text{or } 4005 \text{ fpm.}$$

If $p = 4$ ", velocity = $4005 \sqrt{4"} \quad \text{or } 8,000 \text{ fpm, etc.}$

Before proceeding with the velocity readings, the best possible spot in the duct work must be chosen, which should be from 7 1/2 to 10 duct diameters downstream from the fan, and ahead of any transitions, fittings or dampers that could cause turbulence or unequal flow patterns. The air velocity in a duct varies because of friction drag along the sides, therefore, it is necessary to hypothetically divide the duct cross-section into equal areas and find the velocity pressure in that particular area, then take the square root of each velocity pressure, and find the average. From this, calculate the velocity from:

$$V = 4005 \times \text{average } \sqrt{h}$$

The probe points for a rectangular duct are as shown in Fig. 4-40, which divides the area into 16 equal rectangular parts. The probes for a round duct are spaced as shown in Fig. 4-40, which divides the circle into five equal concentric areas.

When the average velocity has been determined the air volume is found from:

$$\text{cfm} = \text{velocity (fpm)} \times \text{area (sq ft)}.$$

Where the area is the net inside area (taking the duct lining into account).

The above method is as prescribed by the AMCA. If the duct arrangement is such that it is impossible to take readings 7 to 10 duct diameters downstream of the fan and free of disturbing influences, a rough check may be made with an anemometer by measuring the air flow through the filter bank on the suction side. The techniques of using the anemometer will be discussed in the section on balancing.

Having determined the quantity of air flow being delivered by the fan, the next step of the test is to measure the static pressure against which the fan is working. Referring to Fig. 4-41, fans are commonly installed in a plenum, drawing air through an outside air louver, automatic damper and a filter bank, all of which have a measurable pressure drop. The designed pressure loss through the filters can be obtained from the specifications or the manufacturer. The loss through the outside air louvers should not exceed 0.1" water column. The inlet pressure, which

FIELD TEST SHEET

FAN OWNER _____

FAN MFR. _____

FAN NAMEPLATE DATA _____

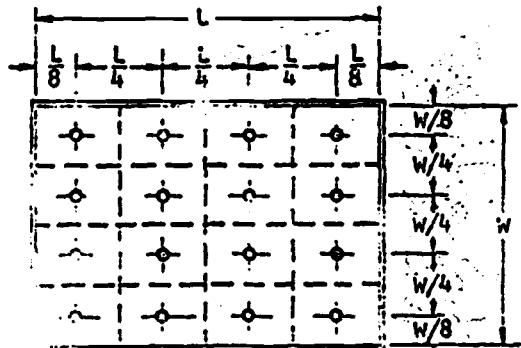
DATE _____ BY _____

FAN RPM _____ APPROX. BHP _____

MOTOR NAMEPLATE DATA _____

READINGS	S P (outlet)	S P (inlet)	V P	√V P
1.				
2.				
3.				
4.				
5.				
6.				
7.				
8.				
9.				
10.				
11.				
12.				
13.				
14.				
15.				
16.				
17.				
18.				
19.				
20.				
TOTAL			XXXXXXX	
AVERAGE				

SKETCH OF INSTALLATION
SHOWING POINTS OF READING



PROBE POINTS IN RECTANGULAR DUCT

Density = $.075 \left(\frac{530}{460 + OF} \right) \left(\frac{\text{Barometric Pres.}}{29.92} \right)$

= _____ lbs. per cu. ft.

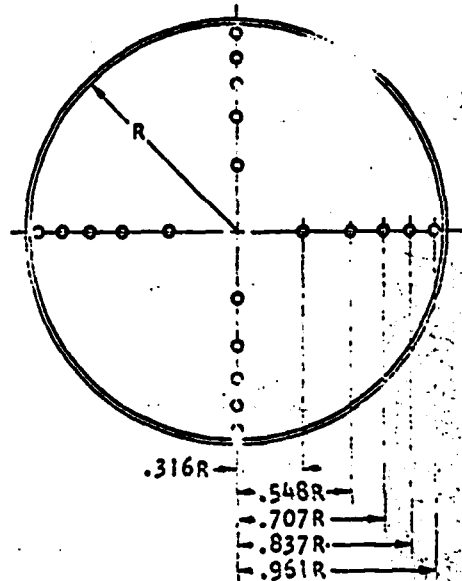
"k" = $\frac{.075}{\text{Density}}$ = _____

"k" times $\left\{ \begin{array}{l} \text{SP} = \text{_____} \text{ " SP} \\ \text{VP} = \text{_____} \text{ " VP} \\ \text{BHP} = \text{_____} \text{ " BHP} \end{array} \right\}$ at st'd density

average duct velocity = $4000 \sqrt{VP}$
 = $4000 \sqrt{\text{_____}}$
 = _____ fpm.

CFM = velocity x duct area
 = _____ x _____ = _____ CFM

Add to the SP any loss due to duct friction between points of readings and fan and due to floor inlet and outlet connections.



PROBE POINTS IN ROUND DUCT

Fig. 4-40



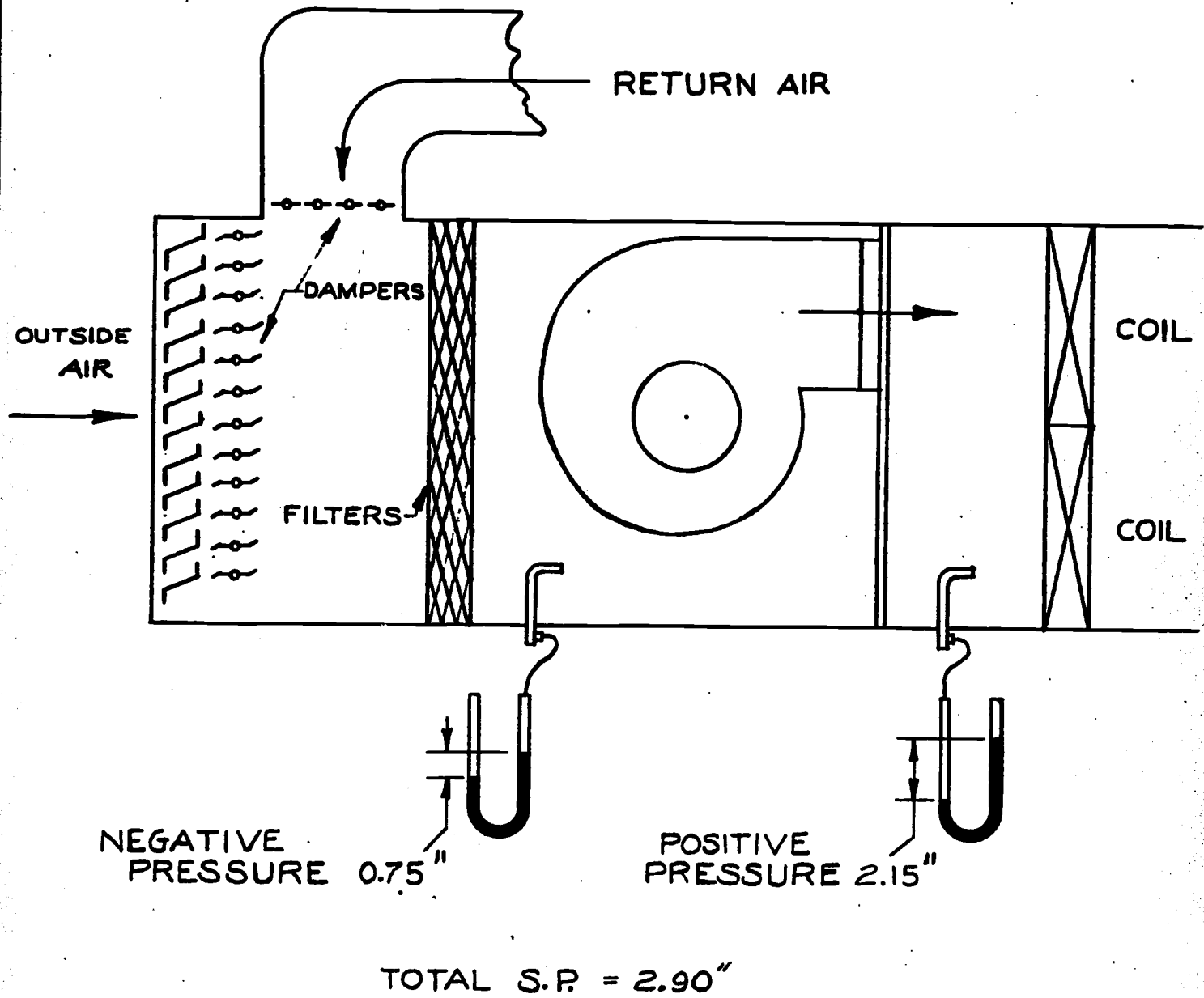


Fig. 4-41

will be negative, can be measured with a Pitot tube or a piece of rubber tubing inserted into the plenum, and facing downstream so as to not pick up any velocity pressure. The fan discharge static pressure is similarly measured in the plenum between fan and coils taking care to keep the probe out of turbulent air. The total static pressure is the arithmetic sum of the two readings, say 0.75" negative pressure plus 2.15" positive pressure = 2.90" total static pressure. If the coils are on the suction side of the fan the method of taking the static pressures are the same; in the inlet and outlet plenums.

The speed of the fan is the next part of the test to be determined, and can be taken with a simple revolution counter or a chronometric tachometer. The speed reading should be accurate within 5 rpm.

The brake horsepower needed to drive a fan is a good indicator of its performance when used in conjunction with the manufacturer's curves. A reasonably accurate method of finding the brake horsepower is to measure the amperes drawn by the motor and applying the following formula to find brake horsepower:

$$\text{brake horsepower} = \frac{\text{volts} \times \text{amps} \times 1.73 \times \text{P.F.} \times \text{efficiency}}{746}$$

746

Volts - the voltage across the motor terminals.

Amps - the average of the current drawn by each of the three "legs" supplying the motor (3 phase).

1.73 is a constant ($= \sqrt{3}$). (For three phase only.)

P.F. is the power factor.

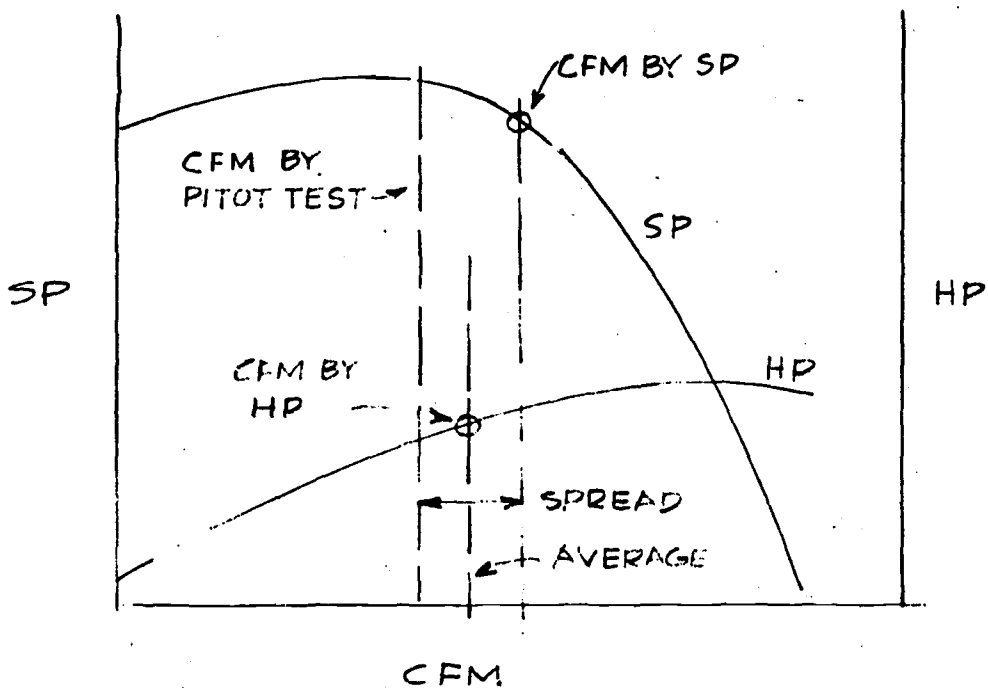
Efficiency is the motor efficiency.

The following table may be used for finding power factor and efficiency:

motor nameplate hp	1	5	20
power factor	.73	.88	.91
efficiency	.73	.82	.84

Finally, the air temperature at the fan inlet should be recorded, as well as the barometric pressure, to correct for the air density if different than that specified on the fan data sheet.

Three essential pieces of information have now been obtained, which, when marked on their respective curves, should show some agreement on the air quantity being produced. Fig. 4-42 shows



TYPICAL FAN CURVE AND FIELD TEST POINTS

Fig. 4-42

PROBABLE EFFECTS OF VARIOUS INLET CONNECTIONS
(These losses do not include friction losses)

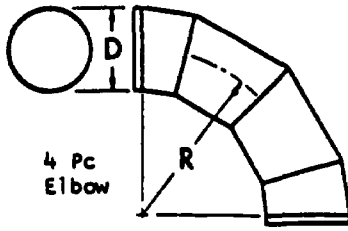

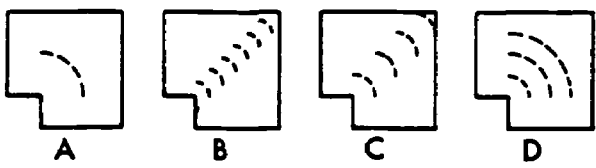
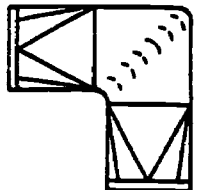
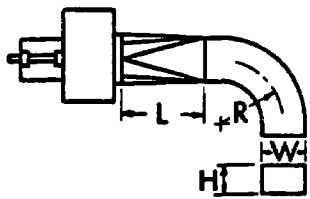
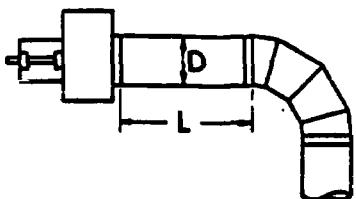
DESCRIPTION		% LOSS IN CFM IF NOT CORRECTED	% INCREASE NEEDED IN FAN SP TO COMPENSATE
 <p>4 Pc Elbow</p>	3 piece elbow $R/D = .5$	12	30
		1.0	13
		2.0	11
		6.0	11
	4 piece elbow $R/D = 1.0$	6	13
		4	9
		4	9
	5 or more piece elbow $R/D = 1.0$	5	11
		4	9
 <p>Mitered elbow</p>		16	42
<p align="center">Square Ducts with Vanes</p>  <p>A B C D</p>		No Vanes	45
		A	18
		B	13
		C	11
		D	9
 <p>Round to Square to Round</p>		8	18
<p align="center">Rectangular Elbows without Vanes*</p>  <p>The maximum included angle of any element of the transition should never exceed 30°. If it does, additional losses will occur. If angle is less than 30° and L is not longer than the fan inlet diameter, the effect of the transition may be ignored. If it is longer, it will be beneficial because elbow will be farther from the fan.</p>		*In all cases use of 3 long, equally spaced vanes will reduce loss and needed sp increase to 1/3 the values for unvaned elbows.	
		$\frac{H}{W} = .25, \text{ \& } \frac{R}{W} = .5$	15
		1.0	9
		2.0	9
		$\frac{H}{W} = 1.00, \text{ \& } \frac{R}{W} = .5$	30
		1.0	11
		2.0	9
		$\frac{H}{W} = 4.00, \text{ \& } \frac{R}{W} = .6$	39
		1.0	18
		2.0	9
		Each 2½ diameters of straight duct between fan and elbow or inlet box will reduce the adverse effect approximately 20%. For example, if an elbow that would cause a loss of 10% in CFM or an increase of 23% in fan SP, if on the fan inlet, is separated from the fan by straight duct the effect of the duct may be tabulated thus:	
		No duct	Loss = 10% - SP needed = 23%
		$L/D = 2\frac{1}{2}$	Loss = 8% - SP needed = 19%
		5	Loss = 6% - SP needed = 13%
		7½	Loss = 4% - SP needed = 9%
		10	Loss = 2% - SP needed = 4%

Fig. 4-44

Courtesy, New York Blower Co.

an example of plotting the results of the velocity probes, horsepower and static pressure on the corresponding curves furnished by the manufacturer. A range of cfm of this magnitude may be considered acceptable as it is due to errors in measurement if the installation is a good one, but if there is a wide divergence of data from predicted performance further investigation should be made. As stated previously, the inlet conditions to the fan have a large effect on its performance. If it appears this might be a contributing factor, a Pitot tube probe should be made on the horizontal and vertical axes of the round duct connection at the inlet. Non-uniform velocities at corresponding reference points will indicate turbulence and spinning. Such conditions can be corrected by revising the duct work or installing straightening vanes. Fig. 4-44 shows the probable losses that will occur with various inlet connections.

Adjustments to Meet Design Requirements

If the fan test data shows agreement with the fan curve but the delivery is below (or above) the desired design figure, some adjustments are necessary: (1) decreasing the system resistance or (2) changing the fan speed. A given duct system develops a resistance that varies with the square of the air volume, as shown in Fig. 4-45.

The point of intersection of the system resistance, OS_1 , with the fan curve $F_1 F_2$ determines the static pressure of the duct system and the air quantity. Assuming the design point is at cfm_2 , it can be seen that the system has balanced out at a higher static pressure and a lower cfm than originally predicted. If the system pressure loss can be reduced so that its resistance curve looks like OS_2 the design cfm can be obtained. Accordingly, the friction loss must be reduced by $SP_1 - SP_3$, based on the flow at cfm_1 . The system will then operate at static pressure SP_2 and cfm_2 , the design volume.

Another approach to increase (or decrease) the air delivery is to change the fan speed up or down. Fig. 4-47 shows a family of fan curves at different speeds.

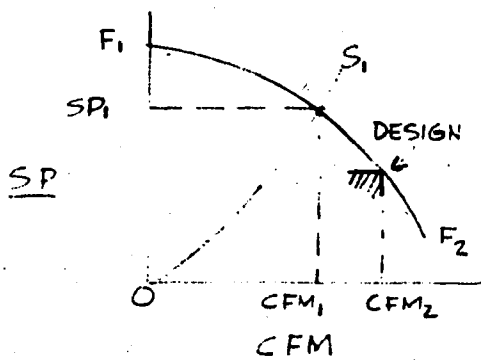


Fig. 4-45

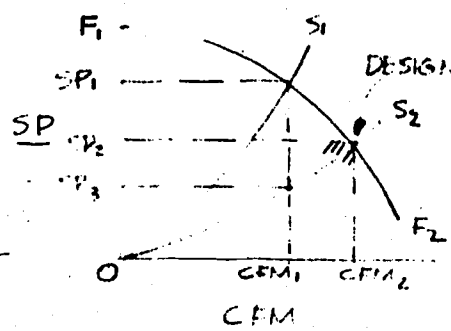
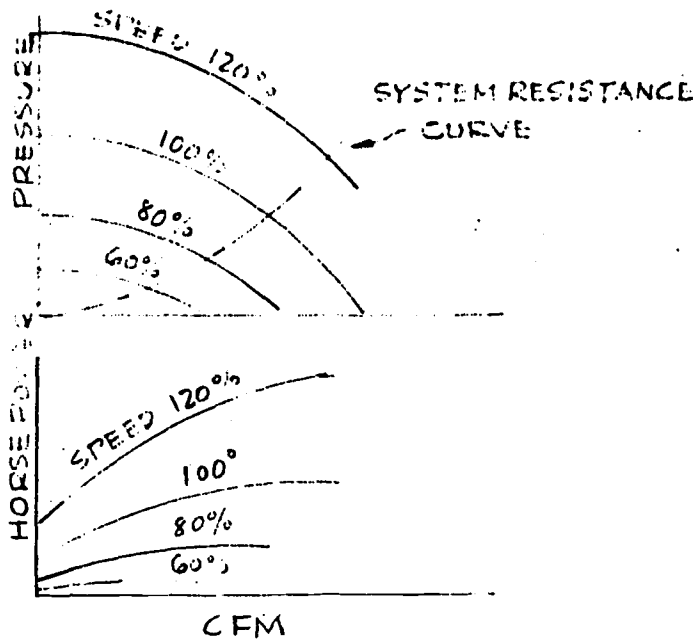


Fig. 4-46



Fan Laws

Fans (and pumps) follow what are commonly called the "Fan Laws". For a given fan handling the gas or weight of air, and with the speed varying:

1. Cfm varies as the speed

$$\frac{\text{cfm}_2}{\text{cfm}_1} = \frac{\text{rpm}_2}{\text{rpm}_1}$$

2. Static pressure varies as the square of the speed

$$\frac{\text{sp}_2}{\text{sp}_1} = \left(\frac{\text{rpm}_2}{\text{rpm}_1} \right)^2$$

3. Brake horsepower varies as the cube of the speed

$$\frac{\text{bhp}_2}{\text{bhp}_1} = \left(\frac{\text{rpm}_2}{\text{rpm}_1} \right)^3$$

Example: A fan was selected to deliver 10,850 cfm at 1 1/2" sp, and to run at 953 rpm, requiring 3.95 bhp. After installation it was found that the system developed 2.0" sp, delivered 9,800 cfm, and used 4.15 bhp. What should the speed be increased to, what static pressure should have been designed for, and what brake horsepower is required?

Solution:

<u>Specified conditions</u>	<u>Actual condition</u>	<u>Final conditions after speed change</u>
10,850 cfm	9,820 cfm	10,857
1.5 sp	2.0 sp	?
953 rpm	953 rpm	?
3.95 bhp	4.15 bhp	?

Fan law 1, cfm varies as the speed:

$$\frac{\text{rpm}_2}{\text{rpm}_1} = \frac{\text{cfm}_2}{\text{cfm}_1} ; \quad \text{rpm}_2 = \text{rpm}_1 \times \frac{\text{cfm}_2}{\text{cfm}_1}$$

$$\text{rpm}_1 = 953 \quad \text{cfm}_1 = 9,800$$

$$\text{rpm}_2 = ? \quad \text{cfm} = 10,850$$

$$\text{rpm}_2 = 953 \times \frac{10,850}{9,820}$$

$$= 1,055 \text{ rpm}$$

Fan law 2, static pressure varies as the square of the speed:

$$\frac{\text{sp}_2}{\text{sp}_1} = \left(\frac{\text{rpm}_2}{\text{rpm}_1} \right)^2 ; \quad \text{sp}_2 = \text{sp}_1 \times \frac{\text{rpm}_2^2}{\text{rpm}_1^2}$$

$$\text{sp}_1 = 2.0 \quad \text{rpm}_2 = 1,055$$

$$\text{sp}_2 = ? \quad \text{rpm}_1 = 953$$

$$\text{sp}_2 = 2.0 \times \frac{1055^2}{953^2}$$

$$= 2.44'' \text{ sp.}$$

Fan law 3, bhp varies as the cube of the speed:

$$\frac{\text{bhp}_2}{\text{bhp}_1} = \left(\frac{\text{rpm}_2}{\text{rpm}_1} \right)^3 \quad \text{bhp}_2 = \text{bhp}_1 \times \frac{\text{rpm}_2^3}{\text{rpm}_1^3}$$

$$\text{bhp}_1 = 4.15 \quad \text{rpm}_2 = 1,055$$

$$\text{bhp}_2 = ? \quad \text{rpm}_1 = 953$$

$$\text{bhp} = 4.15 \times \frac{1,055}{953}$$

$$= 5.60 \text{ bhp}$$

Bibliography

Footnote 1. Reproduced by permission of New York Blower Co., from "Engineering Letters" by Mr. Jack Trickler, Vice President and General Manager of La Porte Operations for the New York Blower Company.

Footnote 2. AMCA Standards, reproduced by permission of the Air Moving and Conditioning Association.

Fan Check-Points

Verify that:

1. Fans are the size, model, drive arrangement and rotation approved by the designer.
2. Fans have not been damaged in shipment.
3. Bearings and shaft are protected from the weather and dirt before and after being set in place.
4. Motor is the correct voltage, hp, phase and speed.
5. Impeller is set for the correct clearance with the inlet cones (per manufacturer's instructions).
6. Impeller is the correct blade type as approved and is to the correct hand.
7. Proper belt guards to meet State Safety Orders are supplied, also screen guard over fan inlet.
8. Shaft diameter and bearings are as specified.
9. Fans have AMCA label if called for in the specifications.
10. Bearings have been greased prior to operation and that grease points are easily reached after installation.
11. The fan shaft is level.
12. All manufacturer's installation instructions have been complied with.
13. Approved vibration mounts have been installed in correct locations.
14. Direction of rotation is correct.
15. V belt drives have been installed per this section.

5. BOILERS

Pressure Classifications

Boilers, more properly called heat generators, are commonly used for furnishing steam or hot water to heating and ventilating systems. They are usually in the low pressure category which, as defined by the A.S.M.E., is 15 psi maximum steam pressure, or 160 psi water and 250° water temperature for a hot water boiler. The sectional cast iron boiler is used for 15 psi steam or 30 psi hot water working pressures. These are available in sizes from 60,000 to 3,430,000 btuh, gas or oil fired. Cast iron boilers (Figs. 5-1 and 5-2) are assembled in sections, the number being determined by the capacity desired. "Push nipples" connect the sections together, the whole assembly being drawn together with tie rods. The burners are cast iron sections of "beds" of small gas jets which are supplied with a mixture of low pressure (2" to 5" pressure) gas and air through a venturi mixing nozzle. The burner bed covers the entire base of the combustion chamber and the burned gas circulates by natural draft past the cast iron heating sections and on out through the flue. Gas fired boilers depending on natural draft to remove the products are fitted with a back draft hood which prevents a back draft coming down the flue from blowing out the burner flame. Oil fired boilers similar to Fig. 5-2, use forced draft, hence do not require a back draft hood.

Steel tube boilers most generally used in heating work are firetube, that is, the hot combustion gas flow through the tubes which are surrounded by water (Figs. 5-3 to 5-5). The gases may make anywhere from two to five passes through the boiler depending on the manufacture. All firetube boilers are forced draft because of the long path the gases must travel, and are available in sizes from 520 to 20,000 mbtuh, oil or gas fired.

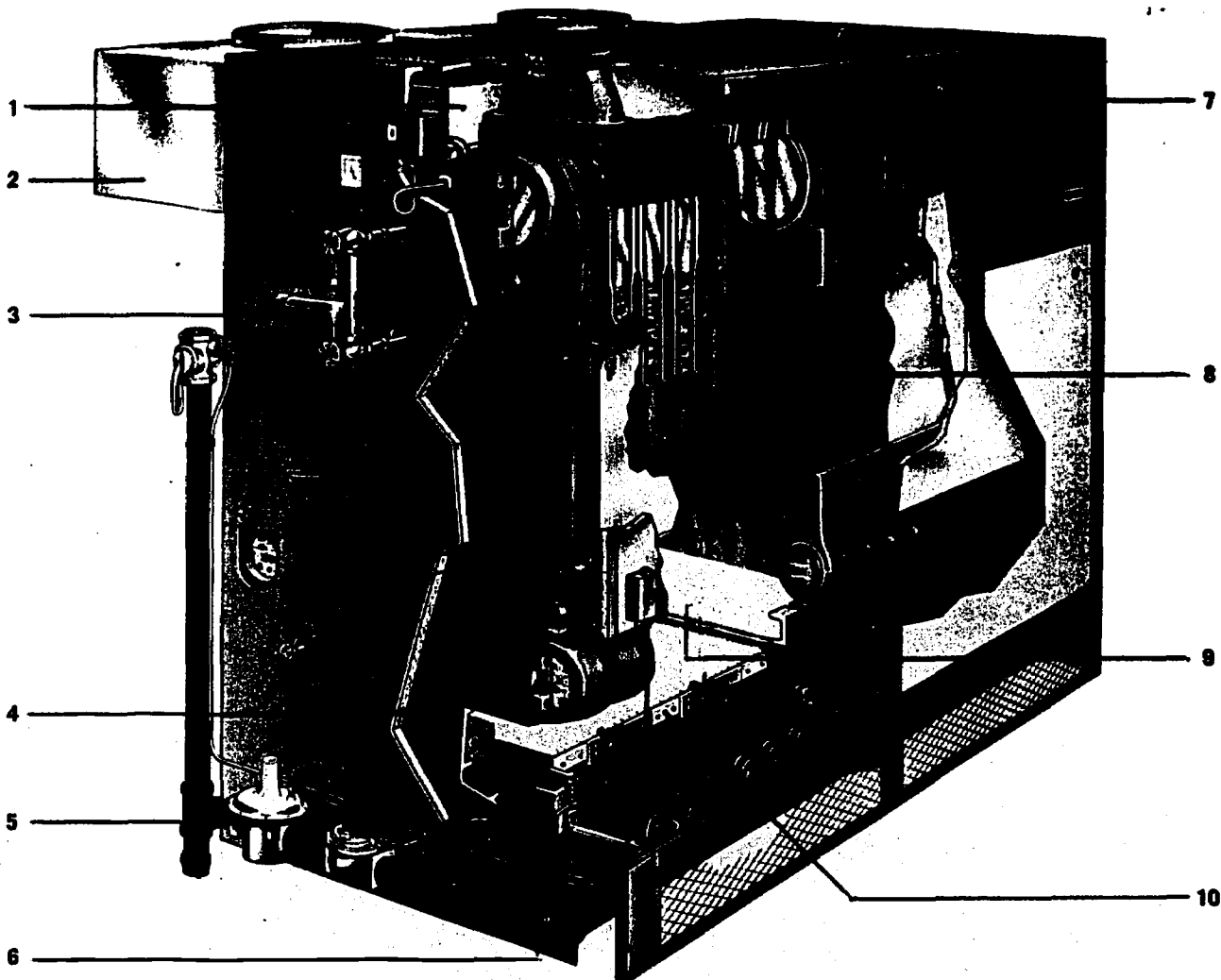
Boilers are classed as high pressure if operated over 15 psi steam and 160 psi water.

Ratings:

Boiler horsepower is a historical and obsolete method of rating a boiler's output that was adopted in 1883 but is still listed by some manufacturers (along with modern ratings). One boiler horsepower is equivalent to evaporating 34.5 lbs of water from and at 212° F feedwater temperature.

EDR. Heating boilers are sometimes rated in terms of square feet of Equivalent Direct Radiation, namely, 240 Btu/hour, which represents the heat given up by the steam condensed by 1 square foot of cast iron radiation, at a steam temperature of 215° F and room temperature of 70° F.

SBI and IBR. The Steel Boiler Institute and the Institute of Boiler and Radiator Manufacturers have developed methods of



1-Flue Canopy -Forms a gas tight connection between flue passages and draft hood. It is completely enclosed by boiler jacket.

2-Draft hood -Locations for maximum flue flexibility. A conventional overhang rear draft hood for low over-all height—and an optional top outlet draft hood.

3-Low Water Cutoff (Steam Boilers) -Located outside jacket. Electrically shuts off main gas valve if boiler water falls to low point.

4-Base Frame -Consists of cast iron panels that are interchangeable front and back for assembly flexibility.

5-Gas Control Train -A.G.A. design certified, automatic diaphragm valve is standard. Special FM, FIA, IRM gas trains available.

6-Manifold -Designed for use with natural or propane gas. Available for right hand or left hand connection.

7-Jacket -Sturdy steel with distinctive brown and beige finish. Includes front cleanout door for easy access and

expanded metal air inlet opening for combustion. Lined with glass fiber insulation to prevent heat loss and keep jacket temperature down. Jacket covers both canopy and manifold for modern "packaged" appearance.

8-Cast Iron Sections -Modular design with precision ground joints for flat, even draw-up. Multiple pin flue surface for higher sectional output. The 8½" offset nipple provides excellent sectional communication for smooth flow and preferred steam quality. Special tankless coil center sections available. Tested for 50 psi (80 psi when specified) water working pressure.

9-Combustion Area -A unique base construction has made possible the design of a single combustion chamber for the complete boiler, reducing the number of supervised pilot burners.

10-Cast Iron Burners With stainless steel ribbon inserts. Feature smooth ignition and extinction, resistance to flashback and easy flame adjustment for natural and propane gases. Only one burner per flue needed.

Courtesy, American Standard Co.

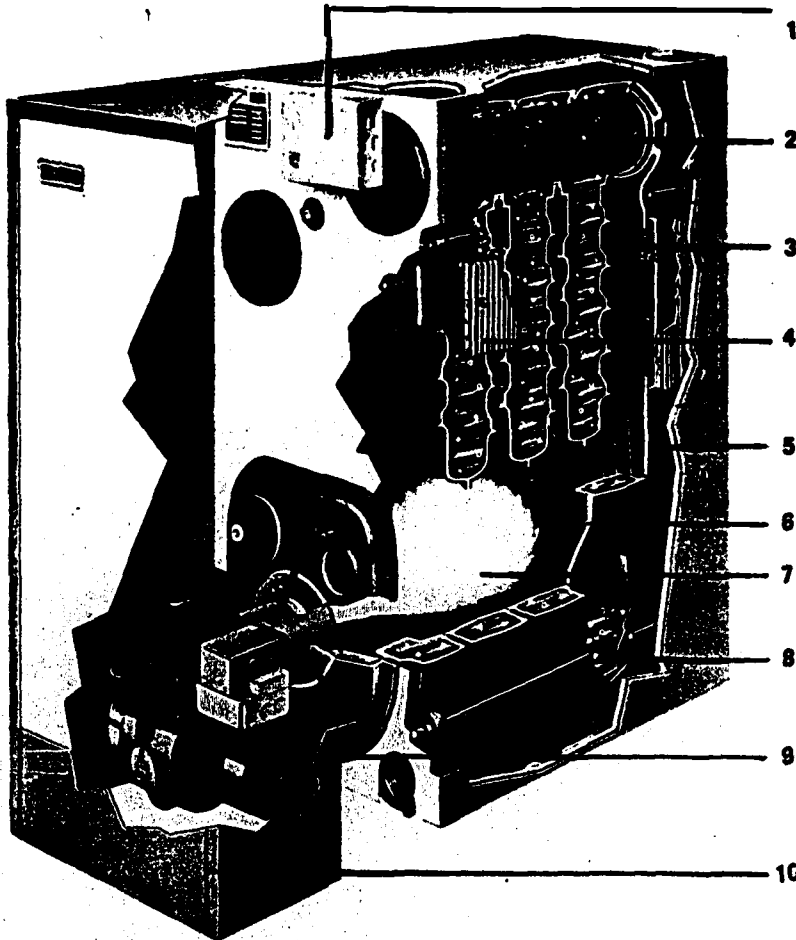
Fig. 5-1

The PFA-3 is the ultimate heating unit for application in smaller apartment or commercial buildings. Designed specifically for light oil, forced draft firing this cast iron sectional unit is available either as a steam or hot water boiler and attains an efficiency of over 80%.

Forced draft boilers in addition to increased operating efficiencies require much less space than conventional boilers of comparable size and eliminate the need for external draft devices such as a high chimney or mechanical draft equipment—the PFA-3 features: compact

wet base design; no separate base or combustion chamber; and the provision for tankless heater in both steam and water boilers. The boiler also features a high efficiency burner and the use of an elastic sealant compound for sealing.

The PFA-3 is manufactured in four sizes ranging from 300 to 526 MBH gross output and is available as a factory assembled standard unit, a split assembly or completely disassembled unit.



1- Controls mounted on front of boiler for ease of maintenance and adjustment.

2- Water Htr. -large, copper coil tankless type. I=W=H rated. Inserted into upper 5" nipple port on forced water boilers; lower nipple port on steam boiler.

3- C.I. Sections -factory assembled, sealed and water pressure tested.

4- Cleanout Panel -permits cleaning of all flue surfaces from right side without dismantling jacket or disturbing burner, controls or accessories.

5- Insulated Jacket heavy glass fiber insulation prevents wasteful heat loss, keeps jacket cool.

6- Sealant -effectively seals sections.

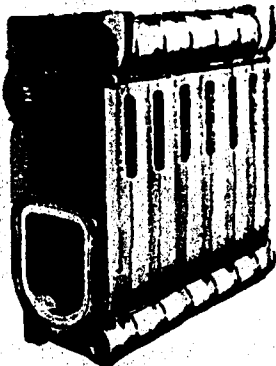
7- -wet base becomes primary heating surface.

8- Wet Base -provides extra heat-absorbing wet base. Waterways completely surround combustion space.

9- Oil Burner -equipped with a high efficiency flame retention burner head.

10- Jacket Extension -matches jacket and has removable front panel for ready access to burner and control; arch-type openings to provide ample air for combustion and circulation.

assembled sections help speed installation time making the PFA-3 ideal as a replacement boiler.



elastic sealant - it is imperative that forced draft boilers be absolutely gas tight. This quality is attained with the PFA-3 by sealing all section joints and canopy connections with elastic compound. (Covered by Patent No. 3,533,379.) The elastic sealant requires less installation time than other gasketing methods and provides a superior airtight seal, which will maintain its integrity over the years.

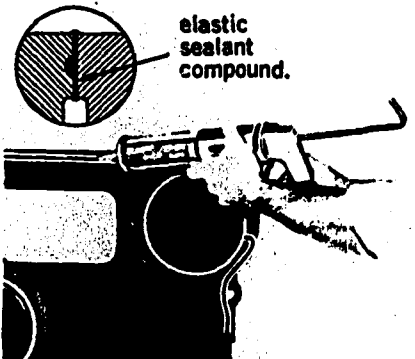


Fig. 5-2 Courtesy, American Standard Co.

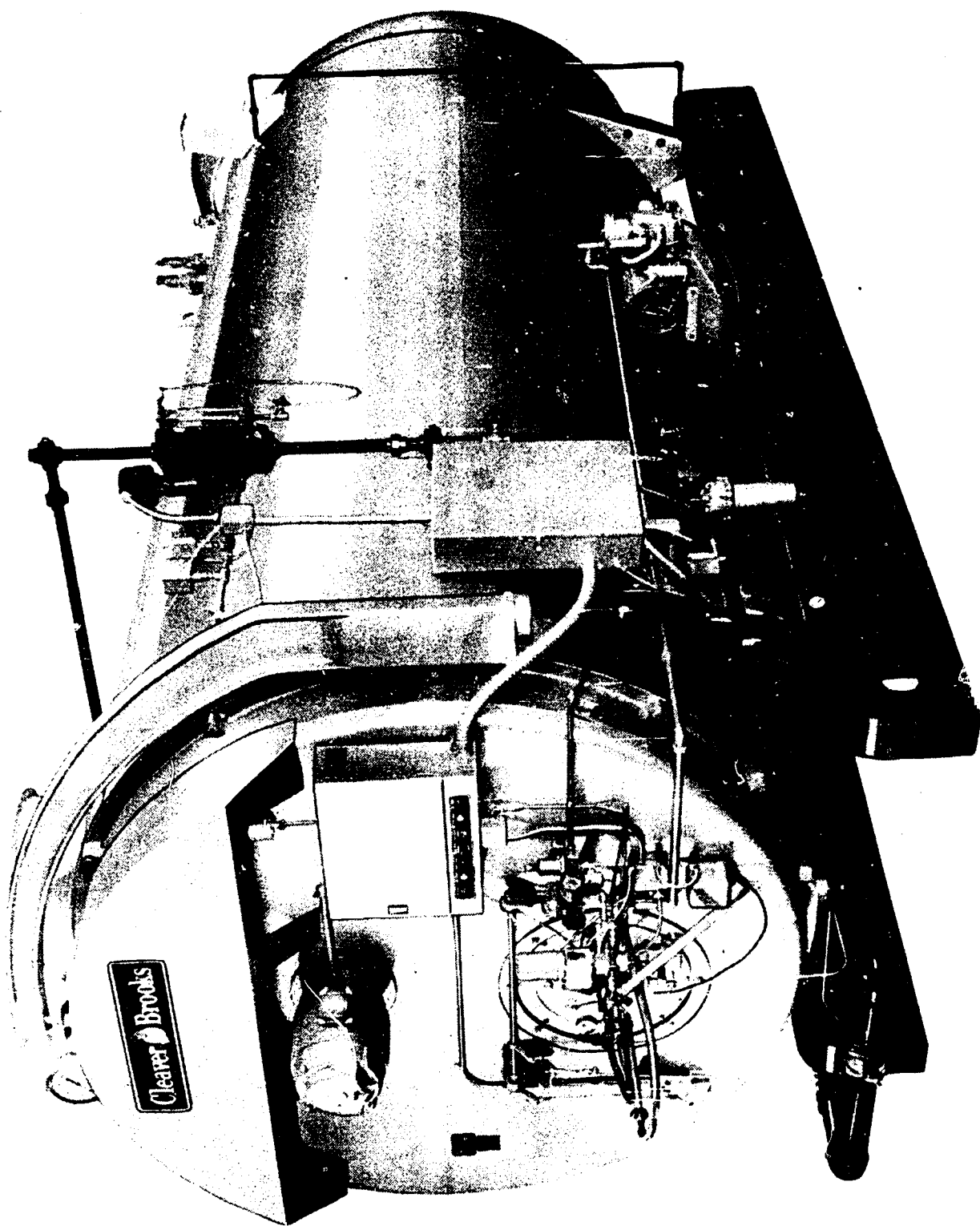


Fig. 5-3a

Courtesy, Cleaver Brooks Co.

A-11555

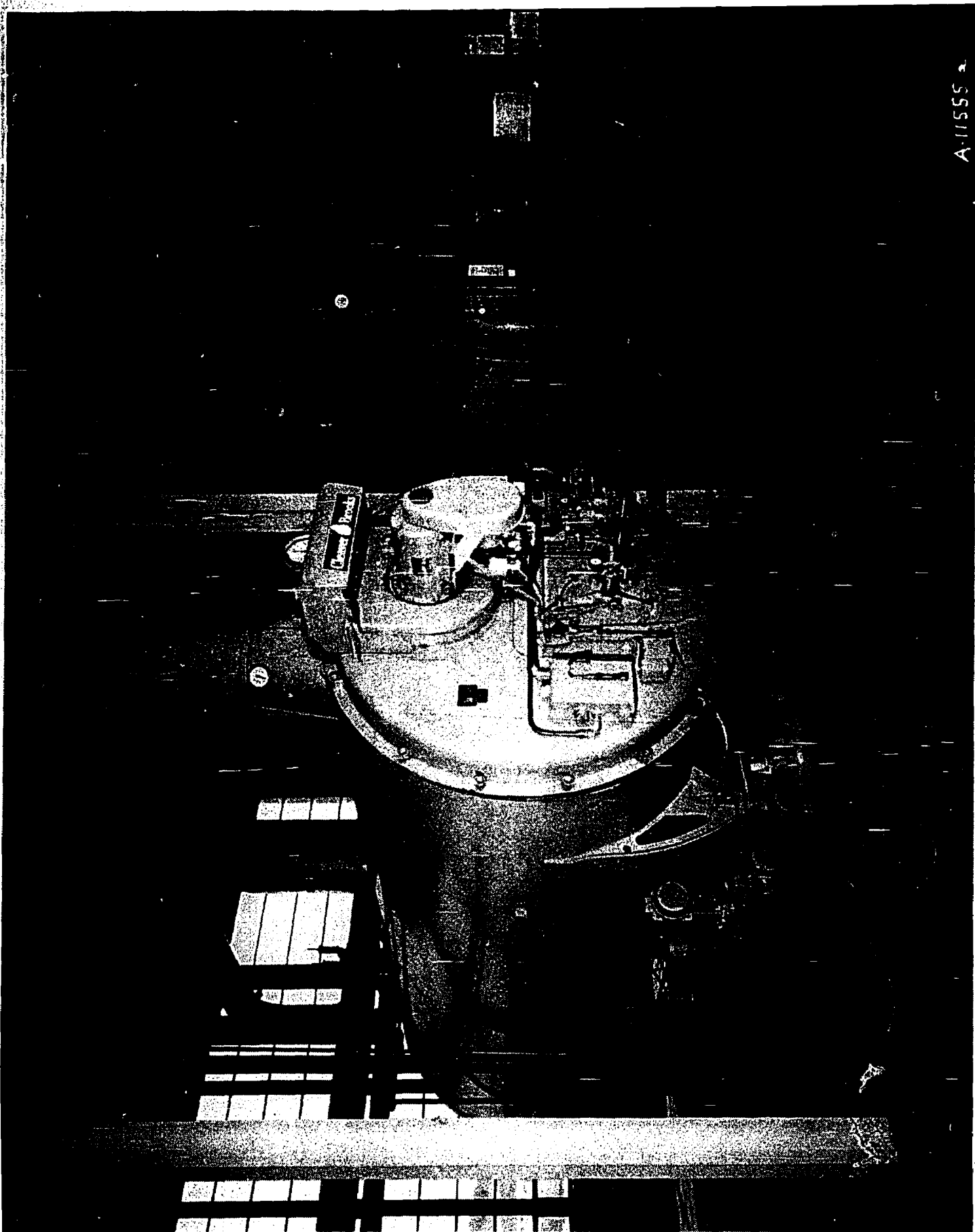
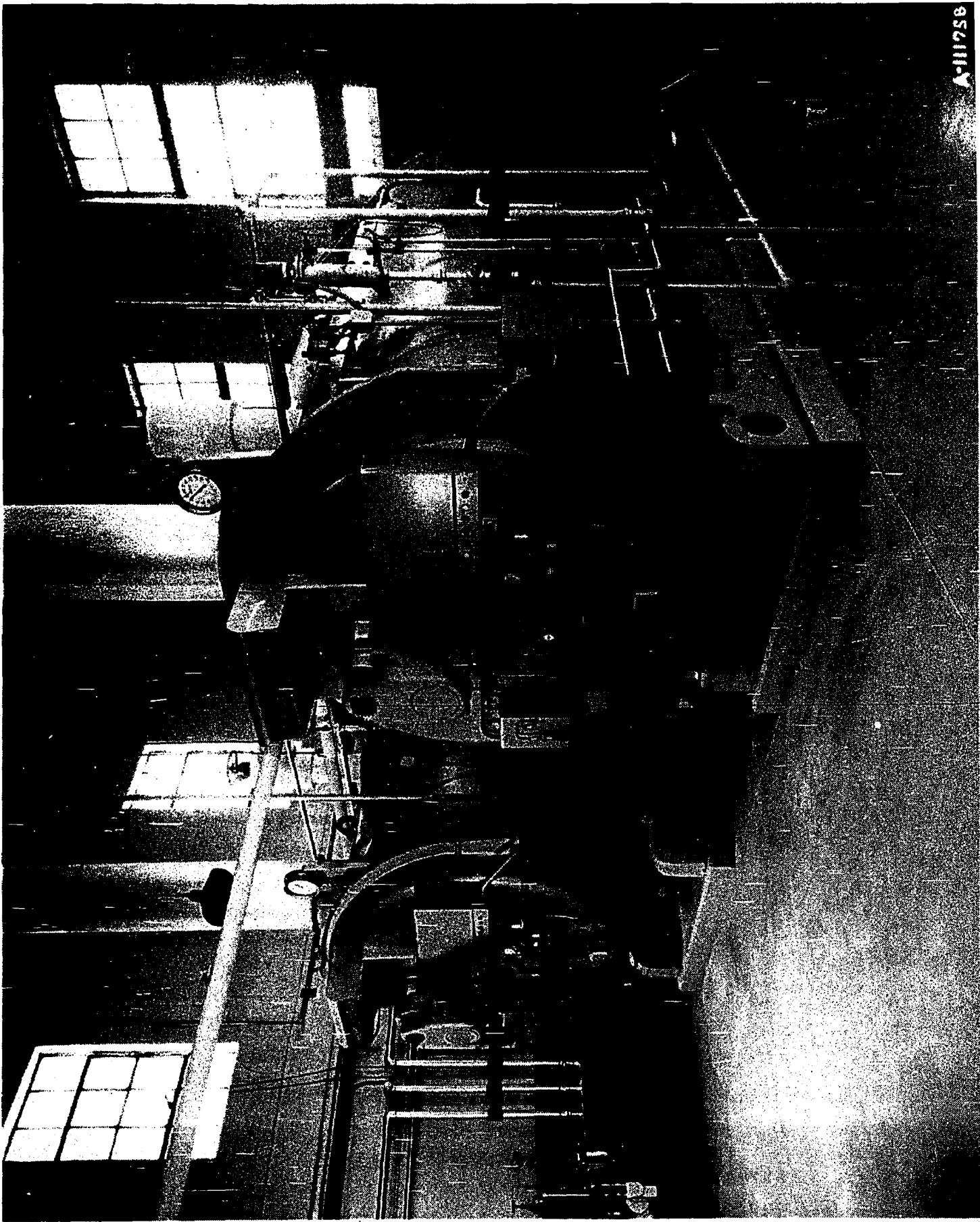


Fig. 5-3b
109

Courtesy, Cleaver Brooks Co.



A-111758

Fig. 5-4

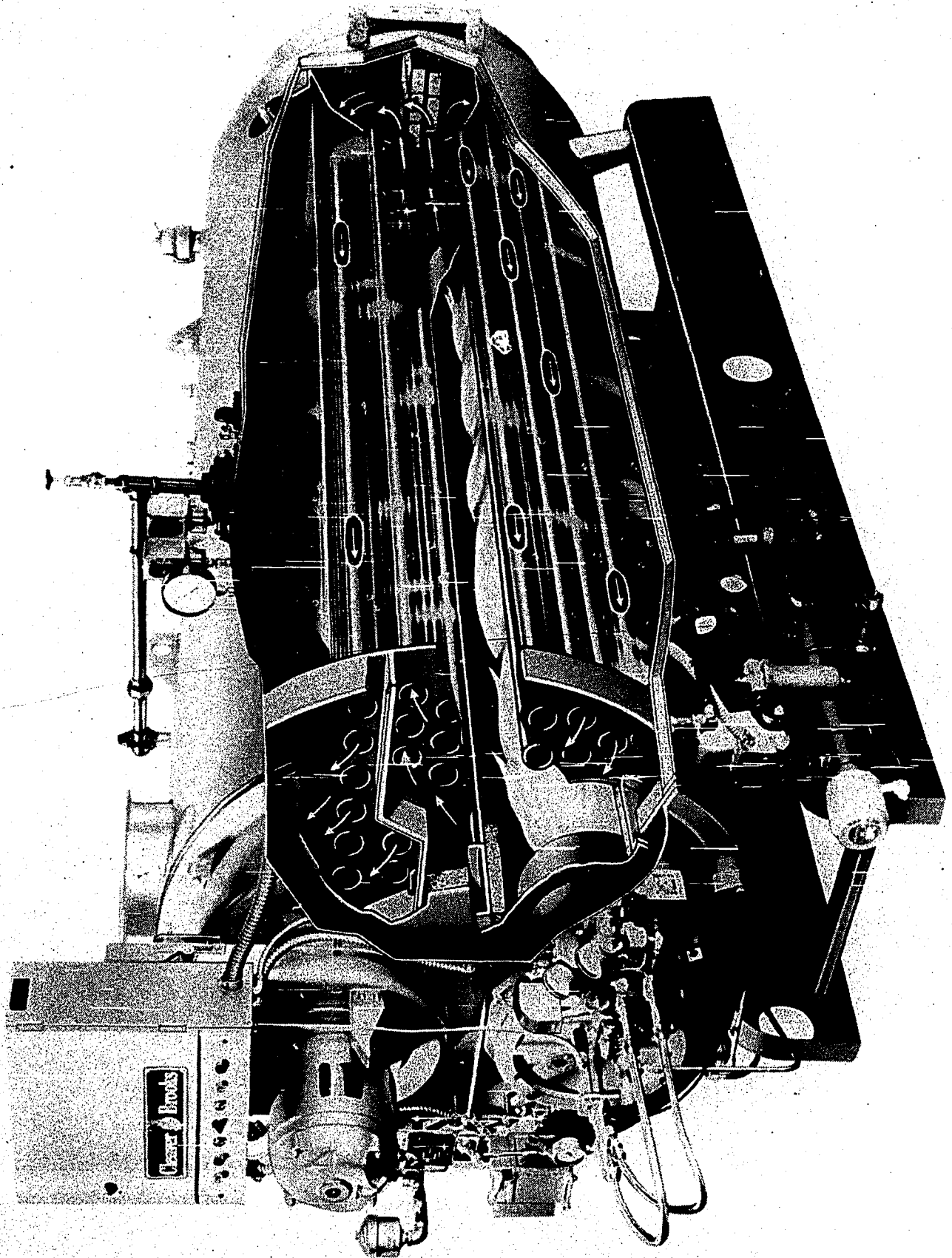


Fig. 5-5

rating to aid the designer in choosing the correct size boiler. Table 5-1 shows a part table of "S.B.I." ratings for steel boilers with the various headings. Table 5-2 shows a sample "1 = B = R" rating.

Btu's per hour output. This states the actual heat, in btu's that has been added to the steam or hot water leaving the boiler in one hour of operation.

Lbs steam per hour. The heat required to evaporate one pound of water at 212° F is 970 btu, and is called the latent heat of the steam. The btu per hour output of rating expressed in lbs of steam per hour can be found by multiplying by 970 btu.

Hot water boilers are rated in btu per hour. The actual heat absorbed by the water is found from the following formula:

$$\text{Btu/hr} = \text{gpm} \times t_{\text{out}} - t_{\text{in}} \times 8.33 \times \text{sp ht of water} (\approx 1.0) \times 60$$

Since the heat generator efficiency is about 80% due to heat losses in the flue gas and radiation losses, the heat input to the boiler is approximately

$$\text{Btu input/hour} = \frac{\text{Btu output per hour}}{0.80}$$

Btu input per hour is measurable in cubic feet of gas per hour, or gallons of fuel oil per hour, whichever method of firing is used.

Testing Boiler Output and Efficiency.

Building heating boilers are not usually tested for thermal efficiency and output to the degree of accuracy needed for large central steam plants, but warrant sufficient checking to prove that the specifications have been met; namely (1) output (2) overall efficiency and (3) combustion efficiency. The output of a steam boiler can be obtained by collecting or otherwise measuring the condensate returned to the boiler, or by metering or weighing the feed water being delivered to the boiler during the test run. The flow through a hot water heat generator can be gotten by means of flowmeters installed in the various branches or main, or by reading the pressure gages at the inlet and outlet of the hot water circulating pump and finding the gpm from the pump curve. The temperature of the water at inlet and outlet is then taken, and the formula (shown above) is used for finding the btu output. (2) Overall efficiency is the ratio of heat output to heat input:

$$\% \text{ efficiency} = \frac{\text{heat output}}{\text{heat input}} \times 100$$

Mechanically-Fired

SBI Rating			SBI Net Rating			SBI Gross Output MBh (7)	(c) Minimum Furnace Volume Cu Ft (8)	(b) Minimum Furnace Height In. (9)	Minimum Heating Surface Sq Ft (10)
Sq Ft Steam (1)	Sq Ft Water (2)	MBh (3)	Sq Ft Steam (4)	Sq Ft Water (5)	MBh (6)				
2,190	3,500	526	1,800	2,880	432	648	15.7	26	129
2,680	4,280	643	2,200	3,520	528	792	10.2	28	158
3,160	5,050	758	2,600	4,160	624	936	22.6	29½	186
3,650	5,840	876	3,000	4,800	720	1,080	26.1	29½	215
4,250	6,800	1,020	3,500	5,600	840	1,260	30.4	30	250
4,860	7,770	1,166	4,000	6,400	960	1,440	34.8	30½	286
5,470	8,750	1,313	4,500	7,200	1,080	1,620	39.1	31½	322
6,080	9,720	1,459	5,000	8,000	1,200	1,800	43.5	31¾	358
7,290	11,660	1,750	6,000	9,600	1,440	2,160	52.1	32¾	420
8,500	13,600	2,040	7,000	11,200	1,680	2,520	60.8	34	500
10,330	16,250	2,479	8,500	13,600	2,040	3,060	73.8	35½	608
12,150	19,410	2,916	10,000	16,000	2,400	3,600	86.8	37½	715
15,180	24,280	3,463	12,500	20,000	3,000	4,500	108.5	40¼	893
18,220	29,150	4,373	15,000	24,000	3,600	5,400	130.2	43	1,072
21,250	34,000	5,100	17,500	28,000	4,200	6,300	151.8	46	1,250
24,290	38,860	5,830	20,000	32,000	4,800	7,200	173.5	48¾	1,429
30,360	48,750	7,286	25,000	40,000	6,000	9,000	216.9	54½	1,786
36,450	58,280	8,742	30,000	48,000	7,200	10,800	260.3	60½	2,143
42,500	68,000	10,200	35,000	56,000	8,400	12,600	303.6	66	2,500

Table 5-1

Automatic-Fired

Gross I = B = R Output MBh (8)	Net I = B = R Rating			Piping and Pickup Factor		Minimum Stack Area ^a Sq In. (14)	Maximum Allowable Draft Loss In. W.G. ^b (15)
	Water MBh (9)	Steam		Water (12)	Steam (13)		
		MBh (10)	Sq Ft (11)				
37	28	24	100	1.333	1.500	50	0.044
146	110	96	400	1.333	1.525	50	0.058
251	188	168	700	1.333	1.492	50	0.072
352	264	210	1000	1.333	1.466	52	0.084
451	338	312	1300	1.333	1.444	73	0.096
547	410	384	1600	1.333	1.424	95	0.108
642	482	456	1900	1.333	1.408	115	0.118
736	552	528	2200	1.333	1.394	135	0.130
829	622	600	2500	1.333	1.382	155	0.141
920	690	672	2800	1.333	1.369	173	0.152
1011	758	744	3100	1.333	1.359	192	0.162
1101	826	816	3400	1.333	1.349	211	0.172
1189	892	888	3700	1.333	1.339	230	0.183
1278	960	960	4000	1.331	1.331	249	0.192
1394	1056	1056	4400	1.320	1.320	274	0.206
1509	1152	1152	4800	1.310	1.310	297
1624	1248	1248	5200	1.301	1.301	318
1739	1344	1344	5600	1.294	1.294	339
1858	1440	1440	6000	1.290	1.290	359
1978	1536	1536	6400	1.288	1.288	377
2102	1632	1632	6800	1.288	1.288	395
2164	1680	1680	7000	1.288	1.288	405
2318	1800	1800	7500	1.288	1.288	426
2473	1920	1920	8000	1.288	1.288	446

Table 5-2

The heat input to a boiler is found by metering the gas or oil for the period of the test run and applying the heating value of the fuel. The exact heating value of the gas (which fluctuates) may be obtained from the supplying utility company and the oil heating value from the supplier. It is usually accurate enough to use 1,000 btu per cubic ft for the gas at standard conditions and 145,000 btu per gallon for No. 2 fuel oil. When gas consumption is read from the utility company's meter it must be corrected to standard conditions for the purpose of the test. The utility company will furnish the meter constant, or it can be easily calculated: Find the inlet gas pressure ahead of the meter with an accurate gage. Assume it reads 5 psi gage. Since the volume of a gas varies inversely with the absolute pressure or

$$\frac{V_2}{V_1} = \frac{P_1}{P_2} \quad \text{or} \quad V_2 = \frac{P_1 V_1}{P_2} \quad \begin{array}{l} V = \text{cubic feet} \\ P = \text{absolute pressure} \end{array}$$

We must use the absolute pressures, which is gage pressure plus atmospheric pressure (14.7 lb per sq in. at sea level). Then, the volume of gas entering the boiler, corrected to standard pressure, is

$$\begin{aligned} \text{Volume} &= \frac{(5 + 14.7) \times \text{volume (read from meter)}}{14.7} \\ &= 1.34 \times \text{Volume (read from meter)} \end{aligned}$$

The volume of a gas also varies directly with the absolute temperature but this may be neglected for these calculations.

We now have enough information to complete the formula as follows:

$$\% \text{ efficiency} = \frac{\text{heat generator output, btu per hour}}{(\text{cubic ft per hour of gas}) (\text{heat content})}$$

The calculation used for oil burning boilers is similar:

$$\% \text{ efficiency} = \frac{\text{heat generator output, btu per hour}}{\text{gallons oil per hour} \times \text{heat content per gallon}}$$

(3) Combustion efficiency.

If a boiler was found to have an overall efficiency of 80%, most of the heat represented by the lost 20% went up the stack, spent in heating the products of combustion. The exact amount of heat thus lost depends on the pounds of flue gas moved and its exit temperature. Each cubic foot of gas or pound of fuel oil, depending on the carbon and hydrogen content, requires a given weight of air for combustion. Under perfect combustion conditions all of the carbon and hydrogen will be completely burned, and the

products of combustion will consist principally of carbon dioxide (CO₂) and the inert gases, such as nitrogen, that make up the atmosphere. However, more air than just the theoretical value is supplied to insure complete combustion. Unburned combustibles present a loss of heat, but more important, cause dangerous explosions and flare backs in the combustion areas. The amount of excess air being supplied to the firebox can be found by sampling the flue gas for carbon dioxide (CO₂) and oxygen (O₂) content, and using a chart similar to Fig. 5-6 and Fig. 5-7, drawn up for the carbon and hydrogen analysis of the fuel being used. As an example, assume an Orsat analysis shows the CO₂ content to be 3%, and the O₂ content to be 5.3%, when burning the fuel shown on Fig. 5-6. The CO₂ line intersects the hypotenuse of the diagram at 30% excess air as does the 5.3% O₂ line. Thus, if the theoretical amount of air needed is 10. cu ft per cu ft of gas, the total air at 30% excess is 1.30 x 10 = 13.0 cu ft per cu ft of gas. The actual loss in the flue gas can be found from Fig. 5-8, knowing the stack temperature at the boiler outlet and the percentage CO₂. The stack temperature is taken with an insertion type mercury or accurate bi-metallic thermometer in the center of the flue gas stream close to the breaching connection. The above figures show the percent overall thermal efficiency, or :

$$\text{Thermal efficiency} = 100 \times \frac{\text{total heat input} - \text{stack losses}}{\text{total heat input}}$$

$$\text{then, stack losses} = (100 - \text{effic}) (\text{heat input}), \text{ btu/hr}$$

The stack losses should be close to the losses figured by the overall efficiency, Figs. 5-8 and 5-9, allowing for small radiation losses.

A CO₂ analysis will be made by the boiler supplier when the unit is adjusted for firing, or may be taken by the utility company upon request. If the specifications require the boiler to produce rated load at a certain CO₂, stack temperature and efficiency, the contractor will gather and submit this data.

Operating and Safety Controls and Trim

Boilers have certain safety requirements and devices that are required by the State Division of Industrial Safety. These are contained in "Boiler Safety Orders" available from the Office of Procurement, Documents Section, P.O. Box 20101, Sacramento 95820, for a nominal sum. The orders adopt the "ASME Code for Pressure Boilers", available at technical book stores, and both of these publications should be available to anyone concerned with the construction inspection of boilers.

Safety Relief Valves, mounted directly on the main drum of a heat generator, are the ultimate, "last ditch" protective devices preventing an explosion from overpressure. Their require-

FLUE GAS ANALYSIS CHART FOR DETERMINING THE AMOUNT OF AIR EMPLOYED

PERCENTAGES OF CO₂, O₂, AND CO ON DRY BASIS AS GIVEN BY ORSAT ANALYSIS.
BASED UPON THE CONDITIONS THAT FLUE GAS CONTAINS NO RAW GAS, H₂, OR FREE CARBON
TWO OF THE CONSTITUENTS, CO₂, CO, AND O₂, NEED ONLY BE KNOWN. THE CHART SERVES
TO CHECK THE ACCURACY OF AN ANALYSIS WHERE THREE CONSTITUENTS ARE DETERMINED.

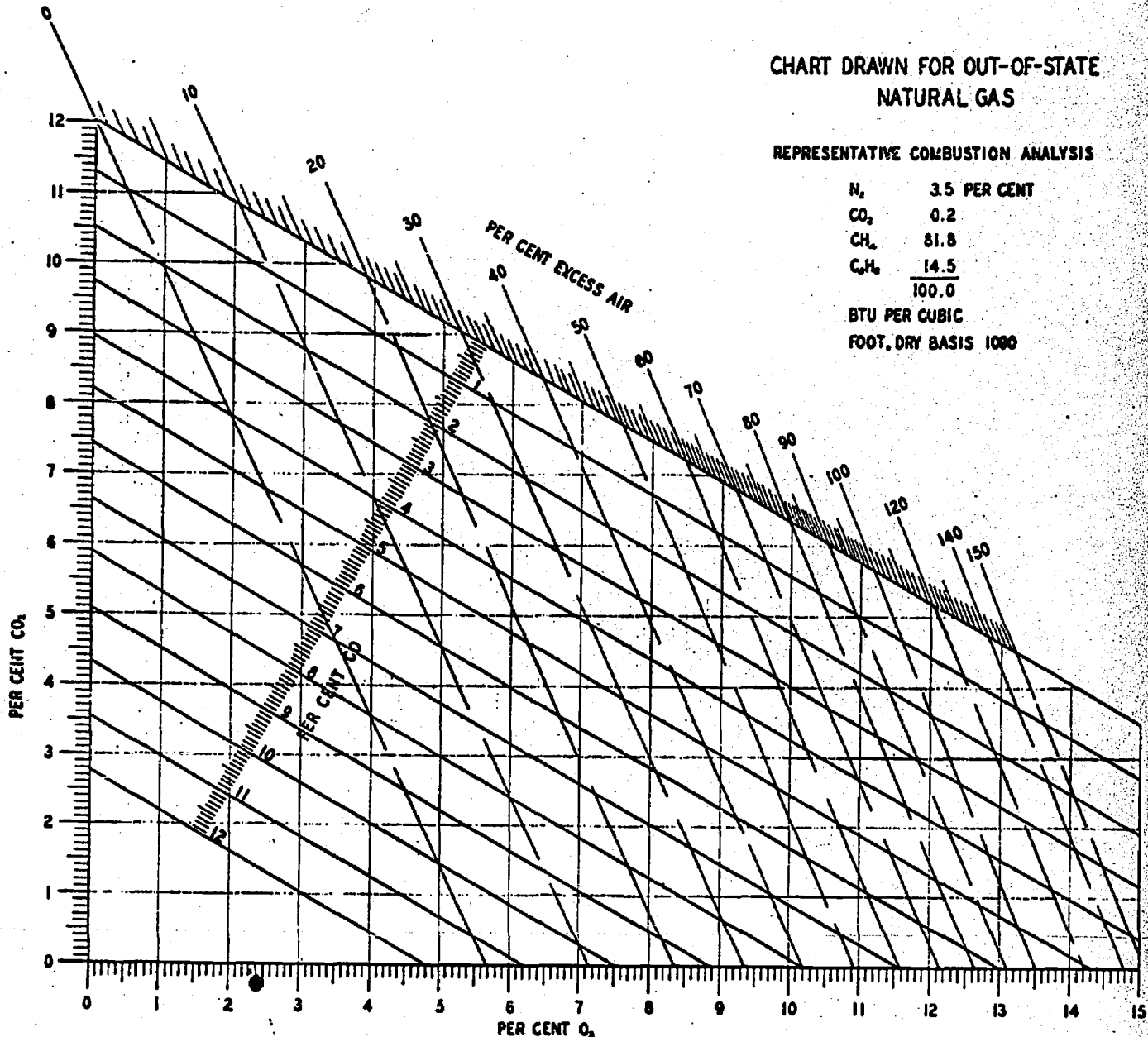


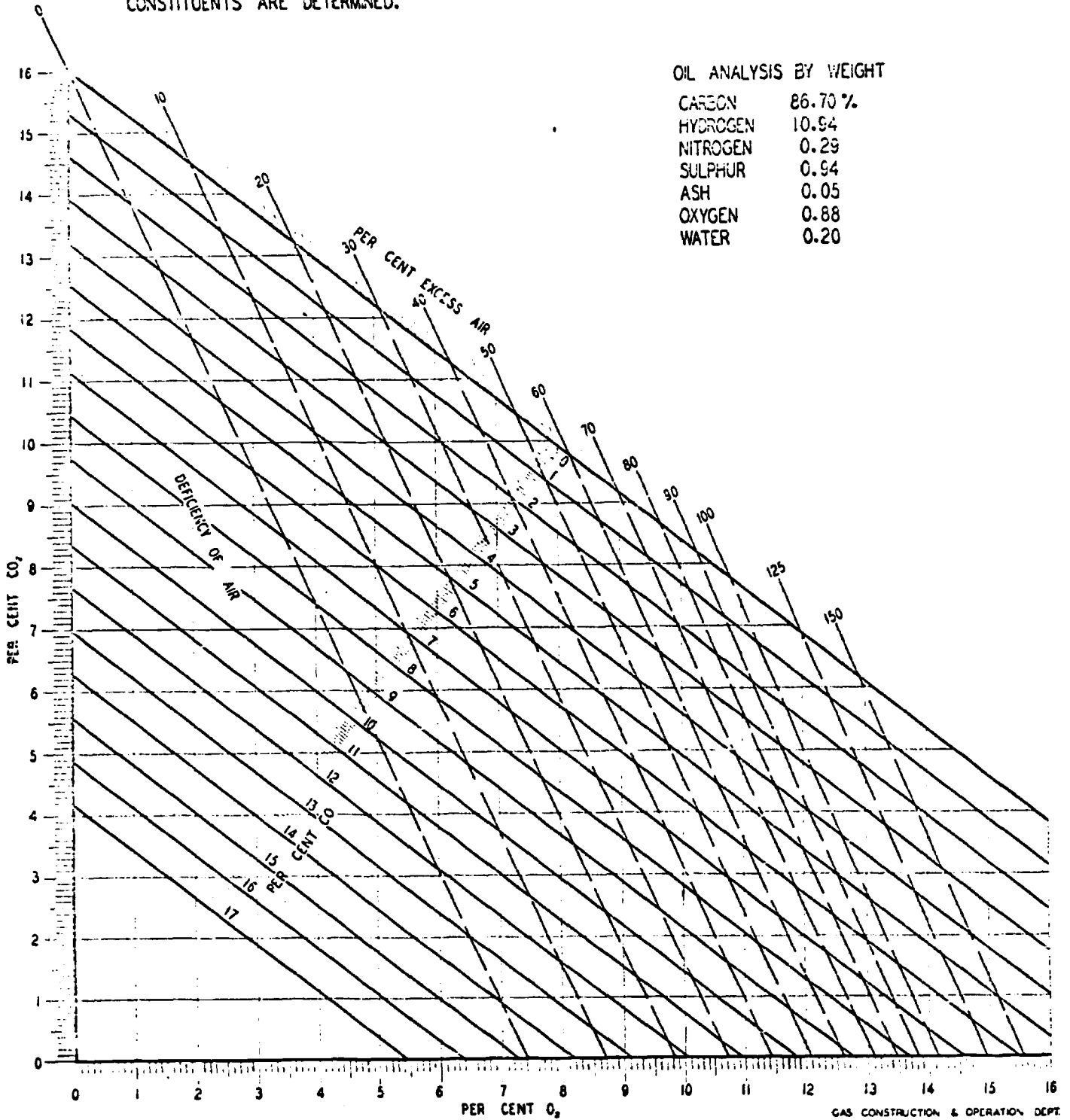
Fig. 5-6

DEPARTMENT OF GAS OPERATION
PACIFIC GAS & ELECTRIC CO.

FLUE GAS ANALYSIS CHART FOR DETERMINING THE AMOUNT OF AIR EMPLOYED - FUEL OIL.

(CALIFORNIA SAMPLE)

PERCENTAGES OF CO₂, O₂, AND CO ON DRY BASIS AS GIVEN BY ORSAT ANALYSIS. BASED UPON THE CONDITION THAT FUEL OIL IS BURNED TO CO₂ AND/OR CO AND WATER VAPOR. TWO OF THE CONSTITUENTS, CO₂, CO AND O₂ NEED ONLY BE KNOWN. THE CHART SERVES TO CHECK THE ACCURACY OF AN ANALYSIS WHERE THREE CONSTITUENTS ARE DETERMINED.



OIL ANALYSIS BY WEIGHT

CARBON	86.70 %
HYDROGEN	10.94
NITROGEN	0.29
SULPHUR	0.94
ASH	0.05
OXYGEN	0.88
WATER	0.20

Fig. 5-7

GAS CONSTRUCTION & OPERATION DEPT.
PACIFIC GAS & ELECTRIC CO

SHEET G-206

OVERALL THERMAL EFFICIENCY CHART FOR 1200 BTU. NATURAL GAS

BASED UPON THE CONDITION THAT NO UNBURNED GAS IS PRESENT AT THE STACK

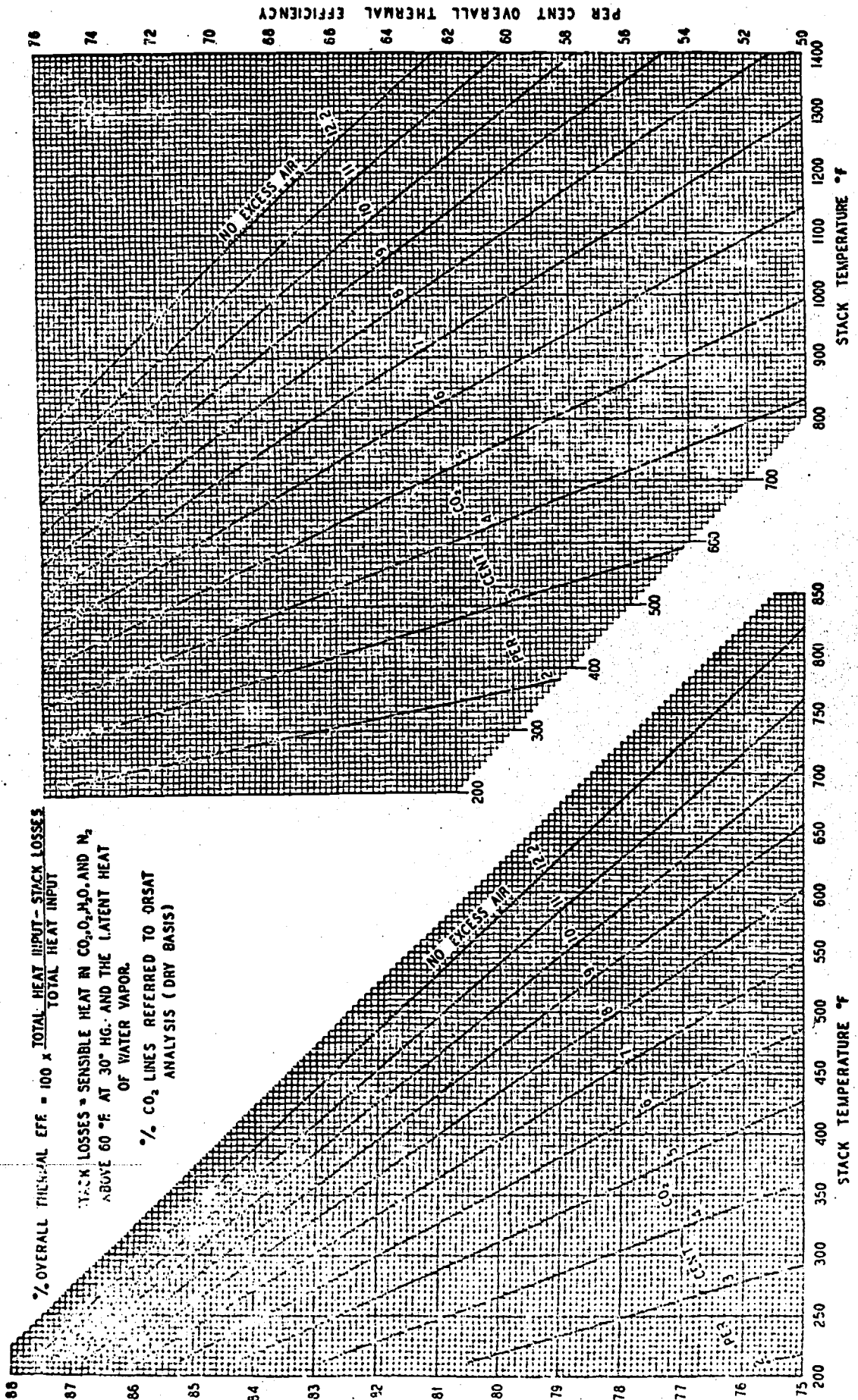


Fig. 5-8

OVERALL THERMAL EFFICIENCY CHART FOR FUEL OIL (CALIFORNIA SAMPLE)

BASED UPON THE CONDITION THAT FUEL IS BURNED TO CO₂ AND WATER VAPOR

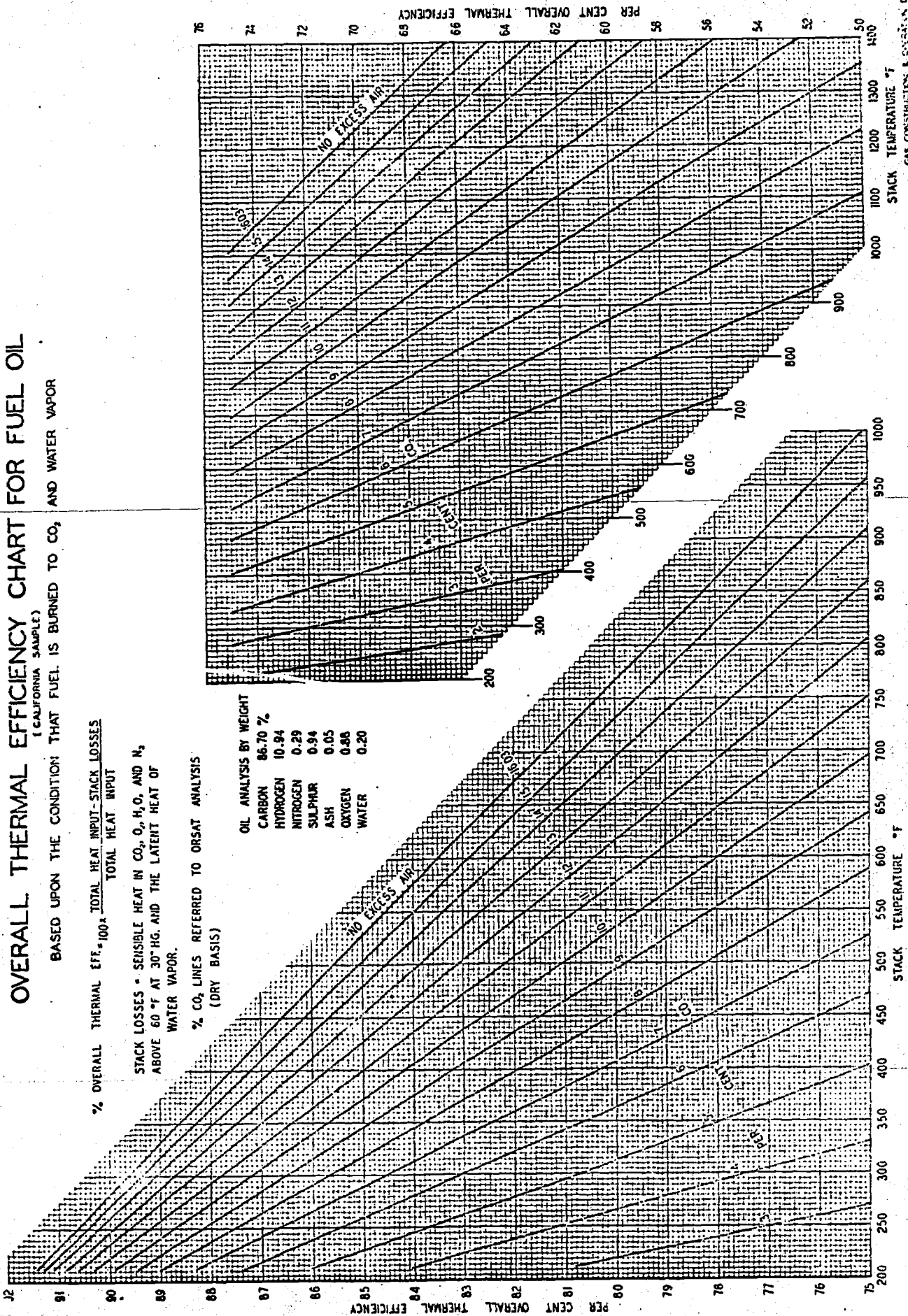
$$\% \text{ OVERALL THERMAL EFF.} = 100 \times \frac{\text{TOTAL HEAT INPUT} - \text{STACK LOSSES}}{\text{TOTAL HEAT INPUT}}$$

STACK LOSSES = SENSIBLE HEAT IN CO₂, O₂, H₂O, AND N₂ ABOVE 60 °F AT 30" HG. AND THE LATENT HEAT OF WATER VAPOR.

% CO₂ LINES REFERRED TO ORSAT ANALYSIS (DRY BASIS)

OIL ANALYSIS BY WEIGHT

CARBON	86.70 %
HYDROGEN	10.94
NITROGEN	0.29
SULPHUR	0.94
ASH	0.05
OXYGEN	0.86
WATER	0.20



GAS CONSTRUCTION & ANALYSIS DEPT
MIDvale GAS & ELECTRIC CO

SHEET G-207

Fig. 5-9

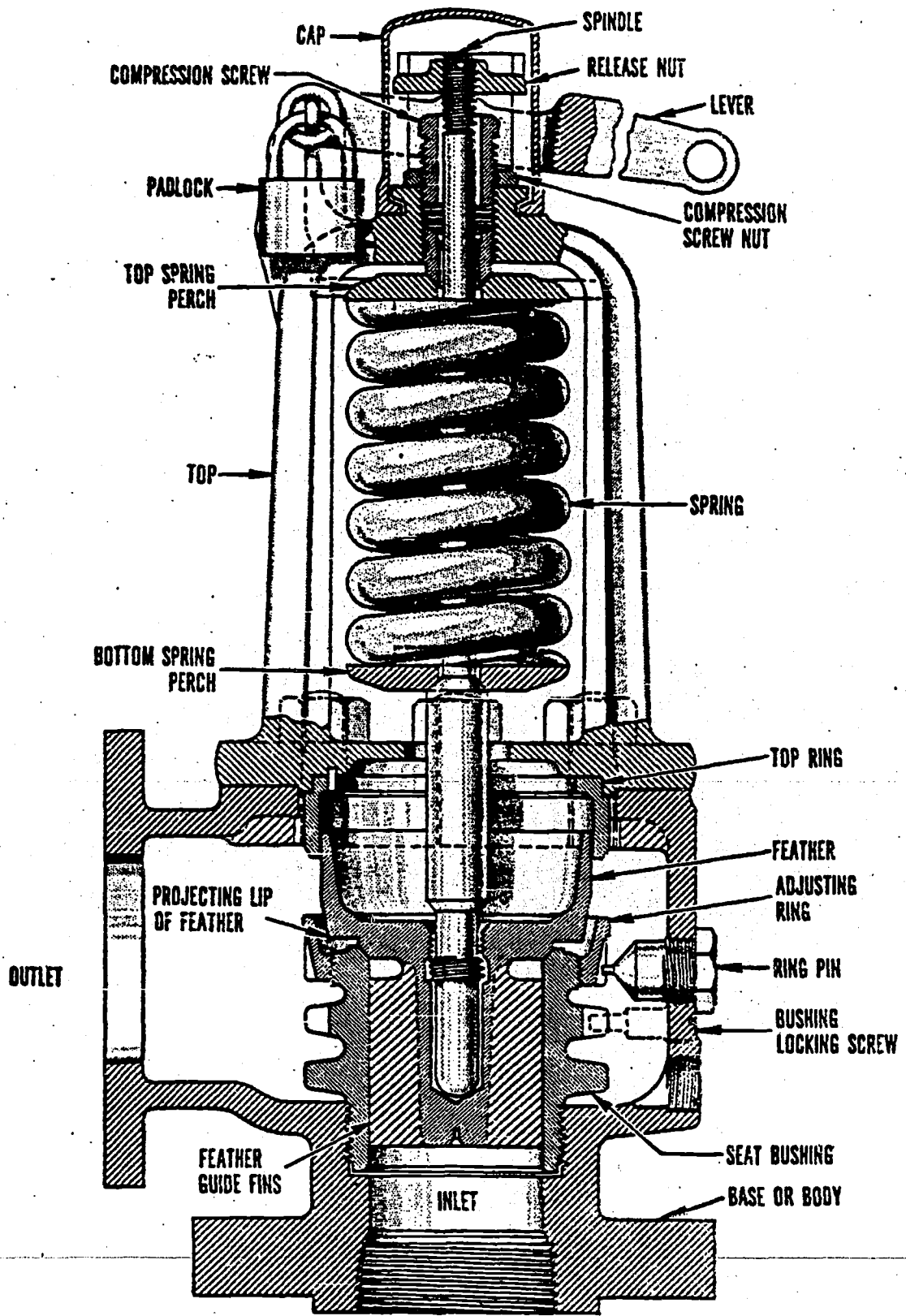


Fig. 5-10

ments as to design and manufacture are specified in the ASME Code for Power Boilers. The heat relieving capacity of the valve is also stamped on the body and this must be equal to or greater than the maximum heat input to the boiler, which may be found on the boiler's nameplate. Safety relief valves are connected directly to the boiler, without reducers or increasers, and never any type of shut off valve in between. The outlet piping is lead to a safe point of discharge, and supported so as to not place any strain on the valve.

Safety relief valves for steam service as regulated by the ASME Code are the pop safety type which open fully at the set relief pressure, and then snap shut after blowing down not more than 4 per cent (but not less than 2 lbs) of the set pressure. The set and closing pressures are adjusted by the manufacturer and sealed. Fig. 5-10 shows a steam pop safety relief valve. Safety relief valves for hot water boilers (Fig. 5-11) open an amount directly proportional to the pressure and are not subject to any blowdown requirements.

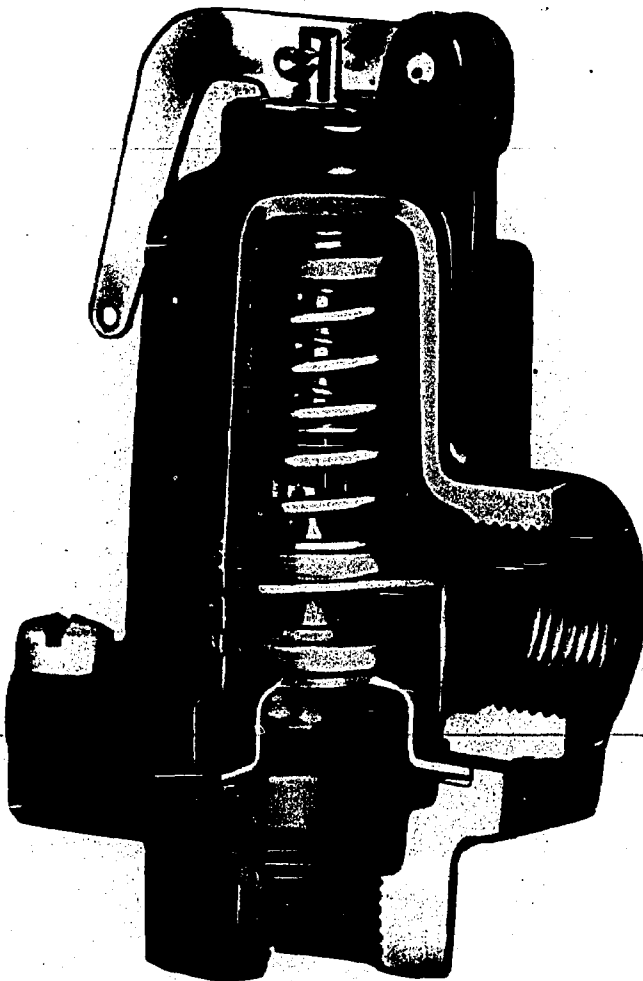


Fig. 5-11 (a)

Courtesy, McDonnell & Miller Co.

All ASME approved safety valves have a lifting lever for manually opening the valve.

A drain must be provided to prevent water from lying against the discharge face of the poppet.

Low water cut-offs (Figs. 5-16 and 5-17) are float operated electric switches that interrupt the circuit holding open the fuel valve should the water level fall below the safe operating level. The State Boiler Safety Orders require a second "back-up" low water cut-off, which operates a second gas valve in series with the first. The second cut-off float chamber is mounted lower on the boiler than the first and has a manual re-set switch. The first cut-off will shut down the boiler if the water level falls to a below-normal level (within limits) but will allow it to start up again if the level is restored. The second cut-off will act to cut off the fire, if for any reason the first fails, and the water falls to an unsafe level. The second cut-off has to be re-set by an attendant who will investigate the cause of the low water before re-lighting the boiler. See Figs. 5-12 to 5-15 for piping connections to and details of low water controllers.*

Operating pressure (or temperature) controllers are pressure or temperature sensing devices which start and stop, or modulate the fuel input to maintain the set pressure or temperature which is desired.

Should they fail to respond to conditions higher than their set points a high pressure or temperature safety controller, with a higher setting, will shut off the fuel input.

High and low pressure fuel safety shut-offs close the fuel valve in the event of abnormally high or low pressures in the fuel supply.

A well constructed, accurate pressure gage is mounted on the boiler and is connected directly to the drum. These should have a calibration screw, and a tee and valve should be provided alongside in the gage piping for connecting an inspector's gage.

A water column is installed on the boiler so that the middle of the glass coincides with the design water level. The latter will be marked on the boiler. The water column is provided with try-cocks at 3 levels for verifying the water level, and should be operable from the working platform or level. (See Addendum pages A-1a. (a) & (b) for Code requirements).

A combustion safety supervisory control system is one that assures that safe conditions exist in a firebox before fuel is introduced, and monitors the ignition period so that if the main flame is not lit in a predetermined number of seconds the fuel valve will be actuated to close. When the main flame has been established

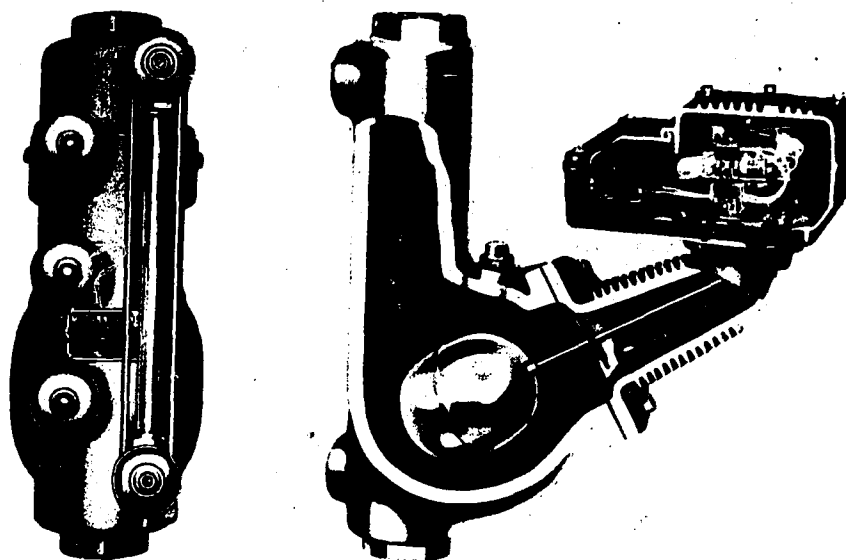


Fig. 5-12
Combination feed water pump controller and
low water cut-off.

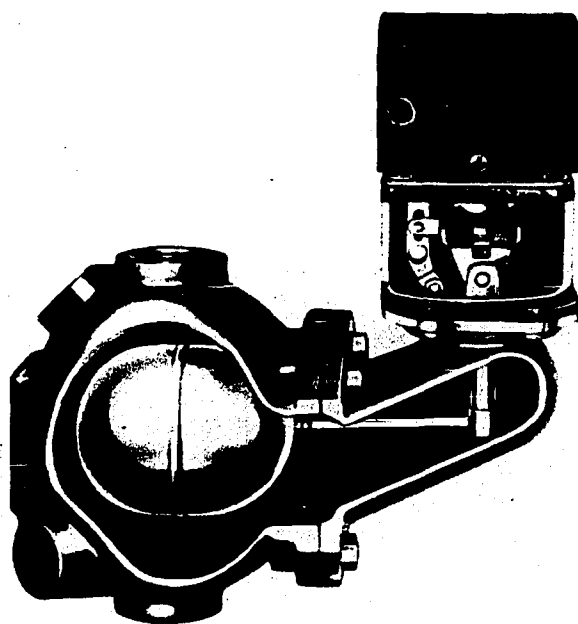


Fig. 5-13
Low water cut-off.

Courtesy, McDonnell & Miller Co.¹

MCDONNELL SAFETY CONTROLS FOR HOT WATER SPACE HEATING BOILERS

*To Comply with 1967 State of California
Boiler Safety Orders*

- All safety controls equalizing piping and blow-off valves 1" size.
- Install all No. 63M Cut-offs at least 1" below Feeder Cut-offs.
- Install air vents at top of all equalizing piping.
- ASME Pressure Relief Valves should be selected with capacity ratings, expressed in BTU per hour, equal to or greater than the gross output rating of the heating boiler.

MCDONNELL & MILLER, Inc., 3500 N. Spaulding Ave., Chicago, Illinois 60618



Drawing No. CAL-DFCO

Printed in U.S.A.

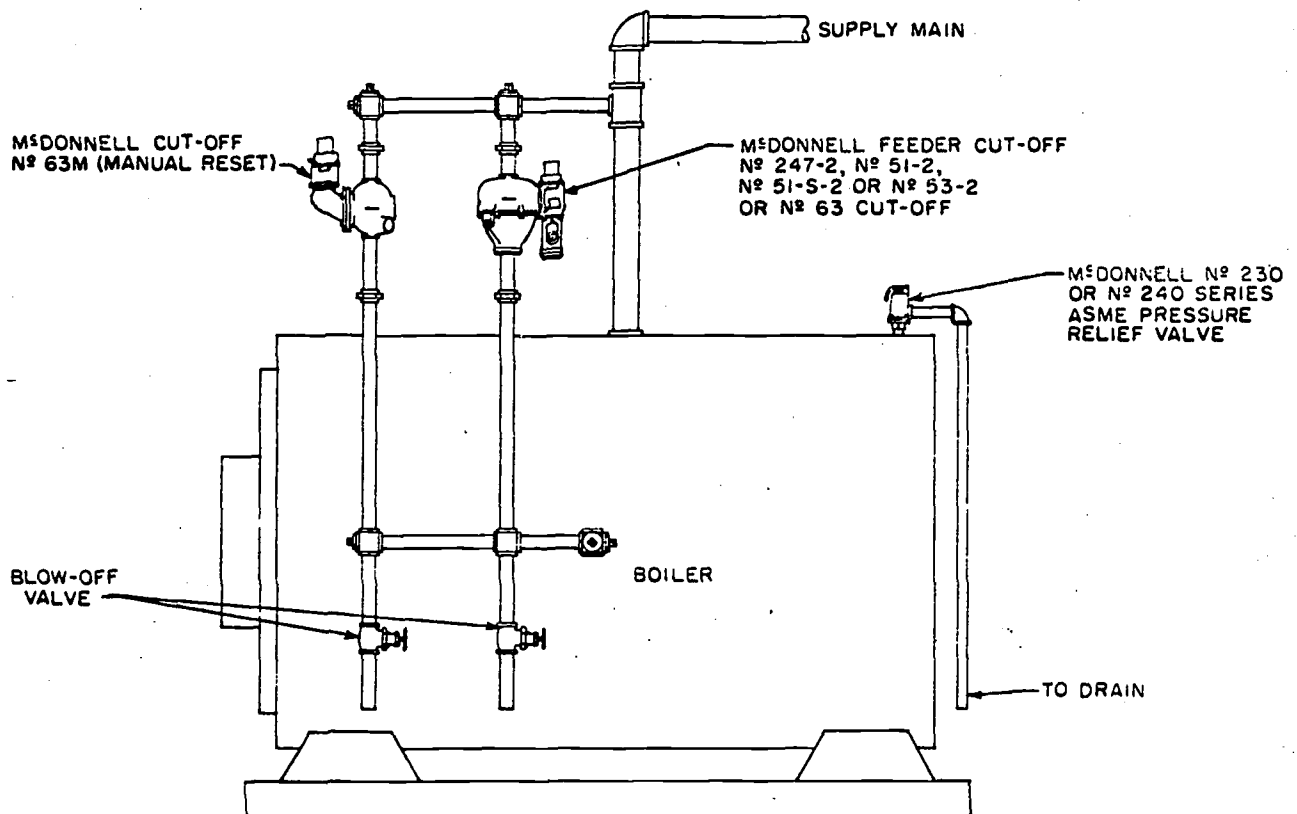
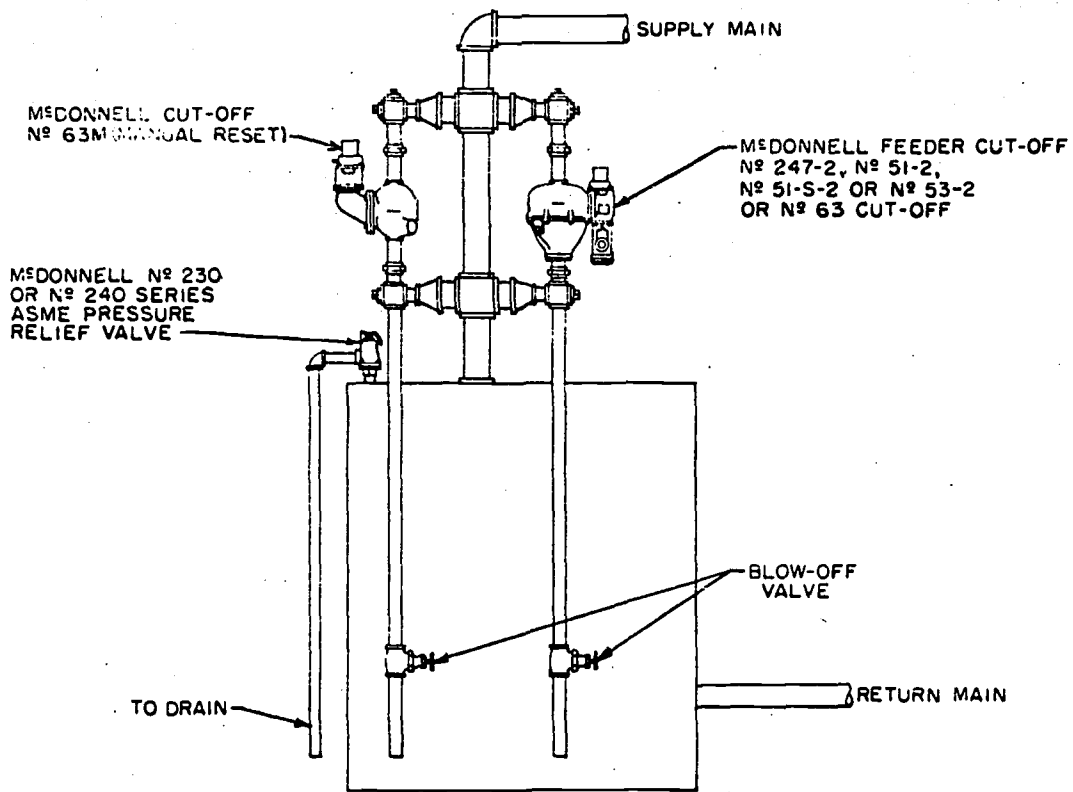


Fig. 5-14¹



(PREFERRED)

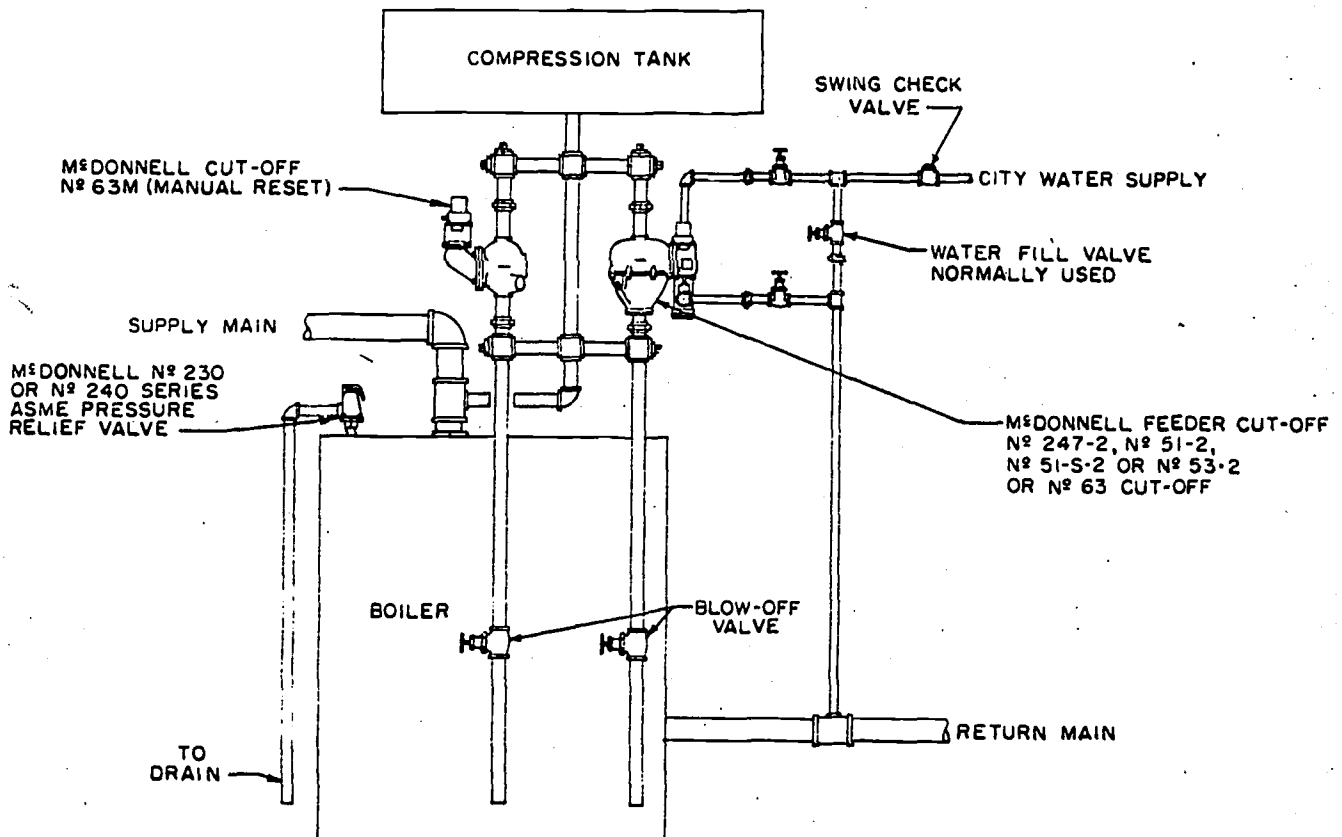
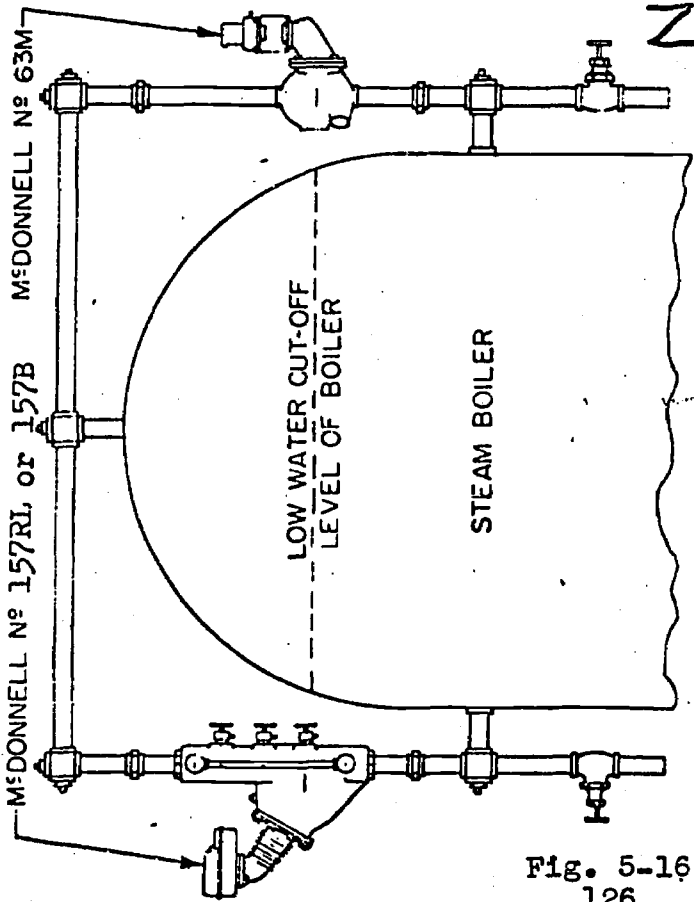


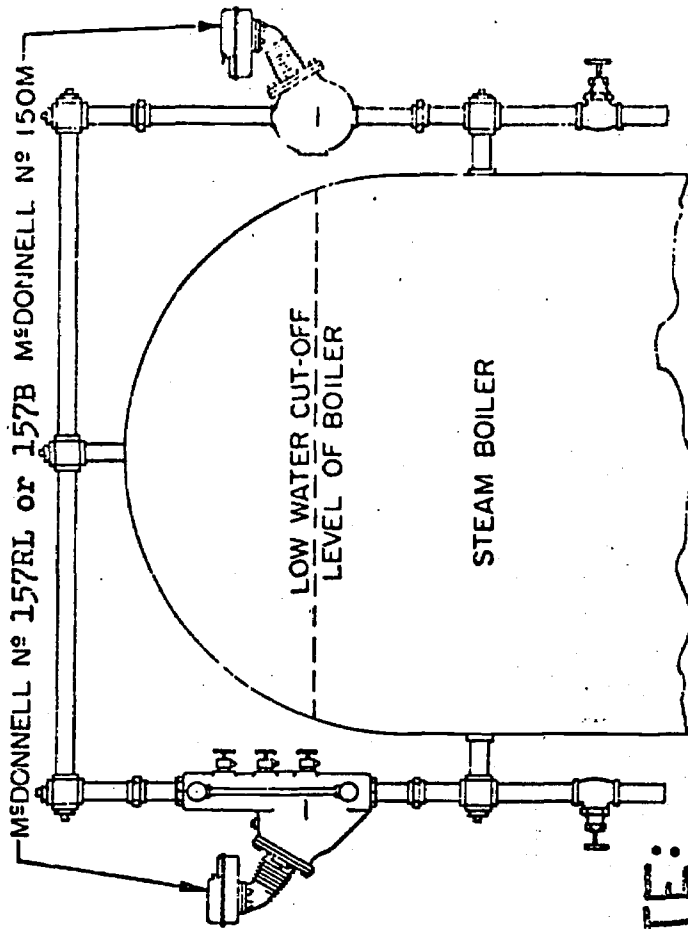
Fig. 5-15¹

MCDONNELL SAFETY CONTROLS FOR
HIGH AND LOW PRESSURE STEAM BOILERS
TO COMPLY WITH THE STATE OF CALIFORNIA BOILER
SAFETY ORDERS



FOR LOW PRESSURE STEAM SYSTEMS
BOILER FEED PUMP CONTROL
AND DUAL LOW WATER CUT-OFF

SECTIONS No 763(d)(1)
No 763(d)(2)



FOR HIGHER PRESSURE STEAM SYSTEMS
BOILER FEED PUMP CONTROL
AND DUAL LOW WATER CUT-OFF

SECTION No 771(b)(2)
REFER No 763(d)

NOTE:

FOR PRESSURE ABOVE
150 PSI. THAT DOES
NOT EXCEED 250 PSI.
USE OUR NO. 194 AND
NO. 94AM CONTROLS
FOR HIGHER PRESSURE

NOTE: INSTALL A 1/2" DIFFERENTIAL
BETWEEN
157RL AND 63M
OR
157RL AND 150M

Fig. 5-16 1
126

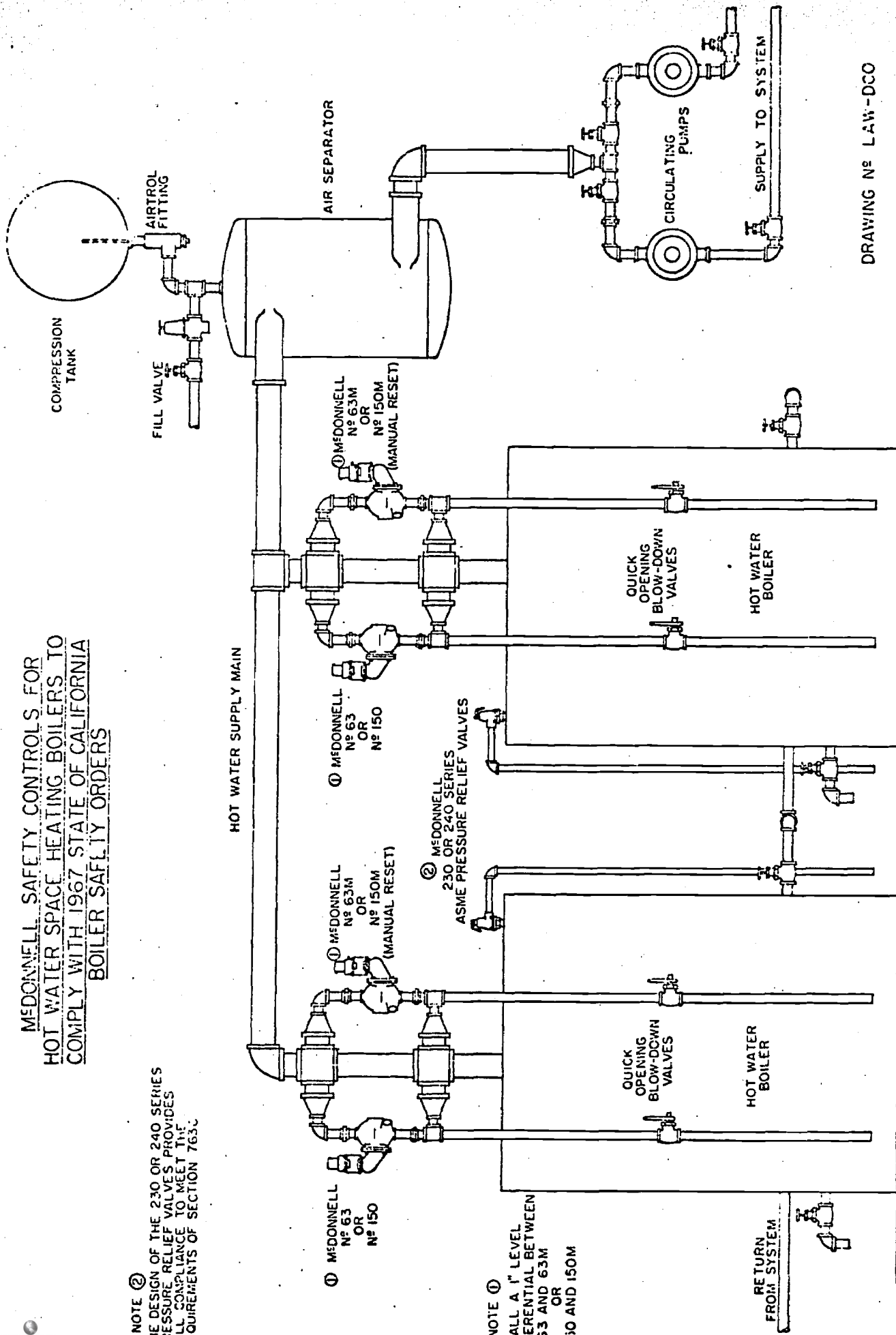
MCDONNELL & MILLER Inc. CHICAGO, ILL.	
MCDONNELL CONTROLS USED TO PROVIDE DUAL LOW WATER CUT-OFF ON STEAM	
MAT'L	BOILERS
No. REQ'D	SCALE
DR. BY	APPR. BY
No.	DATE
	DATE 5-30-22

DATE OF ISSUE

**MEDONNELL SAFETY CONTROLS FOR
HOT WATER SPACE HEATING BOILERS TO
COMPLY WITH 1967 STATE OF CALIFORNIA
BOILER SAFETY ORDERS**

NOTE ②
THE DESIGN OF THE 230 OR 240 SERIES
PRESSURE RELIEF VALVES PROVIDES
FULL COMPLIANCE TO MEET THE
REQUIREMENTS OF SECTION 763.C

Fig. 5-17 1



NOTE ①
INSTALL A 1" LEVEL
DIFFERENTIAL BETWEEN
63 AND 63M
OR
150 AND 150M

DRAWING N° LAW-DCO

safely, the combustion will continue to monitor the flame.

High water and low water alarms are provided on water columns for high pressure steam boilers. These are whistles, or float-operated switches that sound alarm bells.

Boiler Installation

Typically, the heat generator used for building heating systems is a packaged, self supported unit, with trim and most accessories mounted at the factory. It preferable should be set on a level concrete pad for good housekeeping reasons and to prevent rusting of the mounts. The Boiler Safety Orders require hold down bolts sufficient to withstand a seismic sidewise force equal to 0.1 the weight of the filled boiler. In locating the boiler in a room, sufficient space must be allowed to replace tubes, which, in the case of a Scotch firetube boiler, would be a tube length, measured from the front tube sheet. This space must not be blocked by any pipes, lights, ducts, or the like, that would interfere with tube removal or repair. Do not permit conduits, pipes, etc, to be placed over or near access openings into the boiler or handhole cover plates.

Floor Trenches and Drains

Unless the piping drawings were made to suit an exact manufacturer's model, there will be some changes necessary in the piping arrangement. A new piping arrangement should be prepared by the contractor for the designer's approval prior to the construction of the boiler room; as the placement of electrical conduits, piping trenches, floor drains, fuel risers, etc, will be affected. Blowdown valves are installed on the lowest part of the boiler and the blowdown discharge piping is placed in a trench (covered with floor plates) to avoid a tripping hazard. The trench, therefore, should be laid out to suit the location of the blowdown valve. Similarly, floor drains, hopper drains, etc, should be located around the boiler to suit the equipment, such as drains from the low water cut-off chambers and drip-pan elbows. It should be remembered that such drains cannot be connected directly to the drainage system but must discharge to an open funnel. Pipe trenches at the front of the boiler containing fuel, boiler feed water and air services will also be located to suit the piping arrangements and connections at the boiler.

Piping

The steam or hot water lead connected to the boiler outlet must be sufficiently supported on spring hangers so as to not impose any loads due to weight or expansion on the boiler. Normally, the boiler lead will be designed for flexibility between the boiler and main header, so any changes brought about by a change in outlet connections will have to provide equal flexibility.

Another consideration is the length of straight pipe required ahead of flow meter orifice flanges; which, if not available, will require the use of straightening vanes. (See "Instrumentation" section). Steam leads should rise vertically from the boiler outlet to an elbow or large radius bend, and once in the horizontal position, should slope or pitch down away from the boiler to remove condensed steam. The fabrication, testing and inspection of high pressure boiler leads (the section between the outlet and header valve) is under the cognizance of the ASME Code for Pressure Boilers, and must be done in pipe fabricating shops certified by the National Board of Boiler and Pressure Vessel Inspectors. When delivered to the job, such piping will bear a permanently attached metal tag showing the name of the manufacturer and the code stamp. This same requirement holds for boiler feed water and boiler blowdown piping.



ASME CODE STAMP

The ASME Code for Power Boilers* requirements for steam valves and boiler feed water valves are as follows:

Section 59.5.1 - Steam Valves

Each discharge outlet, except safety valve, or safety relief valves, shall be fitted with a stop valve located at an accessible point in the steam-delivery line and as near the boiler nozzle as is convenient and practicable. When such valves are over 2 inch pipe size the valve or valves used on the connection shall be of the outside-screw-and-yoke rising spindle type.....

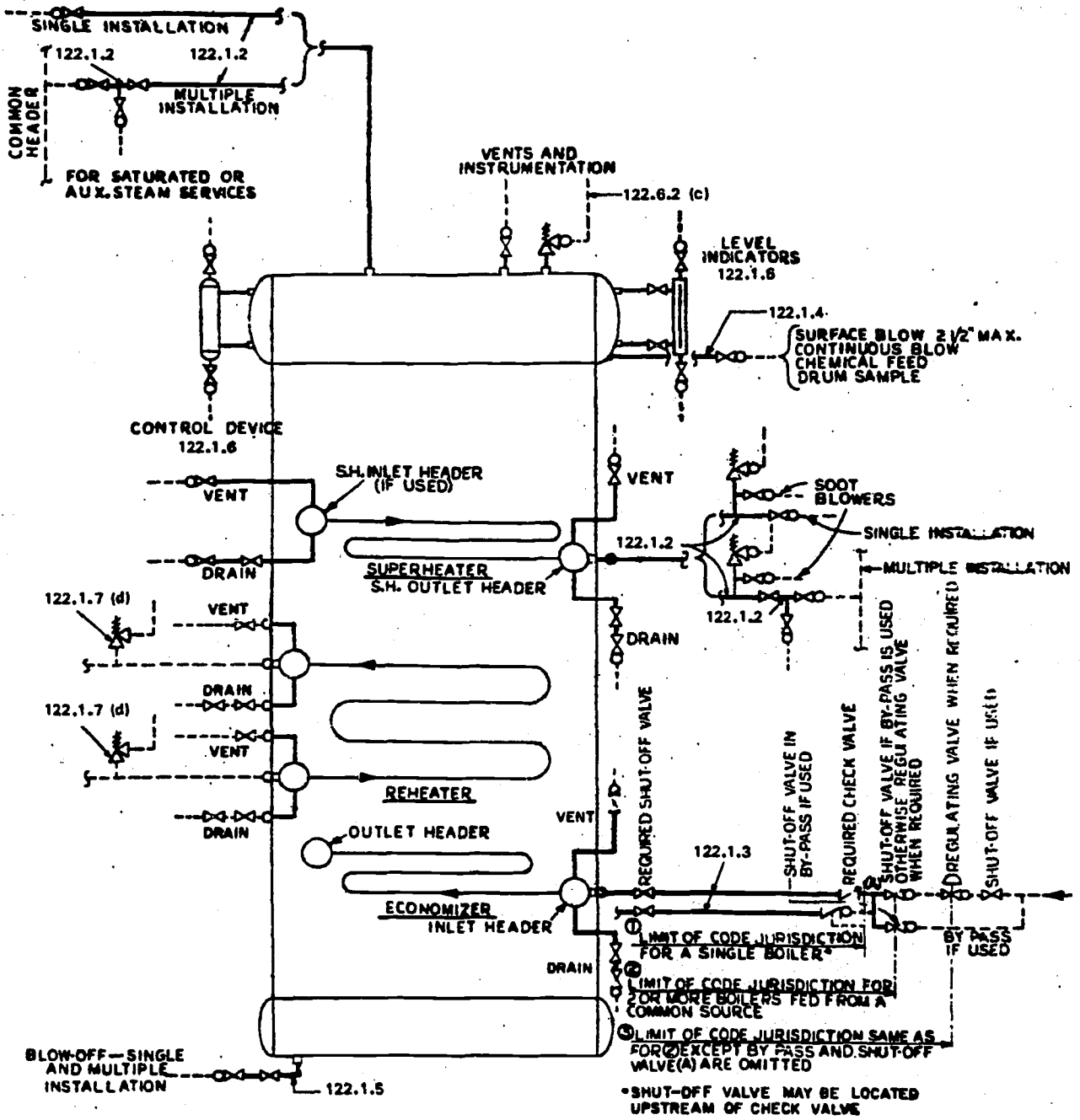
Section 59.5.1.3

When boilers are connected to a common header, the connection from each boiler having a manhole opening shall be fitted with two stop valves having an ample free-blow drain between them. The discharge of this drain shall be visible to the operator while manipulating the valve. The stop valves shall consist preferably of one automatic non-return valve (set next to the boiler) and a second valve of the outside screw and yoke type, or two valves of the outside screw and yoke type shall be used.

Section 59.5.2.1 - Feedwater Valves

..... the feed pipe shall be provided with a check valve near the boiler and a valve or cock between the check valve and boiler. When two or more boilers are fed from a common source there shall also be a globe or regulating valve on the branch to each boiler located between the check valve and the source of supply. (See Fig. 5-10)

* Published by the American Society of Mechanical Engineers, 345 E. 47th Street, N.Y., N.Y.



LEGEND & NOTES:-

- PIPING AND JOINT — ASME SECTION I JURISDICTION
- PIPING AND JOINT — ANSI B31.1 JURISDICTION

NOTE ONLY ONE DRAIN VALVE MAY BE REQUIRED WHEN THE VALVE IS NOT INTENDED FOR BLOW-OFF PURPOSES WHEN THE BOILER IS UNDER PRESSURE. (SEE 122.1.4)

Fig. 100.1.2(b) Code Jurisdictional Limits for Piping Drum Type Boilers

Fig. 5-18

The Code requires that globe valves shall be installed so that the boiler feed pressure is under the seat, the reason being that if the stem should fail or the disc become disengaged from the stem, the pressure will hold the disc off the seat and continue to supply water to the boiler.

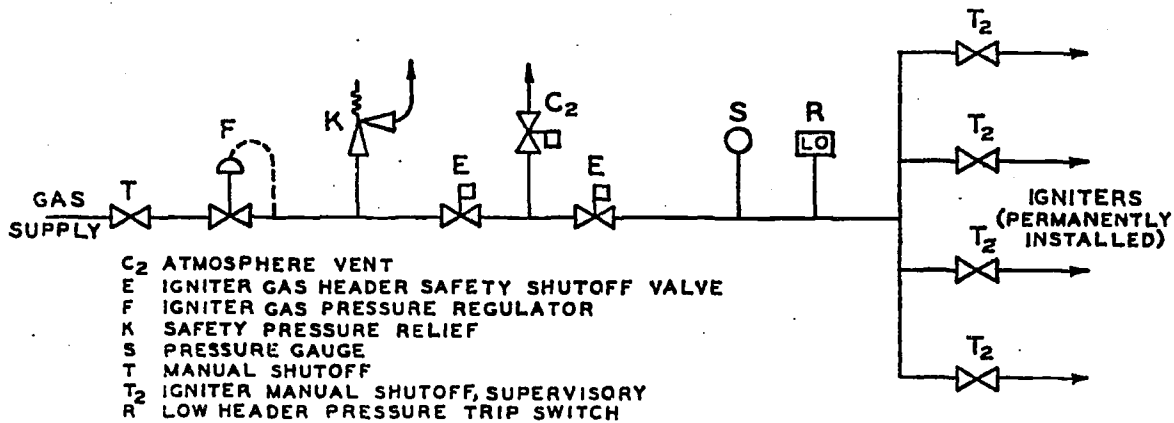
Fuel Piping consists of interruptible and firm gas, and fuel oil supply and return.

Interruptible gas is used when it is available, but it is subject to being shut off when supplies are low during the heating season. Firm (non-interruptible) gas is used for the pilot light, and fuel oil is used as the standby fuel for gas, or full time in localities where natural gas is not available. Natural gas is supplied to the boiler room from the utility company's meter installation. A gas shut-off cock must be installed in the incoming lines, outside the building and easily accessible for securing the boiler room in case of an emergency. The gas lines are led to the boiler, supported from the overhead, or layed in a pipe trench on supports, but never buried under the floor slab. The interruptible gas piping arrangement at the boiler front includes a series of valves and safety controls as shown in Fig. 5-19*. The pressure of the incoming gas and pressure required at the boiler will depend entirely on the pressure drop in the piping and the burner requirement. The firm gas is independent of the interruptible, and has a separate shut-off cock and pressure reducing regulator to suit the pilot flame requirements. Low pressure gas regulators have large diaphragms, the chamber above the diaphragm being vented to allow it to "breathe". In case the diaphragm should break, high pressure gas would escape from the vent causing a dangerous condition. For this reason, the vent connections have an internal tapping for connecting and running a small pipe or tubing to atmosphere. On boilers, the tube may be led into the firebox, which is vented to the atmosphere.

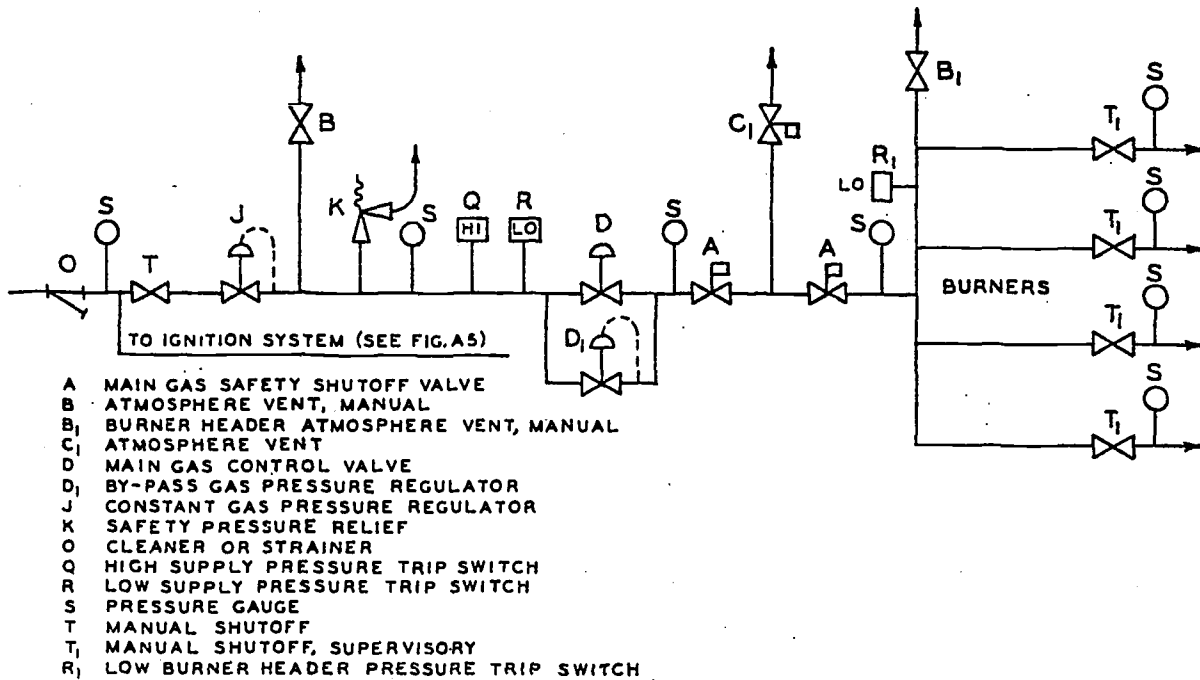
Fuel oil supply and return is usually pumped from an underground supply tank outside the boiler room by a small gear type pump integral with the burner. Any oil not used by the modulating type fuel valve is bypassed back to the storage tank. Where there is a large difference in elevation between tank and boiler, a booster pump may be used.

Boiler feed water is made up principally of condensed returned steam plus a certain amount of make-up water. All steam condensed in the heat exchanger and coils, and collected at various trap sets in the building, is returned through the condensate

* NFPA Bulletin 951 Recommendations



Ignition System — Manual.



Typical Fuel Supply System for Natural Gas-Fired Multiple Burner Boiler-Furnace — Manual.

Fig. 5-19

Reproduced with Permission
of the N.F.P.A.

system to a condensate receiver. This is replenished with treated water as required and pumped back into the boiler, or to a feed water heater, then to the boiler, depending on the size of the plant. As mentioned previously, for high pressure boilers, that part of the feed water piping between the boiler feed water header, or main, and the boiler comes under the cognizance of the ASME Boiler Code for High Pressure Boilers. The Code also requires a secondary source of feed water to be permanently connected to the boiler in the event of failure of the boiler feed pump.

Firebox Inspection

Prior to firing, an inspection should be made of the firebox for shipping damage to the refractory. After tests required by the contract have been completed, the boiler should be cooled down and the firebox re-inspected for signs of flame impingement or any signs of premature failure.

Cleaning

Boilers need to be "boiled out" with a cleaning solution to clean out oil, mill scale and other impurities. Each company has its own formula and procedure which should be followed.

Boiler Water Treatment

A program for treatment of the boiler water should be started immediately following the cleaning procedure. Many times it is overlooked in the contract as to who is responsible for treatment, so this should be settled before the boiler is filled the first time. It must never be left standing cold any period of time partly filled with water as corrosion will start to work at the water line. If the boiler is needed for temporary heat by the contractor, this should be agreed to by the owner and architect. If it is to lie idle after the tests and initial firing, it can be layed up "wet" (full of water) with treatment added to the water as recommended by a consultant.

Uniform Mechanical Code Reference

Section 507 - Labeling of Gas Appliances
Table 5a- Installation Clearances
Section 601 - 607 - Combustion Air Requirements

Footnote 1. Reproduced by permission of McDonnell and Miller, Inc, Chicago, Illinois.


6. HEAT EXCHANGERS

Heat exchangers in heating and ventilating work are used to heat water with steam, heat or (cool) water with water, cool water with refrigerant, and as refrigerant condensers. They are manufactured with U-shaped tubes or straight tubes; the latter with fixed or floating tube sheets. Heat exchangers are also arranged for 1, 2, 4 or 6 passes, that is, the number of times a particle of liquid moving through the tubes travels the length of the exchanger. The number, length and diameter of the tubes, and the number of passes is dictated by the heat transfer rate required. Baffles are sometimes used in the steam inlet to prevent impingement of moisture on the tubes.

Construction Details

Fig. 6-1 shows a U-tube exchanger used for heating water with steam. Steam enters through the large flanged nozzle at the top and follows a zig-zag path through the bundle to the outlet at the opposite end in the bottom. The connection on the horizontal centerline at the drain end is for a vacuum breaker or thermostatically operated air vent.

The half-moon segments (refer to Fig. 6-2) hold the tubes on the proper centers and also act as steam baffles to force the steam to flow across the tubes as it travels towards the outlet. Of course, the steam is condensing as it gives up its latent heat to the cold tubes, and the baffle plates are cut away on the bottom to permit movement of the condensate. The baffle tube supports are held in place with tie rods (Fig. 6-2). The open end of the tubes are rolled into the tube sheet which is held in place between the shell flange and the head. Fig. 6-3 shows a straight tube, fixed tube sheet design. The tube bundle cannot be withdrawn, so tubes are cut out and removed individually for replacement as required. The tubes can be cleaned by rodding out, but this style cannot be used for wide temperature differences. Fig. 6-4 shows a straight tube design with floating head, which can be rodded out, and the tube bundle can be withdrawn.

Heat exchangers come under the ASME Code for Unfired Pressure Vessels, and must bear the Code Stamp: . The following are good installation instructions, prepared by Bell and Gossett Company.

1. Provide sufficient clearance at the stationary tube sheet end of the unit to permit removal of tube bundles from shells. On the packed floating tube sheet end, a space of 3 or 4 feet should be provided to permit the removal of the rear head, packing and retainer rings.
2. Provide valves and by-passes in the piping system so that both the shells and tube bundles may be by-passed to permit cutting out the unit for inspection or repairs.
3. Provide thermometer wells and pressure gauge connection in

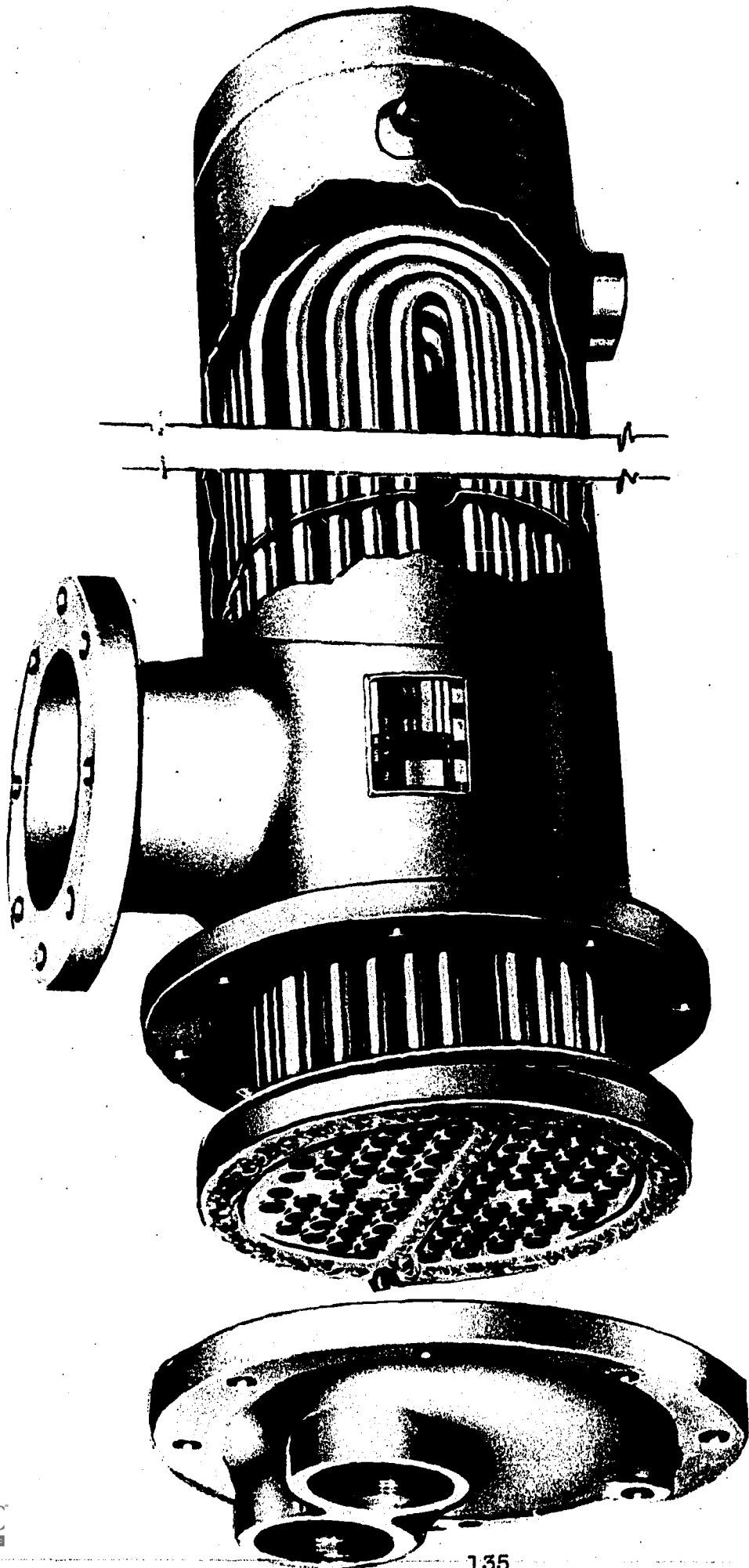


Fig. 6-1

Courtesy, ITT-Bell and Gossett Co.

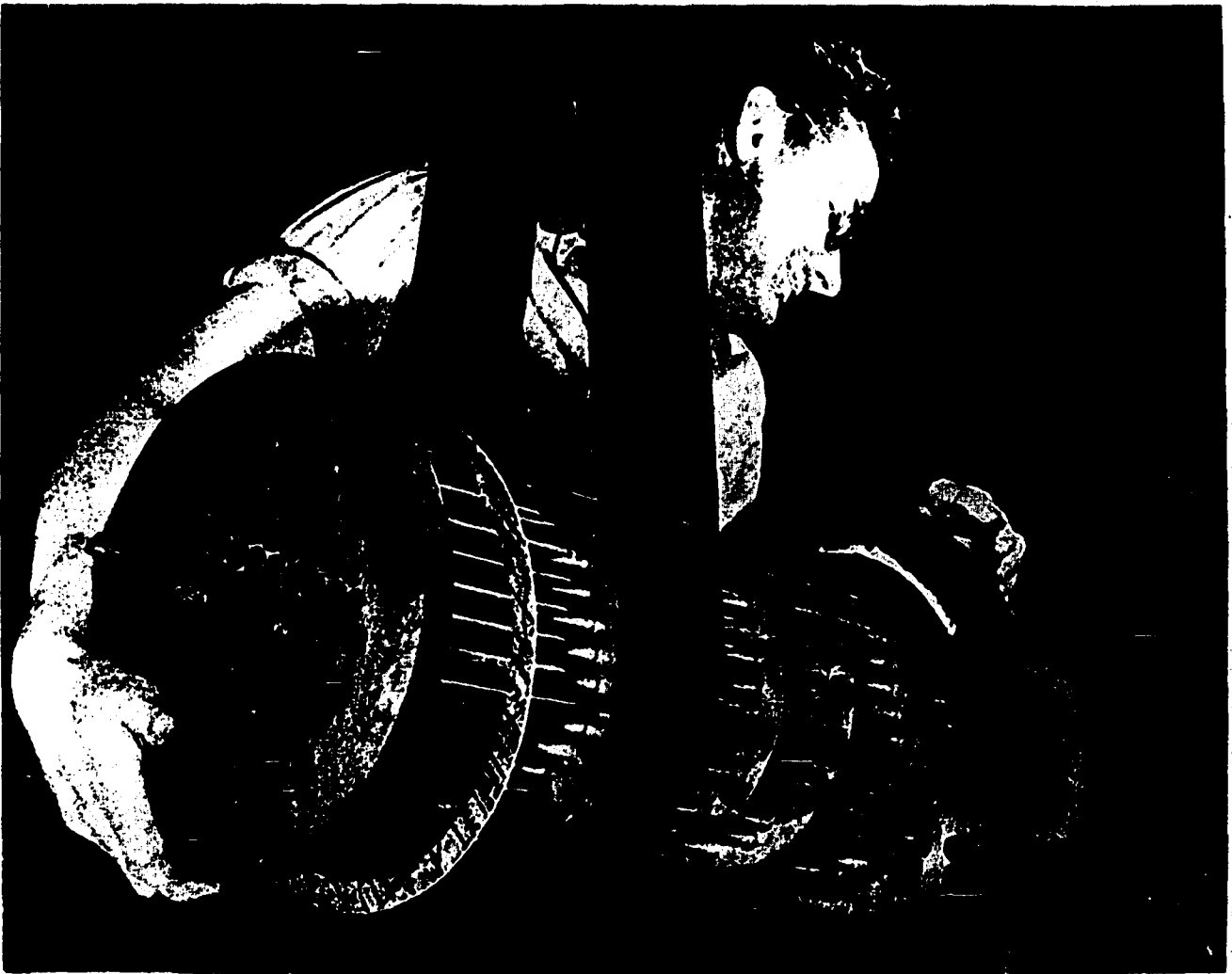


Fig. 6-2

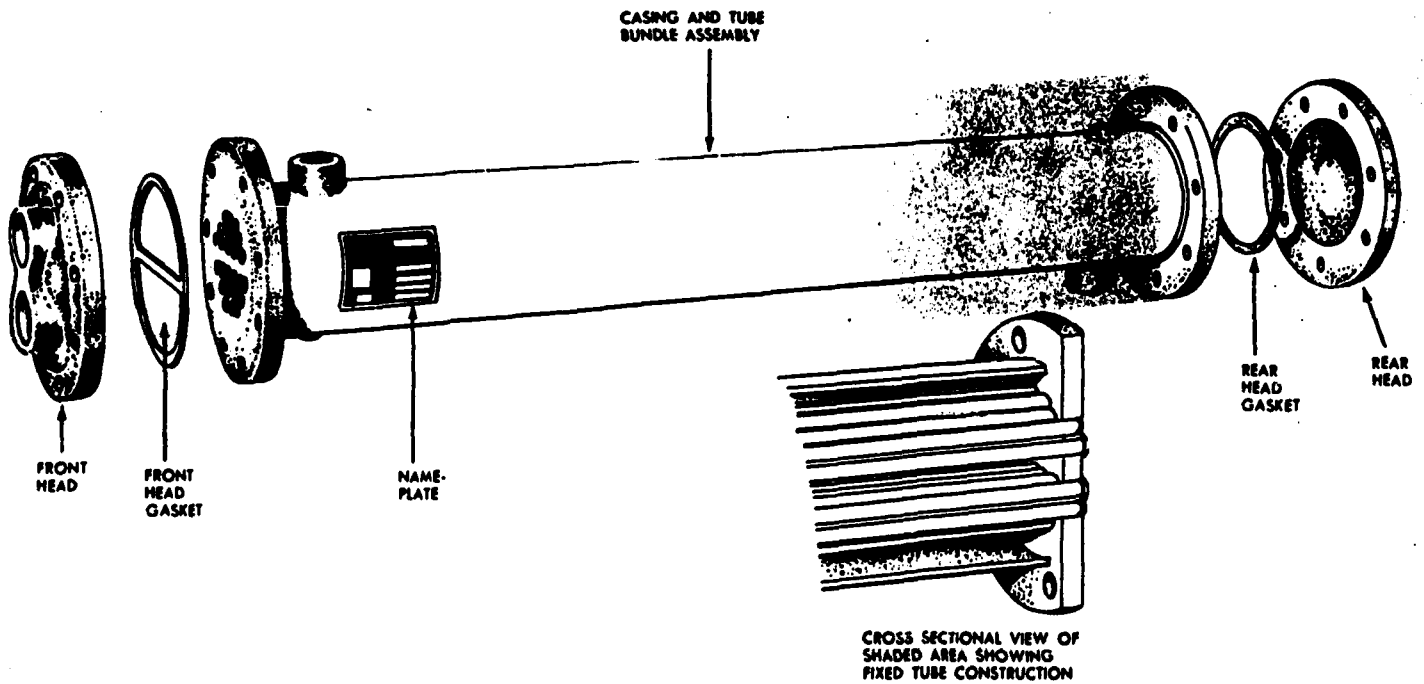


Fig. 6-3

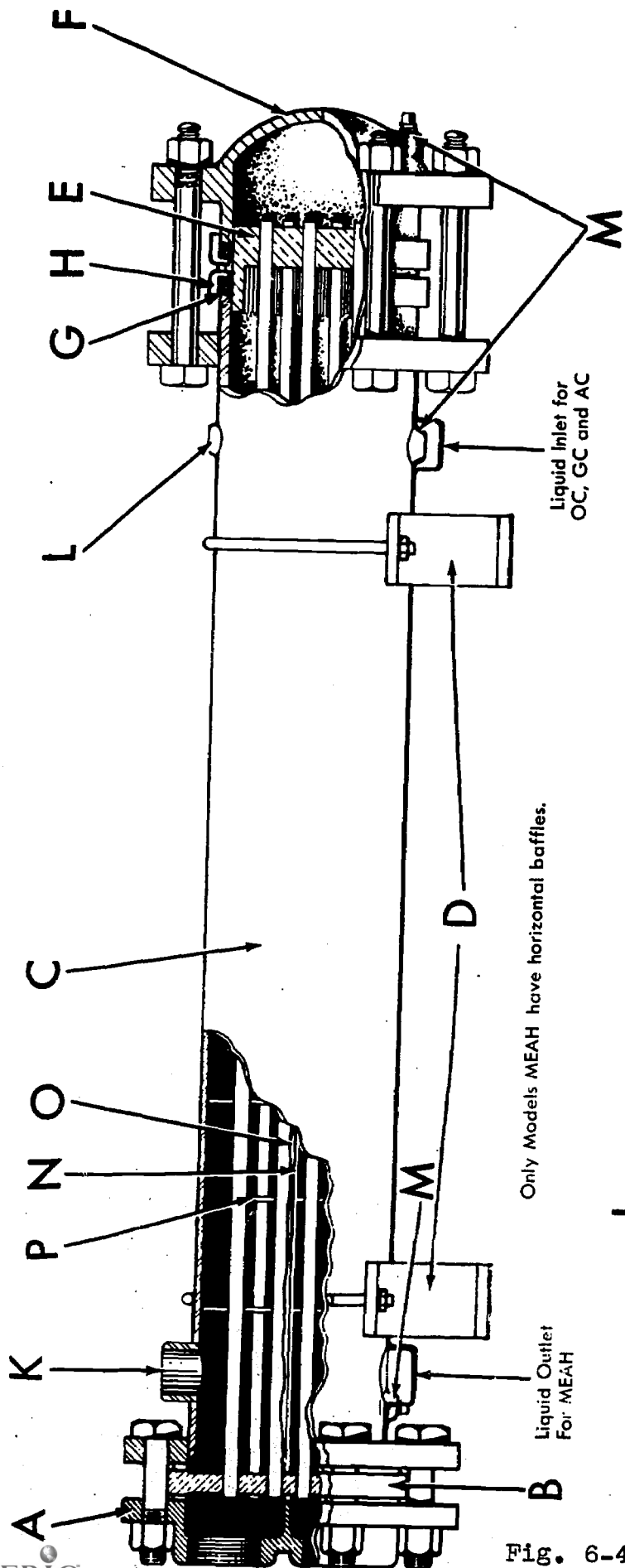


Fig. 6-4

- A—Front Head
- B—Stationary Tube Sheet
- C—Shell
- D—Saddles
- E—Packed Floating Tube Sheet
- F—Rear Head
- G—Packing
- H—Packing Retainer Ring
- J—Head Connections
- K—Shell Connections
- L—Relief Valve Opening
- M—Drains
- N—Horizontal Steel Baffle (Type MEAH only)
- O—Buna Strips (Type MEAH only)
- P—Vertical Segmental Baffles

Only Models MEAH have horizontal baffles.

Liquid Inlet for OC, GC and AC

Liquid Outlet For MEAH

1. When ordering give complete name plate data and part name.
2. Type 3C and AC have no horizontal steel baffle.

Fig. 6-4

Courtesy, IIT-Bell and Gossett Co.

all piping to and from the unit and located as near the unit as possible.

4. Provide convenient means for frequently cleaning the unit.
5. Provide necessary air vent cocks for units so they can be purged to prevent or relieve vapor or gas binding of either the tube or the shell sides.
6. Foundations must be adequate so that exchangers will not settle and cause piping strains. Foundation bolts should be set to allow for setting inaccuracies. In concrete footings, pipe sleeves at least one size larger than bolt diameter slipped over the bolt and cast in place are best for this purpose, as they allow the bolt center to be adjusted after the foundation is set.
7. Loosen foundation bolts at one end of unit to allow free expansion of shells. Oval holes in foundation brackets are provided for this purpose.
8. Set exchangers level and square so that pipe connections may be made without forcing.
9. Inspect all openings in exchanger for foreign material. Remove all wooden plugs and shipping pads just before installing. Do not expose units to the elements with pads or other covers removed from nozzles or other openings since rain water may enter the unit and cause severe damage due to freezing.
10. Be sure entire system is clean before starting operation to prevent plugging of tubes with sand or refuse. The use of strainers in settling tanks in pipe lines leading to the unit is recommended.
11. Drain connections should not be piped to a common closed manifold.
12. Steam hammer can cause serious damage to the tubes of any heat exchanger. A careful consideration of the following points before an installation is made can prevent costly repairs which may be caused by steam hammer.
 - a. A vacuum breaker and/or vent, should be used in accordance with the type of steam system installed.
 - b. The proper trap for the steam system installed should be used.
 - c. The trap and the condensate return line to the trap should be properly sized for the total capacity of the convertor.
 - d. The trap should be sized for the pressure at the trap, not the inlet pressure to the steam controller.

The rate of water flow should be checked for agreement with the design, but should not exceed 7.5 feet per second tube velocity, as higher velocities will cause tube erosion and vibration. Tube velocity can be found from Table 6-1 which shows the velocity obtained with 1 gpm of flow through various sizes and weights of tubes. The velocity varies directly with the gpm through the individual tubes. An excessively high steam velocity entering through the nozzle will also cause vibration of the tubes between the tube spacers and wear a hole at the point of contact between the tube and spacers. Fig. 6-5 shows the allowable steam velocities at various pressures at the steam inlet. The velocity can be calculated from the formula:

$$Q = A \times V; \quad V = \frac{Q}{A}$$

Where Q = lbs of steam per sec x sp volume of steam at inlet pressure *

A = area of nozzle, sq ft.

V = velocity, fps

Excessive steam flow can result if the control valve is oversized and there is a heavy demand on the exchanger. The steam line supplying the condenser should be the same size as the nozzle connection to reduce the steam velocity and reduce erosion from entrained moisture. The condensate outlet also must be piped full size to the trap to allow unrestricted flow, with the trap located well below the shell. At times of low or no steam flow, a slight vacuum is formed in the shell, holding up the condensate. This can be detrimental to the tubes (see page and is prevented by use of a vacuum breaker connected to the shell. A thermostatic air vent valve is also connected to the shell for getting rid of air and noncondensable gases.

* from the steam tables (in appendix)

Tubing Characteristics

O. D. of Tubing	BWG	Thickness	Inside Diameter	Surface External, Sq. Ft. Per Linear Foot	Length in Ft. for 1 Sq. Ft. Surface	Water-GPM at 1 Ft. Per Sec. Velocity
3/8"	16	.065	.495	.1636	6.112	.60
	17	.058	.509	.1636	6.112	.63
	18	.049	.527	.1636	6.112	.68
	20	.035	.555	.1636	6.112	.75
1/4"	16	.065	.620	.1963	5.094	.94
	17	.058	.634	.1963	5.094	.98
	18	.049	.652	.1963	5.094	1.04
	20	.035	.680	.1963	5.094	1.13
3/8"	16	.065	.745	.2291	4.367	1.36
	17	.058	.759	.2291	4.367	1.41
	18	.049	.777	.2291	4.367	1.48
	20	.035	.805	.2291	4.367	1.59
1"	16	.065	.870	.2618	3.817	1.85
	17	.058	.884	.2618	3.817	1.91
	18	.049	.902	.2618	3.817	1.99
	20	.035	.930	.2618	3.817	2.12

Table 6-1

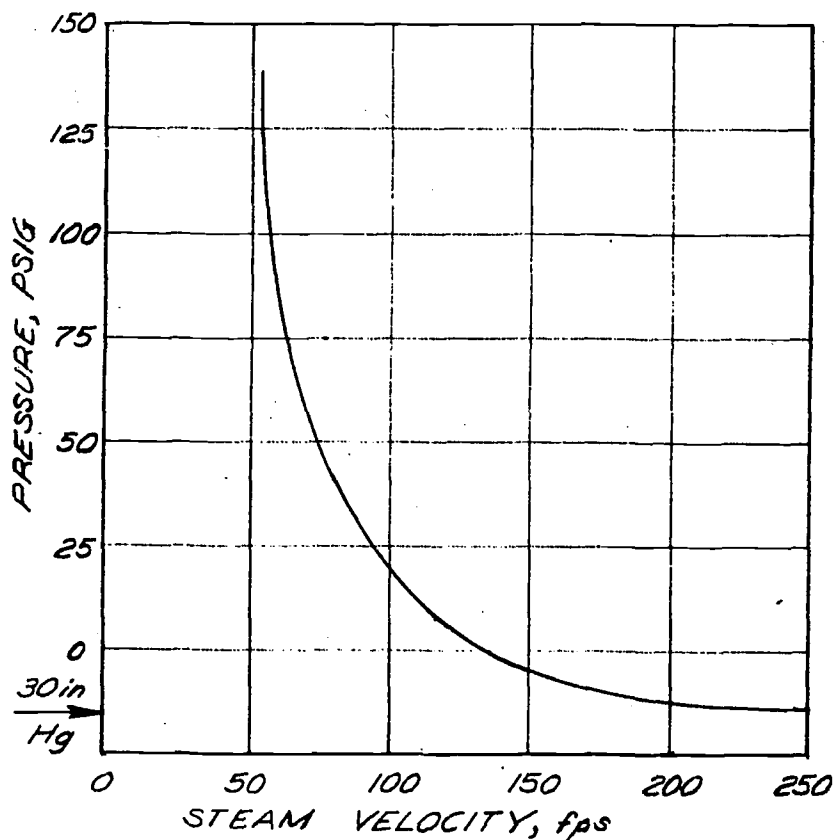


Fig. 6-5

7. COOLING AND HEATING COILS

General

The air in air conditioning systems is heated, cooled and dehumidified by passing it through coils consisting of rows of tubes bonded to aluminum or copper fins. Hot or cold water, steam, or a refrigerant circulates through the tubes. The tubing elements (the primary surface), are usually 5/8" od copper tubing, and the fins (the secondary surface), are usually spaced not more than 12 to the inch. The fins may be flat or ripple shaped and are formed to fit tightly around the tubes. Fig. 7-1 shows general views of various coil types. Fig. 7-2 (a) shows the details of fin construction and attachment to the coil header and Fig. 7-2 (b), a section of a removable header which permits access to be tubes for cleaning water passages. Coils are manufactured in many different arrangements of the number of rows deep and the arrangement of the circuits. Fig. 7-3 shows coil circuiting diagrams for water coils, and Fig. 7-4, for direct expansion coils. Approved submittals for coils often state the circuiting as "half serpentine", "double serpentine", etc, and should be checked by the inspector before installing.

Water Coil Connections

Another important point to check is the supply and return piping connections with regard to the air flow for water coils. Coils are constructed as right or left hand; the hand being determined by facing the direction which the air is flowing and designating the coil connections as either left or right hand. This is illustrated in Fig. 7-5 for even and odd numbers of rows. In order to develop the designed heating or cooling capacity the incoming hot or cold water must be connected on the air leaving side of the coil, and the return water on the air entering side of the coil. Since the inlet is always on the bottom and the outlet is on the top, the coil ends will look like Fig. 7-6 for right hand and left hand styles. If the wrong hand coil is ordered and delivered to the job it will have to be turned end-for-end which will cause problems in relocating piping, control valves, etc. Some coils are furnished with two sets of connections on one end in which case this difficulty will not arise. Each coil should have a means of venting air from the top, and have some provision for completely draining it.

Cooling Coil Condensate Removal

Cooling coils extract copious amounts of water from the air during the cooling and dehumidification process and provision for collecting and disposing of the condensate must be considered. Cooling coils stacked on top of each other should have a gutter at the bottom of each coil to prevent loading the lower coils. Coil face velocities are usually designed for 500-600 fpm to prevent carryover of condensate past the coil face. The bottom coil

should be mounted in a drain pan extending approximately 12" from the coil face, unless the cold plenum floor is water tight and has a floor drain. Chilled water piping penetrations of the plenum surrounding the coil need to be air tight to prevent condensate from being blown out into the fan room.

Steam Heating Coils

Steam coils are constructed and specified with the two arrangements for introducing steam and removing the condensate shown schematically on Fig. 7-7. In Fig. 7-7 (a), steam enters one end and is distributed to the various rows through a common header. The rows are pitched down to the opposite end for the condensate to run out. In Fig. 7-7 (b), a tube-within-a-tube is used where the steam flows through the inside tube, which is perforated at intervals, to the far end. The steam and condensate then flows back to the condensate outlet. Regardless of the tube construction the steam inlet is always at the mid point of the coil and the return is always on the bottom.

Piping Connections for Steam Coils

Figs. 7-8 and 7-9 give application recommendations and piping hook-ups for different coil positions and arrangements by one manufacturer*, but are generally standard for the industry. The coil numbers refer to the designs shown in Fig. 7-7.

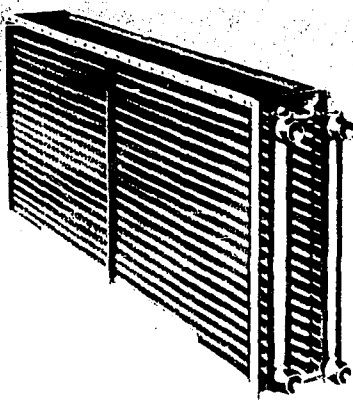
Pressure Tests and Ratings

Water and direct expansion coils are factory pressure tested and are suitable for 250 psig working pressure. Steam coils are rated up to 150 psi for standard coils. (These figures may vary with different manufacturers). It is not advisable to include coils (or any other equipment or valves) in a piping pressure test.

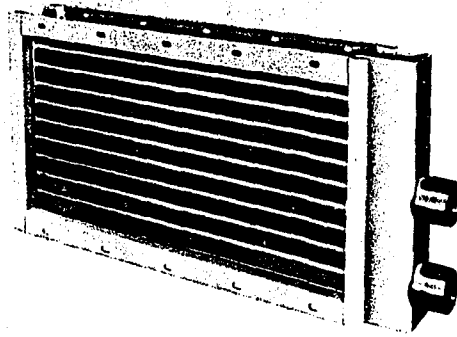
The Air Conditioning and Refrigeration Institute (ARI) has set up standards for rating and testing coils (Standard 410-64). Fig. 7-1 (c) shows the ARI certification seal.

Refer to Uniform Mechanical Code, Section 510, for cooling coil condensate waste requirements.

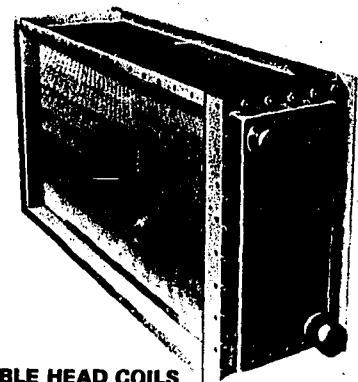
* McQuay, Inc.



WATER COOLING COILS



STEAM COILS



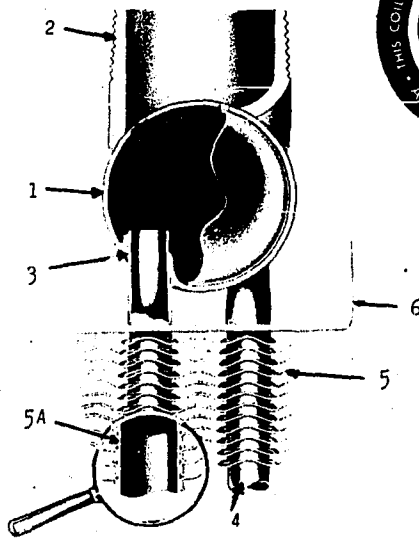
REMOVABLE HEAD COILS

Fig. 7-1

1. **HEADERS** - Extra heavy seamless copper tubing. Tube holes are intruded to provide the maximum brazing surface for added strength. Header end caps are heavy gauge die formed copper. Cupro-nickel headers and Monel end caps are available for special applications.
2. **CONNECTIONS** - Top and bottom connections provided on headers permit coil to be used for either right or left hand air flow.
 - a. **Water Coil Conn.** Steel male pipe supply and return connections (Other materials available on request).
 - b. **Evaporator Coil Conn.** Male Sweat type. Liquid connections are brass and suction connections are copper.
3. **BRAZING** - All joints are brazed with copper brazing alloys.
4. **PRIMARY SURFACE** - 5/8" O.D. round seamless copper tubes on 1-1/2" centers. Cupro-nickel tubes are recommended for applications where high acid or sand content tends to be corrosive or erosive.
5. **SECONDARY SURFACE** - HI-F rippled aluminum or copper die formed plate type fins. 5a Fin collars are full drawn to com-

pletely cover the tubes for maximum heat transfer and to provide accurate control of fin spacing.

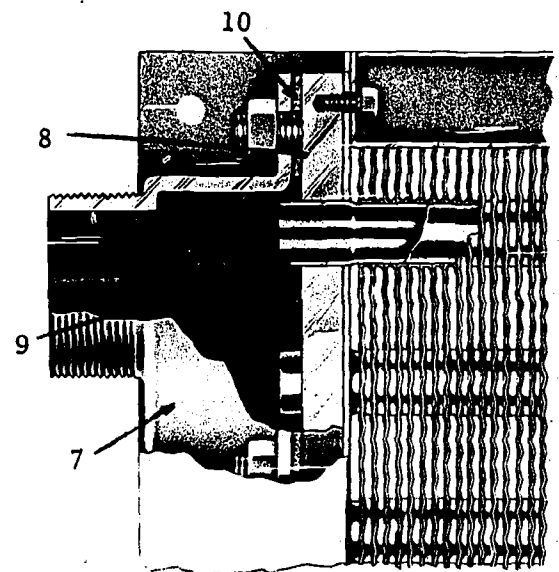
6. **CASING** - Die formed heavy gauge continuous galvanized steel with reinforced mounting flanges (Other materials available on request.) Tie bars and fin angles brace and position the core assembly to prevent damage in shipment.
7. **REMOVABLE HEAD AND WATER BAF-FLES** - The removable head, formed from 1/4" thick hot rolled steel, is bolted to the tube sheet by 9/16" bolts. Four tapped holes are provided in the flanges for jack screws which facilitate removing the head.
8. **TUBE SHEET** - 1/2" thick hot rolled carbon steel. Tube holes are drilled and reamed to provide a smooth surface for the tube.
9. **TUBE SHEET TO TUBE JOINT** - Tubes are rolled tight into the tube sheet without the use of ferrules which prevent proper draining and cleaning.
10. **GASKETS** - Composition cork and neoprene gasket around the perimeter of the head and a neoprene gasket between the water baffles and the tube sheet provide positive sealing and long life.



(7-2a)



(c)



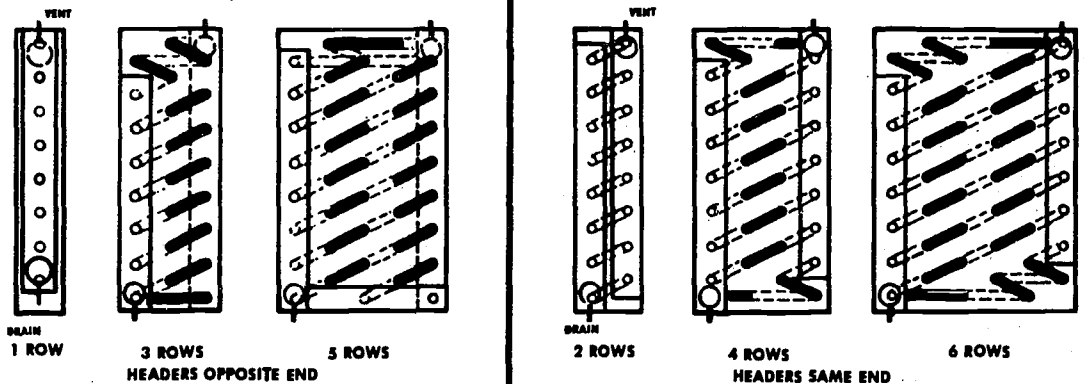
(7-2b)

COIL CIRCUITING DIAGRAMS—WATER COILS

ALL WATER COILS ARE COMPLETELY DRAINABLE BY GRAVITY THROUGH THE DRAIN PLUG IN THE SUPPLY CONNECTION. THE DIAGRAMS ON THIS PAGE SHOW THIS DESIRABLE FEATURE.

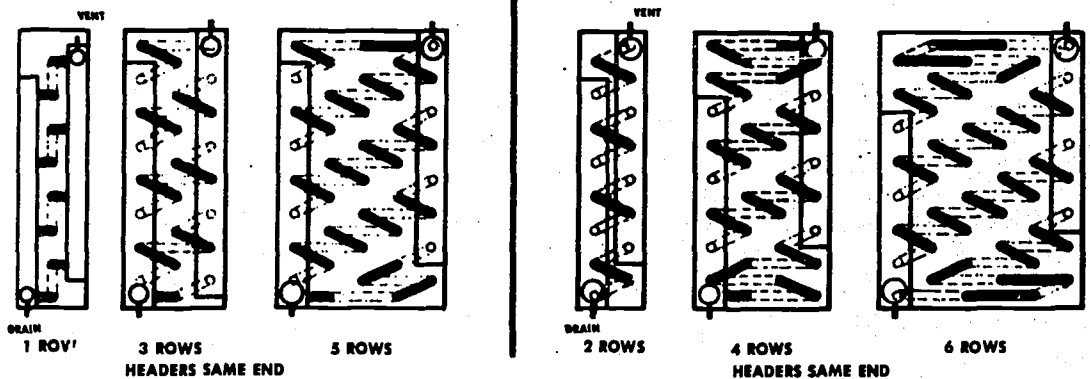
STANDARD SERPENTINE

The number of water circuits is the number of tubes contained in the width of the coil.



HALF SERPENTINE

The number of water circuits is one-half the number of tubes contained in width of the coil. Used to increase water velocity when it becomes less than 0.5 ft. per second with stand-



ard number of circuits. Increasing water velocity increases heat transfer capacity.

DOUBLE SERPENTINE

The number of water circuits is twice the number of tubes contained in the width of the coil. Used when the water velocity exceeds the value which may result in an excessive pressure drop (head).

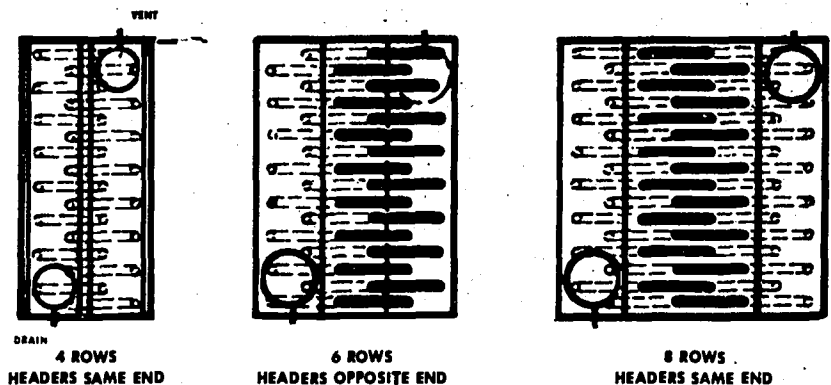


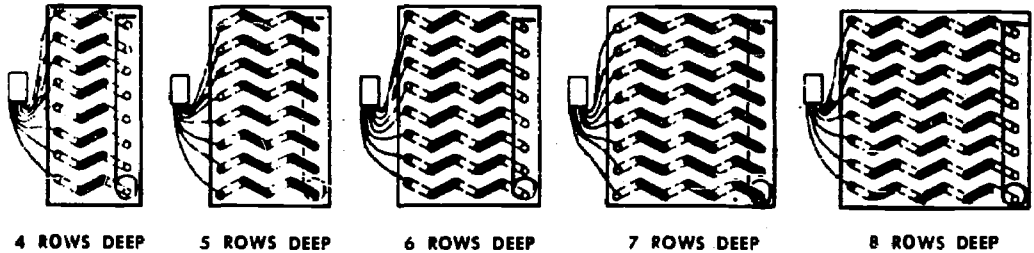
Fig. 7-3

COIL CIRCUITING DIAGRAMS—Direct Expansion Coils

DIRECT EXPANSION COILS ARE CIRCUITED FOR THE REFRIGERANT TYPE SPECIFIED, CIRCUITING ARRANGEMENTS SHOWN ARE FOR REFRIGERANT 12 ONLY.

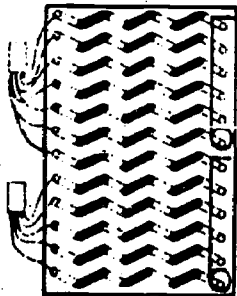
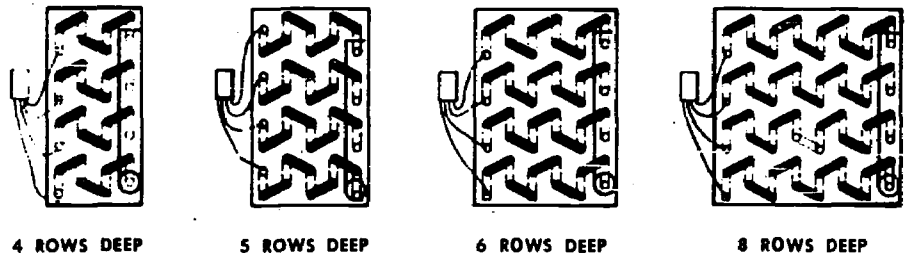
STANDARD SERPENTINE

Any number of tubes wide. Number of circuits is the same as number of tubes wide.



HALF SERPENTINE

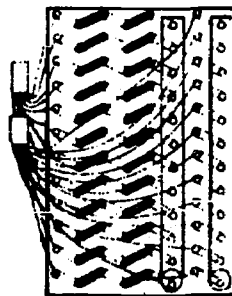
Any even number of tubes wide. Number of circuits is one-half the number of tubes wide.



FACE CONTROL is control of separate portions of the coil with two or more thermal expansion valves. Advantages are better control and more dehumidifying of the air

at low loads. Sometimes used instead of face and by-pass dampers on air conditioning units.

Any coil may be circuited for face control regardless of the number of tubes wide or rows deep.

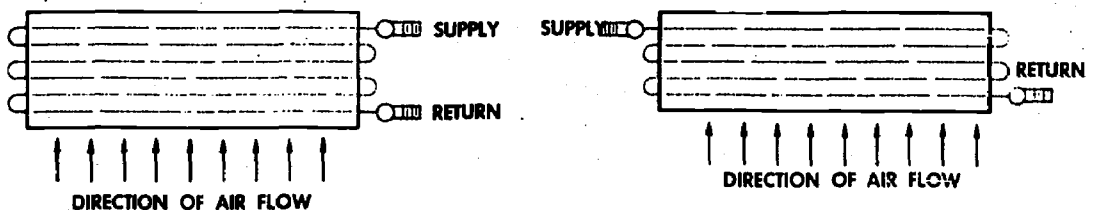


DEPTH CONTROL is control with two or more expansion valves in depth. Used to shorten the circuit length of a Coil and, thereby, reduce the refrigerant pressure drop.

Any coil may be circuited for depth control regardless of the number of rows deep. The Percentage of Total Load Table on page 33 shows how the load will be divided.

Fig. 7-4

HAND ARRANGEMENT FOR COILS

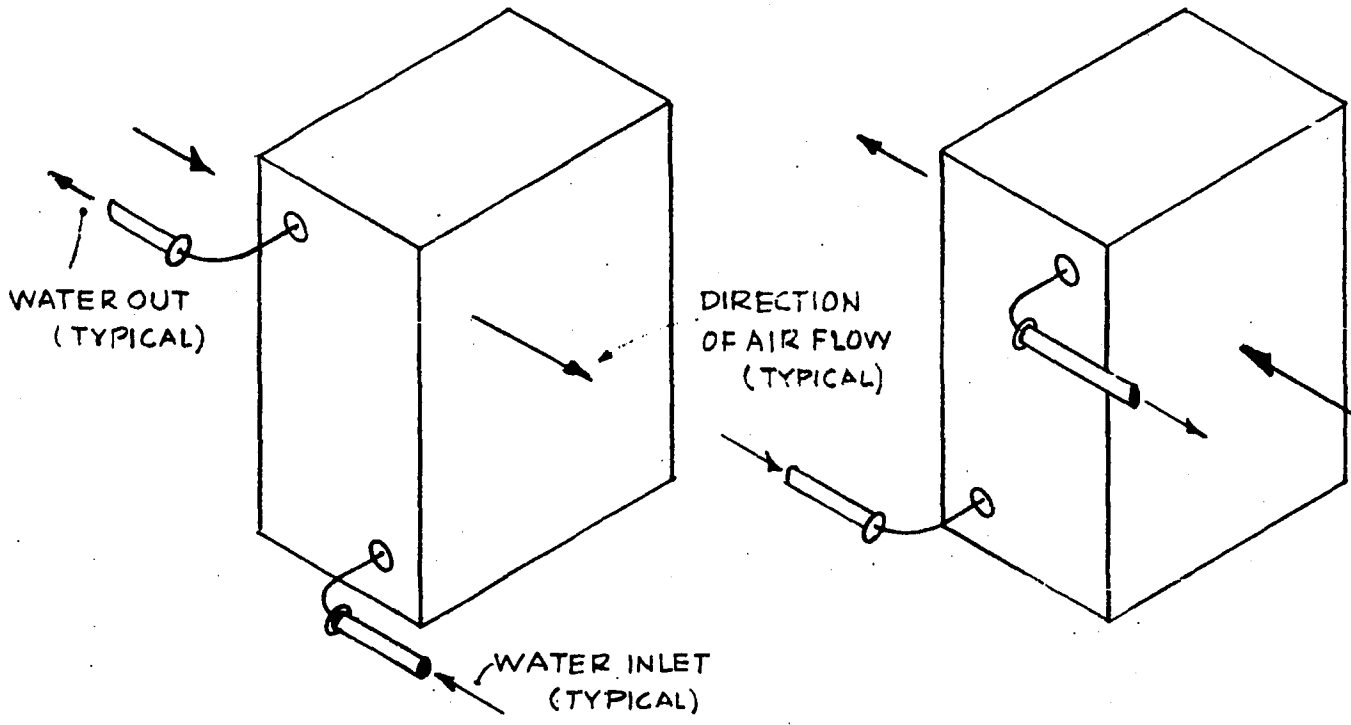


6 ROW
RIGHT HAND
WATER COIL

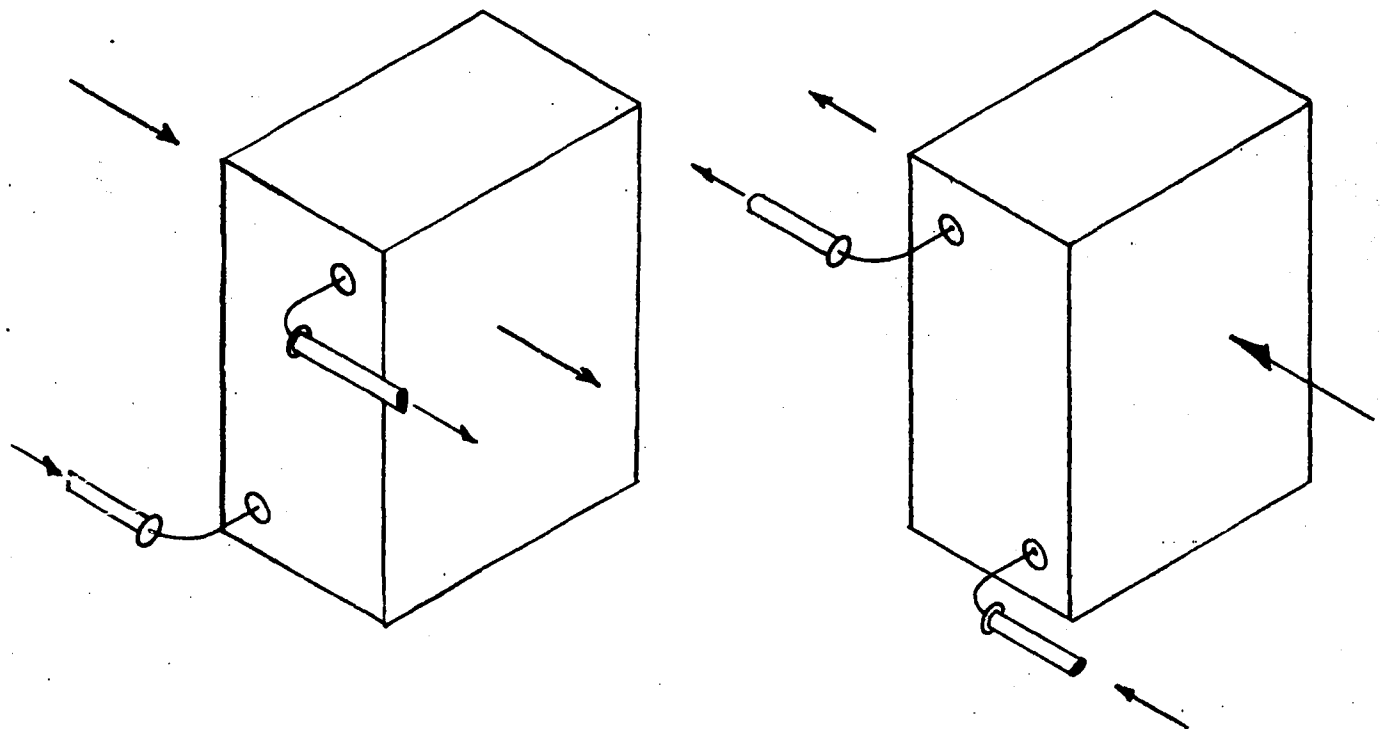
Coil hand is determined by facing the direction which the air is flowing and designating Coil connections as either right or left hand.

5 ROW
RIGHT HAND
WATER COILS

For coils with opposite end connections, Coil hand is determined by the return header location.



CORRECT PIPING CONNECTIONS (COUNTERCURRENT)



IN CORRECT PIPING CONNECTIONS (CONCURRENT)

Fig. 7-6

Select McQUAY HI-F 5 and HI-F 8 Steam Coils from three different circuiting arrangements: the general purpose 5SA and 5SB coils, and two jet tube steam distributing styles – the 5JA and 8JA and the 5RA and 8RA coils – intended for both general and special purpose heating. While each of these arrangements has been carefully designed to serve a particular area in

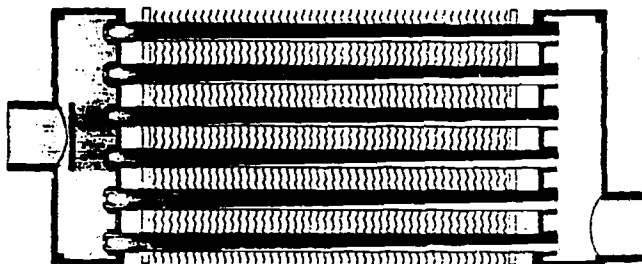
steam coil application, sufficient similarities are present in design and performance to render them interchangeable in many cases.

McQUAY steam coils provide a higher performing heat transfer surface together with a host of exclusive McQUAY features that assure extended coil life.

5SA & 5SB GENERAL PURPOSE STEAM COILS

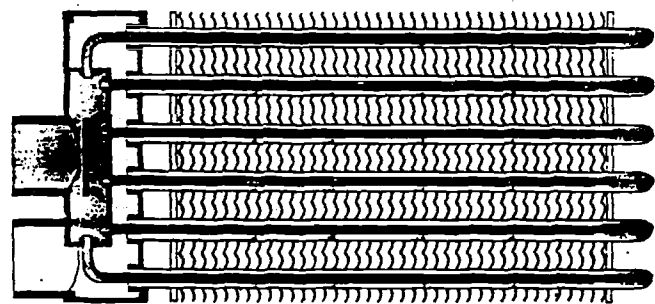
The McQUAY 5SA and 5SB steam coils are specifically designed for economical general purpose heating. Featuring high quality and high capacity, they are an ideal choice for all regular steam applications – heating, reheating, booster and process use.

The sectional diagram illustrates the steam circuiting of this single tube design. A perforated plate type steam baffle directly behind the supply connection ensures even steam pressure across the entire header length. Inlet tube orifices meter a uniform flow of steam into each tube.



(a)

5JA & 8JA JET TUBE DISTRIBUTING COILS



(b)

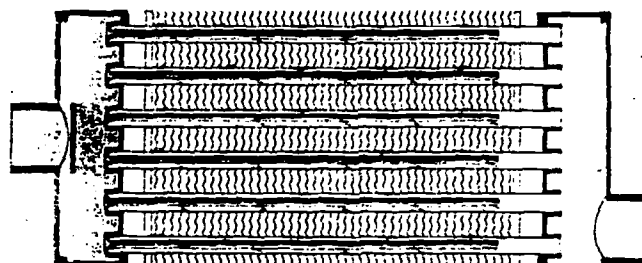
The McQUAY 5JA and 8JA jet tube steam distributing coils are excellent for any general purpose heating applications. With the superior freeze resistance provided by the tube-within-a-tube construction, they are ideal for low temperature preheating and special process application.

The construction, as illustrated, features directional orificed inner tubes, a unique elliptical supply header located inside the heavy duty return header and a circuiting arrangement which provides both supply and return connections at the same end of the coil.

5RA & 8RA JET TUBE DISTRIBUTING COILS

The 5RA and 8RA jet tube steam distributing coils are very similar in design and operation to the "JA" coils except that supply and return connections are located on opposite ends.

The directional orifices properly meter steam along the entire tube length to assure a consistent temperature rise across the full coil face and accelerate condensate removal. This important feature is standard on all McQUAY jet tube steam distributing coils.



(c)

Fig. 7-7

PIPING DATA

APPLICATION RECOMMENDATIONS

Satisfactory operation and service life are best ensured when coils are installed with proper piping, trap, and support arrangement. The following notes and diagrams are recommended:

A. GENERAL

1. Provide separate supports and hangers for the coil and for the piping.
2. Be certain that adequate piping flexibility is provided. Stresses resulting from expansion of closely coupled piping and coil arrangement can cause serious damage.
3. McQUAY standard coils are pitched in the casing when installed for horizontal air flow. The installation should be checked to ensure that the casing is level.
On vertical air flow applications, the coils must be pitched when installed.
4. Do not reduce pipe size at the coil return connection. Carry return connection size through the dirt pocket, making the reduction at the branch leading to the trap.
5. It is recommended that vacuum breakers be installed on all applications to prevent retaining condensate in the coil. Generally the vacuum breaker is to be connected between the coil inlet and the return main, as shown. However, for a system with a flooded return main, the vacuum breaker should be open to the atmosphere and the trap design should allow venting of large quantities of air.
6. Do not drip supply mains through the coil.
7. Do not attempt to lift condensate when using modulating or on-off control.

B. TRAPS

1. Size traps in accordance with manufacturers' recommendations. Be certain that the required pressure differential will always be available. Do not under-size.
2. Float and thermostatic or bucket traps are recommended for low pressure steam. On high pressure systems, bucket traps are normally recommended. Thermostatic traps should be used only for air venting.
3. Bucket traps are recommended for use with on-off control only.
4. Locate traps at least 12 inches below the coil return connection.
5. Multiple coil installations:
 - a. Each coil or group of coils that is individually controlled must be individually trapped.

- a. Coils in series – separate traps are required for each coil, or bank of coils, in series.
- b. Coils in parallel – a single trap may generally be used but an individual trap for each coil is preferred.

C. CONTROL

1. With coils arranged for series air flow, a separate control is required on each bank, or coil, in the direction of air flow.
2. On high pressure installations, a two position steam valve with a face and bypass arrangement is preferred where modulating control is required.
3. Modulating valves must be sized properly – Do not oversize.

D. FREEZING CONDITIONS

(Entering Air Temperature Below 35F).

1. 5JA, 8JA, 5RA and 8RA Coils are definitely recommended.
2. 5 psi steam must be supplied to coils at all times.
3. Modulating valves are not recommended. Control should be by means of face and bypass dampers.
4. Consideration should be given to the use of two or three coils in series with two position steam control valves on that coil or coils which will be handling 35F, or colder, air. The desired degree of control can be attained with a modulating valve on the downstream coil.
5. Provision should always be made to thoroughly mix fresh air and return air before it enters coil. Also, temperature control elements must be properly located to obtain true air mixture temperatures.
6. As additional protection against freeze-up, the trap should be installed sufficiently far below coil to provide an adequate hydrostatic head to ensure removal of condensate during an interruption in the steam pressure. Estimate 3 feet for each 1 psi of trap differential required.
7. On start up, admit steam to coil ten minutes before admitting outdoor air.
8. Provision must be made to close fresh air dampers if steam supply pressure falls below minimum specified.

SYMBOLS FOR PIPING ARRANGEMENTS



GATE VALVE



CONTROL VALVE, MODULATING TWO POSITION



CHECK VALVE

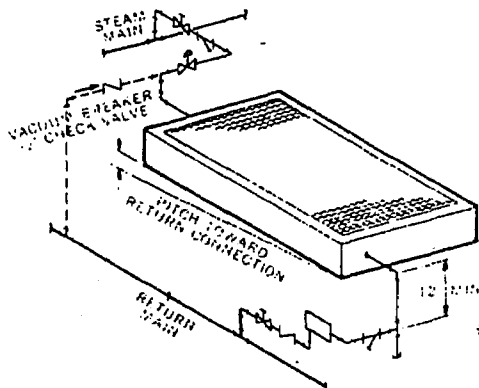


FLOAT AND THERMOSTATIC TRAP



STRAINER

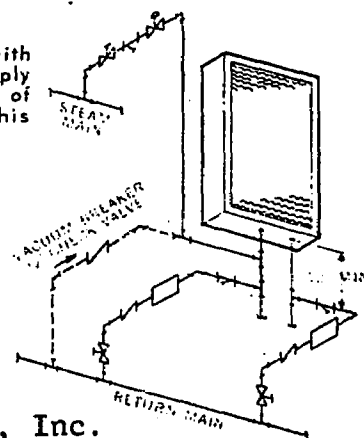
LOW PRESSURE (TO 25 PSI)



*5JA or 8JA Coil installed with tubes vertical. The coil supply piping must be dripped ahead of the coil on an installation of this type.

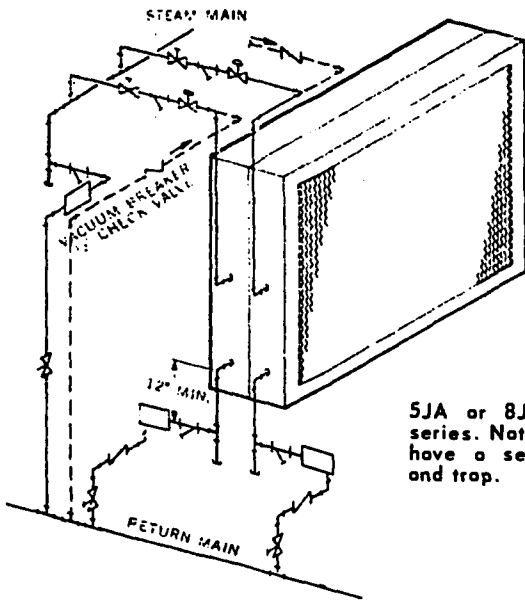
*5RA, 8RA, 5SA or 5SB Coil installed for vertical air flow. Installer must pitch coil toward the return connection on vertical air flow installations. For horizontal air flow installation, the required pitch is built into the casing.

*NOTE: Rating data is ARI Certified only for the standard ARI Coil Orientation, i.e. horizontal tubes, vertical coil face and horizontal air flow.

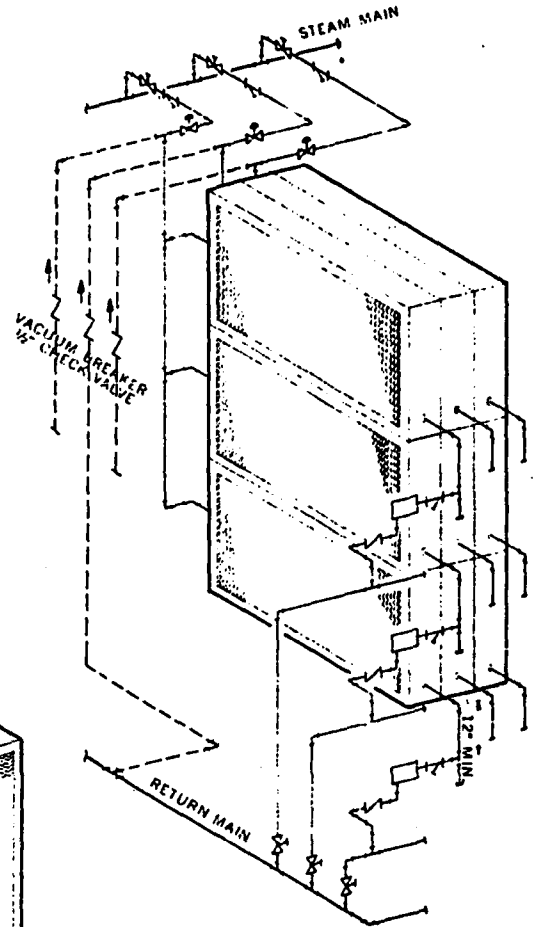


PIPING DATA

LOW PRESSURE (TO 25 PSI)



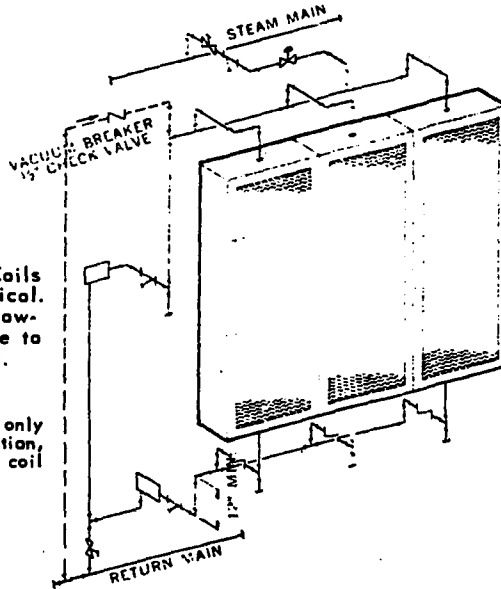
5JA or 8JA Coil installed in series. Note that each coil must have a separate control valve and trap.



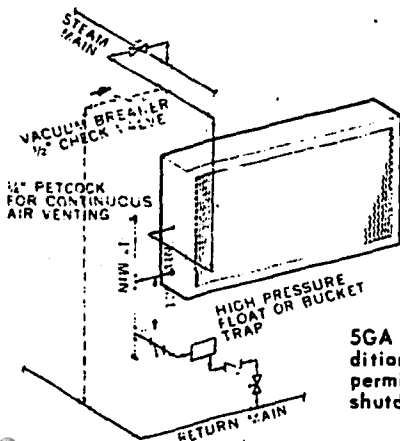
5RA, 8RA, 5SA or 5SB Coils banked three high by three deep. Individual trapping of each coil as shown is preferred. Note that it is necessary to provide a separate control valve for each bank in the direction of air flow.

* 5SA or 5SB Coils installed with tubes vertical. Diagram shows single trap, however, it is always preferable to trap each coil individually.

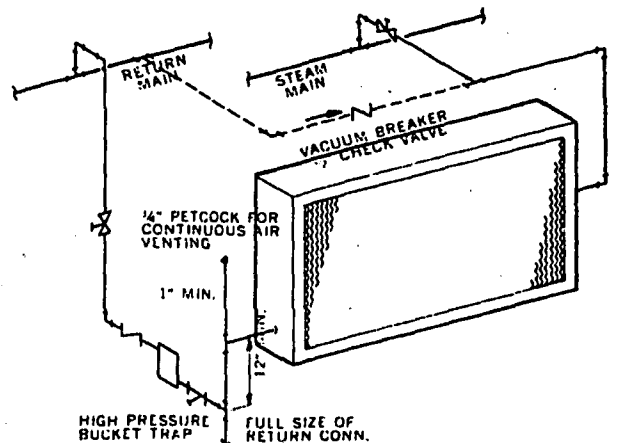
* NOTE: Rating data is ARI Certified only for the standard ARI Coil Orientation, i.e. horizontal tubes, vertical coil face and horizontal air flow.



HIGH PRESSURE (OVER 25 PSI)



5GA or 8GA Coils. Note the addition of a vacuum breaker to permit the coil to drain during shutdown.



5TA, 8TA, 5HA or 5HB Coils. Condensate is lifted to overhead return main.

Fig. 7-9

Cooling and Heating Coil Pointers:

1. Protect finned coils with plywood during construction.
2. Never run air through coils without filters in place.
3. Tight closure between the coil frame and plenum.
4. Tight closure between the hot and cold plenum so air cannot be exchanged between the two.
5. Coils plumb and level.
6. Air vent valves and drain valves are installed.
7. Piping connected for counterflow.
8. Damaged fins to be straightened with a "comb".
9. Tight air seal around piping entering plenum.
10. Piping supported so that no load is imposed on coils.
11. Unions or flanges are installed in piping to allow disconnection for coil removal.
12. Coil ends protruding from plenum to be insulated, with vapor barrier.

8. PUMPS

This section will discuss the various types of designs of pumps associated with heating and ventilating plants; some of the details of their construction; proper installation methods, and testing procedures.

Pump Types

The pump types used the most in heating and ventilating work are the centrifugal, regenerative, axial flow, and rotary designs. The centrifugal pump is produced with a volute shaped casing which converts velocity head to pressure head, or the diffuser type which uses diffusion vanes around the impeller to make the conversion.

Drawing Fig. 8-1 is a schematic diagram of the volute centrifugal, which is not unlike a backward inclined bladed fan. Water enters through the eye of the impeller and is thrown by centrifugal force at a high velocity around the annular space between the impeller and casing and out through the discharge. A section of a diffuser-type centrifugal pump is shown in Fig. 8-2, where the water is thrown through the diffusion ring and around the casing to the discharge. Note the difference in the exterior shapes of the casing; volute vs concentric. Axial flow, mixed flow and radial flow pumps are used for low head, high flow applications such as moving condensing water through cooling towers and refrigeration condensers. These are vertically mounted and take suction from a basin or sump. Fig. 8-4 shows the impeller shapes and salient features and Fig. 8-5 the general arrangement of a mixed flow pump, which is typical for all three styles. Fig. 8-3 illustrates the regenerative type, in which the liquid is acted on by the impeller for nearly a full revolution as it circulates in and out of the impeller vanes. The rotary type pumps are various arrangements of casings containing gears, vanes, pistons, cams, segments or screws.

Typical pump curves for centrifugal, regenerative, and rotary (gear) types are shown in Figs. 8-7, 8-8 and 8-9. As an example of an actual application for the centrifugal pump, Fig. 8-7, "A" is the shut-off condition of highest head and no-flow; point "B" is a throttled flow condition; point "C" the design condition where the system friction curve crosses, and point "D", a condition where the friction head has been drastically reduced (as a line break).

Mechanical Features

Since pumps operate at high speeds, high pressures and temperatures, and have close working clearances, the better pumps are fitted with certain replaceable parts that extend their useful

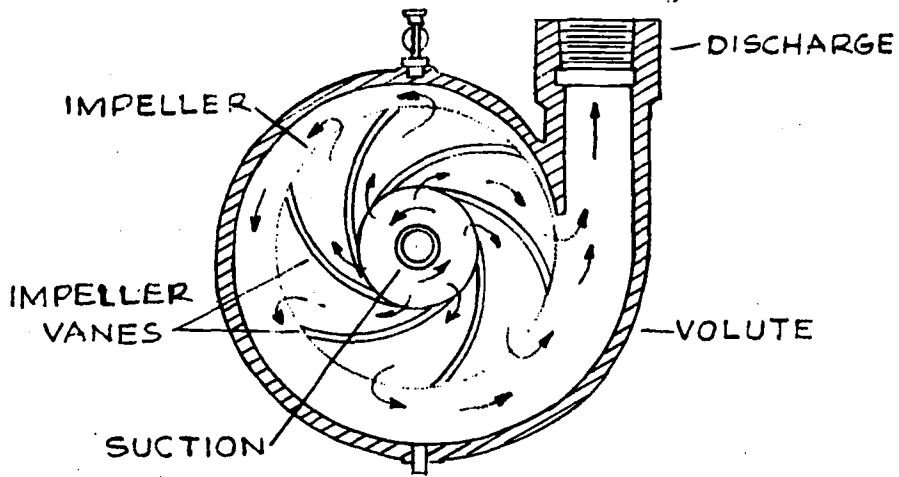


Fig. 8-1

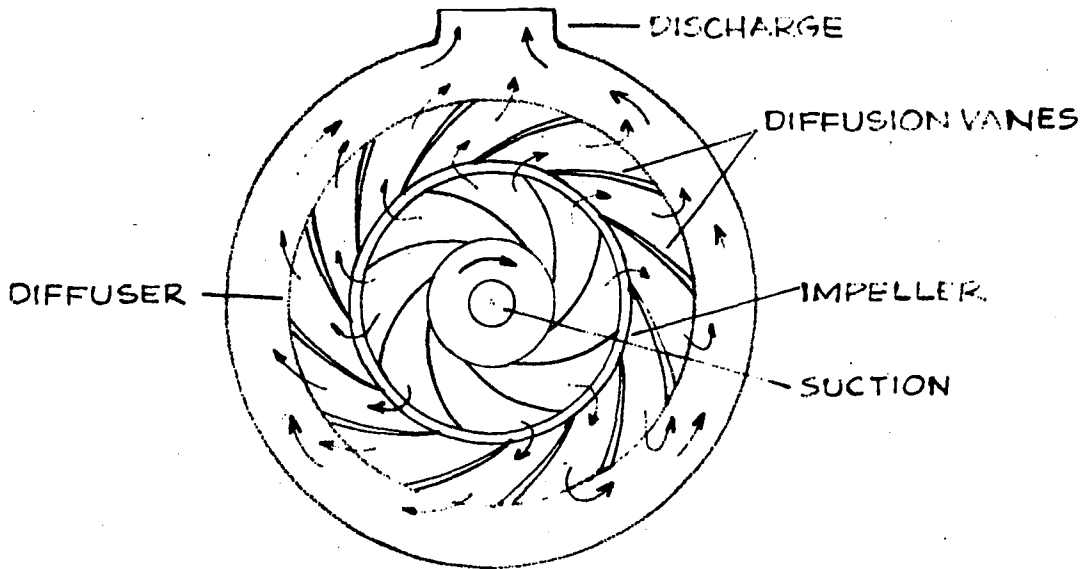


Fig. 8-2

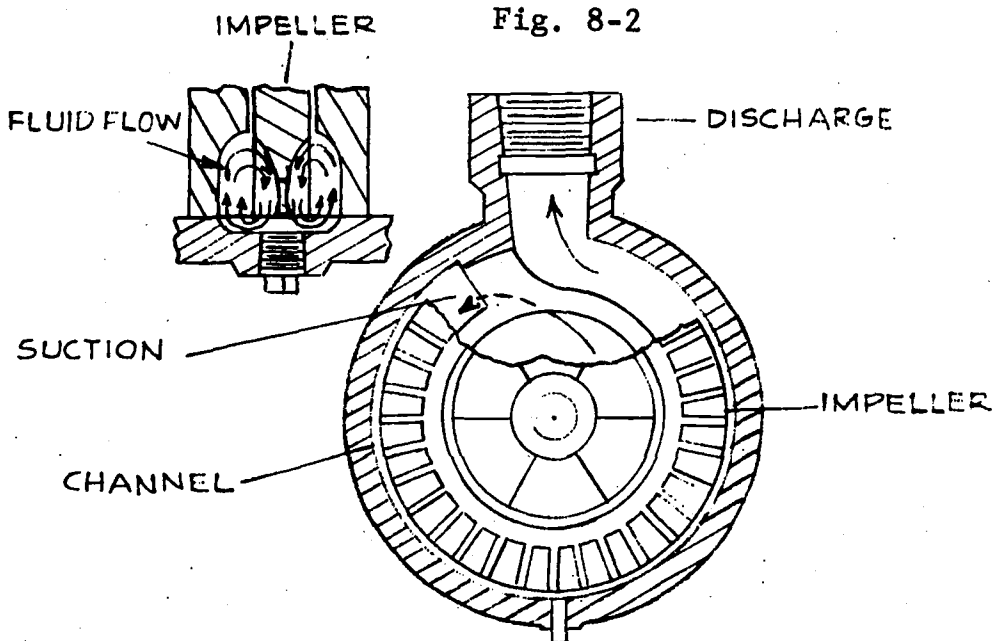
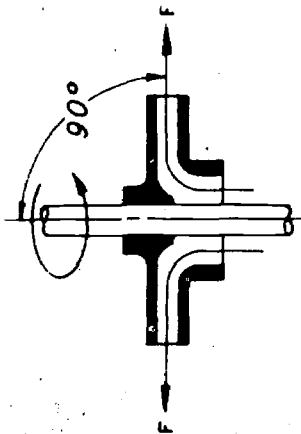


Fig. 8-3

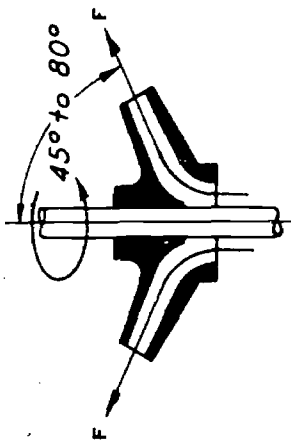
RADIAL FLOW



N_s range 500-3600

RADIAL FLOW In the radial flow pump, the liquid enters the pump in a plane parallel to the axis of rotation and discharges at 90° to it. The force or energy imparted to the liquid is virtually all centrifugal. Radial flow pumps are characterized (hydraulically) by relatively higher heads and lower capacities. Radial flow pumps normally operate at higher speeds, — up to 3600 rpm or greater. Specific speed range is from 500 to 3600.

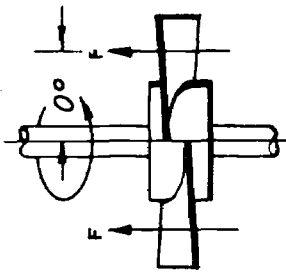
MIXED FLOW



N_s range 3600-8000

MIXED FLOW In the mixed flow pump, the liquid enters the pump in a plane parallel to the axis of rotation and is discharged from the impeller at an angle of from 40° to 80° from the axis. In this design the force or energy imparted to the liquid is a combination of centrifugal force and axial displacement. The hydraulic range of mixed flow pumps is from 10 to 150 feet head and the capacity range may be as high as 30,000 gpm or more. Normal operating speed range up to 1760 rpm, or higher. Specific speed range is from 3600 to 8000.

AXIAL FLOW



N_s range 8000-14000

AXIAL FLOW In the axial flow pump, the liquid enters and leaves the pump in a plane parallel to the axis or shaft. All the force or energy imparted to the liquid is displacement energy. There is virtually no centrifugal force imparted.

The hydraulic head range of axial flow pumps is from 1 or 2 feet to 20 feet, per stage, and the capacity range may be as high as a half million gpm. Normal operating speed range up to 1160 rpm or higher. Specific speed range is from 8000 to 14000.

Fig. 8-4

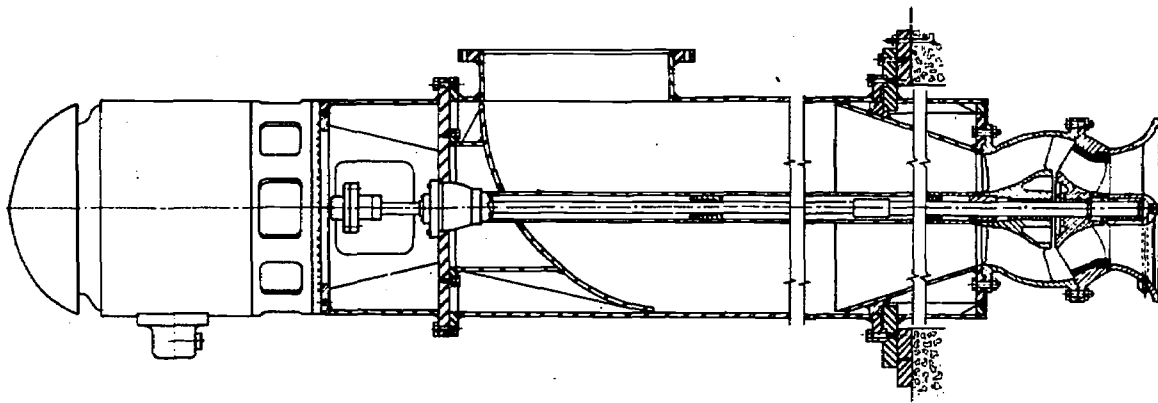
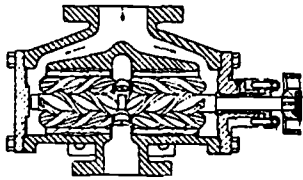
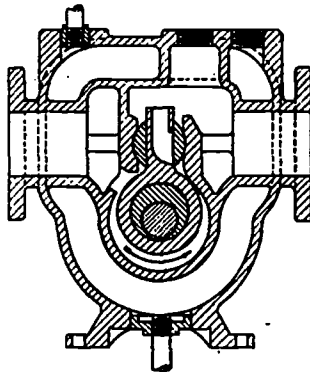


Fig. 8-5

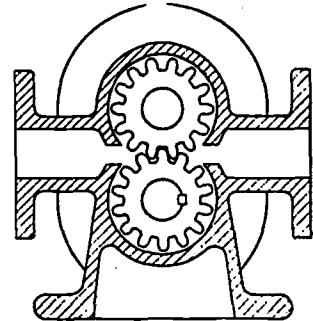
STANDARDS OF HYDRAULIC INSTITUTE
 ROTARY PUMP SECTION



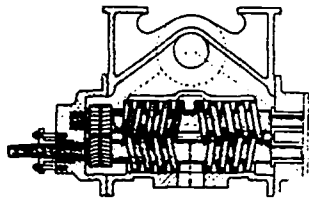
EXTERNAL SCREW TYPE



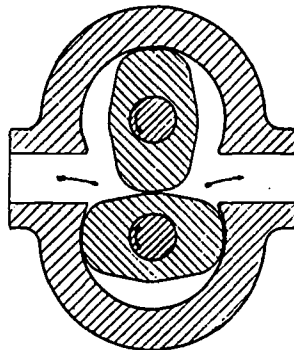
STEAM JACKETED
 CAM & PISTON TYPE



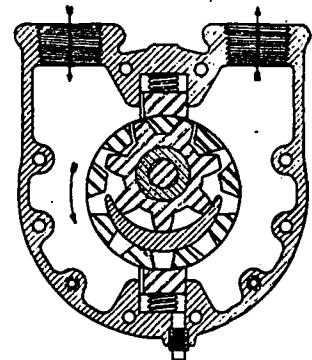
SPUR OR EXTERNAL
 GEAR TYPE



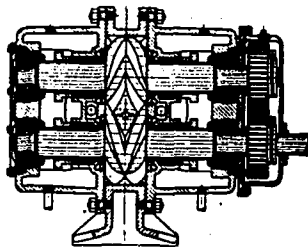
EXTERNAL SCREW TYPE



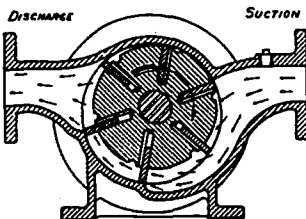
2 LOBE TYPE



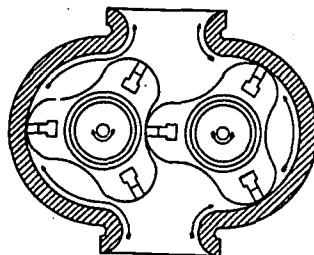
INTERNAL GEAR TYPE



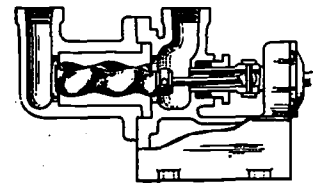
HELICAL GEAR TYPE



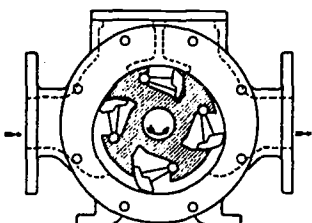
SLIDING VANE TYPE



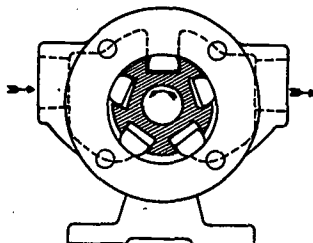
3 LOBE TYPE



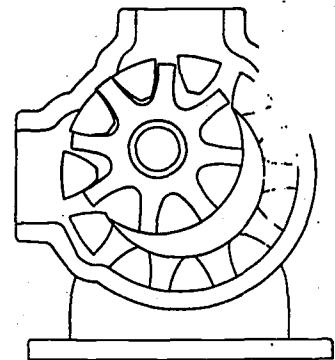
INTERNAL SCREW TYPE



SWINGING VANE TYPE



SPECIAL VANE TYPE



INTERNAL GEAR TYPE

Fig. 8-6 Reprinted from HYDRAULIC INSTITUTE
 STANDARDS, 12th Edition, Copyright
 1969, by Hydraulic Institute, 122
 East 42nd Street, New York, New York,
 10017.

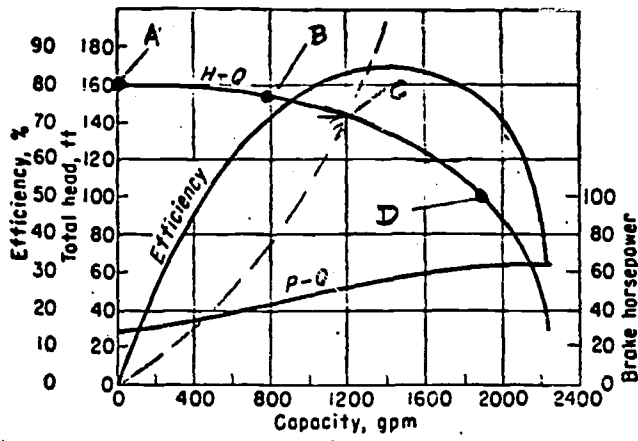


Fig. 8-7

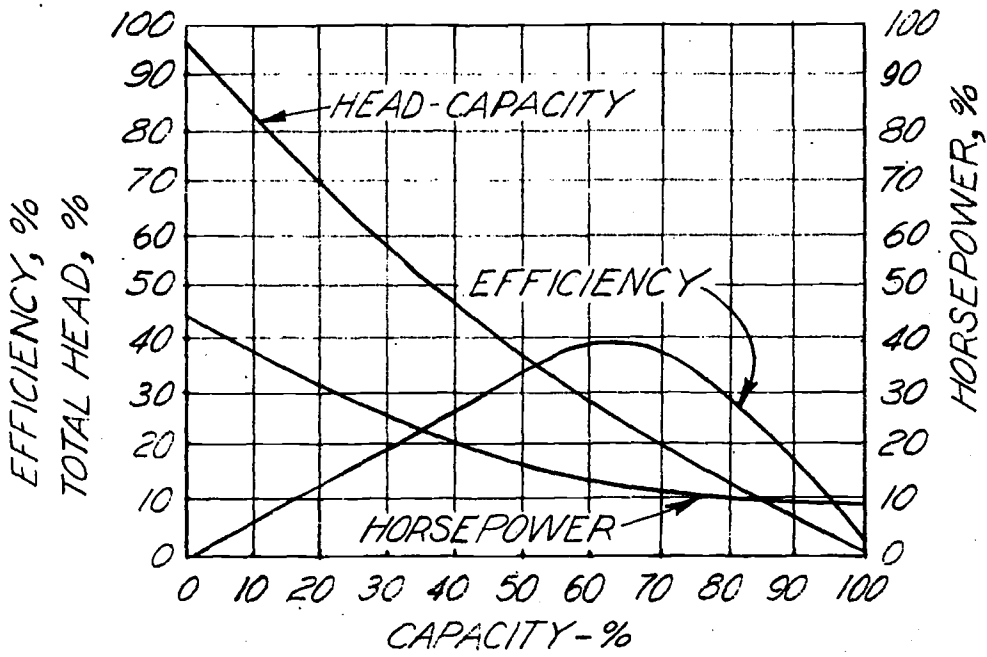


Fig. 8-8

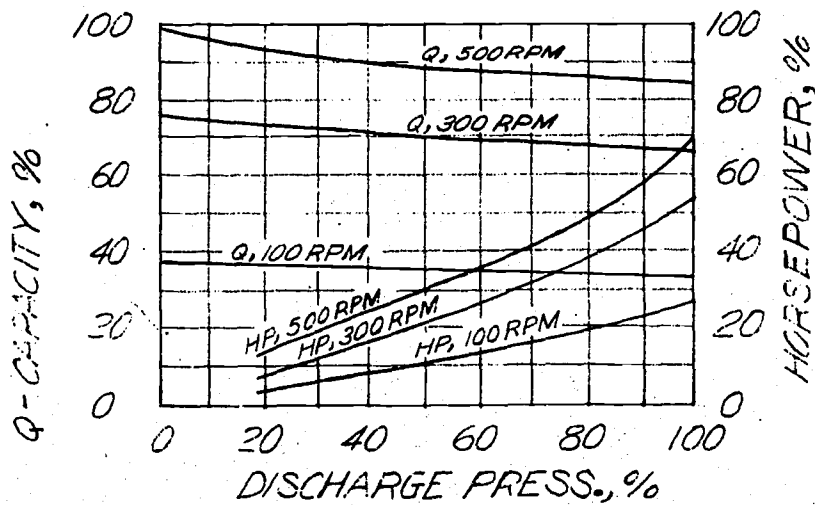


Fig. 8-9

life and increase their efficiency. Fig. 8-10 is a cross-section of a single stage volute centrifugal pump where the encircled Zone "A" shows where the impeller turns inside the casing. There, necessarily, must be a very small clearance between the two, otherwise the high pressure fluid would leak through to the low pressure side. When this clearance has increased past the allowable limit because of erosion, abrasion, etc, a new wearing ring (piece 7) can be installed, restoring the original close clearance. The impeller can also be furnished with wearing rings as shown in the enlarged detail. As shown in Fig. 8-10, many rows of packing are used at each end of the basing to prevent water from leaking out around the shaft. This arrangement is called a "stuffing box". A gland is drawn inward by bolts attached to the pump housing and compresses the packing to obtain the desired tightness around the shaft.

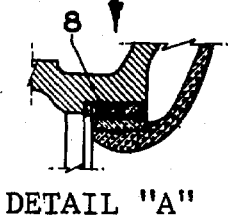
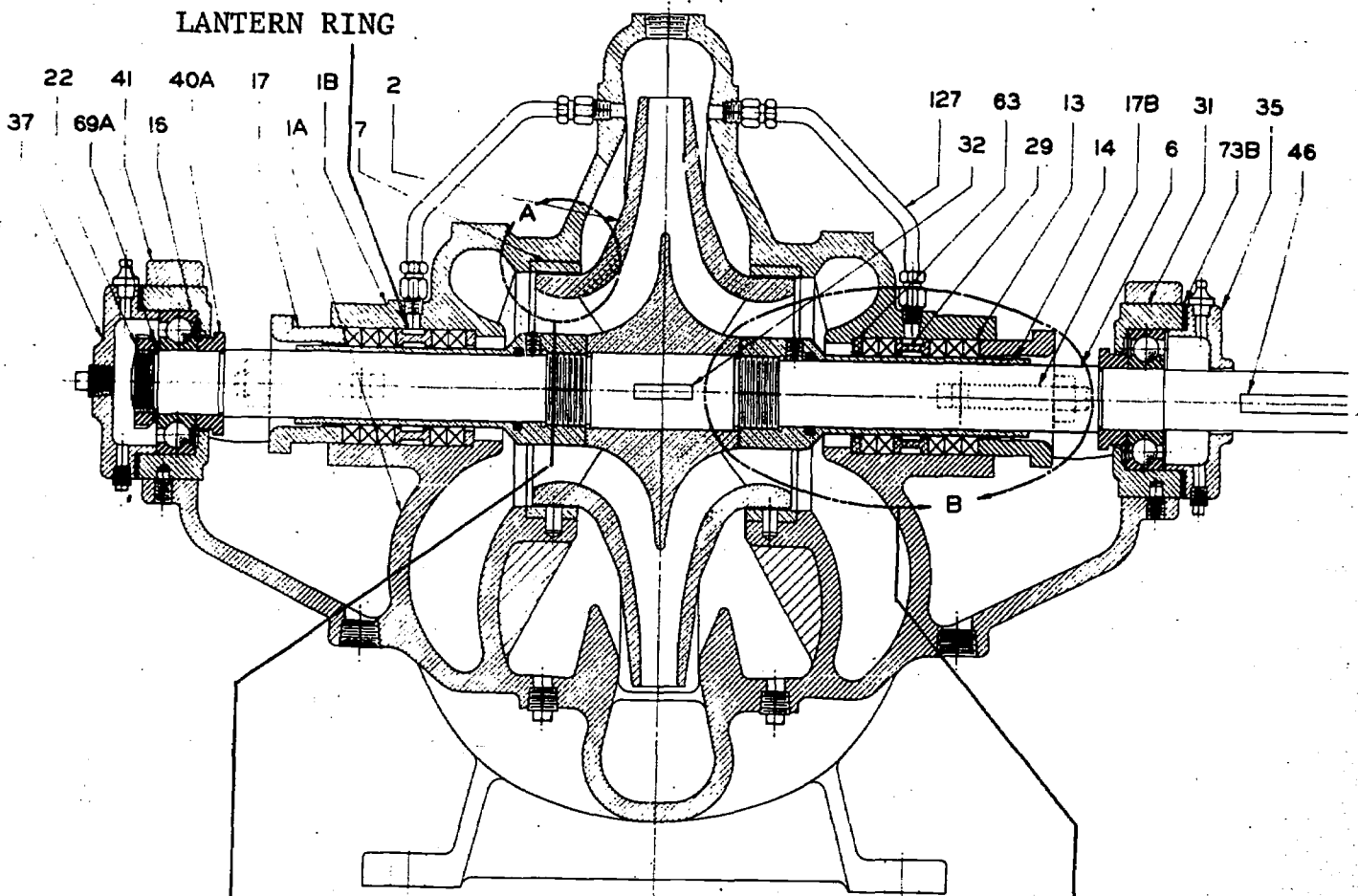
If the packing is tightened too much, it will cut grooves in the shaft, which causes more leakage as well as increasing the load on the motor. If not tightened sufficiently, leakage will be excessive, though some flow (40-60 drops/minute) is necessary to lubricate and cool the packing. Experience and skill on the part of the operator in choosing the proper packing and adjusting it is important. Replaceable sleeves over pump shafts are used to protect them from packing wear as well as general erosion and corrosion. The mechanical shaft seal (Fig. 8-10 (B)) is a popular type of seal that does not use soft packing or require any adjustment once installed. Basically, it consists of two smooth polished surfaces held against each other by compressed springs, forming a closely fitting interface. A small amount of moisture seeps in between the faces (one fixed, one rotating) which is needed to lubricate and cool the surfaces. A properly operating mechanical seal will not throw liquid while turning. Some of the materials used are monel, stainless steel, carbon, and porcelain, depending on the application. Mechanical seals are damaged by rust, mill scale or abrasive dirt usually encountered in new piping systems. They are also affected by the pH of the water. Packed seals and mechanical seals are easily distinguishable on a pump; the former has 2 stud bolts and the gland for "squeezing" the packing, whereas the mechanical seal has a solid plate around the shaft with cap screws which hold the seal in place.

If a pump is operating on a suction lift, water under pressure is injected into the stuffing box by means of lantern ring or water seal cage (Fig. 8-10) which seals the chamber and prevents air from leaking into the pump. There are also applications in heating systems where pumps handle water over 250° F where an outside source of cooling water is piped into the stuffing box, keeping the packing lubricated and cool. Fig. 8-11 shows enlarged details of a mechanical seal and a packed gland.

Pump Foundations

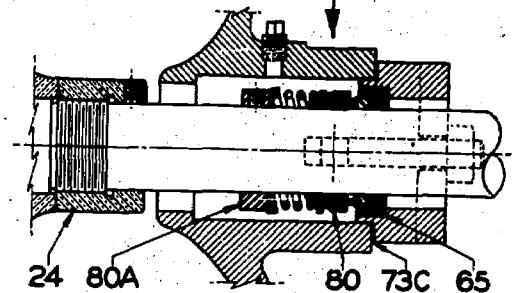
Pumps are usually set on concrete pads and bolted down by 1

LANTERN RING



Zone A—Alternate impeller ring subassembly

Zone B—Alternate mechanical shaft seal subassembly



DETAIL "B"

- 22 BEARING LOCKNUT
- 24 IMPELLER NUT
- 29 LANTERN RING
- 31 BEARING HOUSING
- 32 IMPELLER KEY
- 33 OUTBOARD BEARING HOUSING
- 35 BEARING COVER
- 37 OUTBOARD BEARING COVER
- 40A WATER DEFLECTOR
- 40B GREASE DEFLECTOR
- 41 BEARING CAP
- 46 COUPLING KEY
- 62 OIL THROWER

- 63 STUFFING BOX BUSHING
- 65 MECHANICAL SEAL STATIONARY ELEMENT
- 68 SHAFT COLLAR
- 69A BEARING LOCKWASHER
- 73A CASE GASKET (NOT SHOWN)
- 73B BEARING COVER GASKET
- 73C SEAL GLAND GASKET
- 80 MECHANICAL SEAL ROTATING ELEMENT
- 80A SET COLLAR (MECHANICAL SEAL)
- 107A OIL SEAL
- 125 OIL CUP (CONSTANT LEVEL OILER)
- 127 SEAL PIPING

- 1A LOWER CASING
- 1B UPPER CASING
- 2 IMPELLER
- 6 SHAFT
- 7 CASING RING
- 8 IMPELLER RING
- 13 PACKING
- 14 SHAFT SLEEVE
- 16 BEARING
- 17 GLAND
- 17B GLAND BOLT
- 18 OUTBOARD BEARING
- 20 SHAFT SLEEVE NUT

Fig. 8-10

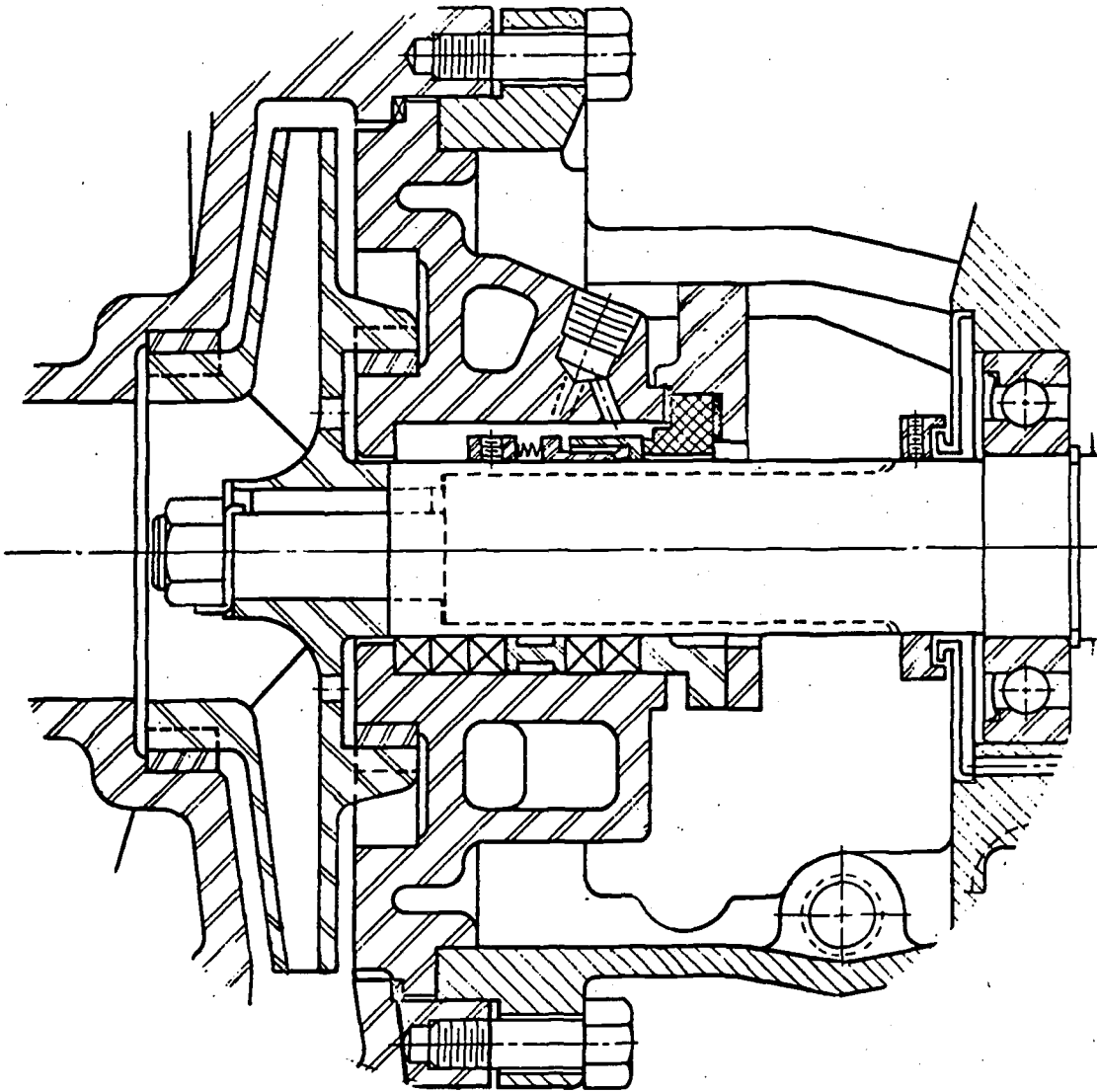


Fig. 8-11

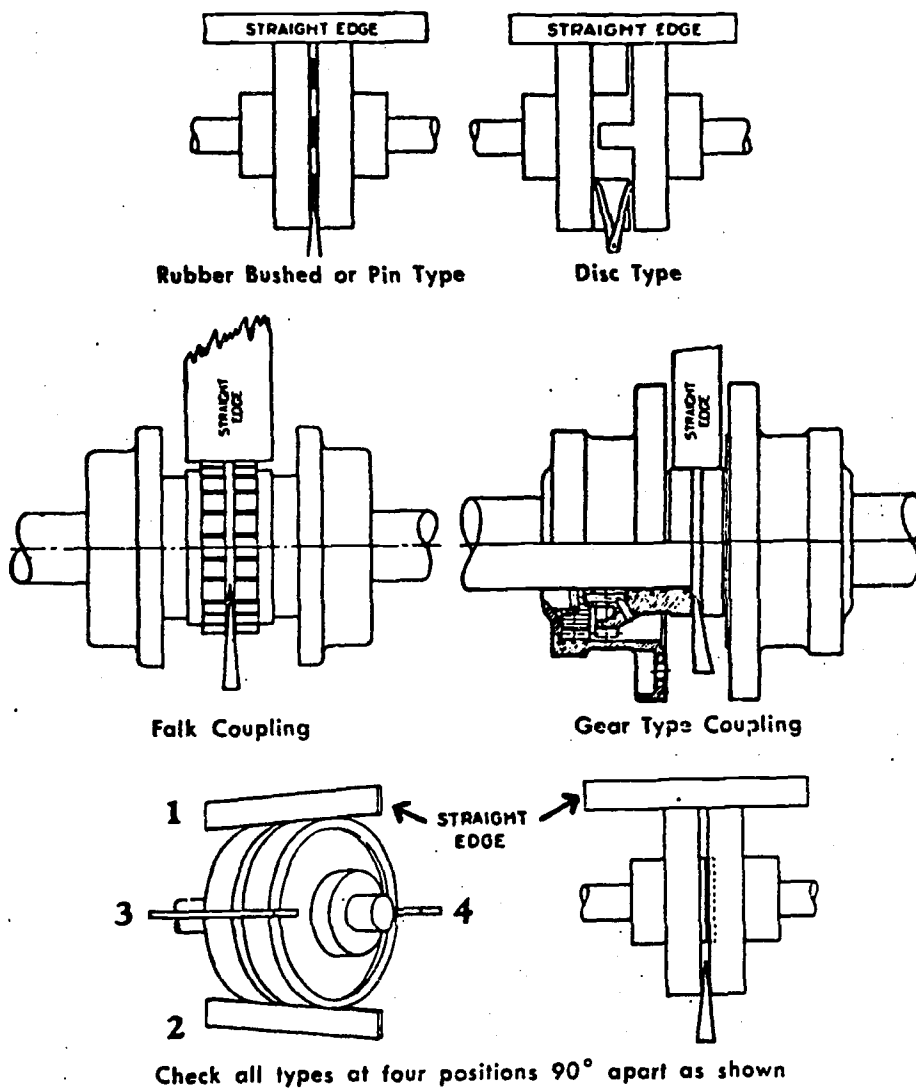
shaped anchors. These are set inside pipe sleeves placed in the pad form prior to being filled with concrete. Separated pumps and motor units are mounted on a cast iron or structural steel bed plate designed to be filled with grout, introduced through large grout holes. This base is set on wedges high enough to permit a grout base of 1" to 2" thick and bolted to the pad. With the flexible coupling in the drive shaft disconnected, the pump is connected to its piping, then the motor is positioned so that the flexible coupling is aligned. A form is then placed around the pump base to retain the soft grout which is a non-shrinking type and is pumped in and rodded to fill all voids. Before the grout has completely hardened, the form is removed and the wedges dug out sufficiently for later removal. After the pump has operated at its normal temperature, final alignment is checked again and the pump and motor doweled in place. This is the procedure recommended by the Hydraulic Standards Institute, but the manufacturer's instructions should be followed in case of conflict.

Piping Connections

One of the biggest factors in the performance of a pumping system is the manner in which the pump suction and discharge piping has been designed and installed. A single line drawing or a schematic diagram of the piping layout sometimes leaves considerable latitude and judgement up to the installer, which can lead to problems if certain principles are not observed.

As with fans, the suction piping to pumps is critical not only from the standpoint of striving for non-turbulent flow at the inlet but also keeping the suction free of air or other vapors. Since the suction piping size is usually 1 or 2 sizes greater (and never smaller) than the pump connection, a reducer is necessary. Connections using a reducing tee or concentric reducer similar to Figs. 8-13 and 8-14, will form air pockets and cause the pump to lose its prime, and also act to reduce the effective cross sectional area of the pipe. Figs. 8-15 and 8-16 show the recommended connections using eccentric reducers. Also, if the suction line is generally horizontal, it should slope upwards to the pump and not have a high point or hump between the source and the pump. In order to avoid a turbulent flow of the fluid at the pump inlet, a connection using a long radius elbow (rather than a short radius) in the vertical plane is the preferred method (Fig. 8-17). Suction piping led into the pump in the horizontal plane should also have the long radius elbow and a straightening section at least 2 diameters long to straighten out the streamline, Fig. 8-18). This is particularly important for double suction pumps, to assure equal flow to both sides of the impeller and equal loads on the thrust bearings. Fig. 8-19 depicts an incorrect arrangement.

The pump suction inlets in basins or sumps, as in cooling towers or hot wells, are critical regarding the shape of the inlet and the location with respect to the bottom and walls of the sump.



COUPLING ALIGNMENT

Fig. 8-12

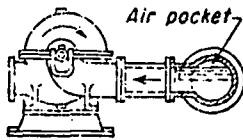


Fig. 8-13

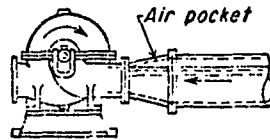


Fig. 8-14

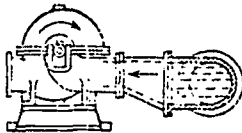


Fig. 8-15

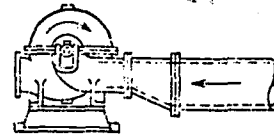


Fig. 8-16

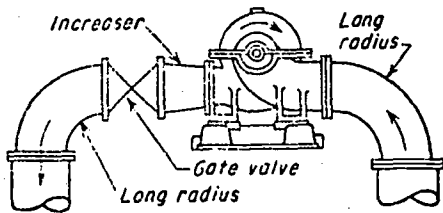


Fig. 8-17

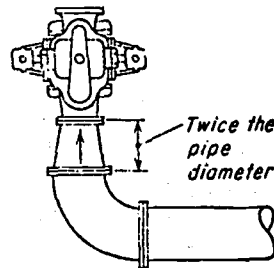


Fig. 8-18

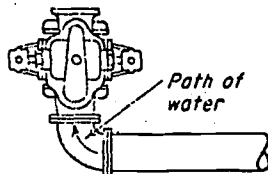


Fig. 8-19

Reprinted from HYDRAULIC INSTITUTE STANDARDS, 12th Edition, Copyright 1969, by Hydraulic Institute, 122 East 42nd Street, New York, New York, 10017.

Other factors are the proximity of multiple suction lines and the velocity and direction of the incoming water supplying the sump. The submerged intake should be fitted with a bell-mouthed inlet to reduce the intake suction loss and provide a full cross-sectional area flow of water to the impeller inlet. It has been found that disturbing vortices and eddy currents around the suction pipe inlet can be avoided by proper design of the sump enclosure, and by holding the height of the intake bell within certain limits. Fig. 8-20 shows a design for a single pump suction. The height of the bell intake is the most critical ($1/2$ to $1/3$ of the diameter); a higher location will reduce pump efficiency. The Hydraulic Institute Standards (Fig. 8-22) shows recommended sump arrangements as well as designs not recommended.

The size of the suction and discharge piping is not necessarily the size of the pump connections; in fact, it is usually 1 or 2 pipe sizes larger. However, the valves, strainers and fittings directly connected to the pump may be either size, so the piping drawing should be very carefully checked. The designer may specify the valves and fittings to be the same size as the pump connections for reasons of economy; in which case the assembly should be closed coupled and compact, without unnecessarily long runs of connecting piping in between components, which add considerably to the friction loss. If an increaser is shown directly at the pump suction and discharge, the valves and fittings are intended to be full line size. As stated before, the suction piping should be connected to the pump with a long radius elbow with at least 2 diameters of straight pipe in between. Never use the outlet of a tee instead of an elbow for the direction change. Pressure gage connections must be made somewhere between the pump connections and the first valve, on suction and discharge. Do not use the air vent connection on top of the volute casing, nor any of the various plugged connections sometimes found around the volute. Some manufacturers provide gage connections directly on the suction and discharge nozzles of the pump, which are satisfactory. Provide gage shut-off valves and syphons for hot water service, and make sure the gage can be screwed off and on without interference. A small receptor is provided under packed stuffing boxes and mechanical seals, tapped for a small pipe to drain off leakage to a hopper drain, and a similar tapping will be found on pump bed plates to drain any drips or spills. In making up the pipe connections, sufficient flanges or unions should be provided for dismantling the piping in order to remove the pump head for repairs. Some close-coupled pumps are designed for withdrawing the impeller and pump base from the rear of the casing, leaving all piping undisturbed. It is imperative that the suction and discharge piping be supported and anchored in such a way as to not impose any loads on the pump casing from dead weight or expansion of piping. A downward thrust on the end of a close-coupled pump causes the shaft and housing to deflect and can cause bearing problems.

Probably the worst thing that happens to a new pump is running dirty water through it at the initial start up and operation.

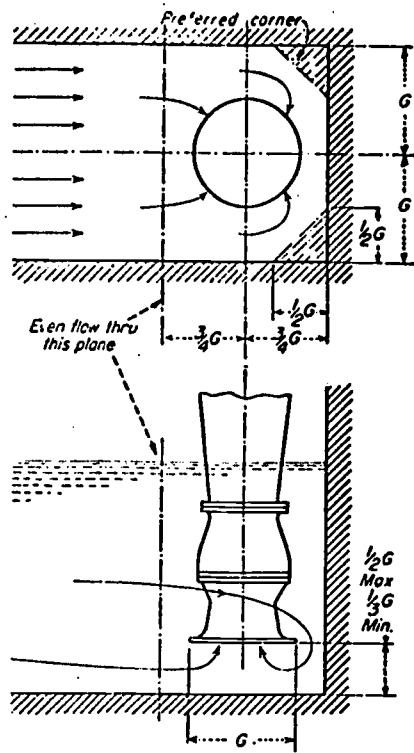


Fig. 8-20

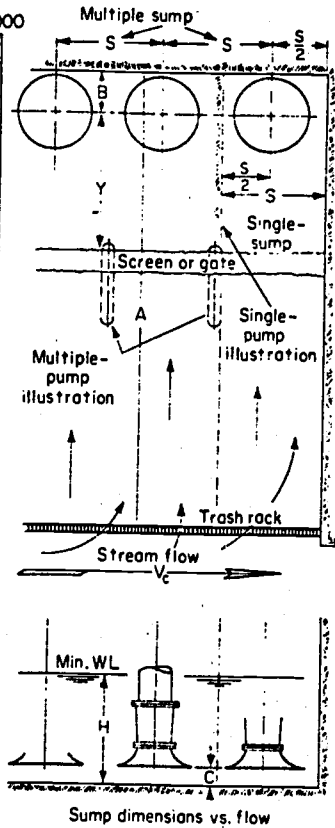
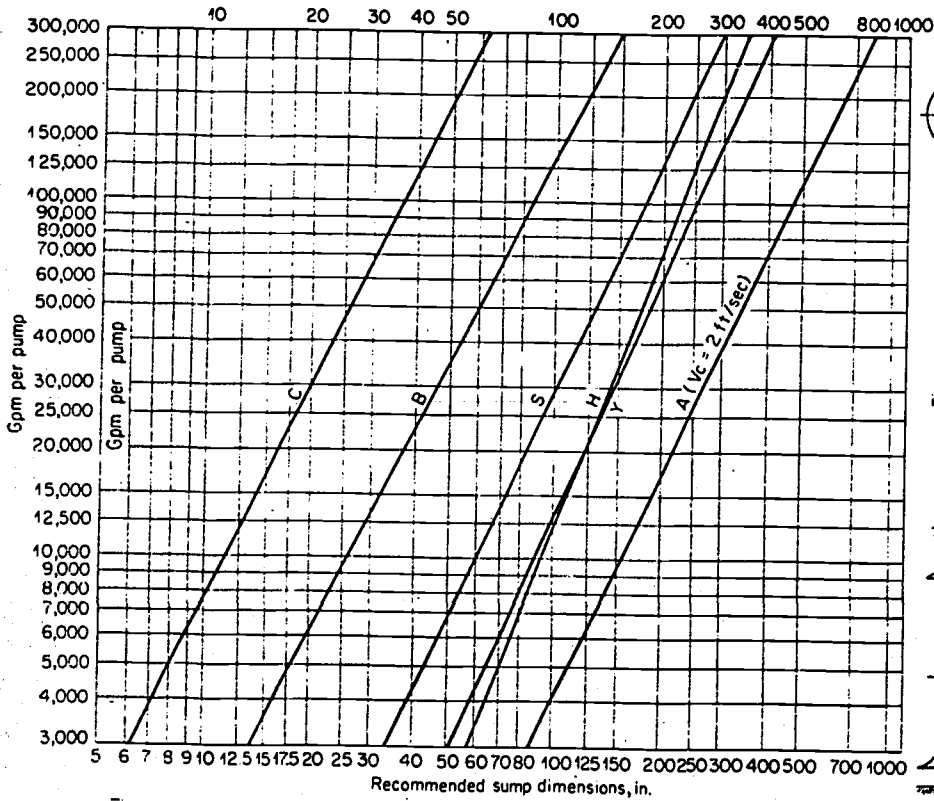
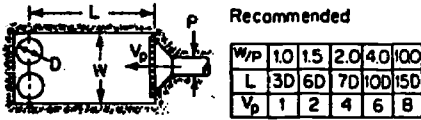
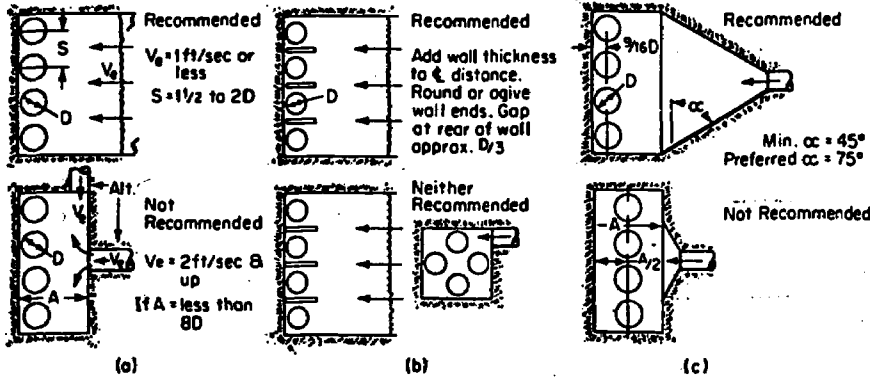


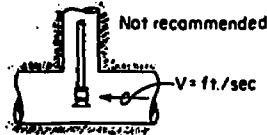
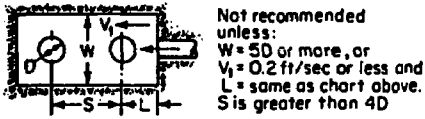
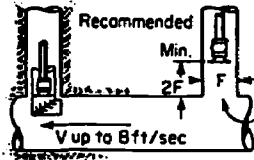
Fig. 8-21

Reprinted from HYDRAULIC INSTITUTE STANDARDS, 12th Edition, Copyright 1969, by Hydraulic Institute, 122 East 42nd Street, New York, New York, 10017.

MULTIPLE PUMP PITS

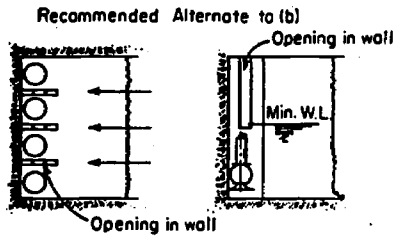


Baffles, grating or strainer should be introduced across inlet channel at beginning of maximum width section



(d)

(e)



(f)

NOTE: Figures apply to sumps for clear liquid. For fluid-solids mixtures refer to the pump manufacturer.

Hydraulic Institute Standards show recommended sump arrangements as well as arrangements that are specifically not recommended. (Hydraulic Institute.)

Fig. 8-22

Reprinted from HYDRAULIC INSTITUTE STANDARDS, 12th Edition, Copyright 1969, by Hydraulic Institute, 122 East 42nd Street, New York, New York, 10017.

Welding slag, rust, mill scale and construction dirt must be removed from the system before the pump is turned over, or damage to the shaft seals and pump internal parts is inevitable. Chemical cleaning of piping (see Section on Piping) will remove such things as mill scale and rust, but diligence on the part of the inspector will prevent sand, pebbles, slag, etc, from being left in the piping at the time of installation.

Testing Pump Performance

It is necessary to find out how much fluid the pump is delivering in order to evaluate the performance of the entire heating and ventilating system. The pump is the "prime mover" of a hot water or chilled water system and the various heat exchangers and coils cannot be expected to produce the desired heat transfer if insufficient water is being circulated. Over-pumping at excessive rates also occur if the head calculations are off, and this can cause noisy operation, premature heat exchanger failures and uneconomical operation. The following data, used with the pump manufacturer's pump curve, is needed to make a field test:

1. Pump head, in feet of water.
2. Flow through the pump, gallons per minute.
3. Motor load, brake horsepower.
4. Pump speed, rpm.

Pump head is found by installing accurate gages on the pump at locations described in "Piping Connections". If the pump suction operates at a vacuum, a compound gage will be necessary. The gages selected should have a range such that the pressure reading will be approximately at mid-scale. The total head produced by the pump may be taken as the difference of the two pressure gage readings.

Gallons per minute is found from flow meters or displacement meters if installed as part of the piping system. If not, the velocity can be measured with a Collin's gage tube which works on the same principle of the Pitot tube. Provision must be made in the piping downstream of the pump for inserting the tube. If none of the above methods are available, the pump curve may be used, entering it with the head and brake horsepower.

Brake horsepower can be estimated from the formula shown on page 97 in the section on Fans.

Pump speed is taken with a revolution center or tachometer.

For direct drive pumps, the motor speed can be taken at the motor end of the shaft, and should be within 5 or 10 rpm of the figure shown on the pump curve or data sheet.

A "fix" on the gpm may now be made by plotting the "head" and "brake horsepower" on the appropriate curves (see Fig. 8-23). If the two indicate the same gpm within a reasonable limit, this may be taken as the estimated flow point (H & BH). If there is a wide disagreement, check the "shut-off" head (for centrifugal pumps only) by slowly closing the discharge valve with the pump running, and read the total heads and horsepower load. If the head is substantially lower or higher than the curve at zero flow, the pump should be checked further. Additional points may be obtained by opening the discharge valve in increments and plotting a test curve for H vs flow and brake horsepower if a flowmeter or other volume measuring device is available. The direction of rotation may be wrong, or the wrong diameter of impeller may be installed. The pump may be air-bound, or the impeller may be on backwards (double suction type). Inordinately high heads and low horsepower requirements indicate unaccounted-for friction losses. Low head and maximum horsepower requirements indicate that the pump is working against a lower head than anticipated. Excessive flows can damage the pump in time, as well as cause the other undesirable effects discussed above. The pump's performance curve can be altered by increasing or decreasing the impeller diameter within certain limits, and this is preferred to throttling the discharge to reduce excessive flow. This change should be made only by the manufacturer.

There is a popular misconception that closing the discharge valve of a centrifugal pump completely while the pump is running will build up a dangerously high pressure in the casing and break it. It can be seen from Fig. 8-23 that at no-flow conditions, i.e., with the discharge valve closed, the pressure will build up to the shut-off figure shown and go no higher. However, the heat caused by the impeller churning the fluid will build up in time sufficiently to cause damage to the impeller. Where pumps are required to run at near-shut-off conditions due to control processes, a bleed line is installed to permit a flow through the pump sufficient to keep it cool.

It must also be recognized that the shut-off head adds to the static pressure imposed on the pump by the system it serves and that the pump casing and seals must be designed for the total of these two heads.

Fig. 8-24 shows the form in which pump curves appear in manufacturers' catalogs. For a given size pump, a family of curves for different diameter impellers are shown, and the horsepower requirements and efficiencies are also given for the entire size range.

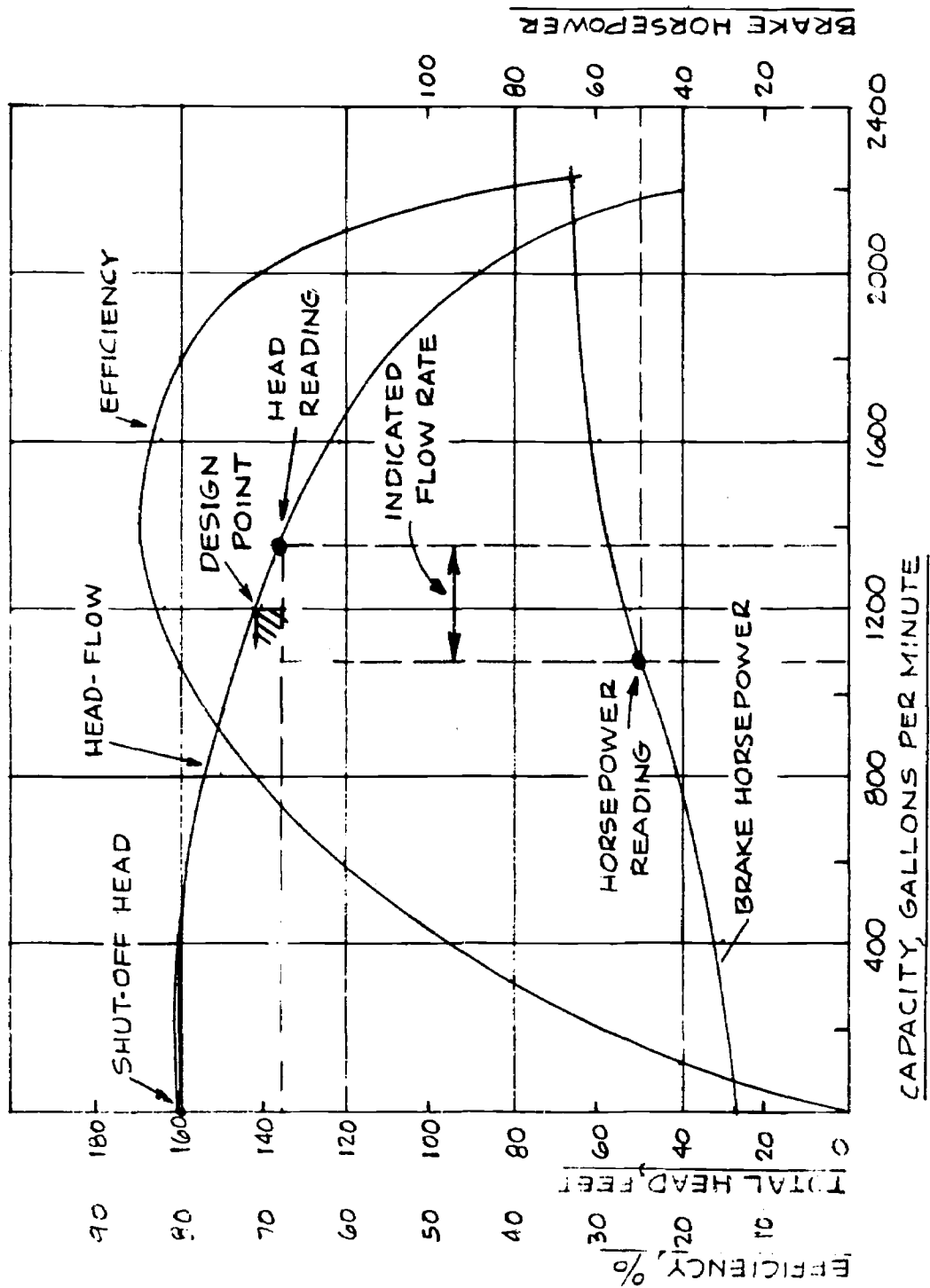
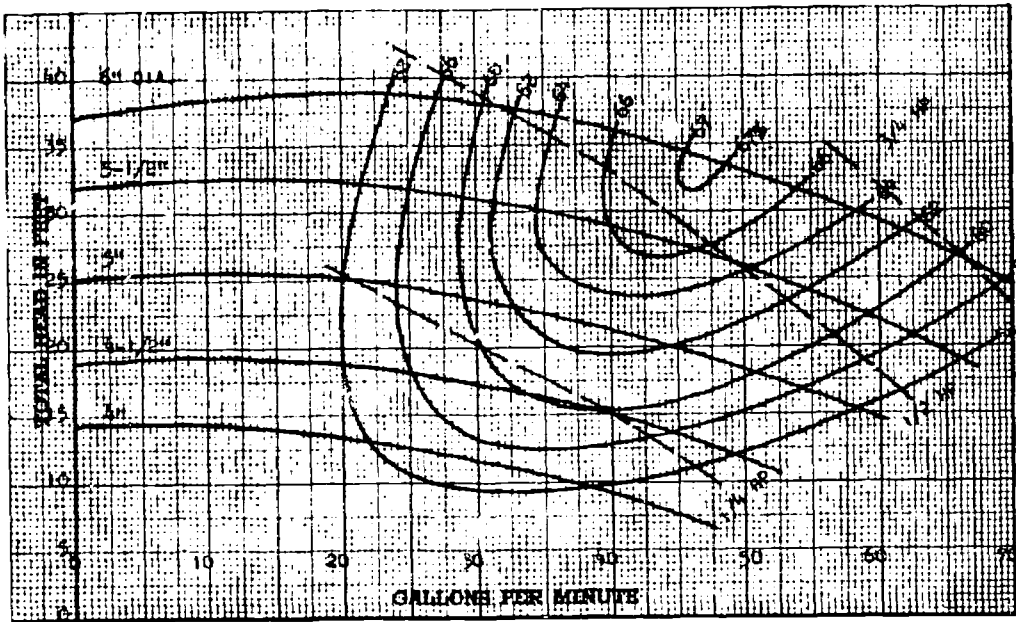
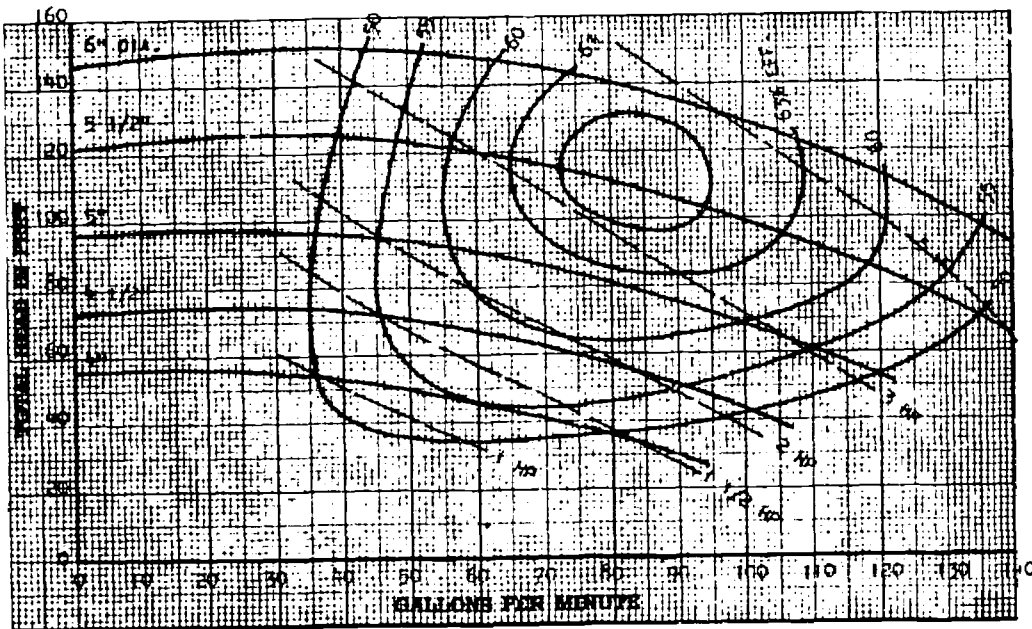


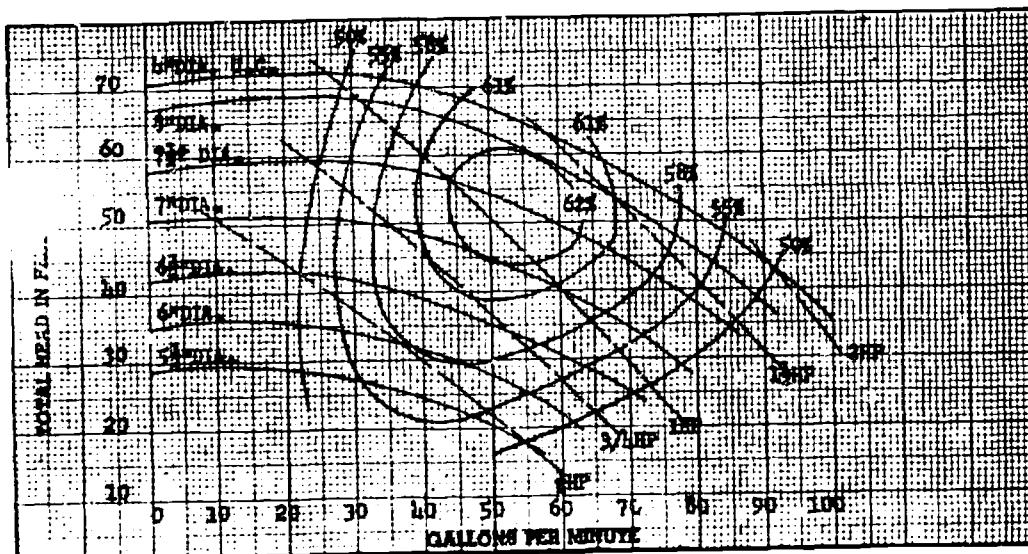
Fig. 8-23



SIZE
 1x2x6
 1750 RPM
 TYPE
 PE, PE-S, PB
 & PB-S
 CURVE NO
 2877435
 IMPELLER NO
 V1731B



SIZE
 1x2x6
 3450 RPM
 TYPE
 PE, PE-S, PB
 & PB-S
 CURVE NO
 2880713
 IMPELLER NO
 V1731B



SIZE
 1x2x8
 1750 RPM
 TYPE
 PE, PE-S, PB
 & PB-S
 CURVE NO
 R1390
 IMPELLER NO
 V1728B

Fig. 8-24



The pump affinity laws are similar to the fan laws:

$$\frac{\text{gpm}_2}{\text{gpm}_1} = \frac{\text{rpm}_2}{\text{rpm}_1}$$

H = head, ft
rpm = revs per minute
gpm = gallons per minute

$$\frac{H_2}{H_1} = \left(\frac{\text{rpm}_2}{\text{rpm}_1} \right)^2$$

$$\frac{\text{bhp}_2}{\text{bhp}_1} = \left(\frac{\text{rpm}_2}{\text{rpm}_1} \right)^3$$

Bibliography

Footnote 1. FMC Corporation, Pump Division,
Indianapolis/Los Angeles, U.S.A.

Pump Check-Points

Verify that:

1. Pumps with separate drives are aligned by a millwright or manufacturer's representative.
2. Pumps are never operated without casing being full of water.
3. Pumps are rotating in the correct direction.
4. The nameplate data corresponds with the submittal and the pump curve data sheet.
5. The seal is packed or mechanical, whichever is specified.
6. Provision is made for draining the bed plate.
7. Proper vibration mounts are installed if specified.
8. Suction and discharge piping is installed in accordance with "good" practice as discussed in this section.
9. If furnished with a packed gland, the nut is loose enough to permit a slight leakage.
10. Water moves through the pump at all times it is operating.
11. Pump operates quietly. A hard, metallic rattling noise indicates a cavitating condition, which, if allowed to continue, will ruin the impeller.
12. The flexible coupling operates quietly; if not, misalignment is indicated.
13. The suction line will always be full of water (for centrifugal pumps).
14. The piping system is free of dirt, slag and scale, before operating the pump.
15. Clean water from an external source (at a higher pressure than the pump discharge) is connected to the sealing connection, if furnished.
16. No moisture other than a negligible weep appears around the mechanical seal when operating.
17. That the piping does not place any strain on the pump by first heating the pipe to its normal operating temperature and disconnecting the piping connections. If the pipe springs away from the normal pump position, it is exerting an unacceptable force on the pump.

3. REFRIGERATION

The Basic Cycle

The reciprocating compression type will be used to illustrate the basic cycle. The major components are shown schematically in Fig. 9-1.

When a liquid boils, it removes heat from its surroundings and becomes a gas. Conversely, when it is liquified by being subjected to pressure and placed in contact with a cool surface, it surrenders this same heat. Liquified substances boil at different temperatures; water boils at 212° F at atmospheric pressure, while freon-12, a commonly used refrigerant, boils at -21.6° F. At room temperature, say 72°, it must be maintained at 73 psig to prevent it from boiling away.

In Fig. 9-1, the compressor maintains a discharge pressure of 93.3 psi (for example) which is the system pressure up to the expansion valve. While the compressor is operating, it pumps refrigerant in the hot gas state through the condenser where its latent heat and the heat of compression is removed by the cooling water, and the refrigerant condenses into the liquid state and is collected in the receiver. The liquid freon fills the pipe up to the expansion valve, which is closed or partly open, depending on the demand for cooling. The thermostatic expansion valve is an automatic throttling device controlled by the pressure and temperature, and separates the "high" side described above from the "low" side, on the suction side of the compressor. As the refrigerant enters this low pressure side it starts to boil and draw heat from the evaporator surfaces until it is completely vaporized. The cold vapor is then drawn into the compressor and compressed to 93.3 psig, completing the cycle. To prevent any return of liquid refrigerant to the compressor and causing damage, the expansion valve shown has a bulb clamped to the suction line that senses any of the colder unevaporated liquid and closes the valve. As a further safeguard, the valve is adjusted to allow the port to open only when the gas has been superheated, generally 10° F. Fig. 9-2 shows such a thermostatic expansion valve. Refer to the appendix for further information regarding expansion valves.

Rating

Refrigeration machinery is rated in btu per hour cooling produced at an evaporator temperature of 5° F and a condensing temperature of 86° F. The rating is also expressed in tons, where 1 ton = 12,000 btu per hour. (The use of the ton unit has its origin from the cooling produced by one ton of ice in one day's time. One pound of ice will produce 144 btu when melted, hence 144 btu x 2000 lbs/ton ÷ 24 hours = 12,000 btu per hour).

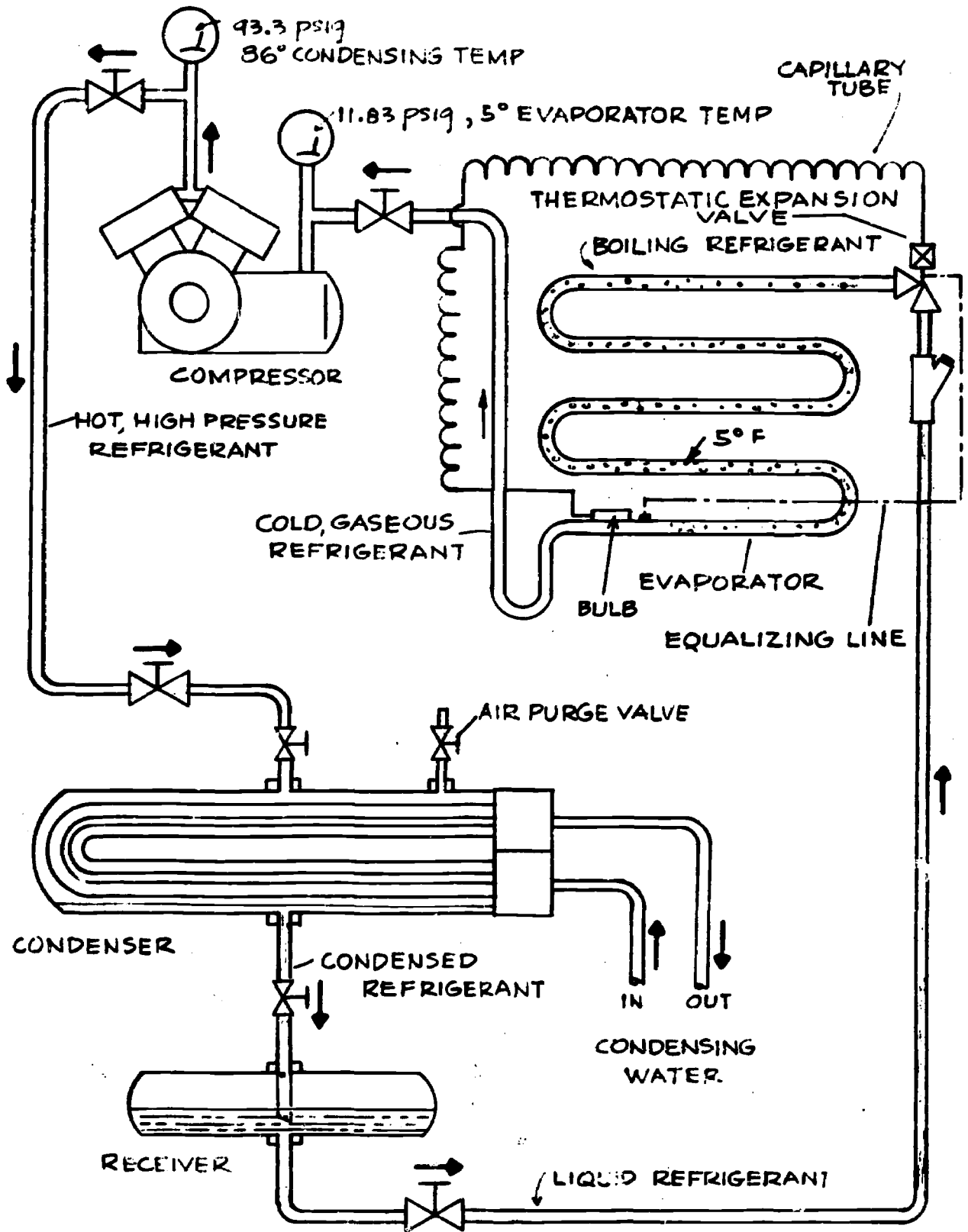


Fig. 9-1

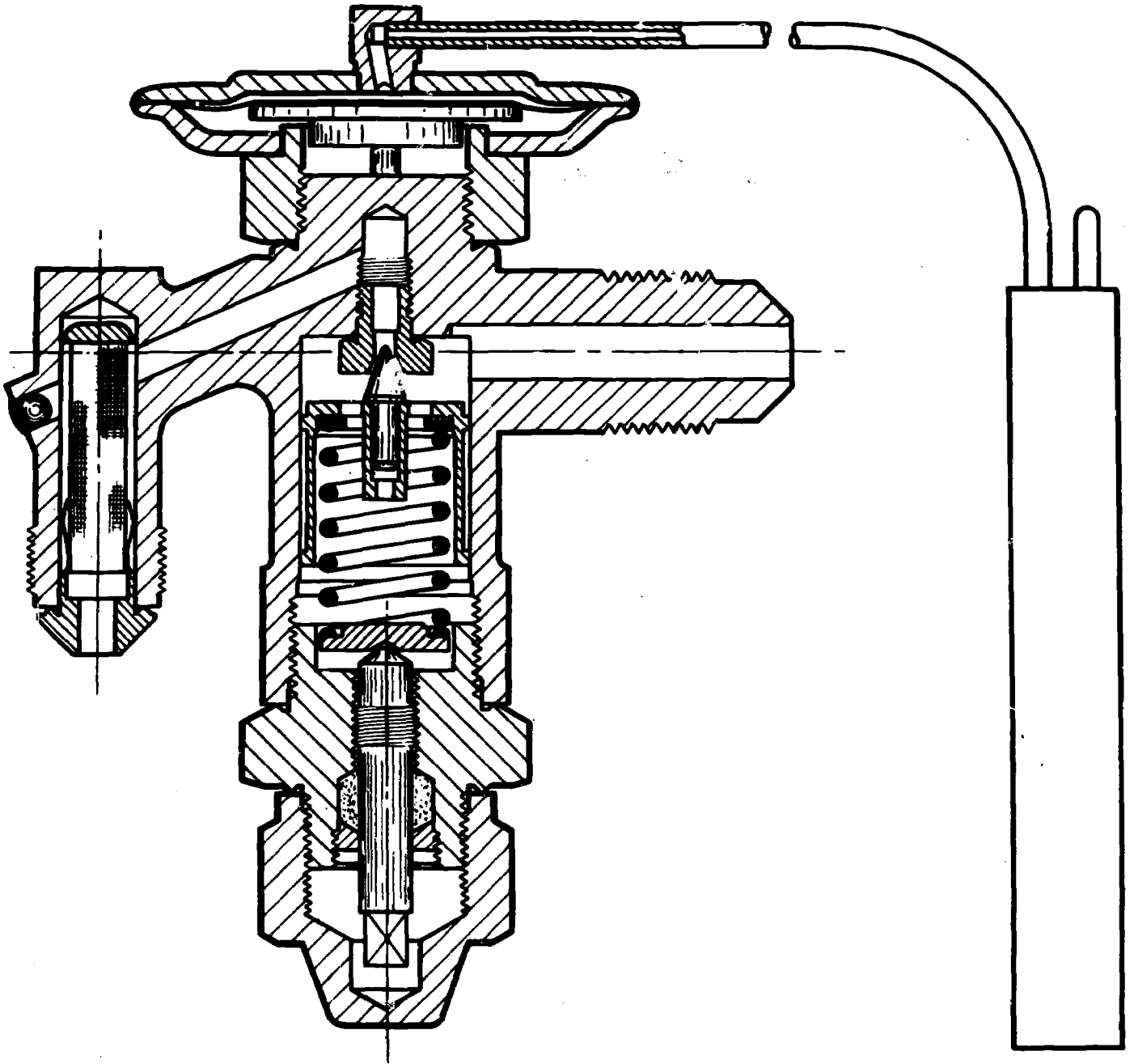


Fig. 9-9

Compressor Types

Refrigeration compressors are manufactured in open and hermetic styles in both the reciprocating and centrifugal designs. (See Figs. 9-3 to 9-6). The open compressor has an external drive. The hermetic compressor has the motor and compressor contained in a single housing. The range of sizes for the different types are approximately as follows:

<u>Style</u>	<u>Ton</u>
Hermetic reciprocating	2-120
Open reciprocating	5-200
Hermetic centrifugal	90-5,000
Open centrifugal	100-10,000

A comparative recent development is the helical rotary screw compressor, with capacities up to 800 tons (Fig. 9-5).

Condensers

The basic types of condensers are :

- a. Water cooled
- b. Air cooled
- c. Evaporative

Water cooled condensers are shell and tube heat exchangers. The not refrigerant gas is introduced into the top of the shell and is condensed on the colder tubes, then drains into a receiver below the condenser. A "purge" valve is provided to manually bleed off air that may collect at the top of the shell. The tubes may be U shaped as shown, or straight, with a rear tube sheet (see Section 6). Condensing temperatures range from 100° - 110° F for recirculated water.

Air cooled condensers utilize finned coils and outside air forced at a high velocity over the coils to carry away the heat. Condensing temperatures range from 110° F to 135° F in hot weather.

Evaporative condensers use a coil sprayed with water to remove the heat by evaporation of water. The vapor formed is carried away by the circulating fan. The remaining water is recirculated and a certain amount of make up is added to replace the part evaporated. The condensing temperatures are in the range of 100° - 115° F.

Receivers are used to allow for surges in the flow of refrigerant as the demand for cooling fluctuates. They also serve as storage

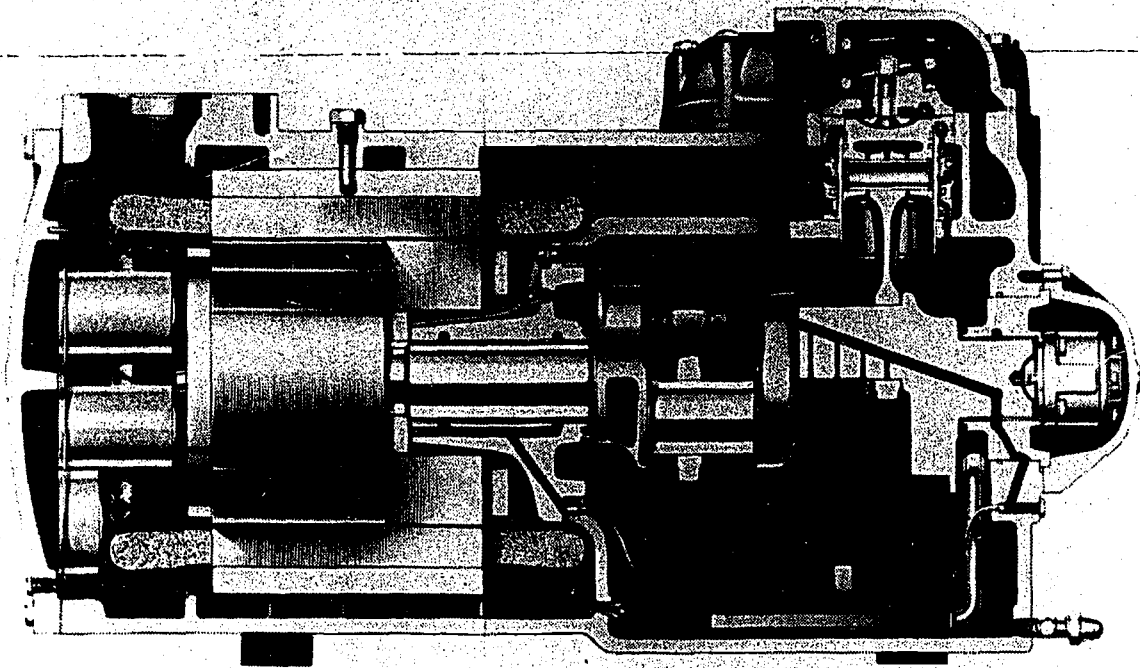


Fig. 9-3-(a) HERMETIC RECIPROCATING COMPRESSOR

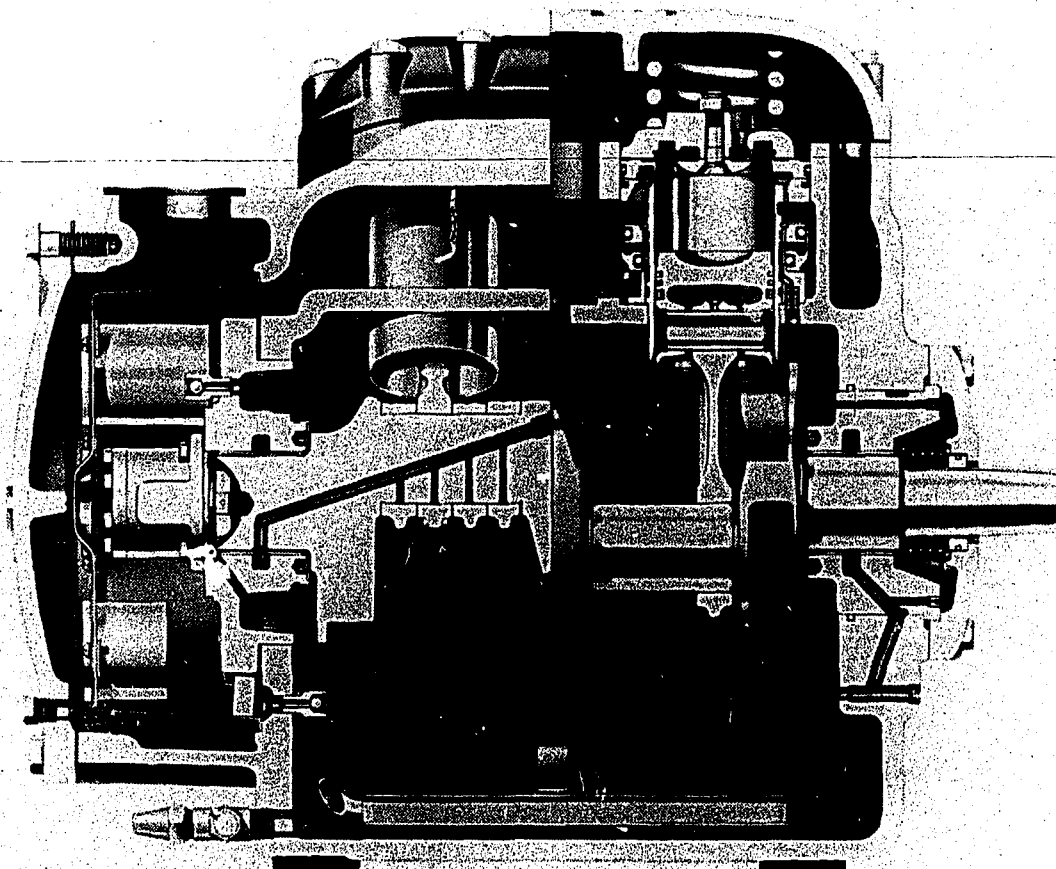


Fig. 9-3-(b) OPEN RECIPROCATING COMPRESSOR

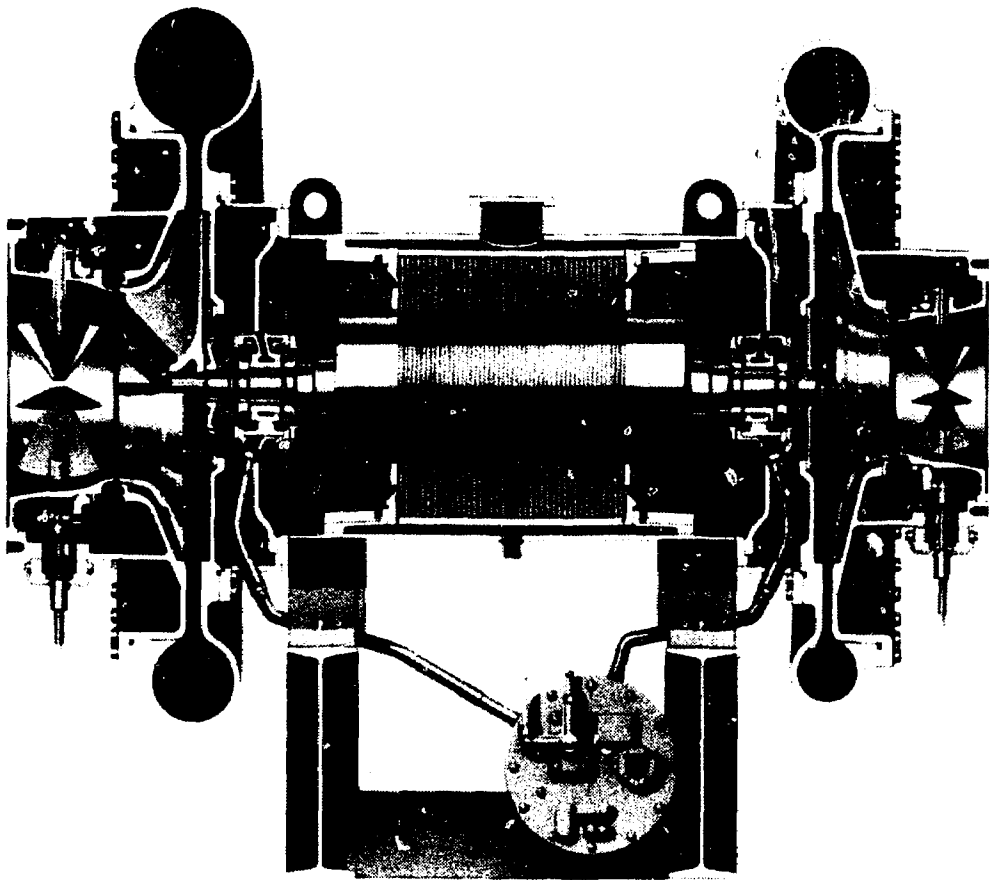


Fig. 9-4-(a) HERMETIC CENTRIFUGAL COMPRESSOR

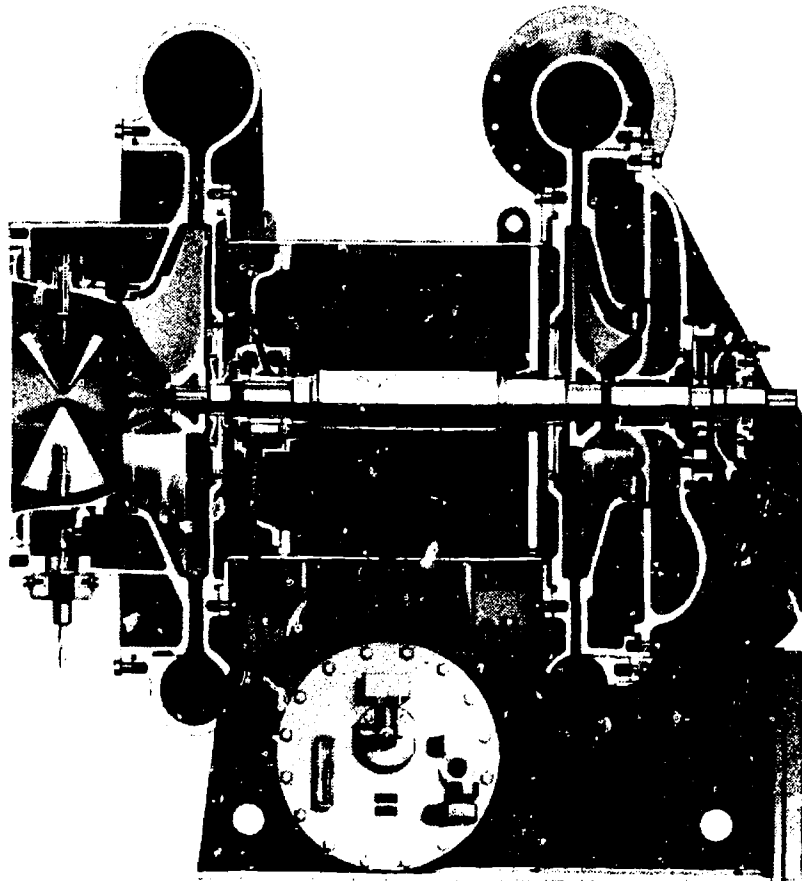
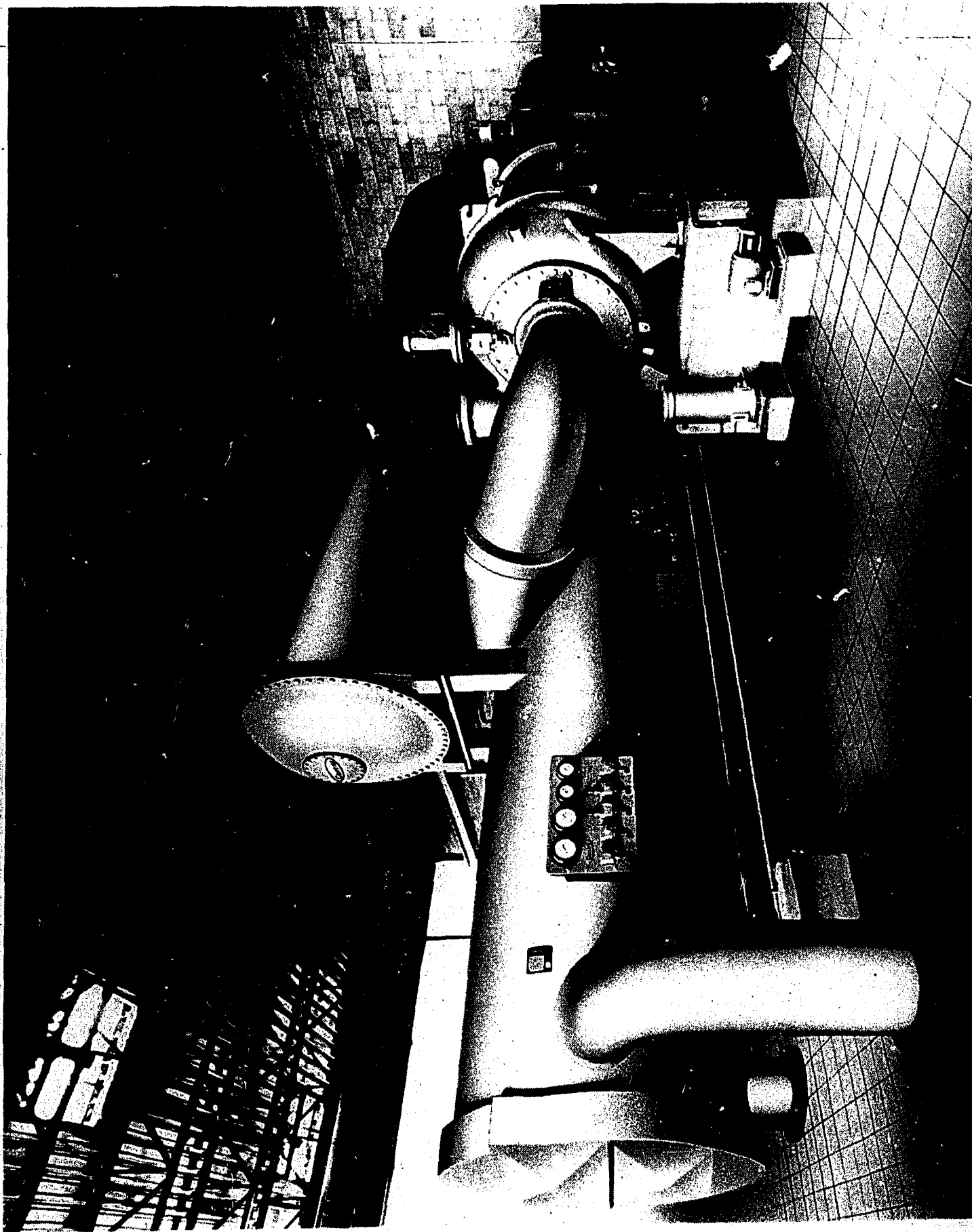
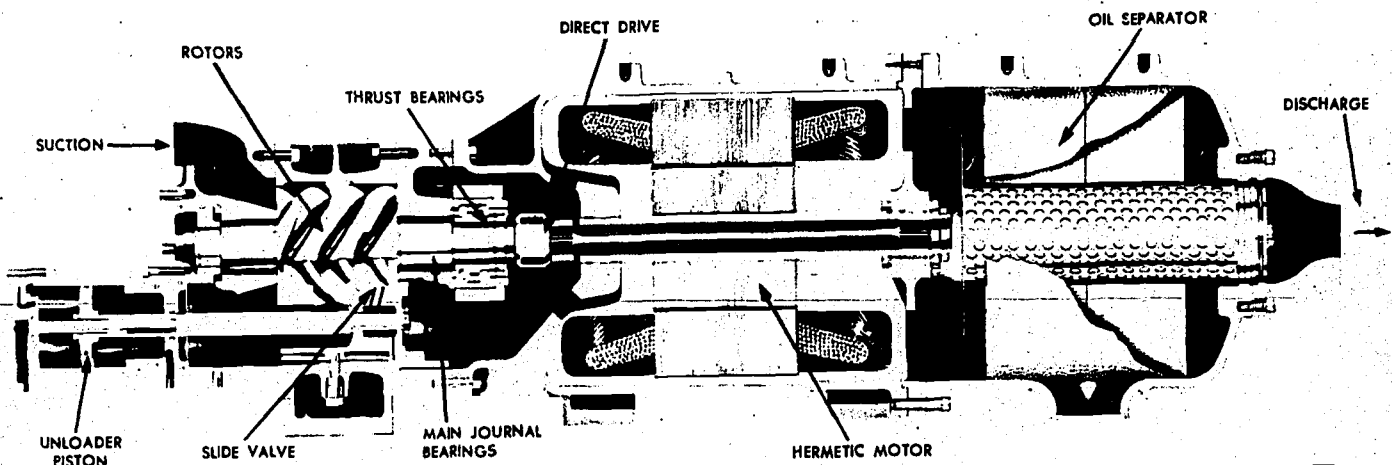
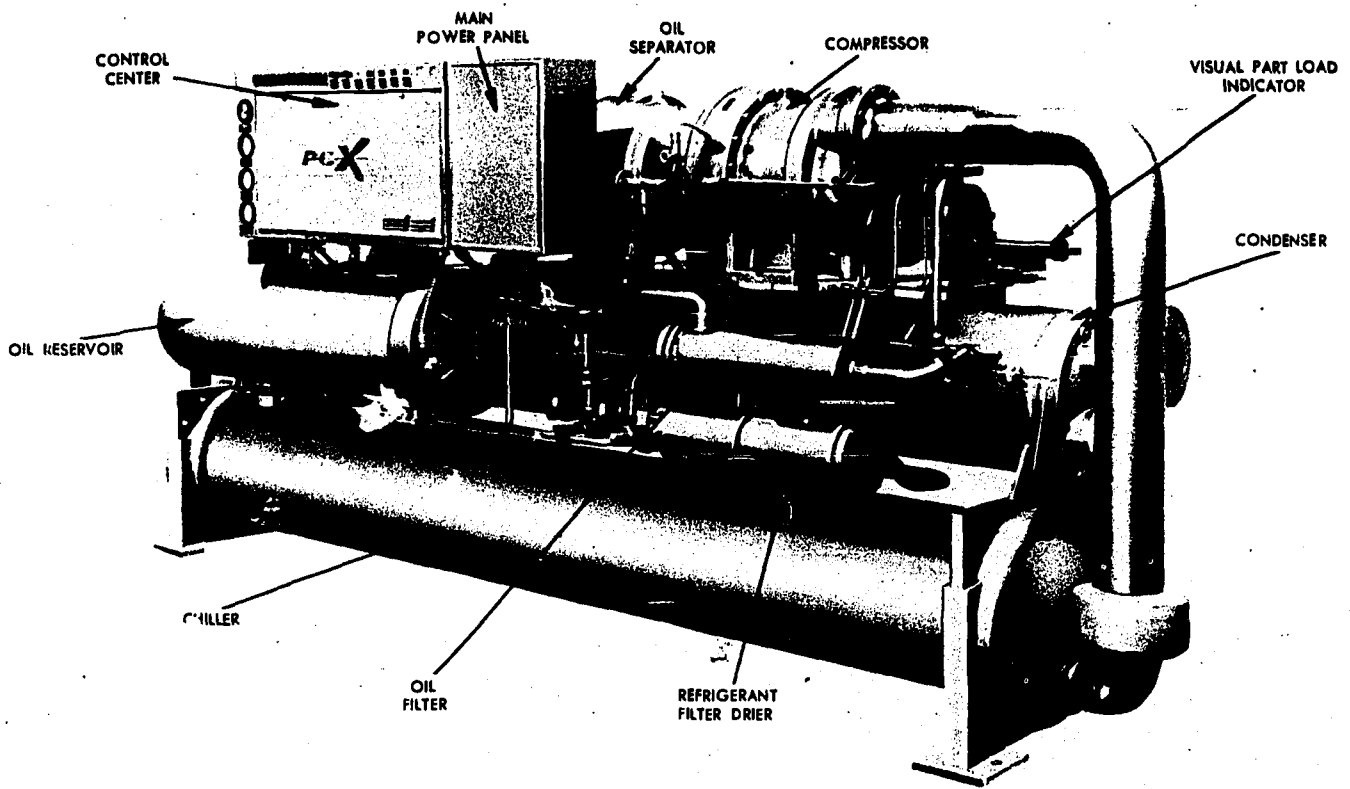


Fig. 9-4-(b) OPEN CENTRIFUGAL COMPRESSOR

Courtesy, Trane Co.



ERIC[®]-6a. LARGE OPEN CENTRIFUGAL CHILLER WITH STEAM TURBINE DRIVE



CAPACITY CONTROL SYSTEM

Figures A & B – show the capacity control slide valve within the rotor housing. Axial movement of this valve is programmed by an exclusive Dunham-Bush electronically initiated, (by variations in chilled water temperature) hydraulic actuated control arrangement. When the compressor is fully loaded, the slide valve is in the closed position (Figure A). Unloading starts when the slide valve is moved back away from the valve stop (Figure B). Movement of valve creates an opening in the bottom of the rotor housing through which suction gas can pass back from

the rotor housing to the inlet port area before it has been compressed. Since no significant amount of work has been done on this return gas, there are no appreciable losses incurred. Reduced compressor capacity is obtained from the gas which is inside the inner part of the rotors and which is compressed in the ordinary manner. Capacity reduction down to 10% of full load is possible by progressive backward movement of the slide valve away from the valve stop. In principle, enlarging the opening in the rotor housing effectively reduces compressor displacement.

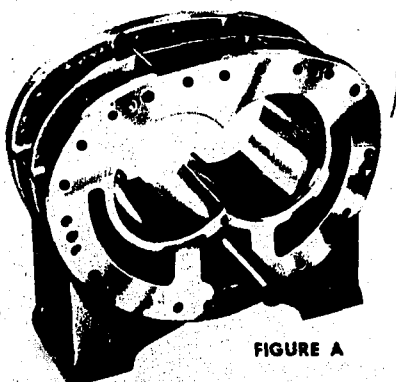


FIGURE A

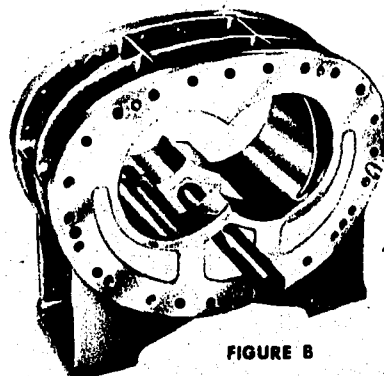
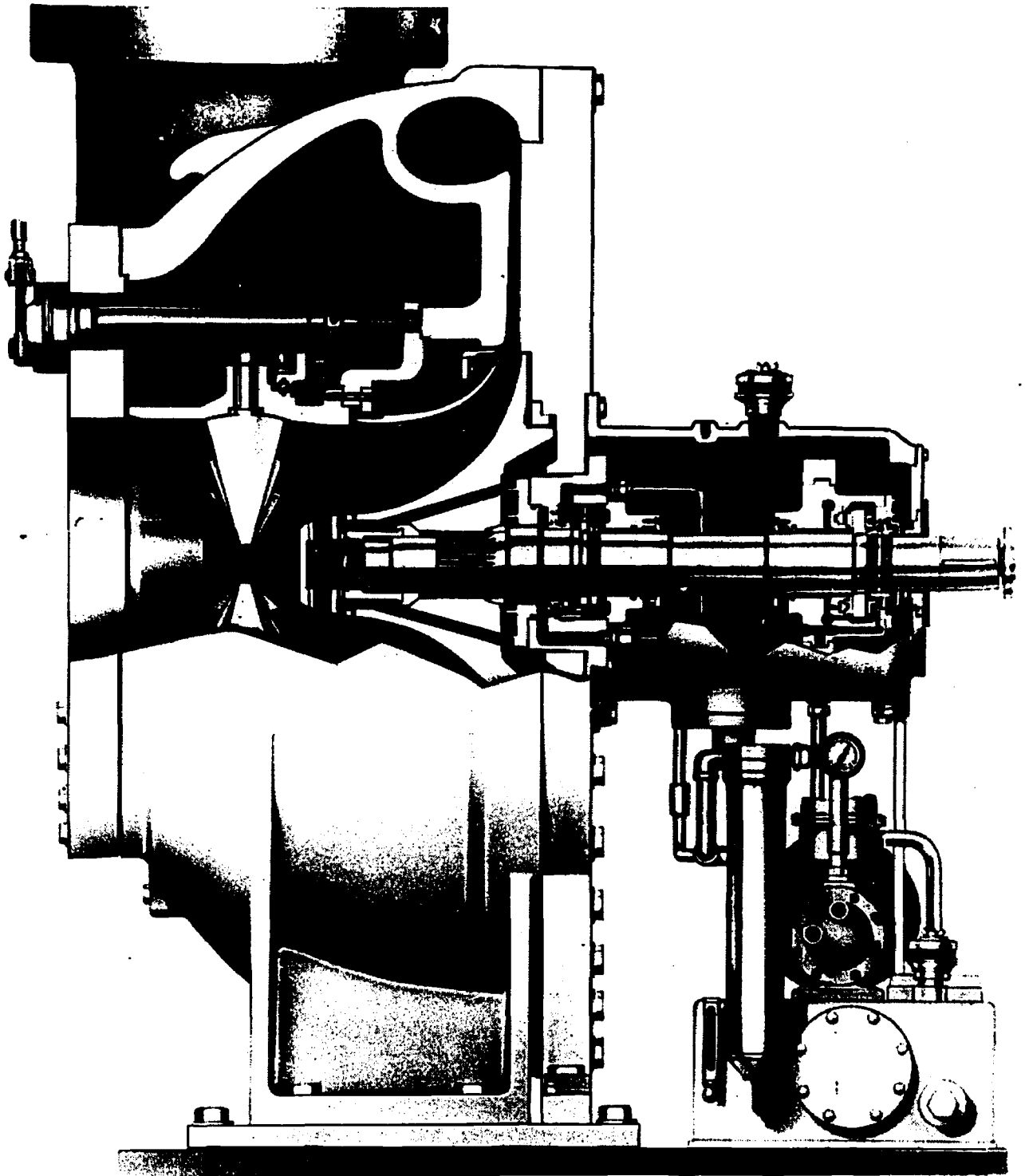


FIGURE B

Fig. 9-5



Carrier Model 17DA Open Drive Centrifugal Compressor

Fig. 9-6b, COMPRESSOR PORTION OF UNIT SHOWN IN FIG. 9-6a

receptacles when it is necessary to pump the refrigerant out of the system, and maintain a liquid seal past the condenser. They are usually fitted with a gage glass or magnetic indicator for checking the level, and are fitted with a safety relief valve. The design and construction of receivers is subject to the requirements of the ASME Code for Unfired Pressure Vessels and must bear the Code stamp.

Evaporators are heat exchangers in some form that permit transfer of heat between the evaporating refrigerant and the medium to be cooled. For cooling air in a closed ventilation system, the evaporator coils consists of many rows of finned tubes through which the refrigerant flows and extracts heat from the air flowing past the fins. Fig. 9-7A shows a typical duct type coil, and also the refrigerant distributor and expansion valve equalizer line.

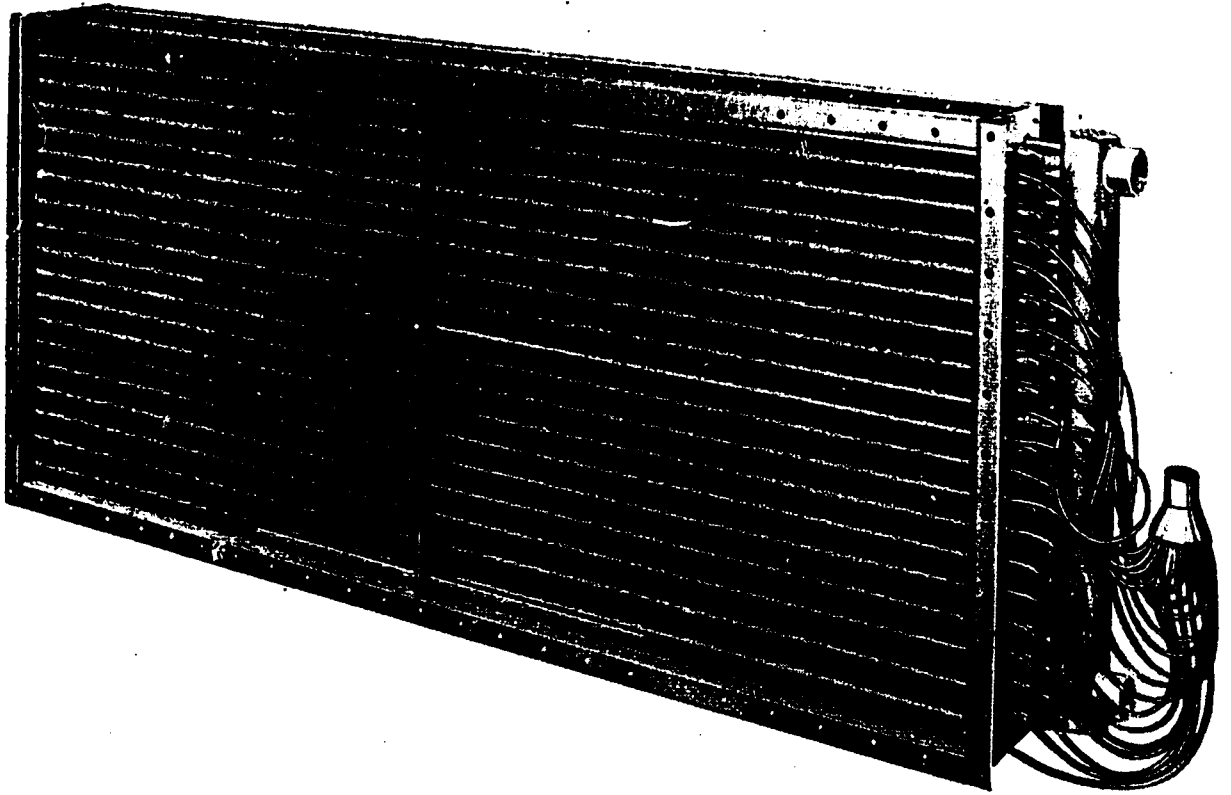
Unit evaporators are used for cooling refrigerated spaces. This unit is hung from and against the ceiling, and recirculates the air by means of propeller type fans. Condensate that collects on the drain pan must be piped to a hopper drain usually located outside the room. Evaporators in refrigerated spaces maintained below 32° F must be defrosted periodically. Such coils are furnished with electrical heating elements placed in between the finned surfaces and under the drain pan. Precautions must be taken to prevent the melted ice from re-freezing in the drain line by giving the drain line a steep slope, and wrapping it with a heating cable and insulation.

Shell and tube evaporators are used in large centrifugal units (Fig. 9-8) where the water being chilled flows through the tubes, and the boiling liquid refrigerant is contained in the lower part of the evaporator shell. The refrigerant level is controlled by a float valve. In a package water chiller similar to Fig. 9-9, the refrigerant flows through the tubes, controlled by a thermostatic expansion valve, and the water is circulated around the outsides of the tubes.

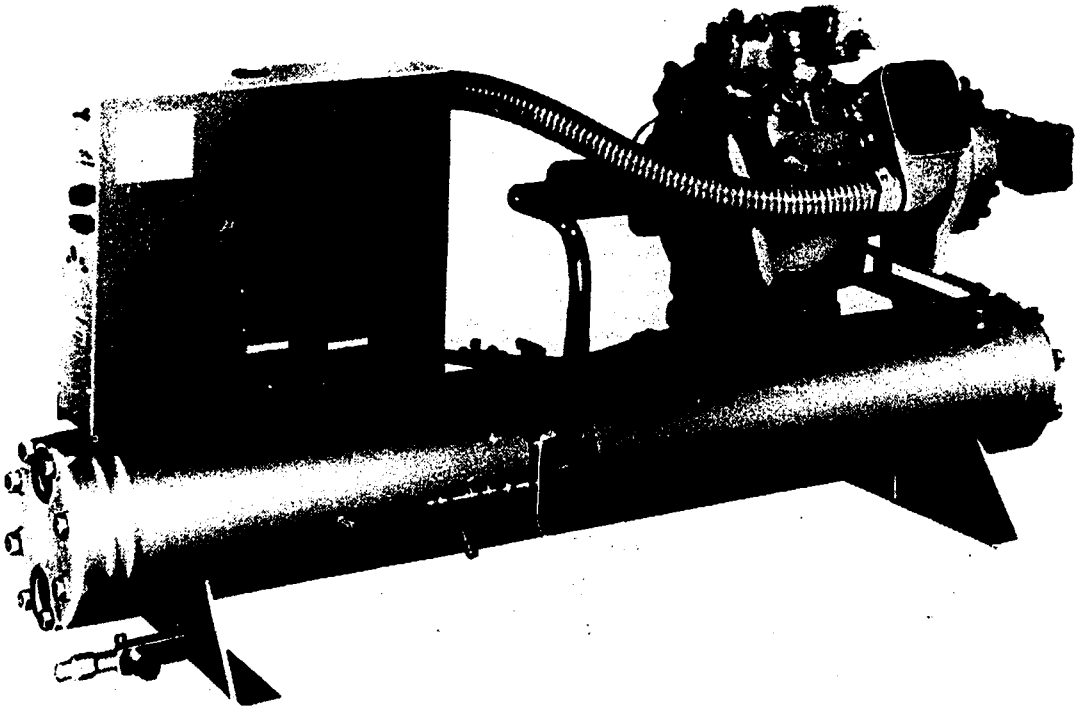
Refrigeration Piping

Most air conditioning systems are designed for use of chilled water supplied by unitized "cold generators", where the compressor, evaporator, condenser and controls are one package requiring only water and electrical hook up. However, there are certain features of freon direct expansion piping systems that the mechanical inspector should be familiar with.

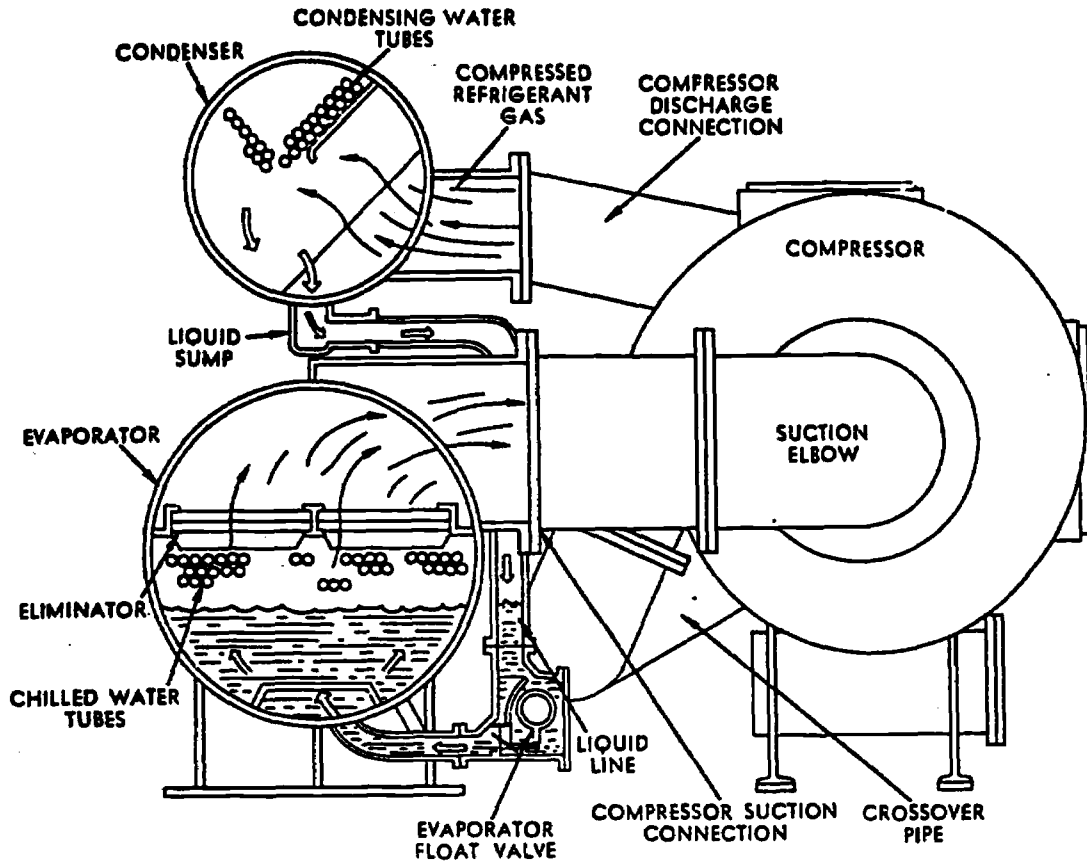
Oil and freon have an affinity for mixing together. During the compression cycle, lubricating oil is picked up with the freon and carried into the system. This causes no problem as long as the freon is in the liquid state, but after the gas has been



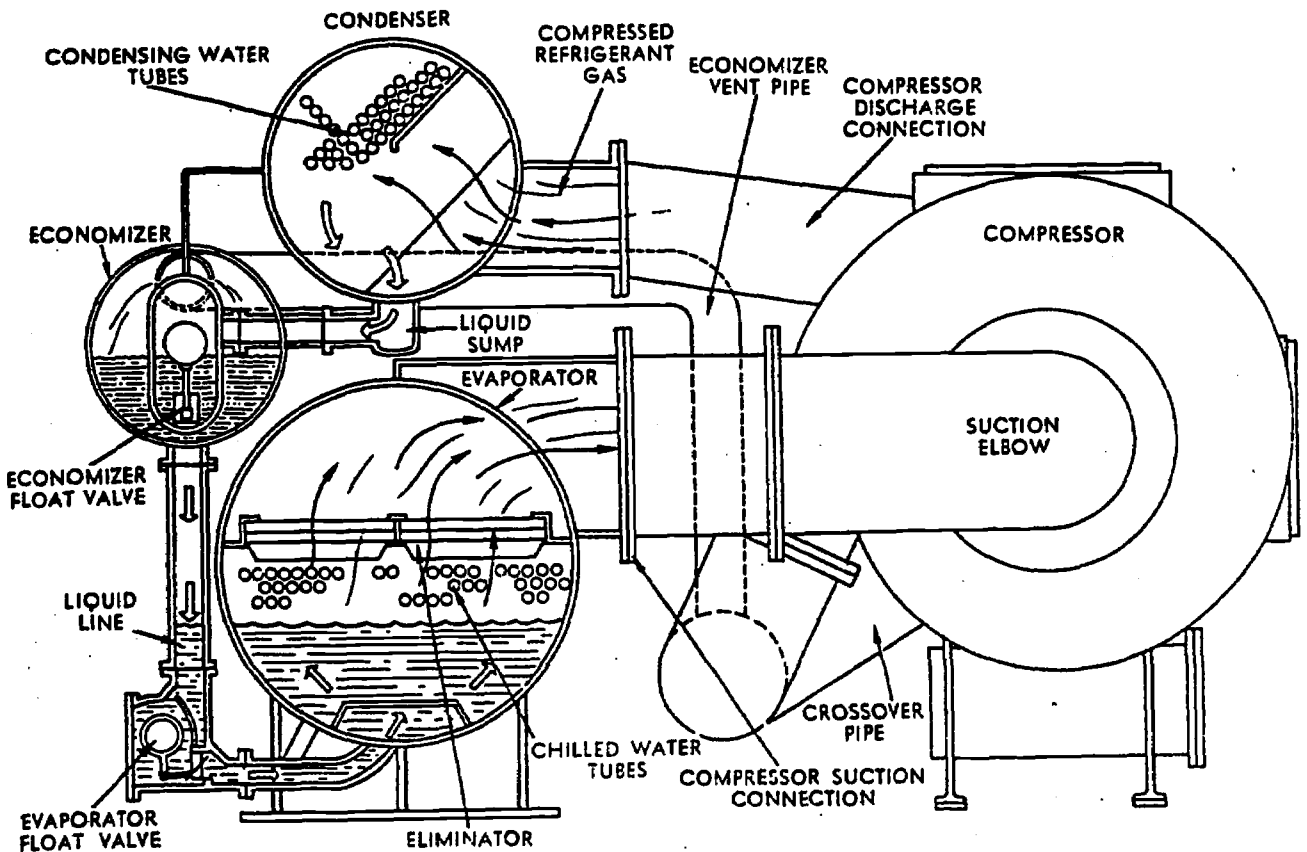
Courtesy, McQuay, Inc.



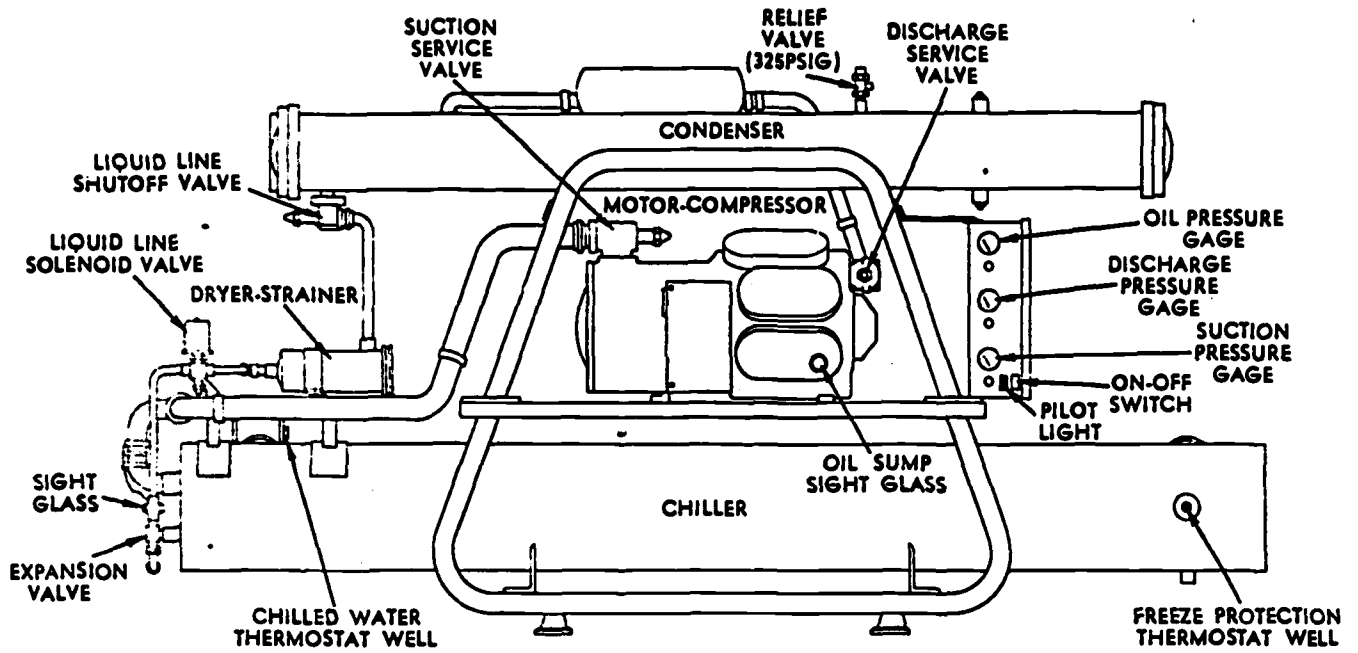
Courtesy, Carrier Co.



—CenTraVac Cycle of Operation



—CenTraVac Cycle of Operation With Economizer



—Typical Cold Generator.

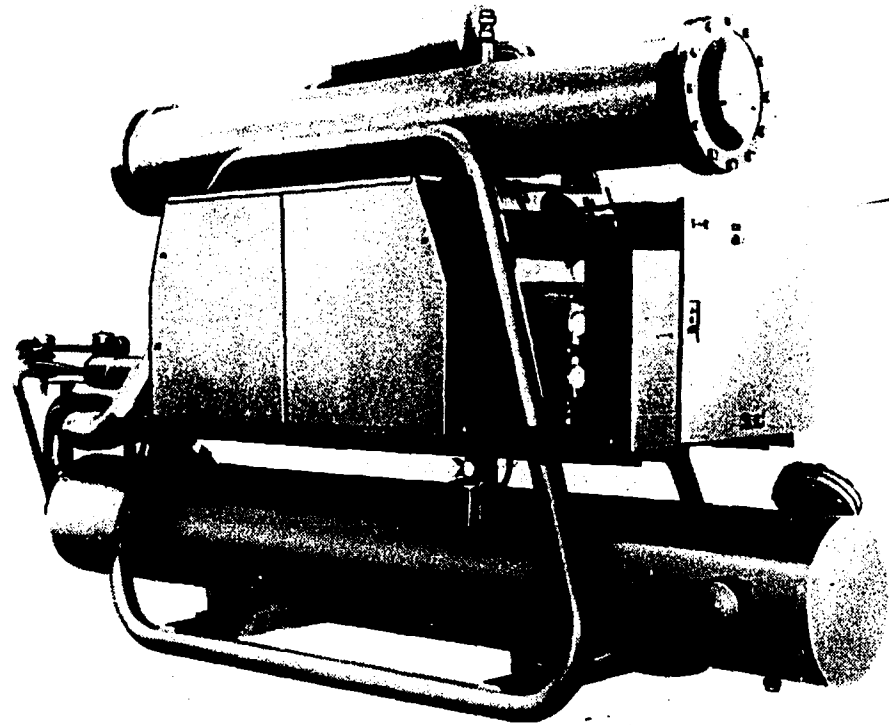


Fig. 9-9

Courtesy, Trane Co.

evaporated to the vapor state, the oil separates out and tends to collect at low points of the evaporator. This is overcome by sizing the piping riser smaller so as to give the leaving freon vapor a velocity high enough to entrain the oil and lift it to a horizontal run where normal velocities will carry it back to the compressor. The overall suction line pressure drop must be kept very low otherwise the capacity of the compressor will be reduced, therefore, the vertical section which is reduced in size is kept as short as possible. Where the compressor has variable capacity control, a double suction riser is used as shown in Fig. 9-10. At high loads the vapors and oil would travel up riser "A", but at light loads, oil collects in the trap forcing the flow up through "B".

When two or more compressors are connected together in parallel, the branches from the common suction line must be arranged for equal pressure drops, as shown in Fig. 9-11, so that the flow of gas and entrained oil is returned in equal amounts to each compressor. An oil level equalizer line, and a gas pressure equalizer is also used to maintain uniform oil levels in the compressor.

Fig. 9-12 shows the recommended hot gas connection to the condenser, with a loop to the floor to trap any condensed gas and prevent it from collecting in the compressor head and causing damage. The check valve prevents vaporized freon from condensing in the hot gas line and collecting in the compressor head.

Refrigeration Tubing, Fittings and Joints

Refrigeration-grade tubing should be used, as it is thoroughly deoxidized and cleaned on the inside and then filled with nitrogen or dry air, and the ends capped. During construction, meticulous care must be taken to keep it clean and dry. Type L hard drawn tubing is the most commonly used, and the sweat type fittings shown in Fig. 2-13 are soldered on with Sil-fos or Easy-flo silver solder (see Section 3). The high temperatures encountered with the use of silver solders oxidize the tubing and fittings and form a scale. To prevent this, nitrogen should be circulated through the tubing when silver soldering.

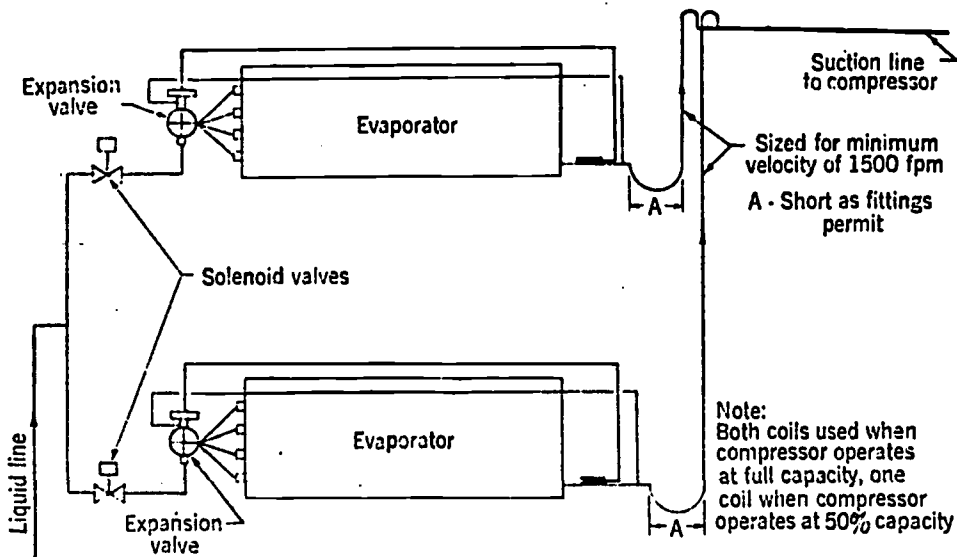
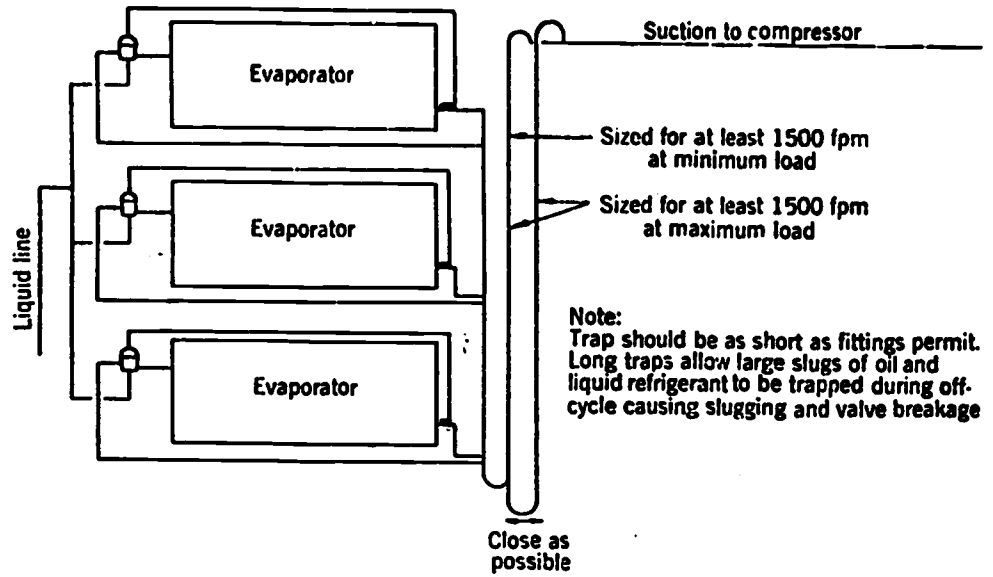
Refrigeration System Cleaning

The following instructions are excerpted from a leading manufacturer's * installation procedures and point out the importance of keeping the system clean:

"The major cause of contaminants in a refrigeration system comes from the lack of care in assembling the piping. Filings and chips from cutting operations, flux and scale from soldering are the most types of foreign materials found in systems.

* Dunham-Bush, Inc.

Suggested piping of coils using a two-pipe riser and with a trap installed.



Piping arrangement for a system using two evaporator coils and two expansion valves.

Fig. 9-10

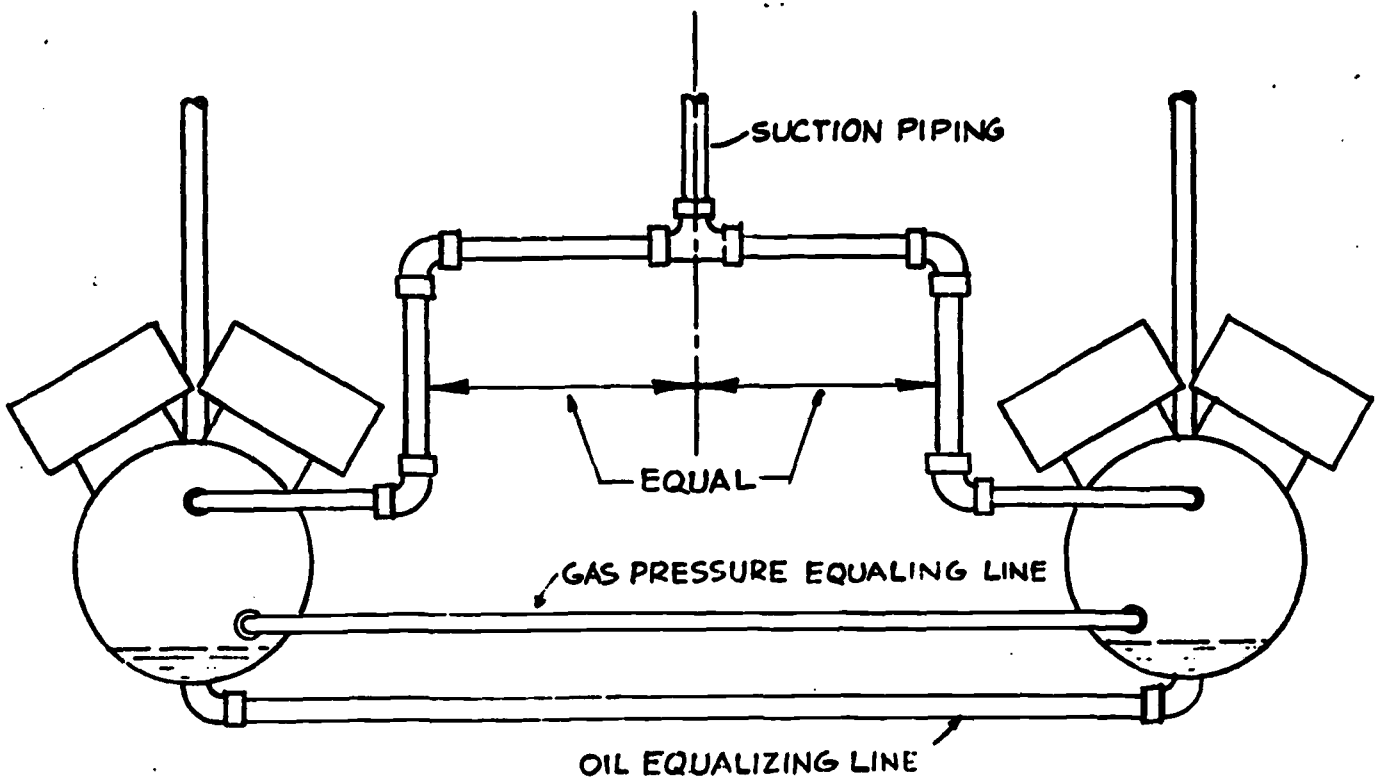


Fig. 9-11

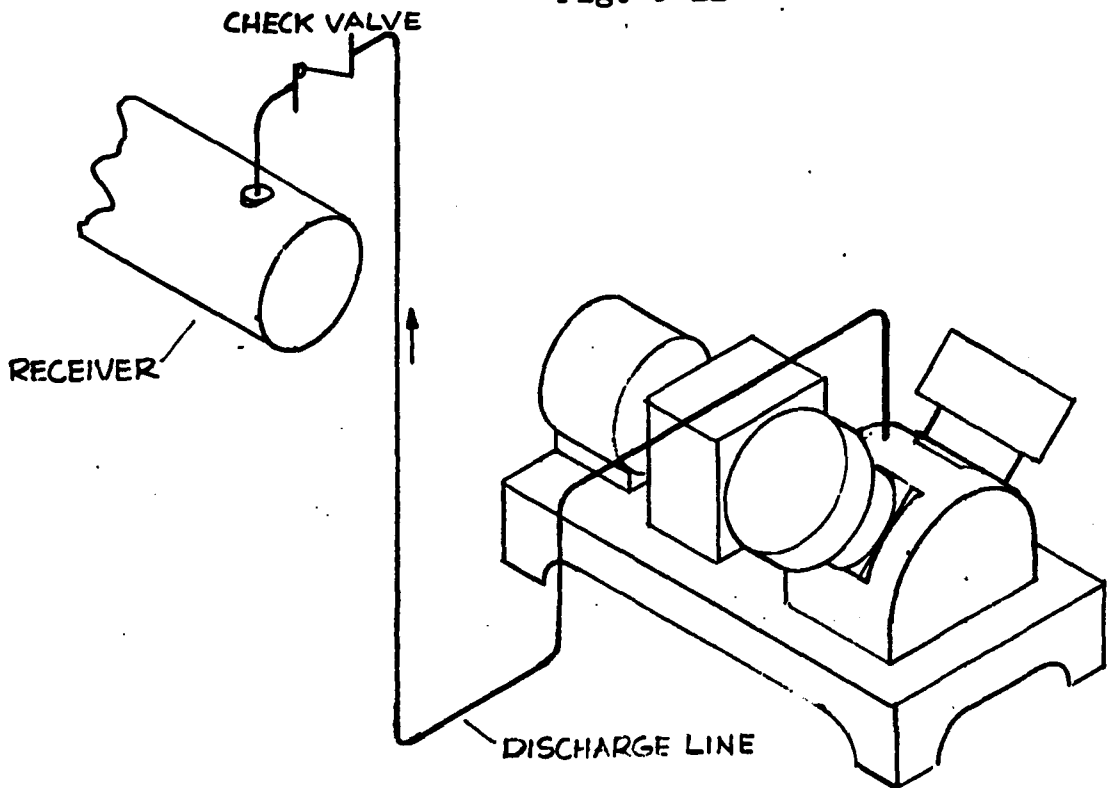


Fig. 9-12

Dust and dirt from improper handling or storage of the tubing and fittings are also a source of the system contaminants.

After a length of tubing has been cut to size and is ready for installation, it should be cleaned. On the larger sizes of tubing cleaning is best accomplished by swabbing out with a cloth saturated with a suitable solvent. Refrigerants 11 or 113 are suitable for this purpose. On smaller lines flushing R-11 through the tube will accomplish the cleaning desire. All tubing and fittings should be cleaned in such fashion. When tubing is soldered, some of the soldering flux and bits of solder may fall inside the tube. Care should be taken when applying flux to a joint so as to not have an excess on the inside of the connection. Also, too much heat on the joint will cause the solder to flow inside and drop out of the joint into the tube and fittings. In the presence of oxygen (air) and under high temperature, scale will form on copper. If excessive heat is applied to fittings, this scale will form and flake off inside the tube."

To prevent this, we recommend circulating dry nitrogen through the tubes while soldering is being done. The nitrogen displaces the air in the tube, and, being an inert gas, prevents oxidation."

Hermetic compressors are subject to electrical breakdowns called "burnouts" caused by impurities in the refrigerant system. This manufacturer* has the following comments:

"The burnout of a hermetic compressor motor in the majority of cases is directly resultant from impurities in the refrigerant system. These impurities may be in the form of dirt, scale, or moisture left in the system at the time of installation. In addition, there could be fluorine and chlorine gases, oxygen and acid due to the breakdown of the refrigerant, oil or insulating materials, or any combination of these. The presence of any contaminating substance can start a reaction resulting in the formation of the others. The ultimate result is a premature failure of the motor compressor.

Field servicing of a system after a hermetic motor burnout is generally a time consuming and expensive operation. Not only must the compressor be repaired or replaced, but the entire system must be thoroughly cleaned of all harmful contaminants left by the burnout. Repeated burnouts generally indicate inadequate system cleanout after the previous failure."

It should be clear from the above that failure to keep impurities out of hermetic piped freon systems can be disastrous.

* Dunham-Bush, Inc.

A cooling tower is a piece of heat transfer equipment that cools water with ambient air by intimate contact of the two. Water is introduced at the top of an enclosure and distributed over a large area of lath or similar material arranged to break the water up into small droplets and films. Air is induced around the outside of the bottom of the enclosure and flows upward through the falling water. The total heat given up by the water to the air is influenced by the degree of contact, air velocity and physical size of the tower, but the outlet of the water temperature is limited by the wet-bulb temperature of the air. The difference between the leaving water temperature and air wet-bulb is called the approach.

Cooling towers evaporate approximately 2 gallons per hour per ton of the refrigeration load. In addition to this loss water should be wasted from the tower at a rate sufficient to prevent a buildup of impurities, roughly equal to the amount evaporated. It is good practice to provide water treatment, and the amount of bleed is determined by the water treatment used. An automatically controlled make-up valve (usually float operated) is used to maintain the water level in the cooling tower sump. The operation of this should be carefully checked to see that it keeps the level up, but does not overflow and waste out the overflow. Factory assembled towers have an anti-vortex baffle at the sump outlet to prevent air from being sucked into the pump.

The condensing pressure of a compression type system must be kept at a certain high level in order to operate properly. The condensing pressure can be controlled by varying the condensing temperature which is governed by the volume or temperature of the condensing water supply. With a piping arrangement as shown in Fig. 9-13, the temperature is controlled by starting and stopping the induced draft fan as more or less cooling is needed. The arrangements shown in Figs. 9-14 and 9-15 also cycle the fan but use temperature controlled valves to bypass part of the water around the tower to maintain the desired water temperature leaving the basin. Flow switches are used in the condenser water supply system to guarantee that water is flowing through the condenser when the compressor is operating. If the flow is interrupted only momentarily the compressor will be stopped. These control features must be considered in the piping arrangement of the condensing water. In Fig. 9-13, a temperature control valve is not used, temperature of the water being controlled by the fan operation. When the system is at rest, the check valve at the pump discharge prevents water from back flowing to the cooling tower basin and passing out through the overflow. Without the check valve, the pump on the next start would quickly empty the basin and suck air before the make-up valve could catch up. The anti-syphon loop prevents the condenser discharge line from emptying on shut down and going out the overflow. In Fig. 9-14, the 3-way diverting valve, when modulating, sends some water to the tower and some to the pump, but when all the water goes to the tower the pipe connected to the bottom outlet of the valve empties the amount "H" down to the level of the basin water level. Then, when the valve closes to the tower and opens to the

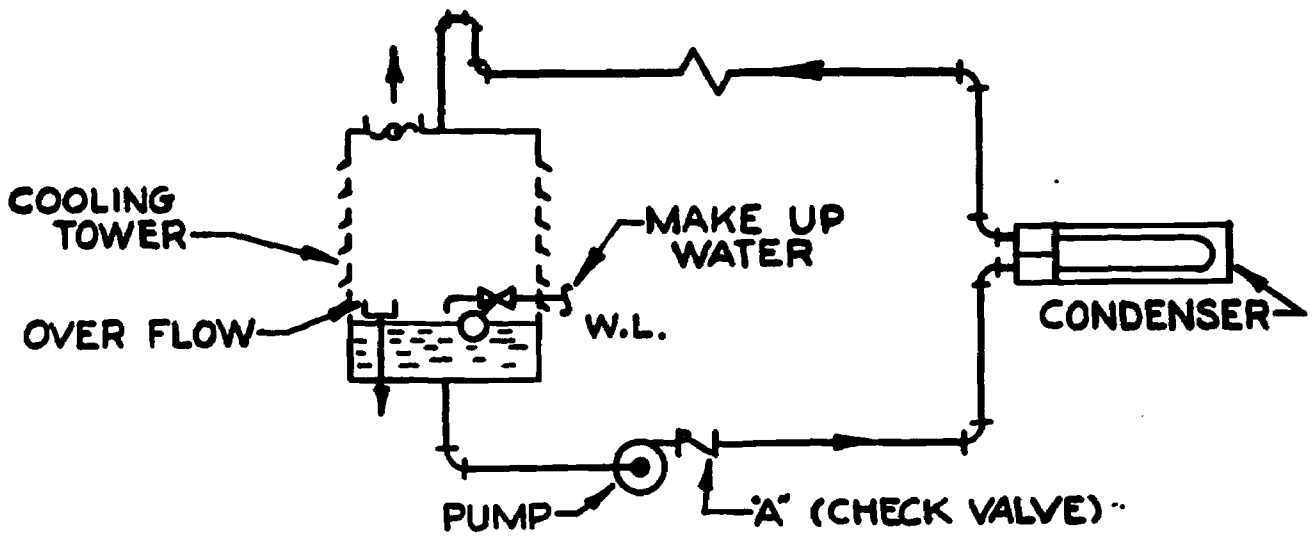


Fig. 9-13

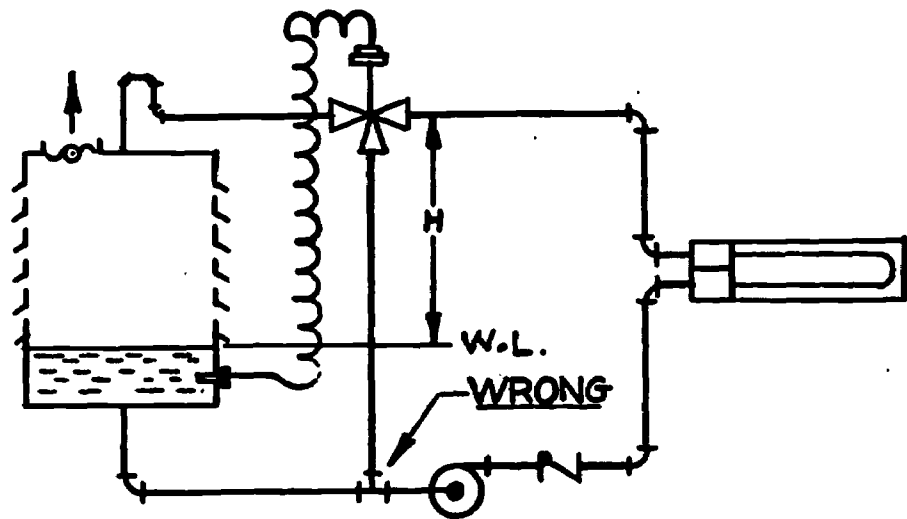


Fig. 9-14

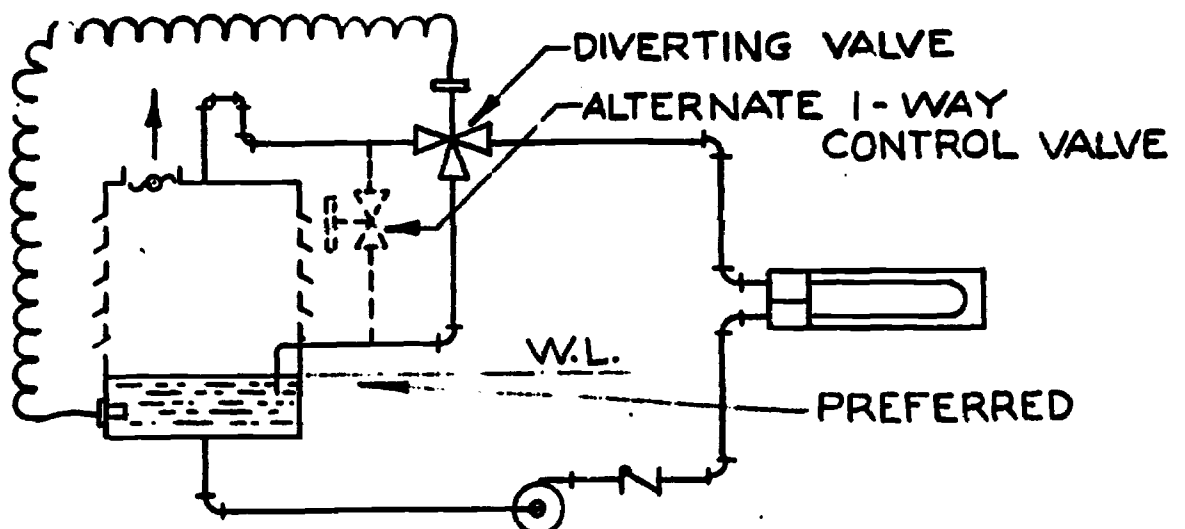
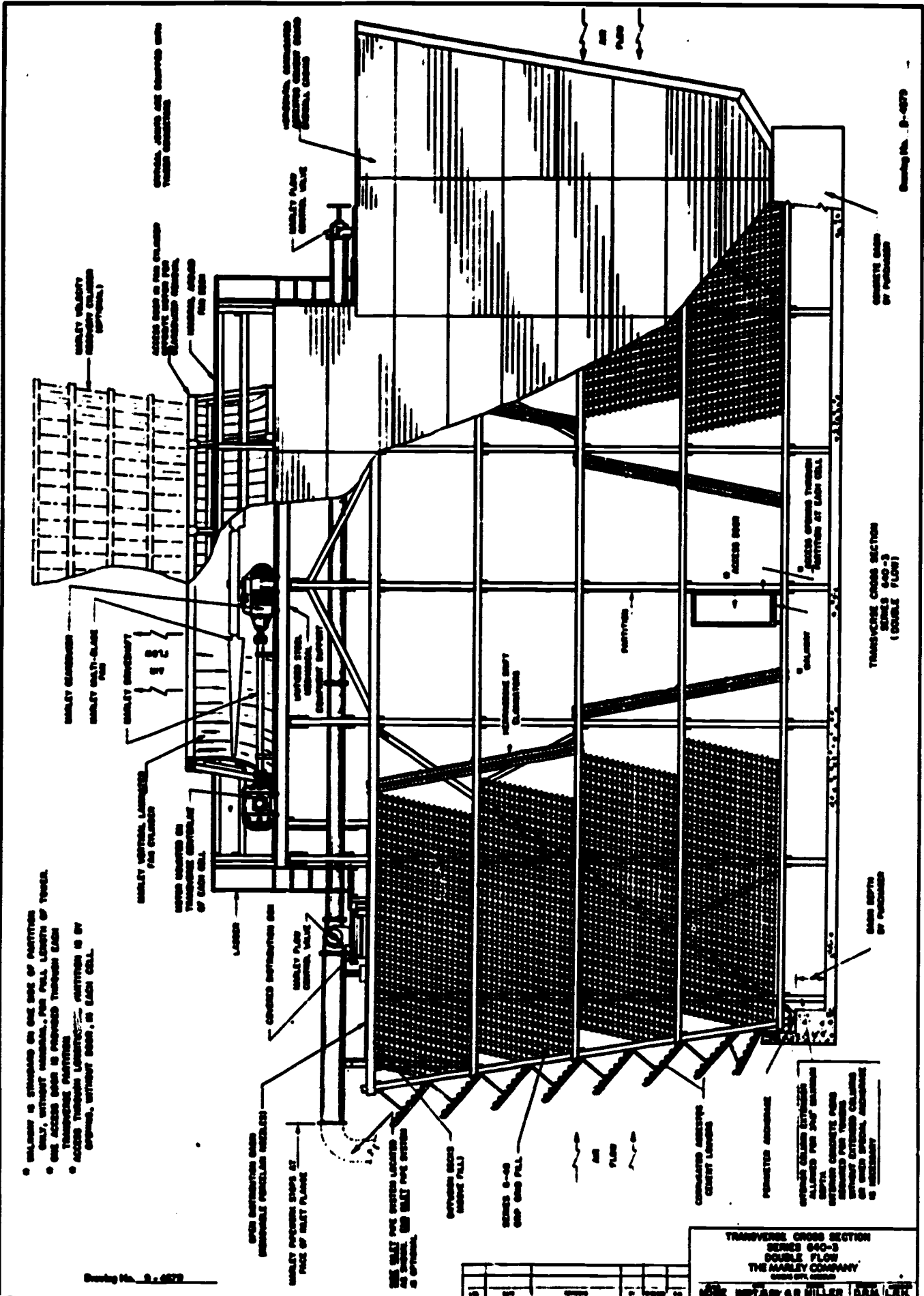


Fig. 9-15
189



- MALLORY IS STIFFENED ON ONE SIDE OF PARTITION ONLY, WITHOUT MALLORY, THE FULL LENGTH OF TOWER.
- ONE ACCESS DOOR IS PROVIDED THROUGH EACH TRANSVERSE PARTITION.
- ACCESS THROUGH LAMINATE PARTITION IS BY GRINDS, UPPER DOOR, IN EACH CELL.

Drawing No. 9-6879

Drawing No. 9-6879

Refrigeration Check-Points

Verify that:

1. Provision is made for an atmospheric vent through the roof for the discharge of a refrigerant safety relief valve or rupture disc.
2. All refrigerant piping materials and equipment is kept clean and dry during the construction. All refrigerant tubing to be kept capped.
3. Valves to be dis-assembled or wrapped in wet cloth to prevent heat damage when brazing or hard-soldering.
4. Nitrogen gas is passed continuously through the tubing during brazing or hard soldering.
5. Liquid line sight glasses are installed ahead of expansion valves and can be easily observed with no obstructions in the way.
6. Joints are made with hard solder (silver base alloy melting above 1000° F), and not soft solder, for tubing over 1/2".
7. Flared compression fittings are not used for lines over 3/4" O.D., and only where such joints are exposed for inspection.
8. Piping does not interfere with removal of equipment components.
9. Piping does not obstruct view of oil level bulls-eyes.
10. Branch tie-in lines of paralleled compressors are of equal length and air piped identically and symmetrically.
11. Refrigerant piping crossing an open space used as a passageway is 7 1/2 feet above the floor and is not placed in public areas, elevator shafts, and the like.
12. Provision is made for expansion and contraction by means of expansion bends, offsets, etc.
13. The smaller sized tubing is protected from bumps, being stepped on, etc.

pump, it pushes a large slug of air ahead, the pump loses suction and the flow switch signals a no-flow condition and shuts down the compressor. This can be avoided by discharging the 3-way valve bottom connection directly into the basin, Fig. 9-15. The 3-way could also be installed below the tower basin water level and thus be submerged at all times if the tower is high enough.

Refer to Uniform Mechanical Code, Chapters 15 and 17, for Refrigeration Equipment requirements.

10. TEMPERATURE CONTROL SYSTEMS

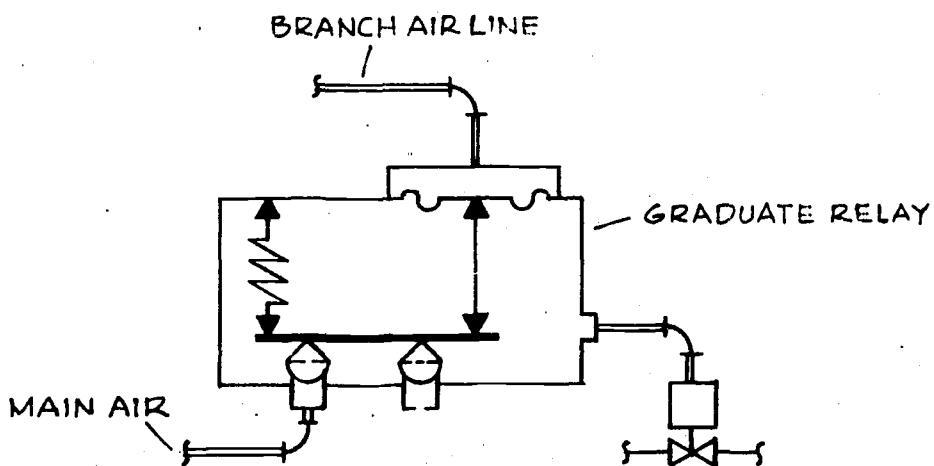
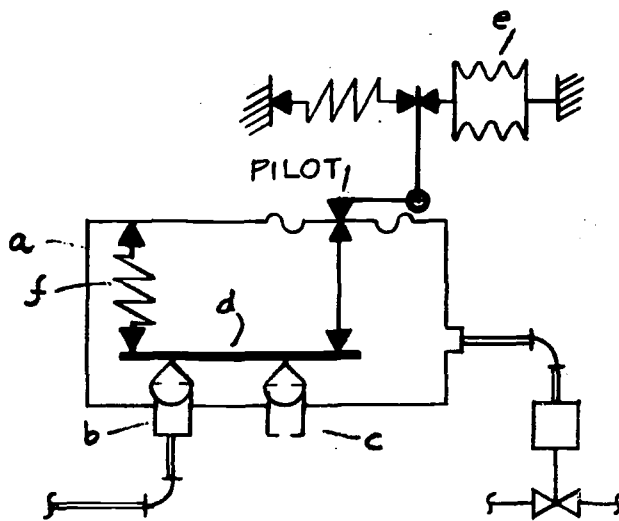
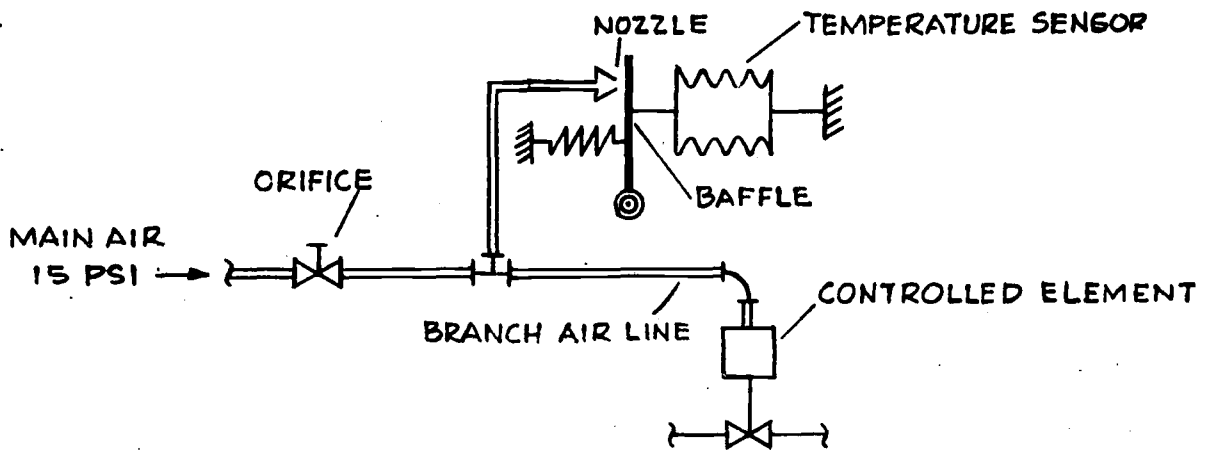
This section will discuss the basic parts of control systems, control terms, and applications of various controllers in a representative air conditioning system. The emphasis will be on air operated controls.

Temperature Control Air Compressor

The air operated, or pneumatic system uses 15 psi air to open or close valves and dampers; stop, start, and control the capacity of equipment and transmit temperature and pressure readings. The source of air is a relatively small compressor and receiver usually located in the mechanical room with other components of the air conditioning system. Air is pumped up to approximately 60 psi pressure and stored in a receiver from which it is reduced to slightly over 15 psi, which is called "main air" pressure. The air furnished to the thermostats and other controllers must be free of dirt, oil vapors and moisture. This is obtained by passing the air through high efficiency air filters (which trap scale, dirt, and oil mist); and through small refrigerated air coolers which dehumidify the air. Even if dehumidifiers are not called for in the contract, a good deal of moisture can be avoided by locating the receiver in a cool place, and by connecting the compressor intake line to the outdoors. This line will have to be increased several sizes greater than the intake size on the compressor to reduce the friction loss. (Check the installation instructions). Large amounts of water collect in receivers and this is best controlled by an automatic tank drainer and blowoff. Compressors and receivers are usually specified to be sized so that the compressor will not run more than 2/3 of the time. After leaving the pressure reducing valve station, the main air is distributed throughout the building by piping or tubing, the size generally being determined by the temperature control contractor. (The test of these air lines should be witnessed by the inspector but is frequently overlooked).

Controllers

A controller is a device which measures a change in temperature (or any other variable) and varies the air pressure to an actuator to restore the original condition. An actuator is a device such as a damper motor, valve or relay, which starts, stops, or varies the operation of a piece of equipment in response to the controller. Pneumatic controllers are the bleed or non-bleed type. Fig. 10-1 shows the basic elements of nearly all air operated controllers; the orifice, nozzle and baffle. Main air is supplied to the restrictor which is connected to a nozzle, which has a slightly larger opening. When the baffle is moved towards and away from the nozzle by some actuating element such as a bellows responding to temperature changes, the pressure



in the diaphragm valve line increases or decreases depending on how much air the baffle lets escape from the nozzle. If the baffle presses tightly against the nozzle, the branch pressure will equal the main pressure, 15 psi. If the baffle does not restrict the nozzle, the air will flow through the nozzle and the branch pressure is 0 psi. Intermediate positions of the baffle will result in branch pressures somewhere between 0 and 15 psi. Air constantly bleeds except when the baffle is tight against the nozzle. Fig. 10-2 shows a non-bleed type of controller. The enclosure a is an air tight enclosure when the valves b and c are seated on their ports by pressure from lever d. The bellows e responds to temperature change (warmer) by expanding. This (the pilot) pressure pushes the right end of the lever down to open the supply port. Supply air then fills the case until the forces on the diaphragm are rebalanced.

Spring f has enough force to seat the supply valve when the forces on the diaphragm are in balance, and to unseat the exhaust port when the pilot pressure becomes less than the internal pressure on the diaphragm. When the exhaust port is unseated, air exhausts from the case and the branch line until the air pressure again balances the pilot pressure. In this way, the controller maintains a branch line pressure corresponding to the force transmitted by the bellows.

The large amount of air wasted from a bleed-type controller can be virtually eliminated with the graduate relay shown in Fig. 10-3. This instrument is substantially the same construction as the non-bleed controller except the branch line pressure from the bleed controller replaces the bellows. An increase in the controller branch-pressure causes an increase in the motor-branch pressure. Since only a very small amount of air is needed to actuate the relay it is possible to adjust the controller restriction to a small opening and reduce the amount of air exhausted. Some thermostats are made with the graduate relay housed in the same case with the nozzle, vane and sensitive element.

Control Terms and Definitions

The following list of control terms appears on temperature control diagrams and must be understood to follow the desired operation of the system:

Throttling range. As stated above, pneumatically operated instruments are controlled by pressure from 0 - 15 psi in most cases. The actual effective range is considered to be from 3 to 13, or 10 psi. The two extremes or limits of travel of a valve or pneumatic motor would occur when the pressure supplying it is 3 psi or 10 psi. Any pressure in between would cause the valve or motor to move a proportionate amount. The change in the controlled variable, such as temperature, that is needed to change the branch pressure from 3 to 13 psi

is called the throttling range. Thus a thermostat that puts 3 psi on the branch at 70° F, and 13 psi at 73° F has a 3° throttling range. At 71.5° F the pressure will be 8 psi.

Sensitivity of a controller is the pounds of air pressure change per unit change of the controlled variable which in the above example is 10 psi divided by 3° or, 3 1/3 pounds per degree sensitivity.

Proportional band (similar to throttling range) is the change in the controlled variable required to move the controlled device from one extreme limit to the other. It is normally used with respect to recording and indicating controllers and is expressed in per cent of the chart or scale range.

Direct acting applies to a pneumatic controller when an increase in the controlled variable causes an increased control pressure.

Reverse acting applies to a pneumatic controller when an increase in the controlled variable causes a decreased control pressure.

Set point is the point at which a controller is set to maintain a certain controlled variable valve.

Control point is the actual valve of the controlled variable which the controller is causing to be maintained at a given time.

Master controller is an instrument whose variable output is used to change a submaster's control point.

Submaster controller is a controller whose set point is changed over a pre-determined range by variations in output from a master controller.

Master pressure is the variable output air pressure from the master controller which changes the submaster controller's set point.

Normally closed applies to a controlled device which closes when all operating force (control pressure, electrical energy) is removed.

Normally open applies to a controlled device which opens when all operating force is removed.

Spring range is the range through which the control pressure must change to produce total movement of the controlled device from one extreme position to the other. For special applications, valves or motors can be fitted with springs that allow them to travel their full movement from 3 to 8 psi, or 8 to 13 psi, or some other similar range.

Temperature controller devices, (masters, submasters, thermostats, etc) must be carefully located so as to sense the true or average temperature they are controlling. An outdoor master should be located on the north side of a building or in a location unaffected by the sun's direct rays or by convective heat from a sunny wall. It also must not be exposed to air being exhausted from the building. Submasters controlling hot or cold plenums should be able to sense the average plenum temperature which is best done with a long capillary "averaging" bulb supported across but not touching the face of the coil it controls. If an instrument must be mounted on the sheetmetal plenum or duct work because of its design, the sheetmetal must be sufficiently reinforced to prevent vibration of the controller. If the sensing element of the control is a bulb to be inserted in a pipe it should be installed inside a thermometer well which projects to the centerline of the pipe. This frequently does not happen because of the make up of the fittings, bushings, etc, and the bulb does not sense the average temperature of the fluid. (This applies to thermometers also). Thermostat locations merit special attention when they are being roughed-in prior to pouring concrete, so as to avoid being placed in the middle of tack boards, back of bookshelves, behind doors, etc. Avoid locating too close to the latch side of door jambs as the impact of the door closing sometimes causes the thermostat to bleed momentarily. Keep thermostats away from obvious heat sources, and away from a direct air blow from an air supply register.

Control valves regulate the flow of hot or chilled water and steam through coils. They are two-way for water and steam, Fig. 10-4, and three-way only for water, Fig. 10-5.

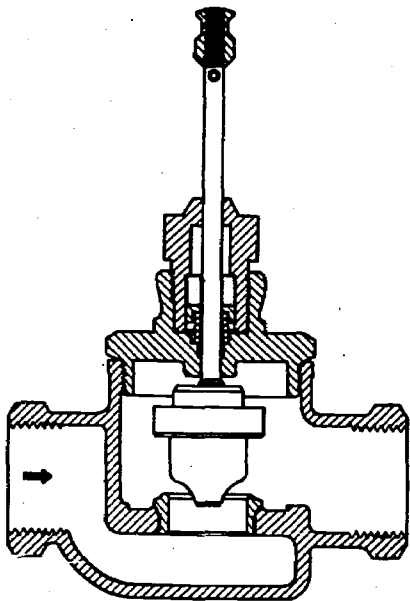
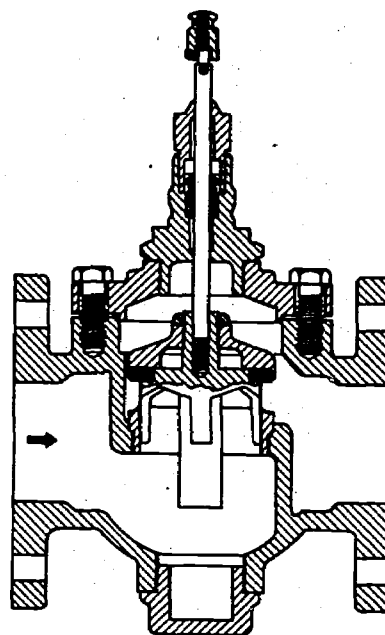
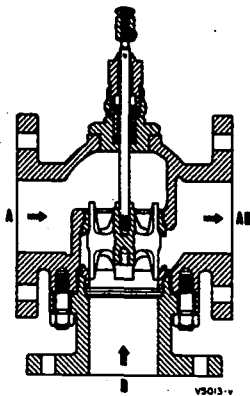


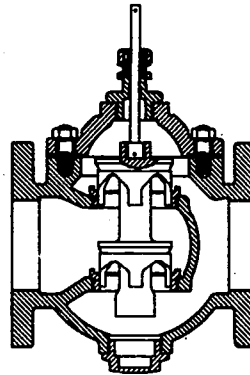
Fig. 10-4



A double ported balanced valve is shown in Fig. 10-6.



Flanged Body Patte



Flanged Body Pattern.

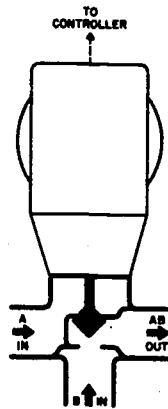


Fig. 10-5

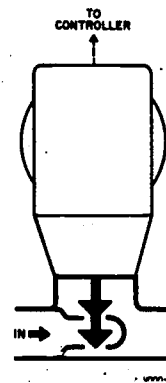


Fig. 10-6

Courtesy, Honeywell, Inc.

Three-way valves have two inlets and one outlet, and are piped to bypass around the source of heating or cooling to give a constant flow through the coil or bypass around the coil (Fig. 10-7 (a)). Fig. 10-7 shows additional arrangements for connecting single and multiple coils. Three-way valve inlets and outlets are marked at each connection and should be connected as shown on the temperature control diagram prepared by the control subcontractor, as the designer's drawings are schematic and may not fit the exact style of valve furnished.

Control valves have an index number called the valve coefficient, C_v , (shown on Fig. 10-7) which tells what the flow through it will be for a given pressure drop.

For non-compressible fluids the flow can be calculated from the formula:

$$Q = C_v \sqrt{P}$$

where C_v = valve coefficient

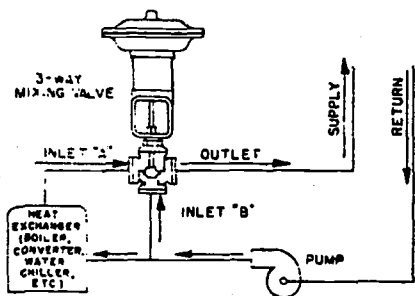
P = pressure drop

G = specific gravity of liquid
(water = 1.0)

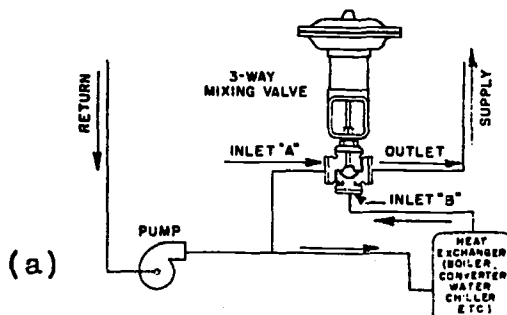
C_v Factor Table

Valve Size (in.)	½		¾	1	1¼	1½	2
C _v Factor	1.1	3.2	4.3	5.7	8.6	13	35
Valve Size (in.)	2½		3	4	5	6	8
C _v Factor	54		80	157	238	347	491

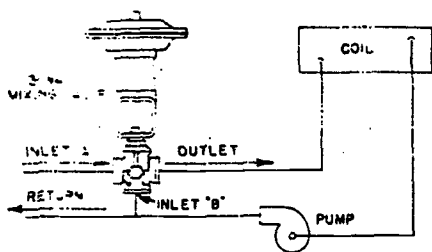
Typical Applications



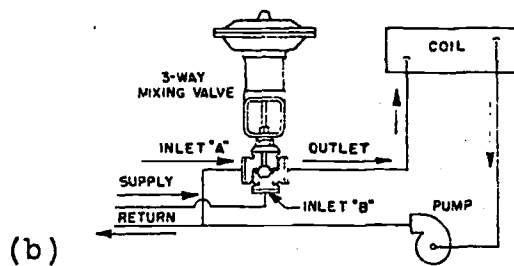
Control of Supply Water Temperature. Valve Normally Closed to Heat Exchanger



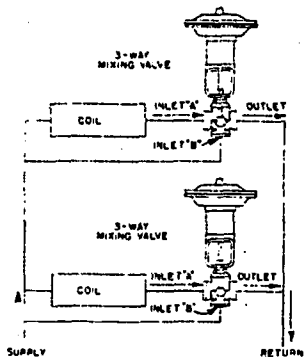
Control of Supply Water Temperature. Valve Normally Open to Heat Exchanger



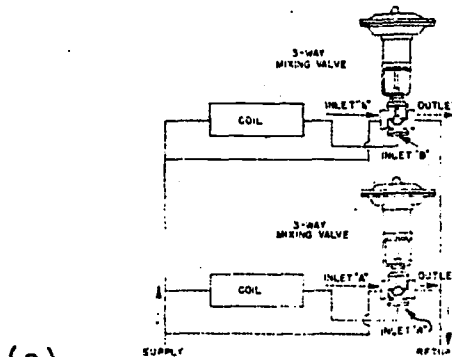
Piping Arrangement for Coil Control with Individual Pump. Valve Normally Closed to Supply



Piping Arrangement for Coil Control with Individual Pump. Valve Normally Open to Supply



Three-Way Mixing Valves on Multiple Coil Installation. Valves Normally Closed to Flow Through Coil



Three-Way Mixing Valves on Multiple Coil Installation. Valves Normally Open to Flow Through Coil

NOTE: Inlet "A" is Normally Closed; Inlet "B" is Normally Open

Fig. 10-7

If a valve has $C_v = 40$, and the pressure difference between inlet and outlet is 25psi, for water the flow is

$$Q = 40 \sqrt{\frac{25}{1}}$$

$$= 200 \text{ gpm.}$$

For saturated steam:

$$W = 2.1 C_v \sqrt{\Delta P} \times \sqrt{P_1 + P_2}$$

where P_1 = inlet pressure, psia

P_2 = outlet pressure, psia

$\Delta P = (P_1 - P_2)$

$W = \text{lbs per hour}$

NOTE: When the absolute downstream pressure is less than 50% of the absolute upstream pressure use 50% of the absolute upstream pressure as the pressure drop,

If a valve controlling steam has an inlet pressure of 15 psig and an outlet pressure of 10psig, and a valve coefficient of 50, the steam flow is:

$$W = 2.1 \times 50 \times \sqrt{15-10} \times \sqrt{(15 + 14.7) + (10 + 14.7)} =$$

$$= 1750 \text{ lbs per hour}$$

These formulas can also be solved by the nomographs found in the appendix.

Electro-pneumatic switches (EP) are electrically operated devices that open or close valves to air lines.

Pneumatic-electric switches (PE) are air operated devices that are actuated by air pressure to open or close an electrical relay or switch.

11. NATURAL DRAFT VENTING SYSTEMS

Gas fired boilers and heaters fired by natural draft must be properly vented so as to provide sufficient oxygen to completely burn the fuel and carry away the products of combustion. Incomplete combustion will result in lowered efficiency and the formation of carbon monoxide, as well as producing a potentially explosive mixture of unburned gas and air. Natural draft occurs because the heated air and combustion products in a stack are lighter than the surrounding outside air and are displaced upward. The "draft", or negative pressure produced by the hot gases depends upon the stack temperature, height, and the friction loss of the venting system.

The requirements for venting of appliances regarding materials, construction and configurations are completely covered in the California Administrative Code, Title 24, Part 4 "Basic Mechanical Regulations (Article M9)". The sizing of venting systems as required by this Code, and also the National Fire Protection Association Bulletin 54, Appendix D, is reproduced on the following pages.

Refer to the Uniform Mechanical Code, Chapter 9, for further venting requirements.

APPENDIX M1-B

Table 1

Capacity of Type B Double Wall Vents Serving a Single Appliance

Height H	Lateral L	Vent diameter—D													
		3"	4"	5"	6"	7"	8"	10"	12"	14"	16"	18"	20"	22"	24"
Maximum appliance input rating in thousands of Btu per hour															
6'	0	46	86	141	205	285	370	570	850	1170	1530	1960	2430	2950	3520
	2'	36	67	103	157	217	285	453	650	890	1170	1480	1850	2220	2670
	6"	32	61	100	149	205	273	433	630	870	1150	1470	1820	2210	2650
	12"	28	55	91	137	190	253	408	610	840	1110	1430	1795	2180	2600
8'	0	50	94	153	235	320	415	660	970	1320	1740	2220	2750	3360	4010
	2'	40	75	120	180	247	322	515	745	1020	1340	1700	2110	2560	3050
	8"	35	66	109	165	227	303	490	720	1000	1320	1670	2070	2530	3030
	16"	28	58	96	148	206	281	458	685	950	1260	1600	2035	2470	2960
10'	0	53	100	166	255	345	450	720	1060	1450	1925	2450	3050	3710	4480
	2'	42	81	129	195	273	355	560	850	1130	1480	1890	2340	2840	3390
	10"	36	70	115	175	245	330	525	795	1080	1430	1840	2280	2750	3340
	20"	NR	60	100	154	217	300	486	735	1030	1360	1780	2230	2720	3250
15'	0	58	112	187	285	390	525	840	1240	1720	2270	2900	3620	4410	5300
	2'	48	93	160	225	316	414	675	985	1350	1770	2260	2800	3410	4080
	15"	37	76	128	198	275	373	610	905	1250	1675	2150	2700	3300	3980
	30"	NR	60	107	169	243	328	553	845	1180	1550	2050	2620	3210	3840
20'	0	61	119	202	307	430	575	930	1350	1900	2520	3250	4060	4980	6000
	2'	51	100	166	249	346	470	755	1100	1520	2000	2570	3200	3910	4700
	10"	44	89	150	228	321	443	710	1045	1460	1940	2500	3130	3830	4600
	30"	NR	78	134	206	295	410	665	990	1390	1880	2430	3050	3760	4550
30'	0	64	128	220	336	475	650	1060	1550	2170	2920	3770	4750	5850	7060
	2'	56	112	185	280	394	535	865	1310	1800	2380	3050	3810	4650	5600
	20"	NR	90	154	237	343	473	794	1185	1650	2200	2870	3650	4480	5310
	40"	NR	NR	NR	200	298	415	705	1075	1520	2060	2700	3450	4270	5140
40'	0	66	132	228	353	500	685	1140	1730	2400	3230	4180	5270	6500	7860
	2'	59	118	198	298	420	579	960	1420	2000	2680	3420	4300	5260	6320
	20"	NR	96	167	261	377	516	860	1310	1830	2460	3200	4050	5000	6070
	40"	NR	NR	NR	223	333	460	785	1205	1710	2310	3020	3840	4780	5820
60'	0	NR	136	236	373	535	730	1250	1920	2700	3650	4740	6000	7380	9000
	2'	NR	125	213	330	470	650	1060	1605	2250	3020	3920	4960	6130	7400
	30"	NR	NR	170	275	397	555	930	1440	2050	2760	3640	4700	5730	7000
	60"	NR	NR	NR	NR	334	475	830	1285	1870	2560	3380	4330	5420	6600
80'	0	NR	NR	239	381	550	755	1260	2020	2980	3900	5100	6450	8000	9750
	2'	NR	NR	217	350	495	683	1145	1740	2460	3320	4310	5450	6740	8200
	40"	NR	NR	NR	275	404	570	980	1515	2180	2980	3920	5000	6270	7650
	80"	NR	NR	NR	NR	NR	NR	NR	850	1420	2000	2750	3640	4680	5850
100'	0	NR	NR	NR	400	560	770	1310	2050	2950	4050	5300	6700	8600	10300
	2'	NR	NR	NR	375	510	700	1170	1820	2550	3500	4600	5900	7200	8800
	50"	NR	NR	NR	NR	405	575	1000	1550	2250	3100	4050	5300	6600	8100
	100"	NR	NR	NR	NR	NR	NR	NR	870	1430	2050	2850	3750	4900	6100

See Figure 1 and Notes for Single Appliance Vents.

APPENDIX M1-B

Table 2

Capacity of Single-Wall Metal Pipe or Type B Asbestos Cement Vents Serving a Single Appliance

Height H	Lateral L	Vent Diameter—D							
		3"	4"	5"	6"	7"	8"	10"	12"
Maximum appliance input rating in thousands of Btu per hour									
5'	0	39	70	116	170	223	312	500	780
	2'	31	55	94	141	194	280	415	630
	5'	28	51	85	128	177	242	390	600
8'	0	42	76	126	185	243	340	542	815
	2'	32	61	102	154	210	294	451	690
	5'	29	55	95	141	194	284	430	648
	10'	24°	49	86	131	180	250	406	625
10'	0	45	84	138	202	270	372	606	912
	2'	35	67	111	168	223	311	505	760
	5'	32	61	104	153	215	299	490	734
	10'	27°	54	94	143	200	274	445	700
	15'	NR	46°	84	130	186	258	422	666
15'	0	49	91	151	222	312	420	684	1040
	2'	39	72	122	186	260	350	570	865
	5'	35°	67	110	170	240	325	540	825
	10'	30°	58°	103	158	222	306	514	795
	15'	NR	50°	92°	144	207	291	488	760
	20'	NR	NR	82°	122°	195	278	466	726
20'	0	53°	101	163	252	342	470	770	1190
	2'	42°	80	136	210	286	392	641	990
	5'	38°	74°	123	192	264	364	610	945
	10'	32°	65°	115°	178	246	345	571	910
	15'	NR	55°	104°	163	228	326	550	870
	20'	NR	NR	91°	146°	214°	306	525	832
30'	0	56°	108°	183	276	384	520	878	1370
	2'	44°	84°	148°	230	320	441	730	1140
	5'	NR	78°	137°	210	296	410	694	1080
	10'	NR	68°	125°	196°	274	388	656	1050
	15'	NR	NR	113°	177°	258°	366	625	1000
	20'	NR	NR	99°	163°	240°	344	596	960
30'	NR	NR	NR	NR	192°	295°	540	890	
50'	0	NR	120°	210°	310°	443°	590	980	1550
	2'	NR	95°	171°	260°	370°	47	820	1290
	5'	NR	NR	159°	234°	342°	474	790	1230
	10'	NR	NR	146°	221°	318°	454°	730	1190
	15'	NR	NR	NR	200°	292°	407°	705	1130
	20'	NR	NR	NR	195°	278°	384°	670°	1080
30'	NR	NR	NR	NR	222°	330°	605°	1010	

See Figure 1 and Notes for Single Appliance Vents.

APPENDIX M1-B

Table 3
Capacity of Masonry Chimneys and Single-Wall Vent Connectors
Serving a Single Appliance

Height H	Lateral L	Single-wall vent connector diameter—D							
		To be used with chimney areas not less than those at bottom							
		3"	4"	5"	6"	7"	8"	10"	
		Maximum appliance input rating in thousands of Btu per hour							
6'	2'	28	33	36	120	130	247	400	500
	5'	23°	48	51	115	154	220	375	500
8'	2'	29	35	38	145	157	285	445	600
	5'	26°	61	57	133	152	246	422	528
	10'	22°	44°	79	123	150	233	400	505
10'	2'	31	31	102	161	220	297	480	722
	5'	28°	55	55	147	202	270	455	710
	10'	24°	49°	85	137	180	261	441	645
	15'	NR	42°	75°	125	175	246	421	634
15'	2'	29°	37	113	175	240	325	500	840
	5'	25°	61	104	163	220	312	521	825
	10'	27°	54°	95	151	214	294	504	774
	15'	NR	46°	87°	135	195	275	451	725
20'	2'	29°	73	123	200	272	374	635	900
	5'	25°	67°	115	133	222	345	504	920
	10'	NR	59°	105°	170	235	320	542	875
	15'	NR	NR	95°	135	217	311	536	835
30'	2'	29°	144°	202	302	374	535	810	1240
	5'	NR	75°	127°	195	270	391	600	1000
	10'	NR	66°	113°	182°	260	370	544	1020
	15'	NR	NR	105°	165°	240°	340	515	975
30'	2'	NR	NR	NR	NR	NR	NR	NR	NR
	5'	NR	NR	NR	NR	NR	NR	NR	NR
	10'	NR	NR	NR	NR	NR	NR	NR	NR
	15'	NR	NR	NR	NR	NR	NR	NR	NR
30'	2'	NR	91°	160°	200°	250°	475	610	1240
	5'	NR	NR	140°	225°	321°	442	770	1220
	10'	NR	NR	125°	215°	301°	420°	725	1140
	15'	NR	NR	124°	195°	275°	395°	605	1000
30'	20'	NR	NR	NR	NR	NR	NR	NR	NR
	25'	NR	NR	NR	NR	NR	NR	NR	NR
Minimum internal area of chimney-A square inches			19	23	28	39	63	95	122

See Table 7 for masonry chimney liner sizes.
 See Figure 3 and notes for single appliance vents.

APPENDIX M1-B

Table 4

Capacity of Type B Double-Wall Vent Serving Two or More Appliances
Vent Connector Capacity

Total vent height "R"	Connector rise "R"	Vent connector diameter—D													
		3"	4"	5"	6"	7"	8"	10"	12"	14"	16"	18"	20"	22"	24"
		Maximum appliance input rating in thousands of Btu per hour													
6'	1'	26	46	72	104	142	185	289	416	577	755	955	1180	1425	1700
	2'	31	55	86	124	168	220	345	496	653	853	1090	1335	1610	1920
	3'	35	62	96	139	189	248	386	556	740	967	1225	1510	1830	2180
8'	1'	27	48	76	109	148	194	303	439	601	805	1015	1255	1520	1810
	2'	32	57	90	129	175	230	358	516	696	910	1150	1420	1720	2050
	3'	36	64	101	145	198	258	402	580	790	1030	1305	1610	1950	2320
10'	1'	28	50	78	113	154	200	314	452	642	840	1060	1310	1585	1890
	2'	33	59	93	134	182	238	372	536	730	955	1205	1490	1800	2150
	3'	37	67	104	150	205	268	417	600	827	1060	1370	1690	2040	2430
15'	1'	30	53	82	120	162	214	333	480	697	910	1150	1420	1720	2050
	2'	35	63	99	142	193	253	394	568	790	1030	1305	1610	1950	2320
	3'	40	71	111	160	218	286	444	640	898	1175	1485	1835	2220	2640
20'	1'	31	56	87	125	171	224	347	500	740	965	1225	1510	1830	2190
	2'	37	66	104	149	202	265	414	596	840	1095	1385	1710	2070	2470
	3'	42	74	116	168	228	300	466	672	952	1245	1575	1945	2350	2800
30'	1'	33	59	93	134	182	238	372	536	805	1050	1330	1645	1990	2370
	2'	39	70	110	158	215	282	439	632	910	1190	1500	1855	2240	2670
	3'	44	79	124	178	242	317	494	712	1035	1350	1710	2110	2550	3040
40'	1'	35	62	97	140	190	248	389	560	850	1110	1405	1735	2100	2500
	2'	41	73	115	166	225	295	461	665	964	1260	1590	1965	2380	2830
	3'	46	83	129	187	253	331	520	748	1100	1435	1820	2240	2710	3220
60' to 100'	1'	37	66	104	150	204	266	417	600	926	1210	1530	1890	2280	2720
	2'	44	79	123	178	242	316	494	712	1050	1370	1740	2150	2590	3090
	3'	50	89	138	200	272	355	555	800	1198	1565	1980	2450	2960	3520

Common Vent Capacity

Total vent height "R"	Common vent diameter													
	3"	4"	5"	6"	7"	8"	10"	12"	14"	16"	18"	20"	22"	24"
	Combined appliance input rating in thousands of Btu per hour													
6'	—	65	103	147	200	260	410	588	815	1065	1345	1660	1970	2390
8'	—	73	114	163	223	290	465	652	912	1190	1510	1860	2200	2680
10'	—	79	124	178	242	315	495	712	965	1300	1645	2030	2400	2920
15'	—	91	144	206	280	365	565	825	1158	1510	1910	2360	2790	3400
20'	—	102	160	229	310	405	640	918	1290	1690	2140	2640	3120	3800
30'	—	118	185	268	360	470	740	1025	1525	1990	2520	3110	3680	4480
40'	—	131	203	296	405	525	820	1180	1715	2240	2830	3500	4150	5050
60'	—	NR	224	324	440	575	900	1350	2010	2620	3320	4100	4850	5900
80'	—	NR	NR	344	468	610	955	1440	2250	2930	3710	4590	5420	6600
100'	—	NR	NR	NR	479	625	975	1670	2450	3200	4050	5000	5920	7200

See Figure 3 and notes for multiple appliance vents.



APPENDIX M1-B

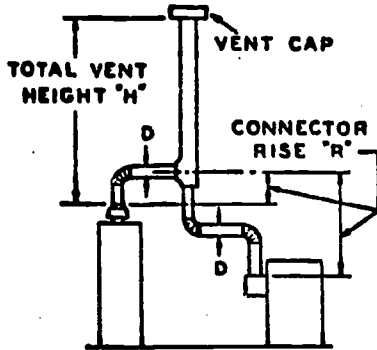


Figure 3

Double-Wall or Asbestos Cement Type B Vents or Single-Wall Metal Vents Serving Two or More Appliances. (See Tables 4 and 5.)

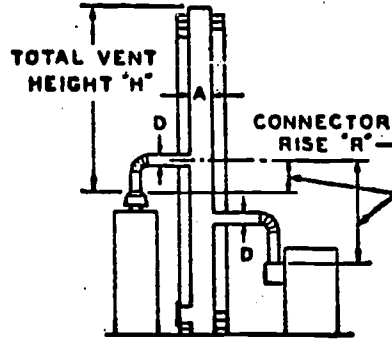


Figure 4

Masonry Chimney Serving Two or More Appliances. (See Table 6.)

NOTES FOR MULTIPLE APPLIANCE VENTS. (See Tables 4, 5 and 6.)

1. Maximum Vent Connector Length $1\frac{1}{2}$ feet for every inch of connector diameter. Greater lengths require increase in size, rise or total vent height, to obtain full capacity.
2. Each 90-degree turn in excess of the first two reduces the connector capacity by 10 percent.
3. Each 90-degree turn in the common vent reduces capacity by 10 percent.
4. Where possible, locate vent closer to or directly over smaller appliance connector.
5. Connectors must be equal to or larger than draft hood outlets.
6. If both connectors are same size, common vent must be at least one size larger, regardless of tabulated capacity.
7. Common vent must be equal to or larger than largest connector.
8. Interconnection fittings must be same size as common vent.
9. Use sea level input rating when calculating vent size for high altitude installation.
10. Designation "NR" in Tables 4, 5 and 6 indicates not recommended.

APPENDIX M1-B

Table 5

Capacity of A Single-Wall Metal Pipe or Type B Asbestos
Cement Vent Serving Two or More Appliances

Vent Connector Capacity

Total vent height "H"	Connector rise "R"	Vent connector diameter—D					
		3"	4"	5"	6"	7"	8"
Maximum appliance input rating in thousands of Btu per hour							
6'-8'	1'	21	40	68	102	148	205
	2'	28	53	86	124	178	235
	3'	34	61	98	147	204	275
15'	1'	23	44	77	117	179	240
	2'	30	56	92	134	194	265
	3'	35	64	102	155	216	293
30' and up	1'	25	49	84	129	190	270
	2'	31	58	97	145	211	295
	3'	36	68	107	164	232	321

Common Vent Capacity

Total vent height "H"	Common vent diameter						
	4"	5"	6"	7"	8"	10"	12"
Combined appliance input rating in thousands of Btu per hour							
6'	48	78	111	155	205	320	NR
8'	55	89	128	175	234	365	505
10'	60	95	136	190	250	395	560
15'	71	115	168	228	305	480	690
20'	80	129	186	260	340	550	790
30'	NR	147	215	300	400	650	940
50'	NR	NR	NR	360	490	810	1190

See Figure 3 and notes for multiple appliance vents.

APPENDIX M1-B

Table 6
Capacity of A Masonry Chimney and Single-Wall Vent
Connectors Serving Two or More Appliances

Single-Wall Vent Connector Capacity

Total vent height "H"	Connector rise "R"	Vent connector diameter—D					
		3"	4"	5"	6"	7"	8"
Maximum appliance input rating in thousands of Btu per hour							
6'-8'	1'	21	30	66	100	140	200
	2'	28	52	84	123	172	231
	3'	34	61	97	142	202	280
	1'	23	43	73	112	171	225
18'	2'	30	54	88	132	189	256
	3'	34	63	101	151	213	289
30' and up	1'	24	47	80	124	182	250
	2'	31	57	93	142	205	282
	3'	35	65	105	160	229	312

Common Chimney Capacity

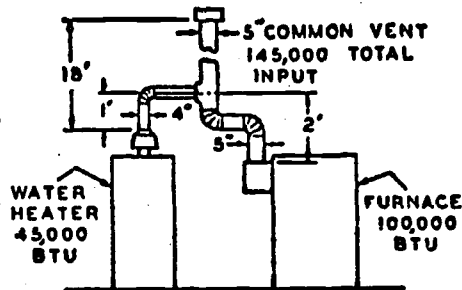
Total vent height "H"	Minimum internal area of chimney—"A" Square inches					
	19	28	38	50	78	113
Combined appliance input rating in thousands of Btu per hour						
6'	45	71	102	142	245	NR
8'	52	81	115	162	277	405
10'	55	89	129	175	300	450
18'	65	105	150	210	360	540
20'	74	120	170	240	415	640
30'	NR	135	195	275	490	740
50'	NR	NR	NR	325	600	910

See Table 7 for Masonry Chimney Liner Sizes.
 See Figure 4 and Notes for Multiple Appliance Vents.

APPENDIX M1-B

Example of Multiple Vent Design Using Table 4 Double Wall Type B Vent

Figure 5
EXAMPLE: Connect a 45,000 Btu water heater with a 1 foot connector rise "R" and a 100,000 Btu furnace with a 2 foot connector rise "R" to a common vent with a minimum total vent height "H" of 18 feet. See Figure 5.



1. WATER HEATER VENT CONNECTOR SIZE

Using Table 4, read down Total Vent Height "H" column to 15 feet and read across 1 foot connector rise "R" line to Btu rating equal to or higher than water heater input rating. This figure shows 53,000 Btu and is in the column for four-inch connector. Since this is in excess of the water heater input it is not necessary to find the maximum input for an 18 foot minimum total vent height. Use a four-inch connector.

2. FURNACE VENT CONNECTOR SIZE

Under Vent Connector Tables read down Total Vent Height "H" column to 15 foot and read across 2 foot Connector Rise "R" line. Note 5 inch vent size shows 99,000 Btu per hour or less than furnace input. However, with 20 foot Total Height read across 2 foot connector rise line. Note 5 inch vent size shows 104,000 Btu per hour. Since 18 foot height is $\frac{3}{5}$ th of difference between 15 and 20 foot heights take difference between 99,000 and 104,000 or 5,000 and add $\frac{3}{5}$ ths of this to 15 foot figure of 99,000. $99,000 + 3,000 = 102,000$ which is maximum input for 18 foot Total Vent Height. Therefore a 5-inch connector would be the correct size for the furnace, providing the furnace had a five-inch or smaller draft hood outlet.

3. COMMON VENT SIZE

Total input to Common Vent is 145,000 Btu. Note that for 15 foot Total Vent Height "H" maximum Btu for 5 inch vent is 144,000. For 20 foot Total Vent Height "H" maximum Btu for 5 inch vent is 160,000.

Therefore for 18 foot Total Vent Height maximum allowable input would be $\frac{3}{5}$ th of difference between 144,000 and 160,000 = $\frac{3}{5}$ th \times 16,000 or 9,600. $144,000 + 9,600 = 153,600$ which is greater than total input to common vent. Therefore common vent can be 5 inch diameter pipe.

12. SOUND CONTROL IN VENTILATION SYSTEMS

There are three aspects of sound control and suppression of noise that are of concern to the mechanical inspector:

1. Internal noises in the ventilation system that are annoying to the building occupants.
2. External noises from outdoor equipment that are objectionable to the occupants of neighboring buildings, or to the general public.
3. Noise detrimental to health.

General

Noise is defined as unwanted sound. Sounds that may go unnoticed in one environment may be unacceptable in another. What may be music to one man may be noise to another. Sound pressure is the pressure at a point measured in a passing sound wave. Sound power is the power expressed in watts which is radiated by an acoustic source. A decibel, which is an electrical engineering term, is 10 times the logarithm, to the base 10, of a ratio of two numbers, as:

$$A = 10 \log_{10} \frac{N_1}{N_2} \text{ decibels (db)}$$

Related to sound measurements, the sound power level in decibels is:

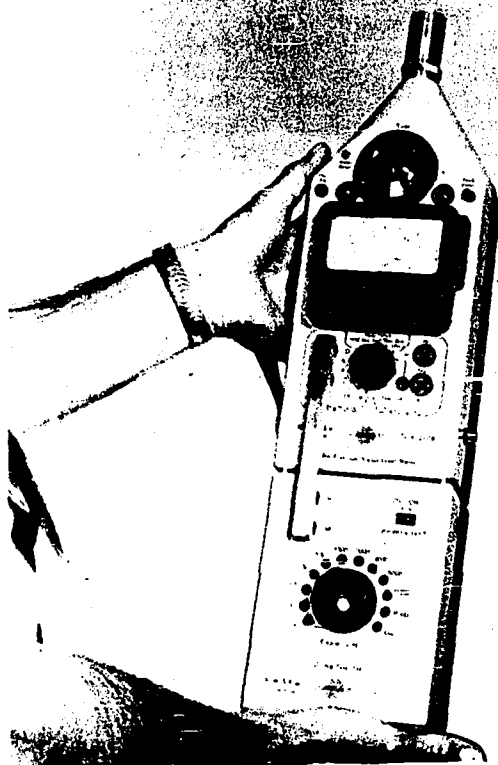
$$L = 10 \log_{10} \frac{W_1}{W_0} \text{ db}$$

where W_1 = the power in watts of an acoustic source

W_0 = a reference power

The reference power commonly used is 10^{-12} watt, which is 0.000000000001 watts. When two sounds are given a decibel rating by using the same reference, they can be compared with each other and it can be stated that one produces more acoustic power than the other.

The sound level meter is the basic instrument used in all sound measurement. It consists of a microphone, an attenuator, amplifier and usually three weighting networks; A, B and C. The A scale gives the most important overall measurement, and is most commonly referred to in government regulations as "dbA". Fig. 12-1 shows a sound level meter. Fig. 12-2 is a comparative chart of overall sound levels.



Impacts and impulses in excess of 140 dB can be measured with a precision analyzer from B & K Instruments, Inc. Unit incorporates a sound level meter with an octave-band filter.

Fig. 12-1

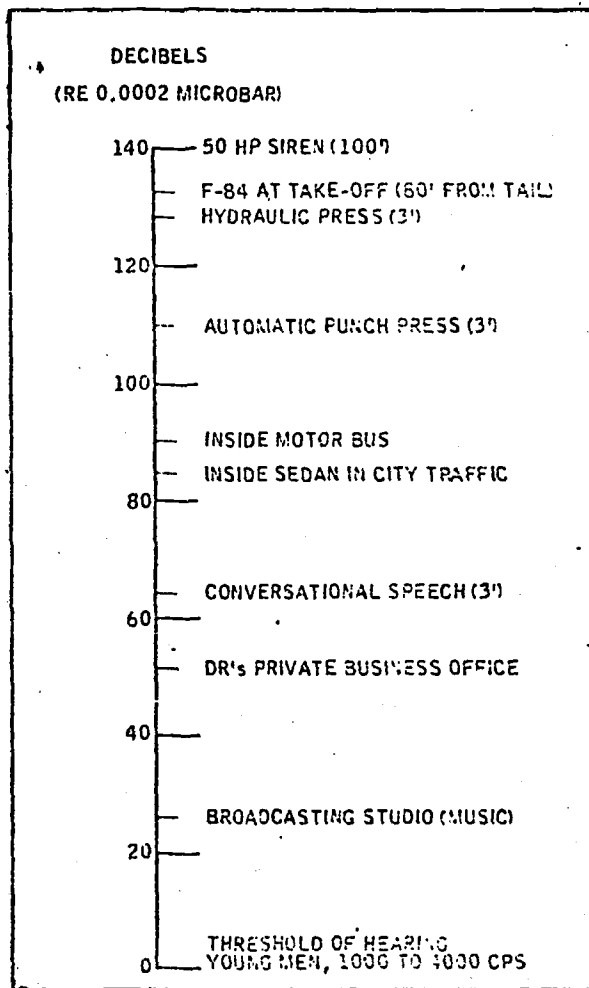


Fig. 12-2

Ventilating System Internal Noises

Generation and transmission of noise can be avoided in some areas by observing the following:

1. Install balancing dampers ahead of the outlets and far enough away so that air noise caused by throttling will not be audible in the room. This duct should be lined.
2. Mixing damper should be tightly sealed when closed, otherwise a high frequency noise will be generated.
3. Check high pressure duct for small joint leaks and around flexible duct connections.
4. Flexible duct connections should have ample material so joint is not taut, and supported so that duct does not hang on the joint.
5. Where sound absorbing units are installed, use flexible duct connections.
6. Support fan units from the overhead with hanger rod vibration isolators.

7. To prevent transmission of sound and vibration from pumps, install flexible joints in the vertical and horizontal runs of the discharge piping.
8. Use resilient lined pipe hangers where supported from the overhead.
9. Use flexible conduit for electrical connections to fans and pumps.
10. At fan discharges, use several diameters of duct length before turning the air.
11. Do not allow air to separate from the sides of the duct walls by changing its direction too quickly after a previous change. Sudden changes in duct shapes cause turbulence, which generates noise.

Ventilating System External Noises

The location of cooling towers and condensing units on or around buildings involves considerable study and research by the designer. Locating such equipment away from possible complaints is usually the least expensive solution. Walls, screens or similar acoustical barriers may produce an acceptable sound level. Enclosures placed around cooling towers should be sized as recommended by the manufacturer so as to not restrict the air flow into the tower, and not cause any recirculation of the discharge air. The various municipalities have adopted noise requirements for ventilating equipment which varies considerably between residential and commercial areas, proximity to freeways, etc, and may or may not take the ambient noise level into account.

The Air Conditioning and Refrigeration Institute* publishes sound rating numbers of outdoor unitary equipment rated in accordance with ARI Standard 270-67. This rating number is used in their Sound Rating Program to predict the sound level before installation.

Noise Detrimental to Health

Noise pollution is now recognized as a major threat to human well-being. Most people are uncomfortable when subjected to a noise level of 80 db and suffer physiological effects above 80 db. Long exposures at 100 db can cause hearing impairment and permanent damage. In recognition of this, the Walsh-Healey Act (Federal) and California State General Industry Safety Orders adopted 90 dbA as the maximum allowable 8-hour exposure. Higher levels are permissible for shorter periods, all as set forth in Fig. 12-3. Noise at these levels is generated by gas turbines, air compressors, induced draft fans and similar equipment in equipment rooms.

* Published by Air Conditioning and Refrigeration Institute, 1815 North Fort Myer Drive, Arlington, Virginia 22209

GROUP 61. NOISE CONTROL SAFETY ORDERS

Article 55. Standards for Occupational Noise Exposure

3870. Purpose. Article 55 sets up standards for the control of and exposure to industrial noise in order to contribute to the conservation of employees' hearing. Daily exposure for the times and noise intensities specified represent conditions under which nearly all workers may be exposed throughout their working years without causing permanent hearing loss sufficient to affect their ability to hear and understand normal speech.

NOTE: Authority cited: Sections 6312, 6500 and 6502, Labor Code.
History: 1. New Article 55 (Sections 3870 through 3872) filed 2-13-68; effective thirtieth day thereafter (Register 63, No. 3).
2. Repealer and new Article 55 (Sections 3870 through 3874) filed 8-20-70; effective thirtieth day thereafter (Register 70, No. 34).

3871. Surveys. Whenever noise levels have been demonstrated to exceed those sound levels in Table I, the employer shall make or cause to have made noise evaluations to determine the magnitude of exposure to employees. Such records shall be maintained and made available to the Division.

3872. Allowable Exposure.

(a) **Intermittent or Continuous Noise,**

Table 1

Total Exposure Time Per Day, Hours	Sound Level dBA
8	90
6	92
4	95
3	97
2	100
1½	102
1	105
½ or less	110
	115

NOTE: Sound levels shall be measured with a sound level meter which meets the ANSI S1.1-1961 Specifications for General Purpose Sound Level Meters standard or equivalent, set on the A scale and slow response. Noise exposures at different levels are combined by adding the fraction of the allowable time used at each exposure. The sum of such fractions should not exceed unity. For example, if an exposure consisted of 1 hour at 100 dBA (allowable 2 hours) and 3 hours at 90 dBA (allowable 4 hours) and 4 hours at less than 90 dBA (no limit) the sum of the fractions of the allowable time used would be $\frac{1}{2} + \frac{3}{4} + 0 = \frac{5}{4}$. Since this is less than 1, the allowable exposure is not exceeded.

(b) **Impact or Impulsive Noise.** Exposure to impact or impulsive noise shall not exceed 140 dB peak sound pressure level.

NOTE: Peak sound pressure levels shall be measured with an instrument having a rise time of 50 microseconds or less (for square waves) and which will measure and display the sound pressure level within 1 dB of the true peak.

3873. Engineering Control of Noise. Whenever the operations reasonably permit, exposures to excessive noise shall be eliminated or at least reduced by engineering or operational controls. When such exposures are not reduced to allowable levels specified in Section 3872, a continuing effective hearing conservation program shall be administered.

3874. Personal Protective Equipment. (a) **When to Be Worn.** Whenever the exposure to noise exceeds the levels given in Section 3872, the employer shall provide and the employees shall use acceptable ear protectors. (For the purpose of these Orders, "acceptable" means acceptable to the Division.)

(b) **Education in Use of Equipment Required.** The employee shall be informed of the locations where the wearing of ear protectors is required and shall be instructed in the use of such ear protectors.

(c) **Provision and Care of Equipment.** Duty of Employer and Employee. It shall be the duty of the employer to provide such ear protectors as may be required and to replace them when necessary. It shall be the duty of the employee to properly use such equipment provided for him and to exercise due care to keep same in efficient and sanitary condition.

What Are Allowable Exposures?

Allowable exposures for intermittent or continuous noise are specified in Table I, Section 3872 of the Noise Control Safety Orders. It is permissible to interpolate the data on allowable exposures. For example, if after all practical efforts to reduce the level the noise level is still 91 dBA and the time is 7 hours, then that exposure would be allowable. Extrapolation is not allowable for short exposures above 115 dBA. The criteria in Table I is based on the fact that short daily exposures are usually intermittent, this assumption is reasonably safe if the sound levels are between 90 dBA and 115 dBA; however, extrapolation above 115 dBA might result in harmful exposure.

It is not necessary to extrapolate the data in Table I for daily exposures of more than 8 hours or to record noise exposures below 90 dBA. If such extrapolations are desired, then it is proper to permit exposures at 87 dBA for 16 hours and at 89 dBA for 10 hours, in accordance with the equal energy concept (or a 3 dB increase when exposure time is cut in half).

The Second Intersociety Committee on Guidelines for Noise Exposure Control are shown in Table A.

You can see that in preparing Table I of California's revised noise control regulations, daily noise exposures of an hour or less were assumed to occur in 7 or more intermittent exposures evenly distributed throughout the day. For longer exposures that accumulatively total more than 4 hours in a day, the noise was assumed to occur in 3 separate exposures. The damage from a single exposure to noise follows the equal energy concept (or a 3 dB increase when exposure time is cut in half).

What About Impact or Impulsive Noise?

Considerable hearing loss can result from impact or impulsive noise. Impact noise frequently occurs where the ambient continuous noise exceeds the levels in Table I of the Noise Control Safety Orders. If ear protectors are worn because of the continuous noise, surveys of the impulsive noise will not be required in most cases.

Table A
ACCEPTABLE EXPOSURES TO NOISE IN dBA
AS A FUNCTION OF THE NUMBER OF
OCCURRENCES PER DAY

Daily Duration Hours Min.	Number of Times the Noise Occurs Per Day						160 up
	1	3	7	15	35	75	
8	90	90	90	90	90	90	90
6	91	93	96	98	97	95	94
4	92	95	99	102	104	102	100
2	95	99	102	106	109	114	
1	98	103	107	110	115		
30	101	106	110	115			
15	105	110	115				
8	109	115					
4	113						

To use the table, select the column headed by the number of times the noise occurs per day, read down to the average sound level of the noise, and locate directly to the left in the first column the total duration of noise permitted for any 24-hour period. It is permissible to interpolate if necessary. Noise levels are in dBA.



13. INSULATION

Insulation is used extensively in air conditioning systems on hot and cold piping, equipment, and for wrapping or lining ducts.

The unit of measurement of the effectiveness of an insulating material is its thermal conductivity, also called the K-factor. This is defined as the amount of heat, in btu per hour that will flow through a panel 1 foot square and 1 inch thick when one face is 1° F hotter than the other, or:

$$\text{Btu per hour, per sq ft} = K \times \text{temp difference/inch thickness.}$$

The K-value for some common heat-insulating materials at 100° F mean temperature are:

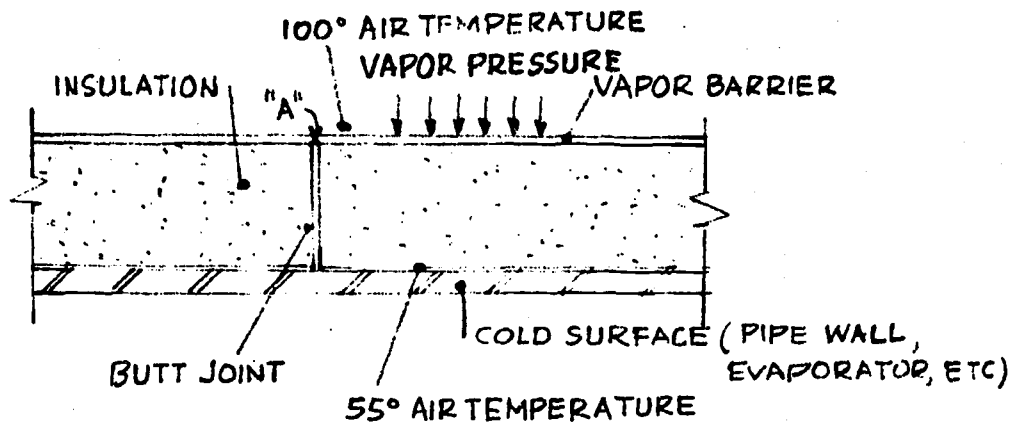
	<u>K-value</u>
calcium silicate	0.33
85% magnesia	0.39
mineral wool (rock, slag, or glass wool blankets)	0.25

For low temperatures the following insulating materials are used:

	<u>K-value</u> (at 100° mean temp)
polystyrene	0.28
polyurethane	0.17
fiber glass	0.30
cork	0.29
cellular glass	0.42
flexible foamed plastic (armaflex)	0.26

Insulation materials have other important properties and differences besides K-values that have to be considered for a given application. For instance, calcium silicate and fiber glass pipe insulation can be soaked with water and not lose its shape, but magnesia will disintegrate. Cellular foam glass has a slightly higher K-value and is more expensive, but has a high compressive strength and is absolutely impervious to water vapor transmission. The limiting high temperatures of various insulating materials varies widely, and this must be observed.

Insulation applied to cold surfaces must be provided with a vapor-tight jacket or barrier to prevent water vapor from passing through the material or joints and condensing on the cold surface.



Referring to the sketch, the vapor pressure of the 100° air is higher than the vapor pressure of the 55° air next to the cold surface and will force moist air through an ineffective vapor barrier, or an unsealed butt joint as at "A". If allowed to continue, the condensate will completely soak all the insulation along the pipe and render it useless. For this reason great care must be taken to install a perfectly tight barrier, and to butter all longitudinal and butt joints with cement before assembling the sections. Vapor barriers are laminated foil and treated papers, coated felts and papers, plastic films, or canvas wrap with 2 or more coats of lagging adhesive. Some pipe insulation is manufactured with the barriers attached. Obtain samples of various canvas weights for identifying the material being used. The following points should be observed in insulating piping and equipment:

1. Piping insulation includes valves, strainers and fittings. Flanges and unions are generally not insulated, except for chilled water.
2. Provide shields at hanger supports to protect the insulation. For very large pipes it may be necessary to insert hard wood blocks at the point of bearing. Shields should distribute the load along the insulation without deforming it.
3. Fill all voids and openings in cold insulation where cut out for hangers or supports with suitable material before applying sealing tape. Insulate hangers that are in direct contact with cold surfaces to prevent sweating.
4. Insulate all piping passing through walls, floors, etc.
5. Stagger butt joints, and coat all joints amply with water-proof cement on cold insulation.
6. Insulate valves up to the bonnet.

7. Install removable metal jacketed insulation sections around heat exchanger heads and similar equipment which have to be opened up for maintenance and repair.
8. The State Division of Industrial Safety requires that all surfaces hot enough to burn flesh shall be insulated (about 160° F).
9. Do not cover any stampings such as ASME name plates or vessels or similar equipment.

Duct insulation is applied to the outside of ducts for a heat barrier only, or to the inside for a heat barrier and sound attenuation. When wrapped around the outside it needs to be cemented to the duct sides and bottom at intervals, and then tied around with wire or steel bands. The joints should be lapped at all joints (2" to 4"). When the insulation is applied internally, the duct size must be enlarged to accommodate the insulation (breadth and width) so that the net inside dimensions will be as shown on the design drawings. The material is held in place with cement and studs and washers; the studs being cemented or welded to the duct side. Edges of the insulation exposed to the air stream are coated with adhesive to prevent erosion and firmly held down to the duct side. Duct liners are furnished with facings of clear or black coatings designed to prevent erosion by the air. Each manufacturer states the limiting velocity that may be used, and also specifies the methods of attaching and finishing the material for various velocity ranges.

A few points to watch for in duct insulation are:

1. Check to see if joints are properly taped before insulator starts.
2. Check duct hangers for attachment to duct and proper tension (no slack).
3. Insulation should be placed between turning vane end plates and ducts.
4. Insulation liner should not interfere with operation of mixing dampers. (Place insulation on outside of damper box).
5. Check insulation density and thickness for compliance with specifications.
6. Check placement of cement on outside of ducts and spacing of tie wires.
7. Access panels on duct to be uncovered or plainly marked.
8. Drops to ceiling outlets are insulated.
9. All insulation sealers, cements, etc, shall meet the Fire Marshall's requirements for fire resistance, smoke generation, etc.

14. AIR DUCTS

Ducts come in a variety of shapes and materials; steel, fiberglass, transite, neoprene coated glass fabric, aluminum, and so on. This section will cover sheetmetal and fiberglass ducts as most relevant to ventilating systems.

Sheetmetal Ducts

Sheetmetal systems are classified as low, medium, or high pressure; low pressure being from 0 to 2" water column, medium pressure 2" to 6", and high pressure 6" through 10" water column. If the duct velocity exceeds 2,000 fpm in the medium and high pressure zones, the system is called "high velocity".

The Sheet Metal and Air Conditioning Contractors National Association (SMACNA), P. O. Box 3506, Washington, D. C. 20007, has developed a standard for low velocity and high velocity duct construction, which is generally specified for the construction of ducts, fittings and appurtenances. The appendix contains some of the pages from the SMACNA Manual showing metal gauges required and stiffening needed for various sizes of rectangular and round ducts in all three pressure groups. Also detailed are the recommended types of seam joints for the different duct sizes. Of particular importance is the data giving the spacing and dimensions of reinforcing angles, designed to prevent "breathing" and sagging of the tops and bottoms of ducts. Stiffening of plenums is frequently overlooked and should be checked for sag, and the plenum observed for movement when the fans are turned on and off. Ducts on the suction side of a fan are subject to collapse if the inlet air damper is closed because of a control malfunction and if there is insufficient duct reinforcing. SMACNA plate 10 shows the recommended hanger arrangements for low and high pressure ducts.

Metal ducts are lined with fiberglass blankets for the insulating effect and sound attenuation, and accordingly must be made large enough to obtain the net (inside) dimensions shown on the drawings. Many times this is overlooked by the contractor who fabricates and lines the duct in the shop, and then the mistake is discovered too late. Duct liner insulation must be furnished with a coating or facing to prevent erosion by the air, and edges have to be coated or taped to prevent peeling and unlaying.

Transverse duct seams are taped with various materials to reduce air leakage; and, if called for in the specifications, should be done whether the duct is lined or not. Some workmen will get careless in making up joints, relying on the tape for air tightness. Tape cannot take the place of a properly made joint. Where ducts are too close to the overhead to hammer closed the standing seams, type A, B, or C drive slips should be used.

Fiber Glass Duct

Fig. 14-1 shows the different forms of fiberglass duct. Ducts constructed of fiberglass board are restricted to 2" w.g. and 3,000 fpm with suitable bracing as recommended by the manufacturer and SMACNA. The board is covered with a thin sheet of aluminum.

Fig. 14-2 shows the method of fabricating a section of duct, where the total of the inside dimensions does not exceed 120", the maximum stock length of the board. Larger ducts are fabricated in pieces. The longitudinal and transverse joints are sealed closed with a self adhering aluminum tape applied with a heated roller iron.

The hanging and bracing requirements recommended by the SMACNA Manual on Fiber Glass Duct (see appendix) should be closely checked by the inspector.

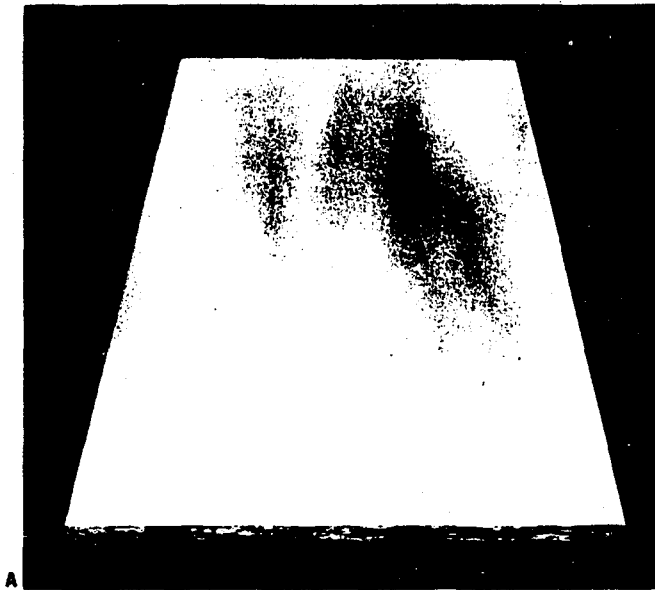
Duct Fittings and Configurations

Turning vanes, shown in Fig. 14-3, are used in square elbows where space limitations prevent installing a round elbow. The round elbow (with a center line radius 1.5 times the duct dimension parallel to the radius) has a smaller friction loss than the vane elbow and should be used where possible. The stock runner for turning vanes is made to fit across the heel of the elbow at a 45° angle to the entering and leaving air stream. This is correct when the elbow has the same entering and leaving dimensions, but when there is a size transition the 45° stock runner places the vanes partially crossways with the air stream and causes turbulence, rather than reducing it. The runner should be modified so that the upstream and downstream edges of the vane line up with the air streams. Where ducts are lined, the vane runners should sit on channel shaped chairs with the lining flush with the runner.

Fig. 14-3a shows an incorrect but commonly used elbow. Nothing is gained by rounding the outer corner; the inner corner should have a radius, or turning vanes used if this is not possible.

Sudden enlargements or contractions (Fig. 14-4) should not be made in ducts because of the energy loss. A slope of 1 in 5 is satisfactory. Where steeper transitions cannot be avoided, vanes placed inside the transition piece will reduce the pressure loss (Fig. 14-6).

The most common problems encountered in the field in installing duct work is insufficient space and obstacles, such as pipes, structural members and lights (in hung ceilings).



A



C

B



D



A Duct Board, standard duty (SD and RSD, or MSD with fiber glass mat liner) or heavy duty (HD or RHD), with factory-applied facings of 3-mil aluminum (A) or Foil-Scrim-Kraft (F), for field or shop fabrication or rectangular ducts and fittings of specified cross-section dimensions. Available with plain, flush edges, or with molded-in male and female "slip-joint" edges (MF) on the long dimension of 1-inch-thick Type SD board.

B Preformed Round with factory-molded male and female "slip-joint" ends. Available with tough, aluminum-pigmented plastic (SR) or 3-mil aluminum (AR) vapor/air barrier jackets.

C Flexible (FLX) with exclusive resin-bonded fiber glass helix covered with resilient fiber glass insulation and jacketed with tough, aluminum-pigmented plastic.

D Micro-Aire FS preformed round, with an integral, embedded foil seal midway in the wall thickness. Primarily for warm air systems, but useful for air conditioning under certain design conditions.

Johns-Manville Co.

Fig. 14-1

FABRICATION MICRO-AIRE DUCT BOARD / THE CENTERLINE METHOD

As its name implies, the Centerline Method of fabrication involves the use of line markings on the board on which the various tools are centered and along which they are guided for accurate cutting. In the Centerline Method, either of two types of longitudinal corner fold configurations may be used — the V-Groove or the Modified Shiplap — and grooving tools are designed for each type.

Each configuration has its merits and the choice is left to the system designer or fabricator. Although in installation, the two types are basically compatible, it is recommended that if automatic grooving machines are used, any hand fabrication of ducts or fittings for the same job be made with the corresponding style of corner folds.

In the following step-by-step instructions, drawings and photographs, the original V-Groove type will be used. This will give the fabricator the fundamental procedures regardless of the type of corner fold ultimately used. A separate section describing the newer Modified Shiplap concept is presented later.

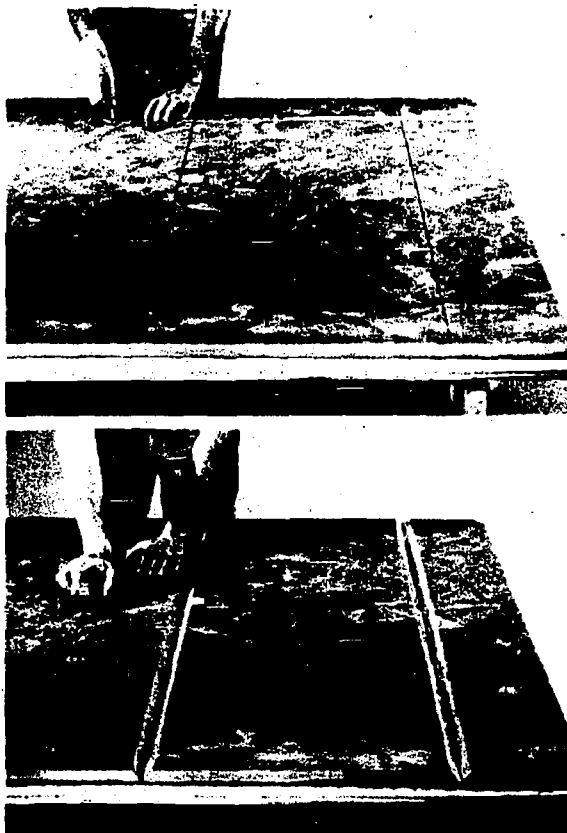
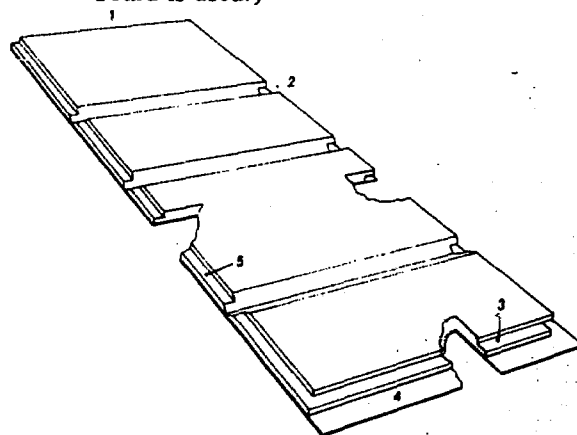


Fig. 14-2

Five basic cutting operations are involved in making a typical section of straight duct:

- (1) Knife cut at stretchout length.
- (2) Grooves for corner folds.
- (3) Rabbet cut for closing corner.
- (4) Cutting and stripping away insulation to expose longitudinal stapling flap.
- (5) Rabbet cuts for male-female slip-joint connections between duct sections. (This step is eliminated when Micro-Aire SD/MF board is used.)

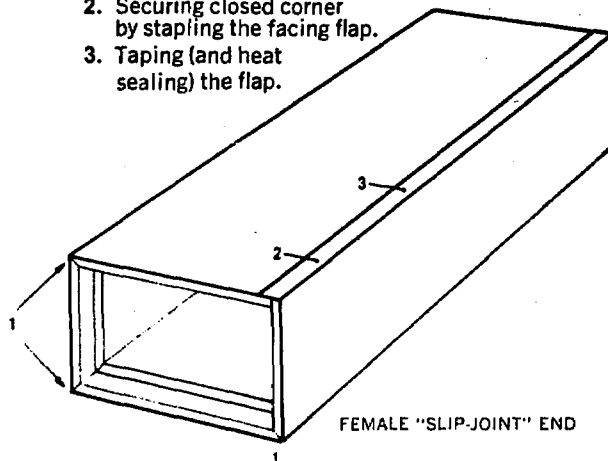


The Centerline Method of fabrication employs the same principles used in fabricating sheet metal ductwork, namely:

- (1) Layout is done on the board prior to cutting and forming.
- (2) Measurements are made in succession from the starting point or preceding mark.

Three final steps make the fabricated board into a duct section:

1. Folding groove corners.
2. Securing closed corner by stapling the facing flap.
3. Taping (and heat sealing) the flap.



Johns-Manville Co.

VANED ELBOW DETAILS

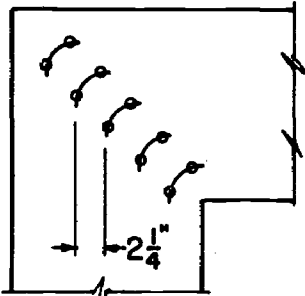
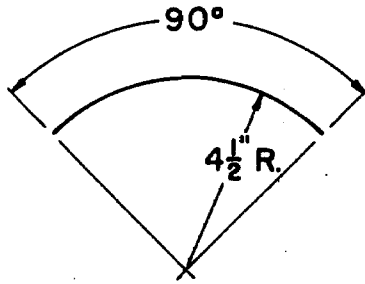
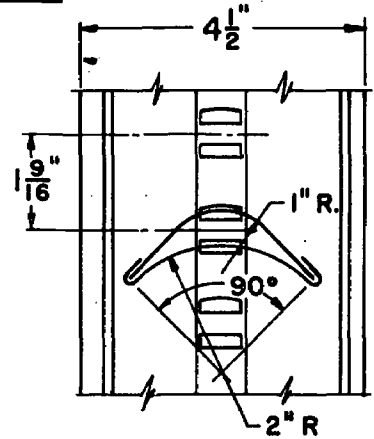


FIG. A
SINGLE VANE ELBOW



DETAIL 1
SINGLE VANE



DETAIL 2
RUNNER

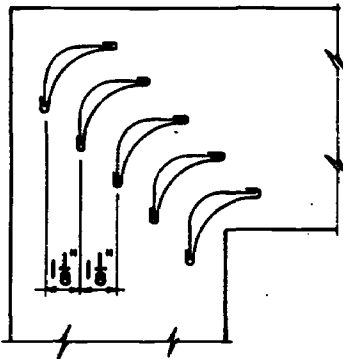
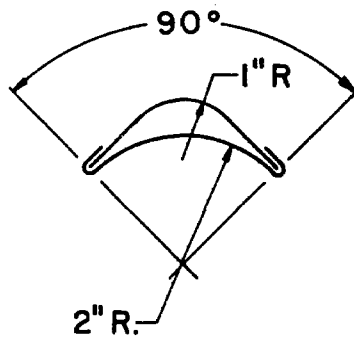
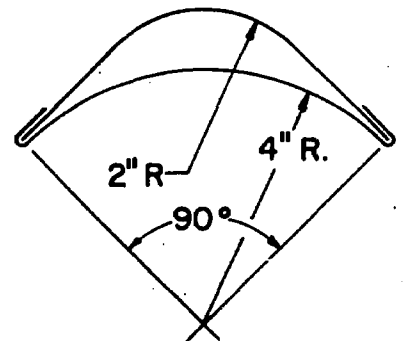


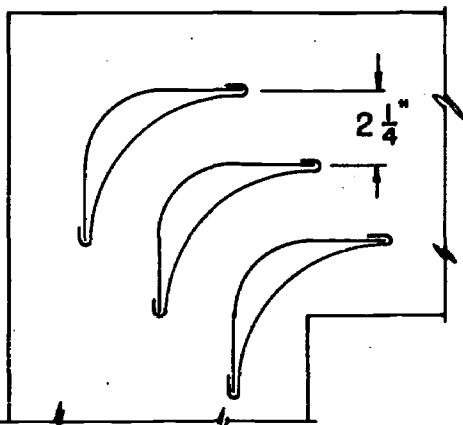
FIG. B
SMALL DOUBLE VANE
SQUARE ELBOW



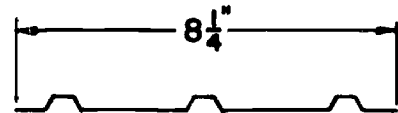
DETAIL 3
SMALL DOUBLE VANE



ALTERNATE DETAIL 4
LARGE DOUBLE VANE



ALTERNATE FIG. C
LARGE DOUBLE VANE
SQUARE ELBOW



ALTERNATE DETAIL 5
LARGE DOUBLE VANE RUNNER

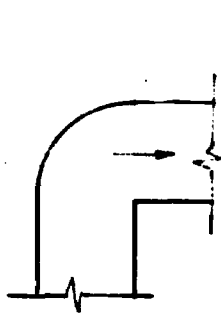


Fig. 14-3a

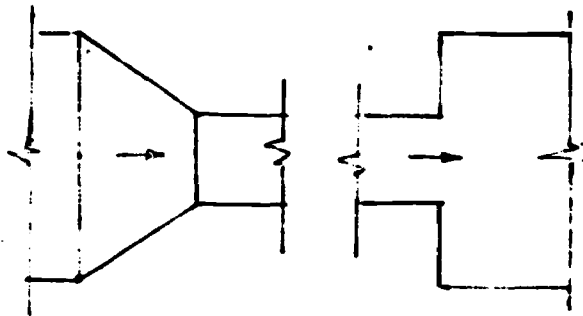


Fig. 14-4

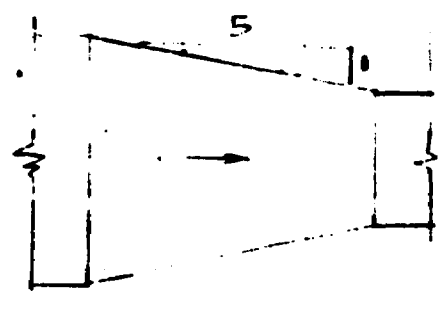


Fig. 14-5

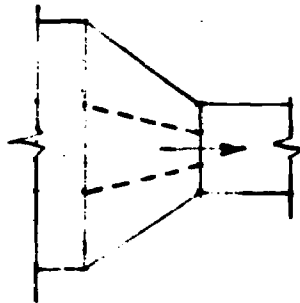


Fig. 14-6

The dimensions of ducts can be changed without impairing the design if the same friction loss per foot is obtained. Equal cross-sectional areas of duct does not mean equal friction losses. A chart (Fig. 14-7) can be used in finding equivalent sizes where a space problem exists.

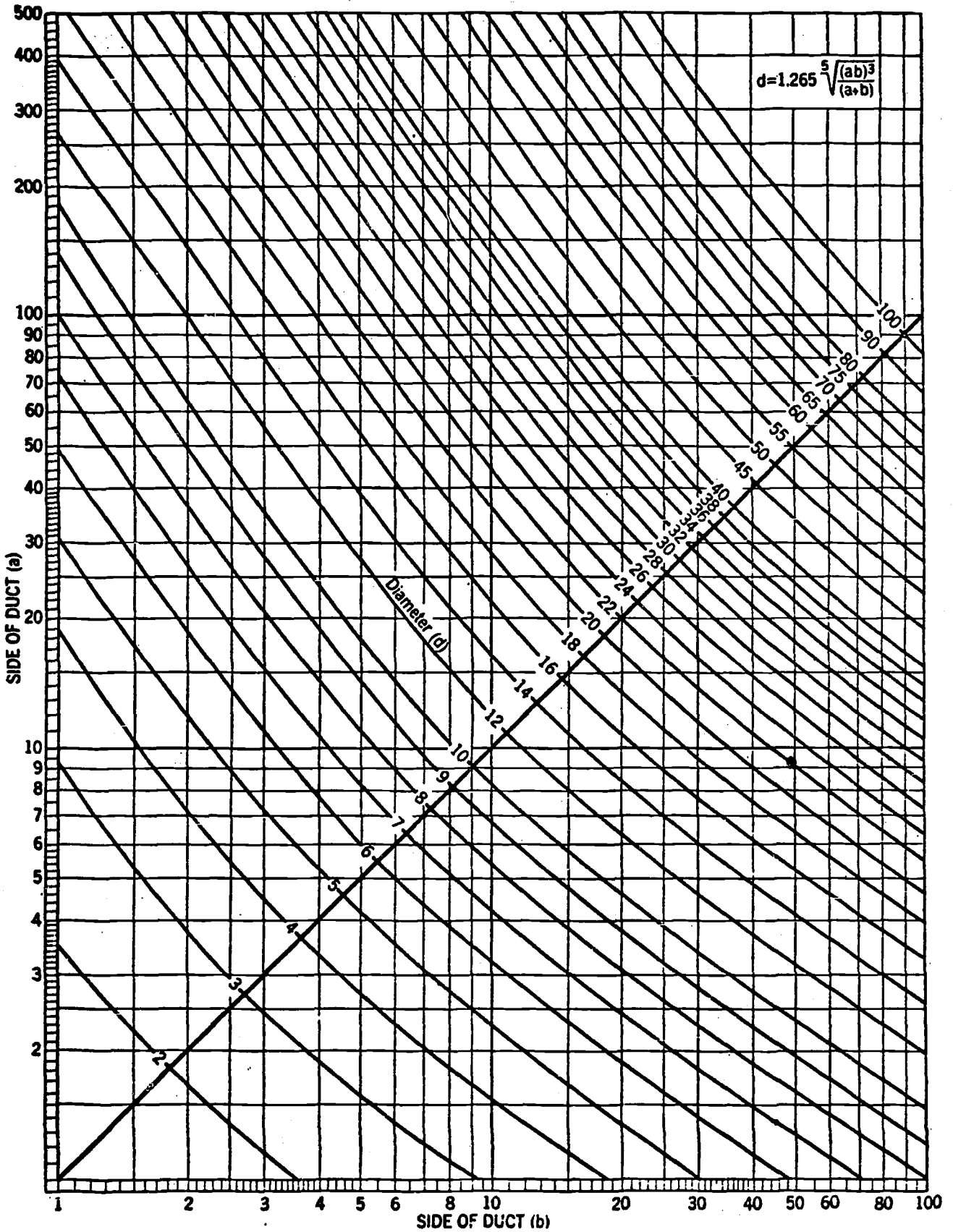
Example:

A 10" x 15" duct must be modified to a height of 8" to clear an obstruction. To find the new width first find the equivalent diameter by entering the chart at "side of duct, (a)" = 15", and "side of duct (b)" = 10", and reading 13.5" diameter, d, on the diagonal line. Now follow the 13.5" line down to the 8" (a) side, and read 19" on (b) side. Thus, the new sized duct is 8" x 19".

The SMACNA manual shows several arrangements for splitting the duct around pipes and stanchions, as well as many other details of duct fittings too numerous to reproduce in this text.

Duct leakage tests are performed on high pressure systems, because a relatively small leak at the higher pressures results in a considerable volume of air. The test procedure and the equipment used are reproduced from the SMACNA Manual on the following pages. What this test determines is the actual air leakage in cubic feet per minute while the duct is continually held at the test pressure. SMACNA recommends a loss no greater than 1% of the system design air flow rate. It is not usually

RECTANGULAR EQUIVALENT OF ROUND DUCTS



Reprinted from the American Society of Heating and Ventilating Engineers Guide, 1941 Chapter 31, Page 575.

Fig. 14-7

possible to test the whole system at once, but in segments; in which case the total leakage of the parts shall not exceed 1% of the total system air flow.

Refer to Uniform Mechanical Code, Chapters 10 and 12, for duct and comfort cooling requirements.

Chapter 10

TESTING FOR LEAKAGE

High velocity ducts must be sufficiently airtight to insure economical and quiet performance of the system. It must be recognized that air tightness in ducts as a practical matter cannot, and need not, be absolute (as it must be in a water piping system). Adequate air tightness can be assured by the application of a pressure test. When air at pressure of 4 inches w.g., or greater, escapes through a small orifice, it will cause noise. As greater amounts of air escape from the orifice, the noise level will increase. Field experience has proven that by eliminating all leaks which are audible to the average person in reasonably quiet surroundings, the total leakage will be less than one (1) percent of the system capacity. Conversely, if a measured leakage test is desired, then the criteria of a maximum permissible leakage of one (1) per cent of the system is a reasonable one.

Test Apparatus

The typical test apparatus (Fig. 10-1) consists of:

1. A source of high pressure air -- a portable rotary blower or a tank type vacuum cleaner.
2. A flow measuring device usually an orifice assembly consisting of straightening vanes and an orifice plate mounted in a straight tube with properly located pressure taps. Each orifice assembly is accurately calibrated with its own calibration curve. Pressure and flow readings are usually taken with U-tube manometers.

Test Procedure

1. Test for audible leaks as follows:

- (a) Close off and seal all openings in the duct section to be tested. Connect the test apparatus to the duct by means of a section of flexible duct.
 - (b) Start the blower with its control damper closed (some small blowers popularly used for testing ducts may damage the duct because they can develop pressures up to 25 inches w.g.).
 - (c) Gradually open the inlet damper until the duct pressure reaches 2 inches w.g. in excess of designed duct operating pressure. The test pressure is read on manometer No. 1. Note that the pressure is indicated by the difference in level between the two legs of the manometer and not by the distance from zero to the reading on one leg only.
 - (d) Survey all joints for audible leaks. Mark each leak and repair after shutting down blower. Do not apply a retest until sealants have set.
2. After all audible leaks have been sealed, the remaining leakage should be measured with the orifice section of the test apparatus as follows:

- (a) Start blower and open damper until pressure in duct reaches 2 inches w.c. in excess of designed duct operating pressure.
- (b) Read the pressure differential across the orifice on manometer No. 2. The leakage rate in cfm is read directly from the calibration curve, similar to that shown in Fig. 10-2. If there is no leakage, the pressure differential will be zero.
- (c) Total allowable leakage should not exceed one (1) percent of the total system design air flow rate. When partial sections of the duct system are tested, the summation of the leakage for all sections shall not exceed the total allowable leakage.
- (d) If all audible leaks have been corrected, it is unlikely that the measured leakage will exceed one (1) per cent of capacity.

If it does, the leaks must be located by more careful listening or by feeling along the joint.

- (e) It should be noted that even though a system may pass the measured leakage test, a concentration of leakage at one point may still result in a noisy leak which, of course, must be corrected.

FREQUENTLY A CONTRACTOR INSTALLING A HIGH VELOCITY DUCT SYSTEM WILL EMPLOY A DUCT JOINT WITH WHICH EITHER HE OR HIS WORK FORCE HAVE NO EXPERIENCE. IN SUCH A CASE, IT IS STRONGLY RECOMMENDED THAT THE CONTRACTOR PROMPTLY TEST THE INITIAL 100 TO 300 FEET OF DUCT BEFORE INSTALLING ANY MORE DUCT. THIS TEST WILL QUICKLY REVEAL WHETHER OR NOT THE WORKMEN CAN MAKE THIS JOINT AIRTIGHT IN AN ECONOMICAL MANNER.

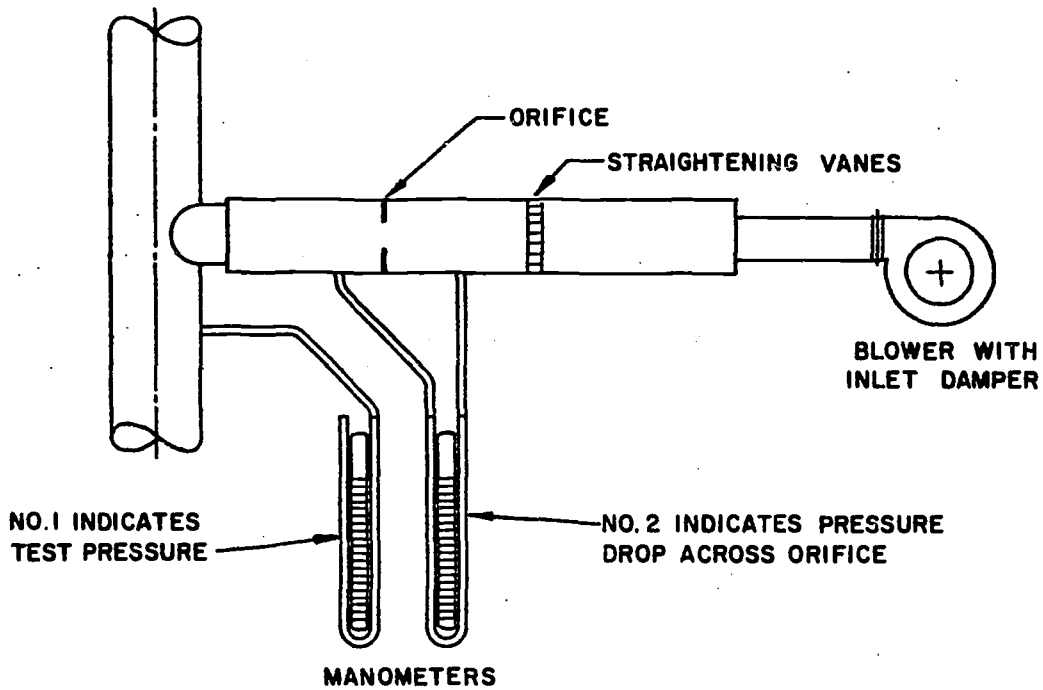


Fig. 10-1

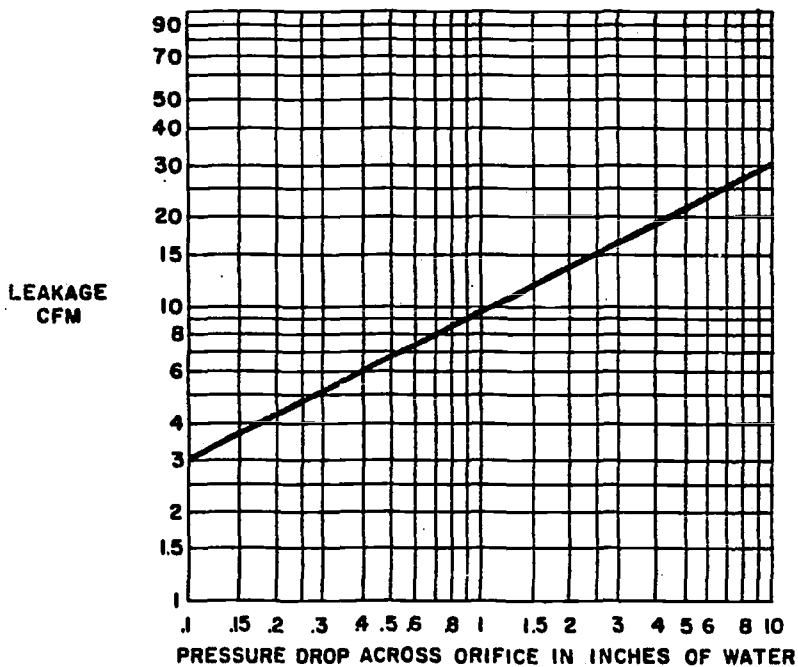


Fig. 10-2

TYPICAL LEAKAGE TEST CURVE

NOTE: TYPICAL LEAKAGE TEST CURVE WILL VARY CONSIDERABLY WITH TEST EQUIPMENT USED.

APPARATUS FOR LEAK TESTING

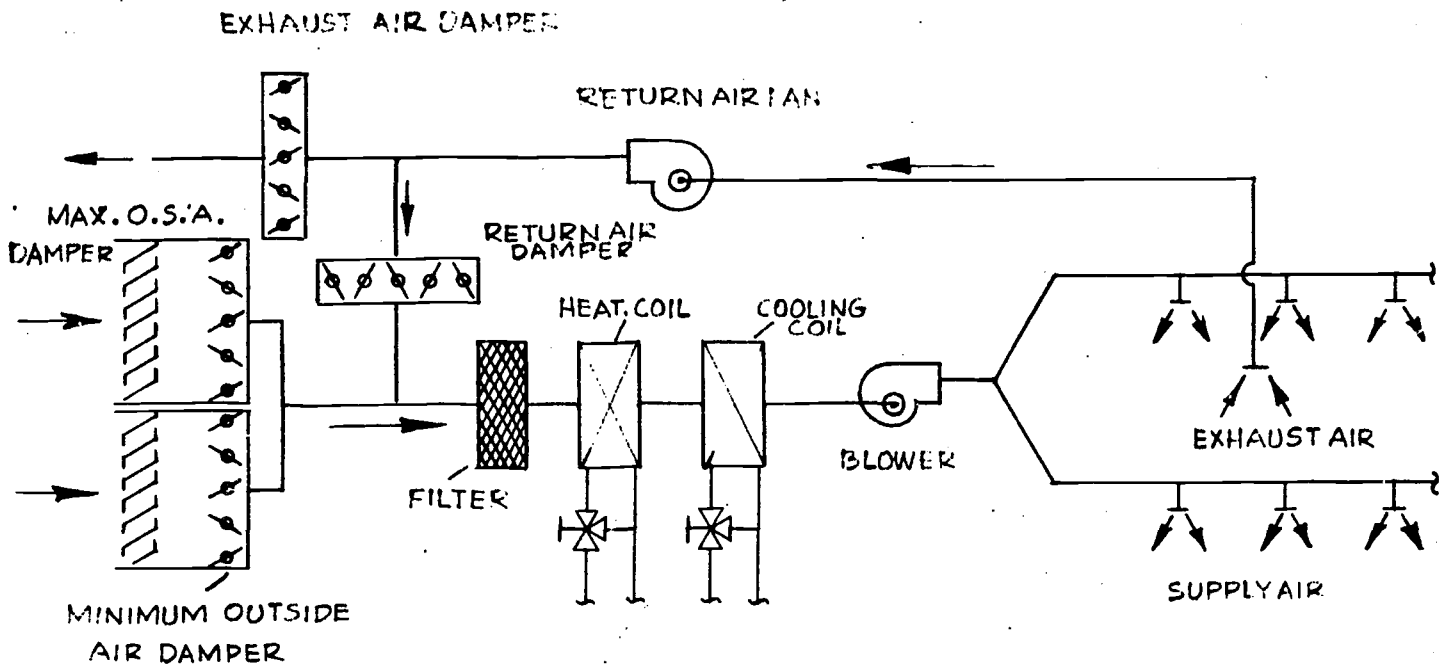
Duct Check-Points

Verify that:

1. Proper metal gage is used consistent with the dimensions of the duct and SMACCNA. Shop fabricated duct should be inspected at the shop, or samples sent to the job site.
2. The duct size is enlarged to allow for interior lining.
3. Elbows are used where possible; otherwise approved turning vanes are used for 90° turns.
4. Damper frames fit tightly inside ducts, and damper blades close tightly with no leakage around ends.
5. Stiffening and bracing of large ducts and plenums are in accordance with SMACCNA standards.
6. Duct seams are hammered shut tightly. Drive seams are used in tight places.
7. Duct seams are taped, supply and exhaust, (where specified).
8. Sufficient space is allowed for applying insulation.
9. Access doors for fire dampers and similar devices inside the duct are located close to the damper.
10. Transitions are made with a 5 to 1 slope where possible.
11. Size changes (to clear interferences) are made in accordance with Fig. 14-7.
12. Aluminum duct is used for moisture-laden air, as evaporative condenser discharges, shower exhaust fan ducts, etc.
13. Exhaust ducts or systems carrying shavings, lint, etc, are smooth inside with no projecting screws and have cleanouts at changes of direction.
14. Ducts are supported per SMACCNA standards, or equal.
15. Balancing dampers are easily accessible and have locking devices.
16. Fire dampers bear the National Board of Fire Underwriters approval seal, or are approved by the State Fire Marshall.
17. Fire dampers are installed in accordance with the manufacturer's instructions (air flow direction, horizontal or vertical, correct temperature rating of fusible links).

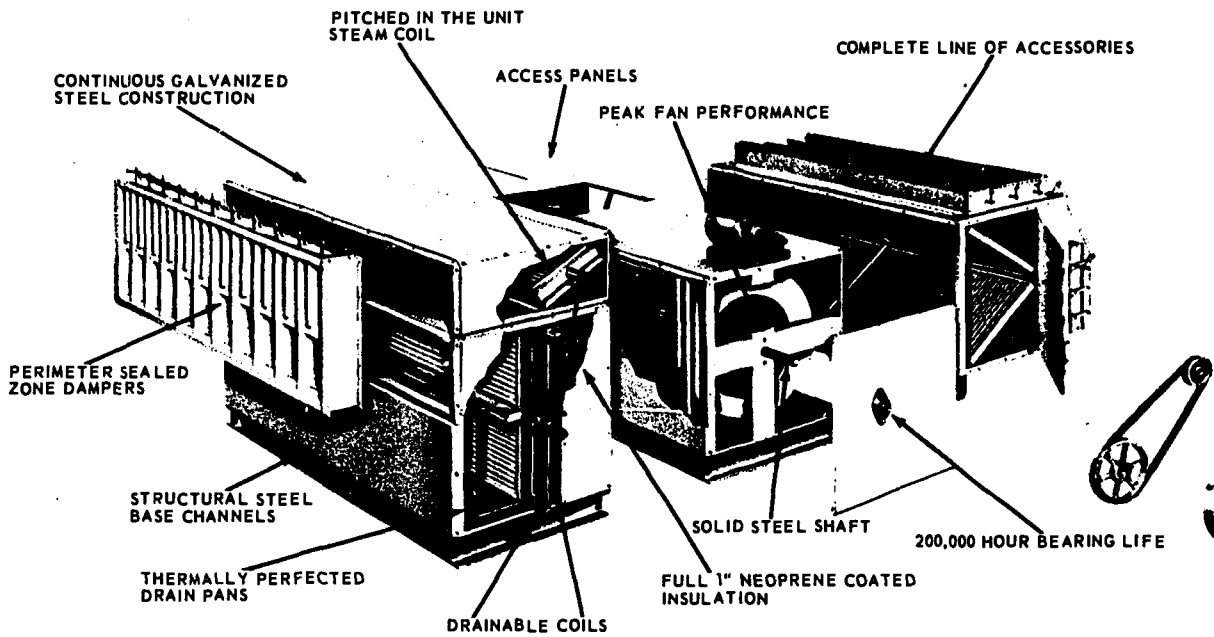
15. TYPES OF VENTILATING SYSTEMS

The principal features of some of the basic air conditioning, heating and ventilating systems will be covered. Many variations of these will be encountered in practice depending on the particular environmental requirements.



Basic Air Conditioning System (Fig. 15-1)

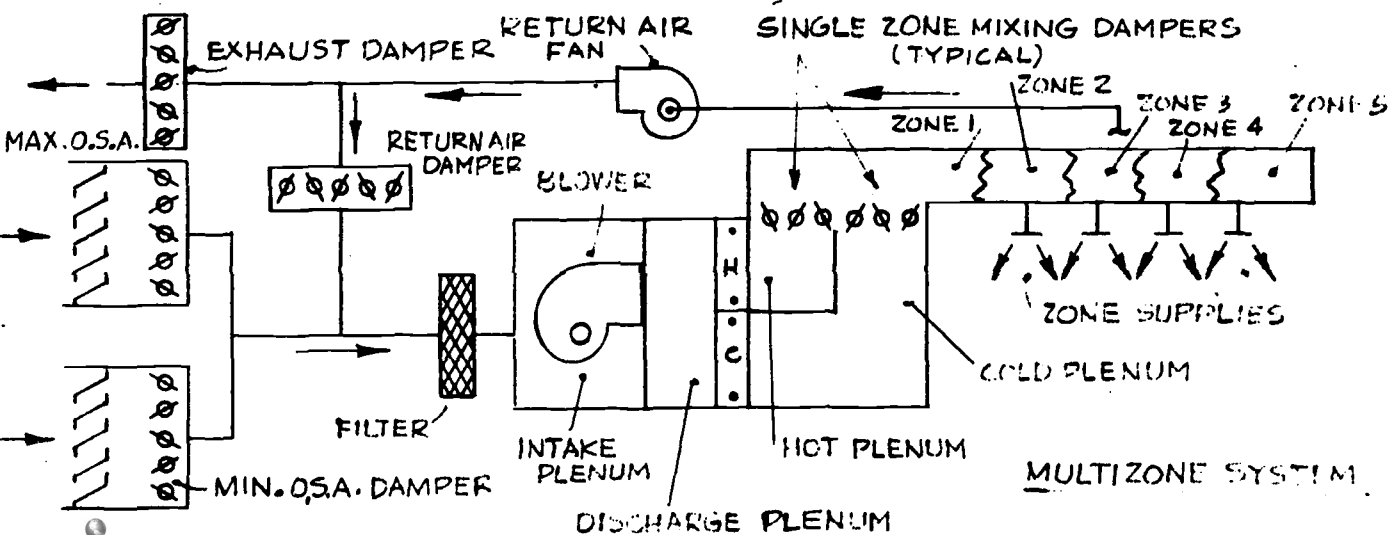
Outside air is drawn in through the maximum and minimum outside air dampers, through the filters, heating and cooling coils, and distributed to the room outlets. The air is exhausted and/or returned to the outside and recirculated back through the conditioning apparatus. The amount of air drawn in from the outside is a minimum during hot or cold weather in the interest of economy. The minimum air damper is set at a certain fixed opening and never closes except when the plant shuts down. The main air damper controller also controls the return and exhaust air dampers so as to maintain the same volume of air flowing through the fan. The system either heats or cools, the heating and cooling coils being controlled by one thermostat.



EXPLODED VIEW OF A MULTIZONE UNIT *COURTESY, McQUAY, INC.*

Multizone System (Fig. 15-2)

Outside air is drawn in through maximum and minimum outside air dampers, or from the recirculation duct, and discharged by the fan into the space upstream of the heating and cooling coils. The air divides between the hot and cold coil, the quantity depending on the openings of the dampers at the outlet of the hot and cold plenums. The entire width of the hot and cold plenums is divided into sections, or zones, each with a separate set of mixing dampers. The individual hot and cold dampers are linked together, but 90° apart, so that as the hot damper is moved to the closed position the cold damper opens, and vice versa. The zone dampers are controlled by a zone thermostat located in one of the rooms in the zone being supplied.



Reheat System (Fig. 15-4)

The reheat system is similar to the Basic Air Conditioning (Fig. 15-1) except the main heating coil is replaced with reheat coils in the supply ducts to separate zones. The reheat coils are controlled by thermostats in the respective zones.

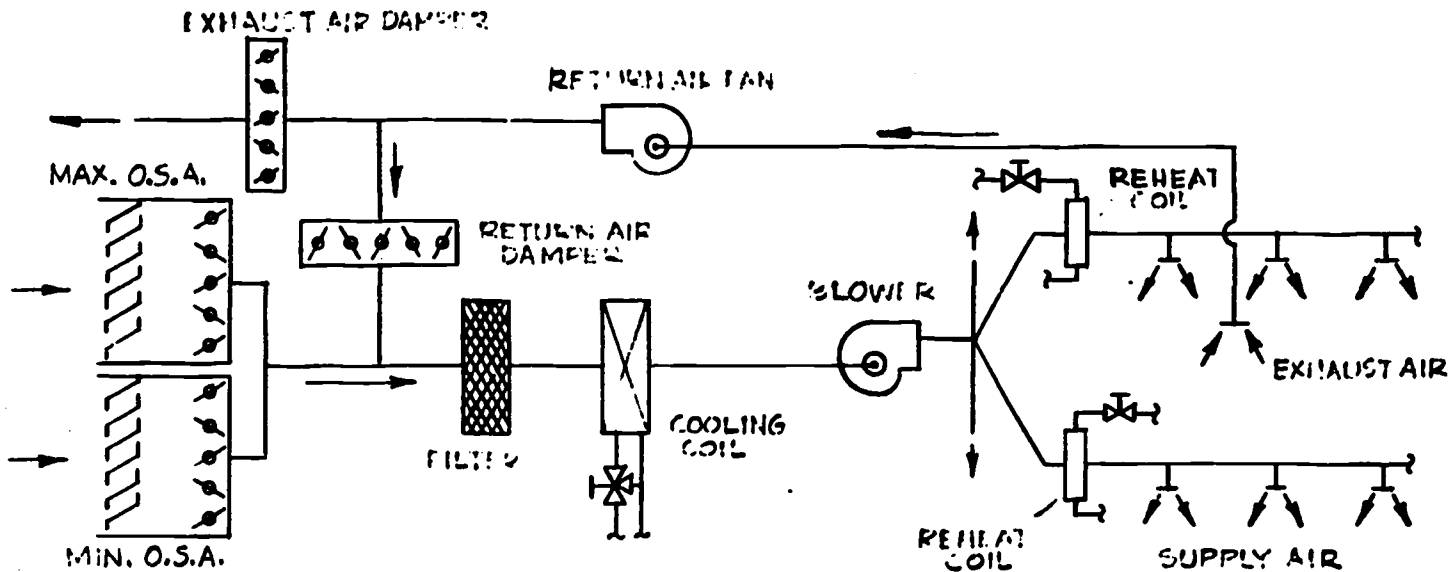
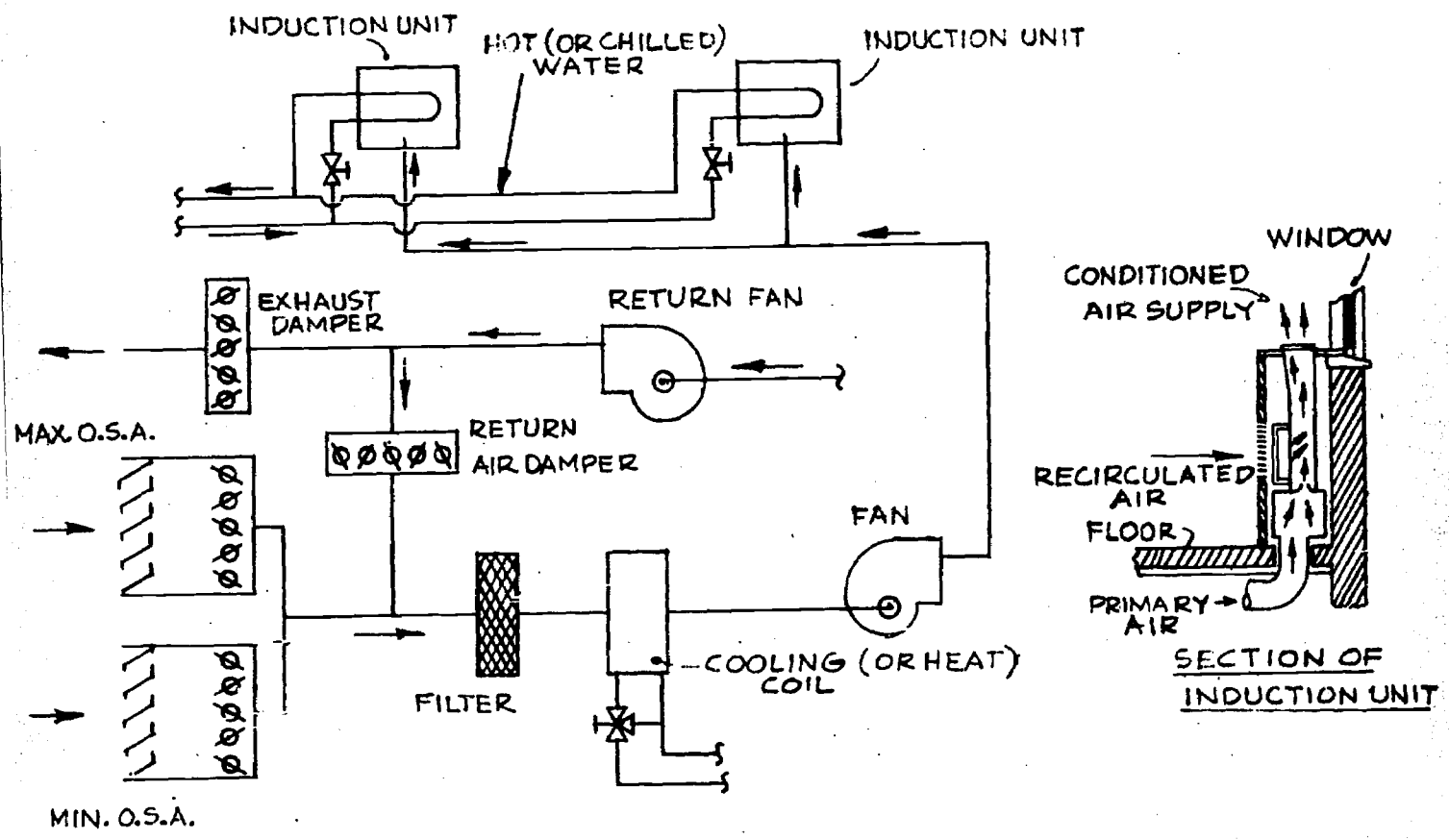


FIG 15-4 - REHEAT SYSTEM

Induction System (Fig. 15-5)

The blower delivers outside or chilled air to the individual room units. The induction units have rows of small jets which deliver the air at a high velocity into the mixing chamber. The aspirating effect draws air through the heating coil which is controlled by a temperature regulating valve and room thermostat. The warm and cold air is mixed and delivered to the room. Induction systems also use tempered or warm air in the duct, and a chilled water coil. The coil is operated at a temperature above the dew point to prevent condensate formation.



INDUCTION SYSTEM

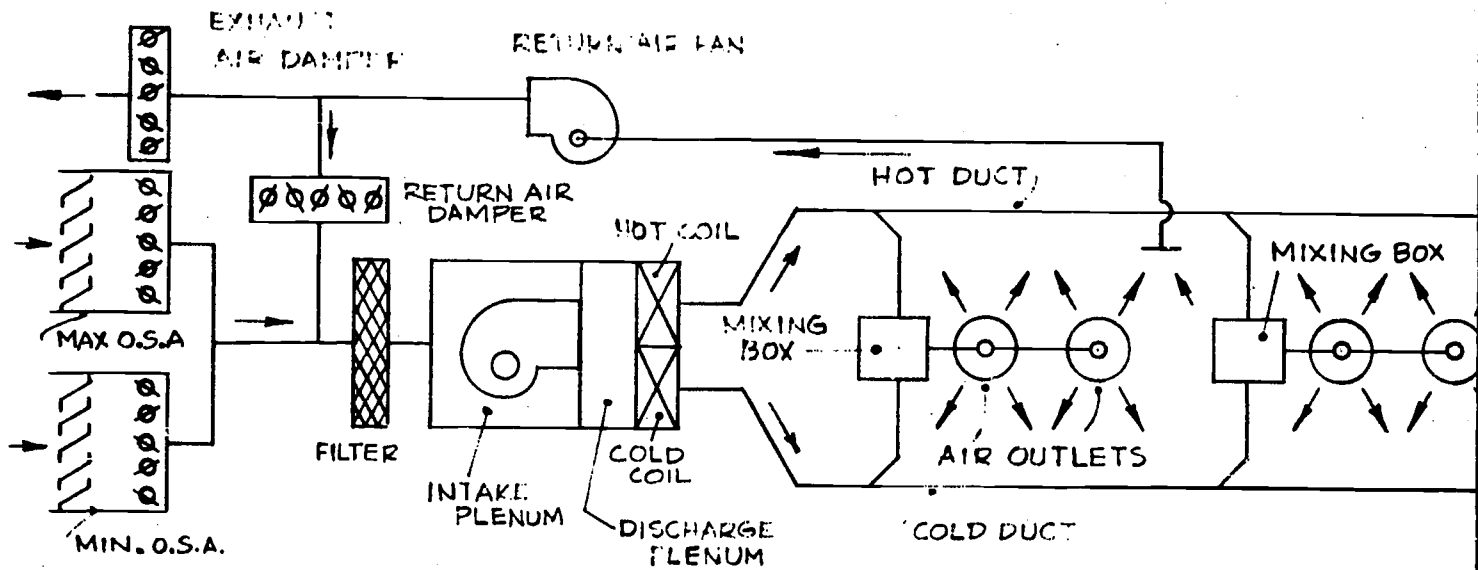
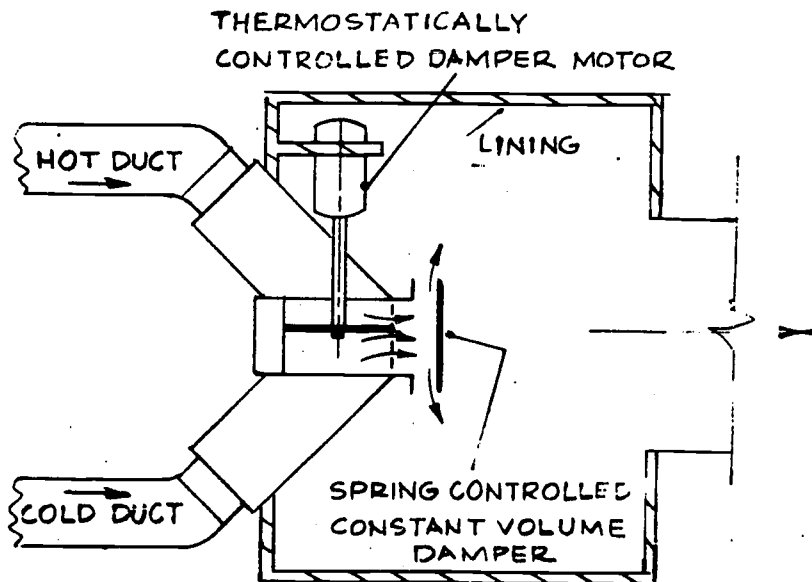


Fig. 15-6



SCHEMATIC DIAGRAM
OF MIXING BOX

Fig. 15-7

High Pressure Dual Duct System (Fig. 15-6)

This system is similar to the low pressure dual duct except it utilizes high velocities and high pressure in moving the air through ducts designed for 6" w.c. pressure. The air is distributed through mixing boxes to the usual diffusers and registers. The schematic diagram of a mixing box (Fig. 15-7) indicates a pneumatically operated motor moving the mixing damper in and out to provide the required temperature as controlled by the room thermostat. The air volume leaving the

mixing box is controlled automatically by a spring loaded volume damper built into the box. The interior is lined with insulation for sound attenuation and heat barrier.

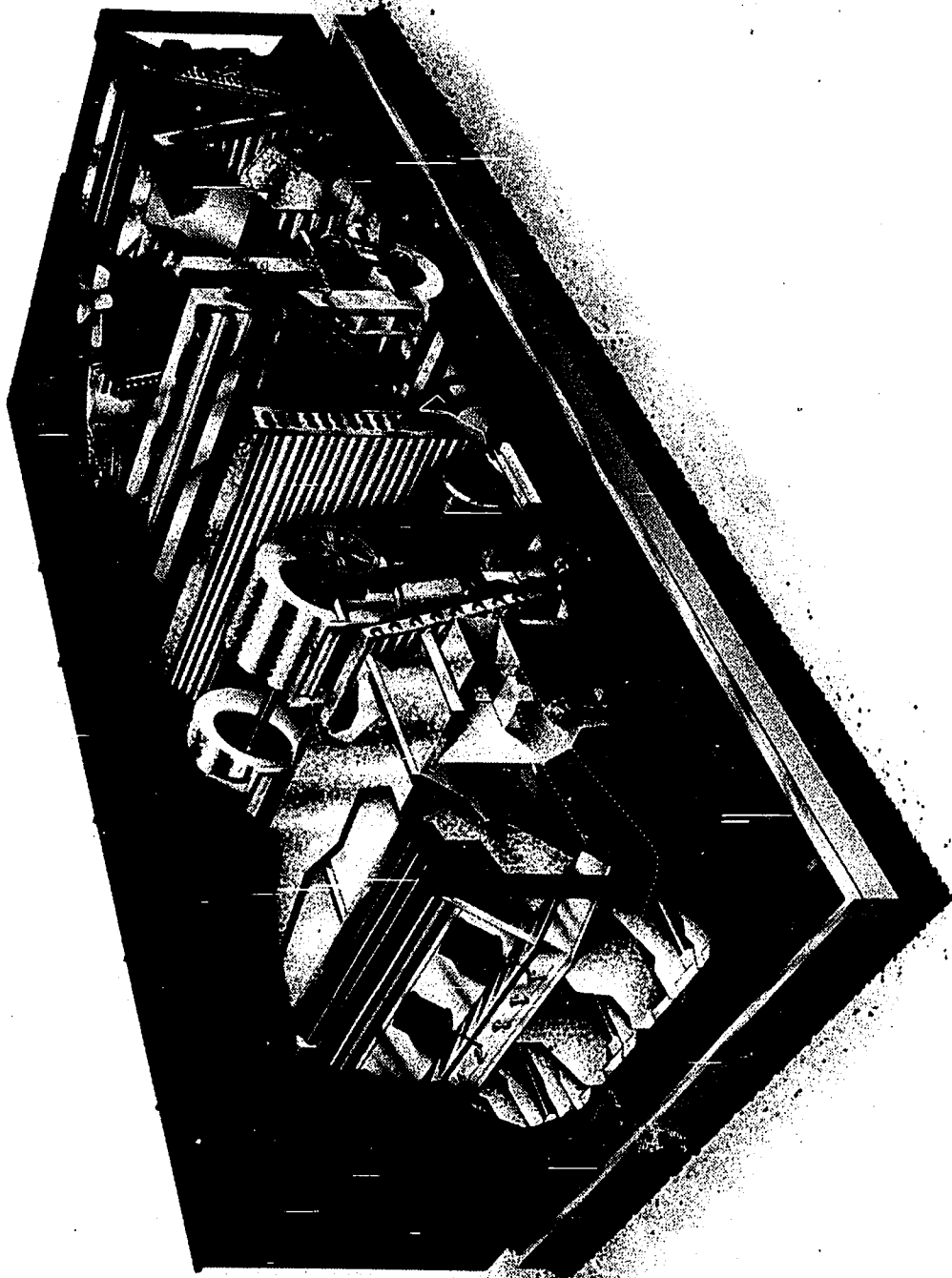


Fig. 15-8 ROOF-MOUNTED PACKAGED A.C. UNIT

16. TESTING AND BALANCING OF VENTILATION SYSTEMS

The importance of adjusting and balancing a ventilation system can not be overemphasized. The proper amount of draftless, noiseless, conditioned air circulated through the occupied spaces represents the product; the sum total of the expense of engineering, mechanical equipment, piping, duct work and controls that have gone into the plant. The balancing technician is not a magician; he cannot produce designed results if the design is off, but many times in the past the ball has been dropped at this crucial stage because of untrained personnel attempting to balance a system. Air balancing is a tedious task and involves going over certain operations several times. The finished result is not a tangible object, and faults and deficiencies may not be apparent until the spaces have been occupied. For this reason a methodical approach in going through the testing must be followed and accurate and truthful records kept. The integrity of a balancing firm is as important as its technical expertise. There is a tendency among some technicians (in the minority) to report readings considerably different than the actual in order to expedite the job. The balancing firm or technician should be directed to report the final cfm readings, as read, even if they are low, if they represent the best results obtainable within the capabilities of the system. This then should be referred back to the designer. The job of the inspector is to be familiar with the methods the balancer is using (or should be using) and verify the data at least on a spot check basis.

The mechanical inspector should review the ventilation duct work drawings at the beginning of the job to determine if there are sufficient dampers provided for balancing the air flow. These should include a manual damper at the following locations:

1. outside air supply
2. return air
3. in each zone of a multizone unit
4. at the branch connection to a main duct
5. at each diffuser or register outlet.

A single damper at the diffuser or register outlet cannot be used to do all the throttling as it will generate objectionable noise in the room being supplied, hence the requirement for a back-up damper at the branch connection.

Provision must also be made for extractors, scoops, etc., for diverting air from main runs to branches (Fig. 16-1).

The various air balancing firms throughout the U.S. and Canada have formed industry supported associations which have done much to standardize methods and procedures. The Associated Air

REGISTER & GRILLE CONNECTIONS

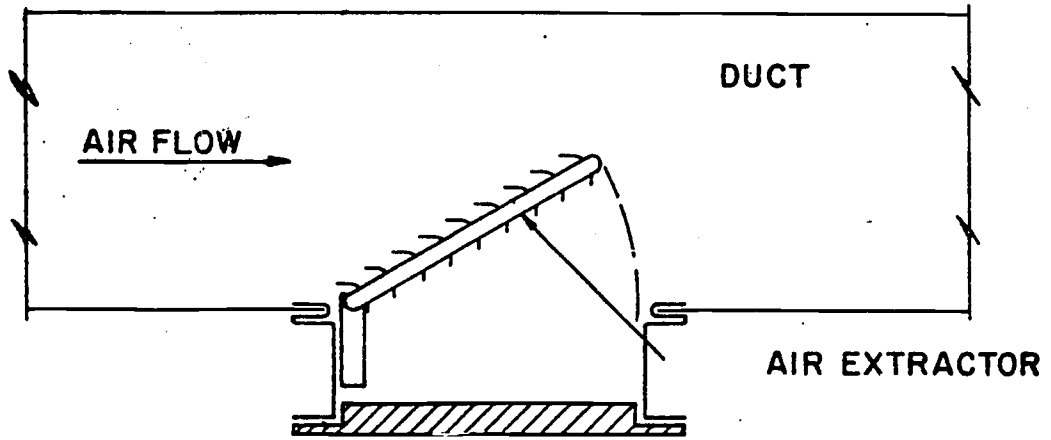


FIG. A

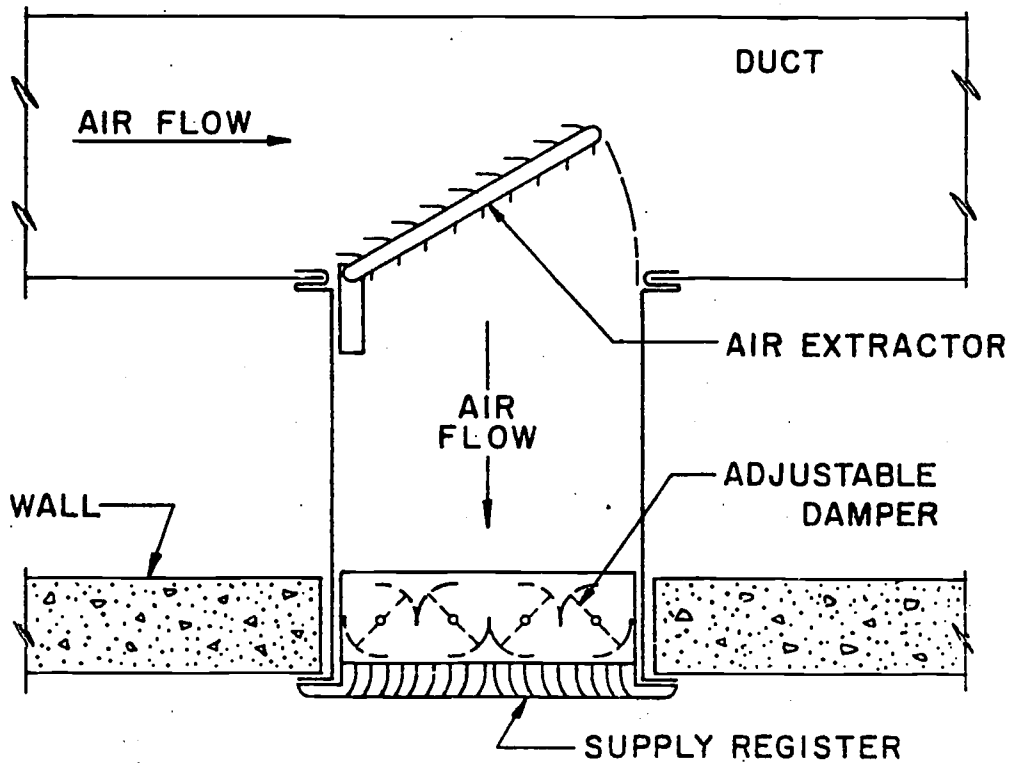


FIG. B

NOTE:
REGISTER CONTAINS VOLUME CONTROL AT GRILLE. GRILLE HAS NO VOLUME CONTROL.

Balance Council* has produced a balancing procedure outline which satisfactorily covers all steps (Figs. 16-2 and 16-3). The corresponding forms developed by AABC are shown in the appendix.

Instruments, Types and Use

Referring to Figs. 16-2 and 16-3, "Balancing Procedure Outline" the duct traverses and static pressure readings require the use of a Pitot tube and U-tube manometer the application of which is covered in Section 4, "Air Movers". The motor load is found with the clamp-on ammeter, and the fan and motor speeds with a tachometer. The air delivered from the individual room outlets is measured by the instrument best suited to the type of outlet. For a register, one of the following may be used:

- a. rotary type anemometer
- b. bridled vane anemometer (Flo-rite)
- c. deflecting vane anemometer (Velometer).

Type (a) and (b) are used by dividing the register in say, 4 equal areas, (by approximation) and taking a reading for each area and finding the average. The reason for this is that a branch outlet taken off at right angles from the main will have an unequal velocity distribution across its width. The velocity must not be found by moving the anemometer back and forth during the minute time interval as this will not give a true average. The anemometer reads directly in feet per minute, hence the reading is taken for one minute. The reading average is then multiplied by the core area, in square feet, which will give the volume in cubic feet per minute:

$$\text{cubic feet per minute} = \text{velocity (fpm)} \times \text{effective area (sq ft)}$$

$$(\text{effective area} = \text{registers manufacturer's effective anemometer area})$$

The Velometer, can be used with the tip prescribed by the manufacturer and the appropriate register factor. However, the rotating anemometer is most generally used. The flow rates for exhaust registers are similarly found, except an average factor of 0.85 multiplied by the duct area may be used.

The measurement of flow from ceiling diffusers is read with a Velometer, using the appropriate tip and factor published by the manufacturer for exact model and size of diffuser being tested. Funnel shaped "hoods" are used for diffusers with perforated plates. The hood is the size of the diffuser at the big end and tapers down to 1 sq ft or 0.5 sq ft at the outlet. The velocity is then read with a velometer or anemometer.

* Nat'l Headquarters: 2146 Sunset Blvd., Los Angeles, Calif. 90026

**AIR DISTRIBUTION SYSTEMS
AABC APPROVED
BALANCING PROCEDURE OUTLINE**

22. In order to meet the required tolerance of the plans & specifications, the following general testing and balancing procedure shall be used.

PHASE ONE:

- A. All supply and return air duct dampers are set at full open position.
- B. All diffuser and side wall grilles are set at full open position.
- C. Outside air damper is set at minimum position.
- D. All controls checked and set for full cooling cycle.
- E. Branch line splitter dampers to open position.
- F. Set all extractors and distribution grids in wide open positions.

PHASE TWO:

- A. Drill all probe holes for static pressure readings, pitot tube traverse readings and temperature readings.
- B. Check motor electrical current supply and rated running amperage of fan motors.
- C. Check fan and motor speeds.
- D. Check available adjustment tolerance.

PHASE THREE:

- A. Make first complete air distribution run throughout entire system recording first run statistics.
- B. Using pitot tube traverse in all main duct, branch duct, supply and return, PROPORTION all air in required amounts to the various main duct runs and branch runs.
- C. Make second complete air distribution run throughout entire system for check on proper PROPORTION of air.

PHASE FOUR:

- A. Using pitot tube traverse set all main line dampers to deliver proper amount of C. F. M. to all areas.
- B. Using pitot tube traverse set all branch line dampers to deliver proper amount of C. F. M. to diffusers and side wall supply grilles in each zone.
- C. Read C. F. M. at each outlet and adjust to meet requirements.
- D. Test and record all items as listed (testing procedure Item C).

TESTING PROCEDURE - ITEM C

The air balance agency shall perform the following tests and balance system in accordance with the following requirements:

Fig. 16-2

1. Test and adjust blower R. P. M. to design requirements.
2. Test and record motor full load amperes.
3. Make pitot tube traverse of main supply ducts and obtain design C. F. M. at fans.
4. Test and record system static pressures, suction and discharge.
5. Test and adjust system for design recirculated air, C. F. M.
6. Test and adjust system for design C. F. M. outside air.
7. Test and record entering air temperatures.
(D. B. heating and cooling)
8. Test and record entering air temperatures.
(W. B. cooling)
9. Test and record leaving air temperatures.
(D. B. heating and cooling)
10. Test and record leaving air temperatures.
(W. B. cooling)
11. Adjust all main supply and return air ducts to proper design C. F. M.
12. Adjust all zones to proper design C. F. M. supply and return.
13. Test and adjust each diffuser, grille and register to within _____% of design requirements.
14. Each grille, diffuser and register shall be identified as to location and area.
15. Size, type and manufacture of diffusers, grilles, registers and all tested equipment shall be identified and listed. Manufacturer's ratings on all equipment shall be used for required calculations.
16. Readings and tests of diffusers, grilles and registers shall include required F. P. M. velocity and test resultant velocity, required C. F. M. and test resultant C. F. M. after adjustments.
17. In cooperation with the control manufacturer's representatives setting adjustments of automatically operated dampers to operate as specified, indicated and/or noted.
18. All diffusers, grilles and registers shall be adjusted to minimize drafts in all areas.
19. As a part of the work of this contract, THE AIR CONDITIONING CONTRACTOR shall make any changes in the pulleys, belts and dampers or the additions of dampers required for correct balance as recommended by Air Balance Agency at no additional cost to Owner.

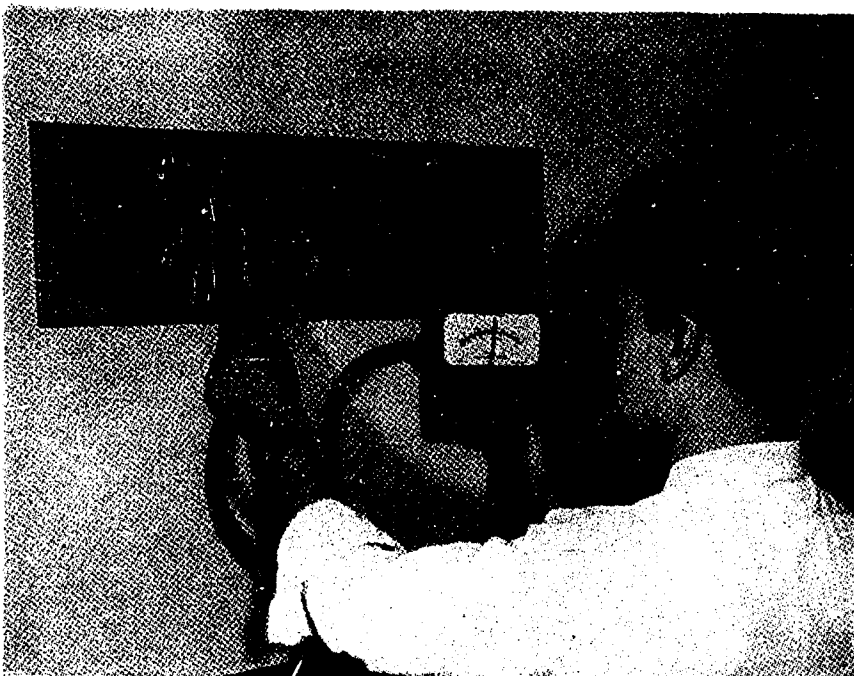
Fig. 16-3

Limitations of Anemometers

The rotary anemometer is individually calibrated at the time of manufacture and should be re-calibrated periodically thereafter. The lower limit of accuracy is about 200 fpm. It should be held in the air stream so that the speed indicator turns clockwise. Deflecting vane anemometers require careful handling and require periodic recalibration. They are available in several ranges of velocity, and should be selected with a mid range of 1,000 fpm since this is the usual diffuser outlet velocity. The Air Diffuser Council (an association of diffuser manufacturers) bases its test code for establishing outlet factors on the Alnor Velometer instrument using a type 2220A tip. Fig. 16-4 illustrates the use of the above instruments.

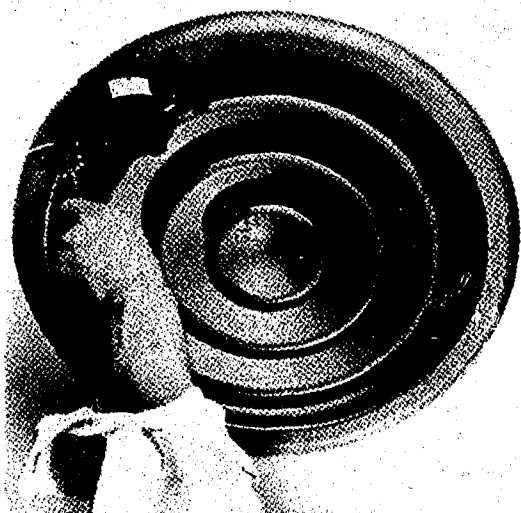
Hydronic Balancing

Also important in the balancing of a system is the setting and recording of hot water and chilled water flow rates. This is made possible with the use of venturi flow nozzles and orifice plate meters permanently installed in the system. Provision is made for connecting the leads of a portable flow indicator upstream and downstream of the flow device, and the flow reading in inches of water pressure differential (generally) is converted to gpm by means of a chart furnished by the manufacturer.

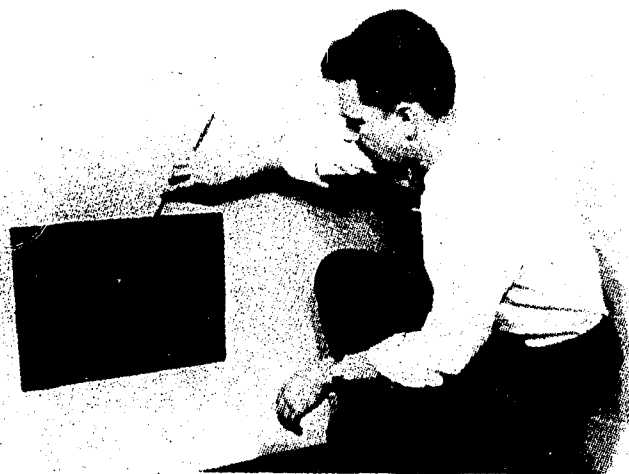


Testing with a Velometer

Procedure for Testing Grilles and Registers with Alnor Velometer



Testing with the FloRite Meter



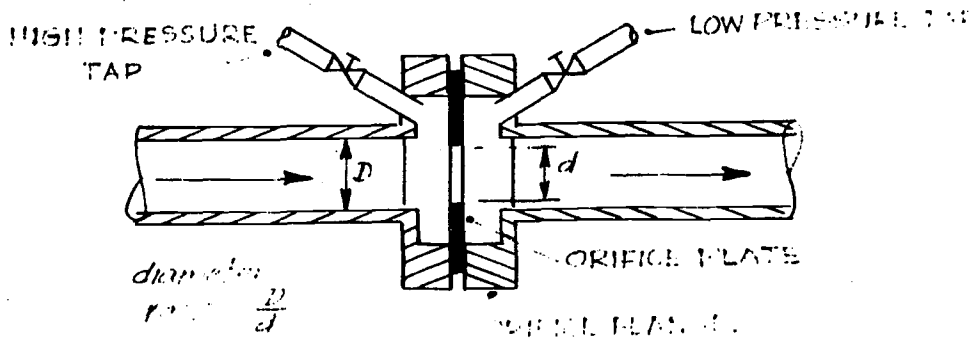
Testing with an Anemometer (Manufactured by Keuffel & Esser Co.)

Reprinted with permission from Tuttle and Bailey, Division of Allied Thermal Corporation.

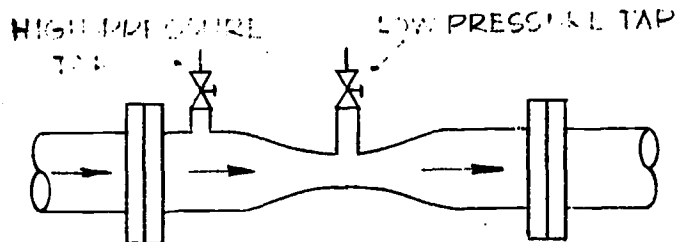
17. INSTRUMENTATION

This section will describe the various types of instruments that are used in heating, ventilating and air conditioning systems and the manner in which they should be installed. The accuracy and hence, usefulness, of a thermometer, gage, flowmeter, etc, depends on how and where it is installed in the system. A device that gives the wrong indications is worse than none at all.

Flow measuring devices include orifices and venturis which are shown schematically in Fig. 17-1.



ORIFICE ELEMENT



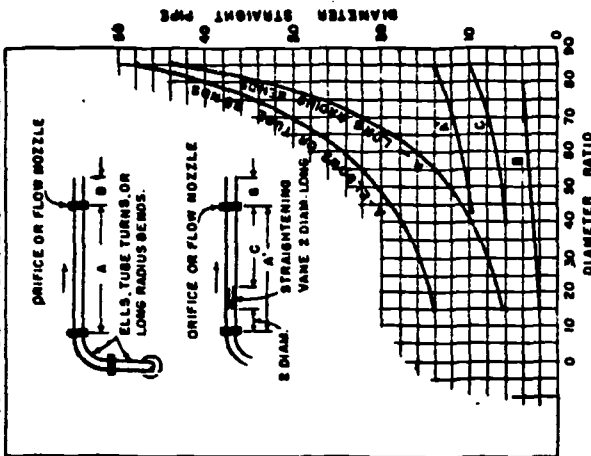
VENTURI ELEMENT

Fig. 17-1

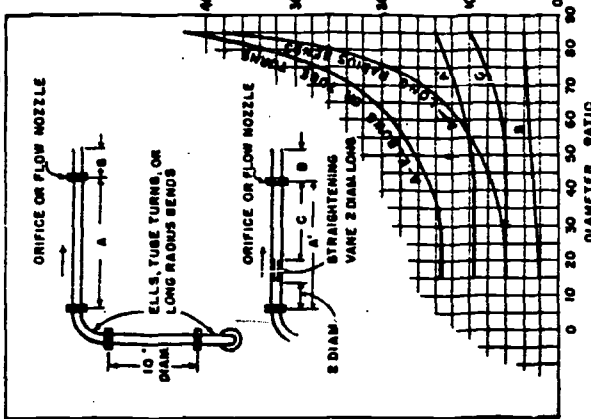
In each case, the water velocity is increased temporarily as it flows through the element. For a given orifice or venturi diameter the flow can be found by measuring the pressure drop across the element. It is mandatory, however, that there be a smooth, non-turbulent flow of the fluid approaching and leaving the device, otherwise an inaccurate reading will result. A smooth upstream and downstream flow is obtained by providing a certain length of straight pipe on both sides, depending on (1) the ratio of the orifice diameter to the pipe diameter and (2) the nature of the disturbing elements upstream and downstream. Referring to Fig. 17-2, various piping configurations

ORIFICE AND FLOW NOZZLE INSTALLATION

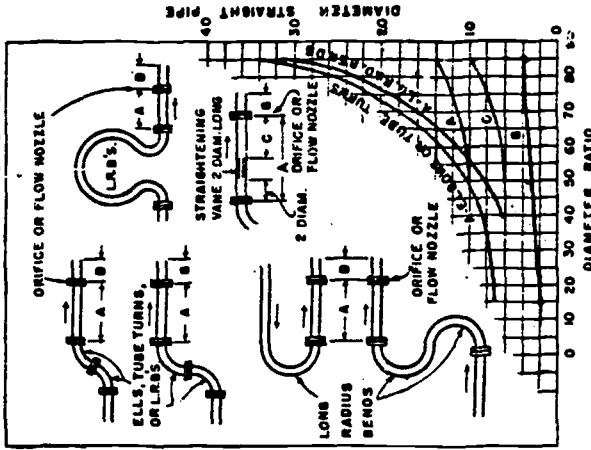
SCHEDULE 4
FOR ORIFICES AND FLOW NOZZLES
FITTINGS IN DIFFERENT PLANES.



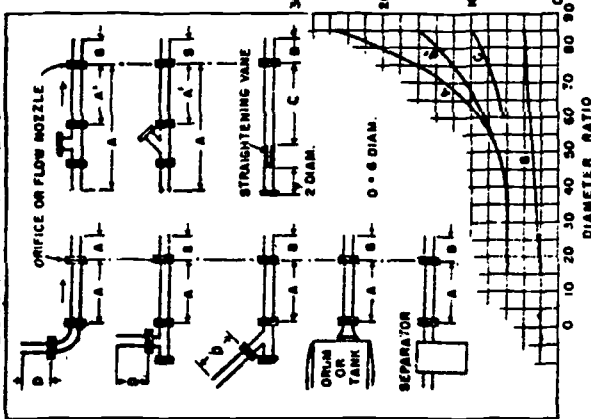
SCHEDULE 3
FOR ORIFICES AND FLOW NOZZLES
FITTINGS IN DIFFERENT PLANES



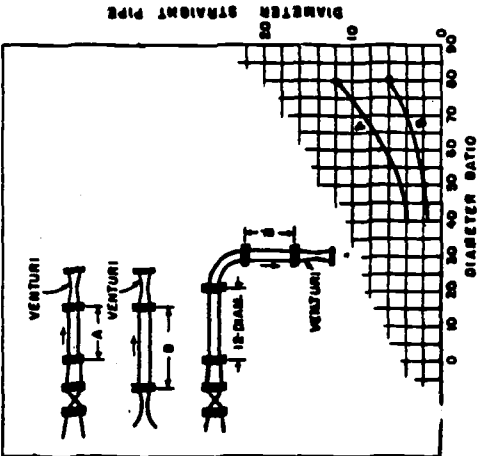
SCHEDULE 2
FOR ORIFICES AND FLOW NOZZLES
ALL FITTINGS IN SAME PLANE



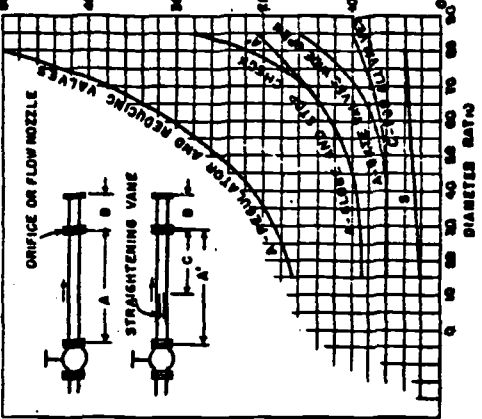
SCHEDULE 1
FOR ORIFICES AND FLOW NOZZLES
ALL FITTINGS IN SAME PLANE



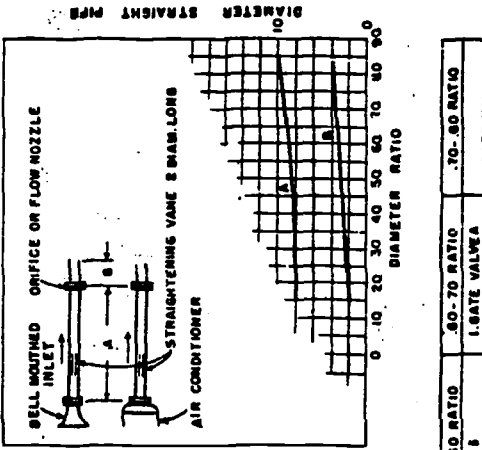
SCHEDULE 8
FOR VENTURI TUBES
BASED ON DATA FROM W.S. PARDOE



SCHEDULE 7
VALVES



SCHEDULE 6
FOR ORIFICES AND FLOW NOZZLES
IN ATMOSPHERIC INTAKE



SCHEDULE 5
FOR ORIFICES AND FLOW NOZZLES
WITH REDUCERS AND EXPANDERS.

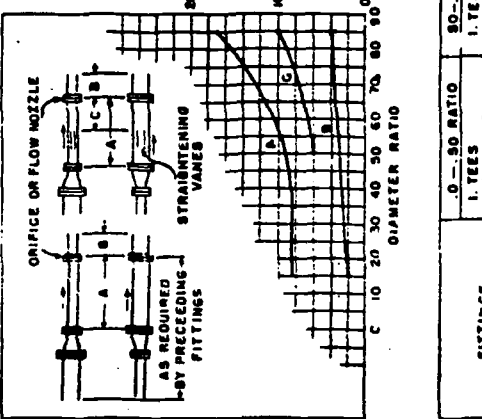


FIGURE 2 — Piping Requirements for Orifices, Flow Nozzles and Venturi Tubes.

FITTINGS ALLOWED ON OUTLET SIDE IN PLACE OF STRAIGHT PIPE.	.0 - .50 RATIO	.50 - .60 RATIO	.60 - 70 RATIO	.70 - .80 RATIO
	1. TEES 2. 45 ELLS 3. GATE VALVES 4. SEPARATORS 5. Y-FITTINGS 6. EXPANSION JTS.	1. TEES 2. EXPANSION JTS 3. GATE VALVES 4. Y-FITTINGS 5. SEPARATORS 6. EXPANSION JTS.	1. GATE VALVE 2. Y-FITTINGS 3. SEPARATOR (IF INLET NECK IS ONE DIAM. LONG)	1. GATE VALVE 2. LONG RADIUS BUNG

Fig. 17-2

are shown with charts giving the orifice location. The diameter ratio (ordinate) is as described above, and the abscissa indicates the diameters of straight pipe; i.e., 20 diameters of 6" pipe = 120 inches, etc. Additional pipe configurations are shown in the appendix. If the space limitations are such that the minimum straight run of pipe ahead of the orifice cannot be obtained, straightening vanes must be used as shown in the schedules. Fig. 17-3 shows some typical straightening vanes. The set of orifice flanges are drilled internally to provide upstream and downstream pressure taps for the orifice plate. The pressure connections are on top of the flanges. The machine screws projecting from the backs of the flanges are jack screws for forcing the flange faces apart. The orifice plate is the paddle type, the handle of which is stamped with the orifice and pipe diameters, and indicates which way the stamped side is to face (upstream or downstream).

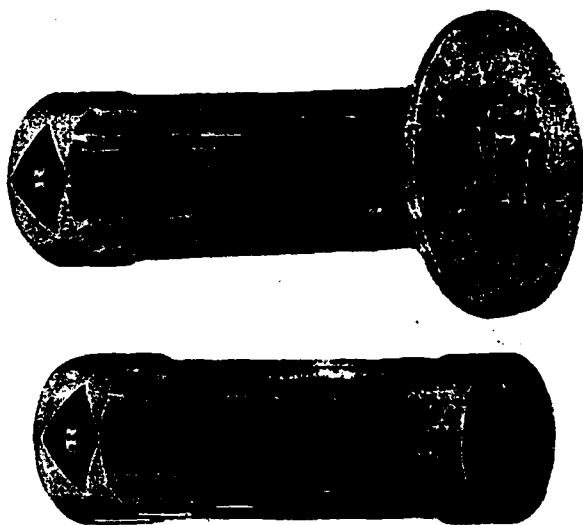


Fig. 17-3



Fig. 17-4



Fig. 17-5

The venturi flow nozzle is not as sensitive to turbulence as the orifice and generally requires 5 pipe diameters upstream and 2 pipe diameters downstream. Orifices used for flow measurement of steam or gases are designed and calibrated for a specific pressure, temperature and density of the medium. Any departure from these stated conditions will cause an erroneous reading, and must be corrected back to the meter standard.

Thermometers should be installed inside thermometer wells in piping, with the bulb in the center of the pipe. The range of the thermometer should be selected so that the normal operating temperature will be at mid-scale. They are best installed at eye height if possible; or with an inclined face if higher,

INSTALLATION INSTRUCTIONS FOR
ALL MODEL RINCO VENTURIS

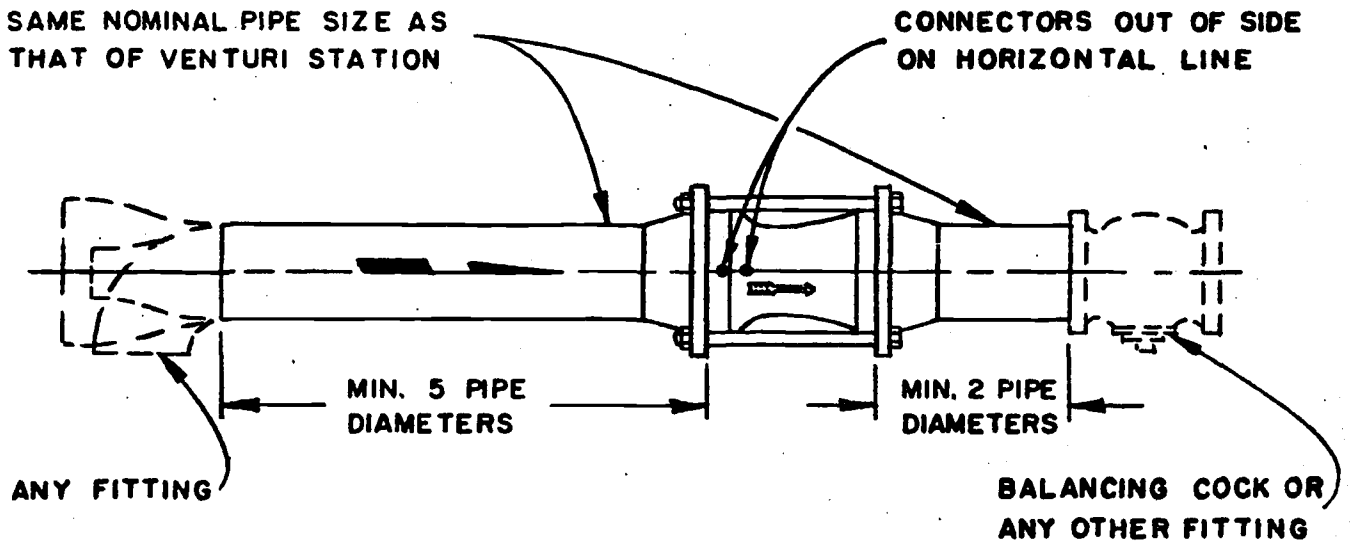


Fig. 17-6

- 1) Note cast direction arrow on venturi and make sure flow is in direction of arrow. Venturi may be installed in any position.
- 2) Red Quick-Disconnect assembly should be installed on red or up-stream tap.
- 3) Green Quick-Disconnect assembly should be installed on green or down-stream tap.

and be visible from the operating level.

Gages should also be selected so that the operating pressure is near to mid-scale as this is the most accurate point. Gage syphons are necessary for steam and hot water service to prevent damage to the gage. Rapidly fluctuating pressures will soon wear out a gage and can be corrected by using a "snubber" fitting in the gage line. Gage connections should not be made on or near fittings where turbulent flow exists, and be arranged so that the gage may be easily installed and removed for calibration. The accuracy of gages can be checked with a "dead weight" gage tester, or by comparison with a test gage of known accuracy.

APPENDIX

Table of Contents

Subject	Title
Commercial Wrought Steel Pipe Data	A-1 and A-2
Copper Water Tube Standards	A-3
Service Pressure for Solder Joints	A-4
Thermal Expansion of Copper Tubing and Steel Pipe . .	A-4
Copper Expansion Loops and Offsets	A-4
Steam Traps	A-5
Thermostatic Expansion Valve Operation	A-6
SMACCNA Duct Standards	A-7
Friction of Air in Pipe (Ducts)	A-8
AABC Air Balancing Test Sheets	A-9
Symbols for Ventilation and Air Conditioning	A-10
Steam Flow Chart for Control Valves	A-11
Liquid Flow Chart for Control Valves	A-12
Orifice Flow Meter Placement for Various Piping Configurations	A-13
Table for Dry Saturated Steam	A-14
Temperature Conversions	A-15
Psychrometric Chart	A-16
Metric and English Measures	A-17
Circumferences and Areas of Circles	A-18
Boiler Gage Glass and Pressure Gage Requirements . . .	A-19
NFPA Codes, Standards, etc	A-20
Section 763 of State Boiler Safety Orders	A-21

COMMERCIAL WROUGHT STEEL PIPE DATA

Note 1: The letters "s", "x", and "xx" in the column of Schedule Numbers indicate Standard, Extra Strong and Double Extra Strong Pipe, respectively.

Note 2: The values shown in square feet for the Transverse Internal Area also represent the volume in cubic feet per foot of pipe length.

Nominal Pipe Size Inches	Outside Diameter (D) Inches	Schedule No. See Note 1	Wall Thickness (t) Inches	Inside Diameter (d) Inches	Area of Metal (a) Sq Inches	Transverse Internal Area See Note 2		Moment of Interior (I) Inches to 4th Power	Weight of Pipe Pounds per Foot	Weight of Water Pounds per Foot of Pipe	External Surface Sq Feet per Foot of Pipe	Section Modulus $\left(\frac{I}{D}\right)$
						Square Inches	Square Feet					
½	0.405	40s	.068	.269	.0720	.0568	.00040	.00106	.244	.025	.106	.00523
		80x	.095	.215	.0925	.0364	.00025	.00122	.314	.016	.106	.00602
¾	0.540	40s	.088	.364	.1250	.1041	.00072	.00331	.424	.045	.141	.01237
		80x	.110	.302	.1574	.0716	.00050	.00377	.535	.031	.141	.01395
¾	0.675	40s	.091	.493	.1670	.1910	.00133	.00729	.567	.083	.178	.02160
		80x	.126	.423	.2173	.1405	.00098	.00862	.738	.061	.178	.02534
¾	0.840	40s	.109	.622	.2503	.3040	.00211	.01709	.850	.132	.220	.04069
		80x	.147	.546	.3200	.2340	.00163	.02008	1.087	.102	.220	.04780
		160	.187	.466	.3836	.1706	.00118	.02212	1.300	.074	.220	.05267
		...xx	.294	.252	.5043	.050	.00035	.0242	1.714	.022	.220	.05762
¾	1.050	40s	.113	.824	.3326	.5330	.00371	.03704	1.130	.231	.275	.07055
		80x	.154	.742	.4335	.4330	.00300	.04479	1.473	.188	.275	.08531
		160	.218	.614	.5698	.2961	.00206	.05269	1.940	.128	.275	.10336
		...xx	.308	.434	.7180	.148	.00103	.05792	2.440	.064	.275	.11032
1	1.315	40s	.133	1.040	.4939	.8640	.00600	.08734	1.678	.375	.344	.1328
		80x	.179	.957	.6388	.7190	.00409	.1056	2.171	.312	.344	.1606
		160	.250	.815	.8365	.5217	.00362	.1251	2.840	.230	.344	.1903
		...xx	.358	.599	1.0760	.282	.00196	.1405	3.659	.122	.344	.2136
1¼	1.680	40s	.140	1.380	.6685	1.495	.01040	.1047	2.272	.649	.435	.2346
		80x	.191	1.278	.8815	1.283	.00891	.2418	2.996	.555	.435	.2913
		160	.250	1.160	1.1070	1.057	.00734	.2839	3.764	.458	.435	.3421
		...xx	.382	.896	1.534	.630	.00438	.3411	5.214	.273	.435	.4110
1½	1.900	40s	.145	1.610	.7995	2.036	.01414	.3099	2.717	.882	.497	.3262
		80x	.200	1.500	1.068	1.767	.01225	.3912	3.631	.765	.497	.4118
		160	.281	1.338	1.429	1.406	.00976	.4824	4.862	.608	.497	.5078
		...xx	.400	1.100	1.885	.950	.00660	.5678	6.408	.42	.497	.5877
2	2.375	40s	.154	2.067	1.075	3.355	.02330	.6657	3.652	1.45	.622	.5606
		80x	.218	1.939	1.477	2.953	.02050	.8679	5.022	1.28	.622	.7309
		160	.343	1.689	2.190	2.241	.01556	1.162	7.440	.97	.622	.979
		...xx	.436	1.503	2.656	1.774	.01232	1.311	9.029	.77	.622	1.104
2¼	2.875	40s	.203	2.469	1.704	4.788	.03322	1.530	5.79	2.07	.753	1.064
		80x	.276	2.323	2.254	4.238	.02942	1.924	7.66	1.87	.753	1.339
		160	.375	2.125	2.945	3.546	.02463	2.353	10.01	1.54	.753	1.638
		...xx	.552	1.771	4.028	2.464	.01710	2.871	13.70	1.07	.753	1.997
3	3.500	40s	.216	3.068	2.228	7.393	.05130	3.017	7.54	3.20	.916	1.724
		80x	.300	2.900	3.016	6.605	.04547	3.894	10.25	2.80	.916	2.225
		160	.437	2.626	4.205	5.410	.03761	5.032	14.32	2.35	.916	2.876
		...xx	.600	2.300	5.466	4.155	.02885	5.993	18.58	1.80	.916	3.424
3¼	4.000	40s	.220	3.548	2.680	9.886	.06770	4.788	9.11	4.29	1.047	2.394
		80x	.318	3.364	3.678	8.888	.06170	6.280	12.51	3.84	1.047	3.140
		40s	.237	4.026	3.174	12.73	.08840	7.233	10.79	5.50	1.178	3.214
		80x	.337	3.826	4.407	11.50	.07986	9.610	14.98	4.98	1.178	4.271
4	4.500	120	.437	3.626	5.678	10.33	.0717	11.65	10.00	4.47	1.178	5.178
		160	.531	3.438	6.621	9.28	.0645	13.27	22.51	4.02	1.178	5.898
		...xx	.674	3.152	8.101	7.80	.0542	15.28	27.54	3.38	1.178	6.791
		40s	.258	5.047	4.300	20.01	.1390	15.16	14.62	8.67	1.456	5.451
5	5.543	80x	.375	4.813	6.712	18.19	.1263	20.67	20.78	7.88	1.456	7.431
		120	.500	4.563	7.953	16.35	.1136	25.73	27.10	7.09	1.456	9.250
		160	.625	4.313	9.696	14.61	.1015	30.03	32.96	6.33	1.456	10.796
		...xx	.750	4.063	11.340	12.97	.0901	33.63	38.55	5.61	1.456	12.980
6	6.625	40s	.280	6.065	5.581	28.89	.2006	28.14	18.97	12.51	1.734	8.50
		80x	.432	5.761	8.405	26.07	.1810	40.49	28.57	11.29	1.734	12.22
		120	.562	5.501	10.70	23.77	.1650	49.61	36.40	10.36	1.734	14.98
		160	.718	5.189	13.32	21.15	.1460	58.97	45.30	9.17	1.734	17.81
...xx	.864	4.897	15.64	18.84	.1308	66.33	53.16	8.16	1.734	20.62		
8	8.625	20	.250	8.125	6.57	51.85	.3601	37.72	23.36	22.47	2.258	13.39
		30	.277	8.071	7.26	51.16	.3553	63.35	24.70	22.15	2.258	14.69
		40s	.322	7.981	8.40	50.03	.3474	72.49	28.55	21.70	2.258	16.81
		60	.466	7.813	10.38	47.94	.3329	88.73	35.64	20.77	2.258	20.58
		80x	.500	7.625	12.76	45.66	.3171	105.7	43.30	19.78	2.258	24.57
		100	.593	7.439	14.96	43.46	.3018	121.3	50.87	18.83	2.258	28.14
		120	.718	7.189	17.84	40.59	.2819	140.5	60.63	17.50	2.258	32.58
		140	.812	7.001	19.93	38.50	.2673	153.7	67.70	16.68	2.258	35.65
...xx	.875	6.875	21.30	37.12	.2578	162.0	72.42	16.10	2.258	37.50		
160	.906	6.813	21.97	36.46	.2532	165.9	74.69	15.80	2.258	38.48		

COMMERCIAL WROUGHT STEEL PIPE DATA (concluded)

Nominal Pipe Size Inches	Outside Diameter (D) Inches	Schedule No. See Note 1	Wall Thickness (t) Inches	Inside Diameter (d) Inches	Area of Metal (a) Sq Inches	Transverse Internal Area See Note 2		Moment of Interior (I) Inches to 4th Power	Weight of Pipe Pounds per Foot	Weight of Water Pounds per Foot of Pipe	External Surface Sq Feet per Foot of Pipe	Section Modulus (I / D)
						Square Inches	Square Feet					
10	10 7.50	20	.250	10.250	8.24	82.52	.5731	113.7	28.04	35.70	2.814	21.15
		30	.307	10.130	10.07	80.09	.5603	137.4	34.24	34.90	2.814	25.57
		40s	.365	10.020	11.90	78.80	.5475	160.7	40.48	34.20	2.814	29.00
		60x	.500	9.750	16.10	74.66	.5185	212.0	54.74	32.35	2.814	39.43
		80	.593	9.564	18.92	71.84	.4989	244.8	64.33	31.13	2.814	45.54
		100	.718	9.314	22.63	68.13	.4732	286.1	79.03	29.53	2.814	53.22
		120	.843	9.064	26.34	64.53	.4481	324.2	89.20	27.96	2.814	60.32
		140	1.000	8.750	39.63	60.13	.4170	367.8	104.13	26.00	2.814	68.43
160	1.125	8.500	34.02	56.75	.3941	399.3	115.65	24.59	2.814	74.29		
12	12 7.75	20	.250	12.250	9.82	117.86	.8185	191.8	33.38	51.07	3.338	30.2
		30	.330	12.000	12.87	114.60	.7972	248.4	43.77	49.74	3.338	38.1
		40	.375	12.000	14.58	113.10	.7854	279.3	49.56	49.00	3.338	43.8
		60x	.406	11.938	15.77	111.93	.7773	300.3	53.53	48.50	3.338	47.1
		80	.500	11.750	19.24	108.43	.7528	361.5	65.42	46.92	3.338	56.7
		100	.562	11.626	21.52	106.16	.7372	400.4	73.16	46.00	3.338	62.8
		120	.687	11.370	26.03	101.04	.7058	475.1	88.51	44.04	3.338	74.6
		140	.843	11.004	31.53	96.14	.6772	541.0	107.20	41.60	3.338	88.1
160	1.000	10.750	36.91	90.76	.6393	641.6	125.49	39.33	3.338	100.7		
180	1.125	10.500	41.08	86.59	.6113	700.5	133.68	37.52	3.338	109.9		
200	1.312	10.126	47.14	80.53	.5592	781.1	160.27	34.89	3.338	122.6		
14	14 0.00	20	.250	13.500	10.80	143.14	.9940	255.3	36.71	62.03	3.665	36.6
		30	.312	13.376	13.42	140.52	.9758	314.4	45.68	60.89	3.665	45.0
		40s	.375	13.250	16.05	137.88	.9575	372.8	54.57	59.75	3.665	53.2
		60	.437	13.126	18.01	135.32	.9397	429.1	63.37	58.64	3.665	61.3
		80	.500	13.000	21.21	132.73	.9217	483.8	72.09	57.46	3.665	69.1
		100	.563	12.814	24.98	128.06	.8956	562.3	84.91	55.86	3.665	80.3
		120	.750	12.500	31.22	122.72	.8522	687.3	106.13	53.18	3.665	98.2
		140	.937	12.126	38.45	115.49	.8020	824.4	130.73	50.04	3.665	117.8
160	1.003	11.814	44.32	109.62	.7612	929.6	150.67	47.45	3.665	132.8		
180	1.250	11.500	50.07	103.87	.7213	1027.0	170.22	45.01	3.665	146.8		
200	1.406	11.188	55.63	98.31	.6827	1117.0	189.12	42.60	3.665	159.6		
16	16 0.00	20	.250	15.500	12.37	188.69	1.3103	383.7	42.05	81.74	4.189	48.0
		30	.312	15.376	15.38	185.09	1.2895	473.2	52.36	80.50	4.189	59.2
		40s	.375	15.250	18.41	182.65	1.2684	562.1	62.58	79.12	4.189	70.3
		60	.500	15.000	24.35	176.72	1.2272	731.9	82.77	76.58	4.189	91.5
		80	.576	14.688	31.82	169.44	1.1760	832.4	107.50	73.42	4.189	116.6
		100	.843	14.314	40.14	160.02	1.1175	1155.8	136.40	69.73	4.189	144.5
		120	1.031	13.938	48.48	152.58	1.0590	1364.5	164.83	66.12	4.189	170.5
		140	1.218	13.564	56.56	144.50	1.0035	1555.8	192.20	62.62	4.189	194.5
160	1.437	13.126	65.74	135.32	.9397	1760.3	223.64	58.64	4.189	220.0		
180	1.593	12.814	72.10	128.90	.8950	1893.5	245.11	55.83	4.189	236.7		
18	18 0.00	20	.250	17.500	13.94	240.53	1.6703	549.1	47.39	104.21	4.712	61.1
		30	.312	17.376	17.34	237.13	1.6407	678.2	59.03	102.77	4.712	75.5
		40s	.375	17.250	20.70	233.71	1.6230	806.7	70.59	101.18	4.712	89.0
		60	.437	17.126	24.11	230.36	1.5997	930.3	82.00	99.84	4.712	103.4
		80	.500	17.000	27.49	226.98	1.5763	1053.2	92.45	98.27	4.712	117.0
		100	.562	16.876	30.79	223.68	1.5533	1171.5	104.75	96.93	4.712	130.1
		120	.750	16.500	40.04	213.83	1.4849	1514.7	138.17	92.57	4.712	168.3
		140	.937	16.126	50.23	204.24	1.4183	1833.0	170.75	88.50	4.712	203.8
160	1.150	15.688	61.17	193.30	1.3423	2180.0	207.96	83.76	4.712	242.3		
180	1.375	15.250	71.81	182.60	1.2684	2498.1	244.14	79.07	4.712	277.6		
200	1.562	14.876	80.66	173.80	1.2070	2749.0	274.23	75.32	4.712	305.5		
220	1.781	14.438	90.75	163.72	1.1369	3020.0	308.51	70.88	4.712	335.6		
20	20 0.00	20	.250	19.500	15.51	298.65	2.0740	756.4	52.73	129.42	5.236	75.6
		30	.312	19.250	23.12	290.04	2.0142	911.0	78.60	125.67	5.236	111.3
		40s	.375	19.000	30.63	283.53	1.9690	1457.0	104.13	122.87	5.236	145.7
		60	.500	18.814	38.15	278.00	1.9305	1703.0	122.91	120.46	5.236	179.4
		80	.576	18.376	48.95	265.21	1.8417	2257.0	160.40	114.92	5.236	225.7
		100	.687	17.938	61.44	252.72	1.7550	2772.0	208.67	109.51	5.236	277.1
		120	.843	17.438	75.33	238.83	1.6585	3315.2	250.10	103.39	5.236	331.5
		140	1.000	17.000	87.18	226.08	1.5762	3754.0	296.37	98.35	5.236	375.5
160	1.250	16.500	100.33	213.82	1.4849	4216.0	341.10	92.66	5.236	421.7		
180	1.468	16.064	111.49	202.67	1.4074	4585.5	379.01	87.74	5.236	458.5		
24	24 0.00	20	.250	23.500	18.65	433.74	3.0121	1315.4	63.41	187.05	6.283	109.6
		30	.375	23.250	27.83	424.56	2.9483	1642.0	94.62	183.05	6.283	161.9
		40s	.500	23.000	39.91	415.48	2.8853	2549.5	125.49	179.87	6.283	212.5
		60	.562	22.876	41.39	411.00	2.8542	2843.0	140.80	178.09	6.283	237.0
		80	.687	22.626	50.31	402.07	2.7921	3421.3	171.17	174.23	6.283	285.1
		100	.968	22.084	70.04	382.35	2.6552	4652.8	238.11	165.52	6.283	387.7
		120	1.218	21.564	87.17	365.22	2.5362	5672.0	296.36	158.20	6.283	472.8
		140	1.531	20.938	108.07	344.32	2.3911	6849.0	367.40	149.06	6.283	570.8
160	1.812	20.376	126.31	326.08	2.2645	7825.0	429.30	141.17	6.283	652.1		
180	2.062	19.876	142.11	310.28	2.1547	8625.0	483.13	134.45	6.283	718.9		
200	2.343	19.314	159.41	292.98	2.0346	9455.9	541.94	126.84	6.283	787.0		

COPPER WATER TUBE STANDARDS
DIMENSIONS AND WEIGHTS
DIAMETER AND WALL THICKNESS TOLERANCES

Nominal Size	Actual O.D. (In Inches)	Average O.D. Tolerances (In Inches)		TYPE K Recommended for use with soldered or compression fittings; for general plumbing involving relatively severe service conditions and for heating, gas, steam and oil lines and underground service		TYPE L Recommended for use with soldered or compression fittings; for general plumbing involving relatively less severe service conditions and for interior applications for heating, gas, steam and oil lines		TYPE M* Recommended for use with soldered fittings only; for interior application for heating and for waste, vent, soil and other non-pressure applications	
		Soft Annealed	Hard Drawn	Nominal wall thickness (In Inches)	Tolerance (In Inches)	Nominal wall thickness (In Inches)	Tolerance (In Inches)	Nominal wall thickness (In Inches)	Tolerance (In Inches)
3/8	.375	.002	.001	.035	.004	.030	.0035
1/2	.500	.0025	.001	.040	.004	.035	.0035
5/8	.625	.0025	.001	.040	.004	.040	.0035
3/4	.750	.0025	.001	.040	.004	.042	.0035
7/8	.875	.003	.001	.065	.0045	.045	.004
1	1.125	.0035	.0015	.065	.0045	.050	.004
1 1/8	1.375	.004	.0015	.065	.0045	.055	.0045	.042	.0035
1 1/4	1.625	.0045	.002	.072	.005	.060	.0045	.049	.004
1 1/2	2.125	.005	.002	.083	.007	.070	.006	.058	.006
2	2.625	.005	.002	.095	.007	.080	.006	.065	.006
2 1/2	3.125	.005	.002	.109	.007	.090	.007	.072	.006
3	3.625	.005	.002	.120	.008	.100	.007	.083	.007
3 1/2	4.125	.005	.002	.134	.010	.110	.009	.095	.009
4	4.625	.005	.002	.160	.010	.125	.010	.100	.009
5	5.125	.005	.002	.192	.012	.140	.011	.122	.010
6	6.125	.005	.002						
8	8.125	.006	.002	.271	.016	.200	.014	.170	.014
10	10.125	.008	.002	.338	.018	.250	.016	.212	.015
12	12.125	.008	.002	.405	.020	.280	.018	.254	.016

*Although not recommended, Type M tube is available in sizes 3/8 in., 1/2 in., 3/4 in. and 1 in. for certain services less severe than those provided in Table I above.

TABLE II

Nominal Size	THEORETICAL WEIGHT (Pounds Per Foot)		
	Type K	Type L	Type M
3/8	0.145	0.126
1/2	0.269	0.198
5/8	0.344	0.285
3/4	0.418	0.362
7/8	0.641	0.455
1	0.839	0.655
1 1/8	1.04	0.884	0.682
1 1/4	1.36	1.14	0.940
1 1/2	2.08	1.75	1.46
2	2.93	2.48	2.03
2 1/2	4.00	3.33	2.68
3	5.12	4.20	3.58
3 1/2	6.51	5.38	4.66
4	8.67	7.61	6.66
5	13.9	10.2	8.92
6	25.0	19.3	16.5
8	40.3	30.1	25.6
10	57.8	40.4	36.7

LENGTHS

- (a) The standard lengths for tubes furnished straight are 12 and 20 feet.
- (b) The standard length for tubes furnished in coils is 60 feet.

LENGTH TOLERANCE

Same as for round seamless tube.

ROUNDNESS TOLERANCE

Same as for round seamless tube.

WEIGHT TOLERANCE

Tube shall not vary in weight by more than 7% from the theoretical weight given in Table II.

TEMPERS

Types K and L — hard and soft tempers.
 Type M — hard temper only.

SQUARENESS OF CUT

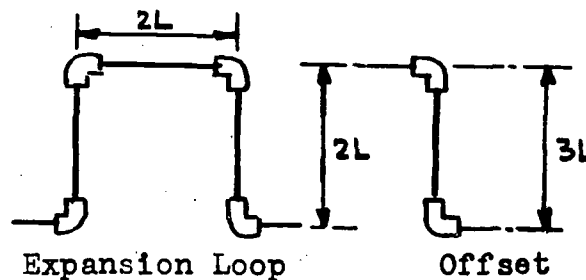
Same as for round seamless tube.



LINEAR EXPANSION OF COPPER TUBING AND STEEL PIPE
(Inches per 100 feet)

TEMP RANGE (F)	COPPER TUBING	STEEL PIPE
0	0	0
50	.56	.37
100	1.12	.76
150	1.69	1.15
200	2.27	1.55
250	2.85	1.96
300	3.45	2.38
350	4.05	2.81
400	4.65	3.25
450	5.27	3.70
500	5.89	4.15

COPPER EXPANSION LOOPS AND OFFSETS



TUBE OD (in.)	LENGTH—L (INCHES) For Travel of								
	½"	1"	1½"	2"	2½"	3"	4"	5"	6"
¾	10	15	19	22	25	27	30	34	38
1¼	11	16	20	24	27	29	33	38	42
1½	11	17	21	25	29	32	36	42	47
1¾	12	18	23	28	31	35	39	46	51
2¼	14	20	25	31	34	38	44	51	57
2½	16	22	27	32	37	42	47	56	62
3¼	18	24	30	34	39	45	53	60	67
4¼	20	28	34	39	44	48	58	66	75
5¼	22	31	39	44	49	54	62	70	78
6¼	24	34	42	48	54	59	68	76	83

Data from Mueller Brass Co.

ARMSTRONG "L" SERIES LARGE CAPACITY STEAM TRAPS

Float and Thermostatic Type for continuous drainage requirements pressures from 0 to 250 psig . . . capacities to 52,000 lbs/hr

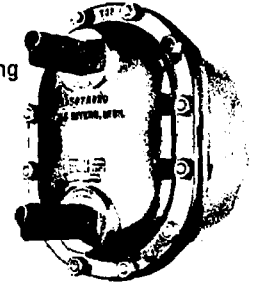
Armstrong "L" Series Steam Traps are king sized float and thermostatic traps. They are designed especially to meet very large capacity needs in services where continuous drainage is essential or desirable.

The float and the lever mechanism are all stainless steel with heat treated chrome steel valve and seat. Lever motion is guided to assure proper valve seating and maximum life for the valve and seat.

The integral thermostatic air vent in "L" Series Traps is a charged multi-convolution beryllium copper bellows caged in stainless steel. It is designed especially for heavy duty industrial applications where highly efficient, uninterrupted service is essential. It is a balanced pressure type that responds to the pressure-temperature curve of steam at any pressure from zero to maximum operating pressure. Thus, air will be vented at slightly below steam temperature throughout the operating range.

"L" Series Traps are offered with either 2" or 2½" connections and are drilled and tapped to accept an integral vacuum breaker when required in low pressure modulating service.

Fig. L-1. Armstrong "L" Series Trap.



DRILLED AND TAPPED FOR OPTIONAL INTEGRAL VACUUM BREAKER (UNDER 150 PSI)

THERMOSTATIC AIR VENT

AIR VENTED TO RETURN LINE

STAINLESS STEEL FLOAT

DRAIN PLUG

GUIDED VALVE LEVER MECHANISM

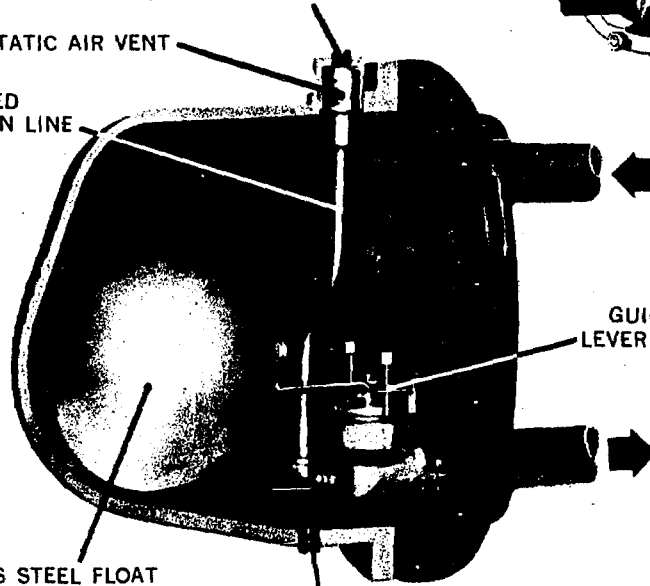


Fig. L-2. Cutaway view of "L" Series Steam Trap.

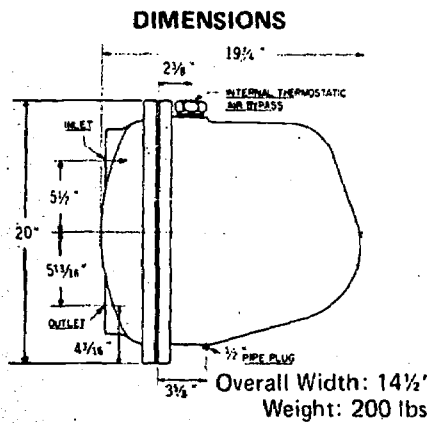
Table A-L. LIST OF MATERIALS

Name of Part	Material
Cap, Body and Cap Extension	ASTM-A-278 Class 30 Cast Iron
Cap Bolting	125,000 lb. tensile bolts
Cap Gaskets	Compressed asbestos
Float Mechanism	Stainless steel with heat treated chrome steel valve and seat
Balanced Pressure Thermostatic Air Vent	Stainless steel and brass with beryllium copper bellows, entire unit caged in stainless steel

Table B-L. MODELS AND CAPACITIES

Capacities are continuous discharge capacities in pounds of condensate per hour at pressure differential indicated with condensate within 5° of steam temperature.

Trap No.	30-L8	30-L10	100-L8	100-L10	150-L8	150-L10	250-L8	250-L10
Connection Size	2"	2-1/2"	2"	2-1/2"	2"	2-1/2"	2"	2-1/2"
Orifice Size	1-5/8"		1-1/8"		7/8"		11/16"	
Pressure Differential, psi	1/2	16,500	8,450	7,300	6,050			
	1	21,000	11,400	9,800	8,100			
	2	26,000	14,500	12,500	10,500			
	5	34,000	20,500	17,000	14,000			
	10	40,500	25,000	20,000	17,500			
	20	46,500	31,500	24,000	20,000			
	30	48,000	35,000	27,500	21,500			
	40	-	38,500	30,500	23,000			
	50	-	40,500	33,500	24,000			
	60	-	43,000	36,000	25,500			
	70	-	45,000	38,000	26,500			
	80	-	47,000	40,000	28,000			
	90	-	48,000	42,000	29,000			
	100	-	50,000	44,000	31,500			
	125	-	-	49,000	34,000			
150	-	-	-	52,000	37,000			
175	-	-	-	-	40,000			
200	-	-	-	-	43,500			
250	-	-	-	-	50,000			



All dimensions are approximate. Use certified print for exact dimensions.

Available with integral vacuum breaker for pressures to 150 psi. Suffix "VB" to Model No. Also available with integral flash release for syphon drainage service. Suffix "CC" to Model No.



Here's how Armstrong Inverted Bucket Steam Traps deliver everything you should get in a trap

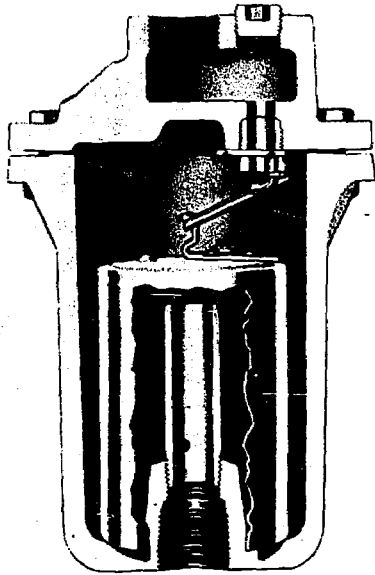


Fig. 5-1. 200 Series bottom inlet, top outlet Armstrong Trap.

1. No Steam Waste
Discharge valve is water sealed. Steam does not reach it.

2. Long Life and Dependable Service
Valve and seat are chrome steel, heat treated, ground and lapped. Free floating valve mechanism is "frictionless." Wear points are heavily reinforced.

3. Corrosion Resistance
All working parts are made of stainless steel.

4. Continuous Air Venting
Vent in top of bucket provides continuous automatic air venting. The steam passing through the vent is less than that required to offset radiation loss from the trap.

5. CO₂ Venting at Steam Temperature
Fixed vent passes CO₂ immediately—there is no cooling lag that would permit CO₂ to go into solution and form corrosive carbonic acid.

6. Operating Against Back Pressure
Since trap operation is governed solely by the difference in density of steam and water, back pressure in the return line has no effect on the ability of the trap to open for condensate and close against steam.

7. Freedom from Dirt Trouble
Condensate flow under the bottom edge of the bucket keeps sediment and sludge in suspension until discharged with condensate. There is no build-up of dirt. There are no close clearances to be affected by scale.

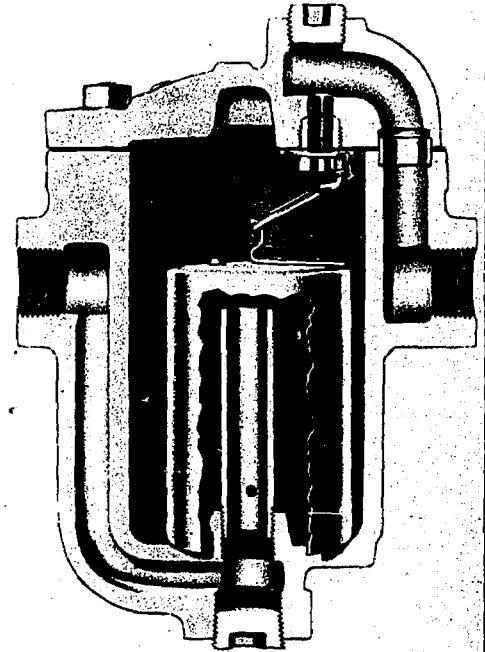


Fig. 5-2. 800 Series side inlet-side outlet Armstrong Trap. Equivalent sizes of 200 Series and 800 Series traps have identical mechanisms.

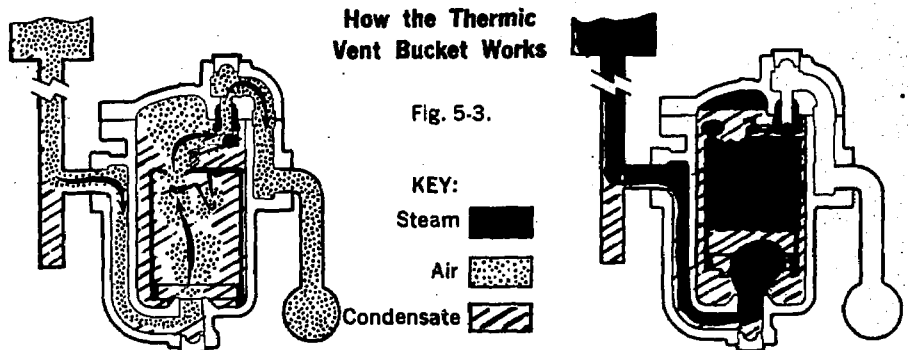
FOR SPECIAL REQUIREMENTS

Heating When Steam Is Turned On

Wherever steam is turned on and off, air will accumulate in piping and steam equipment during the off period. A trap with a thermic bucket will discharge this air 50 to 100 times faster than a standard bucket, reducing heat-up time remarkably. Thermic vent buckets are available for all Armstrong traps for use at pressures up to 125 psig.

Where to Use: Single pipe coils; small on-and-off unit heaters; on-and-off multiple coils; drip points (particularly at ends of steam distribution mains); wherever air will pocket and be discharged ahead of incoming steam.

Operation of the thermic bucket trap is described at the right.



1. Trap cool. Air cannot collect at the top of the bucket because the large vent is wide open. The bucket stays down and holds the trap valve wide open allowing air to escape very rapidly until . . .

2. . . steam reaches the bucket. The bi-metal strip is heated by the steam. This closes the thermic vent. Steam will then collect in top of bucket to impart buoyancy and close the trap valve.

With thermic vent closed, the trap operates as a standard trap as shown in operating drawings on pages 2 & 3.

INSTALLATION OF ARMSTRONG INVERTED BUCKET TRAPS

Before Installing

Run pipe to trap. *Before installing* the trap, clean the line by blowing down at full steam pressure. (Clean any strainer screens after this blow-down.)

Trap Location ABC's

Accessible for inspection and repair
Below drip point whenever possible
Close to drip point

Trap Hook-Ups. For low and medium pressure service, see Figs. 42-1 through 42-8. Follow the Power Piping Code for Drains and Drains when installing high pressure traps.

Shut-Off Valves ahead of traps are needed when traps drain steam mains, large water heaters, etc., where system cannot be shut down for trap maintenance. They are not needed for small steam heated machines—a laundry press, for example. Shut-off valve in steam supply to machine is sufficient.

Shut-off valve in trap discharge line is needed when trap has a bypass. It is a good idea when there is high pressure in discharge header. See also Check Valves.

By-passes (Figs. 42-6 and 42-7). Use only when continuous service is a must. Keep by-passes above traps as shown.

Unions. If only one is used, it should be on discharge side of trap. With two unions, avoid horizontal or vertical in-line installations. The best practice is to install at right angles as in Figs. 42-1 and

42-6 or parallel as in Fig. 42-7.

Standard Connections. Servicing is simplified by keeping lengths of inlet and outlet nipples identical for traps of a given size and type. A spare trap with identical fittings and half unions can be kept in the storeroom. In the event a trap needs repair it is a simple matter to break the two unions slip out the ailing trap, put in the spare and tighten the unions. Repairs can then be made in the shop and the repaired trap, with fittings and half unions, put back in stock.

Test Valves (Fig. 42-1) provide best means of checking trap operation. Use a pet cock or a small globe valve. Provide a check valve or shut-off valve in the discharge line to isolate trap while testing.

Strainers. Install strainers ahead of small traps when dirt conditions are bad or where specified. They are seldom needed with larger size of traps.

Traps No. 880-883 have built-in strainers. When strainer blow down valve is used, shut off steam supply valve before opening strainer blow-down valve. Condensate in trap body will flash back through strainer screen for thorough cleaning. Open steam valve slowly to be sure trap regains its seal.

Dirt Pockets (Figs. 42-1 and 42-7) are excellent for stopping scale and core sand. Clean periodically.

Syphon Installations require a water seal

and a check valve in the trap. Syphon pipe should be one size smaller than nominal size of trap used but not less than 1/2" pipe size.

Elevating Condensate. Do not oversize the vertical riser. In fact, one pipe size smaller than normal for the job will give excellent results.

Check Valves are frequently needed. They are a must if no discharge line shut-off valve is used. Fig. 42-9 shows three possible locations for external check valves—also an Armstrong Internal Check Valve (See page 4). Recommended locations given below.

Discharge Line Check Valves prevent back flow and isolate trap when test valve is opened. Normally installed at location B. When return line is elevated and trap is exposed to freezing conditions, install check valve at location A, Fig. 42-9.

Inlet Line Check Valves prevent loss of seal if pressure should drop suddenly or if trap is above drip point. Armstrong Stainless Steel Check Valve in trap body, location D, is recommended. If swing check is used, install at location C.

Protection Against Freezing. In general, a properly selected and installed Armstrong Trap will not freeze as long as steam is coming to the trap. If the steam supply should be shut off, the trap should be drained manually or automatically by means of a thermo drain or pop drain.

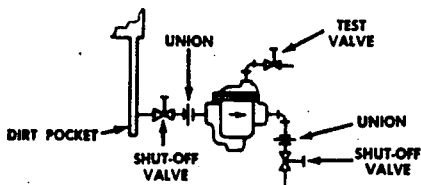


Fig. 42-1. Standard hookup No. 800-814, 880-883 traps, with shut-off valves to isolate trap during testing, inspection or repair. Unions should be at right angles—not in-line—to facilitate trap removal.

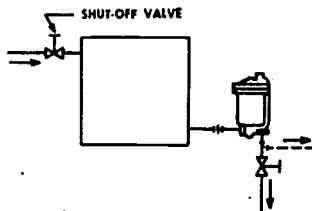


Fig. 42-4. Hookup No. 801 trap (shows how shut-off valve ahead of unit can serve as shut-off for a trap).

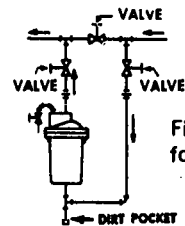


Fig. 42-7. Bypass hookup for No. 211-216 traps.

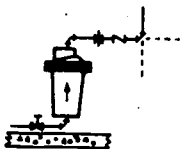


Fig. 42-2. Hookup No. 211-216 traps.

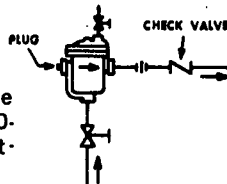


Fig. 42-5. Alternate hookup for No. 800-814 with inlet at bottom.

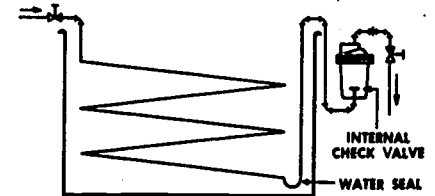


Fig. 42-8. Trap draining syphon.

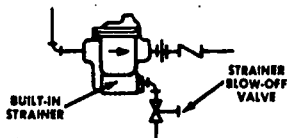


Fig. 42-3. No. 880-883 with strainer blow-down valve.

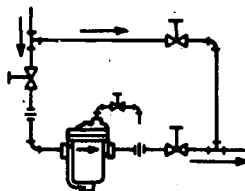


Fig. 42-6. Bypass hookups for No. 800-814 and 880-883 traps.

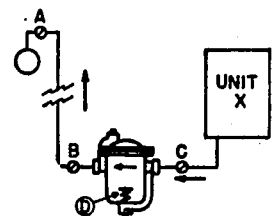


Fig. 42-9. Possible check valve locations.

ARMSTRONG THERMOSTATIC AIR VENTS

for venting air from steam in chamber type heat exchangers pressures to 125 psig

Armstrong offers the Model TV-2 Balanced Pressure Thermostatic Air Vent for positive venting of air from chamber type heat transfer equipment with no loss of steam. Typical applications include jacketed kettles, retorts, vulcanizers, jacketed sterilizers or other contained equipment where air could accumulate at the top of the steam chamber and reduce heat transfer capacity.

The Model TV-2 is a balanced pressure thermostatic air vent that responds to the pressure-temperature curve of steam at any pressure from light vacuum to maximum operating pressure. Air is automatically vented at slightly below steam temperature throughout the entire operating pressure range.

The thermostatic element is a charged, multi-convolution beryllium copper bellows caged in stainless steel. Valve and seat are also stainless steel designed to meet the most rigid cycling specifications known for this type of service.

HOW TO USE THE MODEL TV-2 THERMOSTATIC AIR VENT

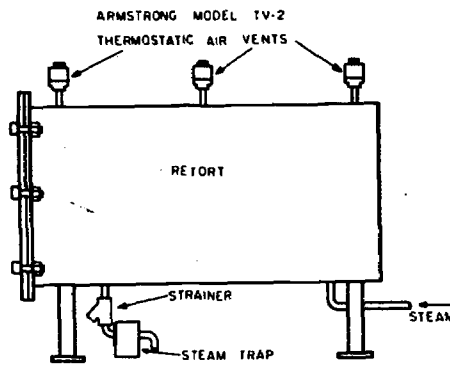


Fig. 13-1. On a retort

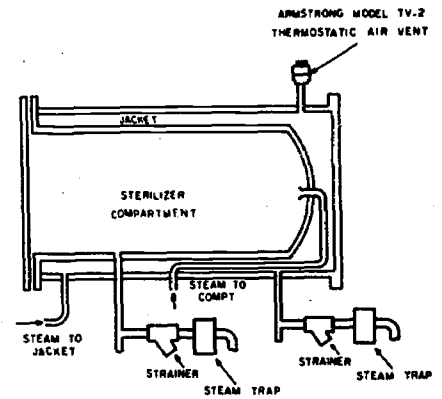


Fig. 13-2. On a sterilizer

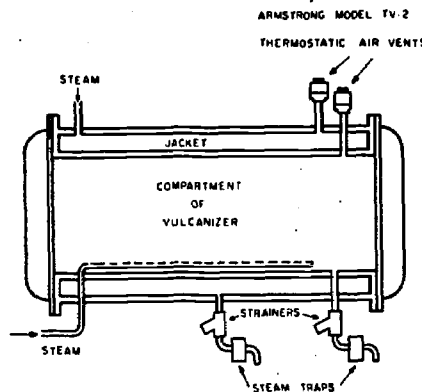


Fig. 13-3. On a vulcanizer

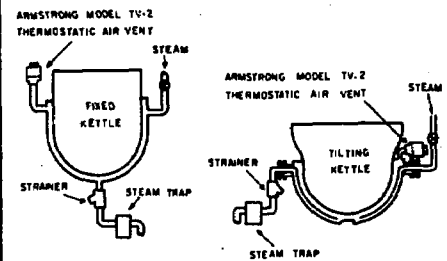


Fig. 13-4. On jacketed kettles

Table A-13. PHYSICAL DATA, MODEL TV-2 AIR VENTS

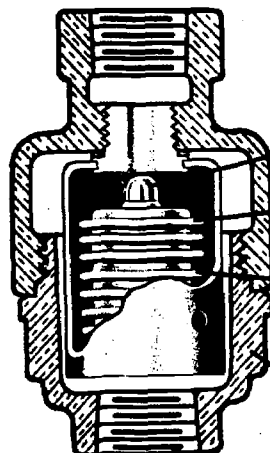
Vent No.	TV-2
Pipe Connections	3/8", 1/2"
Diameter	2 3/16"
Height	3 1/2"
Weight	1 lb. 9 oz.
Maximum Working Pressure	125 psig

Armstrong Model TV-2 Thermostatic Air Vents should be installed at the highest points of steam chambers with inlet connections to the vents higher than the highest points of the chambers. Thus in-

stalled there is minimum hazard of any liquid carryover and air can be vented to atmosphere with no drain line necessary. The drawings above show typical installations on steam chambers.



Fig. 13-5. The Armstrong Model TV-2 Thermostatic Air Vent



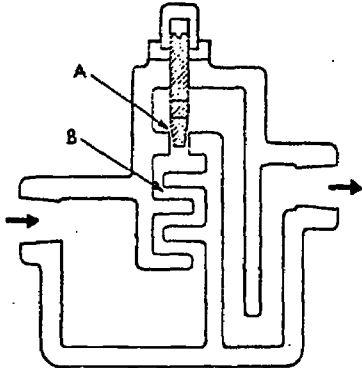
DESIGN FEATURES

- Stainless steel hemispherical valve and seat.
- Thermostatic element comprises a multi-convolution beryllium copper bellows caged in stainless steel.
- Thermostatic element is charged with water to provide positive opening of the valve at slightly below steam temperature and positive closing in the presence of steam throughout the operating pressure range.
- ASTM-B-62 cast bronze body.

CHAPTER 8

THERMODYNAMIC TRAPS

This third class of steam traps utilizes the heat energy in hot condensate and steam to control the opening and closing of the trap.



ORIFICE (LABYRINTH) TYPE – This was one of the earliest thermodynamic traps. In one form it combines an adjustable orifice (A) with labyrinth passages (B) to control the flow of condensate. Due to pressure drop through the LABYRINTH PASSAGES and the adjustable orifice, some condensate turns to flash steam as condensate approaches steam temperature. This provides a measure of automatic flow control, for the nearer the condensate approaches steam temperature the greater will be the flashing and therefore the greater the choking effect of the flash steam.

As with the orifice plate described in CHAPTER No. 3, page 6, if the condensate load does not fluctuate to any great degree this trap is quite satisfactory, but if load, pressure, or temperature vary considerably it is likely to either back-up condensate or blow live steam.

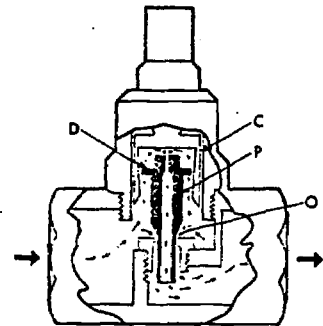
PISTON VALVE TYPE IMPULSE® TRAP – A later and more modern thermodynamic trap is the Impulse Trap.

Without going into the technical details of the engineering theory involved, the operation of this trap is described very simply in the following paragraphs.

This trap in its best known form consists essentially of a piston type valve (P) operating within a CONTROL CYLINDER (C).

The lower end of the valve has a tapered seating surface which opens and closes the ORIFICE (O).

When steam is turned on in the system ahead of the trap, pressure is exerted on the under side of the PISTON DISC (D), on the Valve (P), pushing it upward to open the ORIFICE (O), so the condensate and air can flow out at full capacity.

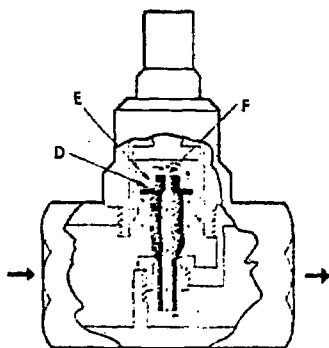


VALVE OPEN

The valve opens wide on start-up for full discharge of condensate and to quickly get rid of any air that may have accumulated in the system.

Valve stays wide open until condensate nears steam temperature.

Opening and closing of this trap is regulated by the slight condensate flow termed the CONTROL FLOW, which goes up past the PISTON DISC (D) to the intermediate pressure area in the CONTROL CHAMBER (E). It then flows out the CONTROL ORIFICE (F) in the hollow stem of the valve to the lower pressure in the discharge part of the trap.



VALVE CLOSED

When condensate nears steam temperature, these pressure drops cause it to flash in the CONTROL CHAMBER (E) and in the CONTROL ORIFICE (F). This chokes the flow through the control orifice which increases the pressure in the CONTROL CHAMBER (E) snapping the valve shut to prevent the loss of live steam.

As long as the condensate remains hot enough to continue the flashing the valve remains closed. When it cools slightly the flashing decreases. This reduces pressure in the CONTROL CHAMBER allowing the valve to reopen and the cycle is repeated.

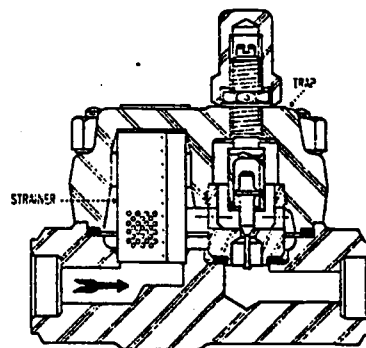
The CONTROL FLOW continuously samples the condensate flow coming to the trap and causes the valve to open or close quickly at the proper time - to open wide on condensate, but close when steam reaches the trap.

Therefore the quick response provided by the control flow in this trap aids in bringing steam equipment up to temperature quickly and in maintaining high even temperatures of the apparatus. This promotes high efficiency of the overall operation.

The CONTROL FLOW consists of only a slight percentage of the full flow through the main orifice. This means that only an amount of condensate equal to this small percentage is required to completely fill the control orifice at all times. When the main valve is closed and as long as this slight amount of condensate flow is maintained there can be no measurable flow of steam through the control orifice.

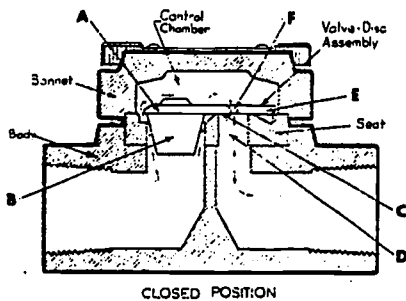
INTEGRAL STRAINER TYPE IMPULSE® TRAP –

For high pressure service in Power Plant and Marine service this trap is made with a built-in or integral strainer, as shown in the illustration. This provides a very compact and sturdy construction for such types of applications.



LEVER VALVE TYPE HIGH CAPACITY IMPULSE® TRAP –

A newer version of the Impulse Trap is the High Capacity Impulse Trap. Designed for extra heavy condensate loads, it operates on the same basic principle as the original type but with a lever action rather than a piston action.

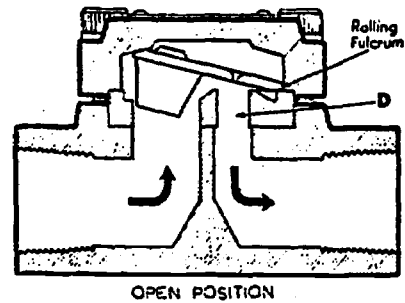


This trap consists of a valve disc (A) to which is attached an inlet valve (B). At point (C) the valve disc acts as an outlet valve, opening and closing the outlet orifice (D) as the valve disc tilts up and down around the fulcrum point (E). A control orifice (F) is provided in the valve disc over the center of the discharge or outlet orifice (D).

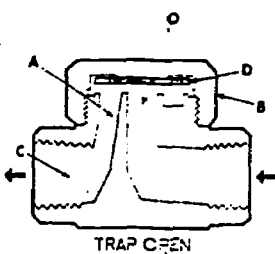
When valve disc is at rest there is a control flow between the inlet valve (B) and its seat. This control flow then goes on out the control orifice (F).

Incoming condensate and air push the disc upward with a tilting action and full flow goes out the discharge orifice (D).

Operation is similar to that of the original Impulse Trap except the control flow combines with the main flow when the valve opens instead of following a separate flow path as in the earlier design. Flashing of the hot condensate controls the closing of the valve disc just as in the original Impulse type and action is governed by the same basic principle of control flow.



DISC TYPE TRAP — One of the most recently developed types of thermodynamic traps is known as the DISC type.



It consists of a round flat DISC (D) positioned over a center INLET ORIFICE (O) and an ANNULAR DISCHARGE (A) leading off through a DISCHARGE PORT (C). All are enclosed within a BONNET (B) mounted on the body of the trap.

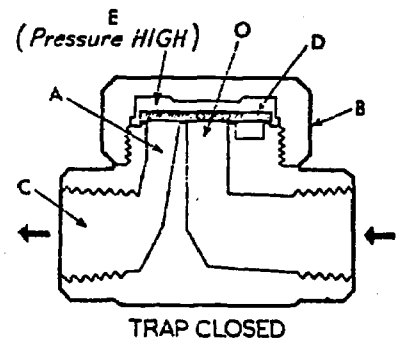
When operation starts, pressure in the INLET ORIFICE (O) pushes the DISC (D) up vertically off the two concentric seating surfaces surrounding the inlet and outlet ports. This allows discharge to flow out through the DISCHARGE PORT (C).

Now when very hot Condensate and Steam come to the trap the high velocity flow outward past the rim of the DISC (D) up into the CHAMBER (E) tends to reduce the pressure on the under side of the DISC causing some of the Condensate to turn to Flash Steam. At the same time the flashing condensate flowing outward at high velocity strikes the side wall of the CHAMBER (E) causing a build up of pressure in the CHAMBER snapping the DISC (D) shut.

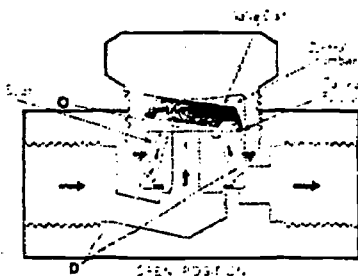
The DISC remains in the closed position until the pressure in the BONNET falls due to the condensing of the steam in the bonnet.

When pressure in the bonnet falls sufficiently the DISC rises, condensate flows out and the cycle is repeated.

This type of trap is essentially a TIME CYCLE device. In other words, under normal operating conditions each time the DISC closes on Steam at a given pressure and temperature it will stay closed for approximately the same length of time. This means that if CONDENSATE comes to the trap in the middle of a cycle, it will have to wait till pressure in the bonnet falls sufficiently to permit the DISC to open.



LEVER DISC TYPE IMPULSE® TRAP — This newest version of the Impulse Trap operates in somewhat the same manner as the Disc Trap described above, except that the valve disc is arranged so that it opens and closes the valve with a tilting action rather than moving straight up and down as in the above type.



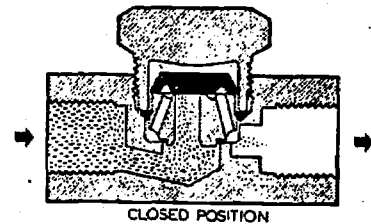
The Lever Disc Impulse Trap is designed primarily for the lighter condensate loads.

When condensate enters this trap it pushes the disc upward with a tilting action because the inlet orifice (O) is off center. (To the left of center in the illustration.) Discharge then goes out through the discharge ports (D) in the seat plate. When steam and steam temperature condensate come to the trap the bonnet fills with steam and the increased pressure closes the disc in a somewhat similar manner to that described for the disc trap above.

The tilting or lever action of the valve in the lever disc trap insures a minimum of wear on the parts and also aids in reducing to a minimum the noise from the trap discharge.

As in the case of the DISC TYPE TRAP, this trap also operates on a time cycle. In other words, the time between opening and closing will be relatively constant for a given set of load and pressure conditions.

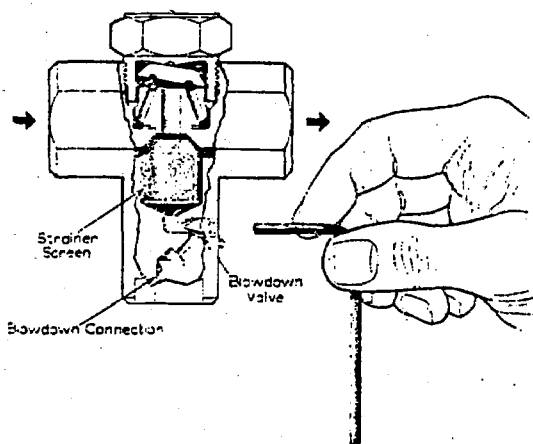
When the lever disc trap is closed by live steam and flash steam entering the bonnet, it stays closed until the steam in the bonnet condenses and also bleeds off slowly between the ground surface of the seat and the disc.



This "bleeding off" actually comprises a very slight control flow similar to that in the other styles of Impulse® Traps, but is so small it is barely perceptible at the trap discharge. Without this slight control flow this type of trap would stay closed for such a long time when steam filled the bonnet, that it would not provide satisfactory operation.

Both the Disc and Lever Disc types of Traps just described are effective from the upper limits of their recommended capacity ratings down to even the very lightest condensate loads.

Several other varieties of disc type traps have recently been made available, but all operate on the same general principles just described for the Disc and Lever Disc types of traps.



COMBINATION TRAP, STRAINER, AND STRAINER BLOWDOWN VALVE – A recent development combining the Lever Disc type Impulse Trap with a strainer and strainer blowdown valve is shown in the adjoining illustration.

It includes all three devices in one compact assembly and, as can readily be seen, affords a considerable saving in labor of installation, space, and weight.

The blowdown valve, operated by a standard Allen wrench, affords a quick and easy method of cleaning the strainer screen.

Like the Lever Disc type described above, this combination trap is designed primarily for the lighter condensate loads.

THERMOSTATIC EXPANSION VALVES *

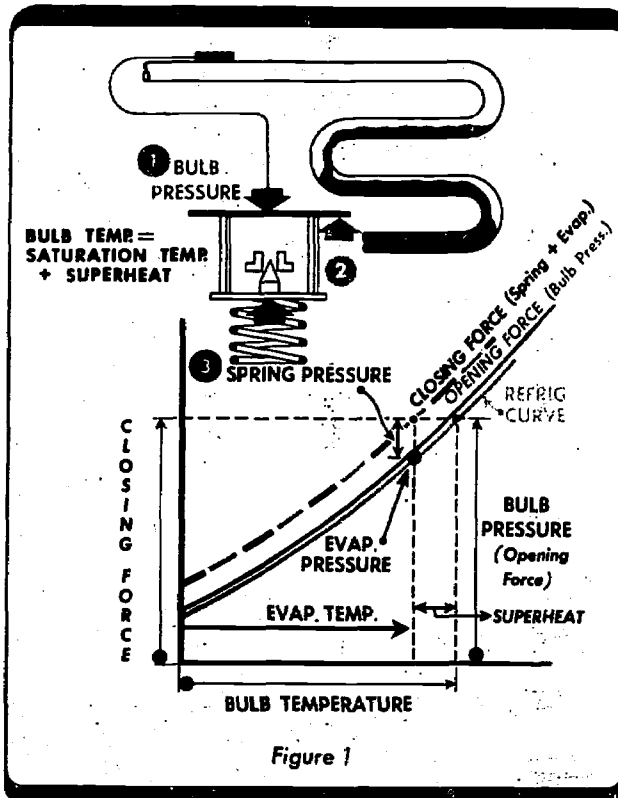
Theory of Operation – Application – Selection

HOW THE THERMOSTATIC EXPANSION VALVE WORKS

Basically, Thermostatic Expansion Valve Operation is determined by three fundamental pressures.

- P₁ Bulb pressure acts on one side of the diaphragm, tends to open the valve.
- P₂ Evaporator pressure acts on the opposite side, tends to close the valve.
- P₃ Spring pressure is applied to the pin carrier and is transmitted through the push rods to the evaporator side of the diaphragm, which also assist in the closing action.

When the valve is modulating, bulb pressure is balanced by the evaporator pressure and spring pressure. P₁ equals P₂ plus P₃.



When the same refrigerant is used in both the thermostatic element and refrigeration system, each will exert the same pressure if their temperatures are identical. After evaporation of the liquid refrigerant in the evaporator the suction gas is superheated – its temperature will

increase. However, the evaporator pressure, neglecting pressure drop, is unchanged. This warmer vapor flowing through the suction line increases the bulb temperature.

Since the bulb contains both vapor and liquid refrigerant (not superheated vapor alone as in the suction line) its temperature *and* pressure increases. This higher bulb pressure acting on the top (bulb side) of the diaphragm is greater than the opposing evaporator pressure and spring pressure which causes the valve pin to be moved away from the seat. The valve is opened until the spring pressure – combined with the evaporator pressure – is sufficient to balance the bulb pressure. Figure-1 illustrates a system with the same refrigerant in both the bulb and evaporator. The two curves Opening Force (bulb pressure) and Evaporator Pressure curve coincide. When Spring Pressure is added to the latter the total Closing Force is shown by the dash curve.

If the valve does not feed enough refrigerant, the evaporator pressure drops or the bulb temperature is increased by the warmer vapor leaving the evaporator (or both) and the valve opens, admitting more refrigerant until the three pressures are again in balance. Conversely, if the valve feeds too much refrigerant, the bulb temperature is decreased, or the evaporator pressure increases (or both) and the spring pressure tends to close the valve until the three pressures are in balance.

With an increase in evaporator load, the liquid refrigerant evaporates at a faster rate and increases the evaporator pressure. The higher evaporator pressure results in a higher evaporator temperature and a correspondingly higher bulb temperature. The additional evaporator pressure (temperature) acts on the bottom of the diaphragm while the additional bulb pressure (temperature) acts on the top. Thus the two pressure increases on the diaphragm tend to cancel out each other and the valve easily adjusts to the new load condition with a negligible change in superheat.

The thermostatic expansion valve will maintain a fully active evaporator under all load conditions.

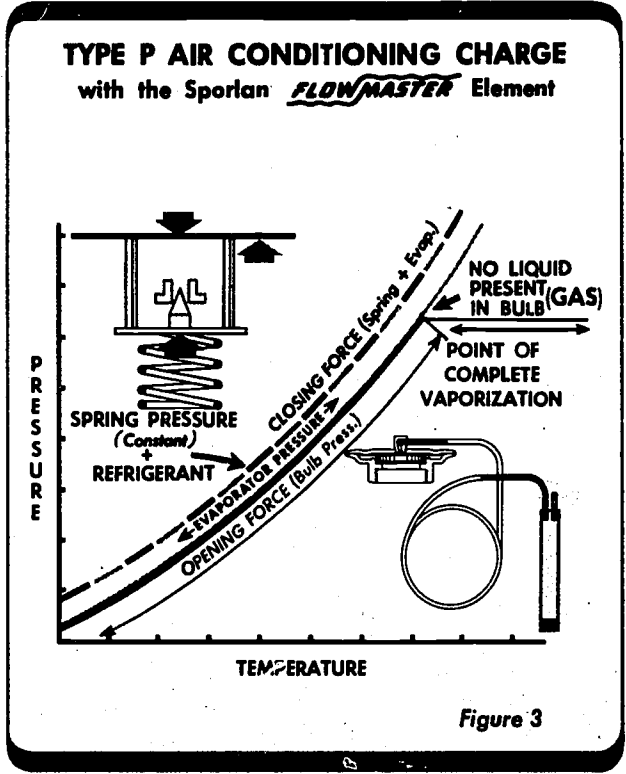
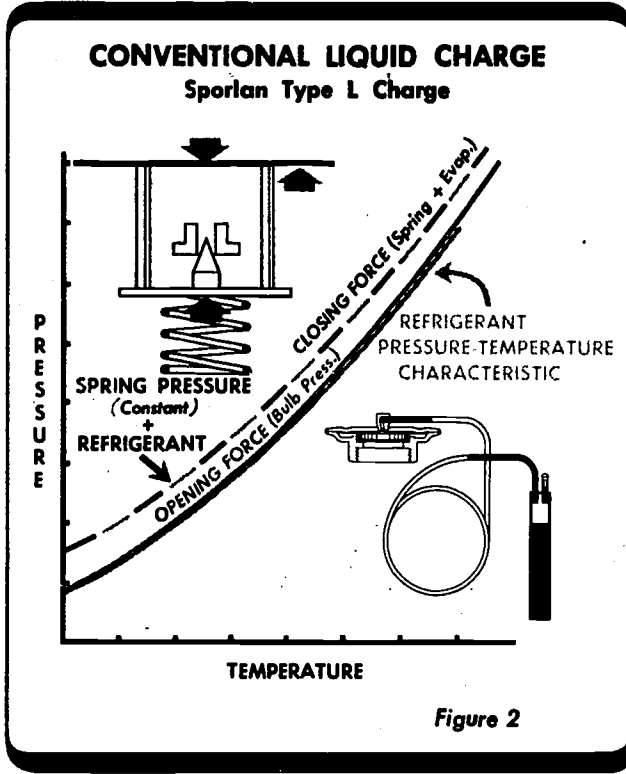
Fixed restrictions and other expansion devices can offer only a compromise in system performance when operating conditions change.

SPORLAN SELECTIVE CHARGES

For the most efficient system performance, Sporlan introduced *Selective Charges* for thermostatic expansion valves, over a quarter of a century ago. Their present universal acceptance throughout the refrigeration industry is evidence of the many operational advantages not possible with conventional charges.

An explanation of the characteristics, design features and advantages of each selective charge follows:

produced by permission
of Sporlan Valve Co.



Design Characteristics:

- 1 Employs same refrigerant in thermostatic element as used within system.
- 2 Bulb volume and amount of charge it contains is such that sufficient liquid will remain in the bulb under all temperature conditions of the diaphragm case and capillary tubing.

Advantages:

Bulb will always control refrigerant flow despite a colder valve or diaphragm case.

Disadvantages:

- 1 When the compressor is started, the suction and evaporator pressures drop. But since the valve bulb is not immediately cooled, the comparatively high bulb pressure opens the valve too much resulting in:
 - a Low superheat and possible floodback to the compressor.
 - b Delayed suction pressure pulldown and possible overloading of the compressor motor.
- 2 With the same valve adjustment, the superheat increases at lower evaporator temperatures where high superheats are more detrimental to system capacity.
- 3 During off-cycle, if bulb is in a comparatively warm location, the bulb pressure may be great enough to open the valve, filling the evaporator with liquid. Another possible cause of floodback at start-up.
- 4 Conventional liquid charged valves have no inherent anti-hunt features.

Application: Because of the definite operating advantages obtained with the use of Sporlan Selective Charges, the use of the Type L charge is generally confined to large capacity ammonia systems and a few unusual applications.

Design Characteristics:

- 1 Pressure limit or maximum operating pressure (MOP) feature. The Sporlan P charge is a patented modification of the conventional limited liquid charge (gas charge). The constituents of this charge are such that at a predetermined valve bulb temperature a maximum bulb pressure is reached. Any increase in bulb temperature above this point also results in virtually no increase in bulb pressure, causing the valve to throttle.
- 2 Sporlan Type P air conditioning charge make use of the patented Flow-Master element which is effective in stabilizing valve control and in materially reducing system hunt. See Page 3.

Advantages of the Sporlan Type P Air Conditioning Charge with *FLOWMASTER* Element:

- 1 Valve closes tightly during off-cycle. During the normal warm up of the evaporator, the point of maximum bulb pressure is reached. Above this point an increase in bulb temperature results in virtually no increase in bulb pressure (opening force). The evaporator pressure (closing force), however, continues to rise and, assisted by the spring pressure, closes the valve tightly.
- 2 Valve remains closed during pulldown. While the evaporator temperature is relatively high, the valve remains closed until the evaporator temperature is reduced below the maximum operating pressure of the charge. This permits rapid pulldown, avoiding floodback and overloading of the compressor motor.



THERMOSTATIC EXPANSION VALVES

INSTALLATION FIELD SERVICE and ASSEMBLY

INSTALLATION

For peak performance, it is important to select a Sporlan thermostatic expansion valve with the correct capacity, selective charge, external or internal equalizer, etc. Equally important is the proper installation, which can determine the success or failure of the entire system.

A. VALVE LOCATION

Thermostatic expansion valves may be mounted in any position, but should be installed as close to the evaporator inlet as possible. If a refrigerant distributor is used, mount the distributor directly to the valve-outlet for best performance. See Bulletin 20-10 for application information on refrigerant distributors.

If a hand valve is located on the outlet side of the thermostatic expansion valve it should have a full sized port. No restrictions should appear between the thermostatic expansion valve and evaporator, except a refrigerant distributor if one is used.

Sporlan Thermostatic Expansion Valves having Selective Charges C, Z, L, or X may be installed and operated in warm or cool locations. The amount of thermostatic charge and the bulb size are such that the bulb always retains control despite a colder valve body or diaphragm case.

To minimize the possibility of charge migration the Sporlan Flow-Master P or G air conditioning charges or ZP refrigeration charges should be installed so that the diaphragm case is warmer than the bulb.

PRECAUTIONS — WHEN VALVE IS INSTALLED AT CONSIDERABLE HEIGHT ABOVE LIQUID RECEIVER

When the evaporator and thermostatic expansion valve are located above the receiver, there is a static pressure loss in the liquid line. This is due to the weight of the column of liquid refrigerant, and this weight may be interpreted in terms of pressure loss in pounds per square inch as shown in Table-2, Page 14, Bulletin 10-10. If the vertical lift is great enough, vapor, or *flash gas* will form in the liquid line causing a serious reduction in the capacity of the thermostatic expansion valve.

When an appreciable vertical lift is unavoidable, precautions should be taken to prevent the accompanying pressure loss from producing liquid line vapor. This can be accomplished by providing enough subcooling of the liquid refrigerant, either in the condenser or after the liquid leaves the receiver. Subcooling is determined by subtracting the actual liquid temperature from the condensing temperature (corresponding to the condensing pressure). The required amount of subcooling necessary to prevent vapor formation in the liquid line is shown in Table-6, Page 16, Bulletin 10-10.

Liquid subcooling is provided by the following methods:

- 1 In the condenser
- 2 Suction — liquid heat exchanger
- 3 Special devices

Method-1 will provide sufficient subcooling for the simple short-coupled system that has only moderate liquid line pressure drop.

Method-2 will usually not provide more than 20°F. subcooling on air conditioning systems operating at normal head pressures. The amount of subcooling will depend on the design and size of the heat exchanger and on the operating suction and discharge pressures.

Method-3 may be used to provide considerable subcooling required for systems with excessive vertical lift. The following special devices are the most commonly used methods.

- a Water coils in heat exchange relationship with the liquid line.
- b Separate refrigeration system.
- c Special heat exchanger which uses a portion of the refrigerant to cool the main body of liquid. See Figure-1.

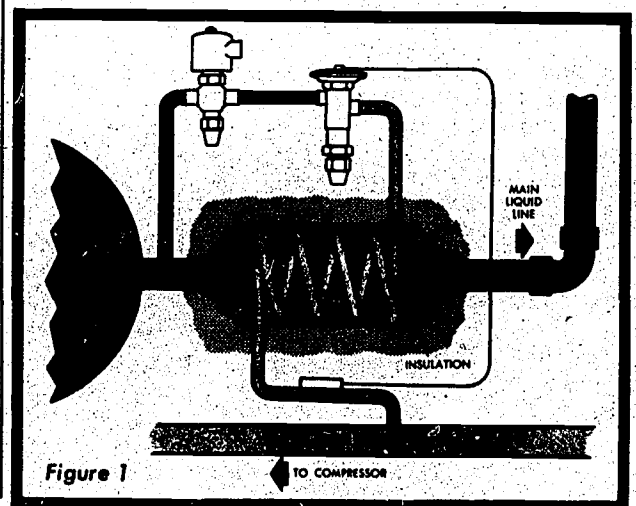


Figure 1

Ordinarily the conventional suction — liquid heat exchanger is installed near the evaporator where the suction vapor is the coolest. When the primary purpose of the heat exchanger is to prevent the formation of flash gas, it should be installed near the receiver **before the vertical lift occurs**. This also applies to the special devices described in Method-3. Subcooling devices installed near the evaporator will, of course, re-condense much of the vapor, but vapor in the liquid line considerably increases friction losses — possibly making the total pressure drop prohibitive. The suction line and liquid line (if subcooled below ambient temperature) should be carefully insulated to minimize heat gain.

IMPORTANT — Preventing the formation of vapor in liquid lines having high pressure losses does not eliminate the requirement that an adequate pressure drop must be available across the thermostatic expansion valve. The capacity tables show valve capacities at pressure drops lower than normal. For thermostatic expansion valve application data and capacities at pressure drops below those listed, consult Sporlan Valve Company.

B. SOLDER TECHNIQUE

It is not necessary to disassemble sweat type valves such as Types S and P when soldering to the connecting lines. Any of the commonly used types of solder such as 50-50, 95-5, Sil-Fos, Easy-Flow, Phos-Copper or equivalents are satisfactory. It is important, however, regardless of the solder used, to direct the flame away from the valve body and avoid excessive heat on the diaphragm, Figure-2. As an extra precaution, a damp cloth may be wrapped around the diaphragm during the soldering operation.

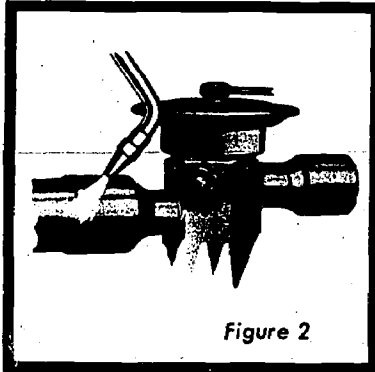


Figure 2

C. BULB LOCATION and INSTALLATION

The location of the bulb is extremely important, and in some cases determines the success or failure of the refrigerating plant. For satisfactory expansion valve control, **good thermal contact** between the bulb and suction line is essential. The bulb should be securely fastened with two bulb straps to a clean, straight section of the suction line.

Application of the bulb to a horizontal run of suction line is preferred. If a vertical installation cannot be avoided, the bulb should be mounted so that the capillary tubing comes out at the top.

On suction lines 7/8" OD and larger, the surface temperature may vary slightly around the circumference of the line. On these lines, it is generally recommended that the bulb be installed at a point mid-way on the side of the horizontal line, and parallel with respect to the

direction of flow. On smaller lines the bulb may be mounted at any point around the circumference, however, locating the bulb on the bottom of the line, is not recommended as an oil-refrigerant mixture is generally present at that point. Certain conditions peculiar to a particular system may require a different bulb location than that normally recommended. In these cases the proper bulb location may be determined by trial.

Accepted principles of good suction line piping should be followed to provide a bulb location that will give the best possible valve control. Never locate the bulb in a trap or pocket in the suction line. Liquid refrigerant or mixture of liquid refrigerant and oil boiling out of the trap will falsely influence the temperature of the bulb and result in poor valve control.

Recommended suction line piping includes a horizontal line leaving the evaporator to which the thermostatic expansion valve bulb is attached. This line is pitched slightly downward, and when a vertical riser follows, a short trap is placed immediately ahead of the vertical line, see Figure-3. The trap will collect any liquid refrigerant or oil passing through the suction line and prevent it from influencing the bulb temperature.

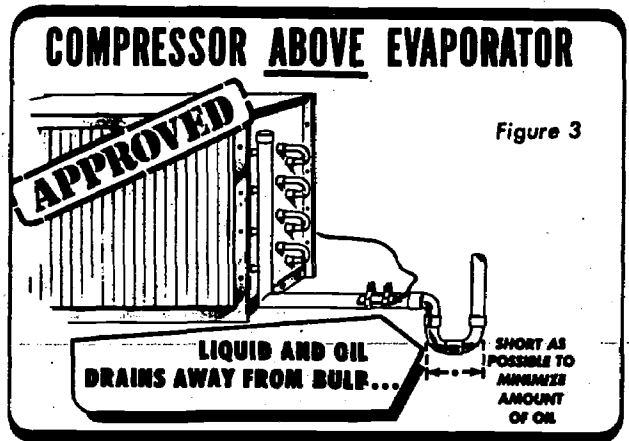


Figure 3

On multiple evaporator installations the piping should be arranged so that the flow from any valve cannot affect the bulb of another. Approved piping practices including the proper use of traps insures individual control for each valve without the influence of refrigerant and oil flow from other evaporators.

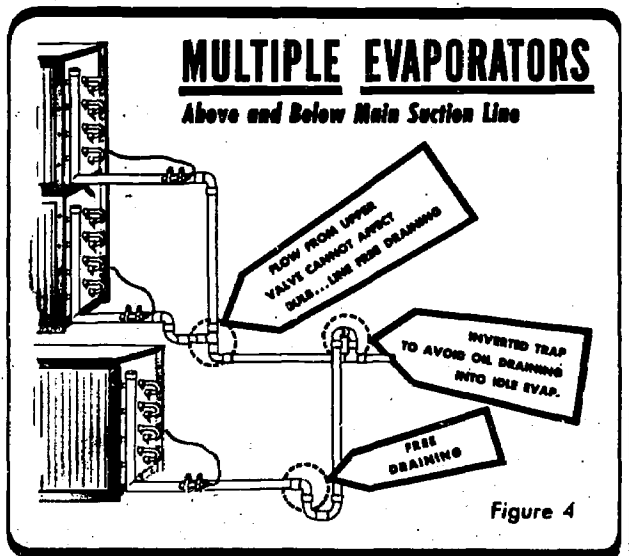


Figure 4

For recommended suction line piping when the evaporator is located above the compressor see Figure-5. The vertical riser extending to the height of the evaporator prevents refrigerant from draining by gravity into the compressor during the off-cycle. When a pump-down control is used, the suction line may turn immediately down without a trap.

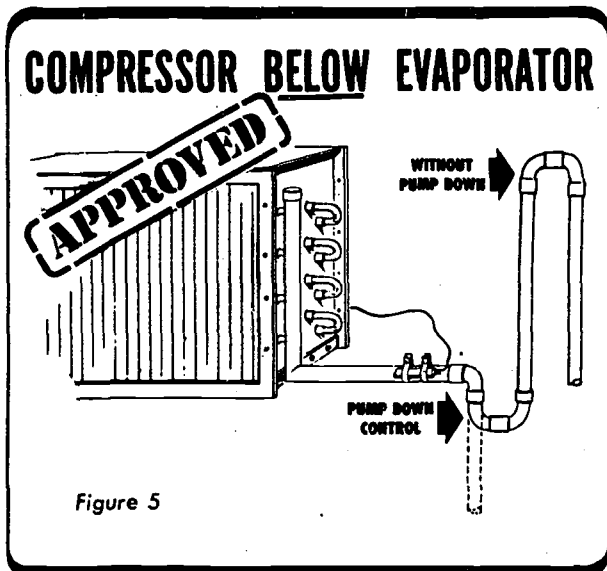


Figure 5

On Commercial and Low Temperature Applications requiring Sporlan Selective Charges C, Z, or X the bulb should be clamped on the suction line at a point where the bulb temperature will be the same as the evaporator temperature during the off-cycle. This will insure tight closing of the valve when the compressor stops. If bulb insulation is used on lines operating below 32° F., use non-water absorbing insulation to prevent water from freezing around the bulb.

On brine tanks and water coolers the bulb should be below the liquid surface where it will be at the same temperature as the evaporator during the off-cycle. When locating the bulb in a brine tank, paint it and the capillary tubing with pitch or other corrosion resistant paint.

If, for practical reasons, the bulb must be located where its temperature will be higher than the evaporator during the off-cycle, a solenoid valve must be used ahead of the thermostatic expansion valve.

On Air Conditioning Applications having thermostatic expansion valves equipped with Flow-Master Types P or G charged elements, the bulb may be located inside or outside the cooled space or duct. The valve body should not be located in the air stream leaving the evaporator. Avoid locating the bulb in the return air stream unless it is well insulated.

D. EXTERNAL EQUALIZER CONNECTION

For a complete explanation of when an externally equalized valve should be used refer to Pages 7 to 9, Bulletin 10-10. Valves supplied with an external equalizer will not operate unless this connection is made.

The equalizer connection should be made at a point that will most clearly reflect the pressure existing in the suction line at the point of bulb location. Although, in most cases the equalizer is connected within several inches of the bulb, occasionally it is located at a more remote point. The pressure difference between the equalizer connection and the bulb location should not exceed those shown in Table-1, Page 9, Bulletin 10-10.

Generally the external equalizer connection is in the suction line immediately down-stream of the bulb, Figure-6. However equipment manufacturers sometimes select other locations that are compatible with their specific design requirements.

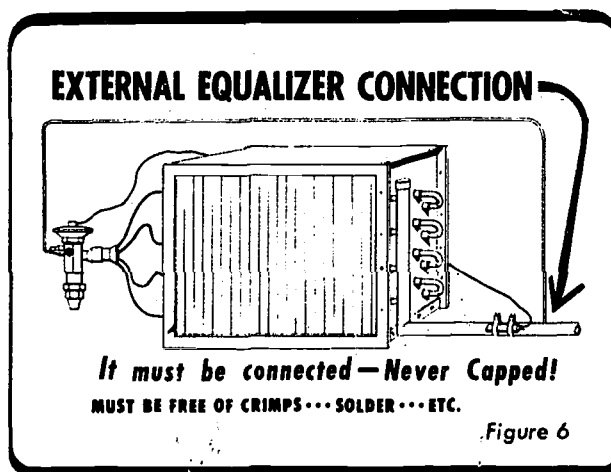


Figure 6

E. DRIERS, STRAINERS, and ACCESSORIES

Most Sporlan thermostatic expansion valves are equipped with built-in inlet screens of varying mesh sizes depending on the valve size and type. These strainers are effective only in removing particles of scale, solder, etc. which could obstruct the closure of the pin and seat.

Moisture and smaller particles of foreign material are equally harmful to the system and must be removed for peak system performance. Field experience has proven, without a doubt, that most expansion valve failures are due to the presence of dirt, sludge, and moisture in the system. Furthermore, the performance and life of other system components are also seriously affected by these foreign materials. The Sporlan Catch-All Filter-Drier removes dirt, moisture, acids, and sludges, and insures the circulation of clean, dry refrigerant through the system at all times.

For all refrigeration and air conditioning applications we recommend that a Sporlan Catch-All Filter-Drier be installed in the liquid line ahead of the thermostatic expansion valve. See Bulletin 40-10 for complete Catch-All specifications.

Further system protection is easily and inexpensively provided with the installation of a Sporlan See-All. The See-All is a combination liquid and moisture indicator that visually indicates if there is a shortage of refrigerant in the liquid line or if the moisture content

of the refrigerant is at a dangerous level. See Bulletin 70-10 for complete See•All specifications.

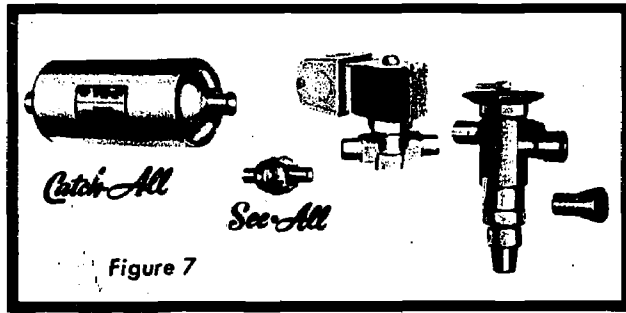


Figure 7

F. TEST PRESSURES and DEHYDRATION TEMPERATURES

For better leak detection an inert *dry* gas such as nitrogen or CO₂ may be added to an idle system to supplement the refrigerant pressure.

CAUTION: Inert gases must be added to the system carefully through a pressure regulator. Unregulated gas pressure can seriously damage the system and endanger human life. Never use oxygen or explosive gases.

Excessive low side pressures can shorten the life of the thermostatic expansion valve diaphragm. Table-7 lists the maximum low side test pressure that can safely be applied with the expansion valve connected to the evaporator. These maximum pressures are well above the minimum field leak test pressures for low sides, listed by the American Standards Association B9 Safety Code.

TABLE 7
MAXIMUM LOW SIDE TEST PRESSURES

VALVE TYPE	psig
NI, F, G, C, S	450
P, H, O & U	425
M, V, & W	400

Table-7 refers to the maximum low side test pressures which are in contact with the underside of the valve diaphragm. Since only the valve inlet fitting and passages (not the valve diaphragm) are subjected to high side pressures, the valve will withstand any reasonable **HIGH SIDE TEST PRESSURES** in excess of the values listed in the ASA B9 Safety Code. The external equalizer line should be disconnected if there is any possibility of exceeding the recommended maximum pressures.

If elevated temperatures are used to assist in dehydrating the system, the thermostatic expansion valve should not be exposed to temperatures exceeding those shown in Table-8.

TABLE 8

MAXIMUM DEHYDRATION TEMPERATURES
DEGREES F°

REFRIG- ERANT	THERMOSTATIC CHARGE						
	G and GA	L	C	Z	X	P Air Conditioning Charge	ZP
12	250	195	190	250	210	250	250
22		**	160	185			
500		**	185	235			
502		†	150	170			
717 (Am- monia)		150	190	235	†	†	†

*Temperatures are for No. 53, 33, 83, 63, 23 & 12 elements.
**Not Available in No. 33 or 63 elements.
†Not Available.

Table-8 refers to the maximum dehydration temperatures when the bulb and valve body are subjected to the same temperature. On L, C, Z, and X charges, 250° F. maximum valve body temperature is permissible **IF THE BULB TEMPERATURE** does not exceed those shown in the table.

G. EXPANSION VALVE ADJUSTMENT

Each Sporlan Thermostatic Expansion Valve is adjusted at the factory before shipment. This factory setting will be correct and no further adjustment is required for the majority of applications. When the application or operating conditions require a different valve setting, the valve may be adjusted to obtain the required superheat.

Some expansion valves are made *non-adjustable* for use on Original Equipment Manufacturers' units. These valves are set at a superheat predetermined by the manufacturers' laboratory tests and cannot be adjusted in the field.

Most *non-adjustable* models are modifications of standard adjustable type valves. This is done by using a solid bottom cap instead of one equipped with an adjusting stem and seal cap. These valves can be identified by an N preceding the standard valve designation. Adjustable bottom cap assemblies are available for converting non-adjustable valves to the adjustable type. However, this is rarely required. If symptoms indicate that a valve adjustment is needed, carefully check the other possible causes of incorrect superheat, Pages 6 to 10, before attempting an adjustment.

HOW TO DETERMINE SUPERHEAT CORRECTLY

- 1 Measure the temperature of the suction line at the point the bulb is clamped.
- 2 Obtain the suction pressure that exists in the suction line at the bulb location by either of the following methods:

- a If the valve is externally equalized, a gauge in the external equalizer line will indicate the desired pressure directly and accurately.

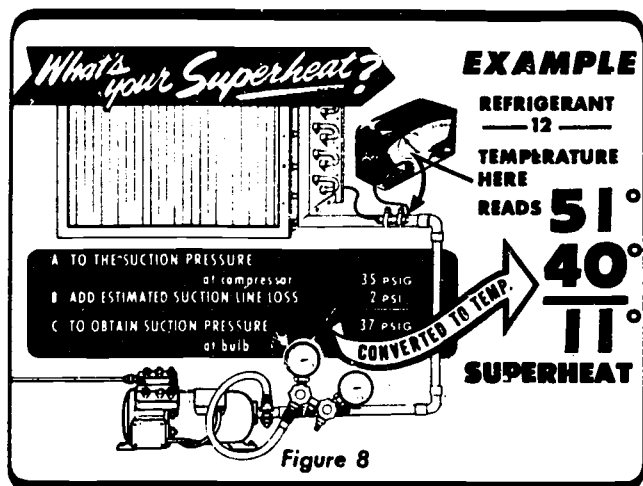
OR

- b Read the gauge pressure at the suction valve of the compressor. To the pressure add the estimated pressure drop through the suction line between bulb location and compressor suction valve. The sum of the gauge reading and the estimated pressure drop will equal the approximate suction line pressure at the bulb.

3 Convert the pressure obtained in 2a or 2b above to saturated evaporator temperature by using a temperature-pressure chart.

4 Subtract the two temperatures obtained in 1 and 3 - the difference is superheat.

Figure-8 illustrates a typical example of superheat measurement on an air conditioning system using Refrigerant-12. The temperature of the suction line at the bulb location is read at 51° F. The suction pressure at the compressor is 35 psig and the estimated pressure drop is 2 psi. . . . 35 psig + 2 psig = 37 psig which is equivalent to a 40° F. saturation temperature. 40° F. subtracted from 51° F. = 11° F. superheat.



NOTE - Subtracting the difference between the temperature at the inlet and outlet of the evaporator is *not* an accurate measure of superheat. This method is *not* recommended since any evaporator pressure drop will result in an erroneous superheat indication.

HOW TO CHANGE THE SUPERHEAT SETTING

To reduce the superheat, turn the adjusting stem **COUNTER-CLOCKWISE**. To increase the superheat, turn the adjusting stem **CLOCKWISE**. When adjusting the valve, make no more than one turn of the stem at a time and observe the change in superheat closely to prevent **over-shooting** the desired setting. As much as 20 minutes may be required for the new balance to take place after an adjustment is made.

If in doubt about the correct superheat setting for a particular system, consult the equipment manufacturer. As a general rule, the proper superheat setting will depend on the amount of temperature difference (TD) between refrigerant temperature and the temperature of the air or other substance being cooled. Where high TD's exist, such as on air conditioning applications, the superheat setting can be made as high as 15° F. without noticeable loss in evaporator capacity. Where low TD's exist, such as in low temperature blower coil applications, a superheat setting of 10° F. or below is usually recommended for maximum evaporator capacity.

For the correct valve setting on factory built equipment, manufacturers' recommendations should be followed. Some manufacturers specify the superheat directly; others may recommend valve adjustment to a given suction pressure at certain operating conditions, or until a certain frost line is observed. Such recommendations, however they are stated, represent the results of extensive laboratory testing to determine the best possible operation.

FIELD SERVICING

The thermostatic expansion valve is erroneously considered by some to be a mysterious and complex device. As a result, many valves are needlessly replaced when the cause of the system mal-function is not immediately recognized.

Actually the thermostatic expansion valve performs only one very simple function — it keeps the evaporator supplied with enough refrigerant to satisfy all load conditions. It is not a temperature control, suction pressure control, a control to vary the compressor's running time or a humidity control.

How effective the valve performs is easily determined by measuring the superheat as outlined in Figure-8. Observing the frost on the suction line, or considering only the suction pressure may be misleading. Checking the superheat is the first step in a simple and systematic analysis of thermostatic expansion valve performance.

- ◆ If not enough refrigerant is being fed to the evaporator—the superheat will be high.
- ◆ If too much refrigerant is being fed to the evaporator—the superheat will be low.

Although these symptoms may be attributed to improper thermostatic expansion valve control, more frequently the origin of the trouble lies elsewhere.

a

if the load temperature is too high and valve does not appear to feed enough - - the superheat is high with a *lower than normal pressure.

THE CAUSE MAY BE:

1 MOISTURE — Water or a mixture of water and oil frozen in the valve port or working parts of the valve will prevent proper operation.

This is the most common source of trouble on expansion valves. Since the valve is the first cold spot in the system, moisture will freeze and block the valve open, closed, or any position in between. If the valve is frozen in the intermediate position so that flow is restricted, the superheat will be high.

REMEDY — Install a Sporlan Catch-All Filter-Drier in the liquid line for removal of moisture from the refrigerant and oil. See Bulletin 40-10.

For additional protection, install a Sporlan See*All Moisture and Liquid Indicator for a positive indication of when a safe moisture level is reached. See Bulletin 70-10.

Excessive moisture has a damaging effect on all system components regardless of the evaporating temperature. It must be removed for trouble-free performance.

2 DIRT or FOREIGN MATERIAL — Material such as scale, drier material, filings, etc. will restrict the flow of refrigerant when it collects in strainers or other liquid line accessories. This produces a shortage of refrigerant at the thermostatic expansion valve port. Conventional strainers frequently allow the material to pass through the screen and obstruct the flow at the valve port. If a See*All is installed downstream of the restriction, bubbles will be visible. This should not be confused, however, with a refrigerant shortage or excessive liquid line pressure loss which are also indicated by bubbles in the See*All.

REMEDY — Locate and remove the foreign material creating the restriction. Install a Sporlan Catch-All Filter-Drier to provide effective filtration of the refrigerant. See Bulletin 40-10.

3 WAX — Certain refrigerant oils will precipitate wax at very low temperatures. Since the thermostatic expansion valve represents the first cold point in the refrigeration cycle, wax is most likely to form at the valve port.

It is difficult to observe the wax in a valve because it exists in solid form only at very low temperatures. By the time the valve has been taken apart, the temperature has increased enough to cause the wax to melt and thus become difficult to detect. When wax is suspected, it can usually be detected on the pin and seat by packing the valve in dry ice while disassembling.

REMEDY — If wax is found, consult the supplier of the refrigerant oil for recommendations.

4 REFRIGERANT SHORTAGE — A See*All or sight glass in the liquid line will show bubbles when the system is short of refrigerant charge. Before adding more refrigerant however, be sure the bubbles are not produced by other causes (See Paragraphs A-2 and A-5).

A lack of refrigerant charge may also be detected by a hissing sound at the thermostatic expansion valve. Some systems not equipped with a liquid line sight glass, will have test cocks or other devices for checking the refrigerant level in the receiver.

REMEDY — Add enough refrigerant to obtain desired result.

5 GAS IN THE LIQUID LINE — As explained in Paragraphs A-2 and A-4 above liquid line vapor can be produced by a partially plugged strainer or drier or by a shortage of refrigerant charge. In addition, gas in the liquid line can be caused by air or other non-condensable gases in the system or by excessive pressure losses in the liquid line as a result of:

- a Long or undersized line.
- b Liquid line vertical lift.

REMEDY — Verify the correct liquid line size for the equivalent length and system tonnage. Consult liquid line sizing data published in many manufacturers' catalogs and in text books. If undersized, repipe with the correct size.

Determine amount of vertical lift, and obtain the resulting pressure loss from Table-2, Page 14, Bulletin 10-10. From Table-6, Page 16, Bulletin 10-10, find required subcooling necessary to prevent gasification with the existing pressure losses. Provide the necessary subcooling by using one of the methods described on Page 1.

*When compressor is equipped with capacity reduction, a low suction pressure will not exist. Instead, compressor will merely unload when pressure is reduced to a pre-set point and load again when the pressure rises. When checking expansion valve performance, a better analysis is possible when unloaders are locked so that the suction pressure will change in response to variations in load or valve feed.

TABLE 1—RECOMMENDED SHEET METAL GAUGES AND CONSTRUCTION FOR RECTANGULAR DUCT
LOW PRESSURE—2" W.G. MAX. LOW VELOCITY—2000 F.P.M. MAX.

Plate No.	Dimension of Longest Side of Duct	Steel Metal Gauges		AT JOINTS					REINFORCING ANGLE SIZE AND MAXIMUM LONGITUDINAL SPACING BETWEEN TRANSVERSE JOINTS AND/OR INTERMEDIATE REINFORCING
		Steel	Aluminum	Plain "S" Slip (B)	Hemmed "S" Slip (C)	Angle Slip (H)	Companion Angles (M)		
				Pocket Lock (K)	Bar Slip (E)	Reinforced Bar Slip (G)	Alternate Bar Slip (F)	Angle Reinforced Standing Seam (J)	
				Drive Slip (A)	Standing Seam (I)*	Angle RFD Pocket (L)			
6	Thru 12"	26	24 (.020)	A-B K	—	—	—	—	
6	13" thru 18"	24	22 (.025)	A-B K	—	—	—	—	
7 7A	19" thru 30"	24	22 (.025)	K	C-E	—	—	—	1"x1"x1/8" @ 5' cc
8	31" thru 42"	22	20 (.032)	K	E-G-K.	—	—	—	1"x1"x1/8" @ 5' cc
9	43" thru 54"	22	20 (.032)	K	E	G	—	—	1 1/2"x1 1/2"x1/8" @ 5' cc
9	55" thru 60"	20	18 (.040)	K	E	G	—	—	1 1/2"x1 1/2"x1/8" @ 5' cc
10	61" thru 84"	20	18 (.040)	—	—	G	H F L	J	1 1/2"x1 1/2"x1/8" @ 2'-6" cc
11	85" thru 96"	18	16 (.051)	—	—	—	H L	M J	1 1/2"x1 1/2"x1/8" @ 2'-6" cc
12	Over 96"	18	16 (.051)	—	—	—	H L	M J	2"x2"x1/4" @ 2'-6" cc

*see plate 13 for inside standing seam construction

H (height dimension)—up to 42"=1"

H (height dimension)—43" to 96"=1 1/2"

H (height dimension)—over 96"=2"

†Roll formed slip shall be 1 1/2" maximum and 2" reinforcing angle fastened to slip when 'H' dimension requires 2" height.

All SMACNA material contained herein is reproduced with permission

PLATE NO. 5 TYPICAL DUCT CONNECTIONS — CROSS JOINTS

Fig. A — DRIVE SLIP—Ends of ducts inserted under cleat. For narrow sides of ducts that are 18" or less. Drive slips that are 19" — 30" must be reinforced with 1" x 1" x 1/8" angle.

NOTE — A combination of drive slip A and any "S" slip B, C, E, F, G, H completes the transverse joint.

Fig. B — PLAIN "S" SLIP—Ends of ducts inserted into open ends of "S". Use on wide sides of small ducts. (Use Drive Slip (A) on narrow sides.)

Fig. C — HEMMED "S" SLIP—Similar to Plain "S" Slip (B) except with edges hemmed to produce stiffness.

Fig. E — BAR SLIP—Similar to Plain "S" Slip (B) except for standing edge which is formed to provide reinforcing.

Fig. F — ALTERNATE BAR SLIP (STANDING "S" SLIP) Same as Bar Slip (E) except standing leg is folded to three thicknesses for stiffness.

Fig. G — REINFORCED BAR SLIP—Similar to Bar Slip (E) except for the addition of a steel reinforcing bar inserted in the standing edge.

Fig. H — ANGLE SLIP—Same as Reinforced Bar Slip (G) except for the use of a reinforcing angle in place of the reinforcing bar. Angle may be inside or fastened to outside of slip.

Fig. I — STANDING SEAM—Ends of adjoining ducts are joined as shown with button

punch at six-inch centers added after assembly.

Fig. J — ANGLE REINFORCED STANDING SEAM—Same as Standing Seam (I) except for reinforcement with angle, one leg of which is fastened to the duct and the other leg is secured to the standing edge of the seam.

Fig. K — POCKET LOCK—Normally used on four sides of a duct. The pocket section is clip punched or "hickey" punched to the duct near corners and then every six inches; the other end is flanged outward to join with second sheet and then hammered down.

Fig. L — ANGLE REINFORCED POCKET LOCK—Same as Pocket Lock (K) with added angle stiffener.

Fig. M — COMPANION ANGLES—Angle frames are riveted, bolted or welded to duct ends and are then bolted together with gasket or caulking to prevent air leakage. Recommended for use where duct sections must be removed periodically.

Some of the above connections may be favored over others in certain parts of the country, and all of them are not listed in Table I. Substitutions can be made for those that are listed provided the same quality of construction is maintained.

NOTE—Arrows on Plate No. 5 indicate preferred air flow direction.

NOTE—"H" on Plate No. 5 indicates dimension as specified in Table No. 1.

TYPICAL DUCT CONNECTIONS

CROSS JOINTS

(NOT TO SCALE)

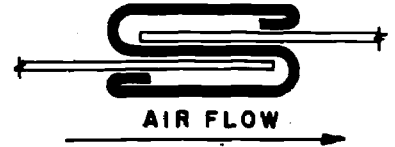
H=HEIGHT REFERRED TO IN DIMENSIONS



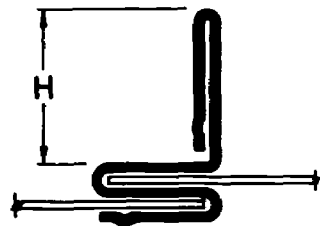
(A)
DRIVE SLIP



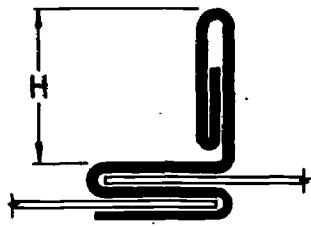
(B)
PLAIN "S" SLIP



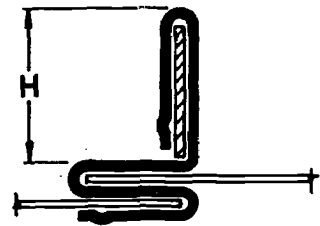
(C)
HEMMED "S" SLIP



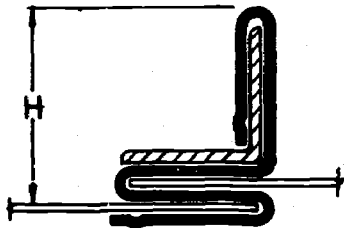
(E)
BAR SLIP



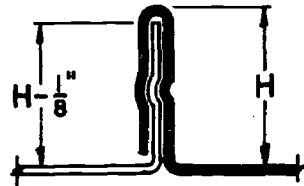
(F)
ALTERNATE BAR SLIP
(STANDING "S" SLIP)



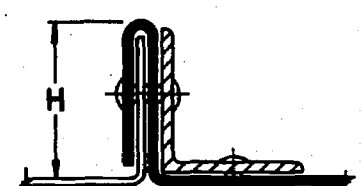
(G)
REINFORCED
BAR SLIP (CLEAT)



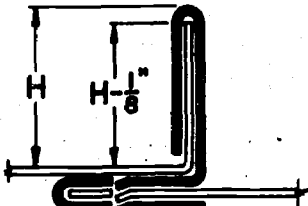
(H)
ANGLE SLIP



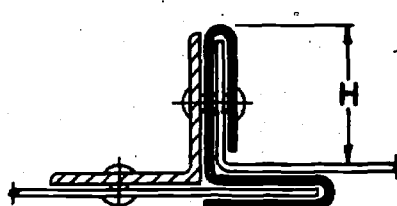
(I)
STANDING SEAM



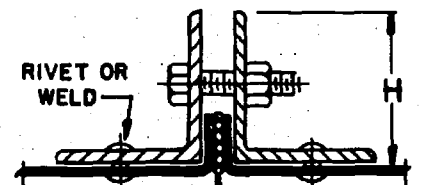
(J)
ANGLE REINFORCED
STANDING SEAM



(K)
POCKET LOCK



(L)
ANGLE REINFORCED
POCKET LOCK



(M)
COMPANION ANGLES
(CAULK OR GASKET)

PLATE NO. 5A — LONGITUDINAL SEAMS

Longitudinal seams which run horizontally on the duct sections are important because these locks must hold the duct pieces securely and tightly—should not leak under pressure—and should be readily and swiftly put together on the job or in the shop.

Fig. N — The commonest type of longitudinal seam is the Pittsburgh lock. Originally formed in the brake or press brake, today roll forming machines are used to form the pocket in one piece and the flange in the other piece. After one piece is inserted in the pocket the “tail” is hammered over to close the lock.

Fig. O — The Acme lock originally called a “lock grooved seam” was popular because it provided snug nesting and a smooth exterior surface. Today this lock is used to join two flat sheet for increased width.

Fig. T — Standing seams or double standing seams are used mostly on the inside of ducts and for certain sizes of ducts where their use leads to economical sheet cutting.

Fig. Z — The “Button Punch Snap Lock” is a recent innovation. Originally the “continuous” snap lock was used on light gauge stove and furnace pipe to permit shipping nested. The pipe section was then “snapped” together.

The “button punch” spaces the “buttons” on approximately two inch centers along the flange to be inserted in the pocket. The continuous sharp fold on the pocket permits the buttoned flange to be “snapped” into the pocket. Detail 1.

The dimensions of the pocket and the flange are critical in high pressures. The pocket and the flange must be formed in a machine suited to the gauge of metal being formed. If this is not adhered to, the pocket will be “loose” and stiffness and air tightness will be lessened.

NOTE — SMACNA has conducted a lengthy testing program on high pressure duct construction. Attention was paid to the button punch snap lock. An official test report on button punch snap lock is included in this manual.

NOTE — Snap lock not recommended for aluminum.

LONGITUDINAL SEAMS

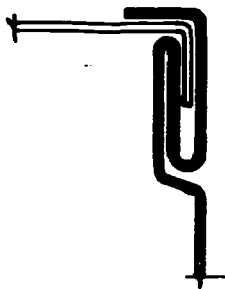


FIG. "N"
PITTSBURGH LOCK

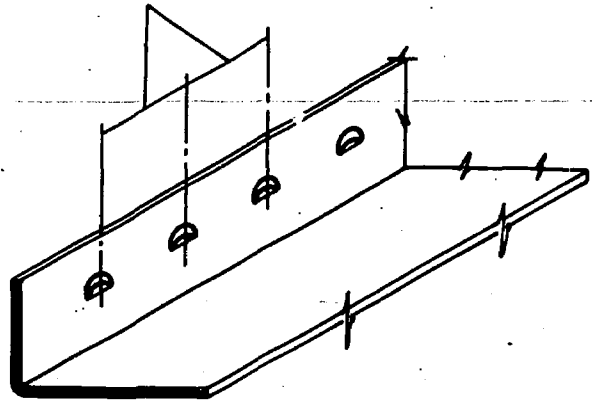


FIG. "Z"
BUTTON PUNCH SNAP LOCK



FIG. "O"
ACME LOCK-GROOVED SEAM

APPROXIMATELY 2" SPACING
BETWEEN "BUTTONS"



DETAIL NO. 1
MALE PIECE-SNAP LOCK

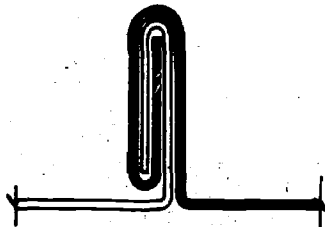


FIG. "T"
DOUBLE SEAM

PLATE NO. 6 -- DUCTS 0 in. THRU 18 in. MAXIMUM DIMENSION

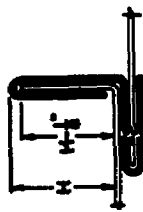
LEGEND



(A)
DRIVE SLIP



(B)
PLAIN "S" SLIP



(K)
POCKET LOCK



FIG. "N"
PITTSBURGH LOCK

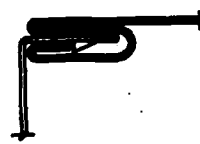


FIG. "Z"

BUTTON PUNCH SNAP LOCK



FIG. "O"

ACME LOCK-GROOVED SEAM

End joints may be up to 10'-0" on centers depending upon the size sheets and equipment available for fabricating ducts.

Steel is 26 gauge or aluminum of .020 thickness is recommended thru 12 in. dimensions, with 24 gauge steel or .025 thickness aluminum for 13 in. thru 18 in. dimensions.

These ducts are usually erected in maximum lengths of 8'-0" or 10'-0".

NOTE - Snap Lock not recommended for aluminum.

Longitudinal joints shown are Pittsburgh Locks (N) or Button Punch Snap Lock (Z) on one or more corners, or Acme Locks, (O) also known as "grooved seams" in the flat side or sides, depending upon the size of sheets available for the size of the duct.

When Plain S Slips (B) are used on the larger sides of the duct, Drive Slips (A) should be used on the narrow sides and the Drive Slips should be folded over on the corner to prevent air leakage. See Plate No. 15.

When Pocket Lock (K) is selected, it is normally used on all sides.

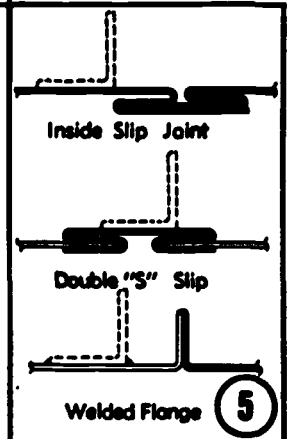
additional duct sections in long straight runs.

Seams and Intermediate Reinforcing

Details in Figs. 3-16 through 3-20 illustrate longitudinal seams and the attachment of intermediate reinforcing angles and rods to the duct. The button punch snap lock is not included in the recommended longitudinal seams, although it did perform satisfactorily in the tests (Chapter 11). Field experience has shown that a partially assembled button punch snap lock seam may withstand the pressure test during construction, but will open up under pressure after several months of operation. Failures of this kind could prejudice consulting engineers against the use of this joint in low velocity duct construction where it has an outstanding record of performance.

Fig. 3-1
Medium
Pressure,
High Velocity
Rectangular
Duct
Construction
for Static
Pressures
in Duct Up
Through
6" W.G.




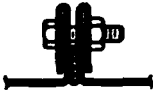
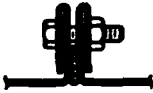

① DIMENSION OF LONGEST SIDE	② GALV. SHEET GA. (ALL FOUR SIDES)	TRANSVERSE		
		BETWEEN JOINTS		⑤ MIN. ANGLE SIZE
		③ WITH TIE RODS	④ WITHOUT TIE RODS	
Up thru 12"	24	No tie rods required	No angle required	None required
13"-18"	24	1 tie rod @ 48" intervals on center-line of duct side	1x1x16 Ga. @ 48"	1x1x16 Ga.
19"-24"	22	1 tie rod @ 48" intervals on center-line of duct side	1x1x 1/8 @ 48"	1x1x 1/8
25"-36"	22	→	1x1x 1/8 @ 32' OR 1 1/4x1 1/4x 1/8 @ 40"	1 1/4x1 1/4x 1/8
37"-48"	22	→	1 1/2x1 1/2x 1/8 @ 30"	1 1/2x1 1/2x 1/8
49"-60"	20	1 1/2x1 1/2x 1/8 @ 24" with tie rod in center	2x2x 1/8 @ 24"	2x2x 1/8 OR 1 1/2x1 1/2x 1/8 with tie rod in center
61"-72"	20	1 1/2x1 1/2x 1/8 @ 24" with tie rod in center	2 1/2x2 1/2x 3/16 @ 24"	2 1/2x2 1/2x 3/16 OR 1 1/2x1 1/2x 1/8 with tie rod in center
73"-84"	18	1 1/2x1 1/2x 1/8 @ 24" with tie rod in center	2 1/2x2 1/2x 3/16 @ 24"	2 1/2x2 1/2x 3/16 OR 1 1/2x1 1/2x 1/8 with tie rod in center
85"-96"	18	1 1/2x1 1/2x 1/8 @ 24" with tie rod in center	←	1 1/2x1 1/2x 1/8 with tie rod in center
97" and Over	18	2x2x 1/8 @ 24" with tie rods @ 48" along angle	←	2x2x 1/8 with tie rods @ 48" along angle



*NOTES: (a) When transverse reinforcing is required on all four sides it must be tied together at each corner by riveting, bolting or welding. When transverse reinforcing is required on only two sides, it must be tied together with either tie rods or angles at the ends. Transverse reinforcing size is determined by dimension of side to which angle is applied. Angle sizes are based on mild steel. Reinforcing made in other shapes or of other materials must be of equivalent strength and rigidity.

REINFORCING*

AT JOINTS

 Welded Flange 6	 Standing Seam 7	 Reinforced Standing Seam 8	 Flanged Joint 9	 Flanged Joint 10	 Companion Angle Flanged Joint 11
MIN. HEIGHT	MIN. HEIGHT	MIN. HEIGHT	MIN. ANGLE SIZE	MIN. HEIGHT	MIN. ANGLE SIZE
5/8"	1"	1"	None Req'd.	1"	1 1/4 x 1 1/4 x 1/8
7/8"	1"	1"	None Req'd.	1"	1 1/4 x 1 1/4 x 1/8
1 3/8"	1 1/4"	1 1/4"	None Req'd.	1 1/4"	1 1/4 x 1 1/4 x 1/8
1 1/8" with tie rod in center	2" OR 1 1/2" with tie rod in center	1 1/2"	1 1/2 x 1 1/2 x 1/8	2"	1 1/4 x 1 1/4 x 1/8
1 3/8" with tie rod in center	1 1/2" with tie rod in center	1 1/2"	2 x 2 x 1/8	1 1/2" with tie rod in center	1 1/2 x 1 1/2 x 1/8
1 1/8" with 2 tie rods	1 1/2" with tie rod in center	1 1/2"	2 x 2 x 1/8	1 1/2" with tie rod in center	2 x 2 x 1/8 OR 1 1/4 x 1 1/4 x 1/8 with tie rod in center
1 3/8" with 2 tie rods	2" with tie rod in center	1 1/2"	2 1/2 x 2 1/2 x 3/16	1 1/2" with tie rod in center	2 x 2 x 3/16 OR 1 1/4 x 1 1/4 x 1/8 with tie rod in center
1 3/8" with 2 tie rods	2" with tie rod in center	←		2" with tie rod in center	1 1/4 x 1 1/4 x 1/8 with tie rod in center
1 3/8" with 2 tie rods	2" with tie rod in center	←		2" with tie rod in center	1 1/4 x 1 1/4 x 1/8 with tie rod in center
1 3/8" with tie rods @ 32" along joint	2" with tie rods @ 48" along joint	←		2" with tie rods @ 48" along joint	1 1/2 x 1 1/2 x 1/8 with tie rods @ 48" along angle

(b) There is no restriction on the length of duct sections between joints. Ducts are normally made in Sections of 4, 8, 10 or 12 feet in length. The longitudinal spacing of the transverse reinforcing between joints may necessarily be less than the spacings recommended in the table in order to conform to the selected length module.

(c) Tie rods up to 36" long shall be 1/4" min. diameter.

(d) Tie rods 37" long and over shall be 3/8" min. diameter.

(e) When 2 tie rods are required, installation to be at 1/2 points across the duct.

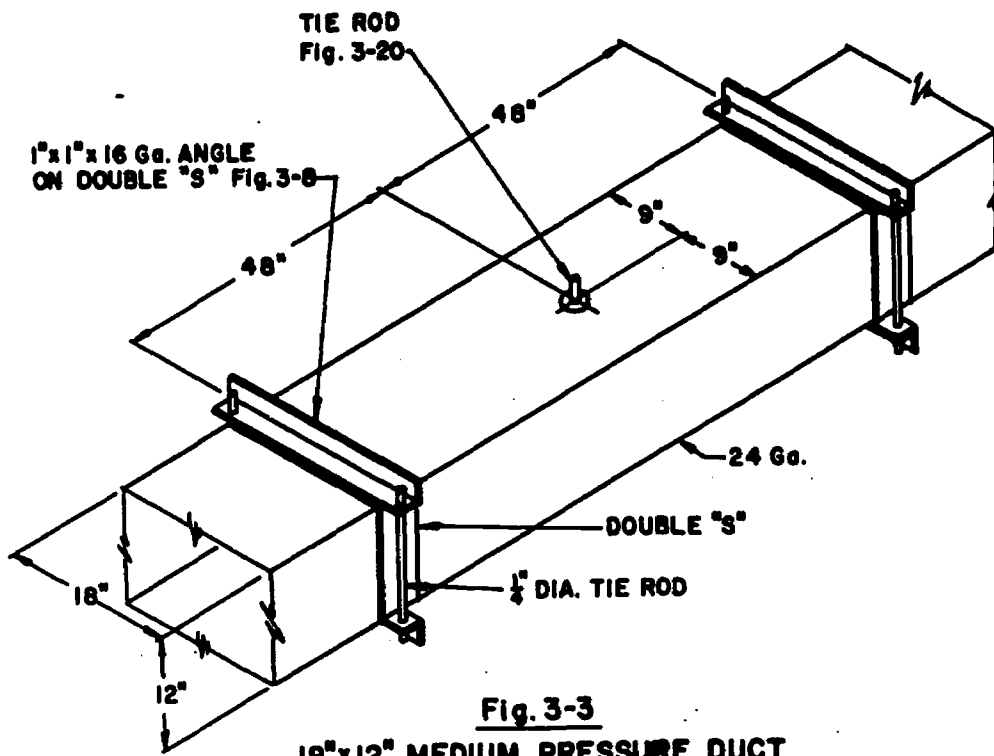


Fig. 3-3
18"x12" MEDIUM PRESSURE DUCT

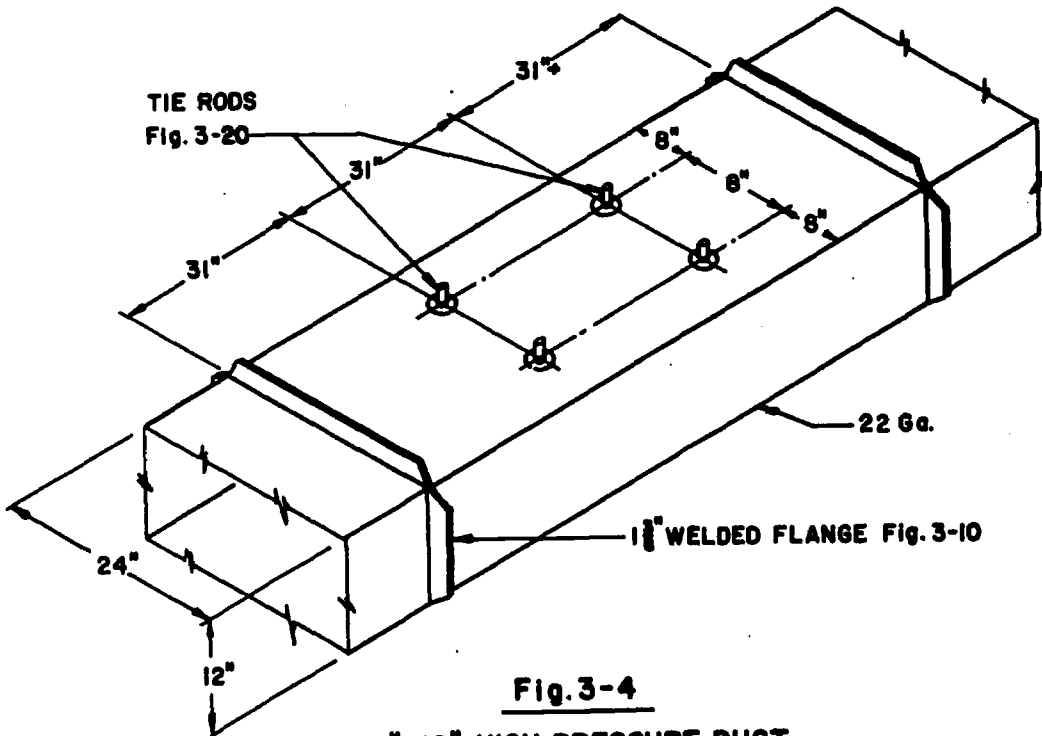


Fig. 3-4
24"x12" HIGH PRESSURE DUCT

REINFORCING*

AT JOINTS

6	7	8	9	10	11	12
Welded Flange	Standing Seam	Reinforced Standing Seam		Flanged Joint	Pocket Lock	Companion Angle Flanged Joint
MIN. HEIGHT	MIN. HEIGHT	MIN. HEIGHT	MIN. ANGLE SIZE	MIN. HEIGHT	MIN. HEIGHT	MIN. ANGLE SIZE
3/8"	1"	1"	None Req'd.	1"	1"	1 1/4 x 1 1/4 x 1/8
7/8"	1"	1"	None Req'd.	1"	1"	1 1/4 x 1 1/4 x 1/8
1 3/8"	1 1/4"	1 1/4"	None Req'd.	1 1/4"	1 1/8"	1 1/4 x 1 1/4 x 1/8
1 1/8" with tie rod in center	1 1/2"	1 1/2"	None Req'd.	1 1/2"	1 1/2"	1 1/4 x 1 1/4 x 1/8
1 1/8" with tie rod in center	2" OR 1 1/2" with tie rod in center	1 1/2"	1 1/2 x 1 1/2 x 1/8	2"	—	1 1/4 x 1 1/4 x 1/8
1 3/8" with tie rod in center	1 1/2" with tie rod in center	1 1/2"	2 x 2 x 1/8	1 1/2" with tie rod in center	—	1 1/2 x 1 1/2 x 1/8
1 3/8" with 2 tie rods	2" with tie rod in center	1 1/2"	2 1/2 x 2 1/2 x 1/8	1 1/2" with tie rod in center	—	2 x 2 x 3/16 OR 1 1/4 x 1 1/4 x 1/8 with tie rod in center
1 3/8" with 2 tie rods	2" with tie rod in center	1 1/2"	2 1/2 x 2 1/2 x 3/16	1 1/2" with tie rod in center	—	2 x 2 x 3/16 OR 1 1/4 x 1 1/4 x 1/8 with tie rod in center
1 3/8" with 2 tie rods	2" with tie rod in center	←		1 1/2" with tie rod in center	—	2 x 2 x 3/16 OR 1 1/4 x 1 1/4 x 1/8 with tie rod in center
1 3/8" with tie rods @ 32" along joint	2" with tie rods @ 48" along joint	←		2" with tie rods @ 48" along joint	—	1 1/2 x 1 1/2 x 1/8 with tie rods @ 48" along angle

(b) There is no restriction on the length of duct sections between joints. Ducts are normally made in Sections of 4, 8, 10 or 12 feet in length. The longitudinal spacing of the transverse reinforcing between joints may necessarily be less than the spacings recommended in the table in order to conform to the selected length module.

(c) Tie rods up to 36" long shall be 1/4" min. diameter.

(d) Tie rods 37" long and over shall be 3/8" min. diameter.

(e) When 2 tie rods are required, installation to be at 1/2 points across the duct.

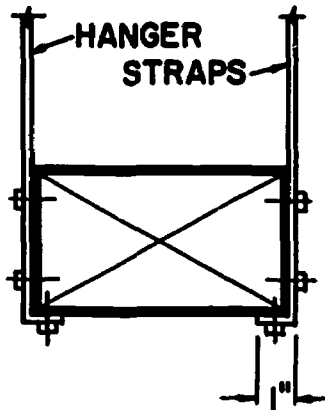
① DIMENSION OF LONGEST SIDE	② GALV. SHEET GA. (ALL FOUR SIDES)	TRANSVERSE		
		BETWEEN JOINTS		⑤ MIN. ANGLE SIZE
		③ WITH TIE RODS	④ WITHOUT TIE RODS	
Up thru 12"	22	No tie rods required	No angle required	None required
13"-18"	22	1 tie rod @ 40" intervals on center-line of duct side	1x1x16 Ga. @ 48"	1x1x16 Ga.
19"-24"	22	2 tie rods @ 40"	1x1x1/8 @ 48"	1x1x1/8
25"-36"	22	→	1 1/4x1 1/4x1/8 @ 32" OR 1 1/2x1 1/2x1/8 @ 40"	1 1/2x1 1/2x1/8
37"-48"	22	→	2x2x1/8 @ 30"	2x2x1/8 OR 1 1/2x1 1/2x1/8 with tie rod in center
49"-60"	20	1 1/2x1 1/2x1/8 @ 24" with tie rod in center	2x2x3/8 @ 24"	2x2x3/8 OR 1 1/2x1 1/2x1/8 with tie rod in center.
61"-72"	20	1 1/2x1 1/2x1/8 @ 24" with tie rod in center	2 1/2x2 1/2x3/8 @ 24"	2 1/2x2 1/2x3/8 OR 1 1/2x1 1/2x1/8 with tie rod in center
73"-84"	18	1 1/2x1 1/2x1/8 @ 24" with tie rod in center	←	1 1/2x1 1/2x1/8 with tie rod in center
85"-96"	18	1 1/2x1 1/2x1/8 @ 24" with tie rod in center	←	1 1/2x1 1/2x1/8 with tie rod in center
97" and Over	16	2x2x1/8 @ 24" with tie rods @ 48" along angle	←	2x2x1/8 with tie rods @ 48" along angle

*NOTES: (a) When transverse reinforcing is required on all four sides it must be tied together at each corner by riveting, bolting or welding. When transverse reinforcing is required on only two sides, it must be tied together with either tie rods or angles at the ends. Transverse reinforcing size is determined by dimension of side to which angle is applied. Angle sizes are based on mild steel. Reinforcing made in other shapes or of other materials must be of equivalent strength and rigidity.

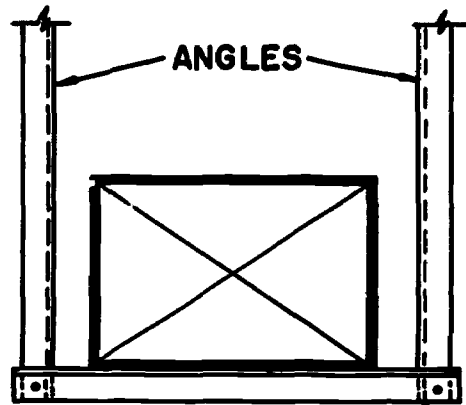
Fig. 3-2
High
Pressure,
High
Velocity Duct
Construction
for Static
Pressures in
Duct Over 6"
W.G. and Up
To 10" W.G.

HANGERS FOR DUCTS

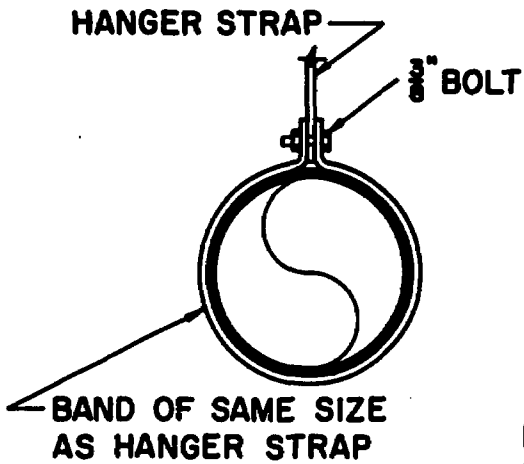
STRAP HANGERS



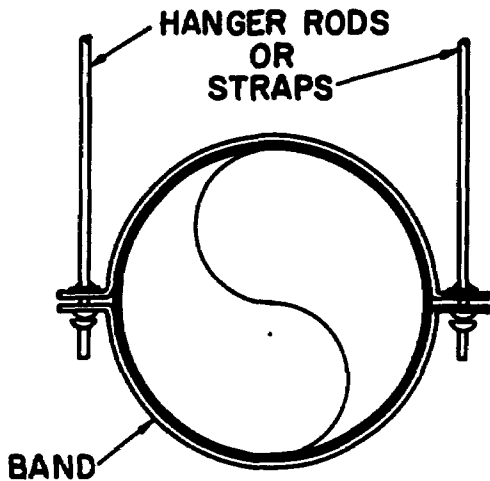
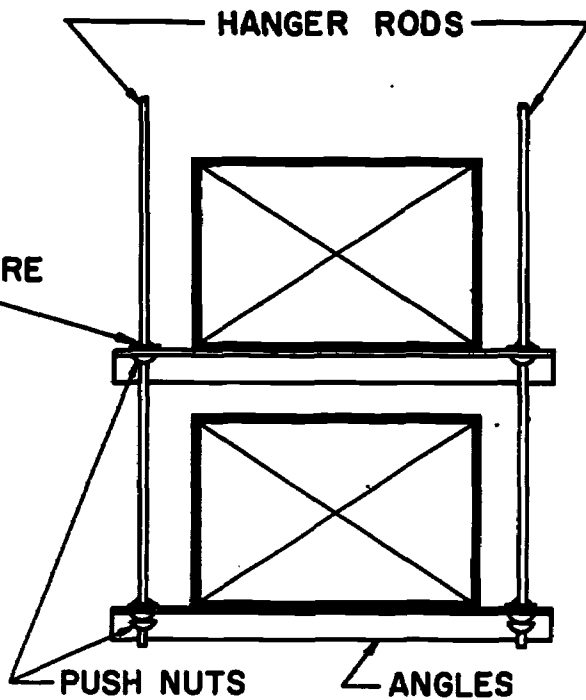
TRAPEZE HANGERS



HANGER STRAP
1/2" BOLT



FIXTURE CLIPS



HANGERS FOR HOT & COLD DUCTS

PLATE NO. 19 – HANGERS FOR DUCTS-UPPER ATTACHMENTS

Many parts of a building, such as heating, plumbing and sprinkler pipe, electrical conduits and fixtures, and ceilings, require hanging. Consequently, there is a continuing effort to improve hanging systems.

The duct hanging system is composed of three elements -- the upper attachment to the building; the hanger itself; and the lower attachment to the duct.

Upper Attachments

Concrete Inserts

The concrete inserts illustrated must be installed prior to placing the concrete. They are used primarily where the duct layout is simple and there is enough lead time to determine accurate placement. Fig. 1, the simplest, is merely a piece of bent flat bar. Fig. 3 and 4 show manufactured inserts available individually or in long lengths; the latter are generally used where many hangers will be installed in a small area, or where individual inserts cannot be precisely spotted at the time of placing concrete.

Concrete Fasteners

Concrete fasteners are installed after the placement of the concrete and the removal of the concrete forms. Their application allows greater flexibility than concrete inserts because their exact location can be determined after all interferences between various trades' work have been coordinated.

Fig. 5 and 6 show variations of powder actuated fasteners which are placed by an explosive charge. These fasteners should not be used in certain lightweight aggregate concretes, nor should they be used in slab sections less than 4 inches thick.

Expanding concrete anchors should be made of steel. Non-ferrous anchors tend to creep with vibration. Fig. 8 illustrates expanding fasteners, the holes for which are drilled either by a carbide bit or by teeth on the fastener itself. The expansion shield is "set" by driving it into the hole and expanding it with the conical plug. The expansion nail, Fig. 9, is a lighter duty fastener, used for small duct and flexible tubing.

In the case of all of the above fasteners, there are possibilities of interference with steel reinforcing in the concrete. The installer must exercise good judgment and have some knowledge of typical reinforcing patterns.

Structural Steel Fasteners

Fig. 7 illustrates the use of a C-clamp which should be used with a retaining clip. Fig. 10 shows a welded stud placed by special welding equipment.

Fig. 11 shows patented devices which are driven on to the flange and will support either a rod or strap type hanger.

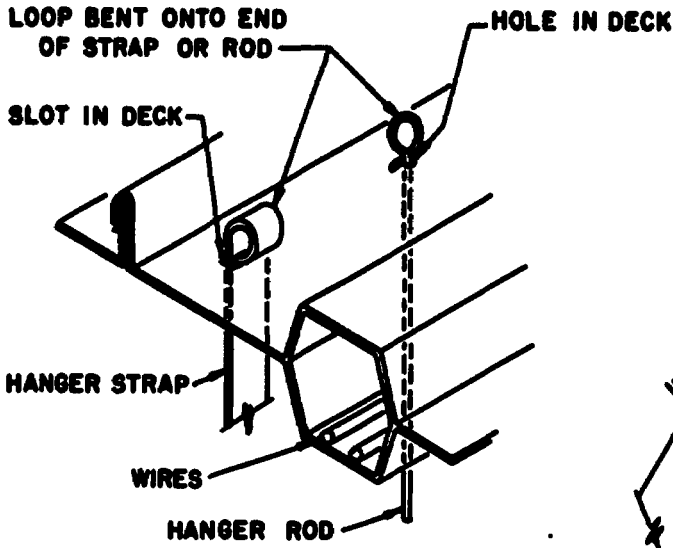


Fig. 5-10

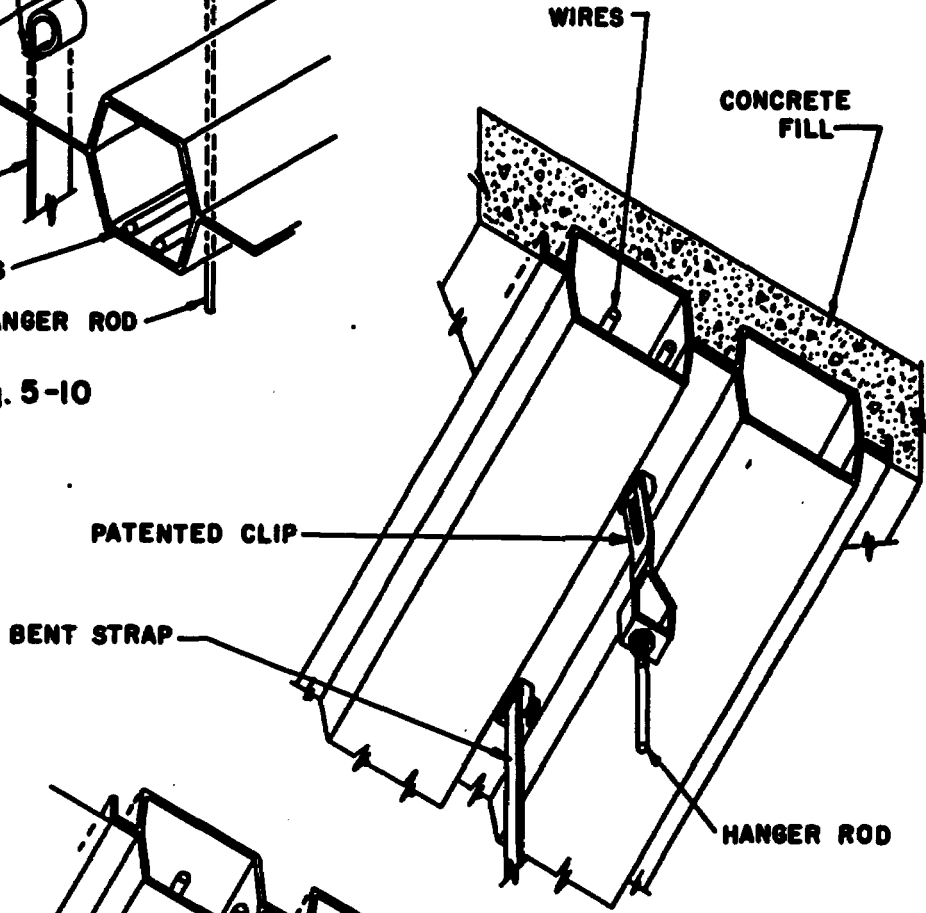


Fig. 5-9

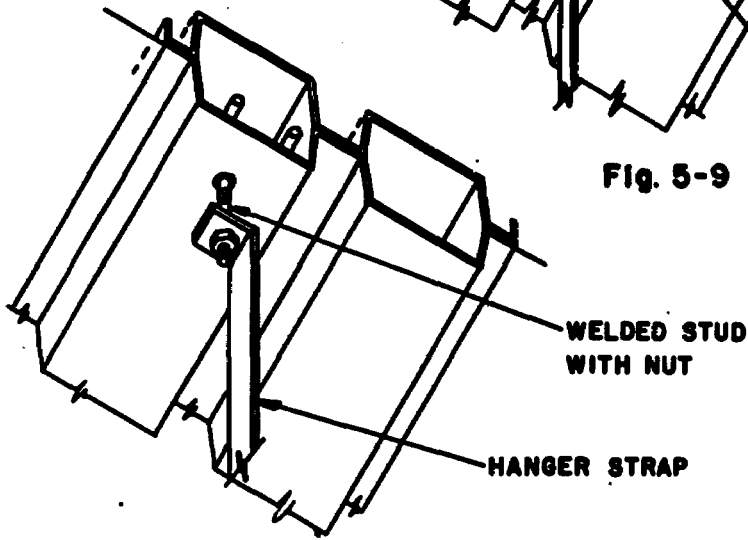


Fig. 5-11

CELLULAR DECK HANGING SYSTEMS

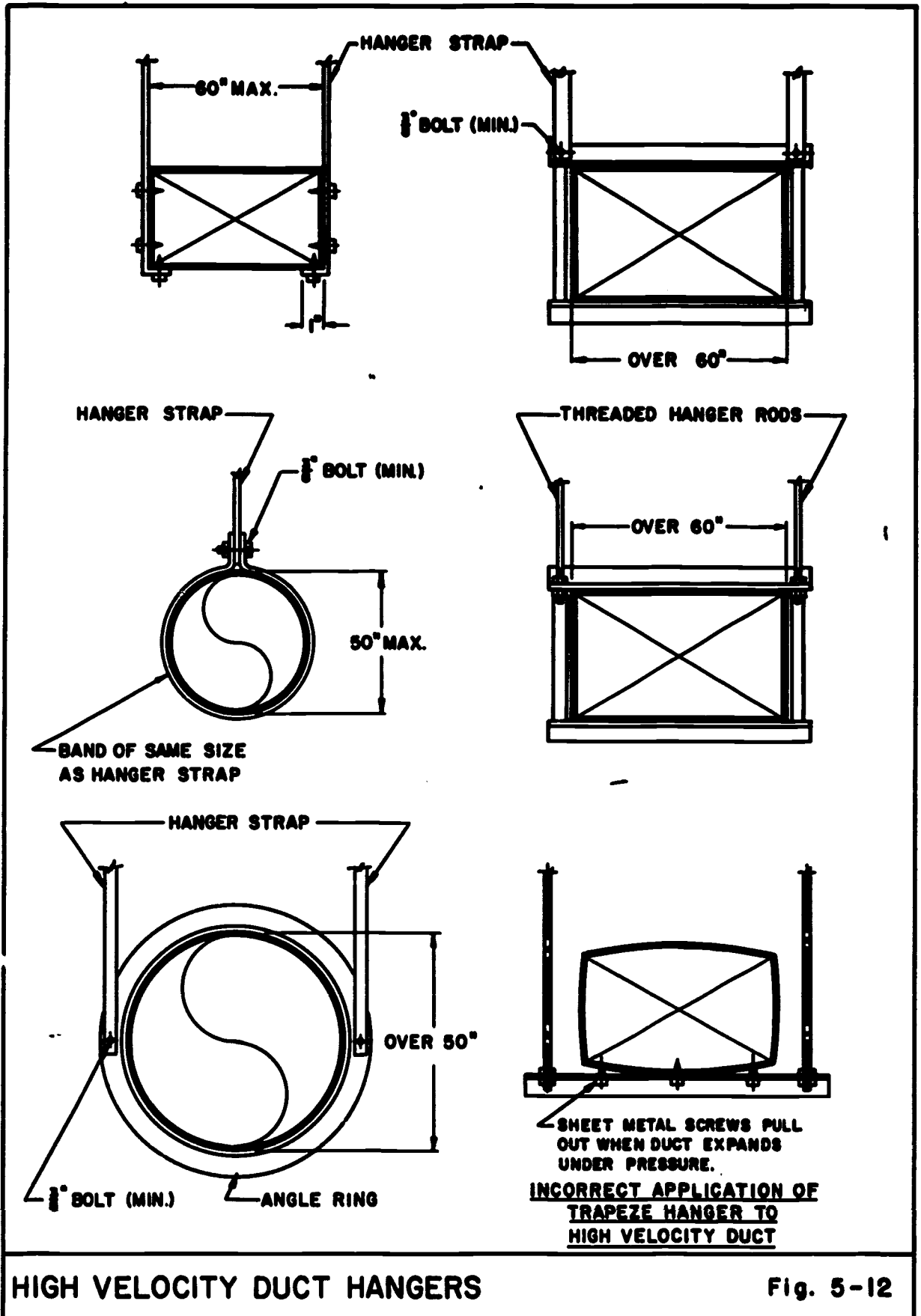


TABLE 1
SCHEDULE OF REINFORCEMENT
RECTANGULAR FIBROUS GLASS AIR DUCTS
SD BOARD 1" THICK

0 THRU 1/2" W.G. MAXIMUM STATIC PRESSURE- 2000 F.P.M. MAXIMUM VELOCITY	
0 Thru 36"	No Reinforcement Required
37" and OVER	Reinforce in Accordance with Table Below (OVER 1/2" THRU 1" W.G.)




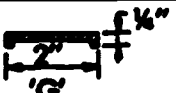








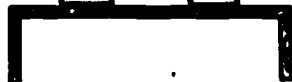









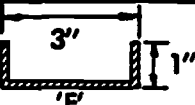
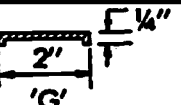
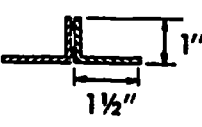
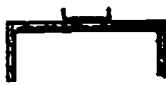

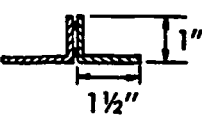
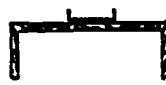

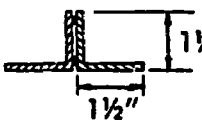
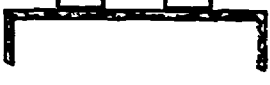
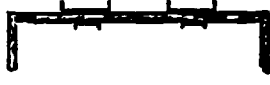
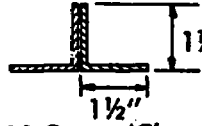


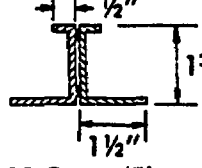
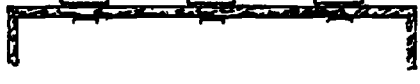
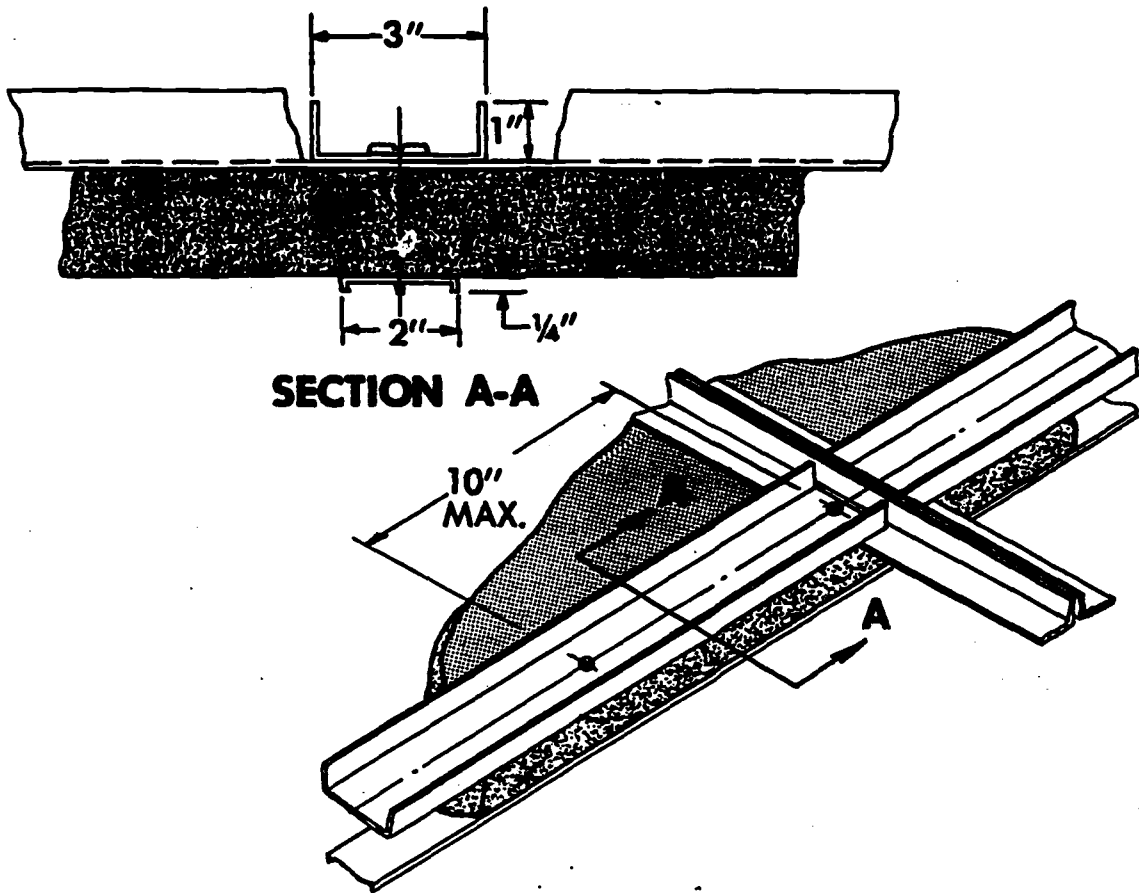
OVER 1/2" THRU 1" W.G. MAXIMUM STATIC PRESSURE-2000 F.P.M. MAXIMUM VELOCITY					
Dimension Longest Side of Duct	Plate Number	Reinforcements			
		Transverse Joint		Lateral	
		Maximum Spacing 48" O.C.		External	Internal
		 'A'	 'D'	 'F'	 'G'
		 'B'		Supply Air Duct	Return Air Duct
0 Thru 24"	None	None		None	None
25" Thru 36"	Supply No. 1			 One 22 Gauge 'F'	 One 22 Gauge 'F' One 22 Gauge 'G'
	Return No. 2	20 Gauge 'A'			
37" Thru 48"	Supply No. 1			 One 20 Gauge 'F'	 One 20 Gauge 'F' One 22 Gauge 'G'
	Return No. 2	20 Gauge 'A'			
49" Thru 60"	Supply No. 3			 Two 20 Gauge 'F'	 Two 20 Gauge 'F' Two 22 Gauge 'G'
	Return No. 4	18 Gauge 'A'			
61" Thru 72"	No. 4			Supply and Return  Two 18 Gauge 'F' and Two 22 Gauge 'G'	
		18 Gauge 'B'			
73" Thru 84"	No. 5			Supply and Return  Three 18 Gauge 'F' and Three 22 Gauge 'G'	
		18 Gauge 'D'			

TABLE 2
SCHEDULE OF REINFORCEMENT
RECTANGULAR FIBROUS GLASS AIR DUCTS
SD BOARD 1" THICK

OVER 1" THRU 2" W.G. MAXIMUM STATIC PRESSURE - 2000 F.P.M. MAXIMUM VELOCITY					
Dimension Longest Side of Duct	Plate Number	Reinforcements			
		Transverse Joint Maximum Spacing 48" O.C.		Lateral	
		'A'	'C'	'F'	'G'
		 	 	 External	 Internal
0 Thru 15"	None	None		None	None
16" Thru 24"	Supply No. 6 Return No. 7	 22 Gauge 'A'		 One 22 Gauge 'F'	 One 22 Gauge 'F' One 22 Gauge 'G'
25" Thru 36"	Supply No. 6 Return No. 7	 20 Gauge 'A'		 One 20 Gauge 'F'	 One 20 Gauge 'F' One 22 Gauge 'G'
37" Thru 48"	Supply No. 8 Return No. 9	 20 Gauge 'B'		 Two 20 Gauge 'F'	 Two 20 Gauge 'F' Two 22 Gauge 'G'
49" Thru 60"	Supply No. 8 Return No. 9	 18 Gauge 'C'		 Two 20 Gauge 'F'	 Two 20 Gauge 'F' Two 22 Gauge 'G'
61" Thru 84"	No. 10	 18 Gauge 'E'		Supply and Return  Three 18 Gauge 'F' and Three 22 Gauge 'G'	

LATERAL DUCT REINFORCEMENT

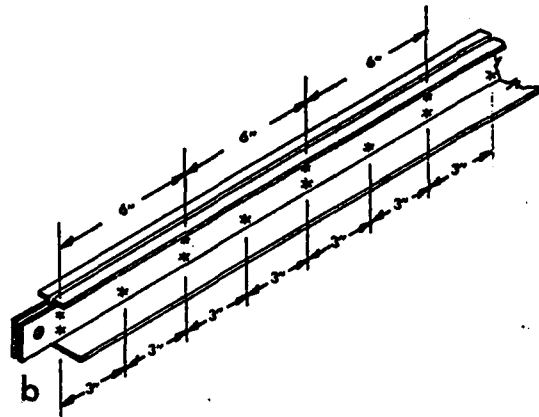
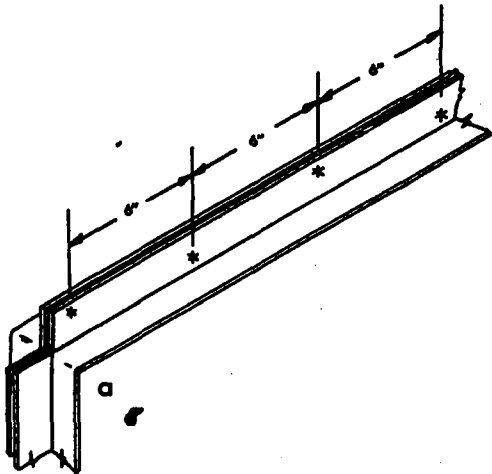
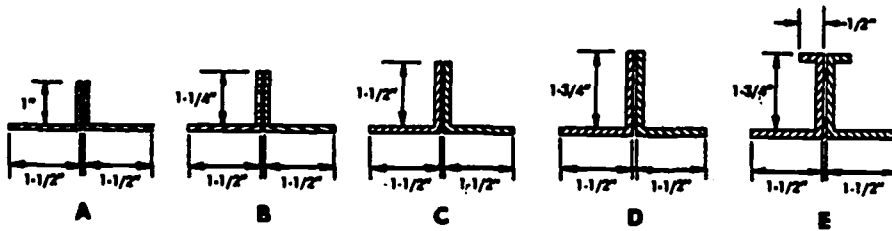


NOTES:

1. Plated sheet metal screws to fasten external reinforcing lateral to internal reinforcing lateral and transverse reinforcing members shall be #10x1-1/2" on 10" maximum centers. When internal laterals are not required, #10x1/2" sheet metal screws shall be used for connecting the external reinforcing laterals to the transverse reinforcing members.

When fabricating reinforced Fibrous Glass Ducts that require internal lateral bracing, cut the smaller internal lateral approximately 1/2" shorter than the actual distance between centerlines of the transverse reinforcements, so that the internal lateral can be fastened to the external lateral at the centerpoint before joining of sections. Working from the open end of the added section, the internal lateral can then be pivoted into position and both internal and external laterals fastened to the base flange of the transverse reinforcing member with a sheet metal screw.

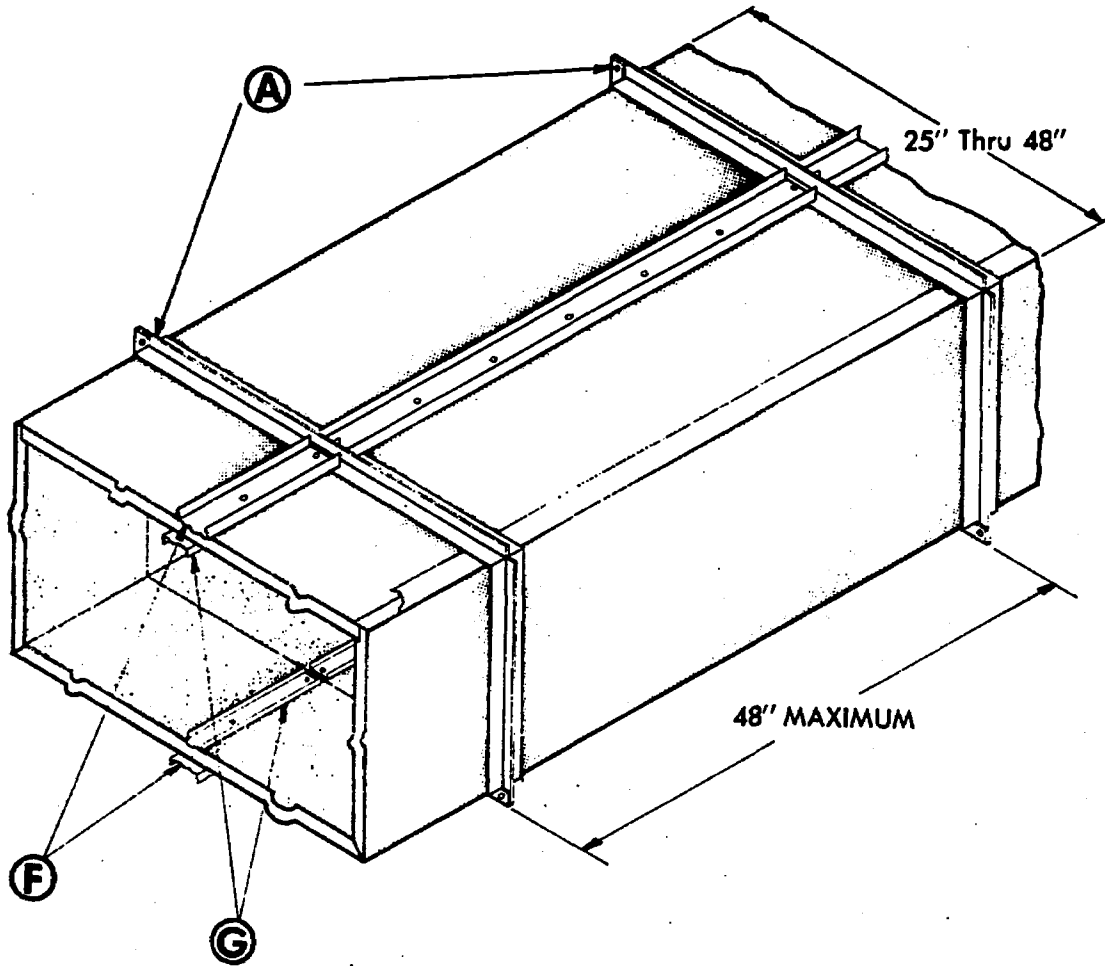
TRANSVERSE REINFORCING MEMBERS AND SPOT WELD SPACING



NOTES:

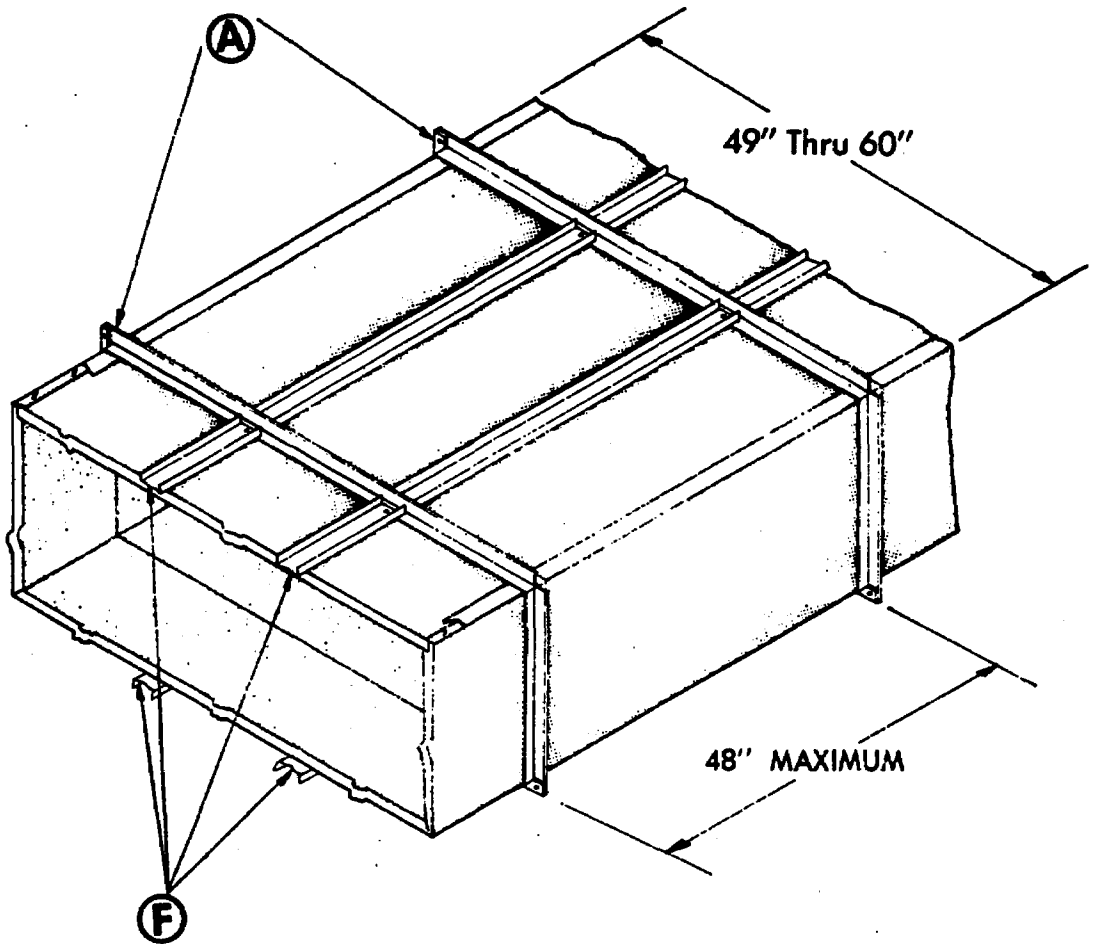
1. Configuration of transverse reinforcing members shall be as shown. All metal shall be galvanized sheet metal of gauges indicated on the Reinforcement Schedules shown on pages 6 and 7
2. Spot welding patterns illustrated above must be adhered to. Distances between welds are maximum and extreme caution shall be exercised to obtain secure welds approximately 1/4" from the top and the bottom of the transverse reinforcing members.
3. Transverse reinforcing members are formed or joined at the duct corners by the following methods:
 - a. Stem is cut and flanges are bent 90°.
 - b. Flanges are removed and the two stems of the structural members are extended beyond the corners and joined with a 1/4" diameter or larger bolt.

TYPICAL REINFORCEMENT RETURN AIR DUCT



OVER ½ IN. THRU 1 IN. W.G.

TYPICAL REINFORCEMENT SUPPLY AIR DUCT

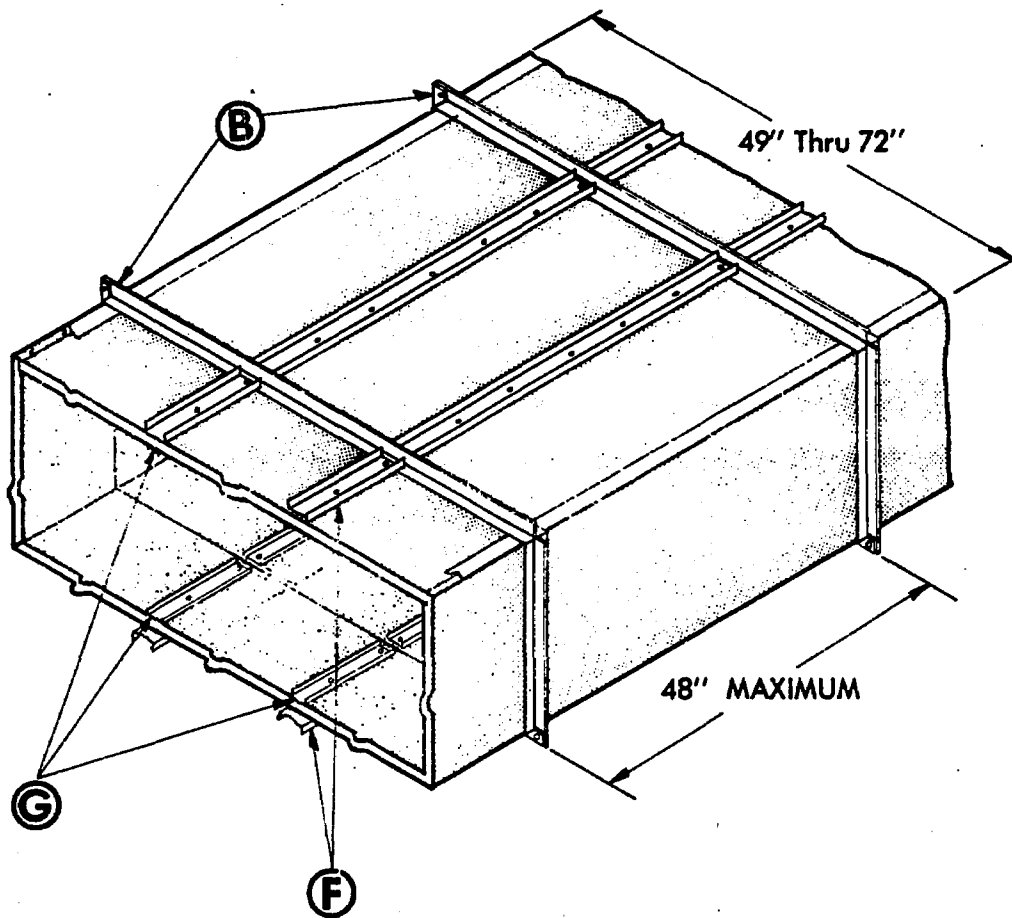


OVER ½ IN. THRU 1 IN. W.G.

SMACNA FIBROUS DUCT MANUAL

Plate No. 3

TYPICAL REINFORCEMENT RETURN AIR DUCT

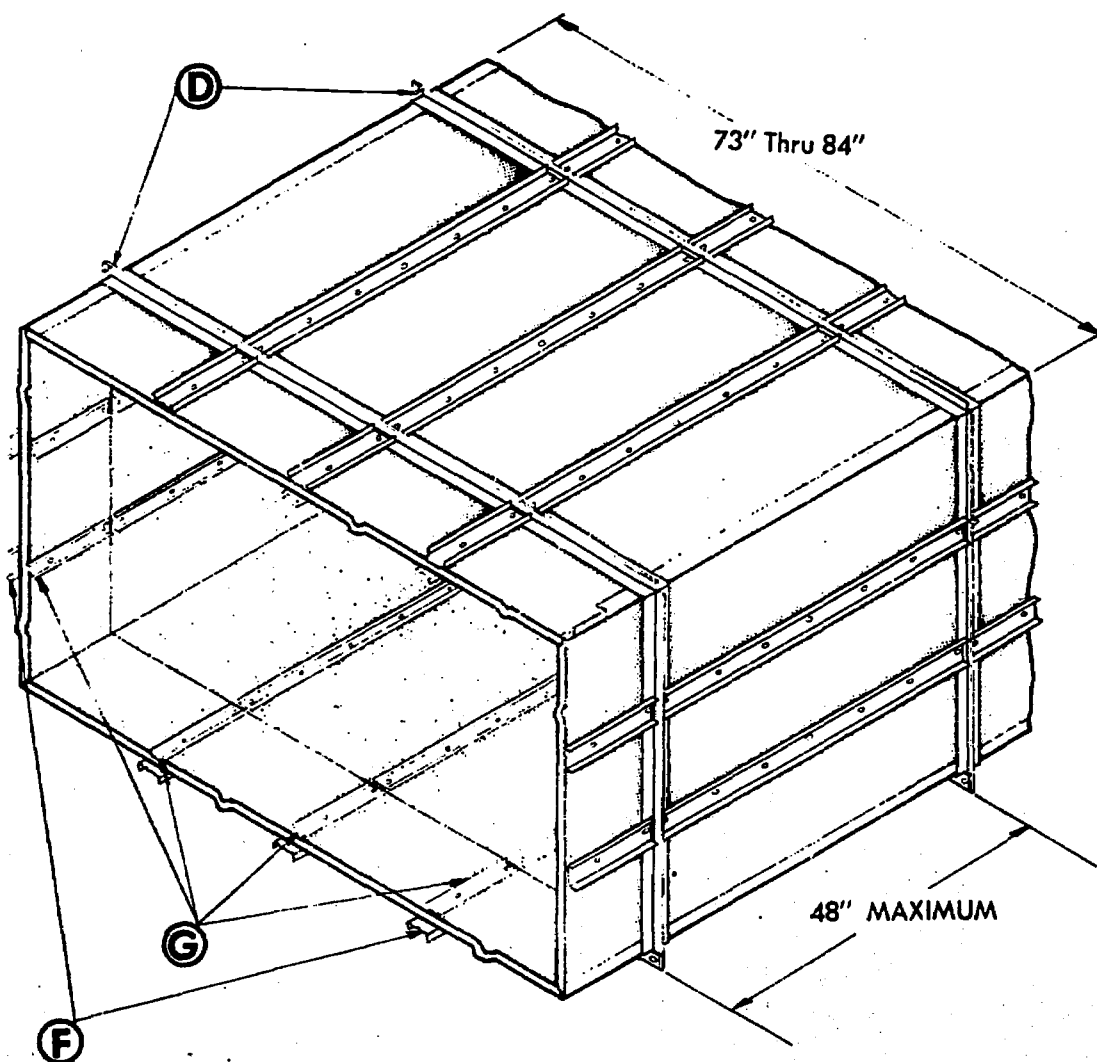


OVER $\frac{1}{2}$ IN. THRU 1 IN. W.G.

SMACNA FIBROUS DUCT MANUAL

Plate No. 4

TYPICAL REINFORCEMENT SUPPLY AND RETURN AIR DUCT

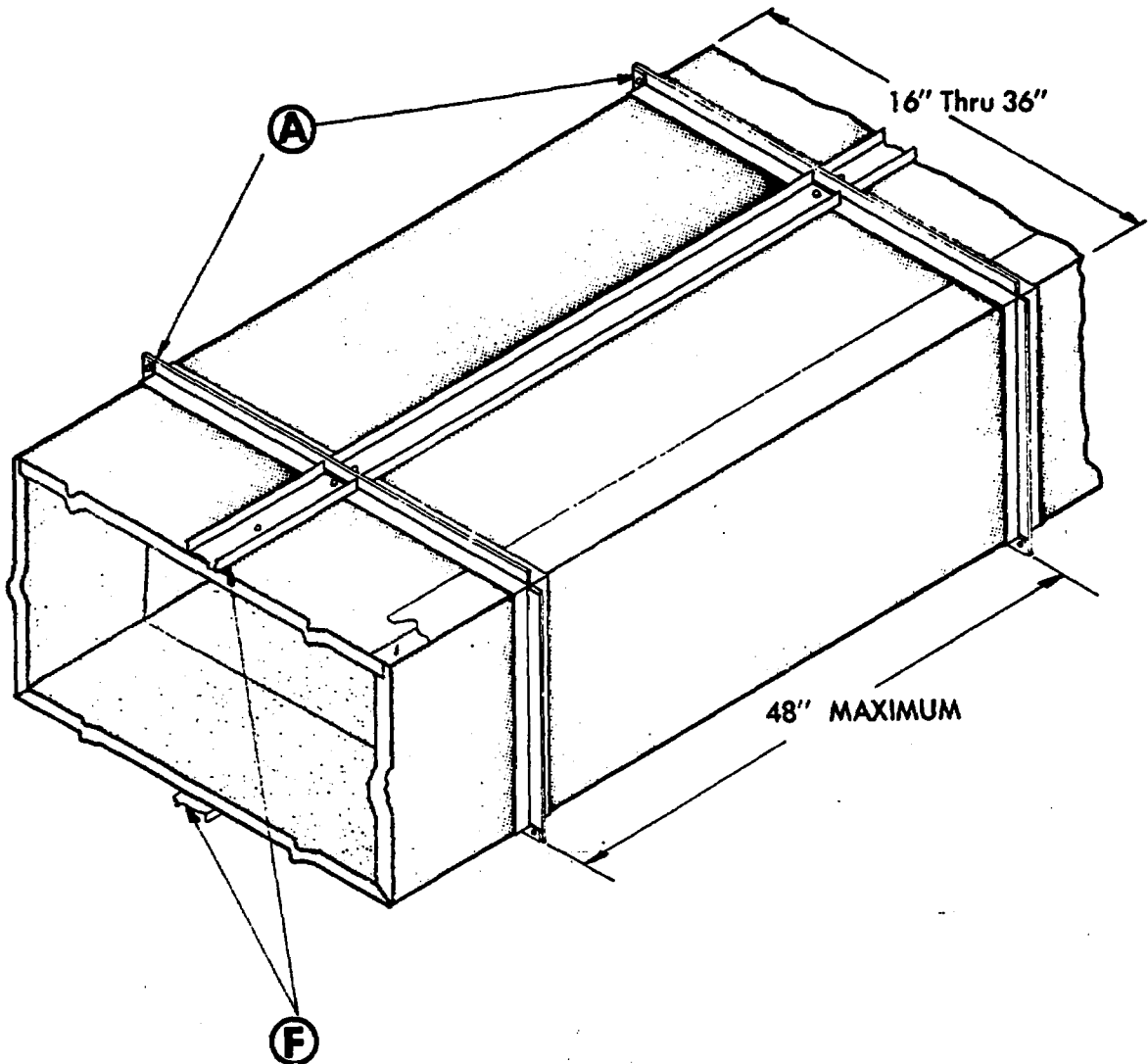


OVER ½ IN. THRU 1 IN. W.G.

SMACNA FIBROUS DUCT MANUAL

Plate No. 5

TYPICAL REINFORCEMENT SUPPLY AIR DUCT

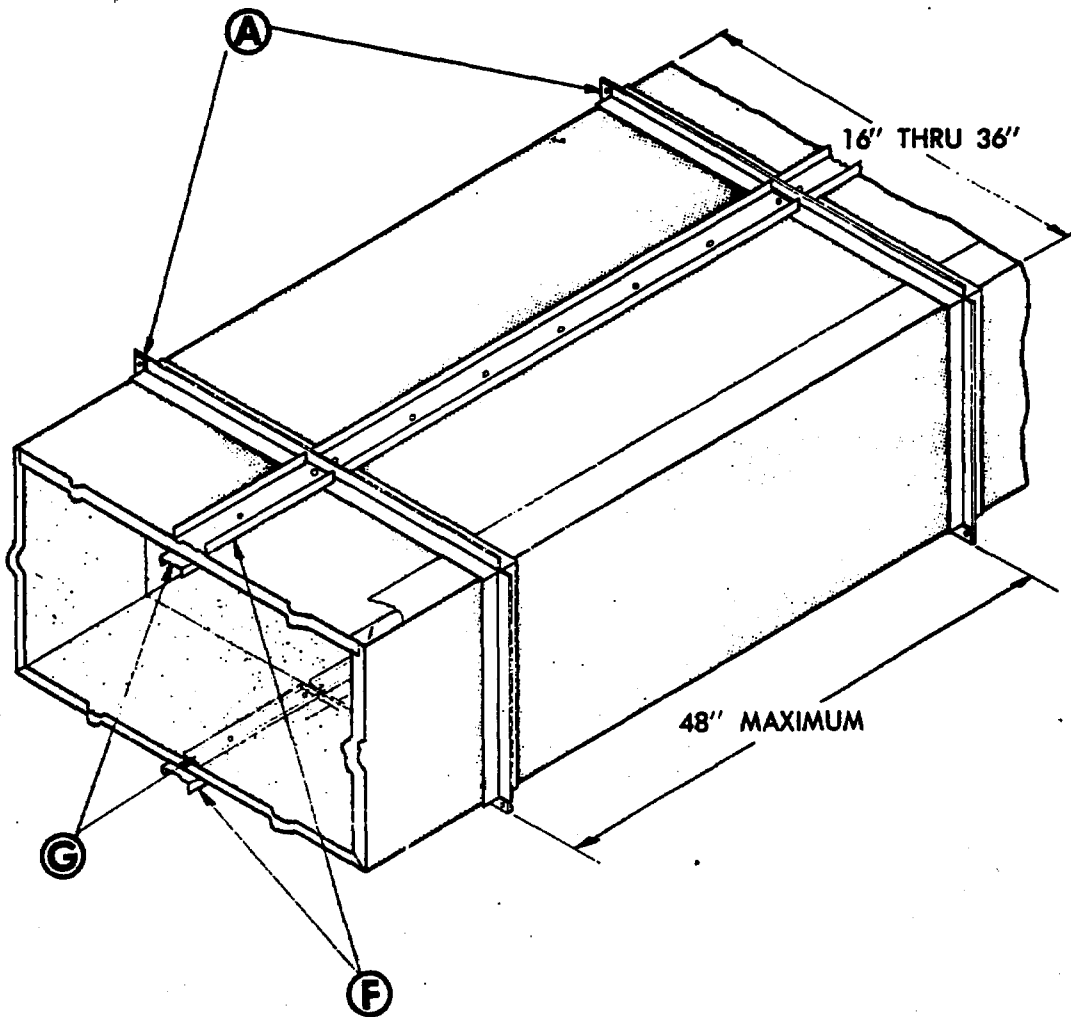


Over 1 In. W.G. thru 2 In. W.G.

SMACNA FIBROUS DUCT MANUAL

Plate No. 6

TYPICAL REINFORCEMENT RETURN AIR DUCT

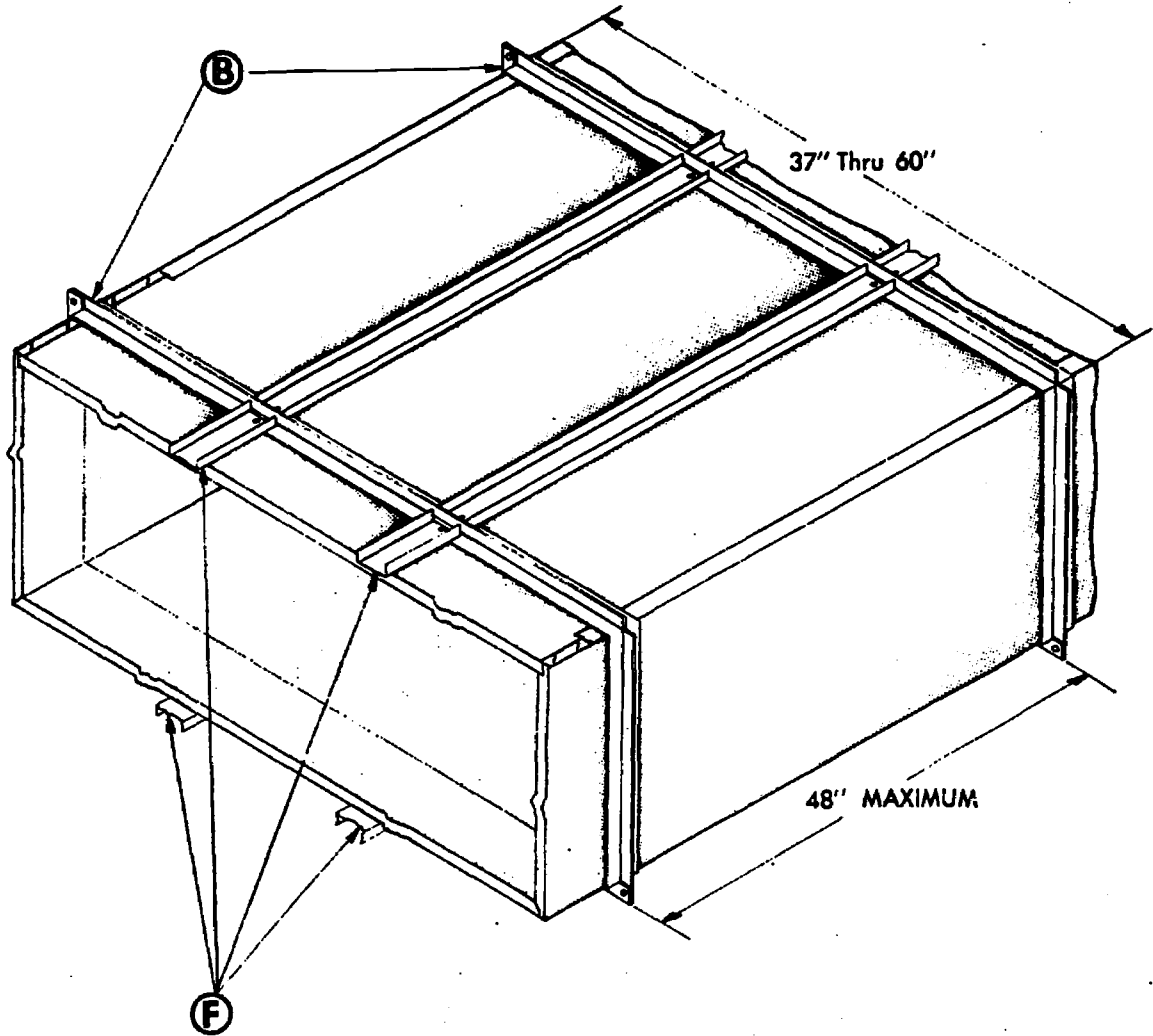


Over 1 In. W.G. thru 2 In. W.G.

SMACNA FIBROUS DUCT MANUAL

Plate No. 7

TYPICAL REINFORCEMENT SUPPLY AIR DUCT

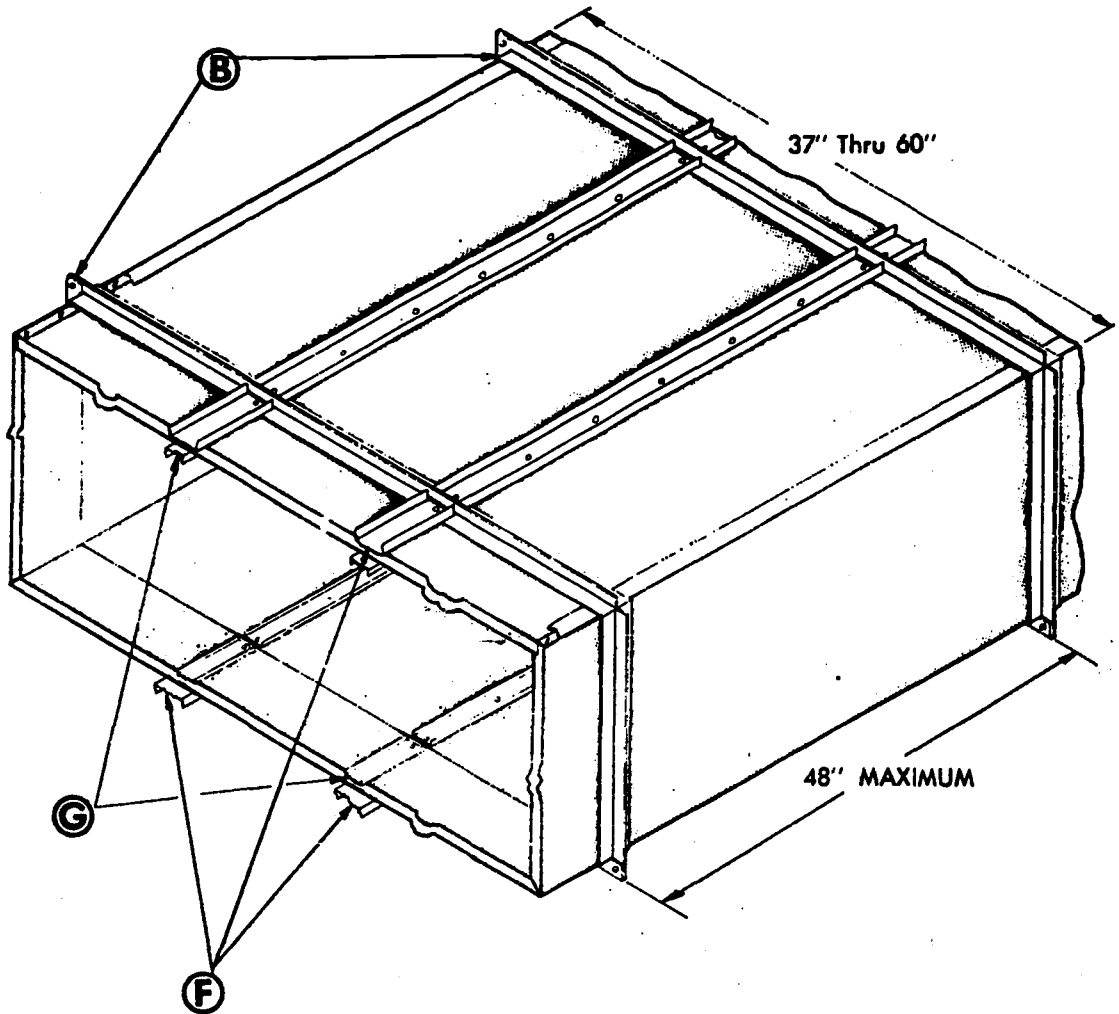


Over 1 In. W.G. thru 2 In. W.G.

SMACNA FIBROUS DUCT MANUAL

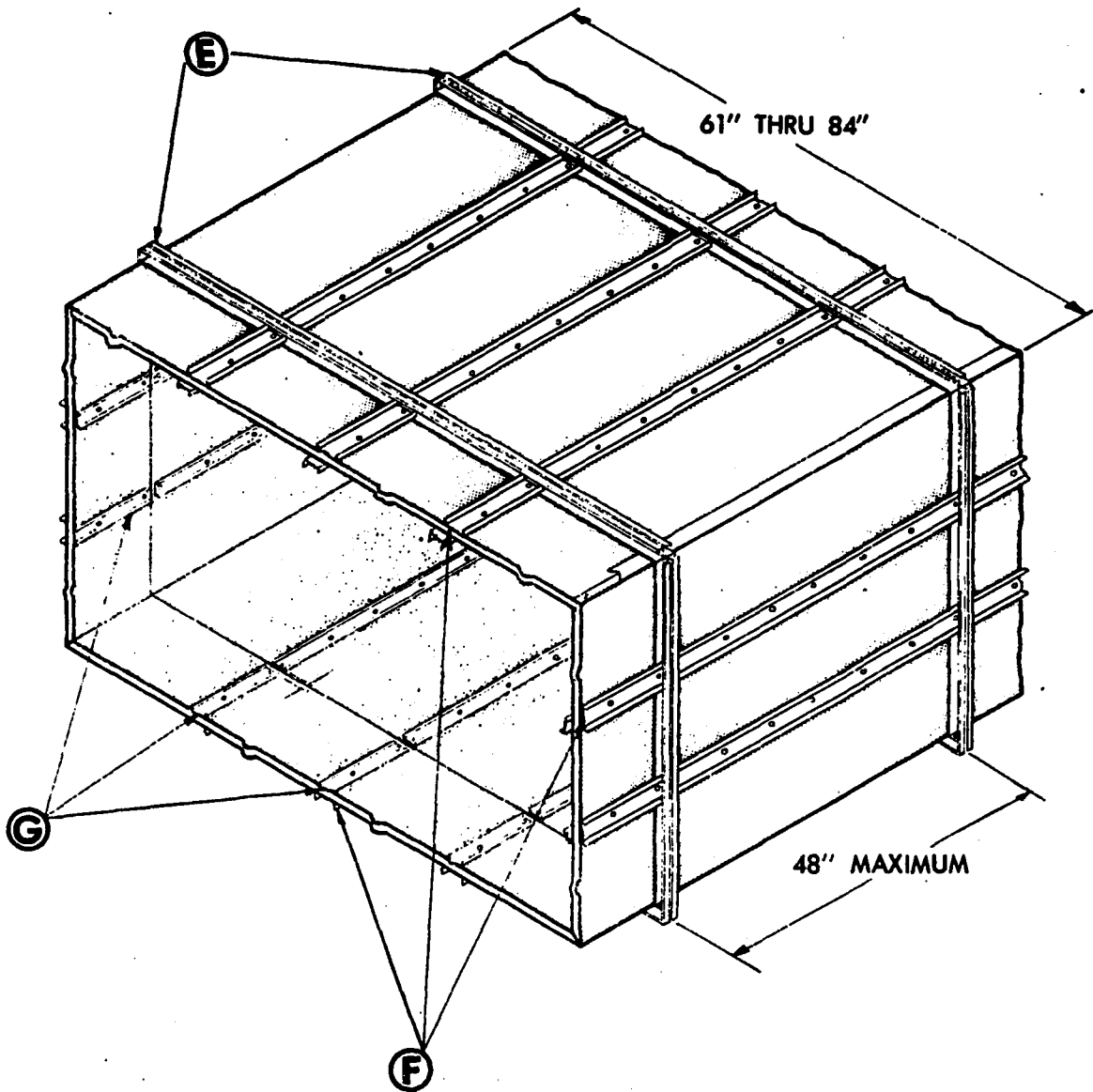
Plate No. 8

TYPICAL REINFORCEMENT RETURN AIR DUCT



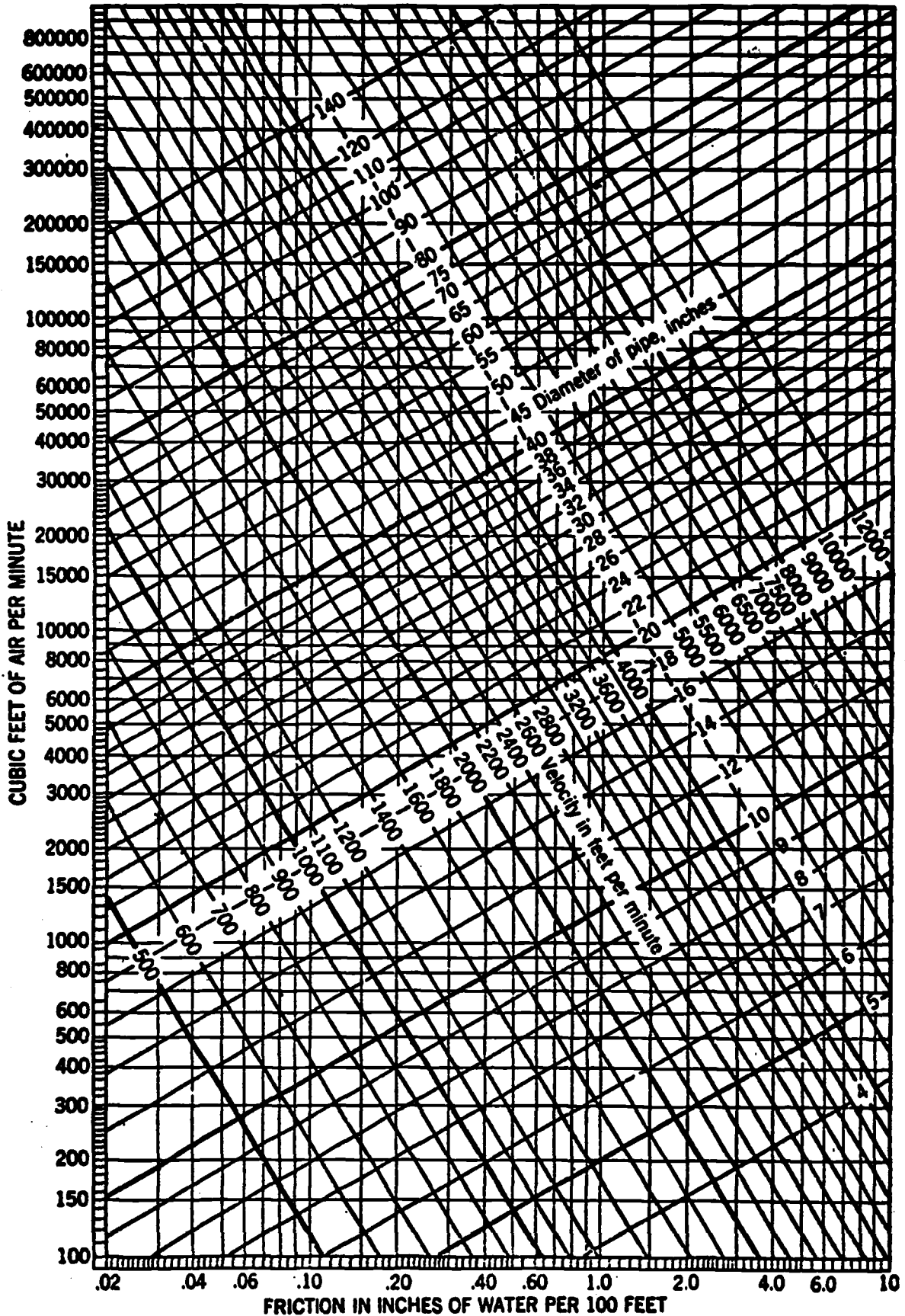
OVER 1 IN. THRU 2 IN. W.G.

TYPICAL REINFORCEMENT SUPPLY AND RETURN AIR DUCT



OVER 1 IN. THRU 2 IN. W.G.

FRICTION OF AIR IN PIPE



Reprinted from the American Society of Heating and Ventilating Engineers Guide 1941, Chapter 31, Page 574.



AIR MOVING EQUIPMENT TEST SHEET

Date _____
Sheet No. _____

Job Name _____ Address _____

Testing & Balancing Agency _____

Unit No.									
Location									
Manufacturer									
Model No.									
Serial No.									
Operating Conditions	Specified	Actual	Specified	Actual	Specified	Actual	Specified	Actual	
Total C. F. M.									
Return Air C. F. M.									
O. S. A. C. F. M.									
Total Static Pressure									
Suction Pressure									
Discharge Pressure									
Fan Sheave									
Motor Sheave									
Belts									
Motor Manufacturer									
Size									
Voltage									
Phase									
RPM Motor									
Amperage	Rated	Running	Rated	Running	Rated	Running	Rated	Running	
RPM Fan									

SYMBOLS FOR VENTILATION & AIR CONDITIONING

SYMBOL MEANING	SYMBOL	SYMBOL MEANING	SYMBOL
FAN & MOTOR WITH BELT GUARD & FLEXIBLE CONNECTIONS		VOLUME DAMPER	
VENTILATING UNIT (TYPE AS SPECIFIED)		GOOSENECK HOOD (COWL)	
UNIT HEATER (DOWNBLAST)		BACK DRAFT DAMPER	
UNIT HEATER (HORIZONTAL)		AUTOMATIC AIR DAMPERS MOTOR OPERATED	
UNIT HEATER (CENTRIFUGAL FAN) PLAN		ACCESS DOOR (AD) ACCESS PANEL (AP)	
THERMOSTAT		DAMPER AS SPECIFIED	
POWER OR GRAVITY ROOF VENTILATOR-EXHAUST (ERV)		ACOUSTICAL LINING	
POWER OR GRAVITY ROOF VENTILATOR-INTAKE (SRV)		SOUND TRAP	
POWER OR GRAVITY ROOF VENTILATOR-LOUVERED		FIRE DAMPER & SLEEVE	
MIXING PLENUM		FLEXIBLE DUCT	
LOUVERS & SCREEN		EXHAUST OR RETURN AIR INLET CEILING (INDICATE TYPE)	
DIRECTION OF FLOW		SUPPLY OUTLET, CEILING, ROUND (TYPE AS SPECIFIED) INDICATE DIRECTION OF FLOW	
SPLITTER DAMPER		SUPPLY OUTLET, CEILING, SQUARE (TYPE AS SPECIFIED) INDICATE DIRECTION OF FLOW	
DUCT SECTION (EXHAUST OR RETURN)		SUPPLY OUTLET WALL	
DUCT SECTION (SUPPLY)		SUPPLY GRILLE (SG)	
DUCT (1ST FIGURE, SIDE SHOWN 2ND FIGURE, SIDE NOT SHOWN)		RETURN GRILLE - NOTE AT CEILING OR FLOOR	
INCLINED DROP IN RESPECT TO AIR FLOW, TOP FLAT		EXHAUST GRILLE (EG)	
INCLINED RISE IN RESPECT TO AIR FLOW, BOTTOM FLAT		EXHAUST OR RETURN INLET-WALL (EG OR RG)	
TURNING VANES		DOOR GRILLE	
		NOTE: GRILLES WITH VOLUME CONTROL DESIGNATE AS - SR, RR OR ER	

SMACNA DUCT STANDARDS

Plate No.3
Page No.5

STEAM FLOW CHART

For saturated steam (100% quality 0 deg superheat) on the inlet side of the valve—connect the pressure drop, scale "A," with downstream pressure, scale "B," and mark the point of intersection on scale "B." From this point draw a line thru 6900 on scale "D" and read the required capacity index on scale "F."

For example, find the valve size required to pass 550 lb/hr at inlet pressure of 25 psi gage with a drop of 10 psi gage.

Connect 10 on scale "A" with 25-10 = 15 on scale "B," mark the point of intersection on scale "B." From this point draw a line thru 550 on scale "D," and read 9.4 on scale "F." Any valve having a capacity index equal to this value will pass the desired amount.

If supply steam is less than 100% quality, or is superheated, the

required capacity (lb/hr) must first be corrected.

Connect the condition point on scale "G" with the required capacity on scale "D," and mark the point of intersection on line "E." Connect 0 on scale "G" with the intersection point on line "E," and mark the corrected quantity on scale "D." Proceed then as for 100% quality steam, using the corrected quantity figure on scale "D."

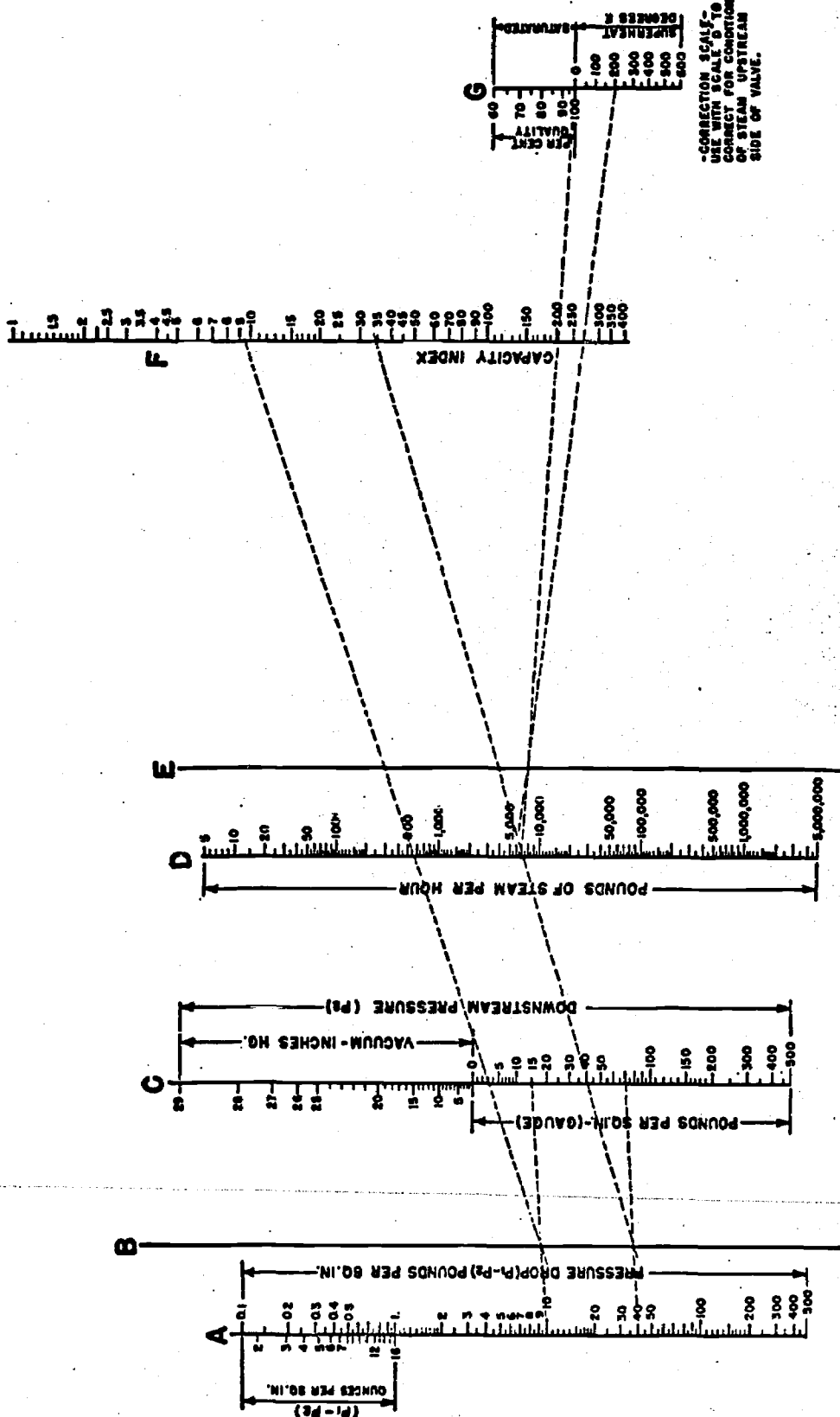
For example, find the valve size required to pass 6000 lb/hr at inlet pressure of 110 psi gage with a drop of 40 psi gage. Inlet steam is at 200 deg superheat.

Connect 200 on scale "G" with 6000 on scale "D," marking the point of intersection on line "E." Connect 0 on scale "G" with the point of intersection on line "E" and mark 6900 on scale "D." Connect

40 on scale "A" with 70 on scale "B," marking the intersection on scale "B." From this point draw a line thru 6900 on scale "D" and read 34 on scale "F." Any valve having a capacity index equal to this value will pass the required amount of steam.

NOTE: When absolute downstream pressure is less than 50% of absolute upstream pressure, use 50% of the absolute upstream pressure as the pressure drop on scale "A," and deduct this value from the upstream gage pressure to determine the downstream gage pressure to use on scale "B" (14.7 psi absolute = 0 psi gage).

For example, with upstream pressure of 125 psi gage and drop of 90 psi, downstream pressure would be 35 psi gage or 50 psi absolute. 50% of absolute upstream pressure, $\frac{125 + 15}{2} = 70$. Use 70 psi as drop, and 125-70 = 55 psi gage as downstream pressure.



Courtesy, Honeywell, Inc.

LIQUID FLOW CHART

Connect the point denoting liquid condition, scale "A," with the pressure drop, scale "B," extending the line to intersect line "C." Connect the latter point with the desired flow, scale "D," extending the line to intersect scale "E." Read the required capacity index (Cv) on scale "E." Three examples are given below.

(1) Find the valve size required to pass 145 GPM of water at 25 psi pressure drop.

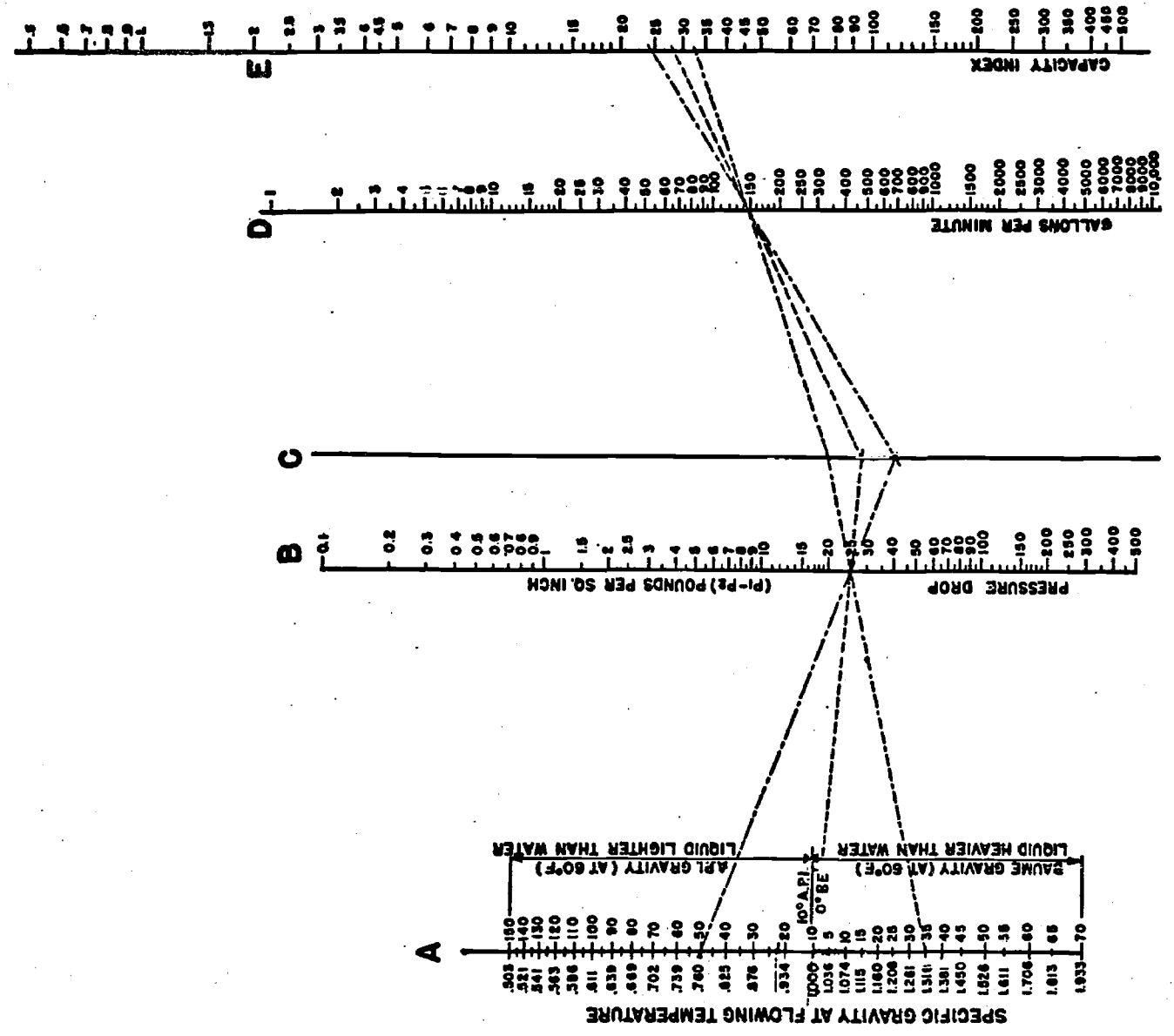
Connect point 1,000, the SpG of water, on scale "A" with 25, scale "B," extending the line to intersect line "C." Connect this point on line "C" with 145 on scale "D," extending this line to intersect scale "E." Read the required Cv of 28 on scale "E." Any valve having a Cv of 28 will pass the desired quantity of water. A 2" V5011 will satisfy the requirement.

(2) If the liquid is other than water, but flowing temperature is 60 F, use as the point on scale "A" the condition properly describing the liquid. For example, find the valve size to pass 145 GPM of petroleum oil at 50 A.P.I. (60 F) at 25 psi drop.

Connect 50 deg A.P.I. on scale "A" with 25 on scale "B," extending the line to intersect line "C." Connect the latter point with 145 on scale "D," extending the line to intersect scale "E." Read the required Cv of 24.5 on scale "E." Select an industrial-type valve having this Cv.

(3) If liquid were heavy gravity such as a salt solution or acid, use the lower part of scale "A." Assume liquid is 35° Bé (60°).

Connect 35 deg Baumé, scale "A," with 25 on scale "B," extending the line to intersect line "C." Connect the latter point with 145, scale "D," extending the line to intersect scale "E." Read the required Cv of 32.5 on scale "E." Select an industrial-type valve having this Cv.



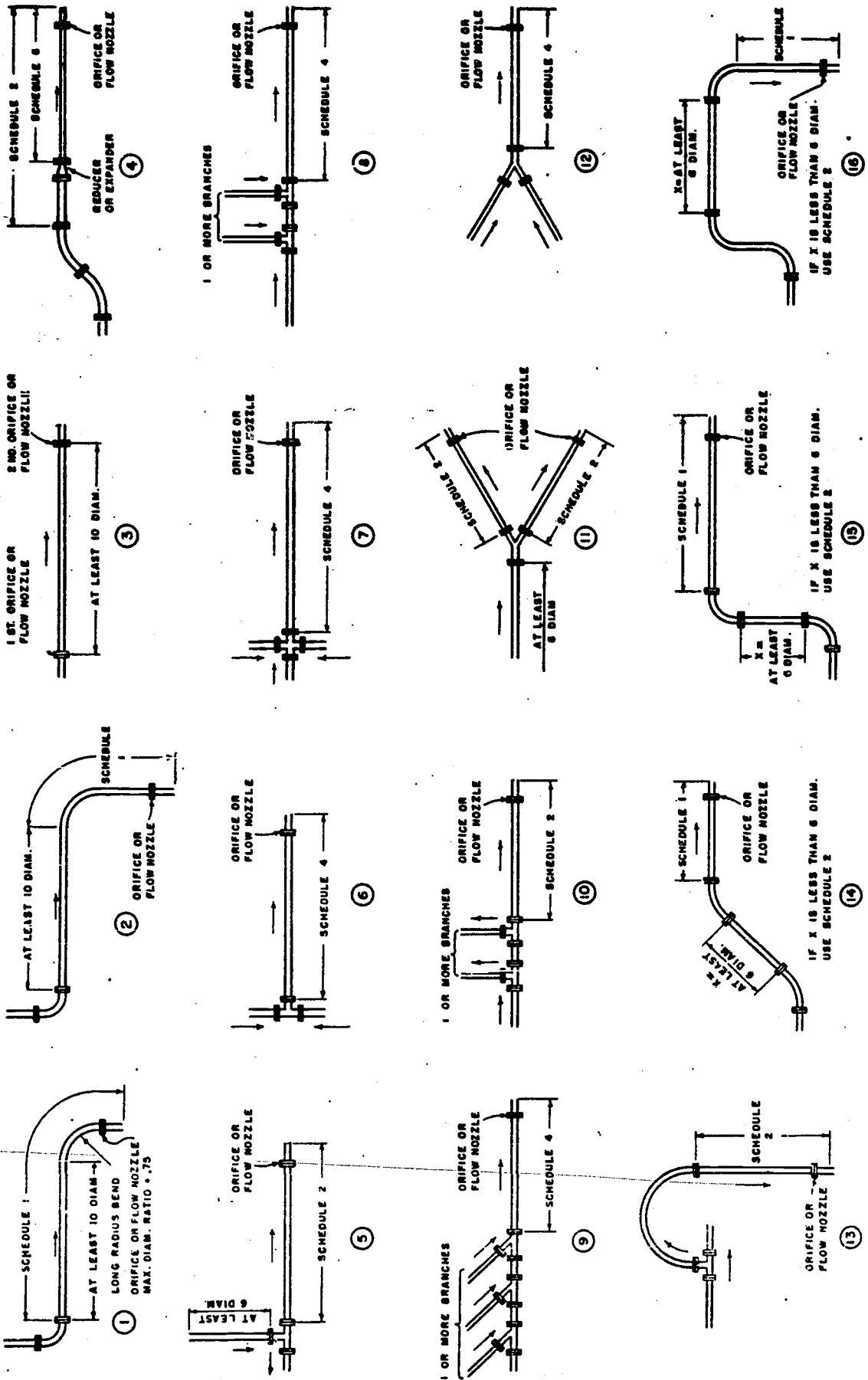


FIGURE 3 — Typical Piping Arrangements with Fittings or Bends in Same Plane. Refer to Figure 2 for Schedule Specifications.

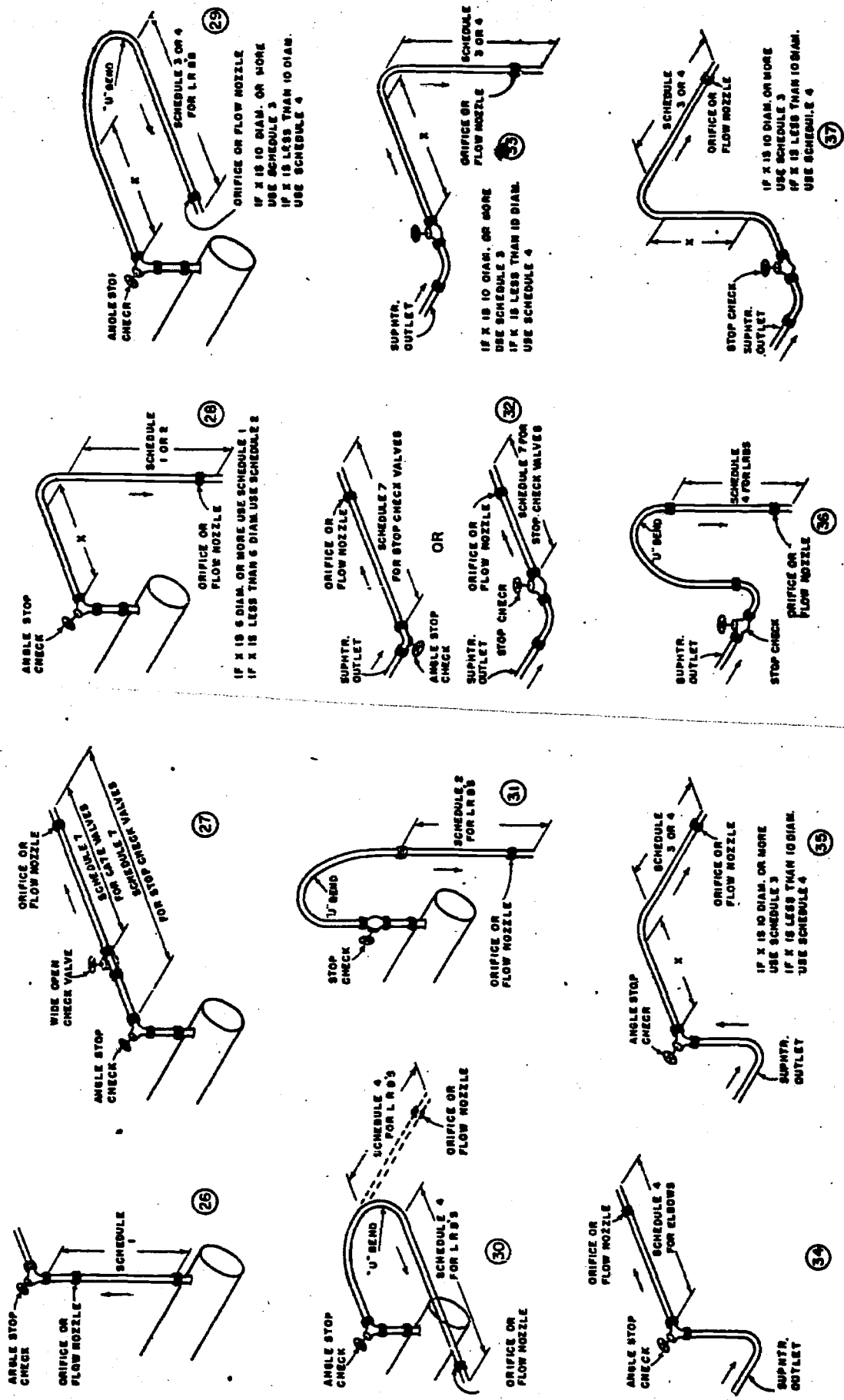


FIGURE 5 — Typical Boiler Outlet Arrangements. Refer to Figure 2 for Schedule Specifications.

DRY SATURATED STEAM: PRESSURE TABLE

Abs Press., Lb Sq In. <i>p</i>	Temp. F <i>t</i>	— Specific Volume —		— Enthalpy —			— Entropy —			— Internal Energy —		Abs Press., Lb Sq In. <i>p</i>
		Sat. Liquid <i>rf</i>	Sat. Vapor <i>rg</i>	Sat. Liquid <i>hf</i>	Evap. <i>hfg</i>	Sat. Vapor <i>hg</i>	Sat. Liquid <i>sf</i>	Evap. <i>sfg</i>	Sat. Vapor <i>sg</i>	Sat. Liquid <i>uf</i>	Sat. Vapor <i>ug</i>	
1 0	101.74	0.01614	333.6	69.70	1036.3	1106.0	0.1326	1.8456	1.9782	69.70	1044.3	1 0
2 0	126.08	0.01623	173.73	93.99	1022.2	1116.2	0.1749	1.7451	1.9200	93.98	1051.9	2 0
3 0	141.48	0.01630	118.71	109.37	1013.2	1122.6	0.2008	1.6855	1.8863	109.36	1056.7	3 0
4 0	152.97	0.01636	90.63	120.86	1006.4	1127.3	0.2198	1.6427	1.8625	120.85	1060.2	4 0
5 0	162.24	0.01640	73.52	130.13	1001.0	1131.1	0.2347	1.6094	1.8441	130.12	1063.1	5 0
6 0	170.06	0.01645	61.98	137.96	996.2	1134.2	0.2472	1.5820	1.8292	137.94	1065.4	6 0
7 0	176.85	0.01649	53.64	144.76	992.1	1136.9	0.2581	1.5586	1.8167	144.74	1067.4	7 0
8 0	182.86	0.01653	47.34	150.79	988.5	1139.3	0.2674	1.5383	1.8057	150.77	1069.2	8 0
9 0	188.28	0.01656	42.40	156.22	985.2	1141.4	0.2759	1.5203	1.7962	156.19	1070.8	9 0
10	193.21	0.01659	38.42	161.17	982.1	1143.3	0.2835	1.5041	1.7876	161.14	1072.2	10
14.696	212.00	0.01672	26.80	180.07	970.3	1150.4	0.3120	1.4446	1.7566	810.02	1077.5	14.696
15	213.03	0.01672	26.29	181.11	969.7	1150.8	0.3135	1.4415	1.7549	181.06	1077.8	15
20	227.96	0.01683	20.089	196.16	960.1	1156.3	0.3356	1.3962	1.7319	196.10	1081.9	20
25	240.07	0.01692	16.303	208.42	952.1	1160.6	0.3533	1.3606	1.7139	208.34	1085.1	25
30	250.33	0.01701	13.746	218.82	945.3	1164.1	0.3680	1.3313	1.6993	218.73	1087.8	30
35	259.28	0.01708	11.898	227.91	939.2	1167.1	0.3807	1.3063	1.6870	227.80	1090.1	35
40	267.25	0.01715	10.498	236.03	933.7	1169.7	0.3919	1.2844	1.6763	235.90	1092.0	40
45	274.44	0.01721	9.401	243.36	928.6	1172.0	0.4019	1.2650	1.6669	243.22	1093.7	45
50	281.01	0.01727	8.515	250.09	924.0	1174.1	0.4110	1.2474	1.6585	249.93	1095.3	50
55	287.07	0.01732	7.787	256.30	919.6	1175.9	0.4193	1.2316	1.6509	256.12	1096.7	55
60	292.71	0.01738	7.175	262.09	915.5	1177.6	0.4270	1.2168	1.6438	261.90	1097.9	60
65	297.97	0.01743	6.655	267.50	911.6	1179.1	0.4342	1.2032	1.6374	267.29	1099.1	65
70	302.92	0.01748	6.206	272.61	907.9	1180.6	0.4409	1.1906	1.6315	272.38	1100.2	70
75	307.60	0.01753	5.816	277.43	904.5	1181.9	0.4472	1.1787	1.6259	277.19	1101.2	75
80	312.03	0.01757	5.472	282.02	901.1	1183.1	0.4531	1.1676	1.6207	281.76	1102.1	80
85	316.25	0.01761	5.168	286.39	897.8	1184.2	0.4587	1.1571	1.6158	286.11	1102.9	85
90	320.27	0.01766	4.896	290.56	894.7	1185.3	0.4641	1.1471	1.6112	290.27	1103.7	90
95	324.12	0.01770	4.652	294.56	891.7	1186.2	0.4692	1.1376	1.6068	294.25	1104.5	95
100	327.81	0.01774	4.432	298.40	888.8	1187.2	0.4740	1.1286	1.6026	298.08	1105.2	100
110	334.77	0.01782	4.049	305.66	883.2	1188.9	0.4832	1.1117	1.5948	305.30	1106.5	110
120	341.25	0.01789	3.728	312.44	877.9	1190.4	0.4916	1.0962	1.5878	312.05	1107.6	120
130	347.32	0.01796	3.455	318.81	872.9	1191.7	0.4995	1.0817	1.5812	318.38	1108.6	130
140	353.02	0.01802	3.220	324.82	868.2	1193.0	0.5069	1.0682	1.5751	324.35	1109.6	140
150	358.42	0.01809	3.015	330.51	863.6	1194.1	0.5138	1.0556	1.5694	330.01	1110.5	150
160	363.53	0.01815	2.834	335.93	859.2	1195.1	0.5204	1.0436	1.5640	335.39	1111.2	160
170	368.41	0.01822	2.675	341.09	854.9	1196.0	0.5266	1.0324	1.5590	340.52	1111.9	170
180	373.06	0.01827	2.532	346.03	850.8	1196.9	0.5325	1.0217	1.5542	345.42	1112.5	180
190	377.51	0.01833	2.404	350.79	846.8	1197.6	0.5381	1.0116	1.5497	350.15	1113.1	190
200	381.79	0.01839	2.288	355.39	843.0	1198.4	0.5435	1.0018	1.5453	354.68	1113.7	200
250	400.95	0.01865	1.8438	376.00	825.1	1201.1	0.5675	0.9588	1.5263	375.14	1115.8	250
300	417.33	0.01890	1.5433	393.84	809.0	1202.8	0.5879	0.9225	1.5104	392.79	1117.1	300
350	431.72	0.01913	1.3290	409.69	794.2	1203.9	0.6056	0.8910	1.4966	408.45	1118.0	350
400	444.59	0.0193	1.1613	424.0	780.5	1204.5	0.6214	0.8630	1.4844	422.6	1119.5	400
450	456.28	0.0195	1.0320	437.2	767.4	1204.6	0.6356	0.8378	1.4734	435.5	1118.7	450
500	467.01	0.0197	0.9278	449.4	755.0	1204.4	0.6487	0.8147	1.4634	447.6	1118.6	500
550	476.94	0.0199	0.8424	460.8	743.1	1203.9	0.6608	0.7934	1.4542	458.8	1118.2	550
600	486.21	0.0201	0.7698	471.6	731.6	1203.2	0.6720	0.7734	1.4454	469.4	1117.7	600
650	494.90	0.0203	0.7083	481.8	720.5	1202.3	0.6826	0.7548	1.4374	479.4	1117.1	650
700	502.10	0.0205	0.6554	491.5	709.7	1201.2	0.6925	0.7371	1.4296	488.8	1116.3	700
750	510.86	0.0207	0.6092	500.8	699.2	1200.0	0.7019	0.7204	1.4223	498.0	1115.4	750
800	518.23	0.0209	0.5687	509.7	689.0	1198.6	0.7108	0.7045	1.4153	506.6	1114.4	800
850	525.26	0.0210	0.5327	518.3	678.8	1197.1	0.7194	0.6891	1.4085	515.0	1113.3	850
900	531.98	0.0212	0.5006	526.6	668.8	1195.4	0.7275	0.6744	1.4020	523.1	1112.1	900
950	538.43	0.0214	0.4717	534.6	659.1	1193.7	0.7355	0.6602	1.3957	530.9	1110.8	950
1000	544.61	0.0216	0.4456	542.4	649.4	1191.8	0.7430	0.6467	1.3897	538.4	1109.4	1000
1100	556.31	0.0220	0.4001	557.4	630.4	1187.8	0.7575	0.6295	1.3780	552.9	1106.4	1100
1200	567.22	0.0223	0.3619	571.7	611.7	1183.4	0.7711	0.6096	1.3667	566.7	1103.0	1200
1300	577.46	0.0227	0.3293	585.4	593.2	1178.6	0.7840	0.5919	1.3559	580.0	1099.4	1300
1400	587.10	0.0231	0.3012	598.7	574.7	1173.4	0.7963	0.5761	1.3454	592.7	1095.4	1400
1500	596.23	0.0235	0.2765	611.6	556.3	1167.9	0.8082	0.5609	1.3351	605.1	1091.2	1500
2000	635.82	0.0257	0.1878	671.7	463.4	1135.1	0.8619	0.4230	1.2849	662.2	1065.6	2000
2500	668.13	0.0287	0.1307	730.6	360.5	1094.1	0.9126	0.3197	1.2322	717.3	1030.6	2500
3000	695.36	0.0346	0.0855	802.5	217.8	1020.3	0.9731	0.1885	1.1615	783.4	972.7	3000
3206.2	705.40	0.0503	0.0503	902.7	0	902.7	1.0380	0	1.0380	872.9	872.9	3206.2

From STEAM TABLES by Keenan,
Keyes, Hill and Moore, published
1969 by John Wiley and Sons, Inc.

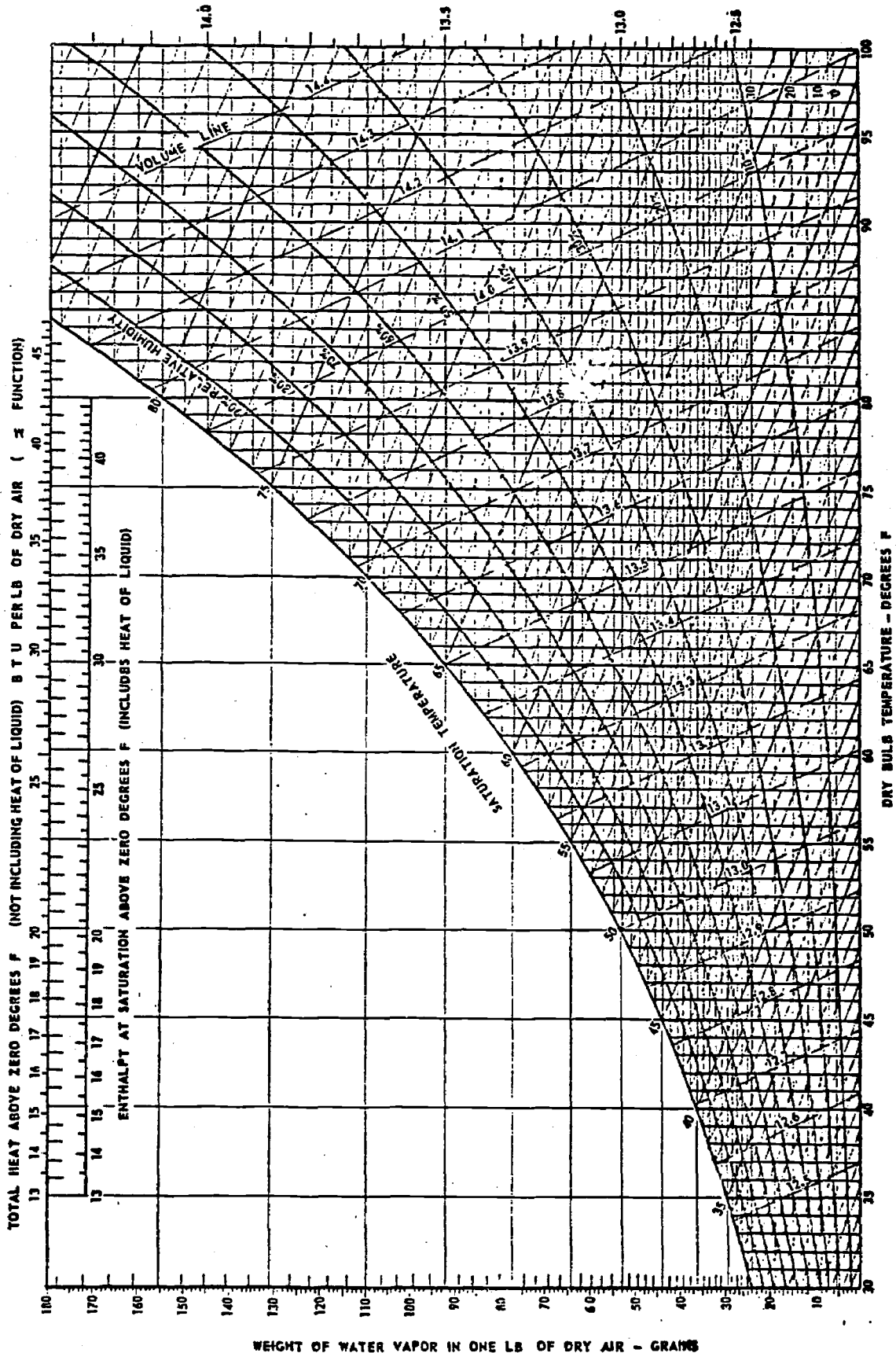
TEMPERATURE CONVERSIONS

Albert Sauveur type of table. Look up reading in middle column; if in degrees Centigrade, read Fahrenheit equivalent in right hand column; if in degrees Fahrenheit, read Centigrade equivalent in left hand column.

-459.4 to 25		26 to 99		100 to 820		820 to 1540		1550 to 2260		2270 to 3000						
C	F	C	F	C	F	C	F	C	F	C	F					
-273	-459.4	-3.3	26	78.8	38	100	212	443	830	1526	843	1550	2822	1243	2270	4111
-268	-450	-2.8	27	80.6	43	110	230	449	840	1544	849	1560	2840	1249	2280	4130
-262	-440	-2.2	28	82.4	49	120	248	454	850	1562	851	1570	2858	1254	2290	4150
-257	-430	-1.7	29	84.2	54	130	266	460	860	1580	860	1580	2876	1260	2300	4170
-251	-420	-1.1	30	86.0	60	140	284	466	870	1598	866	1590	2894	1266	2310	4190
-246	-410	-0.6	31	87.8	66	150	302	471	880	1616	871	1600	2912	1271	2320	4210
-240	-400	0.0	32	89.6	71	160	320	477	890	1634	877	1610	2930	1277	2330	4230
-234	-390	0.6	33	91.4	77	170	338	482	900	1652	882	1620	2948	1282	2340	4250
-229	-380	1.1	34	93.2	82	180	356	488	910	1670	888	1630	2966	1288	2350	4270
-223	-370	1.7	35	95.0	88	190	374	493	920	1688	893	1640	2984	1293	2360	4290
-218	-360	2.2	36	96.8	93	200	392	499	930	1706	899	1650	3002	1299	2370	4310
-212	-350	2.8	37	98.6	99	210	410	504	940	1724	904	1660	3020	1304	2380	4330
-207	-340	3.3	38	100.4	104	220	428	510	950	1742	910	1670	3038	1310	2390	4350
-201	-330	3.9	39	102.2	109	230	446	516	960	1760	916	1680	3056	1316	2400	4370
-196	-320	4.4	40	104.0	114	240	464	521	970	1778	921	1690	3074	1321	2410	4390
-190	-310	5.0	41	105.8	116	240	464	527	980	1796	927	1700	3092	1327	2420	4410
-184	-300	5.6	42	107.6	121	250	482	532	990	1814	932	1710	3110	1333	2430	4430
-179	-290	6.1	43	109.4	127	260	500	538	1000	1832	938	1720	3128	1338	2440	4450
-173	-280	6.7	44	111.2	132	270	518	543	1010	1850	943	1730	3146	1344	2450	4470
-168	-273	-459.4	7.2	45	113.0	138	260	549	1020	1868	949	1740	3164	1349	2460	4490
-162	-270	-454	7.8	46	114.8	143	290	554	1030	1886	954	1750	3182	1354	2470	4510
-162	-260	-436	8.3	47	116.6	149	300	560	1040	1904	960	1760	3200	1360	2480	4530
-157	-250	-418	8.9	48	118.4	154	310	566	1050	1922	966	1770	3218	1366	2490	4550
-151	-240	-400	9.4	49	120.2	160	320	571	1060	1940	971	1780	3236	1372	2500	4570
-146	-230	-382	10.0	50	122.0	166	330	577	1070	1958	977	1790	3254	1377	2510	4590
-140	-220	-364	10.6	51	123.8	171	340	582	1080	1976	982	1800	3272	1382	2520	4610
-134	-210	-346	11.1	52	125.6	177	350	588	1090	1994	988	1810	3290	1388	2530	4630
-129	-200	-328	11.7	53	127.4	182	360	593	1100	2012	993	1820	3308	1393	2540	4650
-123	-190	-310	12.2	54	129.2	188	370	599	1110	2030	999	1830	3326	1399	2550	4670
-118	-180	-292	12.8	55	131.0	193	380	604	1120	2048	1004	1840	3344	1404	2560	4690
-112	-170	-274	13.3	56	132.8	199	390	610	1130	2066	1010	1850	3362	1410	2570	4710
-107	-160	-256	13.9	57	134.6	204	400	616	1140	2084	1016	1860	3380	1416	2580	4730
-101	-150	-238	14.4	58	136.4	210	410	621	1150	2102	1021	1870	3398	1422	2590	4750
-96	-140	-220	15.0	59	138.2	216	420	627	1160	2120	1027	1880	3416	1427	2600	4770
-90	-130	-202	15.6	60	140.0	221	430	632	1170	2138	1032	1890	3434	1432	2610	4790
-84	-120	-184	16.1	61	141.8	227	440	638	1180	2156	1038	1900	3452	1438	2620	4810
-79	-110	-166	16.7	62	143.6	232	450	643	1190	2174	1043	1910	3470	1443	2630	4830
-73	-100	-148	17.2	63	145.4	238	460	649	1200	2192	1049	1920	3488	1449	2640	4850
-68	-90	-130	17.8	64	147.2	243	470	654	1210	2210	1054	1930	3506	1454	2650	4870
-62	-80	-112	18.3	65	149.0	249	480	660	1220	2228	1060	1940	3524	1460	2660	4890
-57	-70	-94	18.9	66	150.8	254	490	666	1230	2246	1066	1950	3542	1466	2670	4910
-51	-60	-76	19.4	67	152.6	260	500	671	1240	2264	1071	1960	3560	1472	2680	4930
-46	-50	-58	20.0	68	154.4	266	510	677	1250	2282	1077	1970	3578	1477	2690	4950
-40	-40	-40	20.6	69	156.2	266	510	682	1260	2300	1082	1980	3596	1482	2700	4970
-4	-30	-22	21.1	70	158.0	271	520	688	1270	2318	1088	1990	3614	1488	2710	4990
-29	-20	-4	21.7	71	159.8	277	530	693	1280	2336	1093	2000	3632	1493	2720	5010
-23	-10	14	22.2	72	161.6	282	540	699	1290	2354	1099	2010	3650	1499	2730	5030
-17.8	0	32	22.8	73	163.4	288	550	704	1300	2372	1104	2020	3668	1504	2740	5050
-17.2	1	33.8	23.3	74	165.2	293	560	710	1310	2390	1110	2030	3686	1510	2750	5070
-16.7	2	35.6	23.9	75	167.0	299	570	716	1320	2408	1116	2040	3704	1516	2760	5090
-16.1	3	37.4	24.4	76	168.8	304	580	721	1330	2426	1121	2050	3722	1521	2770	5110
-15.6	4	39.2	25.0	77	170.6	310	600	727	1340	2444	1127	2060	3740	1527	2780	5130
-15.0	5	41.0	25.6	78	172.4	316	610	732	1350	2462	1132	2070	3758	1532	2790	5150
-14.4	6	42.8	26.1	79	174.2	321	620	738	1360	2480	1138	2080	3776	1538	2800	5170
-13.9	7	44.6	26.7	80	176.0	327	630	743	1370	2498	1143	2090	3794	1543	2810	5190
-13.3	8	46.4	27.2	81	177.8	332	640	749	1380	2516	1149	2100	3812	1549	2820	5210
-12.8	9	48.2	27.8	82	179.6	338	650	754	1390	2534	1154	2110	3830	1554	2830	5230
-12.2	10	50.0	28.3	83	181.4	343	660	760	1400	2552	1160	2120	3848	1560	2840	5250
-11.7	11	51.8	28.9	84	183.2	349	670	766	1410	2570	1166	2130	3866	1566	2850	5270
-11.1	12	53.6	29.4	85	185.0	356	680	771	1420	2588	1171	2140	3884	1571	2860	5290
-10.6	13	55.4	30.0	86	186.8	360	690	777	1430	2606	1177	2150	3902	1577	2870	5310
-10.0	14	57.2	30.6	87	188.6	371	700	782	1440	2624	1182	2160	3920	1582	2880	5330
-9.4	15	59.0	31.1	88	190.4	377	710	788	1450	2642	1188	2170	3938	1588	2890	5350
-8.9	16	60.8	31.7	89	192.2	382	720	793	1460	2660	1193	2180	3956	1593	2900	5370
-8.3	17	62.6	32.2	90	194.0	388	730	799	1470	2678	1199	2190	3974	1599	2910	5390
-7.8	18	64.4	32.8	91	195.8	393	740	804	1480	2696	1204	2200	3992	1604	2920	5410
-7.2	19	66.2	33.3	92	197.6	399	750	810	1490	2714	1210	2210	4010	1610	2930	5430
-6.7	20	68.0	33.9	93	199.4	404	760	816	1500	2732	1216	2220	4028	1616	2940	5450
-6.1	21	69.8	34.4	94	201.2	410	770	821	1510	2750	1221	2230	4046	1621	2950	5470
-5.6	22	71.6	35.0	95	203.0	416	780	827	1520	2768	1227	2240	4064	1627	2960	5490
-5.0	23	73.4	35.6	96	204.8	422	790	832	1530	2786	1232	2250	4082	1632	2970	5510
-4.4	24	75.2	36.1	97	206.6	427	800	838	1540	2804	1238	2260	4100	1638	2980	5530
-3.9	25	77.0	36.7	98	208.4	432	810	843	1550	2822	1243	2270	4118	1643	2990	5550
			37.2	99	210.2	438	820	849	1560	2840	1249	2280	4136	1649	3000	5570

STANDARD PSYCHROMETRIC CHART

CU FT OF MIXTURE IN ONE LB OF DRY AIR



Standard Psychrometric Chart - 29.92 In. Barometer

TABLES AND RULES

METRIC AND ENGLISH MEASURES (continued)

MEASURES OF SURFACE

1	square meter =	10.764	square feet
.0929	square meter =	1	square foot
1	square centimeter	... =	.155	square inch
6.452	square centimeters	.. =	1	square inch
1	square millimeter	... =	.00155	square inch
645.2	square millimeters	... =	1	square inch

MEASURES OF CAPACITY

1	liter = 1 cubic decimeter =	$\left\{ \begin{array}{l} 61.023 \text{ cubic inches} \\ .0353 \text{ cubic foot} \\ .2202 \text{ gallon (Imperial)} \\ 2.202 \text{ pounds of water at } \\ 62 \text{ degrees Fahr.} \end{array} \right.$
28.317	liters =	$\left\{ \begin{array}{l} 1 \text{ cubic foot (6.25} \\ \text{Imperial gallons)} \end{array} \right.$
4.543	liters =	1 gallon (Imperial)
3.785	liters =	1 gallon (American)

MEASURES OF WEIGHT

	Metric		English
28.35	grams =	1 ounce avoirdupois
1	kilogram =	2.2046 pounds
.4536	kilogram =	1 pound
1	metric ton	} =	$\left\{ \begin{array}{l} .9842 \text{ ton of 2240 pounds, or} \\ 19.68 \text{ cwt, or} \\ 2204.6 \text{ lb} \end{array} \right.$
1000	kilograms		
1016	kilograms	} =	1 ton of 2240 pounds
1.016	metric tons		

MISCELLANEOUS

	Metric		English
1	gram per square millimeter =	1.422 Pounds per square inch
1	kilogram per square millimeter	... =	1422.32 Pounds per square inch
1	kilogram per square centimeter	... =	14.233 Pounds per square inch
1.0335	kilogram per square centimeter	} =	14.7 Pounds per square inch
	1 atmosphere		
0.070308	kilogram per square centimeter	... =	1 Pound per square inch

MEASURES OF PRESSURE AND WEIGHT

1 lb. per square inch =	$\left\{ \begin{array}{l} 144 \text{ lb per square foot} \\ 2.0355 \text{ inches of mercury} \\ \text{at 32 degrees Fahr.} \\ 2.0416 \text{ inches of mercury} \\ \text{at 62 degrees Fahr.} \\ 2.309 \text{ ft of water at 62} \\ \text{degrees Fahr.} \\ 27.71 \text{ inches of water at} \\ \text{62 degrees Fahr.} \end{array} \right.$
1 Atmosphere (14.7 lbs per sq in) =	$\left\{ \begin{array}{l} 2116.3 \text{ lb per square foot} \\ 33.947 \text{ ft of water at 62} \\ \text{degrees Fahr.} \\ 30 \text{ inches of mercury} \\ \text{at 62 degrees Fahr.} \\ 29.929 \text{ inches of mercury} \\ \text{at 32 degrees Fahr.} \\ 760 \text{ millimeters of mercury} \\ \text{at 32 degrees Fahr.} \end{array} \right.$
1 Foot of Water at 62 degrees Fahr. =	$\left\{ \begin{array}{l} .433 \text{ lb per square inch} \\ 62.355 \text{ lb per square foot} \end{array} \right.$
1 Inch of Mercury at 62 degrees Fahr. =	$\left\{ \begin{array}{l} .491 \text{ lb or 7.86 oz per sq in.} \\ 1.132 \text{ ft of water at 62} \\ \text{degrees Fahr.} \\ 13.58 \text{ inches of water at} \\ \text{62 degrees Fahr.} \end{array} \right.$

TEMPERATURE

The following equation will be found convenient for transforming temperature from one system to another:

Let F = degrees Fahrenheit; C = degrees Centigrade; R = degrees Reamur.

$$\frac{F-32}{180} = \frac{C}{100} = \frac{R}{80}$$

GENERAL DATA

1 Calorie =	3.968	Btu
1 Btu =	0.252	Calorie
1 lb per sq in. ² =	703.08	kilograms per m ²
1 Kilogram per m ² =	.00142	lb per sq in.
1 Calorie per m ² =	.3687	Btu per sq ft
1 Btu per sq ft =	2.712	calories per m ²
1 Calorie per m ² per degree difference Cent.	} =	.2048	Btu per sq ft per degree difference Fahr.
1 Btu per sq ft per degree difference Fahr.			
1 Btu per lb =	.556	Calorie per kilog.
1 Calorie per kilog. =	1.8	Btu per lb
Water expands in bulk from 40 degrees to 212 degrees =		One twenty-third
A cubic inch of water evaporated under ordinary atmospheric pressure is converted into 1 cubic foot of steam (approximately)			

WEIGHT OF ONE CUBIC FOOT OF PURE WATER

At 32 deg. Fahr. (freezing point)	62.418 lb
At 39.1 deg. Fahr. (maximum density)	62.425 lb
At 62 deg. Fahr. (std. temperature)	62.355 lb
At 212 deg. Fahr. (boiling point under 1 atmosphere)	59.75 lb

CIRCUMFERENCES AND AREAS OF CIRCLES

Dia	Circum.	Area	Dia	Circum.	Area	Dia	Circum.	Area	Dia	Circum.	Area	Dia	Circum.	Area
1/8	.09818	.00077	9	28.274	63.617	19	59.690	283.53	29	91.106	660.52	39	122.522	1194.6
1/16	.19635	.00307	1 1/8	28.667	65.397	1 1/8	60.083	287.27	1 1/8	91.499	666.23	1 1/8	122.915	1202.3
1/32	.39270	.01227	1 1/4	29.060	67.201	1 1/4	60.476	291.04	1 1/4	91.892	671.96	1 1/4	123.308	1210.0
1/64	.58905	.02761	1 1/2	29.452	69.029	1 1/2	60.868	294.83	1 1/2	92.284	677.71	1 1/2	123.700	1217.7
1/128	.78540	.04909	1 3/4	29.845	70.882	1 3/4	61.261	298.65	1 3/4	92.677	683.49	1 3/4	124.093	1225.4
1/256	.98175	.07670	2	30.238	72.760	2	61.654	302.49	2	93.070	689.30	2	124.486	1233.2
1/512	1.1781	.11045	2 1/8	30.631	74.662	2 1/8	62.046	306.35	2 1/8	93.462	695.13	2 1/8	124.878	1241.0
1/1024	1.3744	.15033	2 1/4	31.023	76.589	2 1/4	62.439	310.24	2 1/4	93.855	700.98	2 1/4	125.271	1248.8
1/2048	1.5708	.19635	2 3/8	31.416	78.540	2 3/8	62.832	314.16	2 3/8	94.248	706.86	2 3/8	125.664	1256.6
1/4096	1.7671	.24850	2 1/2	31.809	80.516	2 1/2	63.225	318.10	2 1/2	94.640	712.76	2 1/2	126.056	1264.5
1/8192	1.9635	.30680	2 5/8	32.201	82.516	2 5/8	63.617	322.06	2 5/8	95.033	718.69	2 5/8	126.449	1272.4
1/16384	2.1598	.37122	3	32.594	84.541	3	64.010	326.05	3	95.426	724.64	3	126.842	1280.3
1/32768	2.3562	.44179	3 1/8	32.987	86.590	3 1/8	64.403	330.06	3 1/8	95.819	730.62	3 1/8	127.235	1288.2
1/65536	2.5525	.51849	3 1/4	33.379	88.664	3 1/4	64.795	334.10	3 1/4	96.211	736.62	3 1/4	127.627	1296.2
1/131072	2.7489	.60132	3 3/8	33.772	90.763	3 3/8	65.188	338.16	3 3/8	96.604	742.64	3 3/8	128.020	1304.2
1/262144	2.9452	.69029	3 1/2	34.165	92.886	3 1/2	65.581	342.25	3 1/2	96.997	748.69	3 1/2	128.413	1312.2
1/524288	3.1416	.7854	3 5/8	34.558	95.033	3 5/8	65.973	346.36	3 5/8	97.389	754.77	3 5/8	128.805	1320.3
1/1048576	3.3383	.8940	4	34.950	97.205	4	66.366	350.50	4	97.782	760.87	4	129.198	1328.3
1/2097152	3.5347	1.0272	4 1/8	35.343	99.402	4 1/8	66.759	354.66	4 1/8	98.175	766.99	4 1/8	129.591	1336.4
1/4194304	3.7310	1.1849	4 1/4	35.736	101.62	4 1/4	67.152	358.84	4 1/4	98.567	773.14	4 1/4	129.983	1344.5
1/8388608	3.9274	1.3671	4 3/8	36.128	103.87	4 3/8	67.544	363.05	4 3/8	98.960	779.31	4 3/8	130.376	1352.7
1/16777216	4.1237	1.5749	4 1/2	36.521	106.14	4 1/2	67.937	367.28	4 1/2	99.353	785.51	4 1/2	130.769	1360.8
1/33554432	4.3200	1.8093	4 5/8	36.914	108.43	4 5/8	68.330	371.54	4 5/8	99.746	791.73	4 5/8	131.161	1369.0
1/67108864	4.5163	2.0739	5	37.306	110.75	5	68.722	375.83	5	100.138	797.98	5	131.554	1377.2
1/134217728	4.7126	2.3698	5 1/8	37.699	113.10	5 1/8	69.115	380.13	5 1/8	100.531	804.25	5 1/8	131.947	1385.4
1/268435456	4.9089	2.6982	5 1/4	38.092	115.47	5 1/4	69.508	384.46	5 1/4	100.924	810.54	5 1/4	132.340	1393.7
1/536870912	5.1051	3.0600	5 3/8	38.485	117.86	5 3/8	69.900	388.82	5 3/8	101.316	816.86	5 3/8	132.732	1402.0
1/1073741824	5.3014	3.4563	5 1/2	38.877	120.28	5 1/2	70.293	393.20	5 1/2	101.709	823.21	5 1/2	133.125	1410.3
1/2147483648	5.4977	3.8882	5 5/8	39.270	122.72	5 5/8	70.686	397.61	5 5/8	102.102	829.58	5 5/8	133.518	1418.6
1/4294967296	5.6940	4.3557	6	39.663	125.19	6	71.079	402.04	6	102.494	835.97	6	133.910	1427.0
1/8589934592	5.8903	4.8590	6 1/8	40.055	127.68	6 1/8	71.471	406.49	6 1/8	102.887	842.39	6 1/8	134.303	1435.4
1/17179869184	6.0866	5.3977	6 1/4	40.448	130.19	6 1/4	71.864	410.97	6 1/4	103.280	848.83	6 1/4	134.696	1443.8
1/34359738368	6.2829	5.9724	6 3/8	40.841	132.73	6 3/8	72.257	415.48	6 3/8	103.673	855.30	6 3/8	135.088	1452.2
1/68719476736	6.4792	6.5841	6 1/2	41.233	135.30	6 1/2	72.649	420.00	6 1/2	104.065	861.79	6 1/2	135.481	1460.7
1/137438953472	6.6755	7.2328	6 5/8	41.626	137.89	6 5/8	73.042	424.56	6 5/8	104.458	868.33	6 5/8	135.874	1469.1
1/274877906944	6.8718	7.9185	7	42.019	140.50	7	73.435	429.13	7	104.851	874.85	7	136.267	1477.6
1/549755813888	7.0681	8.6412	7 1/8	42.412	143.14	7 1/8	73.827	433.74	7 1/8	105.243	881.41	7 1/8	136.659	1486.2
1/1099511627776	7.2644	9.4019	7 1/4	42.804	145.80	7 1/4	74.220	438.36	7 1/4	105.636	888.00	7 1/4	137.052	1494.7
1/2199023255552	7.4607	10.1996	7 3/8	43.197	148.49	7 3/8	74.613	443.01	7 3/8	106.029	894.62	7 3/8	137.445	1503.3
1/4398046511104	7.6570	11.0343	7 1/2	43.590	151.20	7 1/2	75.006	447.69	7 1/2	106.421	901.26	7 1/2	137.837	1511.9
1/8796093022208	7.8533	11.9070	7 5/8	43.982	153.94	7 5/8	75.398	452.39	7 5/8	106.814	907.92	7 5/8	138.230	1520.5
1/17592186044416	8.0496	12.8187	8	44.375	156.70	8	75.791	457.11	8	107.207	914.61	8	138.623	1529.2
1/35184372088832	8.2459	13.7694	8 1/8	44.768	159.48	8 1/8	76.184	461.86	8 1/8	107.600	921.32	8 1/8	139.015	1537.9
1/70368744177664	8.4422	14.7591	8 1/4	45.160	162.30	8 1/4	76.576	466.64	8 1/4	107.992	928.06	8 1/4	139.408	1546.6
1/140737488355328	8.6385	15.7878	8 3/8	45.553	165.13	8 3/8	76.969	471.44	8 3/8	108.385	934.82	8 3/8	139.801	1555.3
1/281474976710656	8.8348	16.8555	8 1/2	45.946	167.99	8 1/2	77.362	476.26	8 1/2	108.778	941.61	8 1/2	140.194	1564.0
1/562949953421312	9.0311	17.9632	8 5/8	46.338	170.87	8 5/8	77.754	481.11	8 5/8	109.170	948.42	8 5/8	140.586	1572.8
1/1125899806842624	9.2274	19.1109	8 3/4	46.731	173.78	8 3/4	78.147	485.98	8 3/4	109.563	955.25	8 3/4	140.979	1581.6
1/2251799613685248	9.4237	20.2986	9	47.124	176.71	9	78.540	490.87	9	109.956	962.11	9	141.372	1590.4
1/4503599227370496	9.6200	21.5263	9 1/8	47.517	179.67	9 1/8	78.933	495.79	9 1/8	110.348	969.00	9 1/8	141.764	1599.3
1/9007198454740992	9.8163	22.7940	9 1/4	47.909	182.65	9 1/4	79.325	500.74	9 1/4	110.741	975.91	9 1/4	142.157	1608.2
1/18014396909481984	10.0126	24.1017	9 3/8	48.302	185.66	9 3/8	79.718	505.71	9 3/8	111.134	982.84	9 3/8	142.550	1617.0
1/36028793818963968	10.2089	25.4494	9 1/2	48.695	188.69	9 1/2	80.111	510.71	9 1/2	111.527	989.80	9 1/2	142.942	1626.0
1/72057587637927936	10.4052	26.8371	9 5/8	49.087	191.75	9 5/8	80.503	515.72	9 5/8	111.919	996.78	9 5/8	143.335	1634.9
1/144115175275855872	10.6015	28.2648	9 3/4	49.480	194.83	9 3/4	80.896	520.77	9 3/4	112.312	1003.8	9 3/4	143.728	1643.9
1/288230350551711744	10.7978	29.7325	10	49.873	197.93	10	81.289	525.84	10	112.705	1010.8	10	144.121	1652.9
1/576460701103423488	10.9941	31.2402	10 1/8	50.265	201.06	10 1/8	81.681	530.93	10 1/8	113.097	1017.9	10 1/8	144.513	1661.9
1/115292140220684696	11.1904	32.7879	10 1/4	50.658	204.22	10 1/4	82.074	536.05	10 1/4	113.490	1025.0	10 1/4	144.906	1670.9
1/230584280441369392	11.3867	34.3756	10 3/8	51.051	207.39	10 3/8	82.467	541.19	10 3/8	113.883	1032.1	10 3/8	145.299	1680.0
1/461168560882738784	11.5830	35.9933	10 1/2	51.444	210.60	10 1/2	82.860	546.35	10 1/2	114.275	1039.2	10 1/2	145.691	1689.1
1/922337121765477568	11.7793	37.6410	10 5/8	51.836	213.82	10 5/8	83.252	551.55	10 5/8	114.668	1046.3	10 5/8	146.084	1698.2
1/1844674243330955136	11.9756	39.3187	10 3/4	52.229	217.08	10 3/4	83.645	556.76	10 3/4	115.061	1053.5	10 3/4	146.477	1707.4
1/3689348486661910272	12.1719	41.0264	11	52.622	220.35	11	84.038	562.00	11	115.454	1060.7	11	146.869	1716.5
1/7378696973323820544	12.3682	42.7641	11 1/8	53.014	223.65	11 1/8	84.430	567.27	11 1/8	115.846	1068.0	11 1/8	147.262	1725.7
1/14757393946647641088	12.5645	44.5318	11 1/4	53.407	226.98	11 1/4	84.823	572.56	11 1/4	116.239	1075.2	11 1/4	147.655	1734.9
1/29514787893295282176	12.7608	46.3395	11 3/8	53.800	230.33	11 3/8	85.216	577.87	11 3/8	116.632	1082.5	11 3/8	148.048	1744.2
1/59029575786590564352	12.9571	48.1772	11 1/2	54.192	233.71	11 1/2	85.608	583.21	11 1/2	117.024	1089.8	11 1/2	148.440	1753.5
1/11805915157318112704	13.1534	50.0449	11 5/8	54.585	237.10	11 5/8	86.001	588.57	11 5/8	117.417	1097.1	11 5/8	148.833	1762.7
1/23611830314636225408	13.3497	51.9426	11 3/4	54.978	240.53	11 3/4	86.394	593.96	11 3/4	117.810	1104.5	11 3/4	149.226	1772.1
1/47223660629272450816	13.5460	53.8703	12	55.371	243.98	12	86.786	599.37	12	118.202	1111.8	12	149.618	1781.4
1/944473														

are in open or closed position; and such valves or cocks shall be locked or sealed open. Where stopcocks are used they shall be of a type with the plug held in place by a guard or gland.

122.1.6(c)(5) No outlet connections, except for damper regulator, feedwater regulator, drains, steam gages, or apparatus of such form as does not permit the escape of an appreciable amount of steam or water therefrom shall be placed on the pipes connecting a water column or gage glass to a boiler.

122.1.6(d) Gage Glass Connections

122.1.6(d)(1) Gage glasses and gage cocks that are required by Paras. 122.1.6(b) and 122.1.6(e) and are not connected directly to a shell or drum of the boiler, shall be connected by one of the following methods:

122.1.6(d)(1.1) The water-gage glass or glasses and gage cocks shall be connected to an intervening water column; or

122.1.6(d)(1.2) When only water-gage glasses are used, they may be mounted away from the shell or drum and the water column omitted, provided the following requirements are met:

122.1.6(d)(1.2)(a) The top and bottom gage-glass fittings are aligned, supported and secured so as

to maintain the alignment of the gage pass;

122.1.6(d)(1.2)(b) The steam and water connections are not less than 1-in. pipe size and each water glass is provided with a valved drain; and

122.1.6(d)(1.2)(c) The steam and water connections comply with the requirements of the following Paras. 122.1.6(d)(2) and 122.1.6(d)(3).

122.1.6(d)(2) The lower edge of the steam connection to a water column or gage glass in the boiler shall not be below the highest visible water level in the water-gage glass. There shall be no sag or offset in the piping which will permit the accumulation of water.

122.1.6(d)(3) The upper edge of the water connection to a water column or gage glass and the boiler shall not be above the lowest visible water level in the gage glass. No part of this pipe connection shall be above the point of connection at the water column.

122.1.6(d)(4) An acceptable arrangement is shown in Fig. 122.1.6(d)(4).

122.1.6(e) Each boiler (except those not requiring water level indicators per Para. 122.1.6(b)(2)) shall have three or more gage cocks located within the visible length of the water glass, except

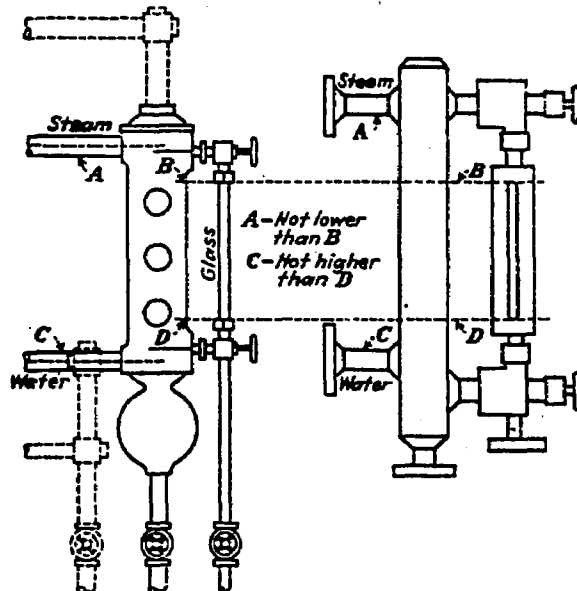


Fig. 122.1.6(d)(4) Typical Arrangement of Steam and Water Connections for a Water Column

From: (ANSI B31.1.0d-1972)

when the boiler has two water glasses located on the same horizontal lines.

Boilers not over 36 in. in diameter in which the heating surface does not exceed 100 sq ft need have but two gage cocks. Electric boilers operating at pressures not exceeding 400 psig need not be fitted with gage cocks.

The gage cock connections shall be not less than 1/2 in. pipe size.

122.1.6(f) Water Fronts

Each boiler fitted with a water-jacketed boiler-furnace mouth protector, or similar appliance having valves on the pipes connecting them to the boiler shall have these valves locked or sealed open. Such valves, when used, shall be of the straightway type.

122.1.6(g) Pressure Gages

Each boiler shall have a pressure gage so located that it is easily readable. The pressure gage shall be installed so that it shall at all times indicate the pressure in the boiler. Each steam boiler shall have the pressure gage connected to the steam space or to the water column or its steam connection. A valve or cock shall be placed in the gage connection adjacent to the gage. An additional valve or cock may be located near the boiler providing it is locked or sealed in the open position. No other shutoff valves shall be located between the gage and the boiler. The pipe connection shall be of ample size and arranged so that it may be cleared by blowing out. For a steam boiler the gage or connection shall contain a syphon or equivalent device which will develop and maintain a water seal that will prevent steam from entering the gage tube. Pressure gage connections shall be suitable for the maximum allowable working pressure and temperature but if the temperature exceeds 406 F, brass or copper pipes or tubing shall not be used. The connections to the boiler, except the syphon, if used, shall not be less than 1/4 in. standard pipe size but where steel pipe or tubing is used, they shall not be less than 1/2 in. inside diameter. The minimum size of a syphon, if used, shall be 1/4 in. inside diameter. The dial of the pressure gage shall be graduated to approximately double the pressure at which the safety valve is set, but in no case to less than 1-1/2 times this pressure.

122.1.6(h) Each forced flow steam generator with no fixed steam and water line shall be equipped with pressure gages or other pressure measuring devices located as follows:

122.1.6(h)(1) At the boiler or superheater outlet (following the last section which involves absorption of heat) and

122.1.6(h)(2) At the boiler or economizer inlet (preceding any section which involves absorption of heat) and

122.1.6(h)(3) Upstream of any shutoff valve which may be used between any two sections of the heat absorbing surface.

122.1.6(h)(4) Each boiler shall be provided with a valve connection at least 1/4 in. pipe size for the exclusive purpose of attaching a test gage when the boiler is in service, so that the accuracy of the boiler pressure gage can be ascertained.

122.1.6(i) Each high temperature water boiler shall have a temperature gage so located and connected that it shall be easily readable. The temperature gage shall be installed so that it at all times indicates the temperature in degrees Fahrenheit of the water in the boiler, at or near the outlet connection.

122.1.7 Valves and Fittings

The minimum pressure and temperature rating for all valves and fittings in steam, feedwater, blowoff and miscellaneous piping shall be equal to the pressure and temperature specified for the connected piping on the side that has the higher pressure except that in no case shall the pressure be less than 100 psig and for pressures not exceeding 100 psig in feedwater and blowoff service the valves and fittings shall be equal at least to the requirements of the ANSI Standards for 125 lb or 150 lb.

122.1.7(a) Steam Stop Valves

122.1.7(a)(1) Each boiler discharge outlet, except safety valve or safety relief valves, or re-heater inlet and outlet connection shall be fitted with a stop valve located at an accessible point in the steam-delivery line and as near the boiler nozzle as is convenient and practicable. When such outlets are over 2-in. nominal pipe size, the valve or valves used on the connection shall be of the outside-screw-and-yoke rising-stem type so

(ANSI B31.1.0-d, 1972)

COMPLETE LIST OF NFPA CODES, STANDARDS, ETC.

Number	Title	Year	Unit Cost	Number	Title	Year	Unit Cost	Number	Title	Year	
0 Series: ADMINISTRATION				50 Series: GASES				200 Series: BUILDING CONSTRUCTION			
2M	Model Drafts for Enabling Legislation	1967	.50	50	Bulk Oxygen Systems	1971	1.00	220	Building Construction, Standard Types	1961	
3M	Hospital Emergency Preparedness	1970	1.00	50A	Gaseous Hydrogen Systems	1969	.50	224	Homes & Camps in Forest Areas	1969	
4	Organization for Fire Services	1971	2.75	50B	Liquefied Hydrogen Systems at Consumer Sites	1971	1.00	231	Indoor General Storage	1970	
4A	Fire Department, Organization of a	1969	.75	51	Welding & Cutting, Oxygen-Fuel Gas Systems	1971	.75	231A	Outdoor General Storage	1970	
6	Industrial Fire Loss Prevention, Organization for	1967	.50	51A	Acetylene Cylinder Charging Plants	1971	1.00	231B	Storage of Cellular Rubber and Plastics	1968	
7	Management Control of Fire Emergencies	1967	.50	51B	Cutting & Welding Processes	1971	1.00	231C	Rack Storage of Materials	1971	
8	Management Responsibility, Effects of Fire	1967	.50	53M	Oxygen Enriched Atmospheres	1969	3.00	232	Protection of Records	1970	
9	Training Reports and Records	1970	.50	54	Gas Appliances & Gas Piping in Buildings	1969	1.25	241	Building Construction and Demolition Operations	1959	
10 Series: EXTINGUISHING APPLIANCES				60 Series: EXPLOSIVE DUSTS				300 Series: MARINE			
10	Installation, Portable Fire Extinguishers	1970	1.00	60	Pulverized Fuel Systems	1961	.60	302	Motor Craft, Fire Protection for	1968	
10A	Maintenance, Use, Portable Fire Extinguishers	1970	1.00	61A	Starch Factories	1971	1.00	303	Marinas & Boatyards, Fire Protection of	1969	
10L	Model Enabling Act, Portable Fire Extinguishers	1969	.50	61B	Grain Elevators, Bulk Handling	1970	.75	306	Control of Gas Hazards on Vessels to be Repaired	1971	
11	Foam Extinguishing Systems	1970	2.00	61C	Flour and Feed Mills, Allied Grain Storage Elevators	1971	1.00	307	Marine Terminals, Operation of	1967	
11A	High Expansion Foam	1970	.75	62	Sugar & Cocoa, Pulverized, Dust Hazards	1967	.50	312	Vessels, Construction & Repair During Layup	1970	
12	Carbon Dioxide Extinguishing Systems	1968	1.50	63	Industrial Plants, Fundamental Principles	1971	1.00	400 Series: AVIATION			
12A	Halon 1301 High Expansion Foam Systems	1971	1.75	65	Aluminum Processing and Finishing	1970	.50	402	Aircraft Rescue Procedures	1969	
13	Sprinkler Systems, Installation	1969	2.50	651	Aluminum Powder Manufacture	1967	.50	403	Aircraft Rescue Services, Airports & Heliports	1971	
13A	Sprinkler Systems, Care, Maintenance	1971	1.00	652	Magnesium Powder or Dust	1968	.50	406M	Handling Crash Fires	1968	
13E	F.D. Operations in Protected Properties	1966	.60	653	Coal Preparation Plants	1971	1.00	407	Aircraft Fuel Servicing	1971	
14	Standpipe and Hose Systems	1971	1.00	654	Plastics Industry	1970	1.25	408	Aircraft Hand Fire Extinguishers	1970	
15	Water Spray Fixed Systems	1969	1.25	655	Sulfur Fires and Explosions	1971	1.00	409	Aircraft Hangars	1971	
16	Foam-Water Sprinkler and Spray Systems	1968	1.00	656	Spice Grinding Plants	1971	1.00	410A	Aircraft Electrical System Maintenance	1968	
17	Dry Chemical Extinguishing Systems	1969	.75	657	Confectionery Manufacturing Plants	1967	.50	410B	Aircraft Breathing Oxygen System Maintenance Operations	1971	
18	Wetting Agents	1966	.50	66	Pneumatic Conveying Systems, Feed, Flour, Grain	1970	.75	410C	Aircraft Fuel System Maintenance	1971	
182M	Hazards of Vaporizing Liquid Agents	1965	.40	664	Woodworking & Wood Flour Manufacturing Plants	1971	1.00	410D	Aircraft Cleaning, Painting & Paint Removal	1971	
19	Automotive Fire Apparatus	1971	1.75	68	Explosion Venting Guide	1954	.75	410E	Aircraft Welding Operations in Hangars	1970	
19B	Respiratory Prot. Equip. for Fire Fighters	1971	1.00	69	Inerting for Fire & Explosion Prevention	1970	1.25	410F	Aircraft Cabin Cleaning & Refurbishing	1970	
191	Portable Pumping Units, F.D. Service	1959	.35	70 Series: ELECTRICAL				411	Aircraft Ramp Fire Hazard Classifications	1970	
193	Fire Dept. Ladders, Use, Maint., Testing	1959	.50	70	National Electrical Code	1971	3.50	412	Evaluating Foam Fire Fighting Equipment	1969	
194	Fire Hose Couplings, Screw Threads, Gaskets	1953	.75	70A	Electrical Code for 1- and 2-Family Dwellings	1969	1.75	414	Aircraft Rescue & Fire Fighting Vehicles	1970	
196	Fire Hose	1971	1.00	71	Central Station Protective Signaling Systems	1970	1.00	415	Aircraft Fueling Ramp Drainage	1966	
197	Initial Fire Attack, Training Standard on	1966	.50	72A	Local Protective Signaling Systems	1967	.60	416	Aircraft Terminal Buildings	1967	
198	Fire Hose, Care	1969	1.00	72B	Auxiliary Protective Signaling Systems	1967	.60	417	Aircraft Loading Walkways	1968	
20 Series: EXTINGUISHING AUXILIARIES				72C				418	Roof-top Heliport Construction and Protection	1968	
20	Centrifugal Fire Pumps	1971	2.50	72C	Remote Station Protective Signaling Systems	1967	.60	419	Airport Water Supply Systems	1969	
21	Steam Fire Pumps	1953	.60	72D	Proprietary Protective Signaling Systems	1967	.60	500 Series: GROUND TRANSPORTATION			
22	Water Tanks	1971	2.50	73	Municipal Fire Alarm Systems	1967	.60	501A	Mobile Home Parks	1971	
24	Outside Protection	1970	1.25	74	Household Fire Warning Systems	1967	.50	501B	Mobile Homes	1970	
25	Rural Fire Protection, Water Supply System	1969	.75	75	Electronic Computer Systems	1968	.75	501C	Recreational Vehicles	1970	
26	Supervision of Valves, Water Supplies	1958	.40	76A	Essential Electrical Systems for Hospitals	1971	1.00	501D	Elec. Std. Rec. Vehicles Parks	1971	
27	Private Fire Brigades	1967	.50	76BM	Electricity in Hospitals	1971	2.50	505	Powered Industrial Trucks	1971	
291	Fire Hydrants, Uniform Marking	1935	.25	76CM	High-Frequency Elec. Equip.	1970	1.00	512	Truck Fire Protection, Good Practices for	1970	
292M	Water Charges, Private Fire Protection	1961	.40	77	Static Electricity, Recommended Practice on	1966	1.00	513	Motor Freight Terminals	1971	
295	Forest, Grass and Brush Fire Control	1965	.75	78	Lightning Protection Code	1968	1.25	600 Series: OPERATING METHODS			
30 Series: FLAMMABLE LIQUIDS				79				601	Watchman or Guard, Instructions & Duties	1968	
30	Flammable and Combustible Liquids Code	1969	1.00	80	Electrical Metalworking Machine Tools	1971	1.50	601A	Standard for Guard Operations in Fire Loss Prevention	1968	
31	Oil Burning Equipment	1968	1.25	80-90 Series: CONSTRUCTION				602	Community Dumps, Good Practice for	1954	
32	Dry Cleaning Plants	1970	.75	80	Fire Doors and Windows	1970	2.00	604	Salvaging Operations	1964	
321	Basic Classification, Flam. & Combust. Liquids	1969	.50	80A	Fire Resistive Walls, Protection of Openings in	1970	.75	700 Series: CLASSIFICATION, TREATMENT MATERIALS			
325A	Flash Points — Trade Name Liquids	1968	2.50	81	Fur Storage, Fumigation & Cleaning	1969	.75	701	Flame-Resistant Textiles and Films	1969	
325M	Fire-Hazard Props., Flam. Liquids, Gases & Volatile Solids	1969	3.00	82	Incinerators, Rubbish Handling	1971	1.25	702	Wearing Apparel, Flammability of	1966	
326	Labeling of Flammable Liquid Containers	1951	.25	85	Fuel Oil & Natural Gas Fired Watertube Boiler-Furnaces	1967	.75	703	Building Materials, Fire Retardant Treatments	1961	
327	Small Tanks and Containers, Cleaning or Safeguarding	1970	.50	85B	Gas-Fired Multiple Burner Boiler-Furnaces	1971	1.75	704M	Fire Hazards of Materials, Identification Systems for	1969	
328	Manholes, Sewers, Flam. & Combust. Liquids in	1970	.75	85D	Fuel Oil-Fired Multiple Burner Boiler-Furnaces	1971	1.75	800 Series: RADIOACTIVE MATERIALS			
329	Underground Flam. & Comb. Liquid Tanks, Leakage from	1965	.50	85E	Pulverized Coal-Fired Multiple Burner Boiler-Furnaces	1971	1.75	801	Radioactive Materials, Facilities Handling	1970	
33	Spray Finishing	1969	1.25	86A	Ovens & Furnaces, Design, Location & Equipment	1971	2.50	802	Nuclear Reactors, Fire Protection for	1960	
34	Dip Tanks	1971	1.25	86B	Industrial Furnaces, Class B	1971	2.00	901	Fire Reporting, Coding System for	1971	
35	Organic Coatings, Mfg. of	1971	1.25	87	Piers & Wharves, Construction & Protection	1971	1.25	901AM	Fire Rep. Field Incident Manual	1971	
36	Solvent Extraction Plants	1967	.60	88	Garages	1968	.75	910	Protection of Library Collections	1970	
37	Stationary Combustion Engines & Gas Turbines	1970	.75	89M	Heat Producing Appliances, Clearances for	1971	1.00	911	Protection of Museum Collections	1969	
385	Tank Vehicles, Flam. & Comb. Liquids	1971	1.25	90A	Air Condit. & Vent. Systems	1971	1.00	TENTATIVE STANDARDS — PROGRESS REPORTS			
386	Portable Shipping Tanks	1970	.50	90B	Warm Air Heat. & Condit. Systems, Residence Type	1971	1.00	5A-T	Recommendations for Evaluating Fire Protection at a New Facility	1970	
393	Gasoline Blow Torches & Plumbers' Furnaces	1969	.50	91	Blower & Exhaust Systems	1961	.50	12B-T	Halogenated Fire Extinguishing Agent Systems (Halon 1211)	1971	
395	Farms and Isolated Construction Projects, Flam. Liquid Storage at	1965	.40	92	Waterproofing, Drainage of Floors	1937	.35	43A-T	Code for the Storage of Liquid and Solid Oxidizing Materials	1971	
40 Series: COMBUSTIBLE SOLIDS				95				56E-T	Standard for Hypobaric Facilities	1971	
40	Cellulose Nitrate Motion Picture Film	1967	.60	97M	Vapor Removal from Cooking Equipment Chimneys, Gas Vents & Heat Producing Appliances, Glossary of Terms	1968	.50	60-T	Standard for the Installation & Operation of Pulverized Fuel Systems	1971	
41L	Model Rocketry Code	1968	.50	100 Series: SAFETY TO LIFE				232AM-T	Manual for Fire Protection for Archives and Record Centers	1970	
42	Pyroxylin Plastics in Factories	1967	.60	101	Life Safety Code	1970	2.00	421-T	Aircraft Interior Fire Protection Systems	1971	
43	Pyroxylin Plastics in Warehouses, Stores	1967	.40	102	Tents, Grandstands & Air-Supported Structures Used for Places of Assembly	1967	.60	200 Series: BUILDING CONSTRUCTION			
46	Forest Products, Outdoor Storage of	1951	.50	203M	Roof Coverings	1970	.50	204	Smoke & Heat Venting Guide	1966	
45A	Outdoor Storage of Wood Chips	1955	.40	206M	Guide on Building Areas & Heights	1970	.50	211	Chimneys, Fireplaces & Venting Systems	1971	
45B	Outdoor Storage of Logs	1971	1.00	214	Water Cooling Towers	1971	1.00	300 Series: MARINE			
47	Lumber Storage Yards, Retail & Wholesale	1961	.50	400 Series: AVIATION				302	Motor Craft, Fire Protection for	1968	
48	Magnesium, Storage, Handling & Processing	1967	.60	500 Series: GROUND TRANSPORTATION				303	Marinas & Boatyards, Fire Protection of	1969	
481	Titanium, Prod., Proc., Hand. & Storage	1961	.60	600 Series: OPERATING METHODS				306	Control of Gas Hazards on Vessels to be Repaired	1971	
482M	Zirconium, Prod., Proc., Hand. & Storage	1961	.50	700 Series: CLASSIFICATION, TREATMENT MATERIALS				307	Marine Terminals, Operation of	1967	
49	Hazardous Chemicals Data	1971	2.75	800 Series: RADIOACTIVE MATERIALS				312	Vessels, Construction & Repair During Layup	1970	
490	Ammonium Nitrate, Storage of	1970	.75	TENTATIVE STANDARDS — PROGRESS REPORTS				400 Series: AVIATION			
491M	Hazardous Chemical Reactions, Manual of	1968	3.25	5A-T				402	Aircraft Rescue Procedures	1969	
492	Separation Distances of Ammonium Nitrate and Blasting Agents from Blasting Agents or Explosives	1968	.50	12B-T				403	Aircraft Rescue Services, Airports & Heliports	1971	
493	Intrinsically Safe Process Control Equipment	1969	.75	43A-T				406M	Handling Crash Fires	1968	
494L	Fireworks Law, Model State	1964	.40	56E-T				407	Aircraft Fuel Servicing	1971	
495	Explosives and Blasting Agents Code	1970	1.25	60-T				408	Aircraft Hand Fire Extinguishers	1970	
	ged Enclosures for Electrical Equipment Installations, Motor Vehicles, Terminals	1971	1.25	232AM-T				409	Aircraft Hangars	1971	
		1970	.50	421-T				410A	Aircraft Electrical System Maintenance	1968	

NFPA Pamphlet Editions

of Codes, Standards, Recommended Practices and Manuals

Prices Quoted are F.O.B. Boston, Mass.

See Reverse Side for Discount Schedule

Fill out by number and mail to:

NATIONAL FIRE PROTECTION ASSOCIATION

60 Batterymarch Street, Boston, Mass. 02110

Date..... Payment in amount of \$..... enclosed.
 Bill ME at address below.

Send to.....
 (Your name - please type or print)

Company.....

Street.....

City-Town..... State..... Zip.....

Remittance **MUST** accompany orders of \$5.00 and under

STANDARD NUMBER	QUANTITY ORDERED	UNIT PRICE	TOTAL COST	STANDARD NUMBER	QUANTITY ORDERED	UNIT PRICE	TOTAL COST
2M		.50		395		.40	
3M		1.00		40		.60	
4		2.75		41L		.50	
4A		.75		42		.60	
6		.50		43		.40	
7		.50		46		.50	
8		.50		46A		.40	
9		.50		46B		1.00	
10		1.00		47		.50	
10A		1.00		48		.60	
10L		.50		481		.60	
11		2.00		482M		.50	
11A		.75		49		2.75	
12		1.50		490		.75	
12A		1.75		491M		3.25	
13		2.50		492		.50	
13A		1.00		493		.75	
13E		.60		494L		.40	
14		1.00		495		1.25	
15		1.25		496		1.25	
16		1.00		498		.50	
17		.75		50		1.00	
18		.50		50A		.50	
182M		.40		50B		1.00	
19		1.75		51		.75	
19B		1.00		51A		1.00	
191		.35		51B		1.00	
193		.50		53M		3.00	
194		.75		54		1.25	
196		1.00		54A		1.00	
197		.50		56A		1.75	
198		1.00		56B		.75	
20		2.50		56C		.75	
21		.60		56D		1.00	
22		2.50		56F		.75	
24		1.25		57		.75	
25		.75		58		1.25	
26		.40		59		1.25	
27		.50		59A		1.75	
291		.25		60		.60	
292M		.40		61A		1.00	
295		.75		61B		.75	
30		1.00		61C		1.00	
31		1.25		62		.50	
32		.75		63		1.00	
321		.50		65		.50	
325A		2.50		651		.50	
325M		3.00		652		.50	
326		.25		653		1.00	
327		.50		654		1.25	
328		.75		655		1.00	
329		.50		656		1.00	
33		1.25		657		.50	
34		1.25		66		.75	
35		1.25		664		1.00	
36		.60		68		.75	
37		.75		69		1.25	
385		1.25		70		3.50	
3		.50		70A		1.75	
3		.50		71		1.00	
72A		.60		306		1.00	
72B		.60		307		.60	
72C		.60		312		.50	
72D		.60		402		2.00	
73		.60		403		1.50	
74		.50		406M		1.00	
75		.75		407		1.75	
76A		1.00		408		.50	
768M		2.50		409		1.50	
76CM		1.00		410A		.50	
77		1.00		410B		1.00	
78		1.25		410C		1.25	
79		1.50		410D		1.00	
80		2.00		410E		.50	
80A		.75		410F		.50	
81		.75		411		.50	
82		1.25		412		.75	
85		.75		414		2.00	
85B		1.75		415		.50	
85D		1.75		416		.50	
85E		1.75		417		.50	
86A		2.50		418		.50	
86B		2.00		419		.75	
87		1.25		501A		1.25	
88		.75		501B		2.50	
89M		1.00		501C		2.00	
90A		1.00		501D		1.00	
90B		1.00		505		1.00	
91		.50		512		.75	
92		.35		513		1.00	
95		1.00		601		.50	
97M		.50		601A		.50	
101		2.00		602		.50	
102		.60		604		.50	
203M		.50		701		.75	
204		.50		702		.75	
206M		.50		703		.40	
211		1.25		704M		.75	
214		1.00		801		.75	
220		.40		802		.75	
224		.75		901		3.50	
231		.75		901AM		1.50	
231A		.50		910		.75	
231B		.75		911		.75	
231C		1.75		Tentative Standards - Progress Reports			
232		1.50		5A-T		1.00	
241		.50		12B-T		2.00	
251		.75		43A-T		1.00	
252		.50					
255		.50					
256		.50		56E-T		1.50	
257		.50		60-T		1.75	
302		1.25		232AM-T		1.00	
303	A-20-(b)	1.00		421-T		1.00	



safety valves cannot be closed off from the boiler at the same time and provided the three-way valve will permit at least full required flow to the safety valve in service at all times.

The user shall maintain all pressure relieving devices in good operating condition. Where the valves cannot be tested in service, the user shall maintain and make available to the inspector records showing the test dates and set pressure for such valves.

History: 1. Amendment filed 11-2-66; effective thirtieth day thereafter (Register 66, No. 38). Approved by State Building Standards Commission.

762. Safety Valves and Pressure Relieving Devices, Fired Pressure Vessels. (a) Boilers (or vaporizers) of the Dow-therm, mercury vapor or similar types shall be fitted with adequate safety relieving devices to assure their safe operation. Safety valves of Dow-therm vaporizers and similar equipment shall be removed at least once each year for inspection and cleaning of any deposits that might affect their operation. (To eliminate the necessity of shutting the unit down for this inspection, a three-way stop valve may be installed under 2 safety valves, each with the required relieving capacity, and so installed that both safety valves cannot be closed off from the vaporizer at the same time; or 2 or more separate safety valves may be installed with individual shutoff valves, in which case the shutoff valve stems shall be mechanically interconnected in a manner which will allow full required flow at all times.)

(b) Fired pressure vessels other than those mentioned in (a) above shall be fitted with safety relieving devices of sufficient capacity to relieve all vapor that can be generated in the vessel during normal operation and shall be fitted with proper controls to assure their safe operation.

History: 1. Amendment filed 11-2-66; effective thirtieth day thereafter (Register 66, No. 38). Approved by State Building Standards Commission.

763. Low-pressure Boilers. (a) All low-pressure boilers shall be installed and fitted with the fittings and appliances required by the Code, and any additional appurtenances required in the following subsections.

(b) When a hot water heating boiler is equipped with an electrically operated circulating pump and electrically operated burner controls, the control switches shall be labeled to show which is for the burner circuit and which is for the pump circuit, or the electrically operated burner controls shall be connected in the electric circuit ahead of the automatic pump switch or the burner control switch shall be mechanically interlocked to the disconnect switch for the circulating pumps.

(c) All low-pressure boilers shall be equipped with one or more pressure relieving device adjusted and sealed so as to discharge at a pressure not to exceed the maximum allowable working pressure of

the boiler. The combined capacity of these devices shall be such that with the fuel burning equipment installed and operating at maximum capacity the pressure cannot rise more than 5 psi above the maximum allowable working pressure of the boiler. All pressure relieving devices shall be installed as required by the Code and be ASME stamped and rated and shall be installed with the valve spindle vertical and shall have a manual lifting device to permit periodic testing.

The discharge from all drains and pressure relieving devices shall be piped to a safe place of discharge and shall have no shutoff valves in the pipe between the pressure relieving device and point of discharge.

A safe place of discharge as used in this section shall be a location where:

(1) The discharge of steam or hot water will not present a hazard to employees.

(2) The discharge of steam or water will not be detrimental to any electrical or other machinery or equipment.

(3) The discharge pipe cannot be readily plugged or otherwise obstructed.

(d) All automatically controlled low-pressure boilers shall be equipped with:

(1) A low-water control that will close the main burner fuel valve when the water in the boiler reaches the lowest operating level, or for boilers with no fixed steam or water line, when the highest permissible operating temperature is reached.

(2) A low-water safety cutout that will shut off the fuel to the burner when the water in the boiler reaches a predetermined level which shall not be below the lowest permissible level, and manual resetting of the low-water control or of the fuel valve or of the emergency control system shall be required to place the boiler back in operation after it has been shut down due to the operation of the low-water safety cutout.

(3) An adjustable operating control and fuel valve to regulate the flow of fuel to the burner to maintain the pressure or temperature below the following limits:

(A) 15 psi gage pressure for steam boilers.

(B) 250° F. water temperature for water boilers.

(4) A high-limit safety control that will shut off fuel to the burner when the pressure in a steam boiler reaches a predetermined maximum not to exceed 15 psi gage or when the temperature in a water boiler reaches a predetermined maximum not to exceed 250° F. The high-limit safety control mechanism shall be in addition to the operating control required in (d) (3) above and manual resetting of the high-limit control or of the fuel valve or of the emergency control system shall be required to place the boiler back in operation after

it has been shut down due to the operation of the high-limit safety control.

(5) (A) A full safety pilot control on boilers equipped with standing pilot burners, other than those included in subsection 763 (d) (5) (B), that will shut off the fuel to the main burner and any extinguished pilot burners if a pilot light is extinguished.

Such device shall actuate to close the safety fuel shutoff valve required in Subsection 763 (d) (6) within the time limits specified for flame failure shutoff in Table 1.

(B) A programmed flame safeguard system on burners equipped with spark ignition that will include a flame failure shutoff time not greater than specified in Table 1. Such system shall require the services of the attendant to place the boiler back into operation if a flame failure should occur while in operation or if the flame is not established within the time limit programmed into the system. Such time limits shall not exceed that specified for flame failure shutoff in Table 1.

Table 1. Flame Failure Shutoff Times (1)

Maximum Firing rate Oil Gal. per hr.	Maximum Firing rate Gas BTU/hr.	Type of Ignition	Maximum time until valve is fully closed, seconds
3 gallons or less		Unproved Pilot or Ignition	90
Over 3 gallons to 7 gallons			30 (2)
Over 7 gallons to 20 gallons			10 (2)
Over 20 gallons		Proved Pilot	60 (3)
	Less than 400,000 BTU	Proved or Unproved Pilot	90
	Over 400,000 BTU	Proved Pilot (4)	10

Note 1. Flame failure shutoff as used in these Orders means the total elapsed time from the time of flame failure or other abnormal condition occurs until the fuel shutoff valve is closed.

Note 2. Where a burner is designed or equipped for a "starting firing rate" of less than the maximum firing rate of the burner, the flame failure shutoff time shown in Table 1 for the lesser firing rate may be used for establishing ignition, provided that firing rate cannot be increased until ignition is proven. The time limit for flame failure shutoff shall be determined by the maximum burner input.

Note 3. The 60-second time limit for flame failure shutoff may be used for burners having less than 20 gallons per hour input if equipped with a proved pilot.

Note 4. In case of pilot flame failure, the proved pilot shall de-energize the safety fuel shutoff valve electrical circuit and cause that valve to close within 10 seconds.

(6) In addition to the operating fuel shutoff valve(s) required in 763 (d) (1) and (3), an additional safety fuel shutoff valve that will be operated by the controls required by

Section 763 (d) (2), (4), and (5). This valve shall be of a type that will close within 2 seconds after being de-energized if the burner input rating exceeds 400,000 BTU/hr.

(7) A means for obtaining adequate combustion chamber purging and for limiting the burner "trial for ignition" time during start up to 15 seconds or that permitted for flame failure shutoff in Table 1, whichever is greater.

(e) All low-pressure boilers shall be equipped with a pressure or altitude gage as required by the code. All water boilers shall be equipped with a thermometer to indicate temperature conditions at or near the hot water outlet. These devices shall be visible to the operator from the operating area.

(f) All low-pressure steam boilers shall be equipped with one or more water gage glass with shutoff valves and drain cocks. These devices shall be located on the boiler, or on a water column, within the permissible water level range for the boiler, (unless specifically exempted by the Code).

(g) All hot water heating systems shall be equipped with a suitable expansion tank that will be consistent with the volume, temperature, pressure, and capacity of the system as required by the Code. All such expansion tanks shall have an allowable working pressure at least equal to the maximum allowable working pressure of the boiler with which they are used, and the maximum allowable working pressure shall be stamped on a nameplate visible after installation.

All expansion tanks connected into systems having boilers designed for more than 30 psi working pressure shall be constructed, inspected, and stamped according to the Code, Section VIII, unless it can be proven to the satisfaction of the Division that the design and construction will provide equivalent safety. Expansion tanks connected into systems having boilers designed for 30 psi or less shall be designed, constructed, and stamped according to the Code, Section VIII, or according to good engineering practices with a factor of safety of at least 4.

All expansion tanks shall be fitted with a means for indicating visually the water level in the tank.

(h) When low-pressure boilers are equipped with a float-type automatic water feeder, such water feeder shall be fitted with a valved drain on the float chamber. Float chambers of other control devices shall also be provided with valve drains on the float chambers.

(i) All valves, fittings, and controls shall be suitable for the pressures and temperatures expected in service and all such devices used in the fuel system shall be suitable for and compatible with the fuel and fuel pressures used. All electrically operated fuel valves shall be of the normally closed type to open only when energized. Fuel valves of a type that will fail to close due to abnormal fuel pressure shall not be permitted. Automatically operated fuel valves shall not be designed with integral manually operated by-passes unless such by-pass is of the constant pressure type.

(j) The electrical circuit for boiler controls shall not exceed 120 volts and shall be 2-wire with 1-conductor grounded and have the controls in the ungrounded conductor.

(k) After installation and before being placed in operation, the employer shall require all controls and burners to be checked for proper operation by a responsible person familiar with burner controls.

Instruction for the proper method of lighting, relighting, and shutting down the burner, type of fuel or fuels to be used, and the maximum fuel pressure shall be shown on a permanent and legible plate attached to the boiler or boiler casing and an operating manual giving complete boiler operating instructions, shall be furnished by the installer for each installation. The employer shall require operating personnel to become thoroughly familiar with these operating instructions before they are permitted to operate the boiler. These instructions shall include an instruction to the operator that the boiler shall not be placed back in service after having been shut down by the operation of the safety fuel shutoff valve required in 763 (d) (6) until the cause of such shutdown has been determined and corrected and the combustion chamber is properly purged.

History: 1. Amendment filed 11-2-66; effective thirtieth day thereafter (Register 66, No. 38). Approved by State Building Standards Commission.

764. Blowoff Valves and Tanks. (a) All boilers subject to these orders shall have blowoff valves and piping installed in accordance with the Code.

(b) All blowoff pipes shall terminate at a safe place of discharge and shall be adequately supported to prevent undue stresses on the valves or lines, and shall not be reduced in size between the blowoff valve and point of discharge.

Blowoff valves constructed with integrally threaded bonnets shall not be permitted.

No blowoff pipe shall discharge directly into a sewer. When the blowoff discharge is to be ultimately led to a sewer, local plumbing codes shall be consulted concerning requirements for discharging products into sewers.

When a blowoff tank is used, it shall be designed and constructed in accordance with good engineering practice for the maximum pressure and temperature expected during the blowdown period with a factor of safety of at least 4. All blowoff tanks shall be provided with means for cleaning and inspection.

History: 1. Amendment filed 11-2-66; effective thirtieth day thereafter (Register 66, No. 38). Approved by State Building Standards Commission.

765. Means of Feeding Water to Boilers. All power boilers subject to these Orders shall be equipped with at least one means for feeding water to the boiler at the maximum allowable pressure. Boilers having more than 500 square feet of water heating surface shall have