

DOCUMENT RESUME

ED 087 618

SE 016 456

TITLE Opticalman 1 and C, Rate Training Manual. [1972 Revised Edition].

INSTITUTION Bureau of Naval Personnel, Washington, D. C.; Naval Personnel Program Support Activity, Washington, D. C.

SPONS AGENCY Department of Defense, Washington, D.C.

REPORT NO NAVPERS-10206-A

PUB DATE 72

NOTE 249p.; Revised 1972

EDRS PRICE MF-\$0.65 HC-\$9.87

DESCRIPTORS *Equipment Maintenance; *Instructional Materials; Military Personnel; Military Science; *Military Training; *Optics; Physics; Post Secondary Education; *Supplementary Textbooks; Technical Education

ABSTRACT

In this revised edition of an earlier publication (ED 070 574), fundamentals of optical instruments on board ships are presented in this rate training manual for regular navy and naval reserve personnel. The manual includes nine chapters: Introduction; Administration and Supervision; Nature of Light; Optical Alignment Instruments; Night Vision Sights; Synchronizers, Servos, and Control Transformers; Tilting Prism Gunsight Telescopes; Rangefinders; and Submarine Periscopes. Step-by-step procedures for disassembling, reassembling, and maintaining optical systems are the major concern of this manual. Included are information about the opticalman rating structure and a reading reference list. (CC)

ED 087618

U.S. DEPARTMENT OF HEALTH
EDUCATION & WELFARE
NATIONAL INSTITUTE OF
EDUCATION

THIS DOCUMENT HAS BEEN REPRODUCED EXACTLY AS RECEIVED FROM THE PERSON OR ORGANIZATION ORIGINATOR. POINTS OF VIEW OR OPINIONS STATED DO NOT NECESSARILY REPRESENT OFFICIAL NATIONAL INSTITUTE OF EDUCATION POSITION OR POLICY.

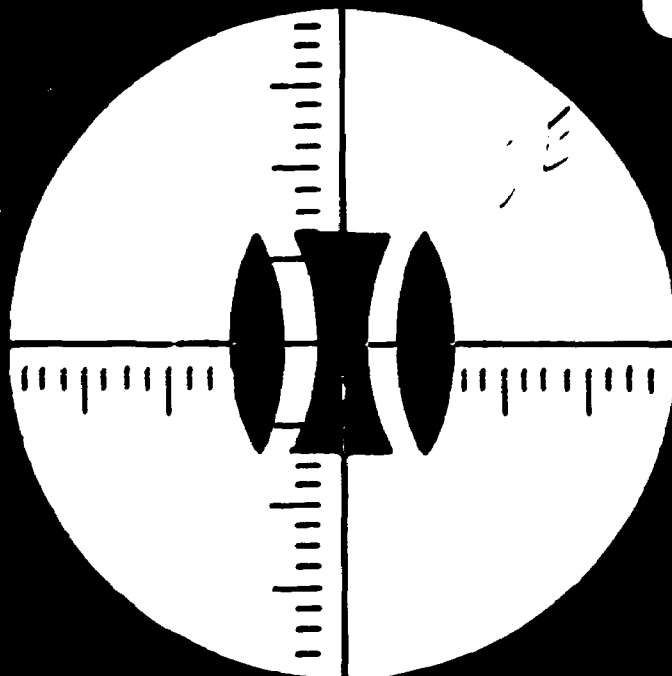

OPTICALMAN 1 & C

NAVAL TRAINING COMMAND

RATE TRAINING MANUAL

NAVTRA 10206 A

SE 016 456

PREFACE

The primary purpose of training is to produce a Navy which can maintain control of the sea and guarantee victory. Victory at sea depends upon the state of readiness of shipboard personnel to perform tasks assigned to them in accordance with the needs of their ship. This Rate Training Manual provides information related to the tasks assigned to Opticalmen First Class and Chief Opticalmen who maintain range-finders, night vision sights, submarine periscopes, tilting-prism gun-sight telescopes, and other optical instruments. It is only when shipboard personnel can and do perform their tasks efficiently that each ship will be adding her contribution which is essential to guarantee victory at sea. As an OM1 or OMC, you will be expected to know the information in this manual and to perform your assigned tasks. The degree of success of the Navy will depend in part on your ability and the manner in which you perform your duties.

This manual was prepared by the Naval Training Publications Detachment, Naval Training Support Command, Washington, D.C. Technical assistance was provided by the Naval Ship Engineering Center, Washington; Submarine Base, New London; Army Supply Depot, Sacramento; Service School Command, Great Lakes; and Naval Examining Center, Great Lakes.

Published by
Naval Training Support Command
First Edition 1950
Revised 1966 and 1972

Stock Ordering No.
0502-051-0310

UNITED STATES
GOVERNMENT PRINTING OFFICE
WASHINGTON, D.C. 1972

THE UNITED STATES NAVY

GUARDIAN OF OUR COUNTRY

The United States Navy is responsible for maintaining control of the sea and is a ready force on watch at home and overseas, capable of strong action to preserve the peace or of instant offensive action to win in war.

It is upon the maintenance of this control that our country's glorious future depends. The United States Navy exists to make it so.

WE SERVE WITH HONOR

Tradition, valor, and victory are the Navy's heritage from the past. To these may be added dedication, discipline, and vigilance as the watchwords of the present and the future.

At home or on distant stations we serve with pride, confident in the respect of our country, our shipmates, and our families.

Our responsibilities sober us, our adversities strengthen us.

Service to God and Country is our special privilege. We serve with honor.

THE FUTURE OF THE NAVY

The Navy will always employ new weapons, new techniques, and greater power to protect and defend the United States on the sea, under the sea, and in the air.

Now and in the future, control of the sea gives the United States her greatest advantage for the maintenance of peace and for victory in war.

Mobility, surprise, dispersal, and offensive power are the keynotes of the new Navy. The roots of the Navy lie in a strong belief in the future, in continued dedication to our tasks, and in reflection on our heritage from the past.

Never have our opportunities and our responsibilities been greater.

CONTENTS

CHAPTER	Page
1. Introduction	1
2. Administration and supervision	6
3. Nature of light	37
4. Optical alignment instruments	54
5. Night vision sights	85
6. Synchros, servos, and control transformers	110
7. Tilting prism gunsight telescopes	118
8. Rangefinders	153
9. Submarine periscopes	208
APPENDIX	
I. Reading reference list	237
INDEX	239

CHAPTER 1

INTRODUCTION

At this stage in your naval career, you must be aware of how important training is to the accomplishment of your own goals and the Navy's mission. Neither objective can be attained unless you continue to acquire the specific knowledges and skills for doing, or doing better, your assigned tasks. When combined with practical experience, the instruction provided by this Rate Training Manual will help you become a proficient worker, and enable you to accept greater responsibilities. The Navy, too, will benefit from your technical competence and sense of personal responsibility.

Your own contribution to "victory at sea" depends largely on your willingness and ability to accept increasing responsibilities. When you became a Third Class Opticalman, you began to accept a certain amount of responsibility for the work of others. Advancement to Second Class meant more responsibility. By studying this manual, you indicate a desire to take on even more.

With each advancement, you acquire increased responsibility not only in matters relating to the occupational requirements of your rating, but in military matters as well. You will find that your responsibilities for military leadership are about the same as those of petty officers in other ratings, since every petty officer is a military person as well as a technical specialist. Your responsibilities for technical leadership are special to your rating and are directly related to the nature of your work. Maintaining rangefinders, periscopes, night vision sights, and other optical instruments calls for teamwork, and requires a special kind of supervisory ability that can only be developed by personnel who have a high degree of technical competence and a deep sense of personal responsibility.

YOUR RESPONSIBILITIES WILL EXTEND BOTH UPWARD AND DOWNWARD. Both officers and enlisted personnel will expect you to translate the general orders given by officers into detailed, practical on-the-job language that can be understood and followed even by relatively inexperienced personnel. In dealing with

your juniors, it is up to you to see that they perform their work properly. At the same time, you must be able to explain to officers any important needs or problems of the enlisted men.

YOU WILL HAVE REGULAR AND CONTINUING RESPONSIBILITIES FOR TRAINING. Even if you are lucky enough to have highly skilled and well trained men in the optical shop, you will still find that more training is necessary. Some of your best workers may be transferred and inexperienced or poorly trained personnel may be assigned to you. Or a particular job may call for skills that none of your personnel have. These and similar problems require you to be a specialist who can train others to perform their assigned tasks.

YOU WILL HAVE INCREASING RESPONSIBILITIES FOR WORKING WITH OTHERS. You will find that many of your plans and decisions affect a large number of people, some of whom are not in the optical shop and some of whom are not even in the same division. It becomes increasingly important, therefore, to understand the duties and responsibilities of personnel in other ratings. Every petty officer in the Navy is a technical specialist in his own field. Learn as much as you can about the work of other ratings, and plan your own work so that it will fit in with the overall mission of the organization.

AS YOUR RESPONSIBILITIES INCREASE, YOUR ABILITY TO COMMUNICATE CLEARLY AND EFFECTIVELY MUST ALSO INCREASE. The basic requirement for effective communication is a knowledge of your own language. Use correct language in speaking and in writing. Remember that the basic purpose of all communication is understanding. To lead, supervise, and train others, you must be able to speak and write in such a way that others can understand exactly what you mean.

A second requirement for effective communication in the Navy is a sound knowledge of the Navy way of saying things. Some Navy terms have been standardized for the purpose of ensuring efficient communication. When a situation calls for the use of standard Navy terminology, use it.

Still another requirement of effective communication is precision in the use of technical terms. A command of the technical language of the Opticalman rating will enable you to receive and convey information accurately and to exchange ideas with others. A person who does not understand the precise meaning of terms in connection with the work of his own rating is at a disadvantage when he tries to read official publications relating to his work. He is also at a great disadvantage when he takes the written examinations for advancement. Although it is always important for you to use technical terms correctly, it is particularly important when you are dealing with lower rated men; sloppiness in the use of technical terms is likely to be very confusing to an inexperienced man.

YOU WILL HAVE INCREASED RESPONSIBILITIES FOR KEEPING UP WITH NEW DEVELOPMENTS. Practically everything in the Navy—policies, procedures, equipment, publications, systems—is subject to change and development. As an OMI, and even more as an OMC, you must keep yourself informed about all changes and new developments that might affect your rating or your work.

Some changes will be called directly to your attention, but others you will have to look for. Try to develop a special kind of alertness for new information. Keep up to date on all available sources of technical information. Information on sources of primary concern to the Opticalman is given later in this chapter.

YOUR JOB

An Opticalman is generally assigned duty in the optical shops on repair ships and tenders. Here he will maintain the advanced optical systems of rangefinders, submarine periscopes, tilting-prism gunsight telescopes, and other optical instruments. A senior Opticalman will have administrative duties to perform, such as preparing or helping his division officer prepare preventive maintenance schedules in accordance with the Planned Maintenance Subsystem of the 3-M System; maintaining records of receipt and expenditure for repair parts and supplies; planning, scheduling, assigning, and releasing repair work in accordance with ship's availabilities; and supervising the training of personnel in repair and overhaul of optical equipment.

Shore duty for Chief and First Class Opticalmen includes recruiting duty and instructor duty at an OM/IM school or Naval Reserve

training center. Also, there are billets for Chief Opticalmen at the Naval Examining Center, Great Lakes, Illinois, where the Navywide advancement examinations are constructed, and at the Naval Training Publications Detachment, Washington, D.C., where Rate Training Manuals, correspondence courses, and other training materials are written and revised.

SCOPE OF THIS TRAINING MANUAL

Before studying this manual, you should know its scope and purpose. Go over the table of contents and note the arrangement of topics. Subject matter can be organized and presented in many different ways. You will find it helpful to get an overall view of this manual's organization before starting to study. Here are some points of interest concerning this manual:

- It must be satisfactorily completed before you can advance to OMI or OMC, whether you are in the Regular Navy or in the Naval Reserve.

- It is designed to provide information on the occupational qualification for advancement to OMI and OMC.

- The occupational qualifications that were used as a guide in the preparation of this manual were those promulgated in the Manual of Qualifications for Advancement, NAVPERS 18068-C (1971). Changes in the Opticalman's qualification occurring after this edition of the Qualls Manual became effective may not be reflected in the topics of this training manual.

- It includes subject matter that is related to both the **KNOWLEDGE FACTORS** and the **PRACTICAL FACTORS** of the qualifications for advancement to OMI and OMC. No training manual, however, can take the place of on-the-job experience for developing skill in the practical factors. When possible, this manual should be used in conjunction with the Record of Practical Factors, NAVPERS 1414/1.

- It is NOT designed to provide information on the military requirements for petty officers. Such information is contained in specially prepared Rate Training Manuals, which are described briefly later in this chapter.

SOURCES OF INFORMATION

It is very important for you to have an extensive knowledge of the references to consult for detailed, authoritative, up-to-date information on all subjects related to the military requirements

and to the occupational qualifications of the Opticalman rating. Many of these references are listed in Appendix I of this manual.

Some of the reference are changed or revised at regular intervals, others as the need arises. When using any publication that is subject to change or revision, be sure you have the latest edition. When using any publication that is kept current by means of changes, be sure you have a copy in which all official changes have been entered.

NAVAL TRAINING (NAVTRA) PUBLICATIONS

Effective 15 January 1972, the Naval Training Support Command and its field activities came directly under the command of the Chief of Naval Training instead of the Chief of Naval Personnel. Training materials published by the Naval Training Support Command after the above date are designated NAVTRA in lieu of NAVPERS; in most cases, the numbers remain as originally assigned. The designators of publications printed before the above date will be changed as each publication is revised.

The naval training publications described here include some that are absolutely essential for meeting your job requirements and some that are extremely helpful, although not essential.

Bibliography for Advancement Study. NAVTRA 10052

This pamphlet provides a working list of material for enlisted personnel who are studying for their advancement examinations. It is revised and issued annually by the Naval Training Support Command. Each revised edition is identified by a letter following the NAVTRA number. When using the bibliography, be sure you have the most recent edition.

The working list contains required and recommended Rate Training Manuals and other references. A Rate Training Manual marked with an asterisk (*) in NAVTRA 10052 is MANDATORY at the indicated rate level. You are responsible, however, for all references at lower levels, as well as those listed for the rate to which you are seeking advancement. A mandatory Rate Training Manual may be completed by (1) passing the appropriate correspondence course based on the manual, (2) passing locally prepared tests based on the manual,

or (3) in some cases, successfully completing an appropriate Navy school.

All references, whether mandatory or recommended, listed in NAVTRA 10052 may be used as source material for the written advancement examinations, at the appropriate levels. In addition, references cited in a mandatory or recommended Rate Training Manual may be used as source material for the examination questions. Figure 1-1 is a modified sample page of the bibliography. It does not show all the references listed in NAVTRA 10052 for the OM rating.

Rate Training Manuals

These manuals help enlisted personnel fulfill their job requirements as expressed by the practical and knowledge factors that they must acquire for advancement. Some manuals are general, and intended for more than one rating; others, such as this one, are specific to the particular rating.

Rate Training Manuals are revised from time to time to bring them up to date. The revision of a Rate Training Manual is identified by a letter following the NAVTRA number. You can tell whether a Rate Training Manual is the latest edition by checking the NAVTRA number and the letter following the number in the most recent edition of the List of Training Manuals and Correspondence Courses, NAVTRA 10061 (revised).

The current editions of Basic Military Requirements, NAVPERS 10054, Military Requirements for Petty Officer 3&2, NAVPERS 10056, and Military Requirements for Petty Officer 1&C, NAVPERS 10057, provide information mostly on general military subjects. The manuals also contain information on the enlisted rating structure; how to prepare for advancement; how to supervise, train, and lead other men; and how to meet your increasing responsibilities.

The basic training manuals—Tools and Their Uses, Blueprint Reading and Sketching, and Basic Electricity—are available for the use of all rates and ratings, as needed. Their use by Opticalmen is essential.

For a complete listing of Rate Training Manuals, consult the List of Training Manuals and Correspondence Courses, NAVTRA 10061 (revised).

OPTICALMAN 1 & C

Ratings (1)	Publications Titles (2)	Text Identification Number (3)	Correspondence Course Identification Number (4)	Applicable Rate Levels (5)
----------------	----------------------------	---	---	-------------------------------------

GROUP IV. PRECISION EQUIPMENT

OPTICALMAN (OM)	*Opticalman 3 & 2	NavPers 10205-A	91386	E-4, E-5
	*Opticalman 1 & C	NavPers 10206	91389-1A	E-6, E-7
	Ordnance Pamphlet	1417		E-4
	Basic Handtools	NavPers (1) 10085-A	91228-1E	E-4
	Basic Electricity	NavPers 10086-B	91224-E 91226	E-4
OPTICALMAN (OM) (Continued)	NavShips Manual, Periscope-Sub- marine types 8B and 8C	324-0447		E-6
	NavShips Manual, Periscope-Sub- marine type 2D	324-0487		E-6
	Engineering Administration	NavPers 10858-D	10992-A2	E-8
	Physical Measurements	NavAir 17-35QAL-2		E-8
	Gunner's Mate G 3 & 2 (Chapters 12, 13)	NavPers 10185-A		E-8
	Ordnance Pamphlet	1857		E-5
	Blueprint Reading and Sketching	NavPers 10077-C	91223-3A	E-5
	NavShips Manuals, Vols. I & II	0924-007-7010		E-6
	Periscope-Submarine type 15	0924-007-7020		E-6
	Ordnance Pamphlet	1858		E-6
	Ordnance Pamphlet	2531		E-6

Figure 1-1.—Sample bibliography (OM).

148.344

Correspondence Courses

Naval correspondence courses are self-study media for providing instruction to personnel in professional naval subjects. They play an important role in helping enlisted personnel train for advancement and in meeting their job requirements. Enlisted personnel may enroll in three kinds of correspondence courses: Enlisted (ECC), Officer-Enlisted (OCC-ECC), and a combination of the ECC and the functional individual training system (ECC-FITS). There is an ECC based on this Rate Training Manual.

TRAINING FILMS

Training films are valuable sources of information on many technical subjects. The United

States Navy Film Catalog, NAVAIR 10-1-777, lists titles and descriptions of films which have been authorized for training and information in the Naval Establishment. This catalog also contains instructions on how to obtain film prints. Catalog supplements are published periodically to provide new listings and corrections.

When selecting a film, be sure to note its year of production which is given in the catalog. Procedures sometimes change rapidly, thus some films become obsolete rapidly. If obsolete only in part, a film may be shown effectively if before or during its showing you point out to trainees the parts that have changed.

CHAPTER 2

ADMINISTRATION AND SUPERVISION

The mission of a repair ship or tender is to make repairs and alterations to ships tended. With this in mind, ships and submarines will be assigned availabilities normally alongside, or near a repair ship or tender. The needs of the ships are normally accomplished in a specified period of time. The ships submit work requests for accomplishment of repairs and these work requests are reviewed, discussed, and details are smoothed out. Communication between ships undergoing repair and the repair officer must be maintained. Progress of work requests is reported, and departure reports are made out at the end of certain availabilities. To aid in the accomplishment of the mission of the ship, you must be able to efficiently organize, supervise, and train your work center personnel. A knowledge of the information presented in this chapter should help you in performing your duties.

As an OMI or OMC, one of your major responsibilities will be to supervise the repair and overhaul of optical instruments. In order to supervise optical shop work most efficiently, you will rely mostly on your past experience in shop work and repair procedures. In addition to this, you will be required to maintain certain records and reports, conduct and supervise an effective training program, and give accurate estimates as to the time required to complete repair work.

It is impossible to cover all the procedures and problems that you will be confronted with as a work center supervisor. By studying this section, you will become aware of some of the things that occur, particularly in regard to the job of setting up shop procedures, and the methods by which everyday problems are solved in an optical shop.

THE REPAIR DEPARTMENT

As an Opticalman First Class or Chief Opticalman, you have a definite need for a thorough understanding of department and division organization and administration.

REPAIR DEPARTMENT ORGANIZATION

The primary function of the repair department is the repair and maintenance of ships (and equipment) assigned by higher authority. A secondary mission of the repair department is the repair of own ship's machinery and equipment. When your assignment sends you to duty ashore, you will work within the framework of an organization having a mission similar to that of a shipboard repair department. A thorough understanding of the team spirit that prevails in the repair procedure will give you a clearer picture as to where you fit into the scheme of the total repair mission.

A department is the backbone of the organizational structure of the ship. The department is limited to certain clearly defined functions such as those related to engineering, repair, or gunnery. This organizational structure permits the commanding officer to delegate responsibilities to lower levels of authority while maintaining overall control and responsibility for the operation of his ship.

The department is subdivided into divisions with respect to smaller areas of responsibility within the department. The head of a department is responsible to the commanding officer for the operation of his department. Departmental and divisional assistants are responsible to the head of department.

As an Opticalman and a supervisor, you will be concerned with the organization of the repair department and the divisions within it. Figures 2-1 and 2-2 show the organization of repair departments aboard two types of repair ships. Notice the structure is basically the same even though the optical shop appears in different divisions.

Repair Officer

The primary responsibility of the repair officer is the maintenance of a well-organized and efficiently operated repair department. To

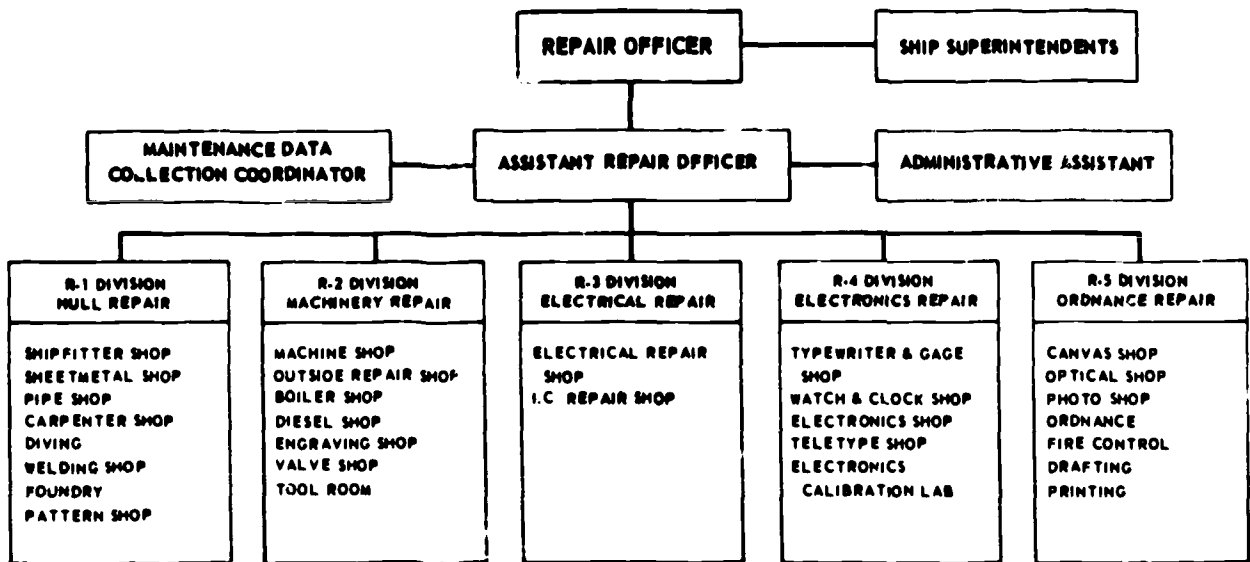

63.10-AR

Figure 2-1.—Organization of repair department on typical repair ship (AR).

accomplish this he issues and enforces departmental orders, he makes frequent inspections to ensure the maintenance of proper standards within the department, and he reviews personnel problems in such matters as training, assignments, and leave. In addition, the repair officer is responsible for operation within the allotment granted or for requesting additional funds when necessary.

The repair officer reviews work requests received. When required, he makes recommendations to the commanding officer regarding the acceptance or rejection of individual jobs according to the capabilities and current workload of the repair department.

Assistant Repair Officer

The assistant repair officer is charged with the responsibilities of the repair officer in the latter's absence; he otherwise discharges such responsibilities as may be delegated to him. He is usually charged with the internal administration of the repair department, the handling of department correspondence, the maintenance of adequate files and records, and the preparation of reports. The assistant repair officer is responsible for the details of the training program for personnel in the repair department. The routing of work requests is also his responsibility, as is the dissemination of any information

(such as department orders) necessary to the welfare of personnel.

In addition to general office administration, the assistant repair officer may be assigned the more specific jobs of keeping progress data on all outstanding work, supervising the photographic laboratory, supervising the drafting room, and preparing requisition data for special material. To perform this latter function he works closely with the supply department in order to expedite the preparation of requisitions and to initiate followup on outstanding requisitions.

DIVISION OFFICERS

Take another look at the repair department division listed in illustration 2-1.

All division officers in the department are responsible for the functions listed below their division designation on the chart. Your division is responsible for ordnance systems repair, and it is generally comprised of the following work centers: optical, fire control, ordnance control, fire control (sonar and underwater), canvas, and instrument.

Duty Repair Officer

A duty repair officer is a repair department officer assigned to serve in this capacity from

OPTICALMAN 1 & C

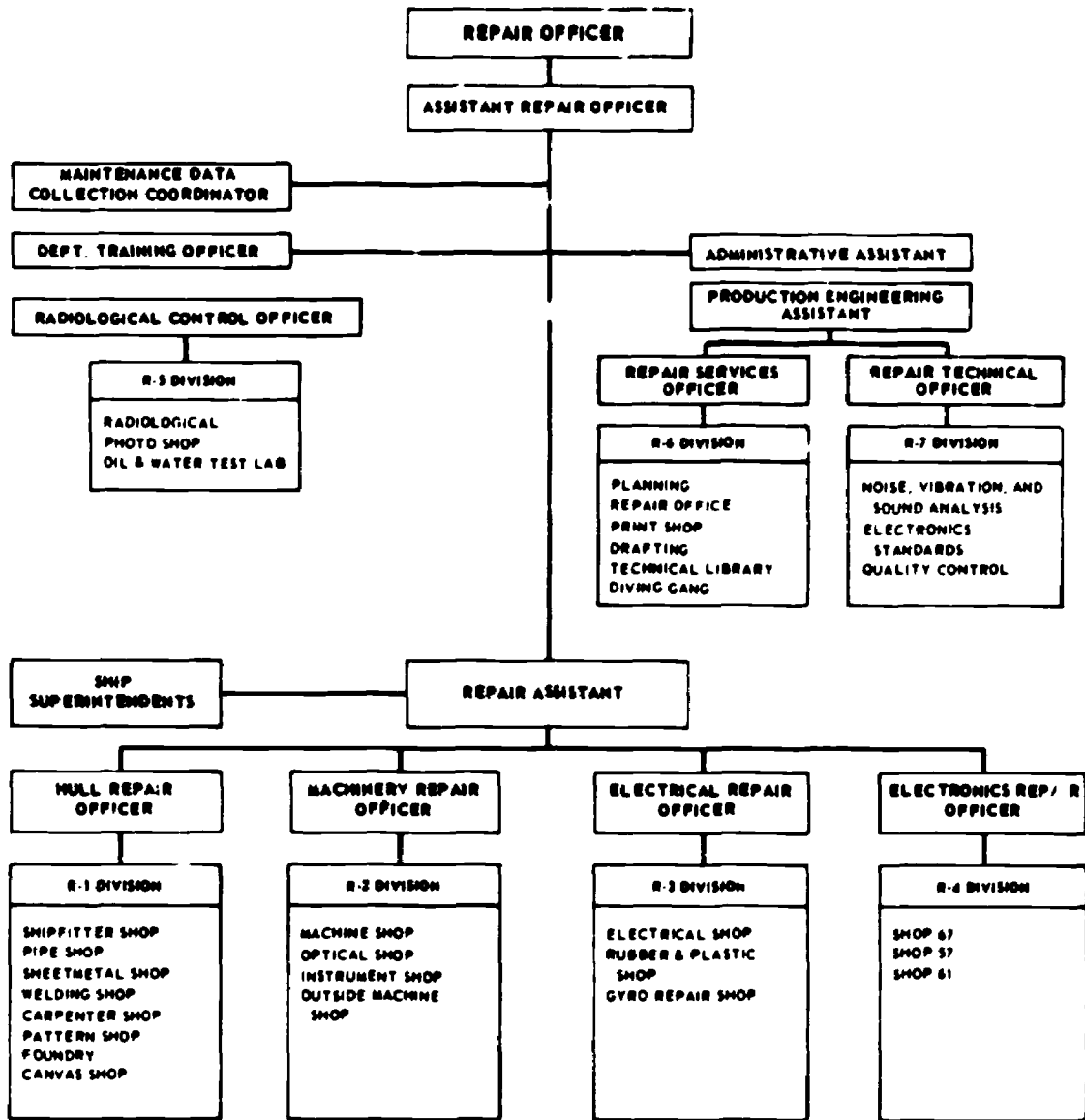

63.10-AS

Figure 2-2.—Organization of repair department on fleet ballistic missile submarine tender (AS).

0800 to 0800 the following day. His responsibilities include the following:

1. Assuming the duties of the repair officer and assistant repair officer in their absence.
2. Inspecting frequently, after normal working hours, repair department working and living spaces.
3. In port, making 2000 reports to the command duty officer relative to the security of the department, the men and boats away from the

ship on repair work, and the approximate time the work center will secure.

4. Reporting to the repair officer, or the assistant repair officer, prior to 1600 on work days for briefing of repairs to be accomplished after normal working hours.

5. Approving, expediting, and supervising emergency repair work after normal working hours.

6. Calling the repair officer when necessary, and performing all assigned duties.

Duty Repair Chief Petty Officer

Each day one chief petty officer from the repair department is assigned the duties of duty repair chief. His tour of duty commences at 0800 and ends at 0800 the following day. He must:

1. Assist the duty repair officer in the performance of his duties.
2. Muster the watch section immediately after quarters, and determine at this time whether men appointed to watches were instructed concerning their duties. NOTE: Watches and duties involved are listed in the Repair Department Organization and Regulations Manual.
3. Inspect berthing spaces and repair department spaces on an AS NECESSARY basis (and after normal working hours) for cleanliness, safety and fire hazards, locked tool cabinets and storerooms; and he must take prompt action whenever necessary by calling the division duty petty officers to have deficiencies corrected.
4. Make inspections of repair department living quarters at reveille and see that duty division petty officers hold reveille promptly.
5. Report to the duty repair officer prior to taps and accompany him in making his inspection of repair department spaces. Deficiencies must be corrected on the spot. Unsatisfactory conditions must be reported by memorandum to the repair officer.

Duty Division Petty Officer

Each day one LEADING petty officer from each division's duty section is assigned as duty division petty officer. On normal work days, his tour lasts from the end of the normal work day until 0800 the following day. On Saturdays, Sundays, and holidays, his tour of duty lasts from 0800 to 0800. His duties include:

1. Inspecting division work center spaces at the end of working hours for security, and making a report to the duty repair officer at 1600 and 1900.
2. Informing the duty repair officer concerning the progress of urgent repair work.
3. Seeing that only authorized personnel use machinery, and that workers are complying

with existing orders, instructions, and safety precautions.

4. Making certain that no fire hazard or accident hazards exist in berthing and work center spaces.

5. Ensuring that tools found adrift are returned to toolrooms and that the toolrooms are locked.

6. In the absence of the work center supervisor, taking charge of the repair work of his division after normal working hours.

SHIP REPAIRS

You may be assigned as ship's superintendent or as a repair department progressman. These jobs require considerable knowledge of repair procedures, especially those relating to administrative practices for processing work requests and for maintaining logs and reports to provide the repair officer with information on the status of work being done on ships alongside. The responsibilities of ship's superintendent and progressman often overlap and you may perform both functions at the same time.

Collectively, the duties of a ship's superintendent and progressman are:

1. Act as coordinator of work on the ships assigned to you.
2. Act as liaison between the ships and the tender in regard to repair department jobs.
3. Report daily to the commanding officers or their representatives of the ships assigned to you, to ensure that the work is progressing satisfactorily as far as the ship is concerned.
4. Report on Friday of each week, to the repair officer, the status of each job, bringing to his attention any high priority job that is lagging. Include in this report recommendations as to the shifting of work, material procurement, and whether or not the job can be completed on time.
5. Maintain a daily progress report or chart which will indicate (a) the percent completion of each job, (b) the availability of plans, sketches, or samples, and (c) the availability of material required for each job.
6. Maintain a followup check on material ordered, to ensure the timely receipt of the material.
7. Obtain signatures from officers concerned in case of cancellation of a work request.
8. Notify the ships to pick up completed material on the tender.

9. Secure signatures from officers concerned on completion of work requests.

10. Notify ship's personnel to witness tests on machinery, compartments, and tanks, occasioned by work performed.

A thorough knowledge of the information included in the following sections will be helpful in the efficient performance of your job as ship's superintendent or progressman.

Repairs and Alterations

Work done to repair and improve ships may be divided into the general categories of (1) repairs, (2) alterations, and (3) alterations equivalent to repairs.

A REPAIR is defined as the work necessary to restore a ship or an article to serviceable condition without change in design, in materials, or in the number, location, or relationship of parts. Repairs may be accomplished by ship's force, by repair ships and tenders, or by naval shipyards or other shore-based activities.

An ALTERATION is defined as any change in the hull, machinery, equipment, or fittings which involves a change in design, in materials, or in the number, location, or relationship of the parts of an assembly, regardless of whether it is undertaken separately from, incidental to, or in conjunction with repairs.

Alterations must be authorized by competent authority. The two types of alterations that are of primary concern to you are NAVALTS and SHIPALTS. A NAVALT is an alteration that affects the military characteristics of a naval ship.

A SHIPALT is an alteration under the technical cognizance of the Naval Ship Systems Command, regardless of whether or not it affects the military characteristics of the ship. Thus an alteration might be only a SHIPALT or it might be both a SHIPALT and a NAVALT. The same principle applies to alterations under the technical cognizance of other systems commands. For example, an ORDALT (ordnance alteration under the cognizance of the Naval Ordnance Systems Command) might be only an ORDALT or it might be both an ORDALT and a NAVALT.

Arrival Conference

When a ship comes alongside for a regular tender availability, an arrival repair conference

is usually held immediately. The conference is attended by representatives of the ship, of the repair department, and (usually) of the type commander. The relative needs of the ship and the urgency of each job are discussed. The arrival repair conference serves to clear up uncertainties for repair department personnel who have received and studied the work requests.

Arrangements are also made for the repair ship to provide the primary services of steam and electricity in sufficient quantity to take care of heating and lighting requirements and to provide limited power for ships alongside. In addition to these services, the repair ship takes over communication watches. Fresh water and fuel requirements are not usually supplied except from barges.

Departure Reports

A departure report is a special report and is prepared by the repair ship or tender for ships undergoing a regular tender availability. The departure report contents may vary from one ship to another, but normally they contain the following entries: Ships accounting number, maintenance control number, item of repair, shops assigned, date completed, man-hours required, number of work requests assigned to the ship, number of work requests cancelled, number of work requests not completed, and reasons for cancellation and not completed jobs.

DUTIES AS A SUPERVISOR

As a leading petty officer, you should know what work is done and what equipment is used by personnel of other Engineering and Hull group ratings. Although it is true that many maintenance and repair jobs can be properly handled within your own division, some jobs will require skills and equipment found only in other divisions.

A cooperative attitude is a requisite of good leadership and supervision. You should show a cooperative attitude when dealing with your men and with men not assigned to your work center, whom you may have to instruct and supervise. Your attitudes will have a definite effect upon the attitudes and the actions of these men.

As an OMI, you may work with a chief who will assign you to handle the operational routine of the optical shop. The chief will depend upon you to help him with many tasks and to

accept any necessary responsibility. Therefore, you must be prepared to assume complete responsibility for the operation of the shop when you are required to be the leading PO.

REPAIR DIVISION WORK CENTER SUPERVISOR

The leading petty officer in each work center is generally the work center supervisor. His duties will be yours when you are the leading petty officer in an optical shop, and they include:

1. Planning, scheduling, and maintaining (under the division officer) the work center work load.
2. Expediting the completion of work requested, and ensuring by frequent inspections that repairs are accomplished in a satisfactory manner.
3. Advising your division officer relative to production lags.
4. Maintaining order and discipline in the work center.
5. Keeping work center equipment clean and in excellent condition, and work center spaces free from fire and accident hazards.
6. Posting operating and safety instructions on all portable and stationary work center machinery and tools.
7. Ensuring that work center personnel are proficient in the operation of ship's equipment and tools before they are assigned (authorized) to use them.
8. Enforcing safe work habits, taking every precaution to prevent injury to personnel and damage to work center equipment because of carelessness and/or improper operation; and if necessary, removing a machine operator from a job.
9. Ensuring that each machine operator takes proper care of and keeps his machine clean.
10. Signing custody receipts for tools and equipment issued your work center, as required; and keeping records of tools issued and taking inventories as directed.
11. Making certain that tool room custodians keep tools in good condition and that they requisition replacements for worn or broken tools. NOTE: In order to maintain proper accountability for tools, keep a check-out and a check-in sheet on tool issues and receipts.
12. Making recommendations on special requests submitted by subordinates in the work

center. (Explain reasons for disapproval to the division officer.)

13. Having the person in charge of a job sign his name in the block provided on the work request (when he completes the job). NOTE: Sign your own name also to indicate that you inspected the work and found it satisfactory.

14. Informing the division duty repair petty officer at the end of the working day of urgent work which must be completed during the night.

Planning the Work

The optical shop supervisor, with the assistance of his leading petty officers, must plan each phase of each job that is assigned to his shop. The planning of the day's work must include the lead jobs, the assist jobs from other repair work centers, the routine upkeep and maintenance, and nonproductive work such as working parties. Lack of good planning will usually result in confusion, delay, and sometimes failure to meet the commitments of the work center. The supervisor must plan for the coordinating of the various steps in the work. This involves consideration of available manpower, equipment, materials, and the workload of the other repair work centers.

Planning does not stop in the work center. The repair officer must know how many productive man-hours are to be available for repair work, during a specific availability, to enable him to know how much work can be accepted during that period of time. This is where estimating comes into the picture. The work center supervisor must have the ability to give an accurate estimate of the time that each of the jobs assigned to his work center will consume. To do this, he will rely heavily on his past experience and the experience of his leading petty officers. He must also estimate the nonproductive man-hours that will be required to meet his work center's obligations to provide for working parties, mess cooks, special liberty, etc.

In planning the work, the capabilities of the men must be considered. Assigning an inexperienced man to a difficult job requires that an experienced man be on hand to give direct supervision at all times. If the work load of the work center is light, this is a good training opportunity. However, if the work center has a heavy workload the inexperienced man would be of more value assigned to a job requiring skills more in line with his ability.

Another question to be answered is the number of men required to accomplish the job. Too many men working on the same piece of equipment is sometimes worse than not enough. Each job will have to be analyzed step by step and then the required number of men assigned.

Still another factor that must be considered is the necessary materials to accomplish the needed repairs. What kind of materials, how much is needed, where is it obtainable, and how much time will be taken to obtain it, are all questions that must be given much consideration. Possibly the material called for in the blueprint is no longer available. The research required in finding a suitable substitute takes time. These factors all must be considered by the supervisor of the optical shop.

There are some materials that can be kept in the optical shop in sufficient quantities to avoid delay caused by frequent trips to the issue room. For some items a 30-day supply is adequate, for others, a 90-day supply may be necessary.

Usually, the OM1 or OMC will know from experience where each item is in the work center; he keeps his locator file in his head. He should also attach a list of the contents to each drawer or cabinet so that the rest of the men in the work center will also know where things are stowed. Remember the importance of good housekeeping in getting the work out. Have a place for everything and keep everything in its place. It is also important that your storage facilities have adequate provision for securing for sea.

Estimating the amount of material required to complete a job is your responsibility. Unless you are able to estimate with accuracy the amount and kind of materials required by your work center, you will either be caught short without the items you need or you will find your work center cluttered with items you do not need. A high inventory level of slow moving materials ties up division funds that might be used to better advantage. Remember that running a work center is like running a business; you must operate within a budget. Much of the guesswork in estimating can be eliminated if you make proper use of records of material expended during the previous quarter. Include the amount of material required for any special work which you know is to be done during the period for which you are estimating. Plan and place work center orders for materials in advance with the supply officer through the division

officer or department head. Do not bypass any of the normal supply channels of authority.

Inventory levels for most consumable items and repair parts are maintained by the supply department. Aboard repair ships or tenders, the OM1 or OMC will assist the supply officer in maintaining the inventory on optical parts. Usually a high limit will be kept on hand. Before the low limit is reached, the OM1 or OMC will request that material be obtained to replenish the stock and maintain the high limit supply. In ordering, take into consideration the rate of use, the balance on hand, and the expected delay in shipment and delivery. Information concerning the procurement, custody, and inventory of repair parts and other supplies is covered in Military Requirements for Petty Officer 1 & C and in Military Requirements for Petty Officer 3 & 2.

In planning a job, the CPO or PO1 in charge of the work center must first perform the job step by step mentally. This procedure will help prevent the unintentional omission of some important step of the job. Once the steps are outlined, consideration should be given to each step to make sure that all requirements are taken into account.

After the job has been analyzed, the sequence of the operations must be determined. In some jobs the more time consuming operations may be performed first so that the largest part of the job is completed first. In other jobs, the less time consuming operations may have to be done before any other operation can be performed.

Once the planning of the work has been done, follow the plans carefully. However, it is also necessary to be flexible, in order to meet any unforeseen circumstances or make emergency repairs. If a change in plans is indicated, the supervisor must reevaluate the whole plan and make such changes as he believes necessary. Careful planning and the followup of these plans will enable you to run your work center with the utmost efficiency and productivity.

Laying-Out and Assigning Work

A Navy optical shop is primarily concerned with repair work. The assignment of work changes constantly according to the amount and type of work being done in the work center. When the workload is light, the less experienced men may be assigned to a complicated job under

the supervision of an experienced petty officer. When the workload is heavy the most experienced men will have to be assigned to the complicated jobs and to those jobs that are of an urgent nature. At times reassignment of work must be made to prevent delays, to accomplish added new work, or to expedite emergency jobs.

INFORMATION ON INCOMING JOBS.—Work requests generally will be received in the work center several days in advance of the work. The work center supervisor should start his planning as soon as possible to gain an advantage of time. Much of the planning may be done before the work is delivered to the work center. Jobs that have been done before may be planned in such a manner that the necessary repair parts are on hand.

PRIORITY OF JOBS.—In planning and scheduling work in the work center you will have to give careful consideration to the priority of each work request. Priorities are generally classified as urgent, routine, or deferred.

Deferred jobs do not present much of a problem, as they are usually accomplished when the workload of the work center is light and there are few jobs of a higher priority to be done. Also, when these jobs are approved it is with the understanding that they will be accomplished when the time, personnel, and equipment are available.

The majority of work requests will have the routine priority assigned to them. Routine jobs make up the normal workload of the work center, and must be carefully planned and scheduled so that the daily organization and production can be maintained at a high standard.

The urgent priority jobs require immediate planning and scheduling. Other jobs, of lower priority, may have to be set aside so that these urgent jobs can be accomplished. At times it may be necessary to assign men to a night shift so that these jobs can be completed on time.

DETERMINATION OF REQUIRED REPAIRS.—When a job is delivered to the work center, one of the first things to be done is to determine what kind of repairs are required. This is where the years of practical experience and up-to-date knowledge on different types of repair procedures are invaluable. During the planning stage, check with some of the leading petty officers in the work center for ideas on how best to accomplish the necessary repairs.

Perhaps one of them may have done the same job before. It may be possible to assign some of the planning work to them; for example, a job of overhauling a periscope may be given to a man in the work center who has demonstrated his ability to do this type work.

After the necessary repairs have been determined, the work center supervisor must ascertain that the repair parts or materials are available. If they are not available on board, they must be requisitioned through the supply department. The activity requesting the repairs may even have the necessary repair parts on hand. If so, they may be used by the repair activity and then replaced when available. Frequently, the repair parts must be manufactured or possible temporary repairs made to the old parts. Matters of this nature must be cleared up before the job is laid out and assigned to less experienced personnel in the work center.

Estimating Time for a Job

Estimating time for the completion of a job requires considerable thought and foresight. Upon your estimate may depend the success or failure of a ship to meet its operational commitments. Failure to complete a job in the allotted time can result in considerable unnecessary expense and loss of valuable time. Each estimate that you make must be realistic, accurate, and dependable. An estimate, in a very real sense, is a guess, but it should be an intelligent guess based on the proper use of records and experience.

For most of the routine jobs that come into the work center, the work center supervisor may give a quick estimate of the probable time of completion. Generally, there is no necessity for completing routine jobs within any set time as long as the repairs are completed before the end of the availability, and in sufficient time for the ship's force to install the repaired equipment.

The estimation of time required to complete jobs of an urgent nature (priority) must be given considerable thought. If a last minute job comes up near the end of the repair period, or if a ship in port for only a day or two requires an urgent repair job, the time required to make the repairs is an important consideration. In jobs such as this, the time estimate must be extremely accurate to avoid the waste which would result from starting a repair job that could not be completed. Frequently, the

final decision will be made by the OM1 or OMC in charge of the optical shop; because of his experience in repair work, his knowledge of the current workload, and his knowledge of the men and machines in the work center, he should be able to give an accurate estimate of the time required to complete almost any repair job.

TEARDOWN TIME.—In any repair job, the instrument to be repaired is disassembled only as much as is necessary to enable the repairs to be made without damage to other parts of the equipment. The teardown time is that time required to disassemble a piece of equipment after it has been delivered to the work center. The teardown time is then doubled to allow sufficient time for reassembly. If it is necessary to do any dismantling before delivery to the work center, an estimate of this time will be made by the ship's force (customer ship) or by other repair department personnel.

MISCELLANEOUS TIME ALLOWANCE.—The final factor to consider in estimating time is often overlooked. This is the time that falls into the category of miscellaneous. Some of the miscellaneous factors are: fatigue from mind and muscle exercise, personal time allowances such as head calls, rest breaks, or meals, and such other items that would not fall into any of the other categories given here.

Once you have made an estimate of time required to complete the job, make a record of it so that you may refer to it later. Once the job has been completed, compare the actual time expended against your estimate. By doing this, you will be able to improve your man-hour estimating skill.

Workload Considerations

The workload of the work center must be carefully considered before a new job is approved for completion within a certain time.

After a decision has been made as to what repairs or replacements are necessary, the petty officer in charge will be able to determine what tools and personnel should be used for the job. The next step is to check on the present and scheduled work. If an urgent priority has been given to the new job under consideration, then the work being done by the repairman will be set aside until the proposed job has been completed. If the new job does not have an

urgent priority, it must be dovetailed, in accordance with its priority, into the schedule of work being done.

Another item that must be decided is the number of hours per day that will be assigned for personnel to work on the new job. If it is to be a routine job, normal working hours will be considered. If it is a rush job with an urgent priority, three shifts will be assigned to the job and men will be working 24 hours a day on it.

In brief, the selection and assignment of personnel will depend upon the magnitude and complexity of the new job under consideration as well as its assigned priority. This in turn depends upon the workload of the shop, except where the new job is given an urgent priority.

Required Parts and Material

After a decision has been made as to the extent and nature of repairs that are required, a check must be made to see if the required material and parts are on board ship. The material must be available before an attempt is made at estimating the time of a repair job. Such items as gaskets, studs, bearings, and shaft keys that may be required must not be overlooked.

Naval ships carry an allowance of repair parts for machinery and equipment on board ship. A check of the ship's COSAL will show if a certain part is supposed to be carried on board. There have been instances where this check has been overlooked. There is certainly no need to manufacture an item such as a gear if the ship carries gears for the instrument that requires repair. Locating available repair parts will save a great deal of time in doing the repair job, and one's estimate can be made accordingly.

Consideration of Things That May Go Wrong

Experience is an excellent teacher of things that may go wrong when doing a repair job. An experienced supervisor can avoid many of the difficulties that may arise in performing repair work. When planning and estimating a repair job, the possible difficulties that may arise should be carefully considered, and extra time allowed for them. Adequate blueprints or other drawings should be on hand. If you have sufficient information before starting the job, and

a clear view as to the total amount of repair work that will be required, it is easier to avoid mistakes and delays.

The repair job itself may cause a certain amount of breakage or damage; and the supervisor who has estimated 30 minutes for removal of the parts may find that the whole job actually takes 4 hours.

Failure to ensure that a man fully understands the details of the work may result in spoiled work. While the supervisor may have all the details on the job, this is not sufficient if the man doing the job ruins it because of lack of information or a misunderstanding as to what should have been done. The supervisor must make sure that the detailed instructions are thoroughly understood by the men doing the actual work. Some relatively inexperienced men fear to appear ignorant and want to make a good showing by saying that they understand the instructions, without fully appreciating what is meant. When the job, or part of it, has to be done over, the original estimated time of completion will no longer hold true.

When the unit that is to be repaired consists of a number of assembled parts, there may be difficulties in removing the various parts. Parts may be rusted or frozen so that it is extremely difficult to remove them. On the original inspection of the items in need of repairs, the supervisor should watch for any indication that the unit may be difficult to disassemble. Then he should make an extra allowance of time in his estimate to cover this phase of the repair job.

If an item fails to pass any required tests after repair, additional work will be necessary. The required tests, and the possibility of additional work associated with tests, must be considered when making an estimate of time required for the repair job.

The time required to deliver the instrument to the work center should not be included on estimated time to do a repair job in the work center. When boat and crane service are involved in a proposed job, this fact should be brought up for consideration by the person or activity requesting an estimate of the time required by the optical shop. When requested to estimate this time of transportation, the supervisor of an optical shop should make an estimate, distinct and separate from that for the work of his own work center. Boat and crane service may be unpredictable at times, and the supervisor should check with the officer of the

deck and the crane operator before making an estimate of this kind.

When planning on the required personnel for the job, a check should be made for the possible inspections, drills, and working parties that may occur which will delay the repair job. If the assigned men cannot be excused from these activities, extra time must be added for the completion of the repair job.

The factors discussed do not make a complete list of things that may go wrong on a repair job, but they indicate the type of things which will have to be considered when estimating the time required to do a repair job.

Supervising Repair Work

One of the most important duties of a First Class or Chief Opticalman is that of supervising the repair work in the optical shop. The supervisor must instruct work center personnel concerning the different repair jobs which have to be done; he must check on the progress of the work, and give additional advice or instructions when necessary; and he should check the completed job to see that it has been done properly and in accordance with his instructions.

After the supervisor of the optical shop has obtained complete information on a new job and has decided what repairs or replacements are necessary, he must then decide who is to do the job. In order to make this decision, the supervisor must know what experience the men have had with different types of repair work, and what skills they have in operating the various machine tools.

The shop supervisor should see that all items coming into the work center are properly tagged. The men in the work center should be instructed to replace any tags which have been removed in order to overhaul an instrument. The mixup of some items, can cause, at the very least, a lot of unnecessary confusion and lost time.

Checking the Progress of Work

The assignment of a job is only the first step in processing a job through the work center. The supervisor of an optical shop must know his men. He should have a fairly good idea of each man's skill, ability, and knowledge for accomplishing the repair work.

The best way in which the work center supervisor can obtain this knowledge is to inspect the work center frequently and check the progress

of the various jobs in the work center. In that way, the supervisor will have a good idea as to which jobs, or which men, will require the most checking or inspecting.

When checking on the progress of work, the supervisor should be sure that the men are observing proper safety precautions in regard to themselves and the machines that they are operating.

In the case of any doubt, the supervisor should check that the men understand his instructions properly or are doing the work correctly as indicated by the blueprint or drawing. If necessary, the supervisor should provide additional instructions to give a better understanding of the job, or to improve workmanship. By frequently talking to the men and answering their questions, the supervisor can prevent jobs from being spoiled, as might happen if we were not available to give the correct details on the jobs. The supervisor who has interest and confidence in his men and their work will find that men have confidence in him as a good work center supervisor.

Complications may develop on some repair job, which may require additional planning and revised repair procedures. By observing the progress of the various jobs, and whether any are ahead or behind the planned schedule, the supervisor will be able to change the schedule of some jobs in order to prevent "bottlenecks" and to keep the most important jobs moving.

Checking on Completed Jobs

When a job has been completed in the work center, the supervisor should inspect and approve the job. Inspection is necessary to ensure that the repair job or the manufactured replacement parts will be satisfactory both to the repair activity and to the ship's force that is going to use and depend upon the equipment that has been repaired. Inspection of parts may be accomplished either visually or by means of measuring instruments. In addition, when applicable, tests are performed to check the condition of repaired equipment.

The completed work request should show the man-hours, the material used, and a full description of the work accomplished. In addition, the necessary records and paperwork should be correct and up to date. When the job has been completed, the interested parties should be notified as soon as practicable; completed jobs

should not be left to accumulate, as some of the items may become mixed up, damaged, or lost.

Before releasing a completed item, the work center supervisor should check to be certain that: (1) The correct work request is signed by a representative of the requesting activity, (2) the identification on the item and on the work request coincide, and (3) all manufacturers' technical manuals and blueprint furnished with the work request are returned.

RECORDS AND REPORTS

As you advance in rating to OM1 or OMC, you will be required to assume more responsibility for the paperwork which is so necessary in a well organized work center. In fact, to avoid bogging down completely in the mass of details, you will probably delegate some of these duties to an assistant in the work center. Keeping all your records up to date will enable you to keep a close check on each job, each workman, and each piece of equipment under your supervision.

Introduction of the 3-M system aboard all tenders has eliminated the requirement for many of the records and reports used in the past. Feedback information is supplied to each division officer and work center supervisor on work request progress by the various reports generated by the 3-M system. For example, the work center supervisors report includes, for each work request, such information as the completion status, man-hours expended and remaining, required completion date, and priority. The key to using the 3-M system to your benefit is to avoid duplication. Do not maintain records when the information is readily available elsewhere. At the same time, you will need to maintain records of information not readily available elsewhere, such as a shop equipment log, record of commonly used Federal Stock Numbers (FSN), and any other record you feel is required. Standard forms are available for records and reports. Further information on records and reports may be found in NavShips Technical Manual, chapter 9004(6).

3-M UTILIZATION AND DOCUMENTATION

The Navy, as well as the other armed services, is required to maintain all weapons systems in the maximum possible degree of combat

readiness. Previous systems for controlling and accomplishing required maintenance could not keep pace with the growing complexity of shipboard maintenance, increased tempo of fleet operations and constant decline in available resources. The Maintenance and Material Management (3-M) System was implemented in 1964 in an attempt to solve these problems. The 3-M system was designed to function as an integrated system which would improve the management of maintenance, and provide for the collection and dissemination of maintenance related information.

The 3-M system is not envisioned as a cure for all equipment problems and attendant maintenance resource demands, nor does it eliminate the urgent need for good leadership and supervision based on experience and reasoned judgment. The system will, however, produce a logical and efficient approach to the solution of maintenance problems, and a large reservoir of knowledge about maintenance.

The 3-M system is an integrated management system which, when fully implemented and properly used, provides for orderly scheduling and accomplishment of maintenance and for reporting and disseminating significant maintenance related information. It is composed of the Planned Maintenance Subsystem, Maintenance Data Collection Subsystem, Workload Planning and Control Subsystem, and Man-hour Accounting Subsystem; it forms the nucleus of a shipboard maintenance program which can contribute significantly toward achieving improved fleet readiness with reduced expenditure of resources.

PLANNED MAINTENANCE SUBSYSTEM

The Planned Maintenance Subsystem (PMS) pertains to the planning, scheduling and management of resources (men, material and time) to perform those actions which contribute to the uninterrupted functioning of equipment within its design characteristics. It defines uniform maintenance standards, and prescribes simplified procedures and management techniques for the accomplishment of maintenance.

The PMS has been developed to provide each ship, each department and each supervisor, with the tools to plan, schedule and control shipboard planned maintenance effectively.

MAINTENANCE DATA COLLECTION SUBSYSTEM

The Maintenance Data Collection Subsystem provides a means of maintenance personnel to record information pertaining to preventive or corrective maintenance actions. The system uses coded data elements for recording much of this information in order to standardize the data collected and to facilitate its processing and use. The failure and corrective action information recorded on the maintenance action documents, and the material usage information recorded on associated supply documents, is retrievable through this system for engineering analysis and maintenance history.

Routine maintenance action reporting is actually accomplished on a multipurpose maintenance data collection form which, occasionally, is augmented by additional information reported on a related supplemental data reporting form. This maintenance data collection form (figure 2-3) is used in reporting the completion or deferral of a maintenance action, or to request needed assistance. The data elements which must be completed to report any one of these categories of maintenance information have been grouped together in separate, clearly labeled sections of the form, to simplify data recording and to facilitate automatic data processing.

A complete discussion of the PMS and MDCS may be found in the military requirements rate training manuals for PO 3 & 2 and PO 1 & C or in the 3-M manual.

MDCS success is dependent upon the accuracy, adequacy and timeliness of the information reported into the system. This, in turn, means that responsible activities can not effectively analyze fleet maintenance problems, develop improvements to fleet equipment, or produce usable fleet maintenance management products unless maintenance and repair personnel actively support and use the MDCS. It is a system in which potential benefits are directly related to the efforts applied. Present programs for improving maintainability and reliability of fleet equipment are dependent upon conscientious adherence to required reporting procedures. The following general guidelines will aid in ensuring complete, accurate and prompt MDCS document submission.

Work center supervisors will submit completed documents daily. To provide the information required by the MDCS, the OpNav 4790

OPTICALMAN 1 & C

OPNAV FORM 4790/2K (1 FEB)
N79-107-770-0002

REPORT SYMBOL OPNAV 4790-1

MAINTENANCE DATA FORM

MAINTENANCE ACTION

CHECK ONE

<input type="checkbox"/> COMPL	<input type="checkbox"/> DEFER	<input type="checkbox"/> WORK REQ
--------------------------------	--------------------------------	-----------------------------------

SHIP NAME/PLANT NUMBER			SECTION I			AS DISCOVERED INFORMATION			
1. UNIT I.D. CODE		2. WORK CENTER		3. JOB NO. NO.		4. EQUIP. I.D. CODE		5. PT	
6. IDENTIFICATION NUMBER		7. APL/ML		8. ALLOCATION (IMP ALT, DRG ALT, P/B DRG, ETC.)					

SECTION II - COMPLETED ACTION									
9. A/T		10. HRS HOURS		11. RAYING DATE		12. COMPLETE DATE		13. REPAIR DATE	
14. COMMENTS									

SECTION III - DEFERRAL ACTION PLANNING									
14. A/T		15. HRS HOURS		16. RAYING DATE		17. DEFERRED DATE		18. REPAIR DATE	
19. COMMENTS									

SECTION IV - REMARKS/DESCRIPTION						INSPECTION BOARD USE					
20. WORK NAME 21. COMMENTS 22. COMMENTS 23. COMMENTS 24. COMMENTS 25. COMMENTS 26. COMMENTS 27. COMMENTS 28. COMMENTS 29. COMMENTS 30. COMMENTS						31. TIME		32. CLASSIFICATION		33. U/S (1) (2)	
										S	
										Y	
										V	
										W	
										E	
										T	
										Z	
										CONT SHEET	
										SHEET NO	
34. CONTACT UNIT/NO			35. CONTACT SUPERVISOR NAME			36. CO SIGNATURE					

SECTION V - FAILED PARTS/COMPONENT							
37. QTY TO LAM		38. QTY PART NO.		39. QTY CODE		40. SERIAL NUMBER	
41. QTY PART NO.		42. QTY PART NO.		43. QTY PART NO.		44. QTY PART NO.	
45. QTY PART NO.		46. QTY PART NO.		47. QTY PART NO.		48. QTY PART NO.	

SECTION VI - SUPPLEMENTARY INFORMATION				REMARKS					
49. BLUE PRINTS, TECH MANUALS, PLANS, ETC. 50. COMMENTS				51. AVAILABLE ON BOARD YES NO		52. PRELIMINARY AND/OR ABNORMAL COMPLIANCE ACTION - REPAIRS		53. S C A C T I O N S S H I P P O B T Y P E	
54. SHOP		55. EST. N/M		56. DOC. N/M		57. LEAD P/S E CODE		58. PLANNER I.D.	
59. TOTAL HOURS		60. O/S DOLLARS		61. INTERNAL		62. DATE OF ESTIMATE - ARRIVAL (DAYS)			
63. TOTAL COST		64. JOB ORDER NUMBER		65. COMMENTS					
66. SHOP NO./REPAIR OFFICER			67. COMPLETED BY			68. ACCEPTED BY			

17.81K

Figure 2-3.—Maintenance Data Form OpNav 4790/2K.



series documents and the DD Form 1348 must be completed, as appropriate, for each reportable maintenance action. It is mandatory that all applicable blocks on the forms be filled in correctly, to avoid rejection during data processing and to ensure accurate information for maintenance history.

Past experience indicates that the guidelines presented in this chapter will be directly applicable and adequate, in most cases, but common sense and good judgment must be exercised in reporting any maintenance action, particularly those not specifically covered by these instructions and examples. The senior maintenance man actively engaged in the maintenance action is responsible for completing the required entries on the maintenance action form and submitting it to his supervisor for review, approval and forwarding.

THE WORKLOAD PLANNING AND CONTROL SUBSYSTEM

The Workload Planning and Control Subsystem (WLP&C) is a management system used in the repair and weapons repair departments of a tender/repair ship. The system provides for a systematic approach to the planning, scheduling, monitoring and reporting of all work accomplished.

The objective of the WLP&C subsystem is to give managers of intermediate level maintenance activities a method to effectively plan and control work accomplished. The system is divided into two phases. One is the planning and estimating of work to be accomplished, and the other is the reporting of work as it is being accomplished.

During the planning phase, work requests (OpNav Form 4790/2K) are received by the maintenance activity. These are screened and used to assign work centers to each work request and estimate the amount of work required. Initial planning action may be significantly changed by arrival conference trade-offs or priority designations.

The WLP&C subsystem is designed to operate within the departmental framework of the basic shipboard organization, and specifically the repair organization of an intermediate level maintenance activity.

The repair officer has primary responsibility for the effectiveness of the WLP&C subsystem within the repair department. The functions assigned to the repair officer of an

intermediate maintenance activity are considered to be those functions now being performed by them or their representatives.

The 3-M coordinator serves as the liaison between the work centers, data services and other personnel within the repair department. The coordinator is responsible for:

Distribution of all workload planning and control products generated by data services, screening and controlling 3-M related documents prior to submission to data services, returning all erroneous documents to work centers or ships concerned, analyzing collected data, and devising reports for the presentation of 3-M information when required.

Upon receipt of all work request documents from the coordinator, data services keypunches the appropriate card type for each document. Sheets 1 and 2 of the work request, work supplement cards, failed parts/components cards, and reports generated by the computer are returned to the coordinator for distribution and/or filing.

An original and two copies of a work request will be received by the repair department for each maintenance action desired. These will normally be delivered as a work package with appropriate screening approval for a scheduled availability period. It is extremely important that the work assigned to the work center, the start and completion date, and the estimate of man-hours be made as realistically as possible. Careful consideration should be given to the length of the availability, manpower available during the period, other work load commitments, and the availability of necessary tools, manuals, and other materials. The planning information entered on the work requests will be the basis of work center work load figures on various reports.

Repair Office Action

The initial action on a work request is performed by the coordinator and it is his responsibility to screen the work request for completeness, legibility, and validity of all entries. In addition, the coordinator will make the following entries, and forward all copies to the repair officer.

Block 39: Availability. Enter the code for the actual type availability under which the job will be accomplished.

Block 42: Repair Activity UIC. Enter the unit identification code of the repair activity.

Repair Officer

It is the responsibility of the repair officer to screen the work request and determine if there are problem areas and/or scheduling difficulties. After the initial review by the repair officer, the work request is returned to the coordinator. The coordinator removes sheet 3 and retains it as a record, forwarding sheets 1 and 2 to the appropriate division officer for job planning. The coordinator must provide each division officer with the expected date and duration of each scheduled availability.

Division Officer/Lead Work Center Actions

Upon receipt of sheets 1 and 2 of the work request the division officer, in conjunction with the lead work center (LWC) supervisor, assist work center (AWC) supervisors, and other involved personnel will plan the job for completion. To expedite processing, the LWC will obtain and document the planning information for the AWCs. The lead work center supervisor is responsible for documenting the following planning information. Enter the information on sheets 1 and 2 of the work request as follows.

Block 34: Initial Action Taken. Enter the appropriate acceptance or rejection code.

Block 35: Repair Work Center. Enter the code which identifies the work center with primary responsibility for completion of the job. When the work center code has only three symbols such as 35A, 35B, etc., enter from left to right in block 35, leaving the fourth space blank.

Block 36: Estimated Man-hours. Enter the estimated man-hours (whole hours) required to complete the lead work center's portion of the job.

Block 37: Repair Assist Work Center. If required, enter the code of the work center or outside repair activity that will assist the LWC. During initial planning if more than one AWC is involved, enter each additional AWC code and the estimated man-hours for each in the blocks labelled "SHOP" and "EST. M/H" provided at the bottom of the form.

Block 38: Assist Estimated Man-hours. Obtain and enter the estimated man-hours (whole hours) for the AWC reflected in block 37.

Block 40: Scheduled Start Date. Enter the Julian date the job is actually planned to be started.

Block 41: Schedule Completion Date. Enter the Julian date the job is actually planned to be completed. Sheet 2 will be forwarded to data services via the coordinator. Sheet 1 will remain on file in the LWC.

Procedures for Documenting Repair Activity Maintenance Action

The work center supervisor is responsible for the correct documentation of all maintenance actions accomplished within his work center. Preprinted/prepunched work supplement cards will be provided by data services. The Work Supplement Card (OpNav Form 4790/2F) will be used primarily to report daily job progress by repair work centers. The DOD Single Line Item Requisition Document (DD Form 1348) is the source document used to record material usage and cost information. Sheet 1 of the work request will be used by the LWC to close out the work request.

WORK SUPPLEMENT CARD OPNAV FORM 4790/2F.—Prepunched/Preprinted cards (fig. 2-4) will be supplied to the LWC and each AWC included in the initial planning phase of the work request. The cards will be used primarily by repair work centers to report daily progress (action taken, man-hours, date) on a work request. It may also be used to record remaining hours, report work delay/status and request additional prepunched/preprinted work supplement cards.

The LWC may use a 4790/2F card to request assistance. The AWC will use the same card to estimate their portion of the job and request prepunched/preprinted cards. Information from these cards is used for the workload planning and control reports. Handscribed (Blank) 4790/2F cards may be submitted whenever the preprinted/prepunched cards are not available by transcribing the appropriate information from the 4790/2K onto the blank card. Blocks 1, 2, 3, 4, and 35, must be transcribed. Blocks A through H of the card will be filled in as appropriate.

A 4790/2F card will be used to document all man-hours expended on each job in progress within the work center. The senior man actively engaged in the maintenance action is responsible for documenting daily progress.

Whenever the remaining hours as listed on WLP&C reports do not accurately reflect the scope of the job for this work center, this

UIC		WC		JSN		EIC		IU NO		LWC		A/C		MOON NAME																					
A IDENT NO		REMARKS:										B		C																					
B ACTION TAKEN		C MANHOURS		C TENTHS		D REMAINING MANHOURS		E ASSIST WORK CENTER		F DATE		G WORK DELAY		H REPLEN		I		J																	
UIC		WC		JSN		EIC		IDENT NO		A/C		LWC		MANHRS		REMAINING MANHOURS		A/C		DATE		JOB DELAY		MOON NAME										UIC	

Figure 2-4.—OpNav Form 4790/2F Work Supplement Card (Front). 17.81F

figure can be revised, either up or down, by simply entering the hours remaining on the job in block D. This can be done by submitting a 4790/2F, or may be included with daily progress information.

A 4790/2F card can be used to report work delays or work stoppage affecting satisfactory progress of a job. The lead work center and each assist work center may use the work delay/stoppages codes (block G) to reflect problems associated with the job in that work center. Work delay/stoppage codes are found on the reverse of the 4790/2F (fig. 2-5). There can be only one work delay/stoppage code effective at any one time for any specific work center. The latest delay code that is submitted will be reflected on WLP&C reports. The delay code 00 will be used to remove the delay status from that work centers WLP&C reports.

Replenishment of the prepunched/preprinted 4790-2F cards can be accomplished by submitting a card for that specific purpose or in conjunction with daily progress documentation by entering the number of cards desired (1-9) in block H.

When additional repair work centers are required to complete the requested work, the lead work center will provide the assist work center with two or more prepunched/preprinted work supplement cards. One is to establish the AWC job planning record, and the other is for

reporting progress prior to data services providing the assist work center with prepunched/preprinted work supplement cards.

Completion of a work request can be reported using a 4790/2F and entering the code 30 in block G. Assist work centers may also report completion of their portion of a job by using code 30 (block G) on the 4790/2F. Sheet 1 of the 4790/2K must be completed (section II) and submitted following the code 30 submission by a lead work center for the job to be closed out.

Occasionally jobs must be reopened after the lead work center or assist work center has reported completion (code 30 on 4790/2F). This can be accomplished by submitting another 4790/2F with the code 40 entered in block G. (Submission of a code 40 4790/2F card will remove the last action taken code from the data processing file. The job may be reestimated at this time by including an entry in the remaining hours block (D). If sheet 1 of the 4790/2K has been processed through data services, the entire job must be resubmitted (new 4790/2K).

Multiple unit work requests on items such as binoculars, printing, photographing, plaques, sound-powered phones, clocks, etc., are permitted by using the words "various" or "miscell" in block 9 of the work request. Block 9 of the prepunched 4790/2F card will always be blank when associated with this type work



CODE:	WORK NOT STARTED	
11. Not Delivered to Work Center	"NOT DELIVERED"
12. Insufficient Information	"INSUFF INFO"
13. Awaiting Parts/Material	"WAITG PARTS/MATL"
14. Lack of Manpower	"LACK MANPOWER"
15. Work Center Equipment Unavailable	"WC EQUIP UNAVAIL"
WORK STARTED BUT STOPPED		
21. Priority Changed	"STP-PRIORITY CHANGE"
22. Insufficient Information	"STP-INSUFF INFO"
23. Awaiting Parts/Material	"STP-WAITG PARTS/MATL"
24. Awaiting Assist Work Center	"STP-WAITG ASSIST WC"
25. Work Center Equipment Unavailable	"STP-WC EQUIP UNAVAIL"
STATUS CODES		
30. Completed-Not Signed Off	"COMPL-NOT SIGNED OFF"
40. Re-Work Required	"RE-WORK REQUIRED"
50-59. Special Purpose	"SPECIAL STATUS"

17.81F

Figure 2-5.—OpNav Form 4790/2F Work Supplement Card (Reverse) Work Delay and Status Codes.

request. These multiple items will always be documented as a single maintenance action unless rejection of individually serialized items is involved. When individually serialized items are rejected, the rejection action taken code must be on a one-for-one basis for each item. For nonserialized items or whenever rejection is not involved, the action taken code that best describes the overall effort will be recorded.

Procedures for Use of the Work Supplement Card by Lead Work Center

Block A: IDENTIFICATION NO. Enter only when a serialized item is REJECTED and block 9 is blank.

Block B: ACTION TAKEN. Enter the code which best describes the action taken when the requested work is completed.

Enter 00 if the job is in progress.

Enter the appropriate REJECTION code when block A contains an entry.

Block C: MAN-HOURS. Enter the direct labor man-hours (to the nearest tenth) expended against the reported action or 0000 may be entered.

Block D: REMAINING MAN-HOURS. May be blank or whole hours may be entered when the

current WLP&C reports inaccurately reflect the man-hours required to complete the requested work.

Block E: ASSIST WORK CENTER. May be blank or the lead work center will enter the assist work center code when requesting assistance.

Block F: DATE. Enter the Julian date for which the card is being submitted.

Block G: WORK DELAY. (for work center supervisor use only) May be blank or if the work has been stopped, enter the code from the back of the card which best describes the stoppage.

If the work is completed, but not signed off, enter status code 30.

After previously submitting status code 30, if the job is not accepted by the requesting activity and must be progressed further or reworked, enter status code 40.

Code 00 will be entered to remove any previously submitted delay/status code.

Block H: REPLENISH. May be blank or when additional prepunched/preprinted work supplement cards are required enter the desired number of cards in this block (9 cards maximum).

A replenishment request and a maintenance action may be documented on the same card.

**Assist Work Center (AWC) Procedures
(Subsequent to Initial Work Request
Planning)**

When requested for assistance on a work supplement card the AWC will receive a minimum of two prepunched/preprinted work supplement cards from the lead work center, ensuring that block E on all cards contains the proper AWC code. One card (planning card) will be used to establish a job planning record for the AWC and will be used for planning information only. The other card(s) will be used by the AWC to report job progress while awaiting prepunched/preprinted work supplement cards. The AWC will complete the entries on the planning card.

PROCEDURES FOR USE OF THE WORK SUPPLEMENT CARD BY AWC.—The procedures for block B, C, F, and H are the same for the LWC and AWC.

Block A: IDENTIFICATION NO. Must be blank.

Block D: REMAINING MAN-HOURS. May be blank or whole hours may be entered when the current WLP&C reports inaccurately reflect the man-hours required to complete the requested work.

Will be entered as the initial estimate when this work center was not included on the initial planning of the work request.

Block E: ASSIST WORK CENTER. May be blank or must be blank if the assist work center code appears in block 37.

Must be entered if block 37 is blank.

Block G: WORK DELAY. (for assist work center supervisor use only) May be blank or if job or portion of the job has been stopped enter the code from the back of the card which best describes the stoppage.

Enter status code 30 when assistance is completed.

**Procedures for Closing Out a
Work Request**

A work request may be signaled (status code 30) as completed when a properly coded supplement card has been processed. However, it will not be closed out until sheet 1 of the work request has been documented and processed through data services.

The lead work center must complete documentation on sheet 1 as follows: Check the

"COMPL" block in the upper right corner of the form.

Block 12: ACTION TAKEN. Enter the action taken code which best describes the completed maintenance action. Enter 00 if an action taken code and job status code 30 were previously submitted on a 4790/2F card.

Block 13: MAN-HOURS. Enter the number of man-hours (to the nearest tenth) expended on the requested maintenance since the last progress card was submitted. Enter 0000 in block 13 if all man-hours have been submitted on 4790/2F cards.

Block 14: RATING/RATE. Enter the rating/rate of the senior man actively engaged in the maintenance action.

EXAMPLES FOR BLOCK 14:

RANK/RATE/GRADE/CODE	ENTRY
ALL OFFICERS/MIDSHIPMEN	O F F
OM1	O M 1
OM2	O M 2
O MSN	O M S N
SN	S N
GS9	G S 9
CIVILIAN	C I V
WAGE BOARD EMPLOYEE (LEVEL)	W B 3
MARINE (PAYGRADE)	M A R 6

Block 15: COMPLETION DATE. Enter the Julian date the maintenance action is completed. (acceptance by requesting activity)

Block 16: STATUS. Enter the status code 5 in this block.

Block 17: CAUSE. Enter the appropriate code which best describes the cause of the failure.

Block F: COMPLETED BY. The senior maintenance man actively engaged in the action will sign this block indicating the job is complete.

Block G: ACCEPTED BY. The repair work center will have the contact person from the requesting ship sign this block to indicate the job has been accepted. The completed sheet 1 of the request will be submitted via normal channels for screening and submitting to data services.

The division officer or designated representative reviews the closeout action, removes sheet 2 from the active file, and forwards sheet 1 to data services via the coordinator. Expedient submission to data services is imperative in order to produce up-to-date reports. After

processing by data services, the repair officer receives sheet 1 of the work request and files it as a record of work requests completed and destroys the previously filed sheet 3.

Error Correction/Deletion Procedures

Error correction procedures are divided into two distinct areas consisting of corrections to planning information and correction to progress information. The critical nature of correction procedure and the resulting impact upon documentation make it necessary that only work center supervisors be allowed to submit correction cards.

CORRECTION TO PLANNING INFORMATION.—Planning information is described as that information submitted to data services on sheet 2 of the work request. Much of this information is prepunched into the daily work supplement cards (4790/2F) and therefore should be closely examined for complete and correct entries. When correction to this information is desired, the work center supervisor will submit a 4790/2K Form to data services, via the coordinator, with the following information:

JCN.—Record the JCN of the job requiring corrections.

Make correction entries in only those data blocks that are required to be changed.

On the top right portion of the 4790/2K write the word "correction."

CORRECTION TO PROGRESS INFORMATION.—Progress information is described as that information recorded in blocks A-G of the 4790/2F card. Most of the block A-G information is of a self-correcting nature based on the next card normally submitted. Therefore, the only correction permitted on progress information is the addition or subtraction of man-hours and correction to action taken codes. If correction to progress man-hours or action taken code is desired, a prepunched 4790/2F must be submitted with the following information:

Block B: ACTION TAKEN. Enter the correct action taken code.

Block C: MAN-HOURS. Enter the hours (to the nearest tenth) to be added or subtracted.

REMARKS. Write the word: "correction" and for block B, enter the previous incorrect action taken code or for block C, indicate either "Add" or "Subtract."

DELETION PROCEDURES.—Deletion procedures are to be used to make corrections and/or deletions when errors in the JCN (UIC, W/C, JSN) or LWC are noted. Corrections to the JCN or LWC are accomplished by submitting a prepunched 4790/2F with the word "deletion" written in the remarks section.

Caution is required in making this type correction in that all records (including progress cards) will be deleted from the file. Resubmission of all information using a 4790/2F Form, with correct JCN and/or LWC, is required in order to place the job back in the active file.

MAN-HOUR ACCOUNTING SUBSYSTEM

The Man-hour Accounting Subsystem is designed to provide local management with essential man-hour utilization, distribution, and assignment information. Effective employment of personnel resources is an important function of command, and the Man-hour Accounting Subsystem provides management with an accurate measure of man-hour employment.

Exception Time Accounting

The Man-hour Accounting Subsystem is based on the "exception principle" wherein each deviation or exception from the normal working day is accounted for and reported. Exception time accounting (ETA) is a term used synonymously for the Man-hour Accounting Subsystem. ETA is intended for use by repair type activities or, more specifically, the repair department of a ship in which maintenance and repair is the primary mission. Basically, ETA will account for the normal seven-hour working day, 0800 to 1600 less one hour for lunch, and for overtime beyond normal duty hours.

ETA complements WLP&C by accounting for the man-hours not documented under the WLP&C. Good management practices using ETA and WLP&C should account for total available man-hours.

When deviations from this ideal situation are necessary, a Daily Exception Card, OpNav Form 4790/2E (fig. 2-6), will be prepared with a ballpoint pen or pencil at the time a person "excepts" from the normal and will be completed at the end of the exception. Only exceptions in excess of 20 minutes (0.3 hr) require the use of an ETA card. When the exception is longer than the scheduled work shift, the card will be completed at the end of the shift and another card

OPNAV FORM 4790-2E(1-65)
DAILY EXCEPTION CARD

FORM ENTERED ASSIGNED

NAME (LAST & INITIALS)

GRADE CODE

ASSIGNED LABOR CODE

CHANGE LABOR CODE TO: (✓)

TYPE OF CHANGE (✓)

X SHORT TERM LOAN TO:

WORK CENTER CODE

1. ASSIGNED
 2. TRANSFERRED
 3. LABOR CODE
 B. OVERTIME

DATE OF CHANGE

HOURS OF CHANGE

DAY MO YR HOURS TENTHS

ASSIGNED LABOR CODE

DATE OF CHANGE

HOURS OF CHANGE

WORK CENTER CODE

LABOR CODE

NAME (LAST & INITIALS)

GRADE CODE

PRODUCTIVE DIRECT

01 DIRECT LABOR

PRODUCTIVE SUPPORT

10 MAINTENANCE ADMIN. & SUPERVISION
 11 MATERIAL CONTROL
 12 TENDER EQUIPMENT MAINTENANCE

SUB CODE

TENTHS OF HOUR KEY

MINUTES	TENTHS
1-2	0
3-8	1
9-14	2
15-20	3
21-26	4
27-33	5
34-39	6
40-45	7
46-51	8
52-57	9
58-60	FULL HR

NON-PRODUCTIVE

20 DELAYS
 21 DUTY ABSENCE
 22 NON DUTY ABSENCE

SUB CODE

652760-0 BSC

17.81E

Figure 2-6.—OpNav Form 4790/2E.

will be prepared for the remainder of the exception as an overtime card. The most frequent exceptions requiring the submission of daily exception cards are:

Each time a person is assigned to, or transferred from, a work center; each time a person performs work other than that covered by his regularly assigned labor code, each time a person is absent from his work center for non-maintenance duties such as ship duties, leave, sick call, or special liberty, and each time a person works more than the normal seven working hours during a single day, or when he works on what is normally considered a "day off" such as Saturday, Sunday, or a holiday.

Daily Exception Card

The daily exception card is designed for automatic data processing and is used to report exception time of each individual covered by ETA.

Labor Utilization Report

The daily labor exception listing, the special labor utilization report, and the three-part monthly actual labor utilization report are the major accounting reports from ETA, and these provide excellent devices for labor utilization analysis.

Exception Time Accounting Codes

The description codes used in ETA for the preparation of daily exception cards and resultant reports.

WORK CENTER CODES.—Codes for repair activity work centers used in ETA that will identify reporting work centers are contained in section III of the Equipment Identification Code (EIC) Manual. These codes will be entered in block A of the daily exception card.

GRADE CODES.—The following grade codes are prescribed for entry in block C of the daily exception card:

Rank/Rate	Code
E-1	001
E-2	002
E-3	003
E-4	004
E-5	005
E-6	006
E-7	007
E-8	008
E-9	009

LABOR CODES.—Labor codes are provided to account for man-hour expenditures within an

organization. The labor codes are divided into three major categories: productive, productive support and nonproductive. Labor subcodes are also provided to enable the maintenance manager to isolate areas where excessive man-hours are being expended. For convenience, subcodes for the major labor code groupings are listed on the reverse side of the daily exception card (fig. 2-7).

Productive Labor Codes.—Only one code is encompassed in this category, Code 01, Direct Labor. Direct labor is labor that is DIRECTLY expended on any equipment (component part, bit, or piece) for which a work center is given maintenance, repair, or manufacture responsibility.

Productive Support Codes.—This category of codes defines labor expended that supports, directs, or controls the direct labor effort. It is frequently referred to as overhead. Productive support comprises Code 10, Maintenance Administration and Supervision; Code 11, Material Control; and Code 12, Tender Equipment Maintenance. The subcodes used in conjunction with productive support codes are prescribed to identify high man-hour consumers if a finer breakdown is desired.

Code 11. Material Control. Charged to this code are man-hours expended in the operation or maintenance of tool cribs and bench or

preissue stockrooms; preparation of requisitions; control of inventory; and receiving, crating, or uncrating supplies. Man-hours spent in storage, issue, and material handling will be charged to this code.

Code 12. Tender Equipment/Work Center Maintenance. Man-hours expended maintaining repair department equipment and work centers. This includes man-hours expended performing daily and weekly PMS or preventive maintenance checks; equipment cleaning, servicing, and preservation; cleaning and preservation of work center.

No corrective maintenance or repair will be charged to this code. Corrective maintenance will be documented as 01 labor.

Nonproductive Codes.—Nonproductive labor is labor expended in activities which do not contribute to or support the accomplishment of the maintenance mission; it is, in a sense, lost manpower. The assigned man-hours lost through delay or absence will be charged to these codes, including delay manhours expended during overtime. Nonproductive codes are Code 20, Delays; Code 21, Duty Absence; and Code 22, Non-duty Absence. The subcodes used in conjunction with nonproductive codes are prescribed to identify high man-hour consumers if a finer breakdown is desired.

<u>LABOR SUB-CODES</u>	
<u>PRODUCTIVE SUPPORT</u>	
10 1	Work Center Supervision
10 2	Workload Planning/Control
10 3	Clerical
10 4	Drafting
10 5	Analysis
10 6	Maintenance Technical Training
12 1	Shp. Equipment Maintenance
12 2	Repair/Weapon's Dept. Equip. Maint.
12 3	Repair/Weapon's Equip. Cleaning & Preservation
<u>DELAYS</u>	
20 1	Awaiting Work
20 2	Awaiting Parts/Material
20 3	Awaiting Transportation
20 4	Awaiting Assistance
20 5	Inclement Weather
<u>DUTY ABSENCE</u>	
21 1	Quarters for Muster/Special Sea Detail
21 2	Department Watch
21 3	Shp./Base Watch
21 4	Condition Watch
21 5	Military Training
21 6	TAD
21 7	Wess. Cooks/Compt. Cleaners
21 8	Vehicle/Boat Operations
21 9	Personnel/Zone Inspection
<u>NON-DUTY ABSENCE</u>	
22 1	Medical Absence
22 2	Personal Affairs
22 3	Leave
22 4	Special Liberty
22 5	Unauthorized Absence
22 6	Confinement
22 7	Non-Judicial Punishment

Figure 2-7.—Reverse side of OpNav Form 4790/2E.

Nonproductive codes will not have man-hours assigned.

Code 20. Delays. This code will apply when man-hours are lost from maintenance, and the loss is beyond the control of the responsible work center. Delays in this category are awaiting work, awaiting parts or material, awaiting transportation, awaiting assistance, and delays due to inclement weather. Delays that exceed 20 minutes (0.3 hr) will be charged to this code or the appropriate subcode.

Code 21. Duty Absence. This code applies to man-hours lost when personnel are required to perform duty outside their primary maintenance assignment. Typical absences in this category are watches, working parties, and similar details.

Code 22. Nonduty Absence. Man-hours lost from maintenance while engaged in nonduty activities. This code will include absence such as leave or special liberty.

CODE ASSIGNMENTS.—A code will always be assigned to identify the primary job requirement and duty of an individual. Many job assignments require that portions of time be devoted to two or more labor codes. In these cases, the primary job of a person will determine his assignment code. Productive direct and productive support labor codes are the only codes that may be assigned; and when required, subcodes under productive support can also be assigned.

OVERTIME REPORTING.—Overtime man-hours in Code 21, Duty Absence and Code 22, Nonduty Absence are not to be reported. Overtime man-hours are reportable only in Code 01, Direct Labor; Code 10, Maintenance Administration and Supervision; Code 11, Material Control; Code 12, Shop Equipment Maintenance; and Code 20, Delays. When reporting overtime, check the applicable labor code block regardless of the assigned labor subcodes.

Administrative Procedures

The control necessary for man-hour accounting is vested primarily in the work center supervisor. Although each individual is responsible for submitting an exception card for himself, when necessary, the success of the man-hour accounting system depends upon the supervisor who ensures that such action is accomplished. The work center supervisor is the primary person for whom the information is

collected and is responsible for the accuracy of the reporting. It is of the utmost importance to the effectiveness of the system that you realize and fulfill your responsibility as work center supervisor.

Own Equipment Maintenance

In order to have a reasonable balance between man-hours indicated on progress reports and ETA reports compared to overall man-hours available, personnel documenting under these procedures must be able to report man-hours expended in the upkeep and/or repair of equipments assigned to them for the purpose of performing maintenance for others. This "own equipment" maintenance can be documented in the following manner.

If the job is involved or of such a duration as to need planning estimates, etc., the responsible work center can submit a work request to itself or to other participating work centers. This work request would be estimated, progressed, and closed out in the same manner as a work request submitted from an organizational level activity.

If the job is not involved, or of short duration and does not need planning estimates, etc., the responsible work center may document this work as a completed maintenance action in accordance with MDC procedures.

MATERIAL CONTROL

The procedures and requirements of material control are applicable to both organization level maintenance ships (DDs, SSs, LKAs, etc.) and intermediate level maintenance activities (tender/repair ship, submarine base, etc.) and serve to describe the interface between maintenance and supply functions under the 3-M system. The procedures and requirements cover only those materials/parts that are maintenance related. Items such as office supplies, cleaning supplies, forms, and similar items that have no maintenance application are excluded from these procedures and requirements.

The remove-replace-repair concept of maintenance has been adopted by the Navy to reduce the cost of "downtime" or ship and equipments requiring repair of overhaul. Proper management of assets to support this concept is obligatory for maintenance and supply personnel at all levels of maintenance.

The mission of the supply department of intermediate level maintenance activities is to provide material support in the repair of other vessels, self-support, and material support to organizational level maintenance ships as required.

It is mandatory that a supply support center (SSC) be established as part of the supply department. The SSC will be divided into three sections: the supply response section, technical library section, and the material control section. These sections will serve as the liaison between maintenance and supply, and will function mainly to meet the material requirements of the organizational and intermediate level maintenance activities.

Rotatable Pools

The primary purpose of the rotatable pool is to provide a facility for the exchange of items of a repairable nature that have been turned into the tender or repair activity for repair. The use of this facility will allow for more rapid response, on the part of the intermediate level maintenance activity, to the requirements of the ships being served. Down time can be reduced and therefore readiness increased, in many cases, by the immediate exchange of a defective item for an operable one.

Preexpended Material

During maintenance work, low cost material such as nuts, bolts, screws and washers are consumed in considerable quantity. The normal issue procedures of such material is costly in terms of manhours and paperwork. The bulk preexpending of such items and their location in maintenance spaces offer significant savings in maintenance manhours by reducing paperwork and waiting time for material. The supply department benefits by a reduced number of issue transactions. Preexpended bins of material are mandatory and will be used to the maximum extent in intermediate level maintenance activities.

Forms

NavSup Form 1250—This is the single line item consumption/management document. It is a five-part document used to request/issue material internally in ships which do not have automated (mechanized) supply records.

DD Form 1348 (fig. 2-8)—This is the single line item requisition document. It is a four- or six-part form used for internal issue of material in ships with automated (mechanized) supply records. This is the form to be used in optical shops for maintenance related supply transactions.

Documentation of Material Usage and Cost Data

Documentation of material usage and cost data on various maintenance transactions requires the joint effort of maintenance and supply personnel. The maintenance man will initiate documentation for transactions involving requests for material from supply, returning material to supply, and reporting "usage only" for items obtained outside the normal supply channels. Documentation of these transactions will be accomplished by utilizing the single line item requisition document, DD Form 1348.

ISSUES FROM THE SHIP'S SUPPLY DEPARTMENT UTILIZING THE DD FORM 1348.—BLOCKS L, M, N. Provide the Unit Identification Code (UIC), Work Center Code (WC), and Job Sequence Number (JSN) from blocks 1, 2, and 3 of the work request pertaining to the maintenance action for which the item is requested. These three codes make up a unique number called the job control number (JCN). Care must be exercised to ensure the same JCN is used on all supply documents relating to the same maintenance action.

Blocks 4, 5, and 6: STOCK NUMBER. Provide the Federal Stock Number (FSN) for all items requested when possible.

Block 8: QUANTITY. Provide the actual quantity required, consistent with the unit of issue, to complete the maintenance action.

Blocks 10 and 11: DOCUMENT NUMBER. The document number will contain two data elements: in block 11 the Julian date of the day that the request for an item was placed with the supply department; in block 10 the next sequential department/division serial number for each transaction.

Block 20: PRIORITY. Provide a single alphabetical code only on items that are not-in-stock (NIS) or not-carried (NC). The code shall be a realistic code assigned by responsible personnel designated by the department head.

43.24

Figure 2-8.—DD Form 1348.

Block 21: REQUIRED DELIVERY DATE. Provide a Julian required delivery date (RDD) only on items that are NIS or NC, and only then when it is imperative for the item to be onboard by a certain date in order to complete maintenance to meet a ship's operating schedule.

Blocks L, M, and N: Enter the UIC, WC, and JSN. This Job Control Number must be identical to that of the associated 4790-2K.

Blocks P and Q. Provide the equipment identification code from the EIC Manual.

Blocks R and S. Provide the APL/AEL code from the work request. In cases where an APL/AEL does not exist, enter "NOT LISTED."

Block U. For all electronic/ordnance items, provide the reference/circuit symbol. This symbol may be found in schematics, circuit diagrams, technical manuals, weapons publications, etc. For hull/mechanical/electrical items enter the noun name using standard abbreviations where necessary, not to exceed 10 characters. Further documentation of the DD Form 1348 will then be accomplished by supply personnel as set forth in appropriate supply directives. After appropriate action has been taken by supply, the maintenance man will receive a copy of the DD Form 1348 with the material. In cases where the material is not available onboard, the work center will be provided a copy marked NIS or NC as appropriate for the work center's status information.

Usage Only Reporting

When a part is required to complete a maintenance action and is obtained from sources other than supply (items such as from cannibalization, salvage or stripping a ship or local manufacture), it is imperative that the data on the part be documented on a DD 1348 as follows:

Block A: SEND TO. Write the words "Usage Only" in this data block to ensure proper reporting of item used.

Block V. Provide the maintenance source code in this block to ensure proper reporting of source of item used. Information in blocks 20 and 21 is not required. Usage of preexpended bin material will not be reported. Further documentation of the DD Form 1348 will be accomplished by supply personnel as set forth in appropriate supply directives.

Replenishment of Preexpended Stocks

Replenishment of preexpended bins at intermediate level maintenance activities is the responsibility of the supply support center. Maintenance personnel responsibilities include only security to prevent pilferage and housekeeping requirements in the bin areas.

GENERAL HOUSEKEEPING

Generally, you can give a work center one good look and tell whether it is efficient and well run. Just make a quick survey for cleanliness, neat tool and stock stowage, and the condition of equipment. If such a survey reveals a high quality of housekeeping, it can also be assumed that the work center is well organized and really turns out the work.

Material and supplies—screws, bolts, and gasket material—must be stored in a convenient, secure, and orderly place. Use cabinets, shelves, bins, and racks arranged in the work center to give the greatest possible amount of free working space.

If work center space permits and sufficient tools are available, each man should have his own stowage drawer and toolbox in which he can keep the tools that are ordinarily used. (No man likes to use a drill bit that someone else has nicked or burnt, and each one likes to have his own hammer, chisels, and screwdrivers.) Besides speeding up production of work, this method of stowage will provide better care and cleanliness of handtools.

If space permits, one corner of the work center may be blocked off for use as a TOOL-ROOM. In this room can be kept such tools as portable power drills, grinders, grinding wheels, large dividers, pipe wrenches, C-clamps, large drill bits, special files, dies, tap wrenches, and diestocks. A striker should be made responsible for keeping the tools in order and issuing them as required. This toolroom job should be rotated among the strikers to give each man an opportunity to learn the names and uses of all the tools.

Tool stowage is an important item in the optical shop. Lockers, racks, drawers, cabinets, and boxes are used for stowing tools. The place selected depends largely on the USE of the tool, the frequency of its use, its size and shape, and its value.

Drill bits, micrometers, torch tips, combination squares, gages, and the like must be stowed so that they are protected from contact with other tools. Edged tools and pointed tools, such as scribes, dividers, and compasses, require special stowage to prevent damage to cutting edges and sharpened points.

Particularly valuable and hard-to-get tools should be kept locked in special lockers, drawers, cabinets, or toolboxes. These include

portable power tools, gages, micrometers, special pliers, wrenches, files, and drills.

Tools frequently used outside the shop should be made up in kits and stowed in convenient toolboxes. Tools used in your work center may be marked with a distinctive color for identification. If so marked, they are not easily mixed with tools that belong to other shops.

Good housekeeping requires that bench tops and power equipment be kept clear of unnecessary tools and material, scrap stock, filings, dirt, and excess oil and grease.

INVENTORY OF TOOLS
AND EQUIPMENT

One of the jobs of the supervisor of an optical shop is to maintain a system of accountability for valuable tools and equipment. He should see that custody cards are made out for tools and equipment requiring custody signatures. These include such items as portable power tools, gages, micrometers, and special sets of handtools. Tools which are of a highly pilferable nature should be accounted for by inventory at regular intervals. All accountable tools issued from the toolroom should be returned at the end of the working day, unless special permission has been obtained to keep them out for a longer period of time.

In making a complete inventory of tools and equipment, the Coordinated Shipboard Allowance List (COSAL) is used. The COSAL is the official source which contains the allowance of machinery, equipment, accessories, tools, and repair parts furnished the optical shop. A detailed description of the COSAL is given in Military Requirements for Petty Officer 3 & 2.

SAFETY

Responsibility for the safety of personnel is vested in the commanding officer. Article 0712 of the U.S. Navy Regulations reads as follows: "The Commanding Officer shall require that all persons concerned are instructed and drilled in applicable safety precautions and procedures; that they are complied with, and that applicable safety precautions or extracts therefrom are posted in appropriate places. In any instance where safety precautions have not been issued or are incomplete, he shall issue or augment such safety precautions as he deems necessary, notifying when appropriate, higher authorities concerned."

While the commanding officer cannot delegate his responsibility for the safety of all personnel under his jurisdiction he must necessarily delegate his authority to all officers and petty officers under his command to ensure that all prescribed safety precautions are understood and enforced according to the above article.

SAFETY ATTITUDES

Although NavShips has considered safety factors in laying out the work center, it is still your direct responsibility to maintain safe practices within the work center. You can also prevent accidents by instituting a program of good housekeeping. However, the maintenance of a clean, orderly work center and the use of safety guards are only partial solutions to the problem. You must also consider the human factors involved in safety and recognize the tendency of some men to consider any information about safety as more of the same old stuff.

Know your men, their attitudes toward safety, their work habits, and their physical and emotional condition. Individuals have many ideas about safety. There are those who have the notion that "accidents only happen to the other fellow." Some people believe in the fatalistic idea that an accident is "an act of God" and nothing can be done about it. Still others think that a certain number of accidents are bound to occur no matter what is done. They believe accidents are the price of progress. You must plan your safety program to break down these false notions and to build up the altitude that accidents ARE PREVENTABLE.

Recognize the fact that it is human for all of us to have temporary lapses. You have probably heard these words: "I don't need the safety goggles; I only want to take one cut on the machine." It is always that "one last cut" that seems to cause all the trouble. Your safety program must be continuous in order to counteract these temporary lapses. Encourage your crew to be safety conscious at all times and soon safe work habits will become second nature.

Teach safety by practicing safety. Set the example for your men to follow. Remember that personnel in sickbay are of no use to you in getting a job completed on schedule. The observance of safety precautions is a matter of good common sense and cannot be over-emphasized. Provide a training program to safeguard your personnel in the never ending war against accidents. There isn't a magic

formula that will produce a successful safety program. Each work center and each job has its own peculiar problems. You must study your men, materials, tools, and equipment. Locate the danger spots and provide adequate guards, signs, and operating instructions for machines and tools. Safety cannot be taught by a list of "do's and don'ts" alone. You must put these measures into use until they become an integral part of your work habits and the work habits of your men.

The following are some precautionary measures that must be observed in order to avoid accidents.

Safety Requirements in Work Areas

Some safety requirements concerning the various work centers aboard ship are: RUBBER MATTING, meeting military specifications, is to be provided on the deck around electrical and electronic equipments which may be contacted by personnel in servicing or tuning equipments and on areas in front of workbenches or tables in electrical and electronics work centers. Such matting is cemented to the deck, except on gratings or removable deck plates.

To ensure that the safety factors that were incorporated in the manufacture of the material are effective, and that the matting is completely safe for use, operation and maintenance personnel must make certain that all foreign substances, which could possibly contaminate or impair the dielectric properties of the matting material, are promptly removed from its surface areas.

For this reason, a scheduled periodic, visual inspection procedure and cleaning practice should be established. During the visual inspection procedure, personnel should make certain that the dielectric properties of the matting have not been impaired or destroyed by oil impregnation, piercing by metal chips, cracking, or other defects. If it is apparent that the matting is defective for any reason, a replaceable section of matting material should be employed to cover the area affected.

ALL SWITCHES and CIRCUIT BREAKERS are to be tagged when opened (see figure 2-9). Before energizing equipment after tags are removed, be sure all assisting personnel are notified and are clear.

Use one hand only (if possible) when required to work on energized circuits and never work alone.

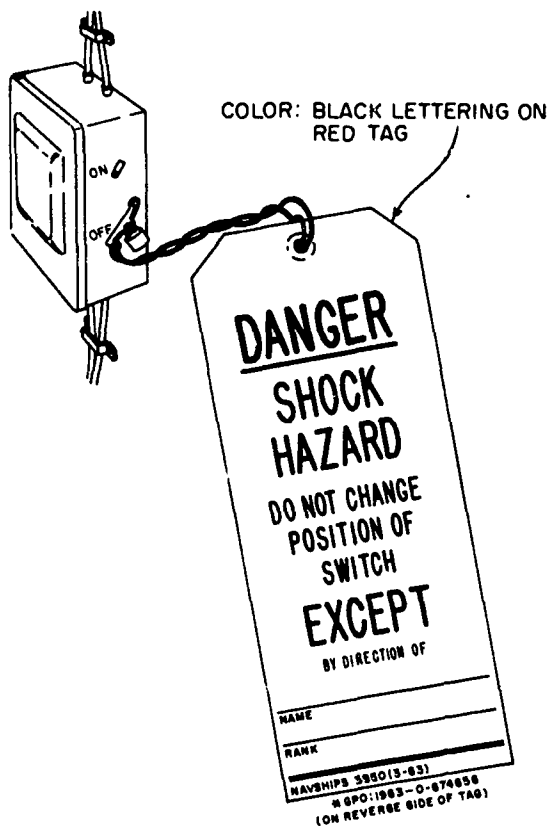

40.67(67B)C
Figure 2-9.—Warning tag.

First aid treatment for electric shock and other applicable electrical safety precautions are to be posted in all areas containing any units of electrical or electronic equipments.

"No Smoking" signs are to be posted in spaces where explosive vapors may be present and "Danger-High Voltage" signs and suitable guards are to be provided to warn all personnel wherever live circuits or equipments are exposed and the voltage exceeds 30 volts.

Safety Precautions Relating to Portable Electrical Equipment

Navy specification for all portable electrical equipment such as drills, grinders, wire brushes, sanders, and scrubbers, require that the electric cord for the tool must be provided with a distinctively marked grounding conductor, in addition to the conductors supplying power to the tool. Past practice was to use red for the grounding conductor in 3-conductor cords and green in 4-conductor cords. The color green is

used for the grounding conductor in all cords for portable electrical equipment. Standardized grounded type plugs and receptacles are installed on all ships. The use of grounding conductors separate from the power cord, and grounding to the ship with alligator clips or other means, are considered unsatisfactory.

Hazards associated with the use of portable power tools are electrical shock, bruises, cuts, particles in the eye, falls, explosions, etc. Safe practice in the use of these tools will reduce or eliminate such accidents. Some of the general safety precautions that you should observe when your work requires the use of power tools are:

Ensure that all metal cased portable power tools are grounded.

Do not use spliced cables unless an emergency warrants the risk involved.

Inspect the cord and plug for proper connection. Do not use any tool that has a frayed cord or a broken or damaged plug.

Connect the cord of a portable power tool into the extension cord before the extension cord is inserted into a live receptacle and unplug the extension cord from the receptacle before the cord of the portable power tool is unplugged from the extension cord.

See that all cables are positioned so that they will not constitute a tripping hazard.

Wear safety goggles when doing work where particles may strike the eyes.

After completing the task requiring the use of a portable power tool, disconnect the power cord and stow the tool in its assigned location.

All portable electrical equipment must be tested before being used for the first time, and periodic tests and inspections must be made thereafter on the equipment, and on the installed receptacles. Generally the Electrician's Mates have a schedule for this testing.

Safety Precautions Related To Rotating Machinery

You should ensure that the following precautions for the safety of personnel are known and observed by the operators of all types of power-driven tools:

Do not attempt to operate a machine with which you are not familiar.

Before operating a machine, see that there is plenty of light to work by.

Do not operate electrically driven machines, either stationary or portable, without

observing the proper electrical safety precautions.

Shut off the power supply to any machine that is being repaired or adjusted; and attach the prescribed warning card to the switch, to ensure that the machine will not be energized by other personnel.

Do not allow machines to run unattended.

Never lean against a machine that is running.

Keep machine guards in position at all times unless removal is authorized by the shop supervisor.

Replace machine guards after repairs or inspections have been completed and before the machine is started.

Do not distract the attention of a machine operator.

Do not wear loose or torn clothing, gloves, neckties, long sleeves, or rings while operating a machine.

If clothing becomes caught in a machine, shut off the power immediately.

When using portable electric equipment around machine tools, take special care that electrical cords are clear or moving parts.

Clamp workpieces securely to the machine, particularly on drill press operations. (Use vises or other adequate holding devices when working on small parts.)

Do not exceed the recommended depth of cut, cutting speeds, and feeds.

Keep the areas around machines clear of obstructions and in a nonslippery condition.

Remove chips with a brush or other suitable tool—never by hand or with compressed air.

Always wear goggles or a face shield when grinding, or when there is danger of flying chips.

Safety Precautions Relating To Handtools

One source of danger that often is neglected or ignored is the use of handtools which are no longer considered serviceable. Any tool with a plastic or wooden handle that is cracked, chipped, splintered, or broken may result in injuries to personnel from cuts, bruises, particles striking the eye, etc. Such tools should be condemned and replaced before they cause accidents.

Another source of danger that often is neglected or ignored is the unsafe work practice

of covering the metal handle of a tool with a layer of friction tape or with a cambric sleeving to form an improvised insulated tool. This practice does not afford an adequate insulating barrier to protect personnel from dangerous voltages; therefore, steps should be taken to ensure that this unsafe practice is discontinued.

When it is necessary to improvise an insulating barrier between the tool and the hand, the approved method is first to apply several layers of approved rubber insulating tape on the metal surface areas to be covered, and then to apply a layer or two of friction tape over the insulating material. In this manner an adequate insulating barrier is provided, and the possibility of accidental contact with a lethal voltage is minimized.

In addition to the use of insulated tools, it often is necessary to take other precautionary measures, such as the use of rubber gloves or rubber blankets, before working on energized circuits.

ENFORCING SAFETY

The purpose of safety rules is to create within the individual an attitude of thinking and acting in terms of safety. Prescribed safety precautions are instrumental in avoiding preventable accidents and in maintaining a work environment which is conducive to good health. Operating procedures and work methods adopted with safety in mind do not expose personnel unnecessarily to injury or occupational health hazards. Accidents which are about to happen can be prevented if the "cause" is detected and appropriate remedial action is taken.

Although responsibility for the safety of personnel is vested in the commanding officer, he frequently delegates his authority to the executive officer and other subordinates to ensure that all prescribed safety precautions are understood and strictly enforced. The commanding officer requires that the personnel under his jurisdiction be instructed and drilled in applicable safety precautions; he requires that adequate warning signs be posted in dangerous areas; and he satisfies himself that such precautions are being observed. It is the responsibility of supervisory personnel to see that safety precautions are strictly adhered to in their own work areas since they, in turn, are under orders from, and are responsible to, the commanding officer; furthermore, each individual concerned shall strictly observe all safety precautions

applicable to his work or duty. Thus, it can be seen that safety is the business of every individual—not just a delegated few.

As an individual, you have a responsibility to yourself and to your shipmates. You must always be alert to detect and report unsafe work practices and unsafe conditions so they may be corrected before they cause accidents.

Each individual must:

1. Report any unsafe condition, or any equipment or material which he considers to be unsafe.
2. Warn others whom he believes to be endangered by known hazards or by failure to observe safety precautions.
3. Wear protective clothing or use protective equipment of the type approved for the safe performance of his work or duty.
4. Report to his supervisor any injury or evidence of impaired health occurring in the course of his work or duty.
5. In the event of an emergency or other unforeseen hazardous condition, each individual is expected to exercise reasonable caution, as appropriate to the situation.

Safety precautions—as all rules, laws, or regulations—must be enforced. It is your duty to take appropriate action any time you see a man disregarding a safety precaution.

SAFETY TRAINING

Training a person to be safety conscious requires constant effort on your part. Lectures during regular training sessions can be helpful but the training of safety must be a continuing process. The safety posters and safety precautions mentioned earlier must be of a nature so that the man can associate the hazard with the job he is performing. You must be constantly alert for the safety hazards present in your environment. By supplementing your safety lectures with personal attention to each hazard, you will be able to make your men more safety conscious.

Safety Precautions Information Sources

Naval Ships Technical Manual is a main source of information for safety precautions used when working on electrical or electronic equipment. Supplemental safety precautions

are contained in the Shore Activity Safety Manual, and the Forces Afloat, Index of Documents.

A new directive (SECNAV INSTRUCTION 5100.10A) to provide current policy and assign responsibility for the Department of the Navy Safety Program. CNO has published a follow-on instruction (OPNAV INSTRUCTION 5100.8) to describe, implement, and assign responsibility for administration of the program.

The manual for shore activities is Department of the Navy, Safety Precautions for Shore Activities, Navy Secretary Office number NavSo P-2455.

Other valuable safety manuals are Electric Shock—Its Causes and Its Prevention, NavShips 250-660-42 and Electric Shock and Its Prevention, NavShips 250-660-45. These two publications contain a discussion of the fundamental principles of electrical safety and a summary of shipboard electrical fatalities over a period of years.

TRAINING

The first impression formed by a new man in the work center will be a lasting one. If the petty officer in charge of an optical shop has a well-planned program for introducing new men to the work in the work center, he has taken a most constructive step toward building high morale. One of the best stimulants for the development of high morale among new men is to have them realize that their boss appreciates their feeling of strangeness and is aware of their desire to make good. There is often a gap between the point at which a man is assigned and the time that he has developed into a satisfied worker. Proper introduction to the work, a well-planned training program, and counseling when necessary will turn the ill-at-ease man into a confident and interested worker.

The work center supervisor (you) will find it a profitable procedure to review with each new man such matters as the mission of the ship and how the work center fits into the overall picture; the policy on drills, liberty and leave; and the man's duties and what is expected of him as an individual.

You should be sincerely interested not only with getting acquainted with the man but in being sympathetic with the problems that may arise in getting settled. The initial contact should be primarily to win the man's confidence. You may later turn the man over to a qualified petty

officer who is capable of completing the introduction process and the early training that is necessary. Usually, considerable information can be given to the new man by an experienced petty officer selected to complete the introduction period.

In carrying out your responsibility for introducing the new worker to the job, you must do a certain amount of planning if the instructions necessary for the proper indoctrination of the new worker are to be carried out effectively.

At this point, it may be well to indicate one fundamental difference between the work of a supervisor and that of his men. The men work with machines and materials, while the supervisor works through people to produce the desired results with the machine and materials. The machines may be operating perfectly and the materials may be of the best quality, but unless the men who handle them are properly instructed, adjusted to their work, and cognizant of their place in the organization and of the policies of the department, they will not be satisfied workers. The supervisor is responsible for developing high morale in his work center.

The first step in this process is attained by properly indoctrinating each new man at the time of his entrance into the work area. There are three general areas of indoctrination.

1. Those dealing with facts, such as the shipboard rules and regulations.
2. Those dealing with the men's attitudes or feelings, their confidence in the organization, pride in the job, and respect for their fellow workers.
3. Those dealing with skills, safe working habits, and quality of work.

SHIPBOARD TRAINING

Shipboard training consists of the regular training program and on-the-job training. Both are effective when properly planned and carried out.

The training program plan should include the subject matter to be covered, frequency of training periods, length of training periods, and the instructor responsible for each lesson. The schedule must be flexible to permit changes when required by heavy or unforeseen workload or when more than one period is required to adequately explain a particular lesson. While specific lessons are usually assigned to the

instructor considered most qualified, keep in mind that instructing is also a "qual" for advancement. Lesser qualified men should not be overlooked as instructors. Their participation in the training program gives them a chance to increase their knowledge and skill through on-the-job training, and it provides a "change of pace" for the trainees.

On-the-job training is best used to teach a specific job to one person and should not be substituted for the regular training program. On-the-job training requires intensive supervision to ensure that the man is learning the job correctly and that adequate explanation is given so that he understands the reasons for the job. If he is taught only the mechanics of a job, then he is limited to that one job. However, if he knows why a job must be done and what it accomplishes, he probably will be able to apply that knowledge to different problems and arrive at their solution.

The training you offer, both by instruction and on-the-job training, should accomplish three purposes:

1. It should give your men a picture of the total operation of the repair department and how each man's job fits into the total operation.
2. It should instruct the men in the knowledge they should have to do their own jobs.
3. It should, in conjunction with correspondence courses and independent reading, help prepare the men to qualify for advancement in rating. You will find the Manual for Navy Instructors a valuable book in preparing your outline and planning your instruction.

The rate training manual, Military Requirements for PO 1 & C provides the mechanics for running a division or work center training program.

JOB ROTATION

Assuming that all of your jobs are assigned to men who are well qualified to do them, don't be misled into a decision that there is no longer a need for training. Every man will not be on the job every day. Thus, some provisions must be made to cover for the man who is on TAD, leave, or the sick list or who is being transferred.

One way to do this is by job rotation. As men become proficient in their jobs, they should be considered for reassignment to different jobs.

They probably will learn faster if the new job is related to the old one, and, if possible, personal preference should be one of the factors in deciding new assignments.

Job rotation should not become a periodic game of "musical chairs." Each reassignment should be a progression from an easier job to a harder one, and the man must stay in each job long enough to develop a sense of responsibility for doing it right. Otherwise, you are apt to end up with a group of men that know a little bit about a lot of jobs but are generally confused about the purpose and procedures for any one of them.

Everyone benefits when more than one man is qualified to handle each of the jobs in the department.

- The ship benefits since, in an emergency, there will be someone to take over a job.
- You benefit because your job of planning work and leave schedules is easier since the most efficient use can be made of personnel.
- The man benefits because of his feeling of accomplishment and pride in his work and his change of advancement is greatly increased.

CHAPTER 3

NATURE OF LIGHT

Many theories have been presented to describe what light is and how it behaves, but as yet no single theory furnishes a satisfactory explanation of all observed phenomena of light.

Before studying this chapter which describes some unusual characteristics and uses of light, you will benefit by reviewing chapter 2 of OM 3 & 2 which gives a brief account of some light theories and principal facts concerning the behavior of light.

INTERFERENCE OF LIGHT WAVES

The wave nature of light has been substantiated by various studies of light interference. These studies have also produced other interesting light facts. Interference in light waves gives us a direct and accurate means for measuring wavelengths. Credence to Einstein's theory of relativity, on the other hand, was provided by unsuccessful endeavors to measure variations in light velocity by the interference methods. Einstein contended that the velocity of light is constant and unaffected by the motions of an observer.

The first man to become interested in the effects of interference was Thomas Young, in 1801. He had the idea that if light were a form of wave motion it must act the same way water would, if subjected to the proper conditions. Since water can show the effects of interference, he felt sure he could produce the same effects with light. To show he was right, he took two similar trains of water waves. He said that if the elevations of one wave coincide with the elevation of the other wave, they must together produce a greater wave; but, on the other hand, if the elevation of one wave coincides with the depression of the other wave and fills up that depression, the waves cancel each other out. From this we get the two phases of interference, constructive and destructive.

Young's theory shows he had come to believe in Huygens' wave theory of light; his theory was opposed to Newton's corpuscular theory.

Young went further into the theory of interference to prove he was right by conducting an

experiment. He took a piece of black paper and put two narrow slits in it, as in figure 3-1(a), about 1 mm apart. Behind the black paper he placed a source of light 3 or 4 meters away. When he looked through the slits at the source of light, he could see a series of dark and light bands, as shown in figure 3-1(b). When he put a red filter between the light source and the slits, the series of dark and light bands became red and black.

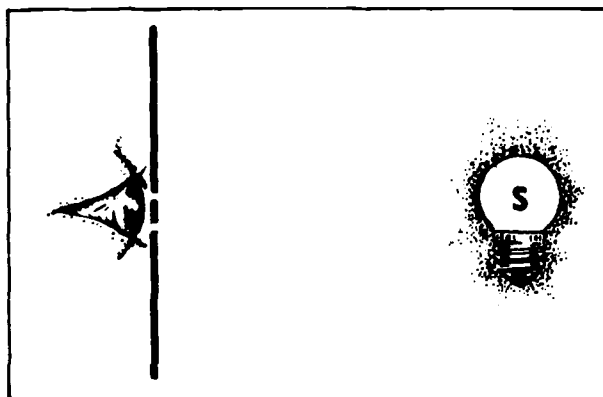

148.1:2
Figure 3-1.—A. Double-slit interference.



148.1:2
Figure 3-1.—B. Fringes produced by double-slit interference.

Figure 3-2 shows the same double-slit interference, but this time we use a monochromatic light source(s). (A monochromatic light source is a single wavelength of a very small range of wavelengths). Slits X_1 and X_2 are parallel to the source and both must be the same distance from it. When light from the source reaches the slits, the slits can then be considered new light sources because they are producing new wave fronts. As the new wave fronts become larger, part of the waves produce constructive interference and make bright bands of reinforced light. While this is happening, the other wave fronts produce destructive interference and make the dark bands of light. These bands of light are hard to see, unless you use a screen of some type to project them on.

A much more convenient method of illustrating interference is to observe it against a lighted background. To do so you need some relatively inexpensive equipment: a monochromatic light source, a piece of flat optical glass, and a flat test surface such as a gage block.

Place the equipment as illustrated in figure 3-3 and press on one edge of the optical flat.

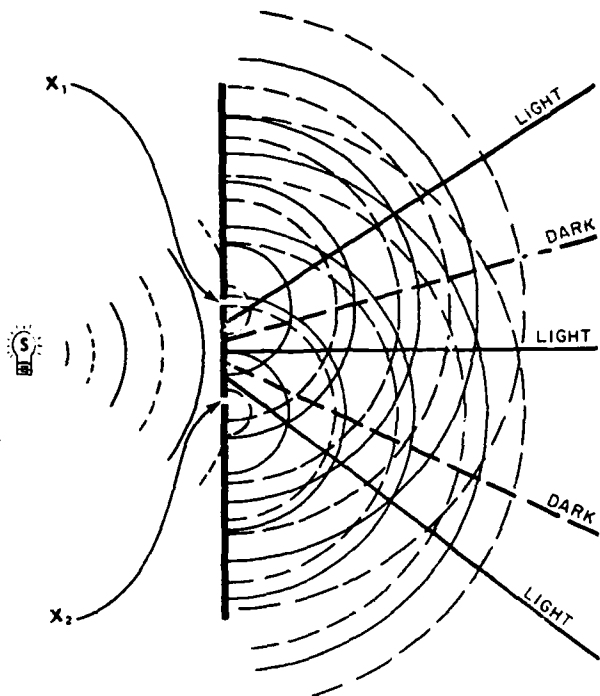

148.3

Figure 3-2.—Double-slit interference wavefront diagram.

Figure 3-4 illustrates the pattern of constructive and destructive interference bands which will appear on the test surface.

APPLICATION

This method of illustrating interference is not just an entertaining experiment but a practical, highly accurate means of measurement. The optical flat is capable of measuring to millionths of an inch. It will give direct

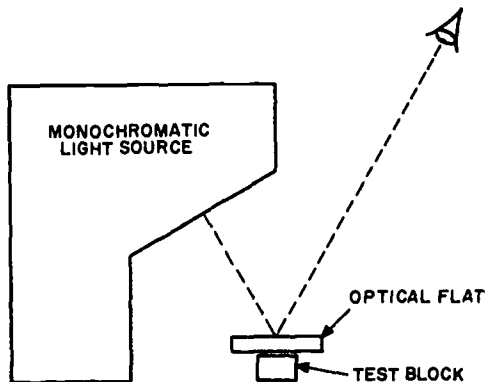

148.207

Figure 3-3.—Interference set-up.

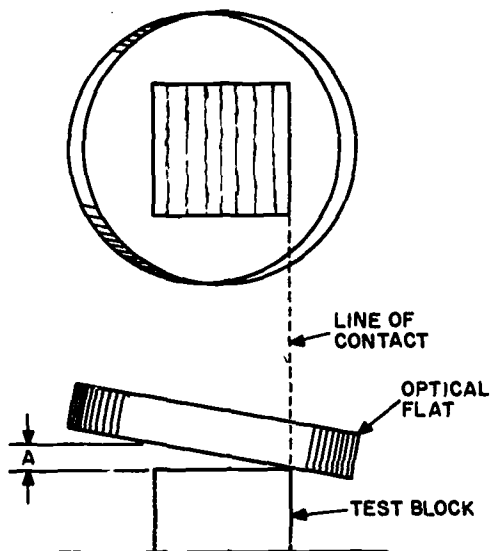

148.208

Figure 3-4.—Relation of fringes to line of contact.

measurement of surface configurations and indirect measurement of size.

Optical Flats

An optical flat is a piece of transparent material such as glass, pyrex, or fused quartz. The flat may be finished on one or both sides to a specified tolerance. Standard flats are round and thick enough to ensure rigidity.

Optical flats come in various sizes and grades. The use to which they are to be put dictates the size and grade you will need. The flat should not be too much larger than the work. The four grades of flats available are reference, master, working, and commercial. The reference grade of optical flats has a measuring surface which is flat to within one millionth of an inch, the master grade is flat to within two millionths of an inch, the working grade to within four millionths of an inch and the commercial grade to within eight millionths of an inch.

The reference grade of optical flats is usually used to check precision gage blocks and other optical flats. The master grade is used to check other measuring instruments whereas the working and commercial grades serve as inspection tools for use in the shops. When ordering and

using the flats, keep in mind the cost of a flat depends primarily on its grade. The more accurate the test surface, the higher the price.

Monochromatic Light Source

As you already know, white light is a combination of all the colors of the spectrum. Using white light as a light source for interference measurements, you would have difficulty in interpreting the fringe pattern produced. Each color or wavelength of light would be interfered with at different points, producing a pattern which would resemble a rainbow. To avoid the difficulty, use a monochromatic light source.

Vapor lamps have the property of emitting a light composed of a few wavelengths. Some lamps which may be used as monochromatic light sources are neon, helium, mercury vapor, and sodium vapor. By far the most common, the helium lamp provides a number of different wavelengths of light but one wavelength is so much stronger, the rest are almost undetectable. The dominant wavelength of the helium light is 23.13 millionths of an inch long.

Operation

The operation of the optical flat is illustrated in figure 3-5. A light ray passing through the

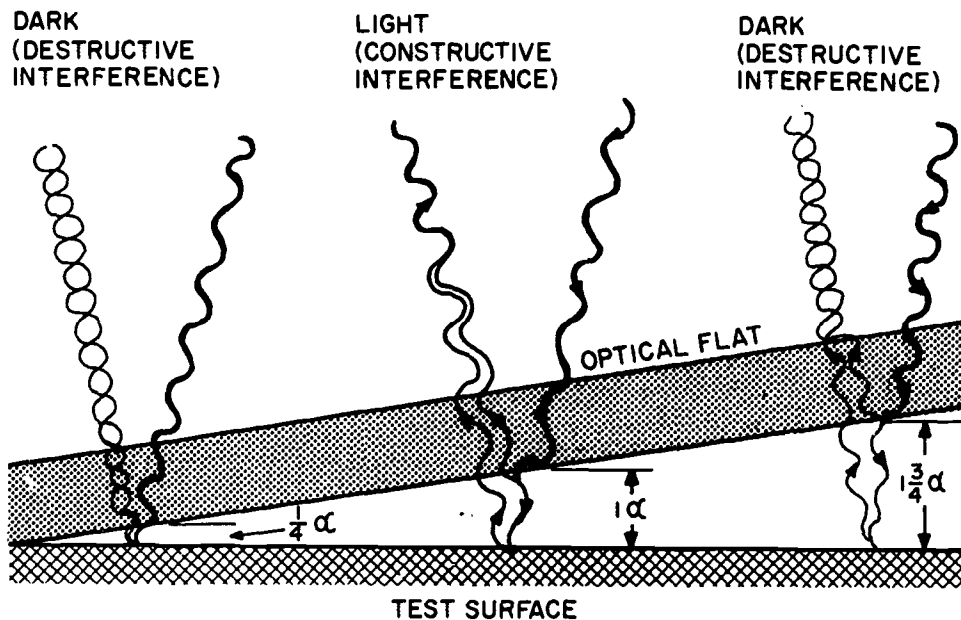

Figure 3-5.—Formation of interference fringes.

148.209

flat strikes the lower polished surface which acts like a half-silvered mirror. A portion of the ray is reflected from the lower surface of the flat while the rest passes through, strikes the test surface and is itself reflected. The distance the light travels between the lower surface of the flat and the test surface determines whether constructive or destructive interference will occur. If the distance is equal to one-half of the wavelength of the monochromatic light source, constructive interference will occur and a bright band of light will appear at that region. Should the distance be one-fourth of the wavelength of the light source, destructive

interference will occur and a dark band will appear in this region.

A bright band of light will appear at each area where the separation of the flat and the test surface is one-half, one, one and one-half, etc. wavelengths. Similarly, a dark band will appear at each region where the separation is one-fourth, three-fourths, one and one-fourth, etc. wavelengths. These dark bands or regions are called interference fringes or fringes for short.

In order for the flat to produce interference fringes, the flat and the test surface must be at some small angle to each other. Should the flat

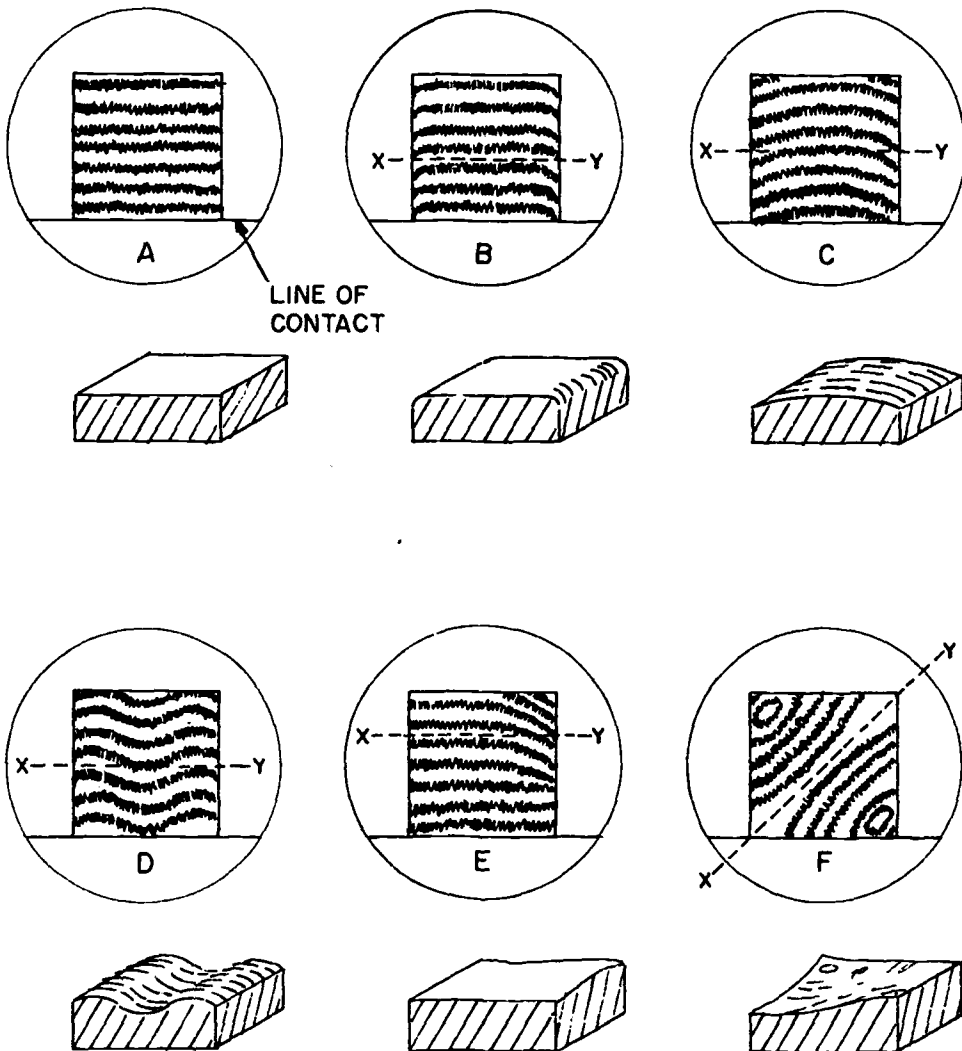

148.210

Figure 3-6.—Typical fringe patterns.

and test surface be parallel, no fringes would appear but the surface would be covered by either a light or dark shade, depending on the distance between the flat and test surface.

INTERFERENCE FRINGE INTERPRETATION

The pattern of fringes produced by the flat and test surface will indicate surface contour. Figure 3-6 illustrates a few contour patterns which might appear during an interference measurement. The test surface A in figure 3-6 is flat as evidenced by the straight, evenly spaced interference bands. The test surface B is flat except for the edges which are rounded off. This can be seen by the fringe pattern dropping off sharply at the edges. C has a high center and lower sides as all the fringes curve toward the line of contact. In D, two high ridges occur one on each side of a valley at the center. The ridges appear to be the same height above a datum plane formed by the edges and the center. E has a rounded off corner but is flat otherwise. F has high spots at the upper left and lower right corners and a valley extending from the lower left-hand to upper right-hand corners.

MEASURING WITH MONOCHROMATIC LIGHT

Referring again to figure 3-5, you see that a bright fringe occurs at points which are half a wavelength different in height from the preceding bright fringe. This half of a wavelength height difference is equal to 11.6 millionths of an inch when a helium light source is used. Dimension A of figure 3-4 is 81.2 millionths of an inch as there are seven bright fringes appearing on the test surface.

Interference Measurements

To use the optical flat as a measurement device, use it in conjunction with gage blocks or similar devices. Figure 3-7 illustrates the setup used to measure the height of an unknown block. The optical flat indicates the difference in height of the two blocks. In figure 3-7 the unknown block is taller than the gage block. Figure 3-8 illustrates a similar setup in which the unknown block is shorter than the gage block. Note the similarity of the fringe patterns. The comparison of figure 3-7 and 3-8 illustrates one of the problems in interpreting interference measurements: whether the unknown block is taller or shorter than the gage block.

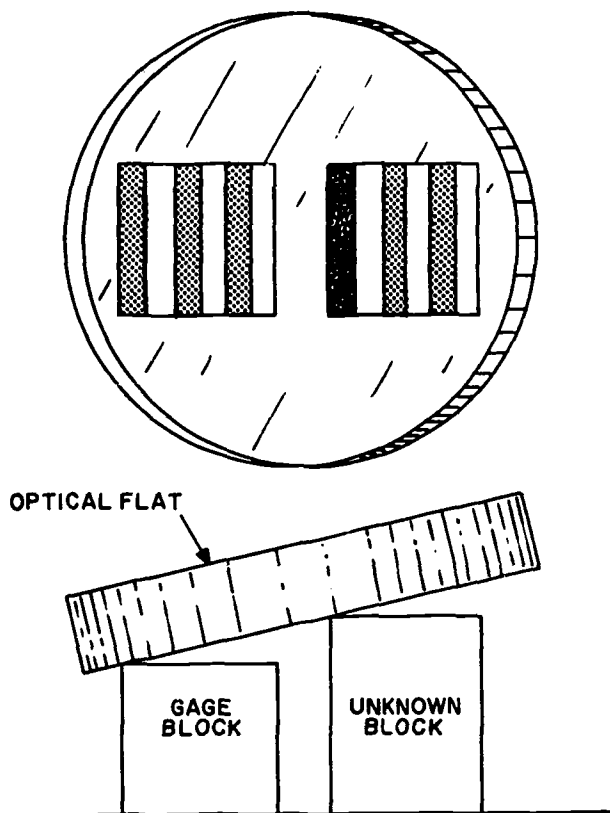

148.211

Figure 3-7.—Fringe interpretation, situation 1.

DISTINGUISHING THE TALLER (OR SHORTER) BLOCK.—Pressure applied gently at a midpoint between the gage or reference block and the unknown or test block will produce a change in the fringe pattern that indicates which is higher, the gage block or the test block. This change in fringe pattern is due to a change in the angle between the gage block surface and the lower surface of the flat.

In situation 1, figure 3-7, the gage block is shorter than the test block. Slight pressure on the upper surface of the flat at a point midway between the blocks will cause the fringe pattern to spread at the gage block and compress at the unknown test block. Figure 3-9 illustrates the fringe pattern of situation 1 once pressure has been applied.

Situation 2, figure 3-8, where the test block is shorter than the gage block, produces exactly the opposite fringe pattern change when pressure

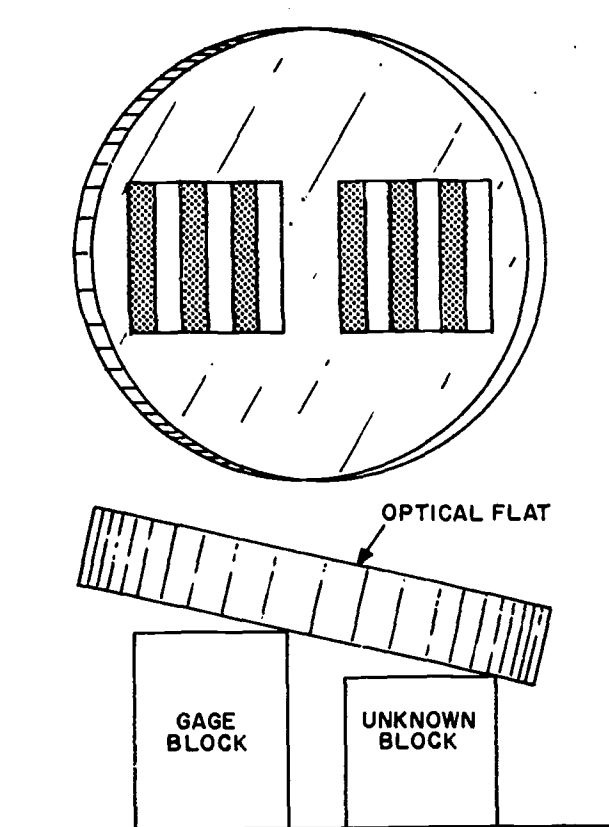

148.212

Figure 3-8.—Fringe interpretation, situation 2.

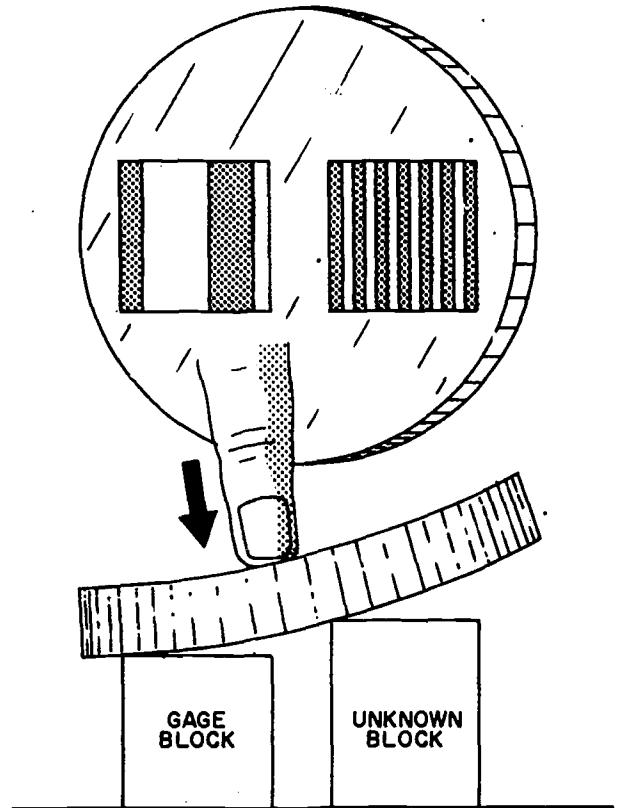

148.213

Figure 3-9.—Fringe interpretation, situation 1.

is applied as shown in figure 3-10. This method of applying pressure to the flat enables you to determine the amount and direction that the unknown test block differs from the gage block.

DETERMINING HEIGHT OF TEST BLOCK.—

Once you know whether the test block is bigger or smaller than the gage block, proceed to determine how much bigger or smaller. The procedure calls for making both direct and indirect measurements. Refer to figure 3-11 which shows the same setup as figure 3-7 and is labeled as follows:

- A, width of gage block
- B, distance between contact edges
- C, maximum elevation of optical flat above gage block
- D, difference in heights of blocks
- G, height of gage block
- H, height of test block.

Dimensions A and B can be measured directly; C, D, and H indirectly. Dimension G is known.

Finding Dimension C.—Again refer to situation 1, figure 3-7, and observe that the same basic fringe pattern occurs on both the gage block and the test block. Using the fringes, you can determine how much the flat is elevated from one edge of the gage block to the other. You have already determined that every fringe produced (center of one band to the center of the next) indicates a change in height of half a wavelength of the source light. For the helium monochromatic light, each band is the equivalent of 11.6 millionths of an inch change in height. For the gage block in figure 3-7 three fringes from one edge to the other indicate a separation at the upper side of three times 11.6 millionths or 34.8 millionths of an inch.

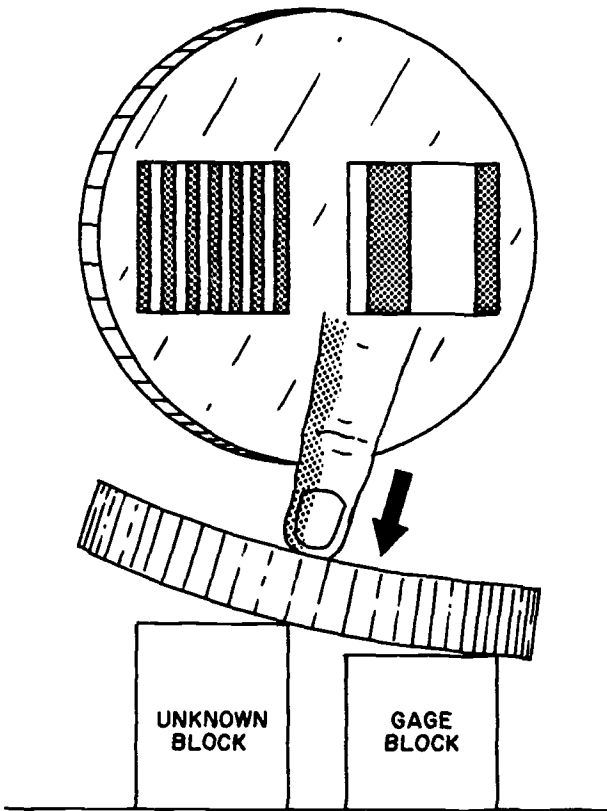

148.214

Figure 3-10.—Fringe interpretation, situation 2.

Finding Dimension D.—You determine D by using a simple formula based on the geometric theorem: In similar triangles the ratios of corresponding sides are equal. The constructions in figures 3-11 and 3-12 show that the optical flat and test surfaces form similar triangles and that sides A and C of one triangle correspond to sides B and D of the other triangle. Applying the theorem, you get

$$\frac{A}{B} = \frac{C}{D} \text{ or } D = \frac{B \times C}{A}.$$

Now D can be computed since A and B are measurable and C was just determined. The accuracy of dimensions A and B should be within one sixty-fourth of an inch.

Finding Dimension H.—In situation 1 where the test block is higher than the gage block, H is the sum of G and D or $G + D$. In situation 2

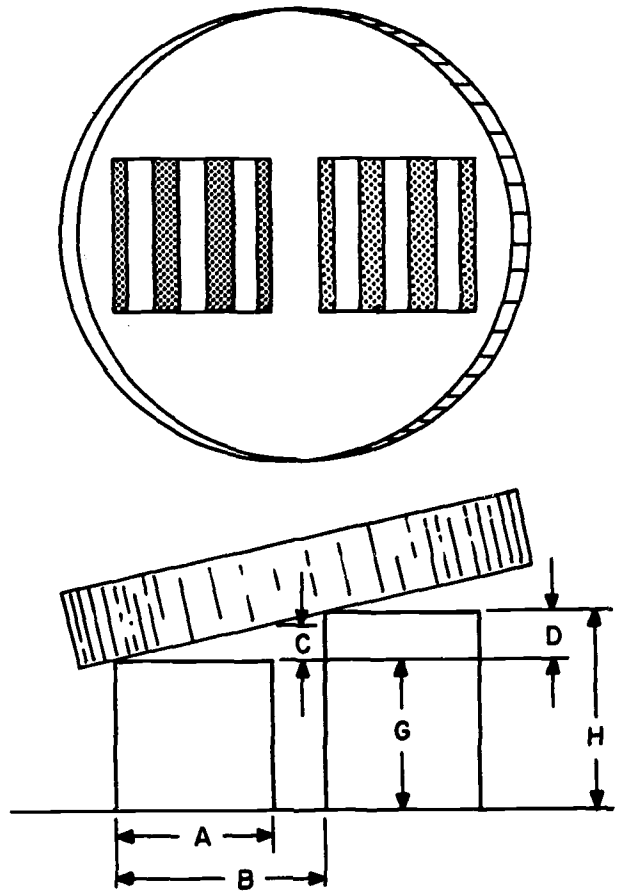

148.215

Figure 3-11.—Height measurement with optical flat.

where the test block is shorter, H is the difference of G and D or $G - D$.

POLARIZATION

Interference has been used to show that light occurs as a wave motion and water waves have been used to illustrate interference. But the generation of energy in the form of water waves is not the same as the generation of energy in the form of light waves. Water waves are generated in only one plane which is perpendicular to the surface of the water whereas a light wave is composed of many components, all perpendicular to the line of propagation. Figure 3-13 illustrates the dissimilarity. The water wave has only vertical components, the light wave has components in all directions, perpendicular to the line of propagation.

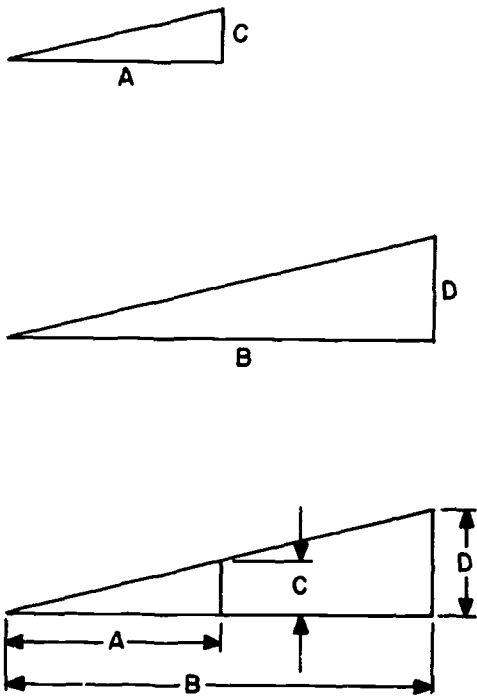

148.216

Figure 3-12.—Similar triangles formed by optical flat and test surfaces.

Polarization is the process by which all the components of a traverse wave of light are eliminated except for a single component perpendicular to the line of propagation. In other words, after polarization, the light wave resembles the water wave.

METHODS OF POLARIZING LIGHT

• There are a number of different methods of polarizing light, two of which are plane polarization and filtration.

Plane Polarization

Polarized light occurs naturally in a process known as plane polarization. The glare from sunlight reflected by water is an example of polarization. This process can occur in any media which is capable of reflecting and refracting light at the same time. Examples include water, glass, plastics, and wax.

Two conditions must exist for plane polarization. First, the incident ray must be both reflected and refracted. Second, the angle of incidence must conform to Brewster's law which states that for complete plane polarization to

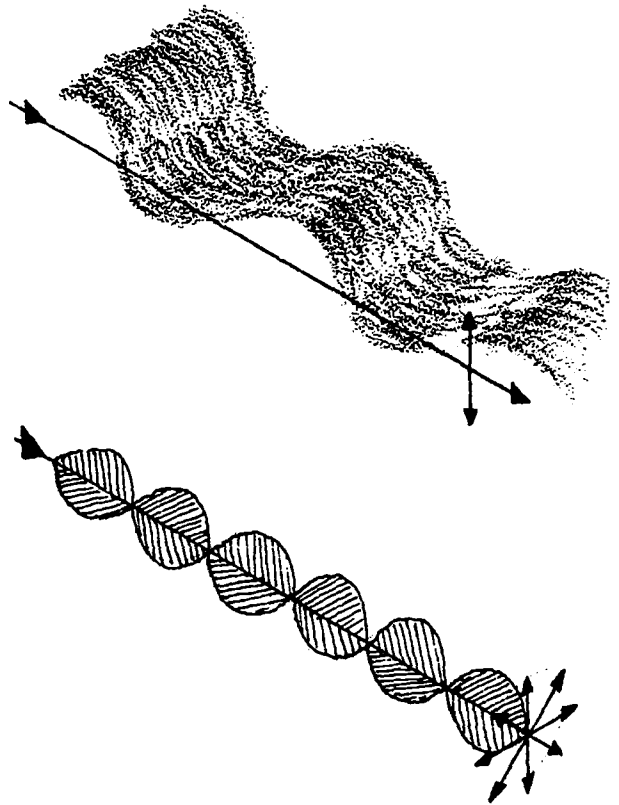

148.217

Figure 3-13.—Traverse waves of water and light.

occur the angle between the reflected ray and refracted ray must be equal to 90°.

Figure 3-14 illustrates the conditions for producing complete plane polarization of light

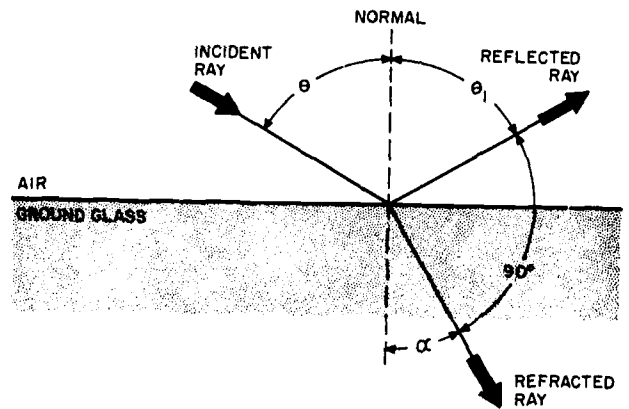

148.218

Figure 3-14.—Plane polarization.

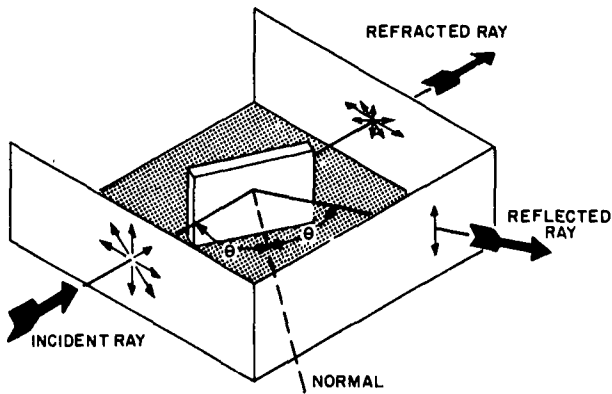

148.219

Figure 3-15.—Plane polarization, component schematic.

upon contact at an interface of air and crown glass. The angle of incidence, in this case, is approximately 56.6° which produces the angles of reflection and refraction necessary for the angle between the reflected and refracted rays

to be 90° . An angle of incidence of approximately 53° is required to produce complete plane polarization at an interface of air and water.

Figure 3-15 is an attempt to illustrate what happens to the various components of the transverse incident wave of light. When the incident ray strikes the surface, a majority of the light is refracted and passes through. This refracted ray is only partially polarized. On the other hand, a relatively weak but completely polarized ray is reflected from the surface.

Glare from the surface of the sea is a common manifestation of this phenomena of light.

Polarizing Filters

One method of producing or eliminating polarized light is through filtration. The discussion of polaroid filters in the Rate Training Manual OM 3 & 2, provides the basic information on the operation of polaroid filters.

Unpolarized light passing through a polarizing filter, becomes polarized light, indicating that all the components of a light wave have been removed except for those lying in a plane parallel

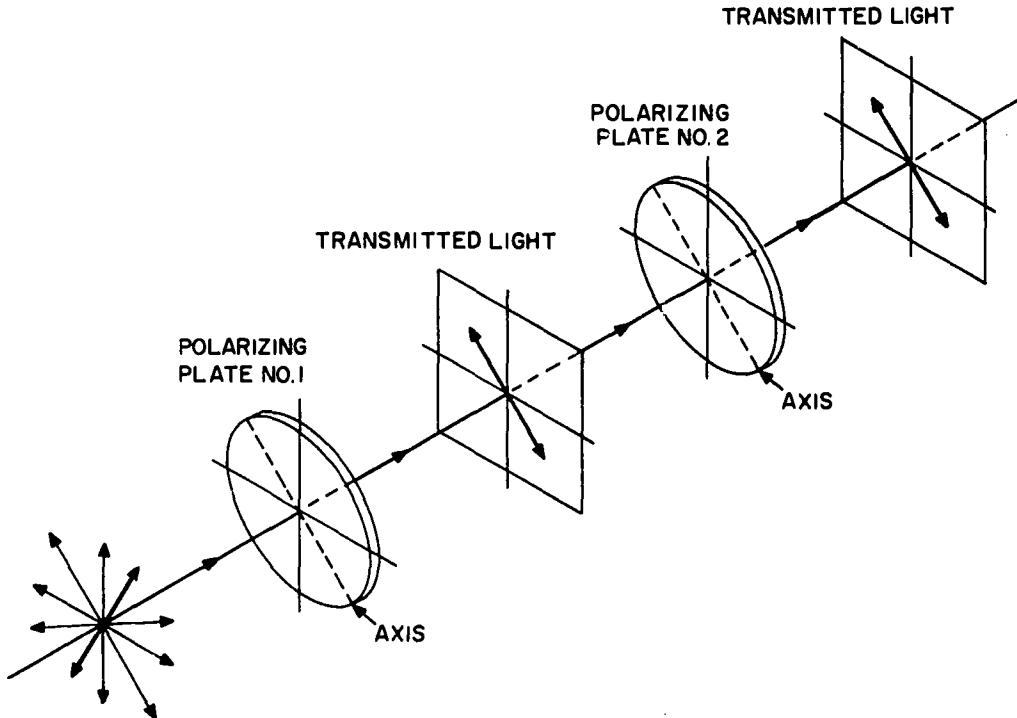

148.220

Figure 3-16.—Transmission of light with filters aligned.

to the axis of the polaroid filter. Figure 3-16 illustrates the function of a polaroid filter with two polaroid filters having their axes aligned. The light which passes through the first polaroid filter also passes through the second polaroid filter.

A simple way to explain the transmission of light by two nonaligned polaroid filters, is to use the vector components of the light from the first filter. Figure 3-17 shows unpolarized light striking a polarizing plate, becoming polarized, then transmitted through a second plate, and emerging as polarized light whose axis is not the same as that emerging from the first filter. The arrow labeled "Vector" indicates the component of the polarized light which will be transmitted by the second polaroid plate. Figure 3-18 illustrates the reduction of transmitted light by a second polaroid filter as the filter is revolved. The vertical arrows indicate polarized light striking a polaroid filter while the other arrows indicate the relative amount of light which would be passed as the filter is rotated.

In the first position the axis of the filter is aligned with the polarized incident light and

nearly all the light is transmitted. As the filter is rotated, less light is transmitted until at the 90° position, no significant amount of light is transmitted.

Through experiments conducted in 1809, Etienne Louis Malus discovered the law in optics that bears his name and determines the relationship of the rotational angle (θ) of a second polaroid filter to the amount of light the second filter will pass.

Malus' law states that the amount of light transmitted by a second polaroid filter is equal to the product of the light intensity striking the second filter and the cosine of the rotational angle (θ) squared. The formula is:

$$L \text{ transmitted} = L \text{ incident} \cos^2 \theta$$

Figure 3-19 is a graph of the percentage of light transmitted by a second polaroid filter versus the rotational angle (θ) between the axes of the two polaroid filters. From the graph you can

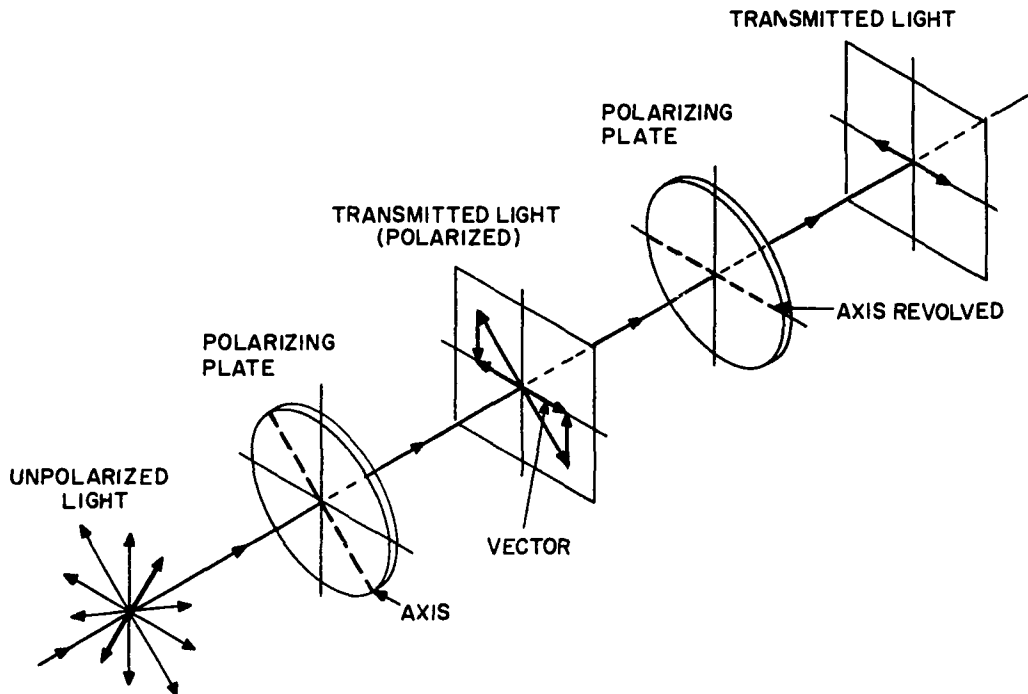

Figure 3-17.—Transmission of light with 2nd filter rotated less than 90° .

148.221

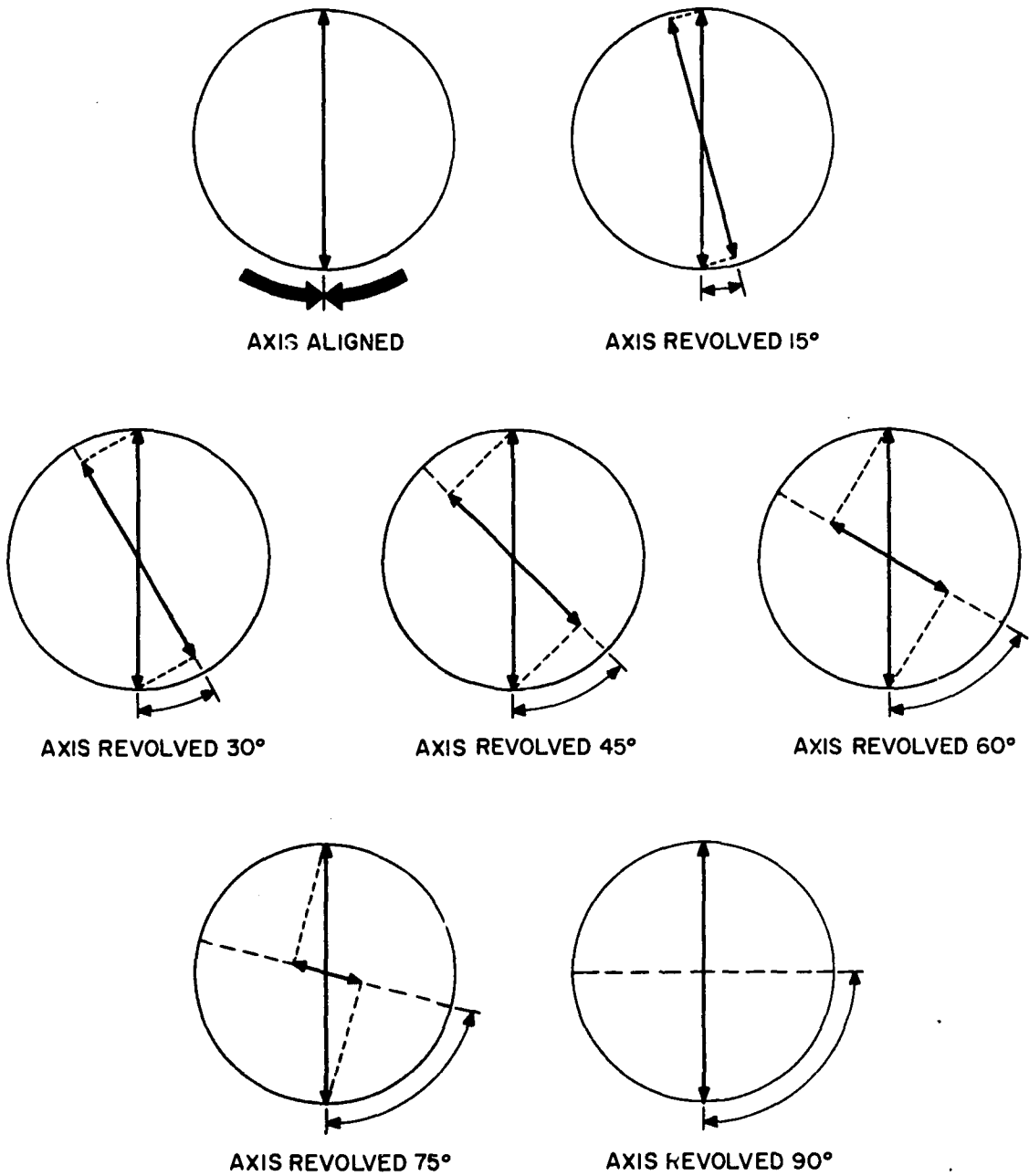

Figure 3-18.—Effect on light transmission by revolution of 2nd polaroid filter.

148.222

determine what percentage of light a combination of polaroid filters should pass.

To measure the percentage of light passed by a polaroid filter, use a light meter such as the

General Electric exposure meter (figure 3-20) and an arrangement like the one in figure 3-21. Measure incident light through an orifice of the same dimension as the free aperture of the

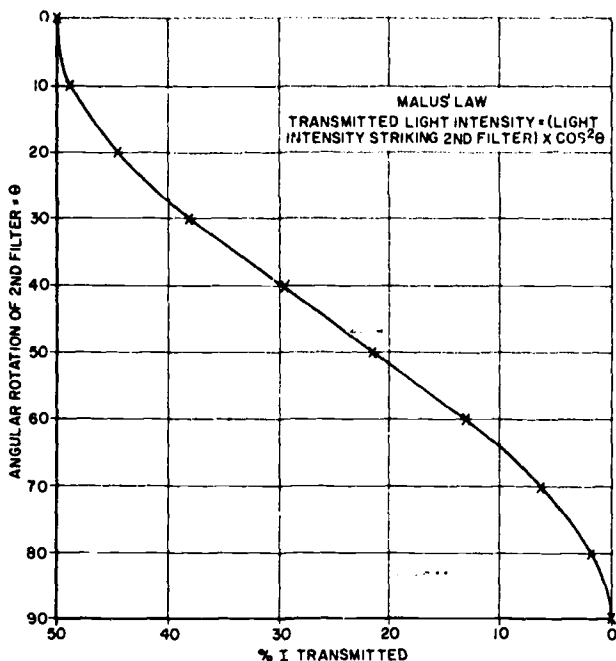

148.223

Figure 3-19.—Relationship of rotational angle and light transmission.

polaroid filter. Then insert the polaroid filter into the orifice and measure the emergent light from the polaroid filter. The percentage of light passed by the filter should conform to the percentage on the graph for each rotational angle of the axis of the filters.

USES OF POLARIZATION

In addition to the common uses listed in OM 3 & 2 for polaroid filters, the process of polarization can be used effectively as a tool.

Whenever a lens or prism is secured in its mount, there is always the possibility of its being subjected to mechanical stress. Stress may cause breakage or deformation and is therefore highly undesirable. This mechanical stress can be easily detected by placing the mounted lens or prism between two polaroid filters which have their axes at 90° to each other. When unpolarized light is viewed through this combination of filters and mounted element, any mechanical stress will appear as an illuminated area against the dark background. Stress in an optical element will produce a stratification or layering of

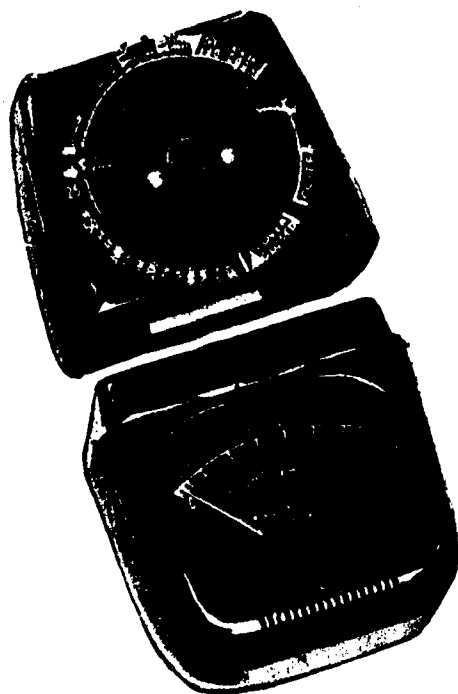

148.224

Figure 3-20.—Exposure meter with dim light hood.

the glass. This stratification will "twist" the light as it passes through the element. The "twist" is actually rotation of the axis of polarization of the light passing through that area which is under stress. The light passing through the area not under stress will be blocked by the second polaroid filter while the light passing through the area under stress, will be partially passed by the second polaroid because of the rotation of its axis of polarization. This partial passing of light by the area under stress will appear as a relatively bright area as in figure 3-22.

AUTOCOLLIMATION

Autocollimation is the process by which a collimated light beam, containing an image of a reticle, is projected from a telescope to a reflecting surface and reflected back into the telescope where it is focused on the plane of the reticle. Figure 3-23 illustrates a common type of collimator used for alignment purposes. It is

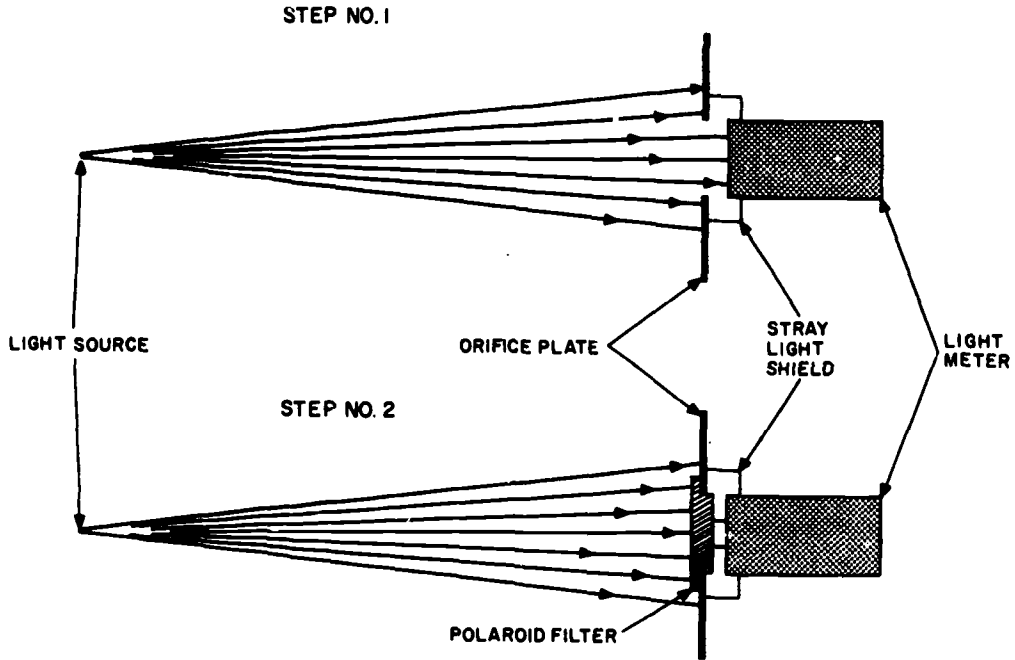

Figure 3-21.—Evaluation of a polaroid filter.

148.225

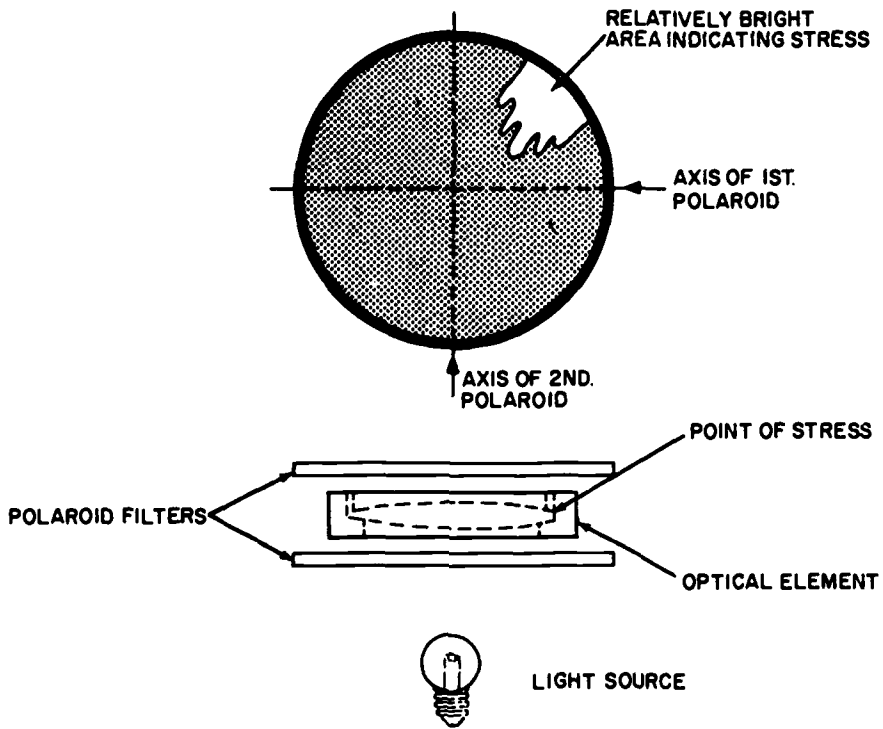

Figure 3-22.—Stress detection with polarization.

148.226

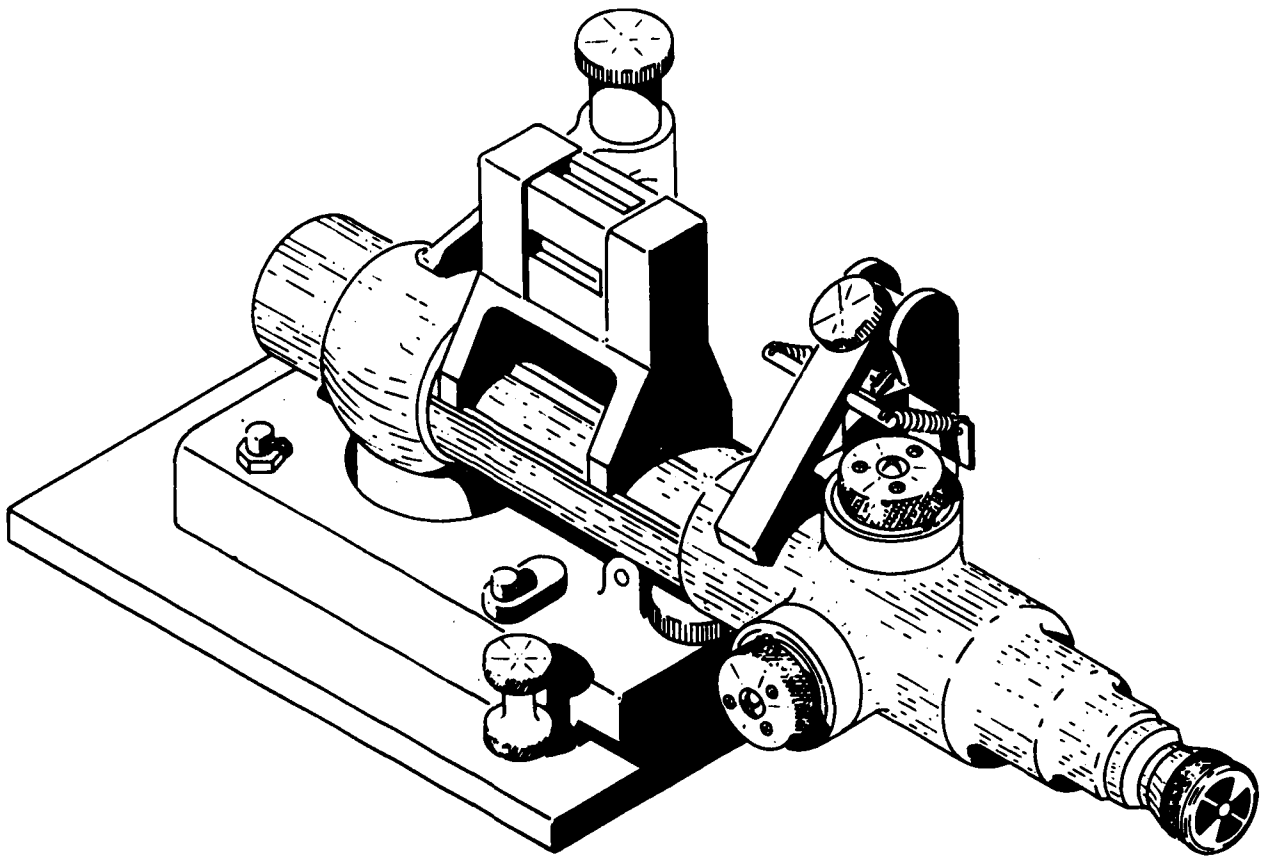

Figure 3-23.—Autocollimator.

148.227

capable of measuring the amount of displacement of the reflected reticle image.

Autocollimation is normally used to establish optical lines and planes which may then be used as references to determine whether or not a surface is square, perpendicular, straight, flat, or true.

Autocollimation has become an accepted method of alignment because it provides a greater degree of accuracy than any of the common mechanical methods.

The process of autocollimation is being used extensively as an alignment method for shafts, bearings, mounts, ways, and navigational instruments.

As a senior Opticalman, you may be called upon to give technical advice or even accomplish an alignment using autocollimation. You may have the occasion to use autocollimation in your work since it is a means of checking alignment

in the Mark 102 tilting-prism gunsight telescope. On submarine tenders having the capability of overhauling FBM submarines, Opticalmen are assigned to the fleet mechanical calibration laboratories where they perform alignment checks on instruments which require the use of autocollimation.

THEORY

In the process of autocollimation, projection of an image is accomplished using a beam-splitting device such as a half-silvered mirror contained within a telescope system. Figure 3-24 illustrates the principle of autocollimation. Light from the source passes through a diffuser and a condenser lens and strikes the beam splitter. The reflected portion of the light beam is focused on the reticle and through the objective lens where it emerges as parallel light upon which is superimposed an image of the reticle. When the light beam strikes a reflecting surface, such as a front-surfaced mirror, it is reflected back into the autocollimation telescope,

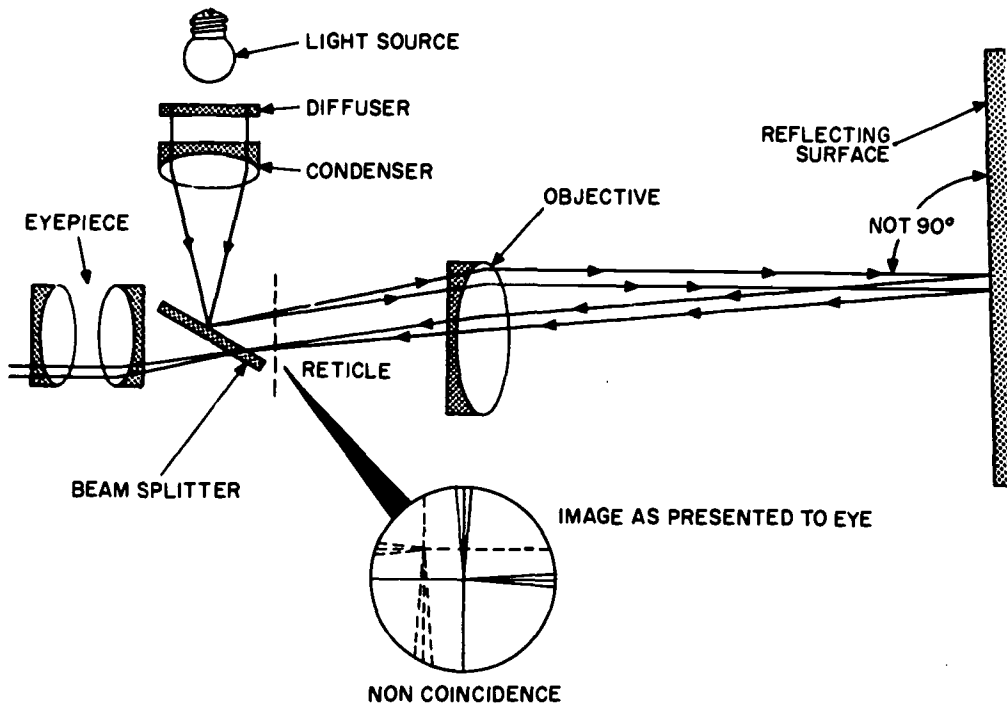

Figure 3-24.—Autocollimation (non-coincidence).

148.228

focused on the reticle, and transmitted into the eyepiece. When viewed through the eyepiece, the image of the reticle and the projected image appear as in figure 3-24 (labeled non-coincidence). Coincidence will occur when the mirror is rotated until its reflecting surface is perpendicular to the line of sight as in figure 3-25. The image would appear as in figure 3-25 (labeled coincidence) indicating the projected and reflected lines of sight are superimposed and the reflecting surface is perpendicular to the line of sight of the instrument.

APPLICATION

To illustrate the use of autocollimation, a typical calibration procedure will be given. Although this procedure is peculiar to repair activities servicing FBM submarines, the use of autocollimation as a tool is not limited to these repair activities.

On board an FBM submarine alignment periscopes are incorporated in the ship's inertial

navigation system. The periscopes consist primarily of an optical tube with mirrors or prisms at each end. Their purpose is to transmit a reference beam of light without introducing any errors. To ensure the accuracy of these alignment periscopes, calibrate them periodically by autocollimation.

Figure 3-26 illustrates a typical test setup for a rhomboid type alignment periscope calibration. Test specifications dictate that the emergent line of sight be parallel to the incident line of sight to within ± 5 seconds of arc. Calibration of the alignment periscopes consists of two separate tests, twist and spread.

The twist and spread tests measure the amount of deviation of the line of sight as illustrated in figure 3-27. Setup for the tests involves aligning the mirror and autocollimator so that the mirror is perpendicular to the line of sight of the autocollimator and the images within the autocollimator are in coincidence. The alignment periscope is then placed so that it intercepts the line of sight of the autocollimator. Since neither the autocollimator nor the mirror

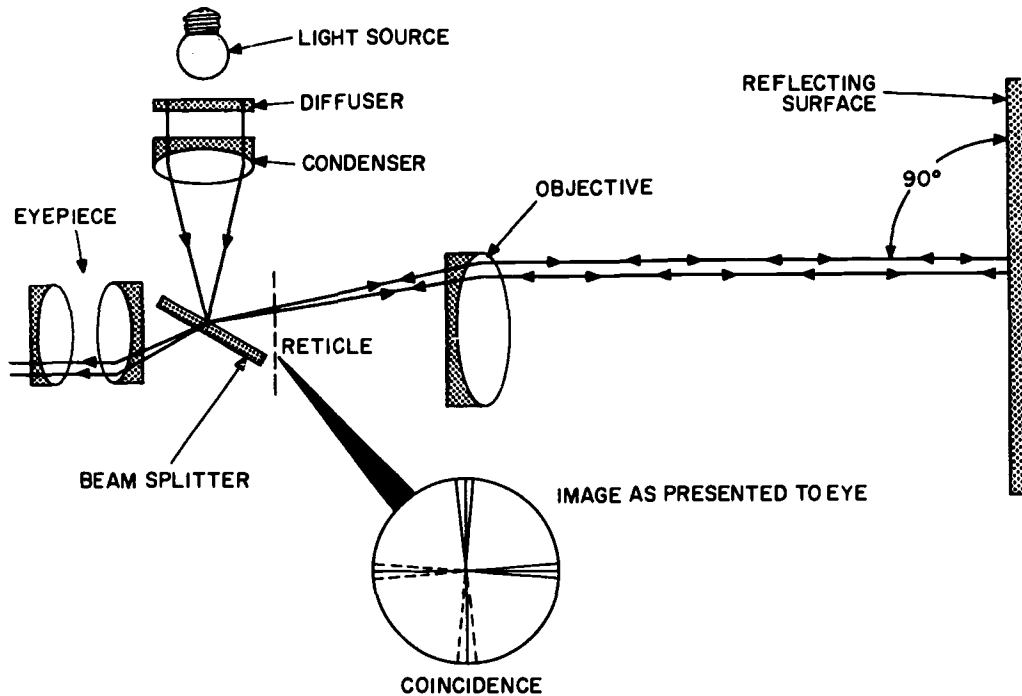
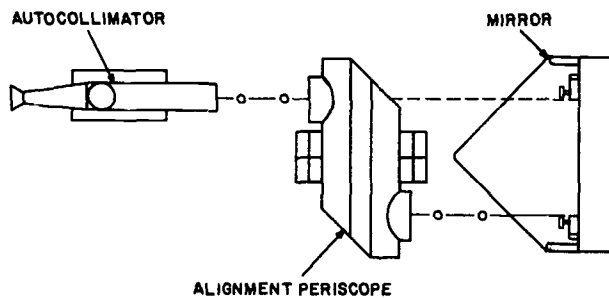

Figure 3-25.—Autocollimation (coincidence).

148.229

has been disturbed, any error indicated by the reflected image of the reticle is introduced by the alignment periscope. Any error measured by the autocollimator is actually double the

amount introduced by the alignment periscope. This double error is due to the fact that the projected image passes through the alignment periscope twice.



148.230

Figure 3-26.—Autocollimation calibration set-up.

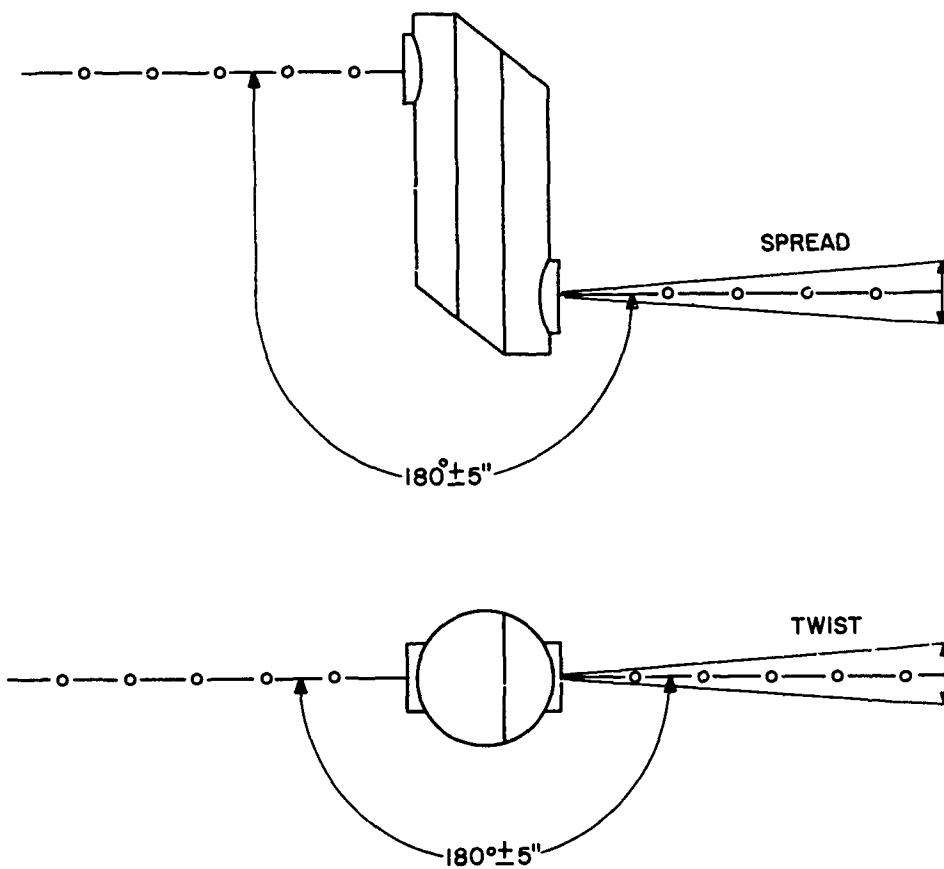

148.231

Figure 3-27.—Spread and twist of line-of-sight.

CHAPTER 4

OPTICAL ALIGNMENT INSTRUMENTS

This chapter concerns equipment that is normally carried in optical shops and that Opticalmen are required to use in the alignment of optical instruments. Because new instruments require alignment, you (as a senior Opticalman) may have to adapt your alignment equipment to these requirements. It may even be necessary for you to develop new procedures to accomplish an effective alignment of an optical instrument with the equipment you have available. This chapter will help you carry out your alignment tasks.

The processes of optical alignment and collimation fall into the category of repair work known as calibration. Calibration is the process of comparing a test instrument to a known or fixed standard. The accuracy of your alignment will be restricted, to a point, by the accuracy of your standard, the collimator. Therefore, since your collimator serves as a reference device it

should be calibrated periodically to ensure its accuracy. According to metrology requirements list, NavAir 17-35 MTL-1, optical alignment equipment should be calibrated at least once in every 12 month period.

COLLIMATORS

Upon completion of the maintenance portion of the overhaul of a piece of optical equipment, it is necessary to make checks of, and adjustments to, the optical system to ensure its accuracy. Those devices normally used for alignment references are collectively called collimators.

MK 5 BINOCULAR COLLIMATOR

The Mk 5 binocular collimator (fig. 4-1) is the most common and widely used of all collimators in optical shops. Its predecessors, the

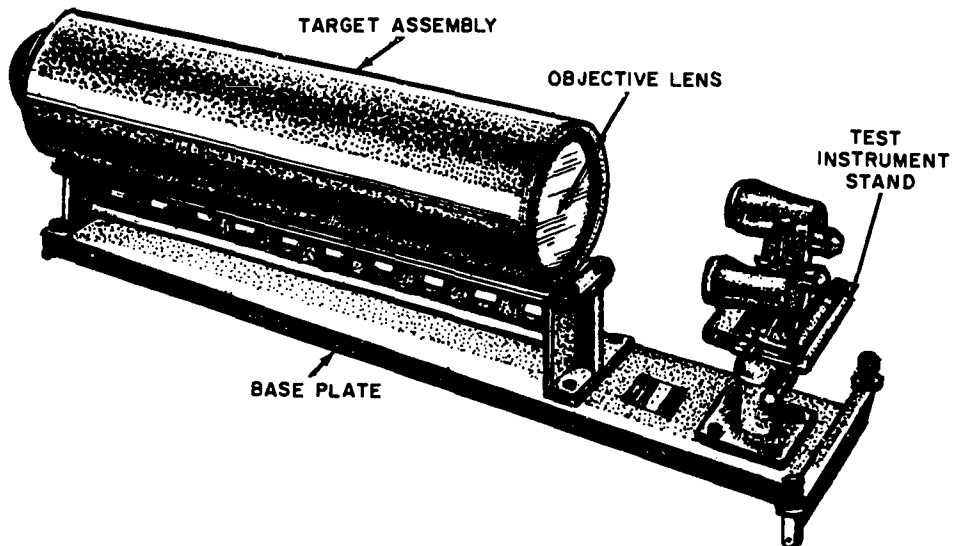

Figure 4-1.—Mk 5 binocular collimator.

148.232

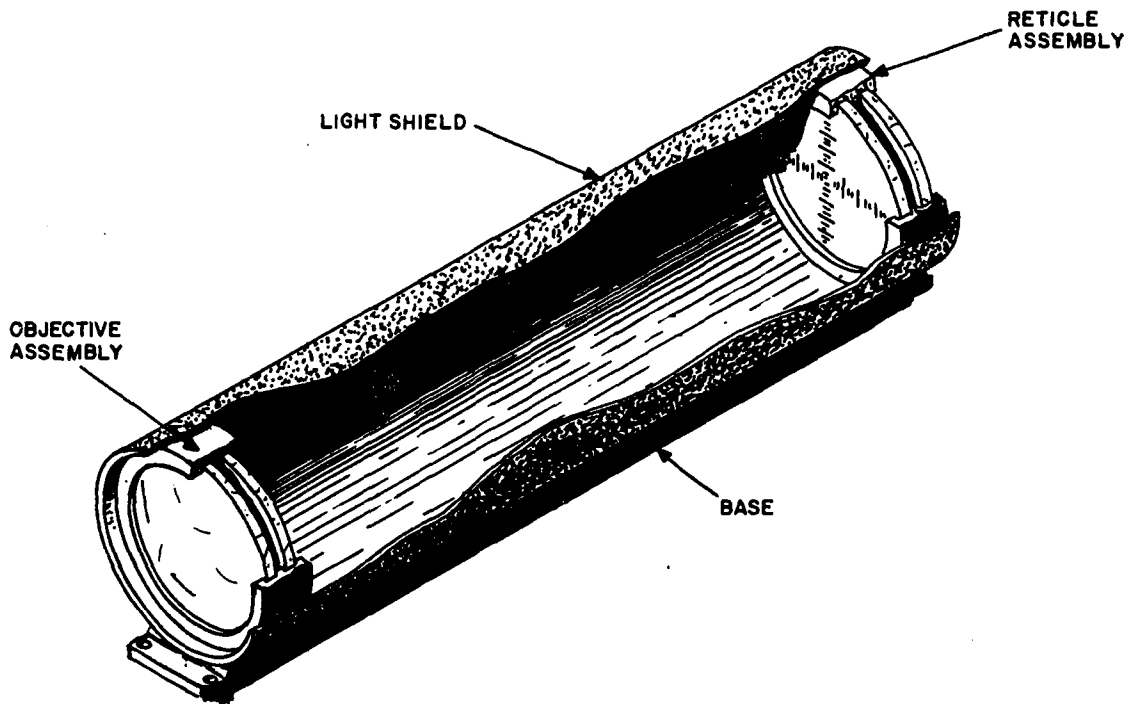

Figure 4-2.—Target assembly cutaway view.

148.233

Mk 3 and Mk 4 binocular collimators, were of similar design with the major difference being in the larger diameter target and objective assemblies of the Mk 5.

Uses

The Mk 5 was primarily designed to align the optical and mechanical axes of hand-held binoculars. As you should know by now, the Mk 5 is used as a reference for many other instruments requiring an infinity target for alignment. Some examples of the versatility of the Mk 5 includes its usage as an alignment reference for sextants, stadimeters, and various other navigational instruments.

Configuration

The Mk 5 collimator consists of a base plate, the target assembly, and fixtures for holding the test instrument (fig. 4-1). The base plate is drilled and tapped to mount and form a rigid support for the target assembly and the test instrument mounting assembly.

The target assembly (fig. 4-2) has its own base upon which are mounted the objective assembly, the reticle and illumination assembly, and the light shield.

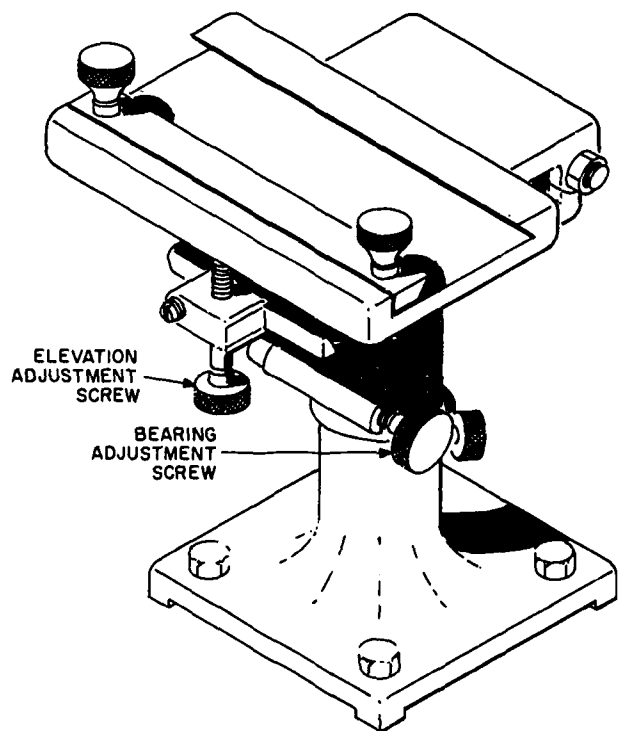

Figure 4-3.—Test instrument mounting stand.

148.234

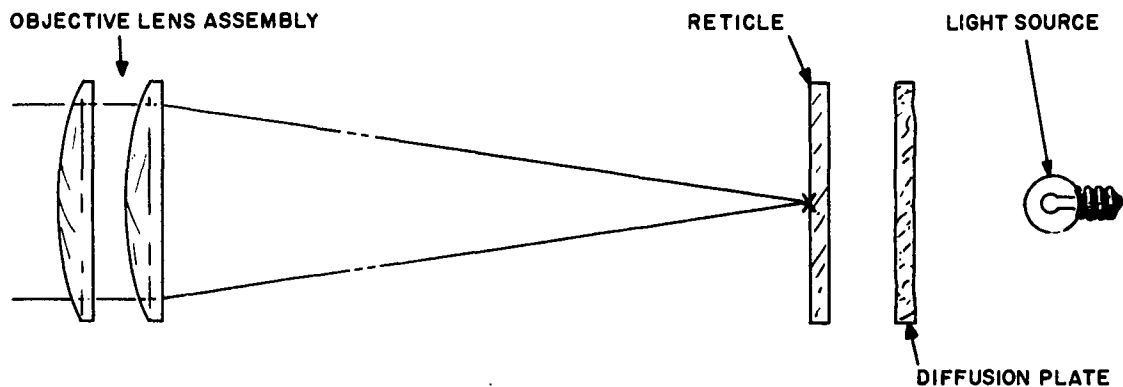

Figure 4-4.—Mk 5 binocular collimator, optical system. 148.235

The test instrument mounting stand (fig. 4-3) is an adjustable stand upon which fixtures to hold binoculars or other instruments may be attached. The instrument fixtures fit into a dove-tail slot from the side of the stand. The stand has a screw and spring loaded adjustment for varying the bearing of the mount and a screen adjustment for adjusting the elevation angle.

Optical System

The Mk 5 collimator optical system consists of an objective lens assembly, a reticle, a

ground-glass screen, and a light source (fig. 4-4). The objective lens is an air-spaced doublet containing two identical convexo-plano elements. The focal length of the objective assembly is approximately 1022.6 mm. The reticle lies at the focal plane of the objective and provides a reference target to which the test instruments are aligned (fig. 4-5). This target is etched on the first surface of the reticle plate and has graduated crosslines on a 13° field. The field is divided into degree and ten minute gradua-

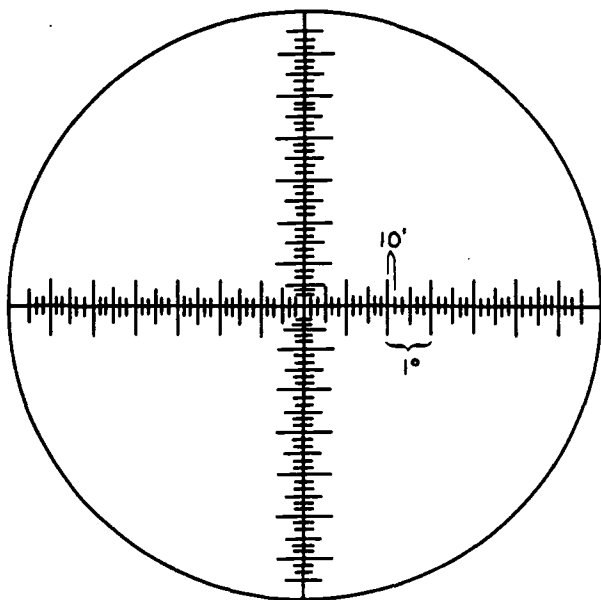

Figure 4-5.—Mk 5 binocular collimator reticle. 148.236

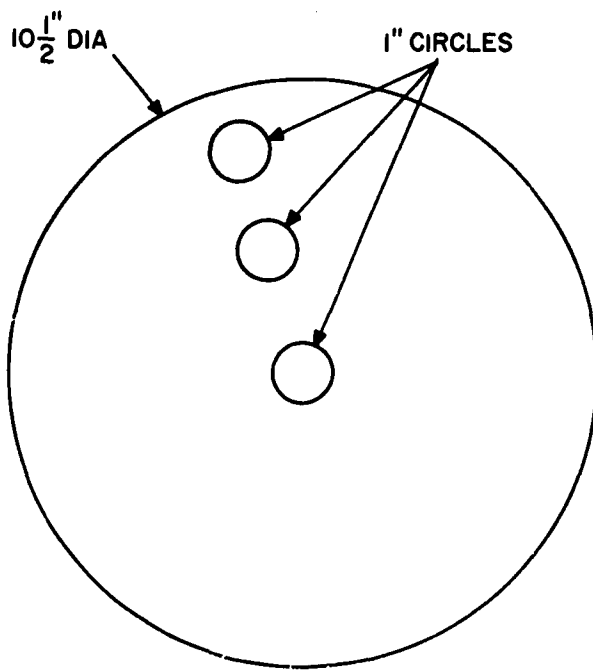

Figure 4-6.—Masking device for Mk 5 collimator check. 148.237

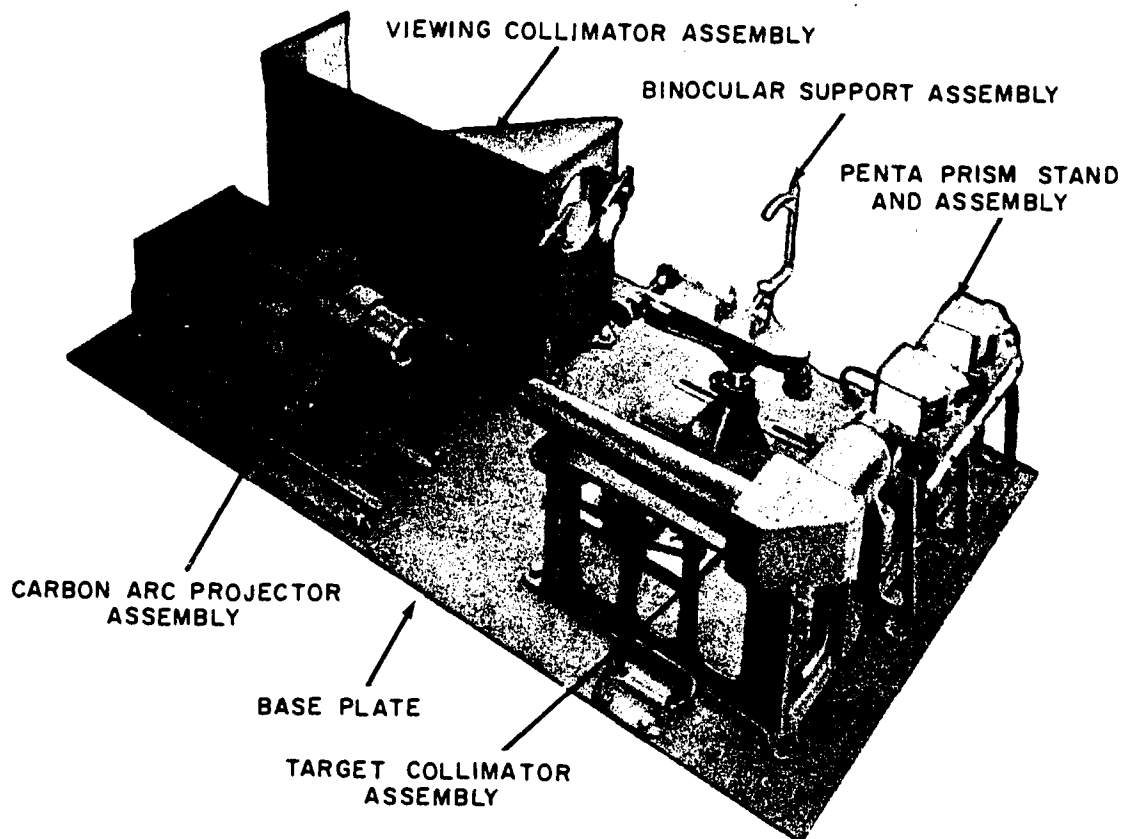

Figure 4-7.—Mk 13 binocular collimator.

148.238

tions which are .3 mm wide. Immediately behind the reticle plate is a ground-glass, green-tinted diffusion plate which provides illumination for the reticle. The light source may consist of either a 40-60 watt frosted or blued incandescent lamp with a reflector or a series of low voltage bulbs which will provide the same light level as the 40-60 watt bulb.

Adjustment

Adjustment of the Mk 5 binocular collimator is not normally required. Should the collimator be abused or in any way become suspect as a reference device, it is your job as a supervisor to insure it is checked. As with other collimators, it should be checked at least every 12 months.

The checks to make to ensure its accuracy as a reference device include proper relationship of objective assembly focal plane and reticle (parallax) and the presence of spherical aberration. Should either defect be present in the

collimator, it will be necessary to remove the error or compensate for it.

Parallax is most easily discerned by using a high-power instrument focused at infinity. Example: Surveyor's transit focused on the moon. Without changing the focus of the instrument, sight on the reticle of the collimator. The reticle should be clear and sharp. Then vary the focus of the reference instrument slightly in both directions. The definition of the reticle should not improve. If repeated checks, by different observers, indicate this is not the case, the objective assembly or the target assembly will have to be moved until the reticle forms a sharp image.

A simple and effective method of testing the perpendicular alignment of the objective is to employ a masking device (fig. 4-6) and an auxiliary telescope. Tape the mask to the front of collimator. By alternately masking different areas of the objective lens, we can discern quickly if the reticle remains at the same focus for all points. What this physically determines

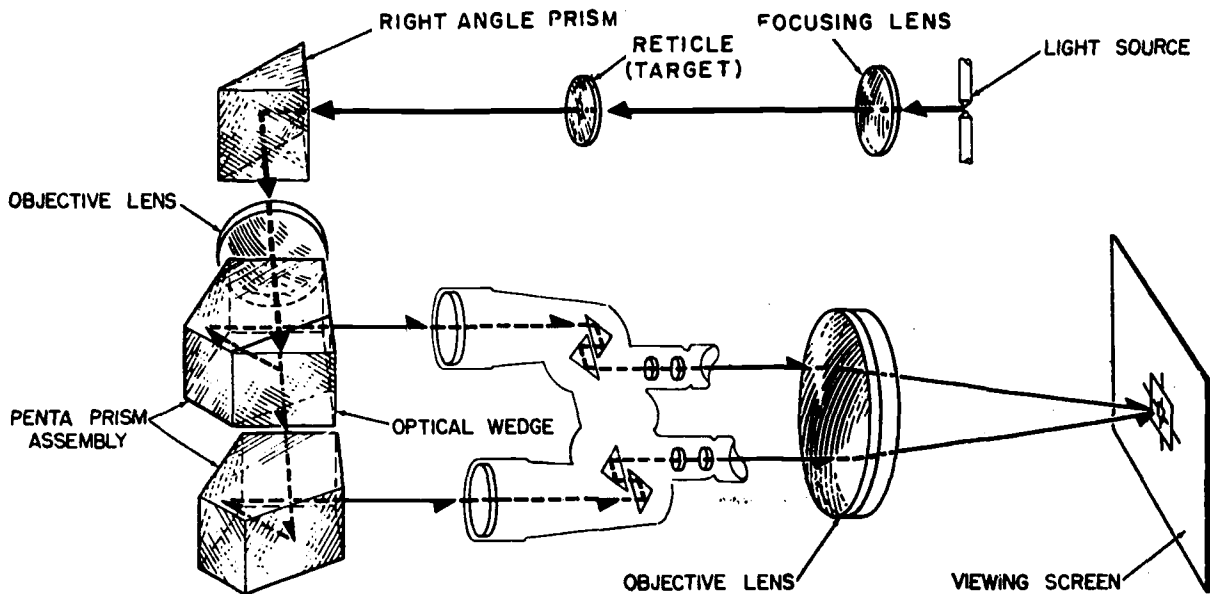

Figure 4-8.—Mk 13 binocular collimator—operational schematic of optical system. 148.239

is that the optical axis of the objective assembly is perpendicular to the plane of the reticle and spherical aberration is at a minimum.

MK 13 BINOCULAR COLLIMATOR

Although not as widely used as the Mk 5, the Mk 13 binocular collimator is found in many optical shops. The basic design of the Mk 13 (fig. 4-7) differs from other binocular collimators in that an image is projected through the binoculars and onto a screen. Due to its design, the Mk 13 affords a rapid check of collimation, prism squareness, equal magnification, diopter setting, and eyepiece eccentricity.

Uses

Although initially designed for use as an alignment device for the various marks and mods of hand-held binoculars, the Mk 13 lends itself to the alignment of other binoculars such as the Mk 90 and Mk 91 pressure-tight binoculars.

Configuration

The Mk 13 binocular collimator (fig. 4-7) consists of a large steel base plate upon which is mounted a carbon-arc projector assembly, target collimator assembly, pentaprism assembly, test instrument support assembly, and viewing collimator assembly.

The instrument support assembly is adjustable laterally to allow for variations in instru-

ments of different types. The projector assembly is adjustable to allow for variations in focusing requirements which arise as the carbon rods are consumed in the process of producing light. The distance between the pentaprisms may be adjusted to allow for variations in inter-objective distances of various test instruments.

Optical System

The optical system of the Mk 13 binocular collimator (fig. 4-8) consists of a carbon-arc light source, focusing lens, reticle, right angle prism, target objective lens, pentaprism assembly, viewing objective, and a viewing screen.

The system functions as follows. The carbon-arc light source provides a high intensity light beam which is focused onto the reticle by the adjustable focusing lens. The reticle image, superimposed on the light beam, is transmitted into the right angle prism, deviated 90° , and then to the target objective lens. The target objective lens transmits a parallel bundle of light into the first pentaprism. The initial reflecting surface of the first pentaprism is half-silvered with a wedge cemented to the half-silvered surface. The light bundle is split as it strikes this first surface, one-half proceeding to the second pentaprism while the other half is deviated 90° towards the viewing collimator assembly. The light bundles emerge from the pentaprism parallel to each other and are focused

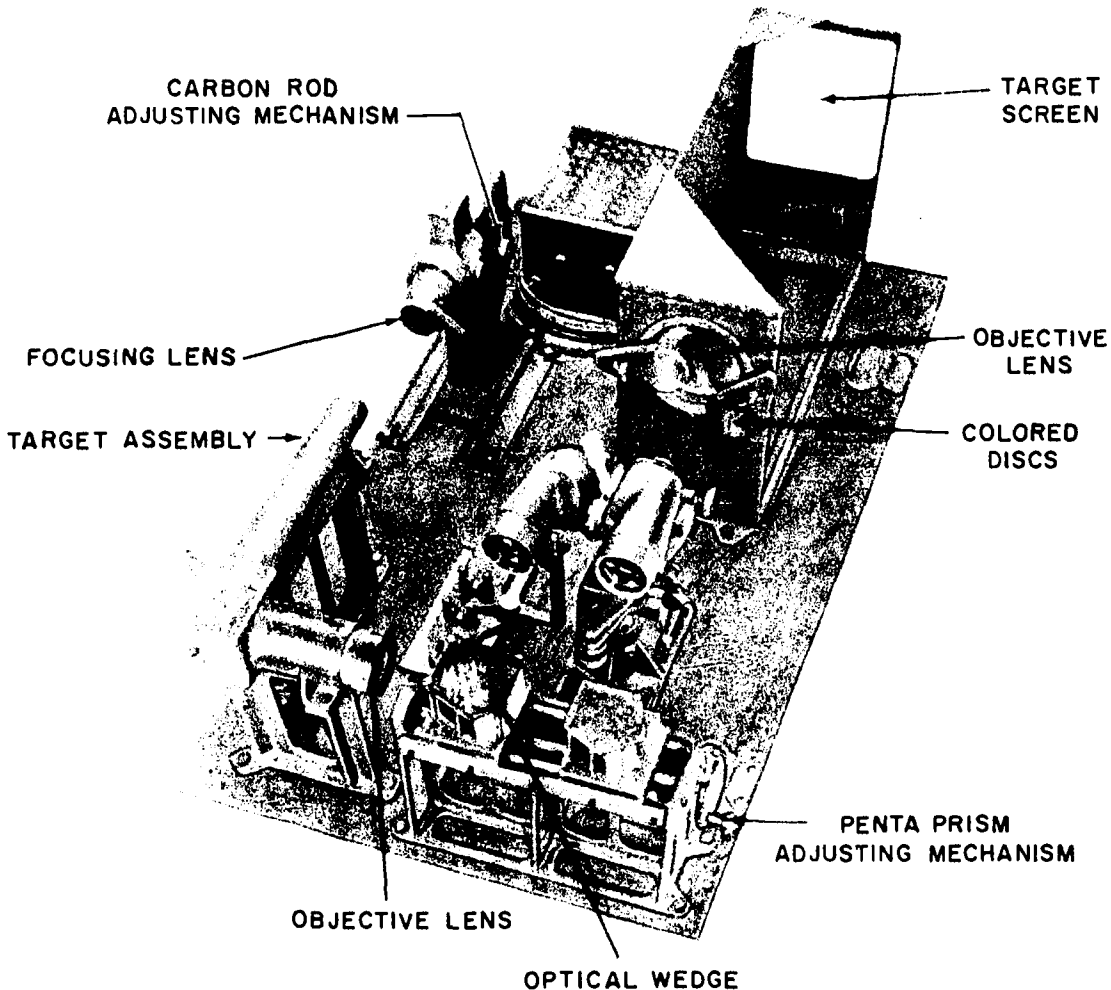

Figure 4-9.—Mk 13 binocular collimator.

148.240

to a single image on the viewing screen after passing through the viewing objective lens. Colored filters are provided immediately in front of the viewing objective lens to identify the individual light beams during collimation.

Operation

When operating the Mk 13, remember the carbon-arc projector is a high intensity light source which is capable of damaging the eyes of anyone who should look directly into it.

The first step in the operation of the Mk 13 is to activate the light source. To do so, energize the power supply and adjust the carbon rods for maximum light output (fig. 4-9).

It may be necessary to readjust the carbon rods during collimation if the collimator is used for extended periods.

Next, adjust the focusing lens until a sharp image is transmitted to the viewing screen. The test instrument may now be installed in the collimator. Adjust the distance between the pentaprisms to afford maximum light transmission into each of the test instrument objectives. NOTE: It is always advisable to check prism alignment whenever an interprism adjustment is made.

If desired, the colored discs may be moved into each line of sight to identify their respective images on the viewing screen.

Adjustment

Whenever the distance between the pentaprisms is changed, a check of the alignment of the two images should be made. Two types of misalignment may occur; twist or tilt of one image in relation to the other and a height differential between the images. Recalling your theory of pentaprisms, you will remember the plane of the emergent ray is 90° from that of the incident ray. As the incident ray is common to both pentaprisms, we know the planes of the emergent rays will be parallel. However, a rotational error may exist between the two emergent rays. See fig. 4-10 for an example of the way the errors produce a height difference in the transmitted images. If the entrance face of the prism is not perpendicular to the incident ray, twist or tilt of the image will result. Both of these errors can be removed utilizing the adjustment screws provided in the base of the second pentaprism mount (fig. 4-11).

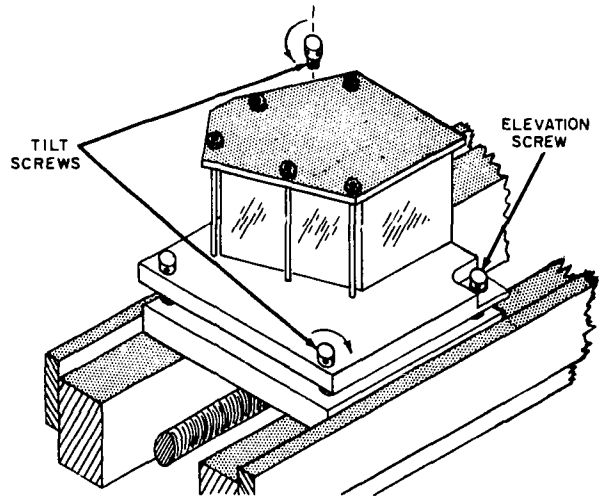

Figure 4-11.—Pentaprism 148.242 stand.

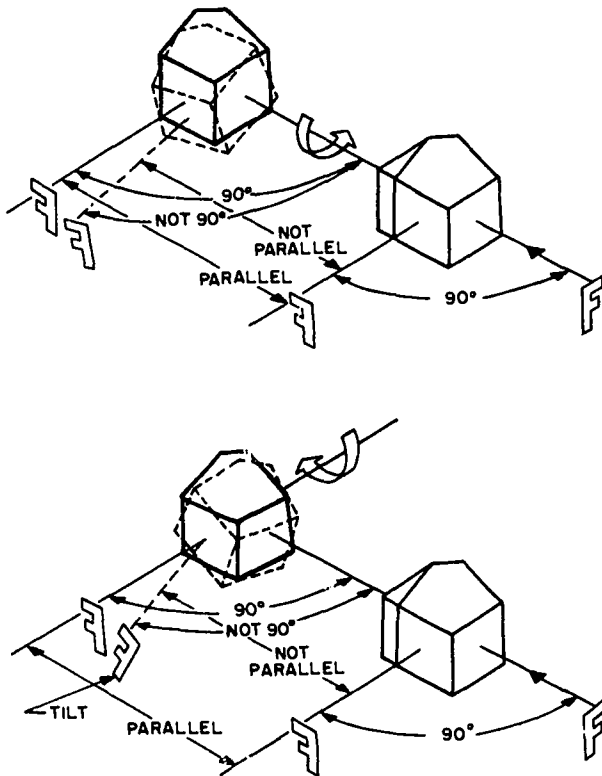

Figure 4-10.—Pentaprism 148.241 rotational error.

There are two other sources of error that should be checked for periodically. Parallax in either the target assembly or the viewing assembly will affect the accuracy of any collimation done on the collimator.

Both the target collimator and viewing objective lens assemblies are adjustable. Therefore, it is possible to adjust for an error in one assembly by introducing an error into the other assembly. It is for this very reason that you must check the accuracy of each assembly independently.

The viewing assembly may be checked for parallax in two ways; either by projecting an infinity target onto the white, opaque screen with an autocollimator or similar device, or by marking a target on the screen with a china marking pencil and making the standard test for parallax. The only purpose of these tests is to ensure that the viewing surface of the screen lies at the focal plane of the viewing objective lens.

The target collimator assembly must be checked to ensure that the light bundle leaving the target objective lens consists of parallel light rays or, to restate it, that the reticle lies in the focal plane of the objective. Again, you are looking for parallax, but in this case it is not possible to project an image into the objective lens and check the results because the reticle is silvered except for the target. Therefore, it will be necessary to either view the target with an auxiliary telescope set for infinity

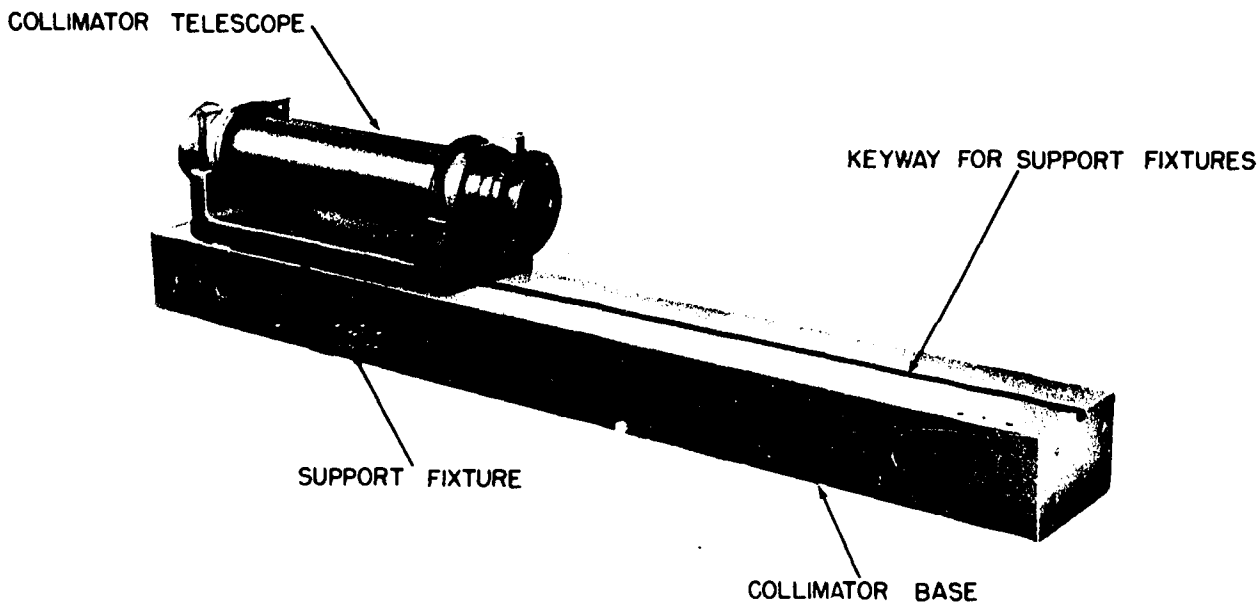

Figure 4-12.—Telescope collimator Mk 4 Mod 0.

137.200

or to project the image onto the screen of a previously adjusted viewing assembly.

Both the viewing assembly and the target collimator assembly can be adjusted by moving their objective assemblies until the proper position is achieved. Once again, do not compensate for error in one system by introducing an error into the other.

MK 4 MOD 0 TELESCOPE COLLIMATOR

The Mk 4 telescope collimator (fig. 4-12) is designed to collimate straight line gunsight telescopes.

Uses

The Mk 4 was designed primarily as a gunsight collimator for those instruments which have a fixed line of sight. As in all reference devices, do not let the design purpose obstruct your ability to adapt this device to other requirements. For example, the Mk 4 is an excellent device for collimating boresight telescopes and other straight line telescopes (fig. 4-13). Notice that the collimator telescope of the Mk 4 provides a crossline at infinity which acts as a reference target.

Configuration

The Mk 4 telescope collimator consists of a base, a collimator telescope, and support fixtures for the various test instruments. The collimator telescope must provide an infinity crossline target but need not be a particular type. The Mk 2, Mk 3, and Mk 15 collimator telescopes are appropriate for your needs.

The alignment of the Mk 4 collimator consists of squaring the collimator telescope reticle

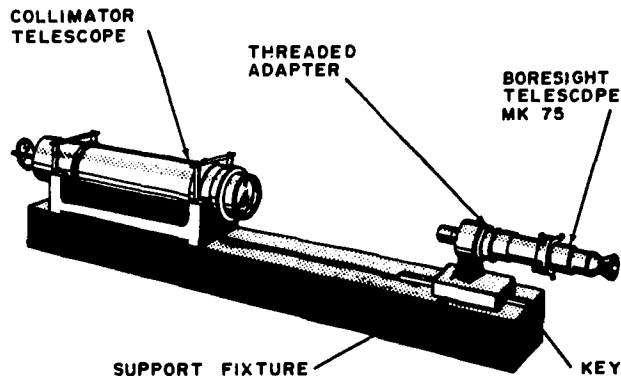

Figure 4-13.—Telescope Mk 148.243 75 installed on telescope collimator Mk 4 Mod 0.

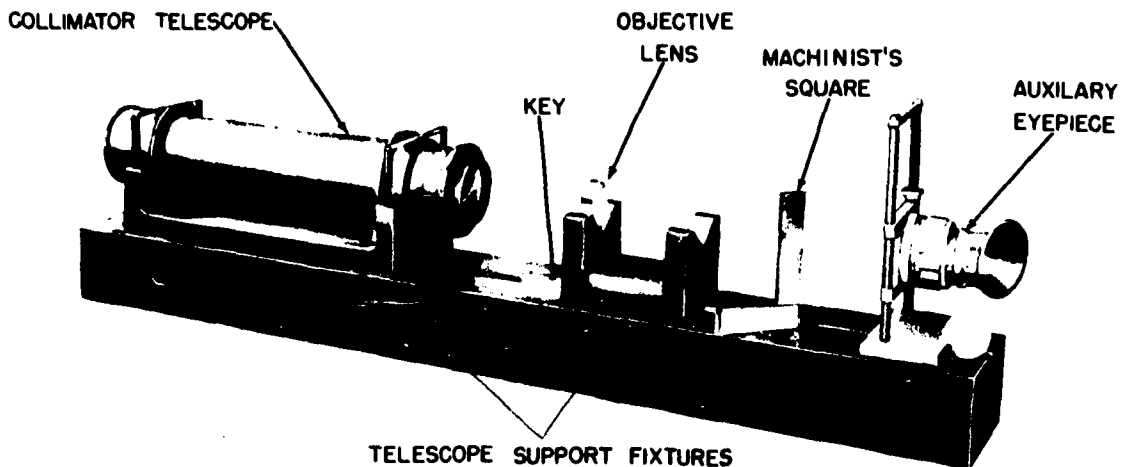

Figure 4-14.—Telescope collimator Mk 4 Mod 0—squaring crosslines of collimator telescope.

137.206

so that the vertical crossline is perpendicular to the bearing surface of the base. To accomplish this, set up an alignment arrangement similar to that in fig. 4-14 which will enable you to align the reticle to the precision square. The objective lens and eyepiece assemblies will establish a focal plane where the square must be placed in order to square the reticle crosslines. Turning the collimator telescope in its support fixture will then allow you to align the crossline to the precision square.

The collimator telescope should also be checked for parallax. The procedure for checking parallax is given later in this chapter.

Once the collimator telescope is squared, the test instrument support fixture can be aligned to it. Figure 4-15 illustrates the steps involved in the setup for test instrument alignment. First, the support fixture must be aligned to the collimator telescope. Then the test instrument is attached and aligned to the collimator telescope.

THE MK 9 TELESCOPE COLLIMATOR

Phasing out of all optical instruments in the Navy which had three lines of sight eliminated the requirement for a telescope collimator with three vertical rows of collimator telescopes. Therefore the Mk 6, which had three rows of collimator telescopes, was superseded by the Mk 9 which had only two rows (fig. 4-16). The Mk 6 collimators in existence were not removed but were upgraded to Mk 9 collimators.

When new Mk 9 collimators are supplied, they have fewer holes in the support base plate than did the Mk 6. The support base plates of the later units also are capable of $\pm 27^\circ$ of deflection while the Mk 6 was designed for only $\pm 17^\circ$ of deflection.

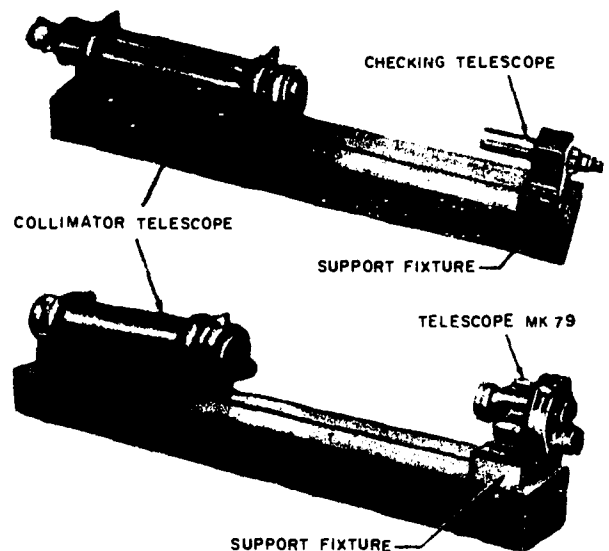

Figure 4-15.—Alignment of support fixture and installation of test instrument.

148.244

Uses

The Mk 9 telescope collimator was designed primarily as a reference device for tilting prism gunsight telescopes. Again do not let the design purpose restrict your adaptability. The Mk 9 base plate provides a large, flat surface which can be used to satisfy other alignment requirements. Figure 4-17 shows an adaptation of the Mk 9 to meet such a requirement. The Mk 9 lends itself extremely well to the same alignment usages as the Mk 4 telescope collimator (fig. 4-18).

Configuration

The base of the Mk 9 is an alloy frame on which are mounted the support brackets and plate (fig. 4-16). The two support brackets are the upright arms of the collimator. The arms are interconnected by the telescope mounting

ways. The support plate is mounted on a tapered bearing so that it can pivot. The steel support plate has tapped holes which are used to secure alignment fixtures and test instruments. The telescope support ways provide a surface for lateral adjustment of the collimator telescope mounts. The collimator telescope mounts are adjustable in bearing and elevation.

Optical System

The optical system of the collimator consists of nine collimator telescopes which provide reference lines of sight. The collimator telescope ways are mounted so as to provide reference angles of -25° , $+25^\circ$, and $+90^\circ$ from the 0° reference set of collimator telescopes. The support brackets are drilled with an additional set of mounting holes which allows the third set of collimator telescopes to be moved to establish

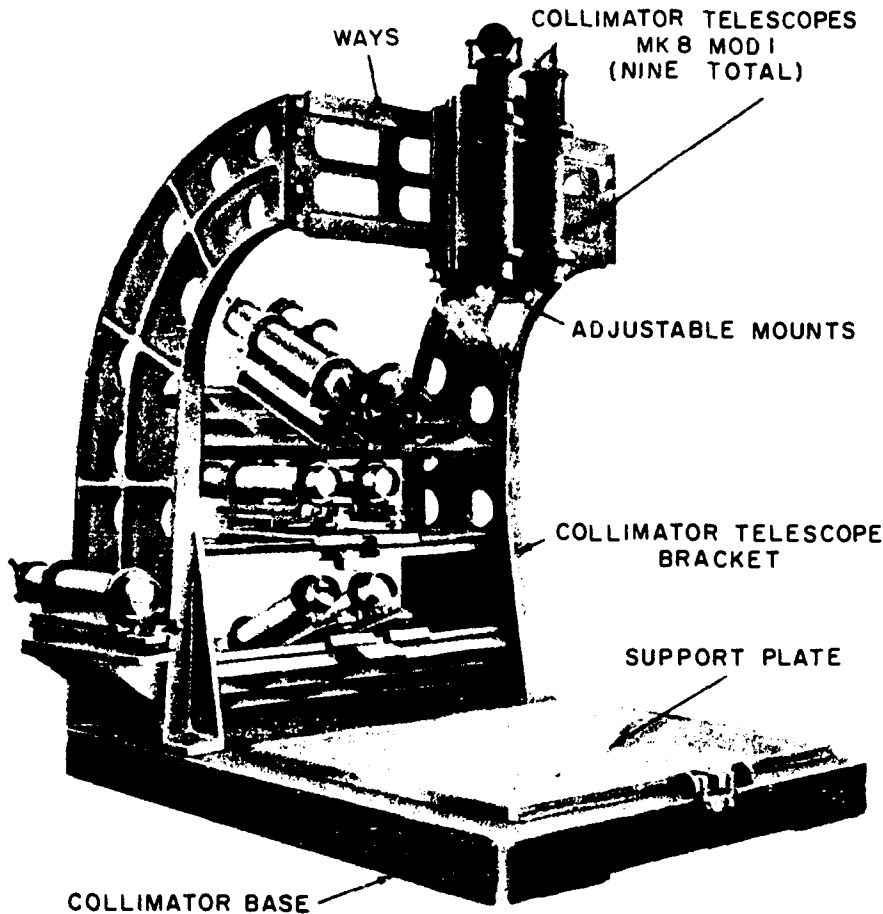

Figure 4-16.—Telescope collimator Mk 9.

148.245

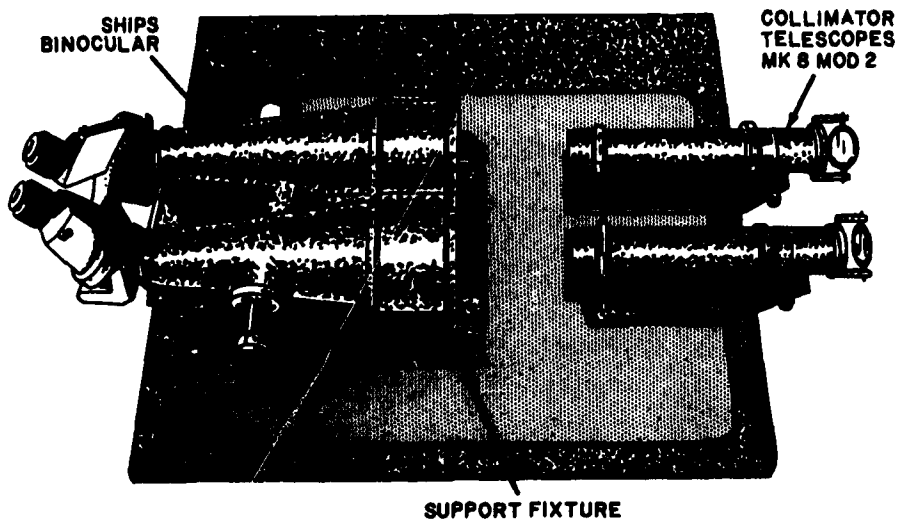

Figure 4-17.—Ships binocular installed in place for collimation.

148.246

an angle of $+45^\circ$ above the 0° set of collimator telescopes.

Figure 4-19 illustrates the means by which the collimator establishes these angles.

Alignment

As the collimator is used for different test instruments, you must align the collimator according to various test requirements.

Figure 4-20 shows a typical alignment arrangement in which the lines of sight of the collimator telescopes are used to align the line of sight of the test instrument to the mounting surfaces of the test instrument.

When aligning the collimator in preparation for using it as a reference device to align tilting prism gunsight telescopes, make sure that a positive relationship exists between the mounting surfaces of the gunsights and the lines of sight of the collimator. Exact relationships of mounting surfaces and lines of sight are available for some instruments in chapter 7. When in doubt, check the appropriate OP or OD for alignment requirements. Figure 4-21 shows the collimator alignment arrangement for the Mk 102 telescope. The "0" degree, or reference set, of collimator telescopes is aligned first to the surface upon which the test instrument is to be mounted. Checking telescopes are normally used for this purpose. The reference collimator must be adjusted so that its crossline is superimposed on the crossline of the checking telescope when the checking telescope is set to

establish the "0" reference. Figure 4-22 illustrates a typical setup for setting the "0" reference set of collimator telescopes. The support plate must be set to 0° deflection when aligning the collimator for alignment of tilting prism gunsight telescopes. After the "0" collimator telescope is aligned to the mounting surfaces, the corresponding bank of telescopes must be set to the required angles in order to check the vertical travel of the elevation system of the gunsight telescope. This normally consists of setting the first collimator telescope to -25° , the third to $+25^\circ$ and the top to $+90^\circ$. The four collimator telescope lines of sight must lie in the same vertical plane, as illustrated in figure 4-23.

SUBMARINE PERISCOPE COLLIMATOR

An optical alignment reference device common to all submarine tenders is the Submarine Periscope Collimator. Figure 4-24 shows the periscope collimator attached to the periscope repair bench, or rail as it is more commonly known. It is used as a reference device for periscopes with the exception of the most sophisticated types of navigational periscopes. Configuration

The rail and collimator are used in conjunction, and form a unit which must be aligned as a single fixture. The rail is primarily a means of support for the submarine periscope while the periscope is being overhauled and aligned. The rail also acts as a base for the collimator.

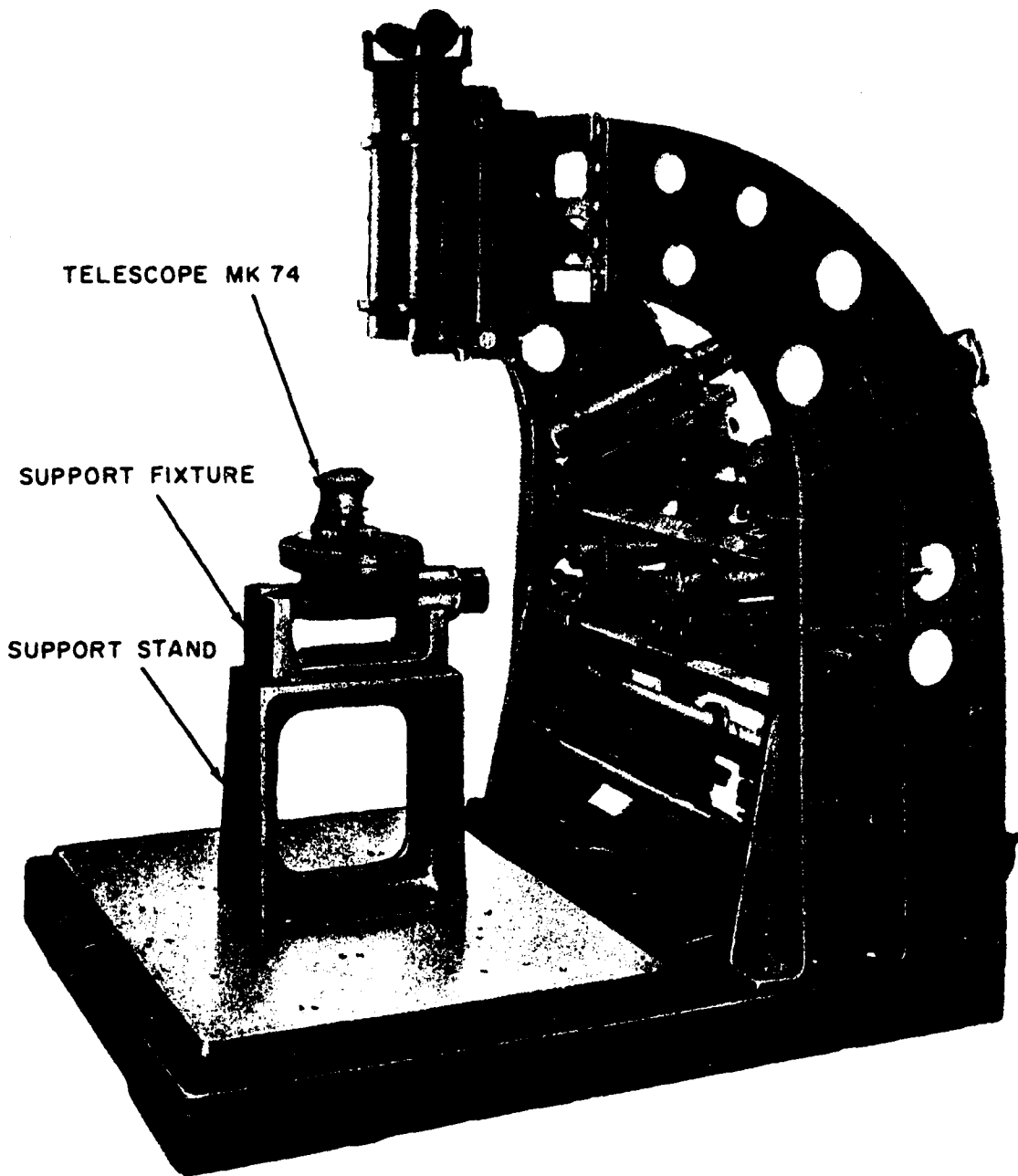

Figure 4-18.—Telescope Mk 74 installed on telescope collimator Mk 9.

148.247

The collimator proper (fig. 4-25) consists of a body tube containing the optical system, a mounting bracket and pivoting arm assembly, and a base plate assembly. The body tube contains the objective lens and the adjustable reticle

mount. The periphery of the tube forms a cylindrical bearing for mounting in the pivot arm assembly.

The pivot arm assembly contains the pivot arm, mounting bracket, and illumination

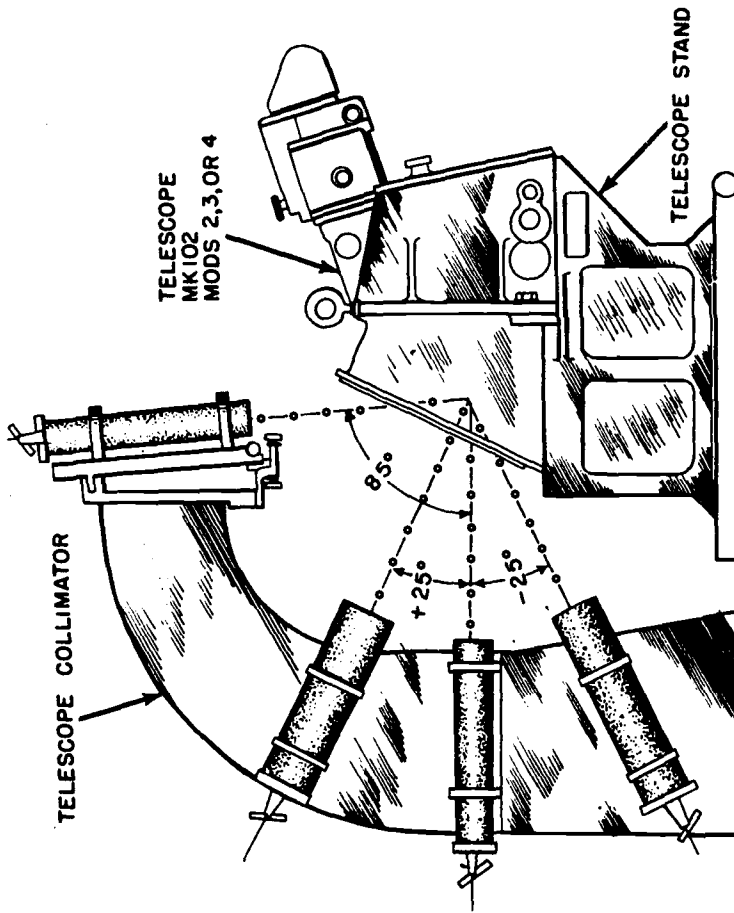

Figure 4-20.—Mk 102 Telescope alignment arrangement. 148.249

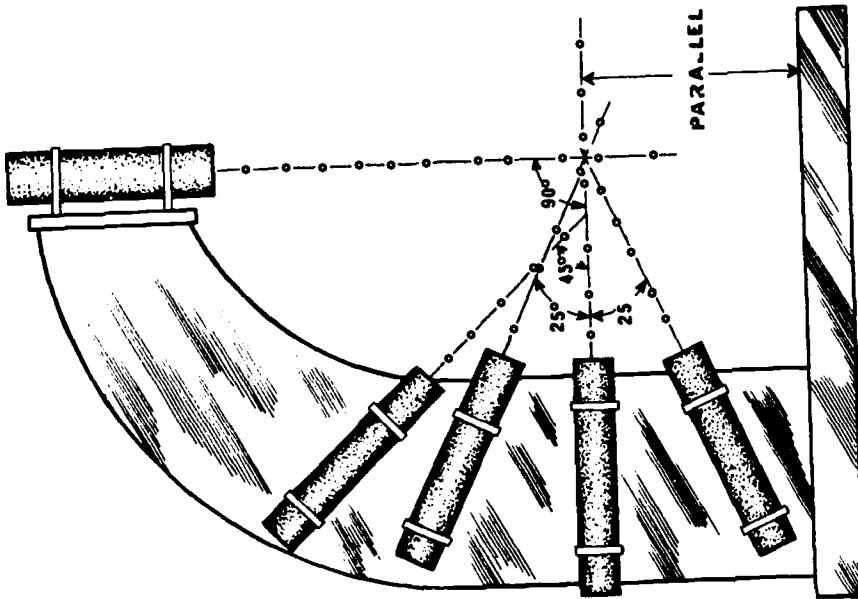
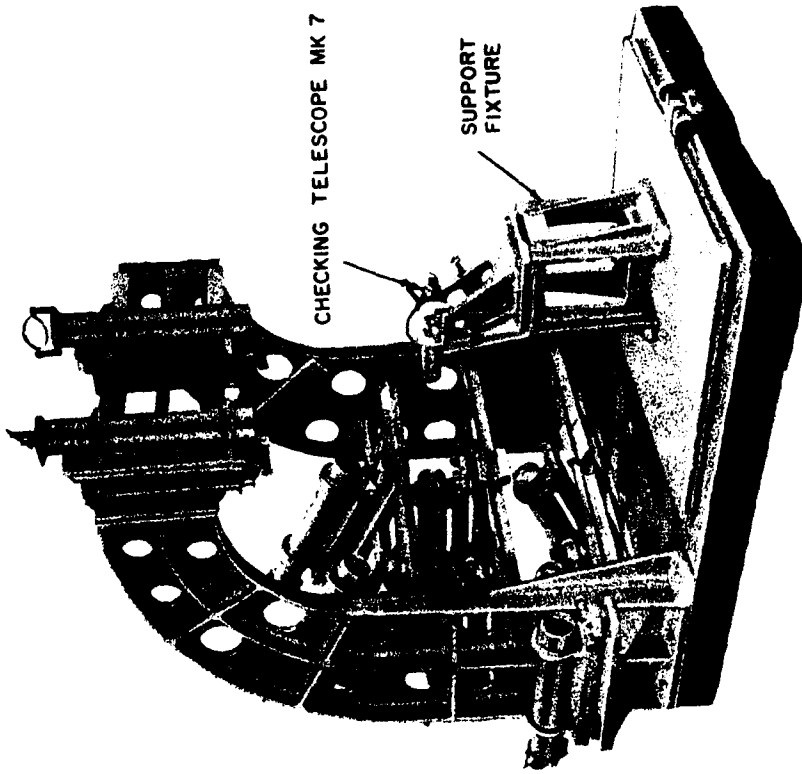
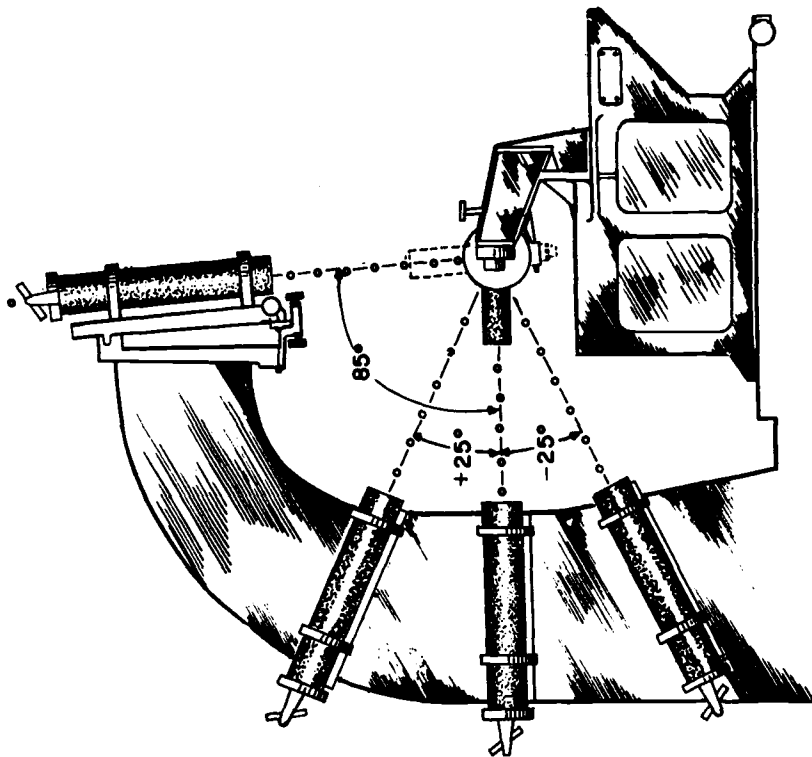

Figure 4-19.—Geometry of reference angles produced by Mk 9 collimator. 148.248



148.251
Figure 4-22.—Typical alignment arrangement for setting "O" collimator telescope.



148.250
Figure 4-21.—Collimator alignment.

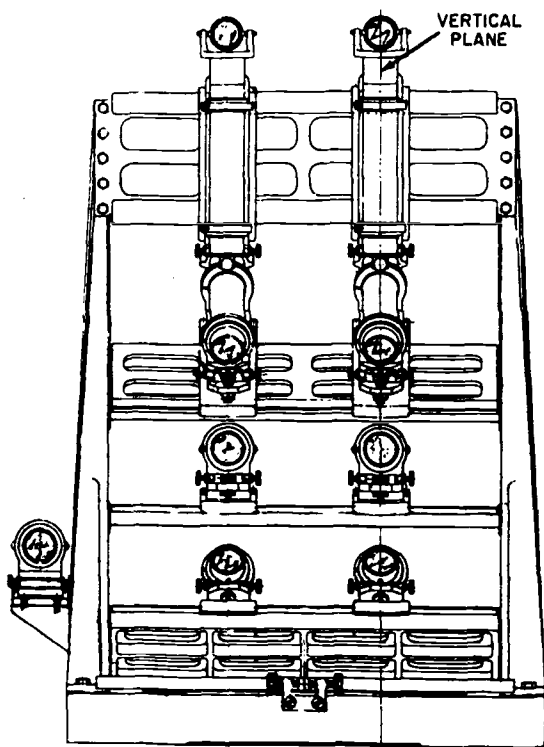

Figure 4-23.—Vertical alignment of collimator bank. 148.252

assembly. The pivot arm also has an engraved index mark which lines up with the line of sight of the collimator.

The arm attaches to the base plate assembly. The base plate assembly has an eccentric bearing which provides a means of adjusting the height of the pivot point of the arm. The base is adjustable, via elongated slots, so that the line of sight of the collimator may be aligned to the axis of the rail.

Optical System

The optical system of the collimator (fig. 4-26) consists of the objective lens and reticle. The light source and diffusion plate provides illumination for the reticle but are not contained within the collimator tube. The objective lens has an equivalent focal length of 481.7 mm ($\pm 1\%$ of focal length) and is an achromatic doublet. The reticle lens (fig. 4-27) is first surface etched with crosslines and eight graduated lines

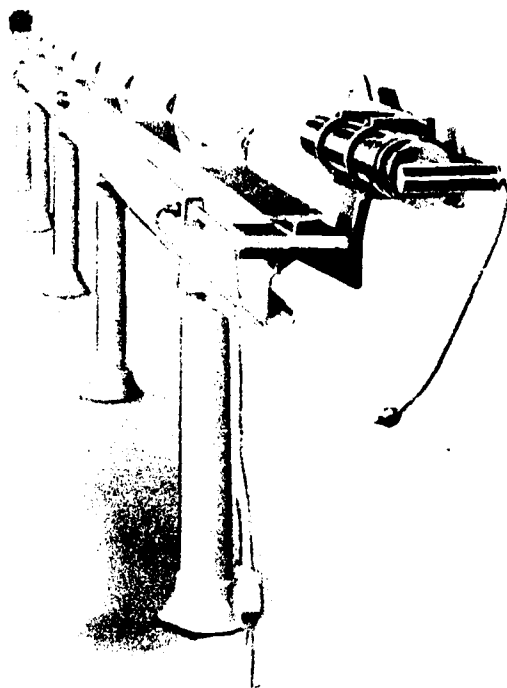

Figure 4-24.—Periscope 148.253 collimator and rail.

which form distance references for the alignment of periscope stadimeters.

A unique feature of the collimator is the adjustable reticle assembly. The assembly adjusts to form an optical target for reference setting of submarine periscopes. A discussion of the way the assembly adjusts is included in chapter 9, Submarine Periscopes.

Alignment

The alignment checks and adjustments are determined by the requirements of the particular periscope to be collimated. The periscope determines what elevation angles are required and what range requirements must be met.

One check common to all tests made with this particular collimator is the parallax test. When the variable reticle assembly is adjusted so that it indicates infinity, no parallax must be present. This setting is used as the reference for all other range setting and, therefore, is very critical as an alignment check.

Rail alignment should be checked periodically as the rail is subjected to weight and stress

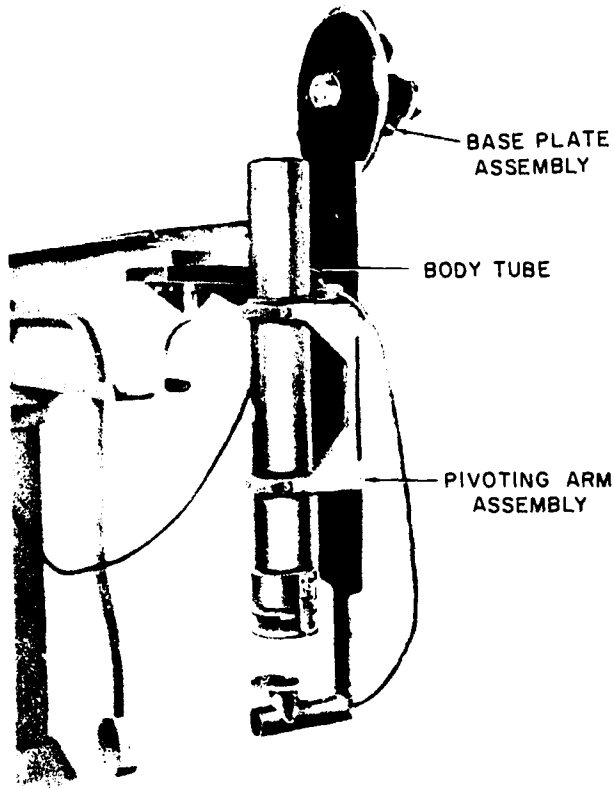

Figure 4-25.—Submarine periscope collimator assembly. 148.254

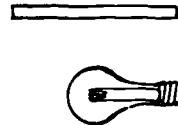
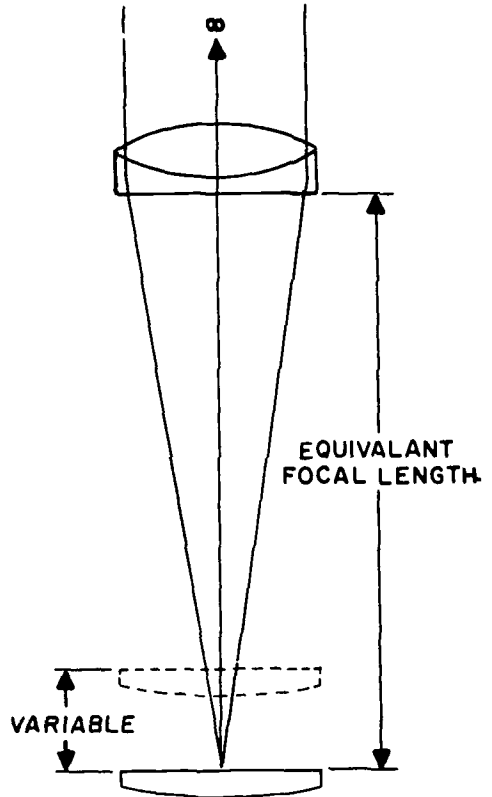

Figure 4-26.—Submarine periscope collimator, optical system. 148.255

changes as the periscopes are aligned. Figure 4-28A shows a typical arrangement which may be used for rail alignment. By aligning the boresight at one end of the rail to the target at the other end, we can establish a line of sight for the axis of the rail. The target may then be moved to each support block position to determine if the rail is aligned throughout its length. If the rail is not true, it will have to be shifted on its pedestals until the physical axis of the rail conforms to the line of sight established by the end positions. Autocollimation may also be used to check rail alignment.

The collimator line of sight must be the same height above the rail as the height of the periscope line of sight. Whether the periscope is installed in the outer tube or not causes a height differential. The collimator height may be adjusted in the same process as the rail alignment. Figure 4-28B shows the collimator positioned for height check. Focus first on the reticle and

check for 0° deflection, then focus on the objective end of the collimator. Adjust the eccentric bushing until the collimator is centered in the field of the boresight telescope (fig. 4-29). Repeat the process until the reticle is superimposed when the collimator is centered. Set the elevation indicator scale at 90° , using the pivot arm index mark as a reference. Lock the elevation scale lock at this setting. The collimator is now adjusted for proper height and elevation angle.

AUXILIARY ALIGNMENT EQUIPMENT

In addition to the collimators already discussed in this chapter, some auxiliary devices are required to effectively accomplish alignment of optical instruments even though these devices may not be common to all optical shops. They will be covered as you will eventually have an occasion to use them. Though all auxiliary equipment cannot be covered, the objective is to provide information about representative types to enable you to adapt your equipment to meet peculiar situations as they arise.

MK 1 AUXILIARY TELESCOPE

The auxiliary telescope (fig. 4-30) is used during the alignment of a majority of optical instruments. It provides an increase in the magnification of the test instrument which tends to amplify errors in alignment thereby making the errors easier to remove. The auxiliary telescope also functions to eliminate errors in the operator's vision. It makes

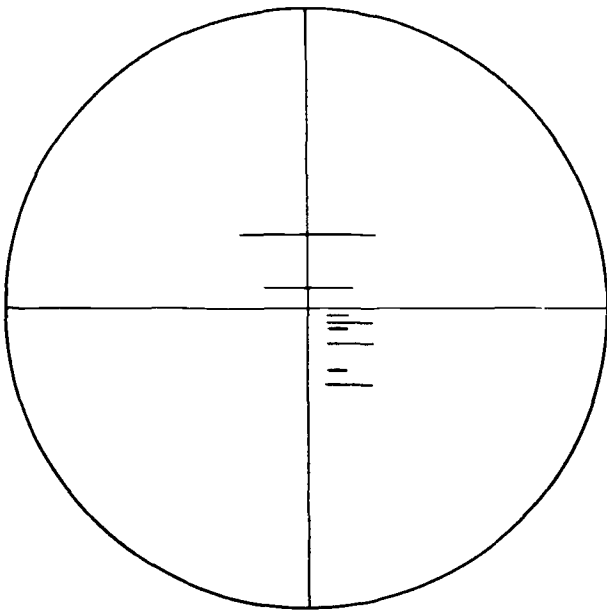

Figure 4-27.—Collimator 148.256 reticle lens, detail drawing.

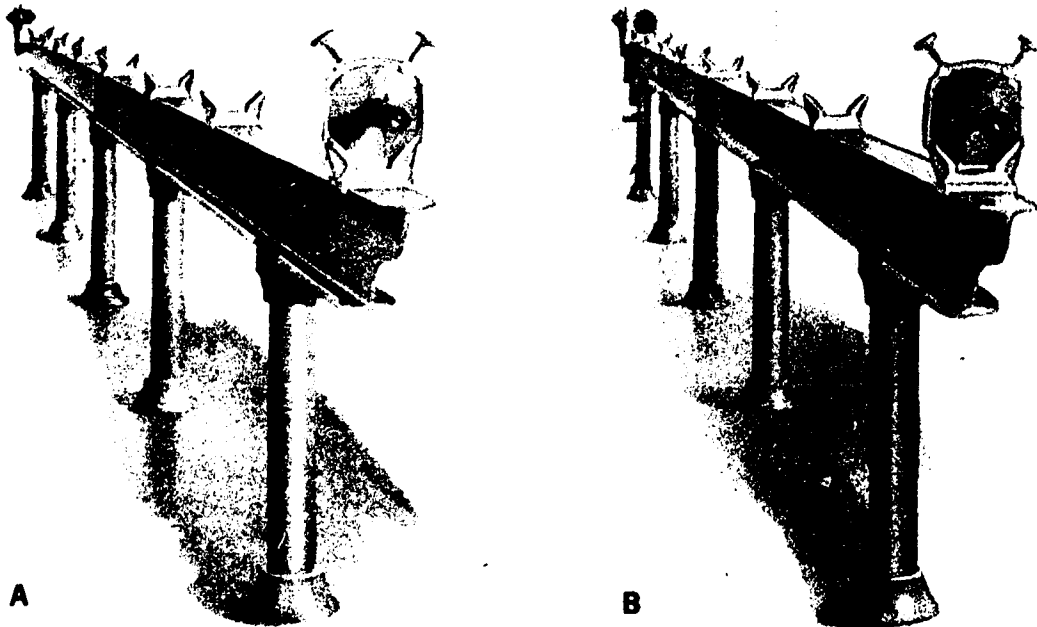

Figure 4-28.—A. Collimator secured in a horizontal position. B. Boresight telescope attached in boresight disk and secured in V-block with clamp bracket; crossline disk in V-block at far end of the optical I-beam bench.

148.257

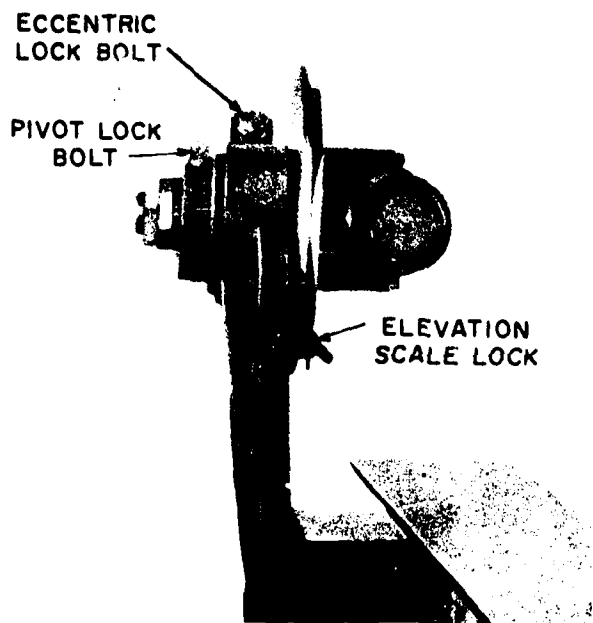

Figure 4-29.—Close-up view 148.258 of collimator from the boresight telescope end of the optical I-beam bench.

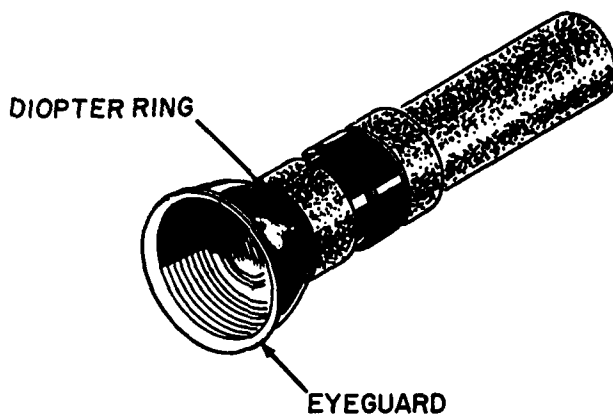

Figure 4-30.—Auxiliary telescope Mk 1. 148.259

Operation

Before using an auxiliary telescope, always set it to your eye. If used for extended periods, recheck the setting of the auxiliary telescope as the dioptric strength of an individual's eye may change due to fatigue or eye strain. To set the auxiliary telescope to your eye, sight through the auxiliary telescope at an infinity target or a target which is at least 2,000 meters away. Adjust the focus of the auxiliary telescope until the image of the target is clear and sharp. Note the indication of the scale on the focusing ring. Taking the average of five indications will produce a more accurate indication of your diopter correction for a particular distance.

Adjustment

The purpose of adjusting the auxiliary telescope is to get it to indicate "0" diopters when parallel light which enters the objective is transmitted as parallel light from the eyepiece. The significance of this adjustment is that all auxiliary telescopes should be adjusted the same. You will find that adjusting all your auxiliaries to "0" diopters will be a time-saving move.

One method of adjusting the auxiliary telescope to "0" diopters is to adjust two or more at one time. Adjust one as you would any other time, that is, to your eye on an infinity target. Sight through the auxiliary being tested and the one adjusted to your eye. Adjust the test auxiliary for a clear, sharp image of the infinity target. The diopter ring should indicate "0" at this point. If it does not, the ring will have to be

possible the consistent adjustment, to a common standard, of all instruments by a variety of technicians.

Configuration

The auxiliary telescope consists of a body tube approximately 6 inches long by 1 inch in diameter. The objective end may or may not have a bearing surface on its periphery. The bearing surface is included on some instruments to be used in conjunction with the accessories designed for use with the auxiliary telescope; the rhomboid attachment, and the stereo comparator.

Optical System

The optical system of the auxiliary telescope consists of a doublet objective lens, a double convex field lens (collective lens), and a doublet eye lens (fig. 4-31).

Essentially we have a rather small astronomical telescope which is a three-power system having a true field of $44^{\circ} 42'$, exit pupil of 5.5 mm, and an eye distance of 13.5 mm.

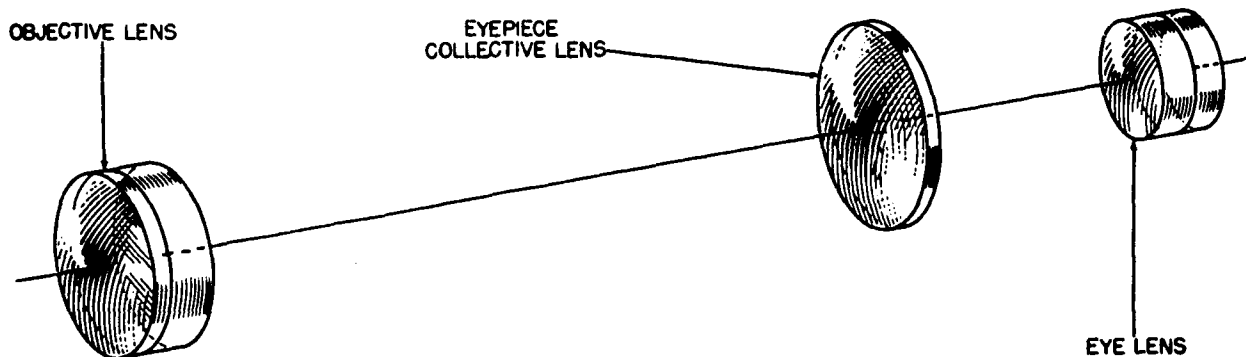

148.260

Figure 4-31.—Auxiliary telescope Mk 1—optical diagram.

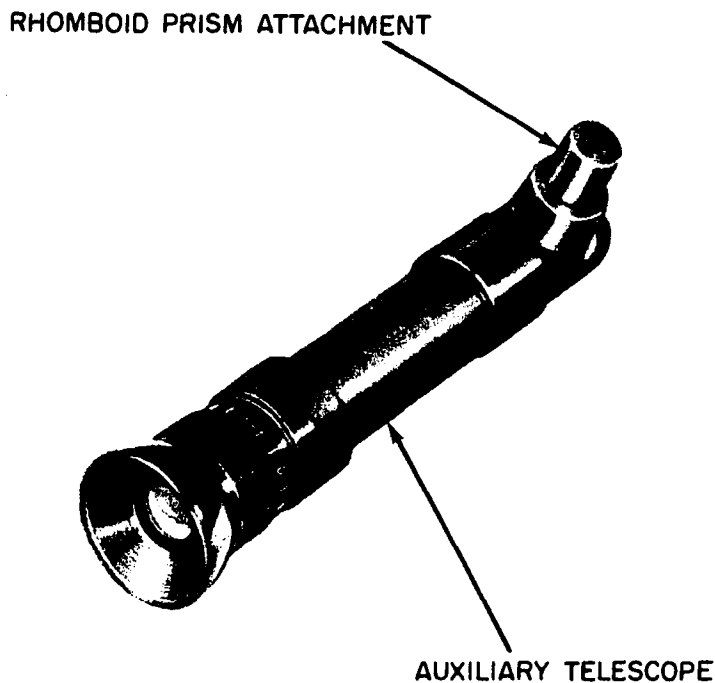

137.205

Figure 4-32.—Auxiliary telescope Mk 1 with rhomboid prism attachment.

moved. Then repeat the procedure exchanging the positions of the auxiliary telescopes. This process should be repeated a number of times, noting the indication of each instrument without

moving the diopter ring in relation to the eyepiece. The average of these indications will be a more accurate setting for "O" diopters than would a single setting.

AUXILIARY TELESCOPE ACCESSORIES

There are two types of accessories commonly used in conjunction with the auxiliary telescope: the rhomboid prism attachment and the stereo comparator.

Rhomboid Prism Attachment

The rhomboid prism attachment (fig. 4-32) is used in conjunction with the auxiliary telescope to provide a second or reference line of sight during the collimation of binoculars.

The rhomboid prism attachment consists of a rhomboid prism 6.2 mm wide by 35.2 mm long mounted in a cylindrical housing which slips over the end of the auxiliary telescope (fig. 4-33).

The rhomboid prism attachment superimposes a second line of sight onto the line of sight of the test instrument as it passes into the auxiliary telescope (fig. 4-34). Any deviation of the line of sight by the test instrument will be readily apparent in the auxiliary telescope as the rhomboid prism attachment line of sight target will not be superimposed on the test instrument line of sight target.

Stereo Comparator

The stereo comparator (fig. 4-35) is designed to compare the two lines of sight of a binocular instrument.

The comparator consists of a 65 mm long by 18 mm wide rhomboid prism contained in a cylindrical housing.

The comparator functions as does the rhomboid prism attachment, superimposing two lines of sight, (fig. 4-36). The comparator rhomboid prism differs radically from that of the rhomboid prism attachment as the comparator prism has a hole bored in its second face which aligns with the line of sight of the auxiliary telescope when the comparator is installed. The bored hole provides an access for one light path while the rhomboid prism provides the second path.

To use the comparator, install it on an auxiliary telescope having the bearing surface for this purpose. Check the alignment, then sight through the test instrument eye piece at an infinity target. The openings in the comparator should line up with the eyepieces of the instrument being tested. Adjust the eyepieces of the

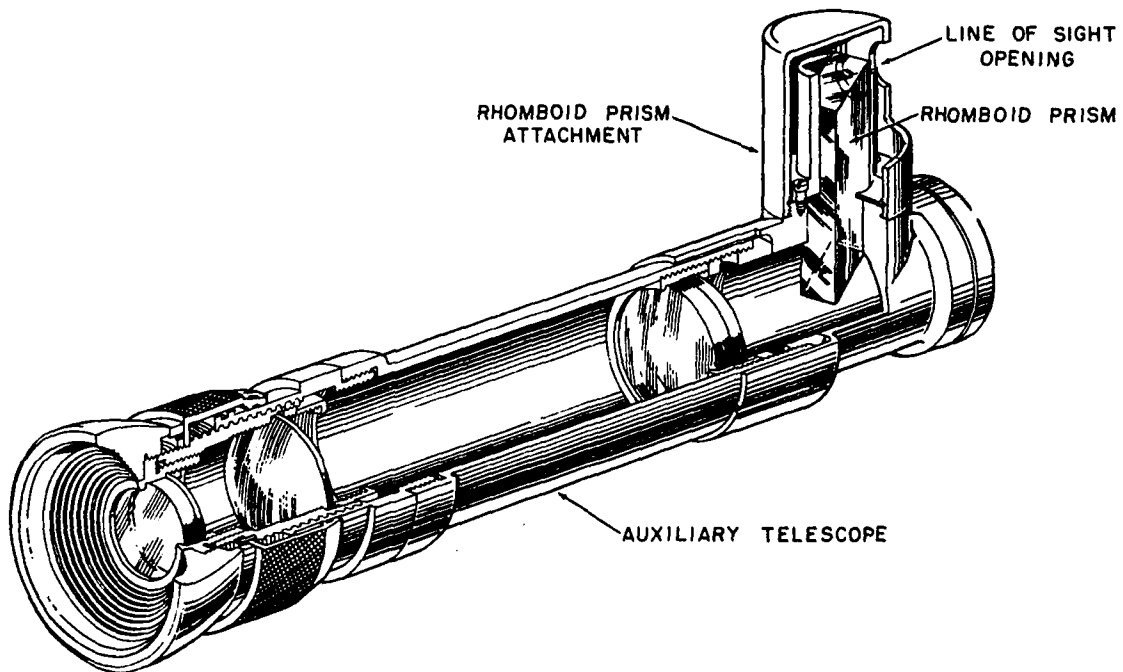

Figure 4-33.—Auxiliary telescope Mk 1 with rhomboid prism attachment—cutaway.

148.261

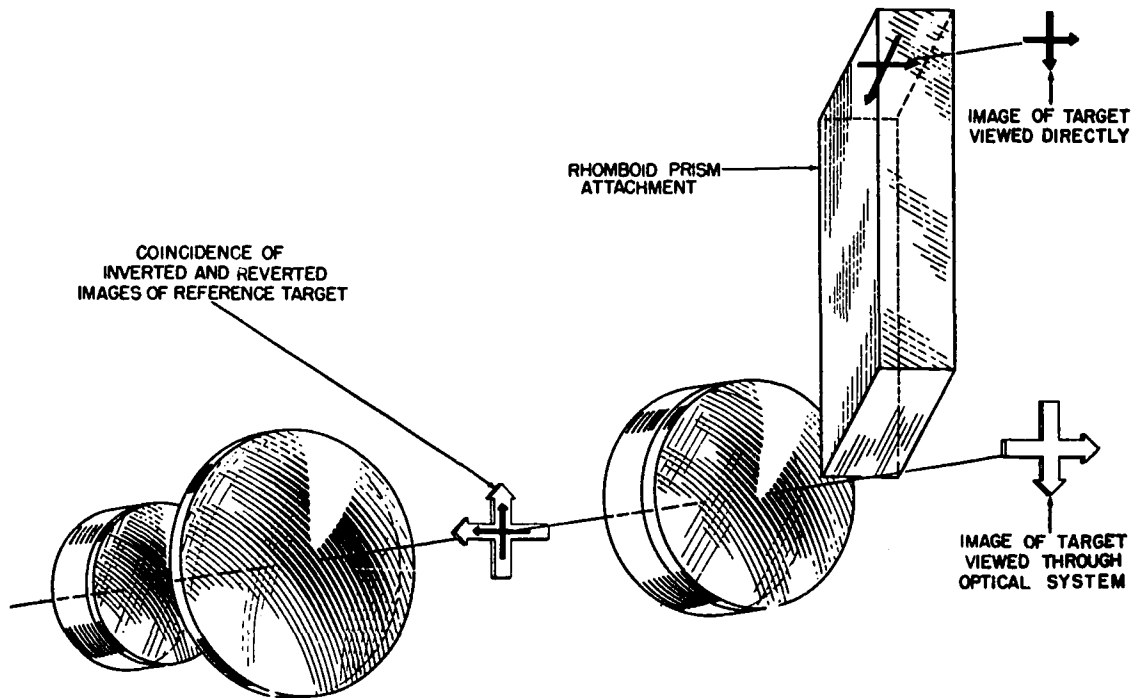

Figure 4-34.—Auxiliary telescope Mk 1 with rhomboid prism attachment—line of sight schematic.

148.262

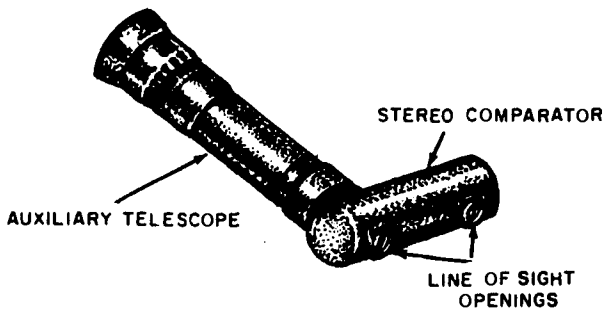

Figure 4-35.—Stereo comparator attached to auxiliary telescope Mk 1.

148.263

test instrument for clear focus of both images. You can now compare the images of the binocular system for alignment.

Due to the design of the prism incorporated in both the rhomboid attachment and the stereo comparator, adjustment is not required for either auxiliary telescope attachment.

MK 2 DYNAMETER

The Mk 2 dynameter (fig. 4-37) is another piece of alignment equipment normally used in conjunction with the aforementioned collimators.

Uses

The dynameter is used as a measurement device to determine the diameter of the exit pupil and the eye relief distance of an optical instrument. Indirectly, it also measures magnification of an instrument.

Configuration

The dynameter is very similar in appearance to the auxiliary telescope. The most notable differences are the addition of a second focusing ring and a millimeter scale on the barrel. Figure 4-38 provides a cutaway view which may be compared to fig. 4-33, a cutaway of the auxiliary telescope.

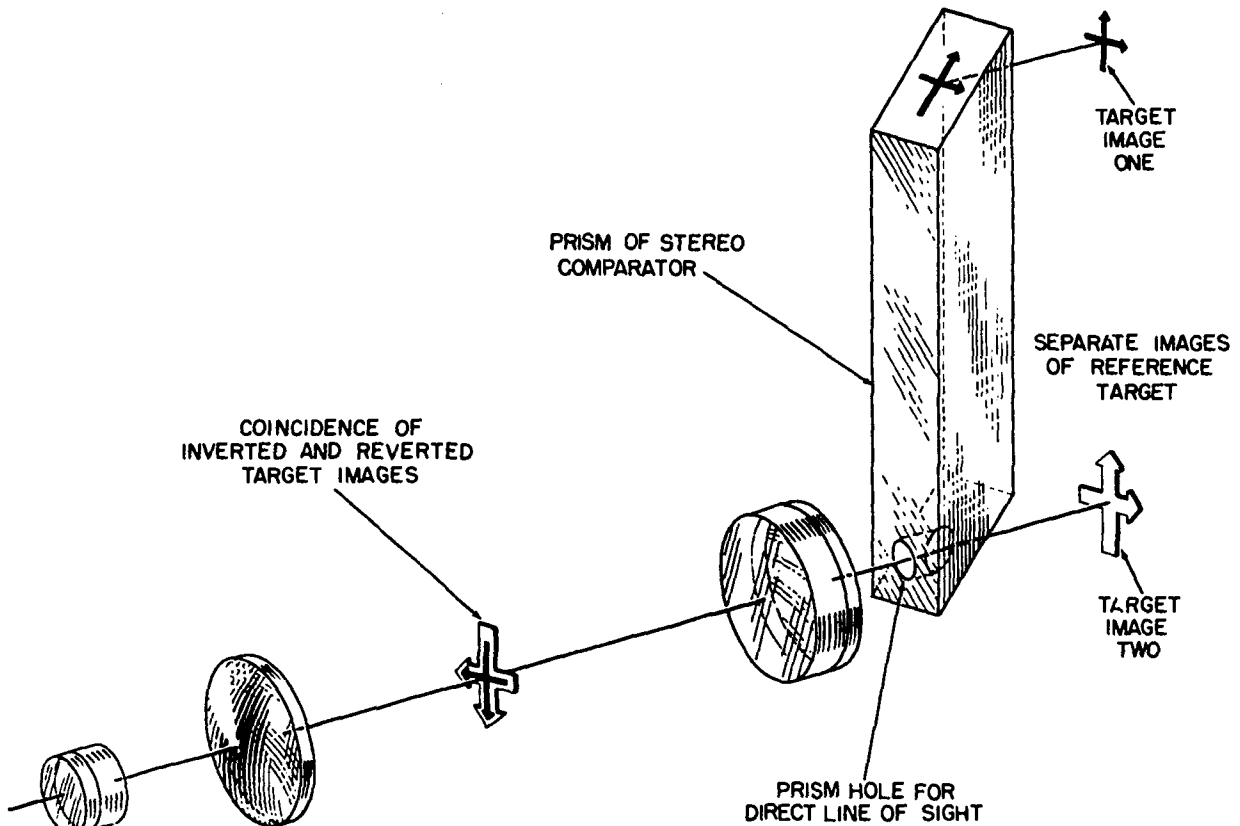

Figure 4-36.—Stereo comparator on auxiliary telescope—line of sight schematic.

148.264

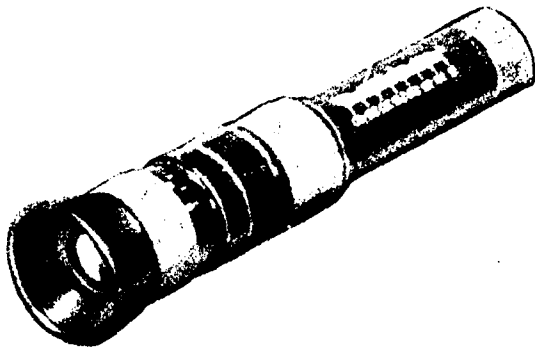

Figure 4-37.—Dynameter Mk 2.

148.265

The system includes a reticle, an erector assembly, and a Kellner type eyepiece. The reticle (fig. 4-40) is ground (frosted) on its front surface and has a millimeter scale etched on its rear surface. The two erector systems have identical doublets with their most positive surfaces facing each other. The eyepiece consists of a double-convex collective and a doublet eyelens. The most positive surfaces of the collective lens and eyelens face each other.

The reticle and first erector are mounted within a draw tube and maintain a set distance between them. This draw tube is moved laterally to measure eye distance and exit pupil.

Operation

The first step in using the dynameter to measure exit pupil and eye distance is to adjust the eyepiece to your eye. Sighting through the dynameter, point it at a distant light source. Rotate the eyepiece focusing ring until the

Optical System

The dynameter's optical system (fig. 4-39) is unusual in that it lacks an objective lens. It contains all the necessary elements for a terrestrial telescope except the objective.

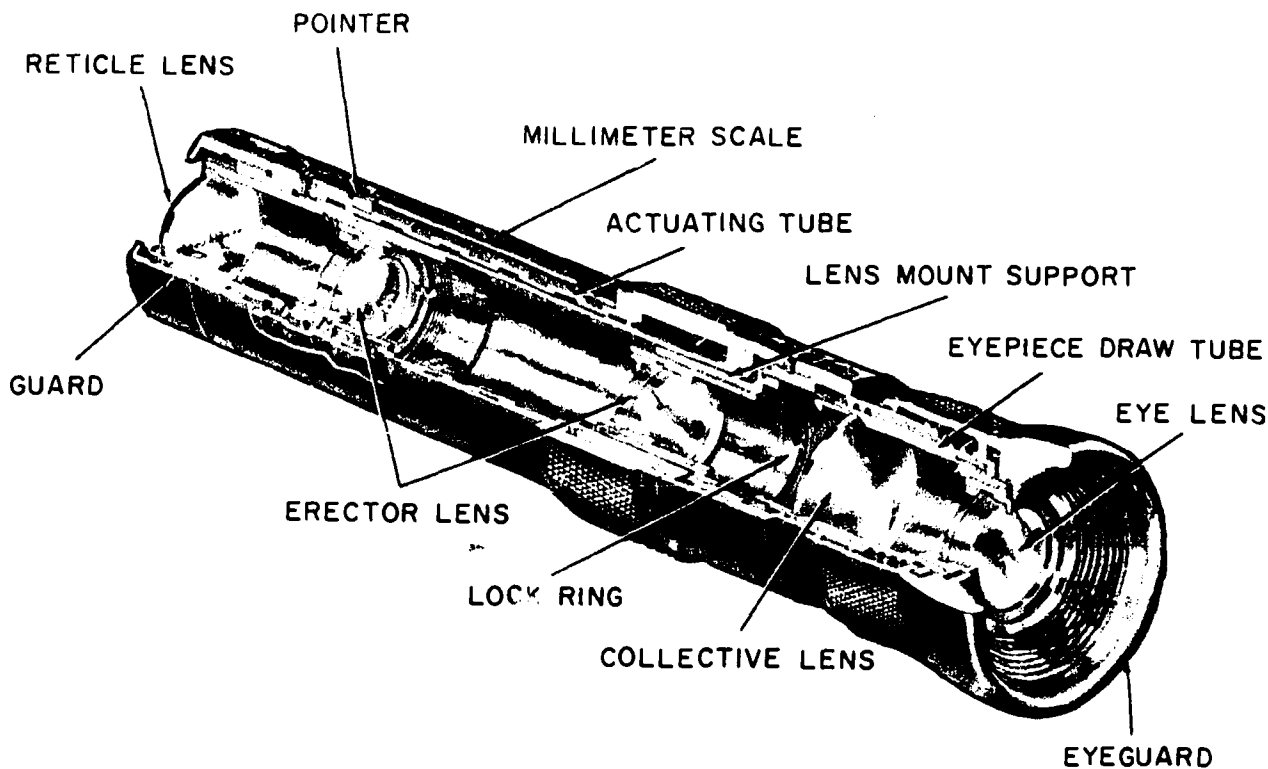

Figure 4-38.—Dynameter Mk 2—cutaway.

148.266

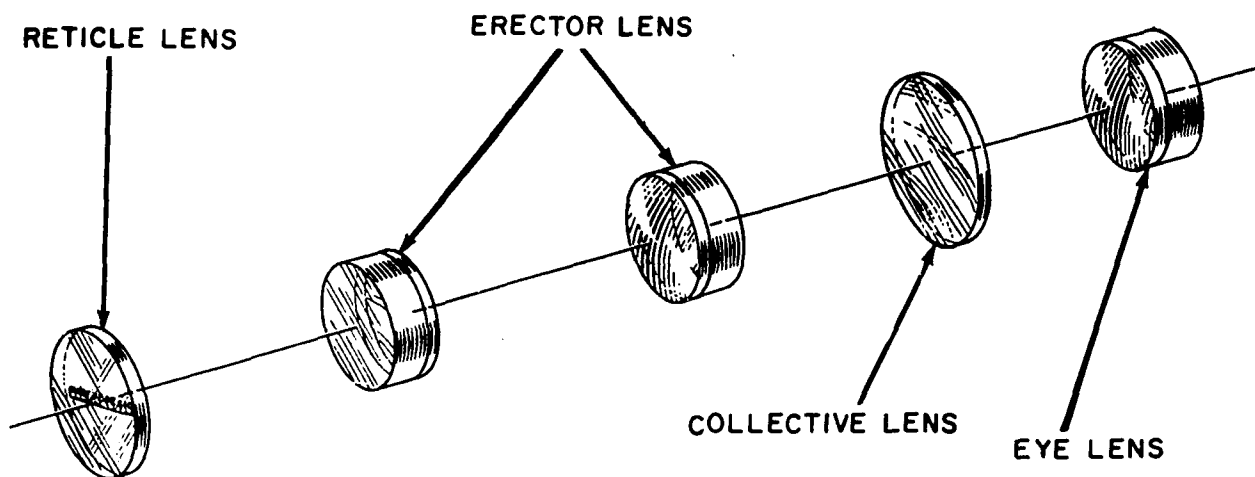

Figure 4-39.—Dynameter Mk 2—optical diagram.

148.267

reticle appears as a sharp image. With the test instrument set at "O" diopters and pointed at an infinity light source, sight through the dynameter and the test instrument. With the end of the dynameter touching the eyepiece of the test

instrument, adjust the draw tube focusing ring until a bright image of the exit pupil appears, superimposed on the reticle (fig. 4-41). Note the size of image of the exit pupil. Without moving the draw tube focusing ring, read the

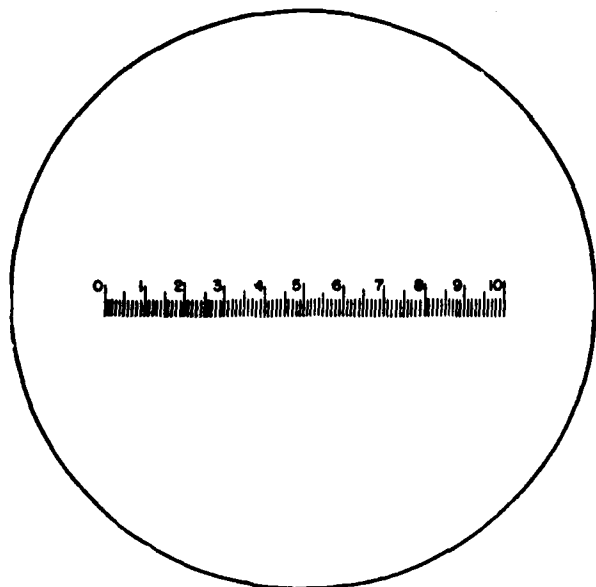

Figure 4-40.—Dynamometer 148.268
Mk 2—reticle scale.

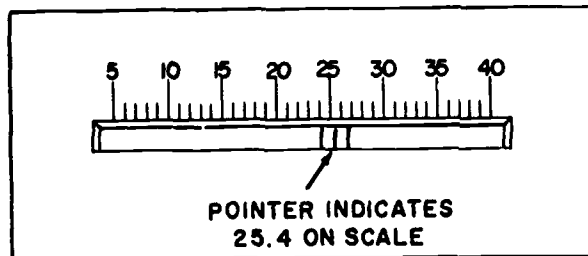

Figure 4-42.—Dynamometer 148.270
Mk 2—draw tube scale.

Adjustment

Periodically the dynamometer must be checked for accuracy as it is a measurement device. Two checks are required: proper setting of the diopter scale and proper indication of the millimeter scale which indicates eye distance. The exit pupil scale is not a variable which must be checked. Checking the diopter scale is accomplished in the same manner in which the auxiliary telescope is checked. The reticle scale must present a sharp image at "0" diopters. If this situation does not exist, adjust the eyepiece diopter ring until it indicates properly.

Checking and adjusting the eye distance scale is another matter. The eye distance is defined as the distance from the rear surface of the eyepiece to the plane of the exit pupil. You measure the eye distance while the dynamometer is physically contacting the rear surface of the eyelens and the exit pupil is sharply defined on the ground front surface of the reticle. This measurement must be checked. Using some arbitrary midpoint on the scale, measure the distance from the front surface of the reticle to end guard of the dynamometer. If the physical measurement of this distance does not correspond to the pointer indication, adjust the dynamometer. The most practical method of adjusting the pointer indication for the proper eye distance is to adjust the end guard. If the pointer indication is too small, you will have to remove material from (take a cut on) the rear end of the guard. If the pointer indication is too great, you will have to shim between the guard and the barrel of the dynamometer.

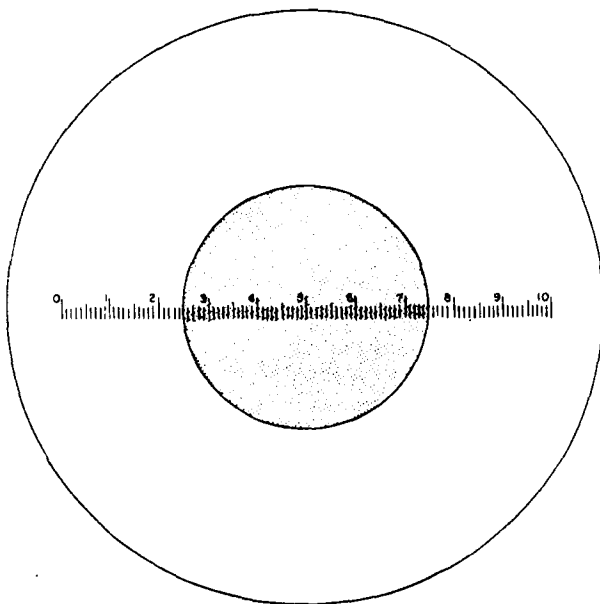

Figure 4-41.—Reticle scale. 148.269

eye relief distance indicated on the millimeter scale on the side of the draw tube (fig. 4-42). Repeat the operation a number of times and average the results.

ALIGNMENT TELESCOPES

The next instruments to be covered in the discussion of alignment devices used in the optical shop are the telescopes used in conjunction with various collimators.

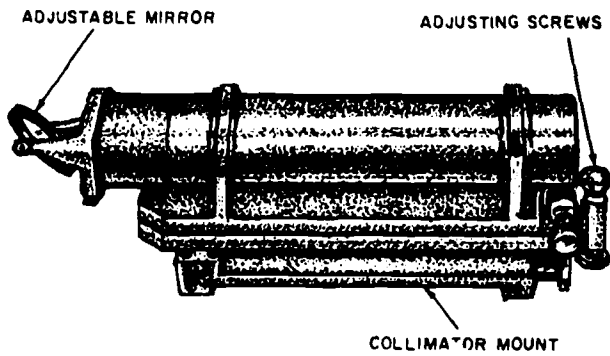

Figure 4-43.—Collimator telescope Mk 8 Mod 1. 148.271

These telescopes fall into two basic classes: checking telescopes and collimator telescopes. The classes shall be discussed separately as they are basically dissimilar.

Collimator Telescopes

The Mk 8, Mod 1 collimator telescope (fig. 4-43) will be used as a typical instrument for the

discussion of collimator telescopes. Collimator telescopes, in general, are alignment instruments designed to provide an infinity target during the alignment of a test instrument.

USES.—Collimator telescopes are commonly used as reference instruments in the alignment of gunsight telescopes, both fixed and tilting line of sight types. Collimator telescopes may also be used in most cases where an infinity target is required, such as rangefinders, ship-mounted binoculars, and navigational instruments.

CONFIGURATION.—The Mk 8, Mod 1 collimator telescope has a tubular body approximately 13 inches long by 3 inches in diameter. The mechanical axis of the telescope consists of two cylindrical bearings machined on the outer periphery of the tubular body. Contained within the tube are the objective and reticle assemblies. At the rear of the telescope either the eye piece assembly or the mirror and diffusing plate assembly may be attached as illustrated in (fig. 4-44).

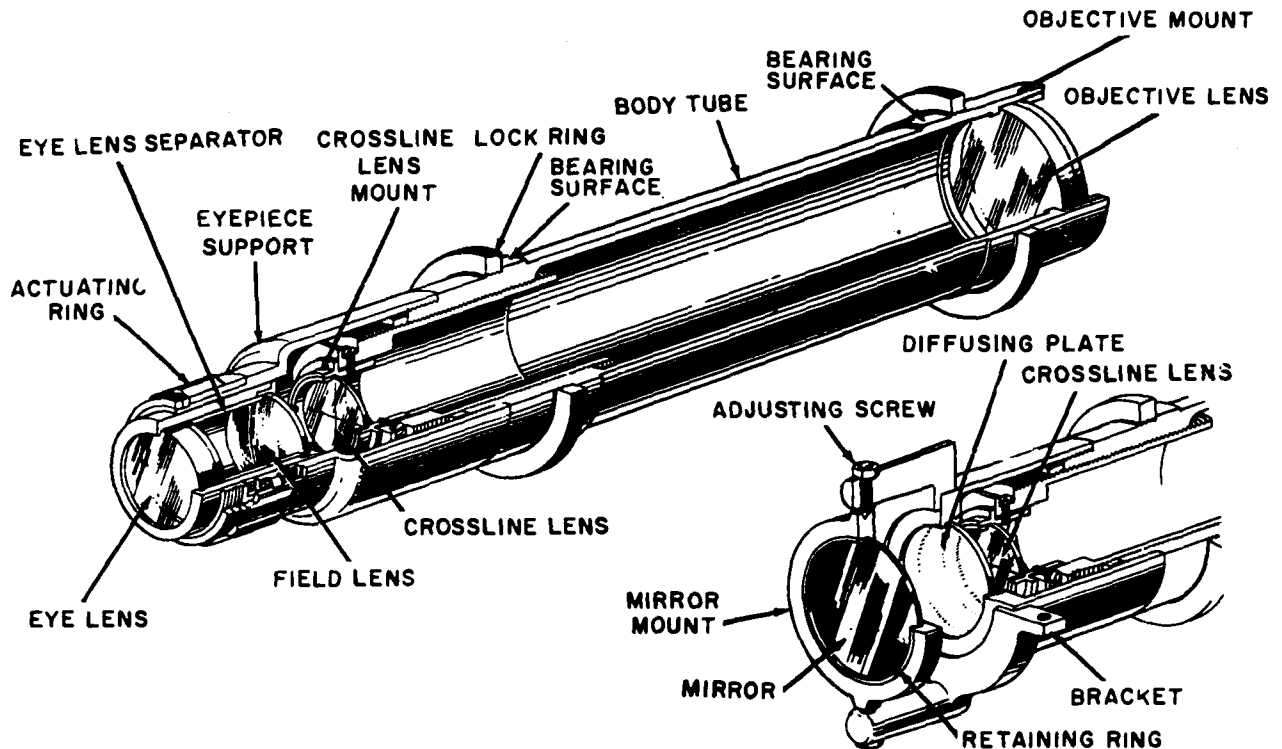

Figure 4-44.—Collimator telescope Mk 8 Mod 1 with auxiliary eyepiece, mirror mount, and diffusing plate—cutaway.

148.272

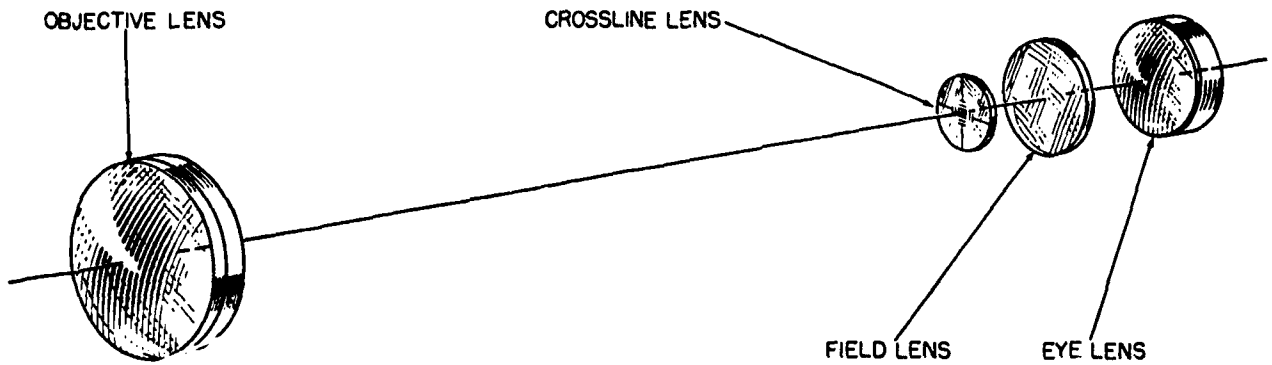

Figure 4-45.—Collimator telescope Mk 8 Mod 1 with auxiliary eyepiece—optical diagram.

148.273

OPTICAL SYSTEM.—The optical system may function as either of two systems: a telescope for alignment of the collimator (fig. 4-45) or a collimator for reference by the test instrument. The objective lens and reticle are common to both.

The objective lens is an achromatic doublet whose most positive face is away from the reticle. The reticle is a plano-parallel plate with the etched surface at the focal plane of and facing the objective lens.

The removable eyepiece is adjustable and contains within its draw tube the element of a Kellner type eyepiece system. The eye piece provides a means of sighting the telescope in order to align it.

By unscrewing the eyepiece assembly and screwing on the mirror and diffusing plate assembly, you convert the telescope into a collimator. The mirror is adjustable so that only that light level required can be directed towards the diffusing plate. The diffusing plate acts as a light source for the illumination of the reticle.

OPERATION.—The operation of the collimator telescope is not normally considered, as the initial alignment and/or adjustment is considered in the adjustment phase. Operation, per se, involves adjusting the mirror for that light level which is appropriate for the instrument being tested.

ADJUSTMENT.—The alignment of collimator telescopes is critical as is all alignment in reference equipment. Two sources of error are

present in the collimator which must be checked. As in all instruments containing a reticle, you must check for parallax. As the collimator telescope has cylindrical bearings, the intersection of the reticle crosslines must lie on the line described by the centers of these bearings.

To check for parallax, install the auxiliary eyepiece and sight the collimator telescope on an infinity target. Using an auxiliary telescope, ensure the reticle lies in the focal plane of the

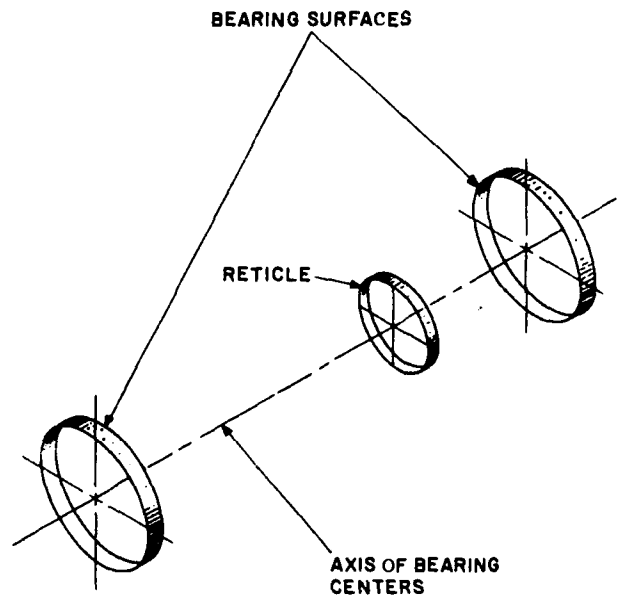

Figure 4-46.—Alignment of reticle and bearing axis.

148.274

objective. If parallax is present, the reticle mount will have to be adjusted laterally by screwing it into or out of the body tube.

To check the position of the reticle in relation to the bearings, mount the collimator telescope in an appropriate fixture so that it will rotate on its bearings.

Figure 4-46 illustrates the proper relation of the reticle crossline to the axis of the bearing surface centers. Next align a second collimator telescope to the first or test telescope. You do this by sighting through the eyepiece of the test telescope and adjusting the second collimator so that the crosslines of both are superimposed. Observing the crosslines, rotate the test telescope in the mount. If the centers of the crosslines do not remain superimposed, the reticle of the test telescope is not aligned to the axis of the bearings and must be adjusted. The reticle mount is adjustable (fig. 4-47) by means of counteracting screws. Remember, loosen the corresponding opposing screw when tightening a screw to avoid damaging the mount. Remove one half the error, set the second collimator telescope to the first, and start the steps again. Repeat this procedure until no eccentricity is evident. The collimator telescope is now internally adjusted and ready to be used as a reference device, once it has been installed in the appropriate collimator and adjusted to the specific test situation.

Checking Telescope

When a test instrument is required to indicate or travel some predetermined angle, there

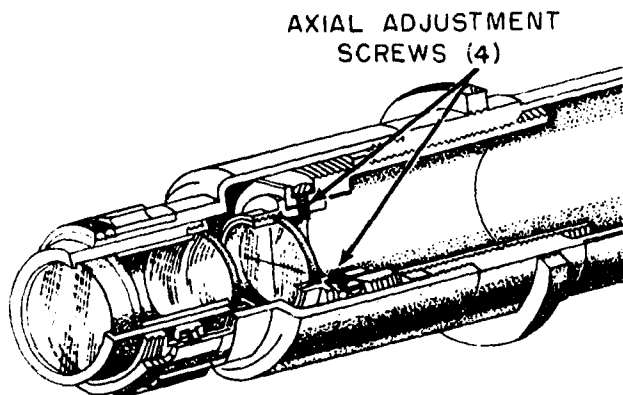

Figure 4-47.—Adjustable reticle mount. 148.275

must be some means of establishing a reference angle for alignment purposes. The checking telescope was designed for this particular purpose. Using the checking telescope, you can determine accurately the angle between two collimator telescopes, and establish vertical and horizontal reference planes.

USES.—The checking telescope was designed to align the collimator telescopes of the Mk 9 tilting prism gunsight telescope collimator. It can be used in situations which require establishing given angles "or planes" between infinity target collimators.

CONFIGURATION.—The Mk 7 checking telescope (fig. 4-48) will be used as a typical instrument for discussion purposes. The checking telescope is a 7.2-power astronomical type telescope which is focused at infinity. The telescope proper has an adjustable eyepiece focus and a rotating eyepiece prism assembly which allows the observer to place the emergent light bundle at that angle most convenient to him. Figure 4-49 shows the various components

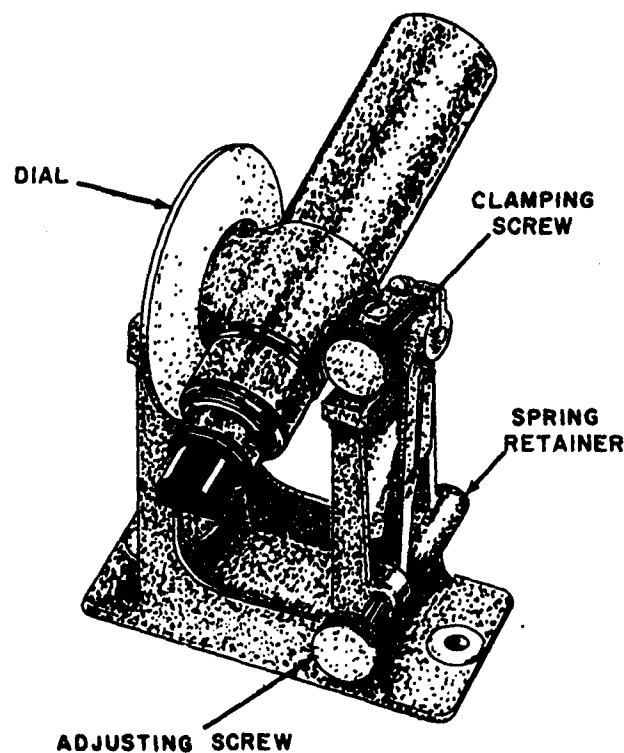

Figure 4-48.—Checking telescope Mk 7. 148.276

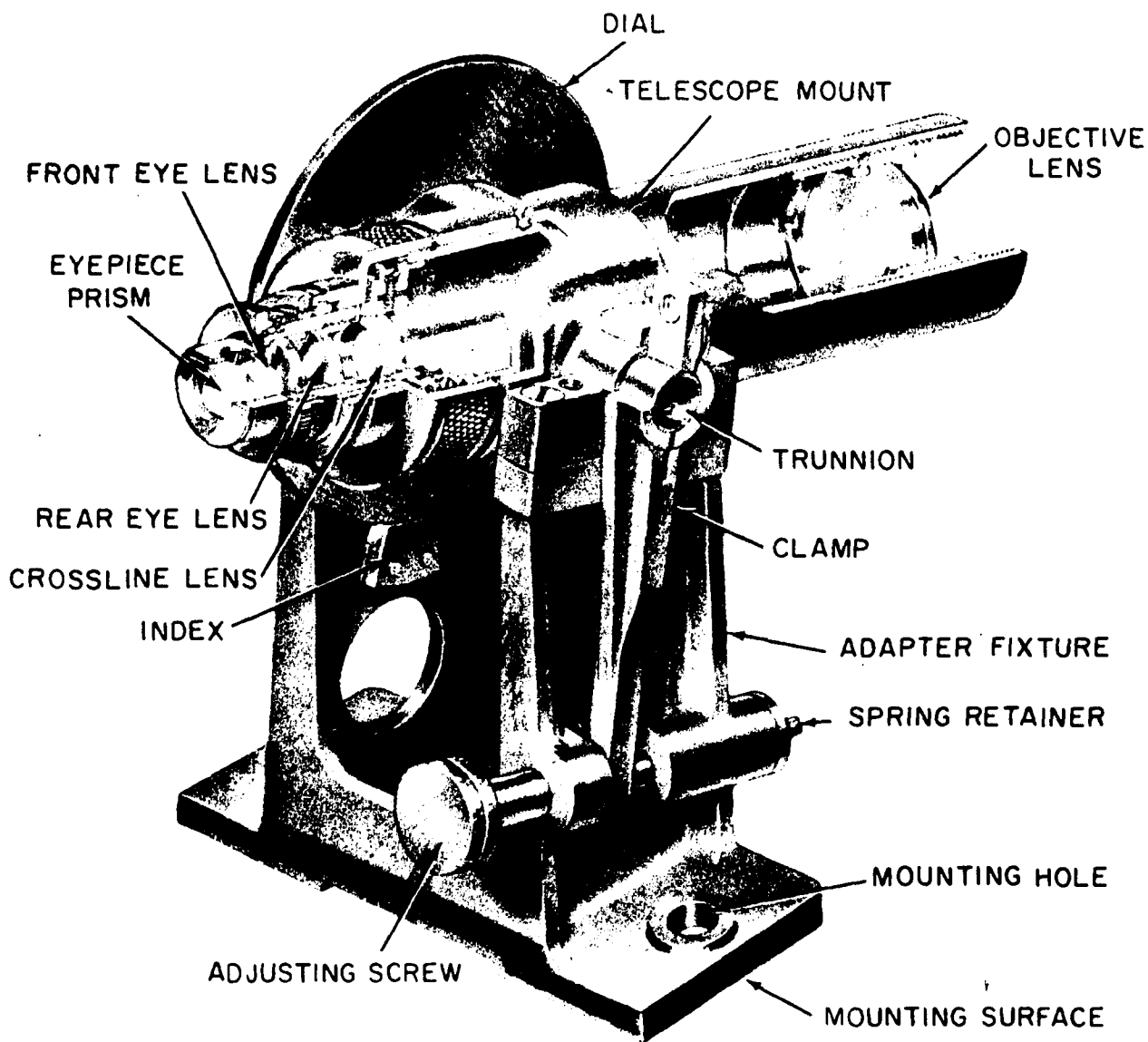

Figure 4-49.—Checking telescopes Mk 7—cutaway.

148.277

of the Mk 7 checking telescope and a typical mounting fixture. Note that the telescope is removable from its mount. The mount pivots on trunnions which are the vertical line of sight arc axis when the telescope is elevated. Also, on the mount is a dial which is graduated to indicate elevation angles in reference to the fixture mounting surface. Figure 4-50 illustrates other mounting arrangements which may be used with the telescope as requirements change. The basic premise with all the fixtures is that the line of sight must correspond to the mounting

surface in the same manner as the instrument that is to be aligned.

OPTICAL SYSTEM.—The optical system (fig. 4-51) consists of a doublet objective lens, a first surface etched crossline plate, a symmetrical eyepiece, and an eyepiece prism.

ADJUSTMENT.—As in all instruments containing a reticle, parallax must be removed. Adjustment for parallax is obtained by moving the objective lens mount as required.

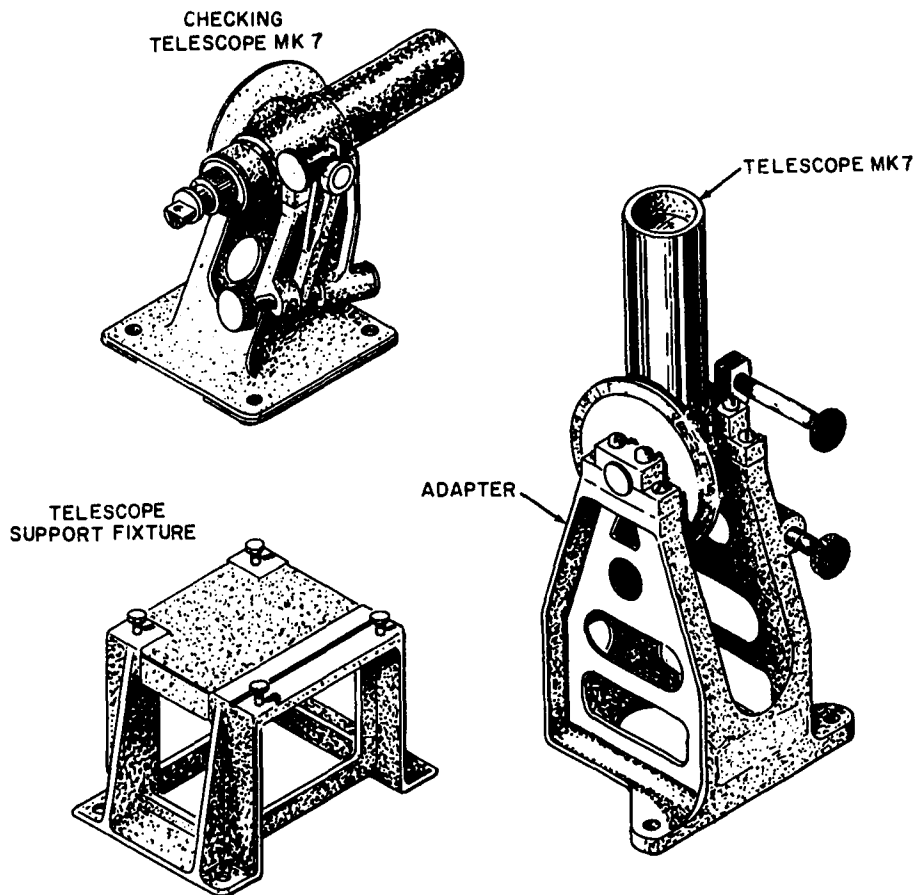

Figure 4-50.—Mk 7 checking telescopes and adapting fixtures.

148.278

The reticle should be axially aligned to the bearing surface that rides in the telescope mount. The alignment procedure is identical to that of the Mk 8 collimator telescope. The diopter scale should indicate properly and can be checked and adjusted in the same manner as the dynamometer.

The mounting fixtures and adapter can also produce error in the line of sight traverse. If the trunnion axis is not parallel to the mounting surface, the telescope will swing an arc which is not perpendicular to the mounting surface.

To test the checking telescope and its adapter fixture, construct a special testing arrangement. Figure 4-52 shows the basic layout of such a testing arrangement. By establishing the lines of sight of the three collimators in a single plane and then pivoting the telescope fixture 180°, you

can determine the trueness of the trunnion axis to the mounting surface. To establish the collimator and checking telescope lines of sight in the same plane, first align collimator #2 to collimator #1. Then place the checking telescope between the collimators. By alternately viewing collimators #1 and #2, you can put the line of sight of the checking telescope into conjunction with the superimposed lines of sight of collimators #1 and #2. Now elevate to 90° and align collimator #3 to the checking telescope. The three collimators and the checking telescope lines of sight are now in the same plane. Rotate the adapter fixture 180° on its mounting surface. Again adjust the checking telescope position until its line of sight corresponds to the lines of sight of collimators #1 and #2. Now sight on collimator #3. The crosslines of the collimators and checking telescope should be

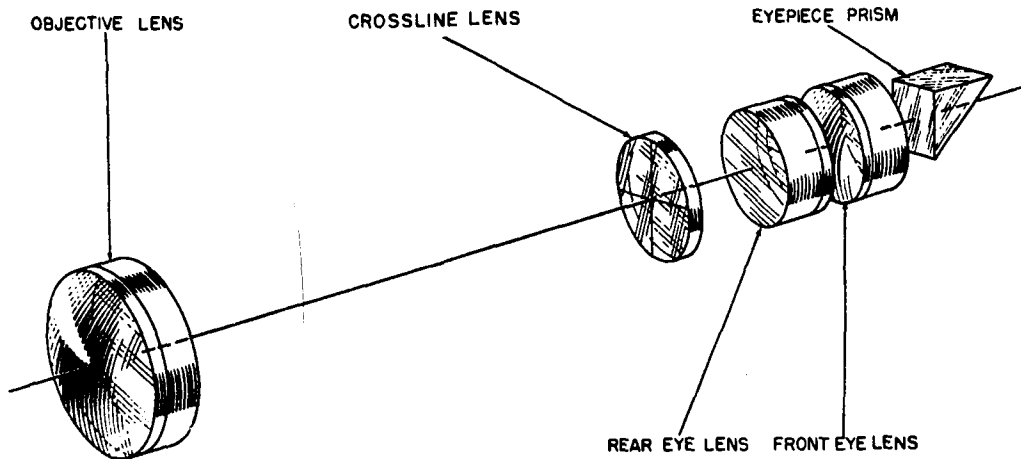

Figure 4-51.—Checking telescope
Mk 7—optical diagram.

148.279

superimposed. If they are not, repeat the test a number of times before making any adjustments. If the error is consistent, the line of sight of the checking telescope is not perpendicular to the

mounting surface at the 90° position. The trunnion bearing mount will have to be shimmed at the surface where it connects to the adapter fixture.

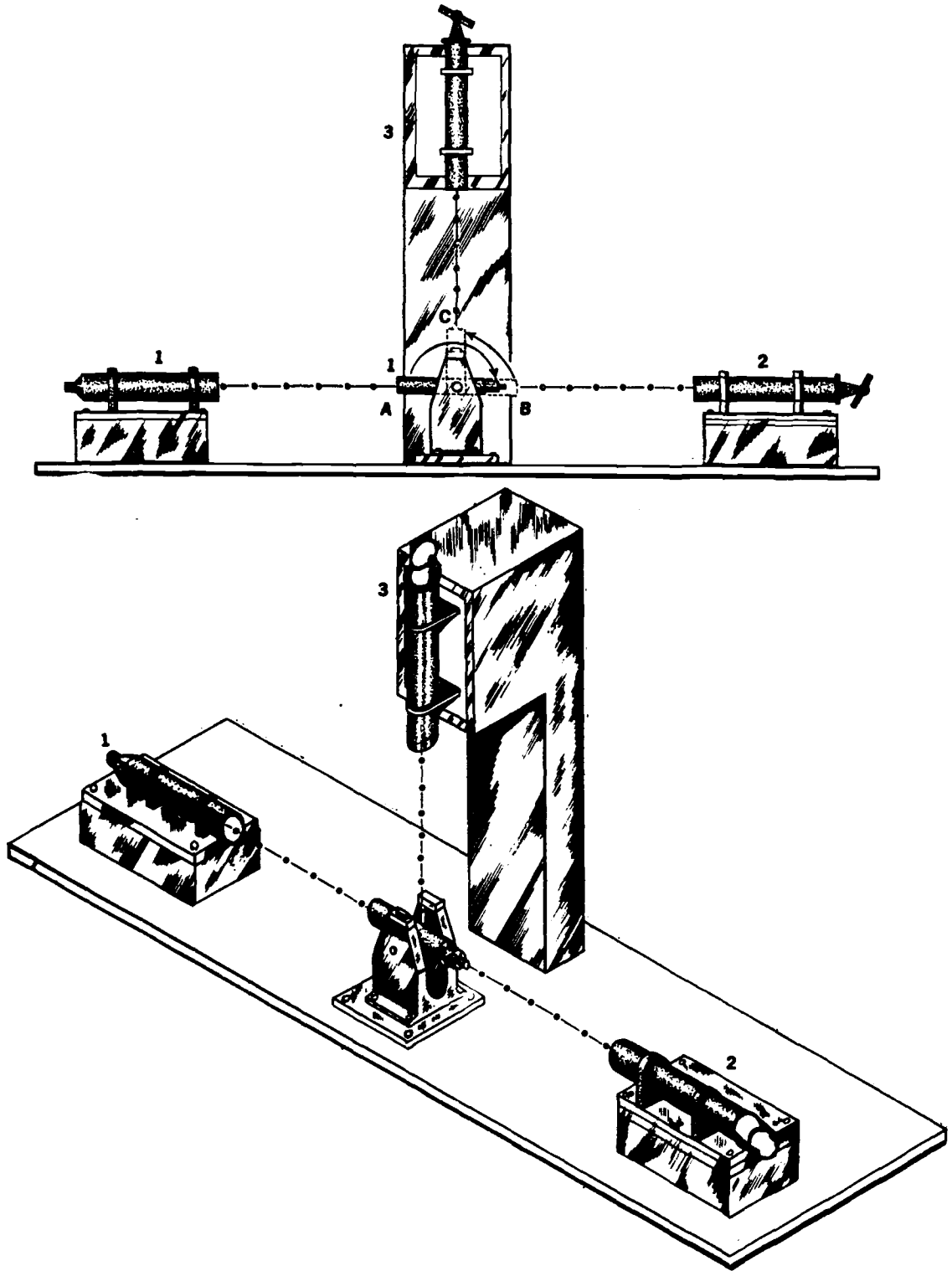

Figure 4-52.—Checking telescope alignment arrangement.

148.280

CHAPTER 5

NIGHT VISION SIGHTS

Over the years the job of navigating a ship has been made easier through the use of optical instruments, radar, loran, satellites, and other aids. Even with these devices, ships get lost at sea or collide with other ships, small craft, buoys, and hard-to-see objects, especially at night in congested waters. To improve their chances of sighting and avoiding such objects, bridge personnel on many ships are using night vision sights (NVS) as well as conventional visual aids.

Night vision sights (NVS) are used aboard many ships to complement other navigational aids. These sights provide the bridge with a visual capability far greater than had been previously possible.

To function effectively as a repairman and inspector of NVS you must know how they operate and how to operate them. In addition to maintenance and test procedures, you must be able to recognize sources of error and tolerances for these errors. It is the purpose of this chapter to provide you with the information necessary to meet these requirements and to expand the basic information on the night vision sights provided in OM 3 & 2. Much of the corrective and preventive maintenance employed on night vision sights is similar to that of other optical instruments and will not be discussed. As this manual is not designed as a maintenance manual, only those procedures peculiar to night vision sights will be identified. It is suggested that you review the basic information on NVS in OM 3 & 2 before proceeding further in this chapter.

DESIGN THEORY

Night vision sights are terrestrial telescopes designed to be as near aplanatic as possible within the physical parameters placed on size, size, and weight. They differ mainly in size and weight. The functions of corresponding assemblies of each type are the same. Therefore a representative type, the AN/TVS-4, will be used to illustrate the theory of operation.

The optical system of the AN/TVS-4 is illustrated in figure 5-1. The primary and secondary mirrors are combined to provide a long focal length objective while maintaining minimal physical length. This type of objective is called CATADIOPTRIC as it evolves the principles of both the reflection and refraction of light. Being spherical, the primary and secondary mirrors tend to produce images which have distortion. This distortion is compensated for by the corrector lenses. The combination of correcting lenses and mirrors makes the objective lens a SCHMIDT-CASSEGRAIN type. It focuses an inverted and reverted image on the intensifier tube (IIT) which erects and intensifies the image. The eyepiece, a modified Erfle type, presents a nearly aplanatic image to the eye.

The entire system provides an intensified and enlarged image to the viewer. The objective assembly and eyepiece assembly combine to provide the magnification while the IIT intensifies the light passing through the system.

GENERAL PRACTICES

Many maintenance procedures in the overhaul of NVS are common to other optical instruments while some are not. The following practices are common to all night vision sights.

Safety

Before performing any maintenance to the night vision sights, be sure to discharge the image intensifier tube. The residual high voltage charge of this tube must be removed to eliminate the hazard of electrical shock while the tube is being removed from its housing.

When removing or replacing the IIT, remove the oscillator first to avoid damage to the input pin of the IIT.

The phosphor screens of the image intensifier tube contain toxic material. If the tube should be broken, use extreme caution to avoid inhaling the phosphor material and to prevent it from coming into contact with the mouth or any open skin wound.

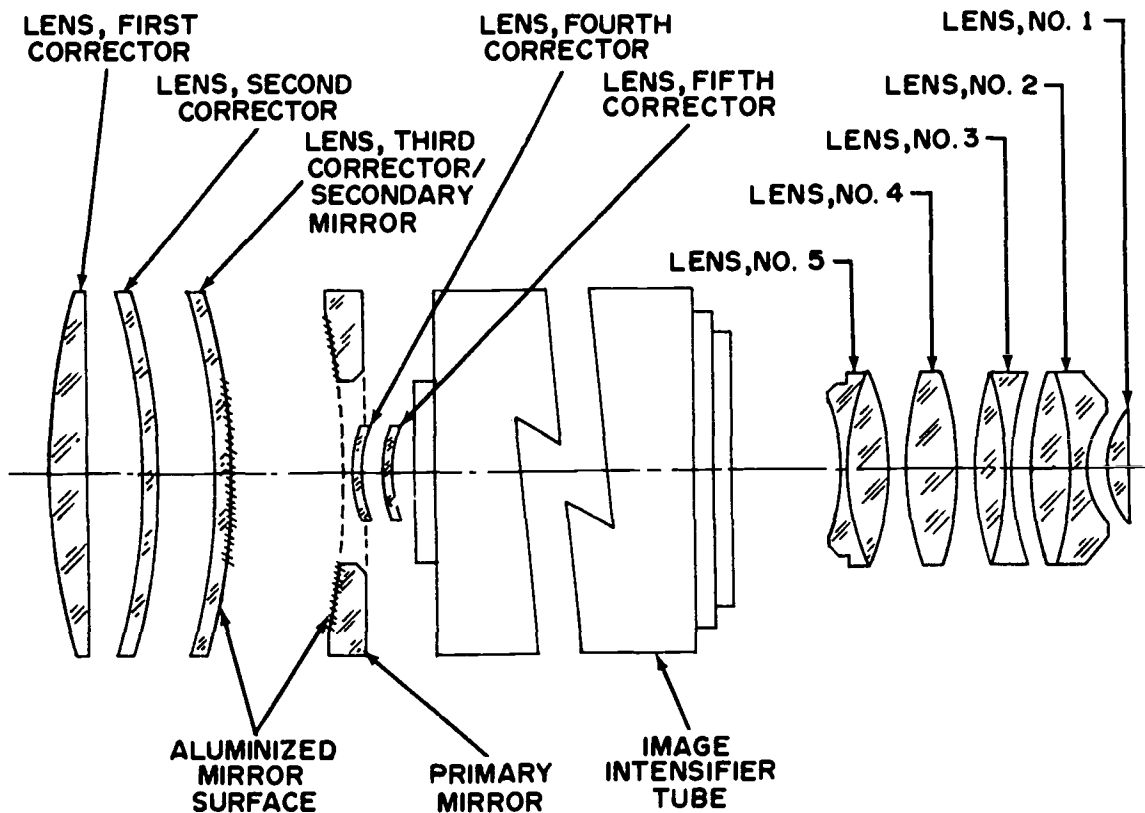

137.544(148A)A

Figure 5-1.—Optical system, AN/TVS-4.

Do not energize the sight in a lighted area. The image intensifier tube is extremely sensitive to light and tube damage will result if the sight is energized in a lighted area.

Cleanliness

The light level at which night vision sights operate is very low, therefore the maximum amount of the incident light must be transmitted. The cleanliness of the objective lens is most important since the incident light has not been enhanced as has the light that passes through the eyepiece.

Lens Blackening

Prior to reassembly of optical cells, the edges of all optical elements must be blackened. The purpose of blackening is to reduce the possibility of internal light reflections and entrance of stray light. Black ink, Federal specification TT-I-558, should be used for blackening the edges of the lenses.

O-Ring Lubrication

O-rings are used in several places in the night vision sights as sealing devices. Before installing an O-ring, lubricate it with a silicone compound which meets military specification MIL-S-8660.

Special Wrenches

Many of the optical elements are held in their respective mounts with retaining rings. Pin wrenches and retaining ring wrenches should be used with caution and only if they are in excellent condition. The preferred method of installing retaining rings is to use a special wrench manufactured for that specific purpose.

Pressurization

The optical cells of the night vision sights are pressurized with dry nitrogen to reduce oxidation and eliminate moisture. Before

disassembling a cell, release the pressure within it. When pressurizing a cell, use only grade A, water-pumped nitrogen. For best results place dry ice and acetone cold trap, similar to the one used in the cycling of submarine periscopes, in the line between the pressure regulator and the optical cell. To reduce the possibility of introducing foreign matter into the cell, increase the pressure within the cell in increments of 1/4 psig or less.

Sealing Compound

When sealing compound is used as a locking device on components, such as the retainer rings or cell assemblies, remove the compound completely before trying to remove the components.

Paint

The exterior surfaces which are to be painted should be coated with a black enamel-epoxy paint. The epoxy paint is used to provide optimum protection for the exposed surfaces of the night vision sight.

Charging Apparatus

The apparatus for charging the objective or eyepiece assemblies of night vision sights differs from the fixtures you are accustomed to using in pressurizing periscopes or gunsights. The night vision sights do not have an air valve assembly as do most other pressurized instruments. Special fixtures are required for charging the subassemblies of night vision sights. These fixtures are not available in the supply system. Therefore, you must manufacture them when needed.

A few considerations are important in the design of a special charging fixture for night vision sights. You must have some means of closing the bleed screws while the assembly is under pressure. Figure 5-2 illustrates one means of closing the bleed screw of a typical assembly that is under pressure. The pressurizing fixture must also have a pressure gage to indicate the amount of nitrogen pressure being applied to the assembly.

In addition, the configurations of the fixture itself must be such that the assembly

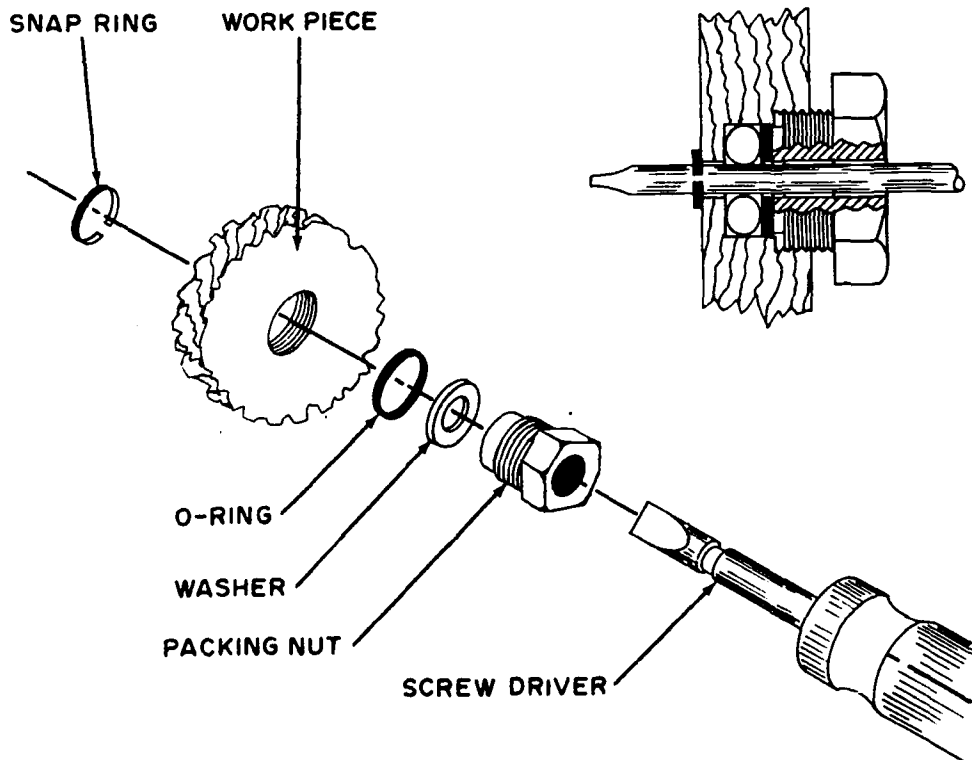

148.284

Figure 5-2.—Bleed screw shut off arrangement.

being charged will not move during the charging process.

ALIGNMENT OF SPACERS.—When replacing spacers within the subassemblies, be sure to align purge holes so that the voids between lenses are charged in the pressurizing process.

IMMERSION AND FOG TEST.—After charging an NVS subassembly with nitrogen, subject it to an immersion and fog test to ensure pressure tightness.

The test consists of immersing the subassembly in hot fresh water ($98^{\circ}\text{F} \pm 5^{\circ}\text{F}$) for approximately five minutes. No bubbles should appear. Cool the subassembly in tap water for approximately five minutes. No internal fogging should appear. Inspect the subassembly for signs of internal moisture. If the subassembly passes this test, it is pressure tight.

AN/TVS-4 NIGHT OBSERVATION DEVICE (NOD), MEDIUM RANGE

The AN/TVS-4 (fig. 5-3) was adapted for Navy use by removing the tripod assembly and providing a shipboard mount. With the associated power supply adapter, the AN/TVS-4 can

be plugged into the ship's service electrical system.

SIGHT DISASSEMBLY

The AN/TVS-4 consists of six major assemblies as illustrated in figure 5-4. Disassembly of the sight should follow a logical sequence. One method is presented for your consideration.

Place the sight, objective end down, on a flat surface as in figure 5-5 to provide the maximum amount of protection during disassembly.

Remove the yoke assembly (fig. 5-6) by first removing the trunnions (pivots) and then the yoke. To remove a trunnion, unfasten the cap screw which secures it in place.

Remove the power supply assembly (fig. 5-7) as a unit from the main housing.

Remove the eyepiece (fig. 5-8) by unscrewing it from the range focus ring.

Following applicable safety precautions, remove the image intensifier tube (fig. 5-9).

The focusing tube can then be removed (fig. 5-10) by first removing the range focus ring and focusing ring stop.

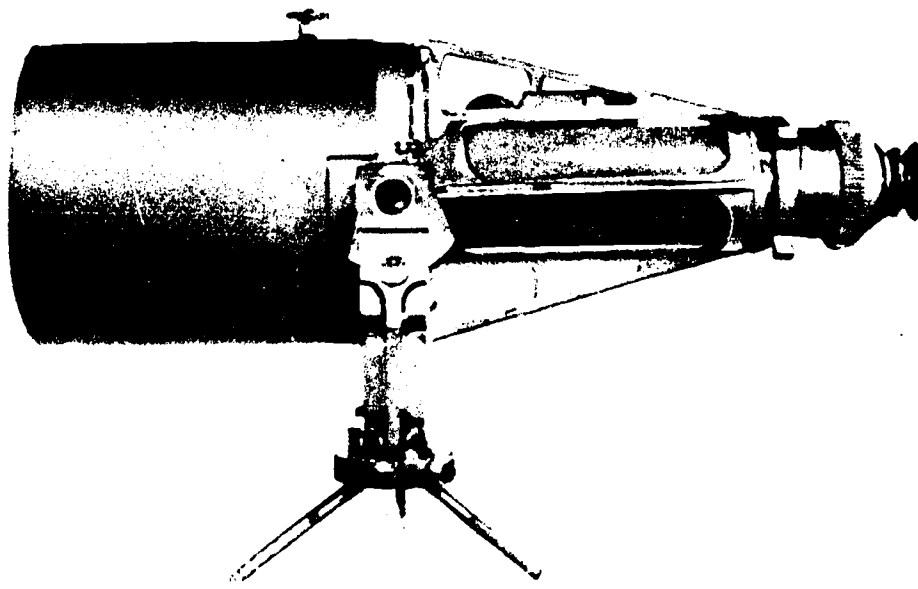

Figure 5-3.—AN/TVS-4.

137.544(148A)B

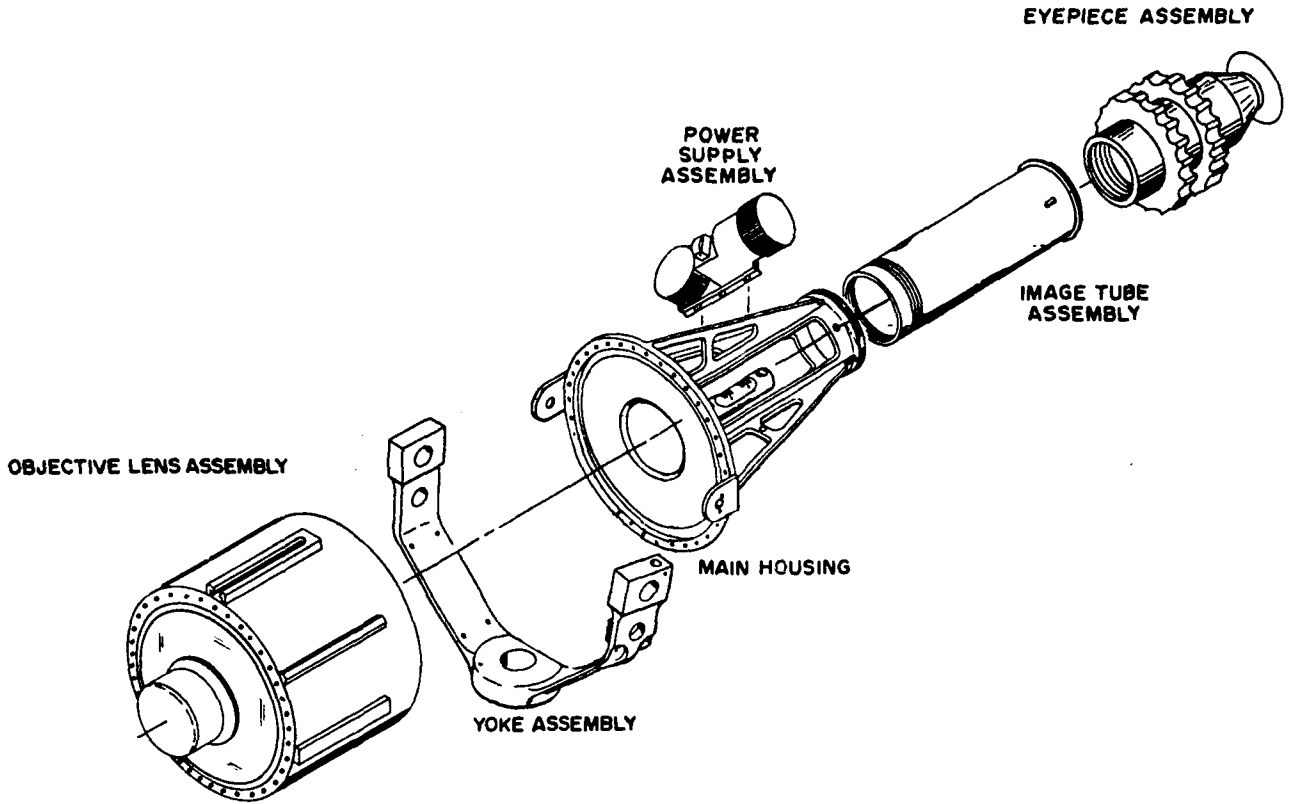
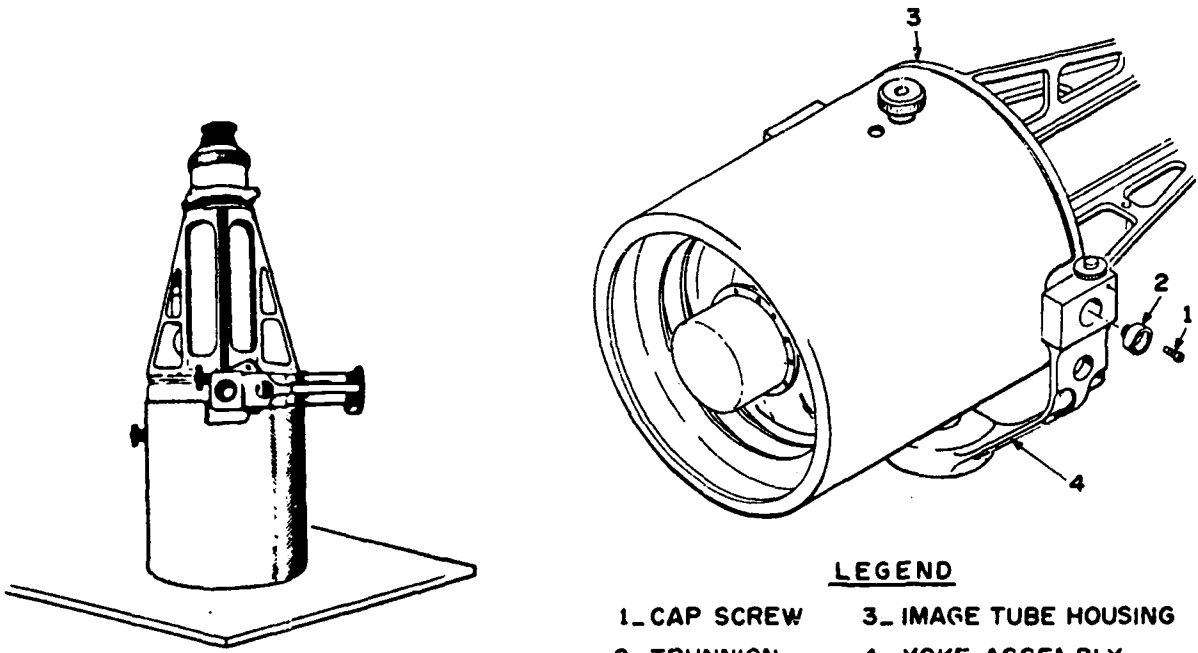

Figure 5-4.—Major assemblies, AN/TVS-4.

137.544(148A)C



LEGEND

- 1_ CAP SCREW
- 2_ TRUNNION
- 3_ IMAGE TUBE HOUSING
- 4_ YOKE ASSEMBLY

137.552.1
Figure 5-5.—AN/TVS-4 disassembly.

148,285
Figure 5-6.—Yoke removal.

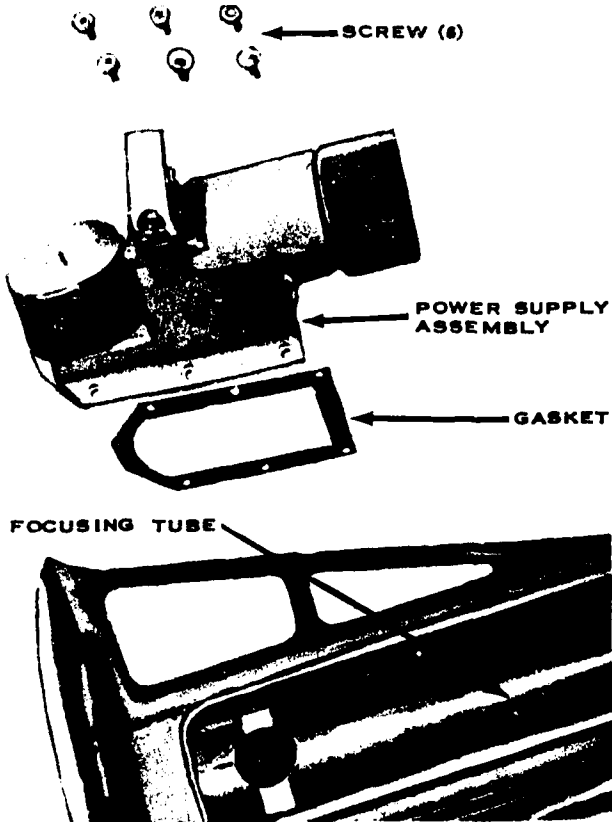

137.551(148A)

Figure 5-7.—Power supply assembly, removal.

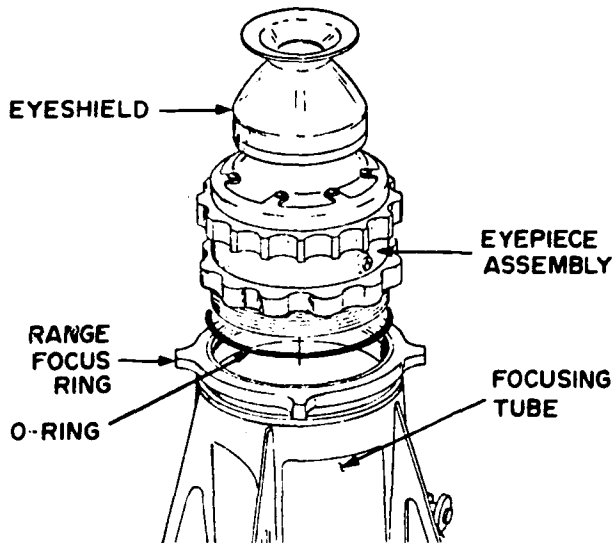

137.550(148A)A

Figure 5-8.—Eyepiece removal.

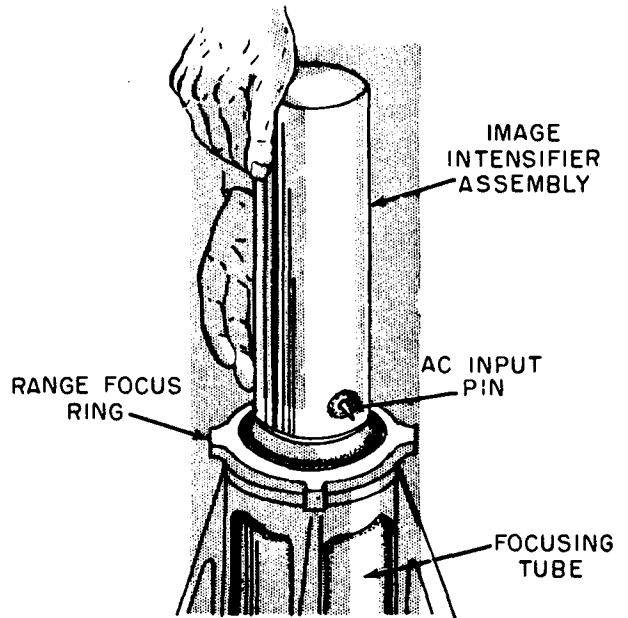

137.547(148A)

Figure 5-9.—Image intensifier assembly, removal.

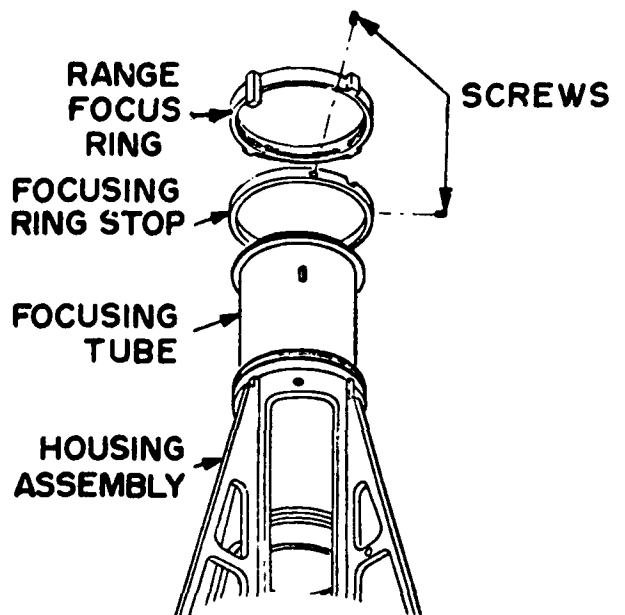

148.286

Figure 5-10.—Focusing tube removal.

The main housing is then removed from the objective assembly (fig. 5-11) and the shade can be removed from the objective assembly.

OBJECTIVE ASSEMBLY

The objective lens assembly (fig. 5-12) contains four subassemblies: the first lens cell assembly, second and third lens cell assemblies, primary mirror assembly, and the fourth and fifth lens cell assemblies. Each of these subassemblies (fig. 5-13) may be removed from the housing as a unit. A word of caution at this point. Prior to removing any of the internal subassemblies from the housing, measure to the nearest 0.0001 of an inch the depth of that subassembly within the housing.

Disassembly

The objective lens housing has an internal pressure of 5 psi which must be released prior to removing the subassemblies. On early models of the AN/TVS-4 the sealing screws are located on the forward end of the housing as shown in figure 5-12. Later models have needle valves at the rear end as in figure 5-13.

Once the pressure has been released, the subassemblies may be removed, as required. The first lens cell assembly and the second and third lens cell assembly are removed from the front of the housing while the primary mirror assembly and the fourth and fifth lens cell assemblies are removed from the rear.

The subassemblies, once removed from the housing, may be disassembled as required.

Reassembly of Subassemblies

Each of the subassemblies must be reassembled prior to insertion into the housing.

FIRST LENS CELL ASSEMBLY.—Refer to figure 5-14 for reassembly. After replacing the lens in its cell and securing the retaining clamp, seal the lens in its cell with sealing compound, MIL-S-7502, class A-1/2. The procedure to be used is as follows: install two setscrews with one empty hole between them; inject sealing compound into the hole between the two setscrews until the compound emerges at the open holes on the other side of the setscrews. Install a setscrew in the fill hole. Repeat this process, changing fill holes, until the cavity between the lens and cell is filled

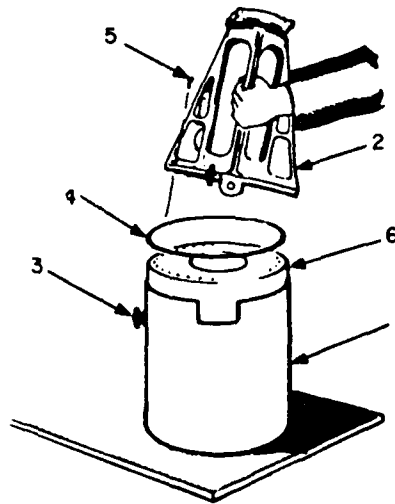

- 1 Objective shade assembly
- 2 Image tube housing assembly
- 3 Shade lock knob
- 4 Sight subassembly
- 5 Cap screws
- 6 Objective lens assembly

137.552.2

Figure 5-11.—Main housing removal.

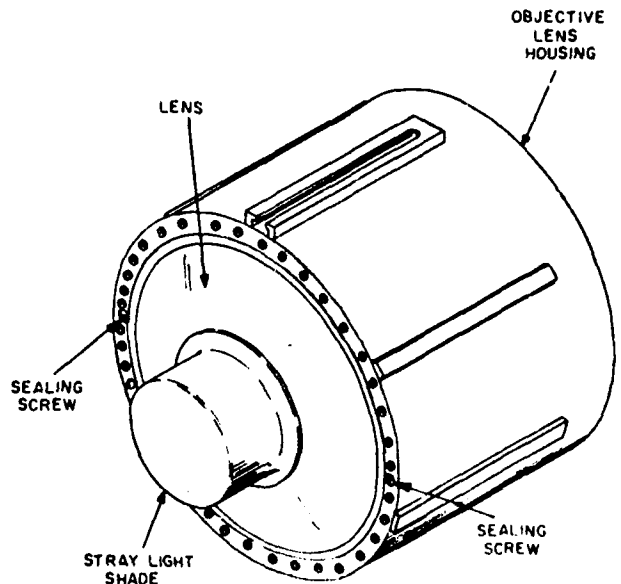

137.544(148A)C

Figure 5-12.—Objective lens assembly.

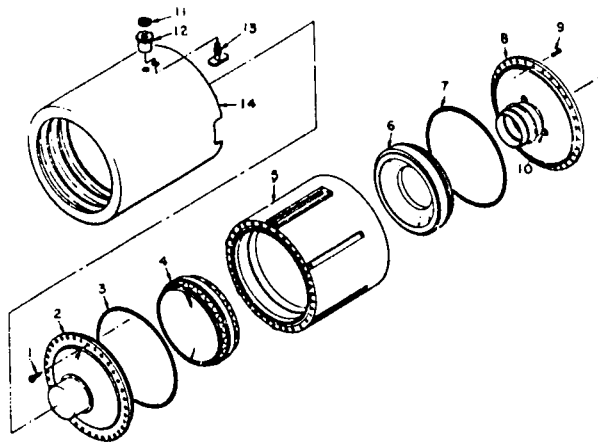

1. CAP SCREW
2. 1ST CELL ASSEMBLY
3. O-RING
4. 2ND CELL ASSEMBLY
5. OBJECTIVE HOUSING ASSEMBLY
6. PRIMARY MIRROR ASSEMBLY
7. O-RING
8. 4TH AND 5TH LENS CELL
9. CAP SCREW
10. VALVE ASSEMBLY
11. RETAINING RING
12. KNOB
13. SHADE CLAMP
14. OBJECTIVE SHADE ASSEMBLY

137.549

Figure 5-13.—Objective lens assembly, exploded view.

with sealing compound. If the stray light shade has been removed it must be rebonded to the center of the lens with the sealing compound, MIL-S-7502, class A-1/2.

SECOND AND THIRD LENS CELL ASSEMBLY.—Do not use acetone or alcohol to clean the third lens because the painted area in the center will be damaged (figure 5-15). Secure the lens pads in place with sealing compound, MIL-S-11030, Type 1 CLI. When the retainer is finger tightened onto the cell, it should be compressing the lens pads slightly. Bond the spacer and retainer with sealing compound, MIL-S-7502, class A2.

FOURTH AND FIFTH LENS CELL ASSEMBLY.—The fifth lens is sealed in its mount with sealing compound, MIL-S-11030, type 1, class 1 (figure 5-16). The shade assembly is bonded to

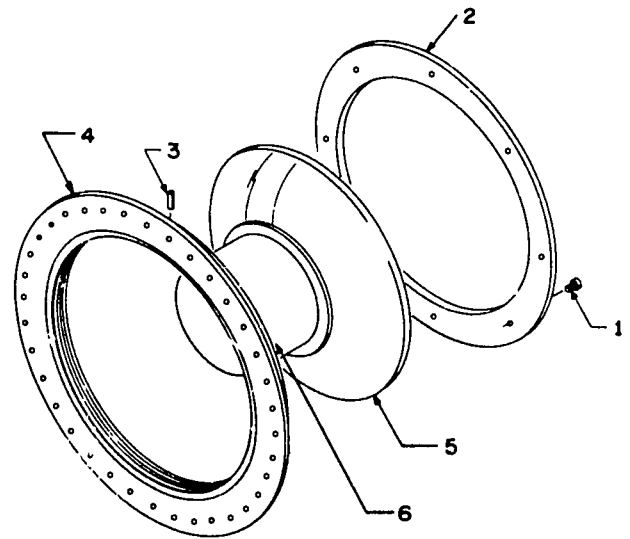

LEGEND

- 1 Setscrew
- 2 Clamp
- 3 Setscrew
- 4 1st lens cell
- 5 1st corrector lens
- 6 Stray light shade

148.287

Figure 5-14.—1st Lens cell assembly, exploded view.

the cell with sealing compound, MIL-S-7502, class A2.

PRIMARY MIRROR ASSEMBLY.—Affix lens pads to the primary mirror (figure 5-17) and finger tighten the retainer, compressing the pads slightly. Use the same technique you used in securing pads to the lenses of the second and third lens cell assembly. Uneven tension on the primary mirror will produce flare or distortion in the image.

Reassembly of Objective Lens Assembly

Reassemble the subassemblies of the objective, referring to figure 5-18 for location of the lenses. When replacing the rear end plate (fourth and fifth lens cell assembly) align the purge holes with the shade guide on the outer diameter of the objective housing. Apply sealing compound MIL-S-7502 to the head of the screws securing the first cell assembly and the rear end plate.

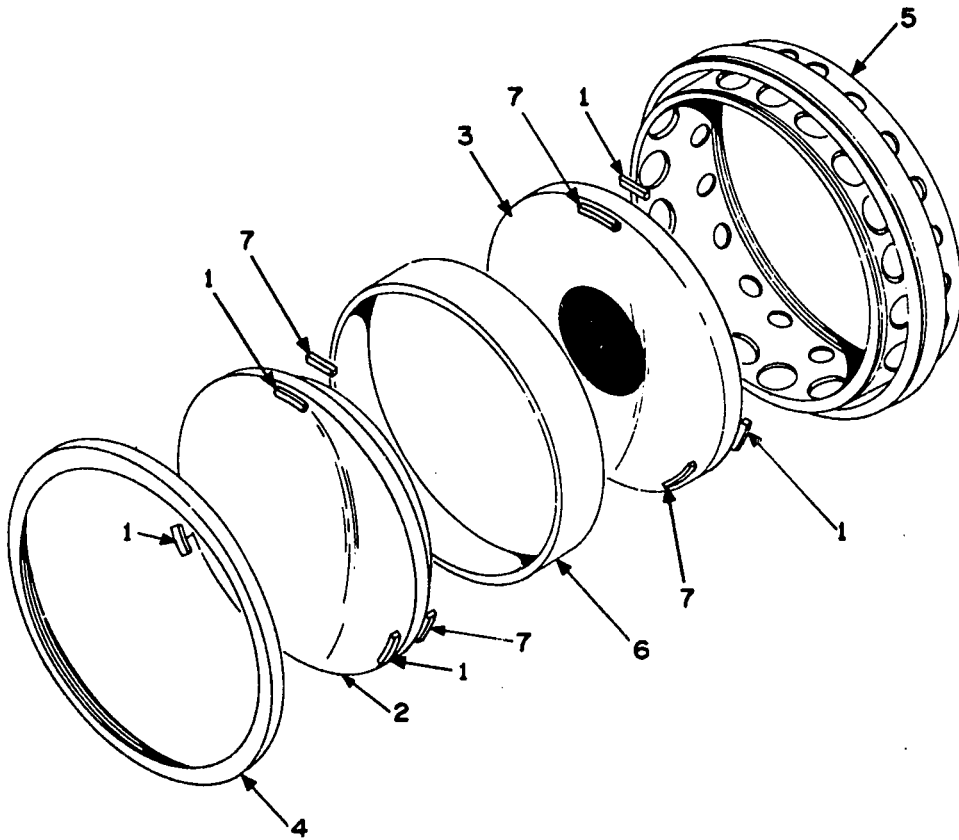

LEGEND

- 1 Lens pad
- 2 2nd corrector lens
- 3 3rd corrector lens
- 4 Retainer
- 5 2nd lens cell assembly
- 6 Spacer
- 7 Tape

148.288

Figure 5-15.—2nd and 3rd Lens cell assembly, exploded view.

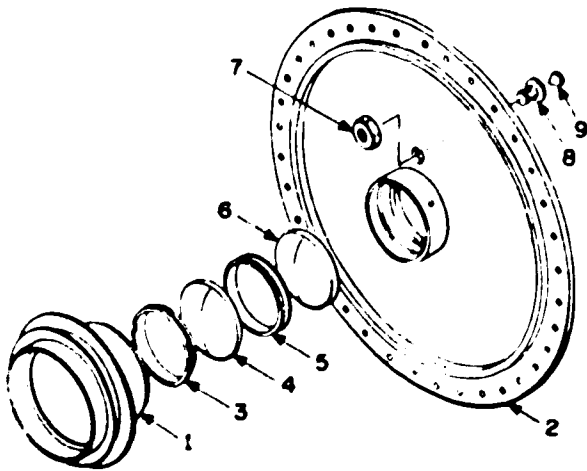

LEGEND

- 1 Shade assembly
- 2 4th and 5th lens cell
- 3 5th lens retainer
- 4 4th corrector lens
- 5 Spacer
- 6 5th corrector lens
- 7 Air valve nut
- 8 Air valve
- 9 Needle valve

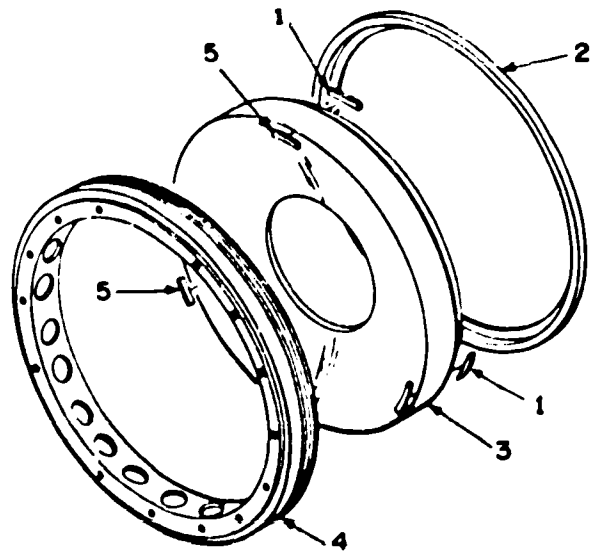

LEGEND

- 1 Lens pad
- 2 Lens retainer
- 3 Primary mirror
- 4 Primary mirror cell assembly
- 5 Tape

148.289

Figure 5-16.—4th and 5th Lens cell assembly, exploded view.

148.290

Figure 5-17.—Primary mirror assembly, exploded view.

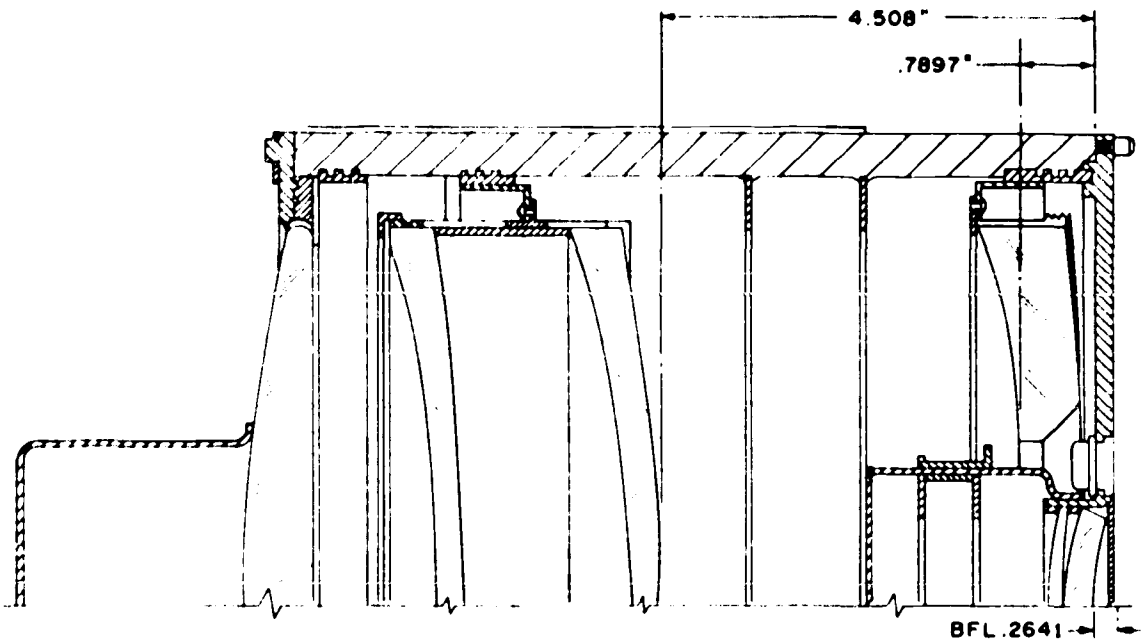

Figure 5-18.—Objective lens assembly. 137.549(148A)B

EYEPIECE ASSEMBLY

Two models of eyepieces are used on the AN/TVS-4. Figure 5-19 illustrated the exterior configurations of both eyepieces. The use of the Mod 2 eyepiece is predominant, therefore, it will be used for discussion purposes. Figure 5-20 shows the position of the lenses and spacers within the eyepiece mount.

Disassembly

Refer to figure 5-21 which is an exploded view of the Mod 2 eyepiece. Remove the focusing ring screws and focusing ring. Loosen the bleed screws and release the pressure in the eyepiece. Remove the focusing follower and its O-ring. The eyepiece may now be removed from the housing. If the lens assembly is to be completely disassembled, soften the sealing compound at lens No. 1 and lens No. 5 with ethyl alcohol before trying to remove them. Once the forward and rear cells have been disassembled, clean the sealing compound from the sealing surfaces.

Reassembly

The first step in reassembly of the eyepiece assembly is to seal lenses No. 1 and No. 5 into their respective cells. Refer to figure 5-22 for location of sealing compound beads. The sealing compound to be used must conform to MIL-S-11030. The sealing compound bead should be continuous. The diameter of the sealing compound bead for lens No. 5 is 1/8 to 3/16 of an inch. The bead for lens No. 1 is 1/32 of an inch in diameter. Lenses No. 1 and No. 5 must be firmly seated to ensure a good seal. Assemble the remainder of the cells. Note: the spacer between lens No. 4 and lens No. 3 has purge holes in it which must be aligned with the longitudinal grooves in the cell. This allows the space between lens No. 4 and lens No. 3 to be pressurized at the same time as the rest of the eyepiece assembly.

Before uniting the front and rear cells, determine the thickness of shim which will be required. The clearance between the front surface of lens No. 2 and the rear surface of lens No. 3 must be 0.008 of an inch. This distance is determined by the shims placed between the front and rear cells (figure 5-23).

To determine the shim thickness, you must measure the distance that each element is

recessed in its mount. The distance between the front cell shim contact surface and the rear surface of lens No. 3 is found by (1) measuring the distance between the rear surface of the front cell and the rear surface of the shim contact surface identified as A in figure 5-23, then (2) measuring the distance from the rear surface of lens No. 3 to the rear surface of the front cell, identified as B. $A - B$ equals the distance between the rear surface of lens No. 3 and shim contact surface. Call this distance X. In other words, $X = A - B$. The distance between the rear cell front shim surface and the front surface of lens No. 2 is identified as Y in figure 5-23. To find the proper shim dimension, subtract Y from X and add 0.008. That is, $X - Y + 0.008 = \text{shim thickness}$. The 0.008 inch added is the proper dimension for the separation of lenses No. 2 and No. 3.

Pressurizing

The eyepiece assembly should have an internal pressure of 5 ± 0.5 psig of dry nitrogen. After the forward and rear cells have been connected, the eyepiece should be subjected to an immersion test to ensure a good seal. With an appropriate adapter and hose, connect the dry nitrogen regulator to the bleed screw hole. Following the instructions in the section on general practices, pressurize the eyepiece to $5 \pm .5$ psig. There should be no leakage when the eyepiece is immersed in fresh water. (Nitrogen escaping at the junction of the adapter and the bleed screw hole is not leakage.)

Once the eyepiece assembly passes the immersion test, charge the eyepiece with dry nitrogen as recommended in the general practices.

Complete the final assembly of the eyepiece after pressurization.

EVALUATION OF THE OPTICAL CELLS

Both the objective assembly and eyepiece assembly must be evaluated prior to final assembly of the sight. The image intensifier tube will limit system resolution and thereby provide an untrue evaluation of the optical cell performance.

The objective assembly must be checked for resolution and back focal length (BFL).

The eyepiece assembly must be checked for turning torque, focus adjust travel, and resolution.

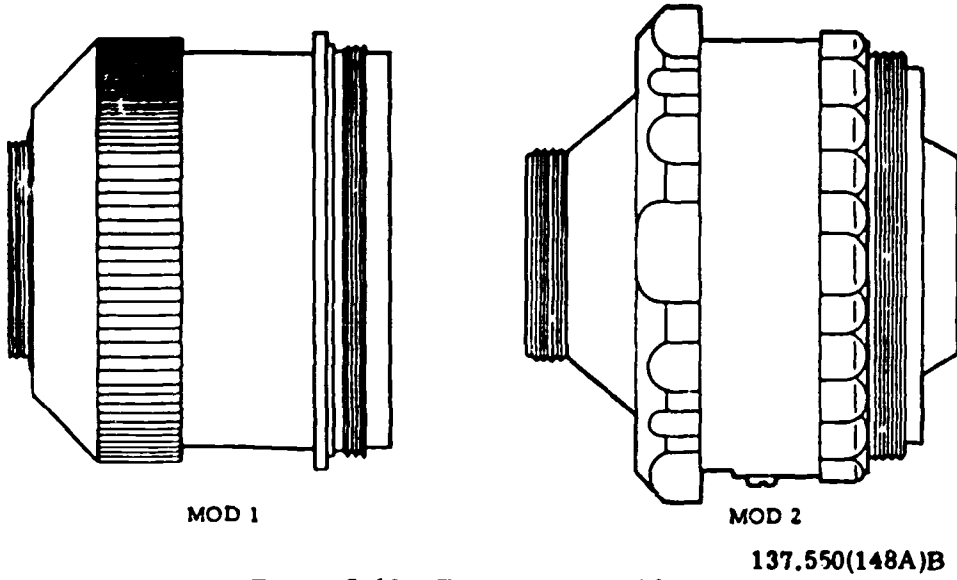
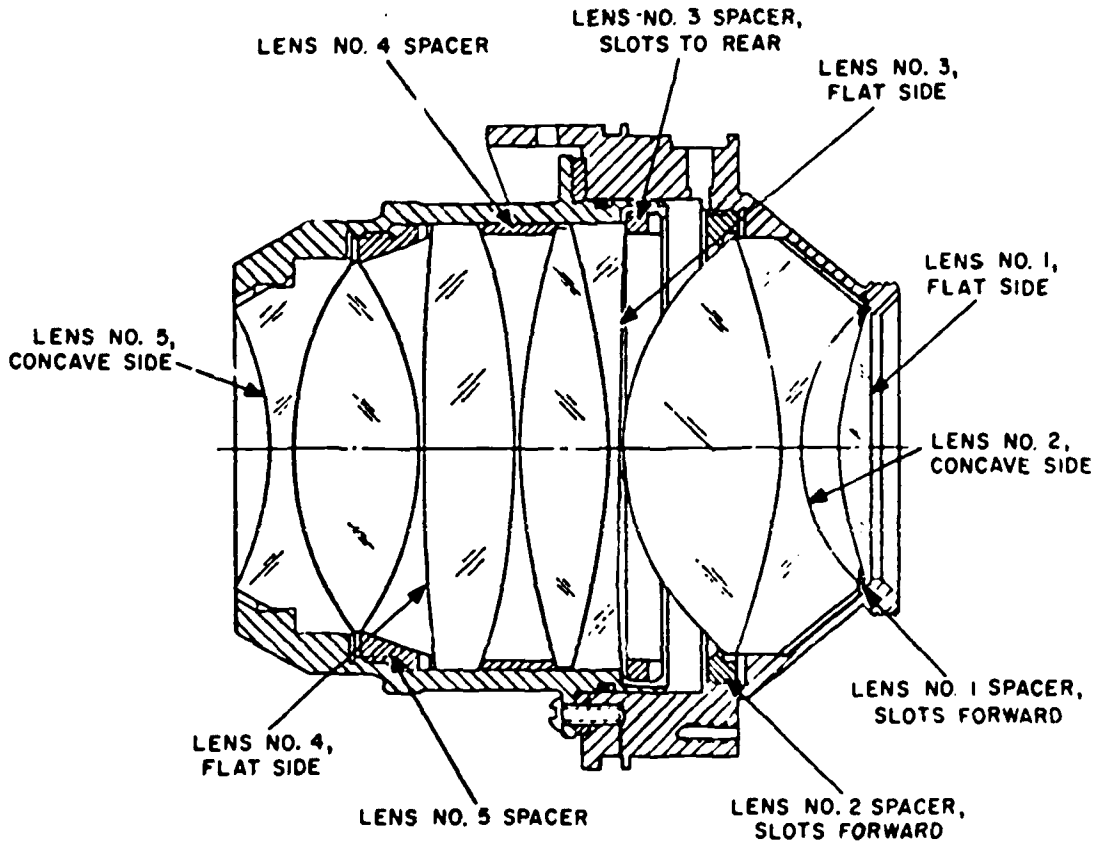
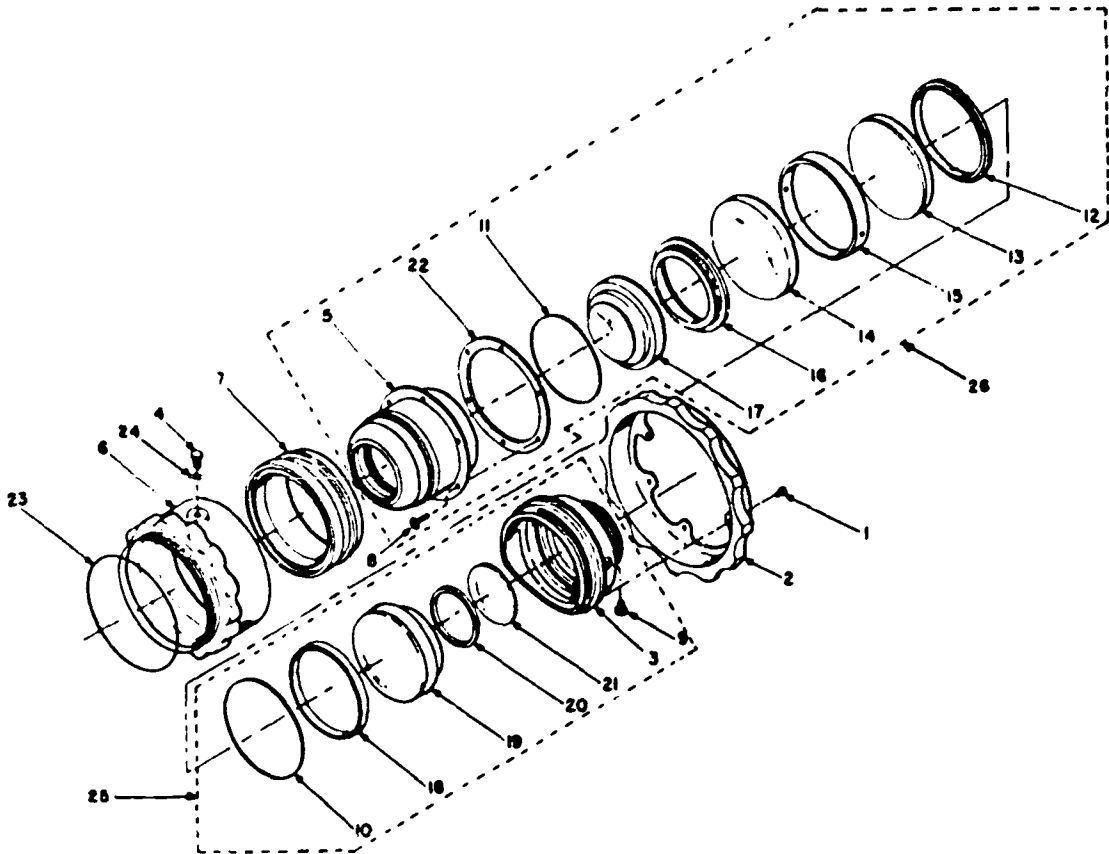

Figure 5-19.—Eyepiece assembly.



137.550(148A)C

Figure 5-20.—Eyepiece assembly, Mod 2.



LEGEND

- | | | | |
|----|--------------------|----|---------------------|
| 1 | Binding Head Screw | 14 | Lens No. 4 |
| 2 | Focusing Ring | 15 | Lens No. 4 Spacer |
| 3 | Rear Cell | 16 | Lens No. 5 Spacer |
| 4 | Follower | 17 | Lens No. 5 |
| 5 | Front Cell | 18 | Lens No. 2 Spacer |
| 6 | Eyepiece Housing | 19 | Lens No. 2 |
| 7 | Convolution Ring | 20 | Lens No. 1 Spacer |
| 8 | Nylon screw | 21 | Lens No. 1 |
| 9 | Bleed Screw | 22 | Shim |
| 10 | O-ring | 23 | O-ring |
| 11 | O-ring | 24 | O-ring |
| 12 | Lens No. 3 Spacer | 25 | Rear Cell Assembly |
| 13 | Lens No. 3 | 26 | Front Cell Assembly |

137.550(148A)D

Figure 5-21. — Eyepiece assembly exploded view.

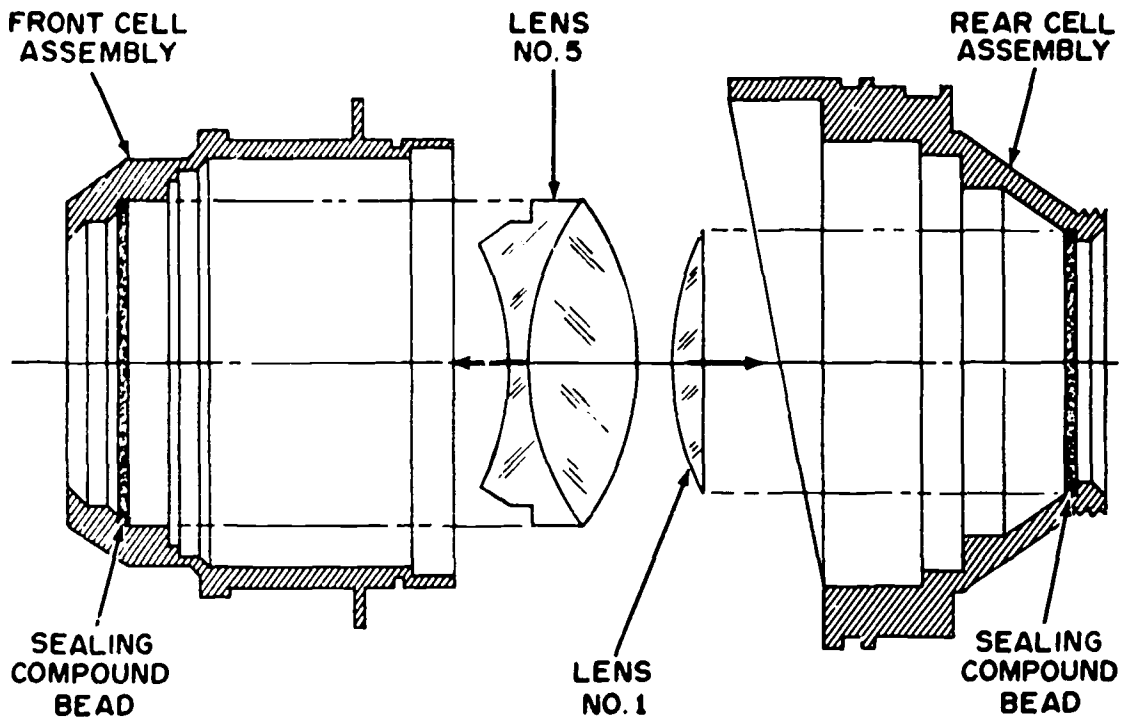

148.291

Figure 5-22.—Installation of lenses No. 1 and No. 5.

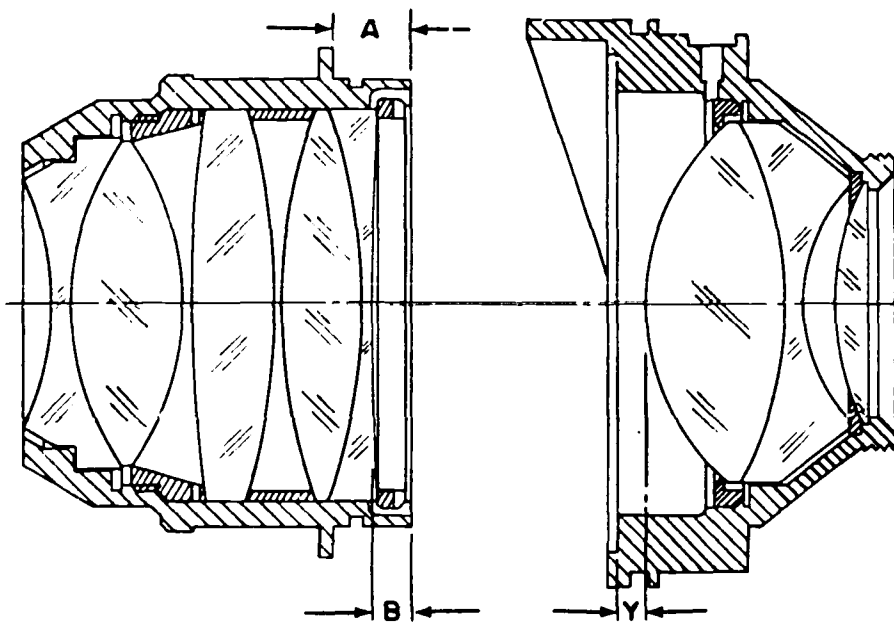

148.292

Figure 5-23.—Cell assembly measurements.

The resolution test should be made under the same conditions as specified in OM 3 and 2. To accomplish this, a special fixture is required to enable the objective lens assembly and the eyepiece assembly to be used as a telescope without the use of the image intensifier tube. Figure 5-24 illustrates the type of test fixture which will allow you to make the resolution tests without the image intensifier tube in the system. The test fixture is attached to the rear of the objective housing and the eyepiece assembly is screwed into it. You now have a seven-power astronomical telescope with which to make the resolution test.

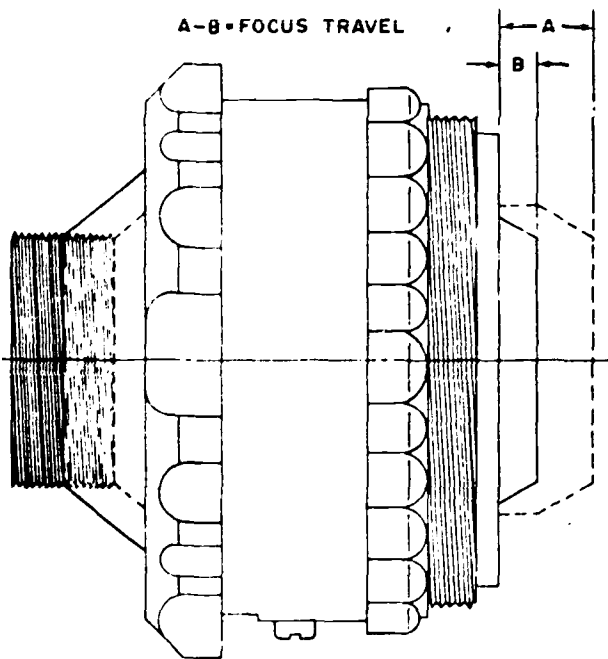

148.293

Figure 5-24.—Resolution test fixture.

The back focal length of the objective lens can be checked with an infinity collimator, a frosted glass plate, and feeler gages. With the objective assembly viewing the collimator, measure the distance at which the image is formed on the frosted plate. The BFL of the objective assembly is 0.250 ± 0.020 inches. The PFL can be adjusted by moving the primary mirror; one-half turn of the mirror changes the BFL by 0.050 inch.

To determine the focus adjust travel, measure the distance the eyepiece travels from one

extreme of focus to the other. Minimum travel of the Mod 2 eyepiece of the AN/TVS-4 is 0.472 inch. Figure 5-25 illustrates how the travel can be measured.

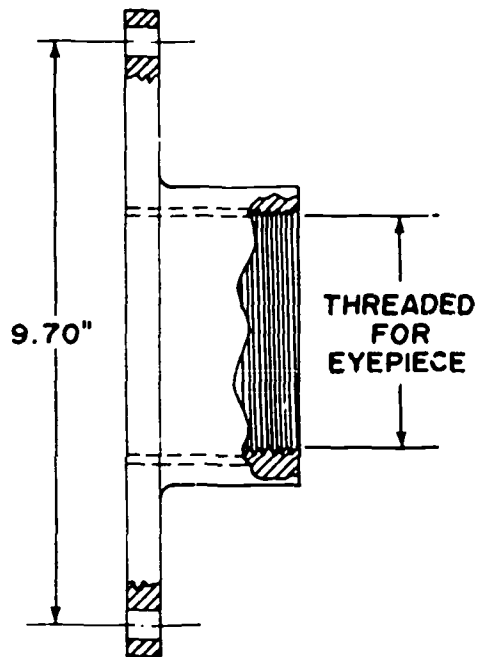

148.294

Figure 5-25.—Focus travel measurement.

The maximum allowable amount of torque required to turn the focus ring is 30 inch-pounds.

POWER SUPPLY ASSEMBLY

Once the power supply assembly has been removed from the main housing, it can be disassembled as required. The power supply components, and the manner in which they are assembled, are illustrated in figure 5-26. The battery is rated at 6.75 volts direct current.

The oscillator output voltage is rated between 2.60 and 2.80 volts. The output frequency of the oscillator must be between 1200 and 2000 hertz.

IMAGE INTENSIFIER TUBE (IIT)

This device is a turn-in item. When replacement is required, a new IIT is drawn from stock and the old IIT is returned to supply for overhaul.

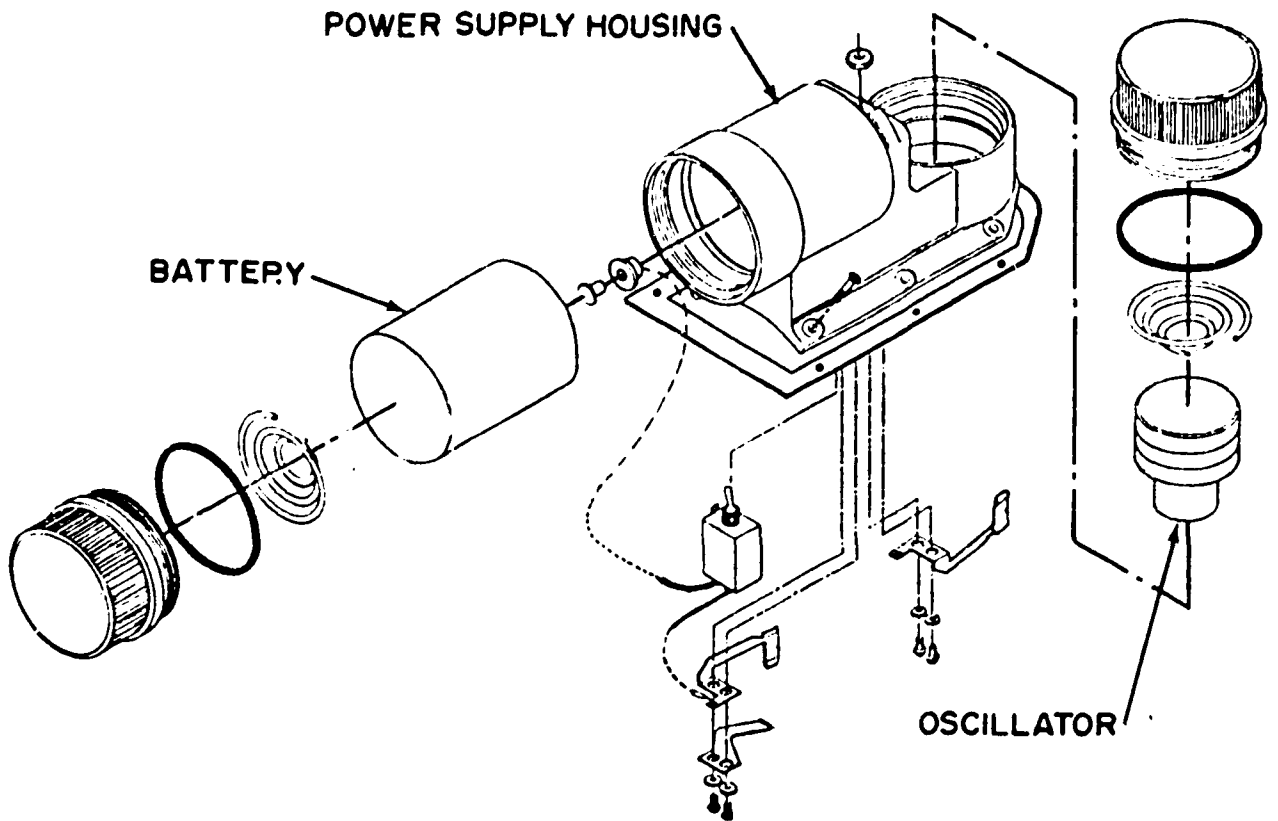

Figure 5-26.—Power supply assembly, Mod 2.

137.551(148A)B

SIGHT REASSEMBLY

Reassembly of the sight is basically the reverse of disassembly.

When installing the image intensifier tube into the range focus tube, align the input pin in the center of the access hole in the focus tube.

SIGHT EVALUATION

The sight, when assembled, should conform to the following specifications:

Magnification	7X to 7.7X
True Field	8°
Diameter of Exit Pupil	0.59 inch
Eye Distance	1.04 inches
Enhancement	minimum 35,000X

The tests for magnification, true field, exit pupil, eye distance, and resolution are covered in OM 3 and 2. The enhancement (amplification)

test must be conducted in a manner which is not common to other optical instruments.

Enhancement Test

Enhancement is the term applied to the light level gain attained with the image intensifier tube. To test the gain, measure the input and output light levels of the night vision sight, which require the use of photometric devices. In the light level gain test, the input light level must be very low, steady, and known. The light level gain of the system is found by dividing the output light level by the input light level.

AN/PVS-2A

The night vision sight, AN/PVS-2A (fig. 5-27), often referred to as the Starlight Scope, consists of four major assemblies: the housing, objective assembly, image intensifier tube, and the eyepiece.

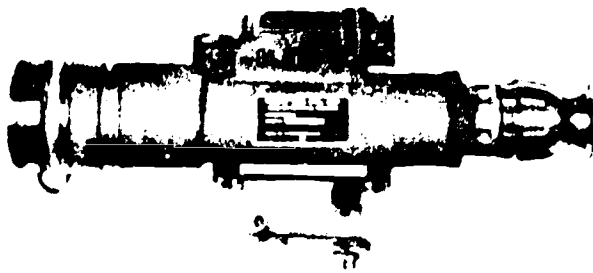

137.546

Figure 5-27.—Night vision sight, AN/PVS-2(A).

The optical system of the AN/PVS-2(A) (fig. 5-28) is essentially the same as that of the AN/PVS-4. The objective lens is smaller but of the same design, and is the Schmidt-Cassegrain catadioptric type. The image intensifier assembly

is smaller but functions identically to that of the AN/TVS-4. The eyepiece of the AN/PVS-2(A) is a modified Erfle type.

SIGHT DISASSEMBLY

Refer to figure 5-29, an exploded view of the sight, for disassembly. The various components of the electrical system are contained within the housing and must be removed separately. Remove the battery and oscillator to guard against accidentally energizing the electrical system. You must take out three set-screws before removing the objective assembly which unscrews from the housing. To remove the eyepiece, unscrew the retaining nut and slip the eyepiece from the housing. Then slide the image intensifier tube from the housing.

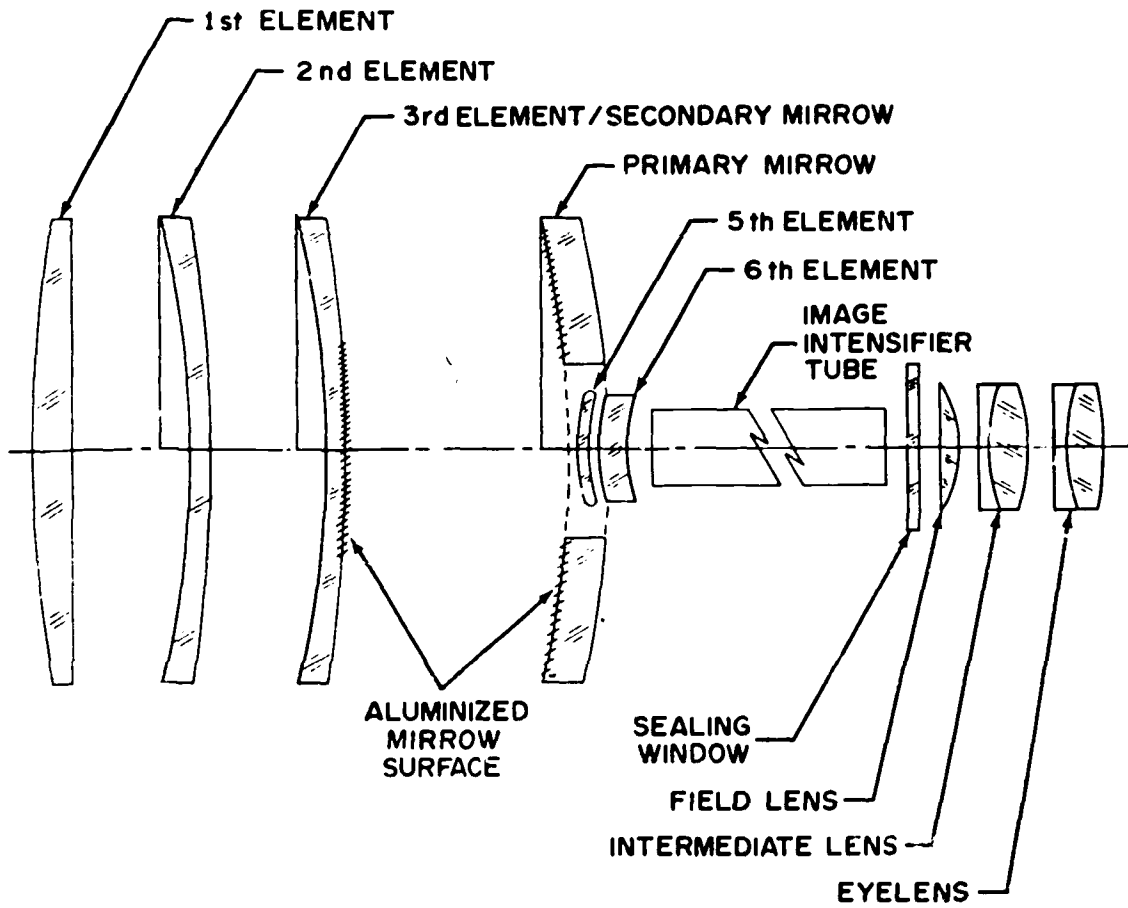

137.546(148A)A

Figure 5-28.—Optical system, AN/PVS-2(A).

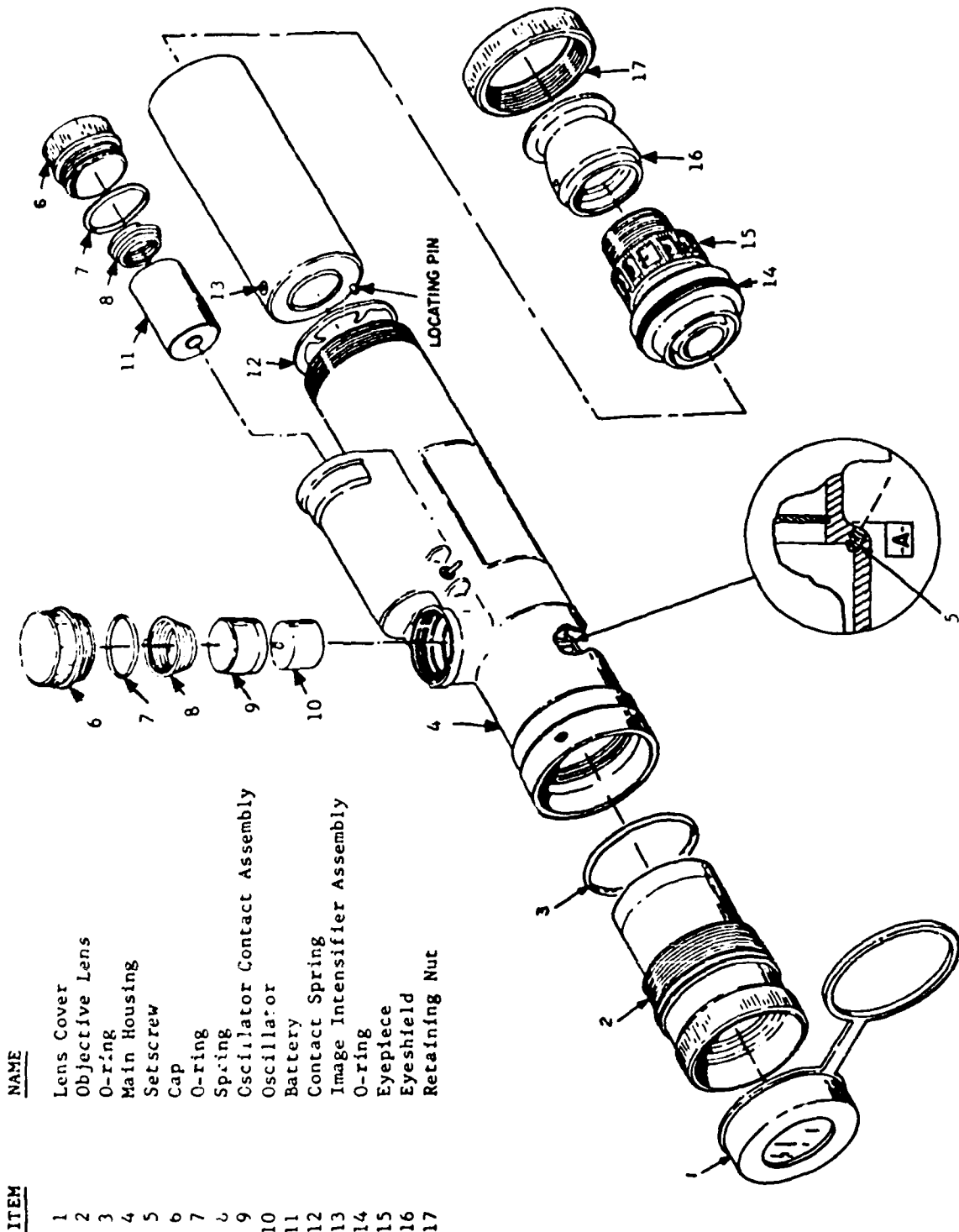

ITEM	NAME
1	Lens Cover
2	Objective Lens
3	O-ring
4	Main Housing
5	Setscrew
6	Cap
7	O-ring
8	Spring
9	Oscillator Contact Assembly
10	Oscillator
11	Battery
12	Contact Spring
13	Image Intensifier Assembly
14	O-ring
15	Eyepiece
16	Eyeshield
17	Retaining Nut

137.546(148A)B

Figure 5-29. —AN/PVS-2A exploded view.



OBJECTIVE LENS ASSEMBLY

The objective lens assembly (fig. 5-30) is a sealed unit which is charged to a pressure of 3.0 ± 0.3 psig. Release this pressure prior to disassembly.

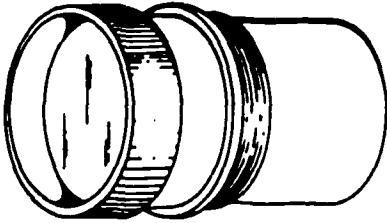

137.546(148A)C

Figure 5-30.—Objective lens assembly.

Disassembly

Refer to figure 5-31 during disassembly. Remove the screw plug and setscrews at the rear of the mount. Remove sealing compound on retainers before trying to remove the retainers. Disassemble the objective lens assembly. The fifth and sixth objective elements are removed from the rear and are held in their cell with sealing compound. This sealing compound must be removed in order to remove the fifth and sixth elements.

Assembly

Once the required maintenance has been performed on the objective assembly, reassembly may be started.

Install the fifth and sixth elements in the lens cell as in figure 5-32. Apply a bead of adhesive, MIL-S-7502, class B-2, at the lens cell and the chamber of the sixth element. Apply a vacuum to the front of the objective housing to draw the adhesive around the sixth element.

A word of caution; do not let the adhesive set up on the polished surfaces of the fifth or sixth elements as this will require the disassembly of the fifth and sixth elements again. Once the adhesive sets up, it must withstand a pressure of 5.0 ± 0.5 psig. To prevent complete rework at a later time, it would be a good idea to pressure test the cell before continuing with the assembly.

The primary mirror and cone are assembled as a unit into the housing. Place a gasket on the cone and then the primary mirror. The unit is then screwed onto the fifth and sixth lenses cell.

Assemble the third element, spacer, second element, and retainer. Do not use excessive torque in tightening the retainer to avoid distortion in the image. Secure the retainer with three equally spaced beads of sealing compound, MIL-S-7502, class A2.

Install the first element O-ring, first element, and retainer. Secure the retainer with three equally spaced beads of sealing compound.

Install the primary mirror adjustment setscrews so that they nearly touch the primary mirror. Install the screw plug with its O-ring.

The objective assembly is now ready for collimation.

Collimation

After overhaul, the objective lens assembly must meet three test criteria; distortion, back focal length, and roll out.

DISTORTION.—Usually caused by too much tension on the second element of the objective, distortion is detected by using a National Bureau of Standards resolution chart. With the eyepiece assembly held so that the focal planes of the eyepiece assembly and objective assembly coincide, view the resolution chart to detect distortion. If distortion is present, the second element retainer will have to be adjusted until the distortion is removed.

BACK FOCAL LENGTH.—Defined as the distance from the rear surface of the sixth element to the focal plane, back focal length should be 0.137 ± 0.030 inches. The back focal length may be measured in a number of ways. The method used on the AN/TVS-4 will work.

ROLL OUT.—Roll out is the difference in the alignment of the mechanical axis and the line of sight.

Only if the AN/PVS-2A is to be used as a gunsight is roll out critical.

To test for roll out, you need a test setup which will allow you to rotate the assembly while viewing the target.

You will have to view the target and image simultaneously, therefore, a stereo comparator of similar device is required. Use a special

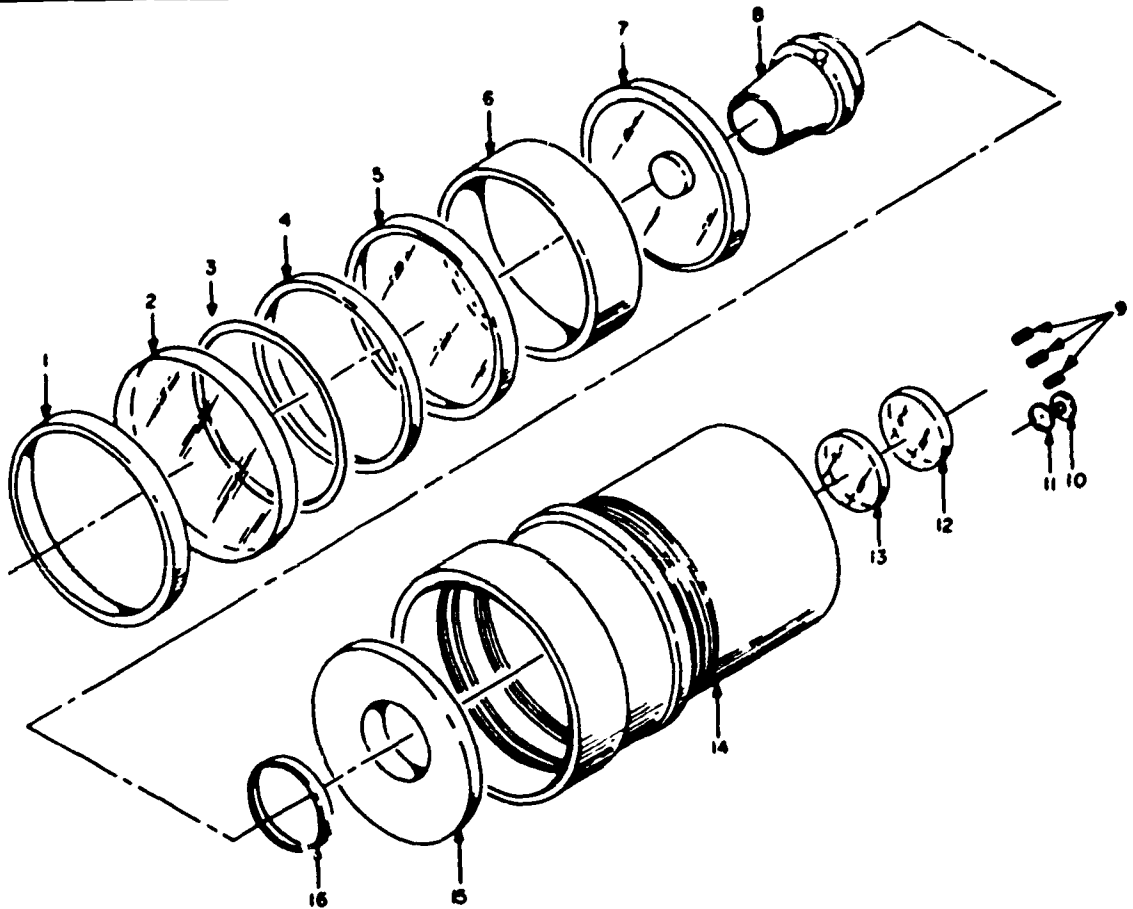

<u>Item</u>	<u>Name</u>	<u>Item</u>	<u>Name</u>
1	Retainer, First Element	9	Setscrews
2	First Objective Element	10	Screw Plug
3	Preformed Packing (O-ring)	11	Preformed Packing (O-ring)
4	Second Element Retainer	12	Sixth Objective Element
5	Second Objective Element	13	Fifth Objective Element
6	Third Element Spacer	14	Objective Lens Cell
7	Third Objective Element (Secondary Mirror)	15	Primary Mirror
8	Cone	16	Primary Gasket

137.546(148A)D

Figure 5-31.—Objective lens assembly, AN/PVS-2(A).

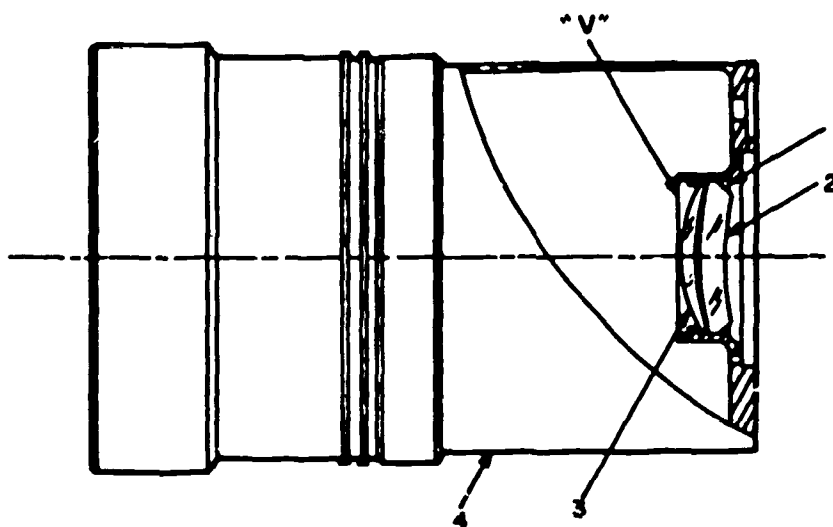

<u>Item</u>	<u>Name</u>
1	Adhesive
2	Sixth Objective Element
3	Fifth Objective Element
4	Objective Lens Cell

148.295

Figure 5-32.—Installation of 5th and 6th objective element.

test fixture such as illustrated in figure 5-33 which allows the eyepiece to be used directly with the objective lens. While viewing through the comparator, superimpose the crosslines by shifting the test stand. Rotate the objective assembly and test fixture. If the crossline does not stay superimposed, adjust the setscrews and test stand until the crosslines remain superimposed as the objective assembly and test fixture is rotated. Be careful in tightening the setscrews as they bear directly on the rear of the primary mirror. It is possible to damage the mirror with too much tension on the setscrews.

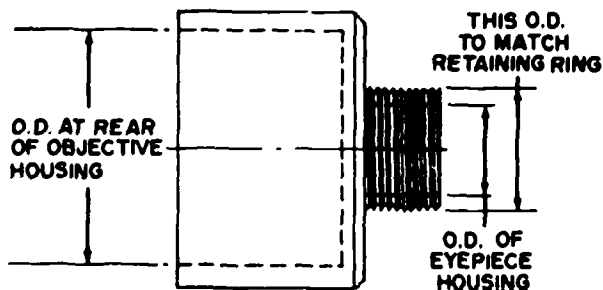

148.296

Figure 5-33.—Special test fixture.

EYEPIECE ASSEMBLY

The eyepiece assembly of the AN/PVS-2A (fig. 5-34) contains three elements: a doublet eyelens, a doublet intermediate lens, and a singlet field lens.

The assembly is under a pressure of 3.0 ± 0.5 psig. Release this pressure prior to disassembly.

Disassembly

Removal of the eyepiece sealing window mount first is recommended to avoid damaging the window (fig. 5-35). The retaining ring, focusing ring, and the drive stud must be removed in order to remove the inner cell. The remainder of the eyepiece may then be disassembled as required. Note: the eyepiece

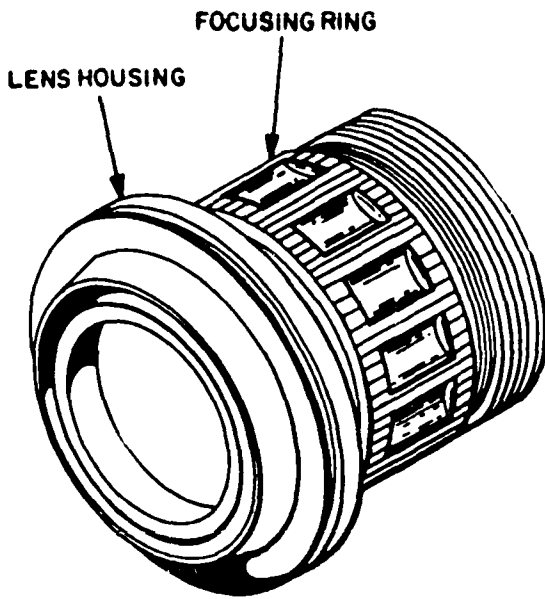

137.550(148A)E

Figure 5-34.—Eyepiece assembly.

sealing window should not be removed from its mount unless absolutely necessary (fig. 5-36). To remove the sealing window, soak the assembly in hot (140°F) water until the adhesive softens.

Reassembly

If the sealing window has been removed from its mount, it must be resealed. Reseal the window with adhesive, SC-B-614606, between the window and the mount, the window and the retainer, and the retainer and the mount (fig. 5-36).

The curvatures at the front and rear of the eyelens are identical. To help determine proper orientation within the mount, the front element (second element in figure 5-37) has a yellow tint on its outer edge. You may have to

remove some of the black ink on its outer edge to determine the proper direction for installation. The yellow-tinted edge should be closest to the objective end when assembled. The gasket between the eyelens and its mount is cemented in place with adhesive, MIL-A-25457.

Complete the reassembly (fig. 5-38 and fig. 5-35). When installing the focusing ring retainer, coat the threads with sealing compound, MIL-S-22473, grade EV.

Pressurization

The eyepiece of the AN/PVS-2(A) does not have a pressurization port. Pressurization of the eyepiece then requires the use of a special fixture such as the one illustrated in figure 5-39. Place the assembled eyepiece into the fixture with the sealing window assembly threaded only partially into the eyepiece housing. The fixture retainer ring will keep the eyepiece in the fixture while you evacuate and pressurize the fixture and eyepiece. When the pressure has built up to 3.0 ± 0.5 psig, the sealing window assembly can be threaded into the eyepiece housing by pressing down and turning the eyepiece at the same time. This seals the eyepiece assembly and it is ready for the immersion and fog test.

SIGHT ASSEMBLY

The sight assembly is basically the reverse of disassembly. Refer to figure 5-29 during reassembly. The slot in the contact spring aligns with a slot in the housing so that the locating pin of the image intensifier assembly will fit into the slot. The index mark on the eyepiece should be on top after installation of the eyepiece.

The AN/PVS-2A sight must meet the same test criteria as that of the AN/TVS-4 except that the maximum torque required to turn the eyepiece is 7 inch-pounds and the eyepiece must travel from -4 to +4 diopters.

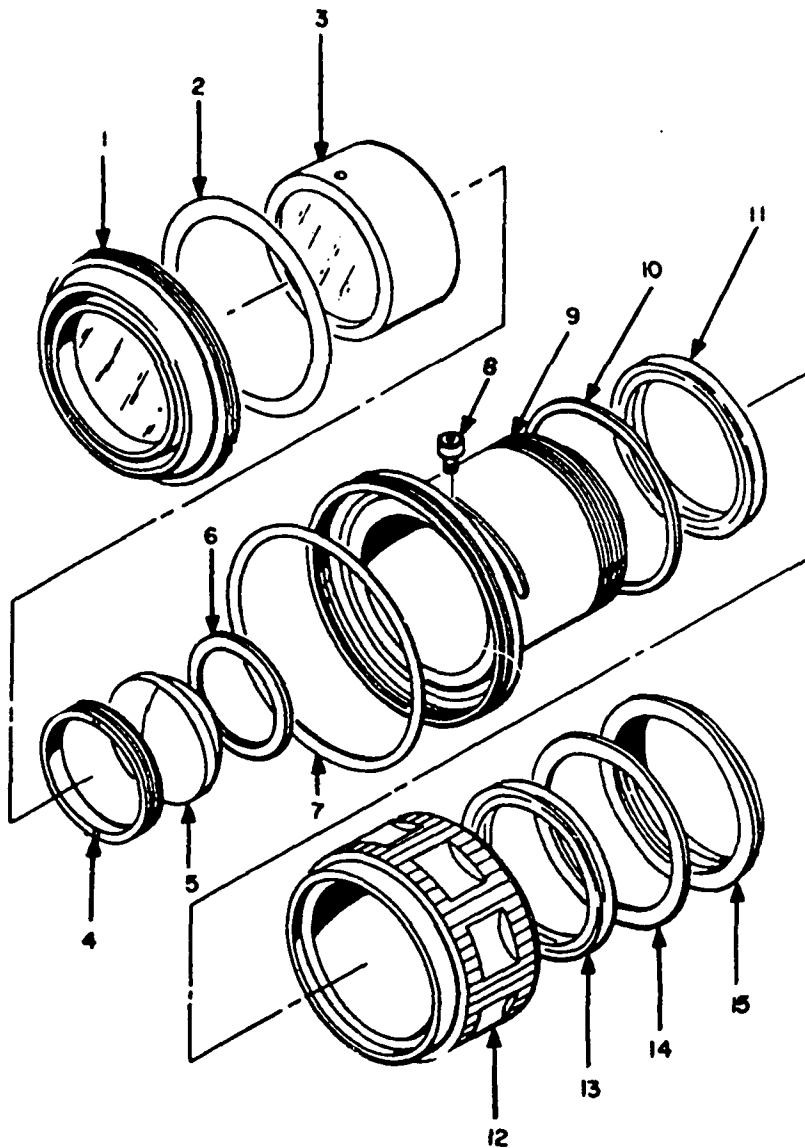

ITEM	NAME	ITEM	NAME
1	Sealing Window Assembly	9	Main Body
2	O-ring	10	Washer
3	Lens Cell Assembly	11	Quad Ring
4	Nut, Retaining	12	Focusing Ring
5	1st & 2nd Elements	13	Quad Ring
6	Gasket	14	Washer
7	O-ring	15	Retaining Ring
8	Drive Stud		

137.550(148A)F

Figure 5-35.—Eyepiece assembly.

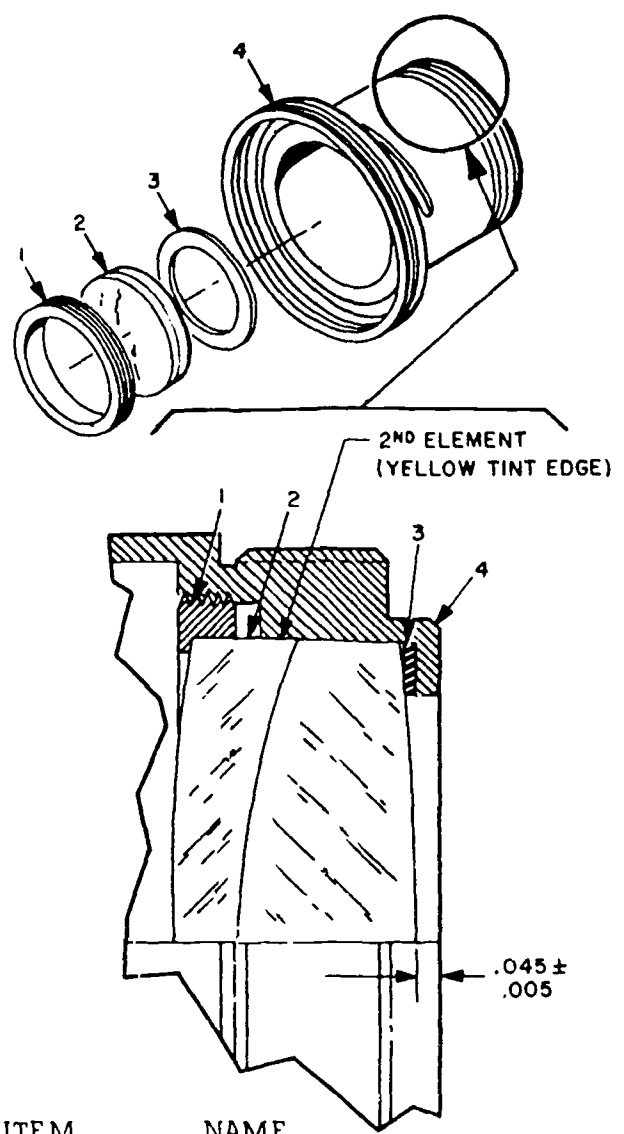
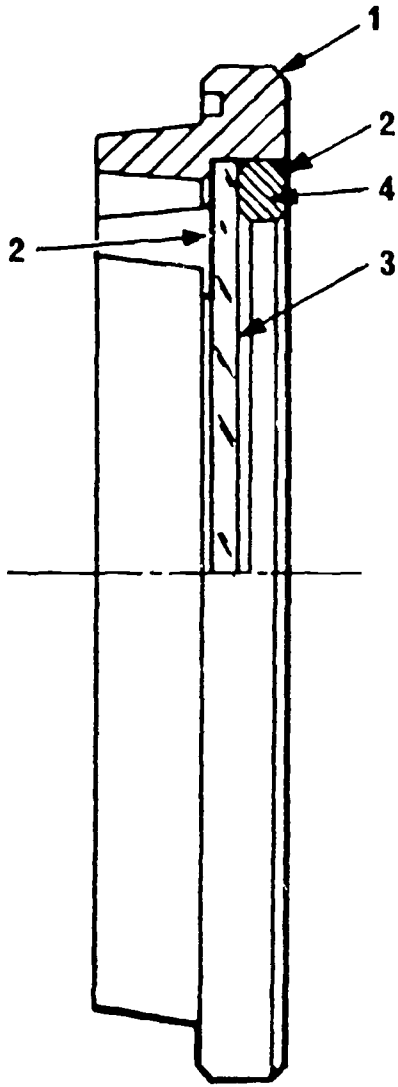

ITEM	NAME
1	Mount, Window
2	Adhesive
3	Window, Eyepiece
4	Ring, Retainer

148.297

Figure 5-36.—Sealing window assembly.

ITEM	NAME
1	Nut, Retaining
2	1st and 2nd Elements (Eyelens)
3	Gasket
4	Main Body

137.550(148A)G

Figure 5-37.—Eyepiece main body assembly.

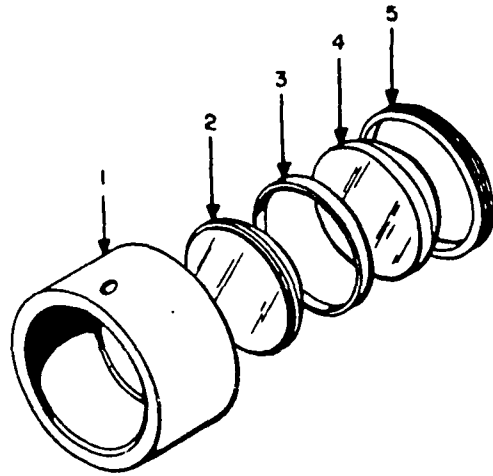

ITEM	NAME
1	Eyepiece Cell
2	5th Element
3	4th & 5th Element Spacer
4	3rd & 4th Element
5	Retainer

148.298
Figure 5-38.—Lens cell assembly.

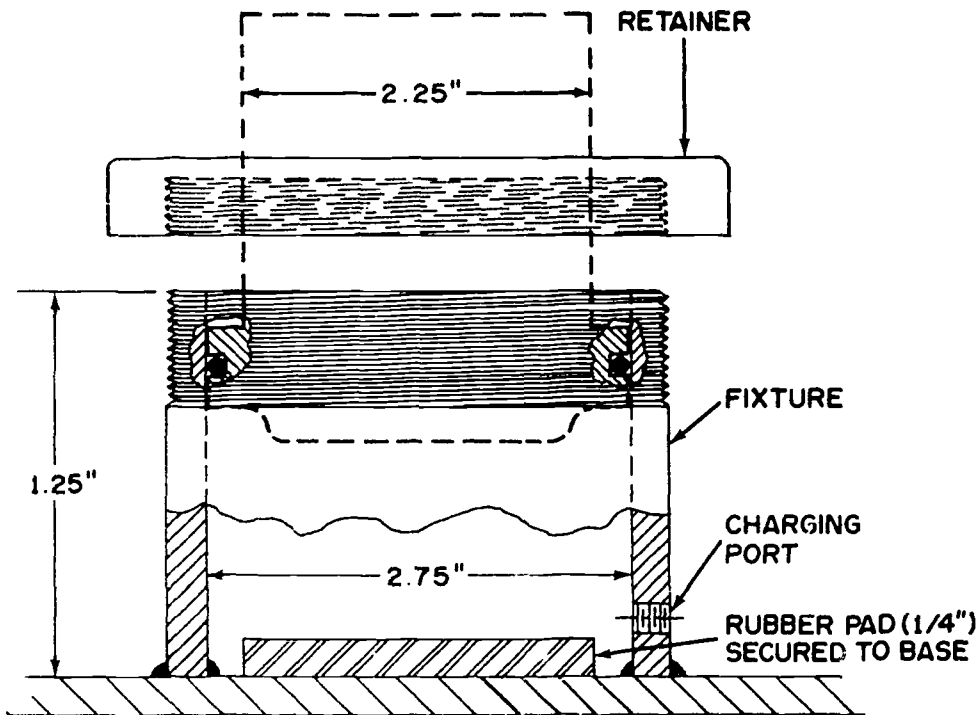

148.299
Figure 5-39.—Eyepiece pressurizing fixture.

CHAPTER 6

SYNCHROS, SERVOS, AND CONTROL TRANSFORMERS

Technological advances in the fields of navigation and fire control have contributed to increased complexity of the equipment which you, as an Opticalman, must maintain. In addition, you are affected directly by the requirement to maintain the optical instruments which have electrical/electronic components. Though it would be nice to have someone else do the maintenance for you, it is impractical—even impossible—for another work center to assist during overhaul and alignment.

The information in this chapter will help you understand the operating principles of optical instruments that use electrical/electronic components and also enable you to do a better job of instrument maintenance, casualty analysis, and quality control. However, you cannot benefit from reading this chapter unless you have a knowledge of basic electricity. You can satisfy the prerequisite by completing the Rate Training Manual, Basic Electricity. If you have already done so, you may find it worthwhile to review topics concerning safety, fundamental concepts of electricity, electrical conductors and wiring techniques, electromagnetism and magnetic circuits, introduction to alternating-current electricity, and electrical indicating instruments.

SYNCHROS

Contained within observation submarine periscopes are two rotary, electromechanical, position-sensing devices known as synchros. The function of these synchros is to provide an electrical output which indicates the elevation of the line of sight.

CONSTRUCTION

A synchro resembles a small electrical motor in size and appearance but operates like a variable transformer. Each synchro contains a rotor, similar in appearance to an armature, and a stator, which corresponds to the field in a motor as shown in figure 6-1. The synchro is usually

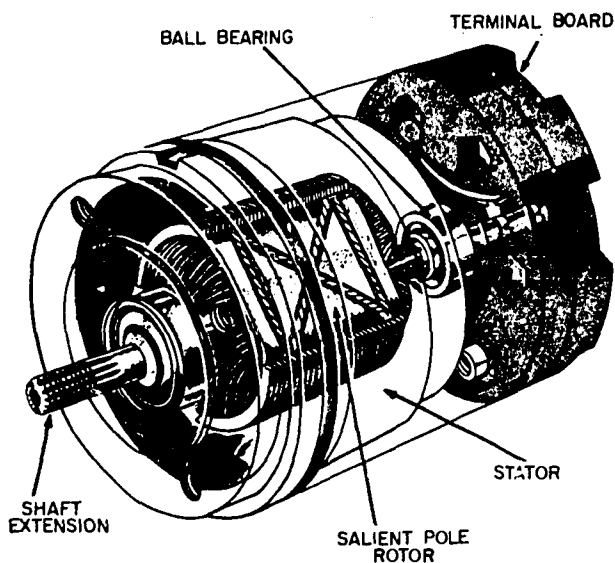

72.42.1

Figure 6-1.—Phantom view of a synchro.

composed of a three-winding, Y-connected stator encased in a cylindrical metal shield and a rotor with one winding. The rotor is mounted within the stator and is free to turn within the stator windings. As the one-winding rotor of a synchro is rotated, the amount of coupling in the three stator windings is varied, producing a variable voltage output that represents the amount and direction of displacement of the rotor from the stator.

The rotor (which is usually the primary winding of the synchro unit) is wound on sheet-steel laminations stacked together and securely mounted on a shaft. To enable the excitation voltage to be applied to this winding, two sliprings are mounted on one end of the shaft and insulated from it. An insulated terminal board, mounted on one end of the cylindrical frame, houses the brushes which ride on the sliprings. This terminal board and another insulated block that is mounted on the other end of the synchro frame contain low friction ball-bearings.

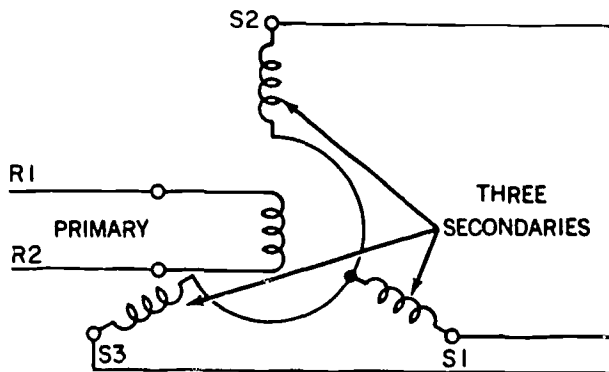

175.6

Figure 6-2.—Transformer with one primary winding and three secondary windings.

OPERATION

The conventional synchro unit is essentially a transformer with a rotatable primary winding and three secondary windings spaced 120° apart as shown in figure 6-2.

When an a-c voltage is applied to the rotor (primary) winding of a synchro, a magnetic field is set up around the soft iron, laminated core of the rotor. This magnetic field induces voltages into the three Y-connected stator (secondary) windings.

Rotor Position Versus Stator Voltage Output

The angular displacement of the rotor from the reference position varies the induced voltage in each stator winding. In other words, as the position of the rotor is changed in relation to the stator, the voltage induced in each stator winding varies.

If the position of the rotor is parallel to one of the stator windings, maximum voltage will be induced into that winding. The voltages induced into the other two stator windings are then equal because their angles of displacement are equal.

The maximum voltage induced in any one stator winding of a 115-volt synchro is 52 volts. This occurs only when the stator winding is parallel to the rotor. The voltage induced in one stator winding, however, cannot be measured because the common point of the three Y-connected windings does not appear as a terminal on the outside of the synchro case. Since the end terminals of the three windings are the

only stator terminals that are led outside the synchro case, only the voltage induced between any two stator terminals can be measured.

Figure 6-3 shows the voltage induced in each stator coil and the voltage between stator terminals when the rotor is parallel to the S2 coil. As the rotor is parallel to the S2 coil, a maximum of 52 volts is induced in the S2 coil. This 52 volts is in phase with (or has the same instantaneous polarity as) the rotor voltage.

Stator coils S1 and S3 are at a 60° angle to the rotor and therefore have less voltage induced in them. The cosine of 60° is .5, thus, coils S1 and S3 have a voltage of $.5 \times 52$ or 26 volts.

The voltages induced in the S1 and S3 coils are 180° out of phase with the rotor voltage. For example, the voltage from S1 or S3 to the common connection will be positive at the same instant that R1 is negative in respect to R2. The S1 and S3 voltages are equal and have the same instantaneous polarities, therefore, there is no difference of potential between terminals S1 and S3.

The S2 coil voltage is in series with and aiding the S1 coil voltage, thus, the voltage from terminal S1 to S2 is $52 + 26$ or 78 volts. Similarly, the S2 to S3 terminal voltage is the sum of the voltages induced in the S2 and S3 coils. It is important to remember that synchros are excited by a single phase supply, therefore, all voltages rise and fall in unison and are either in phase or 180° out of phase.

When the rotor of a conventional synchro transmitter or receiver is aligned parallel with the S2 coil as shown in figure 6-3, the synchro is said to be on electrical zero.

Figure 6-4 shows the synchro rotor positioned 30° counterclockwise (CCW) from the electrical zero position. In this position, the rotor is no longer parallel to the S2 coil, so it induces only 45 volts in the S2 coil ($.866 \times 52 = 45$ volts). Likewise, the rotor is displaced 30° from the S1 coil and induces 45 volts in this coil. The rotor being at right angles (displaced 90°) to the S3 coil induces no voltage in the S3 coil. A voltmeter connected to the stator terminals would show the following: S1 to S2, 90 volts; S2 to S3, 45 volts; and S1 to S3, 45 volts. These stator voltages correspond to the 30° CCW position of the rotor from the electrical zero position. A different combination of stator voltages exists for each angular position of the rotor. Thus, the stator voltages represent the rotor position.

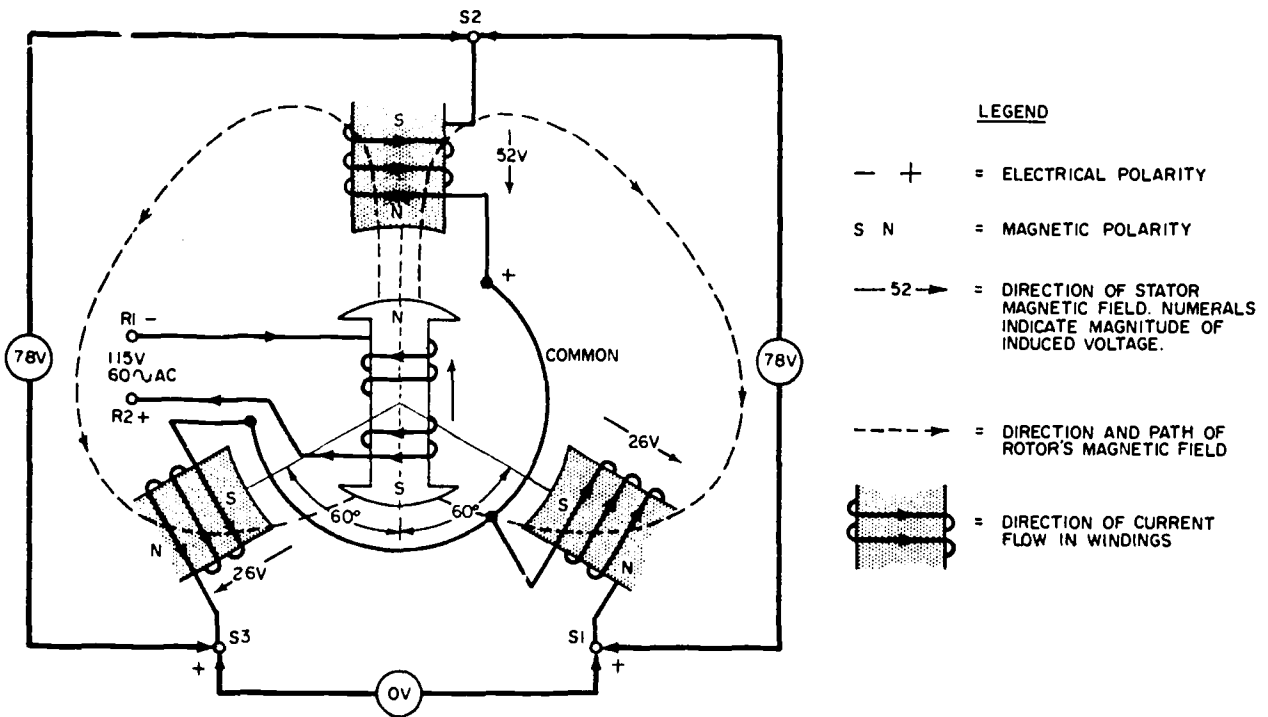
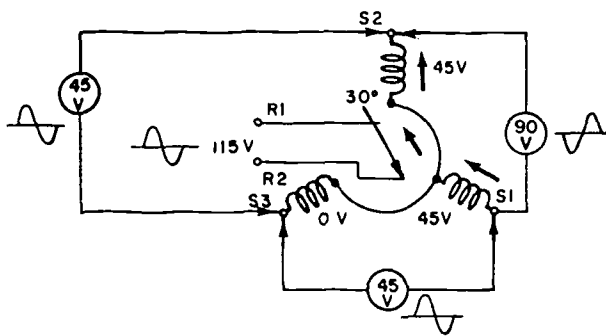

Figure 6-3.—Synchro voltages, rotor at 0°.

12.166



83.71.1

Figure 6-4.—Synchro voltages, rotor at 30°.

The 90 volt terminal-to-terminal stator voltage at the 30° CCW rotor position is the maximum terminal-to-terminal voltage for 115 volt synchros. The maximum voltage induced in any one coil, however, is 52 volts as discussed earlier.

Elevation Indication

Figure 6-5 is a mechanical schematic of the elevation system of a typical observation periscope. Note the location of the synchros. The 36X synchro rotor is coupled to the head prism via a worm and sector gear and a set of bevel gears. When the line of sight is at 0° elevation, the rotor of the synchro is at electrical zero as indicated in figure 6-3. As the training handle is rotated in the direction indicated by the arrows, the line of sight elevates and the voltage at the S₁ and S₃ leads increases, peaks, decreases, and zeros again. This process of voltage cycling repeats as elevation continues until the elevation assembly reaches its limiting stops. During this process, the synchro has been sending electrical signals to a receiver which indicates the elevation of the line of sight.

SERVOS AND CONTROL TRANSFORMERS

Contained within the Mk 102 and Mk 116 tilting prism gunsight telescopes are two control

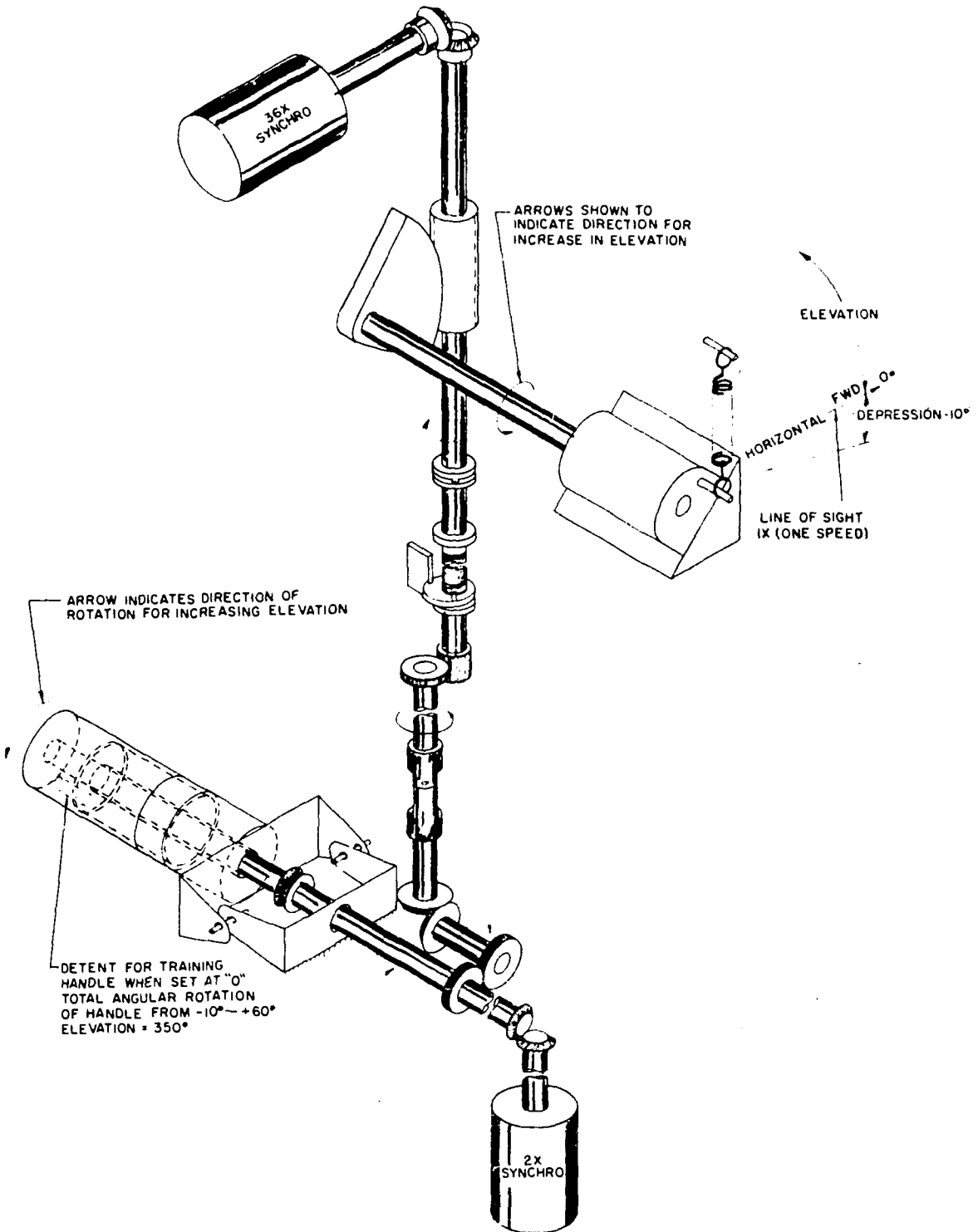

148.281

Figure 6-5.—Submarine periscope elevation system.

transformers and a servo motor-generator. The function of this servo system is to continuously and accurately position the moving optical elements (prisms and mirrors) in response to synchro signals received from the fire control system. Figure 6-6 is a schematic of the elevation system of a Mk 116 telescope. The servo drives the gear train while the control transformer tells the servo how much and in what direction.

SERVO MOTOR-GENERATORS

The servo motor-generator, or servo as it is more commonly known, is the final control element in the servo drive mechanism. It receives power from the amplifier and drives the gear train.

Construction

A servo is a small, bidirectional motor. The servo of the Mk 116 telescope is physically integrated with a position-indicating generator. Figure 6-7 illustrates the Mk 116 servo schematically and shall be used for discussion purposes.

Operation

The motor section of the servo provides the driving force for the gear train. To accomplish this, two control windings are provided which are 180° out of phase to each other. The reference winding is 90° out of phase with both of the control windings. In a no-error situation, the control windings have an equal and opposing amount of voltage applied to them. When required by the fire control system, a higher voltage is applied on the appropriate control winding to provide rotation in the direction desired.

The generator, being on a common shaft with the motor, indicates the amount of travel of the motor shaft. This indication of travel is used in the dampening of the travel of the motor. Dampening is required to reduce overtravel and oscillation of the motor due to its inertia.

CONTROL TRANSFORMERS

A control transformer is, as its name implies, a controlling device which operates on the transformer effect. It is a special purpose synchro which provides information on rotor orientation. The control transformer (CT) has

the same type of three-winding, Y-connected stator and one winding rotor as the synchro. The main difference lies in the manner in which they function. The synchro has a reference voltage applied to its rotor but the control transformer does not. The signal or reference voltage is applied to the stator of the control transformer and, by transformer effect, an error voltage is generated in the rotor windings. The error voltage is a product of desired rotor position versus actual rotor position.

Consider the conditions existing in the system shown in figure 6-8, where a CT is connected for operation with a synchro, and the rotors of both units are positioned at zero degrees. The relative phases of the individual stator voltages with respect to the R1 to R2 voltage of the transmitter are indicated by the small arrows. The resultant stator field of the CT is shown by the large arrow. With both rotors in the same position, the CT stator field is at right angles to the axis of the rotor coil. Since no voltage is induced in a coil by an alternating magnetic field perpendicular to its axis, the output voltage appearing across the rotor terminals of the CT is zero.

Now assume that the CT rotor is turned to 90 degrees, as in figure 6-9, while the CX rotor remains at zero degrees. Since the CT's rotor position does not affect stator voltages or currents, the resultant stator field of the CT remains aligned with S2. The axis of the rotor coil is now in alignment with the stator field. Maximum voltage, approximately 55 volts, is induced in the coil and appears across the rotor terminals as the output of the CT.

Next, assume the CX rotor is turned to 180 degrees, as in figure 6-10. The electrical positions of the synchro and CT are 90 degrees apart, the CT stator field and rotor axis are aligned, and the CT's output is maximum again, but the direction of the rotor's winding is now reversed with respect to the direction of the stator field. The phase of the output voltage is therefore opposite to that of the CT in the preceding example. This means that the phase of the CT's output voltage indicates the direction in which the CT rotor is displaced with respect to the position-data signal applied to its stator.

It is evident that the CT's output can be varied by rotating either its rotor or the position-data signal applied to its stator. It can also be seen that the magnitude and phase of the output depend on the relationship between signal and rotor rather than on the actual position of either.

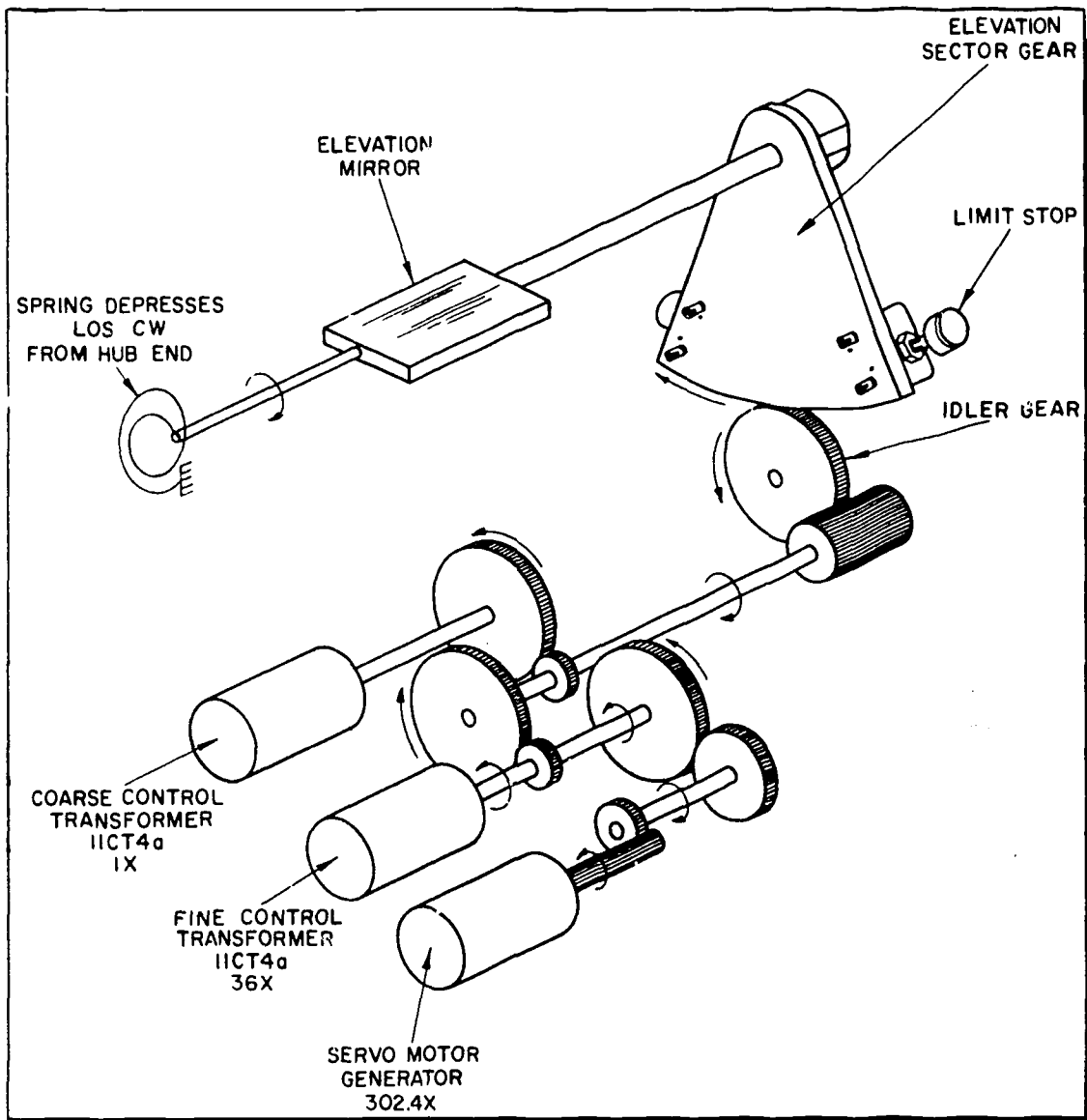

148.282

Figure 6-6.—Elevation servo assembly gear train, schematic diagram.

Since the rotor winding of the CT is never connected to the a.c. supply, it induces no voltage in the stator coils. As a result, the CT stator currents are determined only by the voltages applied to them. The rotor itself is wound so that its position has very little reflected effect on the stator currents. Also, there is never any appreciable current flowing in the rotor, because its output voltage is always applied to a high-impedance load 10,000 ohms or

more. Therefore, the rotor does not turn to any particular position when voltages are applied to the stator.

The rotor shaft of a CT is always turned by an external force, and produces varying output voltages from its rotor winding. Like synchro transmitters, the CT requires no inertia damper, but unlike either transmitter or receivers, rotor coupling to S2 is minimum when the CT is at electrical zero.

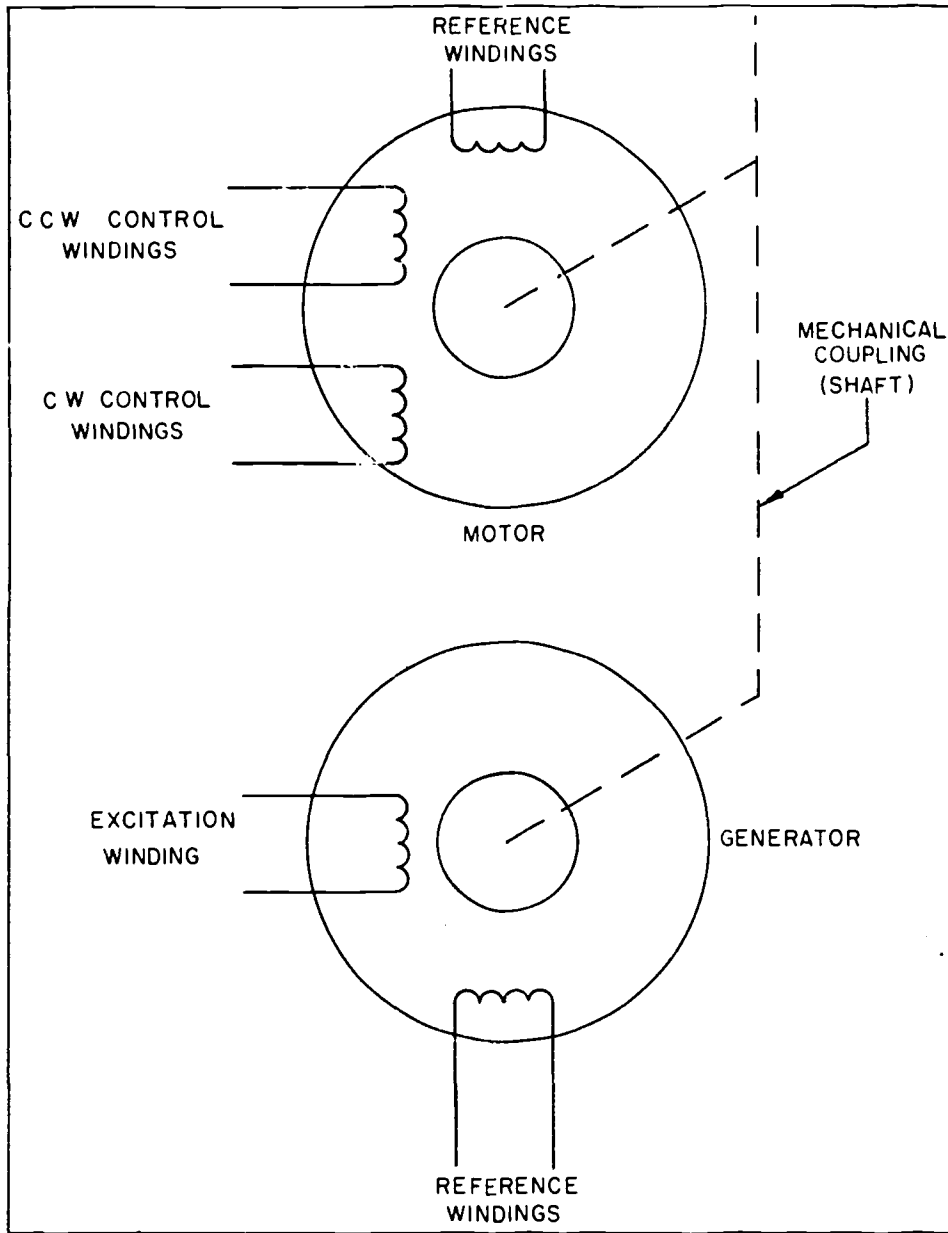

148.283

Figure 6-7.—Servo motor generator. schematic diagram.

When current flows in the stator circuits of a CT, a resultant magnetic field is produced. This resultant field can be rotated by the signal from a synchro transmitter. When the field of the CT stator is at right angles to the axis of the rotor winding, the voltage induced in the rotor winding is zero. When the stator field and the rotor's magnetic axis are aligned, the induced

rotor voltage is maximum. Since the CT's output is expressed in volts, it is convenient to consider its operation in terms of stator voltages as well as in terms of the position of the resultant magnetic field, but it should be remembered that it is the ANGULAR displacement, with respect to the rotor axis, that determines the output of the CT.

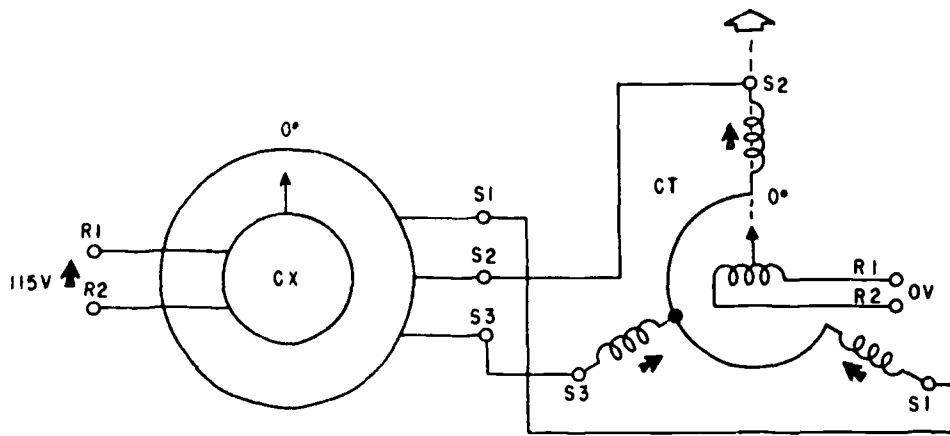

53.22(175)

Figure 6-8.—Conditions in CX-CT system with rotors in correspondence.

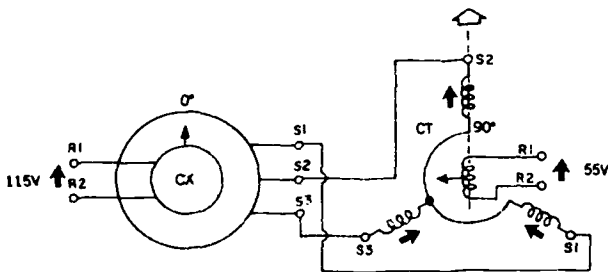

53.22

Figure 6-9.—Conditions in CX-CT system with CX rotor at 0° and CT rotor at 90°.

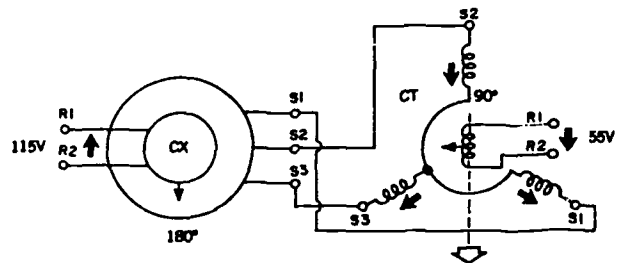

53.23

Figure 6-10.—Conditions in CX-CT system with CX rotor at 180° and CT rotor at 90°.

SYSTEM OPERATION

The servo and CTs operate in conjunction to fix the line of sight of the telescope. This is accomplished by generating a signal in the fire control system which is fed, in turn, to the control transformer. The control transformer generates an error signal which corresponds to rotor location versus ordered rotor location. This error signal is fed to the amplifier which modifies the signal and feeds it to the servo. The servo drives the gear train, reducing the magnitude of the error signal. As

the error signal decreases in magnitude, the servo generator diminishes the speed of the servo to avoid excess overtravel.

Each of the two CTs serve a separate function in that all error signals of a magnitude greater than 1° are handled by the 1 x or single speed CT and all error signals less than 1° are handled by the 36X or thirty-six speed CT. When one CT is operating the servo, the amplifier chops the signal of the other CT.

The alignment of synchros, servos, and CTs will be covered in the alignment section of the appropriate chapter.

CHAPTER 7

TILTING PRISM GUNSIGHT TELESCOPES

The role of the gunsight in Naval warfare has been declining steadily since the advent of radar. Yet gunsights are still, and will continue to be, installed as an integral part of the shipboard fire control system for reasons that will be developed in this chapter. In support of these reasons, the chapter provides a short account on the growth of fire control as a scientific technique, defines the fire control problem, outlines a general solution for it, and describes the part that gunsights play in fire control. In addition, the chapter contains characteristics, operating principles, and maintenance requirements of various tilting-prism gunsight telescopes that are active in the fleet today. This information will help you understand not only why gunsights are used but also how they work. By knowing why and how, you are better prepared to perform your duties of maintaining and repairing gunsight telescopes.

THE GROWTH OF FIRE CONTROL

Fire control has been defined as the practical application of exterior ballistics, and the methods and devices used to control guns and other weapons. Another way to put it, in terms of weapons, missiles, and targets, would be to say that fire control is the process of determining the exact relationship between a weapon and its target, and then using that information to strike that target.

When you think how long it has been since gunpowder and guns first were used in warfare—over six hundred years—it's something of a surprise to realize that fire control as a specialized technique has been with us for a relatively short time.

Early guns, projectiles, and propellants were crude and ineffective—so much so that military men could argue with considerable truth that the crossbow and the long bow were more efficient weapons than early hand guns. Fire control at sea was just as crude, and it stayed that way for a long time, because of the unreliable ammunition and the irregular, handmade equipment of

the early days. It wasn't altogether the lack of proper instruments that delayed the development of fire control. Manufacturing methods were incredibly primitive. Accuracy to ten-thousandths of an inch is commonplace today, but 300 years ago a gun bore five feet long was considered excellent if it was no more than half an inch out of true.

With crude equipment, with projectiles of ballistically poor shapes and sizes, and with the unreliable, sensitive, but weak black powder that was the best that the primitive chemistry of the day could produce, something more than improved fire control equipment was needed.

For hundreds of years there was no substantial improvement in ordnance equipment or gunnery techniques. Gunnery required physical bravery, endurance, and a strong back; its greatest subtleties were in knowing tricks, such as firing your cannon at the top of your ship's roll (so that you could sweep the enemy's rigging as you came broadside) and firing at the bottom of the roll to blast his hull. However, during the Industrial Revolution of the nineteenth century ordnance began to turn into precision machinery, and gunnery began to evolve from the art of individual marksmanship into the scientific technique of fire control that you know today.

You can get a pretty good idea of the tremendous development of fire control by comparing the ranges between ships Naval engagements early and recent.

The Civil War engagement between the Monitor and the Merrimac took place almost entirely at approximately 100-yard range. (Even at this close range, the gunfire of the two vessels did relatively little serious damage.)

By 1905 Naval battles were fought at ranges that varied from 4,000 to 6,000 yards. By the end of World War I improvements in fire control instruments had made 24,000-yard ranges practicable. By the end of World War II developments in gun construction and in ranging and computing instruments raised range limits to 40,000 yards.

THE FIRE CONTROL PROBLEM

The objective of any gun fire control system or technique is to aim the gun or battery and to fire the projectile so that the projectile will meet the target.

Put this way, the objective sounds simple, but as a matter of fact it is far from simple as there are many variables to consider. The path of the projectile is not straight, the target may be moving (and usually is, often at high velocity), and maneuvering in evasive action, the ship on which the gun is mounted is pitching and rolling. The projectile doesn't reach the target instantaneously; it takes time to get there, and during this time the target moves too. The condition of the gun, the gas pressure in the gun chamber, the shape of the projectile, all affect the projectile's flight path. Moreover, once the projectile leaves the gun muzzle, there isn't much that anybody can do about steering it, or correcting its flight path. These many variables combine to form a difficult problem.

But "difficult" is not "impossible." The problem has been solved, so, let's learn a little more about the problem, its solution, and how gunsights fit into the overall picture.

A SIMPLE DEMONSTRATION

The lowly soda-acid fire extinguisher is not a "fire control instrument" in the sense this chapter is concerned with, but it's handier than a real gun would be for demonstrating some of the basic principles of fire control and projectile flight. (See figure 7-1.)

Turn the extinguisher upside down and aim it at its target. First of all, the nozzle is like a gun. You can elevate and depress it (raise and lower the nozzle), and train it (swivel it from side to side).

Second, every drop of liquid coming out is a projectile. There are so many drops that you can see the whole path of projectile movement at once. This is the trajectory.

Third, the stream of liquid strikes the line (or whatever you're aiming at)—that's the target.

As you aim the stream at the target, notice that its path (except at very close range) forms a curve. Therefore, you cannot point the nozzle directly at the target, like the beam of a searchlight. Instead, you must aim a little high.

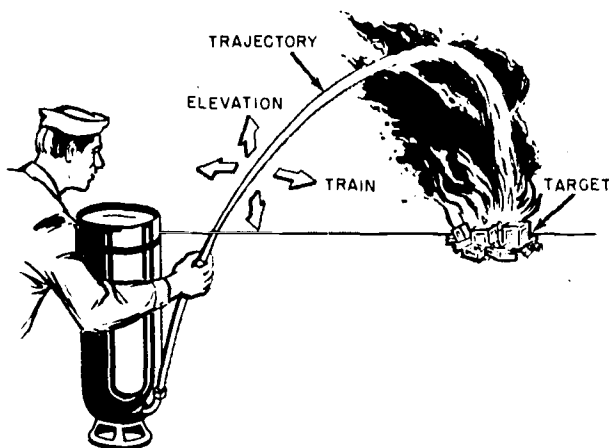

84.196

Figure 7-1.—Demonstration of the principles of fire control.

It's the same with a gun. You don't aim the gun at the target. You aim the gun in such a way as to cause the projectile to hit the target.

Getting back to the fire extinguisher, suppose you walk away from the target. You will have to point (elevate) the nozzle a little higher. (You do the same if your target moves away.) Now suppose a strong breeze strikes the stream, deflecting it away from the target. To compensate for this, you must move the nozzle a little further off your target, in order to hit it.

Last, suppose you operate the extinguisher while swaying in a rocking chair. You have to do a good bit of nozzle-wagging to keep the water stream on target. Of course, if you were really trying to direct the stream at a fire, you wouldn't sit in a swaying rocking chair to do it. But the problem is not unlike that of aiming a gun aboard a pitching, rolling ship.

The fire extinguisher demonstration has taught us something about the behavior of guns and projectiles. But this is only a beginning. The fire control problem is concerned with the relationships of the target, the projectile, the gun that fires it, and aiming the gun for a hit. There are a number of basic concepts to learn.

THE TARGET

The most important thing to know about any target, moving or stationary, is its location relative to the gun firing at it. Knowing its

latitude and longitude isn't enough. You must also have data that can be used to aim the gun. Range and bearing data are needed for aiming at surface targets; range, bearing, and elevation data for aiming at air targets. The terms (range, bearing, and elevation) are defined as follows:

Range—The straight line distance along a line of sight to the target (fig. 7-2). This distance is measured in yards.

Bearing—The direction of the target in the horizontal plane. This direction is either a relative bearing (reckoned from the bow of the ship as shown in figure 7-2) or a true bearing (same as the true compass bearing). The direction is given as an angle measured from the reference point (ship's bow or true north) to the target. Bearing^s are measured in degrees (°) and minutes (') of arc.

Elevation—The direction of the target in the vertical plane (fig. 7-2). Elevation is

also measured in degrees and minutes of arc.

The gun firing at a stationary target can be aimed properly when target range, bearing, and elevation are known. Unfortunately, not many targets are stationary. Besides, even when the target is stationary, your ship usually is not. So you must take into account your own ship's motion.

Target and Own-Ship Motion.

Much of the real job of the fire control system comes in at this point. The surface target may either be approaching or moving away from your ship; its bearing with respect to your ship is also constantly changing. Even if the target is at rest and your ship is moving, the effect is the same, as far as the fire control system is concerned. With air targets, of course, not only range and bearing change constantly (and fast, in comparison with surface targets) but so does

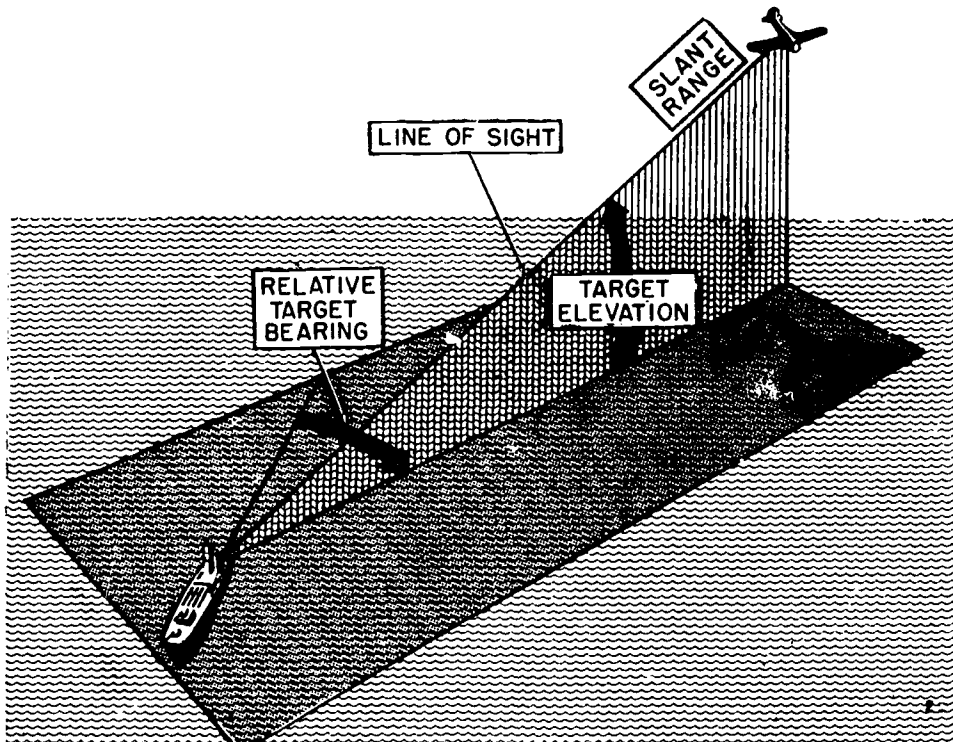

Figure 7-2.—Relative target bearing, range, and target elevation (for an air target).

84.197

elevation. What you have is really a problem in prediction—but it's a problem for a computer rather than a crystal ball. The computer figures out where the target is going to be when the projectile gets to it so that the gun can be aimed accordingly.

The way to do it is to LEAD the target—to aim at a point, ahead of the target and in its path, which the missile and target will reach at the same time. How much lead to give the target—that's the problem.

THE PROJECTILE IN FLIGHT

During flight, a gun projectile is subject to a number of forces which influence its behavior and flight path. Not all are of equal importance. Any fire control system must take into account those that are most important under the circumstances. The most important ones are:

1. Gravity
2. Air resistance
3. Drift
4. Wind

Gravity

Gravity is the most important of these. Its effect is to curve the trajectory.

A projectile in flight is always falling. It has no wings and cannot fly, in the sense of being airborne. Firing it from a gun cannot keep it from falling (fig. 7-3). If you were to fire a projectile at 0° elevation (that is, with the gun perfectly horizontal), and at the same time drop a similar projectile over the side from exactly the same height as the gun, both would fall into the sea at exactly the same instant. Of course, the projectile fired from the gun would be quite some distance away when it hit the water, but it would fall just as fast as the one merely dropped.

Therefore, to keep the projectile in flight until it reaches the target, the gun is tilted or elevated so that it is directed toward a point above the target. If the tilt is correct, the trajectory will pass through the target (fig. 7-4).

The greater the angle of gun elevation the greater the range—up to a point. For there are limits as to how far you can get a projectile to travel this way. Temporarily ignoring air

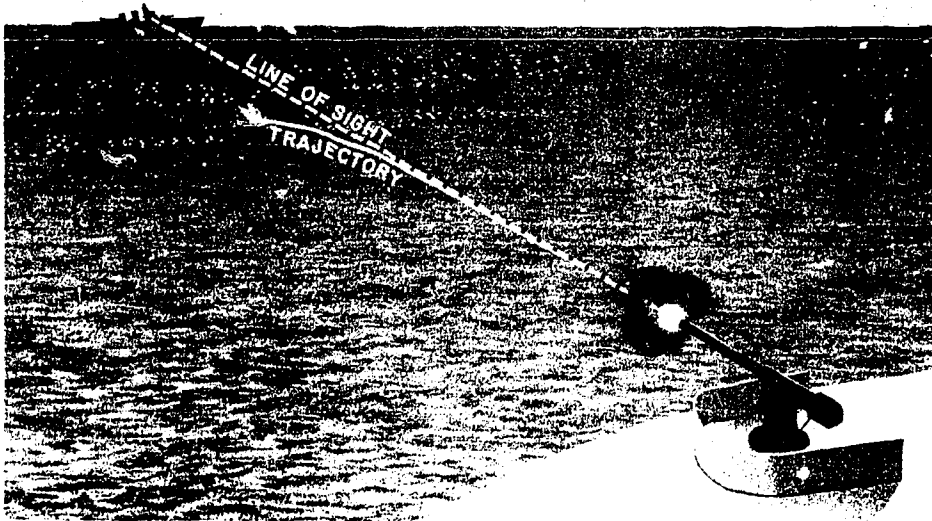

84.198.1

Figure 7-3.—Firing a projectile from a gun cannot keep it from falling.

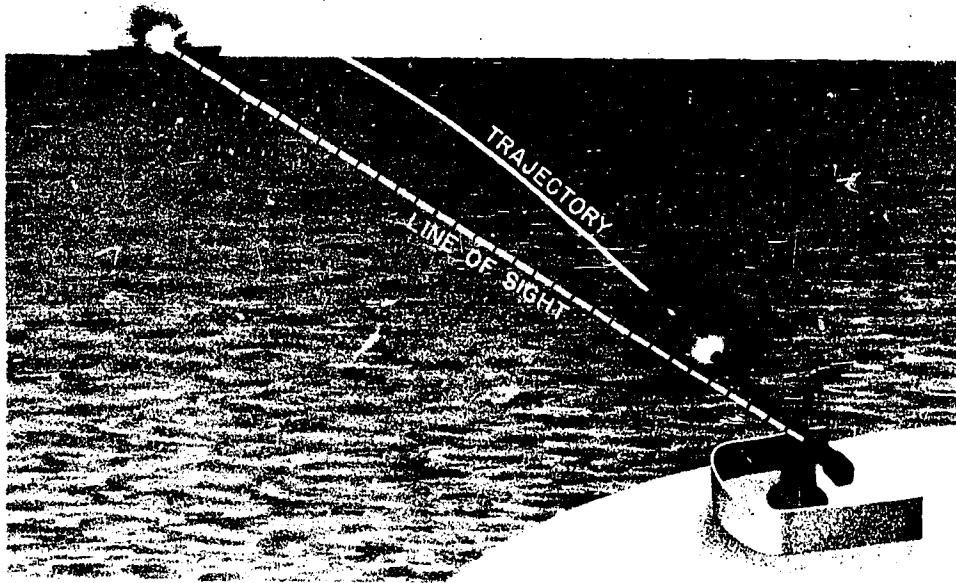

84.198.2

Figure 7-4.—Elevating the gun to increase range.

resistance, you find that range increases with the angle of elevation, up to 45° . After that point, increasing the elevation increases the height reached by the projectile, but decreases the range (fig. 7-5).

Air Resistance

Having dealt with the effect of gravity, you have other factors to take into account. Consider air resistance.

Even today, many people think of the air in our atmosphere as pretty thin stuff. But anything that can support 50-ton aircraft, and cause meteors to heat up to incandescence as they plummet to earth, can't be considered really thin. So it is with projectiles.

The trajectory in vacuum is only theoretical, because it ignores air resistance. But a projectile speeding along at nearly half a mile a second can't ignore air resistance. It doesn't fly through the air; it plows through. Figure 7-6 shows that a disturbance it causes.

The disturbance the projectile makes slows up its flight, keeping it from going as far and as high as it would in a vacuum, and causes it to fall at a steeper angle. Figure 7-7A shows how drastically air resistance shortens the trajectory possible in a vacuum.

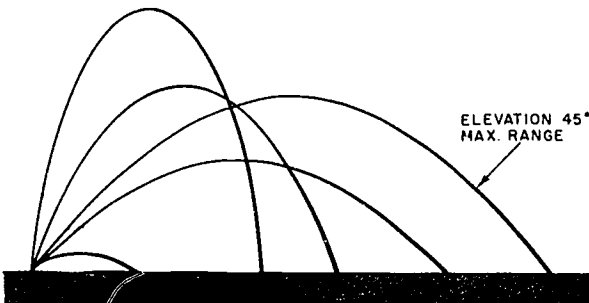

12.3

Figure 7-5.—Theoretical trajectories at various gun elevations (neglecting air resistance).

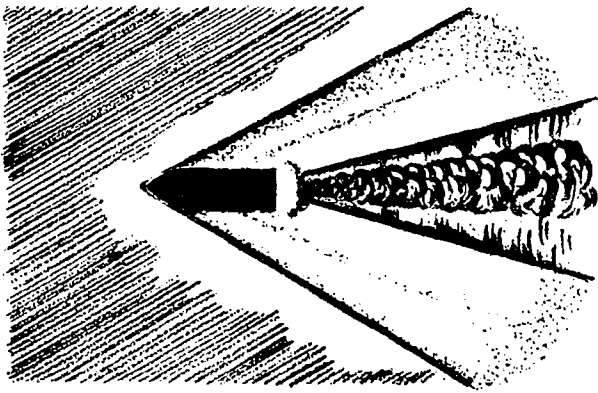

84.199

Figure 7-6.—Portrait of a projectile in flight.

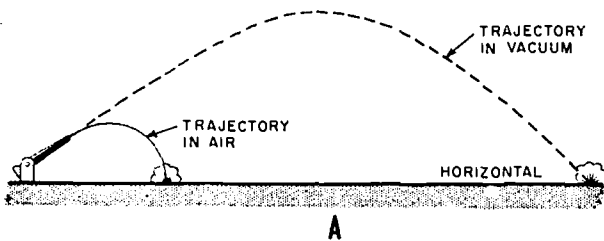

A

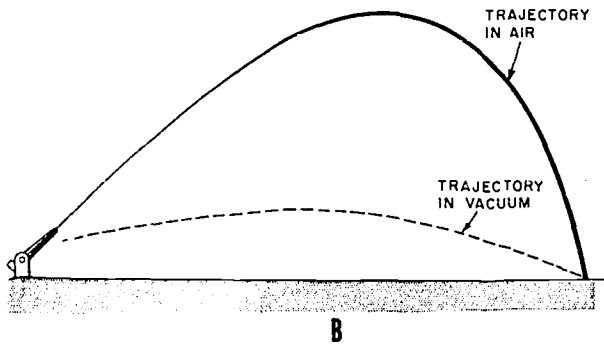

B

12.4.5

Figure 7-7.—Comparison of vacuum and air trajectories. A. In range. B. In gun elevation.

As with the effects of gravity, the way to compensate at least partially for air resistance is to increase range by additional gun elevation. In figure 7-7B, the dotted line shows the trajectory of a projectile in a vacuum. Notice how much additional elevation the gun must have to fire the projectile the same range through air (solid line trajectory).

Air density is not a constant like gravity. It varies with altitude and barometric pressure. The amount of compensation necessary, therefore, depends not only on range, but on how high the projectile will go and on weather conditions at the time of firing.

Wind

In discussing air resistance, it was assumed for simplicity's sake that the air didn't move because the effects of air density on projectile flight exist whether the air is moving or not. But the air does move, and the movement is WIND—the third factor in shaping a projectile's trajectory.

The effect of wind on projectile flight depends on how much wind blows across the line of fire (cross wind), and how much it blows along the line of fire (range wind). The effect of range wind is obvious. It tends either to push the projectile along, or to blow against it and retard it. Similarly, cross wind pushes the projectile either to the right or left, deflecting its path.

Drift

The fourth factor that affects the trajectory of a projectile is drift.

Drift is not a simple effect; it's the product of the interaction of three other factors—namely, the clockwise spin of the projectile, the force of gravity, and air resistance. As the spinning projectile moves through the air, it tends to point slightly above the trajectory, and the air pressure on its underside develops a thrust that tends to tumble the projectile end over end. But like any other rapidly spinning mass, the projectile reacts to a thrust tending to displace its axis of spin by precessing gyroscopically. In this case, the precession movement is a slow turn to the right. The result is that the projectile's course is deflected to the right (fig. 7-8) relatively slowly at first, but more and more as the trajectory lengthens.

The direction of drift depends entirely on the direction of rotation of the projectile. Drift increases with range, but is completely independent of wind.

Because of drift, wind, own-ship and target movements, and so on, you will seldom be able to train your gun directly on the target, except at point-blank range. Just as you must elevate

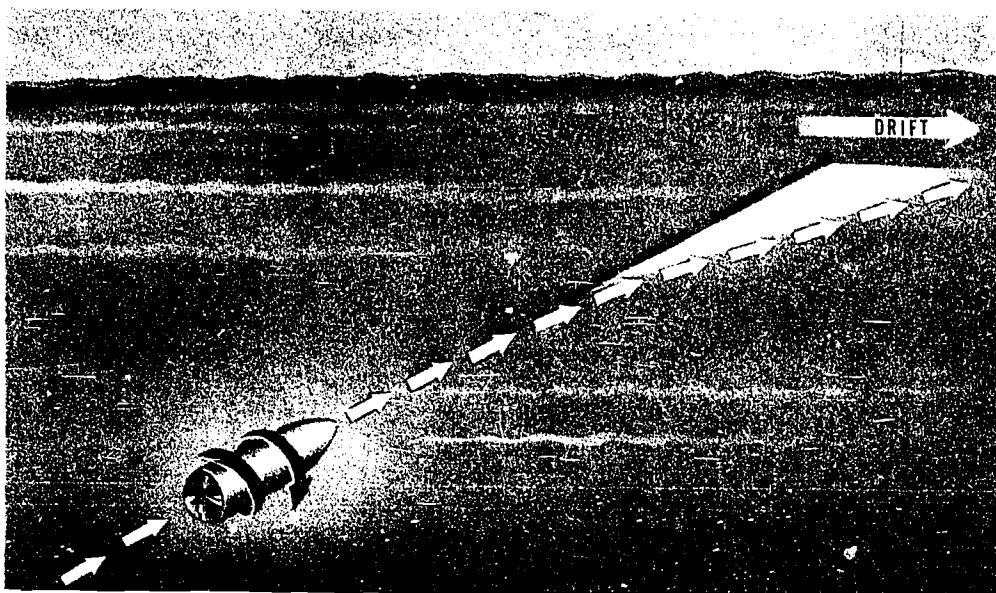

84.200

Figure 7-8.—Clockwise projectile spin causes drift to the right.

your gun to compensate for trajectory curvature in the vertical plane, you must aim your gun laterally off the line of sight to target to compensate for the trajectory curvature these factors cause in the horizontal plane.

APPLYING CORRECTIONS

If projectiles took no time at all to travel from gun to target, and if gravity, air resistance, and the other factors discussed didn't have their ways of distorting the projectile's trajectory from the perfectly straight line that it could theoretically be, fire control wouldn't be much of a problem to the gunner.

However, these factors and their disturbing effects do exist—but so do solutions to the problems they create.

You compensate for the effects of these factors by offsetting the axis of the gun bore from the line of sight, so that the gun axis is at an angle to the line of sight. Or, to be more exact, you measure the offset in terms of two angles, one in the vertical plane, the other in the horizontal.

To determine the values of these two angles, add the angular corrections required to compensate for all the factors discussed. For example, the effects of gravity and air resistance can be compensated for at a given range

by elevating the gun (angular correction in the vertical plane) by an amount that can be calculated. You compensate for drift by deflecting the gun (angular correction in the horizontal plane) again by an amount that can be calculated for a given range. To correct for wind, first find out the direction and velocity of the wind; the correction in terms of gun deflection and elevation can then be calculated. To lead the target by the proper amount, you must know the target's range, bearing, and rate of movement in terms of rate of change of range and bearing; the proper lead in terms of gun elevation, deflection, and rate of change of these can then be worked out.

Add all these, and the sum gives the angles which must be added to those that describe the line of sight (namely, target bearing and target elevation, as illustrated in fig. 7-2) to give the gun position or GUN ORDER that represents correct aim. If the data are correct, and the gun is properly positioned, the projectile is theoretically sure to hit the target.

SIGHT ANGLE AND SUPERRELEVATION

The angle by which a gun is elevated above the line of sight to a surface target so that the projectile's trajectory will pass through the

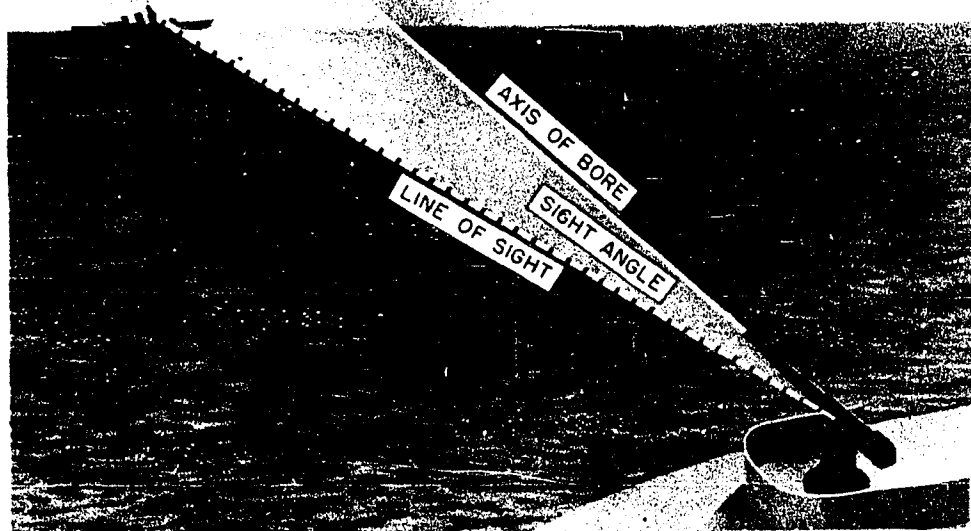

84.198.3

Figure 7-9.—Sight angle.

target is called **SIGHT ANGLE**. (See fig. 7-9). The angle is measured in minutes between the axis of the gun bore and the line of sight. As range increases, so does the amount of sight angle necessary.

With an air target the principle of sight angle still applies. Look at figure 7-10, where you see sight angle in more detail. You can see it is still the angle by which the gun must be elevated above the line of sight to get a hit. Your line of sight itself is elevated here to meet the target. Sight angle is shown to be made up of two smaller angles. One is lead. This corresponds to the target's relative motion during the projectile's time of flight. The other segment is **SUPERELEVATION**. Superelevation is the angle by which the gun must be further elevated to compensate for the projectile's curve downward due to gravity.

Like sight angle, as a whole, superelevation increases with longer ranges. (Refer to fig. 7-11.) But as target elevation increases, superelevation decreases.

SIGHT DEFLECTION

The axis of the gun bore is not only offset from the line of sight vertically, but horizontally as well. This horizontal angle between the line of sight and the gun bore is known as **SIGHT DEFLECTION**. You can see in figure 7-12 that it is made up of three values, two of which you have already studied. You know that because a projectile will drift to the right, the gun must be offset to the left. Wind is another value in sight deflection. Wind blowing across your line of fire calls for another small offset (to the left in the illustration). The third, and major, value in the sight deflection angle is the lead angle. Lead angle is proportional to the relative motion of the target across your line of sight during the projectile's time of flight.

Unlike sight angle, target elevation, superelevation, and target bearing, deflection is measured in mils. A mil is, like a degree or minute, a unit of angular measure. (See fig. 7-13.) It takes a 6400 mils to make a circle

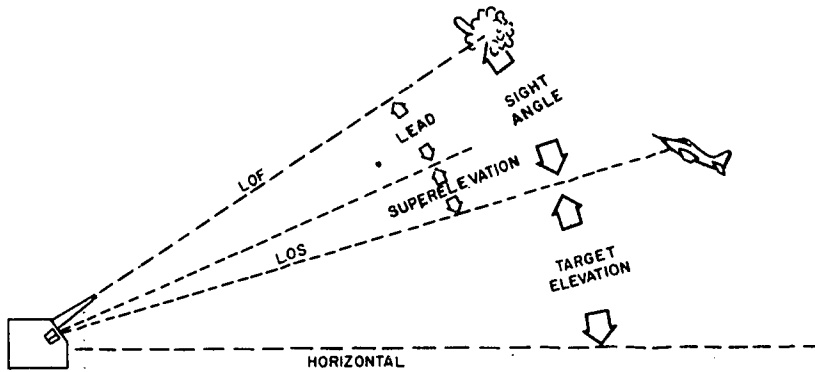

84.201

Figure 7-10.—Target elevation and super-elevation.

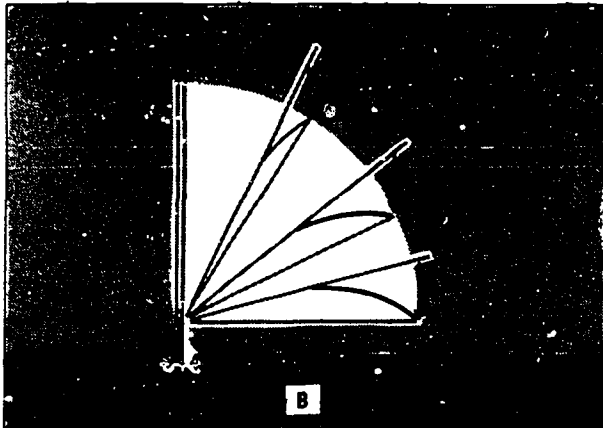
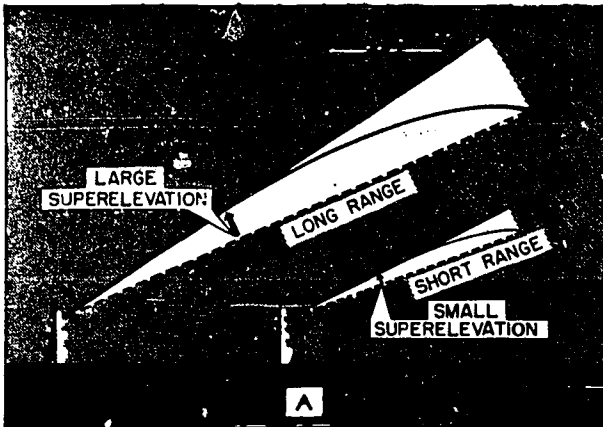

04.404

Figure 7-11.—Effect on super-elevation of
A. Increased range. B. Increased target elevation.

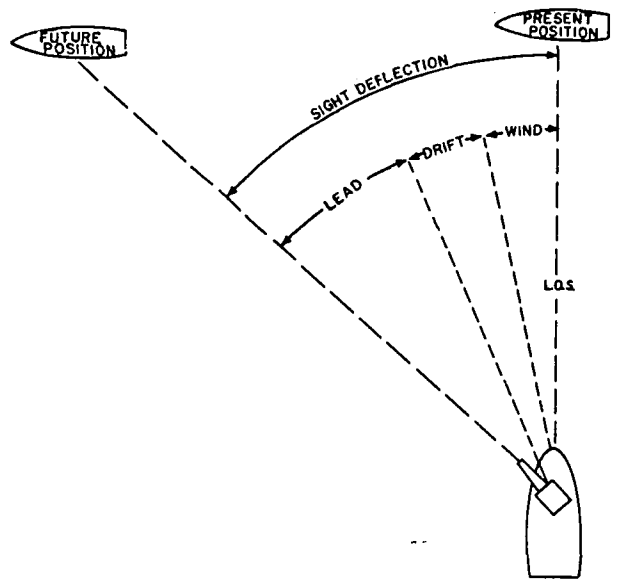

84.203

Figure 7-12.—Sight deflection.

(as compared with 360° to a circle). In U.S. Naval gunnery, the mil is about 3.4 minutes of arc or less than .06°.

INITIAL VELOCITY AND OWN-SHIP FACTORS

So far you've been studying the characteristics of projectile flight and target activity as they effect fire control. But a projectile's

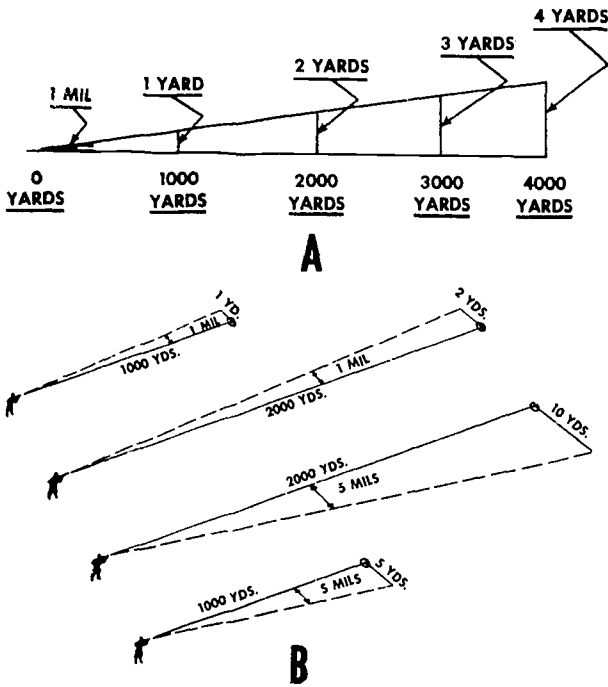

55.145
 Figure 7-13.—The mil. A. What it is.
 B. How to use it.

course depends on its start. Nothing can be done about its behavior once it leaves the muzzle of the gun.

The important things about a projectile's start are how fast it goes (initial velocity) and in what direction.

Initial Velocity

With a given propelling charge, the chief influences on a projectile's initial velocity are:

1. How worn the gun bore is (erosion).
2. Variations in the temperature of the propelling charge of the ammunition.
3. Variations in the actual weight of the projectile.

Own-Ship Factors

The problem of starting the projectile in the right direction is complicated by factors introduced by your own ship. You can calculate accurate corrections for the target and trajectory, and determine just how the gun must be aimed, but the ship itself introduces three important factors that make aiming difficult:

1. Own-ship course and speed affect target motion with respect to the ship. Example: your ship is steaming westward at 10 knots past a stationary target. The effect, so far as fire control goes, is the same as if the target were moving eastward at 10 knots.

2. As the ship rolls from side to side and pitches fore and aft, the gun mount, tilts, causing errors in elevation and train.

3. The circular steel roller paths on which turrets and gun mounts revolve are not exactly parallel to each other or to the plane of the deck.

WEAPON SYSTEMS

The first steps in the functioning of a weapon system are the detection, location, and identification of the target. Ideally, the device performing these functions should detect the target at maximum range, and establish the target's location, orientation, and velocity with respect to own ship, with maximum accuracy and minimum delay. At the same time this device should identify the target both as to exactly what it is and whether it is enemy or friendly. And, ideally, the device performing these functions should be equally efficient regardless of which medium it operates in, regardless of the conditions in that medium, and regardless of interference originating with the enemy, with friendly forces, or with natural causes.

No detecting (for the present let this term include locating and identifying) device or system yet developed measures up without possibility of improvement to any of these ideals. The ideals are useful chiefly as standards by which the effectiveness of detecting devices can be judged. The principal detecting devices now used in the fleet include

- optical devices
- radar
- ECM (electronic countermeasures)
- sonar
- MAD (magnetic airborne detection)

All except the last of these depend on detection of radiation—the first three on electromagnetic radiation, the fourth on sound radiation. MAD depends on detecting differences in magnetic fields.

ECM equipment falls into the passive category when used for detection. But ECM gear also has an active mode for use in jamming the

enemy's electronic detection equipment. Sonar may be either passive or active when detecting subsurface targets. Its active device produces radiation which it detects as a reflection from the target. Radar can only be active.

Optical devices in weapon systems always function to establish target bearing and (for air targets) target elevation. Some optical devices can measure the range to the target. Except for highly unusual atmospheric conditions, in which light rays reflected from the target to your ship are perceptibly bent by refraction, the line of sight is truly straight. Optical devices which incorporate lens systems are designed to magnify the image of the target; this extends the capabilities of the human eye in target detection and identification.

Since optical devices depend on visible light reflected from the target, they are handicapped by darkness (unless the target is luminous), fog, and visible obstacles. Optical devices are always passive since they never provide the light that makes the target visible. An attacking ship, however, can illuminate a target by firing gun projectiles which release parachute-supported flares in the vicinity of the target, or by using aircraft to drop such flares.

At the present time, no optical gunsights for shipboard use depend on light radiation invisible to the unaided eye (such as infrared light), although land forces have such devices for use at close range.

Radar shares many of the characteristics of optical detecting devices. Except for certain atmospheric conditions which to a minor extent distort the paths of the transmitted and reflected pulses, they travel in straight lines. It is quite accurate (to within a degree) in measuring target bearing and elevation, though not quite as accurate as optical devices. It is not severely affected by adverse weather and fog, is just as usable at night as in the daytime.

But radar has disadvantages too. It can be jammed or interfered with by enemy radar transmissions and other countermeasures. It does not permit easy identification by target silhouette or other visible characteristics; it shows only a blip for a target, and may show but one blip for several targets. Compared with optical methods, it requires skills in interpretation of its displays amounting almost to an art. Lastly, radar pulses can be detected by the enemy at much greater ranges than those at which the pulses will reveal to the originating

ship the enemy's presence. In spite of these disadvantages, radar is the primary means of detection used in the fleet today.

Under normal conditions, target location (elevation, bearing, and range) is determined by a remotely located station. The fire-control problem itself is solved elsewhere, and the gun is positioned in elevation and train by power-driven units under the control of signals transmitted from the point where the fire control problem is solved.

Well, then, why have sights in gun mounts?

There are two main reasons. One is that the gun mount may not always be controlled in the manner described above, because of real or simulated casualty. Another is that watching the target through the sights permits a check on the accuracy and performance of the remote-control system.

All gunmounted tilting-prism gunsight telescopes have integral systems which provide for sight angles and sight deflection as discussed in the fire control problem. The systems use two prisms or a mirror/prism combination to direct the line of sight from the target onto the reticle.

The sight angle (fig. 7-14) may be either mechanically or electrically generated and is produced by the elevation element (mirror/prism). The sight deflection (fig. 7-15) may also be generated mechanically or electrically and is produced by the deflection prism.

MARK 61 AND MK 62 TILTING-PRISM GUNSIGHT TELESCOPES

The tilting-prism gunsight telescopes, Mk 61 and Mk 62, are mounted on single 5"/38 caliber gunmounts and are used for checking when the gun is fired remotely and as sights when the gun is fired locally. Figure 7-16 shows the Mk 62 mounted at the trainer's position on the right side of the mount and figure 7-17 shows the Mk 61 mounted at the pointer's and checker's position on the left side of the mount.

The telescopes Mk 61 (fig. 7-18) and Mk 62 are similar. The major difference between the two telescopes is that the Mk 61 has two optical systems (pointer's and checker's) while the Mk 62 has only one. The telescopes are mirror images of each other. The Mk 61 is "left-handed"; the Mk 62 is "right-handed." The Mk 61 contains more components, therefore it will be used for discussion purposes.

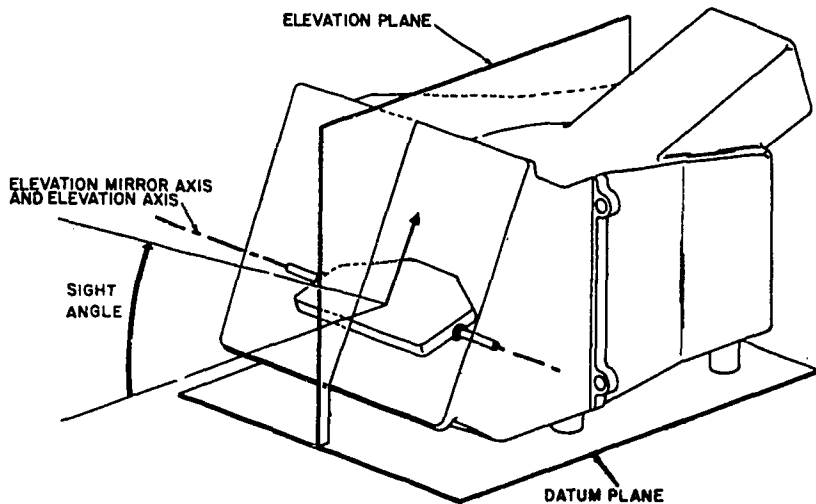

148.300
Figure 7-14.—Application of elevation order in elevation plane.

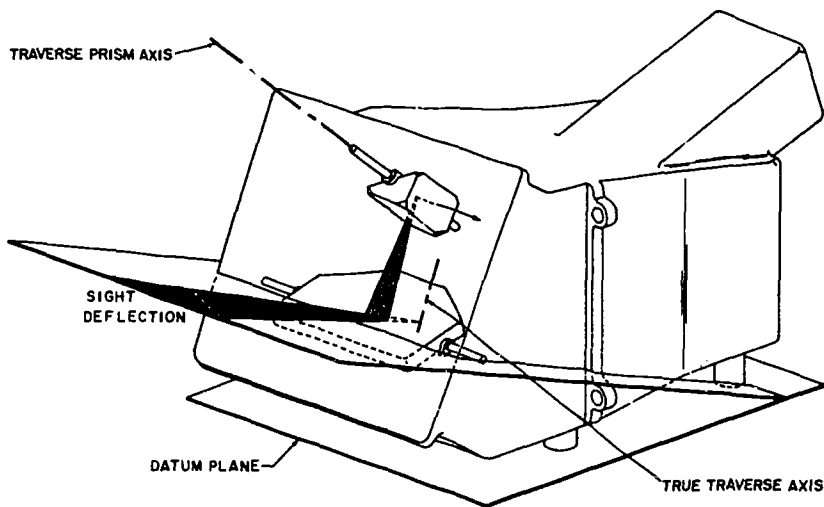

148.301
Figure 7-15.—Application of sight deflection in traverse plane.

OPTICAL SYSTEM

The optical system for the pointer, checker, and trainer are identical except for the deflection prism on the checker's telescope. Figure 7-19 illustrates the optical system of the Mk 61.

Characteristics of the optical systems are:

Line of Sight, limit of travel
Elevation = +85°
Depression = -15°

Deflection - 12° (either side of center-line)
Magnification - 6X
Field - 8°30'
Exit Pupil - .20 inches
Eye Distance
Mk 61 and 62 Mod 0 - 1.24 inches
All others - 1.40 inches.

The optical system consists of a doublet objective lens, a plano-parallel reticle (etched

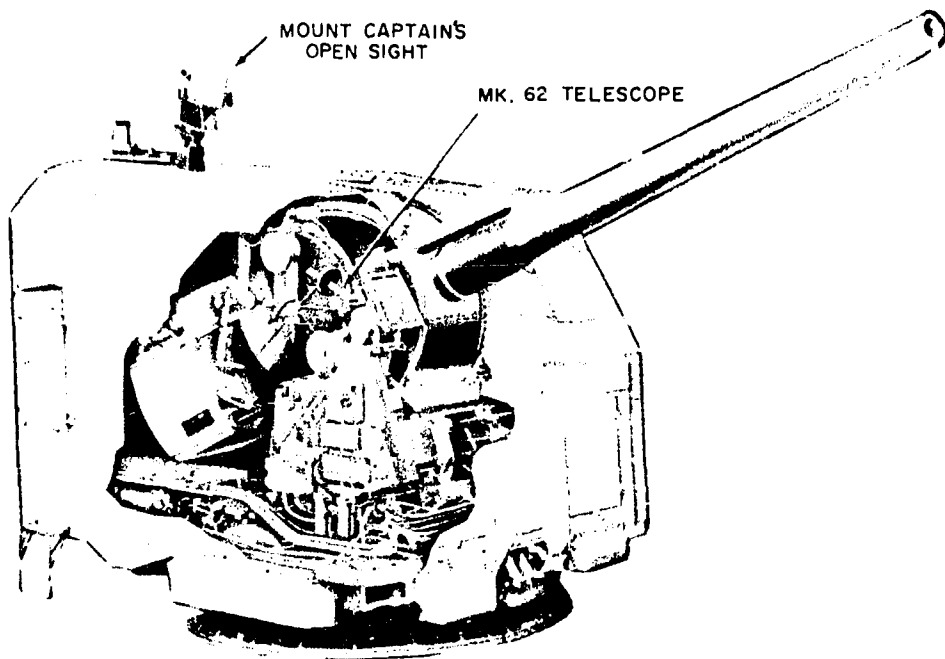

Figure 7-16.—5"/38 Single gunmount (right side). 148.302

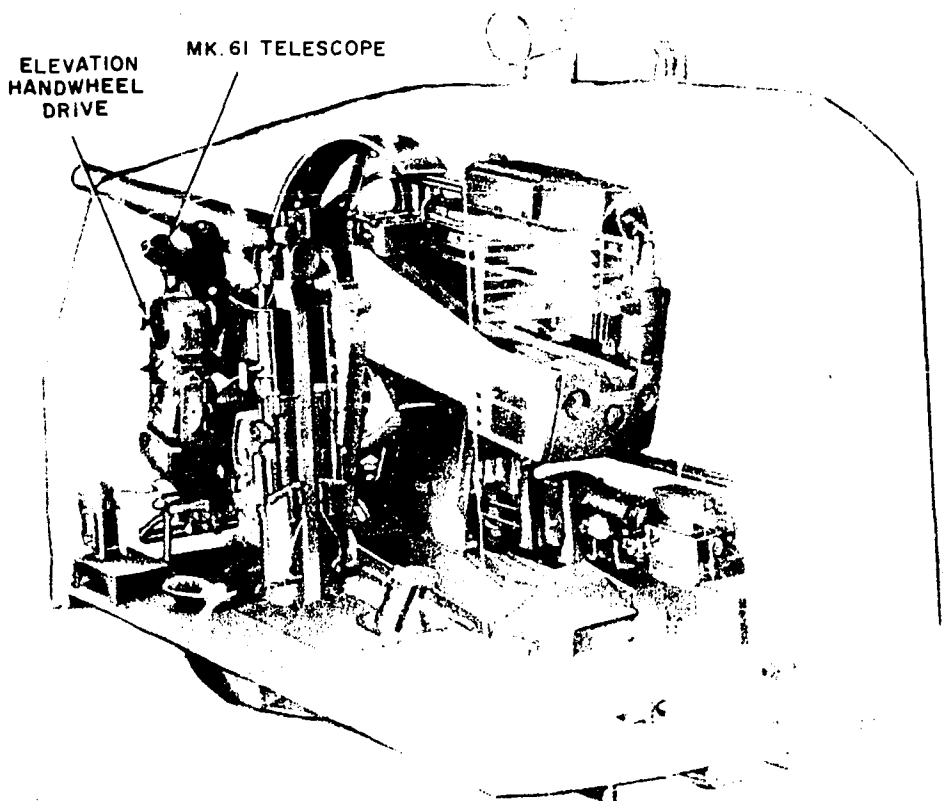
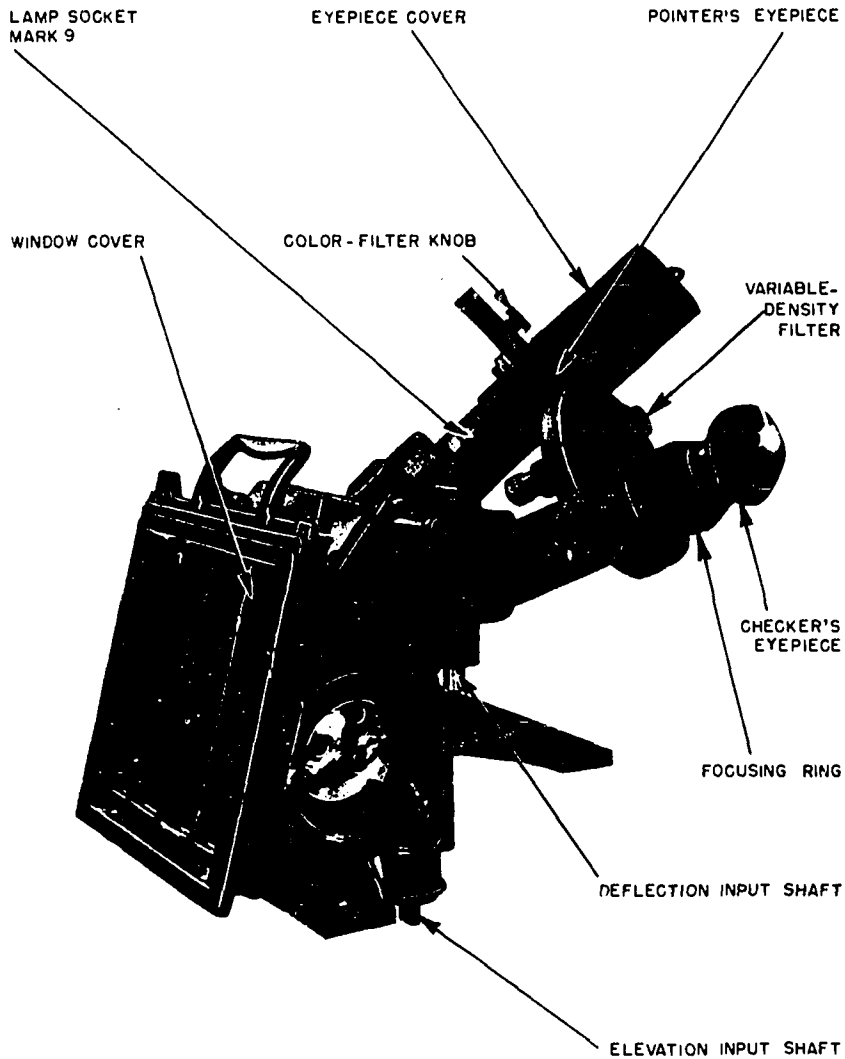

Figure 7-17.—5"/38 Single gunmount (left side).

148.303



148.304

Figure 7-18.—Telescopes, Mark 61 Mods 0, 2, 3, 4; Marks 80 and 84 left front view.

surface facing the objective), a filter, and a two-doublet eyepiece. The elevation and deflection prisms also serve as part of the erecting system for this telescope. Telescopes Mk 61 and Mk 62 have red, yellow, clear, light-neutral, and dark-neutral color filters while all other marks and mods of this type have yellow, red, clear, and variable-density (polaroid) filters.

SIMILAR MARK VARIATIONS

A number of telescopes were manufactured which were similar to the Mk 61 and Mk 62 with the following exceptions.

MK 80.—Similar to the Mk 61 except the elevation system allowed for 100° elevation of the line of sight.

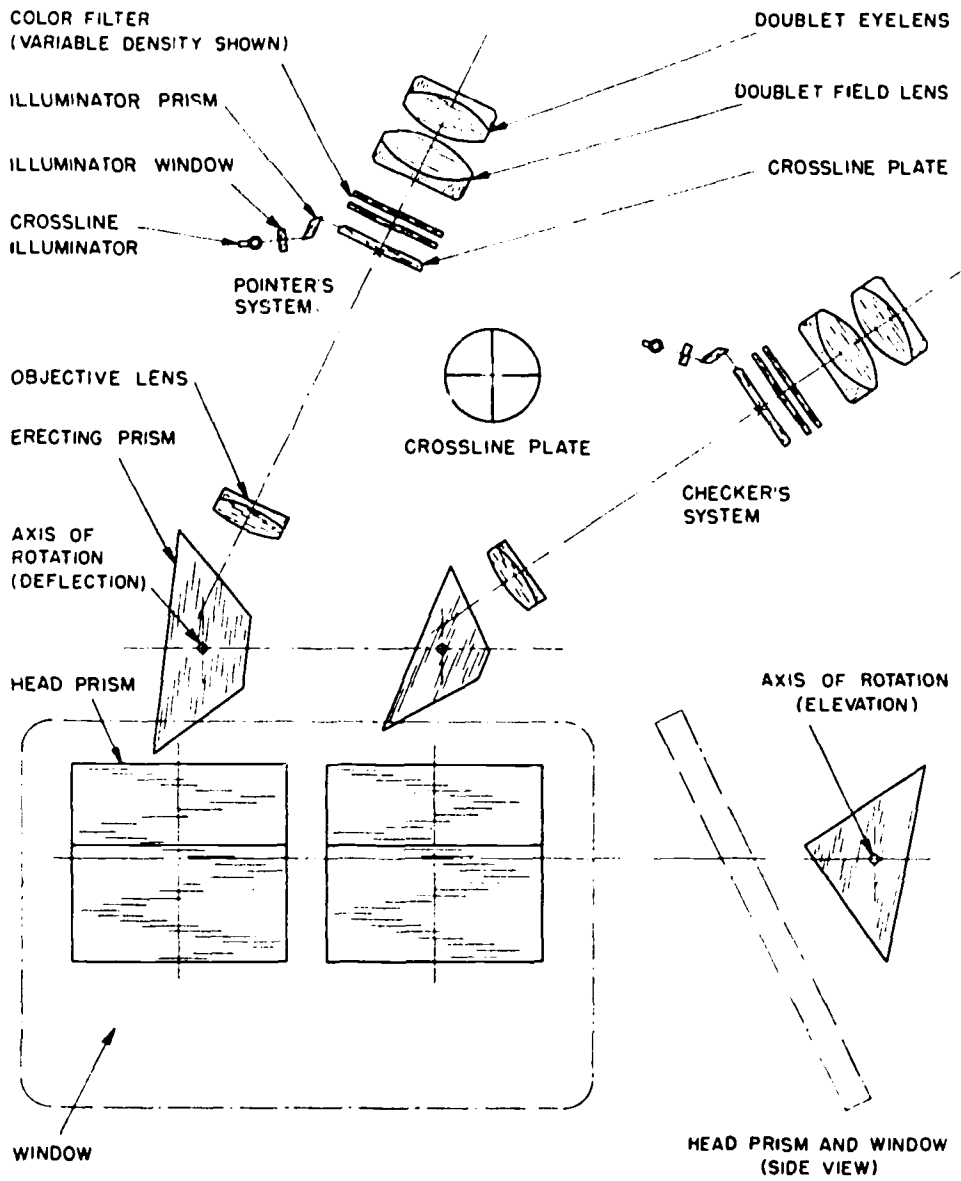

148.305

Figure 7-19.—Telescopes, Mark 61 Mod 2 and Marks 80 and 84 optical diagram.

MK 81.—Similar to the Mk 62 except the elevation system allowed for 100° elevation of the line of sight.

MK 83.—Similar to the Mk 61 except the checkers optical system was not installed.

MK 84.—Similar to the Mk 61 except the deflection system allows 22° deflection of the line of sight to either side of the centerline.

MK 85.—Similar to the Mk 62 except the deflection system allows 22° deflection of the line to either side of the centerline.

CONTROLS

The telescope operator has control of the focus and filter adjustments of the gunsight. With the two knobs located on the filter mount

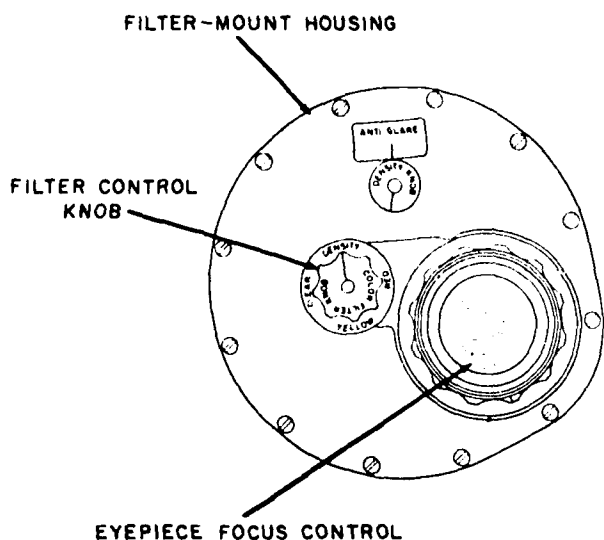

148.306

Figure 7-20.—Top view of filter housing.

housing (fig. 7-20), he controls the type of filter in the line of sight and the density of the polarizing plates when they are in the line of sight. The focus control is of the type common to most early telescopes.

MK 67 AND MK 68

The telescopes, Marks 67 and 68, are mounted on 5"/38 caliber twin gunmounts (fig. 7-21). The 67 and 68 are similar telescopes and are mirror images of each other, the Mk 67 being "left-handed" and the Mk 68 "right-handed." Two Mk 67 telescopes on the left side of the mount are used by the pointer and checker (fig. 7-22) while a single Mk 68 is used at the right of the mount by the trainer. Cross-connected mechanical linkage provides elevation and deflection inputs to the three sights.

OPTICAL SYSTEM

As the telescopes Mk 67 and Mk 68 are similar, only the Mk 67 will be used for discussion purposes. Where notable differences occur, they will be mentioned.

The optical systems of the Mk 67 and Mk 68 are identical. They have the following characteristics:

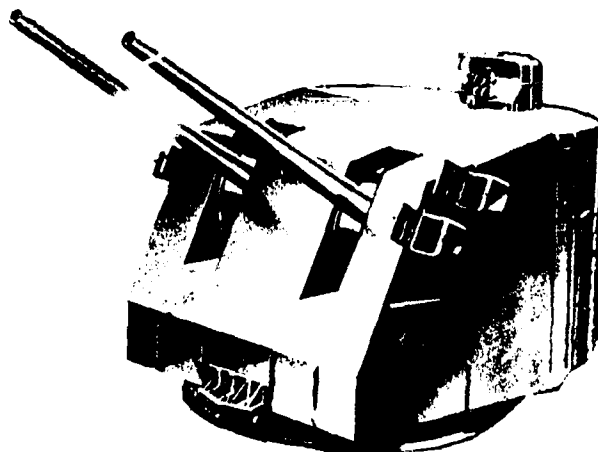

3.121(148A)

Figure 7-21.—5"/38 Twin gunmount.

Magnification - 6X
 True Field - 7°30'
 Exit Pupil - .20"
 Eye Distance - 1.30"
 Limits of Travel of Line of Sight
 Elevation - +85°
 Depression - -15°
 Deflection - ±20°

The optical system (fig. 7-23) is basically a terrestrial telescope with prisms to direct the line of sight. Three erecting systems are used to present an erect and normal image to the eye. The elevation and deflection prisms present an inverted and reverted image which is inclined at an angle of 35° to the perpendicular. The erecting lenses revert and invert the image again. The roof prism presents a normal and erect image to the eyepiece which is inclined at an angle of 35° from the horizontal.

Located between the erector lenses are a red filter, a yellow filter, and a variable-density (polaroid) filter. There is no clear glass plate because the light path is parallel to the erector lenses. The eyepiece is a two-doublet type.

MK 97 MOD 1

The telescopes discussed thus far in this chapter are gunmounted. The Mk 97 is a director-mounted telescope. The director and telescope form an integral part of the Gunfire

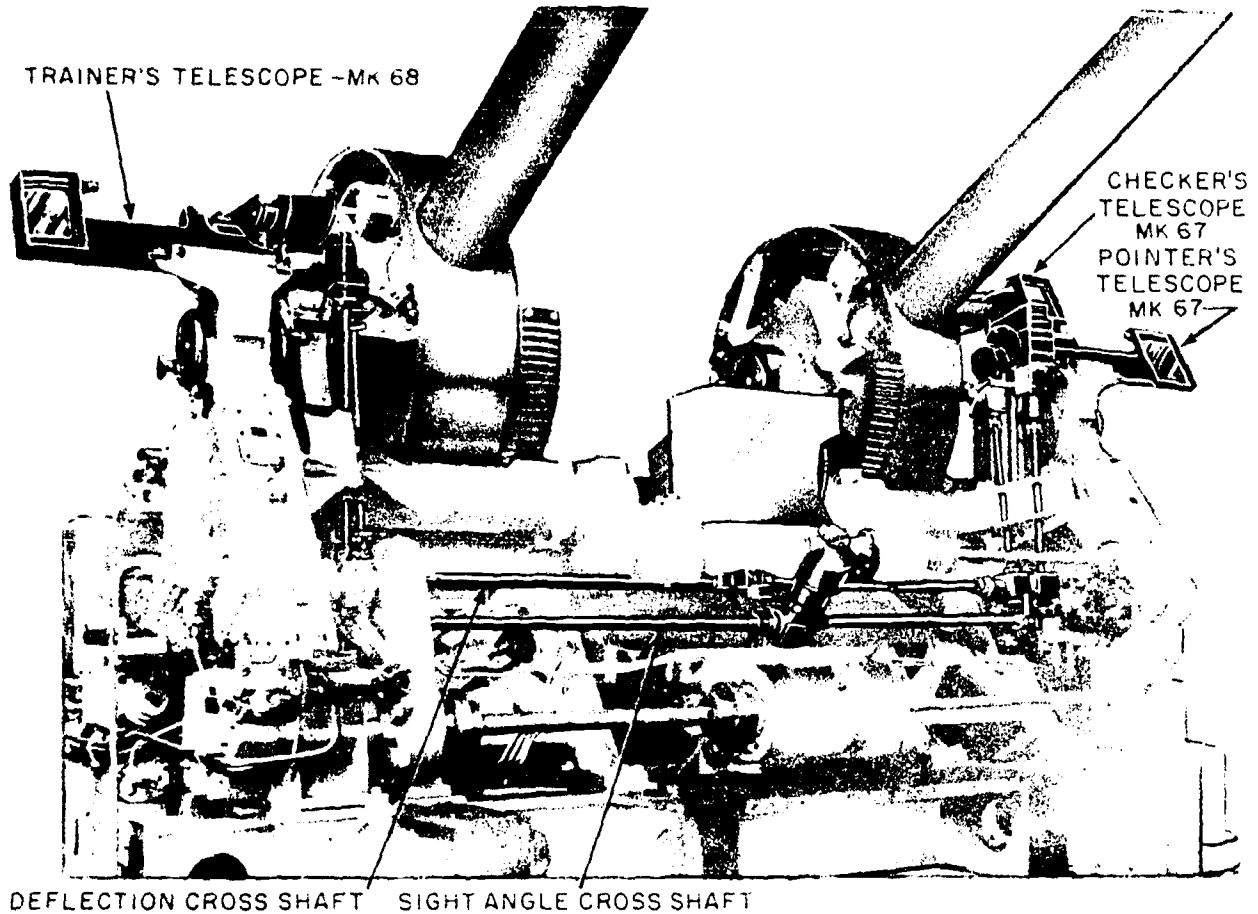

84.209

Figure 7-22.—Arrangement of telescopes.

Control System Mk 56, an intermediate range anti-aircraft system. Designed for use against high-speed subsonic aircraft targets, it provides gun train, gun elevation, and fuze orders for 3", 5", and 6" guns. It is also used against surface targets.

The Mk 56 Director (fig. 7-24) can track targets as the operator follows them with a telescope; it can also track a target automatically, once locked on, by radar. The system measures range by radar.

The Mk 97 Mod 1 telescope (fig. 7-25) is used to acquire and track air and surface targets in the optical mode.

CONTROLS

The gunsight operator has control of focus, filters, interocular distance, illumination, and

headrest position. Location of these controls is illustrated in figure 7-25.

The focus controls are on each eyepiece and allow the operator to adjust the eyepiece to his setting.

The filter control knob serves to vary the density of the polaroid filters and to shift the filters into and out of the line of sight. When the filters are shifted out of the line of sight, compensator plates are shifted into the line of sight.

The interocular control knob varies the distance between the eyepiece, allowing the operator to adjust the eyepieces to his interpupillary distance. Only the left eyepiece moves when this adjustment is made. A scale on the faceplate indicates the interocular setting of the eyepieces.

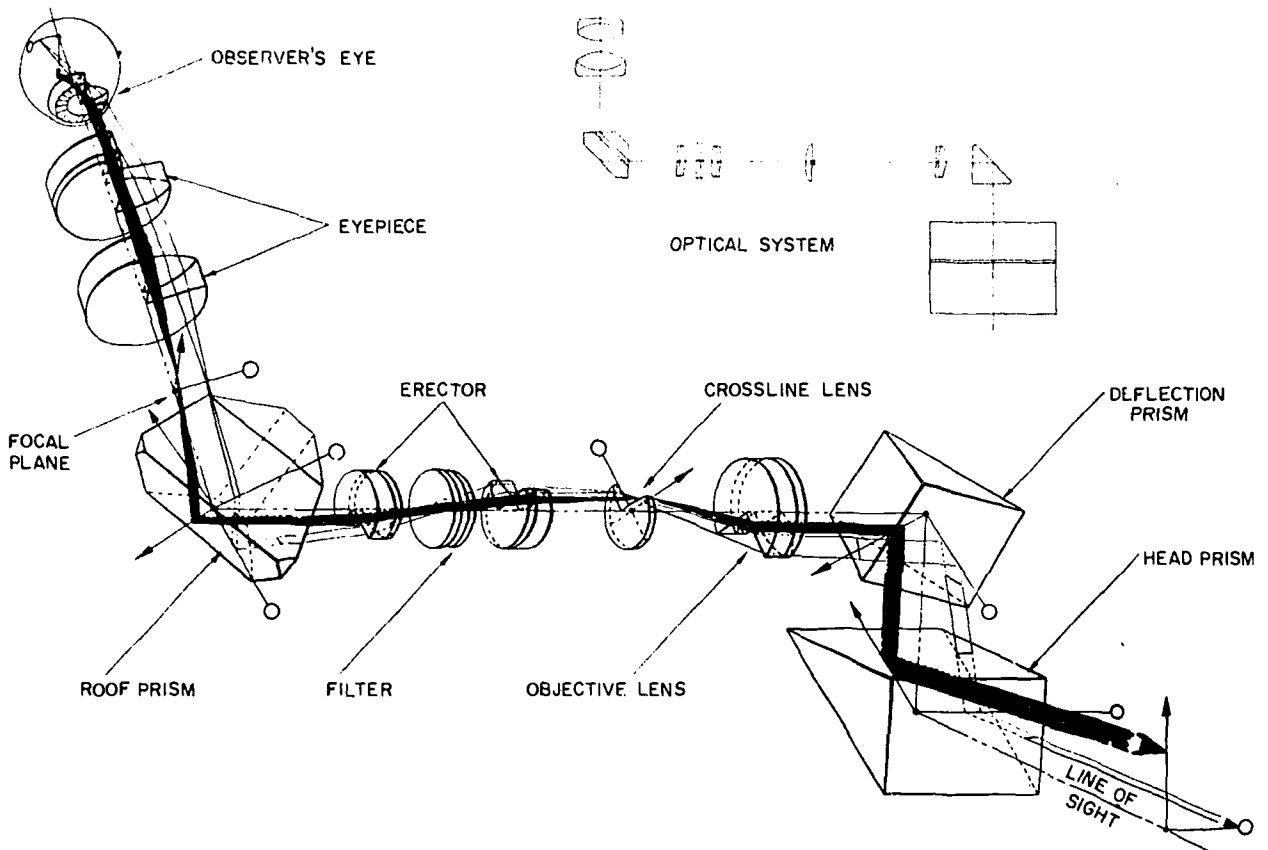

148.138

Figure 7-23.—Optical system, telescope Mark 67.

The reticle illumination control is located on a separate panel beneath the faceplate and serves to energize or deenergize and vary the reticle illumination.

The headrest control knob is used to vary the distance of the headrest from the faceplate, which allows the operator to adjust for facial configurations.

OPTICAL SYSTEM

The telescope, Mk 97 Mod 1, is a binocular system having a single movable mirror to provide elevation and depression of the line of sight (the sight angle). Sight deflection is provided by turning the director.

The following characteristics apply to the optical systems of the Mk 97:

- Magnification - 8X
- True Field - 9°

- Exit Pupil - 6.5mm
- Eye Distance - 25mm
- Limit of Travel of Line of Sight
 - Elevation - +95°
 - Depression - -25°
- Diameter of reticle circles
 - Inner - 3 mils
 - Outer - 15 mils
- Limits of interocular adjustment
 - 60 - 72mm
- Distance between objective centers
 - 80.6mm

The optical system (fig. 7-26) has a unique erection system. The mirror provides inversion of the image before it enters the refractive boundaries while the roof prism reverts the image after it passes through the objective lens.

The two optical systems are identical except for the reticle that is included in the right system of the binocular.

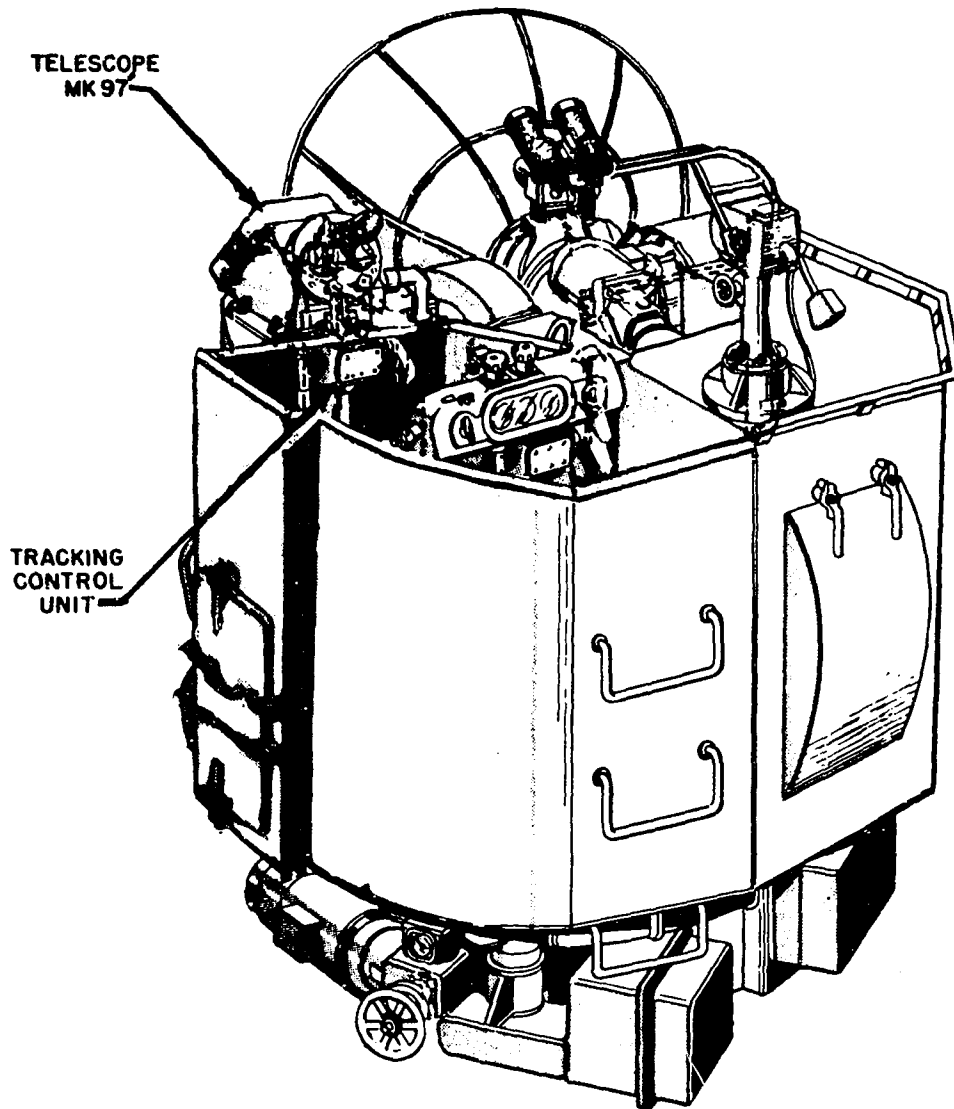

Figure 7-24.—Gun director Mk 56.

92.28

Interocular adjustment is provided by rotating the left rhomboid prism about an axis normal (perpendicular) to its entrant face, allowing for interpupillary adjustments between 60 and 72 millimeters.

The eyepieces are three-element (triplet field lens, doublet intermediate lens, and single eyelens) internal-focusing types that are individually adjustable between +1 and -3 diopters.

Both systems containing a variable-density polarizing filter and a clear glass compensator.

MK 102 TILTING-PRISM GUNSIGHT TELESCOPE

The Mark 102 tilting prism gunsight telescope is used on 5"/54 gunmounts Mark 42 Mods 1 through 8 (fig. 7-27). There is one Mk 102 telescope on each side of the mount in the One Man Control Stations (OMC). Although the gun is normally operated by remote control with the gun fire control system, it is often necessary to control the gun movement locally. Figure 7-28 shows the arrangement of the OMC

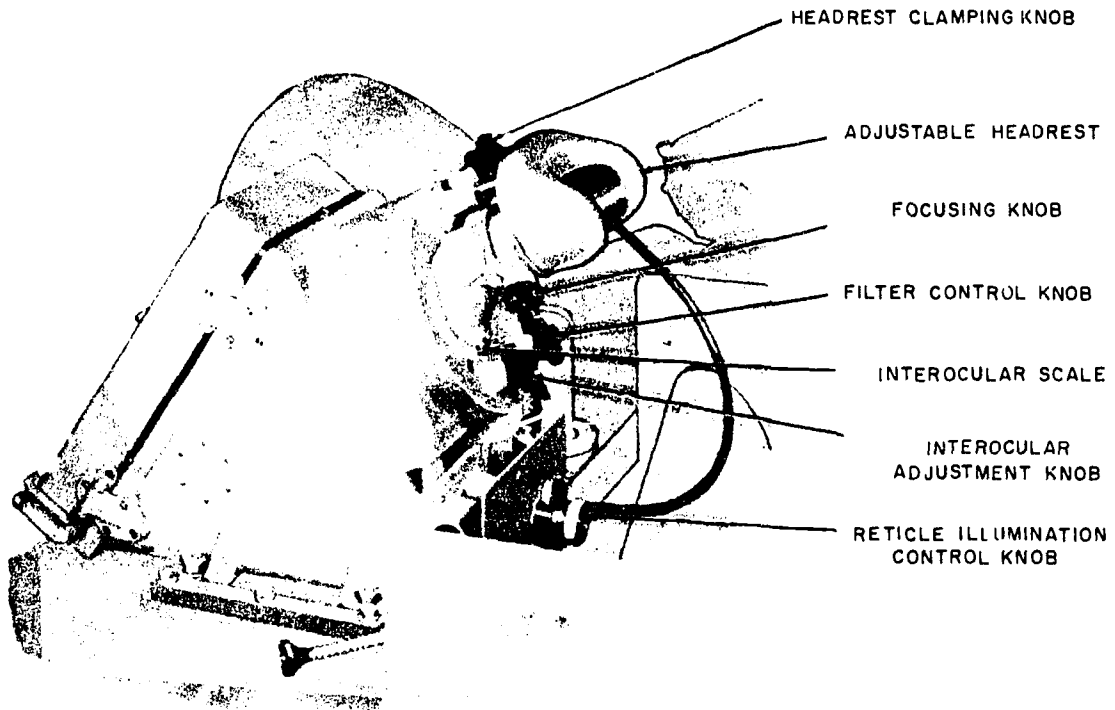

Figure 7-25.—Telescope Mk 97 Mod 1 mounted on director.

148.307

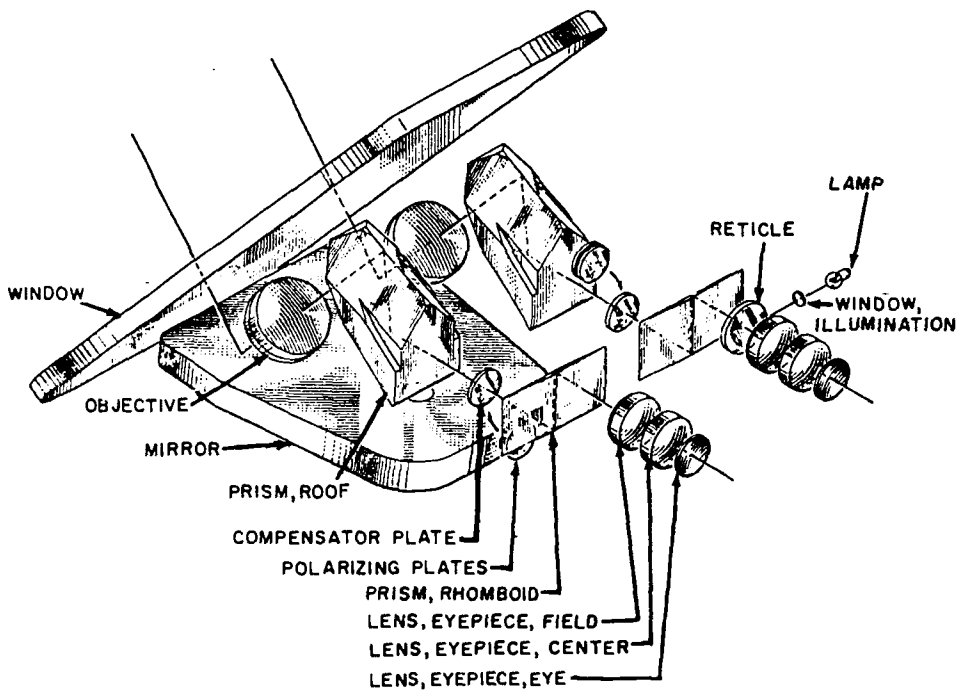

Figure 7-26.—Mk 97 optical system.

148.308

and location of the Mk 102 telescope. The telescopes used at the right and left local control stations are identical.

MODIFICATION DIFFERENCES

The telescopes Mk 102 Mod 2 and 4 (fig. 7-29) are essentially the same except for certain sealing features at the rear cover plate and servo access plates. The illumination window and its retainer are slightly different in the Mod 2 and Mod 4.

The telescope Mk 102 Mod 3 (fig. 7-29) is interchangeable with the Mods 2 and 4 but has numerous design differences.

Comparison of the dissimilar Mods in figure 7-29 reveals differences in the housing and

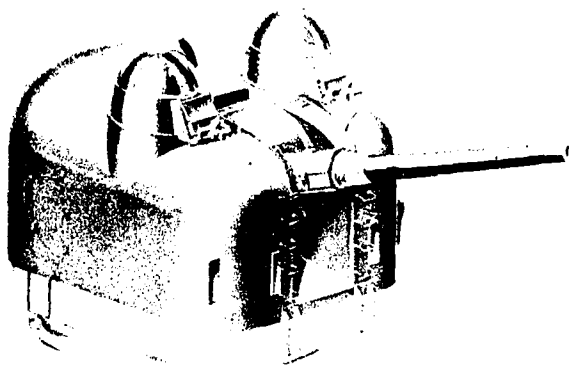

3.123

Figure 7-27.—5"/54 Mount Mk 42.

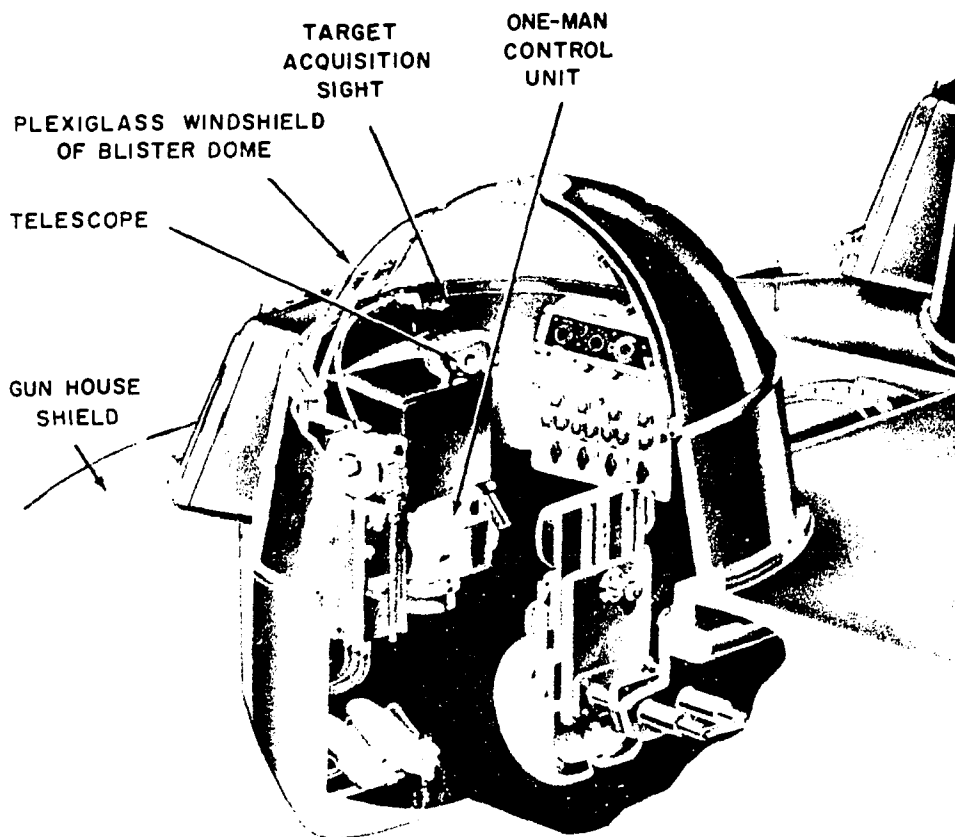

53.230

Figure 7-28.—Left local control station, general arrangement.

	Mod 2	Mod 3	Mod 4
Height	18.8 in.	18.3 in.	18.8 in.
Width	20.5 in.	20.5 in.	20.5 in.
Length	27.5 in.	27.1 in.	27.5 in.
Weight	268.0 lb	300.0 lb	274.0 lb

CONTROLS

The telescope operator has control of four adjustments: focus, filter, reticle illumination, and headrest position. The controls on Mods 2, 3, and 4 function identically but are not located exactly alike. Mods 2 and 4 are similar and will be used for discussion purposes.

FOCUS CONTROL KNOB.—Located on the right side of the telescope case (fig. 7-30), the focus control knob enables the operator to adjust the eyepiece to meet his visual requirements. The knob is graduated to indicate from -3 to +1 diopters and the index is on the case alongside the knob.

FILTER CONTROL KNOB.—Located on the right side of the case (fig. 7-30), the filter control knob enables the operator to select either the variable-density filter or the clear glass plate and to vary the density of the polarizing filter. The knob is engraved to indicate clear and variable-density operating areas.

RETICLE ILLUMINATION CONTROL KNOB.—Located on the left side of the case (fig. 7-31) on Mods 2 and 4, the reticle illumination control knob enables the operator to control the level of reticle illumination or switch it off. The position of the knob is indicated by a plate mounted on the side of the case.

OPTICAL SYSTEM

The optical system of the Mod 2 and Mod 4 are identical but the Mod 3 is not. The following characteristics apply to the Mk 102 telescope:

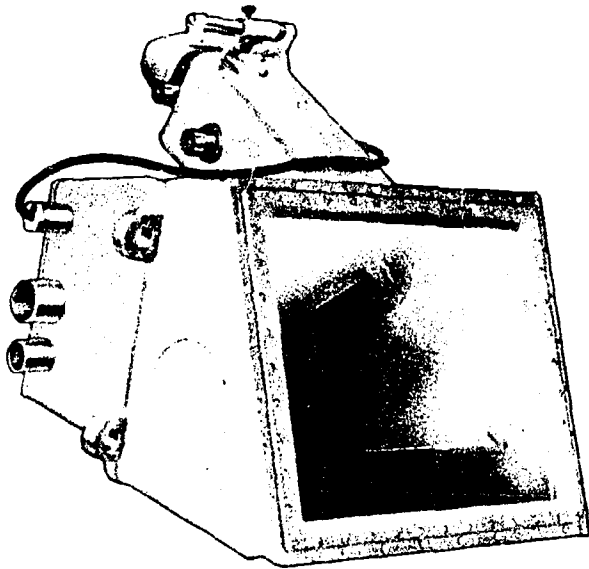

TELESCOPE MK 102 MOD 2 & 4

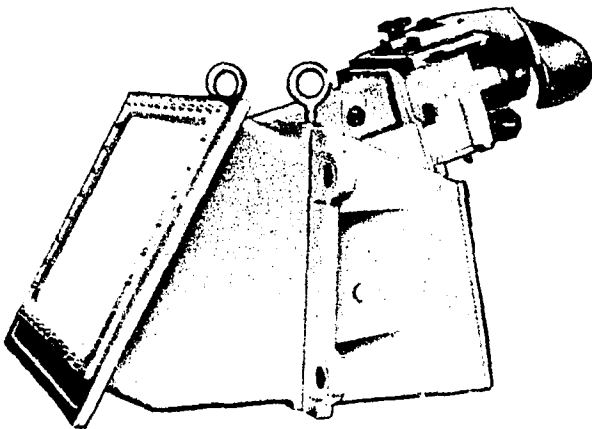

TELESCOPE MK 102 MOD 3

148.309

Figure 7-29.—Telescope Mk 102
Mods 2, 3, and 4.

optical chamber while the dimensions and mounting surfaces are similar. Major differences appear in the optical systems. The servo-drive units differ in detail but their functions are almost identical.

Dimensions and weights of the various mods are as follows:

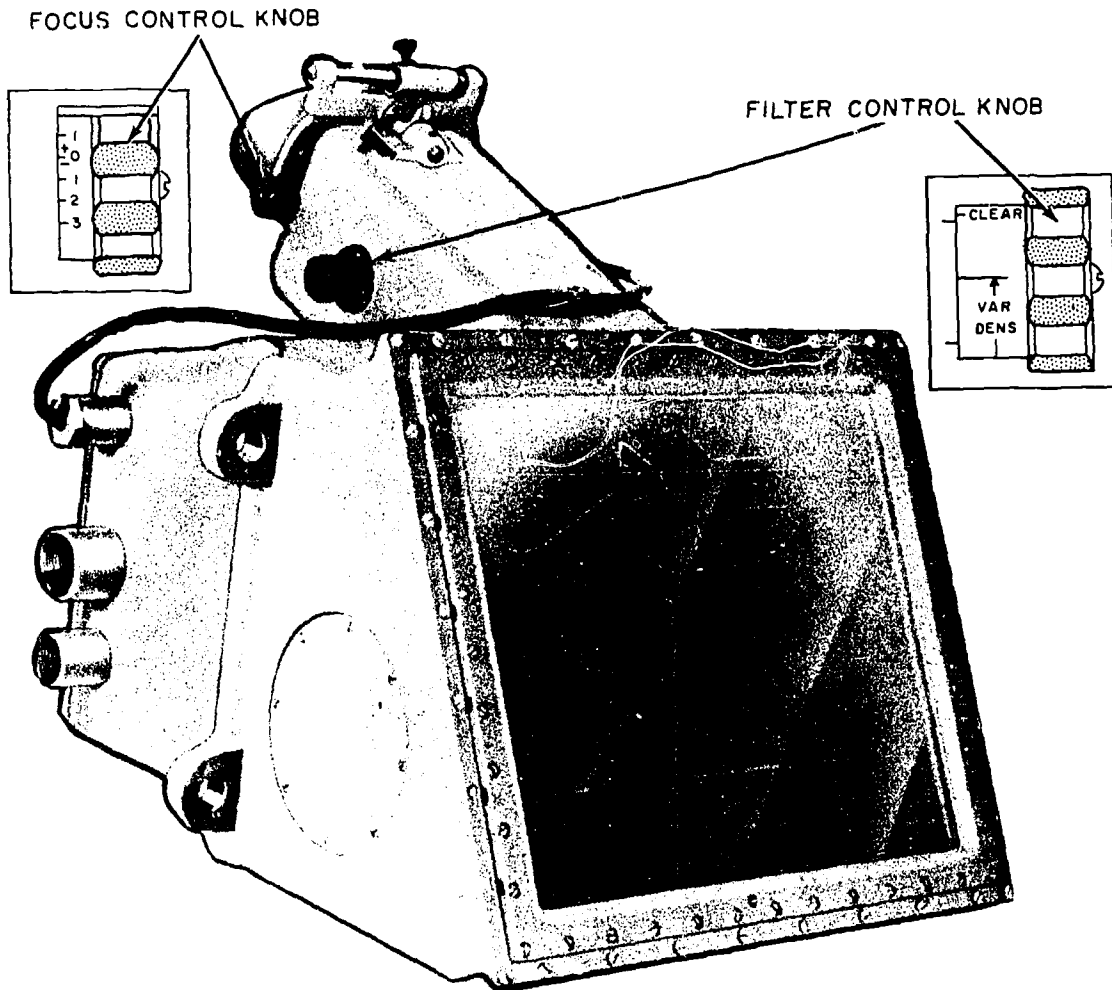

Figure 7-30.—Telescope Mk 192 Mods 2 and 4 controls; front view. 148.310

	Mod 2 and 4	Mod 3		Mod 2 and 4	Mod 3
Magnification	8X	8X	Diameter of Reticle Circles		
True Field	8°	9°	Inner	3 mils	3 mils
Exit Pupil	6.5mm	6.5mm	Outer	15 mils	15 mils
Eye Distance	25-27mm	30mm	Thickness of Reticle Lines	1.5	1.5
Limits of Travel of Line of Sight			Minutes on Apparent Field		
Elevation	+85°	+85°	Range of Focus	-3 to +1	-3 to +1
Depression	-20°	-20°	Diopters	Diopters	Diopters
Deflection	30°	30°			
	To either side of centerline				

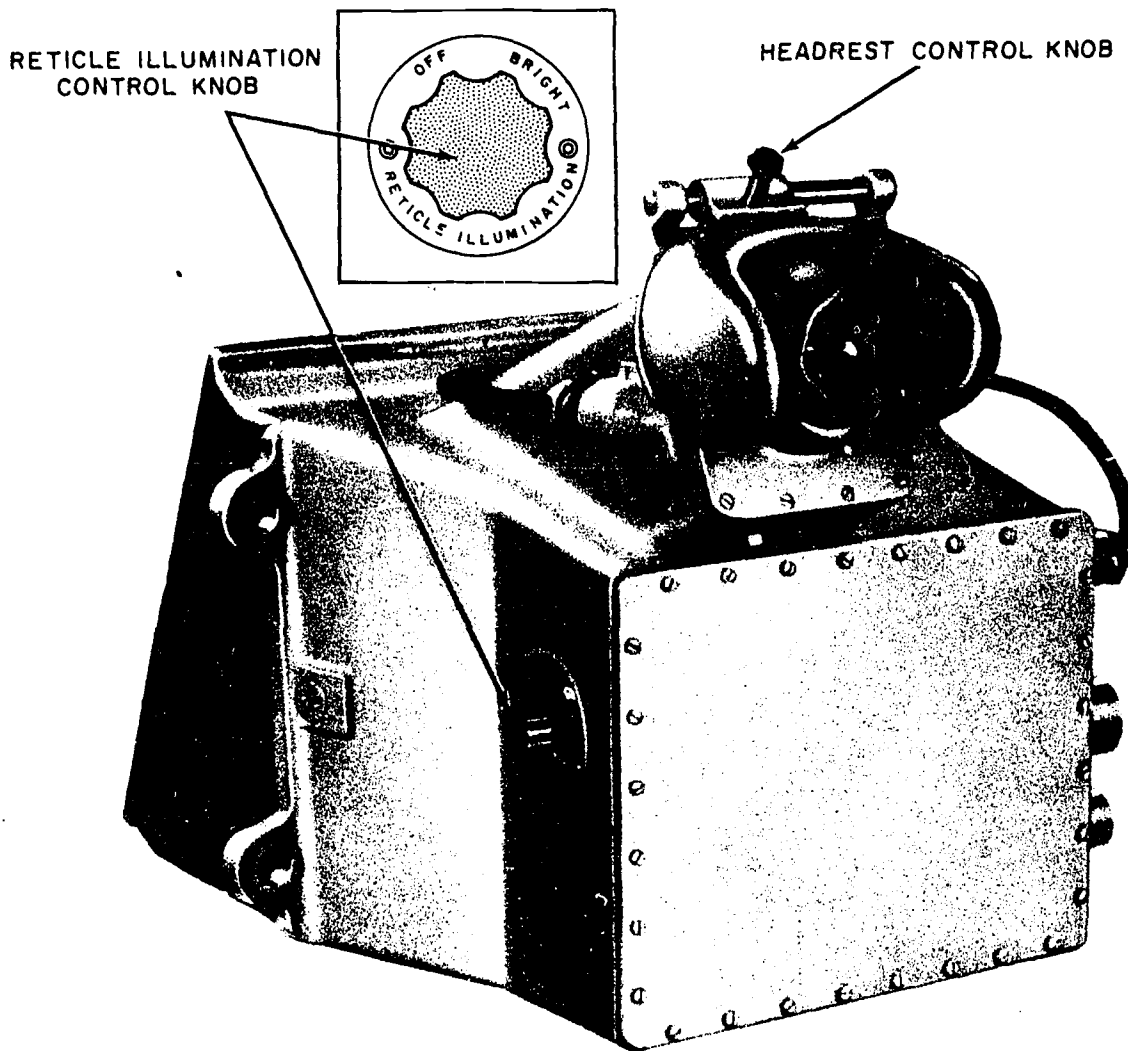

Figure 7-31.—Telescope Mk 102 Mods 2 and 4 controls; rear view. 148.311

The optical system of the Mod 2 or 4 (fig. 7-32) consists of an astronomical telescope (all elements between and including the objective and eyelens), skew penta prism, deflection prism, elevation mirror, and window.

ELEVATION MIRROR.—The elevation mirror is a crown glass, trapezoidal, first-surface reflector whose reflecting face is aluminized and coated with silicone monoxide. This mirror rotates on an axis that parallels the planes of the horizontal and vertical mounting surfaces.

THE DEFLECTION PRISM.—The deflection prism is a right angle prism, silvered on its reflecting surface, and magnesium-fluoride coated on its entrance and exit faces. The axis of rotation of this prism lies in a plane perpendicular to the bottom and front mounting planes and at an angle of 30° above the bottom mounting surface.

ASTRONOMICAL TELESCOPE.—The Mod 2 or 4 telescope is a common astronomical telescope with the exception of the three-element eyepiece, which provides full field illumination.

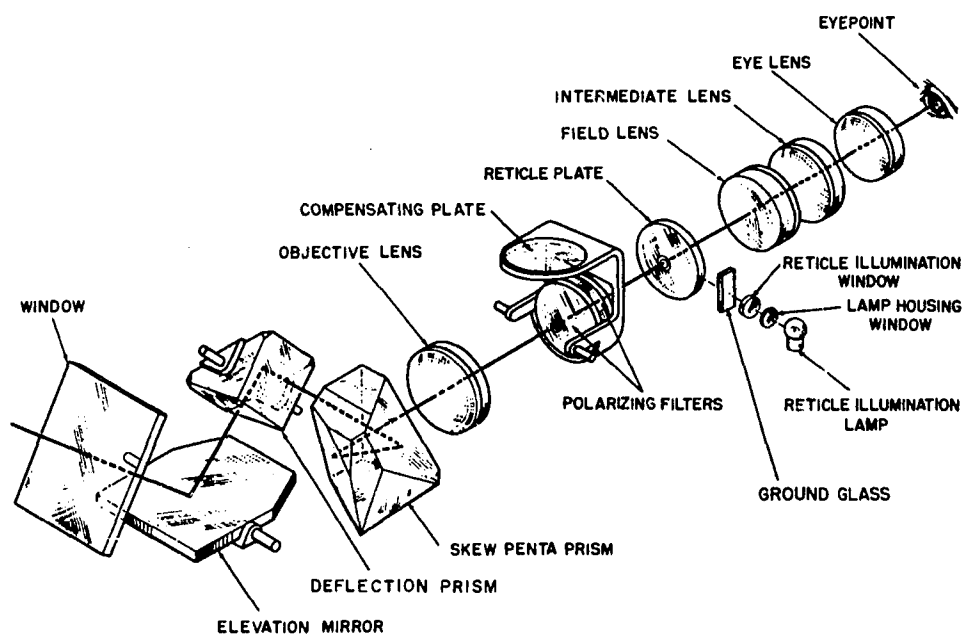

148.312

Figure 7-32.—Telescope Mk 102 Mods 2 and 4; optical diagram.

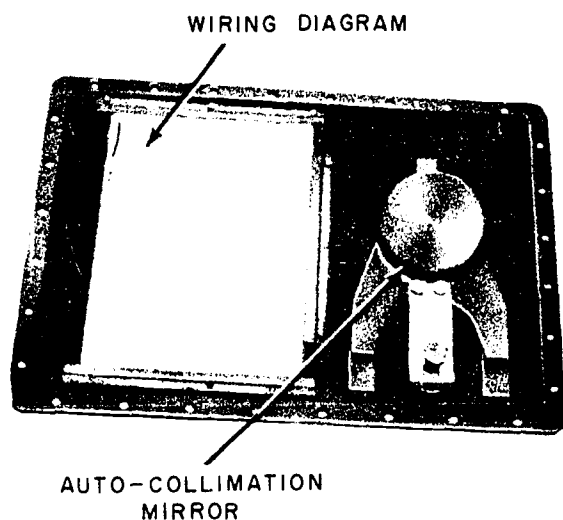

148.313

Figure 7-33.—Rear cover; inside view.

AUTOCOLLIMATION MIRROR.—Provided to check the alignment of the line of sight at 0° elevation and deflection, the autocollimation mirrors (fig. 7-33) is a circular, first-surface, aluminized reflector that has a protective coating of silicon monoxide. The autocollimation

mirror is common to all modifications of the Mk 102.

The optical system of the Mod 3 (fig. 7-34) consists of an astronomical telescope, penta and porro prisms, deflection and elevation prisms, and window.

ELEVATION PRISM.—The elevation prism is a right angle prism with a reflective-coated (silvered) hypotenuse surface and a reflection-reducing film on its entrance and exit faces. The axis of rotation of this prism is parallel to both horizontal and vertical mounting surfaces.

DEFLECTION PRISM.—The deflection prism has the same physical characteristics as the elevation prism but is smaller in size. The axis of rotation of the deflection prism lies in a plane perpendicular to both the vertical and horizontal mounting surfaces. The angle of the deflection rotational axis is 37.5° from the vertical mounting surface.

PORRO AND PENTA PRISMS.—As parts of the erecting system serving the same purpose as the skew penta prism in the Mod 2 or 4, the porro and penta prisms project the line of sight upwards into the telescope. The plane of the horizontal mounting surfaces and the porro

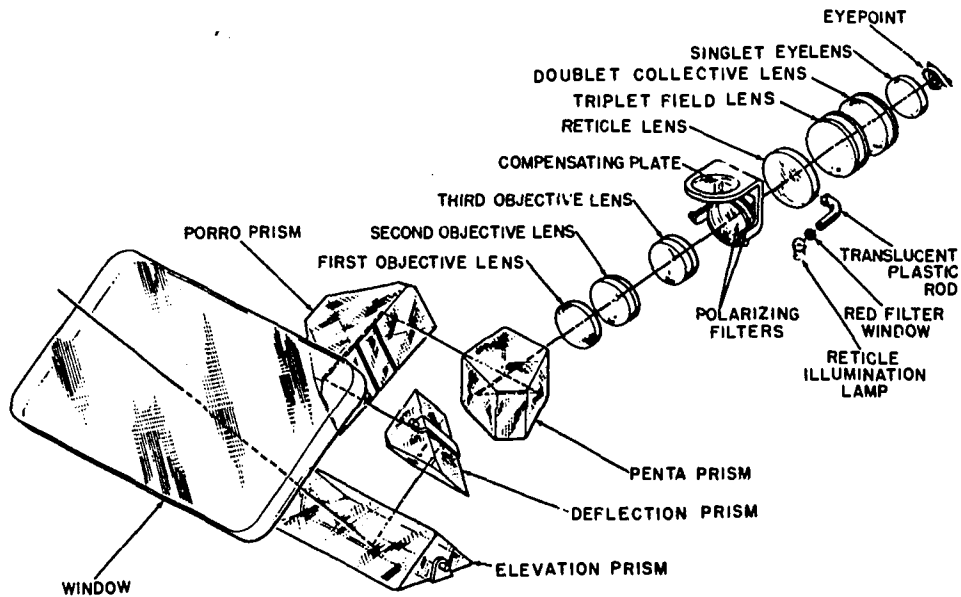

148.314

Figure 7-34.—Telescope Mk 102 Mod 3; optical diagram.

prism are at an angle of 39°; the penta prism is at an angle of 18.5°.

The reflecting surfaces of the penta prism are silvered; those of the porro prism are not. Both prisms have entrance and exit faces coated with magnesium fluoride.

ASTRONOMICAL TELESCOPE.—Although having similar optical characteristics to those of the Mod 2 or Mod 4, the astronomical telescope is designed differently. The eyepiece, consisting of a triplet field lens, doublet collective lens, and a single eyelens, serves the same purpose as the eyepiece of the Mod 2 or Mod 4; the objectives differ radically. The Mod 3 objective is a tele-objective that corrects for chromatic aberration and astigmatism. The reticle has a plano front face and the etched target is on the rear surface which has the cross-sectional appearance of a sine curve, flat on the edges and raised in the center. The curvature on the rear surface of the reticle corrects for spherical aberration.

MK 116 TILTING-PRISM GUNSIGHT TELESCOPE

The Mk 116 telescope is used on the Mk 42 Mod 9 5"/54 gun mount (fig. 7-35) and as a replacement for the nearly identical Mk 102 telescope. The mounting arrangement and fixtures

are identical for both. By comparing the Mk 116 shown in figure 7-36 with the Mk 102 Mods 2 and 4 shown in figure 7-31, you see the similarities in their exteriors. Most of the optical and mechanical elements of the Mk 116 and Mk 102 Mods 2 and 4 are interchangeable. The electrical systems function identically but are composed of different components.

OPTICAL SYSTEM

The optical elements of the Mk 116 are identical to those of the Mk 102 Mods 2 and 4 with the exception of the window which is slightly different due to frame design. The illumination system contains fewer elements but functions the same. The characteristics of the optical system are the same as those of the Mk 102 Mods 2 and 4.

CONTROLS

Operator controls are located conveniently for the adjustment of focus, reticle illumination, and filtering (fig. 7-37). These controls function as do the controls of the Mk 102 Mods 2 and 4.

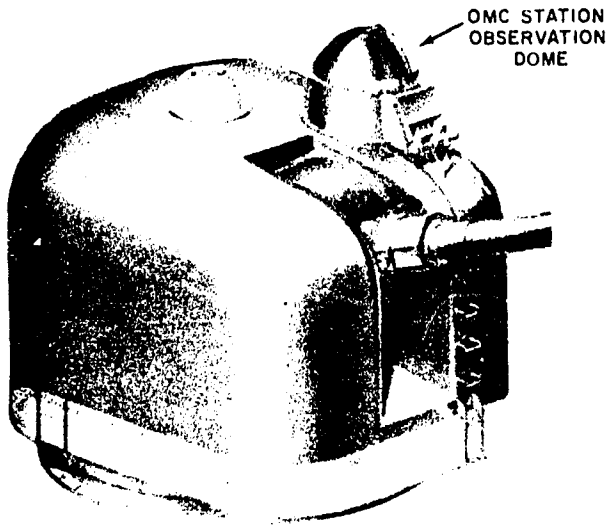

148.315

Figure 7-35.—Right front view of gun.

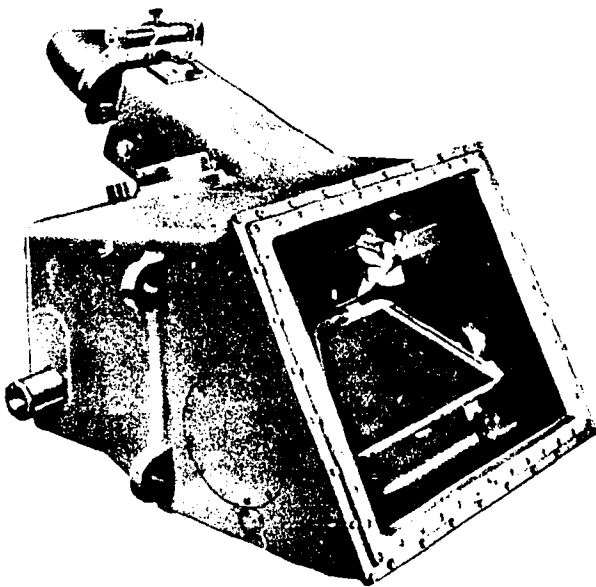

148.316

Figure 7-36.—Telescope Mk 116 Mod 0.

MAINTENANCE REQUIREMENTS

During the predisassembly inspection, checks are made to determine the extent of overhaul required. As in other optical instruments, it is advisable to disassemble only as required to perform maintenance and return the instrument to operating condition.

Whenever practical, the predisassembly inspection should be made before the gunsight is removed from its mount. Due to the size and weight of the gunsight, removal and transportation can be hazardous. Repairs that can be made in place should be. Repairs that might affect the alignment of the instrument should be performed in the shop because a collimation check is required.

The inspection should include all mechanical, optical, and electrical functions and components.

Normally the mechanical inspection will be directed towards appearance and operation. All controls must operate smoothly over their full range. The prescribed amount of gas pressure must be present.

The optical inspection should be directed at proper adjustment, cleanliness and presence of moisture.

The electrical inspection is dictated by the type of gunsight being inspected. While all tilting-prism gunsight telescopes have reticle illumination, only the more recent types are driven by a servo/control-transformer mechanism. The inspection is accomplished by activating each electrical system and checking for proper operation.

In case the instrument is removed from its mount, all mounting surfaces must be protected from damage since they are reference surfaces for alignment purposes.

PRESSURIZATION

All tilting-prism gunsight telescopes are charged internally with nitrogen to reduce the possibility of internal condensation of water vapor and fogging, and to slow down deterioration of internal components due to oxidation.

The recommended pressurizing procedure involves three steps: pressure testing, drying, and charging.

Pressure Testing

The purpose of pressure testing is to ensure that the instrument is gas tight. In pressure testing, you introduce nitrogen into the instrument to the pressure specified in table 7-1; then you inspect for gas leakage, which may be detected by means of a soap or an immersion test.

To perform the soap test, make a thick, frothy solution of soap and water. Apply this

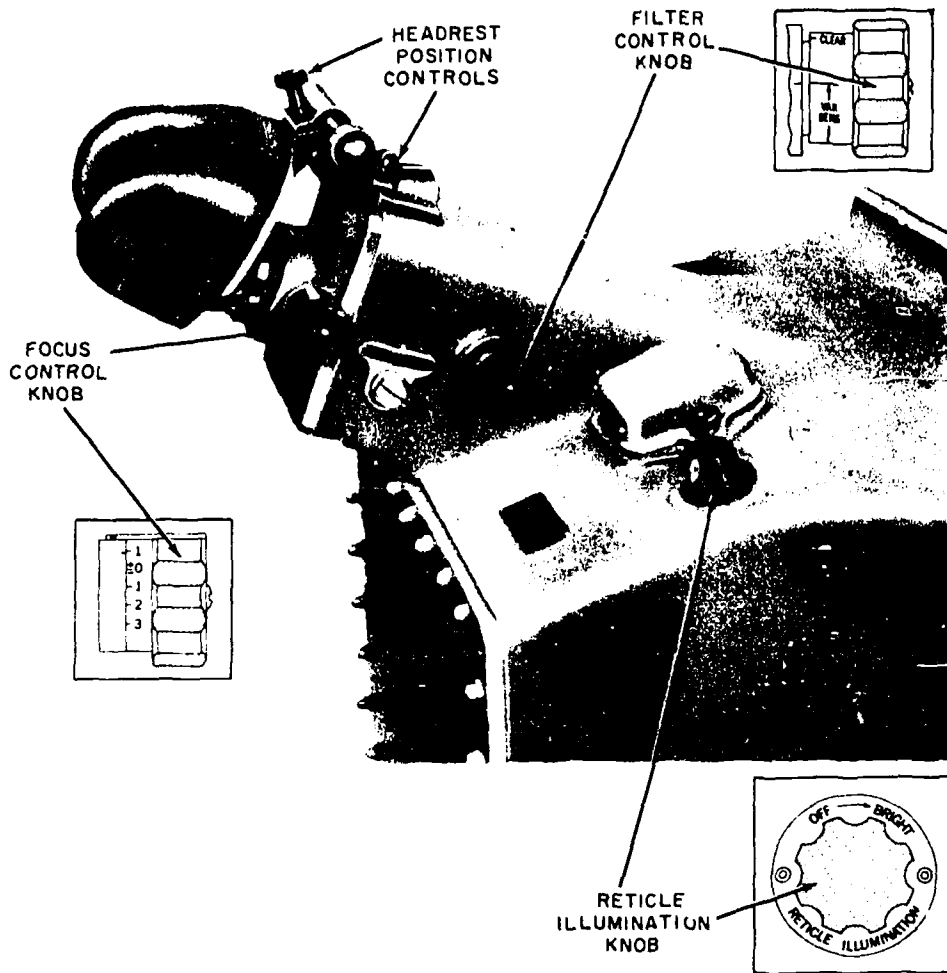

148.317

Figure 7-37.—Telescope Mk 116 Mod 0, controls.

Table 7-1.—Test Pressures

MK	Test Pressure PSIG/72°F	Service Pressure PSIG/72°F
61 and 62	6-8	3-5
67 and 68	6-8	3-5
97	3-4	3-4
102 Mods 2 and 4	3-4	4
102 Mod 3	3-4	1
116	3-4	4-5

solution to all areas where a gas leak might conceivably occur. A gas leak will cause the solution to bubble.

The immersion test gives a more positive indication of gas leaks, especially small ones. Where practical, this test is recommended. The test involves immersing the pressurized instrument into a container of fresh water and looking for bubbles of gas. Do NOT use the immersion test on instruments, such as the Mk 102 and Mk 116, whose electrical components are not protected within the pressurized envelope.

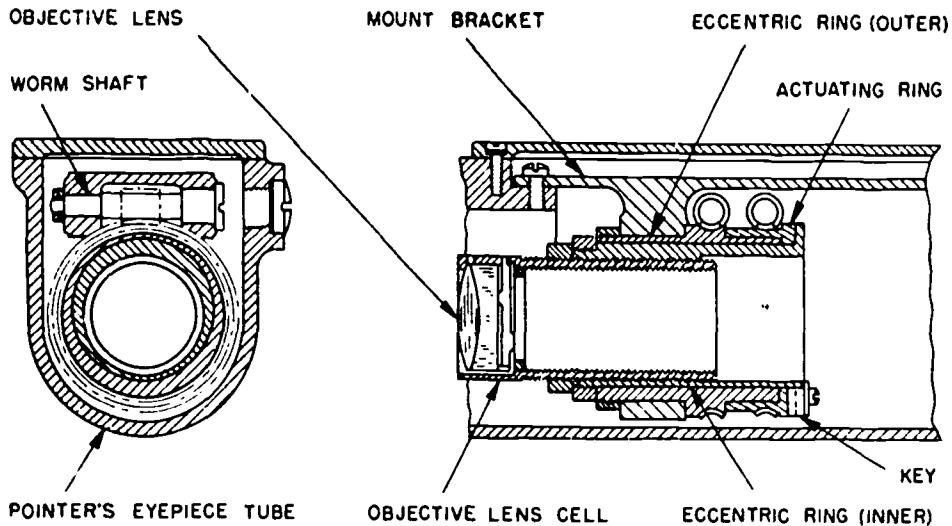

148.319

Figure 7-38.—Telescopes, Mark 61 Mods 0, 2—pointer's objective mount.

Drying

The purposes of drying are to remove moisture from within the instrument and to displace air with nitrogen. You can use either the evacuation or purging method of drying.

The evacuation method is similar to that used on submarine periscopes and is described in OM 3/2. Evacuation, which means pulling a vacuum, is the more efficient method as it removes more residual moisture than does purging.

This is accomplished by "boiling off" the moisture. As the pressure is reduced within a chamber containing water, a point is reached at which the water will boil though it is at room temperature. At 72°F, the vacuum required to make water boil is approximately 29.2 inches of mercury (29.2" Hg). A vacuum of 29.6" Hg is required to boil water at a temperature of 53°F. Evacuation removes residual moisture that may have penetrated pores in the metal, and that purging might not remove. It is a good idea to continue evacuating an instrument after the "boiling" point has been reached to allow the residual moisture to boil and be drawn off as water vapor.

The purging method eliminates moisture much like a sponge does. Dry nitrogen passing over residual moisture will absorb the moisture and carry it away. The only problem in

purging is to get the nitrogen into all areas where moisture may be present.

Charging

Charging refers to the method of pressurizing an instrument with dry nitrogen to a specified service pressure. You may use the method specified for submarine periscopes (cold trap method) in OM 3/2 or you may use the instrument dryer method. The cold trap method is preferred as it provides a lower dew point and therefore less chance of fogging of the instrument. Refer to table 7-1 for instrument service pressures.

COLLIMATION

The collimation of a tilting-prism gunsight telescope involves some of the standard checks of an optical instrument, such as "0" diopters, focusing range, parallax, squareness of the crossline, and the checks for determining whether the elevation and deflection systems are operating properly. The standard optical instrument checks are common and have been discussed previously.

The elevation and deflection checks are unique to tilting-prism gunsight telescopes. Although the collimation setup varies for each telescope, the collimation procedure is basically the same. The elevation and deflection systems

must move the line of sight with respect to a datum plane through specified limits of travel.

Being a binocular system, the Mk 61 telescope has a unique collimation requirement, that is, to ensure the two lines of sight, pointer's and checker's, are parallel. The adjustment for coincidence of the two lines of sight is accomplished with the pointer's objective mount. Parallax, in both systems, must be removed prior to adjusting coincidence of the lines of sight. Although any of a number of alignment instruments may be used to collimate the lines of sight, the Mk 5 binocular collimator is recommended because its large free aperture allows both lines of sight to view the same target. The checker's crossline is superimposed with the collimator's using the elevation and deflection drives and then the pointer's objective mount (fig. 7-38) is adjusted to bring the pointer's crossline into coincidence with the collimator's. Notice the pointer's objective mount is a double-eccentric mount which adjusts in the same manner as the stationary barrel of hand-held binoculars.

Collimation Setup

The setup for checking elevation and deflection systems of tilting-prism gunsight telescopes is basically the same for all marks. The setup equipment required includes the Mark 9 collimator, collimation fixtures, checking telescopes, and the test instrument. The procedure involves mounting the collimation fixture on the collimator support plate, aligning the collimator telescopes with the checking telescope, installing the test instrument, and performing the collimation tests and adjustments. Prior to installing a telescope on its support fixture, clean all foreign matter from bearing surfaces.

Mk 61 and 62 Collimation

The arrangement of the Mark 9 Collimator, collimator telescopes, support fixture, and checking telescope is shown in figure 7-39. With the plate set at 0° deflection and the scale on the checking telescope set at 0° elevation, align the 0° collimator telescopes to the checking telescope. Set the checking telescope to -25°, +25°, and +90° and align the respective set of collimator telescopes.

The collimator is now ready to be used as a reference device for the collimation of the test

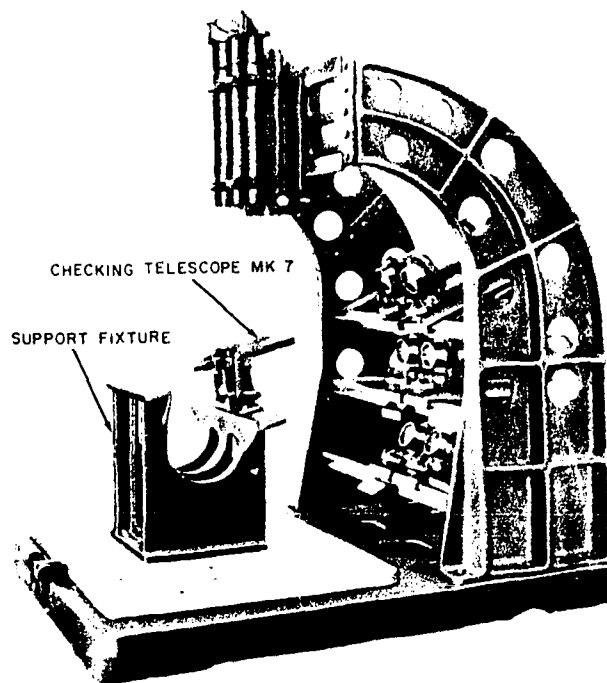
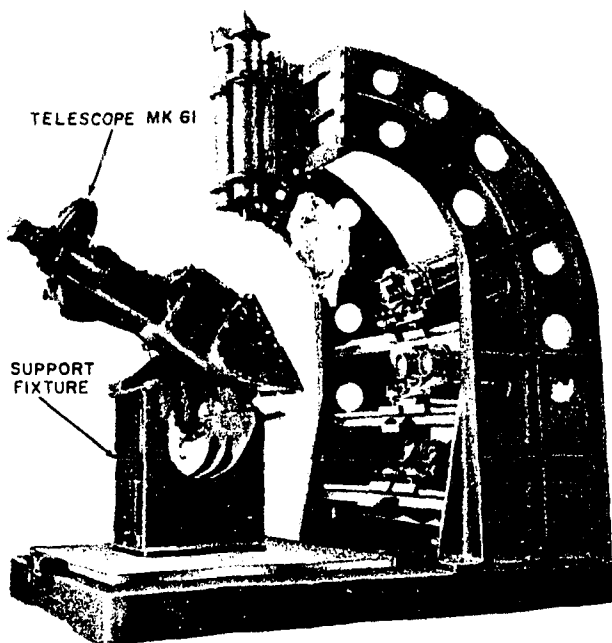

Figure 7-39.—Alignment of telescope collimator Mk 9 for telescope Mk 61.

instrument. Install the telescope (fig. 7-40) on the support fixture and secure in place. The crosslines of the test instrument and collimator telescope should coincide when the assembly marks (fig. 7-41) are aligned. Elevate the line of sight to the 50° position; the test instrument crossline should coincide with collimator telescope crossline or be within ± 2 minutes, which means that the vertical crossline is not more than 2 minutes to either side of the intersection of the collimator crossline. Depress the line of sight until the assembly marks are aligned; the horizontal crosslines should coincide within 1 minute, indicating acceptable backlash error. Depress the line of sight to the -25° position; the vertical crossline should not be more than ± 1 minute out of coincidence. If the instrument passes these tests, it indicates the elevation system is tracking in a plane perpendicular to the horizontal mounting surfaces.

Return the elevation system to the 0° position. To check the deflection system, turn the support plate 12° in either direction. The horizontal crossline should not deviate from the collimator crossline more than ± 1 minute when



148.321

Figure 7-40.—Telescope Mk 61 installed on telescope collimator Mk 9.

the vertical crossline of the test instrument is superimposed.

The mechanical stops in both the deflection and elevation systems must be set. The deflection stops are to be set at $\pm 17^\circ$. Mechanically, this setting is $1 \frac{8}{9}$ turns either side of the 0° position. The elevation system has stops which must engage between 90° and 95° elevation or $13 \frac{1}{2}$ to $14 \frac{1}{2}$ turns of the elevation shaft from the 0° position, and 60° - 65° depression or 9 to 10 turns of the elevation shaft from the 0° position.

Mk 67 and 68 Collimation

The fixture and support required, in addition to the collimator, are illustrated in figure 7-42. The collimator alignment arrangement (fig. 7-43) allows the collimator telescopes to be set for -25° , 0° , $+25^\circ$, and $+90^\circ$. Notice the collimator telescopes are not located in a central position as was the case with the Mk 61 or 62. The alignment check is conducted in the same manner as for the Mk 61 or 62. Figure 7-44 shows the Mk 67 installed ready for an alignment

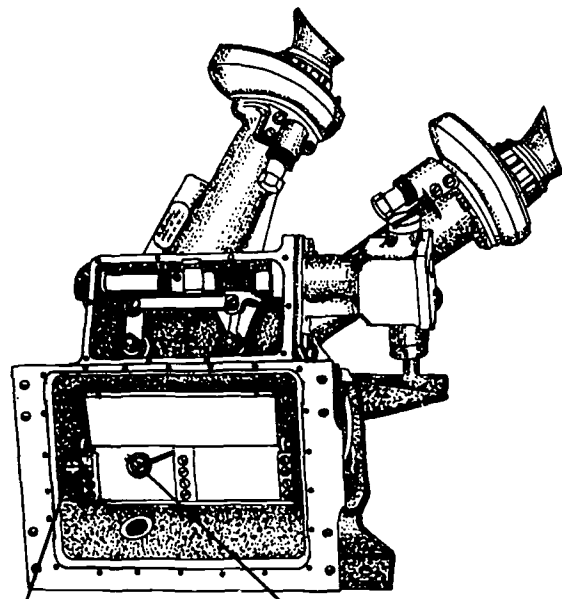
ASSEMBLY MARKS
(HEAD PRISMS)ASSEMBLY MARKS
(DEFLECTION PRISM)

148.322

Figure 7-41.—Telescopes, Mark 61 Mods 0, 2, 3, 4, and Mark 80 front view—covers removed.

check. The tolerances for the deflection system, are ± 2 minutes at 20° deflection from the 0° position. The vertical line is to be within ± 2 minutes at the 90° position. Backlash tolerance is 1 minute.

The stops for deflection are to be set at $\pm 25^\circ$ from the 0° deflection position ($4 \frac{1}{6}$ turns of the input shaft in either direction). The elevation stop is to be set at between 90° and 95° elevation ($13 \frac{1}{2}$ to $14 \frac{1}{4}$ turns of the elevation input shaft from the 0° elevation position). The depression stop is set to allow between 60° and 65° depression ($9 \frac{1}{4}$ to 10 turns of the elevation input shaft from the 0° elevation position).

Mk 97 Collimation

The Mk 97 does not require deflection checks but has a binocular system to align in addition to the elevation checks.

The setup is similar to that of the aforementioned gunsights. That is, the support fixture is mounted on the support plate and the Mk 7 checking telescope on the support fixture; and

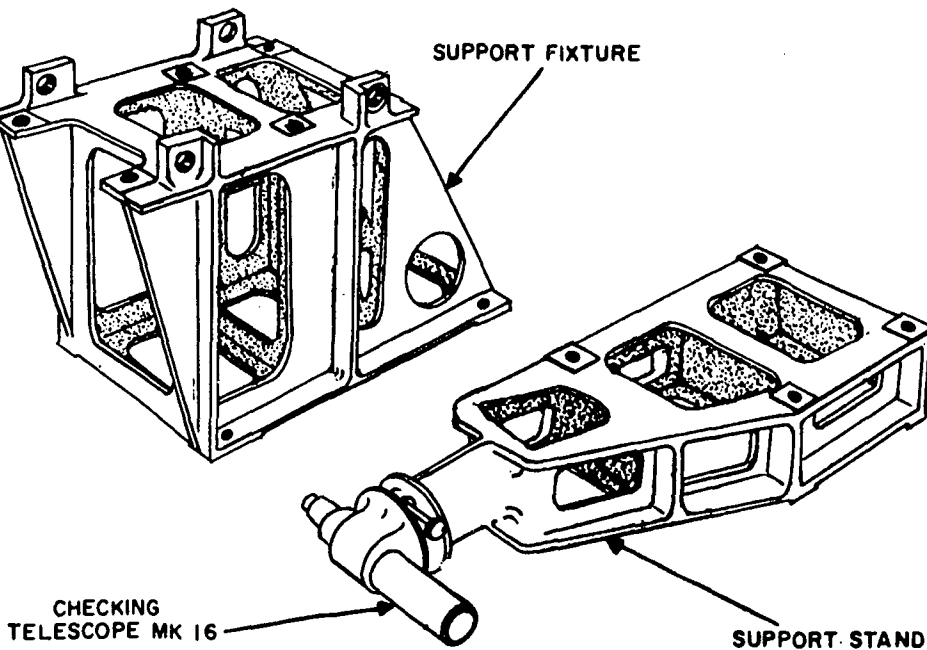

Figure 7-42.—Support fixtures and checking telescope. 148.323

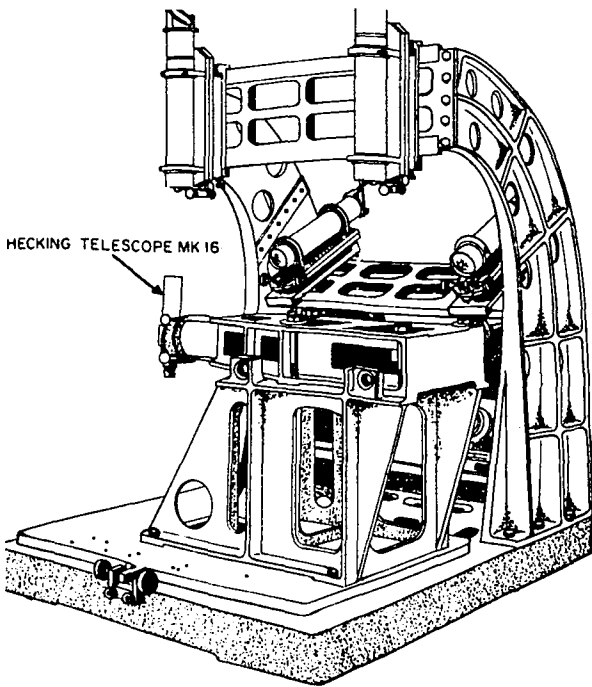

Figure 7-43.—Alignment of telescope collimator Mk 9 for telescope Mk 67. 148.324

the collimator telescopes, are aligned to the -25° , 0° , $+25^{\circ}$, and $+90^{\circ}$ positions.

Two checks should be made before the Mk 97 is installed on the gunsight collimator: Parallax and axis-of-rotation alignment. The parallax check can be most conveniently accomplished on the Mk 5 Binocular Collimator. Remove parallax in both systems.

To check the axis-of-rotation alignment, place the gunsight on a clean precision surface plate. Adjust the drive shaft until the reflecting surface of the mirror is parallel (to within $.00075''$), to the surface plate when measured from front to rear. Now measure the parallelism of the mirror and surface plate from side to side. It must be within $.00075''$. When making these checks, do not drag the indicator across the reflecting surface because damage will result.

Mount the Mk 97 on its fixture as in figure 7-45. Elevation alignment should be within ± 1 minute at the 90° position. The objective eccentric rings provide adjustment when required.

Set the elevation limit stops at -30° and $+100^{\circ}$, which corresponds to $7\frac{1}{2}$ turns and 25 turns of the input shaft, respectively.

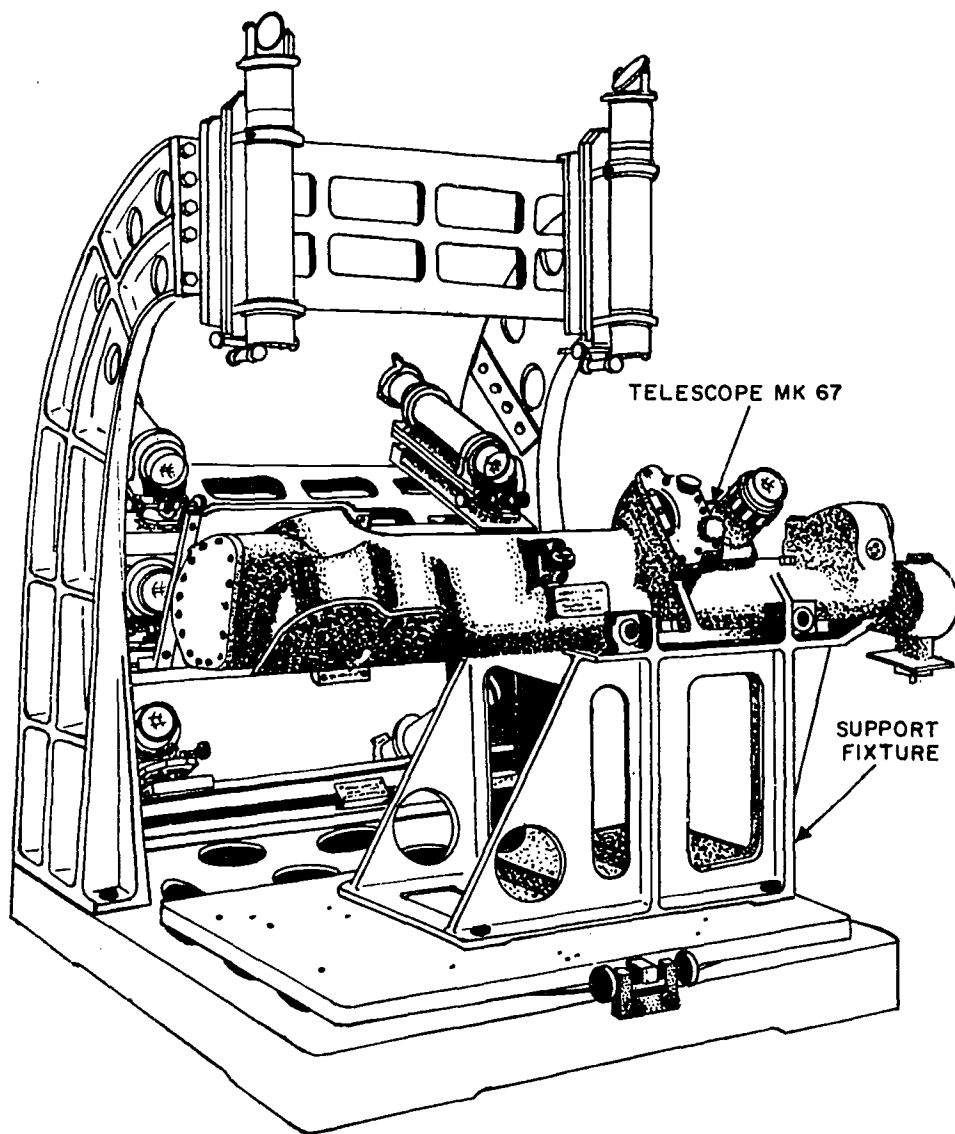

148.325

Figure 7-44.—Telescope Mk 67 installed on telescope collimator Mk 9.

To align the left optical system to the right, set the Mk 97 in front of a Mk 5 Binocular Collimator. Viewing both systems with an auxiliary telescope and stereo comparator attachment, align the left system to the right with the objective eccentric rings of the left optical system.

Mk 102 and Mk 116

These gunsights have the same requirements and test setups. The prime difference between them lies in their electrical systems and therefore does not affect the test configurations.

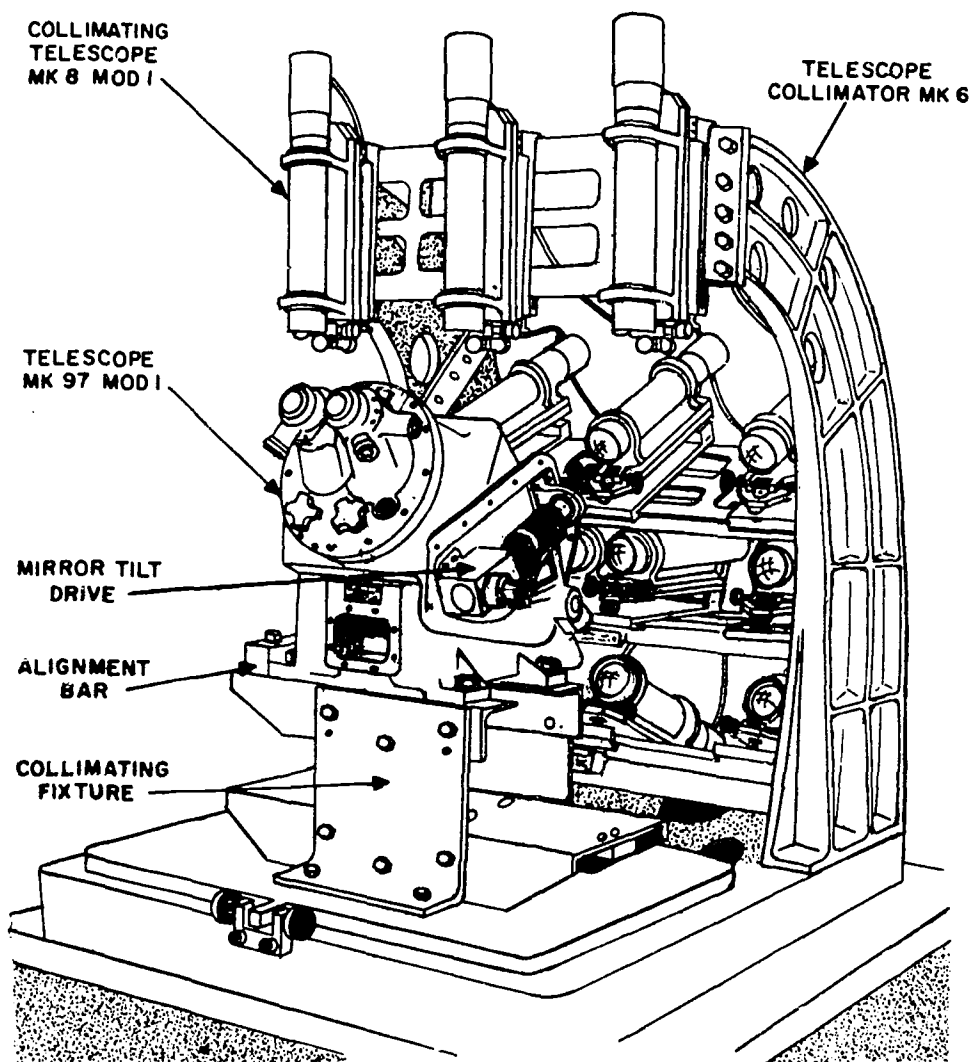

148.326

Figure 7-45.—Telescope Mk 97 Mod 1 on collimator Mk 6/9.

The limit of error in elevation and deflection is ± 2 minutes of arc. The elevation checks are made at -25° , 0° , and $+85^\circ$ while the deflection checks are made at $+30^\circ$, 0° , and -30° .

The alignment of the test fixtures and installations of the gunsight (fig. 7-46) is similar to that of the aforementioned instruments.

On these instruments, input shafts were used to generate elevation and deflection angles.

However, on the Mk 102 or 116 no input shafts are used as elevation and deflection angles are generated electrically. This presents a slight problem for collimation purposes in that no mechanical angle inputs are available externally. It is possible to manually generate elevation and deflection angles by removing the servo chamber cover and revolving the servo gear train by hand.

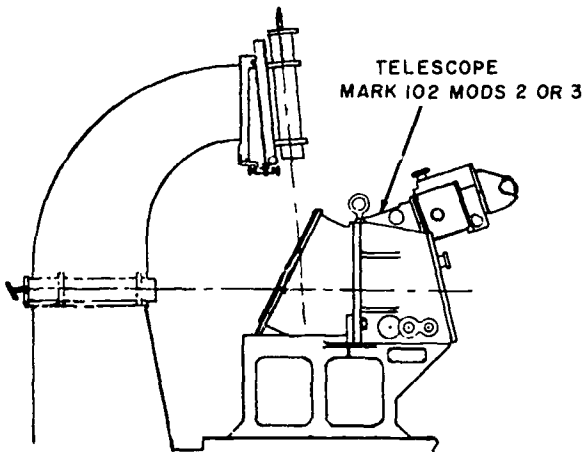
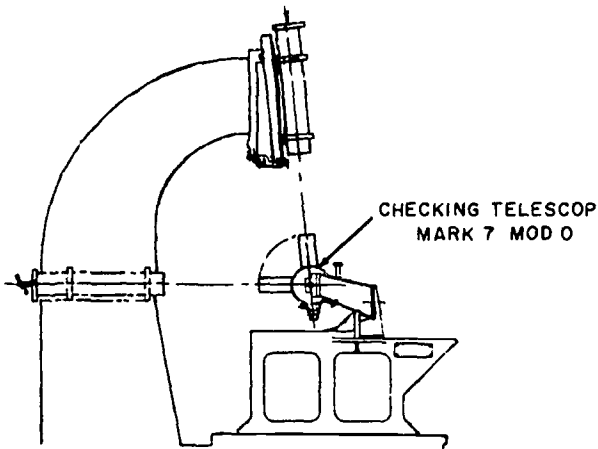

148.327

Figure 7-46.—Arrangement for collimating
telescopes Mark 102 Mods 2 and 3.

The final step in the alignment of the Mk 102 and Mk 116 is to set the servo assemblies so that electrical and optical zeros coincide. To accomplish this, it is necessary to energize the gunsight. If an "in-shop" electrical test arrangement is not available, the zero will have to be set after installation in the gun mount. Basically, the adjustment is made by generating a zero degree elevation and deflection order and then rotating the 36X control transformer until a zero degree optical elevation and deflection is attained.

This can be most easily accomplished with the autocollimation mirror installed. The reflected image must align with the reticle image in both elevation and deflection.

CHAPTER 8

RANGEFINDERS

The rangefinder is another optical instrument used in the solution of the fire control problem discussed in the previous chapter.

In the not too distant past, rangefinders were the primary source of range information aboard naval combatant vessels. Today, they serve as an auxiliary or backup system with radar serving as the primary source of range information.

In addition to fire control, the rangefinder can provide range information for navigation purposes. At short ranges, the rangefinder can provide extremely accurate information. It can also be used in situations which prohibit the use of radar, such as when the target will not produce a radar image. The Mk 21 rangefinder—a small, portable, coincidence type—is used primarily for this purpose.

As a senior Opticalman, you may be called upon to maintain rangefinders or supervise their maintenance. In either case, you must know the fundamentals of operation, capabilities, maintenance techniques, and alignment procedures of rangefinders. This chapter provides you with the knowledge you will apply in maintaining, or supervising the maintenance of, rangefinders.

ANGULAR MEASUREMENTS

All optical ranging devices are capable of measuring angles. The angles, however, are measured in one of three different units: degrees, radians, or mils.

DEGREES

The most common unit of angular measure is the DEGREE which is defined in terms of rotation. Imagine a circle, with one radius drawn in. Pivot the radius at the center of the circle and turn it through one complete revolution, back to its original position. In making one complete revolution, the radius has generated an angle of 360° . Or looking at it another way, divide the circumference of the circle into 360 equal parts, and mark off the divisions. A radius, in rotating from one mark to the next, will generate an angle of one degree.

With the help of optical instruments, you can measure angles smaller than one degree, or measure large angles more precisely. To make convenient smaller units, divide each degree into 60 MINUTES, and each minute into 60 SECONDS. Then your system of angular measurement shapes up like this:

360 degrees equal one complete circle
60 minutes equal one degree
60 seconds equal one minute

The second is the smallest independent unit of angular measure; to measure more precisely than by seconds, you will have to use fractions of a second.

RADIANS

Another fundamental unit of measuring angles is the radian. It has certain advantages over the degree, for it relates the length of arc generated to the size of the angle. Assume that an angle is generated, as shown in figure 8-1, and that the length of the arc(s) described by the extremity of the line segment generating the angle equals the length of the line (r). Then the angle described measures exactly one radian; that is, for 1 radian, $s = r$.

Recall from plane geometry that the circumference of a circle is related to the radius by the formula,

$$C = 2\pi r,$$

which says that the length of the circumference is 2π times the length of the radius. Based on the relationship of arc length, radius, and radians, a circle contains 2π radians.

Since the arc length of the circumference is 2π radians and the circumference encompasses 360° of rotation, it follows that

$$2\pi \text{ radians} = 360^\circ$$

$$\text{or} \quad \pi \text{ radians} = 180^\circ$$

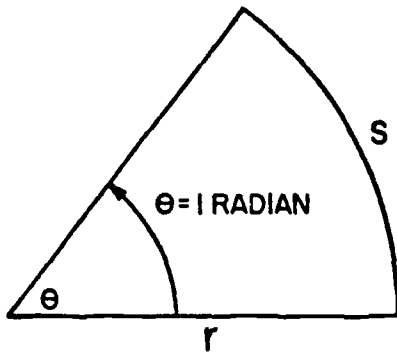

148.328

Figure 8-1.—Radian measure.

By dividing both sides of this equation by π , you find that

$$1 \text{ radian} = \frac{180^\circ}{\pi} \approx 57.2956^\circ$$

This and all other equivalents based on the value of π are only approximate, since π is an irrational number. Reducing 57.2956° to degrees, minutes, and seconds, you get:

$$1 \text{ radian equals } 57^\circ 17' 44.8''$$

To make that figure easier to handle, convert it into seconds. Then,

$$1 \text{ radian equals } 206,265 \text{ seconds}$$

If absolute accuracy is desired in a conversion, convert radians to degrees by multiplying the number of radians by $180^\circ/\pi$; convert degrees to radians by multiplying the number of degrees by $\pi/180^\circ$.

It is customary to indicate degrees by the symbol ($^\circ$) and to indicate radians by number with no name or symbol attached.

MILS

The mil is a unit of angular measurement used for military applications in ranging and sighting. A mil is defined as $1/6400$ of the circumference of a circle, which is equivalent to $3'22.5''$ or 0.00098 radians, approximately.

The importance of the mil in practical applications is that it is approximately $1/1000$ of a radian. A circular arc whose length is $1/1000$

of the radius will subtend an angle of 1 mil. For very small angles the arc (a) and the chord (c) are nearly equal as shown in figure 8-2.

Since the arc and chord are nearly equal (ratio of chord to arc nearly 1) for very small angles, consider them as equals and develop a method of approximating range (R) to a target of known size (c). Recall from the previous section that a radian is the ratio of arc length to length of radius. In figure 8-2 (with c essentially equal to a), the size of angle m in radians is given by

$$m = \frac{a}{r} = \frac{c}{r}.$$

Then the length of radius (r) is expressed as

$$r = \frac{c}{m}$$

If the angle m is expressed in mils ($1/1000$ of a radian), the formula for range is

$$R = \frac{c/m}{1000}$$

$$R = \frac{1000c}{m}$$

If the range is known and it is desirable to find the length (c) of a target, this formula can be written as

$$c = \frac{rm}{1000}$$

These formulas yield good approximations for angles up to several hundred mils and make possible rapid estimates of range to an object of known size.

TRIANGULATION

Ancient farmers in the Nile valley discovered the principle of triangulation by which you can measure a distance that you cannot reach directly. This principle is used in rangefinding. Modern surveyors still use the principle of triangulation to measure distances they cannot get at directly. Astronomers use it to measure the distance of the sun and planets, and some of the nearer stars.

Figure 8-3 illustrates the principle of triangulation, and shows the fundamental triangle of a rangefinder. You are on a ship at point A; another ship is at P; you want to measure her range without leaving your own ship. A surveyor would solve a similar problem on land by laying

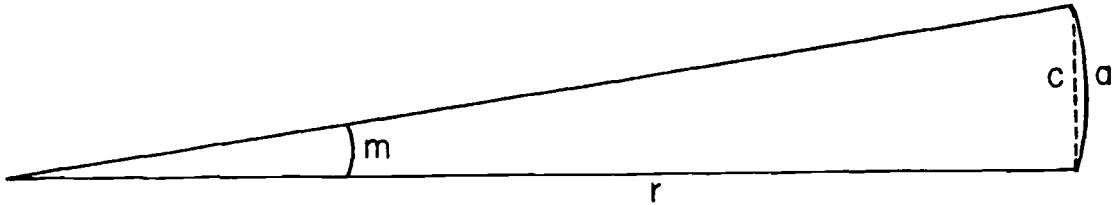
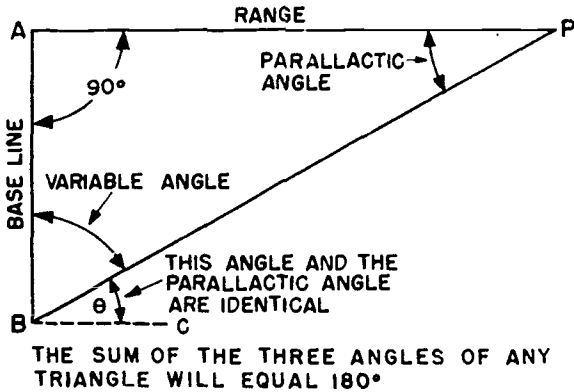

Figure 8-2.—Relationship of arc, chord, and radius.

148.329



148.9

Figure 8-3.—The fundamental triangle of a rangefinder.

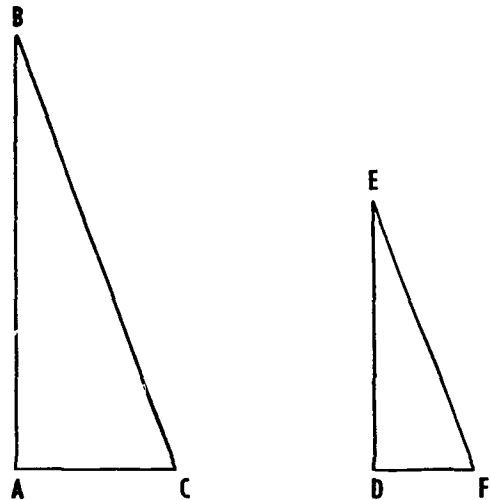

148.10

Figure 8-4.—Similar triangles.

off a line AB, of convenient length, at a right angle to the line of sight AP. He would measure this line AB, as accurately as possible, with his tape measure. Then he would set up his transit at point B, and use it to measure the angle ABP. He would then have all the data necessary to calculate the range AP.

You should have a good knowledge of the principle of triangulation, but we will run through it just for review. It's all based on the principle of similar triangles. (Two triangles are similar when the three angles of one triangle are equal respectively, to the three angles of the other.) The two triangles in figure 8-4 are similar. In any pair of similar triangles, the relationship between corresponding parts is constant. Measure the lines AB and BC (in fig. 8-4), and then divide the length AB by the length BC; if your measurements are accurate, your answer will be 0.9397. Do the same thing with the corresponding parts of the smaller triangle;

measure DE and EF, and divide DE by EF. Your answer will be 0.9397 again.

If you divide AC by BC you will get 0.3420. You can do the same thing with corresponding parts of the smaller triangle, or of any triangle similar to these two; the answer will always be the same.

Look back at figure 8-3. Now, it is obvious how we can solve that whole triangle, and calculate the range AP, by measuring only those parts of the triangle that are on your own ship. How? By comparing APB with some similar triangle we are already familiar with. We know that angle A is a right angle, and we measured angle B using a surveyor's transit. We can easily calculate angle P, because we know that in any triangle the sum of the angles is equal to 180° . Now, if you wanted to, you could draw a

small triangle similar to ABP, measure its sides, and calculate the ratio of the various parts. You would know that the corresponding parts of ABP would have the same ratio.

But we do not need to go to all that trouble. Mathematicians have calculated all these ratios for us, and listed them in table of trigonometric functions.

How can we calculate the range from the facts we know about the triangle in figure 8-3? He does it by setting up an equation that contains the distance he wants to find (AP, the range) and other known quantities. What does he already know? He knows the length of the side AB, and the value of all three angles.

In a right triangle, the side opposite one of the acute angles, divided by the side adjacent to that angle, is the tangent of that angle. Applying this fact to the triangle in figure 8-3, he gets

$$\tan \angle P = \frac{AB}{AP}$$

Here is an equation that combines the unknown (range, AP) and other known quantities. Solving it for the range, AP, he gets

$$AP = \frac{AB}{\tan \angle P}$$

Since he has measured AB and angle P; and can look up $\tan P$ in a table of trigonometric functions, he can solve for AP.

So, using the method of a surveyor, you can calculate the range of a target without leaving your own ship. But you can do it much more quickly with a rangefinder.

In figure 8-3, the points A and B correspond to the two end windows of a rangefinder; the line AB corresponds to the base of the rangefinder and is always constant for that particular rangefinder. You cannot measure the PARALLACTIC ANGLE (angle P) directly, because its vertex is aboard the other ship. But if you imagine a line BC parallel to AP, then angle θ (Theta) will be identical with the parallax angle, and can be easily measured.

The rangefinder has all the information needed to solve the triangle and calculate the range.

In the triangulation formula

$$\tan \angle P = \frac{AB}{AP}$$

you can substitute $\tan \theta$ for its equal $\tan \angle P$. Since AB corresponds to the base of the rangefinder; let B represent the base in yards, also

let R represent the range AP in yards. Now the formula is:

$$\tan \theta = \frac{B}{R}$$

You can see that the range will always be large when compared with the base of the rangefinder, and therefore the angle θ will always be very small. Now this may be surprising, but it is true: for very small angles, the tangent of the angle is almost exactly equal to the angle itself, WHEN THE ANGLE IS EXPRESSED IN RADIANS. So, if θ is in radians, then:

$$\theta = \frac{B}{R}$$

There you have the RANGEFINDER FORMULA.

But suppose you want to express θ in seconds, rather than radians. There are 206,265 seconds in one radian. Therefore,

$$\theta = 206,265 \frac{B}{R} \text{ seconds.}$$

From this formula, you can calculate the value of the parallax angle, θ , for any given rangefinder at any given range. But the job of the rangefinder itself, of course, is to measure θ , and convert it into yards of range.

You estimate the relative distance of two objects by comparing their parallax angles. Since a nearby object has a greater parallax angle than a distant one, you know that the object with the greater parallax angle is closer than the other.

Of course there is a limit to the usefulness of your personal rangefinder, because there is a limit to your STEREO-ACUITY. To the average trained observer, two parallax angles will appear to be equal unless the difference between them is 12 seconds or more. Since the base of your personal rangefinder is short (65 mm is average), its effectiveness is limited to comparatively short ranges.

How can you extend the range? Consider two distant objects, whose parallax angles are 1 second and 2 seconds. To the naked eyes, of course, they will appear to be at the same distance, because the difference in their parallax angles is too small to detect. You cannot tell which of these objects is closer unless you find some way to increase the difference between their parallax angles to 12 seconds or more.

Now suppose that you mount two 12X (12 power) telescopes side by side and parallel, with the centers of their eyepieces about 65

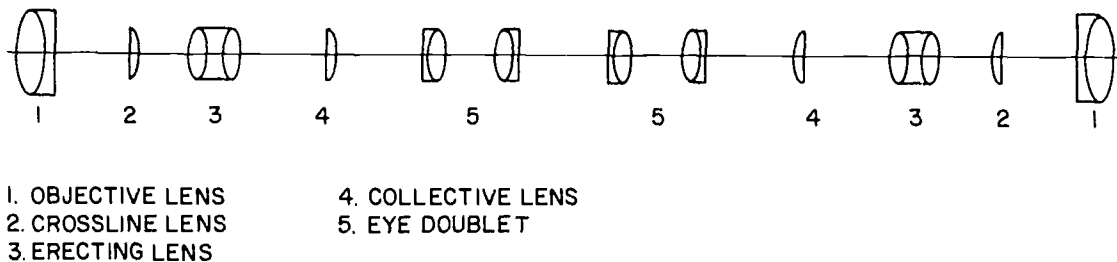

148.11

Figure 8-5.—Telescopic system of a rangefinder.

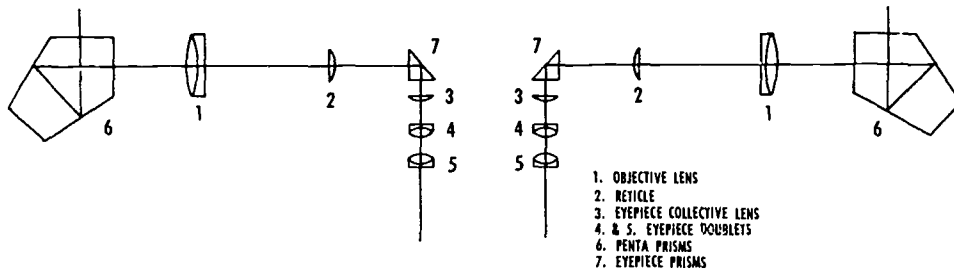

148.12

Figure 8-6.—Basic optical system of a rangefinder.

millimeters apart. You can look through one of these telescopes with one eye, and the other one with your other eye. The telescopes will magnify both objects 12 times, and thus increase their parallactic angles to 12 seconds and 24 seconds, respectively. The difference is now 12 seconds, and you can estimate the relative distance of the two objects.

You could also extend the range of your depth perception if it were possible to increase your interpupillary distance. You can easily see that, for an object at any given distance, increasing the base of the triangle will increase the parallactic angle.

The optical rangefinder uses both these means to extend the range of your depth perception. It provides you with a magnified image of the target. It provides you with two lines of sight through its two end windows, which are much farther apart than the pupils of your eyes. By using a rangefinder with a magnification of 24X, and a base length 100 times your interpupillary distance, you can increase your depth perception by a factor of 2,400.

OPTICAL SYSTEM

You can understand how the optical system of a rangefinder works if you compare it with

other instruments you have already studied. In figure 8-5 you see two simple gunsight telescopes, laid out with all their elements in a straight line. The two eyepieces (doublets) face inward; the two objective lenses are at the ends of the line. Since you now have two lines of sight, through two separate telescopes, you have the essential elements of a rangefinder. But to make it useful, you will have to add a few features. Your two lines of sight are pointing in opposite directions; actually, you want them to converge on a single object. You can do that by adding two reflecting surfaces on the optical axis—one beyond each objective—to deflect the lines of sight forward. To make the incident rays enter your eyes, you must add two more reflecting surfaces to the axis, one near each eyepiece. This optical system is shown in figure 8-6.

A penta prism is used at each objective to reflect rays from the target onto the optical axis. The added prisms (numbered 7) reflect the rays to the observer's eyes. This system will increase your depth perception tremendously. It magnifies your target and effectively increases your interpupillary distance. By using this system, you can easily estimate the

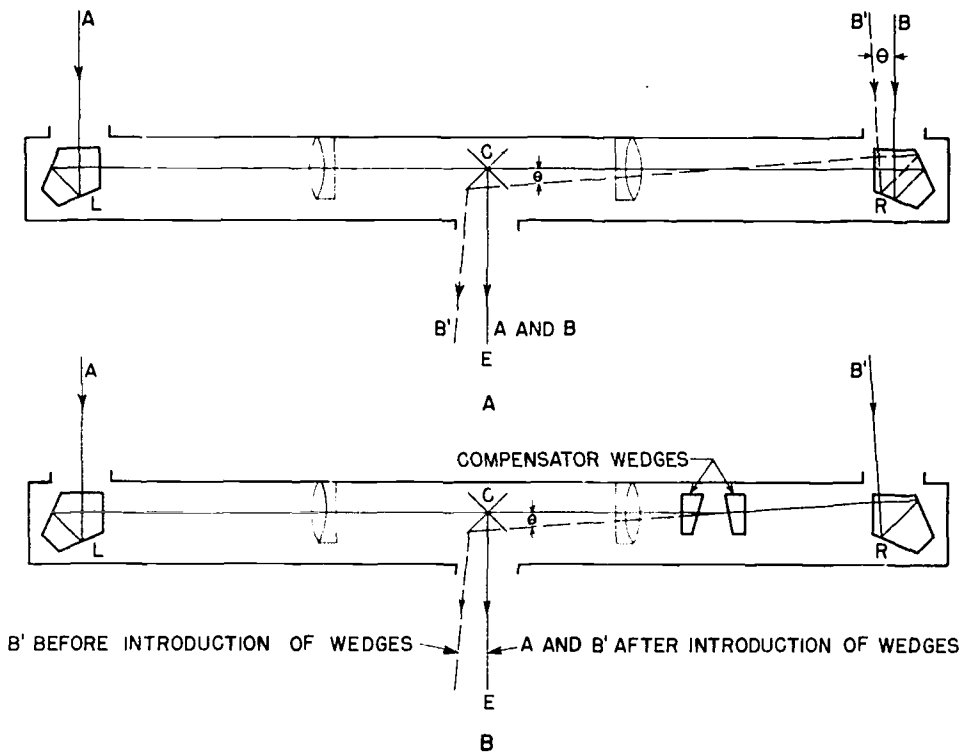

148.13

Figure 8-7.—The rangefinder principle.

relative distance of two objects, even at a great distance. But estimating relative distance is very different from measuring actual distance. To make this system into an effective rangefinder, you must add a measuring device.

The two diagrams in figure 8-7 are schematic drawings of a coincidence rangefinder—the type with a single eyepiece. The cross at C represents a coincidence prism. It enables you to see through both telescope systems at once, with one eye; your field of view appears to be split by a horizontal line; the lower half of the image if formed by one of the telescopes, the upper half by the other.

Look at the upper diagram in figure 8-7. The rangefinder has been turned so that ray A from the target is at a right angle to the optical axis. After reflection in the left penta prism, L, ray A will coincide with the axis; it will strike the center of the coincidence prism at C, and will be reflected to the observer's eye at E.

If your target were at infinity, all rays from a given point on it would be parallel. The ray entering the right penta prism, R, would behave

like ray B—it would be reflected along the axis, and after reflection at the coincidence prism it would coincide with ray A. To the observer, the two halves of the image would appear to coincide and form one unbroken image.

But actually your target will be at a finite distance. The broken line B' represents a ray from a target at this distance. It will strike the face of the right penta prism at a slight angle—the parallactic angle, θ . After reflection in the penta prism it will diverge from the axis at the angle θ , and after reflection in the coincidence prism it will fail to coincide with A. The observer will see a broken image of the target; half the image will be displaced to one side.

In the lower diagram (part B of fig. 8-7), two measuring wedges are inserted. Think of them as a pair of thin prisms. A prism, of course, will deviate a ray of light toward its base. If you choose the prisms carefully, you can get a pair that will deviate the ray B' through angle θ . Then, after the ray passes through the measuring wedges, it will lie on the optical axis,

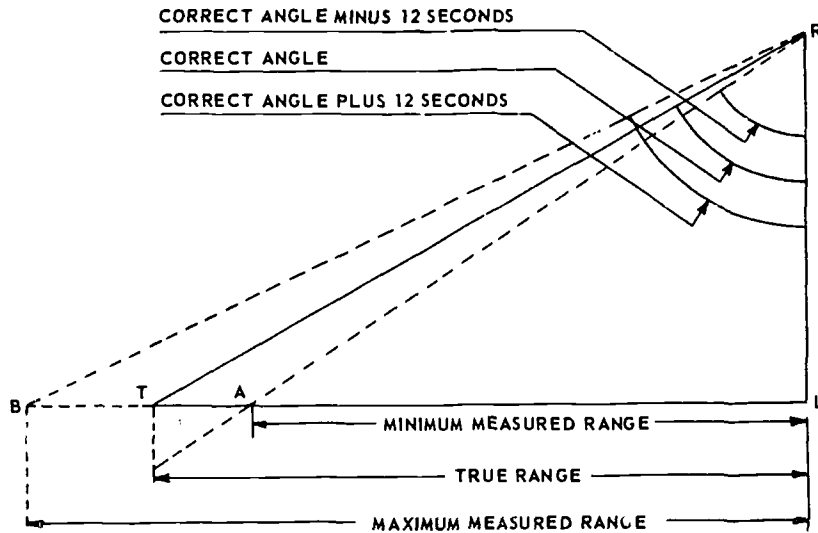

148.25

Figure 8-8.—Possible errors in measuring the parallactic angle.

and the observer will see an unbroken image of the target.

If necessary, you could actually measure ranges this way. By trial and error, you could select one or more prisms that would make the image halves coincide. Then, the deviation of these prisms is the angle θ , and could calculate the range. But this method would be slow, and it would keep the operator pretty busy.

Actually, rangefinders use a simpler principle. The measuring wedges are so mounted that you can rotate them on the axis by turning a knob. The deviation will vary with the amount of rotation. By turning the ranging knob you can rotate the wedges until their deviation is equal to θ . A scale mounted in this system could indicate the amount of rotation. And, by suitable tests on targets at known distances, you can calibrate the scale to show the range in yards.

This is the basic principle of the rangefinder. There is more to it than that, of course, but the other elements are accessories. They help to make the instrument more accurate, and convenient to use, and provide an easy means of calibrating it.

ACCURACY

The operator of a stereoscopic rangefinder makes his range setting by bringing the target and the ranging mark of the reticle to the same

apparent distance. When do the two distances appear to be the same? When the two parallactic angles appear to be the same. The accuracy of a stereoscopic rangefinder is limited by the stereo-acuity of its operator. Two angles will appear to be the same, even to a trained operator, if there is no more than 12 seconds difference between them. So when even the most skilled operator makes stereoscopic contact with a target, his measurement of its parallactic angle may be off by as much as 12 seconds in either direction.

Look at figure 8-8 and assume that a skilled operator is using a stereoscopic rangefinder (LR represents its base line) to range on the target at T. The angle LTR is the true parallactic angle of that target. When the operator turns the ranging knob until the target makes stereoscopic contact with the reticle, he is ready to read the range on the scale. But the parallactic angle he has measured may be in error by as much as 12 seconds in either direction. And this error will be undetectable, no matter how skilled the operator may be.

If he makes the maximum undetectable error on the short side, he will actually measure angle LAR (the true parallactic angle of the target, plus 12 seconds). The range scale will then show the target to be at A, rather than its true position T. If the operator makes the

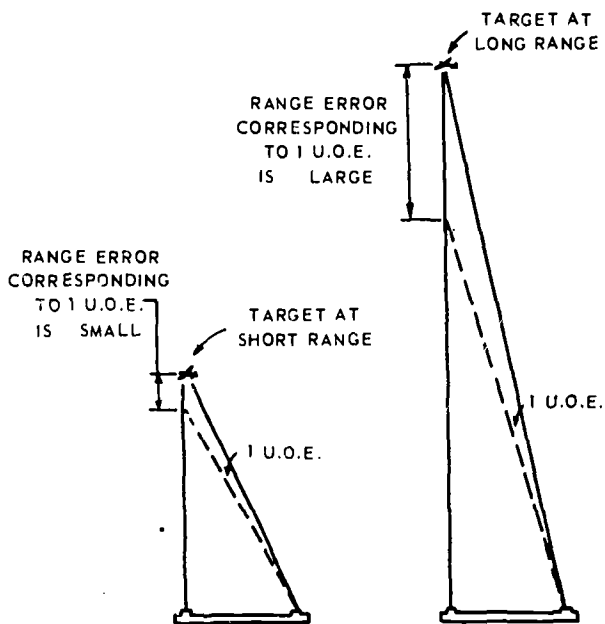

148.26

Figure 8-9.—How a range error equal to one UOE changes with range.

maximum undetectable error on the long side, the range scale will show the target to be at B, rather than at its true position. So a stereoscopic rangefinder does not give the exact position of the target. If the range scale shows the target to be at T, it is actually somewhere between A and B.

When the range scale shows the range to be LT, the reading may be wrong, in either direction, by a certain distance. The range error may be any distance that does not change the parallactic angle (as seen through the eyepiece of the rangefinder). The greatest theoretical distance by which a range reading may be wrong (for a given rangefinder, at a given range) is a useful unit of measurement, called UNIT OF ERROR (UOE). In figure 8-8, the distance AT and BT are each equal to one unit of error. (As you can see, BT is slightly longer than AT. But the difference is so small, compared to the error itself, that it can be disregarded.)

The unit of error also provides a unit for measuring range errors when bursts or splashes are spotted. (These errors can be measured directly in yards, since the apparent distance between the various rows on the reticle varies

with the range.) The UOE also can be used to measure the relative skill of individual operators, since the size, in yards, of an operator's habitual error also varies with range. Consequently, the correction scale is calibrated in units of error. (For a given rangefinder, working at a given range, you can easily convert units of error into yards.)

If the range error caused by one unit of error is a variable number of yards, what determines it? Four things:

First, of course, the stereo-acuity of the rangefinder operator. In order to derive a convenient formula, assume a constant value—12 seconds—for the stereo-acuity of all trained operators.

Second, the magnification of the rangefinder. Remember that errors are caused by undetectable differences in angles AT THE OBSERVER'S EYE. The apparent parallactic angles are increased by the magnification of the instrument.

Third, the range. Figure 8-9 shows two identical rangefinders, ranging on targets at two different ranges. In each case the angular unit of error is the same, but the range error caused by it is much greater at the longer range. The range error increases with the SQUARE of the range in thousands of yards. (For example, assume that for a given rangefinder the unit of error is equal to a range error of 1 yard at a range of 1,000 yards. Then at 2,000 yards the error will be 4 yards; at 3,000 yards it will be 9 yards; etc).

Fourth, the base length of the rangefinder. In figure 8-10 are two rangefinders of different base length, ranging on targets at the same range. Although the angular unit of error of the two instruments is the same, it causes a greater range error in the short-base rangefinder.

When spotting the fall of short in range, the operator reports the range error in units of error. But before he can use that measurement to correct the elevation of the guns, it must be converted into yards. Use the formula:

$$e = \frac{58.2}{BM} \times \left(\frac{R}{1,000} \right)^2$$

Where:

e is the range error, in yards, due to one unit of error,

B is the base length of the rangefinder,

M is the magnification of the rangefinder,

R is the range, and

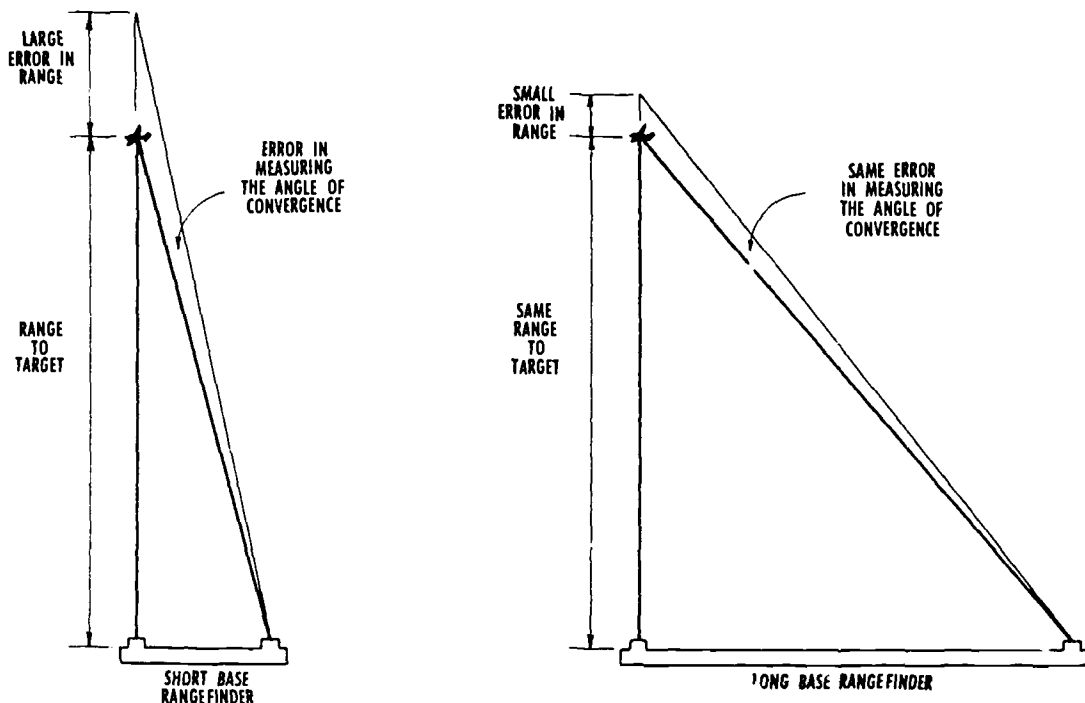

148.27

Figure 8-10.—How range error due to one UOE varies with base length of the rangefinder.

58.2 is a constant, valid only when the operator's stereo-acuity is 12 seconds, and when both B and R are expressed in YARDS.

When using this formula, ALWAYS express the base length in YARDS. The base length of some rangefinders is normally stated in feet or meters which must be converted into YARDS before the formula can be used.

Apply the formula in a sample problem. The Mk 14 rangefinder has a base length of 1.094 yards, and a magnification of 11 X. What is the value, in yards, of its unit of error at 1,000 yards? Substitute in the formula:

$$\begin{aligned} e &= \frac{58.2}{1.094 \times 11} \times \left(\frac{1,000}{1,000} \right)^2 \\ &= \frac{58.2}{1.094 \times 11} \times 1 \\ &= 4.83 \text{ yards} \end{aligned}$$

So, for this rangefinder, the range error due to one unit of error is 4.83 yards at 1,000 yards.

What is it at 2,000 yards? You have already found the value of 58.2/BM; for any given rangefinder the quantity remains constant (unless you change the magnification). Then

$$\begin{aligned} e &= 4.83 \times \left(\frac{2,000}{1,000} \right)^2 \\ &= 4.83 \times 4 \\ &= 19.32 \text{ yards} \end{aligned}$$

For each rangefinder, the units of error must be converted into yards. There are three ways to do this:

1. By using the tables provided for many rangefinders (in the OP's that describe them) that show the value of the unit of error at various ranges.

2. By calculating the value of the unit of error for any particular range by using the formula. First find the value of the constant 58.2/BM.

Then express the range in THOUSANDS OF YARDS, square it, and multiply by the predetermined value of 58.2/BM.

3. By solving the formula for a number of ranges, and then drawing a curve, plotting the value of the unit of error against the range. Thereafter, you can make the conversion by spotting the range on the curve, and then reading the corresponding value for the unit of error.

The formula for unit of error is arrived at by a series of approximations. But the error caused by those approximations is so small, compared to the range error, that we can ignore it. And that formula works for all Navy range-finders, both stereoscopic and coincidence.

In theory, the accuracy of a rangefinder increases in proportion to increases in its base length and magnification. Also, accuracy decreases in proportion to the square of the range. For example, you can expect four times the error when the range is doubled. Being theoretical, this accuracy represents the best performance you can expect from any rangefinder. Its precision in actual practice will be influenced by many things, including visibility, vibration, target contrast, heat waves, and, of course, the skill of the operator. Only under the most favorable conditions can the precision of a rangefinder approach its theoretical value.

TYPES OF RANGEFINDERS

The Navy uses two types of rangefinders: the COINCIDENCE type, and the STEREO-SCOPIC type. The two instruments have many features in common; each consists of two telescopes, one in each half of the instrument. Both types measure the parallactic angle, and calculate the range from that measurement. The principal difference is in the way the target image is presented to the operator's eyes.

The COINCIDENCE RANGEFINDER has a single eyepiece. The operator's field of view is split by a horizontal line; the upper half is formed by one of the two telescopes, the lower half by the other. To operate the coincidence rangefinder, the operator turns the ranging knob—thus rotating the measuring wedges—until the two halves of the image coincide. He can then read the range, in yards, on the scale. When the rangefinder is not set to the proper range, the operator sees a broken target; half the image will be displaced to one side, as in figure 8-11.

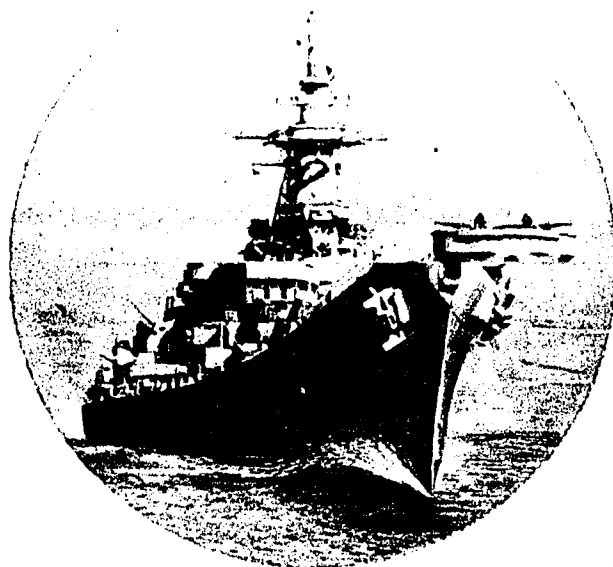

148.14

Figure 8-11.—Field of view of the coincidence rangefinder.

The STEREO-SCOPIC RANGEFINDER has two eyepieces. In ranging with this instrument the operator makes use of his own stereo-acuity—his ability to estimate the relative distance of objects. When he looks through the eyepieces he will see a single, unbroken image of his target. Superimposed on that image he will see a pattern of reference marks. (This pattern is engraved on the reticles in the two telescopes of the rangefinder.) Figure 8-12 shows a typical reticle pattern for a stereoscopic rangefinder.

To the operator, this reticle pattern will appear to be spread out in space—some of the vertical marks will appear to be closer than the diamonds; others will appear to be farther away. (This is an illusion—or "artificial" stereoscopic effect. The patterns of the two reticles are similar but not identical. By viewing a separate reticle with each eye, you get an effect of stereopsis, and the pattern appears to be spread out in space.)

To the rangefinder operator, the center row of reference marks—the diamonds, in figure 8-12, may appear to be closer or farther away, than the target. By turning the ranging knob, and thus rotating the measuring wedges, the operator can make the target appear to move in

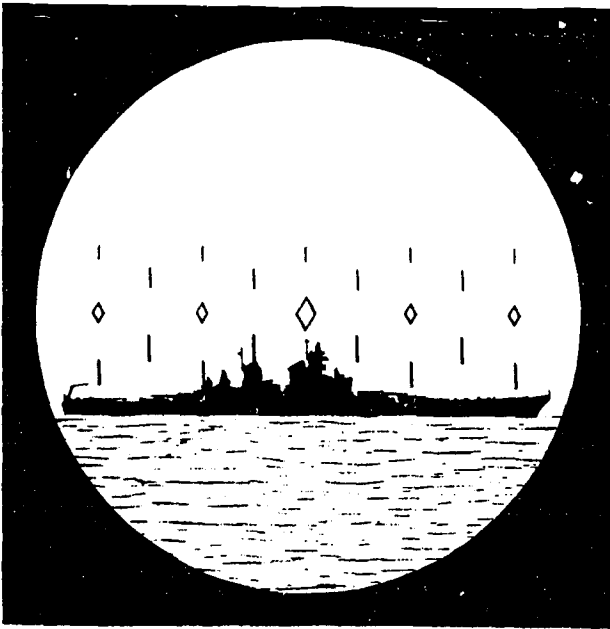

55,294

Figure 8-12.—Field of view in a stereoscopic rangefinder.

either direction. When the target and the diamonds appear to be at the same distance, the rangefinder is properly set, and the operator can read the range on the scale.

In naval use, the stereoscopic rangefinder has largely replaced the coincidence type. If the operators are thoroughly trained, there is no significant difference in the accuracy of the two types. But when ranging on aircraft, or under conditions of poor visibility, a skilled operator can usually get better results with the stereoscopic rangefinder.

COINCIDENCE RANGEFINDER

The main optical system of the coincidence rangefinder includes these elements: end windows, and penta prisms or end reflectors, measuring wedges or compensator wedges, correction wedge, main objective lenses or objective group, astigmatizers, and color filters. Some instruments also have change of magnification lenses. Figure 8-13 shows the optics of a typical coincidence rangefinder. Refer to this illustration as you study the principal elements.

End Windows

An end window is mounted in the front of each end box of the rangefinder. These windows are tightly sealed around the edges, and thus help to keep dirt and moisture out of the instrument. Although the two surfaces of each window have been ground optically flat, they are not quite parallel. Each end window is actually a prism, though a prism of extremely small angle.

By a suitable rotation of an end window, you can make its deviation zero in the plane of triangulation, or you can deviate the incident rays slightly, to either the right or the left. (As you remember from your study of plane geometry, a line and a point determine a plane. The plane of triangulation is the plane determined by the halving line of the rangefinder and the sighting point on the target.) Since the end window can deviate the incident rays, they provide a means of compensating for slight inaccuracies in the reflecting angles of the penta prism, or elsewhere in the instrument. There is an index, and in some instruments a graduated scale, on the outer edge of each end window, or on its frame, to show the setting. (On some rangefinders, the left end window is plane-parallel; only the right end window is used for corrections on these instruments.)

The end windows are set during the final inspection of the rangefinder, after it is manufactured, and after each overhaul. When the rangefinder has become thoroughly stabilized at normal temperature, the inspector checks the internal adjustment, and then rotates one or both end windows to secure a correct reading on an accurately known range. It should not be necessary to reset the end windows in service.

End Penta Prisms or End Reflectors

The penta prisms or end reflectors (often called penta reflectors) deviate the line of sight through an angle of 90° . In most rangefinders, the deviation in the right penta prism or end reflector, although constant, is slightly less than 90° . (You will be told why a little later in this chapter.) A penta prism, by reflecting the image twice, produces an erect, normal image. A plane mirror or a right-angle prism could not be used for this purpose because the image would be reverted. In addition, the deviation of a right-angle prism is not constant—it is 90° only if the incident light is normal to the first surface.

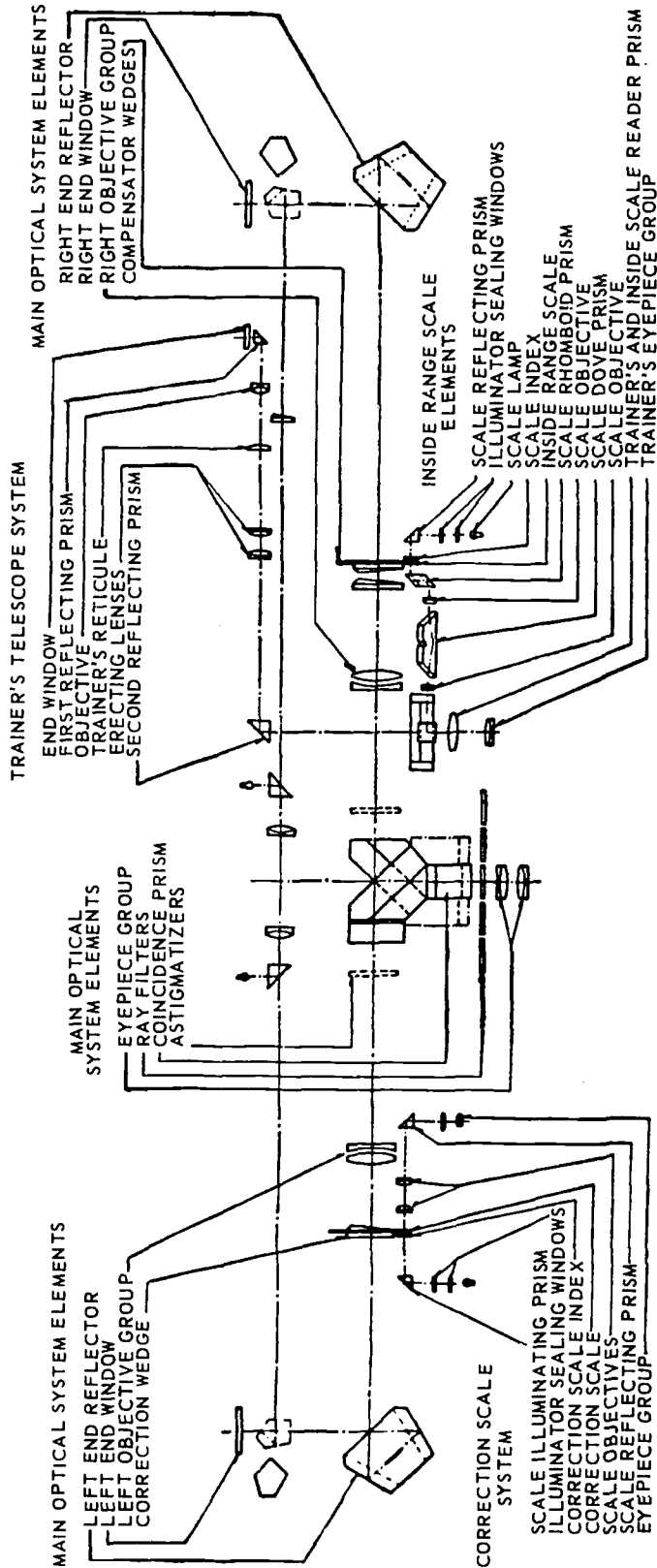

148.15

Figure 8-13. —Optics of the coincidence rangefinder.

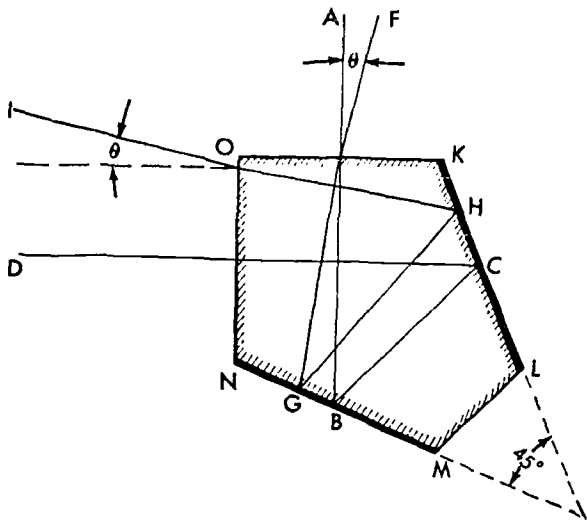

148.16

Figure 8-14.—Principle of the penta prism and end reflector.

In large, long-base rangefinders, the objective lens must be quite large to make the field of view wide enough. These instruments use end reflectors, rather than penta prisms as does the rangefinder of figure 8-14. An end reflector consists of two plane mirrors, rigidly mounted together at an angle of 45° .

The path of light within it is the same as that in a penta prism. Figure 8-14 shows the path of light through a penta prism. A study of this diagram will show you that the deviation is constant, regardless of the angle of incidence. Although the light is refracted at both outside surfaces, the two refractions are equal and in opposite directions. Since the surface refraction can be disregarded, you can see that an end reflector works in exactly the same way.

In a long-base rangefinder, the end reflector has two advantages over the penta prism. First, it is less expensive than a penta prism of sufficient size. Second, and more important, a large end reflector responds quickly to temperature changes; after a change in temperature, the end reflector stabilizes within a short time. A large penta prism, on the other hand, responds slowly, since glass is a poor conductor of heat. For some time after a temperature change, various parts of a large penta prism would be at various temperatures, with resulting distortion and inaccuracy.

Measuring Wedge or Compensator Wedges

Look back at figure 8-7 and review the function of the measuring wedge or compensator wedges. To summarize: they are thin, achromatic prisms, that can be used to deflect the line of sight in one telescope back through the angle θ , so that the two images coincide. There are two general types of deviating wedges: (1) a single measuring wedge, mounted so that you can slide it along the optical axis of the instrument; and (2) two compensator wedges, so mounted that when you turn the ranging knob the two wedges rotate equally and simultaneously, in opposite directions, about the optical axis.

Figure 8-15 illustrates the action of a single measuring wedge. It is mounted on the longitudinal axis of the instrument, between the objective lens and its image plane. As you can see in the illustration, the deviation of the wedge is constant. But the displacement of the line of sight, at the image plane, depends on the position of the wedge along the axis. For any angle θ , and therefore for any range, there is a certain position of the wedge on the axis that will make the two images coincide. You use this system to measure ranges by rigidly attaching a pointer to the wedge, and allowing that pointer to travel over a fixed scale. You calibrate this scale by marking the position of the pointer when targets coincide at accurately known ranges.

Some instruments use a pair of compensator wedges. The two compensator wedges are mounted on the axis of the right-hand telescope, outboard of the objective. Figure 8-16 shows a single prism in the position of the compensator wedges.

The incident ray, as usual, diverges from the axis by the angle θ . The prism will deviate that ray toward its base. For any given angle θ , you can select a prism with exactly the deviation necessary to make the incident rays parallel to the axis when they strike the objective. When the rays are parallel to the axis at the right objective (as they are at the left objective), the two images will coincide.

As mentioned before, this method could be used to measure ranges by trial and error. With a large assortment of prisms handy, you could try them out, one by one, until you found one with exactly the deviation necessary to make the rays parallel to the axis. The paired compensator wedges make ranging practical by providing a continuously variable deviation.

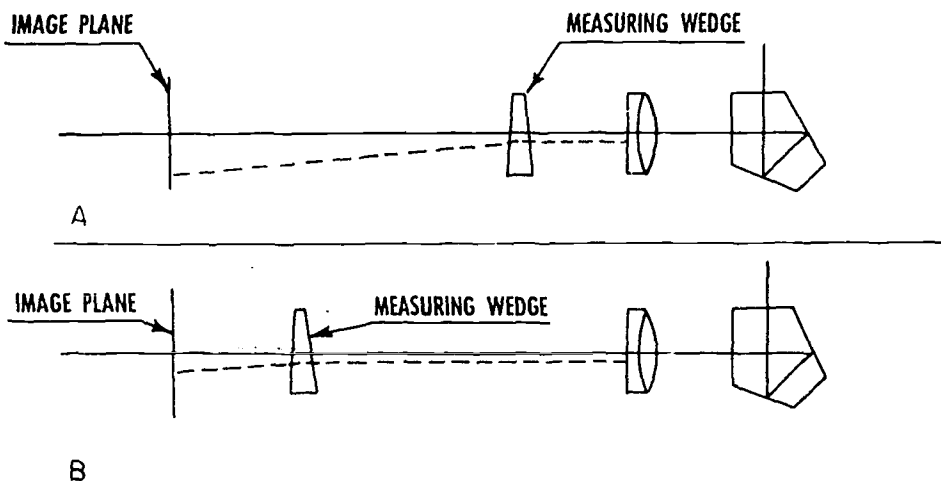

148.17

Figure 8-15.—Action of the single measuring wedge.

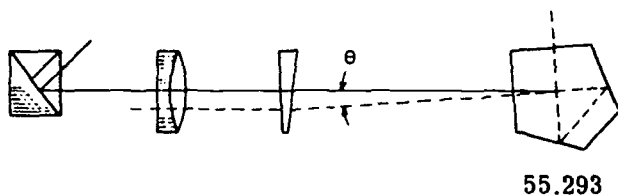
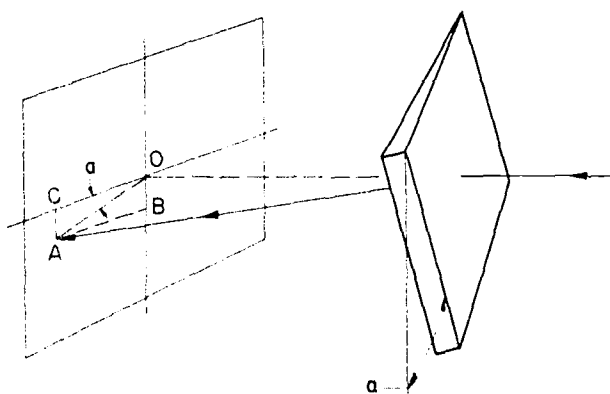

Figure 8-16.—Action of the compensator wedges.

55.293



55.295

Figure 8-17.—Effect of rotating a single wedge.

Any prism, as you know, will deviate the incident rays toward its base. With the base toward the target (as in fig. 8-16), or toward the

operator, all the deviation will be in a horizontal plane. If the base were up or down, all the deviation would be in a vertical plane. If you turn the base to some angle between zero and 90° , the rays will be deviated both horizontally and vertically at the same time.

Figure 8-17 shows what happens when you rotate a single wedge about the optical axis. A screen is used to intercept the deviated ray, to show what happens to it. The line AO shows the total deviation of the ray toward the base of the prism, CA is the vertical component of the deviation, BA the horizontal component. If you keep the wedge at a fixed distance from the screen, then the total deviation OA will be constant, regardless of the angle of rotation. But as you rotate the wedge the horizontal and vertical components will change. The horizontal component of deviation, BA , is the one you need to reduce the parallactic angle to zero. The vertical deviation must be eliminated entirely; otherwise the halving line will fail to split the image—the images will be spread out, or they will overlap.

By using two wedges, rotating through equal angles but in opposite directions, you can keep the horizontal deviation and eliminate the vertical deviation. Figure 8-18 shows how compensator wedges work. Remember that a prism always deviates the ray toward its base.

Since the range is always large compared to the base of the rangefinder, the parallactic angle is always small. The compensator wedges, therefore, are prisms of very low power—the

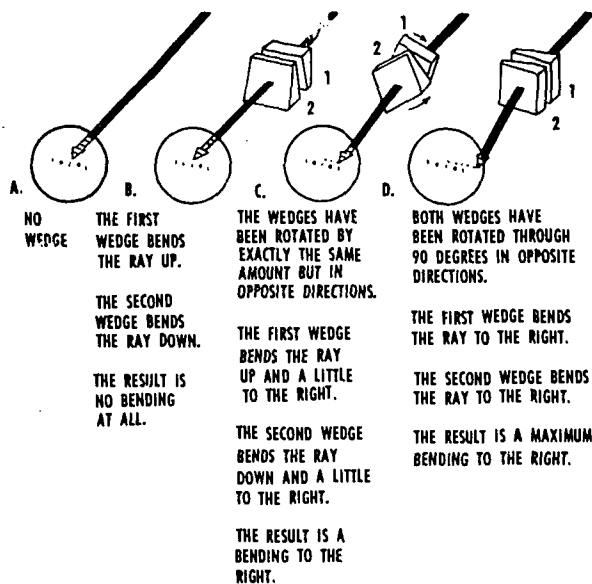

148.18

Figure 8-18.—Refracting a ray of light with two compensator wedges.

angle is sometimes so small you cannot tell which side of the disk is its base. For this reason a small mark is etched at the edge of most wedges. It represents a line from the center of the base to the apex of the prism.

Earlier in this chapter, you were told that the deviation in the right-hand penta prism or end reflector is less than 90° . To understand why, first consider what would happen if the deviation were exactly 90° . Then, for a target at infinity, the incident ray would be deviated parallel to the optical axis. Since the parallactic angle is zero, no deviation is needed in the compensator wedges to make the two images coincide. For a target at infinity, you would turn the base of one wedge up and the base of the other one down, as in part B of figure 8-18.

For a target at the minimum measurable range, the incident rays would deviate from the optical axis, toward the operator, at the maximum parallactic angle. To make them parallel to the axis would require maximum deviation away from the operator; consequently, you would turn the compensator wedges so that both their bases were toward the target. Obviously no rangefinder can measure a range greater than infinity, or less than the minimum measurable range. To cover the whole span of measurable ranges, only rotate the wedges

through 90° ; all measurable ranges will be crowded into 90° on the scale.

You could read the scale more accurately by expanding the calibrations to cover 180° . You can do so by making the deviation in the right penta prism or end reflector less than 90° (by making the angle between the two reflecting surfaces less than 45°). Now, rays from a target at infinity will be deviated away from the axis, back toward the target. To make the images coincide, turn the wedges so that both bases were toward the operator. For a target at mean range, the incident rays would be parallel to the axis after deviation by the penta prism or end reflector. They would require no deviation at the wedges; you would turn one wedge base up and the other wedge base down. At minimum range you would have maximum deviation toward the operator, and would compensate for it by turning both wedge bases toward the target. In this system, as you can see, you need 180° of rotation of the wedges to cover the full span of measurable ranges. And consequently, the calibrations will be spread through 180° on the scale.

Correction Wedge

The correction wedge provides a means for correcting errors in alignment. Like the measuring wedge, the correction wedge is a thin prism of low power. In some instruments it is achromatic; in others it is a simple prism. It is located in the left-hand telescope, and mounted so that it can be rotated by the operator. Rotation of the wedge, of course, deviates the line of sight, both vertically and horizontally. The deviation in the plane of triangulation is the most useful; errors in horizontal alignment are corrected by adjustment of the optical bars, or adjustment of the height adjuster linkage which raises and lowers the end of the optical bar.

Rangefinder operators sometimes disagree as to when the two halves of the image coincide. An operator may find that he habitually makes an error in ranging, and that this error is fairly constant. With experience he can learn the usual amount of his habitual error, and adjust the correction wedge to correct it.

Coincidence Prism

The coincidence prism has three functions: (1) bringing the images formed by the two objectives to a common focal plane where they can

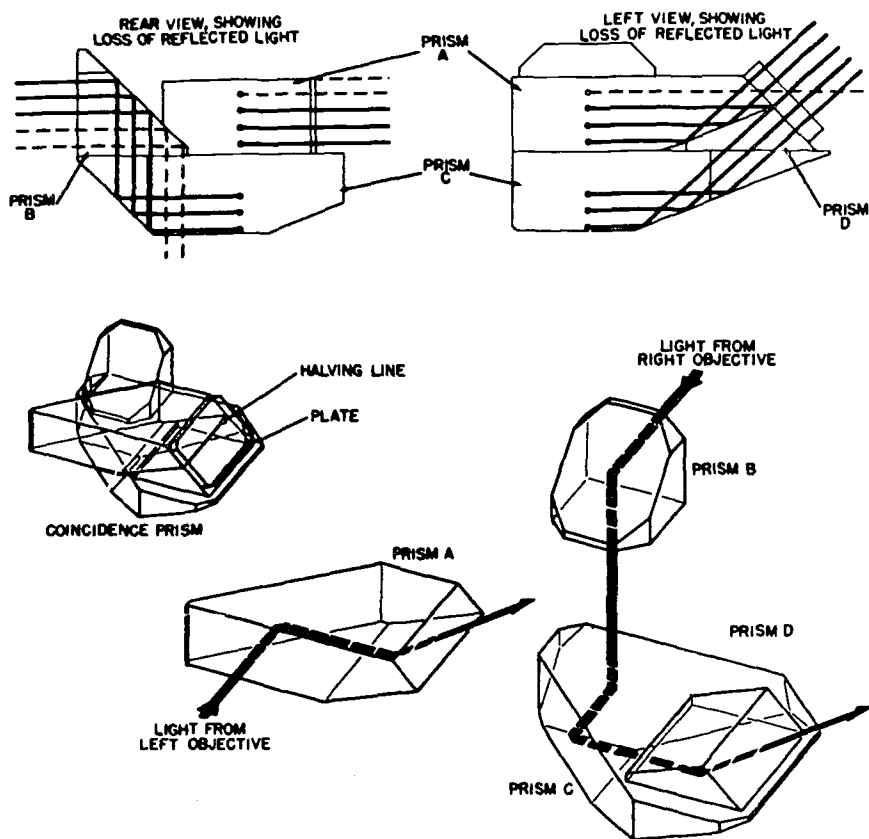

148.19(148A)

Figure 8-19.—Principle of the coincidence prism.

be viewed by the eyepiece, (2) erecting the images, and (3) suppressing the upper half of the right image and the lower half of the left image. Figure 8-19 shows how the coincidence prism accomplishes these functions.

Light rays from the left objective enter prism A and are reflected horizontally 90° toward the eyepiece. Half of these rays are reflected upward by the second reflecting surface of prism A, forming the upper half of the target image. The rays above the center of the prism are lost as they do not strike the second reflecting surface of prism A.

Light rays from the right objective strike prism B of the coincidence prism and are reflected down into prism C. The first and second reflecting surfaces reflect the rays horizontally toward the eyepiece; and third reflecting surface of prism C reflects the rays upward toward the eyepiece. Only the upper portion of the eyepiece rays are transmitted to the eyepiece

because a metal shield serves to crop the lower portion of the rays.

Prism D is cemented to prism C. The image of the target is formed at the exit faces of prisms A and D, which are aligned with a plate (fig. 8-19). The halving line (line which divides the two halves of the image) is located where prisms A and D are cemented together.

The four prisms (A, B, C, and D) are cemented together to form a single unit and the entrance faces of prisms A and B are coated with magnesium fluoride.

Objective Lenses

The function of the objectives is to form real images of the target on the reticles. The objectives are made and mounted with the greatest of precision. If the focus of the objectives are not exactly alike, the magnification of the image in the right and left eye will differ and the range

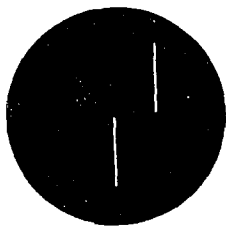

148.20

Figure 8-20.—Astigmatized half-images of a searchlight.

readings will be incorrect. Lack of uniformity in the focus of objectives is readily detected when a target is observed that is not in the center of the field. The right and left objective lenses are therefore selected and adjusted to give the same focus. They are composed of a positive lens of crown glass and a negative lens of flint glass. The objective mounting and the spacing between them must be carefully adjusted to give the correct focus, and they must be held firmly in their mounts without strain.

Eyepiece Group

The eyepiece group is used to view, and to magnify, the composite image reflected by the coincidence prism. The eyepiece has a focusing mount; the usual focusing range is from plus 2 to minus 4 diopters.

You will find several different types of eyepieces in the various marks of Navy rangefinders. The two most common are:

1. The orthoscopic eyepiece (composed of a doublet and a single lens).
2. The achromatic eyepiece (composed of two doublets, with an air space between them). The newer instruments are provided, almost exclusively, with the achromatic eyepiece.

Astigmatizers

The two astigmatizers—one in each telescope—are mounted on the objective side of the coincidence prism. You can throw them simultaneously to the IN position, where they intercept the rays just before they reach the coincidence prism, or to the OUT position, off the axis, where they have no effect on the image.

Each astigmatizer is a simple lens, but with its surface ground to cylindrical, rather than spherical shape. As you may remember, a cylindrical lens produces an elongated image—the image of a single point will appear as a line. The astigmatizers are useful when you are ranging on a searchlight at night. Here your target image is practically a point of light. You would have to manipulate the rangefinder very carefully to get that point image exactly on the halving line, and even then you could never be sure you had made exact coincidence. When you throw the astigmatizers to the IN position, the two half-images of the searchlight become vertical lines of light, perpendicular to the halving line as in figure 8-20. To make exact coincidence you need only turn the ranging knob until the two half-images form a single, unbroken vertical line.

Color Filters

The color filters are mounted between the coincidence prism and the eyepiece. You will find various color assortments in the various marks of rangefinders. These filters have the same function they have in a telescope: they serve to dim a too brilliant image; they help to reduce haze; under some conditions they increase the contrast of your target against its background.

RANGEFINDER MK 21 MOD 2

The Rangefinder Mk 21 Mod 2, (fig. 8-21), is a portable 1 meter base coincidence type used primarily for navigation. It is a 14-power instrument designed to measure ranges between 250 and 10,000 yards.

In use, it may be hand held, mounted in a socket, or supported in a web harness worn by the operator.

The Mk 21 has two eyepieces, one for ranging and one for reading the range scale.

Range Scale Reading System

The left eyepiece, used to read the range scale, consists of a window and dove prism (to facilitate reading the indicated range with the left eye) and a lamp, filter, and condenser lens to illuminate the range scale (fig. 8-22). A scale reader prism is incorporated which provides a magnified view of the scale.

The range scale, (fig. 8-23), is engraved with graduations indicating 5-yard intervals from

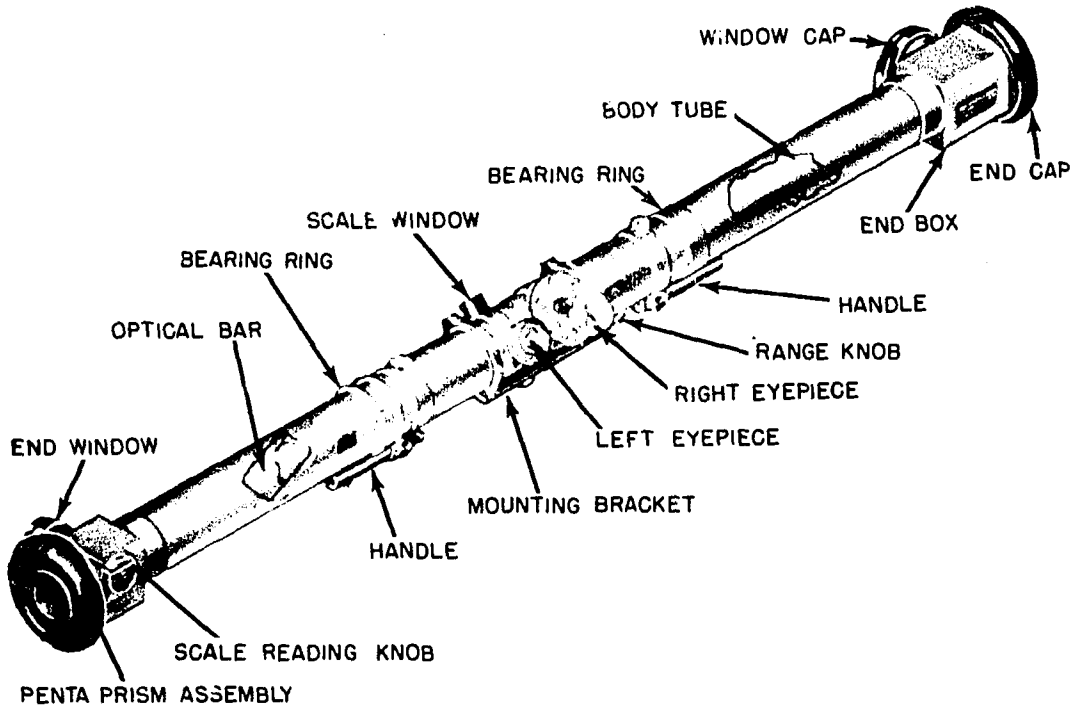

148.330

Figure 8-21.—Location of rangefinder components.

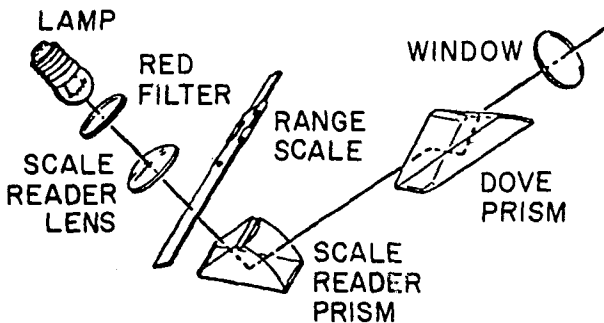

148.331

Figure 8-22.—Range scale reader optical system.

250 to 500 yards; 10-yard intervals from 510 to 1000 yards; 50-yard intervals from 2100 to 5000 yards; 500-yard intervals from 5500 to 10,000 yards; and at 15,000 yards and 20,000 yards. An asterisk marks the infinity graduation with 3 graduations on either side to indicate units of error short of or beyond infinity.

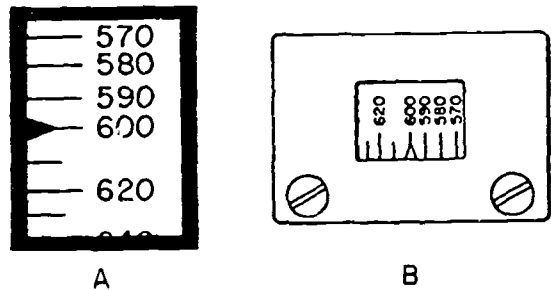

148.332

Figure 8-23.—Views of range scale.

Main Optical System

The main optical system, (fig. 8-24), consists of end windows, penta prisms, astigmatizers, objectives, range wedge, coincidence prism, ray filters, and eyepiece. The various components function as described previously with the exception of the left end window, an optical wedge which deviates the line of sight 1.5 minutes and is mounted in a rotatable bushing. The left end

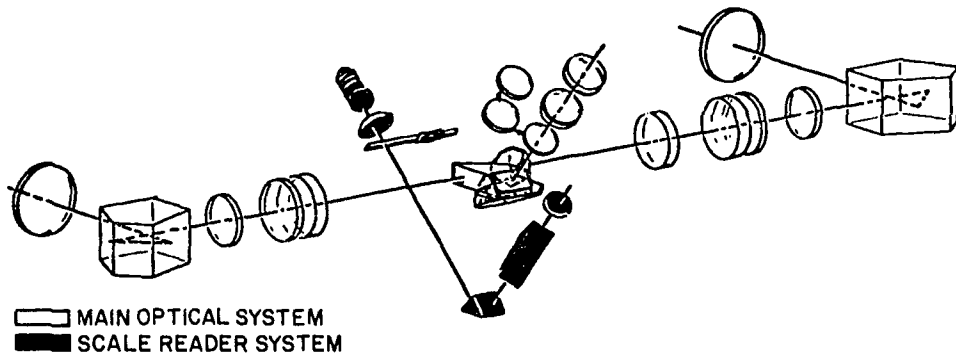

148.333

Figure 8-24.—Rangefinder optical systems.

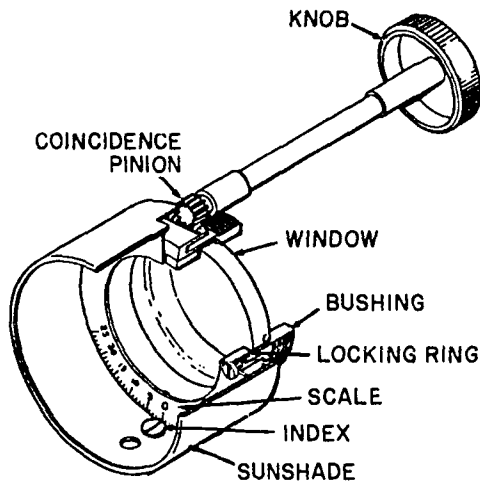

148.334

Figure 8-25.—Left end windows.

window, (fig. 8-25), can be adjusted to provide coincidence when the rangefinder is sighted on a target of known range with the range scale set for that range.

The penta prism mounts are adjustable to remove target lean and halving error. The objectives are adjustable to remove parallax and the coincidence prism can be moved to make the halving lines coincident.

STEREOSCOPIC RANGEFINDER

Like the coincidence rangefinder, the stereoscopic rangefinder uses a measuring wedge, or a pair of rotating compensator wedges, to measure the parallax angle; it shows the result on a scale calibrated to indicate the range in

yards. The two instruments differ in the way the operator determines when the wedges are correctly set. In the coincidence rangefinder he makes two half-images coincide; in the stereoscopic rangefinder he depends on his own stereoscopic vision.

The stereoscopic rangefinder has two eyepieces; the operator's right eye sees the image formed by the right-hand telescope; his left eye sees the other one. The two images fuse together, just as they do when you look through a pair of binoculars.

In each of the two telescopes, in the focal plane of the objective lens, is a reticle. The images of these two reticles, like the two target images, appear to fuse and form a single image. The two reticles are similar, but not identical. Consider, for a moment, a single mark near the center of each reticle. The operator sees a separate mark with each eye; he fuses the two images so that he sees a single mark. But rays from corresponding points on the two marks, as they enter the two eyepieces, are not parallel; they diverge at a small angle. This angle corresponds to a parallax angle. To the operator, viewing the two marks stereoscopically, they appear as a single mark located at a finite distance in space.

Rays from the target, reaching the two eyepieces through separate telescopes, also diverge at a small angle—the parallax angle of the target. If the parallax angle of the reticle marks is smaller than that of the target, the fused reticle image will appear to be more distant than the target; if the parallax angle of the reticle is greater than that of the target, the reticle will appear to be closer.

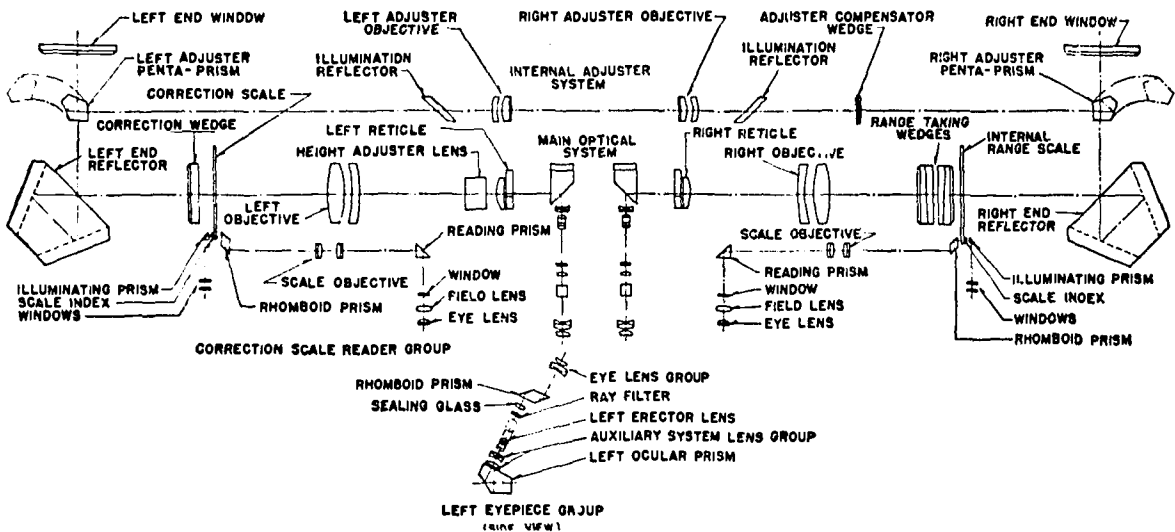

55.300

Figure 8-26.—Optics of the stereoscopic rangefinder.

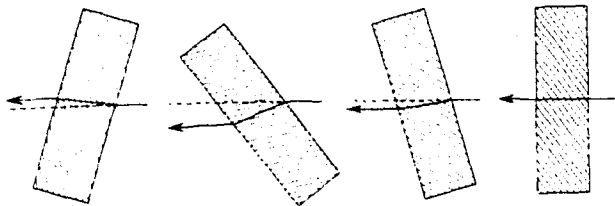

55.299

Figure 8-27.—Principle of the height adjuster.

By rotating the compensator wedges you can change the apparent parallax angle of the target. In the coincidence rangefinder you reduce it to zero; in the stereoscopic rangefinder you make it equal to that of the reticles. The target and the reticle mark then appear to be at exactly the same distance. The amount of rotation of the wedges necessary to make the two angles equal is a measure of the parallax angle of the target; consequently, the scale can be calibrated to show the range in yards.

Figure 8-26 shows the optics of a stereoscopic rangefinder. As you can see, they are similar to those of the coincidence type, except for the central elements. The principal parts fall in two groups:

1. End windows, end reflectors or penta prisms, measuring wedge or compensator

wedges, objective lens groups, correction wedge, eyepiece groups, and color filters.

2. Height adjuster, ocular prisms, reticles, rhomboid prisms, collective lenses, and erector lenses.

In some instruments the erectors also serve as change-of-magnification lenses. There is no astigmatizer; since there is no halving line, you do not need it. All the elements in group 1 above are the same as those of the coincidence rangefinder. They will not be described again. The elements in group 2 are found only in the stereoscopic type.

Height Adjuster

What happens when a ray of light passes through a flat plate of glass? If the ray is normal to the surface, it passes through without any change. If it strikes the surface at a smaller angle, the emergent ray is displaced to one side, though it is still parallel to the incident ray. Figure 8-27 illustrates this principle.

In the stereoscopic rangefinder, the height adjuster is a flat disk of glass in the left-hand optical system. The disk is mounted in bearings, and connected to a knob outside the rangefinder. The operator, by turning the knob and thus tilting the height adjuster, can raise or lower the left-hand target image.

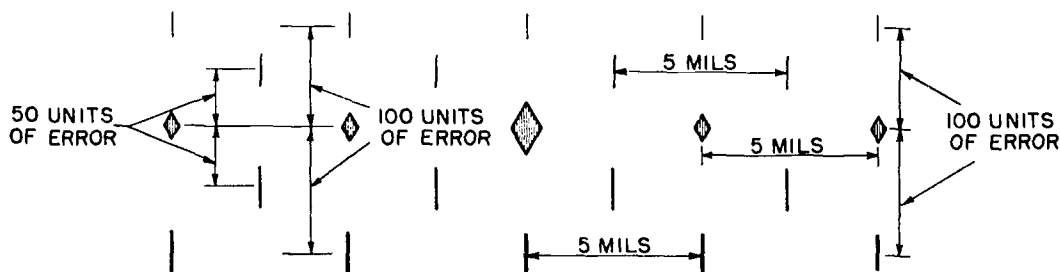

55.304

Figure 8-28.—A typical reticle pattern.

The stereoscopic rangefinder uses its height adjuster for aligning the two optical systems in the horizontal plane, and its correction wedge for vertical alignment.

Ocular Prisms

The two ocular prisms, one for each telescope, are mounted near the center of the instrument. Each prism reflects the image twice, and presents an erect and normal image to the eyepiece. In the newer, double-purpose rangefinders, the prism elevates the line of sight so that, if the lines of sight from the end windows are horizontal, the operator must look downward in order to see the target image. (In the Mk 42, the operator's line of sight is downward at an angle of 25° from the vertical.)

Reticles

The reticles are plano-parallel glass disks with reference marks etched on them. They are usually mounted in the focal plane of the objective lenses. Figure 8-28 shows a typical reticle pattern. (We've added the lettering and arrows to help explain the pattern. On the reticle itself you will see only the vertical marks and the diamonds. In some rangefinders, each reticle is cemented to a convex-plano lens. In most of the recent instruments you will find several sets of reference marks engraved on the reticles.

As you know, the two reticles are slightly different; the operator fuses the two reticle images stereoscopically. All the diamonds appear to be at the same distance; the operator can use any one of them as a reference mark in measuring the range (fig. 8-29). All the marks in any one horizontal row appear to be at the same distance. But the various rows appear to

be at various distances: to the operator, the upper rows appear to be more distant than the diamonds; the lower rows appear closer than the diamonds. The marks in the first rows above and below the diamonds are so spaced that their apparent distance from the diamonds is equal to 50 units of error. (A unit of error is the greatest theoretical distance by which a range reading may be wrong.) The second rows from the diamonds appear to have a range difference of 100 units of error.

In ranging, the operator rotates the compensator wedges until the diamonds and the target appear to be at the same distance. He need not change this setting to measure the distance from the target or a burst or splash. By using the vertical marks for reference, the operator can estimate the spot in units of error, which can then be converted to the equivalent in yards for that particular range.

The spacing, from center to center, between any two adjacent marks in the same row, corresponds to five mils in deflection. Thus the operator can quickly make deflection spots without training the rangefinder off his target.

Rhomboid Prisms

The rhomboid prisms provide a variable interpupillary adjustment. They are so mounted that the distance between their forward faces remains constant. They pivot about a point at the center of the forward face; thus the distance between the rear faces is variable, and can be set for the operator's interpupillary distance.

Each collective lens (sometimes called field lens) gathers light from a rhomboid prism and bends it toward the eyepiece lens.



Figure 8-29.—Target and reticle images.

84.214

AUXILIARY OPTICAL SYSTEMS

In most rangefinders—both coincidence and stereoscopic—you will find several auxiliary optical systems, in addition to the main system. Some of these are used in ranging; others provide a means for adjusting the main optical system. The principal auxiliary systems are: the internal adjuster system, the adjuster scale reading system, the main scale reading system, and the trainer and finder telescope system.

Main Scale Reading System

The main scale reading system is used to read the two range scales: the internal scale connected to the wedges, and the external scale mechanically linked to them. In some instruments the system is so arranged that the operator can see the scale along one side of the field; in others, an assistant rangefinder operator reads the scale through an auxiliary telescope built into the rangefinder. As shown in figure 8-26, the reading telescope consists of an

arrangement of prisms, a transparent scale, an objective lens, a field lens, and an eye lens. The window in the illuminating system protects the airtight seal of the rangefinder.

The external range scale is a second dial, mounted near the outside of the rangefinder tube, so that it can be read through a window without artificial light.

The internal scale is the more important of the two; normally the operator will read only the internal scale. The external scale is provided for use if the illuminating circuit for the internal scale should fail. In inspecting a rangefinder you should check to be sure that both scales give the same reading. If they do not, you will probably find some lost motion in the mechanical linkage; or the coupling between the external scale and the wedges may be out of adjustment.

Internal Adjuster System

The internal adjuster system provides an artificial target, inside the instrument, which

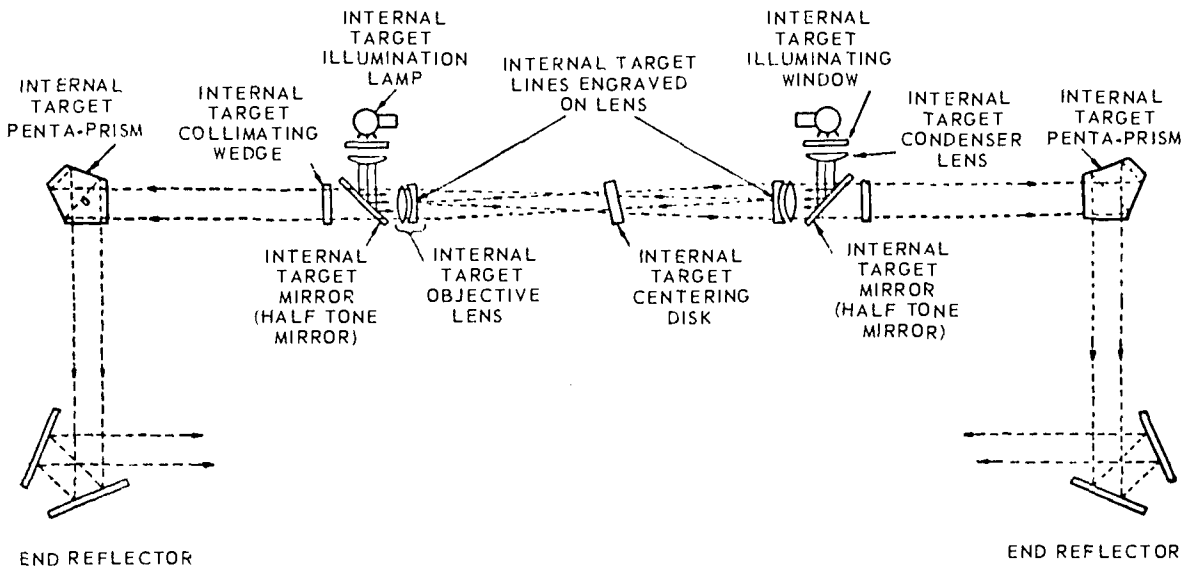

148.21

Figure 8-30.--Internal adjuster system.

can be used to check the range scale. The optics are so arranged that the light from the artificial target, on entering the two main telescopes, appears to come from infinity, or from some selected standard range. The range scale is set for this known distance, and then the wedges are adjusted to give coincidence (or stereoscopic contact) on the artificial target.

A study of figure 8-30 will show you how the system works. The system consists of two objective lenses, located in an adjuster tube mounted alongside the main optical tube of the rangefinder. The objectives are of the same focal length, and they are so spaced that each is at the front focal point of the other. Cemented to each objective is a reticle on which the artificial target—usually two vertical lines—is etched. Thus each target is in the focal plane of the opposite objective. A transparent reflector plate is mounted outboard of each objective.

First, consider the left-hand reflector alone. Light from a small lamp, mounted on the outside of the rangefinder, enters through a window, is reflected from the reflector plate, and illuminates the left target mark. Since this mark is in the focal plane of the right objective, rays from the mark will be parallel after they pass through the right objective. Some of this light will be reflected by the right reflector, and be

lost; the rest will pass through. At the same time, the right target mark is illuminated by the right reflector, and sends out rays which become parallel after passing through the left objective.

At each end of the adjuster tube is a small penta prism. Ordinarily these prisms are swung out of the way, so as not to interfere with the operation of the main optical system. By turning the internal adjuster drive knob, you can crank the two penta prisms into position. This operation automatically closes the shutters over the end windows, to keep external light out of the system.

If the two objectives of the internal adjuster system are so mounted that their optical axes coincide, then the two sets of rays from the two internal targets will both be parallel to that axis. And, after reflection at the two small penta prisms, the two sets of rays will still be parallel to each other. In the stereoscopic rangefinder, the operator will see one target with each eye, and the two images will fuse stereoscopically.

Remember that the deflection in the right-hand penta prism or end reflector is usually less than 90° . This angle differs somewhat in different marks of rangefinders. The angle of deviation of both internal adjuster penta prisms is 90° . So there is one prescribed range at

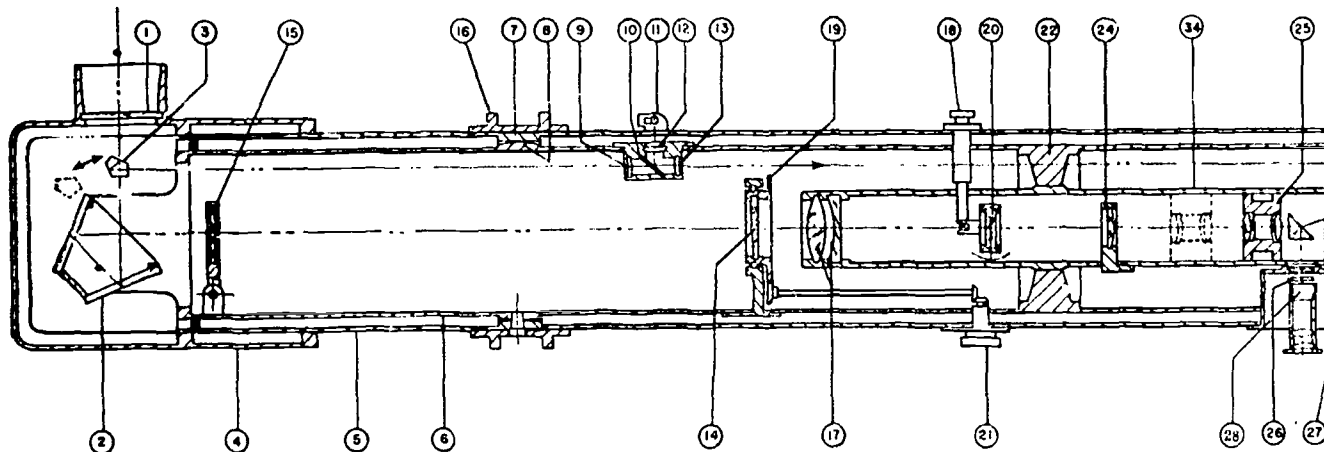

- | | |
|--------------------------------------|---|
| 1. END WINDOW WEDGE | 10. INTERNAL ADJUSTER REFLECTOR |
| 2. END REFLECTOR | 11. INTERNAL ADJUSTER LIGHT |
| 3. INTERNAL ADJUSTER PRISM | 12. INTERNAL ADJUSTER CONDENSING LENS |
| 4. END BOX | 13. INTERNAL ADJUSTER OBJECTIVE RETICLE |
| 5. OUTER TUBE | 14. INTERNAL ADJUSTER CORRECTION WEDGE |
| 6. INNER TUBE | 15. SEARCHLIGHT FILTER |
| 7. INNER TUBE SUPPORT | 16. MAIN BEARING |
| 8. INNER TUBE BEARING | 17. OBJECTIVE LENS |
| 9. INTERNAL ADJUSTER ALIGNMENT WEDGE | |

which the scale **must** be set in order to check its calibration with the internal adjuster system. The operator sets the range scale at this prescribed distance, and then sights through the eyepiece (or eyepieces). In the stereoscopic rangefinder the image of the artificial target must appear to be at the same distance as the ranging mark on the reticles. If it doesn't, the operator must turn the correction knob until it does. He repeats this operation five times, then sets the median correction on the range scale. (With a coincidence rangefinder, of course, the operator must adjust the scale so that the two half-images of the artificial targets make coincidence at the halving line when the range scale indicates the prescribed range.)

On the stereoscopic rangefinder, the internal adjustment is easier to make if the ranging mark on the reticle is centered between the two vertical lines of the artificial target. If it is not centered, turn the internal target adjuster knob (sometimes called the collimator knob) to center it. The artificial target should never appear to

touch the ranging mark; if it does it will interfere with your stereoscopic judgement.

Adjuster Scale Reading System

The correction wedge of the internal adjuster system is similar to a single measuring wedge. The adjuster scale reading system enables you to determine the position of this wedge. On some instruments the position of this wedge is shown on a scale attached to it; on others it is indicated on a dial similar to the outside range scale. The system includes a source of illumination, and lenses for magnifying the scale. On all rangefinders later than the Mk 28, the scale is graduated in units of error.

RANGEFINDER MARK 42

Rangefinder Mark 42 and all Mods are of the stereoscopic, wandermark type, with change-of-magnification input mechanism. The only difference between the various modifications of the

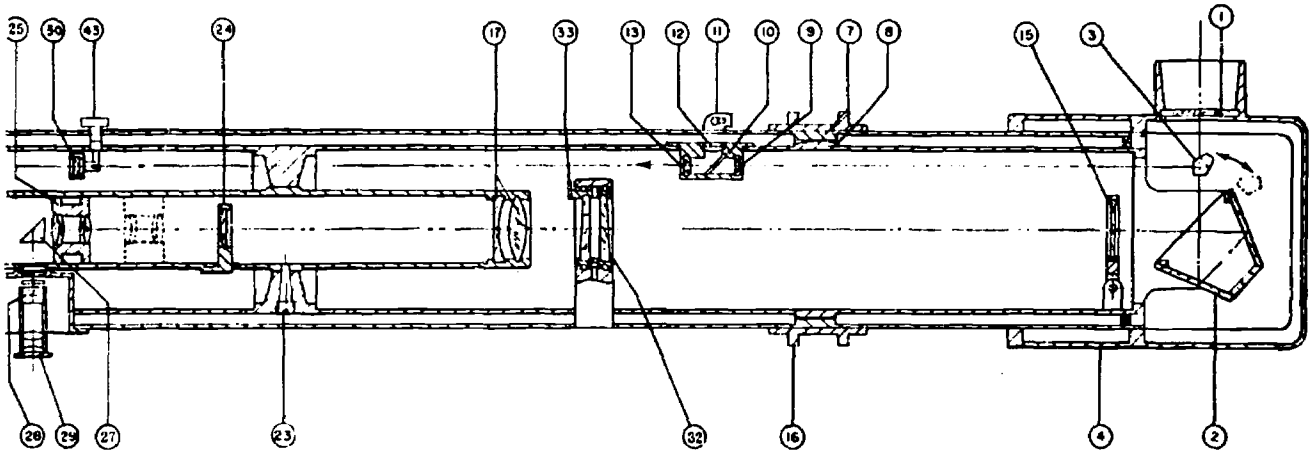

- | | |
|---------------------------------------|--|
| 18. HEIGHT ADJUSTMENT KNOB | 27. EYEPIECE PRISMS |
| 19. CORRECTION SCALE | 28. EYEPIECE RHOMBOID PRISMS |
| 20. HEIGHT ADJUSTMENT PLATE | 29. EYE LENSES |
| 21. INTERNAL ADJUSTER CORRECTION KNOB | 30. INTERNAL ADJUSTER TARGET CENTERING PLATE |
| 22. OPTICAL BAR SUPPORT | 32. COMPENSATING UNIT |
| 23. OPTICAL BAR LOCK STUD | 33. INNER RANGE SCALE |
| 24. RANGEFINDER RETICLE | 34. OPTICAL TUBE |
| 25. ERECTING LENSES | 43. INT. ADJUSTER TARGET CENTERING KNOB |
| 26. COLOR FILTER | |

Figure 8-31.—Cross-sectional view of rangefinder Mk 42 Mod 27.

148.41

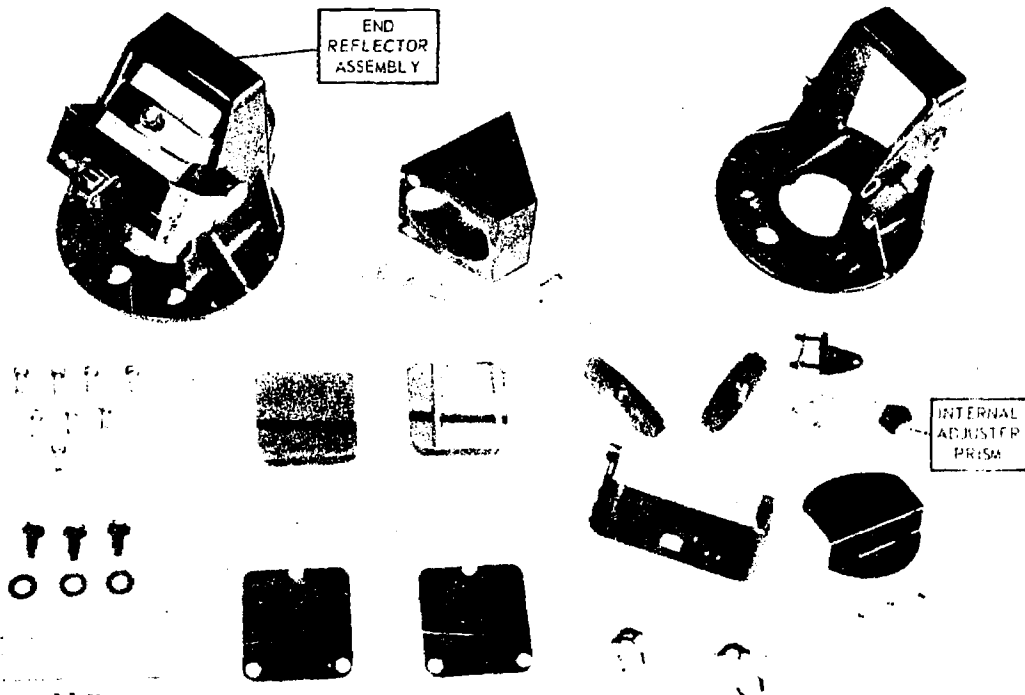

Figure 8-32.—Rangefinder Mk 42 Mod 27 end reflector.

148.42

Mark 42 lies in the general arrangement of certain units. The function of any given unit is the same in all modifications. Figure 8-31 shows a cross-sectional view of the Mark 42 Mod 27 rangefinder.

The main structural elements consists of three tubes: The inner and outer tubes which form a double-walled main tube, and an optical bar (tube) mounted inside the innertube.

End Reflectors

It is essential that the rays of incidence to a rangefinder be reflected at fixed angles in the instrument; this is the function of the end reflectors. If a single prism or mirror with total reflection is used at each end, and either is turned in the plane of triangulation, the angle reflected will not remain a constant. To avoid this difficulty, the end reflectors used in the rangefinder are of the pentagonal prism type, shown in figure 8-32. They have two reflecting surfaces that always reflect at an angle of 90° , even when rotated, if the angle between reflectors is 45° . The right end reflector, however, does not reflect an angle of 90° but is constructed to reflect a fixed angle of $89^\circ 49' 6''$.

The end reflectors used in the Mark 42 rangefinder are of the built-up type, with two silvered glass mirrors mounted to a steel block. The mirrors used on rangefinders Mark 42 Mods 25, 26, and 27 are front-surfaced aluminized mirrors. The mirrors have plane parallel surfaces, and are of sufficient thickness to retain their shape, but are not so thick that changes of temperature will affect them by causing internal distortions. The block is made from a solid piece of steel having an expansion coefficient approximately the same as that of the glass. The mirrors rest on three raised spots which are carefully finished and polished. A steel spring plate with three similar spots holds the mirror firmly to the steel block, yet it is free to expand and contract with temperature changes, without introducing any strain or stress in the reflectors. The underside of each steel block has a three-point bearing, with a ground and lapped finish. The steel blocks are bolted to the brackets fastened to the ends of the inner tube. The only effect of the movement of these reflectors, due to slight deformations of the inner tube, is to throw the images out of adjustment in height, which can be readily corrected by the height adjuster, as will be explained later.

Two end reflectors are shown in figure 8-32; one is shown assembled and fastened in position in its mount, while the other is broken down into its component parts.

OBJECTIVES

The function of the objectives is to form real images of the target on the reticles. The objectives are made and mounted with great precision. If the focus of both objectives is not exactly the same, the magnification of the image seen by the right and left eyes will differ and the range readings will be incorrect. Lack of uniformity in the focus of objectives is readily detected when a target is observed that is not in the center of the field. The right and left objective lenses are therefore selected and adjusted to give the same focus. They are composed of a positive lens of crown glass and a negative lens of flint glass. The objectives are mounted in steel frames and separated by steel spacing rings. The objective mountings and the spacing between them must be carefully adjusted to give the correct focus; the objectives must be held firmly in their mounts without strain.

Eye-piece Prisms

The two eyepiece prisms, which reflect the two lines of sight into the eyepiece, are located in the center of the rangefinder. (They are marked No. 27 in fig. 8-31.)

Figure 8-33 shows the two eyepiece prism mounts of the Mk 42 Mod 27 rangefinder. (The repairman has removed the left prism mount, by taking out the two adjustable locking bolts and one screw.)

Eye-piece Assembly

Refer back to figure 8-31 to identify the principal parts of the eyepiece assembly: the two rhomboid prisms (No. 28), the color filters (26), and the eyepiece lenses (29). The eyepiece assembly is covered in Opticalman 3 & 2, Nav-Pers 10205-A; you should already be familiar with the functions of its parts. The rhomboid prisms, with two reflecting surfaces in each, offset the rays without changing their direction or length of travel. By pivoting on an axis through their front surfaces, the two rhomboid prisms provide an interpupillary adjustment.

The two eyepiece lenses have separate focusing mounts, so that each may be adjusted to provide the observer with a sharp image.

The color filters are so mounted that turning a single knob will bring the filters of the same color into each field. In the rangefinder Mk 42 Mod 27 the filters are arranged in this order: red, yellow, clear, and polaroid.

The eyepiece assembly is mounted on the outer tube of the rangefinder. The outer tube is subject to greater changes due to temperature than either of the other tubes. But the position of the eyepiece is somewhat less critical than that of the other optical groups. The eyepiece has no part in the delicate measurements made by the rangefinder; it serves only as a magnifier to help in the reading of these measurements. Since the eyepiece assembly is completely outside the main gas seal of the rangefinder, you can remove and clean it without breaking the seal.

Erecting Lens System

The erecting lens system has three functions: (1) it provides an erect image of the target; (2) it effectively extends the focal plane of the eyepiece to coincide with the focal plane of the objectives at the reticles; and (3) in some rangefinders it provides a means for changing the magnification. In the rangefinder Mk 42, the erecting system provides a choice of either 12 or 24 power.

The erector lenses are mounted in erector slides. The two slides fit into the optical tube; each slide is connected by a bar to the change-of-power disk. The change-of-power lever rotates the disk; as it rotates, the rods move the slides toward or away from the eyepiece prisms. Spring stops hold the disk in either of its two alternate positions.

Reticles

In the assembling of a rangefinder, the reticles are fixed in the focal planes of the erectors. The objectives are then moved in or out until their focal plane (on a target at a range of 2,000 yards or more) coincides with the plane of the

reticle markings. Each reticle is mounted in a frame that can be rotated about the axis and moved in any direction along the axis. Because the reticle has these two motions, it can be rotated to level its markings, and its center mark can be aligned with the optical axis of the rangefinder. The frame is mounted so that you can remove it without disturbing the other optical parts of the instrument.

Each reticle is a plano-convex lens, with its plane surface toward the objective. The convex surface helps to converge light toward the erector, and thus ensures full illumination of the whole field. The markings are etched on the plane surface; the etched lines are filled with an opaque material, which makes them easier to see. When the reticle illuminator is being used for night ranging, light passes through a lucite rod to the edge of the reticle. The light is then reflected toward the eyepiece from the inner surface of the filled lines.

Compensator Unit

The compensator unit of the Mk 42 is mounted between the right objective and the right end window. It consists of two achromatic wedges, mounted so that you can rotate them about the optical axis. The rotations of the two wedges are equal, and in opposite directions, so there will be no vertical deviation of the image. The wedges are rotated by either the range knob or the change-of-range input mechanism.

Range Scales

There are two range scales. An internal glass scale (No. 33 in fig. 8-31) is secured to the mount of the two wedges. The telescope for viewing this scale is attached to the outer tube of the rangefinder. This scale reading telescope is located about 2 1/2 feet to the right of the eyepieces; your line of sight through it is parallel to that through the oculars.

The external range scale is located in the change-of-range gear box. The scale can be viewed along a line of sight parallel to that through the oculars; or if a prism is swung into position, the scale can be viewed along an axis at an angle of 45° to that of the oculars.

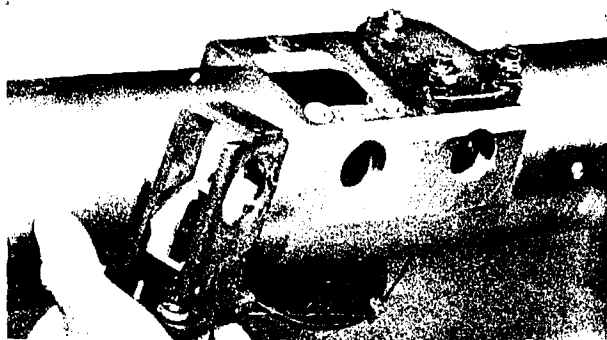

148.45

Figure 8-33.—Eyepiece prism mounts.

mechanism converts the estimated change into actual rotation of the shaft.

At ranges between 2,000 and 72,000 yards, one revolution of the shaft changes the range setting by 50 yards. Counterclockwise rotation (viewing the shaft from its outer end) increases the range reading; clockwise rotation decreases it. At ranges below 2,000 yards, or above 72,000 yards, one rotation no longer corresponds to a 50-yard change in range reading, but will vary depending on how low or how high the range reading is.

The change-of-range mechanism is housed in a gear box, which is mounted on the outer tube

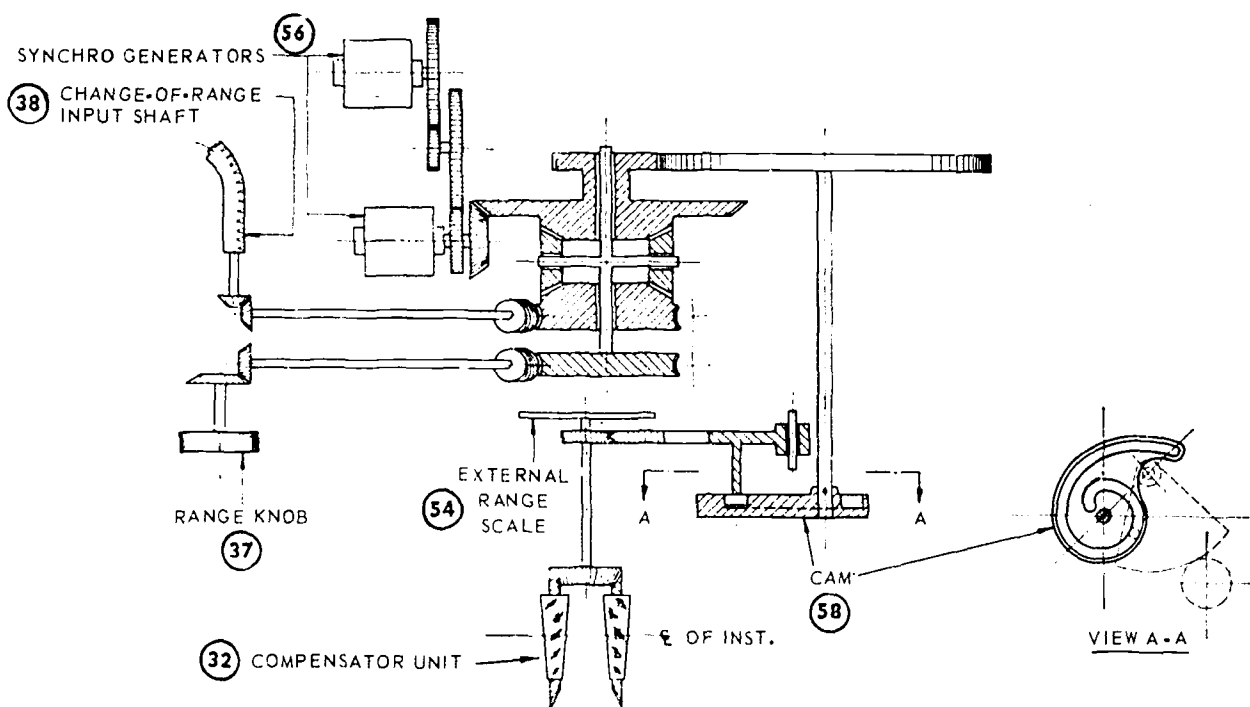

148.46

Figure 8-34.—Change-of-range mechanism (schematic), rangefinder Mk 42 Mod 27.

Change-of-Range Input

Mk 42 rangefinders are fitted with a change-of-range input mechanism. When an operator ranges on a moving target, a computing device introduces the estimated change of range into the rangefinder. The change of range is introduced by rotation of the input shaft; a range conversion of the rangefinder. Figure 8-34 illustrates the

arrangement of the shafts, the differential, the cam, and the compensator. A rotation of either the range knob (No. 37 in fig. 8-34) or the input shaft (38) will cause rotation of the differential. Motion of the differential will be transmitted to the cam (58); motion of the cam is transmitted through a follower and a sector to the compensator unit (32).

Since the input shaft and the range knob are connected to the compensator unit through differential gears, it is possible to rotate either the shaft or the knob without causing a rotation of the other. But the rotation of either of them, or the simultaneous rotation of both of them, will result in rotation of the compensator wedges.

Range Transmission

The two synchro generators (No. 56 in fig. 8-34) are operated by the differential. These generators instantly transmit range readings from the rangefinder to the gun director. Between the limits of 2,000 and 72,000 yards, rotation of the generator rotors is directly proportional to the change in range.

On the range knob is a spring-actuated pushbutton by which the operator can control a light or other signal on the range indicator to show when the range is to be read.

The height adjuster provides a means for moving the left-hand image up or down to bring it to the same apparent height, in relation to its reticle, as the right-hand image.

The height-adjustment unit is mounted on the inner tube of the rangefinder; its mount passes through an opening in the optical bar, and holds the adjustment glass on the optical axis. Since the glass itself is a disk with parallel faces, its longitudinal position is not critical. But it must be far enough from the objective to let all the converging rays pass through the lens.

Correction Wedge

The correction wedge, controlled by a knob, rotates about the line of sight on the rangefinder axis. It corrects known errors of the rangefinder and habitual errors of the individual operator.

The correction scale is secured to the correction wedge mount. An increase in the correction scale reading will cause a decrease in the range scale reading. The telescope for viewing the correction scale is mounted just to the left of the main oculars; the line of sight through it is parallel to that through the oculars.

End Windows

The two functions of the end windows are to provide a transparent, gastight seal and to provide a means for correcting the accumulated errors of the entire optical system of the

rangefinder. Each window is an optical wedge with an extremely small angle; rotation of a window will cause a small change in the apparent parallactic angle.

RANGEFINDER OPERATION

The primary job of the rangefinder operator is to measure ranges accurately, consistently, and with reasonable speed. To do this job successfully he must have a thorough knowledge of rangefinder adjustments, and continued practice in making them. The Opticalman's primary job is repairing the rangefinder—not operating it. But the OM can do his job more efficiently by becoming thoroughly familiar with the operating technique, and by developing maximum skill as a rangefinder operator. Here are some tips on rangefinder operation:

Do not spend too much time on one range setting. If you make a setting carefully and confidently, it will probably be accurate; if you make a setting hesitantly and then back off a little and try again, it may not be as accurate.

There are two ways to make the range setting: by making the original setting too long, and then turning back to the target; or by making the original setting too short, and then working forward to the target. If possible, use the second method, setting original range short and working toward the target. At longer ranges this method can provide a more accurate range setting.

On stationary or slow-moving targets always make the setting in the same direction, whether measuring ranges or calibrating the rangefinder. A fast-moving target can be tracked more smoothly when the settings are made in the direction of target motion.

When the range rate is low (that is, the range is changing slowly), you may not notice when the target drifts out of stereoscopic contact with the reticle. Under such conditions it is advisable to break contact, deliberately and frequently. But keep the break small; simply turn the ranging knob a short distance, then remake the contact. For a skilled operator it is unnecessary to bracket both sides of the target, except under very difficult conditions. (When the range rate is high, the target motion itself will break the stereoscopic contact. Simply bring the reticle back on again.)

On most rangefinders there is a range-signal button (buzzer) mounted at the center of the ranging knob. The buzzer is used to signal when

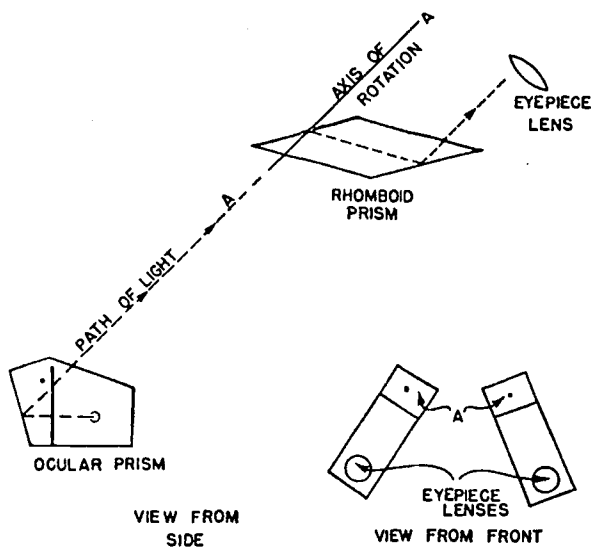

55.298

Figure 8-35.—Interpupillary distance adjustment.

a range setting is made. The buzzer is sounded only while the target and reticle are actually in stereoscopic contact.

As often as possible, practice ranging on moving targets when ranges are being simultaneously measured by some other means. Practice will help you become as skillful as a smooth, fast rangefinder operator. This skill is invaluable in the art of calibrating the instrument. If a rangefinder is not available for frequent practice, use a stereo trainer. Tests have shown that, in the early stages of training, a man can learn as well on the stereo trainer as on the rangefinder.

Avoid these common errors that cause inaccurate ranging:

1. Setting interpupillary distance inaccurately.
2. Setting focus improperly. (If one of the images is slightly blurred, it will decrease stereo perception.)
3. Setting height adjustment improperly. (This also decreases stereo perception.)
4. Making internal adjustments carelessly or with the range scale incorrectly set.
5. Pressing face too hard against the rubber eyeguards.
6. Dirty eyepieces or end windows.
7. Covering the target with the ranging mark of the reticle. (This interferes with stereoscopic

judgment. The ranging mark should appear just above the target, not superimposed on it.)

It is obvious that rangefinders are precision instruments, since the parallactic angles they measure are extremely small. Suppose, for example, that a target at a range of 6,000 yards moves 18 yards toward you. How much does the parallactic angle change? In the Rangefinder Mk 42, the parallactic angle would increase by only 0.00014 degrees (0.5 seconds of arc). Yet, under favorable conditions, this rangefinder can detect that small a change in the parallactic angle.

The elements of the rangefinder must be made and assembled with extreme precision. Any small errors that may be present after assembly can be eliminated by adjustment of the end windows. In addition, the instrument is provided with several checks and adjustments to facilitate accurate ranging. The knobs by which these adjustments are made vary in position on the different marks of rangefinder, and sometimes on different modifications of the same mark. However, the knobs are always labeled.

STEREOSCOPIC RANGEFINDER OPERATION

In the next sections we will discuss the operation of the stereoscopic rangefinder. The operation of the coincidence type is quite similar; differences will be pointed out later. The four basic adjustments of the stereoscopic rangefinder, in the order in which the operator makes them, are:

1. Interpupillary adjustment.
2. Focus adjustment.
3. Height adjustment.
4. Internal adjustment.

Interpupillary Adjustment

Figure 8-35 shows how the rhomboid prisms enable you to adjust the spacing of the eyepieces. Since the image is reflected twice in each prism, it emerges unchanged. You can see that by pivoting the two rhomboid prisms on the axis A-A you can adjust the distances between the eyepieces. Moving the prisms on this axis does not change the length of the path of light, nor change the orientation of the image in any way.

A small knob or lever, located near the eyepieces, controls the interpupillary adjustment. If you do not know your own interpupillary distance, it might be a good idea to measure it. Use an accurate interpupillometer and measure to the nearest 1/4 millimeter. Then, whenever you use or inspect a rangefinder, you can set the interpupillary adjustment to the proper value for your eyes.

The operator must make this adjustment very carefully, to within 1/4 millimeter of the proper setting for his eyes. He should then tighten the locknut, if there is one, to keep the setting from changing while the rangefinder is in use. If parallax is present, a small error in the interpupillary setting can cause serious errors in ranging. The greater the parallax of the instrument, the larger the errors will be. Parallax is present, you remember, when the image formed by the objective does not lie exactly in the plane of the reticle. No matter how carefully you adjust the rangefinder during overhaul, a small amount of parallax will nearly always be present. Parallax is sometimes caused by temperature changes; more often, by variations in range. The objective is positioned so that when a target is at medium range its image will fall in the plane of the reticle. Thus if a target is at extreme range, its image will fall short (on the objective side) of the reticle; if the target is at close range its image will fall beyond (on the eyepiece side of) the reticle.

When a target is at short range, too small an interpupillary adjustment will result in short range readings; too large an adjustment will make the readings too long. For a target at extreme range you have the opposite effect: a large interpupillary adjustment will make the range readings too short; a small one will make them too long. Figure 8-36 shows what happens when the image falls on the eyepiece side of the reticle.

Focus Adjustment

The purpose of the focus adjustment, of course, is to bring the target image sharply into view. Make the adjustment by turning the knurled focusing rings below the eyeguards. The focusing scale is calibrated in diopters. You remember the proper procedure for focusing any telescope: turn the focusing collar to the minus end of the scale, look through the eyepiece, and then turn the collar back toward plus until the image is sharp. This method helps

reduce eyestrain in using the rangefinder; the eyes accommodate more readily to a minus setting than to a plus setting.

Focus the eyepieces one at a time. Keep both eyes open while you focus; when focusing one eyepiece, have someone cover the other end window, if practicable. Of course, if you know the proper setting for your own eyes and know that the focusing scale of the rangefinder is correctly calibrated, you can instantly set the eyepieces to the proper focus for your eyes.

Although it seems obvious, operators sometimes forget that changing the focus will not remedy haze, or darkness, or fogged end windows. The operator should determine the diopter setting for his own eyes, on each instrument he uses, under the best possible conditions. He should use this predetermined setting when conditions are unfavorable for accurate focusing.

Height Adjustment

The height adjustment secures the horizontal alignment of the images in the two rangefinder telescopes. You can change the height adjustment by rotating the height adjuster knob. You will not have to make this adjustment very often, but you should check it each time you use the rangefinder, or whenever you have trouble in fusing the two images.

There are two ways to make the adjustment. In one of these, you aim the rangefinder at the horizon. Keep your eyes on the horizon, and notice the reticle marks without looking at them closely. Turn the ranging knob until you break your stereoscopic fusion of the reticle images, and see two separate images of the reticle pattern. (You will need a little practice before you can do this easily.) Turn the height adjuster knob slowly until the two center marks of the reticle patterns are at exactly the same height above the horizon.

If you are working in the shop, you can use the other method. Cover one of the end windows of the rangefinder and look through the other eyepiece. Train and elevate your rangefinder on some fixed target, and adjust it so that the bottom point of the center reticle mark barely touches the top of the target. Now cover the opposite end window. Train the rangefinder, without elevating or depressing it, to bring the other reticle mark over the same target. Turn the height adjuster knob until the bottom of the mark barely touches the top of the target. This is the more accurate of the two methods, but it

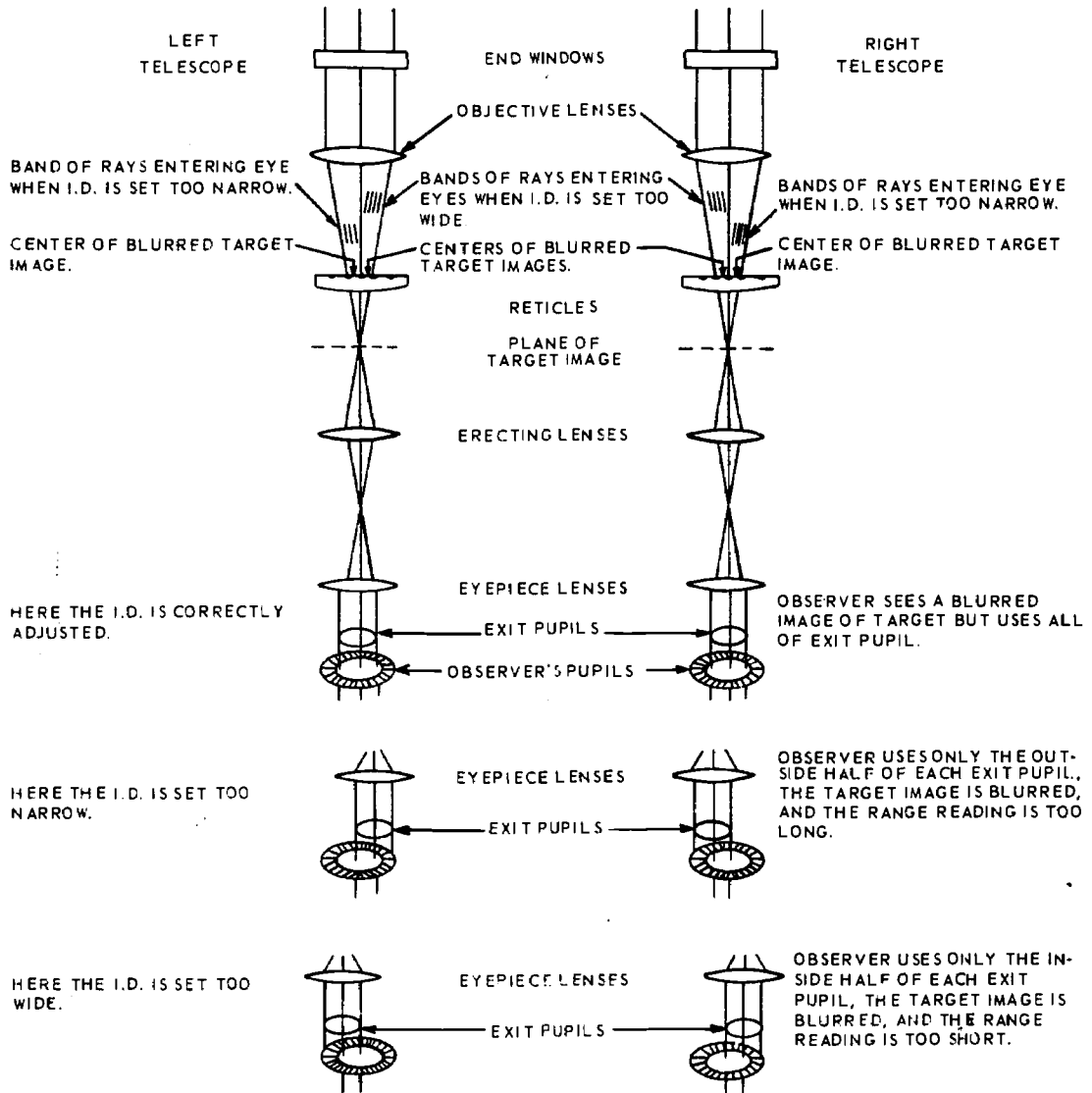

Figure 8-36.—Errors caused by parallax and incorrect interpupillary adjustment.

148.22

requires that the rangefinder mount be absolutely stable.

Internal Adjustment

The internal adjuster system provides an artificial target, inside the instrument, by which you can check the accuracy of the range scale settings. In using the internal adjuster system, the operator will see a target consisting of two vertical lines, with the center mark of the reticle

between them. He then turns the correction knob until the target lines and the reticle mark appear to be at exactly the same distance, and sets the indicated correction on the correction scale.

Figure 8-37, part A, shows the type of internal adjuster target in the Rangefinder Mark 42 Mods 4 and 5. Figure 8-37, part B, represents the target in Rangefinder Mk 42 Mods 6, 8, 9, 10, 11, 12, and 13. In the figure the dotted lines

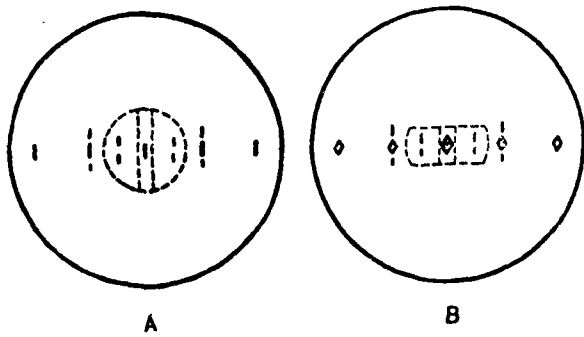

148.23
Figure 8-37.—Reticle and adjuster target.

represent the target. (The reticle marks outside the target are not visible when you use the internal adjuster.) These are the steps in making the internal adjustment of the Mk 42 rangefinder:

1. Set the range scale to 6,000 yards. (The range of the internal target is usually marked on a small plate near the range knob, and indicated on the range scale by a small star.) Set the correction scale at its mid-position—marked "60."
2. Turn the adjuster penta prisms to the "in" position.
3. Illuminate the internal adjuster target.
4. By turning the correction knob, range stereoscopically on the internal adjuster target. Repeat this operation five times, and record the correction scale reading each time. Determine the median reading.
5. Set the correction scale to the median reading. To that reading, add (or subtract) your calibration offset. Now, unless temperature or other conditions change, the rangefinder is properly adjusted.

Other Adjustments

On some instruments you will have to make a few additional adjustments; you will not find all of them on all marks and mods of rangefinders.

1. Headrest adjustment. Adjust it so that your forehead rests comfortably against it when your eyes are at the normal eye-distance. (At normal eye-distance, the rubber eyeguards will rest lightly around your eyes, and exclude all external light.)

2. Color filters. These have the same function as in the coincidence rangefinder. Use them when you need to cut glare or haze, or when you want to increase the contrast of the target against its background.

3. Searchlight filters. These are extremely dark; use them when ranging on a searchlight aimed at your ship.

4. Change of magnification. Some rangefinders are provided with two degrees of magnification. Always use the higher magnification unless you need a wider field of view.

5. Reticle rheostat. This controls the illumination of the two reticles. When ranging at night, adjust the reticle illumination to the minimum usable brightness.

Now look back at figure 8-26. See if you can identify all the parts, and describe their function. But do not try to memorize the details of the optical system; the details will vary considerably between the various Marks and Mods. Concentrate on general principles.

Here is a summary of the steps in preparing a stereoscopic rangefinder for use:

1. Set the interpupillary adjustment.
2. Set the focus.
3. Adjust the headrest.
4. Check the height adjustment; readjust it if necessary.
5. Make at least five internal adjustments, and use the median correction.
6. Use a filter if visibility is poor.
7. When ranging at night, adjust the reticle illumination.

COINCIDENCE RANGEFINDER OPERATION

In most respects, the operation of the coincidence rangefinder is similar to that of the stereoscopic type. Make these adjustments:

1. Set the focus.
2. Check the halving adjustment; readjust if necessary.
3. Make five internal adjustments; use the median correction.
4. Use a filter if visibility is poor.
5. If ranging on a point of light at night, turn the astigmatizers to the "in" position.

All these adjustments are the same as those of the stereoscopic rangefinder, except the halving adjustment and the use of astigmatizers.

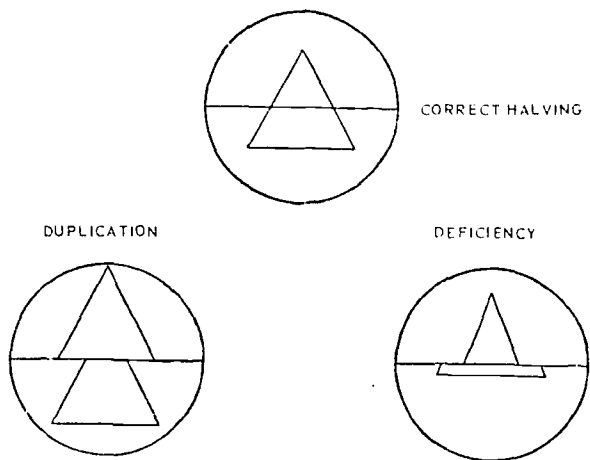

148.24

Figure 8-38.—Effects of duplication and deficiency.

The HALVING ADJUSTMENT secures proper alignment of the two half-images, so that the operator sees a single unbroken image, without duplication or deficiency (see fig. 8-38).

In making the halving adjustment, select a target with a small and clearly defined top, of a shape that will not "telescope" easily. (A pyramid or diagonal is most useful; avoid a mast or other vertical structure.) Use the elevation control to move the halving line slowly up and down over the top of the target. Look closely for any duplication or deficiency.

Be sure that, unless you are ranging on a point of light at night, the ASTIGMATIZERS are "out". If they are "in," they will give you a blurred and streaky image, and make ranging impossible.

RANGEFINDER INSPECTION

Rangefinders must be inspected regularly to keep defects from developing unnoticed. The operator should check these items frequently.

1. Cleanliness of exposed optical surfaces.
2. Supply of lens tissue at the rangefinder station.
3. Cleanliness of eye guards.
4. Lubrication of mount.
5. Helium purity (in antiaircraft rangefinders).

The Opticalman should make a complete inspection every 3 months, and immediately after

the rangefinder has been subjected to rough treatment—for example, prolonged main-battery firing.

STEREOSCOPIC RANGEFINDER INSPECTION

The checklist in figure 8-39 might be used in your inspection of the stereoscopic rangefinder. But do not let the checklist limit your inspection—a list made up beforehand cannot include every possible condition. Record all pertinent information, whether or not you have made a space for it on your checklist.

CLARITY OF SCALES.—The scales must be clean and readable. The internal and external range scales are especially important; the two must read the same within one unit of error. If they do not, look for lost motion in the range-knob linkage.

CLARITY OF IMAGES.—Check the definition in both fields. At the best possible focus, both reticle patterns and both target images should be equally clear. In every telescope system the image will be sharper in the center of the field than at its edges. But if the image is sharper in one of the rangefinder telescopes than it is in the other, you can be sure there is a shifted element or a dirty surface somewhere in the optical system. Look through the end windows for dust, smudges, and moisture.

MOISTURE.—If there is condensed moisture on one of the inner optical surfaces, you can often see it by looking through the end window. If you see any sign of condensation, dry and rechange the rangefinder promptly. (Do not forget to look for moisture in the eyepiece assembly, which is often outside the gas seal.) Even if there is no sign of moisture, check the date on which the instrument was last charged, to see if it is time for recharging.

DIPVERGENCE.—Dipvergence is sometimes called UP-AND-DOWN DIVERGENCE, or STEP. In a properly aligned rangefinder, the rays emerging from the two eyepieces are parallel, or nearly so. If they are not, the operator will suffer from eyestrain; in extreme cases he will not be able to fuse the two images. To test for dipvergence elevate the rangefinder toward clear sky, so that you see nothing but the reticle pattern. Hold your head about 6 inches from the

STEREOSCOPIC RANGEFINDER INSPECTION SHEET

Ship _____ Date _____

Location _____ Mark _____ Mod _____ Serial No. _____

CLARITY OF SCALES _____

CLARITY OF IMAGES: Left side _____
 Right side _____

MOISTURE: End windows _____
 Eyepiece _____
 Gas _____

RANGE OF ADJUSTMENTS	No. of turns clockwise	No. of turns counterclockwise
Height adjustment	_____	_____
Correction knob	_____	_____
Internal target side adjustment	_____	_____

ACCURACY OF INTERPUPILLARY SCALE _____

FOCUS _____

FILTERS: Variable density _____
 Searchlight _____
 Other _____

CLARITY OF INTERNAL TARGET: Left _____ Right _____

RETICLE ILLUMINATION AND STRAY LIGHT:
 Left side _____ Right side _____

PARALLAX _____ CALIBRATION _____

INPUT MECHANISM _____

SATISFACTORY REPAIR DESIRABLE REPAIR URGENT

Inspected by _____

148.35

Figure 8-39.—Inspection sheet.

eyepieces. Look at the center reticle marks, and break their stereoscopic fusion as you do when checking the height adjustment. The two marks should appear to be at the same height.

with an allowable error of one fourth the height.

The dipvergence test is easier if you have a comparator; set it over the eyepieces, as in

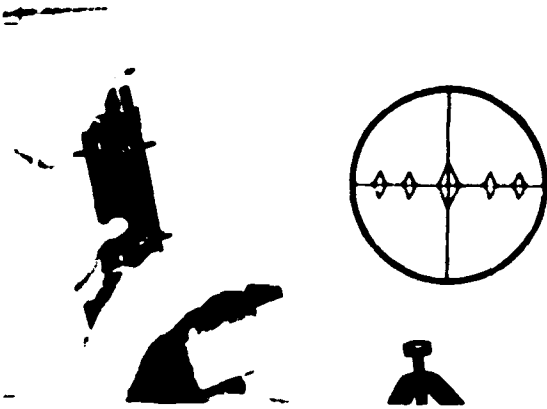

148.36

Figure 8-40.—Using the comparator to test for divergence.

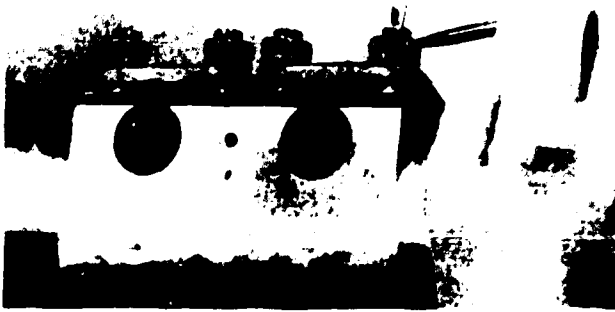

148.37

Figure 8-41.—Adjusting the eyepiece prisms.

figure 8-40. The allowable error is 30 minutes in divergence and 10 minutes in height. To bring the error within tolerance, align the eyepiece prisms by moving their adjustable locking bolts, as in figure 8-41.

RANGE OF ADJUSTMENTS.—Check the limits of the various adjustments. In each, the correct adjustment should fall within the middle third of the total available motion. (At extreme temperatures the correction scale may read outside these limits.) If there is no scale on the adjustment, count the number of turns available between the correct setting and each of the two stops. Check the adjustment mechanism for erratic action; there should be no catching or binding, and no lost motion.

Adjust the interpupillary distance (IPD) scale during each overhaul. During the inspection, check for lost motion between the eyepieces and the scale pointer. If there is no lost motion, it can usually be assumed that the adjustment is still correct. Set the scale and the focus; look through the eyepieces, pressing your face fairly hard against the eyeshields. Check the focus and IPD scales again, to be sure they have not changed.

FOCUS.—Set the rangefinder at its highest power, and set the two diopter scales at zero. Use an auxiliary telescope to look through the eyepieces and focus the auxiliary telescope to give a sharp image of the target and reticle. Now shift to low power. The target and reticles should still be in sharp focus, without resetting either the auxiliary telescope or the diopter scale of the rangefinder.

MAGNIFICATION.—Use a dynameter to check the exit pupil, the eye distance, and the magnification on each side of the instrument as shown in part A of figure 8-42. (When checking for equal magnification during an overhaul in the optical shop, put an aperture stop over the objective to increase the definition, as in part B of fig. 8-42.) To change the magnification on one side of the rangefinder, loosen the setscrew that holds the erecting-lens cell in place. With a scribe, reach through the adjustment hole in the optical bar and rotate the cell, as in figure 8-43. When equal magnification on both sides of the rangefinder is obtained lock the cell in place by tightening the setscrew.



148.38

Figure 8-42.—Checking magnification with a dynameter.

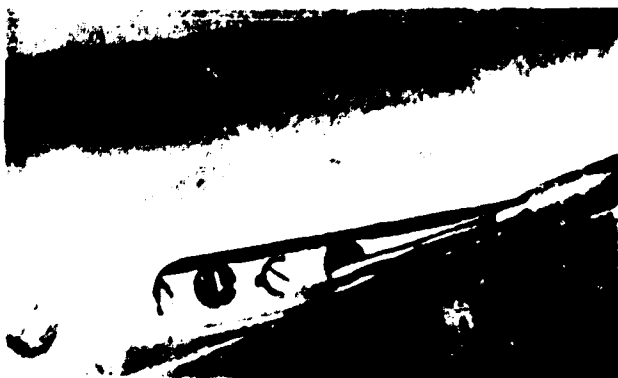

148.39

Figure 8-43.—Rotating the erecting-lens cell.

FILTERS.—Examine the filters for cleanliness and ease of operation. Then make this test: With the clear filter in the line of sight, range on a fixed target and make stereoscopic contact. Then throw the filters in, one at a time. None of the filters should break stereoscopic contact with the fixed target. If one of them does, you will know that the filter's surfaces are not parallel; replace it with a new filter.

INTERNAL TARGET.—The central portion of the internal target should be sharply defined and well illuminated—in other words, easy to range on.

ILLUMINATION.—Make this test at night; a daytime check will give unsatisfactory results. The illumination of the two reticles should be approximately the same. There should be a minimum of stray light and ghost images in the system. If you see stray light in the instrument, remove one bulb at a time until you find the one that is causing the trouble. You can sometimes remove ghost images or stray light simply by adjusting a bulb in its housing.

PARALLAX.—Range on a fixed target at a distance of 2,000 yards or more, and use an auxiliary telescope to check for parallax on each side of the rangefinder. If necessary, unlock the objective cell and adjust it to remove parallax (fig. 8-44).

CALIBRATION.—Check the calibration on the longest available known range, then at short range, and finally at an intermediate range.



148.40

Figure 8-44.—Adjusting the objective.

INPUT MECHANISM.—Rangefinders equipped with input and output mechanisms must be tested electrically. The two synchro units must be set to electrical zero when the range reads 10,000 yards.

SHOCK TESTING.—When you make a test that might be influenced by mechanical shock—the internal adjustment, for example—strike each of the rangefinder bearings with a soft hammer, at each of four points 90° apart. Then repeat the test. If the results are significantly different, they may indicate that one or more of the internal elements is loose in its mounting.

FINDER'S TELESCOPE.—Check to see that the target image, when it is centered in the rangefinder field, is also centered in the finder's telescope. In the finder's telescope the target image, the crosslines or circle, and the inside scale, should all be in focus at the same diopter setting.

Bear in mind that all these inspection tests are intended only to supplement the calibration exercises—not to substitute for them. Some maladjustments of the rangefinder are so elusive that it takes a complete overhaul to find them. But they show up as a history of bad ranging and erratic internal adjustment settings. When the record shows sudden large changes in the correction settings, you can be fairly sure that trouble is developing.

Rangefinder operators will make only the simple adjustments; casualty analysis is your

job. It is up to you to decide, on the basis of your inspections and the calibration logs, when serious trouble exists, and what should be done about it.

COINCIDENCE RANGEFINDER INSPECTION

With a few obvious exceptions, such as interpupillary distance setting, the inspection tests just described will apply equally well to the coincidence rangefinder. Here are a few more tests, which apply to the coincidence type only:

ASTIGMATIZERS.—With the astigmatizers out, range on a slender, vertical target that makes good contrast against its background. Then range on the same target with the astigmatizers in. The two readings should be the same.

HALVING.—Turn the halving adjuster knob through its entire travel, and count the turns. Then turn back half way. The instrument should be approximately in the halving position. Roll the rangefinder in its bearings, and then recheck the halving adjustment.

LEAN.—Range on a target at the right-hand side of the field, and make a careful halving adjustment. Swing the rangefinder in azimuth to bring the target to the left-hand side of the field. The halving adjustment should still be correct.

COMPENSATOR SETTING.—Range on a target near the minimum range, and make a careful halving adjustment. Then range on a target near the maximum range. The halving adjustment should remain correct. (You need not know the true range of the two targets.)

LEAN IN THE INTERNAL ADJUSTER TARGET.—Range on this target, and then turn the halving adjustment until the target is almost hidden under the halving line. Make 10 internal adjustment readings at this setting, and find the median. Rotate the halving adjustment until the halving line covers only a small part of the target. Make 10 internal adjustments at this setting, and find the median. The two median readings should be the same, within one unit of error.

RANGEFINDER CALIBRATION

Complete and accurate calibration data for each rangefinder in service is essential. Correct gun elevation depends primarily on correct measurement of the target range. If the rangefinder readings are inaccurate, the initial salvos will be off in both range and deflection (since drift varies with range). Subsequent analyses of firings may lead to erroneous or conflicting conclusions. Before we can rely on a rangefinder for accurate measurements, we must calibrate it by comparing its readings with other measurements of known accuracy. (The internal adjustment cannot serve the purpose of a complete calibration, since it checks the range scale at only one specified range.)

Although rangefinders are calibrated at assembly, and after each overhaul, their calibration should be checked at every opportunity. Errors can develop from two sources: (1) a slight shift of the end windows (this is rather rare), or of the optical parts of the internal adjuster system or the main optical system; (2) characteristic personal errors of individual operators.

To correct for the constant errors (range error and UOE) found in a rangefinder, you determine an appropriate offset of the correction scale (called "calibration offset" or "index correction"), and apply it to the correction scale after the internal adjustment. Then make a preliminary calibration of the rangefinder by adjusting its end windows; fine calibration for each individual operator must be made by applying his calibration offset to the correction scale. But when you find that all the operators of a particular rangefinder require fairly large calibration offsets in the same direction, it is a good idea to readjust the end windows.

Whenever you make repairs that involve any major optical part between the end windows and the reticles of a stereo rangefinder, or between the end windows and coincidence prism of a coincidence rangefinder, the instrument should be completely recalibrated.

If the rangefinder is properly adjusted, a single calibration offset (for one particular operator) will be good at all ranges. Under certain atmospheric conditions you may get long or short readings at different ranges; but these effects are mostly small, and they are too elusive to be considered in practice. If a rangefinder has two magnifications, you can use the same calibration offset for both. But always use the

highest magnification when you are calibrating the instrument.

When you calibrate a rangefinder, keep these points in mind:

1. Rangefinder errors increase as the square of the range. For that reason, calibration errors that appear insignificant at short range will become serious at long range.

2. When you calibrate a rangefinder against a known range, the probable error of the known range must be considerably less than the probable error of the rangefinder. If the known range has been measured from some point other than the rangefinder you are calibrating, do not forget to apply a suitable correction.

3. Besides the theoretical error, practical considerations limit the accuracy of the rangefinder: heat waves, range rate, vibration, variations in target contrast, etc.

4. Rangefinders are more accurate at high magnification. An instrument with a choice of magnification should be calibrated at its highest power.

5. After a sudden change in temperature, wait several hours before you begin calibration. When you are going to calibrate a turret rangefinder, turn on the turret blowers several hours ahead of time.

6. Variations in the density of the gas inside the instrument (called STRATIFICATION) will cause some inaccuracy in ranges of overhead targets. (This effect is very small when helium is used as the charging gas.)

7. Because of the limitations of lens design, rangefinders are more accurate at the center of the field than at its edges.

CALIBRATION ON MOVING TARGETS

Calibration on moving targets is the method most often used to calibrate a rangefinder against radar. It is suitable for air, surface, or shore targets.

Although rangefinder errors vary as the square of the range, radar error is constant at all ranges. At long ranges a properly calibrated radar is far more accurate than the rangefinder, and you can therefore use it as a standard for calibration. But do not forget that rangefinder errors become very small at short range. At short range a normal internal adjustment provides a more accurate calibration than a check against radar.

On some ships, differential synchros are wired to the radar and rangefinder, and indicate directly the difference in the readings of the two instruments. If this system is not available, you will have to record a series of radar and rangefinder ranges simultaneously. Figure 8-45 shows a form that might be used for this purpose.

The procedure for calibrating a rangefinder against radar on a moving target is as follows:

1. Unless the two instruments are in the same station, or connected by a differential synchro, connect them by telephone.

2. Carefully make all the preliminary adjustments of both rangefinder and radar.

3. Record your internal adjustment settings on the recording sheet, and find the median setting. In the rangefinder calibration log find the calibrating offset that seems most suitable under the existing conditions. If it is plus, add it to (or if it is minus, subtract it from) the median internal adjustment. Set the correction on the correction scale of the rangefinder, and enter it on the recording sheet in the space marked "LA. Used."

4. Track a single moving target simultaneously with rangefinder and radar. The radar operator tracks continuously; the rangefinder operator indicates by buzzer when he is "on target." Record both the rangefinder and the radar ranges whenever the buzzer sounds. Use a separate recording sheet for each instrument; label each sheet with the correct instrument name.

5. Record at least 9 readings—and preferably as many as 15—on each run.

6. Find the error of each rangefinder reading by comparing it with the corresponding radar reading. Convert this difference into units of error, using any of the three methods previously described (the formula, a curve, or the tables in the OP). Record each error on the rangefinder recording sheet; put short errors in the minus column and long errors in the plus column.

7. Find the median of these errors, and enter it on the recording sheet in the space marked "median error." If it is long, mark it plus; if it is short, mark it minus. This figure is the calibration offset. (Be sure you use the MEDIAN, not the mean or average, since occasional wild ranges do not affect the median. To find it: check off the highest error, then the lowest, then the next highest, etc., until only one number is left: that is the median.)

RANGEFINDER RECORDING SHEET

Rangefinder Radar

Location Range 1 Operator Sea, A. B. Recorder Pine, L. S. Date 4/12/-

Run Number 1			Run Number 2			Run Number 3			Run Number 4		
Target Air			Target Air			Target Air			Target Air		
NO.	RANGES	ERROR UOF. (±) (-)	NO.	RANGES	ERROR UOF. (±) (-)	NO.	RANGES	ERROR UOF. (±) (-)	NO.	RANGES	ERROR UOF. (±) (-)
1	11, 450	10 -	1	12, 000	2 -	1	11, 800	- 6	1	8, 500	- 4
2	11, 250	6 -	2	12, 100	0	2	11, 550	- 6	2	8, 550	- 3
3	10, 850	- 4	3	12, 100	- 1	3	11, 750	- 5	3	8, 525	- 4
4	10, 775	- 7	4	12, 000	- 3	4	10, 850	- 6	4	8, 600	0
5	10, 900	- 6	5	11, 900	- 3	5	10, 625	0	5	8, 700	4 -
6	11, 000	- 7	6	11, 900	- 1	6	10, 350	- 2	6	8, 500	7 -
7	11, 100	- 3	7	11, 850	- 1	7	10, 100	- 6	7	8, 425	- 4
8	10, 600	- 5	8	11, 700	0	8	9, 800	- 4	8	8, 400	- 3
9	10, 400	- 4	9	11, 500	- 1	9	9, 750	0	9	8, 400	- 2
10	10, 350	- 5	10	11, 250	2 -	10	9, 625	- 4	10	8, 325	- 4
11	9, 900	- 4	11	11, 250	1 -	11	9, 600	- 5	11	8, 300	- 7
12	9, 800	0	12	11, 150	2 -	12	9, 450	- 6	12	8, 300	- 6
13	9, 700	1 -	13	11, 100	- 1	13	9, 250	- 5	13	8, 325	- 2
14	9, 350	- 6	14	10, 900	0	14	9, 125	- 7	14	8, 350	0
15	9, 325	- 4	15	10, 600	- 2	15	8, 925	- 6	15	8, 375	- 1
Median Error		-4	Median Error		-1	Median Error		-6	Median Error		-3
Calibration Offset Used		-3	Calibration Offset Used		-3	Calibration Offset Used		-3	Calibration Offset Used		-3
Corrected Calib. Offset		-7	Corrected Calib. Offset		-4	Corrected Calib. Offset		-9	Corrected Calib. Offset		-6

I.A. Settings	
1	61
2	61.5
3	61.5
4	60
5	60.5
6	61.5
7	61.5
8	61.5
Median	61.5
Calib. Offset	-3
I.A. Used	58.5

148.29

Figure 8-45.—Rangefinder recording sheet.

8. Add a plus (or subtract, if minus) median error to the calibration offset used; the result is the corrected calibration offset. Enter it in the proper space on the record sheet.

9. Enter the result of each run separately on the rangefinder calibration log. (Fig. 8-46 shows a sample log form.) Be sure you enter the CORRECTED CALIBRATION OFFSET—not the MEDIAN ERROR nor the CALIBRATION OFFSET USED.

10. Determine the calibration offset to be used by each operator pending further tests. Consult the rangefinder calibration log for a particular operator, list his corrected calibration offset for each individual run taken on at least three previous calibration days, and find the median. Use results from more than three days if necessary, to include at least nine individual runs;

or if you suspect that the result from runs on a particular day may be unreliable.

CALIBRATION ON FIXED TARGETS

The simplest way to calibrate a rangefinder is by calibrating on fixed targets. Range on a fixed target at a known distance. By comparing the scale reading with the known distance, you can determine the rangefinder error at that range.

You can sometimes use radar to range on a radar beacon. Alongside each radar beacon is a visible marker that makes a convenient target for the rangefinder. This method is most useful at long ranges.

The procedure for calibrating on any fixed target is as follows:

If necessary you can use the sun, the moon, or a star as a fixed target, by setting the range scale at infinity. You can use the moon either day or night; you can use the sun if the rangefinder has searchlight filters. If you use a star, you will have to make a very accurate height adjustment. This method is useful only when observing conditions are good, and the operators are thoroughly experienced. Experiments show that when inexperienced operators range on an infinity target, they get about three times the spread of readings that they get on targets at a finite distance.

RECORDKEEPING

Calibration results are likely to vary from day to day. To get a reliable calibration offset, the operator should calibrate his rangefinder at every opportunity, and determine the median offset from several days' readings. Using the median of several days' results will tend to nullify the effect of errors made on any one day.

To get the full benefit of rangefinder calibration, the operator must keep accurate records, and apply the results systematically. These records are valuable not only for calibration, but for determining the relative skill of operators as well. By comparing the unit of error spread on the individual recording sheets of various operators, you can get an idea of their relative proficiency: the smaller the spread or scatter, the better the operator.

RANGEFINDER MAINTENANCE

Because of its size, a rangefinder looks like a rugged piece of gear. But you know it is a delicate instrument that must be handled with care. When you overhaul it, you will align the elements within extremely small tolerances. It will take careful handling of the rangefinder to preserve your delicate adjustments. No one should be permitted to touch a rangefinder except the qualified operators and the qualified Opticalmen.

So that the operator will handle his instrument gently, be sure that all the knobs and levers can be turned smoothly, without jerking or forcing. The internal parts of the instrument normally require no lubrication, except during a complete overhaul. To keep oil and oil vapor from reaching the lenses, apply lubricant very sparingly to the parts that extend into the rangefinder. Check the rangefinder mounts

regularly and frequently, and lubricate them whenever necessary.

As much as possible, protect the rangefinder from bad weather. Put canvas boots or metal covers over the end boxes of turret rangefinders and over the whole body of exposed instruments, to protect them from rain and spray. If a rangefinder is unavoidably or accidentally exposed to rain or spray, clean it thoroughly and promptly. Take off the covers in good weather to keep moisture from condensing inside them. But protect the optical elements from direct sunlight; it ages the glass and cement, and introduces temporary inaccuracy because of unequal heating.

Clean a rangefinder the same way you would clean a big telescope. Wipe the body with a clean, dry cloth. Gently remove any grit or salt from the outside optical surfaces with a clean camel hair brush. Finally, polish the surfaces with lens tissue. If there is grease on the surfaces, add a drop or two of alcohol to the tissue.

Thoroughly experienced rangefinder personnel will be able to find the cause of any minor difficulty, and correct it. But the less experienced operators will probably call on you for help. Here is a list of minor rangefinder troubles; you should be able to recognize them and correct them without hesitation:

1. Bulbs loose, burned out, or in wrong receptacles.
2. Rheostat turned too low.
3. Range scale set at wrong range during internal adjustment.
4. Adjuster knob turned only partly into position.
5. Reticle lights on when you make internal adjustment.
6. Change-of-magnification knob between two positions.
7. Color filters part way in.
8. Neutral of polaroid filter unintentionally turned in.
9. Height adjustment incorrect.
10. Astigmatizers unintentionally turned in.
11. Searchlight filter in.

COLLIMATION OF THE MK 42

The initial collimation of the Mk 42 rangefinder is performed during the assembly stage of overhaul. The compensator unit and correction wedge are each aligned before being inserted in the optical tube. Use a Mk 4 telescope

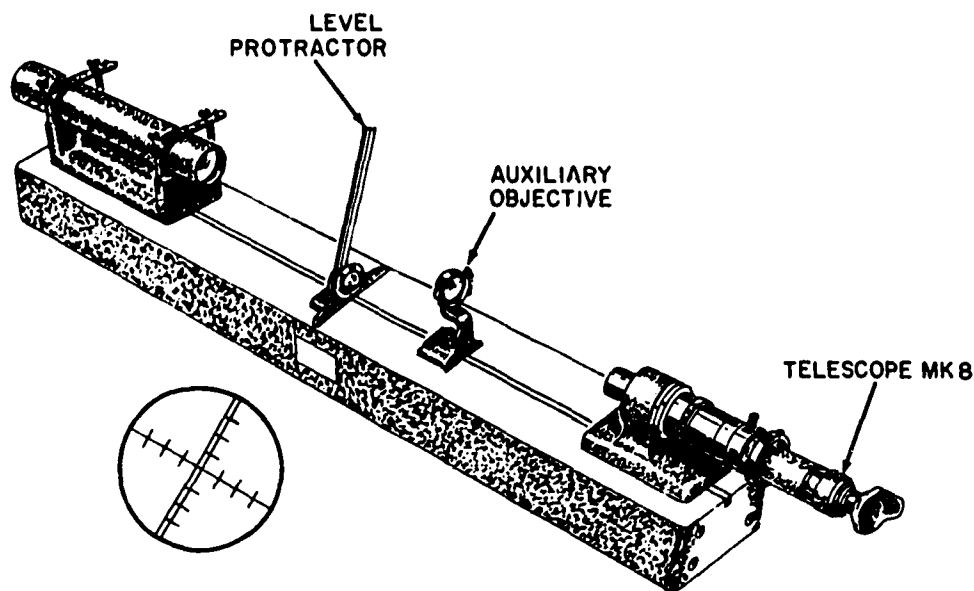

148.70(148A)

Figure 8-47.—Adjusting the collimator telescopes.

collimator or a Mk 2 spotting-glass collimator for the collimation of the compensator unit, correction wedge, and optical tube.

Collimation of the Compensator

The compensator is positioned in the range-finder at an angle of 25° and, therefore, must be collimated at that angle. In collimating, use a setup similar to that shown in figure 8-47. Align the vertical crossline of the boresight parallel to the protractor edge which has been set to 25° . Now remove the auxiliary objective and the protractor and superimpose the collimator telescope reticle on the boresight reticle, being sure not to move the boresight telescope.

Mount the compensator on parallel bars and remove the rear wedge. Set the scale to indicate 1,591 yards, the zero setting for the Mk 42; then temporarily lock it in this position. Install the compensator between the boresight and collimator telescope as shown in figure 8-48. The reticle images will appear as in the insert. Rotate the wedge until the vertical crosslines of the boresight and the collimator telescope are superimposed. The horizontal crossline of the boresight should be below the horizontal crossline of the collimator telescope.

Replace the rear wedge and rotate it until both crosslines are in coincidence.

Unlock the scale and actuate the compensator through its full throw. The horizontal crosslines must stay superimposed and the vertical crosslines must superimpose when the scale indicates 1,591 yards. Readjust the wedges until this condition exists.

Correction Wedge

Using the same test setup as for the compensator, mount the correction wedge as shown in figure 8-49. Set the correction scale to its midposition (indicated as 60). Rotate the correction wedge in its mount until the vertical crosslines of the boresight and collimator telescopes are superimposed and the horizontal line of the collimator telescope is above the horizontal line of the boresight telescope.

To check the setting, move the correction scale off the 60 position and resuperimpose the vertical crosslines by moving the correction scale. When the vertical crosslines are superimposed, the scale must indicate 60.

Optical Tube

The spotting glass collimator, (fig. 8-50), or a similar arrangement is used as a collimation device for the optical tube. The optical tube is mounted on the collimator in special support fixtures as shown in figure 8-51.

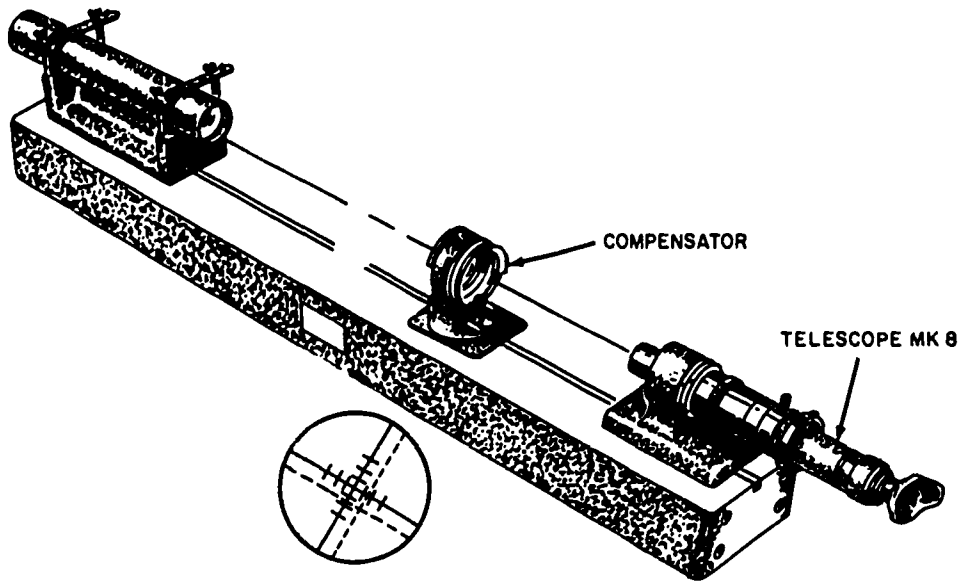

148.335

Figure 8-48.—Rangefinder Mk 14 compensator installed on telescope collimator Mk 4.

The collimator must be aligned before the optical tube is installed. Viewing through one end collimator telescope, rotate the other end collimator telescope and adjust its position until no eccentricity remains. Using an auxiliary objective and machinist's square, align the reticle of the eccentricity free collimator telescope perpendicular to the collimator bed. Align the opposite telescope to the prealigned telescope.

Install the optical tube on the collimator.

Parallax

Remove parallax from both sides of the optical tube by utilizing the auxiliary eyepieces on the collimator telescopes and an auxiliary telescope as with other instruments. Any parallax detected must be removed. To remove parallax in either side, adjust its objective cell in or out as required. The height adjuster must be installed in the left side when you remove parallax.

Lean

When the optical tube is rotated so that the reticle mounting surfaces are parallel with the bed of the collimator, the centers of the

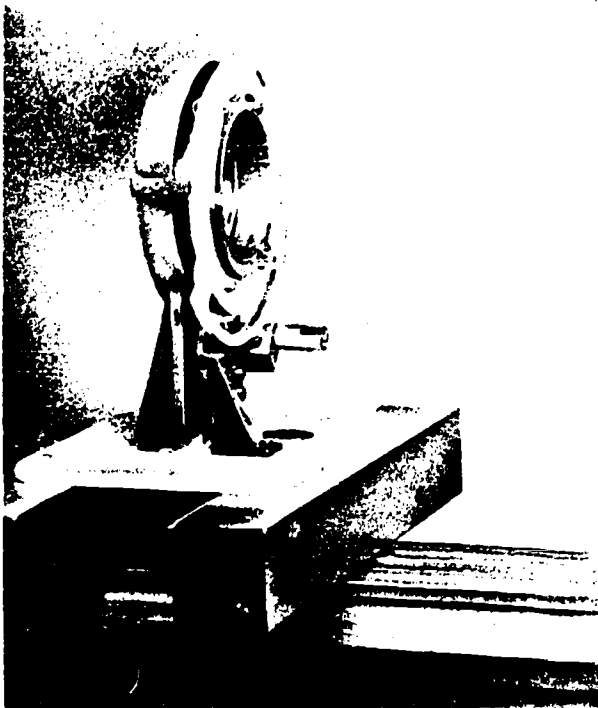

148.73

Figure 8-49.—Correction wedge mounted for collimation.

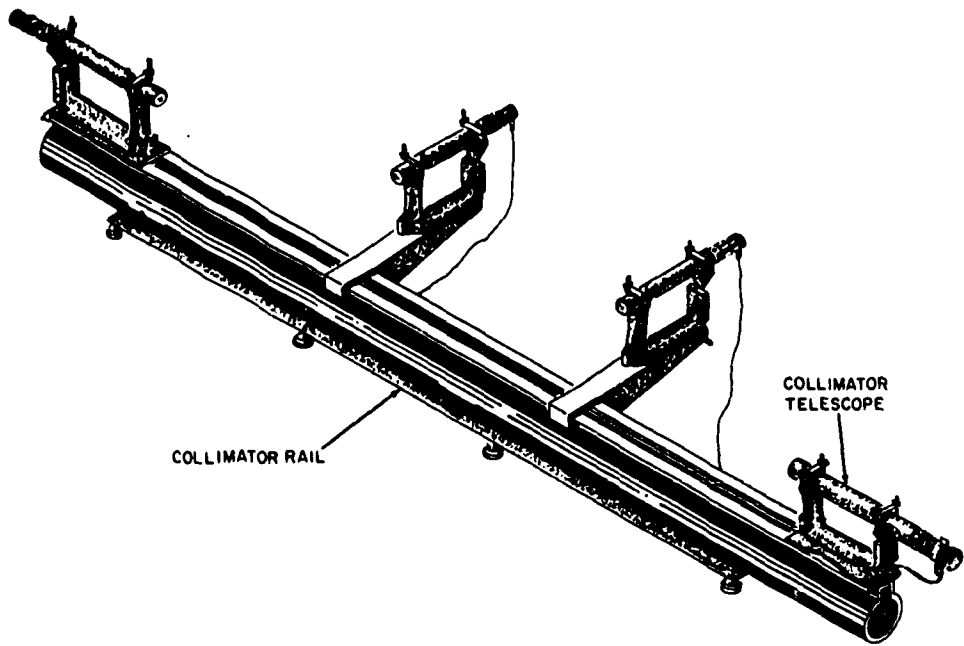

148.336

Figure 8-50.—Spotting glass collimator Mk 2.



148.75

Figure 8-51.—Optical tube, mounted on the collimator.

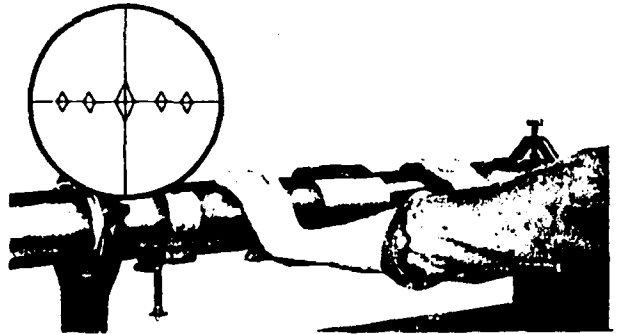

148.76

Figure 8-52.—Centering the diamond.

wandermarks must be parallel to the horizontal crossline of the collimators as shown in figure 8-52. If this is not the case, lean is present and must be removed. Removal of lean is accomplished with the push-and-pull screws on the reticle mount.

sight. Rotating the optical tube will produce eccentricity if the reticle is not properly located. Eccentricity can be removed with the eccentric screws on the reticle mount. When eccentricity is removed, the pattern of movement of the wandermarks should appear as shown in figure 8-53.

Eccentricity

Step and Divergence

Eccentricity results when the reticle is not located precisely at the center of the line of

Step and divergence is produced when the rays leaving the eyepiece are not parallel. Install the

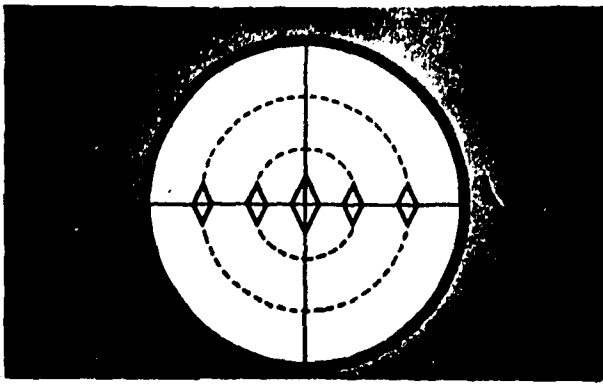

148.78

Figure 8-53.—Diamonds properly collimated through 360° rotation.



148.79

Figure 8-54.—Checking the faceplate position.

faceplate and use a stereo comparator. To check for step and divergence, using one reticle as a reference, adjust its ocular prism until the wandermarks appear centered in the field of view. Viewing through the comparator, remove any vertical or horizontal differences (step or divergence) to the following tolerances: 0 for step, 10' for divergence, and 0 for convergence. The ocular prism opposite the one on the reference reticle side should be adjusted.

Adjusting "0" Diopters

Adjust so that the difference between high and low power is less than 0.2 diopters by moving the individual elements of each erector assembly either closer or farther apart. To adjust

for equal height of eyepieces and zero diopters in high power, move each erector assembly as required.

Final Checking

Once assembled, the rangefinder must be checked on an outside target. Mount the rangefinder where it has an unobstructed line of sight toward a target at an accurately known range of 2,000 yards or more. Then follow these steps:

1. Use a comparator, as in figure 8-54, to check the alignment of the reticle diamonds. If the faceplate is not square with the line of sight, adjust it.
2. Train the rangefinder on the outside target, and use an auxiliary telescope to check for parallax. To remove parallax, release the locking ring on the objective mount, and adjust the position of the objective.
3. Set the height adjuster at midthrow, and check the height adjustment against your outside target. The inserts in figure 8-55 show an improper adjustment. To bring the two target images to the same height, raise or lower one of the images by rotating the corresponding end reflector.

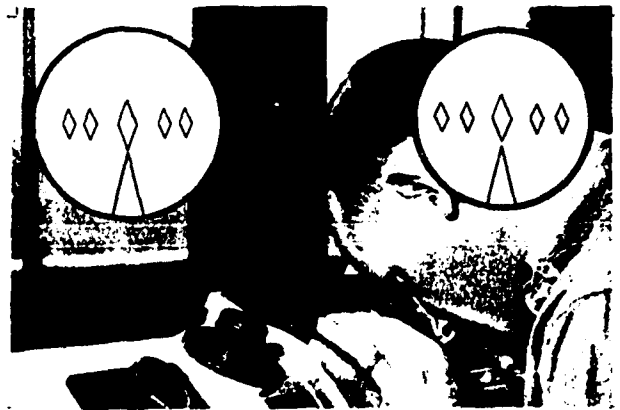

148.80

Figure 8-55.—Checking the height adjustment.

4. Now check for tilt of field. Train the rangefinder to bring the external target into the extreme left of the field. If necessary, use the height adjuster to bring the two target images to

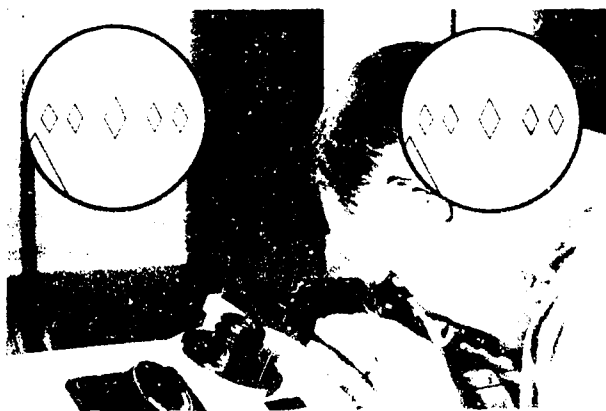

148.81

Figure 8-56.—Checking for tilt of field.

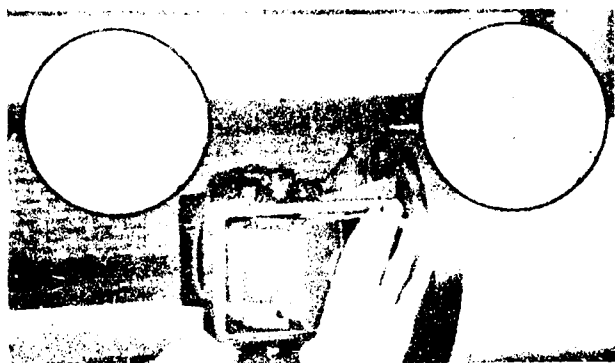

148.82

Figure 8-57.—Correcting tilt of field.



148.83

Figure 8-58.—Checking internal target light.

exactly the same height relative to the left-hand diamonds, as in the inserts of figure 8-56. Then train the rangefinder to bring the target to the extreme right of the field. A difference in height of the target images relative to the right-hand diamonds, as in the inserts of figure 8-57, shows tilt of field. Correct it by rotation of the end reflector, as in figure 8-57.

5. Range on your external target, and carefully read the range through the internal-scale reading telescope. Compare the reading of the external scale; it must be the same, within one unit of error.

Now secure the gear-box cover in place, and attach the range scale illuminator housing. Replace the range knob and its electrical push-button, and secure the knob with its lock screw.

Internal Adjustments

To adjust the internal adjuster system, follow these steps:

1. Set the correction scale at 60—its mid-position; use temporary illumination for this reading.

2. Set the range scale at 6,000 yards; cut in the internal-adjuster prism shift, and illuminate the internal targets.

3. Check the height of the light beam on each side, as in figure 8-58. To adjust the height of the beam, loosen the three adjuster penta-prism bracket screws and turn the eccentric bolt, as in figure 8-59.

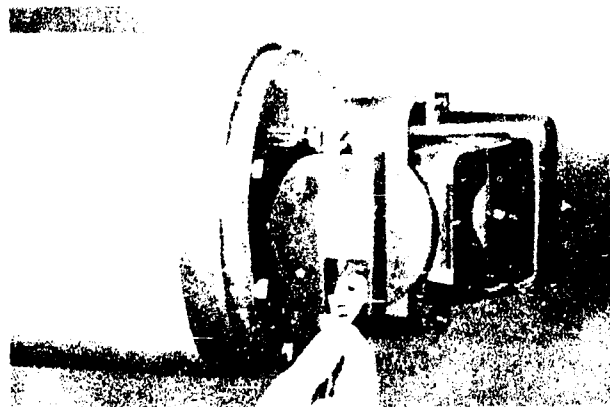

148.84

Figure 8-59.—Aligning the adjuster penta-prism bracket.

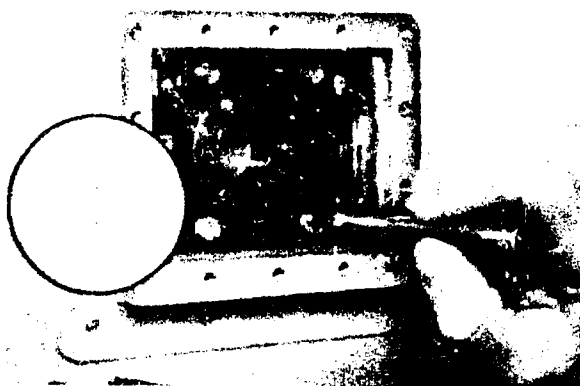

148.85

Figure 8-60.—Adjusting the internal target objective.



148.88

Figure 8-63.—Checking alignment with the first collimator.

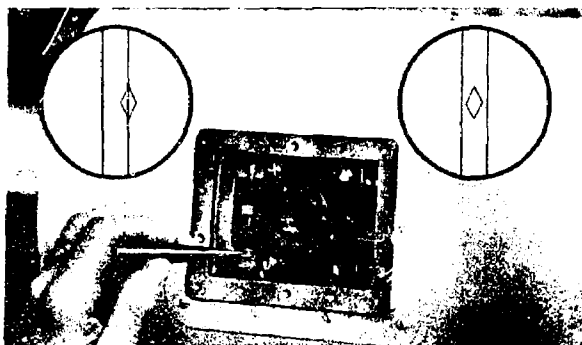

148.86

Figure 8-61.—Rotation of the auxiliary internal adjuster wedge.

4. Examine both targets for lean. If one of them appears to lean, as in the insert of figure 7-45, adjust the internal target objective on the **OPPOSITE** side. The position of the target objective is controlled by the two screws shown in figure 8-60. Slack off one of them and tighten the other.

5. Check the internal targets for true stereoscopic reading. Set the internal adjuster scale at 60, the range scale at 6,000, and the target-centering knob at midthrow. Now sight through the eyepieces without moving the range knob. The internal targets should make stereoscopic contact with the center diamonds of the reticles. If they do not, adjust the auxiliary internal adjuster wedge as in figure 8-61, and then repeat the test.

Replace all illuminating and cover plates on the rangefinder. Replace the windows and scales in the end boxes; mount the end boxes and secure them in place.

Now you are ready to check the alignment of the mechanical and optical axes of the rangefinder. Follow these steps:

1. With the rangefinder hoisted up out of the way, line up two Mk 8 telescopes, as in figure 8-62, so that their reticle images are superimposed.

2. Lower the rangefinder onto a solid base with its left end between the collimators.

3. By adjusting the rangefinder bases, superimpose the image of the center diamond on the image of the collimator crossline intersection as in figure 8-63.



148.87

Figure 8-62.—Aligning the Mk 8 telescopes.

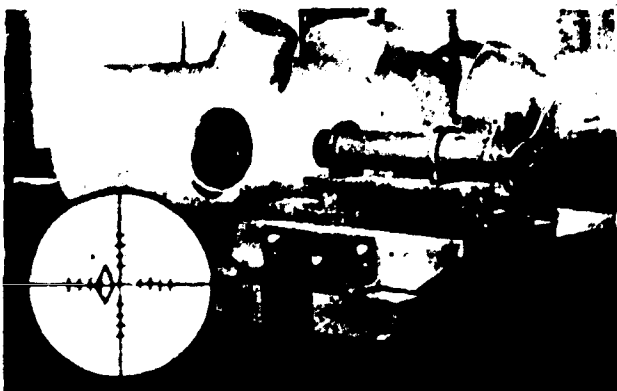

148.89

Figure 8-64.—Checking alignment with the second collimator.

4. Rotate the rangefinder through 180°, and compare the second collimator, as in figure 8-64. The allowable error is 4 minutes. If all previous adjustments were made correctly, the error should be within that tolerance. If it is not, it may be that the end reflectors are not properly seated, or that the reticle is improperly collimated. Find the error, and correct it.

5. Hoist the rangefinder out of the way again, and recheck the collimator alignment. Lower the rangefinder onto its blocks, and repeat the test.

Now range once more on a target at an accurately known distance. With the correction wedge and height adjuster at midposition, make stereoscopic contact with your target. Read the internal scale, and check the result with the known distance. If there is an error, correct it by rotating the end windows, as in figure 8-65, using the engraved scale as a guide.

Replace the end-box cover plates and secure them.

Charge the rangefinder with helium.

Finally, connect the wiring system. First, secure the connection blocks in the wiring box; then reconnect the individual wires, as tagged. Replace the junction boxes and cable clamps. Attach the illuminator housings, cables, and sockets. Check the reticles for equal illumination; if necessary, adjust the slots in their housings.

Now give the rangefinder one final range check. Then it is ready for use.



148.90

Figure 8-65.—Rotating the end window.

COLLIMATION OF THE MK 21

The initial collimation of the Mk 21 is performed during overhaul. The left end window, range wedge, and astigmatizers are collimated individually before being assembled in the optical tube. The optical tube, with its ranging optics, is collimated as a unit. The pentaprisms are adjusted during reassembly.

Range Wedge

The range wedge must be collimated so that its plane of deviation of light is in the plane of triangulation (the plane formed by the line of sight of each telescope and the target (fig. 8-66).

The collimation setup is similar to the compensator and correction wedge setup for the Mk 42, except the crosslines of both telescopes must be squared to the collimator bed and superimposed. Install the range wedge assembly on parallel bars with the rack down and the cell adjusting screws facing the boresight telescope.

The first step in collimation is to adjust the rack parallel to the line of sight of the collimator telescope and boresight telescope. Using an auxiliary objective and machinist's square as you did to square crosslines, alternately set the edge of the square to each end of the rack. If the edge of the square is superimposed on the vertical crossline of the boresight, when moved to either end of the rack, the rack is parallel to the telescope's line of sight.

Rotate the wedge cell until the horizontal crosslines of both telescopes are superimposed

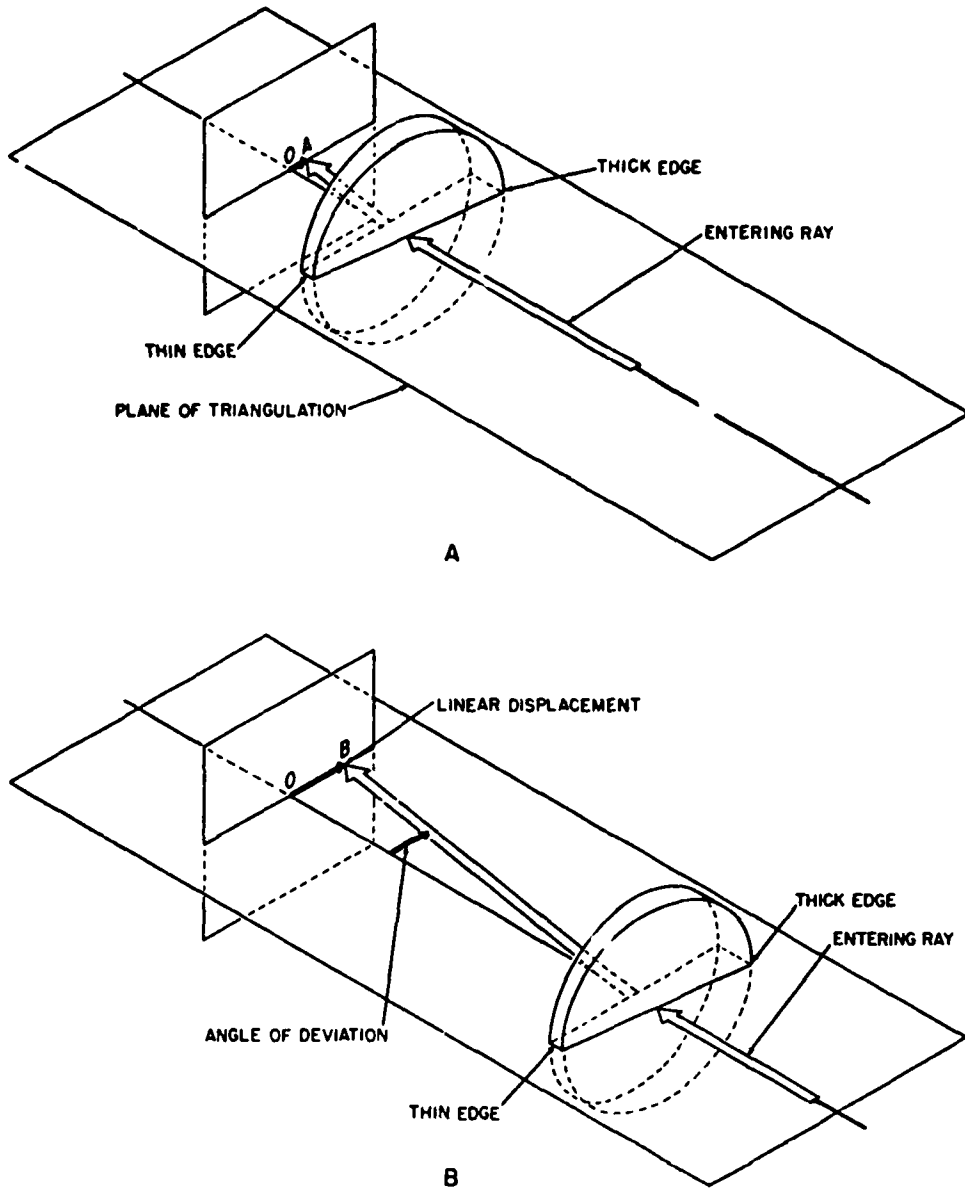

148.337

Figure 8-66.—Displacement produced by a sliding wedge.

and the vertical crossline of the boresight telescope is to the right of the collimator telescope's vertical crossline.

Left End Window

Mount the left end window bushing, with the left end window (fig. 8-67) installed, in a V-block support on the collimator. The two screw holes

in the bushing must be perpendicular to the collimator bed. Use the auxiliary objective to align the screwholes with the vertical crossline of the boresight.

Rotate the end window until both telescope horizontal crosslines are superimposed and the vertical crosslines are parallel. Mark the cell bushing with a pencil to indicate the base of the wedge. The collimator telescope vertical

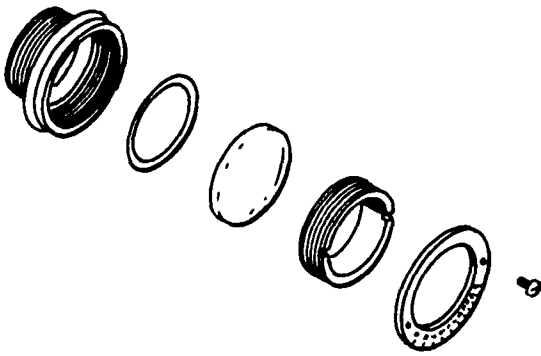

148.338

Figure 8-67.—Left window bushing assembly.

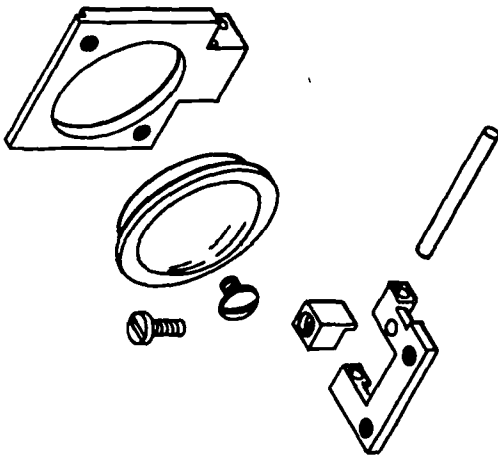

148.339

Figure 8-68.—Astigmatizer mount assembly.

crossline will be deviated towards the base of the wedge. Look through the boresight, you will see that the collimator telescope vertical crossline will be offset from the boresight vertical crossline toward the base of the wedge.

Install the end window scale on the end window bushing with the "O" position of the scale adjacent to the base of the wedge.

Astigmatizers

The astigmatizers (fig. 8-68) must be adjusted so that the elongation of the image they

produce is perpendicular to the plane of triangulation. To adjust, install one astigmatizer between the collimator and boresight telescopes in an upside down position. The plano surface of the astigmatizer lens should be approximately perpendicular to the line of sight. Do this by aligning the astigmatizer lens mount so that it is perpendicular to the lateral edge of the collimator bed and the horizontal (top) surface of the bed.

Tap a pinhole diaphragm over the collimator telescope to provide a point source of light. Viewing through the boresight telescope, rotate the astigmatizer lens until the line of light, produced by the astigmatizer, is parallel to the vertical crossline of the boresight telescope.

Repeat the alignment process for the second astigmatizer lens.

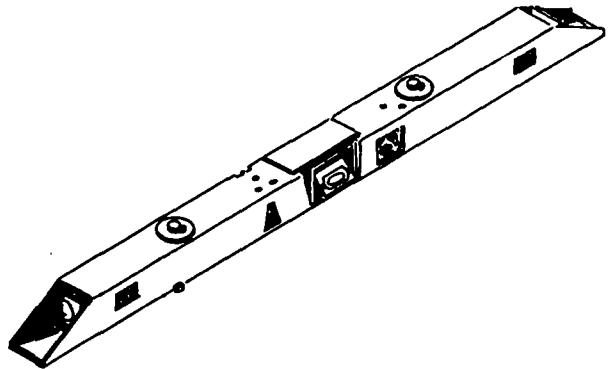

148.340

Figure 8-69.—Optical tube.

Optical Tube

The optical tube, (fig. 8-69), with its components installed, is collimated so that the target images are in coincidence when the image scale is set at infinity. Place the assembled optical tube between two prealigned collimator telescopes. The astigmatizers should be in the "out" position. Position an auxiliary eyepiece over the coincidence prism so that the halving line is in sharp focus.

Parallax

The first step in removing parallax is to set the range scale to infinity. Then, adjust each objective cell to bring its corresponding crossline image into sharp focus.

The astigmatizers must be adjusted so as to maintain coincidence of the halving lines when the astigmatizers are shifted into the line of sight. Shift the astigmatizers into the line of sight. If the halving lines are not in coincidence, adjust the astigmatizer mount which has offset either of the halving lines.

Collimation of Assembled Mk 21

Before installing the sealing caps and end plates, you must remove target lean and height error, if present.

Target lean is checked on the horizon with the rangefinder in a level position. When the rangefinder is rotated so as to shift the horizon above and below the halving line, the horizon should be parallel to the halving line both above and below it. Keep in mind the upper half of the image is formed by the left side of the rangefinder.

To remove lean from either side, adjust its penta prism assembly. The post, (figs. 8-70 and 8-71), may be screwed in or out as required to remove lean.

Height error (or halving error) exists when either duplication deficiency is present as shown in figure 8-72. This error is due to one or both of the prisms being rotated so that they are not in a plane which is 43° to the line of sight of the eyepiece. To remove duplication or deficiency, set the halving knob at midthrow and make the screw adjustment under the 90° corner of the right penta prism (fig. 8-71).

DRYING AND CHARGING THE RANGEFINDER

The primary purpose of changing is to keep moisture from condensing on the optical surfaces; the secondary purpose is to protect the optical elements from the aging effect of oxygen. In charging the rangefinder you pass compressed gas from a cylinder, through a pressure-reducing valve and a dryer, into the instrument. Before the final charging, dry the instrument thoroughly, either by flushing it with dry gas or by repeatedly drawing a vacuum of about 22 inches.

The Navy uses two different gases for rangefinder charging: nitrogen and helium. Nitrogen has one marked disadvantage: it tends to stratify into layers of different indices of refraction. When you elevate the instrument to range on aircraft, light rays will be refracted in passing

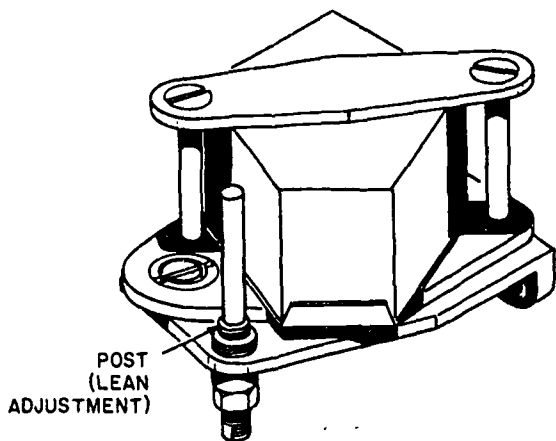

148.341

Figure 8-70.—Left penta prism assembly.

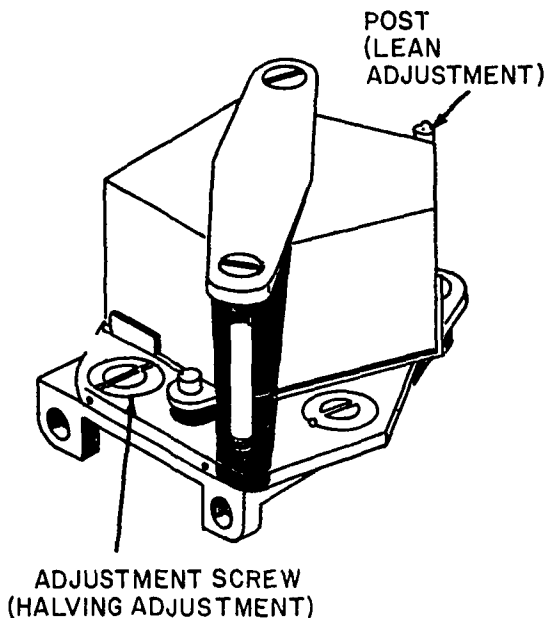

148.342

Figure 8-71.—Right penta prism assembly.

Halving Line Coincidence

The coincidence prism mount must be adjusted so that the halving lines are in coincidence. Loosening the center (hold down) screw, adjust the positioning screws for coincidence of the halving lines.

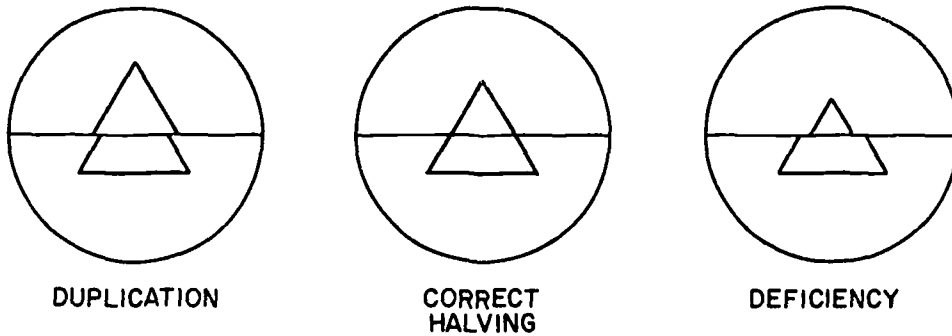

Figure 8-72.—Halving adjustment.

148.343

from one layer of nitrogen to another, thus causing a small error in range setting. For this reason, antiaircraft rangefinders are always charged with helium, which has much less tendency to stratify.

But because its molecules are considerably smaller than those of nitrogen, helium has a greater tendency to leak. The gas purity of helium-filled instruments should be checked every two weeks. You can use a special helium-purity gage for this purpose. If the gage is not available, you can check the helium purity by making two internal adjustments—one when the rangefinder is level and one when it is elevated 90°. There will always be a difference between the two settings. But if you make the check every two weeks, and find that the difference suddenly increases, you can assume that the helium is no longer pure.

Some instruments are designed for helium, others for nitrogen. Always charge an instrument with the gas it is designed for. Helium and nitrogen have different indices of refraction. You know that refraction in an optical element depends on the ratio of its index of refraction to that of the surrounding atmosphere. If you put one gas in an instrument designed for another, you will change the optical characteristics of the whole system. On instruments designed for HELIUM, the charging nipples are always painted ORANGE or YELLOW.

Optical instruments should be recharged every 12 months with dry gas. It is much harder to dry out a damp instrument than it is to keep moisture from condensing in the first place. When an instrument shows any sign of condensation on an internal surface, RECHARGE IT AT ONCE.

Use an Optical Instrument Dryer of the portable type. (This dryer is improperly named; actually, it is a gas dryer, not an instrument dryer.) The dryer contains a quantity of silica gel, which absorbs moisture from the gas passing through it. A part of the silica gel has been impregnated with cobalt chloride, which serves as a moisture indicator. When the indicator begins to turn pink, take the gel out of the dryer, and bake the moisture out of it in an oven. Then return it to the dryer for further use.

Here are three important precautions to remember about drying and charging:

1. Do not use any cylinder gas to charge an optical instrument if the pressure in the cylinder has fallen below 400 pounds per square inch.
2. Instrument drying is most effective at high temperatures. Never try to dry an instrument when the temperature is below freezing.
3. To ensure complete drying, repeat the exhausting and charging cycle several times.

Here is one procedure to follow in drying and charging the Rangefinder Mk 42: Attach the regulator valve to the helium cylinder, using a left-hand thread adapter. Connect the short hose to the outlet side of the dryer. Use the long hose to connect the inlet side of the dryer to the regulator valve on the cylinder. Open the cylinder valve. Set the regulator valve between 7 and 10 pounds pressure. (See fig. 8-73.) Run a small quantity of gas through hoses to be sure they are dry. Then close the cylinder valve. Remove the inlet valve plug from the rangefinder, and connect the short hose to the inlet. (See fig. 8-74.) Open the cylinder valve and build up 5 pounds pressure in the rangefinder. This is the maximum safe pressure you can put in a rangefinder.

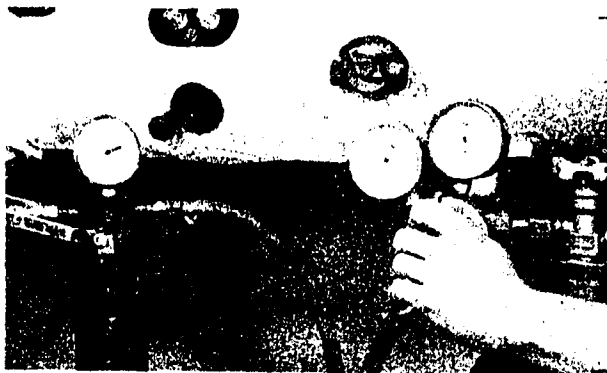

11.99:.100(148)A

Figure 8-73.—Setting the regulator valve.



148.33

Figure 8-75.—Testing for leaks.

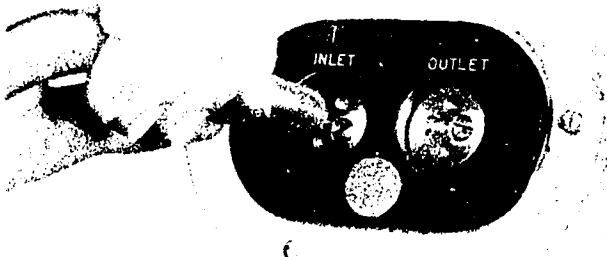

148.32

Figure 8-74.—Connecting the hose to the inlet.

While you maintain this pressure, use a liquid soap solution to test all plates and connections for leaks. (See fig. 8-75.) Attach the hose of the helium-purity indicator to the outlet valve of the rangefinder, and adjust the mechanical and electrical zeros of the indicator. Open the cylinder valve. Run helium, at 5 pounds pressure, through the rangefinder and the helium-purity indicator. (See fig. 8-76.) When the helium-purity indicator shows 97.5 percent helium by volume, close the valves and disconnect the dryer from the rangefinder.

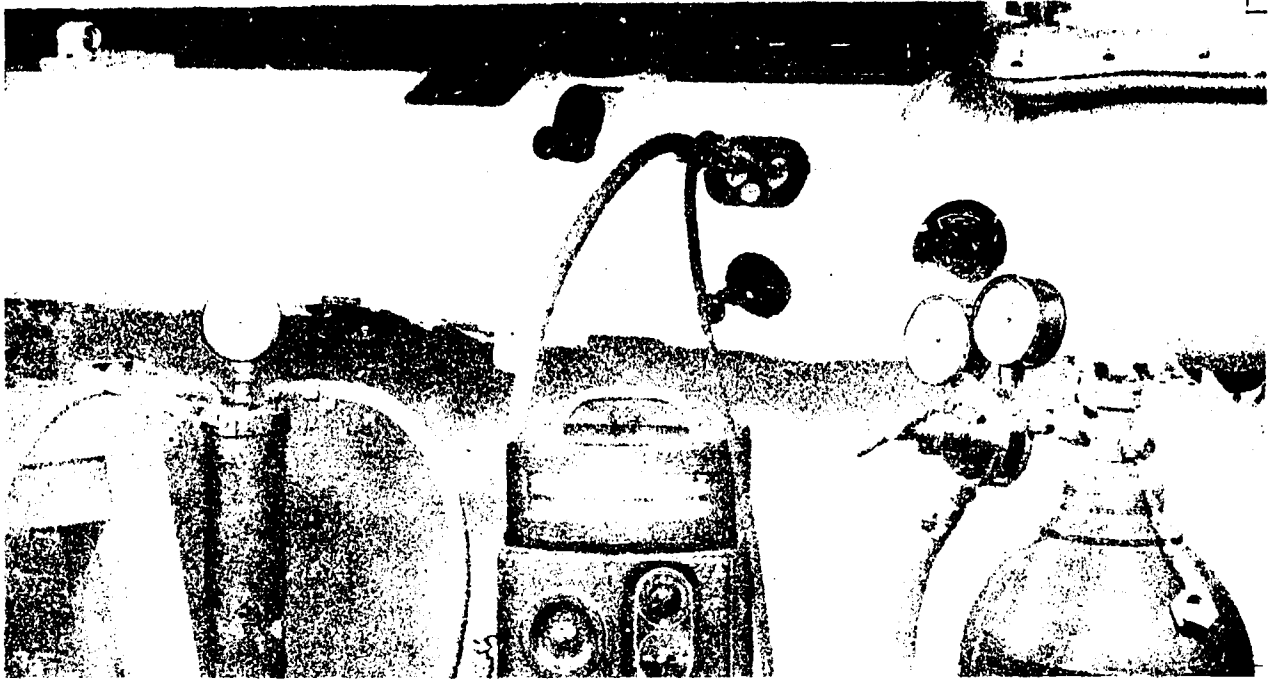

11.99:100(148)B

Figure 8-76.—Running helium through the rangefinder and the purity indicator.

CHAPTER 9

SUBMARINE PERISCOPES

In spite of the many advances in submarine detection devices (radar, sonar, etc.) the periscope is still the submerged submarine's primary tool for the location, identification, and reconnaissance of surface and airborne targets. When submerged, the submarine also depends primarily on the periscope for navigational information.

This chapter is an introduction to submarine periscope maintenance—a job Opticalmen are called on to perform.

Prior to starting work on a particular periscope, or any advanced optical system, be sure to refer to the appropriate technical manual.

IDENTIFICATION OF PERISCOPES

Three common methods of identifying periscopes are: design designations, registry numbers, and type numbers. The first two methods are discussed in Opticalman 3 & 2.

TYPE NUMBERS

The type number of any particular periscope refers to its general design characteristics, and is assigned by NavShips. The numbers assigned are consecutive, beginning with the type 1, an obsolete attack periscope, through type 15, a relatively new general-purpose instrument.

Certain periscopes have acquired both number and letter designations; for example, the type 2A, which is a modification of the type 2, that was used extensively during and after World War II. Today (1972) submarines are being outfitted with the attack types 2D, 2E, or 2F.

These periscopes have the same operational configurations and are used for the same purposes as the old type 2 (a few of which are still in use).

Because of their awkwardness, design designations are seldom used in discussions of periscopes. The type number is mostly used to identify a particular periscope, except in the case of two installed periscopes which are referred to as No. 1 and No. 2 according to their position within the submarine.

Many types of periscopes have been manufactured, with some designed for a particular and unusual need.

TYPE 1.—The forerunner of the modern attack periscope. It had a stadimeter for estimating range and course angle.

TYPE 2.—The attack periscope of the modern submarine. Although the older types 2 and 2A differ greatly from the newer 2D, 2E, and 2F, (fig. 9-1) all attack periscopes have range-measuring devices incorporated in their optical systems and the capability of elevating the line of sight to at least 74° above the horizon. The 2D, 2E, and 2F are built to withstand greater seawater pressures to which they are subjected.

TYPE 3.—An obsolete attack periscope capable of elevating the line of sight 45° above the horizon.

TYPE 4.—The forerunner of all general-purpose periscopes. It was designed with a large head section for greater light transmission, and had a radar capability.

TYPE 5.—A special-purpose instrument designed primarily for photographic reconnaissance, now obsolete.

TYPE 6.—An unusual submarine periscope, now obsolete. The type 6, with its modifications, was an any-height instrument which the observer could use at any height between the top of the sail and the fully extended position. The observer always faced forward while using the instrument. As the rotating portion of the instrument rotated, an internal erecting system provided the observer with an erect image and an indicator showed him in what direction the line of sight was pointing.

TYPE 7.—The forerunner of the modern navigation periscope, now obsolete, was the first night periscope to incorporate synchros into its elevation system.

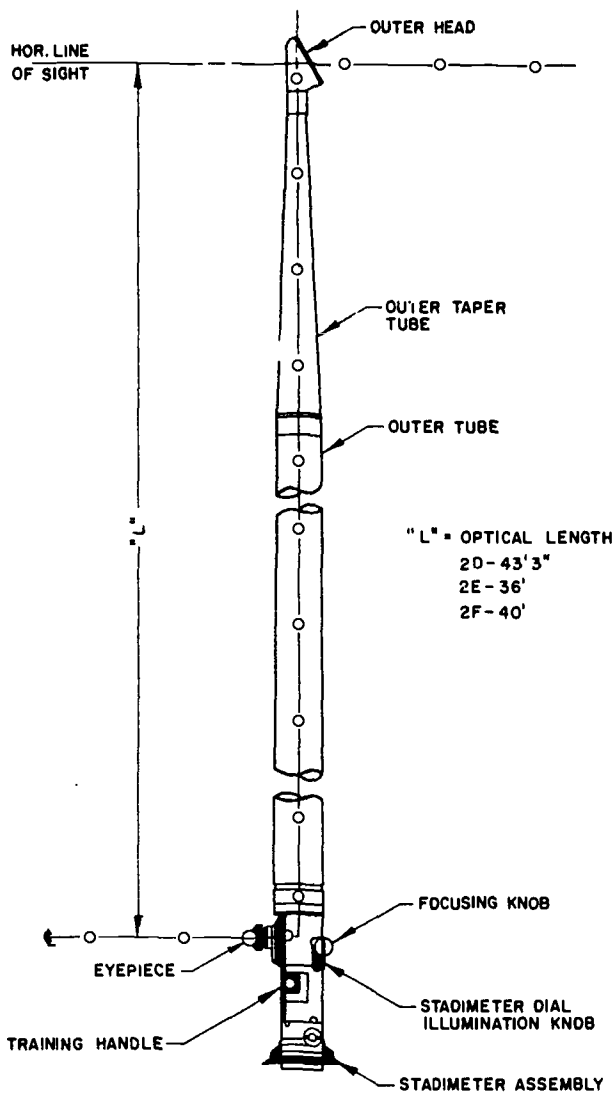

134.101

Figure 9-1.—Attack periscope.

TYPE 8.—The first of a series incorporating the features of the type 4 and 7. Types 8 and 8A were superseded by the more modern 8B and the similar, but shorter, 8C. More versatile and sophisticated than their predecessors, the 8B and 8C are still widely used in modern submarines. Figure 9-2 shows the type 8B with its external components installed.

TYPE 9.—Designed as a night service instrument with celestial navigation capabilities, the type 9, now obsolete, was the forerunner of the type 11.

TYPE 10.—An experimental design of a navigational periscope, now obsolete, the type 10 incorporated a photoelectric cell to control the line of sight.

TYPE 11.—A special-purpose celestial navigation instrument designed for fleet ballistic missile (FBM) submarines. It provides correction information for the ship's gyroscope compass and Sperry Inertial Navigation System (SINS).

TYPE 12 AND TYPE 13.—Type numbers assigned to designs which were never manufactured.

TYPE 14.—A special-purpose deep submergence attack periscope. Internally the type 14 is similar to the type 2D except the type 14 has telemeter illumination and its optical length is 28 feet.

TYPE 15.—Designed to increase the electronic capabilities of the type 8B, the type 15 and its modifications use an optical system similar to that of the 8B, and is gradually replacing the 8B as the general-purpose periscope of today's submarine forces.

Most of the periscopes in use in the fleet today are similar to the type 8B. Therefore, this chapter discusses the 8B generation of periscopes, pointing out the features peculiar to the attack and general purpose types excepting, for security reasons, the ECM and communications systems. The type 8B generation includes the type 2D and further modifications of this type, the 8B and further modifications of this type, and the 15 and its modifications.

PERISCOPE SYSTEMS

The major systems for which you will have maintenance responsibility include the elevation, focusing, power change, ranging, optical, and electrical systems. The 8B periscopes are alike in that their elevation, focusing, or power change systems are similar. Their ranging systems, however, are peculiar to the attack series of the 8B generation. The entire 8B generation has electrical maintenance requirements, but only those with navigational capabilities have synchro alignment requirements.

All these systems are operated from outside the periscope through some form of penetration which must maintain the hermetical seal of the

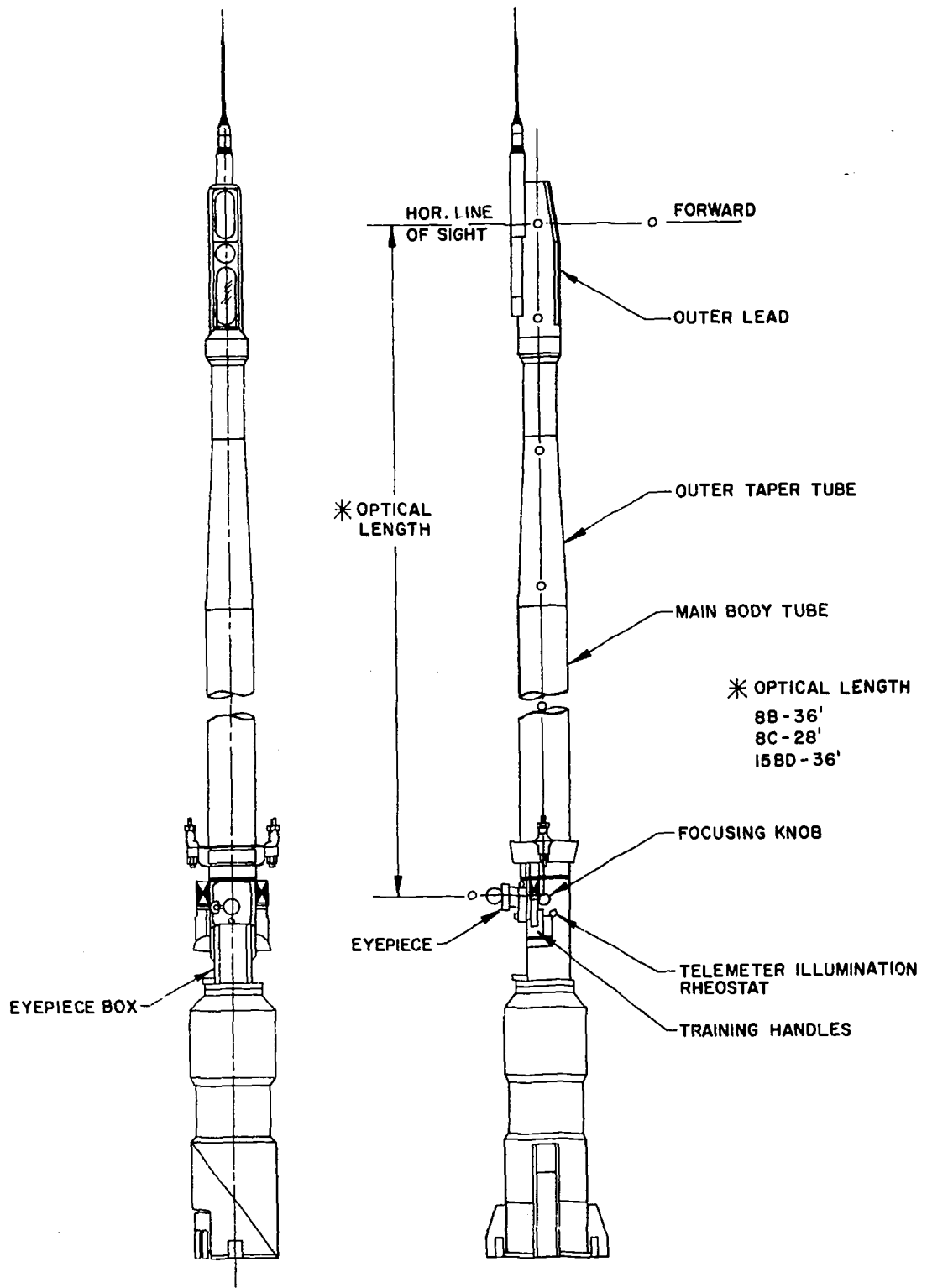
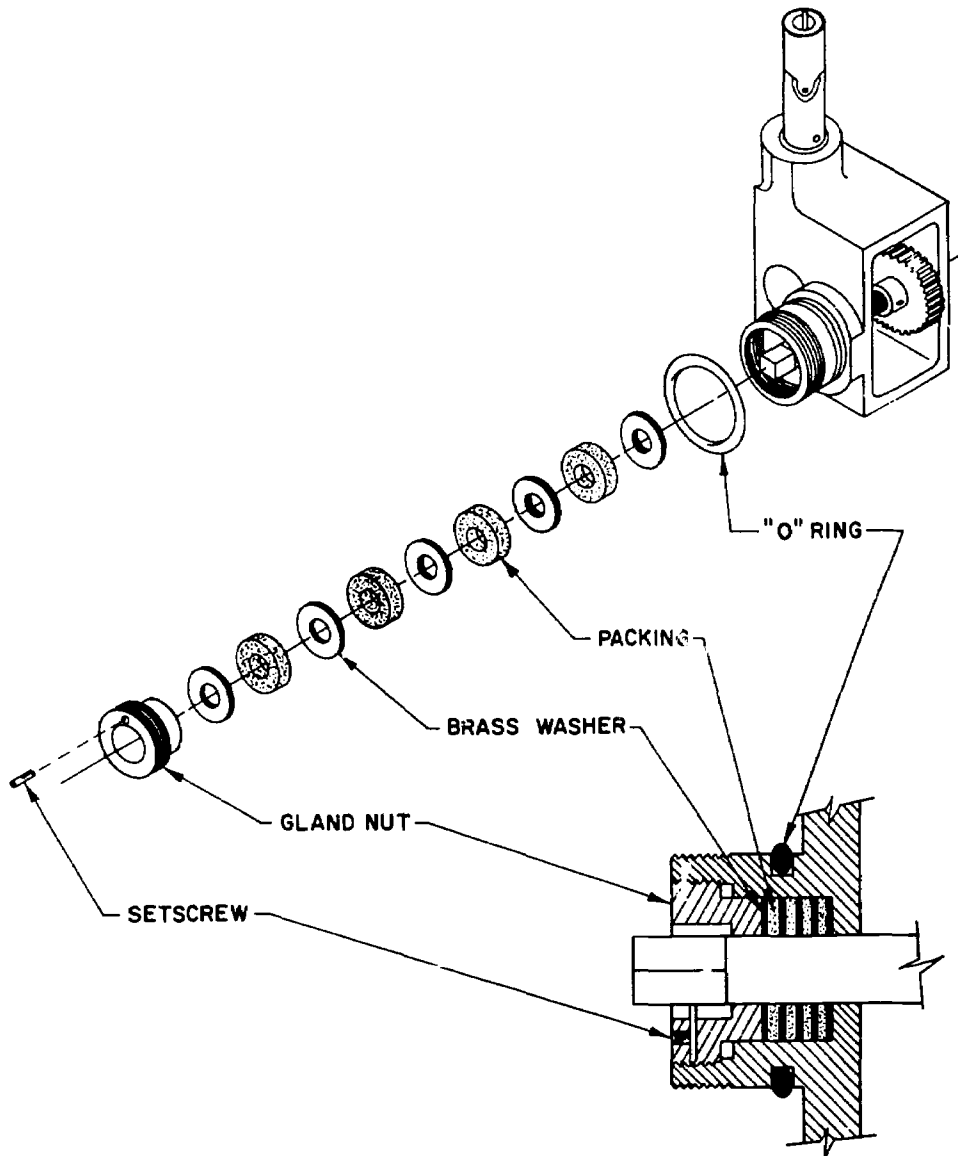

Figure 9-2.--General purpose periscope.

134.101



28.35

Figure 9-3.—Typical stuffing box arrangement.

periscope itself. Stuffing boxes enable motion to be transmitted from outside the periscope, and maintain the hermetical seal.

The stuffing boxes (fig. 9-3) are used on all rotating shafts: elevation, focus, power change, rheostat, and stadimeter (2). They seal against the loss of internal pressure and, should the periscope develop a leak, entrance of sea water into the submarine.

All electrical systems penetrate the periscope through pressure-tight receptacles.

ELEVATION SYSTEM

The primary function of the elevation system of a submarine periscope is to elevate or depress the line of sight as desired by the observer. A secondary function, in the general-purpose types only, is to transmit elevation information electrically for celestial navigation.

The elevation systems (fig. 9-4) are similar for all 8B generation periscopes. The synchros apply only to general-purpose types.

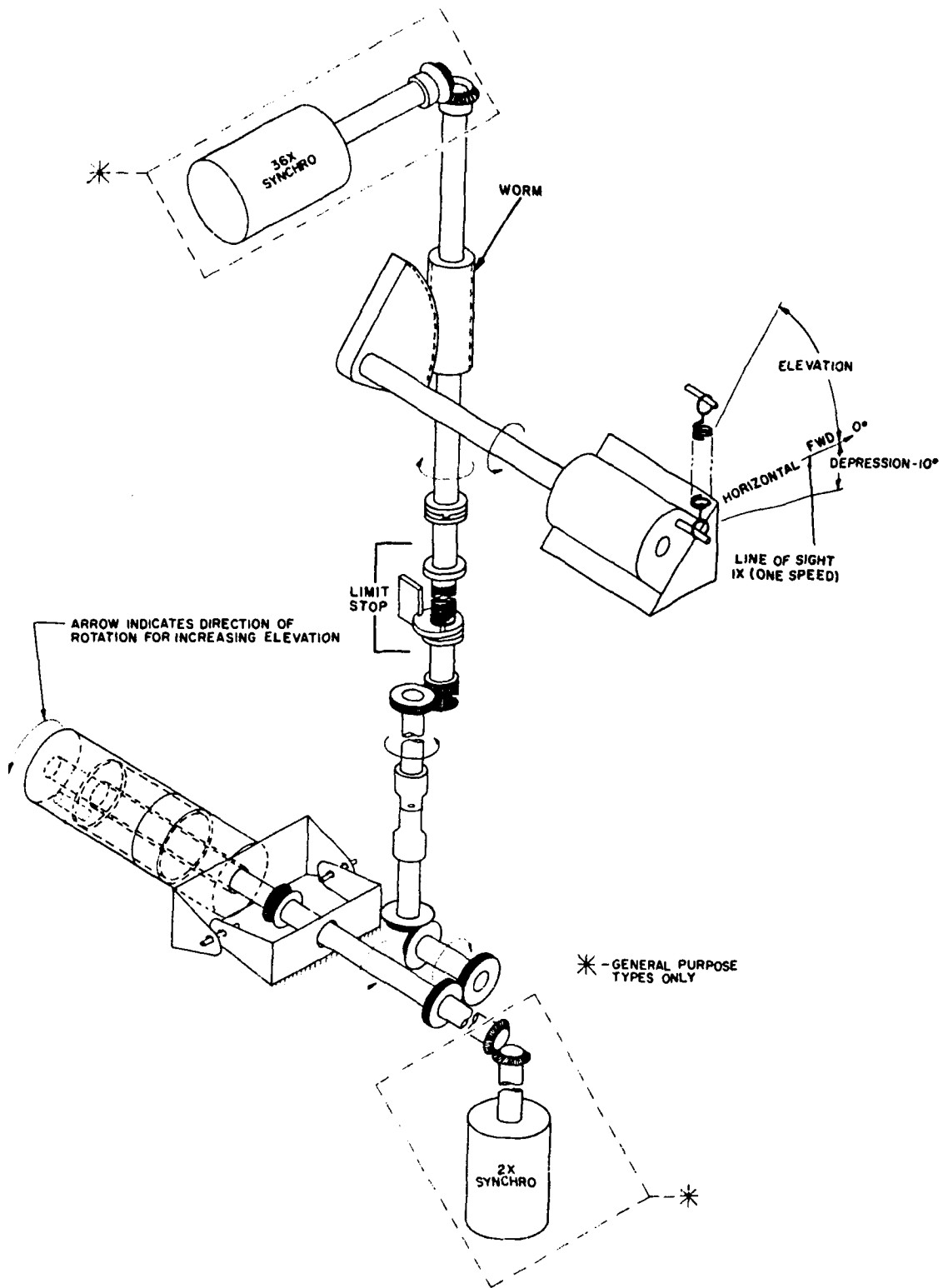
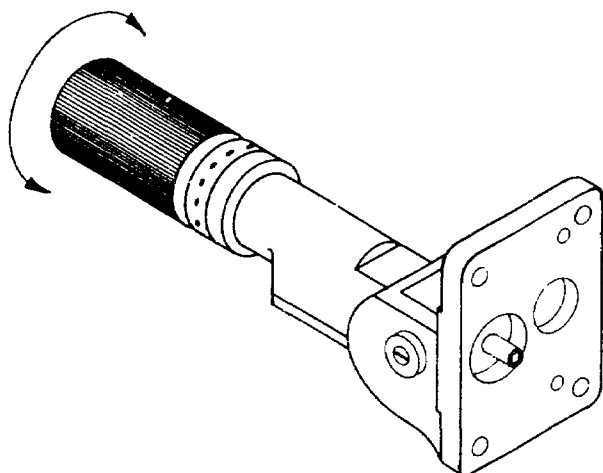

Figure 9-4.—Elevation system.

148.281



148.346

Figure 9-5.—Left (elevation) training handle.

The left training handle (fig. 9-5) controls the elevation or depression of the line of sight. To elevate the line of sight, turn the top of the handle toward you, the observer. Depress the line of sight by turning the top of the training handle away from you.

The motion of the training handle is transmitted through a stuffing box, a series of gears and shafts, and finally to the head prism where it is converted into elevation or depression of the line of sight.

On the attack periscopes, a 4° rotation of the training handle corresponds to a 1° elevation of the line of sight.

On general-purpose periscopes, elevating the line of sight is sensed by two synchros which feed the elevation information to celestial navigation equipment. A 5° rotation of the training handle corresponds to a 1° elevation of the line of sight, which corresponds to a 36° rotation of the 36X (upper) synchro rotor and a 2° rotation of the 2X (lower) synchro rotor.

CHANGE OF POWER SYSTEM

As discussed in Opticalman 3 & 2, the method of changing the power of the periscope is to insert or remove a one-fourth power telescope into the line of sight. This is the primary function of the change of power system (fig. 9-6). The power is changed by rotation of the right training handle (fig. 9-7). The change of power

system of general-purpose periscopes also places a sun filter into the line of sight when desired by the observer. The right training handle of a general-purpose type has features not incorporated in the right training handle of an attack periscope.

The sun filter, for example, is placed into the line of sight by pushing the filter release button towards the periscope and rotating the handle beyond the HIGH POWER position to the FILTER position. The periscope is always in high power when the sun filter is in the line of sight. To remove the filter from the line of sight, push the filter release button towards the periscope and rotate the handle to either the HIGH POWER or LOW POWER position.

Another feature, the power assist actuator, is used to energize a power assist motor for torquing in the direction that the observer desires. When the periscope is being used for celestial navigation, the sextant mark button provides a means for the observer to indicate that the crosslines are superimposed on the target.

The motion of the training handle is transmitted through a stuffing box and through a gear-and-shaft system to the power change rack assembly.

The power change rack assembly (fig. 9-8) converts the rotary movement of the handle into a linear movement of the shifting tapes.

The shifting tapes and the power shifting racks move the power change cubes into and out of the line of sight. The power change cubes contain the elements of the one-fourth power telescope which provides the periscope change of power.

FOCUSING SYSTEM

The various types of periscopes of the 8B generation all have similar focusing systems (fig. 9-9). The system functions to vary the focus between +1.5 and -3 diopters for normal viewing, and to move the focusing erector (and its focal point) approximately 203.2 mm towards the eyepiece for photographic purposes. When the focusing erector is shifted to the photographic position, its focal point is located outside of the eyepiece sealing window.

The focusing knob (fig. 9-10) contains a stop mechanism, engaged by the plunger, which limits the focusing knob travel between +1.5 and -3 diopters for normal viewing. When the photographic position is desired, the plunger is

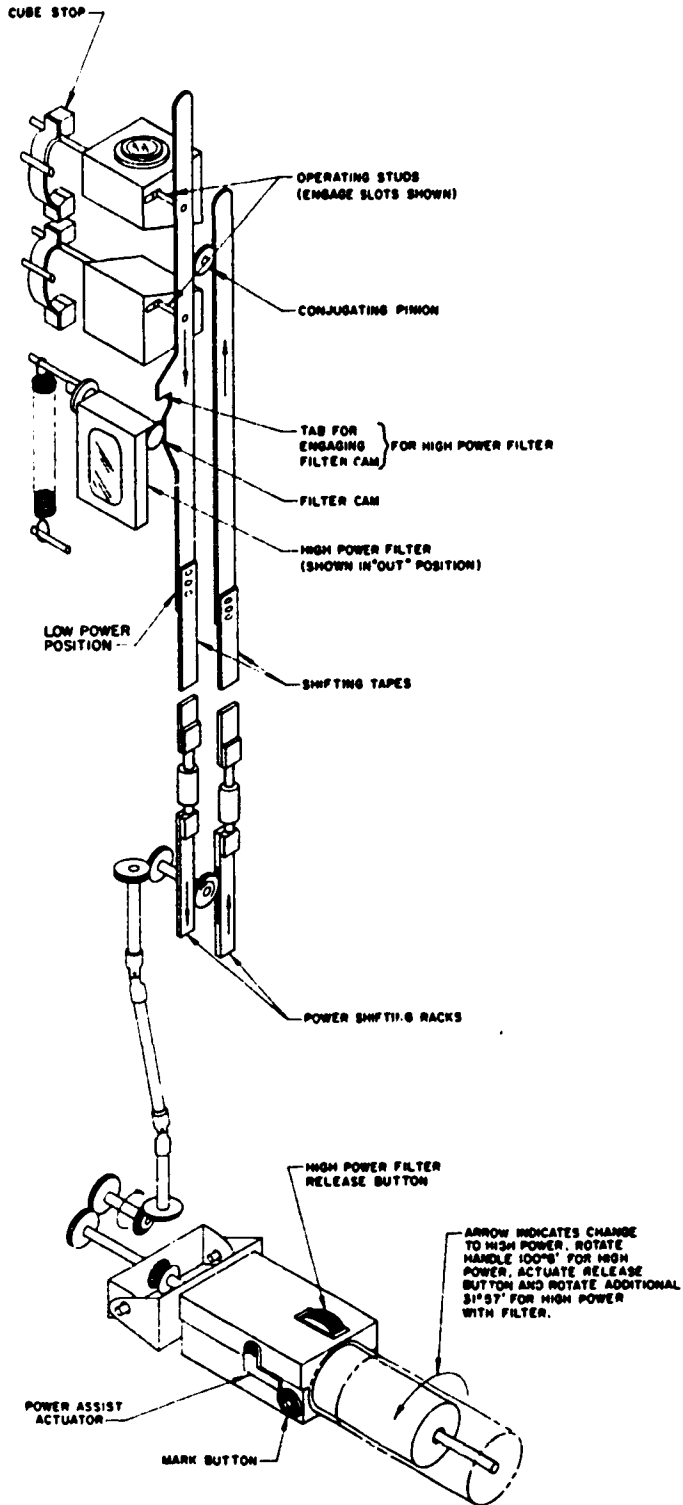

Figure 9-6.—Change of power system.

148.347

withdrawn and locked in the out position which allows the focusing knob to be turned in a minus diopter direction until the camera stop position is reached.

The focusing knob motion is transmitted through a stuffing box and gear-and-shaft arrangement to the focusing erector assembly. This assembly contains a planetary gear arrangement (fig. 9-9) which turns three shafts simultaneously to move the focusing erector laterally along the line of sight.

RANGING SYSTEM

Characteristic of the attack periscopes, the ranging system (fig. 9-11) provides a means of determining target range when target height is known. There are two operating controls on the stadimeter: the in-out lever for shifting the split lens into and out of the line of sight, and the range knob for vertically displacing the two identical images produced by the split lens.

The range indicating mechanism is composed of three rings located at the base of the stadimeter. The lower ring is fixed and has graduations indicating target height in feet. The middle ring is manually rotated and has one index on its lower edge which must be set to the desired target height. The upper edge of the middle ring has two index marks: HP (for high power) and LP (for low power). These marks indicate the target range corresponding to the target height set for the power in use. The target range is read on the upper ring (in yards) which is interconnected to the split lens assembly.

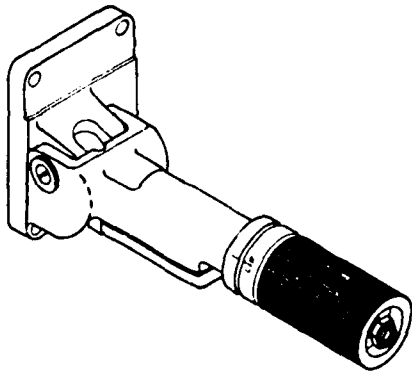

ATTACK TYPES

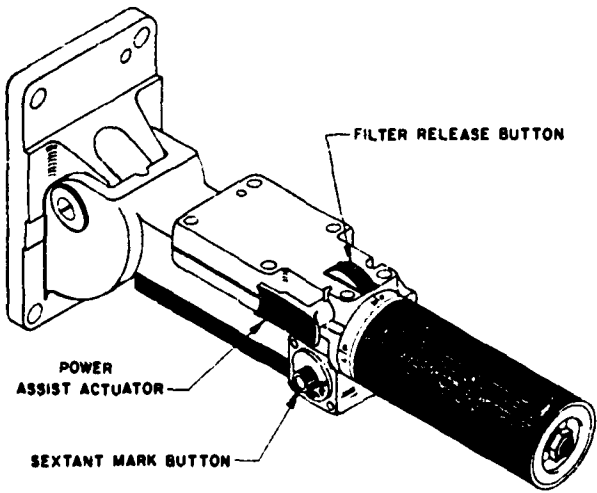

GENERAL PURPOSE TYPES

148.348

Figure 9-7.—Right training handle.

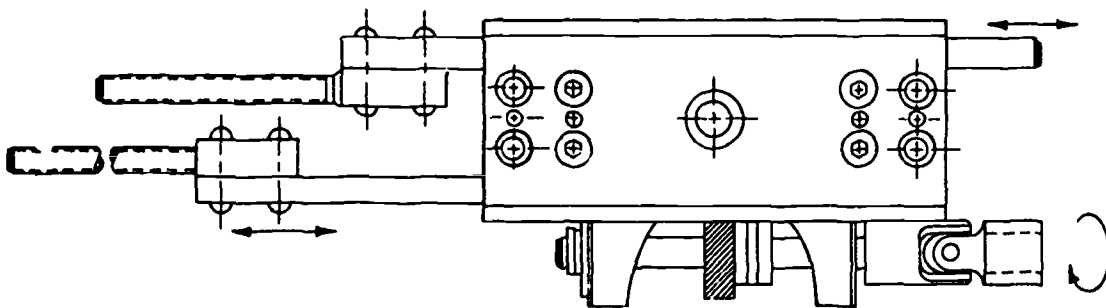

148.349

Figure 9-8.—Power change rack assembly.

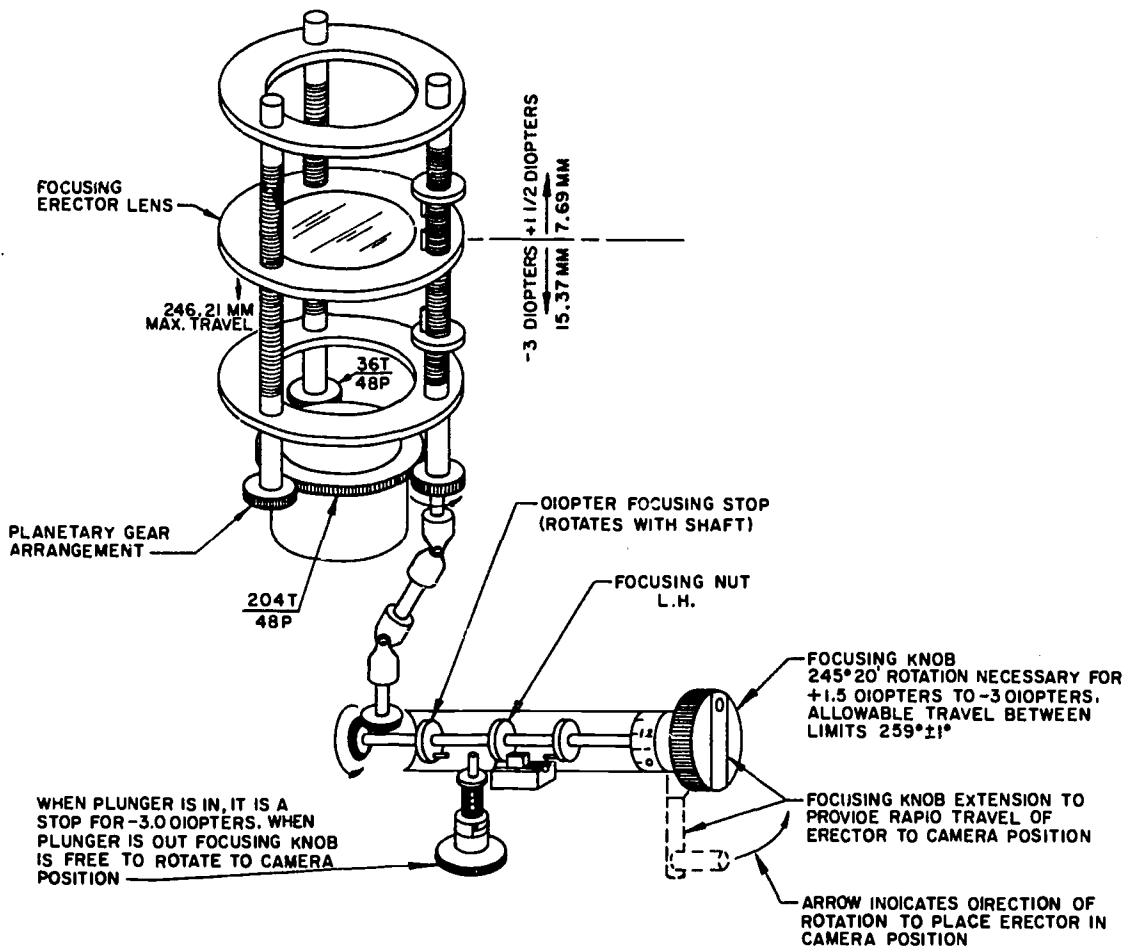

Figure 9-9.—Focusing system.

148.350

OPTICAL SYSTEM

The periscopes of the 8B generation have similar optical systems. It is convenient to discuss the first of these, the 8B, and to point out significant differences in the others, where they occur.

Characteristics

The various types of periscopes of the 8B series have the following optical characteristics in common:

	High Power	Low Power
Magnification	6X	1.5X
True field	8°	32°

High Power Low Power

Focus range -3 to +1.5 diopters for normal viewing; approximately -203.2 mm for the camera focus.

Depression of line of sight 10°

Maximum Elevation

Line of Sight

Attack 74° 74°

General Purpose 60° 60°

Edge of Field

Attack 78° 90°

General Purpose 64° 76°

The exit pupil of the attack periscope is 5 mm when used in the viewing mode and 4.18 mm when used in the range finding mode with the

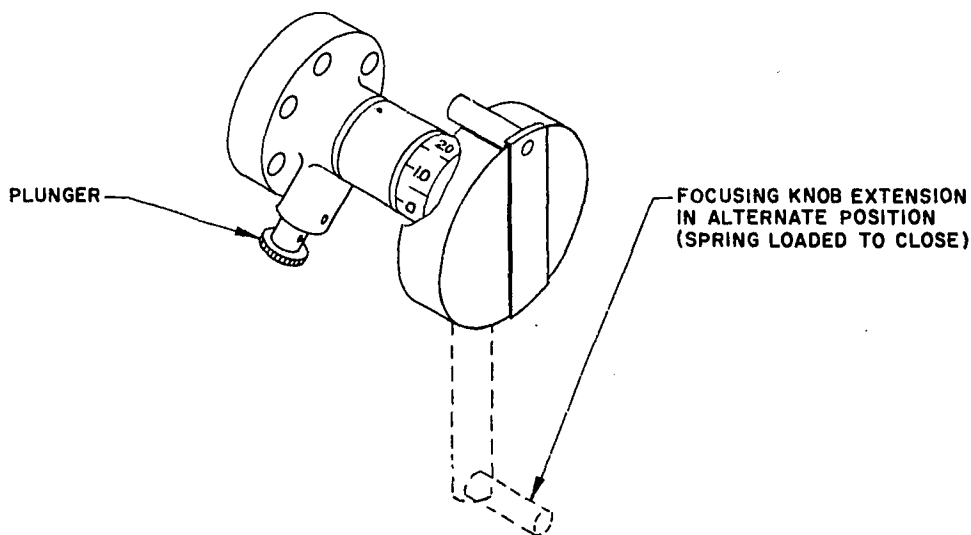

Figure 9-10.—Focusing knob.

148.351

split lens in the line of sight. The exit pupil of the general-purpose type is 7 mm.

Although the function of the various elements within the periscope is basically the same (to transmit the image through the periscope to the observer), the design of the 8B generation differs from its predecessors. The concept of an upper and lower main telescope and an upper and lower auxiliary telescope, as discussed in Opticalman 3 & 2, has been superseded by a single telescope containing relay elements (fig. 9-12). The change of power system (Galilean telescope) has remained essentially the same.

Although the total number of elements within the periscope has increased, the image quality and light transmission have been improved due to the optical design. The total number of elements in the line of sight of the main telescope remains the same for all the 8B generation of periscopes, regardless of their lengths.

Component Functions

The optical elements of all the 8B generation periscopes have the same function even though the elements for a particular type may vary in size and focal length. Refer to figure 9-12 as each element is discussed.

HEAD WINDOW.—Designed to withstand the sea water pressures to which the periscope is subjected, the window distributes heat uniformly

to clear external fogging and prevent ice formation.

HEAD PRISM.—A right-angled prism, with its hypotenuse surface silvered, directs the line of sight downward through the periscope.

GALILEAN TELESCOPE.—A four-power telescope placed in the system in reverse to reduce the power of the periscope when the telescope is rotated into the line of sight. Rotating the Galilean telescope into the line of sight enlarges the field of view and makes possible a rapid search of the horizon when the submarine is at periscope depth.

SUN FILTER.—A plano-parallel plate, the sun filter is used only in the general-purpose periscopes to make observations of the sun for subsurface navigation.

HIGH POWER OBJECTIVE LENS.—Functions as an objective lens normally does.

FIELD FLATTENER.—Serves as a correcting lens to reduce spherical aberrations of the objective lens.

TELEMETER.—The periscope telemeter (fig. 9-13) (reticle lens) performs three functions in the optical system. First, it provides a cross-line in the line of sight at an image plane to give

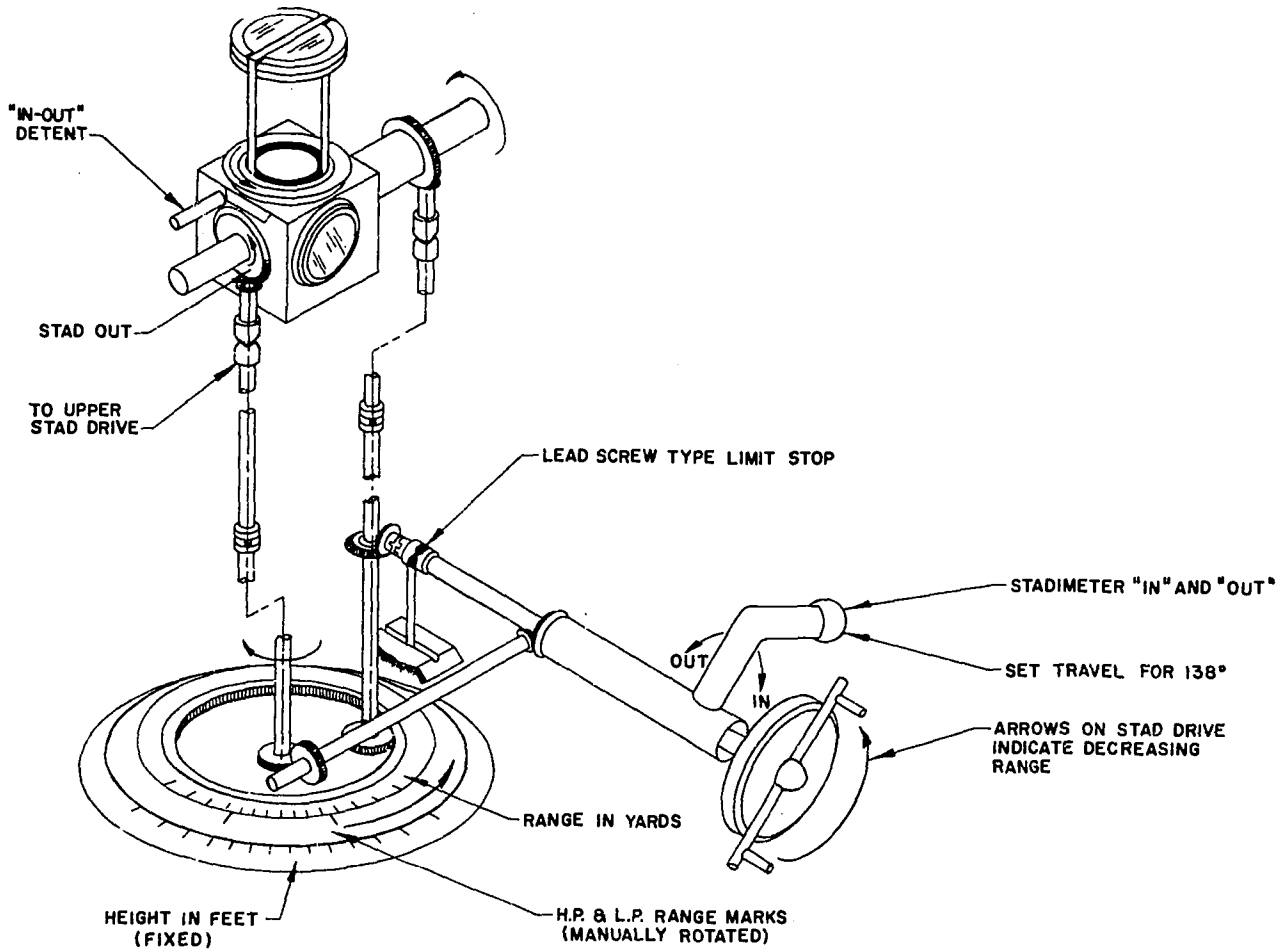

Figure 9-11.—Ranging system.

148.352

a reference in azimuth and bearing. As the periscope is rotated, the vertical crossline is the reference for determining the relative bearing of an object. As the line of sight is elevated, the horizontal crossline (in general purpose types only), is used to measure the elevation angle (azimuth) of an object of celestial body.

Second, the telemeter functions as a ranging device, that is, a device to measure the distance from an object to an observer. Each large division of the telemeter corresponds to an angle of 1° in high power and 4° in low power. Each subdivision corresponds to an angle of $15'$ in high power and 1° in low power. If the height of a target is known, you can determine its range using the telemeter graduations to determine the angle it subtends. If the target is

at a right angle to the line of sight, its length can be used to determine its range.

Third, the rear surface of the telemeter is convex and enables the telemeter to function as a collective lens.

ERECTOR.—Serving to transmit the image through the main body of the periscope, the six erectors of each particular type are identical in construction.

The fifth erector of attack periscopes is mounted in a rotatable cube (fig. 9-14) which contains the fifth erector (identical to the other five erectors) and in its alternate position, a split erector (of equal focal length as the fifth erector) which serves as the primary ranging device of the attack periscope.

The split erector (stadimeter lens) measures the angular height of a target by forming a

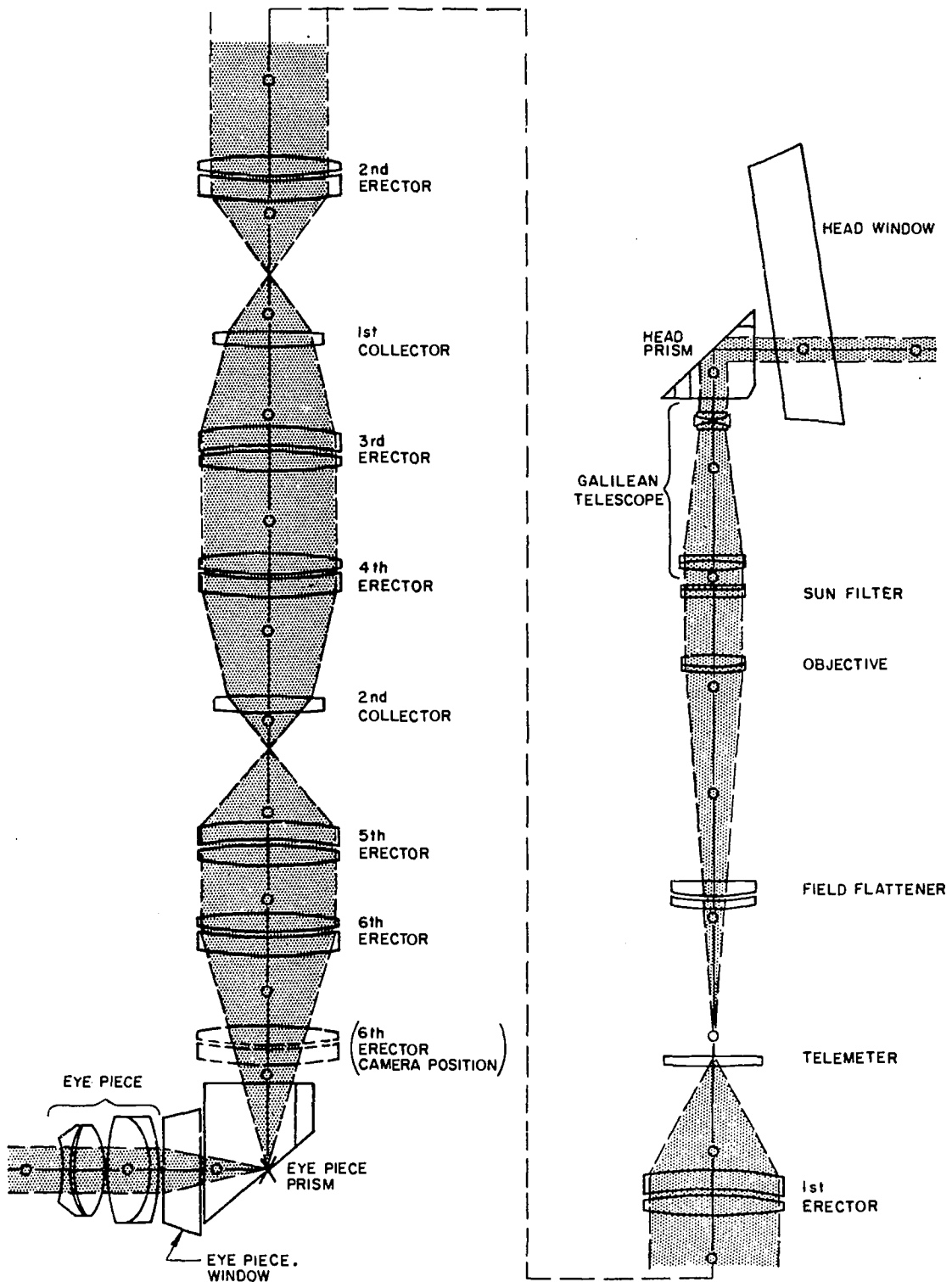
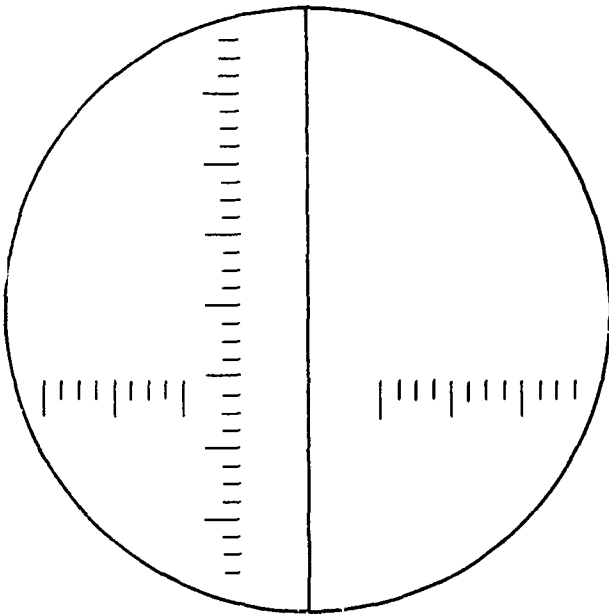
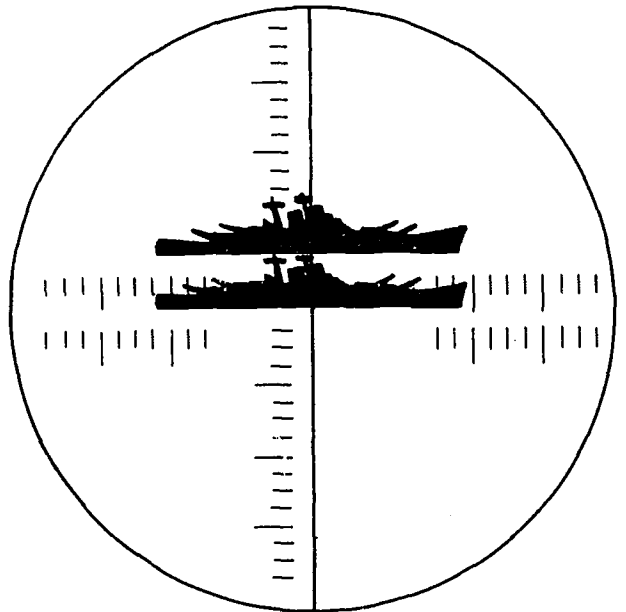

Figure 9-12.—General arrangement of optics.

148.353



148.354
Figure 9-13.—Telemeter.



55.294
Figure 9-15.—Ranging with the stadimeter.

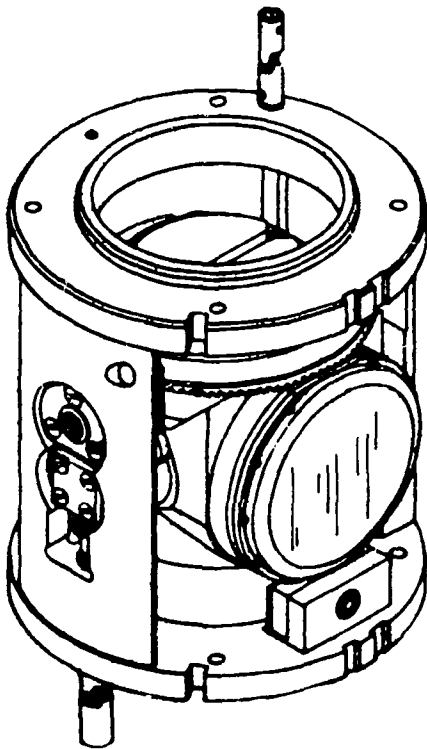

148.355
Figure 9-14.—Stadimeter lens mechanism.

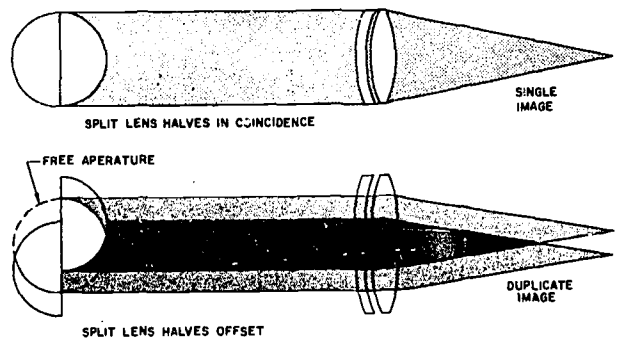

148.356
Figure 9-16.—Operation of the split lens.

double image with the masthead of one image coincident with the waterline of the other image (fig. 9-15).

The double image is formed by offsetting each half of the split lens from the other (fig. 9-16). A telescope will form a complete image of an object even though one-half of its free aperture is obscured. In effect, then, there are two telescopes having a common eyepiece and one-half

MAINTENANCE

The maintenance of submarine periscopes is similar to that of other optical instruments in that the same procedural steps are followed: premaintenance inspection, overhaul, collimation, and charging.

PREMAINTENANCE INSPECTIONS

In general, inspect any periscope prior to its removal and overhaul. The inspection of a periscope should include checking the condition of its optical, mechanical, and electrical system, and the external condition of items subject to wear.

Maintenance inspection sheets should be used to record the preoverhaul and postoverhaul conditions of each periscope. Use the appropriate technical manual for reference when making a maintenance inspection sheet.

CLEANLINESS OF VARIOUS OPTICAL ELEMENTS

Due to the large number of elements in the line of sight of a submarine periscope, cleanliness of all the optical surfaces is extremely important. In the long run it is easier to keep the elements clean (by protecting them against contamination) than to clean them once they get dirty. Whenever any of the inner tube sections are separated, immediately cover the ends to prevent entrance of foreign matter.

Keep in mind that a periscope is overhauled in a horizontal position, but used in a vertical position. Foreign matter inside the inner tube may fall onto the lenses as the periscope is placed upright, causing loss of time and effort due to rework. If practical, the periscope should be tested for cleanliness in a vertical position prior to installation.

You may check the cleanliness of some internal elements, while the inner tube is assembled, by focusing on them with the focusing knob. As the focus is varied, the surfaces of individual elements will appear in focus to the repairman.

Telemeter

Keep in mind that the telemeter is in focus whenever the periscope is being used. Any foreign matter on the telemeter will bother the user.

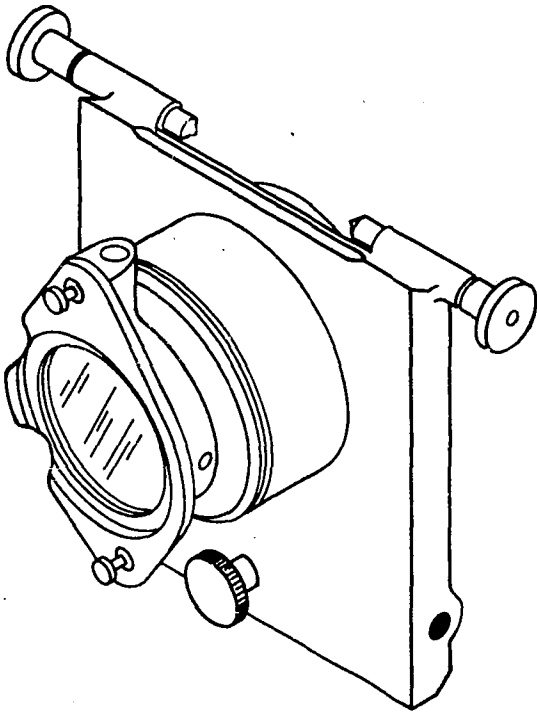

148.357

Figure 9-17.—Eyepiece.

of an objective lens in each. As each half of the split lens is moved laterally, its image is displaced a corresponding amount. When the image displacement is converted into height of the target, the range of the target can be determined. The periscope stadimeter converts target height versus image displacement into range by means of a cam and gears.

COLLECTORS.—Mounted between the second and third erectors and the fourth and fifth erectors, the two collectors are designed to improve image quality.

EYEPiece PRISM.—A right-angled prism used to deflect the line of sight 90° into the eyepiece.

EYEPiece.—A two-doublet, externally mounted, removable assembly (fig. 9-17) which has an integral electrical heater for defogging purposes. The eyepiece can be removed and replaced with a camera to put the periscope in a photographic mode.

Field Flattener and Collector Lenses

Foreign matter on the field flattener or collector lenses may be detected by focusing the periscope from one extreme of the focusing range to the other extreme. The field flattener will come into focus near the negative extreme of the focus range while the collector lenses will come into focus close to the normal viewing focus range.

Eyepiece Prism

The upper surface of the eyepiece prism lies near an image plane and, therefore, any dirt on it will appear in the field of view.

Elements Externally Visible

You should check the cleanliness of various elements without looking through the periscope. Foreign matter can be readily detected on the windows, prisms, Galilean telescope elements, and the eyepiece by visual inspection where it might not be apparent to you when looking through the periscope.

CHARGING

The procedure for charging a submarine periscope is presented in Opticalman 3 & 2. The frequency of charging is determined by its requirement. Each time you charge a periscope, make sure not to contaminate it.

When evacuating the periscope, never leave the vacuum pump unattended. Should the vacuum pump stop for any reason, the vacuum already present in the periscope will draw oil and its vapors from the pump into the periscope with disastrous results. Oil contamination within a periscope requires complete disassembly and cleaning.

A periscope must be recharged at the completion of each overhaul. It should be completely recharged, time permitting, when the service pressure drops below the specified amount. The service pressure will vary according to the temperature and should conform closely to the pressure indicated by table 9-1.

Table 9-1.—Temperature Versus Gage Pressure

Temperature (°F)	Pressure (psig)
100	8.8
90	8.3
80	7.9
70	7.5
60	7.1
50	6.7
40	6.2
30	5.8

COLLIMATION

A submarine periscope has many separate collimation requirements, including the common requirements, such as parallax, "0" diopters, squareness of the telemeter, and elevation of the line of sight. It also has a few uncommon collimation requirements, such as nitrogen compensation, relay system collimation, stadiometer collimation, and displacement.

Nitrogen Compensation

The collimation of a periscope is complicated by the fact that the positioning of the lenses is established while the optical system is surrounded by air (at atmospheric pressure), whereas the optical system is surrounded by dry nitrogen at a pressure of 7.5 psig (at 70°F) when the periscope is in use. As the index of refraction for air is lower than nitrogen's, you must compensate for the effect the difference has on the collimation of a periscope.

As it turns out, if you use an infinity target to collimate the periscope (with the lenses, surrounded by air), it will not be in collimation when charged with nitrogen (at 7.5 psig and 70°F) because nitrogen lengthens the focal lengths of the various elements.

Logically, then, you must compensate for the nitrogen by collimating the periscope at some distance other than infinity. This distance is determined by the spacing of the various lenses and their refractive powers. In other words, different types of periscopes have different collimation distance requirements.

The submarine periscope collimator is designed to reproduce the various collimation distances—optically. See table 9-2 for distances to use in collimating the various periscopes in air to compensate for the introduction of nitrogen.

Table 9-2.—Collimating Distance Requirements

Type of Periscope	Distance	
	HP (feet)	LP (feet)
2	1204	35
2D, E, F	3171	49
8B, 8C, 15B, 15D	3171	52

High Power Collimation

The high power system consists of all of the elements of the optical system (fig. 9-12) from the high power objective to the eyepiece, inclusive. Collimation of the high power system includes the following checks:

1. Upper and lower relay system are of the same power.
2. Periscope is free of parallax when charged with nitrogen.
3. Focusing assembly has sufficient focus travel when charged with nitrogen.
4. Stadimeter of an attack periscope indicates range accurately.
5. Telemeter is squared to the split of the split objective lens (attack periscopes).

Normally, the collimation check is made with the periscope inner tube assembled. The tests to be conducted on the assembled inner tube include:

1. No parallax between the telemeter collimator reticle with the collimator set to the proper object distance.
2. Proper diopter setting to give "0" diopters when periscope is charged with nitrogen.
3. Accurate ranging of attack periscopes.
4. Telemeter squared to split of stadimeter lens on attack periscopes.

Should it be necessary to replace any of the optical elements contained in the high power system or if the inner tube is disassembled for any other reason, the collimation must be re-verified.

For proper magnification of the high power system (and optimum accuracy of the ranging mechanism), the focal lengths of the first and second erectors must not differ more than 1% (12 mm) and the focal length of the third and

fourth erectors must not differ more than 1% (12 mm).

FIRST ERECTOR AND HIGH POWER OBJECTIVE.—With the high power objective, field flattener, telemeter, and first erector installed in the first and second inner taper tubes, place the tubes on the periscope rail in line with the periscope collimator, as shown in figure 9-18. With the auxiliary telescope set to your eye, move the first erector until the telemeter appears sharply defined. Set the periscope collimator to the prescribed distance for high power collimation of the particular type of periscope you are working on. Adjust the high power objective so that images of the collimator reticle and telemeter appear in the same plane (no parallax).

SECOND ERECTOR.—Replace the first collector lens mount with the appropriate crosswire fixture (fig. 9-19). (Refer to applicable maintenance technical manual for specific fixtures.) With the second erector installed, reconnect the first and second inner tubes. Sighting through the second erector with the auxiliary telescope, move the erector to remove parallax between the auxiliary telescope reticle and the crosswire.

THIRD ERECTOR.—Install the third erector into the lower end of the third inner tube and the appropriate crosswire fixture into the upper end of the third inner tube. Sighting through the third erector with the auxiliary, remove parallax by shifting the erector.

FOURTH ERECTOR.—Install the fourth erector into the lower end of the fourth inner tube. Install the appropriate crosswire fixture into the lower end of inner tube No. 5. Sight through the fourth erector and remove parallax.

FIFTH ERECTOR.—Install the appropriate crosswire fixture into the top of the sixth inner tube. Place this tube and the stadimeter lens mechanism assembly on the periscope rail so that the fifth erector is adjacent to the lower end of the sixth inner tube. Sighting through the fifth erector, remove parallax on the crosswire by shifting the entire split lens mechanism closer to or farther from the lower end of the sixth inner tube. When parallax is removed, accurately measure the distance between the flanges of inner tube No. 6 and the stadimeter lens assembly.

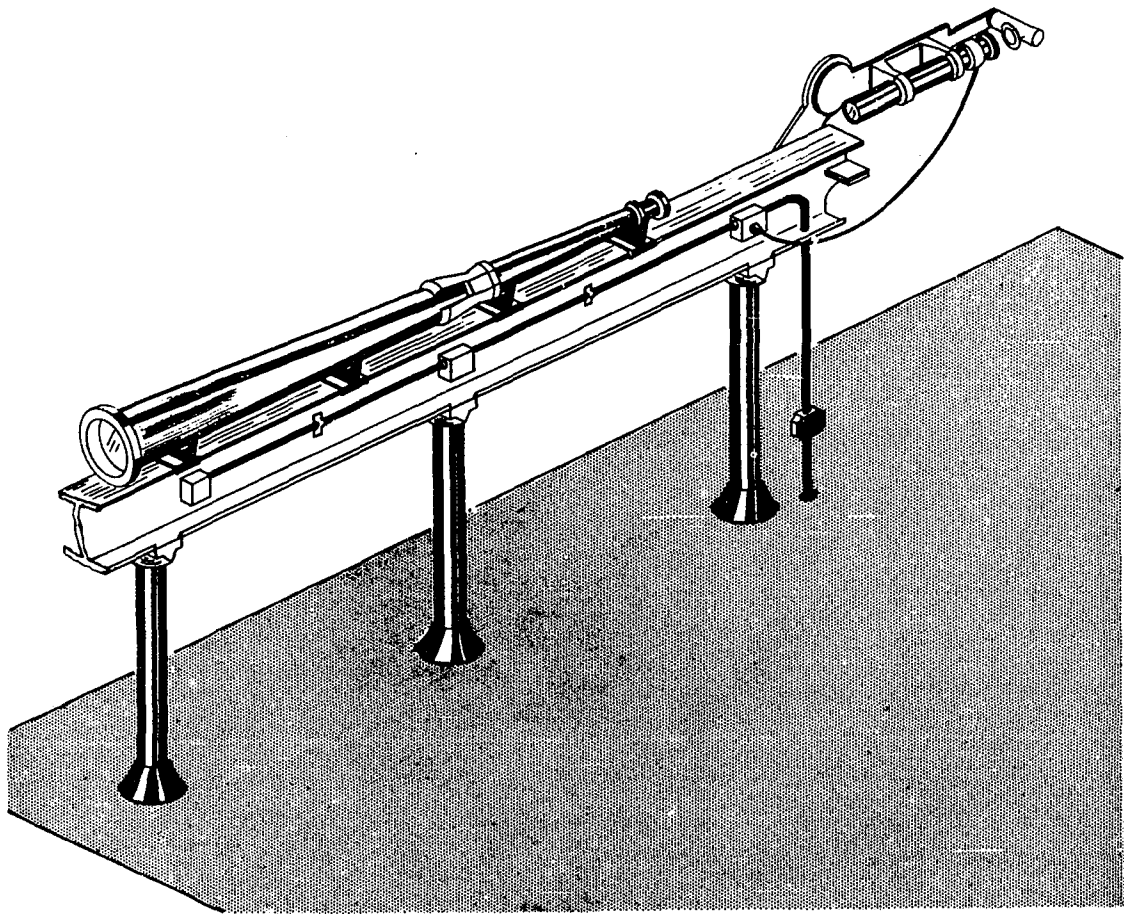

Figure 9-18.—Primary collimation.

148.358

STADIMETER SPLIT LENS.—The fifth erector and the stadimeter split lens must be parfocalized (have their focal planes at the same point) to the point established by the crosswire fixture at the upper end of the sixth inner tube. Use the same setup as for the fifth erector, except that the split lens is in the line of sight. Remove parallax again, by shifting the stadimeter lens mechanism back and forth. Measure the distance between the flanges. It should correspond, within ± 0.5 mm, to the distance measured for the fifth erector. If it does not, shift the fifth erector in its mount to make the measurements correspond. These measurements determine the size of the spacer between the

flanges of the sixth inner tube and the stadimeter lens mechanism.

CORRECT DIOPTRER SETTING.—Assemble the focusing erector assembly, lower tapertube, eyepiece box, and eyepiece on the periscope rail sighting on an infinity target. Remove parallax with the focusing mechanism. This is the "0" diopter setting in air and must be adjusted for "0" diopters when the periscope is charged with nitrogen. The adjustment is made mechanically, not optically. The upper stop of the focusing erector assembly is set so that it allows +1.65 diopters focus travel when the periscope is charged. If not, adjust the stop accordingly.

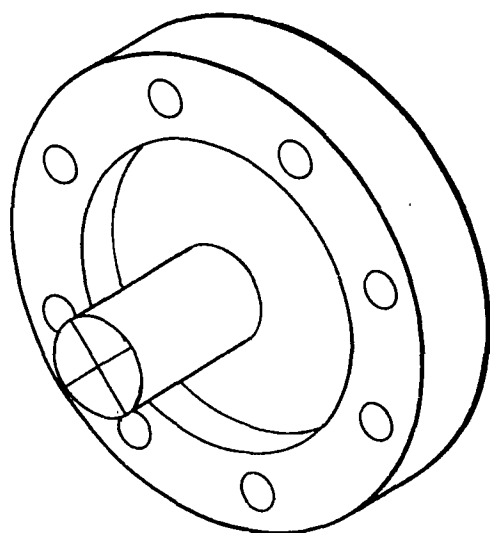

148.359

Figure 9-19.—Typical crosswire fixture.

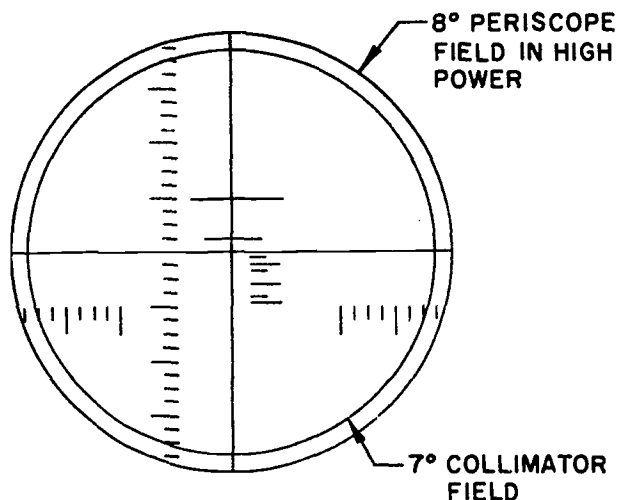

148.360

Figure 9-20.—Alignment of periscope and collimator images.

Low Power Collimation

Once the inner tube is collimated, install the skeleton head and collimate so that it introduces no error.

The errors that may be introduced include parallax, vertical and horizontal displacement of the crosslines, nonsquareness of the

telemeter, and improper amount of elevation and depression of the line of sight.

LOW POWER PARALLAX.—Parallax will be introduced when the Galilean telescope is shifted into the line of sight if the Galilean eyepiece lens mount is not properly adjusted. As discussed previously, you make the adjustment while observing a target at less than an infinite distance. Although the low power collimation distances vary for some types of periscopes, the adjustment procedure remains the same.

To remove parallax in the low power system, first adjust the periscope collimator to the distance specified for the periscope. The Galilean eyepiece is adjustable to accommodate for parallax. Loosen the set screw and screw the eyepiece farther into or out of the mount, as required, to remove parallax. There is no tolerance for parallax; remove any that is detectable.

VERTICAL AND HORIZONTAL DISPLACEMENT OF THE CROSSLINE.—The line of sight of the Galilean telescope must coincide with the line of sight of the rest of the periscope. If not, the position of the image will change when the periscope is shifted from high to low power or vice versa. The result is an error in azimuth or bearing when you change from one power to the other.

To check for displacement, superimpose the reticle (with the periscope in high power) on the crossline of the collimator, as shown in figure 9-20. Now shift the periscope into low power. Figure 9-21 illustrates correct and incorrect collimation for displacement of the collimator. Horizontal or vertical displacement or both may appear in any quadrant of the reticle.

To remove horizontal or vertical displacement, shift the Galilean eyepiece laterally to place its line of sight in coincidence with that of the high power system. The Galilean eyepiece mount is manufactured with elongated holes to allow adjustment to remove this displacement (fig. 9-22). The maximum allowable error for displacement is two minutes horizontal displacement of the vertical crossline and ten minutes vertical displacement of the horizontal crossline.

ELEVATION OF THE LINE OF SIGHT.—Once the skeleton head is installed, it is necessary to check for the proper amount of elevation and depression of the line of sight. Before the check is made, the collimator should be aligned

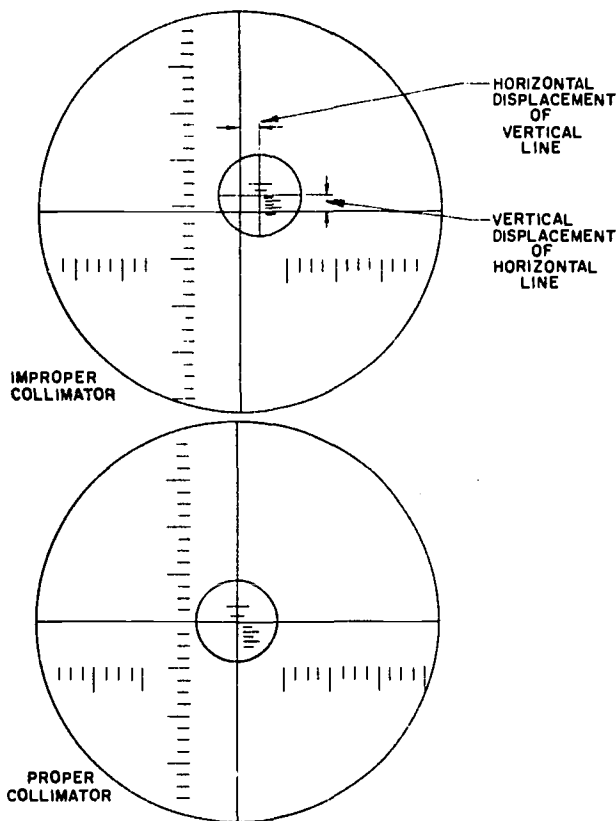

148.361

Figure 9-21.—Displacement check.

(boresighted) so that its line of sight coincides with the periscope's.

The elevation/depression check may not be accurate if the collimator is not aligned because the pivot point of the head prism may not be the same as the pivot point of the collimator. As the collimator pivot is an eccentric, it can be adjusted to the same height above the periscope collimation rail as that of the head prism pivot shaft. Once the pivot points coincide, the elevation and depression tests are made.

Swing the collimator to the proper amount of elevation for your periscope. The periscope must elevate so that the horizontal crossline, at least, touches the intersection of the collimator crosslines. Depress the collimator to -10° . The periscope must be able to depress to -10° . The

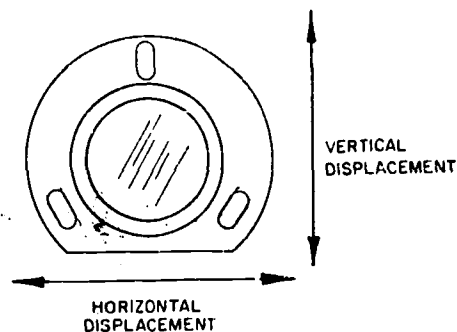

148.362

Figure 9-22.—Galilean eyepiece mount.

elevation/depression stops on the elevation worm screw are set to allow 1° overtravel. If the periscope will not elevate or depress as required, adjust the corresponding stop.

Stadimeter Range Error Test

Range indication error is checked by either of two methods: overlapping or the collimator range check. The collimator range check requires the use of a periscope collimator telescope in conjunction with the periscope, whereas overlapping requires no external target.

OVERLAPPING.—In theory, two fields of view will appear as the split lenses are offset. The two fields will appear to shift vertically and two images of all the telemeter markings will appear except for the vertical crossline (fig. 9-23). Overlapping can provide a rough check of the stadimeter while the periscope is in place.

To perform the test, place the periscope in high power. There should be no distracting objects in the field of view and, ideally, the free aperture should be covered with lens tissue, and a comfortable light level provided. The stadimeter should be in place.

Set the center dial lower index on 100 feet. Now slowly rotate the stadimeter drive handle counterclockwise until the large horizontal graduation corresponding to the center field of one image is superimposed on the first small graduation of the other image (fig. 9-23). The upper graduation of the center dial, marked HP, should indicate 1527 yards. Displace the images farther until the large graduation is superimposed on the second small graduation, causing an indication of 764 yd. The third small graduation should correspond to 509 yd. while the next

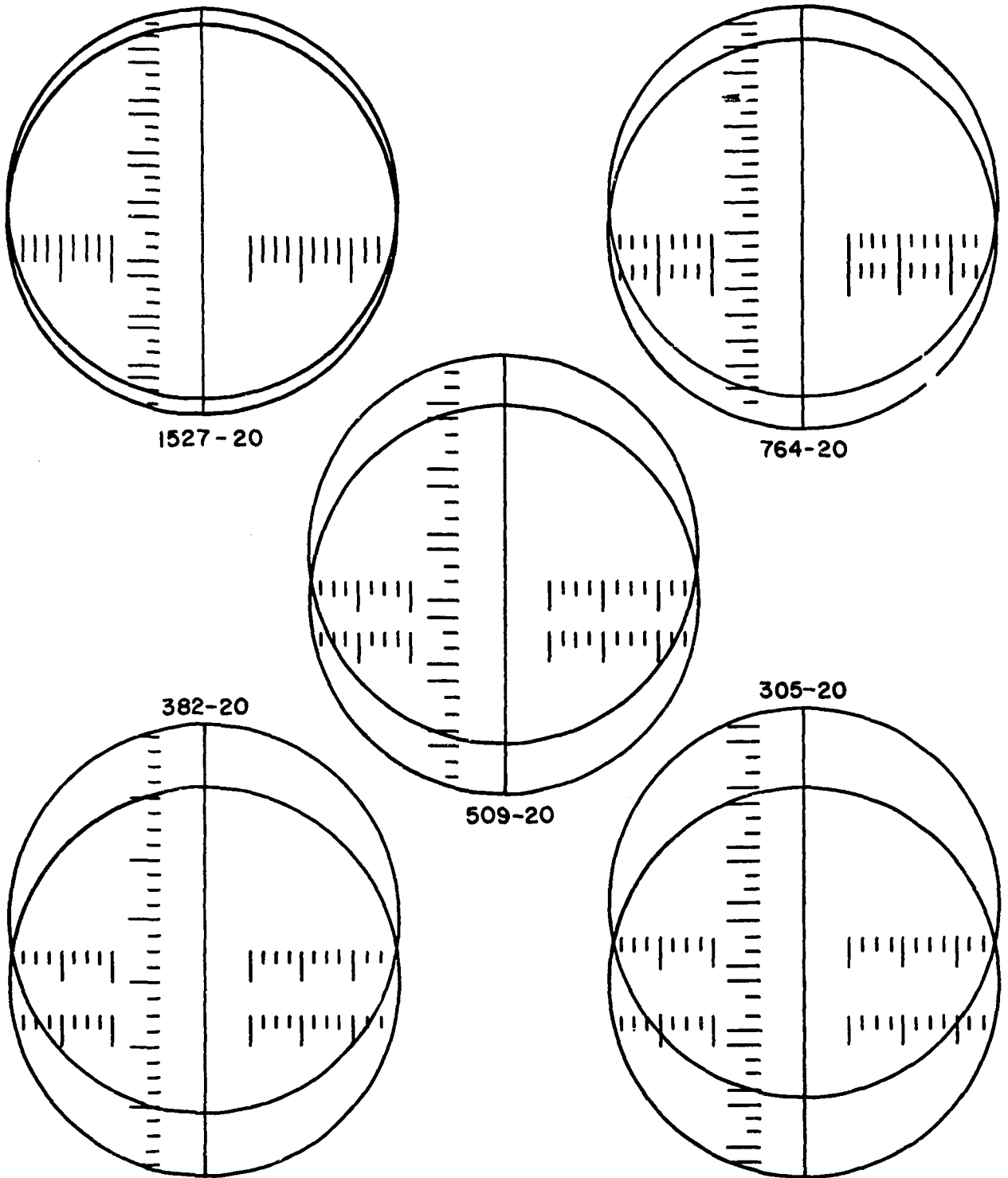

Figure 9-23.—Overlap range references.

148.365

graduation indicates 382 yd and the next small graduation 305 yd.

RANGE CHECK WITH THE PERISCOPE COLLIMATOR.—A better accuracy check of the range measuring system can be performed on the periscope collimator. A greater spread of ranges (11,000 to 400 yd) provides a more accurate check as any error is greatly multiplied at the upper end of the range scale where movement of the lens halves is small.

The range scale is read the same way as in the overlap method. With the periscope in high power, adjust the periscope and collimator so that the image you see looks like figure 9-20. The collimator reticle is used in the same manner as that of the telemeter in the overlap method. As the images are offset, the large graduation of one image is superimposed on each graduation of the other. Using 20 feet as the height reference for the index dial, the respective ranges for each graduation are 11,000 yd, 7,500 yd, 3,500 yd, 1,000 yd, 500 yd, and 400 yd. The various image patterns would appear as in figure 9-24.

All range indications must be within $\pm 2\%$ of the specified range for each test point. For example, at the first point in the overlap method, the stadimeter dial should indicate 1527 ± 31 yd or between 1496 yd and 1558 yd.

INFINITY RANGE POSITION.—The final check of the range measuring system is coincidence of the crosslines. When the stadimeter lenses are offset, no duplication of the vertical crossline should appear (fig. 9-25). When the lens halves are realigned, the horizontal graduation images should coincide.

Should the stadimeter and split lens assembly fail any of these tests, refer to the appropriate maintenance manual for alignment procedures.

Squareness of the Telemeter

Two different sets of circumstances exist for squaring the telemeter of an attack periscope and a general-purpose periscope.

On the general-purpose periscopes, the telemeter is squared to the travel of the head prism. To make the telemeter squareness test, rotate the collimator 45° (in either direction) out of the coincidence position, as shown in figure 9-26. Elevate or depress the line of sight and rotate the periscope until either extreme end of the vertical crossline is superimposed on the

intersection of the collimator crosslines (fig. 9-27). Now elevate or depress (as required) the line of sight so that the other extreme end of the telemeter vertical crossline is at the intersection of the collimator crosslines. The telemeter vertical crossline should be superimposed (within two minutes) on the collimator crossline intersection.

To remove telemeter squareness error in the general-purpose periscopes, rotate the telemeter so as to remove half the error observed at the end of the test and repeat the entire test. The telemeter squareness tolerance is ± 2 minutes of arc.

On the attack periscopes, the telemeter is squared to the split of the split lens. The vertical line of the telemeter must be parallel to the split of the split lens and is checked by displacing the two halves of the split lens to their maximum positions. Duplication similar to that in figure 9-25 will appear if the telemeter is not positioned correctly. Rotate the telemeter mount until all duplication is removed.

SYNCHRO ALIGNMENT

When the periscope is being used as the sighting unit of a celestial navigation system, the elevation of the line of sight is continuously being transmitted electrically by a fine (36-speed) synchro located in the head section and by a coarse (2-speed) synchro located in the eyepiece box. These synchros transmit their signals to remotely located recording devices, which provide navigation information. Any error in the electrical transmission of the elevation angle will cause a corresponding error in navigational information and, therefore, the error must be held within specified limits.

The elevation angle transmission error is determined with an altiscope angle comparator (fig. 9-28). An altiscope error calibration chart, for each individual periscope, can be established by comparing the fine synchro output signals with the known elevation angles established with the comparator.

It is possible to make the synchro error tests with the periscope installed in the submarine using a test arrangement similar to that of figure 9-29.

The preferred method is to make the tests while the skeleton head is removed from the periscope proper. Whenever the periscope is overhauled, a synchro error test should be made. Three separate tests are involved: (1) a backlash

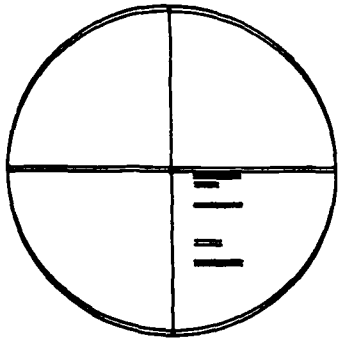

11000-20

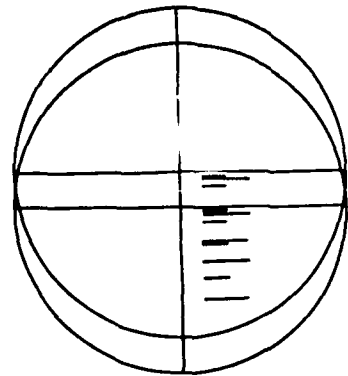

1000-20

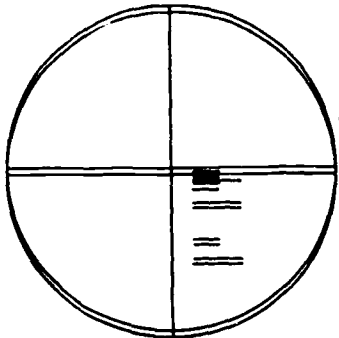

7500-20

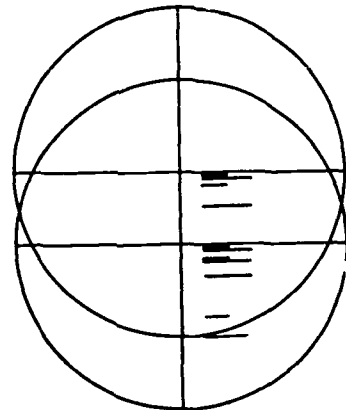

500-20

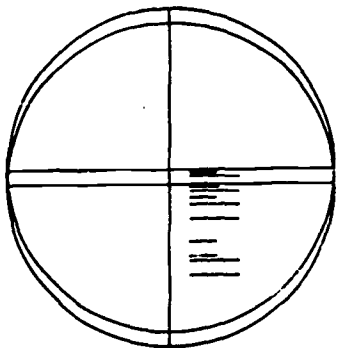

2500-20

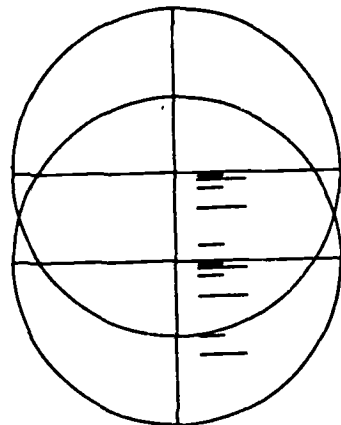

400-20

Figure 9-24.—Collimator range references.

148.366

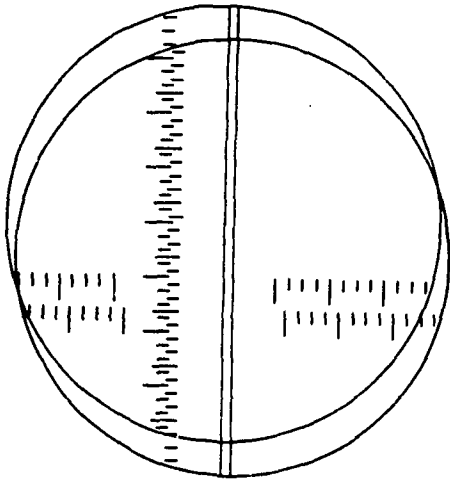

DUPLICATION OF VERTICAL CROSSLINE

148.367

Figure 9-25.—Duplication check.

test to insure the synchro is transmitting elevation data which corresponds to the optical elevation, (2) a test to insure that the head prism is set to electrical zero, and (3) a test to determine whether or not the depression stop angle

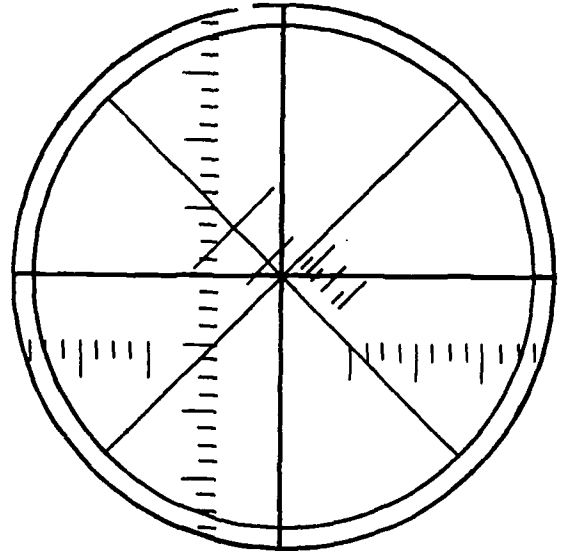

148.363

Figure 9-26.—Collimator in rotated position (H.P.).

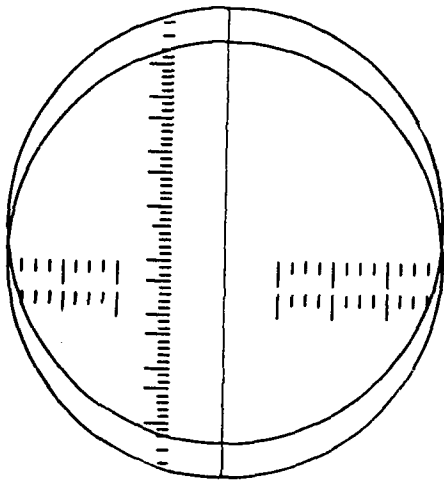

NO DUPLICATION

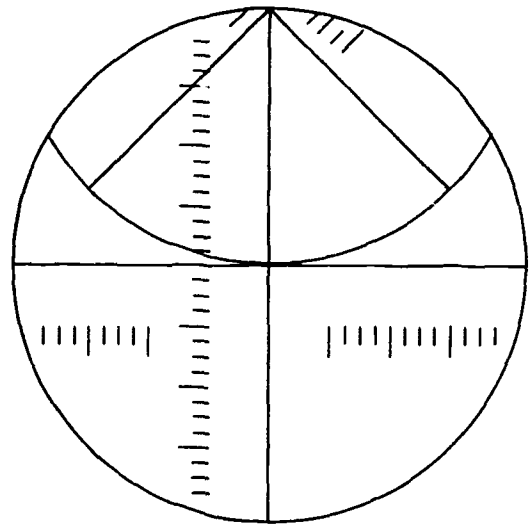

148.364

Figure 9-27.—Squaring the telemeter.

coincides, within error limits, to the stop angle marked on the lower door of the eyepiece box.

Altiscope Angle Comparator

The altiscope angle comparator (fig. 9-28) is a precision device designed to measure the error in synchro transmission of elevation

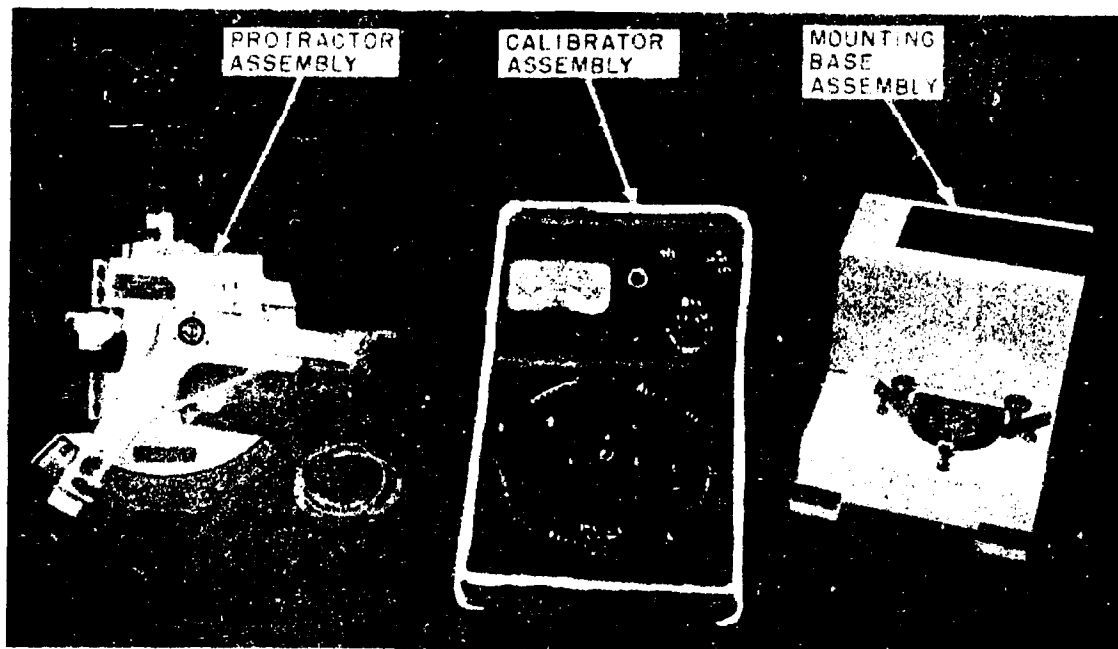
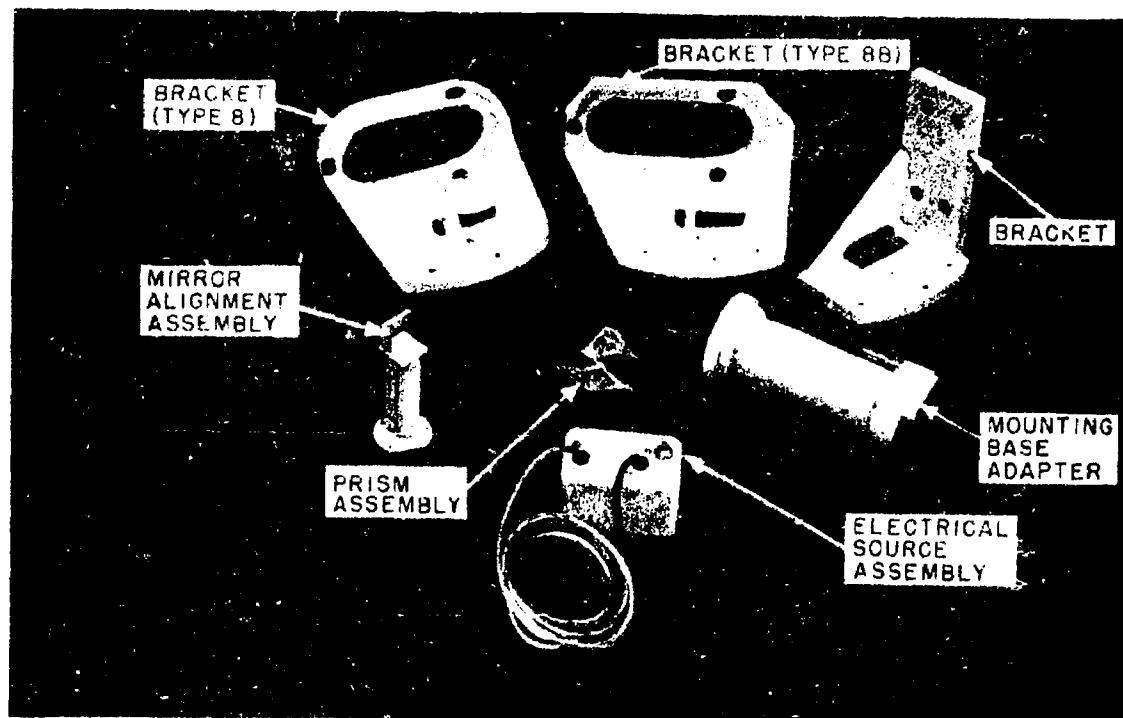

148.368

Figure 9-28.—Altiscope angle comparator.

angles. The comparator is composed of a protractor, calibrator, and accessories.

PROTRACTOR ASSEMBLY.—The protractor (fig. 9-30) accurately establishes elevation

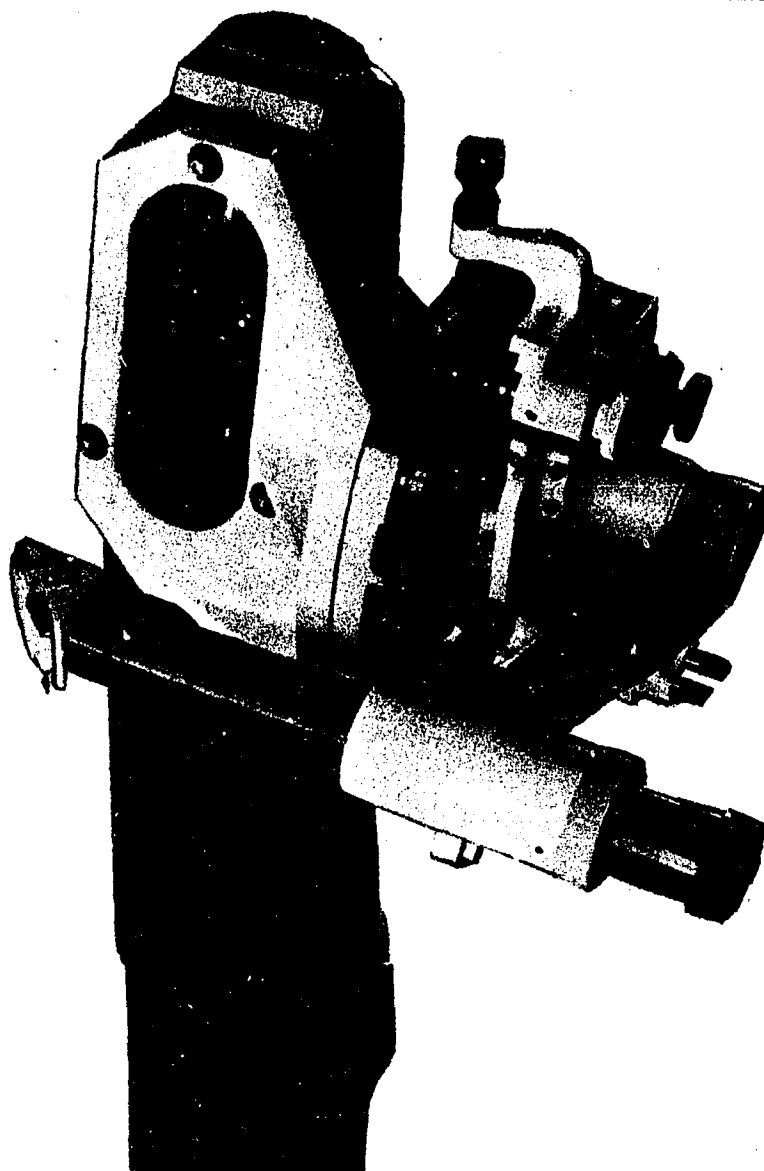

Figure 9-29.—Comparator installed on type 8B periscope.

148.369

angles which are used as a reference for the electrical indications of the 36X synchro.

The calibrated dial contains holes, spaced 2° apart, and locating pins, 5° apart on the arm, to position the telescope at 1° intervals.

A collimating telescope is incorporated in the swinging lever. The telescope functions as an autocollimator because it projects an image (fig. 9-31) which is reflected by the front surface of the head prism.

When using the protractor to check synchro accuracy, first adjust the protractor so that it will introduce no errors. Procedures for protractor alignment are specified in the comparator technical manual.

CALIBRATOR ASSEMBLY.—The electrical calibrator assembly (fig. 9-32) contains a type 15 CT 4A synchro with a rotating vernier arm attached to the rotor shaft, a graduated ring corresponding to the arc of the rotating vernier

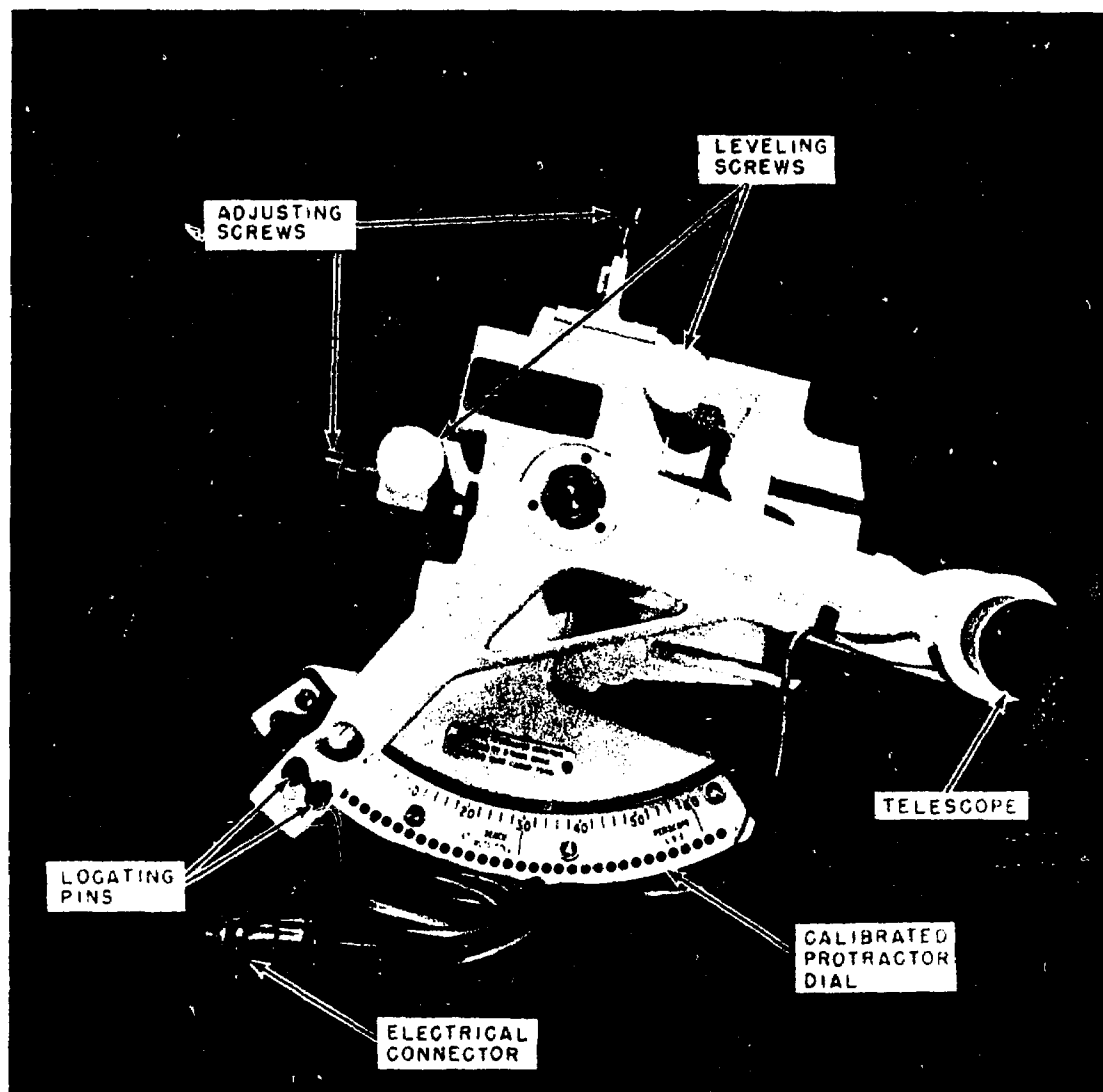
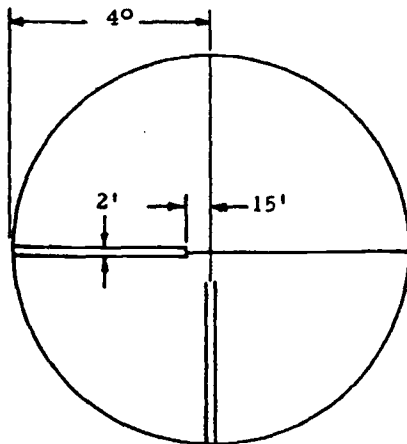

Figure 9-30.—Protractor assembly.

148.370

arm, a multirange voltmeter, various connections, and switches. For maximum accuracy the calibrator should be used in conjunction with a 400-Hz power supply. The meter has three ranges with a full deflection of 2.5, 50, and 200 volts. The switch which controls the voltmeter range is spring loaded in the B range of 200 volts. Do not switch to the C range (50 volts) unless the indication on the B range is less than 50 volts. The A range (2.5 volts) should not be energized until less than 2.5 volts is indicated on the C scale.

The function selector switch selects the test phase to be used. Use "Coarse zero adj." and "Fine zero adj." when adjusting the synchros in the periscope. The "calibrate altiscope" position compares the electrical position of the periscope synchro and the calibrator synchro and indicates the difference on the voltmeter. The "180° test" position is used to test synchro for 180° ambiguity. When you switch to the "180° test" position, an acceptable reading (between 30 and 40 volts on the B scale) or an unacceptable reading (between 190 and 200 volts) will be indicated.



TELESCOPE PRIMARY
RETICLE IMAGE

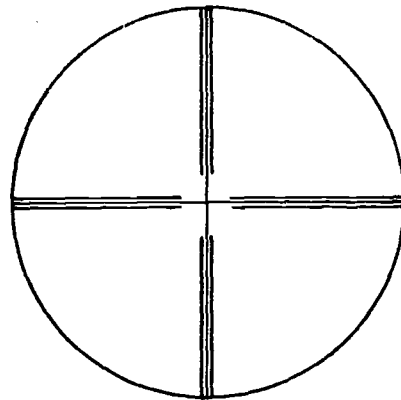

TELESCOPE PRIMARY
& REFLECTED SECONDARY IMAGE

148.371

Figure 9-31.—Reticle image.

Backlash Error

The backlash test determines the condition of the gear train between the head prism and the synchro rotor. Imperfections in the motion transmission system (gear train) will be indicated as synchro error. A series of electrical readings are taken, in 2° steps, between -10° elevation of the head prism and $+60^\circ$. The maximum allowable difference between maximum and minimum electrical readings is six minutes of arc.

Head Prism Electrical Zero

To set the head prism to electrical zero in the shop, you need a small surface plate, "V" blocks, the calibrator assembly, and a dial indicator mounted on an appropriate stand (fig. 9-33).

Make the electrical connections between the calibrator and synchro. Adjust the prism and skeleton head so that the entrant face of the head prism is parallel to the surface plate (dial indicator reads the same for all four corners).

Energize the calibrator (power switch to "on") and check the voltage indication on the meter.

The voltmeter should indicate 0 volts on all three scales. If not, adjust the synchro body until 0 volts is indicated and the 180° test is acceptable. When these tests are satisfactory, the head prism is set to electrical zero.

Depression Stop

The check made to measure the depression angle from 0° optical to the depression stop can be made with the skeleton head in the setup specified for the electrical and optical zero test, or it can be made with the head installed. The procedure is basically the same for both and is outlined in the Altiscope Angle Comparator Technical Manual, NavShips 0924-001-0000. Essentially the process measures the electrical signal at the depression stop which is then converted into an equivalent optical angle. Should the depression stop angle vary from the depression stop angle recorded on the identification plate on the lower door, the measured depression stop angle indication on the name plate should be changed, recorded, and relayed to the personnel responsible for aligning the elevation recording equipment on board the submarine.

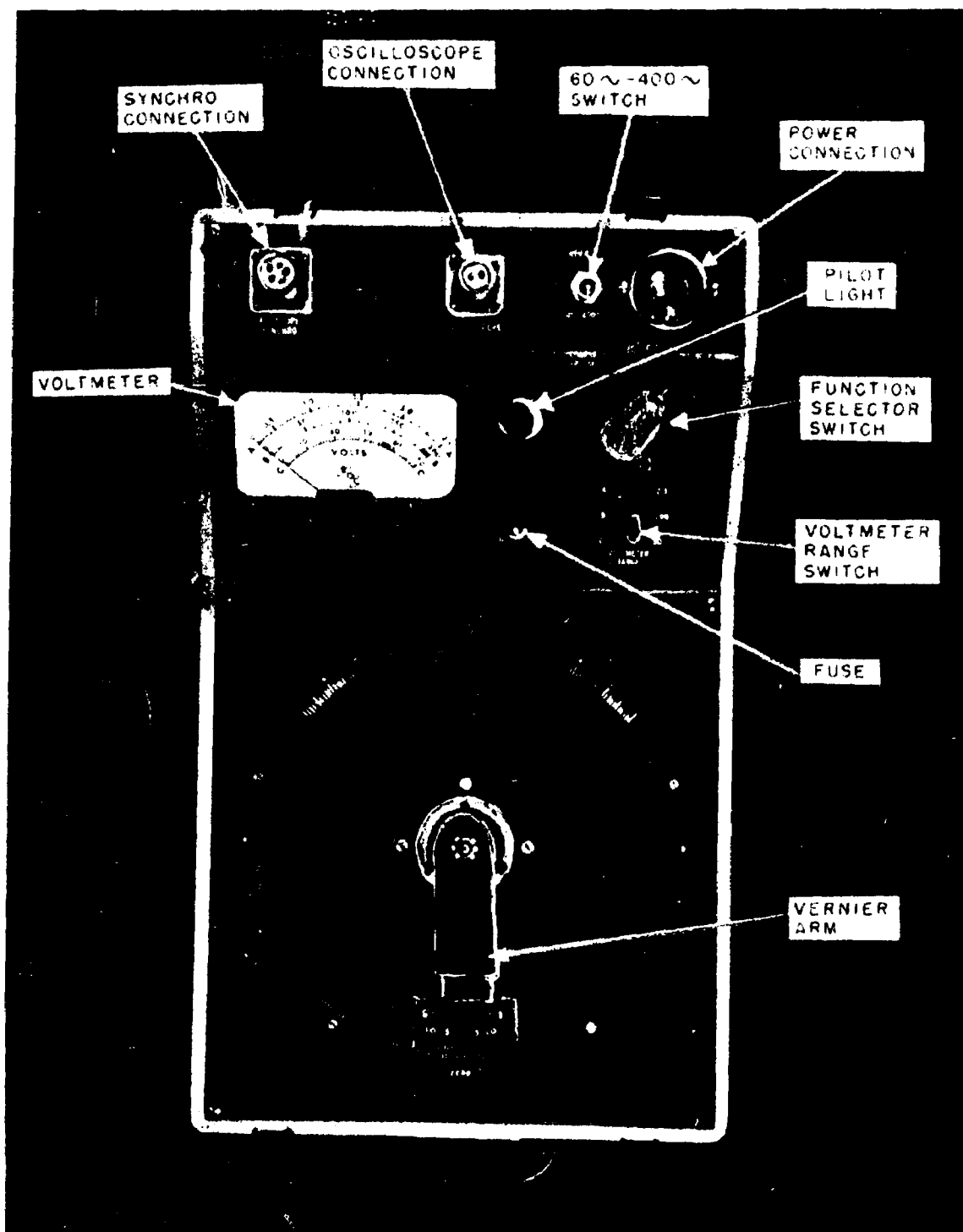
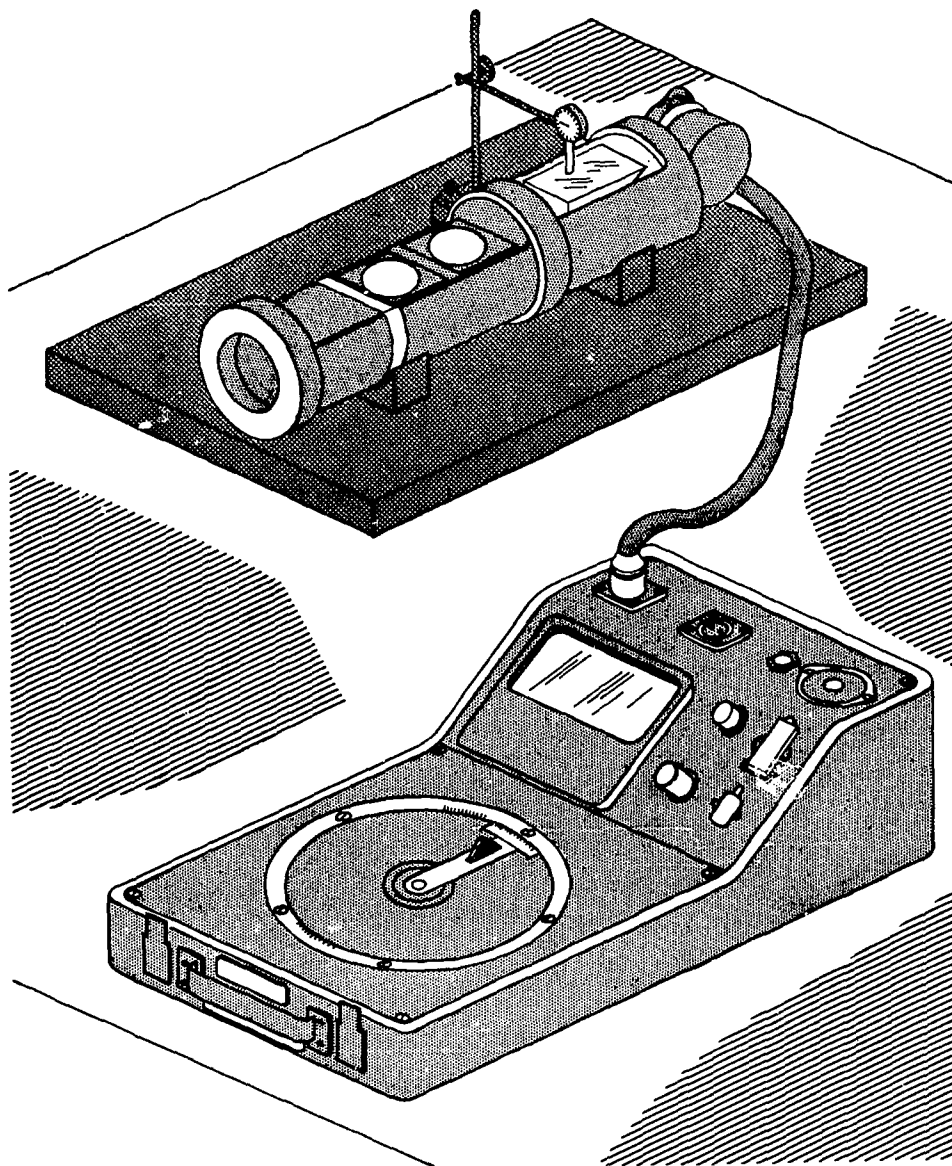

Figure 9-32.—Calibrator assembly.

148.372



148.373
Figure 9-33.—Optical and electrical
zero test set-up.

APPENDIX I

READING REFERENCE LIST

Miscellaneous

OP 434	0630-109-6001	Elementary Optics
OP 463 (change 1, 2)	0630-118-0001	Optical repair data
OP 463 (change 3)	0630-118-0003	Optical repair data
OP 463 (change 4)	0630-118-0004	Optical repair data
OP 463 (change 5)	0630-118-0005	Optical repair data
OP 463 (change 6)	0630-118-0006	Optical repair data
OP 556	0630-144-7001	Stereoscopic Vision
OP 1417	0630-484-5001	Collimators for Optical Instruments
OP 1449	0630-496-8001	Boresight telescopes
OP 1449 (change 1)	0630-496-8002	Boresight telescopes
MIL-HDBK-141		Optical design
MIL-STD-1241A		Optical terms and definitions
NA 17-35QAL-2	0717-080-0010	Physical Measurements
NA 17-35MTL-1	0717-080-0035	Metrology Requirements
NA 17-35MTM-1	0717-080-0070	Measuring tools
NW 17-35NCE-2	0717-080-0060	Navy Calibration Equipment list, Mechanical
OD 3000	0627-030-0001	Lubrication of Ordnance Equipment

Rangefinders

OP 105	0630-014-9001	Rangefinder Care
OP 597	0630-156-7001	Rangefinder Mk 39, 42
OP 597(a)	0630-157-0001	Rangefinder Mk 42
OP 2147	0630-726-7001	Rangefinder Mk 21

Submarine Periscopes

NAVSHIPS TECHNICAL MANUAL, CHAPTER 9006, SECTION III.

NAVSHIPS 0324-026-9000	Periscope Type 2
-029-3000	Periscope Type 2A
-047-5000	Periscope Type 2D (Oper.)
-048-7000	Periscope Type 2D (Maint.)
-048-6000	Periscope Type 2E (Oper.)
-051-5000	Periscope Type 2E (Maint.)
-065-1000	Periscope Type 2F (Oper.)
-065-2000	Periscope Type 2F (Maint.)
-044-2000	Periscope Type 8B/8C (Oper.)
-065-0000	Periscope Type 8B/8C (Maint.)
-044-6000	E E Adapter for 8B/8C/8D
-064-9000	Periscope Type 8D (Oper.)

-065-0000	Periscope Type 8D (Maint.)
-060-6000	Periscope Type 14
0924-007-7010	Periscope Type 15B/D/L vol 1
-007-7020	Periscope Type 15B/D/L vol 2
-007-7021	Periscope Type 15B/D Supplement
-001-0000	Altiscope Angle Comparator

Tilting Prism Gunsight Telescopes

OP 582	0630-152-2001	Telescopes Mk 61, 62, 67, 68
OP 582 (change 1)	0630-152-2002	Telescopes Mk 61, 62, 67, 68
OP 1857	0630-631-3001	Telescope Mk 97
OP 1857 (change 1)	0630-631-3002	Telescope Mk 97
OP 1858	0630-631-6001	Telescope Mk 102
OP 2531	0630-964-7001	Telescope Mk 116
OP 2531 (change 1)	0630-964-7002	Telescope Mk 116 (change 1)
OP 2531 (change 2)	0630-964-7003	Telescope Mk 116 (change 2)

INDEX

A

Accuracy, stereoscopic rangefinder, 159-162
Adjuster scale reader system, 176
Administration and supervision, 6-36
 duties, 10-16
 general housekeeping, 30
 records and reports, 16
 repair department, 6-10
 safety, 30-34
 3-M utilization and documentation, 16-30
 training, 34-36
Air resistance, 122
Alignment telescopes, 77-84
 checking telescope, 80-84
 collimator telescopes, 78-80
Angular measurements, 153-157
 degrees, 153
 mils, 154
 radians, 153
 triangulation, 154-157
AN/PVS-2A, 100-109
 eyepiece assembly, 105
 objective lens assembly, 103-105
 sight assembly, 106
 sight disassembly, 101
AN/TVS-4 night observatory device (NOD),
 medium range, 88-100
 evaluation of the optical cells, 95-99
 eyepiece assembly, 95
 image intensifier tube (IIT), 99
 objective assembly, 91-94
 power supply assembly, 99
 sight disassembly, 88-91
 sight evaluation, 100
 sight reassembly, 100
Arrival conference, 10
Assist Work Center procedures, 23
Astigmatizers, 169, 203
Autocollimation, 48-53
 application, 51
 theory, 50

Auxiliary alignment equipment, 70-84
 alignment telescopes, 77-84
 auxiliary telescope accessories, 73
 Mk 1 auxiliary telescope, 70
 Mk 2 dynameter, 74-77
Auxiliary telescope accessories, 73

B

Bibliography for Advancement Study, 3

C

Calibration, rangefinder, 190-194
 on fixed targets, 192
 on moving targets, 191
 recordkeeping, 194
Change-of-range input, 180
Code assignments, 27
Coincidence rangefinder, 163
 astigmatizers, 169
 coincidence prism, 167
 color filters, 169
 correction wedge, 167
 end penta prisms or end reflectors, 163
 end windows, 163
 eyepiece group, 169
 inspection, 190
 measuring wedge or compensator wedges, 165
 objective lenses, 168
 operation, 185
Collimation, 146-152, 194-204
Collimators, 54-70
 Mk 4 Mod 0 telescope, 61
 Mk 5 binocular, 54-58
 Mk 9 telescope, 62-64
 Mk 13 binocular, 58-61
 submarine periscope, 64-70
Correspondence courses, 5

D

Daily exception card, 25
 Departure reports, 10
 Design theory, 85-88
 charging apparatus, 87
 cleanliness, 86
 general practices, 85
 lens blackening, 86
 O-ring lubrication, 86
 paint, 87
 pressurization, 86
 safety, 85
 sealing compound, 87
 wrenches, special, 86
 Division officer/lead work center actions, 20
 Documenting repair activity maintenance action, procedures for, 20
 Drift, 123
 Drying and charging the rangefinder, 204-207
 Duties, supervisory, 10-16
 Duty division petty officer, 9
 Duty repair chief petty officer, 9
 Duty repair officer, 7

E

Enhancement test, 100
 Erecting lens system, 179
 Error correction/deletion procedures, 24
 Exception time accounting, 24
 Exception time accounting codes, 25
 Eyepiece assembly, 95, 105

F

Fire control problem, 119-127
 applying corrections, 124
 demonstration of, 119
 initial velocity and own-ship factors, 126
 projectile in flight, 121-123
 sight angle and super-elevation, 124
 sight deflection, 125
 target, 119

G

General housekeeping, 30
 Grade codes, 25
 Gravity, 121

I

Identification of periscopes, 208
 Initial velocity and own-ship factors, 126
 Interference fringe interpretation, 41
 Interference measurements, 41
 Interference of light waves, 37-43
 application, 38
 interference fringe interpretation, 41
 measuring with monochromatic light, 41-43
 monochromatic light source, 39
 optical flats, 39
 Interpupillary adjustment, 182
 Inventory of tools and equipment, 30

L

Labor codes, 25
 Labor utilization report, 25
 Light waves, interference of, 37-43

M

Maintenance Data Form OpNav 4709/2K, 18
 Man-hour Accounting Subsystem, 24-27
 Mark variations, 131
 Material control, 27-29
 Material usage and cost data, documentation of, 28
 Mk 1 auxiliary telescope, 70-72
 adjustment, 71
 configuration, 71
 operation, 71
 optical system, 71
 Mk 2 dynameter, 74-77
 adjustment, 77
 configuration, 74
 operation, 75
 optical system, 75
 uses, 74
 Mk 4 Mod 0 telescope collimator, 61
 alignment, 61
 configuration, 61
 uses, 61
 Mk 5 binocular collimator, 54-58
 adjustment, 57
 configuration, 55
 optical system, 56
 uses, 55
 Mk 9 telescope collimator, 62-64
 alignment, 64
 configuration, 63
 optical system, 63
 uses, 63

INDEX

Mk 13 binocular collimator, 58-61
adjustment, 60
configuration, 58
operation, 59
optical system, 58
Mk 21 Mod 2 rangefinder, 169-171
optical system, 170
range scale reading system, 169
Mk 42 rangefinder, 176
Mk 61 and Mk 62 tilting-prism gunsight tele-
scopes, 128-133
controls, 132
optical system, 129-131
similar mark variations, 131
Mk 67 and Mk 68, telescopes, 133
Mk 97 Mod 1, telescopes, 133-136
controls, 134
optical system, 135
Mk 102 tilting-prism gunsight telescope, 136-143
controls, 139
modification differences, 138
optical system, 139-143
Mk 116 tilting-prism gunsight telescope, 143
Monochromatic light, measuring with, 41-43
Monochromatic light source, 39

N

Nature of light, 37-53
autocollimation, 48-53
interference of light waves, 37-43
polarization, 43-48
Night vision sights, 85-109
AN/PVS-2A, 100-109
AN/TVS-4 night observation device (NOD),
medium range, 88-100
design theory, 85-88

O

"O" diopters, adjusting, 198
Objective assembly, 91-94
Objective lens assembly, 103-105
Ocular prisms, 173
Optical alignment instruments, 54-84
auxiliary alignment equipment, 70-84
collimators, 54-70
Optical cells, evaluation of, 94-99
Optical flats, 39
Optical systems,
checking telescope, 81
Mk 1 auxiliary telescope, 71
Mk 2 dynameter, 75
Mk 5 collimator, 56

Optical systems — Continued
Mk 8 Mod 1 collimator telescope, 79
Mk 9 telescope collimator, 63
Mk 13 binocular collimator, 58
Mk 21 Mod 2 rangefinder, 170
Mk 61 and Mk 62 tilting-prism gunsight tele-
scopes, 129
Mk 67 and 68 telescopes, 133
Mk 97 Mod 1 telescope, 135
Mk 102 telescope, 139-143
Mk 116 telescope, 143
rangefinder, 157-159
auxiliary system, 174
submarine periscope collimator, 68
submarine periscopes, 216-221
Opticalman rating,
Bibliography for Advancement Study, 3
correspondence courses, 5
NAVTRA publications, 3
Rate Training Manuals, 3
responsibilities, 1
scope of manual, 2
sources of information, 2
training films, 5
your job, 2
Overtime reporting, 27
Own equipment maintenance, 27

P

Planned Maintenance Subsystem, 17
Polarization, 43-48
methods of polarizing light, 44
plane polarization, 44
polarizing filters, 45
uses of, 48
Power supply assembly, 99
Preexpended material, 28
Preexpended stocks, replenishment of, 29
Pressurization, 144-146
Projectile in flight, 121-123

R

Radians, 153
Rangefinders, 153-207
accuracy, 159-162
angular measurements, 153-157
calibration, 190-194
drying and charging, 204-207
inspection, 186-190
maintenance, 194-204
objectives, 178-181

- Rangefinders — Continued
 - operation, 181-186
 - optical system, 157-159
 - auxiliary, 174
 - types of, 162-181
- Rate Training Manuals, 3
- Reassembly of objective lens assembly, 92
- Reassembly of subassemblies, 91
- Repair department, 6-10
 - division officers, 7
 - officer, 6
 - organization, 6
 - ship repairs, 9
- Repair division work center supervisor, 11-16
 - completed jobs, checking on, 16
 - consideration of things that may go wrong, 14
 - estimating time for a job, 13
 - laying-out and assigning work, 12
 - planning the work, 11
 - progress of work, checking, 15
 - required parts and material, 14
 - supervising repair work, 15
 - workload considerations, 14
- Repair office action, 19
- Repair officer, 20
- Rhomboid prism attachment, 73
- Rhomboid prisms, 173
- Rotatable pools, 28
- Rotor position versus stator voltage output, 111

S

- Safety, 30-34
 - attitudes, 31
 - enforcing, 33
 - handtools, 33
 - information sources, 34
 - portable electrical equipment, 32
 - requirements in work areas, 31
 - rotating machinery, 32
 - training, 34
- Servos and control transformers, 112-117
 - control transformers, 114-116
 - servo motor-generators, 114
 - system operation, 117
- Ship repairs, 9
- Sight angle and super-elevation, 124
- Sight assembly, 106
- Sight deflection, 125
- Sight disassembly, 88-91, 101
- Sight evaluation, 100
- Sight reassembly, 100
- Stadimeter range error test, 226

- Stereo comparator, 73
- Stereoscopic rangefinder, 171-173
 - height adjuster, 172
 - inspection, 186-190
 - ocular prisms, 173
 - operation, 182-185
 - reticles, 172
 - rhomboid prisms, 173
- Submarine periscope collimator, 64-70
 - alignment, 68
 - optical system, 68
- Submarine periscope elevation system, 113
- Submarine periscopes, 208-236
 - identification of, 208
 - maintenance, 221-236
 - charging, 222
 - cleaning elements, 221
 - collimation, 222-228
 - synchro alignment, 228
 - systems, 209-221
 - change of power, 213
 - elevation, 211
 - focusing, 213
 - optical, 216-221
 - ranging, 215
- Supervisory duties, 10-16
- Synchros, 110-112
 - construction, 110
 - elevation indication, 112
 - operation, 111
 - rotor position versus stator voltage output, 111

T

- Telemeter, 221
- Test block, determining height of, 42
- 3-M utilization and documentation, 16-29
 - Maintenance Data Collection Subsystem, 17
 - Man-hour Accounting Subsystem, 24-27
 - material control, 27-29
 - Planned Maintenance Subsystem, 17
 - Workload Planning and Control Subsystem, 19-24
- Tilting prism gunsight telescopes, 118-152
 - fire control,
 - growth of, 118
 - problem, 119-127
 - maintenance requirements, 144-152
 - Mk 61 and Mk 62, 128-133
 - Mk 67 and Mk 68, 133
 - Mk 97 Mod 1, 133-136
 - Mk 102, 136-143

Tilting prism gunsight telescopes — Continued

Mk 116, 143
 weapon systems, 127
Training, 34-36
 job rotation, 35
 shipboard, 35
Training films, 5
Triangulation, 154-157

W

Weapon systems, 127
Wind, 123
Work center codes, 25
Work request, procedures for closing out, 23
Work Supplement Card, OpNav Form 4790/2F, 20
Workload Planning and Control Subsystem, 19

★U.S. GOVERNMENT PRINTING OFFICE: 1973--515810/9

YOU CAN HELP

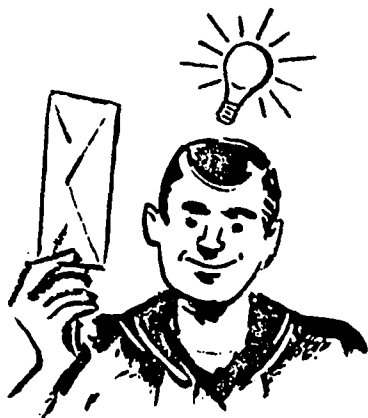

Comments and recommendations received from users have been a major source of textbook improvement. You are invited to submit your constructive criticisms and recommendations. Use this cut-out form, writing your comments and recommendations in the form letter on the back side of this page. Typewrite, if possible, but readable handwriting is acceptable. If you want to make a specific point or indicate a technical correction, do so, but give the source of your information. This could be the text or reference source(s) and page number(s) where it can be found, or a characteristic of a piece of equipment which you can identify, or your personal knowledge about a matter concerning your rate that is wrong in the text. If you have a difference of opinion as to how a statement is made, give your reason(s) for the difference. If you wish to recommend a difference in style, slant, or depth of treatment of any subject matter, write out your point of view in an example.

OFFICIAL BUSINESS

POSTAGE AND FEES PAID
DEPARTMENT OF THE NAVY



DOD 316

Officer in Charge
Naval Training Publications Detachment
Building 220, Washington Navy Yard
Washington, D. C. 20390

This page is preaddressed and franked. After you have completed your letter, fold in thirds, seal with tape and mail. Your interest and assistance are appreciated.

From:

To: Officer-in-Charge, Naval Training Publications Detachment,
Building 220, Washington Navy Yard, Washington, D. C. 20390

Subj: _____ ; comments on
(Title)

--- Cut along dotted line ---

(continue on separate sheet if necessary)