

DOCUMENT RESUME

ED 086 161

IR 000 007

AUTHOR Morrow, James; Wallace, Daniel
TITLE Learning Through Media; An IMC Handbook for Chelmsford Teachers.
INSTITUTION Chelmsford Public Schools, Mass.
PUB DATE 72
NOTE 75p.
EDRS PRICE MF-\$0.65 HC-\$3.29
DESCRIPTORS Audiovisual Aids; *Audiovisual Centers; Concept Teaching; Estimated Costs; *Instructional Media; *Instructional Technology; Language Arts; Language Instruction; Learning Activities; Library Services; Mathematics Instruction; *Multimedia Instruction; *Production Techniques; Resource Guides; Science Instruction; Skill Development; Social Studies; Teaching Guides; Teaching Techniques
IDENTIFIERS *Chelmsford School Systems Instructional Media Ctr

ABSTRACT

This handbook is designed to provide basic information that is necessary to use the Chelmsford School System's Instructional Media Center (IMC). It defines six different media (print, sound, television, photography, movies and design) and suggests a series of separate classroom production activities in each. An emphasis is given to the ways in which media may be used to teach fundamental processes and concepts inherent in five major subject matter disciplines (language arts, science, mathematics, social studies, and foreign languages). It is suggested that a teacher can teach such fundamental skills as translation, grouping, transformation, point of view, cause and effect, and prediction in the context of each subject area. It also provides some practical advice in handling media tools such as projectors, sound equipment, and cameras. The last part introduces technical and library services available at the IMC. The cost of technical services is outlined in the Appendix. (CH)

ED 086161

COLLECTOR'S
EDITION

LEARNING THROUGH MEDIA

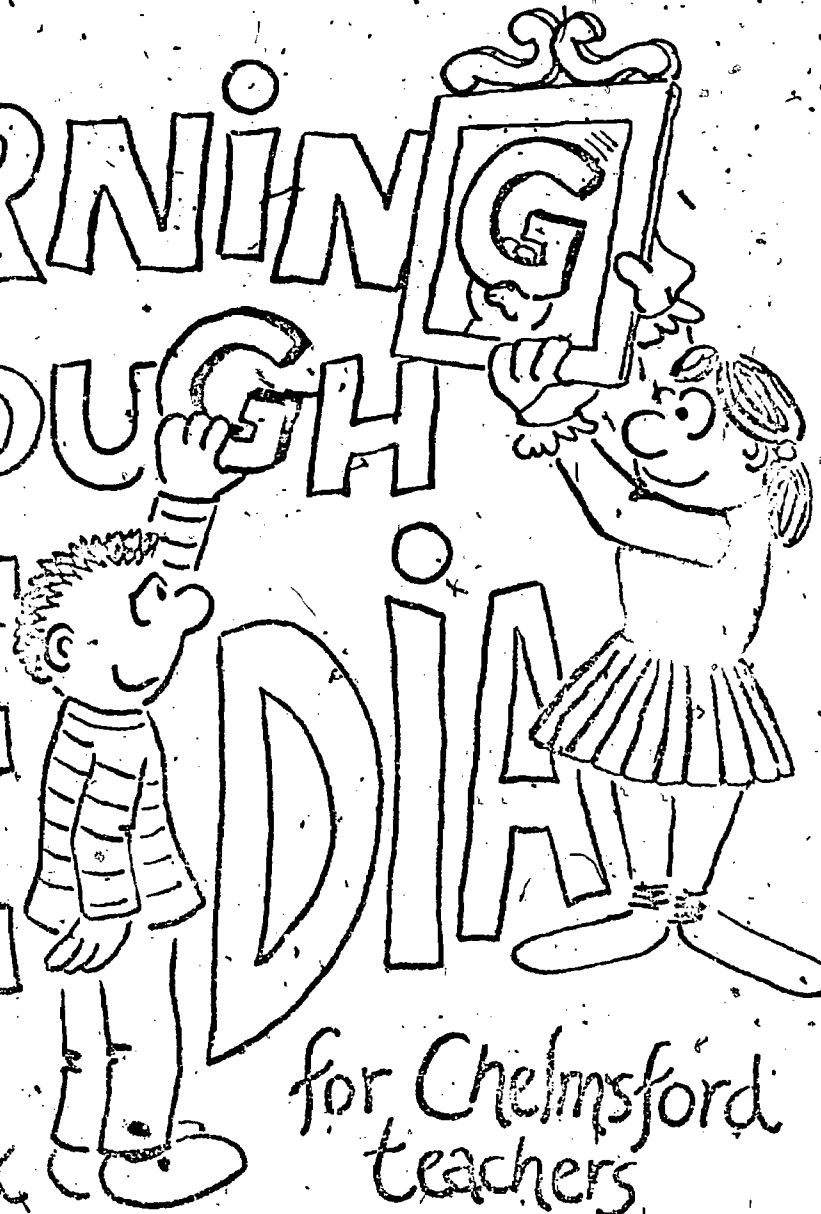

an imc
handbook for Chelmsford
teachers

by Jim Morrow and Dan Wallace

U.S. DEPARTMENT OF HEALTH,
EDUCATION & WELFARE
NATIONAL INSTITUTE OF
EDUCATION

THIS DOCUMENT HAS BEEN REPRO-
DUCED EXACTLY AS RECEIVED FROM
THE PERSON OR ORGANIZATION ORIGIN-
ATING IT. POINTS OF VIEW OR OPINIONS
STATED DO NOT NECESSARILY REPRESENT
OFFICIAL NATIONAL INSTITUTE OF
EDUCATION POSITION OR POLICY

FILMED FROM BEST AVAILABLE COPY

000 007

LEARNING THROUGH MEDIA
an IMC handbook for Chelmsford teachers

© 1972 James Morrow and Daniel Wallace

PERMISSION TO REPRODUCE THIS COPY-
RIGHTED MATERIAL HAS BEEN GRANTED BY

Daniel Wallace

TO ERIC AND ORGANIZATIONS OPERATING
UNDER AGREEMENTS WITH THE NATIONAL IN-
STITUTE OF EDUCATION. FURTHER REPRO-
DUCTION OUTSIDE THE ERIC SYSTEM RE-
QUIRES PERMISSION OF THE COPYRIGHT
OWNER.

Table of Contents

| | |
|--------------------------------------|----|
| INTRODUCTION | 1 |
| 1. MEDIA FOR STUDENT PRODUCTION | 3 |
| a. Print | 3 |
| b. Television | 6 |
| c. Sound | 8 |
| d. Photography | 9 |
| e. Movies | 11 |
| f. Design | 14 |
| 2. MEDIA IN THE CLASSROOM | 17 |
| a. Content and Approaches to Content | 17 |
| b. The Disciplines | 20 |
| 1. Language Arts | 20 |
| 2. Science and Mathematics | 25 |
| 3. Social Studies | 32 |
| 4. Foreign Languages | 36 |
| c. Strategies for Getting Started | 40 |
| 3. MEDIA TOOLS AND TECHNOLOGY | 43 |
| a. Presentation Techniques | 44 |
| b. Those Infernal Machines | 46 |
| 1. 16mm Projectors | 46 |
| 2. Other Projectors | 54 |
| 3. Sound Equipment | 57 |
| 4. Cameras | 59 |
| 4. TECHNICAL SERVICES | 60 |
| a. Teacher Workshops | 60 |
| b. Basic Technology | 61 |
| 1. Transparencies and Graphics | 61 |
| 2. Dry Mounting and Laminating | 63 |
| 3. Sound Transfer | 63 |
| 4. Video-tape Recording and Playback | 64 |
| 5. Slide-Making | 64 |
| 6. Maintenance | 64 |
| 5. LIBRARY SERVICES | 65 |
| a. The Union Card Catalogue | 66 |
| b. School Library Resources | 67 |
| c. Instructional Materials | 68 |
| d. ERIC | 68 |
| APPENDIX | 69 |
| a. Authorization Procedure | 69 |
| b. Basic Costs | 69 |

INTRODUCTION

We learn by doing. Experiences which actively engage our hands and eyes stay with us. Perhaps the true virtue of modern culture is the rich variety of media it affords for understanding and expressing ideas in the arts and sciences. Movies, radio, television, photography, design, and print are available to us not only as sources of information and entertainment, but as graspable tools for active, creative, and, ultimately, educational production.

The basic aim of the Chelmsford School System's Instructional Media Center is to bring the full range of media from the real world into the classroom, just as the curriculum aims to bring the full range of knowledge disciplines from the real world into the classroom. In this sense, "instructional media" may be the wrong term, for it implies that certain media are "instructional" while others are not. To our mind, creative activity in a cultural medium like photography or television involves as much legitimate learning as do more explicitly educational devices like filmstrips, overhead transparencies, or language records.

We want to be honest about our biases. We are here to serve you, but our relationship will be most fruitful to the degree that we meet each other halfway. Our main interest is in helping you work up a particular idea for using cultural media actively in your curriculum. Such ideas might include producing a class newspaper or comic book series, building a unit on advertising (including production in print, design, and television), or grouping some good short films into a screen education course. We are less interested in simply grinding out and stockpiling pre-packaged "instructional materials." Of course, we do not deny the value of having students absorb the content of such materials, but, again, we want to expand their definition - and the sorts of things we collect here - to include media productions (student-produced as well as professionally-produced) like radio plays, tv commercials, short films, comic books, and advertisements. Students react to such media every day, but rarely with the understanding and critical competence that schools can develop.

In short, our concept of media is pluralistic. Too often, teachers come to feel that "media" have no place in their classroom because the usual explanations are confined to commercial "multi-media" packages geared to a pre-determined curriculum, or to the high-powered technology of instructional television, computer terminals, and language labs. Yet design (posters, billboards, magazine layout) is a medium too. So is improvisational drama. And print.

From reading Chapters 1 and 2 of this handbook, you should begin to see how simple devices you and your students might have at home - super-8 movie cameras, Polaroids and Instamatics, cassette tape recorders, even pencils and paper (for drawing, scripting, and creative writing) - can be harnessed to foster active production as the normal classroom mode of learning. We also encourage you to tune up your own creativity by coming to us with plans for super-8 movies, tv shows, slide-tapes, and other tailor-made creations you would like your students to experience and discuss. For those interested in exploring a medium in depth, we shall be offering after-school workshops in photography, television, film, etc. And, of course, we are also here to provide technical services like duplicating cassette tapes, copying slides, and laminating pictures (Chapter 4), and library services like accessioning books, films, and microfiche (Chapter 5).

We hope that Learning Through Media will serve as a catalyst for information exchange--not only with teachers who share our philosophy and find the notions in this book second nature, but with those who have developed other kinds of teaching styles. We want feedback on the relevance of this handbook to your own needs. We'd like to hear descriptions (including anecdotes and curriculum materials) of how you have involved media or other tactics in your teaching. We'll share information and ideas of this sort with all of you through an occasional newsletter.

See you in the IMC.

Dan Wallace

Jim Morrow

The IMC, 251-3861

Chapter 1

MEDIA FOR STUDENT PRODUCTION

This chapter attempts to define a half-dozen different media and the sorts of student production possible in each. These production activities are problem-solving in nature. The idea is not simply to make a film or a sound-tape or a photo-essay, but to have it successfully communicate a pre-determined idea, theme, value, or topic. Thus, an activity like collage-making demands more than simply giving the student a fistfull of magazines, and a bottle of glue and saying, "Here, make a collage." The result in this case would probably not be any more worth looking at than an essay inspired by "Here, write an essay" would be worth reading. Instead, the student and teacher should agree ahead of time what the collage is to accomplish--and whether in fact collage is a good way to accomplish it.

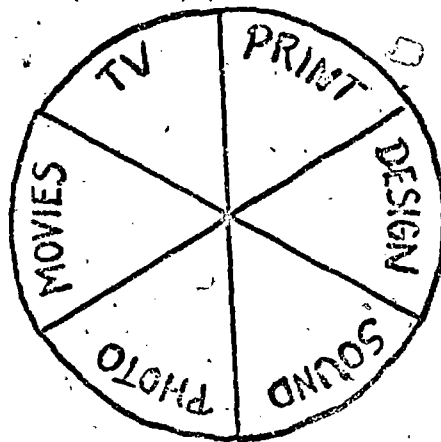

a. Print

While we take it for granted that reading and writing are productively employed in schools, it is often instructive to wrest these processes from their content and take a hard look at the medium of print. By "print" we do not mean only those mass-media forms (books, magazines, newspapers, posters) made possible by the invention of movable type, but all of man's communication in symbolic systems from the earliest forms of the "pictograph" to modern writing and usage.

It is common among some media advocates to distinguish print literacy from something they are fond of calling "visual literacy." The problem with this concept is that it ignores print's heritage in hieroglyphics, ideographs, and other forms of the design medium. Further, the visual literacy notion fails to appreciate the degree to which successful production and communication in the media of film, photography, and television rests on an underpinning of words, both spoken (directions, commentary, dialogue) and written (scripts, titles, instructions). The ultimate bankruptcy of visual literacy lies in the fact that print is about as visual as any medium can get, and that the causes of reading problems in many children are perceptual rather than conceptual. None of this is to imply that non-print media should not be grappled with on their own merits (rather than as mere "audio-visual aids" to textbooks), or that a student's perceptions should not be developed in areas other than the written word. But in the IMC, we believe these goals can be reached without resort to a fancy, self-important redundancy like "visual literacy." (It's a profit-making redundancy, to boot, judging from Kodak's enthusiasm for the term. In case you didn't know, Eastman Kodak does not make ball bearings.)

A rich range of classroom activities have been devised by teachers to give the student a feeling of comfort and control in the medium of words, in addition to building his awareness of the complementary relationship between print and design which has been so important historically.

1. production of a class book, magazine, or newspaper
2. poster-making (wanted posters, political posters, advertisements)
3. writing copy for magazine advertisements and designing the page, including visuals
4. comic book making (and pre-comic forms like illuminated manuscripts, narrative tapestries, victory columns, etc.)
5. code making and breaking
6. writing in hieroglyphics, ideographs, rhesuses and made up languages (like Martian)

7. creating twenty-five-words-or-less contests, crossword puzzles, and other original games
8. newspaper headlining and photo captioning

Unlike most of the other media activities mentioned later in this chapter, print problems generally require little for their solution beyond a selection of paper and markers. You might want to see us about using our "varitype" machine, a gadget which prints newspaper headlines on paper or transparent film in a style of the student's choosing.

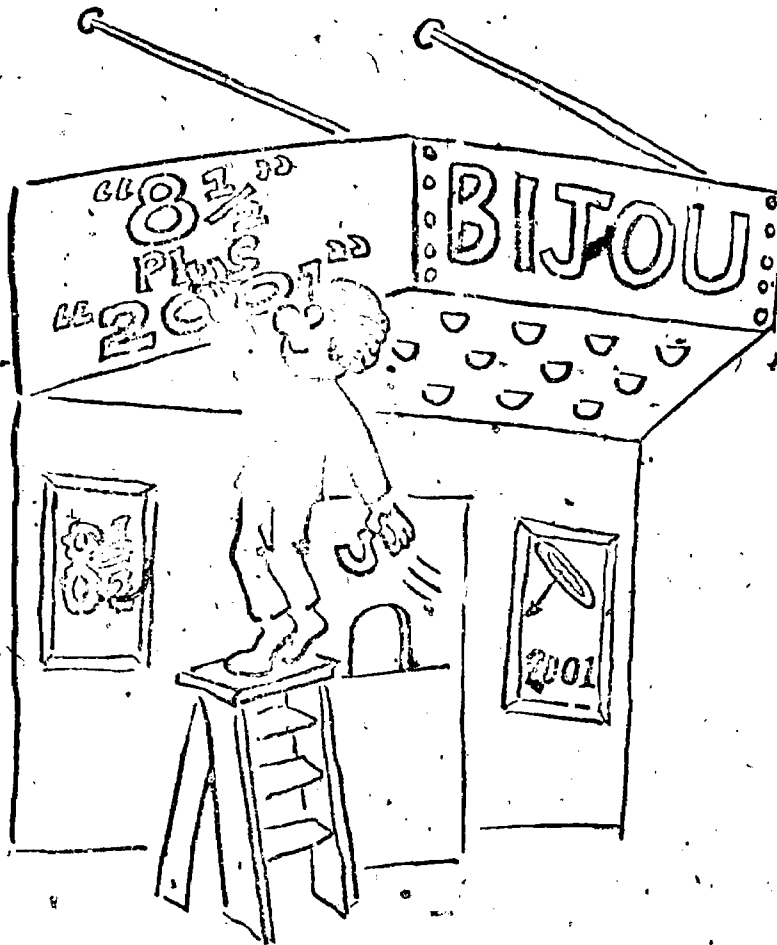

b. Television

The pervasive fact of television in the lives of children is a disarming statistic. Parents and educators are becoming increasingly concerned about the cumulative effect of Bonanza, Bayer Aspirin, and even Sesame Street. For many teachers, the answer is to use television in the classroom as a medium for creative production and active response.

While television was originally conceived exclusively as a "broadcast" medium, the advent of video tape in the late 1950's made it possible to record programs for later viewing. Shows no longer had to be done "live". The implication of video-tape for education is to define tv as a distinct and "manipulable" medium in itself, not merely a way of continuously transmitting a play, skit, discussion, or other sort of staged performance.

Studio Production. The television studios in the IMC and at the school are adaptable to a whole range of video-tape production relating to particular areas of the curriculum. Among these productions are:

1. original comedy and drama shows
2. skits and sketches (biographical, dramatic, etc.)
3. image-music combinations
4. television commercials
5. puppet shows
6. panel discussions, talk shows, game shows
7. instructional programs.

Such shows can involve a whole class. Each student can write some of the material and do some of the acting. Reserve the studio at least a week in advance to avoid conflicts and give us time to line up a crew.

Non-Studio Production. Television is now portable. Most of the above activities can be done right in your own classroom with a light-weight camera, VTR (video-tape recorder), tripod, and tv set. A remarkable machine called the porta-pak is the biggest advance to date. It runs on batteries and is therefore ideal for activities like:

1. documenting a local place or event
2. on-the-street interviews
3. dramatic productions in non-studio locations
(beaches, subway stations, etc.)

Most portable activities involve only a few students (one person can run the entire system), not the whole class. Thus, the medium is especially appropriate to small group research or independent study. Reserve the equipment at least two weeks in advance.

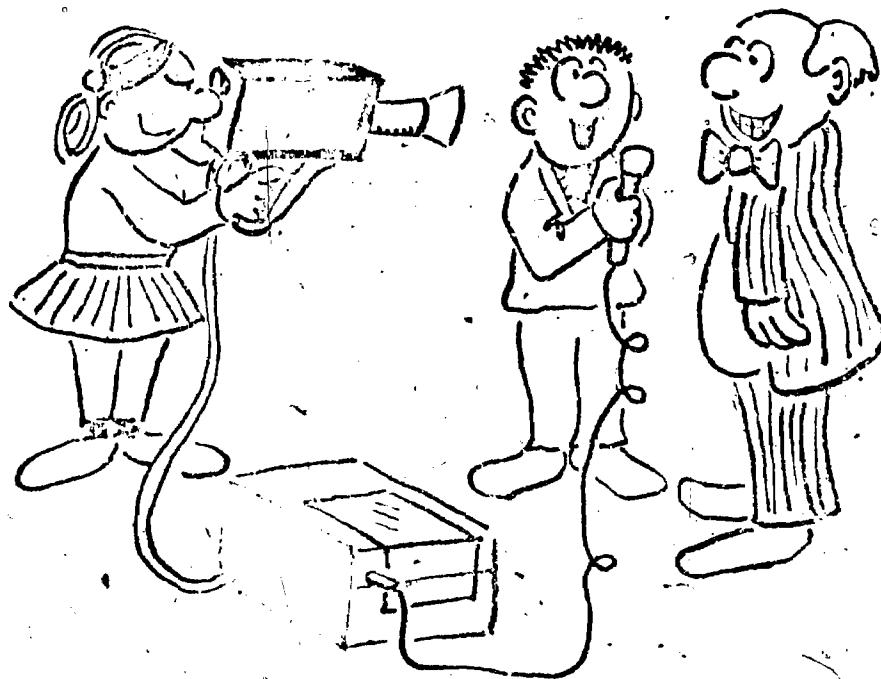

C. Sound

Captured on audio-tape, sound can be every bit as exciting and dynamic a medium as video-tape. Indeed, some educators feel that sound, with its appeal to the mind's eye, is a very visual medium. A high degree of audience imagination is at work in the perception of a radio play - a lamentably unnecessary ingredient in the appreciation of television.

Audio-tape and video-tape are basically the same material - a plastic base coated with iron oxide. Video-tape is generally bigger, coming in half-inch, one-inch, and two-inch formats. Audio-tape for a reel-to-reel machine is a quarter-inch wide. Audio-tape packaged in cassettes is an-eighth-inch wide.

Studio Production. If you have nothing more in your classroom than a reel-to-reel tape recorder and a record player, the world of sound can be opened up to your students through such activities as:

1. radio plays - drama, melodrama, and comedy
2. disk jockey shows - news, records, and patter
3. radio commercials
4. staged interviews with "famous people"

Non-Studio Production. With a portable cassette recorder, activities analogous to those we suggested for the portapak are possible, among them:

1. on-the-street interviews
2. sound essays - capturing an environment through just the sounds it makes

The IMC does not stockpile tape recorders, but you should be able to get one from your school. We are working on a library of audio-tapes demonstrating effective uses of the medium - old radio shows, famous broadcasts, Tony Schwartz's sound essays, etc.

d. Photography

Photography is a chemical process. A compound called silver bromide can be made to appear on paper (prints) or transparent celluloid (slides) in gradations proportional to the amounts of reflected light to which the chemical was exposed inside a camera.

Working With Pictures. Using photography in the classroom does not depend upon an actual picture-taking experience. With a series of photographs culled by yourself or your students from newspapers and magazines, you can produce:

- 1. captioned photos - for a newspaper or humor magazine
- 2. photo essays - a book or mounted series telling a story, making an argument, or communicating a theme
- 3. collages - non-linear photo designs with a thematic point

Picture-Taking. The above "working with pictures" activities can be made more meaningful if you have your students take the pictures themselves. We are presently experimenting with dirt-cheap cameras (the Simplex Snapper and the Snapshooter) and developing systems (the Patterson tank), and will offer a workshop on them. Picture-taking makes a good all-class activity if you can obtain about five cameras and break the class into groups - one camera to a group.

Slide-Tapes. The slide-tape is actually a marriage of two media - sound and photography. Either medium can be the basis of the production. You can start with a sequence of slides (35mm transparencies, generally in color) - either from your own collection, or from a slide library, or taken by the students. The problem then becomes the creation of a taped soundtrack which ties the slides together in some narrative, impressionistic, or instructional way. Or you can start with the soundtrack - a recording of a candid interview, an essay, a piece of music, a poem - and then create a series of slides to go with it. In recent years, the slide-tape has become very popular with educators. Because the visual units are so "manipulable" -

you can pick up a slide - it's possible to concentrate on the process of editing (selecting, timing, and arranging images) without the technical hassles involved in cutting film and tape. The educational emphasis in classroom slide-tape production is usually on these sorts of communication issues, rather than on the technology of synchronization. Numerous devices now on the market enable you to put inaudible "synch signals" on the soundtrack. Upon replay, the signals automatically advance each slide at the appropriate point in the show. Most of these machines are more trouble than they're worth. We would even argue that it's a good experience for students to run their slide-tapes manually, thinking on their feet and anticipating each cue.

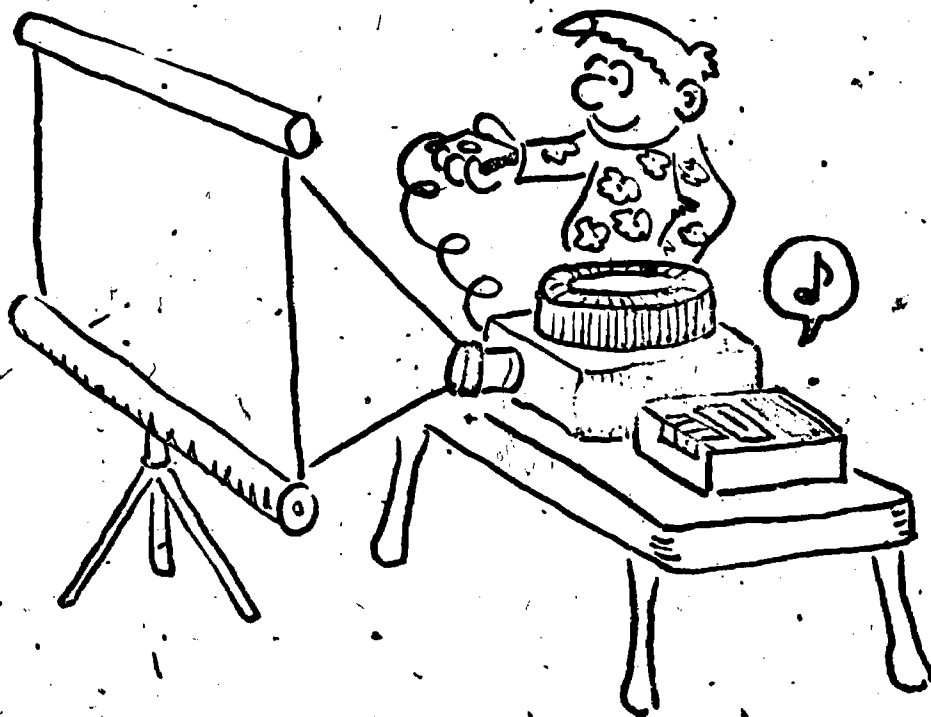

e. Movies

Film is in many ways the most demanding medium of all, but when used with patience and imagination, it is ultimately the most rewarding. Cost and technical complexity used to be major blocks to student film-making, but the advent of inexpensive, cartridge-loading super-8 cameras has changed that. With a super-8 camera, a couple of rolls of film, and a good script, all your students can become successfully involved in the production of a class movie.

We find that there is considerable confusion in the minds of students, and some teachers, as to the differences between film and video-tape. The final products look similar - moving images with sound. But tv is basically an electronic process, whereas film is a photographic process. At the present stage in the development of the two media, the video-tapes that most school systems can produce differ from the movies they can produce in several significant ways.

1. The sort of editing you can do with a movie is much more dynamic than what you can do with a video-tape. The individual shots you take for a movie can be endlessly re-timed and re-ordered, whereas with video-tape it is feasible to have but an occasional "cut", and then only between sequentially-recorded segments. The effect of a film, therefore, often derives from the juxtaposition of images as much as from the content of any given shot. In tv, the basic problem is to record and broadcast a sustained performance in such a way that it is effectively revealed.
2. A movie can be in color. Our video-tape systems record in black and white only.

3. With film, the big special effect is animation. With video-tape, the big special effect is the dissolve, the technique of overlapping shots from different cameras for "synthetic images".
4. Video-tape is much more flexible than film when it comes to the dimension of sound. The voices of tv performers can be recorded simultaneously and in synchronization with the accompanying shots on same piece of tape. Additional sounds - music, sound effects, narration, can be fed in at the same time from other sources (tapes, records, auxilliary microphones), or "dubbed" later. With our present facilities, sound for a movie must come from a separate tape, and lip-synchronization requires continual adjustment of the projector and tape recorder.
5. On the other hand, film is much more flexible than video-tape when it comes to the dimension of the camera. A movie camera can be moved through an endless variety of angles, positions, and locations, whereas a tv camera (with the exception of the porta-pak camera), heavy and attached to cables, generally has to record the action from staid points of view.
6. Movie film must be developed before it can be viewed, whereas with video-tape you have "instant replay."

Fiction Films. This use of the film medium includes the production of original narrative scripts and solving problems, like staging important moments from literature for the camera.

Documentary and Educational Films. Classrooms often produce more meaningful and more lively - instructional movies than do commercial companies. Films that teach need not be didactic, as exciting shorts like Universe and Time Is demonstrate. If your class makes a super-8 educational film that runs less than three minutes, you can have it packaged for viewing on a film-loop projector.

Animated Films. The process of animation enables you to make inanimate drawings and objects come to life. By changing the position of the subject slightly between the exposure of individual frames, an illusion of motion is created. Animation is applicable in both the areas of educational films (charts and diagrams with moving parts, time-lapse phenomena like plants opening) and fiction films (animated cartoons). Pixillation is a term for the animation of three-dimensional subjects like clay models, objects, and people. Because your students will complete their art work at different times and will therefore not need the camera all at once, it is possible with careful scheduling to involve most of a class in animation.

Scratch Films. Also called "drawing on film" and "cameraless animation," this process is a way for every student in the class to make a movie in a few days. Clear 16mm leader can be drawn on frame-by-frame with dyes or, less permanently, magic markers. Similarly, designs can be scratched in the emulsion of unexposed (but developed) color stock. Each student works on a few feet, and then all the pieces are spliced together into a movie which, when projected, dances about the screen with a jazzy, animated effect.

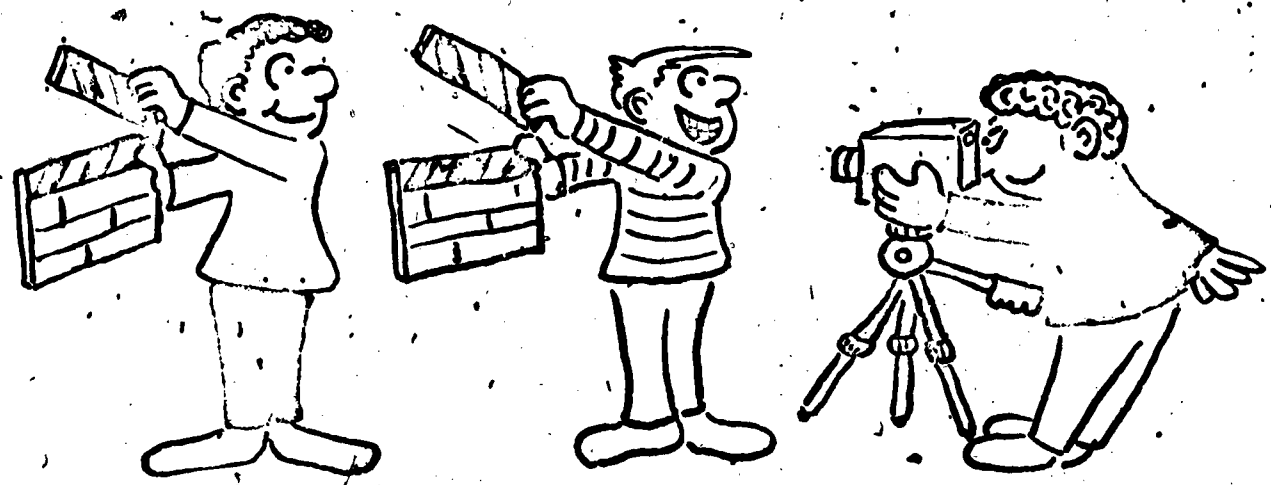

f. Design

Most of the things we see around us - tools, inventions, buildings, furniture, art objects...and works of nature - were created according to principles of design. Design was the first medium to evolve after body language and speech, and it could even be argued that it preceded speech in the form of designed tools and weapons. The design medium includes, of course, traditional forms like painting, sculpture, architecture, woodcuts, and crafts, but its definition can also be expanded to generate classroom activities like:

1. designing a new invention - some practical gadget that would help you get through the day
2. new designs for everyday devices - houses, cars, furniture
3. designing and making masks, clothes, and costumes
4. inventing a new game or sport and designing whatever boards, cards, playing fields, or balls are needed to play it
5. design in nature activities - imagining new life forms on paper, studying the functional basis of plant and animal design
6. creating maps and pictures that tell all about an imaginary planet - its geography, ecology, inhabitants
7. problems in abstract design - creating a picture of a sound, a smell, an idea
8. print/design activities like making comic books, posters, advertisements
9. photography/design activities like mounting pictures on a three-dimensional object designed as an expression of their theme
10. making overhead transparencies, three-dimensional models, and similar learning materials

11. inventing original signs, symbols, logos, and trademarks
12. creating collages based on a pre-developed idea (like race or transportation or the futility of all human endeavor)

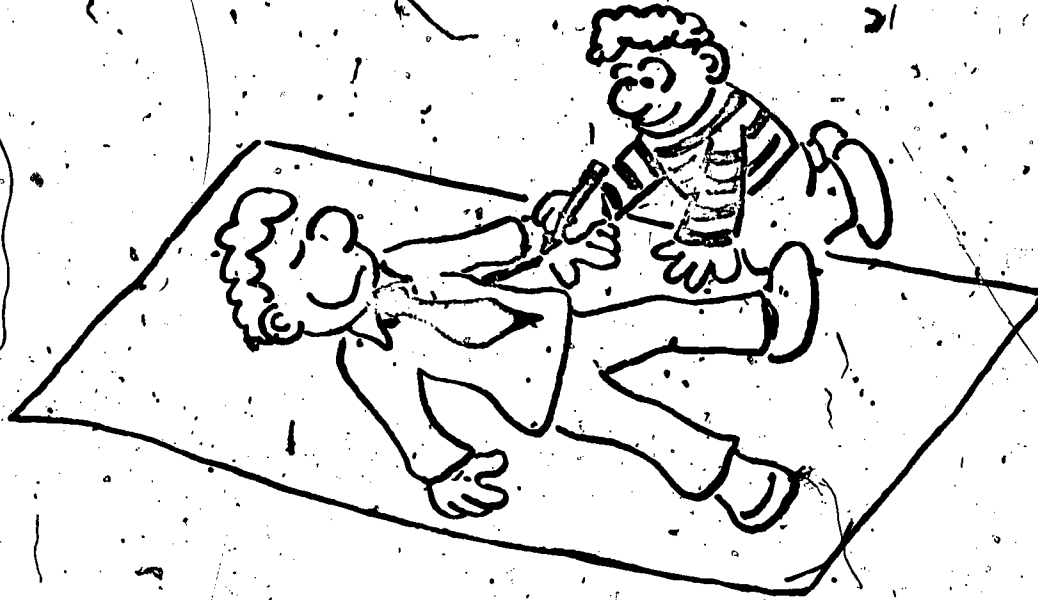

We end this chapter on a theoretical note. Keep in mind that there are differences in the fundamental natures of all the media. These differences should influence your choice of medium as well as the organizational strategies you use to bring a particular medium to your class. To summarize:

1. In design, the individual elements are perceived simultaneously. There is an "all at once-ness" to our initial perception of a collage or a painting. Exceptions to this notion exist (comic books, some three-dimensional sculpture) and at the physiological level it is known that any object is visually perceived through rapid eyeball scansion of different areas of the whole. Nevertheless, most design projects involve a singular, unified, immediate impact (as in an one-panel cartoon or a symbol for peace), rather than the sequential presentation of different images over a fixed period of time (as when telling a story involving different

locations, or summarizing the steps of a particular process).

2. Photography is similar to design in the more-or-less simultaneous perception of a particular work in all its elements. However, in the case of a sequence of photographs (as in a photo essay or a slide-tape), our apprehension is a serial, discontinuous, "one at a time" experience. This use of the medium makes it ideal for the sorts of ideas mentioned above as being inappropriate to most kinds of design (story-telling, etc.).

3. Film is different from photography in that the separate images can be edited together with much more flow and time continuity than is possible with a photo series. Indeed, continuity is the term film makers most often seize upon to describe the basic challenge of creating a movie. Continuity between separate movie images (shots) can be achieved in a variety of ways - matching action (so that movement in one shot picks up at the exact point where it left off in the previous shot), matching the direction and position of the subject from shot to shot, and cutting shots very short. At the same time, film can also achieve a dynamic kind of discontinuity that a photo series cannot. Because shots replace each other on the screen without any perceived time or space in between, visual metaphors and similar effects created by the juxtaposition of two different shots tend to register spontaneously as a third, new idea, and not merely as a sum of parts which the viewer may choose to impose on the work. Where design is a simultaneous medium, film is an instantaneous medium.

4. Television is similar to film in that it presents events as happening continuously over a fixed period of time (generally with accompanying synchronized sound). However, where film achieves its effect as a rule through the editing of separate shots into an impression of continuous time, video-tape productions achieve it by recording actual continuous events continuously. Thus, this medium lends itself to discussions, games and sports, sustained interviews, and plays.

Chapter 2

MEDIA IN THE CURRICULUM

Chapter 1 dealt with media in isolation and suggested a series of separate classroom production activities. We feel, however, that the most valid and far-reaching learning occurs in the classroom when media are used in coordination with each other to explore a particular component of the curriculum. In this chapter, the focus shifts from media per se to ways in which media might be used to explicitly teach fundamental processes and concepts inherent in the subject matter disciplines.

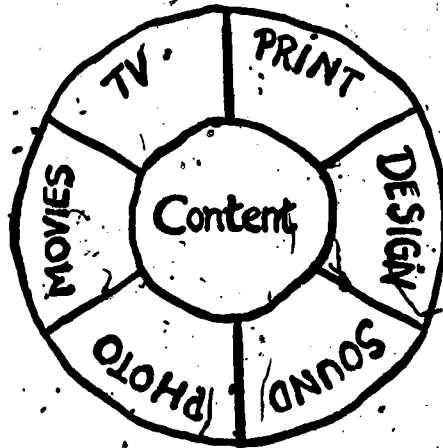

a. Content and Approaches to Content

As we see it, there are two basic types of classroom media activities. In the first type, students engage in production to learn some informational, conceptual, or factual content of the curriculum. This generally involves the whole class working on the same project.

The second type of activity derives from the teacher's diagnosis of the particular educational needs of the students in the class.

These needs fall in the area of basic skills, processes, or approaches implicit in the subject matter content, rather than the subject matter content itself. Such skills are the foundations upon which a student's mastery of formal knowledge and general effectiveness as a person are built.

We apologize for the rather theoretical sound of all this. It may seem out of place in a practical handbook. But we want to emphasize that the more we have tried in the IMC to explicitly teach the basic processes involved in successful media production (as opposed to making a collage for the fun of it or a movie for the sake of it), the more we have felt we were tapping skills of wide applicability to the regular curriculum. In particular, we believe that the following skills can and should be taught in the context of each subject matter discipline:

1. Translation
2. Grouping
3. Transformation
4. Point of View
5. Cause and Effect
6. Prediction

Each of the discussions of the academic disciplines which follow concludes with a section on these skills, the particular activities varying with the discipline at hand. If you find a skill you are especially interested in teaching, you might want to look at how it can be worked out in each subject area, not just your own. Skill activities, after all, are a good way to teach the relatedness of the disciplines; and to help students avoid the tendency to regard human knowledge as a succession of isolated territories. As teachers begin to experiment with this notion, the next step is to start replacing the particular activities in this book with ones that are actually being done in Chelmsford classrooms, as reported to our Newsletter. Indeed, we frankly admit that science and math are not our strong suits, so please give free rein here to your own ideas of what skills are worth learning and how they should be taught. Indeed, we might almost caution you against using these particular activities at all. Even though many have been successfully used, in this book they are just models out of context.

Innovation is your business; we're just here to help if we can.

One final caution: these skills are "developmental". It is unlikely that any two students will have acquired all of them to the same degree, or in the same sequence. (But every student should have a basic grasp of each skill before his basic grasp of the subject matter content can be appreciably improved.) For this reason, teaching these skills often requires a classroom structure in which small groups or individual students are all working on different projects and problems. As far as the media go, the emphasis in skill-building classes is not as much on the creation of finished productions as on the general process of communication.

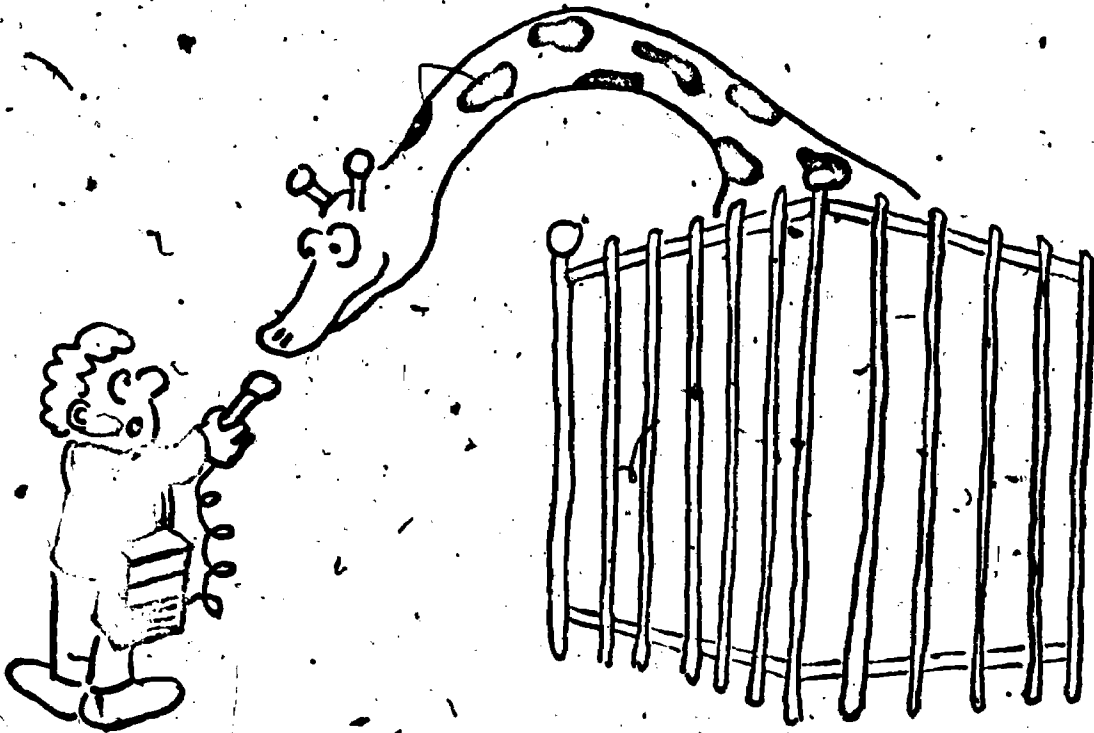

b. The Disciplines

The activities that follow cover five major subject matter disciplines - language arts, science, mathematics, social studies, and foreign languages. That these particular areas of the curriculum are treated does not mean media production is irrelevant to other school subjects, such as art, music, or industrial arts. We would also emphasize that these activities do not form a curriculum in themselves, or even a curriculum unit, but merely illustrate how a production approach can work once you have identified basic skills and other contents that need to be taught:

1. LANGUAGE ARTS

Teachers are becoming increasingly aware that communication in the spoken and written work cannot truly be understood or appreciated in an isolated context. Words are both profoundly affected by and have a profound effect on motion pictures, television, photography, sound, design and all the other media of traditional and popular culture.

a. Print as Content

The relationship between language arts and the print medium is obvious. In one sense, print is the content of any English course. Thus, the usual sorts of print activities are central to a language arts curriculum.

1. analyzing literature in all genres - worthy poems, plays, novels, essays, and short stories
2. creating literature in all genres - student poems, plays, novels, essays, and short stories
3. mechanical and grammatical aspects of writing and speaking

But the true richness of "language", in the broad sense of the concept, inevitably leads to production in the full range of media.

b. Skill Activities

In the context of the language arts, the skill of translation involves changing literal, graphic concepts into symbols and metaphors. Grouping refers not only to ways of relating similar ideas (expressed as written sentences, spoken words, photographic images, etc.), but also to the creation of transitions between groups. Transformation is concerned with what happens to a work from one genre or medium when it is treated in another genre or medium of the student's own choosing. Point of View is crucial to understanding the narrative arts (literature, theatre, film) as well as the biases and perspectives of yourself and others. Cause and Effect in language arts has to do with making meaningful language sequences and with the impact that the traditional and contemporary media have on our behavior.

1. Translation

- a. Show the Stars and Stripes, the dove of peace, play football cheers or Santa Claus' "Ho, ho, ho!"
Discuss what is evoked. Do the same with nonstandard symbols - a sunset, a tree, a color. Have students choose an object, idea, or institution that has personal meaning for them and present it as a symbol.
- b. Take an advertisement - what is the image it conveys, through what means is it conveyed? If you could only change two things in the ad so that a viewer would not buy the product, what would they be?
- c. Have students visualize a poem by making every verbal metaphor into a visual metaphor. Produce the whole as a slide tape, with the poem on the sound track.
Bonnie Sunstein--Grade 8.
- d. Have students write an essay and translate every part of it into a non-literal story (a parable): - Have other students guess the content of the original essay. In what ways has the analogy changed our perception of the original?

2. Grouping

- a. Have students collect from various people answers to a question (such as, "What do you think of the class of '73?"). Have them select those answers which they like and edit them into a radio program which describes the subject with a minimum of narration. Have them list the ways they discovered to effect a transition from one quote to another.
- b. Give the students small construction paper squares and triangles of two colors and have them make a design with all one color on the left and all the other color on the right. Let them do what they will with the center. Then observe the results. Discuss the ways in which the visual movement from one color to the other is made. Build verbal analogies.
- c. Have students collect various sounds (factories, lunchrooms, highways, forests, music) and write descriptions of how one particular sound is similar or dissimilar to another. Have them find (or create) a third sound which explicitly captures whatever quality the first two sounds have in common. Splice it between them. Comment on the effect.
- d. Have students describe a day in the life of a hippie and a day in the life of senior executive. This can be done in any medium chosen by the students (print, film, photo series). Intercut the two stories so that an incident experienced by one person is followed by a similar incident experienced by the other. In what ways is this presentation different from two separate presentations?

3. Transformation

- a. Have students express shock (or some other emotion) in four or five different media: dialogue, collage, dance, sound photography, etc. Have them discuss what they have done. What aspects of the emotion are hard to verbalize? What concepts are best carried by which media?

- b. Record with a tape recorder the number of words it takes to describe the content and effect of a good photograph. Then show it. Is a picture worth a thousand words? What kinds of things are more easily shown than said?
- c. Plan the same play for video-taping, filming, audio-taping, and live performance. How are the productions similar and dissimilar?
- d. Prepare the same theme for poetry, drama, short story, and novel. Consider, for example, the function each convention of these forms has toward the total effect. What do minor characters in a drama become in a short story?

4. Point of View

- a. Have students choose an object and photograph it in six distinct ways (from different heights, through different filters and lenses, from different angles), and discuss how the resulting photographs differ.
- b. Have students retell an incident from a novel or story they are reading from the viewpoint of a character other than the narrator or the main character. Have them dramatize it.
- c. Have students, in groups, produce advertisements for and against specific items. Examples are cigarettes (American Cancer Association vs. the cigarette companies) and cars (Ralph Nader vs. the automobile companies).
- d. Have students watch a commercial television program with an eye for its intended audience. What is the point of view of the audience presumed to be? Have the students produce skits of a single plot first for prime time and then for afternoon television.

5. Cause and Effect

- a. Present a visual story (photographs, illustrations, or cartoon panels) out of sequence to groups of students. Have them arrange the story into its original form. Do the same with scrambled paragraphs or sentences.

Have students make their own visuals for this activity. Make sure that each knows that he needs to include enough clues for his peers to recreate his sequence. Have him (as well as those who view it) write a justification for the order they believe correct.

- b. Give students a photograph of a situation. Have them write a story or essay which explains how this situation came to exist. Unusual or ingenious circumstances should be encouraged (such as a man chased by a frenzied mob...for his autograph).
- c. Give students the effect they are to achieve: to have people buy a product. What devices will achieve this end? What devices are usually used? Have students produce their advertisements in print, sound, or television.

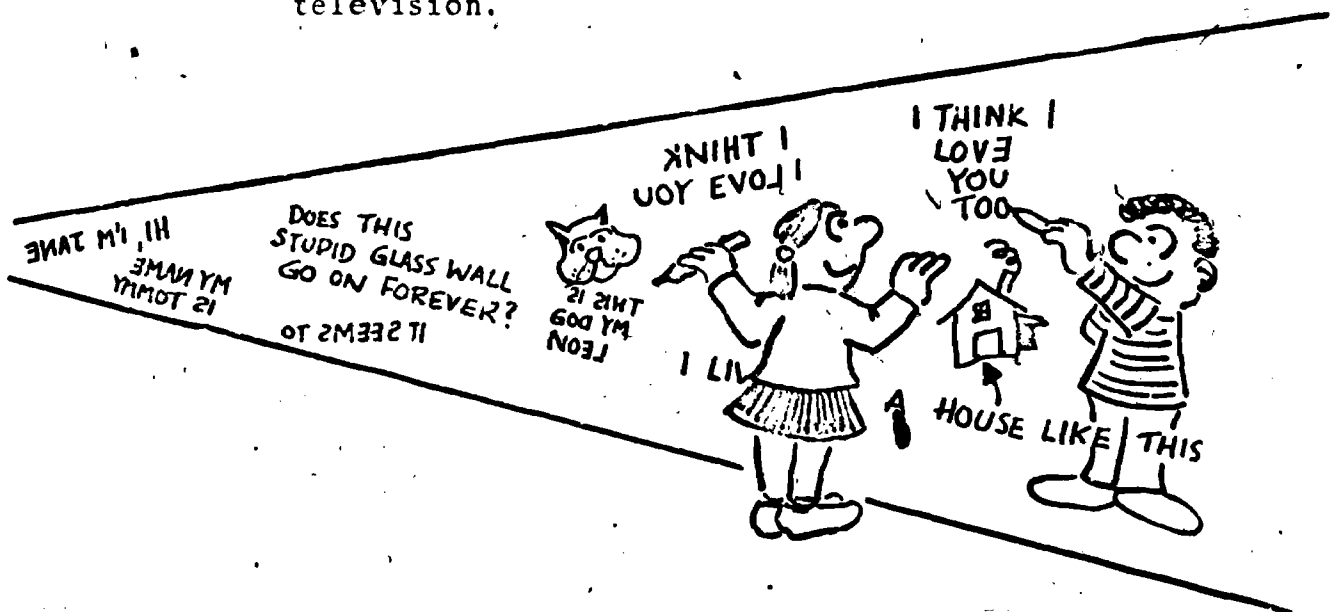

2. SCIENCE AND MATHEMATICS

Teachers of science and math often employ so-called "visual aids" to help get important concepts across, particularly those which can be explained better representationally than in print. The label "aids" suggests that the visual aspects of science and math are tangential, supplemental, trivial even. Yet many educators agree that the degree to which a science or math idea is "visualizable" or at least "diagramable" is basic to its actual nature.

Since "visuals" are a crucial tool in the sciences, it makes sense for students to create their own films, diagrams, and slide-tapes, rather than to simply react to commercially-produced materials of this sort. Indeed, it can be argued that active production of a visual gives the student a grasp on the content and helps him to internalize it to a much greater extent than does passively watching a presentation. The rest of this section discusses several areas of the science and math curriculum in which media can support the concepts being taught.

a. Experiments

Have students produce a super-8 film loop, a tv show, or a slide-tape of an experiment. Before beginning production, consider the options involved in staging the experiment for a camera rather than for yourself or an audience. Film, for instance, can slow movement down or speed it up, thereby facilitating perception of everything from flowers opening to frogs snatching their lunches.

b. History and Biography

Have students present famous moments in the history of science or math - the discovery of Boyle's Law or the Pythagorean Theorem or germs. Choose the most appropriate medium for the content being learned - radio play, tv play, movie, slide-tape, comic book. This can admittedly get hokey, but we have seen it work.

c. Visual Thinking

Have students visualize important scientific and mathematical concepts (such as set theory, or the "structure" of the atom,) first with paper and pencil, then in forms that seem to get the idea across even better - photograph series, transparency with overlays, three-dimensional model, slide-tape, sound-tape, video-tape, or animated film. Which ideas in the sciences are made clearer through visual productions? Which are made more obscure? Which can't be visualized? Try visualizing ideas (infinity, quanta, the limits of the universe) that textbooks generally do not attempt to illustrate. Have students assemble this work into their own textbook for the course, including illustrations, photographs, and transparencies (and even films and tapes), as well as printed pages.

d. Personification

Group students appropriately and have them role-play discrete entities from the "invisible" world - electrons or genes or red blood cells or viruses. Their improvised interactions should be lively and imaginative (lots of dialogue and movement), but scientifically valid. These entities can also be treated as characters in comic books, movies, stories, or plays.

e. Skill Activities - Science

Many of the things that scientists like to study can be thought of as transformation processes (matter into energy, caterpillars into butterflies; elements into compounds, etc.) Grouping as a scientific skill involves making sensitive, relevant observations of data as well as organizing that data into meaningful patterns and categories. Cause and Effect is the skill of deriving and applying scientific laws within specified realms of probability and views of the physical universe. The skill of prediction involves using a scientific theory to foretell the arrival or course of a particular phenomenon, and also using the process by which the theory was deduced - hypothesizing, testing, and drawing conclusions.

1. Transformation

- a. Have students identify chemical and biological processes that occur in their own homes every day (flour becoming bread, cuts healing, plants growing) and organize pictures of them into some sort of presentation (chart, collage, or slide-tape)
- b. Have students create a series of transparencies in which sources of energy (electrical, thermal, nuclear, etc.) are overlaid with examples of their practical use.
- c. Have students experiment with the effects of different nutritive environments on plants or animals of the same species. Record each development as a separate Polaroid photograph or 8 mm movie shot.

2. Grouping

- a. Have students spend a few minutes in their chairs or in various corners of the room just sitting and using only the medium of the body - sensing all the scientifically understood phenomena for which some evidence is now available to their eyes, ears, noses, and skin (oxidation, radiation...photosynthesis?)
- b. Present a considerable amount of data to the class - animal species, plant forms, rock types, etc. Each student should devise his own scheme for organizing the data in chart or model form.
- c. Have students collect pictures or take photographs of common objects or processes that contain particular chemical elements. These can then be grouped into various renditions of the periodic table.

3. Cause and Effect

- a. Present to the class a wholly imaginary planet and a set of scientific facts to go with it (distance from its star, age, size, etc.). Have the students respond in film, creative writing, or video-tape with their image of the planet, based on the effects each of these facts would have on it.
- b. Have students arrange slides of a scientific experiment in the right order. What would be required to reverse the events of the experiment?
- c. Present the class with a series of particular elements of an animal's environment and genetic history. Have the students "construct" the animal, complete with the particular anatomical forms these conditions may have caused, in an appropriate medium.

4. Prediction

- a. Have students build simple weather forecasting instruments and present weather shows on a regular basis to the rest of the school (on tv or radio), based solely on information from these devices. If you're using television, include the weather instruments in the show.
- b. Take movies of normal, everyday motion - but with the camera running faster than normal and held upside down. When these shots are spliced into the movie rightside up, the events will occur in slow motion and backwards in time. Before showing the film, have the class describe exactly how they think each movement will look when it is perceived this way.
- c. Have the student record on movie film or through a series of slides the life cycle of a particular animal of his choosing (frog, butterfly... a dog even). Discuss how successful this creature is from an evolutionary standpoint, and what sorts of forms and behaviors its offspring will probably assume.

- d. Have students engage in a bit of "futurism", science-fiction if you will. Based on present knowledge of scientific possibility, what will the future be like, from a technological standpoint? Ideas may be expressed in any medium (print, design, film, etc.) and should be rooted in fact.

e. Skill Activities - Mathematics

The skill of translation in math is the basic process of taking ideas about space, motion, and quantity from the physical (or mental) world and putting them into mathematical language. Grouping has to do with the theory of sets and the limits within which all the members of a set exist. Transformation is the skill of taking mathematical ideas from one system and abstracting them into another, and observing whether what's happening is logical...or a special kind of illogic (mathematical paradoxes and counter-intuition).

1. Translation

- a. Have students invent their own system of counting and performing basic operations. The bases they work in and the symbols they devise should be as relatively arbitrary as the ones actually in use. Tangible devices may help here - colored chips, blocks, or a home-made abacus.
- b. Divide the class into two groups. One group role-plays a bunch of prominent earth scientists, the other a benign but curious party from outer space. The problem is for the groups to communicate (using verbal noises or pencils and paper) in the only language they are likely to have in common-mathematics.
- c. Make a super-8 instructional film of a fairly complicated verbal problem (involving the speed of cars or runners or rivers, the motion of pendulums, or other equally visualizable elements). Include an animated sequence showing the solution in mathematical language.

2. Grouping

- a. Have students take slides of things in the real world that can be considered sets - houses on a street, a flock of birds, pickets in a fence, etc. Superimpose slides from two different projectors to create possible unions and intersections of sets.
- b. Have students create their own attribute blocks, in two and three dimensions. Stress unusual attributes (smell, number of noses). Have them invent a variety of elimination games that can be played by grouping the blocks on a Venn diagram.
- c. Through film animation, demonstrate how certain problems can be solved only by breaking out of a given mental or mathematical set, such as the famous dot problem:

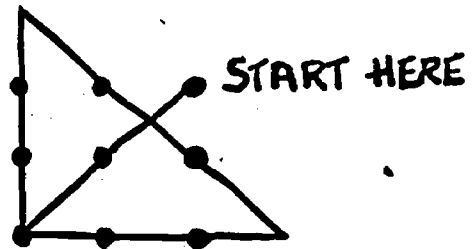
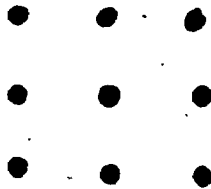

PROBLEM: Connect all nine dots by drawing four lines without lifting your pencil off the paper

SOLUTION: Begin two of the lines outside the area enclosed by the dots

- d. Have students create-through a medium like the short story, the radio play, or the television drama - a world in which everything must occur within a kind of space other than the Euclidian variety. What is life like where parallel lines meet, where everything is in five dimensions, etc.? (Similar to the idea of Flatland.) Given an unreal premise, how mathematically real can you make this world?

3. Transformation

- a. Collect a good set of brain teasers. Produce a tv show in which a panel of experts are challenged with these logic-problems. Five-points for each correct solution:
- b. Collect a set of famous paradoxes. Have each student produce a visual - a slide, a film, a model - which illustrates both the logical and the absurd aspects of particular paradoxes.
- c. Have students build simple computers in the form of two and three-dimensional cardboard models, and then, in pairs, role-play a computer and its programmer. A tape recorder is useful here if the "computer" would like to tape his "output" and a verbal description of his transforming processes ahead of time.
- d. Send the students out with cameras to record objects and areas from the physical environment, and then abstract them into pure geometrical shapes upon which various sorts of calculations may be performed.

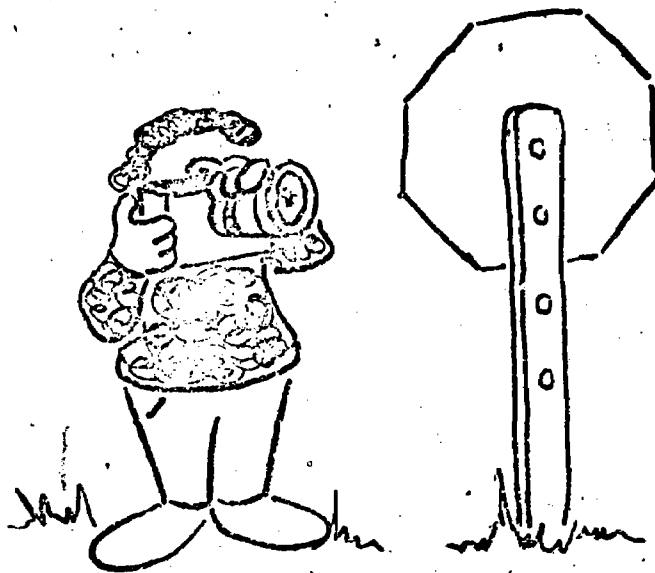

3. SOCIAL STUDIES

Social Studies is such a broad area that the following activities only begin to explore the application of media to your own curriculum development.

a. Politics and Propaganda

Students can come to understand how the mass media are harnessed for political and other sorts of propaganda by producing their own campaign materials (posters, bumper stickers, leaflets), radio and tv "spots", commercials, and so on.

b. Sociological Research

Armed with cassette tape recorders or instamatic cameras, students can go into the community - stores, government offices, private homes - to learn about people from different economic, ethnic, and religious backgrounds. Both interview and "candid" formats are effective for revealing human attitudes and behavior.

c. History and Biography

Famous events and important moments in the lives of famous men and women can be staged for the camera or the microphone.

d. Skill Activities

Point of View in the social studies is the skill of sensing information about a culture and transforming that information into some kind of empathy with the people of that culture. Cause and Effect is the skill of understanding how a particular culture became the way it is - its history and traditions. Prediction is the skill of assessing the culture's strengths and weaknesses as compared with other cultures, and using this assessment as the basis for contemplating its future.

1. Point of View

- a. Produce a tv show along the format of the old What In The World? program - an artifact from a foreign culture is presented to a panel for discussion. The focus should be not simply on identifying the artifact and its function, but on general assumptions and subjective feelings about the culture which produced it.

Do the same thing for objects from modern American culture, with the panel role-playing individuals foreign to that culture. What would an African tribesman make of a stapler? What would a Martian think of a door knob? What would an ancient Roman do with a light bulb?

- b. Have each student periodically fantasize he is a member of a foreign culture and keep a diary from that point of view.
- c. Have the class role-play the people of a particular culture as they are stereo-typed in popular films and books. Then have the students act out the same basic situation (signing a treaty, exchanging gifts, starting a war) in the same roles, but with the conscious intention of avoiding obvious stereotypes or of imposing conventional stereotypes of another role (a villain accepting a gift, etc.)
- d. Have the class produce a propaganda film or slide-tape about a particular culture from the point of view of its own people. How would you change the narration so that the images now fit a film or slide-tape made against the culture in question?

2. Cause and Effect

- a. Have students write and produce a tv show in which an alien from another planet - or an inhabitant from your last social studies unit - visits a particular Earth culture, past or present. The other students in the class must answer his questions about why things are done the way they are in this strange culture.
- b. Have students do a bit of historical research on modern culture by excavating a junk pile as if it were an archeological site. What facts can you deduce about the progress of mankind, circa 1970? Collect the finds in a classroom museum.

- c. Publish a class newspaper "contemporary" with a particular historical era, such as the Renaissance, Colonial America, or the Age of Exploration (Columbus Lands In West Indies). Include events that didn't lead to anything significant in the light of history (but might have been regarded as crucial at the time) as well as those that did.
- d. Do a class project in which students record the history of an imaginary civilization in a single volume, complete with drawings, photographs, maps, even artifacts. Start with a set of givens about the people - their religion, traditions, geography, form of government, discoveries, early history - and deduce logical imaginary facts about their progress. (See, for example, Alex Krakower's account of The Mahauts, in ms. at Penn State University.)

3. Prediction

- a. Have students write about a known historical situation, but with one discrete fact - perhaps even a seemingly trivial one - changed, so that a prediction must be made about the ultimate impact such an alteration would have had on the course of history. The change might be something like: a particular person assassinated or not assassinated, a battle won or lost...a shift in the weather.
- b. Carry the junk pile problem into the future. What is the likely destiny of a culture that employs such artifacts? Students may respond to the problem with a collage or slide-tape based on the theme, "Man's Future History".

- c. Imagine a merging of two cultures that we normally wouldn't expect to absorb each other, say, the United States and Brazil. Have students role-play the consequences. How much, if any, cultural integration or influence, at least, would result?
- d. It is generally believed that the greatest "cultural collision" in the history of the world will come when modern man meets the inhabitants of another planet. Have students do some social-science-fiction writing based on this premise. How might an encounter with an alien culture effect the diversity of Earth's cultures? Will they become more homogenous?

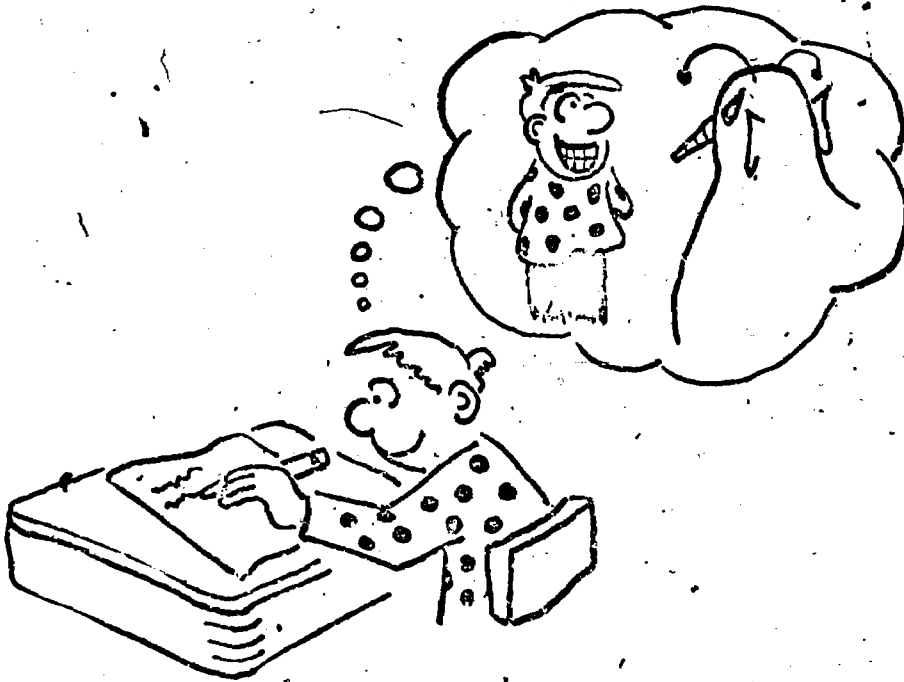

4. FOREIGN LANGUAGES

Long after verb endings and interlinear translations are forgotten, students may retain a sense of a language and its people if the study of that language involves some kind of active production.

a. Cultural Presentations

With visuals culled from books and magazines, students can produce slide-tapes, video-tapes, animated films, or collages that explore some cultural, historical, or geographic aspect of the foreign country whose language is being learned.

b. Using the Language

Students in a Spanish class can express what they have learned not only by reading, writing, and speaking Spanish, but by "doing" Spanish - making a Spanish comic book, or filming a Spanish movie, or producing a Spanish play, or publishing a Spanish newspaper.

c. Learning Materials

Materials like records, tapes, transparencies, and illustrated flash cards can be produced by students as well as commercial companies - often with more satisfactory results. Of course, the materials used in a language class need not be limited to explicitly instructional devices. They can also include media productions actually consumed by the native speakers of that language. Try bringing French newspapers (Le Figaro), comic books (Herge's Les Aventures de Tin-Tin) or films (Jules et Jim) into the classroom.

d. Skill Activities

Point of View in the study of foreign languages is the skill of understanding the various cultures which speak a language, and how the traditions and environments of those cultures influence vocabulary and usage. Translation is the actual skill of rendering one language into another, with the ability to move from literal translation to translation with an ear to nuance and shades of meaning. Transformation is the skill of understanding and manipulating the theoretical and historical-developmental basis of any given language.

1. Point of View

- a. Have students experiment with the fact that people from different parts of the globe sound different! See who in the class can do a French accent, an Italian accent ... a Brooklyn accent.
- b. Present a gibberish exercise in which the nonsensical "language" to be spoken differs from English in some fundamental way - say, it consists of only one word, or it is suñg rather than said.
- c. Have students make a collage of elements of a particular culture (such as snow in Eskimo culture) for which there is a much fuller range of expression than in English. Contrast this collage with a collage of objects and ideas for which the culture under study has no words.
- d. Present the class with written or oral examples of a language with which they are totally unfamiliar, without identifying it. Have the students write down their immediate fantasies of what the culture that speaks (or spoke) such a language must be like. Discuss the results.

2. Translation

- a. Have each student write a paragraph in English describing a newspaper photo or video-tape of a news event. Discuss what sort of thinking is involved in translating images into written words. A variation on the problem is to translate an event into spoken words. Have students practice narrating prize-fights or chess matches à la tv sportscasters.

- b. Try some playful activities in the form of tv improvisations or comic books - devising a "pidgeon" version of the language being studied (something that sounds like Spanish or German but is really nonsense), or making English puns on foreign words. ("Soupçon" means lunch is ready...see also Semple's The French Cat.)
- c. Have each student do three translations (from English into the language being studied or vice-versa) of the same rhymed-verse poem. The first should be a literal, word-for-word translation, even if distortions occur in the sense of the poem. The second should strive to remain faithful to the spirit or "meaning" of the poem, even if this means deviating from the literal. The third should preserve the element of rhyme as well as the element of meaning.

3. Transformation

- a. Have students create words in English (or the language under study) for concepts that have no single name in the language in question. Such inventions should be disciplined by that language's conventions of form and pronunciation. For example, in English there is no word for all the surfaces of a room - floor, ceiling, and walls. Or consider "niblings" - the same idea as siblings, only with nieces and nephews.
- b. Have the class create a lexicon in English (or the language under study) of only twenty words. Which twenty would be most useful for communication in the contemporary culture? In prehistoric times?
- c. Have the class prepare a simple chart of the evolution of the language under study, including the changes that occurred in particular representative words from one historical period to the next.

- d. Set each student tracking down cognates and other evidence for the interbreeding of languages. Present the case in transparency form.



c. Strategies for Getting Started

This section lists a series of strategies - none of them particularly analogous to each other - which we have found can make the difference between media as richer learning and media as chaos.

1. Begin with modest exercises that teach basic communication processes rather than leaping into a full-blown production. For example, if one of your goals is to make a finished super-8 movie, be sure your students understand something about the editing process before they pick up a camera. Give them a problem in splicing different shots together (we can supply some scrap footage) or re-arranging series of photographs, drawings, or comic book panels for new effects.

2. Small groups and division-of-labor are invaluable tactics. It's easy for an individual student to be left out of, say, a film-making activity unless he is part of a group with a particular responsibility (scripting, camera, graphics, etc.) But avoid a group of three members. Two students will collaborate and the third will get lost.

3. Familiarize students with the tools they will be using ahead of time. If you're doing a tv show, for example, bring the class down to the studio before the script is written, for a look around and an explanation of the possibilities of this particular medium.

4. The need to know equipment should not overshadow planning, however. A prepared script is essential to almost all successful media production of a dramatic or documentary nature. Of course, students with high button-pushing and knob-turning drives need some opportunity to get that out of their systems, and there is much merit in loose practice exercises. But a loaded camera should never be given to a student unless he has a precise idea of what he's going to do with it. Otherwise, the usual result is wasted film, batteries, time, and temper.

5. Many headaches can be saved if you handle the numerous mundane details of media production ahead of time. Don't let yourself get caught in the middle of class without a take-up reel, an extension cord, a three-prong adaptor, spindle-adaptors for super-8 projectors and editors, filter keys, batteries, extra film and tape...or the knowledge of how to run a particular machine. (When in doubt, don't hesitate to contact us or a colleague who knows the equipment.)

6. Anything you do with photographic film - prints, slides, or movies - involves having that film developed. Unless you do the developing yourself, don't forget to allow for the cost of developing (usually at least as much as the price of the film...see the Appendix) and to plan something for the class to do while waiting for their film to come back.

7. Be prepared for the climate in the room to differ from that of classes in which each student is doing the same thing. There will be times when a certain level of disorder, noise, and milling around is normal and necessary. But work on keeping the two modes clear in the minds of the students - times when things are loose vs. times to sit and receive instructions.

8. Don't forget to use productions once they are completed. The quality of a student's creativity generally improves when he knows he will have an audience. Show finished and semi-finished projects to other students in the class, to other classes, to other teachers, and to parents. Use a previous year's output as a multi-media kickoff to the new year's curriculum. Send us student productions so that we may catalogue them and put them into general circulation.

9. The last point is a matter of attitude. Teachers sometimes "do media" in their classrooms as a way to relax. Because the focus of a multi-media curriculum is not on hard-nosed information, there is a danger of assuming that no "real" teaching is involved, and everything can be left to the students and a few people in the IMC. Yet effective, successful production in any medium is both difficult and disciplined. If your students are to take their work seriously

and truly learn from it, then you must continually be pointing out mistakes, setting standards, making suggestions, and focusing their attention on communications issues. This is not to say that media should not be fun. Indeed, the fact that it is fun is one of the best arguments for doing it. But media is also hard work.



Chapter 3

MEDIA TOOLS AND TECHNOLOGY

Media-oriented teachers share a healthy contempt for the tools of their trade. Much of the equipment on the market is characterized by bad design, infuriating idiot-proofing, and general chintz. Given these facts, the best approach to media machines is to handle them with care, but not to feel guilty or stupid over the inevitable, normal breakdowns. At the same time, we do expect you to know how these gadgets are supposed to work. A good 80% of our a-v repairs are a result of misuse.

When a machine falls apart in your classroom, for whatever reasons, be sure to let us know about it. Chances are we'll have no reason to be mad at you, although habitual tape-breakers and film-shredders may be denied certain privileges until they are rehabilitated. PLACE A NOTE ON EVERY SICK MACHINE, FILM, OR WHATEVER THAT YOU ENCOUNTER, naming the symptoms or the causes as specifically as you can, or give us a call. Without such a system, malfunctioning equipment and materials will remain in circulation, and everyone will suffer.

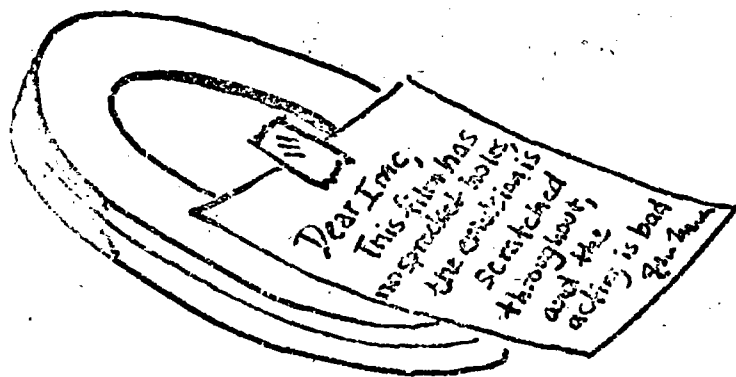

a. Presentation Techniques

For many teachers, the presentation of films, filmstrips, and transparencies in the classroom is simply a matter of turning on the projector bulb. But these productions needn't be that fixed. Their effectiveness can be significantly increased if you manipulate them in certain ways.

Withholding Information. Portions of a transparency can be covered (with your hand, a black piece of paper, a peanut butter sandwich) so that a particular element can be absorbed before others are revealed. Similarly, try playing a movie with the sound turned off, and let the students create their own soundtracks. Or show the movie with the projector lamp off and have the class imagine the visuals.

Interruption. It is often important during a presentation to verbally clarify something that has just been seen or is about to be seen. Shut the projector off momentarily so you won't have to "talk over" its noise or compete with the show's content. Give the kids a chance to do the same thing.

Adding Endings. Shut off the projector before a movie or filmstrip is over and have the students discuss, write, or photograph possible endings. Similarly, you might start in the middle and discuss possible beginnings.

WARNING!

16mm PROJECTORS **EAT** FILMS



IT'S NOT YOUR FAULT

BUT

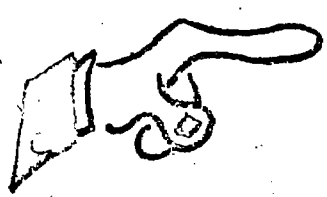

PLEASE TURN OFF THE PROJECTOR WHENEVER THE IMAGE STARTS BOUNCING

OTHERWISE

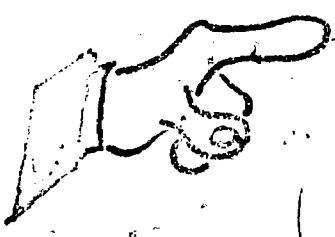

THE SPROCKET HOLES WILL BE TORN AND THE FILM **COMPLETELY RUINED**

b. Those Infernal Machines

There are very few general rules for using a-v equipment. "Take it easy" is the prime order of the day. Turn all those knobs and levers slowly, and don't go from one "mode" to the other (play to rewind, forward to fast forward, drive to overdrive, or whatever) without making distinct pauses in between.

1. 16MM PROJECTORS

This section covers six basic problem areas of 16mm sound movie projectors - bouncing images, bad sound, no sound, incorrect winding, burned-out bulbs, and breaks.

a. Bouncing Images

The important thing to understand about motion picture projection is that the movement of movie film through a projector is intermittent rather than continuous. In other words, the film as it passes in front of the projector bulb is actually held motionless for a split second while the shutter opens and the frame is projected onto the screen. The next frame is then pulled into place by a claw that fits into the sprocket holes, and then that frame is projected. And so on. Because the film is pulled in this discontinuous way, there must be some slack on either side of the point of projection. This slack film is called the loops. When the loops are lost, the claw starts advancing the film unevenly, and you get the most common projector malfunctioning - a bouncing, fluttering, trembling image.

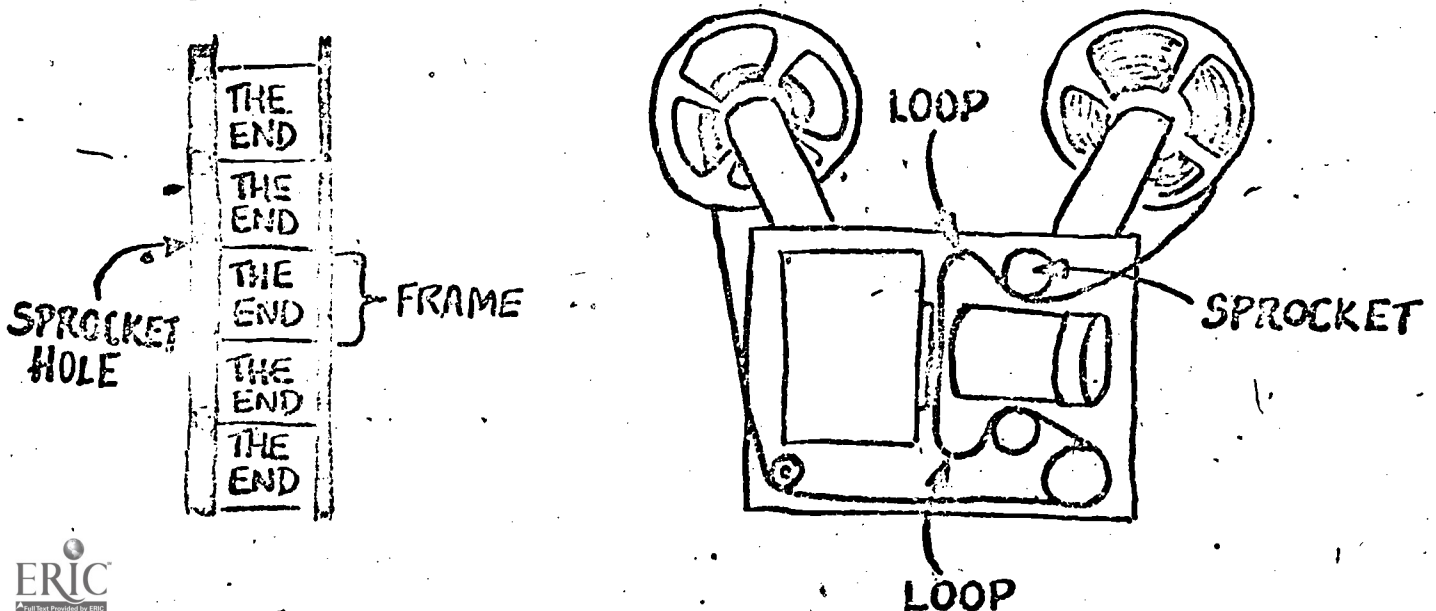

There are two causes of loop loss.

1. The projector has been threaded incorrectly. Make sure you follow the threading diagrams that are printed on the machines. If the projector threads by hand (and few of ours do) check that you have formed large enough loops. If the projector is of the automatic-loading type, check that the film has not somehow gone awry in its travels through the Bell and Howell maze, and do your best to re-load it as if you were threading a manual projector. Remember that a film always unloads off the front of the reel, and usually takes up on the back.

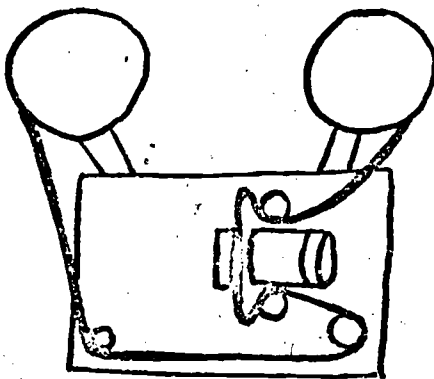

RIGHT

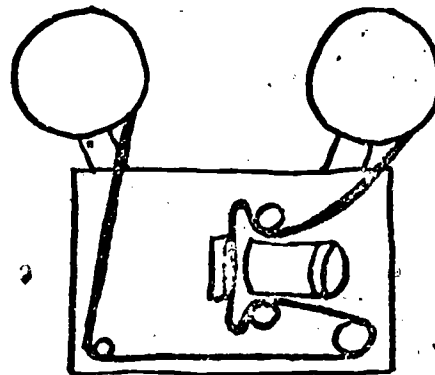

WRONG

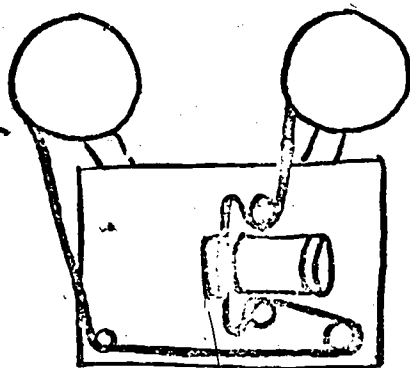

WRONGER

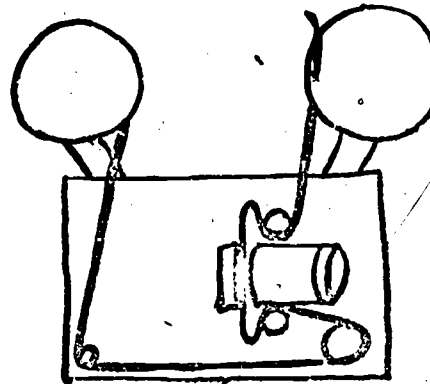

WRONGEST

2. The film has torn sprocket holes. This can be determined by looking at and feeling the sprocket holes that run down one side of the film. If the projector threads by hand, unload it, wind it by hand to a point where the sprocket holes are intact, re-load the film, and try again. If the projector is an auto-load and the film cannot be easily loaded and unloaded at any point in the movie, push the

"System Restorer" while the projector is running. Hopefully, this will advance the film to a point where the sprocket holes are not torn. If this doesn't work and the film still bounces, you'll unfortunately have to forget about showing the movie, and run it backwards out of the projector. PLAYING A BOUNCING MOVIE ON A BELL AND HOWELL AUTO-LOAD PROJECTOR TEARS THE SPROCKET HOLES AND DESTROYS THE FILM FOR GOOD. Many prints of movies have been ruined by teachers who were unwilling to shut off these projectors and run the film out backwards. (We are told that there are certain nimble-fingered individuals in the system who can load and unload Bell and Howell Auto-Load projectors manually. If you're one of them, you don't need this book.)

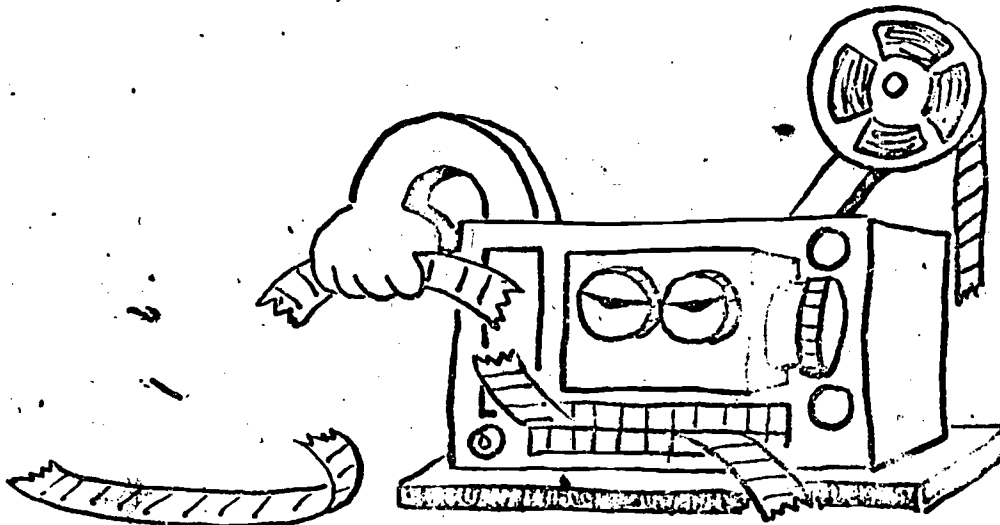

b. Bad Sound. While the movement of a film through the point of projection is intermittent, the movement of the film through the point where the soundtrack is picked up must be continuous. You know, for example, that if a tape recorder spindle or a record player turntable varies in speed, the sound will flutter. For this reason, the bulb which "reads" a movie's "optical track" (squiggly lines printed down the side of the film opposite the sprocket holes) must be located at a spot - 26 frames away, to be exact - below the point of projection, where the movement of the film is continuous.

(In other words, for any given frame of picture in a movie, the corresponding frame of sound is located exactly 26 frames ahead of it.) With this information in mind, you should be able to diagnose the two most common types of "bad" sound.

1. The sound is "out of synch", that is, the lip movements of the people on the screen are noticeably (and annoyingly) not in correspondance with the dialogue. Either the film is a dubbed Mexican horror movie or, more likely, the film has been threaded wrong, with too many or too few frames between the projector lamp and the "excitor lamp" (bulb) which reads the optical track).

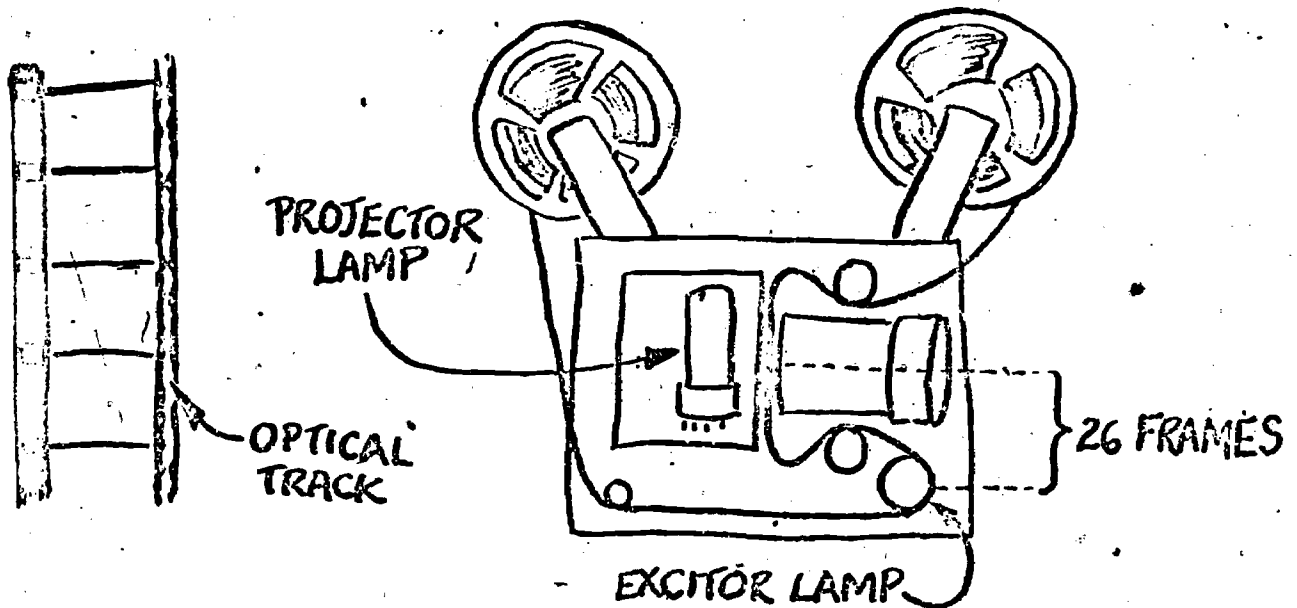

2. The sound is wobbly or fluttery, like everybody in the movie is talking through electric fans. Obviously, the film has not been threaded tightly enough around the drum containing the excitor lamp, and there is too much "give" or slack - the same kind of slack that should be above and below the projector lamp.

c. No Sound. We all wish we had a nickle for every time a 16mm projector was started up in a classroom, a church, a teacher's conference, or an Elk's meeting and the image flashed on the screen while absolutely nothing poured out of the speaker. In theory, there are five, and only five, reasons this might happen.

1. The excitor lamp has burned out.
2. The speaker has not been connected.
3. The amplifier had not been turned on.
4. The amplifier volume has not been turned up.
5. The film has not been threaded around the excitor lamp drum.
(This last is the least likely.)

As long as you hear some kind of snap, crackle, or pop coming through the speaker before you turn on the projector, you know that none of the first four problems are present and the chances are very good that the sound will come on along with the picture.

d. Incorrect Winding. Every once in a while, you will get a film that has been wound incorrectly, so that when you try to project it, either the picture is upside down or you cannot thread it because the sprocket holes are on the wrong side. (Although some enterprising individuals, when faced with this situation, have been known to actually thread up the film and allow the projector to PUNCH A NEW SET OF SPROCKET HOLES IN THE SOUNDTRACK SIDE OF THE FILM. This qualifies as the most ingenious way of all to totally destroy a movie. It happened twice last school year.) When a correctly wound film is placed on a projector, three things will always be true when you stand and face the reel.

1. The reel will begin with the beginning of the movie (generally a title other than "The End").
2. The picture will be upside down (that's right, upside down).
3. The sprocket holes will be on your left.

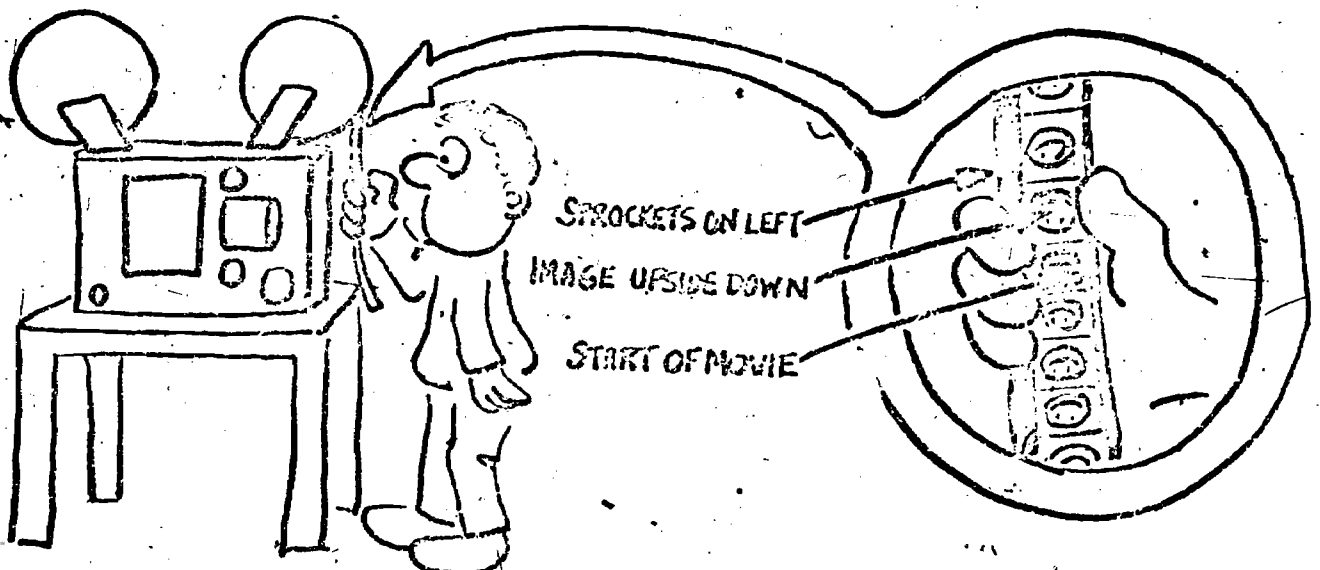

If these things aren't true, wind the film from one reel to the next until they are. At this point, another kind of idiot-proofing (comparable only to Auto-Load) takes its grim toll - the single-key reel. In single-key reels, the hole in the middle of the reel is round on one side and square on the other (in other words, it isn't a hole), which means you can place the reel on the projector spindle only one way. (Double-key reels have squares on both sides.) While this device guarantees that you won't put the movie on the projector backwards, it often prevents you from using the projector's rewind system to straighten out winding errors, and you must resort to bizarre tricks like fitting the reel halfway onto the projector up to the square part of the spindle, and winding the film by hand from one reel to the other. The other trick is to wind the film on pencils, ball point pens, or very stale bread sticks. Best of all, send it to us.

Incorrect winding of a film will never happen if when rewinding it you feed the film either from the bottom of the take-up reel to the bottom of the supply reel, or the top of the take-up reel to the top of the supply reel, but never from the bottom of one to the top of the other.

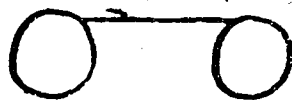

RIGHT



RIGHT



WRONG



WRONG

One final point about rewinding. REWIND on a projector is not the same thing as REVERSE. Many people confuse them, but these are really two different systems. (Reverse is a control which allows you to re-play part of the film in reverse-motion.)

e. Burned-Out Bulbs. The biggest cause of bulbs (projection lamps and excitor lamps) burning out prematurely is moving the projector before the lamp has cooled. This can weaken or break the filament. There is some evidence that leaving the motor on to cool the bulb via the projector fan is not a good idea; so while the jury is still out on that one, keep the motor off whenever it is not needed to project or rewind the movie. (The noise is distracting when you're trying to start a discussion of the film, anyway.) But NEVER MOVE A PROJECTOR IMMEDIATELY AFTER SHOWING A MOVIE. Leave it right where it is for as long as you can.

f. Breaks. If a film breaks, cut the broken end on the trimmer located at the front end of most projectors. Rethread the film and connect it to the taken-up film simply by wrapping it around itself several times. When you hit the break on rewind, stop the projector and connect the two halves by again wrapping the film around itself. Do not fix the break yourself (with Scotch Tape, masking tape, paper clips, LePage Glue Guns, Wrigley's Spearmint, or anything else). This job requires precision equipment.

g. Projection Technique. Here are a few of the fine points of motion picture projection.

1. When you are ready to start the movie, turn the motor on before the lamp (most projectors are designed so you can't do otherwise). As soon as the movie is over, turn the bulb off (to conserve its life) right away and keep just the motor on to run the film out of the projector. All this not only cuts down on bulb replacement (which is expensive), but also prevents every movie from being climaxed with an improvised shadow-puppet play.

2. Check the placement of the projector by turning the motor and lamp on for a moment before you thread up the film. This will allow you to move the projector backwards or forwards for correct image size and to align it left-to-right, without missing any of the movie itself.

3. If you really want to be professional about it, focus the film (and double-check the centering) on the countdown leader while the class is filtering in, so when the film officially starts, the first shot of the movie will flash on the screen, in perfect focus and alignment. This is a more effective beginning for a movie than an unfocused, uncentered, soundless series of numbers.

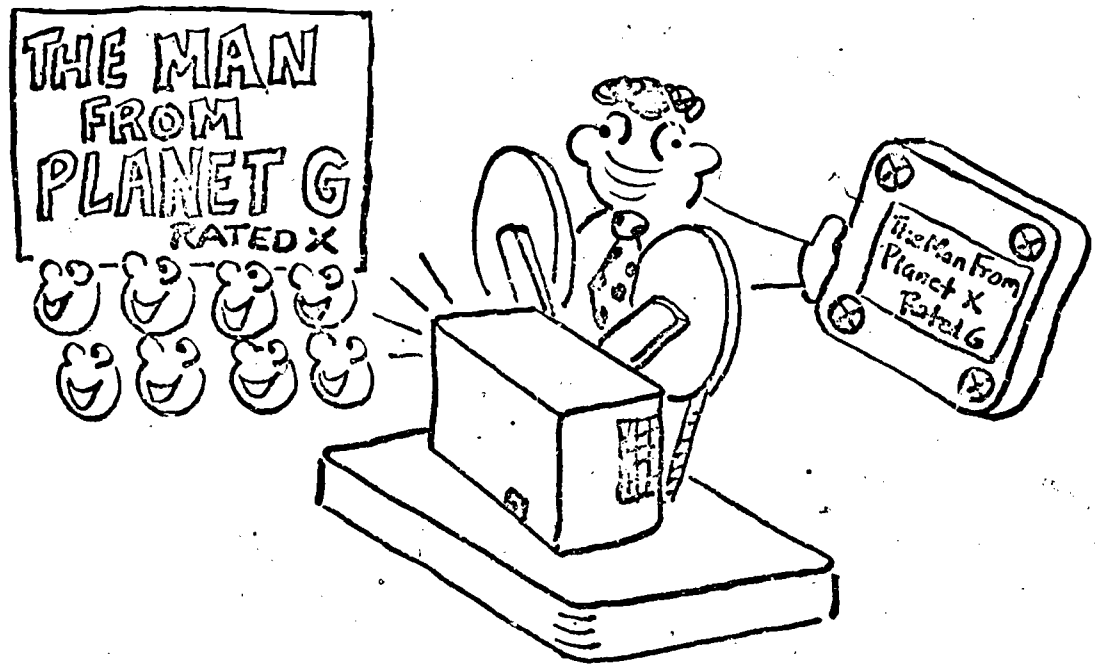

2. OTHER PROJECTORS

Compared with 16mm sound projectors, other projectors are fairly simple. The common ones for school use are overhead projectors, carousel slide projectors, filmstrip projectors, super-8 movie projectors; and filmloop projectors.

a. Overhead Projectors

The big error to avoid here is the "keystone effect", the projection of a trapezoidal image instead of the supposedly rectangular one. This is caused by using a projector set for a slanted screen on a flat screen, or a projector set for a flat screen on a slanted screen. Fiddle with the screen or the projector or both. Another common error is to focus the image without releasing the "brake" next to the focusing knob. Pretty soon, the projector will refuse to stay focused at all.

b. Carousel Slide Projectors

The four most common errors we have noticed when people use carousel-type slide projectors (the kind with the revolving tray) are:

1. Putting the slides in the tray the wrong way. Your chances are only one in four of dropping in a slide so it will project rightside up and correct left-to-right; it can also be projected backwards, upside down, and upside down and backwards. So learn a system. There are really only two tricks involved.

- a. Always load the slide in the tray upside down.
- b. Always load the slide in the tray so the side of the slide with printing on it (which is also the dull or emulsion side) faces the screen.

What this means is that when you are loading the tray, hold each slide up to the light and check its content by turning it so it is right side up and reads correctly right-to-left. Then put it in the tray as if you're trying to make it come out all wrong.

2. Putting two slides in the same slot on the tray. This is guaranteed to jam the projector, or at least pop one slide out like a piece of toast.

3. Trying to take the tray off the machine while the motor is turned off. For reasons best known to Eastman Kodak, it is diabolically tricky and dangerous to do this. We include instructions because you use the same procedure to un-jam a projector; we hope you will never be forced to follow them. Take a coin (really) and use it to turn the slot at the very center of the tray. This releases the tray. It also releases the gadget which keeps the slides from falling out of the BOTTOM of the tray. And so, with the plastic locking ring in place on the TOP of the tray, turn the works upside down and rotate the metal disk with the slot in it until it locks up and won't turn. Then, fish the slide out of the projector (just reach in and pull), put the tray back on the machine, push the "select" bar and turn the tray back to where you were when the trouble began, re-insert the slide you just retrieved, and swear never to use a dog-eared slide again. (If the slide wasn't dog-eared, send us that machine, PRONTO !)

4. Moving the projector before the bulb has cooled. (Run the fan if you must, but it's probably best just to let the thing sit.)

c. Filmstrip Projectors

There are two types of filmstrip projectors in the system - the DuKane and the Standard 1000-C. The Standard is a reliable and straightforward instrument, and we advise only that you check out framing and focus before actually showing the filmstrip. If you'd rather use it to show slides, there should be an adapter for that in the lid of the box. Slide the filmstrip carriage off to the right and slide the other into place. You must put each slide in individually; it won't hold a stack. The DuKane, on the other hand, is a rather sinister machine that allows you to show a filmstrip in which inaudible signals on the record advance the pictures automatically. It can be misused in the following ways:

1. Not fitting the turntable snugly over the flywheel.
2. Not threading the filmstrip over the little metal hurdle (this can rip the filmstrip).
3. Not having the first slide of the actual show on the screen when the record starts, so the pictures are not advanced "in synch" with the sound.

d. Super-8 Movie Projectors

Here the most common errors are:

1. Placing the supply reel so that the film is coming off the back of the reel instead of the front.

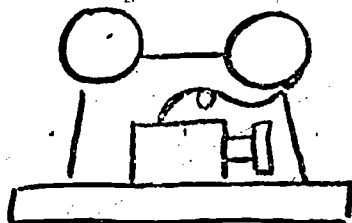

RIGHT

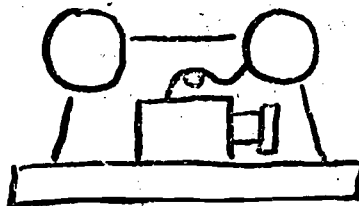

WRONG

2. Placing the pick-up reel on backwards, so that the teeth cannot catch in the sprocket holes of the film.
3. Having the machine on rewind when you're trying to thread it, and confusing rewind with reverse.
4. Starting the film off at the wrong speed. The trick here is to set the speed control at "normal" (rather than "still") first, and then to turn on the motor and lamp.

e. Filmloop Projectors

As far as we can tell, there is nothing you can do wrong with this machine. If you can figure one out, please let us know.

3. SOUND EQUIPMENT

This section offers sound advice in four areas - cassette tape recorders, reel-to-reel tape recorders, record players, and portable loudspeakers.

a. Cassette Tape Recorders

Many portable cassette machines are cheap, and cease to function as much out of fatigue as anything else. We stress this not to legitimize obvious misuse (like pushing the buttons too hard or dropping them down wells), but to encourage you to turn in your recorder for replacement or repair as soon as it starts acting up.

1. Don't use batteries unless you are out of your classroom, and take them out of the machine when you come back. Leaving them in runs them down and can ruin the machine. To guard against this, we distribute batteries separately from the machines.

2. Don't touch the exposed tape in the cassette, as this encourages it to snarl. If the tape becomes loose in the cassette, you can take up the slack by inserting the eraser end of a pencil (just like you were taking a standardized test) in the spindle hole and twirling the pencil.

3. Always go to "stop" as an intermediate stage between any two other modes (such as play to fastforward, play to rewind, rewind to fastforward, etc.)

4. Don't forget that if the microphone is connected, none of the controls (including play) will work unless it is switched "on".

b. Reel-to-Reel Tape Recorders

Reel-to-reel tapes still possess two big advantages over cassette tapes: better sound and the ability to be edited for creative effects.

1. Go easy on the controls. When replaying something you've just finished recording at the beginning of the tape, don't try to avoid re-threading the tape by continually flipping from rewind to stop to play to fast-forward to play to stop to ... In the long run, you'll save more time by simply running the tape completely out of the machine and threading it up again.

2. When recording, don't forget to set the record volume so the sound won't be distorted (volume too high) or full of background noise (volume too low).

3. Like cassette tapes, reel-to-reel tapes can be recorded on both sides. A tape recorded on both sides with a "four-track" (stereo) machine (which you might have at home) cannot be played on a "two-track" (monaural) machine (which you have at school). A tape recorded on both sides with a monaural recorder can be played on a stereo recorder by turning down whichever channel is picking up the sound in the wrong direction (backwards).

c. Record Players

The kind of record player we have in the system is pretty straightforward. Generally the tone control shouldn't be adjusted. Just leave it in the middle, okay?

d. Portable Loudspeakers

Don't forget to turn these things off when you're not using them. Otherwise, the batteries run down. Also, take care not to tug on the microphone cable; it will pull out.

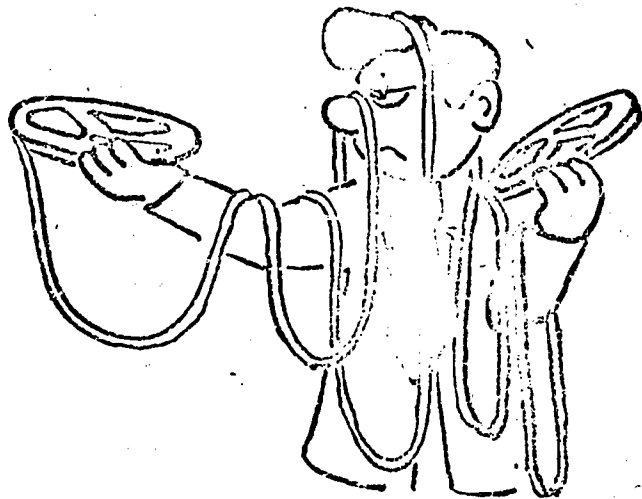

4. CAMERAS

The idea that the camera is every bit as normal a piece of classroom hardware as the projector or record player is still fairly new. Until most teachers can be assumed to have a general familiarity with cameras, it would not be particularly meaningful to list fine points and tips. For the next year or so, training in cameras will be accomplished explicitly through teacher workshops.

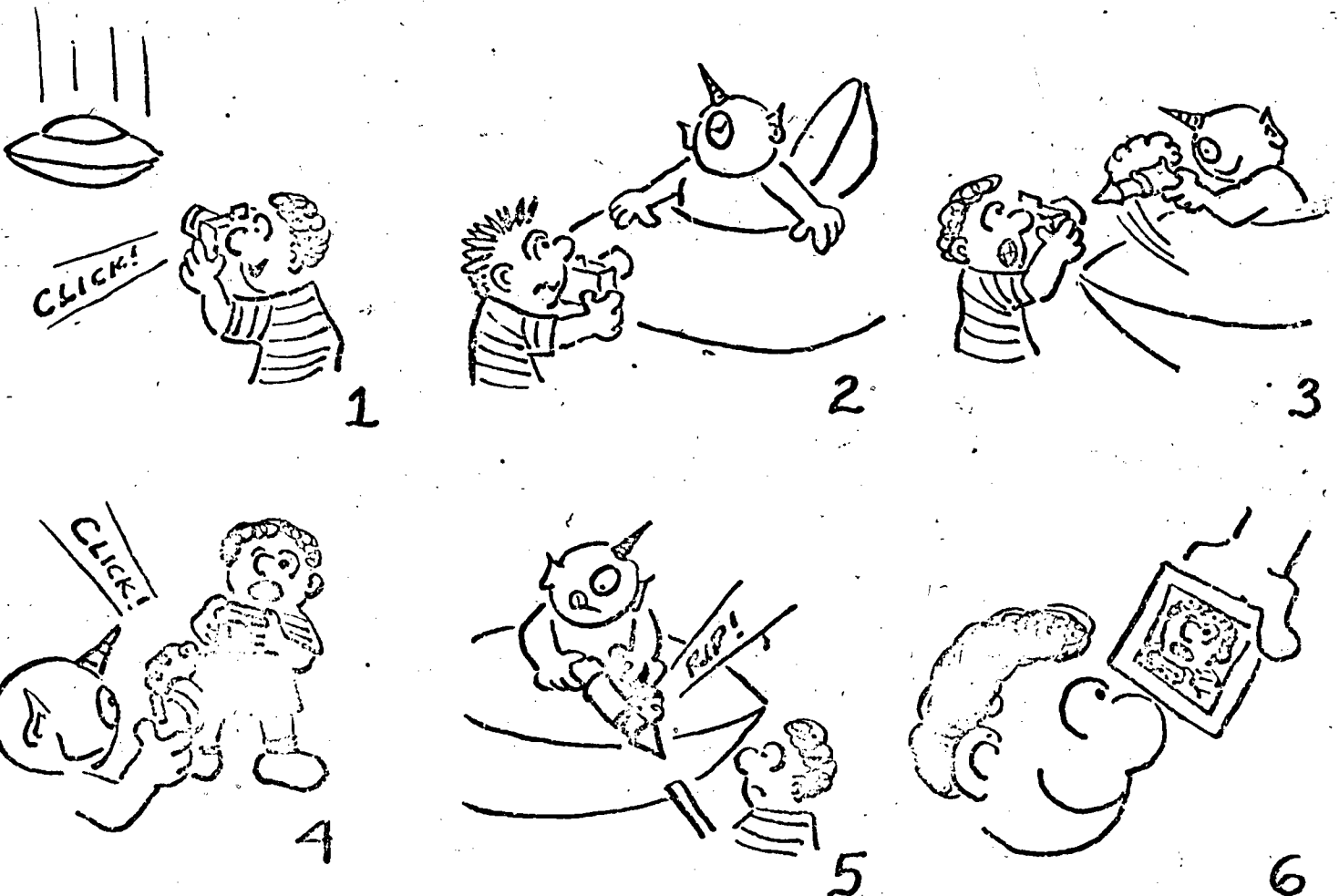

Chapter 4

TECHNICAL SERVICES

While the primary focus of the IMC is the relationship between student media production and the academic curriculum, there is no denying the day-to-day, nuts-and-bolts needs of teachers that our facilities can meet. The cost of these technical services (on a per slide, per transparency, per tape, etc. basis) is outlined in the Appendix. Do not hesitate to let us know of other services you'd like to have available. We'd like to grow to meet your needs.

a. Teacher Workshops

We will offer workshops dealing with any issue raised by this handbook or by the Newsletters to follow, if asked to do so by five or more teachers who are willing to stay after school. In addition, we are planning to offer "general interest" workshops on a regular schedule throughout the year. Two weeks before the meeting, we will stuff mailboxes with fliers describing what we plan to cover (augmentation of social studies kits, portable videotaping, utilization of cassette tape recorders, etc.) and how we plan to cover it (locating problem areas and generating appropriate activities, revising present materials, etc.) Those two weeks will give you time to think, gather materials, and let us know your particular interests or concerns. At any rate, we'll be here for those of you who'd like to talk with us. (Needless to say, these workshops will be voluntary.)

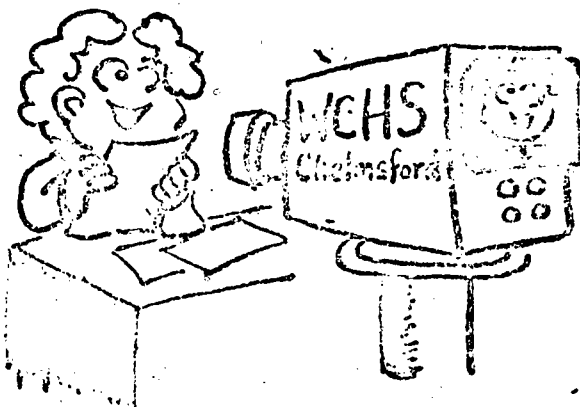

b. Basic Technology

The most conspicuous machines in the IMC provide services in six basic areas: transparencies and graphics, dry mounting and laminating, sound transfer, video-tape recording and playback, slide-making, and maintenance.

1. TRANSPARENCIES AND GRAPHICS

You can produce overhead transparencies and other graphics (charts, maps, graphs, illustrations, cartoons) at the IMC with the help of our local graphic artist and co-author, Jim Morrow. In the case of transparencies, please supplement your verbal description with a few written notes or, better still, a rough sketch of what you have in mind (don't forget about overlays). There are four basic methods by which transparencies may be created at the IMC.

a. Diazo

This is the most common and flexible system, particularly when you need more than one copy of the transparency. The "master" from which the copies are made may be an original design of words and pictures sketched into vellum paper, a ready-made chart or visual of appropriate size (8" x 10"), or even another transparency. Each separate overlay may be in a different color.

b. Thermal

A particularly detailed black and white chart or other graphic is sometimes best reproduced in transparency form using the common thermofax "secretary" machine rather than the diazo process. The original must be made with a carbon-based material (such as pencil, typewriter ink, and most printer's ink, but not ball-point pen ink or water-based marker ink).

c. Hand-Made

A single, one-shot transparency can be made by drawing directly onto a sheet of "acetate" (the plastic substance of a transparency) and adding colors with "magic markers" or transparent tape. This can either be saved for future use, or washed off with a damp rag.

d. Color-Lift

Another one-shot method, this one enables you to turn a color (or black and white) magazine picture into a transparency. The original is destroyed.

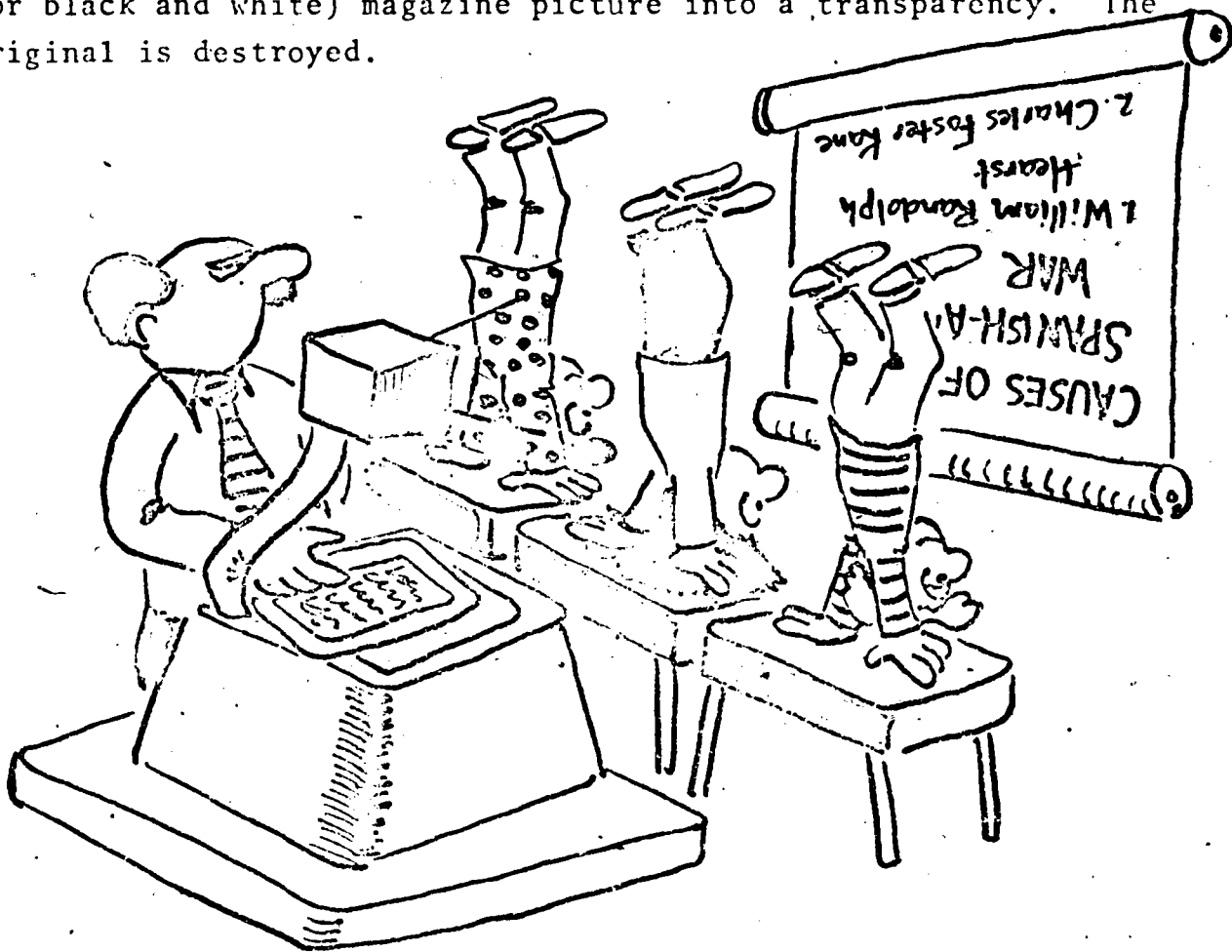

2. DRY MOUNTING AND LAMINATING

These are processes for preserving and presenting pictures from another medium (such as photographs, National Geographic maps, or student drawings). Dry mounting is a way to mount pictures (from magazines, newspapers, etc.) smoothly and permanently on cardboard. A piece of dry mount tissue is inserted between the picture and the cardboard. This arrangement is then heated for about thirty seconds in a dry mount press, which causes the tissue to act like a glue, sealing picture to cardboard. Laminating means to cover a picture with a plastic coating called laminating film. This preserves it from wear, tear, and strawberry jam. A picture may be laminated after it has been dry mounted. The IMC has a laminating machine, but in a pinch the process can be done with a dry mount press or a thermofax machine.

3. SOUND TRANSFER

The IMC is equipped to transfer records to cassettes or reel-to-reel tapes, cassettes to reel tapes, reel tapes to cassettes, cassettes to cassettes, and reel tapes to reel tapes. Make your accompanying notes as detailed and explicit as possible. For instance: are both sides of the master tape recorded on? Should both be transferred? If the copy runs longer than one side, should the recording be continued on the second side, or on a new tape?

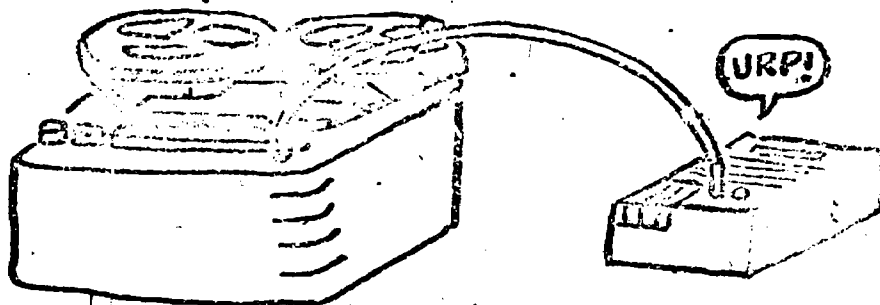

4. VIDEO-TAPE RECORDING AND PLAYBACK

If you would like your class to see a particular selection from our library of taped tv shows, we will try to facilitate this. In the high school and the junior high school, the procedure is fairly simple. For other schools, we will have to bring a portable video recorder (half-inch tape) into your classroom and hook it up to your tv set. Also, the tape may have to be transferred from two-inch tape to half-inch tape. Upon your request, we will add particular shows to the library. Give us a week's notice of the broadcast time.

5. SLIDE-MAKING

Photographic transparencies (for slide series and slide-tapes) produced at the IMC for classroom use fall into three areas: live action shooting (taking a slide of a person, place, event, or object with a regular 35mm or instamatic camera), slide-copying (re-photographing a slide onto another slide), and picture-copying (transferring a magazine picture or other visual onto a slide). The quickest way to get any given slide-job done is for us to work together, with you doing most of the actual slide-taking. We are anxious to give you on-the-spot training in each kind of slide-making.

6. MAINTENANCE

The IMC has people and facilities for repairing equipment, films, books, etc. Again, please attach a detailed note to any malfunctioning machine or material you come across, and send it back to us.

Chapter 5

LIBRARY SERVICES

One of the main functions of the IMC is to be a clearinghouse for educational resources of all types. So far, this handbook has dealt only with resources involved in media production. In addition is a vast quantity of completed materials already owned by the system: books and films and loops and strips and slides and records and tapes and charts and maps and on and on. These materials, be they commercially or locally produced, will be indexed in a Union (master) card catalogue for ready access by the entire school population. (You will ask for an item; the catalogue will locate it, and the courier will transport it.) School library catalogues will index those materials immediately available within their building. And ERIC will provide access to the work of people outside the system. Please keep in mind that if you can't locate a resource, there is always the option of creating one.

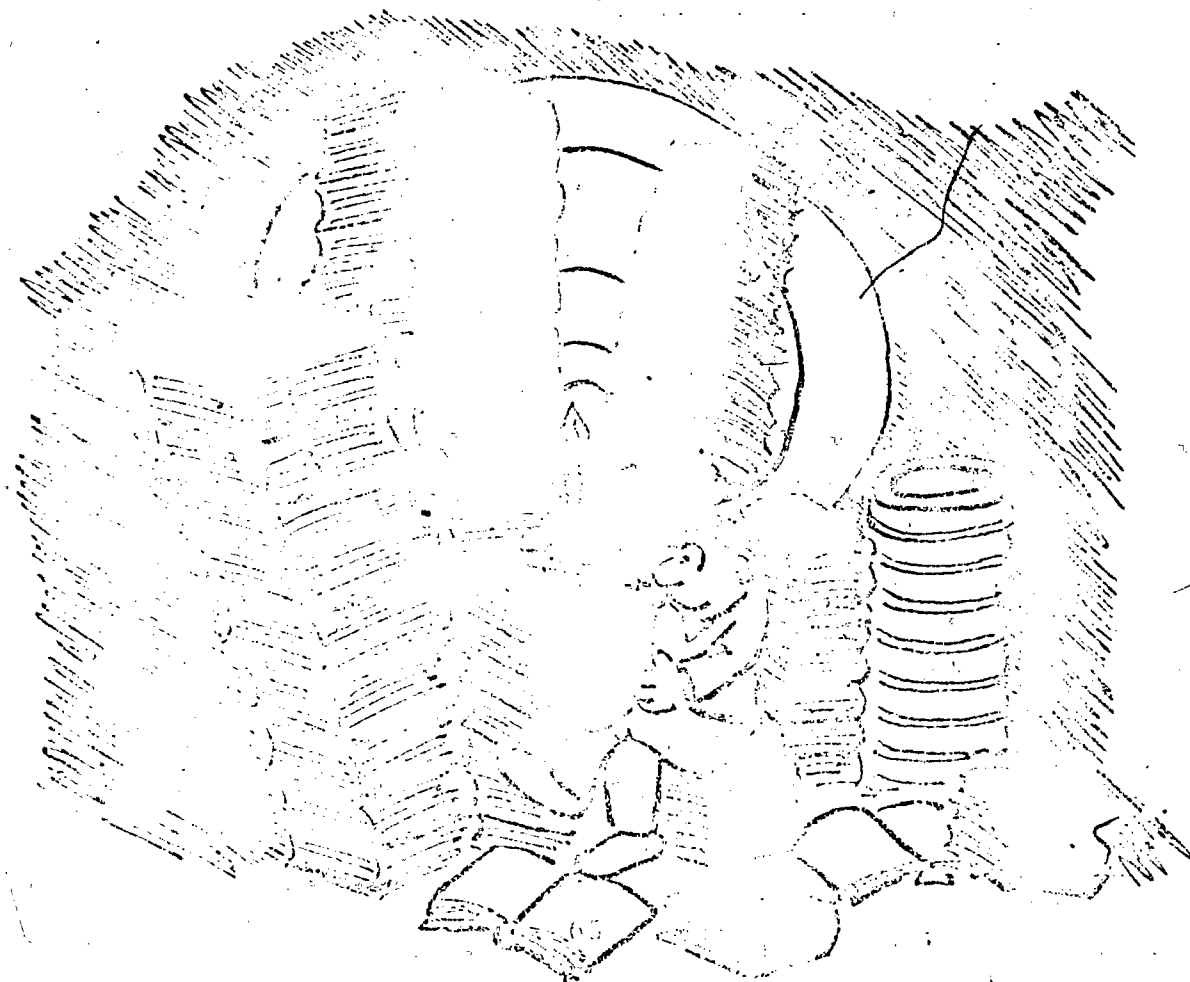

a. The Union Card Catalogue

This central resource is in its infancy. It now encompasses the collections of the school libraries and those materials once distributed by the coordinators. Items which are too expensive to have in individual buildings (like 16mm sound movies) are also indexed and stored in the IMC. While this is already a huge body of material, we hope to expand the catalogue further to include student productions, teacher productions, successful practices, and even human resources.

Certain limitations on the use of the catalogue will be necessary. Otherwise, we would anticipate problems of overlap and repetition. Imagine, for example, that a group of fifth grade teachers work out a unit based on a particular social studies movie, only to find that third graders are shown the movie because it's fun and eleventh graders are shown it because it raises certain issues of film technique. While these are certainly valid uses of the material in question, it doesn't make much sense in terms of the development of an individual student as he advances through the grades.

To protect the effectiveness of materials designed for whole class presentation, we are including grade level restrictions on many items. We hope that this will not be taken as an attempt to drive you from particular kinds of resources. Remember, if you find a film, tape, or slide show you like, you can produce something of similar style or content in your own classroom.

b. School Library Resources

Libraries in individual buildings are slowly growing to fit the specific needs of the people who use them. We need your help here. Selection is a frustrating business, not only because there are so many good sources to influence your choice (friends, past experience, Booklist and other publications available at the IMC) but also because of the lag between choosing and actually getting. However, if you will be patient with us, we definitely give top priority to items that interest you. Do not be shy in asking!

Every school will also have in it a film catalogue from the library at Syracuse University. We have found the descriptions in this well-indexed work quite honest and reliable, and encourage you to make full use of it. The coordinators all have film rental budgets. All we need is your suggestion and their authorization to get you a film. We'll also ask for an evaluation so we'll know whether to recommend the film to others.

If you have a problem beyond the scope of your buildings facility, don't hesitate to ask us. If we can't help, we'll advertise your problem until someone can.

c. Instructional Materials

We have books, films, loops, strips, slides, records, and tapes. Our responsibilities regarding these materials are two-fold. First, we must support their appropriate and creative use. Second, we must strengthen weaknesses in the collection. We can do neither without your cooperation.

To meet the first goal, the IMC's Newsletter will be used to communicate successful practices you have developed. Further, we will store these ideas right with the film, kit, strip, or whatever, to which they apply. If you are willing to share your ideas, we should soon have a wealth of locally tried and tested techniques. Again, we will limit your particular ideas to your grade level, so you won't get kids next year who think you're old hat.

d. ERIC

ERIC, an acronym for the Educational Resources Information Center, is a nationwide information system designed and supported by the U. S. Office of Education. Through a system of clearinghouses, educational documents of all types (pragmatic guides, reports, successful practices, dissertations, etc.) are indexed, abstracted, and put on microfiche (a card form of microfilm). We have direct access to these resources. South Row, Westlands, Byam, Harrington, the High School, the Superintendent's Office, and the IMC have microfiche readers and a subscription to Research in Education, a monthly abstract journal announcing recently completed works in the field of education. The RIE's list several items in each subject area. If you'd like to read the fiche, call in the ED number (which identifies the abstract) to the IMC, and we'll order it for you. We can order 1200 fiches free as part of our subscription to the service, so don't be hesitant.

If the RIE's can't lead to adequate information, we can make a more thorough search using secondary sources. The IMC has a master index as well as access to a computer which can search the total ERIC file. Once you've read the fiche, we'll ask for an evaluation with its return so that we may circulate it to other interested parties.

APPENDIX

a. Authorization Procedure

In order to keep within the budget and to put money where it will benefit the programs as a whole, every expenditure must be authorized by a coordinator, principal, or department head. These people have made allowances in their budget for media projects, however, so you needn't be shy. Just have a clear idea of what you want to do a week or so before you want to do it. When we hear what you're allowed to spend, we'll provide the supplies and whatever assistance you may want.

b. Basic Costs

This appendix will give you ballpark figures for projects you might like to undertake. Please remember that big projects always require more supplies than you initially think of. We'll be glad to help you plan in this area as well as in any other.

1. Design. Most design supplies are also art supplies and are thus handled through your principal.

2. Typography. To make words for charts, posters, transparencies, etc., where polished presentation is desired.

Varityper. This is the machine used by printers to set headlines.

There is a transparency showing all available type.

COST: \$1.00 a foot of type.

Cold Press Lettering. Inexpensive, professional, time-consuming; each letter is set down by hand.

COST: \$1.00 a large poster filled with copy.

Primary Type. Looks like this.

3. Overhead Transparencies. To show stages of a process through the use of overlays, to clarify concepts by presenting them visually.

Diazo. Brilliant color transparency made from vellum master marked with india ink or other opaque material. Each overlay another color.

COST: 27¢ a sheet.

Thermofax. Master is any pencil or typed copy.

COST: 30¢ a sheet.

Other COSTS. Acetate: 4¢ a sheet.

Transparent projection pens: 40¢ a piece.

Cardboard frames: 9¢ a piece.

Plastic frames: 50¢ a piece.

Envelopes: 6¢ a piece.

Hinges (for overlays): 14¢ a set.

4. Slides. To stimulate discussion, to present new material, to show contrasts through juxtaposition, to present a variety of view points, etc.

Production. Live action, copy from good quality photographs, book illustrations, magazine pictures, slides, etc.

COST: 17¢ a slide at the IMC.

28¢ a slide in the classroom with the Ektagraphic unit.

5. Audio Tape. To record interviews/poetry/discussion/ group dynamics/etc.

Production. Modifies existing tapes by adding music/sound effects by editing.

COST: Reel-to-reel (best for splicing), \$1.00 an hour.

Cassette, 57¢ an hour.

6. Slide Tapes. To build students' composing skills, to synthesize or introduce a unit.

Production. Synchronizes slides and audio tape (as above).

COST: \$1.80 a minute (ten slides a minute, average).

Don't let this frighten you; it is very competitive with commercially produced materials.

7. Video Tape. To allow students to see themselves work, to synthesize or introduce a unit.

COST: \$12.00 for a half-hour reel (only size which fits the portable units)

\$18.00 for an hour reel.

These are the only units tape comes in, so you must get a full reel even if you're only doing a five minute spot. However, the whole reel is then available to your department or school for future productions.

8. Film Making. To synthesize or introduce a unit.

COST: Super/8 B&W, \$5.00 for 3 min. 15 sec.

Super/8, color, \$6.50 for 3 min. 15 sec.

16mm, B&W, \$9.00 for 3 min. 30 sec.

16mm, color, \$17.00 for 3 min. 30 sec.

9. Dry Mounting. To lengthen the life of paper or boarding.

Production. To stick photographs, pictures, art work, class projects, etc., to hard boarding.

COST: \$1.20 for a 30" x 40" chart.

10. Laminating. To preserve any of the materials mentioned under Dry Mounting.

Production. Seals the material in transparent film, not too glossy. The dust jackets of all the library books are laminated.

COST: 7¢ an 8 1/2" x 11" page

Color Lift. Makes transparencies from magazine illustrations. Somewhat unreliable and ruins the original.

COST: 7¢ a page.