

DOCUMENT RESUME

ED 085 149

RC 007 494

AUTHOR Savoy, Gordon H.  
TITLE Archery--a Catalyst for Subject Integration.  
PUB DATE Oct 71  
NOTE 11p.

EDRS PRICE MF-\$0.65 HC-\$3.29  
DESCRIPTORS \*Archery; Athletic Activities; \*Curriculum Design;  
Educational Methods; Instructional Design;  
Mathematics; Metric System; \*Outdoor Education;  
\*Physical Education; Program Effectiveness;  
\*Sciences; Teaching Guides  
IDENTIFIERS \*Canada

ABSTRACT

Archery involves skill development in P.E., mathematics, and science. Archery taught at the high school level has 3 main objectives: (1) to determine the distance an arrow will travel if shot into the air; (2) to introduce and familiarize pupils with the metric system; and (3) to reach some objectives laid out in the curriculum revision guides in mathematics and science--to stimulate critical thinking, to develop a process of seeking answers, and to develop ability and skills in 20 objectives, such as observing carefully and collecting and organizing data. The method of approach involves 3 lessons: (1) shoot arrows at 30 degrees, using the metric system as a means of measurement; (2) vary the draw and measure distances and angles after firing arrows with 20, 30, 40, and 50 cm. draws; and (3) graphing draw distance to predict that, in all likelihood, with a 35 cm. pull the arrows would have an angle of impact ranging between 30-40 degrees. (FF)

U.S. DEPARTMENT OF HEALTH  
EDUCATION & WELFARE  
NATIONAL INSTITUTE OF  
EDUCATION

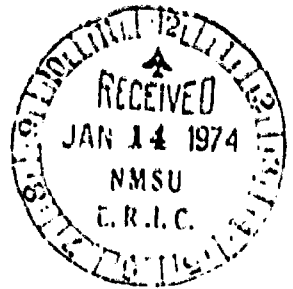

EP 85 7

MARKS STREET SCHOOL - 1971-1972  
ATIKOKAN, ONTARIO

ARCHERY - a Catalyst for Subject Integration

" I shot an arrow into the air  
And it landed - I KNOW where!! "

An Approach by Gordon Savoy, started at Saturn Avenue School in the 1970-71 school year with assistance from Laurie Sundin, Paul Convey, and Vi Eyton.

GENERAL OBJECTIVES:

1. To capitalize on pupil interest in P.E. archery instruction to effect a better academic program in the classroom.
2. To tie in all subject areas under one theme - archery - and reap the benefits of an integrated approach.

A. PRACTICAL OUTDOOR ACTIVITY

SPECIFIC OBJECTIVES:

1. To discover with the pupil a method of determining the distance an arrow will travel if shot into the air.
2. To introduce and familiarize pupils with the metric system.
3. To reach some of the objectives laid out in P.1 J.1 Curriculum Revision Guides in Mathematics and Science.
  - to stimulate critical thinking.
  - to develop a process of seeking answers.
  - to develop ability and skill in:
    - a. observing carefully
    - b. collecting and organizing data
    - c. recognizing anomalies and problems
    - d. defining problems
    - e. creating hypotheses

Specific Objectives, contd.

- f. Making predictions
- g. Planning experiments
- h. controlling variables
- i. making inferences
- j. interpreting data
- k. describing phenomena
- l. forming generalizations
- m. recognizing limitations of generalizations
- n. seeking other situations where generalizations are applicable
- o. handling materials and equipment
- p. making graphs, tables, and models to present data
- q. taking samples from a population
- r. selecting data from books and other sources
- s. expressing ideas in mathematical form
- t. making interpolations and extrapolations

PROBLEM:

What affects the distance travelled by an arrow shot into the air?

{ Pupils had experience with archery in P.E. classes. They also  
{ had an exercise whereby they shot arrows into the air at a ground  
{ target some distance away.

By discussion two main factors affecting distance travelled came to the fore:

1. The distance the string on the bow was drawn back - which we labelled as DRAW.
2. The direction the arrow was pointed in the air - which we labelled ANGLE (meaning angle at which arrow is shot in relationship to horizon)

It was decided that in order to attack the problem scientifically and come up with meaningful results, it was necessary to overcome obvious human error in DRAW and ANGLE. There had to be some method of making these CONSTANT. The following piece of equipment was devised:

EQUIPMENT:

1.

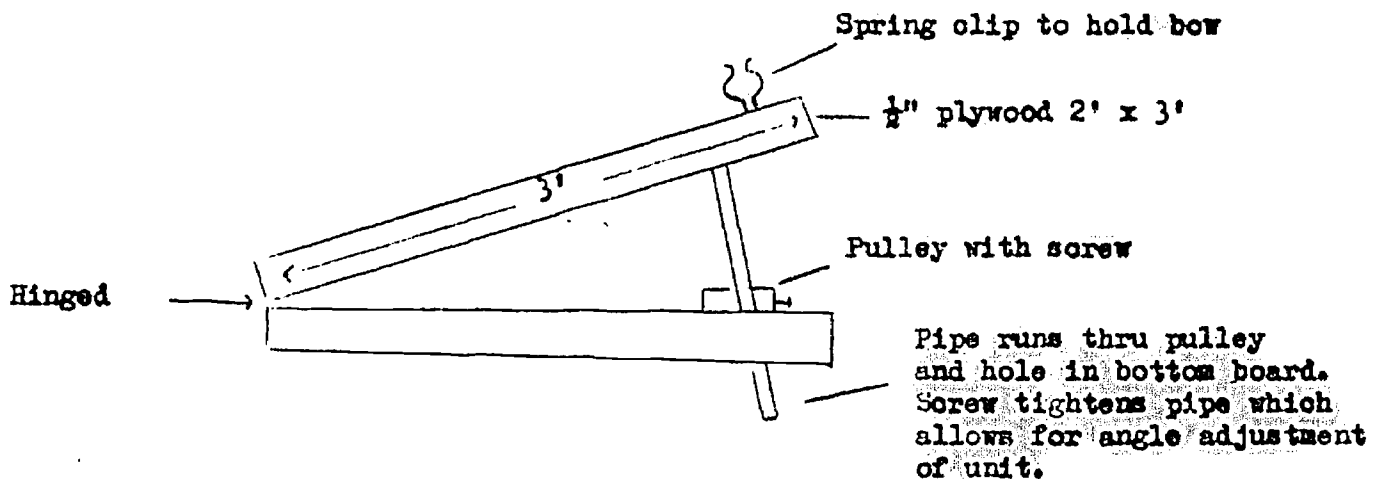

Unit sits on table top outside - we use large park-ground picnic tables, which are very solid. Masking tape is placed on top board and marked with standard unit to measure DRAW.

Unit can be folded for storage.

2. 15 lb. pull bows - used in P.E. class.

26" arrows

100 metre transect line

measuring tapes

blackboard protractors

picnic table

hula hoops

clinometer

FACILITIES:

Lawn area outside front of school. Grassed area is needed for arrows to land into the ground. From this a study of angles of impact/

impact can be made. A grassed area is also easier on arrows.

250' to 300' is needed to measure maximum distance reached by full DRAW and optimum ANGLE. However, a shorter grassed area can be used for lesser DRAWS and other than optimum ANGLES

METHOD:

1st Lesson.

For no particular reason, we decided to start our experimentation shooting arrows at  $30^{\circ}$ . We also decided to use the metric system as our means of measurement - giving us a meaningful tool for becoming familiar with that system. We chose 20 cm. as the second CONSTANT for the first shoot.

We then fired 6 arrows, all with the same bow, all at  $30^{\circ}$ , and all with a 20 cm. draw.

Pupils were awed that the arrows landed close together - even though they had expected it. Yet, why had the arrows not all landed at exactly the same place? Since we had CONSTANT DRAW, CONSTANT ANGLE, shouldn't we get a CONSTANT DISTANCE? We sat on the ground where the arrows had landed and discussed this. Obviously there must be other factors affecting distance - factors which were not CONSTANT and which we weren't controlling (or weren't even able to control). We (this pronoun refers to the pupil-teacher team) came up with the following list:

- human error in drawing to a constant draw
- human error in release; rolling off fingers, snapping of string
- human error in placing arrow nock at exactly same spot on string each time
- human error in placing arrow on bow
- difference in arrows; weight, curve, feathers.
- wind

We also felt that the angle of impact looked interesting, like maybe  $30^\circ$ , and so we measured these angles. The 6 angles measured out at  $35^\circ$ ,  $35^\circ$ ,  $35^\circ$ ,  $30^\circ$ ,  $30^\circ$  and  $25^\circ$ . Can we say at what angle these arrows will land for a 20 cm. draw and a  $30^\circ$  angle shot? We looked at our data and came up with several possibilities:

- a. Range -  $25^\circ$  to  $35^\circ$
- b. Mean (Average) -  $((3 \times 35) + (2 \times 30) + 25) \div 6 = 32^\circ$
- c. Median -  $30^\circ$
- d. Frequency -  $35^\circ$

We can use any of the above APPROXIMATIONS.

We then looked at the distance the arrows had landed. We measured this in metres and centimeters and arrived at an APPROXIMATE distance travelled for the constant draw and angle. We used the same method as in angles above.

We also looked at the arrows on the ground and tried to predict where other arrows might land. We fired other arrows to see how accurate our predictions were - a very interesting exercise. We overcame one girl's "women's intuitive thinking." She had observed a pattern where three consecutive arrows had fallen long, short, and then long of predicted area. The fourth arrow HAD to fall short - which it didn't. She demanded fifth and sixth arrows shot - and they also broke the pattern (We still don't feel she's convinced - she just walks around shaking her head and mumbling to herself.)

We then discussed our findings in the class and developed the following chart to assist us in recording data.

ARROW #	SHOT		IMPACT	
	DRAW	ANGLE	DISTANCE	ANGLE
1	20 cm.	30°	2940 cm.	35°
2	20 cm.	30°	3200 cm.	35°
3	20 cm.	30°	3300 cm.	30°
4	20 cm.	30°	3240 cm.	30°
5	20 cm.	30°	3240 cm.	25°
6	20 cm.	30°	3300 cm.	35°

We concluded:

CONSTANT DRAW + CONSTANT ANGLE =  
ROUGHLY CONSTANT DISTANCE AND  
ANGLE OF IMPACT

We finished by determining to consider a problem for the next lesson.

A long, two hour first lesson, but a lot accomplished in establishing procedure and thinking. Future lessons should move faster.

## LESSON 2.

We decided to leave the angle constant and vary the draw - we then got into the use of the word VARIABLE. We measured distances and angles at approximations after firing arrows with 20, 30, 40 and 45 cm. DRAWS. From our previous data, we estimated the distance arrows would travel at a 25 cm. DRAW - and then fired and approximated. Our estimates were fairly well substantiated.

However,, our 20 cm. DRAW results did not align very well with those of the previous day. We decided this was due mainly to the use of a different bow (although both bows were of a 15 lb. pull)

We discussed the reason for firing 6 arrows rather than 1 or 100. One arrow would not give us results that we could place any faith in, while we didn't have time to fire 100 arrows. Six seemed to be a number which didn't require too much time, and yet allowed us fairly reliable results.

We charted our information in order to get a clearer picture from which to base predictions.

Shoot		Impact	
Draw	Angle	Distance	Angle
20 cm.	30°	1770 cm.	30° - 40°
25 cm.	30°	2480 cm.	
30 cm.	30°	3320 cm.	35°
35 cm.	30°		
40 cm.	30°	6030 cm.	35°
45 cm.	30°	6860	35° - 40°



Lesson 2, contd.

We decided the ANGLE of shot was CONSTANT and the DRAW VARIABLE. The impact DISTANCE was certainly VARIABLE but we could not decide if the impact ANGLE was VARIABLE or CONSTANT. We would leave this to another day.

We predicted that at the 35 cm. draw the DISTANCE the arrow would travel would be about 4675 cm. and the impact ANGLE between  $30^{\circ}$  -  $40^{\circ}$ .

Our next exercise is to graph DISTANCE on DRAW.

### Lesson 3.

From the unknowns in our chart, we predicted that all likelihood with a 35 cm. pull, the arrows would have an angle of impact ranging between  $30^{\circ}$  -  $40^{\circ}$ . We felt that they would fall somewhere between 3320 and 6030 cms. away - 4675 to be precise.

We decided to graph DRAW and DISTANCE to find another way of predicting possible distance with a 35 cm. pull -

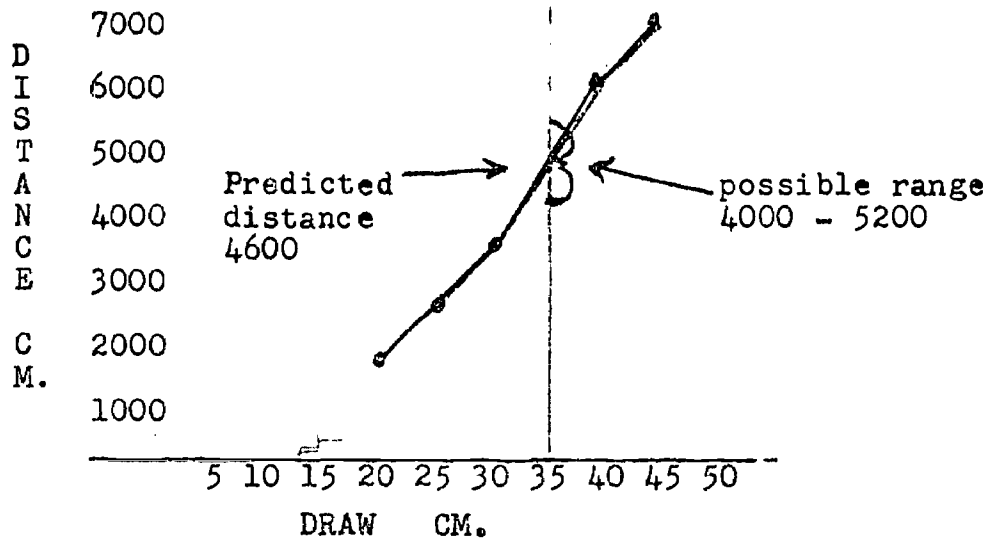

This type of graph preparation and interpretation requires further work.

We fired 6 arrows at a  $30^{\circ}$  ANGLE and 35 cm. pull. The arrows fell within predicted range, but the fact that the arrows were well spread apart from one end of the range to the other, caused pupils to not have too much faith in their prediction. This is a problem with youngsters at this age - they have difficulty in accepting a range in a predicted outcome.

### FURTHER LESSONS:

Most lessons are conducted as teacher demonstration lessons with pupils doing measurement.

Data is collected and organized in graph form back in the classroom.

From graphs, pupils predict outcomes for untried draws, angles, and measurements.

### SUGGESTIONS FOR INTEGRATION:

1. The activity itself involves development of skills in P.E., Mathematics, and Science.

2. Language Arts and History:

- William Tell

- Robin Hood

- Indians of North America

- Chronological development of bows and arrows - other weapons

3. Music - William Tell

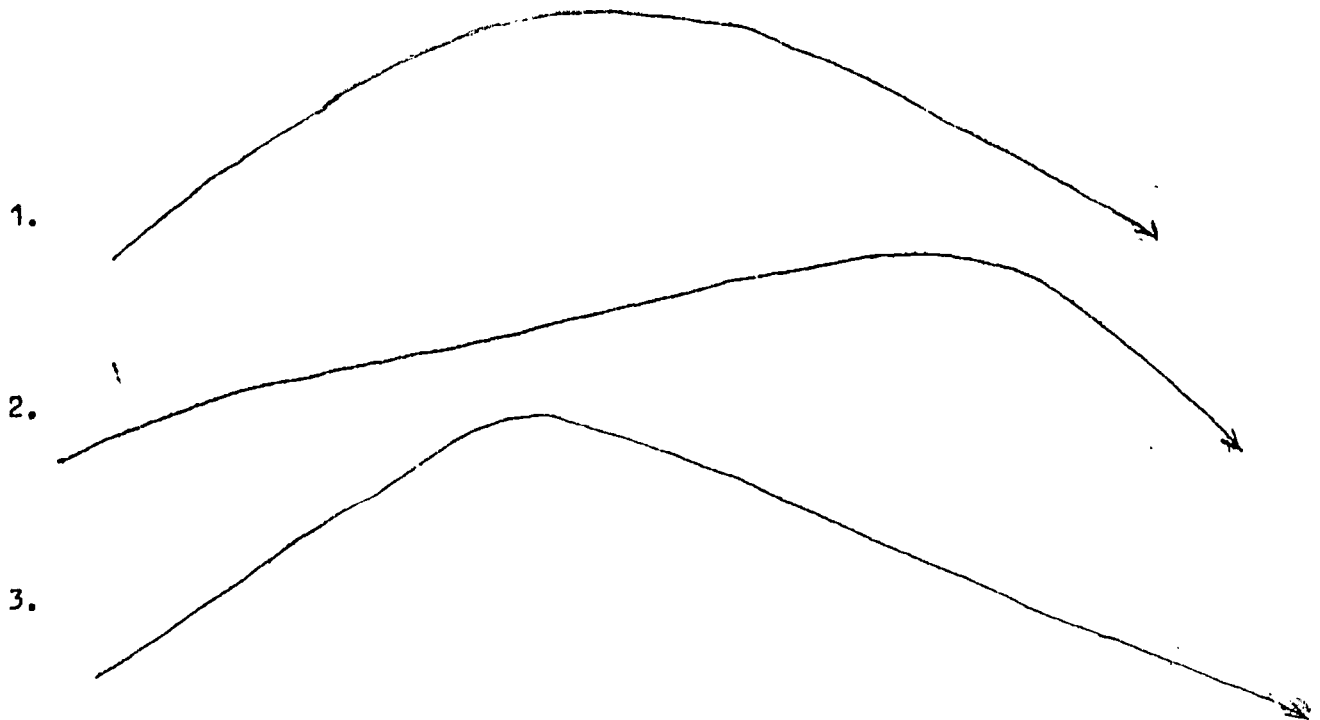

If you were to shoot an arrow into the air, which of the above 3 would you consider to be the flight pattern?

HINT: Consider - angle of takeoff  
- angle of impact  
- horizontal distance travelled

Could you determine the height reached by an arrow?