

## DOCUMENT RESUME

ED 083 692

88

EA 005 529

AUTHOR Foster, Donald M.; Foster, Rick  
TITLE A Career Development Center: A Model for School Employee Development.  
INSTITUTION Santa Clara County Office of Education, San Jose, Calif.  
SPONS AGENCY Office of Education (DHEW), Washington, D.C.  
REPORT NO SIMU-RR-10  
BUREAU NO BR-72-8111  
PUB DATE Aug 73  
GRANT OEG-9-72-0063 (290)  
NOTE 31p.; Related documents are EA 005 356 and 357

EDRS PRICE MF-\$0.65 HC-\$3.29  
DESCRIPTORS Continuous Learning; \*Educational Planning; \*Facility Utilization Research; Job Development; \*Models; \*Nonprofessional Personnel; Occupational Mobility; Planning (Facilities); School Personnel; \*Vocational Development; Vocational Training Centers  
IDENTIFIERS Career Development; Elementary Secondary Education Act Title III; ESEA Title III; Facility Utilization; \*SIMU School

## ABSTRACT

The approach of the present project is to consider educational planning as an integrated process in which the facility becomes an integral part of the evolving education program and the teaching-learning situation. The products or output of the project, therefore, are directed toward the total process of educational planning and the procedures and methodologies which comprise it. In this paper, the authors present the point of view that in the future, the nonteaching personnel in the public schools should be encouraged to participate in learning activities using resources already available within the school plant. The participation of such personnel is seen as part of a program of career development involving lifelong learning, job upgrading, and career mobility. The authors also present a Career Development Model and describe a Career Development System which can, it is believed, provide more satisfied and productive workers (though perhaps fewer in number) and assure greater utilization of school facilities. Implications for facility planning are explored, with emphasis on a specific element of the Career Development Model: the Career Development Learning Center.  
(Author)

ED 083692

U.S. DEPARTMENT OF HEALTH  
EDUCATION & WELFARE  
NATIONAL INSTITUTE OF  
EDUCATION  
1200 K STREET, N.W.  
WASHINGTON, D.C. 20004

# A CAREER DEVELOPMENT CENTER

**Donald M. Foster  
and  
Rick Foster**

Santa Clara County Component  
45 Santa Teresa  
San Jose, California 95110

ED 083692

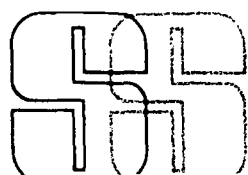

PROJECT  SIMU SCHOOL

ED 083692

A CAREER DEVELOPMENT CENTER  
A Model for School Employee Development

RESEARCH REPORT NUMBER TEN  
OF  
PROJECT SIMU SCHOOL: SANTA CLARA COUNTY COMPONENT

Sponsored by a Grant From  
Department of Health, Education and Welfare  
U.S. Office of Education  
Title III, Section 306  
Elementary and Secondary Education Act

Grant OEG 9-72-0063 (290)  
Project No. 72-8111

Santa Clara County Office of Education  
Glenn W. Hoffmann, Superintendent  
45 Santa Teresa Street  
San Jose, California 95110

August, 1973

## FORWORD

Project Simu School was initiated to consider ways of improving and simplifying the process of educational facilities planning for the educational planner. The initial intent was to develop a highly sophisticated simulation capability through a national coordinating center for educational planning, but early work suggested that a single large-scale simulation procedure was not feasible and that facilities planning could not be thus separated from overall educational planning. The Simu School project accordingly decided to try to develop educational planning procedures and techniques to aid the local educational planner and/or consultant.

The approach of the present project is to consider educational planning as an integrated process in which the facility becomes an integral part of the evolving education program and the teaching-learning situation. The products or output of the project, therefore, are directed toward the total process of educational planning and the procedures and methodologies which comprise it. The final products will be applied by the local educational planning body, the educational system, or members of the community to develop a program of educational services.

The development of planning tools frequently leads to consideration of factors which influence the education program of the school system. New demands which are placed upon the school program contribute to the complexity of the planning process and open opportunities for greater flexibility. New teaching methods as well as new approaches to learning frequently bring about changes in the planning process.

Project Simu School: Santa Clara County Component has addressed some aspects of projected change in educational technology and their effect on the planning of facilities. Some such changes include the possibility of use of "non-school" facilities for learning activities within the community.

This position paper concerns such programs. It presents a rationale for the development of plans for better preparation of non-teaching service personnel and considers facility requirements. The approach chosen by the authors concentrates on the need for self-development by these employees and the creation of a system for filling positions vacated through attrition, growth, promotion, or other factors. Factors which must be considered when planning for these programs in present or new facilities are explained on a less technical level but in a manner which should alert planners to this need as demonstrated in school systems.

Installation of the kind of program described will require additional planning by school district policy makers and by technical planners. It is hoped that the concepts presented herein will expand the horizons of planners so that provision of such programs and facilities may become an integral part of the planning process.

Lester W. Hunt, Director  
Project Simu School: Santa Clara County Component

The project presented or reported herein was performed pursuant to a grant from the U.S. Office of Education, Department of Health, Education and Welfare. However, the opinions expressed herein do not necessarily reflect the position or policy of the U.S. Office of Education, and no official endorsement by the U.S. Office of Education should be inferred.

#### ACKNOWLEDGEMENT

The development of the Career Development Model described in pages 5-19 was supported in part by a contract with the U. S. Department of Labor (#E & D 2192-06). All other components are original to this paper.

Original drawings for Figures 4 through 7 are by Robert Mason, San Diego, California.

## CONTENTS

	<u>Page</u>
1.0 Introduction . . . . .	1
1.1 Overview . . . . .	1
1.2 School Management Problems Which Forecast the Need for a Classified Employee Career Development System . . . . .	1
1.3 Policies Which Can Lead to Establishment of a Career Development Program, with Particular Attention to Inservice Training and Curricula for a "Learning Center" for Classified Personnel . . . . .	3
2.0 The Career Development Model . . . . .	5
2.1 Overview . . . . .	5
2.2 The System . . . . .	8
2.3 The Information Function . . . . .	9
2.4 The Training Function . . . . .	10
2.5 The Administration Function . . . . .	11
2.6 Software for the Model . . . . .	13
2.7 Physical Aspects of the Model . . . . .	13
2.8 Administrative and Para-professional Support . . . . .	13
2.9 Use of the Model by the Employees . . . . .	14
2.10 Using Integer Linear Programming to Effect Mobility . . . . .	18
2.11 Author Note . . . . .	19
3.0 Implications of a Career Development Program for Educational Facility Planning . . . . .	20
3.1 Educational Program . . . . .	20
3.2 Examples of Model Study Carrels . . . . .	21
3.3 Use of Existing Facilities . . . . .	24
3.4 Alternative Existing Facilities . . . . .	24
3.5 New Facilities . . . . .	25
4.0 Conclusion . . . . .	26

## FIGURES

Fig. 1 - Two Concepts of Organization . . . . .	2
Fig. 2 - Overview of a Model for Career Development . . . . .	6
Fig. 3 - Flow Chart of the Career Development System . . . . .	15
Fig. 4 - A Career Development Learning Center . . . . .	21
Fig. 5 - Possible Study Carrel Configuration . . . . .	22
Fig. 6 - Four Study Carrels . . . . .	23
Fig. 7 - A Facility Designed Especially for Self-Study . . . . .	24

## 1.0 Introduction

### 1.1 Overview.

Section 1 of this paper presents the point of view that in the future, the non-teaching personnel in the public schools should be encouraged to participate in learning activities using resources already available within the school plant. Their participation can be seen as part of a program of career development involving lifelong learning, job upgrading and career mobility. Section II presents a Career Development Model and describes a Career Development System which can, it is believed, provide more satisfied and productive workers (though perhaps fewer in number) and assure greater utilization of school facilities. In Section III, implications for facility planning are explored, with emphasis on a specific element of the Career Development Model: the Career Development Learning Center.

### 1.2 School management problems which forecast the need for a classified employee career development system.

1.2.1 Managers in public and private sectors of the economy are being forced to give more consideration to their support personnel. In public agencies, demands by the taxpayer for increased productivity from fewer employees require serious attention. Present management policies and practices regarding motivation, morale, job upgrading, and behavioral criteria for promotion in school districts generally have not kept pace with current conditions.

1.2.2 Educators should be among the first to implement policies which enhance employee satisfaction, optimize utilization of abilities, give constant attention to morale, and increase opportunity for development.

1.2.3 School management (indeed all management) is confronted with continued demands for affirmative action (not limited to aggressive recruitment of minorities), for increased benefits, for job relevance, and for participation in decisions which affect employees.

1.2.4 The quest for meaning in their jobs by workers is caused in part by a collision--that is, the confrontation between an ever more educated labor force and ever more particularized, routinized tasks. The results for all but the dull worker are feelings of frustration, boredom, and insignificance. Such feelings give rise to careless errors, extra absenteeism, high attrition and general unproductivity.

1.2.5 Problems associated with career opportunity are complicated by three commonly accepted beliefs which have become part of our culture through the "Puritan ethic," the concept of

the "never-ending frontier," and by the heroes depicted in 300,000,000 copies (estimated) of Horatio Alger's books. For purposes of this paper, these beliefs are translated as follows: (1) diligence and skill are always rewarded; (2) the upward mobility patterns of an organization are pyramidal; and (3) one is a failure unless he moves upward continually, (the image here usually is a ladder). The latter limits "success" to a narrow, vertical channel and denies the label to lateral mobility within an organization. To reward diligence and skill, managers must consistently utilize predictive criterion measures and establish a firm system of task analyses to measure job performance. The general lack of such criterion measures in personnel practices implies that many promotions are prompted more by a function of time than by performance. The Department of Labor Task Force for Career Development (Region IX) found that some workers felt that minimal performance to avoid alienation of co-workers was a safer way to insure advancement than was outstanding (very visible) performance.

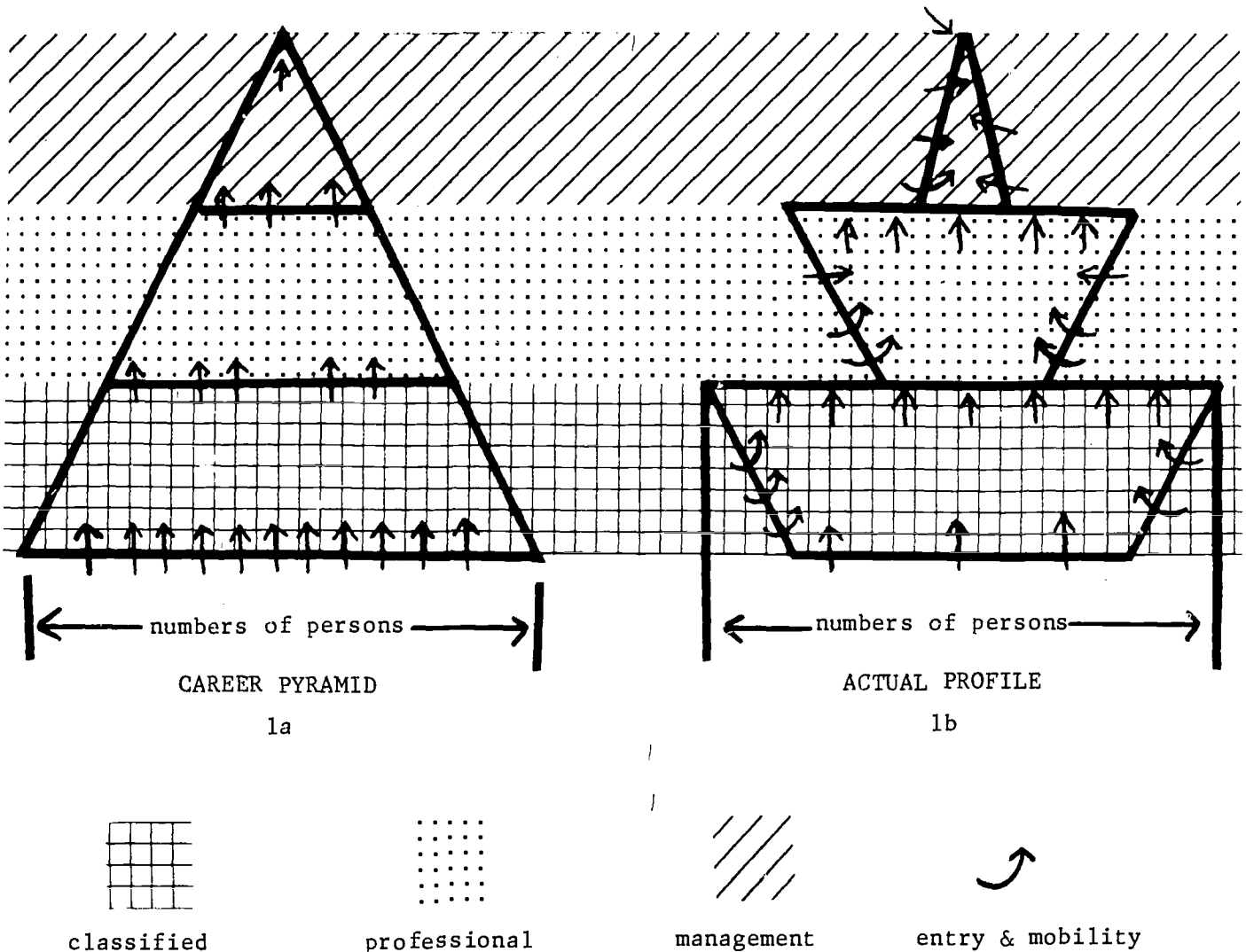

Fig.1

Two Concepts of Organization



- 1.2.6 In most school districts, personnel are categorized in three distinct strata: administrative, professional, and classified (the first two being mostly "certificated"). Also there are often overlapping strata of workers categorically labeled as para-professionals, management interns, etc. Despite these linking strata, however, distinct barriers exist which inhibit upward mobility. Illustrating these strata and the beliefs about mobility commonly held, two concepts showing an organization are presented in Fig. 1.

Depicted as a pyramid (in 1a) is the common notion that entry is at the bottom and that one may, through diligence, skill, night school, and sometimes fortuitous circumstance, rise to the top. If this rather simplistic phenomenon really happened with any significant frequency, Horatio Alger's heroes would not be so extraordinary. A more realistic representation (in 1b) is that of two trapezoids with very little entry at the bottom, lateral entry at the professional strata, and importation of top management at the peak of the structure. The trapezoids are created by annual incremental promotions common to most institutions. Thus, fewer employees are positioned in the lower levels of each trapezoid than in the upper levels.

- 1.2.7 In most school districts, the classified salary schedules contain as few as six steps, and aside from cost of living increments, there is "nowhere to go." If the worker views the organization as a pyramid, holds the view of success as a vertical, narrow channel, and has discovered that minimal performance by others is rewarded equally with his diligence, what can be the result besides frustration? These factors, added to a lack of trust in the adequacy of supervision, dissatisfaction with the job, and disillusionment with the effectiveness of the organization, lead to poor morale (disgruntled employees) and minimally productive workers. A work force composed of minimally productive workers results in proliferation of positions and attrition of efficient and enterprising workers.
- 1.2.8 Discussion of management problems which direct attention to a Career Development Program is but a prelude to policies required of management personnel if a change is to be seriously considered. Subsection 1.3 presents a statement of policy and program commitments which must be established prior to implementation of a Career Development Program.

- 1.3 Policies which can lead to establishment of a Career Development Program, with particular attention to inservice training and curricula for a "learning center" for classified personnel.

- 1.3.1 Public school facilities can be utilized more extensively and by a wider range of clients than is generally the case. Education of the young will remain the primary responsibility

of the school; however, a facility which is in existence, staffed, and operating can be used by adults during many non-occupied hours.

- 1.3.2 A school facility should be designed as a resource for all members of the community, and prototype learning programs should be available for the school district's classified personnel.
- 1.3.3 Organizations will redefine "work" to include activities at varied work stations and the employee's job description will reflect this change.
- 1.3.4 Job descriptions (and responsibilities) will include a time allotment for learning center activities.
- 1.3.5 Agencies will "share" time and costs with employees for most learning center offerings. Facilities which provide opportunities for study will be open during evenings and on weekends. Learning materials will not be limited to job-specific curricula, but may also include materials which are avocational in nature. In fact, many offerings (Spanish language, for example) may be an avocational pursuit for some and job-specific for others.
- 1.3.6 Opportunities for study will avoid traditional inservice programs (including on-site and off-site extension courses) which are sometimes ineffective because they follow the teacher/class approach (typically one teacher and perhaps 21 students). Many individuals zealously conceal their ignorance from their fellow workers, exposing their lack of knowledge only to a few trusted friends and associates. While sending employees to adult education or city college classes may provide a "safe" (from exposure) learning environment, this advantage may be negated by irrelevant curriculum.
- 1.3.7 Curricula for this program will be pertinent to an individual's present job or one to which he aspires, not based on traditional departmentalization (business administration, home economics, vocational shop courses, etc.). The concepts presented in a program of the type envisioned must be relevant to, and organized around, the policies, programs, and operations of the organization rather than reflecting the structure of established disciplines.
- 1.3.8 The kind of learning center needed for this program will combine various media, including easily accessible relevant materials programmed for independent study, and will take advantage of available technology. The plan will include small seminars and will allow individual or group study.

- 1.3.9 Communication linkage will be established between the learning center and district, county or state information centers for immediate news regarding new legislation and revisions of codes, regulations and specifications. This capability will be a service to a whole organization, including management personnel.
- 1.3.10 Present knowledge about individual or group learning and uses of technology will be combined in a program which enhances individual worth, fosters job satisfaction, increases productivity, and makes possible the maximum development of human potential. Section 2 presents a model and a system for career development which can direct energies and resources toward the goals identified above.

## 2.0 The Career Development Model

### 2.1 Overview.

The Career Development Model presented herein contains the following elements: Self-Assessment; Job Analysis and Circuitry Map; Employment Mobility Matrix (individualized); and Individual Development Plan. To facilitate the use of the Model, plans must include provisions for a Career Development Learning Center. Study guides for use in the Learning Center are described as programmed study materials developed for each district and user.

Two partial demonstration projects were initiated in March 1973, using this Model as the basic structure. Region IX of the U.S. Department of Labor (California, Nevada, Arizona and Hawaii) instituted a program which has 25 participants, and a project of the City of San Diego has 30. The Department of Labor project is designed for support level personnel\* and the San Diego project participants are classified as mid-level\*\*. Both projects include elements of testing, counseling, analysis of job mobility possibilities, individual development plans, and training. Neither project has developed an in-house learning center or experiential mobility matrices. Although initially developed for employees of non-school agencies, the Model can be readily adapted for educational use and take advantage of the experience gained through these pilot projects.

Interrelationships of the components of the Model are portrayed in Fig. 2.

---

\* Approximate salary ranges \$4,000-\$7,000 per annum.

\*\* Approximate salary ranges \$7,000-\$11,000 per annum.

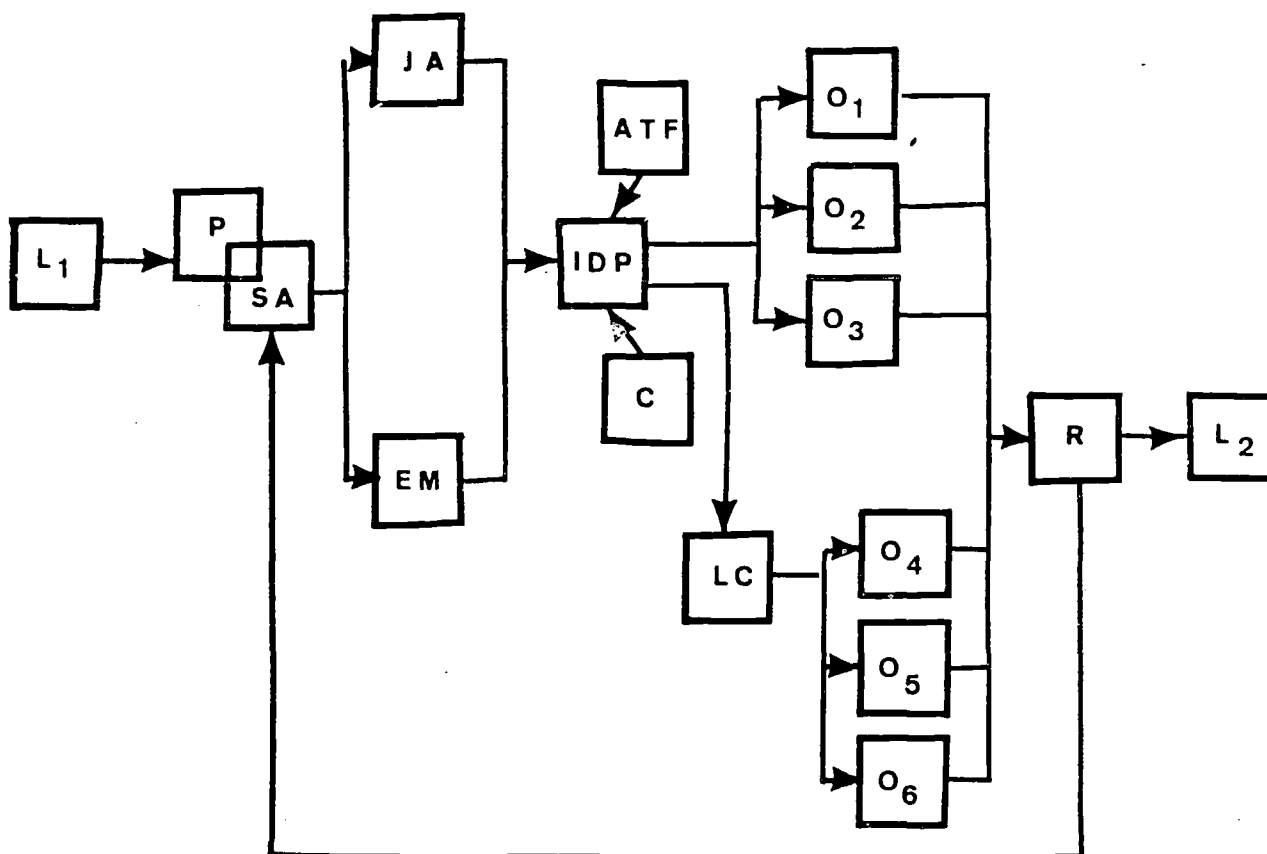

## OVERVIEW OF A MODEL FOR CAREER DEVELOPMENT

Fig. 2

Functions of the components are as follows:

(P) Present Position - The task analysis for the person's present position and his performance record (as measured by performance objectives) are basic information in the Individual Career Development Plan.

(SA) Self-Assessment component enables the individual to profile his/her knowledge, personality characteristics, work and educational experiences, and present level of motivation.

(JA) Job Analysis and Circuitry Map demonstrates in graphic form the pattern for advancement (lattice) in the school. This will show the job classifications, performance requirements, salary ranges, transferability factors, numbers of openings, and the ratios of attrition to openings for change in jobs.

(EM) Experiential Mobility Matrix superimposes an individual's assessment profile onto the agency Job Analysis and Circuitry Map. Through this matching device, the individual can view his/her options for mobility at that moment and for the immediate future. Options available to the employee include the alternative of no study in the Career Development Learning Center. An individual can add to his/her profile appropriate segments from the master curriculum which he/she intends to complete in the Learning Center. He/she may then project this onto the EM in order to view options which will be open when the course of study is complete. Linkage between JA and EM enables the individual to select a job and see what curricular segments must be added to his/her profile in order to qualify for that position.

(IDP) Individual Career Development Plan is based upon a realistic appraisal of the abilities and aspirations of each person, compared with requirements for jobs available within the school or school system. For those jobs to which he/she aspires but is not now qualified he/she may select those offerings of the Learning Center which will qualify him/her. Actuarial data will indicate to individuals their chances of obtaining the position selected once they are qualified. The Experiential Mobility Matrix may be programmed to link together agencies from different branches of government. For example, the City Schools of San Diego could be linked to the Department of Labor, or the Department of Labor to the U.S. Forest Service.

(ATF) Career Development Advisory Task Force will be available to employees in order to verify the effectiveness of the individual's Career Development Plan. The advisory council will represent the agency at the policy, programming, and operational levels, heterogeneous with reference to ethnic origin, sex, and age.

(C) Vocational Counseling will be available as a supportive service to the Career Development Learning Center. Supervisors and department heads will attend a short intensive course in vocational counseling to acquaint them with their responsibilities in that role and with counseling services available in the Career Development Center.

(LC) The Career Development Learning Center is a multi-media learning environment, matching technology with learning theory. Within the Center, the student will have convenient access to cartridge audio tape recorders, random access slide projectors, cassette video tape players, and auto-tutors. Selected texts and reprints, self-administered test materials, and a programmed study guide which outlines each course of study in behavioral terms will be provided. The study outlines will incorporate relevant concepts from the disciplines of administration, both business and public; education, with emphasis on techniques for study, evaluation and performance

objectives: social psychology; urban ethnic affairs; engineering; and the trades. "Bridging" units will link all portions of the program to the specific school district policies, programs and operations.

In the self-instructional environment. Employees may work individually or in small groups. When necessary, speakers or discussion leaders may be invited to participate. Instructors may be present, individually or in small groups, to provide immediate feedback for courses where this is important.

(O) Options indicate those opportunities existing for an individual both with utilization and without utilization of the learning center. The option selected could be the employee's present position.

(R) Career Development Plan is a process and not a static situation. Periodic review of plans will be scheduled within each district. Some agencies may choose to assess or update ID plans annually with semi-annual reviews up to and including the twentieth year. Year 15 of the development plan for an individual may include segments directed toward a creative retirement.

(L) Linkages for this Career Development Model commence with career education projects of the education sector (L<sub>1</sub>) and with the projects for the retired including the Retired Executives Division of ACTION and other innovative projects for the aging (L<sub>2</sub>).

The Learning Center may serve as a clearinghouse for opportunities for the retired and offer creative avocational pursuits.

## 2.2 The System.

Any system that successfully promotes lateral mobility in an organization as complex as a large school system must encompass three major functions:

1. Information about jobs which might become available.
2. Training for jobs.
3. Administration of job moves.

The information function should make the employee aware of any job in the district that might interest him or her. In doing so, it should:

1. Give the employee a notion of what it would be like for him or her to have that job.

2. State clearly the prerequisites for the job so that the employee can chart a course of study for preparation.
3. Give an accurate idea of how long he/she would have to wait before being able to move to the new job.

The training function should be geared to actual requirements for jobs within the district. It should:

1. Contain an assessment subfunction in which the employee could gain a clear picture of his own skills and aptitudes.
2. Be flexible enough that each employee can construct his own curriculum and work through the materials without long waiting periods.
3. Eliminate redundancy from the curricula, allowing employees to study only what they want or need to study and at their own best rate.

Administrators should facilitate mobility and cause more job openings for lateral moves to occur. The system should:

1. Provide a process for determining which applicant gets a job when more than one are applying for it.
2. Define which job moves can be termed "lateral."
3. Reduce new complexities which will arise due to promotion. Specifically, if a manager loses one of his intermediate level employees in a lateral move, the system must tell him whether he is allowed to promote a lower level employee or whether he must accept another lateral move or a promotion from another department.

## 2.3 The Information Function.

### 2.3.1 Informing employees what it is like to have other jobs.

Brief written descriptions of each of the jobs in the district must be prepared, outlining the major tasks and responsibilities of each position. These job descriptions must be stated clearly in performance terms, and should be specific enough to let the employee decide whether he/she wants to know more about the job. Video-tape presentations of each job should complement the written descriptions, providing a realistic picture of task performance involved. Undesirable as well as desirable aspects of the job are to be included. For employees who remain interested after seeing the tapes, provision should be made for a field trip to the job location to see work performed under normal working conditions and perhaps to try out some of the work him/herself.

- 2.3.2 Stating the job prerequisites clearly so that the employee can chart a course of study for job entry preparation.

This will require analysis of the jobs by task. During or before the job task analysis, definitions of component skills must be standardized so that a required skill proficiency level can be assigned to each job. After all the tasks of the various jobs have been analyzed and their prerequisite skills determined, the prerequisites should be published so the employee can determine what he/she lacks and can match requirements to specific courses of instruction offered by the Learning Center.

- 2.3.3 Giving an accurate idea of how long he/she would have to wait before getting the job.

It is important to recognize the danger of unrealistic expectations. If the user of the system has no trust in the predicted payoff date, frustration will erode belief in the system and use of the system will diminish. Accurately computing an expected waiting period will not be simple. The number of openings which have occurred in past years should be quoted, but this may not predict accurately what will happen in the next months. Average waiting times in recent months may be better indicators, but the predictor must also consider how many people holding target jobs are requesting lateral moves and how many others are in the queue to enter the jobs. Ultimately, it is likely that stable patterns will develop for some jobs in which personnel change frequently enough to provide a large statistical base. Other jobs, less frequently involved in moves, may never develop stable patterns. In any case, no reliable historical patterns will be evident during the first months of the program. In these cases, the employee should be given the best guess that can be made from the data available, together with a warning that the waiting period may be much longer than is estimated. Then the person will have to make his/her own decision as to whether to strive for the job, given the level of uncertainty.

## 2.4 The Training Function.

### 2.4.1 Assessment.

The assessment portion of the training function must allow the employee to assess his/her ability and knowledge relative to the skills and aptitudes needed for the jobs in which he/she is primarily interested. Assessment should be accomplished in a manner which does not deter employees who would be shy about exposing their ignorance to others. Competent counselors should be available to assist in assessment when the employee requests it. Many tests can be given and graded by computer terminal. Much



of the assessment will be inherent in the job already held by the employee and testing will not be required. Thus, the testing portion of the assessment need cover only those skill levels that go beyond levels required for the job held currently.

#### 2.4.2 Flexibility and the elimination of redundancy.

Computer terminals can serve as excellent and flexible teaching devices for many skills. Media used should include videotape presentations for which the control is in the student's hand, and other auto-instructional devices. Employees may meet in small seminars when appropriate. The Center should act as a clearinghouse and appointment secretary for those who wish to set up or engage in such seminars. Space should also be provided for employees to meet in groups. To meet specialized prerequisites, the system should allow for tutorials in which a person holding the special job meets regularly with a person seeking the job. Tutorial sessions on a one-to-one basis may benefit the teachers as much as the learners.

### 2.5 The Administration Function.

#### 2.5.1 Providing a way to choose which applicant gets a particular job when more than one employee is applying.

This decision function is by no means simple. Traditionally, administrators have considered such factors as length of service, scores on competitive examinations and how long an applicant has been waiting for the transfer. Consideration of all of these factors may produce a system of considerable complexity. To promote optimal mobility, yet another factor should be taken into account. At any given time, a number of people may be waiting to move to one of the jobs of their choice. Every time one worker transfers from a job, a new opening is created. If someone is waiting to transfer to that job, then the chain of lateral mobility is lengthened. If no one is waiting for such a transfer, however, the lateral chain ends and the job must be filled by promotion or by a new hire. Other things being equal, the mobility system will wish to achieve the most moves, which means that the chains should either form loops or be as long as possible. This is a problem of some theoretical interest and can be attacked by the methods of integer linear programming. The linear programming method can be used to give higher weights to certain moves for certain employees and it is possible that managerial preferences for favoring tenure, merit and waiting time can be reflected adequately in the mathematical coefficients. This procedure is discussed further in section 2.10.

### 2.5.2 Defining which job moves can be termed lateral.

This may or may not be a difficult exercise, depending on how the positions have been defined for purposes of salary administration. If the salary categories are few (four or five, below the managerial class), existing classifications will suffice for inclusion in the model. In many districts, practice has dictated more salary classifications. One nearby school district, for example, has 38 different salary schedules. In this scheme, a bus driver is at level 17, a gardener at level 18, and a maintenance man at level 19. Usually only one or two jobs exist at each level in such a system. Should a gardener wish to become a bus driver, he would lose money. To implement a mobility model, jobs in similar categories need to be reclassified into fewer salary levels. With many similar positions at the same level, there could be lateral movement without salary penalty.

### 2.5.3 Resolving problems with promotions.

Promotions may present a problem, depending on the administrative structure of the district. If promotions have been entirely a function of local supervision, a great deal of cooperation will be required to make mobility real. The career development concept expects a vacancy to stimulate as many lateral moves as can be accommodated whenever a person leaves a position of employment, whether by promotion, resignation or retirement. Although ultimately a promotion or new hire will be required somewhere in the system, it may occur in a department far removed from the one in which the moves began. Of course, not all changes will require an empty slot to start them off. Some moves will be part of a closed chain of job changes, requiring no promotions.

### 2.5.4 Definition of the most desirable rates of mobility.

The administration must define some limitation on mobility, especially for those jobs which are so complex as to require that a new worker be trained for some time before he can be productive. Before allowing a move out of one of these jobs, the management may require that the job be held for some specified length of time. These requirements should be reviewed from time to time because certain aspects of the model (training, the existence of the job task analyses, the fostering of self-awareness through the tutorials) may shorten the time required for a new employee to become fully productive. Conversely, the continual influx of new persons may increase levels of productivity and in some cases, the administration may wish to establish a maximum length of time which they feel most employees should hold a given job.

## 2.6 Software for the Model.

The preceding sections describe the functions which must be accomplished by the software. These are listed below by type and indicate the functions performed. All of these must be completed prior to the beginning of the program.

2.6.1 Printed material: job descriptions; assessment aids; programmed learning materials.

2.6.2 Videotape material: job descriptions; teaching material.

2.6.3 Computer programs--accessible from terminal: transfer status reports (indicating the probable waiting time to move to any given job); assessment aids; teaching aids.

2.6.4 Computer programs--not necessarily accessible from terminal: transfer assignment process (integer linear programming).

## 2.7 Physical Aspects of the Model.

### 2.7.1 The Career Development Center.

Facilities allocated should include a suite of rooms containing the Learning Center, conference rooms, office space for para-professional support, a space for a receptionist-secretary, and filing space.

### 2.7.2 The Learning Center.

This is the location of the study carrels where the computer terminals, video playback devices, etc., are located. The Center is described fully in Section 3.0.

## 2.8 Administrative and Para-professional Support.

The following functions for which personnel must be trained prior to operation of the Model will be performed on an ongoing basis.

### 2.8.1 Clerical and secretarial.

Scheduling of appointments and tutorials and use of conference rooms. Greeting employees as they arrive, showing them how to operate computer terminals and videotape devices, distributing printed material, etc. Finding out if tutorials are desired and making necessary arrangements through para-professionals.

### 2.8.2 Para-professional--routine.

Assistance in assessment and finding out about jobs and in charting a course of study.

### 2.8.3 Para-professional--less frequent.

Preparing for tutorials, locating a tutor from among the people who already have a job, helping him/her to organize what he/she knows to present it to the person being tutored.

## 2.9 Use of the Model by the Employees.

### 2.9.1 The yearly cycle.

At the installation of the program or at the time of hiring of new employees, all employees should be introduced to the Career Development Center and made aware of the services offered. Thereafter, at intervals of a year (or as the local district chooses), the employee should return to the Center to assess his progress and review his goals.

### 2.9.2 The Individual Development Plan.

The Individual Development Plan is the document on which the employee charts his/her course of action and progress through the system. This document will be initiated at the employee's first visit to the Career Development Center and will continue to grow throughout his or her career. The Plan will contain both long-range and short-range objectives. The long-range plan should be revised at the beginning of each yearly cycle. Changes in the short-range plan will be contingent on moves, availability of jobs, training, etc.

### 2.9.3 Flow Chart of Individual Use of the System.

Use of the System by the individual employee is charted in Fig. 3. This illustration indicates full use of the system, although a given individual might not utilize all of the services included. In the interest of simplicity, the many options available to the employee are omitted from the chart.

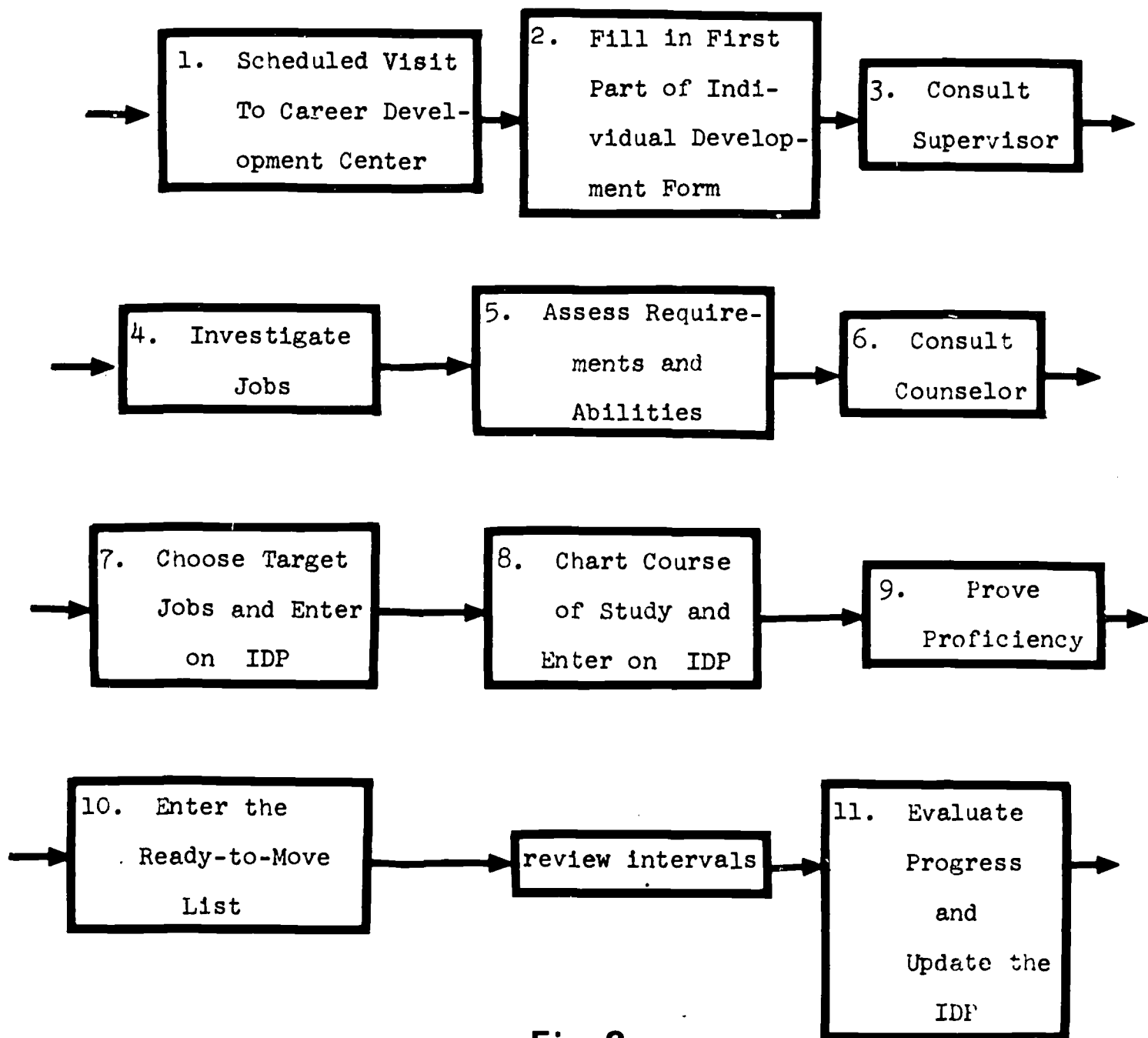

**Fig. 3**

**Flow Chart of the Career Development System**

A brief description of the activity at each block of the chart is presented as follows:

Block 1 - Scheduled Visit to the Career Development Center

Initially, and at intervals thereafter, each employee will visit the Career Development Center to be made aware of options and/or review plans. This will be done on company time and should take only an hour or two. If the person does not wish to consider lateral mobility at that time, this fact will be entered on the Individual Development Plan and he/she need not return until another review period has elapsed.

Block 2 - Fill in First Part of Individual Development Plan Form

If the employee wishes to consider a move, he/she should begin to fill in the IDP. This will guide the employee to think about what sort of a career he/she wants to pursue and for what specific jobs he/she would like to prepare.

Block 3 - Consult Supervisor

The employee must arrange for time to proceed with investigating jobs at the Career Development Center. All Career Development time should be on a cost sharing basis with the system granting one hour of released time for each hour of off-the-job time put in by the employee.

Block 4 - Investigate Jobs

This will begin with reading of the brief written job descriptions following which the employee will view videotapes of the jobs in which he/she has interest. The CDC will arrange for on-site visits to those positions which most attract the employee, allowing the employee to see the job performed in its real setting and to talk with those on that job.

Block 5 - Assess Requirements and Abilities

In this step, the employee will learn about the prerequisites for the jobs which interest him/her. He/she will see how these match the prerequisites of his/her own present and past jobs. Where the new prerequisites are not covered by present and past work experience, the employee will test him/herself to see if he/she qualified. The self-assessment process may require

help from the CDC staff. The computer should be programmed to list and supply the tests which are relevant for a person with a certain history applying for a given job.

#### Block 6 - Consult Counselor

Having assessed his/her abilities and having selected a short list of jobs of potential interest, the employee should consult a counselor on the CDC staff to talk over his/her assessment and the options which are appearing.

#### Block 7 - Choose Target Jobs and Enter on Individual Development Plan

After considering the results of the assessment and planning, the employee should select a maximum of three target positions and enter them on the IDP in priority order.

#### Block 8 - Chart a Course of Study and Enter on IDP

Removal of any deficiencies which stand between the employee and the desired moves is the target of this step. An employee has the option to begin at this point if he chooses to study in the Learning Center for avocational purposes only. The course of study also may include tutorials offered by personnel who already hold a job. In some fields such as gardening and cooking, such tutorials may be of interest to those who are not seeking a change in job.

#### Block 9 - Prove Proficiency

Generally, a series of tests or demonstrations is used for this purpose in a mix which is most appropriate for the job being considered.

#### Block 10 - Enter the Ready-to-Move List

Once proficiency has been proved, the employee can enter the Ready-to-Move List. This list is supplied to the computer every time the program is run to assign lateral moves.

#### Block 11 - Evaluate and Update the IDP

In this step, the employee reflects on his progress and modifies his/her goals, taking into account his/her experience of the immediate past.

## 2.10 Using Integer Linear Programming to Effect Mobility.

This technical section is intended for the mathematician who will set up this aspect of the model. It assumes a familiarity with the terminology of linear programming. In non-technical terms, this is the program that will assign applicants to one of the jobs they have requested in such a way as to maximize mobility. Readers not responsible for the programming function may go to section 2.11.

### 2.10.1 Constraint Equations.

Constraint equations will be of two sorts: employee constraint equations and job constraint equations.

Each employee on the Ready-to-Move List will have a constraint equation. This equation will reflect the fact that he has a job--either his current job or one of the jobs to which he/she wishes to move. The apparent contradiction is due to the fact that constraint equations must account for all possible moves and indicate when the number of employees required for the job have been found.

### 2.10.2 Variables.

Variables will be of two types: those indicating job moves (including non-moving as a special case) and those indicating that a promotion or new hire is required. All variables will be restricted to non-negative integer values. The variables indicating a job move will be specific to each employee. Each employee on the Ready-to-Move List will have:

1. One job-move variable indicating that he keeps his present job. This variable is assigned a coefficient of one (1) in the employee's equation and one (1) in the job equation for his current job. Zero elsewhere.
2. One job-move variable for each job he is ready to move to. These will have coefficients of one (1) in the employee's equation, one (1) in the equation of the job which he would be moved to, and a value in the objective function which will be discussed below.

### 2.10.3 The Objective Function.

The objective is to maximize mobility of those on the Ready-to-Move List. Thus, each job-move variable is assigned a positive coefficient in the objective function. The model will tolerate a differential weighing of these coefficients. Thus, the degree of desirability of a given move may be taken into account.



#### 2.10.4 Initial Solution.

An initial solution can be secured using the code under which each employee retains his job and all deficits are picked up by slacks. This may decrease running time for the computer program.

#### 2.10.5 The Right-Hand Side.

The right-hand side of all employee equations will be one (1). The right-hand side of each job equation will be calculated as follows:

The number of new openings for the job (may be negative or zero) plus,

the number of people who hold that job who are on the Ready-to-Move List, plus,

the number of job vacancies created by promotion (may be zero).

(If this sum turns out to be negative, the slack variable will have to be given a negative coefficient.)

#### 2.10.6 Sequence for Running.

This program will have to run separately for each stratum of lateral mobility. Begin with the top stratum. After mobility for this stratum has been maximized, there may be plans for promotions from the next stratum down. These promotions may result in the removal of some people from the Ready-to-Move List and in the creation of move openings. Once the next stratum has been suitably adjusted, it may be optimized, and so forth.

#### 2.10.7 Timing of Optimization Runs.

The best timing of optimization runs will have to be decided locally. The more people that are on each layer's Ready-to-Move List, the more options the program will have and the more likely it is that all will move where they desire. On the other hand, if it takes a long time to accumulate a larger Ready-to-Move List, the frustration of waiting may be a high price to pay. Some experimentation should be done with the program to determine the point at which a list is long enough to give a reasonable probability that most will get the jobs they want.

#### 2.11 Authors' Note.

The above-explained programming system can be inaugurated as a personnel management tool exclusive of a career development system. Our enthusiasm, however, is for the mathematical element

as a vehicle for the larger system, which includes the Career Development Learning Center. More detail of the Center follows in section 3.0.

### 3.0 Implications of a Career Development Program for Educational Facility Planning

A program of the type described in this paper has broad implications for the educational program of the community and, therefore, for those who plan school facilities.

The existence of a general administrative policy which promotes self-development for career opportunity or for seeking more satisfaction from efforts expended on the job could well dictate modifications in existing work plans for employees. Recognition of broader interests on the part of workers may lead to less emphasis on "task groups" who repeat a similar task again and again in one work period. More emphasis on assignments which allow greater satisfaction from completion of a series of tasks will require more skill on the part of workers, and concurrently, school facilities designed to place more responsibility on "general" workers.

More pertinent to present considerations, however, are the effects of the implementation of such a program on the design of the educational program of the school system and its facilities. Sections which follow describe some of these implications.

#### 3.1 Educational Program.

Adoption of a program leading to self-improvement by classified personnel is a significant first step in broadening the school's educational clientele. To introduce the capability to chart career development plans and aspirations of personnel employed by the schools, and to provide materials (equipment and software) designed to make it possible to engage in study of this kind, opens the potential benefits to others in the community. In serving the self-development requirements of one group (its own classified employees), the school can begin to function as a true community resource. That is, the system for developing job skills and knowledge necessary for internal upward movement (or lateral change for the purpose of achieving job satisfaction) may apply to other workers in the community as well. Expansion of possibilities for learning for one group opens possibilities for workers in other occupations, and thereby increases the "pool" of workers from which all employers can draw qualified personnel.

Utilization of school or other instructional facilities will increase in proportion to the development of this program, extending opportunities for learning to additional members of the community.

### 3.2 Examples of Model Study Carrels.

Spaces and equipment designed for individual study and computer-assisted instruction vary greatly in design and complexity. Though space and equipment plans are not the major part of the program proposed, it should be recognized that the kind of program proposed requires a commitment to success not compatible with reliance on "hand-me-down" technology. In the descriptions which follow, prototype equipment and spaces needed for a program of the type described are illustrated. Each design presented assumes that some degree of on-line computer assistance will be available to the learner.

An integral part of each user's program will be interaction with others who are engaged in an activity which is similar in nature. Counselor/instructor assistance will be available during study sessions. Figure 4 illustrates a type of study arrangement which can provide individual as well as group study of any particular problem. In such a setting, the learner can choose to work with others engaged in a similar activity, or to pursue his study on his own.

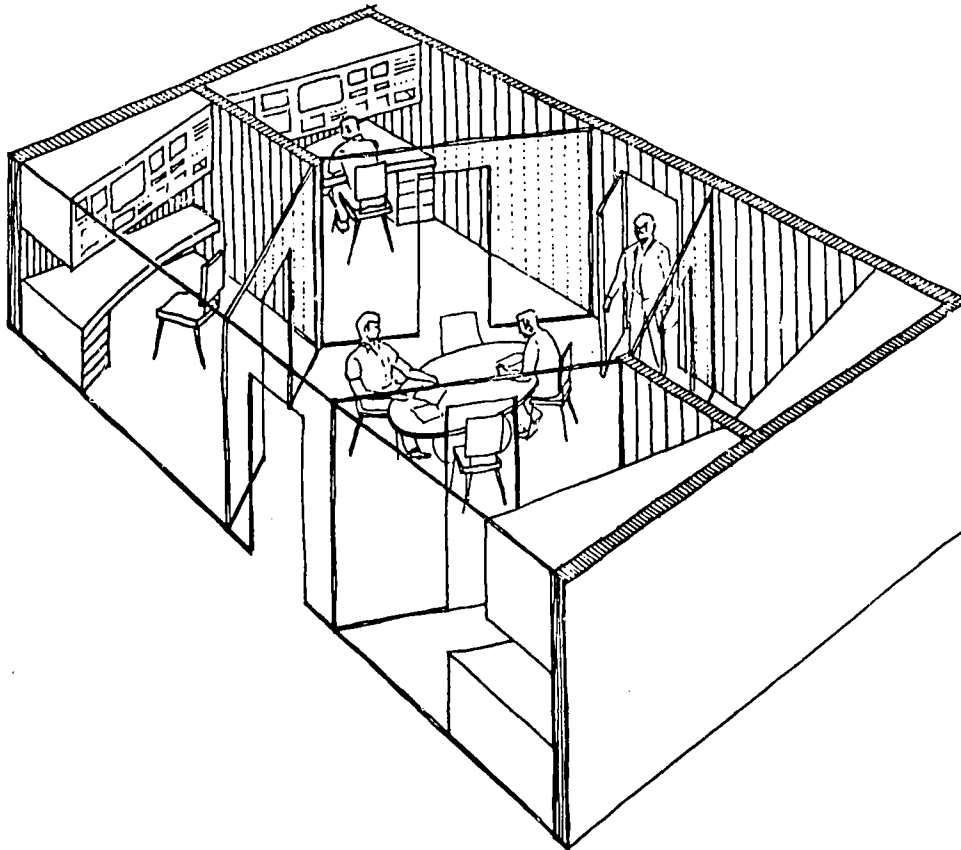

**Fig. 4**

**A Career Development Learning Center**

The concept of providing and encouraging the use of sophisticated equipment for individual study is not limited to a career development program for employees, but should encompass all students in the community. Figure 5 illustrates a type of study space where a variety of media can be at hand, both printed material and audio-visual materials (including simulation), allowing a wide range of learning experiences. The provision of such study spaces will demonstrate to employees (and other participants in the program) the community's recognition of the importance of their educational needs.



**Fig. 5**

**Possible Study Carrel Configuration**

Where new study units cannot be provided, existing space may be converted for such use. Figure 6 represents a type of study space which will provide minimal accommodations for individual study for students (classified employees or other). Given at least 90 square feet of space and the service potential to accommodate necessary electrical installations, study facilities for four persons can be provided. Such an arrangement, common in many of the newer school libraries and resource centers, lends itself to any kind of individual study program.

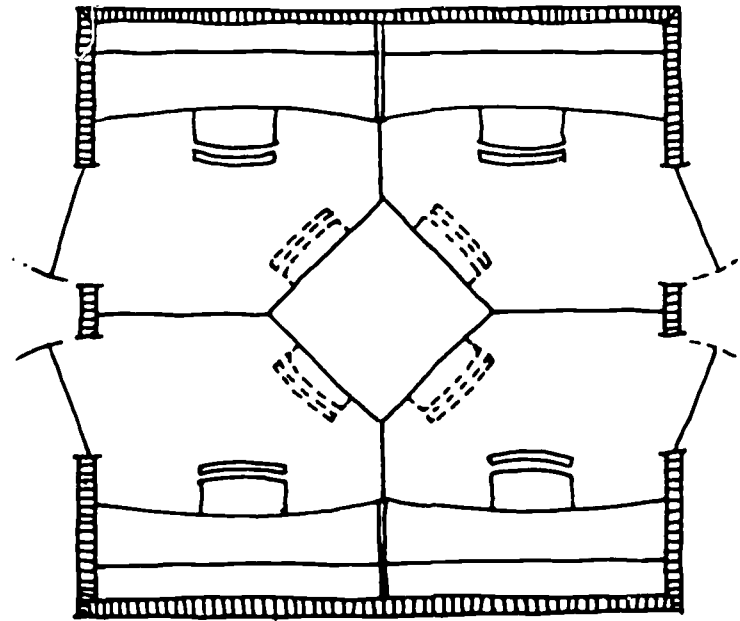

**Fig. 6**  
**Four Study Carrels**

In another possible situation, Fig. 7 shows how part or all of a multi-sided structure can accommodate individual and group study spaces, as part of new or remodeled facilities. Study spaces for career development can, of course, be placed in many kinds of facilities and locations in the schools.

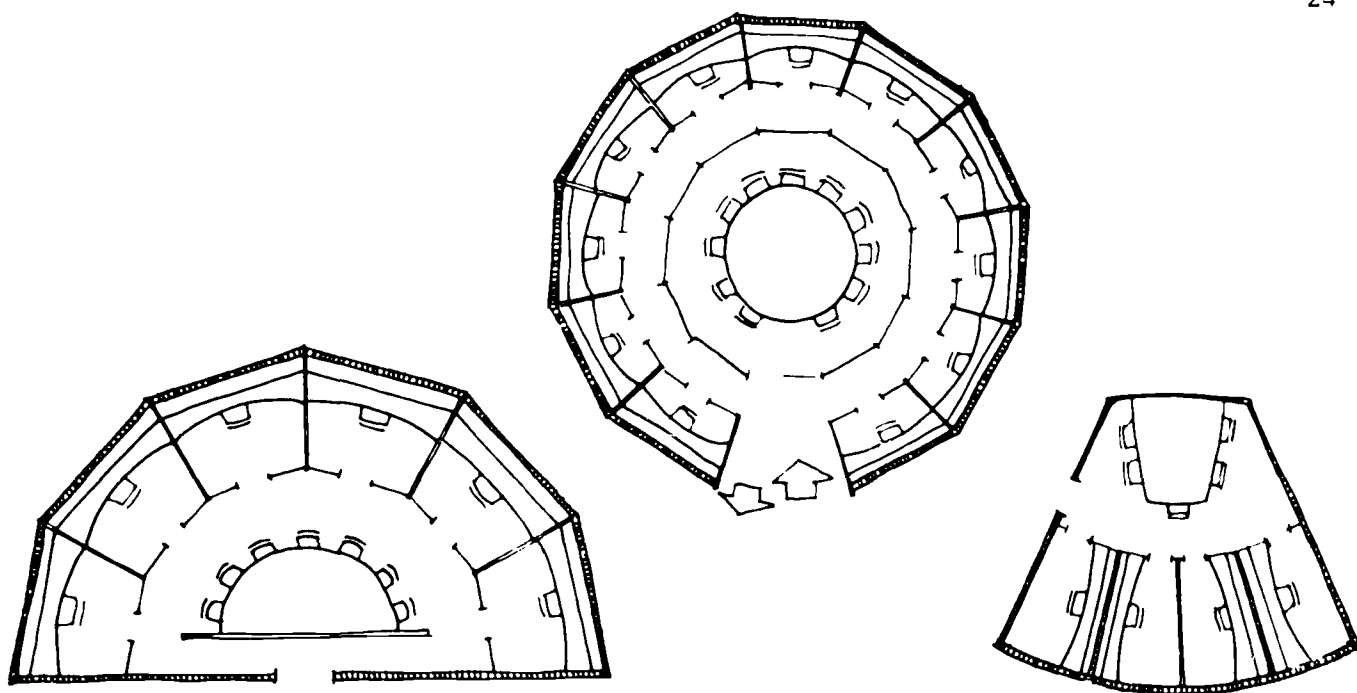

**Fig. 7**

### **A Facility Designed Especially for Self-Study**

#### **3.3 Use of Existing Facilities.**

If the program for self-development which is instituted relies upon existing facilities, modified learning spaces may be required. However, most existing facilities are underutilized and can be available for other student groups before or after the "regular" school day.

The availability of space and equipment for individual programmed study will determine where such special students will work. High schools using computer-assisted instruction will be the most likely locations for the initiation of a program such as the Career Development system which requires the kinds of immediate feedback outlined previously. In the absence of equipment or available spaces for individual computer-assisted instruction, alternatives will be required.

#### **3.4 Alternative Existing Facilities.**

Given the existing circumstances surrounding the planning for school facilities in a community, and the multiplying demands on the educational system, it is possible that alternatives to existing school facilities will need to be sought, possibly through cooperation with other public agencies. For example,

the programs in the City of San Diego and in the Department of Labor in San Francisco (cited earlier in this paper) could potentially provide programmed learning for school employees. Many public agencies with similar needs for employee self-improvement programs could participate in joint programs.

Similarly, school systems with relatively few employees might explore cooperative service agreements with other school systems or colleges. Facilities for such programs, modest or elaborate, might be found in public libraries, city or county buildings, or other public agencies. As a public service, private industry might arrange for access to centers for employee development where self-study activities are carried on in suitable facilities.

From the point of view of those who plan facilities for a school system, a decision to implement the kind of program described in this paper need not require a new building to house the equipment and study spaces. However, a commitment to a plan for career development would suggest the inclusion of such spaces in new buildings being planned.

### 3.5 New Facilities.

Easy access for learners of all ages is a primary argument for the inclusion of a center for career development in a new school building. In facilities dedicated to community education, all "learning spaces" should be located for easy movement of people into and out of the area at all times. The career development program should become part of the total instructional activity of the school. Employees who take advantage of the opportunity for self-improvement should participate as equals in the entire program of the school. Special instructional materials should be provided for them, as for any learner pursuing individualized instruction. Hence, all users of the facilities will study in the same spaces, without a need for separate areas assigned to special programs.

However, the possibility of constructing a special learning center as a separate structure should perhaps be considered as well. Simple, low-cost buildings can house the study centers and can be located in easily accessible areas. To best accommodate the program envisioned in this proposal, a multi-sided structure (or space within a structure) can provide a seminar or small group space surrounded by individual study carrels. Obviously, this can be accomplished in many types of buildings. Physical characteristics of the building itself are of less importance than location, proximity to sanitary facilities, and appearance of the space. Use of study carrels and electronic equipment currently available, or specially designed units, will allow incorporation of a program such as envisioned in this study in any plan for providing facilities for the educational program to serve the community.

#### 4.0 Conclusion

A well ordered and executed Career Development Program, with its many requirements, may appear to be a formidable undertaking. Yet the elements described herein are all within the realm of existing knowledge. Planners should recognize a Career Development Program as an integral part of the successful operation of the school. This requirement will become increasingly obvious as a better educated labor force confronts more segmented and routinized tasks (designed mistakenly to increase production). The demand by workers for increased opportunity and decreased anonymity will intensify. Educational leaders must apply what is known about learning, about individuals, about jobs, about groups and about technology, and translate this knowledge into a program which enhances individual worth, fosters job satisfaction, increases productivity and maximizes human potential for the common good.