

DOCUMENT RESUME

ED 082 012

CE 000 284

TITLE Aircrew Survival Equipmentman 1 and C. NAVPERS
10360-D. Rate Training Manual.
INSTITUTION Bureau of Naval Personnel, Washington, D.C.
REPORT NO NAVPERS-10360-D
PUB DATE 71
NOTE 237p.
AVAILABLE FROM Superintendent of Documents, U.S. Government Printing
Office, Washington, D.C. 20402 (Stock Number
0847-0143, \$2.25)

EDRS PRICE MF-\$0.65 HC-\$9.87
DESCRIPTORS *Aviation Technology; Equipment; Job Training;
*Manuals; *Military Personnel; *Military Training;
*Seamen; Skilled Occupations; Vocational Education
IDENTIFIERS *Aircrew Survival Equipmentman

ABSTRACT

A guide for advancement and training in the Aircrew Survival Equipmentman rating for enlisted personnel of the Regular Navy and the Naval Reserve is provided in this training manual. The chapters outline the qualifications necessary and the responsibilities of Aircrew Survival Equipmentmen involved in blueprint reading and the development of patterns, supply, work center supervision and administration, parachutes and equipment, anti-g suits, oxygen masks, MF 4 pressure suits, carbon dioxide transfer equipment, aircraft mounted oxygen regulators, miniature type regulators, oxygen component test stands, liquid oxygen converters, survival and search and rescue equipment, and sewing machine repair. The guide is illustrated by extensive diagrams, drawings, and photographs. (KP)

FILMED FROM BEST AVAILABLE COPY

ED 082012



AIRCREW

SURVIVAL EQUIPMENTMAN 1 & C

BUREAU OF NAVAL PERSONNEL
RATE TRAINING MANUAL **NAVPERS 10360-D**

U.S. DEPARTMENT OF HEALTH
EDUCATION & WELFARE
NATIONAL INSTITUTE OF
EDUCATION

THIS DOCUMENT HAS BEEN REPRODUCED EXACTLY AS RECEIVED FROM THE PERSON OR ORGANIZATION ORIGINATING IT. POINTS OF VIEW OR OPINIONS STATED DO NOT NECESSARILY REPRESENT OFFICIAL NATIONAL INSTITUTE OF EDUCATION POSITION OR POLICY.

PREFACE

This Navy Training Manual was prepared for enlisted personnel of the Regular Navy and the Naval Reserve who are studying for advancement in the Aircrew Survival Equipmentman (PR) rating. It is based on the professional qualifications for advancement to PR1 and PRC, as set forth in the Manual of Qualifications for Advancement, NavPers 18068 (Series).

The manuscript for this training manual was prepared by the Navy Training Publications Center, Millington, Tennessee, for the Bureau of Naval Personnel. Technical reviews were provided by personnel of the Aircrew Survival Equipmentman Schools, Lakehurst, New Jersey, the Naval Examining Center, Great Lakes, Illinois, and the Naval Aviation Integrated Support Center, Patuxent River, Maryland. Technical assistance was also provided by the Naval Air Systems Command.

1971 Edition

THE UNITED STATES NAVY

GUARDIAN OF OUR COUNTRY

The United States Navy is responsible for maintaining control of the sea and is a ready force on watch at home and overseas, capable of strong action to preserve the peace or of instant offensive action to win in war.

It is upon the maintenance of this control that our country's glorious future depends; the United States Navy exists to make it so.

WE SERVE WITH HONOR

Tradition, valor, and victory are the Navy's heritage from the past. To these may be added dedication, discipline, and vigilance as the watchwords of the present and the future.

At home or on distant stations we serve with pride, confident in the respect of our country, our shipmates, and our families.

Our responsibilities sober us; our adversities strengthen us.

Service to God and Country is our special privilege. We serve with honor.

THE FUTURE OF THE NAVY

The Navy will always employ new weapons, new techniques, and greater power to protect and defend the United States on the sea, under the sea, and in the air.

Now and in the future, control of the sea gives the United States her greatest advantage for the maintenance of peace and for victory in war.

Mobility, surprise, dispersal, and offensive power are the keynotes of the new Navy. The roots of the Navy lie in a strong belief in the future, in continued dedication to our tasks, and in reflection on our heritage from the past.

Never have our opportunities and our responsibilities been greater.

CONTENTS

Chapter	Page
1. Aircrew Survival Equipmentman (PR) rating	1
2. Blueprint reading and the development of patterns	12
3. Supply	18
4. Work center supervision and administration	32
5. Miscellaneous parachutes and equipment	60
6. Anti-g suit, oxygen masks, and Mk 4 pressure suits	99
7. Maintenance of CO ₂ transfer equipment	108
8. Aircraft mounted oxygen regulators	114
9. Miniature type regulators	147
10. Oxygen component test stands	153
11. Liquid oxygen converters	164
12. Survival and search and rescue equipment	172
13. Sewing machine repair	197
Index	226

READING LIST

United States Armed Forces Institute (USAFI) courses for additional reading and study are available through your Educational Services Officer.* The following courses are recommended:

D 700 General Aeronautics
E 275 General Science I
E 276 General Science II
E 290 Physics I

*"Members of the United States Armed Forces Reserve components, when on active duty, are eligible to enroll for USAFI courses, services, and materials if the orders calling them to active duty specify a period of 120 days or more."

CHAPTER 1

AIRCREW SURVIVAL EQUIPMENTMAN (PR) RATING

This training manual is designed to aid the PR2 in preparing for advancement to PR1 and the PR1 in preparing for advancement to PRC. It is based primarily on the professional requirements or qualifications for PR1 and PRC as specified in the Manual of Qualifications for Advancement, NavPers 18068 (Series). In preparing for the advancement examination, this manual should be studied in conjunction with the latest edition of Military Requirements for Petty Officers 1 & C, NavPers 10057-C.

ENLISTED RATING STRUCTURE

The present enlisted rating structure includes two types of ratings: general ratings and service ratings.

GENERAL RATINGS are designed to provide paths of advancement and career development. A general rating identifies a broad occupational field of related duties and functions requiring similar aptitudes and qualifications. General ratings provide the primary means used to identify billet requirements and personnel qualifications. Some general ratings include service ratings; others do not. Both Regular Navy and Naval Reserve personnel may hold general ratings.

Subdivisions of certain general ratings are identified as **SERVICE RATINGS**. These service ratings identify areas of specialization within the scope of a general rating. Service ratings are established in those general ratings in which specialization is essential for efficient utilization of personnel. Although service ratings can exist at any petty officer level, they are most common at the PO3 and PO2 levels. Both Regular Navy and Naval Reserve personnel may hold service ratings.

PR RATING

The Manual of Qualifications for Advancement states that PR's inspect, maintain and repair parachutes, survival equipment, and flight and protective clothing and equipment; pack and rig parachutes; pack, equip, and repair

flotation equipment; repair and test oxygen regulators and liquid oxygen converters removed from aircraft; fit and maintain oxygen masks. flight clothing, antiexposure suits and anti-g suits; test and service pressure suits; operate and maintain carbon dioxide transfer and recharge equipment; operate and repair sewing machines; and supervise the operation of parachute lofts.

In addition to the above listed requirements for the PR, the higher rated PR's must be qualified to review and evaluate completed inspection forms and reports; analyze reports of discrepancies and malfunctions and determine corrective action; interpret directives from higher authorities; schedule and assign workloads; and maintain quality assurance of the work performed.

The PR rating is a general rating and is included in Navy Occupational Group IX (Aviation). There are no PR service ratings.

Figure 1-1 illustrates the path of advancement from Recruit to Master Chief Aircrew Survival Equipmentman, Warrant Officer, or Limited Duty Officer, BuPers Inst. 1120.18 (Series) provides guidance for submission of applications for promotion to Warrant Officer and Limited Duty Officer.

Shaded areas in figure 1-1 indicate career stages from which qualified enlisted men may advance to Warrant Officer (W-1), and selected Commissioned Warrant Officers (W-2 and W-3) may advance to Limited Duty Officer. Personnel in enlisted rates not in a shaded area (fig. 1-1) may advance only as indicated by the connecting arrows.

A wide variety of assignments is available to the PR. In addition to the various types of maintenance activities to which the lower rated PR's are assigned, the PR1 and PRC are eligible for assignment to instructor duty as well as a number of other desirable shore billets. Most of these billets are under the management control of the Bureau of Naval Personnel and are directly associated with training. Others are associated with research, testing, or evaluation. Some of the more desirable billets to which the PR may be assigned are as follows:

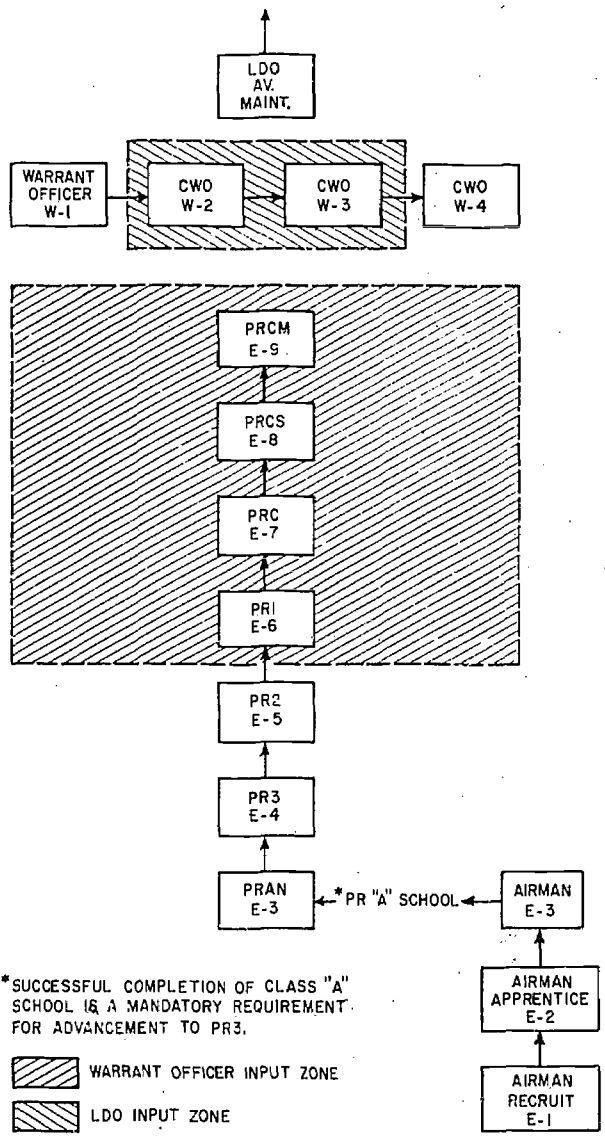

PR.1

Figure 1-1.—Path of advancement.

1. Instructor duty is available at NATTC, Lakehurst, N.J., in both the PR (A) School and PR (B) School.

2. Billets are available at NATTC, Millington, in the AME School and the Aviation Familiarization School (Class P).

3. PR's may be assigned to instructor duty also with a Naval Air Maintenance Training Detachment (NAMTRADETS). NAMTRADETS are located at shore stations on both coasts. Personnel assigned this duty are first sent to Naval

Air Maintenance Training Group headquarters at Millington, Tennessee, for a period of indoctrination and instruction.

4. Chief PR's may be assigned to duty with the Navy Training Publications Center, NAS, Memphis, Millington, Tennessee, as technical writers. This duty involves the preparation and revision of Rate Training Manuals for Group IX (Aviation) ratings.

5. Another billet available to the PRC is with the Naval Examining Center at Great Lakes, Illinois, as an item writer. In this billet, PR's assist in the preparation of servicewide advancement examinations.

There are a number of special programs to which enlisted personnel may be assigned. Some of these involve research, others may involve testing or evaluation. An example of such an assignment is with the Naval Aerospace Recovery Facility at El Centro, Calif.

For a listing of other special programs and projects, reference should be made to the Enlisted Transfer Manual. Others are also announced from time to time in BuPers Notices.

Personnel may indicate their desire for assignment to a specific program or project by indicating such in the "Remark" block of their Rotation Data Card.

As a petty officer, you are already aware of the importance of the PR rating to naval aviation. Pilots and aircrewmen depend upon the PR for the efficient operation of parachutes, full pressure suits, oxygen regulators, and flotation equipment. As higher and higher aircraft speeds and altitudes are attained, improved safety equipments are developed. Thus, the PR's job involves newer and greater responsibilities; and from the lowest level up, he must possess greater technical skills than ever before.

When advanced to PR1 or PRC, even more responsibilities are yours. As a senior petty officer, you must possess more than technical skills. You must assume greater responsibility not only for your own work, but also for the work of others who serve under you. Briefly, the PR1 and PRC must be a skilled mechanic, supervisor, inspector, and instructor, as well as an accomplished military leader. Senior petty officers are therefore vitally concerned with the Naval Leadership Program.

As a result of the Naval Leadership Program a considerable amount of material related to naval leadership for the senior petty officer is available. Studying this material will make you aware of your many leadership responsibilities

Chapter 1—AIRCREW SURVIVAL EQUIPMENTMAN (PR) RATING

as a senior petty officer and will also be of great help in developing leadership qualities. It will not in itself, however, make you a good leader. Leadership principles can be taught, but a good leader acquires that quality only through hard work and practice.

As you study this material containing leadership traits, keep in mind that probably none of our most successful leaders possessed all of these traits to a maximum degree, but a weakness in some traits was more than compensated for by strength in others. Critical self-evaluation will enable you to realize the traits in which you are strong, and to capitalize on them. At the same time you must constantly strive to improve on the traits in which you are weak.

Your success as a leader will be decided, for the most part, by your achievements in inspiring others to learn and perform. This is best accomplished by personal example.

ADVANCEMENT

By this time, you are probably well aware of the personal advantages of advancement—higher pay, greater prestige, more interesting and challenging work, and the satisfaction of getting ahead in your chosen career. By this time, also, you have probably discovered that one of the most enduring rewards of advancement is the training you acquire in the process of preparing for advancement.

The Navy also profits by your advancement. Highly trained personnel are essential to the functioning of the Navy. By advancement, you increase your value to the Navy in two ways: First, you become more valuable as a technical specialist, and thus make far-reaching contributions to the entire Navy; and second, you become more valuable as a person who can supervise, lead, and train others.

Since you are studying for advancement to PO1 or CPO, you are probably already familiar with the requirements and procedures for advancement. However, you may find it helpful to read the following sections. The Navy does not stand still. It is possible that some of the requirements have changed since the last time you went up for advancement. Furthermore, you will be responsible for training others for advancement; therefore, you will need to know the requirements in some detail.

HOW TO QUALIFY FOR ADVANCEMENT

To qualify for advancement, a person must:

1. Have a certain amount of time in grade.
2. Complete the required Rate Training Manuals either by demonstrating a knowledge of the material in the manual by passing a locally prepared and administered test or by passing the Enlisted Correspondence Course based on the Rate Training Manual.

3. Demonstrate the ability to perform all the PRACTICAL requirements for advancement by completing applicable portions of the Record of Practical Factors, NavPers 1414/1.

4. Be recommended by his commanding officer, after the petty officers and officers supervising the work have indicated that they consider him capable of performing the duties of the next higher rate.

5. Demonstrate KNOWLEDGE by passing a written examination on (a) military requirements, and (b) professional qualifications.

Some of these general requirements may be modified in certain ways. Figure 1-2 gives an overall view of the requirements for advancement of active duty personnel; figure 1-3 gives this information for inactive duty personnel.

Remember that the requirements for advancement can change. Check with your educational services office to be sure that you know the most recent requirements.

When you are training lower rated personnel, it is a good idea to point out that advancement is not automatic. Meeting all the requirements makes a person ELIGIBLE for advancement, but it does not guarantee his advancement. Such factors as the score made on the written examination, length of time in service, performance marks, and quotas for the rating enter into the final determination of who will actually be advanced.

HOW TO PREPARE FOR ADVANCEMENT

What must you do to prepare for advancement? You must study the qualifications for advancement, work on the practical factors, study the required Rate Training Manuals, and study other material that is required. You will need to be familiar with the following:

1. Manual of Qualifications for Advancement, NavPers 18068 (Series).

AIRCREW SURVIVAL EQUIPMENTMAN 1 & C

REQUIREMENTS	E1 to E2	E2 to E3	#† E3 to E4	#E4 to E5	† E5 to E6	† E6 to E7	† E7 to E8	† E8 to E9
SERVICE	4 mos. service— or comple- tion of	6 mos. as E-2.	9 mos. as E-3	12 mos. as E-4	24 mos. as E-5.	36 mos. as E-6. 8 years total enlisted service.	36 mos as E-7. 8 of 11 years total service must be enlisted.	24 mos. as E-8. 10 of 13 years total service must be enlisted.
SCHOOL	Recruit Training.		Class A for PR3, DT3, PT3, AME 3, HM 3, PH 3, FTB 3, MT 3.			Class B for AGC, MUC, MNC. ††		
PRACTICAL FACTORS	Locally prepared check-otts.	Record of Practical Factors, NavPers 1414/1, must be completed for E-3 and all PO advancements.						
PERFORMANCE TEST			Specified ratings must complete applicable performance tests be- fore taking examinations.					
ENLISTED PERFORMANCE EVALUATION	As used by CO when approving advancement.		Counts toward performance factor credit in ad- vancement multiple.					
EXAMINATIONS	Locally prepared tests.	See below.	Navy-wide examinations required for all PO advancements.				Navy-wide, selecti..n board.	
RATE TRAINING MANUAL (INCLUD- ING MILITARY REQUIREMENTS)		Required for E-3 and all PO advancements unless waived because of school comple- tion, but need not be repeated if identical course has already been completed. See NavPers 10052 (current edition).					Correspondence courses and recommended reading. See NavPers 10052 (current edition).	
AUTHORIZATION	Commanding Officer		Naval Examining Center					

- * All advancements require commanding officer's recommendation.
- 1 year obligated service required for E-5 and E-6; 2 years for E-7, E-8 and E-9.
- # Military leadership exam required for E-4 and E-5.
- ** For E-2 to E-3, NAVEXAMCEN exams or locally prepared tests may be used.
- †† Waived for qualified EOD personnel.

Figure 1-2.—Active duty advancement requirements.

Chapter 1—AIRCREW SURVIVAL EQUIPMENTMAN (PR) RATING

REQUIREMENTS *	E1 to E2	E2 to E3	E3 to E4	E4 to E5	E5 to E6	E6 to E7	E8	E9
TOTAL TIME IN GRADE	4 mos.	6 mos.	6 mos.	12 mos.	24 mos.	36 mos. with total 8 yrs service	36 mos. with total 11 yrs service	24 mos. with total 13 yrs service
TOTAL TRAINING DUTY IN GRADE †	14 days	14 days	14 days	14 days	28 days	42 days	42 days	28 days
PERFORMANCE TESTS	Specified ratings must complete applicable performance tests before taking examination.							
DRILL PARTICIPATION	Satisfactory participation as a member of a drill unit in accordance with BUPERSINST 5400.42 series.							
PRACTICAL FACTORS (INCLUDING MILITARY REQUIREMENTS)	Record of Practical Factors, NavPers 1414/1, must be completed for all advancements.							
RATE TRAINING MANUAL (INCLUDING MILITARY REQUIREMENTS)	Completion of applicable course or courses must be entered in service record.							
EXAMINATION	Standard Exam	Standard Exam required for all PO Advancements. Also pass Military Leadership Exam for E-4 and E-5.					Standard Exam, Selection Board.	
AUTHORIZATION	Commanding Officer	Naval Examining Center						

* Recommendation by commanding officer required for all advancements.

† Active duty periods may be substituted for training duty.

Figure 1-3.—Inactive duty advancement requirements.

AIRCREW SURVIVAL EQUIPMENTMAN 1 & C

2. Record of Practical Factors, NavPers 1414/1.

3. Training Publications for Advancement, NavPers 10052 (Series).

4. Applicable Rate Training Manuals and their companion Enlisted Correspondence Courses.

Collectively, these documents make up an integrated training package tied together by the qualifications. The following paragraphs describe these materials and give some information on how each one is related to the others.

"Quals" Manual

The Manual of Qualifications for Advancement, NavPers 18068 (Series), gives the minimum requirements for advancement to each rate within each rating. This manual is usually called the "Quals" Manual, and the qualifications themselves are often called "quals." The qualifications are of two general types: (1) military requirements, and (2) professional or technical qualifications. Military requirements apply to all ratings rather than to any one rating alone. Professional qualifications are technical or professional requirements that are directly related to the work of each rating.

Both the military requirements and the professional qualifications are divided into subject matter groups. Then, within each subject matter group, they are divided into PRACTICAL FACTORS and KNOWLEDGE FACTORS.

The qualifications for advancement and a bibliography of study materials are available in your educational services office. The "Quals" Manual is changed more frequently than Rate Training Manuals are revised. By the time you are studying this training manual, the "quals" for your rating may have been changed. Never trust any set of "quals" until you have checked the change number against an UP-TO-DATE copy of the "Quals" Manual.

In training others for advancement, emphasize these three points about the "quals":

1. The "quals" are the MINIMUM requirements for advancement. Personnel who study MORE than the required minimum will have a great advantage when they take the written examinations for advancement.

2. Each "qual" has a designated rate level—chief, first class, second class, or third class. You are responsible for meeting all "quals" specified for the rate level to which you are seeking advancement AND all "quals" specified

for lower rate levels. This manual is written to provide additional or add-on information to that contained in PR 3 & 2, NavPers 10358-D, and it is recommended that the material in this 3 & 2 manual be reviewed.

3. The written examinations for advancement will contain questions relating to the practical factors AND to the knowledge factors of BOTH the military requirements and the professional qualifications.

Record of Practical Factors

Before you can take the Navy-wide examination for advancement, there must be an entry in your service record to show that you have qualified in the practical factors of both the military requirements and the professional qualifications. A special form known as the Record of Practical Factors, NavPers 1414/1 (plus the abbreviation of the appropriate rating), is used to keep a record of your practical factor qualifications. The form lists all practical factors, both military and professional. As you demonstrate your ability to perform each practical factor, appropriate entries are made in the DATE and INITIALS columns.

As a PO1 or CPO, you will often be required to check the practical factor performance of lower rated personnel and to report the results to your supervising officer.

As changes are made periodically to the "Quals" Manual, new forms of NavPers 1414/1 are provided when necessary. Extra space is allowed on the Record of Practical Factors for entering additional practical factors as they are published in changes to the "Quals" Manual. The Record of Practical Factors also provides space for recording demonstrated proficiency in skills which are within the general scope of the rating but which are not identified as minimum qualifications for advancement. Keep this in mind when you are training and supervising other personnel. If a person demonstrates proficiency in some skill which is not listed in the "quals" but which is within the general scope of the rating, report this fact to the supervising officer so that an appropriate entry can be made in the Record of Practical Factors.

When you are transferred, the Record of Practical Factors should be forwarded with your service record to your next duty station. It is a good idea to check and be sure that this form is actually inserted in your service record

Chapter 1—AIRCREW SURVIVAL EQUIPMENTMAN (PR) RATING

before you are transferred. If the form is not in your record, you may be required to start all over again and requalify in practical factors that have already been checked off. You should also take some responsibility for helping lower rated personnel keep track of their practical factor records when they are transferred.

A second copy of the Record of Practical Factors should be made available to each man in pay grades E-2 through E-8 for his personal record and guidance.

The importance of NavPers 1414/1 cannot be over-emphasized. It serves as a record to indicate to the petty officers and officers supervising your work that you have demonstrated proficiency in the performance of the indicated practical factors and is part of the criteria utilized by your commanding officer when he considers recommending you for advancement. In addition, the proficient demonstration of the applicable practical factors listed on this form can aid you in preparing for the examination for advancement. Remember that the knowledge aspects of the practical factors are covered in the examination for advancement. Certain knowledge is required to demonstrate these practical factors and additional knowledge can be acquired during the demonstration. Knowledge factors pertain to that knowledge which is required to perform a certain job. In other words, the knowledge factors required for a certain rating depend upon the jobs (practical factors) that must be performed by personnel of that rating. Therefore, the knowledge required to proficiently demonstrate these practical factors will definitely aid you in preparing for the examination for advancement.

NavPers 10052

Training Publications for Advancement, NavPers 10052 (Series) is a very important publication for anyone preparing for advancement. This publication/bibliography lists required and recommended Rate Training Manuals and other reference material to be used by personnel working for advancement. NavPers 10052 (Series) is revised and issued once each year by the Bureau of Naval Personnel. Each revised edition is identified by a letter following the NavPers number; be SURE you have the most recent edition.

The required and recommended references are listed by rate level in NavPers 10052 (Series). It is important to remember that you are

responsible for all references at lower rate levels, as well as those listed for the rate to which you are seeking advancement.

Rate Training Manuals that are marked with an asterisk (*) in NavPers 10052 (Series) are MANDATORY at the indicated rate levels. A mandatory training manual may be completed by (1) passing the appropriate Enlisted Correspondence Course that is based on the mandatory training manual; (2) passing locally prepared tests based on the information given in the mandatory training manual; or (3) in some cases, successfully completing an appropriate Navy school.

When training personnel for advancement, do not overlook the section of NavPers 10052 (Series) which lists the required and recommended references relating to the military requirements for advancement. All personnel must complete the mandatory military requirements training manual for the appropriate rate level before they can be eligible to advance. Also, make sure that personnel working for advancement study the references listed as recommended but not mandatory in NavPers 10052 (Series). It is important to remember that ALL references listed in NavPers 10052 (Series) may be used as source material for the written examinations, at the appropriate levels.

Rate Training Manuals

There are two general types of Rate Training Manuals. Rate Training Manuals (such as this one) are prepared for most enlisted rates and ratings, giving information that is directly related to the professional qualifications for advancement. Subject matter manuals give information that applies to more than one rating.

Rate Training Manuals are revised from time to time to bring them up to date technically. The revision of a Rate Training Manual is identified by a letter following the NavPers number. You can tell whether a Rate Training Manual is the latest edition by checking the NavPers number (and the letter following the number) in the most recent edition of List of Training Manuals and Correspondence Courses, NavPers 10061 (Series). (NavPers 10061 is actually a catalog that lists current training manuals and correspondence courses; you will find this catalog useful in planning your study program.)

Rate Training Manuals are designed for the special purpose of helping naval personnel prepare for advancement. By this time, you have

AIRCREW SURVIVAL EQUIPMENTMAN 1 & C

probably developed your own way of studying these manuals. Some of the personnel you train, however, may need guidance in the use of Rate Training Manuals. Although there is no single "best" way to study a training manual, the following suggestions have proved useful for many people:

1. Study the military requirements and the professional qualifications for your rate before you study the training manual, and refer to the "quals" frequently as you study. Remember, you are studying the training manual primarily to meet these "quals."

2. Set up a regular study plan. If possible, schedule your studying for a time of day when you will not have too many interruptions or distractions.

3. Before you begin to study any part of the training manual intensively, get acquainted with the entire manual. Read the preface and the table of contents. Check through the index. Thumb through the manual without any particular plan, looking at the illustrations and reading bits here and there as you see things that interest you.

4. Look at the training manual in more detail, to see how it is organized. Look at the table of contents again. Then, chapter by chapter, read the introduction, the headings, and the subheadings. This will give you a clear picture of the scope and content of the manual.

5. When you have a general idea of what is in the training manual and how it is organized, fill in the details by intensive study. In each study period, try to cover a complete unit—it may be a chapter, a section of a chapter, or a subsection. The amount of material you can cover at one time will vary. If you know the subject well, or if the material is easy, you can cover quite a lot at one time. Difficult or unfamiliar material will require more study time.

6. In studying each unit, write down questions as they occur to you. Many people find it helpful to make a written outline of the unit as they study, or at least to write down the most important ideas.

7. As you study, relate the information in the training manual to the knowledge you already have. When you read about a process, a skill, or a situation, ask yourself some questions. Does this information tie in with past experience? Or is this something new and different? How does this information relate to the qualifications for advancement?

8. When you have finished studying a unit, take time out to see what you have learned. Look back over your notes and questions. Maybe some of your questions have been answered, but perhaps you still have some that are not answered. Without referring to the training manual, write down the main ideas you have learned from studying this unit. Do not just quote the manual. If you cannot give these ideas in your own words, the chances are that you have not really mastered the information.

9. Use Enlisted Correspondence Courses whenever you can. The correspondence courses are based on Rate Training Manuals or other appropriate texts. As mentioned before, completion of a mandatory Rate Training Manual can be accomplished by passing an Enlisted Correspondence Course based on the training manual. You will probably find it helpful to take other correspondence courses, as well as those based on mandatory training manuals. Taking a correspondence course helps you to master the information given in the training manual, and also gives you an idea of how much you have learned.

10. You should note that occasionally reference is made in the Rate Training Manual to publications which contain information relative to the rating, but which are not listed in NavPers 10052 (Series). These are known as secondary references and should be reviewed in conjunction with your study of the Rate Training Manual to better prepare yourself for advancement.

INCREASED RESPONSIBILITIES

When you assumed the duties of a PO3, you began to accept a certain amount of responsibility for the work of others. With each advancement, you accept an increasing responsibility in military matters and in matters relating to the professional work of your rate. When you advance to PO1 or CPO, you will find a noticeable increase in your responsibilities for leadership, supervision, training, working with others, and keeping up with new developments.

As your responsibilities increase, your ability to communicate clearly and effectively must also increase. The simplest and most direct means of communication is a common language. The basic requirement for effective communication is therefore a knowledge of your own language. Use correct language in speaking and in writing. Remember that the basic purpose of

all communication is understanding. To lead, supervise, and train others, you must be able to speak and write in such a way that others can understand exactly what you mean.

Leadership and Supervision

As a PO1 or CPO, you will be regarded as a leader and supervisor. Both officers and enlisted personnel will expect you to translate the general orders given by officers into detailed, practical, on-the-job language that can be understood and followed by relatively inexperienced personnel. In dealing with your juniors, it is up to you to see that they perform their jobs correctly. At the same time, you must be able to explain to officers any important problems or needs of enlisted personnel. In all military and professional matters, your responsibilities will extend both upward and downward.

Along with your increased responsibilities, you will also have increased authority. Officers and petty officers have POSITIONAL authority—that is, their authority over others lies in their positions. If your CO is relieved, for example, he no longer has the degree of authority over you that he had while he was your CO, although he still retains the military authority that all seniors have over subordinates. As a PO1, you will have some degree of positional authority; as a CPO, you will have even more. When exercising your authority, remember that it is positional—it is the rate you have, rather than the person you are, that gives you this authority.

A Petty Officer conscientiously and proudly exercises his authority to carry out the responsibilities he is given. He takes a personal interest in the success of both sides of the chain of command . . . authority and responsibility. For it is true that the Petty Officer who does not seek out and accept responsibility, loses his authority and then the responsibility he thinks he deserves. He must be sure, by his example and by his instruction, that the Petty Officers under him also accept responsibility. In short, he must be the leader his title—Petty Officer—says he is.

Training

As a PO1 or CPO, you will have regular and continuing responsibilities for training others. Even if you are lucky enough to have a group of subordinates who are all highly skilled and well trained, you will still find that training is

necessary. For example, you will always be responsible for training lower rated personnel for advancement. Also, some of your best workers may be transferred; and inexperienced or poorly trained personnel may be assigned to you. A particular job may call for skills that none of your personnel have. These and similar problems require that you be a training specialist—one who can conduct formal and informal training programs to qualify personnel for advancement, and one who can train individuals and groups in the effective execution of assigned tasks.

In using this training manual, study the information from two points of view. First, what do you yourself need to learn from it? And second, how would you go about teaching this information to others?

Training goes on all the time. Every time a person does a particular piece of work, some learning is taking place. As a supervisor and as a training expert, one of your biggest jobs is to see that your personnel learn the RIGHT things about each job so that they will not form bad work habits. An error that is repeated a few times is well on its way to becoming a bad habit. You will have to learn the difference between oversupervising and not supervising enough. No one can do his best work with a supervisor constantly supervising. On the other hand, you cannot turn an entire job over to an inexperienced person and expect him to do it correctly without any help or supervision.

In training lower rated personnel, emphasize the importance of learning and using correct terminology. A command of the technical languages of your occupational field (rating) enables you to receive and convey information accurately and to exchange ideas with others. A person who does not understand the precise meaning of terms used in connection with the work of his rating is definitely at a disadvantage when he tries to read official publications relating to his work. He is also at a great disadvantage when he takes the examinations for advancement. To train others in the correct use of technical terms, you will need to be very careful in your own use of words. Use correct terminology and insist that personnel you are supervising use it too.

You will find the Record of Practical Factors, NavPers 1414/1, a useful guide in planning and carrying out training programs. From this record, you can tell which practical factors have been checked off and which ones have not

AIRCREW SURVIVAL EQUIPMENTMAN 1 & C

yet been done. Use this information to plan a training program that will fit the needs of the personnel you are training.

On-the-job training is usually controlled through daily and weekly work assignments. When you are working on a tight schedule, you will generally want to assign each person to the part of the job that you know he can do best. In the long run, however, you will gain more by assigning personnel to a variety of jobs so that each person can acquire broad experience. By giving people a chance to do carefully supervised work in areas in which they are relatively inexperienced, you will increase the range of skills of each person and thus improve the flexibility of your working group.

Working With Others

As you advance to PO1 or CPO, you will find that many of your plans and decisions affect a large number of people, some of whom are not even in your own occupational field (rating). It becomes increasingly important, therefore, for you to understand the duties and the responsibilities of personnel in other ratings. Every petty officer in the Navy is a technical specialist in his own field. Learn as much as you can about the work of others, and plan your own work so that it will fit into the overall mission of the organization.

Keeping Up With New Developments

Practically everything in the Navy--policies, procedures, publications, equipment, systems--is subject to change and development. As a PO1 or CPO, you must keep yourself informed about changes and new developments that affect you or your work in any way.

Some changes will be called directly to your attention, but others will be harder to find. Try to develop a special kind of alertness for new information. When you hear about anything new in the Navy, find out whether there is any way in which it might affect the work of your rating. If so, find out more about it.

SOURCES OF INFORMATION

As a PO1 or CPO, you must have an extensive knowledge of the references to consult for accurate, authoritative, up-to-date information on all subjects related to the military and professional requirements for advancement.

Publications mentioned in this chapter are subject to change or revision from time to time--some at regular intervals, others as the need arises. When using any publication that is subject to revision, make sure that you have the latest edition. When using any publication that is kept current by means of changes, be sure you have a copy in which all official changes have been made.

The reading list at the beginning of this manual consists of USAFI courses that offer additional background material. The educational services officer will always have the most up-to-date information and training manuals applicable to your rating.

In addition to training manuals and publications, training films furnish a valuable source of supplementary information. Films that may be helpful are listed in the U.S. Navy Film Catalog, NavAir 10-1-777.

ADVANCEMENT OPPORTUNITIES FOR PETTY OFFICERS

Making chief petty officer is not the end of the line as far as advancement is concerned. Proficiency pay, advancement to Senior (E-8) and Master (E-9) Chief, and advancement to Warrant Officer and Commissioned Officer are among the opportunities that are available to qualified petty officers. These special paths of advancement are open to personnel who have demonstrated outstanding professional ability, the highest order of leadership and military responsibility, and unquestionable moral integrity.

PROFICIENCY PAY

The Career Compensation Act of 1949, as amended, provides for the award of proficiency pay to designated military specialties. Proficiency pay is given in addition to regular pay and allowances and any special or incentive pay to which you are entitled. Certain enlisted personnel in pay grades E-4 through E-9 are eligible for proficiency pay. Proficiency pay is awarded in two categories: (1) Speciality pay--to designated ratings and NEC's, and (2) Superior performance pay--for superior performance of duty in certain specialties not covered by speciality pay. The eligibility requirements for proficiency pay are subject to change. In general, however, you must be recommended by your commanding officer, have a certain length

Chapter 1—AIRCREW SURVIVAL EQUIPMENTMAN (PR) RATING

of time on continuous active duty, and be career designated.

ADVANCEMENT TO SENIOR AND MASTER CHIEF

Chief Petty Officers may qualify for the advanced grades of Senior and Master Chief Petty Officer which are now provided in the enlisted pay structure. These advanced grades provide for substantial increases in pay, together with increased responsibilities and additional prestige. The requirements for advancement to Senior and Master Chief Petty Officer are subject to change but, in general, include a certain length of time in grade, a certain length of time in the naval service, a recommendation by the commanding officer, and a sufficiently high mark on the Navy-wide examination. The final selection for Senior and Master Chief Petty Officer is made by a regularly convened selection board.

Examination Subjects

Qualifications for advancement to Senior Chief Petty Officer and Master Chief Petty Officer have been developed and published in the Manual of Qualifications for Advancement, NavPers 18068 (Series). They officially establish minimum military and professional

qualifications for Senior and Master Chief Petty Officers.

Training Publications for Advancement, NavPers 10052 (Series) contains a list of study references which may be used to study for both military and professional requirements.

The satisfactory completion of the correspondence course titled Navy Regulations, NavPers 10740-A4, is mandatory for advancement to E-8, and the course titled Military Justice in the Navy, NavPers 10993-A, is required of all personnel advancing to E-9.

ADVANCEMENT TO WARRANT AND COMMISSIONED OFFICER

The Warrant Officer program provides opportunity for advancement to warrant rank for E-6 and above enlisted personnel. E-6's, to be eligible, must have passed an E-7 rating exam prior to selection.

The LDO program provides a path of advancement from warrant officer to commissioned officer. LDO's are limited, as are warrants, in their duty, to the broad technical fields associated with their former rating.

If interested in becoming a warrant or commissioned officer, ask your educational services officer for the latest requirements that apply to your particular case.

CHAPTER 2

BLUEPRINT READING AND DEVELOPMENT OF PATTERNS

The PR is required to develop patterns and layouts in performing the duties of his rating. He must be able to read blueprints in order to fabricate, assemble, and install appendages to existing items, and in many cases (such as fabricating various canvas covers, bags, and other containers) to make up the complete item, including drawing his own plans.

The discussion in this chapter is limited to those aspects of blueprint reading which are directly applicable to the PR rating. However, additional aspects of blueprint reading are increasingly important as the PR plans his career toward eventual attainment of the PRCM rate.

Therefore, the PR is urged to extend his knowledge of blueprint reading by studying *Blueprint Reading and Sketching, NavPers 10077-C*.

The engineer, when making a drawing, may use a number of methods in illustrating objects graphically; however, for our purposes in this manual we will divide them into four main types—orthographic projections, pictorial drawings, isometric drawings, and diagrams.

ORTHOGRAPHIC PROJECTIONS

Orthographic projections are prints which present an object in its true shape and indicate its size. The number of views to be used in

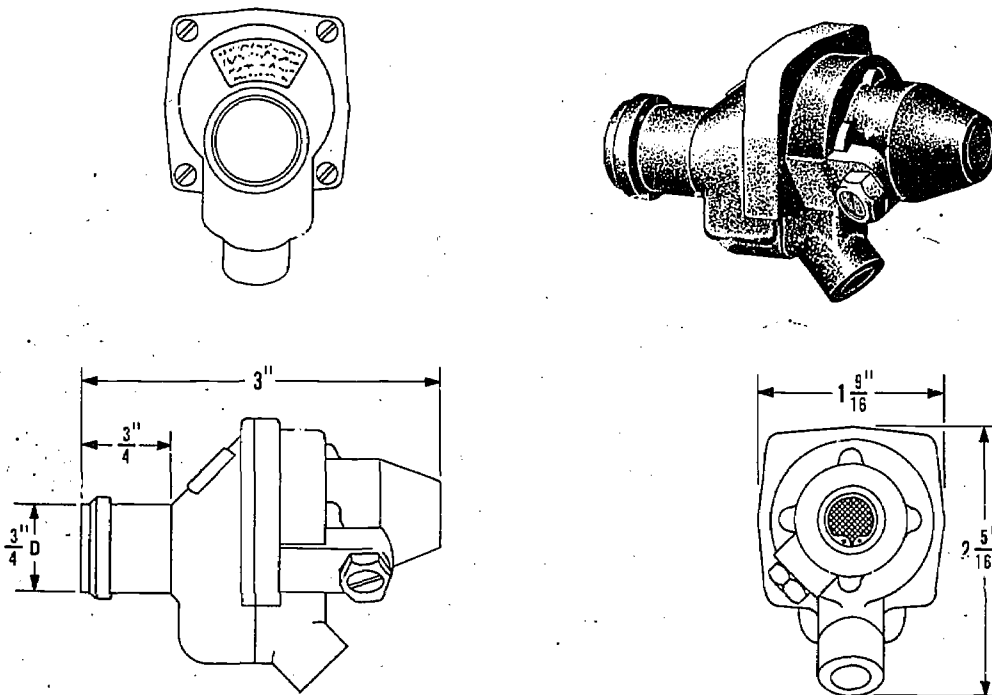

Figure 2-1.—Orthographic projection drawing, and a pictorial view of a miniature regulator.

PR.94

projecting an object is governed by the complexity of the shape of the object. Complex drawings may be drawn showing up to six views; that is, both ends, front, top, bottom, and rear.

It is seldom necessary to show all six views to portray an object clearly; therefore, only those views are drawn which are necessary to illustrate the required characteristics of the object. One-view, two-view, and three-view drawings are the most common. Regardless of the number of views, the arrangement is made with the front view as the principal one.

PICTORIAL DRAWINGS

Pictorial drawings are used to show general location, function, and appearance. They show an object as it appears to the eye, and are not satisfactory for showing complex forms. They are used extensively in conjunction with orthographic projection drawings. Figure 2-1 shows a three-view orthographic projection drawing of a miniature regulator with a pictorial view shown in the upper right-hand corner of the figure.

ISOMETRIC DRAWINGS

Figure 2-2 shows an isometric drawing of a parachute bag. All the lines that are parallel on the parachute bag are also parallel on the drawing. Vertical lines are shown in a vertical position and horizontal lines are drawn at an angle of 30° as shown in figure 2-2. Since all isometric lines are spread equally (120°), the same scale of measurement may be used on the 3 visible sides.

Isometric drawings may be dimensioned, and blueprints of these drawings may be used for making simple objects. However, isometric drawings cannot be used for complicated parts; they are best used as an aid in clarifying the orthographic drawings.

Isometric drawings can be very useful to the PR in making freehand sketches of canvas covers and different types of canvas bags.

DIAGRAMS

There are many types of diagrams, but those of primary interest to PR's may be grouped into two categories, and referred to as system diagrams and component diagrams.

A diagram, whether a system diagram or a component diagram, may be defined as a graphic

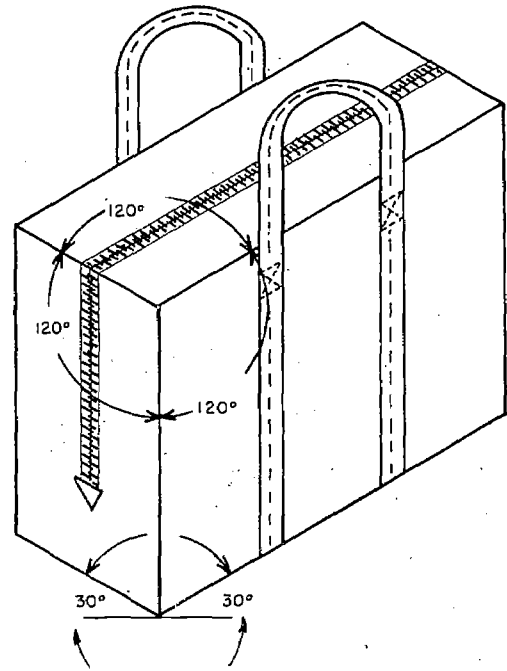

PR.95
Figure 2-2.—Isometric drawings of a parachute bag.

representation of an assembly or system, indicating the various parts and expressing the methods or principles of operation.

Figure 2-3 is an example of a system diagram. This is a diagram of a gaseous oxygen system unit's location, showing the arrangement of cylinders, tubing, mask stowage, regulator, etc.

An example of a component schematic diagram is shown in figure 2-4. This diagram shows the flow of oxygen from the source of supply through the regulator to the mask.

Diagrams of these types are used extensively in Maintenance Instructions Manuals and are invaluable to PR's and other maintenance personnel in identifying and locating components and understanding the principle of operation of various components and systems.

DEVELOPMENT OF A LAYOUT

The term development is applied to the procedure for constructing a guide, or pattern

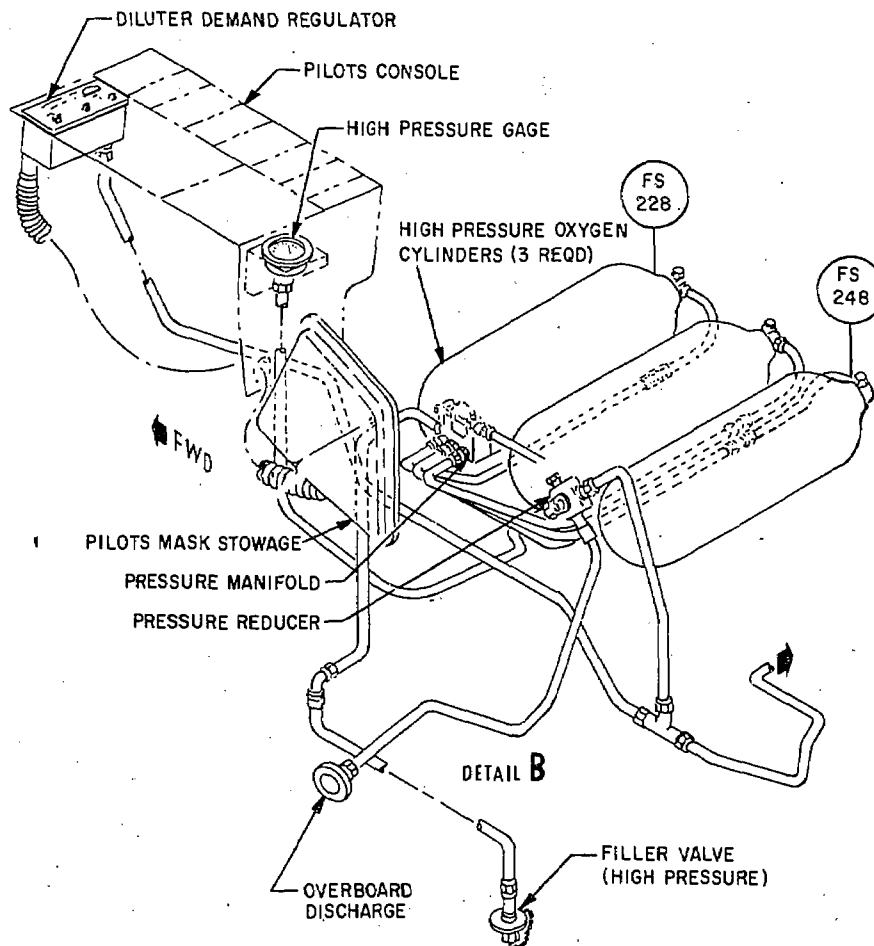

Figure 2-3.—Diagram of a gaseous oxygen system.

PR.96

(layout) on a piece of cloth or canvas which is to be used as a pattern or joined together with seams to form a bag or cover.

To begin a layout, make a reference line on the canvas or cloth parallel to the selvage edge. (NOTE: The selvage edge is cut away before attempting to sew. This helps to prevent uneven stretching of the plies of fabric being sewn.) All measurements can then be made from this reference line. Lines at a known angle or parallel to the reference line can be made by marking off points from a framing square held to the reference line.

Determine the exact dimensions of the object to be drawn and add 1 inch to the length and

1 inch to the width of each piece of material for seam allowance. The 1-inch figure is arbitrary and can be made more or less, depending on the fabric or material. Loosely woven fabrics tend to ravel more readily and therefore require a wide seam, or taping.

Lay out all pieces before cutting and draw centerlines in both the length and width of all pieces near the edge of the material where the marks can be readily seen when sewing. These marks provide a ready reference for checking to see that both pieces fit and that the proper tension is being kept on both top and bottom plies of material.

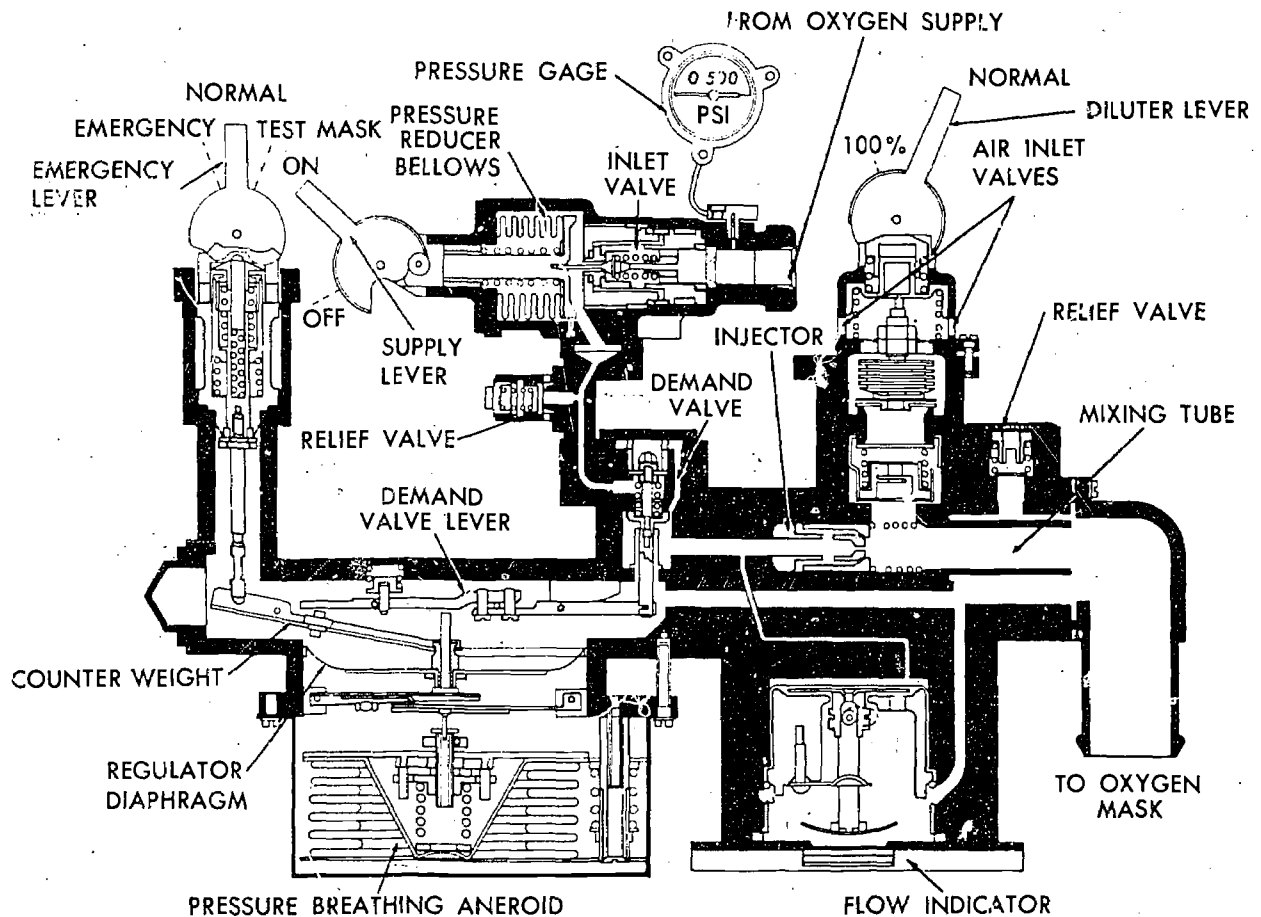

Figure 2-4.—Component schematic diagram.

PR.97

Lay out the location of handles, slide fastener (or other closing device), and all inside and outside appendages before starting to sew. These items must be installed before the final sewing of the item.

A typical layout is shown in figure 2-5. Note that the sum of the side and end of the narrow piece is equal to the sum of the side and end of the wide piece. This is true in all cases when joining two pieces of material to form a rectangular bag, as the perimeters of both pieces must be equal.

Layout and development mean in many cases the interpreting and transcribing of information from blueprints, drawings, and written instructions; therefore, the well-informed PR will

review *Blueprint Reading and Sketching*, NavPers 10077-C.

REPRODUCTION OF DRAWINGS

As an Aircrew Survival Equipmentman you must become familiar with drawing reproduction as you will continually be referring to them in the course of your work.

There are a number of reproductions used. Some of these are as follows:

1. Blueprints - Reproductions on sensitized paper with white lines on a blue background.
2. Diazo (ammonia prints) - Reproduction on sensitized paper with black, brown, blue, purple or maroon lines on white background.

Chapter 2—BLUEPRINT READING AND THE DEVELOPMENT OF PATTERNS

3. Van Dyke - Reproductions on sensitized paper with white lines on brown background.

4. Engineering drawing cards (EDC). The primary purpose of the EDC as well as microfilm, which is used extensively in the reproduction

of drawings, is the space that is saved when they are filed. In addition, the time that is saved locating them is significant. The EDC is shown in figure 2-6. The negative within the EDC shows a canopy of a parachute.

CHAPTER 3

SUPPLY

In maintaining an effective aviator's equipment shop, the PR, especially if in a supervisory billet, will find himself increasingly involved in the details of supporting the man on the job. One of these areas is in the field of aviation supply.

Aviation supply personnel are vital members of the aircraft maintenance team; and the PR, as well as personnel in the other aviation ratings, must work in close harmony with them if successful teamwork is to be achieved. Without adequate material, the maintenance of oxygen equipment and other items of aviator's equipment could not be sustained. The roles of the supply and maintenance organizations and the responsibilities of each must be clearly understood by personnel at all levels.

ORGANIZATION AND FUNCTION OF NAVAL SUPPLY

The command exercising management control over the policies and procedures of the aviation supply organization is the Naval Supply Systems Command. The Commander, Naval Supply Systems Command, is usually a rear admiral who is appointed by the President with the advice and consent of the Senate.

The Aviation Supply Office (ASO) was established in 1941. The function of ASO was the procurement, custody, and issuance of aeronautical spare parts and technical material. This is essentially the function of ASO today under the technical control of the Naval Air Systems Command. Management control of ASO is exercised by the Naval Supply Systems Command.

Some functions of the Naval Supply Systems Command that are of interest to PR personnel are the general functions of ASO. These include the following:

1. Responsibilities for overall determination of requirements, procurement, and distribution of standard aeronautical materials. (Certain materials excepted; such as complete aircraft and engines, complete electronic equipment, major photo equipment, nonstandard and

experimental aerological equipment, and items of naval weapons ordnance equipment.)

2. Maintenance of a complete file of ASO and Naval Air Systems Command contracts, letters of intent, amendments, and change orders, and distribution of all necessary copies of documents to Navy field activities.

3. Stock control of aeronautical materials at all aviation supply facilities, including control of packing, preservation, and distribution of material under ASO cognizance to, from, and between aviation supply facilities and major supply points.

4. Maintenance of complete records of material on order and followup procedures necessary to effect timely deliveries for all material under ASO cognizance.

5. Maintenance of up-to-date records of existing storage facilities at depots, major supply points, and operating stations for aeronautical materials, and control of influx of materials in aviation supply channels so as not to exceed existing storage facilities.

6. Determination and disposition of obsolete and excess aeronautical material under Nav-AirSysCom cognizance.

7. Preparation and distribution of the Navy Stock List of ASO, including interchangeability data.

8. Compilation and distribution of some allowance lists subject to approval by Nav-AirSysCom.

9. Compilation of lists of spare parts to be salvaged from surveyed aircraft.

10. Followup on delivery, stock recording, re-allocating as necessary, and distributing change material promulgated by Nav-AirSysCom.

11. Establishment and maintenance of a statistical unit which assembles, compiles, and analyzes usage data.

12. Maintenance of a representative at each aircraft manufacturer's plant who keeps ASO fully informed, as requested, as to all changes which affect spare parts under procurement.

13. Establishment of an inspection service which inspects aviation supply activities within established naval districts.

APPROPRIATIONS

At one time or another, almost everyone has had the frustrating experience of not being able to requisition from supply some item needed; the usual reason given being, "No funds available." It takes only a short time to realize that the Navy does not operate with unlimited funds. This section and the following section, titled "Operating Budgets," are presented to further an understanding of the system whereby funds are made available at the user activity level for operating expenses.

The main money pool of the government is the General Fund of the Treasury. Funds come into the General Fund from such sources as income taxes, excise taxes, import-export taxes, etc. The only way for money to be expended from the General Fund is by congressional action, which has to be approved by the President. A bill passed by Congress which includes the expenditure of funds from the General Fund is called an appropriation.

An estimate of the amount of money required for the operation of the Defense Department during a given fiscal year is prepared by Department of Defense fiscal experts well in advance of the beginning of the fiscal year. The Congress studies the proposed budget in the light of world affairs, the current domestic economy, and such other considerations as they see fit, then acts upon it. Congress may increase the amount requested, decrease it, or pass it as it is. After Presidential action is completed, the money is made available to the Department of Defense to be spent during a specified year. This is known as an "annual" or "one-year" appropriation.

Congress and the President may also approve "no-year" appropriations for special projects such as large construction programs over an unspecified length of time.

The appropriation by which the PR is most affected is the "current-year" appropriation. After the appropriation or expenditure authorization is received in the Department of Defense, it is prorated among the services as a percentage of their previously submitted budget estimates. The Navy's share is prorated among the various systems commands and bureaus in essentially the same manner; that is, as a percentage of their estimated requirements for the coming fiscal year. The money to be spent for naval aviation is made available to NavAirSysCom. Here, part of the money is allocated to

ASO for the purchase of aircraft spare parts and related equipment in quantities which past usage data has indicated will probably be sufficient for the coming year. These spare parts are furnished to the operating activities at no cost, since their usage has been anticipated and the items paid for in advance. The account from which money was spent to buy these items is known as the Appropriation Purchase Account (APA). Material received in the user activities from this account is known as APA material.

Another part of NavAirSysCom funds is made available to the operating activities in the form of operating budgets as administered by the Fleet Resources Office.

FLEET RESOURCES OFFICE

The Fleet Resources Office (FRO) is established within NAVMATCOM to carry out CNM's assignment as an agent of CNO for administering operating budgets for CINCLANTFLT, CINCPACFLT, CINCUSNAVEUR, CNATRA, and CNRTC (referred to as operating forces commanders). FRO serves as the focal point for formulation, justification, and execution of the budget of those component commands, although decisions as to programing, budgeting, and allocation level are made by CNO. It reviews, coordinates, and compiles budget material in format for submission to higher authority and administers allocations from CNO to the foregoing major claimants, observing all limitations as to program or budget categories and approved reprogramming levels. In the budget formulation process the FRO also coordinates with the budget submissions of the Navy operating forces commanders those budgetary requirements of the Commandant of the Marine Corps which are funded from the Operations, Navy account.

OPERATING BUDGETS

Approved operating budgets concerning naval aviation are authorized by NavAirSysCom to the user activity to spend a certain amount of money during a given length of time for specified purposes. User activities are shore commands, which operate aircraft, and the major air type commanders.

Operating funds for stations, rework facilities, etc., concerned with the operation and maintenance of aircraft and related equipment, are allotted to them by the NavAirSysCom as

AIRCREW SURVIVAL EQUIPMENTMAN 1 & C

an operating budget. Departments within these organizations normally submit their department budget to the station comptroller who reviews and combines the different department budgets into a recommended station budget. Senior PR's may be called upon to assist in furnishing a realistic estimate of division operating expenses and future needs which the department head may use in formulating the department budget.

Since there is a relatively long period between budget submission and the subsequent receipt of funds, the necessity of accurate estimates of future requirements and strict management of materials for which allocated funds are expended cannot be overemphasized.

Operating funds for squadrons and units are apportioned to them by their type commander as an Operating Target (OPTAR). Routine non-aviation expenses for operating squadrons and units are absorbed by the ship or station to which assigned.

OPERATING TARGETS

Funds to finance the operation of aircraft are allotted by the NavAirSysCom to the air type commanders. Operating funds for the squadrons and units are apportioned to them by their cognizant air type commanders as an operating target (OPTAR). An OPTAR is a planned estimate which the air type commander allocates for the financing of aircraft operating costs during a given period of time. OPTAR's are issued on a quarterly basis and unused funds from the previously issued OPTAR revert to the control of the type commander as each new OPTAR is authorized. Type commanders provide OPTAR's to squadrons, units, and ships under their operational control, whether or not the user activity is based ashore.

There are several different types of OPTAR's issued by the air type commanders for aviation purposes. Two that are of interest to PR personnel are flight operations and aircraft maintenance funds. These are discussed in the following paragraphs.

Flight operations funds are used primarily for the purpose of financing actual flight operations; therefore, they have application at the organizational level. These funds finance the following:

1. Aviation fuels and lubricants consumed in aircraft.
2. Liquid oxygen.
3. Aerial film for use in aircraft cameras.

4. Flight clothing and operational equipment authorized in NavAirSysCom Allowance List (NavAir 00-35QH-2).

5. Flight deck safety shoes.

6. Squadron administrative consumable office supplies.

7. Unit identification marks (shoulder patches) for initial issue to newly reported personnel.

8. Material and services required when located at an activity without Navy or Marine Corps intermediate maintenance capability.

Aircraft maintenance funds are provided to organizational and intermediate maintenance activities to finance the cost of various supplies and materials consumed in the performance of aviation maintenance. These funds finance the following:

1. Repair parts, common hardware, lubricants, cleaning agents, cutting compounds, metals, and other materials incorporated into or expended in the performance of aviation maintenance of aircraft, engines, aeronautical components and subassemblies, and Navy maintenance of aviation maintenance support equipment.

2. Fuels and lubricants consumed by aircraft engines in the performance of complete section repairs.

3. Preexpended, consumable maintenance material.

4. Replacement of expendable or consumable allowance list items with material accountability codes B and C. (Allowance list and material accountability codes are discussed later in this chapter.)

MATERIAL IDENTIFICATION

In addition to the task of supervising lower rated PR personnel in the performance of routine duties, senior PR's in some cases have duties that will encompass the task of assisting in the procurement of material and parts used by the production personnel. One important area of material procurement is the correct identification of the items required.

There may be times when a part or some technical material is needed and the stock number is unknown. At other times some material may be on hand and its identity not positively known. A knowledge of the various methods of identifying material other than by stock number will often help speed the completion of a maintenance task. Certain data may be available

which do not identify an item but which may lead to positive identification. The following sections discuss some methods of identifying material.

FEDERAL STOCK NUMBERING SYSTEM

The Defense Cataloging Standardization Act provides for a uniform system of identification, classification, and stock numbering throughout the Department of Defense. It places all like items under a federal stock number bearing a common official government name and is applicable to all agencies within the Department of Defense.

Under the federal cataloging system, federal stock numbers are required for all items that are subject to central inventory management within the Department of Defense. Each Navy item to be stocked under centralized inventory control is assigned a federal stock number which is used in all supply management functions. This federal stock number is listed in supply publications in which the item is referenced.

The Federal Stock Numbering System is intended to create and improve standardization of items of military supply in servicewide use and reduce excess inventories.

Federal Stock Number (FSN)

The FSN is an 11-digit number which furnishes positive identification of virtually all items of supply from purchase to final disposition. The 11 digits are uniformly arranged in groups of 4, 3, and 4 digits, with groups separated by hyphens. The 11 digits are made up of a 4-digit federal supply classification class (FSC) and a 7-digit federal item identification number (FIIN). In addition to the 11-digit number, the Navy supply system utilizes certain code prefixes and suffixes to aid in the performance of various management functions. These codes are of significance only within the Navy and are not used during interservice transactions. When the prefixes and suffixes are used, the FSN is known as a coded FSN.

Figure 3-1 describes the format of a coded FSN, including applicable management codes for an item of supply under the cognizance of ASO.

The following paragraphs discuss the various parts of a coded FSN, and frequent reference to

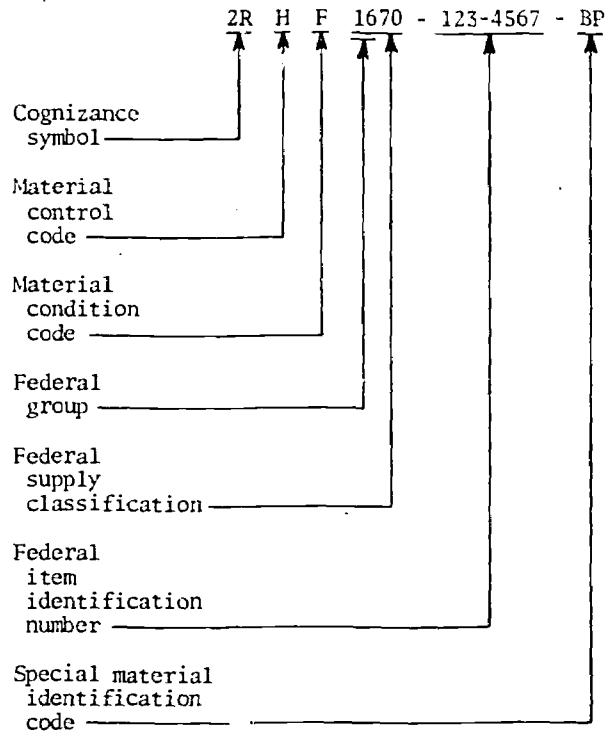

PR.441

Figure 3-1.—Breakdown of a coded federal stock number.

figure 3-1 will assist in understanding the composition of coded FSN's.

A cognizance symbol consists of a 2-digit code prefixed to an FSN to identify and designate the systems command, office, agency, or Navy inventory manager that exercises management control over specific categories of material.

Listed in table 3-1 are some of the more common cognizance symbols that a PR may encounter, together with the type material controlled and the name of the cognizant command or office.

Material control codes divide inventories into segments reflecting similar demand, reparability, or other characteristics. For example, some material control codes reflect either fast or slow moving demand characteristics, while others denote whether the item is to be repaired by intermediate or depot level maintenance activities.

Material condition codes classify material in terms of readiness for issue and use, or to

AIRCREW SURVIVAL EQUIPMENTMAN 1 & C

Table 3-1.—Cognizance symbols.

Symbol	Cognizant activity	Material controlled
1R	Aviation Supply Office.	Consumable aeronautical material.
2R	Aviation Supply Office.	Repairable aeronautical material.
8R	Aviation Supply Office.	Major aeronautical assemblies and equipment.
1I	Naval Supply Depot, Philadelphia.	Forms.
0I	Naval Supply Depot, Philadelphia.	Publications.
9D	Navy Fleet Material Support Office.	Navy owned stocks of special occupational and environmental clothing and textiles.

identify action underway to change the status of material. For example, one material condition code is used to indicate that a particular item is serviceable and ready for issue. If, after issue from the supply system and through use, this item becomes unserviceable, its material condition code would be changed to reflect the requirement for rework, repair, etc. Naturally, upon completion of rework or repair the material condition code would be changed to show that the item is serviceable and ready for issue. Therefore, this code changes from time to time on a particular item, depending on the condition of the material.

The federal supply classification (FSC) class is denoted by the first 4 digits of the FSN and is used to group related commodities together. Each item of supply is classified in one, and only one, 4-digit FSC. The first 2 digits denote the group or major division of commodities, and the last 2 digits denote the class or subdivision of commodities within a group. Aircraft components and accessories are in group 16; therefore, in the FSC 1670, the 16 denotes an aircraft component or accessory and the 70 indicates a particular class within this group, which is parachute assemblies. Other classes in group 16 are indicated as 1660—rigid seat survival kits, 1680—lap belt assembly, etc.

The federal item identification number (FIIN) consists of the last seven digits of the FSN. It serves to differentiate each individual item of supply from all other items of supply. Therefore, each individual item of supply such as liferaft, Mk-4; liferaft, Mk-7; etc., is assigned a separate FIIN. The FIIN in no way determines the position or sequence of the item in relation to other items.

A recent change has replaced the four-character TSMC with a two-letter special material identification code (SMIC). A SMIC is a management code added as a suffix to an FSN to indicate a primary weapon support item, specialized material, or general/common material. ASO has published a conversion guide which cross references the SMIC with the TSMC.

Many variations of coded stock numbers will be encountered in maintenance work. These variations indicate material management responsibilities for the item; flag certain items as recoverable, consumable, high value, etc.; and identify the condition of the material if it is not ready for issue.

Because the variety of codes is so extensive and the trend to single service management of items has caused so many changes in recent years, a list of codes that might be prefixed or

suffixed to a stock number would not be appropriate for this manual. The primary things to keep in mind are that the basic stock number, consisting of three groups of numerals, identifies the item from a technical point of view and that the other codes identify material management characteristics.

STANDARDIZATION OF ITEM NOMENCLATURE

As part of the federal cataloging system, each item of supply is assigned an official government name. Maintenance personnel frequently refer to material by trade name or terminology other than the official government name. Alphabetical indexes in the various stock catalogs and other publications are sequenced by official name. To effectively utilize these publications, it is necessary to become acquainted with the proper nomenclature.

The assignment of names to stock items is practically as important as the assignment of FSN's. When items are inducted into the supply system, official government nomenclature must be assigned. Often this item name plus additional description data will differ from names of items previously used. If difficulty is experienced in locating a familiar item in the catalog, it is possible that the name has been changed to conform to a more general usage. A few examples will show the importance of correct item nomenclature. It will be found that a "swab" is a small stick with a tiny wad of cotton on one end, and is used by the Medical Department. In order to clean the decks it will be necessary to think of a name other than "swab." "Mops" will be found listed in the catalog, together with the correct FSN. Another example of changed nomenclature is "Zipper," which has become "Fastener, Slide Interlocking," etc.

NAVAL MATERIAL CATALOGS

Federal and naval material catalogs provide information necessary to identify and procure items of material for operation and maintenance of activities afloat and ashore. The catalog most commonly used by aviation personnel is the Federal Supply Catalog Navy Management Data List.

The Navy Management Data List (NMDL) consists of two separate sections. One section, the

Fleet Ballistic Missile Weapons System Supplement, has application only to submarine forces and therefore is of little or no value to aviation maintenance personnel.

The other section, titled the Management Data List, includes basic management data necessary for preparing material requisitions. Also, it is the instrument for publishing data relative to stock number changes, unit of issue, unit price, shelf life of material, number of items contained in a package, and associated information.

The NMDL is designed to disseminate management type information as it relates to an FSN. It is not designed to act as a comprehensive catalog of material in the supply system, identify an item to an FSN, or serve as a shopping guide. Therefore, in order to get the necessary FSN or other needed information for making effective use of the NMDL, additional publications must be used in conjunction with the NMDL. These include the Deleted and Superseded FIIN List, the Consolidate Repairable Item List, and the Federal Supply Catalog Navy Master Cross Reference List.

The Deleted and Superseded FIIN List provides historical data of stock number deletions and supersedures. It should be remembered that the FIIN taken from this list is referred back to the NMDL for the requisitioning data.

The Consolidated Repairable Item List contains a listing of Navy managed mandatory turn-in repairable items. It is prepared to assist in identifying Navy managed mandatory turn-in repairable items and pertinent movement priority designators. Some repairable items under the cognizance of ASO and the Nav-AirSysCom are not included in this publication. These are listed in the ASO Master Repair List.

The Federal Supply Catalog Navy Master Cross Reference List provides the means of identifying an item from a reference number (part number, drawing number, etc.) to an FSN. The FSN found in this publication should be referenced back to the NMDL for all pertinent information required in requisitioning material.

IDENTIFICATION SOURCE DATA

As previously stated, positive identification of an item of supply has been accomplished when it is identified to its applicable FSN. For the most part, the FSN is not marked on material; however, most material has some type of data affixed to it that can be used for identification

AIRCREW SURVIVAL EQUIPMENTMAN 1 & C

purposes. Certain data which do not identify an item but which aid in obtaining positive identification are discussed in the following paragraphs.

Manufacturer's Part Number

Normally, the manufacturers of parts stamp, etch, paint, or otherwise affix a part number on each item manufactured. The use of this manufacturer's part number and the knowledge of the part's application (that is, on what equipment it is used) normally lead to the positive identification of the part's nomenclature and FSN. The part number can be ascertained to be correct by reference to the appropriate Illustrated Parts Breakdown (IPB), and the FSN may be obtained by reference to the appropriate Federal and Naval Material Catalogs.

Drawing Numbers

A drawing number consists of letters, numbers, or a combination of both which are assigned to a particular drawing for identification purposes. The activity controlling the drawing (normally the manufacturer) assigns the number in conformance with their drawing number system. One drawing may apply to several items; thus, other distinguishing data may be necessary to identify the item on the drawing.

Source Codes

Item Source Codes are symbols which indicate to a consumer a source of supply for an item required to maintain or repair aeronautical articles. Specifically, these codes indicate whether the item is to be requisitioned from the supply system; to be manufactured; to be obtained from salvage; not to be replaced since the next higher assembly is to be installed; or, due to failure, is in need of complete overhaul or retirement of the assembly or equipment from service.

Source codes are assigned to the material at the time of provisioning. Known or anticipated usage is the primary factor in the assignment of source codes. The ability to manufacture an item within a naval activity is considered to be of secondary importance. In other words, items are normally source coded for purchase and stocking in the Navy supply system if usage is known or anticipated. Source codes for individual items may be revised as experience and usage develop.

Source codes are published as a column of the numerical index of the Illustrated Parts Breakdown, and in other publications as directed by the NavAirSysCom.

Source codes are provided in six series-- P, M, A, N, X, and U.

Source code P series applies to items of supply system stock which are purchased in view of known or anticipated usage and which are relatively simple to manufacture within the Navy if necessary.

Source code M series applies to items which are not purchased but are capable of being manufactured at Navy fleet or rework facilities. These items are normally manufactured upon demand and are not stock numbered.

Source code A series applies to assemblies which are not purchased but which are to be assembled.

Source code N series applies to items (nuts, bolts, screws, etc.) which do not meet established criteria for stocking and which are readily available from commercial sources. These items are purchased on demand.

Source code X series applies to items which, if damaged, would require uneconomical repair. The need for an item, or items, coded X will normally result in recommendation for retirement of that equipment from service.

Source code U applies to items which are not of supply or maintenance stocking significance.

Within each of these source code series, except U, there are one or more subcodes identified by a letter or number appended to the basic code number. These subcodes provide detailed information concerning the procurement or manufacture of various parts within the scope of the particular code series. The applicable Illustrated Parts Breakdown provides ready reference for each of the codes and subcodes as required.

The preceding sections have emphasized some of the many things that may be used to identify or aid in procurement or use of material. The senior PR who is familiar with the methods of identifying material is an asset to a maintenance organization.

AERONAUTICAL ALLOWANCE LISTS

This title is inclusive of publications identified as Allowance Lists (except advanced base lists), Initial Outfitting Lists, and Tables of Basic Allowances.

Chapter 3—SUPPLY

Naval Air Systems Command Allowance Lists, Initial Outfitting Lists, and Tables of Basic Allowances are prepared by the NavAirSysCom or the Aviation Supply Office. In nearly all instances, ASO has the responsibility for preparation; but in all cases, these lists are published by the direction of and approved by the NavAirSysCom. These lists contain the following:

1. The equipment and material (both consumable and nonconsumable) necessary to outfit and maintain units of the aeronautical organization in a condition of material readiness.
2. Substantially all items used with sufficient frequency to justify their issuance to all activities maintaining aircraft or equipment for which the lists are designed.
3. Information concerning stock number, nomenclature, interchangeability, and supersedures.
4. A set of detailed instructions for the application and utilization of the publication.
5. A table of logistic data showing the total weight and cube of all material contained in the list.

In the final analysis, the equipment and spare parts listed in these publications are made available to aircraft operating and maintenance activities in accordance with assigned operational maintenance and logistic responsibilities through appropriate application of allowance lists and outfitting actions. The Aviation Supply Office has the responsibility for continually reviewing and updating allowance lists.

INITIAL OUTFITTING LISTS

Initial Outfitting Lists are publications which indicate the range and quantities of maintenance spare parts considered necessary to support various aeronautical end items. These lists contain repair parts, such as airframe parts, electronic parts, engine parts, and general aeronautical equipment. The material covered by Initial Outfitting Lists is normally retained in supply department stocks until required for issue. This allowance of material is provided to ships or activities and is firm only at the time of initial outfitting. Increases and decreases in both range and/or quantities of material are based upon usage data of each activity concerned. Each series list is designed to support an aircraft, electronic equipment, or some other aeronautical article.

ALLOWANCE LISTS

These are publications which indicate the range and quantities of equipment and material considered necessary for maintenance support of assigned and/or supported aircraft. Generally, these items are in-use items required for daily or continual use, such as parachutes, flight clothing items, aircraft jacks, etc.

TABLES OF BASIC ALLOWANCE

Publications listing equipment and material required by activities for performance of assigned mission are known as Tables of Basic Allowance. They contain both shop equipment and common supporting spare parts. They cover allowances of tools and equipment required for use by fleet squadrons and pilotless target aircraft activities.

A complete listing of Aeronautical Allowance Lists and Tables of Basic Allowance, with NavAirSysCom publication numbers and their effective dates, is contained in NavSup Publication 2002, Section VIII, Part C.

IDENTIFICATION AND TYPES OF ALLOWANCE LISTS

Allowance Lists and Initial Outfitting Lists are identified by the NavAirSysCom publication number 00-35Q (Series), while Tables of Basic Allowance are identified by the NavAirSysCom publication number 00-35T (Series). The following paragraphs discuss some of the various sections of allowance lists.

Section A covers general material such as nuts, bolts, tubing, hose, paint, and other items common to the operation of all aircraft models. Both equipage and consumable supplies are shown in section A.

Section B contains airframe, engine, and accessories maintenance parts peculiar to each type of aircraft. A separate section B is issued for each model of aircraft.

Section C lists the items and quantities of office furniture and laborsaving devices for the administrative support of deployable fleet air activities only.

Section G lists the quantities of handtools, handling and servicing equipment, and material which are made available for maintenance support of aircraft as may be assigned or supported.

AIRCREW SURVIVAL EQUIPMENTMAN 1 & C

Section H is applicable to air task group commanders and all Navy and Marine squadrons operating aircraft or having aircraft assigned. It contains items and quantities of flight operational material considered necessary to maintain the concerned activities in a continual condition of operational readiness.

Section K outlines the general types and classes of aeronautic technical and training publications and forms which are provided as a commissioning allowance for various Navy and Marine Corps aviation activities. It lists those publications and forms which are issued by the Deputy Chief of Naval Operations (Air) and by the Naval Air Systems Command, but does not include publications provided to aviation activities by other Navy Department systems commands and bureaus, by fleet commands, or by non-Navy offices.

Section R comprises Allowances Lists and Initial Outfitting Lists of electronic equipment and material required for the test and maintenance of aeronautical electronic equipments within the Naval Establishment.

Section T is applicable to Navy and Marine Corps aeronautical maintenance activities and lists the allowance of special support equipment required for maintenance support of assigned aircraft. A separate section T allowance is published for each manufacturer.

Section Z includes mobile electric power-plant spare parts and equipment and spare parts support for aircraft support equipment.

The foregoing section list breakdown includes only those sections of professional interest to the PR. The complete list includes allowance lists for arresting gear and catapults, photographic, aerological, etc.

ACCOUNTABILITY CODES

The accountability codes used in allowance lists and most Illustrated Parts Breakdowns are known as Material Accountability Recoverability Codes (MARC). MARC's are assigned only to aeronautical provisioned items to reflect the accountability, recoverability, and repair policy determined for an item of equipment or material required for the maintenance, repair, or rework of an end item. MARC is a system whereby a letter of the alphabet is used as a guidepost by personnel working with aviation material. This system helps personnel to determine the proper method among the following:

1. Requisitioning material with regard to inventory control and fiscal accounting procedures.

2. Accounting for material while in use.

3. Turn-in or disposition of material.

4. Repair or overhaul.

The following paragraphs define the various material accountability codes.

B--Exchange Consumables

Code B is applied to items which are consumable or expendable but normally require item-for-item exchange for issue after the initial outfitting. Such items may contain precious metals, may be highly pilferable, or may be high cost items.

C-Consumables

Code C is applied to all other consumable or expendable items which do not require item-for-item exchange for replacement.

D--Equipage, Support Type

Code D is applied to end items of support equipment which are economical and practical to repair on a scheduled basis through a major rework activity. Code D items are maintained on a custodial signature basis and must be surveyed when lost or missing or when beyond economical repair. After initial outfitting, Code D items require item-for-item exchange for replacement. Every effort should be made to repair Code D items locally or through fleet support activities prior to turning in the item to the supply system as non-RFI material.

E--Equipage, Locally Repairable, Support Type

Code E is applied to end items of support equipment which are to be repaired locally by the using or fleet support activity within their assigned maintenance responsibility. Code E items are maintained on a custodial signature basis when in use, require item-for-item exchange for replacement, and require surveying when lost or missing. The cognizant NavAir-SysComRep may authorize repair of E items through customer service from a major rework activity in order to meet operational commitments.

R-Equipage

Code R is applied to repairable (except end items of support equipment) items which are economical and practical to repair on a programmed basis through a major rework activity. Code R items are repaired by local activities when the extent of the required repair falls within the maintenance capability of the activity. After initial outfitting, these items are issued only on an exchange basis or when necessary to replace an item expended by approved survey.

L—Equipage, Locally Repairable

Code L is assigned to repairable items (except end items of support equipment) which can be repaired by deployable squadrons within their assigned maintenance responsibility upon consideration of the following factors:

1. Manhours and skills required to perform the repair.
2. Total cost of providing necessary support equipment to perform the repair.
3. Total cost of providing necessary repair parts to perform the repair.

Items coded L are scrapped when economical repair is beyond local activity capabilities. After initial outfitting, issues of Code L items are made only when exchange procedures provide for turn-in of the replaced item or when necessary to replace an item expended by approved survey.

AIRCRAFT MAINTENANCE MATERIAL READINESS LIST (AMMRL) PROGRAM

This program has provided for the development of data and documentation needed to determine and establish firm support equipment requirements and inventory control of aircraft maintenance support equipment. It provides for the construction of an Individual Material Readiness List (IMRL) for each aircraft maintenance activity, by name, prescribing items and quantities of aircraft maintenance material required for material readiness of that specific activity to which the list applies.

This program also provides for the construction of material readiness lists to indicate the total quantities of each item authorized within stations, logistic areas, and major operating command areas.

Within the AMMRL program there are several material readiness lists, however, only two are discussed here.

The Application Data Material Readiness List (ADMRL) is used to specify the requirements for each item of aircraft maintenance support equipment against each level of maintenance and selected ranges of each aircraft, engine, propeller, and system for which each item is needed. This data is developed primarily from Aeronautical Allowance Lists. Through the use of electronic data processing machines, this data is used to develop Individual Material Readiness Lists.

The IMRL specifies items and quantities of aircraft maintenance support equipment required for material readiness of the aircraft maintenance activity to which the list applies. As previously stated, this list applies to an activity by name. The NavAirSysComRep is responsible for the preparation of the IMRL for each activity in his cognizant area. It is prepared by extracting from the AMMRL those applicable portions which pertain to the specific aircraft and maintenance material assignments of the activity for which the list is developed.

The IMRL should be continually reviewed and updated by each activity to support current and anticipated changes in aircraft maintenance support equipment requirements. Because the IMRL is continually reviewed and updated and approved by the cognizant command, it is the firm mandatory material readiness list of the activity to which the list applies. The IMRL is actually a composite listing of the various allowance lists previously discussed.

SUPPLY ACTIVITY

The mission of the Supply Activity is to support the operational and maintenance efforts of the activity/ship. Stocks of aviation-oriented material carried are tailored and replenished to this end. Positioning, replenishment, and control of stocks of material in maintenance areas are carried out as a result of joint decisions by the Supply and Maintenance Officers concerned. They determine the range, depth, and related procedures. The Navy Maintenance and Material Management System requires that the cost of material used in maintenance be determined and accumulated in such manner and detail that weapons system costing can be measured. Usage is finely defined as to stock number, within component, within system, within

AIRCREW SURVIVAL EQUIPMENTMAN 1 & C

equipment/weapon/aircraft, in a particular squadron, located in a specific operational area, at a definite point in time. This data is used as an inventory management tool to determine geographic and strategic distribution of stocks of material. In addition, the data is invaluable in establishing the material portions of work standards in maintenance.

SUPPLY SUPPORT CENTER

Maintenance organizations have one point of contact with the supporting supply activity. This single contact point is the Supply Support Center (SSC), which responds to all material requirements of the maintenance organizations. The SSC is an internal organization of the local supply activity. It is made up of two sections—the Supply Response Section and the Component Control Section.

Supply support is available consistent with the operating hours of the maintenance activities supported. If maintenance is being performed 24 hours a day, then supply support is available 24 hours a day.

Supply Response Section

The Supply Response Section (SRS) is responsible for preparing all necessary requisitions (DD Form 1348) and related documents required to obtain material for local maintenance use in direct support of weapon system maintenance. The maintenance organization verbally notifies the supply organization of the need of such material. When material is available locally, the time frame for processing and delivery is as follows:

Priority	Process/Delivery Time
1-3	1 hr
4-8	2 hr
9-20	24 hr

The SRS is responsible for receipt, storage, and issuance of all ready-for-issue pool components. It is responsible for physical delivery of RFI material to maintenance organizations, and the pickup of defective components from the organizational maintenance activity and subsequent delivery to the intermediate maintenance activity. Actual maintenance personnel are not

involved in the physical movement of material between organizations.

This section also performs technical research in regard to completion of requisition documents as well as determining the status of outstanding requisitions and relaying this status to the customer upon request.

Component Control Section (CCS)

The Component Control Section accounts for all components being processed in the intermediate maintenance activities. In addition, records will be maintained on the status of all rotatable pool components.

Supply Screening Unit (SSU)

It is the responsibility of the Supply Screening Unit to initiate disposition action on components that cannot be repaired by the local intermediate maintenance activity. Components will be received from the activity with appropriate record cards, logbooks, the fourth copy of the MAF, and the appropriate condition tag. Using listings and directives from inventory managers, screening personnel will determine disposition of the component in question, including prospective consignee and packaging and preservation requirements prior to movement of material. The CCS must be notified of the status of the component in order that the CCS file and/or record can be updated.

MATERIAL CONTROL WORK CENTER.— In order to maintain an effective aircraft maintenance program, a cooperative working relationship must exist between production and supply. Effective maintenance of complex weapons systems cannot be accomplished without an adequate material supply program. A material control work center is provided in the Organizational maintenance department to act as liaison between the maintenance department and the local supply activity.

The material control work center insures that proper parts, tools, and equipment are available to the production divisions in the required quantities at the proper time. This work center must compile and analyze maintenance usage data and furnish technical advice and information to the local supply activity on the identity and quantity of supplies, spare parts, and material necessary to accomplish the assigned workload.

MATERIAL CONTROL REGISTER

The Material Control Register is used by intermediate and organizational level material control work centers to record all material requested from the Supply Support Center in direct support of weapon system maintenance. Space is provided to record essential information considered necessary to monitor operating target (OPTAR) funds. This information includes part number, priority, quantity, price, date and time ordered, and date and time received. Maintenance control uses the time ordered and time received to help determine Not Operationally Ready Supply (NORS) time used in fulfilling readiness reporting requirements.

MATERIAL REQUISITIONING

The Military Standard Requisitioning and Issue Procedure (MILSTRIP) and Uniform Material Issue Priority System were developed by the Department of Defense to provide a common supply language and more effective supply system operations within the military establishment. This system standardizes forms, formats, codes, procedures, and the priority system.

MILSTRIP employs two forms for the requisitioning and issuing of material. The Single Line Item Requisitioning Document (Form DD 1348) is the basic request document submitted to the applicable supply echelon for material requirements. The issue document is the Single Line Item Release/Receipt Document (Form 1348-1). Form DD 1348-1 is also used to return RFI material to the supply system. As previously stated, these forms will be prepared by the Supply Response Section of supply for all material requested in direct support of weapon system maintenance and by the material control work center for material requested in direct support of weapon system maintenance.

Under the MILSTRIP priority system there is no decision to be made in assigning priorities. The urgency of need combined with the unit's military importance when applied to the priority number chart (table 3-2) indicates the proper priority number and no deviation is allowed.

The force/activity designators represent categories of activities in descending order of military importance, ranging from the combat forces under I to the miscellaneous activities under V. Every activity is assigned one of the five force/activity designators according to

Table 3-2.—Priority number chart.

Force/activity designator	Urgency-of-need categories			
	A	B	C	D
I	1	4	11	16
II	2	5	12	17
III	3	6	13	18
IV	7	9	14	19
V	8	10	15	20

their military importance. These designations are as follows:

I - COMBAT—The highest order of military importance. This designator is not used in peacetime unless approved by the President or the Joint Chiefs of Staff.

II - POSITIONED—U.S. Forces positioned and maintained in a state of readiness for immediate combat or direct combat support.

III - READY—U.S. Forces maintained in a state of readiness to deploy for combat.

IV - RESERVE AND SUPPORT—U.S. Active and Selected Reserve Forces planned for employment in support of approved joint war plans. This category includes training units and units in training for scheduled deployment.

V - OTHERS—All units not otherwise assigned.

Force/activity designators are assigned by the Secretary of the Navy, the Chief of Naval Operations, and Commanders in Chief of Fleets. Authority to make assignments may be delegated to Fleet Commanders with the exception of I - COMBAT. Each activity is advised by the appropriate military commander of the assigned designator which governs the procurement of material for that activity.

The letters across the top of table 3-2 represent different degrees of urgency, in descending order of need, from an extremely serious need under A to routine stock replenishment under D. The urgency category is selected by the requesting activity. Definitions of the urgency-of-need categories for aviation units are as follows:

A - Material and equipment for immediate installation or use to effect emergency repairs

AIRCREW SURVIVAL EQUIPMENTMAN 1 & C

or replacement for an aircraft mechanically incapable of flight, or an aircraft incapable of performing its primary mission.

B - Material required to effect emergency replacement or repairs without which the operational capability of the activity will be impaired and decreased effectiveness and efficiency in accomplishing assigned operational missions and tasks will result.

B also includes material required to effect emergency replacement or repairs without which the activity can operate only temporarily as an effective unit in performing its assigned operational mission and tasks. This includes material required for aircraft overhaul work stoppage.

C - Material required for emergency repairs or replacement of specific units of inoperative equipment or systems not essential to the operational effectiveness or safety of the force/activity.

C also includes material required for scheduled deployment.

D - Material required in preparation for operational readiness; material required for scheduled maintenance of a specific aircraft or system; material required for initial outfitting or filling of allowances; and all stock replenishment actions other than previously prescribed.

If a squadron or unit has been assigned force/activity designator III and a work center supervisor determines that a part or some material is needed which, if not received, will impair the capability of the aircraft to perform its assigned mission, then the priority assigned must be number 6. The only other priorities available to force/activity designated III units or squadrons are 3, 13, and 18.

There are no allowable exceptions to the force/activity designator governed priority number system. Medical or disaster supplies and essential clothing may be requisitioned under priorities 3 and 6, respectively, by any activity regardless of its force/activity designator.

MATERIAL TURN-IN

There are two main reasons for turning in material—the first and most common is the turning in of a damaged, wornout, or otherwise inoperative part in exchange for a like RFI item; and second, returning of material for credit, such as excess material or material received in error.

When it is determined that a needed part is an exchange item, the old part should be cleaned of grease and dirt, drained, flushed, or purged as necessary before turning it in.

When a defective repairable item is turned in, the following forms are required: copies two, three, and four of the multicopy Maintenance Action Form and the Accessory and Component Service Record, when applicable. The supply department uses copy two of the MAF for bookkeeping purposes. Copies three and four of the MAF accompany the item to the intermediate maintenance activity. When repair is completed by the IMA, copy four of the MAF is attached to the RFI item and the item is returned to the supply system.

If material being turned in is no longer required and is RFI, a Single Line Item Release/Receipt Document (DD 1348-1) is submitted with the item. RFI means ready for issue in all respects.

SURVEY OF ACCOUNTABLE MATERIAL

The Survey Request, Report and Expenditure, NavSup Form 154, is the document used to reevaluate or expend lost, damaged, deteriorated, or worn material from the records of the accountable officer as required by U.S. Navy Regulations. Rules and regulations governing survey and the responsibility connected with the accounting for government property are of primary importance to every man in the naval service.

The survey request provides a record showing the cause, condition, responsibility, recommendation for disposition, and authority to expend material from the records. Rough survey requests are prepared by the person or department head responsible for the material to be expended or reevaluated.

TYPES OF SURVEYS

There are two types of surveys with which the PR should be familiar—formal and informal. Each activity normally prepares local regulations outlining the circumstances which determine whether a formal or an informal survey is made. However, the commanding officer may order a formal survey when he feels that circumstances warrant such action.

Formal Survey

A formal survey is required for those classes of materials or articles so designated by the bureau or office concerned, or when specifically directed by the commanding officer. A formal survey is made by either a commissioned officer or a board of three officers, one of whom, and as many as practicable, must be commissioned, appointed in either instance by the commanding officer.

Neither the commanding officer, the officer on whose records the material being surveyed is carried, nor the officer charged with the custody of the material being surveyed, may serve on a survey board.

Informal Survey

Informal surveys are made by the head of the department having custody of the material to be surveyed. Informal surveys are used in cases in which formal survey is not required or directed by the commanding officer. Lost or missing items of flight clothing authorized to naval aviators on individual issue basis (log-book items) are surveyed by inserting a brief explanation as the cause and responsibility for the loss on the DD Form 1348 to be submitted to the supply department for replacement. This statement must be approved and signed by the commanding officer of the unit to which the aviator is attached.

PREPARATION OF A REQUEST FOR SURVEY

A request for survey may be originated by a department, division, or section head, or a designated subordinate, as prescribed by local regulations. Normally, requests for survey are originated in the department having custody of the material being surveyed. The initial survey is made on a rough copy of NavSup Form 154. A statement by the originator is placed on or attached to the request for survey. Included in this statement is information relative to the condition of material; cause or condition surrounding the loss, damage, deterioration, or obsolescence of material; responsibility for cause or condition of material, or reason why responsibility cannot be determined; and recommendation for disposition of material or action to be taken.

Upon receipt of the rough copy, the designated group or section prepares a sufficient number of smooth copies of the request for distribution in accordance with local regulations. The smooth survey request is filled in down to the caption, "Action by Commanding Officer or Delegate." It is then forwarded to the commanding officer who determines whether the survey will be formal or informal. If formal, the survey request is forwarded to the designated surveying officer(s); if informal, it is forwarded to the head of department for survey action.

The statement by the originator as to the cause, condition, etc., is attached to the smooth request for survey for evaluation by the surveying officer(s). After the survey has been completed by the head of department or surveying officer(s), it is returned to the commanding officer for review action. After approval by the commanding officer, the survey request is forwarded to the cognizant fleet command and/or systems command for final review and approval when so required. In the absence of specific instructions, surveys are not forwarded to the Naval Air Systems Command for final review and approval.

After approval, the supply officer expends items as directed by the approved survey.

Requests for replacement of surveyed items must be made on DD Form 1348, and must be accompanied by a certified copy of the approved survey request.

Culpable Responsibility

When a person in the naval service is found to be culpably responsible by a surveying officer or board, the reviewing officer refers the entire matter to such a person for a statement. The reviewing officer must then take such disciplinary action as the circumstances require. He notes on the survey the action taken and informs the Chief of Naval Personnel and the systems command concerned as to the disciplinary action taken. In the case of officers, he must make recommendations as to the inclusion of a statement of the action taken in the record of the officer concerned and inform that person of the final decision in the matter. Action on the survey with respect to the material involved must NOT, however, be withheld pending disciplinary action. (See art. 1953, U.S. Navy Regulations.)

CHAPTER 4

WORK CENTER SUPERVISION AND ADMINISTRATION

As a Chief or First Class PR, you will be assigned duties as parachute loft supervisor. The job of supervising the operation of a loft is a many-sided task. You must procure needed loft equipment, spare parts and other materials. You plan, schedule, and direct work assignments; maintain an adequate file of aeronautical publications; interpret and comply with bulletins and other directives; maintain records and reports; carry on an instructional program for loft personnel; and instruct others in the use of survival equipment.

Some of the necessary techniques have been learned through past experience. Others have to be learned through self-study courses and technical publications. The purpose of this chapter is to acquaint the new or prospective supervisor with some of the more important aspects of parachute loft supervision and administration.

OBJECTIVES OF SUPERVISION

The objectives of supervision are as follows:

1. Operate with maximum efficiency and safety.
2. Operate with minimum expense and waste.
3. Operate free from interruption and difficulty.

While these are the primary objectives of supervision, it is well for the PR who may be assigned these duties, to keep in mind the fact that his new assignment is important to him personally. It affords him an excellent opportunity to gain practical experience toward eventual promotions.

OPERATION WITH MAXIMUM EFFICIENCY AND SAFETY

The operational efficiency of a work center is dependent to a large extent upon how conveniently the workspaces and equipment are arranged in the work center. As some equipment becomes obsolete, and new equipment and new models of equipment are phased into the work

center inventory, the efficiency increases to a certain extent, but may still be short of the full potential. Making a drastic rearrangement to improve the utilization of a single piece of equipment may not be economically feasible; however, a drastic change which results in improved utilization of several pieces of equipment may be worthwhile. The new work center supervisor needs to make an evaluation of the existing work center layout to assure himself that he has the most efficient arrangement possible.

A supervisor should know his men's limitations and capabilities in order to get the most work from them. He should exploit the capabilities of his best men in a twofold manner. If at all possible, he should assign a well qualified man to do a certain job and add to the team other individuals who are less qualified but who are professionally ready for advanced on-the-job training.

The supervisor must anticipate the eventual loss of his most experienced workers through transfers, discharges, etc., and offset this by the establishment of an effective and continuing training program. In addition to raising the skill level of the division, the training program insures that personnel, otherwise qualified, are ready for the advancement-in-rating examination.

A work center safety program must be organized and administered if the work center is to function efficiently. Current Navy directives and local policies are quite specific as to the establishment of safety training programs. A worker is no good to anyone if he is in the sick-bay with an injury caused by unsafe work habits and/or practices.

The keeping of accurate and complete records is another factor in the efficient operation of a parachute loft. This includes records of usage data, work accomplished, and personnel progress. The most efficient recordkeeper is one who has enough records without having his files bulging with useless and outdated material.

Chapter 4—WORK CENTER SUPERVISION AND ADMINISTRATION

A knowledge of the principles of manhour accounting is necessary in the efficient utilization of the manpower available. The supervisor must schedule his workload so that planned absences of keyworkers do not unduly interrupt the daily routine. When scheduling the workload, he must keep in mind the skill levels required for the various tasks, and assign individuals to jobs in such a manner that the work still progresses when any worker is unexpectedly absent.

OPERATION WITH MINIMUM EXPENSE AND WASTE

The efficiency of any operation is directly related to the expense involved. The work center supervisor has the responsibility for ordering and accounting for spare parts and material. He must impress upon his men the need for being thrifty in the use of these materials. There are many ways to economize, and the supervisor and his senior petty officer should always be on the alert for opportunities to point out these ways to the less experienced individuals.

Methods of avoiding waste and unnecessary expense should be included in the work center training program.

OPERATION FREE FROM INTERRUPTION AND DIFFICULTY

The meeting of this objective depends largely upon the extent to which the work center, files, and equipment are maintained. Equipment in good working order, tools in good shape and of the proper type and quantity, and an up-to-date file of applicable publications are all important factors contributing to a smoothly running parachute loft.

The work center functions may be further smoothed by the judicious delegation of authority to individuals next in seniority to the supervisor. The delegation of authority does not relieve the supervisor of the final responsibility for the work accomplishment. It is primarily a means of relieving the supervisor of details. A supervisor who allows himself to become too involved with details loses his effectiveness as a supervisor.

PLANNING WORK CENTER ARRANGEMENT

The average chief or first class may never have the opportunity to plan the layout of the

loft in a new facility. In almost every case the new supervisor takes charge of an already functioning work center, or else, when his squadron or unit moves to a new base, he and his crew are usually assigned to spaces already equipped to service aviator's equipment. In either case, a reevaluation of the shop's layout is indicated. The reevaluation of the work center layout should include finding out from the applicable allowance lists if the work center equipment allowances have been changed in any way. There is no use relocating equipment which involves rewiring or plumbing work if improved replacement models are authorized and available.

PURPOSE OF THE WORK CENTER

A basic consideration in planning a work center layout is the purpose of the work center. When more than one shop is available, the supervisor must decide which work centers are to occupy the spaces and, if necessary, which have to share space. Of two spaces identical in size, one may, for example, be completely unacceptable as a packing room due to the shape of the space, or the ideal location for an oxygen shop may not be used for that purpose if the structural design of the building causes exhaust duct installation problems.

The general function of the work center must be considered in the allocation of space and equipment. The ideal setup contains enough space to have the raft shop, sewing room, dry locker, packing section, and oxygen shops in separate spaces in a centrally located area. Since this is not normally possible, the supervisor must decide what shops are to be combined and in what areas of each space appropriate equipment is to be installed. This decision should be based on factors of safety, economy, functional compatibility, and convenience.

ARRANGEMENT

Following the determination of what shops are to occupy what spaces or areas within a space comes the arrangement of furniture and equipment for the various shops. This arrangement should be made on the basis of utility rather than appearance. Moving an item of equipment into an out-of-the-way corner may greatly improve the appearance of the shop but at the same time reduce the efficiency of

AIRCREW SURVIVAL EQUIPMENTMAN 1 & C

personnel using the equipment and may possibly create a safety hazard. A good rule to follow is to locate equipment where it can be safely used by the greatest number of people with a minimum of effort in the least amount of time.

Workbenches or tables should be positioned with respect to fixed equipment so that the equipment most often used is most quickly and easily reached.

Consideration should be given to installing special lighting such as the explosion-proof, vapor-proof or interference-free types of lighting near workbenches where specific and intricate regulator repairs are performed. This is also true for other special installations such as oxygen outlets for various pressures, with gages and regulators available for the performance of necessary tests of all types of regulators.

A system of stowing tools must be devised. An intelligent system cannot be set up without first determining from allowance lists what tools are required for satisfactory operation of the shop. The place for all tools should be marked or otherwise specified, and everything not being used should be kept in its place.

The shop layout plan should make provision for an information or bulletin board upon which may be posted safety posters, maintenance posters, instructions and notices, plans-of-the-day, and such other information as is appropriate from time to time. The bulletin board should be located in a prominent place in the shop, preferably near the entrance where everyone assigned has to pass at one time or another during the day. Material on the bulletin board should be changed frequently, expired notices promptly removed, the current plan-of-the-day posted early, and other posters and material rotated periodically. If the same material is presented in the same format every day, it is not long before the men begin to ignore the bulletin board and purposes for having it are defeated. New arrangements are noticed and interest is stimulated with variety.

The Naval Air Systems Command, in conjunction with the Naval Ship Systems Command, is responsible for providing adequate aircraft maintenance facilities ashore and afloat (including Aviators Equipment Work Centers). Volume 1, OPNAVINST 4790.2 (Series), provides the policies, concept, organization, and responsibilities of the Naval Aviation Maintenance Program.

SCHEDULING AND ASSIGNMENT OF WORKLOADS

Among the most important factors with which the Chief or First Class PR is concerned as a work center supervisor are the assignment and accomplishment of the scheduled workload. His objective is the satisfactory completion of assigned tasks in a reasonable length of time, and utilizing available men and materials as efficiently as possible. In order to achieve his objective, the supervisor must become skilled in estimating the amount of time to allow for the completion of each task and estimating the number of workers required. He must realize the importance of assigning both qualified and unqualified men to the jobs, consistent with his training program. The supervisor must allow for planned interruptions and yet not operate on so tight a schedule that minor, unplanned interruptions completely disrupt his schedule. The number of air groups, the parachutes assigned each, and the Work Center equipment will have to be taken into consideration in order to determine the number of tables necessary to adequately carry out the prescribed packing schedule. To assure himself that the job is indeed satisfactorily completed, the supervisor must allow adequate time for the Work Center Collateral Duty Inspector to complete an inspection, prior to signing of the Work Request.

ESTIMATING TIME AND PERSONNEL REQUIREMENTS

Most parachute loft tasks are of such a nature that the quality and number of personnel assigned to do them directly affect the time that is required for completion. For this reason, time requirements and personnel requirements are combined and discussed together in this section.

ALLOWING FOR PLANNED INTERRUPTIONS

During an average workday, occasions arise when personnel have to leave their working spaces for one reason or another, thereby delaying the completion of the scheduled work. Some delays can be anticipated, some cannot. Among the delays which can be anticipated are training lectures, immunization schedules, flight schedules, rating examinations, meals, and watches or other military duties.

Chapter 4--WORK CENTER SUPERVISION AND ADMINISTRATION

Before making personnel work assignments, the supervisor should determine what delays can be anticipated. It may be possible to arrange assignments so that work interruption is held to a minimum. When estimating the completion time of a task, the supervisor should allow for these predictable delays.

INSPECTION OF COMPLETED WORK

All work completed by the parachute lofts is subject to inspection by the squadron or unit quality assurance inspectors. This fact in no way relieves the loft supervisor of the responsibility for checking on the quality of work accomplished by his division. Frequent inspections should be made during the progress of the work as well as after completion. The supervisor's inspection should provide affirmative answers to the following questions:

1. Is the work done according to current directives?
2. Do technical materials used conform to specifications?
3. Is the job complete in all respects?
4. Does the workmanship measure up to desired standards?

When parts or components are removed or installed, the supervisor should insure that the necessary functional checks are performed in accordance with existing directives.

When the aircraft maintenance task has been completed, the crew leader is required to complete the Maintenance Action Form. An important function of the supervisor is to review and evaluate the completed MAF. The purposes of the supervisor's review and evaluation are listed below, not necessarily in order of importance:

1. Determine completeness. Ascertain if entries are made in every space required of his work center.
2. Evaluate the items on the completed MAF's which indicate that discrepancies have been found and corrected or parts replaced. Ascertain if causes were determined for each discrepancy and evaluate correctness of steps taken to eliminate the causes. Determine if any combination of discrepancies indicates improper operation or incipient failure of a related part, component, or assembly.
3. Note manhours expended. Determine if estimated maintenance time is realistically reflected in the crew leader's report of manhours used.

In addition to the duties and responsibilities previously mentioned, the supervisor is responsible for the following:

1. The production efforts of the work center as assigned by maintenance control.
2. Maintain the work center register.
3. Inform maintenance control of the status of the workload.
4. Insure that inspections are performed by Quality Assurance.
5. Supervise production efforts of the work center, and insure that qualified personnel, proper tools, and proper techniques are used for each job.
6. Expedite all requests for parts to material control.
7. Coordinate with material control the return of defective components and applicable logs/records to supply.
8. Conduct a training program for assigned personnel.

The work center supervisor is also vital to the operation of the manhour accounting system. He is responsible for the accuracy of all information submitted by the work center. Manhour accounting and other aspects of the 3-M System are discussed later in this chapter.

QUALITY ASSURANCE AND INSPECTION PERSONNEL

Since the responsibility area of the supervisor is the middle ground between management and men, it is incumbent upon him to initiate and administer a work center quality assurance program. His main objective is to improve the state of training of his men until their mental attitude is such that top quality workmanship becomes second nature. How successful he is in achieving this objective is determined by his ability and insight in the following areas:

1. The assignment of the proper number of qualified men to do the jobs, plus on-the-job trainees.
2. Making provisions for adequate on-the-job supervision and inspection.
3. Allowing adequate time to perform safe, high quality jobs.
4. Assuring himself that current directives and publications on safety and aircraft model concerned are available and complied with.
5. Monitoring the training program with respect to timeliness and completeness of coverage. Eliminating out-of-date training material

promptly and introducing important new material as soon as possible after receipt without regard to lesson schedules.

These procedures should result in high quality workmanship by loft personnel and meeting of specifications and quality standards in the work.

Commanding officers are responsible for the inspection and quality of material under their cognizance. The quality assurance concept is fundamentally the prevention of the occurrence/reoccurrence of defects. Achievement of quality assurance depends on prevention, knowledge, and special skills.

There are two types of inspectors: Quality Assurance Inspectors, who are personnel permanently assigned to the Quality Assurance Division as Inspectors; and Collateral Duty Inspectors, who are assigned to a production division such as the parachute loft, and have a secondary duty assignment to inspect work accomplished within their assigned production division.

Quality Assurance Inspectors are selected by the Quality Assurance Officer. Collateral Duty Inspectors are nominated by their division officer and approved by the Quality Assurance Officer after determining that the nominee is fully qualified to inspect the work for which he is responsible. All inspectors will be designated in writing by the commanding officer and their qualification will be reviewed periodically.

It is not feasible for Quality Assurance Inspectors to inspect each job and each product. Accordingly, it is emphasized that an inspection should, in most instances, be accomplished by a Collateral Duty Inspector. However, no Collateral Duty Inspector should inspect work that he has performed as a production worker. The quality assurance officer is responsible for the completeness and adequacy of all inspections including those conducted by Collateral Duty Inspectors.

PERSONNEL WORK ASSIGNMENTS

Work assignments should be rotated so that each man has an opportunity to develop his skills in all phases of loft work. When assignments are rotated, the work becomes more interesting for the men. Another good reason for rotating work assignments is that if one highly skilled man performs all the work of a certain type, the supervisor and the work center are at a great disadvantage in the event the man is transferred from the work center. Less

experienced personnel should be assigned to work with him in order to become proficient in his particular skill. Also, in order to broaden his knowledge of his rate, the expert on one job should be rotated to other tasks when there is no immediate need for his particular skill.

Strikers should be assigned to various tasks so that they acquire experience on all kinds of jobs. A special consideration for the assignment of strikers to jobs is that they should be assigned progressively to jobs of ascending levels of difficulty. A striker may be a useful assistant on a complicated job, but he may not understand what he is doing unless he has worked his way up from basic tasks.

When parts or components are removed or installed, the loft supervisor should insure that the necessary functional checks are performed in accordance with the existing directives.

PLANNING FOR ADVANCED BASE OR FORWARD AREA OPERATIONS

A Chief PR must be able to prepare for advanced base or forward area operations by estimating material and supplies, equipment, and manpower requirements.

In determining requirements for forward area or advanced base operations, it is necessary to consider the following:

1. Mission.
2. Environment.
3. Operating factors.
4. The availability of existing facilities.

A knowledge of the material and manpower requirements as listed in the Advanced Base Initial Outfitting Lists of Functional Components is very helpful. The functional component is one of more than 354 standardized units of the system which the Navy has developed to enable it to build and operate its advanced bases in the least possible time and with a minimum expenditure of planning and logistic effort.

A functional component is a list of the requirements for the performance of a specific task at an advanced base, and consists of a carefully balanced combination of material, equipment, and/or personnel.

Each functional component is classified according to its primary function into 1 of 12 major groups, including aviation. Each major grouping is identified by letter designation and title; the functional components contained in each are identified by a combination letter,

number, and title designation. The major group letter for aviation is H.

H components are designed to provide for maintenance, support, and operation of aircraft in an advanced area under combat conditions, and may be combined with other components to form several types of air stations.

Complete information and data are given in the abridged and the detailed outfitting lists for functional components.

It should be apparent to the PRC that the advanced base requirements may not be exactly as they appear in the Advanced Base Initial Outfitting Lists. In order to use these lists as guides, it is necessary in most cases to alter or tailor them to fit the individual needs of the unit about to deploy.

Other necessary repair parts, supplies, and equipment may be determined from the outfitting and allowance lists for the aircraft or other weapon system to be supported.

It is quite likely that the PRC may be required to advise the personnel office in making assignments of individuals to advanced base or forward area operating units. It seems logical that the number of PR's assigned to deploy be in the same ratio as the percentage of supported aircraft scheduled to deploy. This may be true if the proposed flight hours per aircraft of the detachment exactly equal the planned utilization of the remaining aircraft and if there are no significant environmental problems to be overcome. The list of personnel assigned to deploy should represent a cross section of the skill levels available unless special maintenance factors indicate otherwise. The selection of personnel should be made as objectively as possible so that the deployed unit may function efficiently without working a hardship on the home group.

SAFETY

Operational readiness of a maximum number of aircraft is necessary if naval aviation is to successfully perform its mission. Keeping its aircraft in top operating condition is the principal function of naval aviation maintenance personnel. It is essential that maintenance work be performed with a minimum of injury to personnel and damage to equipment and aircraft.

Aircraft maintenance is inherently hazardous due to the nature of the work, the equipment and tools involved, and the variety of materials

required to perform many repairs and maintenance functions. Factors which can function to increase or decrease these hazards are (1) the experience levels and mental attitudes of assigned personnel and (2) the quality of supervision of the maintenance tasks. Thorough indoctrination of all personnel is the most important single step in maintenance safe working conditions.

The concept of aircraft maintenance safety should extend beyond concern for injury to personnel and damage to equipment and aircraft. Safe work habits go hand-in-hand with flying safety. Tools left in aircraft, improper torquing of fasteners, and poor housekeeping around aircraft can cause conditions which may claim the lives of flying personnel as well as cause strike damage to aircraft. Safety on the ground is equally as important as safety in the air.

A recent type commander letter states in part, "While the increased complexity of our modern aircraft is a factor, it is noted that a large number of maintenance-error-caused accidents and incidents are due, not to complexity of equipment, but to lack of supervision and technical knowledge. Many mistakes are simple ones in routine maintenance."

Safety in aircraft maintenance depends largely upon the supervisory personnel. The standards of quality which they establish are directly reflected in the quality of the aircraft maintenance. The primary duty of the senior petty officers is to supervise and instruct others rather than to become totally engrossed in actual production. Attempts to perform both functions invariably result in inadequate supervision and a greater chance of error. Supervisors must exercise mature judgment when assigning personnel to maintenance jobs. Consideration must be given to each man's experience, training, and ability.

Sometimes overlooked in a maintenance program are the considerations generally grouped under the term "human factors." These factors are important in that they determine if an individual is ready and physically able to do work safely and with quality. Supervisory personnel should be constantly aware of condition such as general health, physical and mental fatigue, unit and individual morale, training and experience levels of personnel, and other conditions which can contribute in varying degrees to unsafe work. Not only is it important that proper tools and protective clothing and equipment be available for use, but also the insistence, by maintenance supervisors that they are used is of

AIRCREW SURVIVAL EQUIPMENTMAN 1 & C

increasing importance with modern high performance aircraft. For example, maintenance personnel are sometimes negligent in the wearing of protective clothing when transferring liquid oxygen.

Technical knowledge also plays a large part in a good maintenance safety program. The complexity of our modern escape and survival equipment systems demands the close attention of well-informed and expert PR's; otherwise, our systems cannot be properly maintained. Technical knowledge is a function of education and training which, incidentally, does not end with graduation from Class A school. Graduation is only the beginning. Any PR worthy of his rate and rating is continually training and learning through self-study and application, and through a personal desire for proficiency and self-betterment. However, technical knowledge by itself is not sufficient unless it is coupled with an old-fashioned craftsmanship that receives gratification and keen satisfaction in doing any job well. The PR who wishes to contribute to safety and reliability improvement must know his job and must develop professional pride in the quality of his work.

It is a continuing duty of every person connected with aircraft maintenance to try to discover and eliminate unsafe work practices. Accidents which are caused by such practices may not take place until a much later date, and their severity cannot be predicted. The consequences may range from simple material failure to a major accident resulting in serious injuries or fatalities.

There are several areas in which the shop supervisor can effectively work to minimize accidents incident to aircraft maintenance. Among these are continuing inspections of work areas, tools, and equipment; organization and administration of safety programs; correct interpretation of safety directives and precautions; and energetic and imaginative enforcement of them.

INSPECTION OF WORK AREAS, TOOLS, AND EQUIPMENT

The parachute loft supervisor should diligently inspect work areas, tools, and equipment to detect potentially hazardous and unsafe conditions and take appropriate corrective action. The PR may be working in the shop, in the hangar, or on the line, and all these areas should be included in the supervisor's inspection.

He should check for explosion or inhalation hazards caused by improper ventilation of working spaces, or careless handling of materials.

Fire hazards present another serious problem. "No Smoking" rules should be strictly enforced. Ground wires should be installed on every aircraft during maintenance to eliminate dangerous static electrical buildups. Spilled oil, grease, and chemicals should be wiped up promptly, and all rags used in the process should be disposed of in covered metal containers.

Handtools should be in good shape, of the proper type, and used only for the purpose for which they were designed.

Insure that equipment is operated only by qualified personnel, and that all safety devices and guards are installed and in good condition. The equipment should also be inspected for broken or damaged components. Check to see that periodic maintenance, servicing, and/or calibration are up to date for those equipments requiring it.

ORGANIZATION AND ADMINISTRATION OF SAFETY PROGRAMS

In accordance with the Navy policy of conserving manpower and material, all naval activities are required to conduct effective and continuous accident prevention programs. The organization and administration of a safety program applicable to parachute lofts are part of the requirements of the loft supervisor. The safety program must be in accordance with local instructions and based on information contained in appropriate United States Navy safety instructions. Work methods must be adopted which do not expose personnel unnecessarily to injury or occupational health hazards. Instructions in appropriate safety precautions are required to be given and disciplinary action taken in case of willful violations.

The work center safety program generally involves three areas of attention—posting of the most important safety precautions in appropriate places, incorporation of safety lessons in the formal training programs, and frequent checks for understanding during the day-to-day supervision of work.

Posted safety precautions are more effective if they may be easily complied with. For example, if a sign on a tool grinder reads "Goggles Required," one or more pairs of safety goggles should be hanging within reach at the machine.

Chapter 4—WORK CENTER SUPERVISION AND ADMINISTRATION

Similarly, the protective clothing poster in the welding shop should be backed up with readily available aprons, gloves, shields, etc.

Fixed posters and signs should be renewed frequently and not allowed to become rusty, faded, or covered with dust and dirt. General safety posters on bulletin boards and other places should be rotated often to stimulate interest. Appropriate safety posters may be obtained from the Aviation Safety Center, Norfolk, Va. through your squadron or unit safety officer.

The formal safety training sessions should utilize films, books, visual aids, or any other suitable technical material. The men should be told more than just what or what not to do. Each safety subject should be explained in detail. The results of unsafe acts are usually the most dramatic and easiest to remember. Causes of accidents and contributing factors should be reviewed and analyzed. Many good ideas for accident prevention have been developed in training sessions.

An extensive series of lessons may be developed over a period of time as latent hazards are recognized. This will aid in keeping the sessions interesting while avoiding too frequent repetition.

It may be well to mention the new man in the work center at this point. A separate safety indoctrination lesson which covers all the major hazards of the work center should be given the new man as soon as he reports for work. No supervisor with an effective safety program and an excellent work center safety record wants to take the chance that the new man may get hurt. Thus, before attending the complete series of safety lessons, the new man is given the separate safety indoctrination lecture.

In the third area of safety program administration—followup—the supervisor does well to delegate authority to his subordinate petty officers to assist him in monitoring the program. Also included in the followup area is a responsibility of the work center supervisor to inquire as quickly and thoroughly as possible into the circumstances of accidents and reports of unsafe practices and take action or make recommendations.

INTERPRETATION OF SAFETY DIRECTIVES AND PRECAUTIONS

Commanding officers and others in authority are authorized to issue special precautions to their commands to cover local conditions and

unusual circumstances. These will be in addition to those currently authorized general precautions disseminated on a Navy wide basis. The work center supervisor has to apply both sets of rules in the administration of his work center safety program.

Safety directives and precautions should be followed to the letter in their specific application. Should any occasion arise in which any doubt exists as to the application of a particular directive or precaution, the measures to be taken are those which achieve maximum safety.

When new safety posters or precautions are posted, it is the responsibility of the work center supervisor to correctly interpret their application to his men. In this way he is able to achieve a unit of thought and action in the observance of the required safety rule.

The organization's safety officer is available to assist in interpreting and suggesting ways of implementing various safety directives and precautions. Current directives require that a safety officer or safety engineer be assigned as head of the safety department, division, branch, or section, whichever is applicable, at all shore stations.

In most instances the hazards involved and the applicable precautions for a given type of work are the same whether the work is done afloat or ashore.

ENVIRONMENTAL CONDITIONS

Regulated temperature and humidity conditions must be maintained in the parachute packing section, storage facilities, and dry locker wherever possible; advanced-base and temporary facilities are the exceptions. The temperature and humidity in the parachute loft must be maintained within specified limits; ideal conditions in the packing loft and dry locker are a temperature of 75° F and a relative humidity of 60 percent. The work center must be kept free of dust and dampness and be well ventilated. Figure 4-1 illustrates the temperature-humidity chart, the shaded area outlines the allowable environmental limits.

These limits are affected by two variables; temperature and relative humidity. Recordings of these variables must be taken three times daily, to insure that favorable conditions are maintained; use the relative humidity and temperature indicator shown in figure 4-2.

Weather conditions depend greatly upon the amount of water in the air. The water may be in

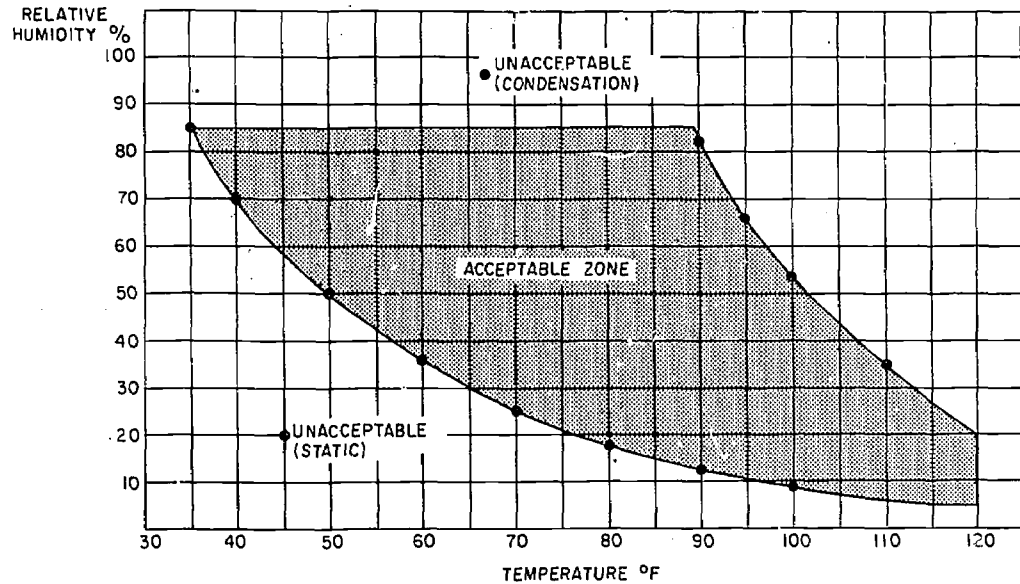

PR.442

Figure 4-1.—Packing loft and dry locker temperature humidity conditions.

liquid water is visible as precipitation or as clouds. The water in which the PR is interested is in a gaseous state.

The relative humidity of a volume of air is the ratio (in percent) between the water vapor actually present and the water vapor necessary for saturation, at a given temperature. For example, air at 70°F can contain approximately 8 grams of water vapor per cubic foot (its capacity). If, however, it contains only 6 grams per cubic foot (its absolute humidity), then it is only 3/4 saturated and its relative humidity is 75 percent. If the temperature of the air changes, capacity also changes, and so does the relative humidity.

The ideal method for regulating air temperature and humidity is an air conditioning system. To insure maximum effectiveness from the air-conditioning unit, continuous checks must be made of the physical conditions of the parachute loft.

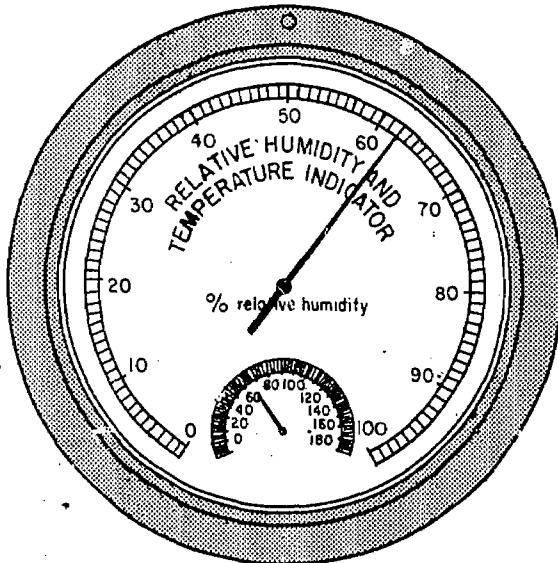

PR.443

Figure 4-2.—Relative humidity and temperature indicator.

HYGROTHERMOGRAPH

The hygrothermograph is the standard recording instrument used by the PR to record temperature and relative humidity in the dry locker.

three forms: gas, liquid, or solid. As gas it is called water vapor, which is invisible. Solid or

The thermometric element of the hygrothermograph is a phosphor-bronze tube of the Bourdon type, which is filled with alcohol. As the temperature rises, the liquid expands and causes the curved tube, one end of which is tightly clamped, to tend to straighten. This expansion causes action in the opposite (free) end of tube which is attached to a link-and-lever assembly. This assembly controls a pen, the inked end of which is in contact with a revolving, clock-operated drum fitted with a chart. In this manner, a continuous record of the temperature is traced on a graduated chart. (See fig. 4-3.)

The humidity element of the hygrothermograph consists of separate bundles of the best grade natural blond human hair about 48 strands in all, spread into 12 groups of 4 strands each. The hair element increases in length with rising or high humidities and decreases in length with falling or low humidities. These changes in

length make it possible to make the humidity markings on a record chart.

The relative humidity hair element is secured at the lower end to a pivoted end clamp. This is similar to that of the temperature element and permits adjustment of hair tension when setting to current humidity. The upper end of the element is attached to a small lever arm that operates the upper lever cam through a vertical link and lever arm to position the pen on the chart. The pen arm is of the pressure gravity type.

Both temperature and humidity are read on a hygrothermograph chart by first finding the point at which the appropriate printed time curve intersects the humidity trace. (See fig. 4-4.)

The intersection point is evaluated in terms of humidity by referring it to the closest of the horizontal printed lines of the chart. These lines correspond to the engraved markings

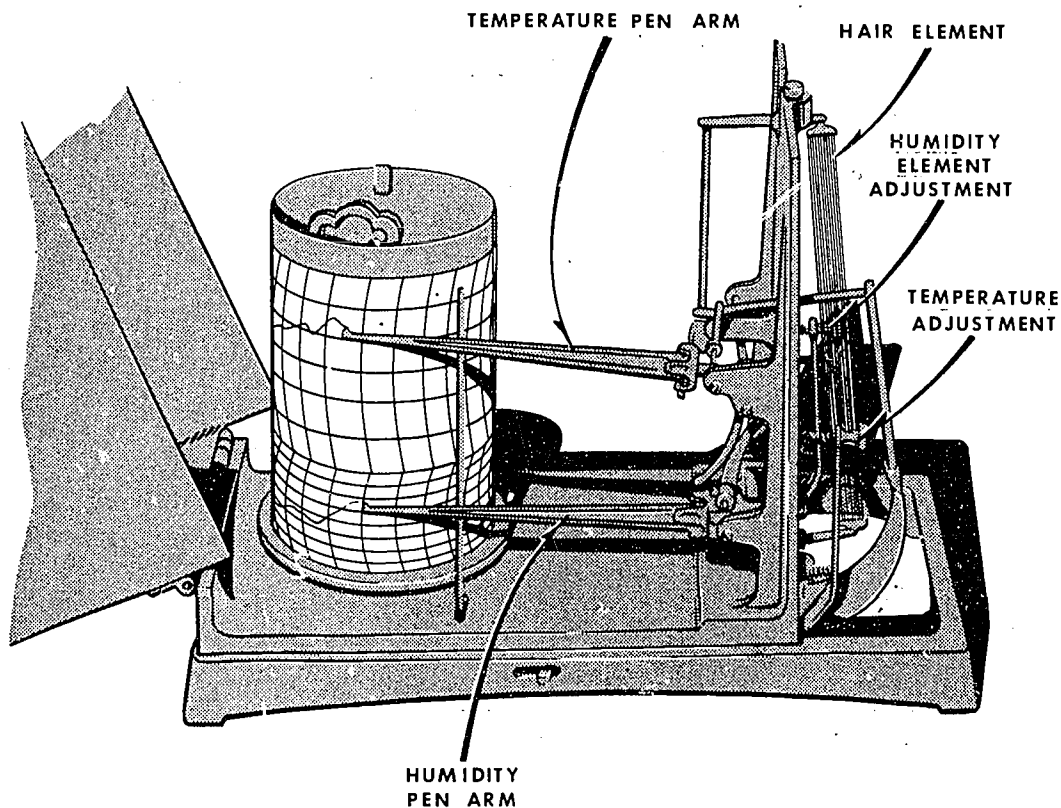
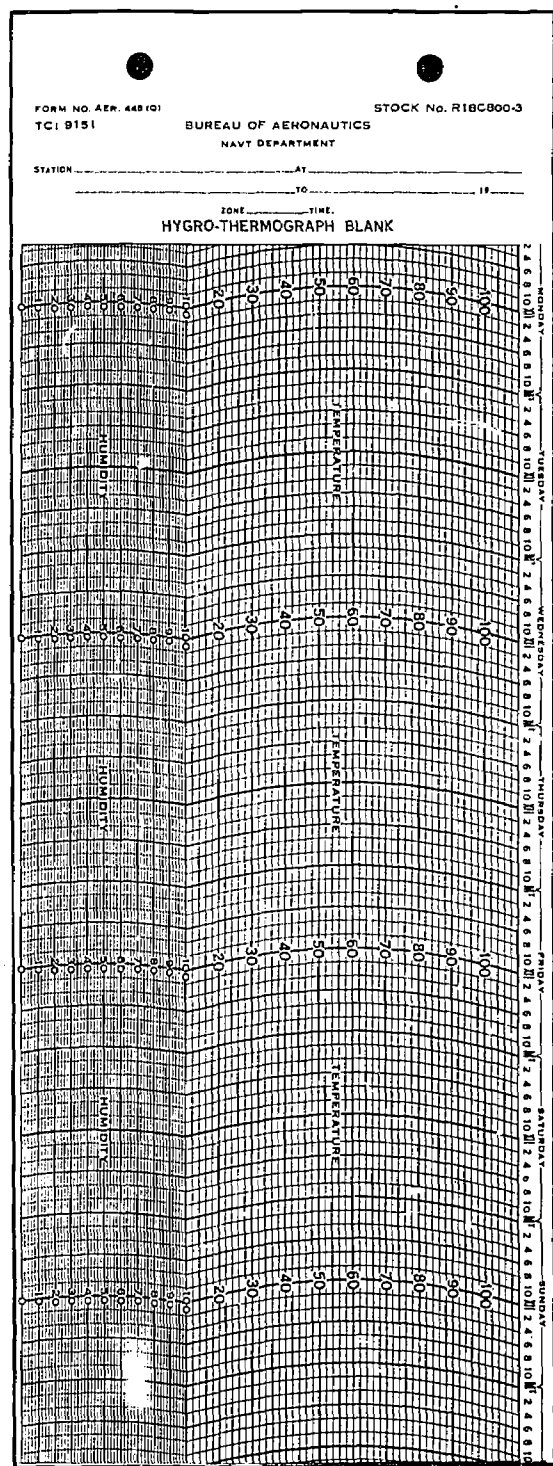

Figure 4-3.—Hygrothermograph.

AIRCREW SURVIVAL EQUIPMENTMAN 1 & C



PR.101

Figure 4-4.--Hygrothermograph chart.

found on temperatures and humidity instruments. Interpolation may be necessary for values of humidity, temperature, and time between those corresponding to the printed lines of the chart.

Operation and Maintenance

There are three main sections of a hygrothermograph that must be serviced. They are the temperature sensing element, the humidity sensing element, and the recording equipment.

TEMPERATURE SECTION.—There are three adjustments that must be made from time to time in the temperature sensing element of the hygrothermograph; they are the range adjustment, the current temperature adjustment, and the pen arm adjustment.

The range adjustment is made only in the calibration of the instrument. Only instrument technicians designated by NavAirSysCom may make this adjustment.

The current temperature adjustment is made at any time when the chart indicates a difference of 5° F or more than from the current temperature readings as taken from the standard air thermometer. The current temperature adjustment is on top of the upper guard bracket and connects to the Bourdon tube. To make the current temperature adjustment, proceed as follows: Turn the current temperature adjustment screw (3 and 4, fig. 4-5) to the left when the hygrothermograph temperature reading is too low, and to the right when it is too high. Correct no more than one-half the error at one time. This is to say that if the error is 8° F to start with, correct 4° F the first time. Wait about 10 minutes, and correct for 2° F. Wait another 10 minutes, and correct for 1 additional degree, and in another 10 minutes, make the remaining 1° correction. Mark the hygrothermograph chart to indicate that the current temperature error was adjusted to zero.

If the hygrothermograph indicates a temperature too low at the time of the daily maximum temperature and a temperature too high at the time of the daily minimum temperature, notify your supervisor of the fact, because the pen arm of the temperature sections needs to be lengthened. The converse is also true. When the maximum temperature of the hygrothermograph is too high, and the minimum temperature is too low, the pen arm needs to be shortened, and your supervisor should be notified of this fact. The adjustment is made by turning the temperature adjustment screw so that the pen is

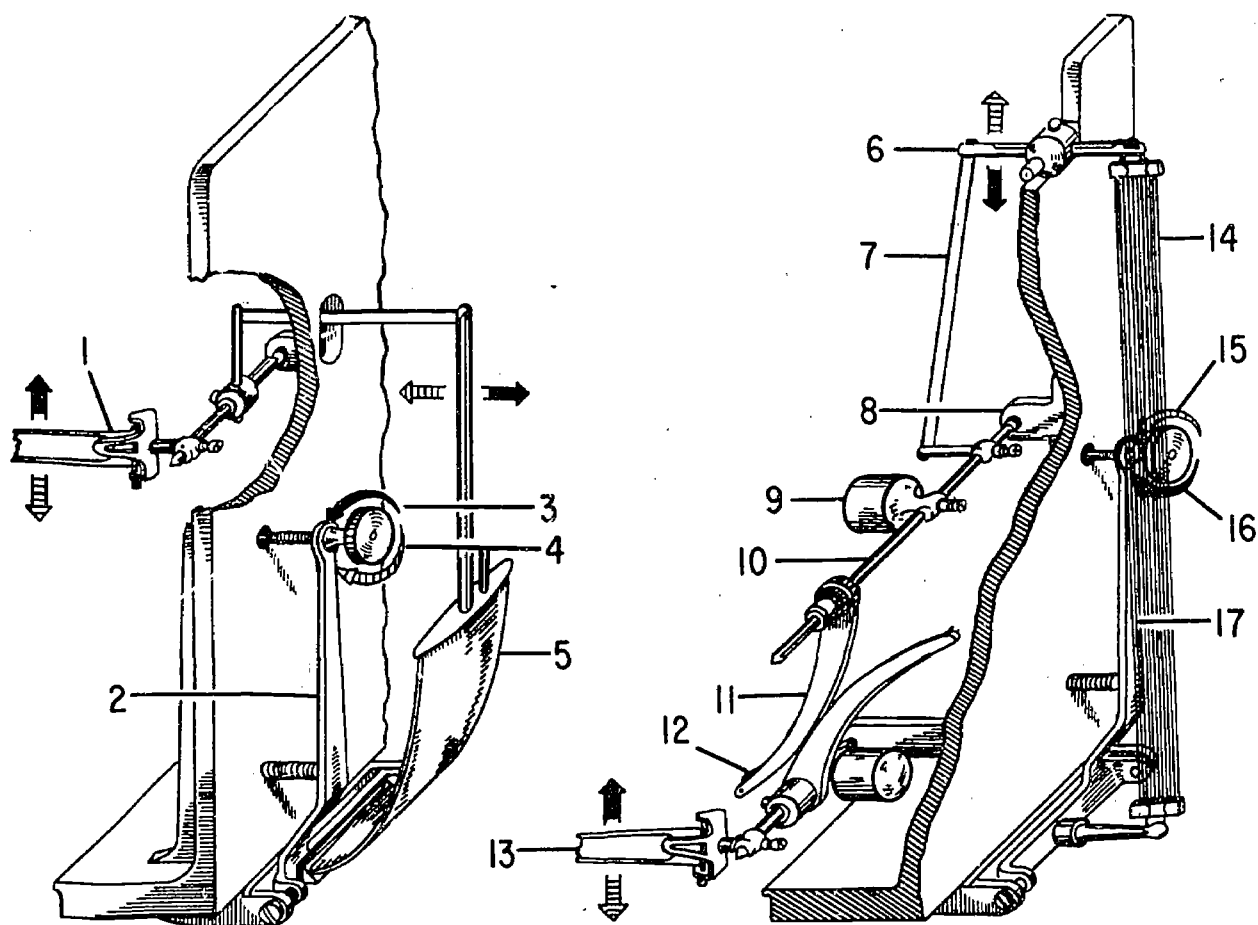

PR.102

- | | | |
|--|-------------------------------------|------------------------------|
| 1. Temperature pen arm. | 6. Hygro lever. | 12. Cam spring. |
| 2. Current temperature adjustment arm. | 7. Hygro link. | 13. Humidity pen arm. |
| 3. Raise pen setting. | 8. Horizontal axis bearing bracket. | 14. Hair element assembly. |
| 4. Lower pen setting. | 9. Counterweight. | 15. Lower pen setting. |
| 5. Bourdon tube thermo unit. | 10. Horizontal axis. | 16. Raise pen setting. |
| | 11. Interpolating cam levers. | 17. Humidity adjustment arm. |

Figure 4-5.—Sensing elements of the hygromograph.

set up or down an equivalent of 10° or 20°. After making the adjustment, renumber the chart accordingly.

Keep the Bourdon tube of the temperature section clean at all times. Use a chamois cloth and jewelers' rouge, but no abrasive. Keep the pen arm clean and penpoint inked.

The pen should be filled one-half full. Use only the prescribed #10 purple instrument ink on the pen for both the temperature and humidity sensing elements. In addition, you should periodically inspect the pen arms of both sections to see if they are bent. When they are bent, report the matter to your supervisor who

AIRCREW SURVIVAL EQUIPMENTMAN 1 & C

will take further action. Bent pen arms are one cause of erroneous readings.

HUMIDITY SECTION.—Make a current humidity adjustment whenever the error exceeds 5 percent. This adjustment is made by means of the humidity adjusting screw. Remove half of the error; then tap the instrument to reduce the effects of friction in the linkage system. Check the accuracy of the adjusted reading and repeat the procedure as necessary.

There is some routine maintenance that you must perform in the care of the humidity section. Clean and re-ink pens at the time the chart is changed, or more often if needed. Clean the hair element weekly, using distilled water applied with a camel's-hair brush. When the hair element is saturated, adjust the pen arm setting to 95 percent. Set the equipment aside for 48 hours before placing it into operation to allow the hair element to acclimate itself. This procedure requires the use of a standby instrument. When the hair element is exposed to low or high humidities for long periods, it tends to become brittle or lax. To renew its elasticity, wash the hairs with ether and then rinse thoroughly with distilled water.

Periodically inspect the hair element for slack or broken hairs. If one hair of an end bundle is slack or broken, or if three hairs of a center bundle are slack or broken, report the matter to your supervisor, because the hair element needs to be replaced. Further, if oil or grease has come in contact with the hair element, the element should be replaced because oil changes the elasticity of the hair. The hair element should never be touched with the hands.

The linkage pivots of the temperature and humidity sections should be oiled every 6 months with one small drop of MIL-L-6085 oil. This oiling is best accomplished with a toothpick, because it prevents applying too much oil to the pivots. Excess oil should be removed.

RECORDING SECTION.—The main recording equipment of the hygrothermograph consists of the chart drum, the chart, and the clock.

Wind the clock 14 half-turns (and never more) whenever the chart is changed. The clock has an 8-day clock movement. It should be serviced once a year by a qualified watch repairman. Always store, stand, handle, or ship the clock in the operating position.

The drum is not interchangeable with any instrument other than another hygrothermograph. Remove it with care and install it with care. When replacing (installing) the drum on the

pinion, you must be careful to center it so that it settles into place with a slight click. When you adjust the position of the drum for a time error, lift the drum enough to disengage the gears. Then turn the drum clockwise so that the correct time will be to the LEFT of the pen. Then settle the drum in the gears and turn it slowly COUNTERCLOCKWISE until the right time is under the pen. Never adjust the time clockwise when the drum is on the pinion with gears engaged, because doing this will loosen the clutch mechanism inside the drum and cause the drum to have too much play.

Change the chart on the first day of the month and every 7 days after that at 0800 L. T (local standard time). Make time checks daily at every 6-hourly observation. Do this by moving the temperature pen arm up the width of two printed temperature intervals on the chart and the humidity pen arm downward the width of two printed humidity intervals. You make the checks in order to determine if the instrument is on time and indicating within the allowable amount of error. Keep in mind that the allowable error for time is 30 minutes. After you remove a chart from the drum indicate all adjustments made.

The hygrothermograph chart is very simply installed and removed from the rotating drum of the instrument, which is spring-operated to run with the accuracy of a clock. Figure 4-6 illustrates the steps used in mounting a chart on the drum.

The hygrothermograph should be mounted on a horizontal platform, centrally located in the dry locker, with the base at least 3 feet from the deck as shown in figure 4-7.

PACKING AREA

The packing area is used for inspection, rigging and packing of parachutes and related components. These tasks must be accomplished under regulated temperature and humidity conditions. Relative and specific humidity limits must be maintained to prevent condensation in automatic parachute actuators, other metal components, and static electricity building up in the parachute canopy materials.

Lighting the parachute loft is very important. Fluorescent lighting has been found to be best, as it gives a flat bright light, free of shadows. Parachute nylon canopy material is subject to deterioration by sunlight and some form of artificial lighting; therefore, parachutes should

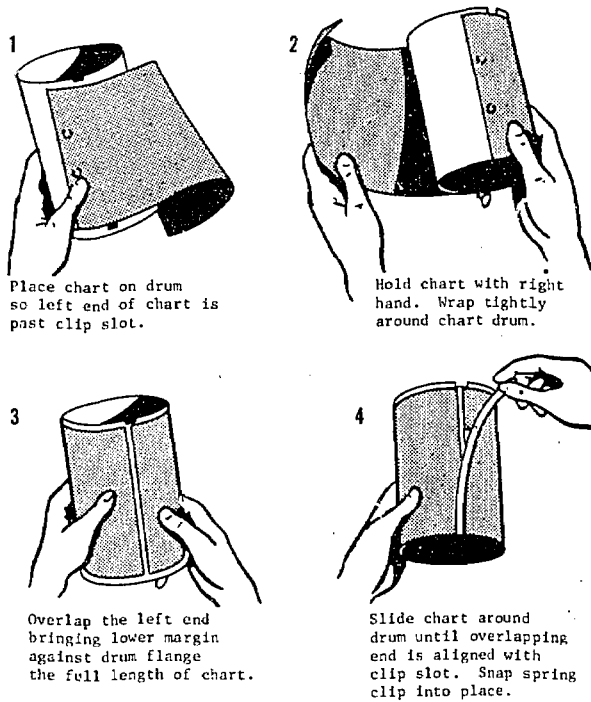

PR.103

Figure 4-6.—Steps in mounting the hygrothermograph chart on the drum.

not be exposed to fluorescent lights closer than 5 feet for long periods of time. Protect parachutes by keeping them under cover except when being repaired.

STORAGE FACILITIES

Bins, shelves, and cupboards must be provided in the parachute loft to accommodate packed or unpacked parachutes and components. These storage facilities should be of the closed compartment type, large enough to contain single parachutes and designed to allow storage of the parachute at least 4 inches from the walls and 12 inches from the deck. The storage area must be well ventilated and free of dust and other contaminants.

DRY LOCKER

The dry locker is used to condition parachutes which have been subjected to excessive

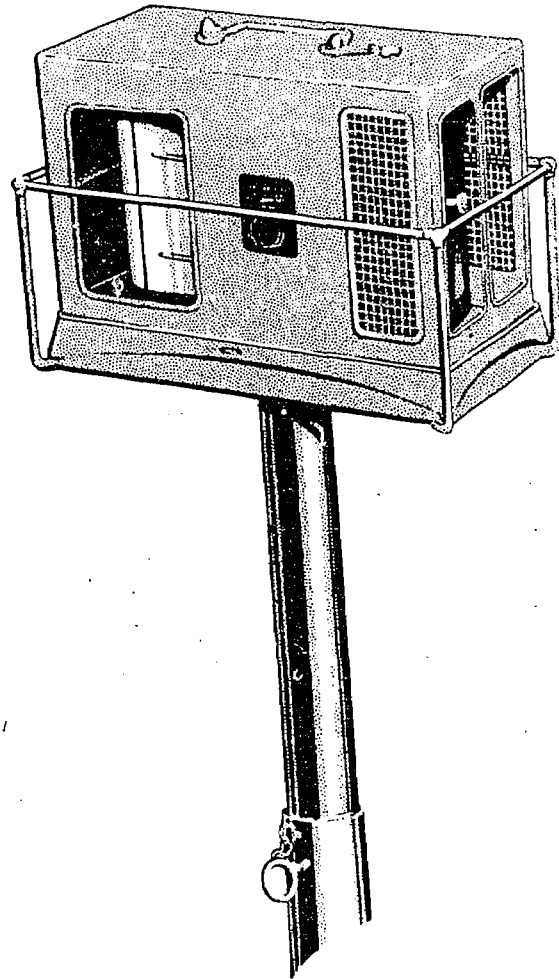

PR.104

Figure 4-7.—Hygrothermograph mounted.

moisture. The dry locker must contain controlled environmental conditions. The parachute hoisting lines should be a minimum of 2 feet apart, and at least 12 inches from bulkheads.

For adequate lighting, the flush type, low heat, incandescent light fixtures are recommended; the dry locker should be devoid of windows or skylights.

Recent changes in the Navy's parachute airing policy negated the mandatory requirement of suspending a parachute in the dry locker for a specified time period. However, the work center supervisor may exercise his own judgment

on the best method of conditioning a parachute as to airing before repack.

TRAINING OF PERSONNEL

Training of loft personnel is a necessary function and one of the most important responsibilities of senior PR's.

A Chief PR and, in many cases, a First Class PR have regular and continuing responsibilities for the training of others. Even if a supervisor is fortunate enough to have a group of men who are highly skilled and well trained, he finds that training is still necessary. For example, the training of strikers and lower rated men for advancement-in-rating examinations is a continuing, never-ending process. Due to the Navy policy of rotation, the best men are eventually transferred and replacements for them received aboard. The replacements, in most instances, require training before they can be relied on to take their places as effective members of the shop organizations. These and similar problems require the loft supervisor to be well versed in the several aspects of training—able to set up as well as to conduct an effective training program for assigned personnel.

Specialized skills are required to maintain and operate present day weapons systems and associated equipments. Some of the types of programs necessary for training personnel in these skills are Navy School Training, Specialized Contractor Training, and In-Service Training. For a discussion of these programs refer to chapter 12, OPNAVINST 4790.2.

ORGANIZING A TRAINING PROGRAM

Organizing a shop training program involves such considerations as planning lessons and job plans, selecting and qualifying instructors, making arrangements for classroom space, phasing the training program with the scheduled workload, procuring visual and other training aids, and determining teaching methods for each lesson or lesson series.

The subject matter areas to be included in the shop training program are (1) material relating to maintenance of aviator's equipment, (2) general material required by the men for advancement-in-rating examinations, and (3) material relating to safety. In most cases lessons fall under more than one of these subject areas.

As soon as supervisory personnel have determined what publications adequately cover the subject areas, the material must be divided into lessons, and lesson guides prepared. It is very helpful to assign numbers to the lessons and provide a personnel training progress record for each individual. These provide a handy index as to the state of training of the work center personnel as a whole.

Whether the work center supervisor teaches the lessons himself or assigns other petty officers to conduct them depends on the state of training of his first and second class petty officers. A requirement for advancement for third class petty officers and nonrated personnel is satisfactory completion of the correspondence course based on Military Requirements for Petty Officers 3 & 2, NavPers 10056-C. Chapter 8 in that Manual sets forth some of the basic principles of training in general and teaching in particular.

An advancement requirement for second and first class petty officers is satisfactory completion of the correspondence course based on Military Requirements for Petty Officers 1 & C, NavPers 10057-C. The latter training course expands and amplifies training theory and introduces job analyses, training aids, and testing.

As he prepares for advancement, the prospective First Class PR is required to demonstrate his ability to formally teach, use various training aids, and to prepare and administer written tests. In order to demonstrate correct instructional techniques the work center supervisor may elect to teach certain lessons himself or assign them to a competent instructor for the same purpose. Later he may assign less proficient petty officers as instructors so that they may acquire the experience necessary for completing their practical factors for advancement.

If at all possible, training sessions should be conducted at the same time of day and on a regular schedule. Factors to consider when scheduling lessons are flight schedules, meal hours, watches, availability of classroom, and aircraft inspection schedules.

Some lessons are better suited for one type of instructional technique than others. The type of presentation for each lesson should be planned in advance. This will also facilitate the rotation of the lessons among the petty officers who require experience in teaching.

The effectiveness of aviation technical training is greatly enhanced by the use of training

Chapter 4—WORK CENTER SUPERVISION AND ADMINISTRATION

aids. The work center supervisor should always be on the alert for scrap material that can be converted to training aids with minimum expense. He must be aware of the existence of applicable training films, and if they are available, schedule them for showing in conjunction with specific lessons. The squadron or unit safety officer or station safety engineer may usually be depended on to supply training aids in support of shop safety presentations.

When planning a training program, the supervisor should decide where the classroom sessions should be conducted. The space selected should preferably be in a quiet area, or at least one with a minimum of noisy distractions. The area should be large enough to accommodate the expected student load and be well lighted. Adequate ventilation will help keep the men awake and interested in the presentation. Convenience is another factor in the selection of classroom space. Some of the desirable space characteristics may, on occasion, have to be sacrificed in order to find a classroom nearer to the working area.

TRAINING PROCEDURES

Training procedures are of two general types—formal and informal.

Formal training is conducted in the classroom through lectures, supplemented by required reading and implemented by the use of all available visual aids. A schedule of training is prepared and published periodically by the maintenance officer. It lists the time of the training, the location of the classroom, names of the men who are to attend, subject of the lesson, and the name of the instructor.

Lesson guides are prepared by the division officer and chief or first class petty officers who are qualified to do so. The lesson guides should contain the title, objective(s), time to be consumed in presenting the lesson, list of instructional aids, list of references, outline for presentation, and a summary of the lesson.

When a petty officer has been assigned to instruct a given lesson, it is his responsibility to procure a copy of the lesson guide and from it prepare his lesson plan. Lesson plans are prepared by each individual instructor, based on the lesson guide and though they may differ from instructor to instructor, they must adequately cover the subject.

Informal training is the practical instruction of men in the performance of maintenance

tasks by means of demonstration and imitation under personal supervision in the shop or on the operating line. Nearly every maintenance task that is undertaken presents an opportunity for on-the-job training. The experienced men of the division are utilized as fully as possible in demonstrating and imparting their skills to the less experienced.

Under this system, the trainee has the opportunity to actually do the job under the supervision of an experienced petty officer. The only equipment necessary is the job itself. It is necessary, of course, that the instructor have an interest in the job and the skill to do it well. The striker or trainee learns by seeing the job performed, and he gains experience by having a chance to participate in the accomplishment of the job.

The nature of informal training makes regular scheduling impracticable. Actually, it is done at every opportunity. A training syllabus is prepared under the guidance of the maintenance officer, with content and scope corresponding with practical factor requirements of the personnel. On-the-job training is reported by the leading petty officer instructors and shop supervisors to the division officers on the training syllabus at regular intervals so that a close watch may be made on individual progress. The records are for review by higher authority and they point out the need for training in special areas as well as certain practical factors. The degree of success in on-the-job training depends on the degree of recognition by each individual of his responsibility to his outfit to impart his skill and knowledge to the man who is trying to learn.

PUBLICATIONS

Aeronautic publications are the sources of information for guiding naval personnel in the operation and maintenance of all aircraft and related equipment within the naval establishment. By proper use of these publications, all aircraft and other aeronautical equipment can be operated and maintained efficiently and uniformly throughout the Navy.

TECHNICAL DIRECTIVES (LETTER TYPE)

In order to standardize the issuance of letter type technical directives, a centralized system for control and issue of all technical directives

AIRCREW SURVIVAL EQUIPMENTMAN 1 & C

concerning modification, inspection, maintenance, or operating procedures, and limits of all naval aircraft and related equipment has been established.

Letter type technical directives contain instructions of a technical nature which cannot be satisfactorily disseminated by revisions or interim revisions to technical manuals. These instructions are disseminated in the form of changes or bulletins, or in special circumstances, by interim changes or bulletins.

The title of a change or bulletin for aircraft and powerplants is made up of four parts. Part one is the aircraft or powerplant model designation; part two, the appropriate title subject; part three, the word "Change" or "Bulletin"; and part four, the sequential number.

The title of a change or bulletin for equipments consists of only three parts—the title subject, the word "Change" or "Bulletin," and the sequential number.

Interim changes and bulletins are titled in the same manner as changes and bulletins with the exception that the word "Interim" is included.

Interim bulletins and changes are issued in the form of naval messages or speedletters. They disseminate information of a temporary nature pending issuance of a formal printed technical directive. These interims are not stocked or available through the publication supply system. They are distributed only to activities which are directly affected by the change, and are not to be ordered.

The title subject of a change or bulletin is one of the following, as appropriate:

- Airframe
- Air Crew System
- Avionics
- Accessory
- Powerplant
- Aviation Armament
- Clothing and Survival Equipment
- Photographic
- Support Equipment
- Propeller

EXAMPLES:

- BuWeps Aviation Clothing and Survival Equipment Bulletin 1-60 Am-1
- Air Crew System Bulletin No. 160 Int.
- Air Crew System Change No. 17
- General Airframe Bulletin No. 1
- Support Equipment Change No. 289

Changes and bulletins are assigned numbers in numerical sequence by the Technical Directives Control Center which is located at the Naval Air Technical Services Facility (NATSF), Philadelphia. Interim changes and bulletins are numbered sequentially with formal changes and bulletins. The number of a change or bulletin issued to supersede an interim change or bulletin is the same.

Changes and bulletins often require amendment or revision. A revision is a completely new edition of an existing directive. A revised directive bears the words "Rev. A," "Rev. B," etc., as appropriate, to denote the first, second, etc., revision to the basic directive after the basic directive number. Amendments are used for minor changes in the original directive. The words "Amendment 1," "Amendment 2," etc., follows the basic directive number.

Changes and bulletins are automatically distributed to all concerned activities through NavWeps Form 5605/2.

Changes and bulletins are issued by technical personnel of NavAirSysCom and are based on Contractor Service Bulletins, Unsatisfactory Reports (UR's) on material defects submitted by field service activities, or other letters of recommendation or proposed modifications from field service activities.

Changes are classified by various "action" categories. Bulletins may be assigned an "action" classification, but it is not mandatory.

The classification "Immediate Action" is assigned to directives which are issued to correct safety conditions, the uncorrected existence of which would probably result in fatal or serious injury to personnel, extensive damage, or destruction of property. Immediate Action directives involve the discontinued use of the aircraft, engines, or equipment in the operational employment under which the adverse safety condition exists, until the directive has been complied with. If the use of the aircraft, engines, or equipment will not involve the use of the affected component or system in either normal or emergency situations, compliance may be deferred, but should be accomplished no later than the next periodic inspection for the aircraft and no later than 6 months from the date of issue for the equipment. The Immediate Action directive is identified by a border of red X's, broken at the top center of the page by the words "IMMEDIATE ACTION," also printed in red.

The classification "Urgent Action" is assigned to directives which are used to correct

safety conditions which, if uncorrected, could result in personnel injury or property damage. Such conditions compromise safety and embody risks calculated to be tolerable within narrow time limits, and may or may not necessitate the imposition of operating restrictions. Urgent Action directives are identified by the words "Urgent Action", printed in red ink at the top of the first page and a border of red diagonals around the cover page.

Routine Action directives are directives concerned with equipment or procedural deficiencies of a material, either mechanical, operational, or tactical in nature, the uncorrected existence of which could constitute a hazard. Continued usage could have an adverse effect on operational efficiency, reduce tactical or tactical support utility, or reduce operational life and/or general service utilization of the equipment. Routine Action directives are identified by the words "Routine Action" printed in black letters at the top of the cover page.

Changes

A change is a technical directive used to accomplish the following:

1. Direct the inspection of equipment that could result in replacement of parts of different physical appearance or identity from that previously installed.

2. Direct a part or material to be added, removed, or changed from the original configuration of the equipment or part that affect the identity, physical appearance, or function of the part or equipment.

3. Direct a part or material to be altered, relocated, or repositioned.

4. Direct test or calibration of parts or equipment that upon completion requires a reidentification of the parts or equipment.

The contents of changes are presented in a standard format and written to specifications in a regular paragraph sequence. Listed below are the paragraphs in their usual order, together with an explanation of their contents.

1. Title. The title consists of the title subject (previously discussed) and the sequential number. **EXAMPLE:** Air Crew System Change No. 107.

2. Subject. This is a short topical subject, usually beginning with a noun to indicate the major component or system affected and ending with a brief statement of the action required.

3. Reference. All previous correspondence and publications relating to the change are listed under this heading.

4. Publications Affected. This paragraph lists all publications, including existing technical directives, which are affected by this change.

5. Reason for Directive. Each change includes a concise and complete explanation of the necessity for the change.

6. Application. This paragraph contains (when applicable) a statement of dependence upon concurrent, prior, or subsequent incorporation of other changes or bulletins. And the major component that the change is to be made to.

7. Compliance. This paragraph contains a statement indicating when the change is to be incorporated, according to its action classification.

8. Man-hours Required. The man-hour requirements for the change are furnished in this paragraph. This information is determined from experience or trial modifications if possible; otherwise, estimates are given. The man-hour data includes the time necessary for unpacking new equipment, disassembly (gaining access to the work area), installation (accomplishing the work), assembly (reinstalling parts removed to gain access), and the necessary operational checks. Also included in this paragraph are the total man-hours and the recommended number of personnel required for the accomplishment of the change.

9. Supply Data. The supply data section specifies the required kits, parts, materials, and special tools necessary to incorporate the change. This data will include information relative to kit or kits required per aircraft, modification of spares in stock, disposition of removed parts, and the size and weight of the kit or kits.

10. Detailed Instructions. This paragraph contains both written instructions and illustrations as necessary for the accomplishment of the change.

11. Identification. The method of marking or reidentifying the equipment or components which are modified in accordance with a change is included in this paragraph.

12. Weight and Balance. Weight and balance information shows either "no effect on weight and balance" or the effect of the change on the basic weights.

13. Log Entry. This section contains a statement concerning the requirements for recording the accomplishment of the change.

AIRCREW SURVIVAL EQUIPMENTMAN 1 & C

14. Signature. Changes always have the authenticating signature of the Navy activity preparing the change.

Normally, the aviators equipment work center supervisor does not have to concern himself with the ordering of the change kits if they are required. Standard aircraft maintenance organization procedures provide for the material control division to order such kits as are required when the change is routed to them for their action.

Bulletins



A bulletin is a technical directive containing instructions and directions to accomplish inspections, calibrations, tests, and adjustments, or additional instructions on standard rework, methods, limitations, and procedures which do not fall within the change definition. A general bulletin may be issued in instances in which the instructions and directions apply to a number of different air crew systems, airframes, etc.

In the past, bulletins (like changes) were issued when required, but were numbered numerically in calendar year series. Under the latest instructions, bulletins are issued and numbered in the same manner as changes.

Bulletins are presented in much the same format as changes except that the "action" classification is not mandatory on bulletins. Other items which are optional on bulletins are the Supply Data and Weight and Balance Data sections.

Interim Changes and Bulletins

An interim change or bulletin is a directive issued to correct a safety or operational condition which embodies risks calculated to be intolerable or tolerable within narrow time limits. Interim changes and bulletins are issued by message to insure speedy dissemination. These directives may not contain the final solution to the condition being experienced.

Interim changes and bulletins are issued only when the action classification is Immediate or Urgent.

Interim changes and those interim bulletins which require continuing action are usually superseded by a regular change or bulletin with the same directive title and number within 90 days from the date of issue. Interim bulletins of a single action nature are not superseded by a bulletin. Changes and bulletins are canceled

by means of the NavSup Publication 2002, Section VIII, Part D.

INSTRUCTIONS AND NOTICES

Instructions and Notices are the two main types of directives provided for in the Navy Directives System which was designed for the purpose of providing a uniform plan of issuing and maintaining directives. Directives may establish policy, organization, methods, or procedures. They may require action to be taken or contain information affecting operations or administration. All Naval Air Systems Command level (and above) originated directives are distributed by the Navy Department Administrations Office, with certain exceptions. Each level of command below Naval Air Systems Command level has an administration office responsible for distributing that level of command directives to its units or addresses below them.

Instructions are those directives containing information of a continuing nature, or requiring action which cannot be completed in less than 6 months. An Instruction has continuing reference value and is effective until the originator subsequently cancels or supersedes it.

Notices are directives of a one-time nature containing information or requiring action which is applicable for only a short time. The effective period of time covered by a Notice is limited to 6 months or less except when program requirements extend for a longer but definite period. In no case may a Notice be issued which is effective for more than a year. Each Notice must contain a specific, stated cancellation date for record purposes.

Instructions and Notices are identified by originator and subject classification. A typical directive identification breakdown follows:

OpNav Instruction 3750.1A. OpNav indicates that this Instruction originated in the office of the Chief of Naval Operations. The 4-digit number 3750 is the subject classification number. This particular number indicates the series on Flight Safety. The number 1 indicates the number of issues the originating office has issued on this subject. (Notices do not have this number). The letter A indicates the number of times this Instruction has been revised; i.e., A for first revision, B for second, etc. If the letter P precedes the subject classification number, it indicates that this is a pamphlet or booklet type publication. Example: P 5215.1A. The

Chapter 4—WORK CENTER SUPERVISION AND ADMINISTRATION

security classification of a publication is also included in the subject classification number. Example: 5307.1 is unclassified, 05307.1 is classified CONFIDENTIAL, and 005307.1 is typical of a SECRET directive.

There are 13 major subject classification number groups, ranging from the 1000 group to the 13000 group. The 13000 group is set aside for aeronautical and astronautical material. Other important groups for the PR are the 1000-Military Personnel, 3000-Operations and Readiness, and 4000-Logistics.

Changes to Instructions are accomplished by revisions (major or substantial), changes (limited, pen and ink or page replacement), and supplements which add to what is already in effect. Changes may be either permanent or interim.

Each command issues a 5215 directive semi-annually which lists all directives by subject, subject number, revisions issued in the last 6 months, and those in effect.

Directives are filed by subject classification number, originator, and consecutive number.

WORK CENTER FILES

There are two general categories of records required of all shop supervisors. These include records required by the activity for operational purposes and those needed by the shop chief for the efficient management of his shop. It is advisable to keep the system of records as simple as possible and still maintain the necessary control. Too few records, however, can lead to uncertainty, encourage guessing, and sometimes lead to embarrassing situations. In order for records to be of maximum benefit and provide adequate control, it is necessary that records and publications be filed in the shop in such a manner that they may be quickly located.

The Navy has adopted a filing system which provides a definite place for every piece of correspondence and uniformity in filing throughout the naval establishment. In the relatively few years this system has been in use its merits have greatly exceeded any real or imagined disadvantages. The filing system is an integral part of the Navy Directive System. The 13 major subject classification group numbers are further subdivided into primary, secondary, and sometimes, tertiary breakdowns. Each subject group symbol must have 4 or 5 digits to be complete. An example of subject classification number breakdown is as follows:

13000—Aeronautical and Astronautical Material

13400—Systems, Components, and Accessories.

13480—Parachutes and Aerial Pickup Delivery, and Cargo Tiedown Equipment.

13480.1—Parachute: disposition after use by personnel for emergency use.

While directives (Instructions and Notices) utilize the standard subject group classification numbers and breakdowns of the Navy Directive System, many other types of publications do not. When file material other than Instructions and Notices are received in the shop, they should be assigned a file symbol based on the subject group classification number as listed in SecNav Instruction 5210.11 and SecNav Instruction 5215.1A. The correct application of file symbols assures uniformity in filing.

Personnel who have a working knowledge of the subject classification system and the manner in which all records are filed can locate required material expeditiously at any activity to which they may be assigned.

The most important filing operation is classifying (assigning file symbols) since it determines where papers are to be filed so that they may be located quickly. Each paper received in the shop for filing should have the shop file symbol assigned regardless of whether or not a file symbol already appears on it. The proper coding should be determined by the most important, definite, or concrete subject mentioned; the purpose or general significance of the document; the manner in which similar documents are sought; and the file symbol under which documents of a similar nature are filed.

The actual filing responsibility should be assigned to one person in the shop. All material awaiting filing should be placed in one basket only; and to avoid accumulations, should be filed daily.

When material can be properly filed under two or more headings, one or more cross-reference forms should be inserted in the files at the appropriate places to indicate just where the document is filed. The cross-reference should indicate the following:

1. Originator of the letter, serial number, file symbol, and date.
2. Addressor of letter.
3. Subject of letter.

AIRCREW SURVIVAL EQUIPMENTMAN 1 & C

4. Addressee of letter.
5. Where letter is filed.
6. Brief of letter of applicable part of text.

Extra copies of the basic document may be used instead of the cross-reference form. Cross-referencing, while serving a useful purpose, should be kept to a minimum to conserve space.

Another handy tool for keeping shop files in good order is the "file out" card. This may be a locally prepared form that is inserted into the files whenever a piece of file material is charged out to another office, shop, or person, to help keep track of its whereabouts. All "file outs" should be checked periodically to prevent misplacement of material. Care must be taken that records are not released to unauthorized persons.

A ready index should be provided for the shop files so that material may be more easily located. The index should be set up according to the 13 major subject classifications in the Navy Directive System and further subdivided into categories corresponding to the list of standard subject classification numbers contained in SecNav Instruction 5210.11 (Series), Navy-Marine Corps Standard Subject Classification System.

PROCUREMENT OF PUBLICATIONS

The Navy has available publications that are specifically prepared to assist maintenance personnel; however, either through lack of knowledge of their existence, the procedure for obtaining them, or plain indifference by supervisory personnel, the work center personnel are often deprived of the benefits they are intended to provide.

There are four main methods of procuring publications relating to naval aircraft maintenance.

The first method is initial outfitting. The Naval Air Technical Service Facility will provide the prospective commanding officer of a newly commissioned or reactivated ship, station, or activity an outfitting of general aeronautical publications. Normally this outfitting will be furnished 6 months prior to commissioning unless otherwise requested.

The second method is aeronautical technical publication outfitting. An Aeronautical Technical Publication Outfitting Allowance consists of those publications applicable to a particular model of aircraft. Initial distribution is provided

by the Naval Air Technical Services Facility to a newly commissioned or reactivated activity. Upon change in mission or aircraft custody which requires a different set of publications, the activity must submit a request to the Naval Air Technical Services Facility for an Aeronautical Technical Publication Outfitting Allowance, applicable to the model designation of the aircraft involved.

The third method of procuring publications is through inclusion on automatic distribution lists. The Naval Air Technical Services Facility normally provides for the distribution of certain future issues of new and revised publications directly to affected activities. Activities desiring to receive future issues of new and revised publications must submit NavWeps Form 5605/2, Mailing List Request for Aeronautical Publications, to the Commanding Officer, Naval Air Technical Services Facility, 700 Robbins Avenue, Philadelphia, Pennsylvania. Aviators Equipment supervisors desiring to receive particular issues, reissues, and revisions of publications should make their requirements known to the maintenance office so that they may be included on the next submission of Form 5605/2.

The fourth method of procuring publications is by ordering individual publications direct. The Single Line Item Requisitioning System Document (DD Form 1348 or DD Form 1348M) is used by activities when requisitioning manual type publications on a one-time requirement. The use of DD Form 1348, DD Form 1348M, or DD Form 1149 will not result in being placed on the automatic distribution list to receive future issues of revisions of the publication ordered.

Detailed information concerning the availability of aeronautical publications may be found in the Naval Aeronautical Publication Index. The complete index is made up of five parts, as follows:

NavSup 2002, Section VIII, Parts C and D—Numerical Sequence List.

NavAir 00-500A—Equipment Applicability List, Volumes 1 through 7.

NavAir 00-500B—Aircraft Application List.

NavAir 00-500C—Directives Application List by Aircraft Configuration.

NavAir 00-500D—Letter Type Directives Equipment and Subject Applicability List.

NavSup 2002, Section VIII, Parts C and D, contain a complete numerical listing of all available naval aeronautical publications distributed by NavAirSysCom and stocked for issue as of the date of publication. This numerical

Chapter 4--WORK CENTER SUPERVISION AND ADMINISTRATION

listing contains all available publications by code number, title, security classification, and date of issue. Publications are subdivided into subject groups according to type of aircraft or equipment, or component thereof.

Part C contains a numerical listing of manual type publications. In addition a cross reference index is provided in the back of Part C to reference those publications which may be of joint interest to the Navy, Air Force, Army, etc.

Part D is a numerical listing of all letter type publications.

NavAir 00-500A—Contains a cross reference index listing of NavAirSysCom publications of aircraft components and related equipment according to model, type or part number. The list contains two lines of information for each item. Numbers are listed in strict alpha/numeric sequence, except for several small sections.

An example of the use of the Equipment Applicability List, NavAir 00-500A, is as follows:

A work center supervisor is having minor difficulties with an LR-1 liferaft. He goes to the technical library to look for information in the 00-500A pertaining to that piece of equipment but he has no idea what the publication number is of the technical manual he is seeking.

The only known bit of information about the liferaft is—the type number—which in this case is LR-1. The PR selects the Equipment Applicability List Index 00-500A to find the applicable publication, remembering that the index list numbers are in strict alphanumeric sequence, the PR must screen the pages until he finds the letters LR, the number 1 will appear in the second entry. Thus, LR1 appears in the first column on the top line. Reading from left to right the following information appears: Vendors code and nomenclature, (Life Raft).

The second line furnishes the technical manual number (13-1-6.1); the code number, indicating the type manual—85, designating the manual as a miscellaneous type; the technical data stock number for requisitioning the manual—0713-020-10100; and the availability code "A" indicating the manual is available and may be requisitioned from the supply system.

NavAir 00-500B contains a listing of NavAirSysCom technical manuals grouped according to their application to an aircraft. This part of the index does not contain a listing of any letter type publications, and the manuals are listed by publication number only.

NavAir 00-500C contains a listing of the active NavAirSysCom technical directives with

respect to their applicability to an aircraft. It is arranged by aircraft series, by aircraft configuration, and by Airframes/Aircraft Bulletin and/or Change numbers.

NavAir 00-500D contains a cross reference index listing of NavAirSysCom letter type technical directives. There are two parts assigned; Part A, Equipment Index, and Part B, Subject Index.

Part A—will contain a listing of all active NavAirSysCom letter type technical directives on aircraft components and related equipment by model, type, and part number. Each number will fall in alphanumeric sequence of its cognizant equipment series.

Part B—will contain a complete listing of active NavAirSysCom letter type technical directives by subject, arranged in the following manner:

1. Prime system.
2. Component part of the system.
3. Airframe title, Bulletin/Change number.

SECURITY OF CLASSIFIED PUBLICATIONS

The problem of security of classified publications in the work center files is generally limited to ways and means of stowing, using, accounting for, and disposing of such publications in accordance with existing directives. The basic Navy security directive relating to the safeguarding of classified information is the Department of the Navy Security Manual for Classified Information, OpNav Instruction 5510.1 (Series). Its provisions apply to all military and civilian personnel and to all activities of the Naval Establishment. The application of security measures regarding work center files may be further influenced by locally issued directives which supplement the basic directive.

All personnel in the Naval Establishment are individually responsible for assuring that knowledge of classified information which they prepare or handle is made available only to persons who have clearly established a legitimate "need to know." Classified material is procured for the work center files because it is needed during the performance of some related maintenance function. Use of these publications by loft personnel should be anticipated and steps taken to procure security clearances for selected personnel most likely to require the information.

The work center supervisor must initiate procedures that insure him positive control of

all classified publications for which he is custodian. The first problem of custody is stowage. The Navy Security Manual discusses stowage containers of varying degrees of integrity. Also provided in the manual are specific requirements for safeguarding combinations and keys for locks, as these, to various extents, affect the protective capabilities of the different types of containers.

Classified publications that are no longer required in the work center should be returned to the Classified Material Control Officer for disposition by transfer or destruction, as appropriate.

PROCUREMENT AND CUSTODY OF EQUIPMENT

The Aviators Equipment work center supervisor is responsible for ordering maintenance spare parts and material, tools, and other equipment necessary for the accomplishment of assigned maintenance tasks. Necessarily related to this responsibility are requirements for controlling the use of consumable materials, maintaining and accounting for tools and material held on a custody signature basis, and, when required, the preparation and submission of evaluation reports.

TOOLS

Ordering of tools is accomplished in much the same manner as ordering of aircraft spare parts. The need for a tool should develop during a periodic tool inventory in order to eliminate a work delay which might develop if a required tool was first discovered missing or damaged during the progress of a job.

Unlike aircraft parts, which should not be stocked in the work center, the Section G Allowance Lists provide for each activity performing Organizational Maintenance to have on hand a certain quantity of tools. The applicable allowance lists should be cross-checked with a current tool inventory and any deficiencies made up as soon as possible.

In some cases, it may be determined that some tools on the allowance lists are not needed or that the allowed quantity exceeds actual requirements. In such cases, those tools should not be ordered just to have them collect dust on the toolroom shelves. In addition, excess tools serve to complicate the periodic inventories.

INVENTORY AND RECORDS

When the work center is first set up and the initial allowance of tools and equipment is drawn, inventory cards should be made up on each item. These cards should include the name of the item, quantity, manufacturer, model, stock number, date of acquisition, cost, and dates and nature of repairs and replacement parts.

Some items should be kept in the work center toolroom or special cabinet; others placed in individual toolboxes and issued to the workers. A toolbox inventory record should be prepared in duplicate with the original filed in the work center files and the duplicate copy placed in the toolbox, preferably in an oil and grease resistant envelope.

A monthly inventory should be conducted beginning with the toolboxes and ending with the toolroom count. The periodic inventory should be more than just an item count. Since each item is sighted, it provides an opportunity to ascertain if the tools in actual use are being maintained in good repair. If they show evidence of damage or improper use, appropriate corrective action should be taken. The men should be encouraged to make good use of delay time by tool maintenance and equipment servicing.

MAINTENANCE FORMS AND RECORDS

Maintenance record forms are provided to enable aircraft maintenance activities to schedule daily maintenance requirements, assign work in a preplanned manner, establish responsibility for work performed, and record component replacement and discrepancies discovered as well as the corrective action taken. Most of the entries of these forms are made in code form. Their use makes data recording and reporting easier, faster, and more accurate since there is no duplication. Information is recorded once and only once by the worker himself or in some cases by the supervisor.

This system of maintenance data reporting is designed so that each worker, when accomplishing a job, converts a narrative description of the job into codes and enters the coded information on certain standard forms known as "source documents." These source documents are collected and transmitted to a data services activity where the information is transferred onto electric accounting machine cards. These cards are then used to produce periodic machine reports, listing and summarizing the

Chapter 4—WORK CENTER SUPERVISION AND ADMINISTRATION

submitted data. The reports are supplied to maintenance supervisors to provide assistance in planning and directing the maintenance effort.

In order that the workers may easily convert narrative descriptions of the actions they perform into coded information on the source documents, the applicable codes are made readily available in a format which is easily understood and easy to use. All of the codes are published in looseleaf binders which are called Work Unit Code Manuals. Each shop or work center normally has several manuals for each type of weapons system or equipment type they maintain. The source documents that the work center personnel are required to use and a brief explanation of the general use of each are given in the following paragraphs.

MAINTENANCE ACTION FORM (MAF)

Two maintenance action forms are in use. The single page form and the multicopy (four copy) form. The single page form is used primarily to record maintenance action not involving processing of reparable components or items. The multicopy form is used to record removal and subsequent processing of a reparable component or item within an Intermediate maintenance activity. The design of this form permits essential coded information to carbon through to succeeding copies.

SUPPORT ACTION FORM (SAF)

This is a single copy Electric Account Machine (EAM) card which is utilized to record data related to manhours expended in accomplishing repetitive, nonrepair tasks such as servicing, engine buildup, parachute inspection, cleaning, painting, etc.

MAN-HOUR ACCOUNTING

The effective use of available manpower is an important function of maintenance management. Man-hour accounting is an important part of the Maintenance Data Collection System. The purpose of collecting man-hour data is to provide management with essential information necessary to more efficiently plan and direct the distribution of assigned personnel.

This system is based upon the "exception" principle; that is, only the deviations or exceptions from normal are reported. Through the

use of master rosters, electric account machine cards, and machine processed reports, the system provides summaries of the hours expended by maintenance personnel during the normal working day or in an overtime status. Basically, the system is designed so that the normal working hours for each person assigned to the maintenance activity are allotted or assigned to work centers by types of labor at the beginning of each reporting period. Exceptions from these normal working hours, or labor types, are reported by use of Man-hour Accounting (MHA) Cards. Data processing machines add or subtract the exceptions reported on the MHA Cards from the initial man-hour allotment. These exceptions and the working hours allotted at the beginning of the period serve as the basis for the daily and monthly man-hour accounting reports mentioned in the foregoing. These reports are forwarded to the maintenance officers and supervisors for validation and utilization. Each supervisor and worker must thoroughly understand the importance of the system, its operation, and the need for continual accuracy. Detailed instructions pertinent to the content and use of man-hour accounting reports are contained in the following paragraphs.

At the beginning of each reporting period, generally the first of the calendar month, man-hours are assigned to every work center to which personnel are assigned. These man-hours are based on an 8-hour work day 5 days per week for every person assigned. Not included in these "Original Assigned Manhours" are any hours for work on Saturdays, Sundays, or holidays during the month. If every person assigned to the work center could be continuously employed throughout the month during all the time available for work, there would be no need for man-hour reporting, as the time would be accounted for on the Maintenance Action Form. Since continuous employment is not possible, each worker must report what he did when he was not working during any period in excess of 20 minutes, or approximately three-tenths of an hour.

To simplify reporting of hours spent in a labor category other than that for which assigned, a group of MHA Cards is provided for every worker assigned. A card is initiated each time a person excepts from normal for a period in excess of three-tenths of an hour and is completed at the end of the exception. The most frequent exceptions requiring the submission of

AIRCREW SURVIVAL EQUIPMENTMAN 1 & C

MHA Cards are (1) each time a person is assigned to, or transferred from, a work center or organization, (2) each time a person performs work in other than his regularly assigned labor code, (3) each time a person is absent from his work center for nonmaintenance purposes such as watches, leave, sick, special liberty, etc., and (4) each time a person works overtime during a single work day or on his day off (holiday, Sunday, etc.).

MHA Cards are, for the most part, prepunched and preprinted. However, handscribed cards have a place in the system.

Handscribed MHA Cards are normally used to report (1) newly assigned personnel, (2) temporarily assigned personnel, and (3) whenever prepunched, preprinted cards are not available.

The use of the blocks and spaces on the MHA Card, MAF, and SAF are discussed in OpNavInst 4790.2, Volume III, Chapter 2.

TECHNICAL DIRECTIVE COMPLIANCE FORM (TDCF)

The TDCF is a single page form that is used to document all technical directive maintenance actions. It will also be used by reporting custodians for preplanning workload and material requirements and for configuration accounting. Data obtained from the form will allow identification of all direct man-hours expended complying with Technical Directives. Maintenance Control will originate sufficient copies of the TDC form upon receipt of each approved applicable Technical Directive. A sample of the TDCF as it applies to the Aviators Equipment work centers is shown in figure 4-8. Information for completing the form can be found in OpNavInst 4790.2 (Series).

REGISTERS

In addition to the source documents, maintenance and material control registers are provided for utilization by supervisors to provide essential information needed to control the maintenance and material procurement efforts. They also provide a method to monitor documentation of these efforts. The registers specified for use in maintenance data reporting (MDR) are as follows:

1. Organizational Maintenance Control Register.
2. Organizational Work Center Register,

3. Organizational and Intermediate Material Control Register, and
4. Intermediate Maintenance Register.

MAINTENANCE INSTRUCTION FORM

OpNav Form 4790/35 is provided for use by the maintenance administrators as the standard form for the interpretation and/or amplification of technical directives and maintenance requirements received from higher authority. These forms may also be used to issue local technical instructions. The maintenance instruction is usually prepared by the cognizant division; however, it may be drafted by any division designated by the Aircraft Maintenance Officer. A review of the draft should be conducted by the quality assurance division as well as the maintenance control division prior to approval by the aircraft maintenance officer.

The maintenance instruction must be prepared carefully, with attention to the precept that it is the instrument by which the division officer directs his men. Command directives in the form of messages are often so brief that, to be understandable at the working level, they need considerable amplification and background information. On the other hand, lengthy and detailed directives prepared for all aviation activities may be received. Only parts of these directives may be applicable locally, and the directives need condensation and selection to adapt them to local conditions. Three purposes for which the maintenance instruction may be used are as follows:

1. Work of a one-time nature, which requires the issuance of a Single Action Maintenance Instruction (SAMI).
2. Work that may recur at intervals, for which a Continuing Action Maintenance Instruction (CAMI) is issued.
3. When the need arises to disseminate technical information within the activity, a Technical Information Maintenance Instruction (TIMI) is issued.

MAINTENANCE REQUIREMENTS CARDS (MRC)

The prescribed maintenance requirements as promulgated in the Periodic Maintenance Requirements Manual are presented to the maintenance man in the form of Maintenance Requirements Cards (MRC's). Each MRC contains

Chapter 4—WORK CENTER SUPERVISION AND ADMINISTRATION

TECHNICAL DIRECTIVE COMPLIANCE FORM OPNAV FORM 4790/43 (10-69) 54 0167-770-4600															
1. JOB CONTROL NUMBER T99-0238-164			2. TYPE EQUIP. YPAA		3. BU/SER NO. 0		4. ACTION ORG T99		5. WORK CENTER 800		6. MAINTENANCE LEVEL 1 ORG <input type="checkbox"/> 2 INT <input checked="" type="checkbox"/> 3 DEP <input type="checkbox"/>			7. ACTION DATE 0238	
STATISTICAL DATA	8. SYSTEM 91	9. STATUS C	10. ITEMS PROC 4	11. MAX HRS 1.0	12. EMT 1.0	13. INTERIM <input checked="" type="checkbox"/> YES <input type="checkbox"/> NO		14. TECHNICAL DIRECTIVE IDENTIFICATION 1 CODE 67 2 BASIC NO. 264 3 REV. 4 AMD 5 PART 6 KIT 00						15. CORR	
	16. OLD ITEM 1 MFR 2 SERIAL NUMBER				17. NEW ITEM 1 MFR 2 SERIAL NUMBER										
	18. PART NUMBER				19. PART NUMBER										
MAINT. CONTROL	A. PRI 2	B. PRIMARY WORK CENTER 800		C. ASSISTANT WORK CENTERS			D. BY DATE 0240	E. EST M/H 0.3	F. CREW SIZE 1	G. KIT RECD. <input type="checkbox"/> YES <input checked="" type="checkbox"/> NO		H. SE RECD. <input type="checkbox"/> YES <input checked="" type="checkbox"/> NO		I. REMARKS	
MATERIAL	A. MATERIAL/KIT STOCK NUMBER				B. DATE ORDERED		C. STUB NO.		D. DATE RECEIVED		F. ISSUED BY				
	E. REMARKS None Required										G. DELIVERED BY				
WORK CENTER	A. STATUS ↑	C. REMARKS Comply with										G-STATUS CODES			
	B. SAMPLING NO 10-70	IACSB-264										A-ASSISTING WORK CENTER			
												C-COMPLIED WITH			
LOGS & RECORDS	D. ACCOMPLISHED BY J.L. Cannon	E. INSPECTED BY W.C. Poole				F. SUPERVISOR C.J. Collom				P-PREVIOUSLY COMPLIED WITH					
	A. COMPLIANCE RECORDED ON HISTORICAL RECORDS <input type="checkbox"/> LOG <input type="checkbox"/> ACCESSORY CARD										B. DATE SIGNATURE				
	C. CONFIGURATION FORM <input type="checkbox"/> YES <input checked="" type="checkbox"/> NO				DATE		SIGNATURE		D						

PR.444

Figure 4-8.—TDCF Work Center copy.

one or more detailed maintenance requirements. Illustrations, clearances, tolerances, charts, and part numbers are included when required. All minimum requirements for the accomplishment of any particular periodic maintenance task (Preflight, Postflight, Daily, Calendar, Special, or Conditional inspection), or portions thereof, are contained in a set of these cards. The work plan, or order of performing the requirements, is prearranged in two manners. The Preflight, Postflight, and Daily inspections are performed item by item in sequential order arranged on consecutively numbered cards. The Calendar inspection work is controlled by order of arrangement of the items on the MRC's, and in

addition, employs a Sequence Chart for scheduling of the cards. The Calendar MRC's are not necessarily scheduled in card number sequence.

No part of any scheduled maintenance is certified or signed off on the Maintenance Requirements Cards. Therefore, the cards may be used as many times as their condition permits.

Locally established periodic maintenance requirements, not covered by the published Maintenance Requirements Card sets, can be added in two ways; (1) The requirement can be added to existing cards. This will necessitate an adjustment to the individual card time, plus a possible adjustment of the Sequence Chart of

AIRCREW SURVIVAL EQUIPMENTMAN 1 & C

the card in the Calendar sets or (2) by the use of blank cards provided for this purpose. When using this method, the new cards generated at the local level can be numbered consecutively following the last number of the published set (with the designation "local"), or assigned suffix numbers .1, .2, .3, etc., which are added to the number of the related cards of the published set (also with the designation "local").

A Master File Copy of current Maintenance Requirements Cards must be maintained within the aircraft maintenance department. This master file copy will reflect all revisions to the published card sets plus locally added requirements. The quality assurance division is normally charged with this responsibility.

UNSATISFACTORY MATERIAL CONDITION REPORT (UR)

The Maintenance Data Collection System provides data required for reporting routine defects and failures. The Unsatisfactory Material Condition Report (UR), OpNav Form 4790/47, is used for special situations as follows:

1. Report hazards to flight safety. The report in such instances, will serve as a followup to a flight safety message.
2. Report errors and omissions in aircraft equipment manuals.
3. Report aeronautical equipment found discrepant as a result of design deficiency, faulty manufacture, faulty overhaul, or faulty preservation/packaging.
4. Make special reports on any weapon system or equipment specifically requested by the Naval Air Systems Command for special reliability studies.

The UR, OpNav Form 4790/47, is a four-part, carbon interleaved, snap out form. Detailed instructions for preparation and submittal of the UR form are printed on the cover of each set.

SEVEN/FOURTEEN DAY INSPECTION TAG

The 7/14 day inspection tag is used to record the 7/14 day inspection. Information recorded must include the inspector's full name, rate, and date of inspection. Each time a 7/14 day inspection is performed the old tag must be discarded and a new tag affixed. Tags must be secured snugly to a spring opening band by using a

surgeon's knot backed up with a square knot. Position the tag under a spring opening band so that the date of inspection, recorded at the top of the tag, will be visible.

For more detailed information on the 7/14 day inspection refer to the Aviation-Crew Systems Personnel Parachute Manual, NavAir 13-1-6.2.

PARACHUTE HISTORY CARD

The parachute history card, NavAir Form 104790/7, must provide a complete record of the service, maintenance, and custodial description of a parachute assembly. The card must list historical data elements and perform a complete documentary function necessary to provide evidence of inspections and maintenance task accomplishments.

Required entries that must be recorded on the Parachute History Card are as follows:

1. Parachute serial number.
2. Manufacturer.
3. Date of manufacture.
4. Contract number.
5. Type of parachute.
6. Part numbers of the canopy, harness, pack, and pilot chute.
7. Date that the parachute assembly was placed into service.
8. Automatic actuator type and serial number, date of installation, expiration date, time delay, cartridge load lot number, and inspection cycle. This information, in part, must be recorded in the upper right hand corner of the card front.
9. Repairs, modifications, and changes.
10. Signature of person performing modifications.
11. Date, place, and signature of person packing the parachute.

NOTE: The 7/14 day inspection data must not be recorded on the Parachute History Card.

For more detailed information on the Parachute History Card, refer to the Aviation-Crew Systems Personnel Parachute Manual, NavAir 13-1-6.2.

SHOP PROCESS CARDS

Shop Process Cards contain maintenance information pertaining to the minimum requirements for the performance of any particular periodic maintenance task. The cards may depict the following:

Chapter 4—WORK CENTER SUPERVISION AND ADMINISTRATION

1. Illustrations.
2. Clearances.
3. Tolerances.
4. Charts.
5. Part numbers as required.

Shop process cards act as a ready reference and the work plan, or order of sequence in performing the maintenance work requirements, is prearranged for the type of aircrew survival equipment being serviced.

Each step of the maintenance task, published on the shop process card, includes a paragraph number that refers to the applicable paragraph in one of the NavAir 13-1-6 (Series) AirCrew Systems Manuals.

Shop process cards are provided in separate decks for the type of equipment being serviced. Maintenance task accomplishments are not certified on the shop process cards; therefore, the cards may be used as often as their condition permits.

Provisions are made for adjustment or additions to the existing cards and for use by Collateral Duty or Quality Assurance inspectors. Work must not proceed past the inspection points indicated on the shop process card without approval of the inspector.

Master file copies of the Shop Process Cards reflecting all revisions to the published card decks plus locally added requirements are maintained by the Maintenance Department.

CHAPTER 5

MISCELLANEOUS PARACHUTES AND EQUIPMENT

MISCELLANEOUS EQUIPMENT FOR REPAIR AND UPKEEP OF PERSONNEL AND NONPERSONNEL PARACHUTES

Many of the items of equipment necessary to repair and maintain personnel parachutes are the same as those required for nonpersonnel parachutes. Therefore, fabric, tapes, webbing, thread and cord, and hardware for both types are included in this chapter.

NYLON THREAD

Nylon thread conforming to MIL-T-7807B-1 is used in the manufacture and repair of all types of parachutes. The minimum breaking strength in pounds for nylon threads and cords are as follows:

Thread size		Cord size	
A	2.75 pounds	3	24.00 pounds
B	5.50 pounds	6	50.00 pounds
E	8.50		
FF	16.00 pounds		

NYLON CORD

Cord conforming to MIL-C-5040B(ASG) is used for suspension lines for pilot chutes and main parachute canopies. Type I cord, with a breaking strength of 100 pounds is used for pilot chutes, and type III cord (550 pounds breaking strength) is used for all suspension lines of personnel parachutes. Cords used for suspension lines of nonpersonnel parachutes usually conform to the specifications outlined in the specification for the particular parachute in question.

NYLON REINFORCING TAPE

Reinforcing tape must conform to MIL-T-5038C. These tapes have many uses such as edgings, making hesitator loops, parachute container reinforcement, and general strengthening of stress areas.

Many tapes can be identified by their weave. For instance, type II is a plain weave. Type IV is composed of two ground warps. Type VI is a herringbone type which differs only slightly from type IV.

Type II is 3/4 inch wide and has a minimum breaking strength of 400 pounds. Type IV tape comes in both 1-inch and 1 1/2-inch widths. The 1-inch width has a breaking strength of 1,000 pounds, while the strength of the 1 1/2-inch width is 1,500 pounds. Type VI tape is 3/4 inch wide and has a breaking strength of 425 pounds.

NYLON WEBBING

Soft textile nylon webbing is used for constructing parachute harnesses. This webbing has a tensile strength of 6,000 pounds, is olive drab or sage blue, and is 1 23/32 inches wide. The webbing used in the construction of drag (deceleration) chutes and various cargo slings is usually type VIII cotton.

NYLON TUBULAR WEBBING

Tubular webbing is neutral in color and is used in reinforcement of the parachute canopy. It is manufactured in several widths and tensile strengths to meet various demands. The most widely used in the Navy are:

1/2-inch	1,000 pounds tensile strength.
9/16-inch	1,500 pounds tensile strength.
1-inch	3,000 pounds tensile strength.

The 1/2-inch webbing is used as a pilot chute connector cord replacement on all parachutes, except the MBEU, which uses the 9/16-inch width. The 1-inch width is used for reinforcing the skirt hem.

For proper webbing use, refer to the following specifications:

MIL-W-4088B (USAF).
MIL-W-6134B.
MIL-W-5625D.

NYLON PARACHUTE CLOTH

Unless otherwise specified, parachute cloth is neutral in color. It is manufactured in accordance with the requirements in Specification MIL-C-7020D. This specification states that the maximum weight of parachute cloth can be no more than 1.1 ounces per square yard. The minimum breaking strength can be no less than 42 pounds per inch of width, and the minimum tear resistance is 5 pounds for both warp and filler thread. The air permeability in cubic feet per minute per square foot of cloth is 80 to 120.

HARDWARE

Hardware for use in the manufacture of parachute harnesses must conform to Specification MIL-H-7195. PR's are seldom required to replace a piece of hardware on a parachute harness. Therefore, since there are so many configurations of this type of hardware, no attempt will be made to cover it in this manual. Should it be necessary to replace a piece of hardware, be sure that the item used is the exact item called for in the specification covering the harness being repaired.

Surveyed harnesses may be cut up and the hardware salvaged for future use on locally manufactured rigs such as alyards, cargo drop slings, etc.

PARACHUTE ACTUATOR

The Master Specialties actuator is a pyrotechnic device, utilizing energy derived from an explosive cartridge to withdraw the ripcord from a packed parachute. Firing of the cartridge is controlled by an aneroid assembly which functions at a present altitude (14,000 feet) to release the firing mechanism.

Maintenance of the Master Specialties actuator is limited to the replacement of exploded or outdated cartridges, visual inspection and replacement, when necessary, of Teflon seal and cartridge after firing, and adjustment of the aneroid.

The procedures for testing, repairing, overhauling, and adjusting the automatic parachute actuator is covered in chapter 9 of Aircrew Survival Equipmentman 3&2, NavPers 10358-D.

DROGUE CHUTES

There are a number of different types of drogue chutes used in the Navy today such as

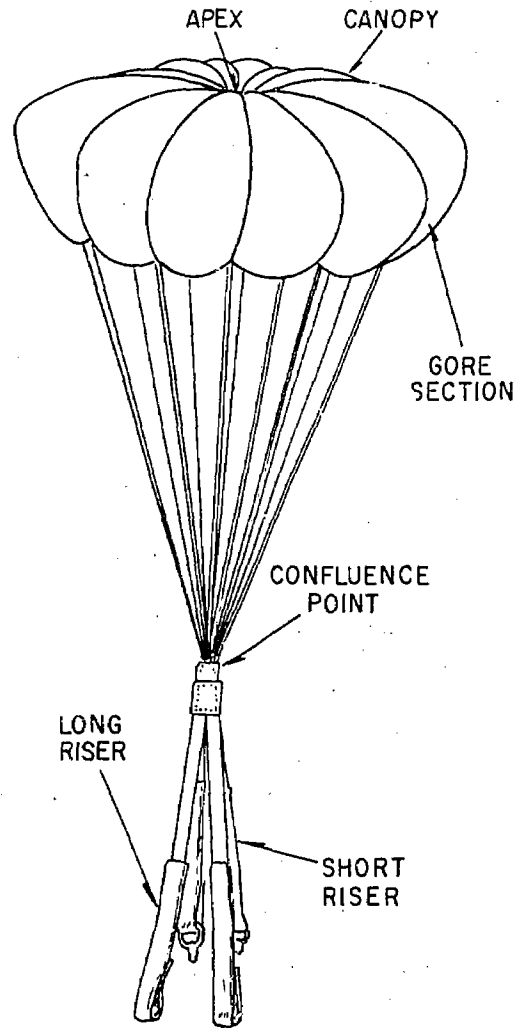

PR.27

Figure 5-1.—RA-5C drogue chute.

the Martin-Baker duplex drogue parachute which is discussed in Aircrew Survival Equipmentman (PR) 3 & 2 in chapter 8. Another type is the drogue chute used in the RA-5C aircraft, which is shown in figure 5-1. It consists of a drogue chute mounted in a headrest.

The functions of the drogue chute are to decelerate and stabilize the seat in the airstream, and to pull open the NB-7E personnel parachute during seat/man separation. The drogue chute is a 52-inch, ribless guide surface type. The canopies are made of 4.75-ounce-per-square-yard nylon fabric. The suspension lines are 3/4 inch wide nylon webbing, having a tensile

strength of 2,250 pounds. There are 12 gores and 12 suspension lines. The riser portion is made of 1 3/4 inch wide webbing, having a tensile strength of 10,000 pounds. The ends of the risers are protected by leather buffers. All four riser legs are secured together by webbing at the confluence point.

FABRIC CONTAMINATION INSPECTION AND REMOVAL

Parachute assemblies must be carefully inspected for evidence of contamination. The various types of contamination are acid, alkaline, salt water, fresh water, perspiration, mildew and fungus, fire fighting agents, mud, dirt, and petroleum.

ACID AND ALKALINE

Parachute assemblies suspected of acid or alkaline contamination must be tested with pH test paper. A pH reading of 5.0 to 9.0 is in the safe zone. Readings below 5.0 indicate excess acidity, and readings above 9.0 indicate excess alkalinity.

To test for excess acidity or alkalinity dampen the suspected area with distilled water. NOTE: Handle test paper by one end or edges only to prevent obtaining a false reading.

Place a piece of full range test paper (0.0 to 14.0 pH) on dampened area. A color change will indicate the approximate pH and which specific shortrange test paper to use. Place a piece of shortrange test paper indicated in the above test on the dampened area. The color change indicates the pH factor of the affected area. By matching the test strip with the applicable range color chart supplied with the pH indicator kit, acid or alkaline strength can be determined.

If contamination is found, care must be used to prevent contact between the contaminated area and other portions of the assembly, as this could spread the damage.

If acid contamination is found, the affected parachute assembly must be forwarded to supply for screening.

If alkaline contamination is found, rinse with cool, fresh water until a safe pH reading is attained. Carefully inspect for deteriorated portions, repair or replace any affected areas.

SALT WATER CONTAMINATION

Parachutes that have been contaminated by salt water must be cleaned, inspected, and

treated as soon as possible after contamination. Any portion of a parachute assembly which has been immersed in salt water for a period of more than 24 hours must be turned into supply for screening. Any portion of a parachute assembly which has been contaminated by salt water and cannot be cleaned within 36 hours must be turned into supply for screening. Clean any parachute assembly contaminated by salt water as described later in this chapter.

PERSPIRATION CONTAMINATION

Any parachute assembly which is stained with perspiration must be cleaned as described later in this chapter. After cleaning, the fabric affected must be closely inspected to insure that deterioration has not taken place. Scrap or repair any damaged portion of the parachute assembly.

FRESH WATER CONTAMINATION

Any parachute that has been contaminated by fresh water must be dried as soon as possible. The assembly must then be inspected for signs of stains by oil, hydraulic fluid, mud, etc. Such stains must be removed by cleaning as described later in this chapter.

MILDEW AND FUNGUS CONTAMINATION

If mildew or fungus is present on a parachute assembly, wash the affected area with a mild soap and water solution. Rinse the affected area thoroughly with clean, fresh water and hang the assembly by vent lines in a wet locker to dry.

FIRE FIGHTING AGENTS CONTAMINATION

If a parachute assembly is contaminated with firefighting agents, forward to supply for screening.

PETROLEUM PRODUCTS CONTAMINATION

Oil, grease, hydraulic fluid, and other petroleum stains must be removed by repeated applications of a mild soap and water solution. Each application must be followed by a rinse in clean, fresh water. Hang the assembly by vent lines in a wet locker to dry.

CLEANING PARACHUTE ASSEMBLIES

Cleaning of parachute assemblies should be held to a minimum and done only when necessary to avoid malfunction or deterioration.

Do not scrub fabric with any cleaning implement or against itself, do not brush fabric. Do not pick at or try to break off dried or caked mud. Wrap all metal fittings in heavy flannel cloth.

Hang the parachute assembly by vent lines and thoroughly shake to remove all sand, dust, and mud. If the assembly is wet, immerse it in clean, fresh water not over 120°F. Gently move the parts by hand until all air pockets are removed. Agitate by hand until water flows through and around the fabric. **MACHINE AGITATION MUST NOT BE USED.**

After 5 to 10 minutes, lift the assembly from the tub and allow to drain as completely as possible. Drain and rinse the tub and refill with water; repeat the 5 to 10 minute wash twice.

If the parachute has dried before the first rinse is performed, the first rinse must be preceded by a 2- to 3-hour soaking in a tub filled with clean, cool, fresh water. If a large tub is not available, hang the assembly by the canopy vent lines and spray clean using clean, fresh water not over 120°F.

Do not use a forced-heat dryer. Do not wring water from the canopy.

Place the cleaned parachute assembly into a low speed dryer and spin dry. If a low-speed dryer is not available, hang the parachute assembly by vent lines in a wet locker only until dry. When the assembly is completely dry, remove the flannel cloth from the metal fittings.

If the parachute assembly has stains which cannot be removed by the procedure described in the foregoing paragraphs, it must be forwarded to a depot-level maintenance activity for additional cleaning. Attach a report of the nature and location of stains.

CARGO PARACHUTES

Although the use of cargo parachutes is not a primary concern of the Navy, it is sometimes necessary for naval aircraft to engage in aerial cargo dropping operations. There are necessarily a number of types of cargo parachutes, since conditions and circumstances determine the kind of equipment and types of assemblies to be used. For example, supplies or equipment may have to be dropped to men in liferafts at

sea, marooned on an island, in a jungle, or in a mountainous region. At other times it may be necessary to drop equipment behind enemy lines.

The occasion may arise when cargo parachutes and rigs have to be improvised. With a few adaptations, surveyed man-carrying type parachutes may be used. All such parachutes must be stenciled "CARGO" in large letters to assure that the units are never returned to man-carrying service.

The cargo parachutes discussed in this section are standard U.S. Air Force equipment and are available to naval activities through regular supply channels.

TYPES G-1 AND G-1A

Types G-1 and G-1A cargo parachutes are used in conjunction with various containers, cartons, packs, and slings designed especially for handling and enclosing supplies and equipment most likely to be delivered by air.

The canopies and lift webs for the G-1 and G-1A are identical; however, different packs are used. The pack for the G-1 is composed of two parts—the pack body and the pack cover, with the static line a part of the cover. The pack for the G-1A is a 1-part unit with the static line forming a separate assembly.

Description of Canopy

The flat, circular type canopy shown in figures 5-2 and 5-3 is 24 feet in diameter and has a 12-inch diameter vent at the apex. This canopy is made of twenty-four 1-piece solid rayon gores, and is issued in five different colors—green, light blue, natural, red, and yellow. There is no limitation to the service life of the G-1 or G-1A parachutes.

Lengths of rayon tape, referred to as upper and lower lateral bands, reinforce the assembly by encircling the canopy inside the skirt and vent hems. On some canopies a lower lateral band outer reinforcement is sewed to the inner circumference of the skirt and is looped loosely around each suspension line.

The 24 suspension lines are actually made of 12 lengths of rayon tape, with each length of tape running continuously over the canopy from connector loop to connector loop. Unstitched areas of suspension lines on the canopy are protected by radial bands which form channels for the lines. Two lift webs are separated by a spreader, and the suspension lines are attached to the connector loops.

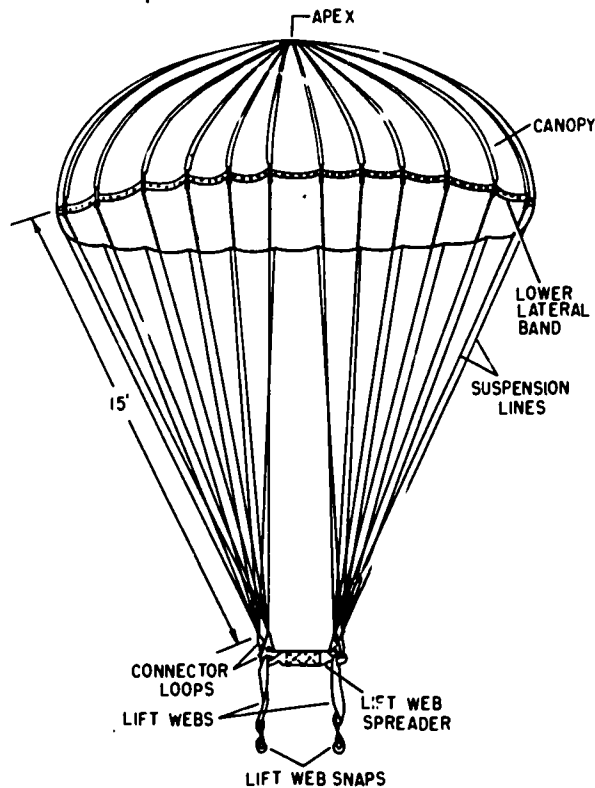

PR.4
Figure 5-2.—G-1 and G-1A parachutes showing canopy and lift webs.

Canopy Repairing

Loose or broken stitching areas can be re-stitched without removing the old stitching. Use natural, size E nylon thread. Stitch 8 to 10 stitches per inch, using Singer Model 31-15 sewing machine or equivalent for the tape.

DARNING.—Darn holes or tears not exceeding 1 inch in length with size E nylon thread. The procedure for darning is the same as given for personnel parachutes in Aircrew Survival Equipmentman 3 & 2, NavPers 10358-D.

RECTANGULAR PATCHING.—Damaged areas that do not extend to any of the gore seams may be repaired with rectangular patches as follows:

1. Turn the canopy inside out and lay it out on the repair table, centering the gore to be patched on the table.

2. Place a patch pattern that is 3 inches longer and 3 inches wider than the damaged area on the material to be used for patching so that the edges of the pattern are parallel to the warp and filler of the material. Mark the material according to the pattern. Cut the patch from the material according to the marking.

3. Fold back the edges of the patch 1/2 inch and baste with thread, using 2 stitches per inch. Place the patch over the hole to be patched, making sure the warp and the filler of the patch and that of the canopy gore run parallel to each other. Baste the patch to the gore, using 2 stitches per inch.

4. Stitch the patch on the canopy by sewing at the edge of patch, using natural, size E nylon thread. Stitch 8 to 10 stitches per inch, using the Singer Model 31-15 sewing machine or equivalent. Place the first row of stitches 1/16 inch from the edge of the patch. Sew completely around the patch and overlap the stitches 2 inches to make secure.

Turn the canopy right side out and cut out the damaged material around the hole. Fold under the edges of the material around the hole 1/2 inch and baste. Sew completely around the patch 1/16 inch from edge of the hole, overlapping the stitches 2 inches. Remove the basting and complete a third row of stitches between the other two rows. Sew completely around the patch and overlap 2 inches.

CHANNEL-TO-CHANNEL PATCHING.—A large damaged area may be repaired with a channel-to-channel patch up to 5 feet in length. The patch may extend to either the lower or upper lateral band seam, depending on the location of the damaged area.

The procedure is the same as for the rectangular patching with the following exceptions:

If the patch is to cover a lower lateral band that is equipped with a reinforcing tape, remove the stitches and raise the tape so that the patch may be installed under the tape. If the lower lateral band reinforcing tape is loosened, replace with a double row of stitching. Reproduce as closely as possible all stitching that was removed.

REPLACEMENT OF A GORE.—If a channel-to-channel patch cannot be used to repair a gore adequately, the badly damaged gore may be replaced as follows:

1. Remove the suspension line channel radial bands on both sides of the damaged gore.

2. To cut the gore or to prepare a pattern for the gore, refer to figure 5-4. From point A,

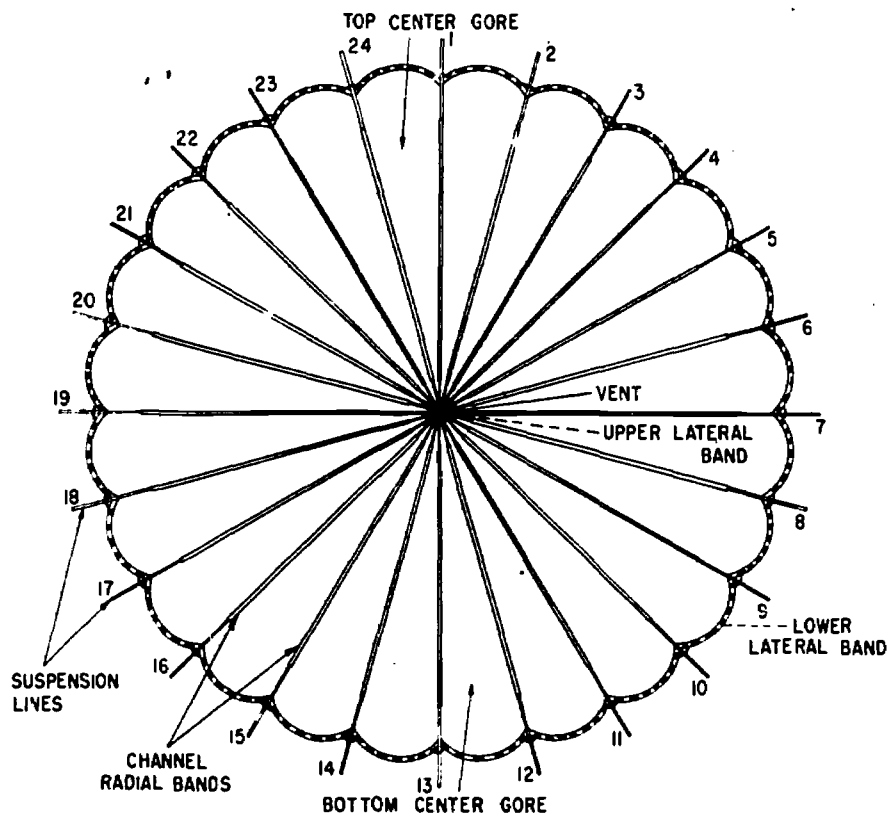

PR.5

Figure 5-3.—G-1 and G-1A canopy laid out flat, top view.

measure 12 feet 11 inches along the selvage edge to find point B. From point A, measure 3 feet along a perpendicular to find point C. Connect points B and C. From point B, measure 12 feet 11 inches back along line BC to find point D. Connect points D and A. To find line EF, slide a rule back from point B until the perpendicular line EF measures 2 3/4 inches. Cut the gore or pattern along lines ADEF. In cutting the gore, line AB must always lie along the selvage edge or parallel to it.

3. Install the new gore, adapting the procedure given for channel-to-channel patching. Replace the suspension line channel radial bands.

Splicing the upper lateral band is accomplished in the same manner as given for splicing

the lower lateral band. The upper lateral band is not replaceable.

Repairing Suspension Lines

The 24 suspension lines are made of 12 lengths of natural, 1/2 inch wide, type II rayon tape. Each length of tape is approximately 56 feet 10 inches long when measured under a 10-pound tension. Each suspension line is 15 feet long from the edge of serving on the connector loop to the skirt of the canopy.

Splicing the suspension line is done in the same manner as given for splicing the lower lateral band.

Suspension lines may be replaced as follows:

1. Remove the stitching that secures the damaged line to the canopy and connector loops.

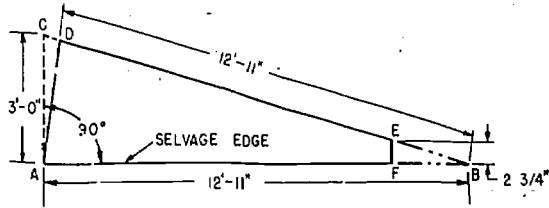

PR.6

Figure 5-4.--Canopy gore dimensions, including seam allowance.

Remove the servings and tape at appropriate connector loops and remove damaged line.

2. Place the new suspension line under a 10-pound tension and cut a 57-foot 4-inch length. The length of the new suspension line is 6 inches longer than the required length of the suspension line to allow for any margin of error, since other undamaged lines may have been stretched with use of the parachute.

3. Dip the ends of new line in a paraffin-beeswax mixture. Place the line through the proper channel radial bands on the canopy.

4. Place the new line in proper position with the other lines at the connector loops. Lay the parachute out on the packing table and apply equal tension to new and old suspension lines.

5. Form a 3-inch loop, making certain that any excess line is cut off before final sewing

and serving, using 5 to 7 stitches per inch on a 7-31 sewing machine to secure the lines. Wrap the loop with 1-inch adhesive tape. Make two 1-inch servings 5 inches apart using cotton 6 cord.

Repairing Lift Webs

The lift web assembly consists of two webs 34 inches long and a spreader made of natural, type VIII, cotton webbing. Lift web snaps are attached to the ends of the lift webs.

Lift webs, spreader, and snaps should not be repaired. The lift web assembly may be replaced as follows:

Fabricate lift webs with type VIII cotton webbing and attach as shown in figure 5-5. Stitch 6 to 8 stitches per inch, using a 7-31 sewing machine.

Fabricate the lift web spreader from the same type webbing, and attach as shown in figure 5-6. Use the same stitches and sewing machine as for the lift web.

Description of G-1 Pack

The G-1 pack consists of two main parts, the pack body and the pack cover. A 15-foot static line is attached permanently to the cover.

PACK BODY.—The pack body is 12 inches square and 3 3/4 inches high with an open end. The bottom consists of inner and outer squares of heavy duck, with an enclosed plywood base for easier handling. There are nineteen 1/4-inch brass grommets and one 3/8-inch brass

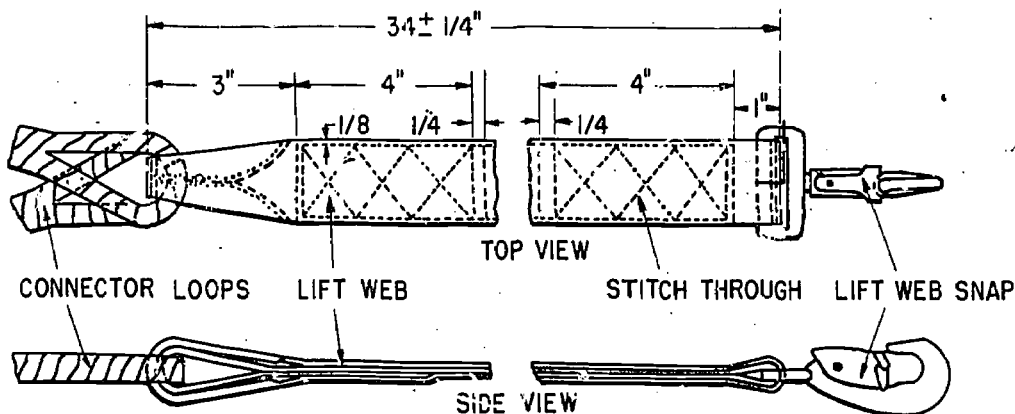

PR.7

Figure 5-5.--Lift web, top and side views.

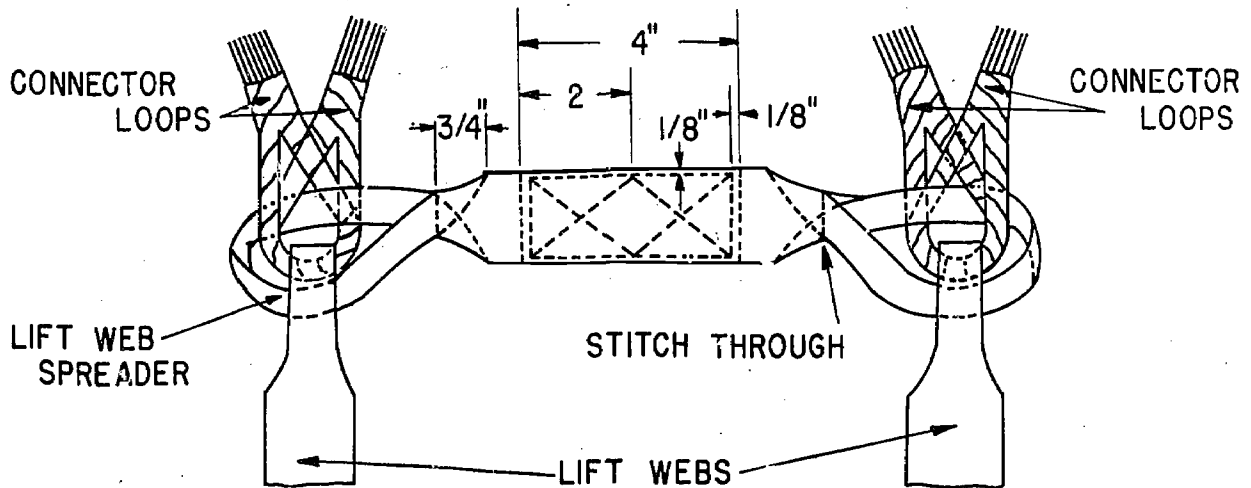

Figure 5-6.—Lift web spreader, showing method of securing to lift webs.

PR.8

grommet around the open end edge of the side of the pack body. Tiedown webs are sewed to the inner bottom of the pack body with web ends passing through the corners of the pack body.

PACK COVER.—The pack cover is 12 1/8 inches square and 6 1/2 inches high with an open end which fits over the pack body. There are sixteen 1/4-inch brass grommets and four 3/8-inch grommets around the edge of the side of the pack cover. The larger grommets are located where the ends of the static line webs meet the edge of the pack cover. The static line webs are sewed to the inside of the pack cover. The 15-foot static line is looped through the pack cover and around the static line webs where the webs cross at the log hole in the pack cover top. Figure 5-7 shows the inside of the pack body and cover.

Repairing Pack Bottom and Cover

Restitching and darning the pack bottom and cover may be done by following the same procedure as for restitching and darning the canopy. Holes or tears that are more than 3/4 inch in diameter or length require patching. Patch the side or bottom with the same type material used in the original construction. The type of patch used depends on the location and the extent of the damage. When patching, use 6 to 8 stitches per inch with a 111 W 151 sewing machine or equivalent.

Parachute Log Record Pocket

The parachute log record pocket is located in the bottom of the pack body, and is made of the same material as the pack body side and bottom. There is a pull tape for ease of removing the packing card. The binding tape and pull tape are made of 3/4-inch, type III, cotton reinforcing tape.

Static Line

The static line is made of natural, type VIII, cotton webbing and is provided with a static line snap. The static line should not be repaired; it should be replaced.

Replace the static line by removing the damaged line from pack cover and fabricating and installing a new line. Use 6 to 8 stitches per inch, sewing on a 7-31 machine.

Description of G-1A Pack

The G-1A pack and static line, unlike the G-1 pack and static line, are separate assemblies.

The G-1A pack is a single unit, consisting of a cotton duck side panel and inner and outer bottom panels. (See fig. 5-8.) The four cover flaps are part of the same piece of duck as the side panel, with the cover loops formed from the cover loop strap. A top reinforcing strap is attached to the outside of the pack beneath

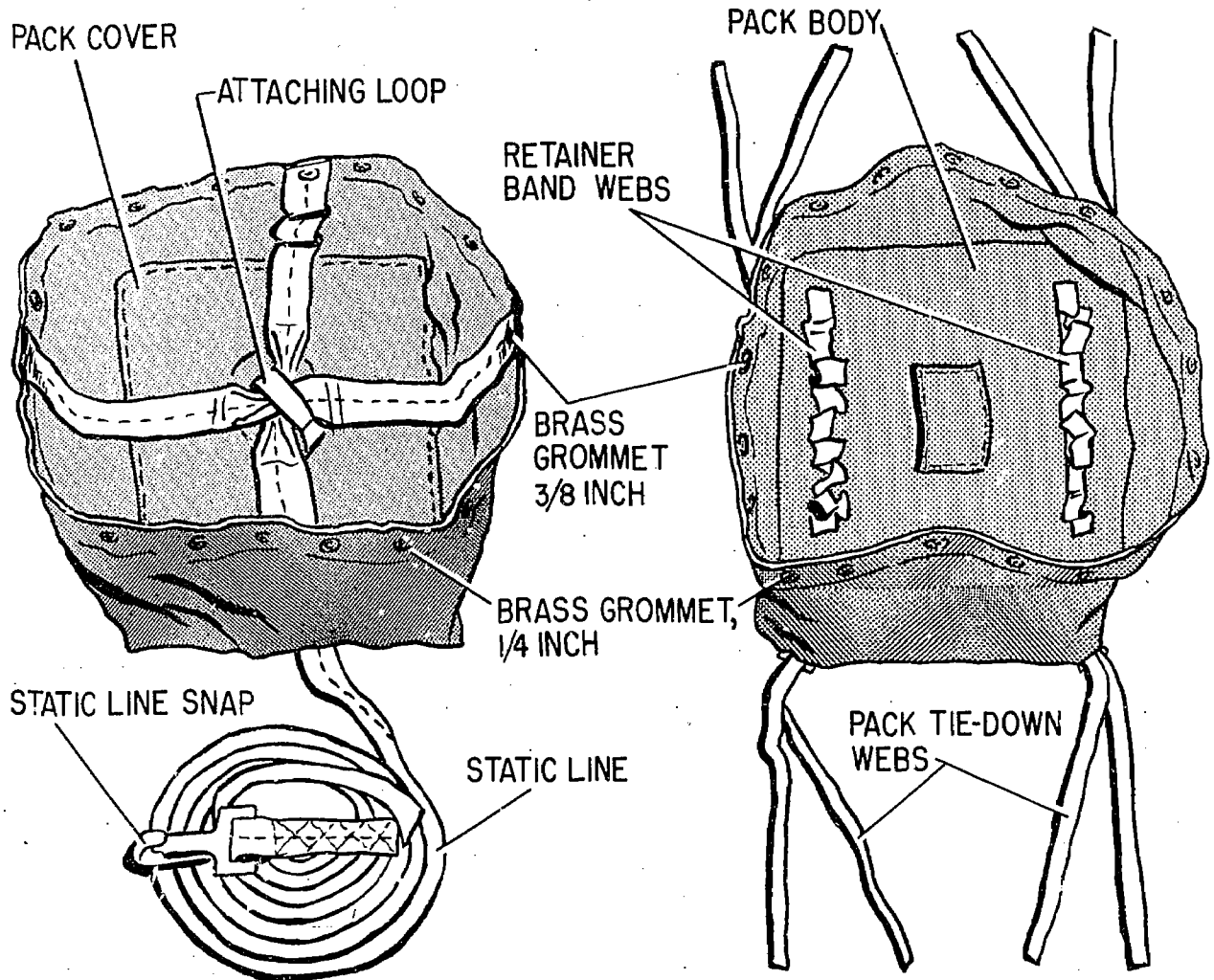

Figure 5-7.--G-1 pack body and cover, showing inside view.

PR.9

the flaps, with two static line retaining straps attached to the top reinforcing strap. Two suspension line retaining band keepers are attached to the inner bottom panel, and four pack tie-down straps are attached near the four bottom corners.

*The static line is a mildew-proofed, 15-foot 4-inch length of olive drab type VIII cotton webbing with a snap at one end, an attaching loop at the other end, and a pack opening loop 4 3/4 inches from the attaching loop.

REPAIRING.--The restitching, darning, and patching is done in the same manner as given for the G-1 pack.

G-1 Packing Procedure

After the parachute is laid out on the packing table and an even tension is applied, check the continuity of the suspension lines. The canopy is now whipped and folded identically to the man-carrying parachute canopy.

ATTACHING BREAK CORD.--To attach the break cord to the canopy bridle loop and the break cord attaching loop of the static line, proceed as follows

Place the pack cover on the packing table near the canopy apex. Obtain a 24-inch length

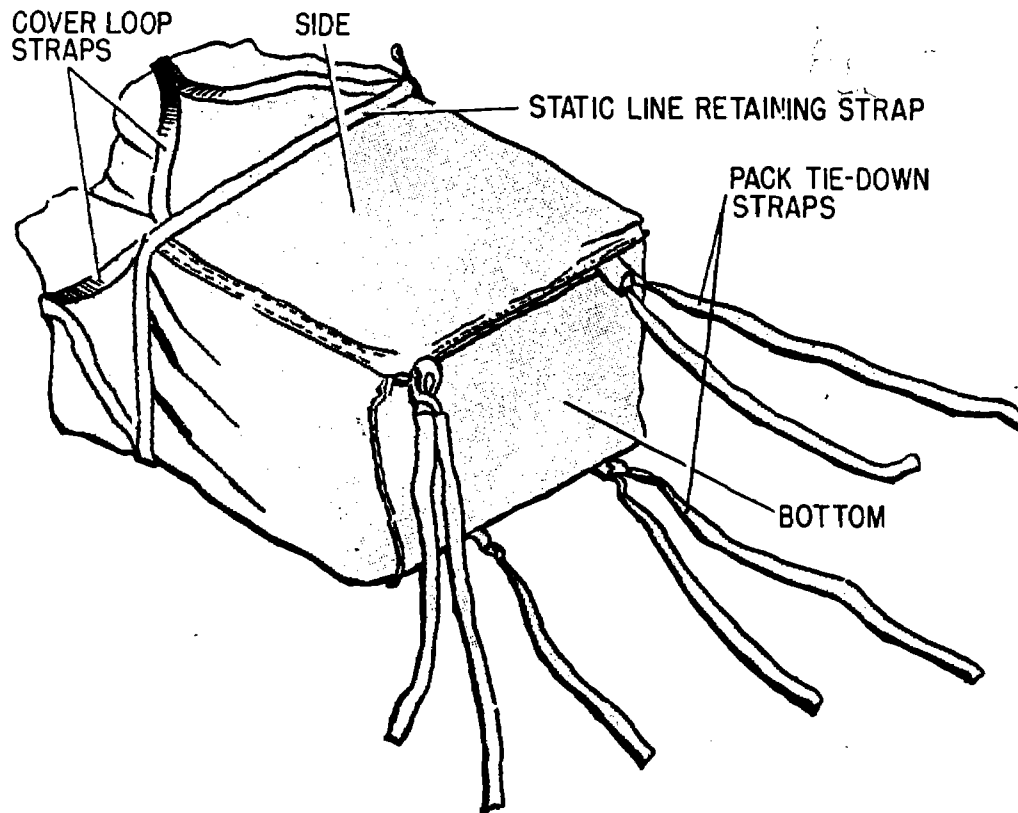

Figure 5-8.—G-1A pack, showing outside.

PR.10

of 1/4-inch cotton tape. Three turns of 6 cord may be used if this tape is not available.

As shown in figure 5-9, pass one end of the break cord through the bridle loop. Place the two ends together and stretch the break cord taut. Pass each running end of the break cord through the attaching loop on the static line from opposite directions. Tighten the break cord so that the loop formed by the break cord is approximately 3 inches in length. Tie the ends together with a surgeon's knot and a square knot, then tie the ends around the break cord with three alternating stitches.

STOWING SUSPENSION LINES.—To stow the suspension lines, release the tension on the lines and canopy; then place the lift webs, spreader, and connector loops on the pack body.

Arrange the suspension lines the width of the pack body, with the first stow at lower left and the second stow at lower right. Secure the stows with the retainer rubber bands attached to the suspension line retainer band webs. (See fig. 5-10.) Continue this procedure until the suspension lines are stowed, leaving 12 to 14 inches of suspension lines between the last stow and the canopy skirt.

PACKING CANOPY.—To pack the canopy, unhook the bridle loop from the table and remove the shot bags. Pack the canopy on the pack body in the same manner as packing a man-carrying parachute, using accordion folds. The edges of the folded canopy are to be kept the same width and length as the pack body.

CLOSING PACK.—To close the pack, draw the pack cover down over the folded canopy and

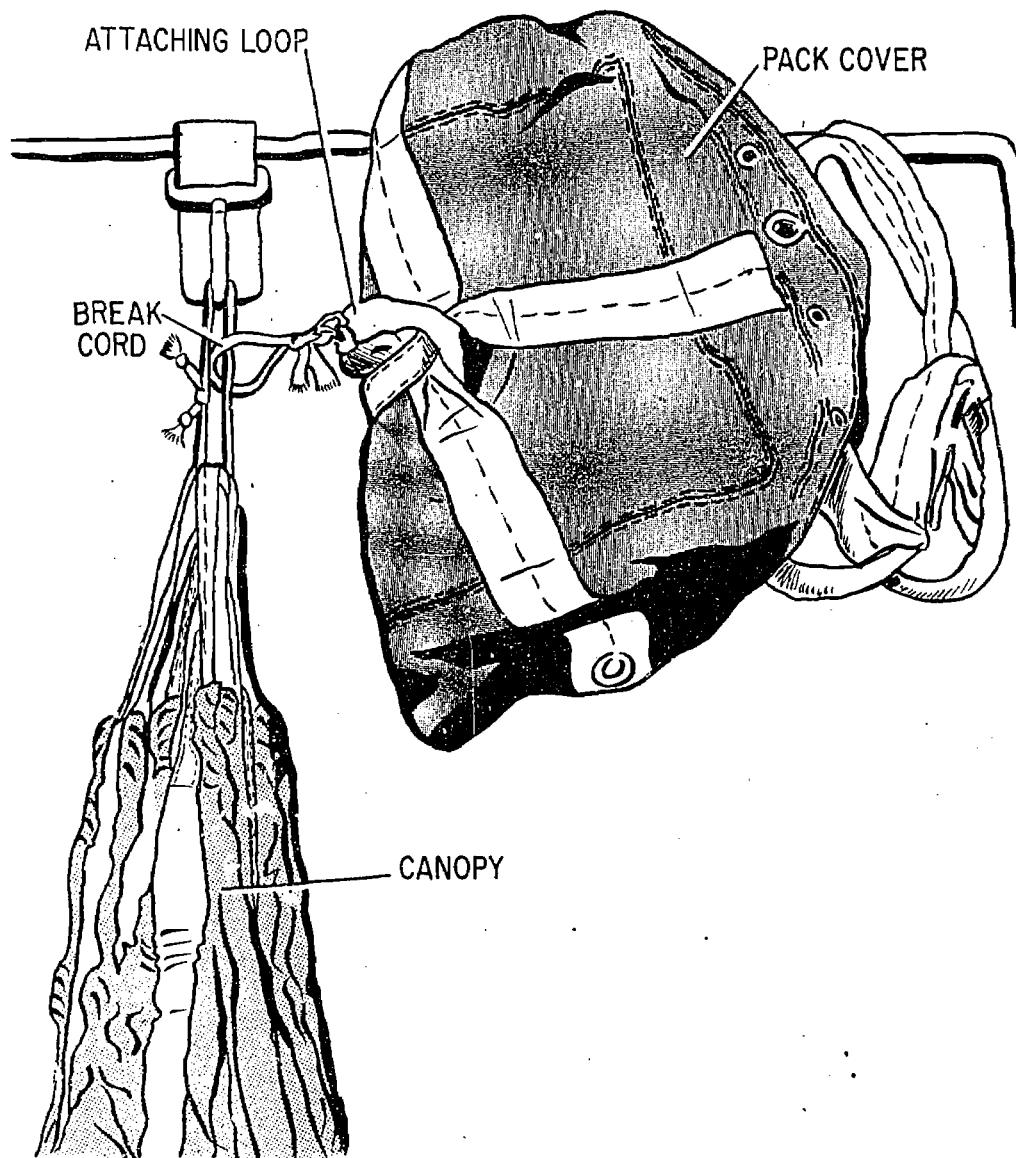

Figure 5-9.—Break cord attached to bridle loop and attaching loop.

PR.11

pack body. As shown in figure 5-11, lace the pack body and pack cover loosely by passing two turns of 6 cord through opposite grommets of the pack body and pack cover sides. Tighten the lacing so that the pack cover fits snugly over the pack body, grommet over grommet, and tie the ends of 6 cord together with a surgeon's knot and a square knot.

Accordion fold the static line in folds approximately 12 inches long and hold with rubber

retainer band. The G-1 cargo parachute assembly is now packed and ready for use as shown in figure 5-12.

G- A Packing Procedure

To whip and fold the canopy of the G-1A cargo parachute, follow the same procedure as for the G-1 cargo parachute.

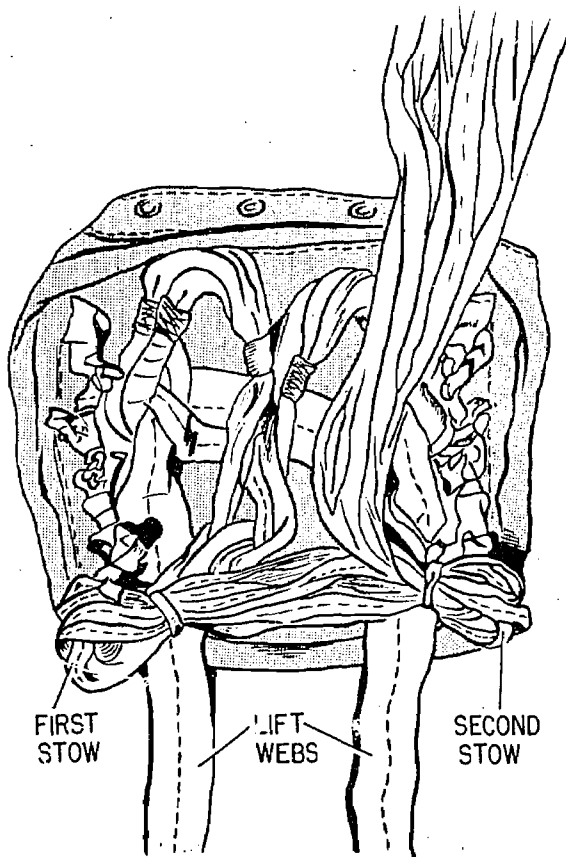

PR.12

Figure 5-10.—Suspension lines, showing first and second stows.

ATTACHING BREAK CORD.—To attach the break cord to the canopy bridle loop and the break cord attaching loop of the static line, proceed as follows:

Place the static line (separate unit) on table near the canopy apex. Using 1/4-inch tape or 6 cord, make a 3-inch loop, securing the bridle loop to the attaching loop in the same manner as attaching the break cord for the G-1 cargo parachute. (See fig. 5-13.)

STOWING SUSPENSION LINES.—To stow the suspension lines in the pack, release tension on the suspension lines and canopy. Open the pack and roll down the side of the pack to aid in stowing the lines.

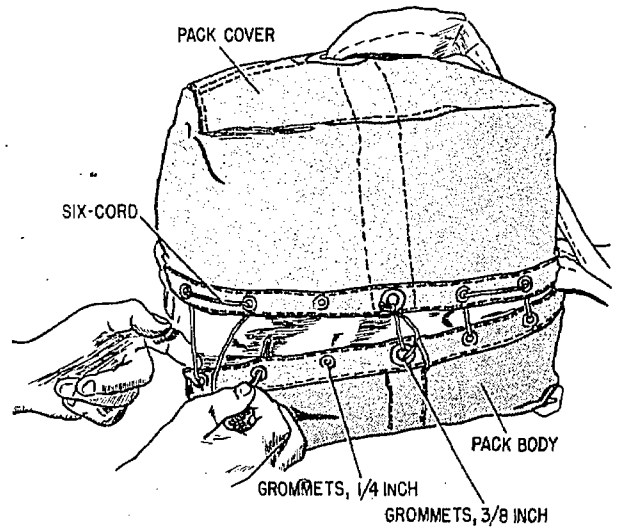

PR.13

Figure 5-11.—Closing the G-1 pack, showing cover being laced loosely to the body.

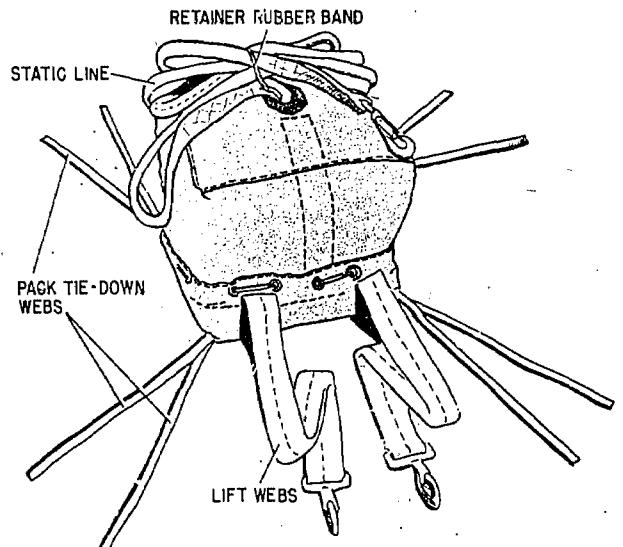

PR.14

Figure 5-12.—The G-1 cargo parachute assembly, packed and ready for use.

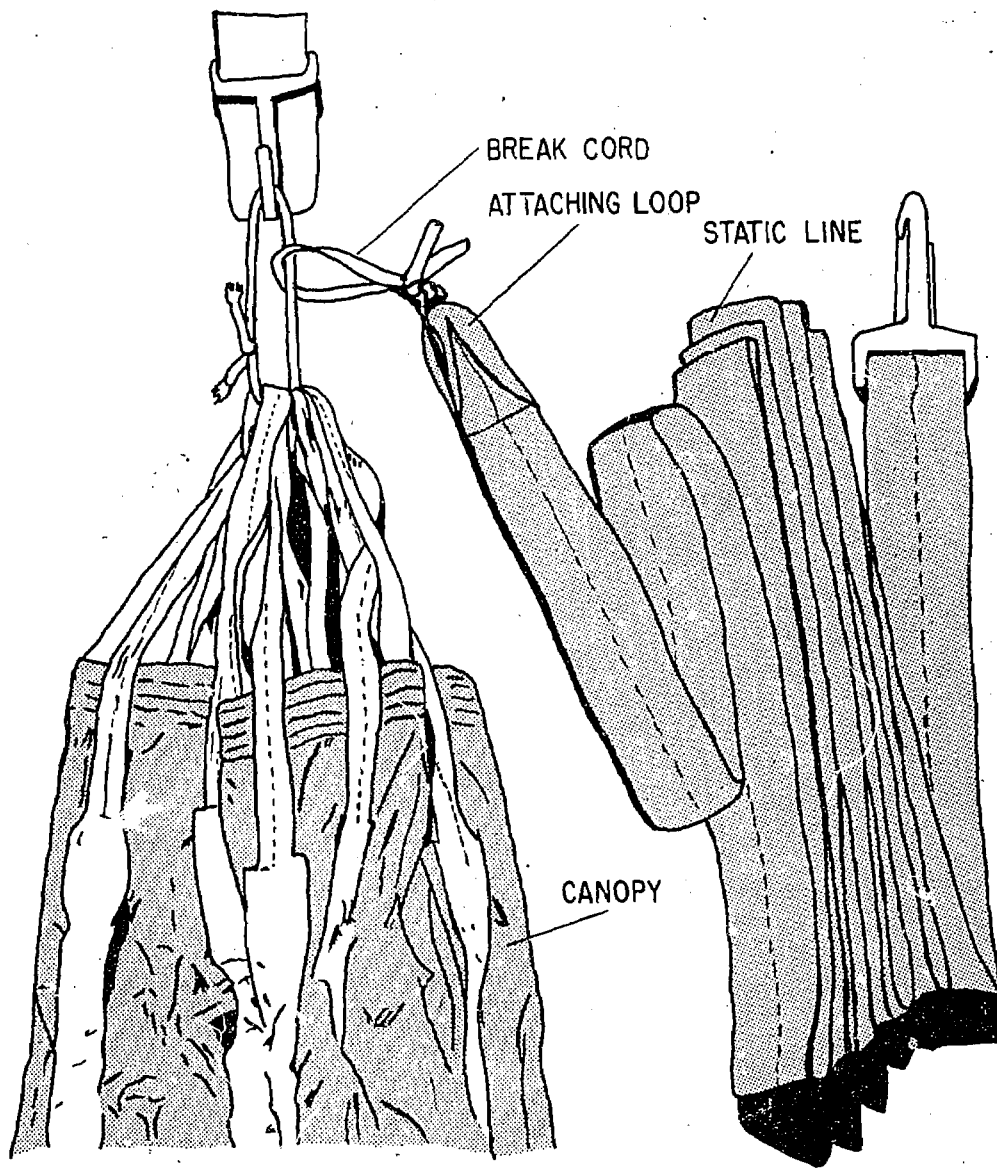

Figure 5-13.—G-1A break cord attached to the bridle loop and the attaching loop.

PR.15

Place lift webs, spreader, and connector loops over the rubberbands attached to the suspension line retainers on the false bottom of the pack. Stow the suspension lines, following the procedure given for the G-1 cargo parachute.

PACKING CANOPY.--To pack the G-1A canopy, adapt the procedure for packing the G-1 canopy.

CLOSING PACK.--To close the pack, proceed as follows:

Chapter 5—MISCELLANEOUS PARACHUTES AND EQUIPMENT

Fold cover flaps over the canopy, making certain that the static line emerges from the side of the pack opposite the lift webs.

Insert one end of a length of 1/4-inch tape through three cover loops on flaps, through the pack opening loop on the static line, and through the fourth cover loop (fig. 5-14). Draw the tape tight and tie the free ends of the tape together with a surgeon's knot and a square knot.

Fold the static line in accordion folds approximately 12 inches long. Stow on top of pack, holding the stows with retainer rubberbands attached to the retainer webs. Figure

5-15 shows the G-1A cargo parachute packed and ready for use.

CONTAINERS (TYPE A-3 THROUGH A-10)

A-3 Container

The type A-3 container consists of a 5-gallon capacity metal can. A canvas cover extends beyond the top of the can to form a holder for the parachute canopy.

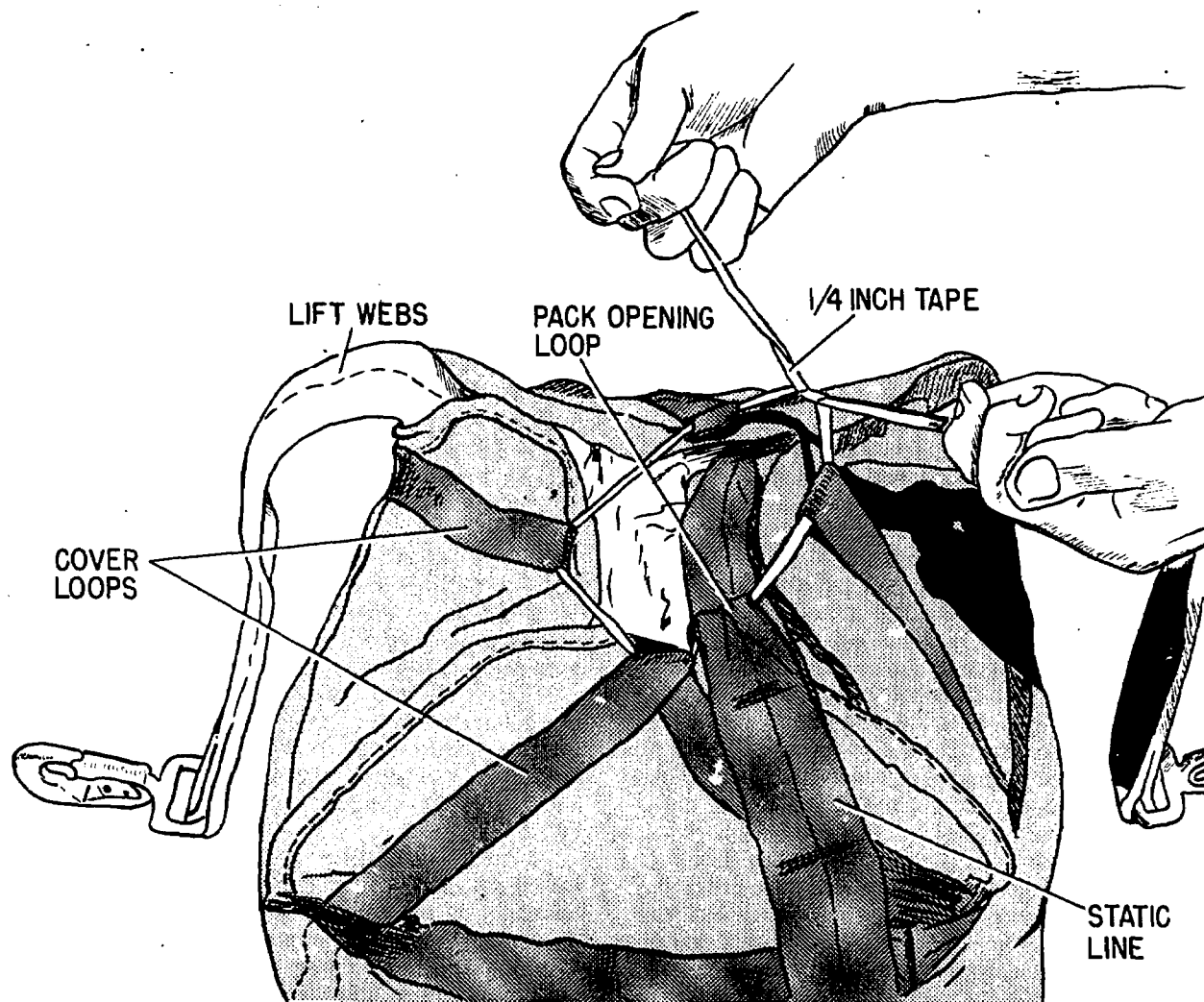
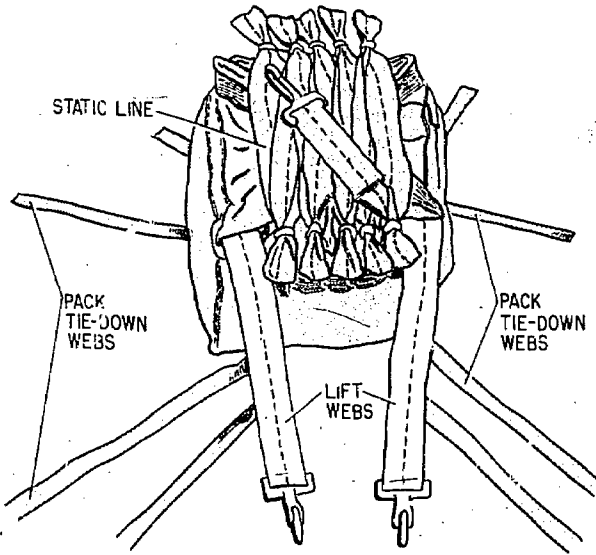

Figure 5-14.—Closing the G-1A pack.

PR.16



PR.17

Figure 5-15.—The G-1A cargo parachute, packed and ready for use.

The extension of the canvas cover beyond the bottom of the can provides a pocket for a shock-absorbing landing pad. A pack cover is provided to fit over the parachute pack, and to this cover a static line is attached. The bottom of the canvas cover is closed by means of a 50-foot rope weighted with a 5-pound sandbag. This weighted rope uncoils during the drop but remains attached to the bottom of the unit for retrieving in the event of tree landings.

When the container is filled, the canvas cover is drawn completely over the can and the shock-absorbing pad is placed under the bottom.

PACKING AND RIGGING.—Close the bottom of the canvas cover by lacing the free end of the 50-foot line through the grommets, drawing up tight, and securing with a bowline knot. The canopy is whipped and folded in the usual manner. Attach one group of lines to each of the 4 webbing loops. Lay the suspension lines in folds on the sewed-in canvas flap forming the bottom of the parachute pack portion of the canvas cover. The folded canopy is laid in accordion folds on top of the suspension lines.

Tie a 100-pound cord about 12 inches in length to the webbing loop inside the pack cover. Tie the free end of the pilot chute connector cord, from which the pilot chute has been

removed, to the 100-pound cord loop, using a bowline knot.

Tie the loose end of the sandbag to the top webbing loop aligned with the D-rings on the outside of the container cover by passing a single turn of 6 cord through the grommet in the sandbag, through the webbing loop, and through the loop inside the pack cover. Tie the sandbag rope to the webbing at each end of the D-ring, using one turn of 6 cord. Coil the remainder of this rope and tie in the bottom of the assembly.

Pull the pack cover down over the assembly and fasten by threading one turn of 6 cord through the webbing loops on the pack cover and through the second row of webbing loops on the container cover.

A-4 Container

The type A-4 container consists of an adjustable canvas container and a suspension harness made from webbing. The container is approximately 12 x 24 x 30 inches in size when fully loaded.

One end of the container is open for loading, and is closed by means of flaps laced together with cord. The other end is equipped with sets of tape for tying up excessive fabric after the container has been loaded. The top is equipped with webbing straps and V-rings for attachment of the parachute, and is reinforced with a steel frame containing two steel loops for engaging the bomb shackle. The bottom is reinforced with plywood. The container is furnished with two corrugated fiber boxes. It may be used with or without the boxes.

PACKING AND RIGGING.—When the container is packed with supplies, the weight of the contents should not exceed 200 pounds.

Figure 5-16 illustrates the construction of the A-4 container. There are two sets of connections on the top, one pair of steel loops for engaging the bomb shackle, and a pair of web straps with V-rings for attachment of the parachute.

When the container is loaded, the open end is closed by lacing with the 6-foot length of braided cord furnished with the container. Tighten the excess fabric by tying the pairs of webbing tapes together at the other end of the container. The parachute assembly is tied to the end of the container, and the tie-tapes of the parachute pack are passed around the container harness webbing.

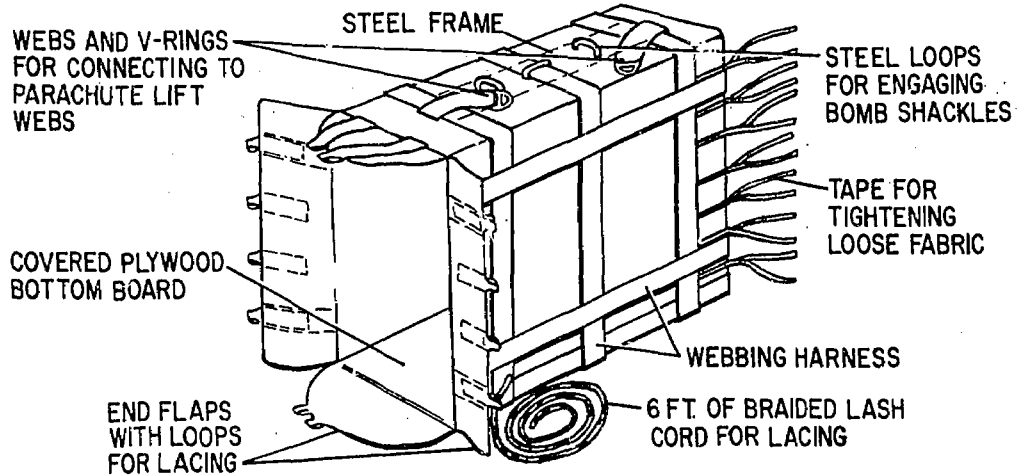

Figure 5-16.—Type A-4 container assembly.

PR.18

Snap the lift webs of the parachute to the V-rings on the web straps at the top of the container. To prevent the lift webs from pulling out of the pack under slipstream pressure, tack the webbing to the pack.

together, using bayonet fittings or snaphooks. Tighten the webbing to suit the load.

Attach the parachute to either end of the container by tying the tapes on the corners of the pack to the tabs on the end of the container cap.

Hook the lift webs of the parachute to the V-rings and tack the webs to the edge of the end cap.

A-5 Container

The type A-5 container consists of a heavy sheet of canvas 15 feet long by 56 inches wide, with a pad of felt 40 inches wide running down the center. The canvas edges fold inward over the load, and the unit is rolled into a roll about 18 inches in diameter over which removable end flaps are fitted. It is used in conjunction with the standard aerial delivery parachutes, types G-1 and G-1A. The type A-5 container was developed for the aerial delivery of rifles and similar equipment and supplies.

PACKING AND RIGGING.—Place the container roll flat, with the rifles placed about 12 inches apart down the center with the butts alternating. The container will accommodate about 12 rifles to a roll. The spaces between the rifles are filled with ammunition.

Fold the canvas flaps at the outer edges over the ends of the rifles and roll the container about the equipment to make a compact roll. Draw the end caps over the ends of the roll and secure by fastening the adjustable webbing.

A-6 Container

The type A-6 container consists of a corrugated fiber carton, into which the contents are packed; a canvas cover, fitting over and protecting the carton; a webbing sling or harness, for suspending the container to the parachute assembly; and a shock-absorbing pad, attached to the bottom of the container.

This container is used in conjunction with the standard cargo parachutes, types G-1 and G-1A for the delivery of miscellaneous supplies and equipment. The dimensions of the corrugated fiber carton are 12 x 12 x 30 inches. Figure 5-17 shows three plastic water bags packed in the A-6 container.

A-7 Container

The type A-7 container consists of an adjustable webbing sling developed specifically for

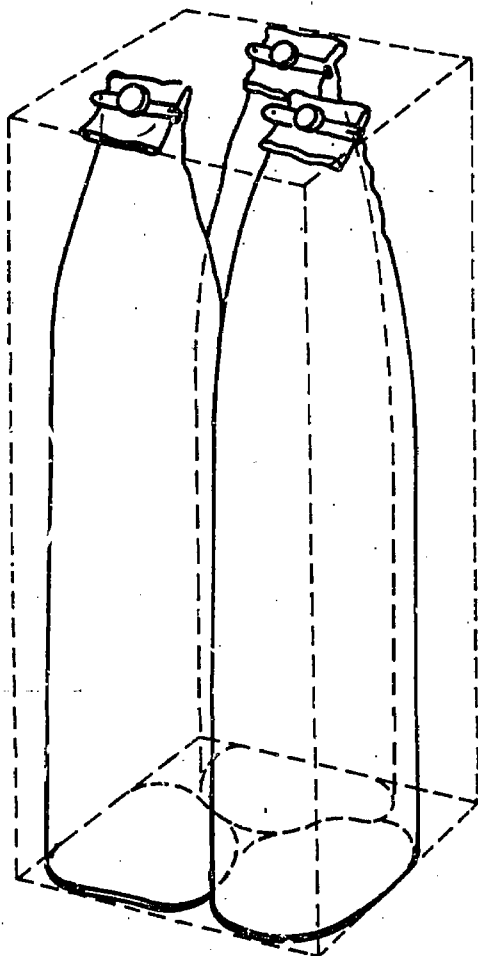

PR.19
Figure 5-17.--Three plastic waterbags packed in the A-6 container.

use in delivering 30-, 45-, and 50-caliber arms and 37-mm ammunition. However, since this sling is adjustable, it can be adapted readily for the delivery of other supplies, including standard 5-gallon cans of water or gasoline, as shown in figure 5-18. The type A-7 container is also used with the G-1 and G-1A parachutes.

PACKING AND RIGGING.--The webbing sling is strapped around the standard ammunition box (or other load) with the V-ring on top. When the sling is used with three 5-gallon cans, padding should be inserted between the cans.

Attach the parachute assembly on either side of the load by tying the tapes on the pack corners to the webbings on top and bottom of the load.

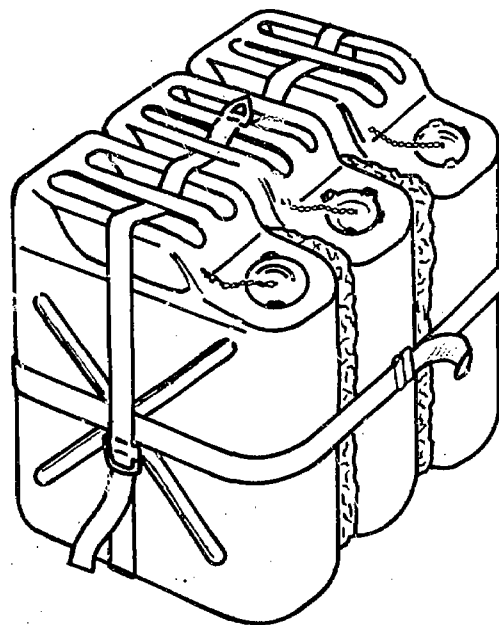

PR.20
Figure 5-18.--The A-7 adjustable sling and the sling adapted to three 5-gallon cans.

Hook the lift webs of the parachute to the V-rings on top of the sling.

A-8 Container

The A-8 container consists of a rigid, octagon-shaped, collapsible container constructed of reinforced fiberboard. The container is 50 inches long and 18 inches in diameter. It is intended for delivery of rifles, and is used with the types G-1 and G-1A parachutes.

A-9 Container

The type A-9 container consists of an adjustable webbing sling developed for the aerial delivery of 60-, 75-, and 81-mm fiber ammunition cases, and is used in conjunction with the standard types G-1 and G-1A cargo parachutes.

A-10 Container

The type A-10 container consists of a cargo net approximately 9 feet square. It is intended for delivery of miscellaneous equipments of

Chapter 5—MISCELLANEOUS PARACHUTES AND EQUIPMENT

suitable size and is also used with the types G-1 and G-1A parachutes.

LAUNCHING INSTRUCTIONS AND RESTRICTIONS

To reduce as much as possible the risk of damage to the loads, containers should be dropped at a maximum speed of 150 miles per hour, and at a minimum altitude of 300 feet.

All containers of this type can be manually launched from openings in the aircraft. When they are launched from openings in the aircraft, the entire 15 feet of static line is utilized.

All containers, with the exception of types A-7 and A-10, can be launched from internal or external bomb racks. When they are launched from internal bomb racks, the full 15 feet of the static line is used. When launching from external bomb racks, the static line is shortened to 10 feet by winding the line around the bomb shackle attachment so that it does not interfere with the launching mechanism.

Containers, types A-5 and A-9, are equipped with D-rings for engaging bomb shackles. These containers can be launched from bomb racks when the dimensions of the load are such that these D-rings are spaced to fit standard bomb shackles. It is absolutely essential that the free end of the static line be attached to some structural member of the aircraft.

TYPES G-11 AND G-11A

The G-11 and G-11A cargo parachutes are used for heavy drop aerial delivery. The two parachutes differ only in minor details, and the procedures for handling are essentially the same.

The G-11A canopy assembly is flat, circular in shape, and is 100 feet in diameter. It is divided into 120 gores, each gore being constructed of 13 panels. The canopy has 60 suspension lines. For packing purposes, the suspension lines are considered as ending at the skirt. They are numbered from 1 to 120, counterclockwise, when facing the skirt from the connector links.

Inspection

The G-11 and G-11A parachutes are visually inspected every 60 days, or more often if conditions warrant such inspection. The condition of the canopy, suspension lines, webbings, and

pack should be checked for tears, excessive moisture, mildew, and stains.

Layout

A working space approximately 155 feet long is required for packing operations, provided tension is applied at the clevis loops of the riser. (See fig. 5-19.) If a packing surface of this length is not available, tension may be applied at the connector links. In this case, a surface approximately 85 feet long is sufficient. If packing tables of this length are not available, a suitable area may be prepared from a smooth section of concrete floor where the surface can be painted to eliminate the normal abrasive action of concrete. This method of packing is recommended only where packing tables are not adequate.

Packing

Because of the extreme large size and the limited use of the G-11 and G-11A cargo parachutes by the Navy, the packing procedures are not covered here. For the step-by-step procedure, reference should be made to the applicable maintenance and packing manual.

PARACHUTE RELEASE ASSEMBLIES

Two types of release assemblies are available for use when making heavy drops by cargo chutes. These are the jaw type and the finger type.

JAW TYPE

The jaw type parachute release assembly consists of a body assembly, two spring assemblies, two suspension slings, and two cutters. The steel body assembly consists of a left- and right-hand body steel shaft. The bodies are keyed to the shaft and held in place by flat washers and locking nuts, or split washers and conventional nuts. The mouth of the body assembly provides a seat for the suspension pin, and side plates cover the open ends to prevent these pins from sliding out. The jaws, which provide recesses for the cutters, are held to the lower end of the bodies by hinge pins.

Release Spring Assemblies

Two release spring assemblies are screwed into the body assembly behind the suspension

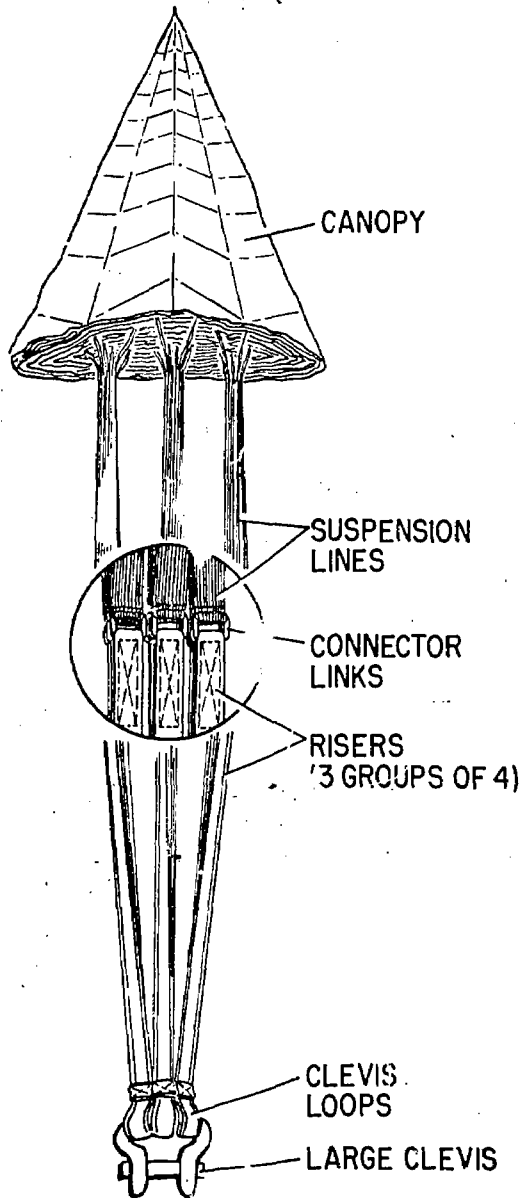

PR.22
Figure 5-19.—Layout of G-11 and G-11A parachutes.

pin seat. Each assembly consists of a housing which holds the assembly, a plunger which pushes against the suspension pin, a spring which applies tension on the plunger, an adjusting screw which regulates the tension, and a cap which covers the open end of the housing. Two types of springs, lightweight and heavyweight,

are issued with the release assembly. The light springs (bronze color) are used with loads requiring one 100-foot parachute; the heavy springs (silver or black color) are used with loads requiring two 100-foot parachutes.

Suspension Slings

Two 2-foot suspension slings are used with the release assembly. A permanent 2-foot sling is fixed at one end to the shaft of the release assembly and at the other end to the clevis assembly on the parachute risers or parachute riser extensions. The second 2-foot suspension sling is fixed at one end to the large clevis assembly on the load suspension slings and at the other end to the suspension pin which fits into the mouth of the assembly.

Cutters

Two reefing-line cutters (fig. 5-20) are used with each release assembly. The cutters are inserted through the jaws and upper recesses of the body assembly and are tied in place with cord, or authorized substitute material, which is inserted through the holes in the upper recesses and the cutters.

In operation (fig. 5-21), the firing wire is pulled out by the deploying parachute, and the firing plunger locking ball is pushed down into its recess by the firing plunger. The firing plunger, under spring tension, travels forward until the firing pin strikes the percussion cap. The cap then fires the charge through the fuse chamber; and after 10 seconds, the fuse fires the charge in the activating chamber. The activating charge then pushes the cutter blade forward, shearing the silk cord which passes through the holes on the cutter.

Operation

An understanding of the operation of the release assembly will aid the PR in properly preparing, installing, and adjusting the assembly. Generally, the operation of the release assembly follows the order shown in figure 5-21 (A), (B), (C), and (D).

As shown in view (A), when the main cargo canopy starts to deploy, it pulls on the large clevis assembly which connects the parachute risers to the permanent 2-foot sling on the release assembly. The clevis assembly, which is tied to the firing wires in the two reefing-line

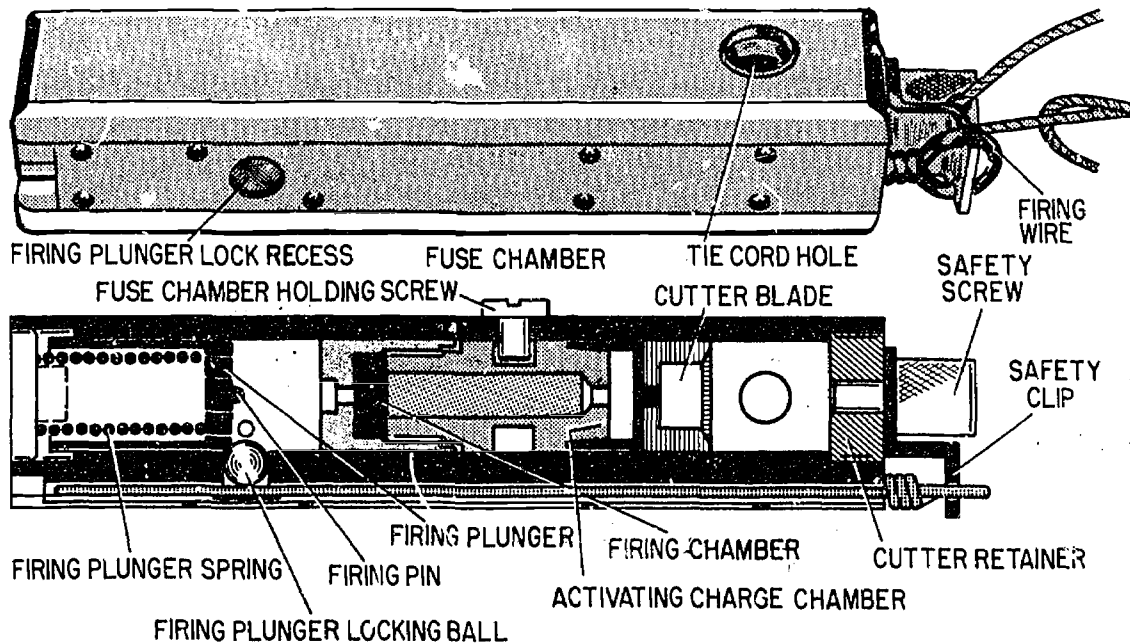

Figure 5-20.—Reefing line cutters.

PR.23

cutters, pulls out the wires and activates the cutters.

In the 10 seconds that elapse between the pulling of the firing wires and the firing of the cutters, the load receives the opening shock of the main cargo parachute, rebounds slightly, and settles again with its weight pulling on the suspension pin in the mouth of the release assembly.

The cutters fire and cut the suspension line that holds the cutters in the release assembly. After the cord has been cut, the cutters are free to dropout of the recesses in the top of the body assemblies, as shown in view (B).

After the cutters have fallen out, the jaws pivot open, as shown in view (C): The suspension pin remains seated in the mouth of the release assembly as long as the weight of the load pulls on the 2-foot suspension sling, thus overcoming the tension on the release springs behind the suspension pin.

As the load strikes the ground, the suspension pin is relieved of the weight which holds it in the assembly. The release plungers, under spring tension, push the suspension pin out of the mouth of the release assembly, as shown in view (D). The load is then freed from the

parachutes, preventing the parachutes from dragging or upsetting the load.

FINGER TYPE

The finger type, or multifinger, release assembly consists of a steel body with two body plates; release lever, release arm link, and a release arm. Pivoted on hinge pins at the edge of the body are the large and small cutter retainers.

The suspension finger slings used with the multifinger release assembly are constructed of six plies of nylon webbing. To permit the close fitting of release fingers over the release arm of the body assembly, as shown in figure 5-22, the slings are issued in two different lengths. The fingers pivot on hinge pins on the finger links.

One reefing-line cutter is used with the multifinger release assembly. The cutter is inserted through the large and small cutter retainers of the body. The operation of the cutter is on the same principle as the operation of the cutters used on the jaw type release.

Two types of springs may also be used with the finger type release assembly. Lightweight or heavyweight springs may be used, and the

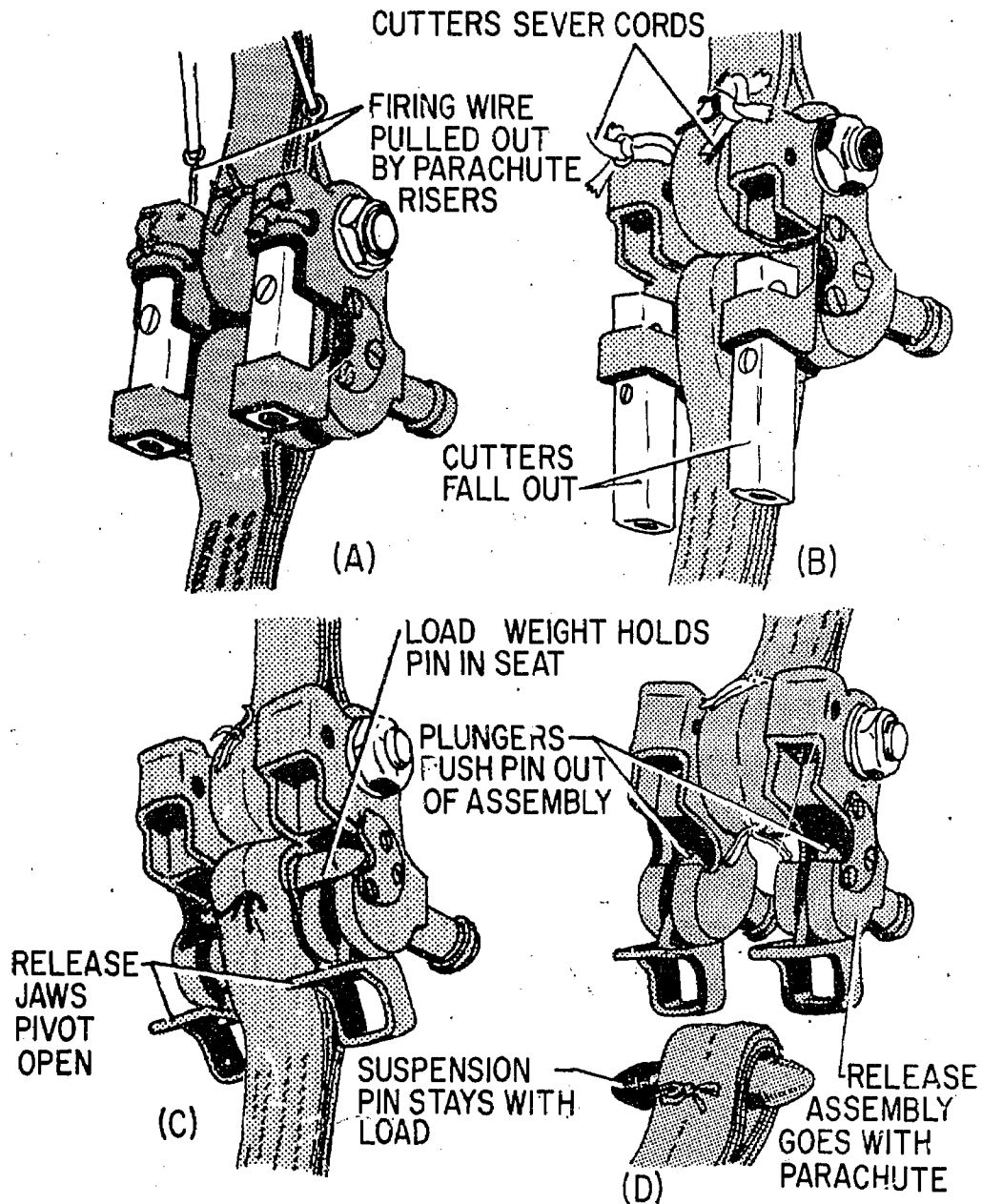

Figure 5-21.—Operation of release assembly.

PR.24

weight of the load being used with the release assembly determines whether a light or heavy spring will be used and whether the spring is placed at the No. 1 or No. 2 force point of the release lever.

Operation

As the main cargo parachute deploys, the riser extension of the parachute breaks the safety cord holding the riser link to the release

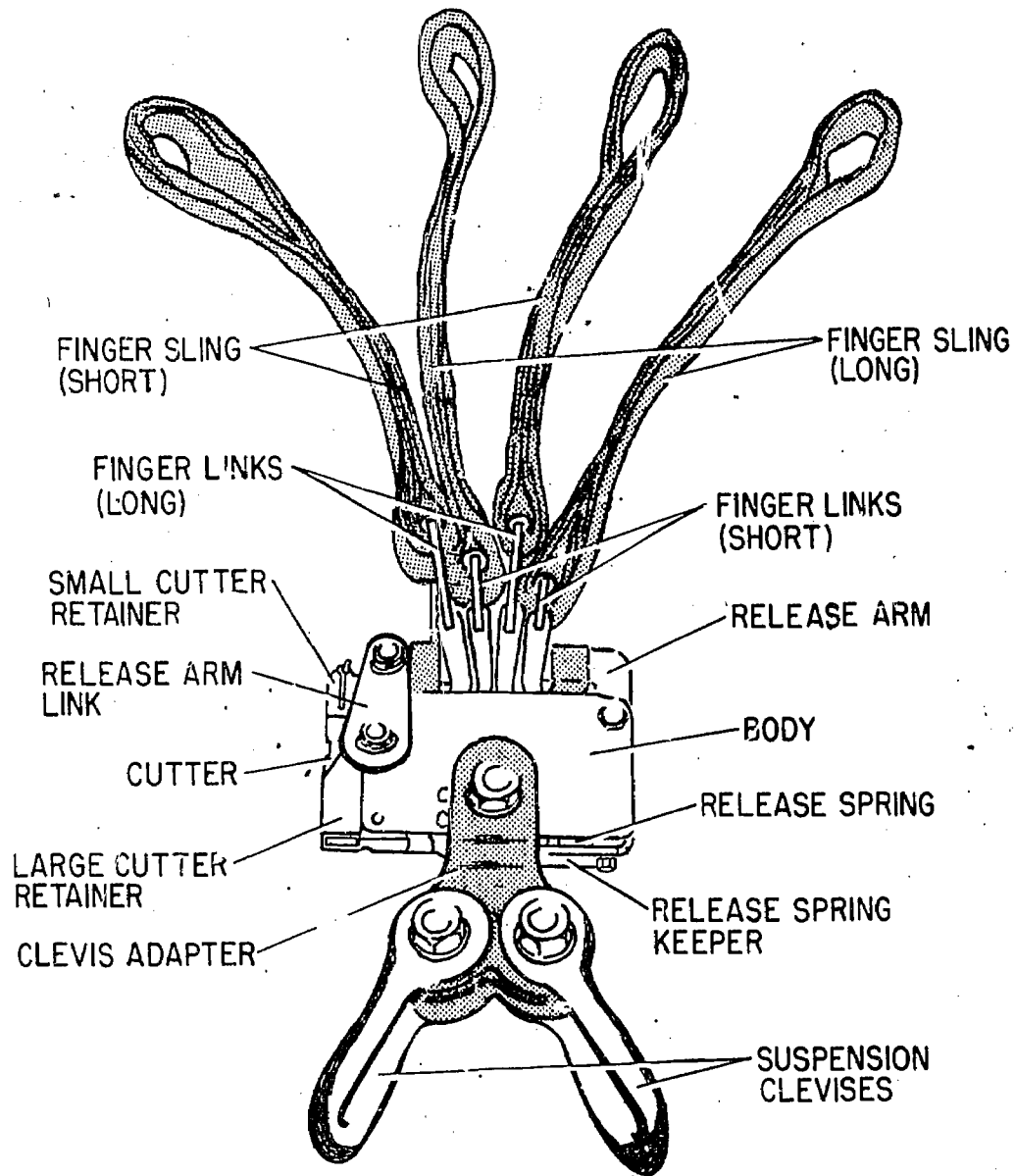

Figure 5-22.—Finger type (multifinger) release:

PR.25

arm, then pulls the firing wire out of the time cutter.

In the 10 seconds that elapse between the pulling of the firing wire and the firing of the cutter, the load receives the opening shock of the main cargo parachutes. Then the load rebounds slightly, and settles again with its weight

pulling against the release arm link, holding the link stud in the body plates.

The cutter fires and cuts the suspension line casing that holds the cutter in the retainers. After the line has been cut, the cutter is forced out of the small cutter retainer by the cutter

ejecting spring and rotates in the lower cutting retainer.

After the cutter has fallen out, the release arm link is free to pivot outward. However, as long as the weight of the load pulls against the assembly, the link stud will be held in the notch in the body plate.

As the load strikes the ground, the release arm link is relieved of the weight which holds it in the assembly. The release lever, under spring tension between the body plates, is thus able to pivot upward, pushing the link stud out of the notch in the body plates.

The drag of the parachutes then pulls the release arm upward (fig. 5-23) until the fingers (which are hooked around the release arm) clear the slot that holds the fingers closed between the body plates. As soon as the fingers are clear, they spread open, freeing each parachute separately from the load, thus preventing the parachutes from dragging or upsetting the load.

DECELERATION PARACHUTES

Deceleration parachutes are used for the purpose of shortening the landing roll during landings at shore bases when additional braking is required and for emergency on aborted take-offs. The deceleration parachute for the F-4B aircraft is a 16-foot ring slot parachute which is stowed in a fiberglass container in the tail cone.

The drag chute is controlled from the cockpit by the cockpit control handle. A cable joins the handle, the release and jettison mechanism, and the door latch mechanism. Rotating the handle aft without depressing the button on the handle releases the door latch mechanism. The spring-loaded actuator then opens the drag chute door, and at the same time the hook lock is positioned over the drag chute attach ring into the lock position. A spring-loaded pilot chute opens and pulls out the drag chute.

The drag chute is jettisoned by depressing the button on the handle, pulling aft enough to clear the detent, pushing forward a small amount, and then releasing the handle. The release and jettison mechanism then returns to the normal position, permitting the drag chute to pull free. Leading particulars for the F-4B aircraft deceleration parachute are indicated in table 5-1.

Table 5-1.—F-4B deceleration parachute.

Weight of parachute	22 lb
Filk of parachute	1,600 cu in.
Maximum deployment speed . . .	200 knots
Parachute diameter (open) . . .	16 ft
Type	Ring slot type
Handle operating force	55 lb

DECELERATION PARACHUTE MAINTENANCE

Instructions for packing, inspecting, repairing, installing, and removing deceleration parachutes are provided in the Maintenance Instructions Manual for each naval aircraft so equipped. The following instructions apply to the F-4B series aircraft and are taken from NavAir 01-245FDB-2-2.3.

Packing

Place the drag chute on the packing table and temporarily secure the apex to the table with the vent line tie. Stretch out the entire canopy and shroud lines. The manufacturer's stenciled decal must be on top and the shroud lines equally divided, 10 lines on each side. The drag chute components are shown in figure 5-24.

Spread the connector links, shroud lines and risers as shown in figure 5-25. Secure the connector hooks to the table device in the order shown. Disconnect and secure the vent lines again with the vent lines equally divided in relation to the shroud lines. Secure the drag chute with enough tension to allow the shroud lines to snap into place when raised from the table. The canopy is now ready for folding.

FOLDING THE CANOPY.—Where qualified PR's are available, the canopy should be whipped and folded in the conventional two-man-team method. Where such PR's are not available the canopy should be folded by the following one-man method.

Fold the left-hand gores as shown in figure 5-26. The fabric of the gores must be folded neatly downward. A shot bag may be placed on

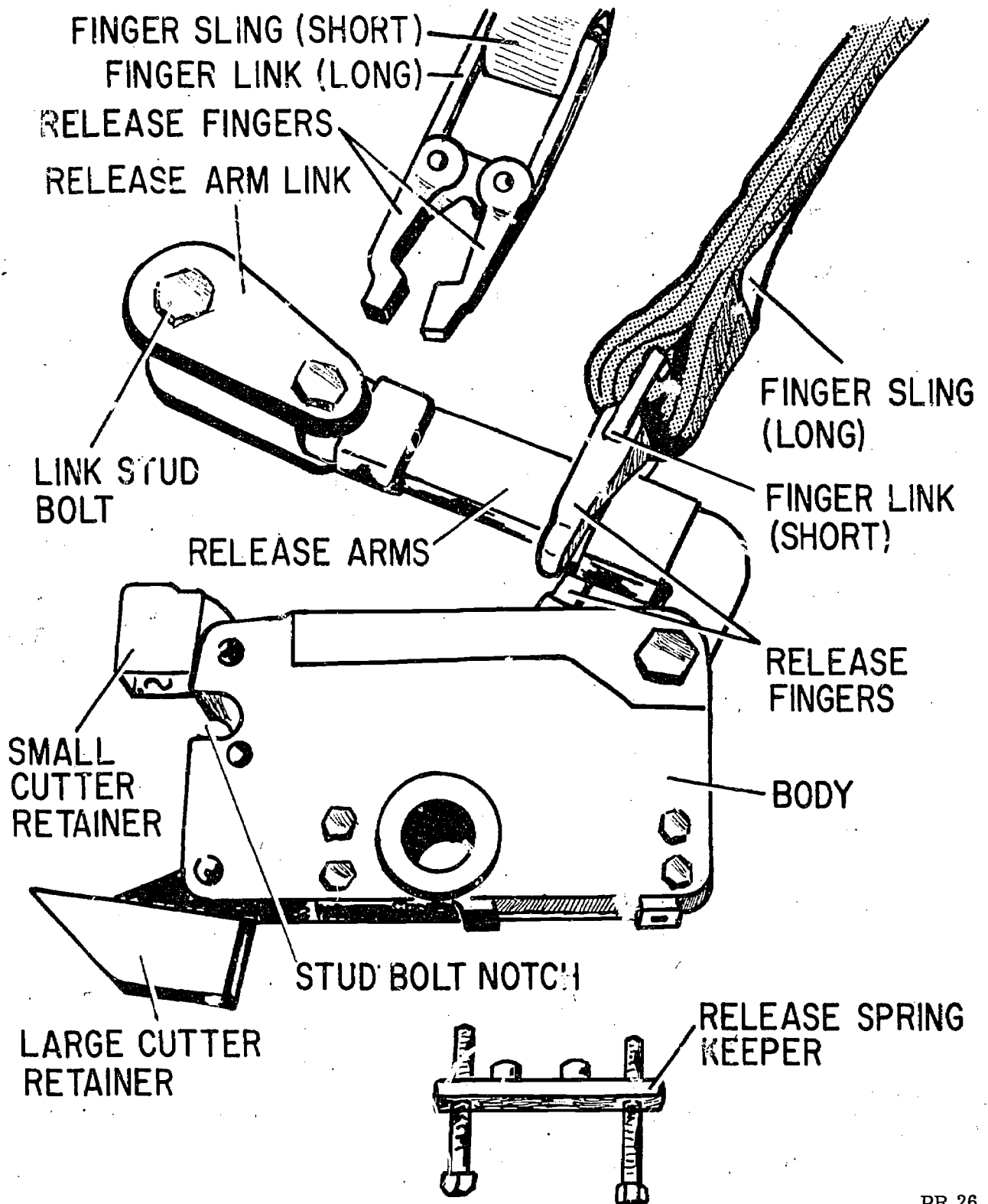
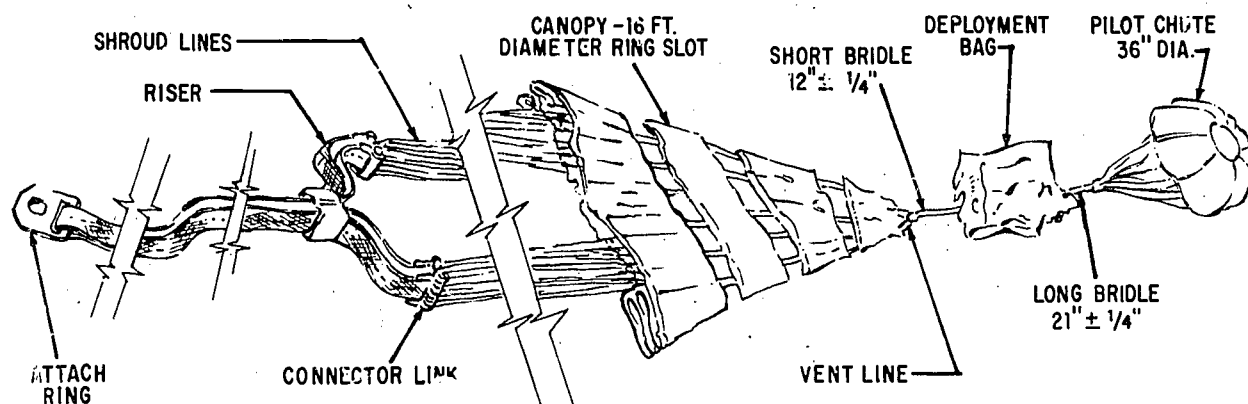
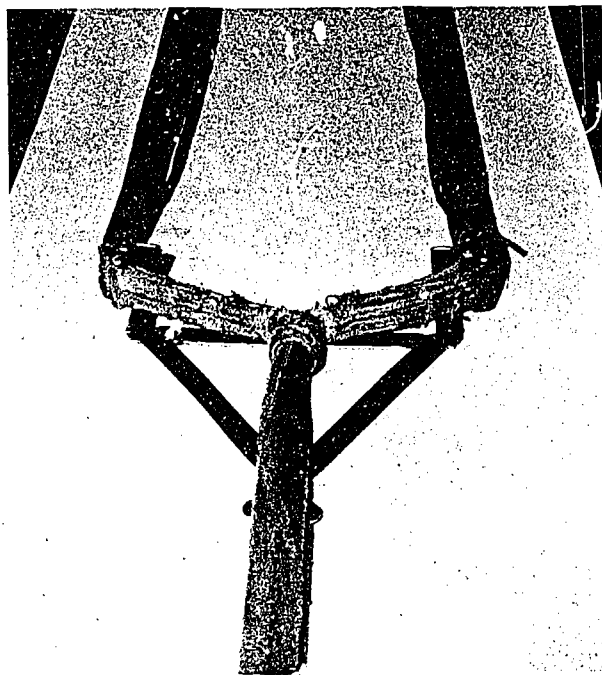

Figure 5-23.—Operation of finger type release assembly.



PR.445

Figure 5-24.—Drag chute components.



PR.446

Figure 5-25.—Connector links, shroud lines, and risers (spread).

the folded left-hand gores to hold them in place while the right-hand side is being folded. Fold the right-hand side gores in the same manner as the left-hand side.

Complete the folding of the gores by grasping the top gore and pulling it to the left and pulling

the bottom gore to the right as shown in figure 5-27. Check the entire canopy for neatness and smooth, flat, folded gores to insure minimum thickness and volume of the canopy.

Figure 5-28 shows the canopy properly folded and shot bags placed over the shroud lines to keep them in place in preparation for the following packing steps.

Neatly fold left- and right-hand gores in-board so the canopy will be approximately the width of the deployment bag as shown in figure 5-29. Remove the shot bags from the shroud lines and place a shot bag on the canopy to hold it in place.

Place the first fold in the deployment bag. Reach inside and grasp the canopy as shown in figure 5-30, and fill the corners of the bag as each fold is made. While placing the canopy in the bag, strive to keep the shroud lines lying smooth and as straight as possible.

Grasp the canopy as shown in figure 5-31 and neatly accordion fold the second fold into the deployment bag. Continue folding the canopy, folding each new fold over the previous fold until the entire canopy is folded into the deployment bag as shown in figure 5-32.

When folding is completed, peel the bag back to the edge of the folded chute compartment and pull out flaps as shown in figure 5-33.

Two loops of shroud lines go inside the bag before the lower flap is folded, as shown in figure 5-34.

Fold the upper flap down under the lower flap and pull the loops of the upper flap through the opening in the lower flap as shown in figure 5-35.



Figure 5-26.—Folding left-hand gores.

PR.447

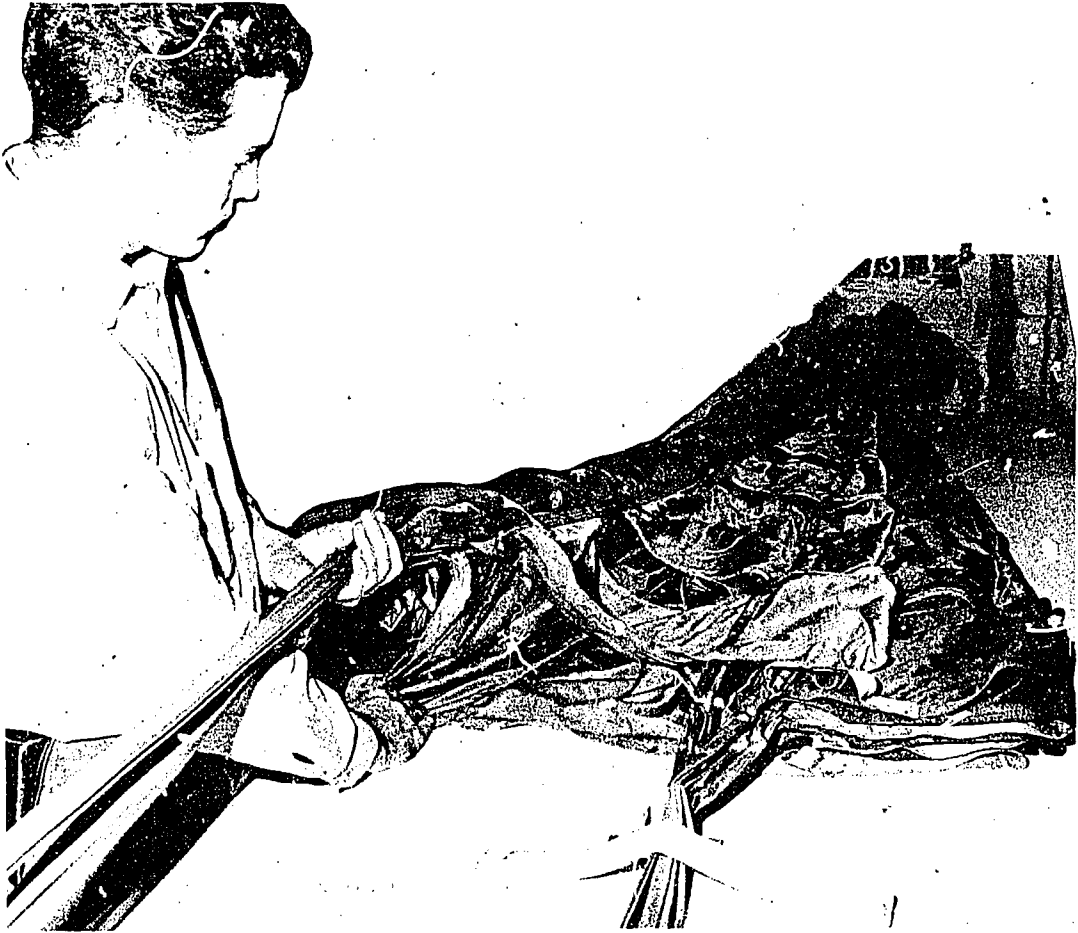
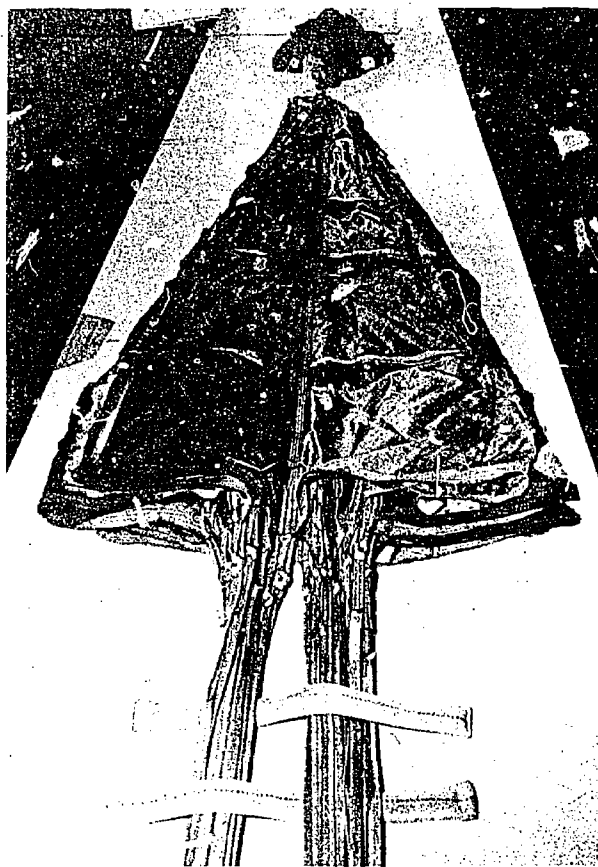

Figure 5-27.—Complete folding of gores.

PR.448



PR.449

Figure 5-28.—Canopy properly folded.

Form a loop of the left-hand group of suspension lines and stow them through the left locking loops. Form a loop of the right-hand group of suspension lines and stow them through the right locking loop. Figure 5-36 shows the suspension lines in the locking loops. If a cord is used to pull the shroud lines through the loops, remove the cord slowly as heat resulting from friction could damage the shroud lines.

Accordion fold the suspension lines on the stowage flap shown in figure 5-37. Make each fold slightly longer than the flap and free of twists. Fasten each fold with a snap retainer loop. It is important that six loops on each side are used so that the connector links are properly stowed.

Position the connector links and risers as shown in figure 5-38. Accordion fold the risers, placing two folds under each large retaining loop. Approximately 50 inches of risers must remain after the last loop has been snapped.

Grasp the stowage flap and fold three times back into the deployment bag as shown in figure 5-39. Do not roll the flap into the deployment bag.

Fold side flaps in, upper flap down, and lower flap up. Tie each loop with one strand of cord as shown in figure 5-40 and figure 5-41.

Accordion fold the pilot chute bridle and the pilot chute vanes. Place the pilot chute spring in the center of the compartment, separate the canopy into two equal halves, and compress the spring. Fold the flap with the cone first, then the flap with the grommet. Insert the cone through the grommet and install a locking pin to keep the flaps from opening as shown in figure 5-42.

Separate the canopy into quarters as shown in figure 5-43. Fold the flaps with lugs closed and insert the cone through the lugs. Install a locking pin to keep the flaps closed.

Tuck the canopy between the coils of the spring of the pilot chute and install a streamer wire through the cone.

Enter the applicable information in the drag chute logbook and stow a duplicate logbook in the pocket provided in the deployment bag. Figure 5-44 shows the F-4B deceleration chute packed and ready to stow in the aircraft.

INSPECTION AND CLEANING.—Inspect all parts for scoring, corrosion, nicks, and structural deformation or failure.

Clean all parts with solvent and dry with clean, dry air at approximately 20 psi.

Repair

Mend single holes three eighths of an inch in diameter or less, in the canopy, pilot chute, and deployment bag, by darning. Use a warp thread taken from a new piece of identical material.

Patch holes over three eighths of an inch and under 12 inches in diameter from the inside of the damaged item as described in the following paragraphs. For repair of holes 12 inches or more in diameter, refer to the current handbook of maintenance instructions for the specific model chute. The same reference is recommended for the repair of gore sections.

Lay the damaged section of the item on a table with the outside of the item toward the flat surface of the table. Hold the item in place with push pins so that the area around the hole lies flat. Mark an area around the hole approximately 1 inch from the edge of the hole on all



PR.450

Figure 5-23.—Canopy folded to the width of the deployment bag.



PR.451

Figure 5-30.—Placing first fold into the deployment bag.

sides with tailor's chalk. This will be the size of the patch when the edges of the patch have been turned under.

Cut out a patch from new material one-half inch larger all around than the marked-out area on the item. Be sure to use the same type of material as that which makes up the area under repair. Fold the edges of the hole back against the side on which the patch will lie and sew with a single row of stitching, using size E thread.

Fold the edges of the patch under a distance of one-half inch on each side. Lay the patch on the canopy with the folded edge against the item and the edges of the patch on the marks. Sew with one row of size E nylon thread one-eighth inch from the edge of the patch, through the item being repaired and the patch, and one row of stitching one-eighth inch from the edge of the hole through the item and the patch.

DAMAGED SUSPENSION LINES.—A damaged suspension line may be repaired by reinforcing the damaged section with a piece of 9/16-inch wide nylon tubular webbing, 1,500 pounds tensile strength. The nylon tubular webbing must extend 4 inches on each side of the damaged area. Superimpose the new webbing over the damaged area and stitch in place with size FF nylon thread, applying six to eight stitches per inch.

BROKEN SUSPENSION LINES.—A broken suspension line may be repaired by making a splice from new webbing that will extend 6 inches on each side of the break.

A-3D DECELERATION PARACHUTE SYSTEM.—The A-3D deceleration parachute is of the same ring-slot construction as the F-4B. The principles of packing and installation are similar, with certain variations.

The canopy is composed of a series of annular rings with annular slots between the rings, hence the name "ringslot." It is 24 feet in diameter, with 28 gores and 28 lines. The drag chute suspension lines are continuous from skirt to skirt. The pilot chute is a coiled-spring, vane type. Installation and components of the A-3D deceleration parachute is shown in figure 5-45.

The cloth parts of the gores are of considerably heavier material than that employed in personnel parachutes. The lower gore section is of 3.5 ounce nylon cloth and the other gore sections are of 2.25 ounce nylon cloth.

For complete packing, installation, and repair instructions for the A-3D deceleration parachute, refer to NavAir 01-40ATC-2-13, Maintenance Instructions Manual, A-3D2Q Aircraft, Section XIII, Deceleration Parachutes.

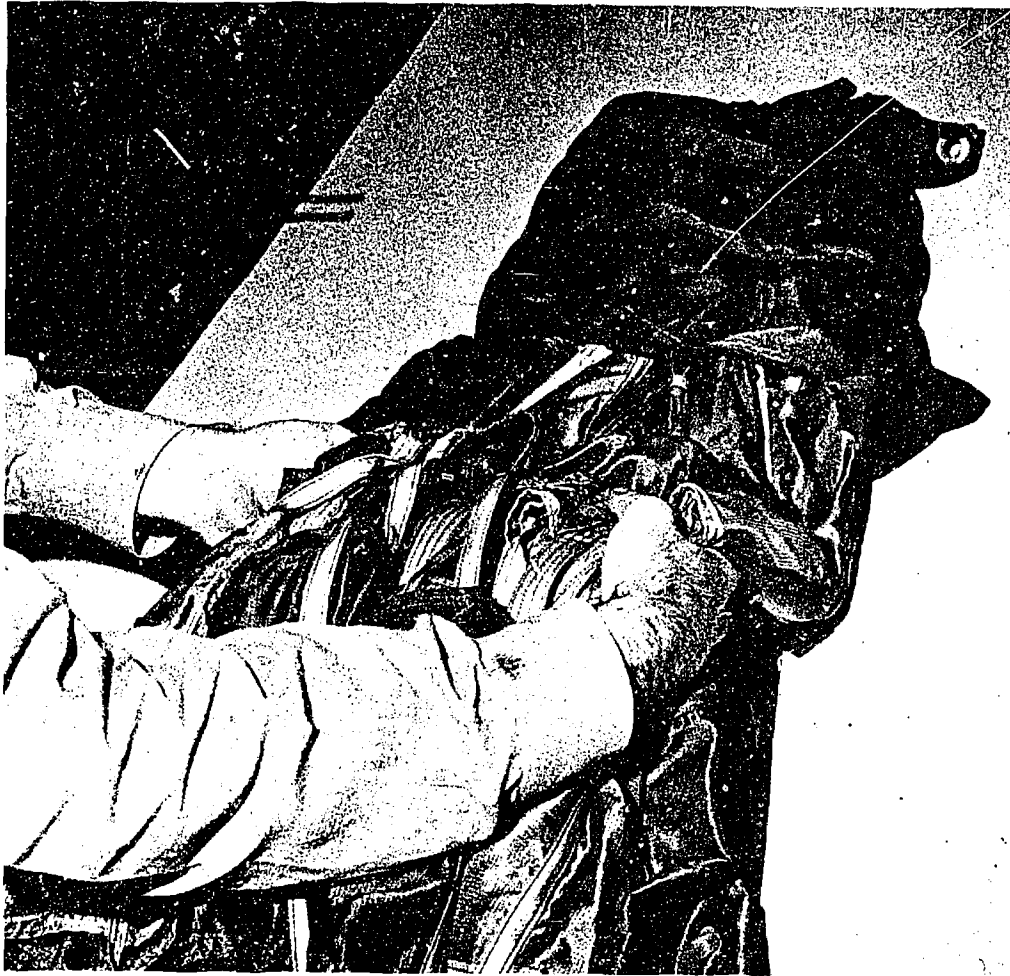
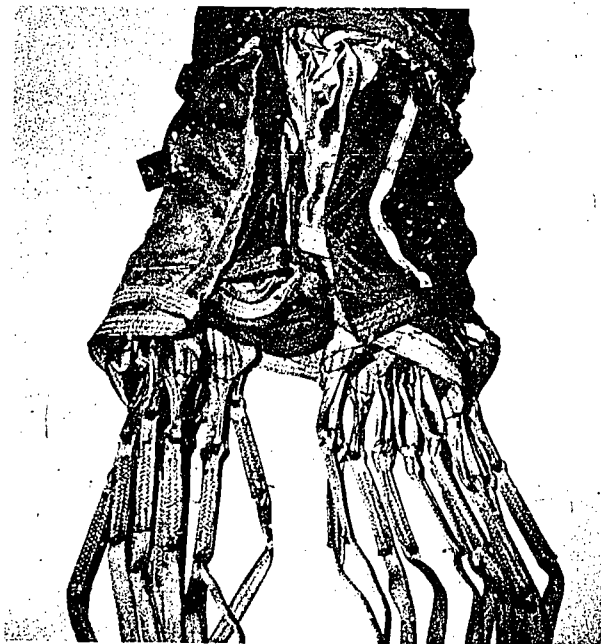

Figure 5-31.--Second fold being placed in deployment bag.

PR.452



PR.453
Figure 5-32.—Position of canopy prior to last fold.



PR.454
Figure 5-33.—Flaps pulled out.



PR.455
Figure 5-34.—Lower flap folded.



PR.456
Figure 5-35.—Upper flap down over lower flap.



PR.457
Figure 5-36.—Suspension lines in locking loops.



PR.458
Figure 5-37.—Suspension lines accordion folded.

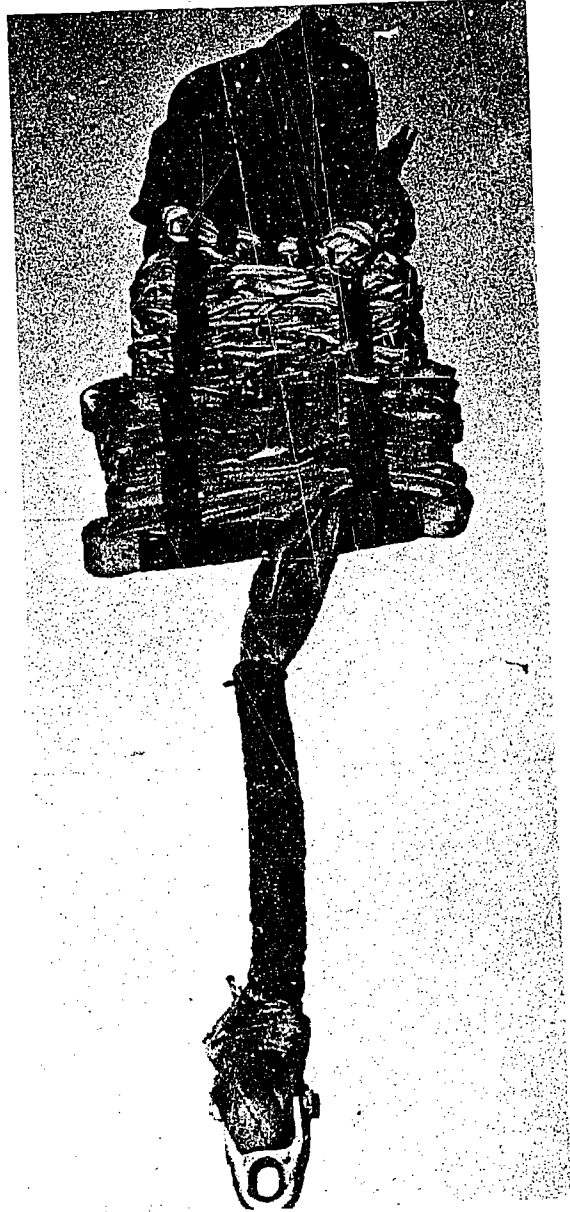

PR.459

Figure 5-38.—Connector links and risers, accordion folded.



Figure 5-39.—Stowing flap into deployment bag.

PR.460



Figure 5-40.—Folding flaps.

PR.461

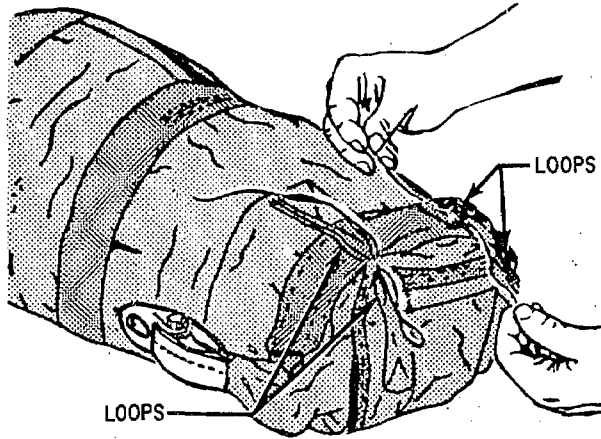

Figure 5-41.—Tying loops. PR.462

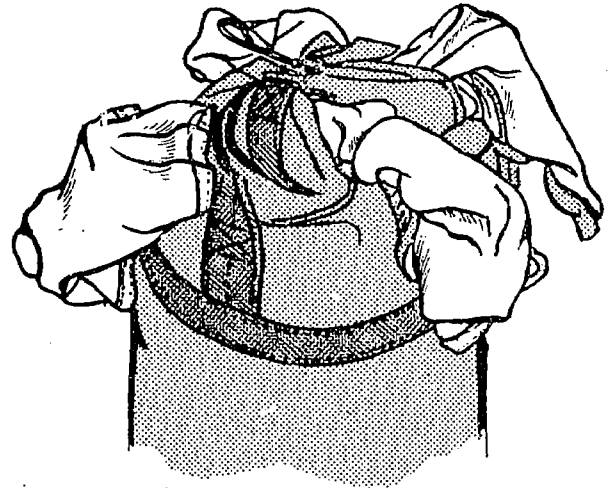

Figure 5-43.—Pilot chute separated into quarters. PR.464

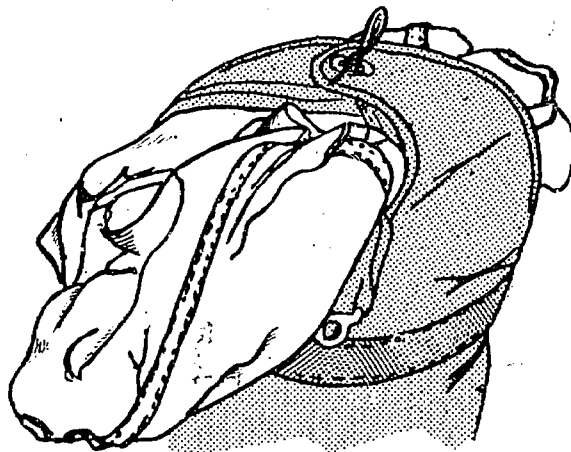

Figure 5-42.—Pilot chute separated into equal halves. PR.463

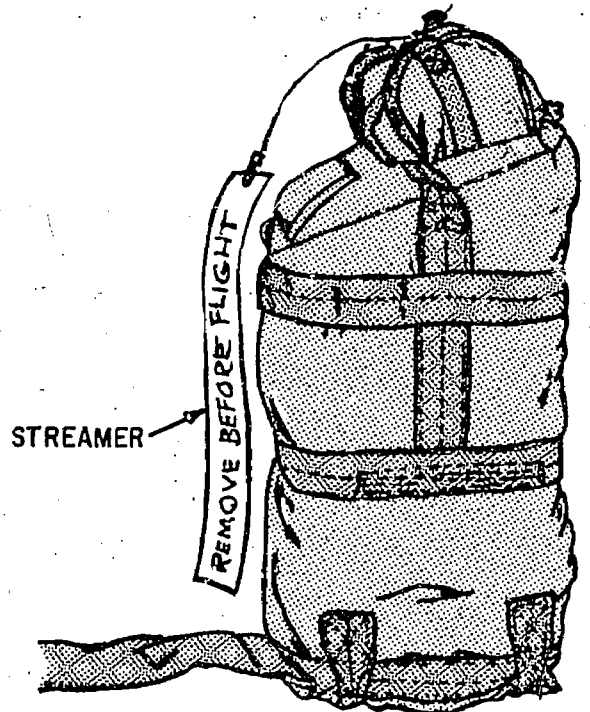
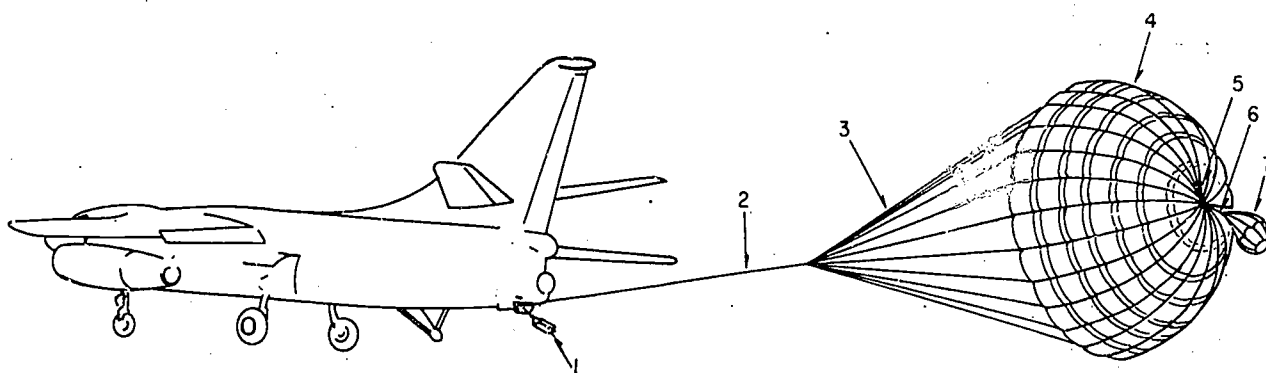

Figure 5-44.—Deceleration chute packed and ready to stow. PR.465



PR.28

- | | | |
|----------------------|-----------------|------------------------|
| 1. Deployment bag. | 4. Main canopy. | 6. Pilot chute bridle. |
| 2. Riser. | 5. Vent lines. | 7. Pilot chute. |
| 3. Suspension lines. | | |

Figure 5-45.—Deceleration parachute installation in an A-3 series aircraft.

CHAPTER 6

ANTI-G SUIT, OXYGEN MASKS, AND MK 4 PRESSURE SUITS

ANTI-G SUITS

Anti-g equipment is currently installed in high performance aircraft to counteract the effects of prolonged acceleration on the pilot. The ill effects of such acceleration range from excessive fatigue and decreased alertness to blackout and unconsciousness.

EFFECTS OF ACCELERATION

It is generally stated in relation to anti-g suits, that for each unit corresponding to the pull exerted by the earth's gravitational field, the force of inertia in acceleration is proportional to the square of the velocity and inversely proportional to the radius of the turn. For example, at 5 g's the pilot's body is exposed to a force of inertia which increases its weight and that of its components 5 times.

Grayout and blackout are physiological anoxic states directly related to the diminished blood volume reaching the eye and higher cerebral centers during and following periods of high acceleration. During these periods, the blood tends to pool in the blood vessels of the legs and abdomen, thus diminishing the amount of blood returning to the heart, and the cardiac output is therefore reduced. Thus, grayout and blackout with disturbances in the state of consciousness are merely symptoms of successive steps of anoxia of the brain. These symptoms are directly proportional to the amount of g's, the reduced cranial blood supply, and the length or time these factors are acting.

Without anti-g coveralls, the average pilot can momentarily withstand 4.5 or 5.5 g's without losing vision or blacking out. With anti-g coveralls, the average pilot is capable of withstanding 6.0 to 7.0 g's. This protection is available only for sustained accelerations of 4 to 5 seconds or longer in maneuvers other than snap maneuvers. It is emphasized that the anti-g equipment does not offer protection in snap maneuvers where 10 to 12 g's can be applied in approximately 1 second.

FITTING THE ANTI-G SUIT

The Mk-2A anti-g suit is issued to the individual aircrewman in accordance with the Section H, Allowance List, NavAir 00-35QH-2. The suit is furnished in four sizes and has five interconnected bladders which are constructed of polychloroprene coated nylon cloth. These bladders are attached to the air pressure source with a single quick-disconnect hose. The Mk-2A cutaway anti-g coverall is cut away at the buttocks, groin and knees for ease of comfort and mobility. The suit is equipped with entrance slide fasteners located at the waist and legs, and has six adjustment lacings. Two leg pockets with slide fastener closures are provided.

The Mk-2A anti-g coverall is illustrated in figure 6-1.

The anti-g coverall is individually fitted to the aircrewman because everyone's measurements do not conform with standard size requirements. With a proper fit the lace adjustments should be tightened approximately half-way, and the cutouts should expose the knees, groin and buttocks without binding or hindering movement.

NOTE: With the suit bladders deflated, the lace adjustments must be tightened to provide a snug, comfortable fit, especially at the waist.

When the proper fit is obtained, the inflated bladders should compress the waist, thighs, and calves firmly with equal stress distributed over the entire area.

The suit provides a range of 1.0 to 2.0 g protection against blackout, depending on the variations in the tightness of fit, and whether the HIGH or LOW setting on the anti-g pressure regulating valve is used.

A feature of the anti-g valve is the push-button at the top which may be operated manually to test the anti-g equipment on the ground or in level flight. Prior to each flight, the PR should make certain the pilot depresses this button to check the operation of the system.

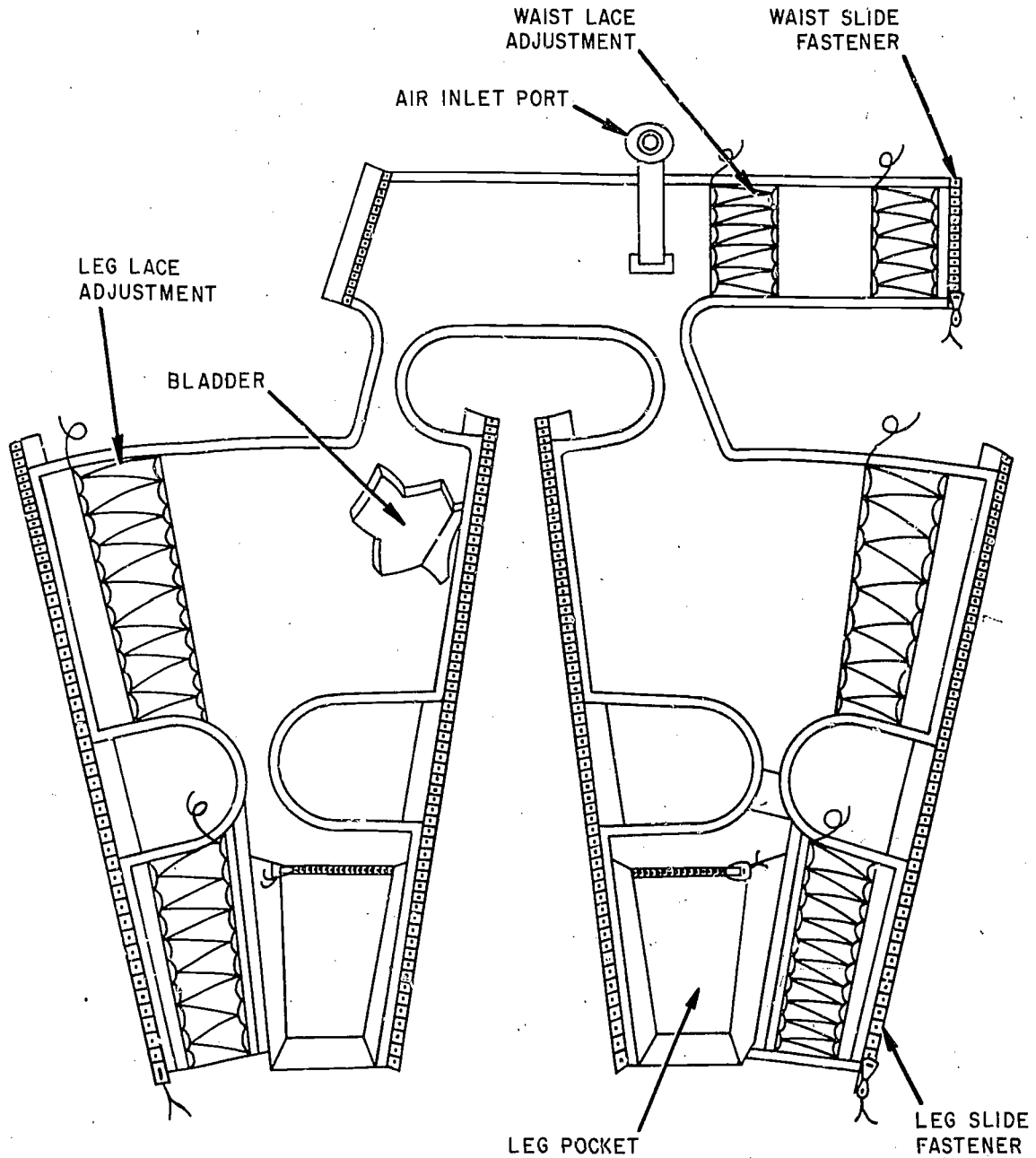

PR.466

Figure 6-1.—The Mk-2A anti-g coverall.

This feature also makes possible the inflating of the coveralls in long flights from time to time in order to relieve venous congestion of the legs and stiffness and tension of the body by a massaging effect on the inflating bladders.

It is emphasized that anti-g equipment is effective in reducing fatigue under subblackout accelerations and especially so at high altitudes where factors of mild anoxia, lowered pressures, and acceleration may be cumulative.

While high accelerations may not be encountered at high altitudes, the anti-g suit is still of considerable value for antifatigue characteristics. Where higher accelerations are encountered, such as combat flight at lower altitudes, the anti-g equipment is even more important. Therefore, to improve combat preparedness and efficiency, the PR must make certain that all pilots concerned are thoroughly indoctrinated in the use of anti-g equipment.

TEST AND MAINTENANCE

The Mk-2A cutaway anti-g coverall has no shelf life limitations and the in-service anti-g suit may remain in service until it fails the pressure test.

Preflight Check

The preflight is performed by the user prior to each flight, and in no case must the preflight check interval exceed a period of two weeks. The preflight check consists of the aircrewman visually inspecting the coverall slide fasteners, seams and stitching, laces and lace loops, anti-g hose, and the entire unit for tears and holes. If any discrepancy is noted, the coverall and hose must receive a periodic inspection.

Original Issue and Periodic Inspection

The original issue/periodic inspection must be performed at the time of issue and every 91 days thereafter, work to be performed at the lowest maintenance level possible. This inspection consists of subjecting the anti-g coverall to the preflight check and in addition performing a pressure test.

The pressure test consists of inflating the anti-g suit bladder to a pressure of 5 pounds per square inch (psi). The bladder pressure must not fall more than 1.0 psi in the first 30 seconds. A pressure drop greater than 1.0 psi in the first 30 seconds constitutes a failure. Coveralls that fail the pressure test must be stricken from service as repairs or replacement of the bladders or inlet port are not authorized.

NOTE: Quality assurance inspection points must be verified as summarized in the Aviation-Crew Systems Personnel Protective Equipment Manual, NavAir 13-1-6.7.

Cleaning the Anti-G Coverall

To clean the Mk-2A anti-g coverall, seal the air inlet port with a cork or rubber stopper, and immerse the suit in a mixture of lukewarm water and bacteriostat detergent and allow to soak for five minutes. Wash by hand for two minutes and remove the coveralls from the mixture, then rinse the coveralls in cool fresh water until all traces of the detergent have disappeared. To dry, hang the coveralls on a wooden hanger in a dry, well ventilated space.

Use of the Equipment

All pilots of aircraft in which anti-g equipment is installed should wear the anti-g suit to become familiar with its functioning and advantages. It is particularly important that it be worn in the early stages of operational and gunnery training in fleet type aircraft. It is on these flights that the pilot may miscalculate and pull excessive g's for a sufficient time to cause blackout or unconsciousness.

OXYGEN MASKS

Oxygen masks are pilot's personal equipment, and after the initial fitting, they are retained by the individual to whom issued. Fitting, adjustments, maintenance, cleaning, and incorporating modifications are the responsibility of the Aircrew Survival Equipmentman of the supporting activity. Oxygen masks are the final link in conveying oxygen from the aircraft system to the user and one important factor to remember about identifying an oxygen mask is its compatibility with the oxygen system with which the mask is to be mated.

Two types of oxygen masks are discussed in this section. They are the PRESSURE BREATHING MASK and the DEMAND OXYGEN MASK.

A-13A PRESSURE BREATHING MASK

The A-13A oxygen masks currently in use are issued in three sizes: small, medium, and large. Due to the two types of materials used in the construction of the A-13A masks, a brief description of each style will be discussed.

The A-13A oxygen mask (silicone) is dark olive in color, constructed of silicone (elastomer materials), and is described as being "tacky" to the touch.

AIRCREW SURVIVAL EQUIPMENTMAN 1 & C

The physical characteristics of this mask which represent improvement over older masks are as follows:

1. Longer shelf life.
2. Contains ozone resistant properties.
3. Lack of odor.
4. Has less facial irritation.

Cleaning of the A-13A masks must be accomplished as often as service conditions require but not less than once every three months.

The older style A-13A oxygen masks are issued in three sizes; small, medium, and large. They are medium green in color and constructed of stock which has a high crude rubber content compounded to resist mildew and remain flexible at low temperatures. Cleaning requirements are the same for both styles of the A-13A oxygen masks. All A-13A oxygen masks currently in use are satisfactory for flights up to 50,000 feet altitude without regard to service life if properly maintained.

Fitting the A-13A Oxygen Masks and Retainer Release Assembly to the APH-6/6A/7 Helmets

Fitting must be accomplished by inserting the proper size oxygen mask into a corresponding size mask adapter and harness assembly. Thread the mask adapter straps through the retainer release as shown in figure 6-2.

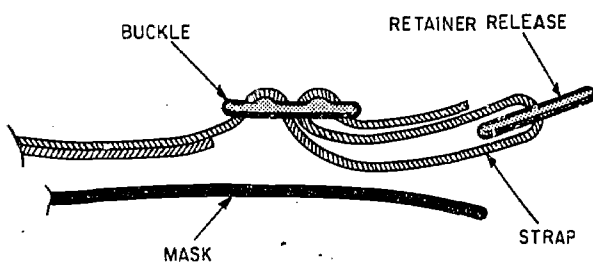

PR.467

Figure 6-2.—Method of attachment, mask adapter to retention-release assembly.

Don the helmet and insert the release assembly into the second notch of the retainer track. (See fig. 6-3.)

Adjust the mask and mask adapter to the face by first adjusting the two lower mask adapter straps, then the two upper straps. Angle adjustment can be accomplished by

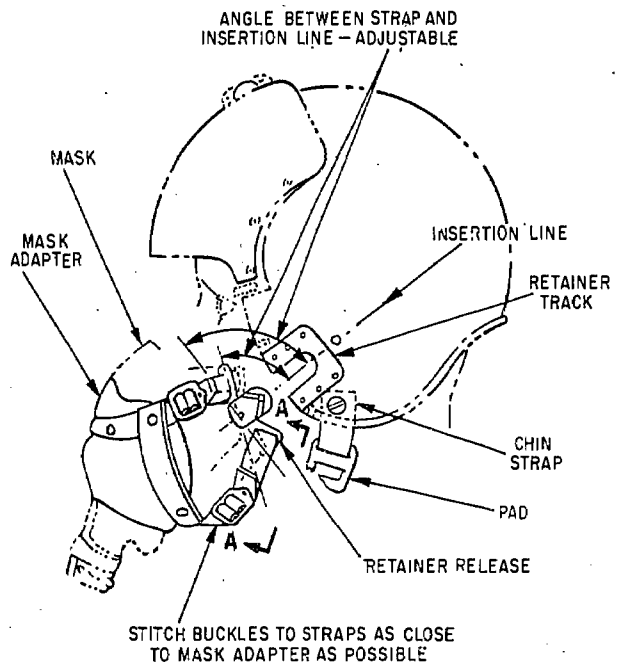

PR.468

Figure 6-3.—Mating the mask and adapter to helmet.

loosening the screw located on the rear inner face of the release assembly. After the angle is adjusted to the individual's fit, tighten the screw. Adjust the four adjustable straps to provide a snug fit of the oxygen mask, maintaining equal tension on all straps. Make sure that the retainer releases are in the same notch position on each side of the helmet, otherwise the mask will not be centered on the face.

Once adjusted, the straps need never be adjusted again since there is approximately 1/2 inch adjustment on each side by further insertion of the retainer release into the retainer track.

A-13A Mask and Retainer Release Assembly Modifications

The inner parts and mask components are the same for all A-13A oxygen masks, but due to the make and use of elastomer materials used in the construction of the silicone masks, a laminar seal is not required.

If specifically requested by the aircrewman, a laminar seal must be applied to the silicone mask by use of special bonding materials.

Chapter 6—ANTI-G SUIT, OXYGEN MASKS, AND MK 4 PRESSURE SUITS

All older style A-13A oxygen masks must have laminar seals affixed in order to remain in a serviceable status.

When applicable, shims may be required to obtain a functional fit; this modification of the retainer release to provide webbing clearance when attached to the helmet is shown in figure 6-4.

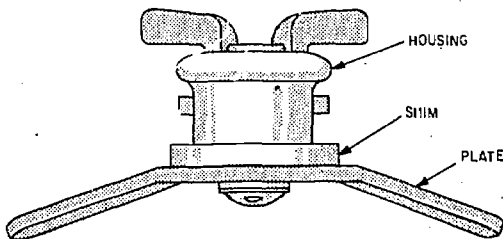
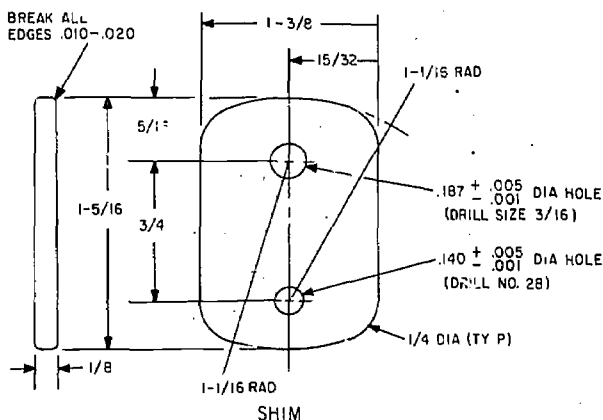

RETAINER RELEASE ASSEMBLY

PR.469

Figure 6-4.—Retainer release assembly shim.

A-14A DEMAND OXYGEN MASK

The A-14A oxygen mask is designed to be used with the demand oxygen system only. The mask is available in four sizes—large, medium, small, and extra small. It is designed to supply adequate oxygen during bodily exercise in extreme cold at an altitude up to 37,500 feet. With added precaution adequate oxygen is supplied to 40,000 feet. The same general line of maintenance procedure applies to this type mask as it does with the A-13A. Being simpler in construction and lacking the valves and internal sealing arrangement incorporated in

pressure types, the A-14A is easier to maintain in a serviceable condition. However, the same major rules apply to both masks. They must be clean and leakproof. Through repeated bendings, the nose wire (A-14A) might become broken. When it does, replace the mask.

To test the A-14A for proper fitting, hold the mask to the face with one hand, plug the quick disconnect fitting with the other hand, take a deep breath and hold it. Remove the hand holding the mask to the face, and the mask should cling to the face.

MARK IV FULL PRESSURE SUIT

The Mk IV full pressure suit is an individual fitted garment worn by pilots and aircrewmembers. The suit offers protection against rapid decompression, windblast, and cold, and gives complete protection from hazards of extreme altitude. In addition, it affords protection from cold water with comparable characteristics of the antiexposure suits. It is automatic and operates under all conditions including ejections. The suit will immediately become pressurized by ventilation air when ambient absolute pressure falls below 3.4 psi. The headpiece (helmet) contains the breathing system which is separated from the rest of the suit by a face seal. Microphones and earphones are incorporated in the headpiece. The headpiece also includes crash helmet features.

The suit assembly consists of seven components—torso, helmet, gloves, boots, anti-g suit, flotation garment assembly, and underwear. (See fig. 6-5.)

The suit is a close fitting, continuous wear, omnienvironmental garment designed for use in flights above 50,000 feet altitude. The specific application of the Mk 4 full pressure suit is detailed by the Chief of Naval Operations.

If the full pressure suit is to operate as intended, it is necessary that ground personnel insure that preventive maintenance be performed with care.

UNDERWEAR

During use, the underwear may become dampened by perspiration. It should be laundered between flights as needed. It may be washed in an automatic washer or by hand, using warm water and a mild soap. After washing it should be hung to dry or tumble dried with warm air only. Rapid drying may cause

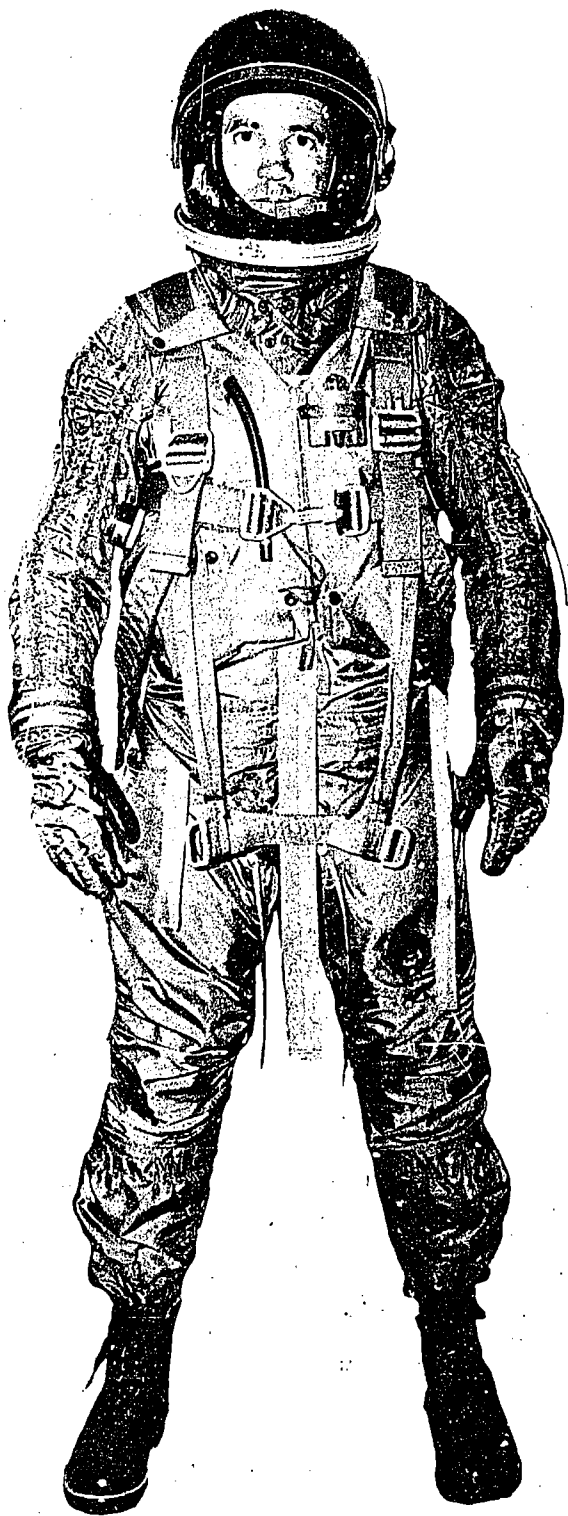

PR.29

Figure 6-5.—Mk 4 full pressure suit and components.

excessive shrinkage. If the Trilok patches are attached by Velcro tape, they should be removed before laundering and replaced after the garment is dry.

ANTIBLACKOUT GARMENT

The antiblackout garment should be cared for in the same manner as the standard anti-g suit. Bladders should be periodically inflated and checked for leakage, and the inlet connection should be checked to make sure that it makes a proper connection with the antiblackout port fitting.

TORSO

Extreme care should be exercised at all times with the torso section. Eliminate all sharp projections which might puncture or snag the torso in all areas where suits are handled or worn.

Make a periodic inspection of all components and be especially careful in checking the outer garment for signs of excessive wear, rips, snags, and tears.

The neck bearing should turn freely. To accomplish this, periodically drop several drops of Dow Corning 510 silicone fluid between the races. This is easily done by using a hypodermic needle filled with the fluid. To clean the bearing it must be disassembled. Disassemble by removing the retaining ring lock screws, the retaining ring, the backup ring, the quad ring, and the Teflon seal. Separate the inner and outer races and remove the ball bearings. Clean the bearings with Freon 113, dry thoroughly, and reinstall in the inner race groove. Reassemble in the reverse order.

Inspect the pressure sealing entrance zipper and relief zipper for tears in the rubber sealing lips and loose or missing zipper teeth. For ease in operation of the zippers, periodically apply a light film of silicone grease, MIL-L-4343A or MIL-I-8660A.

GLOVES

The gloves should be inspected periodically to make sure that there are no obvious tears or cuts. Check the zipper for damaged or missing teeth. Check the O-ring for damage and make sure that it is properly lubricated. Keep the leather of the gloves soft and pliable with an occasional application of a leather dressing.

BOOTS

Check all port fitting nozzles and plugs for ease in locking and unlocking.

The PR should make a visual inspection followed by pressurization (empty) of the entire pressure suit assembly prior to each flight. The suit should be pressurized to 3.0 psi and the leakage rate determined. NOTE: Procedure for testing is explained later in this chapter.

Occasionally, the suit must be tested for the proper operation of the relief valve. For these tests it must be inflated to 3.5 to 4.0 psi. WARNING: Do not pressurize the suit without the sock endings being enclosed in the boots.

The boots should be cared for like any good footwear. Keep good laces in the boots and inspect them periodically for damage and excessive wear.

FLOTATION GARMENT

Care to be afforded the flotation garment is the same as that for a standard inflatable life preserver. Inflate periodically and check for leaks in the compartments. A visual inspection should be made for completeness of the assembly and any indication of damage. It should be partially inflated and stored in an extended position for long storage periods. This type storage will prevent creases in the compartments which might tend to cause a leak.

Before each flight, check the garment to see that all air is removed. Any trapped air will expand at altitudes, causing partial inflation of the garment and discomfort to the wearer.

HELMET

The helmet should be handled carefully at all times. A plastic carrying case is provided with each helmet, and it is recommended that the helmet be kept in its case when not in use. Handle the sponge face seal carefully, and check for rips or tears. Check the metal ring at the base of the helmet for any damage which might cause an improper engagement with the neck bearing.

CAUTION: The oxygen hose contains communications system wiring which could be easily damaged by rough handling. Never use this hose as a handle.

Check the visor and tinted lens for cleanliness and scratches. Clean with a nonabrasive soap and clean water. Remove grease with

hexane, kerosene, or white gasoline, and use only a soft cloth to apply the cleaning solvent—never rub the surface with an abrasive.

Antifogging solution is recommended for use on the visor to prevent fogging. Apply a thin film with a cotton swab and remove excess when dry.

The ON-OFF button should be left in the ON position when not in use. This will avoid a permanent set in the O-ring inside the regulator.

Check the visors for ease in raising and lowering and operation of the button latches. Check the face seal and the O-ring for damage.

GENERAL PRECAUTIONS

Pressure suit equipment must be stored in an area free from dirt and away from excessive heat. The suit should be dried and ventilated after each wearing.

Do not smoke while handling or wearing the suit. A spark could melt a hole in the fabric, and if 100 percent oxygen is being used a serious fire could result.

TESTING

One of the PR's most important tasks is that of testing and maintaining full pressure suits. It is only while wearing these individualized pressure chambers that we can fly into rarefied atmosphere without fear of explosive decompression in the event of a failure of the pressurized cabin. The importance of quality workmanship cannot be overemphasized when dealing with these lifesaving devices.

The testing procedures given in the following paragraphs are typical setups; for actual testing of the equipment, refer to the latest revision of the appropriate NavAir Instructions.

SUIT LEAKAGE

Certain preparations must be made before testing the full pressure suit, and these preparatory steps are required for most tests. In cases in which other procedures are necessary, only the steps which differ from those listed below will be given:

1. Close main entrance, relief, waist, ankle, and neck zippers.
2. Snap the neck straps in place.
3. Insert sock endings into the boots and connect the four boot couplings.

AIRCREW SURVIVAL EQUIPMENTMAN 1 & C

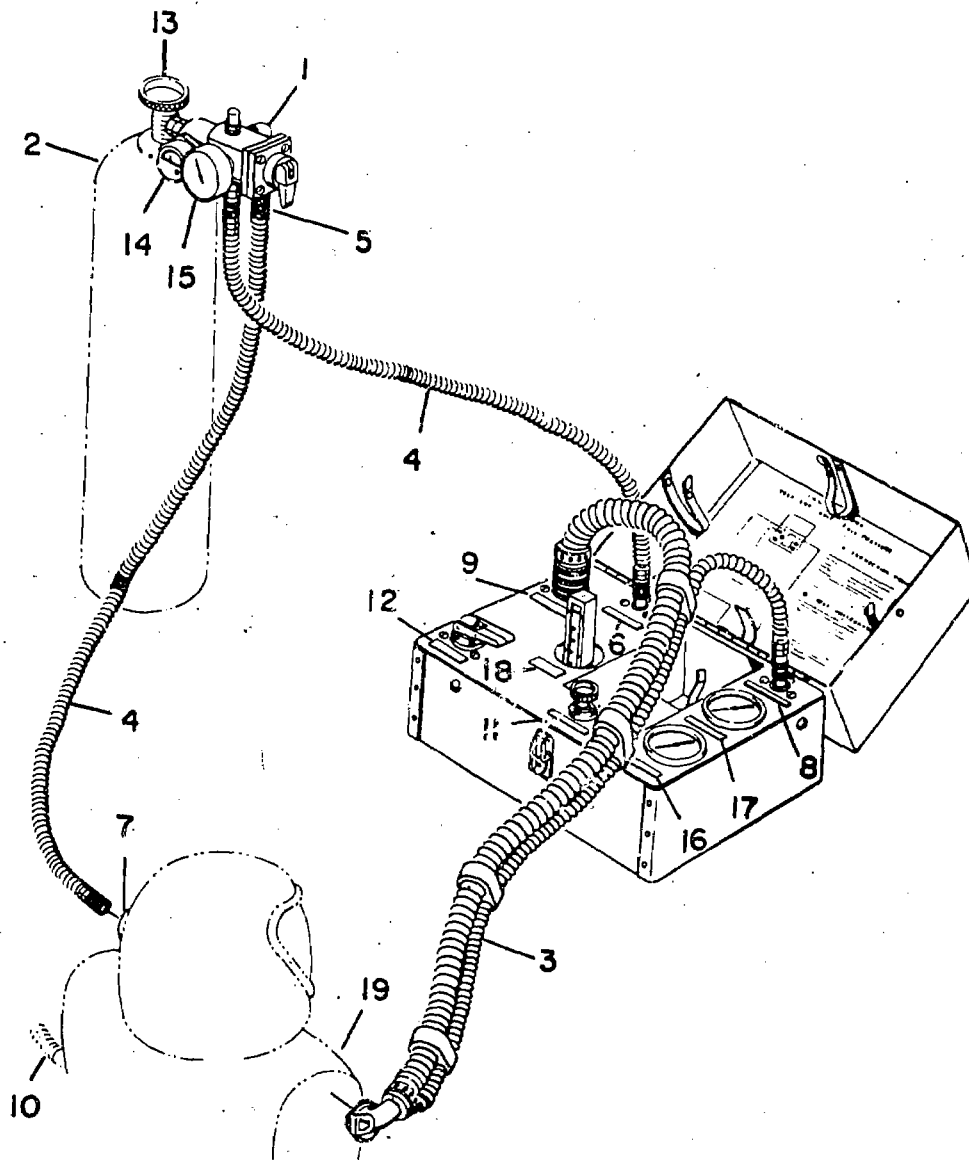

PR.38

- | | |
|---|---------------------------------------|
| 1. Oxygen cylinder reducer assembly. | 11. Control pressure knob. |
| 2. Oxygen cylinder. | 12. Suit leakage valve handle. |
| 3. Suit exhaust and pressure hose assembly. | 13. Oxygen cylinder valve |
| 4. Oxygen supply hose assemblies. | 14. Oxygen gage. |
| 5. Quick disconnect. | 15. Pressure gage. |
| 6. Test set oxygen inlet. | 16. Control pressure gage, 0-10 psig. |
| 7. Headpiece oxygen regulator. | 17. Suit pressure gage, 0-10 psig. |
| 8. Test set pressure indicating inlet. | 18. Flowmeter. |
| 9. Test set suit exhaust. | 19. Pressure suit. |
| 10. Ventilating air source. | |

Figure 6-6.—Test set assembly showing connections of the suit.

Chapter 6—ANTI-G SUIT, OXYGEN MASKS, AND MK 4 PRESSURE SUITS

4. Install plug (part No. 3P2060-1) into the antiblackout port.

5. Install plug (part No. 2P2066-1) into the pressure sensing port.

6. Install test plate (part No. 4P2053-1) in the neck bearing.

Suit leakage tests are performed on the portable test kit shown in figure 6-6. NOTE: Item 5 of figure 6-6 is not connected when the headpiece is not used as a part of the test.

To test the suit for leakage, the headpiece is attached, and a plug (part No. 3P2060-1) is installed in the ventilating port instead of the ventilating hose. Turn off the suit leakage valve (12, fig. 6-6) and oxygen regulator (7). Turn the suit control pressure knob (11) fully counterclockwise. Supply oxygen at 50 to 75 psi and lower the facepiece. Turn the headpiece regulator ON momentarily to inflate the facepiece seal.

WARNING: Do not leave the headpiece regulator ON for more than 10 seconds.

Adjust the pressure knob (11) until suit pressure is approximately 3.0 psi and install

a safety valve cap assembly over the pressure relief valve. Increase pressure to 4.0 psi and turn on the suit leakage valve. Maintain suit pressure at 4.0 psi and observe the flowmeter (18). Maximum allowable leakage for the entire suit is 10 lpm for a used suit and 5 lpm for a new one.

PRESSURE RELIEF VALVE TEST

The pressure relief valve test setup is the same as for the suit leakage setup except that no safety valve cap assembly is installed.

Gradually increase pressure to 3.4 psi and check to see that there is no leakage from the pressure relief valve. Observe the pressure gage while increasing pressure and increase until the safety valve cracks. The valve should relieve before the pressure reaches 4.0 psi and reseal before it goes back down to 3.5 psi.

NOTE: Do not overpressurize when testing the suit or its components. If damage is noted during testing, release pressure and make necessary repairs before continuing tests.

CHAPTER 7

MAINTENANCE OF CO₂ TRANSFER EQUIPMENT

CO₂ transfer units are supplied to the Navy by the C-O-Two Fire Equipment Company of Newark, New Jersey, and the Walter Kidde Company of Belleville, New Jersey. Both of these units and their related equipment are discussed in this chapter.

C-O-TWO TRANSFER UNIT

The transfer unit shown in figure 7-1 is furnished with the motor, stand, hose, and adapters. The cylinder stand and cylinder are not a part of the unit and must be provided locally. The motor-driven pump is designed with one cylinder, operating on the single-acting reciprocating principle. It is manufactured from corrosion-resistant metal, and is mounted on a base support. Mounted on a sliding base, the motor can be adjusted to maintain the proper tension on the drive belt. The working pressure of the pump is approximately 3,500 psi, and the unit is capable of transferring 80 percent (about 40 pounds) of the carbon dioxide from a fully charged 50-pound supply cylinder.

The pump head is fitted with a frangible safety disk designed to relieve pressure in the pump between 2,700 psi to 2,900 psi. When the disk ruptures, a safety disk nut prevents any recoiling action. Ruptured disks are easily replaced.

The lower half or crankcase end of the pump is ruggedly constructed. The crankcase proper is made of close-grained nickel iron which is fitted with a well-baffled breather, an oil filter, and a drain plug. A positive oil seal is provided at the crankshaft. The crankshaft (center crank, counterbalanced construction) is made in one piece of drop-forged, heat-treated steel. At each end of the crankshaft is an extra large tapered adjustable roller bearing (single-row, antifriction type).

The connecting rod (shaped in the conventional I-section common to automotive design) is also made of drop-forged, heat-treated steel. A shim-adjusted babbitted bearing is provided at the crankpin. The wristpin in the crosshead is of hardened polished steel and is furnished with a graphite bronze bushing, fitted with an oil groove. The crosshead, made of wear-resistant material, is also fitted with an oil groove.

The lubricating system is the automatic-controlled splash type, while the oil flow is regulated by a fixed orifice in the oil trough.

Packing is provided at the entrance of the piston rod into the cylinder which is especially designed for tightness at high working pressures and for ease of adjustment.

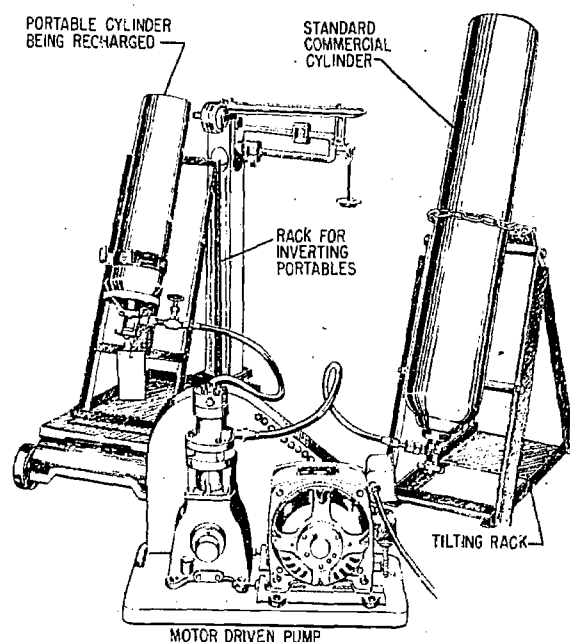

PR. 39

Figure 7-1. —C-O-Two transfer unit.

Chapter 7—MAINTENANCE OF CO₂ TRANSFER EQUIPMENT

The drive from the motor to the pump is a combination of V-belt drive pulleys and gears. The small gear and large pulley are assembled together as a unit, and are both fitted with ball bearings and mounted on the idler shaft. Both pulleys are carefully balanced. A single guard is secured over both gears and pulleys.

The motor furnished as standard equipment is the 1-horsepower capacitor start induction type. It is suitable for operation on either a 110- or 220-volt, single-phase, 60-hertz circuit. (A d-c motor is also available.) An enclosed control switch is located accessibly on the side of the motor.

SERVICE AND OPERATIONAL INSTRUCTIONS

After receiving the equipment, examine components for damage. If the unit is damaged, do not attempt repairs (under ordinary circumstances). Return it to the supply officer who will direct its reshipment to the manufacturer.

Since the oil has been drained from the crankcase of the pump for shipment to field activities, make certain it is filled with a standard grade of SAE No. 20 lubricating oil before starting the unit. On pumps equipped with an oil filter plug and measuring stick, fill only to the upper groove on the stick. On a unit equipped with an oilcup on its side and having no measuring stick, fill to within one-fourth inch of the top of the cup. Other than the crankcase, there is only one point on the pump that requires lubrication. This point is on the shaft of the idler gear and pulley and is equipped with an alemite lubrication fitting. In spite of the fact that the pulley shaft has been prelubricated at the factory, it is advisable to relubricate the area with two or three applications (grease gun shots) of light cup grease before starting. The motor bearings contain enough grease to last for approximately 2 years, under average conditions.

Before running the pump, and electric circuit compatible to the motor must be found or be installed in the shop. Unless otherwise specified, motors are wired to operate on 110-volt, 60-hertz, single-phase circuits. When 220-volt, 60-hertz, single-phase current is available, the hookup of the motor should be rearranged so that it can be operated on this

circuit. A 220-volt wiring diagram is shown on the nameplate of the motor. The plug on the end of the lead conducting the current to the motor from the power outlet should be equipped with a grounding wire, or third wire which is usually insulated by a white covering. Regardless of whether a three-pronged plug or a pigtail (coming out of the lead near a two-prong plug, fitted with a clip) is used, the system to which this grounding wire is attached must also be grounded in order for the unit to be protected.

Always "run-in" a new pump, or one that has been idle for a long time. This action, accomplished with the CO₂ hoses disconnected, is performed as a check for lubrication to make certain that all parts are thoroughly treated. After turning off the pump, wipe off all excess lubricants.

Before pumping carbon dioxide, examine all line connections on both the inlet and outlet hoses. Make certain that all connections between components are tight. This is important since carbon dioxide is stored under high pressure (approximately 850 psi at an atmospheric temperature of 70° F). Tighten connections with a wrench no larger than 12 inches, using a slow steady pull.

The transfer unit will pump carbon dioxide in its liquid phase only. This is true of all CO₂ transfer units. Since the amount of liquid carbon dioxide contained in a fully charged cylinder varies with the pressure and temperature (a standard 50-pound cylinder contains approximately 40 pounds of carbon dioxide in its liquid phase and approximately 10 pounds in its gaseous phase at an atmospheric temperature of 70° F), it follows that the cooler the supply cylinder and the cylinder being recharged, the more efficient the operation of the transfer unit will be. Consequently, all cylinders should be kept in the coolest location possible. Conversely, the time required to charge an empty cylinder increases with increased temperature of the cylinder.

After all the liquid carbon dioxide is transferred from the supply cylinder, which is approximately 80 percent of the net contents, the efficient transfer of CO₂ to the cylinder being recharged will cease. After this, another fully charged supply cylinder must be used to finish charging the cylinder to its full rated capacity. The majority of gas remaining in the other supply cylinder can be used when recharging another EMPTY CYLINDER, as the

AIRCREW SURVIVAL EQUIPMENTMAN 1 & C

gas will transfer itself under its own pressure until the pressure in both cylinders is equal. Through this method, the most economical use of the contents of the supply cylinder is made.

To prevent expansion of carbon dioxide in the supply hose, and consequently blocking the hose with CO₂ "snow," the valve should have an outlet opening of at least one-eighth inch in diameter — preferably three-sixteenths inch. Standard supply cylinders in 50-pound sizes are obtainable with or without a syphon tube. When ordering cylinders, specify the ones with a syphon tube. Those without syphons must be inverted during the transfer process.

MAINTENANCE

Once every month, inspect the level of the oil in the crankcase and see that it is within the limits specified.

Once every 6 months, lubricate the idler shaft with two or three applications of light cup grease; also, lubricate the gear teeth with a thin coating of the same grease. With a small brush, apply a light coating of vaseline to the piston rod. To do this, dip the brush in vaseline and hold the brush against the piston rod while rotating the gears manually until the piston rod has been coated completely. If necessary, tighten the packing at the piston stem. A special wrench is needed for this operation. Do not tighten excessively. Because of the design of the packing, it is necessary to make only a snug adjustment in order to have it hold tightly.

Keep the commutator of the motor clean. Under normal operating conditions, the commutator will require only occasional cleaning with a dry piece of nonlinting cloth. Never lubricate the commutator.

Drain and refill the crankcase at least once every 2 years. The bearing housings of the motor which also need attention at this time should be cleaned and regreased by a qualified electrician.

Piston Rod Packing

Piston rod packing should be replaced once every 2 years.

To replace the piston rod packing the steps involved are as follows:

1. Remove the six bolts on top of the cylinder head. Remove the cylinder head.

2. Loosen hex nut (fig. 7-2) at the bottom of the piston rod.

3. Remove the three bolts which hold the cylinder body to the crosshead guide unit.

4. Raise the cylinder body and unscrew the piston rod from the crosshead so that it clears the base.

5. The piston rod packing is now in a position to be replaced. Remove the locknut from the piston rod, and then remove the piston rod packing nut.

6. When replacing the flanged type packing, remember that the packing nut serves only to hold the packing in place. Tightening the nut excessively WILL NOT increase its efficiency; the packing nut should not be forced down tight enough to damage the packing flange.

7. After replacing the packing and packing nut, mount the cylinder body on the crosshead guide, making certain that the locknut is replaced on the piston rod before screwing it into the crosshead.

8. Screw the piston rod into the crosshead until the top edge of the piston packing is flush with the top of the cylinder body, with the crosshead in the uppermost position. (See fig. 7-2.) Check this adjustment by rocking the crank back and forth before tightening the locknut at the bottom of the piston rod.

9. Replace the piston head and tighten all the mounting bolts.

WALTER KIDDE TRANSFER UNIT

The Walter Kidde unit, like the C-O-Two unit, is designed and manufactured expressly for the purpose of transferring carbon dioxide in its liquid form from one cylinder to another. The unit is supplied complete with the necessary adapters, recharging valves, safety disks and bushings, nuts, bolts, and washers for making connections to the cylinders, and for minor adjustments to the unit. Pumps, models 4211 and 4211-1, are driven by a 3/4-horsepower motor and are equipped with a safety switch and lead fitted with a plug. Three-prong plugs and three-wire leads should be substituted for the ordinary two-wire, and two-prong arrangement. Pump models 4306 and 4306-1 are driven by a single-cylinder, four-cycle 3/4-horsepower air-cooled engine. Figure 7-3 illustrates the W. K. electric recharge unit, model 4211.

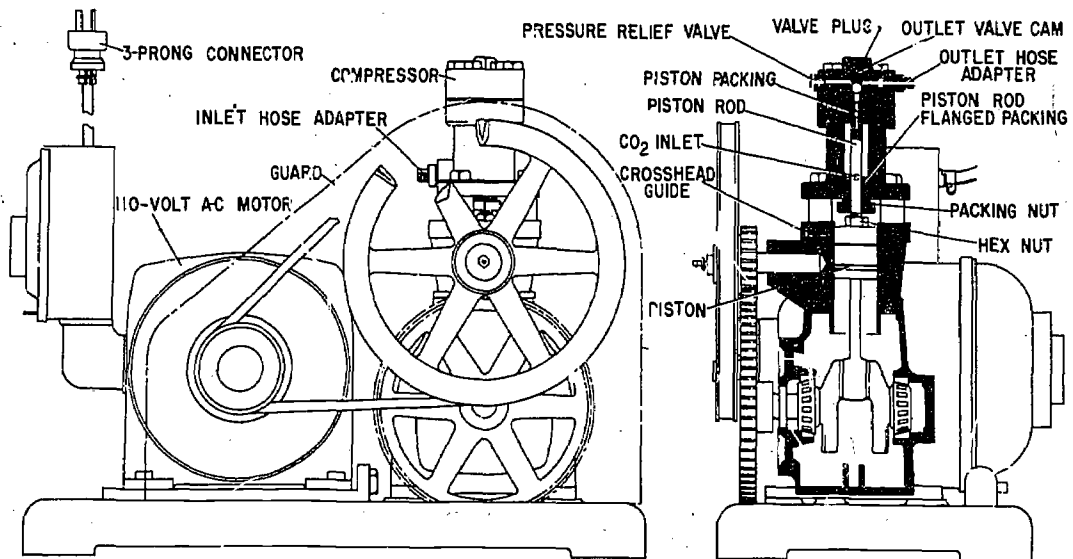

Figure 7-2.—Cross section of C-O-TWO transfer unit.

PR. 40

SERVICE AND OPERATIONAL INSTRUCTIONS

Much of this information has been discussed for the C-O-Two transfer unit and need not be repeated; however, where a difference has been noted, it will be discussed.

After uncrating and inspecting the unit, make certain that the crosshead clears the packing nut. To do this, turn the master gear attached to the crankshaft. The mechanism must work freely.

Fill the crankcase with a standard grade of SAE 20 motor oil. **CAUTION: DO NOT** use any oil or grease in the cylinders or in any of the adapters or hose connections used to convey carbon dioxide. (Since this precaution was not specifically stated in the instructions for the adapters connected to the C-O-Two pumping unit, it is not implied that oil or grease can be used in the adapters of the C-O-Two Company's equipment.) In any case, follow the manufacturer's instructions, adding or subtracting nothing contained in their respective manuals. Obviously, however, where the Nav-AirSysCom directives are concerned, they will take precedence over the manufacturer's instructions.

Instead of a 12-inch wrench, W.K. instructions direct the use of one 10 inches long to tighten all hose-connecting joints. While tightening, care should be taken not to twist the hose.

A strainer and strainer adapter (fig. 7-4) are inserted into the inlet line (at the supply cylinder) to the pump to prevent any dirt or turnings which may accumulate in the supply cylinder from blowing over into the pump and impairing the action of the valves. Knowledge of the function of the strainer in relation to a possible trouble area is important to the technician when attempting to analyze the cause of malfunctioning pump valves or other associated parts.

MAINTENANCE

With respect to lubrication, the instruction book for this equipment simply recommends inspecting the oil level in the crankcase periodically and changing it as necessary. Here, experience with pumps dictates the time of action. One can establish and maintain a schedule compatible with the experience gained through operating the equipment. The plunger packing needs no oil.

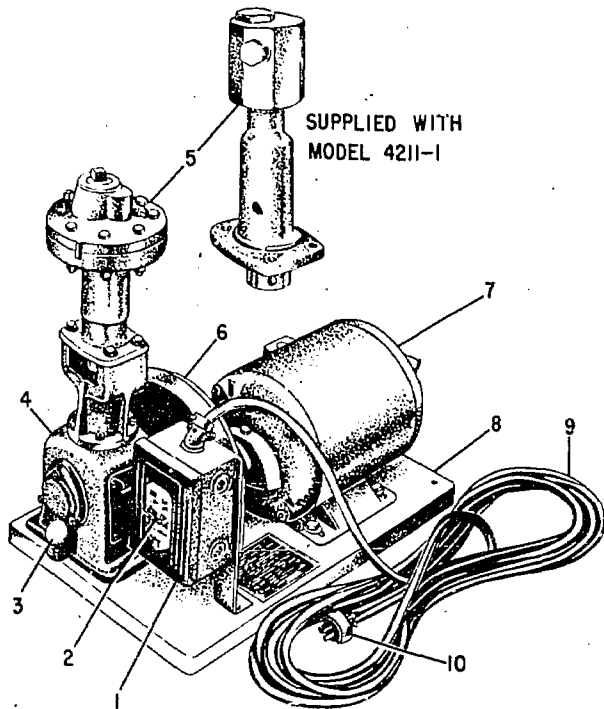

- | | |
|---------------------------|---------------------------------|
| 1. Multibreaker. | 6. Gear guard. |
| 2. Power switch. | 7. Motor. |
| 3. Oil filler cap. | 8. Base. |
| 4. Running gear assembly. | 9. Power cable. |
| 5. Compressor assembly. | 10. Change to three-prong plug. |

PR. 41

Figure 7-3. — Walter Kidde electric CO₂ transfer unit, model 4211.

Plunger Packing

Vapor leaks at the plunger packing are sometimes impossible to overcome. An invisible vapor leak will not affect the performance of the pump and no particular effort need be made to eliminate a leak unless it reaches the point at which it becomes visible. If a leak should develop at the lower end of the plunger, tighten the plunger guide, shown in figure 7-4, with a rod supplied (approximately 3/8" by 6"). Do not bind the plunger by tightening it too snugly. When it is no longer possible to adjust the tightness of the

plunger guide, new packing should be inserted as follows:

1. Remove the compressor body from the frame by unscrewing the four bolts which hold the compressor body to the crosshead guide and remove the pin which holds the plunger to the crosshead.

2. Place the compressor body in a vise, and remove the plunger guide and old packing. Insert only the two large pieces of packing and the spacer. Then insert the plunger guide and turn it down as far as possible to compress and form the packing around the plunger. This operation will cause the plunger to bind,

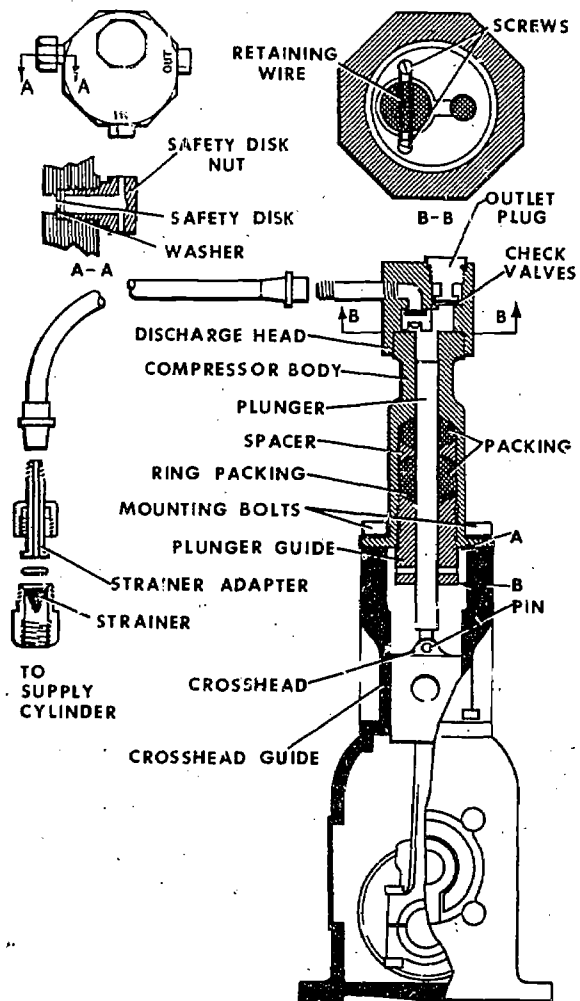

PR. 42

Figure 7-4. — Compressor assembly of the Walter Kidde CO₂ transfer unit.

Chapter 7—MAINTENANCE OF CO₂ TRANSFER EQUIPMENT

but it can be freed by turning and working the plunger up and down a few times.

3. Remove the plunger guide and insert the small ring of the packing. Install so that the level fits the packing already in place and the plunger guide. Replace the plunger guide and turn it in until the maximum dimension between the body at point (A) and end of the plunger guide (B) is $1 \frac{3}{16}$ inches. If the plunger guide is not screwed in sufficiently, the crosshead will strike the plunger guide. The plunger can be freed by working it back and forth several times.

4. Replace the compressor body, extending the plunger sufficiently so it can be lined up with the crosshead and the pin being replaced. After connecting the end of the plunger with the crosshead, which may have had to be moved to its top position in order to accomplish the connection, tighten the bolts securely. Turn the master gear through several revolutions by hand to be certain the crosshead does not strike the plunger guide.

Safety Disk

Figure 7-4 illustrates the safety disk arrangement located in the discharge body. The method of removal and replacement of the safety disk is self-evident in the illustration;

however, never use a disk that is stronger or weaker (tensile strength capacity) than specified.

Cleaning

Recharging pump connections should be kept free of foreign matter. If a decrease is noted in the amount of carbon dioxide transferred (it should be approximately 80 percent of the supply cylinder), remove the two check valves (fig. 7-4) in the compressor head and clean them. To do this, remove the discharge head body (right-hand thread). Then remove two screws and retaining wire. The inlet check will then be accessible. The outlet check can be removed by unscrewing the plug. Clean both checks and the seat thoroughly.

The strainer on the inlet line (from the supply cylinder) should be cleaned frequently for maximum efficiency of the pump.

Periodically tighten all bolts on the compressor head and frame.

NOTE: Remember that you are dealing with high pressure gas. Before attempting to recharge any extinguisher, become thoroughly acquainted with the recharging pump and the methods of recharging. Carefully read the instructions that pertain to the recharge pump and be sure that all connections are tight at all times.

CHAPTER 8

AIRCRAFT MOUNTED OXYGEN REGULATORS

Oxygen regulator maintenance formerly was entirely the responsibility of the PR. However, under the current rating structure, personnel of the AME rating are responsible for checking regulators installed in aircraft and for their removal and installation, while PR's are responsible for shop testing and maintenance. Malfunctioning regulators are therefore removed from the aircraft by the AME and delivered to the regulator repair shop, where the PR performs the necessary shop maintenance. The AME then reinstalls the regulator in the aircraft.

Although it is not always necessary to completely disassemble a regulator to make the necessary repairs, this chapter covers disassembly and reassembly of one of the various types of regulators now being used by the Navy, and describes the recommended methods of determining and remedying malfunctions. The first section of this chapter discusses some of the problems involved in establishing and organizing a regulator repair shop.

REGULATOR REPAIR SHOP

SPACE REQUIREMENTS

Adequate space for the installation of all necessary equipment must be available before undertaking the maintenance of oxygen regulators. Approximately 600 square feet of floor space is the minimum requirement for the establishment of a combined oxygen and carbon dioxide shop. This size shop is suitable for the support of approximately 200 aircraft. More space should be provided where larger numbers of aircraft are serviced, and separate rooms for the various shop functions are also desirable. In addition, a loading ramp for the handling of oxygen and CO₂ storage cylinders should be provided.

EQUIPMENT REQUIREMENTS

An oxygen regulator test stand, workbenches, storage bins, a machinist's vice, necessary

handtools, and special regulator tools are required for an adequate oxygen regulator shop. The special tools are listed in the applicable sections of this chapter.

SHOP ORGANIZATION

Segregation of all equipment relating to oxygen regulators is highly desirable, either by partitioning the shop or grouping this material in a separate section. This section should also be in a dirt- and dust-free area. The vacuum pump may be located in this area, under the bench supporting the regulator test stand. In addition, a regulator workbench and adjacent storage space should be provided. Personnel working in this segregated area would be undisturbed and would be in a position to use the equipment with maximum effectiveness.

AUTOMATIC POSITIVE PRESSURE AND COMPOSITE DILUTER DEMAND OXYGEN REGULATORS

AUTOMATIC POSITIVE PRESSURE REGULATORS

The automatic positive pressure diluter demand oxygen regulators, Pioneer-Central Types 2867 and 2873, are used in high-altitude flight to supply oxygen under pressure to the user. The regulator illustrated in figure 8-1 is the 2867-B2. The difference between the 2867 and the 2873 is that the 2873 does not incorporate the inlet and shutoff valve assembly. They both automatically mix air and oxygen at a ratio which depends upon altitude. The mixture is delivered to the user upon inhalation. A pressure breathing mask, such as the A-13A, must be used with these regulators. With a tight mask, these regulators, supplying 100% oxygen, can be used up to 50,000 feet under normal conditions. At altitudes above approximately 35,000 feet, positive pressure is supplied to the user.

COMPOSITE REGULATORS

Composite diluter demand regulators, Pioneer-Central Types 2872 and 2874, are also

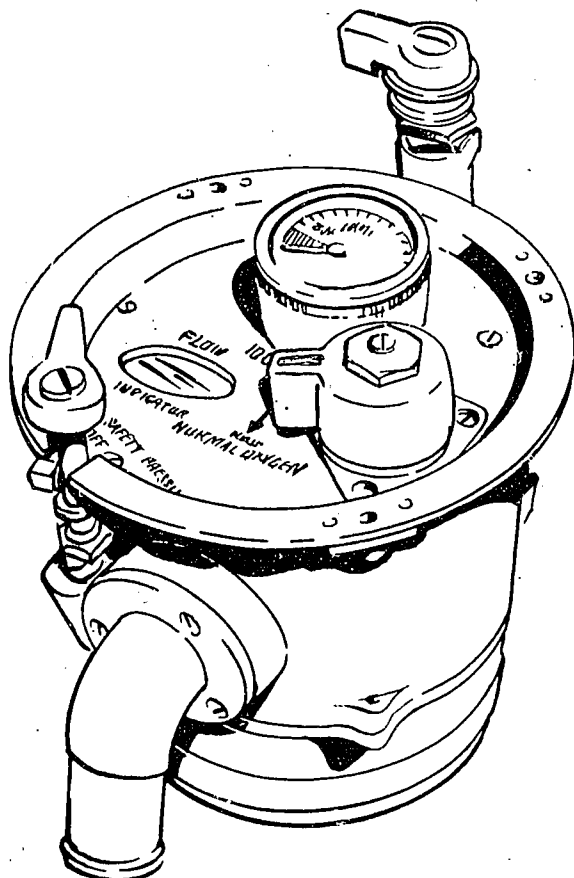

PR.43
Figure 8-1.—Three-quarter view of automatic positive pressure diluter demand oxygen regulator, Pioneer-Central Type 2867-B2.

used for high-altitude flight. The difference between the 2872 and 2874 is that the 2872 has an inlet and shutoff valve assembly; the 2874 does not. They have a service ceiling of 40,000 feet and are used with the A-13A pressure mask. These regulators do not incorporate a pressure breathing back, otherwise they are identical in appearance to the automatic positive pressure regulators.

DISASSEMBLY OF AUTOMATIC POSITIVE PRESSURE AND COMPOSITE DILUTER DEMAND OXYGEN REGULATORS

Since disassembly of all of these regulators is a similar operation, only the step-by-step

procedure for disassembling the 2867-B2 regulator is presented in this section.

The following Bendix special tools and test equipment are required:

BENDIX PART NUMBER	NOMENCLATURE
QB70065-1	Wrench, Fixed Spanner
QB70737-5	Wrench, Piloted Spanner
QB70750-9	Wrench, Piloted Spanner
QB71259-1	Adapter, Pressure Gage
QB71260-1	Wrench, Hex Key
QB72025-1	Wrench, Slotted Socket
TQ-12-A	Wrench, Torque (0-150 inch-pounds)
TQ-50-A	Wrench, Torque (0-600 inch-pounds)
508	Gage (0-100 psi)
609	Key, T-Handle

Removal of Blinker Tube and Pressure Tube Assemblies

The blinker tube assembly is removed first in order to clear the flow tubes on the regulator inlet assembly. Remove the shield. Using a QB72025-1 wrench, take off the blinker tube, being careful not to damage the lead seals on each end of the tube. Remove the inlet tubing shield and the pressure gage tubing at the inlet and shutoff valve assembly. Remove the four steel screws that attach the inlet and shutoff valve assembly to the case.

CAUTION: Loosen all four screws evenly to prevent damaging the inlet valve stem.

Disassembly of Inlet and Shutoff Valve Assembly

After removing the inlet valve assembly from the regulator case, place the inlet valve body in a vise. Using a 3/4-inch hexagon socket wrench equipped with a 3/8-inch drive and adapting it to the torque wrench TQ-50-A, remove the inlet valve assembly and the O-ring from the inlet body. Carefully remove the retainer and sintered bronze filter assembly, as the inlet valve assembly is spring loaded. Remove the compression spring, valve, seat insert, and O-ring from the inlet housing. Remove the shutoff valve assembly from the inlet valve body.

It is not necessary to disassemble the shutoff valve assembly unless repair or replacement is required. If disassembly is required, follow

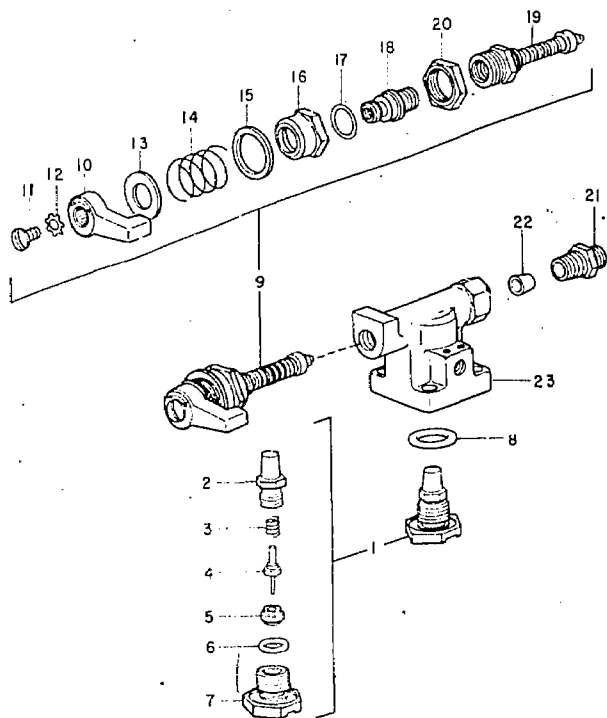

PR.44

1. Inlet valve assembly.
2. Retainer and sintered bronze filter.
3. Compression spring.
4. Valve.
5. Seat insert.
6. O-ring.
7. Inlet valve housing.
8. O-ring.
9. Shutoff valve assembly.
10. Shutoff valve arm.
11. Screw.
12. External lockwasher.
13. Special washer, large.
14. Spring.
15. Special washer, small.
16. Shutoff valve stem stop.
17. Washer.
18. Actuating screw.
19. Valve and guide assembly.
20. Locknut.
21. Union nipple.
22. Sintered bronze filter.
23. Inlet valve body.

Figure 8-2.—Exploded view of inlet and shutoff valve assembly.

the order indicated by numbers 10 through 20 in figure 8-2. If the shutoff valve is disassembled, determine whether the seat on the valve and guide assembly is lead or nylon. These two different seats on the valve and guide assembly are not interchangeable. Never clean the sintered bronze filters contained in these regulators with any cleaning solvent. They are to be cleaned by reverse flushing with dry, clean, oil-free air.

Removal and Disassembly of Aneroid and Check Valve Assembly

After the air valve knob assembly has been removed from the top of the regulator case, remove the air valve screen and gasket. Using the fixed spanner wrench, unscrew the aneroid and check valve assembly from its chamber in the case. The aneroid and check valve assembly is now disassembled by spreading the prongs and removing the check valve assembly from the aneroid housing. Remove the check valve disk by spreading the prongs, but do not remove the air check valve spring unless replacement is necessary. Remove the aneroid from the aneroid housing case, then remove the screw, throttling plate, and spring washer from the aneroid assembly. Remove the nut and the aneroid from the aneroid housing.

Removal and Disassembly of Mounting Plate and Oxygen Pressure Gage

Remove the safety pressure lever from the safety pressure shaft. If this is not done, the mounting plate cannot be removed. Take the six screws out of the mounting plate and lift it off the regulator case.

The oxygen pressure gage should not be separated from the mounting plate unless replacement is necessary. Any damage to the pressure gage or tubing will necessitate replacement of the entire pressure gage assembly.

Removal of the Oxygen Flow Indicator Assembly

Remove the masking tape that temporarily held the flow indicator parts within the chamber. As shown in figure 8-3, lift off the glass dial and gasket. It is not necessary to separate the gasket from the dial unless replacement of either is required.

Before removing the oxygen flow indicator assembly, observe the position of the black and white portions of the plate in relation to the case. The black portion is located toward

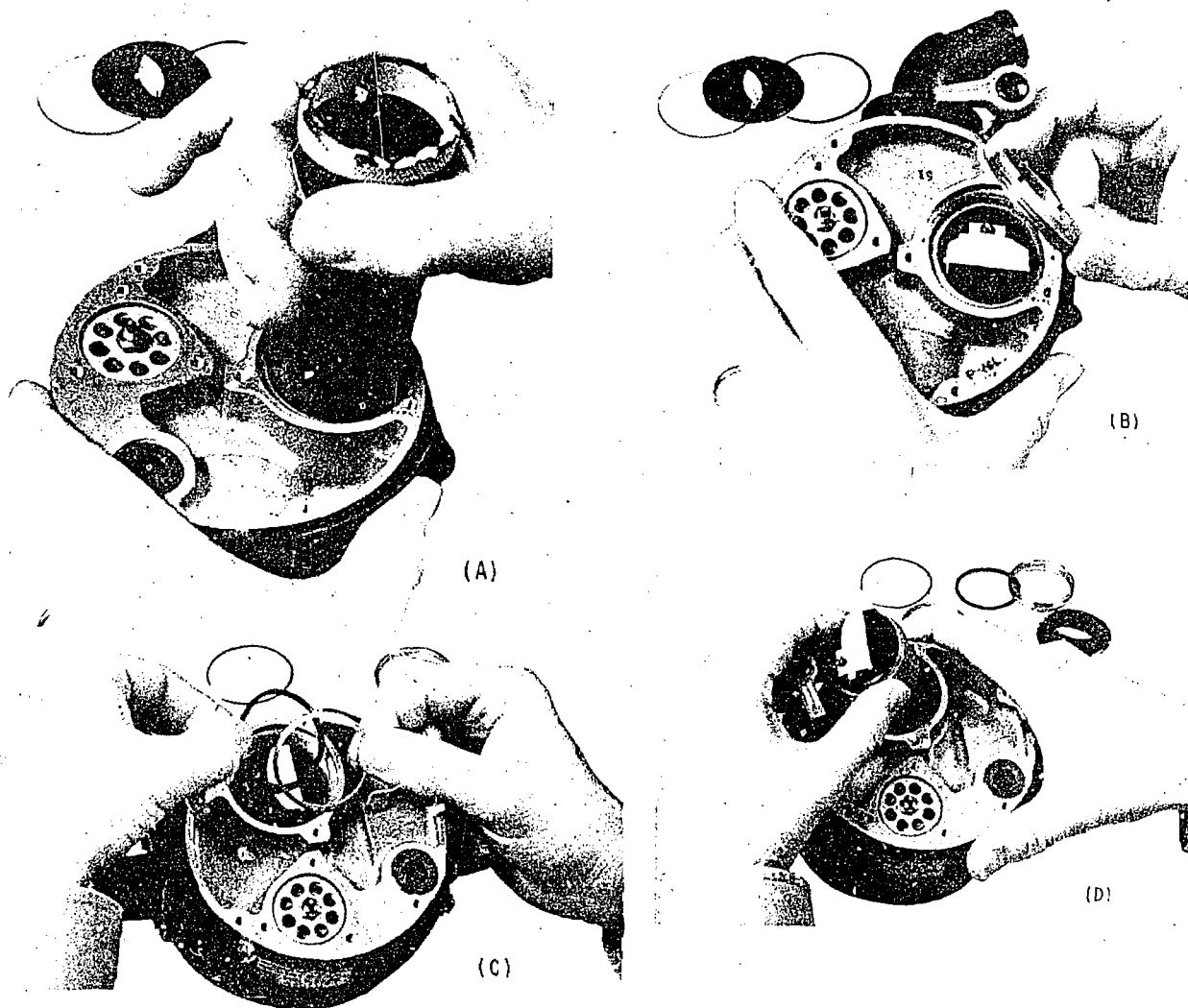

Figure 8-3.—Procedures for removal of flow indicator.

PR.45

the inlet and shutoff valve assembly. The flow indicator assembly must be reassembled in the same position. Using the fixed pin spanner wrench QB70065-1, remove the retaining ring. Extreme care must be taken when using the fixed pin spanner wrench. If it is not positioned correctly, it will damage the lever and plate assembly of the flow indicator assembly.

Holding the blinker in the center of the case, remove the slope ring. Using tweezers or a jeweler's screwdriver, pry out the packing washer that rests between the frame and the

flow indicator case. Lift the case out of the chamber. Figure 8-4 shows an exploded view of the disassembly flow indicator assembly. Disassembly of the oxygen flow indicator is not authorized. If it is damaged in any way, the entire flow indicator assembly must be replaced.

Removal of Regulator Back Assembly

In order to continue the disassembly of the parts mounted on the case, the assemblies attached to the back of the case must be removed first.

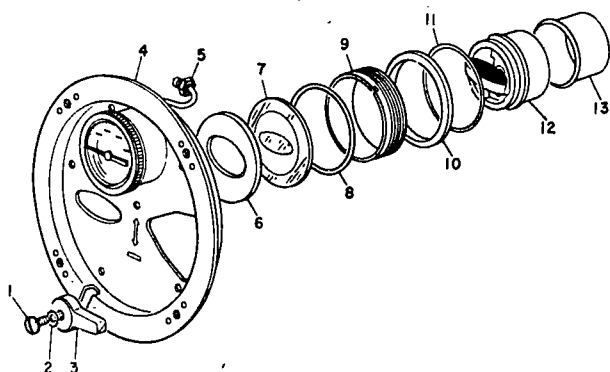

PR.46

- | | |
|---------------------------------|------------------------------|
| 1. Screw. | 7. Dial glass. |
| 2. Lockwasher. | 8. O-ring. |
| 3. Safety pressure lever. | 9. Retaining ring. |
| 4. Mounting plate. | 10. Ring. |
| 5. Oxygen pressure gage tubing. | 11. Packing washer. |
| 6. Gasket. | 12. Flow indicator assembly. |
| | 13. Piston seal. |

Figure 8-4.—Exploded view of mounting plate and flow indicator assembly.

Remove the four screws in the pressure breathing housing assembly and lift off the regulator case. (See fig. 8-5.) Lift off the diaphragm assembly. Further disassembly of the diaphragm assembly must not be attempted. Remove the screws and separate the housing from the plate and lever assembly. The screw and nut at the end of the ratio lever (long bar) must not be tampered with unless it is found to be out of calibration during testing. Loosen and remove the pressure breathing button (hex nut). Loosen the set-screw and slide the retaining strap over the aneroid cover. Unscrew the aneroid cover to separate the housing assembly from the aneroid assembly. Take out the three small screws and remove the aneroid from the cover.

Removal and Disassembly of Counterweight Lever and Bracket Assembly

Take out the two screws that secure the counterweight and bracket assembly to the case and lift from the regulator case.

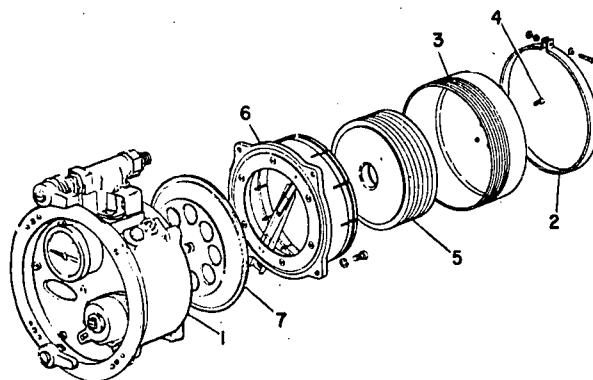

PR.47

- | |
|---|
| 1. Oxygen regulator assembly. |
| 2. Retaining strap. |
| 3. Pressure breathing aneroid cover. |
| 4. Screw. |
| 5. Pressure breathing aneroid assembly. |
| 6. Pressure breathing housing assembly. |
| 7. Diaphragm assembly. |

Figure 8-5.—Exploded view of diaphragm and pressure breathing back assembly.

Demand Valve Assembly

The demand valve is not removed. If damaged in any way, **UNDER NO CIRCUMSTANCES** will the PR attempt any repairs or replacements on the demand valve assembly. If damaged, or should replacement of any part of the demand valve be necessary, **REPLACE THE REGULATOR.**

Removal and Disassembly of the Injector Assembly

Remove the outlet and, using the piloted spanner wrench QB70750-9, unscrew the mixing tube. Remove the compression spring and the piston with the O-ring. Remove the injector housing and gasket. The injector nozzle is an integral part of the injector housing.

Removal and Disassembly of Pressure Reducer Assembly

Using a 3/8-inch open-end wrench and the T-handle wrench 609, loosen the pressure reducer nut (wrench 609 holds the stem). Take

Chapter 8—AIRCRAFT MOUNTED OXYGEN REGULATORS

off the nut and two gaskets. Only on the 2867 and newer regulators can the T-handle key wrench be used. These regulators have a hole drilled through the case from the injector chamber for access to the pressure reducer bellows stem. On the older regulators the hex key wrench QB71260-1 must be used to remove the pressure reducer. Reinsert the hex key wrench or T-handle wrench and screw out the pressure reducer bellows. Remove the spring dampener from the pressure reducer bellows and the chamber liner from the pressure reducer chamber. No further disassembly of the pressure reducer is authorized.

REGULATOR MAINTENANCE

CLEANING AND INSPECTION

General cleaning is essential after disassembly. For cleaning parts, use sonic energy. If sonic energy cleaning equipment is not available, clean all parts of the regulator with oxygen cleaning compound conforming to specification MIL-C-8638 (Aer). Dry with clean, dry, oil-free air. Clean, dry, oil-free air is compressed air that has been compressed with a pump lubricated with water vapor. Any parts, such as gaskets, diaphragms, etc., made of rubber are never washed. Under no circumstances should oil or any lubricant be used on the regulator.

Inspect the individual regulator parts for damage, nicks, scratches, burrs, deterioration, and signs of wear. Insure that mating parts, such as the inlet valve pin and seat and the check valve disk and aneroid housing, are smooth and free from scratches or burrs that may cause leakage or malfunction. Inspect the diaphragm and piston seal for holes, tears, and signs of wear. Replace all worn, damaged, or distorted screens, springs, gaskets and screws.

REASSEMBLY AND TESTING

Connect the tube and pressure gage assembly to a source of high-pressure oxygen (1,800 psi) to check the operation of the pressure gage. Check the pressure gage on decreasing pressure at 1,500, 1,000, and 500 psi. It must read correctly within plus or minus 50 psi.

Reassembly of Inlet and Shutoff Valve Assembly

Insert the O-ring, seat insert, valve, and compression spring in the inlet valve housing

in the order shown in figure 8-2. Using torque wrench TQ-12-A and a 3/8-inch socket, tighten the retainer and filter assembly to a torque of 30 to 40 inch-pounds. Using torque wrench TQ-50-A and a 3/4-inch socket, tighten the inlet valve assembly to 300 inch-pounds. Use of greater force may turn the head off the seat. Install the sintered bronze filter and the union nipple in the inlet valve body.

Apply a small amount of Dow Corning DC-7 to the outer threads of the valve and guide assembly. Place the locknut on the valve and guide assembly. Apply a small amount of Dow Corning DC-7 to the threads and install the actuating screw in the valve and guide assembly. Install the shutoff valve assembly in the inlet valve body. Slip the shutoff valve arm over the serrations of the actuating screw. Using the shutoff valve arm for leverage, tighten the actuating screw finger tight. After the actuating screw is tight, relocate the shutoff valve arm to the OFF position, as shown in figure 8-6. Open the shutoff valve by turning the shutoff valve arm counterclockwise approximately 180 degrees. Lift off the shutoff valve arm, being careful to leave the actuating screw in the same position. Install the washer in the shutoff valve stem stop. Using two wrenches, tighten the shutoff valve stem stop and the valve and guide assembly locknut.

After the assembly has been tightened, check the rotation of the shutoff valve arm from OFF to ON. There should be approximately a 180-degree inboard rotation. It is important that the rotation be inboard, as the mounting of this regulator in some aircraft will not allow outboard rotation. Install the small special washer, the spring, the large special washer, and the shutoff valve arm to the valve and guide assembly. Secure the shutoff valve arm with the screw and external lockwasher.

Testing the Inlet and Shutoff Valve Assembly

After the inlet and shutoff valve assembly has been reassembled, the following test must be performed. Apply a small amount of thread lubricant MIL-T-5542B (antiseize compound) to the pipe threads of the union nipple. Connect the inlet and shutoff valve assembly to a controllable source of oxygen and apply 1,600 to 2,000 psi through the nipple and dip the assembly into a container of water. There must be no leakage, which would be indicated by

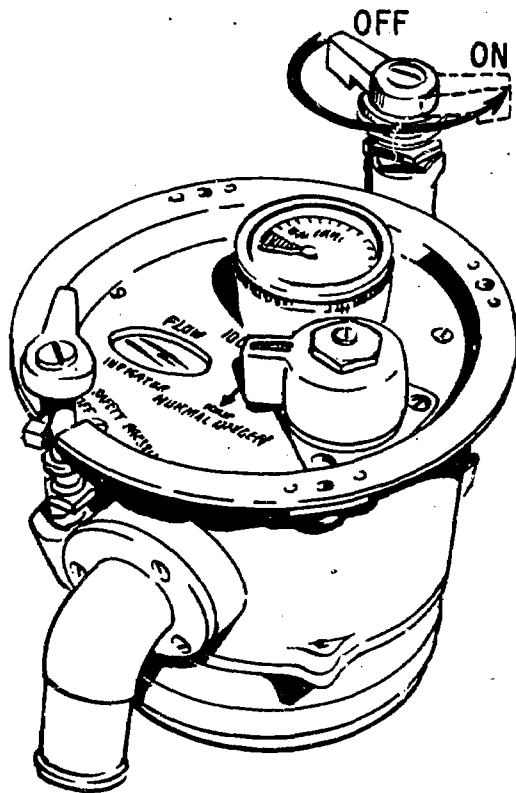

PR.48

Figure 8-6.—Position of shutoff valve arm.

bubbles. Turn off the pressure and release the 1,600 to 2,000 psi in the line. Apply 50 psi pressure and repeat the test. There must be no leakage.

Installing Pressure Reducer Assembly

Scribe a mark on the case, aligning the hole in the case that goes to the lower demand valve chamber with one of the holes in the pressure reducer chamber liner. Insert the pressure reducer assembly into the threaded hole in the case.

Using the T-handle key, or appropriate tool as shown in figure 8-7, screw the pressure reducer assembly into the case. When there are enough threads showing on the inside of the case, assemble the two gaskets and start the pressure reducer stem nut. Place the pressure reducer dampener into the slot on the pressure reducer assembly. Carefully insert the widest end of the pressure reducer chamber liner in the case

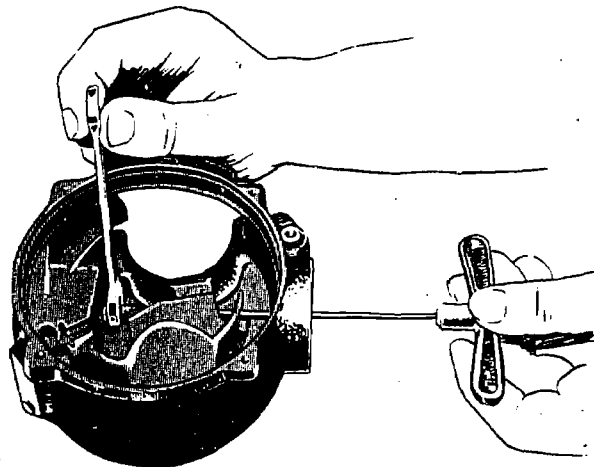

PR.49

Figure 8-7.—Adjusting the pressure reducer assembly using T-handle key No. 609 for 2837, 2872, 2873, and 2874 regulators.

and around the pressure reducer assembly. Be sure that one of the holes in the pressure reducer chamber liner is aligned with the scribe mark on the case. If this is not done, there will be a restricted flow of oxygen to the demand valve chamber.

Hold the pressure reducer nut with an open end wrench as shown in figure 8-7. Turn the pressure reducer assembly with the T-handle key counterclockwise until the top of the bellows is below the top of the case. On a flat, smooth surface, press the pressure reducer chamber liner flush with the case. Be sure the liner is flush with the case and the pressure reducer dampener is properly seated. Tighten the pressure reducer nut.

Install the gasket, and secure the inlet and shutoff valve assembly to the case with four screws.

Adjusting the Pressure Reducer Assembly

Close off the high-pressure gage hole in the inlet valve. Attach the pressure gage adapter QB71259-1 to the hole provided in the side of the case on the pressure side of the demand valve chamber. Attach a 0-100 psi gage to the gage adapter. Connect the regulator union

to a controllable source of pressure. Adjust the inlet oxygen pressure to 100 psi. Loosen the pressure reducer stem nut with an open-end wrench. Using the T-handle key, adjust the pressure reducer stem screw until the gage reads between 55 and 65 psi as shown in figure 8-7. The pressure is usually set at an average of 60 psi. If the pressure is below 55 psi turn the pressure reducer stem screw clockwise with the T-handle key. If the pressure is above 65 psi turn the pressure reducer stem screw counterclockwise. When the proper adjustment is obtained, lock the pressure reducer stem screw by tightening it in place with the T-handle key and tightening the pressure reducer nut with the open-end wrench.

Apply soap solution around the plug and pressure reducer nut. Check for leaks around these parts. There must be no signs of leakage. Make several checks by lifting the demand valve lever assembly. Remove all traces of soap solution from the parts.

Demand Valve and Inlet Valve Leak Test

With the pressure of 100 psi still applied to the inlet and shutoff valve assembly, draw a soap film over the injector opening. There must be no leakage, as indicated by expansion of the soap film. If a leak is indicated, observe the pressure on the pressure gage. If the gage shows a steady rise of pressure above the pressure reducer setting, a leaking inlet valve is indicated. Replace the inlet valve assembly.

Adjusting the Demand Valve Lever

Use a lever setting gage, if available. With the pressure of 100 psi still applied to the inlet and shutoff valve assembly, hold the lever setting gage across the back of the regulator case. Position the end of the lever setting gage over the end of the demand valve lever assembly, as shown in figure 8-8. Adjust the setscrew until the demand valve lever assembly just touches the lever setting gage. Turn off the oxygen supply and disconnect the regulator.

In case a lever setting gage is not available, the following method may be used for adjusting the demand valve lever. Hold a straightedge across the back of the regulator case. Position a scale perpendicular to the straightedge over the demand valve lever. Adjust the setscrew in the demand valve lever to measure $33/64$ inch from the tip of the demand valve lever to the end of the scale.

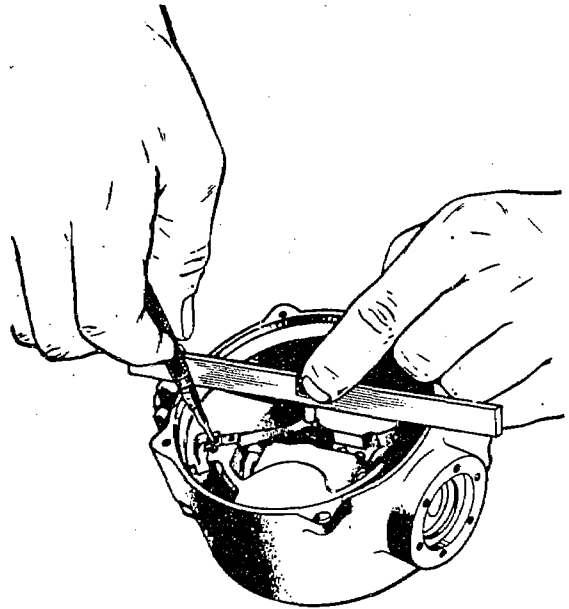

PR.50

Figure 8-8.—Adjusting the demand valve lever.

Installing the Counterweight Lever and Bracket Assembly

The counterweight lever and bracket assembly is replaced in the reverse order of removal. The counterweight lever must move freely in the recess in the case. The function of the counterweight lever is to insure proper performance of the regulator when the aircraft is involved in violent maneuvers.

Reassembling and Installing the Injector Assembly

Apply a small amount of DC-7 to the O-ring seal.

Place the gasket on the injector housing. Place the O-ring on the injector piston. Insert the injector piston with the O-ring, and the compression spring in the injector housing.

Position the injector assembly as shown in figure 8-9. The slot in the injector must be aligned with the hole in the case that leads to the air valve chamber. If these holes are not aligned, there will be a restricted flow of air into the mixing tube. This condition will be indicated by showing a low air reading during the oxygen

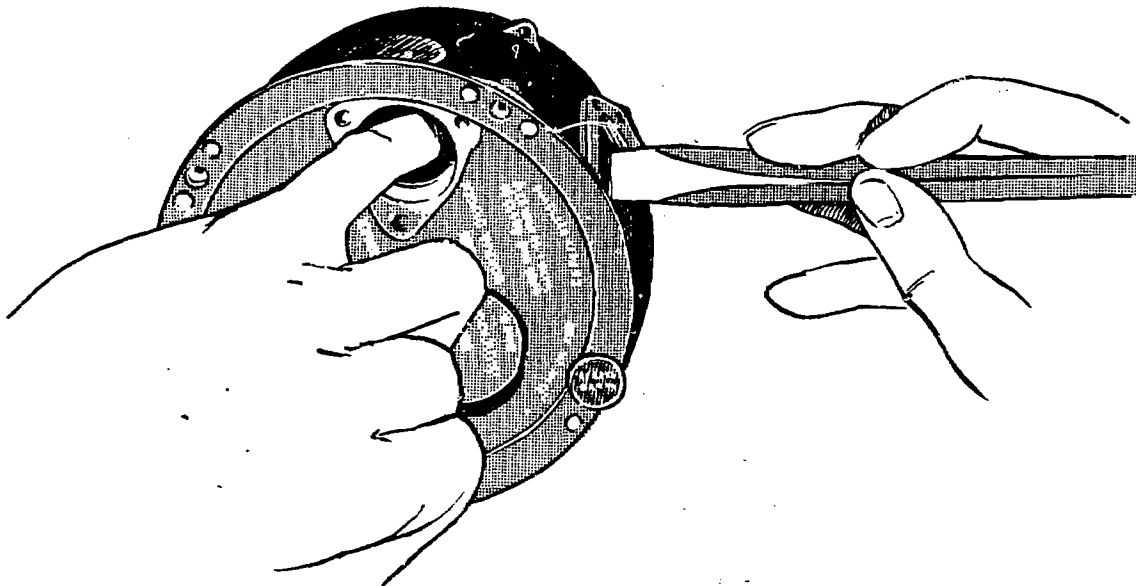

Figure 8-9.—Positioning the injector housing.

PR.51

ratio test. Lock the injector assembly in this position by screwing in the mixing tube, using the piloted spanner wrench QB70750-9. The mixing tube should be screwed in tightly to insure firm seating of the injector assembly against the gasket.

Testing the Injector Assembly

Connect the inlet and shut-off valve assembly to a controllable source of oxygen pressure. Apply 150 psi pressure. Fully depress and release the demand valve lever several times to check the injector for vibration. If the injector assembly howls, the O-ring on the injector piston must be replaced. Secure the oxygen pressure to the regulator and remove the pressure from the regulator by depressing the demand valve lever.

Replacement of the Safety Pressure Mechanism

If the safety pressure shaft was removed, replace the shaft and tighten the setscrew in the case. Install the spring seat and the spring on the screw. Install the nut and locknut on the

screw. Attach these parts to the bottom of the safety pressure shaft assembly. Make certain that the screw is secured in the shaft all the way.

Reassembling the Diaphragm and Housing Assemblies

Hold the diaphragm assembly so that the diaphragm plate is facing downward. Depress the diaphragm screw and engage it with the U-portion of the counterweight lever. Install the gasket in the case. Secure the hex nut on the long lever by means of the screw and washer placed between the nut and the lever. For initial setting of the ratio clamp, the center of the ratio screw will be $7/32$ inch from the outboard edge of the slot. Attach the plate and lever assembly to the housing using six screws. Position the pressure breathing housing assembly so that the long lever is over the safety pressure opening in the case adjacent to the injector assembly. Secure the housing assembly using the four screws and lockwashers. Fasten the pressure breathing aneroid assembly inside the aneroid cover using three screws. Screw the aneroid cover into the housing assembly all the

Chapter 8—AIRCRAFT MOUNTED OXYGEN REGULATORS

way, and back off approximately two turns. Do not lock the pressure breathing aneroid assembly in place with the strap. The aneroid must be calibrated in the test stand before the strap is tightened.

Installing the Flow Indicator Assembly

Carefully pull the piston seal over the oxygen flow indicator assembly. Place the assembly in the case so that the black portion of the blinker plate moves away from the inlet and shutoff valve assembly when it operates. Position the oxygen flow indicator assembly so that the centerline of the blinker plate is aligned evenly across the chamber in the case. Install the packing washer and slope ring. Using the fixed pin spanner wrench QB70065-1, secure the retaining ring. Install the O-ring, dial glass, and gasket. Temporarily place a piece of masking tape over the dial glass to hold it in the case.

Installing the Mounting Plate and Oxygen Pressure Gage Assembly

Install the plug, O-seal lock, and screw in the case where the 0-100 psig gage was installed. Using the slotted socket wrench, secure the screw. Place the slot in the mounting plate and oxygen pressure gage assembly under the safety pressure shaft. Remove the masking tape from the dial glass. Carefully align the screw from the pressure gage assembly with the opening in the inlet and shutoff valve assembly. Turn the screw in a few threads, and then secure the mounting plate and pressure gage assembly to the case with the six screws. Tighten the screw on the oxygen pressure gage tube. Install the blinker tube assembly. Tighten the screws using the slotted socket wrench. Install the tube shields. Install the tube filter, gasket, elbow, retainer plate, and safety pressure arm; secure them with the screws. Attach the sealing cap.

Reassembling and Installing the Aneroid and Check Valve Assembly

Secure the aneroid to the aneroid housing cover, using the nut. Secure the throttling plate and the spring washer to the aneroid assembly. Be sure there are no nicks or scratches on the throttling plate. Attach the aneroid housing to the aneroid housing cover.

As a preliminary adjustment, turn the aneroid assembly in the aneroid housing until

the throttling plate is about one-eighth inch above the seat in the aneroid housing. Lock the aneroid assembly at this adjustment by tightening the nut. This preliminary adjustment is an aid in making the final adjustment which is made during the aneroid closure test. If the results of the test meet the requirements, no further adjustment is necessary.

Attach the spring adapter assembly to the aneroid check valve retainer assembly. On this regulator the spring tension is adjusted by a small setscrew in the spring retainer. Insert the aneroid check valve spring and the check valve disk in the aneroid check valve retainer assembly. Spread the prongs of the aneroid check valve retainer assembly just enough to seat it on the aneroid housing. Using the fixed spanner wrench QB70637-5, screw the aneroid and check valve assembly into its chamber in the regulator case. Place the screen, gasket, and the air valve knob on top of the aneroid assembly and secure to the case with three screws.

PREPARING A PERFORMANCE SHEET

In order to perform the various tests required, a performance worksheet must be prepared. A simple, easy-to-use worksheet is shown in table 8-1. To properly fill in the performance worksheet, percentages must be computed and figures converted from liters per minute (lpm) to inches of water pressure. This is necessary since the regulator test stands measure in inches of water, rather than liters per minute. The procedure for filling in the worksheet will be covered in the sequence of the performance test listed on the worksheet shown in table 8-1.

The first performance test that requires a conversion is the flow indicator test: The 5 and 20 lpm flows required to perform the test must be converted to inches of water. This is accomplished by use of the oxygen regulator test stand output graph. Since the air valve is in the normal and also in the 100% position during this test, the zero altitude air line and the zero altitude oxygen line on the output graph will be used. Reading across the bottom of the output graph, determine the 20 lpm line. Follow the 20 lpm line up the graph until it contacts the zero altitude output air line. From this point, read from right to left across the graph. The figure at the left side of the graph will be the indicated inches of water for the actual 20 lpm flow. Repeat this procedure, using the zero altitude oxygen line to convert the 5 lpm flow.

AIRCREW SURVIVAL EQUIPMENTMAN 1 & C

Table 8-2.—Flow suction characteristics.

Inlet Pressure psi	Minimum Outlet Flow lpm	Maximum Suction At Outlet (inches of water)
Sea level:		
50	30	0.45
50	40	0.75
150	70	1.50
15,000 ft:		
50	30	0.45
50	80	0.75
150	75	1.50

Table 8-3.—Oxygen ratio chart.

Flow at Sea Level (lpm)	Altitude	Allowable Percent Oxygen	
		Min.	Max.
15	10,000	6	35
50	10,000	6	35
85	10,000	6	35
5	15,000	14	100
15	15,000	14	42
50	15,000	14	42
15	20,000	24	55
50	20,000	24	55
85	20,000	24	65
5	25,000	40	100
15	25,000	40	80
50	25,000	40	80
85	32,000	98	100

maximum oxygen percentage (column 2) and dividing the sum by 2. As an example, the

minimum of 6% is added to the maximum of 35%. The sum of the minimum and maximum is 41%. The sum, 41%, is divided by 2. The average oxygen percentage becomes 20.5%. This figure is placed in column 3. Column 3 is to be filled in completely, using this procedure.

Column 5 is indicated output. The actual output figures in column 4 are converted from liters per minute to inches of water and placed in column 5. This is accomplished by the use of the test stand output graph. Since the air valve is in the normal position during this test, the output air lines on the output graph will be used. Follow the same procedure as in previous conversions, reading the actual flows across the bottom of the graph, up to the appropriate output air line, and to the left across the graph for the indicated inches of water pressure. Complete the conversion of all the figures in column 4 and place them in column 5.

Column 6 is the corrected indicated output. The oxygen conversion graph is used to convert the indicated output figures in column 5 to corrected indicated output. The flowmeters on the test stands are calibrated with air. Since an air and oxygen mixture is being measured during this test, and oxygen is 11.5% heavier than air, this correction must be made. The indicated output, in inches of water, is read across the bottom of the conversion graph. This point is followed up on the graph to the appropriate percentage line and then left to the corrected indicated figure. All the indicated output figures in column 5 are converted to corrected indicated output in this manner and placed in column 6 on the performance check worksheet. This is the output figure used when performing the oxygen ratio test.

Column 7 is the actual high air input. To compute the actual high air figure, subtract the low oxygen percentage (column 2) from 100%. Then multiply the remainder by the actual output (column 4). The answer will be in liters per minute. As an example, 6% is subtracted from 100%. The remainder is 94%. The remainder, 94%, is multiplied by 15, the actual output figure from column 4. The answer is 14.10 lpm which is placed in column 7. Complete column 7 by following this procedure.

Column 8 is the actual low air input. Compute the low air input in the same manner as the high air input except that the high oxygen percentage in column 2 is subtracted from 100% instead of the low oxygen percentage. As an example, 35% is subtracted from 100%. The

Chapter 8—AIRCRAFT MOUNTED OXYGEN REGULATORS

remainder is 65%. The remainder, 65%, is multiplied by 15, the actual output figure in column 4. The answer is 9.75 lpm which is placed in column 8. Complete column 8 by following this procedure.

Column 9 is the indicated high air input. The actual high air input figures in column 7 are converted to indicated high air input using the test stand input graph. The actual high air input is read across the bottom of the input graph. This point is followed up the graph to the appropriate altitude line and left across the graph to the indicated input figure. This indicated high air input figure is placed in column 9. Complete column 9 by following this procedure.

Column 10 is the indicated low air input. The actual low air input figures in column 8 are converted to indicated low air input in the same manner that the actual high air input figures were converted to indicated high air input. Complete column 10 using this procedure.

Column 11 is used for recording the reading taken from the output manometer on the test stand during the oxygen ratio test. This reading must fall between the indicated high air and indicated low air input figures in columns 9 and 10 for the regulator to satisfactorily pass the oxygen ratio test.

PRESSURE BREATHING TEST

The purpose of the pressure breathing test is to determine whether the pressure breathing back is delivering the positive pressure in accordance with the positive pressure schedule outlined in NavAir 03-50A-48. (See table 8-4.) The positive pressure loading at 100 lpm ambient flow must not decrease by more than 1.25 inches of water from the positive pressure loading at 10 lpm ambient flow.

The positive pressure loading at 0.01 lpm ambient flow must not increase more than 1.25 inches of water above the positive pressure loading at 10 lpm ambient flow.

The altitude, minimum pressure, and maximum pressure columns are filled in from table 8-4. The 10 lpm, 100 lpm, and 0.01 lpm flows must be converted to inches of water. Since the regulator is delivering 100% oxygen at pressure breathing altitudes, the output oxygen lines on the output graph are used for this conversion. Follow the same procedure as outlined in previous tests. Since the test stands cannot measure 0.01 lpm, a zero flow will be used for this portion of the test.

Table 8-4.—Positive pressure values.

Altitude (feet)	Positive Pressure (inches of water)	
	Min.	Max.
35,000	-	3.5
37,000	-	5.7
39,000	-	8.0
40,000	2.0	9.4
41,000	4.0	10.2
41,500	6.0	10.8
42,500	8.0	12.0
43,000	10.0	12.5
50,000	-	18.0

SAFETY PRESSURE TEST

The 10 lpm and 50 lpm flows used during the safety pressure test must be converted to inches of water. Since the air valve is in the 100% position during this test, the zero altitude output oxygen line on the output graph will be used to convert the figures. Follow the same procedures as outlined in the previous tests.

TESTING PROCEDURE

The composite and automatic positive pressure diluter demand regulators must undergo and pass rigid leak and performance tests. If a regulator does not perform properly, it may cause injury or death to flight personnel. It is the PR's job to insure that service regulators perform properly at all times. Table 8-1 shows a suitable worksheet for all the tests required for these regulators. All leaks must be remedied before proceeding to the performance tests.

Unless otherwise specified, tests must be performed at an atmospheric pressure of 29.92 inches of mercury and at a room temperature of approximately 77°F. If the test conditions, are materially different from these, allowances must be made. Unless otherwise specified, all tests are to be conducted with the external oxygen supply valve fully open. After completion of the oxygen regulator tests, disconnect the tube from the outlet and close the external

AIRCREW SURVIVAL EQUIPMENTMAN 1 & C

supply valve. Remove the regulator from the inlet. Rotate the safety pressure knob to ON, relieving the trapped oxygen from the regulator through the outlet.

Be sure all parts of the regulator and all equipment used for testing are absolutely free from oils and grease or any other material that is not approved for use in the presence of high-pressure oxygen. The presence of oil or grease may cause spontaneous combustion and explosion.

PRETESTING

Before individual tests are made, it is recommended that all regulators be cycled for 30 minutes at approximately 20 lpm with an inlet pressure of 200 psi and the air valve on NORMAL. This check is performed to show up defects in the regulators that may be the result of improper assembly.

HIGH-PRESSURE LEAK TEST

The high-pressure oxygen leak test is performed to determine whether or not the parts inside the regulator are leaking. A leak is indicated by a bubble appearing when a film of soapy water is applied to the regulator outlet. The high-pressure leak test is performed with the safety pressure in the OFF position. Apply pressures of 50, 150, and 1,800 psi to the inlet of the regulator. There must be no leakage indicated when a soap film is drawn over the outlet.

Causes and remedies for high-pressure leakage are listed as follows:

Cause: Leaking inlet valve.

Remedy: Remove the inlet valve assembly and test by dipping in a container of water. If bubbles appear around the pin, rebuild the inlet assembly and replace the pin. If bubbles show around the valve, tighten it to 125 inch-pounds.

Cause: Pressure reducer set too high.

Remedy: Reset the pressure to 55 to 65 psi.

Cause: Leak in the pressure reducer bellows.

Remedy: Replace the pressure reducer bellows.

Cause: Leak around the pressure reducer nut.

Remedy: Replace the packings and tighten the pressure reducer nut.

Cause: Weak demand valve spring.

Remedy: Replace the regulator. The demand valve acts as the pressure safety release

on these regulators. Instead of the seat of the demand valve being pushed away from the valve, the seat is lifted away from the valve. With the pressure working on the seat of the demand valve, a weak demand valve spring would allow an escape of oxygen through the valve, even though the pressure reducer is set correctly.

As mentioned before, disassembly of the demand valve on the composite and automatic positive pressure diluter demand regulators is not authorized except at a major overhaul station. The only possible remedy then for a weak demand valve spring would be to turn the regulator in to the Supply Department for major overhaul.

Cause: No play in the ratio lever or pressure breathing back.

If this condition exists, the ratio lever would be exerting pressure on the counterweight lever. The counterweight lever, through linkage, depresses the diaphragm button, lifting the seat away from the demand valve.

Remedy: Readjust the safety pressure so there is a slight play between the end of the shaft and the ratio lever.

Cause: Demand valve lever set too high.

Remedy: Reset the demand valve lever so that it is 33/64 inch below or inside the bottom edge of the case. Use the lever setting gage if available; otherwise use a straightedge and scale, as previously described.

OVERALL LEAK TEST

The overall leak test is performed only on the 2867 and the 2872 regulators.

With 1,800 psi applied to the regulator inlet and the safety pressure knob in the OFF position, open the shutoff valve; 1,800 psi will be indicated on the pressure gage. Close the shutoff valve and remove the regulator from the pressure source. The pressure indicated on the pressure gage must not drop more than 100 psi in 2 minutes.

The causes and remedies for the overall leak test are the same as for the high-pressure leak test.

SHUTOFF VALVE LEAK TEST

The shutoff valve leak test is performed only on the 2867 and 2872 regulators.

With the safety pressure rotated to the ON position and the shutoff valve closed, apply 1,800 psi to the inlet of the regulator. With a

soap film over the outlet, there must be no evidence of leakage.

Causes and remedies for shutoff valve leakage are listed as follows:

Cause: Marred shutoff valve seat.

Remedy: Replace the shutoff valve.

OUTWARD LEAK TEST

The outward leak test is to determine if there is any outward leakage of oxygen from the regulator case.

Testing for outward leaks on all regulators can best be accomplished by use of an outward leak tester which can be manufactured locally. Figure 8-10 illustrates a locally manufactured outward leak tester.

5. Allowable leakage is 1.5 lpm.

Causes and remedies for outward leakage are as follows:

Cause: Leakage through the air check valve on NORMAL. This is caused by a faulty air check valve disk or seat.

Remedy: Replace the air check valve disk or the aneroid housing.

Cause: Leakage through the air check valve on 100%. This is caused by loose air valve housing screws or a faulty housing gasket.

Remedy: Tighten the air valve housing screws. If necessary, replace the air valve housing gasket.

Cause: Ruptured diaphragm.

Remedy: Replace the diaphragm.

Cause: Faulty diaphragm gasket.

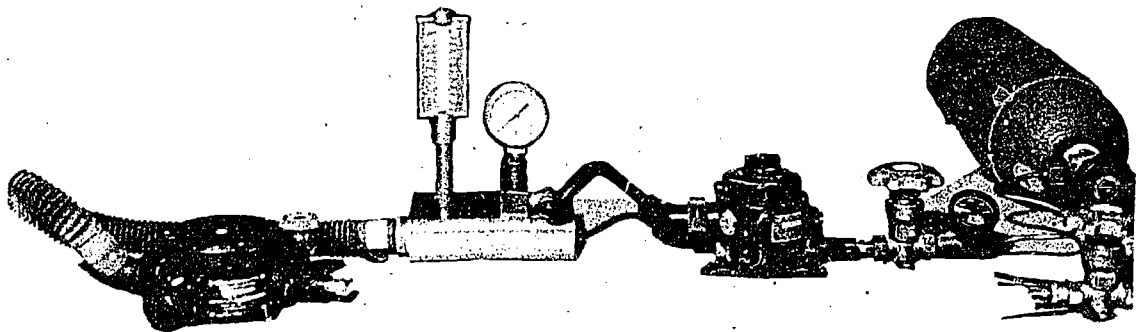

Figure 8-10.—Outward leak tester, manufactured locally.

PR.52

Oxygen pressure is applied to the outlet of the regulator by turning the manual pressure breathing top of the regulator clockwise. The amount of pressure is indicated on the pressure gage. Any outward leakage will act as a flow, and will register on the oxygen manometer.

Procedure for performing the outward leak test on the composite and automatic positive pressure diluter demand regulators follows:

1. Connect the outlet of the regulator to the hose on the outward leak tester.

2. With the air valve in the NORMAL position, apply 1 inch of water pressure to the regulator outlet.

3. Allowable leakage is 0.5 lpm.

4. With the air valve in the 100% position, apply 10 inches of water pressure to the regulator outlet.

Remedy: Replace the gasket.

Cause: Loose outlet elbow.

Remedy: Tighten outlet screws.

Cause: Chipped knife edge on the air valve lever.

Remedy: Replace the air valve lever.

Cause: Scarred or distorted air valve body gasket.

Remedy: Replace the air valve body gasket.

Cause: Loose screws or subassemblies.

Remedy: Tighten all screws and subassemblies.

INWARD LEAK TEST

The inward leak test is to determine if there is any ambient air leaking into the regulator case. The inward leak test is performed in the

AIRCREW SURVIVAL EQUIPMENTMAN 1 & C

test stand at sea level. The procedure is as follows:

1. Mount the regulator in the test stand with the diaphragm on a horizontal plane.
2. Air valve knob on 100% position.
3. Oxygen supply turned off.
4. Open the outlet valve until 1-inch suction is indicated on the pressure suction manometer. Open the outlet valve with caution as 1-inch suction is easily obtained inside the regulator.

5. Allowable leakage is 0.5 lpm and will be indicated on the output manometer. When using the OTS 565 test stand, any indication of leakage will be considered excessive leakage since it is impossible to measure 0.5 lpm on the manometer.

Causes and remedies for inward leakage will be the same as for outward leakage with the exception of the air check valve assembly. The air check valve opens inward; therefore, it cannot be considered a cause for inward leakage.

FLOW INDICATOR TEST

The flow indicator test is performed as follows:

1. Set the air valve in the NORMAL position.
2. Apply an inlet pressure of 150 psi.
3. Apply suction to the outlet to indicate a flow of 25 lpm.
4. Observe the flow indicator to see that it is operating.
5. Set air valve in the 100% position.
6. Apply suction to the outlet to indicate a flow of 5 lpm.
7. Observe the flow indicator to see that it is operating.

Causes and remedies for flow indicator being inoperative are as follows:

Cause: Leaking piston seal.

Remedy: Replace the piston seal.

Cause: Leaking flow indicator gasket.

Remedy: Tighten retaining ring or replace gasket.

FLOW SUCTION TEST

The flow suction test is performed to measure the amount of suction required to draw a specific flow through the regulator. In order to perform the flow suction test, it will be necessary to complete the flow suction block of the performance worksheet as explained earlier in this chapter.

Flow suction test procedure is as follows:

1. Set the air valve in the 100% position.
2. Adjust the inlet pressure to 50 psi.

3. Open the outlet valve to the first indicated flow.

4. Record the suction indicated on the pressure suction manometer.

5. Open the outlet valve to the next indicated flow.

6. Record the suction reading.

7. Increase the inlet pressure to 150 psi.

8. Open the outlet valve to the next indicated flow.

9. Record the suction reading.

10. Close the outlet valve and adjust the inlet pressure to 50 psi.

11. Open the outlet valve to 10 lpm.

12. Place the glass on the chamber.

13. Start the buzzer.

14. Open the bypass valve and ascend to 15,000 feet.

15. Close the bypass valve and set the first indicated flow with the outlet valve.

16. Record the suction reading.

17. Set the next indicated flow.

18. Record the suction reading.

19. Increase the inlet pressure to 150 psi.

20. Set the next indicated flow.

21. Record the suction reading.

22. Decrease the indicated flow.

23. Open the inlet valve and descend to sea level.

Causes and remedies for high suction are as follows:

Cause: Pressure reducer pressure set too low.

Remedy: Reset the pressure to 55 to 65 psi.

Cause: Pressure reducer liner installed upside down, causing a restricted flow to the demand valve.

Remedy: Install the liner properly.

Cause: Low demand valve lever setting.

Remedy: Reset the demand valve to 33/64 inch below the edge of the regulator case.

Cause: Excessive back pressure from the injector assembly during high flows.

Remedy: Replace the injector spring with a weaker one.

Cause: Strong demand valve spring.

Remedy: Replace the regulator.

ANEROID CLOSURE TEST

The aneroid closure test is to determine at what altitude the aneroid shuts off the flow of ambient air into the regulator.

Procedure for the aneroid closure test is as follows:

Chapter 8—AIRCRAFT MOUNTED OXYGEN REGULATORS

1. Set the air valve in the NORMAL position.
2. Inlet pressure is 150 psi.
3. Place the glass on the chamber.
4. Open the outlet valve to approximately 40 lpm.
5. Observe the altimeter; it should stop climbing between 28,000 and 32,000 feet.
6. If the altimeter continues to climb above 30,000 feet, decrease the outlet flow to 20 lpm.
7. When the altimeter stops climbing, or slows to 60 feet in 10 seconds, the aneroid is considered closed.
8. Record the altitude on the performance worksheet.
9. Close the outlet valve, open the inlet valve, and return to sea level.

Causes and remedies for the air valve failing to close or closing too late are as follows:

Cause: Cocked aneroid.

Remedy: Replace the aneroid.

Cause: Scarred or dirty throttling plate and seat.

Remedy: Polish with 0000 polishing paper. Clean with Freon 113, and dry with clean, oil-free air. If the throttling plate or seat is scarred too deep, it will necessitate replacement.

Cause: Aneroid and throttling plate too far from the seat.

Remedy: Readjust the aneroid by turning it clockwise, approximately 1/4 turn per 2,000 feet.

Aneroid air valve closes too soon:

Cause: Aneroid and throttling plate set too close to the seat.

Remedy: Readjust the aneroid by turning it counterclockwise, approximately 1/4 turn per 2,000 feet.

Adjusting the aneroid is a trial-and-error method, but the only possible way to accomplish the adjustment. With a little practice, a proper adjustment can usually be made on the first attempt. An ideal aneroid air valve closure is 30,000 feet.

If, when performing the air valve closure test, the altimeter will not indicate a climb, the aneroid and throttling plate is too close to the seat either by adjustment or because of an expanded aneroid. An adjustment will have to be made or the expanded aneroid replaced.

OXYGEN RATIO TEST

The oxygen ratio test is to determine if the proper mixture of cylinder oxygen and air is being delivered to the user. Oxygen ratios vary

for different altitudes and flows. The regulator must meet the percentage requirements listed in the manual for the regulator. Complete the oxygen ratio chart on the performance check worksheet (table 8-1).

Procedure for performing the oxygen ratio test follows:

1. Set the air valve on NORMAL.
2. Inlet pressure is 150 psi.
3. Place the glass on the chamber and ascend to the first test altitude using the outlet valve.
4. Set the corrected indicated output with the outlet valve while adjusting the inlet valve to maintain the correct test altitude.

The altimeter must be holding steady when the readings are taken.

5. Read the input manometer and record the figure in the proper column (column 11) on the performance check worksheet.

Keep in mind that the test stand was calibrated with air, therefore, it will only measure air. If the ratio of air is within the high and low limits, it is understood that the proper amount of oxygen is being delivered.

6. Set all the required flows at the altitude as in steps 4 and 5.

7. Climb to the next test altitude by closing the inlet valve and opening the outlet valve as required.

8. Repeat steps 4, 5, and 6 at each test altitude.

Causes and remedies for incorrect air-oxygen ratio are as follows:

High air at 10,000 and 15,000 feet:

Cause: Weak air check valve spring.

Remedy: Turn the adjusting screw in the air check valve retainer clockwise.

Low air at 10,000 and 15,000 feet:

Cause: Strong air check valve spring.

Remedy: Turn the adjusting screw in the air check valve retainer counterclockwise.

Cause: Leaky injector.

Remedy: Tighten the mixing tube to seat the injector tighter on the gasket. Replace the injector gasket or seat as necessary.

Cause: Injector positioned incorrectly.

Remedy: Reposition the injector housing. The slot in the housing should be aligned with the slot in the air valve chamber.

High air at 20,000 feet:

Cause: Excessive throttling plate movement. The distance between the throttling plate and the aneroid housing seat is too great.

Remedy: Replace the shouldering screw with one having a longer shoulder. Place a drop of glyptol on the threads.

Low air at 20,000 feet:

Cause: Insufficient throttling plate movement. The distance between the throttling plate and the aneroid housing seat is not great enough.

Remedy: Replace the shouldering screw with one having a shorter shoulder. Place a drop of glyptol on the threads.

High air at 25,000 and 32,000 feet.

Cause: Aneroid not closing soon enough.

Remedy: Readjust the aneroid clockwise to close sooner.

PRESSURE BREATHING TEST

The purpose of the pressure breathing test is to insure that the pressure back is delivering the proper positive pressure at the specified altitudes. The pressure back must meet the positive pressure schedule as outlined in the manual for the regulator. Complete the pressure breathing chart on the performance check worksheet (table 8-1) as described earlier in this chapter.

Procedure for performing the pressure breathing test follows:

1. Set the air valve in the NORMAL position.
 2. Inlet pressure is 150 psi.
 3. Place the glass on the chamber and open the outlet valve to indicate a 10 lpm flow.
 4. Open the bypass valve and ascend to the first test altitude.
 5. Close the bypass valve, and if necessary, adjust the outlet valve to indicate a 10 lpm flow.
 6. Record the pressure suction manometer reading.
 7. Increase the outlet flow to 100 lpm.
 8. Record the pressure suction manometer reading.
 9. Decrease the outlet flow to 0.01 lpm.
- Since 0.01 lpm cannot be measured on the OTS 565 test stand, decrease the outlet flow to zero.
10. Record the pressure suction manometer reading.
 11. Open the outlet valve to indicate 10 lpm.
 12. Ascend to the next test altitude using the bypass valve.
 13. Repeat steps 5 through 10 at each test altitude until the test is completed.
 14. Return to sea level using the inlet valve.

Causes and remedies for incorrect pressure breathing pressures are as follows:

High pressure back readings:

Cause: Pressure back screwed in too far.

Remedy: Readjust the pressure back counterclockwise.

Prior to performing the pressure breathing test, it is wise to initially set the pressure back. This is accomplished by screwing the pressure back in until a delivery of pressure is noted. Then screw the pressure back out 2 full turns. The final adjustment should be made using the 43,000-foot reading as a guide. Generally, if the 43,000-foot pressure is correct, the other altitude pressures will fall in correctly.

Low-pressure back readings:

Cause: Pressure back not screwed in far enough.

Remedy: Readjust the pressure back clockwise.

If adjustment of the pressure back does not allow the proper calibration, it may be necessary to adjust the ratio lever. Set the clamp farther out toward the end of the slot in the lever to give lower outlet pressures at high altitudes and higher pressures at low altitudes. Set the clamp closer to the center of the lever to obtain the opposite results.

At the completion of the adjustment procedure, lock the aneroid cover in place by means of the strap.

SAFETY PRESSURE TEST

The purpose of the safety pressure test is to determine the amount of positive pressure being delivered by the safety pressure. The safety pressure is manually operated. The purpose of the safety pressure is to prevent inboard mask leakage.

Procedure for performing the safety pressure test follows:

1. Air valve is set in the 100% position.
2. Inlet pressure is 150 psi.
3. Open the outlet valve to indicate a 10 lpm flow.
4. Actuate the safety pressure.
5. Record the pressure suction manometer reading.

The pressure suction manometer must indicate 1.75 ± 0.25 inches of water.

6. Increase the outlet flow to 50 lpm.
7. Record the pressure suction manometer reading. (The pressure drop indicated on the pressure suction manometer must not exceed 1 inch of water.)

8. Shut off the safety pressure.

9. Close the outlet valve.

Causes and remedies for high safety pressure readings are as follows:

Cause: Excessive spring tension.

Remedy: Decrease the pressure on the spring. Using two wrenches, loosen the stop nut and adjust the spring nut to the desired pressure reading. This operation can be performed while the regulator is in the test stand with a flow passing through the outlet.

Causes and remedies for low safety pressure readings.

Cause: Insufficient spring tension.

Remedy: Increase the pressure on the spring by adjusting the spring nut to the desired pressure reading.

Excessive pressure drop with a 50 lpm flow would be caused by a weak spring. A weak spring must be replaced with a stronger one. After the desired safety pressure has been attained, tighten the locknut. This will insure a constant spring tension, thereby delivering the proper amount of safety pressure to the user.

It is imperative that all the mentioned tests be performed, and all leakage and malfunctions be remedied before the regulator is issued for installation in an aircraft.

BENDIX SEAT MOUNTED REGULATOR

The Bendix 29252-A-2 regulator is a seat mounted regulator used both in flight and in an emergency. It is so designed that with a nominal inlet pressure of 70 psi it will deliver diluted oxygen from sea level up to approximately 30,000 feet, where 100 percent oxygen is automatically delivered to 50,000 feet, the service ceiling of the regulator. The regulator is designed to be used with the A-13A oxygen mask. It delivers automatic safety pressure not in excess of 2 inches of water pressure, from sea level up to 35,000 feet, and delivers automatic pressure breathing from 35,000 feet to 50,000 feet, not to exceed 18 inches of water pressure.

OPERATION

Oxygen enters the inlet of the regulator (1) shown in figure 8-11 at a nominal pressure of 70 psi. It then passes through the inlet filter (2) and flows past the demand valve (3) to the inlet pressure chamber (23), where it acts against the inlet piston (24). The piston then moves downward against the valve spring, leaving the check valve (16) free to open and permit the intake of ambient air through the air dilution port (27) (air valve normal). The incoming oxygen also flows past the needle valve chamber (4) until the pressure is equal

to that of the inlet pressure exerted on the opposite side of the demand valve diaphragm (10).

Upon inhalation, a pressure drop is created in the mask. The pressure drop is sensed through the sensing line (14) to the area adjacent to the breathing diaphragm (8). The breathing diaphragm will then move in the direction of the pressure drop to contact the pilot valve lever (9). This action will cause a pressure drop in the demand valve upper chamber (6), allowing the inlet pressure to unseat the demand valve and deliver oxygen to the user. The pressure will drop in the upper demand valve chamber since oxygen will escape through the pilot valve at a faster rate than it can enter through the needle valve. An orifice plate is installed in the passage leading to the upper demand valve chamber to stabilize the pressure and dampen any tendency for over response and flutter.

Upon exhalation, pressure will build up in the mask. The pressure rise is sensed through the sensing line to the area under the breathing diaphragm and the breathing diaphragm will move away from the pilot valve lever enabling spring tension to close the pilot valve. The pressure in the upper demand valve chamber will build up and close the demand valve, shutting off the flow of oxygen to the user.

Air Dilution

As the oxygen flows past the demand valve, it proceeds to the nozzle. The nozzle will restrict the oxygen flow, creating a high velocity jetstream. The jetstream draws air in through the air dilution ports when the dilution knob is in the normal position.

Air Ratio Aneroid

The air ratio aneroid, with the throttling plate attached, is designed to expand and meter the flow of air to give the correct percentages of air and oxygen as altitude increases. The air ratio aneroid will automatically close off all air dilution at approximately 30,000 feet. The 100 percent oxygen then travels through the regulator outlet to the user.

Automatic Air Shutoff

The automatic air shutoff device replaces the visual blinker assembly. It is more positive in that loss of oxygen pressure also closes off the air supply and requires activation of the

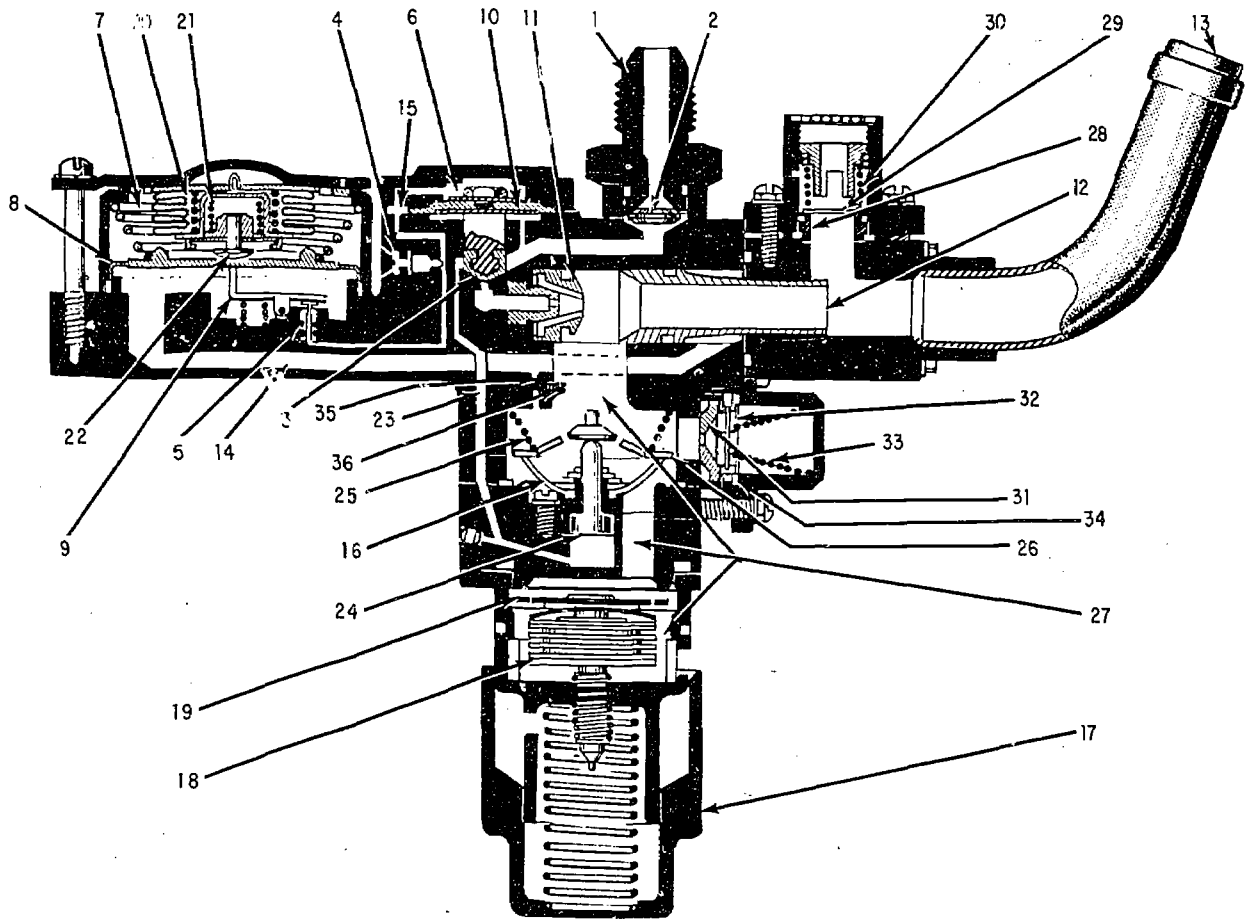

PR.53

- | | | |
|--------------------------------|---------------------------------------|--------------------------------|
| 1. Inlet fitting. | 13. Outlet fitting. | 24. Piston. |
| 2. Inlet filter. | 14. Sensing line. | 25. Return spring. |
| 3. Demand valve. | 15. Restricting orifice. | 26. Spring retainer. |
| 4. Needle valve. | 16. Check valve. | 27. Air dilution port. |
| 5. Pilot valve. | 17. Dilution knob. | 28. Relief valve seat. |
| 6. Upper demand valve chamber. | 18. Air ratio aneroid. | 29. Relief valve plate. |
| 7. Safety pressure spring. | 19. Throttling plate. | 30. Relief valve spring. |
| 8. Breathing diaphragm. | 20. Pressure breathing aneroid. | 31. Dump valve seat. |
| 9. Pilot valve lever. | 21. Maximum pressure spring. | 32. Valve plate and diaphragm. |
| 10. Demand valve diaphragm. | 22. Pressure breathing contact screw. | 33. Dump valve spring. |
| 11. Nozzle. | 23. Inlet pressure chamber. | 34. Exhaust holes. |
| 12. Venturi. | | 35. Booster hole. |
| | | 36. Adjusting screw. |

Figure 8-11.—Bendix 29252 regulator.

Chapter 8—AIRCRAFT MOUNTED OXYGEN REGULATORS

emergency oxygen supply. If the inlet pressure to the regulator drops to between 25 and 39 psi, the check valve will close the air port, thus preventing the intake of ambient air. The device is extremely important in the altitude range of 15,000 to 30,000 feet, when the regulator is on dilution. Without this device, and with an inlet pressure of less than 40 psi virtually all of the breathing gas would be ambient air. With an inlet pressure of 40 psi or greater the piston moves up and compresses the check valve spring, which allows the check valve to open and allows normal intake of ambient air.

Automatic Safety Pressure

Automatic safety pressure is accomplished by a safety pressure spring incorporated into the regulator to deliver a maximum of 2 inches of water pressure to the mask from sea level to 35,000 feet. The safety pressure spring exerts pressure on the breathing diaphragm at all times. Upon exhalation, the spring tension must be overcome to close the pilot valve and shut off the flow of oxygen to the user. In this manner safety pressure is maintained in the mask at all times.

Dump Valve

Incorporated in the regulator is a dump valve. The purpose of the dump valve is to aid in exhalation, due to a response lag in the regulator which would ordinarily prevent the demand valve from closing off at the exact moment of exhalation. Such a lag would otherwise result in a pressure built up in the mask breathing hose and regulator. This lag is caused by the length of breathing hose due to the regulator being seat mounted.

During inhalation, the high velocity of oxygen passing through the injector nozzle causes a reduced pressure in the air dilution chamber. This same reduced pressure, which operates the air dilution system, also operates the dump valve. The reduced pressure is sensed from the dilution chamber through the hole in the dump valve seat. It is also sensed through the tiny calibrated hole in the dump valve plate and in the housing chamber where the dump valve spring is located. At the end of an inhalation cycle the dump valve housing is sufficiently evacuated so that when a pressure buildup starts to occur pressure is unbalanced across the dump valve, causing the plate to lift from

its seat. The excess pressure is relieved and the dump valve closes.

Pressure Breathing

Pressure breathing is controlled by an Aneroid that expands as altitude increases. At approximately 35,000 feet the aneroid will expand and the aneroid screw will contact the breathing diaphragm and depress the pilot valve lever. This will cause a pressure drop in the upper demand valve chamber allowing the demand valve to open. The pressure exerted by the aneroid must be overcome during exhalation to close the demand valve. In this manner an increasing pressure is maintained in the mask as altitude increases up to 43,000 feet.

A maximum pressure of 16 ± 2 inches of water pressure is controlled by the maximum pressure spring. The spring is contained within the pressure breathing aneroid. The aneroid contacts the breathing diaphragm by means of the maximum pressure control screw in which the action of the aneroid is nullified by a compression spring. By this action a maximum outlet pressure of 16 ± 2 inches of water pressure is maintained. This action of the spring takes place at approximately 50,000 to 55,000 feet.

Relief Valve

A relief valve is incorporated in the outlet portion of the regulator to prevent excessive pressure buildup in the mask. Whenever pressure in the outlet chamber reaches $24 - 2$ inches of water pressure, the relief valve will unseat and vent the excessive pressure. As the outlet pressure reduces to 15 inches of water pressure, the relief valve will seat and become leak-tight. This prevents a leaking pilot valve or demand valve from building up excessive pressure in the mask.

Booster Operation

The minute flow of oxygen through the pilot valve tends to slightly increase the pressure under the breathing diaphragm. This increased pressure tends to close the pilot valve too soon at flows of 70 to 100 lpm. To counteract this, the excess pressure buildup under the diaphragm is drawn from the sensing line by means of the booster hole located in the air check valve chamber. The pressure acting on the breathing

AIRCREW SURVIVAL EQUIPMENTMAN 1 & C

diaphragm is then reduced, allowing the pilot valve to operate more freely. Due to the location of the booster, adjacent to the injector area, a low pressure area is created, allowing pressure under the breathing diaphragm to escape more readily.

TEST PROCEDURES

All tests are conducted with the regulator in a horizontal plane and the air dilution control down. Tests performed on the test stand are calibration, safety pressure test, aneroid closure test, oxygen ratio test, check valve test, and the pressure breathing test.

Overall Leakage

Place the diluter control to 100 percent and cap the outlet port. Apply 75 psi to the inlet pressure and soap the mating surfaces of the inlet fitting and regulator body. There must not be any evidence of leakage.

Relief Valve

Place the diluter control on normal and cap the inlet port. Apply 16 inches of water pressure at the outlet of the regulator; the maximum allowable leakage is 0.01 lpm. Apply 24 inches of water pressure to the outlet of the regulator; the relief valve must vent 40 lpm at a pressure no greater than 24 inches of water pressure. Decrease the pressure at the outlet to 15 inches of water pressure; there must be no allowable leakage.

Calibration

Mount the regulator in the test stand; place the dilution control in normal, and apply 75 psi inlet pressure and zero flow. Obtain a safety pressure of 1.8 inches of water pressure using shims as necessary. Place the dilution control in 100 percent position and increase the output flow to 70 lpm. Adjust the regulator needle valve to obtain an indication of 0.2 inches of water pressure. Adjust the booster screw to obtain an indication of 0.5 ± 0.1 inches of water pressure. Check the safety pressure test points and make slight adjustments of the bleed and booster screw to obtain final calibration.

Safety Pressure Test

Mount the regulator in the test stand and apply 75 psi inlet pressure, with the dilution

control on normal. Record the pressure suction manometer reading on the performance sheet. Hold zero flow for 5 minutes and record the pressure suction manometer reading on the performance sheet. The pressure suction manometer reading must not exceed 2 inches of water pressure. Maintaining the inlet pressure at 75 psi, record the pressure suction manometer reading on the performance sheet for flows of 70 and 100 lpm at sea level and 34,000 feet. Returning to sea level, place the dilution control on 100 percent and record the pressure suction manometer reading on the performance sheet for flows of 70 and 100 lpm at sea level and 34,000 feet. Decrease the inlet pressure to 40 psi, maintain 34,000 feet altitude, and record the pressure suction manometer reading for flows of 0 to 55 lpm at 34,000 feet and sea level. For flows of 0 to 100 lpm the recorded pressure must not drop below minus 2 inches of water pressure, nor exceed +2.0 inches of water pressure.

Aneroid Closure Test

Place the diluter closure on normal and apply 90 psi inlet pressure. Put the test stand glass on the chamber and open the outlet valve to indicate 40 lpm. The altimeter will stop climbing when the air dilution aneroid has closed. The aneroid must close between 28,000 and 32,000 feet. Record the altimeter reading on the performance sheet.

Oxygen Ratio Test

With the diluter control on normal, apply 75 psi inlet pressure. Open the outlet valve and ascend to the first test altitude on the performance sheet. Adjust the inlet valve for the required test flows. Set the inlet valve to maintain the correct test altitude, and record the input manometer reading on the work sheet for all flows at test altitude. Repeat the above steps for all test altitudes and flows on the oxygen ratio table. NOTE: The bypass valve will have to be opened to climb above aneroid closure altitude.

Pressure Breathing Test

Place the diluter control on normal and apply 75 psi inlet pressure. Adjust the outlet valve to indicate 10 lpm. Open the bypass valve and ascend to the first test altitude. Record the pressure suction manometer reading; the reading must fall between minimum and maximum on the positive pressure table.

Maintenance

Some of the more common malfunctions that may occur in the Bendix 29252 regulator and the procedures to follow to remedy these malfunctions can be found in table 8-5.

For further information on the Bendix 29252 seat mounted regulator, refer to the applicable manufacturer's manual.

MD1 OXYGEN REGULATOR

DESCRIPTION

The (MD-1) regulator is designed for use with pressure type masks to provide the correct oxygen and air mixture in the correct ratio (depending on altitude) and deliver this mixture at the correct oxygen pressure to the mask upon inhalation. With a tight mask and the diluter control lever in the NORMAL OXYGEN position, the regulator provides correct breathing mixtures at altitudes up to 43,000 feet for normal use and for short periods up to 50,000 feet during emergencies. The operating pressure ranges from 50 to 500 psi.

The regulator weighs approximately 2.85 pounds; is 4 7/32 inches long, 5 3/4 inches wide, and 3 inches high; and installs in a mounting panel using conventional Dzus fasteners.

OPERATION

All controls and indicators necessary for indication of performance and control of operation of the MD-1 regulator are placed on an illuminated panel with the regulating components of the unit attached to the mounting plate and controls assembly. General characteristics and performance for which the equipment is designed are illustrated in figure 8-12 and are described as follows: Supply oxygen entering through inlet at (1) is filtered and passed through the manifold inlet assembly into the first stage reduction chamber (3) by the action of inlet supply valve (2). The pressure of the flowing oxygen is registered on the oxygen supply pressure gage. Chamber (3) is provided with the first stage relief valve assembly (4) to protect the regulator against overpressures.

Demand valve assembly (5) is opened when the pressure differential across the demand outer diaphragm (6) forces down the demand valve lever assembly (7). The pressure differential exists during the inhalation cycle of the user by creating a reduction in the pressure

outlet (3). Reductions in pressure at outlet (8) are sensed in the demand diaphragm chamber (9) through sensing port (10).

During periods of flow, the oxygen passes through the venturi assembly (11). At the venturi assembly the flow of oxygen mixes with ambient air which enters the regulator through inlet ports (12). The addition of ambient air to oxygen is controlled by the manual diluter control lever (13) and by the diluter aneroid assembly (14) which automatically produces a 100 percent oxygen concentration at altitudes above 32,000 feet.

Aneroid check valve assembly (15) prevents a flow of oxygen out through inlet ports (12). Emergency pressure control lever (16) applies force to the emergency pressure control test spring (17) which mechanically loads the outer diaphragm (6) through the control lever and center assembly (18). Mechanical loading of the outer diaphragm (6) provides positive pressure at the regulator outlet.

Automatic pressure and pressure breathing at altitudes above 30,000 feet are provided through pneumatic actuation of the aneroid assembly (19). This function begins at near 27,000 feet altitude. The force exerted on the diaphragm assembly (20) by the aneroid assembly actuates the pressure breather valve assembly (21), and oxygen flows to the diaphragm and plate assembly (22). The diaphragm and plate assembly is pressure loaded by this volume of oxygen actuating on the demand valve lever assembly (7) to the extent that positive pressure is built up at outlet (8) as the altitude is increased. Additional safety is obtained through the inclusion of the second stage relief valve assembly (23) in the regulator.

OPERATION INSTRUCTIONS

Every crewmember should know the exact location and use of the regulator at his station. The oxygen mask hose is connected to the coupling end of the breathing hose installed on the outlet of the regulator. The breathing hose clip is then attached to the parachute harness or clothing to permit freedom of motion.

Normal Operation

The following procedure must be followed prior to flights requiring the use of oxygen equipment for breathing. Place the pressure breathing control lever (fig. 8-13) in the SUPPLY ON position. Place the diluter control

AIRCREW SURVIVAL EQUIPMENTMAN 1 & C

Table 8-5.—Common malfunctions in the Bendix 29252 series regulators.

Trouble	Probable cause	Remedy
Overall leakage.	Damaged or improperly installed breathing diaphragm. Improperly positioned plate cover. Loose body screws. Damaged preformed packing on aneroid housing. Damaged preformed packing on outlet tube. Damaged preformed packing on mounting block. Leaking relief valve. Leaking air valve disk. Loose inlet fitting. Damaged inlet fitting O-ring.	Replace or install correctly. Reposition. Tighten. Replace. Replace. Replace. Clean or readjust. Replace or clean. Tighten fitting. Replace O-ring.
Relief valve.	Vents below 16 inches of water pressure. Vents 40 lpm at a pressure greater than 24 inches of water pressure. Excessive leakage at 16 inches of water pressure: a. Damaged relief valve/seat. b. Damaged relief valve disk.	Increase spring tension (clockwise). Decrease spring tension (counterclockwise). Replace seat. Replace disk.
Safety pressure.	Fails 5 minute leakage test (outlet pressure exceeds 2 inches of water pressure in 5 minutes): a. Leak at main valve seat. b. Leak at pilot valve seat. c. Insufficient shims on demand valve. d. Lack of sealing force from pilot valve spring. e. Ruptured breathing diaphragm. f. Expanded aneroid.	Clean or replace. Clean or replace pilot valve seat. Recheck height of main valve (.014±.002 inch above adjacent area of main valve housing). Replace pilot valve spring. Replace breathing diaphragm. Replace breathing diaphragm.
Safety pressure high with zero flow.	Safety pressure spring too strong. Faulty pilot valve seat.	Remove shims or replace spring. Replace seat.

Chapter 8—AIRCRAFT MOUNTED OXYGEN REGULATORS

Table 8-5.—Common malfunctions in the Bendix 29252 series regulators—Continued.

Trouble	Probable cause	Remedy
Safety pressure high at high flow rates.	Venturi too far in housing. Faulty injector nozzle. Booster screw too far out of housing.	Reset venturi. Replace nozzle. Readjust.
Safety pressure low at 70 lpm flow.	Faulty outlet hose or fitting. Safety pressure not set high enough at zero flow. Booster screw too far in housing. Needle valve too far out of housing.	Replace. Reset safety pressure. Reset booster screw. Reset needle valve.
Safety pressure low with 100 lpm flow with air valve in normal position.	Faulty outlet hose or fitting. Inlet filter clogged. Faulty injector nozzle.	Replace hose or fitting. Replace inlet filter. Replace nozzle.
Regulator "chugs" during high flow rates.	Needle valve out of adjustment. Clogged inlet filter.	Readjust needle valve. Replace filter.
Aneroid closure.	Closes below 28,000 feet. Closes above 32,000 feet.	Turn the aneroid assembly counterclockwise. Turn the aneroid assembly clockwise.
Oxygen ratio.	Low air at 10,000 and 15,000 feet. Low air at 20,000 feet. High air at 20,000 feet. Low air at 25,000 and 32,000 feet. High air at 25,000 and 32,000 feet.	Replace injector nozzle. Replace throttling plate screw with one having a shorter shoulder. Replace throttling plate screw with one having a longer shoulder. Adjust the air valve aneroid counterclockwise. Adjust the air valve aneroid clockwise.
Pressure breathing.	Low pressure breathing. High pressure breathing. Erratic pressure breathing reading: a. Faulty pressure breathing aneroid. b. Vent holes in aneroid assembly and aneroid cover not aligned.	Turn adjusting screw counterclockwise. Turn adjusting screw clockwise. Replace aneroid. Realign.

lever in the **NORMAL OXYGEN** position. Connect the oxygen mask hose to the quick connect, place mask to face, and check out function of the mask in the prescribed manner.

While at ground level, the regulator will not normally supply oxygen from the supply system to the mask. The emergency pressure control lever must therefore be used in order to check out the oxygen supply function of the regulator at low altitudes. The emergency control lever is spring loaded in the **TEST MASK** position and will return to **NORMAL** position under typical operating conditions.

Abnormal Operation

Place the diluter control lever in the **100% OXYGEN** position if existence of carbon monoxide or smoke, or other poisonous or irritating gases are suspected in the area. This procedure shuts out the ambient air. This checkout of the regulator may be used at all altitudes.

Emergency Operation

Switch emergency pressure control lever to **EMERGENCY** position when evidences of

AIRCREW SURVIVAL EQUIPMENTMAN 1 & C

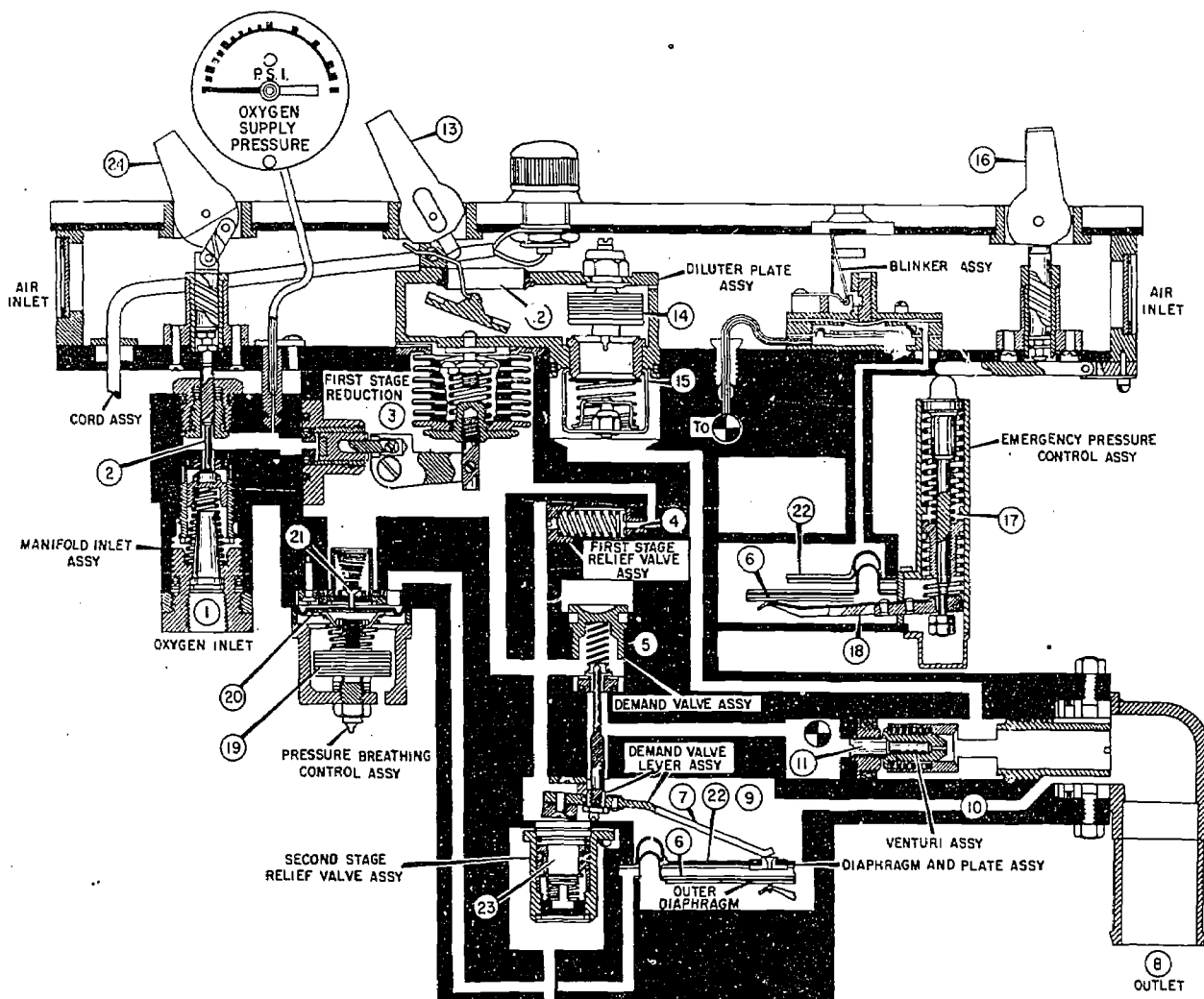

PR.54

- | | | |
|------------------------------|---------------------------------------|---------------------------------|
| 1. Inlet. | 10. Sensing port. | 17. Test spring. |
| 2. Inlet supply valve. | 11. Venturi assembly. | 18. Control lever. |
| 3. Reduction chamber. | 12. Inlet port. | 19. Aneroid. |
| 4. Relief valve. | 13. Diluter control lever. | 20. Diaphragm. |
| 5. Demand valve. | 14. Diluter aneroid. | 21. Pressure breather valve. |
| 6. Diaphragm. | 15. Check valve. | 22. Plate assembly. |
| 7. Demand valve lever. | 16. Emergency pressure control lever. | 23. Relief valve. |
| 8. Outlet. | | 24. Supply valve control lever. |
| 9. Demand diaphragm chamber. | | |

Figure 8-12.--MD-1 regulator operational drawing.

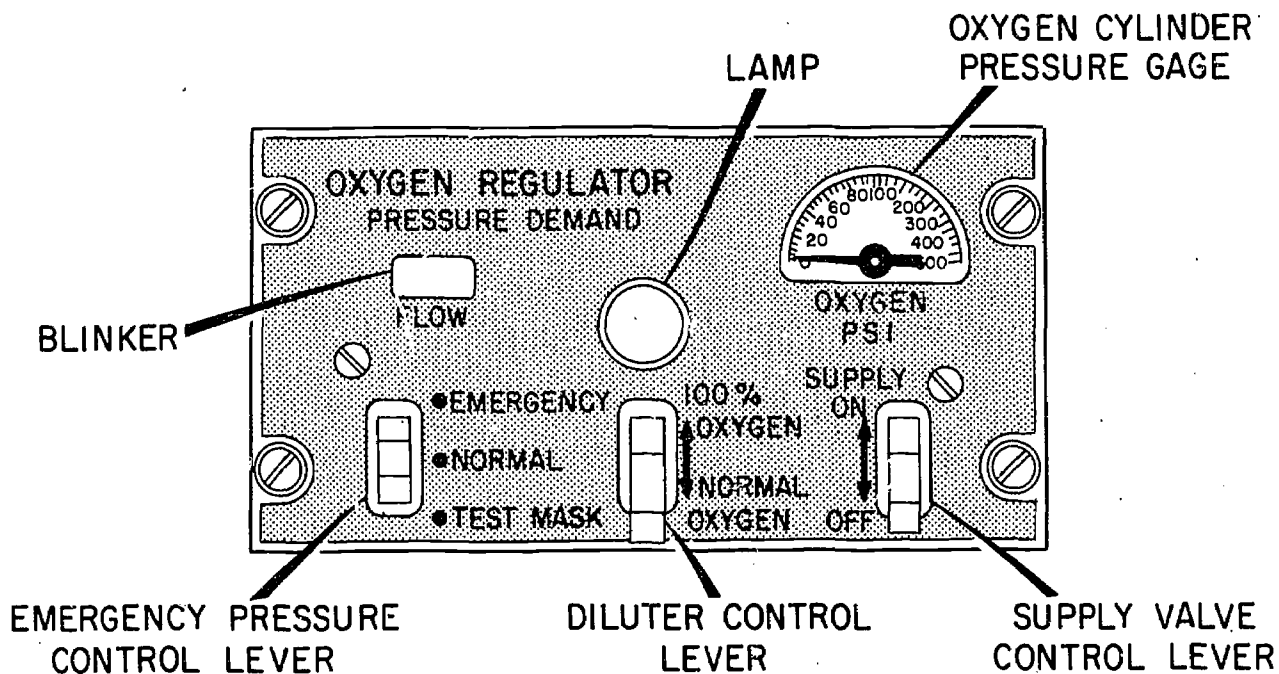

Figure 8-13.—Regulator operating controls and indicators.

PR.55

inadequate oxygen supply are present. When in the EMERGENCY position, the regulator delivers 100 percent oxygen to the user, at a positive safety pressure.

Personnel assigned to perform maintenance operations on the equipment are cautioned to become thoroughly familiar with the functions and physical components of the equipment by a careful and complete study of the information contained in the Overhaul Instructions Manual.

Parts Replacement

If a malfunction in a component part other than the lamp occurs, the regulator should be removed from the aircraft. Replacement of parts is limited to the replacing of a faulty lamp. Do not attempt to repair or replace any other parts of the regulator.

Periodic Inspection

Table 8-6 outlines the various inspections for the regulator.

In-Flight Check

Each crewmember should make a periodic check of the regulator at his station during flight, and report or remedy any of the following as applicable:

1. Any symptoms of lack of oxygen or other illness.
2. Any improper positioning of a control lever.
3. Leaks in any tubing or connections.
4. Low or improper reading on oxygen cylinder.
5. Failure of blinker to indicate FLOW.

Equipment Shutdown

The equipment shutdown is performed as follows:

1. Switch pressure breathing control lever to the SUPPLY OFF position.
2. Remove mask from the face and disconnect oxygen mask hose at the quick disconnect coupling.

AIRCREW SURVIVAL EQUIPMENTMAN 1 & C

Table 8-6. —Periodic inspection of MD-1 regulator.

Component	Nature of inspection	Inspection time
Plastic lighting plate.	Visual check for faulty markings, cracks, or discoloration.	*120 hours.
Lamp.	Visually check electrical performance.	Preflight.
Cord Assembly.	Visually check electrical insulation and contact.	*120 hours.
Outlet.	Visually check for secure attachment and correct positioning.	*120 hours.
Housing.	Visually check for cracks.	*120 hours.
Connecting point and gage reading.	Visually check for indication of leakage.	Preflight.
**Inlet port screen.	Visually check for evidence of dirt and obstruction.	*120 hours.
Panel assembly.	Visually check legibility of markings.	Preflight.
<p>* Or as established in existing directives.</p> <p>**Presence of an unduly large amount of dirt or dust on screens is an indication that regulator should be removed and thoroughly cleaned.</p>		

MAINTENANCE

Maintenance is limited to service, replacement adjustment, and minor repair. Minor repair is confined to that work which can be performed without disassembly, or with partial disassembly of the equipment which does not require the use of specialized shop testing and calibration equipment. Instructions for major repairs and for disassembly requiring the use of specialized shop testing and calibration equipment are covered in the Overhaul Instructions Manual (NA 03-50GDA-502), and such work is performed by specialized overhaul shops engaged in such work.

Minor Repairs

Minor repairs are limited to checking the security of components. Tighten any loose

connections, screws, or bolts. Loose cable connections should be resoldered.

Cleaning

Cleaning of the equipment consists of wiping off the regulator with a clean, dry, lint-free cloth. Make certain that the plastic lighting plate is free of dirt so that legibility of markings and visibility of indicators are not impaired. Pay particular attention to condition of screened inlets in the sides of the regulator housing.

Troubleshooting

Troubleshooting information for the regulator is shown in table 8-7.

Chapter 8—AIRCRAFT MOUNTED OXYGEN REGULATORS

Table 8-7. --Troubleshooting.

Trouble	Probable cause	Correction
Oxygen cylinder pressure gage fails to indicate proper pressure with fully charged pressure source.	Defective gage. Blocked or leaking supply line. Defective manifold inlet assembly.	Replace regulator. Replace or clean supply line to regulator. Replace regulator.
Oxygen not available at mask with proper source to to regulator and other than "emergency" setting on regulator.	Regulator controls improperly positioned. Hose to mask is kinked. Regulator not functioning properly.	Correct position of controls. Straighten hose and reposition outlet. Replace regulator.
Oxygen not available at mask with proper pressure source to regulator and regulator control set at "emergency."	Kink or other malfunction between hose and mask. Faulty linkage from emergency pressure control lever.	Replace or readjust equipment as necessary. Replace Regulator.
Oxygen available at mask but flow is not indicated.	Defective blinker assembly.	Replace Regulator.
Gage pressure drops when regulator is not in use.	Loose or leaking connections. Defective manifold.	Tighten or replace connections as necessary.
Improper mixture of air to oxygen.	Defective regulator.	Replace Regulator.
Panel light fails to light.	Burned out lamp. Faulty light assembly. Faulty electrical hookup to power source.	Replace lamp. Replace Regulator. Repair electrical hookup.

TEST PROCEDURES

The tests contained in this section are to be performed under bench test conditions, utilizing OT-198-1 and OT-201 test stands. Any regulator which fails to meet these tests should be returned to facilities capable of performing overhaul operations on the regulator.

The regulator should be mounted in a horizontal plane in the test stand OT-198-1. When

the pressure and temperature existing at the time of tests are not specified, it should be understood that the test will be made at atmospheric pressure of approximately 29.92 inches of mercury and at a room temperature of approximately 77°F. When tests are made with atmospheric pressure or room temperature differing materially from the above values, proper allowances must be made for the differences from the specified condition except

AIRCREW SURVIVAL EQUIPMENTMAN 1 & C

that all outlet flows must be measured at approximately 77°F and ambient pressure. The inlet pressure should be adjusted to 150 psi during all tests except when otherwise specified.

Emergency Pressure Test

The emergency pressure test is performed as follows:

1. Place the supply lever on the regulator in the ON position.
2. Apply a pressure of 150 psi to the regulator inlet. Note the pressure at the outlet.
3. Place the emergency lever in the EMERGENCY position.
4. Adjust the test stand for a flow of 10 liters per minute from the regulator. The pressure at the outlet of the regulator should be 3.5 ± 0.5 inches of water as indicated by the test stand.
5. Adjust test stand for a flow of 80 liters per minute.
6. Place the diluter lever in the 100% OXYGEN position. The pressure at the outlet should not be less than 2.0 inches of water.
7. Adjust the test stand for a flow of 10 liters per minute.
8. Place the emergency lever in the TEST MASK position. The regulator should deliver an outlet pressure in the range of 6 to 16 inches of water as indicated by the test stand.

Flow Suction Test

Place the supply lever in the ON position. Adjust inlet pressures to the regulator as specified in table 8-8. The flows indicated in table 8-8 must be drawn from the regulator. Set the diluter lever on the regulator successively at NORMAL OXYGEN and 100%

Table 8-8. —Suction flow characteristics.

Inlet pressure psi	Outlet Flow (Liters per minute)	Maximum Outlet Suction Inches of Water
50	30	0.45
50	50	0.70
150	90	1.00

OXYGEN. At ground level with either increasing or decreasing flows, the suction required to produce the flows given in table 8-9 should not exceed the suction values given. After suction is reduced to zero, the flows should not exceed 0.01 liter per minute.

NOTE: All measurements of the outlet suction pressure must be made directly at the outlet of the regulator.

Safety Pressure and Pressure Breathing Test

This test is performed as follows:

1. Place the supply lever in the ON position.
2. Adjust inlet pressure to the regulator at 150 psi.
3. Place the diluter lever in the NORMAL OXYGEN position.
4. At the delivery pressures specified in column 1 of table 8-9 (corresponding to a particular flow) the regulator should be within the altitude range specified in column 2 of the table.

Oxygen Ratio Test

The oxygen ratio test is performed as follows:

1. Place the supply lever in the ON position.
2. Adjust inlet pressure to the regulator at 150 psi.
3. Place diluter lever in the NORMAL OXYGEN position.
4. The ratio (by volume) of cylinder oxygen delivered to the total gas delivered by the regulator at various altitudes should be as specified in table 8-10.

Outward Leak Test

The outward leak test is performed as follows:

1. Place the supply lever in the OFF position.
2. Apply a pressure of 17 inches of water to the regulator outlet through a flow measuring device. This 17 inches of water pressure should be maintained, and the flow necessary to maintain this pressure must not exceed 0.12 liter per minute. During this test the relief valve must not be covered since the allowable leakage through this valve at 17 inches of water is included in the given leakage value of 0.12 liter per minute.

Outlet Leakage Test

Perform the outlet leakage test as follows:

1. Place the supply lever in the ON position.
2. Adjust inlet pressure to the regulator at 150 psi.

Table 8-9. --Safety pressure and pressure breathing characteristics.

Outlet pressure for 10 liters per minute flow (inches of water)	Altitude range for Column 1 (mm of mercury)	Maximum outlet pressure increase for zero liters per minute (inches of water)	Maximum outlet pressure decrease for indicated flow (inches of water)
1.0	258.0 to 138.0	1.0	0.9 for 70 liters per minute
2.0	236.0 to 134.0	1.3	1.3 for 135 liters per minute
8.5	127.5 to 110.5	1.3	1.3 for 135 liters per minute
15.0	102.1 to 87.3	1.3	1.3 for 135 liters per minute

NOTE: The outlet pressure for the altitude range of 225.6 to 138 mm of mercury must not fall below 0.01 inch of water for a flow of 0 to 10 liters per minute. The outlet pressure for the altitude range of 87.3 to 138 mm of mercury must not fall below 0.01 inch of water for a flow of 0 to 70 liters per minute.

3. Place a film of leak test compound across the outlet fitting of the regulator. The film should not advance more than 1/16 inch in 3 seconds.

4. Repeat the test 3 or 4 times to make certain the bubble is not increasing in size because of the temperature difference inside and outside the regulator.

Flow Indicator Test

Perform the flow indicator test as follows:

1. Place the supply lever in the ON position.
2. Adjust the inlet pressure to the regulator at 150 psi.

3. Place diluter lever in the NORMAL OXYGEN position.

NOTE: At sea level the flow indicator must be fully open at a flow of 20 liters per minute.

4. Place diluter lever in 100% OXYGEN position. (At sea level the flow indicator must be fully open at a flow of 8 liters per minute.)

5. With the test stand adjusted for an altitude sufficient to give 17 inches of water delivery pressure, the flow indicator should be fully open at an ambient flow of 12 liters per minute. When the flow is reduced to zero the flow indicator should close immediately.

Inward Leakage Test

The inward leakage test is performed as follows:

1. Place the supply lever in the OFF position.
2. Place the diluter lever in the 100% OXYGEN position.

3. Connect a flowmeter to the outlet of the regulator.

4. Apply a suction of 10 inches of water to the outlet through the flowmeter. The leakage must be less than 0.2 liter per minute.

Relief Valve Test

The relief valve test is performed as follows:

1. Place the supply lever in the OFF position.
2. Place the diluter lever in the 100% OXYGEN position.

3. Apply a gradually increasing pressure to the outlet of the regulator.

4. The relief valve should vent 45 liters per minute at a pressure not greater than 3.0 inches of mercury. The relief valve must not leak in excess of 0.01 liter per minute at 17 inches of water pressure.

AIRCREW SURVIVAL EQUIPMENTMAN 1 & C

Table 8-10. —Oxygen ratio.

Altitude (feet)	Outlet flow (liters per minute)	Percent cylinder oxygen added.	
		Minimum	Maximum
10,000	15	6	35
10,000	50	6	35
10,000	85	6	35
15,000	5	14	100
15,000	15	14	42
15,000	50	14	42
20,000	15	24	55
20,000	50	24	55
20,000	85	24	65
25,000	5	40	100
25,000	15	40	80
25,000	50	40	80
32,000	85	98	100

CHAPTER 9

MINIATURE TYPE REGULATORS

ROBERT SHAW-FULTON 226-20004 MINIATURE REGULATOR

The type 226-20004 (Series) miniature regulator is mounted on the body for both use in flight and bailout or emergency. It is so designed that with an inlet pressure of 40 to 90 psi, it delivers 100 percent oxygen automatically to the user between the altitudes of 0 to 50,000 feet. The regulator incorporates automatic safety pressure buildup to a maximum of

2 inches of water below 35,000 feet and automatic pressure breathing for altitudes above 35,000 feet. It integrates with the A13-A oxygen breathing mask: The assembly weighs 2.3 ounces and is about 2 5/8 inches in length and 2 5/8 inches in width, including the inlet port.

The 226-20004 regulator consists of a demand actuating paddle, sensing diaphragm, demand valve diaphragm, safety-pressure spring, pressure breathing aneroid, aneroid vent, aneroid chamber, and relief valve, as shown in figure 9-1.

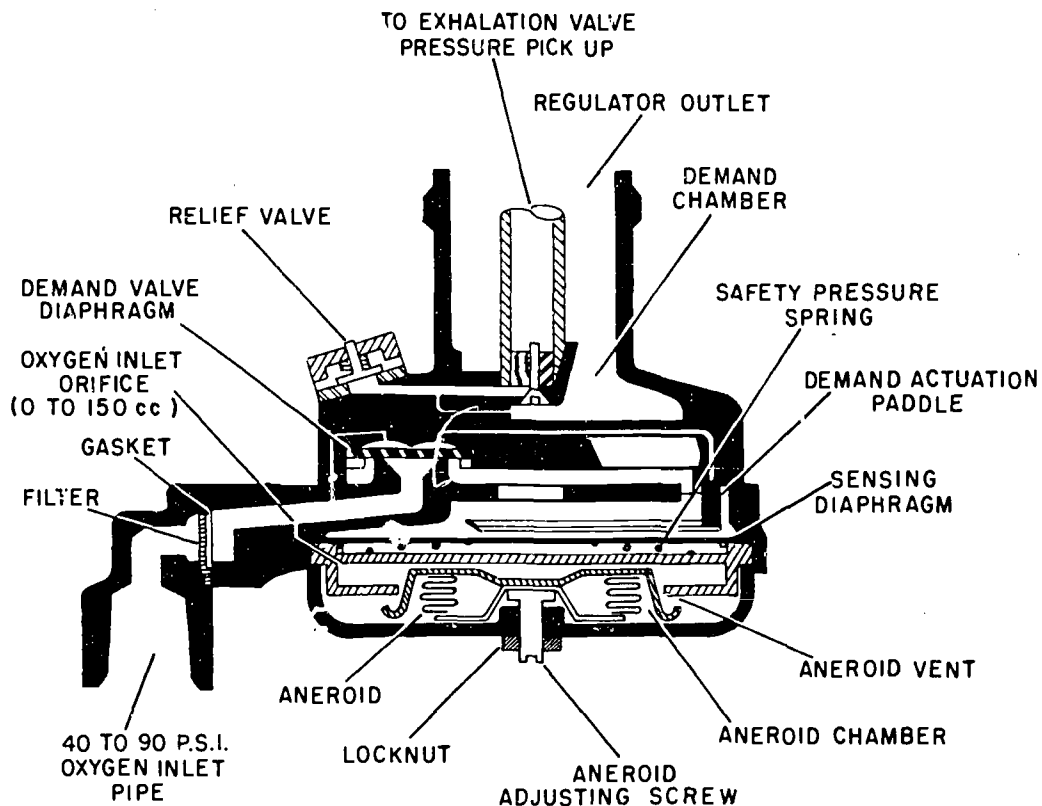

Figure 9-1.—Oxygen regulator 226-20004.

PR.56

AIRCREW SURVIVAL EQUIPMENTMAN 1 & C

OPERATION

Inlet pressure of 40 to 90 psi is directed through the inlet to the demand valve diaphragm. A small passage from the inlet line also directs this pressure to the back side of the demand valve diaphragm; thus, the pressure is balanced on both sides of the diaphragm but the greater area on the back side of the diaphragm provides a positive sealing force.

A second passage from the back side of the diaphragm links this area to the sensing chamber through the pilot valve. Spring tension of the paddle assembly on the pilot valve flap seals the pilot valve, resulting in a static, or no flow condition.

Upon inhalation, a pressure drop is transmitted to the sensing chamber through the sensing port. This will cause the sensing diaphragm to depress the paddle and unseat the pilot valve.

Since the pilot valve is drilled at 0.0135 inch and the inlet orifice is 0.008 inch, oxygen will escape faster than it can be replaced, causing a pressure drop in the area on the back side of the demand valve diaphragm. This will allow the inlet pressure to unseat the demand valve and a flow of oxygen will be directed out the outlet adapter to the user.

Upon exhalation, the pressure is directed through the sensing port forcing the sensing diaphragm away from the demand actuating paddle.

This allows the pilot valve flap to stop the flow of oxygen through the pilot valve. The pressure will once again balance on both sides of the demand valve diaphragm, causing the valve to seat and the flow of oxygen to cease.

Safety Pressure

The safety pressure spring exerts pressure on the sensing diaphragm. This action causes the unseating of the pilot valve and the regulator will flow until enough pressure is exerted on exhalation to overcome the safety pressure spring. Maximum safety pressure is 2 inches. No minimum is indicated but it cannot go negative; an ideal setting for this regulator is 1 inch of water pressure.

Pressure Breathing

A constant bleed of 100 to 150 ccm of oxygen is directed into the aneroid chamber. This

bleed is vented to ambient air through the vent holes in the aneroid cover below pressure breathing altitudes. As altitude increases, the aneroid expands, contacting the aneroid seat, restricting the escape of the bleed.

As pressure builds up in the aneroid chamber, it exerts pressure on the sensing diaphragm which causes the regulator to flow. The regulator will flow until enough pressure is exerted on exhalation to overcome the bleed pressure built up in the aneroid chamber.

Relief Valve

The relief valve is the maximum pressure control device for this regulator. It will unseat at 16 plus or minus 2 inches of water pressure, preventing mask pressures from exceeding that figure.

The relief valve linkage tube is connected to the compensating pickup tube of the exhalation valve by a silicone rubber tube.

A small orifice allows pressure in the demand valve chamber to be sensed in the relief valve. If the pressure exceeds 16 plus or minus 2 inches of water pressure, the relief valve will unseat, relieving the pressure in the linkage tube. This will cause a drop in the linkage tube allowing the exhalation valve to open and relieve the excess pressure in the mask.

NOTE: Excess mask pressure is relieved through the exhalation valve of the mask and not the regulator relief valve.

TESTING THE 226-20004 SERIES REGULATORS

The following tests are used with the 226-20004 series regulators: overload test, demand valve leakage test, body leakage test, automatic safety pressure test, automatic positive pressure breathing test, and maximum pressure control test.

Overload Test

Plug the inlet pipe shown in figure 9-1 and apply a pressure of 25 inches of water to the outlet of the regulator for 2 minutes.

Demand Valve Leakage Test

Apply a pressure of 150 psig to the inlet pipe and maintain a static flow condition at sea level for 5 minutes. After 5 minutes, the regulator

Chapter 9—MINIATURE TYPE REGULATORS

outlet pressure must have exceeded 2 1/2 inches of water.

Body Leakage Test

Plug the inlet pipe and apply a pressure of 11 inches of water to the outlet of the regulator. The leakage must not exceed 20 cc per minute.

Automatic Safety Pressure Test

Connect a piezometer resistor assembly to the outlet of the regulator and apply a pressure of 40 psig to the inlet pipe. A positive pressure maintained by the regulator at a flow of 0 and 70 lpm at sea level must not be less than zero or exceed 2 inches of water.

Increase the inlet pressure to 50 psig. Positive pressure maintained by the regulator at a flow of 0 and 100 lpm at a simulated altitude of sea level, 10,000, and 30,000 feet must not be less than zero or exceed 2 inches of water.

Automatic Positive Pressure Breathing Test

Connect the piezometer resistor assembly to the outlet of the regulator. Apply a pressure of 40 psig and a flow of 10 lpm to the inlet pipe. Vary the simulated altitude from sea level to 43,000 feet. The automatic positive pressure breathing device must take over between 35,000 and 39,000 feet as indicated by the rapid increase in manometer pressure indication.

Increase the simulated altitude to 43,000 feet with the flow remaining at 10 lpm. Record the positive pressure maintained by the regulator. Adjust the flow to 100 lpm and record the positive pressure maintained by the regulator. The pressure must not exceed 12.5 inches of water nor be less than 9.2 inches of water at 43,000 feet.

Repeat the above step, using an inlet pressure of 90 psig.

Maximum Pressure Control Test

Plug the inlet pipe and establish a flow of 200 cc per minute into the outlet of the regulator. The relief valve must maintain pressure at 16 ± 2 inches of water at the regulator outlet. Reduce the flow to 20 cc per minute. The outlet pressure must not drop below 11 inches of water.

NOTE: When the regulator is flowing to atmosphere do not stop the flow suddenly by placing the hand over the outlet.

TROUBLESHOOTING

Troubleshooting information for the 226-20004 (series) oxygen regulator is shown in table 9-1.

CLEANING

Wash all metal parts in oxygen systems cleaning compound (Specification MIL-C-8638 (Wep)). Flush through small diameter holes through parts using polyethylene squeeze bottles containing oxygen systems cleaning compound. Blow dry with dry, water-pumped nitrogen.

INSPECTION

Examine all metal sealing surfaces for nicks, scratches, and foreign material. Examine the inlet filter and remove any foreign substance. Check the noise suppressor screen in the body subassembly and remove any foreign material. The name plate must be examined for condition and legibility.

FIREWEL F2700

The F2700 (Firewel) is a personnel-mounted miniature oxygen breathing regulator used both in flight and bailout or emergency conditions. It is designed to operate on an inlet pressure of 40 to 90 psi, and delivers 100 percent oxygen automatically to the user from the ground up to 50,000 feet. In addition, the regulator incorporates automatic safety pressure buildup to a maximum of 2 inches of water pressure.

OPERATION

The F2700 regulator consists of a tilt type demand valve, a demand diaphragm, pressure-breathing aneroid capsule, orifice bleed assembly, pressure control valve capsule, and relief valve capsule.

Oxygen enters the inlet of the regulator at 40 to 90 psi and flows to the demand valve. This inlet pressure holds the demand valve in the closed position. Oxygen then flows through the orifice bleed assembly and into the pressure control valve. From this valve it enters the aneroid chamber.

AIRCREW SURVIVAL EQUIPMENTMAN 1 & C

Table 9-1. — Troubleshooting information.

Trouble	Probable cause	Remedy
Continual increase of mask pressure below 35,000 feet.	Pilot valve leakage due to improper adjustment of paddle assembly, or to worn or contaminated pilot valve seat or flap.	Adjust paddle assembly, replace pilot valve flap, or replace inlet body subassembly.
	Main valve leakage due to worn or contaminated main valve diaphragm or main valve seat.	Replace main valve or valve body subassembly.
	Expanded aneroid assembly.	Replace aneroid assembly.
Safety pressure exceeds 2 inches of water and holds constant.	Safety pressure spring too strong.	Replace diaphragm spring.
	Inlet filter clogged.	Clean or replace inlet filter.
Regulator outlet pressure becomes negative.	Pilot valve improperly adjusted.	Adjust paddle assembly.
	Safety pressure spring too weak.	Replace diaphragm spring.
	Relief valve spring too strong.	Replace relief valve compression spring.
Relief valve does not relieve at maximum pressure of 18 inches of water.	Relief valve spring too weak.	Replace relief valve compression spring.
Relief valve relieves at less than minimum pressure of 14 inches of water.	Relief valve spring too weak.	Replace relief valve compression spring.
Pressure breathing cuts in below 35,000 feet.	Aneroid improperly adjusted.	Adjust aneroid.
	Aneroid expanded.	Replace aneroid.
Pressure breathing cuts in above 39,000 feet, or mask pressure is less than prescribed.	Aneroid improperly adjusted.	Adjust aneroid.
	Aneroid seat worn or dirty.	Replace aneroid seat.
	Relief valve leakage.	Replace relief valve compression spring.
	Case leakage.	Replace leaking part of body assembly.

Chapter 9—MINIATURE TYPE REGULATORS

When the user inhales, a pressure drop occurs in the demand chamber, and the demand diaphragm moves in the direction of the pressure drop. This causes the diaphragm to contact the demand valve stem and open the demand valve, allowing oxygen to flow to the mask. When the user exhales, pressure builds up in the demand valve chamber, moving the diaphragm away from the demand valve stem, thus allowing the demand valve to close. The inlet pressure again seats the demand valve and shuts off the flow of oxygen to the mask.

A constant flow of oxygen is transmitted from the oxygen source through the inlet bleed orifice, through the pressure control valve to the aneroid chamber, and finally exhausted through the orifice bleed ventholes. As altitude increases, the aneroid expands and restricts the passage of the oxygen into the aneroid chamber. This in turn causes a buildup in pressure in the pressure chamber. Consequently, as the altitude increases, the flow of oxygen through the aneroid chamber is further restricted and the pressure increases. This pressure forces the diaphragm to make contact with the demand valve stem, opening the demand valve. Upon completion of the inhalation cycle, enough pressure must build up in the demand chamber to overcome the pressure in the pressure chamber. In this manner a positive pressure is maintained in the mask at altitudes above 35,000 feet. This pressure is sensed back through the pressure control valve to the bottom side of the exhalation valve.

A relief valve is incorporated in the pressure chamber which is set to unseat between 14 and 18 inches of water pressure; this insures that no greater than 18 inches of water pressure is delivered to the user.

NOTE: Cleaning, inspection, testing, repair and replacement of parts are to be done in accordance with current applicable instructions.

BENCH TESTING F2700 REGULATORS

F2700 regulators must be subjected to the following tests every 60 days:

1. Automatic positive pressure breathing test.
2. Maximum pressure control.
3. Vibratory control.

Instructions for performing the above tests are contained in NavWeaps 13-10FA-1, Handbook, Overhaul Instructions.

NOTE: No regulator should be rejected for failure to meet the specified performance until the OTS 565 test stand is modified by a miniature regulator test stand modification kit, P/N MA-20163.

BENDIX 29211 B-1 AND C-1 MINIATURE REGULATORS

The 29211 B-1 and C-1 oxygen breathing regulators are mounted on the body for use both in flight and in case of emergency. They are so designed that, with an inlet pressure of 40 to 90 psi, they deliver 100 percent oxygen automatically to the user between the altitudes of 0 to 50,000 feet. The regulators incorporate automatic safety pressure buildup to a maximum of 2 inches of water below 35,000 feet and automatic pressure breathing for altitudes above 35,000 feet. They are designed to be integrated with the A13-A oxygen breathing mask. The regulators weigh 3 ounces, and are about 2 1/3 inches in length and 1 33/64 inches in diameter. They are designed to operate between a temperature range of -65°F to 160°F.

The 29211 B-1 miniature regulator consists of a demand valve, demand valve diaphragm, breathing diaphragm, pilot valve, pilot valve lever, safety-pressure spring, evacuated aneroid, and adjustable orifice.

OPERATION

Safety Pressure

The force of the safety-pressure spring (maximum of 2 inches of water pressure) imparts motion of the breathing diaphragm to the pilot lever, opening the pilot valve. When the pilot valve opens, oxygen is bled from the demand valve chamber at a rate faster than the leakage through the orifice; thus causing an imbalance of pressure on the demand diaphragm. This movement of the diaphragm is in the direction of the lowest pressure. This movement causes the opening of the demand valve, and oxygen flows to the mask. The pressure at the outlet is sensed through the sensing line to the breathing diaphragm. When the mask pressure on the demand side of the diaphragm is equal to the safety spring pressure on the aneroid side of the diaphragm, the system is balanced and the pilot and demand valves close. By this action, a safety pressure of a maximum of 2 inches of water is maintained in the oxygen mask up to approximately 35,000 feet.

AIRCREW SURVIVAL EQUIPMENTMAN 1 & C

Inhalation

The pressure at the sensing line is lowered while breathing in, causing the pilot valve to open and oxygen to flow from the demand valve.

Exhalation

The pressure at the sensing line is increased while breathing out, causing the pilot valve to close; thus the pressure becomes equal on both sides of the demand valve diaphragm, causing it to close. Breathing out is accomplished through the A13-A oxygen mask exhalation valves.

Pressure Breathing

The pressure breathing control chamber consists of an aneroid mechanism, preset to begin

expanding at approximately 35,000 feet, and to supply the correct positive pressure in the pressure breathing oxygen mask as ambient conditions change. The evacuated aneroid is calibrated to expand and exert a force on the pilot valve levers. This action supplies oxygen at the positive pressure required for an individual at the various increasing altitudes. The regulator operation in the pressure breathing range is the same as that described under "Safety Pressure." The additional aneroid force causes the required pressure at the outlet of the regulator. The aneroid assembly contains a maximum pressure control spring that is calibrated to compress when the regulator pressure exceeds 18 inches of water or 50,000 feet altitude. Then further expansion of the aneroid does not increase pressure. By this operation, sufficient pressures are maintained in the oxygen mask for pressure breathing altitudes.

CHAPTER 10

OXYGEN COMPONENT TEST STANDS

The Aircrew Survival Equipmentman is responsible for shop testing aircraft oxygen system components, including regulators, liquid oxygen converters, control valves, relief valves, aneroids, and other items. The AME is responsible for checking system components in the aircraft; however, in case of a suspected malfunction and for periodic maintenance testing, the component is removed from the aircraft and brought to the oxygen shop where it is tested by the PR. This testing is accomplished with the use of various types of test equipment, some of which are discussed in this chapter.

REGULATOR TEST STANDS

Regulator test stands are designed for testing oxygen regulators for flow capacities, oxygen concentrations, pressure characteristics, and various leakage tests at different simulated altitudes. This chapter covers the 62-A-116-E1, the OTS-565-566 test stands, and the 59-A-120 Liquid Oxygen Converter Test Stand.

OXYGEN SYSTEM COMPONENTS TEST STAND 62-A-116-E1

The oxygen system component test stand is designed to test and evaluate the functions of miniature regulators, console type and seat mounted regulators, diluter demand regulators, full pressure suit controllers, full pressure suit helmets, emergency oxygen systems, and liquid oxygen converter components.

The test stand consists of an oxygen pressure and vacuum system with valving and instrumentation necessary to measure, test, and evaluate the performance and operating characteristics of the components described at simulated altitudes up to 150,000 feet. Figure 10-1 shows a pictorial view of the 62-A-116-E1 oxygen system components test stand.

Manometers

Mix one part of green manometer fluid concentrate with ten parts of distilled water. Fill the output, input and vent manometer wells to zero. Fill the mercury manometer to zero with triple distilled mercury. Fill the inclined pressure suction manometer to zero with blue fluorlube gage oil. All manometer fluids are supplied with the test stand.

Pump

Check the pump for sufficient amount of lubricant. The 62-A-116-E1 is shipped wired for use with 208/220-volt a.c., 3-phase, 60-Hz (cps) power source. If a 440-volt a.c., 3-phase, 60-Hz power source is to be used, check Nav Air 17-15BC-11 for conversion details. The pump switch must be in the off position before the power plug is connected to a power source. Turn the pump on and run it for at least 30 minutes and check for the following:

1. Check the pump motor drive shaft for proper rotation direction (clockwise, as viewed from back of stand).

2. Recheck the lubricant fluid level in the vacuum pump, and refill if necessary. Use only a lubricant such as cellulube No. 220.

Test Stand Leak Test

The 62-A-116-E1 test stand must be given an oxygen pressure test and an altitude chamber leakage test prior to testing any system components. These two tests are covered in chapter 18 of Aircrew Survival Equipmentman 3 & 2, NavPers 10358-D. The high altitude chamber leakage test is performed monthly.

Vacuum Pump

The vacuum pump lubricant level should be between the indicated marks while the pump is running. To add lubricant, remove the filter from the exhaust port, while the pump is running, and pour fluid into the reservoir. The frequency of vacuum pump lubricant changes is dependent on pump use and pump performance. To change lubricant, refer to NavAir 17-15BC-11 for step by step detail.

Inspect polyethylene tubing, fittings, and connections for pinholes, dirt and dust, bends, kinks, or surface abrasions and heat blister. This is performed on a weekly inspection.

The vacuum pump drive belts and pulley are inspected biweekly to include the following: The tension of the belt, pulley alignment, and excessive belt wear.

Test Stand Inspection

Perform a weekly inspection of gages, manometers, and flowmeters for correct calibration of gages, proper fluid level in manometers, and cleanliness of glass tubes.

An inspection to include the following must be performed monthly:

1. Inspect the oxygen and air inlet connectors for dirt or foreign matter, corrosion, stripped threads, and badly scored surfaces.
2. Inspect gaskets at bulkhead fittings and the vacuum pump filter for deterioration and proper fit and alignment.
3. Inspect copper tubing for corrosion tightness of soldered points.
4. Check altitude chamber for cleanliness, proper fit and alignment of gaskets, leaks or corrosion at pipe fittings, excessive scratches on chamber door, and wear of door gasket.
5. Inspect all control valves for cleanliness and tightness of mounting nuts and knobs. If valves are hard to operate, use a small amount of fluorolube conforming to MIL-H-19457 to the valve shaft.
6. Every 6 months inspect the altitude controller unit for pointer alignment, legibility of nomenclature, and worn or broken gear teeth.

Refer to table 10-1 for the periodic inspection checks applicable to the oxygen system components test stand.

Table 10-2 may be used as an aid in troubleshooting and in diagnosing and correcting various malfunctions of the oxygen components test stand. For additional maintenance details, refer to NavAir 17-15BC-11.

OTS 565 SERIES TEST STAND

The OTS-565-566 test stands are relatively old, and are gradually being replaced throughout the Navy by the 62-A-116-E1 components test stand. However, until their replacement is complete the PR can expect to encounter these older test stands frequently. The operation procedures for the two stands are covered in Aircrew Survival Equipmentman 3 & 2, NavPers 10358-D.

OTS 565 Inspection and Maintenance

The test stand must be inspected every 6 months for the following:

1. Check all rubber tubing connections for signs of wear or cracking.
2. The altimeter must be checked against a master altimeter to make certain it is within tolerance.
3. Inspect the rubber sealing gasket around the chamber. Keep the chamber glass cover clean and free of chips.

LEAK CHECK.—Inspect the stand for leakage daily before running any tests. Evacuate to about 50,000 feet, hold for about 2 minutes, and drop the altitude to 40,000 feet. Close the valves fingertight. Time the rate of altitude loss for 5 minutes or more. The leak rate should not be more than 100 feet per minute.

VALVE REPLACEMENT.—Remove the handle of the valve to be replaced. Remove the entire valve assembly by freeing its hose clamps and pipe clamps. Unscrew the valve from the piping, taking care not to bend or otherwise damage the assembly. Install a new valve, using a suitable thread sealer such as glyptol, maintaining the original orientation of the piping assembly angles. Fit the assembly into the test stand. If the angles of the valve assembly have to be adjusted, again remove the assembly and adjust the angles to make a good fit. Replace all screws and clamps. Check all joints for leakage, tightening where necessary.

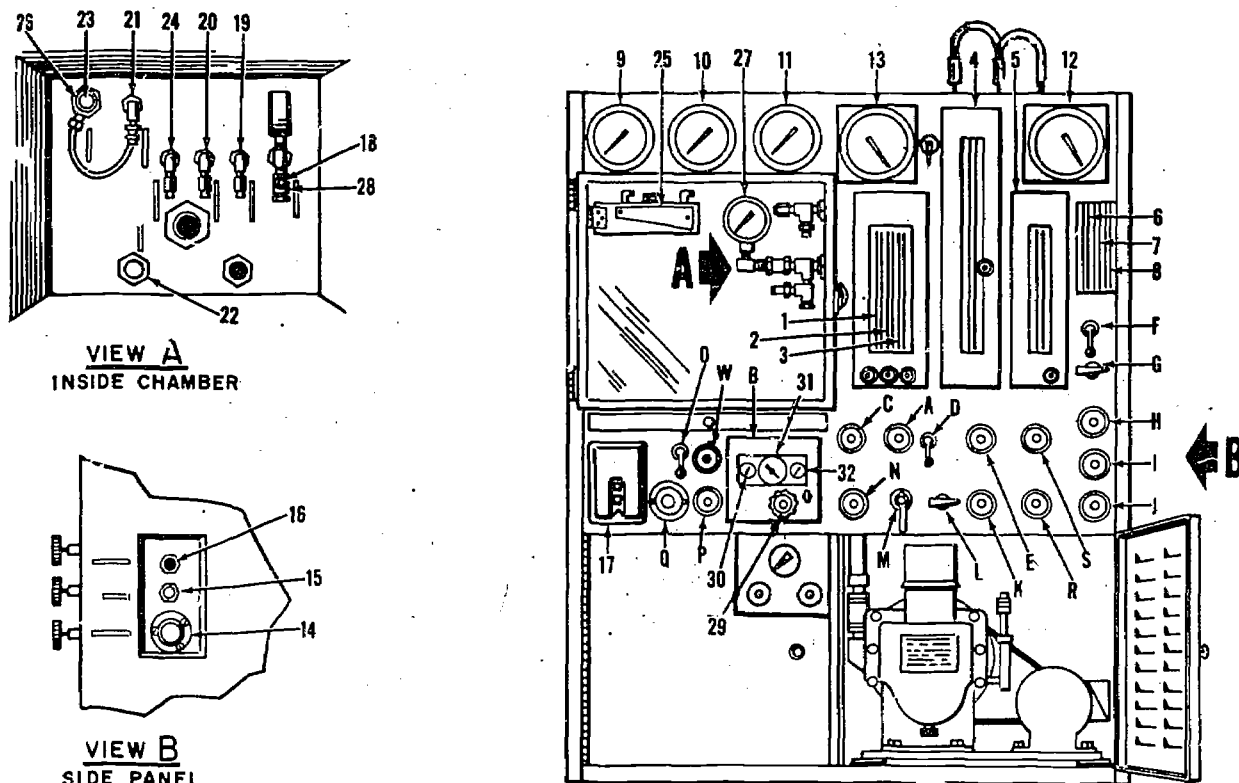

Figure 10-1. — Oxygen Test Stand 62-A-116-E1

PR. 58

Table 10-1. — Periodic inspection.

Nature of inspection	Inspect for	Nature of inspection	Inspect for
Vacuum pump lubricant level.	Correct lubricant fluid level with pump operating.	Copper tubing.	Corrosion; tightness of soldered joints.
Vacuum pump drive belts and pulleys.	Correct belt tension and pulley alignment; excessive belt wear; tightness of pulley set-screws.	High altitude chamber.	Cleanliness; proper fit and alignment of all gaskets; leaks or corrosion at pipe fittings; excessive scratches on chamber door; wear at door gasket.
Polyethylene tubing, fittings and connections; rubber couplings.	Correct fit, pinhole leaks, dirt, or excessive dust; radical bends, kinks, or surface abrasions; heat blisters.	All test stand tubing and piping.	Areas that could cause leakage; tightness and proper alignment.

AIRCREW SURVIVAL EQUIPMENTMAN 1 & C

LEGEND FOR FIGURE 10-1.

- | | | |
|---|--|--|
| A. INPUT Valve | 2. INPUT FLOW Manometer | 19. LOW PRESSURE CONNECTION (Altitude Chamber) |
| B. ALTITUDE CONTROLLER | 3. VENT FLOW Manometer | 20. 200 CC LEAKAGE CONNECTION (Altitude Chamber) |
| C. OUTPUT Valve | 4. PRESSURE SUCTION Manometer | 21. REFERENCE TAP Connection (Altitude Chamber) |
| D. PRESSURE SELECTOR Valve | 5. HG Manometer | 22. INPUT Port (Altitude Chamber) |
| E. LEAKAGE CONTROL Valve | 6. ROTAMETER LEAKAGE Flowmeter | 23. OUTPUT Port (Altitude Chamber) |
| F. LEAKAGE Selector Valve | 7. ROTAMETER LEAKAGE Flowmeter | 24. HELMET REFERENCE TAP Connection (Altitude Chamber) |
| G. LEAKAGE ON-OFF Valve | 8. ROTAMETER LEAKAGE Flowmeter | 25. PRESSURE SUCTION Manometer |
| H. VENT PRESSURE Valve | 9. SUPPLY PRESSURE Gage | 26. Piezometer |
| I. VENT AMBIENT Valve | 10. REGULATED HIGH PRESSURE Gage | 27. O ₂ INPUT PRESSURE Gage |
| J. FLUTTER DAMPENER Valve | 11. REGULATED LOW PRESSURE Gage | 28. Tee Connector |
| K. CHAMBER BLEED Valve | 12. ALTIMETER HIGH RANGE Indicator | 29. Controller Set Knob |
| L. INLET PRESSURE ON-OFF Valve | 13. ALTIMETER LOW RANGE Indicator | 30. Controller Supply Gage |
| M. FLOW SELECTOR Valve | 14. 220/440V INPUT Connector | 31. Controller Altitude Gage |
| N. LOW PRESSURE REGULATOR | 15. O ₂ INPUT Connector | 32. Controller Output Gage |
| O. REFERENCE PRESSURE SELECTOR Valve | 16. O ₂ FILLING Connector | |
| P. CONTROLLER REGULATOR | 17. PUMP CONTROL Switch | |
| Q. HIGH PRESSURE REGULATOR | 18. O ₂ INPUT Connection (Altitude Chamber) | |
| R. SUIT SIMULATOR REFERENCE SHUTOFF Valve | | |
| S. BOTTLE CHARGING Valve | | |
| 1. OUTPUT FLOW Manometer | | |

Table 10-1. -- Periodic inspection--Continued

Nature of inspection	Inspect for	Nature of inspection	Inspect for
Gages and manometers; flowmeters.	Correct calibration of gages; proper fluid level in manometers; cleanliness of manometer and flowmeter tubes.	Electrical plugs, connectors, and wiring.	Various physical damage; bent pins, loose connectors; alinement and security of cables.
Corrosion, dirt, or other foreign matter; stripped threads or scored surfaces.	Oxygen and air inlet connectors.	All panel mounted valves and controls.	Tightness of mounting nuts and knobs; cleanliness; and other physical defects.
Gaskets at bulkhead fittings and vacuum pump filter.	Partial or general deterioration; proper fit and alinement.	Altitude controller unit.	Pointer alinement, legibility of nomenclature; worn or broken gear teeth. (external).

Chapter 10—OXYGEN COMPONENT TEST STANDS

Table 10-2.—Troubleshooting.

Trouble	Probable cause	Remedy
<p>Excessive chatter and/or seizure of the vacuum pump.</p>	<p>Dirt in the cellulube fluid.</p>	<ol style="list-style-type: none"> 1. Remove oil drain cap and drain fluid from pump. Replace oil drain cap. 2. Loosen clamps and slide pipe coupling toward top of tube and fitting assembly. 3. Pour approximately 3 or 4 ounces of No. 220 cellulube lubricant conforming to Military Specification MIL-H-19457, into intake nipple. 4. Operate vacuum pump for approximately 2 minutes. Stop pump. 5. Repeat steps 1, 3, and 4, six times. Pump will now operate satisfactorily without chattering or seizing. 6. Replace pipe coupling between tube and fitting assembly and intake nipple. Secure coupling with clamps.
<p>Failure to obtain or maintain a satisfactory vacuum within the high altitude chamber.</p>	<p>Leakage from loose pump fittings; loose fittings at panel control valves and bulk-head fittings at high altitude chamber.</p> <p>Worn oil case gasket or worn housing seal gasket.</p> <p>Excessive dirt in cellulube fluid.</p>	<p>Correct repair or tighten fittings as necessary.</p> <p>Replace seal as necessary.</p> <ol style="list-style-type: none"> 1. Remove oil drain cap and drain fluid from pump. Replace oil drain cap. 2. Loosen clamps and slide pipe coupling toward top of tube and fitting assembly. 3. Refill pump with approximately 3 pints of No. 220 cellulube lubricant conforming to Military Specification MIL-H-19457. 4. Operate vacuum pump continuously for approximately 8 hours. During this time observe motor and pump units for signs of overheating or other abnormal indications. 5. Repeat steps 1 and 3.

AIRCREW SURVIVAL EQUIPMENTMAN 1 & C

Table 10-2. — Troubleshooting—Continued.

Trouble	Probable cause	Remedy
SUPPLY PRESS. Gage does not indicate zero with no pressure applied or reads improper pressure during operation.	Leakage at fittings or connections. Gage requires calibration or is defective.	Tighten or replace fittings or connections. Calibrate gage. Repair or replace as necessary
REGULATED HIGH PRESS. Gage indicated a pressure when HIGH PRESS. REGULATOR is in the neutral position.	Gage requires calibration or is defective. HIGH PRESS. REGULATOR is defective.	Calibrate gage. Repair or replace as necessary. Repair or replace as necessary.
REGULATED HIGH PRESS. Gage is inaccurate or erratic during operation.	Leakage at fittings or connections. Gage requires calibration or is defective.	Tighten or replace fittings or connections. Calibrate gage. Repair or replace as necessary.
REGULATED LOW PRESS. Gage indicates a pressure when HIGH PRESS. REGULATOR and LOW PRESS. REGULATOR are in the neutral position.	Gage requires calibration or is defective. Regulator (Q or N) is defective.	Calibrate gage. Repair or replace as necessary. Repair or replace as necessary.
REGULATED LOW PRESS. Gage indicates a reading in excess of 175 psi.	Pressure guard out of adjustment or defective.	Adjust, repair, or replace as necessary.
REGULATED LOW PRESS. Gage is inaccurate or erratic during operation.	Leakage at fittings or connections. Gage requires calibration or is defective.	Tighten or replace fittings or connections. Calibrate gage. Repair or replace as necessary.

Chapter 10—OXYGEN COMPONENT TEST STANDS

Table 10-2. —Troubleshooting—Continued

Trouble	Probable cause	Remedy
<p>O₂ INPUT PRESS. Gage indicates a reading when test stand is under pressure with INLET PRESS. On-Off Valve in the OFF position.</p>	<p>Gage requires calibration or is defective.</p> <p>INLET PRESS. On-Off Valve is defective.</p>	<p>Calibrate gage.</p> <p>Repair or replace as necessary.</p> <p>Repair or replace as necessary.</p>
<p>O₂ INPUT PRESS. Gage indicates a reading in excess of 150 psi.</p>	<p>Pressure guard out of adjustment or defective.</p>	<p>Adjust, repair, or replace as necessary.</p>
<p>O₂ INPUT PRESS. Gage is inaccurate or erratic during operation.</p>	<p>Leakage of fittings or connections.</p> <p>Gage requires calibration or is defective.</p>	<p>Tighten or replace fittings or connections.</p> <p>Calibrate gage.</p> <p>Repair or replace as necessary.</p>
<p>ALTM HIGH RANGE Indicator or ALTM LOW RANGE Indicator is inaccurate or erratic during Operation.</p>	<p>Leakage at fittings or connections.</p> <p>Plastic tubing defective.</p> <p>Gage requires calibration, or is defective</p> <p>REF. PRESS. SELECTOR Valve defective.</p>	<p>Tighten or replace fittings or connections.</p> <p>Replace applicable tubing.</p> <p>Calibrate gage.</p> <p>Repair or replace as necessary.</p> <p>Repair or replace as necessary.</p>
<p>OUTPUT FLOW Manometer, INPUT FLOW Manometer, VENT FLOW Manometer, PRESS. SUCTION Manometer, and HG Manometer do not maintain a set reading, when remaining instruments are known to be accurate.</p>	<p>Scale of manometer incorrectly zeroed.</p> <p>Faulty manometer components.</p> <p>Leakage at fittings or connections.</p> <p>Plastic tubing defective.</p>	<p>Zero scale and check accuracy.</p> <p>Add indicating fluid to units as required.</p> <p>Repair or replace as necessary.</p> <p>Tighten or replace fittings or connections.</p> <p>Replace applicable tubing.</p>

AIRCREW SURVIVAL EQUIPMENTMAN 1 & C

Table 10-2. — Troubleshooting—Continued

Trouble	Probable cause	Remedy
ROTAMETER LEAKAGE Flowmeters continually indicate incorrect reading.	Flowmeter requires calibration.	Calibrate.
	Dirty or damaged float or tube.	Clean float and tube.
	Defective flowmeter components.	Repair or replace as necessary.
	Leakage at fittings or connections.	Tighten or replace fittings or connections.
	Plastic tubing defective	Replace applicable tubing.

VOL-O-FLO ELEMENT CLEANING.—Disconnect the Vol-O-Flo element from the tubes which lead to the Vol-O-Flo manometers. Disconnect the flow element from the rest of the plumbing system by removing the hose clamps and rubber tubes at the ends of the element. Before the element is removed, put a directional mark on it so that on reassembly it will be connected the same way as initially. Using about a gallon of water with a teaspoon of detergent, flush the element in reverse from the direction in which air normally goes through it. For this operation, it is well to cap the two pressure taps on the side of the element to avoid spillage of the cleaning fluid.

After the element has been well flushed, the detergent should be rinsed out immediately with clean water. The element should then be replaced in the test stand and air passed through it for about an hour to insure that it is completely dry. After drying the element, the test stand should be leak tested and an intercomparison test performed.

MANOMETER CLEANING.—Remove the glass manometer panel. Disconnect the rubber tubing attached to the pressure-suction manometer and remove the nuts and washers which secure the manometer to the test stand. Remove the manometer.

In order to remove the dual Vol-O-Flo manometer, it is necessary to first remove the manometer elements and piping.

Preparatory to cleaning, drain the manometer by opening the plug at the bottom of the case. Remove the drain plug and remove the overflow check valve at the top of the case. Pass a cylindrical tube cleaning brush soaked in alcohol completely through the tube several times. Rinse with clean alcohol and blow the tube dry, using very dry air or gas. If dry gas is not available, permit the tube to air dry naturally. Do not wipe the inside of the tube, or blow it out with your breath. The overflow check valve should be soaked in alcohol until all dirt and particles are removed.

The well can be cleaned with a brush soaked in alcohol after removing the large cleanout plug on the back of the well. Rinse the well with fresh alcohol and dry as above. Reassemble the manometer and replace on the stand. Refill with King blue oil to the approximate zero level after adjusting the scale to center of adjustment.

INTERCOMPARISON.—The inlet and outlet Vol-O-Flo manometer should be intercompared every 2 weeks. Cap the oxygen supply fitting in the chamber and evacuate the chamber to 5,000 feet. With the bypass valve closed, adjust the flow to each, 5, 50, and 85 lpm, main-

taining the simulated altitude. Record the inlet and outlet indications simultaneously. Repeat this procedure at 15,000 and 30,000 feet. After applying the corrections in the existing calibration charts, the flows should agree to within 2 percent of 1 lpm, whichever is greater. If they differ by more than this for any test point, the manometers should be cleaned as previously described, and recompared. If the agreement is still unsatisfactory, the flow elements should be turned in for recalibration. It is important that these tests be conducted so that the chamber altitude is not changing when readings are taken; also, time should be permitted for the chamber temperature and room temperature to equalize to within approximately 33° F.

Modifications

The OTS-565 must be modified for testing miniature regulators and other oxygen components. Instructions for incorporating the modification are given in NavAir 17-15BC-505 and other applicable publications.

OTS-566 TEST STAND

The OTS-566 test stand is designed for testing diluter demand oxygen regulators under simulated altitude conditions. It was designed especially for use aboard ship, but can be used ashore as well. The OTS-566 incorporates Vol-O-Flo gages instead of manometers; otherwise it is practically identical to the OTS-565. These gages require no fluid, thus the roll of the ship has no effect on the readings.

Calibration Charts

Three copies of the calibration charts are supplied with each test stand. For testing diluter demand regulators, a table of test points (ratio performance chart) can be set up. This table can be computed from the Vol-O-Flo element calibration curves and the performance requirements for the regulator, published in the Service Instruction Manual for the regulator to be tested.

Once a table has been established for a particular regulator, the operator has no need to make any correction to the Vol-O-Flo manometer readings, other than for temperature variation. The calibration curves show that the ambient flow at any indication varies with

gas composition and varies slightly with altitude. The input Vol-O-Flo element calibration depends only on altitude and temperature since only air is passing through the element. Similarly, the output Vol-O-Flo element calibration depends only on altitude and temperature when the regulator is operated with the diluter control turned off, in which case only oxygen is being passed. When the regulator is operated with the diluter control turned on, a variable air-oxygen mixture passes through the output Vol-O-Flo element.

TEMPERATURE CONSIDERATIONS.—On the linear type Vol-O-Flo element, the reading for a given flow is dependent on the gas (air, oxygen, or mixture), altitude, pressure, and temperature. The Vol-O-Flo elements are calibrated at the factory at a specified temperature, usually 72° F. If the test stand is operated in the temperature range of 65° to 80° F, temperature corrections may usually be neglected.

If greater accuracy is required or if the test stand is used at temperatures outside this temperature range, a temperature correction may be applied as follows: Determine the temperature for which the test stand was calibrated. If the test stand was calibrated against a field standard calibrator, the temperature of calibration is that for which the field standard correction curves were made. For each degree Fahrenheit the test stand is operating above the calibration temperature, the reading will be too high by 0.15 percent. For each degree Fahrenheit below the calibration temperature, the Vol-O-Flo manometer reading will be 0.15 percent too low. These temperature corrections are in addition to and independent of corrections for altitude or gas mixture.

LIQUID OXYGEN CONVERTER TEST STAND 59-A-120

Liquid oxygen converters are designed to store oxygen in the liquid state and deliver gaseous oxygen to the user in the correct breathing temperature as required. In order to do this each converter must be in reliable working condition.

The converter test stand is designed to test the various functions of the converter to insure its reliability by providing a means of

AIRCREW SURVIVAL EQUIPMENTMAN 1 & C

periodic maintenance tests and adjustments. All instruments, mechanisms, and equipment of the stand are capable of operating accurately when subjected to the normal pitch and roll of a ship.

DESCRIPTION

The test stand is composed of a differential pressure gage, three other pressure gages, four linear flow elements, a liquid oxygen quantity gage capacitor type tester, a flowmeter indicator, a bell jar, a heat exchanger, the required test adapters and connection hoses, and the necessary integral piping, wiring, hoses, and valves. Figure 10-2 shows the Liquid Oxygen Converter Test Stand 59-A-120.

PRINCIPLES OF OPERATION

The test stand tests liquid oxygen converter components and accessories for leaks, flow settings, and quantity gaging. Two low-range linear flow elements are provided for checking accessories and components for leakage. Two higher range linear flow elements are provided for making rate-of-flow tests. A 0- to 10-inch water gage is used in conjunction with the linear flow elements. A pressure gage with a 0- to a 15- and a 0- to a 165-psig range is provided for making pressure checks. The differential pressure gage included is an extremely sensitive pressure-differential indicating device which operates on the bellows principle with a range of 0 to 100 inches of water.

MAINTENANCE AND INSPECTION

Periodic inspection and preventive maintenance should be correlated with the periodic inspections tabulated in table 10-3.

Cleaning

All external parts of the test stand are cleaned by using a vapor degreasing method, with stabilized trichloroethylene in conformance with Specification MIL-T-7003. Clean the dial glasses with a soft cloth. Clean the test adapters and test connection hoses supplied in the accessory tray. Clean the terminals of the liquid oxygen quantity gage capacitor type tester. Be

sure that all parts of the test stand are completely free from oils and grease, or any other material that is not approved for use in the presence of high-pressure oxygen.

The bell jar sealing O-ring must be cleaned with a solution of distilled water and Rohm and Haas Triton X-100.

NOTE: Never apply oil, grease, or any other material that is not approved for use in the presence of high-pressure oxygen to any part of this stand at any time.

Table 10-3. -- Periodic inspection chart.

Inspection	Daily	Weekly	Monthly
Leak Test.		X	X
Test Pressure Gage (PG-1) Zero.	X	X	X
Low Pressure Test Gage (PG-4) Zero.	X	X	X
Differential Pressure Gage (DF-1) Zero.	X	X	X
Pressure Regulator Valve (R-1) Setting.		X	X
Bell Jar Pressure Relief Valve (V-3) Setting.			X
Test Pressure Gage (PG-1) Calibration.			X
Low Pressure Gage (PG-4) Calibration.			X
Differential Pressure Gage (DF-1) Calibration.			X
Flowmeter Indicator (PG-2) Zero.	X	X	X
Linear Flow Element (FLM-1, 2, 3, and 4) Reading Test.			X
Linear Flow Element (FLM-1, 2, 3, and 4) Calibration.			X

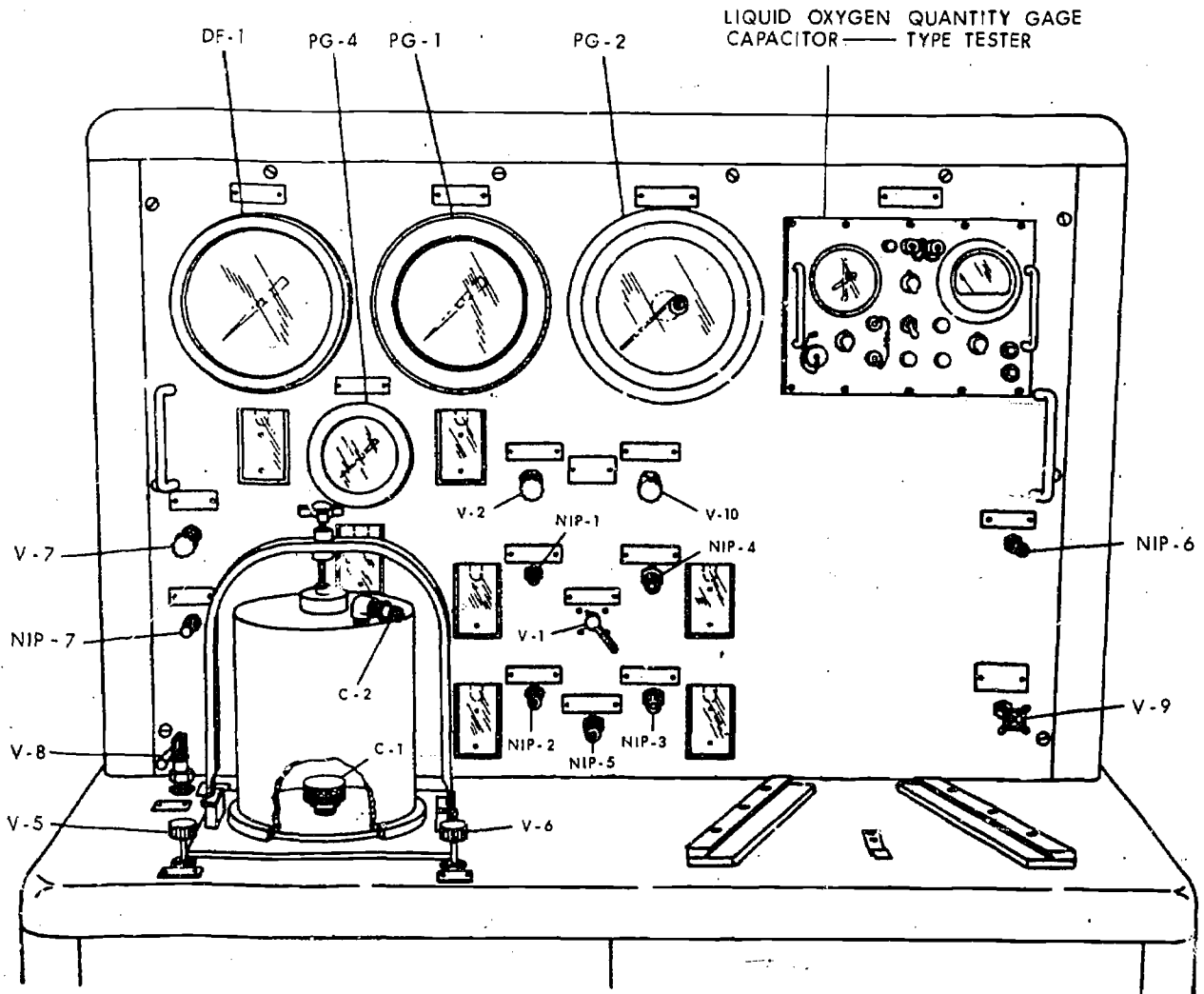

Designator	Item	Designator	Item
C-1	Bell jar bottom coupling.	PG-2	Flowmeter indicator gage.
C-2	Bell jar top coupling.	PG-4	0-15 psig low pressure test gage.
DF-1	0-100" H ₂ O differential pressure gage.	V-1	Flowmeter selector valve.
NIP-1	0-0.25 lpm flowmeter connection.	V-2	Test pressure gage to bell jar valve.
NIP-2	0-1 lpm flowmeter connection.	V-5	System bleed valve.
NIP-3	0 - 50 lpm flowmeter connection.	V-6	Oxygen supply valve.
NIP-4	0 - 100 lpm flowmeter connection.	V-7	Differential pressure bleed valve.
NIP-5	Converter supply outlet connection.	V-8	Differential pressure shut-off valve.
NIP-6	Supply to converter connection.	V-9	Converter supply flow control valve.
NIP-7	Differential pressure gage connection.	V-10	Test pressure gage buildup and flow valve.
PG-1	0-160 psig test pressure gage.		

Figure 10-2. --Liquid Oxygen Converter Test Stand 59-A-120.

PR. 59

CHAPTER II

LIQUID OXYGEN CONVERTERS

Most naval combat aircraft are equipped with liquid oxygen (LOX) systems. A component of this system is the converter which the PR will be responsible for testing and checking. The AME is responsible for the general maintenance and servicing of the converter as well as removing it from the aircraft and delivering it to the PR for testing. Electrically operated quantity indicating system components are maintained by the personnel of the AE rating.

AIRCRAFT CONVERTERS

The aircraft liquid oxygen converter is a portable, stainless steel, double walled, thermos style vessel, with an annular space having a partial vacuum. The annular space is evacuated to 1/10 of 1 micron. The container is used for the storage of liquid oxygen prior to the liquid-to-gas conversion. The components necessary for conversion and control of the liquid oxygen are included as part of the converter. Most LOX converters are similar to the one shown in figure 11-1.

Aircraft converters are made in various sizes, the size being determined by the capacity of the converter in liters. The most common size is the 10-liter capacity converter.

COMPONENTS

The components necessary for the storage, conversion, and control of liquid oxygen are assembled as a unit, and the unit is commonly referred to as the converter. Included in the assembly are the container and the following components: combination valve, (filler valve, buildup and vent, and one relief valve), pressure closing and opening valve, check valve, and two quick-disconnect couplings. The electrical receptacles for the quantity indicating system and a carrying handle are provided on the container.

Container

The container consists of an inner and outer shell of stainless steel, separated by a vacuum.

A blowout disk in the outer shell of the container minimizes danger to personnel if excessive pressure builds up as a result of a liquid oxygen leakage. Liquid oxygen leaking from the inner shell into the vacuum area expands at a ratio of 1 to 862. Excessive pressure on the outer shell will burst the blowout disk before the shell itself can burst.

Filler Valve

The filler valve used in most liquid oxygen systems is a combination filler, buildup and vent valve. The filler portion of the valve is essentially a spring loaded check valve, designed along with the servicing equipment to form a liquid tight seal during the filling operation, and forming a gastight seal when the servicing hose is removed. A removable cap keeps out dirt and dust.

Pressure Control Valves

The pressure control valve used in most converters is a combination pressure control valve which consists of two valves internally connected in a single housing. These two valves, the pressure closing and pressure opening, are both controlled by spring loaded bellows which are vented to the atmosphere. The pressure closing valve is spring loaded to the open position, and the pressure opening valve is spring loaded to the closed position.

The pressure closing valve maintains operating pressure within the converter by closing at a predetermined pressure level to terminate the buildup sequence of the converter operation. When there is no demand for oxygen, normal heat exchange causes a gradual rise of pressure in the converter until, at a pressure slightly higher than the operating pressure, the pressure opening valve opens and allows gaseous oxygen to be supplied on demand through the pressure-opening valve to the supply line.

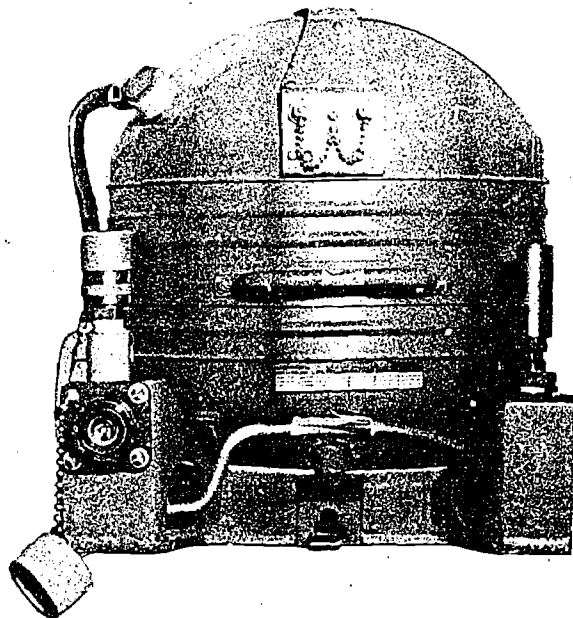

PR.60
Figure 11-1.—The 29044-1-A1A Liquid Oxygen Converter.

Relief Valves

A relief valve in the converter system provides for relief of excess system pressure. The valve is set to relieve at a given pressure and to reseal at a given pressure. The relief valve in most LOX systems is set to open at 110 psi.

The valve is spring loaded to the closed position. The relief valve provides for pressure relief of the container when removed from the oxygen system and protects the entire oxygen system when installed and connected in the aircraft.

Because of heat transfer in the system, approximately 1 liter of liquid oxygen will be lost overboard through this valve during a 24-hour period when the system is not in use.

Quick-Disconnect Couplings

Quick-disconnect couplings are provided for the rapid and positive couplings of the oxygen lines. The fixed (male) half of the coupling is mounted on the container and the disconnect

(female) half is attached to a flexible oxygen supply and vent line.

The coupling for the supply line contains a spring loaded check valve in each half. These check valves close automatically when the coupling halves are disengaged. The vent coupling has no check valves; however, it forms a positive seal for the vent line so that excessive system pressures will be vented overboard.

Heat Exchanger

The purpose of the heat exchanger is to raise the temperature of the evaporated liquid oxygen in order to insure that the pilot will suffer no ill effects from consuming oxygen at extremely low temperatures.

Heat exchangers are made of aluminum alloy sheet, with a winding passage running through the center to allow oxygen flow. The warmed gaseous oxygen flows from the heat exchanger to the shutoff valves and to the flight crew's regulators.

OPERATION OF THE CONVERTER

When filling the converter, the buildup and vent valve must be in the vent position. The combination valves will automatically be placed on vent upon connection of the filler hose to the filler valve. The LOX under pressure flows through the filler valve and into the bottom of the converter. As the LOX rises in the converter, gaseous oxygen, caused by boiloff within the system, is vented overboard. The converter is full when liquid flows from the overboard vent in a steady stream. The filling time must be in accordance with the applicable converter manual.

System Buildup

After the filler hose has been disconnected, the buildup and vent valve will be placed in the buildup position. On systems with combination valves, the system is automatically placed on buildup as the filler valve is disconnected. Gas pressure on top of the LOX forces the liquid into the buildup coil. The transfer of LOX through the coil allows the liquid to warm up and gasify. The gas then passes through the pressure closing valve and buildup and vent valve into the top of the converter. This cycle continues until the normal operating pressure of the converter is attained and the pressure closing valve closes.

AIRCREW SURVIVAL EQUIPMENTMAN 1 & C

Buildup time is in accordance with the applicable converter manual.

Normal Operation

The user inhales, which creates a pressure drop in the supply line up to the differential check valve. The check valve unseats because of greater pressure on the liquid phase than on the supply line phase, allowing LOX to flow into the supply line, where it almost immediately turns to a gas. Pressure then builds up in the supply line because of expansion of the gaseous oxygen, closing the check valve.

In a standby condition, if no demand is made on the system, pressure will build up throughout the system. This will cause the closing valve to close at approximately 75 psi. As the system pressure continues to build up to 80 psi, the pressure opening valve will open and place the gas side or top of the converter open to the supply line. With no demand being made to the system, pressure will continue to build up until the low pressure relief valve relieves at the required pressure as stated in the converter manual.

If for some reason the pressure relief valve located on the converter fails to operate, the pressure relief valve located in the system, usually in the cockpit, will relieve excess pressure. As the user inhales, oxygen is drawn off the top of the converter and the supply line, and pressure holds the liquid check valve closed. Additional oxygen demand reduces pressure down to approximately 80 psi, where the pressure opening valve closes. Continued demand reduces the pressure in the supply line until a 5 psi differential exists between the supply line and the converter. The differential check valve then opens, allowing LOX to flow from the liquid side of the converter into the supply line, and the system reverts to normal operation.

TESTING THE 29044-1-A1A LIQUID OXYGEN CONVERTER

LOX converters are tested by the use of the Liquid Oxygen Converter test stand 59A120 or 31 TB 1995. NavWeps 17-15BC-12 and NavWeps 17-15BC-8 contains operation, maintenance, lubrication, and periodic inspection instructions for the test stand. They also contain instructions for testing various types of liquid oxygen converters such as the Bendix-Pioneer-Central, Aero and Linde converters.

The tests for the 29044-1-A1A include the check valve flow leakage test, the check valve flow test, the check valve leakage test, the relief valve leakage test, the relief valve capacity test, the buildup valve vent port leakage test, and testing for proper setting of the pressure closing and pressure opening valve.

Check Valve Flow Leakage Test

Operate the check valve assembly through one cycle, increasing the pressure from 4 to 7 psi gage and returning it to 4 psi gage. At the completion of the cycle, the leakage at 4 psi gage should not exceed 0.03 liter per minute.

Check Valve Flow Test

At a flow rate of 5 liters per minute gaseous oxygen, the inlet pressure should not exceed 7 psi gage. (This test can be made by adjusting the inlet pressure to 7 psi, in which case the flow should be at least 5 liters per minute.)

Check Valve Leakage Test

Apply a pressure of 10 psi gage to the outlet port of the check valve. The leakage in the checked direction should not exceed 0.03 liter per minute of gaseous oxygen. If the leakage is greater than 0.03 liter per minute, the O-ring packing and preformed packing of the check valve must be replaced. The check valve must then be reassembled and retested.

Relief Valve Leakage Test

Operate the relief valve assembly through one cycle, increasing the pressure from 100 to 120 psi gage and returning it to 100 psi gage. At the completion of the cycle, the leakage at 100 psi gage should not exceed 0.03 liter per minute.

Relief Valve Capacity Test

Using the liquid oxygen converter components and accessories test stand 59A120, apply a pressure of 120 psi gage to the relief valve assembly. Measure the capacity of the valve with a rotometer. The valve should be capable of passing at least 100 liters per minute.

Buildup Valve Vent Port Leakage Test

Set the filler, buildup, vent and relief valve assembly in the buildup position and plug the gas port. Apply a pressure of 100 psi gage to the buildup port. The combined leakage around the filler head and through the vent port should not exceed 0.07 liter per minute.

Setting the Opening and Pressure Closing Valve to Operating Pressure

Make certain the pressure opening and pressure closing valve inlet and outlet are correctly positioned. The pressure closing valve setting should be 75 psi gage. Set the pressure closing valve in accordance with figure 11-2 and proceed as follows:

Close the bleed valve V-5 and supply valve V-6, then open supply valve V-6 to obtain a slow

increase of pressure as indicated on the 160 psi supply gage. The pressure, as indicated by the supply gage when the pointer of the differential gage starts to move off zero, is the closing pressure of the valve. Turning the spring adjusting screw clockwise on the Pressure Closing and Pressure Opening Valve Assembly will increase the closing pressure of the valve. Release the pressure by opening the bleed valve.

The pressure opening valve setting should be 80 psi gage. To set the pressure opening valve, a minimum pressure of 77 psi gage should be maintained from supply when supply valve V-6 is opened. Increase the pressure through valve V-6 slowly. The pressure, indicated on the supply gage when the pointer of the differential gage starts to move toward zero, is the opening pressure of the valve. Turning the spring adjusting screw counterclockwise decreases the opening pressure. Release the pressure by opening the bleed valve. Recalibrate

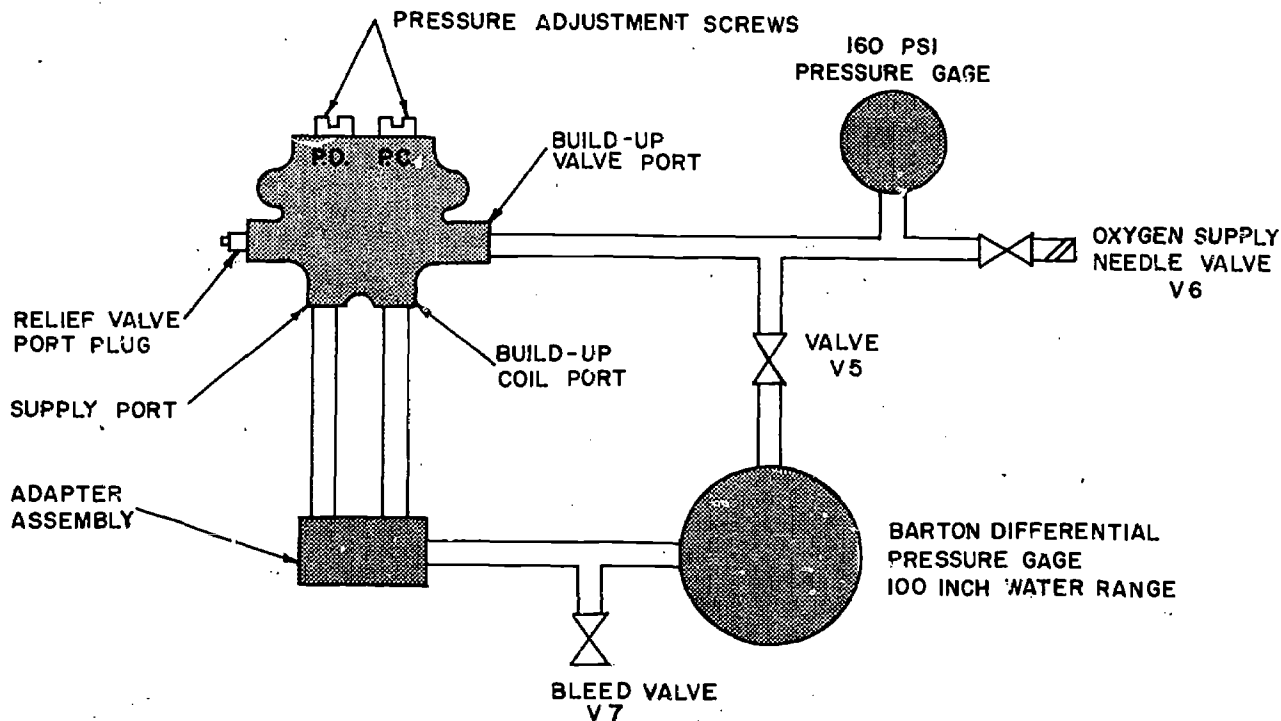

Figure 11-2.—Setting pressure opening and pressure closing valve assembly to operating pressure.

PR.61

the pressure opening valve for 80 psi. Upon inspection, the valve should open at 80 ± 1 psi gage.

Test Specifications

Unless otherwise specified, perform all tests at an atmospheric pressure of between 28.92 and 30.92 inches of mercury, and at a temperature of between 72° F and 82° F. When tests are made with values differing from those specified, make allowance for the differences in specified conditions.

Nitrogen used in testing the converter should conform to Military Specification MIL-N-6011. Oxygen used in testing the converter should conform to Specification BB-0-925, Grade A, Type 1.

PURGING THE CONVERTER

Purging is a procedure used to flush the contents from LOX converters in conformance with the Maintenance Requirement Cards during applicable aircraft check cycles, as soon as possible after a report of in-flight odors by pilots or aircrew, and when tests show presence of odor. Purging is accomplished by using hot, dry, gaseous nitrogen, water pumped, with the gas temperature preferably 122° C (250° F) conforming to Federal specification BB-N-411.

Empty the converter and if time permits allow the system to warm up to ambient temperature; this will conserve large quantities of purge gas. Connect a source of dry gaseous nitrogen to the oxygen system using the filler valve adapter. Connect the heating unit between the nitrogen and the converter and pass hot nitrogen through the system at 10 to 50 psi, preferably 30 psi for a minimum of 2 hours. Exit gas should be over 100° F or in accordance with purging equipment instructions before concluding the purge.

Stop the nitrogen flow, disconnect the source, and place the buildup and vent valve in the buildup position. Fill the system immediately with LOX.

Continue passing LOX through the system after it has been filled and collect a liquid sample to be tested for odor. Pour approximately 200 milliliters into a clean 400-ml beaker or similar container after covering the bottom of the beaker with a clean, dry filter paper or other absorbent paper. (A milliliter, abbreviated ml, represents the same volumetric capacity as a cubic centimeter.) Provide a watchglass cover or some other means of partially covering the top of the

beaker as the 200 ml of liquid evaporates to dryness. This will prevent atmospheric constituents from being absorbed by the exposed liquid. Permit the liquid to evaporate to dryness and warm up to approximately room temperature in an area free from air currents or extraneous odors.

When the liquid has completely evaporated, the watchglass can be removed and the beaker contents smelled at frequent intervals until the accumulated frost on the outside of the beaker has completely melted. Odors, if present, will be most prevalent when the beaker has warmed to nearly room temperature.

If odors are detected in the converter, purge the system again and continue testing to discover the source and extent of contamination. For example, if an aircraft converter contains unacceptable oxygen, test the contents of the supplying trailer. If odors persist, arrange for the equipment to be cleaned at a Naval Air Rework Facility.

Table 11-1 contains the use limits as applicable to converters in service. Except in an emergency, local commands at deployed activities must use the following guides for determining the use of LOX which does not conform to the normal use limits:

1. The risk on use is minor if CO₂, halogenated Freons, and solvents do not exceed 3 times the use limits.
2. LOX is not recommended for use when any of the following apply:
 - a. Methane (CH₄) exceeds 50 ppm.
 - b. Acetylene exceeds 0.10 ppm.
 - c. Ethylene exceeds 0.40 ppm.

DRAINING THE CONVERTER

To drain a converter with a manual buildup and vent valve place the buildup and vent valve in the vent position. Place the filler hose connection on the filler valve and the buildup and vent valve in the buildup position. Pressure will build up in the converter and force the liquid out through the filler valve. Do not drain the LOX on the ground; provide a suitable metal container. On systems utilizing an automatic filler buildup and vent valve, connect a capped filler adapter to the filler valve. This places the system in the vent position. Remove the capped off tubing from the rear of the converter, tip the converter, and allow the liquid to run out. To remove the remaining liquid, remove the filler adapter and allow the system

Chapter 11—LIQUID OXYGEN CONVERTERS

Table 11-1.—Use limits of aviators breathing oxygen.

Contaminant or descriptive condition and unit of measurement	Allowable limit
Odor	Shall contain no odor
Purity (% by volume)	99.5 (min.)
Carbon Dioxide (ppm by volume)	10 (max.) @ 70° F*
Methane (ppm by volume)	50 (max.) @ 70° F*
Acetylene (ppm by volume)	0.1 (max.) @ 70° F
Ethylene (ppm by volume)	0.4 (max.) @ 70° F
Ethane and other hydrocarbons (ppm by volume)	6 (max.) @ 70° F
Halogenated compounds: Refrigerants (freons, etc.) (ppm by volume)	2 (max.) @ 70° F
Solvents (trichloroethylene, carbon tetrachloride, etc.) (ppm by volume)	.02 (max.) @ 70° F
Water (ppm by volume)	14 (max.) @ 70° F

*70° F and 760 MM pressure.

to pressurize. This will remove any remaining liquid in the converter.

SAFETY PRECAUTIONS

Safety precautions to be observed in handling LOX are as follows:

1. Keep work area, tools, clothing, and equipment free of oil and grease.
2. When handling LOX, wear goggles or a face shield, gloves, high top safety shoes and an apron of asbestos, leather, rubber or plastic.
3. Do not smoke, or use open flames near LOX.
4. In the event that the liquid oxygen is spilled on clothing, the clothing should be removed immediately. If liquid oxygen comes in contact with the body and there is a reason to suspect that some part of the body has been frozen or severely chilled, thoroughly wash the area with clean water and seek immediate medical treatment.
5. Do not leave liquid oxygen in a closed container or trapped in a line between two valves. Open a valve on one end to avoid excessive pressure buildup.
6. Spillage of liquid oxygen on floors or deck areas should be avoided. In case of accidental spillage, the area should be thoroughly ventilated.
7. Only qualified, or authorized personnel being trained and under supervision, will operate liquid oxygen equipment.
8. Have a cold water hose available while handling liquid oxygen.

TROUBLESHOOTING

Refer to table 11-2 for possible troubles, probable causes, and remedial action for the 29044-1-A1A liquid oxygen converter.

AIRCREW SURVIVAL EQUIPMENTMAN 1 & C

Table 11-2.—Troubleshooting chart.

Trouble	Probable cause	Remedy
Evaporation loss exceeds allowable tolerance.	Leak in tubing connections or pipe threads. Partial loss of container vacuum.	Check all connections for leaks with approved soap solution. Replace the container.
Converter fails to fill within the specified time.	Water trapped in the filling line may freeze and restrict the flow of liquid oxygen. Check for presence of water or ice and maintain filling in dry condition. Insufficient venting of the converter. Insufficient quantity of liquid oxygen in the supply tank.	Remove all liquid oxygen and purge the converter with dry nitrogen or dry gaseous oxygen. Allow the converter to completely vent off before starting filling operation. Check the contents of the supply tank before filling operation.
Converter fails to build up to operating pressure within specified time.	Insufficient quantity of liquid oxygen in the converter. Improper pressure closing valve setting. Excessive overall leakage. Damaged filler valve or buildup and vent valve.	Check by weighing the converter before and after filling. Remove and test. Check all tubing and connections for leaks with an approved leak test solution. Tighten or replace as necessary. Check both valves for excessive leakage.
Converter will not maintain proper delivery rate.	Damaged check valve. Incorrect length of supply line from supply port to flow rator.	Remove and replace. Length of line should be such length to maintain stable flow.

Chapter 11—LIQUID OXYGEN CONVERTERS

Table 11-2.—Troubleshooting chart--Continued.

Trouble	Probable cause	Remedy
Excessive overall leakage.	<p>Leak in the pipe threads and connections.</p> <p>Excessive leakage of probe seal.</p>	<p>Check all connections for leaks with an approved leak test solution.</p> <p>Check torque of retainer nut for correct in.-lb.</p> <p>Remove probe and replace the seal. Torque the retainer nut to the proper value.</p>
Probe fails to meet tolerance of capacitance test.	Nonlinear probe.	Replace the probe.
Probe shorted out.	<p>Moisture in the converter container.</p> <p>Moisture in the probe well.</p>	<p>Purge the container with dry, hot nitrogen or dry, hot gaseous oxygen. Temperature not to exceed 65.56° C (150° F).</p> <p>Remove the probe well. Cap and purge the well with dry nitrogen or dry gaseous oxygen until the well is dry.</p>

CHAPTER 12

SURVIVAL AND SEARCH AND RESCUE EQUIPMENT

Survival on land and sea, in all types of climates, calls for a wide variety of survival items to aid the pilot and aircrewman. As a First Class or Chief PR, you must be familiar with such equipment and insure that flight personnel have equipment available which is reliable for personal safety in flight as well as for escape and survival in case of emergency. In many operating activities, it will be your responsibility to insure that flight personnel are instructed and trained in the use of this equipment and in the techniques of personal safety and survival.

The information contained in this chapter is for the purpose of aiding in preparing and carrying on a course of instruction for the flight personnel of your outfit and is taken from NavAir 00-80T-56, AF Manual 64-3, -4, and various other official publications.

SURVIVAL AT SEA

The Navy has seen to it that the newest products and human ingenuity have been perfected and made available to the PR for the saving of lives. Well-considered preparation, familiarization, and instruction in the use of survival equipment, made while there is time to prepare, will help flight personnel when an emergency exists. Every individual should be instructed to dress to cope with the physical conditions of the area over which he must fly and fight.

It is the responsibility of the PR to insure that proper gear is prepared for all aircraft. Survival equipment is useless to the crew if it is in the parachute loft or on the hangar deck. Aircraft must be checked before take-off to see that the required items are aboard and in good condition.

BAILING OUT

The facts in the following discussion are presented as they would be stated to an aviator prior to his first bailout.

Remember that the techniques for bailing out vary with the specific type of aircraft. Be sure to know the general rules, and master the technique for that particular aircraft.

Most parachutes are equipped with an automatic parachute actuator which will open the parachute at 14,000 feet or below. If the parachute being used does not have an automatic parachute actuator, do not pull the ripcord until you see that you are well clear of the aircraft (unless you are below 500 feet). After the chute opens, you may have time to orient yourself. If over or near land, use your time to get an idea of the lay of the land, see where your aircraft is going to land, or spot a farmhouse.

After the chute is opened, look up and check the canopy to see if any suspension lines are over the canopy. Shake them off the canopy by grasping the riser that controls those particular lines.

Oscillation will cause you to swing under the canopy, pendulum fashion. This can prove dangerous upon landing. Do not attempt to stop oscillation below 500 feet because the procedure increases your rate of descent. If you are above 500 feet, place your right hand well up on the front risers and your left hand on the left rear riser, then pull down slowly and hold. After approximately 30 seconds, release very slowly. Do this several times until the oscillation is reduced to a negligible amount.

Maneuvering the chute can help avoid dangerous ground objects. This is done by slipping the chute. In order to slip the chute forward, reach well up on the two front risers and pull down as far as possible. To slip to the rear, use the two rear risers. To slip to the right, pull the right forward riser with your left hand and the right rear riser with your right hand. Do just the opposite to slip to the left. When letting up on the slip, release the risers slowly.

PARACHUTE LANDINGS IN WATER

Under some conditions the most desirable place to make a parachute landing is in the water. The primary objective is to get free

from the parachute harness at the proper time. Entering the water wearing the harness greatly hampers the movements of the individual; however, under no circumstances should the harness be left too soon.

Depth perception over water is wholly unreliable for accurately judging distance. In fact, there have been instances where jumpers have left the harness as much as 200 feet above the water. Severe injury may result from such a fall.

The objective is to leave the harness at the instant contact is made with the water; however, while still airborne, the pararaft should be removed from the kit container and slowly lowered until the full length of the retainer strap has been payed out. When deployment is desired while using the RSSK assemblies, the aircrewman pulls the yellow release handle. The lower container falls away but remains attached to the upper container by the dropline. The liferaft, attached to the dropline, is automatically inflated.

After sliding out of the harness upon contact with the water, the body will submerge only to the shoulders or head. The life preserver should then be inflated.

In the event the wearer for some reason does not slide clear of the harness and it is necessary to deflate the canopy due to high winds on the water surface, this is accomplished by pulling in on any top suspension line or group of suspension lines.

All personnel parachutes except training parachutes have a series of nylon fabric pockets on the exterior surface of the parachute canopy. The pockets are sewn to the canopy skirt between the radial seams, on alternate gores, with the open section of the pocket facing toward the apex of the canopy. The purpose of the pockets is to capture water to locally anchor that part of the canopy and use the wind to force the remainder of the canopy down on the water. This eliminates the possibility of being dragged through the water by the inflated canopy in high winds, with the attendant hazard of drowning.

Still another method of deflating the parachute in the water or on land in high winds is the use of the cartridge actuated webbing cutter. The webbing cutter is to be used to sever the right-hand riser of nonintegrated parachute assemblies. The device cuts only one riser and does not eliminate the need for immediate parachute divestment in order to prevent being pulled under the water by the sinking parachute. If

wearing an integrated harness, which combines the restraint and harness systems, this is accomplished by opening the Koch release fittings.

Before inflating the pararaft, all the snaps holding the pararaft in the case should be released. This will prevent tearing the raft body during inflation in case any of the flap securing snaps jam. If possible, the parachute should be saved and everything secured to the tiedowns on the pararaft for future use. An inventory of the equipment provided in the pararaft kit should then be taken. The individual should be thoroughly familiar with the use of the equipment before it is needed, because in many instances a person has only a few seconds to put this equipment into operation.

AIRCRAFT DITCHING

The pilot should conduct dry runs on practice ditchings with his crew to eliminate confusion and waste of time in case of an actual emergency ditching. Each crewman should know which exit he will use as well as a secondary exit in case he cannot reach his main exit. Commanding officers should time their crews to determine the length of time it takes to abandon or to ditch an aircraft. Each aircraft has an abandon aircraft bill and a ditching bill which is posted at each crewman's position.

The procedures which should be followed after ditching are described on the following pages: included are instructions relative to rescue from the water, care of the raft, protection from exposure in various climates, signaling techniques, and raftsmanship. For more detailed instructions on survival at sea, reference should be made to NavAir-00-80T-56.

RESCUE FROM WATER

Stay clear of the aircraft (out of fuel-saturated waters), but in the vicinity, until it sinks.

Search for missing men.

Salvage floating equipment; stow and secure all items and check rafts for inflation, leaks, and points of possible chafing. Bail out the raft. Be careful not to snag it with shoes or sharp objects.

In cold oceans, wear an exposure suit, if available. Rig a windbreak, spray shield, and a canopy. If you are with others, huddle together; exercise regularly.

AIRCREW SURVIVAL EQUIPMENTMAN 1 & C

Check the physical condition of all aboard. Give first aid if necessary. Take seasickness pills if available. Wash traces of fuel from your body.

If there is more than one raft, connect all rafts with at least 25 feet of line. Connect rafts only at lifeline around outer periphery of the raft. Unless the sea is very rough, shorten the line if an aircraft is heard or seen. Two or more rafts tied close together are easier to spot than scattered rafts.

Get the emergency radio into operation. Directions are on the equipment. Use the emergency transceiver only when aircraft are known to be in the area. Prepare other signaling devices for instant use.

Keep compasses, watches, matches, and lighters dry. Place them in waterproof containers.

In warm oceans, rig the sunshade and the canopy. Keep your skin covered. Use sunburn cream and chapstick. Keep your sleeves rolled down and your socks pinned up or pulled up over trousers. Wear a hat and sunglasses.

Make a calm estimate of the situation and plan a course of action carefully.

Ration water and food; assign duties to the crew. Use the canopy or paulins for catching and storing rainwater.

Keep a log. Record the navigator's last fix, time of ditching, names and physical condition of personnel, ration schedule, winds, weather, direction of swells, times of sunrise and sunset, and other navigation data. Inventory all equipment.

Keep calm. Save water and food by saving energy. Do not shout unnecessarily. Do not move around unnecessarily. Keep your sense of humor sharp; use it often. Remember that rescue at sea is a cooperative project. Search aircraft contacts are limited by the visibility of survivors. Increase visibility by using all possible signaling devices. Keep mirrors handy; use the radio whenever possible; use the signal panel and the dye marker when you think an aircraft can see them.

Rescue by Helicopter

Research, development, test, and evaluation of air rescue devices has been continuous since the helicopter became the primary rescue vehicle. The sling (horse collar), which for years was the primary air rescue device, is still in use today. The Boyd seat, an aluminum

three-prong seat which was introduced in the late 50's, was an improvement over the sling because it had the capability of lifting two persons simultaneously and it required no special training to use—just sit on the prong and hold on. This device, like the sling, is also still in use.

Within the past 3 years, two new devices have been introduced and will ultimately replace the sling and seat. The primary device for helicopter rescue of survivors will be the Navy two-prong rescue hook in combination with the Kaman penetrator. The Kaman penetrator will be used as a sitting platform in those cases where a V-ring is not available on the survivor's flight gear. The X-872 Rescue Net will be an alternate rescue device and will be used in rescue operations where conditions make its use more advantageous.

Rescue is accomplished by attaching the helicopter cable hook to the rescue seat, horse collar or net, and lowering it to the survivor. If none of the above listed equipment is available, the survivor may be hoisted by attaching the helicopter hook to the torso harness lift ring.

CARE OF RAFT

Be sure that the raft is properly inflated. If main buoyance chambers are not firm, top off with pump or oral inflation tube. See that the valve is open before pumping (to open, turn to the left). Inflate cross seats where provided unless there are injured men who must lie down. Do not overinflate. Air chambers should be well rounded but not drum tight. Close the valve tight. Regularly check inflation. Hot air expands; therefore, on hot days release some air, and add air when the weather cools.

Always throw out the sea anchor or improve a drag from the raft case, or bailing bucket, or roll of clothing. A sea anchor will help you stay close to the ditching site, and the searcher's problem will be easier. Wrap the sea anchor rope with cloth so that it will not chafe the raft.

Be careful not to snag the raft. In good weather, take off shoes; tie them to the raft. Do not let fishhooks, knives, ration tins, and other sharp objects damage the raft. Keep them off the bottom of the raft.

Rig the spray and windshield when anticipating stormy weather. When a canopy is provided it should remain erected at all times. Keep the

raft as dry as possible. Keep it properly balanced. All men should stay seated, the heaviest men in the center.

Leaks are most likely to occur at valves, seams, and underwater surfaces. Only the Mk 20 liferaft is stocked with emergency repair facilities, and they can be repaired with the repair plugs provided. Most multiplace rafts have buoyancy tubes separated into two chambers. If one chamber is damaged, keep the other fully inflated.

Secure equipment by lashing it to the raft and storing it in raft pockets and kit containers. Keep these closed when not in use. Keep dry such items as flashlights, signal guns, and flares.

PROTECTION AGAINST EXPOSURE

In Cold Oceans

You must stay dry and keep warm. If you are wet, get down behind the windshield. Remove, wring out, and replace outer garments or get into dry clothing, if possible. Dry your hat, socks, and gloves.

If you are dry, share clothes with those who are wet. Give them the most sheltered positions on the raft. Let them warm their hands and feet against your body.

Put on any extra clothing available. If no exposure suits are provided, drape extra clothing around your shoulders and over your head. Keep your clothes loose and comfortable. Try to keep the floor of the raft dry. For insulation, cover the floor with canvas or cloth.

Huddle with the others on the floor of the raft. Spread extra tarpaulin, sail, or parachute over the group. If you are on a 20-man raft, lower canopy sides. Take mild exercise to restore circulation. Repeatedly bend and open fingers and toes. Exercise shoulders and buttock muscles. Warm hands under armpits. Periodically, raise your feet slightly and hold them up for a minute or two. Move your face muscles frequently to detect frostbite. Shivering is normal—it is the body's way of quickly generating heat.

Give extra rations to men suffering from exposure to cold.

In Warm Oceans

Protection against the sun is most important. Exposure to the sun increases thirst,

wasting precious water and reducing the body's water content. The sun also causes serious burns. Improvise and get under a sunshade. If you are on a 20-man raft, erect the canopy and furl the sides. Use the paulin, light side up, to attract attention; blue side up for camouflage in unfriendly waters. In rigging the sunshade, leave space for ventilation. In a 1-man raft, use the spray shield for a sunshade.

Keep the body well covered. Do not throw any clothes away. Roll down your sleeves; pull up your socks. Close your collar. Wear a hat or improvised headgear. Use a piece of cloth as a shield for the back of your neck. Wear sunglasses or improvise eye cover from cloth.

SIGNALING

One man, a group of men, or even an aircraft, is not too easy to spot from the air, especially when visibility is limited. Emergency signaling equipment is designed to make you bigger and easier to find.

Emergency Radio

The aircraft radio or emergency radio is the best rescue aid. Try to make contact at once. Try to get a fix; if the radio is serviceable, transmit your position. When using the aircraft radio, save the battery; try to get an engine or auxiliary generator to operate and charge the battery.

Use smoke by day, bright flame by night. Add engine oil, rags soaked in oil, or pieces of rubber (matting or electrical insulation) to make black smoke; add green leaves, moss, or a little water to send up billows of white smoke. Keep plenty of spare fuel on hand.

Signaling aids, such as flares and smoke grenades, must be kept dry. Use them only when friendly aircraft are sighted or heard.

Mirror

Practice signaling with the mirror in the kit. A mirror can be improvised from a ration tin by punching a hole in the center of the lid. Keep the mirror clean. On hazy days, aircraft can see the flash of the mirror before survivors can see the aircraft; so flash the mirror in the direction of the aircraft when it is heard, even when it cannot be seen. When using the mirror, follow the instructions printed on its back.

Pyrotechnic Pistol

The "pyro pistol," as it is often called, is standard equipment for naval aircraft, including training aircraft, and is used to fire aircraft signals. The Pyrotechnic Pistol AN-M8 is a breechloading double action signal pistol. The barrel is hinged to the frame and is held in firing position by the breechlock. The plastic grips, backplate, and cover plate fasten to the aluminum frame and act as a housing for the firing mechanism.

To load the pistol, lift up the breechlock. This unlocks the breech and swings the breech up. Insert the round and close the breech. CAUTION: When loading and firing, care should be taken never to point the pistol toward other personnel or vessels. The star charges can inflict severe burns or start fires. When firing the pistol by hand, it should be held with the elbow slightly bent to absorb the shock of recoil.

The pistol must be kept in serviceable condition at all times. After each firing, it should be cleaned thoroughly and all principal parts wiped down with an oily cloth. When assembled, the exposed parts should be wiped off with a dry cloth. To remove powder residue, the bore should be swabbed out with a cloth dampened with an approved bore cleaning solvent.

Mk 13 Mod 0 Signal

The Mk 13 Mod 0 is a combination distress signal for either day or night use. Because of its small size and weight, it can be carried in the pockets of lifevests or flight suits and on liferafts. The signal is especially adapted for use by aircraft personnel downed at sea. The signal consists of a metal cylindrical outer case with each end closed by a soldered cap. Each cap has an attached pull ring large enough for the insertion of the index finger. The signal has two inner cans—one contains an orange smoke pyrotechnic and the other a flare pyrotechnic. A brass pull wire is attached to the bottom of each cap through an ignition cap. Both ends of the signal are covered by paper caps to prevent the metal cans from being pulled off accidentally.

Instructions for using the signal are printed on the cylindrical outer case. The flare end of the signal (for night use) has raised projections extending around the body about one-fourth inch from the cap. These serve as an identification

so that the signal can be correctly operated even in total darkness. When the "day" end is used, orange smoke is emitted; and when the "night" end is used, a pyrotechnic candle is lighted. Each section of the signal is designed to be held comfortably in the bare hand while it is functioning. To operate the signal, proceed as follows:

1. Tear cap from end to be ignited.
2. Flip pull ring over signal rim.
3. Push ring down to break seal.
4. If seal does not break, push ring until it bends against case.
5. Flip the bent ring back to original position and use as lever to break seal.
6. After the seal breaks, point the signal away from your face and body and give a sharp yank on the pull ring. Hold the signal at arm's length 45° from horizontal.
7. Douse the signal in water immediately after use in order to cool the metal parts.
8. The signal should be retained for use of the opposite end.

Special safety precautions applicable to the operation of this signal are as follows:

1. Never attempt to ignite both ends of the signal at the same time.
2. Do not handle the signal roughly.
3. Hold the signal properly to prevent drippings from hitting the hand.

Illumination Signal Kit

The Illumination Signal Kit Mk 79 Mod 0 is a hand held signal used for day or night signaling.

Each kit consists of one surface signal projector, Mk 13 Mod 0 and seven hand fired signals, Mk 80 Mod 0, inserted in a bandolier. This kit may be carried in lieu of the 38 caliber revolver.

Specifications and operation procedures are given in Aircrew Survival Equipmentman 3 & 2, NavPers 10358-D.

Dye Markers

The dye packet contains a small quantity of crystalline dye compound (3 to 3 1/4 ounces). When the compound is exposed to water, it slowly dissolves while producing a brilliant yellowish-green fluorescence. Fluorescein dye is very effective for marking a relatively large area which can surround or trail (depending on sea and weather conditions) personnel who are adrift at sea. Under moderate sea conditions,

Chapter 12- SURVIVAL AND SEARCH AND RESCUE EQUIPMENT

it takes from 20 to 30 minutes for the dye to dissolve, and after a period of 1 hour it loses its value completely. Under good conditions and while the marker lasts, it can be seen from a distance of approximately 10 miles at 3,000 feet altitude.

An exterior orange-yellow envelope (6 x 5 x 1 inches) serves the purpose of (1) providing a waterproof container for the dye compound contained in a loosely woven bag; (2) acting as an anchoring point for the dye pouch which is secured to a long tape; and (3) supporting a tape across the top of the envelope which is used to tie the marker to lifevests and other basic items of survival. The accessories container of each size raft is supplied with six markers.

Lights

At night use flashlights, pen lights, recognition light, strobe light SDU-5/E, the survival light which is attached to the lifevest or the blinker signal light of the Gibson Girl. Any light can be seen over water for several miles.

Survival Escape and Evasion Kit (SEEK)

Because of its contents, the SEEK kit is a very useful item on land and sea. It is designed in two parts which may be stored in the survival vest. The contents of the kit are not designed for any specific area. Both containers are similar in design and are labeled "part 1 medical" and "part 2 general." The identity of each item is printed on the outside of each part.

Whistle

At night or in fog use the whistle from the emergency kit to attract surface vessels or people on shore, or to locate another raft if it becomes separated.

RAFTSMANSHIP

Use of Equipment

Take every precaution to prevent the raft from turning over. In rough weather, keep the sea anchor out from the bow; sit low in the raft, with the passengers' weight distributed to hold the weather side down. Do not sit on the sides or stand up. Never make sudden movements without warning the other men. Do not

tie a fishline to yourself or the raft; a large fish may capsize the raft.

In rough seas tie the stern of the first raft to the bow of the second and rig the sea anchor to the stern of the second raft. Use approximately a 25-foot line between rafts; adjust the length of the line to suit the sea. Keep the sea anchor line long; adjust its length so that when the raft is at the crest of a wave, the sea anchor will stay in a trough. In very rough weather, keep a spare sea anchor rigged and ready for instant use in case the one that is out breaks loose.

When the sea anchor is not in use, tie it to the raft and stow it so that it will hold immediately if the raft capsizes.

To right multiplace (except 20-man) rafts, toss the righting rope over the bottom, move around to the other side, place one foot on the flotation tube, and pull on the righting rope. (See fig. 12-1.) If you have no righting rope or if you cannot improvise one from the sea anchor line, a belt, or a shirt, slide up on the bottom, reach across, grab the lifeline on the far side, and then slide back into the water, pulling the raft back and over. Most rafts are equipped with righting handles on the bottom. The 20-man raft is identical on both sides and therefore requires no righting.

If several men are in the water, one should hold down the far side of the multiplace 4-, 7-, or 12-man raft while the rest climb in singly from the other side. Grasp the seat to haul yourself in, or use the boarding ladder provided on the newest types of raft. Without help; the best place to board the raft is over the end. If the wind is blowing, board the raft with the wind at your back. The 20-man raft is provided with a deflated boarding station, which is hand-inflated after occupants are aboard.

To board the 1-man raft, climb in from the narrow end, slide up as nearly horizontal as possible.

Rafting Ashore

Going ashore in a strong surf is dangerous. Take your time. Select the landing point carefully. Try not to land when the sun is low and straight in front of you. Try to land on the lee side of an island or of a point of land. Keep your eyes open for gaps in the surf line, and head for them. Avoid coral reefs and rocky cliffs. Coral reefs do not occur near the mouths of fresh water streams. Avoid rip

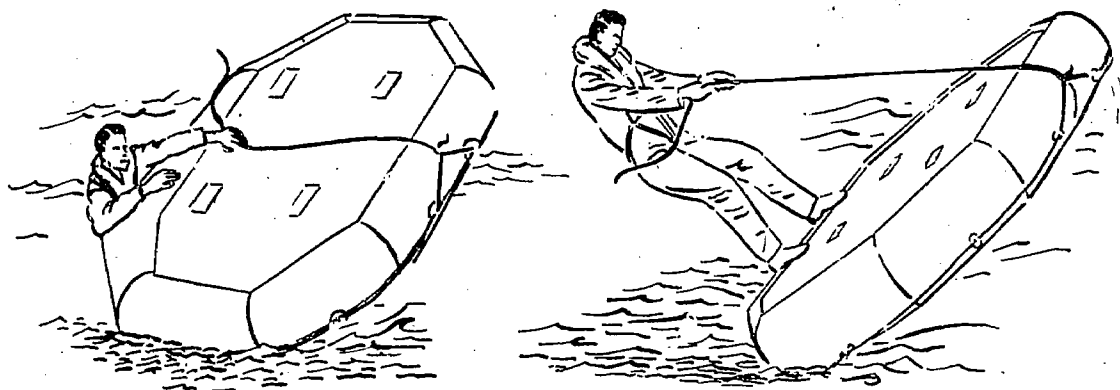

Figure 12-1.—Righting a multiplace raft.

PR.62

currents or strong tidal currents which may carry you far out to sea. Either signal shore for help or sail around and look for a sloping beach where the surf is gentle.

If it is necessary to go through surf to reach shore, take down the raft mast. Keep your clothes and shoes on to avoid severe cuts. Adjust and inflate your lifevest. Trail the sea anchor over the stern with as much line as you have. Use the oars or paddles and constantly adjust the sea anchor to keep a strain on the anchor line. It will keep the raft pointed toward the shore and prevent the sea from throwing the stern around and capsizing the raft. Use the oars or paddles to help ride in on the seaward side of a large wave.

Surf may be irregular and velocity may vary, so the procedure must be modified as conditions demand. A good method of getting through surf is to have half the men sit on one side, half on the other, facing each other. When a heavy sea bears down, half should row toward the sea until the crest passes; then the other half should row toward the shore until the next sea comes along.

Against strong wind and heavy surf, the raft must have all possible speed to pass rapidly through the oncoming crest in order to avoid being turned broadside or thrown end over end. If possible, avoid meeting a large wave at the moment it breaks.

In a medium surf with no wind or offshore wind, keep the raft from passing over a wave so rapidly that it drops suddenly after topping the crest.

If the raft turns over in the surf, try to grab hold.

As the raft nears the beach, ride in on the crest of a large wave. Paddle or row hard and ride it onto the beach as far as possible. Do not jump out of the raft until it has grounded. Then get out quickly and beach it.

If you have a choice, do not land at night. If you have reason to believe that the shore is inhabited, lay away from the beach, signal, and wait for the inhabitants to come out and bring you in.

SURVIVAL ON LAND

PARACHUTE LANDINGS

All personnel who fly, frequently or occasionally, should be instructed in parachute landings other than routine landings under ideal conditions. Although routine landings should not be disregarded, special emphasis should be given to high wind landings and landing in trees.

High Wind Landings

Landing safely with a parachute in high wind is not an easy task. The initial touchdown may

seriously injure the jumper or make him unconscious, making it impossible for him to defend himself. However, proper technique is extremely helpful in reducing the chances of death or injury during high wind landings. The danger lies in the fact that a high wind is capable of keeping the canopy inflated and dragging the jumper across the ground, thus causing serious injury or possibly death. The jumper is responsible for deflating the canopy after landing, so he should be thoroughly indoctrinated in the method of deflating the canopy.

The jumper may elect to unsnap his harness during the descent and allow the harness to pull from his body after touchdown. This unsnapping may only be done if the jumper can move back and sit in the sling of the harness, with no weight on the leg straps. To slide back into the harness sling, grasp the main sling on each side near the seat, apply pressure towards the knees and kick the knees sharply toward the chest. Disconnect the snaps attaching both leg straps first and then the chest snap, but do not remove the arms from the body straps. Grasp the lift webs with each hand and extend the arms over the head and then release the harness at the instant the feet touch the ground. In many cases it is impossible to use this technique due to body configuration, bulky clothes, etc.

The development of the Koch canopy release and the cartridge actuated webbing cutter enables the pilot to disconnect the canopy from his harness as soon as he lands. This release makes it possible for the aviator to free himself of the canopy without his being dragged over the ground or through the water by the wind.

Instructions should be emphasized to never tamper with the safety lock on the ejection snaps of the canopy release during descent. Accidentally releasing the ejection snaps during descent will release the canopy from the harness and the body will be dropped into a free fall.

If the parachute is not equipped with ejection snaps and the jumper cannot safely release the leg snaps, he should be instructed to land with the harness fully snapped. Since unsnapping a harness while being dragged across the ground is almost impossible, collapsing the canopy by deflating can be accomplished regardless of wind velocity if the jumper remains calm and applies the deflating technique with determination. Deflation on land is accomplished by pulling in on any bottom suspension line or

group of suspension lines until the canopy is pulled beneath the jumper. (See fig. 12-2.)

The deflating process can burn the hands and fingers. The lines should be grasped with a sideward twisting motion of the hands and wrists as each new snubbing grip is made along the lines. After the canopy has been deflated, it is a good practice to sit on the canopy while unsnapping and preparing to slide out of the harness.

Excellent practice can be accomplished deflating a canopy on a windy day. Using a surveyed parachute in an open field, two men can whip the canopy until it is inflated. This will drag the wearer across the ground; and after a few tries, he will be able to deflate the canopy with proficiency. For safety purposes, a few men should be present close to the inflated canopy. In the event the wearer is unable to deflate the canopy on his first try, the canopy can be deflated by a man catching the peak of the canopy and running around into the wind. On some stations, a wind machine is provided for the purpose of practicing the deflation of canopies under simulated high wind conditions.

Tree Landings

When landing in trees, do not grasp the risers. Cross the arms in front of the face, and bury the face in the crook of either elbow. To protect the hands, place them in the armpits. Keep the feet and knees together until you stop falling. Do not attempt to brake the descent through the trees by grasping at limbs. Take your time in climbing down. If you can, wait for rescue. If you cannot, try to make a rope from the risers and suspension lines of the parachute.

In ground landings at night, prepare for a normal landing as soon as the parachute opens, and be ready for contact at any time. Surprisingly enough, statistics show that fewer men have been injured on night jumps than day jumps. Perhaps because landing is a surprise, the jumper does not have a chance to tense up for the unexpected. If you see that you are going to land in telephone or power wires, which are usually quite high and spaced several feet apart, put the hands above the head, palms flat against the inside of the front risers. Keep the feet and knees together, toes pointed, to avoid straddling a line.

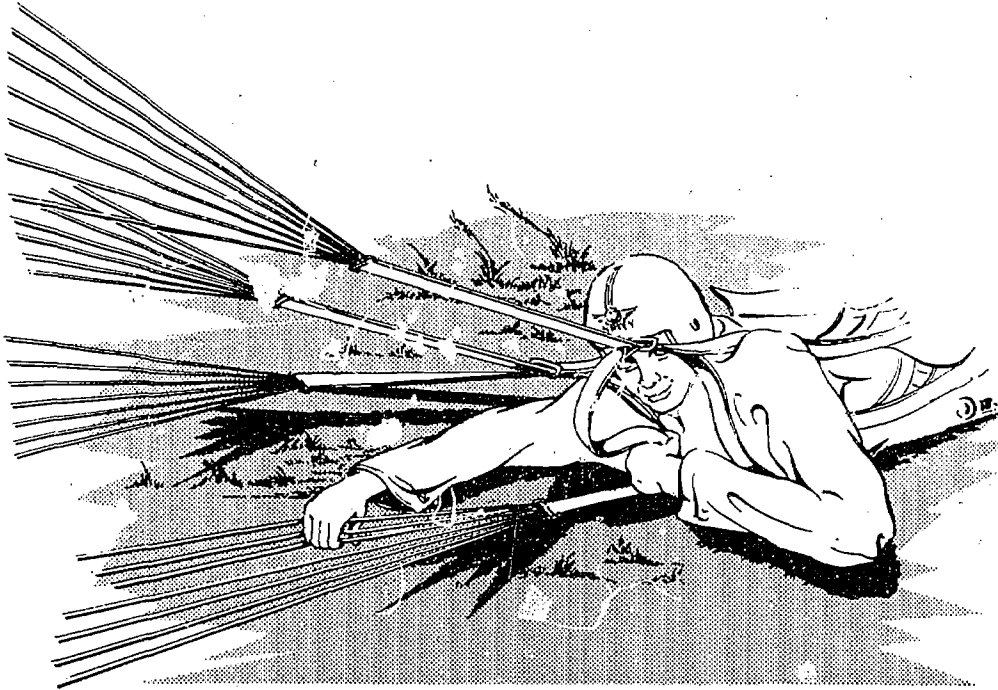

Figure 12-2.—Denating the parachute canopy.

PR.63

SURVIVAL AFTER CRASH LANDING

General

Stay away from the aircraft until the engines have cooled and spilled gas has evaporated.

Check injuries. Give first aid. Make the injured men comfortable. Be careful when removing casualties from the aircraft, particularly men with injured back and fractures.

Set up temporary shelter for protection from the wind and rain. If a fire is needed, start it at once. In cold weather, make hot drinks.

Get your emergency radio operating on schedule and have other signaling equipment handy.

Now relax and rest until you are over the shock of the crash. Leave extensive preparations and planning until later.

After resting, organize the camp. Appoint individuals to specific duties. Pool all food and equipment in charge of one man. Prepare a

shelter for protection from rain, hot sun, snow, wind, cold, or insects. Collect all possible fuel. Try to have at least a day's supply of fuel on hand. Look for a water supply, and for animal and plant food.

Prepare signals in order to be recognized from the air. Place the cloth signal panel in the open where it can be seen.

Start a logbook. Include date and cause of crash; probable location; roster of personnel; inventory of food, water, and equipment; weather conditions; and other pertinent data.

Determine your position by the best means available, and include this position in the radio messages. If position is based on celestial observations, transmit the observations also.

If you have bailed out, try to make your way to the crashed aircraft. The rescuers can spot it from the air even when they cannot see a man.

Stay with the aircraft unless briefing instructions have been to the contrary. Do not leave the aircraft unless you know that you are

within easy walking distance of help. If you travel, leave a note giving planned route (except in hostile territory). Stick to your plan so rescuers can locate you.

You are the key man in the rescue. Help the search parties to find you and follow their instructions when they sight you. Do not collapse when you are sighted or when the rescue party arrives. They can use all the assistance you can give. Do not take chances which might result in injury. You will be easier to rescue if you are in one piece.

The following will speed up your rescue:

Conserve power of electronic equipment. Use it according to procedures given in your briefing.

Sweep the horizon with your signal mirror at frequent intervals.

Shelter Construction

In any area, a shelter can be improvised from parts of the aircraft and emergency equipment or from natural materials in the vicinity.

The kind of shelter that is made depends on whether protection is needed from rain, cold, heat, sunshine, or insects, and also whether the camp is only for a night or for many days.

Choose the location for the camp carefully. Try to be near fuel and water—especially water.

Do not make camp at the base of steep slopes or in areas where you run the risk of avalanches, floods, rockfalls, or battering by winds.

Arctic

In winter, protection from cold is the immediate and constant problem. Keep dry, avoid snowblindness, check for frostbite.

To stay dry, keep snow out of your boots, gloves, and clothing; avoid open water. Overexertion causes perspiration which will freeze inside your clothing, thus decreasing effective insulation and increasing the chances of freezing. Always remove outer clothing when working or moving; when you stop, throw your outer garments over your shoulders or replace them to avoid chilling. If you have shelter at night, remove your underclothes and air them, or let them get cold and beat the frost out with a stick. Keep hands and feet dry.

Collect wood, gasoline, oil, heather, brush, or peat for fuel. Build a fire at a safe distance from the aircraft and get under shelter.

If the aircraft is flyable, drain oil; insulate wheels from ice with boughs or canvas; leave brakes off; remove battery and protect it from freezing.

If down in a glacier area, be on your guard against falling into crevasses. Rope the party together, preferably three men to a rope. As you walk, probe the snow in front of you with a pole or ice ax to detect crevasses covered by thin snow.

In summer, protect yourself against insects. Keep dry.

In the winter, a shelter against the cold will be needed.

Do not live in the aircraft—it will be too cold. Try to improvise a better insulated shelter outdoors.

Camp in timber if possible, to be near fuel. If you cannot find timber, choose a spot protected from wind and drifting snow. Do not camp at the bases of slopes or cliffs where snow may drift heavily or come down in avalanches.

In timbered country, a good winter shelter is a lean-to. Lay the covering boughs shingle-fashion, starting from the bottom. If you have a canvas, use it for the roof. Close the ends with fabric or boughs.

Keep the front openings of all shelters crosswind. A windbreak of snow or ice blocks set close to the shelter is helpful.

In making shelters, remember that snow is a good insulator.

In timberless country, make a simple snow cave or burrow by digging into the side of a snowdrift and lining the hole with grass, brush, or tarpaulin. Snow caves must be ventilated. If the snow is not deep enough to support a roof, dig a trench in a drift and roof it with snow blocks, tarpaulin, or other materials.

In wooded country, make a tree-pit shelter if snow is deep enough. Enlarge the natural pit around a tree trunk and roof it with any available covering.

Reconnoiter for cabins and shelter houses. They are likely to be located along bigger streams, at river junctions, along blazed trails in thick, tall timber leeward of hills.

Prevent carbon monoxide poisoning by providing good ventilation in closed shelters in which a fire is burning.

Do not sleep directly on the snow. Provide insulation under your sleeping bag or body. Lay a thick bough bed in shingle-fashion, or use seat cushions, tarpaulins, or even an inverted and inflated rubber life raft if available.

AIRCREW SURVIVAL EQUIPMENTMAN 1 & C

Keep your sleeping bag clean, dry, and fluffed up to give maximum warmth. To dry the bag, turn it inside out, beat out frost, and warm it before the fire. Wear only dry clothes to bed. Keep them loose. Turn over with, rather than in, the sleeping bag.

In the summer, shelter against the rain and insects will be needed. Choose a camp site near water but on high, dry ground if possible. Stay away from thick woods as mosquitoes and flies will make your life miserable. A good camp site is a ridge top, cold lake shore, or a spot that gets an onshore breeze.

If you stay with the aircraft, use it for shelter. Cover openings with netting or parachute cloth to keep insects out. Do your cooking outside to avoid carbon monoxide poisoning. Make your fire at a safe distance from the aircraft.

Make a simple outdoor shelter by hanging a tarpaulin over the wing of the aircraft; anchor the ends to the ground by weighting them down with stones. A tent can be quickly improvised by placing a rope or pole between two trees or stakes and draping a parachute over it; make the corners fast with stones or pegs.

A fine shelter for drizzly weather and protection against insects is a tepee made from the parachute. In it you can cook, eat, sleep, dress, and make signals—all without going outdoors. Use 6 panels of parachute for a 2-man shelter, 12 to 14 panels for a 3-man paratepee. This shelter is worth building if you decide to stay in one spot for some time.

Avoid sleeping on the bare ground. Provide some sort of insulation under yourself—soft boughs are good. Pick a bed site on level, well-drained ground free from rocks and roots. If you have to sleep on bare ground, dig depressions for your hips and shoulders and try out the site before you set up your shelter or spread your bedding.

SIGNALING.—Keep snow and frost off aircraft surfaces to make a sharp contrast with the surroundings. Build your fire on a platform so it will not sink in the snow. A standing spruce tree near timber line burns readily even when green. Build a "bird nest" of quickly flammable material in the branches to insure a quick start.

Tramp out signals in the snow. Fill them in with boughs, sod, moss, or fluorescent dye water. In brush country, cut conspicuous patterns in vegetation.

In tundra, dig trenches, turn sod upside down at side of trench to widen signal.

A parachute tepee stands out in the forest or on the tundra in summer, especially at night with a fire inside.

Remember, sound does not carry well through snow. If the entire party is in a snow cave or igloo, you may not hear rescue aircraft. Keep someone on guard as a spotter. Build the spotter a windbreak but do not roof it.

Use smoke by day, bright flame by night. Add engine oil, rags soaked in oil, or pieces of rubber (matting or electrical insulation) to make black smoke; add green leaves, moss, and a little water to send up billows of white smoke. Keep plenty of spare fuel on hand.

Signaling aids, such as flares and smoke grenades, must be kept dry. Use them only when friendly aircraft are sighted or heard.

Signal with a flashlight or the blinker signaling light of the emergency radio. If the aircraft landing lights are intact and you can get the engine to run, remove the lights and extend them for signaling, but do not waste the battery—save it for the radio.

Place or wave the yellow-and-blue cloth signal panel in the open where it can be seen. Spread out parachutes. Make a pattern of orange-colored Mae Wests. Line up cow! panels from engine nacelles upside down on aircraft wings or ground; polish the inside surfaces—they make good reflectors. Arrange your ground signals in big geometric patterns rather than at random—they will attract more attention that way. The radio balloon or kite makes a good signal.

Use the fluorescent dye available in the life-raft or life preserver kit for signaling on water or snow. Use it carefully, for a little goes a long way; use it only downwind for the dye will penetrate clothing or food. On rivers, throw it out into the current for a quick spread.

Desert

Water will be your biggest problem in the desert. While 1 pint represents the daily minimum for continued health of an average man, some people may have smaller or larger requirements. In an emergency, the ration may be cut down to 10 ounces. However, it is believed that maximum survival is obtained by using water on the basis of a 16- to 32-ounce daily ration. Do not drink the daily ration all at once. If possible, drink your ration four times a day. If you become ill and need all your water, drink it.

Chapter 12—SURVIVAL AND SEARCH AND RESCUE EQUIPMENT

Keep your head and the back of your neck covered and get into shade as soon as possible to reduce sweating and loss of body water. Travel only at night.

A shelter mostly from sun and heat will be needed. Use whatever natural shade you can find, such as a cave, rock ledge, or wall of a dry stream bed. A dry canyon in the desert is a dangerous camping ground; cloudbursts may cause sudden and violent floods which sweep along a dry valley in a wall of roaring water.

Do not use the inside of the aircraft for shelter in the daytime—it will be too hot. Get under the shade of a wing if you have no other shelter.

If you stay with the aircraft, a good shade-shelter can be made easily by tying a spread-out parachute as an awning to the wing, leaving the lower edge at least 2 feet clear of the ground for air circulation. Use sections of aircraft tubing for tent poles and pegs. Make sure the aircraft is securely moored and the wing solidly guyed to prevent movement in a storm.

If the aircraft is not available, make a shelter of your parachute. Two layers of cloth separated by several inches of airspace are cooler than a single thickness.

In winter months and especially at night, desert temperatures may drop to freezing and heavy rains may sometimes occur. Use the inside of the aircraft for protection from cold and rain. Do your cooking outside to prevent carbon monoxide poisoning.

SIGNALING.—A good improvised flare can be made from a tin can filled with sand and soaked with gasoline. Light it with care. Add oil and pieces of rubber to make dense smoke for daytime signal. Burn gasoline or use other bright flame at night.

Dig trenches to form signals or line up rocks to throw a shadow.

If there is any brush in the area, gather it in piles and have it ready to light.

Smoke fires and smoke grenades are best for use in daytime. Flares and bright flames are hard to see.

The mirror is a very good desert signal; practice using it.

Tropics

In the tropics try to pick a camp site on a knoll or high spot in an open place well back from swamps. You will be bothered less by

mosquitoes, the ground will be drier, and there will be more chance of a breeze.

Do not build a shelter under large trees or trees with dead limbs. They may fall and wreck the camp or hurt someone. Do not sleep or build a shelter under a coconut tree.

In the wet jungle forest, a shelter from dampness will be needed. If you stay with the aircraft, use it for shelter. Try to make it mosquito-proof by covering openings with netting or parachute cloth.

The easiest improvised shelter is one made by draping a parachute or tarpaulin over a rope or vine stretched between two trees or by propping it up on poles.

A good rain shelter can be made by covering an A-type framework with a good thickness of palm or other broad leaves, pieces of bark, or mats of grass. Lay the thatch shingle-fashion with the tips of leaves pointing downward, starting from the bottom and working up, so the rain will shed off.

Take shelter from rain, sun, and insects. Malaria-carrying mosquitoes and other insect pests are the immediate dangers of the tropics—protect yourself against bites.

Do not leave landing site without carefully blazing or marking your route. Use your compass. Know in what direction you are going.

SIGNALING.—Set up fires and other signals in natural clearings and along edges of streams, or make a clearing. Signals under dense jungle growth will not be seen.

FIRE MAKING

You may need fire for warmth, for keeping dry, for signaling, for cooking, or for purifying water by boiling.

Do not build the fire too big. Small fires require less fuel and are easier to control; and their heat can be concentrated. In cold weather small fires arranged in a circle are much more effective than one large fire.

Preparing Fireplace

Prepare the location of the fire carefully. Clear away leaves, twigs, moss, and dry grass, so that you do not start a grass or forest fire. If the ground is dry, scrape down to the bare dirt. If the fire must be built on snow, ice, or wet ground, build a platform of logs or flat stones.

To get the most warmth and to protect the fire from wind, build it against a rock or wall of logs which will serve as a reflector to direct the heat into your shelter. Cooking fires should be walled in by logs or stones, not only to concentrate the heat but also to provide a platform for the cooking pot.

Kindling and Fuel

Most fuels cannot be started burning directly from a match. Some easily flammable kindling to start the fire burning will be needed. Good natural kindling materials are thin sticks of dry wood, dry bark, wood shavings, palm leaves, twigs, loose ground-lying lichens, dead, upright grass straw, and ferns. If sticks are used for kindling, split them and cut long thin shavings, leaving the shavings attached. Crumpled paper or empty waxed ration boxes are good kindling. Store kindling in a shelter to keep it dry. A little gasoline poured on the fuel before it is lighted will help it start burning. DO NOT pour gasoline on a fire already started even if it is only smoldering.

For fuel, use dry standing dead wood and dry dead branches. Dead wood is easy to split and break—pound it on a rock. The inside of fallen tree trunks and large branches may be dry even if the outside is wet; use the heart of the wood. Almost everywhere, green wood that will burn can be found, especially if finely split. In treeless areas, find other natural fuels, such as dry grass which can be twisted into bunches, peat dry enough to burn (found at the top of undercut river banks), dried animal dung, animal fats, and sometimes even coal, oil shale, or oil sand lying on the surface. If no natural fuels are available, and you are with the aircraft, burn gasoline and lubricating oil or a mixture of both.

Fire Making With Matches and Lighter

Prepare a fireplace. Get all materials together before trying to start the fire. Make sure that matches, kindling, and fuel are dry. Have enough fuel on hand to keep the fire burning. Arrange a small amount of kindling in a low pyramid, close enough together to permit flames to lick from one piece to another. Leave a small opening for lighting.

Save matches by using a candle (if available) to light the fire. If you have no candle, use a

"shave stick," or make a faggot of thin, dry twigs, tied loosely. Shield the match from the wind, and light the candle or faggot. Apply the lighted candle or faggot to the lower windward side of the kindling, shielding it from the wind.

Small pieces of wood or other fuel can be placed gently on the kindling before lighting or can be added after the kindling begins to burn. Lay on smaller pieces first, adding larger pieces of fuel as the fire takes hold. Do not smother the fire by crushing down the kindling with heavy wood. Do not make the fire too big. Do not waste fuel.

Fire Making With Special Equipment

If you have a fusee signal flare in your kit, light it by striking the self-contained flint and steel. Although it may mean wasting a signal, a fire can be lighted from the flame.

Some emergency kits contain small fire starters, cans of special fuels, windproof matches, and other aids.

Fire Making Without Matches

First, find or prepare one of the following kinds of tinder: very dry powdered wood, finely shredded dry bark, or the shredded pith of a dead palm frond; lint from unraveled cloth, cotton, twine, rope, or first-aid gauze bandage, fuzzy or woolly material scraped from plants; fine bird feathers or birds' nests, fieldmouse nests, or fine wood dust produced by insects, often under bark of dead trees. Tinder must be bone-dry. Make it burn more easily by adding a few drops of gasoline or by mixing it with powder taken from a cartridge. Once tinder is prepared, put some in a waterproof container for future use.

Once you have the tinder, light it in a place sheltered from the wind. Several additional methods of starting a fire are described in the following paragraphs.

Flint and Steel

This is the easiest and most reliable way of making a fire without matches. Use the flint fastened to the bottom of the waterproof match case. If you have no flint, look for a piece of hard rock from which you can strike sparks. If it breaks or scars when struck with steel, throw it away and find another. Hold your hands close

over the dry tinder; strike flat with a knife blade or other small piece of steel, with a sharp, scraping, downward motion so that the sparks fall in the center of the tinder. The addition of a few drops of gasoline before striking the flint will make the tinder flame up—for safety, keep your head to one side. When the tinder begins to smolder, fan it gently into a flame. Then transfer the blazing tinder to the kindling pile or add kindling gradually to the tinder.

Burning Glass

Any convex lens 2 inches or more in diameter can be used in bright sunlight to concentrate the sun's rays on the tinder and start it burning.

Friction

There are many methods of making fire by friction (bow and drill, fire plough, fire thong, etc.), but all require practice. If you are proficient in one of these methods, use it, but remember that flint and steel will give the same results with less work.

Electric Spark

If you are with the aircraft, and have a live storage battery, direct a spark onto the tinder by scratching the ends of wires together to produce an arc.

Burning Aircraft Fuel

If you are with the aircraft, you can improvise a stove to burn gasoline, lubricating oil, or a mixture of both. Place 1 to 2 inches of sand or fine gravel in the bottom of a can or other container and add gasoline. Be careful when lighting; the gas may explode at first. Make slots at the top of the can to let flame and smoke out, and punch holes just above the level of the sand to provide a draft. To make a fire burn longer, mix gasoline with oil. If there is no can, simply dig a hole in the ground, fill it with sand, pour on gasoline, and light; take care to protect your face and hands.

You can use lubricating oil for fuel with a wick arrangement. Make the wick of string, rope, rag, or even a cigarette, and rest it on the edge of a receptacle filled with oil. Also, soak rags, paper, wood, or other fuel in oil and throw them on the fire.

A stove can be made of any empty waxed ration carton by cutting off one end and punching a hole in each side near the unopened end. Stand the carton on the closed end; stuff an empty sack loosely inside the carton, leaving an end hanging over the top; light this end—the stove will burn from top down and will boil more than a pint of water.

Useful Hints

Do not waste matches by trying to light a poorly prepared fire. Do not use matches for lighting cigarettes; get a light from the fire or use a burning lens. Do not build unnecessary fires; save your fuel. Practice primitive methods of making fires before all the matches are gone.

Carry some dry tinder with you in a waterproof container. Expose it to the sun on dry days. Adding a little powdered charcoal will improve it. Collect good tinder wherever it can be found.

Collect kindling along the trail before making camp. Keep firewood dry under shelter. Dry damp wood near the fire so it can be used later. Save some of the best kindling and fuel for quick fire making in the morning.

To split logs, whittle hardwood wedges and drive them into cracks in the log with a rock or club; split wood burns more easily.

To make a fire last overnight, place large logs over it so that the fire will burn into the heart of the logs. When a good bed of coals has been formed, cover it lightly with ashes and then dry earth. In the morning the fire will still be smoldering.

Fire can be carried from one place to another in the form of a lighted punk, smoldering coconut husk, or slow-burning coals. When you want a new fire, fan the smoldering material into flame.

Do not waste fire making materials. Use only what is necessary to start a fire and to keep it going for the purpose needed. Put out the fire upon leaving the camp site.

Arctic

Do not build a fire under a snow-covered tree—snow may fall and put out the fire.

Low, dead, needle-bearing branches of standing spruce trees are good fuel. On the tundra, wood is scarce. Look for any woody bush or shrub; burn roots as well as stems. Look for

dry twigs in willow thickets, or for dry grasses. On the coasts, look for driftwood.

Animal fat and bones can be used as fuel. Put chunks of fat on a stick or bone framework or on top of a perforated can with a wick of greasy cloth or Sphagnum moss underneath, and light the wick. Congealed oil can be burned in the same way.

A candle burning in a tin can makes a simple heater for the shelter.

In cold weather, drain oil from the aircraft and store it for fuel. If the temperature is not low enough to solidify the oil, leave it in the aircraft and drain it off when needed.

Desert

In some deserts fuel is extremely scarce. Wherever you find plant growth, utilize all twigs, leaves, stems, and underground roots for burning. Dry animal dung, more commonly found along traveled routes, gives a very hot flame.

Tropics

In the tropics, wood is plentiful—even if it is wet outside, the heart of dead wood will be dry enough to burn. Dry wood can also be found hanging in the network of vines or lying on bushes.

In palm country, good tinder can be obtained by using the fibers at the bases of palm leaves. The insides of dry termite nests make good kindling.

Green leaves thrown on a fire make a smudge that will help keep off mosquitoes.

Keep spare wood dry by stowing it under the shelter. Dry out wet kindling and fuel near the fire for future use.

SURVIVAL EQUIPMENT AND TECHNIQUE

The shotgun load for the survival rifle/shotgun has an effective range of 15 yards against birds and an effective range of 10 to 15 yards against small animals. Do not waste ammunition on long shots, especially long wing shots.

The survival rifle can kill at ranges over 200 yards, but chances of hitting game in a vital spot at ranges over 100 yards are very slight.

Remember, most big game is actually killed at ranges under 60 yards. Unless it is impossible to secure a clean kill by closer stalking,

never attempt to kill by shooting over 100 yards. Make sure of your first shot, for it may be your last one at that particular animal—and your ammunition supply is limited.

Follow these rules when hunting:

1. Get as close as possible to the game before shooting.

2. Do not shoot rapid fire. One shot will do the job if aimed properly.

3. Fire from as steady a position as possible. Remember, survival rifles are light and any unsteadiness on your part due to exertion or excitement will set the barrel to trembling. The prone position is best for a steady shot, but sitting or kneeling positions may have to be used. Use a rest such as a log or stone for the barrel whenever possible; but put your hand between the rest and the gun barrel or the gun will shoot wild. Never fire offhand unless time prevents your taking another position.

4. Aim at a vital spot. The shoulder or chest is probably the best spot for medium and large game. Do not shoot unless a vital spot is open.

5. Do not trust your first shot even if game appears to have fallen dead. Reload immediately, but keep your eye on the game.

6. Look for blood if game runs away after the first shot. If blood is found, wait 30 minutes before following. Wounded game will lie down and stiffen if given time.

During the winter, remove all lubricants and rust prevention compounds from weapons. Strip them completely and clean all parts with a solvent. Gasoline or lighter fluid may be used if available. Normal lubricants thicken in cold weather and slow down the action. In cold weather, weapons function best when absolutely dry.

A major problem is to keep snow and ice out of the working parts, sights, and barrel. Even a small amount of ice or snow may disable the weapon, so careful handling is essential, especially in snow. Improvise muzzle and breech covers, and use them. Carry a small stick in your pocket to clean the sights and breechblock.

Weapons sweat when they are brought from extreme cold into a heated shelter; and when they are taken out again into the cold, the film of condensation freezes. This ice may seriously affect their operations; so leave them outdoors or store them in unheated shelters. If the shelter is not greatly warmer than the outside temperature, bring the weapons inside; but place them at or near floor level, where the temperature is lowest. When the weapons are

taken into a heated shelter for cleaning, remove all the condensed moisture before cleaning. They may sweat for an hour.

If a part becomes frozen, do not force it. Warm it slightly, if possible, and move it gradually until unfrozen. If it cannot be warmed, try to remove all visible ice or snow and move it gradually until action is restored.

Before loading the weapon, always move the action back and forth a few times to insure that it is free and to check the ammunition.

If the weapon has a metal stock, pad it with tape or cloth, or pull a sock over it to protect your cheeks.

CUTTING TOOLS

Cutting tools are important aids to survival in any environment. For best results, use them and care for them properly.

When using an ax, do not try to cut through a tree with one blow. Rhythm and aim are more important than force. Too much power behind a swing interferes with your aim. When the ax is swung properly, its weight will provide all the power needed.

Before doing any chopping, clear away all obstructions. A branch, vine, or brush can deflect an ax onto your foot or leg. Remember, an ax can be a wicked weapon. Figure 12-3 illustrates correct usage of the ax.

A broken handle is difficult to remove from the head of the ax. Usually the most convenient way is to burn it out. For a single-bit ax, bury the blade in the ground up to the handle, and build a fire over it. For a double-bit, dig a little trench, lay the middle of the ax over it, cover both bits with earth, and build the fire.

If you have to improvise a new handle, save time and trouble by making a straight handle instead of a curved one like the original. Use a young, straight hardwood without knots. Whittle it roughly into shape and finish it by shaving. Split the end of the handle that fits into the ax-head. When the handle has been fitted, pound a thin, dry hardwood wedge into the split. After using the ax for a short time, pound the wedge in again, and trim it off flush.

The survival kit may include a file or a whetstone. If you have no sharpening tool, look for a natural whetstone. It will be needed to sharpen your knives and axes.

Any sandstone will sharpen tools; but a gray, somewhat clayey sandstone gives better results than a pure quartz. Quartz can be recognized

instantly by scratching the knife blade with it—quartz is the only common mineral that will bite into steel, cutting a bright groove with every grain.

If sandstone cannot be found, look for granite or any glittering, crystalline rock except marble. If granite is used, rub two pieces of the stone together until they are smooth before using one as a grindstone.

Axes can be sharpened best by using both file and whetstone, but a stone alone will keep the ax usable. Use the file every few days, the whetstone after each using.

Survival weapons are built to withstand survival conditions, but they do require intelligent care if they are to function when needed.

Keep weapons clean and protected when not in use. Keep the action, receiver walls, bolt and assembly, and especially the barrel clean and free from oil, dirt, snow, or mud. If the barrel is obstructed by mud, snow, or any foreign substance, clean it out before shooting. Never try to shoot out an obstruction. The barrel will burst.

Do not use a weapon as a club, hammer, or pry bar. It is a precisionmade instrument on which your life may depend.

Do not over-oil a weapon. Only a few drops on moving parts are needed.

A piece of cloth on a string pulled through the barrel is a handy substitute for a ramrod and cleaning patch.

If the barrel must be given a thorough cleaning and no powder solvent is available, pour boiling water through it from the breech. Mop up the excess water by pulling a cloth on a string through the barrel and the hot barrel will dry itself.

Wire Escape and Evasion Saw

The wire escape and evasion saw is a handy piece of equipment to have when in timber country. It can be used to perform many tasks in survival such as cutting up game, fish, wood which can be used for fires, cutting poles to make a lean-to for shelter, and many other uses.

The saw will cut easily in any direction. However, for the most efficient operation, use as follows:

1. Keep blade taut and straight; work movement of arms as though one arm was spring-loaded and the other pulled the blade.

2. Short strokes are most effective; only use as much of the blade as needed.

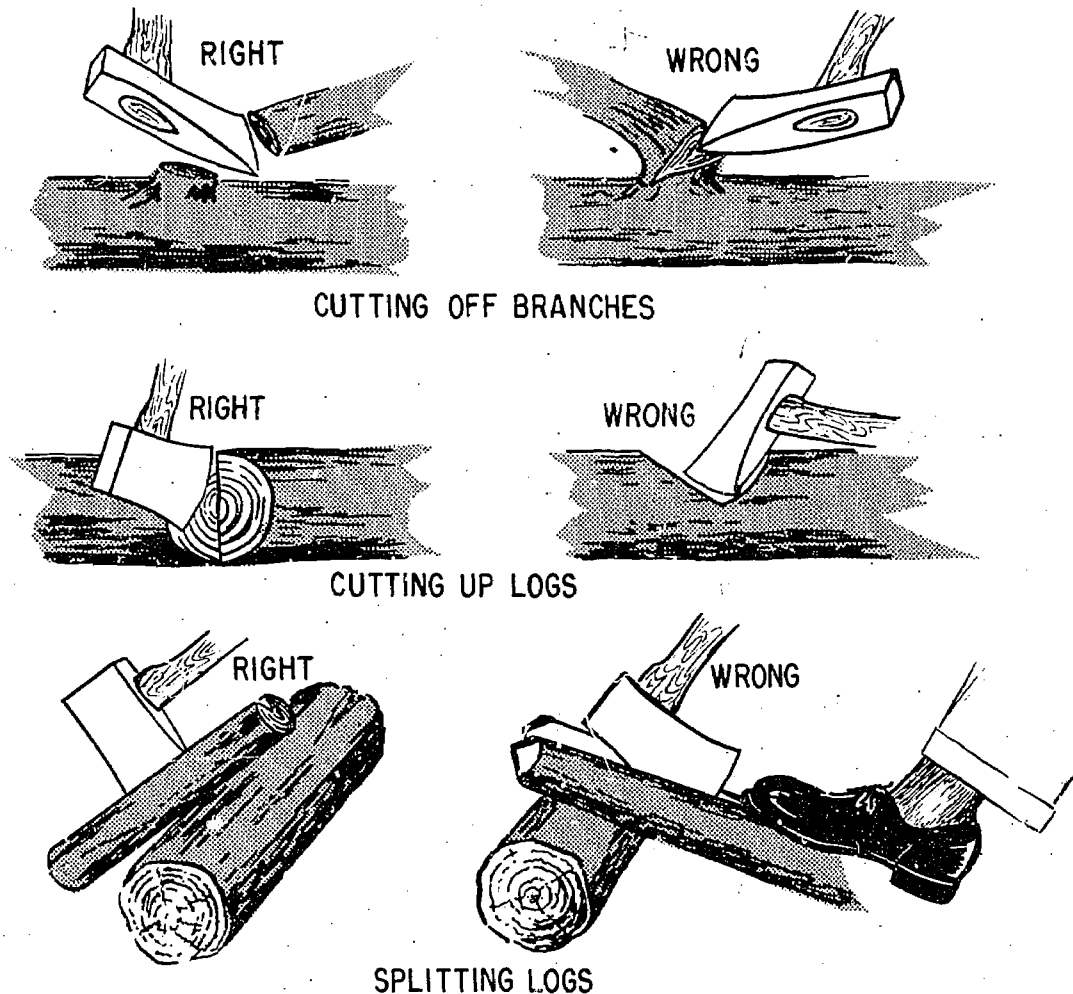

Figure 12-3.—Proper use of axes.

PR.64

3. Light pressure is best; heavy pressure will jam and kink the blade.

4. Avoid sharp bends.

5. Metal and wood can be severed with ease if strokes are true in direction.

6. If the blade breaks, replace the lug on the unbroken section. The saw will work well even with a 4-inch section of blade.

CLOTHING

Think twice before discarding any clothing. Clothing used properly can keep you cool as well as warm. It protects also against sunburn,

insects, pests, and scratches. It can be used for barter.

Try to keep clothing clean and in repair. Clean clothes are better insulators than dirty clothes and they last longer.

Try to keep clothing and shoes dry; use a drying rack in front of a fire. Do not put wet shoes too close to the fire or they will stiffen and crack.

Arctic

It is important to wear clothing properly to keep warm and dry.

Insulation combined with body heat is the secret of warmth. Insulation is largely determined by the combined thickness of all the garments worn. Outer clothing should be wind-proof.

Avoid sweating; it is dangerous because it leads to freezing. When exerting yourself, cut down sweating by opening the clothes at the neck and wrists and loosening at the waist. If you are still warm, remove mittens and headgear, or take off a layer or two of outer clothing. When you stop work, put your clothes on again to prevent chilling.

Wear clothing loosely. Tight fits cut off circulation and increase danger of freezing. Keep ears covered with scarf.

Do not get your boots too tight by wearing too many socks.

If you have no socks and your boots are big enough, stuff dry grass or kapok from aircraft-cushions around your feet—it will collect the frost and make fine insulation against cold. To maintain the insulation value, dry the material and fluff it up when it becomes compacted.

Felt boots, mukluk boots, or moccasins with the proper socks and insoles are best for dry cold weather; shoe-pacs (rubber-bottomed, leather-topped boots) are best for wet weather. Frozen boots or shoe-pacs are unmanageable.

If you lose your boots or if your socks are wet and you have no spares, improvise footgear by wrapping parachute cloth lined with dry grass or kapok around your feet.

Keep clothing as dry as possible. Brush snow from clothes before entering a shelter or going near a fire. Beat out frost before warming garments; dry them on a rack before the fire. Dry socks thoroughly. Do not get boots too near the fire.

Wear one or two pairs of mittens at a time, if they are available.

Wear sunglasses or improvise a pair to prevent snowblindness.

Keep clothing as clean as possible. Replace missing buttons and repair holes promptly.

In strong wind or extreme cold, wrap yourself in your parachute and get behind shelter.

At night, arrange dry spare clothing loosely around your shoulders and hips; it will help keep you warm.

If you fall in water, roll in dry snow to blot up moisture. Roll, then brush off snow. Roll again, until all water is absorbed. Do not take off shoes until you are in shelter.

Desert

Wear clothing for protection against sunburn, heat, sand, and insects. Keep the body and head covered during the daytime.

Wear long pants and shirts with sleeves rolled down. Keep them loose and flapping to stay cooler.

Wear a cloth neckpiece to cover the back of the neck from the sun. If you have no hat, make a headpiece like that worn by the Arabs. (See fig. 12-4.) A pilot chute is adaptable as a parasol for use in the desert; do not be too proud to use one. During dust storms, wear a covering for the mouth and nose; parachute cloth will do.

If you have lost your shoes or they wear out, make sandals as illustrated in figure 12-4.

Tropics

Keep your body covered to (1) help prevent malaria-carrying mosquitoes and other pests from biting you; (2) protect your skin against infections caused by scratches from thorns or sharp grasses; and (3) prevent sunburn in open country.

Wear long pants and shirts with sleeves rolled down. Tuck your pants in the tops of your socks and tie them securely, or improvise puttees of canvas or parachute cloth to keep out ticks and leeches.

Loosely worn clothes will keep you cooler.

Wear a mosquito headnet or tie an undershirt or tee shirt around your head. Wear it especially at dawn and dusk.

In open country or in high grass country, wear a neckcloth or improvised head covering for protection from sunburn and dust. (See fig. 12-4.) Move carefully through high grass; some sharp-edged grasses can cut your clothing to shreds.

If you lose your shoes or they wear out, you can improvise a practical pair of sandals by using the rubber sidewall of a tire or a piece of bark for the soles, with parachute cloth or canvas for the uppers and heel straps.

Dry clothing before nightfall to avoid discomfort from cold.

If you have an extra change of clothes, especially socks, keep them dry to replace wet clothing.

Wash clothing, especially socks, daily. Dirty clothes not only rot but may lead to skin diseases.

USING SKIVVY SHIRT
AS IMPROVED
PROTECTION FROM
SUN AND BLOWING
SAND

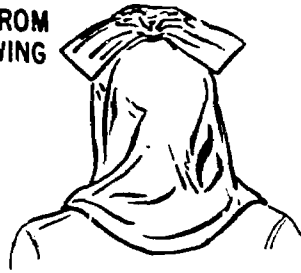

IMPROVED SHOE FOR JUNGLE
OR DESERT USE
(PK-2 CONTAINER)

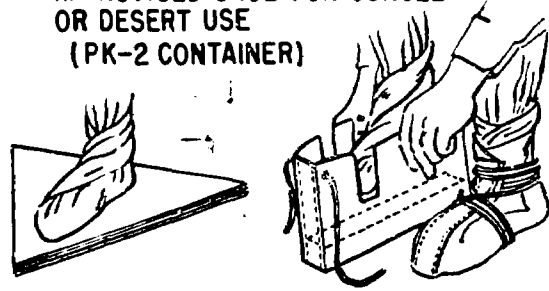

IMPROVED FACE CLOTH
FOR PROTECTION
FROM BLOWING
SAND



IMPROVED
NECKCLOTH FOR
PROTECTION
FROM THE SUN



4 PIECES OF
PARACHUTE
CLOTH

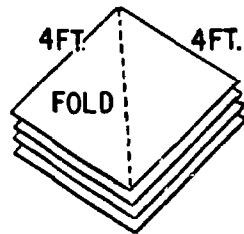

MAKING AN ARAB TYPE HEADDRESS

PR.65

Figure 12-4.—Improved protective clothing for jungle or desert.

FIRST AID

Many men have died needlessly due to the lack of first aid or improperly applied first aid. Knowledge of first aid techniques is the key to preventing these deaths. You may be called upon to use your knowledge of first aid at any time. Your actions at such a time may result either in saving a man's life or in his needless

death. Knowledge of the following items may be found in Standard First Aid Training Course, NavPers 10081-B:

1. Methods of restoring breathing by artificial respiration.
2. Methods of stopping bleeding.
3. Methods of dressing injuries.
4. How to treat burns, shock, and heat exhaustion.

SEARCH AND RESCUE EQUIPMENT

Other than the standard items which are part of the aircraft's inventory, the Navy has provided various droppable kits to be used for search and rescue. Some of these kits can be dropped in free-fall fashion, while others are too fragile for such rough treatment, and must be delivered by small cargo type parachutes. There is no physical limit to the different kinds of equipment that can be rigged for emergency rescue operation. The mental limit, to a great extent, depends on the PR and how well he has prepared himself to cope with emergency rescue techniques.

There are a number of tailormade droppable kits available through Supply. Descriptions of some of these kits, along with information concerning operation of the equipment, are included in this section.

ADSK-2 (AIR DROPPABLE SURVIVAL KIT)

The ADSK-2 consists of an assortment of survival equipment packed into an interior fabric container, and stowed within a metal outer container equipped with a 12-foot flat parachute for dropping from an aircraft in flight to survivors. The interior fabric container is constructed of a rubber-coated nylon cloth fabric, and is equipped with a continuous slide fastener that runs from the top of one side of the container down, around the bottom, and up to the top of the other side. When fully packed, the fabric container is approximately 13 inches in diameter and 36 inches in length.

The outer metal container consists of a steel cylindrical body assembly with a rounded nose, a parachute stowage pan assembly, a metal cover plate, and a cable lanyard assembly for securing the cover plate. The outer metal container assembly is 14 inches in diameter and has an overall length of approximately 40 inches. The parachute is a 12-foot flat canopy type.

Aviation Clothing and Survival Equipment Bulletin No. 29-58 gives a complete description of the ADSK-2 and lists the survival equipment to be carried in the kit. This bulletin should be read and used by all personnel concerned with outfitting the ADSK-2 Air Droppable Survival Kit.

Figure 12-5 shows the outer metal container, with parachute riser snaps assembled, and the interior fabric container.

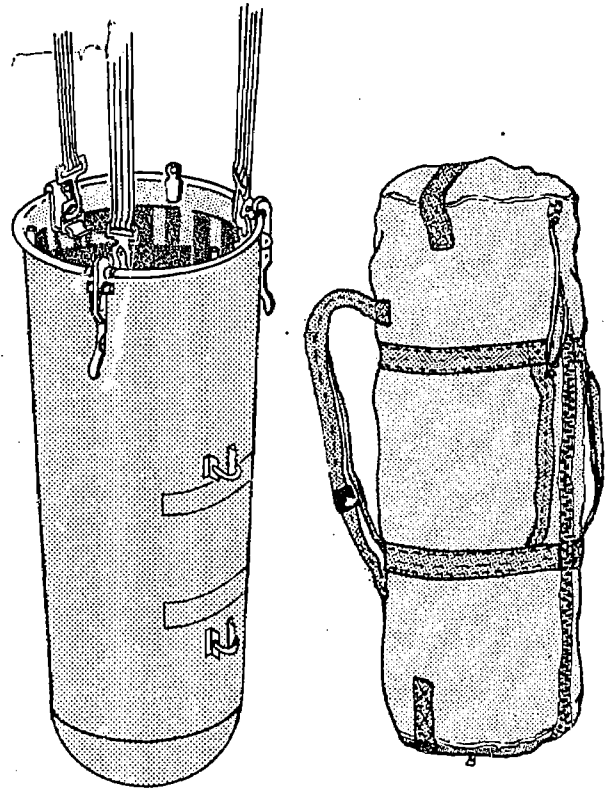

PR.66

Figure 12-5.—Outer metal container, with parachute riser snaps assembled, and the interior fabric container.

ADR-1 RATION KIT

This kit is designed to provide distressed personnel a maximum amount of water so they can maintain the pint-of-water-a-day considered the average requirement for survival. The size of the kit when packed is 21 x 8 x 6 inches. It can be carried and can be dropped from any type aircraft with suitable space. No special dropping technique is required to release the kit from aircraft as it is small enough to be thrown from a cockpit. When the kit is dropped, the aircraft should approach the area as slowly as possible (90 to 100 knots indicated air speed) and at about 100 feet altitude. The kit is buoyant and floats high in the water. The approach should be made into the wind, and the kit should be dropped upwind of survivors. The kit can be secured to a parachute harness or other emergency gear by means of a lanyard

AIRCREW SURVIVAL EQUIPMENTMAN 1 & C

and snaphooks provided. A list of the equipment included is as follows:

- 4 Desalting kits.
- 1 Water storage bag.
- 1 Solar still.
- 1 Jackknife.
- 6 Ration tablet containers.
- Length of cotton twine.

AN/CRT-3A RADIO TRANSMITTER (GIBSON GIRL)

The AN/CRT-3A emergency radio transmitter is used to transmit distress signals, and is carried in most multiengine aircraft. It is also carried in all rescue aircraft and can be dropped to survivors by means of a parachute attached to the container. The container holds the transmitter with the crank attached, one collapsible box kite, one signal light, two hydrogen generators, two transfer units, two balloons, and two spare antennas. The transmitter has a range of up to 1,600 miles, depending on atmospheric conditions. (See fig. 12-6.)

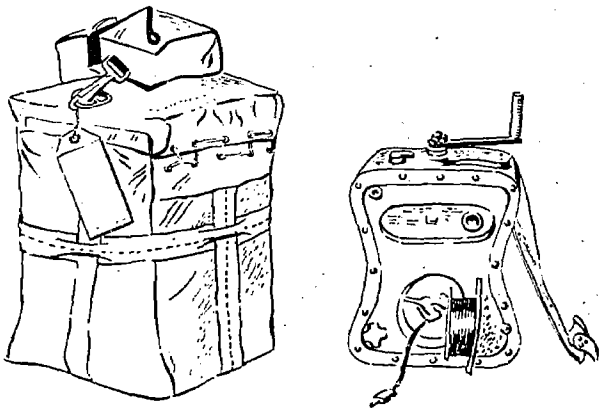

PR.67

Figure 12-6.—AN/CRT-3A radio transmitter (Gibson Girl).

If at all possible, it should be dropped over water, for the possibility of damage to the transmitter is very great when dropped on land. When it is dropped by parachute, the static line should be secured to some part of the aircraft, the aircraft slowed down to its slowest safe

speed, and the transmitter dropped at 300 to 500 feet. The direction of drift should also be taken into consideration when making the drop. If the transmitter is dropped to men in water, it should be dropped upwind; to men in a raft, downwind. In case more than one item is to be dropped, they should be tied together.

If the aircraft is ditched, the transmitter should not be tossed out until the aircraft comes to a complete stop, for there may be more than one impact. When the aircraft has stopped, the container should be thrown out an escape hatch. It will float and can be picked up after other equipment has been removed and the raft has been boarded. If convenient, it should be tied to the raft.

There are two means of raising the antenna, by kite or balloon. If there is enough wind, the kite should be used; if there is no wind, then the balloon may be used. The antenna should never be left up during a storm. There may be severe injuries to personnel as a result of lightning striking and traveling down the antenna.

To set up the transmitter for operation on water, remove the transmitter from the container; then remove the ground wire, unroll it, and drop it into the water. Remove the cotter key from the face of the container, and the antenna compartment will open. With the compartment door fully open, place the cotter key in the slot at the back of the door. This locks the door open. If the kite is being used, remove it from the container and assemble. Estimate the speed of the wind and secure the antenna to the kite either at the point marked WINDS 7 TO 15 MILES PER HOUR or at the point marked WINDS 15 TO 40 MILES PER HOUR.

If the generator and balloon are being used, remove the top from the can containing the balloon. Insert the small end of the transfer unit into the neck of the balloon, making sure that the transfer unit is inserted fully into the neck of the balloon. Take the key supplied with the generator and remove the end of the generator marked TOP. Screw the threaded end of the transfer unit into the threaded depression in the center of the generator. Remove the bottom of the generator with the key supplied and, holding the handle of the transfer unit, insert the generator into the water until the water is even with the top of the generator. It might be necessary to shake the generator slightly to get water into the carbide to begin action. Do not smoke while the balloon is being filled as

hydrogen is explosive. It will take about 30 to 40 minutes to get all the gas from the generator. When the unit stops generating, remove the transfer unit from the generator and throw the generator away. The residue is caustic and will cause burns. Attach the antenna to the balloon and pay it out. Speed can be controlled by the brake on the drum. Turn the brake clockwise to tighten and counterclockwise to let the drum run free.

When the antenna is up, the operator should secure the transmitter by placing it between his legs, running the strap under his legs, and screwing it in the matching position on top.

The transmitter has a selector switch and three positions marked 8364 AND 500 KILOHERTZ, MANUAL, and LIGHT. By placing the selector switch at 8364-500 and turning the crank 80 to 100 rpm an automatic SOS will be transmitted alternating 40 seconds on 8364 kHz and 40 seconds on 500 kHz. The probable daytime range of 8364 will be between 500 and 750 miles. The nighttime range may be increased greatly.

On 500 kHz, when transmitting at sea under ideal conditions, the Gibson Girl has a range of 250 to 500 miles. Transmitting on land, the range may be reduced to as much as 5 to 10 miles.

By placing the selector switch at the manual position, a message or steady tone can be transmitted by using the key on the left side of transmitter.

When the generator light is on, it indicates that maximum voltage (24-31 v) has been reached, and it will do more harm than good to crank any faster. By plugging a signal light in the transmitter and turning the selector switch to LIGHT, a steady light can be obtained or a blinker can be sent by using the key.

The international distress frequency is 500 kHz, and international law requires that all ships and stations maintain silence and guard this frequency for two 3-minute periods during each hour, from 15 to 18 and 45 to 48 minutes past the hour. These are excellent times for transmission.

If no lakes or rivers can be found to use as ground, a hole should be dug in the earth and the ground cable buried. Damp earth makes a good ground. The hole can be dampened by urinating in it and packing the earth around the ground cable. A good ground is important.

CAUTION: When the kit is dropped by parachute, the parachute static line should not be

attached to any part of the body of the person dropping it.

SEARCH AND RESCUE (SAR) KIT

The SAR kit is designed for dropping from a P-3 aircraft to survivors at sea. It consists of two Mk-7 liferafts packed into containers and an equipment container of survival equipment. (See fig. 12-7.)

The SAR kit liferaft and equipment containers are constructed of nylon duck cloth and secured by nylon thread. Each raft is packed in a special container. The survival equipment container has a pouch on each side capable of holding approximately 500 feet of 3/8-inch yellow polyethylene line, the 1000-foot long buoyant polyethylene retaining line, and two nylon static lines. The retaining line is 3/8 inch, 8-stranded, hollow-braided round polyethylene rope. The static lines are 25-foot lengths of nylon cord, type III, with one end terminating in a spring clip and the other forming a bowline and loop for attachment to the inflation valve. A variety of survival equipment is provided and the quantities are based on supporting an average of fourteen survivors.

For information relating to reference numbers, items, and supply data for the SAR kit, refer to the Aviation-Crew Systems Survival Kits and Items Manual, NavAir 13-1-6.3.

SURVIVAL RADIOS AND RESCUE BEACONS

Three types of emergency survival transmitters are used by pilots and aircrewmembers. The first, a hand-size radio beacon which has a self-contained battery and emits a distinctive signal, is normally mounted in the pilot's or aircrewman's RSSK (rigid seat survival kit), so that it is activated automatically upon seat ejection. The second, in addition to its beacon capability, contains a voice transmitter-receiver to allow a downed pilot to communicate with rescuers. The third, usually found aboard multiengine aircraft, has a multichannel capability; it is the AN/CRT-3A (Gibson Girl) and was previously discussed in this chapter.

International agreement has standardized the beacon signal of all emergency and survival radios: it sounds like the whoop-whoop-whoop of emergency alarms on Navy ships. This feature is accomplished by periodic modulation of

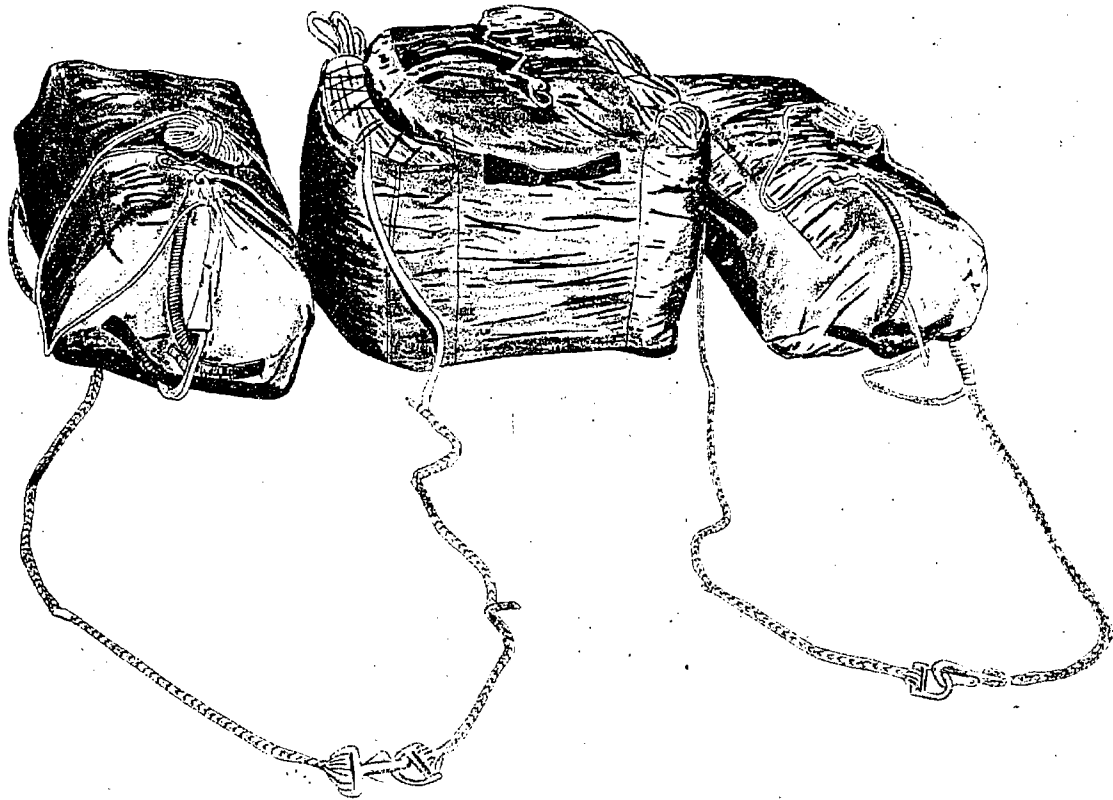

Figure 12-7.—Search and Rescue (SAR) Kit.

PR.470

the RF (radio-frequency) beacon signal with a swept (varying) audio tone. This modulated beacon signal also permits reliable bearings to be taken by UHF direction finding equipment.

Although the Navy has many types of survival radios and beacons available, only those particular radios and beacons currently in use and recently procured will be discussed in this section—the RT-60, AN/PRC-63, AN/PRC-90, and AN/URT-33. (See fig. 12-8.)

RT-60 RADIO RECEIVER-TRANSMITTER

The RT-60 is a dual channel unit, and channel selection is accomplished by mechanical switching of a channel selector switch. The RT-60 provides two-way voice communication with any standard UHF airborne communication equipment on two discrete channel frequencies.

It automatically generates and transmits the standard emergency audio tone. There are five modes of operation, as follows:

1. Receive. The antenna is extended completely until the base ring appears and an audible hissing sound indicates that the receiver is on.

2. Channel selection. For channel selection, turn the channel selector switch to the desired setting.

3. Transmit. Depression of the T-R switch turns the receiver off and the transmitter carrier on for voice modulation or CW operation.

4. Swept tone. For a swept tone signal, the tone lever is moved downward.

5. Simultaneous transmission and aural monitoring of the swept tone. When the T-R switch is depressed, the TONE switch comes on. Simultaneous tone transmission and aural monitoring takes place only on guard.

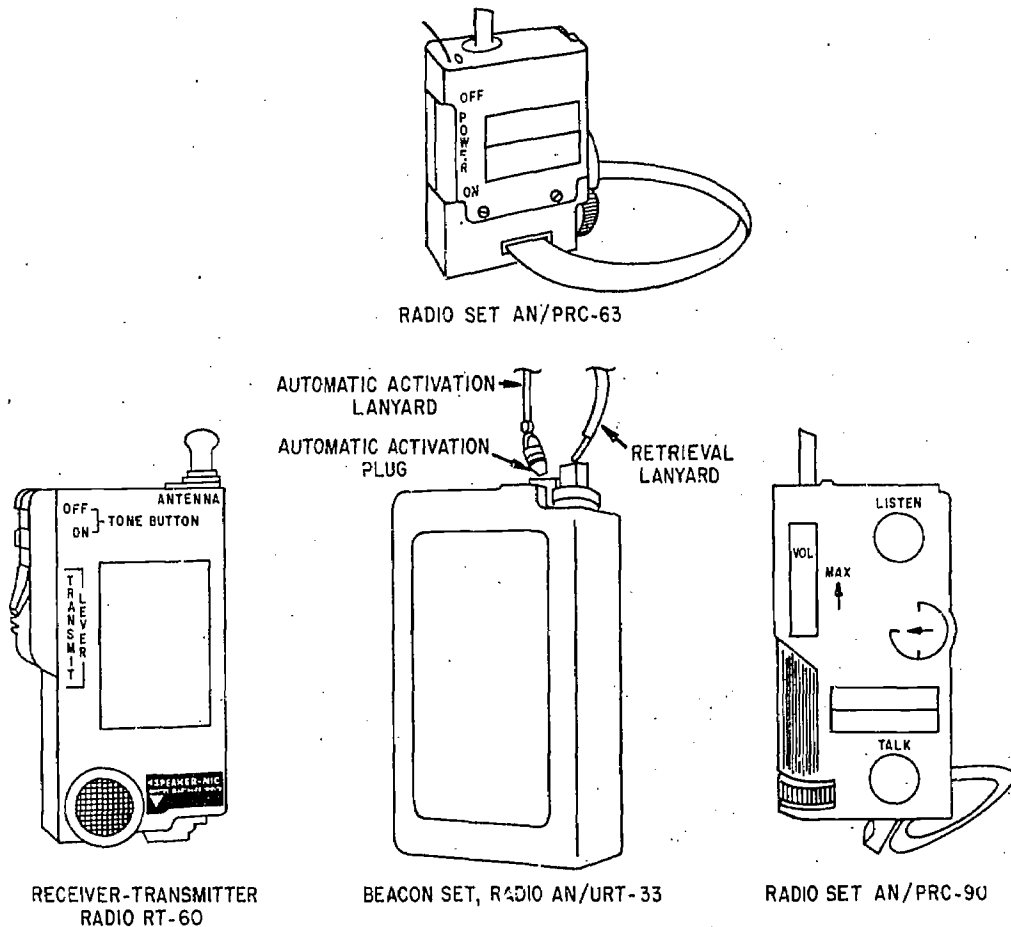

PR.471

Figure 12-8.—Survival radios and beacons.

AN/PRC-63 RADIO SET

The AN/PRC-63 is basically a single channel radio designed so that the beacon is automatically actuated. It is used by the Navy as a personal survival radio only. The AN/PRC-63 occupies about 16 cubic inches, and has a MTBF (mean time between failure) of 800 hours. It presents no serious shock hazard to the operator.

The AN/PRC-63 has been designed to be worn on the flight clothing or lifejackets of aircrewmen. This radio generates and transmits the standard emergency audio swept tone or a continuous wave signal and is capable of providing two-way voice communication with

searching aircraft. The radio is designed to be compatible with all types of airborne direction finding and UHF receiving and transmitting equipment.

A slide actuator turns the radio on (beacon mode) or off and a rocking toggle actuator is used to change from beacon transmit to either voice transmit or voice receive. A volume control is located in the upper right-hand corner of the set and controls the sound level of the beacon tone and the receiver. No other controls are required. The design is such that the set can be operated with either hand, gloved or bare. If the user should release the toggle actuator after the radio has been turned on, the set will automatically return to the beacon

AIRCREW SURVIVAL EQUIPMENTMAN 1 & C

mode of operation. It uses solid state components mounted on a compact printed circuit board and a standard mercury battery pack. It can be operated with one hand.

The AN/URT-33 transmits a pulse modulated RF signal that is swept tone and crystal controlled. Its signal is concentrated and factory set to operate on guard. When the beacon is installed in the RSSK, the pilot or aircrewman should release it as quickly as possible to insure the best radiation and maximum propagation of the beacon signal. After he descends, the pilot can remove the unit from the RSSK (if recovered) and use the beacon to back up his personal radio.

In the manual operation sequence, the beacon is simple to operate. A slide switch is used to turn it on or off. When the unit is to be operated, the lanyard plug is pulled from the switch, the flexible antenna (if connected) is removed and the telescopic antenna is fully extended. Except for a 3-foot retrieval lanyard, no other controls are required. The set can be operated by one hand, gloved or bare.

AN/PRC-90 DUAL CHANNEL RESCUE TRANSCEIVER

The AN/PRC-90 is the survival radio most recently procured for use by the Navy. This dual channel rescue transceiver is a logical extension of the single channel AN/PRC-63. The AN/PRC-90 occupies about 23 cubic inches, weighs about 1 1/2 pounds and is factory set to transmit on guard as well as transmitting an emergency beacon swept tone signal and an MCW (modulated continuous wave) signal. This set also provides two-way voice communication on specific crystal controlled frequencies. Each channel receives UHF transmissions when selected.

Rotation of the FUNCTION switch from OFF to the beacon channel permits automatic transmission of the beacon signal. A push-to-talk button located on the right side is used to transmit on the voice channels. Transmission of the MCW signal is accomplished only by selection of the MCW channel and utilization of the MCW key. To control the set's sound level, a volume

control has been provided in the upper left-hand corner. This set has been designed so that it can be operated with either hand, gloves or bare.

AN/URT-33 RADIO RESCUE BEACON

The AN/URT-33, a radio rescue beacon designed to automatically begin operation during egress from a stricken aircraft, is installed in the RSSK of the aircraft's personnel escape system. Although it is automatically activated, the beacon can be switched to the manual operating mode at the discretion of the pilot. The AN/URT-33 weighs just over 1 pound and occupies 9 cubic inches.

Precautions

To insure better operation of survival radios and beacons, observe the following precautions:

1. Once on the ground, attempt to operate from a clear area.
2. Freezing temperatures (32° F or 0° C) reduce the operating life of survival radio and beacon batteries 12 to 15 percent. This is a temporary condition, however, and can be remedied by removing the battery from the radio and placing it against a warm part of the body.
3. Hold the antenna vertically and attempt to keep the radio more than 14 inches above the ground.
4. If attempting to signal an aircraft that is at a high altitude or approximately overhead, tilt the antenna slightly in a direction which places the edge of a hypothetical doughnut in line with the aircraft.

NOTE: Because all survival radios and beacons operate on emergency frequencies and reception of signals on these frequencies immediately initiates air-sea-land rescue operations, it is essential that these devices function only in actual emergencies. Radios and beacons are frequently handled by aviation personnel and are subject to inadvertent actuation. It is important that users insure that their personal survival equipment is off when not in use.

CHAPTER 13

SEWING MACHINE REPAIR

The PR is called upon to repair parachutes and survival equipment in all types of maintenance activities. Although lower rated men perform much of this work, the task of keeping the sewing machines in top running condition falls on the senior PR. Qualified machine operators may assist in this work under supervision; however, determining the causes of malfunctions, making major adjustments, and replacing parts are responsibilities of the First Class or Chief PR.

Service manuals covering lubrication and adjustment of each class and variety of sewing machine are provided by the manufacturer. Frequent reference to the appropriate manual should be made when performing maintenance of any kind on sewing machines.

CLASS 111 SEWING MACHINES

At least one machine of the 111 W variety can be found in almost any parachute loft. Machines of this class are designated as 111 W 151, 111 W 152, 111 W 153, 111 W 154, and 111 W 155. A brief description of each of these machines is included in this section, pointing out their differences and specific uses. All of these machines except the 111 W 151 are equipped with alternating pressers (walking dogs). The 111 W series machines are alike except for minor differences. Maintenance procedures presented in the following section are those recommended specifically for the 111 W 151, 111 W 155, and the 31-15; in most cases, maintenance for the 111 W 155 machine will apply to other 111 W models as well.

SEWING MACHINE 111 W 151

The Model 111 W 151 sewing machine is a single-needle, lockstitch, rotary hook textile sewing machine, for high-speed straight seaming of medium-heavy materials. In parachute maintenance and repair, this machine is used primarily for general repair sewing.

The 111 W 151 sewing machine differs from other models of Class 111 in that it has a single presser foot instead of the alternating presser foot. Hence, the back of the machine arm casting for the 111 W 151 does not have the lifting rockshaft mechanism that is located above the knee lifter lever on other machines of this class. The 111 W 151 has a maximum speed of 3,500 stitches per minute.

The major assemblies for feeding material and stitching seams derive their power from the arm shaft, which is connected to the balance wheel. Proper operation, maintenance, and repair of the 111 W 151 sewing machine are based upon an understanding of the line of power and the interrelation of all components.

Timing Sequence for the 111 W 151

The first step in timing the 111 W 151 is to set the feed driving eccentric on zero stitches per inch (0 spi). Set the needle bar. With the needle bar in its lowest position (needle bar crank in the horizontal position, the rounded portion on the top and driving stud at the bottom), the connecting link will be vertical. Set the needle bar with the upper timing mark just visible at the base of the needle bar rock frame and tighten the needle bar pinch screw. The needle bar is then properly set.

To set a needle bar which has no mark, set the feed eccentric for 8 stitches to the inch. Then set the needle bar so that when it rises $3/32$ inch from its lowest position and the point of the sewing hook is at the center of the needle, the needle eye will be about $1/16$ inch below the hook point.

The next step is to time the arm shaft with the hook drive shaft. With the connection belt removed, rotate the balance wheel toward the operator until the thread takeup lever is at its highest point, then aline the arrow on the hook drive shaft collar with the timing plate arrow, and replace the connection belt. Rotate the balance wheel and check. The next step is to center the feeding action. For this step the feed driving eccentric must be set on 0 spi.

With the needle entering the feed dog, center the needle in the hole in the feed dog with a distance of $17/32$ inch between the needle bar and the presser bar. In centering the feeding action the following sequence should be followed:

Hold the needle centered in the feed dog with a $17/32$ -inch space between the needle bar and presser bar. Tighten the feed driving crank and feed driving rockshaft crank pinch screws, being sure that the crank is flush with the end of the feed driving rockshaft and parallel with the bed. Next, tighten the needle bar rock frame rockshaft crank pinch screw in the back of the uprise. NOTE: The shank of the presser foot is $17/32$ inch wide and may be used for measuring the space.

The next step is to set the sewing hook to or from the needle. This is done by moving the hook saddle left or right as necessary, the hook should pass the needle as closely as possible without touching. When this is done, retighten the hook saddle screws. Next, set the sewing hook with the needle. With the needle bar on the upstroke, the lower timing mark on the needle bar should be just visible at the base of the needle bar rock frame. Set the point of the sewing hook in the center of the needle $1/16$ inch above the eye. To advance the sewing hook, move the hook drive gear to the right; and to retard, move the hook drive gear to the left.

NOTE: The first screw in the hook pinion gear and the second screw in the hook drive gear are splined screws. The hook drive gear must be centered in relation to the sewing hook shaft at the bottom of the hook saddle.

The 111 W 152 is a single needle, lockstitch, compound feed machine with a vertical-axis sewing hook, and alternating pressers having $3/8$ lift. It has a safety clutch which prevents the hook from being damaged or getting out of time due to accidental strain. The maximum stitch length is 5 to the inch. The machine is used for stitching light leather work such as leather gloves and jackets.

The 111 W 153 and 154 are similar to the 111 W 152 but are used for heavy work such as tents, covers, and upholstery.

SEWING MACHINE 111 W 155

The Model 111 W 155 sewing machine is equipped with a vertical-axis rotating hook to carry the bobbin. No backstitching or darning can be done with this machine. The front or vibrating foot, the needle, and the feed dog move

in unison. Together they move the cloth away from the operator with each completed stitch. The back presser foot, or lifting presser, holds the fabric while the vibrating presser foot rises and moves forward.

The working space on this machine is $10\ 1/2$ inches. The maximum operating speed is 3,500 stitches per minute. This machine can be regulated to sew from $3\ 1/2$ to 32 stitches per inch. The proper needles to use for this machine are of class 135, variety 17, and the sizes of the needles run from 12 to 24. The motor used on the 111 W 155 sewing machine is a Singer electric transmitter, series S59, 210-230 volts, $1/3$ -horsepower, 60-cycle.

The distance between the needle bar and the presser bar on the 155 is $21/64$ inch.

MAINTENANCE AND REPAIRS

Major sewing machine repairs consist primarily of replacing damaged or worn parts. The instructions given in this section cover the near-complete disassembly of the 111 W 155 machine. However, since disassembly means complete resetting and retiming, the PR is cautioned not to strip the machine beyond those steps necessary for the replacement of the defective part. In stripping assemblies, note which screws are set into splines in the various shafts, since the machine cannot be retimed if setscrews are not properly positioned during re-assembly. An understanding of the line of power shown in figure 13-1 will aid in making repairs.

Inspection and Cleaning of New Equipment

If the equipment is crated when received, remove the crating and packing material very carefully without damaging the parts. Watch for and save any special instructions, parts lists, tools, spare parts, and parts which may have been shaken loose from the machine during shipment.

When a machine is received, and before it is installed or used, it must be thoroughly cleaned. All grease, grit, and corrosion preventives must be removed. Dry-cleaning solvent or diesel fuel oil may be used for cleaning. Small parts may be washed in the solvent; large parts should be sponged off with a rag dipped in the cleaning agent. Gasoline should not be used; the lead compounds in gasoline are poisonous and corrosive.

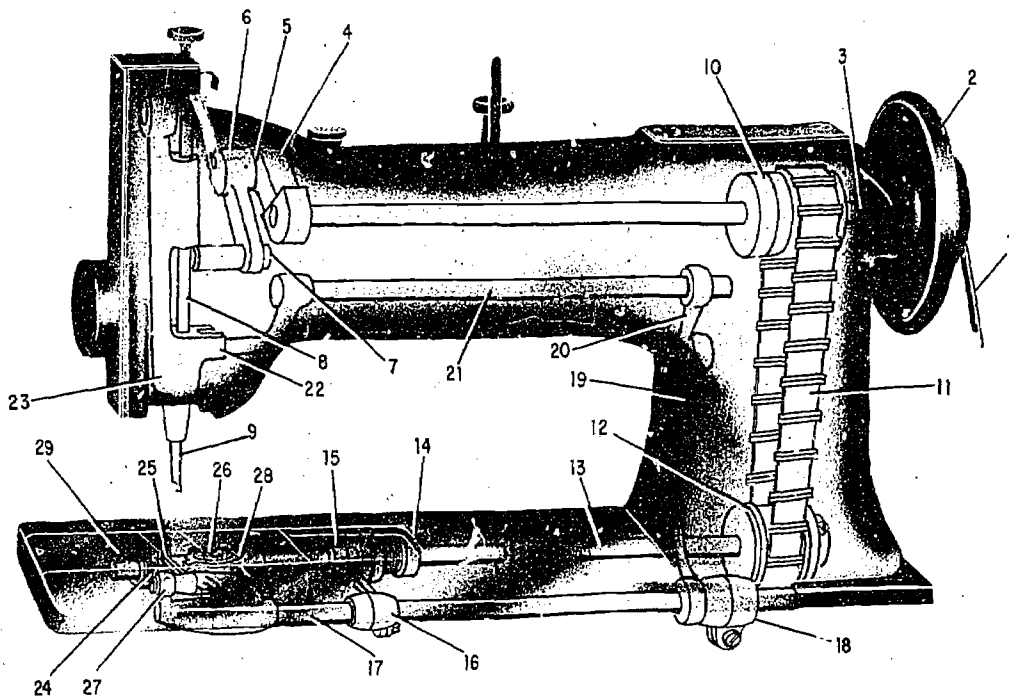

PR.68

LINE OF POWER TO NEEDLE:

1. Round leather belt.
2. Balance wheel.
3. Arm shaft.
4. Needle bar crank.
5. Needle bar driving stud.
6. Needle bar connecting link.
7. Needle bar connecting stud.
8. Needle bar.
9. Needle.

LINE OF POWER TO THE NEEDLE BAR ROCK FRAME:

3. Arm shaft.
10. Arm shaft connection belt pulley.
11. Arm shaft connecting belt.
12. Safety clutch pulley.
13. Hook driving shaft.
14. Feed driving eccentric.
15. Feed driving connection.
16. Feed driving crank.
17. Feed driving rockshaft.
18. Feed driving rockshaft crank.
19. Needle bar rock frame rockshaft crank connection.
20. Needle bar rock frame rockshaft crank.
21. Needle bar rock frame rockshaft.

22. Needle bar rock frame slide block.
23. Needle bar rock frame.

LINE OF POWER TO THE FEED DOG:

3. Arm shaft.
10. Arm shaft connection belt pulley.
11. Arm shaft connecting belt.
12. Safety clutch pulley.
13. Hook driving shaft.
14. Feed driving eccentric.
15. Feed driving eccentric connection.
16. Feed driving crank.
17. Feed driving rockshaft.
24. Feed bar.
25. Feed dog.

LINE OF POWER TO THE SEWING HOOK:

3. Arm shaft.
10. Arm shaft connection belt pulley.
11. Arm shaft connecting belt.
12. Safety clutch pulley.
13. Hook driving shaft.
26. Hook driving gear. (Located under bobbin assembly; cannot be seen in the illustration.)
27. Sewing hook shaft. (Cannot be seen in illustration.)
28. Sewing hook.

Figure 13-1.—Line of power transmission.

The installation of the machine received should be accomplished by following the instructions packed with each new sewing machine.

Examine the nameplate on the motor to see whether it is made to operate on the electrical current provided. Lubricate and test the machine by hand before connecting the belt between the motor and head. The motor should turn in a direction which will cause the balance wheel to turn toward the operator. If it turns in the wrong direction, the leads in the switch box should be disconnected and interchanged.

Adjustments and Repairs

The PR must be able to examine a sewing machine which is sewing improperly, or look at a row of stitches made by this machine and be able to diagnose the cause of the trouble. After making his diagnosis he must also be able to make the proper adjustment and/or repair. In making these adjustments and repairs he will find the troubleshooting chart (table 13-1) a valuable aid in determining the cause and remedy for many different malfunctions.

Stitch Regulator

The 111 W 155 sewing machine can be set to sew from 3 1/2 to 32 stitches per inch, as determined by the following operations:

Hold down the feed regulating plunger in the bed of the machine until it drops into the slot in the feed driving eccentric cam. (See fig. 13-2.) Note that there are two plungers in the bed of the machine. The other plunger (the lock ratchet plunger) is for use in reengaging the safety clutch (explained later). After the plunger drops into the notch, hold it in while rotating the balance wheel backward to shorten the stitch, or forward to lengthen the stitch.

CAUTION: DISENGAGE THE BUTTON BEFORE ATTEMPTING TO SEW. DO NOT ENGAGE THE BUTTON WHILE MACHINE IS IN OPERATION.

The stitch indicator disk (which can be seen through the hole shown in fig. 13-3), normally turns with the balance wheel. The number seen through the hole while the plunger is pressed into the slot of the feed driving eccentric flange indicates the length of stitch for which the machine is set. To test the accuracy of the indicator, sew a measured inch, count the number of stitches being sewed to the inch, and compare the counted number with the number revealed

through the stitch indicator hole when the plunger is engaged in the feed eccentric.

NOTE: The stitch indicator disk does not control the number of stitches per inch; it only indicates how the feed driving eccentric is set. All feeding action originates and is controlled by the feed driving eccentric.

If the stitch indicator disk is not accurately set, it should be adjusted as follows:

With a pencil or tailor's crayon, make two parallel lines 1 inch apart on a scrap of fabric. Sew a line of stitches across both lines and at right angles to them. Count the stitches per inch and adjust the stitch regulator until the machine is sewing 8 stitches per inch.

Open the cover plate on top of the machine arm, and turn the balance wheel until the setscrew hole in the edge of the indicator disk comes into view. Run a screwdriver into this hole, as indicated in figure 13-3, and loosen the screw so that the indicator disk does not turn with the balance wheel.

Hold down the plunger and turn the balance wheel until the plunger drops into the notch in the feed driving eccentric flange. Do not turn the balance wheel after the plunger engages the notch.

Without disturbing the balance wheel and with the plunger still engaging the notch, turn the stitch indicator dial until the figure "8" appears through the hole. Tighten the setscrew in the indicator disk. The machine will then be set to sew 8 stitches to the inch, and the indicator disk should indicate accurately.

Thread Tensions

The bobbin thread tension is regulated by the spring on the outside of the bobbin case. Do not take the bobbin case out of the hook assembly to change the tension. Use a small screwdriver to turn the setscrew in the center of the spring (near the thread slot in the bobbin case). To increase the tension, turn the setscrew to the right.

The tension on the needle thread is controlled by the thumb nut in front of the tension disks. (See fig. 13-2.) To change the needle thread tension, lower the presser foot, causing the tension disks to close, and turn the thumb nut as necessary to put the correct tension on the thread. To increase the tension, turn the thumb nut to the right. Keep in mind that the tension on the needle thread can be regulated only when the presser foot is down.

Chapter 13—SEWING MACHINE REPAIR

Table 13-1. —Troubleshooting chart.

Trouble	Probable cause	Remedy
Thread breakage.	<p>Thread controller.</p> <p>Right twist thread.</p> <p>Hook point piercing needle thread.</p> <p>Needle eye too small.</p> <p>Burr on needle point.</p> <p>Hook out of time.</p> <p>Too much tension.</p> <p>Improper threading sequence.</p> <p>Thread unwinding incorrectly.</p> <p>Thread breaks when clearing work.</p>	<p>Adjust spring tension. Adjust spring stop.</p> <p>Change to left twist.</p> <p>Set hook to needle.</p> <p>Select larger size.</p> <p>Remove burr.</p> <p>Retime.</p> <p>Adjust tension springs.</p> <p>Rethread.</p> <p>Adjust stand and/or spool.</p> <p>Adjust tension release. Thread takeup lever not at highest point.</p>
Skipped stitches.	<p>Hook too far from needle.</p> <p>Hook out of time.</p> <p>Needle bar improperly set.</p> <p>Needle not all the way into bar.</p> <p>Needle incorrectly alined.</p> <p>Thread too large for needle eye.</p> <p>Hook washer pushing needle.</p> <p>Thread controller spring out of adjustment.</p>	<p>Move hook saddle.</p> <p>Retime.</p> <p>Reset.</p> <p>Insert correctly.</p> <p>Insert correctly.</p> <p>Select correct needle.</p> <p>Adjust washer.</p> <p>Adjust tension and stop.</p>

AIRCREW SURVIVAL EQUIPMENTMAN 1 & C

Table 13-1. —Troubleshooting chart—Continued.

Trouble	Probable cause	Remedy
Thread jamming under throat plate.	Operating machine without material. Failure to hold free end of threads for first stitches. Bobbin case opener incorrectly adjusted.	Unthread when running without material. Maintain pressure. Readjust opener.
Thread bunching under material.	Failure to hold free end of threads for first stitches. Needle thread not between tension disk.	Maintain pressure. Thread disk.
Thread jamming under bobbin case.	Turned balance wheel backwards when needle was threaded. Thread, dirt, lint, under bobbin case.	Remove jam. Remove case, clean replace.
Stitches not in line.	Insufficient presser foot pressure. Feed dog too low.	Add spring pressure. Set height to one full tooth.
Not stitching as indicated.	Indicating disk loose. Indicating disk incorrectly set. Automatically changing stitches.	Reset and tighten. Reset and tighten. Adjust reed eccentric gib.
Noisy knee lifter.	Spring improperly adjusted. Lifting rock lever rod too close to connection lever rod.	Adjust while operating. Adjust for operating.
Material damaged by scuffing.	Presser foot pressure too great. Feed dog too high.	Regulate pressure. Set one full tooth or less.

Chapter 13—SEWING MACHINE REPAIR

Table 13-1. —Troubleshooting chart—Continued.

Trouble	Probable cause	Remedy
Sluggish operation.	Improper oil or accumulation of foreign matter.	Clean with recommended solvent; dry and oil.
Feed failure.	Armshaft not in time with sewing hook driving shaft.	Retime by takeup lever and timing collar plate.
	Lifting fork inverted.	Install properly.
	Feed crank pinch screw loose.	Center feed and tighten pinch screw.
	Feed eccentric out of spline.	Reset eccentric.
	Set at zero feed.	Set for stitching.
Failure to make stitch.	Machine out of time.	Inspection and retiming.
	Needle threaded from wrong side.	Thread correctly.
	Hook too far away from needle.	Reset hook saddle.
	Wrong variety needle.	Change to correct length.
	Bent needle.	Change.
	Needle not all the way into the needle bar.	Insert correctly.
	Safety clutch disengaged.	Clear jam. Reengage clutch.
Binds.	Alternating pressers improperly set.	Reset to lift equally.
	Bobbin case opener set too close.	Set to allow needle thread passage around bobbin case lug.
	Arm shaft friction washer missing.	Install friction washer.
	Balance wheel improperly set for end tolerance.	Tighten adjusting screw, back off 1/4 turn, tap screw with mallet.

Table 13-1. — Troubleshooting chart—Continued.

Trouble	Probable cause	Remedy
Binds.	Needle bar too high or too low in frame.	Reset needle bar.
	Feed-driving connection against eccentric body.	Set connection flush with cam.
	Hook guard washer rubbing opener lever link.	Replace washer. Adjust hook assembly for tolerance.
	Pinion gear against saddle.	Relocate on hook shaft.
	Driving gear against saddle.	Relocate to center on centerline of hook shaft.
	Bobbin case thread jam.	Remove case, clear, reinstall.
	Feed dog against throat plate.	Adjust to proper height. Adjust to center of throat plate.
	Feed bar hinge stud screw.	Adjust for operating tolerance.

Safety Clutch

A safety clutch, located in the lower belt pulley, prevents damage to the splined drive shaft and gears in the event of a jammed sewing hook. When a jam occurs, the latching lever disengages from the notch in the shaft collar, thereby permitting the lower belt pulley to turn freely on the hook drive shaft until it is reengaged.

To reengage the safety clutch after it has been operated automatically, press down the plunger nearest the uprise so that it engages in the lock ratchet on the hook driving shaft, and turn the balance wheel backward. The plunger will hold the hook driving shaft until the safety clutch locking lever turns around the collar and drops into the original notch. This

operation will reengage the clutch without disturbing the timing of the hook. Release the plunger, and turn the balance wheel forward to sew.

Setting Timing Arrows

When the thread takeup lever is at its highest point, the arrow stamped on the timing collar of the hook driving shaft will point to the arrow stamped on the timing plate attached to the underside of the bed. (See fig. 13-4.) When the machine is so set, the arm shaft and the hook driving shaft are properly timed.

If the thread takeup lever is not at its highest point when the timing arrows are matched, the procedure for setting the machine is as follows:

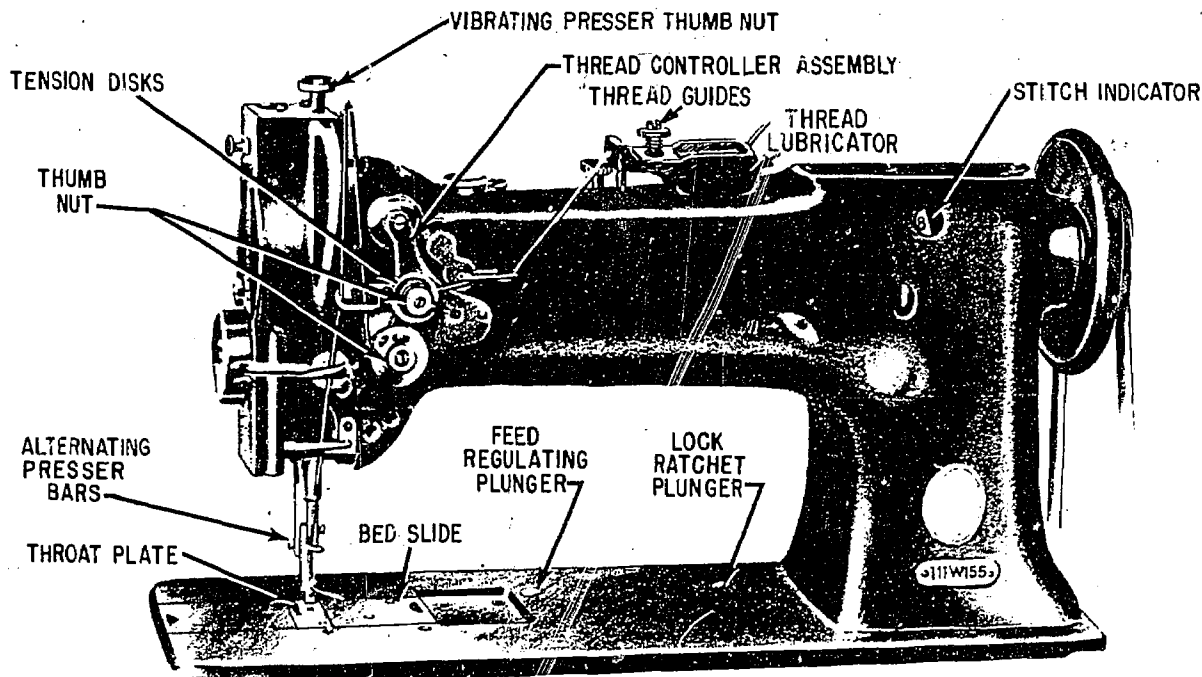
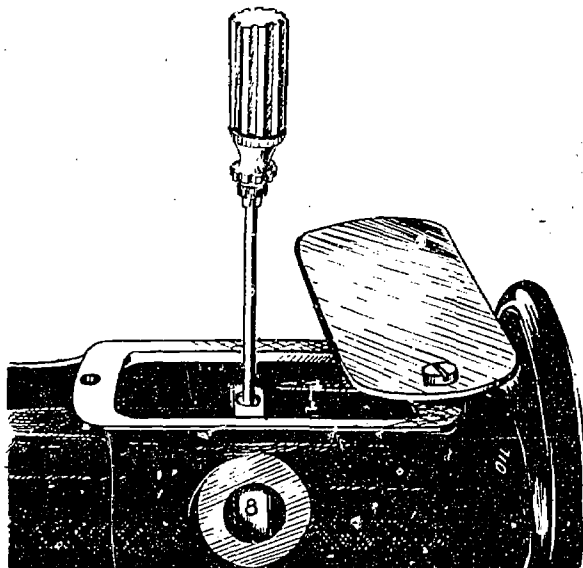

Figure 13-2.—Model 111 W 155 sewing machine.

PR.69

Remove the arm shaft connection belt from the safety clutch pulley. Turn the balance wheel forward until the takeup lever reaches its highest point.

Rotate the safety clutch pulley with the fingers until the two arrows are matched. Keeping the takeup lever at its highest point and with the arrows matched, replace the arm shaft connection belt.



PR.70

Figure 13-3.—Adjusting the stitch indicator.

Adjusting Relative Height of Lift of Vibrating and Lifting Pressers

The amount of lift of vibrating and lifting presser feet should be regulated according to the thickness of the material being sewed. The feet should lift just high enough to clear the material. As a rule, the vibrating and lifting pressers should lift an equal height, but some grades of work may require that they lift an unequal height. To change the relative lift of the presser feet loosen the screw (2, fig. 13-5) at the back of the machine. Move the presser bar upward or downward as required, then securely tighten the screw.

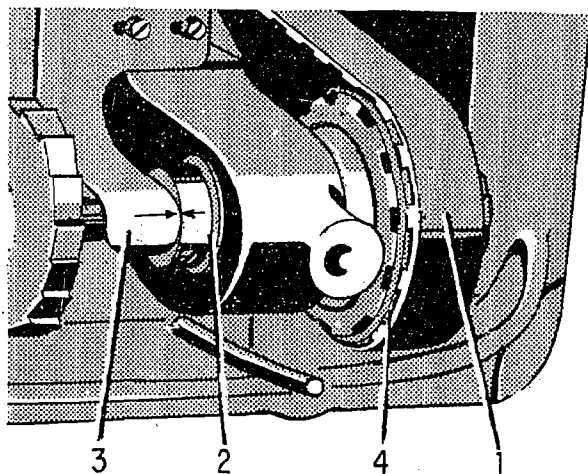

PR.71

1. Arm shaft connection belt.
2. Arrow on arm shaft connection belt timing collar.
3. Arrow on arm shaft connection belt timing plate.
4. Safety clutch pulley.

Figure 13-4.—Timing arrows.

Adjusting Height of Lift of Vibrating and Lifting Pressers

When centering the feeding action on the 111 W 155, the distance between the presser bars should be $21/64$ inch. The 111 W 155 has two adjustment points on the alternating pressers, which have a total height of $1/2$ inch. To change the height of lift of the presser feet, loosen the setscrew (1, fig. 13-5) in the feed lifting eccentric. Turn the balance wheel forward until the adjusting screw is accessible. The adjusting screw is not visible in figure 13-5, but will be located approximately in the same position as the setscrew when the balance wheel is turned forward. To increase the amount of lift, turn the adjusting screw counter-clockwise. To decrease the amount of lift, turn the adjusting screw clockwise. Then turn the balance wheel forward and retighten the setscrew.

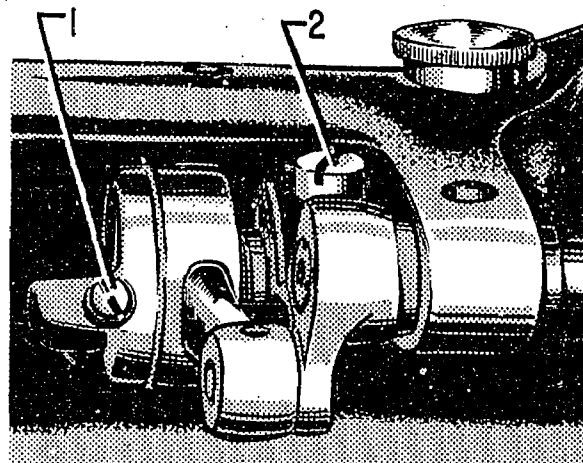

PR.72

1. Setscrew for the adjusting screw for adjusting the height of lift.
2. Setscrew for adjusting the relative height of alternating pressers.

Figure 13-5.—Adjusting the relative height and the height of lift of the vibrating and lifting pressers on machine 111 W 155.

Timing Sewing Hook with Needle

With the needle bar on the upstroke ($3/32$ inch above its lowest point), the point of the sewing hook should be in the center and $1/16$ inch above the eye of the needle.

If the needle bar does not have timing marks, turn the balance wheel forward until the needle bar has descended to its lowest position. Set the point of the needle even with the bottom of the feed dogs, rotate the balance wheel toward the operator until the needle bar has risen $3/32$ inch, then set the sewing hook with the needle.

If the needle bar does have timing marks, rotate the balance wheel forward until the needle bar is at its lowest position. Set the needle bar with the upper timing mark just visible at the base of the needle bar rock frame. Rotate the balance wheel forward until the needle bar has risen $3/32$ inch (the distance to the lower timing mark just visible at the base of the needle bar

rock frame). Set the point of the sewing hook in the center of the needle $\frac{1}{16}$ inch above the eye.

To test for the correct timing of the needle, see that the thread takeup lever is at its highest point, that the timing arrows are matched, and that the hook crosses the center of the needle $\frac{1}{16}$ inch above the eye on the upstroke. If the test is not satisfactory, or if the sewing hook is not picking up the thread, the machine should be timed in accordance with the procedures just given.

To set the sewing hook with the needle, loosen the two screws in the hub of the hook driving gear (fig. 13-6). Be careful to keep the spot or spline screw in the slot cut into the driving shaft. Tap the hook driving gear along the shaft. If the hook is too slow, tap the gear to the right; if the hook is too fast, tap the gear to the left.

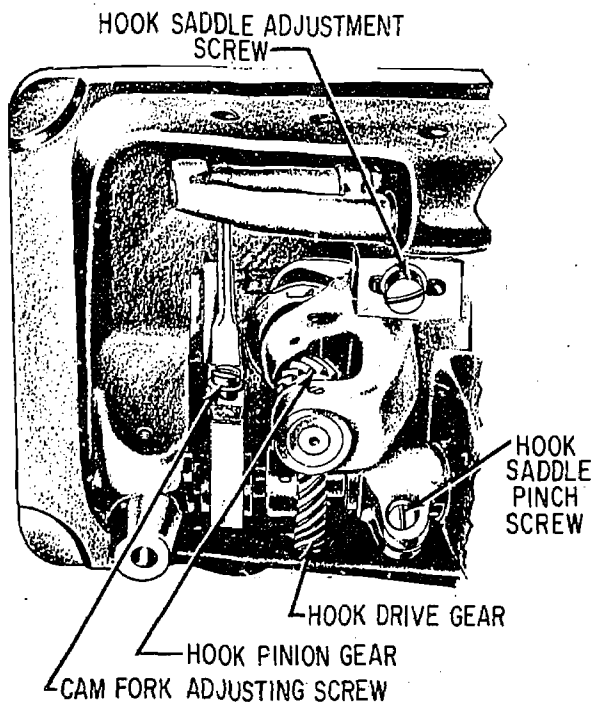

PR. 73

Figure 13-6.—Hook saddle and adjustments.

When the hook crosses the needle at a point $\frac{1}{16}$ inch above the eye of the needle, securely tighten the two screws in the hub of the gear.

Be certain that the position screw is in the slot in the shaft. Make certain that the timing arrows mentioned are matched when the hook is correctly timed.

Raising and Lowering Needle Bar

Before attempting to raise or lower the needle bar, see that the needle is set correctly and is as far up in the needle clamp as it will go. Set the feed eccentric to indicate 0 stitches. Remove the faceplate, and take off the throat plate so the needle and hook can be seen.

Loosen the needle bar connecting stud pinch screw, and raise or lower the needle bar as required. When the needle rises $\frac{3}{32}$ inch from its lowest position, the point of the hook should be crossing the center of the needle at a point $\frac{1}{16}$ inch above the eye.

Procedure for setting the marked needle bar follows:

Needle bars which have been installed by the factory have 2 lines across the bar about 2 inches above the lower end. When the needle bar (fig. 13-7) is at its lowest position, the upper mark should be just visible at the end of the needle bar rock frame. If a marked needle bar must be raised or lowered, loosen the needle bar connecting stud pinch screw, and raise or lower the bar until the upper mark is just visible at the bottom of the needle bar rock frame when the bar is at its lowest position. Then retighten the screw.

If the hook is out of time after changing the height of the needle bar, follow the timing instructions previously given.

Setting Sewing Hook To or From Needle

The point of the hook should pass as close to the needle as possible without touching it. If the hook is too far from the needle, it will divide and cut the strands of the needle thread. If the point of the hook strikes the needle, it will be blunted or otherwise damaged.

The procedure for setting the hook to or from the needle follows:

Turn the balance wheel forward until the point of the hook stands opposite the center of the needle. Loosen the two screws which hold the hook saddle. Tap the hook saddle to the right or left as required to bring the hook as close to the needle as possible without touching it. Retighten the screws.

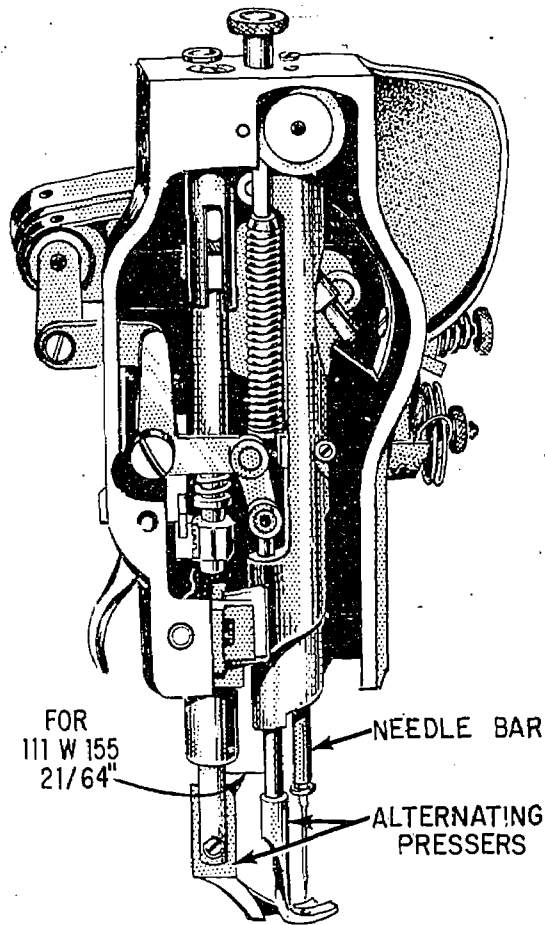

PR.74
Figure 13-7.—End view of machine (with faceplate removed).

The function of the hook guard washer (needle guard), which is attached to the bottom of the sewing hook, is to prevent the point of the hook from striking the needle if the needle is deflected toward the hook when passing through the material.

The needle guard can be bent with a small pair of pliers until it prevents the hook point from striking the needle, but it should not be bent outward enough to deflect from its normal path.

If setting the hook closer to the needle throws the hook out of time with the needle, retune the hook.

Removing, Cleaning, and Replacing Bobbin Case

The bobbin case may be removed from the hook without taking the hook out of the machine. To remove the bobbin case, proceed as follows:

Remove the bed slide, throat plate, and feed dog to reveal the parts shown in figure 13-8. Remove the bobbin case opener.

Remove the hook gib by removing the two screws which hold it to the body of the hook. The gib and screws are shown removed from the machine in figure 13-9. Lift the bobbin case out of the hook body. Clean the bobbin case with dry-cleaning solvent or diesel fuel. Gasoline must not be used for this purpose.

After the bobbin case and hook gib have been replaced, replace the throat plate so that the bobbin case lug fits into the slot in the bottom side of the throat plate. Then replace the bobbin case opener.

The bobbin case opener should be adjusted so that it permits the needle thread to pass the triangular projection on the bobbin case and then pass between the bobbin case lug finger and the bottom of the throat plate.

Raising or Lowering Feed Dog

The normal adjustment of the feed dog is as follows:

It should rise no higher than the depth of the teeth above the throat plate when, at its highest position.

To adjust the feed dog, remove the throat plate, clean all lint and dirt from the teeth of the feed dog, replace the throat plate, tip the machine back on its hinges, and turn the balance wheel forward until the feed dog rises to its highest position.

Loosen the feed lifting cam fork screw. Raise or lower the feed bar as necessary to make the feed dog stand the distance of a tooth above the throat plate when the dog is at its highest position. Tighten the feed lifting cam fork screw when the proper adjustment is accomplished.

When this adjustment is made, be careful that the underside of the feed dog does not drop low enough to strike the sewing hook.

Adjusting the Feed Driving Eccentric

A feed driving eccentric (fig. 13-10) is provided with a gib which can be adjusted to take

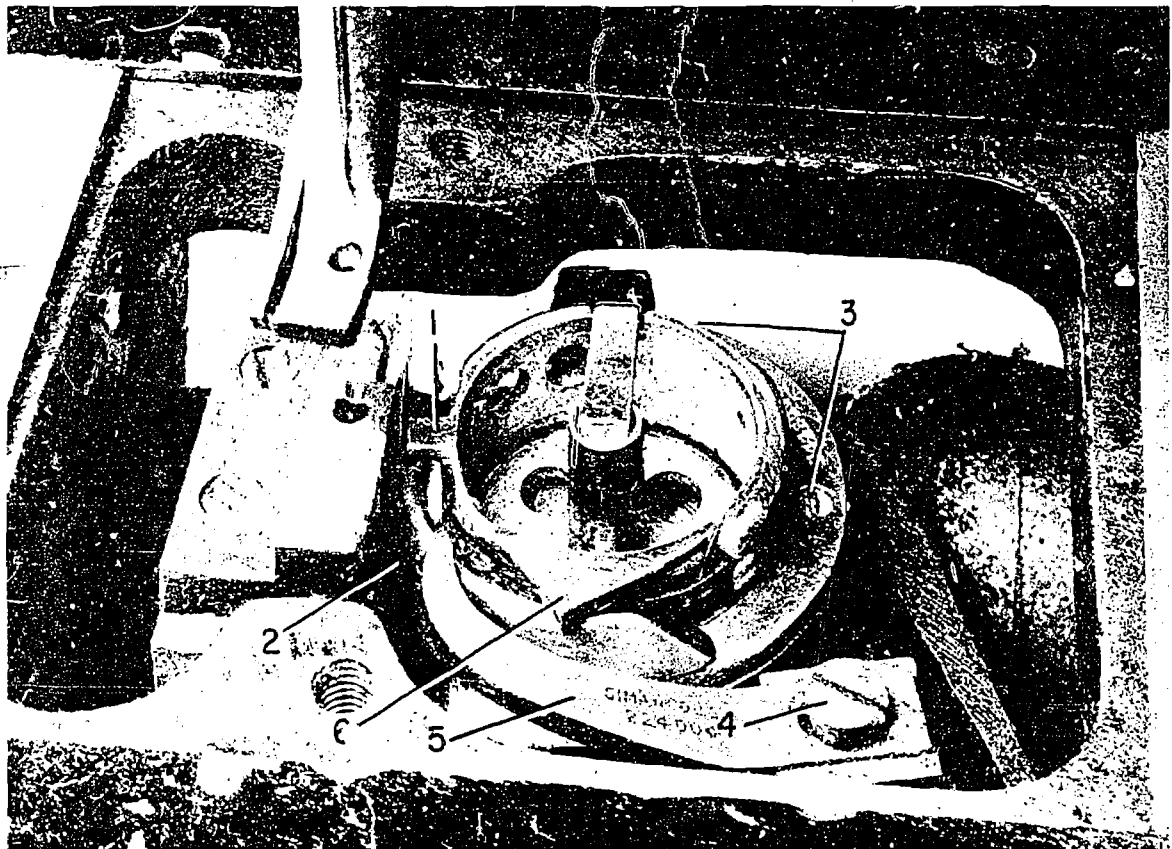

PR.75

- | | |
|--------------------------------------|------------------------------|
| 1. Bobbin case lug. | 4. Bobbin case opener screw. |
| 2. Hook guard washer (needle guard). | 5. Bobbin case opener. |
| 3. Hook gib screws. | 6. Bobbin case projection. |

Figure 13-8.—Bobbin case assembly with throat plate and bed slide removed.

up any wear or loose motion between the feed driving eccentric and the feed driving eccentric body.

To adjust the gib, loosen the two locking screws near the end of the gib. Tighten the screws until all play is eliminated and the eccentric fits snugly in the slot in the eccentric body or flange. Retighten locking screws.

The adjusting spring presses against the feed eccentric flange to prevent it from moving out of position. If the setscrews in the collar are loosened, the collar may be moved to the right or left to change the pressure. The collar

should be set so that the pressure of the spring holds the flange in firm contact with the feed eccentric body.

Removing the Replacing Arm Shaft Connection Belt

To remove the arm shaft connection belt, remove the balance wheel, then loosen the screw which holds the arm shaft bushing. The bushing can then be removed from the machine. Remove the belt from the lower pulley, then lift the belt up through the arm cap hole as far as possible

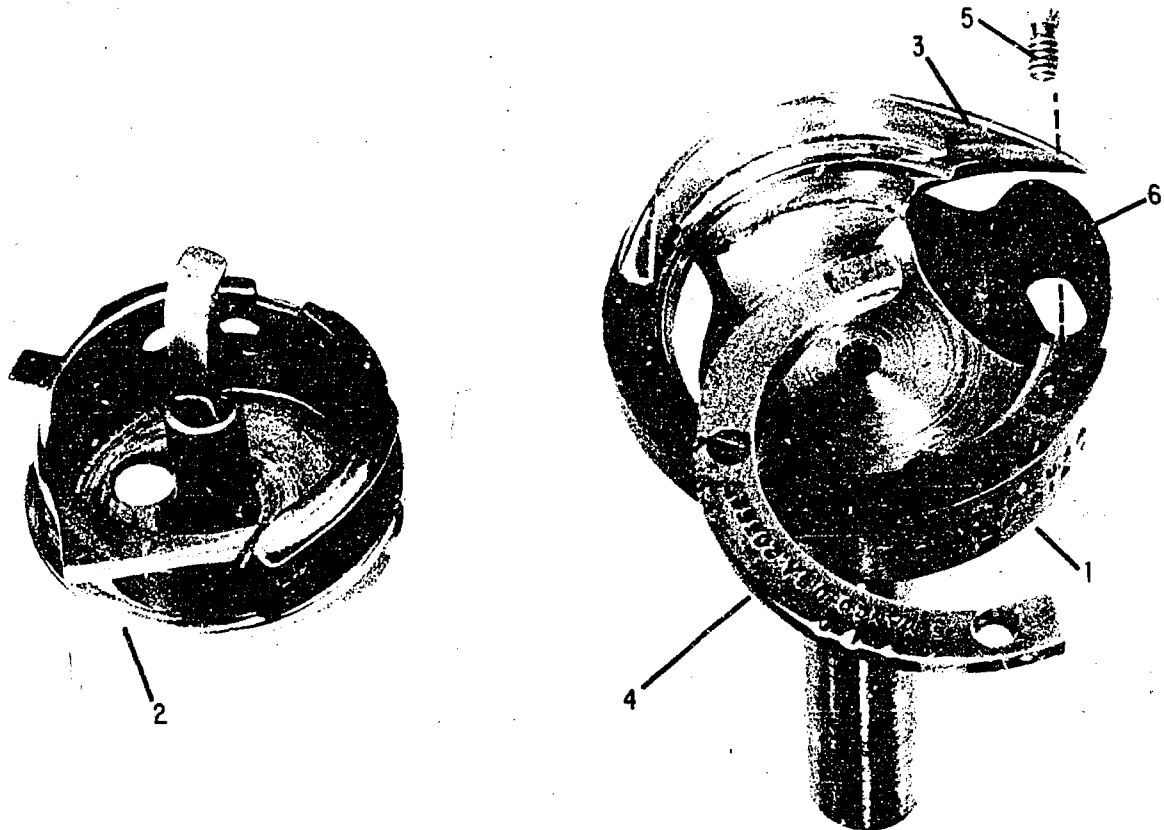

- | | |
|-------------------|-----------------------|
| 1. Hook body. | 4. Hook gib. |
| 2. Bobbin case. | 5. Gib screw. |
| 3. Point of hook. | 6. Hook guard washer. |

PR.76

Figure 13-9.—Hook assembly disassembled.

and draw it out through the space normally occupied by the arm shaft bushing. (See fig. 13-11.)

To replace the belt, work it through the space normally occupied by the arm shaft bearing and draw the belt down into the rise of the arm and over the arm shaft connection belt pulley. Replace the bearing with the oil hole up and tighten the bearing setscrew. Replace the balance wheel and tighten the balance wheel setscrew. Replace the balance wheel adjusting screw. Turn the balance wheel forward until the thread takeup lever is at its highest point and set the timing arrows as previously explained. Slip the

connection belt over the safety clutch pulley. Reset the balance wheel adjustment screw by backing out 1/4 turn and striking with mallet.

Removing and Adjusting Tension and Thread Controller

The tension and thread controller is composed of two tension controlling components, one assembled on the tension stud and the other on the thread controller stud. (See fig. 13-12.) The spring and disks on the tension controller place tension on the thread when the presser foot is down. The spring in the thread controller

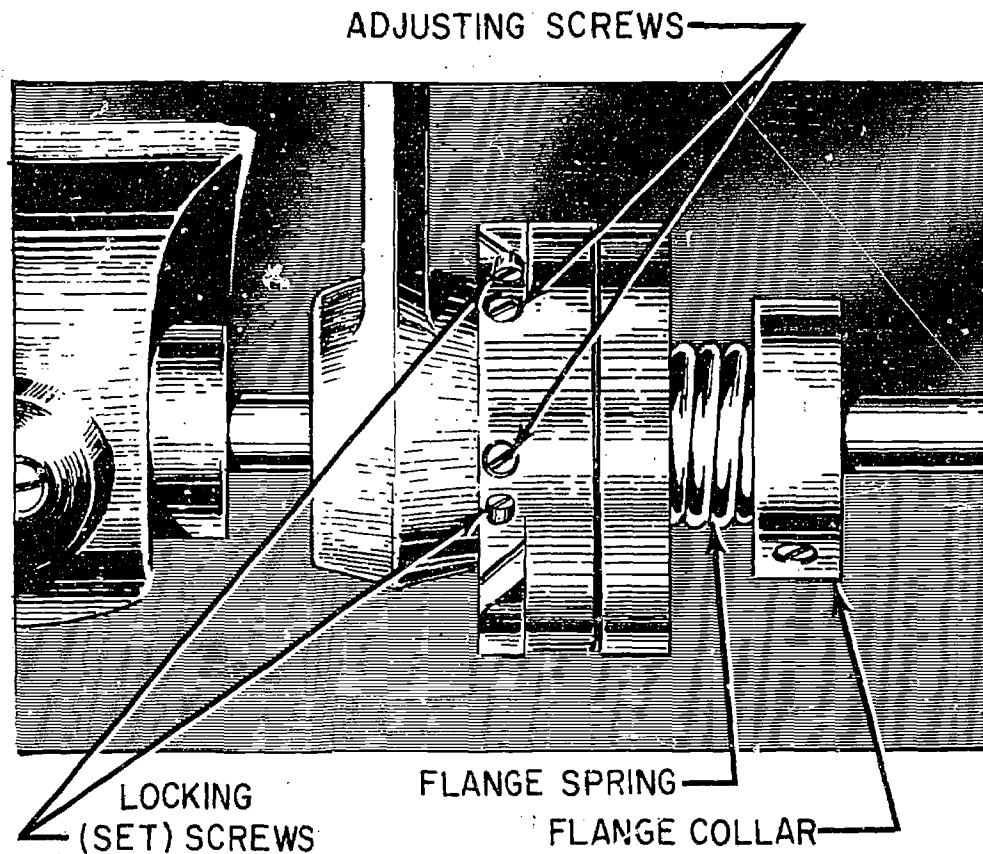

Figure 13-10.—Feed eccentric.

PR.77

pulls slack out of the thread between the time the thread takeup lever starts down and the needle point reaches the material.

The tension controller is adjusted with the thread controller stud. The spring stop is adjusted by loosening the screw and moving the stop to the right or left as necessary to stop the action of the spring as the needle enters the material. The amount of the tension will vary with the kind of thread being used.

SINGER SEWING MACHINE 211 W 151

This machine performs the same functions as the 111 W 151. It is a newer model, more streamlined and modern in appearance and has some design features not found in the 111 W 151

machine. (See fig. 13-13.) These features include a new lubrication system, a thread takeup lever guard, a thread lubricator, and a new stitch indicator among other improvements.

The 211 W 151 sewing machine is a high-speed (4,000 rpm maximum), single-needle, lockstitch type machine, designated for sewing medium to heavy weight fabrics. It is belt-driven and has a rotary hook on a vertical axis which makes two revolutions for each stitch.

It is equipped with a safety clutch (fig. 13-14) that must not be tampered with as the torque is preset at the factory. If the hook is obstructed by foreign matter, the clutch will disengage, and will reengage only after the area has been cleared. The feeding mechanism is compound drop and needle feed with the maximum stitch length at 5 stitches per inch.

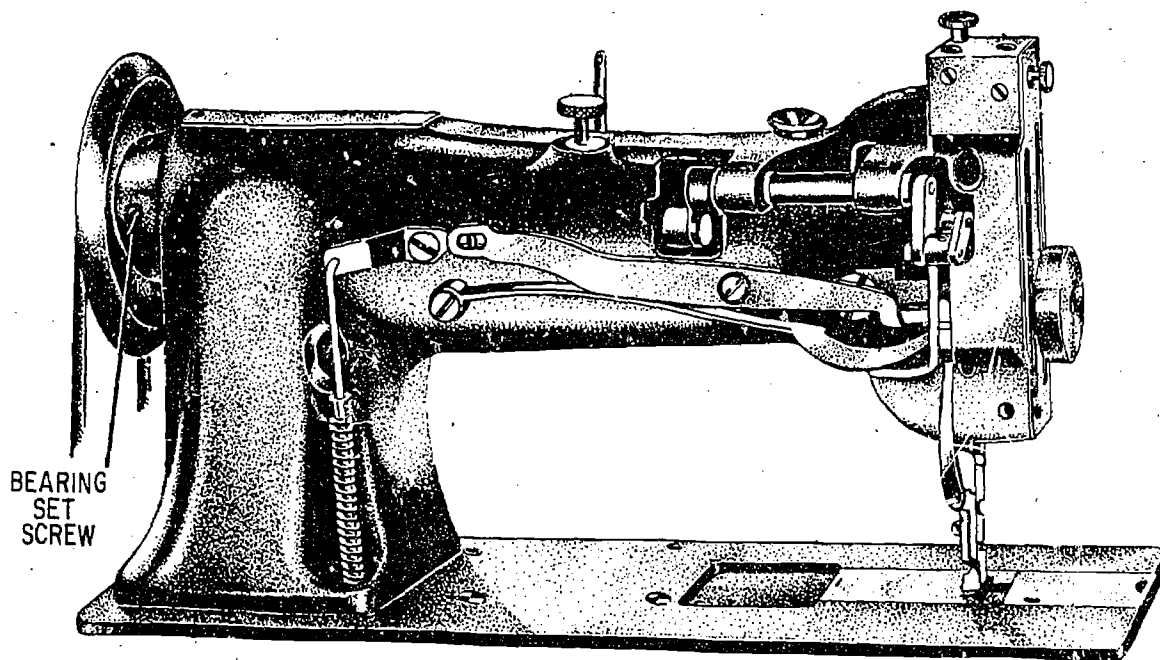

Figure 13-11.—Rear view of machine.

PR.78

Other features of the machine include a hinged presser foot, a presser bar lift of $1/4$ inch, a needle bar stroke of $15/16$ inches, and a bed which is $20\ 3/8$ inches long by 7 inches wide and a space of $12\ 1/2$ inches to the right of the needle.

NEEDLES

The needles used in this machine vary according to the distance desired under the presser foot. Use 135 x 7 needles with machines set with $1/4$ -inch clearance under the presser foot, and 135 x 17 needles with those set with $3/8$ -inch clearance (lift).

ADJUSTMENTS

Setting Needle Bar

Place the needle bar up into the needle bar holder as far as possible. Hold in this position and turn the balance wheel toward the operator until the needle bar is at its lowest position. When in this position, set the bar so that the

upper timing mark is just visible below the needle bar frame, and tighten the needle bar connecting stud pinch screw.

In the case of a needle bar without timing marks, set the machine to 0 stitches per inch and place the needle bar up in the holder as far as possible. Turn the balance wheel by hand until the bar is at its lowest position. After reaching the lowest position of the needle bar, continue turning the balance wheel toward the operator until it reaches $3/32$ inch above its lowest point, then set the eye of the needle $1/16$ inch below the point of the sewing hook.

Setting Needle

To set the needle, insert the needle shank as far as possible into the needle bar with the long groove of the needle to the left and tighten the screw. (See fig. 13-15.)

Relative Position of Needle Bar and Presser Bar

To set the relative position of the needle bar to the presser bar, loosen the needle bar rock

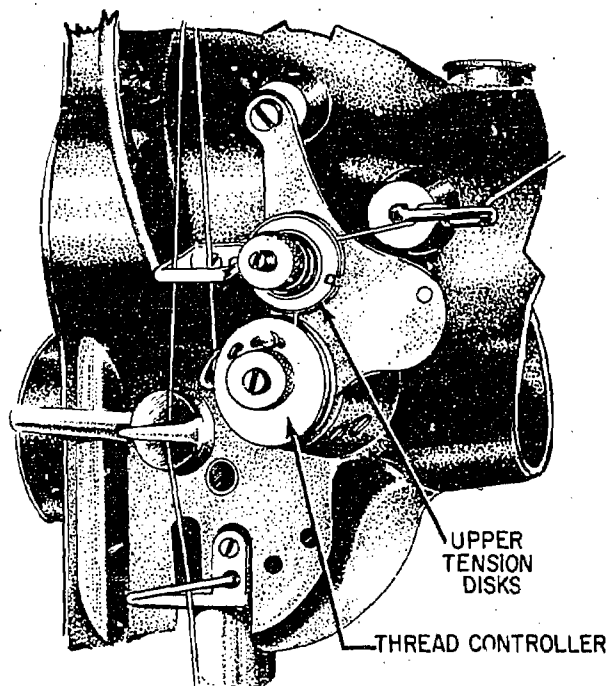

PR.79

Figure 13-12.—Tension and thread controller.

frame rockshaft clamp screw located behind the cover plate on the front upright position of the arm (fig. 13-16). Set the needle bar so that the distance between the needle bar and presser bar is $17/32$ inch. Retighten clamp screw. NOTE: A handy tool for use in making this adjustment can be manufactured locally from a thin piece of metal stock filed to exactly $17/32$ -inch width. This gage should be placed between the two bars while the clamp screw is being tightened. This will enable the operator to keep pressure on the loose needle bar.

Adjustment Height of Sewing Hook

Before attempting to adjust the height of the sewing hook, it is necessary to make up a feeler gage for use when testing the height. This gage can be made of 0.032-inch shim stock, or a regular feeler gage of 0.032 can be cut or trimmed down so that it will fit in the small groove in the throat plate which retains the bobbin case stop finger.

After testing with the gage and the hook height is found unsatisfactory, turn the balance wheel

so that the two setscrews in the bottom of the hook are accessible; loosen with an Allen wrench. Remove the cloth washer from the bobbin case and turn the hook until the height adjusting screw is directly under the hole in the bobbin case. (See fig. 13-17.) Turn the screw in to raise the hook, and out (while pressing down on hook) to lower. Set so that gage will barely pass between the throat plate and bobbin case stop finger. Retighten the Allen setscrews and turn adjusting screw in so that a slight tension is left on the screw.

Setting Sewing Hook To or From Needle

To set the relative position of the hook saddle to the needle, loosen the hook saddle adjusting screws (fig. 13-18) and slide the hook saddle to the right or left as necessary in order to set the point of the hook as close as possible to the needle (without actually touching). After setting the hook saddle, check the clearance between the hook drive gear and the face of the hook saddle. This clearance should be 0.008 inch; if out of tolerance, reset by loosening the screw and setscrew in the hook drive gear and moving the gear to the right or left to the proper clearance.

Timing Bobbin Case Opener

To set the bobbin case opener, the balance wheel is turned toward the operator until the lower timing mark on the needle bar is barely visible below the needle bar frame on its upward stroke. Tip the machine back and loosen the two Allen screws in the bobbin case opener drive gear, then line up the timing marks by turning the opener shaft with a screwdriver. The timing marks are located as follows: one on the flange of the opener, and the other on the hook saddle (fig. 13-17). Adjust the opener so that it lightly touches the bobbin case and turns it enough to make a sufficient opening for a free passage of thread between the bobbin case stop finger and the throat plate. Tighten the screws in the bobbin case opener drive gear.

Raising Or Lowering Feed Dog

To raise or lower the feed dog, remove the throat plate and clean all lint and dirt from between the grooves and teeth of the feed dog. Tip the machine back and turn the balance wheel

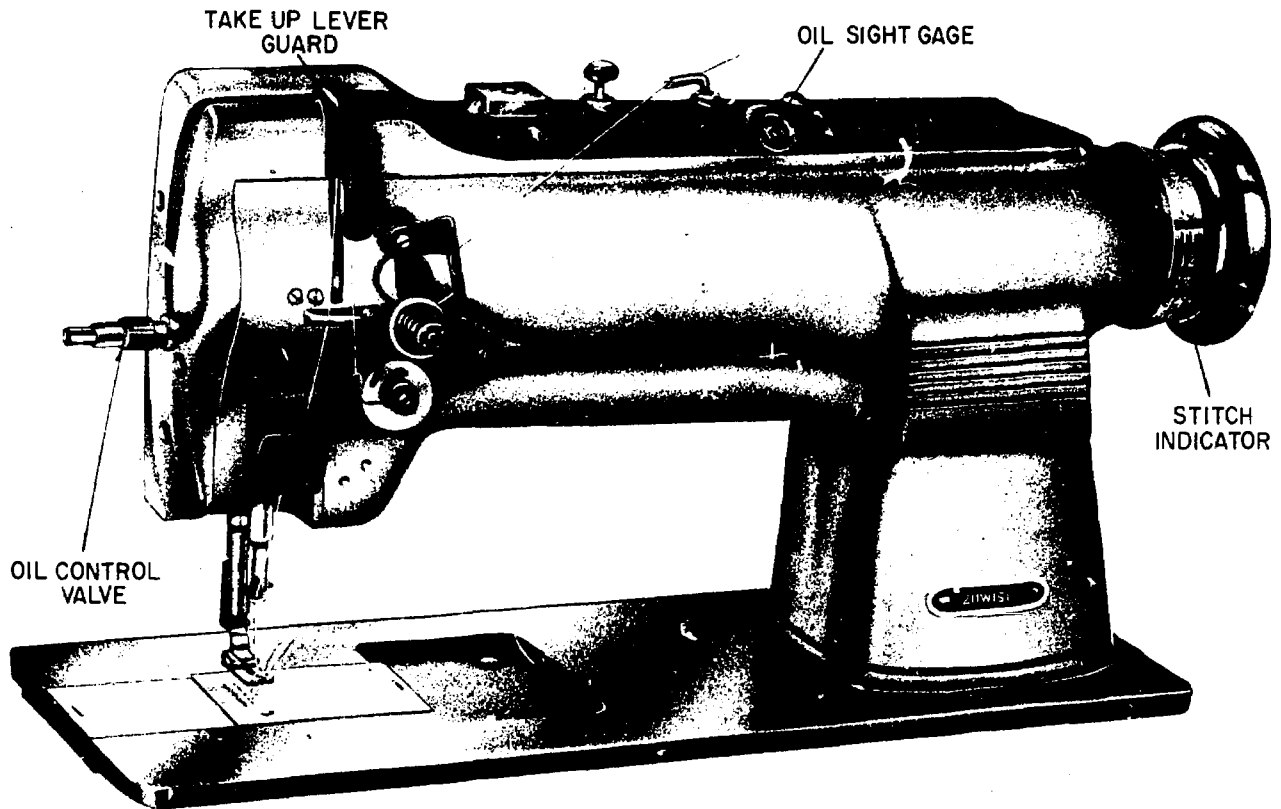

Figure 13-13.—The 211 W 151 sewing machine.

PR.80

toward the operator until the feed dog is in its highest position. Loosen the screw in the feed lifting cam fork and raise or lower the dog as desired, then retighten screw. **NOTE:** A properly set feed dog will show a full tooth above the throat plate when at its highest position.

After adjusting the feed dog, check to see that the needle is properly set in the hole in the feed dog. If adjustment is needed, loosen the pinch screws in the feed driving rock frame and set the needle so that when it is all the way down it will be slightly forward of center in the hole. Retighten pinch screws. The feed adjustment points are illustrated in figure 13-19.

Adjusting Feed Eccentric

The feed eccentric (fig. 13-20) may occasionally need adjustment to remove play caused from wear of the gib, or looseness between the

feed eccentric and the eccentric body. To adjust the gib, loosen the two locking screws, then turn inward on the adjusting screws until all play is eliminated and the eccentric fits in the slot properly.

CAUTION: LOCKING SCREWS MUST BE LOOSENED BEFORE ATTEMPTING TO LOOSEN ADJUSTING SCREWS TO PREVENT DAMAGE TO THE SCREWS. RETIGHTEN SCREWS AFTER ADJUSTMENT IS MADE.

The feed eccentric collar may be moved to the right or left to change spring tension, but it is ordinarily set flush with the hub of the eccentric body.

Changing Length of Stitch

To change the length of stitch, stop the machine and depress the button in the bed of the machine. Turn the balance wheel toward the

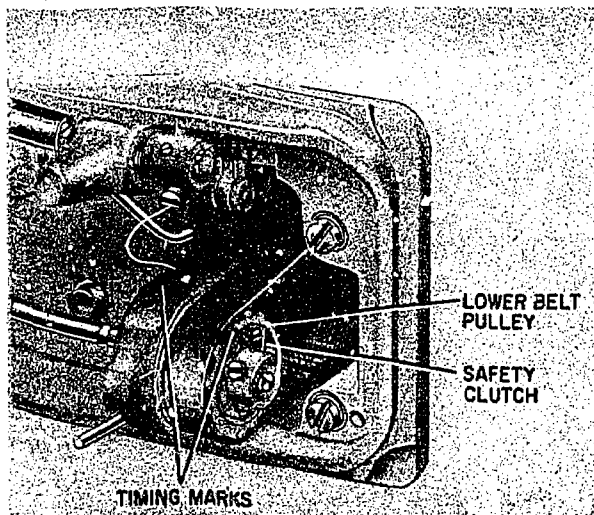

PR.81
Figure 13-14.—Safety clutch and lower belt pulley.

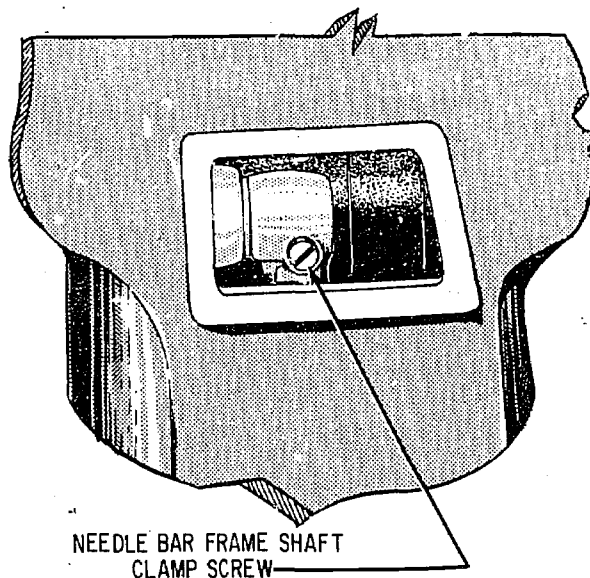

PR.83
Figure 13-16.—Needle bar rock frame rockshaft clamp screw.

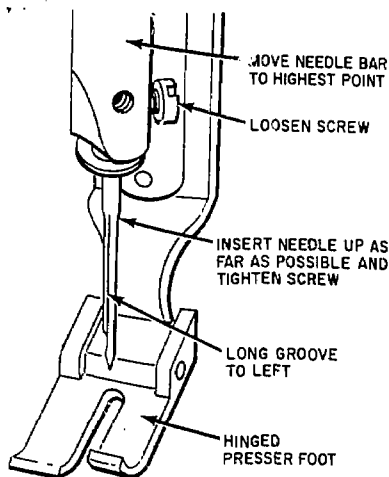

PR.82
Figure 13-15.—Setting the needle.

operator by hand until the button drops (clicks). Then turn the balance wheel until the number representing the desired stitches per inch is lined up with the mark on the arm of the machine. (See fig. 13-13.) Release the button.

CAUTION: DISENGAGE THE BUTTON BEFORE ATTEMPTING TO SEW. DO NOT ENGAGE THE BUTTON WHILE MACHINE IS IN OPERATION.

Removal of Components

To remove the hook, remove the presser foot, throat plate, and feed dog, then loosen the two Allen screws in the hub of the hook and lift the hook off the hook shaft. To remove the bobbin case from the hook assembly, loosen the hook gib screws, lift off the gib, and then lift out the bobbin case.

Removing Arm Shaft Connection Belt

When the arm shaft connection belt is disconnected for any reason, the machine will be completely out of time. Therefore, the needle should be removed before removing the belt, to prevent damage. To remove, slide the belt off the lower belt pulley, loosen the screws in the machine pulley and remove the pulley and ball bearing which come out through the end of the arm.

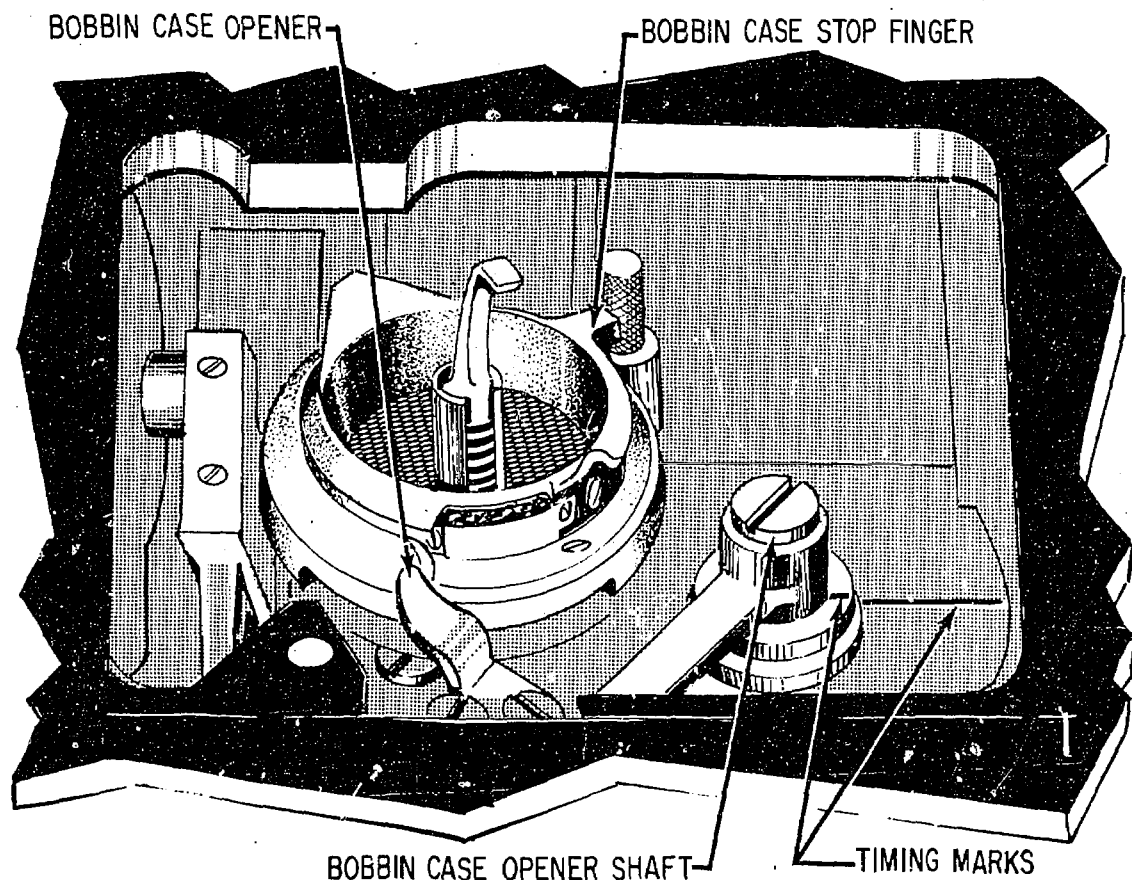

Figure 13-17.—The 211 W 151 hook assembly adjustments.

PR.84

Replace the belt by reversing this procedure. Remove the end play from the shaft by lightly setting the setscrews and tapping the balance wheel into position with the palm of the hand and then securely setting the setscrews. Place the belt over the upper belt pulley and line up the timing marks on the lower belt pulley and on the bed of the machine. While holding the lower belt pulley in position, turn the balance wheel toward the operator until the thread takeup lever is at its highest position, then slide the belt onto the lower belt pulley. The arm shaft connection belt and the lower belt pulley are illustrated with the safety clutch in figure 13-14. CAUTION: DO NOT TAMPER WITH THE SAFETY CLUTCH. TORQUE IS PRESET AT THE FACTORY.

LUBRICATION

The hook saddle is equipped with an oil reservoir (fig. 13-18) which contains oil to be pumped to the bobbin case raceway. The flow of this oil is controlled by a control valve screw located just aft of the bobbin case opener in the hook saddle. For more oil, turn the valve screw clockwise; counterclockwise for less oil. CAUTION: DO NOT ADJUST FLOW OF OIL WITHOUT FIRST LOOSENING THE LOCKING SCREW LOCATED ON THE SIDE OF THE HOOK SADDLE JUST ABOVE THE CAM SHAFT GEAR. AFTER ADJUSTING THE CONTROL VALVE SCREW FOR PROPER FLOW, RETIGHTEN THE LOCKING SCREW.

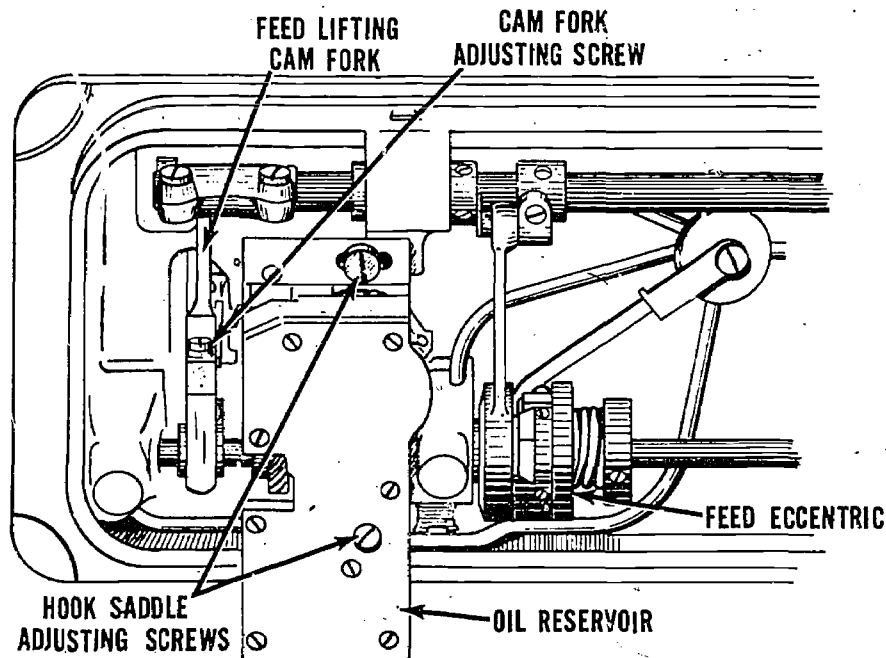

PR.85

Figure 13-18.—Hook saddle assembly showing bobbin case raceway oil reservoir.

When the machine is used extensively, check the oil level in all reservoirs twice daily. Fill the reservoirs in the hook saddle, the head, and the arm to the high mark on the gage and saturate the wicks in the oil tubes in the bed of the machine.

Needles do not vary in length within the same class and variety.

ADJUSTMENTS

Timing Needle With Shuttle

When the needle and shuttle are correctly timed, the point of the shuttle on its forward stroke passes across the diameter of the needle at a point $1/16$ inch above the eye of the needle when the needle is on its up stroke.

To time the machine so that the needle and shuttle operate properly (setting needle bar), proceed as follows:

See that the needle is of correct class and variety and that it is pushed up into the clamp as far as it will go. Remove the faceplate and loosen the screw in the needle bar connecting stud. Move the needle bar up or down as may be required to bring the needle eye into correct position when the shuttle point passes across the needle. Tighten the screw, and test the adjustment by observing the operation of the needle

SEWING MACHINE 31-15

The 31-15 sewing machine, commonly referred to as a tailoring machine, is an oscillating type machine which makes a lockstitch. It is intended for sewing clothing, is excellent for nylon cloth sewing, and is used for sewing lightweight canvas up to 8 ounces. This machine has a maximum speed of 2,200 stitches per minute. The length of stitches varies from 7 to 32 stitches per inch. The Singer Sewing Machine 31-15 is illustrated in figure 13-21.

Needles for the 31-15 machine are of class and variety 16 x 87. The needles are available in sizes from 14 to 23. The needles vary in size according to the number. The smaller the number, the smaller the eye of the needle.

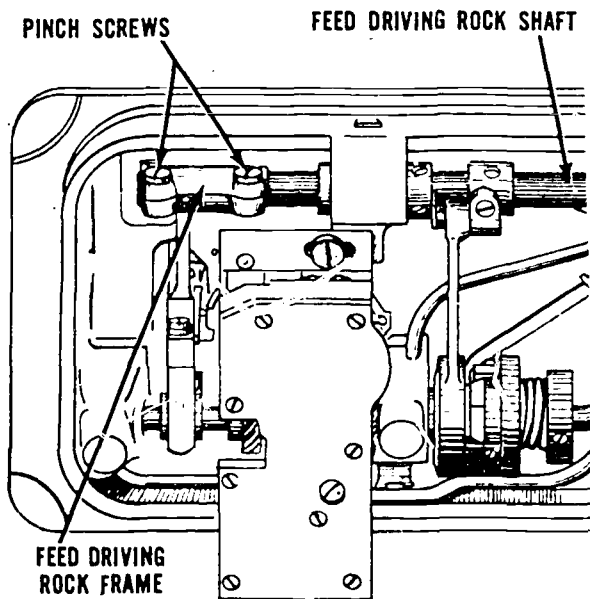

PR.86

Figure 13-19.—Feed adjustment for the 211 W 151 sewing machine.

and shuttle while the balance wheel is slowly turned by hand.

Timing Feed Dog With Needle

If the needle is correctly timed with the shuttle, the feed dog should be on its down stroke and level with the throat plate when the point of the needle reaches the material. If the balance wheel is turned forward, the needle should enter the material and come back up. After the needle has cleared the material on the upstroke, the feed dog should then rise above the throat plate and push the material forward the distance of one stitch.

To time the feed dog (feed driving eccentric), proceed as follows:

See that the needle is correctly set and timed with the shuttle. Loosen and press the feed regulator thumbscrew to its lowest point. The machine will then make its longest stitch.

Open the round cover plate on the uprise, as shown in figure 13-22. Loosen the feed eccentric setscrew. When the setscrew is loosened, the feed dog can be moved without moving the needle. By hand, turn the eccentric until the feed dog has completed its feeding action and is even with the throat plate on the down stroke. With the thread takeup lever at its highest point, retighten the feed eccentric setscrew. Test their timing after each adjustment of the feed dog.

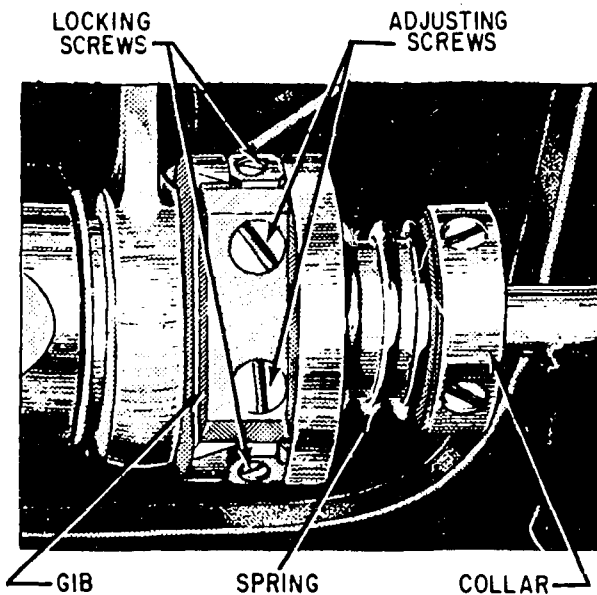

PR.87

Figure 13-20.—The feed eccentric.

Raising and Lowering Feed Dog

The feed dog is normally adjusted for sewing fabrics used in flight clothing, such as jackets, woolen shirts, and pants. When correctly adjusted, it rises just enough for the teeth to show their full length above the throat plate. For sewing extra heavy material (like that in overcoats) or for extra light material, the feed dog may need to be raised or lowered by adjusting the feed lifting rockshaft crank.

Before adjusting the height of the feed dog, see that it is in time with the needle. If the timing is correct, turn the balance wheel forward until the dog reaches its highest point. Loosen the screw on the crank, and adjust the height of the feed dog up or down as desired. Tighten the screw and test the adjustment by hand turning the balance wheel forward. A change in the height of the feed dog may throw the needle and feed dog out of time. Therefore, check and adjust the timing of the needle and feed dog as necessary.

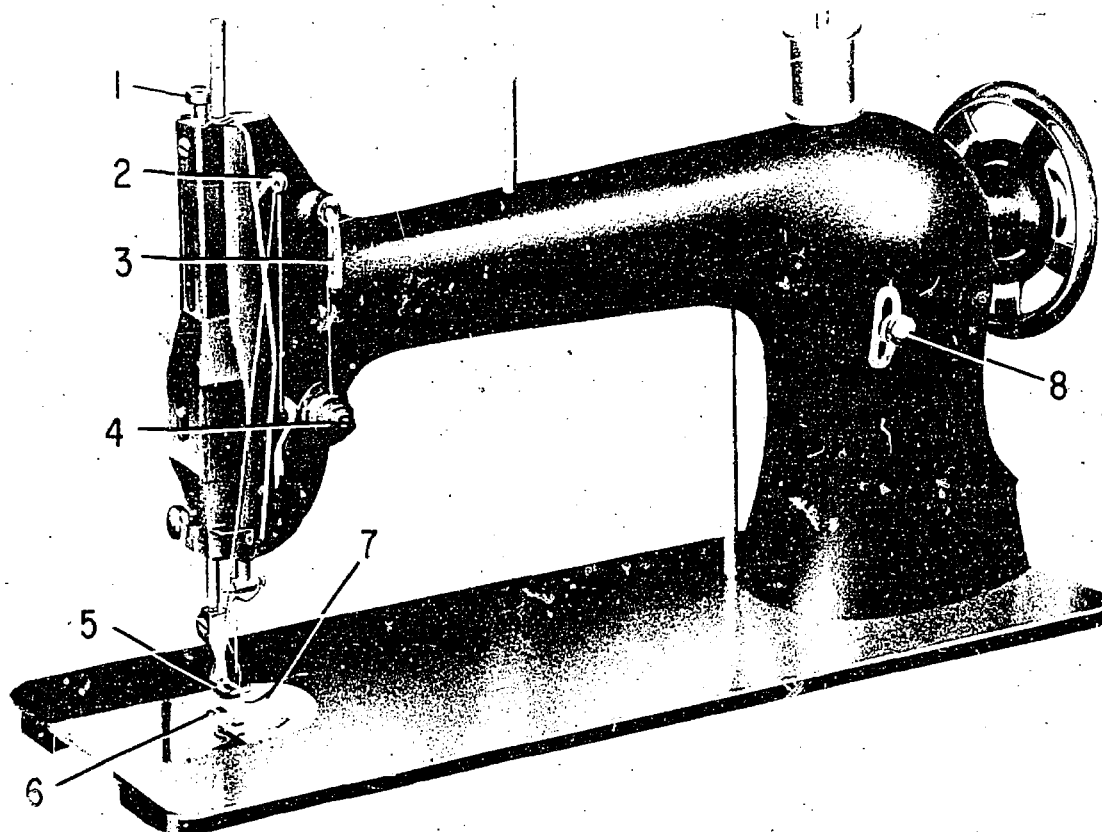

PR.88

- | | | |
|------------------------------------|----------------------------------|------------------|
| 1. Pressure regulating thumbscrew. | 3. Thread retainer. | 6. Feed dog. |
| 2. Thread take up lever. | 4. Tension regulating thumb nut. | 7. Throat plate. |
| 5. Presser foot. | 8. Feed regulator thumbscrew. | |

Figure 13-21.—Singer Sewing Machine 31-15.

CLASS 7 SEWING MACHINES

The Singer Heavy-Duty Sewing Machine Models 7-31 and 7-33 are identical in performance.

DESCRIPTION

Class 7 sewing machines are all single-needle lockstitch machines designed for medium and heavy work on canvas, duck, or light leather materials. In parachute maintenance and repair, this machine is used primarily for the sewing of pack trays and webbing.

The Model 7-33 sewing machine (fig. 13-23) utilizes a drop feed consisting of alternating presser feet and a feed dog to carry the material through the machine during sewing. The vibrating presser foot and the serrated lugs of the double feed dog move in unison to push the material through the machine with each upstroke of the needle. The lifting presser foot then holds the material in place while the next stitch is being made and while the feed dog and vibrating presser foot move back into position for the next stroke.

Both the 7-31 and 7-33 machines use needles of class and variety 7 x 1 and 7 x 5; sizes available range from 19 to 31. The maximum

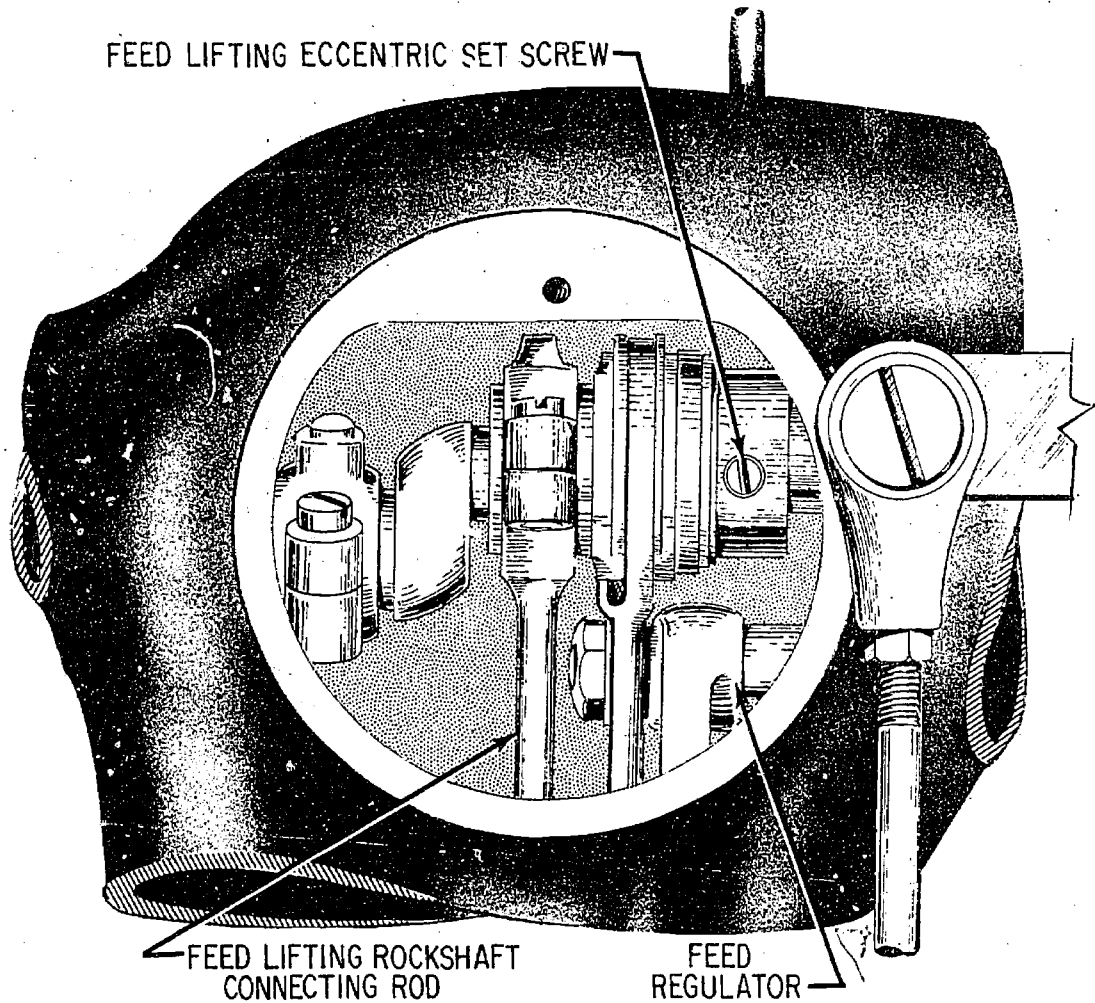

Figure 13-22.—Feed cam and regulator, cover plate removed.

PR.89

recommended speed of both machines is 550 stitches per minute.

These heavy-duty machines employ a long-beak, oscillating cylinder shuttle which holds the bobbin vertically beneath the throat plate. With each rotation of the arm shaft, the shuttle oscillates half a turn and back again. This oscillation allows the hook to catch the needle thread, loop it around the bobbin, and thus form the stitch.

NOTE: Refer to the appropriate Singer servicing manual when making adjustments to these machines.

ADJUSTMENTS AND REPAIRS

Setting the Needle Bar

To set the needlebar, remove the two screws holding the throat plate to the machine bed, and lift out the throat plate. Turn balance wheel forward until the point of the sewing hook is directly in line with the needle. Loosen the two setscrews in the needlebar connecting stud (fig. 13-23). Raise or lower the needlebar as necessary until the needle eye is $\frac{1}{32}$ inch below the

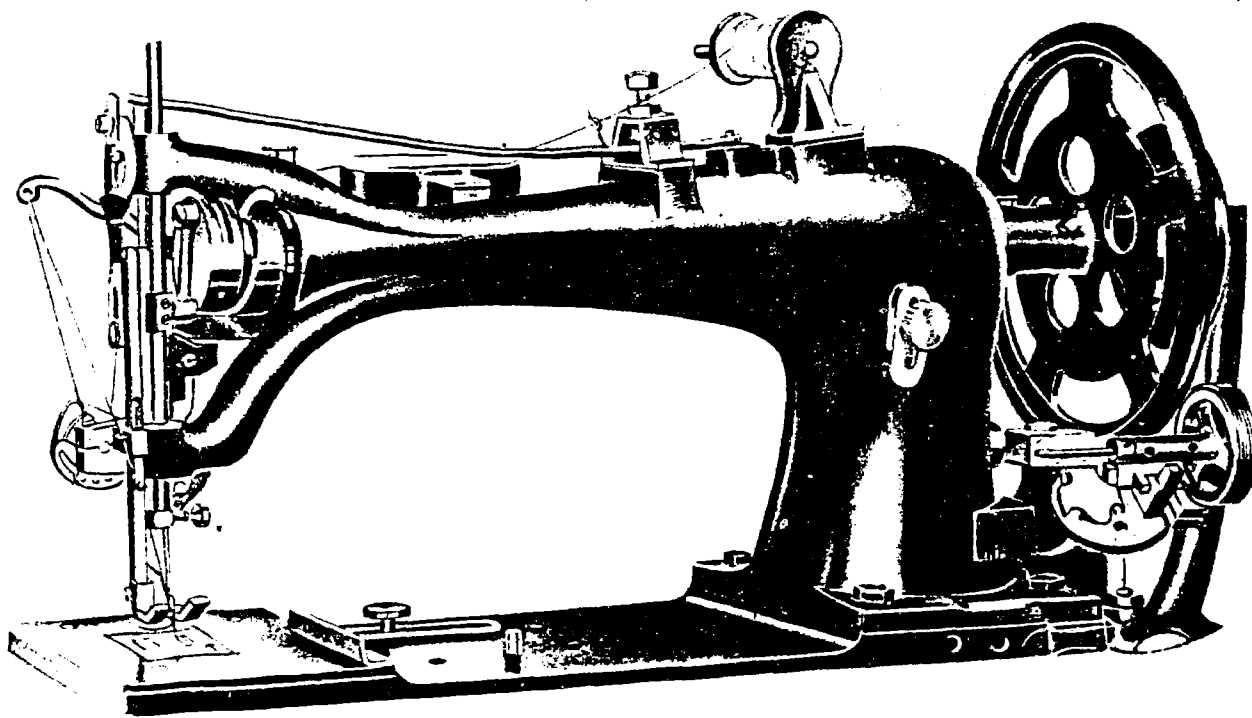

Figure 13-23.—Model 7-33 sewing machine.

PR.90

point of the hook. Tighten the two setscrews in the needle bar connecting stud.

A simplified method of setting the needle bar is to measure the height of the needle bar above the upper needle bar bushing of a machine that is properly set. This measurement may vary with the type of needle being used in the machine. However, with 7 x 1 needles, the height of the bar above the bushing will be approximately $2 \frac{3}{8}$ inches when the needle bar connecting stud is at its highest position.

Timing Sewing Hook

The timing of the sewing hook is permanently fixed by the construction of the shuttle assembly. Therefore, if the machine is correctly assembled, no adjustment for timing is required.

Setting Sewing Hook

To set the sewing hook, loosen the shuttle race frame clamping screw and the two setscrews

in the oscillating shaft collar beneath the machine bed. (See fig. 13-24.) Move the shuttle race frame slightly to the left or right, as necessary, to bring the point of the hook as close to the needle as possible without touching the needle. Tighten the clamping screw securely and move the oscillating shaft collar up against the frame. Tighten the setscrews in the collar.

Raising or Lowering Feed Dog

Loosen the lifting rockshaft crank clamping screw. Turn the crank up or down on the feed lifting rockshaft to bring the feed dog to the correct height. Tighten the clamping screw securely.

Timing Feed Dog

To time the feed dog, remove the arm side cover at the back of the machine. Loosen the two setscrews in the feed cam and set the cam for earlier or later movement of the feed dog,

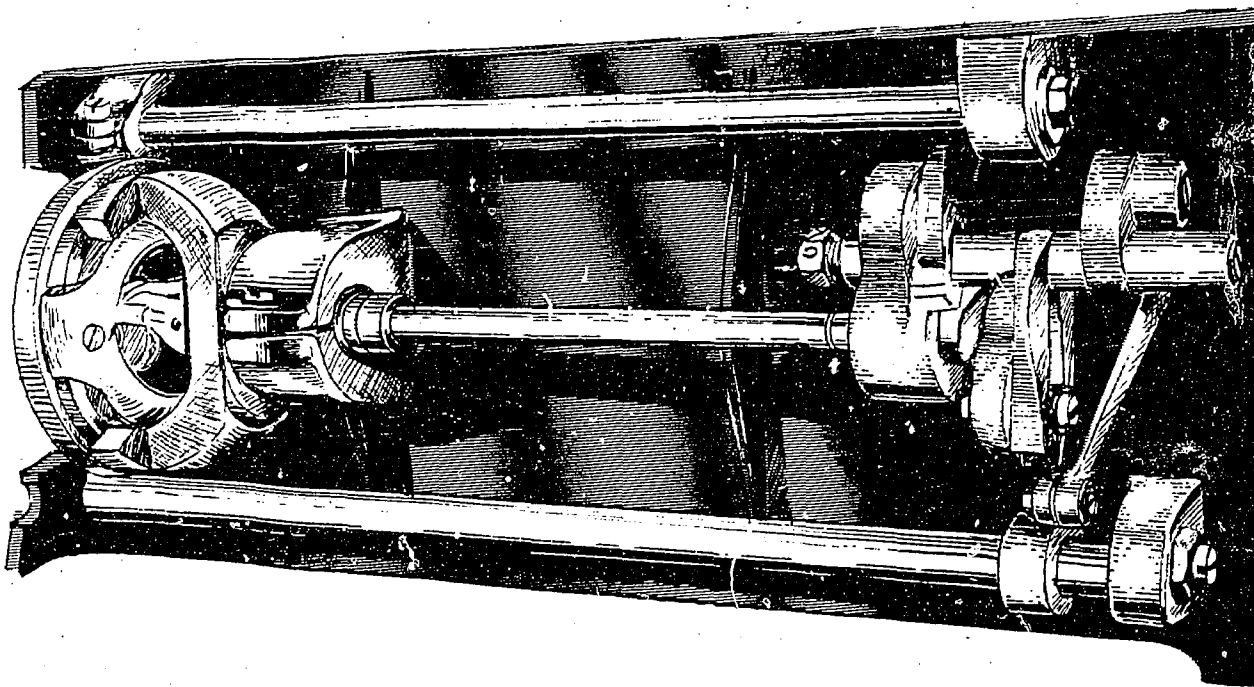

PR.91

Figure 13-24.—Bed assembly.

as required, by turning the cam about the arm shaft.

Tighten the setscrews and test the feed dog timing by hand-turning the balance wheel. The feed dog should complete its feeding action at the same time that the thread takeup lever completes its upward stroke. When the feed dog is correctly timed, tighten the setscrews in the feed cam and replace the side cover.

SINGER CLASS 143

The Singer Class 143 is a zigzag machine. Although there are other zigzag machines, the Class 143 is considered a typical example. The discussion here is therefore limited to the 143 W 2 and 143 W 3.

The 143 W 2 has an aluminum alloy vibrating needle bar frame and a rotary hook. It is especially adaptable to overseaming and zigzag stitching on general fabrics, lightweight leather, and parachute fabrics.

The 143 W 3 is similar to the 143 W 2 except that the maximum needle throw (width of stitching) is 3/16 inch for the 143 W 2 and

5/16 inch for the W 3. Both machines use needles of the 135 x 7 class and variety. Figure 13-25 is an X-ray view of a typical zigzag machine showing the relationship of the working parts.

ADJUSTMENTS

As on other types of sewing machines, senior PR's must be able to adjust and make repairs to many different zigzag type machines. When making adjustments or repairs to machines with which you are unfamiliar, it is always best to consult the instructions manual for the machine being repaired. The following adjustments are general and cover only the 143 W 2 and W 3 machines.

Regulating Length of Stitch

To regulate the length of stitch, depress the lever (4) on the uprise and, at the same time, turn the balance wheel forward until the lever engages in the notch in the stitch regulator flange. Hold the lever in the notch and turn the

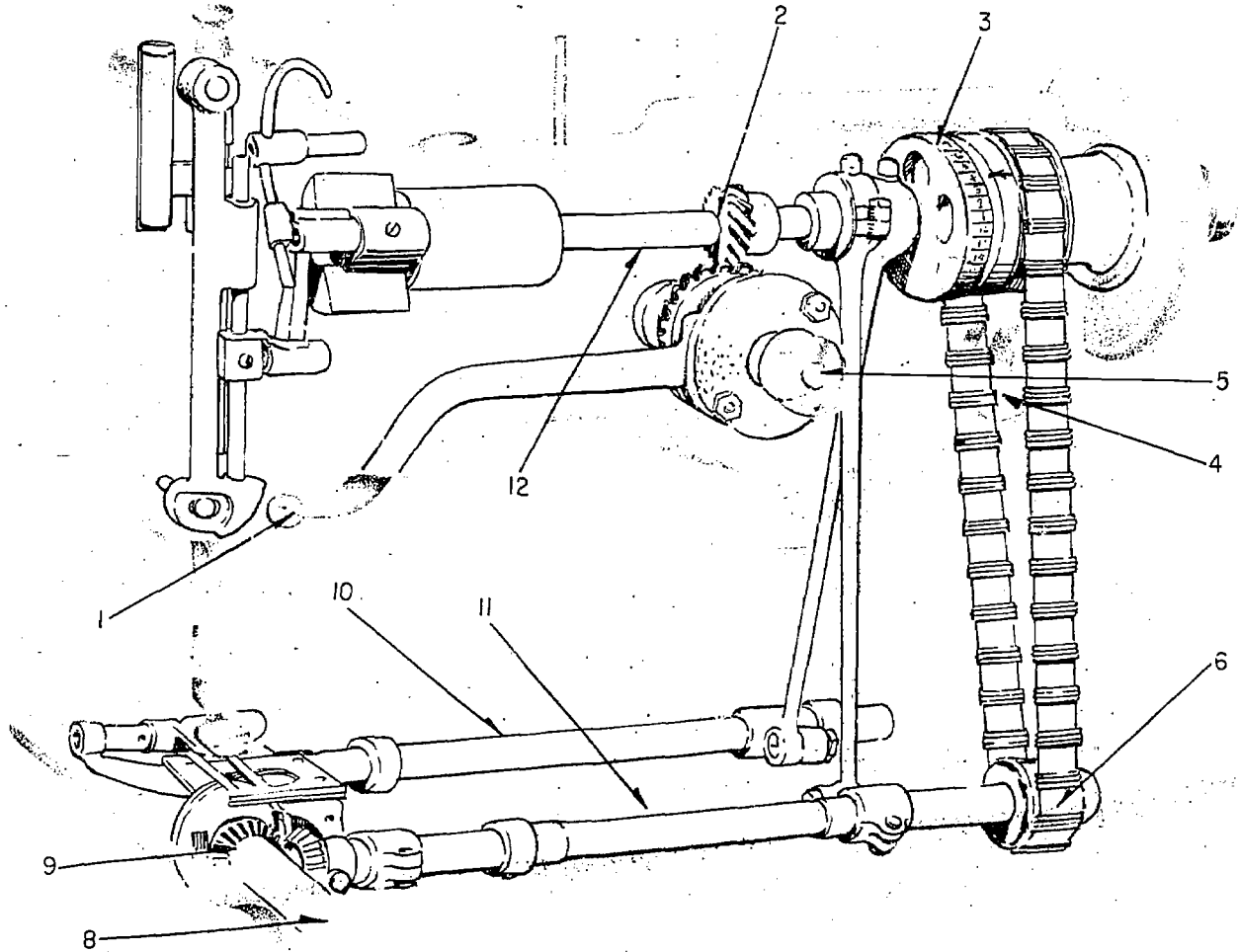

PR.92

- | | | |
|----------------------------|-----------------------------|-----------------------------|
| 1. Eccentric stud. | 5. Regulating spindle head. | 9. Hook pinion gear. |
| 2. Vibrator pinion gear. | 6. Lower belt pulley | 10. Feed driving rockshaft. |
| 3. Stitch regulator. | 7. Hook drive gear. | 11. Hook drive shaft. |
| 4. Stitch regulator lever. | 8. Hook spindle screw. | 12. Arm shaft. |

Figure 13-25.—X-ray view of zigzag sewing machine.

balance wheel backward or forward (as necessary) until the desired number of stitches per inch is shown opposite the arrow on the stitch regulator.

turning the knurled knob on the needle vibrator regulating spindle head (5) at the front of the machine. To increase the width of stitch, turn the regulating spindle head to the left, and right to decrease.

Regulating Width of Bight

Setting Needle Bar

The extreme width of stitch (needle throw) on the 143 W 2 is $\frac{3}{16}$ inch; it is $\frac{5}{16}$ inch on the 143 W 3. The width of bight is regulated by

The two adjustment marks on the needle bar are $\frac{3}{32}$ inch apart. To set, insert the needle

AIRCREW SURVIVAL EQUIPMENTMAN 1 & C

bar up into the needle bar frame so that the upper mark is just visible at the lower end of the needle bar frame with the bar at its lowest position. The eye of the needle should be $\frac{1}{16}$ inch below the point of the hook, and the long thread groove toward the operator.

Setting and Timing the Needle Bar Frame

Turn the regulating spindle head all the way to the right. This will cause the machine to sew a straight stitch. The needle should be centered in the hole in the throat plate. If not, loosen the setscrew which holds the eccentric stud (1), and turn the stud until it is centered. Turn the needle regulating spindle head to the extreme

left for the widest throw. Turn the balance wheel forward until the needle is at its lowest position. The needle bar should start to move in a sideward movement as the needle starts to rise. If it does not, advance or retard the vibrator gear pinion (2).

Timing Sewing Hook

Turn the balance wheel toward the operator until the needle bar is all the way down and has risen until the lower timing mark is just visible below needle bar frame. Loosen the setscrews in the lower belt pulley (10, fig. 13-26) and set hook point to center of needle eye. Retighten setscrews.

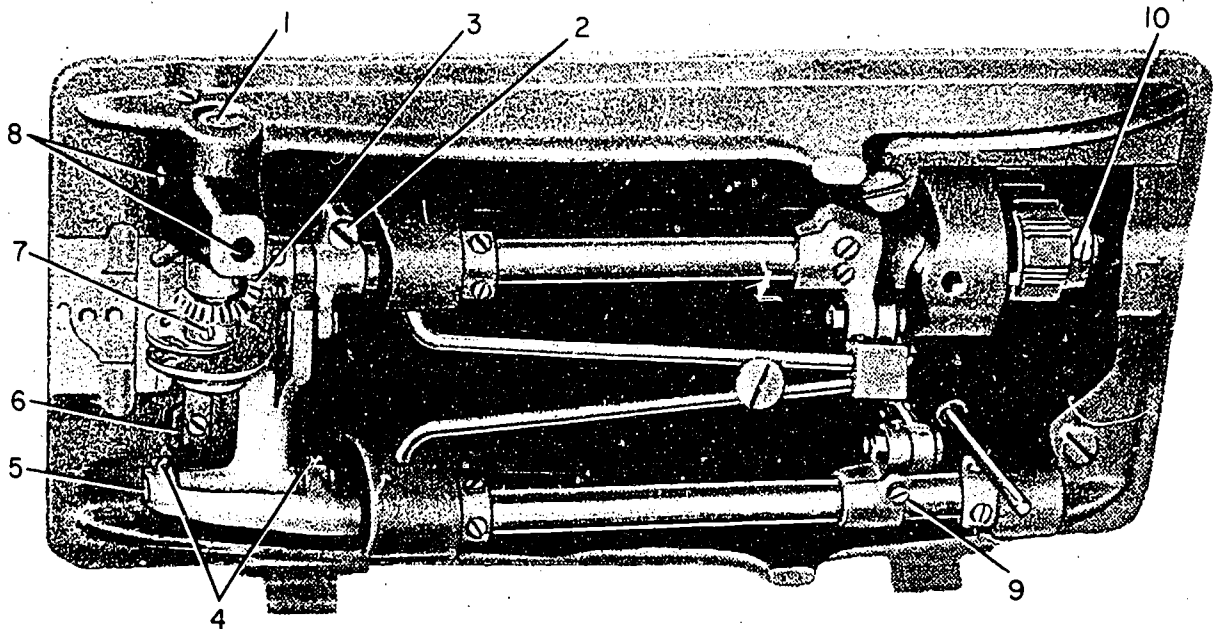

PR.93

- | | |
|---------------------------------------|---|
| 1. Hook spindle screw. | 6. Bobbin case stop. |
| 2. Feed dog adjusting screw. | 7. Hook pinion gear setscrews. |
| 3. Hook drive gear. | 8. Hook shaft retaining screws. |
| 4. Feed dog eccentric stud setscrews. | 9. Feed driving arm connection pinch screw. |
| 5. Feed dog eccentric stud. | 10. Lower belt pulley setscrews. |

Figure 13-26.—Adjustments in the bed of machine.

Setting Hook To or From Needle

Loosen the two hook shaft retaining screws (8) and the two screws in the hook pinion gear (7), and slide the hook to the correct position. Retighten the hook shaft retaining screws. Set the gear in the proper place on the shaft—gear aligned with hook drive gear—and retighten the two setscrews to hold the hook in position.

Removing the Hook

Remove the bobbin case stop (6), loosen the hook spindle screw (1) a few turns and tap it lightly to loosen the hook. Then completely remove the hook spindle screw and withdraw the hook.

Raising or Lowering Feed Dog

The feed dog should show a full tooth above the throat plate when at its highest position. To adjust the dog, remove the throat plate and make sure that all lint, dirt, or other obstruction is removed, then replace the throat plate. Turn the balance wheel forward until the feed dog is at its highest position, then loosen the feed dog adjusting screw (2), and raise or lower the feed dog as required. Retighten adjusting screw to hold the feed dog in position.

To prevent the feed dog from striking either end of the slots in the throat plate, loosen screw (9) and move the feed dog forward or backward (as necessary) until the longest stitch can be taken without striking the throat plate.

Removing Arm Shaft Connection Belt

The belt is removed from this machine in the same manner as the 31-15. Remove the balance wheel and bushing. Remove belt from lower belt pulley and lift out through hole around arm shaft.

SAFETY PRECAUTIONS

Before making any adjustments that may require contact with moving parts, cut off the

motor or disconnect the drive belt. This is particularly important when changing needles. If the motor is not disconnected, stepping on the foot treadle will start the machine and may drive needles through the operator's hand or fingers.

While making electrical connections, be careful not to touch bare terminals or wires, since current required to run these sewing machines is usually of sufficient amperage to be dangerous.

Be sure that the balance wheel always turns over toward the operator of the machine. Never turn the balance wheel more than a half turn backward. Do not operate a machine without material beneath the presser foot. If it is necessary to test run a machine, remove needles, bobbins, and presser foot, or place a scrap of material beneath the presser foot. Keep the bed slide plates closed while machine is in operation.

SUPPLY

It is the responsibility of the PR in charge of the workcenter to anticipate the loss or damage of certain small parts. Many sewing machine parts are not standard supply items and must be obtained through open purchase.

While there is a difference in information that must be furnished by the PR, these non-standard items are nevertheless ordered through the supply department in a manner similar to that used for requisitioning standard stock items. A requisition is submitted to the supply department in accordance with local directives. This requisition must be signed by the commanding officer or his designated representative and should include the following:

1. Complete description, including manufacturer's part number.
2. Suggested source of supply.
3. The type or style of sewing machine for which the part is intended.
4. A certification that no standard stock item is suitable.

The supply department will then take action to obtain the material from the appropriate commercial source.

INDEX

- A-3 container, 73
- A-4 container, 74
- A-5 container, 75
- A-6 container, 75
- A-7 container, 75
- A-8 container, 76
- A-9 container, 76
- A-10 container, 76
- A-13A, 101
- A-14A, 103
- Accountability codes, 26-27
- Accounting man-hour, 55
- Action changes, 48
- Actuator, parachute, 61
- ADMRL, 27
- ADR-1, 191
- ADSK-2, 191
- Advance base operations, 36
- Advancement, 3-10
 - how to prepare for, 3-8
 - opportunities for petty officers, 10-11
 - to senior and master chief, 11
 - to warrant and commissioned officer, 11
- Aeronautical allowance lists, 24-25
- Aircraft ditching, 172
- Aircraft fuel, burning of, 185
- Aircraft Maintenance Material Readiness List (AMMRL) Program, 27
- Air dilution, 134
- Air droppable survival kit (ADSK-2), 191
- Air ratio aneroid, 134
- Air valve closure, 125
- Allowance lists, 24-26
 - aeronautical, 24-25
 - identification and types of, 25-26
 - section C, 25
 - section H, 26
 - section K, 26
 - section T, 26
- Ammonia prints, 15
- AMMRL, 27
- AN/CRT-3, 192
- Aneroid, air ratio, 134
- Aneroid and check valve assembly:
 - installation of, 123
 - reassembly of, 123
- Aneroid assembly:
 - disassembly of, 116
 - removal of, 116
- Aneroid closure test, 130, 136
- Annual appropriation, 18
- AN/PRC-63, 195
- Antiblackout garment, 104
- Anti-g suit Mk-2A, 99
- AN/URT-3, 196
- Application Data Material Readiness List, 27
- Appropriation Purchase Account (APA), 19
- Appropriations, 18, 19
- Artic:
 - clothing, 188
 - survival, 131
- Area, packing, 44
- Arm shaft connecting belt, 209-210, 215-216
- ASO, 18
- Automatic air shutoff, 134
- Automatic positive pressure regulator, 114
- Automatic safety pressure, 135
- Aviation Supply Office, 18
- Axes, 188
- Bailing out, 172
- Beacon:
 - radio rescue, 196
 - rescue, 193
- Bench testing F2700 Regulators, 151
- Bendix:
 - regulators:
 - 29211 B-1 and C-1 miniature, 151-152
 - 29252, 134
 - seat mounted, 133
 - tube, removal of, 115
- Blueprints, 15
- Bobbin case, 208, 213
- Booster operation, 135
- Boots, Mk IV, 105
- Budgets, operating, 19-20
- Bulletins, 48, 50
 - interim, 50
- Burning glass, 185
- Calibration, 136
- Calibration charts, 161
- CAMI, 56
- Canopy repairing, 64
- Card, Parachute History, 58
- Cards, Maintenance Requirement, 56
- Cards, Shop Process, 58
- Care of raft, 172, 174

INDEX

- Catalogs, naval material, 23
- CCS, 28
- Changes, action, 48
- Charts, calibration, 161
- Check valve:
 - assembly, 116
 - flow test, 166
 - leakage test, 166
- Chute, drogue, RA-5C, 61
- Cleaning and inspection of regulators, 119
- Cleaning the Mk-2A, 101
- Cloth, nylon parachute, 61
- Codes:
 - accountability, 26-27
 - material condition and control, 21
 - source, 24
 - special material identification, 22
- Cognizance symbols, 22
- Completed work, inspection of, 35
- Component Control Section (CCS), 28
- Composite diluter demand regulators, dis-assembly of, 115
- Composite regulators, 114
- Conditions, environmental, 39
- Consolidated Repairable Item List, 23
- Continuing action maintenance form, 56
- Control center, technical directive, 48
- Control Register, Material, 29
- Converter:
 - aircraft, 164
 - draining of, 168
 - purging of, 168
 - troubleshooting of, 169
- Cord, nylon, 60
- Cargo parachutes:
 - type G-1, 63
 - type G-1A, 63
- Coverall, anti-g, Mk-2A, 99
- Counterweight lever:
 - disassembly of, 118
 - installation of, 121
 - removal of, 118
- Couplings, quick-disconnect, 165
- Culpable responsibility, 31
- Current-year appropriation, 19
- Custody of tools, 54

- Darning, 64
- Deceleration parachutes, 82
- Deleted and Superseded FIIN List, 23
- Demand oxygen mask, A-14A, 103
- Demand valve assembly, 118
- Demand valve lever, adjusting of, 121
- Desert clothing, 189
- Desert survival, 182

- Designators:
 - forced/activity, 29
 - urgency-of-need, 30
- Development of a layout, 13
- DD form 1348, 52
- Diagrams, 13
- Diaphragm assembly, reassembling of, 122
- DiazC, 15
- Diluter demand regulators, composite, 114
- Directives:
 - immediate action, 48
 - interpretation of, 39
 - technical, 47
 - urgent action, 48
- Draining the converter, 168
- Drawing numbers, 24
- Drawings:
 - isometric, 13
 - pictorial, 13
 - reproduction of, 15
- Drogue chutes, 61
- Dump valve, 135
- Dye markers, 176

- EDC, 17
- Electric spark, 185
- Emergency pressure test, 144
- Emergency radio, 175
- Engineering drawing cards (EDC), 17
- Enlisted rating structure, 1
- Environmental conditions, 39
- Equipment:
 - custody, 54
 - procurement, 54
 - requirements, regulator repair shop, 114
 - shutdown, MD1, 141

- Facilities, storage, 45
- Facility, Naval Air Technical Services, 48
- Federal:
 - Item Identification Number (FIIN), 21
- Stock:
 - Number (FSN), 21
 - Numbering System, 21-23
 - Supply Classification (FSC), 21
- Feed dog, 208, 213-214, 218, 221-222, 225
- Feed driving eccentric, 208-209, 214
- FIIN, 21
- Files, work center, 51
- Filler valve, 164
- Fire making:
 - general, 183
 - with flint and steel, 184
 - with lighter, 184
 - with matches, 184

AIRCREW SURVIVAL EQUIPMENTMAN 1 & C

- Fire making—Continued
 - without matches, 184
 - with special equipment, 184
- Fireplace, preparing of, 183
- Firewel F2700 Regulator, operation of, 149-151
- First aid, 190
- Fleet Resources Office (FRO), 19
- Flotation garment, Mk IV, 104
- Flow:
 - indicator:
 - assembly, installing, 123
 - test, 130, 145
 - suction test, 125, 130, 144
- Force/activity designators, 29
- Forms, maintenance, 54-56
- Forward area operations, 35
- Friction, 185
- FRO, 19
- FSC, 21, 22
- FSN, 21
- Fuel, 184
- Full pressure suit (Mk IV), 103

- G-1 pack, 66
- G-1A packs, 67
- G-11 cargo parachute, 77
- G-11A cargo parachute, 77
- Garment, antiblackout, Mk IV, 104
- General fund, 18
- Gibson girl, 192
- Glass, burning, 185
- Gloves, Mk IV, 104

- Hardware, parachute harness, 61
- Heat exchanger, 165
- Helmet, Mk IV, 104
- High-pressure leak test, 128
- Humidity, relative, 39, 40
- Hydrothermograph, 40-44

- Identification of material, 20
- Identification source data, 23-24
- Immediate action directives, 48
- IMRL, 27
- Individual Material Readiness List, 27
- In-flight check, MD1, 141
- Information, sources of, 10
- Initial Outfitting Lists, 25-26
- Injector assembly, 118-122
- Inlet and shutoff valve assembly, 119
- Inlet valve assembly, 115
- Inspection:
 - of completed work, 35
 - of Mk-2A, 101
 - personnel, 35
- Inspection—Continued
 - regulator test stand, 154
 - tag, 7/14 day, 58
 - work area, 38
- Instructions, 50
- Instruction, technical information maintenance, 56
- Intercomparison, 160
- Interim bulletins, 50
- Interpretation of directives, 39
- Inventory, 54
- Inward leakage test, 145
- Inward leak test, 129
- Isometric drawings, 13
- Item nomenclature, standardization of, 23

- Kindling, 184
- Kit:
 - SAR, 192
 - survival, escape, and evasion, 177

- Layout, development of, 13
- Leakage test, 166
- Leak test of demand valve, 121
- Lift webs, repairing of, 66
- Lights, 177
- Liquid oxygen converter (29044-1-A1A), testing of, 166
- Liquid oxygen converter test stand, 161

- MAF, 55
- Maintenance:
 - CO₂ transfer unit, 110
 - forms, 54-56
 - of hydrothermograph, 42
 - records, 54
 - requirement cards, 56
 - Walter Kidde CO₂ unit, 111
- Man-hour accounting, 55
- Manometers, 153, 160
- MARC codes, 26-27
- Mask:
 - demand oxygen, A-14A, 103
 - oxygen, pressure breathing, A-13A, 101
- Material:
 - codes, 21
 - control:
 - Register, 29
 - Work Center, 28
 - identification, 20-21
 - requisitioning, 29-30
 - turn-in, 30
- MD1 oxygen regulator:
 - cleaning, 142
 - operation, 137

INDEX

- MD1 oxygen regulator—Continued
troubleshooting, 142-143
- MILSTRIP, 29
- Miniature regulator, Robert Shaw-Fulton 226-
20004, operation, 148
- Mirror, 175
- MRC, 56
- NATSF, 48
- NavAir:
form 104790/7, 58
00-500-A, B, C, and D, 52
- Naval:
Air Systems Command, 18
Air Technical Services Facility, 48
material catalogs, 23
supply, organization and function, 18
Supply Systems Command, 18
- NavSup 2002, 52
- NavWeps form 5605/2, 48
- Navy:
directive system, 51
Management Data List (NMDL), 23
Master Cross Reference List, 23
- Needle:
bar, 207, 212-213, 220-221, 223, 224
correct timing, 207, 217, 218
- NMDL, 23
- Nomenclature, 23
- Normal operation, MD1, 137
- NORS, 29
- Notices, 50
- No-year appropriation, 19
- Numbers, drawing, 24
- Nylon parachute material, 60-61
- Objectives of supervision, 32
- Office, Fleet Resources, 19
- One-year appropriation, 19
- Operating:
budget, 19-20
target (OPTAR), 20
- Operation:
Bendix seat mounted regulator, 133
instructions, MD1, 137
of:
Bendix 29211 B-1 and C-1 miniature
regulator, 151-152
hygrothermograph, 42
the work center, 32, 33
- Operational instructions:
CO₂ transfer unit, 109
Walter Kidde unit, 111
- Operations:
advance base, 36
- Operations—Continued
forward area, 36
- OpNav form 4790/35, 56
- OPTAR, 20
- Organizational work center register, 56
- Organization:
maintenance control register, 56
of a training program, 46
regulator repair shop, 114
- Orthographic projections, 12
- Outfittings lists, initial, 25
- Outlet leakage test, 144
- Outward leak test, 129, 144
- Overall leak test, 128
- Oxygen:
flow indicator assembly, 116
pressure gage, 116, 123
ratio test, 131, 136
- Pack bottom and cover, repairing of, 67
- Packing:
area, 44
piston rod, 110
plunger, 112
procedures, 68
- Parachute:
cargo, 63
cleaning, 63
cloth, nylon, 61
contamination, 62
deceleration, 82
history card, 58
landing:
high wind on land, 178
in trees, 179
in water, 172
release assemblies, 77
- Part number, manufacturer's, 24
- Parts replacement, MD1, 141
- Patching:
channel-to-channel, 64
rectangular, 64
- Pay, proficiency, 10-11
- Performance sheet, preparation of, 123
- Periodic inspection, MD1, 141
- Personnel:
inspection, 35
quality assurance, 35
training, 46
- Pictorial drawings, 13
- Pistol, pyrotechnic, 176
- Planning, work center, 33
- Pocket, parachute log record, 67
- Preflight test, Mk-2A, 101

AIRCREW SURVIVAL EQUIPMENTMAN 1 & C

- Pressure:
breathing:
mask, 101
test, 127, 132, 136
control valve, 164
reducer assembly:
adjustment, 120
disassembly, 118
installing, 120
removal, 118
regulators, automatic positive, 114
relief valve test, 107
tube assembly, 115
Pretesting, 128
Procurement of tools, 54
Proficiency pay, 10-11
Program, organization of a training, 46
Programs, safety, 38
Projections, orthographic, 12
Protection against exposure:
in cold oceans, 175
in warm oceans, 175
PR rating, descriptions of, 1-3
Publications, 47
procurement, 52
security, 53
Pump, regulator test stand, 153
Purging the converter, 168
Purposes of the work center, 33
Quality assurance personnel, 35
RA-5C, 61
Radio:
emergency, 175
receiver-transmitter, 194
rescue beacon, AN/URT-33, 196
set, AN/PRC-63, 195
transmitter, AN/CRT-3, 192
Raftsmanship, 177
Rating structure, enlisted, 1
Ration kit (ADR-1), 191
Readiness List Program, Aircraft Maintenance
Material (AMMRL), 27
Receiver-transmitter, radio, 194
Records, maintenance, 54
Register, 56
Regulator:
back assembly, 117
Bendix:
seat mounted, 133
29211, 151-152
composite diluter demand, 115
Firewel F2700:
bench testing, 151
Regulator—Continued
Firewel F2700—Continued
operation, 149-151
maintenance, 119
miniature, Robert Shaw-Fulton 226-20004,
148, 149
oxygen, MD1, 137
repair shop, 114
test stands, 153
Reinforcing tape, nylon, 60
Relative humidity, 39, 40
Release assemblies:
finger type, 79
jaw type, 77
parachutes, 77
Relief valve, 135, 165
capacity test, 166
leakage test, 166
test, 145
Repair shop, regulator, 114
Report, unsatisfactory material condition, 58
Reproduction of drawings, 15
Requisitioning, material, 29-30
Rescue:
by helicopter, 172
from water, 173
net, X-872, 174
transceiver, AN/PRC-90, 196
Responsibility, increased, 8-10
RFI, 30
Rifle, survival, 186
RT-60, 194
SAF, 55
Safety, 37
clutch, 204
disk, CO₂ transfer unit, 113
precautions, LOX converters, 169
pressure:
mechanism, 122
test, 127, 132, 136
programs, 38
SAMI, 56
SAR kit, 193
Saw, wire escape and evasion, 187
Scheduling shop workloads, 34
SecNav Instruction:
5210.11, 51
5215.1, 51
Security of publications, 53
Selvage, 14
Senior and Master Chief, advancement to, 11
Service instructions:
CO₂ transfer unit, 109
Walter Kidde unit, 111

INDEX

- Seven/fourteen (7/14) day inspection tag, 58
Sewing hook, 206-207, 213
Shelter construction, 181
Shop:
 process cards, 58
 workload, scheduling of, 34
Shutoff valve:
 disassembly of, 115
 leak test, 128
Signal:
 kit, illumination, 176
 Mk 13, Mod 0, 176
Signaling, 175, 182, 183
Single action maintenance form, 56
SMIC, 22
Source codes, 24
Sources of information, 10
Space requirements, regulator repair shop, 114
Special Material Identification Code (SMIC), 22
SRS, 28
SSC, 28
SSU, 28
Standardization of item nomenclature, 23
Static line, 67
Stitch regulator, 200
Stock Numbering System, Federal, 21-23
Storage facilities, 45
Suit, anti-g, Mk-2A, 99
Supervision, objectives of, 32
Support action form, 55
Supply activity, 27-30
Surveys, 30-31
Survival:
 after crash, 180
 and Rescue (SAR) kit, 193
 at sea, 177
 rifle, 186
Suspension lines, repairing of, 65

Tables of Basic Allowances, 25
Tape, reinforcing nylon, 60
Technical:
 directive compliance form, 56
 directives, 47
 Directives Control Center, 48
 information maintenance instruction, 56
Temperature, 39, 40
Tension and thread controller, 210-211
Test:
 aneroid closure, 130, 136
 buildup valve, 167
 check valve flow, 166
 emergency pressure, 144
 flow:
 indicator, 130, 145
 Test—Continued
 flow—Continued
 suction, 125, 130, 144
 leak:
 high pressure, 128
 inward, 129, 145
 outward, 129
 outlet, 144
 overall, 128
 shutoff valve, 128
 oxygen ratio, 125, 131, 136
 preflight, Mk-2A, 101
 pressure:
 breathing, 127, 132, 136
 relief valve, 107
 procedures, 127, 136, 143
 relief valve, 145, 166
 safety pressure, 127, 132, 136
 stand, 153, 154, 161
 Testing:
 full pressure suit, 105
 series regulator 226-20004, 148-149
 Thread:
 nylon, 60
 tensions, 200
 TIMI, 56
 Timing arrows, setting of, 204-205
 Torso, Mk IV, 104
 Training, 46
 Transceiver, rescue, dual channel, AN/PRC-90,
 196
 Transfer unit, CO₂, 108, 110
 Tropic:
 clothing, 189
 survival, 183
 Troubleshooting the 226-20004 series regula-
 tor, 149
 Tubular webbing, nylon, 60
 Types of surveys, 30

 Underwear, Mk IV, 103
 Unsatisfactory Material Condition Report (UR),
 58
 Urgency of need designator, 30
 Urgent action directives, 48

 Vacuum pump, 154
 Valves, 164-165
 Van Dyke, 17

 Walter Kidde CO₂ transfer unit, 110
 Warrant and commissioned officer, advance-
 ment to, 11
 Webbing, 60
 Whistle, 177

AIRCREW SURVIVAL EQUIPMENTMAN 1 & C

Wire escape and evasion saw, 187

Work:

 area inspection, 38

 center:

 files, 51

Work—Continued

 center—Continued

 operation, 32, 33

 purpose, 33

 load, shop scheduling, 34