

DOCUMENT RESUME

ED 077 627

RC 007 055

AUTHOR Satterlee, James L.; Malan, Vernon D.
TITLE History and Acculturation of the Dakota Indians.
INSTITUTION South Dakota State Univ., Brookings. Agricultural
Experiment Station.
SPONS AGENCY Department of Agriculture, Washington, D.C.
REPORT NO SD-Fam-126
PUB DATE [72]
NOTE 81p.; Not available in hard copy due to marginal
legibility of original document

EDRS PRICE MF-\$0.65 HC Not Available from EDRS.
DESCRIPTORS *Acculturation; *American History; *American Indians;
*Cultural Background; Culture Contact; Economics;
Education; Family (Sociological Unit); Family Life;
Federal Programs; Group Structure; Health; Migration
Patterns; Politics; Racial Characteristics; Religion;
Reservations (Indian); Sociocultural Patterns;
*Tribes

IDENTIFIERS *Dakotas; Sioux

ABSTRACT

Relating the history of the Dakota Indians from their origins to the present time, this document also examines the effects of acculturation on these Sioux people. Beginning with the Paleo-Indians of North America, it details the structure of the Dakota culture and attempts to acculturate the Indians into white society. Historical and current implications of acculturation for these tribes are investigated through family structure, education, health and welfare, religion, politics, and economics. An extensive reference bibliography ends the document. (KM)

ED 077627

HISTORY AND ACCULTURATION OF THE DAKOTA INDIANS

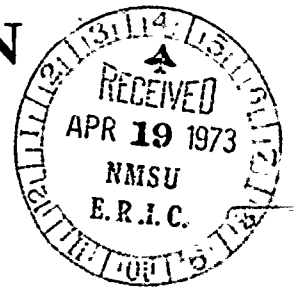

U.S. DEPARTMENT OF HEALTH,
EDUCATION & WELFARE
NATIONAL INSTITUTE OF
EDUCATION

THIS DOCUMENT HAS BEEN REPRODUCED EXACTLY AS RECEIVED FROM THE PERSON OR ORGANIZATION ORIGINATING IT. POINTS OF VIEW OR OPINIONS STATED DO NOT NECESSARILY REPRESENT OFFICIAL NATIONAL INSTITUTE OF EDUCATION POSITION OR POLICY.



RC007055

Agricultural Experiment Station
South Dakota State University
Rural Sociology Department
Brookings, South Dakota

PREFACE

Since the first printing of a publication in 1956 entitled Acculturation of the Dakota Indians, a steady demand has been made upon the Department of Rural Sociology for copies. Since the original, two more printings have taken place (1968 and 1970) so as to meet demands of the public for this information. In the last two years, with increased interest in the Indian situation in South Dakota, students, agency officials and the public in general have indicated a need for more information pertaining to the culture of the Dakota people prior to white contact and the assimilation process.

With these recent demands in mind, the author has attempted to incorporate information pertaining to the early events predating Indian-White contact. (Parts 1). It is not the intent of this enlarged publication to delve in detail on specific events or personalities during this period, but rather to present only an anthropological overview of the Dakota peoples. It is hoped that through this exposure the reader will be stimulated to go on to select books and materials to fill in the detail of this period in South Dakota history.

Dr. James L. Satterlee
Department of Rural Sociology

Cover Design: A Plains Warrior Doing the Dog Dance, from a painting by Karl Bodmer of Pehriska-Rupa, 1834; Northern Natural Gas Collection, with the permission of the Joslyn Art Museum.

[1972]

Dedicated to the late

VERNON MALAN*

Few students of the American Indian have done more than the late Dr. Vernon Malan* to bring together in his original publication the characteristics of the traditional culture of the Dakota Sioux and the ramifications of these characteristics on their acculturation. Malan's work provided us with the indispensable link between the nostalgic past of these people and the reality of the problems they encounter today.

While serving as a staff member in the Department of Rural Sociology during the years 1952-1965, Dr. Malan focused his research on the Dakota Culture. He was intrigued by the traditions of the Dakota Culture and set out to analyze the problems of acculturation in light of these traditions. Even as one tours the various reservations today, mention is made of Malan and the respect the Dakota people had for him in his attempts to understand their problems, and disseminate this understanding to others.

James L. Satterlee

* Professor Vernon D. Malan died as a victim of an auto collision in Corvallis, Oregon, July of 1967.

Table of Contents

	Page
Preface	
I. INTRODUCTION.	1
II. ORIGINS OF MAN TO THE NEW WORLD	2
Bering Straits	2
Beringa.	2
Oceanic Theory	3
III. PALEO-INDIANS IN NORTH AMERICA.	4
IV. ROUND BUILDERS OF THE PLAINS.	5
V. HISTORY OF THE DAKOTA SIOUX	9
Linguistic Groups.	9
Westward Migration	10
VI. STRUCTURE OF DAKOTA CULTURE	14
Sioux of the West (Yankton and Teton).	14
Kinship.	14
Economics.	17
Religion	17
Government	18
Sioux of the East (Santee)	19
Kinship.	19
Economics.	20
Religion	20
Government.	20
VII. ACCULTURATION AS A SOCIAL PROCESS	21
Definition of Acculturation.	22
Culture Change and Acculturation	22
VIII. IMPLICATIONS OF ACCULTURATION FOR THE DAKOTA INDIANS.	24
Some Sociopsychological Aspects of Acculturation	25
Enforced and Permissive Acculturation.	28
Traders.	29
Missionaries	30
Government Agents.	31
Agriculturists	32
Dysfunctions of the Acculturative Process.	33
Elimination of means of subsistence.	33
Destruction of the kinship groups.	35
Symptoms of disorganization.	36

IX. PROBLEMS OF ACCULTURATION.	38
Family Problems	38
Family security	40
Hospitality	42
Socialization of children	43
Veneration of the aged.	45
Broken families	46
Economic Problems	46
Land-resources.	48
Working skills.	49
Money economy	50
Gift giving	51
Political Problems.	52
Administration of the Indian Agency	54
The ration system	55
Educational Problems.	57
Cultural isolation.	57
The boarding schools.	58
Educational opportunities	59
Religious Problems.	60
Denominational missionary programs.	61
Marginal religious activities	62
Health and Welfare Problems	63
X. SUMMARY AND CONCLUSIONS.	65
REFERENCE BIBLIOGRAPHY	67

HISTORY AND ACCULTURATION OF THE DAKOTA INDIANS

by

Dr. James L. Satterlee*

Dr. Vernon D. Malan

I. INTRODUCTION

In order to fully understand and appreciate those events which led to the final submission of the American Indian to the majority white culture it is necessary to look to the historical antecedents predating White-Indian contact. The original ways of living of the American Indian are not easily understood by the modern man who believes the material progress of his generation to be the highest advancement of civilization. In all societies there is a strong tendency for the majority group to assume that their values, attitudes, and behavior are superior in all regards to the habit patterns and customs that dominated the lives of minority groups. They are suspicious of strange practices which conflict with their learned ideas of the appropriate and correct ways of living. If they exhibit some curiosity about the customs of the minority, they are usually anxious to learn of them for the purpose of making an invidious comparison with their practices. It is the unusual person who is able to suppress his own prejudices and view clearly the ways of minorities through the value system of the minority group rather than through his own pattern of beliefs.

Often one hears that such behavior as alcoholism, sexual promiscuity, unemployment, suicide, etc., when exhibited by Indians, is but a carry-over from the old culture which was typified by such characteristics. Nothing could be further from the truth as will be demonstrated throughout these writings. The traditional cultures of the American Indian possessed many of the same values and virtues upheld by the protestant ethic. Such deviant behavior as cited earlier must be seen as a result of an acculturational process which denied the American Indian the right to retain those institutions of family, religion, and economics which served to uphold their traditional values. Such behavioral patterns as reflected in high rates of alcoholism, suicide, and unemployment are fairly recent phenomena in the life of the Indian. Through a better understanding of the lasting traditional culture of one group of American Indians, The Dakota, it is hoped that such misconceptions of cause and effect may be alleviated.

Parts II-V of this pamphlet are intended to provide the reader with a brief historical background so as to place the Dakota Indian into perspective with his predecessors in American Indian history.

*Dr. J. L. Satterlee, Associate Professor of Sociology, Department of Rural Sociology, South Dakota State University. Dr. V. D. Malan, Professor of Sociology, Department of Sociology, South Dakota State University (deceased - 1967).

Parts VI-X which contain the original works of Dr. Malan (1956) focus on the acculturation process and the ramification of such a process on present-day Indian-White problems.

II. ORIGINS OF MAN TO THE NEW WORLD

Anthropological evidence has substantiated that man did not evolve in the New World (North and South America) but rather migrated to this area via several possible routes. Archaeological evidence of primate evolution in the New World would indicate that the highest level to which the primate developed is that of the New World monkey. Since it was necessary for man to migrate to the New World, a number of questions may be raised as to what routes were followed and why such migration took place. Presently one must look to several possible answers.

Bering Straits: One theory which has for some time been widely accepted by Anthropologists is that of the Bering Straits land-bridge. Evidence of man's migration from Siberia onto the Alaskan Peninsula has placed a date of 40,000+ years to this journey through the archaeological finds of Taber Man in Alberta, Canada in 1963.¹ This route would assume the path of migration to be through Alaska onto the Canadian shield and into the present United States east of the Rockies in such states of Montana, Wyoming, Colorado--(Map #1).

Beringa: Other evidence which provides for another theory would assume a land-bridge much wider than the 56 miles projected under the Bering Straits theory. This route of entry is known as the Beringa Theory. It is estimated that with a 450 feet drop in sea level during the Wisconsin glaciation a land bridge some 1300 miles wide would have existed between the two continents. The presence of certain animals in the New World which have their origins in the Old World and which would have found such a route as set forth in the Bering Straits impassible can be accounted for by this theory. Also finds such as Marmes Man in the State of Washington and other similar in nature can be better accounted for by Beringa which would open alternative routes along the new submerged western coast line of Canada and the United States.²

¹Stalker, H.A. "Geology and Age of Early Man Site at Taber, Alberta," American Antiquity, Vol. 34, No. 4, 1969, p. 428.

²"Marmes Projection," The Pollman Herald, Oct. 8, 1968.

Oceanic Theory: A third theory of man's origin of the New World, that of the Oceanic Theory, supposes that migration from the South Pacific may have resulted through the utilization of ocean-going craft. Evidence of native tribes of South America possessing many polynesian characteristics, artifacts found in California and similarities of Northwest Coast Indian such as Hootka, Haida, Tlinget and Kwaitutl would support such a theory.¹

Other theories such as Atlantis (the Sunken Island utopia set forth in the writings of PLATŌ), Vaganner Theory of continental drift, Lost Tribes of Israel, and such expeditions such as Kon Tiki and Ra II by Thor Hyerdahl have added little to the understanding of man's earliest origin in the New World. Presently one must accept the Bering Straits, Beringa, and Oceanic theories as being the most credible with the former (Bering and Beringa) accounting for the major migrations.²

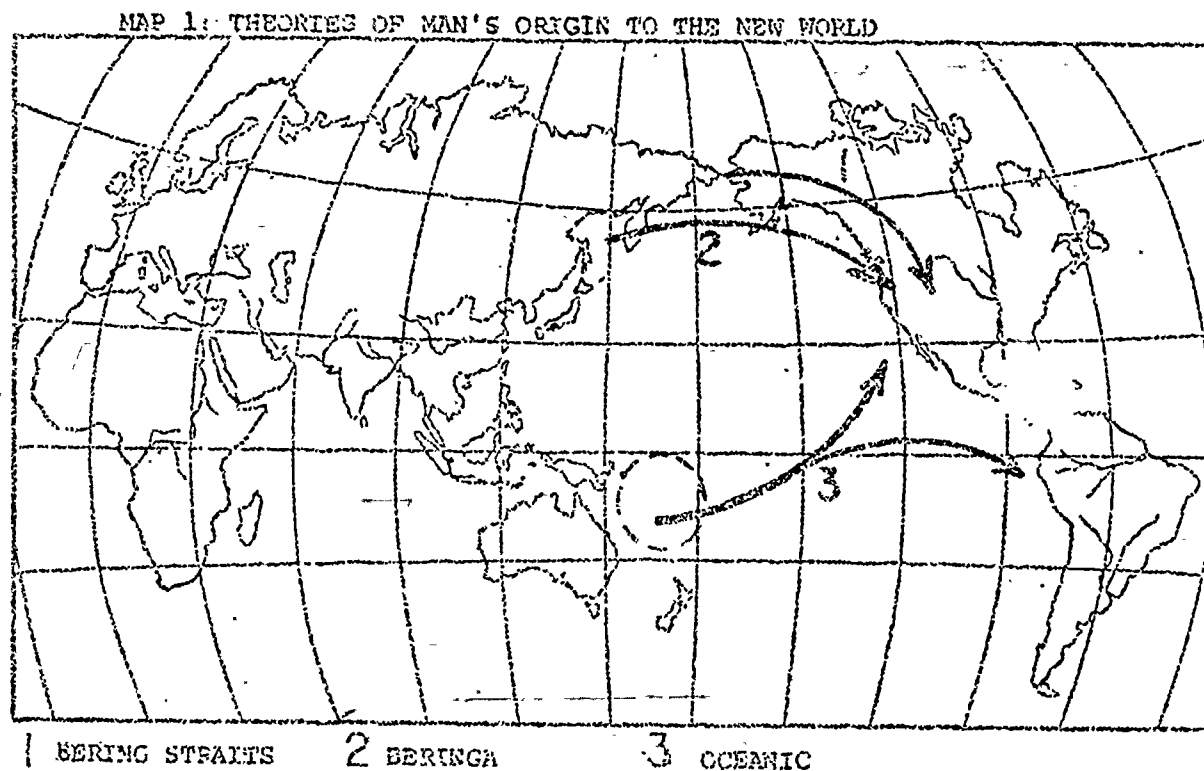

¹Steward, Julian and Louis Faron. Native People of South America. McGraw-Hill Book Co., New York, NY, 1959.

²For a discussion of these alternative explanations, see: J. Jennings. Prehistory of North America. McGraw-Hill Book Co., 1968.

III. PALEO INDIANS IN NORTH AMERICA

Regardless of the routes used to reach the New World, we find the earliest Indians having arrived somewhere about 40,000+ years ago. By 6500 B.C. he had already reached the southern tip of South America. During this period and up until approximately 4500 years ago (2500 B.C.) those Indians residing in the New World are referred to as the "Paleo-Indians" (paleo = old).

Specific names have been attached to the Paleo-Indians in the United States based on archaeological finds. Such Paleo-Indian cultures as Folsom, Clovis and Sandia in the American Southwest; Lindenmeir Man of Colorado and Abilene Man of Texas are somewhat representative of the cultures of the early Paleo-Indians. (See map #2).

Life among the Paleo-Indians was that characterized by early hunters and gatherers. No known animals of domestication such as the dog or horse are found in these sites. The major means of subsistence was that of the now extinct long horned Folsom bison, plains elephant, elk, the giant beaver, antelope, musk ox, mastadon, along with a lush vegetation.

MAP 2: EARLY MAN IN THE UNITED STATES

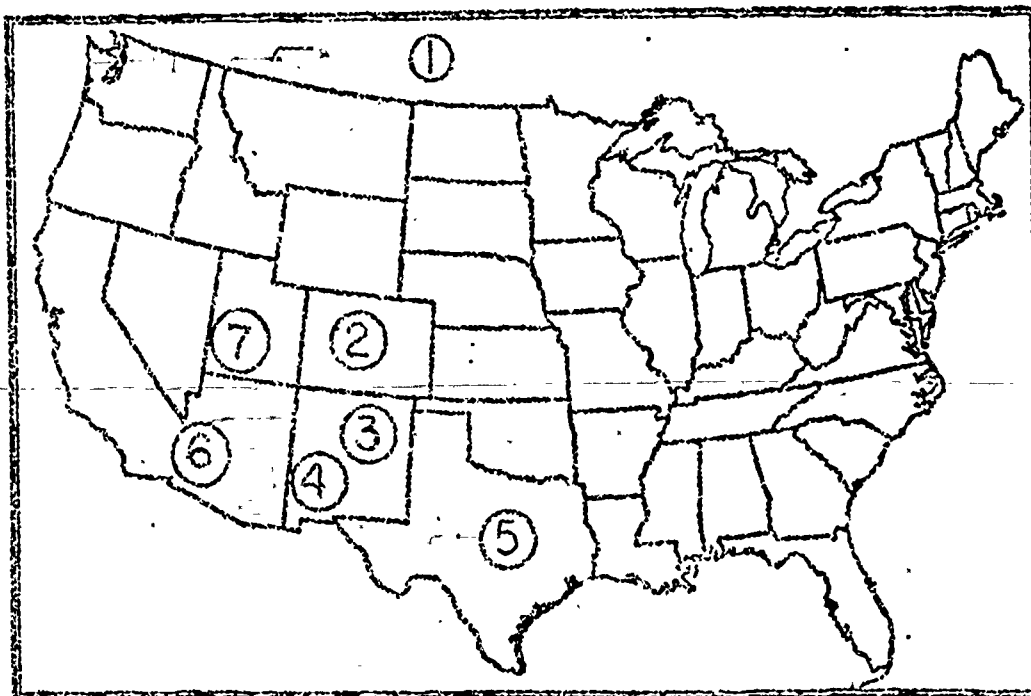

- | | | |
|-----------------------|---------------------------|--------------|
| 1 Taber Man (40,000) | 4 Sandia Man (10-20,000) | 7 Folsom Man |
| 2 Lindenmeir Man | 5 Abilene Man (10-20,000) | |
| 3 Folsom Man (15,000) | 6 Folsom Man (15,000) | |

¹Spencer, Robert F. and J.J. Jennings. The Native Americans. Harper and Row book Co., 1965, p. 36.

Deadfalls (driving over cliffs) were a common means of downing prey along with "fire drives" to stampede herds to such entrapments.

Weaponry consisted of the lance or spear in addition to the atlatl or spear thrower (a short stick used as an additional lever) giving the projectile greater distance, speed and accuracy. Other tools in the form of fluted projectile points, sharpened stone scrapers and knives were also to be found.

Western Plains Paleo-Indian culture spread eastward so as to leave archaeological remains throughout the Midwest and Eastern seaboard. Generally, these sites outside the western plains are more recent in age (7500 B.C.) as compared to the earliest western sites which date to 15,000 years ago.

IV. MOUND BUILDERS OF THE PLAINS

Following the earlier migrations of Paleo-Indians throughout the Plains states came a new grouping of Indian cultures often referred to as The Mound Builders. Anthropologists indicate the earliest arrival on the Plains was approximately 1000 A.D.¹ The origins of these more recent migrants to the Plains (South Dakota, Nebraska, Kansas, Texas, and Oklahoma) was that of the fertile river valleys of Ohio, Indiana, and Illinois. Accompanying this eastern influence is evidence of contact from the American Southwest as Mogollon traits from the Arizona and New Mexico cliff dwellers are found throughout these sites.²

In contrast to the earlier Paleo-Indian residents of the plains, these new residents combined the hunting-gathering features with incipient agriculture. Corn, beans, and squash were raised in the flood plains of numerous rivers. Also in contrast to the earlier nomadic residents the villages of these new residents were more permanent. Housing consisted of earthen lodges. Storage or cache pits are to be found through their housing and villages.

Basic tools consisted of bone awls, fishhooks, and needles. Hoes made from bison shoulderblades and shaft straighteners from bison ribs were common. The bow and arrow, grooved stone hammers and axe heads, bone knives and fleshers are but a part of the increasing complex tool kit possessed by these people. Pottery, a typical feature among sedentary farmers, is quite distinctive. Without the wheel the pottery was of a coiled type pressed flat by malleation from a rib or grooved paddle.

The most distinguishing feature left behind by these peoples is that of the burial mound. Such mounds 60 to 120' in diameter and 10-15'

¹Spencer, op. cit., p. 78.

²Ibid., p. 78.

at the crest entombed the burial of humans as well as caches of food and weaponry. Although less productive than burial mounds to the East, still the fossil remains along with the stone scrapers, hammers, points, pottery, bone needles and handles, etc. provide the archaeologist with many insights into their culture.

Villages usually consisted of 8-10 earthen rectangular lodges up to 25' in diameter and sunken a few inches into the ground. Four to five center posts with other posts leaned against these served as the main support for the lodge. Inside cache pits reflecting their reliance on horticulture as well as a fireplace are usually found.¹

Near the end of the 1400's and into the early sixteenth century tree ring analysis would indicate a long and devastating drought and wind storms across the Plains. The abandonment of many of these villages during this time coincides with a similar phenomena which drove Indians out of surrounding areas as well as the cliff dwellers of Colorado, New Mexico, and Arizona.² Indications from archaeological digs in the Upper Plains would indicate dust deposits over these sites ranging from 1' in Western Nebraska to nearly 7' at the Sommers site near Pierre, South Dakota.³

Soon to follow the retreat of these sedentary villagers in the early 1500's was the migration to the Plains by those villagers known as the Hidatsa, Mandan, Arikara, and Pawnee. Probably best known of these groups were the Mandan. Lewis and Clark's expedition of the early 1800's recorded in great detail the culture of these people along the Missouri River.

The villages were rather large, with several dozen closely spaced earth lodges clustered in no particular order around a central open area, where ceremonies and games were held. Located on terraces above the Missouri River, the villages were protected by high post palisades with a deep ditch just outside. The houses were quite large, ranging from 40 to 80 feet in diameter. Several nuclear families occupied each lodge; the families were members of the same extended family of a matrilineal kinsgroup. The villages were almost deserted during the summer hunt and again during the winter, when temporary quarters were taken up in protected wooded areas in the valley, where game and firewood were more plentiful.

¹Jennings, op. cit., pp. 242-244.

²Jennings, op. cit., p. 239.

³Jennings, op. cit., p. 249.

The lodges were round and built of timber, with earth and sod covering in the familiar Plains pattern (see diagram 1). The size of the structures necessitated large center posts as the major supports; rafters radiated outward from the crossbeams of the four center posts to plates upon the shorter posts set at the edge of the circular floor. Upon the rafters, willows and grass or thatch were spread to support the earth covering. The roof was open in the square area formed by the central crossbeams on the center posts. This opening was the only source of sunlight and was also the smoke hole. In bad weather, a shield -- sometimes it was one of the round buffalo-hide bull-boats used for ferrying the river -- was placed over the smoke hole. There was a short, covered entryway also made of timber and earth. The arrangement of facilities inside the lodge was evidently more or less standard. The fire was within the square formed by the central supports. There were curtained bunklike beds around the back or side walls. On the right of the fire area or behind the fire opposite the entrance was a family shrine or altar where ceremonial objects were kept. At other locations would be a sweat bath, a stall for a favorite horse and food for him, food-storage areas, and extra clothing. Buffalo-robe seats were ranged around the fire. In the floor were deep, jug-shaped storage pits for corn and other food. Outside the lodges were innumerable scaffolds or racks for drying both vegetable and meat products.

Although the lodges were roomy and comfortable, they would not have fitted modern conceptions of creature comfort or sanitation. One of these villages was described by an early visitor as "filthy," with villainous smells everywhere assailing him. He complained of the swarming dogs and children and described the village as a hogpen. This description can be supported on archaeological grounds because thick midden or garbage dumps are scattered all through the village. Often one can associate a midden area with a specific lodge. The towns would have been malodorous quagmires after a rainstorm, with only slightly less stench in dry seasons.

The Mandan artifact list, of course, reflects both hunting and horticulture, the latter involving the sunflower as well as the familiar maize. Tobacco, important in ritual and ceremony, was grown by the men; the rest of the gardening was done by women and children on small plots in the loose, rich soils of the Missouri River Valley floor. The gardening tools included a wooden digging stick, a bison-scapula hoe, and an elk-antler or willow-branch rake. Corn and beans were planted together, with sunflower around the edges of the field. Squash was grown in separate patches. Agriculture was surrounded with ritual and ceremony to provide supernatural aid in production. In addition to gardening, the women tanned skins, made clothing of all sorts, made pottery of good quality, gathered wood, did much of the work of house building and maintenance, cared for children, prepared food, and did other chores. The men hunted, fought if need be, performed many important ceremonies, and competed in games and contests. When necessary, they assisted the women in the heavier labor of harvest and construction.

Given the near-certainty of ample food from the inexhaustible herds and the products of the fertile valley gardens, the Mandan had a rich ceremonial life centered on the vision quest and a number of "medicine" bundles that gave various kinds of "power." Some bundles were quite specific in their effect on crop fertility or weather; others had to do with curing disease. Self-torture was an important element in the religion and was a dominant theme in some of the ceremonies.¹

Figure 1: Mandan Earth Lodge

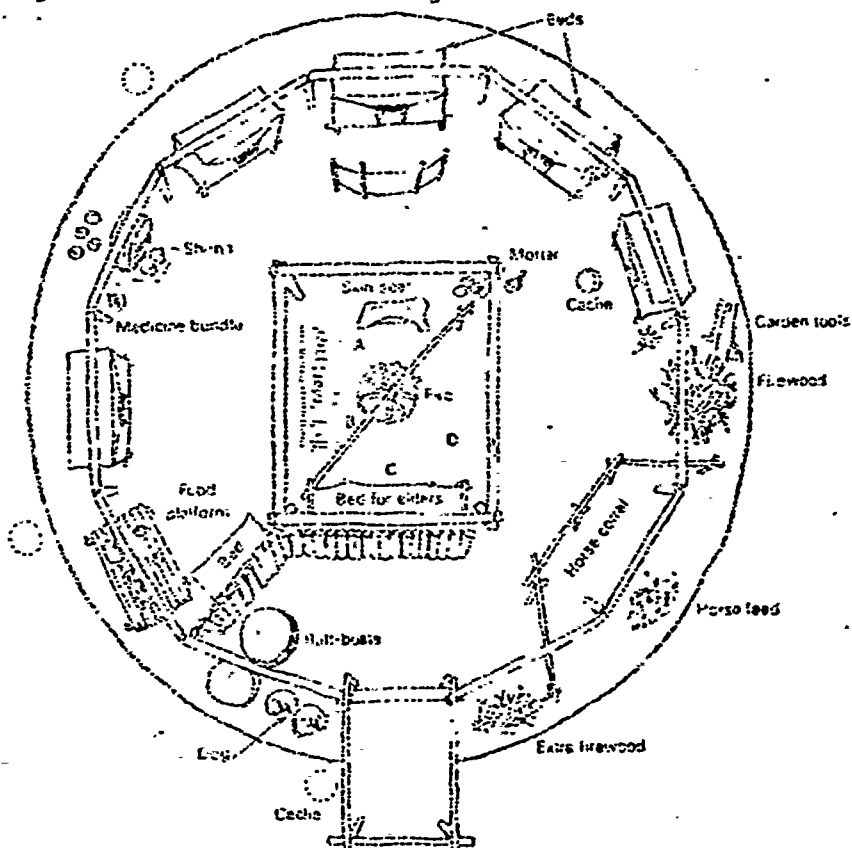
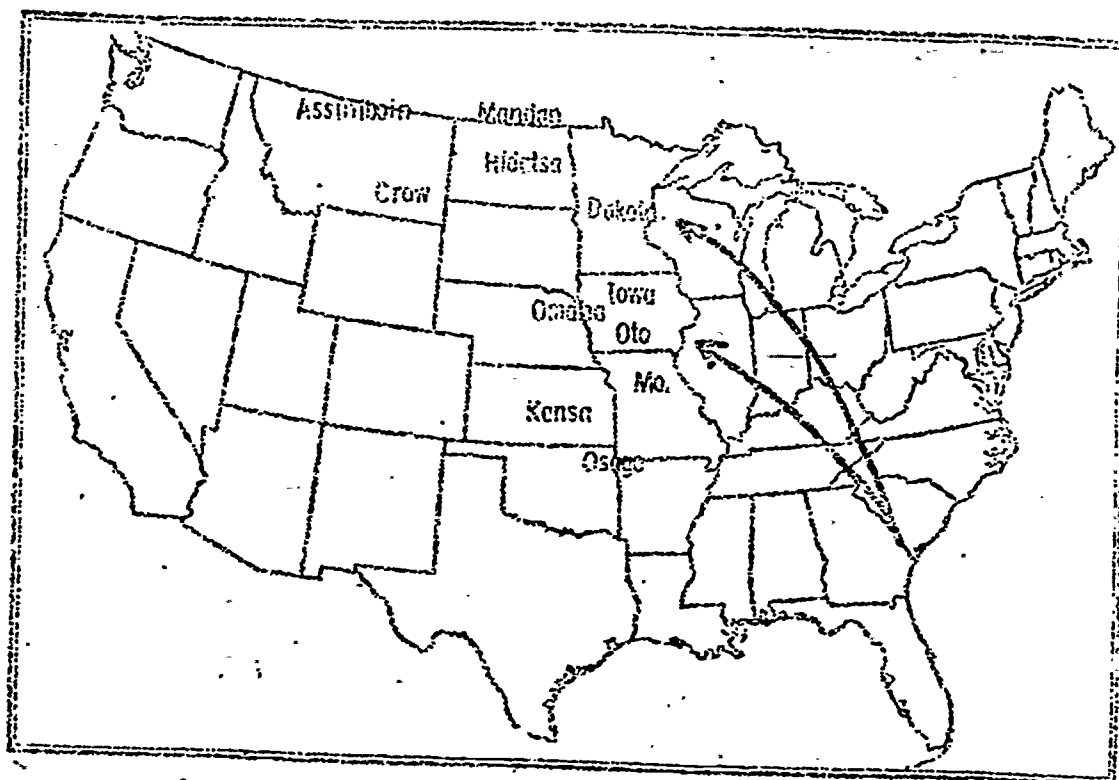

Diagram of a twelve-post Hidatsa earth lodge. A, B, places of honor for guests; C, grandfather's place to make arrows; D, cool's place. The cooking kettle was suspended from diagonal pole over the fireplace. (After Lewis 1854)

By the time the White-man reached the plains in the late 1500's, two distinct subcultures existed in this area. In the prairie country of the lower Missouri River basin were the various Siouan-speaking peoples including Osage, Missouri, Kansa, Otos, Gnahas, Iowas and Poncas. To the north of them were the Caddo-speaking Arikaras and Siouan speaking Mandans and Hidatsas. To the west were the Caddo speaking Pawnee and to the south the Wichitas. (See map #3) All practiced agriculture, supplementing this with hunting efforts. Many of the traits possessed by the peoples were a combination of the earlier mound builders and the late nomads to be displaced from east of the Mississippi River.

¹Jennings, *op. cit.*, pp. 241-245.

Map 3: Eleven Tribes of the Sioux Language



V. HISTORY OF THE DAKOTA SIOUX

Linguistic Groups:

Before tracing in any detail the migration of Dakota peoples westward, a word need be said about linguistic groups. The Dakota were but one of eleven tribes speaking the Siouan language. Others were Mandan, Hidatsa, Crow, Iowa, Oto, Missouri, Omahas, Pincas, Osage and the Kansas. At the same time there were five linguistic groups other than the Sioux which played a part in settlement of the Plains: Algonkian, Athabaskan, Caddoan, Kowan, and Oto-Aztecan. (See Figure #2)

Within the Dakota nation there were three dialects of Siouan language spoken. "Dakota" was spoken among bands of the Santee tribe, "Nakota" among the Yankton tribe and "Lakota" among the members of the Teton tribe. (See page for discussion of tribes and bands.)

Figure #2

PLAINS INDIAN LINGUISTIC GROUPS

<u>Algonkian</u>	<u>Athabaskan</u>	<u>Caddoan</u>	<u>Kiowan</u>	<u>Siouan</u>	<u>Uto- Artecan</u>
Blackfoot	Sarsi	Pawnee	Kiowa	Mandan	Shoshone
Cheyenne	Kiowa-	Arikara		Hidatsa	Comanche
Arapaho	Apache	Wichita		Crow	Ute
Gross-				Dakota	
Ventre				Iowa	
Plains				Oto	
Cree				Missouri	
Ojibwa				Omaha	
Chippewa				Ponca	
				Osage	
				Kansa	

Westward Migration

Following the earlier migration of the Hidatsa, Arikara and Mandan to the Upper Midwest were those people known as the Dakota and Cheyenne. The Dakota have been traced to agricultural settlements in the 1500 and 1600's on the eastern seabards near the Lumber and Santee Rivers in southern North Carolina.¹ In the early 1600's they are to be found settled in similar villages along the Ohio and Arkansas Rivers in the states of Ohio and Indiana. Any detail as to the way of life during these two settlements is at the present sketchy. Without the horse and based on what is known of the tribes in similar geographic setting, one would have to assume an agricultural way of life with supplementation through hunting and gathering. The Dakota were pushed westward by increased European settlement in the east and were found residing in the western Great Lakes region in the state of Minnesota beginning with the late 1600's. Detail as to their way of life becomes increasingly more available as now contact with traders and missionaries are made.

It will be necessary at this point in the discussion to distinguish the tribes, and bands of the Dakota in that their migratory and settlement patterns will differ significantly.

The structure of the Dakota can be best visualized in an organization chart designating the various levels of association. However, it must be recognized that among nomadic peoples such organization serves not as a governing structure but rather only for purposes of association; marriage and at times alliances. In contrast the highly

organized "nations" of the east such as Iroquois and Cherokee, where government and social control was rendered by the superstructure, the Dakota lived in small groups (Tiyospayes) quite independent of any other outside means of control. (Figure 3).

The Dakota Nation was organized into three major tribes; Teton, Santee and the Yankton. Beneath each tribe were a number of groupings known as bands (clans among the Santee) which were further sub-divided into a number of extended families (Tiyospayes). Each Tiyospaye was a completely independent unit which served allegiance to the band (clan) and tribe but was not governed in any way by the higher structure, except in those cases where the people may form alliance for various purposes such as hunting, summer encampments, etc. There were no band or tribal chiefs but rather all positions in Dakota government were to be found within the Tiyospaye. Such outstanding figures as Red Cloud, Crazy Horse, and Sitting Bull were dignitaries within separate Tiyospayes and not band or tribal leaders.

Figure 3

DAKOTA ORGANIZATIONAL STRUCTURE

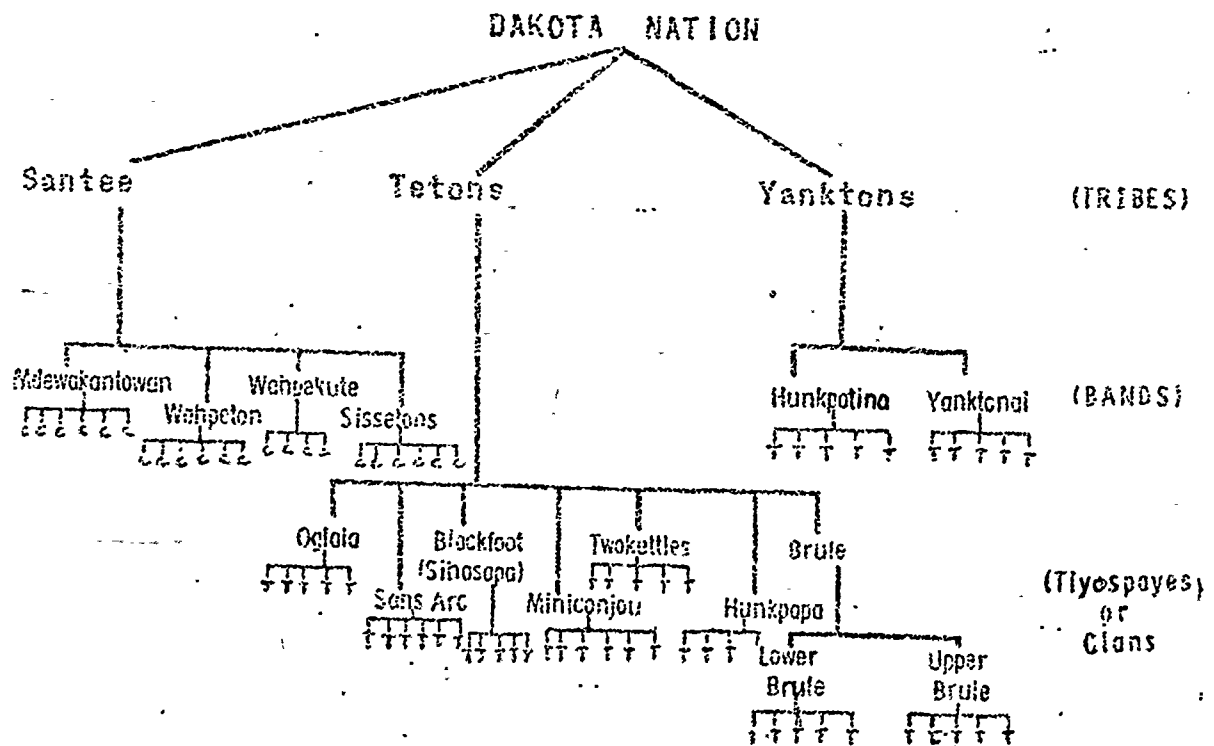

We will return to discuss in more detail the intricacies of their organization in Part VI.

Returning to our discussion of early migrations, we find the Dakota peoples near the western edge of the Great Lakes in the late 1600's and early 1700's. As pressure from the east continues the Dakota people will be forced into the areas known as Minnesota and Eastern South Dakota by the Chippewa. The Cheyenne Indian will also be forced westward spending time in South and North Dakota, later joining the Mandan and then moving further westward to the Black Hills of South Dakota and Eastern Wyoming.

The Teton took up residence in the Lake Traverse area at the head waters of the Minnesota and Red Rivers. The Santee located near Mille Lacs Lake in north central Minnesota while the Yankton will settle further south in Minnesota. During this period, the Sioux lived mainly in scattered villages throughout the lake-studded woodlands. They practiced a mixed economy of horticulture, hunting and wild rice gathering. Seasonally, many of the groups made bison-hunting expeditions out on the adjacent prairie lands.

The three tribes of the Dakota (Teton, Santee, Yanktons) will go their separate ways in that by 1700 maps have them divided into the "Sioux of the East" (Santee) and the "Sioux of the West" (Yankton and Tetons).¹ The Tetons moved westward into the present area of South Dakota driving the Arikara northward and settling in the grasslands along the Missouri River. The Yanktons follow soon afterward taking up residence along the southern border of South Dakota near the James River. The Santee will remain in Minnesota taking up residence in the old Teton country near Lake Traverse and extending as far south as the junction of the Minnesota River and Blue Earth River at the present site of Mankato, Minnesota. (see map #4).

The last movement will have a lasting effect on the culture of the Dakota as it will be at this time (1750-1770) that the "Sioux of the West" (Teton and Yankton) will first be introduced to the one-toed Spanish horse. Introduced to the Dakota by the Cheyenne, the horse will have a dramatic effect on the life of these people.² The horse first being brought to the New World by the Spaniards in 1493 will be brought north from Mexico through trade and stealing by Apache and Comanche Indians. Because of early scarcity, the horse was used by some tribes only for hunting while others such as Utes and Shoshoni had a fully-mounted hunting and cavalry developed.³

¹Ehanna Woyakapi, p. 6.

²For a detailed discussion of introduction and effects of the horse on the Plains Indian's way of life see: Leacock, Eleanor B. and Lurice, N.O., North American Indians in Historical Perspective, 1971, Random House, pp. 204-207.

³Leacock, p. 204.

With the adaptation of the Dakota semi-agricultural way of life to the horse, came those associated features of nomadism. The tepee as a new form of housing, the travois adapted from the dog to the horse became the means of transporting belongings. Agriculture became of minor importance as now the hunting of buffalo supplemented through collection of such products as berries, turnips, etc. became the major means of subsistence.

While the "Sioux of the West" were involved in this transition to a nomadic way of life the "Sioux of the East" (Santee) continued to reside in the central Minnesota area. The Santee received their name (Santee = knife) from their residence near Mille Lacs Lake in Northern Minnesota. (Mille Lacs was knife shaped). Gradually during the 1700's the Santee were pushed further and further west in Minnesota by the Chippewa Indians so by 1783 they were to be found along the head waters of the Minnesota and Red Rivers near Lake Traverse.

In 1851 a treaty meeting at St. Peter, Minnesota ceded all lands in Minnesota and Iowa to the whites at 6¢ per acre. Failure of the white government to carry through on promises made in food allotments and the fact that much of that money which was allocated for land transfer was given to trading companies which had alleged depredation claims against the Santee, ultimately resulted in the Minnesota uprising of 1862 in which a number of bands of Santee took part. Upon the capture and trial of such bands the Santee Dakota were divided and placed on reservations at Crow Creek on the Niobrara River, some in Nebraska and others on the Sisseton-Wahpeton Reservation in northeastern South Dakota near Fort Ridgley (presently Fort Sisseton).

VI. STRUCTURE OF DAKOTA CULTURE

Due to the differences in culture demonstrated by the "Sioux of the West" (Yankton and Teton) as opposed to the "Sioux of the East" (Santee), it will be necessary to discuss these separately. The major means of subsistence (agriculture vs. hunting and gathering) serves to provide each grouping with a quite different "way of life."

Sioux of the West (Yankton and Teton)

A great deal of the literature devoted to the Dakota Sioux has focused on these groups in that much of the confrontation between Indian and whites was with these two groups. The Teton Dakota being the most notorious, produced such outstanding leaders as Red Cloud, Sitting-Bull and Crazy Horse.

Kinship: Returning to our earlier discussion of the organization of the Dakota, the Yanktons and Tetons possessed a structure based on the Tiyospaye as the basic unit. Both tribes consisted of bands (Teton = seven; Yankton = two) which in turn were made up of numerous extended families known as Tiyospayes. (See Figure #4) A Tiyospaye consisted of 10-20 conjugal families (husband-wife-children combinations) united by strong kinship ties and served for all practical purposes as one large family with most all persons related.

Figure 4

DAKOTA
TIYOSPAYE
(Clans)

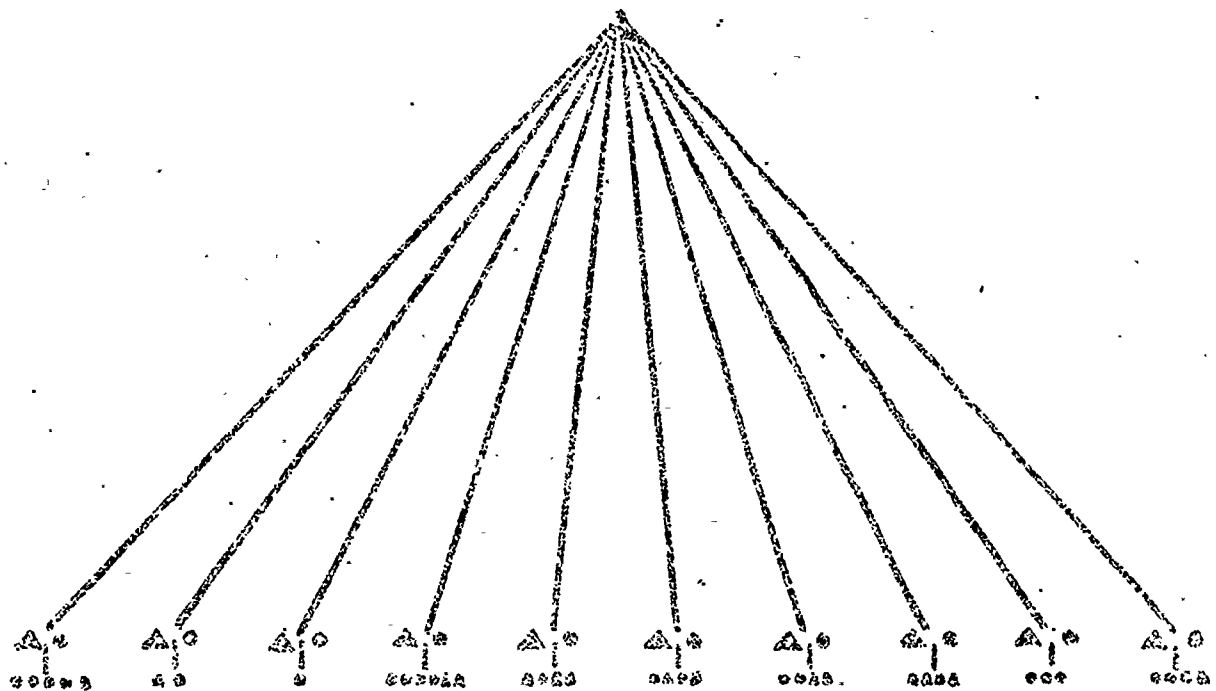

Because of the demands of mobility in their nomadic way of life the people were required to reside in small groupings so as to maintain themselves in a hunting and gathering way of life. This small kinship unit was totally autonomous and as will be seen later, will elect its own leadership and operate totally independent of any other affiliations.

As an extended family unit the kinship ties were such that any one person within the unit benefited by many close relatives. As a matrilocal group (husband moves to tiyospaye of his wife's relatives) a child may have at any one time numerous fathers and mothers in at least two tiyospayes (See Figure 5). In Figure 5 one will note that Ego's mother's sisters and father's brothers will all be considered as parents with the same obligations to his welfare as his own biological parents. The children of these other mothers and fathers (aunts and uncles in white society) would be either brothers and sisters or first cousins to Ego. Such kinship ties provided the youngster with a source of security unbeknown to the outsider. He would grow to know that his first allegiance to

sacrifice, fight and die would be to his Tiyoaspaye and then secondly to his own conjugal family. Although multiple marriage was possible, most often families were monogamous. Roles of men and women differed as men were expected to fight and hunt while the domestic chores of collecting, food preparation, packing and repacking the household belongings and child rearing were primary duties of the female.

Figure 5
DAKOTA INDIAN KINSHIP

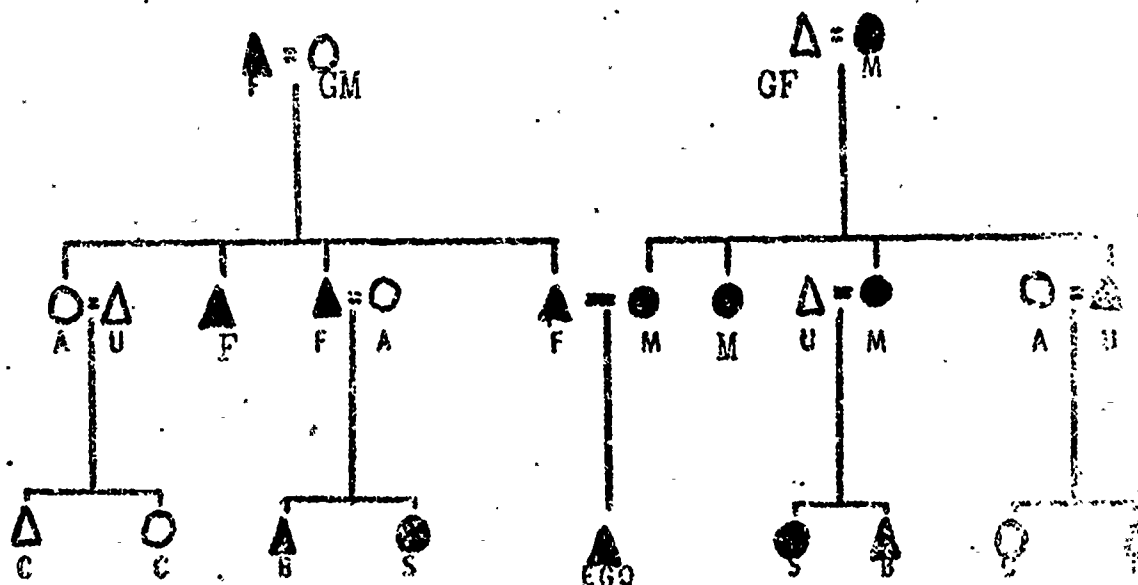

Children were taught by example with little or no physical punishment rendered as shaming served much the same purpose. Maternal grandparents played a major role in childrearing as often the maternal grandmother supervised the rearing of her grandchildren. Extreme devotion and respect was afforded all relatives and especially the aged.

Usually the conjugal family was not large as even childless couples had children through this unique extended family system. As a communal society all families joined in the hunts and foodstuffs were divided quite equally based on need.

Mate selection came through mutual choice based on a bride price (payment to the bride's father) usually consisting of horses. Mates had to be selected from other Tiyoaspayes in that all eligible mates within one's own would be considered as brothers, sisters, or first cousins.

Economics: As has been pointed out numerous times previously the Yaniktons and Teton were of a hunting and gathering way of life. Foodstuffs were communal property whereas one's horses, weaponry, housing, etc. were personal property to be disposed of as seen fit by its owner. Even though such a feature as personal property did exist, one of the greatest virtues among the Dakota was that of hospitality or the sharing of one's property upon demand. Wealth will be measured on one's tradition of giving rather than accumulating. This feature will later come to be a major obstacle to successful individual entrepreneurship forced upon the Dakota under the reservation way of life. The Indian viewed himself as a part of nature, no more nor no less than any other living thing. As he felt himself to be kin to all living things, he then felt it quite impossible to take from this life more than was needed for simple subsistence. To kill bison or to reap the produce of wild plants beyond one's daily needs was to exploit nature for which such violation he would need to pay retribution.

Religion: The above discussion concerning the Indian's relationship to nature leads us to a discussion of his religious system. Similar to that of most hunters and gatherers, the Dakota will base his religious beliefs on that which is of primary importance to him for survival, that being nature. Often referred to as "The Hoop of Nations" or "The Great Circle of Nature," the system was based on equal relationship of man to all other life forms (see Figure 6). The Indian dare not exploit the relationship for it

Figure 6: Comparison of Christianity and the Great Circle of Nature

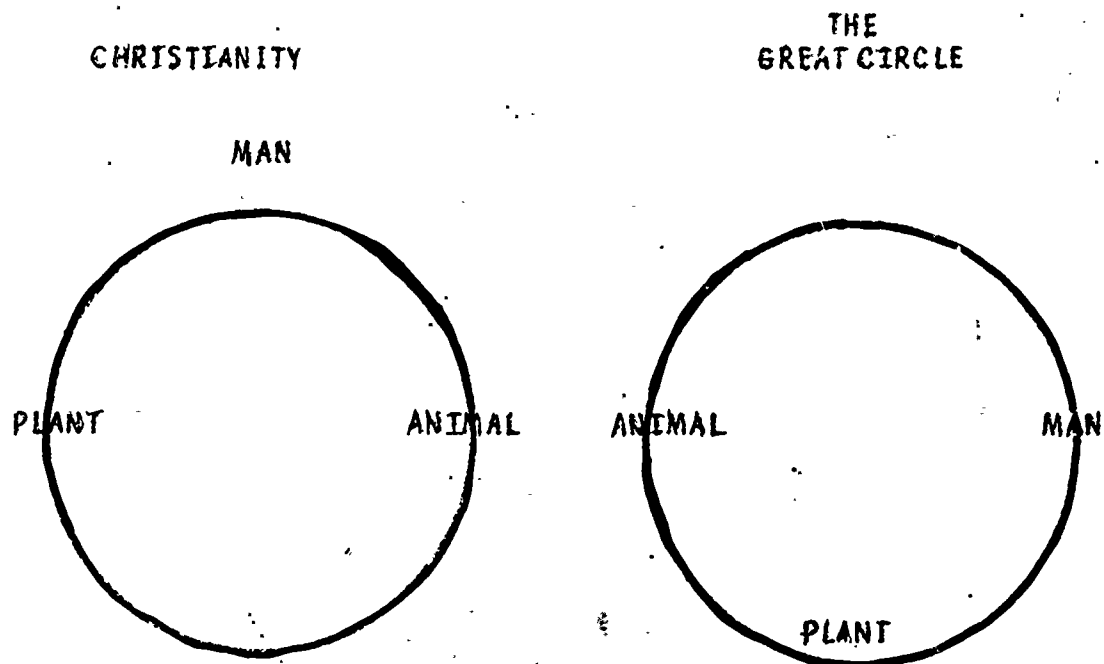

would be necessary for him to rely on that same life time and time again for survival. The annual Sun Dance served a major purpose in the Indian's attempt to restore the harmony of all life forms as he paid retribution through physical pain and gifts to restore this balance in nature. In contrast, the Christian beliefs of the white differed significantly in that man was superior to all other life forms and for this reason felt no guilt in the exploitation of other life forms in the name of hunting, trapping, farming and ranching. This basic difference will serve to prevent the white man's religion from ever playing a major role in Indian ritual.

Government: The only true governing system was to be found within each independent tiyospaye. It was here that one finds the council and chief. (see Figure 7). The tiyospaye council was made up of a number of elected elderly males who usually were not active warriors at the time of their election. Had they been outstanding as hunters and warriors in their younger years, their chances of election were much greater. The council in turn elected one of its own as the chief. These were the men of wisdom.

Figure 7
 DAKOTA
 TIYOSPAYE GOVERNMENT ORGANIZATION

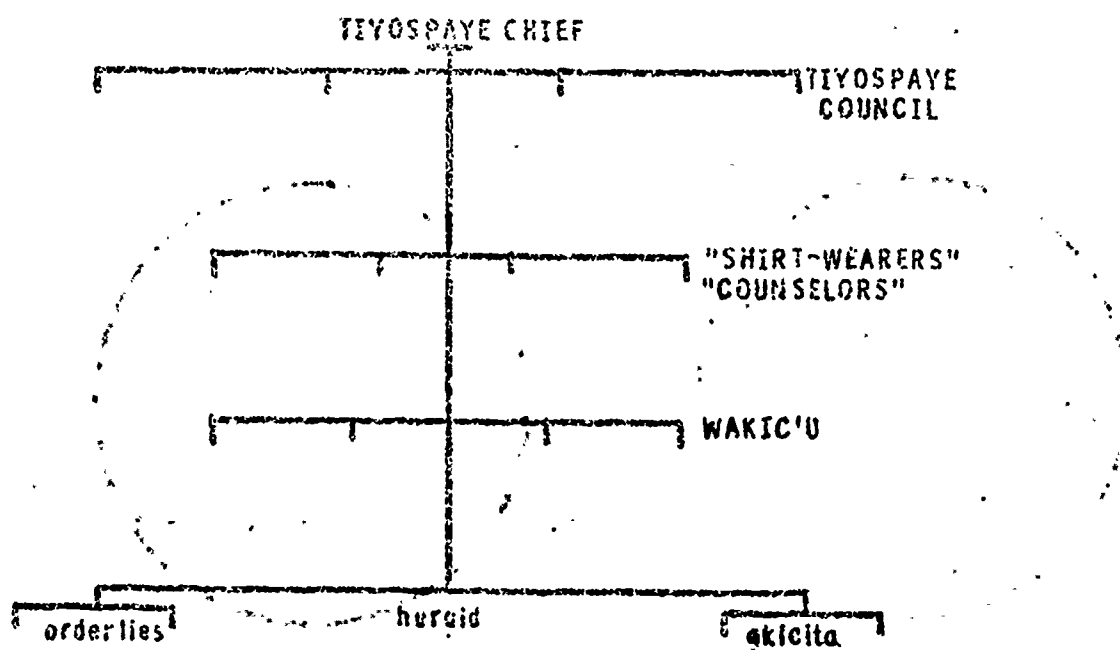

Below this level of government was a group of elected young men (shirt-wearers or counselors) noted for their skill in hunting and bravery in war. It was this group that made the day to day decisions for the tiyospaye based on the advice and wisdom of the council.

Directly below this group were a number of men who served in the capacity of judge and jury for violations within the tiyospaye. The "wakincu" as they were known, played an important role in the maintenance of justice among the members of the group.

At the lowest level of government were several groups of men assigned specific duties. The "herald" served as the person responsible for public announcements of the council, shirt-wearers and "wakincu" decisions. The "orderlies" served to provide for the needs of these higher groups while in session. The "Akitcita" were the policemen of the tiyospaye responsible to the "wakincu" for apprehending violators.

The governing process was truly that of a democracy in that all households had an opportunity for participation through their male head. Few decisions were made without the consultation of all responsible parties.

SIoux OF THE EAST (Santee).

As was pointed out previously, numerous differences occur between the structure of the Sioux of the East and West. Whereas our previous discussion of Teton and Yankton focused on a nomadic way of life, this discussion of the Santee is based on a more sedentary agricultural group of Dakota Indians located in Northeastern South Dakota.

Kinship: Where the Tetons and Yanktons referred to the basic unit as tiyospayes, the Santee referred to theirs as "clans." (see Figure "8). Named after geographical localities these clans were different than those of the west in that they were somewhat less independent. Again, the Santee practiced a restrictive courtship and mating process as well as matrilineal residence and polygamy similar to the Tetons and Yankton. The extended family feature of multiple parents and major role played by grandparents in childrearing was the same also. (see Figure "5).

Figure 6
SISSETON-WANPETON POLITICAL ORGANIZATION

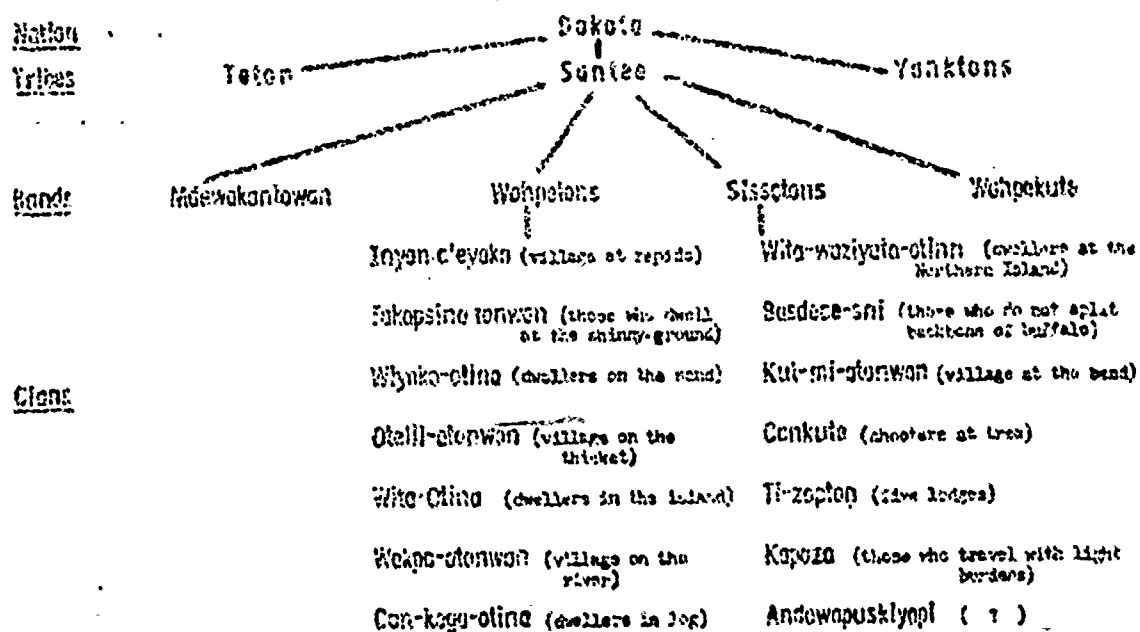

Economics: Whereas the Sioux of the West took upon a nomadic hunting and gathering type of economy, the Sioux of the East continued in a more settled agricultural way of life. Communal hunts each summer lasting several weeks were undertaken, but for the most part the Santee were gardeners living in permanent villages. The role of females in the economic endeavors of the Santee incorporated the gardening as well as those same features of child-rearing, collecting, etc. entered into by Teton and Yankton women. Santee men remained as hunters, fishermen, trappers, and warriors and saw "tilling the soil" as the role of women only. Corn, beans, squash, and pumpkins were the main gardening crops with wild rice as a collecting item. Where the highly portable tipi was used for housing among the Teton and Yanktons, the Santee used both the tipi as well as a more permanent structure (lodge) made of bark with a gabled roof known as a tipi-tonka.

Religion: Similar to the religious practices of the "West," the Santee also practiced a belief in man's equality to other life forms (see Figure 6). Combined with the "vision quest" this ceremony played a major part in summer encampments which brought many clans together.

Government: Where the tiyospaye of the Teton and Yanktons were for the most part independent entities as far as government, the sedentary

feature of the Santee provided for a more interdependent relationship between clans. Each clan had a wakincun or counselor representing them on the band council and each wakincun had an equal vote in the decisions of the band. Temporary chiefs who were in charge of hunts and battles were appointed for each event. The chief or wakincun of each smaller group came to this position by election which was based on his traits of individual wisdom and powers. (Figure 9)

Figure 9
SISSETON-WAHPEYON CLAN ORGANIZATION

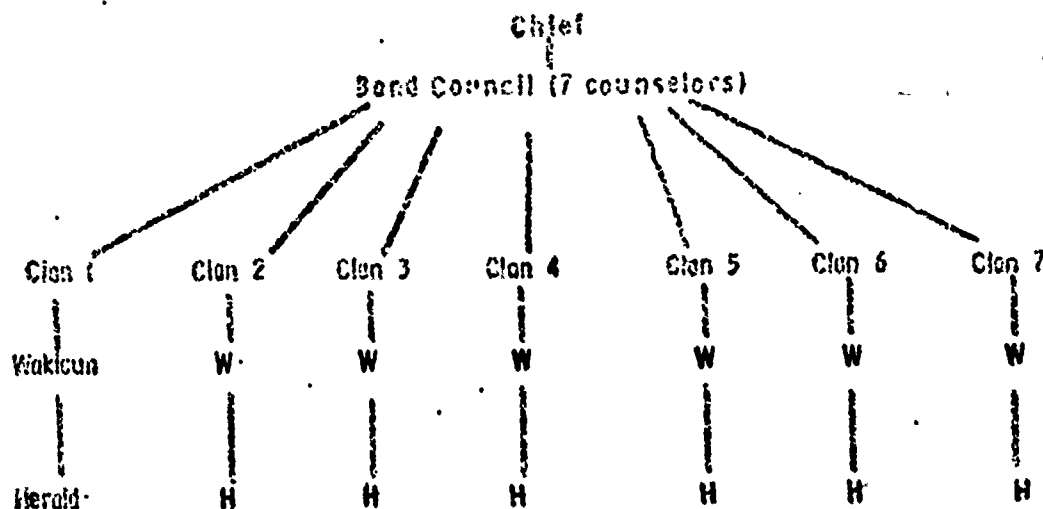

VII. ACCULTURATION AS A SOCIAL PROCESS

The traditional patterns of living found among the Dakota Indians were incompatible with the education of the American frontiersmen and were regarded as inferior. The frontiersmen believed in the superiority of his culture and any who disagreed must either immediately adjust to the new pattern or suffer annihilation. The Indian could recognize the utility of some of the frontiersman's equipment to satisfy his desire for survival, such as horses, steel knives, and repeating rifles; but was not at all impressed with the seeming disregard of spiritual and moral values exhibited by the frontiersman. Two widely varying patterns of thinking and acting were therefore in contact on the American frontier.

Definition of Acculturation: The process of culture change resulting when differing groups are in "continuous first-hand contact" and the subsequent modification of the original culture patterns of either or both groups will be referred to as acculturation.¹ This study will attempt to analyze the changes which have taken place in the culture patterns of the Dakotas since their first contacts with the American frontiersmen. These changes have not taken place without large-scale disruption of the Dakota way of life and without disorganizing results in the life of the individual Indians. The society of the Dakotas is consequently beset with unending problems of adjustment which are most apparent on the reservations located in the rural areas of South Dakota.

Culture Change and Acculturation: Differential rates of change in the process of acculturation are associated with social disorganization. Comparison between the Dakota Indian and White American cultures indicates the latter as a more dynamic, rapidly changing culture. The Dakota culture had been changing also, but the rate of change was considerably slower. The first contacts of the Dakotas were with traders, and their influence was felt primarily in the introduction of new material apparatus and techniques; but they made little effort to change the more basic culture patterns. The Dakotas easily accepted the diffusion of goods which offered utility or decoration not previously enjoyed by them. Missionaries were not as successful in introducing new ways because their teachings violated some of the basic premises of Dakota culture, although there was sufficient similarity in spiritualism to provide a basis for acceptance of the new religion by some of the Dakotas.

The Dakotas actively resisted acceptance of the White man's culture only when they began to realize that the encroachments of the settlers on their lands could only result in the extermination of the buffalo which was their main means of subsistence. Then they were forced to fight for their way of life. Although the fight was futile because of the overwhelming odds against them, the Dakotas were able by shrewd maneuvering and bravery to provide the army of the northern plains with plenty of headaches before they were finally subjugated and placed on reservations under the control of the government.

The government policy on the reservations was two-fold: military supervision and enforced acculturation. The only possible Indian response to military force was appeal for supernatural aid exemplified in the Ghost Dance Religion. The second policy, acculturation, was designed for the education of children. It was hoped that "by encouraging missionaries to Christianize them, by teaching them to farm and to become self-supporting, by forcing White man's dress, and by consistently damning native institutions like those of the chief, the band, medicine man, soldier societies, and Sun Dance," the Dakota youth would learn to accept the White culture pattern. These policies were to be supported by threats of withdrawal of government rations from non-conformists, at a time when the Dakotas were almost entirely dependent upon the agency for food. The only response from the Indians to this policy was passive resistance, and since they were isolated on reservations, lacking contact with most of the outside society, they were

¹Robert Redfield, Ralph Linton, and Melville J. Herskovits, "Memorandum for the Study of Acculturation," American Anthropologist, XXVIII (March, 1936), 149.

able to retain many of their old cultural values and transmit them to their children, in spite of the efforts of the missionaries and the schools.¹

The history of culture change for the Dakotas appears to divide itself logically into the five phases suggested by Nekeel:²

1. Acceptance of the horse and trade goods from White culture, leading to prosperity and expansion in population and territory.
2. Struggle for sovereignty.
3. Acceptance of reservation life through military defeat and loss of subsistence.
4. Appeal to supernatural aid and rejection of White culture.
5. Passive acceptance of White acculturation.

With this historical pattern of culture change in mind, it is not surprising that the Dakotas have still not completely accepted all aspects of White civilization. Their resistance to or, at best, passive acceptance of the traits of the dominant culture meant that changes in their basic values came about very slowly. At the same time, the values of the White culture were undergoing increasingly rapid changes associated with improved technology and the only possible result was a tremendous lag between the rates of culture change in the two societies.

Not only were the rates of change unequal between the two cultures, but they were even more uneven within the Dakota culture. Many of the Dakotas accepted the material and superficial aspects of White culture, but rejected the beliefs, attitudes, and values of the dominant society. Some individuals completely reformed their beliefs to fit their new knowledge, while other individuals refused to accept anything but the traditional knowledge of the tribal group. Those who were willing found the task of learning new ways almost insurmountable, since they had grown to adulthood with a vastly different cultural environment. The result was confusion and disillusionment for the Dakotas. They found many conflicts in the White man's values and between the old and new values which could not be easily resolved by individuals accustomed to the consistent value structure of their traditional society.

The older Dakotas, unable to remove those conflicts, remained largely unassimilated, and found solace in the recalling of past glories and the preservation of the old ways. They escaped from

¹Scudder Nekeel, A Short History of the Teton Dakota, State Historical Society of North Dakota, 1943, p. 194.

²Ibid., p. 140.

their present miseries into a world of illusion, and when forced to face troubles exhibited a stoic disregard for their own personal welfare. The younger generation, however, could not completely escape, and they were forced to undergo the rigors of the educational and control programs instituted by the government on the reservation. But when they went home, they were under the influence of the "old folks" and were consequently taught the values of the Dakota society. They became a marginal group, living in both societies and being only partly assimilated. The conflict in values between the two cultures is most evident in this generation, and they exhibit many of the symptoms of disorganization accompanying the disintegration of Dakota culture. In many cases, these younger Dakotas are becoming parents of a new generation which will become largely assimilated into the White culture, since the influence of the older people will continue to decline as they are unable to provide solutions to the problems of living in modern society.

There are, however, a number of factors which support anti-acculturation attitudes among the Dakota Indians. The most important of these is the pattern of discrimination, prejudice, and segregation which they must face in the white society off the reservation. Less important are such factors as lack of skills in dealing with the external society, dependency upon the Bureau of Indian Affairs, respect for unassimilated parents and grandparents, and other social and economic problems which have remained unsolved. Segregation on the reservation makes it possible for anti-acculturation attitudes to exist, but it is largely the treatment of the Indians in the external society which causes such hostile attitudes to exist.

VIII. IMPLICATIONS OF ACCULTURATION FOR THE DAKOTA INDIANS

Anthropologists are of the opinion that the Teton Dakota branch of the Siouan nation has the most typical of all Plains Indian cultures. On the Great Plains, which extend from Canada to Mexico and from the Mississippi to the Rocky Mountains, the Teton Dakotas occupied the North Central area. They were likewise the center of a great and powerful Indian civilization extending throughout the plains. Their civilization was so influential that today their cultural characteristics are copied by anyone who wants to depict the American Indian in art; and if anyone wishes to look like an Indian, he dons the scalp shirt and war bonnet of the Teton Dakotas. Before the arrival of the English-speaking ploughman on the plains, the Dakota culture appeared destined to sweep the continent and absorb the French traders and frontiersmen in the process. Many of the Hudson Bay Company men had completely assimilated the plains Indian culture, and the early frontiersmen usually became Indians at least in thought and habit. "Old Bill Williams is said to have offered his corn-cob pipe to the sun, like any shaman. Kit Carson lived in a tipi and counted coups."¹ During the period of early contact between Dakota

¹Stanley Vestal, New Sources of Indian History, 1850-1891, p. 193.

and White culture, the Indian way of life tended to dominate. The influence of Dakota culture was being extended and the power of the nation was increasing.

Some Sociopsychological Aspects of Acculturation. Relations between Teton and White became strained as the immigration of American frontiersmen and agriculturalists into the plains increased. The White invaders had preconceived ideas about Indians which caused them to assume an attitude of superiority. They did not observe the same principles of living as the Dakotas, and violated all the rights of the natives who possessed the land, at the same time looking upon these people with disdain. The traditional attitudes toward the Indians were well summarized by General de Trobriand.¹

The majority were convinced that the simplest and only means of settling the "Indian question" was to exterminate "all the vermin." This opinion prevails throughout all the frontier, especially in the towns and settlements of any importance. Others, more just and more moderate, believe that the Whites have been far from blameless, and attribute to them, at bottom, the causes of the hostilities that broke out during the war, and that are still being carried on. These latter informants are few in number, and while they declare that the poor Indians have been treated like dogs, that they have been lied to, robbed, pillaged, and massacred, they would be just as prompt as the others in shooting on sight any red-skin suspect that crossed their path.

There is considerable evidence that the Dakotas were always considered as actual or potential enemies. The tribes which were friendly had no protection because the Whites professed that they could not distinguish between friendly and hostile Indians. Any man who could tell the difference was under suspicion as "a friend of the Indian," or "a renegade White."

Many false ideas of the Indians were invented in order to justify the White attitude of superiority, and this attitude has endured to this day. For example, it is not uncommon for the police to jail a mildly intoxicated Indian, while a severely drunk White may be escorted home and told "to sleep it off." The justification of this discrimination is rationalized by recalling the stereotype of the "dangerous drunken Indian." Furthermore, the Indians living on the reservations in South Dakota today are stereotyped as unprogressive because they refuse to change their customs, while actually for most of them there is nothing in their cultural system which prescribes change.

The only possible reaction of the Dakotas to the superior and domineering attitudes of the Whites was defense of their way of life and their homeland. Resentment and bitterness were expressed by the Dakotas in regard to the unjust treatment they received at the hands of the White invader.²

¹Phillippe de Trobriand, Army Life in Dakota, pp. 12-13.

²John G. Neihardt, Black Elk Speaks, p. 138.

Wherever we went, the soldiers came to kill us, and it was all our own country. It was ours already when the Wasichus made the treaty with Red Cloud, that said it would be ours as long as grass should grow and water flow. That was only eight winters before, and they were chasing us now because we remembered and they forgot.

Leaders of the Dakotas such as Red Cloud, Sitting Bull, and Crazy Horse gained prominence because of their resistance to the depredations of the invaders.

As the Wasichus became better known to the Dakotas, faults in the White man's culture pattern became obvious to the Indians. The White men appeared to care little for their own people and to take everything from each other if they had an opportunity, so that while some had more than they could possibly use, others were starving. From the Dakota point of view, the Dakota way of showing concern for their people and sharing material goods was much better. Moreover, the Dakotas loved freedom to move about, while the Whites treated them like prisoners, penning them up like animals in a cage on reservations and pointing guns at them if they tried to escape. Certainly, reservation life with regulated government ration was not suitable for a warrior longing to rove again with his people over the great prairies and mountain ranges. Accustomed to the satisfaction of providing food for his family through buffalo hunting, it was better for a warrior to return empty-handed from the chase and to feel the pangs of hunger while awaiting a more successful hunt "than living the life of a squaw, sitting about a campfire."¹

The humiliation of trying to walk the White man's road was usually accepted more gracefully by the older people than by the young. The morale of the young warrior was poor; he was despondent and morose because of his many grievances for which the White man was to blame-- the destruction of the buffalo, the imprisonment on reservations, and the ruin of his life values. Supernatural aid failed him, suicide was for women, but to die fighting the enemy would bring glory. There was an incentive to strike the first White man to cross his path and gain revenge against those responsible for all his people's troubles. The Dakotas were also aware that the best Whites with whom they had contact violated the very principles they were being told were necessary to salvation. They could only conclude "that the Whites are a race who violate their taboos, to the Indian mind a thing unthinkable, a wicked folly almost incredible."²

Is it any wonder that the attitudes of the Dakota Indians, which have been described, prevented complete acceptance of the American culture? And yet the Dakotas were forced to deal with this new American

¹Julia B. McGillycuddy, McGillycuddy Agent, p. 77.

²Decost Smith, Indian Experiences, p. 205.

culture. The situation today among the Indians in South Dakota may be largely explained in terms of the conflicting attitudes which result when a group of people are influenced by two cultures but cannot live completely in either. Some members of the Dakota community accept the new attitudes, and others still accept the old, but most vacillate between the two standards of value or accept no standard at all. In most communities, the nonconformer is brought into line by sanctions of family, religion, education, and government imposed by the group; but in Dakota society, any attempt to impose old cultural sanctions only produces greater deviation among those who have accepted the new ways of living. The sanctions of the new culture are largely exercised by the government agency which is impersonal, and while demanding conformity in some areas, does not effectively change the basic attitudes which are deeply embedded in those who have clung to the older way of life against great odds.

Despite the increasingly strong impact of White civilization, the nonmaterial culture pattern of the Dakotas has retained a degree of vitality and significance in the lives of those Indian people that is difficult for many people to comprehend. When they have accepted material traits from the dominant culture, these traits have often been used for the purpose of insuring survival of earlier culture patterns. The core of Dakota personality structure is frequently the surviving elements of Teton-Dakota culture, although in many external segments of a Dakotan's life history are found behavior patterns and personality characteristics reflecting his position as a marginal man in American society. The Dakota individual is very likely to suffer from personal insecurity in this marginal social position, "with its poverty, lack of adequate roles and cultural objectives, and social conflicts arising out of lost controls and changing attitudes."¹

As each Dakota man or woman now looks back to the past either from experience or through the stories which have been told him, he senses the self-assurance and the ability of his ancestors to cope with life. They were united and secure in the life they followed, and their institutions gave good reinforcement within the group. By comparison, the modern Indian way of life is one of emptiness, one in which family and community are losing their integration. The contemporary life, as compared with the culture that was functioning in the middle nineteenth century, is only a shadow. Attitudes and values of that culture still strongly affect the behavior patterns of the people, but some of its social institutions are gone or are only vestigial. The realization of cultural loss and being neither Indian nor White in any cultural sense adds to the Indian's insecurity and isolation in the modern world.

¹Gordon Macgregor, Warriors Without Weapons, p. 121.

Thus the old Dakota Indians have only bitter memories of their past and their children have dim hopes for the future. The traditional ways have been largely shattered under the impact of the ponderous American culture, and new ways have not as yet been worked out to provide adjustment patterns acceptable in a complex culture.

Enforced and Permissive Acculturation. The early explorers and travelers who visited the Dakota Indians found these people to be generally friendly, often looking upon the pale-faces with superstitious awe and hailing them as benefactors who brought many useful and ornamental articles. Jonathan Carver recorded in his diary:¹ "As soon as I had reached the land, two of the chiefs presented their hands to me, and led me, amidst the astonished multitude, who had most of them never seen a White man before, to a tent...and ever after they treated me with great respect."

If this friendly relationship between the bearers of two different culture systems had continued, it is likely that the acculturation process would have been expedited. The social learning typical of friendly cultural contacts is referred to as permissive acculturation. This process involves imitation of the desirable cultural forms, such as habits, skills, and attitudes, which are best able to satisfy the culturally acquired drives of the group. As long as imitative learning can take place in an atmosphere of freedom, it is almost inconceivable that acculturation can in any sense be a disruptive process. Learning to speak a new language, to prepare and eat new foods, or to use new and more efficient tools which have been introduced from another culture should be no more disruptive than any new discovery or invention occurring within the culture system. In brief, voluntary imitative learning which does not involve radical readjustments for the individuals is the principal means by which permissive acculturation takes place and although it may proceed slowly, it is usually highly effective.

In many cases of acculturation, however, there are conditions which prevent free exchange of culture traits. One of the groups may feel that their culture traits are superior; and when they also have a predominant position of power, they are likely to attempt to force their culture system upon the subordinate group. This enforced acculturation implies that the ruling group will exercise sanctions against any member of the minority group who does not almost immediately change over to the new culture pattern. The Europeans in their contacts with aboriginal peoples were especially prone to insist upon enforced acculturation, and the result was resistance to imitative learning among the native groups. Then the Europeans made things still more difficult by establishing barriers which made it impossible to adopt the cultural traits even if the minority peoples had wished to do so. For example, the Europeans would introduce metal implements and utensils to a nonliterate group, but provide them with no knowledge of the manufacture of these instruments in the event that they were not available through trade.²

¹Jonathan Carver, Travels Through the Interior Parts of North America, p. 81.

²This discussion of permissive and enforced acculturation is based on the theoretical position expressed by A. Irving Hallowell, Culture and Experience, pp. 318-323. Imitative learning is used in this source to mean voluntary copying of culture traits.

In the early contacts between the Dakota Indian and Anglo-European culture, both permissive and enforced acculturation were evident, although the latter predominated. At the very beginning, the acculturative process was largely permissive and was carried out by the traders, who played a promotional role in persuading the Dakotas to adopt new tools and equipment. The next group to exert considerable influence was the missionaries, who were the salesmen of nonmaterial beliefs and moral attitudes. For the most part, their activities were permissive and limited to providing the Dakotas with a new religion, although they frequently attempted to convince the Dakotas that they should give up their old ways of nomadic life and settle in a place where missions could be permanently established. Enforced acculturation was primarily the program of the government agents and military forces that had charge of the Dakotas after they were coerced into reservations. But the policies of the government depended upon the attitudes of various groups that came in contact with the Dakotas, and therefore all these groups were responsible for the efforts to enforce acculturation. Perhaps the greatest influential group to which the government was responsive was the agriculturists who were demanding cession of Indian lands to the government so that these lands would be available for their agricultural expansion or land speculation. These four classes--traders, missionaries, government functionaries, and agriculturalists--should each receive consideration as agents promoting acculturation, since each class illustrates certain distinct elements in the total acculturative process of the Dakotas, these elements in turn differentiating this contact situation from any other.

The Traders--The role of the trader was to offer the Dakota goods, such as steel knives, kettles, and guns, which did not conflict with former habits but added comfort and convenience. These were readily accepted by the Dakotas; and along with acquisition of horses; these goods made it possible for the tribes to prosper and expand in population and territory. Much of the actual trading was carried on with Frenchmen who established friendly relations and inter-married freely with the Dakotas. The French fur traders attached no stigma to marriage into the tribes, and the Dakota family who had a daughter married to a trader was looked upon with envy because she had gained an honorable position. Even today the French traders are mentioned as a class apart from other White people with whom the Dakota have been in contact.

The close association of the traders with the Dakotas during this period greatly stimulated exchange of culture traits. The goods offered by the traders provided better means of satisfying basic needs, and this was sufficient motivation to insure their acceptance by the Dakotas. The nonmaterial values of the French traders were presented without pressure to the Dakotas for their acceptance or rejection; and while some "imitative learning" was apparent, the full acceptance of White culture values could not take place, especially since, in all likelihood, the trader was converted to the culture values of the Dakotas. The acceptance of material

traits by the Indians did at times make it necessary for them to readjust their thinking in certain nonmaterial culture areas and created new secondary drives unsatisfied under their present culture system. But the traders were unconcerned about these changes in the value structure, and therefore the Dakotas were able to make the necessary adjustments so that their culture pattern was improved rather than disrupted.

The Missionaries--The teachings of the missionaries regarding new religious beliefs and practices met with some resistance among the Dakota people. In order for these Indians to accept new religious beliefs, it was necessary that the pragmatic value of the idea be demonstrated in the satisfaction of their basic or secondary drives. The supernatural experience of these people had to be related to their rewarding activities if learning a Christian value system was to be motivated. One way this could be accomplished was by reducing through Christianity the dismay of the Dakotas when their own native beliefs failed. However, the missionaries usually attempted to eradicate completely the native religion and to impose Christian morality. The only possible result of such strategy was to create resistance among the Dakotas. If the missionaries had used the native beliefs as a framework in which to introduce Christianity, the results could have been quite different.

The purported objective of missionary work was to "civilize" the Dakota, and the missionaries indiscriminately tried to drive out practices which, they believed, impeded the progress of the Indians toward a civilized state. They influenced the Bureau of Indian Affairs to impose regulations not only against the Sun Dance but also against many other ceremonies and customs unrelated to religion. Indian couples who had been married for a long period under the tribal ceremony, for example, were forced to marry according to the Church ritual before their conjugal state was recognized in the Church.¹

One old couple, who had only a vague idea of its meaning finally consented to remarriage by the Church. An audience filled the church building and the aged couple stood in front of the minister. When the august personage in black questioned, "Will you take this woman to be your wife?" the old fellow looked incredulously at the minister, then at the interpreter, hesitatingly waiting for some light on the confusing question. After a moment or so he said, "Why, she is my wife." At the minister's next question, "Will you care for this woman through health and through sickness?" a puzzled expression, mingled with exasperation, came upon the old man's face, but he quickly explained, "I have always cared for her. Everytime she gets sick I send for the medicine-man." But when the minister exhorted them to let no man put them asunder, the old fellow quite feelingly let it be known that "We have been married these many years, and no man has ever come between us, so do you think anyone can now?"

¹Luther Standing Bear, Land of the Spotted Eagle, p. 114.

According to the treaty signed in 1868 with the Dakota Indians, they were guaranteed the right to worship in their accustomed manner. In spite of this guarantee, a few years later Agent McGillycuddy issued a proclamation that the Sun Dance would no longer be permitted at Pine Ridge. He justified this action on the grounds that proper agencies had been established and schools and churches built through which the Teton Dakotas must adopt White ways in consideration of food and annuities. He insisted that the physical pain suffered in the Sun Dance was contrary to civilized custom and retarded the progress of the Dakotas toward acculturation. This method of forcing the Dakotas to give up their old culture practices could only have the opposite effect than that intended by the missionaries. The acculturation process was accelerated when the missionaries made use of the old practices to introduce the new, but retarded when they attempted to replace the old with the new through enforced controls.

Government Agents--Both the traders and missionaries were in the vanguard of frontier expansion and did not engage in full scale effort to change the culture patterns of the Dakotas. They were in no position to force changes, but had to use persuasive measures to introduce new equipment and beliefs if they were to continue to live and work among the Indian people. Although they sometimes exerted indirect pressure on the Dakotas, enforced acculturation was not possible until the reservation period and the control of the Indian Agent had been established. These conditions were only possible after the Dakotas had been made vulnerable by their contacts with Whites and their subsequent military defeat.

The hostile groups of Indians were defeated only by starvation after a long and disastrous military campaign had been carried out against them. Although they capitulated to the government authority on the reservation, they were by no means reconciled to it. In the evenings, they sat around the lodges smoking their pipes, dreaming of past glories, reciting tales of bravery, and envisioning a return to their earlier freedom.

The desire for colonization and economic exploitation expanded the American frontier, and colonization and exploitation could only be accomplished after the native population on the plains had been conquered and forced to accept the sovereignty of the American government. If the Dakotas did not submit, they were decimated or displaced; and if they were forced to submit by conquest, conditions were created which directly or indirectly forced them to make cultural readaptations for which they were totally unprepared. New and destructive diseases were introduced; the buffaloes were killed, destroying their principal means of subsistence; their family and kinship patterns were upset; their freedom was restricted. Consequently, new problems resulted that the Dakota could not solve by means of their own cultural pattern; and they had, as yet, no means of learning some new mode of adaptation.

The Indian agents were consistently hampered and antagonized by the older members of the Teton Dakota tribes who fretted under the enforcement of a way of life they could not understand. The old chiefs felt that the agents were destroying Indian traditions and inducing the younger generation to desert their people. ; It was degrading to the old warriors

to work as laborers, use their ponies to draw wagons, eat beef instead of buffalo meat or venison, and become farmers and send their children to the government boarding schools.

The friction between the agents and the Dakotas was abetted by the lack of a consistent federal policy. The Dakotas had frequent cause to accuse the government of infidelity when agreements, which they reached with the government in good faith, were broken, their rights disregarded and their claims ignored. The government would guarantee to them their land as reservations forever, and then invariably it would violate these agreements. Instead of defending the Dakotas against White encroachment on their lands as promised, the federal authorities would send soldiers to protect the White intruders and subjugate the Indians.

Agriculturalists--The culmination of enforced acculturation was reached with the massacre of a small band of Teton Dakotas at Wounded Knee in 1890. This event took the heart out of Dakota resistance to White dominations and began a period of passive acceptance of White culture. The Indians were encouraged to settle on small farms, to build permanent homes, to raise grain and cattle, to send their children to government boarding schools, and generally to adapt themselves to the ways of the White farmers. The Dakotas however, found the life of the small farmer dreary and confining after their earlier pattern of hunting and raiding; and although a few members of the tribe made meager attempts at planting and irrigating crops, the main attempts at farming were similar to those of Red Cloud in 1875 who "gave permission for the women to try their hand at it."¹

The life of the small farmer did not have as much appeal to the Dakotas as the life of the cowboy who roamed with great herds of cattle over the plains of Nebraska and the Dakotas. The cowboys became the chief culture-bearers to the Dakotas because they lived out-of-doors, moved independently, and were the equal of the Indian as horsemen and marksmen. The former way of life of the Dakotas could easily be converted to these activities, and the generation of Indians originally placed on reservations took to them avidly. They were attracted to the cattle economy, and made an excellent transition to the culture of the White plainsman as their herds prospered.

The result was that the Dakotas appeared to be making a serious attempt to gain a self-sustaining existence and to imitate the dress, the bearing and the customs of the cowboy. But in the background was the conquering and feeding government which stirred no genuine regard in the mind of the Dakota; and the agents of this government, aware of the erosion problem, were forced to decree that in most cases the Dakotas could not be cowboys on the small amount of land allotted to them. The Dakotas could not understand the decrees that destroyed their early efforts at adaptation. They could not rebel; they could only express their discontent over the policies which forbade them to search for the blessings of White civilization.

¹George E. Hyde, Red Cloud's Folk, p. 115.

Some of the Dakotas were able to adapt themselves to the new order in spite of all the barriers placed in their path. They became the basis of a progressive group which was Christianized and friendly to the White culture. Yet many others refused to change, hated the government, and were antagonistic to any innovation. But it is worth noting that in the short time since these Indians roamed the plains, the amazing thing is that some of them were able to make a readjustment. The tragic figure was the chief who had been to Washington and had seen the White settlements and had returned to his people convinced that the Americans were too powerful to be successfully opposed. They were misunderstood by many of their own people, and at the same time were not accepted by the Whites. The son of one of these men reported his father's reaction as follows:¹

My son, since I have seen all those cities, and the way the Long Knife People are doing, I begin to realize that our lands and our game are all gone. There is nothing but the Long Knives (or White people) everywhere we went, and they keep coming like flies. So we will have to learn their ways, in order that we may be able to live with them.

Dysfunctions of the Acculturative Process. It is apparent that the contact of White and Dakota cultures was accompanied by a large variety of anxiety-arousing situations for the Indians. The acquired drives of the Dakotas were not the basic pain avoiding drives which have motivated many native peoples to accept the inevitable domination of the conquerors. On the contrary, Dakota culture inculcated in individuals a desire to suffer for their people in order to guarantee that the society would not be destroyed. The sad situation which the Dakotas faced was that their traditional bravery under dangerous conditions did not eliminate the enemy; and in spite of their best efforts, they were threatened by death, disease, loss of home and livelihood, and ultimate destruction of their whole manner of life.

Anxiety drives are very strong motives to action; they demand immediate relief. The Dakotas had the strongest possible incentives to defend the old culture pattern. They successfully resisted the White encroachments for a long time, but they were finally defeated. And then the destruction of the Dakota society proceeded pell-mell. The most effective programs that the Americans could use to subjugate the Indians were those that destroyed the means of subsistence and the kinship groupings, and these were systematically carried out. The result was a loss of life-meaning for the Dakotas and the appearance of a variety of disorganization symptoms.

Elimination of Means of Subsistence.—The elimination of the principal source of Dakota food supply was accompanied by great anxiety among the tribes. It was not merely that the loss of the buffalo would result in hunger and starvation; but the rations offered them by the Americans did not satisfy their acquired appetites for those foods that

¹Luther Standing Bear, My People, the Sioux, p. 151.

had been an integral part of their existence. The rations issued by the government were nutritionally adequate. But they were not psychologically rewarding, and even under the stress of hunger were sometimes refused. Elimination of the food supply may also result in new occupational demands which cannot be met within old culture patterns. Thus, in spite of all kinds of government pressures, men who had been warriors and hunters could not change into farmers because of the occupational inhibitions in the Indian culture. The older Indians can remember the times before the foreigners migrated into their land, killed the buffalo, and plowed the soil; and while they can no longer revolt against the intruders, they can dream that tomorrow it will all be over; the government agencies will disappear, and the Supreme Court will restore to them their lands, their buffaloes, and their gold--or at least pay for having taken them. In the meantime, why worry about farming?

The Dakotas were fully aware of the intention of the frontiersmen when they destroyed the buffaloes. One of their leaders dramatically stated their awareness.¹

It was not hard to see that the White people coveted every inch of land on which we lived. Greed, human greed, wanted the last bit of ground which supported Indian feet. It was land--it has ever been land--for which the White man oppresses the Indian and to gain possession of which he commits any crime. Treaties that have been made have been but vain attempts to save a little of the fatherland--treaties holy to us by the smoke of the pipe--but nothing is holly to the White man. Little by little, with greed and cruelty unsurpassed by the animal, he has taken all. The loaf is gone and now the White man wants the crumbs.

White methods of exploiting the natural resources of the continent were completely out of joint with Dakota ideas of land use. Of those reservations, lands which were supposed to belong to the Dakotas for all times, two-thirds have been lost because they could not adapt their culture and economy fast enough to White methods.²

The loss of their means of subsistence caused the Dakotas to hope only for some sort of divine aid in their dilemma. The government often gave smaller rations of food than promised, and sometimes the rations were very poor. Although they might turn down a ration of beef cattle, because they were so few and so poor, after a while they had to take them or starve. Black Elk summed it up: "So we got more lies than cattle, and we could not eat lies."³

The Great Plains were highly respected and the earth was worshipped for what it produced by the Dakotas. They believed that "the earth was bountiful," that they were "surrounded with the blessings of the great

¹Luther Standing Bear, Land of the Spotted Eagle, p. 244.

²Land Planning Committee, Indian Land Tenure, Economic Status, and Population Trends, p. 1.

³John Neihardt, Black Elk Speaks, p. 253.

mystery."¹ The old men of the Dakotas were amazed by the strange philosophy of the White man who "hews down the forest that has stood for centuries in its pride and grandeur, tears up the bosom of mother earth, and causes the silvery water courses to waste and vanish away," and while he thus "ruthlessly disfigures God's own pictures and monuments, he daubs a flat surface with many colors, and praises his work as a masterpiece."²

The history of the Great Plains has been a story of land exploitation by the Americans; and the Dakotas, living in the midst of this area, were unavoidably affected. The bulk of the Dakota population lives and functions in rural areas, where even with the most efficient use of their land resources, the majority lack sufficient land to support them adequately. They have managed, however, on a greatly diminished life-base to maintain themselves for several generations. This struggle for survival on very limited resources has been possible only because elements of their old value system, such as sharing and economic cooperation, have endured in spite of the difficult economic situation on the reservations. The Dakotas have convincingly demonstrated the old, all-important truth that the social heritage of a people will endure even under the most adverse conditions.

Destruction of the Kinship Groups.---The key to the understanding of Dakota social organization was their system of kinship groups. It was through the extended family that parents and grandparents instilled in their children the customs and values of Dakota life. This pattern of learning could not be broken by defeat, subjugation, or reservations, as long as the kinship community remained intact. This type of community organization exemplified in the tribal group of related individuals was abhorrent to those who wished to destroy the old system of Dakota values. The government hit upon the idea of allotment of land as a means of dissolving the tribal association and thereby substitute an individual status. The allotment system would thus weaken or destroy the cooperating unit of tribal organization. But in so doing, the allotment advocates were also assailing the only sound foundation upon which it was possible to rebuild a transformed Dakota social and economic organization.

The holding of land under an allotment system was very confusing to the older Dakotas. They observed that men came with instruments to survey the land, and on the basis of a few stakes driven into the ground, moved them to new locations. A subsequent survey might cause them to move again, and changes in reservation boundaries might force them to once again leave a piece of land where they were settled and happy. One of the old Dakota chiefs complained of this treatment to the agent.³

Father, we are getting tired of this; we should like to settle down and never move again, but before we pull down our lodges I want to ask you a question: When the Great

¹Standing Bear, op. cit., p. 38.

²Charles A. Eastman, The Indian Today, pp. 149-150.

³Julia B. McGillycuddy, McGillycuddy Agent, p. 127.

Father puts boundaries around an Indian reservation why doesn't he take a range of mountains or a river which the Great Spirit marks the country with and which never moves? These stakes that the White man puts up are all the time rotting away and when he puts them back he never puts them in the same place; they always move closer to the Indian and cut off some of his land. Where shall we move now, Father?

In the process of moving the tribal groups, the social cohesion and integration were likely to suffer.

Settlement on family farms and dispersion of kinship groups did not by any means completely change the Dakota mode of social behavior, but it did weaken the pattern of authority and control in the tribal group. The older people retained the vestiges of their traditional ceremonies and customs, but the ultimate result was to destroy the faith of their children in the old sanctions and beliefs. In changing the basis of their economic and tribal organization, the momentum of the old culture was preserved for a while through childhood training; but eventually the younger generation became dependent upon government rations and individual efforts in raising cattle, because the old family pattern had been swept from under them.

Symptoms of Disorganization—The contemporary Dakota Indian on the reservation is confronted with the conflicting values of a dual environment. He lives partly in a disintegrating Indian society and partly in a distinctly marginal White society. Neither of these societies offers the Dakotas a value system which is sufficiently challenging to gain his complete adherence. He is faced, then, with problems of social adjustment which he frequently lacks the training to solve. The resultant personal disorganization of his life is a product of his transition from Indian to White society; and in collective form this disorganization is regarded as the major problem of the contemporary Dakota society. This problem of social disorganization is dramatized by symptoms such as poverty, broken families, alcoholism, and crime. Actually, these symptoms are found among many groups in American society which are undergoing the transition from one culture system to another and experiencing the demoralizing effects of commercialism. Obviously, the symptoms are not the real cause of the illness; they are merely the surface manifestation of the unsolved conflicts in values which are found among marginal peoples undergoing a period of cultural transition.

One type of effort to solve a value conflict upon the part of a minority person is to make every effort to identify himself with the dominant group. He may attempt to acquire the superficial symbols of economic success or hasten to embrace the obvious values in Christianity as a means of gaining social prestige in the dominant society. In the case of the Dakota youth, this tendency to imitate the more powerful Whites instead of their elders leads to a decline in the authority of their parents over them. Torn loose from their old foundations of security in the Indian family, they suffer from anxiety about their acceptance and security in White society.

Seeking for acceptance in the dominant group may be only temporarily rewarding to Dakota youth. Barriers of language, dress, and custom may be difficult for them to overcome, and they may find that their efforts meet with punishment rather than reward. They may find themselves the subject of ridicule and invidious comparison, and usually they will lack the privileges accorded to members of the dominant group. In some cases, their reaction, as a way out of confusion and frustration, is a return to their native society where they attempt to revive and perpetuate their original cultural values.

During this transition period of civilization, there is great suffering among the people attempting to change their pattern of living. The catastrophe of disorganization is apparent under the best of conditions. The Dakotas, in addition, found that conditions off the reservation were laden with discriminatory practices and stereotyped thinking toward Indians which greatly impeded their progress toward adjustment. It is not surprising, then, that so many of them showed symptoms of personal disorganization; but it is equally amazing that some of them have managed to develop sound adjustments and well integrated personalities, despite all the handicaps of their way of life.

IX. PROBLEMS OF ACCULTURATION

The process of acculturation is sometimes accompanied by unstable conditions in the changing culture. These instabilities are usually called problems, but in a sense they are not really problems requiring a specific solution. Instead they are a set of conditions which are defined as a problem by people who cannot understand the changes which are taking place. There is no real problem for those who understand and accept the changes taking place in Dakota society; it is the outsider, looking in, who defines the changing conditions in Dakota society as a set of problems.

The culture of any group of people has certain areas of major emphasis where the changes occur. The most commonly accepted cultural areas are family, economic system, political system, education, religion, health and welfare. It is possible for purposes of analysis to separate these major cultural areas and examine the changes which are taking place in each area, realizing all the time that these changes are all related to each other. Thus in describing the "problems" or changing conditions in Dakota society this division will be used.

Family Problems--It is first necessary to describe the organization of the Dakota family, which goes back many generations, before the current changes in family structure can be understood. An excellent analysis of the Dakota family has been presented in Ella Deloria's book, Speaking of Indians, and the treatment in this source is more detailed than can be presented in this pamphlet. It is possible, however, to review some of the main culture traits of the early Dakota family that have been described in Professor Deloria's work.

The basic social unit in Dakota society was the tiyospaye, an extended family group made up of individual biological families and held together by blood ties. Perhaps ten to twenty related families made up this small band or tiyospaye. At the head of a band was usually an elderly man of ability, dignity, and prestige who was able to gain the loyalty of all band members. Since relationships were calculated to much more distant relatives than would be the case in the American family, it was possible for the individual families to associate themselves with a number of different bands; and if dissatisfied in one, they could join another. At certain times for celebrations and important events, a number of these bands camped together as a tribe, and related bands frequently carried on in common such activities as hunting.

The kinship pattern expressed through the tiyospaye was the basic organization of Dakota society. This pattern provided a system of family relationships upon which practically everything else depended. As long as a man had relatives, he could count on their cooperation and help; without relatives, he was completely destitute. The regulation of social relations depended solely on a specialized set of attitudes and code of behavior clearly defined in the kinship pattern. A man simply was not humanized unless he carried out to the letter all the rules of civility, good manners, and responsibility imposed by the kinship pattern. It is difficult for the modern individualist to understand how binding kinship sanctions were on the Dakotas. It was the willingness to sacrifice, fight, and die for his people that made a Dakota warrior great.

The kinship relationships in Dakota society were extremely complex. The Dakota youth, in addition to his biological father and mother, had a close relationship with a number of other adults whom he also accepted as father and mother. These secondary parents included all the brothers of his father and the sisters of his mother. The male cousins of his father were also "fathers," just as the female cousins of his mother were "mothers." But, on the other hand, his mother's brothers and male cousins were considered uncles, while his father's sisters and female cousins were considered aunts. This meant that when his blood relatives married, all their new relatives became his relatives too. Thus in the extended family group there was always an older group, the fathers, mothers, uncles and aunts as the core of the group, and a younger group composed of brothers, sisters, and cousins. Kinship ties are assiduously traced and remembered, and no matter how distant a relative might seem, he would be claimed by the Dakotas.

Social activities within the kinship organization were based on various forms of respect expressed in family group relationships. Respect was shown by the use of kinship terms of address, including the proper attitude and behavior prescribed by kinship.¹

As you said "Uncle" -- or "Father" or "Brother" -- in either address or reference, you must immediately control your thinking of him; you must assume the correct mental attitude due the particular relative addressed and you must express that attitude in its fitting outward behavior and mien, according to the accepted convention. Thus, term, attitude, behavior, in the correct combinations, were what every member of society must learn and observe undeviatingly. They were standard and inexorable; they had always been. One simply was born into their rule and conformed to them invariably as a matter of course. The more correctly he could do this, whatever the personal sacrifice involved at times, the better member of the group he was, the better his standing as a Dakota, the higher his prestige as a person.

Respect was also shown in affection and loyalty toward blood brothers, and such respect was heightened by filial devotion to parents, their brothers and sisters, and grandparents.

There was no formal entry into or departure from the extended family group. If a newcomer appeared in a band, and it was not known how he should be placed in the kinship system, the band treated him kindly until they could establish through some mutual relative his place in the new group. The person coming into the group then assumed the proper attitude and behavior that were associated with his kinship relationships.

Social pressure made members of the extended family group aware that their behavior reflected on the group's prestige. Since all members shared equally in any prestige gained by the group, willingness to cooperate was more important than the amount of help given; and unless an individual was perverse or handicapped, he would do nothing that might detract from the prestige of the kinship

¹Ella Deloria, Speaking of Indians, pp. 29-30.

band. If someone did commit an act which harmed such a close-knit group, he was immediately in the public eye, and his relatives could only make excuses for him, that he was under an evil spell or that he didn't know what he was doing, in order to maintain the status of their group. The offending individual was constantly reminded that no Dakota existed except as a member of the kinship group, that his actions must never bring sadness to his relatives who deserved only the greatest respect and consideration.

The biological family unit was usually not very large, for even with plural wives the number of children was small due to high infant mortality and voluntary spacing of child-births. But it did not matter if one did not have many biological brothers and sisters, because in each camp circle the family was surrounded by related families in a unifying ring. It was common for the older people to live in their own tipi near their children who were married, in case they needed help themselves or could offer help to others. Two biological families might live together in a time of emergency, but no matter how poor a family might be, it was more desirable for young couples to have a shelter of their own. In the biological family, the same respect relationships were maintained as in the extended family, and each member's "social standing is rated by the nicety with which one gauges the proper nuance to different persons within the same category, observing the proper degree of duties, avoidances, respect, and joking."¹

The tiyospaye operated as a unit in almost all social activities; the men hunted together; the women worked together; and the children played together. This cooperation was only natural because all members were closely related and were included in the family circle. Cooperation among those related by blood was the basis of their family organization and was essential to the group and the individual in the attainment of prestige. Competition and conflict were almost completely muted by the rules, rights, duties, and responsibilities required of the members in the extended family group.

Family Security--The social and psychological security of the traditional Dakota kinship group offered members a degree of personal freedom unmatched in most modern families of differing cultures. Each individual was valued and protected simply because he was related to the group, and there was always the satisfaction that the sources of his security were multiple--family, kinship, and tribal. If any failed, security was still provided by the others. It was a family system that offered the maximum of unconditional and unsolicited affection to the individual.

The only possible way to destroy the kinship system was to break up these family groups and force the Dakotas to deny their grouphood. It did not take the White Americans long to attempt this destruction. General Miles suggested that the Dakotas could best be controlled on the reservations if every effort was made to break up

¹Jeanette Mirsky, "The Dakota," in Cooperation and Competition Among Primitive Peoples, ed. by Margaret Mead, p. 394.

the kinship bands. He wrote, "By this means the Indians will become independent of their tribal relations, and will not be found congregated in the large and unsightly camps that are now usually met with about their agencies."¹ Many of the government agents agreed with this policy, but they were a little too optimistic about changing the traditional family pattern.

The attraction of family is not easily erased from the Indian nature after centuries of close and rewarding tiyospaye life. Even today many young Dakotas who do not feel at home in general American society return to the security of the reservation family. Admittedly, much of the security of earlier times has been lost, but there is still enough of it left so that they can feel more comfortable in the groups of their own society than in an impersonal, often hostile society including very few groups in which they can hope for acceptance.

The degree of stability still retained in the Dakota family on the reservation is largely dependent upon the assumption of the responsibility for its direction and support by the mother. The mother's role did not suffer as much as that of the males by the destruction of the hunting and fighting culture. The hunt and the raid were men's activities, and while the hunters and warriors lost their reason for being, the duties of mother and housewife continued and were even increased by the isolation of the household on the family allotment. The Dakota women had always shared equally with the men the joys and sorrows of tribal living. Although their duties were different from those of the men, they were equally important to the continuation of the family group. The Dakota female exerted the chief influence in the internal affairs of the family, but she did not interfere in the activities reserved for the men outside of the household. It was desirable that she possess dignity, skill, physical endurance, modesty, and spiritual insight. This type of woman was certainly well suited to the task of holding a family group together when the ruins of the old way of life came tumbling down about her family.

The Dakotas resisted the changes in their family system which the government attempted to force upon them. This resistance is well illustrated in the following quotation from Charles A. Eastman:²

I was directed not to recognize a plurality of wives, such as still existed among a few of the older men. Old White Bull was a fine example of the old type, and I well remember his answer when I reluctantly informed him that each man must choose one wife who should bear his name. "What!" he exclaimed, "these two women are sisters, both of whom have been my wives for over half a century. I know the way of the White man; he takes women unknown to each other and to his law. These two have been faithful to me and I have been faithful to them. Their children are my children and their grandchildren are mine. We are now living together as brother and sisters. All the people know that we have been happy together, and nothing but death can separate us."

¹Nelson A. Miles, Personal Recollections and Observations, p. 347.

²Charles A. Eastman, From the Deep Woods to Civilization, pp. 184-5.

Yet the unity and security of the Dakota family was bound to bend under the influence of White pressure, and although the tiyospaye camp circle has been broken and associations within the extended family are less frequent and intensive, there are still a few members of the extended family close by who can be depended upon in times of distress.

Some of the kinship terminology has been retained among families still speaking the Siouan tongue, and some of the roles of family relationship are still played by members of an extended family living in the same neighborhood. The influence of grandparents is often vital in adherence to the kinship observances among the Dakota youth who might otherwise be lax in their behavior. It is likely that the old courtship and marriage customs are not enforced, because it is impossible for the adults to conduct the severe chaperonage and to enforce the male-female avoidances typical of an earlier day. Friendships formed in schools and neighborhoods overcome the former courtship pattern and permit practically free, individual mate selection.¹

Marriages are now made with little or no family sanction or symbolic expression of contract between the two families or the two persons involved. Formerly the man-made gifts to the girl's parents, and his father's sisters and mother's brothers' wives equipped the new tepee of the couple with the necessary furnishings. Marriages of social importance were celebrated with an elaborate feast and religious performance. Today, the couple are married by a local missionary or a justice of the peace outside the reservation. The couple are more likely to announce that they are going to be married than to ask permission, and the man makes no gift payment.

The free choice of mates outside the family often conflicts with the kinship attitudes of the young Dakota's extended family, and he may therefore be confused by the necessity to abide by both social codes.

When a family first received their land under the allotment system, the members usually selected adjoining land. It was not uncommon for members of the original bands to receive allotments along the same creek, enabling the descendants of the bands to maintain community groupings. Although in these communities the families can still trace their relationship to a common band, in each new generation the individual family gains in importance as the common relationship becomes weaker and less meaningful. Moreover, many of the functions performed by the extended family in the past, such as caring for the destitute, insane, feebleminded, and delinquent, have been taken over by other agencies on the reservation. The tiyospaye is disappearing from Dakota life with the expected result of reducing the security available through the family system.

Hospitality--In addition to providing security, the Dakota tiyospaye operated as an agency of hospitality and sharing. Just as all tasks were performed by everyone in accordance with his ability in order to promote the common good of the extended family, so, likewise, all food was shared. But this did not mean that all goods were pooled to be shared alike. As long as the material was in a person's possession, it was his sole right to give it away

¹Macgregor, op. cit.; p. 63.

or keep it for himself. However, his kinship responsibilities might impel him to surrender it willingly to a relative who was in need or to whom he owed special devotion or protection. "It made him ready and happy at all times to give up anything whenever a situation developed challenging him to rise to his full stature as a relative."¹

The kinship bands were not made up of a static membership, since individuals might leave the group in which they were born and join some other group for a time. Thus while membership was a matter of birth, residence was a matter of choice. General gatherings or encampments might bring several bands together, and at this time hospitality reached its highest development. It was a time of celebration, visiting, exchange of news, and general good time, and relatives vied with one another in giving gifts and sharing their material goods. It was a form of group hospitality. Just as a man could expect hospitality when he went to reside for a time with a band other than the one in which he was raised, so, also, when kinship groups were together the same hospitality was given to all members of the other band.

The patterns of hospitality among the Indians on the reservation today still exist, but in a quite different form. In place of the feasts and gift-giving on such occasions as a son's first kill or a child's ear piercing, property is given away at funerals, weddings, and other social occasions. An illustration of the continuation of the hospitality pattern is the annual Fourth of July celebration, which in some measure has replaced the Sun Dance as a time to get together and share money and goods collected during the year with the poorer members of the group. The main difficulty encountered today in extending the traditional hospitality is that families who have accumulated material wealth are taken advantage of by destitute relatives who have no means of repaying the hospitality.

The conflict in values of the old and new cultures caused by pressures to accumulate and share material wealth is apparent in the individual who tries to save. If he continually refuses to give away his property, he may be practically forced off the reservation, or, which can be equally bad for him, he will lose his prestige in the kinship group. The changing attitudes toward property are creating adjustment problems for those who reject the generosity pattern, while those who share with their relatives are taken advantage of and are unable to fit into the accepted pattern of wealth accumulation in White American society.

Socialization of Children--Not only in their hospitality pattern did the kinship group function as a unit. Care of children was an extended family responsibility, and any woman could go away to visit another band with the assurance that her "sisters" and other relatives would see to it that the child did not go hungry or stray off or was not abused. It was not necessary to have anyone promise to look after the child, because the relative's kinship responsibilities in this respect were simply taken for granted. Even if his biological mother was at home, the Dakota child still had this multiple protection. At an early age,

¹Deloria, op. cit., p. 42.

he had contact with a great number of relatives who felt responsible for him; he never had to face the bewilderment of meeting an unpredictable stranger--he was born into a tiyospaye.

Children very rapidly learned their social duties, since they were in constant contact with relatives who were conditioning them by example and suggestion. Even in learning to speak, the child's first words and sentences were kinship obligatory terms. The training was reinforced by the warm and loving attention given the child by a large number of parents. The small child was permitted almost complete indulgence, thus developing in him an affectionate loyalty toward his parents. Rewards were used to encourage the child from an early age to accept responsibility for his own actions and to cooperate in family activities.

Other relatives were as important in the socialization of the child as the biological and secondary parents, and the first things the child learned were the proper term of address and behavior expected for each of these relatives. The grandparents, for example, practiced warmth, ease, and indulgence in their relations with their grandchildren to the greatest possible degree. It was not possible for a grandfather to refuse any request made of him, and so the grandchild had to learn not to impose too greatly on his grandfather's generosity. Thus each child obtained from the combined teaching of his relatives a well-rounded training which enabled him to take his place in adult society. A boy was taught how to meet emergencies and to protect himself by his uncles; and he was taught to be brave by his elder brothers and cousins.

The training of Dakota youth included the mastery of many skills. A boy was expected in his teens to be able to shoot with bow and arrow and to break and ride horses. By this time, "he has heard old men tell of their deeds of prowess, he has been taught the meaning of the various insignia with which a man decorates himself, he has seen young warriors come home leading horses and carrying scalps, and he has seen how their bravery brought joy to all their kin." In addition, he has been honored by his uncles' giving him horses, but he has seen that only those young men who have stolen horses can honorably purchase a wife," and "his elder brothers have taught him how to court a girl." When the time came for him to seek a vision, he was "taught and prepared either by an elder cousin or by a man with important supernatural power." This was also the time of training in the art of warfare, even if he failed to achieve spirit control.

The Dakotas were never cruel to their children, and any parent who harmed his own child would have been considered crazy. Therefore, when the Dakotas first observed White child-rearing practices, they were shocked at the ill-treatment and corporal punishment used in training White children. They also observed White parents "punish their own children by pulling their ears until they cried," and therefore, "when a Sioux called the White man Flop Ears, it was no mere derisive nickname;

¹Mirsky, op. cit., p. 423

it suggested that dark cruelty of which no decent Indian parent was ever guilty.¹ Attempts were made by the government agencies during the early reservation period to change Dakota ideas of child training to conform to the White pattern. Indian mothers were actually given rules to follow for the nursing of infants, along with the peculiar threat that food would be withheld if they failed to conform. In spite of this coercion, it can be assumed that the mothers followed their "spoiling" customs when not under the watchful eye of health and other authorities.

Dakota parents still display a strong affection for their children and in turn the children usually show great filial devotion. This affection would also be extended to other relatives, for it is likely that the youth was not raised in only one biological family. As the families on the reservations today have less stability than formerly, the child may be shifted from home to home, but this does not have the bad effects expected in White society. Relatives are happy to care for the child, and today if a child deliberately leaves the home of his parents, or that of a relative, his action is publicly recognized as a reflection upon those who probably failed to provide the attention and affection to which the child was entitled.

Veneration of the Aged--In the old Dakota culture a man gained in respect as he got older, particularly if he could remind the younger men of many brave feats which he has performed in war and on the hunt. A younger man also spoke with respect for his elders, and the veneration of the aged would never permit a young man to contradict or argue with an old man. The grandfathers were esteemed by the youth as wise men who, because of their vast experience and knowledge of the best ways, should be consulted before a hunting or fighting party set out, and young men were likely to submit to their injunctions with alacrity.

The grandmother was also highly respected, because she remained gentle and uncomplaining toward the younger generations. She frequently took much of the burdensome work off a daughter who was raising a family. She was careful to see that the children were properly reared and helped in their early childhood training. If she admonished the children, she simply said, "See, nobody does so," meaning, "You must not, either."² In Dakota society this mild admonishment was usually sufficient to deter the children, because they had great respect for their grandparents.²

But the changes which have taken place in the Dakota culture in recent years have in some degree undermined the traditional veneration of grandparents. The grandfather still attempts to function as a counselor to the youth, but he no longer has his former prestige because he has not been able to participate in the activities by which the men in the past used to gain prestige, and he has not been able to keep up

¹Vestal, op. cit., p. 196.

²Deloria, op. cit., p. 44.

with the changes going on in Dakota society. The grandmother is still the person to whom the child turns in times of need or crisis, but her generosity and kindness are often abused by young people today. It is not unusual for divorced couples to send their children to live with her; or even though a young man is old enough to support himself, he will visit his grandparents for long periods of time, contribute nothing to the household, eat the old person's rations and spend her assistance check.

Broken Families--The old Dakotas did not take the marriage vows lightly, in spite of their simplicity and directness. Although the marriage ceremony was a matter of giving gifts such as ponies, saddles, or buffalo robes to the bride's family, usually involving little formal ceremony, the marriage ties were sufficiently binding and influential in a small band so that broken families were very uncommon. However, if conflict did develop in the biological family, the solution was to leave before the tension became unbearable. Not only could the wife return to her family band, children could at times decide to live for a time in another band or with grandparents, or whole families might leave the kinship group if it seemed wise to avoid an uncomfortable situation.

The tendency to break marital ties has been greatly accelerated by contact with American life. Unsatisfactory domestic relations are commonplace on the reservations. The biggest domestic problem is lack of income, and the wife is in no position to exert pressure on her husband to earn more while the husband never suggests that the available funds be more wisely expended. Husband and wife take little responsibility for each other's actions, and distrust between the married couple is not at all unusual. In this kind of economic and domestic situation, application of the old cultural tradition of avoiding tension as a means of adjustment results in frequent temporary and permanent separations. Another factor which may increase tension in the contemporary Dakota family is the presence of relatives in the household, although this is not nearly as important as a cause of trouble because of the kinship and hospitality patterns previously described. The effect of overcrowded Dakota households is not nearly so demoralizing as congested living in a modern city, but the strain under which kinship obligations are now functioning suggests that this problem may loom larger in the future.

Economic Problems--The buffalo hunting economy of the Plains Indians was so appealing to aboriginal peoples that it rapidly spread throughout the American continent. The hunting pattern of the Teton Dakotas was similar to that of other Plains Indians except that they emphasized group cooperation to a greater extent than any other tribe. It was especially the case when the buffalo were scarce that cooperation between tribal groups was vital to success. The bands hunted individually, but every effort was made to distribute the kill among the family groups. If a large herd was encountered by one band, they killed only what they could use and then passed the rest along to the nearest band. Large encampments of Dakotas were made only for celebrations or protection, because there were never enough buffalo in any area to support more than a minimum number of bands. As the bands moved about, however,

they followed a pattern, generally camping and hunting in the same region during the same season. In this way, they did not interfere with the hunting of neighboring bands and could more accurately gauge the available feed supply.

The acquisition of horses by the Plains Indian contributed greatly to the prosperity and freedom of the buffalo hunting economy. Prior to the introduction of horses, the Dakota Indians had to laboriously stalk the buffalo on foot, the meat had to be carried in packs on their backs, traveling was limited, and there were frequent periods of insufficient food. Once they began to obtain horses, however, the warrior and his family could hunt the buffalo with greater ease and success. Horses were the only things regarded as personal property in the Dakota tribes. Warriors were willing to risk their lives to obtain a horse as a prize in battle or as a reward for risking their lives to steal the animal from another tribe.

Since a young man could not inherit horses from his father, because a person's property was distributed outside the immediate family when he died, running off the horses of an enemy was the honorable way for a young man to make his start in life.¹ The members of a successful horsestealing expedition were greeted upon their return with great demonstrations, and the participants were "regarded as heroes and brave warriors." When the whole camp had gathered around the camp fire to welcome the returned warriors, they related "the history of their expedition, each giving his individual experience and adventures to attentive listeners."²

The available food was utilized to promote the welfare of the group, and was not considered as personal property to be hoarded or sold dearly. In fact, food was freely given to anyone who visited a Dakota camp. When the first White men visited the Dakota villages, they were given the best available food and were not expected to pay. Naturally, when the Dakotas went to visit the White man's villages, they expected this courtesy to be returned. Instead, however, they were expected to pay when they asked for something which they believed should have been freely and generously offered to them in the first place. Therefore, they could not help believing the owner of the goods to be ungenerous.

The Dakota attitude was such that goods and possessions were of no great value. Property did not influence social position in the tribe unless it was used as a gift to honor someone. Accumulation of goods and long-continued possession of material things were suspect. Prestige attached to property was not in the good itself, but in the way the possessions were presented as an honor in an informal naming ceremony or a highly formalized, conspicuous Sun Dance celebration. Property is extremely unimportant to the Dakota when compared with human relations. But if it could be used to improve or solidify human relations, property achieved importance. A young man might have his gift of a horse to his bride's father supplemented by several of his uncle's horses in order

¹Lewis F. Crawford, Rekindling Camp Fires, pp. 283-284.

²Miles, op. cit., p. 315.

that their family could make a good impression. But it was not the amount of the gift, it was the cooperation, expressed through sharing of possessions, which gave the family prestige and respectability.

Land Resources--Early commercial contact with the Whites placed little strain on the land resources of the Great Plains; but later the settlers were anxious to convert the Indians to agriculture. Captain Meriwether Lewis reported his observations on this matter.¹

...With what consistency of precept with practice can we say to the Indians whom we wish to civilize, that agriculture and the arts are more productive of ease, wealth, and comfort than the occupation of hunting, while they see distributed over their forests a number of White men engaged in the very occupation which our doctrine would teach them to abandon. Under such circumstances it cannot be considered irrational in the Indians to conclude that our recommendations to agriculture are interested, and flow from a wish on our part to derive the whole emolument arising from the peltries and furs of their country, by taking them to ourselves.

There was a basic difference between the Dakotas and the Whites in their attitude toward the use of land resources. The Dakotas, believing that "mother" earth gave birth and sustained life for all living creatures, loved and revered the earth. The people were therefore kin to all other living things, all possessing equal rights. The Caucasian philosophy, on the other hand, was that man is superior to the natural order. Things of the earth were earthly--belittled and despised--to be heartlessly destroyed in order to promote man's right to live. This difference in attitude caused much misunderstanding between Indian and White. The Dakotas accused the invaders of indiscriminately hewing down the forests, exterminating the buffalo, killing the beaver and dynamiting his wonderfully constructed dams, "allowing flood waters to wreak further havoc," and silencing "the very birds of the air."²

The wanton waste of natural resources and callous indifference toward the land shown by most White settlers caused real resentment among the Dakotas. They looked upon the settlers as usurpers of their country, responsible for confining them on reservations with insufficient resources and nothing to do. Thus the Indians were forced to take up agriculture in which they were unskilled. They had to give up war-like activities and the chase to depend upon uncertain crops which their honest labor could not always provide on inadequate land resources.

Today the major reservation problem is low income resulting from this lack of resources. Agriculture provides less than thirty percent

¹Elliot Coues, History of the Expedition Under the Command of Lewis and Clark, Vol. III, pp. 1236-1237.

²Standing Bear, Land of the Spotted Eagle, p. 166.

of all income received by the Pine Ridge Indians. About twenty percent of their income comes from non-agricultural employment, and over fifty percent comes from government sources, including wages and federal and state relief. It is quite clear that the available land can never possibly provide enough to support these Indians even at their present low standard of living.¹

Working Skills--The male skills of the Dakota culture were hunting and fighting. Hunting was the routine method by which the warrior provided his family with food; and fighting was his sport, the field in which he could gain the attention of his fellow men. Even hunting called for a more warlike and aggressive behavior than sedentary farming, an occupation which, when compared with their former activities, appealed little to them and thrilled them less.

It was reported that Red Cloud said:²

Father, the Great Spirit did not make us to work. He made us to hunt and fish. He gave us the great prairies and hills and covered them with buffalo, deer, and antelope. He filled the rivers and streams with fish. The White man can work if he wants to, but the Great Spirit did not make us to work. The White man owes us a living for the lands he has taken from us.

Because this attitude conflicted with the traditional desirability of working with the soil on the American frontier, the Indians were called "lazy." Actually hard work in hunting or fighting was welcomed by the Dakotas; they simply preferred their tribal ways to the work skill required in settled agriculture.

For a brief time in the early years, there was some success on the reservations in teaching warriors to take care of herds and flocks, but even the life of the rancher and cowboy was not sufficiently dramatic and varied to erase the old ways from the minds of the Dakotas. For the youth there was little instruction in agriculture to prepare him for farming, and his life was therefore practically devoid of any goals: "He could hope neither for glory in Plains Indian type of warfare, nor for success in terms of the American scale of values."³ What is described as "Indian shiftlessness" is largely a lack of any appealing goal.

Even if a Dakota had training and developed new work skills, there was no guarantee that he could become a financial success. This point is illustrated in the following story of a Dakota youth.⁴

¹H. D. McCullough, Economy of the Pine Ridge Reservation, p. 809.

²McGillycuddy, op. cit., p. 103.

³George Devereux, Reality and Dream, p. 10.

⁴Deloria, op. cit., p. 124.

He got his "Sioux benefit" and spent it all on a course in auto mechanics, for that was his bent. He was sometimes homesick in the distant city where he trained, but he did not go home till he finished. Then he set up a little shop back of his home. People brought work to him, though some came without any money to pay for the work. But he was related to them all. He would not dream of saying, "Show me first your money," but went ahead and did their work. Some paid; others, who were obviously too poor, he told not to bother. This was what a Dakota relative should do.

Money Economy--To understand the economic values of the Dakotas, it is necessary to realize that money and ambition were insignificant in comparison with a dream, a cloud in the sky, or change in the wind. Symbolic events and experiences could challenge their deepest thoughts, but material possessions in themselves meant nothing to them. A few of the older Dakotas realized that these economic values could not survive in a society dominated by a money economy. Charles Eastman's father said to him that the old ways were best in the Dakota society.¹ "But here is a race which has learned to weigh and measure everything, time and labor and the results of labor, and has learned to accumulate and preserve both wealth and the records of experience for future generations."

The incompatibility of the two ways of economic life are easily observable in the old Dakota who shares his money with friends and relatives until he needs further assistance. According to Dakota values, he has gained in prestige in the eyes of his group for his generosity and hospitality; but according to American economic values, he has failed to manage his money properly.

There is often a stigma attached to the accumulation of wealth among Indian families on the reservation. The status of the family may be expressed in the phrase, "They have money." This remark is a condemnation of a family that does not conform to the Dakota values. Accumulation of property is therefore a basis for social ostracism.

The economic teachings which Indian children receive at home are often directly contradictory to the precepts heeded by Horatio Alger for participation in a dollar civilization. Individuals who might wish to compete economically are frequently subject to intangible ridicule; and, anyway, their economic ambitions are invariably defeated by their loyalty to their family group. Professor Deloria presents a good illustration of the problem:²

Here is a man, a Hampton graduate. He comes home with some advanced ideas. He has had a simple course in business. He decides to try his wings. He buys out the local trader and starts in. He would do all right, perhaps, if he were in another community. But now his uncle comes, asking for credit, "Of course." And he even adds, remembering his uncle's great regard for his mother who is now dead, "But, Uncle, you need never pay."

¹Charles A. Eastman, From Deep Woods to Civilization, p. 8.

The thinking of the Dakotas about monetary matter is even apparent in their language. The customary way to say "I bought this" is "I took this." The ideas of "he sold it to me," "he gave it to me," and "I paid him," the Dakota language expresses simply as "I gave him." Exchanging items of equal worth between relatives is an idea that they could not understand.¹

But private property in land is taking on new meaning to the Dakotas since the rental and sale of allotments have been made possible. At their present stage of acculturation, money obtained by leasing or selling the land means obtaining cash with little effort, but then the real value of the land to an agricultural economy is not realized. In like manner, the position of the wage-worker is better than the farmer's because cash is not considered property in quite the same sense as goods and therefore not subject to the rules of hospitality. The wage earner can also hide his money and appear poor, while food and objects are always apparent to relatives with whom sharing is expected. Spending money is approved, so the wage-worker is in a better position to live a life of some luxury by spending the money on himself as long as he does not accumulate material possessions.

There has been some improvement in dealing with the money economy among those families on the reservation who have had some success as farmers or ranchers. The government policy of dealing with families as an economic unit has caused some changes in attitudes and values, and naturally some economic customs of the dominant society are bound to find acceptance in a limited number of cases. But the great majority are still confused about the money economy, and their adjustments to it are more suitable to a noncompetitive society than to our modern, highly competitive economic system.

Gift-giving--It is evident that possession of property had no prestige value in the Dakota culture. But to publicly express love and respect for others by giving them property or giving it away in their name--that was the highest expression of cooperation in the extended family. Gift-giving was not a direct exchange, but there was always giving and receiving among all members of the kinship group so that no one person was likely to suffer hardship. Gifts were given on all ceremonial occasions, including those occasions when relatives mourned a lost brave or when they rejoiced over the triumph of a warrior. As a matter of fact, any time it was appropriate to help a neighbor or honor a relative was considered a gift-giving occasion.

These people were understandably confused when they found that wealthy White visitors refused to show them the same generosity. Yankee thrift and sharp practices could only be abhorrent to the Teton Dakotas. They concluded that the White strangers were stingy and inhospitable.

¹South Dakota Department of Public Instruction and South Dakota Indian Commission, Indians of South Dakota, p. 46.

The feasts and "give-aways" are still carried out by the reservation Dakotas whether or not they can afford it. To ignore the death of a relative and to fail to give gifts at that time caused such criticism that mourners feel obligated to conform to the old customs. Whatever social cohesion still exists among the kinship group depends upon the ideal of generosity. It is not surprising that individual families find it difficult to reject this custom which prevents their accumulation of material goods. The practice may be somewhat mitigated by the realization that most families have limited resources badly needed for their immediate requirements. But on the other hand, it is not uncommon for a family to visit relatives and depend upon their hospitality no matter what the drain on the budget might be.

The old moral values of the Dakotas were based on respect, loyalty, and duties to other members of the extended family group. It was the moral obligation of the individual to cooperate, be generous, and promote the family interests by every means at his command. In an economic system based on highly valued material possessions, these moral principles are partially obstructed by the desire to promote individual economic interests. Again the youthful Dakota finds himself in an untenable position between the old moral obligations and the new material culture.

Political Problems--The close kinship ties of the Dakota Indians were vital to their social control organization. Each family formed a part of the camp circle and in the center of the circle was the council-tipi, the focus of community life. At this central point gathered the council composed of elderly men of experience and prestige from the family groups within the encampment. The council along with the chief decided upon a variety of group activities; they made plans for the buffalo hunt, called bands together for intratribal meetings, and settled disputes.

The usual method of settling questions in the council was by discussion. The people often gathered to talk things over. They gave speeches in which by gifted oratory they tried to convert the opposition. The older men were usually able to exert the greatest influence because they were respected for their wisdom, yet a young man might also be heard if he prefaced his remarks with the following words: "My father will hear my words with indulgence for I am young and without experience; I have not yet taken my place in the councils among those whom age has given wisdom or valor has made illustrious."¹

The chief did not have any extensive control, usually having authority only in his own little camp of kinsmen because of his position as head of the band. Equality was highly stressed among the warriors, and thus a chief must be outstanding in order to gain his position. It seems likely that, particularly after contact with the Whites, a strong leader could draw support from other bands in waging war. As soon as the emergency was over, however, the authority of the leader would be confined once again to his own small band.

¹Trobriand, op. cit., pp. 126-127.

Leadership among the Dakotas required sacrifice. The war leader must always be in the forefront of battle and must always protect his followers at the risk of his own life. The leader of a band must consider the welfare of the group rather than his own personal glory. He must be the first to give gifts, but the last to receive them. He must help the unfortunate, and expect no aid in return. He must be a real servant of his people.

The control function in the band was performed by akicita or "soldier societies." They were associations of the outstanding young men who were chosen each year to act as the policing unit. An invitation to join the society was given on the basis of individual accomplishments and family group prestige. Thus the societies ensured the cooperation of the most powerful extended families. If a young man refused the honor, it meant that he was failing in his duties; and, as a result, the prestige of his family suffered. Additional police functionaries might be added to the regular societies on special occasions when extra service was required.

The soldier societies were under the domination of the council and chiefs, and they followed orders given to them by the chief, as an executive officer, after the orders had been agreed upon in council. It was also possible for members of the soldier societies to be members of the council which discussed and agreed upon the activities of the band in ceremonial life, war, and the food quest.

The functional roles of police societies were maintaining order, protecting group status, preserving beneficial relations with the supernatural, and guarding the tribe's material possessions. Their work was especially important during the buffalo hunt or military expedition. They were required "to keep order while the party was in movement, guarding against surprise attacks, restraining the overzealous, urging on the stragglers, and insuring that no one left the group without proper authority."¹ In the camp, their duties were to act as guards, prevent violations of tribal orders, settle disputes, detect and judge the innocence or guilt of suspects, punish guilty individuals, and compensate individuals harmed by the crimes of others.²

The social control of the soldier societies was greatly supplemented by group sanctions. The satirical sanction was essential in Teton Dakota society to indicate disapproval in an informal way. The sanction of group commendations, as in the public recital of meritorious deeds, was the formal means of expressing approval. Although information on family group sanctions is limited, they were undoubtedly strong in expressing both approval and disapproval in an informal way. As pointed out in the section on family problems, it was the close identification with the family group which guaranteed that the individual would fulfill his obligations and responsibilities.

¹Fred Eggan, Social Anthropology of North American Tribes, p. 347.

²Norman D. Humphrey, "Police and Tribal Welfare in Plains Indian Cultures," Journal of Criminal Law and Criminology XXXIII (May, 1943), p. 160.

Administration of the Indian Agency--From the beginning, the White men failed to understand the political organization of the Dakota tribes. They thought of the chieftaincies as monarchies like those of Europe, and they held the chiefs responsible for matters over which they had absolutely no control. Much of the difficulty between the Whites and Indians arose over treaties. The American government invariably wanted to deal with chiefs who could be counted upon to enforce the provisions of the treaty on all the warriors, when actually no chief in the Indian social structure could possibly have such authority. However, such limitations on the chief's power did not disturb the agents of the government, for they blissfully continued to assume that absolute power was vested in the chieftaincy.

When a chief did sign a treaty, he was taking a risk that his actions would not be approved by his people. In many cases, the government actually attempted to create chiefs who could not possibly have any authority in the Dakota nation; and those synthetic chiefs, considered traitors and usurpers, had to have protection because their lives were in danger from their own people. Yet governmental representatives sometimes assumed that treaties signed by these synthetic chiefs were binding on all the people of the tribes. Even if the treaty was signed by legitimate leaders, there was danger of misunderstanding or misrepresentation. When the government attempted to enforce some of those treaties, the Dakotas would then realize that they had been swindled.

To make matters even worse the government agents sent out to deal with the Dakotas were usually political appointees with little knowledge of the Indians. Usually anxious to promote themselves at the expense of others, and frequently downright dishonest, they could not be counted on to be just. About 1870, in an effort to reduce the mishandling of Dakota affairs, it was decided by Congress that the agents should be nominated by the churches, which would assume responsibility for their actions. Yet one of the Dakota agents, "who went to church twice on Sundays and twice during the rest of the week and spent most of his time in communion with ministers, was indicted on thirty-two counts, including charges of larceny, embezzlement, conspiracy, fraud, falsification of public records, and forgery in all their degrees."¹

The problem of administration was further complicated by a conflict of policy between the War Department and the Indian Bureau. The military men were pulling one way with their philosophy that the Dakotas must be forced to submit to the exploitation of superior power. Pulling in the other direction were the Indian agents who talked "progress" and "humanity" as they enriched themselves through an almost uninterrupted series of frauds.²

From the point of view of the Indians, it was generally a toss-up as to whether the Army was to kill them or the

¹Hyde, op. cit., p. 188.

²Vestal, op. cit., p. 214.

Indian Bureau was to rob and starve them. However, an impartial compromise was effected, so that these enterprises were attempted alternately and in rotation.

The social control organization in the tribal groups was rapidly breaking down under such maladministration. Traders gave warriors medals and papers naming them as chiefs in return for protecting them. The Indian agents and military officers followed the same practice with different warriors, and even the missionaries in some cases did the same thing. Every tribe had a large number of members claiming some sort of vague chieftaincy not in any way related to election by the tribe itself.

As the Dakota establishments on the reservations became more permanent, a native police force was established by the agent. Some of the older leaders, such as Spotted Tail and Red Cloud, tried to gain control of these forces, but the agent in charge was usually able to control them, particularly after some of the older chiefs died; and so the loyalty of the police to the tribe began to decline. The chieftaincy was vitiated by the loss of basic functions--performance of brave deeds and support of a powerful family. As the old men with war honors died, quarrels arose over succession, and since the government offered no support to the institution, the function of tribal leader definitely began to decline in importance.

The extension of sovereignty over the Dakotas by formal means has come about concomitantly with their enforced readaptation on individual farms in local settlements and isolated communities. Gradually, the soldiers were withdrawn, and the administrator and the civil servant assumed control. Administration then became more efficient, honest, and humane; but after their early experiences with government agents, it was difficult for the Dakotas to trust those who deserved and needed trust in order to help them make the necessary adjustments.

The main problem of reservation administration at the present time is this distrust of agency employees. There is certainly plenty of reason for the Dakotas to question the sincerity of members of a hierarchical organization which emphasizes advancement and distrust of anyone "lower." The inconsistency of the agency policies is interpreted by the Indians as hypocrisy. The discrepancy between theoretical ideology and real practice has caused the government to lose the battle for democracy. The older Indians, reared in a true hunter democracy, are fully aware of the lack of equality and democracy in a government agency emphasizing position and advancement.

The Ration System.--The Dakotas were an honorable people, and thus they assumed that such a great personage as Uncle Sam would do well by them. They could not doubt his generosity, because it was inherent in their gift-giving values that "if someone makes me glad with a gift, I am mindful not only of the gift but also the spirit that prompted him.

I am honored by his regard toward me; he gives freely without any provision to safeguard himself."¹ It was in this spirit that the Dakotas accepted rations from the government. After all, it was not charity. From the point of view of their culture, it was the duty of Uncle Sam to give to the poor, especially those who were made poor through circumstances they could not control. It was Uncle Sam's way of showing that he was an honorable generous benefactor; and although they could not at present give gifts in return, if ever a time came when they could, they certainly would not be found wanting.

Since the Dakotas did not wish to be like White men, but since the government insisted on making them so, then it was logical for the Indians to believe that they should be supported while being forced to make the transition from one culture to another. Red Cloud expressed this belief in his list of wants:²

For seven generations to come, I want the government to give us Texas steers for our meat. I want the government to issue for me hereafter flour, coffee, and tea, and bacon of the best kind, and shelled corn, and beans, and rice, and dried apples, and saleratus, and tobacco, and salt and pepper for the old people. I want a wagon--a light wagon--with a span of horses and six yoke of work cattle for each family. I want a sow and a boar, and a cow and a bull, and a sheep and a ram, and a hen and a cock for me. I want some White men's houses built at this agency for the Indians....nice, black, shiny furniture, dishes and a scythe, and a mowing machine, and a sawmill....

On rations days the Indians flocked to the agencies to receive the rations and give the agent their opinions of the way he has handling their goods. They called the agent "our White man" and thought of him as a kind of butler given them by the Great Father to serve them. But their attitudes concerning the rationing system soon changed. They were constantly spying on the agent, because they often had grounds to suspect he was stealing from them. Also, it became impossible for the Dakotas to continue their gift-giving conception of rations when they were used as a threat to support enforced acculturation. Members of the tribes began to regard the agencies merely as ration stations. They would simply move from one to another and claim their share of goods, visiting with relatives for a time. They became completely dependent upon the government for support. The Indian department wanted them to become self-supporting, and concluded that this could only be done by cutting off their rations. When this severe measure was put into effect, starvation followed, and anxiety increased among the tribes who had no means of feeding themselves by their own labor. Pauperization had resulted from their loss of subsistence under circumstances which made self-sustenance impossible.

¹Deloria, *op. cit.*, pp. 129-130.

²Hyde, *op. cit.*, p. 245.

The policy of discontinuing rations has prevailed to the present day with minor exceptions. In some degree, this negative policy has been compensated for by various types of categorical government assistance and aid from private welfare agencies. The most obvious results have not been changes in the Dakota way of life, but rather a lower standard of living, dependence upon the agency, pauperization, and inadequate social control.

Educational Problems.--In Dakota society, the children were taught informally through example and suggestion and formally through ceremonies held at various stages in the child's development. The educational system was designed for only one purpose--to teach the young person the best ways of living in Dakota society. Some of the principles receiving special attention were hospitality, generosity, respect for relatives, and endurance of hardship and suffering. It was an education in human relations, designed to fit the individual into his rightful place in his kinship group.

The childhood training pattern in the Dakota culture has been described in a preceding section dealing with family problems. It is not necessary, then, to treat this matter in detail here, but we can proceed to some of the changes which have taken place in educational practice as a result of the acculturation process.

Cultural Isolation.--It is quite apparent that the cultural development of Dakota society has been limited by isolation. Before they had contact with western civilization, the Dakotas were isolated by natural circumstances. On the reservations they have been isolated by government policy, and off the reservations by segregation and discrimination. The opportunities for learning new ways of living are definitely limited by isolation, because the home group can only perpetuate in their known practices.

Charles Eastman has described his education as an Indian in the following words.¹

From childhood I was consciously trained to be a man; that was, after all, the basic thing; but after this I was trained to be a warrior and a hunter, and not to care for money or possessions, but to be in the broadest sense a public servant. After arriving at a reverent sense of the pervading presence of the Spirit and Giver of Life, and a deep consciousness of the brotherhood of man, the first thing for me to accomplish was to adapt myself perfectly to natural things--in other words, to harmonize myself with nature. To this end I was made to build a body both symmetrical and enduring--a house of the soul to live in--a sturdy house, defying the elements. I must have faith and patience; I must learn self-control and be able to maintain silence. I must do with as little as possible and start with nothing most of the time, because a true Indian always shares whatever he may possess.

¹Eastman, op. cit., pp. 1-2.

This was typical of the content of Dakota education. Dr. Eastman then proceeds to explain his education in boarding schools and colleges under the white man's system and to describe the limitations on the acquirement of the White man's knowledge, those limitations enforced by isolation.

Besides Dr. Eastman, there were others who also went out into the White man's world for an education and then came back to help their people. Many times the Dakotas who return realize they cannot overcome the overwhelming problems, and they resign themselves to the ways of their isolated people. But this "return to the blanket," as it is called by White men, is not considered a defeat by the Indian. It is his way of finding something spiritual to support him when he finds the outside world hostile and unrewarding. A remarkable illustration was the case of Plenty Horses, who was on trial for killing an army officer. He frankly admitted the crime and said:¹

I am an Indian. Five years I attended Carlisle and was educated in the ways of the White man. When I returned to my people I was an outcast among them. I was no longer an Indian. I was not a White man. I was lonely. I shot the lieutenant so I might make a place for myself among my people. Now I am one of them. I shall be hung and the Indians will bury me as a warrior. They will be proud of me. I am satisfied.

It is the insecurity of the Dakotas in society off the reservations which causes them to continue to isolate themselves. Such isolation has an effect on childhood education because the parents are not sympathetic towards the attempts to prepare their youth for a life they do not themselves value or understand. Much of the confusion and uncertainty about non-reservation life is transmitted to the children by the parents so that the young people likewise feel insecure in any environment except the one with which they are familiar.

The Boarding Schools.---Dakota children were taken from their parents to be sent to schools designed to teach them the American way of life. At the same time, the children were receiving their earliest training in the home where they were taught the Dakota way of life. Naturally, this dual educational system was extremely confusing. It was not uncommon for children to sing brave songs on their way to the boarding schools, because they expected to die at the hands of the White teachers. The strong kinship attachment probably complicated the attempts at boarding school education more than any other single factor. For example, if a young Dakota was doing well in school, he would still run away to see a sick parent, even if it meant that he would miss the final examination.

Another difficulty encountered in Indian education is that involving the transmission of the life values and drives of the White community to the child. It has sometimes been assumed that education can directly control individual behavior; but the fallacy of this assumption is seen in the Dakota drives that are not necessarily conditioned by

¹McGillycuddy, op. cit., p. 272.

education. The schools are filled with educators who teach the children according to American standards, and believe they are doing a good job. The attitudes of the teacher when the Indian child fails to conform to the instructional pattern is that the child, mentally backward, has failed. Actually, the truth may be that the teacher has failed. Sound principles of education hold that the individual motivation to learn is more important than the educational system, and the boarding schools have frequently violated this principle by pitching the educational system at a level that has no relation to the previous experience and training of the child.

The teaching of history to American children gives them great pride in their ancestors. The child can identify himself with the frontiersmen who, in the face of great hardships, conquered this rich and beautiful country, fought desperate savages, and performed heroic deeds. It must be apparent that this kind of history cannot produce the pride of identification in Dakota children. To the Dakota children, the frontiersmen turn out to be those who treated their ancestors as inhuman savages, stole their land, destroyed their society, and diseased their bodies.

Yet despite the great differences in ideology, many Dakota parents honestly desired that their children obtain a White boarding school education. The children then interpret the conflicting teachings of home and school as a part of the opportunism required of them. They are usually able to live in two value systems without open rebellion or inner signs of conflict. However, if the conflict should reach the surface, the standard Dakota solution is to avoid the situation by running away from it. For example, children have been known to suggest that they be sent to a different school as a solution to a disciplinary problem.

Educational Opportunities.--In the early Dakota society every person had an established place in the group as he grew up. The opportunities were limited but they were sure and secure. But compared to their position of relative security in the former life, the majority of Dakota youth today have few opportunities and little security. The Dakota father usually has no career or social role into which he can introduce his son, and the parents are in no position to pay for an extended vocational or professional education. At fourteen or fifteen the youth can compete successfully with his unskilled father as a wage earner, and he need not have much training. Educational opportunities are thus limited by family working experience.

In a few cases, there is actual opposition to educational advancement, based on the desire to maintain the old order. Some feel that "it is against our religion to change the customs that have been practiced by our people ages back."¹ But such native resistance is reduced in such degree as the imposed educational system understands the cultural values of the resisting group. Education can be a powerful force for voluntary or permissive acculturation if it is sympathetic and understanding and if it opens opportunities for learning the new culture, but it is a deterrent to acculturation if it lacks sympathy and understanding and reduces these opportunities.

¹Eastman, op. cit., pp. 24-25.

There is plenty of evidence that Dakota children do not lack the ability to take advantage of available educational opportunities.¹ However, they sometimes suffer an "educational lag" because of poor schools, language barriers, or indifference. Lack of social adjustment may cause the Dakota youth to mask his superior educational ability. It is a well known fact that all the ability in the world cannot overcome discouragement, failures, economic hardships, and social isolation.

The old virtues of Dakota society may at times operate as a limiting factor on educational opportunity. A virtue in one culture may be defined as a vice in another.²

It is known that some of the first Indian students in American universities often failed to show whether or not they knew anything about a subject under discussion. They were unaware of the fact that as a consequence of their behavior they were assumed not to know their lesson, while their teachers were unaware that a well-educated Sioux boy does not speak his mind in the presence of people who know a subject better.

Limited educational opportunities restrict the ease and speed of culture change for the Dakotas. The destruction of their old culture system has already been largely accomplished, and they can only hope for the future if opportunities are available to learn a new culture.

Religious Problems.--The religious beliefs of the original Dakota culture were based on the awareness of a Supernatural Power that pervaded all things. This mystical Power was deserving of great respect, and one must always remain humble and helpless before it. It was undignified for the Dakotas to defy this Power or to turn to it only in time of need.

The people were influenced by religious considerations in all areas of their life. The requirements of Dakota religion were concrete and tangible. A man was expected to observe certain taboos, make the necessary sacrifices, perform the prescribed rites, be honest with his neighbor and generous to the unfortunate. These duties were matters of fact; either he has or has not performed them. If he failed to live up to the social ideal, he was shamed by his neighbors, because every man was in part judge and defender of the public good.

The Power of the World was described as a circle in which everything had a place. Black Elk gave this explanation of the Supernatural Power:³

In the old days when we were a strong and happy people, all our power came to us from the scared hoop of the nation, and so long as the hoop was unbroken the people flourished. The flowering

¹Erik H. Erickson, "Observations on Sioux Education," The Journal of Psychology, VII (Jan., 1939), 116-117, and Macgregor, op. cit., p. 125.

²Erickson, op. cit., p. 118.

³Neihardt, op. cit., p. 198.

tree was the living center of the hoop, and the circle of the four quarters nourished it. The east gave peace and light, the south gave warmth, the west gave rain, and the north with its cold and mighty wind gave strength and endurance. This knowledge came to us from the outer world with our religion. Everything the Power of the World does is done in a circle.

Life was also cyclical in nature, and at certain stages in the cycle, rituals were performed to maintain the unbroken hoop. These rituals, quite complicated and detailed, have been very well described in Joseph Brown's The Sacred Pipe.

It was the custom for a young man to seek some definite influence through a vision to guide his future. The youth prepared for the "vision-quest" by cleansing himself through the sweat bath and taking into his confidence a relative who would prepare an "altar" for him at some distance from the camp. Then the young man slipped away and went to the shrine, where through fasting and prayer, he hoped to have a religiously significant vision, one which would give him power to accomplish supernatural feats. Fasting and self-torture sometimes made it possible for him to obtain a "vision", which was then interpreted by the advisor or some member of the group with special religious power.

The most important religious ceremony in the Dakota culture was the Sun Dance. The central theme of the Sun Dance was self-torture as a sacrifice to the Supernatural for help in the past. However, it combined a large number of recognized prestige-getting patterns such as gift-giving, counting coup, virginity, and vision-quest. As the highest form of worship of the Supernatural Power, it well exemplified the religious devotion of the Dakota people.

Denominational Religious Activities.--Missionary activities among the Dakotas began in the early stages of cultural contact with the Americans. The importance of missionaries in the acculturation process was discussed earlier, but some of the problems of denominational activities not previously mentioned will be dealt with here.

In the 1860's the churches on the reservation were assigned various groups to work with, so that the Dakotas might be spared the difficulty of choosing between different denominations. Agent McGillicuddy explained that this policy "had been decreed to avoid confusing the heathen mind." He added with a touch of humor "that it had been ordained that the Red Cloud Indians should travel to heaven by the Episcopal route; the Catholic Church was detailed to save the souls of the Sitting Bull Indians; the Presbyterian method was prescribed to lead the Yanktons to salvation; while to the Congregationalists was assigned the responsibility of Christianizing the Lower Brule Sioux."¹

¹McGillicuddy, op. cit., pp. 106-107.

However, the chief source of conflict in missionary activities has not been denominational. The Dakota culture patterns of marriage, polygamy, and divorce were not in accordance with the tenets of the Christian churches, and the Indians resisted the efforts of the denominations to wipe out their traditional family behavior. It was not uncommon for older Dakotas to caution the young people not to be married in a public church ceremony, lest they be expected to choose between remaining with an undesirable mate and breaking church rules.

The old funeral ceremonies, particularly the mourning and gift-giving after burial, are still widely practiced. Widows may still cut off their hair, wail, and dress in rags as soon as death has occurred; but self-torture has been abandoned. The church ceremony for the dead is conducted according to the denominational requirements, and burial is underground. The Dakotas have been forced to inter their dead, even though this custom conflicted with their former belief that burial interfered with the passage of the spirit to the other world.

In many ways the services of the churches on the reservation are similar to those of any small rural church. In one way, however, the Dakotas differ from most church-goers. They can shift from one denomination to another and from Christian to non-Christian practices with no apparent difficulty. They are usually willing to seek divine power from all possible sources. It seems likely that they carry over into their adopted Christian religion certain elements of their native religion, such as continuous seeking for supernatural aid, divine or miraculous cures, social participation, and moral behavior.

We may safely infer that Christianity for the Dakotas was only significant when interpreted according to their former religion, and that church organization became important only as it served as a focus for group activities replacing old tribal participation. Since the religion of the Dakotas conflicted with missionary teachings on many points, Christianity at first made little progress in gaining authority over Dakota morality. But in recent years, as acculturation proceeds, the younger generations are generally accepting Christian ritual and ceremonial practice in an effort to adapt themselves to the dominant American culture pattern.

Marginal Religious Activities.—A number of so-called "pagan" cults have appeared at different times in the history of the Teton Dakotas, and one of these cults still has a large following on the reservations. These cults, fusions of Christian and native religious elements appeal to a people suffering from exploitation. They offer to their followers temporary security from some of the injustices of present-day society. The ritual and ceremony observed by the members of these cults can be adopted by the older people in order to replace some of their lost religious customs. But, as we should expect, the younger people have not been attracted to these cults, because they have little knowledge of the traditional beliefs and rites that stem from the past.

The best historical example of a marginal religious movement is the Ghost Dance Religion. Popular in the last decade of the nineteenth century, it held out to the Indians the hope of a Messiah who would save them from the Whites. Those Dakotas who did not like their position on the reservation and longed for their old way of life were induced to join the movement. Many of them danced and sang in anticipation of the second coming, until they were forced to stop by the government.

The Peyote cult or Native American Church is more recent than the Ghost Dance and still is quite influential on the reservations. An escapist cult, it answers many of the psychological and religious needs of the Dakota people. Some vestiges of Dakota religion are also found in the present-day Yuwipi cult based on the magic performances of "Medicine men." Both the Peyote and Yuwipi cults are typical of transitional societies looking for a solution to problems that appear too difficult for human comprehension.

Health and Welfare Problems.--The abrupt changes required in their mode of living when the Dakota people were placed on reservations caused them considerable suffering. The Dakotas were unaccustomed to an indoor and sedentary life generally in a limited space with impure air. Moreover, they were forced to submit to the necessity of artificial heat and additional clothing. Frequently, their food was indigestible because they didn't know how to prepare it. Lastly, the quality of the food was sometimes very poor. They were given diseased cattle, moldy flour, and rancid bacon in some of the government rations.

The most severe problem of all was actual starvation, and some of the older tribal members recall the days when the Dakota people were forced to surrender because they had nothing to eat.¹

Now hunger is a hard thing to bear, but not so hard when all are sharing the same want in the same degree; but it is doubly hard to bear when all about is plenty which the hungry dare not touch. Sentences imposed upon those who, through hunger, take for their starving bodies, are to me inconceivably cruel, even to my now altered and accustomed viewpoint.

The dietary changes were so great, the confinement and the lonesomeness so poignant for Dakota children that nearly one-half of them died when they were forcibly taken from their parents to attend schools off the reservation. Yet those remaining on the reservation were likely to suffer greatly from lack of vitamins and minerals required for adequate nutrition. The reservation Dakotas were unable to maintain good health on their usual fare of beans, rice, bread, coffee, and occasional beef. Thus diseases are much more frequently contacted by the Dakotas because of nutritional imbalance.

¹Standing Fear, op. cit., pp. 163-164.

Many of the diseases well known in American society, such as small-pox, scarlet fever, measles, and diphtheria, were introduced for the first time to the Dakotas by the early settlers. Because the Indians lacked resistance and possessed no remedies for these maladies, these diseases exacted a heavy toll of the population. The medical techniques of Western culture were not immediately available through the acculturative process, and so their only resort was to apply their own non-scientific remedies, frequently causing the disease to take a more virulent form.

During the reservation period, the Indian service attempted to ban the practices of the Dakota medicine man, but the shaman continued to be prescribed for the sick in spite of all efforts to discourage him. Many of the old warriors were prejudiced against the White man's medicine. They were especially afraid of anaesthesia and surgical operations. Their ignorance of the germ theory caused illness to be spread rapidly among a people who refused to isolate any sick member from their company. This practice caused tuberculosis to become the scourge of the Dakotas. As long as they felt well and could see nothing wrong with their bodies, they refused hospitalization or they would leave the sanatorium before the disease was arrested or cured. When the tubercular patient returned home, he was frequently given more attention because of the fear that his death was near. Thus he usually spread the disease to other family members.

Medical treatment was hampered on the reservations by an inadequate supply of available physicians and by the distances necessary for the Dakota family to transport a sick member to the doctor or hospital. It has also been hampered by Indian failure to cooperate. The medical profession has preached with only partial success against such native treatments as the peyote, which impedes the program for effective tuberculosis control.¹

One Indian described tuberculosis as merely a "bad condition" of the blood, which backs up in the body. Eventually, it dams up into the lungs and comes up into the throat and suffocates a person. Peyote, however, purifies the blood, and thus it can effect a "cure."

There will continue to be far too much sickness among reservation people as long as they are ignorant of what are now accepted as basic health precautions.

The welfare practices which worked well under formal tribal living are no longer practicable. Sharing with the needy, assisting the weak, ministering to the sick were the bounden duties of the leaders of the original Dakota societies. In times past, the Tetons had an organization of outstanding men known as the "Silent Eaters" which had the specific duty of looking out for the welfare of all people. These conditions have changed along with all other aspects of Dakota culture, and the reservation Indians are faced with serious problems of aiding those members of their group who cannot help themselves.

¹Robert H. Ruby, The Oglala Sioux, p. 55.

X. SUMMARY AND CONCLUSIONS

An attempt has been made in the first part of this pamphlet to provide the reader with an understanding of the relationship of the Dakota Indians to those who predated them in the settlement of the New World. Paleo-Indians, Mound Builders and early agricultural peoples preceded the Dakota to the Plains. We have seen that the Dakota were first forced west by pressure of white Europeans as well as other tribes seeking new lands for settlement. The Dakota, made up of three tribes, numerous bands and a multitude of tiyospayes and clans differed somewhat from tribe to tribe in their way of life. The western Tetons and Yanktons based their way of life on a truly nomadic way of life in contrast to the more settled agricultural way of life exhibited by the Santee. Even though differences occur in settlement patterns, the religion, family and value systems of the Dakota were very similar.

Many of the characteristics of government possessed by the "Sioux of the West" in their nomadic way of life led to misunderstanding between themselves and whites as often tribal chiefs were sought by the white-government when in reality none were to be found. Treaties were entered into based on an elaborate tribal government when only tiyospaye or band could legally do so. Whether such an understanding by the white would have made a difference in the final outcome of the Dakota's destiny is open only to speculation.

In this pamphlet the process of acculturation among the Dakota Indians--the change which has taken place in Dakota culture as a result of contact with the dominant Caucasian society--has also been analyzed. We may conclude from this study that in general culture change was most likely to occur among the Dakotas when the new culture elements satisfied some basic or secondary drive of the people. Culture change was likewise dependent upon the manner in which the new ideas were introduced to them. If the changes were attempted through coercion, they were not so readily accepted as those made voluntarily. The policies of the traders, missionaries, government agents, and agriculturalists were investigated to determine the extent of enforced and permissive acculturation. Enforced acculturation was usually accompanied by resistance to change. The disruption of family patterns, the loss of the means of subsistence, and the social disorganization of Dakota society were the most evident results of the acculturation process.

The changes taking place in Dakota society as a result of the acculturation process have been regarded as "social problems." They take on a "problem" aspect because of the conflicts created between the internal values of Dakota society and the external values of the larger society, or because of conflicts in the value systems of different groups within Dakota society, or finally, because of value conflicts in the personality and attitudes of individual members of Dakota society. In this study, problems were analyzed in the major institutional areas--family, economic, political, educational, religious, health and welfare.

The fact that the Dakota extended family group is being replaced by the individualistic modern family structure has caused a decline in the security offered by the Dakota family. Cooperative working and sharing

of material possessions have been disappearing as basic attributes of Dakota society. The child rearing patterns have been undergoing changes which are reflected in conflicts regarding the merits of traditional Dakota and modern American practices. As a result, the influence of the aged members of Dakota society has been decreasing, especially when the young people have become more conversant with contradictory values in the society outside of the reservation. Family disorganization has been apparent in high rates of divorce and separation typical of the younger Dakota families.

So long as those people are dependent upon agriculture, the land base on the reservations is inadequate to support the Dakota population currently living there at a minimum level. At the same time, most of the Dakotas lack the necessary working skills required to make an adequate living off the reservation; nor are they fully familiar with the workings of the money economy of the modern industrial system. Economic equality and cooperation, exemplified in the traditional gift-giving pattern, does not work well side by side with a highly competitive system of individual economic enterprise.

In the past, the inconsistent policies of the Indian Bureau have been extremely confusing and demoralizing to the Dakotas. They are aware of the inefficient administration that has characterized the government in the handling of Indian affairs. Promises which the government made to the Dakotas have been ruthlessly broken whenever convenient. Furthermore, the promise to feed the Indians through a ration system was used either to coerce or to pauperize the Dakota people.

At present, segregation of the reservations, resulting in isolation from the culture of the dominant society, encourages retention of Dakota culture patterns. Moreover, the schools provided for the Dakota children have frequently used educational methods designed to teach non-Indians and were therefore highly inappropriate to the cultural situation in which the Dakota child would grow up. Isolation, both geographical and social, was a definite factor limiting educational opportunities for Dakota children. Clearly, the willingness of the Dakotas to accept the culture of the dominant society was restricted by the extent to which they were able to take advantage of available educational opportunities.

The moral code of traditional Dakota religion did not coincide perfectly with the teaching of the Christian missionaries, thereby contributing additional conflicts. The social and economic injustices and exploitation which the Dakotas suffered from the dominant society induced them to experiment with irrational religious cults and movements as a means of escaping the consequences of their dilemma. A mixture of pagan and Christian religious elements was clearly evident in the ritual of these marginal religious activities.

Such problems as inadequate nutrition, unsanitary living conditions, high incidence of contagious disease, and limited health resources are bound to accompany the present social situation on the reservations. These problems are symptomatic of the general level of living and the health education of the Dakota people.

Effective solutions to many of the problems summarized above are in progress. The Dakota Indians have already proved themselves capable of adjusting to demands for great change in their traditional way of life. As they increase their knowledge and understanding of American society, and its relation to their own culture, they will continue to discover other solutions mutually advantageous to both cultures.

REFERENCE BIBLIOGRAPHY

The following references are very useful in studying the culture of the Dakota Indians:

Allen, Charles W. "Red Cloud and the U.S. Flag," Nebraska History. XXII:77-88, 1941.

Allison, E. H. "Surrender of Sitting Bull," South Dakota Historical Collections. VI:231-70, 1912.

Astrov, Margot Luise Therese. American Indian Prose and Poetry. Capricorn Books, 1962.

Baity, E. (C.) Americans Before Columbus. Viking Press, 1951.

Book of Indians. American Heritage Publishing co., 1961.

Brown, Dee. Bury My Heart At Wounded Knee. Bantam Books, 1970.

Brown, Joseph. The Sacred Pipe. Norman, Oklahoma: University of Oklahoma Press, 1953.

Britt, Albert. Great Indian Chiefs. New York: Whittlesey House, 1938.

Bryant, Charles S. and A. B. Murch. A History of the Great Massacre by Sioux Indians in Minnesota. Cincinnati, 1864.

Byrne, P. E. The Red Men's Last Stand. London: A. M. Philpot, 1927.

Carley, Kenneth. "As Red Men Viewed It," Minnesota History. 38:126-49, 1962.

Carver, Jonathan. Travels Through the Interior Parts of North America. Minneapolis: Ross and Haines, 1956.

Chardon, Francis A. Chardon's Journal at Fort Clark, 1834-1839. South Dakota Historical Association, 1932.

Clark, W. P. The Indian Sign Language. Philadelphia: L. R. Hamersly & Company, 1885.

Collier, John. Indians of the Americas. New York: The New American Library, 1947.

The Commission on the Rights. The Indian. University of Oklahoma Press, 1966.

The Commission on the Rights, Liberties and Responsibilities of the American Indian. The Indian, America's Unfinished Business. University of Oklahoma Press, 1966.

- Coues, Elliot. History of the Expedition Under the Command of Lewis and Clark. Vol. I and Vol. III. New York: Francis P. Harper, 1893.
- Crawford, Lewis F. Rekindling Camp Fires. Bismarck, North Dakota: Capital Book Company, 1926.
- The Dakota Bark House. St. Paul Institute, 1951.
- Daniels, Walter Macbray. American Indians. Wilson, 1957.
- Deland, C. E. "The Aborigines of South Dakota," South Dakota Historical Collections. 3:267-586; 4:273-730, 1906-1908.
- Delano, Alonzo. Life on the Plains and Among the Diggings. Ann Arbor: University Microfilms, 1966.
- Deloria, Ella. Speaking of Indians. New York: Friendship Press, 1944.
- Denig, Edwin Thompson. Five Indian Tribes of the Upper Missouri. University of Oklahoma Press, 1961.
- Denig, E. T. "Indian Tribes of the Upper Missouri," Annual Report of the Bureau of American Ethnology. 46:375-628, 1930.
- Densmore, F. Teton Sioux Music. Bureau of American Ethnology, Bulletin 41, 1918.
- Devereux, George. Reality and Dream. New York: International Universities Press, 1951.
- Downey, Fairfax David. Indian Wars of the U.S. Army, 1776-1865. Doubleday, 1963.
- Driver, Harold. Indians of North America. University of Chicago Press, 1961.
- Eastman, Charles. From the Deep Woods to Civilization. Little, Brown, and co., 1926.
- Eastman, Charles A. The Indian Today. Garden City, New York: Doubleday, Page & Company, 1915.
- Eastman, Charles Alexander. The Soul of an Indian, an Interpretation. Houghton-Mifflin, 1911.
- Eggan, Frederick Russell. The American Indian; Perspectives For the Study of Social Change. Aldine Publishing co., 1966.
- Egan, Fred. Social Anthropology of North American Tribes. Chicago: The University of Chicago Press, 1955.
- Eiseley, L. C. "The Paleo-Indians: Their Survival and Diffusion," In B. Meggers and C. Evans, eds., New Interpretations of Aboriginal American Culture History, pp. 1-11. Washington: Anthropological Society of Washington, 1955.

- Embry, Carlos B. America's Concentration Camps. D. McKay co., 1956.
- Erikson, Erik Homburger. "Observations on Sioux Education," The Journal of Psychology. VII (January, 1939), 101-156.
- Ewers, J. C. The Blackfeet. Norman: University of Oklahoma Press, 1958.
- Ewers, J. C. The Horse In Blackfoot Indian Culture. Bureau of American Ethnology, Bulletin 159, 1955.
- Ewers, J. C. "The Last Bison Drives of the Blackfoot Indians," Journal of the Washington Academy of Science, 29:355-360, 1949.
- Ewers, J. C. "Of the Assiniboine," Bulletin of the Missouri Historical Society. 8:121-150, 1952.
- Ewers, J. C. "Of the Crow Nation," Bureau of American Ethnology. Bulletin, 151:1-74, 1953.
- Ewers, John C. Plains Indian Painting. Palo Alto, California: Stanford University Press, 1939.
- Fenton, William Nelson. American Indian and White Relations to 1830. University of North Carolina Press, 1957.
- Fey, Harold Edward. Indians and Other Americans: Two Ways of Life Meet. Harper, 1959.
- Forbes, Jack D. The Indian In America's Past. Prentice-Hall, 1964.
- Garland, Hamlin. "General Custer's Last Fight As Seen By Two Moon," McClure's Magazine. 11, 1898.
- Garland, Hamlin. The Book of the American Indian. Harper, 1923.
- Gregg, Josiah. Commerce of the Prairies. Ann Arbor University Microfilms, 1966, (2nd edition).
- Gridley, Marion E. Indian Legends of American Scenes. New York: M. A. Donahue & Company, 1939.
- Gridley, Marion. Indians of Today. Chicago, 1960.
- Grinnell, G. B. The Fighting Cheyennes. Norman: University of Oklahoma Press, 1956.
- Grinnell, G. B. The Cheyenne Indians. New Haven: Yale University Press, 1923.
- Hafer, Le Roy. Relations With the Indians of the Plains, 1857-1861. A. H. Clark co. 1959.
- Hagan, William Thomas. Indian Police and Judges. Yale University Press, 1966.

- Hallowell, A. Irving. Culture and Experience. Philadelphia: University of Pennsylvania Press, 1955.
- Hallowell, A. I. "The Impact of the American Indian on American Culture," American Anthropologist. 59:201-217, 1957.
- Harmon, George Dewey. Sixty Years of Indian Affairs. Chapel Hill, North Carolina: The University of North Carolina Press, 1941.
- Haury, E. W. "Tree Rings -- the Archaeologist's Time Piece," American Antiquity. 1:98-108, 1935.
- Havighurst, Robert J. and Neugarten, Bernice. American Indian and White Children. Chicago: The University of Chicago Press, 1955.
- Hodge, F. W. Handbook of American Indians North of Mexico. Bureau of American Ethnology, Bulletin 30, 2 volumes, 1907-1910.
- Hoebel, E. A. The Cheyennes: Indians of the Great Plains. New York: Holt, Rinehart, and Winston, Inc., 1960.
- Humphrey, Norman D. "Police and Tribal Welfare in Plains Indian Cultures," Journal of Criminal Law and Criminology. XXXIII (July-August, 1942), 147-161.
- Hunter, John Dunn. Manners and Customs of Several Indian Tribes Located West of the Mississippi. Ross & Haines, 1957.
- Hyde, George E. Red Cloud's Folk. Norman, Oklahoma: University of Oklahoma Press, 1937.
- Hyde, George E. Spotted Tail's Folk. Norman, Oklahoma: University of Oklahoma Press, 1961.
- Irving, Washington. A Tour of the Prairies. University of Oklahoma Press, 1956.
- Jablow, J. The Cheyenne in Plains Indian Trade Relations, 1795-1840. Monographs of the American Ethnological Society, No. 19, 1951.
- Jackson, Donald. Custer's Gold; The U.S. Cavalry Expedition of 1874. Yale University Press, 1966.
- Jackson, Helen Maria Hunt. A Century of Dishonor. Harper and Row, 1965.
- Jennings, J. D. "The Archaeology of the Plains: An Assessment (with Special Reference to the Missouri River Basin)," National Park Service, Memorandum of Agreement No. 14-10-011-287. Department of Anthropology, University of Utah, 1955.
- Jennings, Jesse. Prehistory of North America. Mc Graw-Hill, 1968.
- Johnston, Mary Antonio. Federal Relations With the Great Sioux Indians of South Dakota, 1887-1933. Catholic University of America Press, 1948.

- Kinietz, William Vernon. The Indians of the Western Great Lakes, 1615-1760. University of Michigan Press, 1940.
- Kinietz, W. V. "The Indian Tribes of the Western Great Lakes," Occasional Contributions from the Museum of Anthropology of the University of Michigan. 10:161-225, 1940.
- La Farge, Oliver. A Pictorial History of the American Indian. Crown Publishers, 1956.
- Land Planning Committee. Indian Land Tenure, Economic Status, and Population Trends. Part X of the Supplementary Report of the Land Planning Committee to the Natural Resources Board. Washington: U. S. Government Printing Office, 1935.
- Linderman, Frank Bird. American, the life Story of a Great Indian. Day, 1930.
- Linton, Ralph. Acculturation in Seven North American Indian Tribes. D. Appleton-Century Co., 1940 (Reprinted by Appleton-Century-Croft, 1963).
- Llewellyn, K. N. and E. A. Hoebel. The Cheyenne Way. Norman: University of Oklahoma Press, 1941.
- Lowie, R. H. Indians of the Plains. New York: McGraw-Hill Book Company, Inc., 1954.
- Lowie, R. H. The Crow Indians. New York: Holt, Rinehart, and Winston, Inc., 1935.
- Macgregor, Gordon. Warriors Without Weapons. Chicago: University of Chicago Press, 1946.
- Malan, V. P. The Dakota Indian Community. Agricultural Experiment Station, South Dakota State University.
- Malan, V. P. The Dakota Indian Economy. Agricultural Experiment Station, South Dakota State University, 1963.
- Malan, V. P. The Dakota Indian Family. Agricultural Experiment Station, South Dakota State University, 1958.
- Malan, V. P. The Dakota Indian Religion. Agricultural Experiment Station, South Dakota State University.
- Malan, V. The Social System of the Dakota Indians. Cooperative Extension Service, South Dakota State University, 1962.
- Malan, V. To Change A Culture. Agricultural Experiment Station, South Dakota State University.
- Malan, V. Tuberculosis Among South Dakota Indians. Farm and Home Research, Summer, 1956.

- McGillycuddy, Julia B. McGillycuddy Agent. - Palo Alto, California: Stanford University Press, 1941.
- McLaughlin, James. My Friend the Indian. Boston: Houghton Mifflin Company, 1910.
- McLaughlin, Mary L. Myths and Legends of the Sioux. Bismarck, North Dakota: Bismarck Tribune Company, 1916.
- McNickle, D'Arcy. They Came Here First: The Epic of the American Indian. Lippencott, 1949.
- Mead, Margaret and Nicolas Calas. Primitive Heritage. New York: Random House, 1953.
- McKeel, H. Scudder. "An Anthropologist's Observations on Indian Education," Progressive Education. XIII (March, 1936), 151-9.
- McKeel, H. Scudder. A Short History of the Teton-Dakota. State Historical Society of North Dakota, 1943.
- McKeel, S. "The Economy of a Modern Teton Dakota Community," Yale University Publications in Anthropology, 6:1-14.
- Metcalf, Samuel Lytler and Hunt, William G. A Collection of Some of the Most Interesting Narratives of Indian Warfare in the West. 1821.
- Miles, Nelson A. Personal Recollections and Observations of General Nelson A. Miles. New York: The Werner Company, 1896.
- Mirsky, Jeannette. "The Dakota," from Cooperation and Competition Among Primitive Peoples. Edited by Margaret Mead. New York: McGraw-Hill Book Company, 1937.
- Mishkin, B. Rank and Warfare Among the Plains Indians. American Ethnological Society, Memoir 3, 1940.
- Mohr, Walter Harrison. Federal Indian Relations, 1774-1788. Philadelphia, 1933.
- Mooney, J. The Ghost Dance Religion. Annual Report of the Bureau of American Ethnology, 14, 1896.
- The Movement For Indian Assimilation, 1860-1890. University of Pennsylvania Press, 1963.
- Murdock, George Peter. Ethnographic Bibliography of North America. Human Relations Area Files, 1960.
- Neihardt, John G. Black Elk Speaks. Rahway, New Jersey: Quinn and Boden Company, 1932.
- Oehler, C. M. The Great Sioux Uprising. Oxford University Press, 1959.

- Oliver, Symmes Chadwick. Ecology and Cultural Continuity as Contributing Factors in the Social Organization of the Plains Indians. University of California Press, 1962.
- Olson, James C. Red Cloud and the Sioux Problem. University of Nebraska Press, 1965.
- Oswalt, Wendell H. This Land Was Theirs. Wiley, 1966.
- Photiadis, J. Program Planning -- An Inservice Training Manual. Cooperative Extension Service, South Dakota State University.
- Provinse, J. H. "The Underlying Sanctions of Plains Indian Culture." In F. Eggan, ed., Social Anthropology of North American Indian Tribes, pp. 341-376. Chicago: University of Chicago Press, 1937.
- Prucha, Francis Paul. American Indian Policy in the Formative Years. Harvard University Press, 1962.
- Quimby, George Irving. Indian Life in the Upper Great Lakes, 11,000 B. C. to A. D. 1800. University of Chicago Press, 1960.
- Radin, Paul. The Story of the American Indian. Liveright, 1944.
- Riggs, Mary B. Early Days at Santee. Santee Normal Training School Press, 1928.
- Robinson, Doane. A History of the Dakota or Sioux Indians. Minneapolis: Ross and Haines, 1967.
- Roe, F. G. The Indian and the Horse. Norman: University of Oklahoma Press, 1955.
- Roe, F. G. The North American Buffalo. Toronto: University of Toronto Press, 1951.
- Ruby, Robert H. The Oglala Sioux. New York: The Vantage Press, 1955.
- Sandoz, Mari, Cheyenne Autumn. New York: Hastings House, 1953.
- Satterlee, J. Dakota Indian Values: Yesterday and Today. Department of Sociology, South Dakota State University, 1968.
- Satterlee, J. The Dakota Tiyospaye. Department of Rural Sociology, South Dakota State University, 1968.
- Schoolcraft, Henry Rowe. Information Respecting the History, Condition and Prospects of the Indian Tribes of the United States. Lippencott, Grambo & Co., 1852-1857.
- Service, Elman R. A Profile of Primitive Culture. Harper, 1958.
- Shafter, Mary Severance. American Indian and Other Folk Dances for Schools Pageants and Playgrounds. Barnes, 1927.

- Smith, Decost. Indian Experiences. Caldwell, Idaho: The Caxton Printers, 1943.
- South Dakota Department of Public Instruction and South Dakota Indian Commission. Indians of South Dakota. Pierre, South Dakota, July 31, 1954.
- Spenser, Robert F. The Native Americans. Harper and Row, 1965.
- Squires, John L. American Indian Dances. Ronald Press, co., 1963.
- Standing Bear, Luther. Land of the Spotted Eagle. Cambridge, Massachusetts: The Riverside Press, 1933.
- Standing Bear, Luther. My People, the Sioux. Cambridge, Massachusetts: The Riverside Press, 1928.
- Steiner, Stan. The New Indians. New York: Dell Publishing Co., 1968.
- Steiner, Stan. The Way. New York: Vintage Books, 1972.
- Stone, Eric. Medicine Among the American Indians. Hafner Publishing co., 1962.
- Stoutenburgh, John Leeds. Dictionary of the American Indian. Philosophical Library, 1960.
- Textor, Lucy E. Official Relations Between the United States and the Sioux Indians. Palo Alto, California: Leland Stanford Junior University Publications, 1896.
- Thomas, C. Introduction: Report on the Mound Explorations of the Bureau of American Ethnology. Annual Report of the Bureau of American Ethnology, 12, 1894.
- Thomas, Sidney J. "A Sioux Medicine Bundle," American Anthropologist. XLIII (1941), 605-609.
- Thwaites, Reuben G. Early Western Travels. Vol. XXII and Vol. XXVII, Cleveland: The Arthur H. Clark Company, 1906.
- Trobriand, Philippe Regis Denis de Keredern de. Army Life in Dakota. Chicago: The Lakeside Press, 1941.
- Underhill, Ruth Murray. Red Man's America. University of Chicago Press, 1953.
- Underhill, Ruth Murray. Red Man's Religion. University of Chicago Press, 1965.
- U. S. Congress, Senate Committee on Indian Affairs. Indian Affairs, Laws and Treaties. U. S. Government Printing Office, 1904.
- U. S. Public Health Service. Health Services for American Indians. Office of the Surgeon General, 1957.

- Utley, Robert ii. The Last Days of the Sioux Nation. New Haven: Yale University Press, 1963.
- Vandiveer, Clarence A. The Fur-Trade and Early Western Exploration. Cleveland: Arthur H. Clark Company, 1929.
- Van Every, Dale. Disinherited: The Lost Birthright of the American Indian. Morrow, 1966.
- Vestal, Stanley. New Sources of Indian History, 1850-1891. Norman, Oklahoma: University of Oklahoma Press, 1934.
- Vestal, Stanley. Sitting Bull, Champion of the Sioux. Boston: Houghton Mifflin Company, 1932.
- Vestal, Stanley. Warpath. Boston: Houghton Mifflin Company, 1934.
- Walker, J. R. "The Sun Dance and Other Ceremonies of the Oglala Division of the Teton Dakota," American Museum of Natural History, Anthropological Papers. 16:51-221, 1917.
- Wallis, W. D. The Canadian Dakota. American Museum of Natural History, Anthropological Papers 148, 1947.
- Washburn, Wilcomb E. The Indian and the White Man. New York University Press, 1964.
- Wedel, W. R. "Plains Archaeology," American Antiquity. 2:24-32, 1961.
- Wedel, Waldo Rudolph. Prehistoric Man on the Great Plains. University of Oklahoma Press, 1961.
-
- Will, George Francis. Corn Among the Indians of the Upper Missouri. Lincoln University of Nebraska, (1964, 1917).
- Willman, Paul I. Death on the Prairie. Macmillan, 1934.
- Wingert, Paul Stover. American Indian Sculpture. J. J. Augustin, 1949.
- Wissler, Clark and others. Adventures in the Wilderness. Yale University Press, 1925.
- Wissler, C. The American Indian. New York: The Macmillan Company, 1938.
- Wissler, Clark. "European and American Indian Cultures in Contact," from Race and Culture Contacts. Edited by E. B. Reuter. New York: McGraw-Hill Book Company, 1934.
- Wissler, C. "Material Culture of the Blackfoot Indians," American Museum of Natural History, Anthropological Papers. 7:1-64, 1911.
- Wissler, C. North American Indians of the Plains. New York: American Museum of Natural History. Handbook Series, 1927.

Wissler, C. "The Origin of the American Indian." Natural History Magazine: September, 1944.

Wissler, C. "The Social Life of the Blackfoot Indians," American Museum of Natural History, Anthropological Papers. 5:1-175, 1911.

Wissler, C. Societies and Ceremonial Associations in the Oglala Division of the Teton-Dakota. American Museum of Natural History, Anthropological Papers, Vol. 11, 1912.