

DOCUMENT RESUME

ED 077 230

EM 011 144

AUTHOR Knoop, Patricia A.; Welde, William L.
TITLE Automated Pilot Performance Assessment in the T-37: A Feasibility Study. Final Report (May 1968-April 1971).
INSTITUTION Air Force Human Resources Lab., Wright-Patterson AFB, Ohio. Advanced Systems Div.
REPORT NO AFHRL-TR-72-6
PUB DATE Apr 73
NOTE 454p.
EDRS PRICE MF-\$0.65 HC-\$16.45
DESCRIPTORS *Aircraft Pilots; *Automation; Aviation Technology; *Evaluation Techniques; Feasibility Studies; *Flight Training; *Measurement Techniques; Military Training; Student Evaluation

ABSTRACT

Air Force investigators conducted a three year program to develop a capability for automated quantification and assessment of in-flight pilot performance. Such a capability enhances pilot training by making ratings more objective, valid, reliable and sensitive, and by freeing instructors from rating responsibilities, allowing them to concentrate upon instruction and safety. Researchers implemented instrumentation for recording T-37 flight data and developed hardware and software for measuring pilot performance using recorded flight data. Flight data were then collected and measurement techniques tested, the results of which indicated that automated measurement was feasible. The program also showed that additional data must be acquired for each student, that it is difficult to prepare in-flight data, and that it is necessary to blend automated proficiency ratings with subjective evaluations of students by instructors in order to achieve an optimum evaluation. (PB)

ED 077230

AFHRL-TR-72-6

**AUTOMATED PILOT PERFORMANCE ASSESSMENT
IN THE T-37: A FEASIBILITY STUDY**

**PATRICIA A. KNOOP
WILLIAM L. WELDE**

TECHNICAL REPORT AFHRL-TR-72-6

APRIL 1973

Approved for public release; distribution unlimited.

**AIR FORCE HUMAN RESOURCES LABORATORY
AIR FORCE SYSTEMS COMMAND
WRIGHT-PATTERSON AIR FORCE BASE, OHIO**

FILMED FROM BEST AVAILABLE COPY

74
174
ERIC
Full Text Provided by ERIC

NOTICE

When Government drawings, specifications, or other data are used for any purpose other than in connection with a definitely related Government procurement operation, the United States Government thereby incurs no responsibility nor any obligation whatsoever; and the fact that the government may have formulated, furnished, or in any way supplied the said drawings, specifications, or other data, is not to be regarded by implication or otherwise as in any manner licensing the holder or any other person or corporation, or conveying any rights or permission to manufacture, use, or sell any patented invention that may in any way be related thereto.

Copies of this report should not be returned unless return is required by security considerations, contractual obligations, or notice on a specific document.

AIR FORCE/56780/31 May 1973 -- 100

027107

AFHRL-TR-72-6

**AUTOMATED PILOT PERFORMANCE ASSESSMENT
IN THE T-37: A FEASIBILITY STUDY**

*PATRICIA A. KNOOP
WILLIAM L. WELDE*

U.S. DEPARTMENT OF HEALTH,
EDUCATION & WELFARE
OFFICE OF EDUCATION
THIS DOCUMENT HAS BEEN REPRO-
DUCED EXACTLY AS RECEIVED FROM
THE PERSON OR ORGANIZATION ORIG-
INATING IT. POINTS OF VIEW OR OPIN-
IONS STATED DO NOT NECESSARILY
REPRESENT OFFICIAL OFFICE OF EOU-
CATION POSITION OR POLICY.

Approved for public release; distribution unlimited.

AFHRL-TR-72-6

FOREWORD

This report describes an in-house research program conducted between May 1968 and April 1971 in support of the mission of the Advanced Systems Division, Air Force Human Resources Laboratory, Wright-Patterson AFB, Ohio. This research was documented under the following projects: Project 1710 entitled "Training for Advanced Air Force Systems" with Dr. Ross L. Morgan serving as Project Scientist, and Project 6114 entitled "Simulation Techniques for Aerospace Crew Training" with Mr. Carl F. McNulty serving as Project Scientist.

The efforts of several individuals who collectively were instrumental in formulating and obtaining support for this program, establishing initial design concepts, and managing the program during its early phases are recognized. These individuals include Lt Col Melvin S. Majesty, Dr. Donald E. Meyer, and Dr. Herbert J. Clark, all formerly with this Division; and Dr. Theodore E. Cotterman of the Training Technology Branch of this Division.

Special recognition is extended to Mr. Fred E. Kirk of the Test Instrumentation Branch, 4950th Test Wing for his invaluable efforts in the instrumentation and maintenance of the data acquisition system. Also, Mr. Eugene H. Guthrie of the Computing and Information Systems Branch, 4950th Test Wing deserves special recognition for his contribution in the development of computer techniques for the calibration and analysis of the recorded data.

Other individuals deserving commendation are Major Alan E. Walker and Captain Richard C. Oliver of the Flying Training Division, Air Force Human Resources Laboratory, for their dedication in conducting the student data collection flights. The contribution of Major W. Neely Johnson from the Air Training Command Pilot Instructor Training School for his inflight demonstrations of the training maneuvers is gratefully acknowledged.

AFHRL-TR-72-6

The authors appreciate the support and cooperation of the pilots from the Fighter Operations Branch of the 4950th Test Wing. The efforts of Jean F. Hixson, Lt Col, USAFR, in preparing Appendix V of this report are gratefully acknowledged. In addition, the valuable contributions of the Data Reduction Branch, 4950th Test Wing in reformatting flight data for compatibility with data processing equipment are appreciated. Finally, the authors extend thanks to Headquarters, Air Training Command, Randolph AFB, Texas, for the preparation of maneuver analyses and helping to define the requirements and scope of this effort.

This report has been reviewed and is approved.

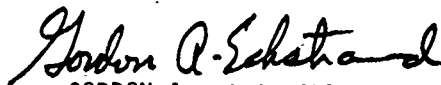

GORDON A. ECKSTRAND
Director, Advanced Systems Division
Air Force Human Resources Laboratory

ABSTRACT

Research was conducted to develop a capability for quantification and assessment of in-flight pilot performance for utilization in Undergraduate Pilot Training (UPT). This feasibility effort was directed to overcoming the disadvantages of the traditional subjective rating of a pilot trainee's performance by the instructor pilot. This was accomplished through the development of an automated, objective performance measurement system that possesses the characteristics of reliability, validity, and sensitivity. A T-37B was instrumented to digitally record 24 flight and engine parameters. An extensive computer software system was developed with which to reduce, calibrate, and analyze the recorded data from the lazy 8 and barrel roll maneuvers, and compute performance measures. Criterion values for the two maneuvers were developed by utilizing task analysis data, narrative descriptions, and recorded in-flight maneuver performance of a highly qualified Air Training Command instructor pilot. Utilizing recorded data from 16 students and 4 instructors, experimental performance measures were derived through an iterative analytic approach.

Study results indicated that lazy 8 performance assessment can be accomplished using the flight parameters of roll angle, pitch angle, and airspeed in a single summary error measure. Barrel roll measurement is dependent upon roll and pitch angle, acceleration (g force), and roll rate. A definite relationship between roll and pitch was determined to be critical to measurement. Discussions of measurement validation methods, debriefing plots, a sampling rate study, instrumentation techniques, and problem areas are provided.

SUMMARY AND CONCLUSIONS

PROBLEM

Traditionally, pilot performance has been assessed by an instructor pilot applying a subjective rating scale which places the student in one of several skill categories. Subjective rating is largely a matter of judgment and is subject to many sources of unreliability and invalidity. In addition, it places an unnecessary burden on the instructor who must apply it in-flight, and provides no way of assessing solo performance of students or of pilots transitioning to single seat aircraft. The purpose of this study was to develop improved methods of pilot proficiency assessment which would produce more valid, reliable, and sensitive measures of proficiency; and which would free the instructor from responsibilities associated with in-flight subjective rating, that detract from his attention to instruction and safety. The particular problem to which the study was addressed was T-37 pilot performance measurement in the Undergraduate Pilot Training (UPT) program.

APPROACH

The approach was to develop and implement instrumentation for recording T-37 flight data; and to develop technology and computer software for automatically measuring pilot performance using the recorded flight data. Twenty-four flight variables were recorded at rates of 10 and 100 samples per second using appropriate sensors and a data acquisition system which encoded the data in digital form on magnetic tape. Software was developed for calibration of the data and for producing an initial condensed print-out for purposes of maintaining a continual check on the instrumentation. Automated measurement studies, addressing two representative maneuvers, were conducted using the calibrated flight data recorded for a number of students and instructor pilots. The approach used was to compute measures that were initially selected on the basis of Air Training Command maneuver analyses and which possessed content validity; then test and, as necessary, revise the measures based on experience with the data. Correlation between the derived measures and instructor pilot ratings was also investigated to address inter- and intra-rater reliability and to identify measures which

AFHRL-TR-72-6

consistently failed to reinforce the ordering of performances achieved by the rating system.

RESULTS

A summary error measure for the lazy 8, based on the flight parameters of roll, pitch, and airspeed, was developed. Criteria were based on data from skilled pilots, and the measure accounted for 67% of the variance in subjective ratings for the data used to formulate criteria. In contrast, no significant correlations existed between the measure and subjective ratings for student data. Upon investigation, this was found to be primarily due to inconsistency between instructor pilots' rating techniques and standards. Using validation techniques which do not depend on subjective ratings, face-validity of the error measure as applied to student data was demonstrated. Good validation was not possible due to lack of sufficient data per individual student.

For the barrel roll, the parameters of roll, pitch, normal acceleration, and roll-rate were used as a data base for measurement. It was found that the roll/pitch relationship and not roll or pitch as single variables, is critical to measurement. The constancy of roll rate and maximum excursions of normal acceleration are also critical. Considerable difficulty was encountered in developing criteria for this maneuver due to variance in performance technique.

Debriefing charts were developed for use in pictorially describing the performance of each maneuver and conveying measures and diagnostic comments to instructor and student. Central charts for both the lazy 8 and barrel roll consisted of plots of pitch versus roll.

During the effort, data were collected on the lazy 8, and barrel roll (about 160 performances of each), and seven other UPT maneuvers. With the major exception of ground-reference data, the variables recorded appear to form a sufficient data base for measurement within UPT. Techniques were developed for determining required sampling rates. For pitch angle, a rate of one per second was found to be adequate for both the lazy 8 and barrel roll.

CONCLUSIONS

This study achieved its original goals of establishing feasibility and developing prototype techniques for automated measurement. One disappointing aspect of the effort was inability to adequately validate results (beyond the content validity inherent in the measures) due to lack of sufficient data per student. Future efforts should rely heavily on within-subject sampling for validation of measures; however, concurrent validation using subjective ratings is also worthwhile investigating so long as it is applied as a necessary (not sufficient) test and results are interpreted with the cautions identified in the report.

The most surprising aspect of the study, and one which essentially caused it to require twice the time and effort originally estimated, was the level of effort needed to acquire and prepare for use good in-flight data. In part this was due to the prototype nature of the effort, and many of the problems encountered can be prevented in future studies. However, there are a number of types of problems characteristic of in-flight data collection for which details cannot be anticipated. Sufficient time and manpower must be programmed to take care of such problems on an as-required basis.

Automated proficiency assessment must be blended properly with subjective evaluation of certain primary skills that do not lend themselves to automated measurement. Such a system can provide more valid and reliable measurement techniques than ever before employed. This can greatly enhance pilot selection and training and will also lay the groundwork for important research in such areas as simulator-to-aircraft transfer of training. Future efforts are required to expand the technology to other maneuvers in the UPT curriculum and to develop similar techniques for other aircraft.

TABLE OF CONTENTS

SECTION		PAGE
I	INTRODUCTION	1
	1. Problem	3
	a. Requirements of Objective Performance Measurement Systems	4
	b. Applications	9
	c. Immediate Application and Program Genesis	13
	2. Approach	13
	3. Report Outline	17
II	AIRBORNE DATA ACQUISITION SYSTEM	18
	1. T-37B Aircraft	18
	a. Aircraft Description	18
	b. Role of T-37 in UPT	18
	c. Flight Test Support	20
	2. Aircraft Instrumentation	21
	a. Recorded Parameters	21
	b. Sensor Systems	23
	c. Recording System	29
III	GROUND-BASED DATA CALIBRATION SYSTEM	38
	1. Overview	38
	2. Tape Format Conversion	40
	a. Recorder Tape	40
	b. Processor Tape	40
	c. Blocked Tape	40
	3. Calibration	42
	a. Calibration Data and Procedures	42
	b. Computed Variables	44
	c. Calibrated Tape Format	46
	d. Tape Capacity	46
	e. Print-Out Format	49
	f. Calibration Software	49
IV	SAMPLING RATE STUDY	51
	1. Introduction	51
	2. Approach	52
	a. Discussion	52
	b. Software	53
	3. Results	55
V	BASIC PERFORMANCE MEASUREMENT SYSTEM	60
	1. General Approach	60
	2. ATC Maneuver Analyses	61
	a. Lazy 8	61
	b. Barrel Roll	62
	c. Normal Landing	71
	3. Theoretical Measures	72
	a. Description	79
	b. Software Implementation	119
	c. Summary of Theoretical Measures Investigation	133

TABLE OF CONTENTS (Contd)

	PAGE
4. Measurement System	135
a. Punched Card Records of Maneuvers	135
b. Lazy 8 Experimental Measures	137
c. Barrel Roll Experimental Measures	139
d. Debriefing Plots	143
e. Summary of Experimental Measures	144
VI FLIGHT TESTING AND DATA COLLECTION	148
1. Operating Procedures	148
a. Tape Handling	146
b. Recorder Operating Procedures	150
2. Calibration Procedures	151
3. Maneuver Data Collection Procedures	153
a. UPT Student Data	156
b. Instructor Pilot Data	158
c. Summary	160
VII MEASUREMENT ANALYSIS	161
1. Lazy 8	162
a. PIT Instructor/Pilot	163
b. AFHRL and ATC Instructors	164
c. Students	168
d. Within-Subject Sampling as a Basis for Measurement Development	169
e. Comparison of Instructor Rating Standards	179
f. Summary and Results for Lazy 8 Measurements	211
2. Barrel Roll	212
a. Student Data	212
b. PIT Instructor Data	227
c. Summary	227
3. Other Maneuvers: Typical Data	229
VIII DISCUSSION AND ADDITIONAL REMARKS	235
1. Problems	235
2. Euler Angles Computation	237
3. Modeling of Normative Data	238
4. Debriefing Plots Analysis	239
5. Measurement Approach	239
6. Measurement Results	241

TABLE OF CONTENTS (Contd)

APPENDICES:		PAGE
I	Calibration Data and Calibration Block Diagrams for Recorded Flight Data	247
II	Illustration of Initial Print-Out Format	263
III	Software for Data Calibration and Initial Print-Out	267
IV	FORTTRAN Programs for a Sampling Rate Study	287
V	Extended Analysis of the Normal Landing Task	291
VI	Executive Program for Lazy 8	307
VII	Major Functions of Barrel Roll Measurement Subroutine	313
VIII	Illustration of Output from Experimental Measurement Programs	315
IX	Initial Plots Generated for Nine Lazy 8 Performances	319
X	Stick Position Plots for Representative Lazy 8 Maneuvers	347
XI	Roll vs Pitch Plots for Representative Lazy 8 Maneuvers	353
XII	Airspeed Plots for Representative Lazy 8 Maneuvers	361
XIII	Punch and Print Program	365
XIV	Sample Output of Lazy 8 Experimental Measurement Program	371
XV	Sample Output of Barrel Roll Experimental Measurement Program	379
XVI	Debriefing Plots for Four Lazy 8 Performances	383
XVII	Debriefing Plots for Two Barrel Roll Performances	397
XVIII	Representative Barrel Roll Plots	415
REFERENCES		446

LIST OF ILLUSTRATIONS

FIGURE		PAGE
1	T-37 Cockpit	19
2	T-37 Instrumentation Diagram	25
3	Recorder Control Panel	31
4	Flight Data Processing Flow	39
5	Flight Recorder Tape	41
6	Magnetic Tape Format	48
7	Nature of Error Computation for Sampling Rate Study . .	52
8	Sample Print-Out for Sampling Rate Study	54
9	Sampling Interval Plot for Pitch (Lazy 8, N= 46)	57
10	Sampling Interval Plot for Pitch (Barrel Roll, N= 44). .	58
11	Lazy 8 Maneuver Profile	63
12	Barrel Roll Positions	67
13	Normal Landing Maneuver Profile	73
14	Maneuver Diagram for Lazy 8	80
15	Lazy 8 Maneuver Diagram	97
16	Possible Criterion Flight Paths for Barrel Roll	106
17	Criterion vs Actual Flight Paths for Barrel Roll . .	107
18	Barrel Roll Maneuver Diagram	116
19	Stick Position Plot for Lazy 8	123
20	Roll vs Pitch for Lazy 8 (12-17-69-20/High Good)	123

LIST OF ILLUSTRATIONS - Cont'd

FIGURE		PAGE
21	Roll and Pitch vs Time for Lazy 8	124
22	Altitude vs Time for Lazy 8	125
23	Airspeed vs Time for Lazy 8	125
24	Heading vs Time for Lazy 8	126
25	Ground Track for Lazy 8	126
26	Stick Position Plot for Lazy 8	127
27	Roll vs Pitch for Lazy 8 (12-19-69-27/Fair)	127
28	Roll and Pitch vs Time for Lazy 8	128
29	Altitude vs Time for Lazy 8	129
30	Airspeed vs Time for Lazy 8	129
31	Heading vs Time for Lazy 8	130
32	Ground Track for Lazy 8	130
33	Distribution of PIT Instructor Lazy 8's Across Rating Categories	164
34	Pitch and Roll Measures for PIT Instructor Lazy 8's [Mean \pm 1 σ]	165
35	Airspeed and Altitude Measures for PIT Instructor Lazy 8's [Mean \pm 1 σ]	166
36	Roll and Time Measures for PIT Instructor Lazy 8's [Mean \pm 1 σ]	167
37	Airspeed Error Measures for PIT Instructor Lazy 8's [Mean \pm 1 σ]	168
38	Airspeed Excursion and Rate Measures for PIT Instructor Lazy 8's [Mean \pm 1 σ]	169

LIST OF ILLUSTRATIONS - Cont'd

FIGURE		PAGE
39	Time Measures for PIT Instructor Lazy 8's [Mean \pm 1 σ]	170
40	Roll vs Pitch Plot	173
41	Airspeed Plot	174
42	Altitude Plot	175
43	Combination Error Measure for 47 PIT Instructor Lazy 8 Performances	183
44	Sample Annotated Debriefing Plot	185
45	Distribution of Instructor Pilot Lazy 8's Across Rating Categories	186
46	Distribution of Student Lazy 8's Across Rating Categories	189
47	Pitch and Roll Measures for Student Lazy 8's [Mean \pm 1 σ]	191
48	Airspeed and Altitude Measures for Student Lazy 8's [Mean \pm 1 σ]	192
49	Roll and Time Measures for Student Lazy 8's [Mean \pm 1 σ]	193
50	Airspeed Error Measures for Student Lazy 8's [Mean \pm 1 σ]	194
51	Airspeed Excursion and Rate Measures for Student Lazy 8's [Mean \pm 1 σ]	195
52	Time Measures for Student Lazy 8's [Mean \pm 1 σ]	196
53	Combination Error Measures for 42 Student Lazy 8 Performances	200

LIST OF ILLUSTRATIONS - Cont'd

FIGURE		PAGE
54	Pitch and Roll Measures for Single Student Performances of the Lazy 8	202
55	Airspeed and Altitude Measures for Single Student Performances of the Lazy 8	203
56	Roll and Time Measures for Single Student Performances of the Lazy 8	204
57	Airspeed Error Measures for Single Student Performances of the Lazy 8	205
58	Airspeed Excursion and Rate Measures for Single Student Performances of the Lazy 8	206
59	Time Measures for Single Student Performances of the Lazy 8	207
60	Combination Error Measure for Single Students' Performances of Lazy 8	208
61	Distribution of Student Barrel Rolls Across Rating Categories	213
62	Symmetry, Circle, and Correlation Measures for Student Barrel Rolls	214
63	Correlation, G, and Roll Measures for Student Barrel Rolls	215
64	Angle, Rate, and Time Measures for Student Barrel Rolls	216
65	Pitch Angle Measures for Student Barrel Rolls	217
66	Altitude Excursion Measures for Student Barrel Rolls	218
67	Airspeed Excursion Measures for Student Barrel Rolls	219
68	Average Student Barrel Roll Performances	224
69	Average Altitude Excursions for Student Barrel Rolls	225

LIST OF ILLUSTRATIONS - Cont'd

FIGURE		PAGE
70	Average Airspeed Excursions for Student Barrel Rolls . .	226
71	Loop	229
72	Stall	230
73	Cloverleaf (1/2)	231
74	Maximum Performances Climbing Turn	232
75	Immelmann	233
76	Cuban 8	234

LIST OF TABLES

TABLE		PAGE
I	Performance Parameters Recorded by the Data Acquisition System	22
II	Description of Equipment Installed in the T-37 (948) . .	24
III	Errors Observed in Trial Attempt to Curve-Fit Calibration Data	43
IV	Computed Flight Variables	45
V	Order of T-37 Aircraft Variables on Calibrated Tape . .	47
VI	Fractional Part of Pitch Errors $\leq X$ for Various X^1 Values	56
VII	Lazy 8 Maneuver Analysis	64
VIII	Normal Landing Maneuver Analysis	74
IX	Preliminary Lazy 8 Performance Criteria	81
X	Summary of Performance Measures for Lazy 8	94
XI	Definitions of Terms Used in Table X	96
XII	Summary of Performance Measures for Barrel Roll	112
XIII	Definitions of Terms Used in Table XII	114
XIV	Parameters Calibrated In-Flight	154
XV	Summary of UPT Student Data Collection Flights	157
XVI	Summary of Instructor Data Collection Flights	159
XVII	Correlations Between Measures and Subjective Ratings for P/T Instructor Lazy 8 Performances	171
XVIII	Indicants of Intra- and Inter-Instructor Variance on Lazy 8 Performances	187
XIX	General Student Data	190
XX	Correlations Between Measures and Subjective Ratings for Student Lazy 8's	197
XXI	Correlations Between IP Ratings and Measures	210
XXII	Correlations Between Measures and Subjective Ratings for Student Barrel Rolls	220

SECTION I

INTRODUCTION

This report documents a three-year exploratory development effort in the area of quantitative assessment and automated measurement of pilot performance. The effort involved the instrumentation of a T-37B aircraft, collection and calibration of student and instructor performance data, and the development of objective measurement techniques for selected training maneuvers.

The development of performance measurement techniques with all of the appropriate characteristics (objectivity, reliability, etc.) is one of those problems which has truly withstood the test of time. Witness the following extract from a 1952 technical report (Smith, Flexman, and Houston, 1952):

"An examination of the training program and a survey of previous research on pilot training indicate that, for the most part, objective standards did not exist and that measures of pilot proficiency were not sufficiently reliable or discriminating for use as effective criterion measures for training research."

The prevailing truth and existence of statements such as above attest not only to the difficulty and complexity of (pilot) performance measurement as a research problem, but also to its recognized importance over the years.

The importance of measurement as a research problem is due to the fact that measurement is a fundamental requirement which pervades all of training, education, and any associated research. It is not possible to perform good research in training innovations, for instance, unless a valid method exists for measuring the results of training. Neither is it possible to optimize training and achieve good quality-control in pilot "production" if it is necessary to rely on rudimentary subjective

judgments of performance which place a student in one of a few rating categories. Much training oriented research of the future can benefit considerably from the development of valid performance measurement techniques; and some very beneficial research is strictly dependent on such developments.

The above remarks hopefully help to place measurement, as a critical problem, in its proper perspective. Despite its criticality, however, measurement is largely a means to many ends and not necessarily an end in itself. For this reason it is too often treated as a "nice to have" but nonessential ingredient in a training or research system, and attention is turned to more popular endeavors with more immediate and visible dividends. The authors contend that this is why the measurement problem has persisted over the years -- not because it is unsolvable, and not because of its difficulty in the context of complex tasks such as flying.

Traditionally, in an introductory section such as this, one would address in detail three major topics: (1) the problem, why it is difficult to solve, and what characteristics should exist in a good performance measurement system; (2) why the problem is important and what the many applications of its solution are; and (3) what, if anything, is different about the approach used in this study from all of the previously tried approaches. The first topic has been discussed at length in literally every measurement report published, beginning in the 1940's. (In fact, in many reports, discussion of the problem is the essence of the text!) It will be treated only in summary fashion in this report.

The second topic, if addressed completely, could result in another technical report. The authors choose to categorize the applications of measurement into two general classes and will present just a few representative examples of each class.

The third topic, the approach, covers both the method of acquiring data and the methods of treating it. It is the latter of these which

is most controversial. The approach documented in this report is only one of those being pursued by the authors. Therefore, in addition to summarizing the approach in this Introduction, it is evaluated in Section VIII and compared with another, more highly automated approach.

1. PROBLEM

From a historical perspective, interest in the measurement of the proficiency of aircrew personnel can be traced to the World War I period, and the work on the selection of military pilots. Even after these many years of endeavor, the measurement and assessment of in-flight pilot performance is a long way from being successfully achieved, and less than complete information is provided by present measures and methods. The measurement of pilot performance is sufficiently difficult due to the inherent nature of the human and the environment in which he operates that unfortunately, in many instances, the practice has been to obtain what is measurable rather than what is desired or required.

There are two general methods or approaches in which performance measurement can be categorized. The most common is the evaluation of performance qualitatively — the subjective method. The second approach represents a goal that is the subject of this report, and that is the assessment of performance quantitatively — the objective method. These two methods are not strictly a dichotomous classification, but rather represent a continuum of performance measurement. On the one side there exists the strictly personal judgment and rating of performance, and on the other end of the continuum is a completely automated performance measurement and assessment system. The middle area of this performance measurement dimension consists of various techniques whereby the human observer may record performance and then compare this data with pre-established standards to provide an evaluation of the quality of performance. The desired goal of an effective performance measurement system is to capitalize on the advantages of an automated, objective system and yet retain some of the unique capabilities afforded by the human evaluator so a comprehensive assessment of performance can be achieved.

a. Requirements of Objective Performance Measurement Systems

The significant problem in developing an objective pilot performance measurement system consists of acquiring data and developing analytic and software techniques which derive, from that data, measures that are reliable, valid, and sensitive. Also, the practical aspect of pilot acceptability must be addressed for such a system to be successful. Each of these factors will be discussed in turn.

(1) Reliability

Basically reliability refers to consistency or stability in the recorded data and computed measures upon repetition. Reliability is essential in both the acquisition or recording of performance data and in the measurement of performance using that data. When the performance of the same individual is scored on different occasions, reliability is the opposite of variability.

Several sources of variability inherent in customary measurement situations, which hinder reliable measurement of pilot performance, include the following (Reference 1):

1. A major source of variability is a function of variations in the environment in which performance is being measured. Variability may be introduced in the in-flight environment by differences in traffic, weather, amount of turbulence, wind direction and velocity, visibility, etc., producing "between-flying conditions" unreliability. In addition, situational factors such as unexpected noise, extreme temperatures, g forces, and other distractions may further affect performance scores.

2. A second source of unreliability is a function of fluctuation associated with the operation of the system in which an individual's performance is being measured. Variation in scores due to system instability may reflect random fluctuations either in the mechanical components or in other human components in the system.

3. Response-evaluating instruments used and personnel participating during proficiency assessment are a third possible source of unreliability. The equipment used during measurement must be carefully calibrated prior to testing.

4. The fourth source of unreliability is a function of the particular sample of items (parameters) selected for inclusion in the test instrument.

5. The complexity of the behavior being evaluated is a fifth type of influence on the reliability of a proficiency measure. Since it is possible that an individual's proficiency level may fluctuate considerably from one dimension to the next and across time, each component element in a sense represents a somewhat different test.

6. A sixth source of unreliability is attributable to the change in the physiological condition of the pilot himself. This includes emotional state, motivation, susceptibility to fatigue and stress, variation in the individual rate of adaptation, and many others.

To minimize unreliability in the data itself, the hardware and software components of the performance measurement system require a high degree of reliability or repeatability. Calibration of equipment must be conducted on a continuing basis to be able to determine inaccuracies in the data or complete component failure. This includes checking the reliability of the power supply output, parameter sensor operation regarding resolution, range of values, response rate, and environmental effects, recording device operation, and any interface equipment. The software processes involved in data reduction, conversion, analysis, and plotting should be closely monitored to avoid data loss. Accurate records of flight conditions and mission requirements should be maintained to facilitate the interpretation of the assessed pilot performance data based upon the actual conditions under which the performance was flown and recorded.

The technique of performance measurement, which develops the final measures, must (1) eliminate any remaining data unreliability and (2) produce reliable measures. There is no standard technique for eliminating data unreliability because each case must be treated individually depending on the source of unreliability. One example is in the recording of normal acceleration (g force) using an accelerometer. The data are not reliable indicators of sustained acceleration, which would expectedly be the focus of interest. Even with filtering, the recording would pick up some instantaneous effects of gust loading. Therefore it would not be acceptable to sample this data at discrete points. Instead some method of smoothing should be applied to the data through the development of appropriate software.

Of primary importance, ultimately, the measures that are developed must be reliable indices of performance. One example of when reliability would not be assured is if unrealistic criteria were applied. A derived measure may be considered reliable in that it consistently reflects a comparison with the criteria; but it could be an unreliable (and invalid) index of performance due to the inappropriateness of the criteria. Without proper precautions, it is entirely possible to induce unreliability in the measures themselves through improper treatment of, what is otherwise reliable, performance data.

(2) Validity

This refers to the degree to which the measuring or testing process correctly measures the variable intended to be measured. Validity can be categorized into various kinds, but the one that is most appropriate to the problem of in-flight pilot performance measurement is empirical validity. Essentially, this is based upon the relation between performance scores and a criterion, the latter being a direct indication of performance goals. Criterion-referenced proficiency measures permit assessment of performance and provide information on the degree of competence considered independently of the performance of others. Such measures permit one to determine whether an individual has reached a given performance standard, hence, the test.

absolute scoring is sometimes applied. Performance is measured against a definitive task specification that has previously been determined either by analysis, subjective judgments by a panel of experts, or numerous successful performances, sampled from large population.

In addition to a criterion-referenced measure or performance standard, proficiency measures can also be distinguished as norm-referenced measures. A norm-referenced proficiency measure evaluates an individual's proficiency in terms of a comparison between his performance and the performance of other members of the group. Norm-referenced measures can be considered a relative scoring method since they are related to level of performance at a selected moment in time during the process of learning a specified task. Such measures are of limited value in measurements intended for quality control, because they are not referenced to fixed performance standards. However, by employing an objective measurement system, norm-referenced measures may be of significant training value for improving the student's performance through more feedback via class competition. Also, the average class performance can be readily determined with a norm-referenced measurement system.

An automated performance measurement system inherently permits the assessment of pilot performance to be highly valid, since performance can be recorded on-line for numerous system variables. In most in-flight evaluations, performance data is seldom recorded until the flight has been completed, which introduces inaccuracy simply due to the inability of the individual to remember features of performance relevant to success. Furthermore, greater detail regarding the performance is afforded with an automated system since more flight parameters can be recorded and more data accrued per unit of time than is possible with human observation. Because of multi-dimensional role of the instructor in the in-flight training environment, a serious difficulty can frequently occur whereby the instructor's ability to detect and assess subtle differences in performance when they, in fact, exist is jeopardized.

AFHRL-TR-72-6.

(3) Sensitivity

The reliability with which and method by which a measure changes whenever the pilot's performance changes is known as measurement sensitivity. This fundamental requirement for an objective pilot performance measurement system pertains to the fact that performance should be discriminated into as many categories of proficiency as possible (Whenever feasible, continuous measures of performance should be obtained), and the rate of change of the measures with respect to skill acquisition must be known. Thus, the sensitivity of the measurement system relates to (1) the resolution capability of the sensors to discriminate each parameter into values that meaningfully reflect pilot performance and (2) the development of measures to an acceptable measurement scale; i.e., interval scale.

(4) Acceptability

Pilot acceptability becomes a rather important factor when the time arrives for making the decision to implement an automated pilot performance measurement system that has been proved to possess reliability, validity, and sensitivity. Too often, concern is expressed that the instructor pilot will be replaced in the training environment by an automated device. However, whatever the level of sophistication of automated performance measurement, the human observer must always be an integral part of the total measurement system. In the complexity of flight environment, there are specific behavioral skills which do not lend themselves to quantification or objective scoring. It is in these areas where the human observer can make more subtle judgments and more appropriate evaluations than is possible with any electromechanical device.

At least the following behavioral factors should and will continue to be evaluated by the instructor:

1. decision making capability
2. ability to plan effectively

AFHRL-TR-72-6

3. coordination and smoothness of control
4. maturity — willingness to accept responsibility, ability to accomplish objectives, judgment, and reactions to stress, unexpected conditions, and aircraft emergencies.
5. confidence — proportionate with the individual's level of competency
6. motivation (attitude) — the manner in which it affects performance
7. ability to time share attention and efforts appropriately in an environment of simultaneous activities
8. coordination with other crew members
9. knowledge and systematic performance of tasks
10. fear of flying
11. motion sickness
12. air discipline — adherence to command authority and assigned tasks.

The presence of an instructor is required and recommended for in-flight training and evaluation. The judgment of the instructor regarding the student's total flying capability, however, can be supported by the objective assessment of psychomotor skills with an in-flight pilot performance measurement system.

b. Applications

The applications possible for an automated, objective pilot performance measurement system can be categorized in two classes: (1) applications which enhance flying training in its operational context; and (2) applications which make research possible.

(1) Operational Flying Training

Five examples of how operational flying training can be enhanced with an automated measurement system are discussed:

(a) Inflight Evaluation Enhanced

The aircraft is a prime example of a complex system where the large number of interacting elements lessens the chances of deriving reliable and easily interpretable performance measurement data. The dynamics of the in-flight environment and complexity of flying, involving a large number of procedural, judgmental, and perceptual-motor activities, imposes a tremendous burden upon the instructor to assimilate and synthesize the student's performance and provide a reliable and valid evaluation. Any attempt at manual recording procedures is fruitless since the instructor is unable to effectively time-share the activities of observing and recording multiple parameters at an adequate sampling rate and accuracy to provide the necessary pilot performance measurement data. There are many subtle aspects of flying which do not lend themselves to recording, and automated performance measurement systems normally permit assessment of only those actions by the pilot which result in some effect on the aircraft. This permits the instructor to concentrate on the evaluation of those qualitative behaviors reflecting on the student's ability to effectively and safely cope with the flight environment.

(b) Objectivity Achieved

In subjective evaluations, considerable variation occurs in the performance ratings of the instructors as a function of:

- (1) judgments made without reference to a definitive standard since the same maneuver may be flown satisfactorily in a number of different ways,
- (2) different standards of performance which are employed due to differences in the instructor's knowledge and proficiency,
- (3) operational flight experience and training affecting the perspective and judgment of instructor ratings,
- (4) performance ratings relating to what the instructor deems are the critical aspects of the job,
- (5) possibility

of bias and halo effects existing from the instructor-student relationship, (6) different conception of the specific grading system regarding the flight parameters incorporated, weighting assigned, and the range of the qualitative categories, and (7) difficulty of comparing actual performance with what the average proficiency level should be at any moment in time. Subjective measures generally lack the accuracy and reliability needed for effective performance measurement because of their dependence upon the judgment and veracity of the individual observer. The antithesis of this is an objective measure that is founded on data that is free from personal and emotional bias. The greatest objectivity is attained when a permanent record of behavior is obtained at the time of performance by an automated data acquisition system.

(c) Training Facilitated

An automated performance measurement system relieves the instructor of the burden of in-flight evaluation, and permits him to concentrate on the job for which he is most professionally qualified, teaching flying. The instructor can devote complete attention to developing the procedural, judgmental, and perceptual-motor skills in the student during the flight, which maximizes the effectiveness of the training sortie. Additionally, the aspect of flight safety is enhanced by reducing the in-flight tasks of the instructor and possibly eliminating the requirement for the "head-in-the-cockpit" situation.

(d) Playback Capability Provided

Automated performance measurement also provides the means for playback of critical mission phases for demonstration and instructional purposes. This playback capability can be performed in the simulator and even correlated with earlier simulator or aircraft missions. Furthermore, it is an excellent method for quantifying the rate of learning and affording the opportunity to diagnose consistent weaknesses in performance.

(e) Solo Performance Assessed

It is also possible to record pilot performance during solo flights, which provides the instructor a method whereby he can maintain

continuity and assess the stability of performance across dual and solo flights. Without an automated measurement system of the type developed in this study, it is not possible to assess solo performance, even though it is an important criterion. This would include performance in single-seat aircraft (e.g., A-7D) as well as regular student solo performance in training aircraft. In-flight recording and subsequent automated measurement of solo performance will enhance both basic pilot training and transition training by providing the first and only means of measuring performance of this type.

(2) Research

Following are selected examples of capabilities and/or new knowledge, the research and pursuit of which will be greatly enhanced when sensitive, objective measurement systems are developed:

1. Replacement of highly sophisticated and expensive simulators with lower fidelity and less costly simulators and trainers by having the capability to definitively assess the transfer-of-training effects (simulator to aircraft) with regard to the factor of simulator fidelity. For example, it would be possible to determine if six degrees-of-freedom motion systems and full color and/or field-of-view visual systems contribute sufficiently to transfer-of-training to be cost effective.

2. Replace more aircraft time with simulator time, and know the resulting effects on training.

3. Develop adaptive training methods (impossible without performance measurement).

4. Develop completely automated simulator instruction for use in proficiency training.

5. Accurately predict operational and combat performance of pilots based upon their in-training performance.

6. Improve pilot trainee selection and reduce the wash-out rate.

c. Immediate Application and Program Genesis

The need for objective performance measurement has been recognized and continually advocated by the Air Force, one of the largest agencies involved in pilot training. The recognition of this requirement culminated in a research request (RTR-68-25-A) directed to the Advanced Systems Division of the Air Force Human Resources Laboratory (AFHRL) at Wright-Patterson AFB, Ohio, by the Air Training Command. A research project was initiated in 1968 entitled Pilot Performance Measurement System to develop an in-flight data recording system and a ground-based automated performance assessment capability for utilization in UPT.

2. APPROACH

The objective of this research effort was to develop prototype methods for quantitative assessment and automated measurement of pilot performance. The approach to achieving this objective was to (1) develop methods of acquiring reliable and accurate in-flight performance data; (2) develop methods of measuring pilot performance using the acquired data; and (3) perform preliminary tests of the derived methods. In scope, the acquisition of in-flight data was designed to be applicable to all in-flight performance, but investigation of methods for measuring performance using the data was limited to two representative maneuvers: the lazy 8 and the barrel roll.

Before describing the approach in more detail, it is appropriate and necessary to define and clarify the term "performance measure" as used within the framework of this study:

A performance measure, as the term is used in this report, is a number that is selected from or computed from recorded performance data, and which, in itself, effects a comparison or directly contributes to the drawing of a comparison between (1) actual performance and a standard or criterion; or (2) actual performance and the normative performance of a selected population.

AFHRL-TR-72-6

Recorded in-flight data do not necessarily constitute performance measures. Similarly, the act of recording in-flight data does not constitute the measurement (assessment) of performance.

With these introductory remarks, we will next describe in outline form the approach that was pursued in this study. The approach consisted of accomplishing the following tasks:

1. Developing hardware and software required for acquiring and calibrating in-flight pilot performance data.
 2. Developing performance measurement techniques and implementing them in software.
 3. Collecting extensive data on the lazy 8 and barrel roll and some representative data on other maneuvers.
- .. Testing the measurement techniques.

Each of these tasks will be discussed in turn.

Acquisition and Calibration of In-Flight Performance Data. This required the development of hardware and software subsystems. From a hardware standpoint, a T-37 aircraft was instrumented to record a number of flight and engine variables, such as roll angle, pitch angle, stick position, RPM, airspeed, altitude, and heading. This required the installation and calibration of a digital flight recorder system and parameter sensors such as gyros, transducers, accelerometers, and potentiometers. In addition to initial installation of the instrumentation package, numerous modifications were completed during the first several months of use as problem areas were revealed regarding flight safety, electrical power distribution, resolution of recorded variables, and recording reliability.

From a software standpoint, computer programs were written to (1) convert the aircraft magnetic tape to a tape physically compatible with data processing equipment; (2) calibrate the data, or convert it

AFHRL-TR-72-6.

to engineering units; (3) produce a magnetic tape record of the calibrated data for use in the measurement research; and (4) produce a condensed print-out of the data for use in testing the accuracy and reliability of the in-flight recording system.

Development of Performance Measurement Techniques. This required the identification of performance measures and the development, testing, and print-out of the measures using the recorded data. The approach to accomplishing this was to (1) analyze each of the maneuvers to be measured, with particular attention to the ATC published criteria for performance; (2) develop a set of theoretical measures based solely upon the information in the maneuver analyses; (3) compute the theoretical measures for initial representative performances; (4) using the initial data, develop a refined set of measures, called experimental measures herein, for application to a broad spectrum of student and instructor performances; and (5) test the validity of the experimental measures and, from them, select final measures for future applications.

This approach is called (by the authors) an "analytic" approach because it is based strongly on detailed analyses of the maneuvers to be measured. During the period of the program, an alternative approach that is more highly automated was pursued under contract using some of the same data collected in this investigation. For this reason, the data collection effort, to be described next, was responsive to contractual requirements in support of the alternative approach as well as to the central requirements of the study as reported in this document.

Data Collection. The data collection was pursued in three phases. Phase 1 consisted of collecting data to establish and verify the accuracy and reliability of the in-flight data acquisition and ground-based data calibration systems. For this phase, specific performance requirements were outlined based on the parameters to be tested during each flight. Flight test pilots then flew sorties in accordance with the outlined requirements.

AFHRL-TR-72-6

Phase 2 was devoted to collection of data which supported related contractual requirements as well as the requirement for representative instructor pilot (IP) data for this study. For this, a highly qualified IP from the ATC Pilot Instructor Training (PIT) school flew a number of lazy 8's and barrel rolls and provided subjective ratings for each performance. As per request, he attempted to fly a variety of performances to illustrate perfect performance as well as typical student errors encountered during this maneuver.

Phase 3 was to collect data on students and instructor pilots at Williams AFB, Arizona. This data was required primarily to test and validate measures, as described below.

Testing the Measurement Techniques. Content validity was built in to the measures initially selected for investigation as a result of the selection-method employed (i.e., Air Training Command training and evaluation criteria and maneuver analyses served as the bases for selection). While content validity is a useful and necessary consideration, it is not an apriority that it is sufficient in itself. Therefore, a number of supplemental validation techniques that are more empirical in nature were also considered.

One technique that constituted part of the original study design was to employ within-subject sampling and examine "measure-progress" across training. This would provide an additional necessary (but not sufficient) validation test in that candidate measures consistently exhibiting zero or negative "slope" when plotted against trial-number, for example, would be highly subject to question. Conversely, those exhibiting opposite characteristics would still be considered likely candidates. Due to problems discussed elsewhere in this report, sufficient data per student were not collected to permit pursuit of this test.

An alternative supplemental method that was applied in this study is that of investigating concurrent validity, which means comparing the experimentally derived measures with some other direct and independent measure of proficiency. Again, within the context of the subject at hand, this validation method must be considered as another necessary (with qualifications) but not sufficient test. The reason for this is that although an independent measure of proficiency in UPT is readily available, it is not as discriminating (sensitive) as the measures to be developed; and, since it is based on human judgment, its reliability must be considered subject to question.

AFHRL-TR-72-6

The independent measure most readily available for use is the instructor pilot's rating of performance, generated on a four-point scale (excellent, good, fair, unable). Because of the properties of these ratings, as outlined in the preceding paragraph, their utility within the context of concurrent validation is limited to distinguishing between new experimental measures which (a) tend to reinforce the ordering dictated by the ratings, and therefore should definitely be considered further, and (b) consistently do not reinforce the ordering, and therefore should be considered highly subject to question.

In this report, concurrent validation, in the context described above, is explored by analyzing correlations between potential quantitative measures and instructor pilot ratings. Summarily, this analysis serves several useful functions: (1) it provides a preliminary foundation for investigating inter- and intra-rater reliability; (2) it provides data which contributes to validity considerations by flagging measures which should be considered highly questionable; and (3) it provides a basis for demonstrating where/when derived measures do and do not reinforce the ordering achieved by the existing ATC rating system. (In this last regard, where derived measures do not reinforce the ratings, other supplemental validation methods that are applied should ultimately be used to prove the derived measures are "correct" -- if only for instructor and Command acceptance of the new system.)

3. REPORT OUTLINE

In this report, the four tasks briefly described above, are presented in the order listed. Sections II and III present the hardware and software subsystems developed for data acquisition and calibration, and the initial tests performed on the system. Section IV presents a sampling-rate study done to establish methodology for empirically determining required recording rates. Section V describes the development of performance measures and measurement techniques to be applied and tested. Section VI describes the scope of and methods employed in data collection. Section VII describes the analyses and tests performed on the measurement techniques and presents the results derived. The last, Section VIII, summarizes the findings.

For the casual reader interested in a good overview of the research effort at the expense of all details, it is recommended that attention be focused on Sections II, III, VII, and VIII.

SECTION II
AIRBORNE DATA ACQUISITION SYSTEM

1. T-37B AIRCRAFT

A T-37B aircraft with a USAF tail number of 58-1948 (hereafter referred to as 948) was bailed to the Air Force Systems Command (AFSC) by the Air Training Command (ATC) to support the research requirements of the AFHRL Pilot Performance Measurement System Program.

a. Aircraft Description

The T-37B is a low-wing, twin-engine jet trainer with side-by-side seating (student pilot flies from the left seat). Manufactured by Cessna, the aircraft has a gross weight of 6600 pounds and an internal fuel load for a normal training mission duration time of 1 hour 15 minutes. The aircraft includes full instrumentation for IFR flight. Figure 1 represents the cockpit arrangement of 948. The dual-control flight control system is manually operated with an electrical trim tab system for the ailerons, elevator, and rudder. The aircraft has full aerobatic and spin capability with a g-load limitation of +6.67 and -2.67 g's. (A +4g limitation was imposed during a large percentage of the research program flights due to structural problems in the T-37 fleet.) Airspeeds for the aircraft are: takeoff at 90 knots; a maximum of 382 knots; a final approach speed of 100 knots; and a touchdown speed of 75-80 knots. Some of the noteworthy operational features the T-37 affords are excellent out-of-the-cockpit visibility, good handling characteristics, and high reliability.

b. Role of T-37 in UPT

The T-37 has proved to be a valuable training vehicle in Undergraduate Pilot Training (UPT). Introduced into the Air Force primary flying training program in 1957, UPT students fly the T-37 for approximately 90 hours. The performance and handling characteristics of the T-37 provide an excellent medium through which UPT students can progress from a low-performance and a simple-mission aircraft (T-41) to

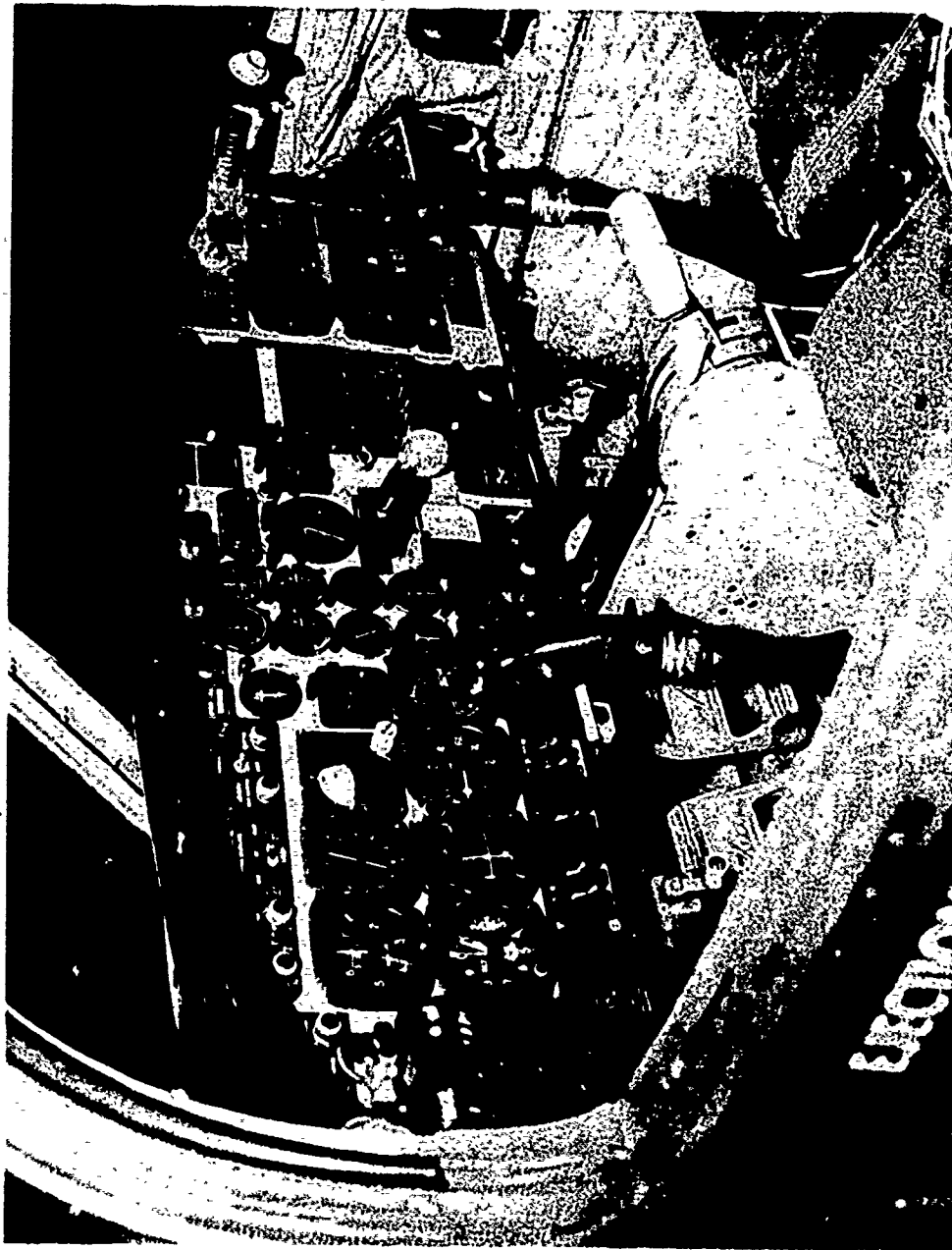

Figure 1. T-37 Cockpit

AFHRL-TR-72-6

a high-performance and more operationally oriented mission aircraft (T-38A).

Utilized principally for contact (VFR) flying training, basic instrument training, and some navigation and formation flying, the T-37 flying training curriculum outlines a total of 68 sorties (55 dual, 13 solo). The contact phase of the T-37, with which this research program was solely concerned, specifies that 42 sorties (29 dual, 13 solo) will be flown in 54.7 hours. The instructional units contained in the contact phase include: aircraft familiarization, fundamental maneuvers (stalls, spins, traffic pattern), supervised solo flights, area checkout, advanced (aerobatic) maneuvers, night flying, and check flights.

The role of the T-37 in UPT is presently undergoing minor revision through a reduction in emphasis and the number of flying hours in specific areas of the UPT curriculum.

c. Flight Test Support

In May 1968, the T-37 (948) was transferred to Wright-Patterson AFB, Ohio, and placed under the operational control of the Directorate of Flight Test of the Aeronautical Systems Division (currently designated the 4950th Test Wing). Flight Test responsibilities for supporting the aircraft and the research program included:

1. Assigning a Test Director to coordinate all Flight Test support agencies and AFHRL research requirements with regard to the instrumented aircraft.
2. Engineering design, installation, calibration, and maintenance of the data acquisition system.
3. Maintenance for the T-37 aircraft.
4. Providing a qualified test pilot and a scheduling service for the equipment calibration and data collection flights.

AFHRL-TR-72-6

5. Computer data reduction support by processing the one inch aircraft magnetic tape and producing a one-half inch IBM compatible tape.

6. Photographic documentation of the project.

7. Radar flight following during the missions.

2. AIRCRAFT INSTRUMENTATION

The T-37 948 was instrumented with a data acquisition system by Flight Test at Wright-Patterson AFB. This equipment installation was considered to be a Class II modification, which is a temporary change to the standard configuration of an aerospace vehicle that is essential to the successful accomplishment of research, development, test, and evaluation (RDT&E) program in compliance with AFR 80-14 and AFSCR 80-23. However, the Class II modification did not place any restrictions upon the operational capability of the aircraft with regard to IFR flight, aerobatic maneuvers, or other UPT training maneuvers. All engineering design, installation, maintenance, flight safety, and quality control functions were accomplished in the same manner as if the data acquisition system were a permanent installation in 948.

a. Recorded Parameters

Upon activation by the instructor pilot, the data acquisition system recorded pilot performance on 17 continuous and 7 discrete flight and engine parameters. An additional 8 parameters were obtained via computational techniques from the 24 recorded parameters. Table I provides (1) a listing of each of the 32 recorded and computed parameters, (2) the aircraft component or system from which the recorded values originated, (3) the sensor that converted the various forms of flight or engine data into the correlated changes in electrical output to the magnetic tape recorder, (4) the range of values for each recorded parameter, (5) sampling rate that the data was recorded, and (6) the resolution or sensitivity achieved.

TABLE I
PERFORMANCE PARAMETERS RECORDED BY THE DATA ACQUISITION SYSTEM

Parameter	Component	Sensor	Range	Record Rate	Resolution
1. Heading	J-4 Compass	Synchro-Follower	0-360°	10 per sec	± 1°
2. Altitude	Pitot-Static	Transducer	0-30,000 ft	10 per sec	± 166 ft
3. Airspeed	Pitot-Static	Transducer	0-350 kts	100 per sec	± 2 kts
4. Pitch Angle	ND-1 Gyro	Synchro-Follower	± 0-82°	100 per sec	± 1.5°
5. Roll Angle	ND-1 Gyro	Synchro-Follower	0-360°	100 per sec	± 1.5°
6. Acceleration (g force)		Accelerometer	-1 to +5 g	10 per sec	± 0.3 g
7. Pitch Rate		Rate Gyro	90° per sec	10 per sec	
8. Roll Rate		Rate Gyro	180° per sec	10 per sec	
9. Yaw Rate		Rate Gyro	70° per sec	10 per sec	
10. Longitudinal Stick Position	Elevator Cable	Potentiometer	-15 to +25°	100 per sec	
11. Lateral Stick Position	Left Aileron Cable	Potentiometer	± 16°	100 per sec	
12. Rudder Position	Rudder Cable	Potentiometer	± 24°	100 per sec	
13. Left RPM	Tach Generator	Frequency Converter	0-100%	10 per sec	-1% RPM
14. Right RPM	Tach Generator	Frequency Converter	0-100%	10 per sec	-1% RPM
15. Left Throttle Position	Throttle	Potentiometer	0-64°	10 per sec	
16. Right Throttle Position	Throttle	Potentiometer	0-64°	10 per sec	
17. Flaps		Potentiometer	0-100%	10 per sec	1%
18. Landing Gear		Switch	Up or Down	10 per sec	
19. Speed Brakes		Switch	In or Out	10 per sec	
20. Thrust Attenuator		Switch	In or Out	10 per sec	
21. Elevator Trim Tab-Up	Trim Tab Switch	Switch	On or Off	10 per sec	
22. Elevator Trim Tab-Down	Trim Tab Switch	Switch	On or Off	10 per sec	
23. Time		Clock	0-24 hrs	10 per sec	1 sec
24. Record Number		Counter	0-999	10 per sec	1
25. Vertical Velocity		Computed			
26. Pitch Rate		Computed			
27. Roll Rate		Computed			
28. Yaw Rate		Computed			
29. Turn Rate		Computed			
30. Longitudinal Stick Rate		Computed			
31. Lateral Stick Rate		Computed			
32. Rudder Rate		Computed			

Since the research program represented a study in feasibility throughout, the parameters selected for recording do not necessarily represent an optimum set to reflect in-flight pilot performance. Rather, the instrumented parameters signify an initial attempt, based on experience and intuitive judgment, at evolving a meaningful set of variables from which performance measures could be developed to assess actual pilot performance. To be precise, the parameters listed in Table I have previously undergone several iterations of analysis and modification. The effectiveness of these parameters with regard to the characteristics of reliability, validity, and sensitivity in recording in-flight pilot performance is contained in a later discussion that concludes Section II.

b. Sensor Systems

The selection of sensors for each of the recorded parameters was based on the estimated resolution requirements for conducting pilot performance measurement research. With the exception of the altitude, g, pitch rate, and roll rate parameters, those flight and engine measures have either equalled or exceeded the predetermined resolution requirements. It is necessary to point out at this time that some of the recorded parameters were discarded by the authors early in the development of performance measurement techniques as not being applicable to the maneuvers being investigated. Thus, the determination of the resolution achieved from these unessential parameters was not pursued.

The sensors and recording equipment were strictly off-the-shelf components that had proved to be reliable in previous Flight Test projects. Table II presents a description of the dimensions, weight, power requirements, and cost of the equipment installed in 948 that comprised the data acquisition system. The approximate physical location of the equipment installed in 948 is indicated in Figure 2.

TABLE II
 DESCRIPTIVE OF EQUIPMENT INSTALLED IN THE T-37 (948)

NOMENCLATURE	DIMENSIONS			WEIGHT (LBS)	ELECTRICAL POWER REQUIREMENTS				COST		
	L	W	H		DC VOLTS	AMPS	AC VOLTS	FREQ		VA	PH
Pulse Code Modulator	12.6	9.2	9.5	32	28	3	115	400	230	1	\$ 76,000
Tape Recorder	20	10	9	44	28	8					28,000
Signal Conditioning Unit	10	10	6	18	28	.5					1,000
Digital Recorder Control	6	5.5	5	1.5							750
Recorder Remote Control	6	5.5	5	1.5							500
Power Supply - Inverter	.5	4	5.5	3			115	400	100	1	200
Synchro Converter	4.5	3	5.5	3.5			115	400	115	1	200
Altitude Transducer	3.5	2.5	2.5	1							390
Airspeed Transducer	3.5	2.5	2.5	1							390
Vertical Gyro	11	6	6.5	10	28	4.5	115	400	330	1	900
Accelerometer	5	5	2	1	28	2					100
Frequency Converter (2)	12	6	10	2			115	400	100	1	800
Rate Gyro Unit	8	8	10	10			115	400		3	800
Phase Adapter	10	5	3	1			115	400		1	100
TOTALS				129.5							\$110,130

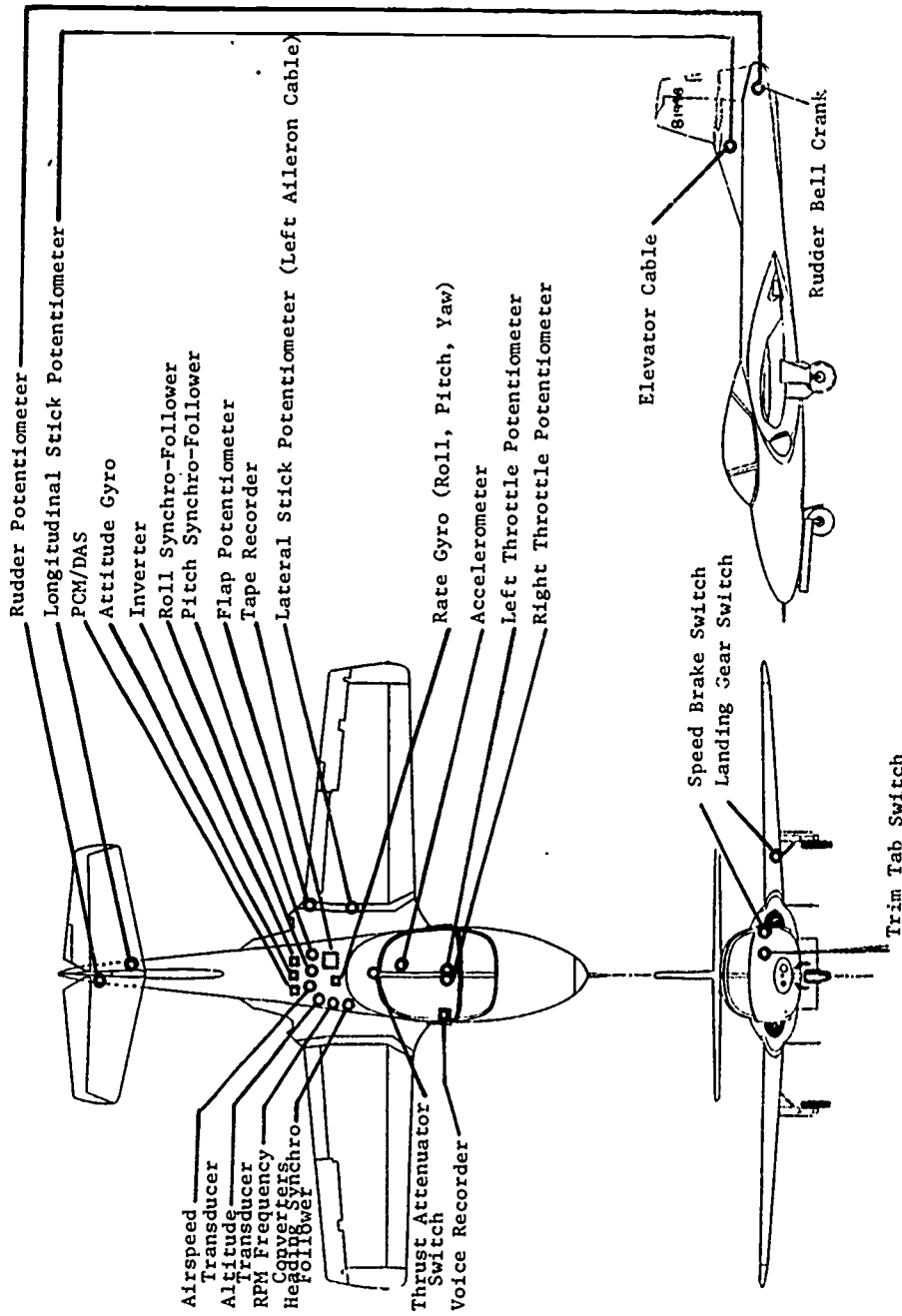

Figure 2. T-37 Instrumentation Diagram

The following is a cursory description of the recorded parameters including the components employed in the sensor systems and the displays provided to the pilot in the cockpit:

(1) Heading

The T-37B aircraft normally contains a J-2 slaved directional gyro system. However, due to excessive precession errors and a basic lack of responsiveness encountered during calibration flight tests when performing high pitch and bank angle maneuvers (e.g., lazy 8 and barrel roll), a J-4 compass system was substituted in 948. The J-4 system added the capability for (1) latitude correction, (2) a synchronizer switch to provide a normal means of orienting the gyro to the signals from the remote compass transmitter, and, most importantly, (3) a 15-second fast slave cycle that could be induced whenever the function selector switch was moved from the MAG (magnetic) to the DG (directional gyro) position and returned to MAG by the instructor pilot. A synchro-follower provided the signal output from the compass to the Pulse Code Modulation/Data Acquisition System (PCM/DAS). The heading system was excited by +5 volts DC over a range of 0-360° with approximately 0.0128 volts representing 1°. The effective resolution achieved was $\pm 1^\circ$ from the cockpit instrument, which consisted of a standard T-37 heading indicator with a fixed card and rotating needle. A heading set knob permitted the compass card to be rotated by the pilot.

(2) Altitude

A Model 7000 altitude transducer manufactured by Computer Instruments Corporation provided a signal output to the PCM/DAS for aircraft pressure altitude. The altitude transducer was linked directly with the normal aircraft pitot-static system. With a voltage output of +5 DC over a range of 0-30,000 ft, each 100 ft was represented by approximately 0.0150 volts. The effective resolution achieved with the parameter of altitude varied between 139 and 189 ft error on the data collection flights with a mean resolution of ± 166 ft. A standard three-pointer altimeter was located on the left side of the cockpit with which the transducer was correlated.

(3) Airspeed

The airspeed signal to the PCM/DAS was transmitted by a Model 7100 Computer Instruments Corporation airspeed transducer. Connected to the pitot-static system of the aircraft, the +5 volt DC transducer output covered 0 to 350 knots IAS with approximately 0.0118 volts representing 1 knot. The resolution achieved was a fairly constant error of +2 knots from the standard airspeed indicator on the left side of the cockpit.

(4) Pitch and Roll Angles

The T-37 has an attitude-indicating system consisting of a MD-1 vertical gyro and a MM-3 attitude indicator located on the left instrument panel. Due to the possibility of affecting the safe operation of this system by attaching a synchro-follower, a second MD-1 gyro was installed in 948 that provided a +5 volts DC output from the synchro-follower directly to the PCM/DAS. Within the pitch limitation of the gyro of $\pm 82^\circ$, an effective resolution of $\pm 1.5^\circ$ of the pitch angle as indicated on the MM-3 attitude indicator was achieved. Approximately 0.0144 volts represented 1° of pitch attitude. The roll angle parameter had a full 360° capability from the gyro and a resolution error of $\pm 1.5^\circ$ from the indicated bank angle. A voltage output of 0.0143 represented 1° roll angle.

(5) Acceleration (g Force)

Acceleration along the Z axis of the aircraft was sensed by a separate accelerometer that was installed in 948 and correlated in-flight with the standard g meter located in the center of the instrument panel. With a +5 volts DC output from the accelerometer to the PCM/DAS, approximately 0.140 volts represented 0.1g. An effective resolution of $\pm 0.3g$ was obtained with the parameter system.

AFHRL-TR-72-6.

(6) Pitch, Roll, and Yaw Rates

A single unit containing rate gyros for the pitch, roll, and yaw axes was installed and powered by 115 volt, 400 cycle, single phase AC. The outputs from the gyros were transmitted through a Signal Conditioning Unit to the PCM/DAS. Pitch rate was represented by approximately 0.0553 volts DC for 1° per second over a range of 0-90° per second. Roll rate was represented by approximately 0.0259 volts DC for 1° per second over a range of 0-180° per second. Yaw rate was represented by approximately 0.0680 volts DC for 1° per second over a range of 0-70° per second. The resolution achieved on these three parameters was not empirically ascertained because of the lack of a cockpit indication with which to compare the accuracy of the rate gyros in-flight.

(7) Longitudinal and Lateral Stick Position, Rudder Position

The pilot's movement of the aircraft control stick and rudder pedals was recorded by linking "pots" (potentiometers) to the elevator cable, left aileron cable, and rudder cable that produced a +5 volt DC signal to the PCM/DAS. The longitudinal stick position had a range of -15° for forward stick (elevator down) to +25° for aft stick (elevator up) with approximately 0.1238 volts representing 1° of elevator travel. The lateral stick position had a range of ±16° in which 0.1526 volts represented 1° of aileron travel. Rudder pedal input had a range of ±24° so that 0.1027 volts represented 1° of rudder travel.

(8) Engine RPM

The RPM of the left and right engines was recorded by linking frequency converters to the tach generators. Approximately 0.0500 volts represented 1% RPM for the left engine and 0.0400 volts for the right engine over a range of 0-100%. A somewhat constant resolution error of -1% RPM was achieved when compared with the two tachometers on the center instrument panel in the cockpit.

(9) Throttle Position

The left and right throttle positions were recorded by a +5 volt DC output from pots linked to the throttle. With a range of 0-64° from the CUTOFF position to 100% engine RPM, approximately 0.0689 volts represented 1° movement for the left throttle and 0.0659 for the right throttle.

(10) Flaps

The position of the wing flaps was recorded by a pot output of +5 volts DC that was linked to the flap indicator signal to the cockpit instrument. With a range of 0-100% (0-40°), 1% of flap movement was represented by approximately 0.0475 volts within 1% resolution.

(11) Landing Gear, Speed Brakes, Thrust Attenuator, Flapator Trim Tab Up and Down

The operations of these systems were recorded as discrete events by linking the switch signal directly to the PCM/DAS.

A complete listing of the calibration data for the recorded flight and engine parameters may be found in Appendix I.

c. Recording System

The actual recording of the parameter data transmitted by the various sensor systems was accomplished by two components, an analog-to-digital converter and a digital tape recorder.

(1) Analog-to-Digital Converter

A Pulse Code Modulation/Data Acquisition System (Model 101) manufactured by Brown Engineering Co. (Reference 2) converted the analog signals from the sensors to a digital format and transmitted the output to the magnetic tape recorder. The PCM/DAS possesses the functional capability of (1) accepting up to 30 analog signals varying between ± 5 volts, (2) sampling 6 of these analog signals at 100 times per second and the remaining 24 at 10 times per second, (3) converting these analog

AFHRL-TR-72-6

signals to a 10-bit digital representation plus a sign bit, (4) providing an output format containing 98 data words and 2 sync words per master frame (major cycle), and (5) generating a binary coded decimal (BCD) representation of the elapsed time in hours, minutes, and seconds from a stable time reference.

(2) Digital Tape Recorder

A 16-channel Leach tape recorder (Model MTR-3200) recorded the PCM/DAS digital signals on a 1-inch magnetic tape. Powered by +28 volts DC, the tape recorder was operated at a speed of 7-1/2 inches per second. The tape capacity of 3/4 mil and 2,400 feet loaded on an 8-inch reel provided 60 minutes of recording time. The recorder unit was located in a lower fuselage bay area with a remote control unit in the cockpit.

(3) Cockpit Recorder Control Panel

The acquisition of in-flight pilot performance data was controlled by the instructor pilot (in the right seat) through the operation of the magnetic tape recorder with the Recorder Control Panel. This control unit shown in Figure 3 was located between the ejection seats in an area formerly occupied by a map and data case. A description of the Recorder Control Panel switch functions (left to right and top to bottom) follows:

(1) MASTER SW (ON-OFF) - controls power to the entire data recording system.

(2) INVERTER

(a) red FAIL light - illuminates to signal inverter failure.

(b) ON-OFF switch - 115-volt, 400-cycle, single-phase AC power supply which provided 5 volts DC excitation for all the pots.

(3) COUNTER - three-digit counter that continuously codes record number on the tape.

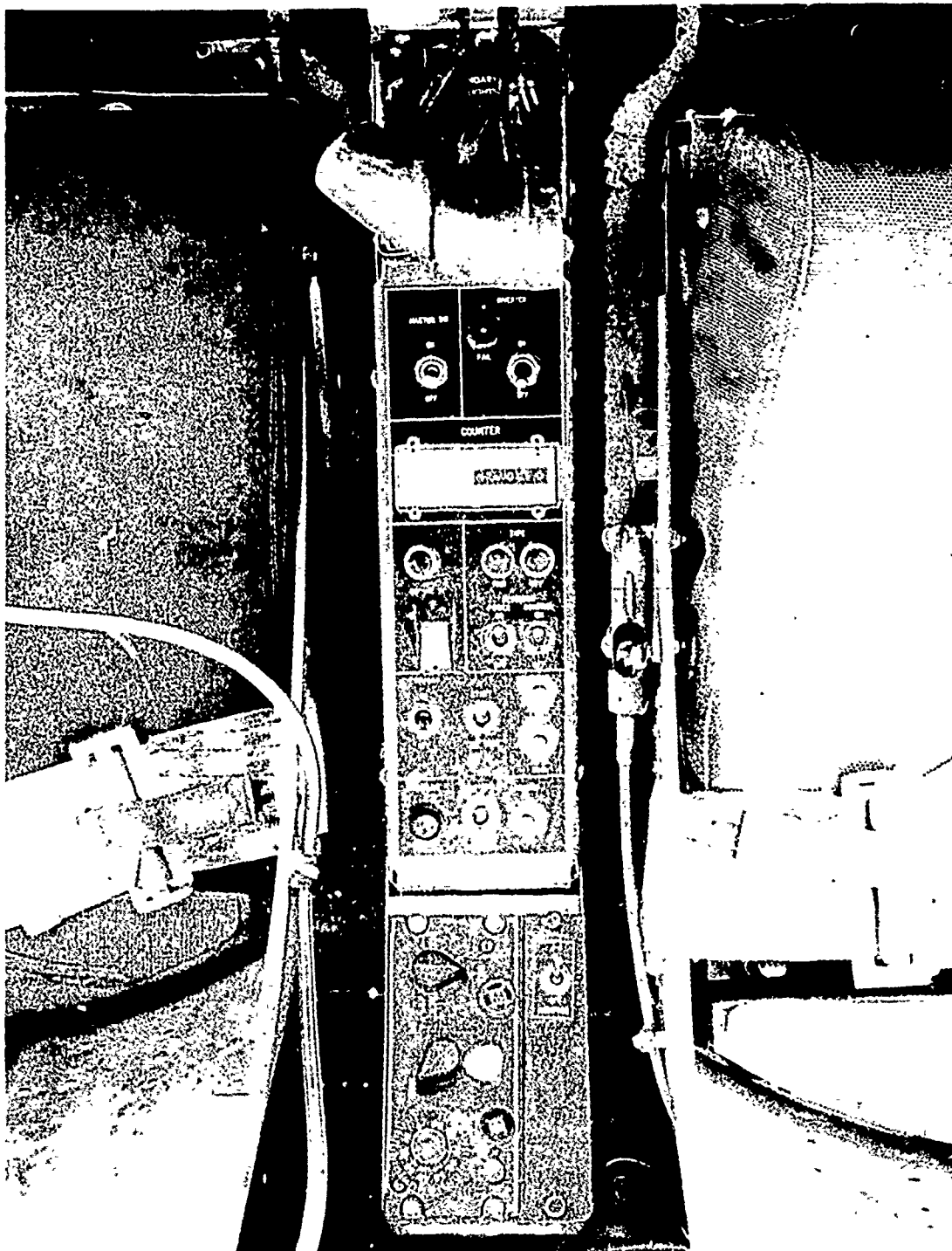

Figure 3. Recorder Control Panel

AFHRL-TR-72-6

(4) GROUND-TC-FLIGHT guarded switch.

(a) OFF (guard up) - permits local manual operation of recorder on the ground for purposes of checkout, tape loading, and maintenance.

(b) ON (guard down) - recorder in remote mode controlled only by adjacent RECORDER POWER and CONTROL switches.

(c) green light - illuminates when recorder is set for remote cockpit operation.

(5) TAPE RECORDER controls

(a) left amber light - illuminates when recorder is ready for data recording and extinguishes during tape operation.

(b) right amber light - illuminates when recorder is operating.

(c) POWER switch (ON-OFF) - provides 28-volt DC power to tape recorder.

(d) CONTROL switch (ON-OFF) - operates tape recorder for data acquisition purposes.

(6) PCM/DAS (ON-OFF) - provides 28-volt DC power to the Pulse Code Modulation/Data Acquisition System.

(7) TIME CODE switch

(a) START - inputs a continuous time signal to the tape.

(b) OFF position resets the clock to zero.

(8) PILOT EVENT button - permits momentary coding on tape of a significant event when depressed.

AFHRL-TR-72-6 .

- (9) AUTO. CAL. button - initiates an automatic 300-millisecond internal calibration program sequentially on each scoring parameter.
- (10) PCM/DAS POWER fuse - a 1-1/2 amp fuse protecting the system.
- (11) RECORD NO. - advances counter one number when depressed.

Just aft of the Recorder Control Panel is located the J-4 Compass System Control Panel which contains the following switch functions:

- (1) DEC/SET/INC Synchronizer Switch - permits manual slaving of the gyro to the signal from the remote compass transmitter by using the MAG annunciator window as a slaving reference.

- (2) DG/MAG Function Selector Switch

- (a) operates in a non-slaved mode by selecting the DG position.

- (b) operates as a slaved heading system in the MAG position by using the signals from the remote compass transmitter located in the left wing tip.

- (c) a 15-second fast slaving cycle is induced when the function selector switch is moved from the MAG to DG position and returned to MAG.

- (3) Latitude Correction Knob (LAT) - reduces the apparent precession caused by the higher latitudes when operating in a non-slaved mode.

A J-4 POWER switch was installed adjacent to the J-4 Control Panel to provide system power.

(4) Audio Tape Recorder

A Norelco portable audio tape recorder (Model 150) was utilized to record all interphone and UHF radio communications in the aircraft. The transistorized recorder operated on five 1.5 volt (C cell) batteries at a tape speed of 1-7/8 inches per second that provided 30 minutes' recording time on each side of the C-60 cartridge. A holder was installed on the right sidewall of 948 (see Figure 1) in which the recorder was placed during the flight. A "Y" cord was locally fabricated that would interface between the normal aircraft interphone jack and the tape recorder.

(5) System Effectiveness

The effectiveness of the data acquisition system must ultimately be evaluated in terms of the capability it provided in the development of measurement methods and the quantitative assessment of in-flight pilot performance. This system effectiveness is directly related to the three fundamental requirements of an objective pilot performance measurement system - reliability, validity, and sensitivity.

The data acquisition system overall provided a degree of reliability that was considerably better than was originally expected. Many of the problems encountered early in the program during the calibration flights were corrected by modifications and improvements to the sensor systems and power supply. The subsequent data collection flights conducted at Williams AFB, Arizona, with students and instructors were virtually unhampered by equipment failure in the instrumentation package. The Leach magnetic tape recorder did cause some difficulty occasionally that was usually corrected by cleaning the tape head. At one point in the student data collection phase, the tape recorder had to be returned to the manufacturer's facility for overhaul.

A rather serious problem was experienced throughout the entire Pilot Performance Measurement Program with the heading parameter. As stated earlier, a J-4 compass system was substituted for the normal J-2

system in the T-37 due to excessive precession errors with the original system. This change was quite valuable since the J-4 system proved to be more stable and any precession encountered during the flight could be quickly eliminated by manually inducing the fast slave cycle between recorded maneuvers. However, inherent limitations of the heading sensor system with the synchro-follower permitted the accurate recording of heading ($\pm 1^\circ$) only in the southeast, southwest, and northwest quadrants, or specifically between 090 and 360°. Anytime the aircraft turned to the northeast (360-090°), the recorded data was erroneous. This heading restriction could be compensated for somewhat by performing the maneuvers on southern and westerly headings. Unfortunately this was not always possible due to the constraints imposed upon the aircraft operations by the ATC airspace requirements. Although the parameter of aircraft heading was the primary reference variable in the lazy 8 maneuver, the lack of full 360° recording capability inhibited the development of performance measures and forced the authors to eliminate it as a measurement variable.

The sensitivity achieved from altitude was somewhat less than the predetermined requirement of 50 ft, but the actual altitude error of ± 166 ft was still sufficiently accurate to permit meaningful measurement research on the lazy 8 and barrell roll maneuvers. However, for other types of maneuvers, such as the 360° overhead traffic pattern, the altitude error would have to be reduced considerably before appropriate performance measures could be developed. The altitude error encountered appeared to vary to some extent from one day to the next, perhaps as a function of temperature or humidity. Generally the altitude recorded from the surface of 5500 ft was less than the actual mean sea level altitude of the aircraft. At approximately 5500 ft, a crossover occurred such that the recorded altitude became greater than the actual altitude of the aircraft (positive error), and the error increased slowly but progressively as a function of increasing altitude. The altitudes between 2500 and 8500 ft resulted in the most accurate data on aircraft altitude.

AFHRL-TR-72-6

Initially, it appeared the gyro limitation of $\pm 82^\circ$ would pose a problem for the accurate recording of pitch angle; but, subsequent student data collection flights revealed the maximum pitch angle for the two primary maneuvers of interest did not exceed 70° . Thus, the attitude gyro was quite satisfactory regarding the range of values sensed as well as the $\pm 1.5^\circ$ resolution from the indicated pitch and roll angle. In the over-the-top maneuver such as loop, clover-leaf, Immelmann, etc., the vertical limitation of 82° affected the capability to accurately reconstruct the actual maneuver. Of course, the 360° roll capability of the MD-1 gyro and a resolution of $\pm 1.5^\circ$ bank angle provided accurate performance data on that parameter irrespective of the maneuver performed. It was possible to experience some degradation in the accuracy of pitch and roll data whenever insufficient time was allocated between maneuvers with large pitch and roll excursions. An attitude fast erection system switch on the instrument panel could be activated within certain operational limitations by the pilot whenever the attitude indicator was precessed excessively.

The parameters of acceleration (g force), pitch rate, roll rate, and yaw rate were quite adversely affected by turbulence and gust loads. Large spikes in the data indicated the sensor systems of these four parameters were too sensitive for accurate recording of in-flight data.

With respect to the validity of the in-flight pilot performance data, the basic philosophy adopted was that the recorded values should correlate as closely as possible with the values displayed on the respective cockpit flight or engine instrument from which the pilot derived his information. Thus, there was less concern regarding a minimal error existing between the actual parameter value and instrument reading than any error encountered between the instrument reading and recorded value. However, the cockpit instruments of the more significant parameters (e.g., heading, altitude, and airspeed) were calibrated by bench checks, tower fly-bys, and pacer aircraft flights to ascertain their real-world accuracy and the extent of inherent errors existing that affect the instrument indications such as mechanical error,

AFHRL-TR-72-6

scale error, installation/position error, reversal error, and hysteresis error.

SECTION III
GROUND-BASED DATA CALIBRATION SYSTEM

1. OVERVIEW

Considerable data processing and logistics effort was required to convert the recorded flight data into a form suitable for research and analysis. The physical characteristics of the flight recorder tape made it incompatible with the data processing equipment available for extensive data analysis. This necessitated an initial conversion of the data to IBM-compatible tape. The operating system characteristics of the data processing installation supporting the study made necessary a reformatting of data prior to calibration. Also, the quantity of data involved necessitated the development and rigid adherence to an extensive data-cataloging system.

While these requirements are not necessarily unique to this particular study, they were complicated by the fact that different sources had to be used for various portions of the data processing effort. The initial conversion of the data to IBM-compatible tape was accomplished by the ASD Flight Test Data Reduction Branch, whereas all subsequent data processing work was done by the ASD Computing and Information Systems Branch using different equipment. Among other things, this amplified problems inherent in reading and writing magnetic tape. In addition, data analysis requirements, as anticipated, varied as the research progressed, and several different programmers were subsequently involved. This resulted in more data-passes than desired and, to enhance reliability and simplify data handling, necessitated the transfer of individual flight maneuvers data to cards. Figure 4 illustrates the general flow of data and the order in which various processing and research tasks were accomplished.

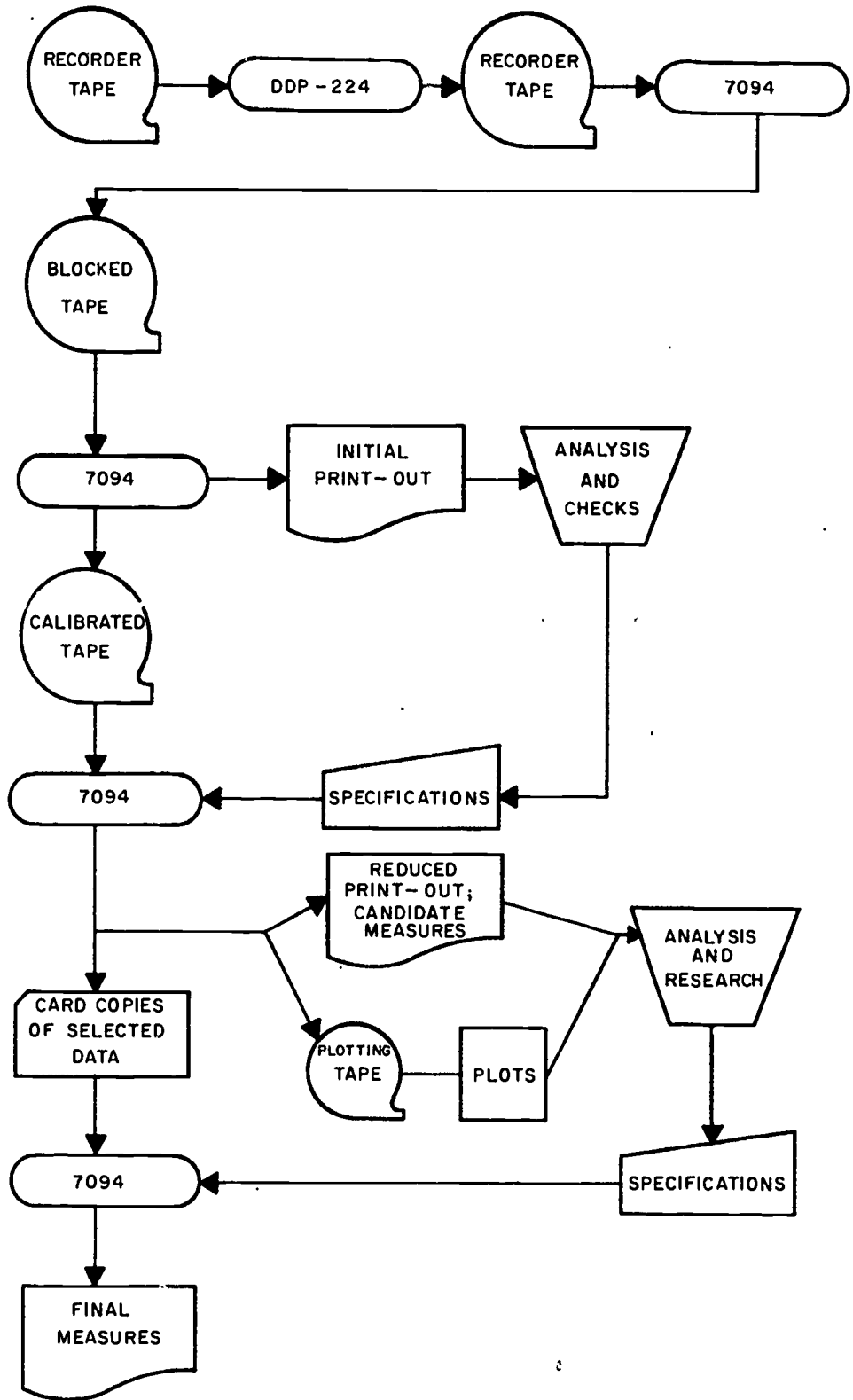

Figure 4. Flight Data Processing Flow

AFHRL-TR-72-6

2. TAPE FORMAT CONVERSION

a. Recorder Tape

The flight data, as it appears on the recorder tape, consists of successive frames of 100 words each. The 1st and 100th words of each frame are sync words, the 2nd through 97th words are data words, and the 98th and 99th are time words.

The tape is 1 inch wide and has 16 tracks (14 recorded). Figure 5 illustrates the information format and the order of the recorded variables stored repeatedly in each 100-word frame. Each frame represents 0.1 seconds of data. Since the recording speed of the tape is 7.5 inches per second, the data density on the tape is 133 bits per inch (BPI) per track.

The recorder tape is read on an Ampex FR-1200 recorder-reproducer, processed through a DDP-24 system, and written on 1/2 inch processor tape.

b. Processor Tape

As it appears on the processor-tape, the flight data are formatted in 1230-word records, each word of which has a parity bit (bit 1), sign bit (bit 2), and ten magnitude bits (bits 3-12). There are 12 frames of 100 words apiece, each preceded by 2 frame-delineation words (7777_8 , 7777_8). The first two words of each record are the record number, and the last four words contain all zeros. The record length of 1230 12-bit words makes it possible to convert each record into 410 36-bit words for compatibility with the IBM 7094. The processor tape density is 556 bits per inch (BPI).

c. Blocked Tape

All operations on the data subsequent to the conversion from recorder to processor tape were accomplished using a 7094/7044 Direct Coupled Computing System (DCS). In the DCS, the IBM 7044 computer processes all input/output, and the system requires that magnetic tape

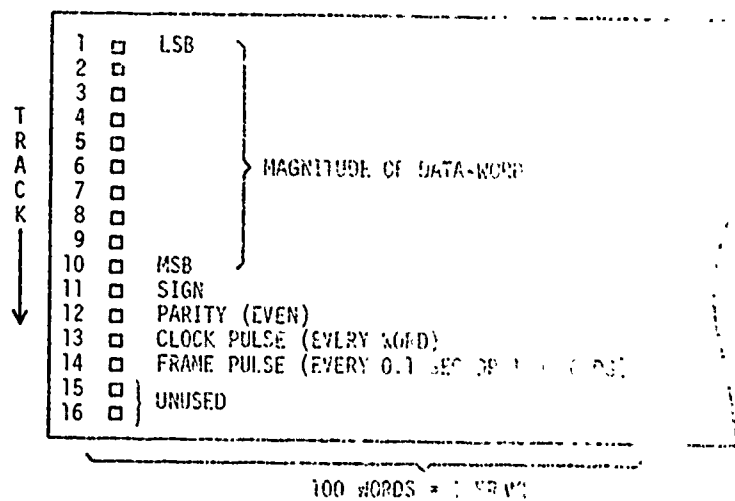

WORD	VARIABLE	WORD	DESCRIPTION
1	Sync	42	...
2-7	100/Sec Words	43	...
	Pitch, Roll, Long.	44	...
	Stick Position, Lat.	45	...
	Stick Position.	46	...
	Rudder Position.	47	...
	Airspeed	52-57	100/Sec Words
8	Thrust Attenuator		...
9-11	None	58	Left RPP
12-17	100/Sec Words	60	PP RPP
18	Roll Rate	61	Pitch Rate
19-21	None	62-67	100/Sec Words
22-27	100/Sec Words	68	Count Airspeed
28	None	69-71	None
29	Trim Tab Up	72-77	100/Sec Words
30	Trim Tab Down	78-81	Time
31	None	82-87	100/Sec Words
32-37	100/Sec Words	88-91	None
38	Altitude	92-97	100/Sec Words
39	Heading	98-99	...
40	Yaw Rate	100	sync
41	Acceleration (g Force)		

Figure 5. Flight Record Format

AFHRL-TR-72-6

input be blocked into successive 460-word records. Therefore, a blocked tape had to be prepared from each processor tape prior to beginning calibration and other computations.

To generate the blocked tape, the 12-bit words on the processor tape were picked up three at a time to form 36-bit 7094-compatible words. These words were written onto the blocked tape in binary records of 460 36-bit words at a density of 800 BPI.

3. CALIBRATION

a. Calibration Data and Procedures

Calibration of the flight data required a conversion of each recorded digital number to volts, then a conversion from volts to parameter values. For the conversion to volts, the following formula was applied:

$$\text{Volts} = 0.0051281 (\text{recorded number}) - 0.1256$$

This formula was derived from data published in a Brown Engineering manual (Reference 2).

For conversion from volts to parameter values, calibration data derived by instrumentation personnel were used. An attempt was made to curve-fit the calibration data using (1) a single linear fit for each set of calibration data as well as (2) a quadratic fit. The fits were evaluated by a comparison with data obtained through linear interpolation. Considering the magnitude of the errors obtained with either type of curve fit (see Table III) and considering the likely (and eventually all too true) requirement of frequent alterations to the calibration data, it was decided that linear interpolation must be used.

TABLE III
 ERRORS OBSERVED IN TRIAL ATTEMPT TO CURVE-FIT
 CALIBRATION DATA

Word	Maximum Error		Units
	Quadratic fit	Linear fit	
Pitch	1.47	1.69	Deg
Roll	.61	.58	Deg
Stick Pos. (Long.)	.48	1.54	Deg
Stick Pos. (Lat.)	.82	.87	Deg
Rudder Pos.	1.25	1.61	Deg
Airspeed	6.47	11.02	Knots
Roll Rate	2.04	23.80	Deg/Sec
Altitude	31.48	1972.07	Ft
Yaw Rate	15.45	15.45	Deg/Sec
Acceleration	.62	.64	g's
Flap Pos.	2.58	4.95	Percent
Throttle (LH)	1.12	.99	Deg
Throttle (RH)	1.93	2.27	Deg
RPM (LH)	.14	.34	Percent
RPM (RH)	.53	.52	Percent
Pitch Rate	6.73	6.89	Deg/Sec

Appendix I shows the calibration data and calibration block diagram for all recorded variables except (1) discrete variables, (2) event number, and (3) time. The calibration data were stored on cards to simplify updating and were read into the 7094 and interpolated linearly to effect the calibration. Discrete variables were converted to 1 if volts were greater than or equal to 2.5, and to 0 otherwise. No calibration was required for the event number. Time is recorded on the flight tape as a type of BCD quantity and required special treatment for conversion to hours, minutes, and seconds. As recorded, time consumes two 12-bit words, with individual bits therein weighted BCD as follows:

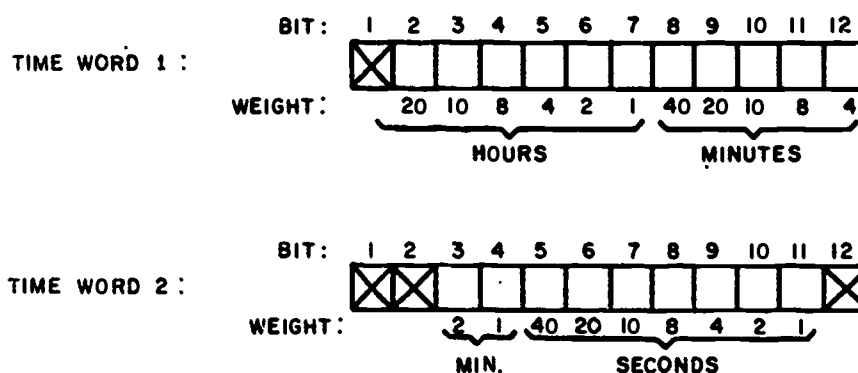

During the calibration run, time was converted to seconds by appropriately adding products of weights and bits as indicated above, multiplying the result by 60, in the case of minutes, and 3600, in the case of hours, and summing.

b. Computed Variables

Some additional variables were computed from the recorded flight data at the time of data calibration. The computed variables are summarized in Table IV. The first five variables in the table were computed because they were believed to be potentially useful in measurement. Pitch, roll, and yaw angles were computed solely as a check on the recorded pitch and roll values and the recorded body-axis rates. Time was computed as a check on the recorded time and the sampling frequency.

TABLE IV
COMPUTED FLIGHT VARIABLES

<u>Variable</u>	<u>Computed From</u>	<u>Using</u>
1. Vertical Velocity	Altitude	Numerical Differentiation
2. Longitudinal Stick Rate	Longitudinal Stick Position	
3. Turn Rate	Heading	
4. Lateral Stick Rate	Lateral Stick Position	
5. Rudder Rate	Rudder Position	
6. Pitch	Pitch Rate	Euler Angles & Numerical Integration
7. Roll	Roll Rate	
8. Yaw	Yaw Rate	
9. Time	Recording Frequency	Cumulative Summation

Unfortunately, little use could be made of any of the computed variables with the exception of time. The primary reason was because spurious "glitches" in the data destroyed computational continuity. In addition, numerical differentiation amplified all noise and thereby rendered the variables computed useless. Some experiments with other methods of computation were attempted. However, the importance and urgency of other problems to be contended with and the main research to be conducted quickly forced abandonment of the computation of additional variables during calibration. It was decided that such computations, if required, should be attempted only after smoothing of the data.

c. Calibrated Tape Format

As recorded on the calibrated tape, each data word is an IBM 7094 36-bit floating point binary word, with a sign bit (bit zero), 8-bit exponent field (bits 1-8), and 27-bit mantissa (bits 9-35). The data are recorded on 1/2 inch, 7-channel magnetic tape at a density of 800 BPI. Record length is 460 words, with words 1, 2, and 460 used as control words meaningful only in connection with the 7094/7044 DCS.

The data are placed on the tape in successive groups, each group representing all data for 1.2 seconds of real time. The order of the data as it appears on the tape is illustrated in Table V. All data recorded at a sampling rate of 100 per second appear first, e.g., the first 1.2 seconds of pitch data, or 120 samples of pitch, appear first, followed by each of the remaining 100 per second sampled variables. Data recorded at 10 per second follows. The tape format is illustrated in Figure 6.

d. Tape Capacity

Each binary data word consumes 36 bits or 6 frames on the tape. At a recording density of 800 BPI, this is equivalent to 6/800 inches of tape per word. There are 9 words recorded at 100 per second and 25 words at 10 per second, for a total of 1150 words per second, or 1380 words in 1.2 seconds. At 460 words per record, there are about

TABLE V

ORDER OF T-37 AIRCRAFT VARIABLES ON CALIBRATED TAPE

Variable	Units	No. of Consecutive Samples in 1.2 Seconds
1. Pitch	Deg	120
2. Roll	Deg	↓
3. Long. Stick Pos.	Deg	
4. Lat. Stick Pos.	Deg	
5. Rudder Position	Deg	
6. Airspeed	Knots	
7. Long. Stick Rate	Deg/Sec	
8. Lat. Stick Rate	Deg/Sec	
9. Rudder Rate	Deg/Sec	
10. Thrust Attenuator	Discrete	
11. Roll Rate	Deg/Sec	
12. Trim Tab Up	Discrete	↓
13. Trim Tab Down	Discrete	
14. Altitude	Ft	
15. Heading	Deg	
16. Yaw Rate	Deg/Sec	
17. Acceleration	g's	
18. Flap Position	Percent	
19. Speed Brakes	Discrete	
20. Landing Gear	Discrete	
21. Throttle Pos. (L)	Deg	
22. Throttle Pos. (R)	Deg	
23. RPM (L)	Percent	
24. RPM (R)	Percent	
25. Pitch Rate	Deg/Sec	
26. Event Number	-----	
27. Time	Sec	
28. Roll-Computed	Deg	
29. Vertical Velocity	Ft/Sec	
30. Rate of Turn	Deg/Sec	
31. Yaw	Deg	
32. Pitch-Computed	Deg	12
33. Time-Computed	Sec	

AFHRL-TR-72-6

3 records per 1.2 seconds of data. Therefore, for each 1.2 seconds (3 records) of data, we require

$$\frac{6}{800}(1380) + 3(\text{IRG}) = 10.35 + 2.25 = 12.6 \text{ inches of tape,}$$

where IRG = 3/4 inches = length of inter-record gap. With 2350 feet of tape (standard reel, allowing for leader and trailer), it is possible to store

$$\frac{12(2350)}{12.6} (1.2) = 2686 \text{ seconds}$$

worth of data, or about 45 minutes. Normally, this resulted in two calibrated tapes per flight.

e. Print-Out Format

During the calibration run, an initial print-out of the data at one sample per second is produced. This print-out is used for quick checks of the system (i.e., verification of revised calibration data, guarantee that total recording system is operating accurately, etc.) and preliminary measurement research. The data are printed in columns using three pages to represent 50 seconds of data.

An illustration of the print-out format is provided in Appendix II. Recorded time is printed in the left-most column of all pages. Page 1 (of every 3 pages) is used to present all variables normally associated with movement about the lateral axis of the aircraft. Page 2 presents variables associated with movement about the longitudinal or vertical axes. Page 3 presents engine and discrete variables, the event number, computed time, and a record number.

f. Calibration Software

The calibration programs are listed in Appendix III. A main program and seven subroutines were developed to (a) calibrate the data; (b) write the calibrated data on magnetic tape; and (c) print the

AFHRL-TR-72-6

calibrated data at one sample per second. The program's approximate number of statements (including comments and data), and main function of each are as follows:

<u>PROGRAM</u>	<u>LANGUAGE</u>	<u>STATEMENTS</u>	<u>FUNCTION</u>
Main	Fortran	108	Control program
Cyclex	Fortran	60	Extract, calibrate, and store data in 100-word blocks
Calbrt	Fortran	41	
Aitken	Fortran	114	
Stores	Fortran	19	Array-storage
Selecx	Fortran	54	Arrays data for printout and calls print when page is full
Prints	Fortran	40	Prints data, 1/sec
Xtratc	Map	87	Tape handling
IOCS	Map	171	
Units	Map	17	
TOTAL:		711	Routines

SECTION IV
SAMPLING RATE STUDY

1. INTRODUCTION

At the onset of this study, a decision had to be made regarding the in-flight sampling rate which would be adequate for purposes of performance measurement. Error in one direction would result in redundant data, contributing to the already difficult problem of data handling. Error in the opposite direction would result in a lack of sufficient data to accomplish the research.

The popular existing approach to determining required sampling rates is to base the decision on sampling theory, which relates the worst case natural frequency of the aircraft to the sampling rate that effectively allows the entire "waveform" to be reproduced. This approach has been employed for years in the area of flight simulation. However, it is conceivable that such an approach would only guarantee the sufficiency, not the necessity, of the amount of data to be recorded. This is particularly true in light of the present intended use of the data, i.e., performance measurement of selected flight maneuvers.

For lack of better guidelines, the sufficiency of 10 and 100 times-per-second sampling rates was intuitively assumed for launching the present study. An investigation of the necessity for such rates for those flight variables relevant to measurement on each flight maneuver is required, however, before specification of an optimal recording system can be made. In support of this, an initial sampling rate study was conducted, the primary purpose being to establish a methodology for such investigations.

2. APPROACH

a. Discussion

The recorded data were sampled at a number of different sampling intervals (e.g., every 0.05 seconds, every 0.01 seconds, etc.). For each test run, or each sampling interval used, tests were made to determine the errors that would result from generating the between-sampling-interval data from the sample-points using linear interpolation. In other words, the question addressed was, "If the only data available were those values sampled at an interval of n seconds, and intermediate data were then generated using those sampled values, what errors could be expected in the generated data?" Figure 7 illustrates this concept.

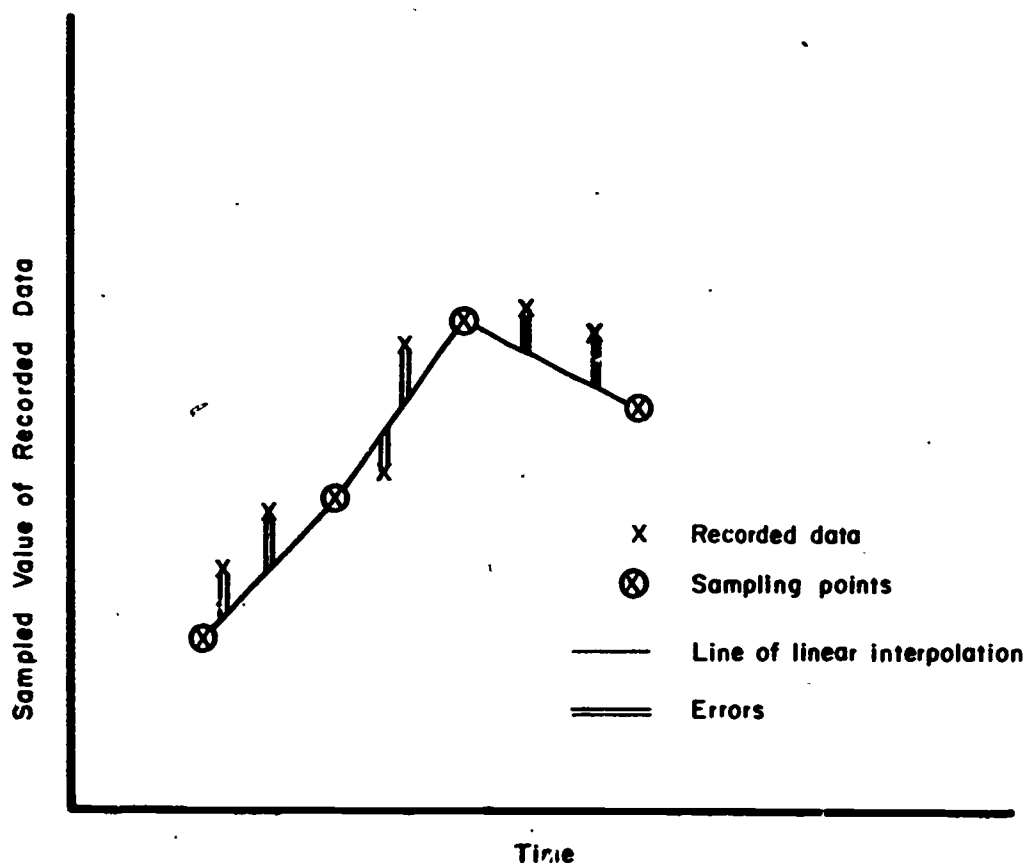

Figure 7. Nature of Error Computation for Sampling Rate Study

As a test case for the study, pitch angle was examined during the performance of (a) 46 lazy 8 maneuvers and (b) 44 barrel roll maneuvers. Pitch was recorded in-flight at a sampling interval 0.01 seconds. Sampling intervals of 0.05, 0.10, 0.50, 1, 2, 3, 4, and 10 seconds were tested. An error distribution (histogram) for each maneuver and each sampling interval was then constructed.

b. Software

Appendix IV presents the FORTRAN program listings of routines used in the experiment. Portions of a typical print-out are presented in Figure 8. In Figure 8a, the first seven columns present (1) the event number (ENVO) of the maneuver; (2) sampling rate tested; (3) the total number of points comprising the maneuver as recorded on tape; (4) the "resolution" error (RES) tested, which was the tolerance within which an error was not counted and beyond which it was counted (RES set to zero for this application); (5) the number of times a tested point produced an error which exceeded RES; (6) the worst error (one with largest magnitude) encountered; and (7) the time into the maneuver (seconds) at which the worst error occurred. The remaining twelve columns present the number of errors whose absolute value lay in the range indicated at the top of the respective column.

Figure 8b summarizes the data in terms of fractional parts. The 3rd column presents the part of all samples tested in which any error was detected. Subsequent columns present the part of all samples-in-error in which error magnitudes fell in the indicated range.

Since the two types of maneuvers to be examined were intermixed on several different tapes, it was most expedient to compute the summary of all data by hand, following the several necessary computer runs. Each computer run produced results as shown in Figure 8 for all lazy 8's and barrel rolls on one tape, plus additional computations which aided the hand-summarization (by maneuver) of all data.

SAMPLING ANALYSIS FOR FLIGHT CF 12-17-69

VAR IS PITCH

EVMN	RATE	SAMP	NO.	EXCD.	EPP	TIMES	WPRST	TIME												
								0-0.5	0.5-1.	1-1.5	1.5-2.	2-2.5	2.5-3	3-3.5	3.5-4	4-5	5-10	10-20	GR-20	
19.	0.75	4680	0.	024.	1.099	31.55	1988.	63.	0.	0.	0.	0.	0.	0.	0.	0.	0.	0.	0.	0.
19.	0.17	4680	0.	3016.	1.216	30.59	2537.	70.	0.	0.	0.	0.	0.	0.	0.	0.	0.	0.	0.	0.
19.	0.57	4680	0.	4168.	1.425	30.59	3529.	217.	0.	0.	0.	0.	0.	0.	0.	0.	0.	0.	0.	0.
19.	1.07	4680	0.	4477.	1.434	31.59	4558.	359.	0.	0.	0.	0.	0.	0.	0.	0.	0.	0.	0.	0.
19.	2.07	4680	0.	4397.	2.364	32.93	2570.	462.	148.	35.	0.	0.	0.	0.	0.	0.	0.	0.	0.	0.
19.	3.07	4680	0.	4797.	4.560	34.73	2420.	828.	423.	181.	162.	113.	37.	41.	178.	0.	0.	0.	0.	0.
19.	4.07	4680	0.	4378.	6.859	33.77	1766.	1099.	479.	199.	257.	192.	49.	60.	184.	243.	0.	0.	0.	0.
19.	10.07	4680	0.	3092.	32.889	34.73	339.	300.	313.	260.	91.	68.	59.	42.	179.	871.	574.	897.	0.	0.
20.	0.05	9600	0.	3842.	2.172	25.99	3763.	75.	1.	0.	0.	0.	0.	1.	0.	0.	0.	0.	0.	0.
20.	0.10	9600	0.	5927.	3.748	25.99	5830.	84.	2.	1.	0.	0.	0.	1.	0.	0.	0.	0.	0.	0.
20.	0.50	9600	0.	8468.	2.523	34.07	8295.	227.	17.	9.	5.	1.	0.	0.	0.	0.	0.	0.	0.	0.
20.	1.00	9600	0.	9114.	2.547	35.17	8747.	308.	26.	23.	11.	0.	0.	0.	0.	0.	0.	0.	0.	0.
20.	2.00	9600	0.	9554.	4.046	31.05	7389.	1691.	294.	32.	29.	23.	23.	22.	1.	0.	0.	0.	0.	0.
20.	3.00	9600	0.	9365.	4.605	26.21	5777.	1709.	819.	445.	363.	92.	54.	57.	49.	0.	0.	0.	0.	0.
20.	4.00	9600	0.	9363.	4.948	22.19	4028.	1871.	1256.	710.	497.	340.	142.	206.	323.	0.	0.	0.	0.	0.
20.	10.00	9600	0.	8987.	12.056	55.21	1453.	1142.	1185.	807.	665.	380.	193.	188.	493.	1354.	1122.	0.	0.	0.
21.	0.05	9600	0.	3579.	1.726	25.99	3504.	74.	1.	0.	0.	0.	0.	0.	0.	0.	0.	0.	0.	0.
21.	0.10	9600	0.	5758.	1.216	26.99	5682.	74.	0.	0.	0.	0.	0.	0.	0.	0.	0.	0.	0.	0.
21.	0.50	9600	0.	8406.	1.093	25.79	8649.	353.	5.	0.	0.	0.	0.	0.	0.	0.	0.	0.	0.	0.
21.	1.00	9600	0.	4695.	1.196	26.99	8162.	522.	15.	0.	0.	0.	0.	0.	0.	0.	0.	0.	0.	0.
21.	2.00	9600	0.	8910.	1.675	59.15	7670.	1774.	107.	9.	0.	0.	0.	0.	0.	0.	0.	0.	0.	0.
21.	3.00	9600	0.	8960.	2.563	19.31	5113.	2002.	1125.	506.	193.	11.	0.	0.	0.	0.	0.	0.	0.	0.
21.	4.00	9600	0.	8756.	3.872	18.03	4550.	1575.	955.	921.	725.	358.	180.	42.	0.	0.	0.	0.	0.	0.
21.	10.00	9600	0.	8082.	17.584	55.35	1770.	1077.	682.	467.	582.	259.	268.	275.	580.	2007.	1085.	0.	0.	0.

EVMN	DEL	CT	%	LE 0.5	LE 1.	LE 1.5	LE 2.	LE 2.5	LE 3.	LE 3.5	LE 4.	LE 5.	LE 10	LE 20	LE INF
19.	0.10	0.6	0.576	0.559	1.000	1.000	1.000	1.000	1.000	1.000	1.000	1.000	1.000	1.000	1.000
19.	0.50	0.9	0.944	0.957	1.000	1.000	1.000	1.000	1.000	1.000	1.000	1.000	1.000	1.000	1.000
19.	1.00	1.0	0.515	0.556	1.000	1.000	1.000	1.000	1.000	1.000	1.000	1.000	1.000	1.000	1.000
19.	2.00	0.9	0.675	0.583	0.558	0.992	1.000	1.000	1.000	1.000	1.000	1.000	1.000	1.000	1.000
19.	3.00	0.9	0.564	0.757	0.655	0.897	0.930	0.957	0.965	0.975	1.000	1.000	1.000	1.000	1.000
19.	4.00	0.9	0.390	0.641	0.750	0.796	0.854	0.878	0.899	0.902	0.944	1.000	1.000	1.000	1.000
19.	10.00	0.9	0.585	0.140	0.238	0.303	0.326	0.343	0.358	0.368	0.413	0.632	0.775	1.000	1.000
20.	0.05	0.4	0.579	0.599	0.595	1.000	1.000	1.000	1.000	1.000	1.000	1.000	1.000	1.000	1.000
20.	0.10	0.6	0.584	0.599	0.595	0.999	0.999	0.999	1.000	1.000	1.000	1.000	1.000	1.000	1.000
20.	0.50	0.9	0.569	0.996	0.999	1.000	1.000	1.000	1.000	1.000	1.000	1.000	1.000	1.000	1.000
20.	1.00	0.9	0.560	0.553	0.556	0.990	1.000	1.000	1.000	1.000	1.000	1.000	1.000	1.000	1.000
20.	2.00	1.0	0.777	0.555	0.586	0.990	0.993	0.995	0.998	1.000	1.000	1.000	1.000	1.000	1.000
20.	3.00	1.0	0.617	0.759	0.587	0.334	0.973	0.983	0.989	0.995	1.000	1.000	1.000	1.000	1.000
20.	4.00	1.0	0.430	0.625	0.763	0.839	0.892	0.928	0.944	0.966	0.966	1.000	1.000	1.000	1.000
20.	10.00	0.9	0.162	0.289	0.421	0.511	0.585	0.627	0.649	0.669	0.724	0.875	1.000	1.000	1.000
21.	0.05	0.4	0.575	1.000	1.000	1.000	1.000	1.000	1.000	1.000	1.000	1.000	1.000	1.000	1.000
21.	0.10	0.6	0.587	1.000	1.000	1.000	1.000	1.000	1.000	1.000	1.000	1.000	1.000	1.000	1.000
21.	0.50	0.9	0.557	0.999	1.000	1.000	1.000	1.000	1.000	1.000	1.000	1.000	1.000	1.000	1.000
21.	1.00	1.0	0.538	1.000	1.000	1.000	1.000	1.000	1.000	1.000	1.000	1.000	1.000	1.000	1.000
21.	2.00	1.0	0.788	0.557	0.555	1.000	1.000	1.000	1.000	1.000	1.000	1.000	1.000	1.000	1.000

Figure 8. Sample Print-Out for Sampling Rate Study

3. RESULTS

Table VI summarizes the results obtained for the lazy 8 and barrel roll pitch-angle sampling rate study. The heavy line indicates the boundary which delineates the point in the error distribution where an asymptote is apparently reached. (The results must be interpreted in terms of this asymptote rather than solely in terms of the number of errors within certain bounds because of the existence of data spurs, or glitches.

Table VI suggests that for the lazy 8, little would be gained using a sampling interval smaller than 1.0 seconds. Increasing the interval from 1.0 to 2.0 would effectively double the worst-case error. For the barrel roll, an interval smaller than 0.10 seconds would apparently be unnecessary. A slight increase in worst-case error would be experienced in a sampling-interval increase from 0.1 to 0.5 or 1.0. The real breakpoint occurs with intervals at 2 seconds or larger.

It would appear, then, that, for pitch-angle, a sampling rate of 1 per second for both maneuvers would be optimal, with slightly improved accuracy possible in the barrel roll by going to 10 per second. (Of course this investigation considered only a discrete set of test intervals, and a more thorough study may show a 5 or 7 per second rate optimal for the barrel roll.) If the pitch accuracy tolerance were $\pm 2^\circ$ for both maneuvers, then a rate of 2 per second on the lazy 8 and 1 per second on the barrel roll would probably be required.

This type of information is of some benefit both for specifying recording systems and for performing measurement analyses. Figures 9 and 10 show how the data can be presented graphically to provide immediate indication of the adequacy of any proposed sampling rate for various error tolerances. Using Figure 9, for example, it is easy to discern the sampling intervals which would provide comparable results for, say, an error tolerance of $\pm 2^\circ$.

TABLE VI

FRACTIONAL PART OF PITCH ERRORS $\leq x$ FOR
VARIOUS x^1 VALUES

		Error Magnitude (x)					Lazy 8 (N = 46)				
Δ	\leq	0.5	1.0	1.5	2.0	2.5	3.0	3.5	4.0	5.0	10.0
SAMPLING INTERVAL (SEC)	.05	.960	.988	.991	.991	.991	.991	.992	.992	.992	.993
	.10	.968	.988	.990	.991	.991	.991	.991	.991	.992	.993
	.50	.942	.987	.990	.991	.991	.991	.991	.992	.992	.993
	1.0	.913	.984	.990	.991	.991	.991	.992	.992	.992	.993
	2.0	.711	.917	.971	.986	.989	.990	.991	.991	.991	.992
	3.0	.506	.731	.850	.920	.956	.972	.980	.984	.989	.990
	4.0	.376	.580	.697	.778	.844	.895	.930	.949	.967	.987
	10.	.121	.204	.274	.334	.387	.432	.471	.503	.552	.753

		Error Magnitude (x)					Barrel Roll (N = 44)				
Δ	\leq	0.5	1.0	1.5	2.0	2.5	3.0	3.5	4.0	5.0	10.0
SAMPLING INTERVAL (SEC)	.05	.960	.985	.988	.989	.990	.990	.991	.991	.991	.993
	.10	.961	.983	.986	.987	.988	.988	.988	.989	.989	.991
	.50	.923	.974	.982	.985	.985	.986	.986	.986	.987	.988
	1.0	.861	.962	.980	.984	.985	.986	.986	.987	.987	.989
	2.0	.639	.813	.887	.926	.949	.963	.974	.979	.983	.988
	3.0	.477	.674	.768	.820	.855	.881	.905	.924	.948	.984
	4.0	.361	.538	.637	.703	.750	.784	.811	.832	.871	.967
	10.	.098	.173	.239	.299	.353	.392	.428	.460	.506	.649

¹x represents the error magnitude. The table shows the fractional part (how many) of the total errors that were $\leq x$ at each sampling interval tested. For example, at $\Delta = 1.0$ (lazy 8), 98.4% of the errors incurred were ≤ 1.0 in magnitude.

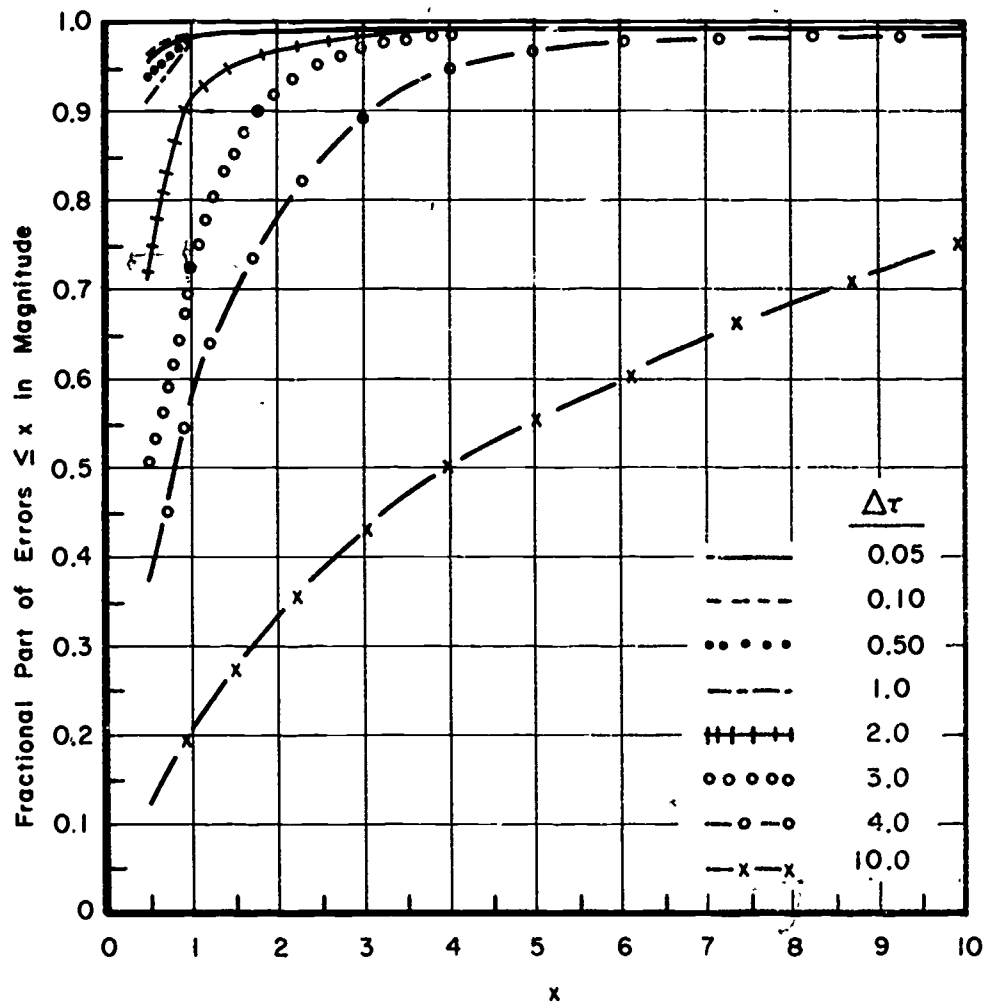

Figure 9. Sampling Interval Plot for Pitch (Lazy 8, N = 46)

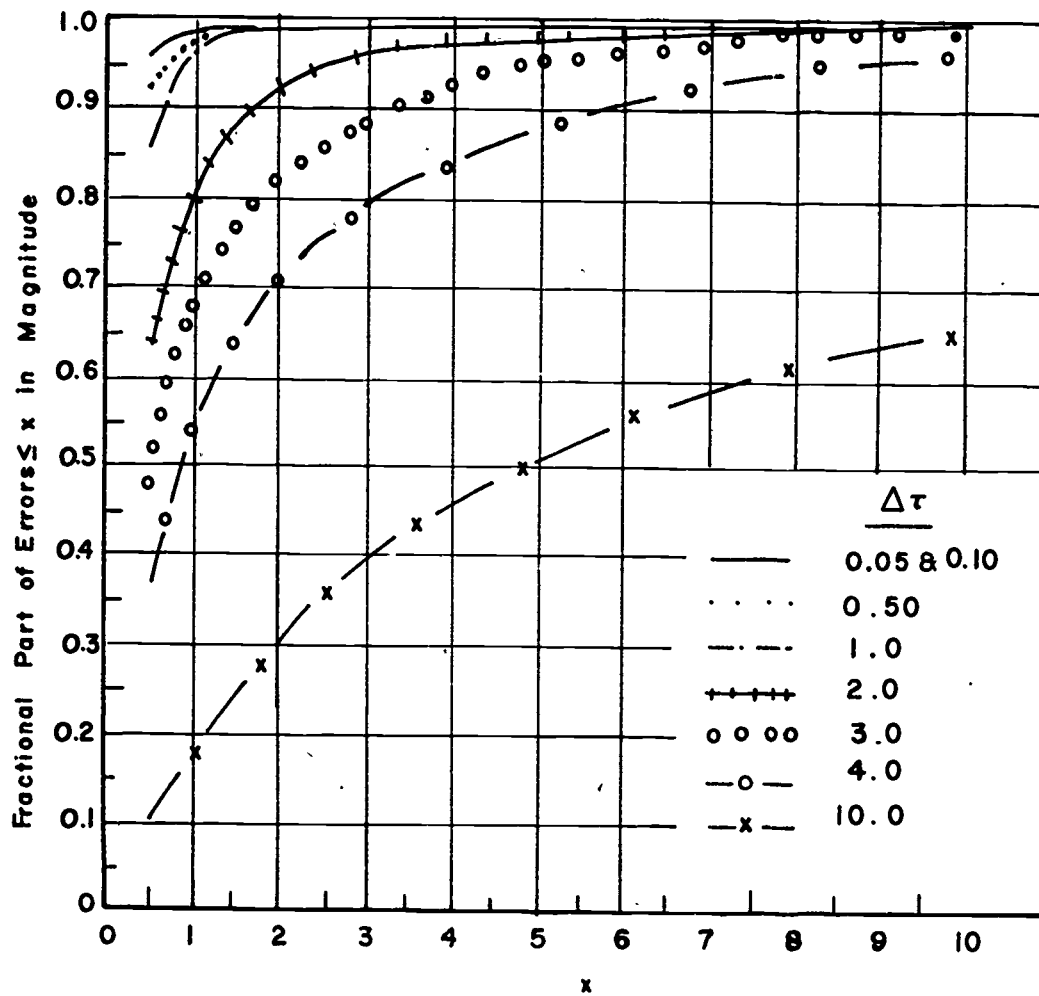

Figure 10. Sampling Interval Plot for Pitch (Barrel Roll, N= 44)

AFHRL-TR-72-6

In addition to developing the type of data presented here, the sampling rate analysis could include a matching of the error distribution to the portion of the maneuver being flown. For this purpose, maneuver-sections could be delineated using a Boolean Time Function approach, wherein necessary and sufficient conditions for each state or group of states of the aircraft, relating in turn to sections of the maneuver, are identified using logical operators (Reference 3). This could lead to an identification of the portions of the maneuver which, from a sampling-rate standpoint, load the requirements most heavily. These portions may or may not be critical in performance measurement and, hence, the sampling rate may be adjustable for a reduction of requirements.

SECTION V
BASIC PERFORMANCE MEASUREMENT SYSTEM

1. GENERAL APPROACH

The approach consisted of several distinct but interrelated tasks. Summarily, these tasks were:

1. Perform analysis of the maneuvers to be studied in detail.
2. Develop theoretical measures based strictly on the results of the analyses.
3. Compute the theoretical measures for representative performances to determine which measures have face-validity.
4. Develop experimental measures consisting of (a) those theoretical measures which appear valid and (b) other measures derived through examination of the data.
5. Compute the experimental measures for a broad sample of student and instructor data and perform analyses to validate the measures.

The maneuver analyses were performed by Air Training Command. The analyses included (1) a maneuver description, (2) an itemization of maneuver elements, or separate portions of the maneuver, and (3) for each maneuver-element, the primary pilot tasks, the knowledge and skill required, and suggested error tolerances on critical parameters. Supplementing the information provided in the Primary Flying Manual (Reference 4), the task analyses provided a fair "picture" of each maneuver in addition to an indication of Air Training Command standards of performance, insofar as it was possible at that time to quantify these standards.

Theoretical measures were then developed based on the maneuver-analyses. This was accomplished during the instrumentation/test flight phases of the study, so that quite early in the preliminary data-collection phase, measurement programs were available to enable data analysis and research to be initiated.

AFHRL-TR-72-6

These preliminary measurement programs were applied to early performances of the Flight Test pilots. The resulting data were analyzed to determine expected ranges of the critical flight parameters and evaluate the face validity of the various theoretical measures. Also, those portions of the maneuvers and/or those pilot skills which seemed the most feasible candidates for automated measurement were identified.

Final measurement programs were then developed for analysis of each student and instructor/pilot performance. These programs computed a variety of experimental measures believed to be relevant to performance evaluation. In addition, they produced automated plots of certain combinations of variables to produce a "picture" of the most relevant features of each performance.

The remainder of this Section is devoted to a description of how each of the above tasks was accomplished and, where applicable, how measurement programs were implemented.

2. ATC MANEUVER ANALYSES

a. Lazy 8

(1) General Description

The lazy 8 is a maneuver requiring simultaneous turning and climbing or descending so that a horizontal figure eight is described about a selected reference point located on the horizon.

This analysis assumes that the aircraft is in the local flying area in level flight between maneuvers.

Also assumed is that the student is in a post-solo phase of the T-37, is able to control the aircraft in turns of specified bank angles, and to maintain straight and level flight.

AFHRL-TR-72-6

For analysis purposes, the heading indicated on the compass should be used as a primary reference although the student will perform the maneuver using outside references.

(2) Maneuver Elements

Figure 11 illustrates the nine maneuver elements of the lazy 8. The element numbers coincide with the circled task analysis numbers (Table VII).

(3) Maneuver Analysis

Table VII presents the analysis of the lazy 8 as developed by Air Training Command.

b. Barrel Roll

(1) General Description

The barrel roll consists of an aerobatic roll maneuver of 360° bank about a selected reference point located ahead of the aircraft.

The student must maintain a constant angle off a selected reference point through the 360° of bank with constantly changing pitch attitudes and airspeeds.

Positive seat pressures must be maintained and roll rate must be constant.

The student must coordinate rudder, elevator, and aileron deflection from normal.

(2) Maneuver Elements

The maneuver is divided into five segments (Figures 12a through 12e):

1. Entry, which is not considered an integral part of the maneuver, but is important for identifying the reference point and establishing maneuver orientation.

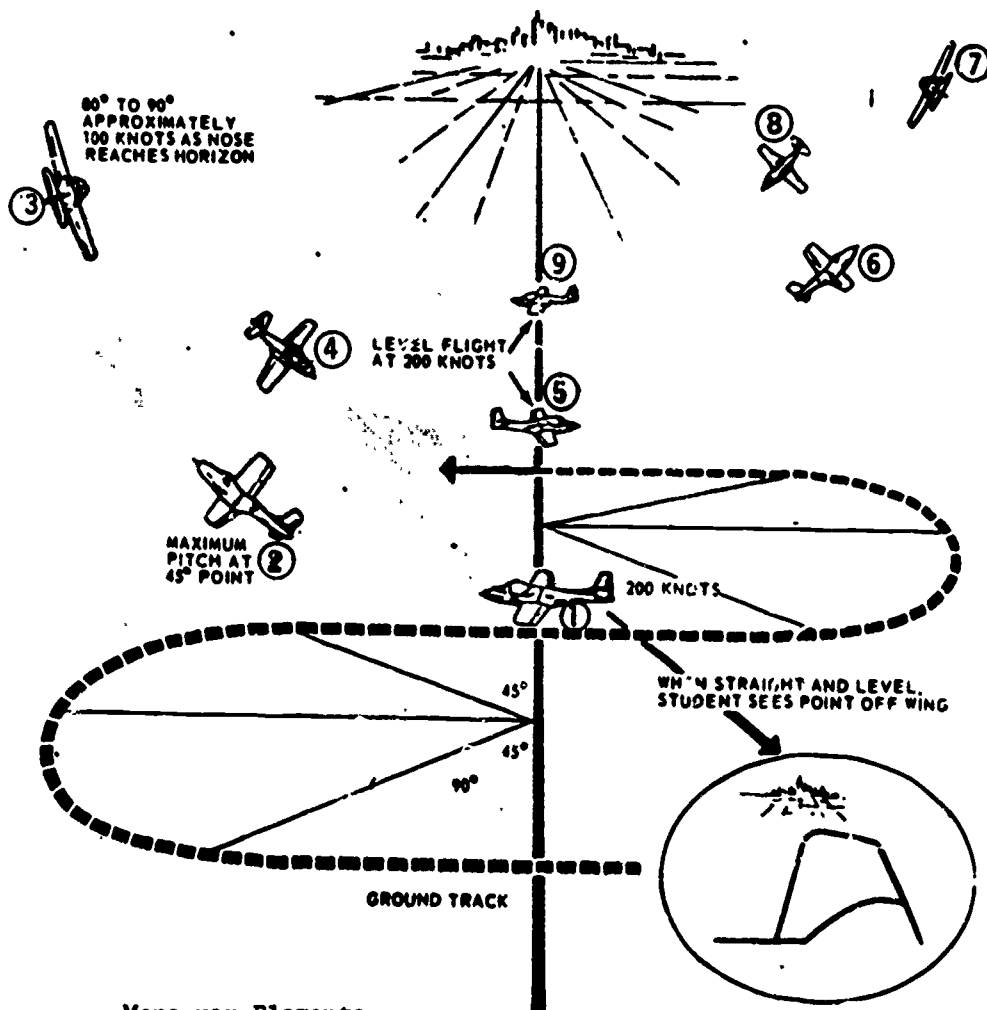

Maneuver Elements

- 1 Maneuver entry
- 2 45° turn point
- 3 90° turn point
- 4 135° turn point
- 5 180° turn point (midpoint of maneuver)
- 6 135° turn point (direction opposite from 0.1-0.5)
- 7 90° turn point
- 8 45° turn point
- 9 Maneuver termination (straight and level flight)

Figure 11. Lazy 8 Maneuver Profile

TABLE VII
LAZY 8 MANEUVER ANALYSIS

Maneuver Element Element Sub-Part	Purpose: What does the crewman do? Why is it done?	Knowledge and Skill Required	Tolerance (Task criteria) How well -
1.0 Maneuver Entry 1.1 Clear area 1.2 Set airspeed 1.3 Set power 1.4 Select reference point	Visually ensures no other aircraft will conflict with maneuver. Set up aircraft condition and orientation for reference point (on wing tip). Straight and level flight.	Procedural knowledge in ATCM 51-4 200 kts 90% power level flight 5000 Ft A.G.L. +	No omissions or incompletes +3 kts $\pm 1\%$ +0 ft/min climb or descent above 5000' A.G.L.
1.5 Begin maneuver	Start climbing turn in direction of reference point.	Direction of turn. Proper back pressure application for bank rate change.	1-2 g's
2.0 45° Turn point 2.1 15° turn point	Continue climbing turn in direction of reference point. As airspeed decreases, elevator and aileron deflection is increased to continue bank and pitch change. As 45° turn point is reached, the pitch attitude change (vertical velocity) is reversed in order for nose to reach horizon at 90° turn point.	Flying skill to reach: -13-15° of bank 15° of turn 1/3 of highest pitch attitude (45° point) -27 - 30° of bank 30° of turn 2/3 of highest pitch attitude -40-45° of bank 45° of turn	+4° $\pm 4^\circ$ $\pm 10\%$ +4° $\pm 4^\circ$ $\pm 10\%$ +4° $\pm 4^\circ$ $\pm 10\%$
2.2 30° Turn point		Highest pitch attitude in maneuver	
2.3 45° Turn point		Normal skill, to reach: -53-60° of bank -60° of turn -2/3 of highest pitch attitude	+4° $\pm 4^\circ$ $\pm 10\%$
3.0 90° Turn point 3.1 60° Turn Point	Continue climbing turn (although pitch attitude is decreasing) in direction of reference point. Bank angle continues to increase and some back pressure is released to allow nose to fall to horizon at 90° point.	-67-75° of bank 75° of turn -1/3 of highest pitch attitude	+4° $\pm 4^\circ$ $\pm 10\%$
3.2 75° Turn point			

TABLE VII
LAZY 8 MANEUVER ANALYSIS

Maneuver Element Element Sub-Part	Purpose: What does the crewman do? Why is it done?	Knowledge and Skill Required	Tolerance (Task criteria) How Well
3.3 90° Turn point	Maximum bank angle is reached	-80-90° of bank -90° of turn -Level flight (vertical velocity = zero) attitude -A/S -100 kts IAS	$\pm 4^\circ$ $\pm 4^\circ$ $\pm 5^\circ$ ± 5 kts
4.0 135° Turn point 4.1 105° Turn point	The turn is continued in the same direction. The pitch attitude is now less than zero and bank angle is constantly being changed toward zero degrees. Reference point is now on opposite side of longitudinal axis.	Normal skill to reach: - bank angle = to 3.2 - 105° of turn - negative pitch attitude = 1/3 of highest pitch attitude at 45° turn point	$\pm 4^\circ$ $\pm 4^\circ$ $\pm 10^\circ$
4.2 120° Turn point		-bank angle = to 3.1 - 120° of turn - negative pitch attitude = 2/3 of highest pitch attitude at 45° turn point	$\pm 4^\circ$ $\pm 4^\circ$ $\pm 10^\circ$
4.3 135° Turn point	Negative vertical velocity is maximum	- bank angle = 2.3 - 135° of turn - negative pitch attitude = pitch at 45° turn point	$\pm 4^\circ$ $\pm 4^\circ$ $\pm 10\%$

TABLE VII (Concluded)
LAZY 8 MANEUVER ANALYSIS

Maneuver Element Element Sub-Part	Purpose: What does the crewman do? Why is it done?	Knowledge and Skill Required	Tolerance (Task Criteria) How well -
5.0 180° Turn point	Continue descending turn in same direction. At 130° point descent rate should have started to decrease. This will require some back pressure to arrest movement about lateral axis; and g forces should increase. Student should be aware of bank angle vs amount of turn left to accomplish. Also to be taken into account is that aircraft should not come to level flight (zero vertical velocity) until turn is completed and bank angle is zero.	Sufficient motor skill to reach the following: -Angle bank = 2.2 -150° Turn -negative pitch attitude = 2.2 -Angle of bank = 2.1 -165° Turn -negative pitch attitude = 2.1 -0° Bank -Heading = to 180° from maneuver start -Airspeed = 200 kts -Pitch attitude	+4° bank error +4° turn error ±10% pitch error
5.1 150° Turn point			
5.2 165° Turn point			
5.3 180° Turn point			
5.4 Maneuver Continuation	Start the climbing turn in direction of reference point (Bank will be opposite to first 180° of maneuver). Same as 2	Direction to turn. Proper back pressure application for bank rate change. Same as 2	1-2 g's
6.0 135° Turn point	Same as 3	Same as 3	Same as 2
7.0 90° Turn point	Same as 4	Same as 4	Same as 3
8.0 45° Turn point	Same as 5	Same as 5	Same as 4
9.0 Maneuver termination			Same as 5

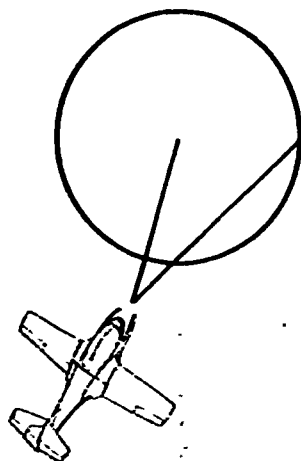

Figure 12a. Maneuver Start

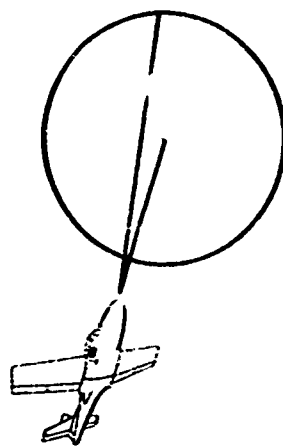

Figure 12b. 90° Roll Point

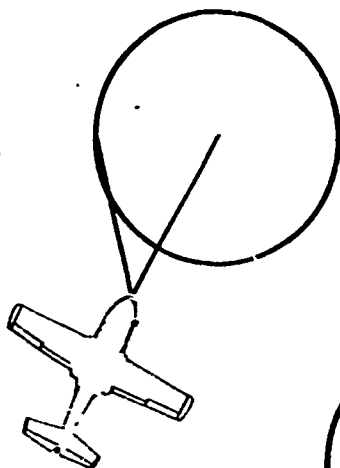

Figure 12c. 180° Roll Point

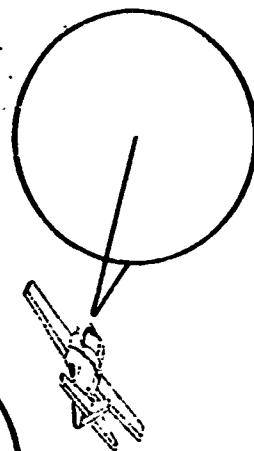

Figure 12d. 270° Roll Point

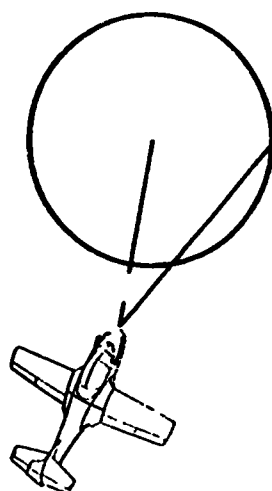

Figure 12e. Maneuver End

Figure 12. Barrel Roll Positions

2. First quarter roll (0 - 90° roll)
3. Second quarter roll (90 - 180° roll)
4. Third quarter roll (180 - 270° roll)
5. Fourth quarter roll (270 - 360° roll)

(3) Maneuver Analysis

Clearing the Area. This ensures visually that no other aircraft flight path would be in a position to conflict with maneuver area. It can be accomplished by a 180° turn or two medium (40°) to steep (60°) banked turns in opposite directions of sufficient duration to visually clear the maneuver area.

Selection of Reference Point. The reference point is usually an isolated cloud formation of small size or a section line stretching to horizon. The selected point must be easily identifiable and should contrast enough with surroundings so the student has no difficulty in keeping an eye on it.

Entry to Barrel Roll. After selection of the reference point, the throttles are adjusted to 90%. The nose of the aircraft is then lowered below the reference point to attain an airspeed of 200 to 230 knots. The aircraft is then rolled right or left with the aircraft continuing the descent until 20-30° to one side of the reference point. The wings are then rolled level to simultaneously allow the aircraft nose to come to level flight attitude.

First Quarter of Roll. The student notes his angle off the reference point. This angle alpha (α) is between a line parallel to the longitudinal axis of the aircraft projected forward from the pilot and a line projected to the reference point. This reference point should remain in the same position on the windscreen throughout the maneuver regardless of aircraft attitude. A climbing turn is executed toward the reference point to simultaneously reach 90° of bank when the nose is alpha (α) degrees above the horizon. At this point, the

longitudinal axis of the aircraft should be in the vertical plane which passes through the reference point. Constancy of roll rate is the major difficulty in this task segment. Control deflection must be increased to compensate for decreasing airspeed.

Second Quarter of Roll. The aircraft is rolled to an inverted level flight position (180° bank, 0° pitch) to the angle α off the reference point. Although pitch attitude is decreasing, aircraft airspeed is continuing to decrease. Increased aileron deflection is therefore necessary to keep roll rate constant. Back pressure is still necessary during the initial portion of this maneuver segment to turn the aircraft to the proper angle off. As the aircraft approaches 135° of bank, elevator control deflection is now decreased since lift on the wings is being exerted in the same direction as the force of gravity.

Third Quarter of Roll. The roll is continued from wings-level inverted position to 90° of bank and a diving angle equal to angle α . At this 270° of roll point, the longitudinal axis of the aircraft is again in the vertical plane through the reference point. During the roll of 135° of bank, back pressure is nominal because lift is still being generated in a downward direction. As the 135° roll point is reached, back pressure is slowly increased. Aileron deflection from the 180° roll point is decreased as airspeed begins to increase to keep roll rate constant.

Fourth Quarter of Roll. The aircraft is now rolled from 270° bank and diving attitude to the erect position. The reference point should again be equal to angle α . From the 270° bank point, aileron deflection will continue to decrease while back stick pressure will increase to decrease the dive angle. Roll out of bank and back pressure should be coordinated to properly come to level flight and angle α , simultaneously.

AFHRL-TR-72-6

(a) Performance Tolerances

Following are estimates of realistic performance tolerances for some of the more relevant variables of this maneuver:

Segment	Variable	Tolerance
1	RPM Entry IAS ² Minimum Altitude ³ Offset of nose from reference point	90% \pm 1% 200-230 knots 5000 ft AGL 20° \gg < 60°
2-5 (4-quarters)	RPM g Force Angle off (alpha) between nose and reference point	90% \pm 1% constant 1 \gg < 4g \pm 10%

(b) Significant Performance Factors

Quantitative Factors:

Variable	Range
1. Airspeed	100 to 260 knots
2. Heading	Entry Heading, 20 to 60° off reference point
3. RPM	90% \pm 1%
4. Degree of Bank	0 - 360°
5. Angle Off (alpha) Error	\pm 10%
6. g Force	1 \leq g \leq 4

Qualitative Factors:

1. Smoothness in coordinated control movement
2. Continuity of maneuver

²It is mandatory that at least 200 knots IAS be attained for entry.

³Maneuver will not be started or terminated below 5000 ft.

AFHRL-TR-72-6

3. Quickness in discerning and applying the required control movements in various aircraft orientations.

4. Confidence and positiveness in controlling aircraft.

c. Normal Landing

Although detailed analysis in the study was limited to the lazy 8 and barrel roll maneuvers, an analysis of the normal landing was also developed. Some preliminary work requisite to measurement research on the landing task has also been accomplished. The task analysis and preliminary follow-up analysis are documented below.

(1) General Description

A circular approach to the active runway consisting of:

1. An initial approach to the active runway 1000 ft AGL (above ground level)
2. A level 180° turn with simultaneous reduction of airspeed to a downwind position
3. Speed brake, landing gear, and flap lowering
4. A descending 180° turn to align with the active runway
5. A glide path to the touchdown point in the first 1000 ft of the runway.

This analysis assumes the student is in early stages of aircraft checkout through termination of T-37 flying.

Also assumed is that the student is capable of level flight, turning, level flight with airspeed changes, and descending turns while maintaining airspeed.

AFHRL-TR-72-6

Displacement from runway (ground track) cannot be taken from aircraft instrumentation⁴ and would necessarily be a result of instructor verbal input.

(2) Maneuver Elements

Figure 13 illustrates the six maneuver elements of the normal landing.

(3) Maneuver Analysis

Table VIII presents the task analysis of the normal landing as developed by Air Training Command.

(4) Extended Analysis of Normal Landing

By utilizing the maneuver analysis, information in the primary flight manual (Reference 4), and personal knowledge of the normal landing task, we developed an extended analysis of the task. This was accomplished as a first step in (a) properly segmenting the maneuver for measurement purposes and (b) identifying basic ATC criteria as they apply to various segments of the task. The results are presented in Appendix V.

3. THEORETICAL MEASURES

Theoretical measures were developed using maneuver-analysis data for the lazy 8 and barrel roll maneuvers. These measures constituted a "first guess" at an appropriate set of measures and were based solely upon ATC criteria. Their computation was accomplished through the development of appropriate software, which was then used to compute the theoretical measures for a sample of flight test pilot performances. The following paragraphs are devoted to a description of the theoretical measures and the rationale underlying their development, the implementation of software for their computation, and initial tests.

⁴Instrumentation, for this study, did not include a means of determining ground track.

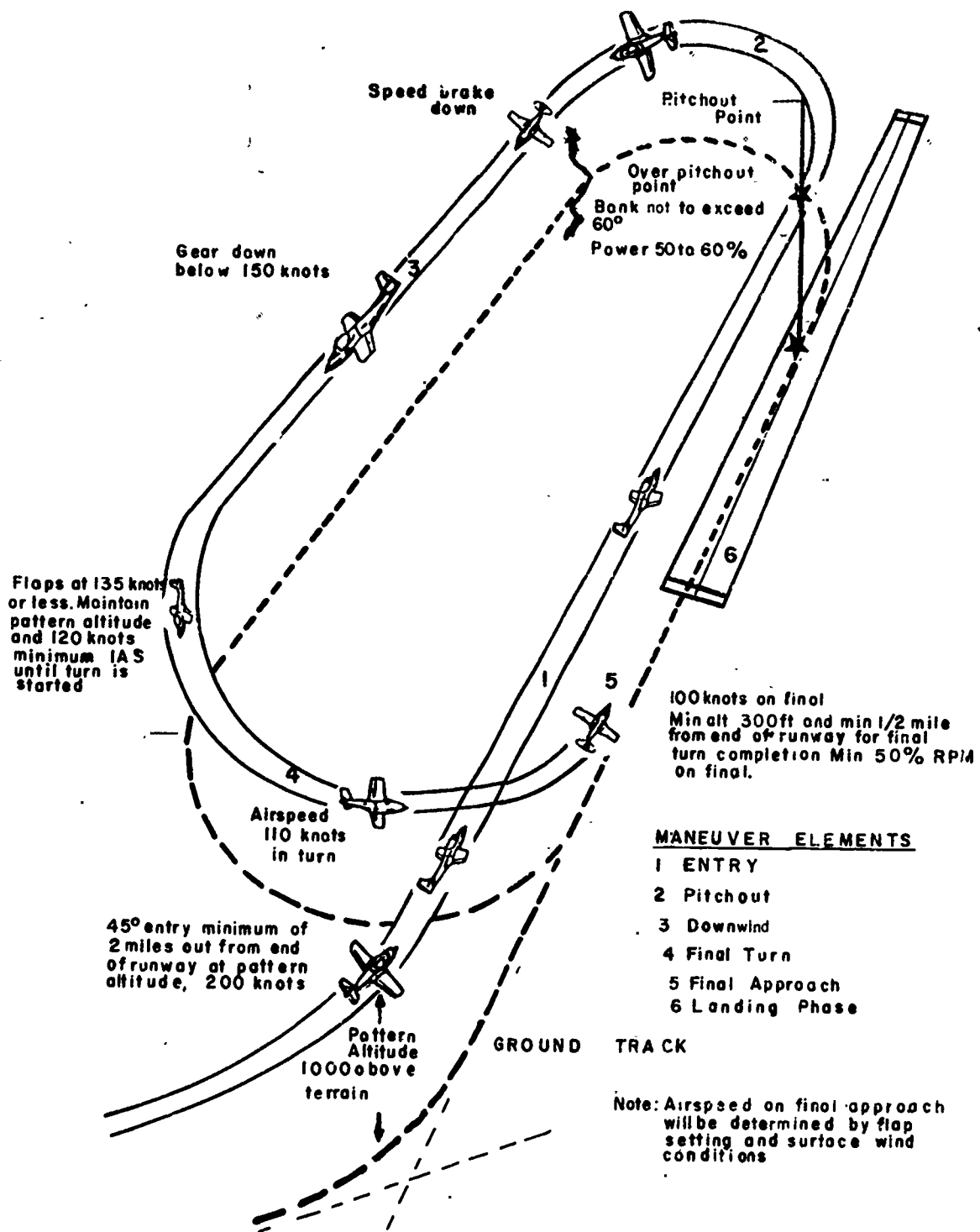

Figure 13. Normal Landing Maneuver Profile

TABLE VIII
NORMAL LANDING MANEUVER ANALYSIS

Maneuver Element Element Sub-Part	Purpose What does the crewman do? Why is it done?	Knowledge and Skill Required	Tolerance (Task criteria) How well -
1.0 Maneuver Entry Initial 1.1 Turn to initial 1.2 Runway alignment	Aircraft is turned 45° to align with runway. Student rolls out of turn to align with extension of runway center line.	Maintain level flight in turn, 1000 ft altitude (AGL) 200 kts IAS, 45-60° of bank. Maintain 1000 ft AGL. Judgment needed to time roll out initiation and termination to coincide with runway extension.	+5 kts IAS +100 ft altitude 45° > < 60° bank ±100 ft altitude
1.3 Drift correction (If necessary)	Turns to and maintains a heading to compensate for crosswinds (if necessary).	Knowledge of air mass drift in relation to ground track. Straight and level flight. 200 kts IAS 1000 ft AGL.	±5 kts IAS ±100 ft altitude
1.4 Pitchout point	Initiates steep bank 180° turn to downwind. Reduces power to 50-60%.	When to pitch - usually 3000 ft from approach end to middle length of runway. Skill to roll into level turn 1000 ft AGL, bank angle 45-60°. Power requirements 50-60%.	±2% RPM +100 ft altitude 45° > < 60° bank
2.0 Pitchout 2.1 0-90° Turn 2.2 90° - Rollout	Continues bank angle of 45° > < 60°. Maintain level flight 1000 ft AGL. Ensure throttles adjusted 50-60% RPM. Continue aircraft in turn. Vary bank angle so as to roll out at pre-selected lateral distance from runway.	Skill necessary to maintain constant bank angle, holding altitude despite changing airspeed. Angle of attack will constantly increase. Skill necessary to maintain level flight 1000 ft AGL. Knowledge of ground track for downwind lateral distance from runway. Judgment when to initiate rollout.	Bank angle 45° > < 60° ±100 ft altitude Bank angle < 60° Altitude ±100

TABLE VIII (Contd)
NORMAL LANDING MANEUVER ANALYSIS

Maneuver Element Element Sub-Part	Purpose: What does the crewman do? Why is it done?	Knowledge and Skill Required	Tolerance (Task Criteria) How well -
2.3 Rollout Termination	Rollout of turn approximately 1/2 mi laterally from run- way.	Skill necessary to maintain 1000 ft AGL despite decreasing air- speed. Judge termina- tion of rollout to hold heading of approxi- mately 180° from landing heading.	Altitude ± 100 ft Lateral distance - -0 +1/4 mi
2.4 Drift correction (if necessary)	Establish a heading necessary to hold lateral displacement from runway.	Knowledge of air mass drift problems and corrective action (heading change or crab).	
3.0 Downwind 3.1 Speed Brake Extension	Maintain level flight 1000 ft AGL and ground track parallel- ing runway compensating for air mass drift (if present). Speed brake extended to decrease airspeed.	Skill necessary to maintain altitude of 1000 ft AGL despite changing airspeed and trim needs. Knowledge of speed brake extension procedures.	Altitude ± 100 ft
3.2 Landing Gear Extension	Gear extended at 150 kts or below. Gear checked. Minimum IAS 120 kts, power adjusted as necessary.	Knowledge of gear lowering procedures, airspeed limi- tations and gear checks. Checks are: red lite in handle out, three green lites on, handle is down, warning horn has stopped blowing and hydraulic pressure is 1250-1550 psi.	Altitude ± 100 ft IAS 120 > < 150 kts
3.3 Flap Extension	Flaps extended prior to initiating final turn. IAS must be 120 > < 135 kts.	Mechanics of flap lowering. Knowledge of when to initiate final turn. This is opposite an imaginary point on the extended runway centerline 1/2 mi. from approach end of runway.	Altitude ± 100 ft IAS 120 > < 135 kts Turn point +1/8 mi. -0 mi

TABLE VIII (Contd)
NORMAL LANDING MANEUVER ANALYSIS

Maneuver Element Element Sub-Part	Purpose: What does the crewman do? Why is it done?	Knowledge and Skill Required	Tolerance (Task criteria) How well -
3.4 Base Turn to Final Approach	Initiate descending turn toward runway. Bank angles less than 45°. Normal bank angle is 20 - 30°. Vertical velocity of less than 1000 fpm descent. IAS 120 kts.	Skill to roll into bank of less than 45°. Initiation of descent at less than 1000 feet per minute.	IAS 120 >< 135 kts Bank angle 20° >< 45°
4.0 Final Turn 4.1 0-90° of Turn	Descending turn is continued. Rate of descent for this portion of turn should be sufficient to descend approximately 350 ft. Adjust power as necessary to maintain 110 kts. Trim to reduce control pressures. Makes gear check to appropriate control agency.	Skill necessary to maintain bank angle of approximately 20-30°, rate of descent to descend 350 ft in this 90° turn and ability to adjust power to maintain 110 kts. Skill to trim aircraft and knowledge of proper terminology.	Bank 20° >< 45° Altitude ±100 IAS +10 kts -0
4.2 90° to rollout on final	Continues descending turn. Adjusts bank angle up to 45° to align with runway. Rate of descent maintained to roll out a minimum of 300 ft AGL and maximum of 500 ft. Maintains 110 kts. Maintains smooth rate of descent.	Skill necessary to judge bank necessary to rollout on runway centerline without necessity to use maximum bank angle of 45°. Throttle adjustment to maintain 110 kts. Rate of descent continued to rollout at optimum altitude of 300 ft AGL.	Bank 20° >< 45° IAS +10 kts -0
4.3 Rollout on final turn	Rolls out of turn to align with runway. Slows to 100 kts. Retrims aircraft as necessary to reduce control pressures.	Skill necessary to time rollout. Power adjustment to maintain 100 kts. Proper trim procedures.	IAS +10 kts -0 Heading +10° of runway heading

TABLE VIII (Contd)

NORMAL LANDING MANEUVER ANALYSIS

Maneuver Element Element Sub-Part	Purpose: What does the crewman do? Why is it done?	Knowledge and Skill Required	Tolerance (Task criteria) How well -
5.0 Final Approach 5.1 Glidepath	Establish pitch attitude to descend at steady rate of 100 kts IAS. RPM adjusted as necessary. RPM must be a minimum of 50% until landing is assured.	Knowledge necessary to visualize proper aim point on runway and skill to fly aircraft in a steady rate of descent toward this aim point. Ability to adjust power to maintain 100 kts.	IAS --0 +10 kts Descent rate < 1000 fpm
5.2 Centerline alignment	Maintain ground track over extended centerline of runway. If crosswind exists, establish wing low method of drift correction. This involves using rudder to keep aircraft longitudinal axis aligned with runway centerline and aileron to hold aircraft over extended runway centerline.	Knowledge of mechanics of drift correct using wing low method and skill to maintain proper ground track.	Lateral displacement - no error Heading $\pm 3^\circ$
6.0 Landing Phase 6.1 Roundout	As aircraft approaches runway, angle of attack is slowly increased to slow rate of descent. Power is adjusted to idle. As airspeed decreases below 100 kts, angle of attack must further increase to hold minimum rate of descent prior to touch down. Pitch attitude will be approximately 5° , wings held level, drift correction maintained, if necessary.	Judgment as to when to initiate roundout without leveling off or initiating a climb. Skill to maintain this lesser rate of descent so that aircraft will not stall out too high above runway and result in hard landing. Skill to maintain drift correction if necessary.	IAS 75 > < 100 kts Descent rate < 500 fpm Heading $\pm 3^\circ$ Lateral displacement - no error

TABLE VIII (Concluded)

NORMAL LANDING MANEUVER ANALYSIS

Maneuver Element Element Sub-Part	Purpose: What does the crewman do? Why is it done?	Knowledge and Skill Required	Tolerance (Task criteria) How well -
6.2 Touchdown	Touchdown is allowed to occur in first 1000 ft of runway at approximately 75-80 kts IAS. Drift correction and pitch of 5° maintained.	Skill to attain and maintain pitch attitude of approximately 5° touchdown in first 1000 ft and to maintain aircraft on the runway without lateral deviations.	IAS 75-80 kts Descent rate < 200 fpm Heading $\pm 3^\circ$ Lateral displacement - no error
6.3 Rollout and Turn Off	Aircraft is gradually slowed to allow runway turnoff. Nose is gradually lowered to runway and brakes are applied in slow steady and increase of pressure. Drift correction must still be applied, (if necessary) to keep T-37 from weathervaning into wind because of large tail surface and center of gravity. Aileron deflection must be maintained to keep aircraft from slipping sideways.	Skill to lower nose slowly to runway and to maintain control deflection to compensate for crosswind, if present. Skill to manipulate brake pedals at a steady pressure and to slow down at a rate to allow runway turnoff without stopping on runway.	IAS < 75 kts Heading $\pm 3^\circ$ Lateral displacement - no error

a. Description

(1) Lazy 8

As suggested by ATC, the primary reference variable in this maneuver (for purposes of developing theoretical measures) was aircraft heading. Criteria for most other variables were functions of heading. The criterion for heading itself was computed as a function of the initial heading selected by the pilot upon entering the maneuver.

The lazy 8 is a maneuver consisting of two symmetrical parts. Therefore, criteria and initial measurement methods were developed only for the first half of the maneuver, but were applicable to the second half as well. Theoretically, we may regard the lazy 8 as two successive performances of a "half lazy 8," both done in opposite directions and with smooth transition and no hesitation between performances.

Figure 14 and Table IX together sketch the maneuver and the performance criteria suggested by ATC in their maneuver analysis. This information was used in developing mathematical expressions for the criteria and tolerances for bank, pitch, vertical velocity, airspeed, altitude, g's, and RPM. Then measures were developed based on a comparison of recorded data with criteria and, where applicable, with tolerances.

The following discussion presents, first, the individual theoretical measures (denoted S_i) developed for each aircraft variable. These S_i measures indicate how much the performance differed from ATC criteria, and where applicable, tolerances.

Next, combined theoretical measures are described. These consist of linear combinations of selected S_i measures to provide a single measure for each of several aspects of the performance. One combination measure, for instance, reflects how well the pilot's transition from descent to level flight at the 180° turn point is synchronized with the transition to zero bank angle.

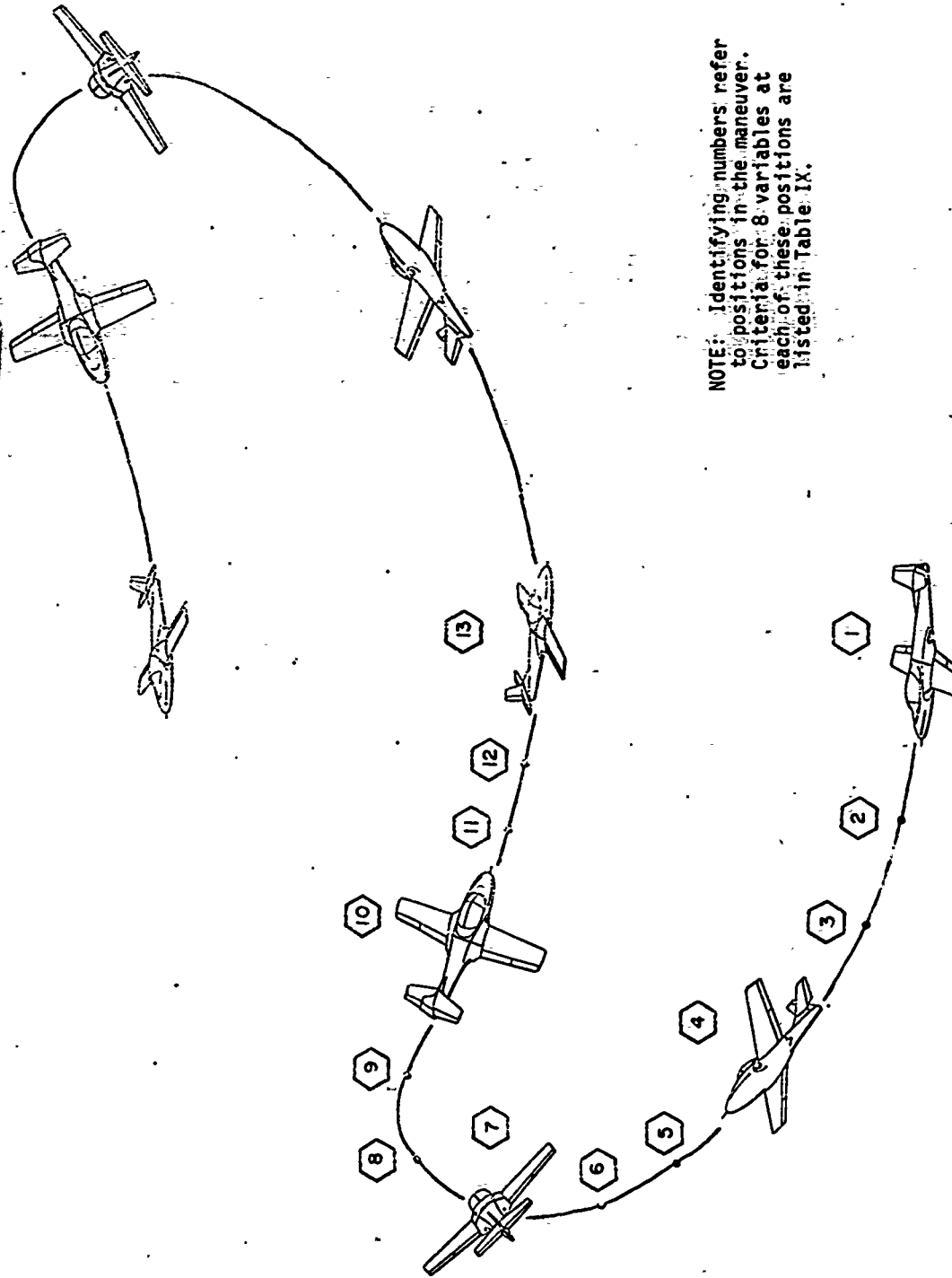

NOTE: Identifying numbers refer to positions in the maneuver. Criteria for 8 variables at each of these positions are listed in Table IX.

Figure 14. Maneuver Diagram for Lazy 8.

TABLE IX
PRELIMINARY LAZY 8 PERFORMANCE CRITERIA

	1*	2	3	4	5	6	7	8	9	10	11	12	13	Tolerance
Bank	0	13-15	27-30	40-45	53-60	67-75	80-90	67-75	53-60	40-45	27-30	13-15	0	+4
Turn	0	15	30	45	60	75	90	105	120	135	150	165	180	+4
Pitch	0	1/3 H	2/3 H	H	2/3 H	1/3 H	0	-1/3 H	-2/3 H	-H	-2/3 H	-1/3 H	0	+10%
Vertical Velocity	0	←	R/C	≥ 0	→	→	0	←	R/C	≤ 0	→	→	0	+0
Airspeed	200	←	100	≤ AS	≤ 200	→	100	←	100	≤ AS	≤ 200	→	200	+5
Altitude	A	←	A	≤ ALT	≤ MAX	→	MAX	←	A	≤ ALT	≤ MAX	→	A	---
9	1-2												1-2	---
RPM	90	90	90	90	90	90	90	90	90	90	90	90	90	+1

1 Tolerance = ±3
 2 Tolerance = ±5
 3 Tolerance = ±3
 4 H = Maximum pitch attained in maneuver
 5 A = Starting altitude; A ≥ 5000
 6 MAX = Maximum altitude attained in maneuver

*Numbers heading columns 2-13 refer to positions in the maneuver (see Figure 14)

AFHRL-TR-72-6

Finally, a "total score" is developed from the combination measures to provide a single indicant of total performance. This is a weighted sum of the combination measures, with the weights consisting of "best guesses" for this theoretical measures development.

(a) Bank Angle

To express mathematically the criteria and tolerances relevant to bank angle, linear relationships have been established between Bank (B) and Turn (T) from the information in Table IX.

When turn is 15°, bank should be 13 - 15°; when turn is 30°, bank should be 27 - 30°, etc. Since it is desirable to have a continuous bank criterion, and not just a check at discrete turn-points, a function relating bank to turn would be preferable. This also simplifies programming (easier to code one function than to do table look-ups and interpolation). The functions:

$$\text{Bank} = \text{Turn or } B = T$$

and
$$\text{Bank} = \frac{8}{9} \text{ Turn or } B = \frac{8}{9} T$$

approximately represent the upper and lower bounds for bank angle for all points of turn from 0 to 90°. Therefore, the criterion for this region is:

$$\frac{8}{9} T \leq B \leq T$$

The tolerance for bank, as provided in Table IX, is $\pm 4^\circ$. Therefore $(T + 4)$ and $(\frac{8}{9} T - 4)$ represent the upper and lower tolerances. Similar analysis was performed for 90 to 180° turn region and the following mathematical expressions for criteria and tolerances were derived:

For $0^\circ \leq T \leq 90^\circ$:

$$\frac{8}{9} T - 4 \leq \left\{ \frac{8}{9} T \leq B \leq T \right\} \leq T + 4 \quad (1)$$

AFHRL-TR-72-6

For $90^\circ < T \leq 180^\circ$:

$$\frac{8}{9} (175.5 - T) \leq \left\{ \frac{8}{9} (180 - T) \leq B \leq 180 - T \right\} \leq 184 - T \quad (2)$$

where T = the degrees of turn made (i.e., degrees of heading-change)
and B = the angle of bank.

In inequalities (1) and (2) above, the most extreme quantities represent tolerance limits, while the criteria themselves are represented by the portions of the inequalities within brackets.

The measures desired for bank angle should reflect (1) whether or not, and to what extent, the basic criteria are satisfied, and (2) whether or not, and to what extent, the tolerances are exceeded. Separate measures are desired for each of these considerations, because different weights may be required in performance evaluations depending upon whether criteria are not satisfied, but tolerances are; or whether neither is satisfied.

Let⁵

$$M_i = \begin{cases} B_i - T_i, & T_i \leq 90, \text{ AND } B_i > T_i \\ \frac{8}{9} T_i - B_i, & T_i \leq 90, \text{ AND } B_i < \frac{8}{9} T_i \\ B_i - 180 + T_i, & T_i > 90, \text{ AND } B_i > 180 - T_i \\ \frac{8}{9} (180 - T_i) - B_i, & T_i > 90, \text{ AND } B_i < \frac{8}{9} (180 - T_i) \\ 0, & \text{otherwise} \end{cases}$$

where the subscript i refers to the value of the variable at the i^{th} sampling instant.

⁵
 $x = \begin{cases} Y, & L \\ Z, & K \end{cases}$ is interpreted as follows: $X = Y$ if L is true and $X = Z$ if K is true.

Let

$$N_i = \begin{cases} B_i - T_i - 4, & T_i \leq 90, \text{ AND } B_i > T_i + 4 \\ \frac{8}{9} T_i - 4 - B_i, & T_i \leq 90, \text{ AND } B_i < \frac{8}{9} T_i - 4 \\ B_i - 184 + T_i, & T_i > 90, \text{ AND } B_i > 184 - T_i \\ \frac{8}{9} (175.5 - T_i) - B_i, & T_i > 90, \text{ AND } B_i < \frac{8}{9} (175.5 - T_i) \\ 0, & \text{otherwise} \end{cases}$$

The values M_i and N_i respectively provide the amount by which criteria are exceeded and the amount by which tolerances are exceeded. Integrating each of these, we obtain:

$$S_1 = \int_0^T M_i \, dT$$

$$S_2 = \int_0^T N_i \, dT$$

S_1 is an integrated error measure showing the extent to which bank criteria are exceeded; S_2 , similarly, shows the extent to which bank tolerances are exceeded.

(b) Pitch Angle

The required pitch angle has been established by ATC as a function of the maximum pitch angle attained in the maneuver (Table IX). Call this maximum pitch angle H . As indicated in Table IX, pitch should reach its maximum (H) at the 45° turn point, should then decrease to zero by the 90° turn point, should reach its negative maximum ($-H$) at the 135° turn point, and should then return to zero again at the 180° turn point. The change in pitch should be a linear function of the degree of turn.

AFHRL-TR-72-6

The following criterion inequalities were computed from the information in Table IX. As in the case of bank angle, the portions of the inequalities within brackets represents the basic criteria, whereas the portions outside the brackets represent tolerances.

Let P = Pitch Angle

and T = Degrees of Turn:

For $0^\circ \leq T \leq 45^\circ$:

$$\frac{0.9HT}{45} \leq \left\{ \frac{HT}{45} = P \right\} \leq \frac{1.1HT}{45}$$

For $45^\circ < T \leq 90^\circ$:

$$\frac{0.9H(90-T)}{45} \leq \left\{ \frac{H(90-T)}{45} = P \right\} \leq \frac{1.1H(90-T)}{45}$$

For $90^\circ < T \leq 135^\circ$:

$$\frac{1.1H(90-T)}{45} \leq \left\{ \frac{H(90-T)}{45} = P \right\} \leq \frac{0.9H(90-T)}{45}$$

For $135^\circ < T \leq 180^\circ$:

$$\frac{1.1H(T-180)}{45} \leq \left\{ \frac{H(T-180)}{45} = P \right\} \leq \frac{0.9H(T-180)}{45}$$

The performance measures desired should reflect the deviation from the criteria plus any deviation outside the tolerance limits.

Let

$$M_i = \left\{ \begin{array}{l} \left| P - \frac{HT}{45} \right|, \quad T \leq 45 \quad \text{AND} \\ \quad \quad \quad \frac{0.9HT}{45} \leq P \leq \frac{1.1HT}{45} \\ \left| P - \frac{H(90-T)}{45} \right|, \quad 45 < T \leq 90 \quad \text{AND} \\ \quad \quad \quad 0.9H + \frac{(T-45)(5+0.9H)}{-45} \leq P \leq 1.1H + \frac{(T-45)(5-1.1H)}{45} \\ \left| P - \frac{H(90-T)}{45} \right|, \quad 90 < T \leq 135 \quad \text{AND} \\ \quad \quad \quad \frac{(T-90)(0.9H+5)}{45} - 5 \leq P \leq \frac{(T-90)(1.1H-5)}{45} + 5 \\ \left| P - \frac{H(T-180)}{45} \right|, \quad T > 135 \quad \text{AND} \\ \quad \quad \quad \frac{(T-135)(3+0.9H)}{-45} + 0.9H \leq P \leq \frac{(T-135)(3-1.1H)}{45} + 1.1H \end{array} \right.$$

For each sampling instant, i , the M_i above reflects the absolute value of the difference between the actual and criterion pitch angles whenever tolerances are not exceeded.

AFHRL-TR-72-6

Let

$$N_i = \left[\begin{array}{l} P - \frac{1.1HT}{45}, T \leq 45 \text{ AND } P > \frac{1.1HT}{45} \\ \\ \frac{0.9HT}{45} - P, T \leq 45 \text{ AND } P < \frac{0.9HT}{45} \\ \\ P - \frac{1.1H(90-T)}{45}, 45 < T \leq 90 \text{ AND} \\ \\ P > \frac{1.1H(90-T)}{45} \\ \\ \frac{0.9H(90-T)}{45} - P, 45 < T \leq 90 \text{ AND} \\ \\ P < \frac{0.9H(90-T)}{45} \\ \\ P - \frac{1.1H(90-T)}{45}, 90 < T \leq 135 \text{ AND} \\ \\ P > \frac{1.1H(90-T)}{45} \end{array} \right]$$

AFHRL-TR-72-6

and

$$N_i = \begin{cases} \frac{0.9H(90-T)}{45} - P, & 90 < T \leq 135 \text{ AND} \\ & P < \frac{0.9H(90-T)}{45} \\ \\ P - \frac{1.1H(T-180)}{45}, & T > 135 \text{ AND} \\ & P > \frac{1.1H(T-180)}{45} \\ \\ \frac{0.9H(T-180)}{45} - P, & T > 135 \text{ AND} \\ & P < \frac{0.9H(T-180)}{45} \end{cases}$$

For each sampling instant, i , the N_i above reflects the amount by which tolerances are exceeded. Integrating, we obtain the following measures:

$$S_3 = \int_0^T M_i dT$$

$$S_4 = \int_0^T N_i dT.$$

S_3 and S_4 are integrated error measures showing the extent to which pitch criteria and tolerances, respectively, are exceeded.

(c) Vertical Velocity

Based on the information in Table IX, vertical velocity (V/V) should be zero at the 0° , 90° , and 180° turn points. Further, V/V should be positive from $T = 0^\circ$ to $T = 90^\circ$ and negative from $T = 90^\circ$ to $T = 180^\circ$. There is no tolerance for error.

AFHRL-TR-72-6

Let $R_1 = V/V$ when turn = 0°

$R_2 = V/V$ when turn = 90°

$R_3 = V/V$ when turn = 180°

Then one measure may be computed as:

$$S_3 = |R_1| + |R_2| + |R_3|$$

This gives us the sum of absolute vertical velocity errors at the 0° , 90° , and 180° turn points.

Let

$$R_1 = \begin{cases} |V/V|, 0 \leq T \leq 90 \text{ AND } V/V < 0 \\ V/V, 90 < T \leq 180 \text{ AND } V/V > 0 \\ 0, \text{ otherwise} \end{cases}$$

Then

$$S_6 = \int_0^T R_1 dT / \text{TIME}$$

Where time is number of seconds for that half of the maneuver.

This gives the integral error on the V/V direction from $T = 0^\circ$ to $T = 180^\circ$.

One other aspect of V/V needs to be checked. The V/V should become zero at the 180° turn point at the same time that the angle of bank becomes zero. Neither should occur before the other.

Let T_1 = the time at which V/V first becomes zero when $135^\circ \leq T \leq 180^\circ$ and T_2 = the time at which bank first becomes zero when $135^\circ \leq T \leq 180^\circ$. If either V/V or bank does not become zero within the period designated, set T_i ($i = 1$ or 2) to 0.

AFHRL-TR-72-6

Compute

$$S_7 = \begin{cases} |T_1 - T_2|, & T_1 \neq 0 \text{ AND } T_2 \neq 0 \\ -1, & T_1 = 0 \text{ OR } T_2 = 0 \end{cases}$$

S_7 tells us the elapsed time, in seconds, between points where V/V and bank become zero. If S_7 is -1, this means the quantity was unmeasurable.

(d) Airspeed

Airspeed should be 200 knots on entry, i.e., at the 0° turn point, with a tolerance of ± 3 knots. At the 90° and 180° turn points, airspeed should be 100 and 200 knots respectively, with a tolerance of ± 5 knots. At all other points in the maneuver, airspeed must be more than 100 knots, and less than 200 knots.

Let

$$MM_1 = \begin{cases} A - 200, & A > 200 \text{ AND } 2 \leq T \leq 178 \\ 100 - A, & A < 100 \text{ AND } 2 \leq T \leq 178 \\ 0, & \text{otherwise} \end{cases}$$

where A = airspeed in knots.

Then compute

$$S_8 = \int_0^T MM_1 d\bar{T}$$

S_8 is an integrated error measure showing how much the airspeed criteria are exceeded from 2 to 178° of turn. It checks for deviation below 100 knots or above 200 knots.

To check airspeed at the 0, 90, and 180° turn points, we will compute:

$$S_9 = |A_0 - 200|$$

$$S_{10} = |A_{90} - 100|$$

$$S_{11} = |A_{180} - 200|$$

where A_K = airspeed at $T = K$.

(e) Altitude

The main requirement on altitude is that the maximum altitude attained in the maneuver (ALT_{MAX}) should occur at the 90° turn point. We can further hypothesize that altitude should be the same at the 0° turn point as it is at the 180° turn point and the same at the 90° turn point as it is at the 270° turn point, because this is a symmetrical maneuver. Further, altitude should be monotonically increasing from $T = 0°$ to $T = 90°$ and monotonically decreasing from $T = 90°$ to $T = 180°$.

First, a measure is needed to check that the maximum altitude is attained at the 90° turn point. Also, if ALT_{MAX} is not attained at the 90° turn point, we should record (1) where ALT_{MAX} is attained and (2) how much ALT_{MAX} differs from the altitude attained at 90°. In monitoring altitude it will be necessary to check the entire maneuver from start to completion rather than to check one half independent of the other half.

Let AA_1 = maximum altitude obtained from $T = 0°$ to $T = 360°$.

Let ALT_K = Altitude obtained at $T = K°$

TT_1 = Degrees of turn when AA_1 occurs.

AFHRL-TR-72-6

Compute

$$S_{12} = | \text{ALT}_{180} - \text{ALT}_0 | \quad \underline{\text{How much does altitude at turn} = 180^\circ \text{ differ from starting altitude?}}$$

$$S_{13} = | \text{ALT}_{360} - \text{ALT}_0 | \quad \underline{\text{How much does altitude at turn} = 360^\circ \text{ differ from starting altitude?}}$$

$$S_{14} = | \text{ALT}_{90} - \text{ALT}_{270} | \quad \underline{\text{How much does altitude at turn} = 90^\circ \text{ differ from altitude at turn} = 270^\circ?}$$

$$S_{15} = | \text{AA}_1 - \text{ALT}_{90} | \quad \underline{\text{How much does MAX altitude differ from altitude at turn} = 90^\circ?}$$

$$S_{16} = | \text{TT}_1 - 90 | \quad \underline{\text{How far off was the pilot from } 90^\circ \text{ when MAX altitude occurred?}}$$

(f) Acceleration (g Force)

The main requirement on g force is that it be between 1 and 2 g's at the start ($T = 0$) and end ($T = 360$) of the maneuver.

Let

$$G_K = \begin{cases} G - 2, & G > 2 \text{ at } T = K \\ | - G, & G < 1 \text{ at } T = K \\ 0, & \text{otherwise at } T = K \end{cases}$$

Then compute

$$S_{17} = G_0$$

$$S_{18} = G_{360}$$

This gives us absolute deviations outside criteria for g's at the start and end of the maneuver.

(g) RPM

RPM must be 90% throughout the maneuver. A tolerance of $\pm 1\%$ is specified.

Let

$$AM_i = \begin{cases} RPM_i - 92, & RPM_i > 92 \\ 88 - RPM_i, & RPM_i < 88 \\ 0, & \text{otherwise} \end{cases}$$

Compute

$$S_{19} = \int_0^T AM_i \, dT$$

S_{19} is an integrated error measure showing how much the RPM tolerances were exceeded over the maneuver.

Table X presents a summary of the above measures $S_1 - S_{19}$ (See Table XI for a definition of terms used in the summary table).

Figure 15 is a maneuver diagram for the lazy 8 showing which portions of the maneuver are checked by each experimental performance measure. Continuous measures, as depicted in Figure 15, are ones which monitor one or more performance variables continuously for a discrete time interval. Discrete measures monitor certain performance variables at selected discrete points in the maneuver.

(h) Combined Theoretical Measures

For experimental purposes, the following scaled measures and combinations thereof were computed and printed, in addition to the individual S_i measures. The assigned weights are based on the authors' judgment as to measure-criticality. The scaling is based on the expected ranges in Table X and is designed to produce combined measures that range from 0 to 100 to standardize the measures. For example, S_1 and S_2 are the individual theoretical measures pertaining to degree of bank. Their expected ranges are, for each, 0 to 3000 (See Table X).

TABLE X
SUMMARY OF PERFORMANCE MEASURES FOR LAZY 8

No.	Variable	Measure	Expected Range	Beg. ¹ Cue	End ¹ Cue	Pass ² Count
1	Bank; Turn	$\int_0^T M_i dt$	0 - 3000	0	180	1
2	Bank; Turn	$\int_0^T N_i dt$	0 - 3000	0	180	1
3	Pitch; Turn	$\int_0^T M_i dt$	0 - 3000	0	180	2
4	Pitch; Turn	$\int_0^T N_i dt$	0 - 3000	0	180	2
5	Vertical Velocity	$ R_1 + R_2 + R_3 $	0 - 1500	0	180	1
6	Vertical Velocity	$\int_0^T R_i dt$	0 - 7000	0	180	1
7	Vertical Velocity; Bank	$\left\{ \begin{array}{l} T_1 - T_2 , T_1 \neq 0, \text{ and } T_2 \neq 0 \\ -1, \text{ otherwise} \end{array} \right\}$	(-1) - 17	135	180	1
8	Airspeed	$\int_0^T MM_i dt$	0 - 120	2	178	1
9	Airspeed	$ A_0 - 200 $	0 - 50	0	0	1
10	Airspeed	$ A_{90} - 100 $	0 - 50	90	90	1

¹Beginning and end cues are expressed in terms of degrees of turn

²Estimated number of data passes required in computing the measure

TABLE X (Concluded)
SUMMARY OF PERFORMANCE MEASURES FOR LAZY 8

No.	Variable	Measure	Expected Range	Beg. ¹ Cue	End ¹ Cue	Pass ² Count
11	Airspeed	A ₁₈₀ - 200	0 - 70	180	180	1
12	Altitude	ALT ₁₈₀ - ALT ₀	0 - 1200	0	180	1
13	Altitude	ALT ₃₆₀ - ALT ₀	0 - 1200	0	360	1
14	Altitude	ALT ₉₀ - ALT ₂₇₀	0 - 1200	90	270	1
15	Altitude	AA ₁ - ALT ₉₀	0 - 1200	0	360	1
16	Altitude	TT ₁ - 90	0 - 270	0	360	1
17	g Force	G ₀	0 - 9	0	0	1
18	g Force	G ₃₆₀	0 - 9	360	360	1
19	RPM	$\int_0^T AM_1$	0 - 190	0	180	1

TABLE XI

DEFINITIONS OF TERMS USED IN TABLE X

T	=	degree of turn since start of maneuver
B	=	angle of bank
M_i	=	amount by which bank-angle criteria are exceeded
N_i	=	amount by which bank-angle tolerances are exceeded
$ M_i $	=	absolute value of the difference between actual and criterion pitch angles
$ N_i $	=	amount by which pitch angle tolerances are exceeded
R_1	=	V/V when $T = 0^\circ$
R_2	=	V/V when $T = 90^\circ$
R_3	=	V/V when $T = 180^\circ$
R_i	=	error in direction of Vertical Velocity
T_1	=	time when V/V becomes zero at $135^\circ \leq T \leq 180^\circ$
T_2	=	time when bank becomes zero at $135^\circ \leq T \leq 180^\circ$
A	=	airspeed
MM_i	=	absolute value of airspeed error at $2^\circ \leq T \leq 178^\circ$
A_K	=	airspeed at $T = K$
AA_1	=	maximum altitude obtained at $0 \leq T \leq 360^\circ$
TT_1	=	turn when AA_1 occurs
ALT_K	=	altitude at $T = K$
G_K	=	absolute value of g force at $T = K$
AM_i	=	RPM error at i th sampling instant

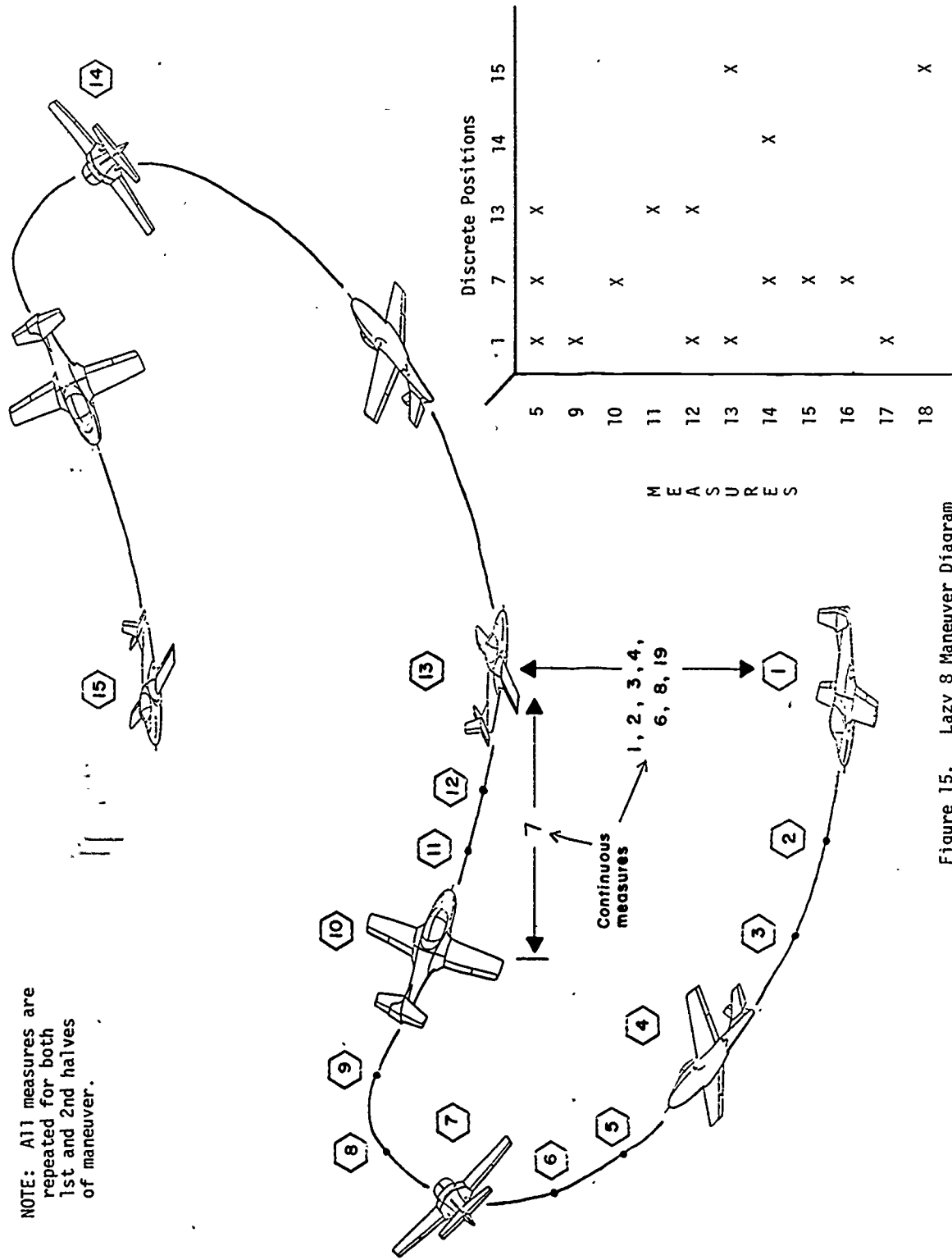

NOTE: All measures are repeated for both 1st and 2nd halves of maneuver.

Figure 15. Lazy 8 Maneuver Diagram

The weights assigned to them are 1 for S_1 (which tells how much criteria are exceeded) and 3 for S_2 (which tells how much tolerances are exceeded). Therefore $S_1 + 3S_2$ is a linear weighted combination of S_1 and S_2 . Since both are expected to range from 0 to 3000, $(S_1 + 3S_2)$ could range from 0 to 12,000. By dividing $S_1 + 3S_2$ by 120, the range would be from 0 to 100; e.g.,

$$0 \leq \frac{S_1 + 3S_2}{120} \leq 100$$

Since this is an error-measure (the higher the value the worse, theoretically at least, the performance), we can convert it to a score by subtracting it from 100; e.g.,

$$0 \leq 100 - \frac{S_1 + 3S_2}{120} \leq 100$$

The combined theoretical measures, each derived as explained above, are presented below for each of several measurable characteristics of performance. They are referred to as "scores" because of the scaling applied, but essentially they are measures of performance computed by combining various individual theoretical measures.

Degree-of-Bank Score (DBS). Measure of how well the pilot's bank angle compares with ATC criteria as a function of degrees of turn. (Separate measure for each half of maneuver.)

$$DBS = 100 - \frac{S_1 + 3S_2}{120}$$

Pitch Angle Score (PAS). Measure of how well the pilot's pitch angle compares with ATC criteria as a function of degrees of turn. (Separate measures for each half of maneuver.)

$$PAS = 100 - \frac{S_3 + 3S_4}{120}$$

Vertical Velocity Score 1 (VVS1). Measure of how well the pilot's transitions from climb to descent, and the reverse, are synchronized with the 0, 90, and 180° turn points. (Separate measures for each half of maneuver.)

$$VVS1 = 100 - \frac{S_5 + 3S_6}{225}$$

Vertical Velocity Score 2 (VVS2). Measure of how well the pilot's transition from descent to level flight (momentarily) at the 180° turn point is synchronized with his transition to a zero bank angle. (Separate measures for each half of maneuver.)

$$VVS2 = 100 - 5.8 S_7$$

Airspeed Score (ASS). Measure of how well the pilot's airspeed at the 0, 90, and 180° turn points compares with ATC criteria, and how well his airspeed throughout the maneuver remains within the bounds specified by ATC. (Separate measures for each half of maneuver.)

$$ASS = 100 - \frac{S_8 + 4(S_9 + S_{10} + S_{11})}{8}$$

Altitude Score 1 (AS1). Measure of the symmetry of the pilot's performance of the maneuver as judged by comparing his altitudes at the 0 and 180° turn points, the 0 and 360° turn points, and the 90 and 270° turn points. (One measure for entire maneuver.)

$$AS1 = 100 - \frac{S_{12} + S_{13} + S_{14}}{36}$$

Altitude Score 2 (AS2). Measure comparing the maximum altitude in the entire maneuver with the altitude attained at the 90° turn point; and comparing the degrees of turn achieved when the highest altitude was attained with 90°. (Separate measures for each half of maneuver.)

$$AS2 = 100 - \frac{S_{15} + S_{16}}{14.7}$$

g force Score (GFS). Measure of how well pilot's g force at start and end of maneuver remained within bounds specified by ATC. (One measure for entire maneuver.)

$$GFS = 100 - 5.5 (S_{17} + S_{18})$$

RPM Score (RPMS). Measure of how well pilot maintains the required RPM on both engines throughout the maneuver. (Separate measures for each half of maneuver.)

$$RPMS = 100 - 0.53 S_{19}$$

Total Score. Measure how well all of the criteria are satisfied.

$$\begin{aligned} \text{SCORE} = \frac{1}{\text{TOT}^*} & \left[7 ((\text{DBS}) + (\text{PAS})) + 6 (\text{AS1}) \right. \\ & + 5 (\text{AS2}) + 4 (\text{VVS1} + \text{VVS2}^*) + 3 (\text{ASS}) \\ & \left. + 2 (\text{RPMS}) + \text{GFS} \right] (100) \end{aligned}$$

$$\text{where } \text{VVS2}^* = \begin{cases} \text{VVS2}, & \text{VVS2} \leq 100 \\ 0, & \text{VVS2} > 100 \end{cases}$$

$$\text{and } \text{TOT}^* = \begin{cases} 3900, & \text{VVS2} \leq 100 \\ 3500, & \text{VVS2} > 100 \end{cases}$$

Miscellaneous Data

1. Time to complete maneuver
2. Maximum and minimum pitch angles in each half of maneuver
3. Maximum altitude and corresponding T
4. Number of data samples in each half of maneuver
5. Number of inflections in the roll and pitch curves
6. The S_i measures averages over the entire maneuver.

(2) Barrel Roll

In a manner similar to that for the lazy 8, individual theoretical measures for the barrel roll will be described first, treating each of the following measurement variables independently: attitude, RPM, airspeed, g's, and roll rate. Following the individual measures, combined measures will be described.

(a) Attitude

Possibly the most pertinent performance measure for this maneuver is one reflecting the pilot's skill in attitude control, i.e., skill in maintaining a constant angle, θ , between the pilot's line of sight to the selected reference point and the pilot's line of sight projected forward and parallel to the longitudinal axis of the aircraft. This angle must remain constant throughout 360° of continuous roll, the suggested error tolerance being $\pm 10\%$.

The major difficulty of measuring this aspect of the performance is that no method exists, on the basis of the recorded flight data, for determining the location of the selected reference point. Therefore, the criterion angle, θ , and the criterion flight path are both nebulous.

Three approaches were developed for measuring this part of the performance. One involves computing two projected criterion flight paths on the bases of certain key measures taken at various points during the maneuver. Measures based upon each projected criterion flight path are made. The second approach involves taking a number of measures throughout the maneuver which check the symmetry of the flight path. The third approach involves computing a projected criterion flight path based upon a type of "best fit" of a correctly shaped flight path to the observed flight path. These three approaches are described below.

Attitude Measure A. This measure begins with the computation of two projected criterion flight paths, each of which is based on the assumption that two of the pilot's actual attitudes are correct.

AFHRL-TR-72-6

Let H_1 = the pilot's initial heading

H_2 = the heading attained during the maneuver which differs most, in absolute value, from H_1

and P_1 = the pilot's largest positive pitch angle.

It is hypothesized that in the perfect maneuver, a plot of heading versus pitch angle, suitably scaled, should result in a perfect circle. What we do not know about this criterion circle is its size, although we know it must pass through the point $(H_1, 0)$, i.e., the starting position for heading and pitch angle.

To construct a projected criterion circle, we may use the starting position and one other position. For one criterion circle, we select H_1 and H_2 . This assumes that the pilot's heading is correct at (1) the start of the maneuver and (2) the end of the second quarter of the maneuver. The criterion circle would thus have its center heading at

$$C_1 = \frac{1}{2} \left([H_1 + H_2] \text{ MOD } 360 \right)$$

and would have a radius of

$$R_1 = \begin{cases} |H_1 - C_1|, & |H_1 - C_1| \leq 180 \\ |360 - H_1 + C_1|, & |H_1 - C_1| > 180 \end{cases}$$

Let X_i = sampled heading at $T = i$

Y_i = sampled pitch angle at $T = i$

Then the criterion circle is

$$(X_i - C_1)^2 + Y_i^2 = R_1^2 \quad (3)$$

Now, to construct a second (alternative) projected criterion circle, we may use the starting position, H_1 , and the pilot's largest positive pitch angle, P_1 . This assumes that (1) the pilot's heading is correct at the start of the maneuver, and (2) the pilot's pitch is correct at the end of the first quarter of the maneuver.

AFHRL-TR-72-6

This criterion circle would have its center heading at $C_2 = B$, where B is the heading held when P_1 is recorded. The radius of the circle would be $R_2 = P_1$.

Then the second criterion circle is

$$(x_1 - C_2)^2 + y_1^2 = R_2^2 \quad (4)$$

The measure we want is the variance of the actual flight path from each of the alternative criterion circles:

$$S_1 = \int_0^T |R_1^2 - (x_1 - C_1)^2 - y_1^2| dT \quad (5)$$

$$S_2 = \int_0^T |R_2^2 - (x_1 - C_2)^2 - y_1^2| dT \quad (6)$$

Attitude Measure B. This attitude measure checks the symmetry of the performed maneuver. First we define the following:

H_1 = initial heading

H_2 = heading when bank first becomes 90°

H_3 = heading when bank becomes 180°

H_4 = heading when bank becomes 270°

H_5 = heading when bank returns to 0°

P_1 = initial pitch angle

P_2 = pitch angle when bank becomes 90°

P_3 = pitch angle when bank becomes 180°

P_4 = pitch angle when bank becomes 270°

P_5 = pitch angle when bank returns to 0°

For perfect symmetry in the maneuver, the following should hold:

1. $|H_1 - H_2| \text{ MOD } 360 = |H_3 - H_2| \text{ MOD } 360$
2. $H_1 = H_5$
3. $H_2 = H_4$
4. $P_1 = P_3 = P_5 = 0$
5. $|P_2| = |P_4|$
6. $20^\circ \leq |H_2 - H_1| \text{ MOD } 360 \leq 30^\circ$
7. $P_2 > P_1 \vee P_3 \vee P_4 \vee P_5$
8. $P_4 < P_1 \vee P_2 \vee P_3 \vee P_5$
9. ALT when H_1 is obtained = ALT when H_3 is attained
10. $| \text{ALT when } H_1 \text{ is obtained} - \text{MAX ALT} |$
 $= | \text{ALT when } H_1 \text{ is obtained} - \text{MIN ALT} |$

The specific measures to be taken to reflect the degree to which the above criteria are met are given below:

1. $S_3 = \left| |H_1 - H_2| \text{ MOD } 360 - |H_3 - H_2| \text{ MOD } 360 \right|$
(Checks heading symmetry for half of maneuver.)
2. $S_4 = |H_1 - H_5| \text{ MOD } 360$
(Checks heading equality at start and end of maneuver.)
3. $S_5 = |H_2 - H_4| \text{ MOD } 360$
(Checks heading symmetry at 90° and 270° Roll points.)
4. $S_6 = |P_1| + |P_3| + |P_5|$
(Checks that Pitch = 0 when it should.)
5. $S_7 = \left| |P_2| - |P_4| \right|$
(Checks for pitch symmetry.)
6. $S_8 = \begin{cases} 0, & 20^\circ \leq |H_2 - H_1| \text{ MOD } 360 \leq 30^\circ \\ \left| |H_2 - H_1| \text{ MOD } 360 - 20 \right|, & |H_2 - H_1| \text{ MOD } 360 < 20^\circ \\ \left| |H_2 - H_1| \text{ MOD } 360 - 30 \right|, & |H_2 - H_1| \text{ MOD } 360 > 30^\circ \end{cases}$

(Checks that reference point is initially 20 to 30° off the longitudinal axis of the aircraft.)

$$7. S_9 = | \text{MAX } (P_i) - P_2 | \quad (i = 1, 3, 4, 5 \text{ if } \text{MAX} > P_2; \text{ else } 0)$$

(Checks that MAX Pitch is achieved at Roll = 90°.)

$$8. S_{10} = | P_4 - \text{MIN } P_i | \quad (i = 1, 2, 3, 5 \text{ if } \text{MIN} < P_4; \text{ else } 0)$$

(Checks that MIN Pitch is achieved at Roll = 270°.)

$$9. S_{11} = | \text{ALT}_a - \text{ALT}_b | \quad \text{where } \text{ALT}_a = \text{ALT at } H_1 \\ \text{and } \text{ALT}_b = \text{ALT at } H_3$$

(Checks for altitude symmetry.)

$$10. S_{12} = \left| | \text{ALT}_a - \text{ALT}_x | - | \text{ALT}_a - \text{ALT}_n | \right|$$

where $\text{ALT}_x = \text{MAX ALT}$

and $\text{ALT}_n = \text{MIN ALT}$

(Check for altitude symmetry.)

Attitude Measure C. This attitude measure involves computing a projected criterion flight path based upon a type of "best fit" of a correctly shaped flight path to the observed flight path. The major assumption is that the starting point for the maneuver is accurate. This is reasonable, since the pilot selects his own starting point in relation to his reference point, or vice versa. Surely, the true criterion flight path is a circle passing through the starting point H_1 . Furthermore, a diameter of the circle passes through H_1 and is parallel to the earth. Figure 16 illustrates some of the possible criterion flight paths based on this information alone. The idea here is to compute a single criterion flight path, and the method selected for so doing is to minimize the integral error between the observed flight path and the criterion. Figure 17 illustrates several hypothetical observed flight paths and the approximate criterion flight path that would be computed in each case.

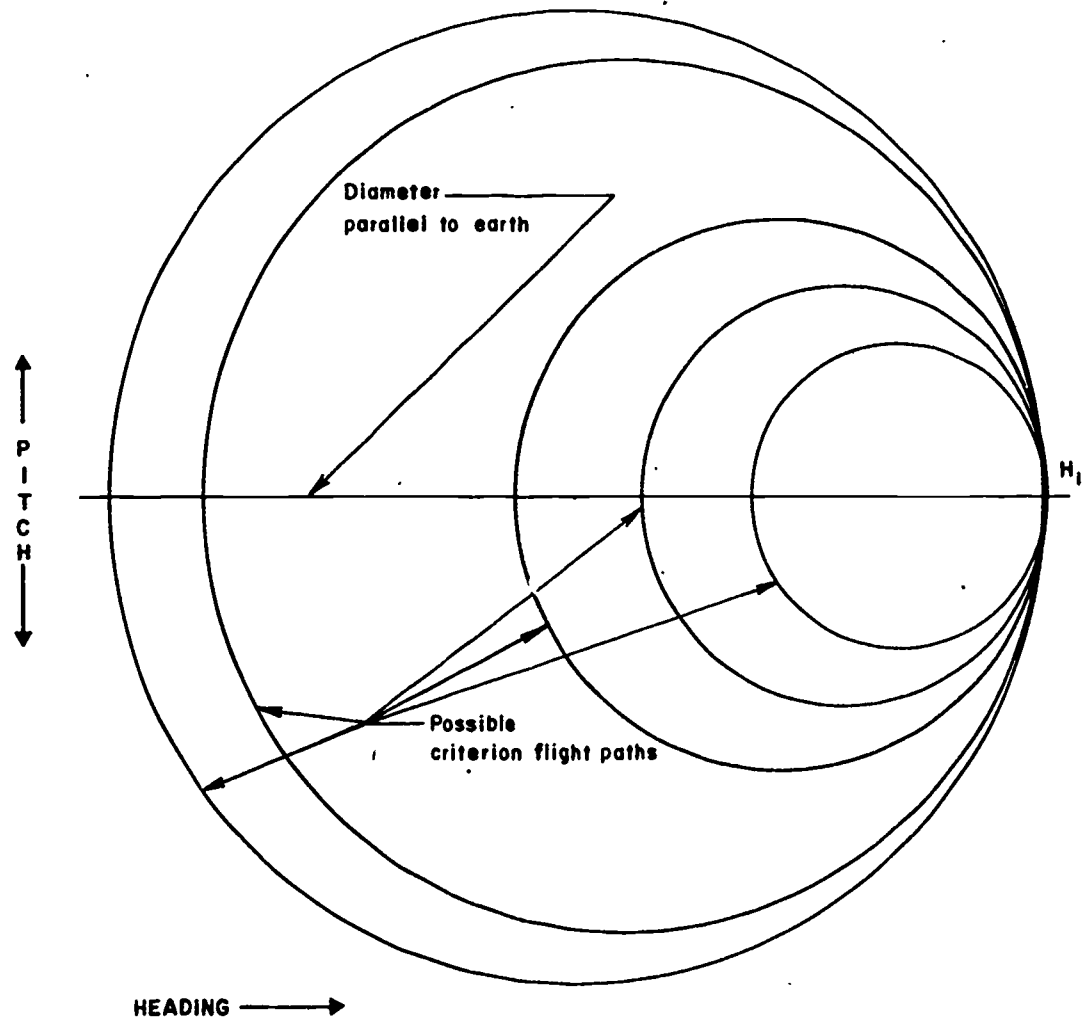

Figure 16. Possible Criterion Flight Paths for Barrel Roll

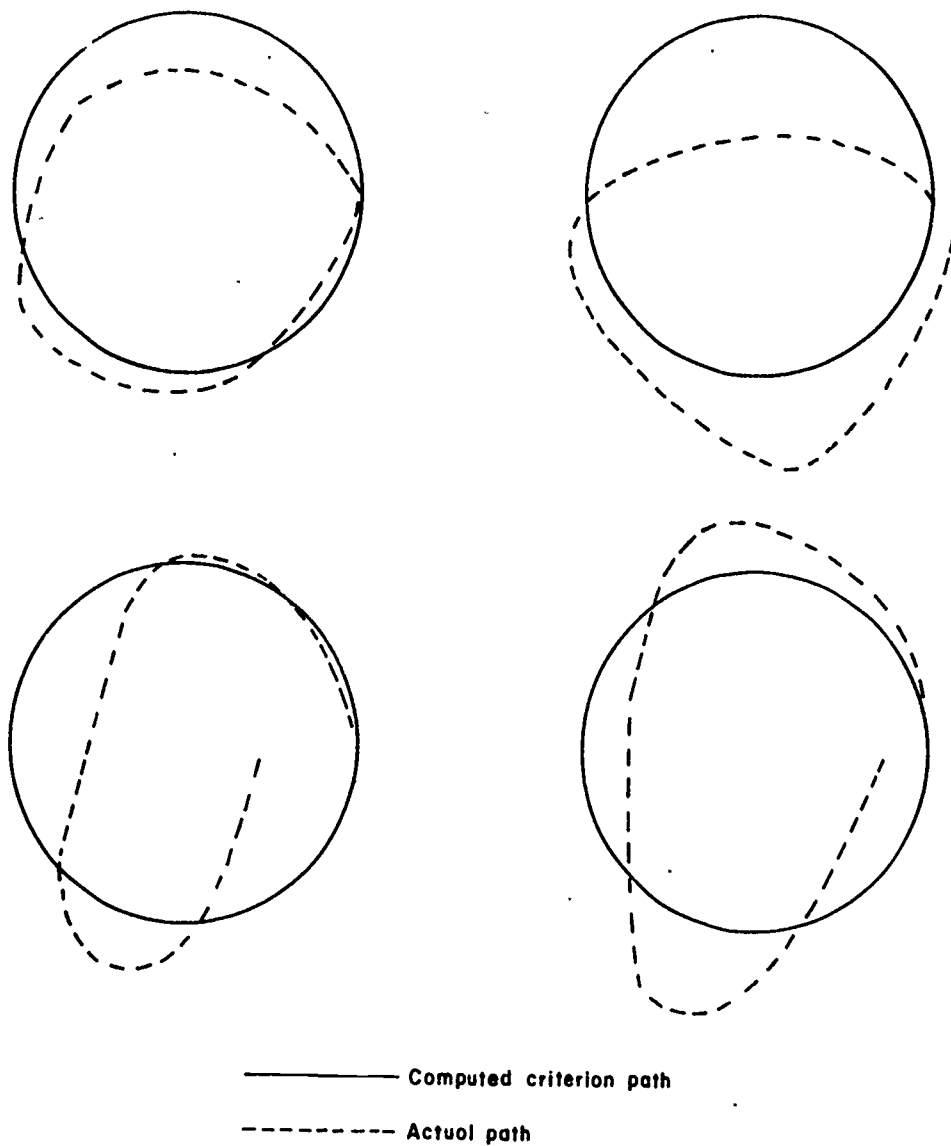

Figure 17. Criterion vs Actual Flight Paths for Barrel Roll

AFHRL-TR-72-6

Let X_i = observed heading at $T = i$

Y_i = observed pitch angle at $T = i$

H_1 = heading at start of maneuver

and R = radius of the criterion circle.

Then the equation of the criterion circle is:

$$(X_i - [H_1 \pm R])^2 + Y_i^2 = R^2 \quad (7)$$

where R is unknown at the present and the + or - sign in the first term is determined by whether the barrel roll is performed to the right (+) or to the left (-). (In computing $H_1 \pm R$, appropriate modifications would need to be made if a crossing of 0° heading occurs, i.e., use modulo 360° .) Now we shall expand the terms in Equation 7 and solve for R in terms of X_i , Y_i , and H_1 :

$$X_i^2 + [H_1 \pm R]^2 - 2 X_i [H_1 \pm R] + Y_i^2 = R^2$$

$$X_i^2 + H_1^2 + R^2 \pm 2 H_1 R - 2 H_1 X_i \mp 2 X_i R + Y_i^2 - R^2 = 0$$

$$\pm 2 H_1 R \mp 2 X_i R = 2 H_1 X_i - X_i^2 - H_1^2 - Y_i^2 \quad (8)$$

$$R = \frac{2 H_1 X_i - X_i^2 - H_1^2 - Y_i^2}{2 (\pm H_1 \mp X_i)}$$

Now the integral equation we wish to minimize in order to arrive at a value for R is

$$\int_0^T \left| R - \frac{2 H_1 X_i - X_i^2 - H_1^2 - Y_i^2}{2 (\pm H_1 \mp X_i)} \right| dT$$

AFHRL-TR-72-6

To do this, we select

$$R = \frac{1}{n} \sum_{i=1}^n \frac{2H_i X_i - X_i^2 - H_i^2 - Y_i^2}{2(\pm H_i \mp X_i)} \quad (9)$$

The measure desired is the variance of the actual flight path from the criterion circle, now fully determined by the derivation of R:

$$S_{13} = \int_0^T |R^2 - (X_i - [H_i \pm R])^2 - Y_i^2| dT$$

This is an integrated error measure of the deviation between criterion and actual flight paths, as determined by roll and heading angles.

(b) RPM

RPM must be maintained at 90% ($\pm 1\%$) throughout the maneuver. A straightforward measure may be taken:

Let

$$M_i = \begin{cases} |RPM_i - 90|, & |RPM_i - 90| \geq 1 \\ 0, & |RPM_i - 90| < 1 \end{cases}$$

where RPM_i is the actual value of RPM at $T = i$.

Then the RMS error is

$$S_{14} = \left(\frac{1}{n} \sum_{i=1}^n M_i^2 \right)^{\frac{1}{2}}$$

where n is the number of samples taken in which $M_i \neq 0$.

This measures the average RPM error when tolerances are exceeded.

(c) Airspeed

No definite restrictions are placed upon airspeed except during entry to the maneuver. On entry, airspeed must be at least

AFHRL-TR-72-6

200 knots and should not exceed 230 knots. Straightforward measures may be taken as follows:

Let T_1 and T_n represent the times at which entry to the maneuver is begun and completed, respectively. Let

$$M_1 = \max_{1 \leq i \leq n} |AIRSP_i - 200|$$

$$M_2 = \max_{1 \leq i \leq n} |AIRSP_i - 230|$$

Then compute

$$S_{15} = \begin{cases} 0, & AIRSP_i \geq 200 \\ M_1, & AIRSP_i < 200 \end{cases} \quad \begin{array}{l} \text{Entry airspeed deviation} \\ \text{under 200 knots.} \end{array}$$

$$S_{16} = \begin{cases} 0, & AIRSP_i \leq 230 \\ M_2, & AIRSP_i > 230 \end{cases} \quad \begin{array}{l} \text{Entry airspeed deviation} \\ \text{over 230 knots.} \end{array}$$

(d) g Force

.g-force is to be maintained at $1 \leq G \leq 4$ throughout the maneuver. The measure we shall take will reflect the integrated error on g when it exceeds the bounds, i.e., when $G < 1$ or $G > 4$.

$$S_{17} = \int_0^T D_G dT$$

$$\text{Where } D_G = \begin{cases} 0, & 1 \leq G \leq 4 \\ G - 4, & G > 4 \\ 1 - G, & G < 1 \end{cases}$$

(e) Roll Rate

Roll rate is to be held constant throughout the maneuver. A measure of constancy may be obtained by differentiating Roll Rate (RR) with respect to time. Thus, we shall compute

$$S_{18} = \frac{1}{n} \sum_{i=1}^n \left| \frac{dRR}{dT} \right| \quad \frac{\text{Measure of the constancy of roll rate.}}{\text{of roll rate.}}$$

(Note that the absolute value of the derivative is used to avoid term-cancelling.)

Table XII presents a summary of the measures S_1 through S_{18} (See Table XIII for a definition of terms used in the summary table.)

(f) Combined Theoretical Measures .

Figure 18 is a maneuver diagram for the barrel roll with indications of the portions of the maneuver checked by each experimental performance measure. The "continuous measures" indicated in Figure 18 are ones which monitor one or more performance variables every sampling instant over a discrete time interval. Other measures monitor performance variables at several discrete positions during the maneuver.

For experimental purposes, the following scaled measures and combinations thereof were computed and printed in addition to the individual S_i measures. As described in the section on the lazy 8, the weights were determined by the authors based on the judged criticality of individual measures; and scaling was performed to produce combined measures ranging from 0 to 100.

Entry Airspeed Score (EAS). Measure of how well the pilot holds the correct entry airspeed to the maneuver. Failure to hold at least 200 knots is weighted more heavily than failure to remain below 230 knots.

$$EAS = 100 - \frac{3S_{15} + S_{16}}{2}$$

TABLE XII
SUMMARY OF PERFORMANCE MEASURES FOR BARREL ROLL

No.	Variable	Measure	Expected Range	Beg. Cue ¹	End Cue ¹	Pass Count ²
1	Heading; Pitch	$\int_0^T R_1^2 - (x_1 - c_1)^2 - y_1^2 dt$	0 - 30,000	SQ1	EQ4	2
2	Heading; Pitch	$\int_0^T R_2^2 - (x_1 - c_2)^2 - y_1^2 dt$	0 - 30,000	SQ1	EQ4	2
3	Heading	$ H_1 - H_2 \text{ MOD } 360 - H_3 - H_2 \text{ MOD } 360$	0 - 30°	SQ1	EQ2	1
4	Heading	$ H_1 - H_5 \text{ MOD } 360$	0 - 60°	SQ1	EQ4	1
5	Heading	$ H_2 - H_4 \text{ MOD } 360$	0 - 60°	SQ2	EQ3	1
6	Pitch	$ P_1 + P_3 + P_5 $	0 - 90°	SQ1	EQ4	1
7	Pitch	$ P_2 - P_4 $	0 - 60°	SQ2	EQ3	1
8	Heading	$\begin{cases} 0, & 20^\circ \leq H_2 - H_1 \text{ MOD } 360 \leq 30^\circ \\ H_2 - H_1 \text{ MOD } 360 - 20, & H_2 - H_1 \text{ MOD } 360 < 20^\circ \\ H_2 - H_1 \text{ MOD } 360 - 30, & H_2 - H_1 \text{ MOD } 360 > 30^\circ \end{cases}$	0 - 30°	SQ1	EQ1	1
9	Pitch	$\text{MAX}(P_i) - P_2 \quad (i = 1, 3, 4, 5)$	0 - 60°	SQ1	EQ4	1
10	Pitch	$P_4 - \text{MIN}(P_i) \quad (i = 1, 2, 3, 5)$	0 - 60°	SQ1	EQ4	1

¹Beginning and end cues refer to start (S) or end (E) of quarters (Q) 1, 2, 3, or 4 of the maneuver.

²Estimated number of data-passes required in computing the measures

TABLE XII (Concluded)
SUMMARY OF PERFORMANCE MEASURES FOR BARREL ROLL

No.	Variable	Measure	Expected Range	Beg. Cue ¹	End Cue ¹	Pass Count ²
11	Altitude	$ ALT_a - ALT_b $	0 - 3000 ft	SQ1	EQ2	1
12	Altitude	$ ALT_a - ALT_x - ALT_a - ALT_n $	0 - 3000 ft	SQ1	EQ4	1
13	Heading; Pitch	$\int_0^T R^2 - (X_i - [H_1 \pm R])^2 - Y_i^2 dt$	0 - 30,000 ft	SQ1	EQ4	2
14	RPM	$\left(\frac{1}{n} \sum_{i=1}^n M_i^2 \right)^{1/2}$	0 - 10%	Entry	EQ4	1
15	Airspeed	$\left\{ \begin{array}{l} 0, \text{ Airsp}_i \geq 200 \\ M_2, \text{ Airsp}_i < 200 \end{array} \right\}$	0 - 50 kts	Start Entry	End Entry	1
16	Airspeed	$\left\{ \begin{array}{l} 0, \text{ Airsp}_i \leq 230 \\ M_3, \text{ Airsp}_i > 230 \end{array} \right\}$	0 - 50 kts	Start Entry	End Entry	1
17	g force	$\int_0^T D_G dt$	0 - 3T	Entry	EQ4	1
18	Roll rate	$\frac{1}{n} \sum_{i=1}^n \left \frac{dRR_i}{dt} \right $	0 - 10°/sec ²	SQ1	EQ4	1

TABLE XIII

DEFINITIONS OF TERMS USED IN TABLE XII

R_1	=	radius of computed criterion circle No. 1
X_i	=	sampled heading at $T = i$
C_1	=	center heading of computed criterion circle No. 1
Y_i	=	sampled pitch at $T = i$
R_2	=	radius of computed criterion circle No. 2
C_2	=	center heading of computed criterion circle No. 2
H_1	=	initial heading
H_2	=	heading when bank becomes 90°
H_3	=	heading when bank becomes 180°
H_4	=	heading when bank becomes 270°
H_5	=	heading when bank returns to 0°
P_1	=	initial pitch angle
P_2	=	pitch angle when bank becomes 90°
P_3	=	pitch angle when bank becomes 180°
P_4	=	pitch angle when bank becomes 270°
P_5	=	pitch angle when bank returns to 0°
ALT_a	=	altitude when H_1 is obtained
ALT_B	=	altitude when H_3 is obtained
ALT_x	=	maximum altitude obtained
ALT_n	=	minimum altitude obtained
R	=	radius of computed criterion circle No. 3
M_i	=	$\begin{cases} RPM_i - 90, & RPM_i - 90 \geq 1 \\ 0, & RPM_i - 90 < 1 \end{cases}$
M_2	=	$\text{MAX}_{1 \leq i \leq n} AIRSP_i - 200 $

AFHRL-TR-72-6

TABLE XIII (Concluded)
DEFINITION OF TERMS USED IN TABLE XII

$$M_3 = \max_{1 \leq i \leq n} | \text{AIRSP}_i - 230 |$$

$$D_g = \left\{ \begin{array}{ll} 0, & 1 \leq G \leq 4 \\ G - 4, & G > 4 \\ 1 - G, & G < 1 \end{array} \right\}$$

RR_i = roll rate at i th sampling instant

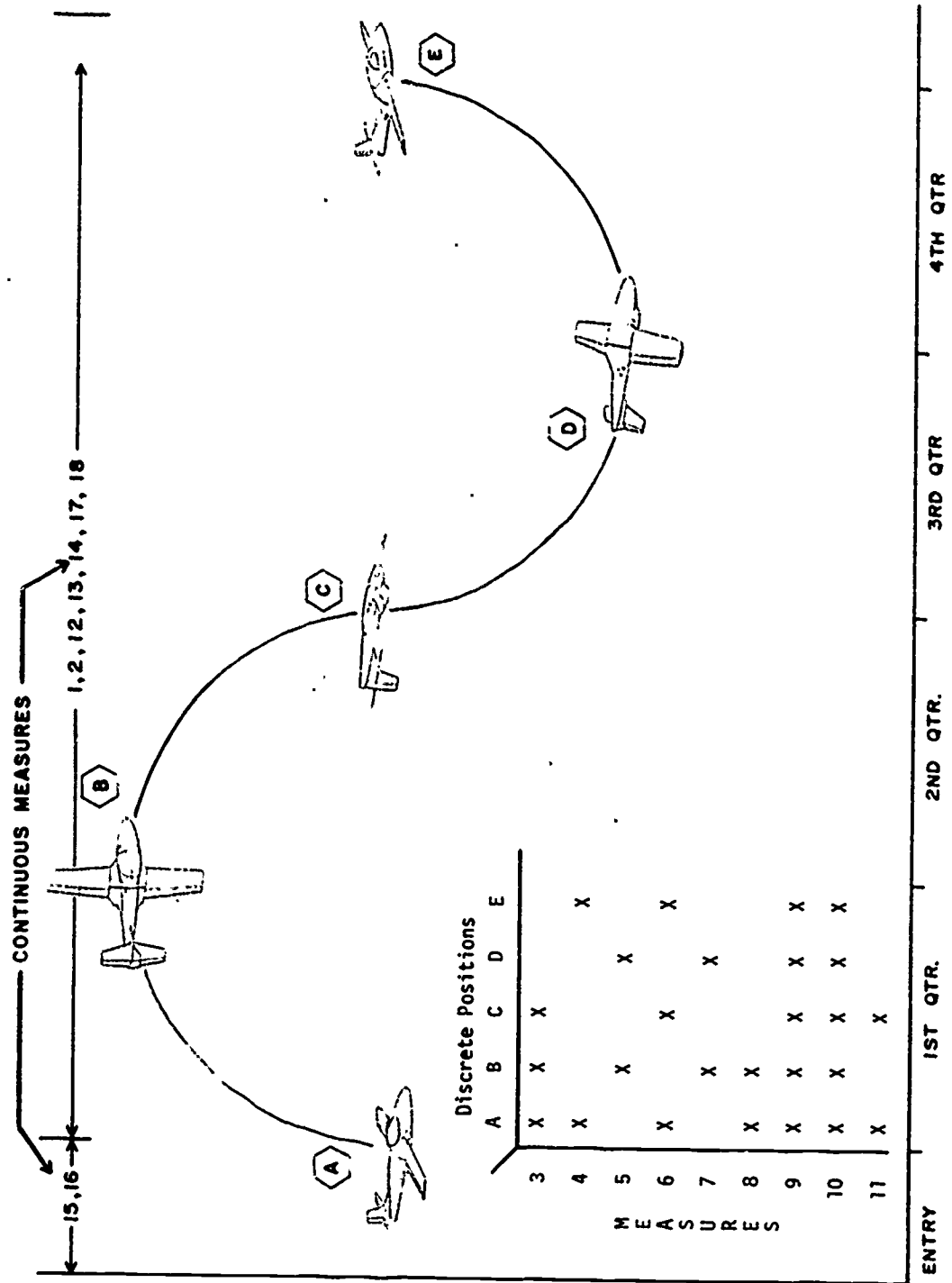

Figure 18. Barrel Roll Maneuver Diagram

Attitude Score 1 (AS1). Measure of how well the pilot's flight path compares with a criterion flight path based on the assumption that the pilot's attitude and position are optimum at the start of the maneuver and at the end of the second quarter.

$$AS1 = 100 - \frac{S_1}{300}$$

Attitude Score 2 (AS2). Measure of how well the pilot's flight path compares with a criterion flight path based on the assumption that the pilot's attitude and position are optimum at the start of the maneuver and the end of the first quarter.

$$AS2 = 100 - \frac{S_2}{300}$$

Attitude Score 3 [Heading] (AS3H). Measure of the symmetry of the pilot's performance of the maneuver as judged by aircraft heading at various points. This includes checks on (a) comparison of heading change over first and second quarters; (b) comparison of headings at start and end of maneuver; (c) comparison of headings at "top" and "bottom" of maneuver; and (d) the pilot's reference angle to the chosen reference point.

$$AS3H = 100 - \frac{4S_3 + 3S_4 + 2S_5 + S_6}{4.5}$$

Attitude Score 3 Pitch (AS3P). Measure of the symmetry of the pilot's performance of the maneuver as judged by aircraft pitch angle at various points. This includes checks on (a) zero pitch at 0, 180, and 360° roll points; (b) comparison of pitch magnitudes at "top" and "bottom" of maneuver; (c) whether maximum and minimum pitch angles are attained at the 90 and 270° roll points, respectively.

$$AS3P = 100 - \frac{3S_7 + 2S_9 + 2S_{10} + S_6}{5.1}$$

Attitude Score 3 [Altitude] (AS3A). Measure of the symmetry of the pilot's performance of the maneuver as judged by aircraft altitude at various points. This includes checks on (a) altitude at 0 and 180° roll points and (b) comparison of the maximum and minimum altitude excursion with respect to the starting altitude.

$$AS3A = 100 - \frac{S_{11} + S_{12}}{60}$$

Attitude Score 3 [Total] (AS3T). Measure of the symmetry of the pilot's performance of the maneuver as judged by aircraft heading, pitch angle, and altitude at various points. This is composed of a scaled combination of the preceding three attitude measures.

$$AS3T = \frac{AS3H + AS3P + AS3A}{3}$$

RPM Score (RPMS). Measure of how well the pilot achieves and maintains the required RPM on both engines throughout the maneuver.

$$RPMS = 100 - 10 S_{14}$$

g Force Score (GFS). Measure reflecting the amount by which the pilot exceeds the g-limits during the maneuver.

$$GFS = 100 - \frac{100 S_{17}}{3T}$$

where T = total time to complete maneuver (seconds).

Roll Rate Score (RRS). Measure of the constancy of roll rate throughout the maneuver.

$$RRS = 100 - \frac{S_{18}}{15}$$

Attitude Score 4 (AS4). Measure of how well the pilot's flight path compares with a criterion flight path based on a "best fit" of a correctly shaped flight path to the actual performance.

$$AS4 = 100 - \frac{S_{13}}{300}$$

AFHRL-TR-72-6

Total Score. Measures how well all criteria are met.

$$\text{SCORE} = \frac{1}{29} \left[6(\text{AS4}) + 5(\text{AS3T}) + 4(\text{RRS}) \right. \\ \left. + 4(\text{AS1}) + 4(\text{AS2}) + 3(\text{GFS}) + 2(\text{EAS}) + \text{RPMS} \right]$$

Miscellaneous Data:

1. Time to complete maneuver
2. Center headings of criterion circles 1 and 2
3. Radius of criterion circle 3
4. $H_1 - H_5$
5. $P_1 - P_5$

b. Software Implementation

(1) Lazy 8 Program

A lazy 8 measurement program consisting of an executive routine and a large subroutine was written in FORTRAN IV and implemented on an IBM 7094 computer. The executive routine required approximately 300 FORTRAN statements and performed the following major functions:

1. Search magnetic tape for the event number corresponding to the maneuver to be analyzed.
2. Read the data.
3. Generate basic plotting data.
4. Print all pertinent data at intervals of 1/2 second.
5. Call the measurement subroutine that computes the theoretical measures described previously.

A listing of the executive routine is provided in Appendix VI.

AFHRL-TR-72-6

The plotting data generated were for producing plots of the following variables:

1. Roll vs Pitch
2. Roll and Pitch vs Time
3. Altitude vs Time
4. Airspeed vs Time
5. Heading vs Time
6. Approximate Ground Track⁶
7. Cockpit Stick Position

The data selected for print-out at two samples per second are:

1. Roll
2. Pitch
3. Heading
4. Altitude
5. Airspeed
6. Left RPM
7. Right RPM
8. Longitudinal Stick Position
9. Lateral Stick Position
10. Degrees of Turn into Maneuver
11. Approximate Ground-Speed
12. Vector for Computing Ground Track (ALTX)
13. Acceleration

⁶This plot was generated using heading and a computed, approximate groundspeed (GS). The GS was calculated using simple trigonometric functions for the airspeed vector and pitch angle, and is accurate only for no-wind, small-angle-of-attack conditions.

AFHRL-TR-72-6

The measurement subroutine required about 500 FORTRAN statements and performed the function of computing and printing the theoretical performance measures.

Program execution required setup of two magnetic tapes, one of which contained the calibrated flight data and the other of which was a scratch tape for plotting-data. Program execution resulted in generation of (1) a plotting-tape, (2) data print-out, (3) theoretical measures, and (4) an estimate of the time requirement for the off-line plotting job. Subsequently, a request for plotting had to be submitted. Plotting time for each of the seven plots averaged 10.8 minutes, using a Calcomp magnetic tape plotting system (30-inch drum).

(2) Barrel Roll Program

The barrel roll measurement program was implemented analogously to that for the lazy 8. The executive routine was nearly identical, the major differences being (1) a change in one of the plots produced, i.e., heading vs pitch instead of roll vs pitch; and (2) the variables were printed at 10 per second instead of 2 per second.

The measurement subroutine required about 300 FORTRAN statements. The major functions of the subroutine are described in Appendix VII.

Program execution procedures were the same as those described for the lazy 8 program.

(3) Initial Tests

Initial tests were made by analyzing the theoretical measurement program results of approximately 30 lazy 8 and barrel roll performances, flown by both Flight Test pilots and an instructor pilot. For each performance, a condensed print-out of critical variables, seven plots, and the previously described theoretically based measures were generated. This data was used in making a decision about formal analysis and measurement requirements for subsequent data to be collected in the study.

AFHRL-TR-72-6

Appendix VIII illustrates representative print-outs and theoretical measures from the lazy 8 and barrel roll measurement programs. In the illustrated print-out for the barrel roll, the reader will note that two columns are devoted to each of the angles roll, pitch, and heading. This was done to provide space for printing both the recorded angles and Euler angles, designed to be computed using recorded body-axis rates. This was considered desirable to perform a dual check on the recording of angular rates and the recorded angles. Unfortunately, one of the rate gyros developed problems during the study, and the Euler angles effort was abandoned to the priority of other matters. In the print-out, the columns containing all zeros were the ones intended to hold Euler angle data.

Figures 19 through 32 illustrate the set of plots produced for two sample lazy 8 performances. For each set of plots, indication is given thereon of the subjective rating assigned in-flight to the corresponding maneuver performance, the first having been rated a high "Good" and "Fair" for the second one. The performing pilot (a PIT instructor) illustrated typical performances and provided the subjective ratings himself subsequent to flying the maneuver.

Two of the plots deserve special comment. The stick-position plot emulates the movement of the control-stick as "viewed" from the pilot's position in the cockpit. The plot is generated by graphing lateral (right/left) versus longitudinal (fore/aft) stick position. The roll versus pitch plot is overlaid on a linearized approximation of ATC criteria, as specified in the maneuver analysis.

Early in the flight test and initial data analysis phase, it was realized that recorded aircraft heading (See Figures 24 and 31) would present problems. The directional gyro from which the recording was taken had the normal precession and lead-lag errors to be expected in an instrument of its type and age. As a result, true aircraft heading could, at best, be only estimated during and immediately after aerobatic maneuvers. In addition, the method of instrumentation technique for

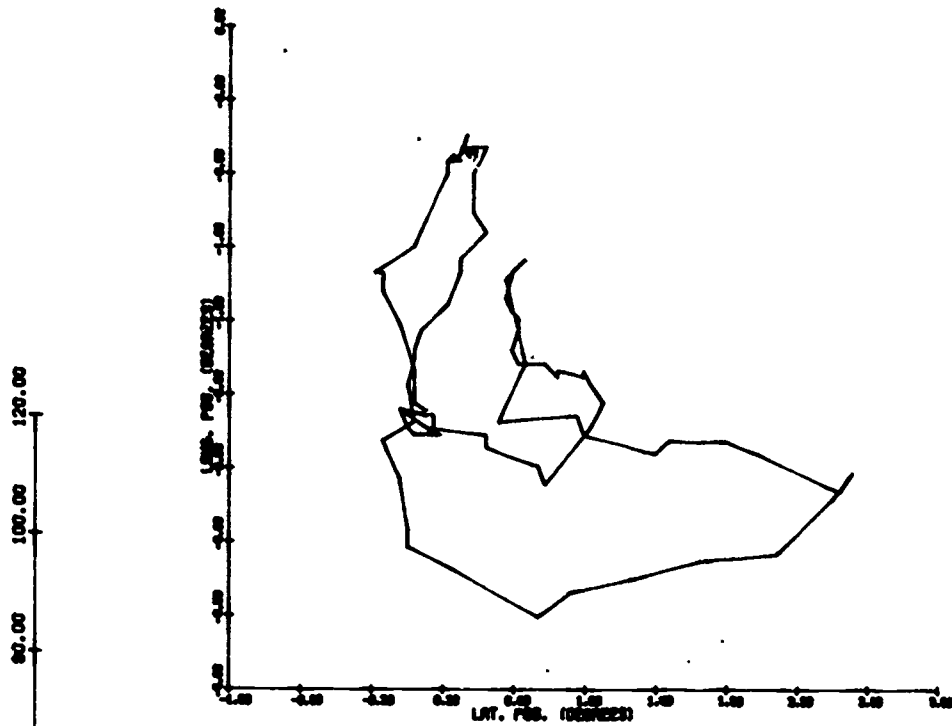

Figure 19. Stick Position Plot for Lazy 8

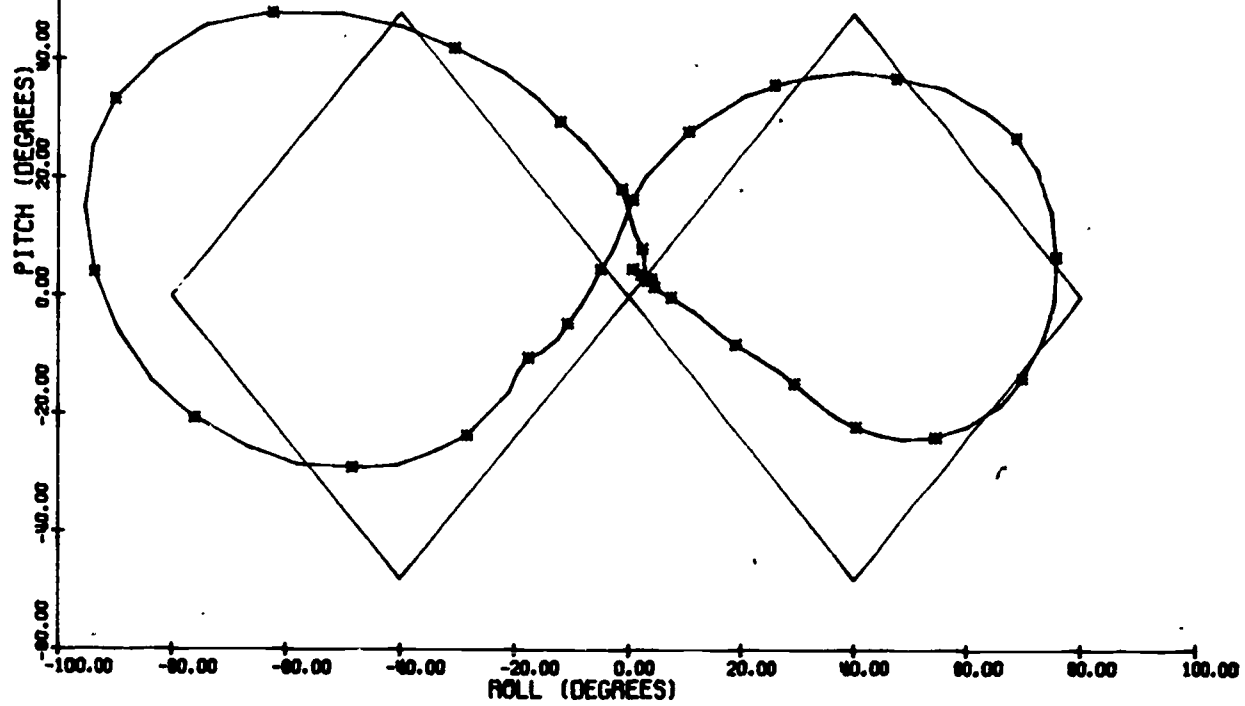

Figure 20. Roll vs Pitch for Lazy 8 (12-17-69-20/High Good)

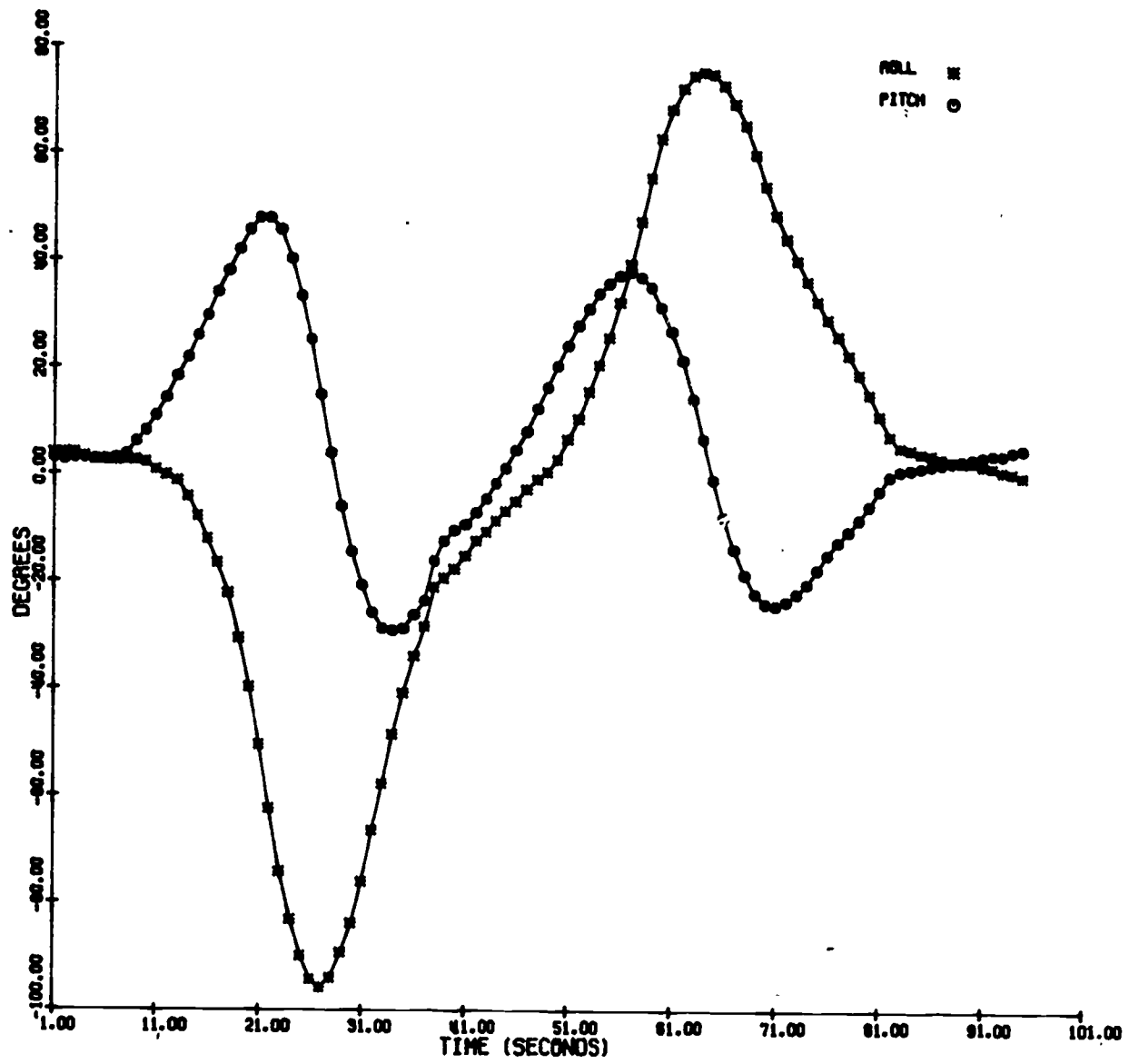

Figure 21. Roll and Pitch vs Time for Lazy 8

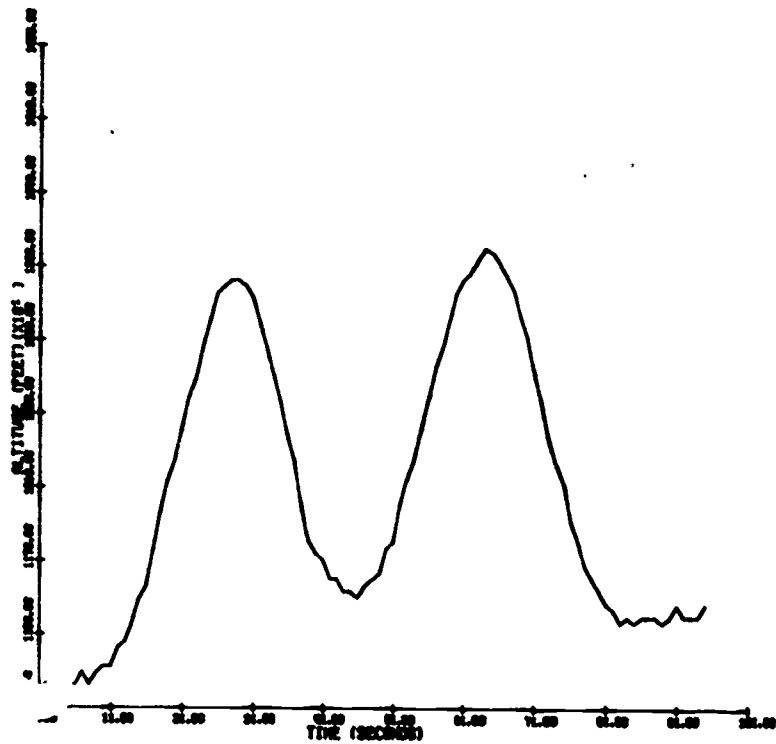

Figure 22. Altitude vs Time for Lazy 8

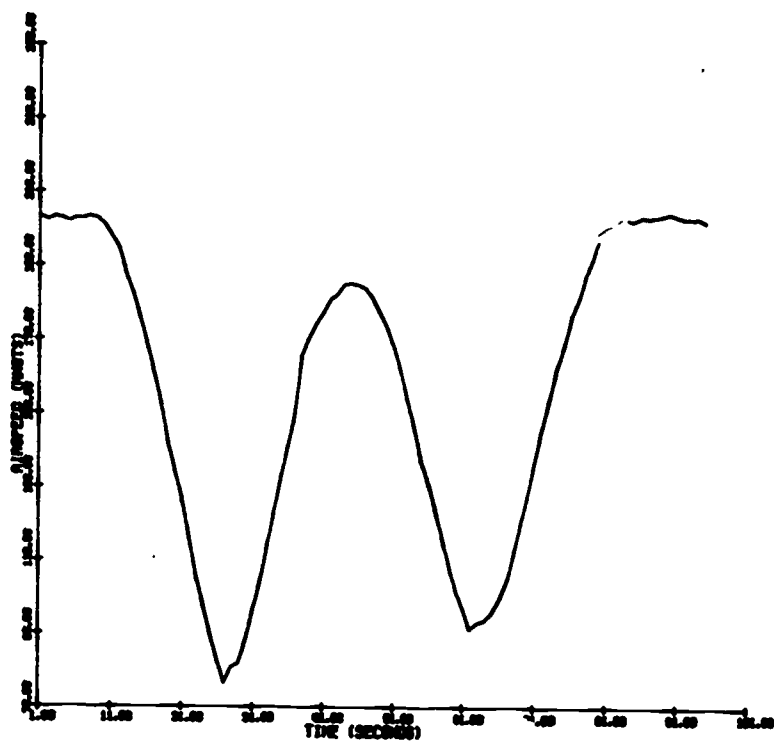

Figure 23. Airspeed vs Time for Lazy 8

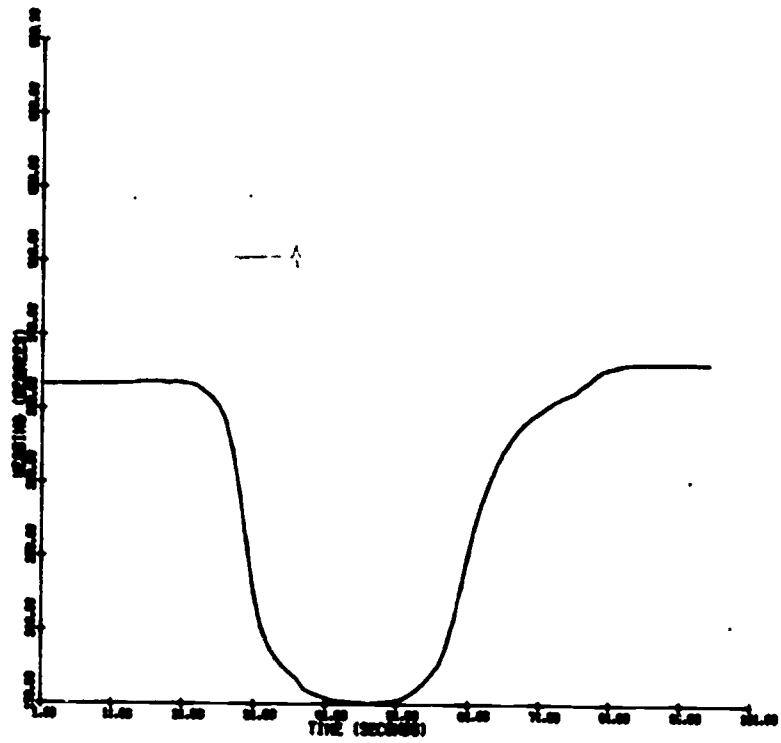

Figure 24. Heading vs Time for Lazy 8

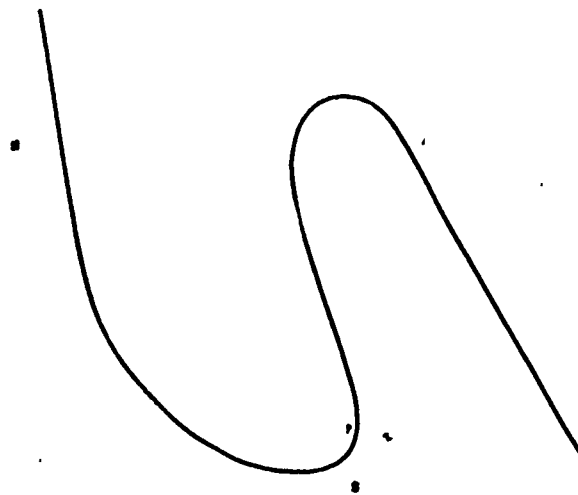

Figure 25. Ground Track for Lazy 8

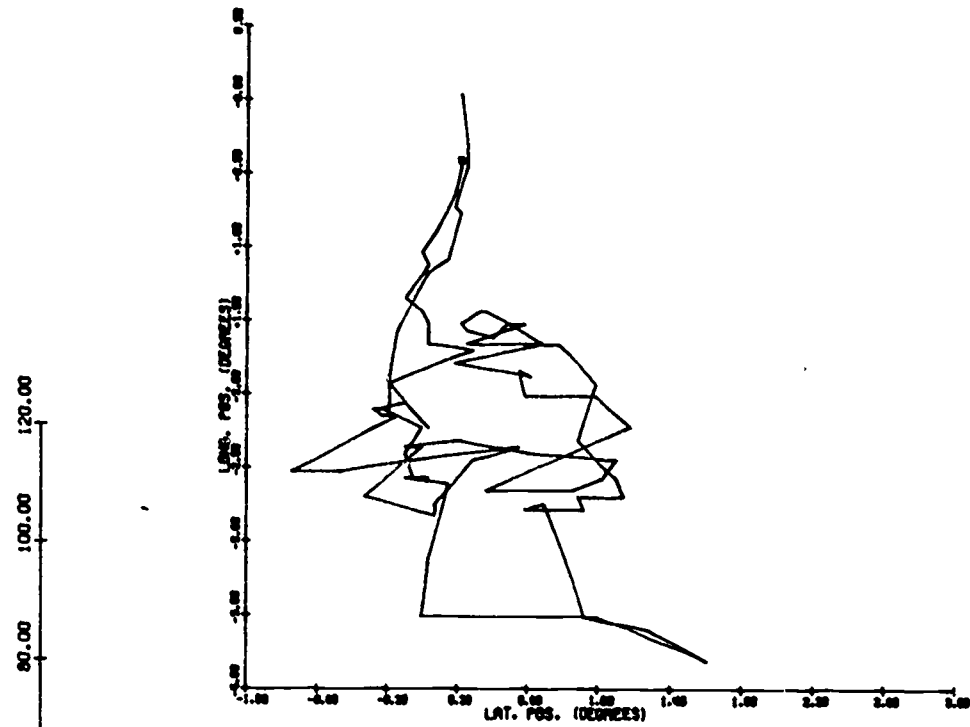

Figure 26. Stick Position Plot for Lazy 8

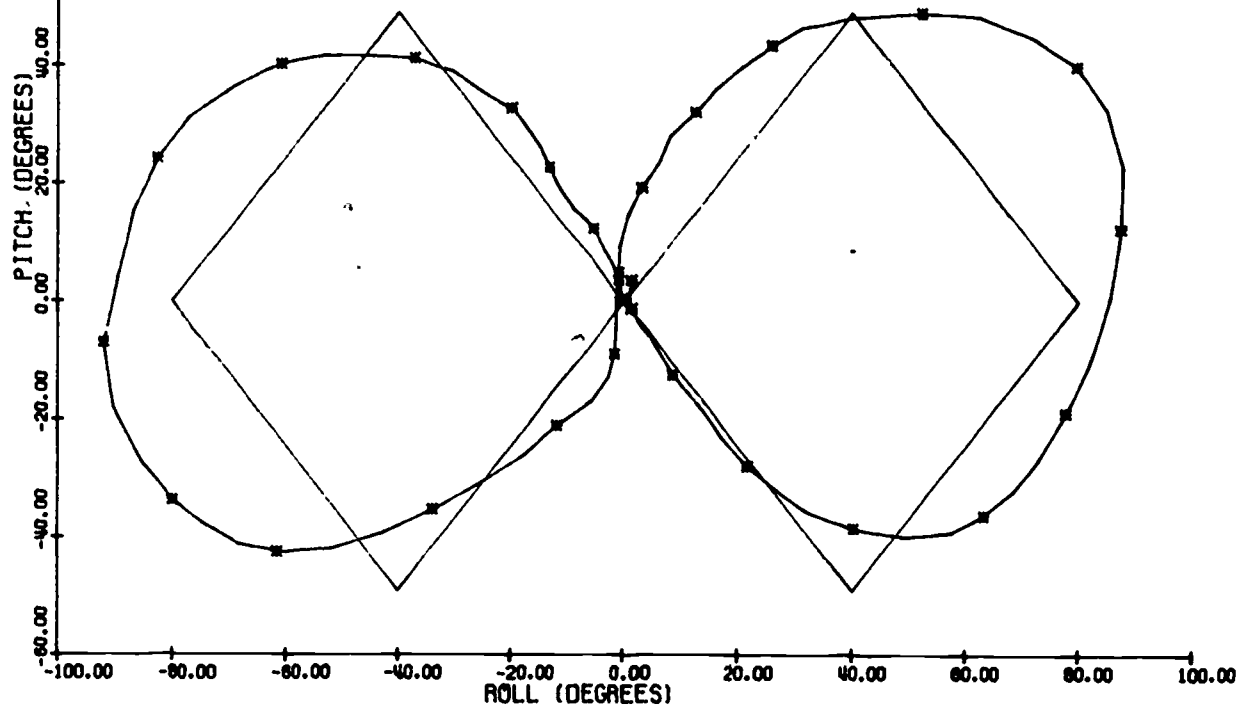

Figure 27. Roll vs Pitch for Lazy 8 (12-19-69-27/Fair)

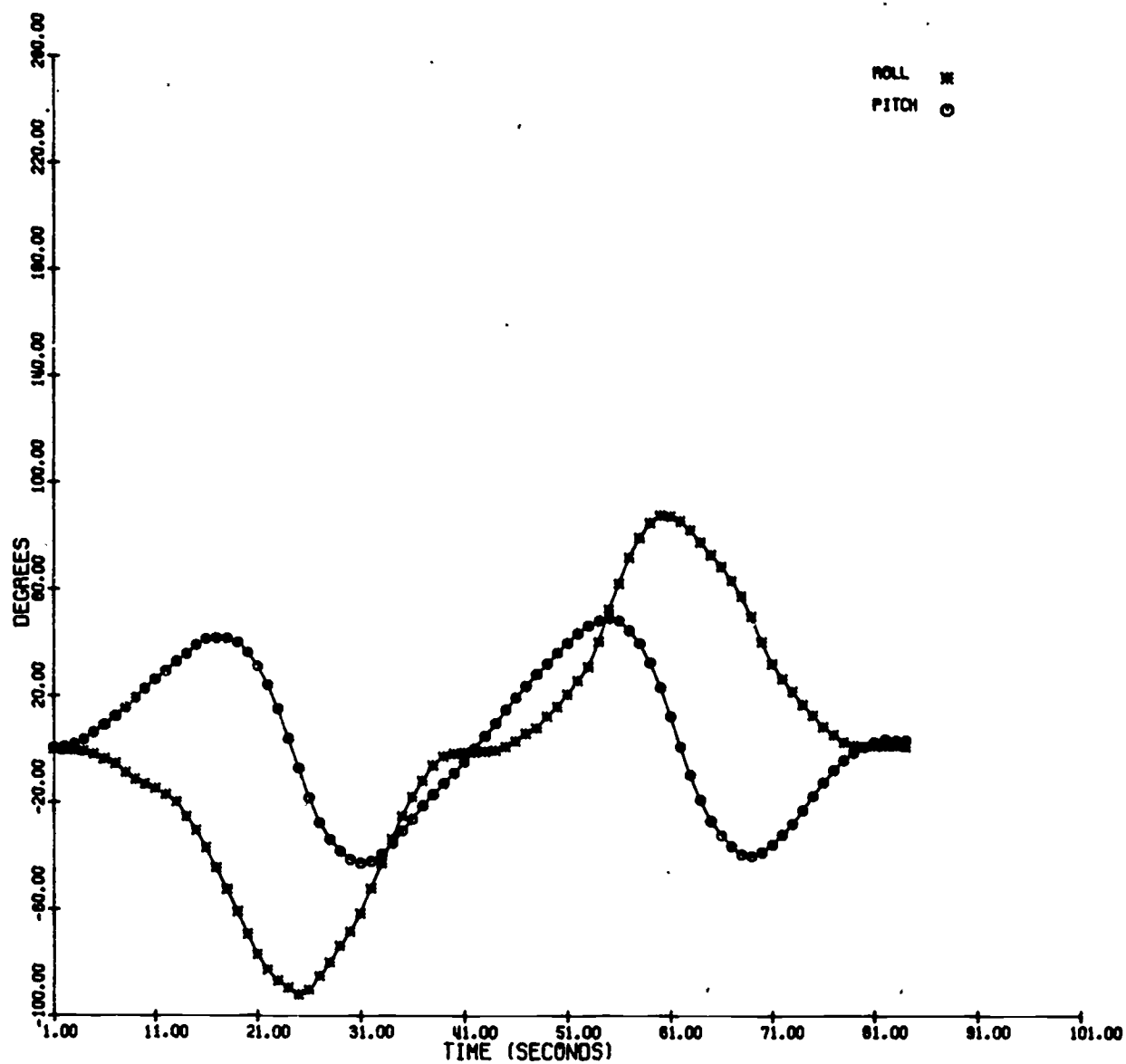

Figure 28. Roll and Pitch vs Time for Lazy 8

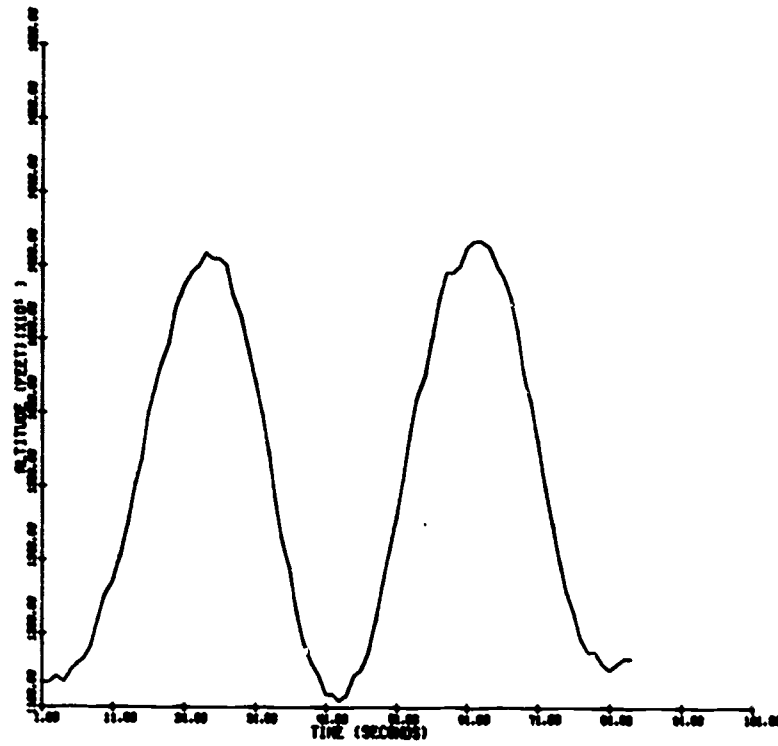

Figure 29. Altitude vs Time for Lazy 8

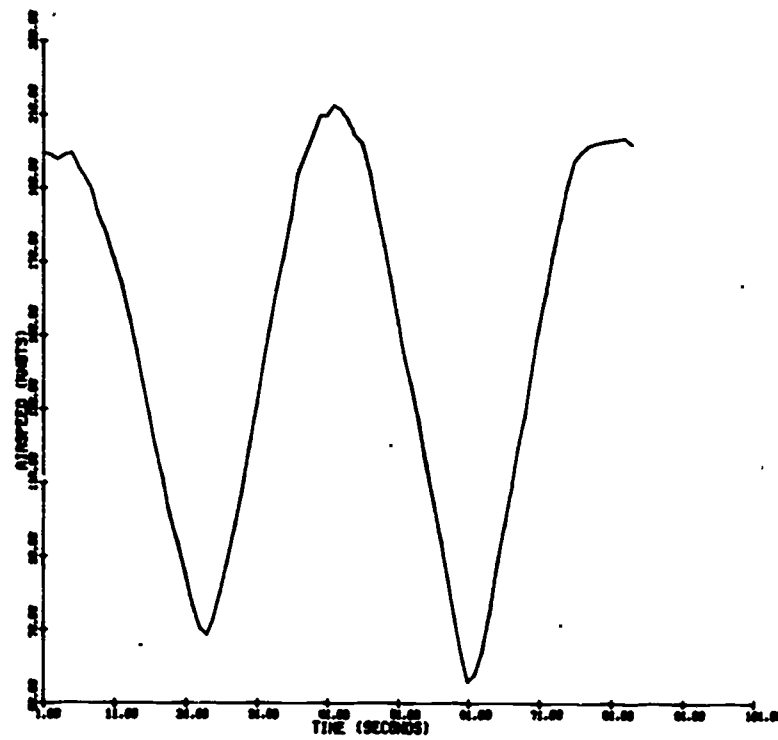

Figure 30. Airspeed vs Time for Lazy 8

AFHRL-TR-72-6

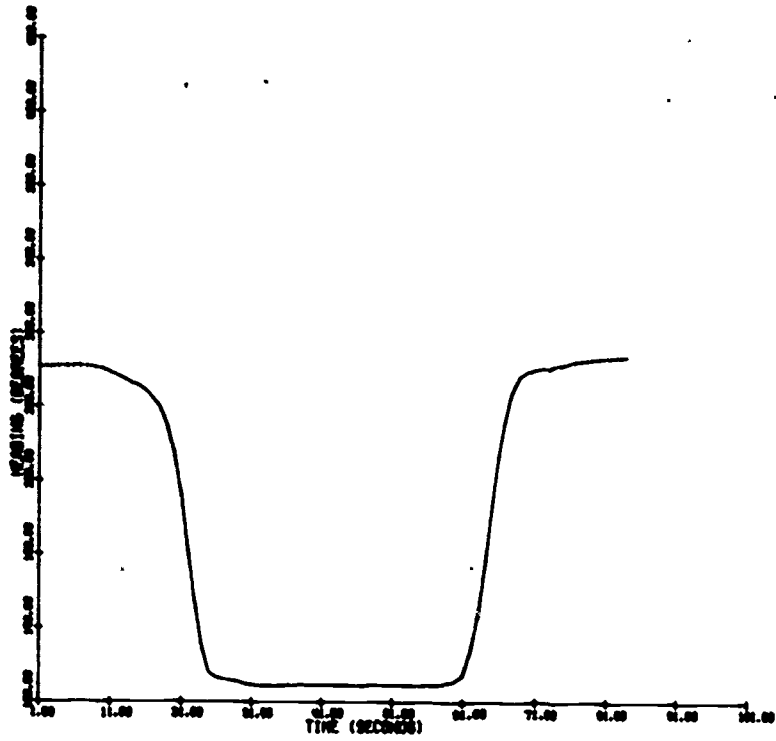

Figure 31. Heading vs Time for Lazy 8

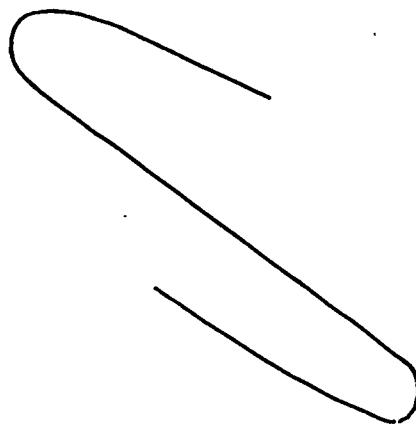

Figure 32. Ground Track for Lazy 8

AFHRL-TR-72-6

recording aircraft heading (See Section II) with the inherent limitation of the synchro-follower caused erroneous readings in the 0-90° arc.

Although the task-analysis data for the lazy 8 indicated that heading should be the basic measurement reference variable, we elected to omit it from the list of measurement variables for two reasons: (1) the problems experienced with its accurate recording, and the lack of time and money with which to correct the problems; and (2) the dependent nature of heading as a variable. We postulated that the variables roll, pitch, time, and airspeed would provide performance-relevant data which is inclusive of the information that aircraft heading provides. (In part, this was a rationalization of the problem at the time the decision was made; after-the-fact, however, it appears to have been a justifiable move considering the scope of the effort.)

Appendix IX illustrates nine additional sets of lazy 8 plots, excluding heading versus time and the heading-based plot of ground track. Again, the corresponding subjective ratings are indicated on the plots, and they are arranged in order of decreasing skill, as judged by the instructor pilot.

The theoretical measures and plots, such as those in Appendix IX, were used in making a number of the observations which helped to form a basis for specification and development of a revised measurement program. No attempt was made to thoroughly test the validity of the theoretical measures other than to correlate them superficially with the instructors' subjective ratings. Primarily, their usefulness consisted of supplementing the plots to provide a better descriptive indication of the nature of the performance and in providing a preliminary indication of the utility of ATC-criterion-referenced measures. The observations that were made will be discussed now through reference to the sample plots in Appendix IX, numbered consecutively 1-45 for aid in reference.

First consider the stick position plot. Selected plots of stick position were annotated by hand to show where various events took place, such as where the largest pitch angles occurred and where the maneuver was half-completed. The most significant observation was that as the aircraft initially approaches about 40 - 50° of turn in each half of the maneuver, the direction of movement of the stick was reversed. Apparently, this illustrates the pilot's attention to the over-banking tendency of the aircraft. A stick position plot which annotates these points could be of value in basic flying instruction. A slight indication of increased stick movement as skill degrades was also noticed. An example of this may be seen by comparing Plot 1 with Plot 41 (Appendix IX). This trend was not always consistent, however, and could easily be caused by varying environmental factors in-flight.

The analysis of stick position resulted in the decision to abandon its further consideration in this study. Without scientific evidence, we propose that stick position analysis would be most applicable in (a) basic flying training studies and (b) take off and landing studies. For documentation and possible reader interest, several additional stick position plots are presented in Appendix X.

The roll versus pitch plot proved to be the most singularly informative plot of those considered. Consider Plot 2 in Appendix IX. This performance began to the left (can be seen from the initial roll direction in Plot 3). Initially, the pilot pitched up without rolling, then completed a roll to -90° with relatively little change in pitch. He reached -90° of roll and began a decrease in roll prior to attaining his zero pitch position. In the roll-out of the first half of the maneuver, he returned to zero pitch prior to wings level. In the second half, he attained maximum positive pitch at roughly 30° roll and held this pitch angle while he continued to roll through about 70°. Again, he reached maximum bank and began to roll out prior to zero pitch. Upon ending the maneuver, he reached zero pitch prior to wings level. In both halves of the maneuver, he pitched up further than he pitched down, which is contrary to the ATC criteria as presented in the task analysis.

The performance represented by Plot 2 was rated low "Excellent." Comparing Plot 2 with Plots 12, 17, 22, 27, 32, 37, and 42 ("fair" and "unsatisfactory" performances), one can gain some immediate insights to measurement of the lazy 8 maneuver. For example, plot 2 exhibits symmetry, about the same pitch excursions in each half of the maneuver, and a relatively smooth, continuously changing roll/pitch relationship. All or some of these characteristics are lacking to some degree in the other plots. In plot 32, for instance, roll is held relatively constant at the MAX-roll points in the maneuver, and pitch is allowed to reduce from a MAX plus to a MAX minus all at once. In plot 37, very little change in pitch is exhibited while a rapidly changing roll is evident. In plots 12 and 17, lack of symmetry is obvious. In plot 42, uneven change in roll with respect to pitch is seen at the end of the left half of the maneuver. Additionally, by considering the roll-pitch plot and the airspeed plot together, it is possible to postulate precisely why (or why not) the airspeed criteria are met by a given performance. As will be discussed later, it appears likely that an individual trained in interpreting the plots can accurately discriminate at least four skill levels using only the roll-pitch and airspeed plots.

The plot of roll and pitch versus time provided little contributing information relevant to measurement that could not be deduced from other plots. The altitude plot was considered possibly relevant because in the better performances there was a consistent overall altitude gain that was not observed consistently in the less skilled performances. Also, the reason for this altitude gain in correct performance of the lazy 8 was an intriguing question. Appendices XI and XII present additional roll versus pitch plots and airspeed plots which represent the same group of performances shown in Appendix X.

c. Summary of Theoretical Measures Investigation

Theoretical measures were determined using the ATC maneuver analyses, in which criteria and tolerances were estimated for various flight parameters. The measures consisted of comparisons of flight data with these criteria and tolerances.

AFHRL-TR-72-6

Programs were written to (1) compute and print out the theoretical measures; (2) print the raw data itself; and (3) plot selected variables. The programs were run using a small amount of flight test and instructor pilot performance data.

Essentially, the theoretical measures investigation was an initial "shot-in-the-dark" using, as a basis for trial measurement, the ATC information available at the start of the program. For launching the study and bringing to light both the operational and theoretical problems regarding measurement of the lazy 8 and barrel roll, the investigation was 100% successful. However, for demonstrating any kind of validity of the theoretical measures (and, thus, encouraging the investigators at that time), the results may be considered disastrous.

A serious problem occurred that was not originally anticipated with regard to the use of aircraft heading as a primary reference variable. Due in part to instrumentation problems, and due in remainder to the lead/lag characteristics of the heading gyro from which the recording was taken, heading itself was unreliable. Therefore, any measure which relied on heading as a reference was unreliable.

From the data plotted in the theoretical measures investigation, it was possible to discern a number of questionable characteristics of the ATC criteria that were applied. A prime example is the criterion that maximum and minimum pitch angles be equal in magnitude. Other criteria appeared to be valid and to represent a sound basis for measurement, e.g., the "circle" measures for the roll/pitch relationship in the barrel roll.

Based on observations such as these, it was concluded that textbook criteria very definitely cannot be assumed to represent an adequate basis for quantitative measurement, although it may provide initial guidelines. Rather than pursue this avenue further, (i.e., attempt to legitimately validate or disprove the original set of ATC criteria), the decision was made to formulate a new set of measures. This new set was based not on ATC criteria, but on (1) a logical analysis of that criteria made

possible through the initial application; and (2) insights into the performance of the maneuvers gained through examination of actual data.

The new set of measures and other related program outputs considered necessary to conduct the study constitute the measurement system ultimately applied to a broad spectrum of student and instructor data. This measurement system is described next.

4. MEASUREMENT SYSTEM

This subsection describes the measurement system designed for analyzing performance and computing measures for a broad spectrum of student and instructor lazy 8's and barrel rolls. Prior to the specification of this system and the associated measures, an investigation was made of a set of theoretical measures based solely upon ATC criteria. As discussed in the preceding summary, this investigation laid the groundwork for identification of the measures and other desirable program-outputs to be described below. To differentiate the measures to be described below from the theoretical measures previously discussed, the new ones will be referred to as experimental measures. (This name also attests to the fact that the new set of measures is experimental in nature.) The measurement system consisted of separate programs for the lazy 8 and barrel roll which (1) computed experimental measures, (2) plotted key performance variables, and (3) produced a summary print-out of measurement-relevant raw data. In addition, initiating programs were developed to record significant data on cards for each maneuver, which was then used as input to the actual measurement programs.

a. Punched Card Records of Maneuvers

Considerable difficulty was encountered in locating and reading maneuver data on magnetic tape. This difficulty was attributed to three factors: (1) the magnetic tapes were not new, (2) the identifying event numbers for the maneuvers were often not recorded correctly on the tape due to instrument errors, and (3) the data typically contained

AFHRL-TR-72-6

"glitches" apparently caused by intermittent noise on the recording channels. Because the data would require more than one "pass" for analysis, and because it was to be retained for other future studies, it was necessary to "deglitch" the data and store it on punched cards. The variables to be thus recorded were selected on the basis of their expected usefulness in measurement of performance.

The variables selected for storage on cards were as follows (shown in the order punched):

<u>Lazy 8</u>	<u>Barrel Roll and Other Maneuvers</u>
Roll	Roll
Pitch	Pitch
Heading	Heading
Altitude	Altitude
Airspeed	Airspeed
	Normal Acceleration
($\Delta T = 0.5$ secs)	($\Delta T = 0.4$ secs)

The program which accomplished the punching and which, additionally, printed out selected variables is listed in Appendix XIII. For the lazy 8, 1.5 seconds of data could be represented on each punched card, resulting in approximately 40 or 50 cards per performance. For the barrel roll (and all other maneuvers), one card represented .8 seconds of data, resulting in about 40 cards per performance of the barrel roll.

In addition to the recorded data, cards were punched to document the month, day, year, and event-number of the maneuver, the total number of data points punched, the subjective rating provided for the maneuver, and, when applicable, the direction in which the maneuver was performed.

Data "deglitching" was accomplished partly by the program and partly by hand. The program, prior to punching, checked for obvious recording errors (e.g., variables out of range) and corrected the data at that point by setting it equal to the preceding values. Hand analysis was then required to remove "glitches" overlooked by the program and, when necessary, smooth out the step-function effect sometimes resulting from corrective action of the program over a longer-than-ordinary time interval. This process worked satisfactorily but was extremely time consuming.

The format in which the cards were punched is as follows:

Card 1:	Month, Day, Year, Event Number	3I5,F7.0
Card 2:	Number of recorded points	I5
Card 3:	Rating, Direction	2I5
Remaining Cards:	Data for lazy 8	3(F5.0,F4.0,F5.0, F7.0,F5.0)
	Data for barrel roll and others	2(F5.0,F4.0,F5.0, F7.0,F5.0,F5.1)

b. Lazy 8 Experimental Measures

Following is a description of forty-one measures designed to be computed for each performance of the lazy 8 maneuver:

- (1) MAX_1 - Maximum positive pitch in first half of maneuver
 - (2) MIN_1 - Minimum pitch in first half of maneuver
 - (3) MAX_2 - Maximum pitch in second half of maneuver
 - (4) MIN_2 - Minimum pitch in second half of maneuver
 - (5-8) $ROLL_i$ (i = 1, 4)
 - (9-12) $ARSP_i$ (i = 1,4)
 - (13-16) $ALTX_i$ (i = 1,4)
 - (17) $MAX + ROLL$ - Maximum positive roll
- } Roll, airspeed, and altitude change [since start of maneuver] at points of MAX_1 , MIN_1 , MAX_2 , and MIN_2 .

(18) MAX - ROLL - Maximum negative roll

(19) Time Half 1 }
 (20) Time Half 2 } Time (seconds) required to perform
 each half of the maneuver.

(21) Total Time - Total maneuver time

(22) E_1 - Starting airspeed minus 200

(23) E_2 - First minimum airspeed minus 100

(24) E_3 - MAX airspeed at middle of maneuver minus 200

(25) E_4 - Second minimum airspeed minus 100

(26) E_5 - Ending airspeed minus 200

(27) $E_6 = \sum_{i=1}^5 |E_i|$

(28) $E_7 = \sum_{i=1}^3 |E_i|$

(29) $E_8 = \sum_{i=3}^5 |E_i|$

(30) E_9 }
 (31) E_{10} } Absolute value of the airspeed-
 (32) E_{11} } change between the five local
 (33) E_{12} } maxima and minima (e.g., $E_9 =$
 abs. val. of difference between
 starting airspeed and first local
 minimum airspeed).

(34) E_{13} }
 (35) E_{14} } |Change in airspeed| divided by
 (36) E_{15} } change in time over the four
 (37) E_{16} } intervals of the maneuver
 referenced above by E_9 through
 E_{12} .

(38) T_1 }
 (39) T_2 } Time (seconds) during intervals
 referenced above by E_9 through
 E_{12} and E_{13} through E_{16} .

AFHRL-TR-72-6.

$$\begin{array}{l} (40) T_3 \\ (41) T_4 \end{array} \left. \vphantom{\begin{array}{l} (40) T_3 \\ (41) T_4 \end{array}} \right\}$$

In addition, measures of roll, airspeed, and altitude excursion are computed at specified points throughout the maneuver. The points are composed of all local maximum and minimum pitch values plus intermediate points at multiples of 1/3 times the local extrema.

The measures program produces for each performance of the lazy 8, (1) a print-out of roll, pitch, heading, altitude, and airspeed at $\Delta T = 0.5$; and (2) the experimental measures. In addition, the program computes means and standard deviations of all measures for selected groups of performances. Sample output is shown in Appendix XIV.

c. Barrel Roll Experimental Measures

Following is a description of thirty-six measures designed to be computed for each performance of the barrel roll maneuver.

(1) Symmetry Measures

Let X_i = pitch values sampled at $|\text{roll}| = 10^\circ, 20^\circ, \dots, 180^\circ, 170^\circ, \dots, 10^\circ.$

($i = 1, 35$)

$$M_1 = \frac{1}{9} \sqrt{\sum_{i=1}^9 (|X_i| - |X_{36-i}|)^2} \quad \text{Measures symmetry of quarters 1 and 4}$$

$$M_2 = \frac{1}{9} \sqrt{\sum_{i=9}^{17} (|X_i| - |X_{36-i}|)^2} \quad \text{Measures symmetry of quarters 2 and 3}$$

$$M_3 = \frac{1}{17} \sqrt{\sum_{i=1}^{17} (|X_i| - |X_{36-i}|)^2} \quad \text{Measures symmetry of halves 1 and 2}$$

(2) Roll/Pitch Circle Measures

Let Roll_i and Pitch_i ($i = 1, 71$) be the sampled roll values and corresponding pitch angles at $\text{Roll} = 5^\circ, 10^\circ, \dots, 180^\circ, 175^\circ, \dots, 5^\circ$.

Let

$$x_i = |\text{ROLL}_i| - 90$$

$$y_i = \frac{90 (\text{PITCH}_i)}{|\text{PITCH}_{\text{MAX}}|}$$

where $\text{Pitch}_{\text{MAX}}$ = maximum absolute value of all Pitch_i

$$z_i = \frac{|\text{PITCH}_{\text{MAX}}|}{90} \left[\sqrt{x_i^2 + y_i^2} - 90 \right]$$

Then

$$M_4 = \frac{1}{36} \sqrt{\sum_{i=1}^{36} z_i^2} \quad \text{Compares roll and pitch with circle criterion over half 1}$$

$$M_5 = \frac{1}{36} \sqrt{\sum_{i=36}^{71} z_i^2} \quad \text{Compares roll and pitch with circle criterion over half 2}$$

$$M_6 = \frac{1}{71} \sqrt{\sum_{i=1}^{71} z_i^2} \quad \text{Compares roll and pitch with circle criterion over maneuver}$$

(3) Constancy - Measures on Rates and g's

These measures check the constancy of roll rate, pitch rate, and g's by computing regression coefficients and correlation.

Let Roll_i , Pitch_i , and G_i be the values of roll (arranged to go from 0 to 360°), pitch, and g's at time-increments of 0.4 seconds ($i = 1, K$). Using a 5-point Lagrange formula, compute:

$$Y_{1i} = \text{roll rate}$$

$$Y_{2i} = \text{pitch rate}$$

AFHRL-TR-72-6

and denote

$$Y_{3i} = G_i$$

$$X_i = \text{Roll}_i$$

Define

$$B_L = \frac{K \left(\sum_{i=1}^K x_i y_{Li} \right) - \left(\sum_{i=1}^K x_i \right) \left(\sum_{i=1}^K y_{Li} \right)}{K \left(\sum_{i=1}^K x_i^2 \right) - \left(\sum_{i=1}^K x_i \right)^2}$$

$$A_L = \frac{\sum_{i=1}^K y_{Li} - B_L \sum_{i=1}^K x_i}{K}$$

$$R_L = \frac{K \sum_{i=1}^K x_i y_{Li} - \left(\sum_{i=1}^K x_i \right) \left(\sum_{i=1}^K y_{Li} \right)}{\sqrt{K \sum_{i=1}^K x_i^2 - \left(\sum_{i=1}^K x_i \right)^2} \sqrt{K \sum_{i=1}^K y_{Li}^2 - \left(\sum_{i=1}^K y_{Li} \right)^2}}$$

Then

$M_7 = A_1$	}	Roll rate regression coefficients
$M_8 = B_1$		
$M_9 = R_1$		Roll vs. roll rate correlation
$M_{10} = A_2$	}	Pitch rate regression coefficients
$M_{11} = B_2$		
$M_{12} = R_2$		Roll vs. pitch rate correlation
$M_{13} = A_3$	}	Normal acceleration regression coefficients
$M_{14} = B_3$		
$M_{15} = R_3$		

AFHRL-TR-72-6

Let M be the value of i at the point where Roll_i first becomes $\geq 45^\circ$, and let N be the value of i at the point where Roll_i last is $\geq 45^\circ$. Set $j = 1$ at $i = M$, and $j = K = N - M + 1$ at $i = N$. Compute M_i , for $i = 16, 24$ by replacing i with j in the foregoing analysis. Then M_{16} to M_{24} are the same measures as M_7 to M_{15} over the interval $|\text{Roll}| \geq 45^\circ$.

(4) Miscellaneous Measures

- (1) M_{25} - Maximum g's in first half
- (2) M_{26} - Maximum g's in second half
- (3) M_{27} - Minimum g's in whole maneuver
- (4) M_{28} - $|\text{Roll}|$ at MAX positive pitch
- (5) M_{29} - $|\text{Roll}|$ at MAX negative pitch
- (6) M_{30} - Maximum roll rate
- (7) M_{31} - Minimum roll rate
- (8) M_{32} } = MAX. and MIN. pitch rate
- (9) M_{33} }
- (10) M_{34} - Total time for maneuver
- (11) M_{35} } = Time for first and second halves
- (12) M_{36} }

In addition, measures of pitch, roll rate, pitch rate, roll-pitch "error" (based on circle criterion), heading excursion, altitude excursion, and airspeed excursion are computed for every 10° of roll.

The measures program produces, for each performance of the barrel roll (1) a printout of roll, pitch, heading, altitude, airspeed, and g's at $\Delta T = 0.4$; and (2) all experimental measures described above. Sample output is shown in Appendix XV.

d. Debriefing Plots

A debriefing plot, as the term is used in this study, is a graph of one or more flight variables which, when supplemented by selected performance measures, assists one in evaluating the performance diagnostically. Through a select combination of debriefing plots and measures, the authors' intent was to show that performance can be evaluated after-the-fact more diagnostically and with better skill discrimination than is possible (or at least feasible) in-flight.

Three such plots were developed for the lazy 8:

1. Airspeed vs time
2. Pitch vs roll
3. Altitude vs time

In addition to generating the plots themselves, computer programs also annotated each plot with measurement-relevant information. For example, the airspeed plot was designed to include the location and value of local maximum and minimum pitch values.

Examples of these plots for four lazy 8 performances are presented in Appendix XVI. In addition to the computer generated graphs and annotations, additional comments are included on the plots to (1) explain the annotations and (2) point out some highlights illustrating the type of diagnostic information contained in the plots.

Eight debriefing plots were designed for the barrel roll:

1. Roll, pitch, airspeed, and altitude vs time
2. Heading vs time
3. g's vs time
4. |Roll| vs Pitch
5. Roll/Pitch Polar Plot

$$\theta = \text{Roll}$$

AFHRL-TR-72-6

$$R = |\text{Pitch}|$$

$$\text{Plot } X = R \cos \theta \text{ vs } Y = R \sin \theta$$

6. Pitch vs Roll
7. Altitude vs Roll
8. g's vs Roll

Examples of these plots for two performances of the barrel roll are illustrated in Appendix XVII.

e. Summary of Experimental Measures

Section VIII of this report discusses the results of applying the experimental measures to a broad selection of student and instructor performances. For convenience in reference, the experimental measures are summarized below:

(1) Lazy 8

<u>No.</u>	<u>Units</u>	<u>Experimental Measures</u>
1	Deg	Max. (positive) pitch in half 1 (max. 1)
2	Deg	Min. (negative) pitch in half 1 (min. 1)
3	Deg	Max. (positive) pitch in half 2 (max. 2)
4	Deg	Min. (negative) pitch in half 2 (min. 2)
5	Deg	Roll at max. 1
6	Deg	Roll at min. 1
7	Deg	Roll at max. 2
8	Deg	Roll at min. 2
9	Kt	Airspeed at max. 1
10	Kt	Airspeed at min. 1
11	Kt	Airspeed at max. 2
12	Kt	Airspeed at min. 2

AFHRL-TR-72-6

<u>No.</u>	<u>Units</u>	<u>Experimental Measures</u>
13	Ft	Altitude excursion at max. 1
14	Ft	Altitude excursion at min. 1
15	Ft	Altitude excursion at max. 2
16	Ft	Altitude excursion at min. 2
17	Deg	Max. positive roll
18	Deg	Max. negative roll
19	Sec	Time to perform half 1
20	Sec	Time to perform half 2
21	Sec	Total time for maneuver
22	Kt	Start airspeed - 200
23	Kt	1st min. airspeed - 100
24	Kt	Max. airspeed, end 1st half, - 200
25	Kt	2nd min, airspeed - 100
26	Kt	End airspeed - 200
27	Kt	Sum of measures 22-26 (all maneuver)
28	Kt	Sum of measures 22-24 (half 1)
29	Kt	Sum of measures 24-26 (half 2)
30	Kt	Airspeed excursion 1st quarter
31	Kt	Airspeed excursion 2nd quarter
32	Kt	Airspeed excursion 3rd quarter
33	Kt	Airspeed excursion 4th quarter
34	Kt/Sec	Rate of change of airspeed 1st quarter
35	Kt/Sec	Rate of change of airspeed 2nd quarter
36	Kt/Sec	Rate of change of airspeed 3rd quarter
37	Kt/Sec	Rate of change of airspeed 4th quarter
38	Sec	Time 1st quarter

AFHRL-TR-72-6

<u>No.</u>	<u>Units</u>	<u>Experimental Measures</u>
39	Sec	Time 2nd quarter
40	Sec	Time 3rd quarter
41	Sec	Time 4th quarter

(2) Barrel Roll

<u>No.</u>	<u>Units</u>	<u>Experimental Measures</u>
1	Non-Dim.	Symmetry between quarters 1 and 4
2	Non-Dim.	Symmetry between quarters 2 and 3
3	Non-Dim.	Symmetry between halves 1 and 2
4	Non-Dim.	Comparison with circle - half 1
5	Non-Dim.	Comparison with circle - half 2
6	Non-Dim.	Comparison with circle - maneuver
7	Non-Dim.	Roll rate regression coefficients
8	Non-Dim.	
9	Non-Dim.	Correlation: roll vs roll rate
10	Non-Dim.	Pitch rate regression coefficients
11	Non-Dim.	
12	Non-Dim.	Correlation: roll vs pitch rate
13	Non-Dim.	Normal acceleration regression coefs.
14	Non-Dim.	
15	Non-Dim.	Correlation: roll vs normal acceleration
16-24	Non-Dim.	Same as 7-15, but for $ \text{Roll} \geq 45^\circ$
25	g	Max. g half 1
26	g	Max. g half 2
27	g	Min. g whole maneuver
28	Deg	Roll at max. positive pitch

AFHRL-TR-72-6

<u>No.</u>	<u>Units</u>	<u>Experimental Measures</u>
29	Deg	Roll at max. negative pitch
30	Deg/Sec	Max. roll rate
31	Deg/Sec	Min. roll rate
32	Deg/Sec	Max. pitch rate
33	Deg/Sec	Min. pitch rate
34	Sec	Total time for maneuver
35	Sec	Time half 1
36	Sec	Time half 2

SECTION VI
FLIGHT TESTING AND DATA COLLECTION

The calibration of the data acquisition system was conducted principally at Wright-Patterson AFB, whereas the data collection flights on maneuver performance were accomplished predominantly at Williams AFB. Specifically, a total of 40 calibration flights and 51 maneuver data collection flights were conducted throughout the program. However, 17 of the flights flown in support of the Pilot Performance Measurement Program resulted in no useful data being obtained due to system malfunction or weather. The total flying time on 948 was 114.7 hours over 91 sorties.

Maintenance support for the aircraft and data acquisition system was provided by Flight Test at Wright-Patterson AFB and by Air Training Command technicians assigned to the Directorate of Maintenance at Williams AFB. Pilots from the Fighter Test Squadron and AFHRL research psychologists flew the calibration flights. All of the UPT student data collection flights were flown at Williams AFB with one of the AFHRL instructor pilots.

1. OPERATING PROCEDURES

The procedures discussed in this section have evolved from operational experience with the data acquisition system and resulted in the development of the most efficient method of recording calibration and maneuver data, within specific restrictions, for pilot performance measurement research.

a. Tape Handling

Prior to each flight, the one inch mag tape was installed in the Leach tape recorder according to the following procedures:

1. Check that all cockpit switches on the Recorder Control Panel are in the OFF position.

AFHRL-TR-72-6

2. Apply 28 VDC ground power to the aircraft.
3. Turn the recording system MASTER SW to the ON position on the cockpit Recorder Control Panel.
4. Raise the guard on the GROUND TO FLIGHT switch and move this switch to the GROUND position.
5. Turn the TAPE RECORDER POWER switch to the ON position.
6. Remove the cover on the Leach tape recorder located in the lower fuselage bay area.
7. Check that the recorder POWER switch is in the ON position (When power is on, the STOP button will be RED).
8. Load the mag tape on the recorder with the supply reel on the right and take up reel on the left.
9. Actuate the FAST FORWARD switch and allow the tape to run for five seconds before activating the STOP button.
10. Place cover on tape recorder.
11. Return the TAPE RECORDER POWER switch to OFF position on cockpit Recorder Control Panel.
12. Return the GROUND TO FLIGHT switch to ON position (guard down).
13. Return COUNTER to zero.
14. Return MASTER SW to OFF position.

Subsequent to the flight, the tape was down-loaded and transported to the Data Reduction Branch of Flight Test. At Williams, the tapes were boxed and shipped via commercial air the same day of the flight. It became imperative to reduce the tape and print-out the data as quickly as possible in order to ascertain if all the parameter sensor systems and the tape recorder were operating properly. A minimum of three days was normally required between the student data flight at Williams AFB and a check of the data that was performed by the authors at Wright-Patterson.

AFHRL-TR-72-6

b. Recorder Operating Procedures

Upon taxiing to the number one position for takeoff, the data acquisition system was turned to a standby mode and an automatic calibration cycle initiated as follows:

1. MASTER SW - ON
2. INVERTER switch - ON, red light out
3. PCM/DAS switch - ON
4. RECORDER POWER switch - ON,
(TAPE OFF amber light on)
5. Check GROUND TO FLIGHT switch - ON
(guard down), green light on
6. TIME CODE switch - ON
7. RECORDER CONTROL switch - ON
8. Complete equipment calibration check;
(rapid sequence)
 - a. Change record number
 - b. Depress AUTO CAL button
 - c. Change record number
9. RECORDER CONTROL switch - OFF

After flying under radar control to the designated area where the calibration tests or maneuvers were to be performed, the instructor pilot commenced the data collection by turning the RECORDER CONTROL switch to the ON position and changing the record number by depressing the RECORD NO. button. The record number was changed at the beginning and end of each maneuver in order to facilitate the visual examination of the data print-out and provide discrete events for computer data processing. The recorder was turned off during extended periods of time when data was not being scored, such as climb and descent. By employing this method of tape conservation, the 60 minute mag tape was of sufficient duration to record in excess of the average mission flying time of 1.3 hours.

AFHRL-TR-72-6

Frequently the audio tape recorder was utilized on the mission. It proved to be an effective method for obtaining the instructor pilot's comments and critique of the student's performance narrative account of a maneuver being demonstrated by the IP, weather information, system malfunctions, and other qualitative data pertinent to describing the quantitative recording of performance.

2. CALIBRATION PROCEDURES

Precise procedures were established for the calibration of the flight and engine parameters with the corresponding cockpit instrument. The flight crew was briefed on the parameters and method of calibration prior to each flight. A Test Data Card was used to indicate the parameters to be calibrated and the value and record number of each data point. Additional information that was written on the Test Data Card included:

1. Aircraft type and number (T-37B/948)
2. Flight test project number (7184/604)
3. Date
4. Flight number
5. Pilot
6. Data recorder
7. Takeoff time
8. Landing time
9. Mission duration
10. Current altimeter setting
11. Auto calibration record number

AFHRL-TR-72-6

The basic parameter calibration procedures were provided to the flight crew in the form of a checklist:

1. Set current altimeter setting in left altimeter and record setting on Test Data Card.
2. Prior to recording any calibration data, depress the AUTO CAL. button for one second with the recorder on.
3. Turn recorder on for the entire period that one parameter is being calibrated, so that data will reflect transition from one step to another.
4. Obtain a minimum of 5 seconds' scoring for each incremental step after the parameter is stabilized at the desired value.
5. Upon stabilizing at a new parameter step, depress RECORD NO. button to advance the counter, which signals the beginning of a 5-second' scoring period.
6. Write counter reading on Test Data Card for each parameter step.
7. Complete the scoring in succession when two steps are designated by a bracket.
8. Any deviations from normal calibration procedures should be noted on the data card or audio tape recorder.

Checklist item number 7 refers to a procedure used during the calibration of a parameter of reversing the established trend to determine if the resolution of the sensor system would be able to identify a small change in the opposite direction! Another technique used was to calibrate the parameter entirely in one direction (e.g., increasing airspeed) and then repeat the same data points but proceeding in the opposite direction (e.g., decreasing airspeed). Thus, two recorded data points could be compared for the same parameter value so that an assessment could be made of the reliability of the sensor system.

Table XIV indicates those parameters that were able to be calibrated in-flight, the range over which the calibration occurred, incremental steps established, and the magnitude of the reversal interjected in the general trend of the parameter.

3. MANEUVER DATA COLLECTION PROCEDURES

Flights conducted to gather maneuver performance data from instructor pilots and UPT students utilized the same operational procedures previously described in this section, plus several additional procedures.

The AFHRL instructor pilots provided descriptive information regarding the student on the Test Data Card as follows:

1. ATC Syllabus Instructional Unit flown (Sorties were all from the Contact, Dual, Advanced Maneuvers Instructional Units).
2. Number of last Contact, Advanced Maneuver Instructional Unit Flown, including date of flight, and whether flight was dual or solo.
3. Total hours of T-37 flying time accumulated by the student to date.
4. Prevailing weather: ceiling, visibility, turbulence.
5. Instructor comments on capability of student with respect to the class norm at that stage of training (e.g., low average, outstanding, solid and smooth student).
6. Mid-phase (contact) check ride grade.
7. Coded description of the maneuver performed such as L-8-L, a lazy-8 initiated to the left; B-R-R, a barrel roll to the right; PATT-L, a normal 360° overhead traffic pattern with a left break.

Instructor's grade on each maneuver performed by a student, another instructor pilot, or a maneuver demonstrated by the AFHRL IP.

TABLE XIV
PARAMETERS CALIBRATED IN-FLIGHT

PARAMETER	CALIBRATED RANGE	INCREMENTAL STEP CHANGE	REVERSED INCREMENTAL
1. Heading	0-360°	10°	5°
2. Altitude	1,200-20,000 ft	100 ft	50 ft
3. Airspeed	80-280 kt	10 kt	2 kt
4. Pitch Angle	0-70 (climb and dive)	5°	5°
5. Roll Angle	0-90° (left and right)	5°	5°
6. g Force	0 to +4.0 g	0.5g	0.5g
7. Longitudinal Stick Position	Neutral to Full Deflection Forward and Aft		
8. Lateral Stick Position	Neutral to Full Deflection Left and Right		
9. Rudder Position	Neutral to Full Deflection Left and Right		
10. RPM	60-100%	1%	1%
11. Flaps	0-100%	20%	50%
12. Landing Gear	Up and Down		
13. Speed Brakes	In and Out		
14. Elevator Trim Tab Up	On and Off		
15. Elevator Trim Tab Down	On and Off		
16. Time	0-60 sec	10 sec	

AFHRL-TR-72-6

The rating system employed on the maneuver data collection flights was the standard ATC rating scale. This is an absolute rating scale whereby the student's performance is judged against the perfectly flown maneuver whether he is an experienced instructor or a neophyte student pilot. No consideration is given to the type or amount of training the student has received. The categories of the rating scale are:

Excellent (E) - The student performed the maneuver correctly, quickly, and efficiently.

Good (G) - The student performed the maneuver with little hesitation and no assistance.

Fair (F) - The student performed the maneuver, but made some false starts, repetitions, or minor errors of omission or commission.

Unable to Accomplish (U)¹ - The student lacked sufficient knowledge, skill, or ability to perform the maneuver without assistance.

Another procedure instituted for the maneuver data collection flights was a brief calibration of several parameters during the climb or immediately after level off. The purpose of this calibration procedure was to ascertain, on a regular basis, that the more important sensor systems and magnetic tape recorder were operating properly. The instructor recorded a single data point and record number on the Test Data Card while the student flew the aircraft in a steady-state condition on the following parameters:

1. Heading
2. Altitude
3. Airspeed
4. Pitch Angle
5. Roll Angle

¹Sometimes referred to in the report as unsatisfactory.

AFHRL-TR-72-6.

6. g Force
7. RPM

Immediately upon receipt of the computer print-out from these maneuver data flights, the authors would visually examine each of these seven parameters at the specific record numbers indicated on the Test Data Card. A comparison was made of the recorded data point and the instrument reading to determine if the data point fell within the normal resolution capability for that parameter. Also, a flight-by-flight plot of each parameter was accomplished to provide trend information on the reliability of the parameter sensor system. If any malfunction was revealed in the data acquisition system during these cursory calibration checks, the data collection flights were temporarily suspended until the equipment problem had been analyzed and corrected by the instrumentation technicians. The infrequent system malfunctions usually required the magnetic tape recorder head to be cleaned or the tape drive unit to be repaired.

a. UPT Student Data

A total of 31 UPT student pilots from the classes of 7105 and 7106 flew aircraft 948 on maneuver data collection flights conducted by the two AFHRL instructor pilots. Table XV presents a summary of these flights.

The original plan developed for the UPT data collection phase was that nine to twelve UPT student pilots would be randomly selected from two flights from each of the two classes. The intent was to collect maneuver data from these students at approximately four intervals during their Contact, Advanced Maneuver phase of flying. In this manner, the authors felt that representative data would be acquired to reflect the learning process on the two primary maneuvers, lazy 8 and barrel roll. However, as shown in Table XV, only six of 31 students flew more than one data collection flight in 948. Such factors as the rapid rate of student progression in the T-37 phase, conflict in scheduling missions for the appropriate ATC instructional units, turn-around capability

TABLE XV
SUMMARY OF UPT STUDENT DATA COLLECTION FLIGHTS

STUDENT	FLIGHTS	LAZY 8	BARREL ROLL	TRAFFIC PATTERN	OTHER MANEUVERS
1	2	4	5	2	
2	1	3	1	5	
3	1	3	2	0	
4	1	2	2	1	Immelmann - 2
5	1	2	2	4	
6	4	10	8	4	Cloverleaf-2, Aileron Roll-1
7	1	3	3	1	Immelmann -1, Cuban 8-1
8	1	2	4	1	
9	2	3	4	1	Cuban 8-1
10	1	3	0	1	
11	1	3	3	1	Immelmann-1
12	2	5	4	7	Immelmann-1
13	1	2	0	0	
14	2	6	4	1	Loop-1
15	1	2	1	3	Cloverleaf-2, Immelmann-3
16	1	2	1	1	
17	1	1	1	4	Immelmann-2
18	1	2	2	0	Loop-1, Immelmann-1
19	1	2	3	0	
20	1	2	3	0	
21	1	2	2	0	Immelmann-1
22	3	6	5	2	Vertical S, Immelmann-1
23	1	2	3	1	
24	1	0	4	2	
25	1	2	6	1	
26	1	2	0	4	
27	1	2	3	1	Cloverleaf-1
28	1	2	4	1	Cuban 8-1
29	1	4	3	0	
30	1	2	2	0	
31	1	1	1	3	Cloverleaf-2, Immelmann-1
TOTALS	40	87	86	52	

AFHRL-TR-72-6

of 948, and the requirement to fly UPT students on a non-interference basis all posed serious limitations to the achievement of the original goals for student data collection. In effect, the data acquired provided a larger sample size and thus a more representative range of skill level of UPT student pilots, from which to draw lazy 8 and barrel roll maneuver data for the analysis and development of performance measures. However, measurement validation was hampered due to lack of sufficient data per individual student.

b. Instructor Pilot Data

Maneuver data was collected from five T-37 instructor pilots and is summarized in Table XVI. A highly qualified instructor from the T-37 Pilot Instructor Training (PIT) program was temporarily assigned to the Pilot Performance Measurement System program for the purpose of flying lazy 8 and barrel roll maneuvers that represented the range of skill manifested by UPT student pilots on these maneuvers. The PIT IP flew at least 10 lazy 8's and 10 barrel rolls for each of the four skill rating categories - E, G, F, and U. Additionally, the IP described the maneuver verbally as he was performing it. Recorded on the audio tape, the narrative consisted of pointing out the significant parameters and criterion points utilized to teach the maneuver in ATC, normal range of values around the criterion points, factors that affect the IP's rating of the maneuver, and common errors experienced by UPT students. Examples of the IP's description of the maneuvers can be found in the following Section.

Instructors 1 and 2 were the AFHRL IP's that conducted the student data collection flights while Instructors 3 and 4 were line ATC IP's. The maneuver data from these five instructor pilots provided the authors with base-line data with which to formulate performance measures for the quantitative assessment of student pilot performance.

TABLE XVI
SUMMARY OF INSTRUCTOR DATA COLLECTION FLIGHTS

INSTRUCTOR	FLIGHTS	LAZY 8	BARREL ROLL	TRAFFIC PATTERN	OTHER MANEUVERS
PIT	7	48	+7	7	Loop -1
IP -1	21	12	11	2	Immelmann-3
IP -2	27	11	12	1	Immelmann-2
IP -3	1	0	0	1	Vertical S, Immelmann-1
IP -4	1	3	2	1	
TOTALS	57	74	72	12	

AFHRL-TR-72-6

c. Summary

Several factors were encountered in the flight testing and data collection phase that, to a certain extent, altered the design of the Pilot Performance Measurement System program. Primarily these factors consisted of limitations in the recording of the heading parameter, reduced resolution capability for altitude, reliability problems experienced with the magnetic tape recorder, and the difficulty in the timely scheduling of UPT student pilots. This in no way detracts, however, from the achievements and effectiveness of the program which, in retrospect, is considered to have been quite successful.

SECTION VII
MEASUREMENT ANALYSIS

In this Section, final measures are developed for recommended applications in measurement of the lazy 8 and barrel roll. Also included are some relevant observations that unfolded regarding standardization within and between instructors in both their performance and rating of the maneuvers, performance criteria, and methods that should be employed in developing and validating measures in future efforts.

The authors have elected to present these findings in the general order in which they developed during the investigation. First, lazy 8 measures for the instructor pilot from the ATC Pilot Instructor Training (PIT) school are summarized and discussed. The measures are correlated with the subjective ratings, which were provided in-flight by the performing pilot. This is done for the purposes detailed on pages 16-17 of this report. With the guidance of these correlations, and with the added benefit of observing trends of the measures (mean and standard deviations) across different skill levels, a simple combination of selected measures is then developed and shown to account, in itself, for at least 67% of the variance in subjective ratings.

The AFHRL instructor pilots' lazy 8 performances are then examined. Due to a deficit in the amount of data collected on instructors as well as a lack of even distribution of the performances across all four subjective rating categories (as judged by the instructors themselves in-flight), the only topic pursued is inter- and intra-instructor variance in performance. For this investigation, the PIT instructor pilot is compared with AFHRL and ATC instructor pilots. It can be shown, for example, that if two different IP's demonstrated the lazy 8 for a given student, one could expect as much as 27 knots difference in the value of airspeed at one critical point in the maneuver.

Next, experimental measures for student performances of the lazy 8 are examined. As in the case of the PIT IP data, correlations are computed between measures and subjective ratings. Contrary to the PIT data, few of the correlations are significant, and the simple combined measure which discriminated skill levels quite well in the PIT case appears worthless when applied to the student data.

At this point, the subject of validation technique is addressed. The authors propose (and, but for lack of sufficient data, would have used) within-subject sampling as an ultimate basis for validation as well as development of measure. This validation technique is demonstrated by using data for one student, for which, fortunately, sufficient data were collected to at least illustrate the concept. Despite the complete lack of validity of the combined-error measure seen in its application to student data and comparison with subjective ratings, validity is supported by the trend of the measure, as it varies across one student's performances.

To further support the lack of confidence that should be placed in subjective ratings as evidence of measurement validity, a comparison is made of instructors' rating standards. This is pursued by comparing the correlations between measures and subjective ratings for one IP with those for a second IP. It is shown that while the number of significant correlations does not increase appreciably when considering one IP at a time, the strength of the correlations for various measures differs markedly between the two IP's. This suggests a difference in emphasis that is placed by the two IP's on various aspects of the performance.

Finally, for the lazy 8 at least, a set of final measures is recommended along with a summary of related findings.

The barrel roll is treated next, but not as extensively as the lazy 8, due to lack of sufficient data. The experimental measures for student data are presented as well as their correlations with

AFHRL-TR-72-6

subjective ratings. The indications are that to a much greater extent than in the lazy 8, standards must be determined for the barrel roll. Based on the data examined, specific measures are recommended for validity testing in future studies.

Finally, some plots of selected variables for other maneuvers are presented. The maneuvers are:

- Loop
- Stall
- Cloverleaf
- Max. Performance Climbing Turn
- Immelmann
- Cuban 8

These maneuvers were not addressed from a measurement standpoint, but are briefly presented here merely for possible reader interest.

With this introduction, the next topic presented is the measurement analysis, beginning with the lazy 8.

1. LAZY 8

a. PIT Instructor/Pilot

For 47 performances by a single PIT instructor, the experimental measures were computed. The performances were rated in-flight by the performing pilot, and the ratings are distributed across the four rating categories as shown in Figure 33.

For each measure, the mean and standard deviations were plotted as shown in Figures 34 through 39. In addition, each measure was correlated with the subjective ratings assigned to each performance. The resulting correlation coefficients are presented for all performances, all right performances, and all left performances in Table XVII.

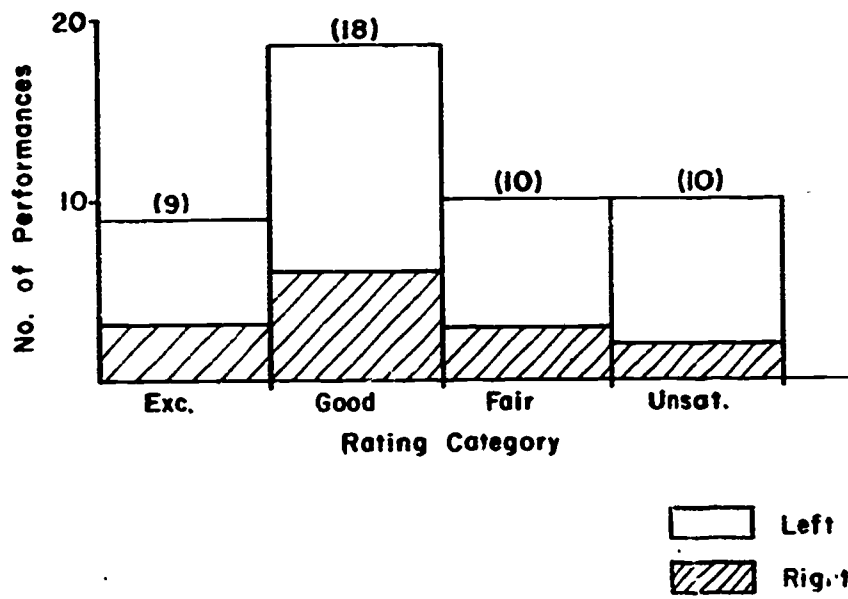

Figure 33. Distribution of PII Instructor Lazy 8's Across Rating Categories

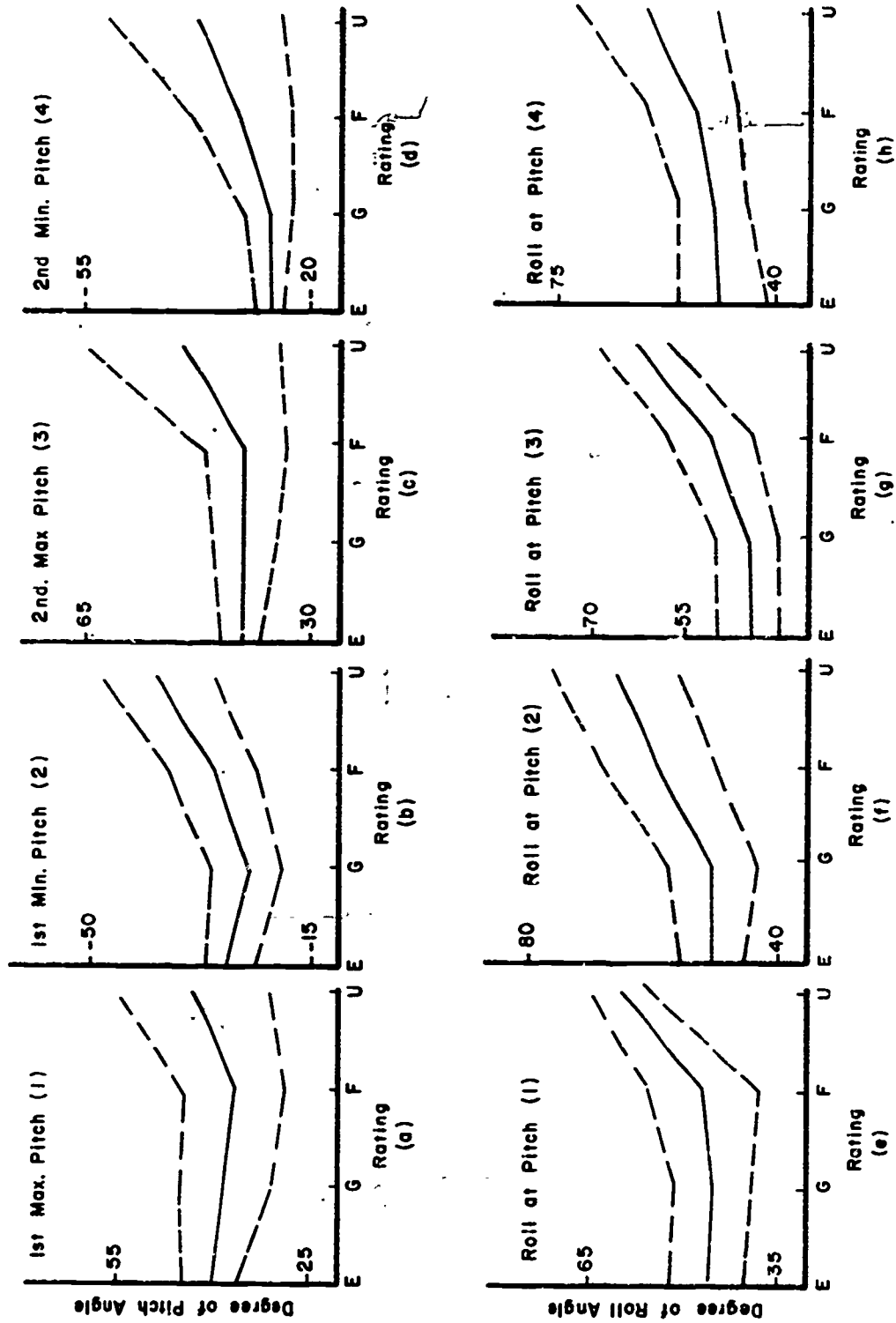

Figure 34. Pitch and Roll Measures for PIT Instructor Lazy 8's
[Mean $\pm 1\sigma$]

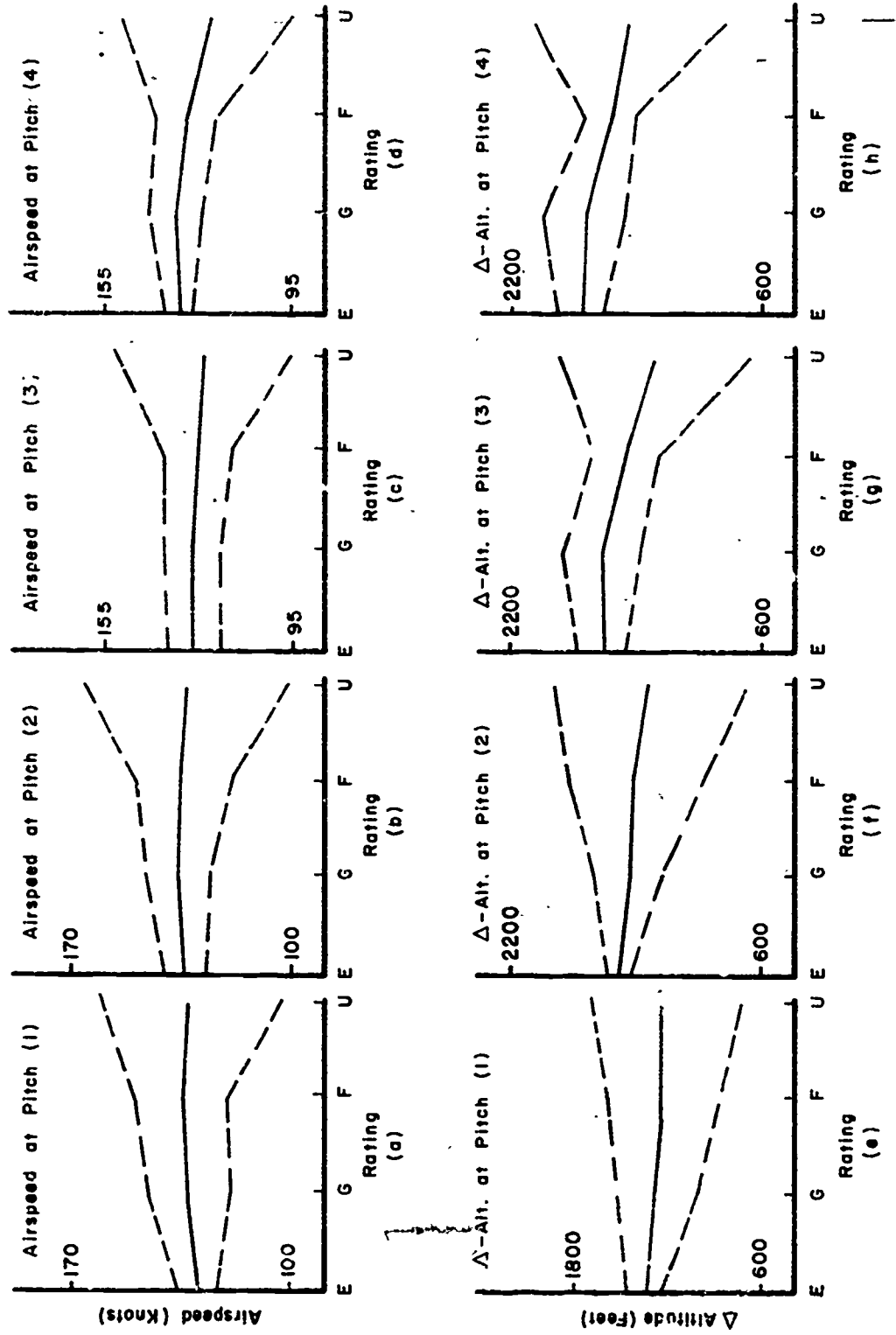

Figure 35. Airspeed and Altitude Measures for rIT Instructor Lazy 8's
[Mean $\pm 1\sigma$]

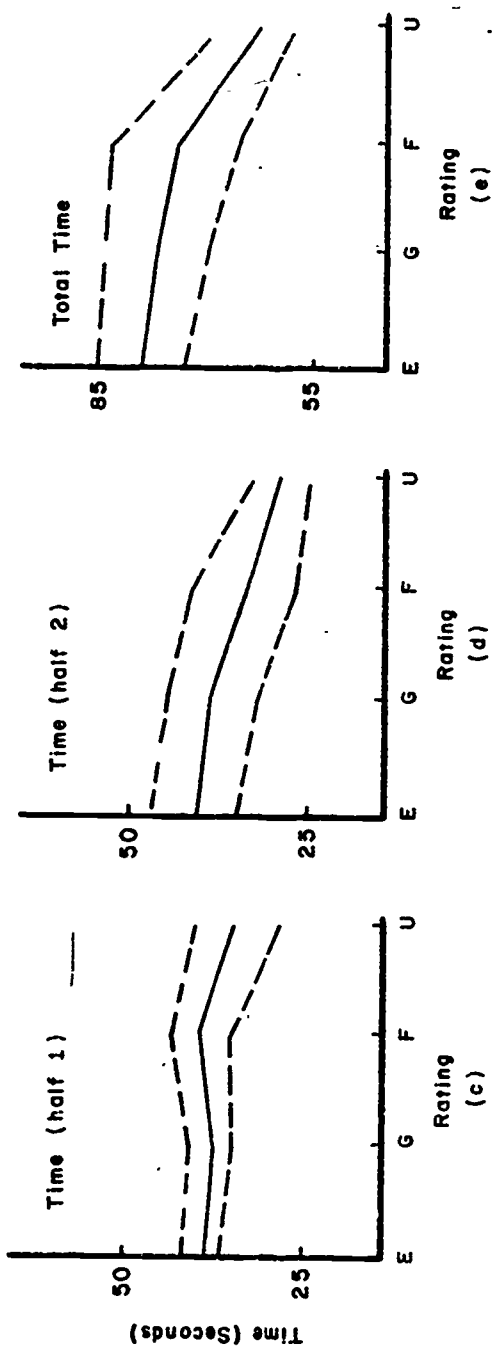
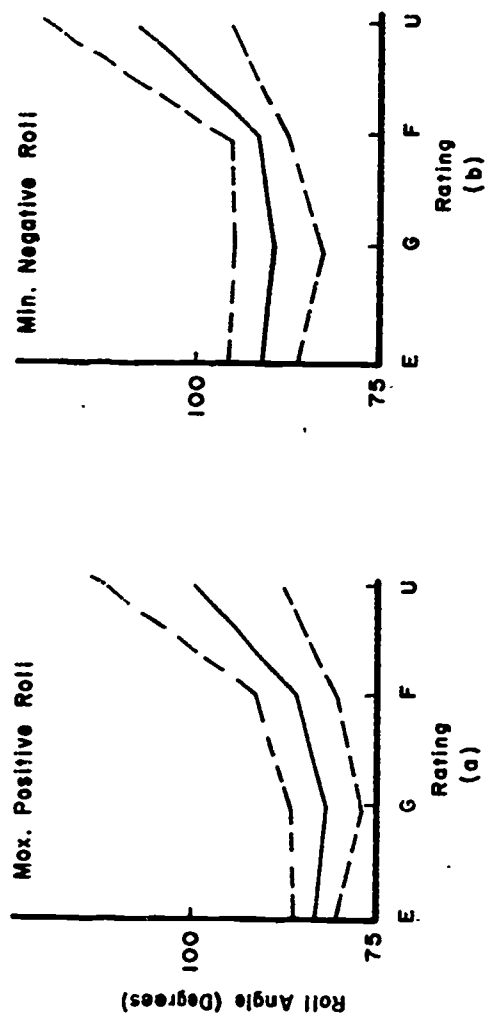

Figure 36. Roll and Time Measures for PIT Instructor Lazy 8's
[Mean ± 1σ]

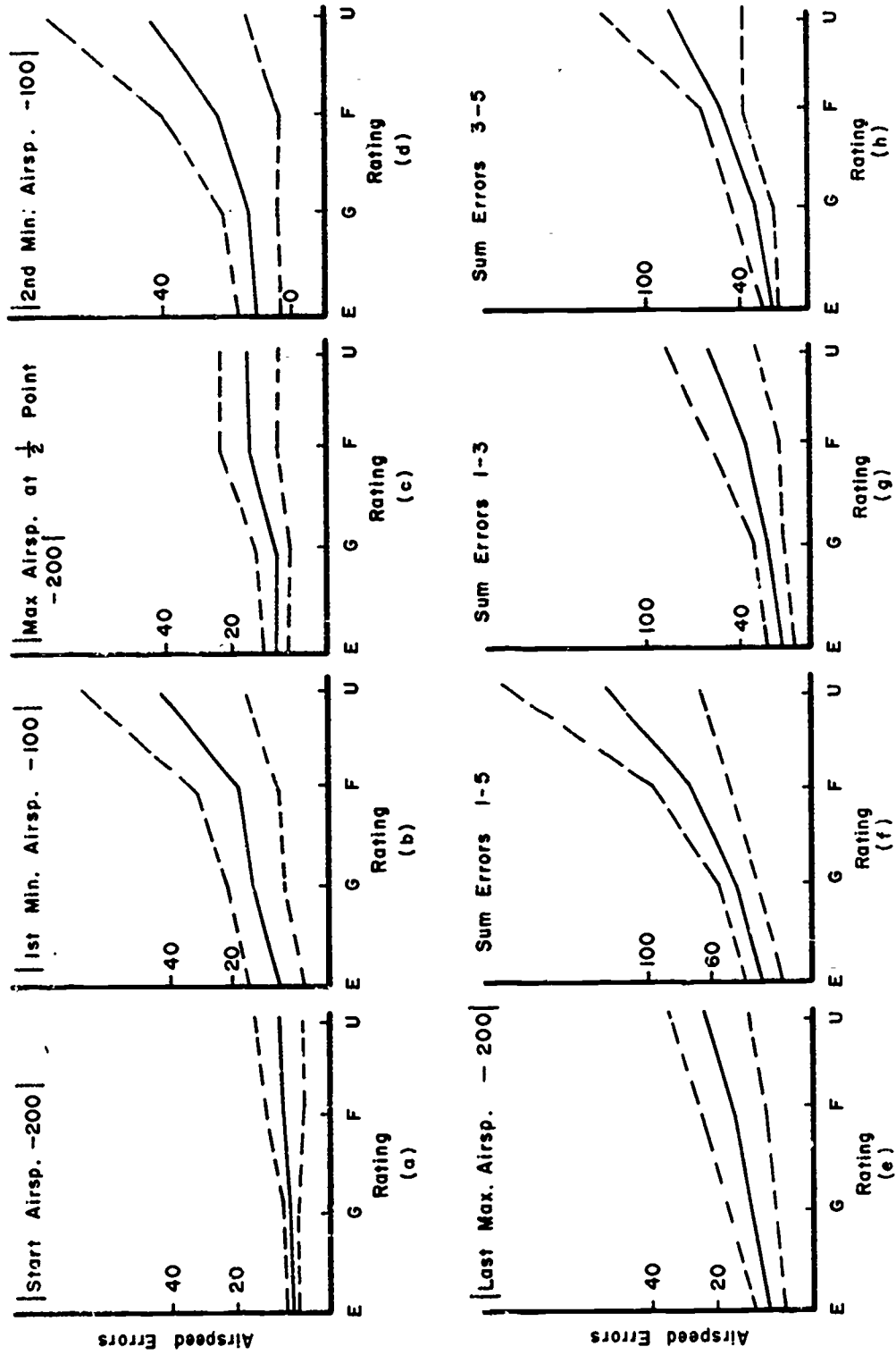

Figure 37. Airspeed Error Measures for PIT Instructor Lazy 8's
 [Mean $\pm 1\sigma$]

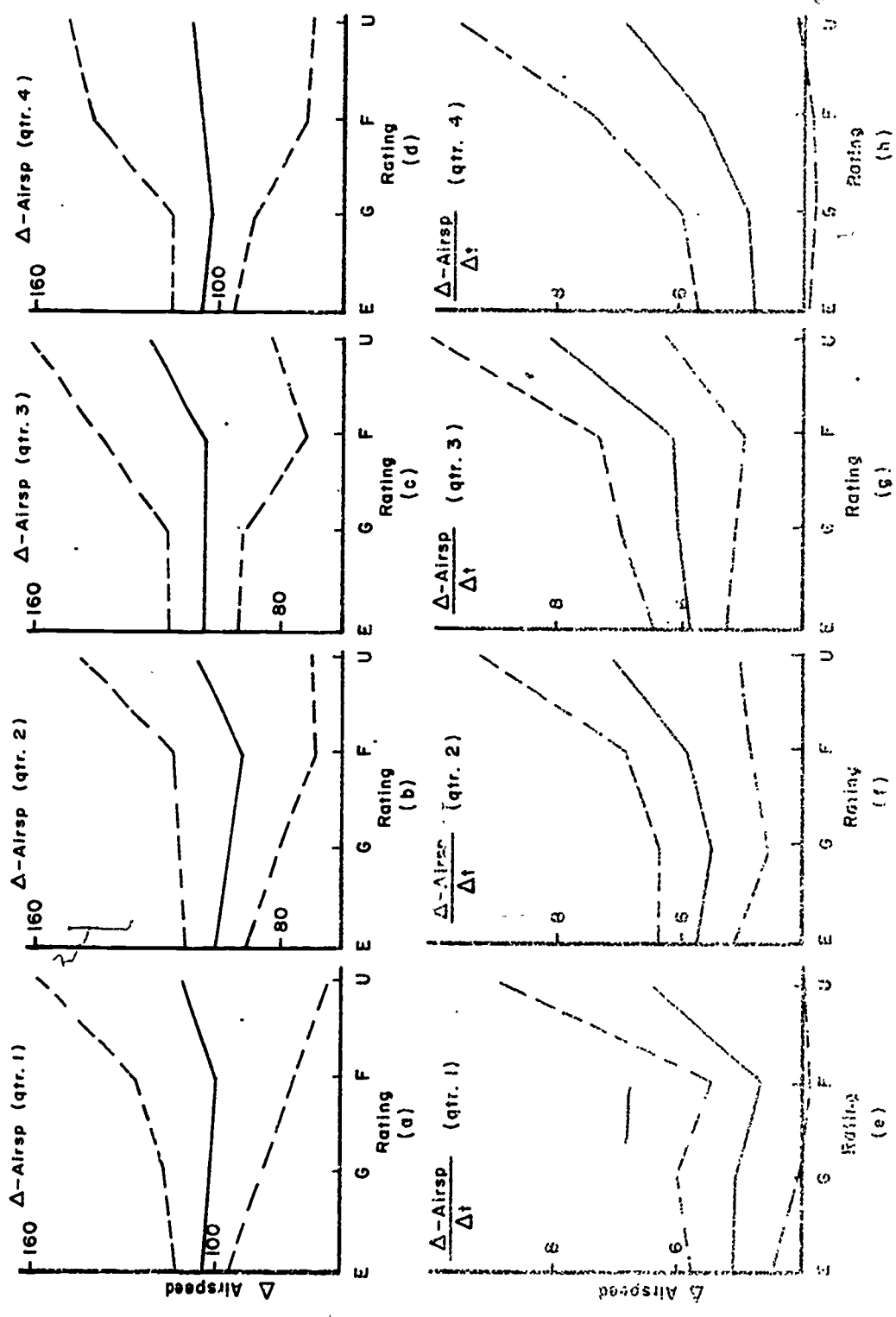

Figure 38. Airspeed Excursion and Rate Measures for PIT Instructor
 Lazy 8's [Mean $\pm 1 \sigma$]

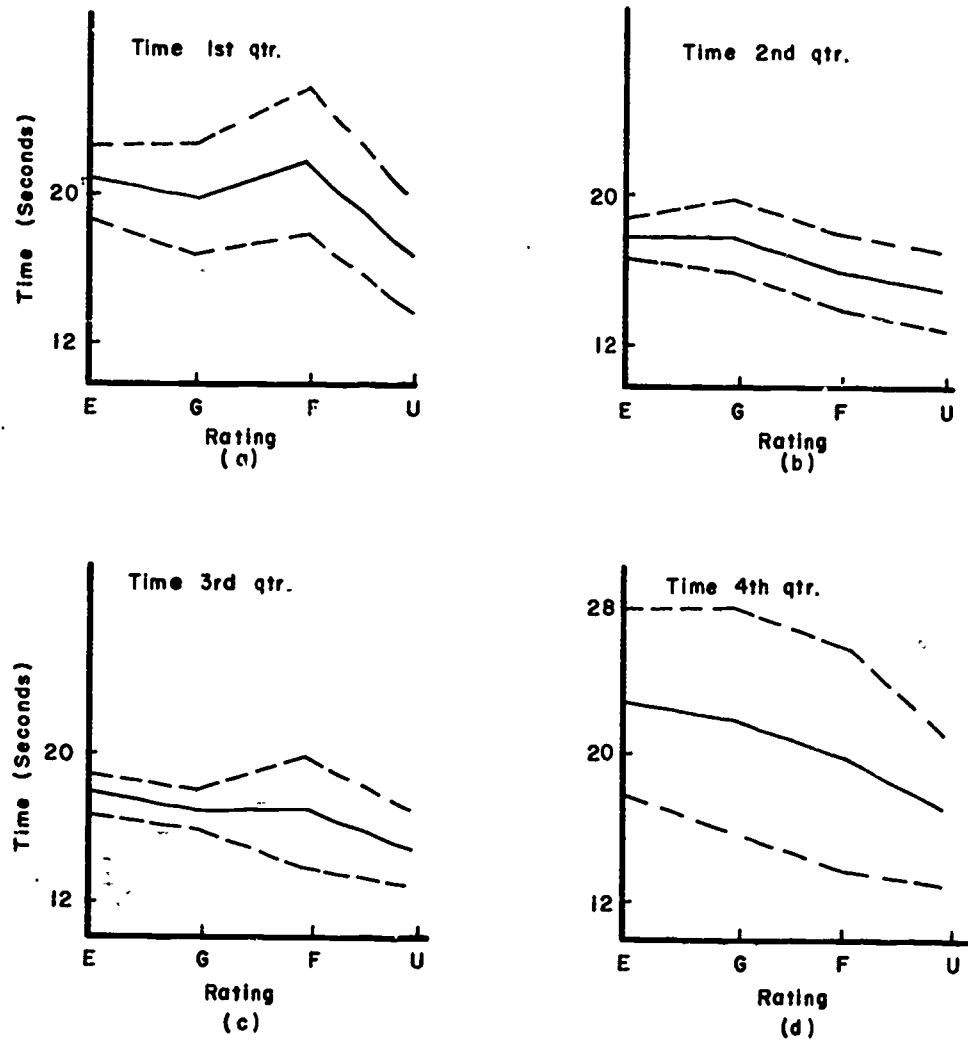

Figure 39. Time Measures for PIT Instructor Lazy 8's [Mean ± 1σ]

TABLE XVII

CORRELATIONS BETWEEN MEASURES AND SUBJECTIVE RATINGS FOR PIT INSTRUCTOR LAZY 8 PERFORMANCES

Measure	Correlation Coefficients		
	All	Right	Left
1. Max. 1 Pitch (1)	-0.11	-0.16	-0.09
2. Min. 1 Pitch (2)	0.51*	0.48	0.53*
3. Max. 2 Pitch (3)	-0.29	-0.66	-0.15
4. Min. 2 Pitch (4)	0.46*	0.72*	0.40
5. Roll (1)	-0.54*	-0.32	-0.60*
6. Roll (2)	-0.60*	-0.59	-0.73*
7. Roll (3)	-0.74*	-0.56	-0.80*
8. Roll (4)	-0.48*	-0.52	-0.60*
9. Airspeed (1)	-0.06	0.17	-0.09
10. Airspeed (2)	0.00	0.24	-0.05
11. Airspeed (3)	0.09	0.67	-0.14
12. Airspeed (4)	0.25	0.64	0.14
13. Altitude (1)	0.27	-0.06	0.12
14. Altitude (2)	0.15	0.05	0.18
15. Altitude (3)	0.31	-0.06	0.40
16. Altitude (4)	0.33	0.13	0.37
17. Max. Roll	-0.64*	-0.31	-0.72*
18. Min. Roll	0.60	0.66	0.56*
19. Time (half 1)	0.23	-0.33	0.56*
20. Time (half 2)	0.60*	0.47	0.57*
21. Total Time	0.61*	0.42	0.68*
22. Airspeed Error 1	-0.41*	-0.41	-0.42
23. Airspeed Error 2	-0.62*	-0.66	-0.62*
24. Airspeed Error 3	-0.43*	-0.47	-0.43
25. Airspeed Error 4	-0.58*	-0.87*	-0.48*
26. Airspeed Error 5	-0.58*	-0.70	-0.54*
27. Sum (1-5)	-0.74*	-0.87*	-0.70*
28. Sum (1-3)	-0.69*	-0.74*	-0.67*
29. Sum (3-5)	-0.71*	-0.87*	-0.66*
30. Delta Airspeed (1)	-0.09	-0.35	-0.02
31. Delta Airspeed (2)	-0.07	-0.28	-0.02
32. Delta Airspeed (3)	-0.22	-0.59	-0.05
33. Delta Airspeed (4)	-0.05	-0.64	0.15
34. Airspeed Rate (1)	-0.27	-0.33	-0.29
35. Airspeed Rate (2)	-0.38*	-0.47	-0.36
36. Airspeed Rate (3)	-0.51*	-0.63	-0.46*
37. Airspeed Rate (4)	-0.40*	-0.68	-0.27
38. Time (1)	0.31	-0.04	0.40
39. Time (2)	0.57*	0.49	0.59*
40. Time (3)	0.50*	0.05	0.61*
41. Time (4)	0.40*	0.36	0.44

*Significant to 0.01 level

AFHRL-TR-72-6

Debriefing plots for each performance were also produced and used as an aid in the analysis. Where available the pilot's voice transcript was attached to the appropriate set of plots. Sample plots for one of the performances are presented in Figures 40 through 42. (Refer to Appendix XVI for interpretation of the plots.)

Using this data it was possible to make a number of general observations that provide insight to general performance of the lazy 8 as well as to its measurement. These observations are presented next. They are based primarily on the data in Figures 34 through 39.

(1) General Observations

The following observations are based exclusively on the PIT Instructor performance data as shown in Figures 34 to 39, Table XVII, and (although not shown) the debriefing plots. In the ensuing presentation of the observations, this qualification prevails. No use will be made of additional qualifiers (e.g., "it appears...") as is the normal tendency when presenting data of this type.

In performance of the lazy 8, positive pitch excursions exceed negative pitch excursions by at least 10 (Figure 34, a-d). This is not in accordance with the original maneuver analysis performed by ATC. Since the airspeed should vary between 200 and 100 knots, the probable reason for positive and negative pitch excursions being unequal is (a) the pilot attends to airspeed and not to pitch and (b) the aircraft accelerates and gains airspeed in a nose-down configuration faster than it decelerates and loses airspeed in a nose-up configuration.

Generally, greater pitch excursions, both positive and negative, are experienced in the poorer performances. Also much more variance in pitch occurs in the second half of the maneuver than in the first half for poor performances. This is probably due to the accumulated effect of errors on other parameters incurred in the first half (especially airspeed errors) and the ensuing attempt on the part of the pilot to "make up" for these errors in the second half. Pitch variance

12-19-69
 ENVO- 70
 (1 LEFT)

(12-19-69 EVNO 71 1 LEFT)

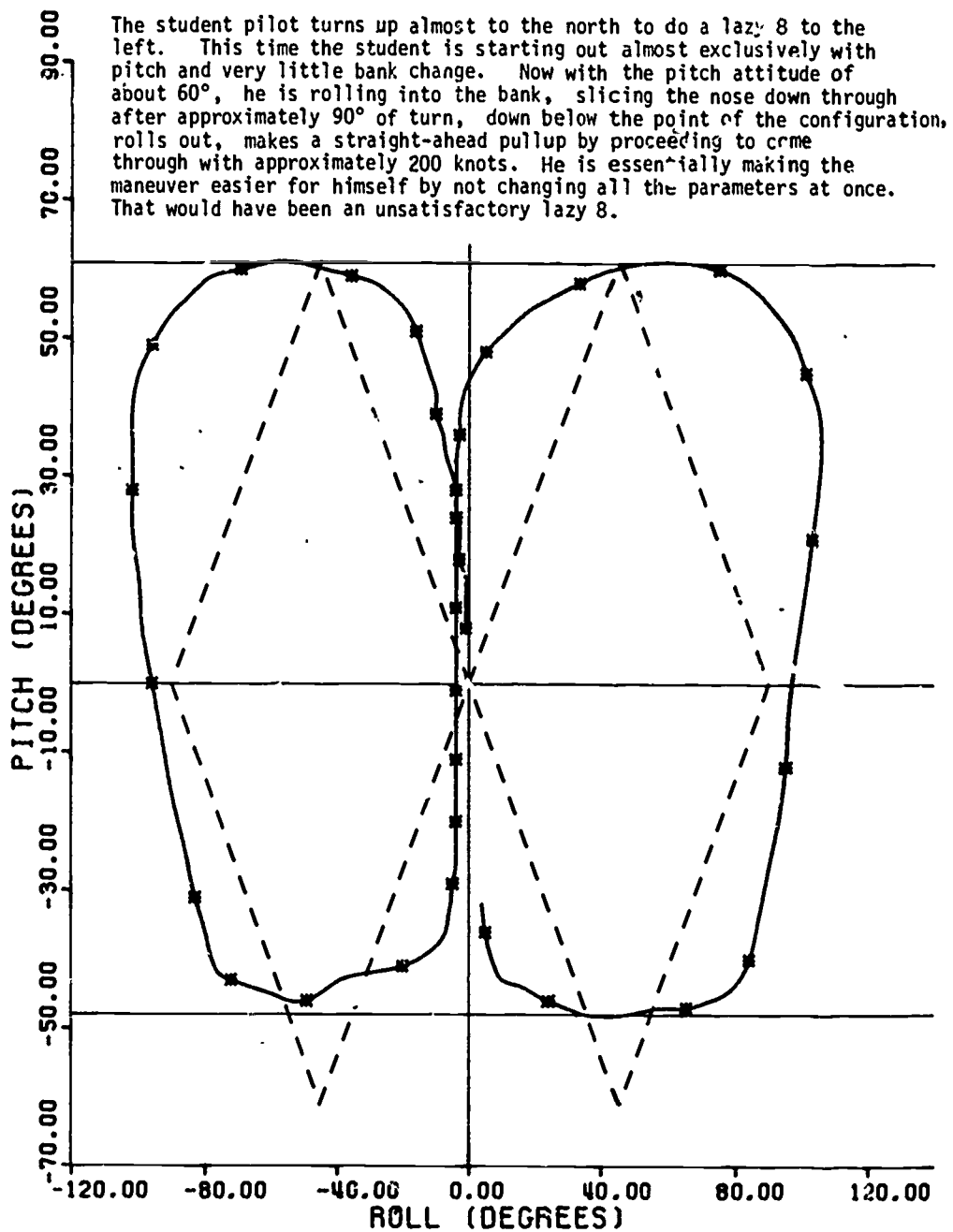

Figure 40. Roll vs Pitch Plot

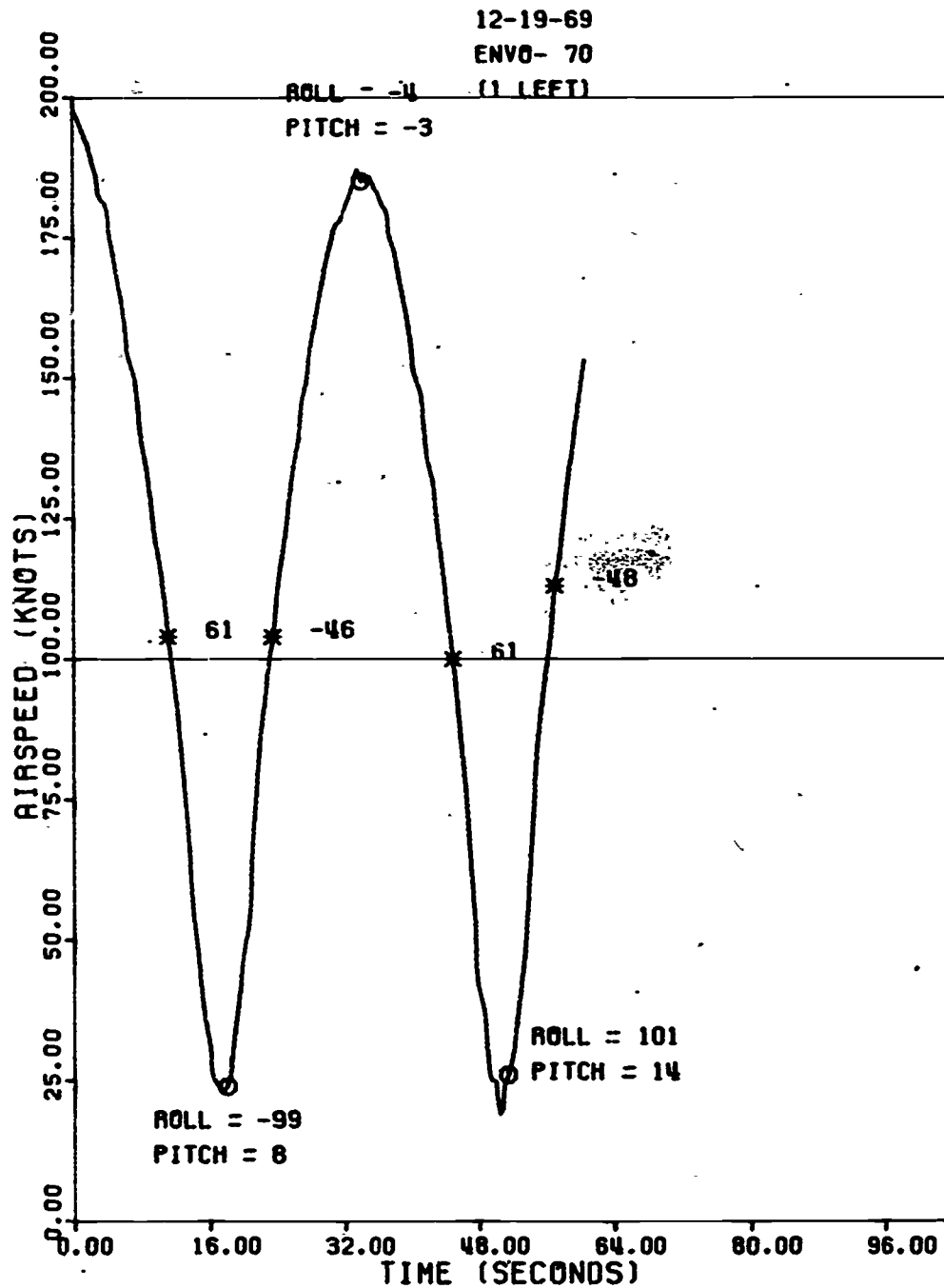

Figure 41. Airspeed Plot

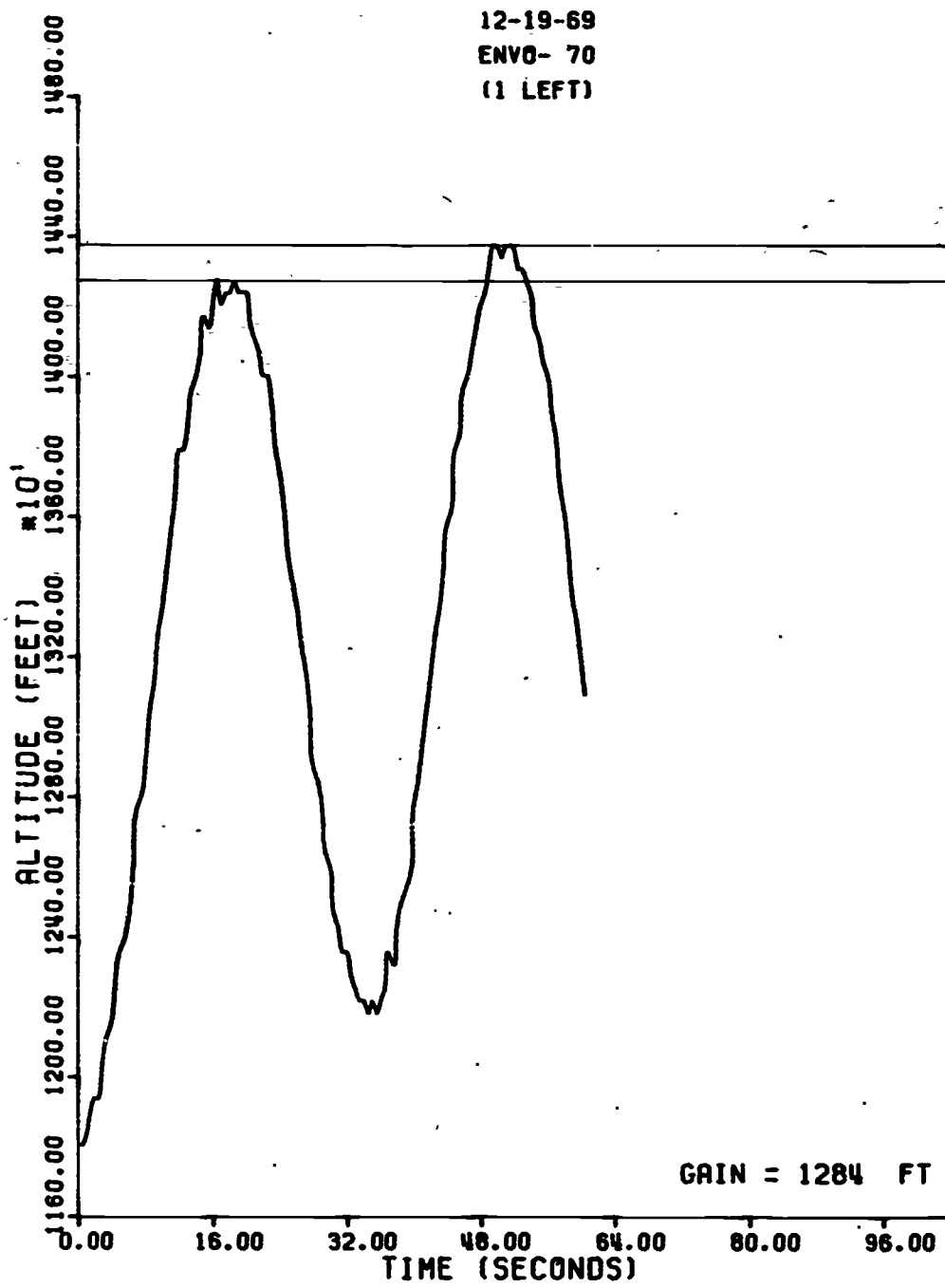

Figure 42. Altitude Plot

AFHRL-TR-72-6

noticeably increases as skill ratings decrease (e.g., as ratings proceed from excellent to unsatisfactory).

As skill ratings decrease, there is a noticeable increase in the value of roll angle achieved at the points of local maximum and minimum pitch (Figure 34, c-h). Thus, both roll and pitch exhibit wider excursions for lower skilled performances.

There is a very evident increase in the variance on airspeed measures as skill ratings decrease (Figure 35, a-d). This is particularly obvious in discriminating fair from unsatisfactory performance. However, there is little change in the actual airspeed measures themselves, the only possible exception being in the fourth quarter of the maneuver where the measures are lower for unsatisfactory performances.

There is an observable increase in the variance on altitude excursions as skill ratings decrease, but this is true for only the first half of the maneuver (Figure 35, e-n). In the second half, the same tendency is observed only from fair to unsatisfactory degradation. Over the whole maneuver, an overall altitude gain ranging from 100 to 1000 ft is usually observed, but there is no apparent correlation between altitude gained and skill level.

The maximum positive and negative roll angles achieved in the maneuver show a definite increase in value as skill ratings vary from the excellent or good category to fair and unsatisfactory (Figure 36, a-b). Again, this supports previously discussed observations regarding greater parameter excursions in general as skill ratings decrease. The variance on maximum roll angles shows an increase only from fair to unsatisfactory performances.

There is a general decreasing trend in the time taken to perform the maneuver as skill ratings decrease, but there is no significant change in variance (Figure 36, c-e). This illustrates a tendency to

AFHRL-TR-72-6

perform the maneuver faster (and with wider pitch and roll excursions) in the lower skill categories; however, time as a measure is not expected to be significant.

Airspeed errors and the variances thereof show a noticeable increase as skill ratings decrease, particularly at the points of maximum positive or negative roll (i.e., at the end of the first and third quarters of the maneuver, Figure 37, a-h).

Airspeed excursions show an obvious increase in variance as skill ratings decrease (Figure 38, a-d). This is particularly evident in the second half of the maneuver from the excellent/good to the fair/unsatisfactory categories.

The rate of change of airspeed with respect to time is generally lower in the first and fourth quarters than in the second and third quarters (rates begin and end slowly with respect to the middle portions of the maneuver) (Figure 38, e-h). The widest variances occur as well in the first and fourth quarters, particularly for unsatisfactory performances.

Contrary to guidelines used by many instructors in teaching and performing the lazy 8, the value of airspeed at points of maximum positive and negative pitch does not appear to be 150 knots as judged by the PIT Instructor data. Observation of this came first from analysis of the debriefing plots and is substantiated by the mean-data presented in Figure 35 (a, b, c, and d). Following is a presentation of the first several lazy 8s flown by the PIT instructor and, where available, his recorded comments. In addition to providing a number of insights to the correct performance of the maneuver, this presentation will illustrate the errors incurred when the pilot attempted to use 150 knots as a check point; and the improvement of the performances when he apparently abandoned its use.

AFHRL-TR-72-6

Performance 1 (11-18-69, event 4)

Rating: Good

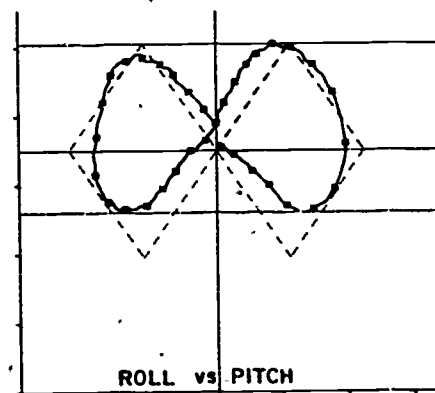
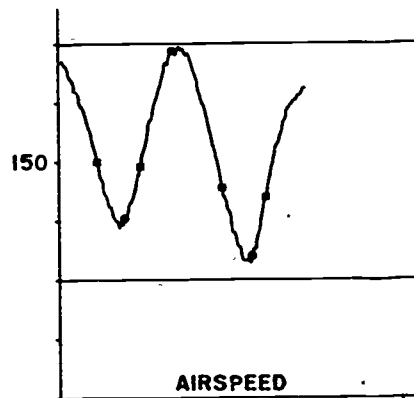

Pilot's Commentary: "As you know, the lazy 8 is a maximum performance maneuver where we will attempt to fly the airplane through a wide range of airspeeds, bank angles, and pitch attitudes. Power is 90%, our entry airspeed is 200 knots; speed brake is up. To accomplish the maneuver we will start a climbing turn very similar to a climb for a maximum performance climbing turn, planning to have our maximum pitch attitude after 45° of turn, or right about now. Airspeed should be approximately 150 knots. The nose begins to come down at this time. Bank is still increasing. Nose through the horizon after 90° of turn, down to its lowest point. You will notice that the airspeed was high during the point the nose came through the horizon, down to the nose lowest after 135° of turn. Back up to 200 knots and level flight now. Try to correct the mistake I made during the first half of that one by increasing my pitch more during the first half of this next maneuver and getting my airspeed down, planning to come through after 90° of turn. Airspeed still a little high, about 114 knots. Nose lowest after 135, back up to level flight after 180° of turn. End of maneuver. I would have graded that one about a low good or a high fair. Lets call it a good maneuver."

AFHRL-TR-72-6

Performance 2 (11-18-69, event 5)

Rating: Good

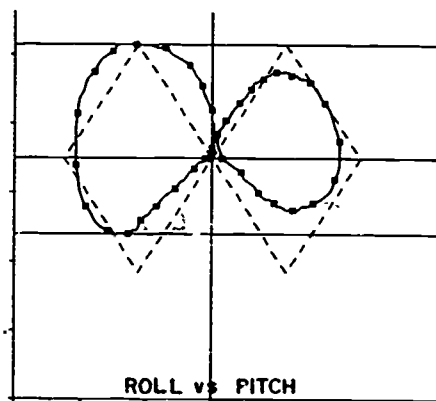
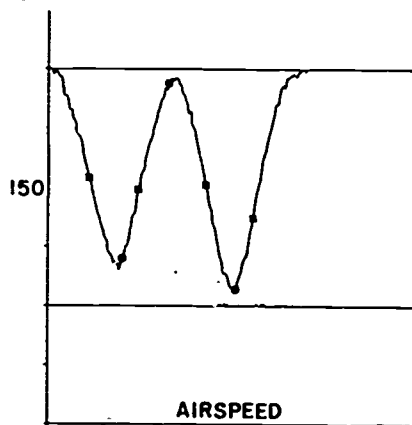

Pilot's Commentary: "Ready to start into lazy 8 number 2. Continuing the maneuver, trying to adjust my airspeed this time so that it comes down to 100 knots, and you will notice that I did not get it. We will come back to straight and level flight, 200 knots, and I will again try to get the pitch up further so that I get down to 100 knots. And I am still coming through with 112. Now the reason I am grading this good is that I have the basic nose track correct. However I am not hitting the proper parameters. This maneuver is complete and I would have graded it good."

Performance 3 (11-18-69, event 6)

Rating: Good

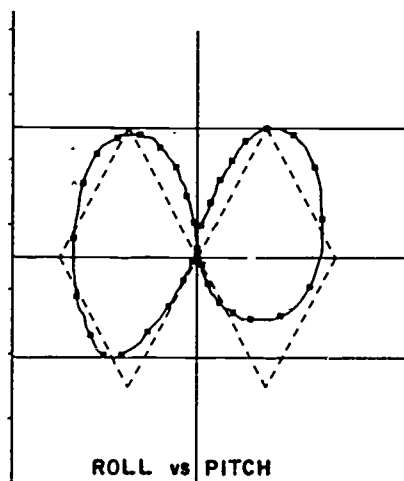
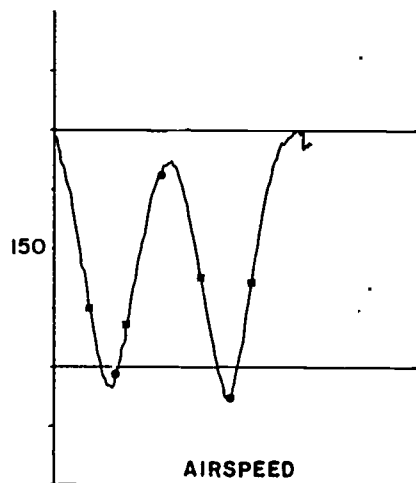

AFHRL-TR-72-6

Pilot's Commentary: "Okay, I will again attempt to correct. Apparently the cooler day has given me a good deal more aircraft performance than I was expecting. I am starting the nose-up at a higher rate of change than I have been doing, getting maximum pitch after 45°. Bank continuing to increase. Nose-down through the horizon after 90° of turn, airspeed 98 knots. At its lowest after 135° of turn. I am not getting the nose-down low enough; as a result I am coming back through with a little lower airspeed on this one... 95 knots at its lowest; now let us go down a little lower as the bank decreases, planning to come back to level flight again at 200 knots and straight and level flight. End of lazy 8 number 3. I would have graded that one a high good or low excellent. Call it a good. I'd like to get just one excellent while we are out here today!"

Performance 4 (11-18-69, event 7)

Rating: Excellent

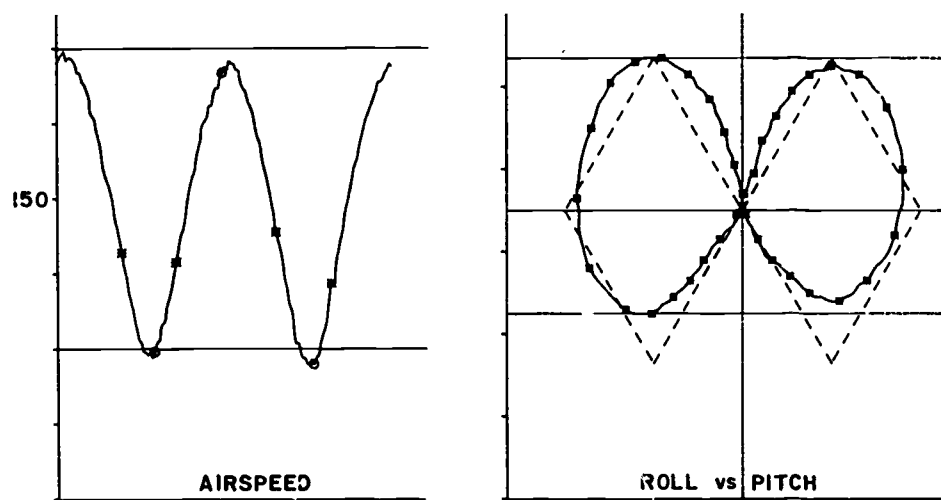

Pilot's Commentary: None recorded

AFHRL-TR-72-6

Performance 5 (11-18-69, event 13)

Rating: Good

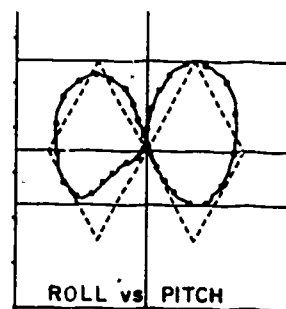
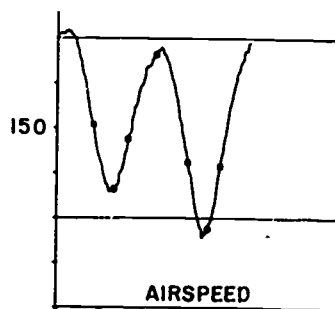

Pilot's Commentary: "Starting our pullup...get the pitch attitude to its highest point at 45° of turn; and I'm through with high airspeed again. Try to correct it on the second half of this maneuver, nose lowest after 135 with approximately 150 knots. Again I will attempt to correct by pulling the nose up at a faster rate to begin with, airspeed at its lowest after 90° of turn, pitch at its lowest on 45°, back to straight and level after 180°. That one I would have graded good. The reason for the good is a low airspeed during the first half of the maneuver. The second half I thought was a pretty good maneuver."

(2) Simplified Combination Error Measure

Based on the foregoing observations and analysis data, a simple combination error measure was derived and computed for each performance. The measure is based on criteria for roll, pitch, and airspeed determined from the representative data. The criteria are:

- M_1 = First max. positive pitch = 40°
- M_2 = First min. negative pitch = -26°
- M_3 = Second max. positive pitch = 40°
- M_4 = Second min. negative pitch = -26°
- $M_{5,6,7,8}$ = Roll at $M_1, 2, 3, 4$ = 45°
- $M_{9,10,11,12}$ = Airspeed at $M_1, 2, 3, 4$ = 133 knots

AFHRL-TR-72-6

The combined measure is

$$M = \sum_{i=1}^{12} |c_{M_i} - r_{M_i}|$$

where c_{M_i} = criterion M_i

and r_{M_i} = recorded M_i .

Figure 43 shows this computed measure for the 47 PIT instructor lazy 8s.

Note that the measure easily and clearly discriminates between excellent and fair levels of performance. Fair versus unsatisfactory is also discriminated well, the only exception being a performance that was judged to be unsatisfactory by the instructor but which was commented upon as being "maybe a low fair" by the same instructor. Similarly, other performances whose assigned ratings appear questionable by standards of the measure were found to have associated instructor comments supporting the measure's validity (Figure 43).

This measure alone accounts for 67% of the variance in instructor ratings, considering all performances. If ratings for the three performances footnoted in Figure 43 are changed as dictated by the instructor's recorded comments, the measure would account for 72% of the variance.

In light of the simplicity of the measure (sampling three variables at four discrete points in the maneuver) and the fact that absolutely no weighting was performed in its computation (straight error sum), the results are quite remarkable. It is hypothesized that use of an integrated error measure on the roll/pitch relationship and the employment of linear weighting would easily improve the measure 20 to 25%, as evaluated by its correlation with subjective ratings.

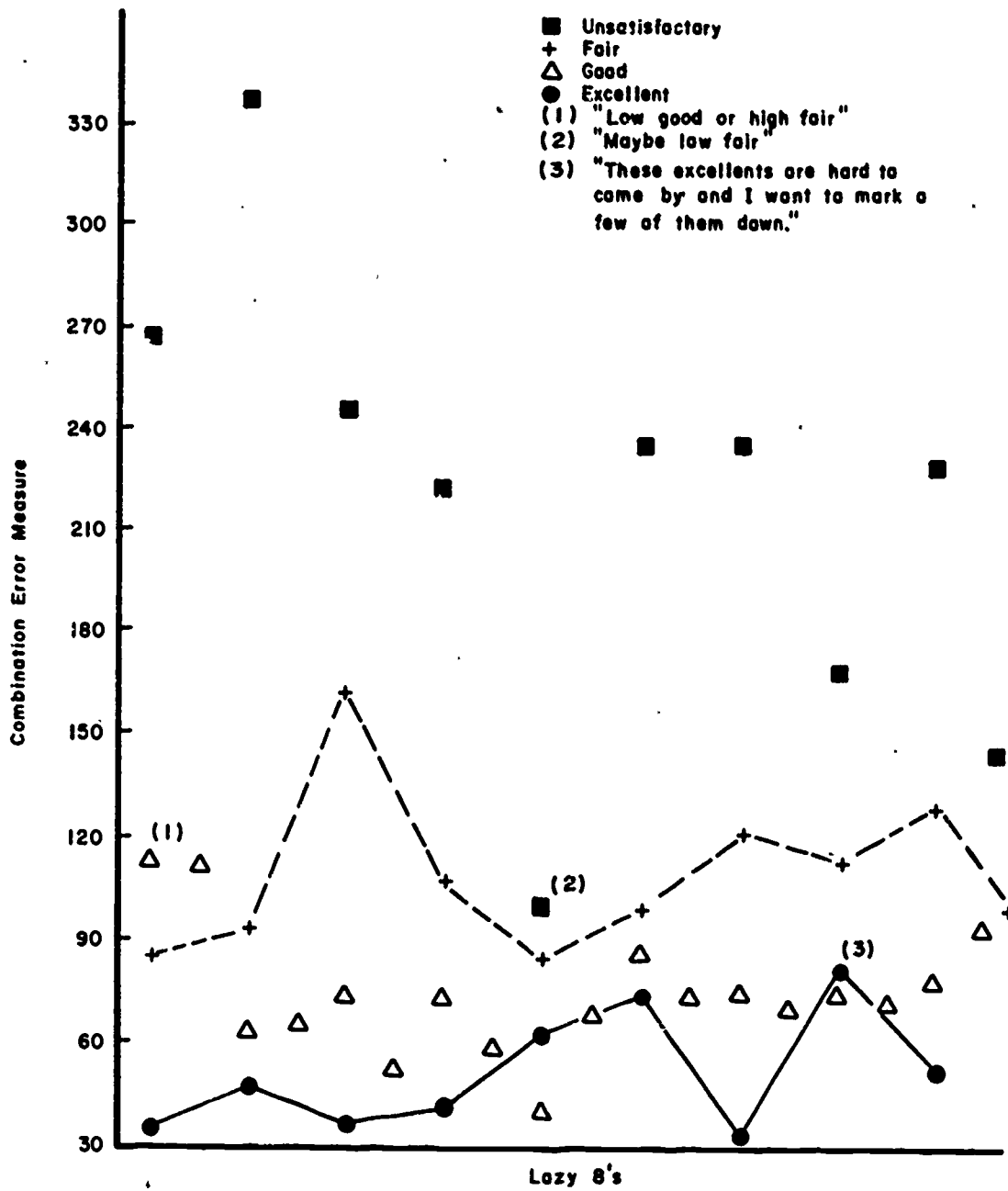

Figure 43. Combination Error Measure for 47 PIT Instructor Lazy 8 Performances

(3) Debriefing Plots

Figure 44 shows a smoothed mean roll-pitch profile for the PIT instructor excellent left performances. Also shown for comparison is an example of unsatisfactory performance as it might be overlaid and annotated in a finished debriefing plot.

b. AFHRL and ATC Instructors

Sixteen Lazy 8 performances by four different instructor pilots were analyzed. Most of these were performed during student-instruction to demonstrate proper performance of the maneuver. The performances were rated by the IP's and are distributed across the rating categories as shown in Figure 45; some performances have no rating associated with them.

With so few samples per IP, little could be gained by analysis of mean measures versus rating category or by correlations of measures with subjective ratings. It is of interest, however, to examine intra- and inter-instructor variance and technique. For this purpose, thirteen measures (numbers 1-12 and 27 in Table XVII) were selected for analysis.

Since only one sample was obtained for one of the four instructors, he was omitted from the analysis. Included, then, were three AFHRL or ATC IPs and the PIT IP, the latter's performances being chosen as all those rated excellent. Table XVIII shows the average standard deviation for each measure, taken across all 4 pilots; and the standard deviation of the average measures. The former provides some indication of intra-instructor variance; the latter provides indication of inter-instructor variance.

For most measures, the amount of variation between the average performances of the IPs is roughly equivalent to the amount of variation within a given IP. To interpret the meaning of these statements, we shall use the example of measure number 9, the airspeed sampled in the third quarter of the maneuver at the point of maximum positive pitch.

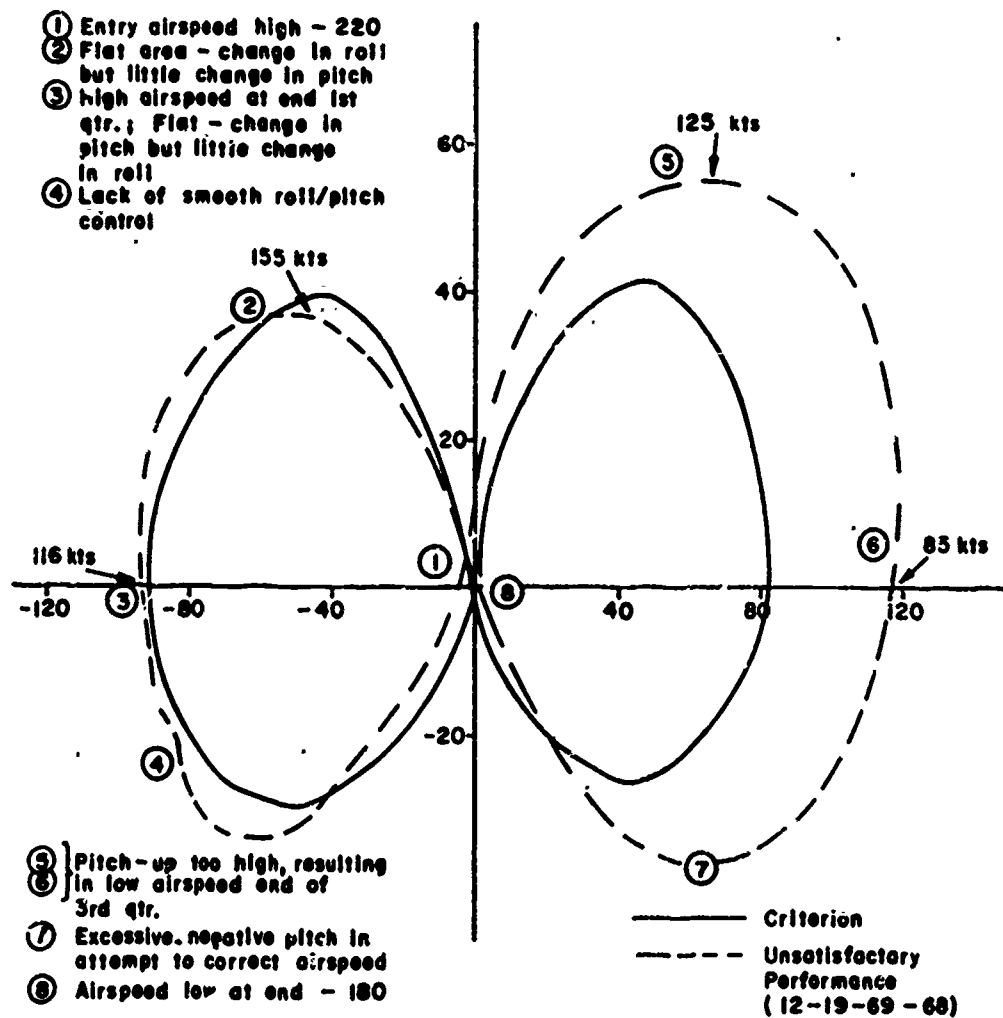

Figure 44. Sample Annotated Debriefing Plot

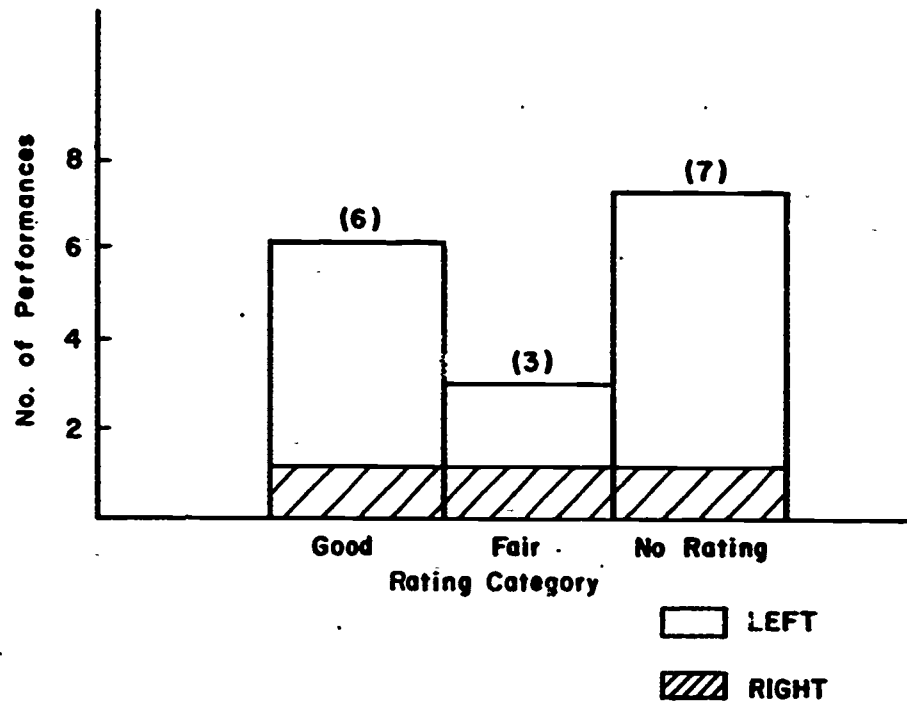

Figure 45. Distribution of Instructor Pilot Lazy 8's Across Rating Categories

TABLE XVI:1

INDICANTS OF INTRA- AND INTER-INSTRUCTOR VARIANCE
ON LAZY 8 PERFORMANCES

Measure	Units	Intra-Instructor* Variance Ind.	Inter-Instructor** Variance Ind.
1. 1st max. pitch	Deg	6	1
2. Roll	Deg	5	5
3. Airspeed	Kts	7	6
4. 1st min. pitch	Deg	4	5
5. Roll	Deg	5	7
6. Airspeed	Kts	10	7
7. 2nd max. pitch	Deg	4	1
8. Roll	Deg	6	5
9. Airspeed	Kts	9	9
10. 2nd min. pitch	Deg	4	6
11. Roll	Deg	5	7
12. Airspeed	Kts	8	8
13. Sum airsp. errs	Kts	10	4

* Average standard deviation for 4 IPs

** Standard deviation of averages of measures for 4 IPs

AFHRL-TR-72-6

The statement implies the possibility that (1) a given IP's demonstration of the maneuver could be expected to result in an airspeed variation (on this measure) of 18 knots; and (2) if two different IPs demonstrated the maneuver, the variation could be as much as 27 knots, considering all performances of both IPs.

Measures 1 and 7, the maximum positive pitch values in the 1st and 3rd quarters, show very little inter-instructor variance. Although each IP could be expected to vary ± 4 to ± 6 degrees, the instructors are consistent in that their average performances would probably vary by only $\pm 1^\circ$. Similarly, measure 13, the sum of 5 airspeed errors, shows consistency across instructors insofar as average performances are concerned.

c. Students

Forty-two performances of 16 different student pilots were analyzed, with the performances rated by the accompanying IP and distributed across rating categories as shown in Figure 46. Table XIX lists general data on the students comprising the sampling population. Also shown in Table XIX are codes representing which of two IPs flew with and rated each student.

Figures 47 to 52 illustrate plots of mean and standard deviations for the 41 measures. Correlations between measures and subjective ratings for all student performances are provided in Table XX. Debriefing plots were also generated for use in the analysis.

Roll and pitch excursions and variances increase slightly as skill ratings decrease. However, the amount of increase from fair to unsatisfactory is noticeably less than for the PIT instructor data. This could be due to different rating-standards between IPs.

Airspeed values at points of maximum pitch excursion are noticeably higher for students than for the PIT IP. Variances in the unsatisfactory performances are less.

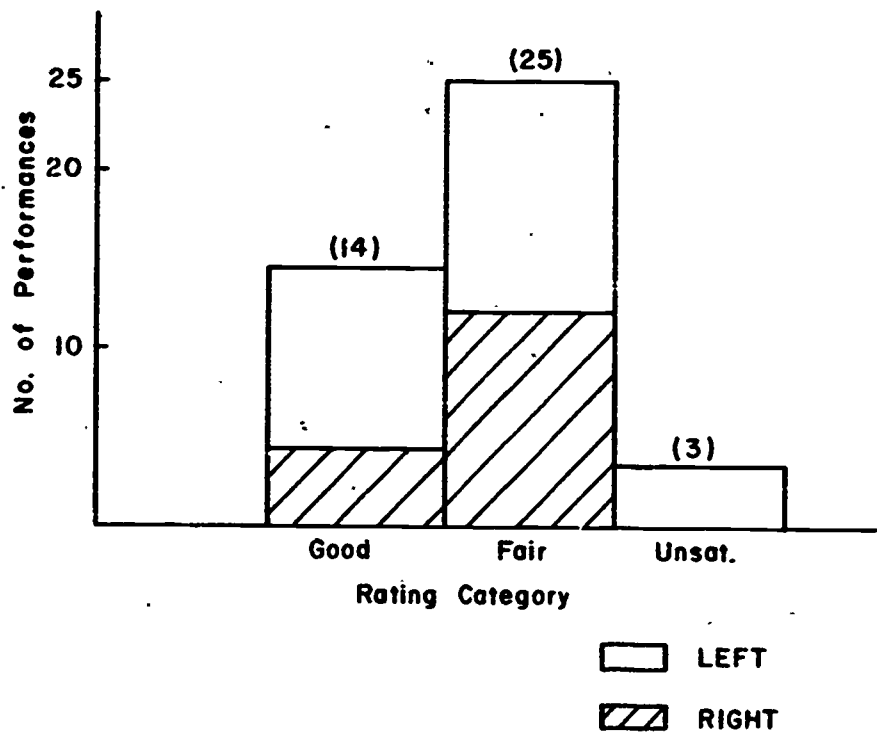

Figure 46. Distribution of Student Lazy 8's Across Rating Categories

TABLE XIX
GENERAL STUDENT DATA

Student Number	Samples*	Midphase Grade	IP's Estimate of Ability	Other Instructor Comments	IP
1	43.5 (2)	92	Average	None	1
2	47.2 (2)	---	Abv. Avg.	First time for Lazy 8s	2
3	39.0 (1)	89	Average	Flight cut short due to student complaining of severe headache	2
4	53.6 (2)	---	---	None	1
5	46.0 (2)	83	Avg. to sltly Abv. Average	Very smooth a/c control. Problem on midphase was procedural	2
6	47.0 (3) 49.5 (2) 67.7 (3) 49.9 (3)	89	Average	Washback from preceding class due to personal problems. Has good attitude and wants to fly.	2
7		86	Weaker than Avg.	Required several extra rides in pre-solo phase	2
8	52.0 (2)	87	Below Avg.	"Clanks" easily	2
9	42.2 (1)	95	Outstanding	Has previous flying experience and was controller; best I've flown with	2
10	37.7 (2)	85	Average	1st try at Lazy 8; good motivation	1
11	49.8 (2)	93	Well above avg	Will probably finish in top 5 of class	2
12	45.0 (4) 52.1 (1)	89	Abv avg.	Ability not well reflected by midphase; 3 previous dual rides working on Lazy 8	2;1
13	37.6 (1)	89	Low avg.	None	1
14	55.9 (4) ?? (2)	73	Weak	Washback; several instructors; weak on proced. but not bad stick and rud.	2
15	52.4 (2)	88	Average	None	1
16	64.9 (1)	93	Strong	None	1

* X (Y) (Z): X = total T-37 hours prior to recorded sortie
 Y = no. of Lazy 8s on this recorded sortie
 Z = no. of calendar days between recorded sorties

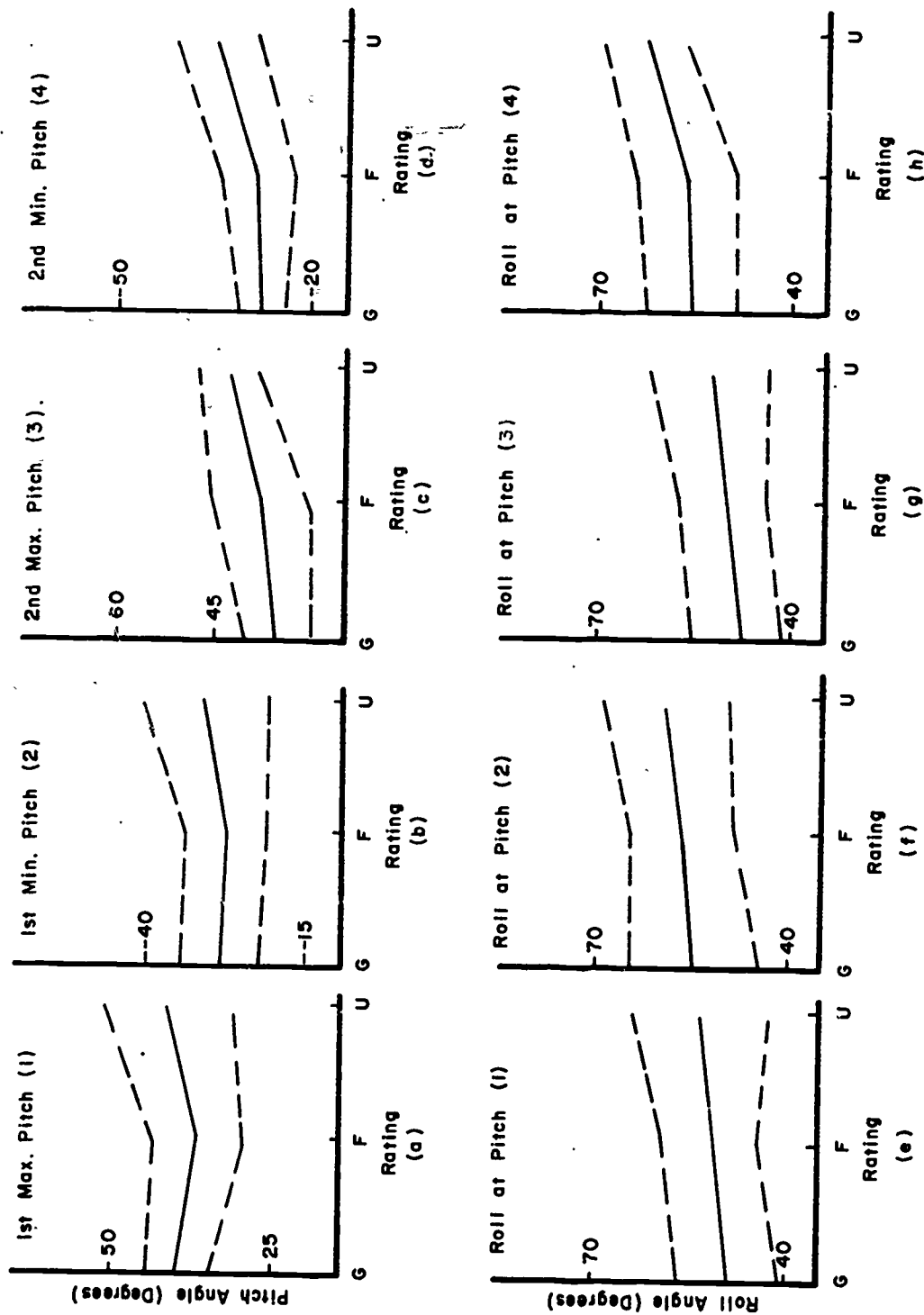

Figure 47. Pitch and Roll Measures for Student Lazy 8's [Mean + 1σ]

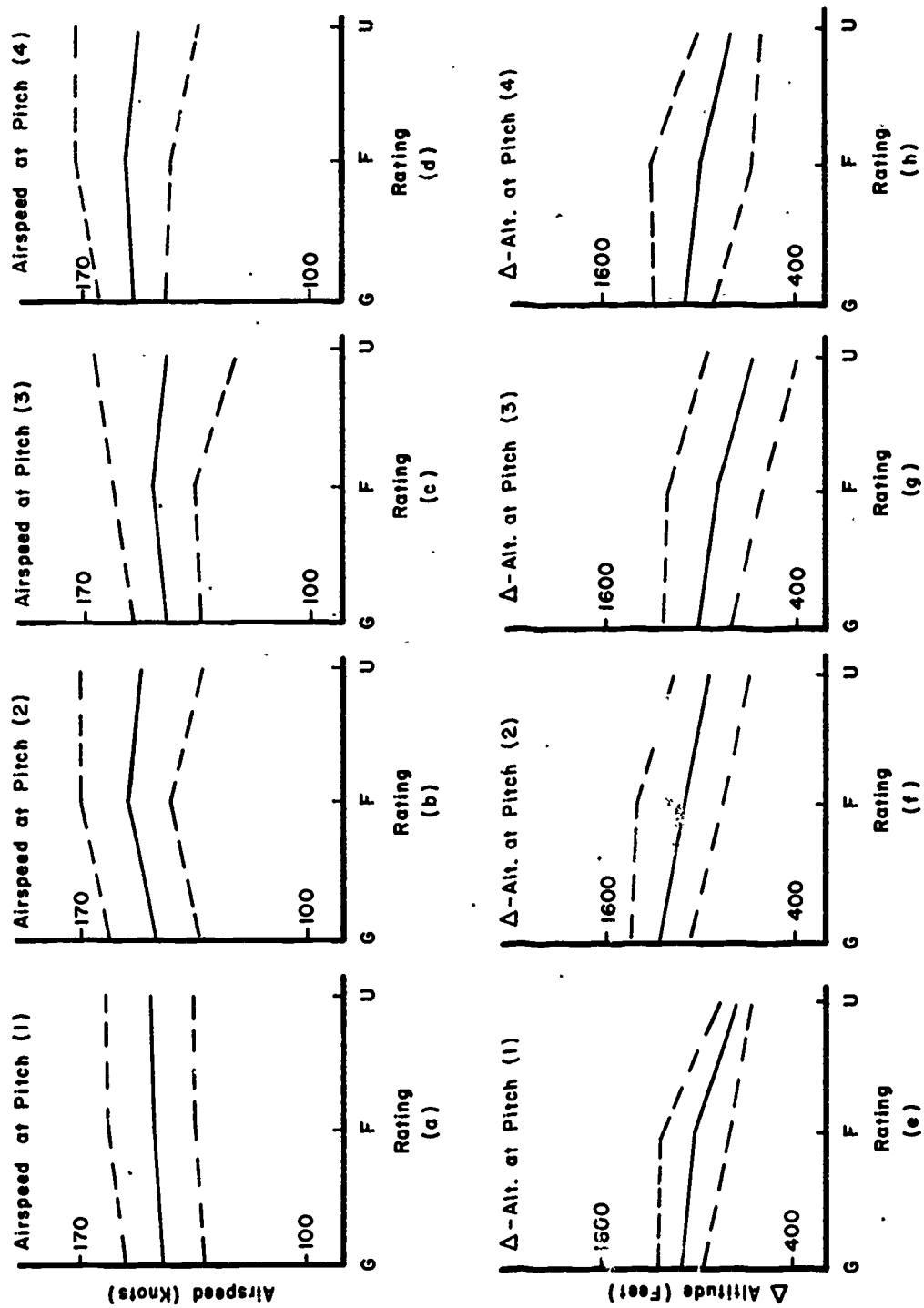

Figure 48. Airspeed and Altitude Measures for Student Lazy 8's
[Mean $\pm 1\sigma$]

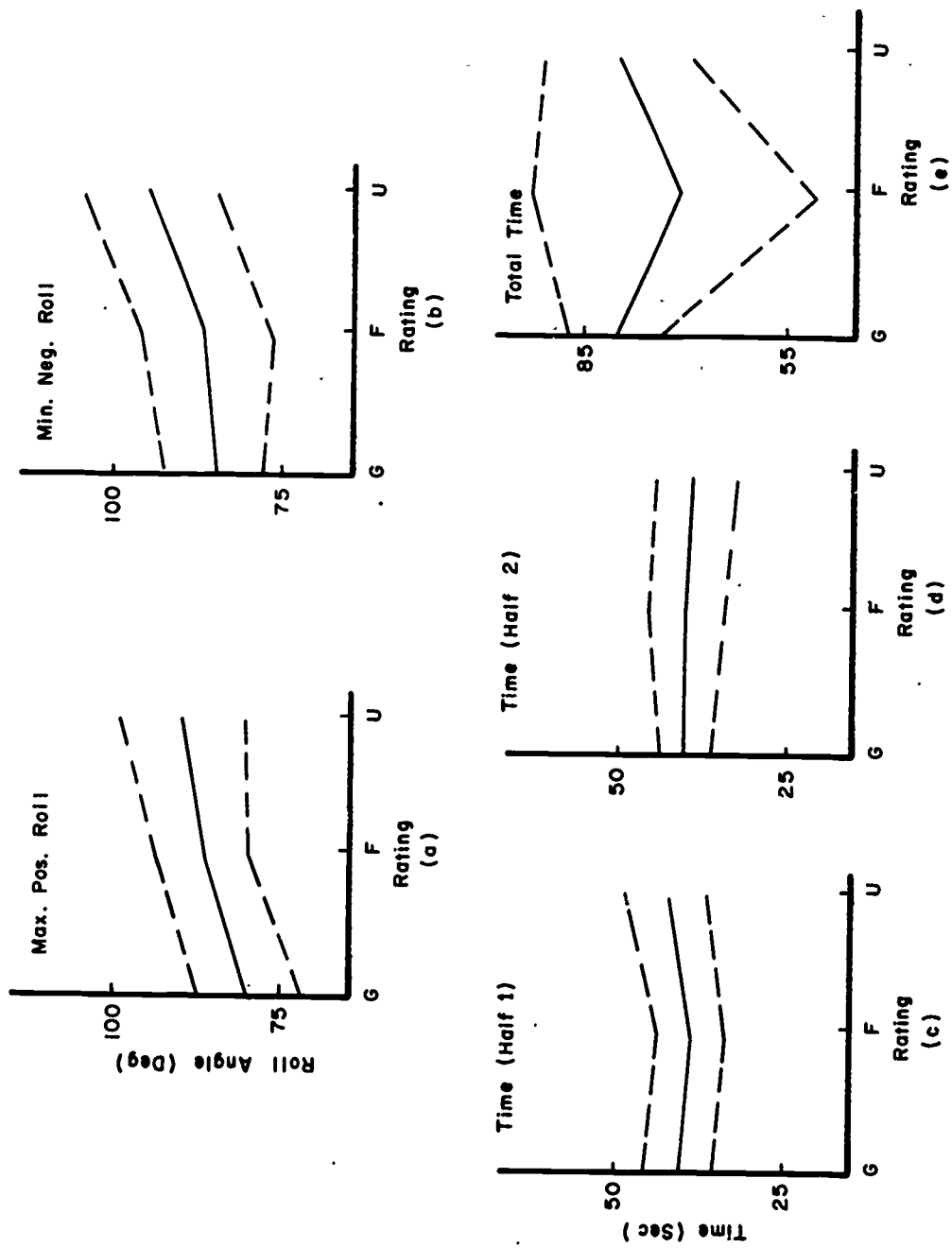

Figure 49. Roll and Time Measures for Student Lazy 8's [Mean $\pm 1\sigma$]

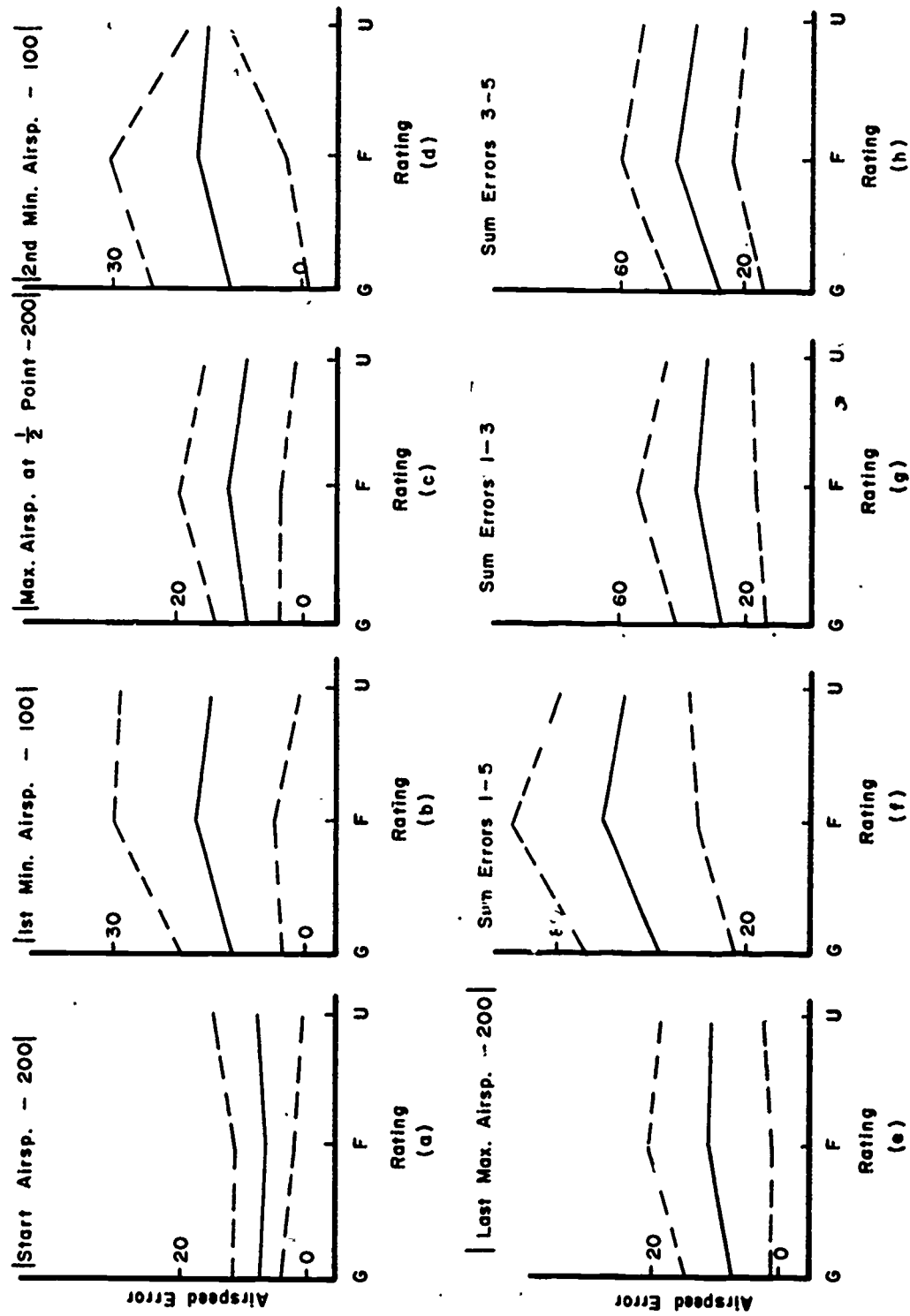

Figure 50. Airspeed Error Measures for Student Lazy 8's [Mean $\pm 1\sigma$]

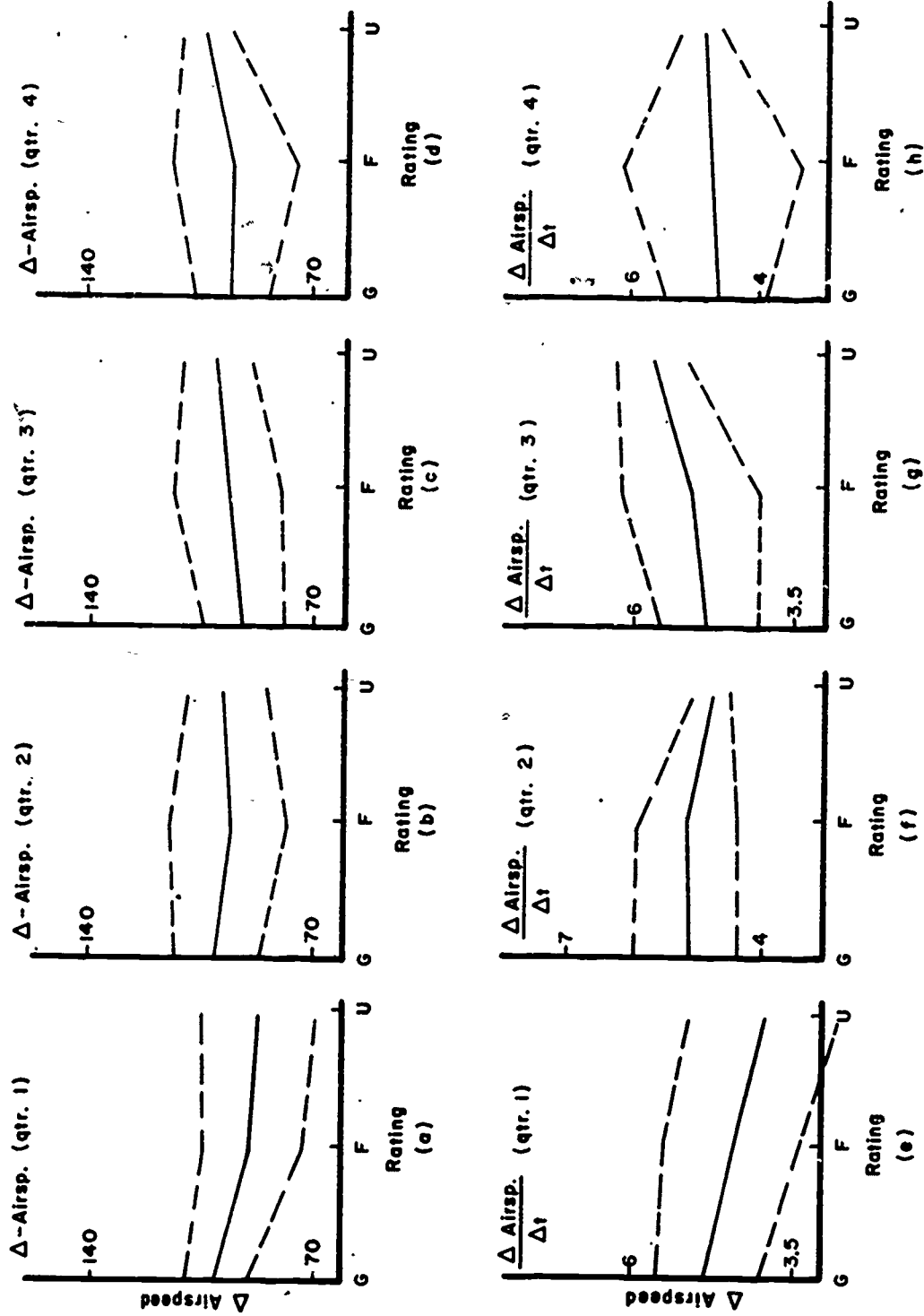

Figure 51. Airspeed Excursion and Rate Measures for Student Lazy 8's
 [Mean $\pm 1\sigma$]

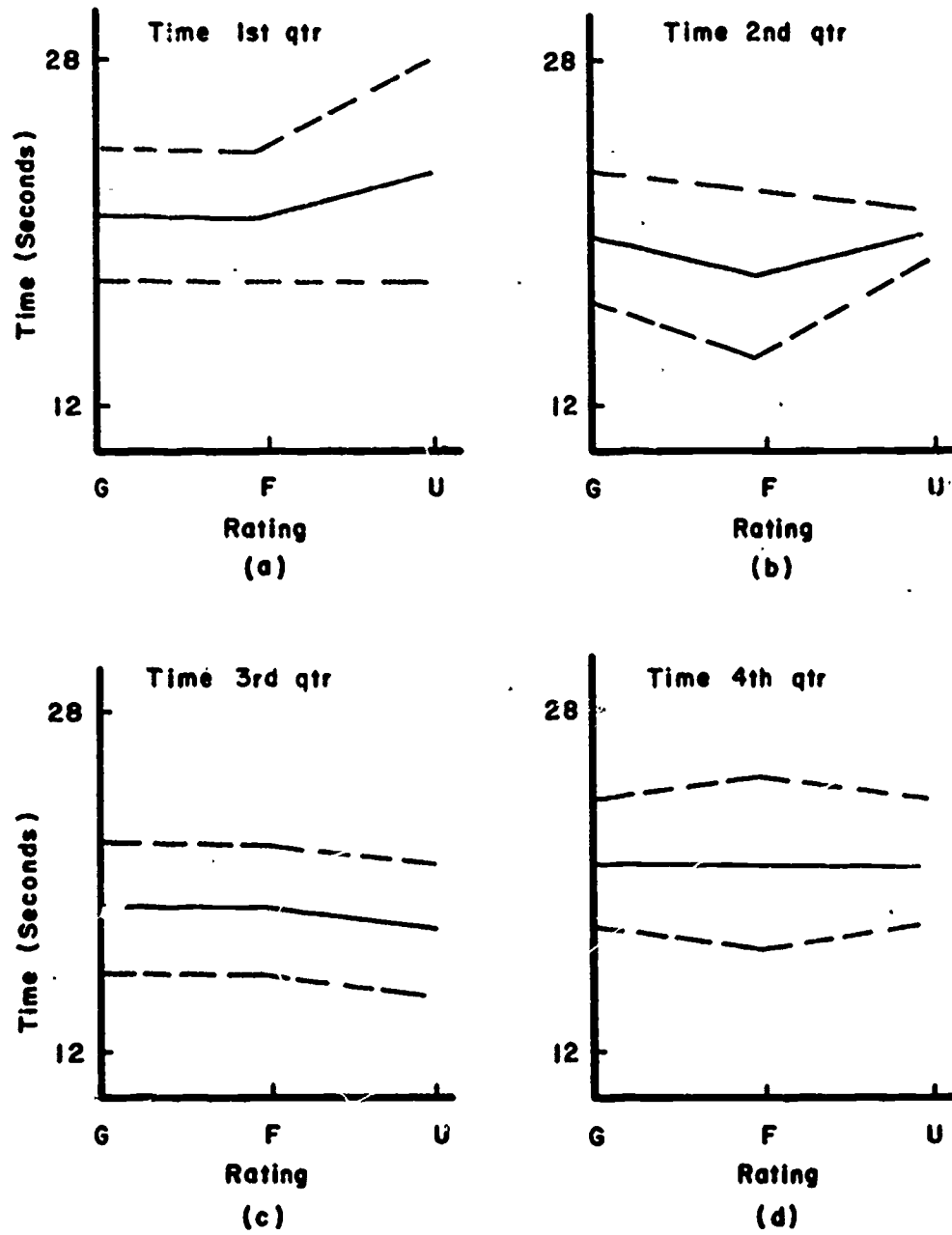

Figure 52. Time Measures for Student Lazy 8's [Mean $\pm 1\sigma$]

TABLE XX

CORRELATIONS BETWEEN MEASURES AND SUBJECTIVE RATINGS
FOR STUDENT LAZY 8s

Measure Number	Correlation Coefs.		
	All	Right	Left
1. Max. 1 Pitch (1)	0.05	0.48	-0.12
2. Min. 1 Pitch (2)	0.02	0.30	-0.03
3. Max. 2 Pitch (3)	-0.28	0.02	-0.38
4. Min. 2 Pitch (4)	0.27	0.02	0.44**
5. Roll (1)	-0.21	-0.04	-0.32
6. Roll (2)	-0.17	-0.60**	-0.02
7. Roll (3)	-0.25	-0.12	-0.30
8. Roll (4)	-0.17	-0.24	-0.16
9. Airspeed (1)	-0.20	-0.44	-0.11
10. Airspeed (2)	-0.21	-0.54**	-0.08
11. Airspeed (3)	-0.07	-0.15	-0.05
12. Airspeed (4)	-0.04	-0.10	-0.02
13. Altitude (1)	0.29	0.20	0.41**
14. Altitude (2)	0.31**	0.33	0.33
15. Altitude (3)	0.27	-0.02	0.39**
16. Altitude (4)	0.26	0.12	0.32
17. Max. Roll	-0.39**	-0.45	-0.40**
18. Min. Roll	0.21	0.21	0.23
19. Time (half 1)	0.02	0.45	-0.12
20. Time (half 2)	0.07	-0.22	0.21
21. Total Time	0.13	0.20	0.10
22. Airspeed Error 1	0.03	0.01	0.04
23. Airspeed Error 2	-0.19	-0.30	-0.15
24. Airspeed Error 3	-0.16	-0.38	-0.06
25. Airspeed Error 4	-0.15	-0.11	-0.18
26. Airspeed Error 5	-0.14	0.03	0.25
27. Summary (1-5)	-0.24	-0.34	-0.20
28. Summary (1-3)	-0.19	-0.42	-0.11
29. Summary (3-5)	-0.27	-0.32	-0.25
30. Delta Airspeed (1)	0.35**	0.46	0.33
31. Delta Airspeed (2)	0.09	0.26	-0.00
32. Delta Airspeed (3)	-0.16	-0.08	-0.22
33. Delta Airspeed (4)	-0.06	0.15	-0.19
34. Airspeed Rate (1)	0.25	0.28	0.24
35. Airspeed Rate (2)	0.05	-0.07	0.11
36. Airspeed Rate (3)	-0.23	0.10	-0.44**
37. Airspeed Rate (4)	-0.06	0.09	-0.15
38. Time (1)	-0.05	0.34	-0.16
39. Time (2)	0.10	0.36	-0.11
40. Time (3)	0.10	-0.24	0.32
41. Time (4)	0.00	-0.06	0.04

* Significant to 0.01 level

** Significant to 0.05 level

AFHRL-TR-72-6.

Altitude excursions for students are on the order of 300 and 600 ft less (in first and second halves of maneuver, respectively) than for the PIT IP. This is probably due to the varying environmental conditions (and, therefore, aircraft performance) in which the sorties were flown. The AFHRL and ATC IP data shows altitude excursions similar to those of the students, suggesting that it is not due to differences between students and IPs as classes of subjects.

Maximum roll angles attained in the maneuver have greater variance across all skill categories for students than for the PIT IP. Similarly, the total time to perform the maneuver, while having about the same mean, has much wider variances.

Unlike the PIT case, airspeed errors appear to have no relationship to skill category for the student data (Figure 50). It is strongly suspected that this is due to a difference in rating-standards among IPs, i.e., a difference in the assumed importance of airspeed in grading the maneuver. This is substantiated later in this Section where we examine trends of measures for an individual student; it also signals clearly one of the shortcomings of using IP ratings as a guide in the development of measures.

Another major difference between the student and PIT data is the airspeed value at the points of maximum pitch excursion. Recall that the PIT IP at first was striving for 150 knots at these points and was forced to reduce this value to about 133 knots in order to accomplish the maneuver correctly. However, 150 knots appears to work satisfactorily as judged by the student data. It is suspected that differences in aircraft performance in different environmental conditions is the reason.

Correlations between measures and subjective ratings for students are, in general, insignificant. This is in direct contrast to the PIT case, where a number of significant coefficients were found. Again, this appears to be due to the IP's rating techniques for the student data, and this will be further substantiated later in this Section.

The combination error measure that discriminated performances so well for the PIT data (Figure 43) was computed for the student data. The results are shown in Figure 53. The complete lack of discrimination is evident.

d. Within-Subject Sampling as a Basis for
Measurement Development

Until now, we have referenced instructor ratings as a guideline for the development of measures and for demonstrating their face-validity. This approach, as the sole approach, has serious shortcomings because it is based on the assumptions that (1) all instructors or raters apply the same standards and, for the most part at least, are consistent and reliable in their use of the (four) rating categories; and (2) the standards that are applied are valid. The authors contend that neither assumption is true.

This is not to say that the use of instructor ratings as initial guidelines in the development of measures is not valuable. A great deal of insight to the measurement of maneuvers can very definitely be attained by examination of subjective ratings. However, the use of subjective ratings in the development of objective measures is in itself a dichotomy, and such use must be made with caution and with the understanding that both reliable standards and rating-standardization can be expected to be lacking in the subjective system.

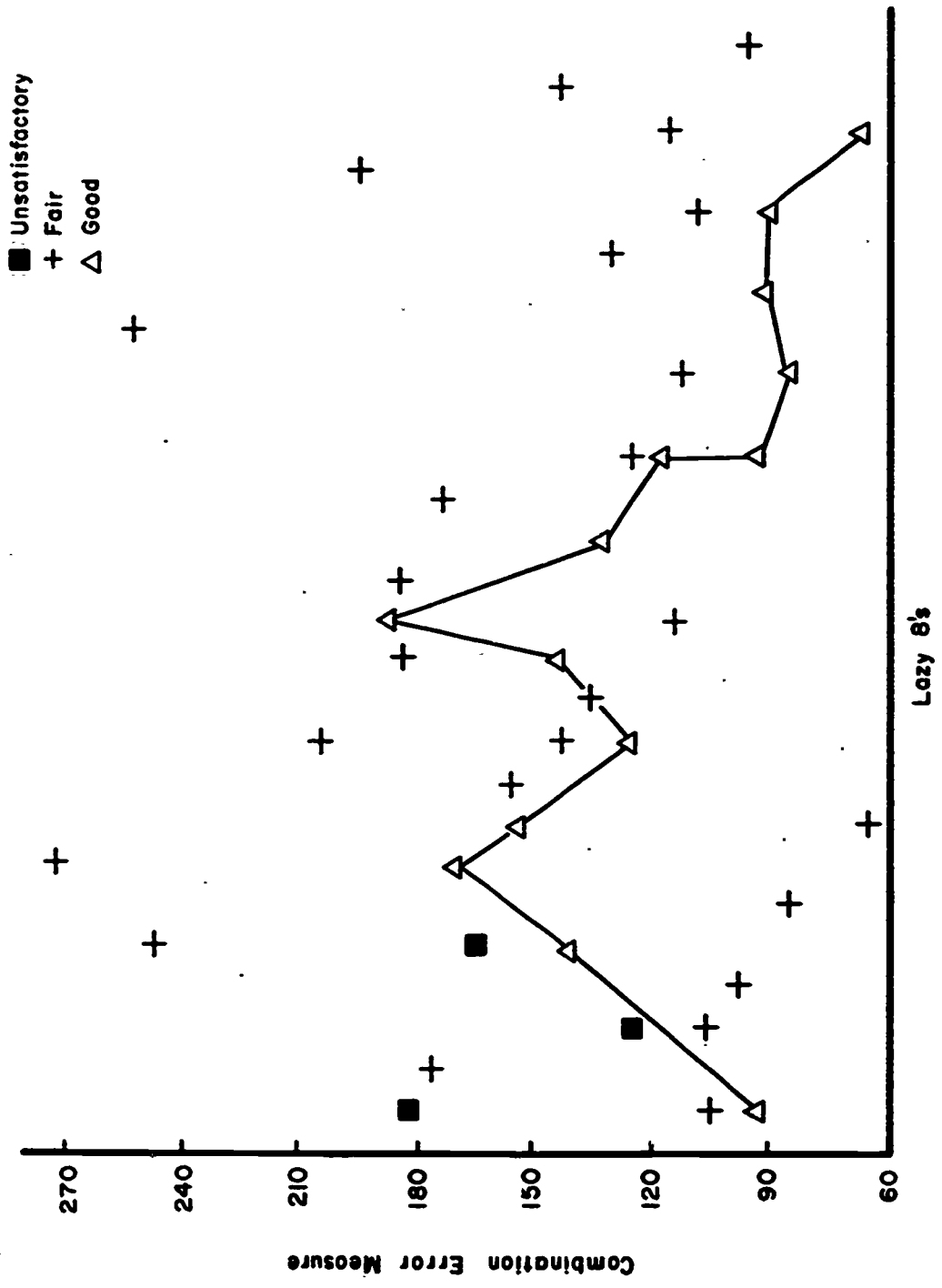

Figure 53. Combination Error Measures for 42 Student Lazy 8 Performances

Another approach is to accomplish measurement development and (equally important) to validate measures using within-subject sampling. With this approach, the major assumption is that learning occurs with time and practice of a maneuver. Individual measures that are developed should reflect all or a part of that learning through their trends from day No. 1 of instruction on a maneuver through the final day of training for each student.

In the present study, this approach was originally a part of the experimental design; however, it was impossible to apply in toto due to difficulties encountered in collecting a lot of data per student for all students sampled. It was possible, however, to attain sufficient data for one student to illustrate the approach. These results will be discussed next.

(1) Example for a Single Student

For student number 6 (Table XIX), eight performances of the lazy 8 were recorded during three different sorties. The sorties were separated by 1.5 and 17.2 flight hours and by 2 and 19 days, respectively. For reference, the performances are numbered 1 to 8, with 1-3 flown on the first sortie recorded, 4-5 on the second sortie, and 6-8 on the third sortie. (In order, the sorties were rated F, F, F, F, F, G, G, F.)

Figures 54 to 59 show each of the individual measures for the 8 performances of this student. Figure 60 shows the combination error measure for this student and for a second student (no. 14) for which 6 performances were recorded on 2 separate sorties. One measure whose trends are more obvious than others is the change in airspeed in the 4 quarters of the maneuver (Figure 58, a-d). Assuming the ATC excursion limits of 100 to 200 knots is correct, this measure should trend to 100 knots. The plots demonstrate this clearly. Also, the airspeed error measures (Figure 57) show a distinct decrease in error from early samples to later samples.

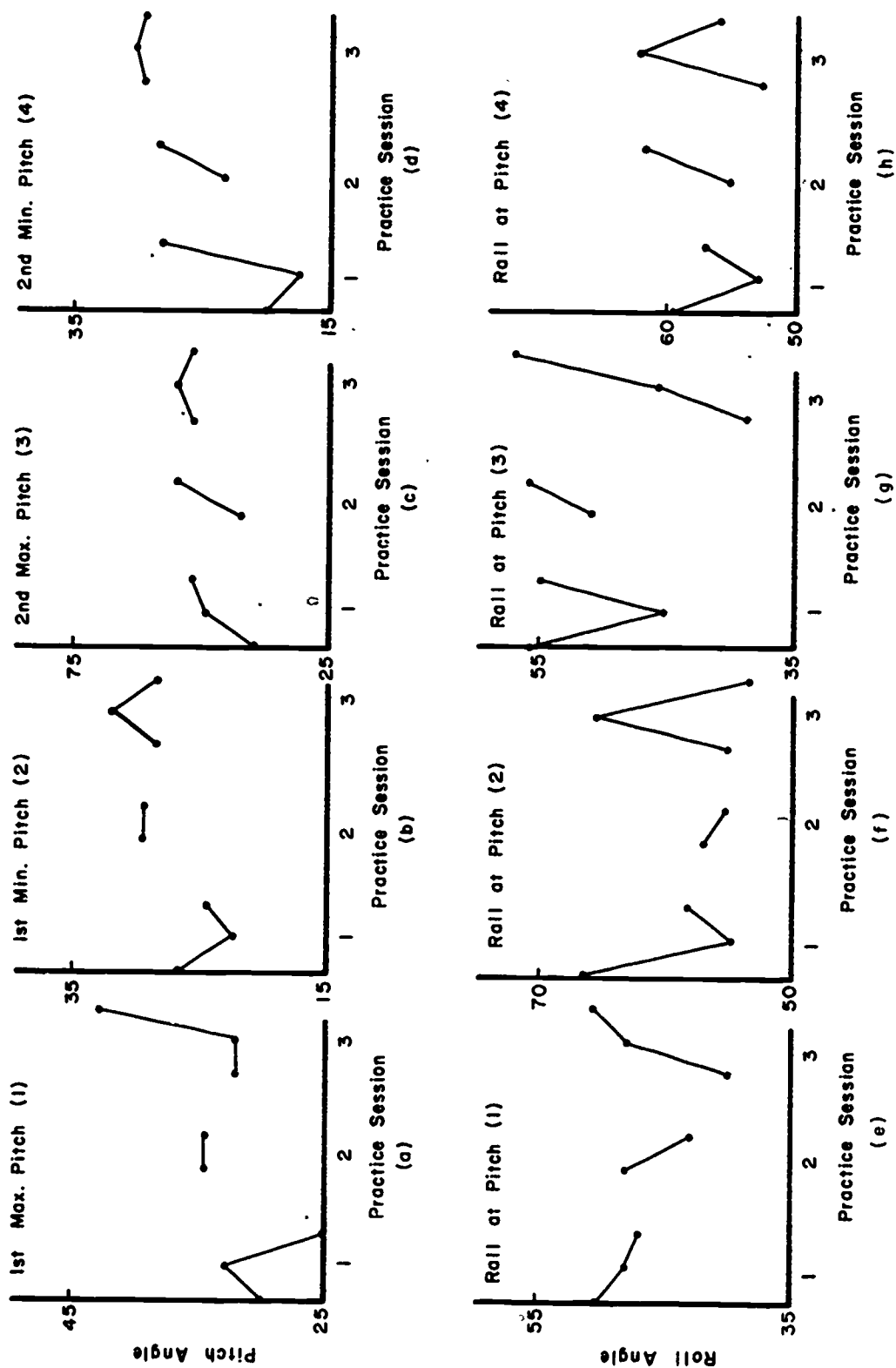

Figure 54. Pitch and Roll Measures for Single Student Performances of the Lazy 8

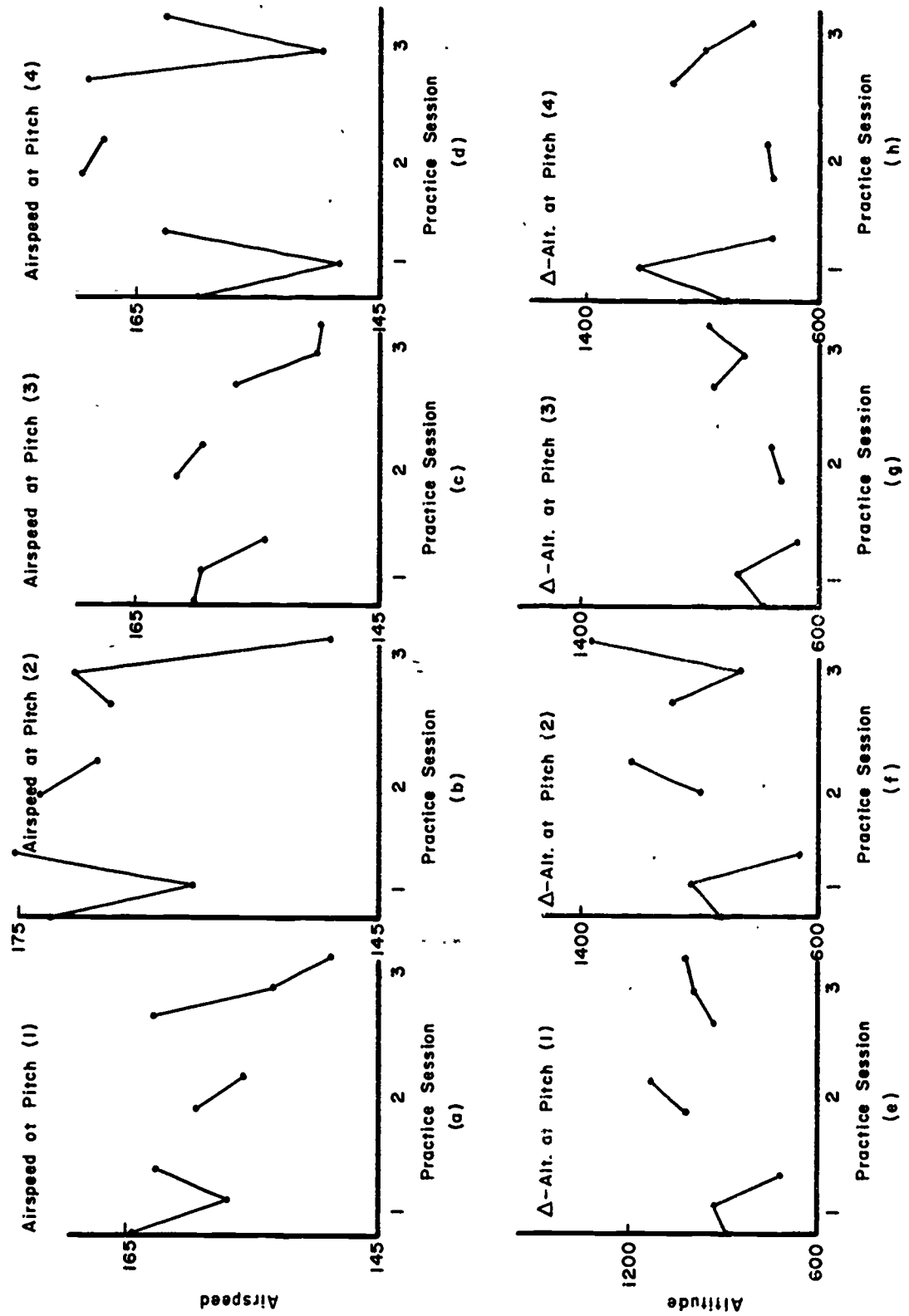

Figure 55. Airspeed and Altitude Measures for Single Student Performances of the Lazy 8

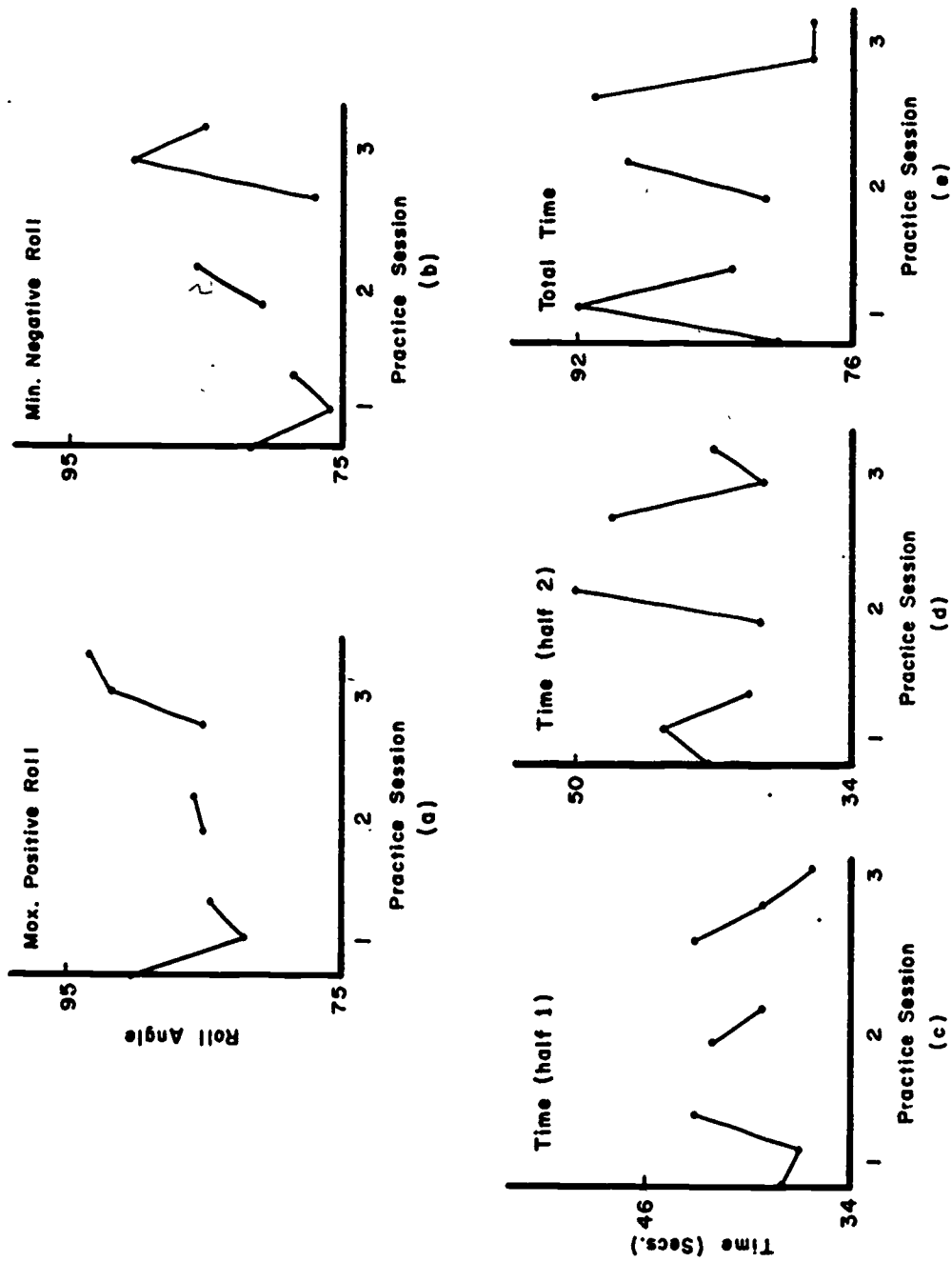

Figure 56. Roll and Time Measures for Single Student Performances of the Lazy 8

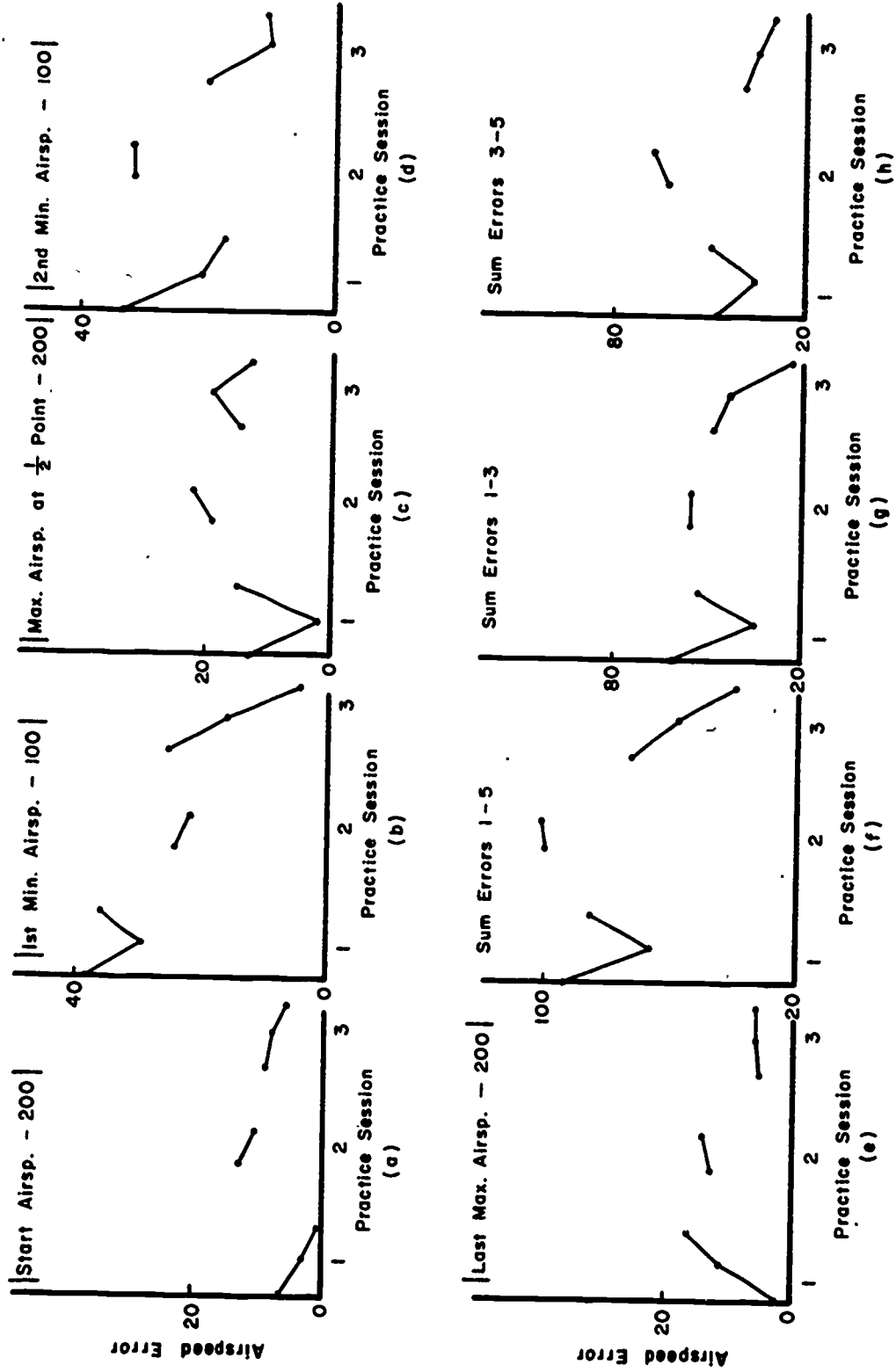

Figure 57. Airspeed Error Measures for Single Student Performances of the Lazy 8

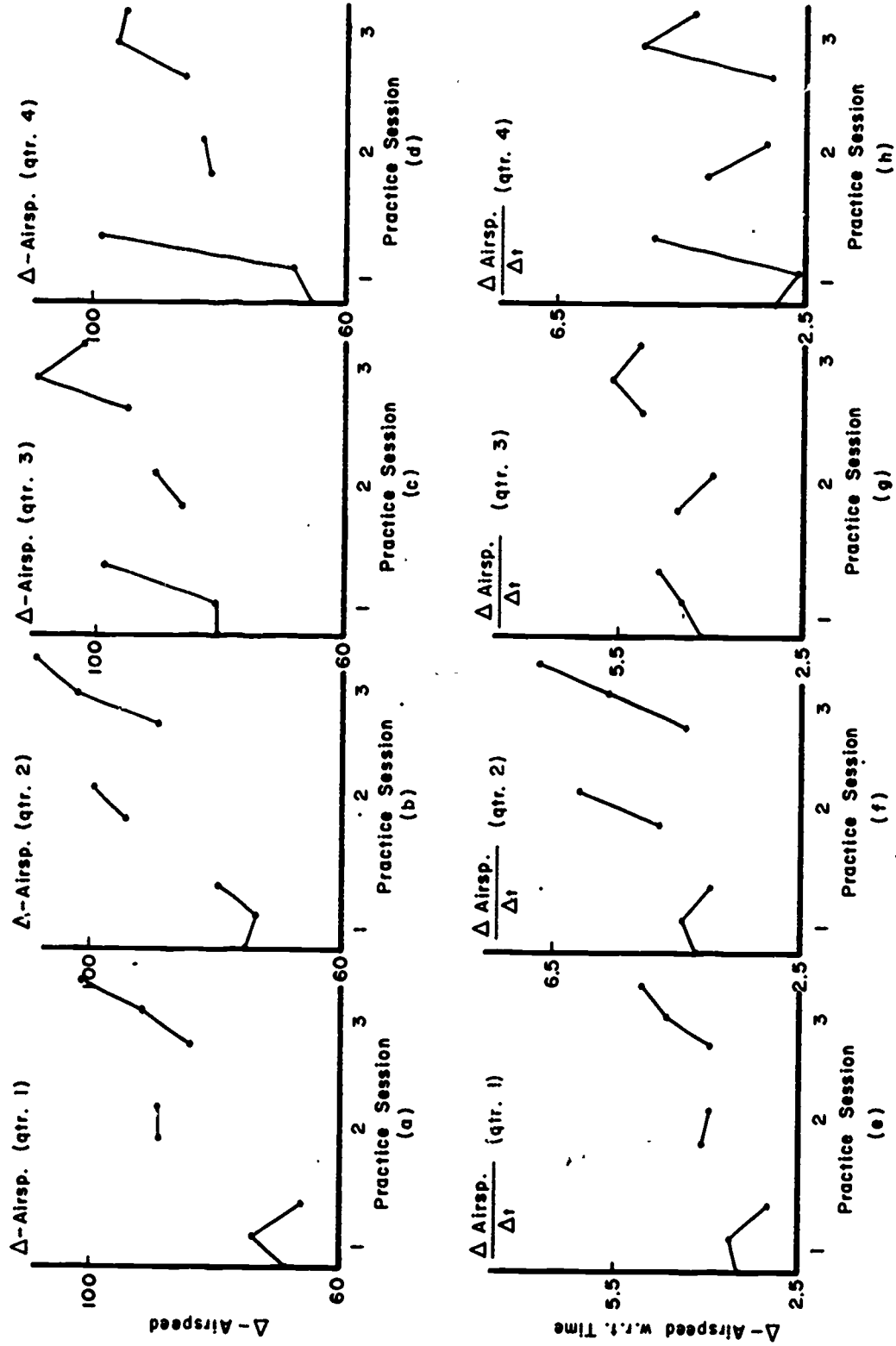

Figure 58. Airspeed Excursion and Rate Measures for Single Student Performance of the Lazy 8

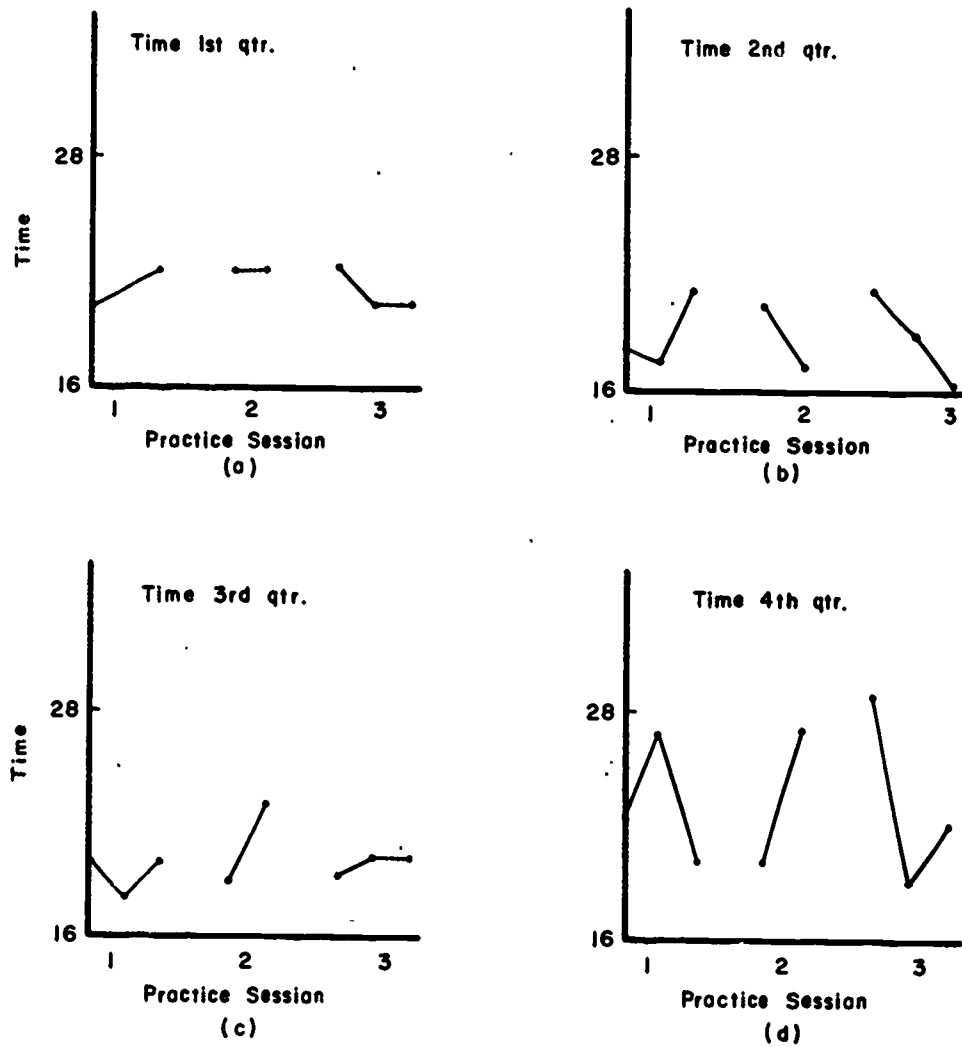

Figure 59. Time Measures for Single Student Performance of the Lazy 8

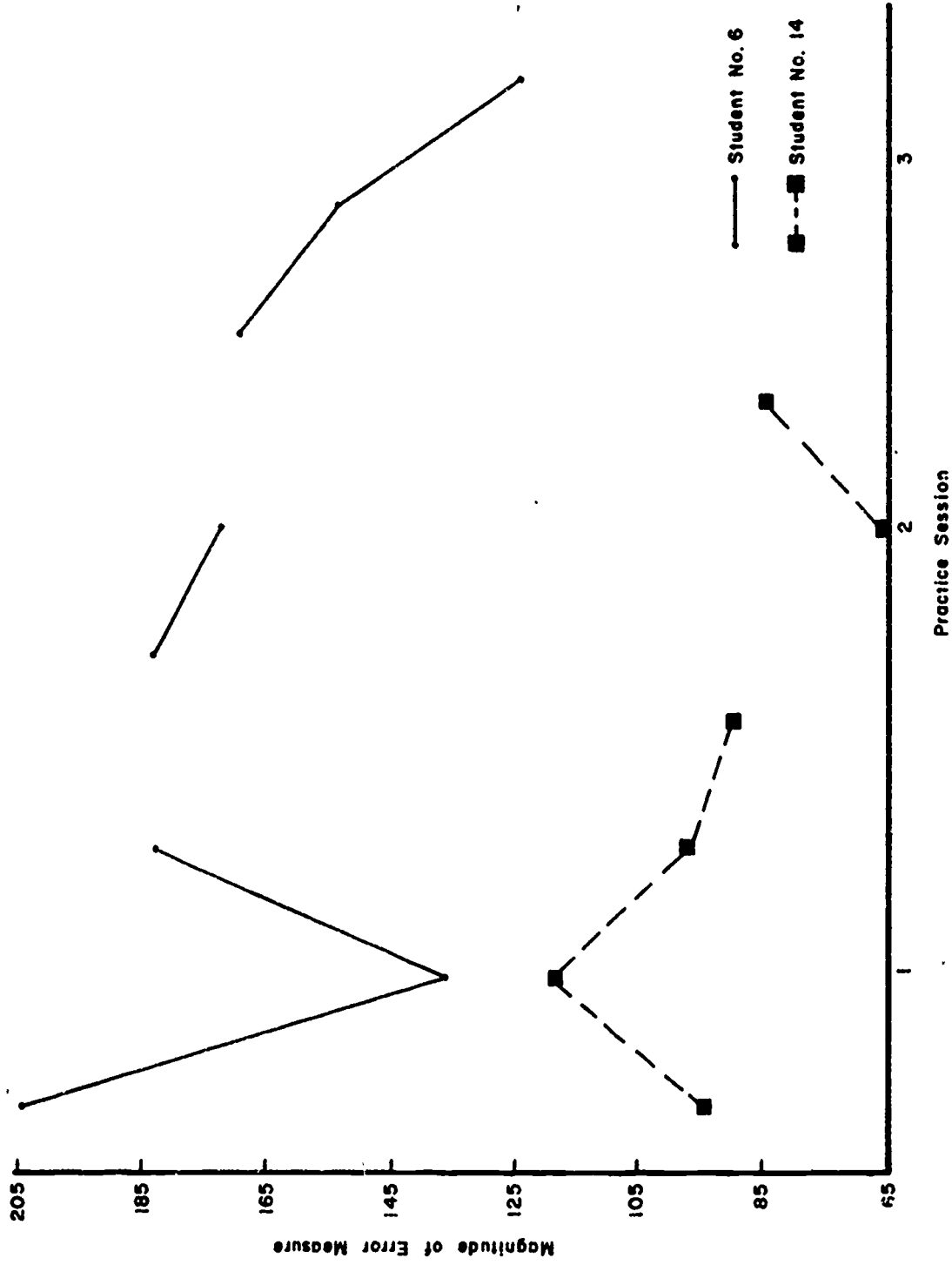

Figure 60. Combination Error Measure for Single Students' Performance of Lazy 8

Also relevant is the combination error measure of Figure 60. Although there was little if any correlation between this measure and the subjective ratings for all students (Figure 53), the trends of this measure across single student sorties show definite trends toward a decrease in error, as would be expected. On the Figure 60 plot, the measure is also shown for students numbers 6 and 14. Both students' data substantiates the validity of the measure despite its lack of correlation with subjective ratings.

e. Comparison of Instructor Rating Standards

Because of the low correlations between measures and subjective ratings for the student data (Table XX), inconsistency between the two involved IPs is suspect. To pursue this idea a little further, separate correlations for each IP were computed and are shown in Table XXI along with those for both IPs together.

The number of significant correlations (0.05 level or better) does not increase appreciably considering one IP at a time. However, some significant differences between correlations for the two IPs are noted. For IP-1, a significant positive correlation exists for the first maximum positive pitch, whereas only a small correlation (0.08) is shown for IP-2. Also, for the value of roll at the first minimum negative pitch, IP-1 shows a correlation of opposite sign and roughly equal level of significance to that of IP-2.

For altitude variations, correlations for IP-2 are consistently higher than for IP-1. At the point of first maximum positive pitch, for example, correlations were 0.66 and 0.16 for IP-2 and IP-1, respectively.

For time measures, correlations for the two IPs are generally small but of opposite signs. The most significant difference is for time to perform the second quarter of the maneuver, where the correlations are -0.62 and 0.35 for IP-2 and IP-1 respectively.

TABLE XXI
CORRELATIONS BETWEEN IP RATINGS AND MEASURES

Measure Number	IP-1 n=31	IP-2 n=11	Both IPs n=42
1. Max. 1 Pitch (1)	0.37**	0.08	0.05
2. Min. 1 Pitch (2)	-0.10	-0.27	0.02
3. Max. 2 Pitch (3)	-0.11	-0.27	-0.28
4. Min. 2 Pitch (4)	-0.09	0.37	0.27
5. Roll (1)	-0.14	-0.01	-0.21
6. Roll (2)	-0.28	0.33	-0.17
7. Roll (3)	-0.34	-0.05	-0.25
8. Roll (4)	0.00	0.08	-0.17
9. Airspeed (1)	-0.25	-0.40	-0.20
10. Airspeed (2)	-0.37**	-0.23	-0.21
11. Airspeed (3)	-0.14	-0.36	-0.07
12. Airspeed (4)	-0.06	-0.25	-0.04
13. Altitude (1)	0.16	0.66**	0.29
14. Altitude (2)	0.27	0.48	0.31**
15. Altitude (3)	0.19	0.54	0.27
16. Altitude (4)	0.16	0.60	0.26
17. Max. Roll	-0.31	-0.26	-0.39**
18. Min. Roll	0.03	-0.14	0.21
19. Time (half 1)	0.29	-0.48	0.02
20. Time (half 2)	-0.02	0.19	0.07
21. Total Time	0.27	-0.25	0.13
22. Airspeed Error 1	0.19	-0.22	0.03
23. Airspeed Error 2	-0.35	-0.27	-0.19
24. Airspeed Error 3	-0.25	-0.07	-0.16
25. Airspeed Error 4	-0.25	-0.74**	-0.15
26. Airspeed Error 5	-0.03	-0.30	-0.14
27. Summary (1-5)	-0.34	-0.44	-0.24
28. Summary (1-3)	-0.30	-0.25	-0.19
29. Summary (3-5)	-0.37**	-0.46	-0.27
30. Delta Airspeed (1)	0.48*	0.45	0.35**
31. Delta Airspeed (2)	0.24	-0.01	0.09
32. Delta Airspeed (3)	-0.01	-0.30	-0.16
33. Delta Airspeed (4)	0.16	-0.20	-0.06
34. Airspeed Rate (1)	0.38**	0.48	0.25
35. Airspeed Rate (2)	-0.06	0.63**	0.05
36. Airspeed Rate (3)	-0.03	-0.36	-0.23
37. Airspeed Rate (4)	0.14	-0.05	-0.06
38. Time (1)	0.01	-0.35	-0.05
39. Time (2)	0.35	-0.62**	0.10
40. Time (3)	0.02	0.32	0.10
41. Time (4)	-0.08	-0.04	0.00

* Significant to 0.01 level

**Significant to 0.05 level

These and other differences between the signs and magnitudes of the correlations substantiate the questionable degree of consistency between the two IPs insofar as ratings are concerned. This small sample of ratings, particularly for IP-2, cannot be expected to provide a basis for proof-positive statements regarding rating consistency, but it certainly warrants raising a question and supports the contention that IP ratings cannot be used as the sole basis for measurement development.

f. Summary and Results for Lazy 8 Measurement

Based on the foregoing analysis of lazy 8 data from three different sources (instructor of instructor-pilots, standard instructor pilots, and students), the following recommendations are made for measurement of this maneuver:

A summary error measure should be computed, using parameters of roll, pitch, and airspeed. The measure used in this study is

$$M = \sum_{i=1}^{12} |M_i - C_i|$$

where M_i and C_i are the recorded individual measures and the criteria for pitch, roll, and airspeed sampled at the four points of local pitch extremes.

An improved error measure should be computed and evaluated based on a continuous comparison between roll/pitch measures and criteria. This can be accomplished using the formula

$$M = \int_{-P}^P \int_{-r}^r |A - C| \, dr \, dp$$

where A and C are curves for actual (recorded) and criterion roll/pitch relationship, p is pitch, and r is roll.

AFHRL-TR-72-6

Debriefing plots showing roll vs pitch and airspeed should be generated and annotated. On the plots, diagnostic aids should be printed in the form of individual measures and comments. Examples of such plots are shown in Appendix XVI.

Measures should be validated using repeated samples per student. Little reliance, except for initial guidance, should be placed in correlations between IP ratings and measures.

The criteria computed from the PIT IP data appear valid. However a larger sample of data is required to ascertain true validity. (This may result in slight alteration of the parameter criterion values.)

Environmental conditions (temperature and humidity) that significantly affect aircraft performance should be considered in the development of quantitative criteria.

2. BARREL ROLL

a. Student Data

Forty-eight student performances of the barrel roll were analyzed. The performances were rated by the accompanying IP and are distributed across skill categories as shown in Figure 61. Figures 62 to 67 show the plots of mean and standard deviations for the 47 measures. Correlations with subjective ratings are provided in Table XXII.

Most of the student performances (75%) were judged in the "fair" category. This of course must influence our interpretation and reliance upon data trends across skill categories as well as the correlations. So although some insights to barrel roll measurement can be determined using the existing data, tests will be necessary in future efforts using (1) a better data sample with respect to each skill category and (2) more samples per student.

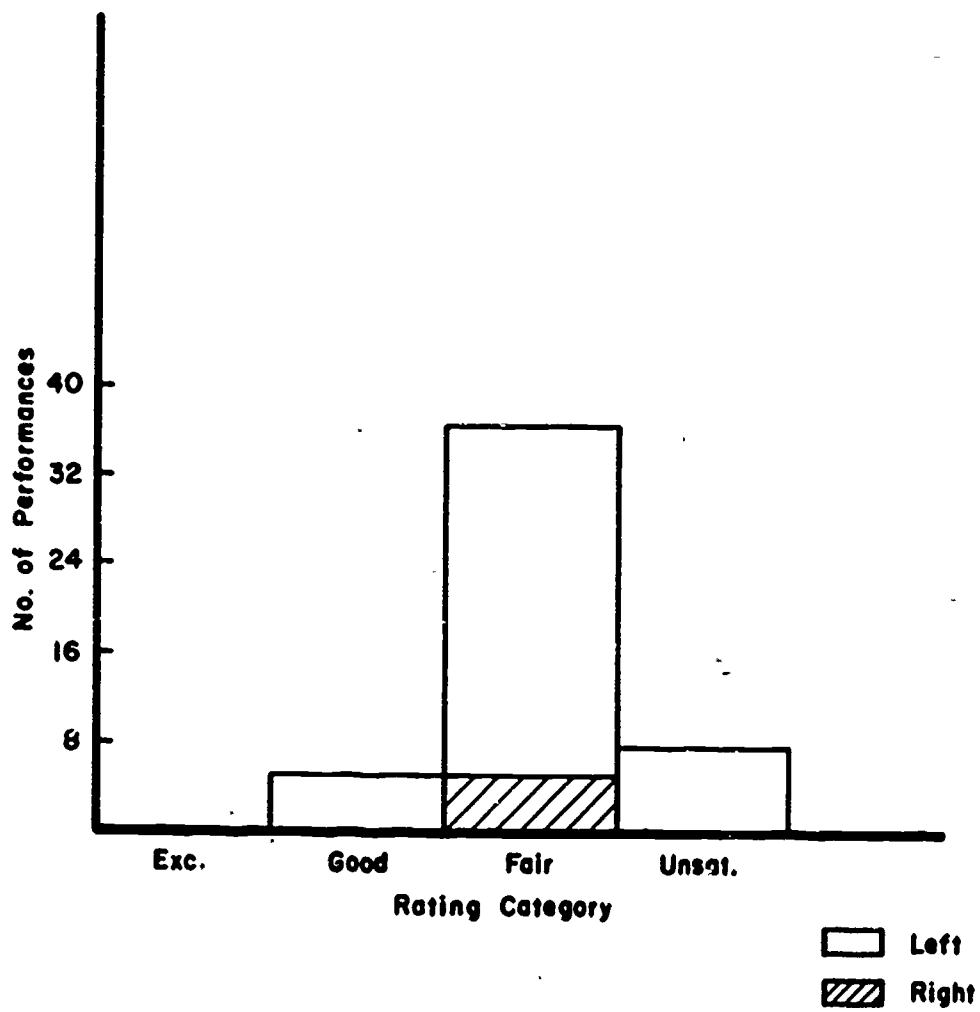

Figure 61. Distribution of Student Barrel Rolls Across Rating Categories

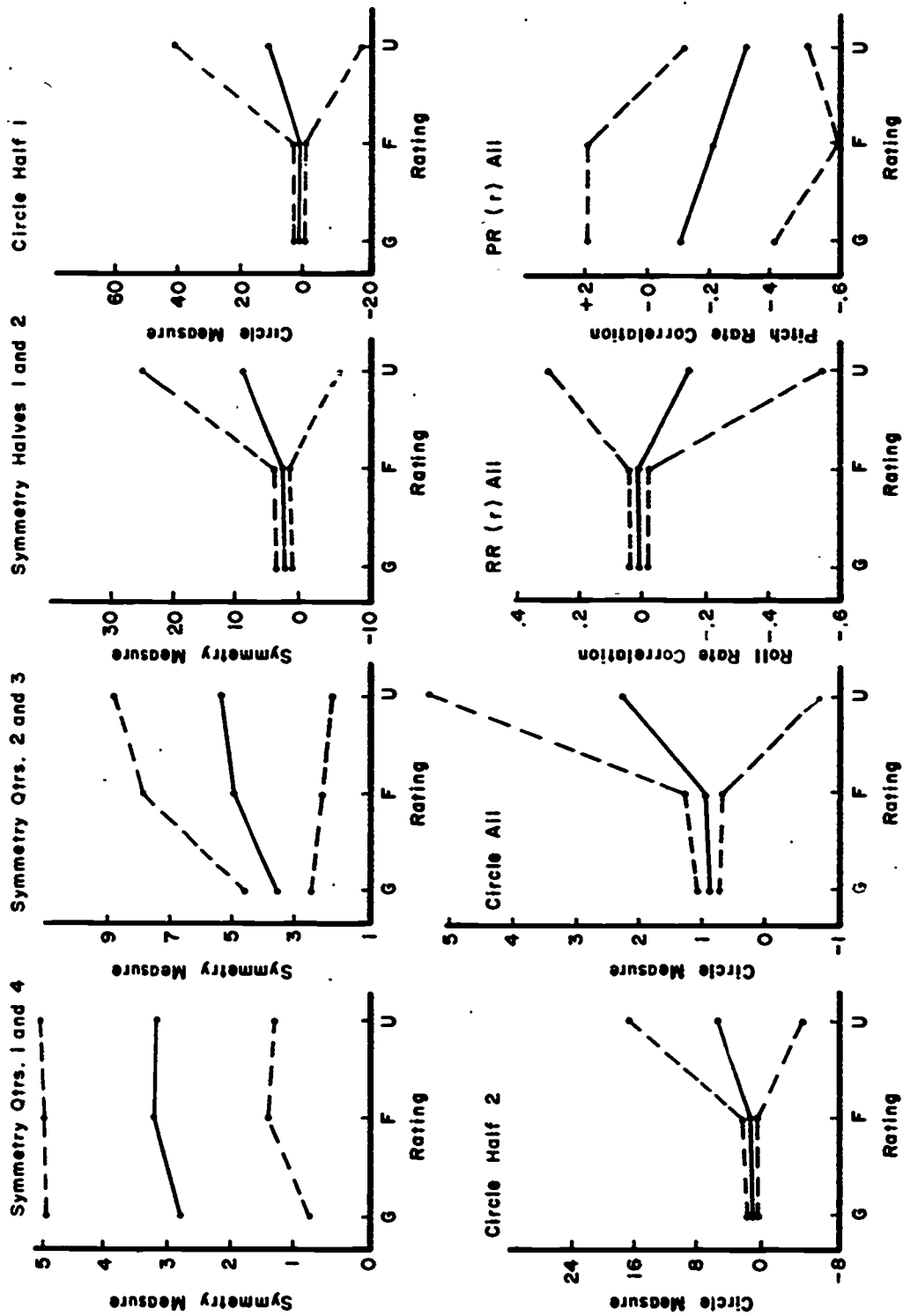

Figure 62. Symmetry, Circle, and Correlation Measures for Student Barrel Rolls

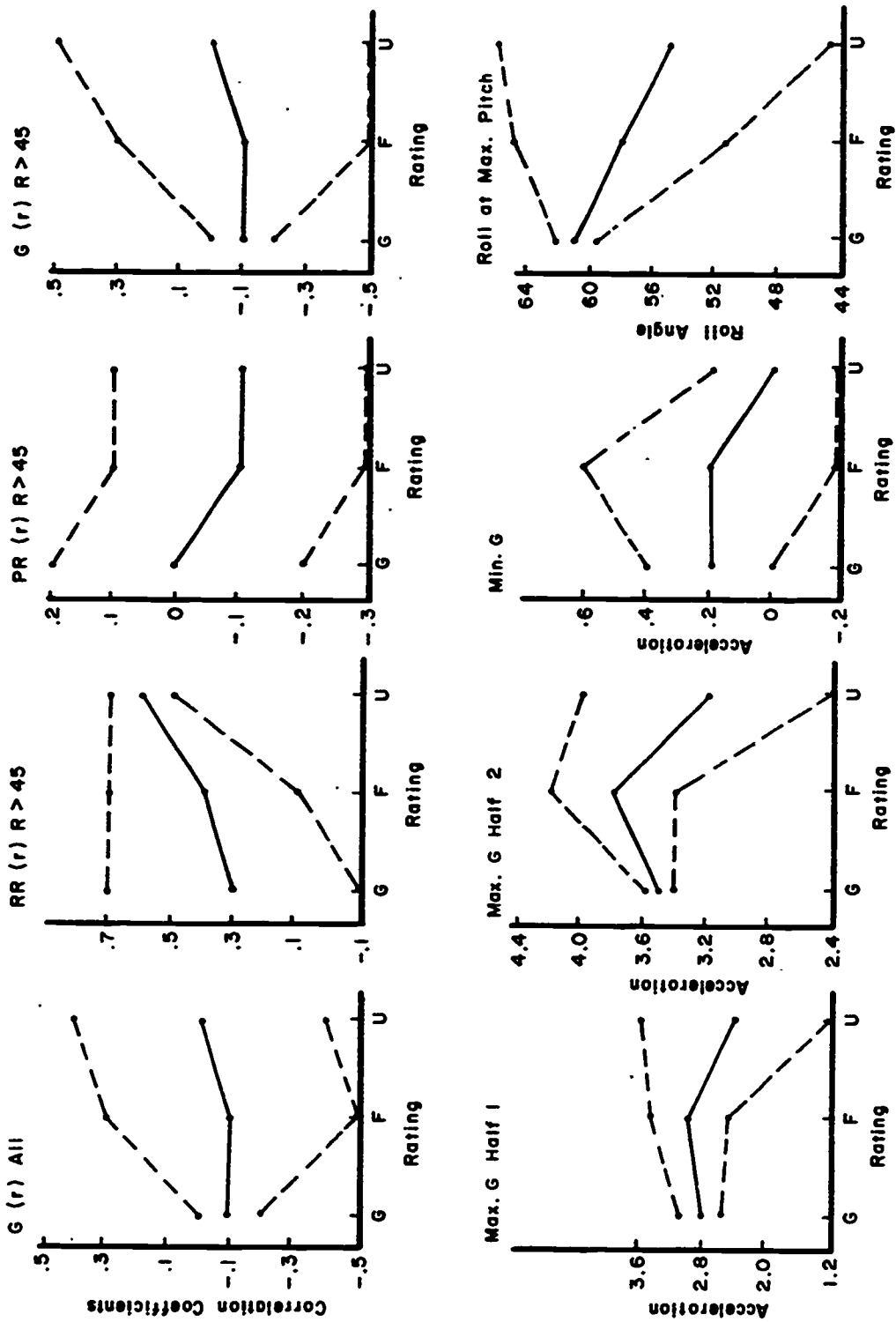

Figure 63. Correlation, G, and Roll Measures for Student Barrel Rolls

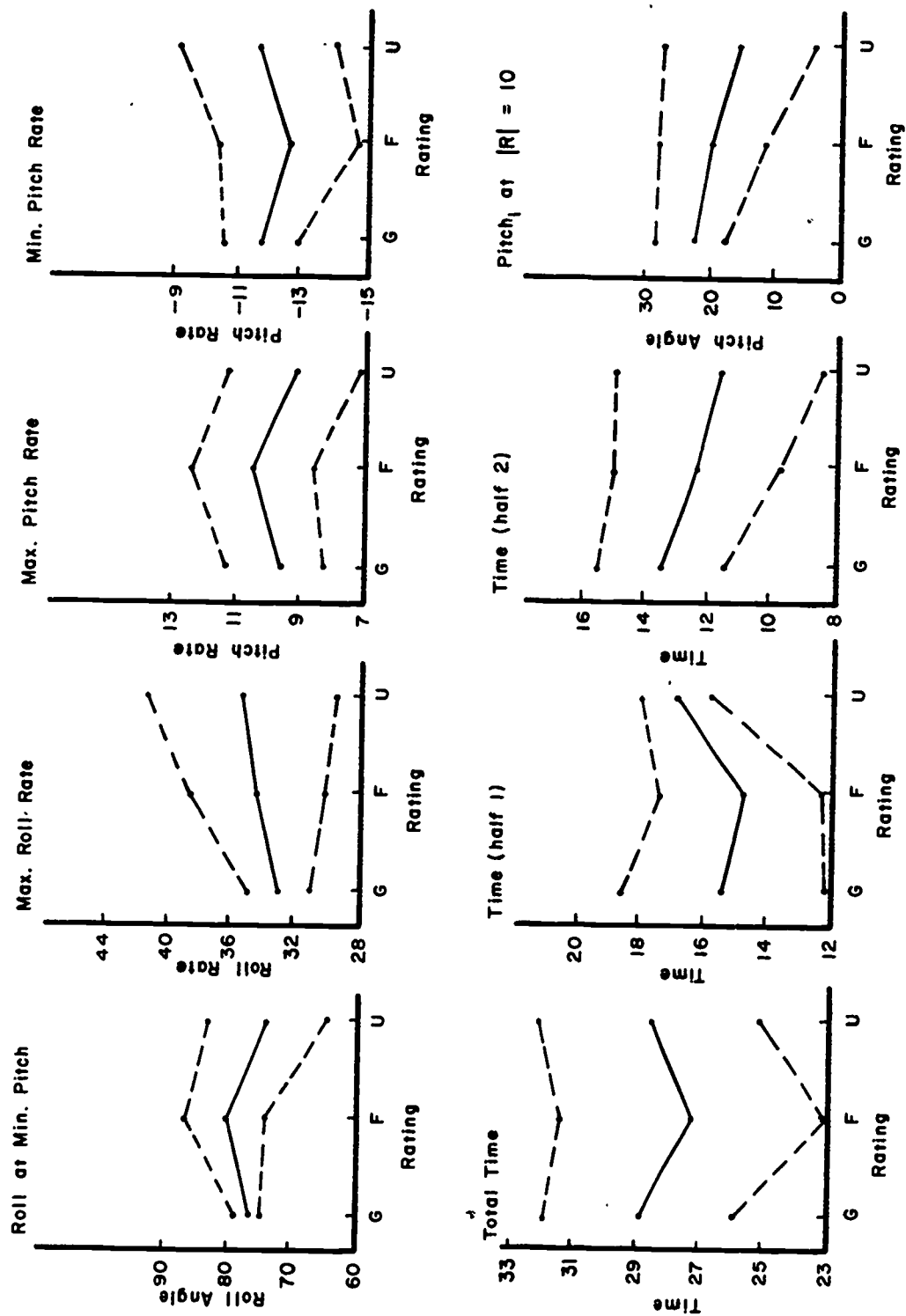

Figure 64. Angle, Rate, and Time Measures for Student Barrel Rolls

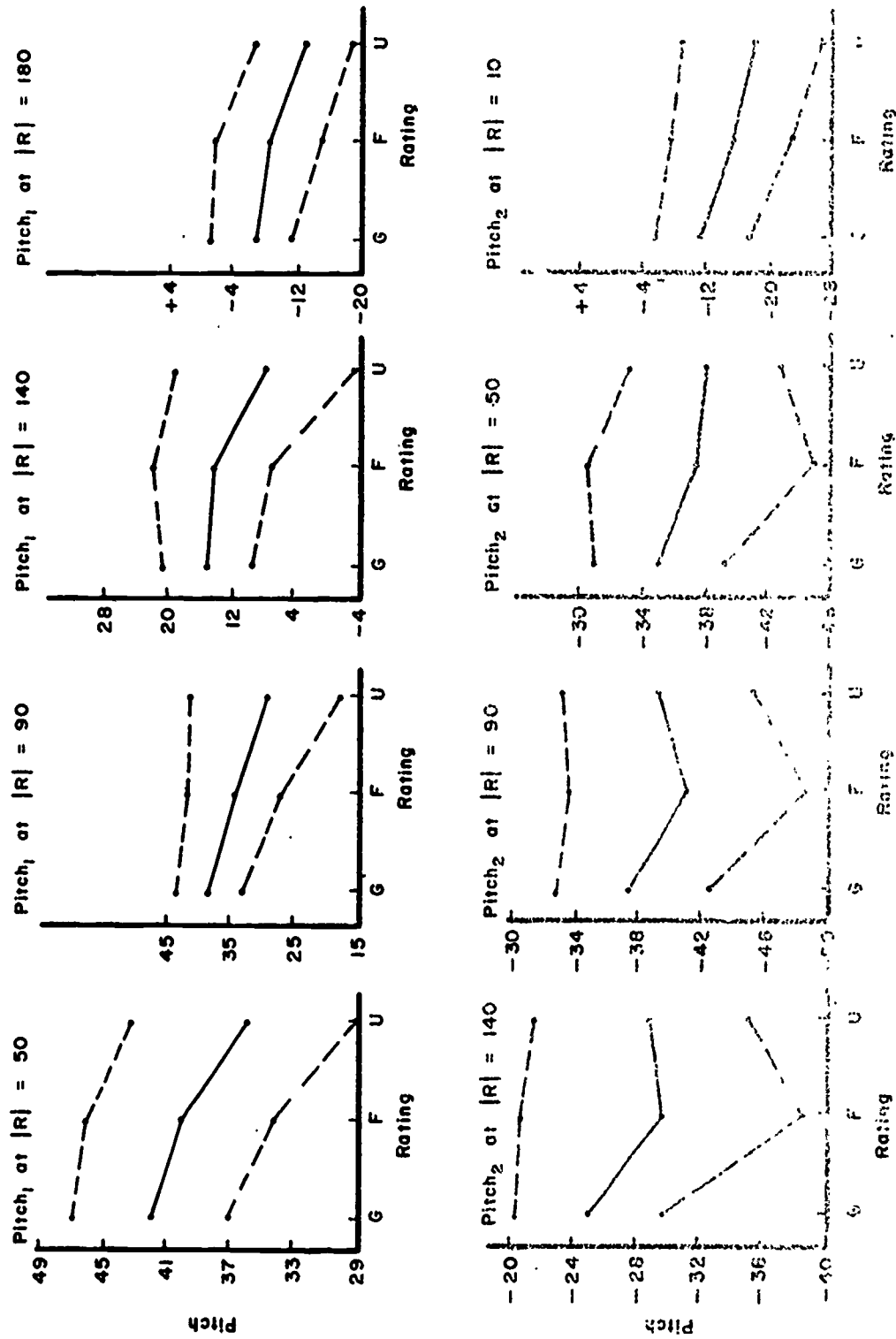

Figure 65. Pitch Angle Measures for Student Barrel Rolls

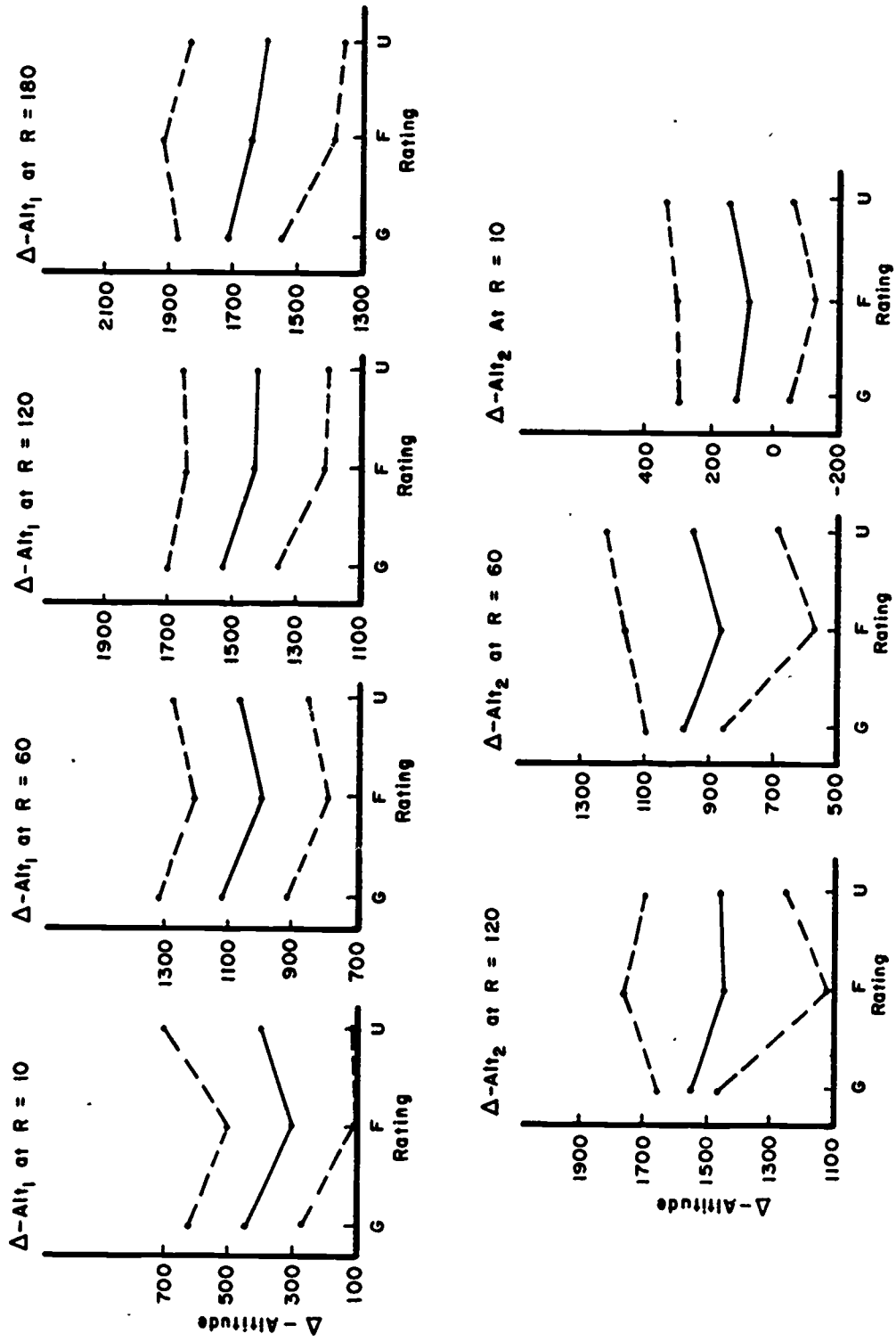

Figure 66. Altitude Excursion Measures for Student Barrel Rolls

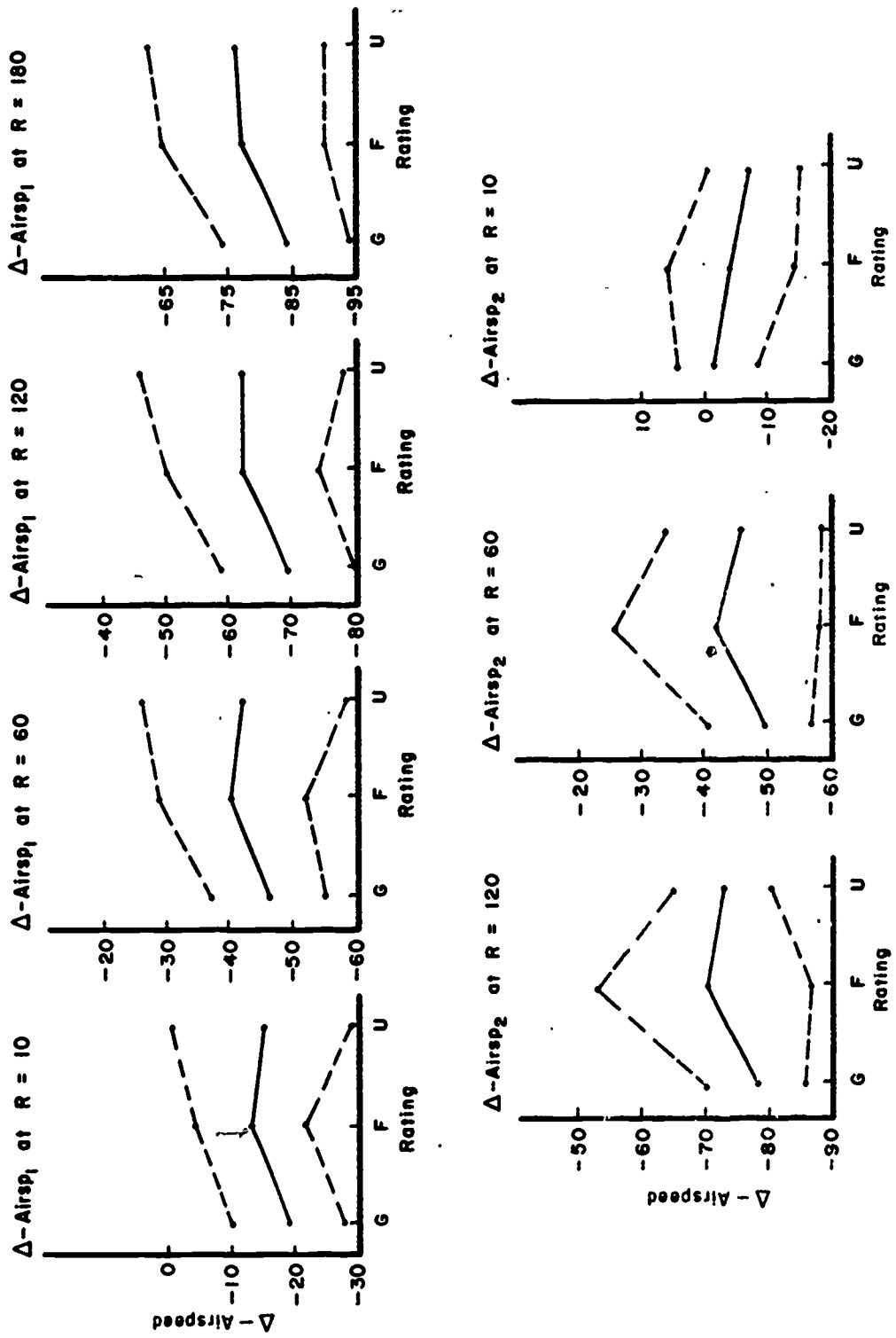

Figure 67. Airspeed Excursion Measures for Student Barrel Rolls

TABLE XXII
CORRELATIONS BETWEEN MEASURES AND SUBJECTIVE RATINGS
FOR STUDENT BARREL ROLLS

Measure	Correlation Coefficients	
	All (N=48)	Left (N=43)
1. Symmetry (1-4)	-0.05	-0.05
2. Symmetry (2-3)	-0.15	-0.16
3. Symmetry (Halves)	-0.32*	-0.32*
4. Circle 1	-0.27	-0.27
5. Circle 2	-0.31*	-0.31*
6. Circle All	-0.31*	-0.31*
7. RR Correlation All	0.24	0.24
8. PR Correlation All	0.11	0.14
9. g Correlation All	-0.04	-0.06
10. RR Correlation R > 45	-0.31*	-0.33*
11. PR Correlation R > 45	-0.01	0.01
12. g Correlation R > 45	-0.06	-0.11
13. Max g 1	0.17	0.18
14. Max g 2	0.19	0.20
15. Min g	0.18	0.19
16. Roll Max Pitch	0.21	0.22
17. Roll Min Pitch	0.15	0.15
18. Max RR	-0.13	-0.15
19. Max PR	0.11	0.12
20. Min PR	-0.04	-0.04
21. Time (Total)	-0.01	-0.00
22. Time 1	-0.19	-0.19
23. Time 2	0.18	0.18

TABLE XXII (Concluded)
CORRELATIONS BETWEEN MEASURES AND SUBJECTIVE RATINGS
FOR STUDENT BARREL ROLLS

Measure	Correlation Coefficients	
	All (N=48)	Left (N=43)
24. P (R = 10)	0.22	0.24
25. P (R = 50)	0.26	0.27
26. P (R = 90)	0.28	0.29
27. P (R = 140)	0.23	0.24
28. P (R = 180)	0.24	0.26
29. P (R = 140)	0.09	0.09
30. P (R = 90)	0.04	0.04
31. P (R = 50)	0.10	0.10
32. P (R = 10)	0.22	0.22
33. Δ - ALT (R = 10)	0.02	0.03
34. Δ - ALT (R = 60)	0.04	0.05
35. Δ - ALT (R = 120)	0.10	0.10
36. Δ - ALT (R = 180)	0.11	0.13
37. Δ - ALT (R = 120)	0.05	0.07
38. Δ - ALT (R = 60)	-0.01	0.00
39. Δ - ALT (R = 10)	-0.04	-0.04
40. Δ - ARSP (R = 10)	-0.08	-0.09
41. Δ - ARSP (R = 60)	-0.06	-0.05
42. Δ - ARSP (R = 120)	-0.13	-0.13
43. Δ - ARSP (R = 180)	-0.15	-0.17
44. Δ - ARSP (R = 120)	-0.06	-0.10
45. Δ - ARSP (R = 60)	-0.02	-0.04
46. Δ - ARSP (R = 10)	0.14	0.14

*Significant to 0.05 level.

AFHRL-TR-72-6

There is a distinct increase in variance as skill ratings decrease in the symmetry measure on quarters 2 and 3. No significant increase is noted for quarters 1 and 4, however. This indicates that more variance in the roll/pitch relationship is exhibited in the inverted attitude, as may be expected. A distinct increase in variance is also noted for halves 1 and 2 as skill ratings vary from fair to unsatisfactory.

Circle measures, which are error measures, increase in value as well as variance as skill ratings decrease. From this data and from the debriefing plots, it is postulated that the circle measure will prove to be one of the best single indicies of performance skill.

Of the constancy measures on roll rate, pitch rate, and normal acceleration, only the roll rate measure for $|\text{roll}| > 45$ appears significant from the standpoint of significant correlations. However, the plot shows that as skill ratings decrease, the correlation increases toward 1.0, indicating less variance in roll rate itself. This is the opposite from that which was expected based on the maneuver analysis, and requires further investigation in future efforts. In addition, variance of the correlation decreases as skill ratings decrease, though one would expect an increase.

Maximum G measures show a slight increase as skill ratings vary from good to fair, but a decrease in value and increase in variance with reduction to unsatisfactory. This may indicate that max. G measures may discriminate higher-skill performances better than lower-skill ones; or that lower-skill performance patterns are typically flatter on top and dished-out on the bottom, resulting in much less normal acceleration on the average. Minimum G measures show a decrease from fair to unsatisfactory, indicating the known tendency to "get light" on top when unskilled in performance of this maneuver.

Roll at maximum pitch is approximately 60 to 62° for good performances and decreases noticeably as skill ratings decrease (with an accompanying increase in variance). This suggests a tendency (as skill degrades) to pitch-up, with relatively little roll when roll to the inverted position. This tendency can also be clearly seen in the debriefing plots and supports the validity of the circle measures, which are based on a criterion of evenly and constantly changing roll and pitch. A surprising point regarding roll at maximum pitch is that theoretically it should be 90° to maintain a constant offset angle from the reference point. However, none of the highly skilled performances, including those of instructors, exhibit this. It appears that the requirement for a constant offset angle may be an unrealistic criterion, both from the standpoint of human ability, and perhaps, aircraft performance ability.⁸

The pitch measures at various values of roll are most easily analyzed via the plot of Figure 68. The unsatisfactory performances exhibit a smaller maximum positive pitch angle and pitch reduces to zero before roll has reached 180°. All performances exhibit a linear as opposed to a smooth, curvilinear roll/pitch relationship in the second quarter of the maneuver.

Figures 69 and 70 show similar plots for altitude and airspeed excursions. Little, if any, relevant measurement information can be expected to exist in these measures.

The correlations between measures and subjective ratings (Table XXII) indicate only four significant measures. Although any number of alternative combinatory measures could be postulated, the data are insufficient to permit validation, so none were computed for the barrel roll in this study.

⁸Plans exist to test the realism of this criterion using a flight simulator. We attempted to test it in the aircraft, but despite specific attempts on the part of the pilots, they were unable to achieve 90° roll at maximum pitch and still complete the maneuver satisfactorily in all other respects.

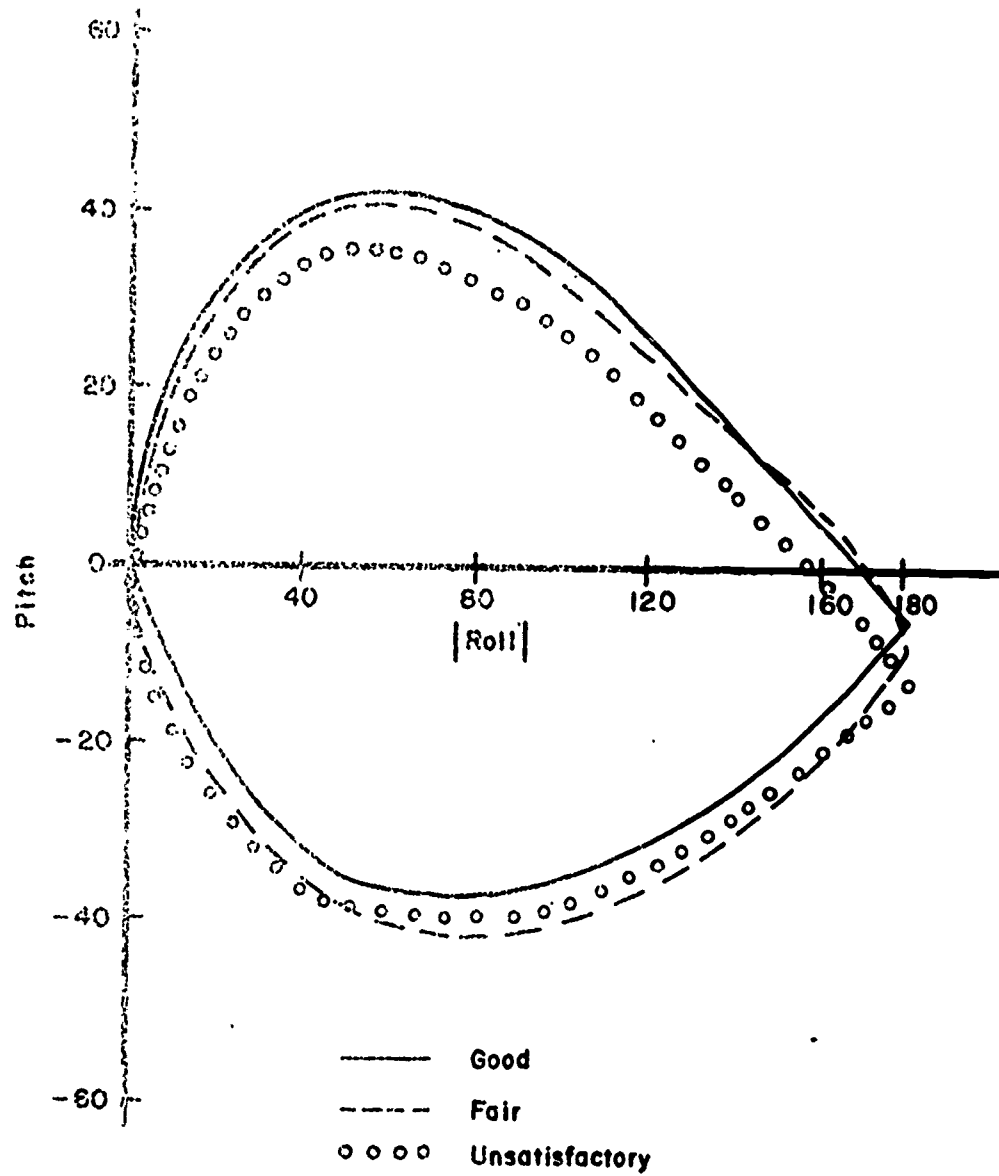

Figure 68. Average Student Barrel Roll Performances

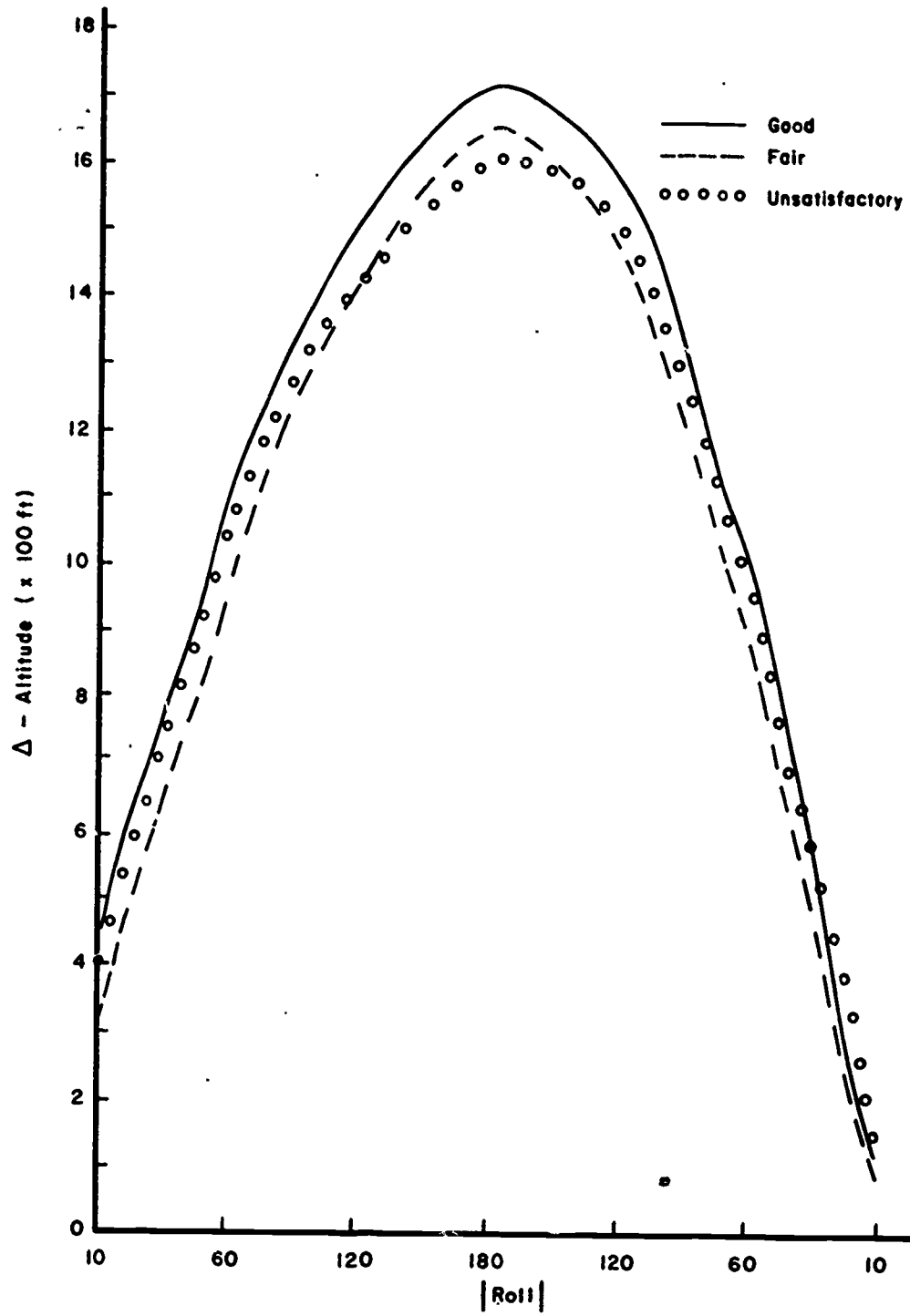

Figure 69. Average Altitude Excursions for Student Barrel Rolls

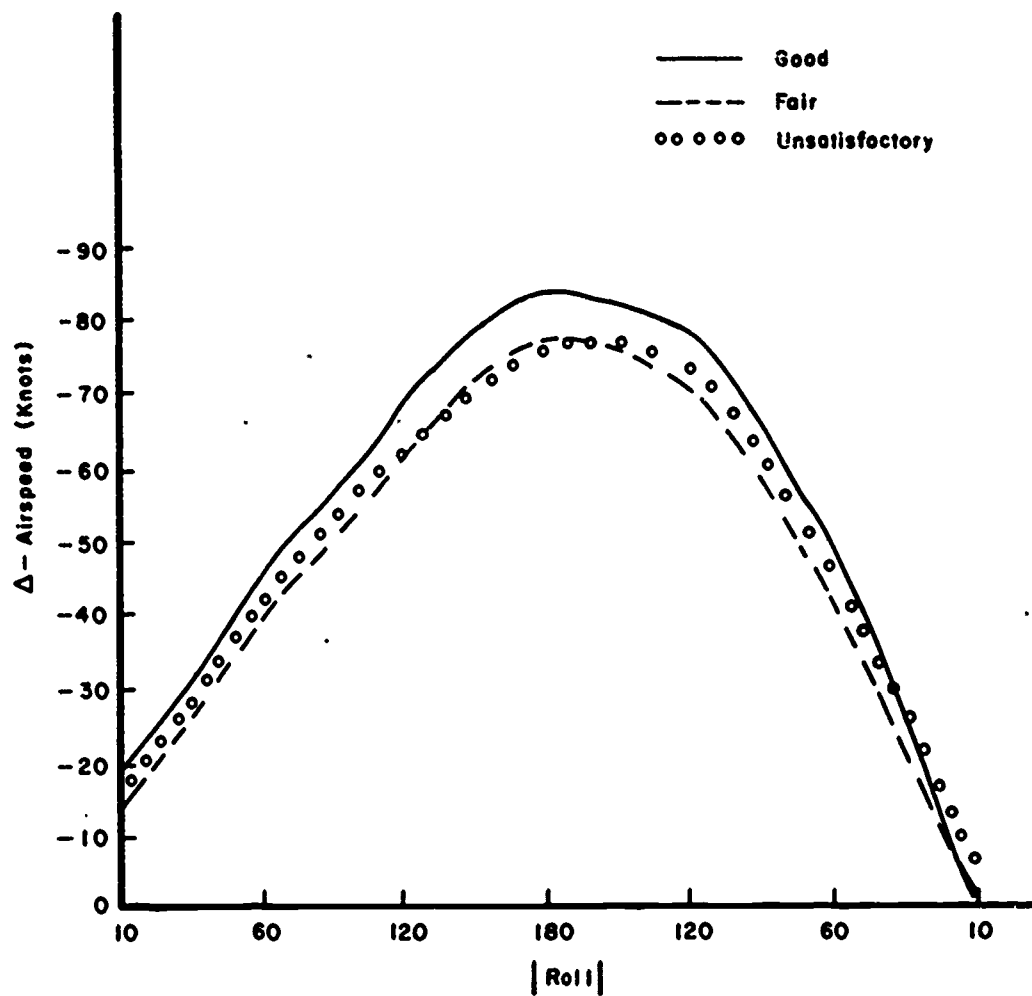

Figure 70. Average Airspeed Excursions for Student Barrel Rolls

b. PIT Instructor Data

Due to time limitations, barrel roll measures were not computed for the PIT Instructor data. However, debriefing plots were generated for 41 performances, and their analysis gives additional insights to the measurement of this maneuver. Several plots are presented in Appendix XVIII, along with the transcribed pilot comments.

It can be seen, in viewing the plots, that the roll/pitch relationship is very relevant to measurement. This supports the trends indicated in the student data. Many of the conditions described in pilots' comments are clearly demonstrated by the roll/pitch plot, e.g., dishing out on the bottom, excessive pitch without sufficient roll, "flat" portions of the maneuver, and too much initial back pressure.

c. Summary

Unfortunately, not nearly enough barrel roll data was collected to form supportable recommendations about measurement of this maneuver. The major deficit is successive samples per student needed to develop and validate measures. Based on the data collected, it is theorized that the following measures are valid and should be investigated further:

1. Roll/Pitch Circle Measures
2. Maximum and Minimum G's
3. Constancy of Roll Rate
4. Symmetry Measures

Further studies should also address the questions raised earlier regarding roll value at maximum pitch, and whether or not maintenance of a constant offset angle is a realistic criterion. Further, the authors found a distinct difference between instructors in their method of performing the barrel roll insofar as g control is concerned. Realistic criteria on g's need to be determined.

AFHRL-TR-72-6

Measurement-wise, it is obvious that less was accomplished on the barrel roll than on the lazy 8. This was due primarily to lack of sufficient data; but contributing factors are (1) time limitations on the study, with more emphasis having been placed on the lazy 8, and (2) an apparent inconsistency in criteria for the barrel roll, and subsequently, a great necessity for computing standards (which has not yet been accomplished).

3. OTHER MANEUVERS: TYPICAL DATA

Some representative data were plotted for maneuvers other than the lazy 8 and barrel roll. This data will be used to support follow-on studies in this subject area. As a matter of interest and documentation, typical plots of roll, pitch, airspeed and altitude are presented for several of these other maneuvers in Figures 71 through 76.

7-14-70
ENVG- 37
(3 LEFT)

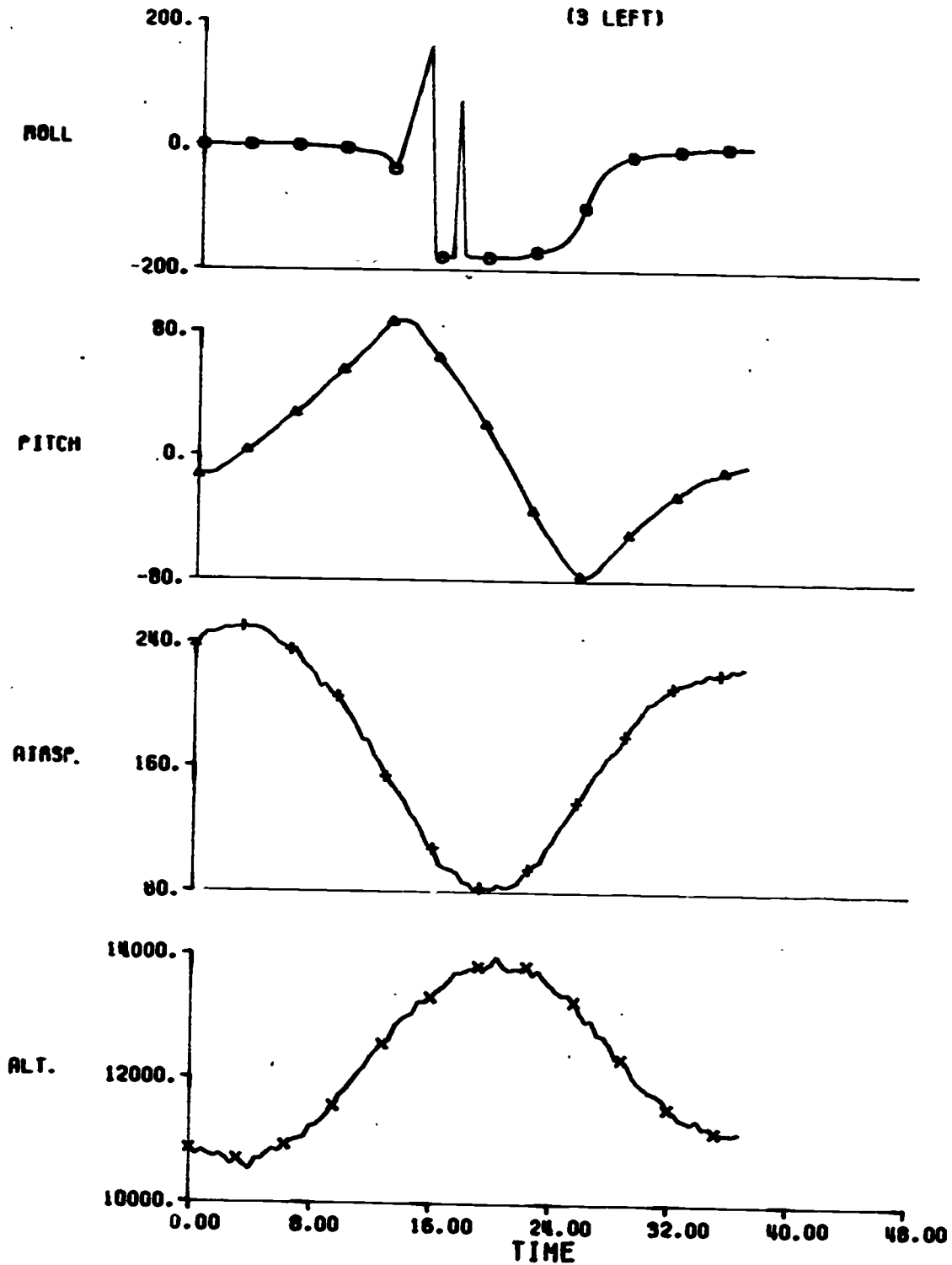

Figure 71. Loop

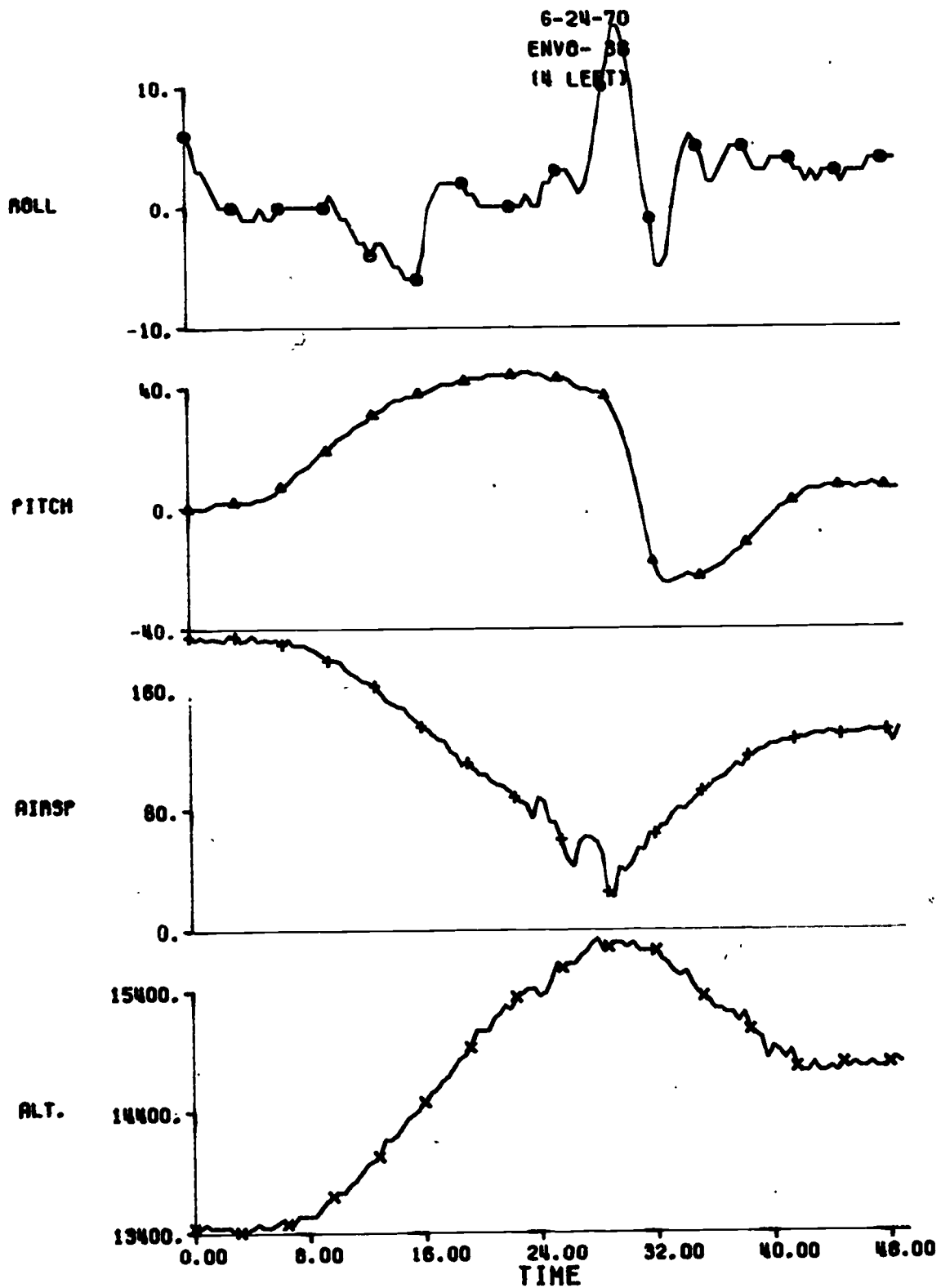

Figure 72. Stall

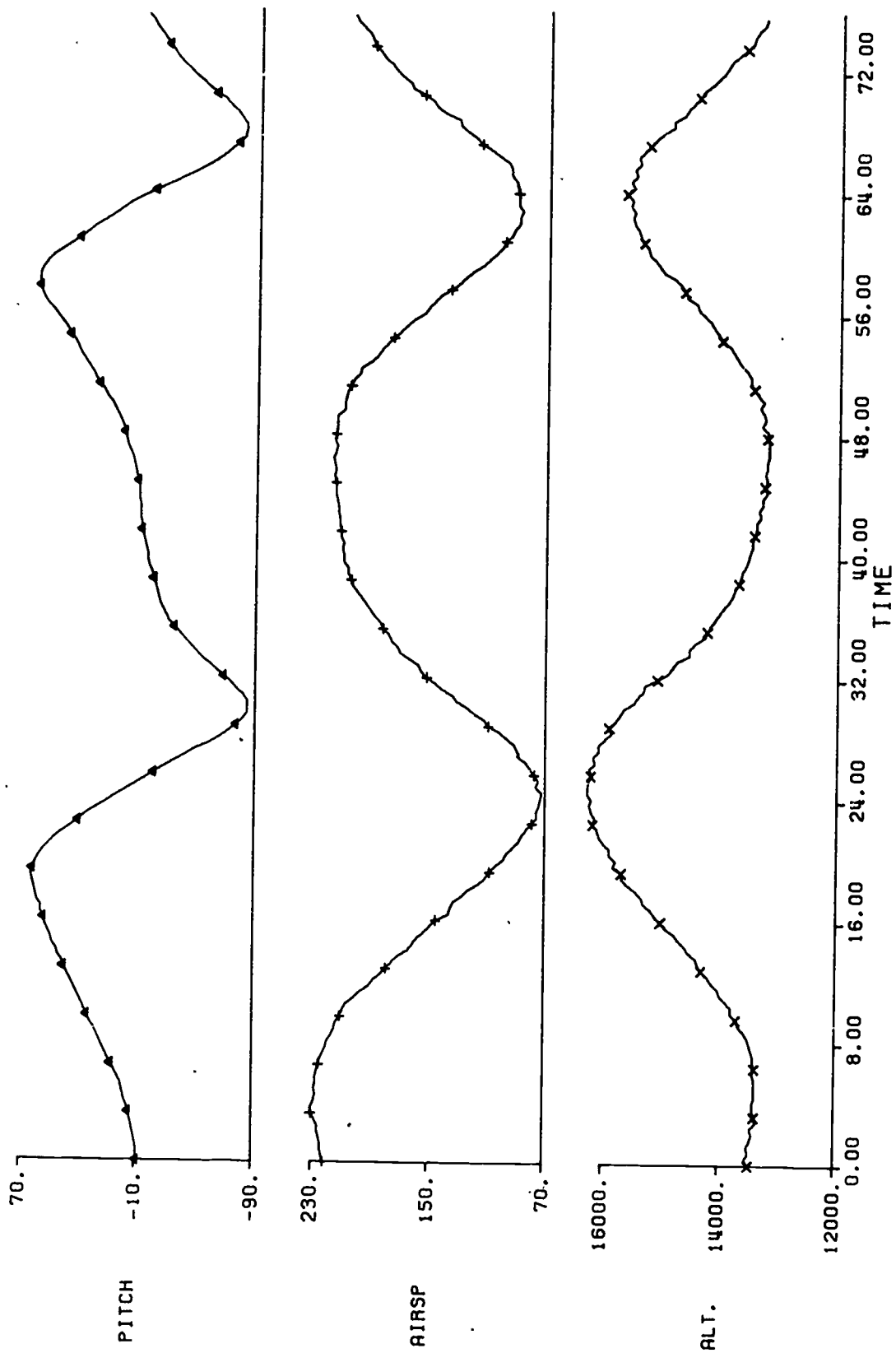

Figure 73. Cloverleaf (1/2)

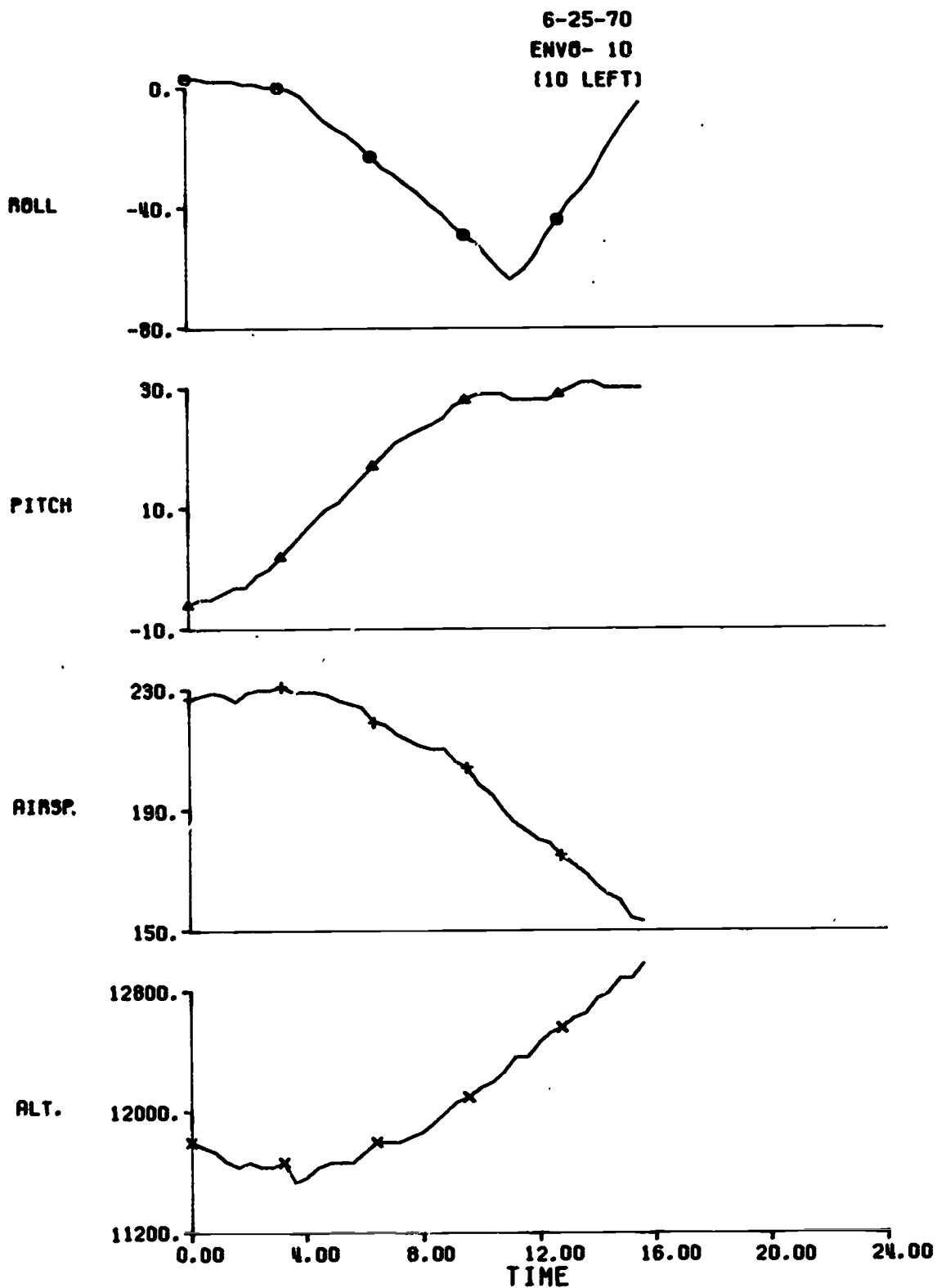

Figure 74. Maximum Performance Climbing Turn

AFHRL-TR-72-6

6-25-70
ENVG- 14
(2 LEFT)

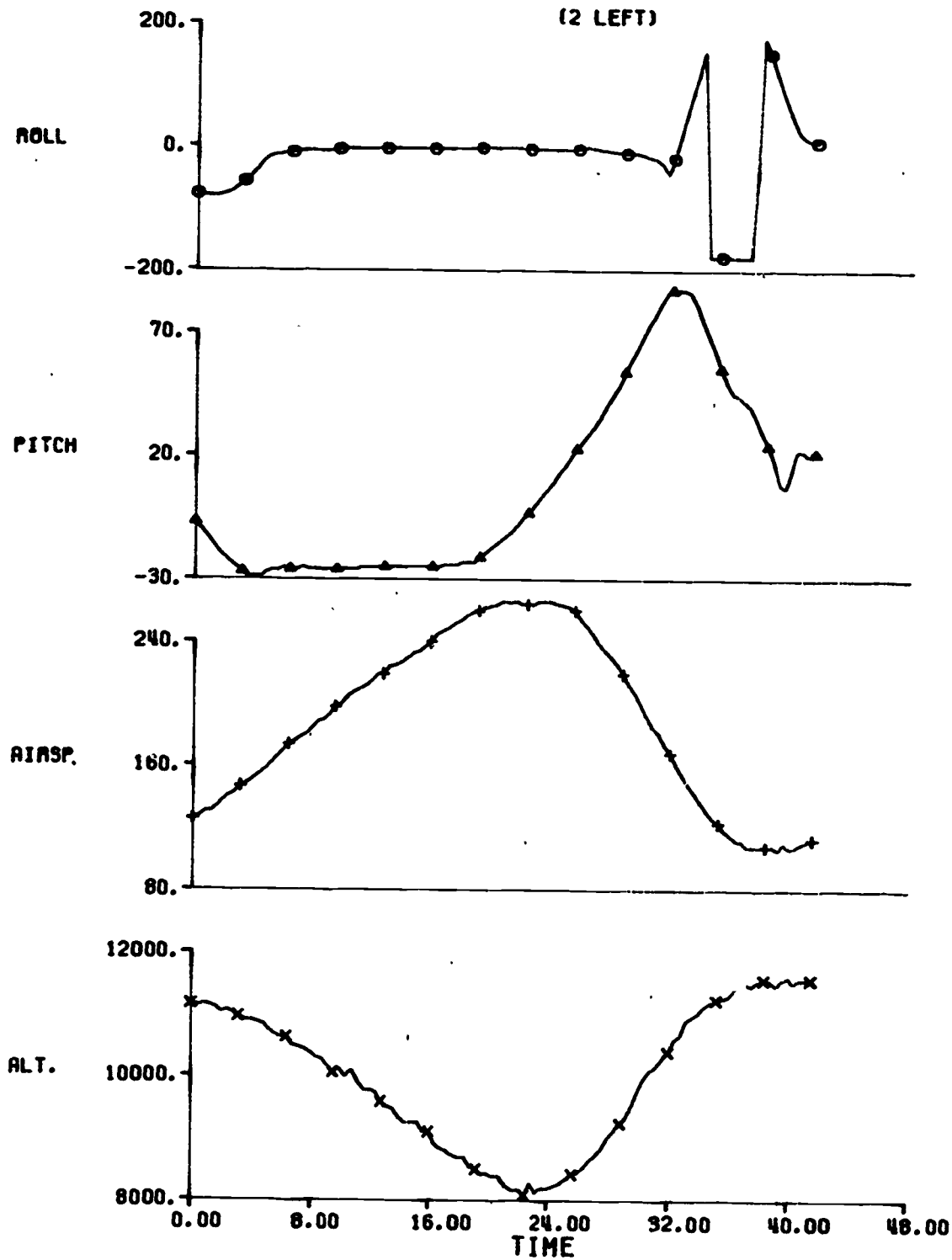

Figure 75. Immelmann

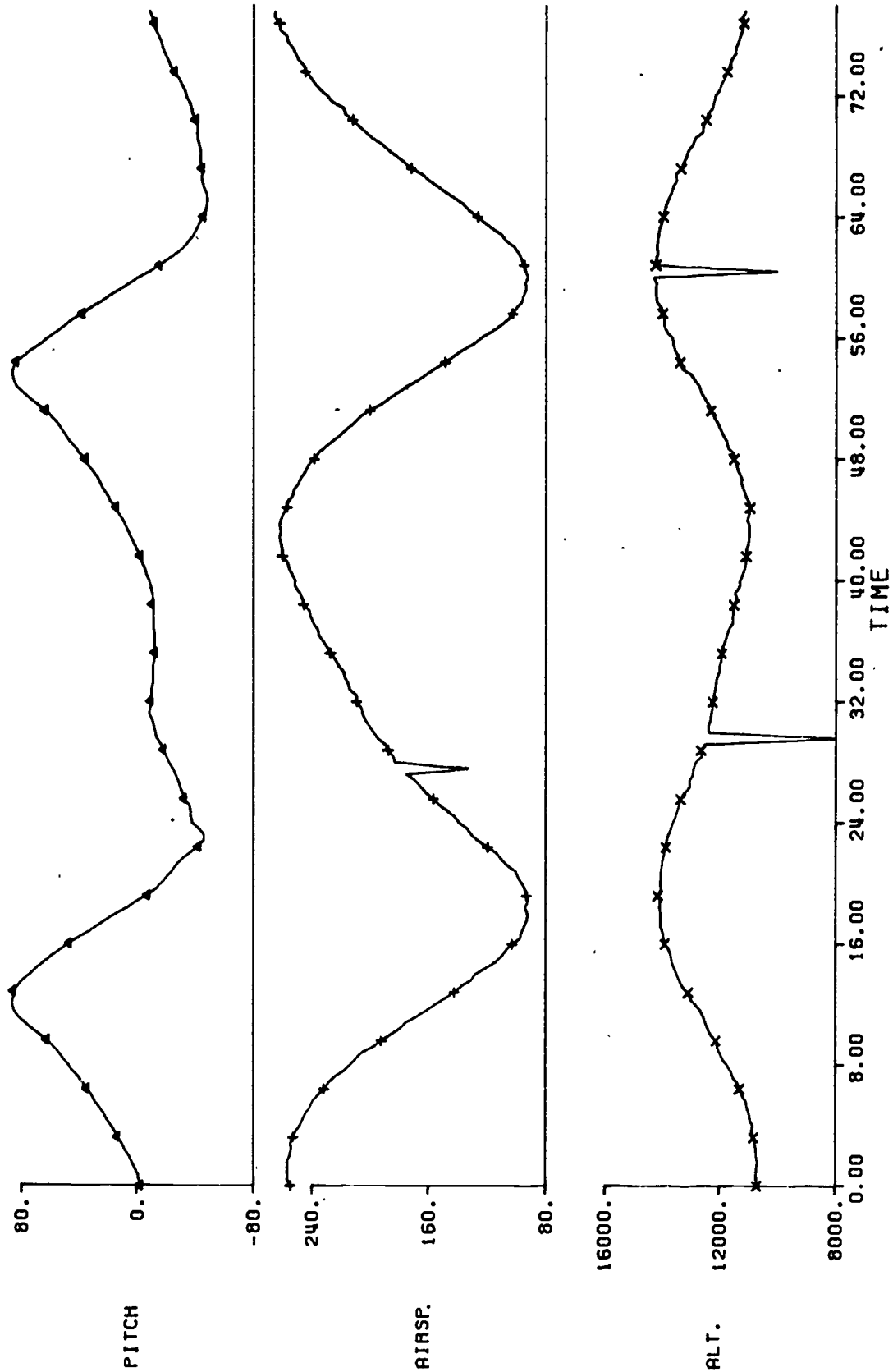

Figure 76. Cuban 8

SECTION VIII

DISCUSSION AND ADDITIONAL REMARKS

It is fortunate that at the onset of this program the authors were a little naive about the problems and difficulties that plague collectors of in-flight data. Otherwise, that which has resulted in an extremely worthwhile and timely effort may have been put off had there been more realistic original estimates of the time and level-of-effort required to complete the program. As it turned out, only 30 to 40% of the total effort (manhours) expended was actually devoted to the central issue, e.g., development of measurement techniques for two representative maneuvers; the bulk of the effort was devoted to establishing the machinery, so to speak, for data collection, reduction, calibration, and analysis. In a way, the results and benefits of the effort are therefore actually greater than originally anticipated, because in addition to accomplishing the major goals related to feasibility of quantitative measurement, (i.e., knowing what to do), the authors have compiled an impressive list of "what not to do" in the future. So in addition to providing a summary of central results, this Section will be devoted to some of the major problems encountered (and lessons learned) in accomplishing an effort of this type.

1. PROBLEMS

It is not easy to obtain good in-flight performance data and reduce it to a form suitable for analysis. Recognition of this, and provision for sufficient personnel to handle problems as they arise, is necessary to a successful conduct of related studies. In the study being reported, the limited availability of equipment and support personnel made it necessary to obtain the needed support from two different data processing installations. This complicated the already difficult job by requiring inter-installation coordination and by creating additional problems through the use of different tape units for producing and reading data. In addition, control of personnel was not possible, and several different programmers were assigned to the program over its tenure.

AFHRL-TR-72-6

This required almost continual education of these new people regarding data formats and program objectives. Finally, no control existed over the utilization of data processing equipment, and turn around time from flight to calibrated data was considerably longer than it should have been for efficient operation due to higher priority programs competing for use of the equipment.

The in-flight data acquisition equipment represented no exception to "Murphy's Law," particularly because it was largely (off-the-shelf) used equipment. Partway through the program problems arose with the heading transducer that were never completely rectified despite several recalibrations. (Later, it was determined that a new transducer is required.) Other equipment malfunctions occurred from time to time, seriously delaying data collection schedules and validating the importance and necessity of establishing a rigorous periodic recalibration and preventive maintenance program for the airborne equipment. This would hopefully minimize the requirement for the unscheduled, on-call type of maintenance that upsets schedules.

Operational problems also confounded the problem. Despite planning-precautions, flightline personnel often failed to clean the recorder heads as required, and data from several sorties were lost. This occurred most often during the last several weeks of off-site data collection and was in part the reason why sufficient validation data was not successfully collected. Another operational problem regarded in-flight use of the recorder through cockpit controls. Each instructor was briefed on recorder operation, but evidently the briefings were not thorough enough. On several successive sorties, the participating IP turned the recorder off between maneuvers, and this resulted in losing some data at the end or beginning of maneuvers. It also caused "glitches" in the data at the time the recorder was turned off or on and destroyed the continuity of the time-count.

AFHRL-TR-72-6

It is also important, in projecting schedules for studies like this, to consider not only anticipated aircraft maintenance downtime, but special requirements for modifications and inspections. For example, data collection was interrupted on two separate occasions for flap-hinge mods and wing spar inspections. These sound innocent enough, but in the case of this study the aircraft was bailed to Flight Test and they, therefore, accomplished the mods. Scheduling of hangar space and personnel to accomplish the work was perhaps more of a problem than it would be with a regular training aircraft in the ATC fleet.

For student data collection, the arrangement with ATC included assurance that normal schedules and curricula would not be interfered with. This made collection of large quantities of data per student per maneuver difficult.

The effort was conducted 100% in-house and necessarily attempts were made to minimize any direct costs. At the onset of the program, some surplus recorders were obtained. These proved unusable. The recorder and instrumentation gear finally installed was used equipment, not in itself bad, but necessitating some additional test and parts replacement early in the program.

The effort was largely prototype and investigatory in nature and considerable effort was expended on alternative solutions to problems as they occurred:

2. EULER ANGLES COMPUTATION

One small side-effort concerned the computation of Euler angles from recorded rates. This was investigated for three reasons: (1) It would provide an additional check on the relative accuracies with which rates and angles are recorded, (2) It would allow angles through all attitudes to be generated without necessitating all-altitude roll and pitch transducers, (3) It would provide the only good test conceivable on the accuracy of rate information. Programs were written to compute angles from rates. Results showed that recorded rate information was

AFHRL-TR-72-6

too noisy to produce good results and the effort was abandoned to the priority of other problems.

3. MODELING OF NORMATIVE DATA

Another side-effort concerned taking a closer look at computation of norms or standards. Although used to some extent in this study, mean-performances are not believed to be infallible representations of standards, any more than the mean is always a good representation of any data.

In studying the formal description and ATC criteria for the lazy 8 maneuver, the idea occurred that functions representing both roll and pitch versus degrees-of-turn may be easily approximated using trigonometric functions. For example roll angle increases to a maximum at turn = 90°, decreases to zero at turn = 180°; then repeats this pattern. In simplest form, we could represent this motion by a sine wave multiplied by the maximum roll angle attained in the maneuver (80 - 95°).

Pitch behaves similarly but has an amplitude equal to the largest pitch angle attained in the maneuver and a frequency equal to twice that of the roll function.

An harmonic analysis of a function is a truncated Fourier Series approximation to the function defined at discrete, equidistant points over a finite interval. The function approximation is of the form

$$F(x) = a_0 + \sum_{n=1}^k [a_n \cos(nx) + b_n \sin(nx)].$$

In addition to providing a model of performances, the function's coefficients (a_i and b_i) could provide useful measures. For instance, in order for all a_i coefficients to be zero, two characteristics must be present in the data: (1) perfect symmetry and (2) zero pitch at 0 and 90° turn points. The farther from zero the a_i are, the farther the data are from having the above two characteristics.

AFHRL-TR-72-6

A program was written to accept as inputs the number of performances to be harmonically analyzed, the number of harmonics to be used in the model, and the recorded data. It then printed out the derived Fourier coefficients and the data generated by stepping the model from 0 to 180° turn by increments of 5°. Results indicate that this is an extremely promising approach to modeling the data, resulting in much more realistic and useful standards than can be represented by the mean.

4. DEBRIEFING PLOTS ANALYSIS

A respectable amount of time was devoted to conceptual analysis of the debriefing plots. After becoming familiar with the plots and learning to read them, forty of the plots were shuffled and attempts were then made by the authors to judge from the plots alone whether each performance was E, G, F, or U. Out of 40 performances, only 8 were classified incorrectly. This was an insignificant test, done as much out of idle curiosity as for any other reason, and not exactly uncontaminated in design. However, it convinces the authors that a properly indoctrinated instructor could evaluate performances using debriefing plots alone and do the job at least as well and much more diagnostically than he can on-site (in-flight).

Further experimentation was done in this area by devising plastic overlays for the plots on which were sketched standard profiles $\pm 1\sigma$. This is helpful in interpreting the performances and diagnosing errors. The approach of using overlays instead of plotting the performances against standards would be useful in analyzing the data and debriefing the student based on his deviation from norms as well as his deviation from standard criteria.

5. MEASUREMENT APPROACH

In this effort, the approach to the development of performance measures was "analytic" in that it involved and required considerable desk-analysis of both the criteria (ATC) and the recorded data. Maneuver analyses were performed, measures were postulated, results

AFHRL-TR-72-6

were examined, a new set of measures was postulated based on the initial results, and finally, these measures were applied to a broad spectrum of student and instructor performances. Analysis of the final results included investigating correlations between the measures and subjective ratings and then, to a more limited extent, examining the trends of measures across individual student performance.

The result of this effort was that a good set of prototype measures for the lazy 8 was developed, and a similar set for the barrel roll. Unfortunately, the measures for the barrel roll were less defensible than were those for the lazy 8, because of insufficient data. The validation of these measures was somewhat hampered by such factors as lack of IP performance standardization, questionable "text book" criteria for the two maneuvers, lack of IP rating standardization, and the necessity of using within-subject sampling as a basis for both the development and validation of measures.

The approach itself was time-consuming to apply due to the need for continual interaction with large quantities of data. It is a workable approach given proper manpower support and it enjoys an affinity with logical human performance aspects of the maneuvers that is perhaps lacking in other more highly automated approaches. It lacks the desirable characteristics of requiring less effort to pursue the second time than the first, because for each maneuver examined, new and different problems arise and each must be treated individually.

It is appropriate at this point, to remark that throughout the duration of this program, another entirely different approach to developing measurement methods was pursued using some of the same data. The alternate approach lies at the opposite end of the spectrum from this analytic approach with respect to automation and global applicability. To pursue the alternate approach, certain functions of the data had to be determined and computed. Identification of these functions was enhanced through results, as they unfolded, from the analytic approach. Thus the two approaches were largely conducted in a complementary

AFHRL-TR-72-6

fashion, even though the results from each are reported independently. References 3 and 5 document the alternate approach.

After having applied this "analytic" approach and, concurrently, a more automated approach (which is based on adaptive modeling), the consensus is that neither suffices independently - at least now. The analytic approach, although workable, is simply too time-consuming to be effective in, say, developing measures for an entire training curriculum. Also, it suffers from a standardization standpoint in that one is never really sure he is finished when using it. This is in turn due to a fundamental weakness of the approach in that the types of measures it addresses represent only a subset of all possible measures. (Conversely, the alternate approach, References 3 and 5, addresses an extremely broad spectrum of measures.)

The analytic approach has several noteworthy merits, the main one of which is the in-depth understanding one must obtain of the maneuver and related performance techniques, and subsequently the application of logic and judgment to the problem that would be possible only through the utmost in programming sophistication on an automated basis.

The point to be made is that the analytic approach is too "manual" to be efficient on a large scale application and does not address all types of measures. More automated approaches take the labor out of the job, are widely applicable, and address a broad spectrum of measures, but they require an element of human judgment to be practical. A blend of the two types of approaches appears ideal.

6. MEASUREMENT RESULTS

For the lazy 8, measurement can be accomplished using roll, pitch, and airspeed. This was demonstrated in this study through the development of a simple error measure, with criteria consisting of values for the variables computed from skilled pilot's data. An improvement on this error measure is believed possible through application of continuous rather than discrete error computations as discussed in Section VII.

AFHRL-TR-72-6

The time and scope of this effort did not permit further pursuit of this idea, however.

The above statements are made without the essential justification that good validation, beyond the content validity that existed, would provide. When accomplished, validation should include the previously discussed tests based on within-subject sampling. Concurrent validation using instructor ratings, if conducted, should be pursued as a necessary (not sufficient) test, and then only with the cautions previously identified.

The barrel roll measures could not be developed to the extent they were for the lazy 8 due to lack of sufficient data. From the information examined, however, it appears that roll, pitch, normal acceleration, and roll-rate will provide the necessary data base. Roll and pitch are not relevant as single-variable measures; rather, it is their relationship that forms the essential measure. The nature of a criterion relationship could not be well defined; according to published criteria, it appears to be circular, but the actual data of skilled pilots does not support the validity or realism of this criterion. To a greater extent than in the lazy 8, standards must be determined for this maneuver. Roll rate measures should reflect the constancy of this value after the maneuver is underway. Measures on g's should reflect maximum excursions, but here again criteria are lacking, and little standardization among IPs was found.

From a diagnostic standpoint, the debriefing charts would form an appropriate media for conveying both measures and diagnostic comments to the instructor or student. This would provide the necessary information on not just how well the student performed, but why and where he performed poorly.

It is compelling to bring out one final idea relating to measurement. This idea is not original with the authors, and it was not pursued in this study, but it was so obvious in this study and is so central to any final measurement design that this discussion would be incomplete without mentioning it. The idea is that measurement of individual performances of a maneuver cannot effectively be considered independent'y, even if

AFHRL-TR-72-6

one is only concerned with one performance at the time. Rather, the distribution of measures on successive trials, and if one desires, the subsequent probability of successful performance based on that distribution is the important consideration. Therefore, measures themselves should ultimately be expressed in terms of the resulting distribution. This automatically takes into account both the measure(s) achieved and inter-performance variance, both of which are considered relevant to pilot evaluation.

AFHRL-TR-72-6

APPENDICES

AFHRL-TR-72-6

APPENDIX I
CALIBRATION DATA AND
CALIBRATION BLOCK DIAGRAMS FOR
RECORDED FLIGHT DATA

AFHRL-TR-72-6

Parameter: Heading

Units: Degrees

Parameter Input	Transducer Output		Parameter Input	Transducer Output
360	0		170	2.730
350	0.128		160	2.879
340	0.281		150	3.017
330	0.404		140	3.155
320	0.563		130	3.324
310	0.701		120	3.468
300	0.840		110	3.616
290	0.988		100	3.744
280	1.137		90	3.913
270	1.280		80	4.001
260	1.424		70	4.170
250	1.567		60	4.246
240	1.711		50	4.282
230	1.864		40	4.308
220	2.003		30	4.334
210	2.151		20	4.359
200	2.305			
190	2.448			
180	2.581			

Calibration Block Diagram

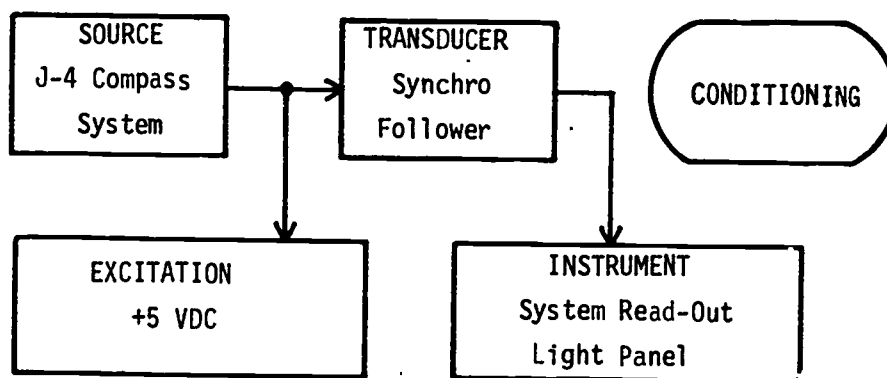

AFHRL-TR-72-6

Parameter: Altitude Units: Feet (x1000)

Parameter Input	Transducer Output		Parameter Input	Transducer Output
0.89	0.133			
1.0	0.163			
1.5	0.225			
2.0	0.292			
2.5	0.379			
3.0	0.450			
4.0	0.647			
6.0	0.896			
8.0	1.206			
10.0	1.480			
12.0	1.787			
14.0	2.100			
16.0	2.397			
18.0	2.689			
20.0	3.002			
22.0	3.309			
24.0	3.596			
26.0	3.908			

Calibration Block Diagram

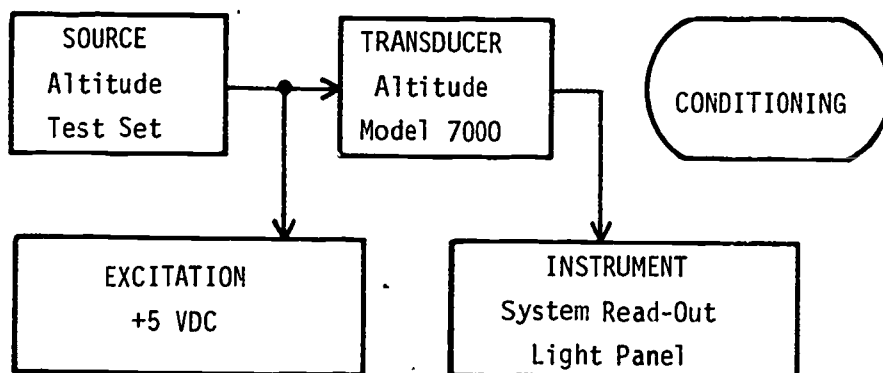

AFHRL-TR-72-6

Parameter: Airspeed

Units: Knots

Parameter Input	Transducer Output		Parameter Input	Transducer Output
0	0.491			
60	0.7836			
70	0.9065			
80	1.091			
90	1.152			
100	1.310			
120	1.585			
140	1.864			
160	2.165			
180	2.438			
200	2.723			
220	3.006			
240	3.267			
260	3.529			
280	3.790			
300	4.025			

Calibration Block Diagram

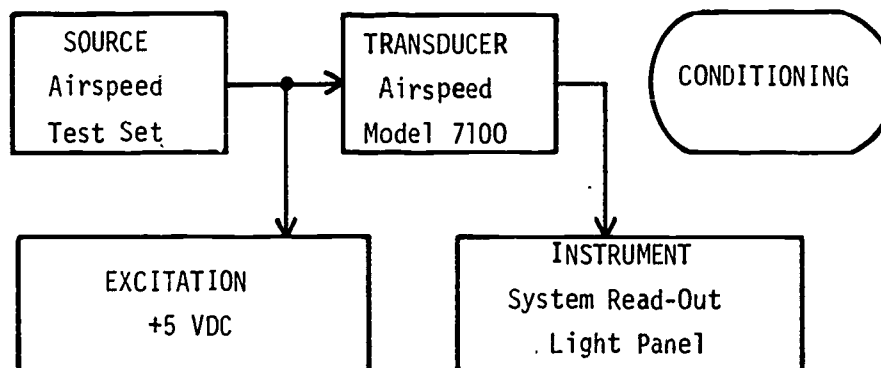

AFHRL-TR-72-6

Parameter: Pitch Angle

Units: Degrees

Parameter Input	Transducer Output		Parameter Input	Transducer Output
70	3.50			
60	3.36			
50	3.22			
40	3.08			
30	2.94			
20	2.79			
10	2.65			
0	2.50			
-10	2.36			
-20	2.21			
-30	2.07			
-40	1.93			
-50	1.77			
-60	1.63			
-70	1.49			

Calibration Block Diagram

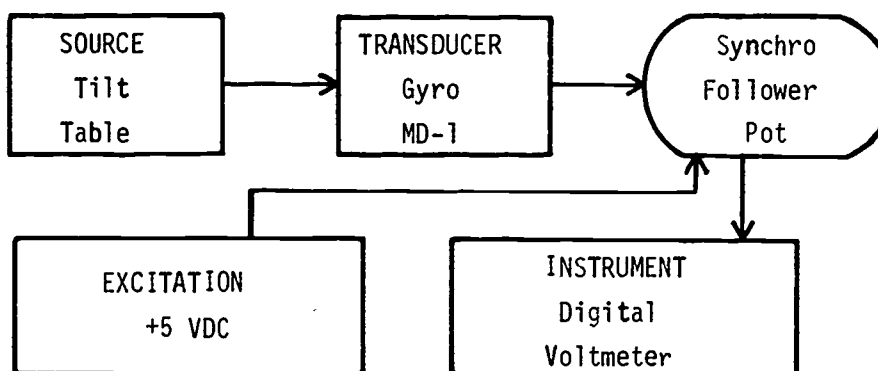

AFHRL-TR-72-6

Parameter: Roll Angle

Units: Degrees

Parameter Input	Transducer Output		Parameter Input	Transducer Output
180	5.00		- 10	2.36
120	4.27		- 20	2.21
110	4.12		- 30	2.07
100	3.98		- 40	1.93
90	3.83		- 50	1.77
80	3.68		- 60	1.63
70	3.53		- 70	1.48
60	3.39		- 80	1.34
50	3.25		- 90	1.19
40	3.10		-100	1.05
30	2.95		-110	0.91
20	2.79		-120	0.84
10	2.65		-180	0
0	2.50			

Calibration Block Diagram

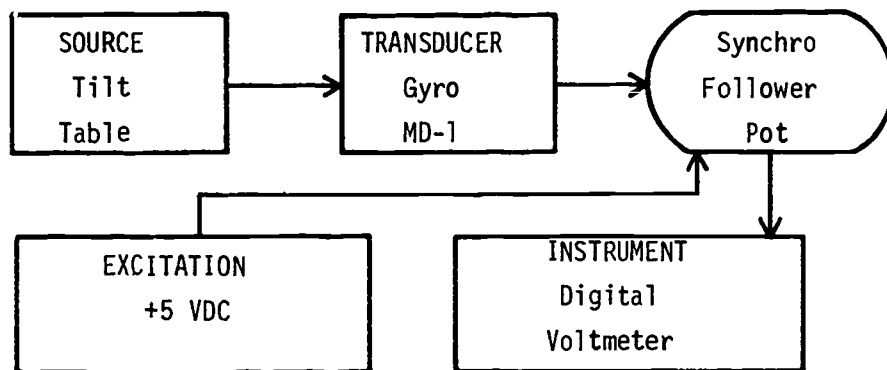

AFHRL-TR-72-6

Parameter: Acceleration

Units: g's

Parameter Input	Transducer Output		Parameter Input	Transducer Output
-7	-4.9			
+7	+4.9			

Calibration Block Diagram

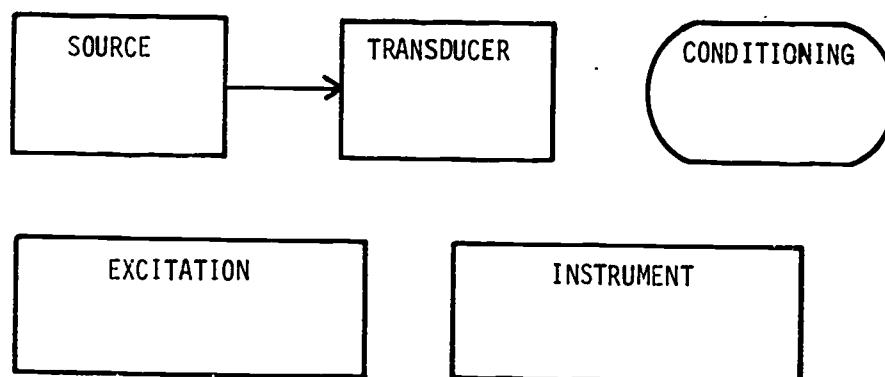

AFHRL-TR-72-6

Parameter: Pitch Rate

Units: Degrees/Second

Parameter Input	Transducer Output		Parameter Input	Transducer Output
90	4.98		-10	-0.53
80	4.47		-20	-1.08
70	3.92		-30	-1.635
60	3.36		-40	-2.21
50	2.79		-50	-2.77
40	2.23		-60	-3.34
30	1.66		-70	-3.90
20	1.095		-80	-4.45
10	0.545		-90	-4.99
0	0			

Calibration Block Diagram

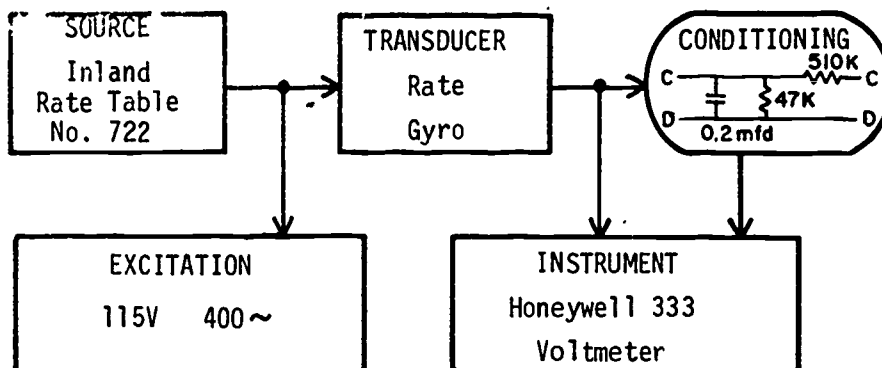

AFHRL-TR-72-6

Parameter: Roll Rate

Units: Degrees/Second

Parameter Input	Transducer Output		Parameter Input	Transducer Output
180	4.66		- 20	0.495
160	4.13		- 40	-1.0
140	3.595		- 60	-1.5
120	3.07		- 80	-2.03
100	2.545		-100	-2.545
80	2.03		-120	-3.03
60	1.51		-140	-3.60
40	1.0		-160	-4.125
20	0.49		-180	-4.65
0	0			

Calibration Block Diagram

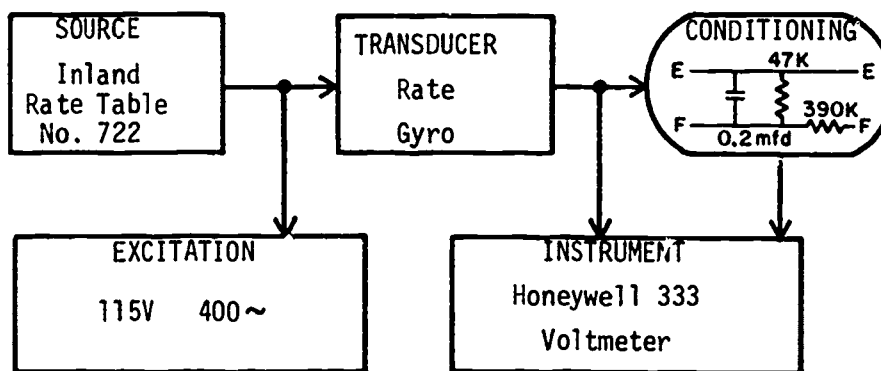

AFHRL-TR-72-6

Parameter: Yaw Rate

Units: Degrees/Second

Parameter Input	Transducer Output		Parameter Input	Transducer Output
70	4.75			
60	4.135			
50	3.501			
40	2.84			
30	2.14			
20	1.425			
10	.705			
0	0			
-10	-0.73			
-20	-1.45			
-30	-2.165			
-40	-2.87			
-50	-3.54			
-60	-4.17			
-70	-4.78			

Calibration Block Diagram

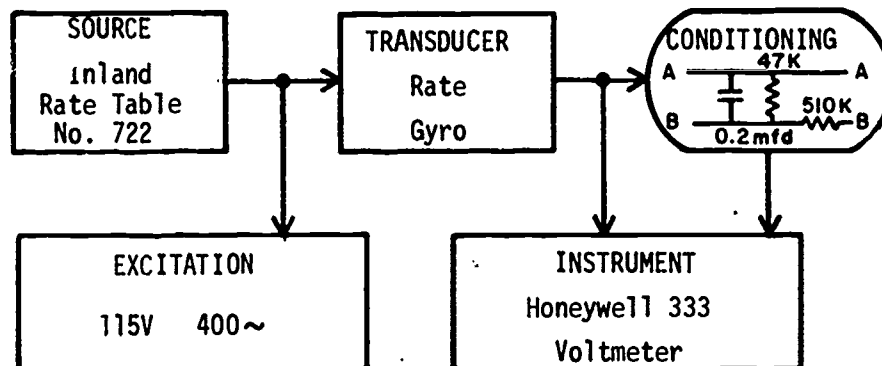

AFHRL-TR-72-6

Parameter: Longitudinal Stick Position Units: Degrees

Parameter Input	Transducer Output		Parameter Input	Transducer Output
-14.9	0.16			
-10.	0.60			
- 8.	0.78			
- 6.	1.00			
- 4.	1.24			
- 2.	1.45			
0	1.66			
2.	1.88			
4.	2.14			
6.	2.36			
8.	2.59			
10.	2.84			
12.	3.09			
14.	3.32			
16.	3.57			
18.	3.83			
20.	4.10			
22.	4.34			
24.9	4.74			

Calibration Block Diagram

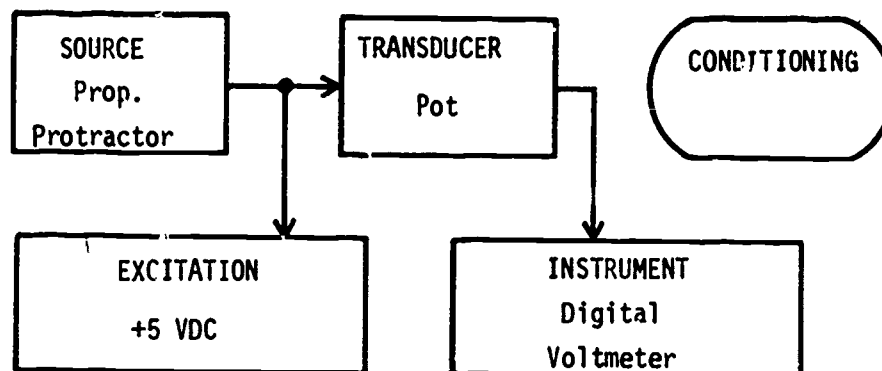

AFHRL-TR-72-6

Parameter: Lateral Stick Position

Units: Degrees

Parameter Input	Transducer Output	Parameter Input	Transducer Output
15	0.27		
14	0.45		
12	0.81		
10	1.11		
8	1.43		
6	1.69		
4	1.94		
2	2.24		
0	2.48		
- 2	2.75		
- 4	3.00		
- 6	3.28		
- 8	3.61		
-10	3.89		
-12	4.23		
-14	4.59		
-16	5.00		

Calibration Block Diagram

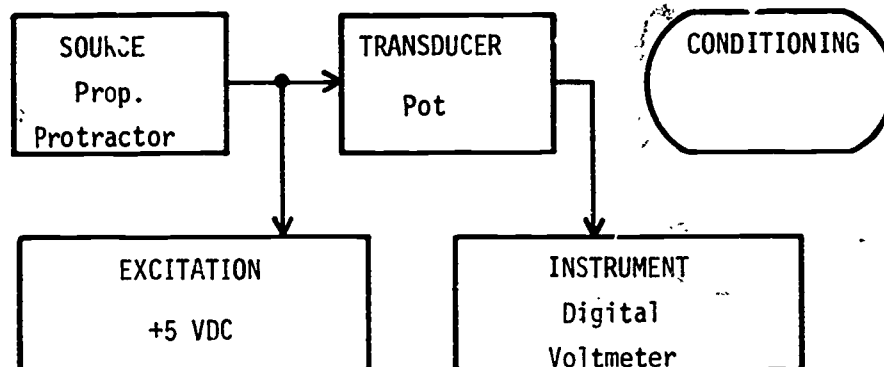

AFHRL-TR-72-6

Parameter: Rudder Position

Units: Degrees

Parameter Input	Transducer Output		Parameter Input	Transducer Output
24	0.07		- 2	2.80
22	0.4		- 4	3.00
18	0.8		- 6	3.20
14	1.18		- 8	3.40
10	1.57		-10	3.60
8	1.78		-14	4.00
6	2.00		-18	4.40
4	2.17		-22	4.80
2	2.40		-24	5.00
0	2.54			

Calibration Block Diagram

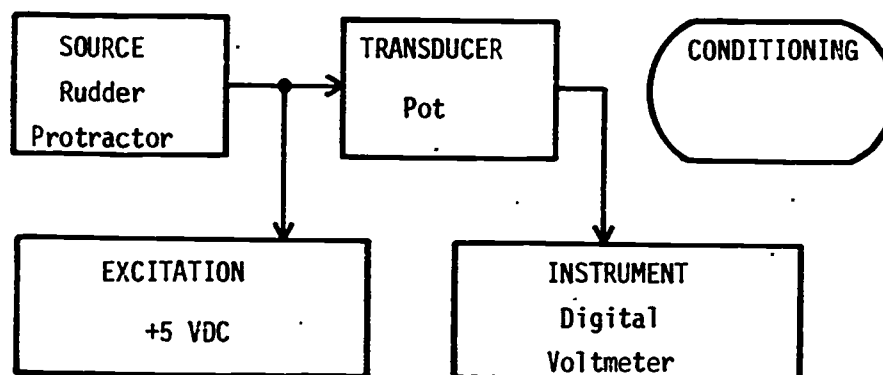

AFHRL-TR-72-6

Parameter: Engine RPM

Units: Percent

Parameter Input	Transducer Output		Parameter Input	Transducer Output
14.28	0.7			
28.57	1.4	L		
42.85	2.11	E		
57.14	2.82	F		
71.42	3.55	T		
85.71	4.28			
100.	5.00			
14.28	0.56			
28.57	1.12	R		
42.85	1.69	I		
57.14	2.27	G		
71.42	2.82	H		
85.71	3.45	T		
100.	4.00			

Calibration Block Diagram

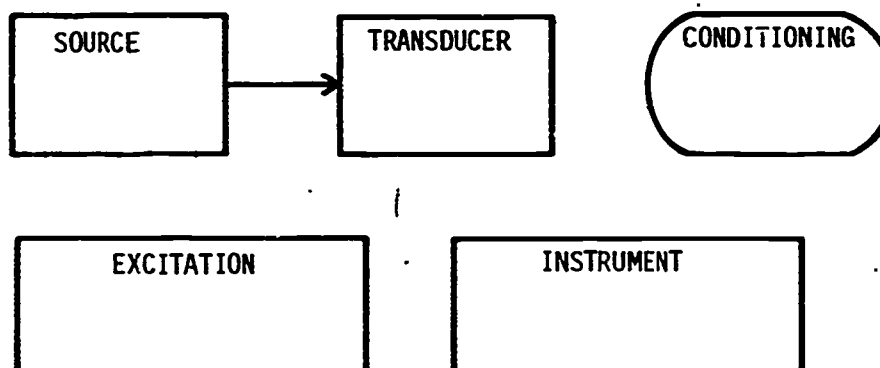

AFHRL-TR-72-6

Parameter: Throttle Position

Units: Degrees

Parameter Input	Transducer Output		Parameter Input	Transducer Output
0	0.23			
16	1.72	L		
32	2.76	E		
48	3.72	F		
64	4.64	T		
0	0.39	R		
16	1.82	I		
32	2.87	G		
48	3.85	H		
64	4.61	T		

Calibration Block Diagram

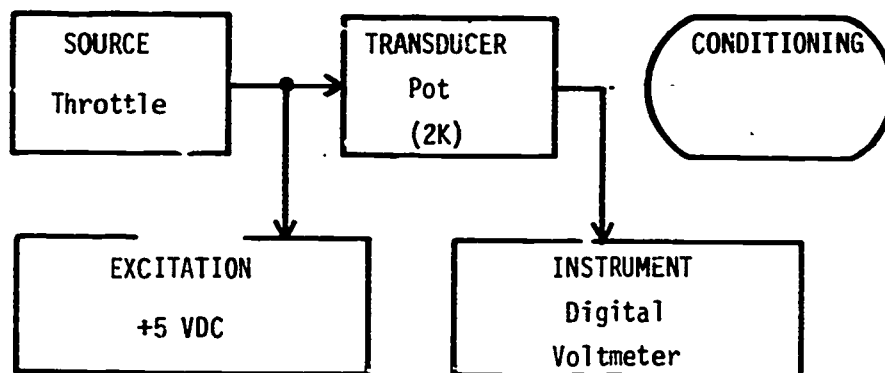

AFHRL-TR-72-6

Parameter: Flap Position

Units: Percent

Parameter Input	Transducer Output		Parameter Input	Transducer Output
0	4.86			
20	3.76			
40	2.85			
60	1.90			
80	1.00			
100	0.11			

Calibration Block Diagram

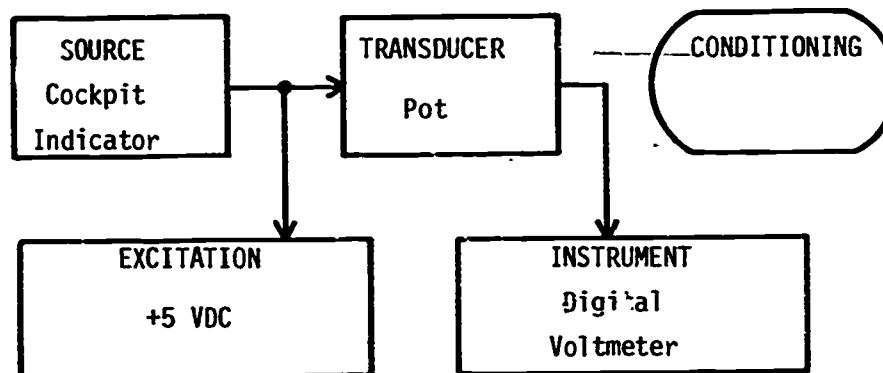

AFHRL-TR-72-6

APPENDIX II

ILLUSTRATION OF INITIAL PRINT-OUT FORMAT

Note: Three pages of computer print out
were required to represent approximately
50 seconds of data.

Page 1

Time	Airspeed	Altitude	Vertical Velocity	Pitch (Actual)	Pitch (Computed)	Pitch Rate	Stick Pos. (Long.)	Stick Rate (Long.)	Elevator Tab Up	Elevator Tab Down	Normal Acceleration
968.00	191.68	1590.50	-----	1.37	-----	1.63	1.75	-11.15	0.	0.	1.33
969.00	189.90	1661.24	-----	0.34	-----	1.63	1.57	14.86	0.	0.	1.31
970.00	188.56	1661.24	-----	1.37	-----	1.07	1.12	-13.38	0.	0.	0.97
.
.
.

NOTE: Page 1 was formatted to represent variables that are primarily relevant to movement of the aircraft vertically and/or about the aircraft y-axis.

Time	Heading	Turn Rate	Roll (Actual)	Roll (Computed)	Roll Rate	Stick Pos. (Lateral)	Stick Rate (Lateral)	Lateral Acceleration	Yaw (Computed)	Yaw Rate	Rudder	Rudder Rate
968.00	328.91	-----	-52.07	-----	-2.21	0.51	1.22	-----	-----	4.32	1.84	0
969.00	323.61	-----	-48.61	-----	-1.25	0.88	0	-----	-----	4.63	1.79	-1.59
970.00	320.78	-----	-41.88	-----	-7.97	2.01	6.48	-----	-----	0.79	1.88	8.75
.
.
.

NOTE: Page 2 was formatted to represent variables that are primarily relevant to movement of the aircraft horizontally and/or about the aircraft X or Z axes.

Time	Throttle (Left)	RPM (Left)	Throttle (Right)	RPM (Right)	Speed Brake	Flaps	Landing Gear	Thrust Attenuator	Event Number	Time Cycle	Record
968.00	21.86	76.66	16.20	78.09	1.00	0.57	1.00	0.	65.00	2450.10	2042.00
969.00	21.86	76.16	16.20	77.83	1.00	0.49	1.00	0.	65.00	2451.10	2043.00
970.00	21.86	75.96	16.06	76.03	1.00	0.49	1.00	0.	65.00	2452.10	2044.00
.
.
.

NOTE: Page 3 was formatted to represent variables that pertain to engine settings, discrete pilot actions and aircraft configuration, and record-keeping data.

AFHRL-TR-72-6

APPENDIX III
SOFTWARE FOR DATA CALIBRATION
AND
INITIAL PRINT-OUT

AFHRL-TR-72-6

```
$JOB 0,5,5000 69-026,GUTHRIE, ROOM 209 BLOCK
$$SETUP A(1) X1895,X1856,-9 UNIT 14 22 OCT 70 FLIGHT 2-8
$IRJOB GUTHRE MAP
$IRFTC T37DAT M94,XR7,NODECK
C $SETUP A(1) READ THE RAW DATA (36 BIT WORDS WRITTEN AT 556 DFNSITY
C IN NON DCS BLOCKING) FROM TAPE X1895 AND SKIP AS MANY AS 9
C REDUNDANT RECORDS. ACCOMPLISH DCS BLOCKING AND WRITE OUT THE RAW
C DATA AT DFNSITY 800 ON TAPE X1856 AND REWIND.
C DIMENSION A(410)
C INTEGER RECORD
C READ AND COUNT THE RECORDS WRITTEN ON TAPE X1856.
C RECORD=0
C THE SYMBOLICS FOR SIO. (CALL READ) AND UNITS ARE IN THE MAIN DECK
1 CALL READ (14,A,K,N)
RECORD=RECORD+1
IF (MOD(RECORD,100).NE.0) GO TO 4
PRINT 5,RECORD
5 FORMAT (8H RECORD=,I6)
4 N=N+1
GO TO (1,2,3),N
C CALL FXEM GIVES AN ERROR TRACE AND RETURNS CONTROL TO THE SYSTEM
C SYMBOLICS NOT INCLUDED
3 CALL FXFM
2 RECORD=RECORD-1
PRINT 5,RECORD
STOP
END
```

```
$IRLDR SIO. 25 SEP 67 SIO.0000
$TFTX SIO. SIO.0001
*N *,*7(*7(*7-0 '75 74 ' '549 7 '74074875974956976 5 976776 4M7'6 7 'SIO.0002
*N97P**7X$7V*X-16 E $76'4 2' $7' 5 7- 76776 74(5M'447' (44' ' U5M'76'SIO.0003
*N8()**7V*7V*7 4 2' X' ' '6 '69G 05 Y5 (G7 757'69) 07695 Y)7 75'7'0 SIO.0004
*N96(((X(*X(*7 7E(0 G7Z76 5 774 4 99M'5 7' (4 79M'5 7- 76776 447' '4M'SIO.0005
*N7G)(*7(*7X*7 76 G6)76'4 2' )' ' '6 '69G 05 )G7 757'69) 0) 07695 Y)7 SIO.0006
*N'RX)*7**7X*7 75'7'- 0 5 7- 76776 76'4 2' ' ' X7494M776 0677577'0 5 SIO.0007
*N'NX(*7(*7(*7 -6,5 7- 7'++ 5597' 0 559449' X 74-02X83' 25690 SIO.0008
*T'*(**77 * )P 9 8 SIO.0009
```

```
$CDICT SIO. SIO.0010
*N XZ*84 1**)P84 *)P U'(PP S'*(P U'**( X'(*)-6 P*)- ( )*- (*P- ((*- SIO.0011
*19Z'(((**-- ( )G- SIO.0012
$DKEND SIO. SIO.0013
$IRLDR UNITS 18 SEP 69 UNITS000
$FILE UNITS 'UNIT14',A(1),INPUT,BIN,RLK=410 UNITS001
$FILE UNITS 'UNIT15',A(2),INOUT,BIN,RLK=1080 UNITS002
$FILE UNITS 'UNIT16',A(3),INOUT,BIN,RLK=1080 UNITS003
$FILE UNITS 'UNIT17',A(4),OUTPUT,BIN,RLK=1080 UNITS004
$FILE UNITS 'UNIT18',A(5),OUTPUT,BIN,RLK=1080 UNITS005
$FDICT UNITS UNITS006
*J (('42' *(7PPPPP72P *(1'PPPPP72P *(1'PPPPP72P *(1'PPPPP UNITS007
*49P7P' 2P *(6PPPPP UNITS008
```

```
$TFTX UNITS UNITS009
*T =*7*XG I H I G ) UNITS010
$CDICT UNITS UNITS011
*V *($ 4 1*(P 4 X.' X.' 9X.' 8X.' 9X.( 7 UNITS012
$DKEND UNITS UNITS013
' END OF FILE CARD
```

AFHRL-TR-72-6

```
$JOB          0,5,5000      69-026 GUTHRIE ROOM 209 START
$SF7UP A(1)   X1856,NORING UNIT 14  15 OCT 70  FLIGHT 2-5
$SFTUP A(2)   X1914 UNIT 15
$SFTUP A(3)   TAPE          UNIT 16
$IRFTC T37DAT M94,XR7,NODECK
C  EACH FOOT OF MAGNETIC TAPE AT 800 DENSITY WILL HOLD 1300 36BIT
C  FLOATING POINT WORDS INCLUDING DCS BLOCKING. 1700 RECORDS REQUIRE
C  1805 FEET OF TAPE. 1700*((12*25)+(120*9))/1300
C  THE WORD RECORD WHEN USED IN REFERENCE TO UNITS 15 AND 16 MEANS
C  ((A240(I,J),I=1,120),J=1,6) PLUS ((A24(I,J),I=1,12),J=1,25)=1380 WDS
C  $SFTUP A(1) X1856 DCS BLOCKED RAW DATA
C  $SETUP A(2) X1914 TAPE TO CONTAIN THE FIRST 1700 RECORDS OF
C  CALIBRATED DATA
C  $SETUP A(3) TAPE IF THERE ARE MORE THAN 1700 RECORDS AN ADDITIONAL
C  TAPE IS REQUIRED ON UNIT 16
C  DIMENSION A(410),M(100),WORDS(100),TAPES(2)
C  COMMON /A1/ N12,N120,RECORD,IUNIT,N,TAPE,INP(100),JCOL(100),
C  XARRAY(51,18),YARRAY(51,18),JCAL(100),I24,I240
C  COMMON /A2/ J1,A24(24,25),A240(240,9),CYCLE,SET
C  INTEGER RECORD,SET
C  NAMELIST /NAM1/ ITAPE,IP,IPD
C  READ (5,1) TAPE
C  TAPE THE REEL NUMBER TO BE MOUNTED ON A(1) UNIT 14
1  FORMAT (A6)
   READ (5,NAM1)
   J1516=15
   SFT=0
   CYCLE=0.0
   RECORD=0
   J1=0
   IUNIT=14
C  READ AND WRITE INTEGER CONTROL VECTORS
C  JCOL(100) CONTAINS THE COLUMN NUMBER (J) OF XARRAY(NP,J) AND YARRAY
C  (NP,J)
   READ (5,2) (JCOL(I),I=1,100)
2  FORMAT (20I4)
C  INP(100) CONTAINS THE NUMBER OF POINTS (NP) OF XARRAY(NP,J) AND
C  YARRAY(NP,J)
   READ (5,2) (INP(I),I=1,100)
C  JCAL(100) CONTAINS THE COLUMN NUMBER OF THE CALIBRATED DATA TO BE
C  STORED IN A240(I,J) AND A24(I,J-6)
   READ (5,2) (JCAL(I),I=1,100)
   WRITE (6,97) (JCOL(I),I=1,100)
97  FORMAT (12H0JCOL VECTOR/1X/(1X,20I6))
   WRITE (6,98) (INP(I),I=1,100)
98  FORMAT (11H0INP VECTOR/1X/(1X,20I6))
   WRITE (6,99) (JCAL(I),I=1,100)
99  FORMAT (12H0JCAL VECTOR/1X/(1X,20I6))
C  READ AND WRITE THE CALIBRATION DATA
   DO 3 J=1,18
```

MAIN00
MAIN01
MAIN02
MAIN04
MAIN05
MAIN06
MAIN07
MAIN08
MAIN09
MAIN10
MAIN11
MAIN12
MAIN13
MAIN14
MAIN15
MAIN16
MAIN17
MAIN18
MAIN19
MAIN20
MAIN21
MAIN22
MAIN23
MAIN24
MAIN25
MAIN26
MAIN27
MAIN28
MAIN29
MAIN30
MAIN31

```

      READ (5,4) LABFLX,LABELY,NP
4     FORMAT (A6,5X,A6,5X,I2)
      READ (5,5) (XARRAY(I,J),I=1,NP)
      READ (5,5) (YARRAY(I,J),I=1,NP)
5     FORMAT (10F8,3)
      WRITE (6,49) LABFLX,LABFLY,NP
49    FORMAT (1H0,A6,5X,A6,5X,I2)
      WRITE (6,50) (XARRAY(I,J),I=1,NP)
      WRITE (6,50) (YARRAY(I,J),I=1,NP)
50    FORMAT (1H0,10F12,3/(1X,10F12,3))
3     CONTINUE
      PRINT 13,J1516
13    FORMAT (6H UNIT=,I4)
      N12=0
      N120=0
      CALL CYCLFS (A,M,WORDS)
      N12=J2
      N120=120
9     CALL CYCLFS (A,M,WORDS)
C     DIFFERENTIATE VERTICAL VELOCITY=A24(I,21),TURN RATE=A24(I,22),STICK
C     RATE LONGITUDINAL=A240(I,7),STICK RATE LATERAL=A240(I,8),RUDDER RATE
C     =A240(I,9)
      DO 6 I=1,12
      A24(I,21)=DIFF (A24,24,25,1,6,0.1)
6     A24(I,22)=DIFF (A24,24,25,1,7,0.1)
      DO 7 I=1,120
      A240(I,7)=DIFF (A240,240,9,1,3,0.01)
      A240(I,8)=DIFF (A240,240,9,1,4,0.01)
7     A240(I,9)=DIFF (A240,240,9,1,5,0.01)
      IF (RECORD.GT.2) GO TO 48
      A24(I,20)=A240(I,2)
      A24(I,23)=0.0
      A24(I,24)=A240(I,1)
C     INTEGRATE ROLL=A24(I,20),YAW=A24(I,23),PITCH=A24(I,24)
48    DO 8 I=2,13
      A24(I,20)=A24(I-1,20)+0.05*(A24(I,2)+A24(I-1,2))
      A24(I,23)=A24(I-1,23)+0.05*(A24(I,8)+A24(I-1,8))
      A24(I,24)=A24(I-1,24)+0.05*(A24(I,17)+A24(I-1,17))
8     CONTINUE
C     WHEN I APPROX. 0 WRITE OUT CALIBRATED DATA ON UNIT 15 (J1516=15) OR ON
C     UNIT 16 (J1516=16)
      IF (APF.EQ.0) GO TO 10
      WRITE (J1516) ((A240(I,J),I=1,120),J=1,9)
      WRITE (J1516) ((A24(I,J),I=1,12),J=1,25)
10    CALL SELFCT (IP,IPD)
C     SUBROUTINE SELFCT SETS N=2 WHEN AN END OF FILE IS ENCOUNTERED
      GO TO (21,22),N
C     SHIFT THE CURRENT CYCLE OF CALIBRATED DATA TO THE PREVIOUS CYCLE

C     STORAGE AREA SO AS TO ALLOW THE DIFFERENTIATION AND INTEGRATION
C     TO BE CONTINUOUS
21    DO 15 I=13,24
      DO 15 J=1,25
15    A24(I-12,J)=A24(I,J)
      DO 16 I=121,240
      DO 16 J=1,9
16    A240(I-120,J)=A240(I,J)
      IF (RECORD-1701) 9,11,12
11    J1516=16
      PRINT 13,J1516
      GO TO 9
17    I. (RECORD-3401) 9,22,22
22    CALL PRINT
      STOP
      END

```

```

MAIN32
MAIN33
MAIN34
MAIN35
MAIN36
MAIN37
MAIN38
MAIN39
MAIN40
MAIN41
MAIN42
MAIN43
MAIN44
MAIN45
MAIN46
MAIN47
MAIN48
MAIN49
MAIN50
MAIN51
MAIN52
MAIN53
MAIN54
MAIN55
MAIN56
MAIN57
MAIN58
MAIN59
MAIN60
MAIN61
MAIN62
MAIN63
MAIN64
MAIN65
MAIN66
MAIN67
MAIN68
MAIN69
MAIN70
MAIN71
MAIN72
MAIN73
MAIN74
MAIN75
MAIN76
MAIN77
MAIN78
MAIN79
MAIN80
MAIN81
MAIN82
MAIN83
MAIN84
MAIN85

```

AFHRL-TR-72-6

```

$IPFC CYCLFX M94,XR7,DFCK
SUBROUTINE CYCLFS (A,M,WORDS)
C SUBROUTINE CYCLFS EXTRACTS,CALIBRATION AND STORES FOR MAJOR FILE
C OF 100 WORDS
  DIMENSION A(410),M(100),WORDS(100)
  COMMON /A1/ N12,N120,RECORD,IUNIT,N,PF,INP(100),
  IXARRAY(51,18),YARRAY(51,18),JCAL(100,124,12)
  COMMON /A2/ J1,A24(24,25),A240(240,24),CYCLF,T
  INTEGER RECORD,SFT
  RECORD=RECORD+1
C CALL READ (IUNIT,A,K,N) THIS SUBROUTINE PERMITS DIRECT CALLS FROM
C FORTRAN IV TO IOCS AND ALLOWS THE CALLING PROGRAM TO CONTROL
C CONTROL IF AN END OF FILE OR PERMANENT REDUNDANCY IS ENCOUNTERED
  CALL READ (IUNIT,A,K,N)
C WRITE OUT THE FIRST FOUR RAW DATA BINARY RECORDS.
  IF (RECORD.LT.5) WRITE (6,17) (A(I),I=1,410)
10  FORMAT (9H1A MATRIX/1X/(1X,8016))
  N=N+1
C K=NO. WORDS IN RECORD A, GOOD READ (N=1), END OF FILE (N=2),
C PERMANENT REDUNDANCY (N=3)
  GO TO (1,2,3),N
1  IF (K.EQ.410) GO TO 7
  WRITE (6,4) K,RECORD,TAPF,N
4  FORMAT (12HOTHER ARE ,15,3X,17HWORDS IN RECORD ,15,3X,5HON TAPE
 1 ,A6,3X,2HN=,15)
  CALL FXFM
2  WRITE (6,5) TAPF,RECORD,N
5  FORMAT (33HEND OF FILE ENCOUNTERED ON TAPE ,A6,11H IN RECORD,16,
 12X,2HN=,15)
  DO 17 I=13,24
  DO 17 J=1,25
17  A24(I,J)=0.0
  DO 18 I=121,240
  DO 18 J=1,9
18  A240(I,J)=0.0
  RETURN
3  WRITE (6,6) TAPF,RECORD,N
6  FORMAT (42HPERMANENT REDUNDANCY ENCOUNTERED ON TAPE ,A6,
 113H IN RECORD ,16,3X,2HN=,15)
  CALL PRINT
  CALL FXFM
7  I24=N12
  I240=N120
C DO 12 MAJOR CYCLES WITHIN ONE 410 (36 BIT) WORD RECORD.EACH CYCLE HAS
C 100 (12 BIT) DATA WORDS
  DO 9 I=2,376,34
  CYCLF=CYCLF+1.0
  I24=I24+1

  DO 8 J=1,100
  M(J)=0
8  CALL A MAP CODED SUBROUTINE TO EXTRACT THE NECESSARY 12 BIT DATA
C WORDS AND CONVERT THE TIME WORDS TO SECONDS
  CALL XTRACT (A(I),M(2))
C CONVERT THE 12 BIT INTEGER WORDS (STORED ONE PER 36 BIT WORD) TO REAL
C FLOATING POINT WORDS AND PERFORM THE NECESSARY CALIBRATION
  CALL CALBRT (M,WORDS)
  CALL STORE (WORDS)
9  CONTINUE
  RETURN
  END

```

AFHRL-TR-72-6

```
$IRFTC STORES M94,XR7,DECK
  SUBROUTINE STORE (WORDS)
    COMMON /A1/ N12,N12C,RECORD,IUNIT,N,TAPE,INP(100),JCOL(100),
    IXARRAY(51,18),YARRAY(51,18),JCAL(100),I24,I240
    COMMON /A2/ J1,A24(24,25),A240(240,9),CYCLE,SFT
    INTEGER SET
    DIMENSION WORDS(100)
    DO 1 L=1,100
      J=JCAL(L)
      IF (J.EQ.0) GO TO 1
      IF (J.GT.6) GO TO 2
      IF (J.EQ.1) I240=I240+1
      A240(I240,J)=WORDS(L)
      GO TO 1
2     A24(I24,J-6)=WORDS(L)
1     CONTINUE
      A24(I24,25)=CYCLE/10.0
    RETURN
  END
```

4

AFHRL-TR-72-6

```
SIR:TC SFLFCX DECK,M94,XR7
SUBROUTINE SELECT (I,ID)
C FROM THE CALIBRATED DATA STORED IN A24 AND A240 SELECT THE SERIES IP.
C IP+IPD,IP+2IPD+...TO BE PRINTED
COMMON /A1/ N12,N120,RECORD,IUNIT,N,TAPE,INP(100),JCOL(100),
IXARRAY(51,18),YARRAY(51,18),JCAL(100),I24,I240
COMMON /A2/ J1,A24(24,25),A240(240,9),CYCLF,SET
COMMON /A3/ PAGE1(50,12),PAGE2(50,13),PAGE3(50,12)
INTEGER RECORD,SET
1 IF (I.LF.12) GO TO 2
I=I-12
RETURN
2 J=10*I-9
J1=J1+1
PAGE1(J1, 1)=A24(I,19)
PAGE1(J1, 2)=A240(J,6)
PAGE1(J1, 3)=A24(I,6)
PAGE1(J1, 4)=A24(I,21)
PAGE1(J1, 5)=A240(J,1)
PAGE1(J1, 6)=A24(I,24)
PAGE1(J1, 7)=A24(I,17)
PAGE1(J1, 8)=A240(J,3)
PAGE1(J1, 9)=A240(J,7)
PAGE1(J1,10)=A24(I,4)
PAGE1(J1,11)=A24(I,5)
PAGE1(J1,12)=A24(I,9)
PAGE2(J1, 1)=A24(I,19)
PAGE2(J1, 2)=A24(I,7)
PAGE2(J1, 3)=A24(I,22)
PAGE2(J1, 4)=A240(J,2)
PAGE2(J1, 5)=A24(I,20)
PAGE2(J1, 6)=A24(I,2)
PAGE2(J1, 7)=A240(J,4)
PAGE2(J1, 8)=A240(J,8)
PAGE2(J1, 9)=A24(I,3)
PAGE2(J1,10)=A24(I,23)
PAGE2(J1,11)=A24(I,8)
PAGE2(J1,12)=A240(J,5)
PAGE2(J1,13)=A240(J,9)
PAGE3(J1, 1)=A24(I,19)
PAGE3(J1, 2)=A24(I,13)
PAGE3(J1, 3)=A24(I,15)
PAGE3(J1, 4)=A24(I,14)
PAGE3(J1, 5)=A24(I,16)
PAGE3(J1, 6)=A24(I,11)
PAGE3(J1, 7)=A24(I,10)
PAGE3(J1, 8)=A24(I,12)
PAGE3(J1, 9)=A24(I,1)
PAGE3(J1,10)=A24(I,18)
PAGE3(J1,11)=A24(I,25)

PAGE3(J1,12)=RECORD-1
IF (J1.LT.50) GO TO 35
CALL PRINT
35 I=I+ID
GO TO 1
END
```

AFHRL-TR-72-6

```
$IRFTC PRINTS DECK,M94,XR7
  SUBROUTINE PRINT
  COMMON /A2/ J1,A24(24,25),A240(240,9),CYCLE,SET
  COMMON /A3/ PAGE1(50,12),PAGE2(50,13),PAGE3(50,12)
  INTEGER SET
  IF (J1.EQ.0) RETURN
  SET=SET+1
14  WRITE (6,31) SET
31  FORMAT (13H1PAGE 1 SFT,15/
C      5X,4HTIME,10H AIRSPEED,11H ALTITUDE,10H VFRT
1ICAL,5X,5HPITCH,7X,5HPITCH,4X,5HPITCH,12H STICK POS.,13H STICK
2RATE,11H ELEVATOR,11H ELEVATOR,8X,6HNORMAL/32X,8HVELOCITY,10H
3 (ACTUAL),12H (COMPUTED),5X,4HRATE,5X,7H(LONG.),6X,7H(LONG.),5X,6
4HTAB UP,11H TAB DOWN,14H ACCELERATION/1X)
  WRITE (6,41) ((PAGE1(IR,IC),FLAG1(IR,IC),IC=1,12),IR=1,J1)
41  FORMAT (1X,F7.2,A1,F9.2,A1,F10.2,A1,F9.2,A1,F9.2,A1,F11.2,A1,F8.2,
1A1,F11.2,A1,F12.2,A1,F10.0,A1,F10.0,A1,F13.2,A1)
  WRITE (6,32) SET
32  FORMAT (13H1PAGE 2 SFT,15/
C      4X,4HTIME,9H HEADING,4X,4HTURN,6X,4HROLL,8X,4HR
1OLL,5X,4HROLL,12H STICK POS.,12H STICK RATE,7X,7HLATERAL,9X,3HYA
2W,6X,3HYAW,8H RUDDER,9H RUDDER/21X,4HRATE,10H (ACTUAL),12H (C
3OMPUTED),5X,4HRATE,12H (LATFRAL),12H (LATERAL),14H ACCELERAT
4ON,12H (COMPUTED),5X,4HRATE,13X,4HRATE/1X)
  WRITE (6,42) ((PAGE2(IR,IC),FLAG2(IR,IC),IC=1,13),IR=1,J1)
42  FORMAT (1X,F7.2,A1,F7.2,A1,F7.2,A1,F9.2,A1,F11.2,A1,F8.2,A1,F11.2,
1A1,F11.2,A1,F13.2,A1,F11.2,A1,F8.2,A1,F7.2,A1,F8.2,A1)
  WRITE (6,33) SET
33  FORMAT (13H1PAGE 3 SET,15/
C      5X,4HTIME,11H THROTTLE,7X,3HRPM,11H THROTTLE
1,7X,3HRPM,8H SPEED,5X,5HFLAPS,10H LANDING,7X,6HTHRUST,9X,
25HFVENT,9X,4HTIME,7X,6HRECORD/14X,6H(LLEFT),4X,6H(LLEFT),4X,7H(RIGHT
3),10H (RIGHT),8H BRAKE,16X,4HGFA,13H ATTENUATOR,8X,6HNUMBER
4,8X,5HCYCLE/1X)
  WRITE (6,43) ((PAGE3(IR,IC),FLAG3(IR,IC),IC=1,12),IR=1,J1)
43  FORMAT (1X,F7.2,A1,F10.2,A1,F9.2,A1,F10.2,A1,F9.2,A1,F7.0,A1,F9.2,
1A1,F9.0,A1,F12.0,A1,F13.0,A1,F12.1,A1,F12.0,A1)
  J1=0
  RETURN
  END
```

AFHRL-TR-72-6

\$IRMAP	XTRATC	DECK
XTRACT	SAVE	(1,2,4)
	CLA	3,4
	STA	N1
	STA	N3
	STA	N6
	STA	N10
	CLA	4,4
	STA	N2
	STA	N4
	STA	N7
	STA	N8
	STA	N12
N1	LDQ	**
	RQL	25
	PXA	,0
	LLS	10
	CHS	
N2	STO	**
	AXT	-1,2
	AXT	-1,1
N3	LDQ	** ,1
	AXT	3,4
N5	RQL	1
	PXA	,0
	LLS	10
	CHS	
N4	STO	** ,2
	RQL	1
	TXI	**1,2,-1
	TXI	N5,4,1
	TXI	**1,1,-1
	TXH	N3,1,-32
N6	LDQ	** ,1
	RQL	1
	PXA	,0
	LLS	10
	CHS	
N7	STO	** ,2
	RQL	1
	TXI	**1,2,-1
	RQL	1
	PXA	,0
	LLS	10
	CHS	
N8	STO	** ,2
	PXA	,0
	AXT	0,4

AFHRL-TR-72-6

	RQL	1
N9	RQL	1
	TQP	**2
	ADD	SEC1,4
	TXI	**1,4,-1
	TXH	N9,4,-11
	TXI	**1,1,-1
N10	LDQ	**1
	AXT	0,4
	RQL	1
N11	RQL	1
	TQP	**2
	ADD	SEC2,4
	TXI	**1,4,-1
	TXH	N11,4,-10
	TXI	**1,2,-1
N12	STO	**2
	RFTURN	XTRACT
SFC1	DFC	240
	DFC	72000
	DEC	36000
	DEC	28800
	DEC	14400
	DEC	7200
	DEC	3600
	DEC	2400
	DFC	1200
	DEC	600
	DEC	480
SFC2	DFC	120
	DFC	60
	DFC	40
	DFC	20
	DEC	10
	DEC	8
	DEC	4
	DEC	2
	DEC	1
	FND	

SIRMAP	SIO.	DECK	SEPT	DOWDFLL	SIO. 000
		TTL	SIMPLIFIED	IOCS	SUBROUTINE
		*	SIMPLIFIED	INPUT-OUTPUT	CONTROL SYSTEM - 21 SEPTEMBER
		*	THIS	SUBROUTINE	PERMITS DIRECT CALL FROM
		*	FORTRAN	IV TO IOCS	ROUTINES(OPEN,READ,WRITE,CLOSE)
		*			
		*	THE	VARIOUS	CALLING SEQUENCES ARE-
		*	CALL	CLOSE(N,M)	
		*	N=	LOGICAL	TAPE
		*	M=(0=	NO	REWIND, NO EOF ON OUTPUT)
		*	=(1=	REWIND,	WRITE EOF ON OUTPUT)
		*	=(2=	NO	REWIND, WRITE EOF ON OUTPUT)
		*	=(3=	REWIND,	UNLOAD, WRITE EOF ON OUTPUT)
		*	MODIFIED	SIO.	TO RETURN THE WORD COUNT IN K
		*	CALL	READ(N,A,K,J)	
		*	N=	LOGICAL	TAPE
		*	A=	LOCATION	OF DATA AREA FOR READ
		*	K=	NUMBER	OF WORDS TO BE READ
		*	J=	STATUS	SWITCH(0=GOOD READ),(1=END OF FILE),(2=PERM REDUN)
		*	CALL	WRITE(N,A,K)	
		*	N=	LOGICAL	TAPE
		*	A=	LOCATION	OF AREA FOR WRITE
		*	K=	NUMBER	OF WORDS TO BE WRITTEN
		*	CALL	BKSFIL(N,M)	
		*	N=	LOGICAL	TAPE
		*	M=	NO.	OF FILES
			SPACE	2	
	READ	CONTRL	READX,READY		
	WRITE	CONTRL	WRITX,WRITY		
	CLOSE	CONTRL	CLOX,CLOSY		
	BKSFIL	CONTRL	BKSFY,BKSFY		
			SPACE	2	
		REM	SAVE	AND	EXIT FOR ALL ROUTINES
	SAVE	SAVEN	(2,4),1		
		SXA	LK,DR,4		
		TRA	1,1		
	EXIT	AXT	**,1	EXIT	ROUTINE
		RETURN	SAVE		
		SPACE	2		
		REM	CLOSE	SUBROUTINE	
	CLOSX	SXA	EXIT,1		
		TSX	SAVE,1	SAVE	ROUTINE
		CLA*	4,4	SET	REWIND OPTION
		PAC	0,1		
		LDQ	PREFIX	ROTATE	PREFIX CONSTANT
		RQL	0,1	TO	FORM DESIRED PREFIX
		SLQ	CLOF1+1	PZF,MZF	PTW,MON
		TSX	FVIO,1	FIND	LOC(FCB)
					SIOCS005
					SIOCS006
					SIOCS007
					SIOCS008
					SIOCS009
					SIOCS010
					SIOCS011
					SIOCS012
					SIOCS013
					SIOCS014
					SIOCS015
					SIOCS016
					SIOCS017
					SIOCS018
					SIOCS019
					SIOCS020
					SIOCS021
					SIOCS022
					SIOCS023
					SIOCS024
					SIOCS025
					SIOCS026
					SIOCS027
					SIOCS032
					SIOCS034
					SIOCS035
					SIOCS036
					SIOCS037
					SIOCS038
					SIOCS039
					SIOCS040
					SIOCS042
					SIOCS043
					SIOCS044
					SIOCS045
					SIOCS046
					SIOCS047
					SIOCS048

AFHRL-TR-72-6

	CLA	F.	STORE LOC(FCB)	SIOCS049
	STA	CLOSE1+1		SIOCS050
CLOSEJ	TSX	.CLOSE,4	CALL TO IOCS	SIOCS051
	PZE	**		SIOCS052
	TRA	EXIT	RETURN	SIOCS053
CLOSY	BSS	0		
	SPACE	2		SIOCS054
	REM	READ SUBROUTINE		SIOCS055
READX	SXA	EXIT,1		
	TSX	SAVE,1	SAVE ROUTINE	SIOCS057
	SXA	RFAD2,4		SIOCS058
	CLA	4,4	FIND READ ADDRFS	SIOCS059
	STA	READ1+3		SIOCS060
	CLA	5,4		
	STA	QQ		
	STZ*	6,4	ZERO FRROR SWITCH	SIOCS064
	TSX	FVIO,1	FIND LOC(FCB)	SIOCS065
	CLA	E.		SIOCS066
	STA	READ1+1		SIOCS067
	STA	OPN+1		SIOCS068
	STA	CLS+1		SIOCS069
	PAC	0,1		SIOCS070
	LDI	1,1	FCB WORD 2	SIOCS071
	LFT	003000	WAS PREVIOUS USE INPUT	SIOCS072
	TRA	*+2	NO, MUST RESET	SIOCS073
	TRA	READ5	YES, GO CHECK OPEN	SIOCS074
	LFT	040000	IS FILE CLOSED	SIOCS075
	TSX	CLS,2	NO, CLOSE IT	SIOCS076
	LDI	1,1		SIOCS077
	RIL	003000	SET TO INPUT (00)	SIOCS078
	STI	1,1		SIOCS079
	TRA	*+2		SIOCS080
READ5	LNT	040000	IS FILE OPEN	SIOCS081
	TSX	OPN,2		SIOCS082
READ1	TSX	.READ,4	CALL TO IOCS	SIOCS083
	PZF	**		SIOCS084
	PZE	READ2,,READ3	FOF,,REDUN	SIOCS085
	IORT	**,,**		
	LXD	*-1,1		
QQ	SXA	**,1		
	TRA	EXIT		SIOCS087
READ2	AXT	**,4	RESTORE IR4	SIOCS088
	CLA	=1	SET EOF SWITCH	SIOCS089
	STO*	6,4		SIOCS090
	TRA	EXIT	RETURN	SIOCS091
REAJ3	XEC	READ2	RESTORE IR4	SIOCS092
	CLA	=2	SFT PFRM REDUN	SIOCS093
	STO*	6,4	SWITCH	SIOCS094
	TRA	EXIT	RFTURN	SIOCS095
READY	BSS	0		

AFHRL-TR-72-6

	SPACE	2		SIOCS096
	RFM	WRITE SUBROUTINE		SIOCS097
WRITX	SXA	EXIT,1		
	TSX	SAVE,1	SAVE ROUTINE	SIOCS098
	CLA	4,4	FIND WRITE ADDRESS	SIOCS100
	STA	WRITE1+2		SIOCS101
	CLA*	5,4	FIND NO WORDS	SIOCS102
	PAX	0,1		SIOCS103
	SXD	WRITE1+2,1		SIOCS104
	TSX	FVIO,1	FIND LOC(FCB)	SIOCS105
	CLA	F.		SIOCS106
	STA	WRITE1+1		SIOCS107
	STA	OPN+1		SIOCS108
	STA	CLS+1		SIOCS109
	PAC	0,1		SIOCS110
	LDI	1,1	FCB WORD 2 TO INDICATORS	SIOCS111
	LFT	001000	EXAMINE FOR PREVIOUS ACTIVITY	SIOCS112
	TRA	WRITE5	PREVIOUS NOT INPUT	SIOCS113
	LFT	040000	INPUT IS FILE CLOSED	SIOCS114
	TSX	CLS+2	NO CLOSIF IT	SIOCS115
	LDI	1,1		SIOCS116
	RIL	003000	SFT BITS FOR OUTPUT (01)	SIOCS117
	IIL	001000		SIOCS118
	STI	1,1		SIOCS119
	TRA	**2		SIOCS120
WRITE5	LNT	040000	IS FILE OPEN	SIOCS121
	TSX	OPN+2	NO OPFN FILE	SIOCS122
WRITE1	TSX	*WRITE,4	CALL TO IOCS	SIOCS123
	PZE	**		SIOCS124
	IORT	***		
	TRA	EXIT	RETURN	SIOCS126
WRITY	BSS	0		SIOCS127
	SPACE	2		SIOCS128
	RFM	BACKSPACE FILE ROUTINE		
BKSFY	SXA	EXIT,1		SIOCS130
	TSX	SAVE,1	SAVE ROUTINE	SIOCS131
	TSX	FVIO,1	FIND LOC(FCB)	SIOCS132
	CLA	F.		SIOCS133
	STA	CLS+1		SIOCS134
	STA	BSKFL,1+1		SIOCS135
	LXA	LK,DR,4		SIOCS136
	CLA*	4,4	FIND NO. OF FILES	SIOCS137
	PAX	0,1		SIOCS138
	TXL	EXIT,1,0	EXIT IF 0	SIOCS139
	TSX	CLS+2	CLOSE FILE	SIOCS140
BSKFL1	TSX	*NDSFL,4	BACKSPACE 1 FILE	SIOCS141
	PZE	**,*6		SIOCS142
	TIX	BSKFL1,1,1	CONTINUE FOR M FILES	
	TRA	EXIT	COMPLETE GO HOME	SIOCS143
BKSFY	BSS	0		SIOCS144
	SPACE	2		SIOCS145
	RFM	OPEN AND CLOSE ROUTINE		SIOCS146
OPN	TSX	*OPN,4		SIOCS147
	MZF	**		SIOCS148
	TRA	1,2		SIOCS149
CLS	TSX	*CLOSE,4		SIOCS150
	MON	**		SIOCS151
	TRA	1,2		SIOCS152
	SPACE	2		SIOCS153
	RFM	ROUTINE TO LOCATE FILE CONTROL BLOCK		SIOCS154
FVIO	CLA	3,4	FIND LOGICAL NUMBER	SIOCS155
	STA	**4		SIOCS156
	CALL	*FVIO,(**,*F,)		SIOCS157
	T-A	1,1	-FTU-N	SIOCS158
	SPACE	2		SIOCS159
	RFM	CONSTANTS AND VARIABLES		SIOCS160
	SPACE	1		SIOCS161
	RFM	THE FOLLOWING CONSTANT USED TO ESTABLISH		SIOCS162
	RFM	OPEN AND CLOSE PREFIX BY SHIFTING		SIOCS163
	RFM	WITH THE DESIRED OPTION CODE, THE NORMAL PREFIXES		SIOCS164
	RFM	OF -1,+2,-0, AND +0 CAN BE OBTAINED		SIOCS165
PREFIX	MON			SIOCS166
E.	PZE	0		SIOCS167
LK,DR	LDIR			SIOCS168
	END			

AFHRL-TR-72-6

```
$IRMAP UNITS 17,M94,DFCK
      ENTRY  .UN14.
      .UN14. PZF UNIT14
UNIT14 FILE  .A(1),INPUT,BIN,BLK=410
      ENTRY  .UN15.
      .UN15. PZE UNIT15
UNIT15 FILE  .A(2),INOUT,BIN,BLK=1080
      ENTRY  .UN16.
      .UN16. PZE UNIT16
UNIT16 FILE  .A(3),INOUT,BIN,BLK=1080
      ENTRY  .UN17.
      .UN17. PZF UNIT17
UNIT17 FILE  .A(4),OUTPUT,BIN,BLK=1080
      ENTRY  .UN18.
      .UN18. PZF UNIT18
UNIT18 FILE  .A(5),OUTPUT,BIN,BLK=1080
      END
```

END OF FILE CARD
 X1856 92 RECORDS BY COUNT
 \$NAM1 ITAPE=1,IP=1,IPD=10\$

0	1	2	3	4	5	6	0	0	0	0	1	2	3	4	5	6	7	0	0	
0	1	2	3	4	5	6	8	0	0	0	0	1	2	3	4	5	6	9	10	11
12	1	2	3	4	5	6	13	0	0	14	1	2	3	4	5	6	15	16	17	
18	1	2	3	4	5	6	0	0	0	0	1	2	3	4	5	6	0	0	0	
0	1	2	3	4	5	6	0	0	0	0	1	2	3	4	5	6	0	0	0	
0	15	27	19	17	19	16	-1	0	0	0	15	27	19	17	19	16	19	0	0	
0	15	27	19	17	19	16	13	-1	-1	0	15	27	19	17	19	16	18	35	15	
2	15	27	19	17	19	16	6	-1	-1	5	15	27	19	17	19	16	5	7	7	
19	15	27	19	17	19	16	-3	0	0	0	15	27	19	17	19	16	0	0	0	
0	15	27	19	17	19	16	0	0	0	0	15	27	19	17	19	16	-2	0	0	
0	1	2	3	4	5	6	7	0	0	0	1	2	3	4	5	6	8	0	0	
0	1	2	3	4	5	6	9	10	11	0	1	2	3	4	5	6	12	13	14	
15	1	2	3	4	5	6	16	17	18	19	1	2	3	4	5	6	20	21	22	
23	1	2	3	4	5	6	24	0	0	0	1	2	3	4	5	6	0	0	0	
0	1	2	3	4	5	6	0	0	0	0	1	2	3	4	5	6	25	0	0	
WORD02	PITCH 15																			
3.50	3.36	3.22	3.08	2.94	2.79	2.65	2.50	2.36	2.21											
2.07	1.93	1.77	1.63	1.49	20.	10.	0.	-10.	-20.											
70.	60.	50.	40.	30.																
-30.	-40.	-50.	-60.	-70.																
WORD03	ROLL 27																			
5.00	4.27	4.12	3.98	3.83	3.68	3.53	3.39	3.25	3.10											
2.95	2.79	2.65	2.50	2.36	2.21	2.07	1.93	1.77	1.63											
1.48	1.34	1.19	1.05	0.91	0.84	0.00														
180.	120.	110.	100.	90.	80.	70.	60.	50.	40.											
30.	20.	10.	0.	-10.	-20.	-30.	-40.	-50.	-60.											
-70.	-80.	-90.	-100.	-110.	-120.	-180.														
WORD04	STICKO 19																			
.16	.60	.78	1.00	1.2	1.45	1.66	1.88	2.14	2.36											
2.59	2.84	3.09	3.32	3.57	3.83	4.10	4.34	4.74												
-14.9	-10.	-8.	-6.	-4.	-2.	0.	2.	4.	6.											
8.	10.	12.	14.	16.	18.	20.	22.	24.												
WORD05	STICKA 17																			
.27	.45	.81	1.11	1.43	1.69	1.94	2.24	2.48	2.75											
3.00	3.28	3.61	3.89	4.23	4.59	5.00														
15.	14.	12.	10.	8.	6.	4.	2.	0.	-2.											
-4.	-6.	-8.	-10.	-12.	-14.	-16.														
WORD06	RUDDER 19																			
.07	.4	.8	1.18	1.57	1.78	2.00	2.17	2.40	2.54											
2.80	3.00	3.20	3.40	3.60	4.00	4.40	4.80	5.00												
24.	22.	18.	14.	10.	8.	6.	4.	2.	0.											
-2.	-4.	-6.	-8.	-10.	-14.	-18.	-22.	-24.												
WORD07	AIRSPD 16																			
.491	.7836	.9065	1.019	1.152	1.310	1.585	1.864	2.165	2.438											
2.723	3.006	3.267	3.529	3.790	4.025															
0.	60.	70.	80.	90.	100.	120.	140.	160.	180.											
200.	220.	240.	260.	280.	300.															

AFHRL-TR-72-6

WORD18	ROLLRT	19								
4.36	4.13	3.595	3.07	2.545	2.03	1.51	1.0	.49	0.	
-.495	-1.0	-1.51	-2.03	-2.545	-3.08	-3.60	-4.125	-4.65		
180.	160.	140.	120.	100.	80.	60.	40.	20.	0.	
-20.	-40.	-60.	-80.	-100.	-120.	-140.	-160.	-180.		
WORD28	LATACC	13								
2.09	1.91	1.74	1.57	1.46	1.30	1.15	0.99	0.83	0.67	
0.52	0.36	0.20								
2.0	2.5	2.0	1.5	1.0	.5	0.	-.5	-1.0	-1.5	
-2.0	-2.5	-3.0								
WORD3E	ALTITD	18								
.133	.163	.225	.292	.379	.450	.647	.896	1.206	1.480	
1.787	2.100	2.397	2.689	3.002	3.309	3.596	3.908			
890.	1000.	1500.	2000.	2500.	3000.	4000.	6000.	8000.	10000.	
12000.	14000.	16000.	18000.	20000.	22000.	24000.	26000.			
WORD39	HEADNG	3E								
0.	.128	.281	.404	.563	.701	.840	.988	1.137	1.280	
1.424	1.567	1.711	1.864	2.003	2.151	2.305	2.448	2.581	2.730	
2.879	3.017	3.155	3.324	3.468	3.616	3.764	3.913	4.001	4.170	
4.246	4.292	4.308	4.334	4.359						
360.	350.	340.	330.	320.	310.	300.	290.	280.	270.	
260.	250.	240.	230.	220.	210.	200.	190.	180.	170.	
160.	150.	140.	130.	120.	110.	100.	90.	80.	70.	
60.	50.	40.	30.	20.						
WORD40	YAWRTE	15								
4.75	4.135	3.501	2.84	2.14	1.425	.705	0.	-.73	-1.45	
-2.165	-2.87	-3.54	-4.17	-4.78						
70.	60.	50.	40.	30.	20.	10.	0.	-10.	-20.	
-30.	-40.	-50.	-60.	-70.						
WORD41	NORACC	2								
-4.9	+4.9									
-7.0	+7.0									
WORD48	FLAPPO	6								
4.86	3.76	2.85	1.90	1.00	.11					
0.	20.	40.	60.	80.	100.					
WORD51	THROTL	5								
.23	1.72	2.76	3.72	4.64						
0.	16.	32.	48.	64.						
WORD58	THROTR	5								
.39	1.82	2.87	3.85	4.61						
0.	16.	32.	48.	64.						
WORD59	RPMLFT	7								
.7	1.4	2.11	2.82	3.55	4.28	5.00				
14.28	28.57	42.85	57.14	71.42	85.71	100.00				
WORD60	RPMRHT	7								
.56	1.12	1.69	2.27	2.88	3.45	4.00				
14.28	28.57	42.85	57.14	71.42	85.71	100.00				
WORD61	PITCHR	19								
4.98	4.47	3.97	3.36	2.79	2.23	1.66	1.095	.545	0.	
-.53	-1.08	-1.635	-2.21	-2.77	-3.34	-3.90	-4.45	-4.99		
90.	80.	70.	60.	50.	40.	30.	20.	10.	0.	
-10.	-20.	-30.	-40.	-50.	-60.	-70.	-80.	-90.		
	END OF FILE CARD									

GLTHRE
CALPTR EFN SOURCE STATEMENT - IFN(S) -

7/14/69

```

SUBROUTINE CALPTR (M,WCRDS)
DIMENSION M(100),WCRDS(100)
COMMON /A1/ N12,N120,REGCRD,IUNIT,N,TAPE,INP(100),JCOL(100),
IXARRAY(51,18),YARRAY(51,18),JCAL(100),I24,I240
DO 1 L=1,100
NP=INP(L)
IF (NP) 2,7,3
7  WCRDS(L)=0.0
GO TO 1
2  IGC=-NP
GO TO (4,5,6,8),IGC
4  WCRDS(L)=0.0
WORD=M(L)
VOLTS=0.0051281*ABS(WORD)-0.1256
IF (WCRD.LT.0.0) VOLTS=-VOLTS
IF (VOLTS.GE.1.0) WCRDS(L)=1.0
GO TO 1
5  WCRDS(L)=M(L)
GO TO 1
6  M(L)=-M(L)
C  EVENT NUMBER    P 5 200 100 80 40 20 10 0 * 2 1    THAT IS BCD AND NOT
C  BINARY COUNT
M1=(M(L)/256)*100
M2=MCD(M(L),256)
M1=M1+(M2/16)*10+MCD(M2,16)
WCRDS(L)=M1
GO TO 1
8  WORD=M(L)
VOLTS=0.0051281*ABS(WORD)-0.1256
IF (WCRD.LT.0.0) VOLTS=-VOLTS
WCRDS(L)=VOLTS
GO TO 1
3  WORD=M(L)
VOLTS=0.0051281*ABS(WORD)-0.1256
IF (WCRD.LT.0.0) VOLTS=-VOLTS
J=JCOL(L)
CALL AITKEN (XARRAY(1,J),YARRAY(1,J),VOLTS,WCRDS(L),DIF,51,NP,1,K1
1,JJ)
1  CONTINUE
RETURN
END

```

49

GLTHRE
AITKA - EFN SOURCE STATEMENT - IFN(S) -

07/14/69

```

SUBROUTINE AITKER (X,Y,XI,YI,DIF,M,N,INT,K1,J)
C
C DIMENSION X(M),Y(M),XX(11),YY(11),DIFF(11)
C CHECK TO CROP THE FIRST BAD POINT FROM EITHER SIDE AND CONTINUE
C M=MAXIMUM DIMENSION OF X AND Y VECTORS
C N=NUMBER OF POINTS IN THE X AND Y VECTORS; THIS CALL
C LEFT AND CHANGE (LRS=1) RIGHT AND CHANGE (LRS=2)
C LEFT ALWAYS (LRS=3) RIGHT ALWAYS (LRS=4)
C X=4 5 6 7 8 XI=5.5 K WOULD BE 2
C PARAMETERS
C X=INDEPENDENT VARIABLE Y=DEPENDENT VARIABLE N=NUMBER POINTS
C XI=GIVEN X YI=REQUIRED Y
C K1=POSITION OF THE LEFT MOST X USED J=THE NUMBER OF POINTS USED
C
C INTEGER Z
C J=1
C DIF=C.0
C DIFF(1)=1.CE37
C K1=
C YI=C.0
C IF (N.GT.1) GO TO 90
C WRITE (6,4) N
4 FORMAT (3HCN=,I12,3X,5CHTHERE ARE LESS THAN TWO POINTS IN THE (X,Y
1) TABLE.)
C CALL FXEM
90 IF (X(1).GT.X(N)) GO TO 1900
C IF (XI-X(1)) 500,600,800
500 K=1
C LRS=4
C GO TO 2800
600 K1=1
C YI=Y(1)
C RETURN
800 IF (XI-X(N)) 1200,900,1100
900 K1=N
C YI=Y(N)
C RETURN
1100 K=N
C LRS=3
C GO TO 2800
1200 LL=1
C LU=N
1300 IF ((LU-LL).EQ.1) GO TO 1400
C LI=(LU+LL)/2
C IF (XI-X(LI)) 1800,1700,1600
1600 LL=LI
C GO TO 1300
1700 K1=LI
C YI=Y(LI)
C RETURN
1800 LU=LI
C GO TO 1300
1900 IF (XI-X(1)) 2000,600,500
2000 IF (XI-X(N)) 1100,900,2100
2100 LL=1

```

6

7

AFHRL-TR-72-6

```

      LU=L
2200 IF ((LU-LL).EQ.1) GO TO 1400
      LI=(LL+LU)/2
      IF (X1-X(LI)) 2400,1700,2500
2400 LL=LI
      GO TO 2200
2500 LU=LI
      GO TO 2200
1400 K=LL
      LRS=2
2800 K1=K
      IF (INT.EQ.0) RETURN
      IPS=C
      XX(J)=X(K)-X1
      YY(J)=Y(K)
2900 IPS=IPS+1
3000 J=J+1
      IF (J.GT.11) GO TO 5900
      IF (J.LE.N) GO TO 3700
5800 J=J-1
      YI=YY(J)
      C1F=C1FF(J)
      RETRN
3700 GO TO (3900,4100,3900,4200),LRS
3800 LRS=2
3900 K=K-IPS
      IF (K.GT.0) GO TO 4500
      IF (LRS.EQ.3) GO TO 5800
4000 K=K+IPS
      LRS=4
      IPS=1
      GO TO 3700
4100 LRS=1
4200 K=K+IPS
      IF (K.LE.A) GO TO 4500
      IF (LRS.EQ.4) GO TO 5800
4300 K=K-IPS
      LRS=3
      IPS=1
      GO TO 3700
4500 XX(J)=X(K)-X1
      YY(J)=Y(K)
      LD=J-1
      GO 4600 I=1,LD
      TI=XX(J)-XX(I)
      IF (TI.NE.0) GO TO 4600
      WRITE (6,3)
3  FORMAT (27H DIVISION BY ZERO IN AITKEN)
      WRITE (6,1) X1,K1,J,(X(Z),Y(Z),Z=1,N)
1  FORMAT (1HC,1PE20.6,2I10/1X/(LX,1PE20.6))
      CALL FX=M
4600 YY(J)=((YY(I)*XX(J))-(YY(J)*XX(I)))/TI
      C1FF(J)=ABS(YY(J)-YY(J-1))
      IF (C1FF(J).GE.C1FF(J-1)) GO TO 5900
      IF (K.LT.K1) K1=K
      IF (2-LRS) 3300,2900,2900

```

AITKNC56
AITKNC57
AITKNC58
AITKNC59
AITKNC60
AITKNC61
AITKNC62
AITKNC63
AITKNC64
AITKNC65
AITKNC66
AITKNC67
AITKNC68
AITKNC69
AITKNC70
AITKNC71
AITKNC72
AITKNC73
AITKNC74
AITKNC75
AITKNC76
AITKNC77
AITKNC78
AITKNC79
AITKNC80
AITKNC81
AITKNC82
AITKNC83
AITKNC84
AITKNC85
AITKNC86
AITKNC87
AITKNC88
AITKNC89
AITKNC90
AITKNC91
AITKNC92
AITKNC93
AITKNC94
AITKNC95
AITKNC96
AITKNC97
AITKNC98
AITKNC99
AITKN100
AITKN101
AITKN102
AITKN103

AITKN104
AITKN105
AITKN106
AITKN107
AITKN108
AITKN109

123

124

130

SLTRRE
AITKN - EFN SOURCE STATEMENT - IFN(S) -

07/14/69

AFHRL-TR-72-6

APPENDIX IV
FORTRAN PROGRAMS FOR A SAMPLING RATE STUDY

03/26/70

RESOLV - EFN SOURCE STATEMENT - IFN(S) -

```

DIMENSION ARAY(9700)
DIMENSION TEP(12)
DIMENSION A(120,9),B(12,25),EVND(50),XCNT(50),DEL(10)
DIMENSION ARXZ(50,10),AR(50,10,12),ARTCT(50)
DIMENSION IRTF(50),SUM(12)
COMMON ARAY,DELTA,V,RESCL,CCLNT,W,TKEEP,L
COMMON TEP
READ(5,500)N,M,IMCN,ICAY,IYR
WRITE(6,1000)IMCN,ICAY,IYR
WRITE(6,1003)
1003 FORMAT(13H VAR IS PITCH/1H /)
READ(5,501)(EVND(I),I=1,N)
READ(5,501)(XCNT(I),I=1,N)
READ(5,502)(DEL(I),I=1,M)
READ(5,730)(IRTF(I),I=1,N)
730 FORMAT(14I5)
500 FORMAT(5I5)
501 FORMAT(12F5.2)
502 FORMAT(12F6.2)
503 FORMAT(8F8.4)
WRITE(6,1001)
DO 20 I=1,N
22 READ(16)((A(IY,JY),IY=1,120),JY=1,9)
READ(16)((B(IY,JY),IY=1,12),JY=1,25)
DO 21 J=1,12
X=AMOD(B(J,18),100.0)
IF(EVND(I)-X)21,3,21
21 CONTINUE
GO TO 22
3 IA=1
30 READ(16)((A(IY,JY),IY=1,120),JY=1,9)
READ(16)((B(IY,JY),IY=1,12),JY=1,25)
DO 5 K=1,120
IF(K-1)101,101,100
100 IF(A(K,6))800,801,801
801 IF(A(K,6)-250.1802,802,800
802 IF(ABS(A(K,2))-360.)803,803,800
803 IF(B(K,6))800,800,101
800 ARAY(IA)=ARAY(IA-1)
GO TO 5
101 ARAY(IA)=A(K,1)
5 IA=IA+1
X=IA/10
IF(X-XCNT(I))30,6,6
6 IA=IA-1
RESCL=X.
WRITE(6,1010)
1010 FORMAT(1H /)
DO 50 K=1,M
DELTA=0.01
V=DEL(K)
L=IA
CALL TSTRE
1000 FORMAT(1H1,5X,33HSAMPLING ANALYSIS FOR FLIGHT CF 12,1H-12,1H-12/
11H /)

```

```

1001 FORMAT(1H ,5X,4HSAMP,2X,3HNO.,6X,11HTIMES WORST/32H EVNO RATE SAMP
1 RES. EXCEC. ERR,4X,4HTIME,2X,4HJ-.5,1X,66H.5-1. 1-1.5 1.5-2. 2-2
2.5 2.5-3 3-3.5 3.5-4 4-5 5-10 10-20 GR-20/1H /)
WRITE(6,1CC2)EVNO(I),V,L,RESCL,COUNT,w,TKEEP,(TERR(KL),KL=1,12)
1002 FORMAT(F4.0,F6.2,I5,F5.1,F6.0,F8.3,F6.2,12F6.0)
ARXZ(I,K)=COUNT
AR(I,K,1)=TERR(1)
DO 600 KL=2,12
KM=KL-1
600 AR(I,K,KL)=AR(I,K,KM)+TERR(KL)
50 CONTINUE
ARTCT(I)=L
20 CONTINUE
DO 602 I=1,N
DO 602 J=1,M
DO 601 K=1,12
601 AR(I,J,K)=AR(I,J,K)/ARXZ(I,J)
602 ARXZ(I,J)=ARXZ(I,J)/ARTCT(I)
WRITE(6,6C2)
DO 605 I=1,N
WRITE(6,6C7)
DO 604 J=1,M
WRITE(6,606)EVNO(I),DEL(J),ARXZ(I,J),(AR(I,J,K),K=1,12)
604 CONTINUE
605 CONTINUE
603 FORMAT(1H /1H /6H EVNC,4X,3HDEL,4X,4HG1 C,4X,
15HLE .5,3X,5HLE 1.,2X,6HLE 1.5,3X,5HLE 2.,
22X,6HLE 2.5,3X,5HLE 3.,2X,6HLE 3.5,3X,
35HLE 4.,3X,5HLE 5.,2X,5HLE 10,
43X,5HLE 20,3X,6HLE INF/1H /)
606 FORMAT(F5.0,2X,F6.2,2X,F6.1,2X,12(F6.3,2X))
607 FORMAT(1H /)
DO 750 LM=1,3
DO 752 J=1,M
WRITE(6,6C7)
DO 751 LX=1,12
751 SUM(LX)=0.
DO 753 I=1,N
IMT=IKTF(I)
IF(IMT-LM)753,754,753
754 DO 755 K=1,12
755 SUM(K)=SUM(K)+AR(I,J,K)
WRITE(6,6C6)EVNO(I),DEL(J),ARXZ(I,J),(AR(I,J,K),K=1,12)
753 CONTINUE
WRITE(6,78C)(SUM(K),K=1,12)
780 FORMAT(23X,12(F7.3,1X))
752 CONTINUE
750 CONTINUE
STOP
END

```

TST - EFN SOURCE STATEMENT - IFN(S) -

```

SUBROUTINE TSTRE
DIMENSION ARAY(9700)
DIMENSION TERR(12)
DIMENSION ANUM(13)
COMMON ARAY,DELTA,V,RESCL,CCUNT,W,TKEEP,L
COMMON TERR
DO 1 I=1,12
1  TERR(I)=0.
   ANUM(I)=0.
DO 2 I=2,8
2  ANUM(I)=ANUM(I-1)+.5
   ANUM(9)=4.
   ANUM(10)=5.
   ANUM(11)=10.
   ANUM(12)=20.
   ANUM(13)=10000.
   TKEEP=-1.0
   W=-1000.
   M=V/DELTA
   CCUNT=0.0
   LFT= L-M
DO 20 J=1,LET,M
P1=ARAY(J)
KT=J+M
P2=ARAY(KT)
DMR=J-1
T1=DMR*DELTA
DMR=KT-1
T2=DMR*DELTA
XML=(P2-P1)/(T2-T1)
XLS=P1-XML*T1
KAX=J+1
KAY=J+M-1
DO 4I=KAX,KAY
DMR=I-1
T=DMR*DELTA
TEST=XML*T+XLS
X=ARAY(I)-TEST
XX=ABS(X)-RESCL
IF(XX)4,4,5
5  CCUNT=CCUNT+1.0
DO 3 K=1,12
IF(XX-ANUM(K))3,3,30
30 IF(XX-ANUM(K+1))32,22,3
32 TERR(K)=TERR(K)+1.0
3  CCNTINUE
IF(XX-W)4,6,6
6  W=XX
   TKEEP=T
4  CCNTINUE
20 CCNTINUE
RETURN
END

```

AFHRL-TR-72-6

APPENDIX V

EXTENDED ANALYSIS OF THE NORMAL LANDING TASK

J. F. Hixson, Lt Colonel, USAFR

1. INTRODUCTION

Measurement analysis of the 360° overhead traffic pattern involves a sequential examination of the individual and combined aeronautical and procedural skills incorporated in this maneuver. For purposes of interpretation of data and analysis of skills involved, the flight maneuver is broken into eight phases. This maneuver conforms to the 360° standard overhead pattern for the T-37 as outlined in ATC Manual 51-4, (Reference 4).

The eight phases are as follows (See Figure A):

- IA Entry
- IB Approach to Runway (Overhead)
- II Initial Overhead to Pitchout
- III Pitchout and First Quarter Turn toward Downwind (0° to 90° turn)
- IV Second Quarter Turn to Downwind (90 to 180° turn)
- V Downwind
- VI First Quarter Turn to Final (180 to 270° turn)
- VII Second Quarter Turn onto Final (270 to 360 turn)
- VIII Final Approach

2. DISCUSSION OF MANEUVER SEGMENTS

- a. Phases IA and B, Entry and Approach Phase of Normal Overhead Pattern (See Figure B)

The student discerns a heading that is 45° to the heading of the active runway (the runway to be landing on). He approaches the field on this heading at an altitude of 1000 feet; airspeed 200 knots; RPM 80% (approximately) to a point where his 45° turn will place his aircraft on a flight path that will begin at least two miles from the approach end of the active runway and on a ground pattern that would describe a line directly down the center line of the runway.

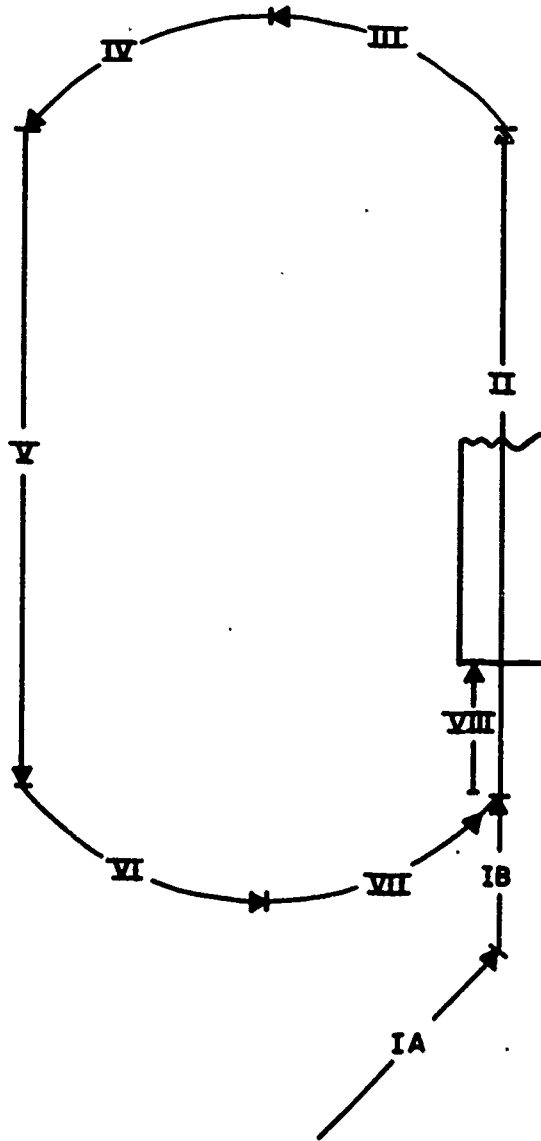

Figure A. Task Segments for 360° Overhead Landing Pattern

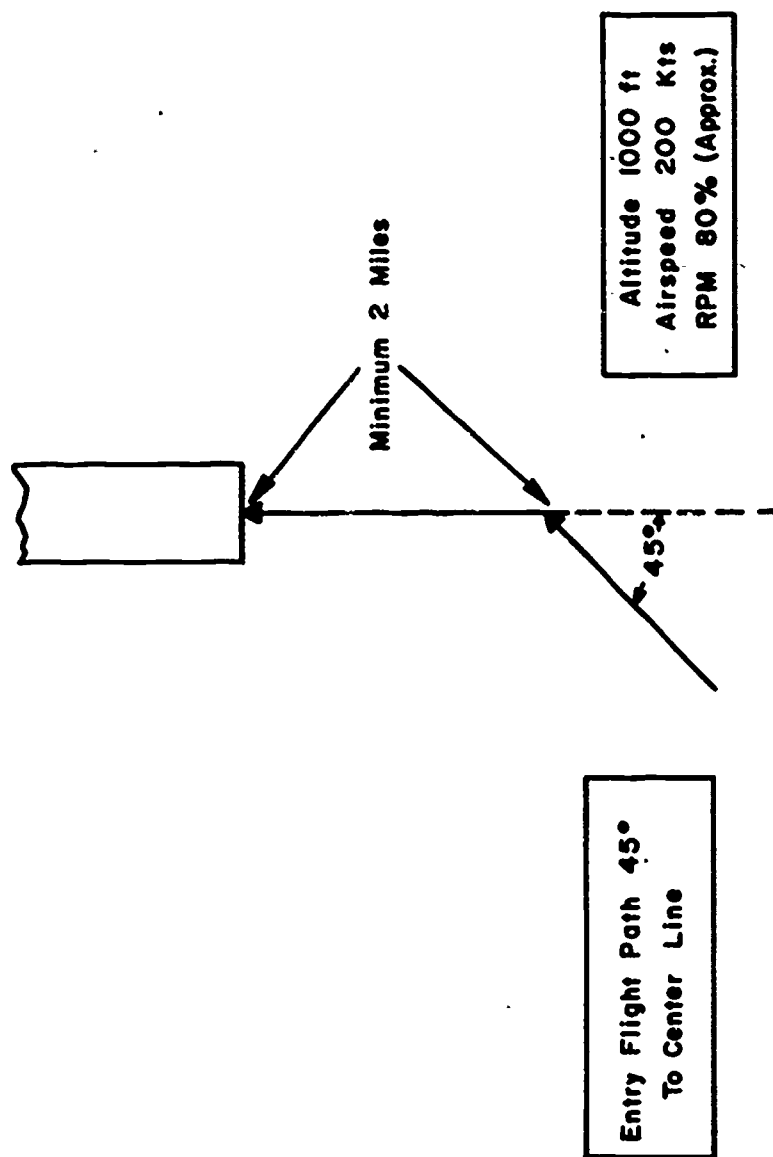

Figure B. Entry and Approach Phases of 360° Overhead Pattern

AFHRL-TR-72-6

b. Phase II, Initial Overhead to Pitchout Phase of Normal Landing (See Figure C)

The student maintains an altitude of 1000 feet; 200 knots; RPM 80%, to a point at least 3000 feet beyond the approach end of the runway, and not beyond the halfway mark of the runway. Somewhere within this region the student executes his pitchout. At pitchout, he banks the aircraft (not over 60°) and retards his throttle setting to one of 50-60% RPM while maintaining pattern altitude (1000 feet).

c. Phases III and IV, Pitchout, First and Second Quarter Turns to Downwind of Normal Overhead Pattern (See Figures D and E)

The pitchout initiates a continuous 180° turn by the student, with consideration given to wind conditions. When properly executed, rollout will be accomplished at a point even with the pitchout initialization point and on a parallel path to the active runway. This part of the flight path is called the downwind leg. Throughout this turn, an altitude of 1000 feet is maintained. Additional back pressure (hence trim) is needed to maintain the altitude because of the decrease in the power setting at pitchout (50-60%).

d. Phase V, Downwind Leg of Normal Overhead Pattern (Figure F)

As rollout on the downwind leg is accomplished, the student lowers the speedbrakes to reduce the airspeed to 150 knots or lower. As the aircraft passes below 150 knots, gear is dropped and airspeed continues to drop off. Throughout these operations, an altitude of 1000 feet is maintained and increased power setting may be necessary to hold airspeed and altitude. An altitude of 1000 feet is maintained throughout the landing pattern through the point of flap lowering. At no time on the downwind is the airspeed permitted to drop below 120 knots. (Increased power setting may be necessary as drag increases to maintain airspeed and altitude.)

AFHRL-TR-72-6

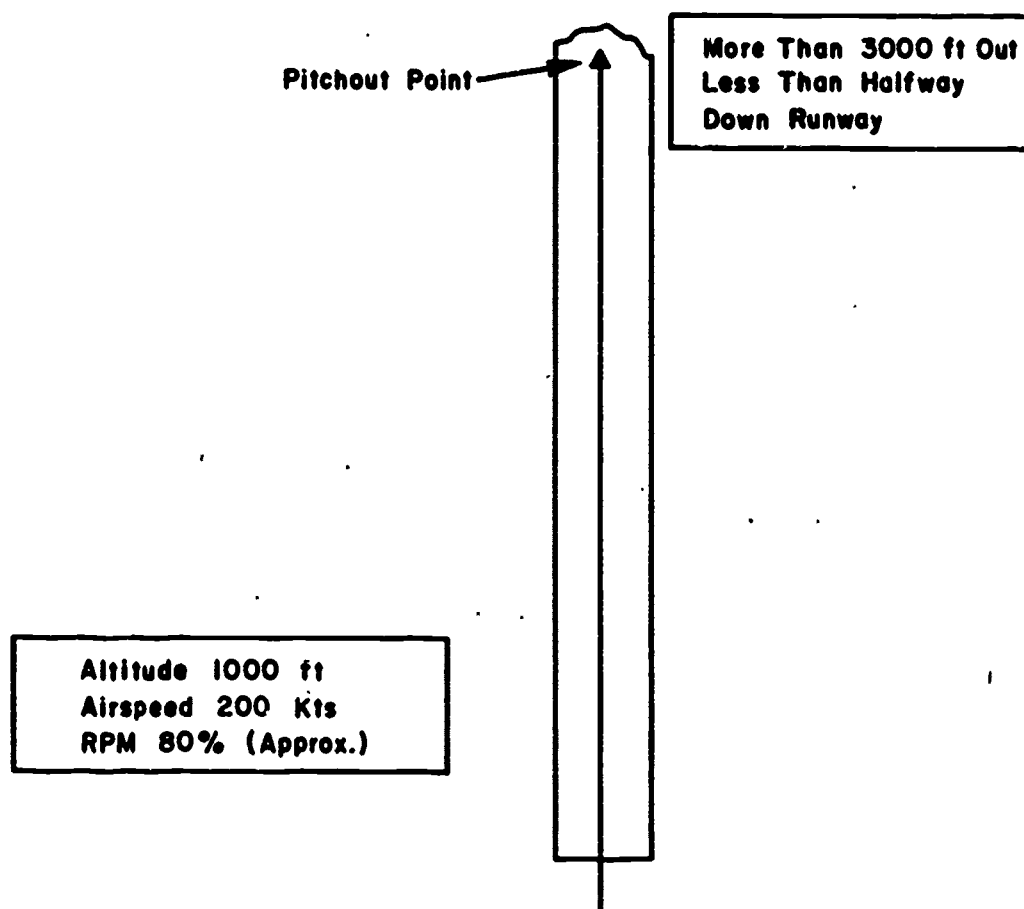

Figure C. Initial Overhead to Pitchout Phase of 360° Overhead Pattern

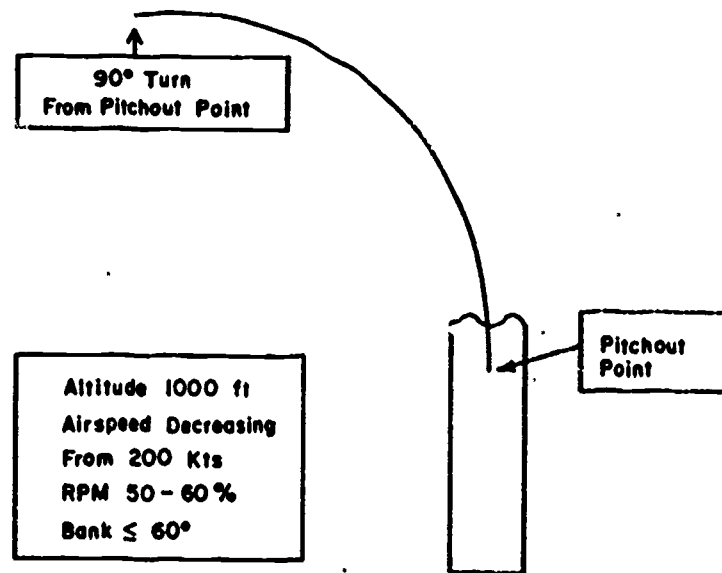

Figure D. Pitchout and 1st Quarter Turn Phase of 360° Overhead Pattern

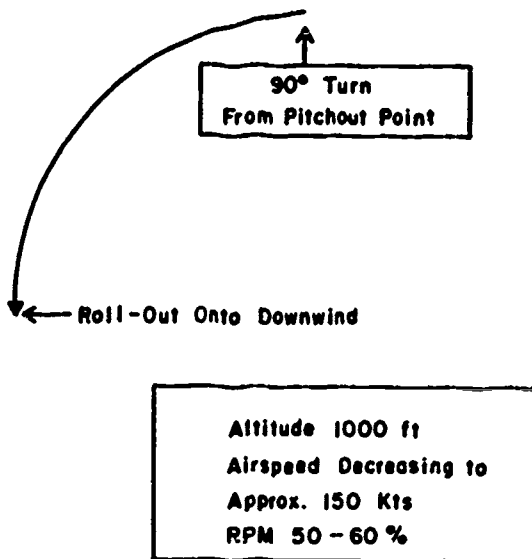

Figure E. 2nd Quarter Turn to Downwind Phase of 360° Overhead Pattern

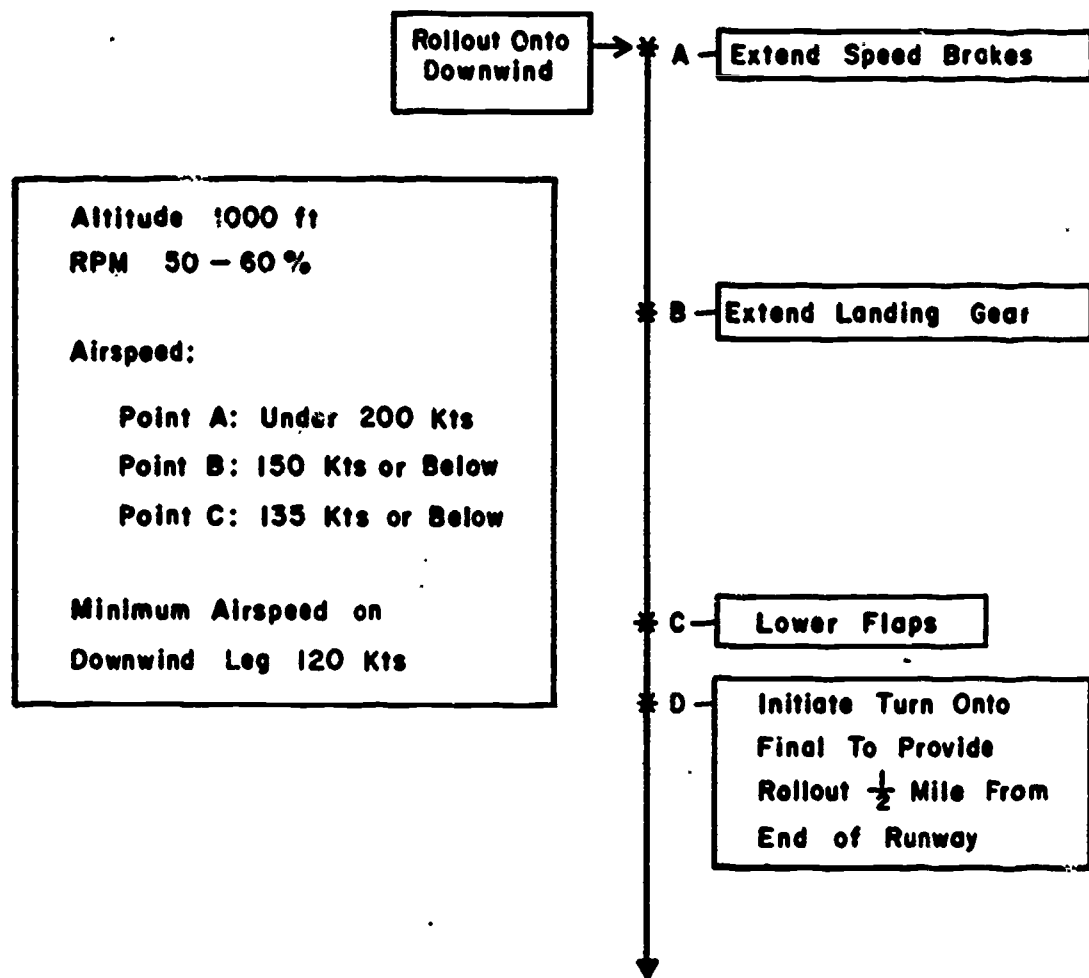

Figure F. Downwind Phase of 360° Overhead Pattern

- e. Phases VI and VIII, First and Second Quarter Turn to Final Phase of Normal Overhead Pattern (Figures G and H)

A descending turn is initiated with a decrease in airspeed to 110 knots. The student takes into consideration the wind and distance from the runway so that rollout will be made at a predetermined position at least one-half mile from the end of the runway with an altitude of at least 300 feet. At no time is the bank to be over 45° or the airspeed to be less than 110 knots.

- f. Phase VIII, Final Approach Phase of Normal Overhead Traffic Pattern (Figure I)

The student will rollout on the final approach at least one half mile from the approach end of the runway at an altitude of no less than 300 feet. The rollout should be at such a heading as to result in a ground path in line with the runway. Airspeed is lowered to 100 knots during the final approach and letdown.

3. NARRATIVE DESCRIPTION OF THE 360° STANDARD OVERHEAD TRAFFIC PATTERN AS OUTLINED IN ATC MANUAL 51-4*

Entry into the landing pattern is initiated at a 45° angle to the active runway. All turns in the maneuver are in the same direction, depending on whether the pattern is a right or left hand pattern. Initial pattern altitude is 1000 feet and pattern airspeed is 200 knots (approximately 80% RPM).

Initial leg of landing pattern is in line with and over the center line of the active runway.

After a position between 3000 feet from the approach end of the runway and one half of the runway is reached, ditchout is accomplished.

*Throughout the entire flight pattern, the student will be expected to execute coordinated flight maneuvers and evidence a smoothness in the execution of procedures. Proper clearing of area, adjustments for wind, traffic, and understanding of necessary cockpit procedures are assumed within the realm of capability and understanding of the student, as well as the expected procedure for the 360° overhead standard pattern.

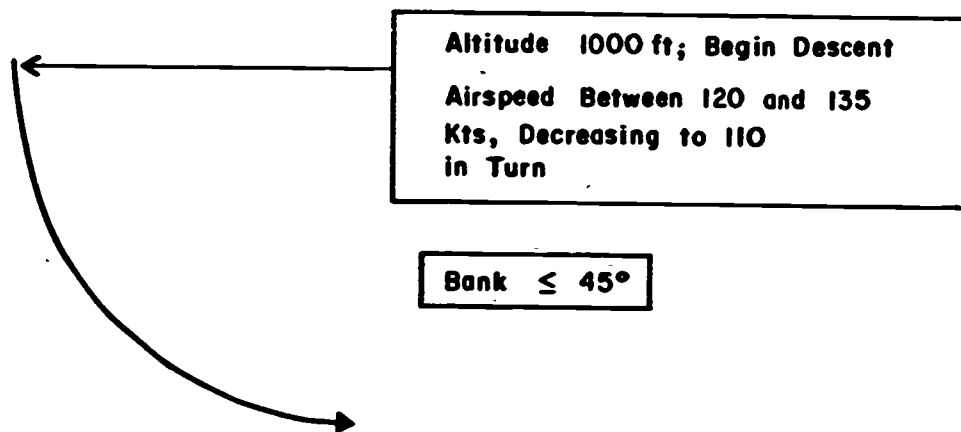

Figure G. 1st Quarter Turn to Final Phase in 360° Overhead Pattern

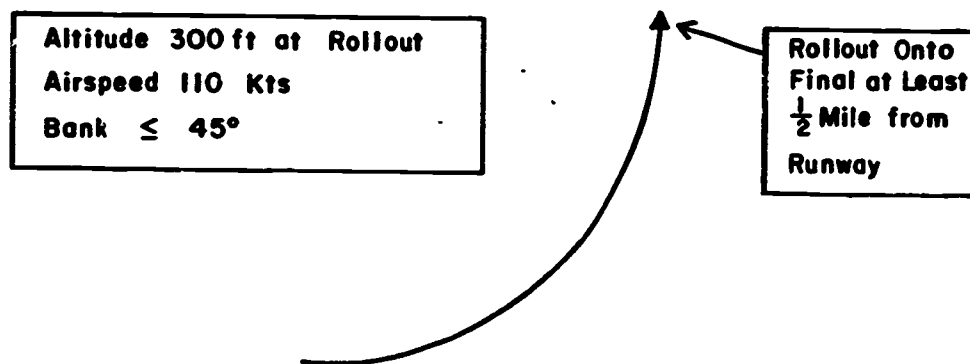

Figure H. 2nd Quarter Turn to Final Phase of 360° Overhead Pattern

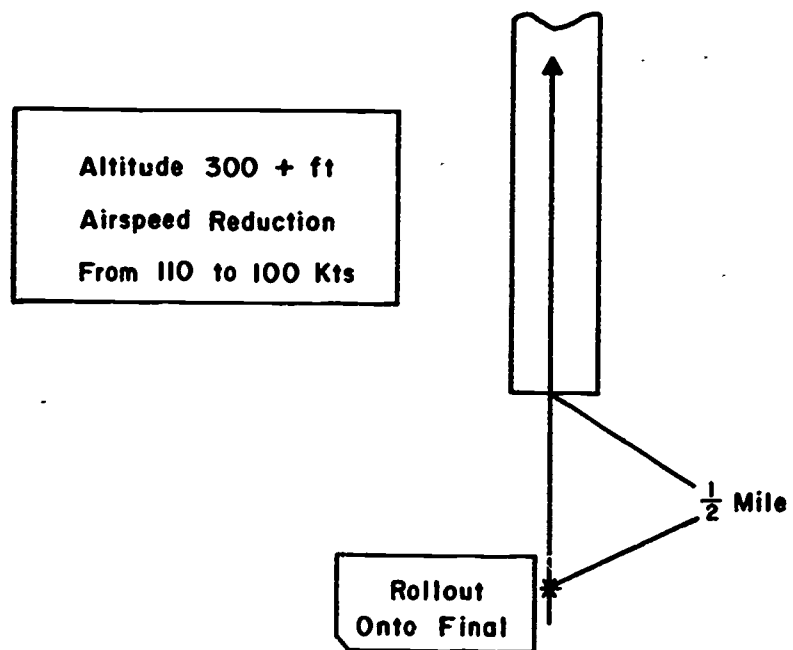

Figure I. Final Approach Phase of 360° Overhead Pattern

AFHRL-TR-72-6

This constitutes a nearly simultaneous bank in pattern direction, and reduction of power to between 50 and 60%. (If one is to precede the other, bank should precede reduction in power.) The bank is not to exceed 60°.

In maintaining pattern altitude of 1000 feet, there is a continuous 180° turn designed to bring the pilot out on the downwind leg position of the pattern. The rollout for downwind should be accomplished approximately in line with the pitchout position to initiate a ground pattern parallel to the active runway. During the turning interval, the pattern altitude of 1000 feet is maintained as airspeed decreases, due to the reduction in power.

After the rollout on downwind is accomplished, speed brakes are applied to bring the airspeed down to 150 knots or below. The aircraft should be approximately one half of the way on the downwind leg. Gear should be dropped at this point, continuing the reduction of airspeed to 135 knots or below (never below 120 knots). Pattern altitude of 1000 feet above the terrain should be maintained at all times. Power necessary to maintain airspeed and altitude should be used.

Wing flaps should be dropped prior to initiating turn that will bring the aircraft out on final approach. THIS SHOULD BE DONE WHILE AIRCRAFT IS STILL IN LEVEL POSITION, AIRSPEED LESS THAN 135 KNOTS, BUT NOT LESS THAN 120 KNOTS, AND ALTITUDE STILL 1000 FEET.

Initiate continuous turn onto final approach; bank is not to exceed 45°. Nose is lowered to begin descent, and airspeed is decreased to 110 knots in the turn. Turn and descent is judged to permit aircraft to rollout on final approach at least one half mile from the end of the runway at an altitude of NOT LESS THAN 300 FEET.

A straight descent is maintained until touchdown. Airspeed is decreased to 100 knots for final approach.

4. Skills Required

Mastery of the 360° Standard Overhead Traffic Pattern is mandatory prior to a student's ability to fly an aircraft solo. The skills involved in this maneuver will have been presented to the student as individual skill techniques prior to accomplishment of the landing pattern. Measurement of the basic skills are of prime importance in ascertaining proficiency. The skills in mention, and the areas of the maneuver in which they are employed, are defined as follows:

Directional Control. The skill of being able to determine and maintain a heading, determine and maintain proper ground track depending on wind conditions, rollout on a predetermined heading from varying degrees of bank from level, and ascending or descending flight.

Altitude Control. The skill of being able to maintain altitude, level off at a predetermined altitude either from a climb or descent; maintain altitude with varying airspeed or with varying degrees of bank, and in a rollout from a banked turn within varying degrees of bank.

Airspeed Control. The skill of maintaining a desired airspeed, or establishing a desired airspeed, the ability to change an airspeed, then establish the attitude to hold the airspeed as in a descent, or the skill to establish the attitude to attain a predetermined airspeed.

Rolling Into and Maintaining a Desired Bank (Without Varying). The ability to make a coordinated turn without varying airspeed or altitude, and the ability to roll into and out of this turn without over-controlling. Also, the ability to rollout onto at a predetermined heading.
The skill-composites and knowledges that need to be considered for measurement are:

Straight and Level Flight. The ability to maintain the aircraft in straight and level flight involving the maintenance of heading and altitude.

AFHRL-TR-72-6

Level Turns. The ability to make a coordinated turn without losing altitude or over-controlling to maintain proper bank.

Descending Turns. The ability to maintain the proper airspeed, bank, and rate of descent without excess banking.

Maintenance of Altitude at Varying Airspeed or Power Setting. The ability to maintain a given altitude while varying the power setting. In the traffic pattern maneuver, this involves reducing the airspeed while holding altitude.

Straight Descent. The ability to maintain directional control of the aircraft while losing altitude at a given airspeed and a constant glide angle.

Varying Degrees of Bank. The ability to coordinate a roll into the desired bank and maintain this bank without loss of altitude, unless so desired. Also, the ability to determine and hold a prescribed degree of bank.

Ability to Judge Rate of Turn. The ability to predetermine the position to initiate a given rate of bank, or alter a rate of bank within limits in such a manner that the rollout places the aircraft on the desired ground path.

Ability to Rollout Onto a Desired Heading. The ability to place the aircraft on the desired heading after completion of a turn.

Ability to Determine Wind Drift and Angle. Basic knowledge of wind and wind drift angles that permits rolling out to a predetermined heading that will effect the desired ground path.

Knowledge of Procedures. Basic knowledge of aircraft procedures for landing and for the landing pattern that will produce desired changes in airspeed, altitude, direction, etc., at the prescribed position

AFHRL-TR-72-6

in the landing pattern are essential to accomplish the landing pattern as prescribed.

The student is expected to execute coordinated flight maneuvers and demonstrate a smoothness in the execution of procedures throughout the entire flight pattern.

5. PRELIMINARY PERFORMANCE MEASURES FOR THE
NORMAL OVERHEAD 360° TRAFFIC PATTERN

Patterns will present different profiles because of the different procedural requirements due to such variations as single engine landings, touch and go landings, right or left hand patterns, and patterns executed with varying degrees of flaps. In general, measures should address at least the following parameters:

Altitude. Measurement of how well the pilot's altitude compares with ATC criteria throughout the maneuver. Measures ability to maintain altitude through different power settings, while accomplishing cockpit procedures.

Airspeed. Measurement of how well the pilot remains within the ATC limits as he follows the normal procedure for the landing pattern.

Degree of Bank. Measures the pilot's ability to accomplish a 180° turn without exceeding a given maximum bank, and his ability to judge the necessary angle of bank needed to complete the turn within a certain area, rolling out at a prescribed position on a definite heading.

Vertical Velocity. Measures the ability of the pilot to transition from level flight attitude to a descending attitude and to anticipate the required rate of descent.

Attitude. Determines the pilot's ability to hold altitude by changing the attitude at different power settings.

AFHRL-TR-72-6

RPM. Measures how well the pilot conforms to ATC standards and procedures throughout this maneuver for either normal or single engine performance.

AFHRL-TR-72-6

APPENDIX VI
EXECUTIVE PROGRAM FOR LAZY 8

This program reads the calibrated data, performs basic computations (estimated ground speed, altitude-change, and degrees of turn), prints data at a sampling rate of 2/second, calls the measurement subroutine, and generates plotting data.

AFHRL-TR-72-6

KNR0P
LAZY8 - EFN SOURCE STATEMENT - IFN(S) -

```
CPRINT MEASURE VARIABLES FOR LAZY 8 MANEUVER
DIMENSION AR(10,83)
DIMENSION A(120,9),B(12,25),EVNO(25)
DIMENSION XCNT(25)
DIMENSION ZX(120),ZY(120),DATA(438)
COMMON AR,L
CALL PLOTS(DATA,438)
CALL PLOT(0.0,0.8,-3)
ICOUNT=.
IEV=1
READ (5,500) N
READ (5,501) (EVNO(I),I=1,N)
601 READ (5,501) (XCNT(I),I=1,N)
ITEST=-10
1 READ(16) ((A(I,J),I=1,120),J=1,9)
READ(16) ((B(I,J),I=1,12),J=1,25)
DO 20 I=1,12
X=AMOD(B(I,18),100.0)
IF(=VNO(IEV)-X) 2,3,2
3 IF(ITEST) 4,5,5
4 WRITE (6,300) EVNO(IEV)
L=0
TIME=0.0
ITEST=0
5 IA=10*(I-1)+1
L=L+1
AR(1,L)=A(IA,2)
AR(2,L)=A(IA,1)
AR(3,L)=B(I,7)
AR(4,L)=B(I,6)
AR(5,L)=A(IA,6)
AR(6,L)=B(I,15)
AR(7,L)=B(I,16)
AR(8,L)=A(IA,3)
AR(9,L)=A(IA,4)
AR(10,L)=B(I,9)
ANL=3.14159265*AR(2,L)/180.0
SXLK=SIN(ANL)
CXLK=COS(ANL)
ALTX=SXLK*AR(5,L)*6080.0/3600.0
GS=CXLK*AR(5,L)
TURN=ABS(AR(3,L)-AR(3,1))
IF(ICOUNT-4) 201,200,201
200 WRITE (6,301) TIME,A(IA,2),A(IA,1),B(I,7),B(I,6),A(IA,6),B(I,15),
1B(I,16),A(IA,3),A(IA,4),TURN,GS,ALTX
TIME=TIME+0.5
ICOUNT=0
GO TO 600
201 ICOUNT=ICOUNT+1
GO TO 600
2 IF(ITEST) 20,7,7
7 CONTINUE
CALL ELAZY8
READ(5,500)IVPLOT
IF(IVPLOT)700,82,82
```

AFHRL-TR-72-6

KNLOP
LAZYV2 - EFN SOURCE STATEMENT - IFN(S) -

10/13/69

CSTART PLOT ROUTINE

```
82 KK=C
DO 90 IK=1,L,10
KK=KK+1
ZX(KK)=AR(1,IK)
90 ZY(KK)=AR(2,IK)
CALL SYMBOL(-0.6,-1.1,C.1,25HROLL VS. PITCH FOR LAZY 8,0,25)
CALL SCALE(ZX,10.0,KK,1,10.0)
CALL SCALE(ZY,9.0,KK,1,10.0)
CALL LINE(ZX,ZY,KK,1,1,11)
CALL AXIS(0.0,0.0,14HROLL (DEGREES),-14,10.0,0.0,ZX(KK+1),ZX(KK+2)
1,10.0)
CALL AXIS(0.0,0.0,15HPITCH (DEGREES),15,9.0,90.0,ZY(KK+1),ZY(KK+2)
1,10.0)
ZX(1)=0.
ZX(2)=40.
ZX(3)=80.
ZX(4)=40.
ZX(5)=0.
AMX=0.0
DO 91 LA=1,KK
V=ABS(ZY(LA))
IF(V-AMX)91,91,92
92 AMX=V
91 CONTINUE
ZY(1)=0.
ZY(2)=AMX
ZY(3)=0.
ZY(4)=-AMX
ZY(5)=0.
DO 93 LA=6,10
LB=LA-5
ZX(LA)=-ZX(LB)
93 ZY(LA)=ZY(LB)
ZX(11)=ZX(KK+1)
ZX(12)=ZX(KK+2)
ZY(11)=ZY(KK+1)
ZY(12)=ZY(KK+2)
CALL LINE(ZX,ZY,10,1,0,0)
CALL PLOT(12,C,0.0,-3)
KK=C
DO 94 IK=1,L,10
KK=KK+1
ZX(KK)=KK
94 ZY(KK)=R(1,IK)
CALL SYMBOL(-0.6,-1.1,C.1,34HROLL AND PITCH VS. TIME FOR LAZY 8,0,
134)
CALL SCALE(ZX,10.0,KK,1,10.0)
CALL SCALE(ZY,9.0,KK,1,10.0)
CALL LINE(ZX,ZY,KK,1,1,11)
CALL AXIS(0.0,0.0,14HTIME (SECONDS),-14,10.0,0.0,ZX(KK+1),ZX(KK+2)
1,10.0)
CALL AXIS(0.0,0.0,7HDEGREES,7,9.0,90.0,ZY(KK+1),ZY(KK+2),10.0)
KK=C
DO 95 IK=1,L,10
KK=KK+1
```

AFHRL-TR-72-6

KRPOP
L4ZYYB - EFM SOURCE STATEMENT - IFN(S) -

10/13/69

```
95 ZY(KK)=AR(2,IK)
CALL LINE(ZX,ZY,KK,1,1,1)
CALL SYMBOL(8.0,8.9,0.1,4ROLL,0,4)
CALL SYMBOL(8.7,8.8,0.1,11,0,-1)
CALL SYMBOL(8.0,8.5,0.1,5HPITCH,0,5)
CALL SYMBOL(8.7,8.5,0.1,1,0,-1)
KK=L
DO 96 IK=1,L,10
KK=KK+1
96 ZY(KK)=AR(4,IK)
CALL PLOT(12.0,0.0,-3)
CALL SYMBOL(-0.6,-1.1,0.1,25ALTITUDE VS. TIME FOR LAZY 8,0,28)
CALL SCALE(ZY,9.0,KK,1,10.0)
CALL LINE(ZX,ZY,KK,1,1,1)
CALL AXIS(0.0,0.0,14HTIME (SECONDS),-14,10.0,0.0,ZX(KK+1),ZX(KK+2)
1,10.0)
CALL AXIS(0.0,0.0,15ALTITUDE (FEET),15,9.0,90.0,ZY(KK+1),ZY(KK+2)
1,10.0)
KK=L
DO 97 IK=1,L,10
KK=KK+1
97 ZY(KK)=AR(5,IK)
CALL PLOT(12.0,0.0,-3)
CALL SYMBOL(-0.6,-1.1,0.1,25HAIRSPEED VS. TIME FOR LAZY 8,0,28)
CALL SCALE(ZY,9.0,KK,1,10.0)
CALL LINE(ZX,ZY,KK,1,1,1)
CALL AXIS(0.0,0.0,14HTIME (SECONDS),-14,10.0,0.0,ZX(KK+1),ZX(KK+2)
1,10.0)
CALL AXIS(0.0,0.0,16HAIRSPEED (KNOTS),16,9.0,90.0,ZY(KK+1),ZY(KK+2)
1,10.0)
KK=L
DO 98 IK=1,L,10
KK=KK+1
98 ZY(KK)=AR(3,IK)
CALL PLOT(12.0,0.0,-3)
CALL SYMBOL(-0.6,-1.1,0.1,27HEADING VS. TIME FOR LAZY 8,0,27)
CALL SCALE(ZY,9.0,KK,1,10.0)
CALL LINE(ZX,ZY,KK,1,1,1)
CALL AXIS(0.0,0.0,14HTIME (SECONDS),-14,10.0,0.0,ZX(KK+1),ZX(KK+2)
1,10.0)
CALL AXIS(0.0,0.0,17HEADING (DEGREES),17,9.0,90.0,ZY(KK+1),ZY(KK+2)
12,10.0)
CALL PLOT(12.0,0.0,-3)
ZX(1)=0.0
ZY(1)=0.0
KK=1
DO 99 IK=1,L,10
KK=KK+1
ANGLE=3.14159265*AR(3,IK)/180.
SXX=SIN(ANGLE)
CXX=COS(ANGLE)
ANGB=3.14159265*AR(2,IK)/180.
GS=AR(5,IK)*COS(ANGB)
ZX(KK)=ZX(KK-1)+GS*SXX
80 ZY(KK)=ZY(KK-1)+GS*CXX
CALL SYMBOL(-0.6,-1.1,0.1,23GROUND TRACK FOR LAZY 8,0,23)
```

KNDDP

LAZYB - EFN SOURCE STATEMENT - IFN(S) -

10/13/69

```

CALL SCALE(ZX,9.0,KK,1,10.0)
CALL SCALE(ZY,9.0,KK,1,10.0)
CALL LINE(ZX,ZY,KK,1,1,14)
CALL SYMBOL(4.5,9.2,0.1,1HV,0,1)
CALL SYMBOL(9.2,4.5,0.1,1HE,0,1)
CALL SYMBOL(4.5,-0.2,0.1,1HS,0,1)
CALL SYMBOL(-0.2,4.5,0.1,1HW,0,1)
CALL PLOT(12.0,0.0,-3)
KK=0
DO 81 KK=1,1,10
KK=KK+1
ZX(KK)=AR(9,IK)
81 ZY(KK)=-AR(9,IK)
CALL SYMBOL(-0.6,-1.1,0.1,30HSTICK POSITION PLOT FOR LAZY B,0,30)
CALL SCALE(ZX,10.0,KK,1,10.0)
CALL SCALE(ZY,9.0,KK,1,10.0)
CALL LINE(ZX,ZY,KK,1,0,0)
CALL AXIS(0.0,0.0,19HLAT. POS. (DEGREES),-19,10.0,0.0,ZX(KK+1),ZX(
1KK+2),10.0)
CALL AXIS(0.0,0.0,20HLONG. POS. (DEGREES),20,9.0,90.0,ZY(KK+1),ZY(
1KK+2),10.0)
CALL SYMBOL(ZX(1),ZY(1),0.1,14,0,-1)
CALL PLOT(12.0,0.0,-3)
700 CONTINUE
IF(IEV=4)9,9,6
9 IEV=IEV+1
ITEST=-10
600 XXX=XCNT(IEV)
ALL=L
IF(ALL-XXX)20,7,7
20 CONTINUE
GO TO 1
8 CONTINUE
500 FORMAT(15)
501 FORMAT(12F5.0)
300 FORMAT(11H1,16HLAZY B NUMBER F5.0/1H /1H /56X,4HLEFT,3X,5HRIGHT,
14X,5HLONG.,6X,4HLAT.,2X/5H TIME,4X,4HROLL,3X,5HPITCH,2X,
27HHEADING,5X,6HALTITUDE,2X,8HAI'RSPE.D,3X,3HRPM,4X,3HRPM,4X,
33HST. POS.,3X,8HST. POS.,3X,4HTURN,3X,2HGS,5X,4HALTX/1H /)
301 FORMAT(F6.1,2X,F5.0,3X,F5.0,4X,F5.0,6X,F7.0,5X,F5.0,2X,F5.0,2X,
1F5.0,6X,F5.1,6X,F5.1,2X,F5.0,1X,F5.0,1X,F5.0)
CALL PLOT:
STOP
END

```

AFHRL-TR-72-6

APPENDIX VII
MAJOR FUNCTIONS OF
BARREL ROLL MEASUREMENT
SUBROUTINE

AFHRL-TR-72-6

Program

Subroutine Proper

Major Functions

1. Computes maximum and minimum points of selected arrays
2. Computes raw measures
3. Computes scaled combined measures
4. Computes "scores"
5. Calls subroutine "read" and "back" and function "amod"

Subroutine "read"

1. Reads one record of calibrated data (1.2 seconds)
2. Places variables in common

Subroutine "back"

1. Backs-up magnetic tape to the first record whose event number is specified in the calling vector.

Function "amod"

1. Computes roll angle modulo 360 to correct for instrumentation idiosyncrasy in 0 to 90° region.

AFHRL-TR-72-6

APPENDIX VIII
ILLUSTRATION OF OUTPUT FROM
EXPERIMENTAL MEASUREMENT PROGRAMS

DATA PRINT-OUT FOR FLIGHT OF 11-20-69

LAZY 8 NUMBER 47													
Time	Roll	Pitch	Heading	Altitude	Airspeed	Left RPM	Right RPM	Long. St. Pos.	Lat. St. Pos.	Turn	Gs	Alt x	Acel
0	-0.	5.	360.	9586.	200.	87.	88.	1.0	0.2	0.	199.	32.	1.03
0.5	-0.	7.	360.	9650.	200.	87.	88.	1.1	0.1	0.	198.	40.	1.06
1.0	-1.	8.	360.	9715.	200.	87.	88.	1.2	0.1	0.	198.	46.	1.22
1.5	-1.	10.	360.	9715.	200.	87.	87.	1.3	0.1	0.	197.	56.	1.22
.
.
.

MANEUVER NUMBER 47. FLIGHT OF 11-20-69

PERFORMANCE ANALYSIS FOR LAZY-8 MANEUVER

I. INDIVIDUAL MEASURES

S	HALF-1	HALF-2	S	HALF-1	HALF-2	S	HALF-1	HALF-2
1	655.81	248.54	7	10.70	-1.00	13	521.62	521.62
2	521.33	144.52	8	0.20	59.78	14	476.04	476.04
3	1.28	3.15	9	5.64	17.68	15	510.92	510.92
4	728.67	377.83	10	19.63	13.69	16	18.29	18.29
5	0.	353.66	11	17.24	3.86	17	0.	0.
6	84.14	81.74	12	380.16	380.16	18	0.	0.
						19	42.19	46.13

SCALED COMBINED MEASURES

WEIGHTED

MEASURE	HALF-1	HALF-2	HALF-1	HALF-2
BANK	81.50	94.32	45.51	41.66
PITCH	81.77	90.53	45.66	39.98
R/C	98.88	97.34		
R/C	37.94	105.80		
AIRSPEED	78.72	74.91	78.73	79.08
ALTITUDE	61.73	61.73		
ALTITUDE	64.00	64.00		
G-FORCE	100.00	100.00		
RPM	77.64	75.55		

II. OVERALL SCORES

SCORE HALF-1 = 73.64

SCORE HALF-2 = 81.41

MANEUVER TIME = 72.00 SECONDS

MAX PITCH 1 = 38. MAX PITCH 2 = 45. MAX ALT = 12148. AT 72. DEG OF TURN

MIN PITCH 1 = -28. MIN PITCH 2 = -25.

ANALYZED 402. SAMPLES 1st HALF AND 318. SAMPLES 2ND HALF.

NO. RR REVERSALS = 12 NC. PR REVERSALS = 28

1.256	0.925	0.006	1.537	353.662	165.884
33.320	21.095	380.158	521.623	476.037	510.923
0.123					
9.700	0.083	23.325			
18.294	0.	0.			

AFHRL-TR-72-6

MANEUVER NUMBER 19. FLIGHT OF 12-17-69

PERFORMANCE ANALYSIS FOR BARREL ROLL MANEUVER

I. INDIVIDUAL MEASURES

S	MEASURE	S	MEASURE	S	MEASURE
1	16693.30	7	25.82	13	13579.30
2	14042.13	8	16.24	14	2.07
3	3.76	9	0.	15	0.
4	5.30	10	0.	16	0.
5	0.34	11	1139.60	17	0.70
6	46.37	12	434.86	18	20.04

SCALED COMBINED MEASURES

MAIN PARAMETERS	MEASURE
ENTRY AIRSPEED	100.00
ATTITUDE (1)	44.36
ATTITUDE (2)	53.19
ATTITUDE (HDG.)	39.36
ATTITUDE (PITCH),	75.72
ATTITUDE (ALT.)	73.76
ATTITUDE (TOT.),	79.61
RPM	79.28
G-FORCE	99.06
ROLL-RATE	98.66
ATTITUDE (3)	54.74

II. OVERALL SCORE* 71.99

MANEUVER TIME * 25.00 SECONDS

101.42	100.86	-99.64	104.28	100.52
100.52	100.17	98.98	8.89	21.18
-33.72	-47.00	3.76		

AFHRL-TR-72-6

APPENDIX IX
INITIAL PLOTS GENERATED FOR
NINE LAZY 8 PERFORMANCES

12-17-69-21

Low
Excellent

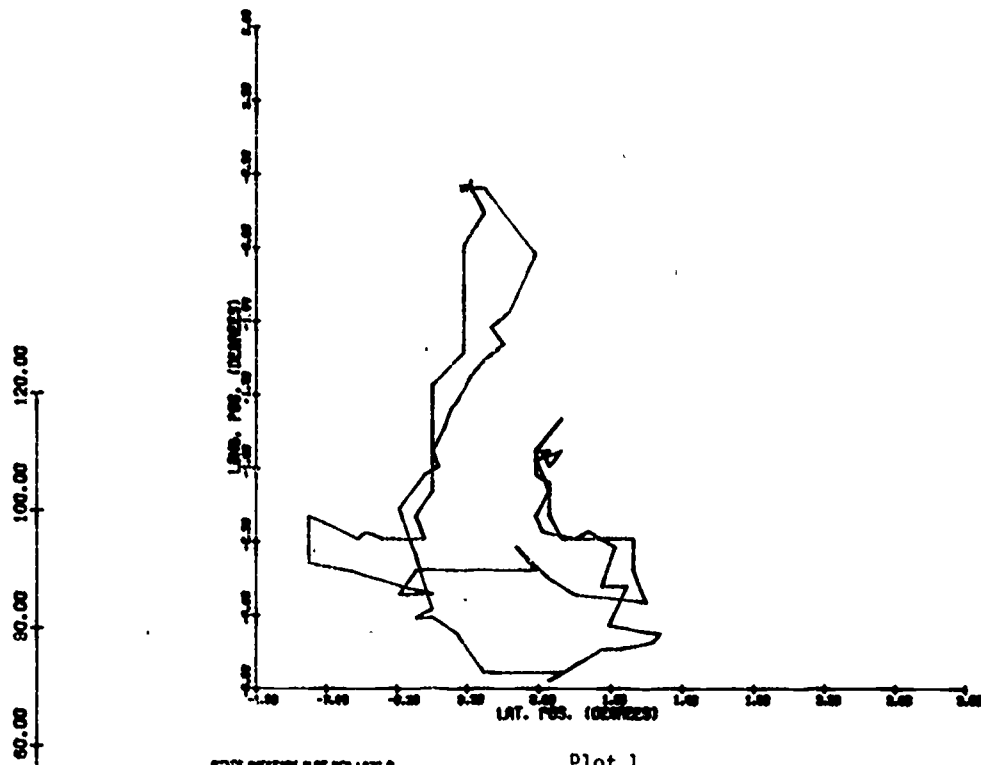

STICK POSITION FOR LAZY 8

Plot 1

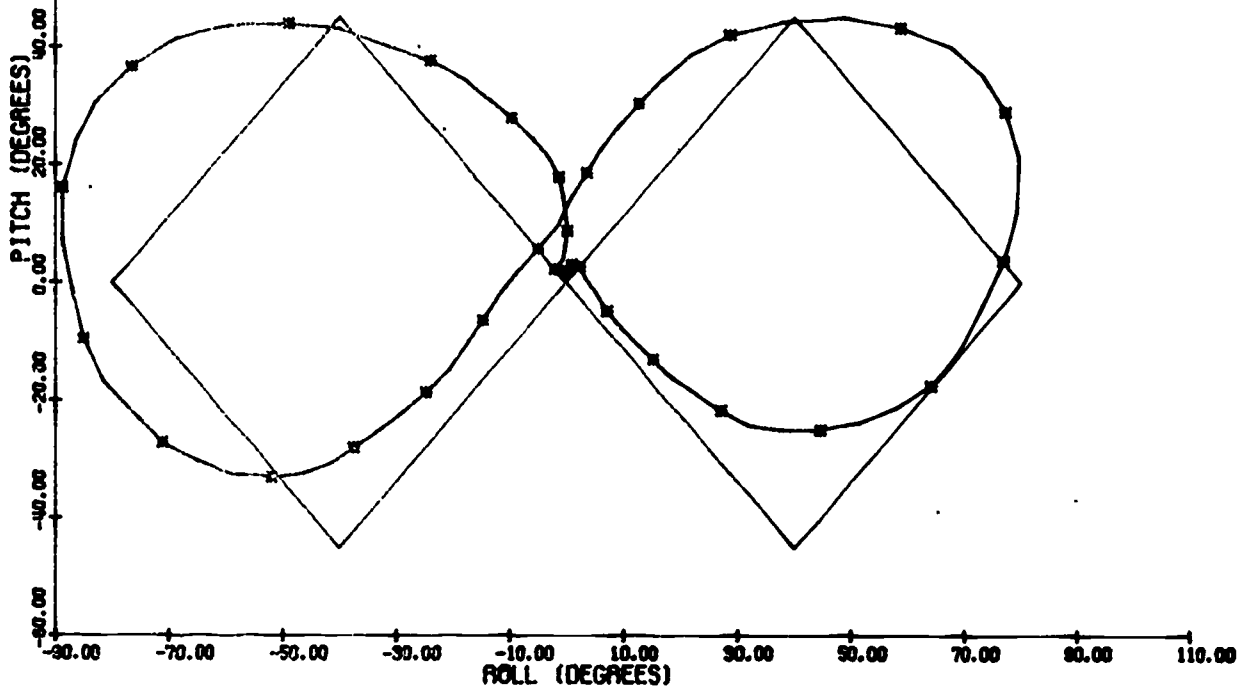

ROLL VS. PITCH FOR LAZY 8

Plot 2

AFHRL-TR-72-6

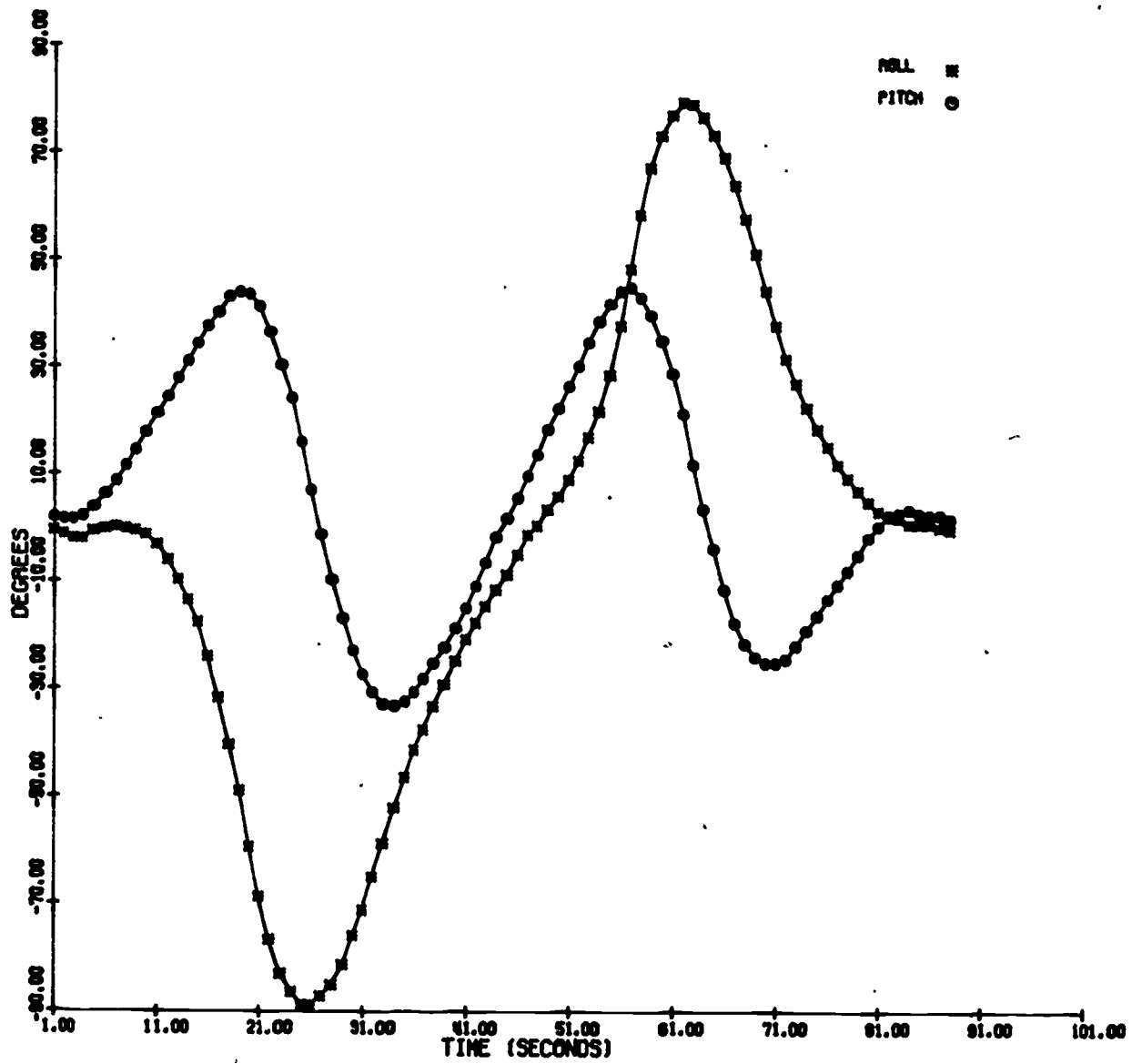

Plot 3

ROLL AND PITCH VS. TIME FOR LARY 8

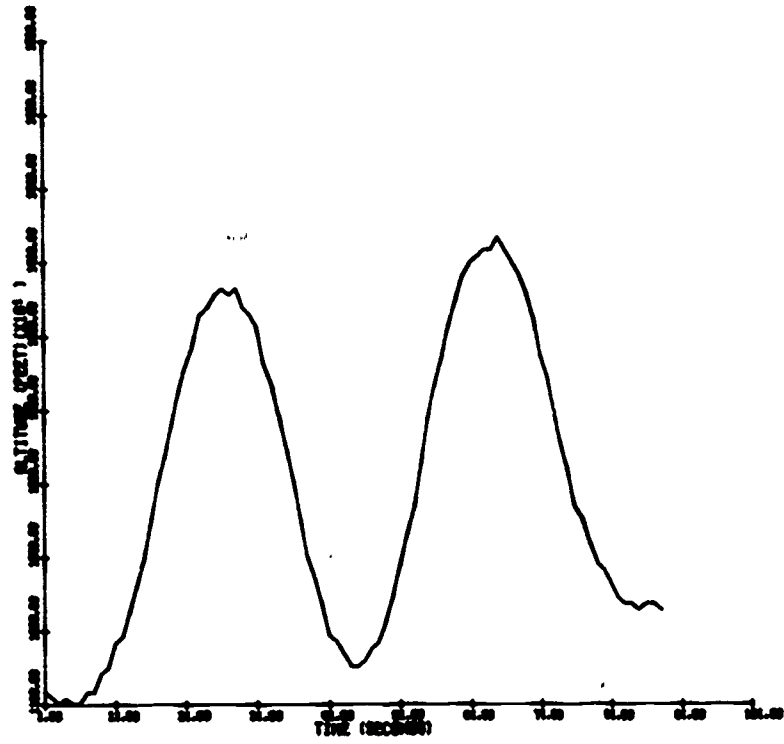

AMPLITUDE vs. TIME FOR LIST 0

Plot 4

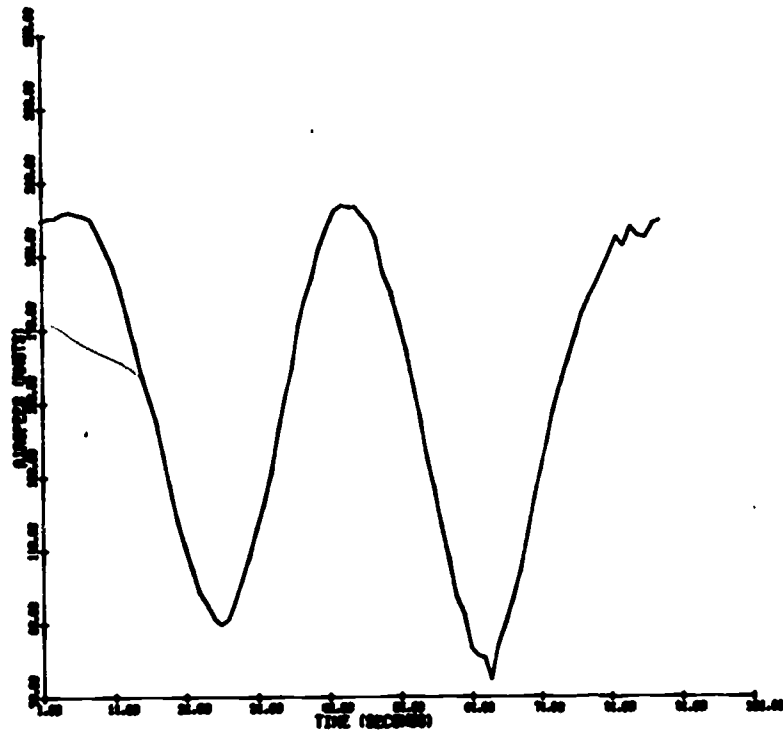

AMPLITUDE vs. TIME FOR LIST 0

Plot 5

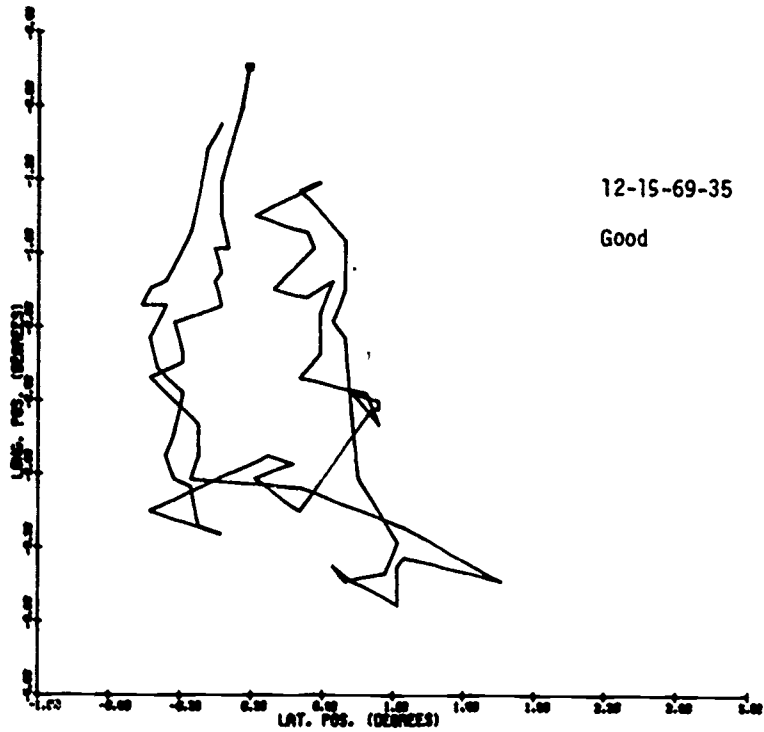

SPYDR POSITION PLOT FOR LAZY 8

Plot 6

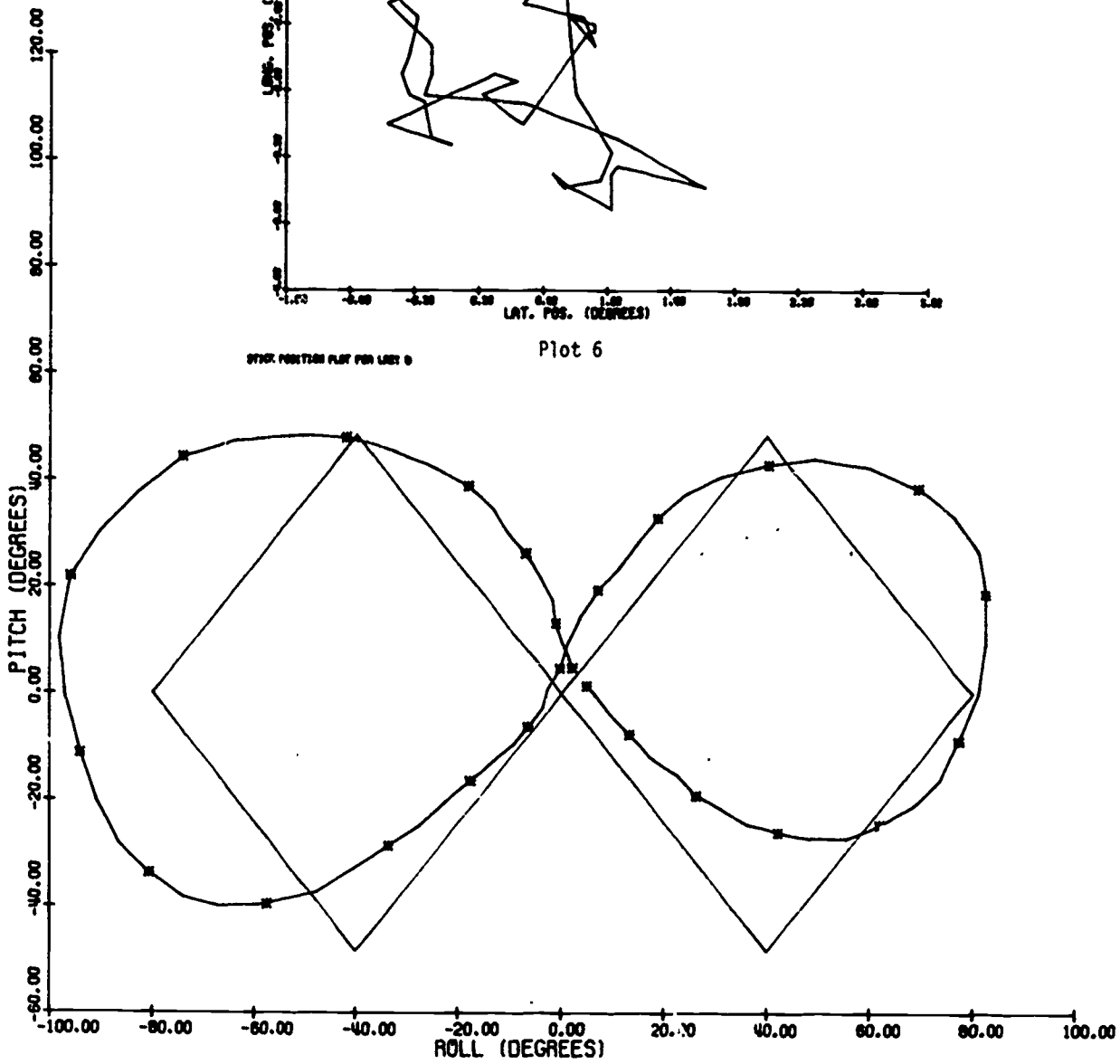

ROLL VS. PITCH FOR LAZY 8

Plot 7

AFHRL-TR-72-6

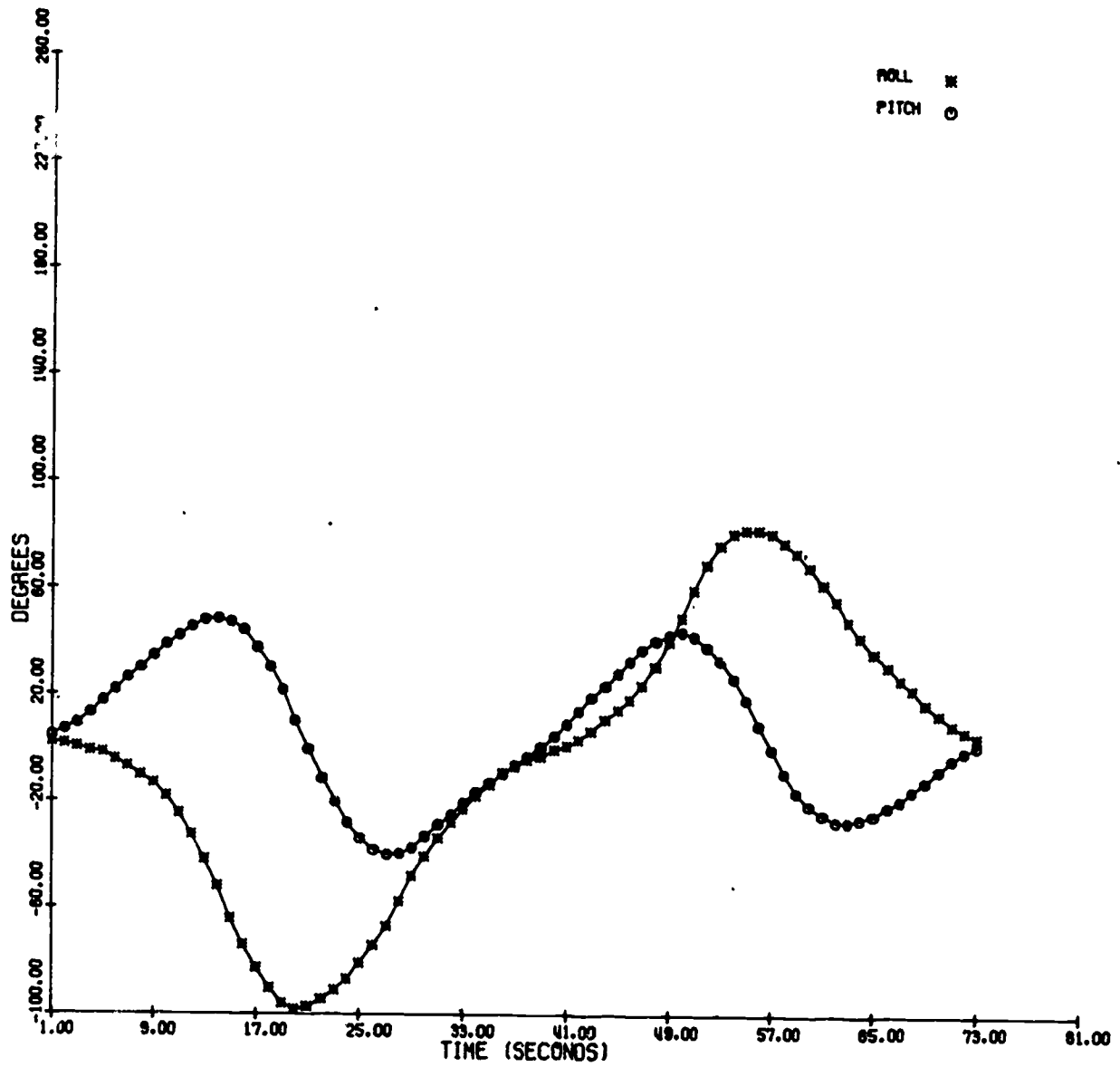

ROLL AND PITCH VS. TIME FOR LAZY 8

Plot 8

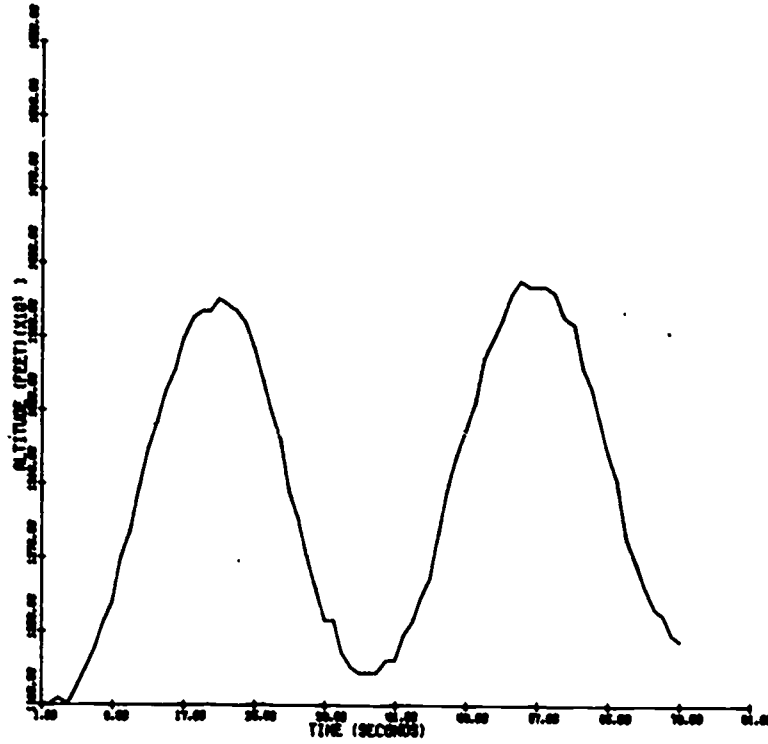

ALTITUDE VS. TIME FOR LIFT 9

Plot 9

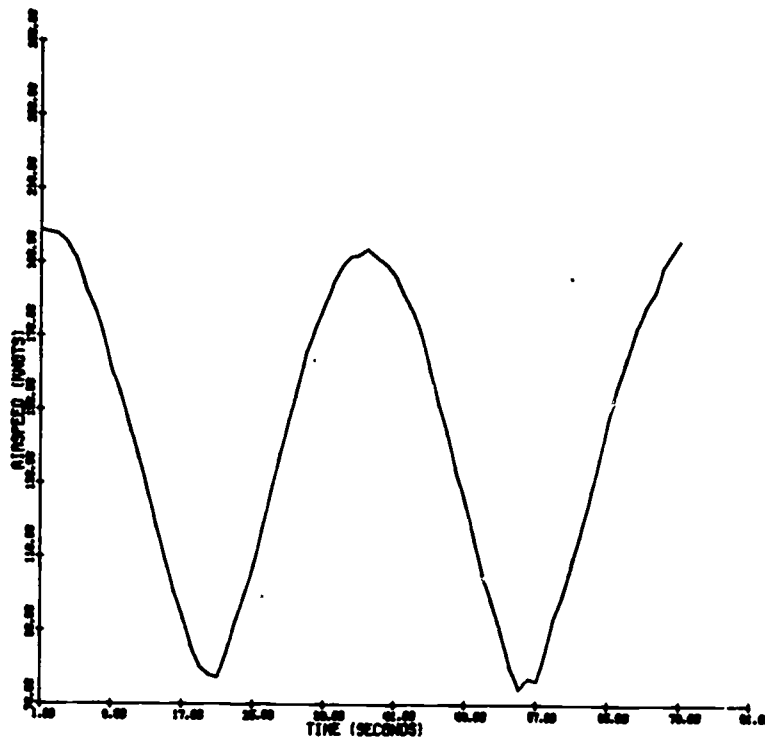

ALTITUDE VS. TIME FOR LIFT 9

Plot 10

AFHRL-TR-72-6

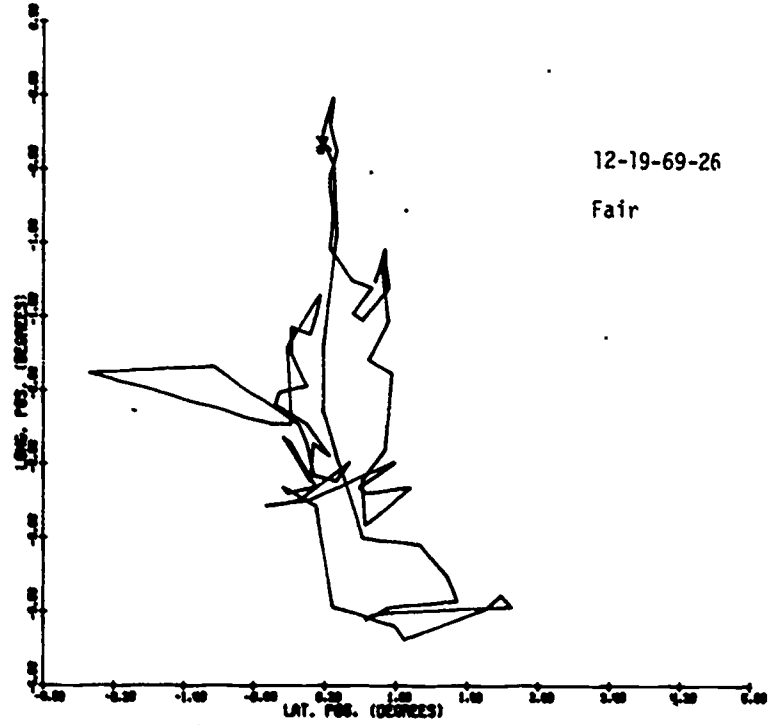

12-19-69-26

Fair

STICK POSITION PLOT FOR LAZY 6

Plot 11

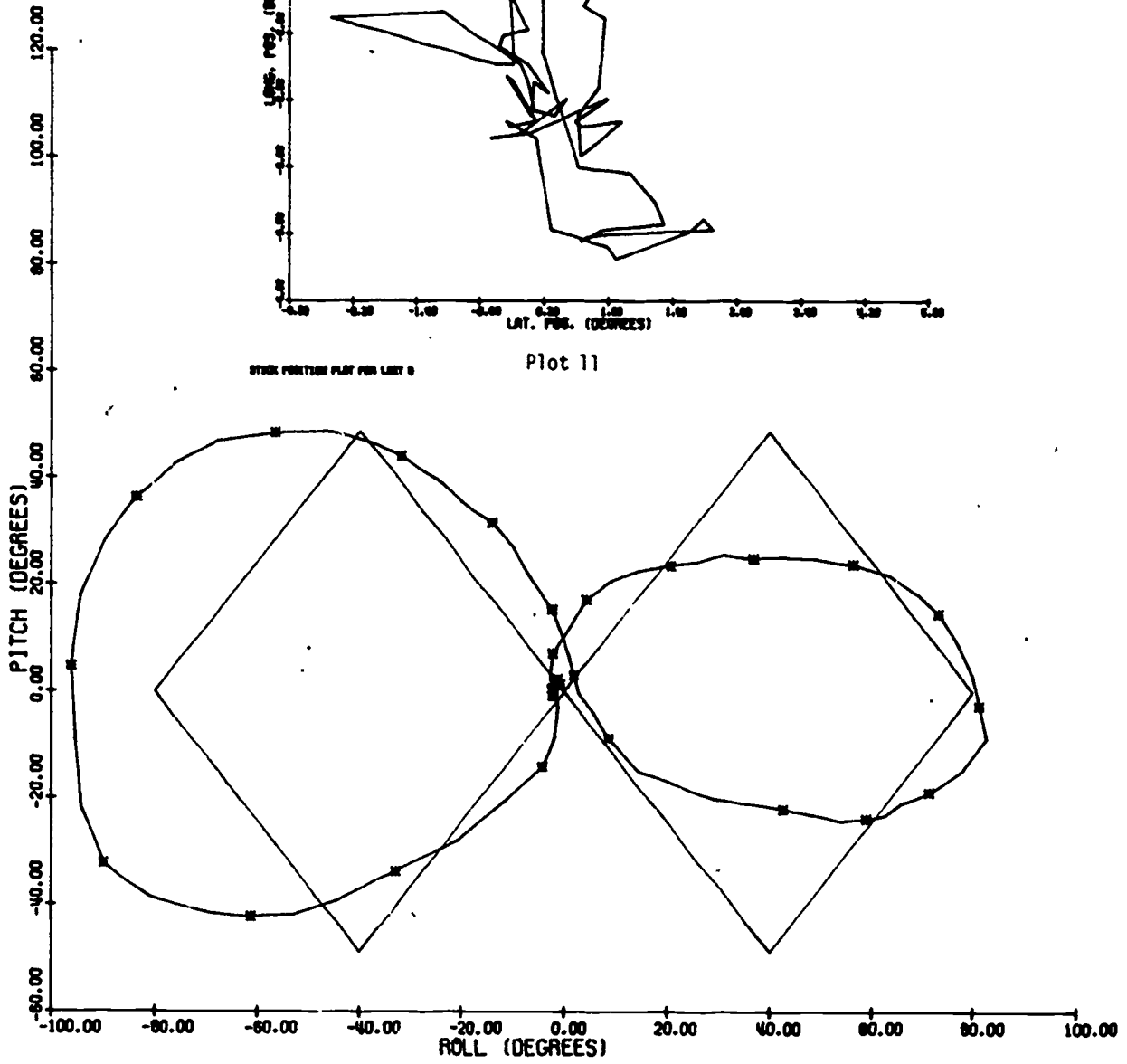

ROLL VS. PITCH FOR LAZY 6

Plot 12

AFHRL-TR-72-6

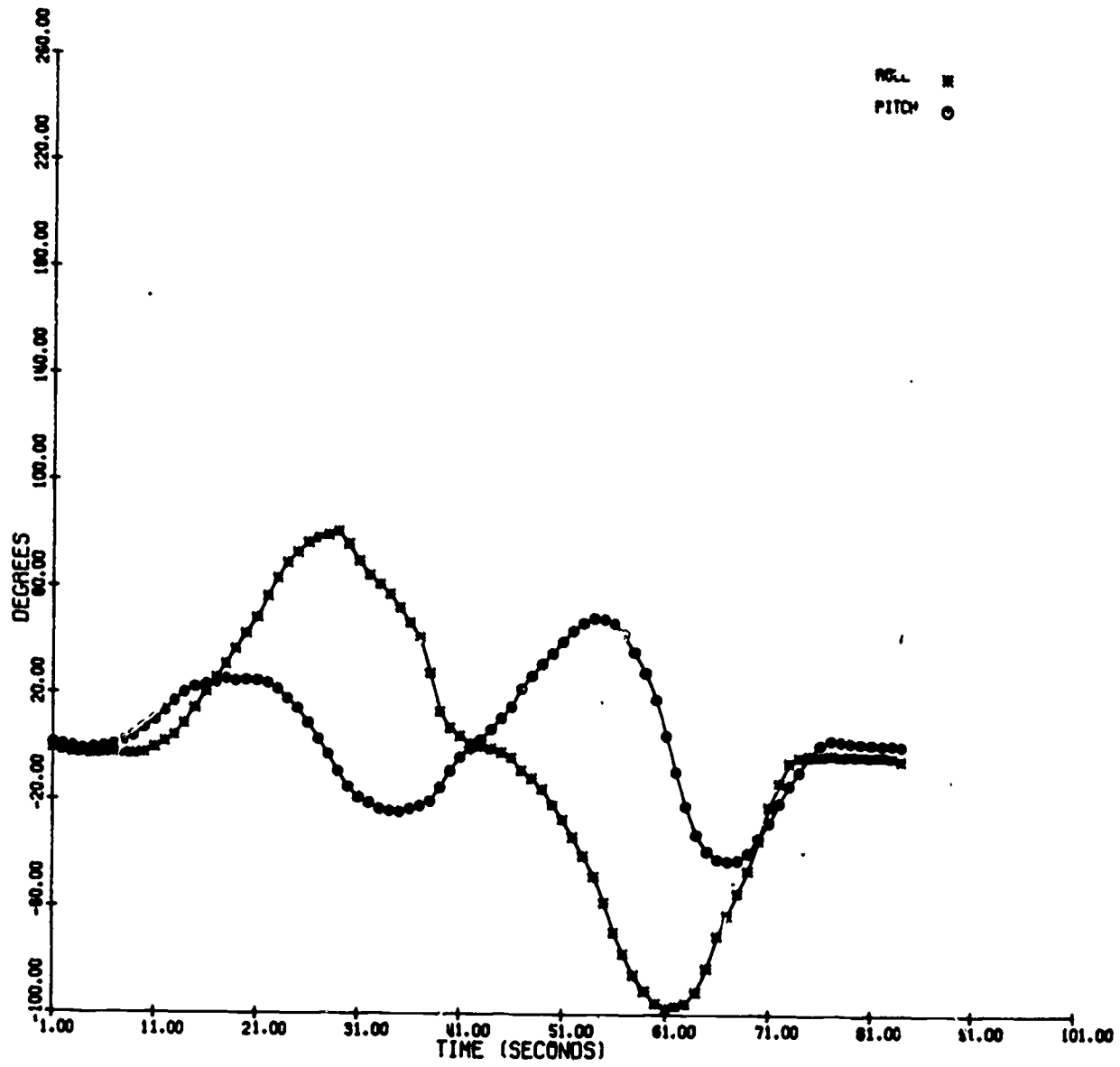

Plot 13

ROLL AND PITCH VS. TIME FOR LAZY 8

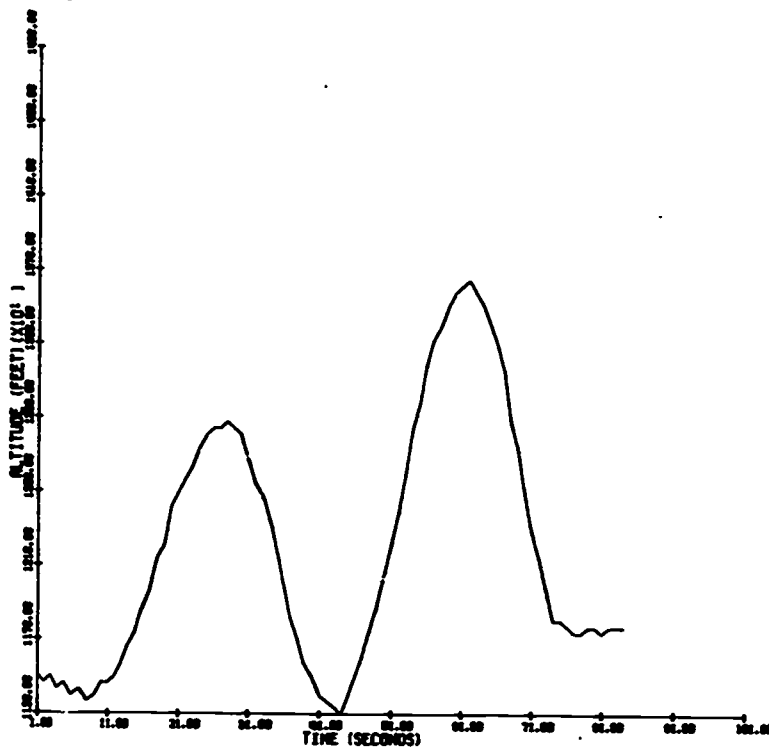

Plot 14

ALTITUDE VS. TIME FOR LANE 0

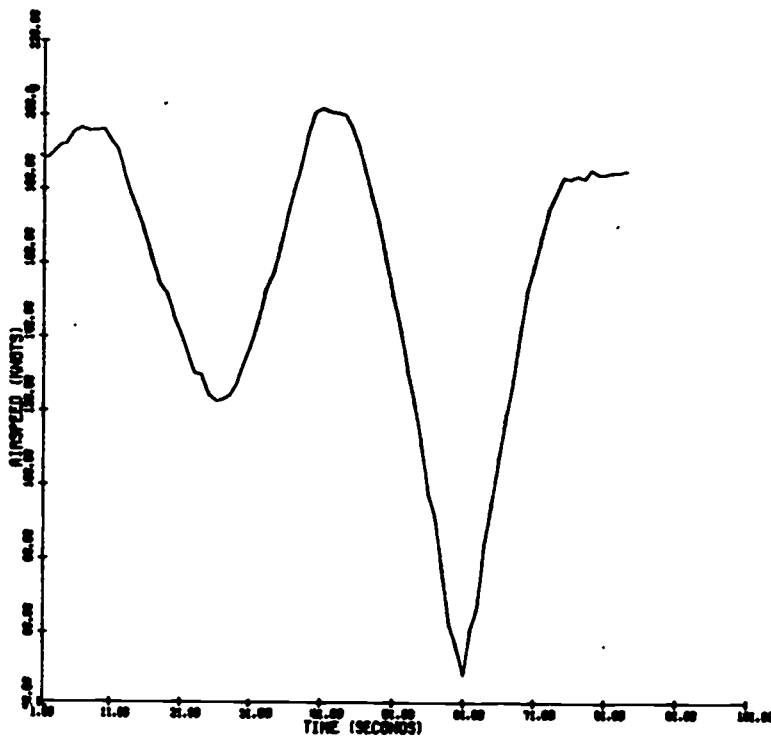

Plot 15

AIRSPEED VS. TIME FOR LANE 0

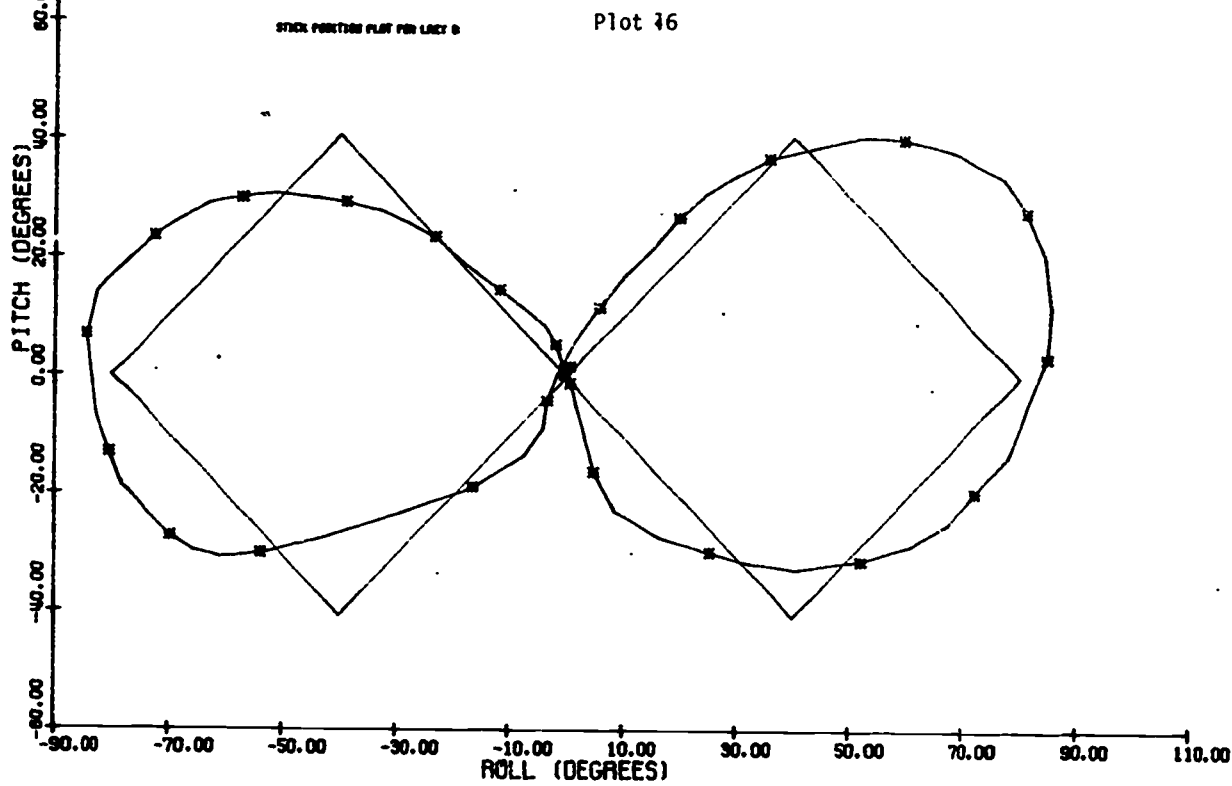
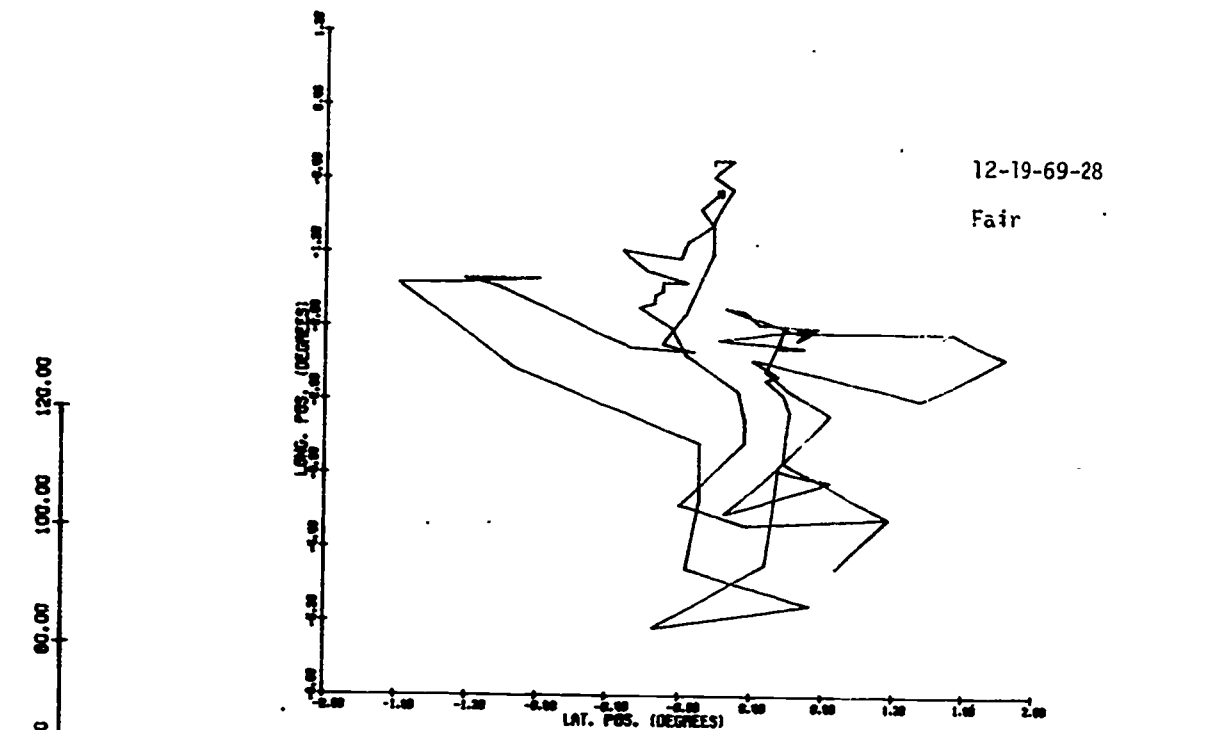

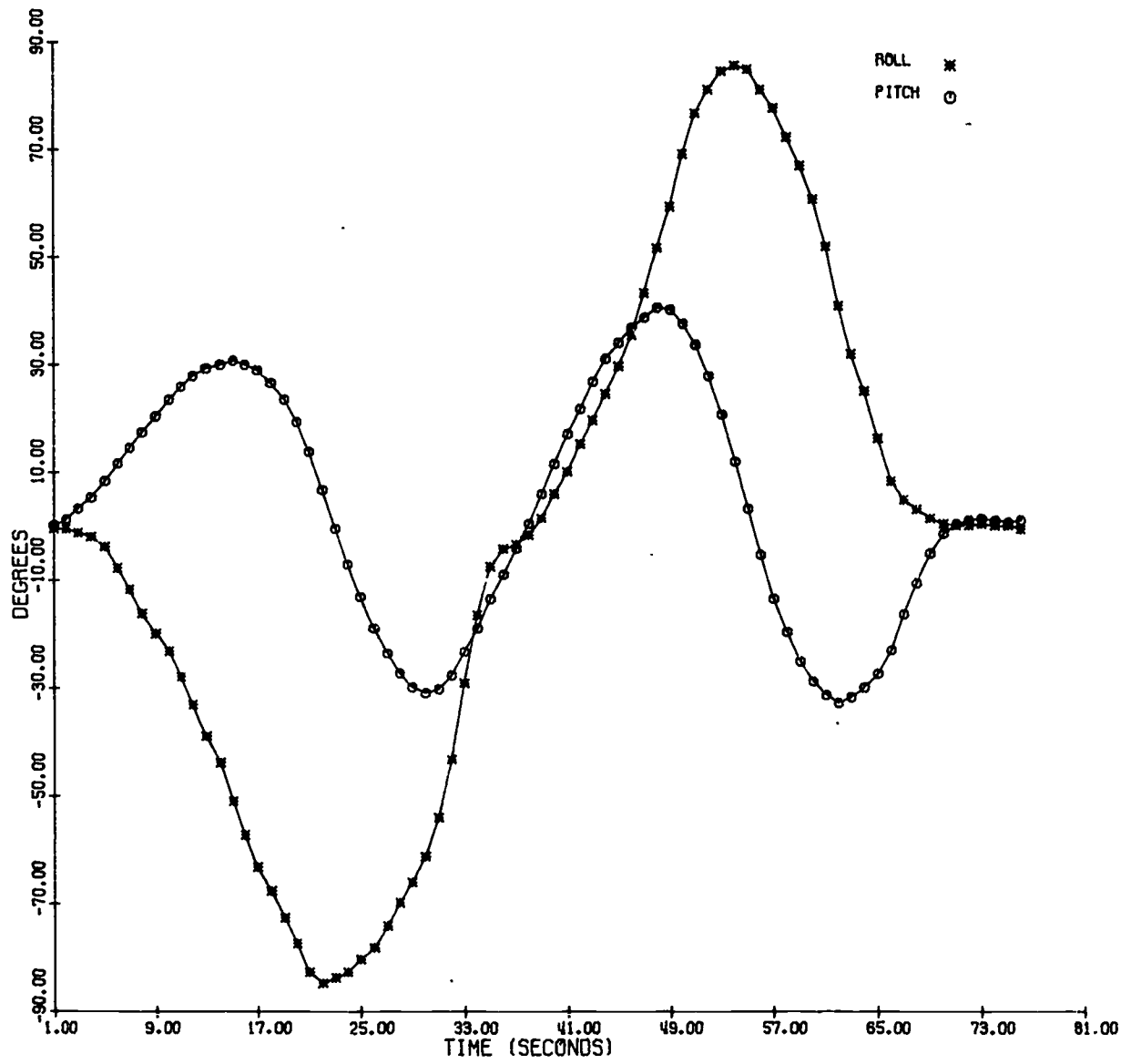

ROLL AND PITCH VS. TIME FOR LAZY 8

Plot 18

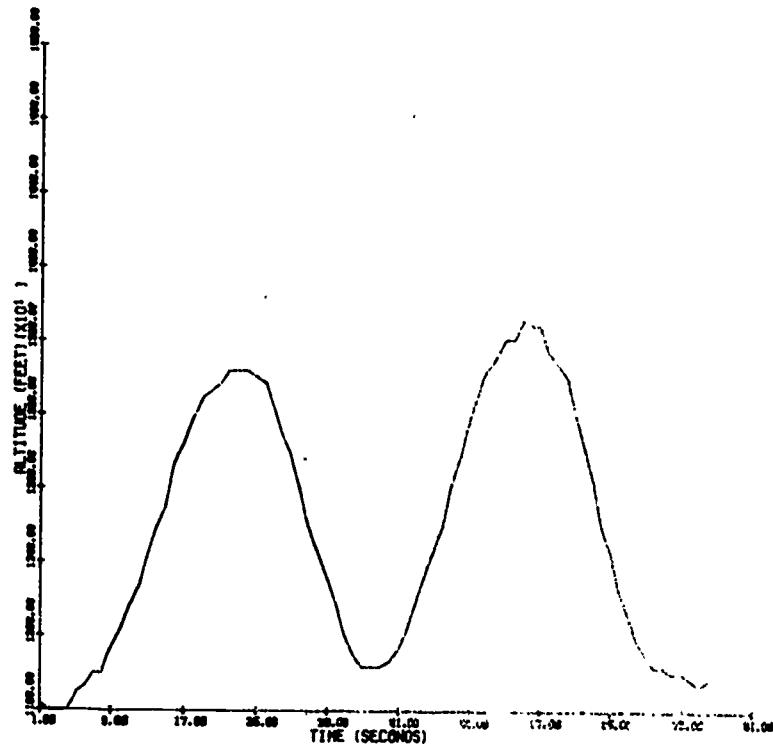

ALTITUDE VS. TIME FOR LANT 0

Plot 19

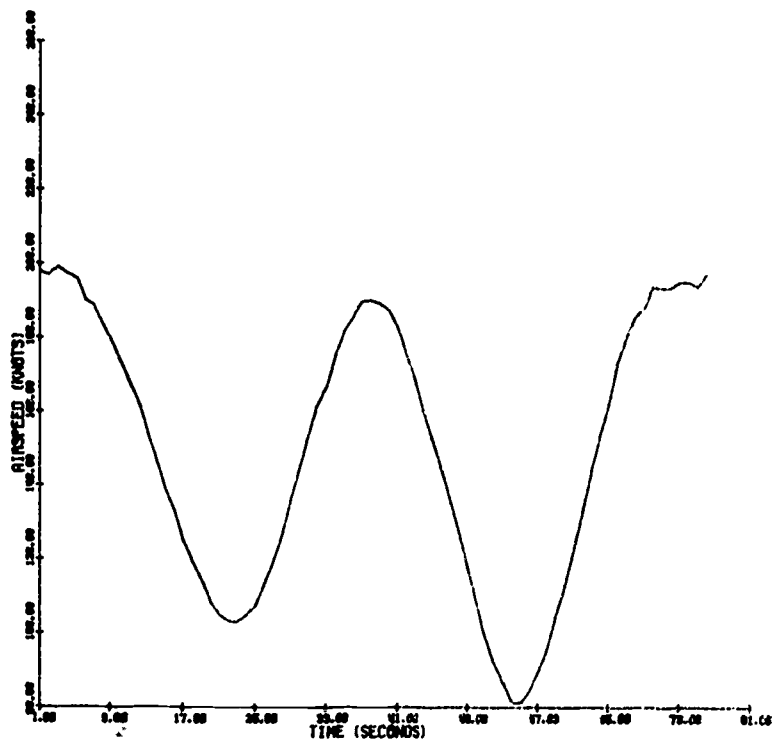

ALTITUDE VS. TIME FOR LANT 0

Plot 20

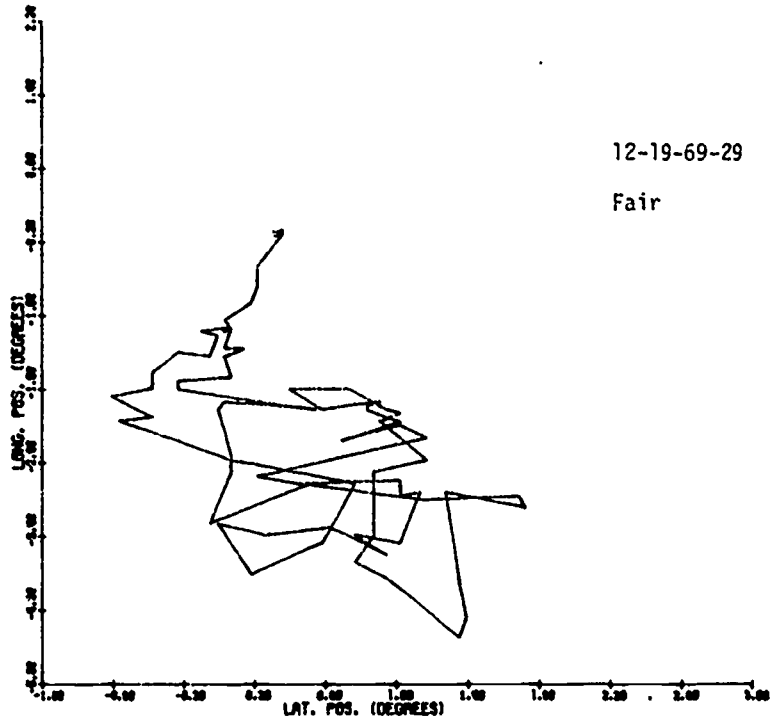

STICK POSITION PLOT FOR LAZY 9

Plot 21

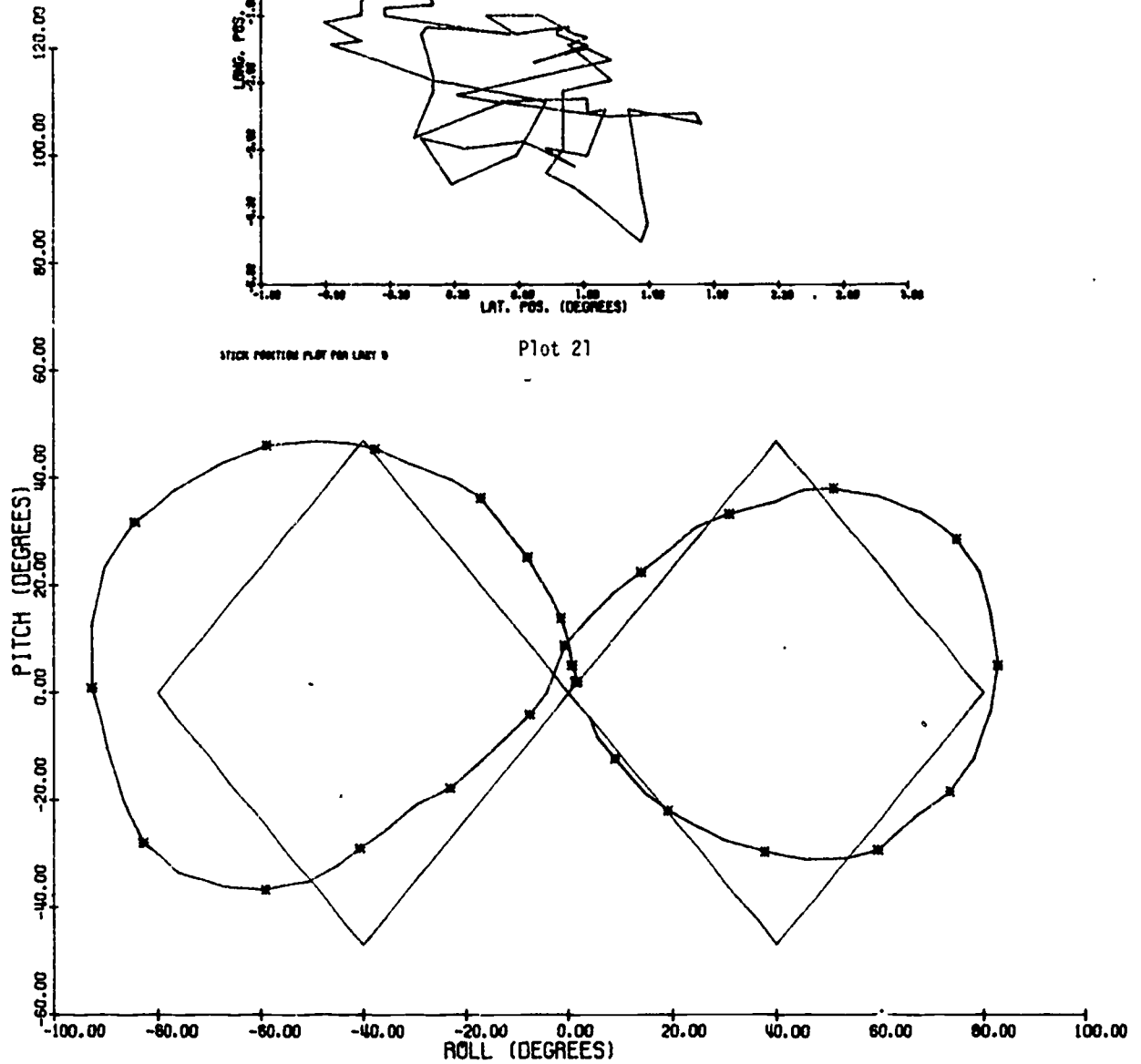

ROLL VS. PITCH FOR LAZY 9

Plot 22

AFHRL-TR-72-6

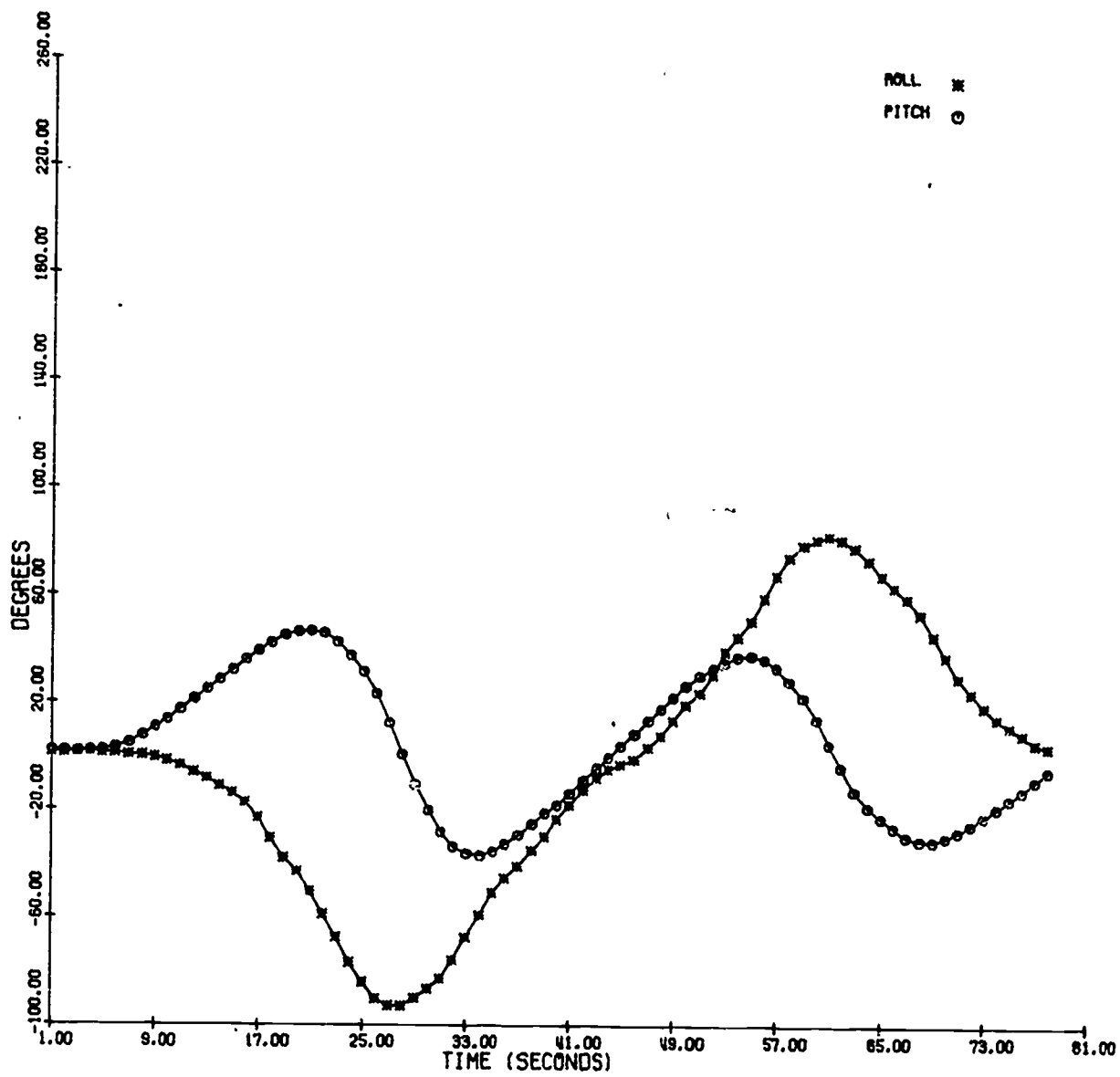

ROLL AND PITCH VS. TIME FOR LAZY 8

Plot 23

AFHRL-1R-72-6

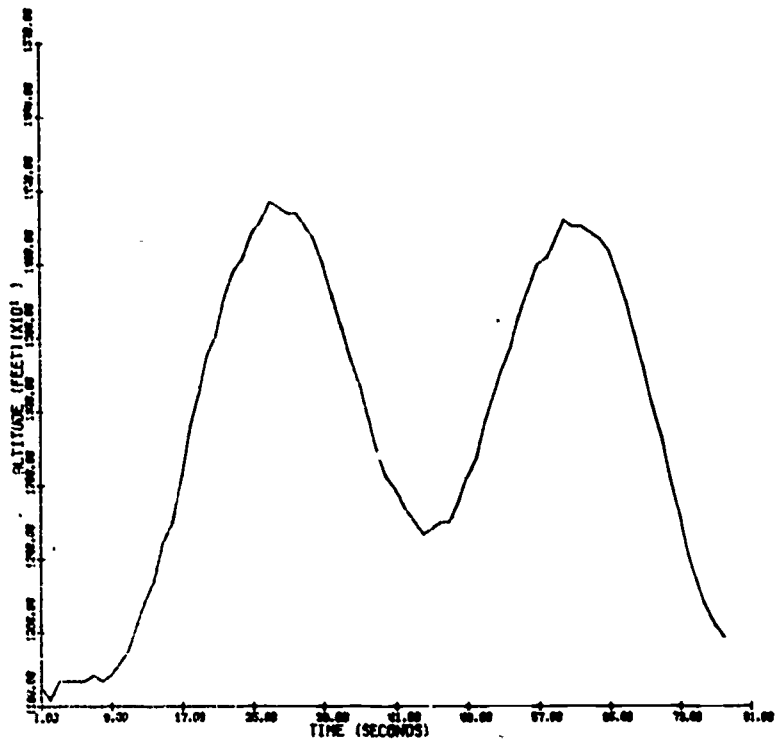

Plot 24

ALTITUDE VS. TIME FOR LIFT 0

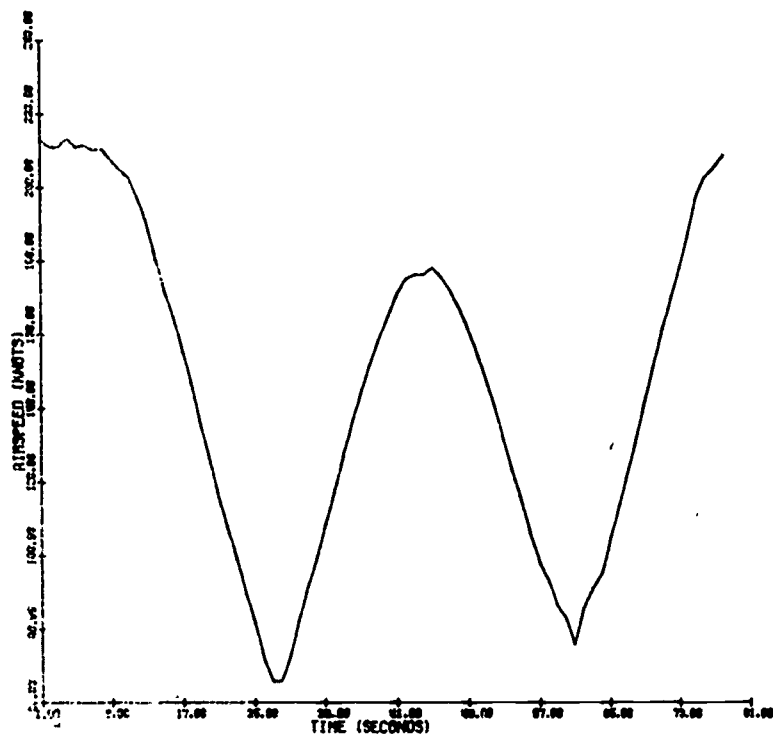

Plot 25

AIRSPEED VS. TIME FOR LIFT 0

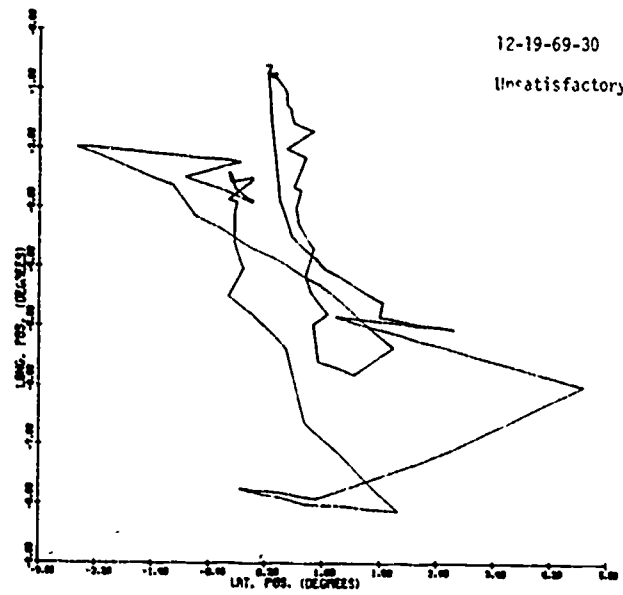

12-19-69-30
Unsatisfactory

STICK POSITION PLOT FOR LAZY 8 Plot 26

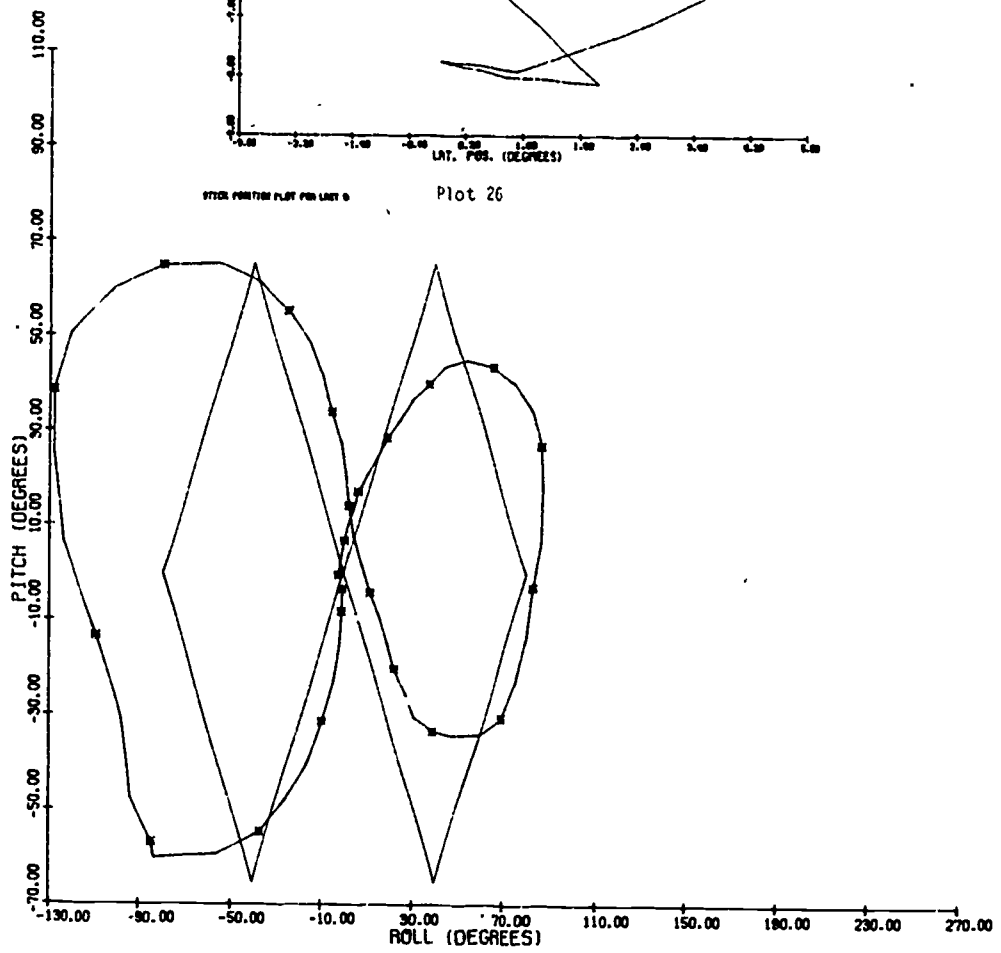

ROLL VS. PITCH FOR LAZY 8

Plot 27

AFHRL-TR-72-6

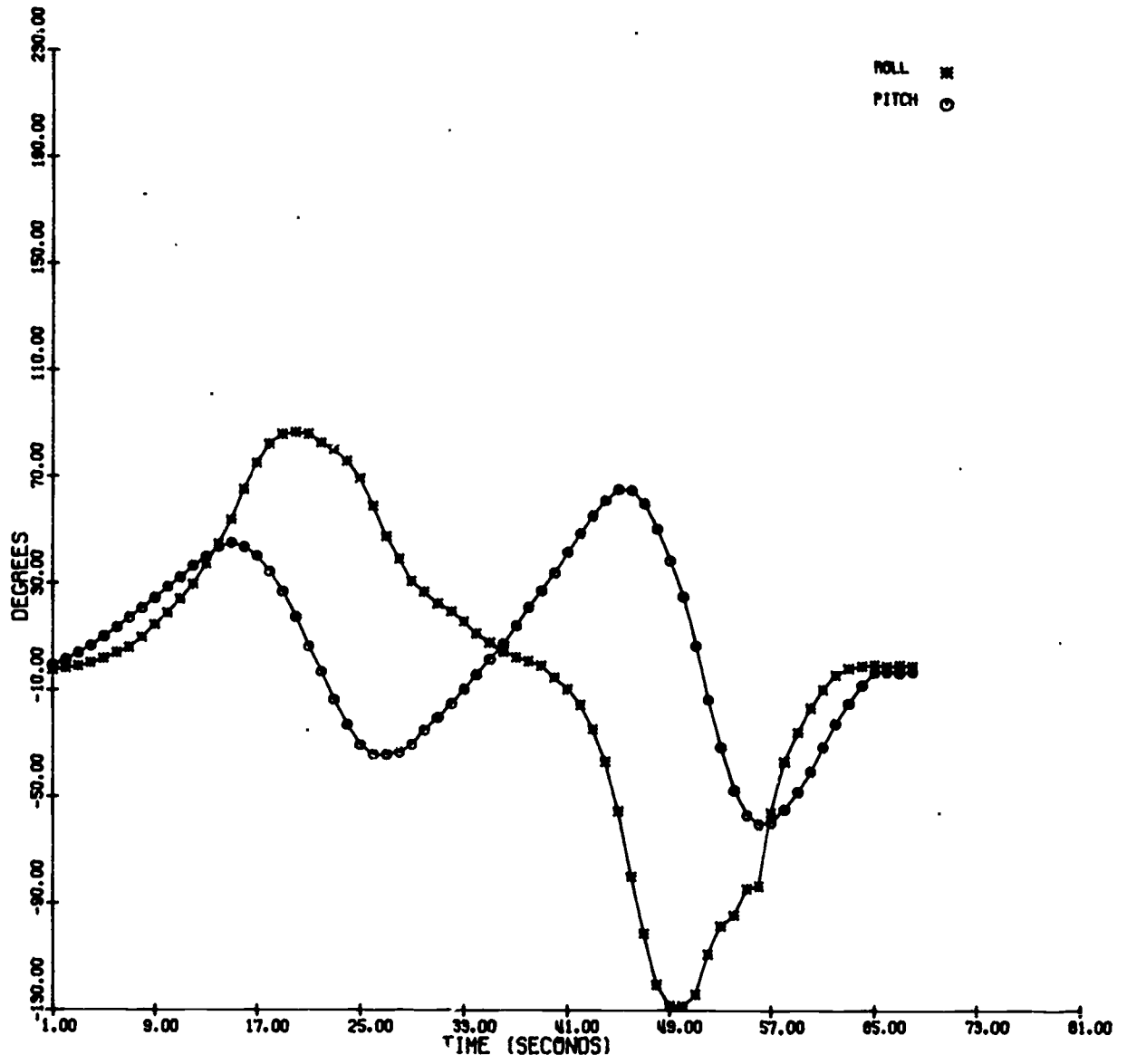

Plot 28

ROLL AND PITCH VS. TIME FOR LAZY 8

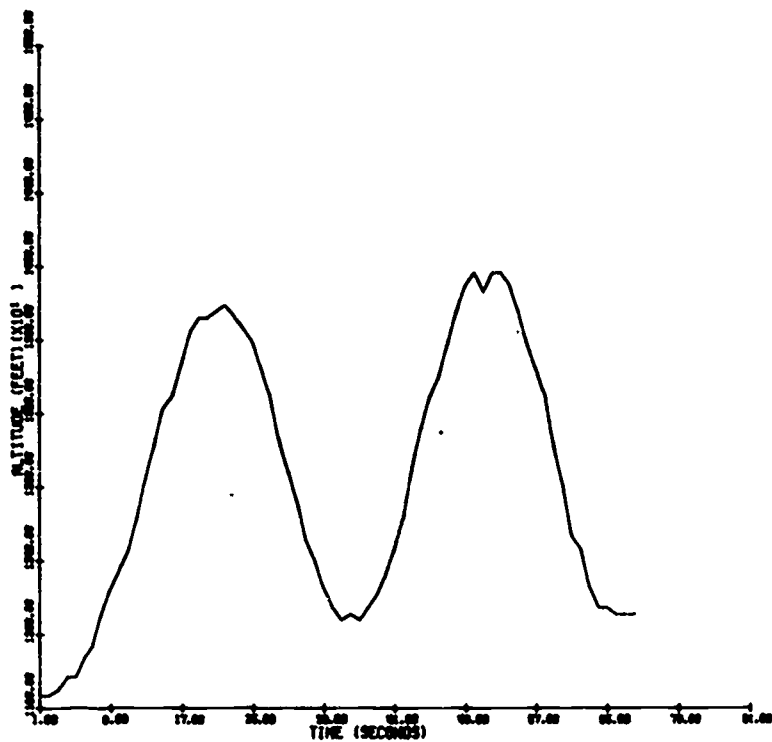

Plot 29

ALTITUDE VS. TIME FOR LAY 0

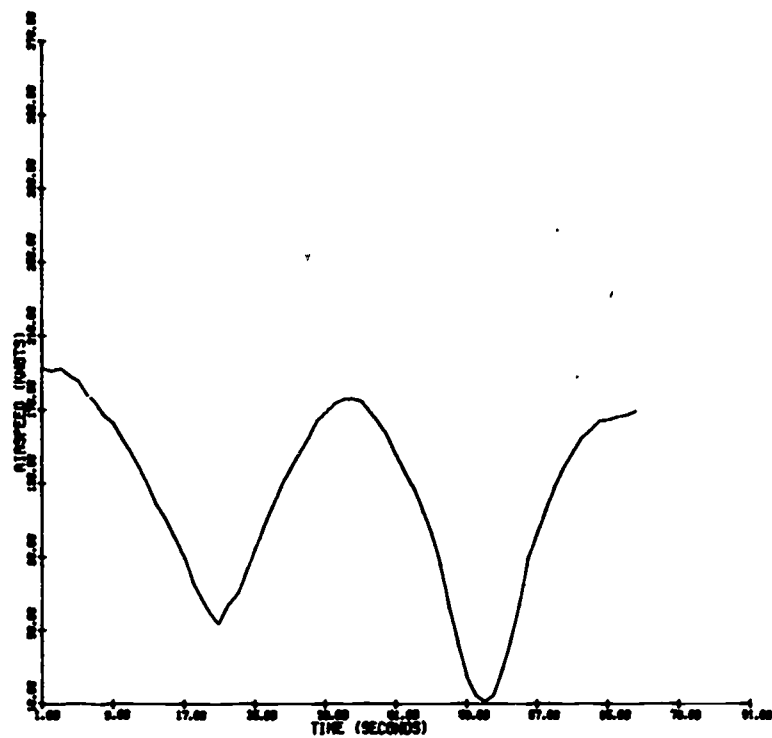

Plot 30

ALTITUDE VS. TIME FOR LAY 0

12-19-69-31
Unsatisfactory

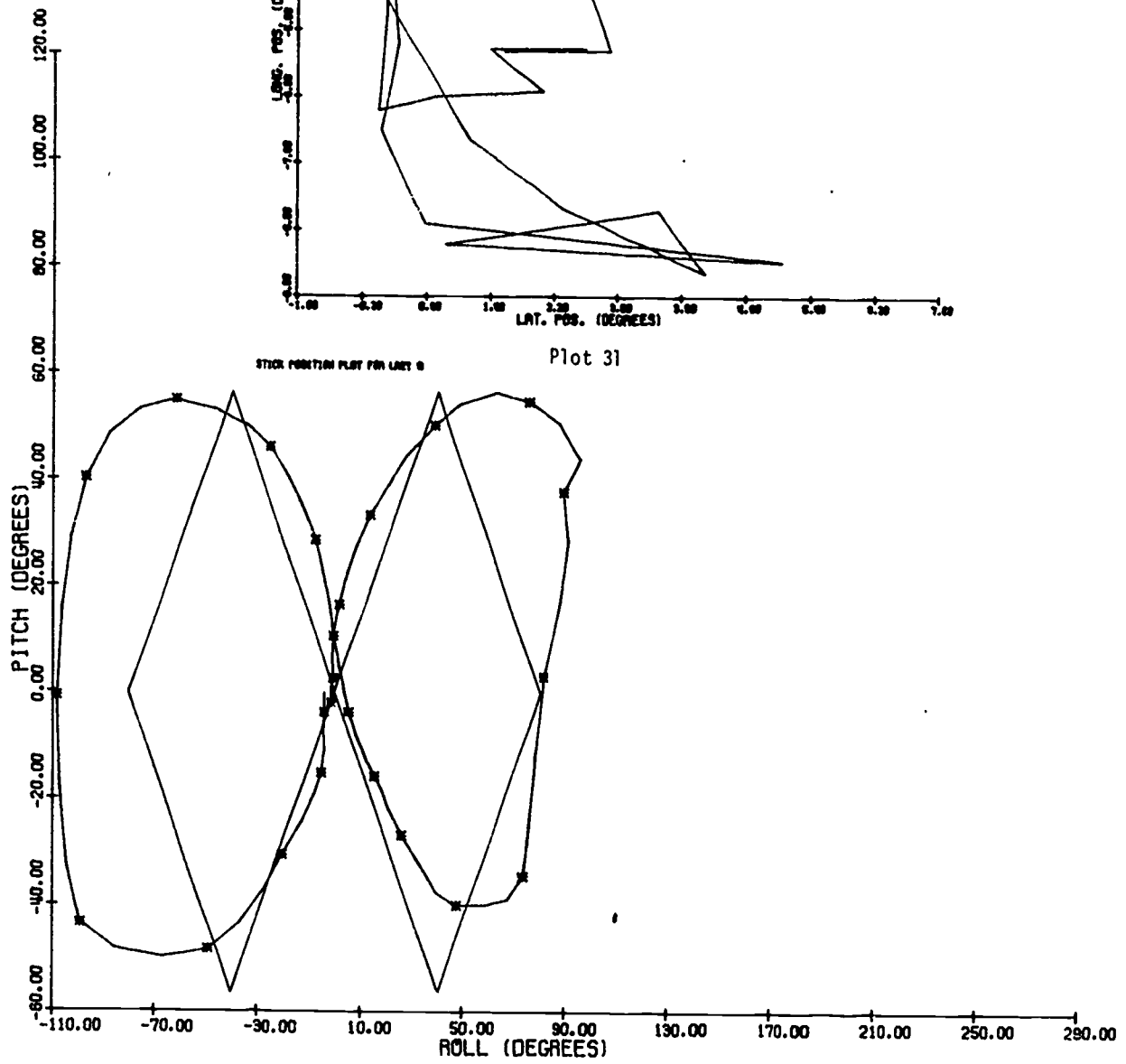
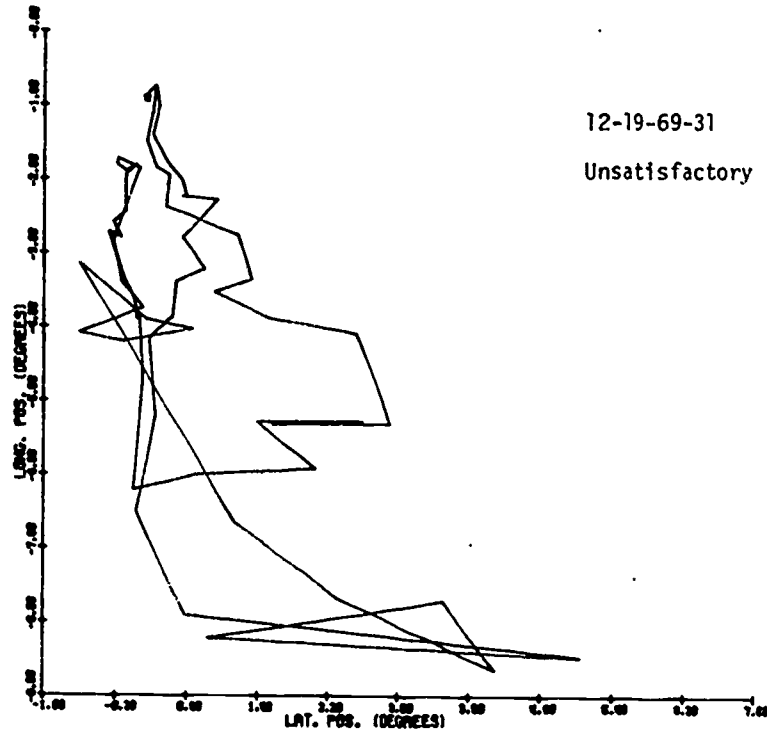

ROLL VS. PITCH FOR LAZY 8

AFHRL-TR-72-6

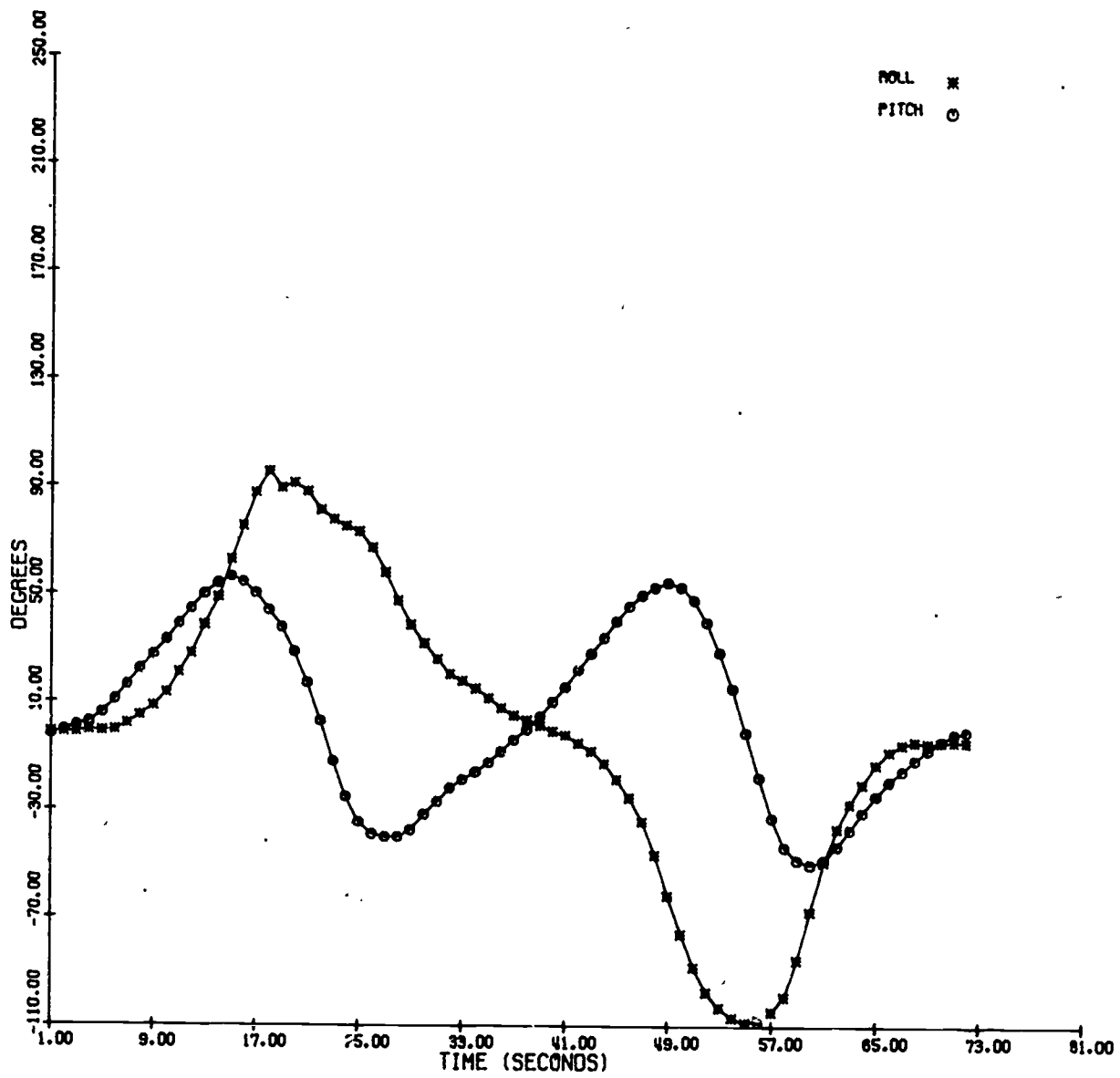

Plot 33

ROLL AND PITCH VS. TIME FOR LAZY 8

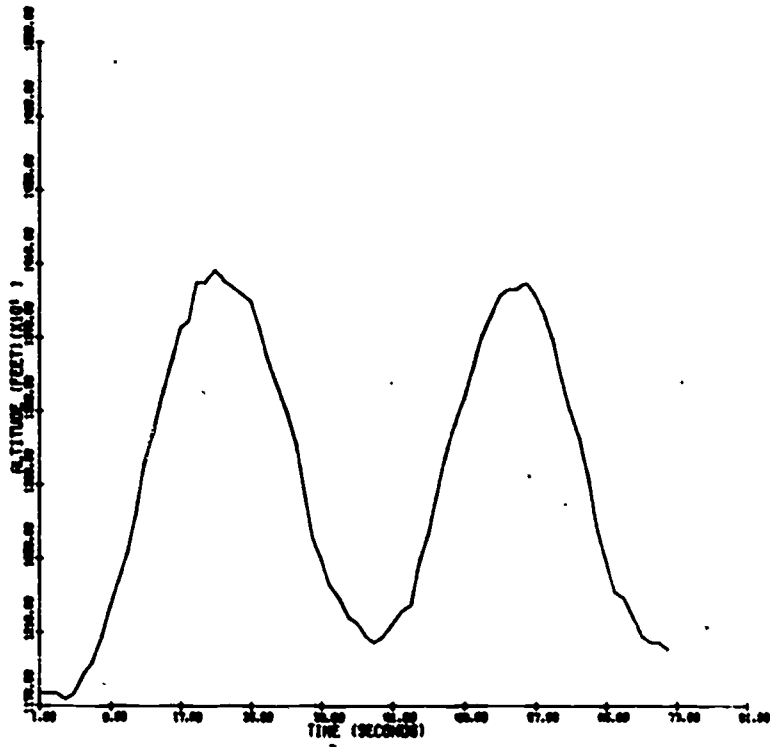

Plot 34

ALTITUDE VS. TIME FOR LIFT 0

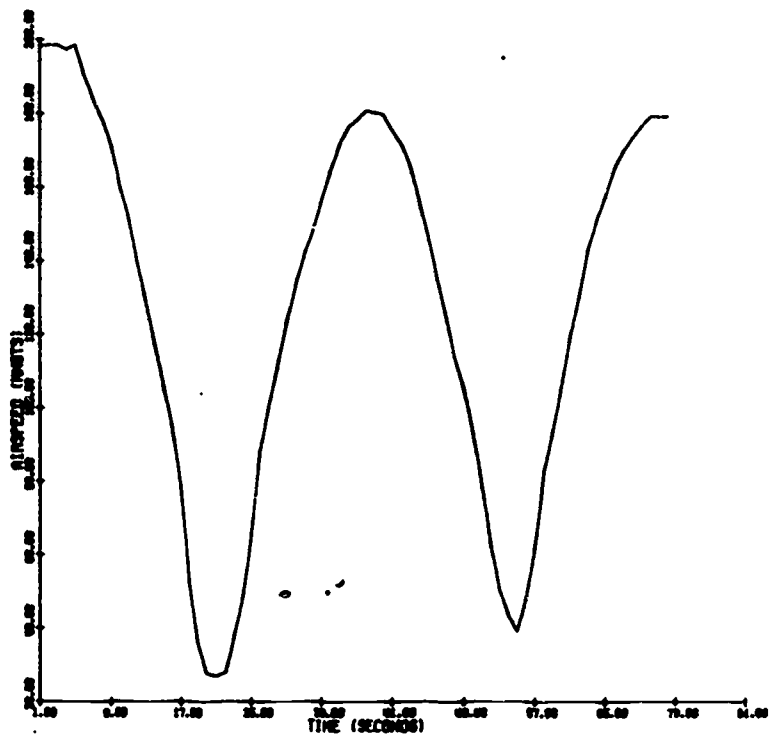

Plot 35

ALTITUDE VS. TIME FOR LIFT 0

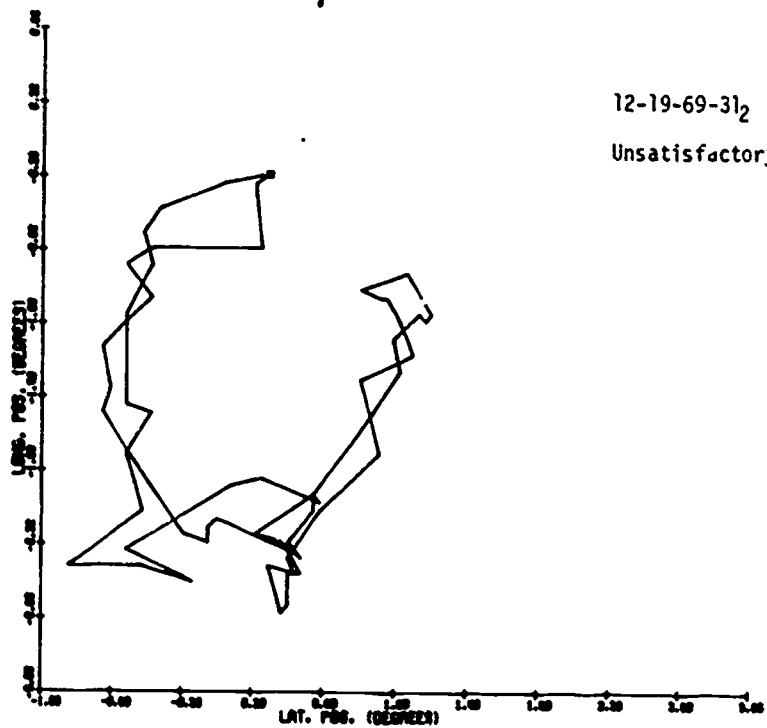

12-19-69-31₂
Unsatisfactory

ROLL POSITION PLOT FOR LAZY B

Plot 36

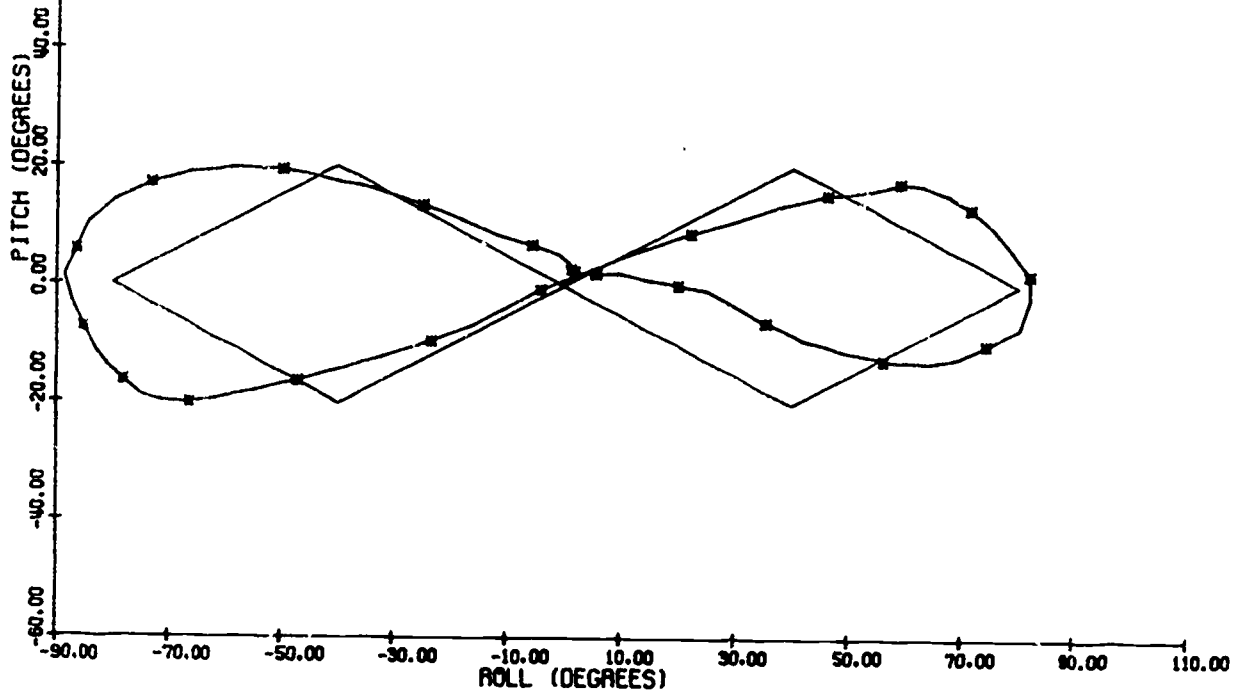

ROLL VS. PITCH FOR LAZY B

Plot 37

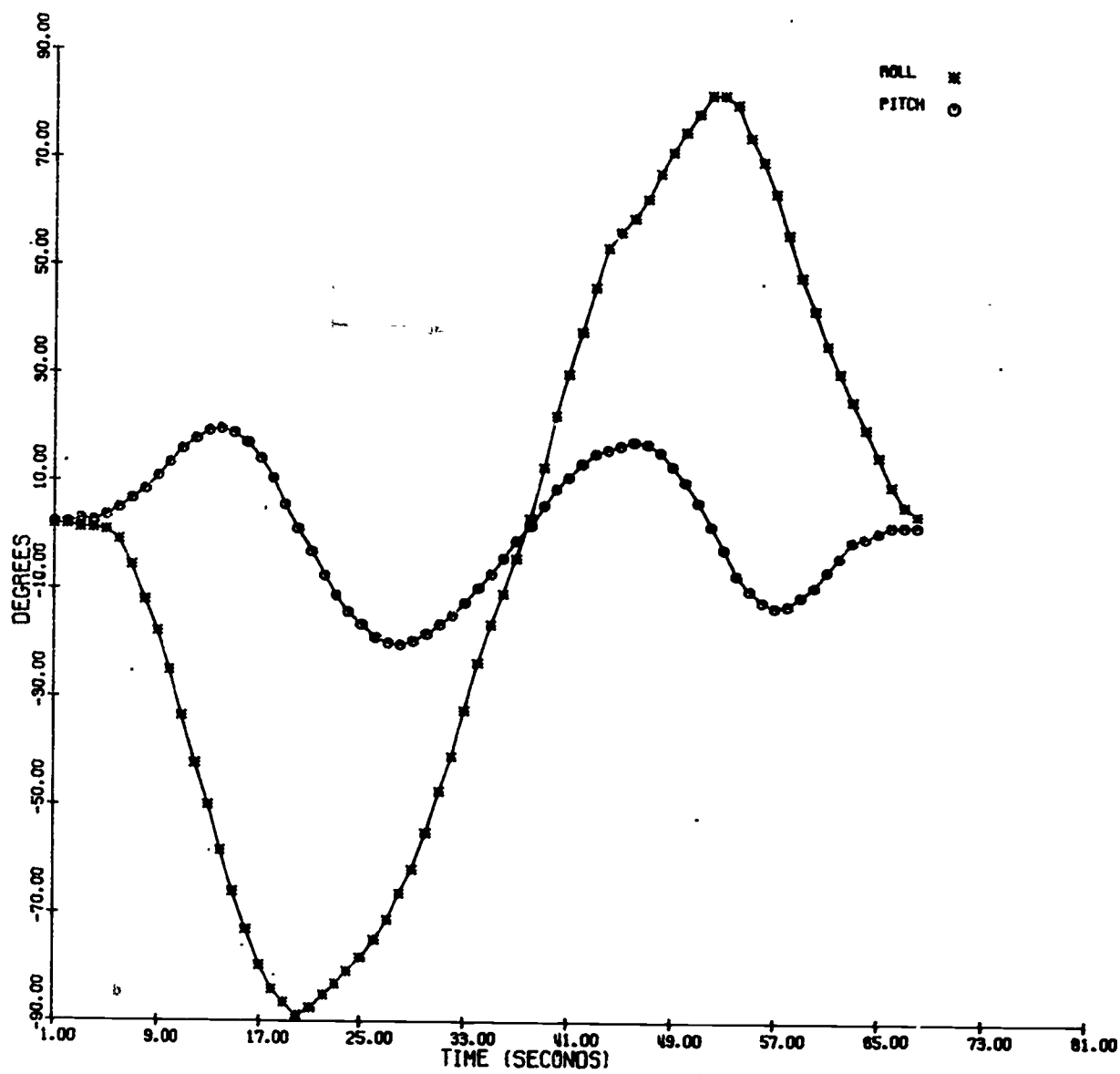

Plot 38

ROLL AND PITCH VS. TIME FOR LAZY 8

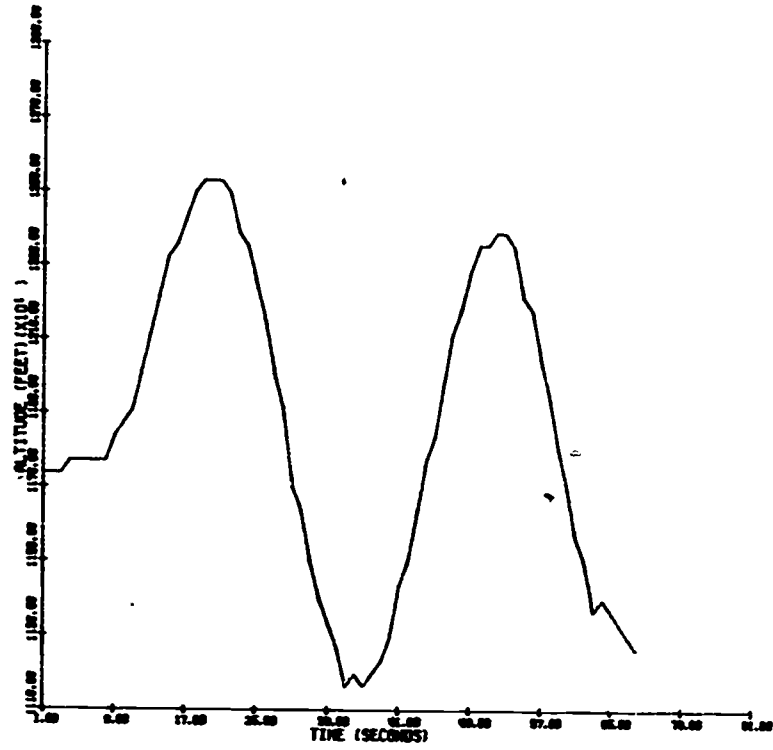

Plot 39

ALTITUDE VS. TIME FOR LEG 0

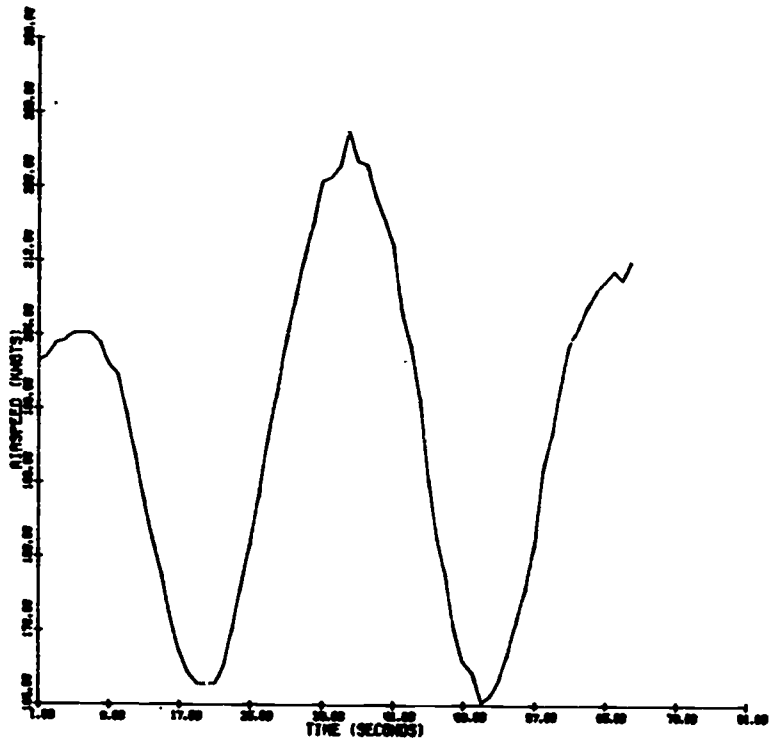

Plot 40

ALTITUDE VS. TIME FOR LEG 0

12-19-69-34
Unsatisfactory

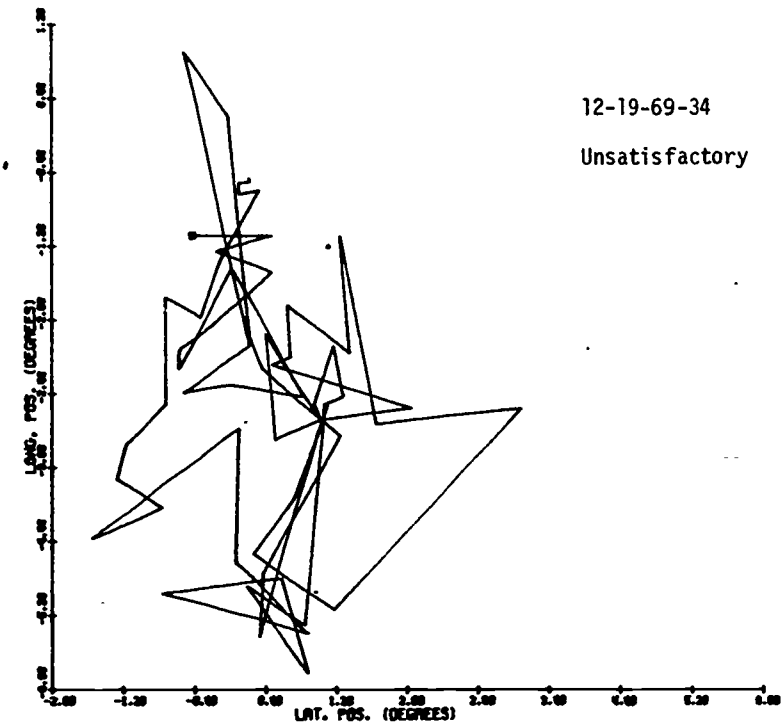

STICK POSITION PLOT FOR LAZY 8

Plot 41

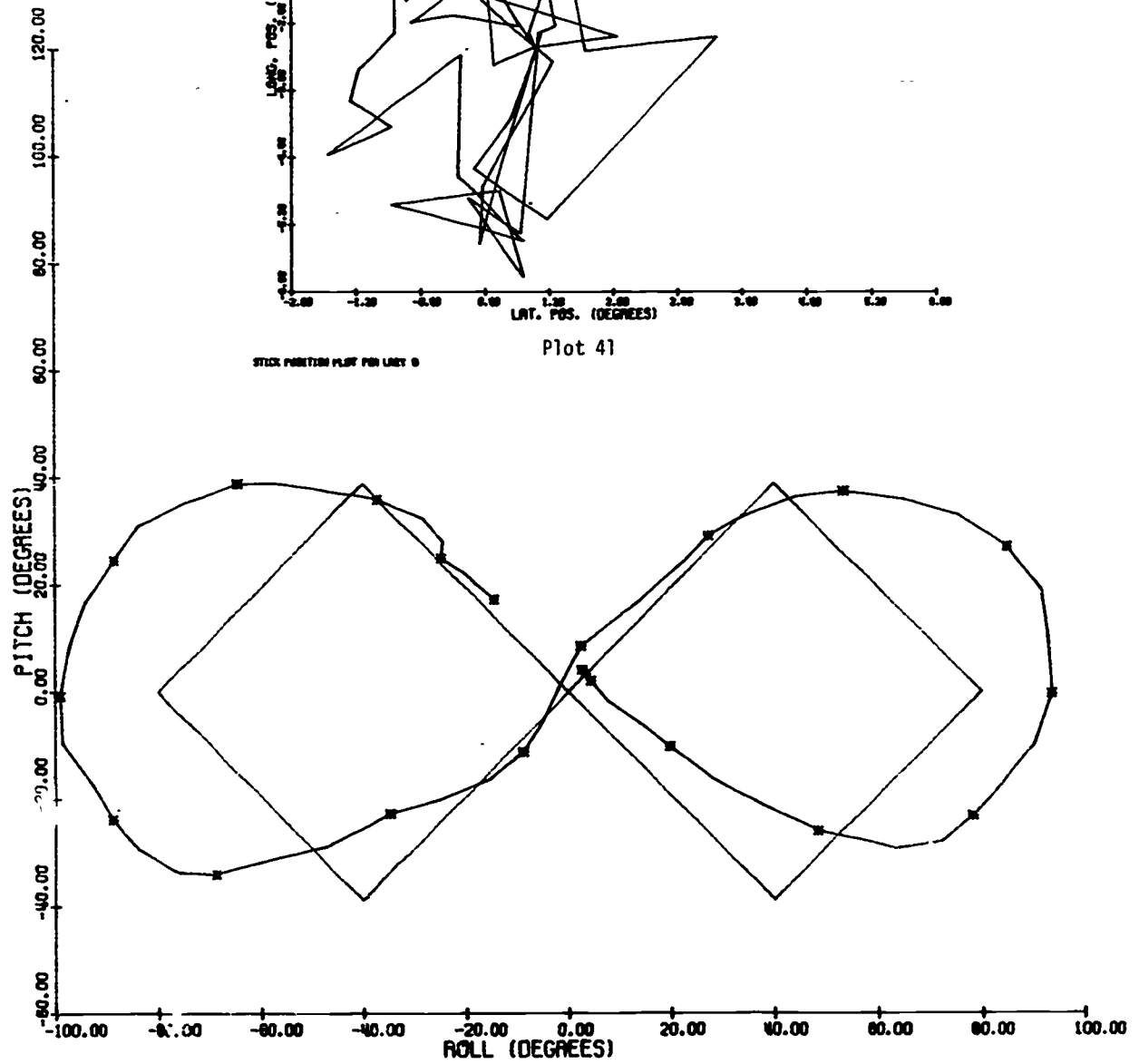

Plot 42

ROLL VS. PITCH FOR LAZY 8

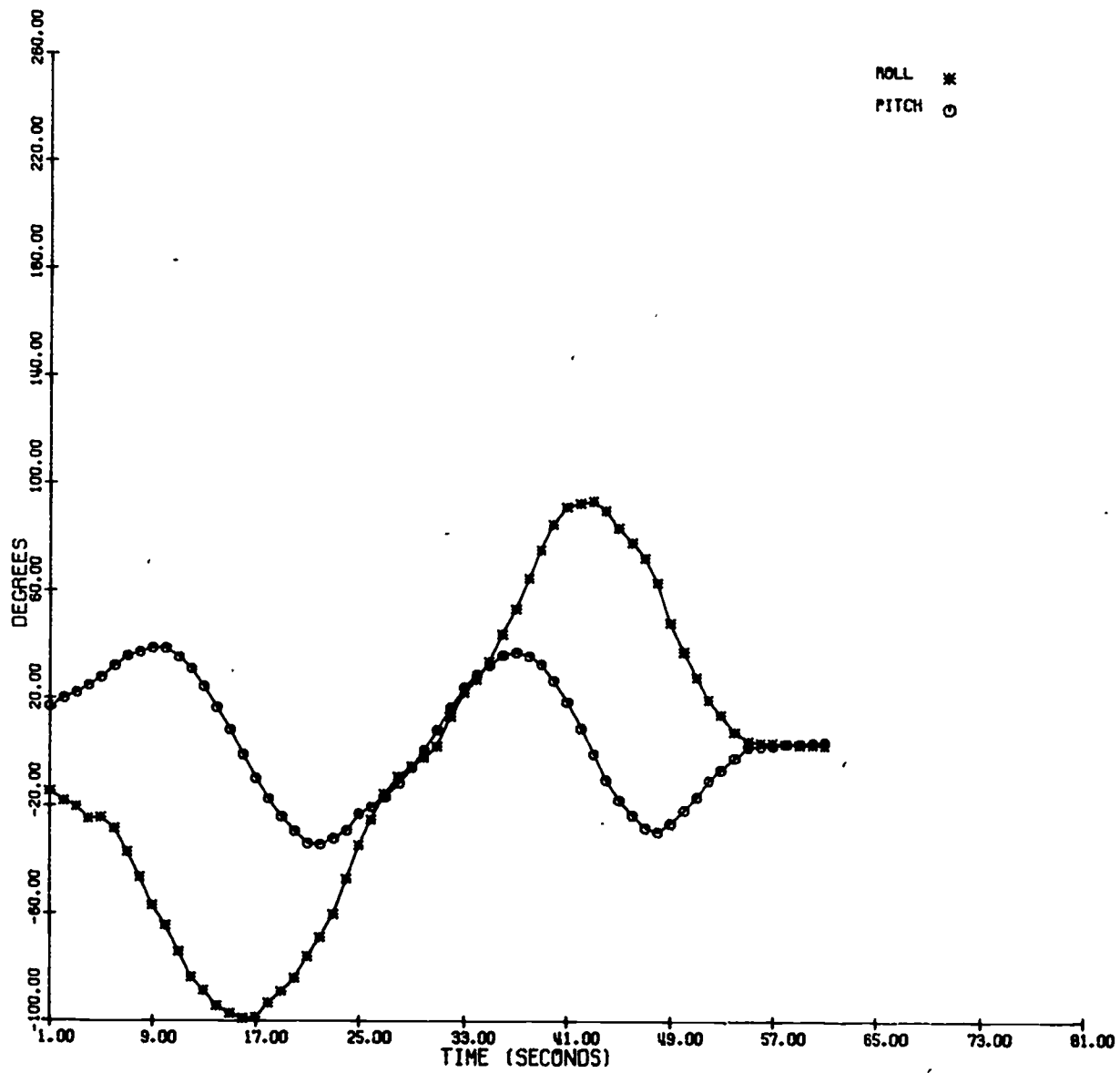

Plot 43

ROLL AND PITCH VS. TIME FOR LAZY 8

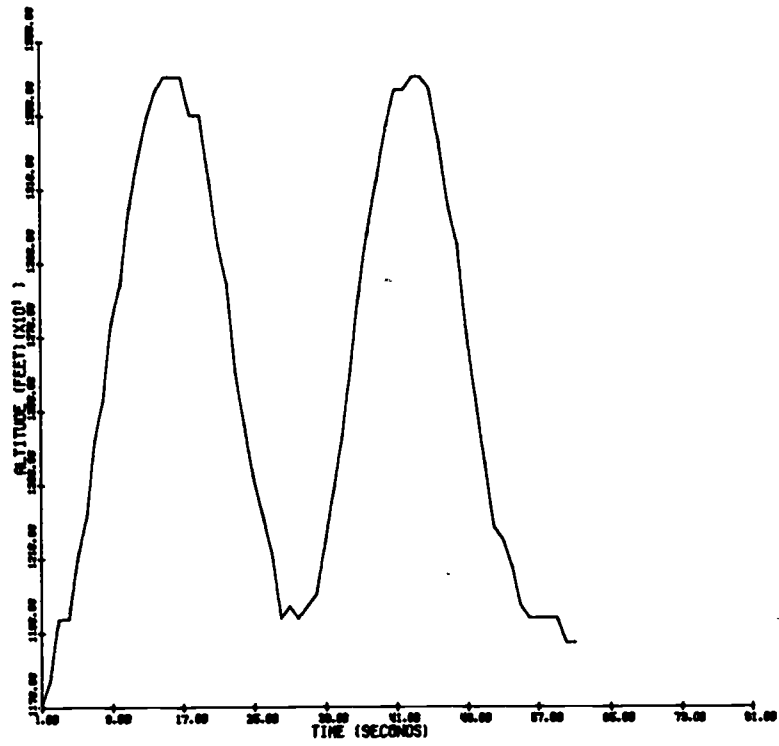

Plot 44

ALTITUDE VS. TIME FOR LAKE 9

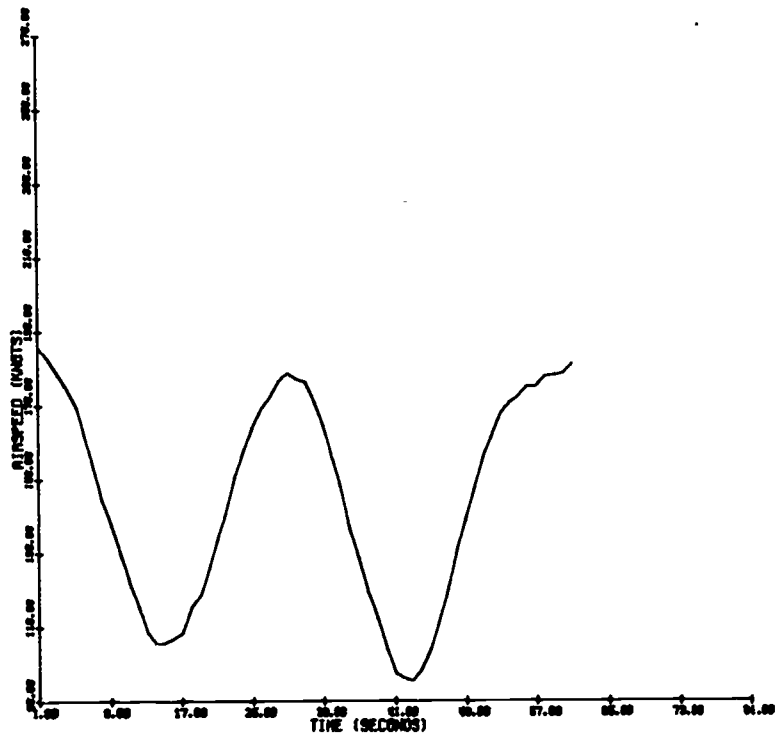

Plot 45

ALTITUDE VS. TIME FOR LAKE 9

AFHRL-TR-72-6

APPENDIX X

STICK POSITION PLOTS FOR REPRESENTATIVE
LAZY 8 MANEUVERS

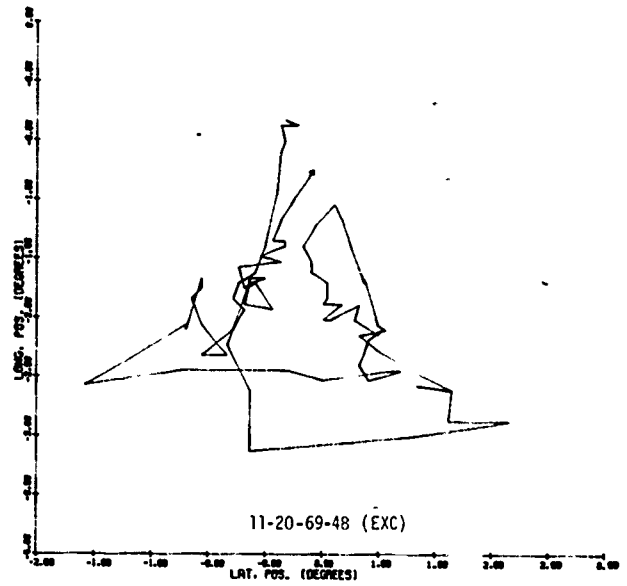
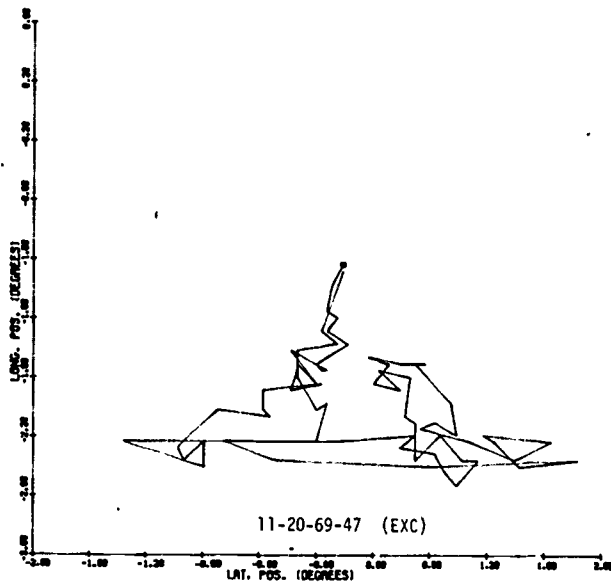

STICK POSITION PLOT FOR LAT 0

STICK POSITION PLOT FOR LAT 0

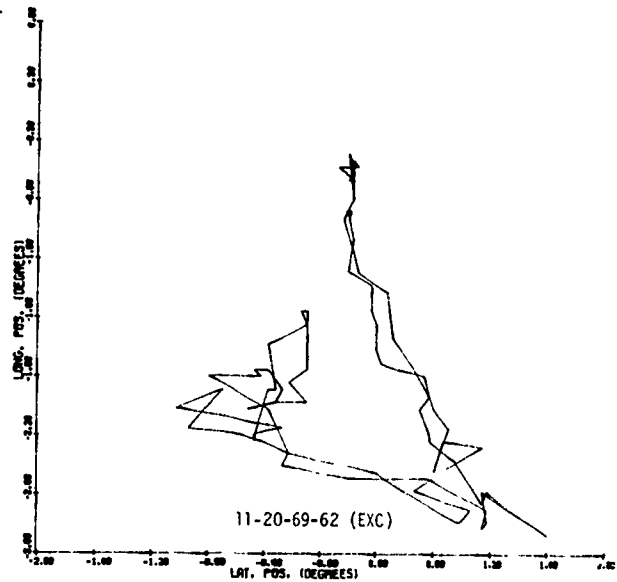
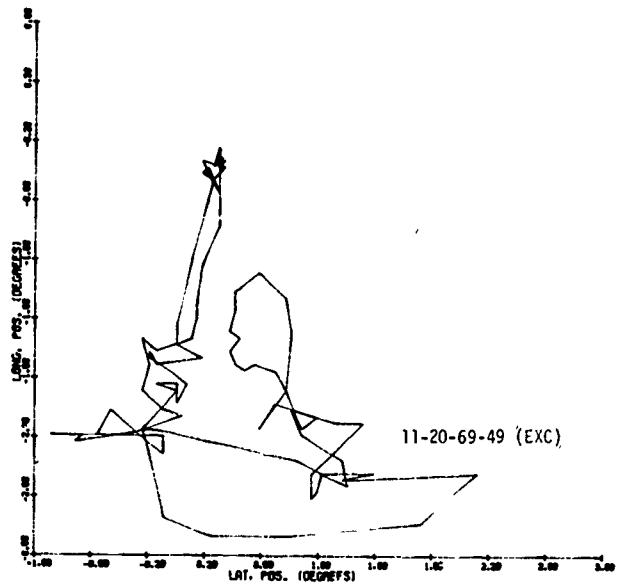

STICK POSITION PLOT FOR LAT 0

STICK POSITION PLOT FOR LAT 0

AFHRL-TR-72-6

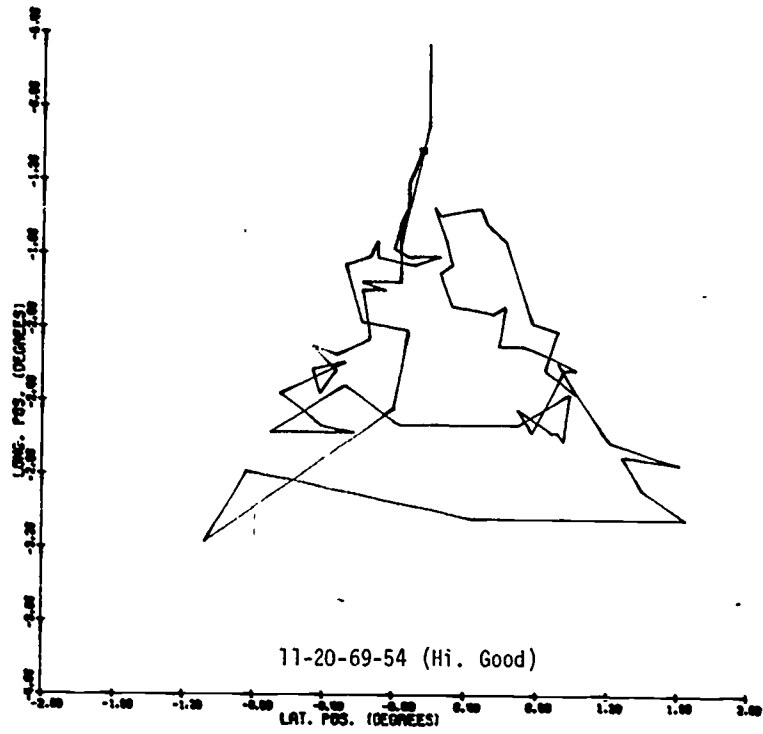

STICK POSITION PLOT FOR LAYER 6

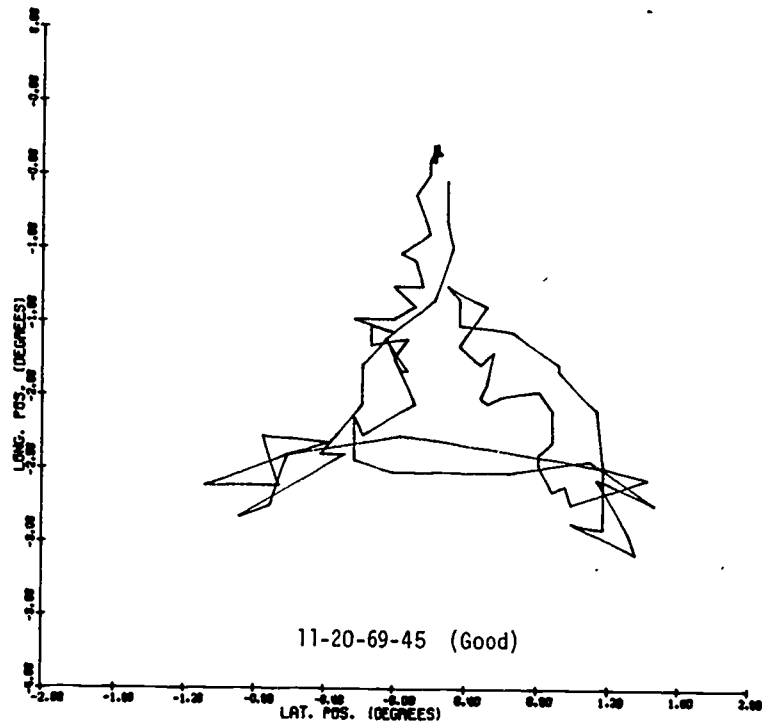

STICK POSITION PLOT FOR LAYER 6

AFHRL-TR-72-6

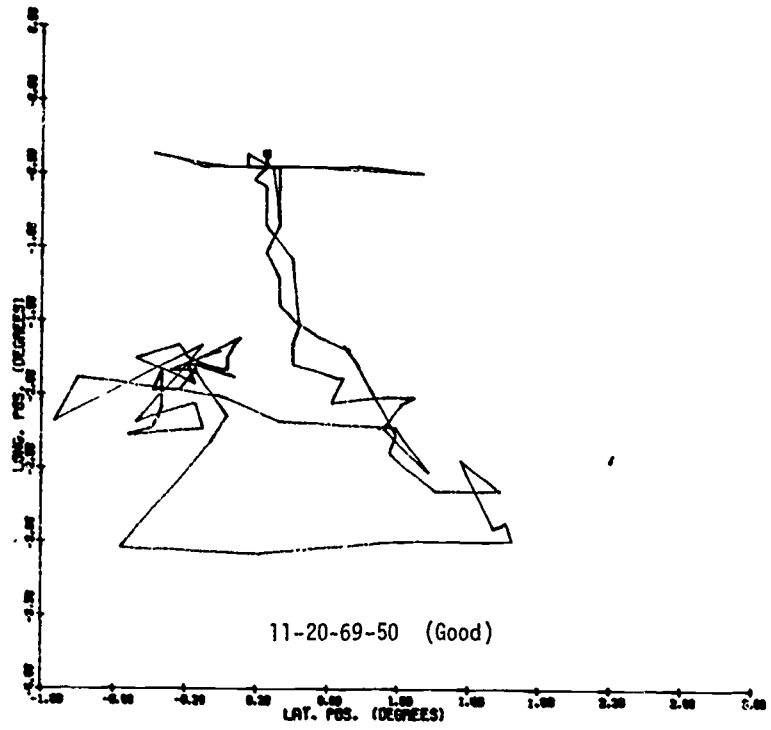

STICK POSITION PLOT FOR LIST 0

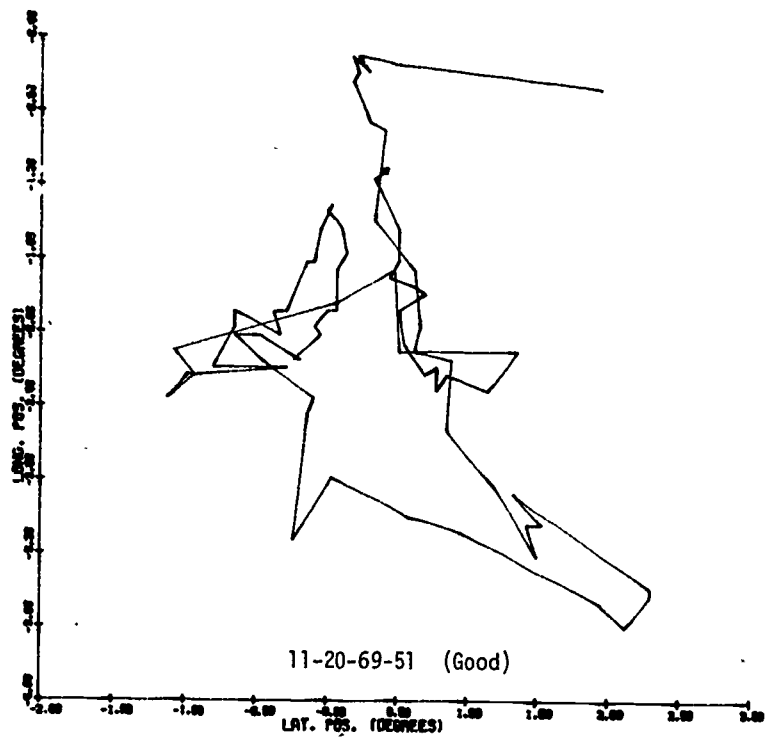

STICK POSITION PLOT FOR LIST 0

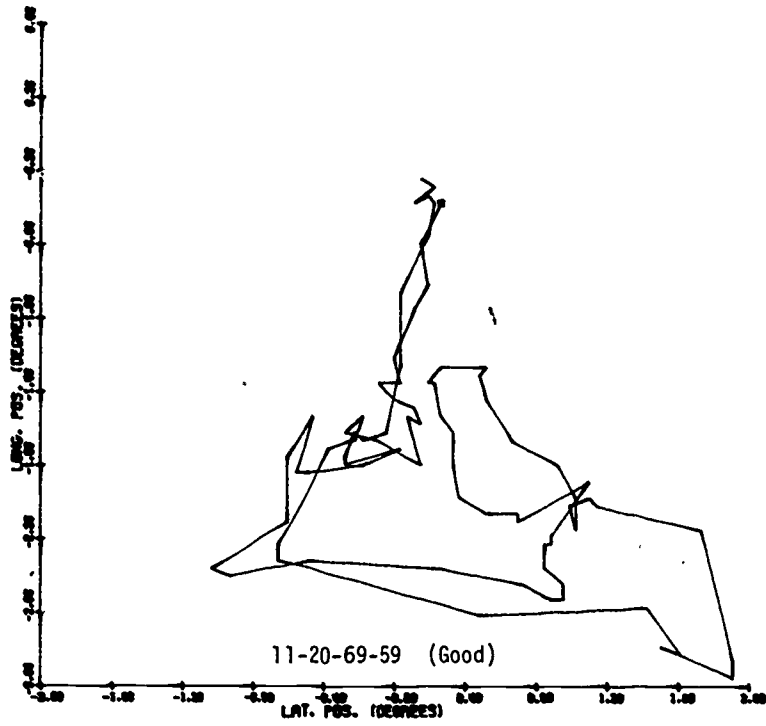

STICK POSITION PLOT FOR LNEY 0

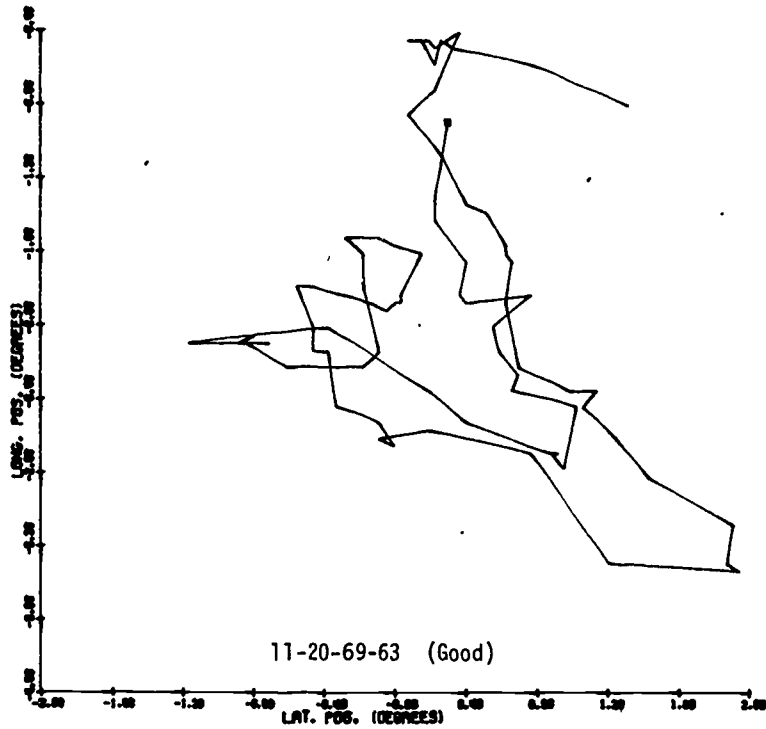

STICK POSITION PLOT FOR LNEY 0

AFHRL-TR-72-6

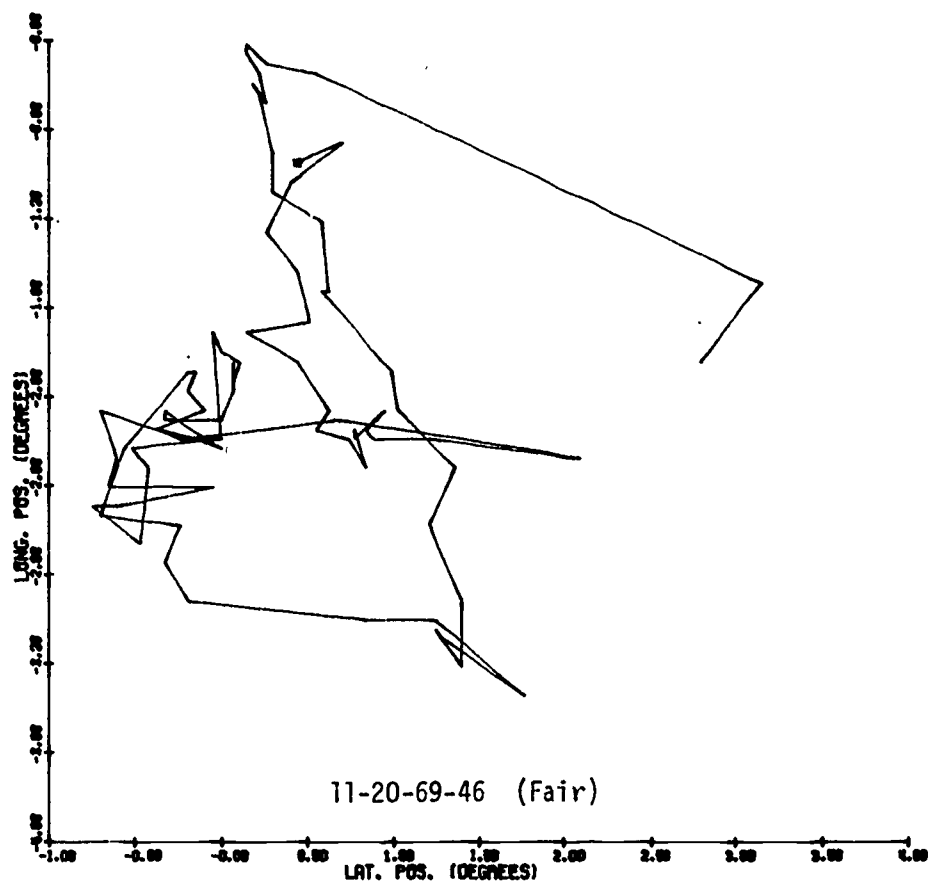

STICK POSITION PLOT FOR LINE 9

AFHRL-TR-72-6

APPENDIX XI
ROLL VS PITCH PLOTS FOR REPRESENTATIVE
LAZY 8 MANEUVERS

AFHRL-TR-72-6

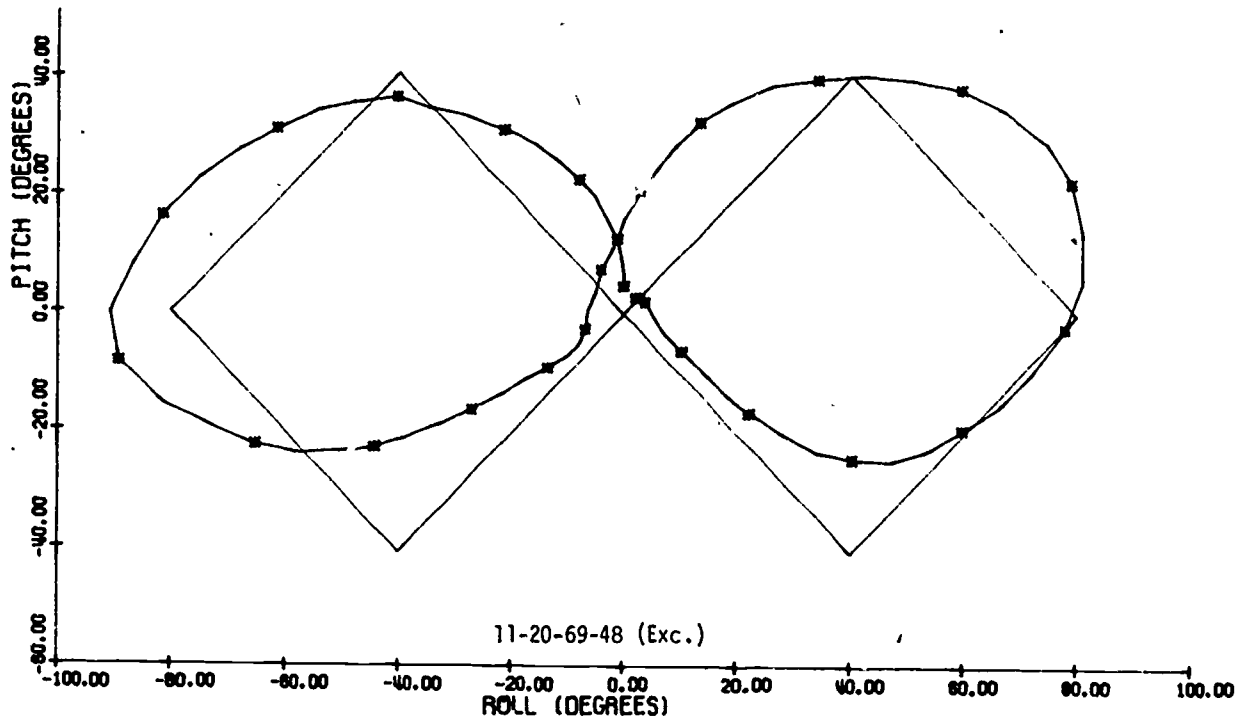
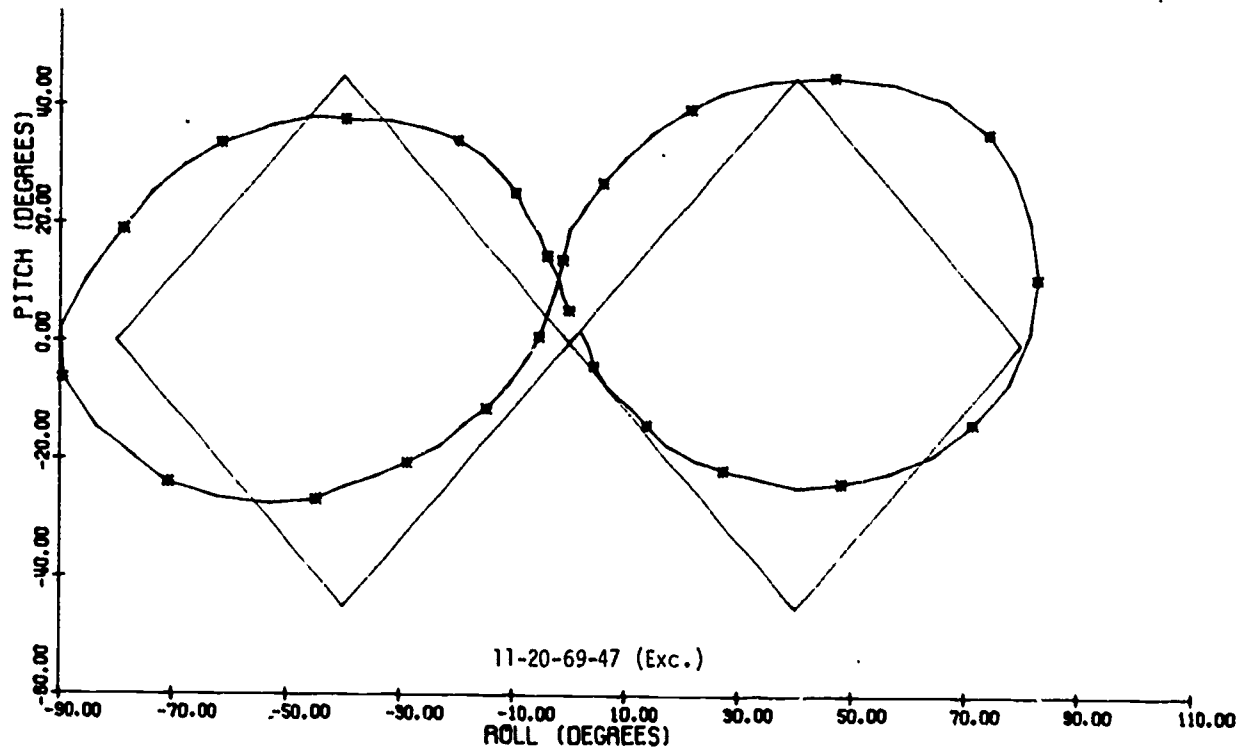

ROLL VS. PITCH FOR LAZY 8

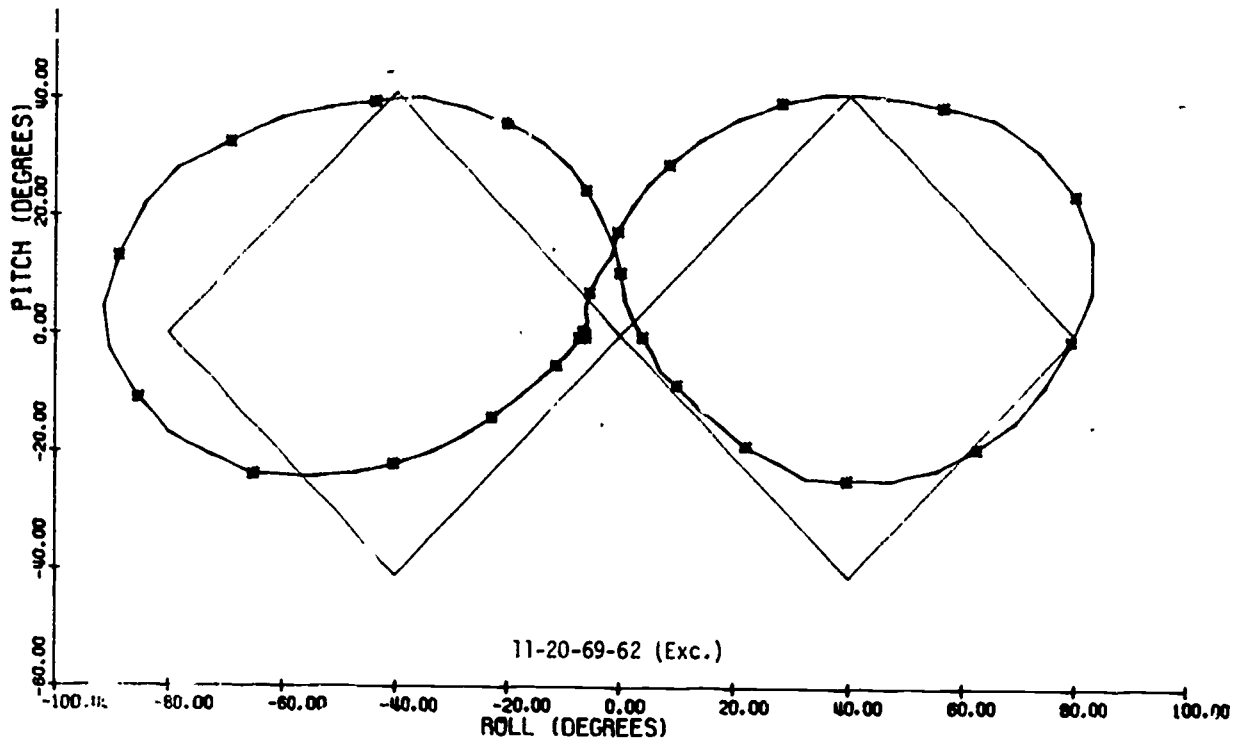
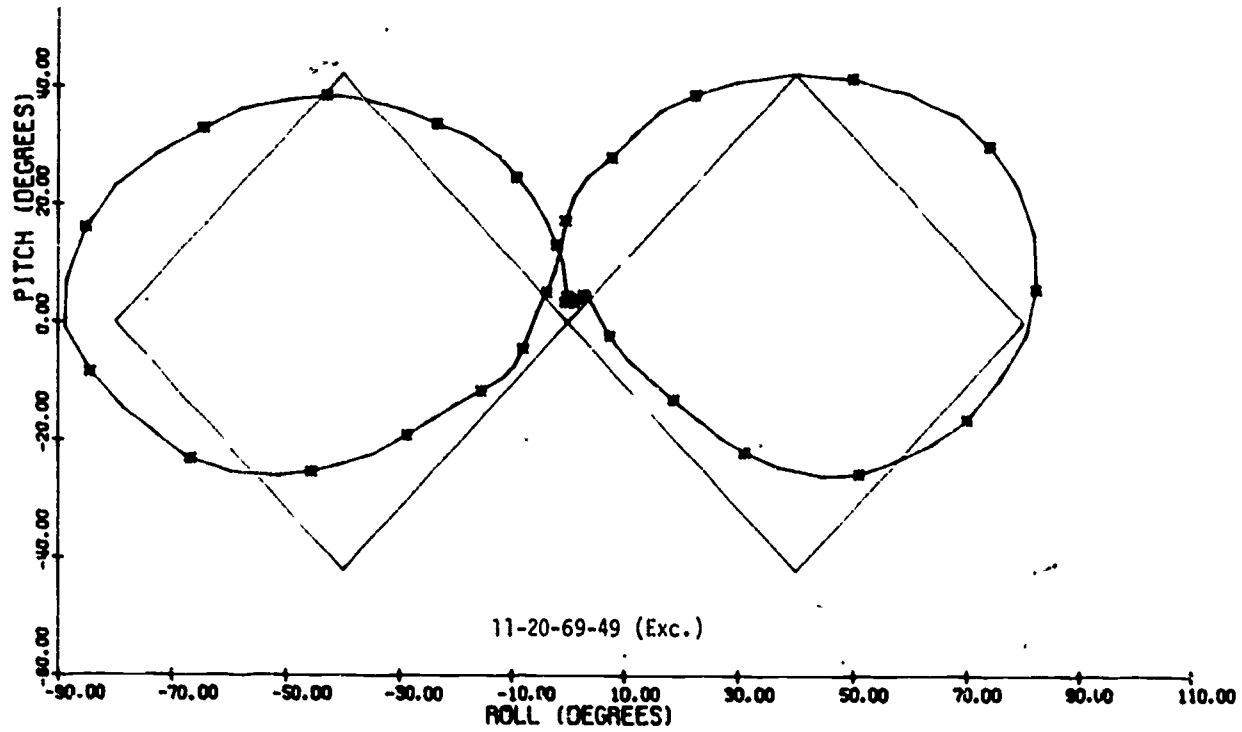

ROLL VS. PITCH FOR LAZY 8

AFHRL-TR-72-6

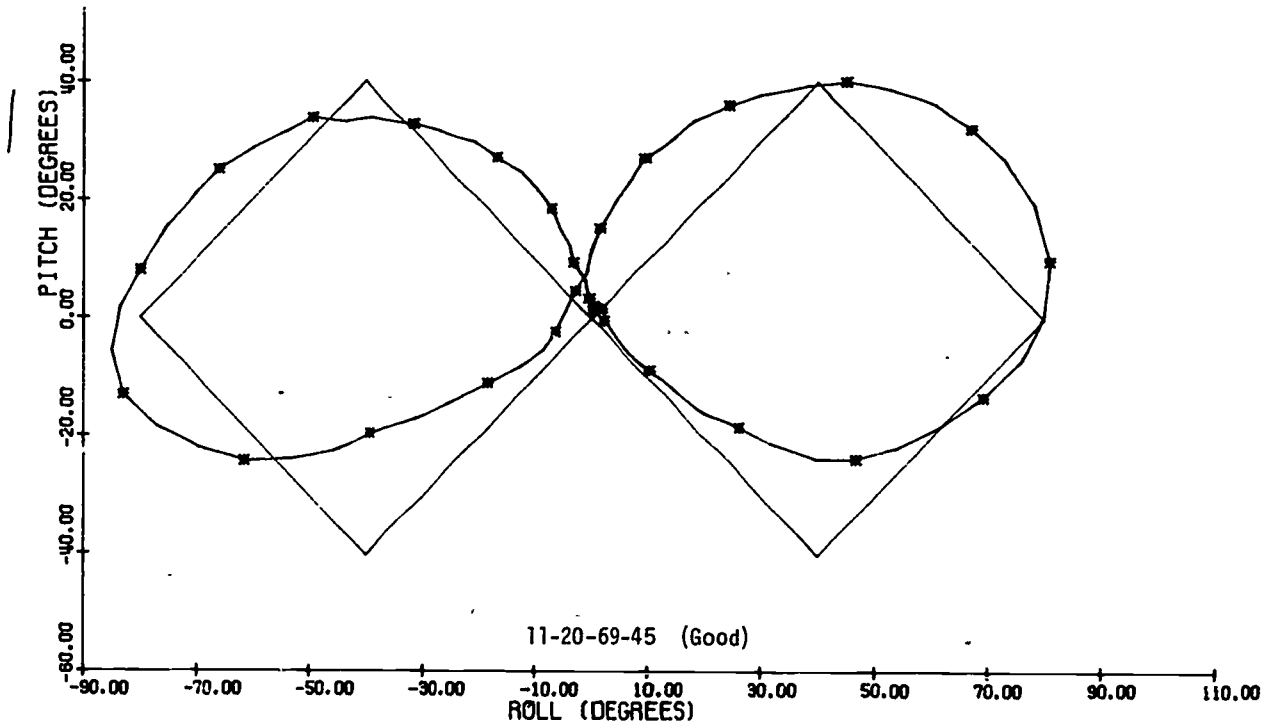
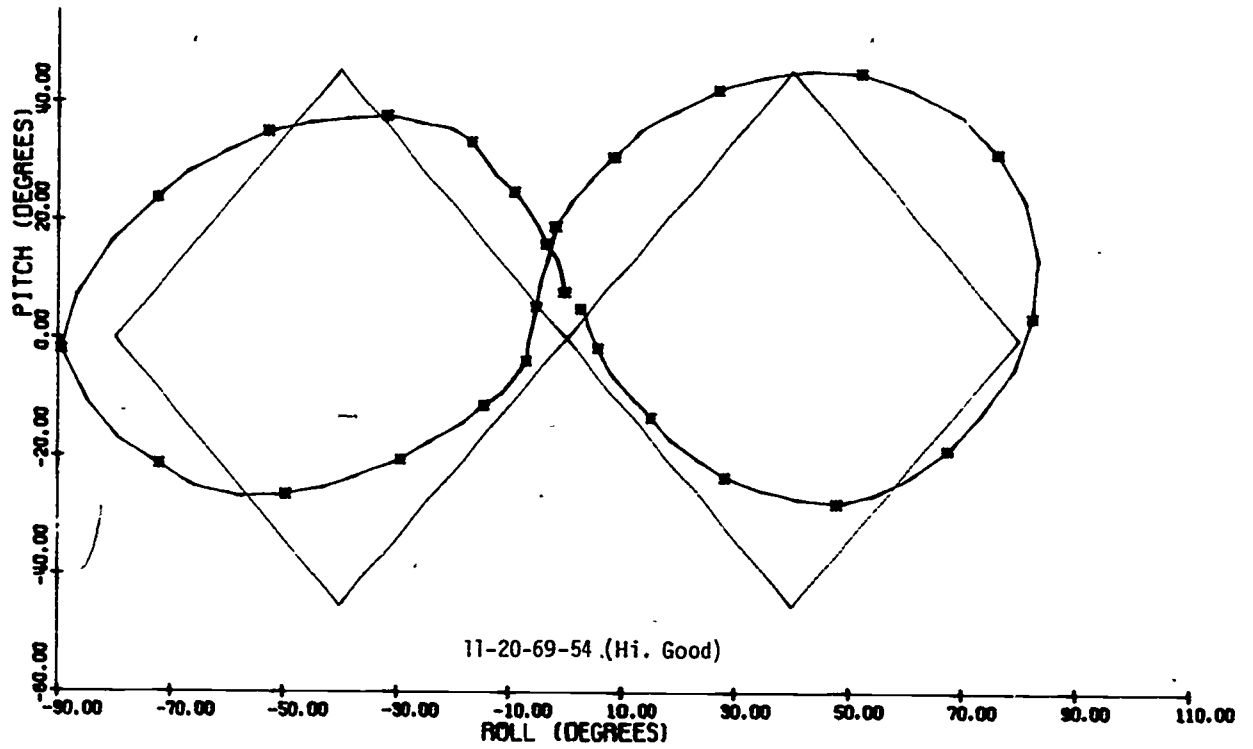

ROLL VS. PITCH FOR LAZY 8

AFHRL-TR-72-6

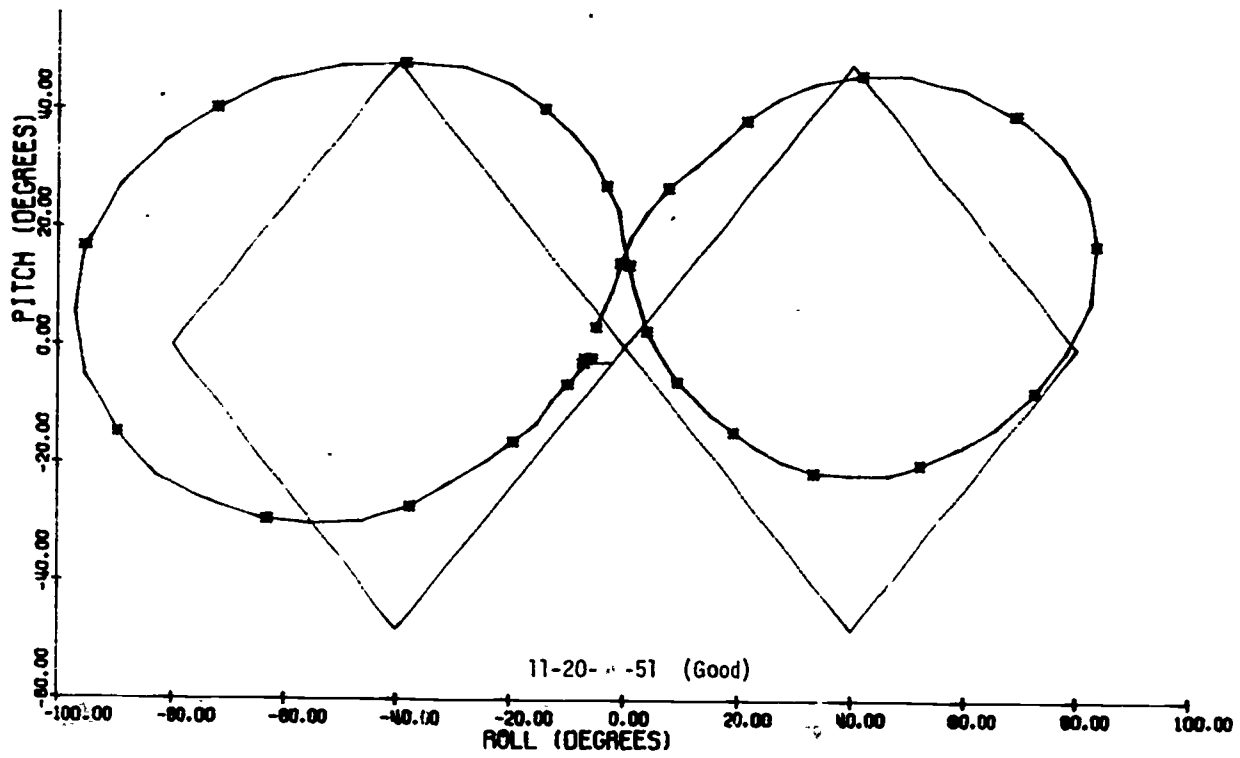
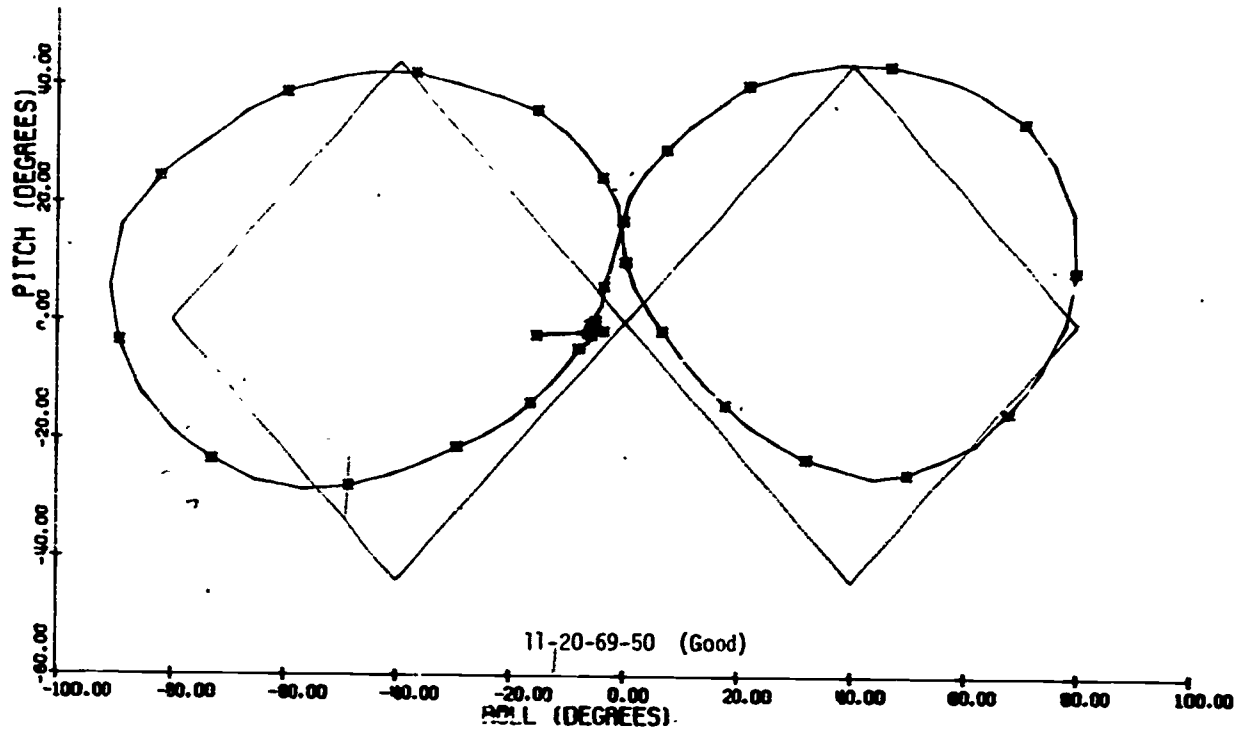

ROLL VS. PITCH FOR LAZY 8

AFHRL-TR-72-6

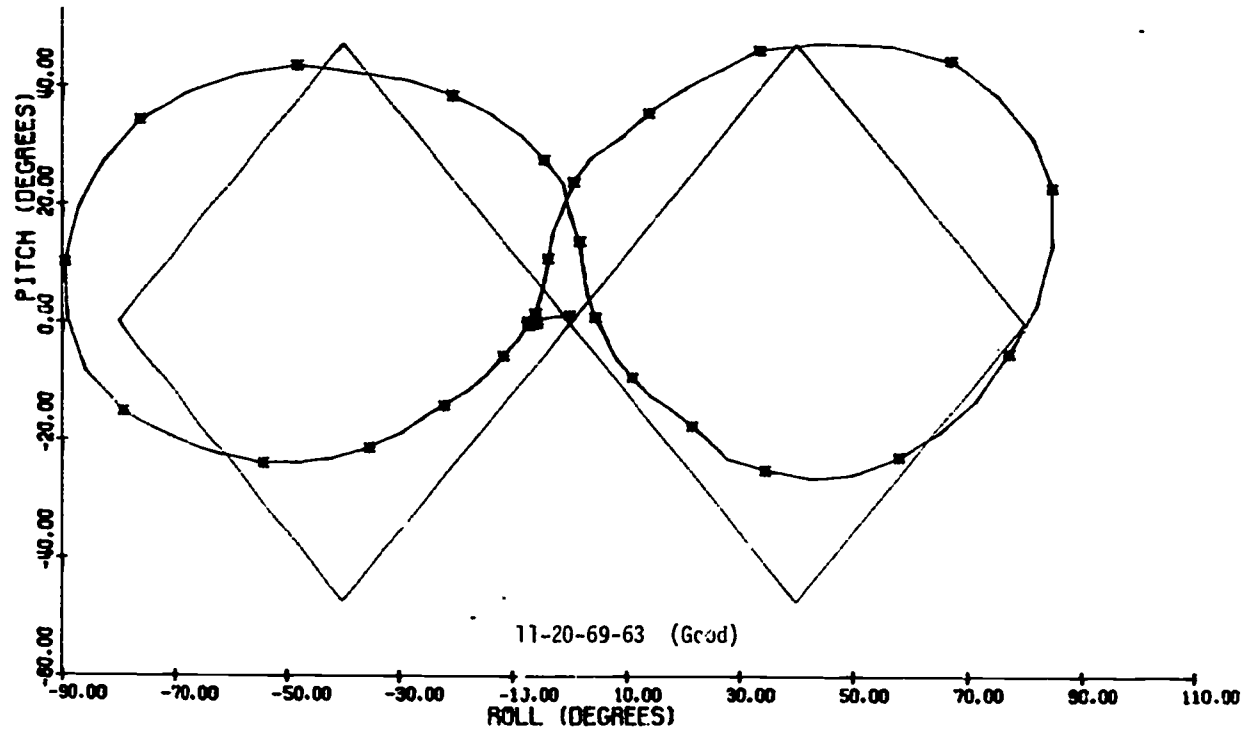
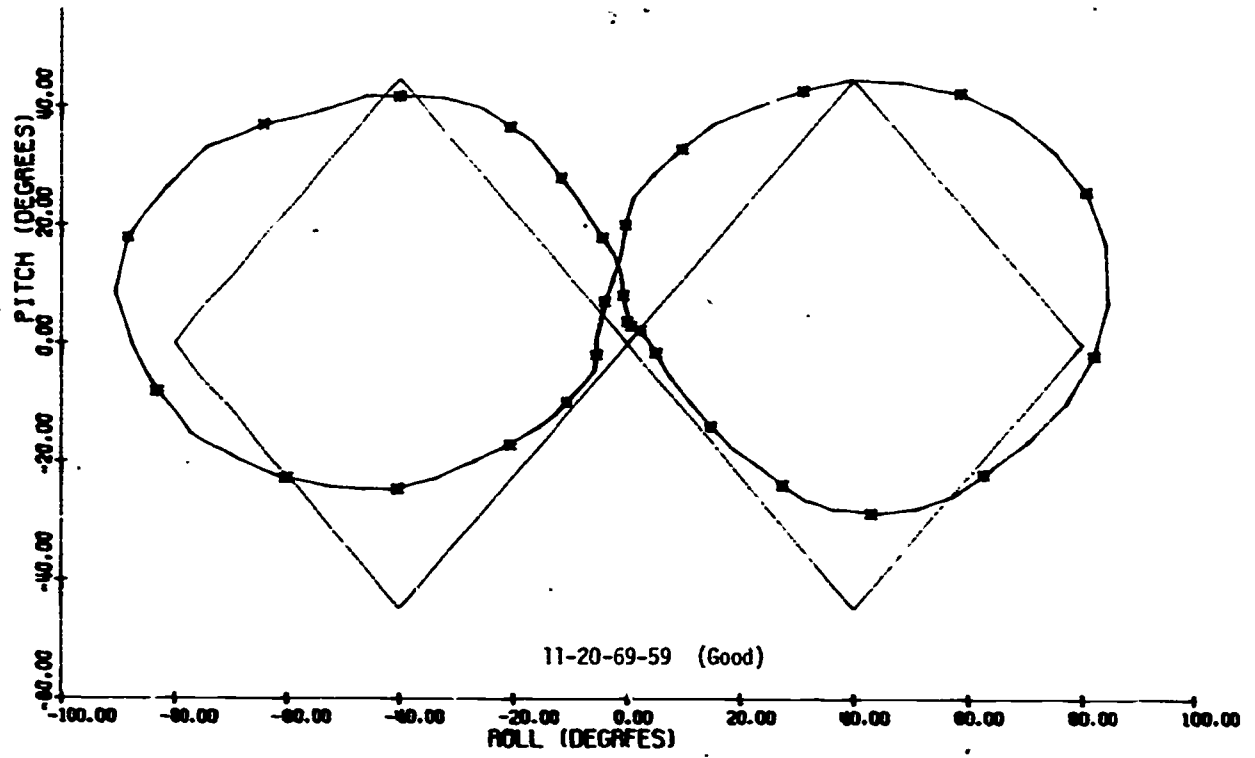

ROLL VS. PITCH FOR LAZY 8

AFHRL-TR-72-6

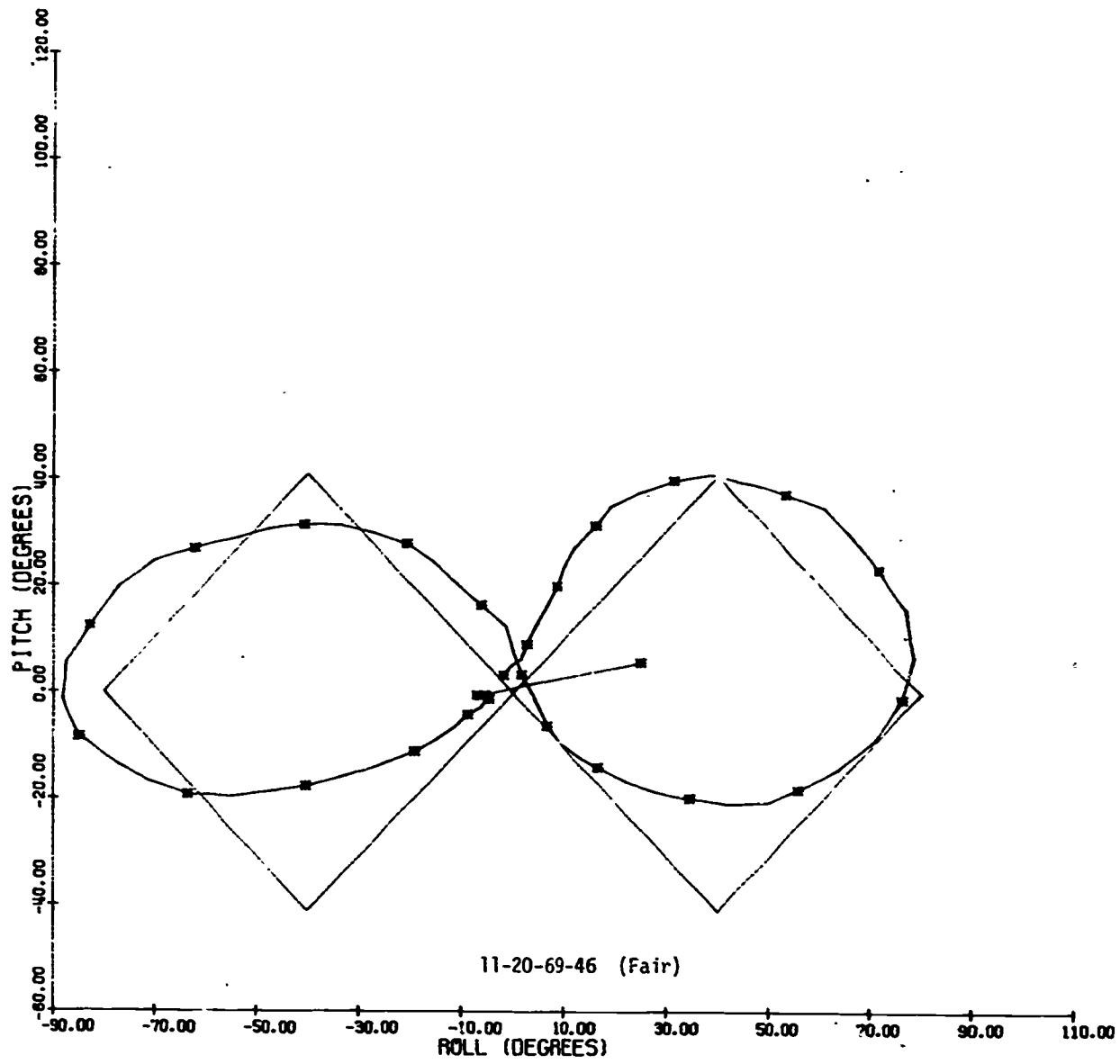

ROLL VS. PITCH FOR LAZY 6

AFHRL-TR-72-6

APPENDIX XII
AIRSPEED PLOTS FOR REPRESENTATIVE
LAZY 8 MANEUVERS

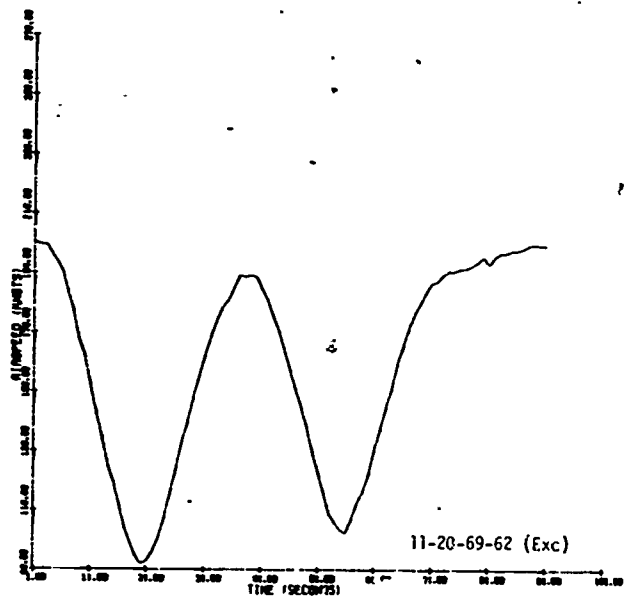
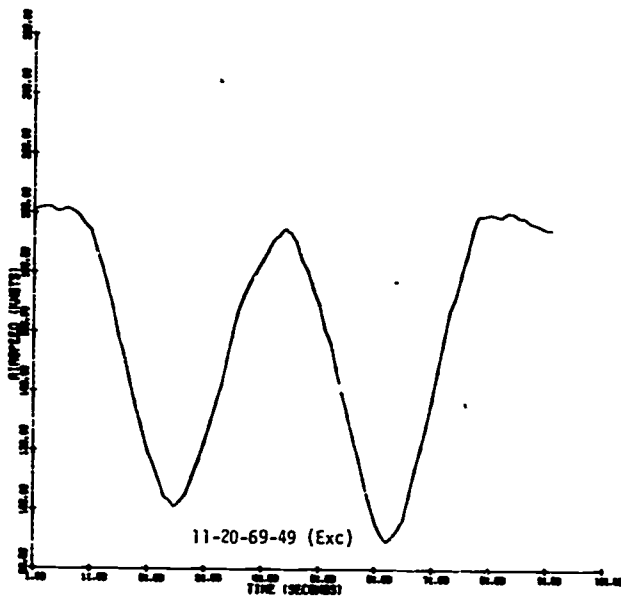
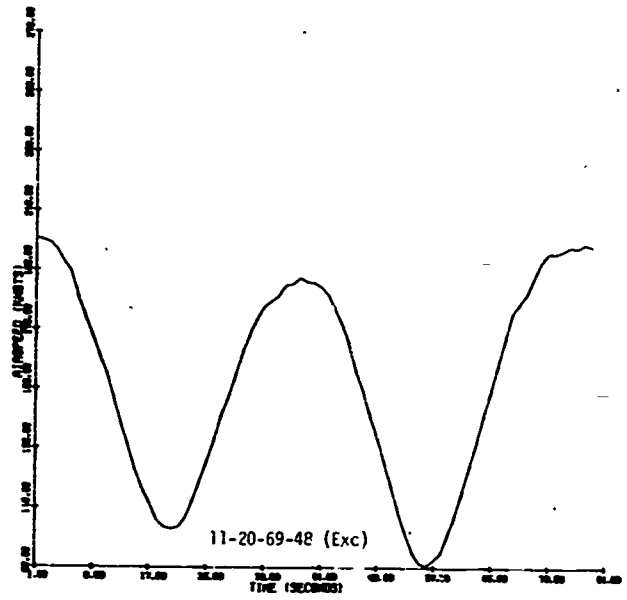
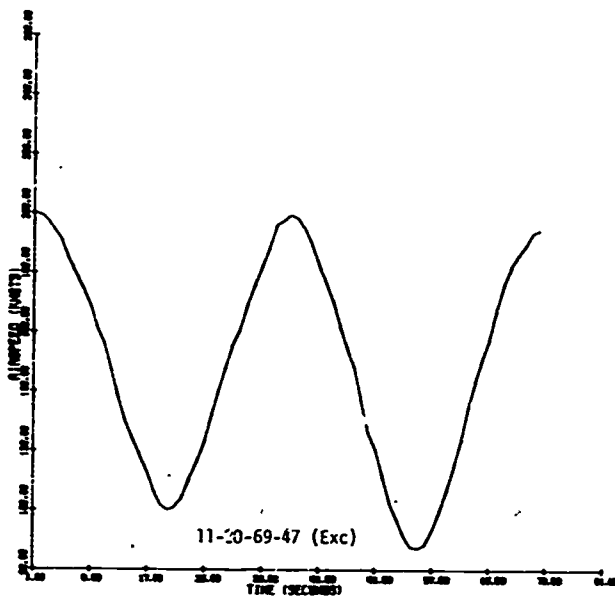

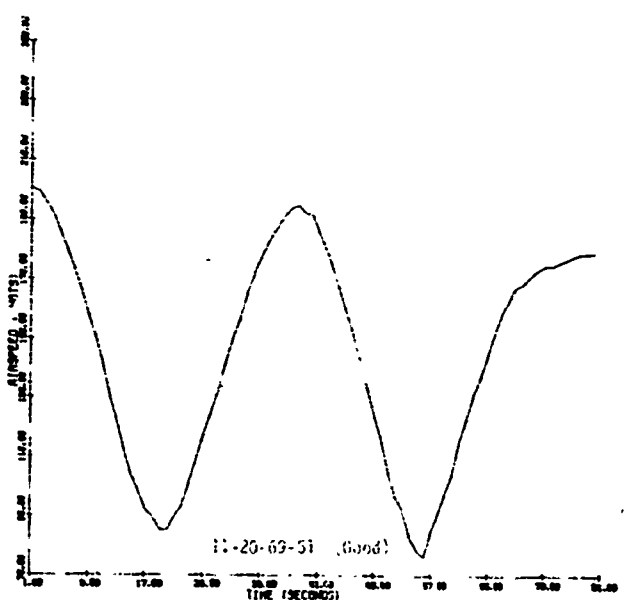
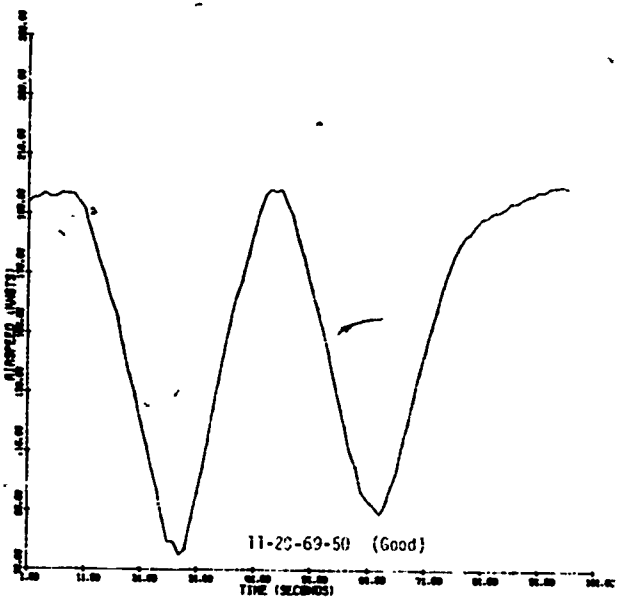
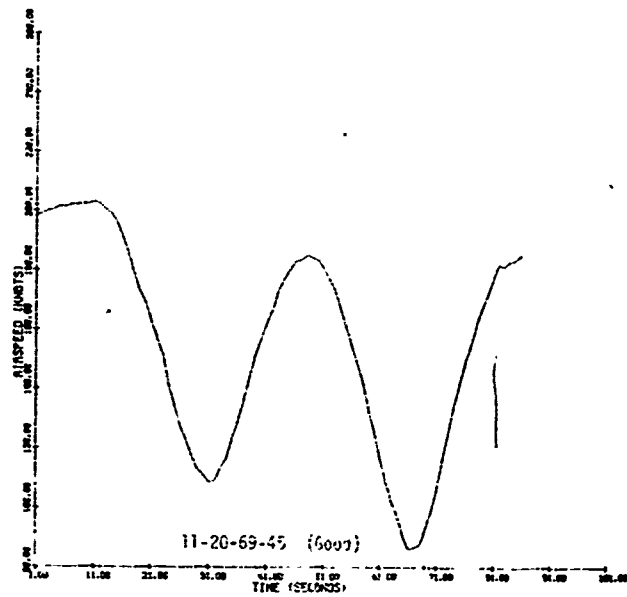
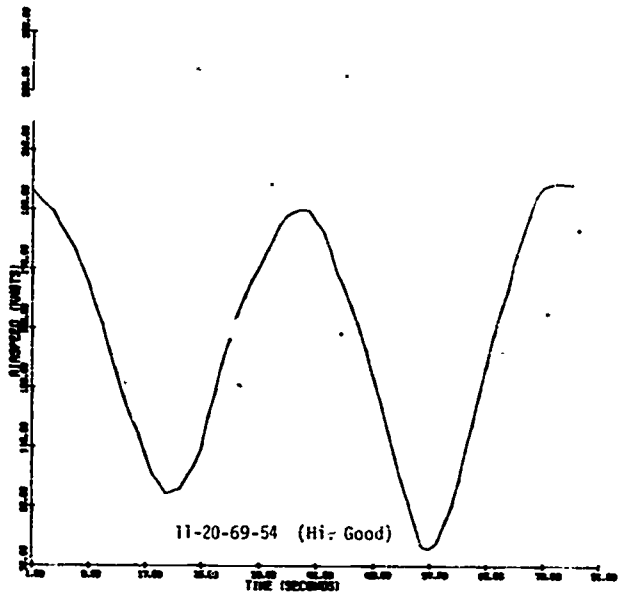

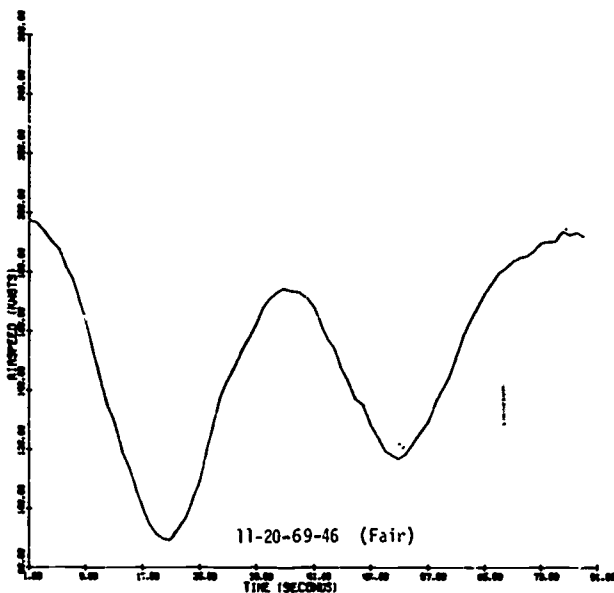
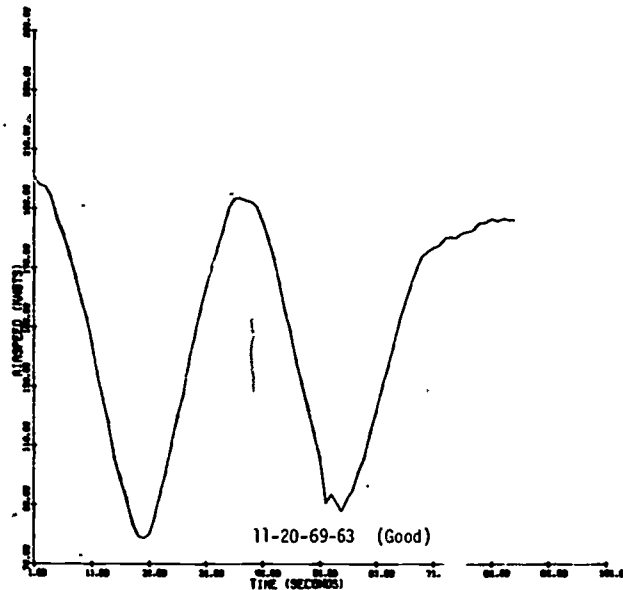
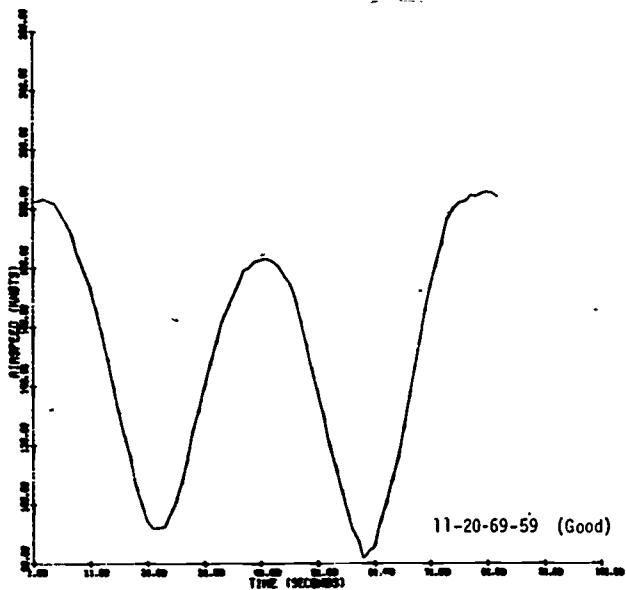

AFHRL-TR-72-6

APPENDIX XIII
PUNCH AND PRINT PROGRAM

AFHRL-TR-72-6

PUNCH AND PRINT PROGRAM

This program prints at $\Delta t = 0.5$ and punches cards at

$$\Delta t = \begin{cases} 0.4, & \text{Barrel Roll and Others} \\ 0.5, & \text{Lazy 8} \end{cases}$$

-
- Input CrDS: (1) \$ Setup A A(3) AAAA T37DXX, ~~N~~ RING
(2) Month, Day, Year
(3) N
(4) KODE = $\begin{cases} + & \text{Lazy 8} \\ - & \\ \text{or} & \text{other maneuver} \\ 0 & \end{cases}$
(5) evno
(6) Duration

KNCCP
LAZYY8 ~ EFF SOURCE STATEMENT - IFH(S) -

07/10

CPRINT MEASURE VARIABLES FOR LAZY S MAN=LVLR

```

DIMENSION AR(10,1500)
DIMENSION IMM(25)
DIMENSION A(120,9),B(12,25),EVNO(25)
DIMENSION XCNT(25)
ICOUNT=4
IEV=1
REAC(5,5011)IMON,ICAY,IYR
5012 FORMAT(3I5)
REAC(5,500) N
PEAC(5,1501)(IMM(I),I=1,N)
1501 FORMAT(12I5)
REAC(5,501)(EVNO(I),I=1,10)
601 REAC(5,501)(XCNT(I),I=1,N)
4030 CONTINUE
ITEST=-10
1 REAC(16)((A(I,J),I=1,120),J=1,9)
REAC(16)((B(I,J),I=1,12),J=1,25)
CC 20 I=1,2
X=AMCC(B(I,18),100.0)
IF(ITEST)9710,5,5
9710 CONTINUE
IF(EVNO(IEV)-X) 2,3,2
3 IF(ITEST) 4,5,5
4 WRITE(6,350)IMON,ICAY,IYR
WRITE(6,300)EVNO(IEV)
ICOUNT=4
6751 WRITE(7,6760)IMON,ICAY,IYR,EVNO(IEV)
6760 FORMAT(15,15,15,F7.0)
6750 CONTINUE
XERPT=EVNO(IEV)
L=0
TIME=0.0
ITEST=0
5 IA=10*(I-1)+1
L=L+1
6004 CONTINUE
IF(L-1)820,820,821
821 IF(A(IA,6))822,826,826
826 IF(A(IA,5)-350.)827,827,822
827 IF(ABS(A(IA,2))-360.)9411,9411,822
9411 IF(B(I,6))822,822,820
822 CC 823 MOM=1,10
823 AR(MOM,L)=AR(MOM,L-1)
GC TC 824
820 CONTINUE
AR(1,L)=A(IA,2)
AR(2,L)=A(IA,1)
AR(3,L)=B(I,7)
6005 AR(4,L)=B(I,6)
AR(5,L)=A(IA,6)
AR(6,L)=B(I,15)
AR(7,L)=B(I,16)
AR(8,L)=A(IA,3)
AR(9,L)=A(IA,4)

```

KLEFF

ZYVY

SOURCE STATEMENT - IFA(S) -

077.0.

```

      AR(1,L),AR(2,L)
#24 CONTINUE
      ANGLE=360*PI*AR(1,L)/180.0
      CYCLES=ANGLE
      ACTY=TIME*44*(54.140000.0/3600.)
      GC=TIME*AR(1,L)
      I=INT(.5+ACTY)-AR(1,L)
      IF (I.GE.4) I=I-4
700 WRITE(5,10) TIME,AR(1,L),AR(2,L),AR(3,L),AR(4,L),AR(5,L),AR(6,L),
      I,AR(1,L),AR(2,L),AR(3,L),TURN,SS,ALT,AR(10,L)
      TIME=TIME+.5
      ICOUNT=I
      GC=GC+.50
201 ICOUNT=ICOUNT+1
      GC=GC+.50
      2 IF (I.EQ.7) GO TO 7
      7 WRITE(6,731)
731) FORMAT(2H XZ)
      GO TO 20
7729 CONTINUE
6755 LYZX=LYZ
      IF (I.EQ.1) I=1.0,15.0,15.0,15.0
1520 NDCEL=4
      LYZX=(I-1)/4.0
      WRITE(7,500) LYZX
      WRITE(7,554) ((AR(I,JC), I=1,5), JC=1,L,NDCEL)
      I=AR(I,JC), JC=L-L,NDCEL)
      GC=GC+.50
1524 FORMAT(F5.0,F4.0,F5.0,F7.0,F5.0,F5.0,F5.0,F4.0,F5.0,F7.0,F5.0,
      F5.0)
1522 NDCEL=5
      LYZX=(I-1)/5+1
      WRITE(7,500) LYZX
      WRITE(7,554) ((AR(I,JC), I=1,5), JC=1,L,NDCEL)
6754 FORMAT(F5.0,F4.0,F5.0,F7.0,F5.0,F5.0,F5.0,F4.0,F5.0,F7.0,F5.0,F5.0,
      F4.0,F5.0,F5.0)
6752 CONTINUE
700 CONTINUE
      IF (I.EQ.7) GO TO 7
      9 IFV=I*V
      I=I*V-10
      LE0
600 XXX=XXX*(I*V)
      ALL=1
      IF (ALL-XXX) 0,7729,7729
20 CONTINUE
      GO TO 1
      8 CONTINUE
500 FORMAT(I)
501 FORMAT(2F5.0)
500) CONTINUE, TABLAZ, NUMBER, F5.0/1H /1H /56X,4HLEFT,3X,5HRIGHT,
      3X,4HLEFT,3X,4HLAT,3X/5H /1H,4X,4HROLL,3X,5HPITCH,2X,
      27H,3H,3X,3HALTITUDE,3X,8H,3AIRSPEED,3X,3HRPM,4X,3HRPM,4X,
      3HST,3X,3X,3HST,3X,3X,4HTUR,3X,2HGS,3X,4HALT,5X,4HACCL/
      3X,2X

```

AFHRL-TR-72-6

KNCCP

LAZYY8

- EFN SOURCE STATEMENT - IFH(S) -

07/16/

```
301 FCRMAT(F6.1,2X,F5.0,3X,F5.0,4X,F5.0,6X,F7.C,5X,F5.0,2X,F5.0,2X,  
1F5.0,6X,F5.1,6X,F5.1,2X,F5.0,1X,F6.0,1X,F5.0,2X,F6.2)  
350 FORMAT(1H1,20X,29HDATA PRINTOUT FOR FLIGHT OF I3,1H-I3,1H-I3/  
11H /)  
STGP  
END
```

AFHRL-TR-72-6

APPENDIX XIV
SAMPLE OUTPUT OF LAZY 8
EXPERIMENTAL MEASUREMENT PROGRAM

AFHRL-TR-72-6

RECORDED VALUES¹
EVENT 47 (11-20-69)

TIME	ROLL	PITCH	HEADING	ALTITUDE	AIRSPEED
0	0	5	360	9586	200
5	-8	22	359	9940	185
10	-26	36	358	10713	156
15	-61	34	340	11536	118
20	-90	2	308	11772	101
25	-62	-26	251	11468	132
30	-29	-21	215	10677	169
35	-7	-3	201	10218	197
40	0	19	201	10324	182
45	21	40	218	11030	148
50	67	41	255	11806	103
55	82	2	304	12148	88
60	48	-24	344	11772	124
65	18	-17	358	10996	167
70	3	-1	360	10465	193

¹Recorded values shown here at 5 second intervals; actual print-outs showed values at 0.5 second intervals.

AFHRL-TR-72-6

FLIGHT OF 11-20-69, EVNO 47

PITCH	ROLL	ARSP	ALTX
5.00	-0.	200.00	0.
12.67	-2.80	197.05	177.89
25.33	-10.23	179.60	596.00
38.00	-42.80	134.80	1517.40
25.33	-73.74	106.14	2079.19
12.67	-83.75	100.42	2175.80
0.	-90.68	101.70	2186.00
-9.00	-88.54	105.52	2206.45
-18.00	-79.46	115.07	2158.34
-27.00	-51.00	141.75	1646.00
-18.00	-23.00	176.00	914.01
-9.00	-13.00	192.00	667.00
0.	-5.50	197.86	596.00
15.00	-0.57	187.76	646.37
30.00	9.00	162.99	1049.37
45.00	46.67	120.67	1983.33
30.00	78.37	92.63	2392.76
15.00	83.00	87.00	2557.92
0.	81.08	88.79	2557.91
-8.33	76.81	94.20	2515.37
-16.67	66.97	103.10	2469.79
-25.00	40.00	135.00	2051.00
-16.67	17.28	169.44	1387.86
-8.33	8.37	186.00	1099.56
2.00	2.00	195.00	879.00

AFHRL-TR-72-6

FLIGHT OF 11/20/69

ENVO 47 (4, LEFT)

AIRSPEED COMPUTATIONS

NO.	ERROR	
1	0.	SUM(1-5) = 18.00
2	0.	
3	0.	SUM(1-3) = 0.
4	-13.00	
5	-5.00	SUM(3-5) = 18.00

	EXCURSION	TIME	RATE
1	100.000	19.0	5.3
2	100.000	17.0	5.9
3	113.000	17.5	6.5
4	108.000	18.0	6.0

RESULTS OF ANALYSIS: STANDARD DEVIATION AND MEAN FOR ALL GROUPS

	GROUP 1 EXC.		GROUP 2 GOOD		GROUP 3 FAIR		GROUP 4 UNSAT.		GROUP 5 RIGHT-EXC.	
	MEAN	S.D.	MEAN	S.D.	MEAN	S.D.	MEAN	S.D.	MEAN	S.D.
MAX(1) PITCH	40.11	3.69	38.11	6.88	36.46	7.79	43.10	12.30	40.33	4.73
MIN(1) PITCH	-27.78	3.96	-25.28	5.81	-30.10	7.98	34.50	7.17	-25.33	3.51
MAX(2) PITCH	40.89	2.89	40.22	5.06	40.10	7.23	43.60	14.87	39.33	2.08
MIN(2) PITCH	-26.00	2.35	-25.89	3.66	-30.00	7.12	37.00	14.22	-27.00	4.36
ROLL (MAX 1)	46.08	5.45	44.90	5.93	44.29	9.22	58.98	8.26	46.06	5.85
ROLL (MIN 1)	50.66	5.30	50.89	7.04	48.82	9.19	63.60	8.14	44.61	2.33
ROLL (MAX 2)	45.39	5.39	44.65	4.63	41.74	5.55	61.08	8.59	46.17	9.52
ROLL (MIN 2)	48.49	6.88	50.11	5.27	42.12	9.14	60.27	11.90	56.23	5.05
FSP (MAX 1)	130.28	6.56	134.02	14.04	135.54	15.14	133.34	25.56	123.83	5.01
FSP (MIN 1)	134.61	5.91	137.81	9.99	137.07	18.14	133.28	34.04	130.36	8.52
FSP (MAX 2)	127.03	7.79	127.56	8.82	125.00	10.10	125.52	27.38	134.42	8.50
FSP (MIN 2)	132.22	4.48	133.79	8.84	130.45	8.32	122.57	27.20	129.34	4.33
ALT (MAX 1)	1342.23	125.4	1272.97	272.03	235.27	364.79	1259.17	479.89	1352.22	72.64
ALT (MIN 1)	1520.61	74.77	1464.10	238.34	1427.58	438.90	1544.28	625.35	1538.31	62.14
ALT (MAX 2)	1621.46	170.5	1629.91	280.36	1501.00	228.05	1508.82	629.18	1527.17	100.36
ALT (MIN 2)	1780.61	159.4	1754.33	268.91	1582.94	169.52	1462.37	644.85	1828.4	99.94
MAX + ROLL	82.62	2.73	81.91	4.83	82.30	5.14	101.40	12.75	84.46	4.15
MAX - ROLL	91.11	4.62	88.71	6.37	-92.20	5.17	-108.90	12.54	-89.92	6.18
TIME HALF 1	38.5	2.76	37.81	3.25	39.90	4.19	34.65	5.68	37.17	1.04
TIME HALF 2	40.72	5.85	39.42	5.72	33.30	7.12	28.75	4.24	43.83	8.89
TOTAL TIME	79.22	6.18	77.22	6.96	73.70	8.74	63.40	5.37	81.0	7.86
1	1.67	2.00	2.61	2.00	3.20	4.50	5.30	7.34	2.33	2.52
2	7.22	7.60	13.17	8.51	19.26	12.11	42.60	25.16	12.0	11.53
3	5.56	4.39	7.44	5.95	1.90	9.33	14.00	9.40	8.33	3.79
4	10.67	6.46	13.72	7.90	23.20	17.27	47.60	32.36	6.33	5.13
5	3.44	4.82	9.39	8.40	14.90	10.18	22.80	13.01	2.33	3.21
6	28.56	10.97	46.33	13.16	76.70	25.56	133.10	85.75	31.33	16.20
7	14.44	10.04	23.22	8.95	33.70	21.12	63.10	29.99	22.67	12.90
8	19.67	5.29	30.56	12.06	52.00	15.15	84.00	44.46	17.0	5.29
9	105.33	7.91	101.89	17.08	102.50	25.23	111.70	47.54	109.67	12.58
10	102.11	9.55	96.94	16.26	93.20	23.38	107.60	38.33	103.67	9.87
11	105.78	11.46	104.61	13.44	105.40	33.21	123.00	59.20	96.67	8.39
12	107.00	9.81	103.33	13.85	103.20	34.64	109.20	59.80	102.67	7.23
13	5.13	.74	5.11	1.01	4.89	0.14	6.34	2.52	5.67	.95
14	5.77	.55	5.53	.93	5.88	0.97	7.17	2.05	5.87	.66
15	5.94	.58	6.06	.92	6.22	1.22	8.20	1.87	5.50	.78
16	4.81	.89	4.90	1.12	5.52	1.79	5.88	2.84	4.13	1.22
17	20.78	2.39	20.19	2.66	21.30	3.88	17.00	2.33	19.5	1.32
18	17.72	.87	17.61	1.64	15.30	1.54	14.85	2.15	17.67	1.15
19	17.83	1.37	17.33	1.40	15.33	2.24	14.80	2.11	17.67	1.15
20	22.94	5.05	22.08	5.63	19.45	6.16	16.75	3.94	26.17	7.82

ITEM	GROUP 6 LEFT-EXC.		GROUP 7 RIGHT-GOOD		GROUP 8 LEFT-GOOD		GROUP 9 RIGHT-FAIR		GROUP 10 LEFT-FAIR	
	MEAN	S.D.	MEAN	S.D.	MEAN	S.D.	MEAN	S.D.	MEAN	S.D.
MAX(1) PITCH	40.00	3.28	39.33	8.48	27.50	6.77	21.87	8.14	39.43	7.26
MIN(1) PITCH	-29.00	3.25	-21.83	4.26	-27.00	4.5	-21.00	1.75	-3.57	5.22
MAX(2) PITCH	41.87	1.08	39.67	6.09	40.10	4.74	44.00	10.44	33.53	3.29
MIN(2) PITCH	-21.50	0.75	-27.17	3.54	-25.25	3.70	-31.87	11.08	-29.29	6.29
ROLL (MAX 1)	55.00	3.12	45.41	3.99	44.53	6.55	34.22	3.51	50.52	7.76
ROLL (MIN 1)	53.55	3.15	44.28	4.20	50.20	5.72	48.17	3.97	50.52	4.77
ROLL (MAX 2)	45.00	3.12	45.10	3.57	44.43	5.32	45.81	7.21	51.95	3.23
ROLL (MIN 2)	44.62	3.15	55.10	2.71	47.61	4.8	54.31	3.56	51.73	6.28
TRSP (MAX 1)	133.51	4.62	124.80	12.46	130.84	12.52	137.56	16.85	134.52	15.99
TRSP (MIN 1)	130.74	4.75	132.61	9.66	143.40	9.78	143.42	13.21	133.45	16.10
ARSP (MAX 1)	123.33	4.16	132.21	9.67	125.23	7.76	125.82	13.65	125.65	9.06
ARSP (MIN 1)	133.55	4.13	133.96	9.35	133.71	9.00	125.82	12.01	132.50	7.43
ALT (MAX 1)	131.76	156.84	134.26	223.49	125.32	295.80	100.87	330.52	1329.54	356.59
ALT (MIN 1)	131.76	82.76	1498.33	168.40	1440.99	271.93	1130.17	443.87	1553.05	398.25
ALT (MAX 2)	168.51	185.73	1527.63	271.32	1681.03	281.28	1375.74	204.58	1555.57	228.99
ALT (MIN 2)	1756.71	186.01	1721.93	289.34	1770.32	269.30	1627.92	69.45	1564.51	200.44
MAX + ROLL	82.00	1.55	81.12	2.73	82.58	5.41	80.00	2.55	89.00	3.92
MAX - ROLL	-91.83	4.12	88.55	5.78	-59.42	7.05	-91.57	3.79	-92.71	3.77
TIME HALF 1	4.17	1.93	36.33	1.89	41.53	4.12	37.5	1.04	40.79	3.01
TIME HALF 2	35.23	3.12	43.00	5.55	44.31	4.55	41.50	10.49	30.50	3.61
TOTAL TIME	79.42	5.68	79.33	6.52	76.17	7.20	79.5	9.93	71.29	7.71
E 1	1.33	1.35	1.67	1.51	1.03	2.11	4.03	3.21	6.00	3.23
E 2	4.83	5.1	15.33	8.82	12.08	8.7	15.57	3.73	21.57	14.51
E 3	4.17	4.26	7.83	6.91	7.25	5.74	10.67	12.66	13.43	7.51
E 4	12.83	6.27	13.50	5.68	12.61	9.04	37.57	19.09	17.00	14.51
E 5	4.00	5.65	7.67	8.21	10.25	8.72	10.00	6.08	16.85	11.80
E 6	21.17	8.98	46.00	14.13	45.70	12.10	75.33	19.26	75.25	28.47
E 7	18.33	3.32	24.83	4.26	22.42	10.82	23.57	11.26	4.00	24.34
E 8	21.00	3.22	29.00	15.02	31.23	10.97	51.23	11.06	49.29	13.75
E 9	105.17	4.15	109.00	15.32	93.31	17.60	89.33	18.50	107.55	27.69
E10	101.33	10.23	102.	18.56	94.17	15.07	83.57	3.21	97.57	27.75
E11	110.35	10.37	99.00	18.21	107.42	10.13	117.00	30.71	100.43	27.59
E12	109.17	10.78	99.17	10.46	105.42	15.13	121.00	38.94	99.29	32.60
E13	4.37	0.72	5.75	.86	4.79	0.97	4.73	1.12	4.57	0.81
E14	5.72	0.53	5.95	1.10	5.32	0.79	5.18	0.17	5.17	1.04
E15	6.16	0.74	5.67	.92	6.25	0.78	6.02	1.99	6.31	0.94
T 1	5.15	0.59	3.95	.60	5.13	1.03	5.28	2.79	5.76	1.46
T 2	21.42	2.33	19.00	1.55	20.79	2.04	19.00	1.20	25.00	3.70
T 3	17.73	0.52	17.33	1.57	17.73	1.73	16.17	1.04	13.94	1.89
T 4	17.92	1.36	17.33	.86	17.33	1.54	18.53	2.93	13.71	1.85
T 5	21.33	1.44	25.67	5.19	20.29	5.13	25.33	9.78	16.93	2.01

ITEM	GROUP 11 RIGHT-UNSAT.			GROUP 12 LEFT-UNSAT.			GROUP 13 RIGHT			GROUP 14 LEFT			GROUP 15 ALL		
	MEAN	S.D.		MEAN	S.D.		MEAN	S.D.		MEAN	S.D.		MEAN	S.D.	
MAX(1) PITCH	50.50	7.78		41.25	12.79		29.50	8.66		39.06	8.01		29.19	8.16	
MIN(1) PITCH	-37.00	7.24		-34.83	10.25		-24.70	5.29		-31.64	8.03		-27.50	8.17	
MAX(2) PITCH	60.50	7.78		45.50	15.00		41.50	9.77		41.52	8.43		42.11	8.72	
MIN(2) PITCH	-51.00	7.07		-32.50	11.71		-32.07	11.43		-27.91	7.18		-27.15	8.75	
ROLL (MAX 1)	59.72	5.12		58.37	5.73		45.22	7.9		49.86	8.53		45.17	8.41	
ROLL (MIN 1)	55.25	5.34		55.04	7.53		45.55	4.78		54.51	8.51		53.71	9.72	
ROLL (MAX 2)	64.50	4.05		62.75	6.00		53.21	8.75		50.97	8.93		50.17	8.87	
ROLL (MIN 2)	57.25	5.22		57.27	9.73		57.52	7.1		50.29	7.62		52.47	9.71	
CRSP (MAX 1)	105.57	1.99		140.01	25.17		124.77	11.99		137.23	15.97		135.51	17.00	
CRSP (MIN 1)	105.25	3.13		142.04	34.92		151.19	15.73		138.66	18.97		136.50	18.04	
CRSP (MAX 2)	99.87	6.50		129.48	26.84		125.82	13.27		126.00	14.70		123.27	14.71	
CRSP (MIN 2)	98.33	10.37		123.37	27.27		125.72	14.43		132.13	14.44		130.59	14.34	
ALT (MAX 1)	1529.25	23.59		1188.55	497.08		1514.75	272.73		1257.91	341.11		1273.55	320.42	
ALT (MIN 1)	1724.25	90.17		1255.54	671.77		1460.26	264.57		1437.28	409.08		1442.72	373.47	
ALT (MAX 2)	1873.00	87.58		1219.02	578.79		1515.29	213.22		1540.19	425.91		1532.76	371.47	
ALT (MIN 2)	1867.00	104.55		1377.46	701.32		1735.91	202.11		1529.82	413.78		1660.77	368.37	
MAX + ROLL	91.50	4.75		105.36	12.94		81.21	4.96		89.00	11.40		87.28	10.25	
MAX - ROLL	-119.50	14.35		-106.25	11.42		-92.12	12.11		-94.34	9.53		-92.29	10.25	
TIME HALF 1	35.25	1.05		35.73	6.02		37.59	5.83		39.59	5.83		39.19	5.10	
TIME HALF 2	31.25	1.77		28.15	4.53		40.73	7.16		32.18	3.94		34.73	6.87	
TOTAL TIME	59.50	2.33		61.88	4.76		74.29	7.28		72.03	5.88		71.93	8.89	
E 1	4.50	3.34		7.00	8.12		2.79	2.46		3.33	1.13		3.67	4.55	
E 2	59.50	19.09		38.38	26.94		20.37	19.14		19.15	19.42		19.57	19.02	
E 3	21.50	3.24		12.13	9.58		16.50	3.12		9.21	7.86		9.87	7.72	
E 4	75.00	19.30		40.50	11.92		24.97	25.78		20.79	20.67		22.22	22.15	
E 5	25.00	3.49		22.00	17.33		9.80	9.44		13.36	11.93		12.21	11.33	
E 6	183.50	15.26		120.00	64.86		59.29	51.57		67.24	48.21		57.53	49.28	
E 7	35.50	12.02		37.50	20.93		31.36	23.6		31.09	23.98		31.2	24.96	
E 8	121.50	11.92		74.53	43.51		43.92	27.78		43.78	29.93		44.40	32.05	
E 9	151.00	22.83		100.83	46.51		111.76	24.90		101.36	27.15		102.72	26.58	
E 10	135.00	22.52		100.00	39.54		103.79	21.11		97.51	25.92		99.45	23.17	
E 11	153.50	16.26		115.33	40.07		116.14	20.33		106.56	23.94		108.91	25.86	
E 12	155.00	11.31		99.00	37.74		111.88	25.10		101.74	22.25		105.61	25.25	
E 13	7.84	1.01		6.22	2.73		5.82	1.77		5.12	1.28		5.31	1.52	
E 14	3.74	0.58		6.78	2.12		6.15	1.53		5.92	1.34		3.99	1.33	
E 15	9.33	1.39		7.92	1.95		6.24	1.31		6.63	1.23		3.55	1.45	
E 16	3.57	0.65		4.44	3.04		4.94	2.06		5.67	1.75		3.45	1.35	
T 1	19.75	6.29		18.51	2.73		19.21	1.74		20.29	3.76		19.97	3.25	
T 2	15.75	0.77		14.53	2.28		16.91	1.45		16.55	2.20		16.58	2.09	
T 3	16.50	0.71		14.33	2.13		17.01	1.76		16.38	2.20		15.74	2.09	
T 4	17.50	0.		16.56	4.44		24.34	6.59		18.35	4.39		20.55	5.70	



AFHRL-TR-72-6

APPENDIX XV
SAMPLE OUTPUT OF BARREL ROLL
EXPERIMENTAL MEASUREMENT PROGRAM

BAFTEL ROLL MEASURES

MO-DA-YR	EVNO	13.	DIR-RATING
7-31-76			-13 3
NO.	DESCRIPTION		MEASURE
1	SYMMETRY	QTRS. 1,4	5.86
2		QTRS. 2,3	1.16
3		HLVS. 1,2	3.11
4	CIRCLE:	HALF 1	1.46
5		HALF 2	1.19
6		ALL	.95
7	REG. CO-EFS. AND CORREL.	R-A	-12.06
8		B	-.01
9		R	-.19
10	A-ALL MANEUVER	FR-A	6.45
11		B	.00
12		R	.15
13		G-A	2.25
14		B	-.00
15		R	-.15
16	B-ROLL > 45	FR-A	-20.35
17		B	.00
18		R	.65
19		FR-A	7.15
20		B	.00
21		R	.04
22		G-A	2.69
23		J	-.01
24		R	-.47
25	MAX G	HALF 1	3.64
26		HALF 2	4.10
27	MIN G		.20
28	ROLL AT MAX PITCH		55.00
29	ROLL AT MIN PITCH		81.00
30	MAX ROLL RATE		2.92
31	MIN ROLL RATE, ROLL > 20		-29.58
32	MAX PITCH RATE		10.21
33	MIN PITCH RATE, ROLL > 20		-11.67
34	TIME	ALL	24.40
35		HALF 1	12.00
36		HALF 2	12.40

SUMMARY PRINT-OUT

ROLL	PITCH	ROLL RATE	PITCH RATE	Z'	HEADING EXCURSION	ALTITUDE EXCURSION	AIRSPEED EXCURSION
10	22.0	6.04	5.21	99.1	1.00	134.00	0.
20	27.5	13.5	4.94	1.57	2.00	326.14	-7.00
30	30.2	10.9	2.37	-2.67	2.00	497.60	-16.0
40	32.0	13.3	.764	-1.72	1.67	534.33	-23.6
50	32.3	15.2	2.22	-4.18	3.	668.00	-28.3
60	31.2	13.1	-2.42	-6.94	-5.40	795.24	-37.0
70	29.2	11.4	-3.54	-10.4	-18.2	926.75	-39.6
80	26.1	9.79	-3.54	-14.6	-45.0	1002.0	-44.5
90	21.2	12.0	-5.37	-19.8	-86.6	1129.4	-50.0
100	16.0	18.3	-7.68	-23.8	-113.	1177.4	-56.4
110	12.7	19.1	-7.41	-25.4	-122.	1236.0	-57.2
120	9.1	22.5	-8.54	-24.6	-125.	1230.7	-59.4
130	5.20	25.9	-8.00	-22.1	-126.	1256.1	-58.7
140	2.73	26.4	-6.44	-18.1	-127.	1256.1	-60.8
150	20.0	26.4	-6.54	-13.7	-129.	1249.6	-59.5
160	-2.84	26.1	-7.48	-9.00	-130.	1236.0	-57.4
170	-5.67	22.4	-8.22	-4.12	-131.	1236.0	-56.5
180	-12.5	12.5	-8.71	1.65	-130.	1236.0	-54.9
-170	-20.4	23.7	-9.17	.766	-133.	1242.3	-50.0
-160	-23.6	27.4	-9.34	-1.31	-135.	1116.2	-44.2
-150	-27.3	28.6	-10.2	-2.39	-128.	1084.5	-42.5
-140	-30.3	30.4	-9.71	-2.59	-124.	1036.5	-38.8
-130	-33.3	31.3	-8.64	-3.61	-119.	991.85	-33.2
-120	-38.7	32.8	-7.54	-1.87	-109.	960.87	-28.8
-110	-38.1	34.5	-5.34	-1.80	-99.6	877.33	-26.3
-100	-39.3	30.5	-3.06	-1.44	-88.2	831.31	-23.2
-90	-40.3	24.1	-2.15	-0.700	-71.9	772.00	-20.7
-80	-41.0	25.0	-0.64	.252	-56.7	671.7J	-18.2
-70	-40.7	23.1	2.00	.737	-46.3	591.10	-11.9
-60	-39.4	24.0	4.51	.703	-38.2	527.80	-6.10
-50	-36.9	21.1	6.81	.132	-32.1	334.10	-2.80
-40	-32.9	16.0	8.35	-1.02	-26.9	275.87	.375
-30	-26.9	16.2	10.1	-2.68	-23.4	186.14	4.57
-20	-20.3	10.8	10.2	-3.36	-22.0	-9.4280	8.43
-10	-12.0	9.06	6.67	-2.63	-20.3	-134.00	13.0
-1	0.	-2.38	0.	99.1	-19.4	-317.00	19.0
						-521.50	17.5

DIR-RAILING
10 10

WMO
I.F.

MO-DA-YK
0-16-70



AFHRL-TR-72-6

APPENDIX XVI
DEBRIEFING PLOTS FOR
FOUR LAZY 8 PERFORMANCES

LAZY 8

IP Rating: Excellent
 Direction: Left

11-20-69
 ENVO- 47
 (4 LEFT)

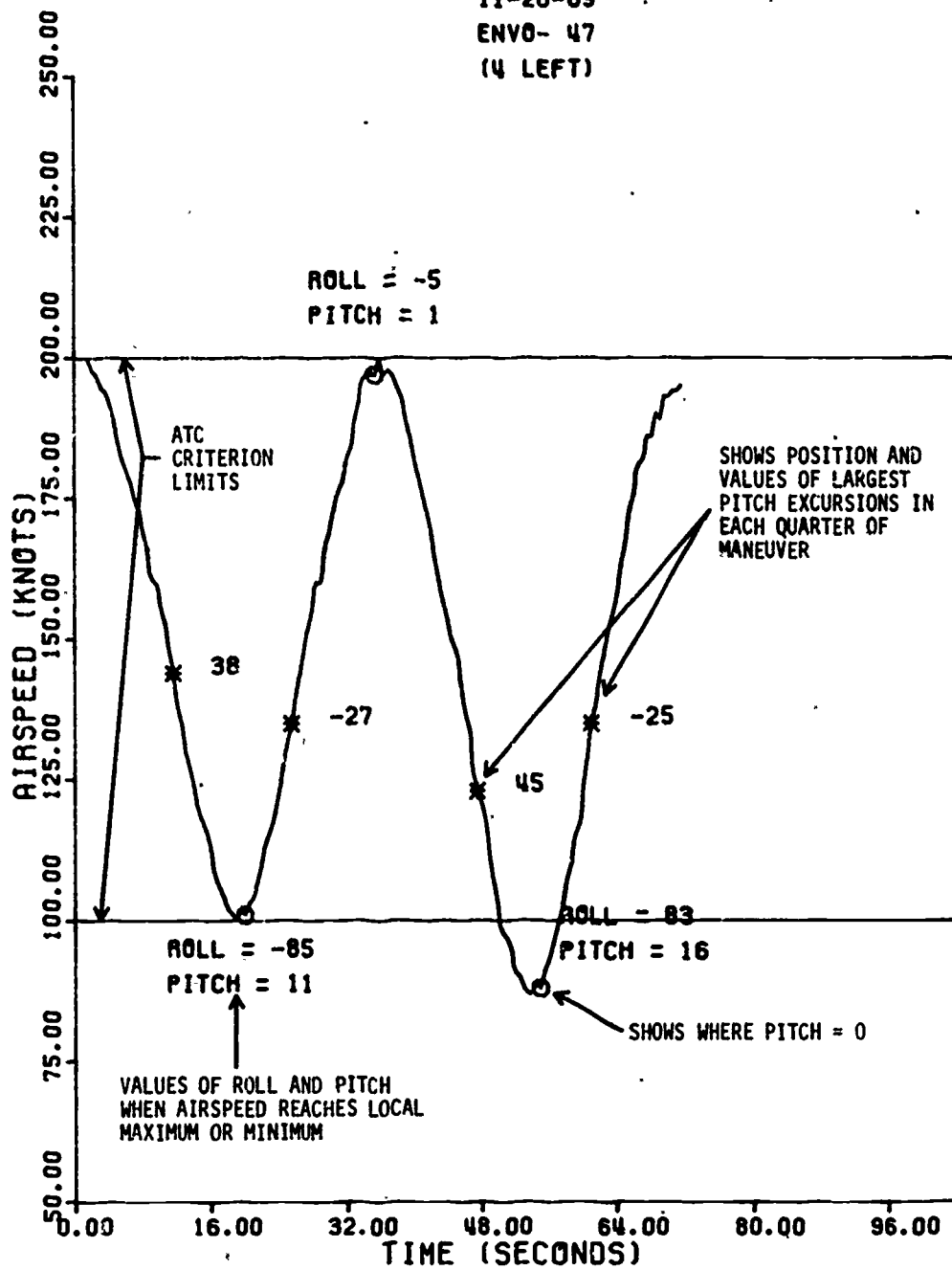

LAZY 8

IP Rating: Excellent
Direction: Left

11-20-69
ENVO- 47
(4 LEFT)

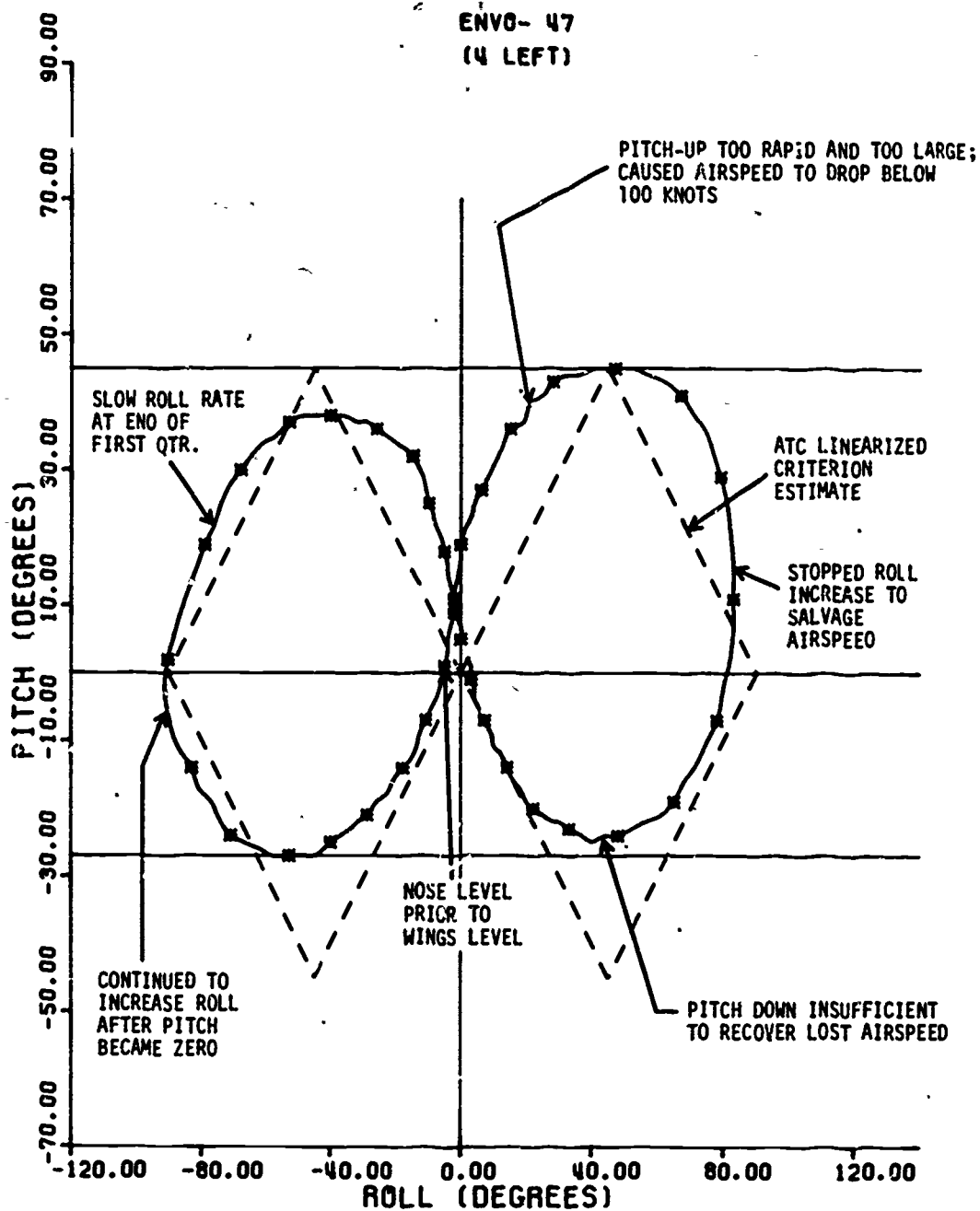

LAZY 8

IP Rating: Excellent
Direction: Left

11-20-69
ENVO- 47
(4 LEFT)

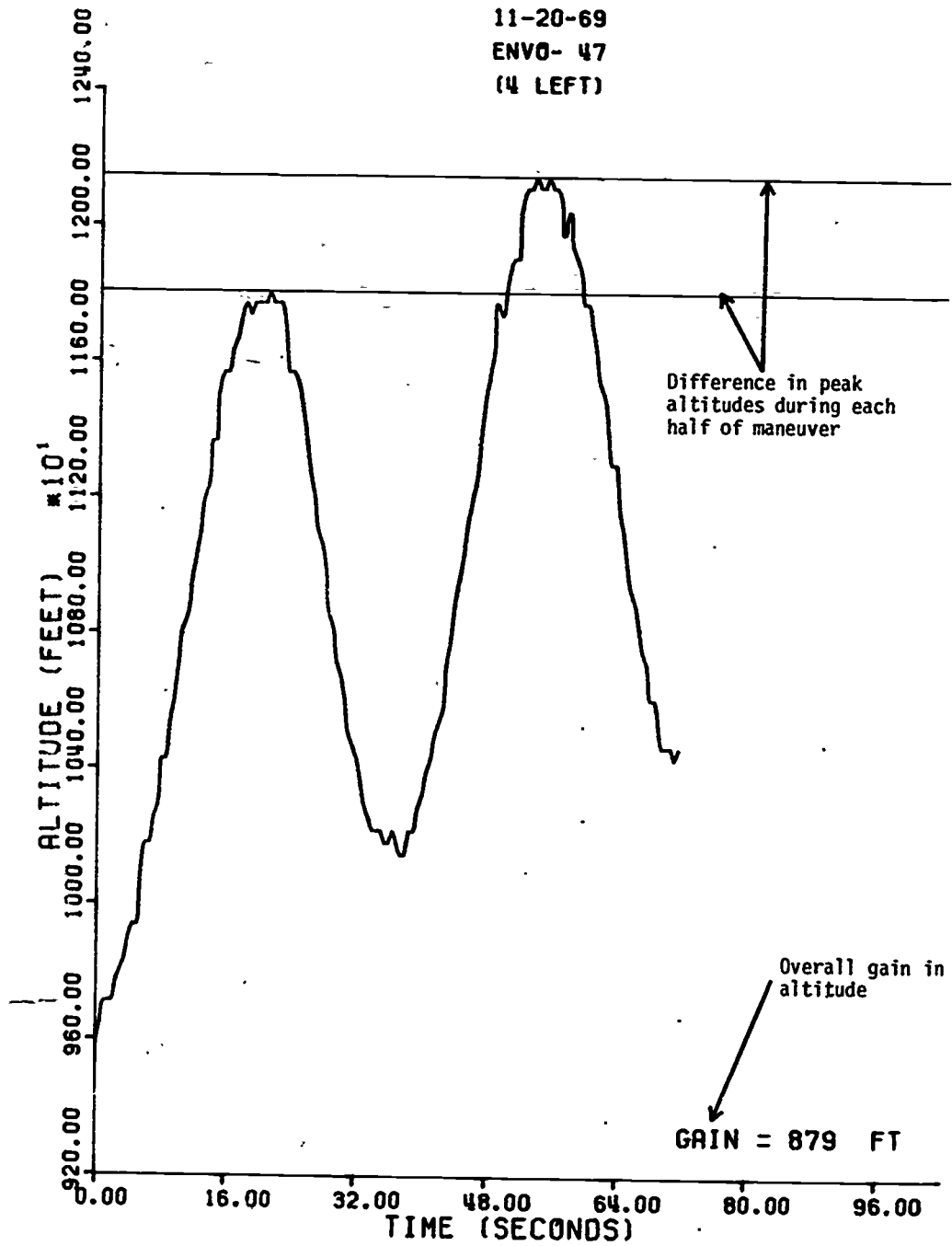

LAZY 8

IP Rating: Good
Direction: Left

11-18-69
ENVO- 4
(3 LEFT)

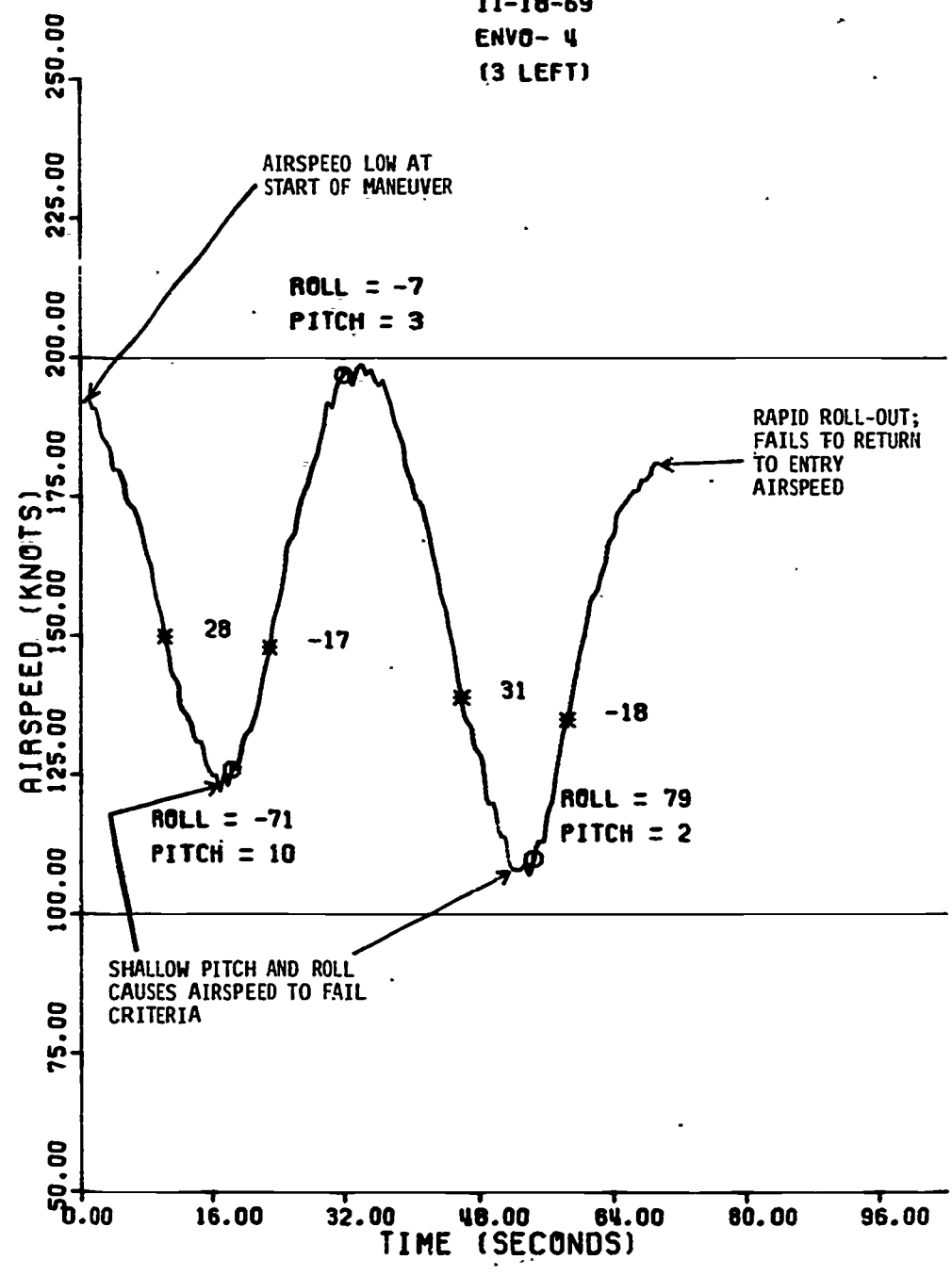

LAZY 8

IP Rating: Good
DIRECTION: Left

11-18-69
ENVO- 4
(3 LEFT)

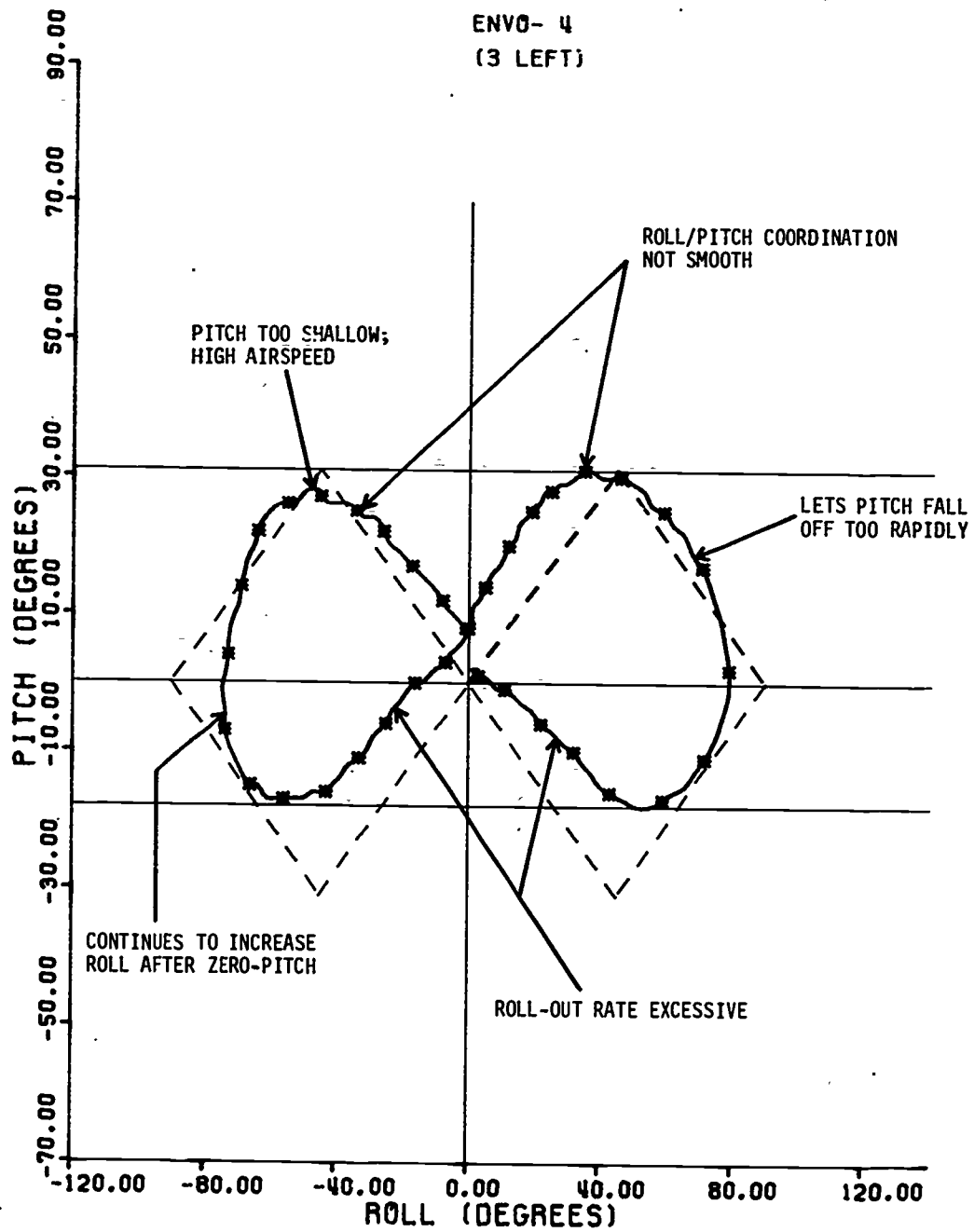

AFHRL-TR-72-6

LAZY 8

IP Rating: Good
Direction: Left

11-18-69
ENVO- 4
(3 LEFT)

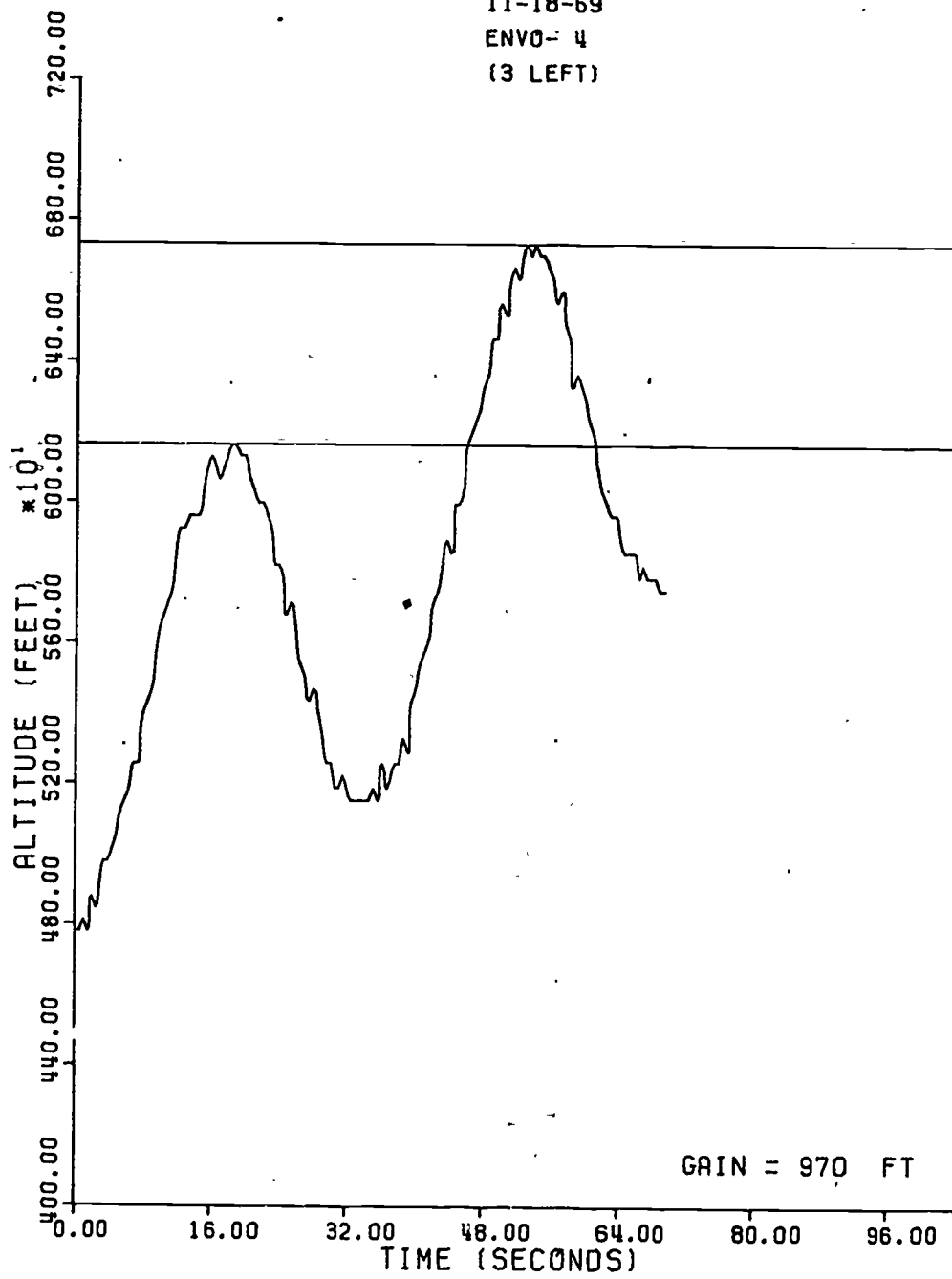

LAZY 8

IP Rating: Fair
Direction: Left

12-19-69
ENV0- 65
(2 LEFT)

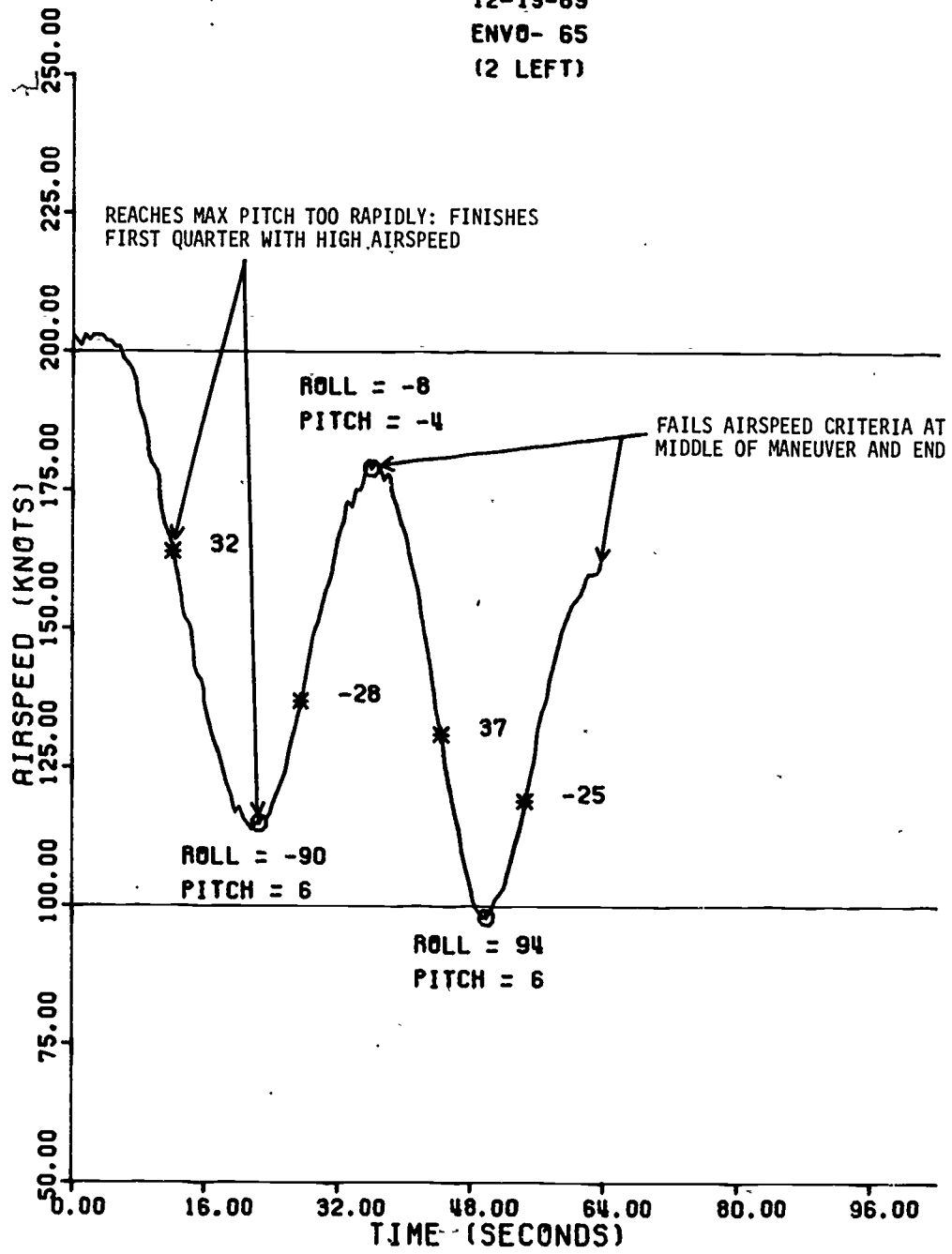

LAZY 8

IP Rating: Fair
Direction: Left

12-19-69
ENVO- 65
(2 LEFT)

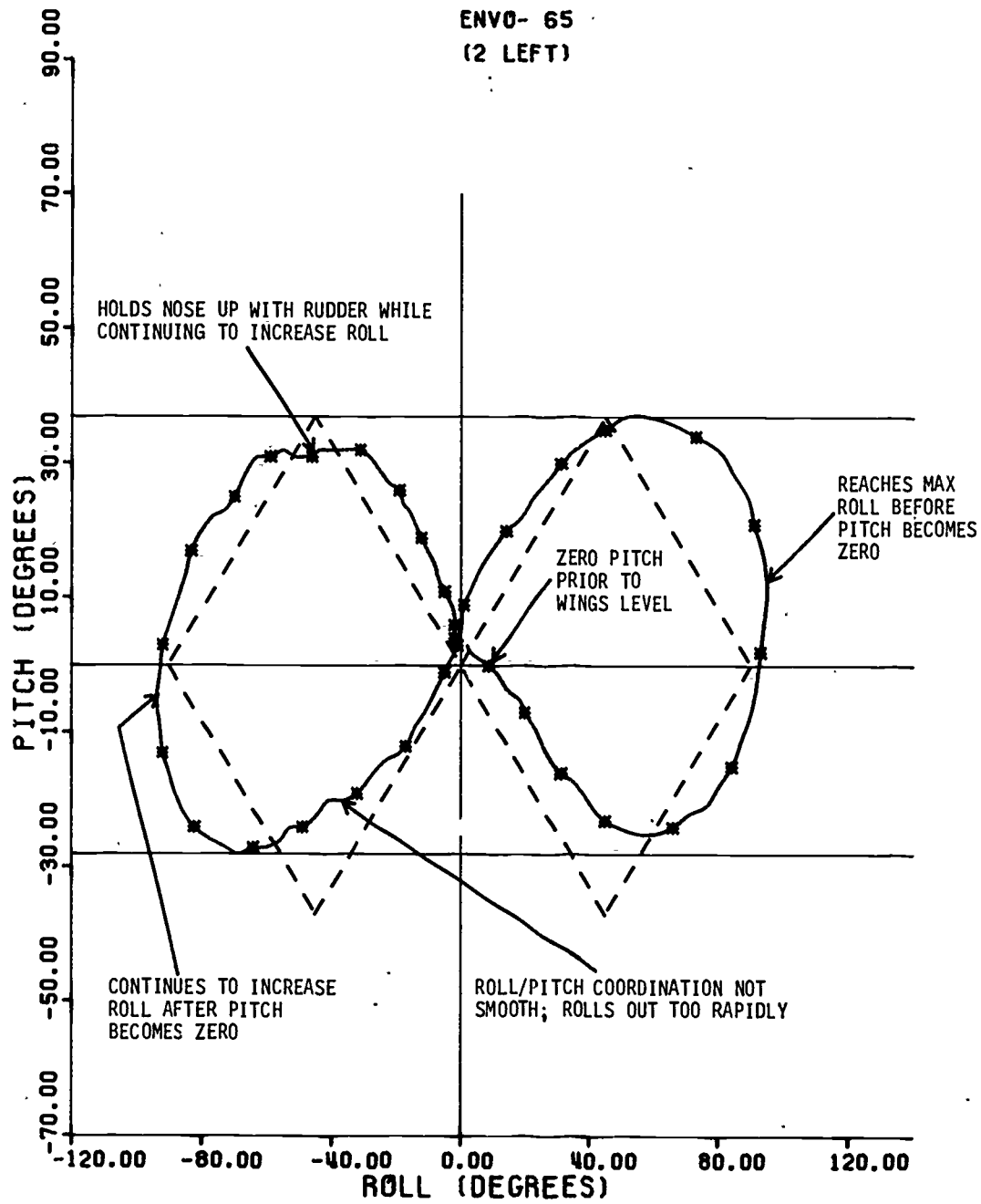

AFHRL-TR-72-6

LAZY 8

IP Rating: Fair
Direction: Left

12-19-69
ENV0- 65
(2 LEFT)

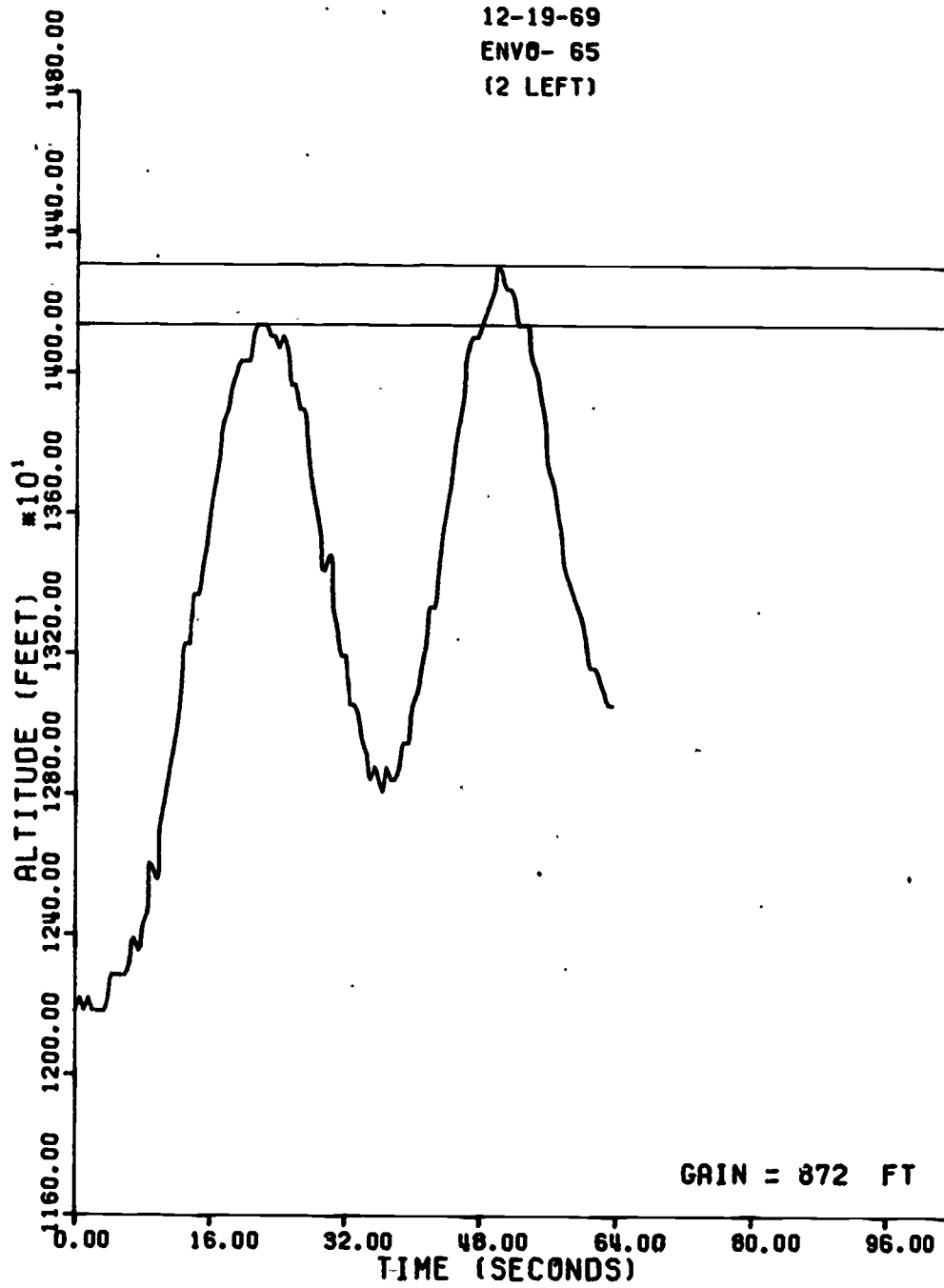

LAZY 8

IP Rating: Unsatisfactory
Direction: Left

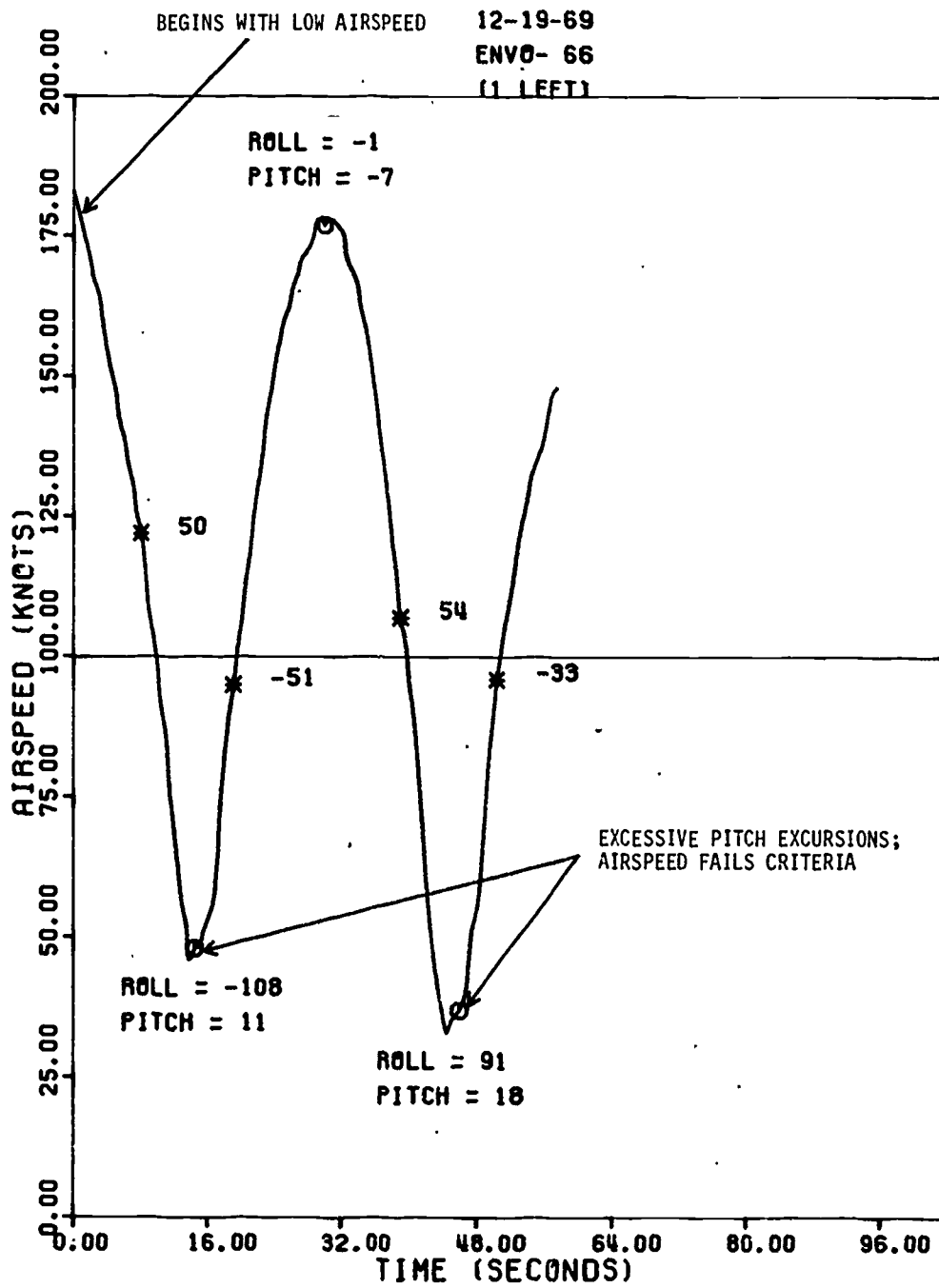

LAZY 8

IP Rating: Unsatisfactory
Direction: Left

12-19-69
ENV0- 66
(1 LEFT)

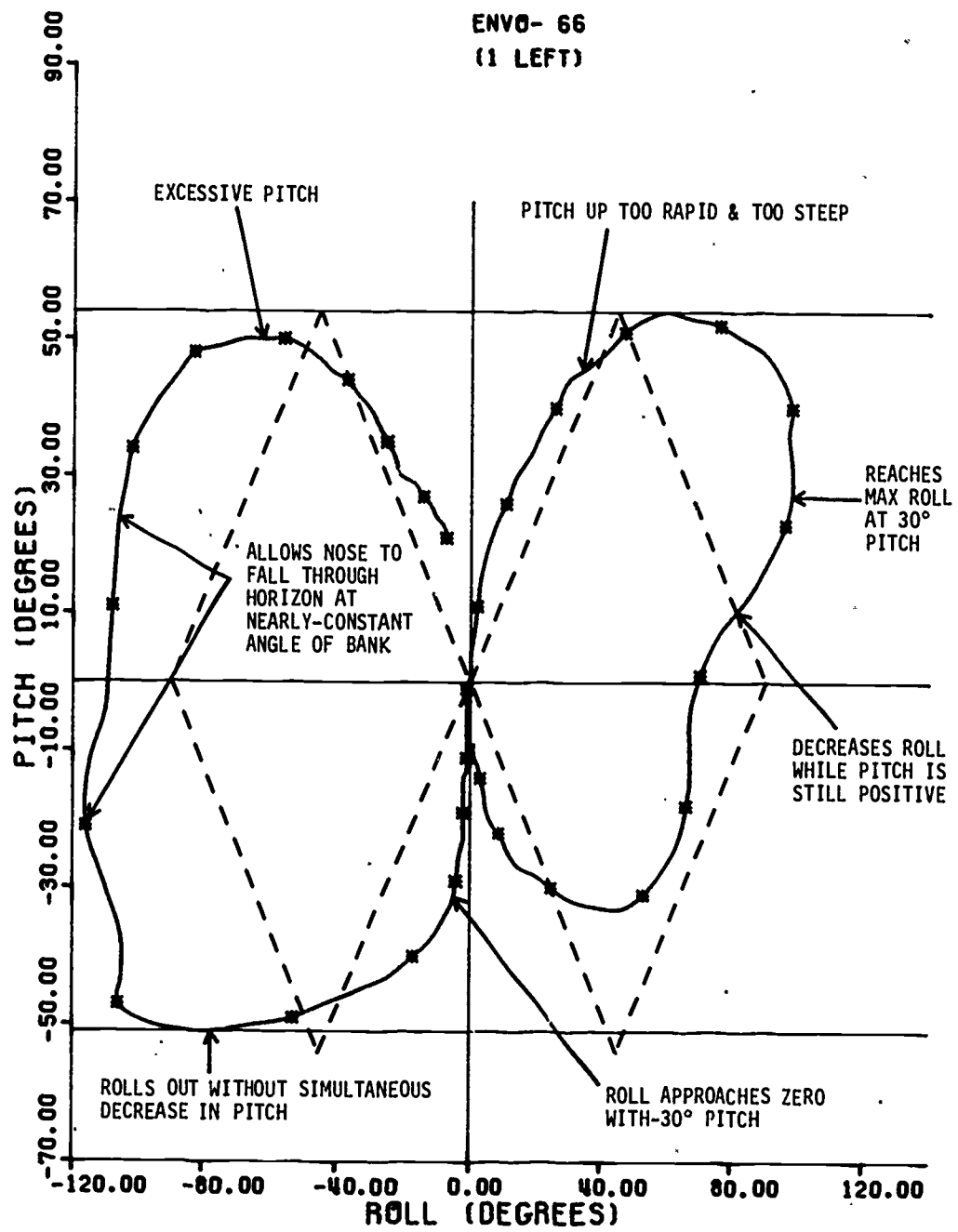

AFHRL-TR-72-6

LAZY 8

IP Rating: Unsatisfactory
Direction: Left

12-19-69

ENV0- 66

(1 LEFT)

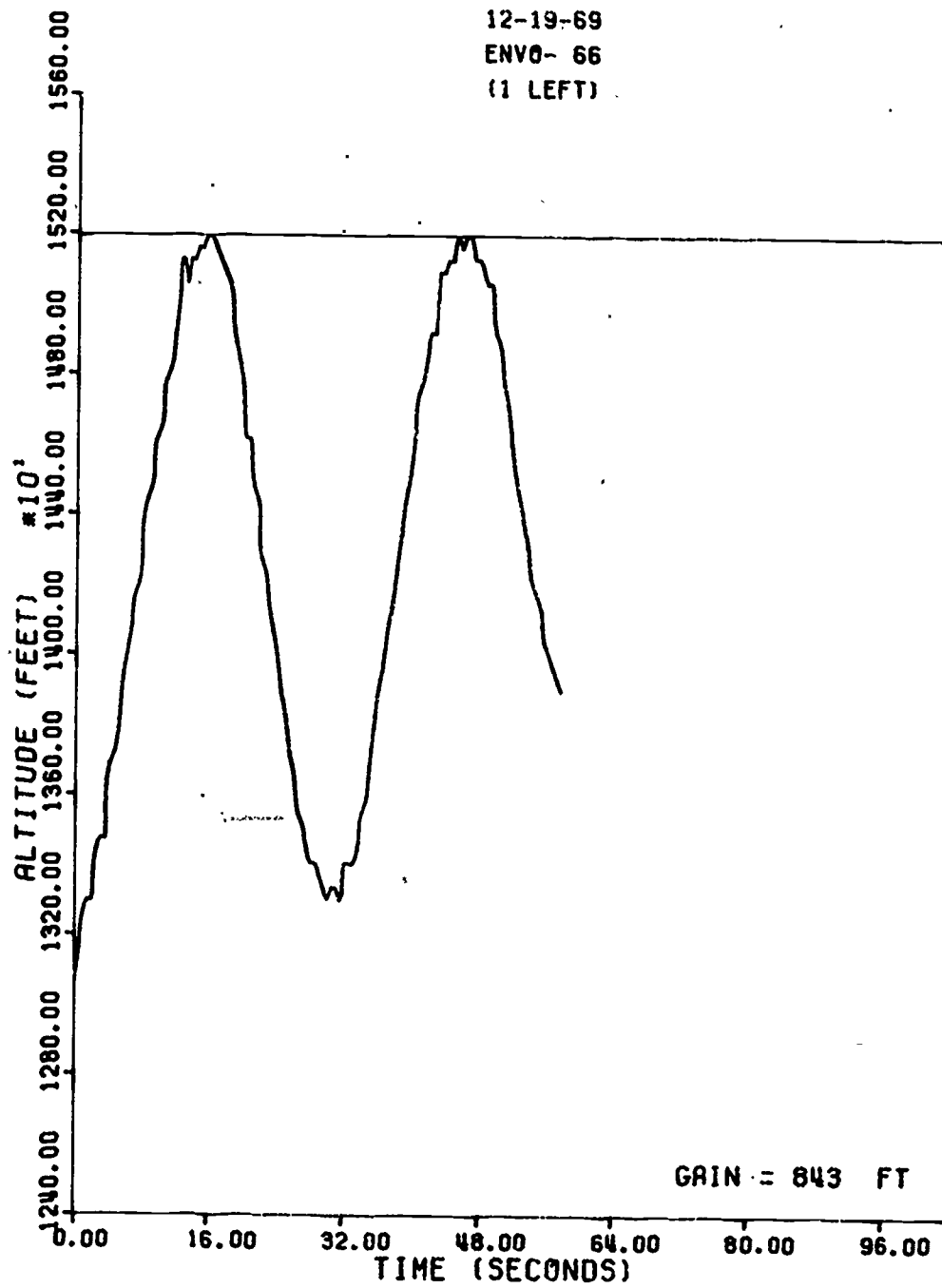

AFHRL-TR-72-6

APPENDIX XVII

DEBRIEFING PLOTS FOR TWO
BARREL ROLL PERFORMANCES

AFHRL-TR-72-6

7-10-70
ENV0- 15
(2 LEFT)

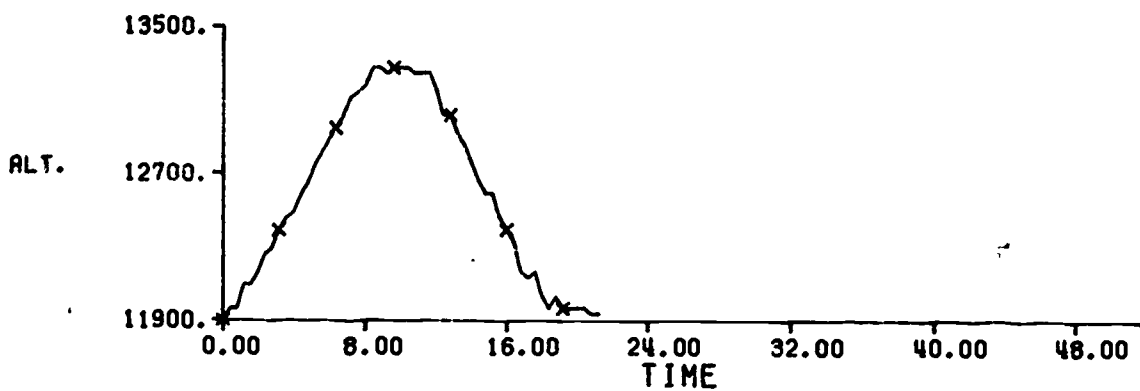
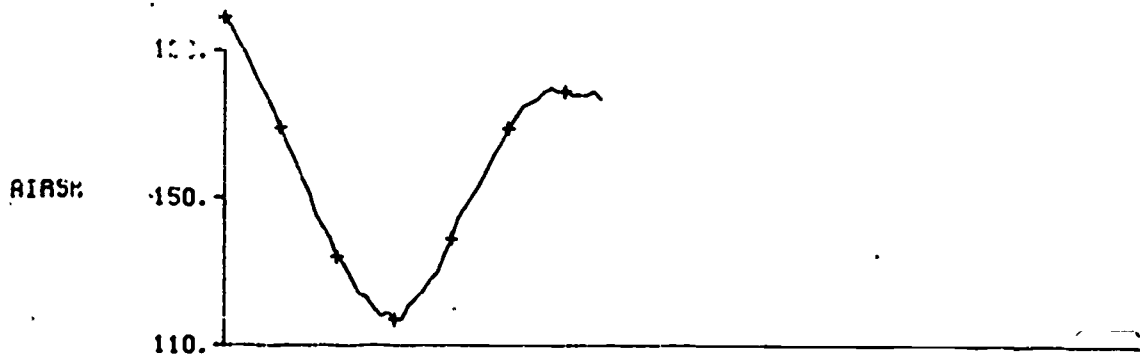
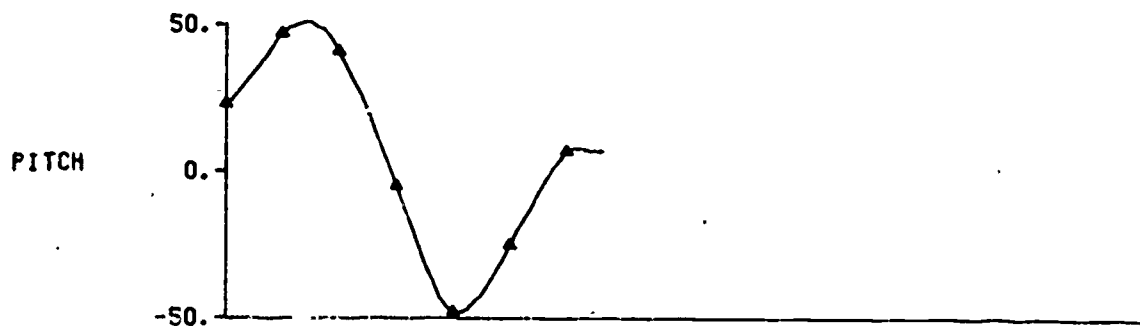
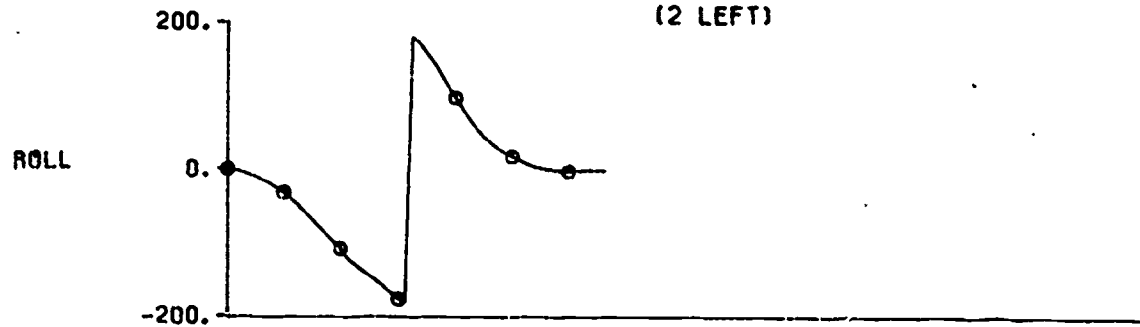

AFHRL-TR-72-6

7-10-70
ENVO- 15
(2 LEFT)

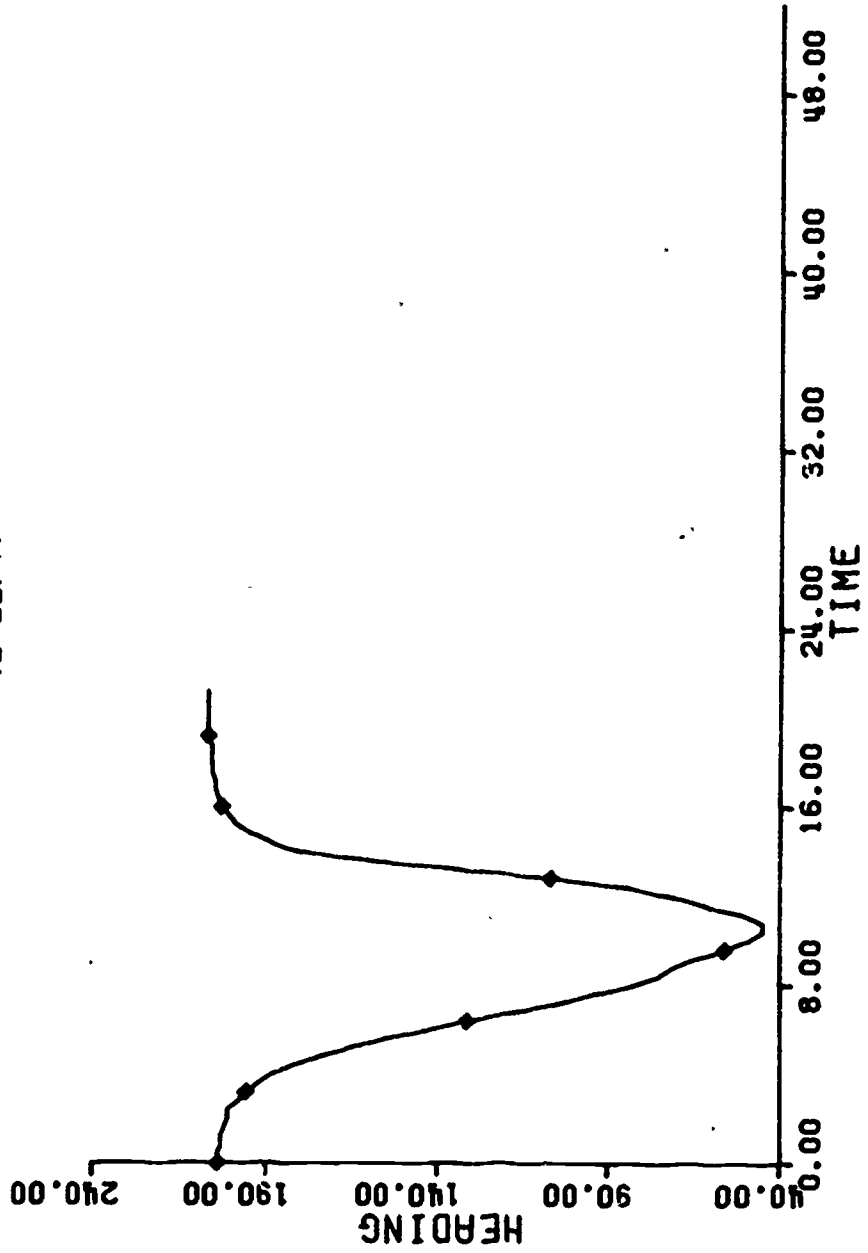

AFHRL-TR-72-6

7-10-70
ENVG- 15
(2 LEFT)

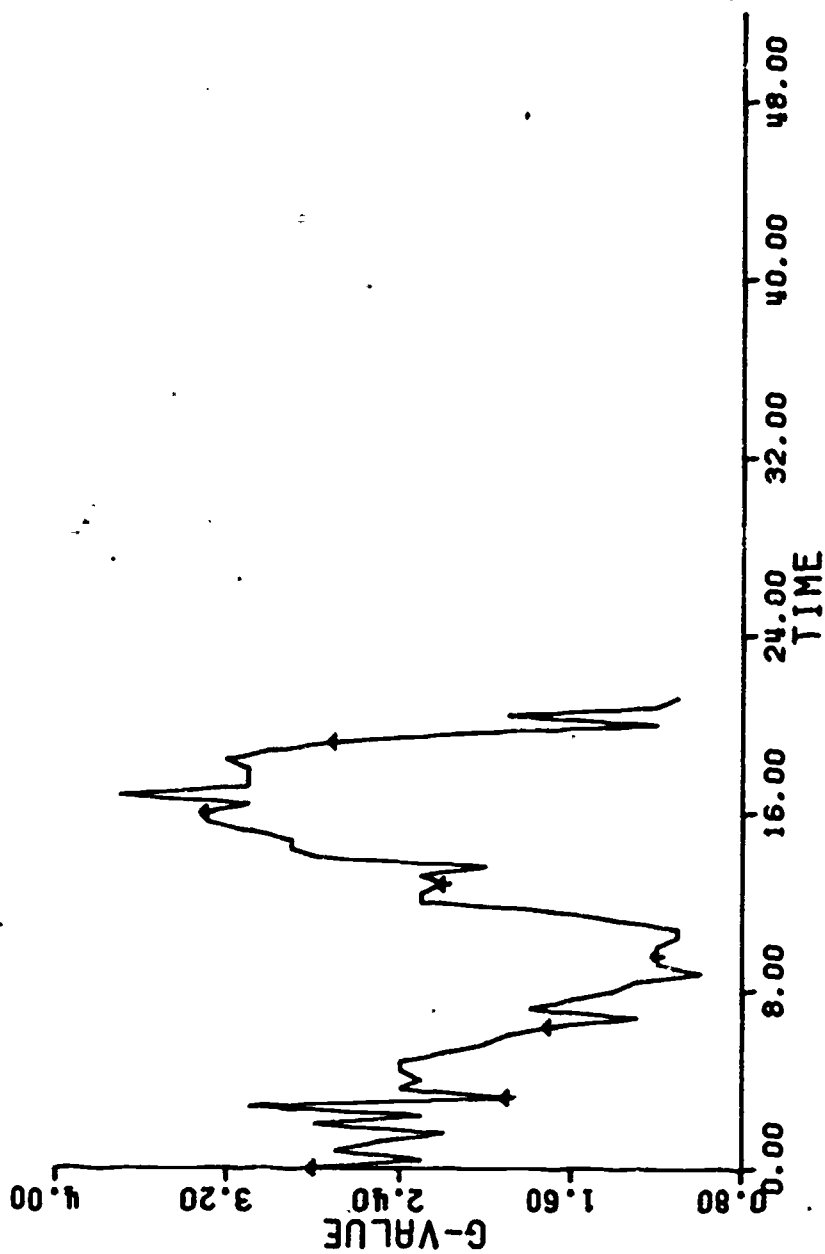

AFHRL-TR-72-6

7-10-70
ENV0- 15
(2 LEFT)

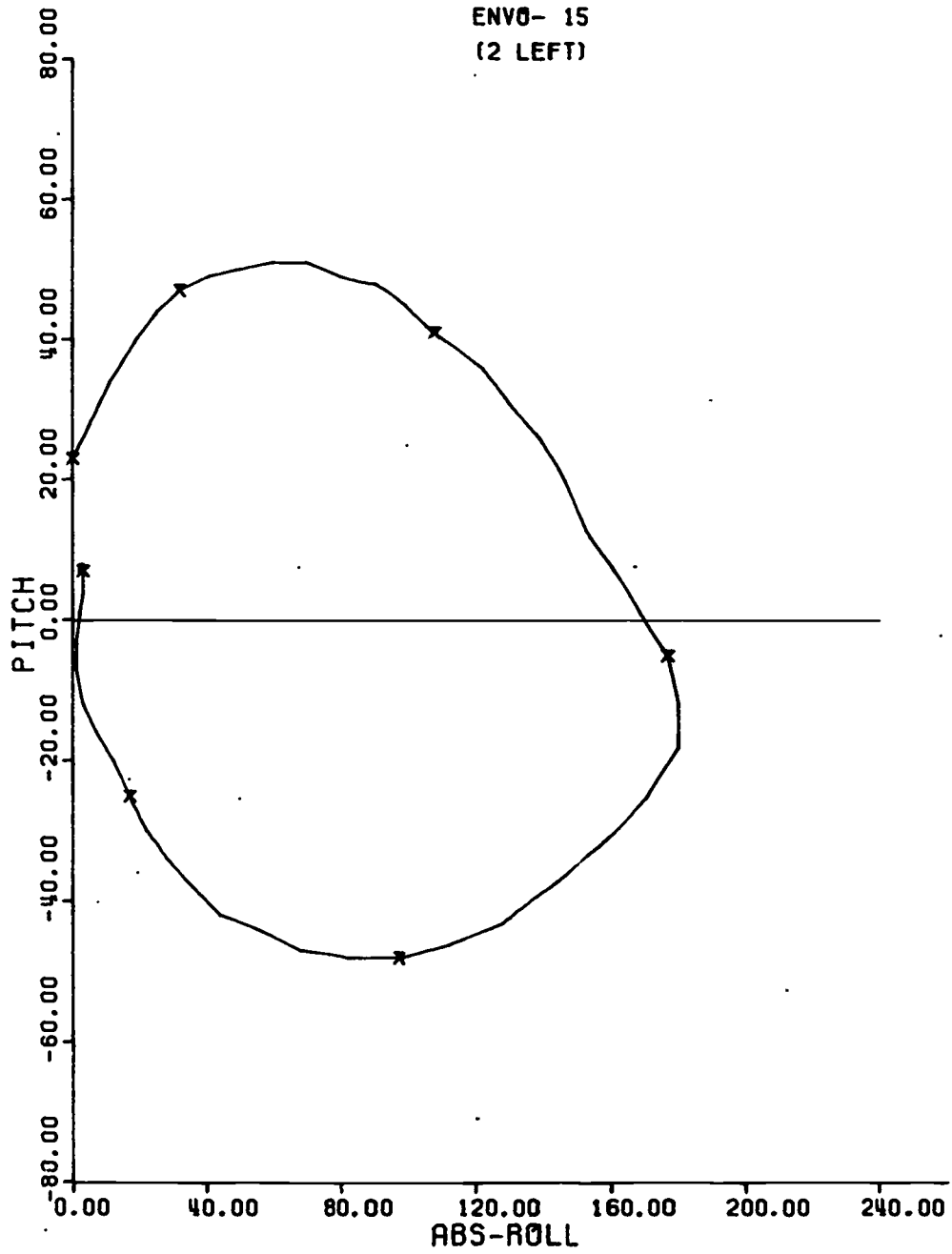

AFHRL-TR-72-6

7-10-70
ENV0- 15
(2 LEFT)

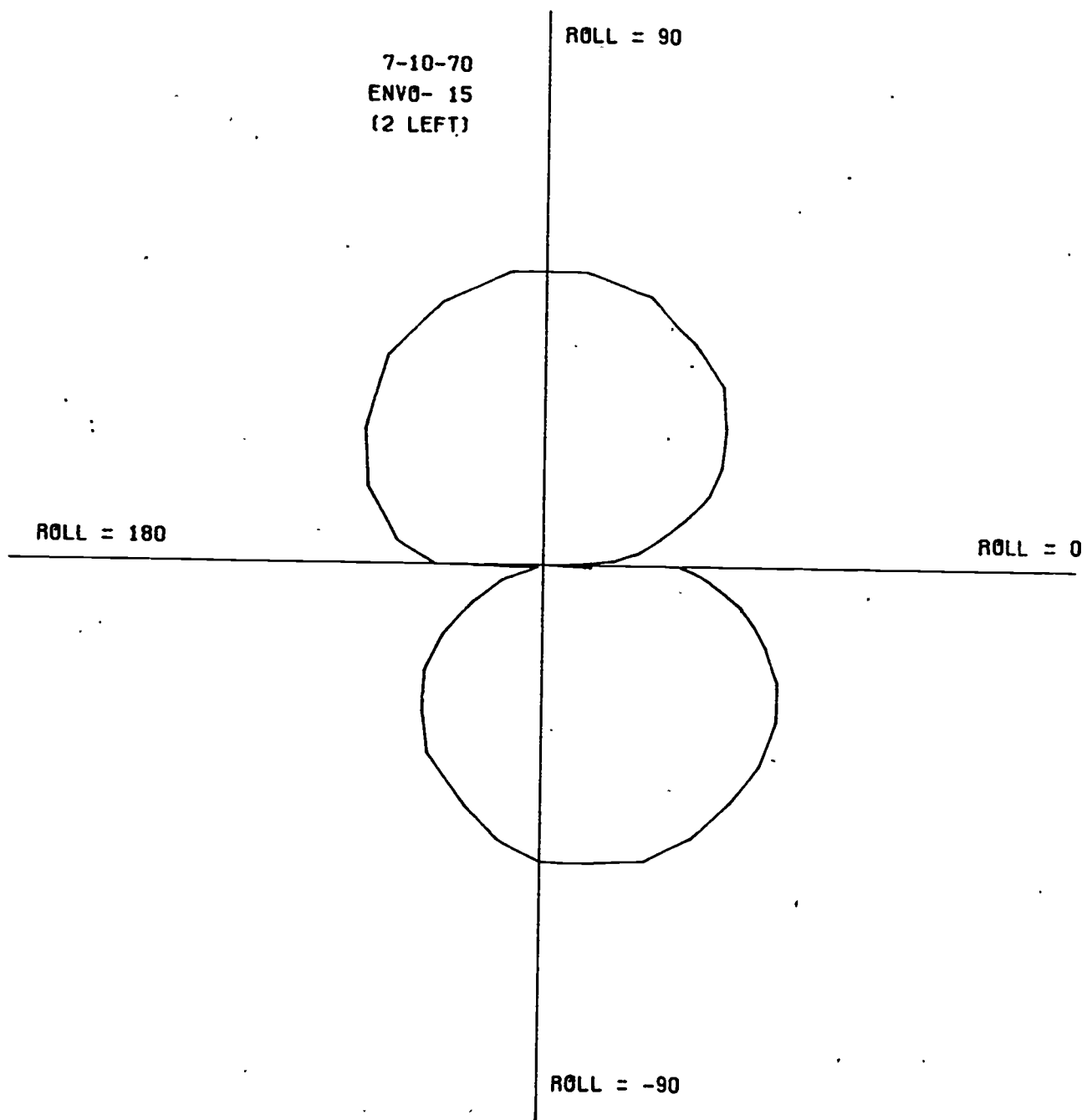

ROLL-PITCH PLOT

AFHRL-TR-72-6

7-10-70
ENV0- 15
(2 LEFT)

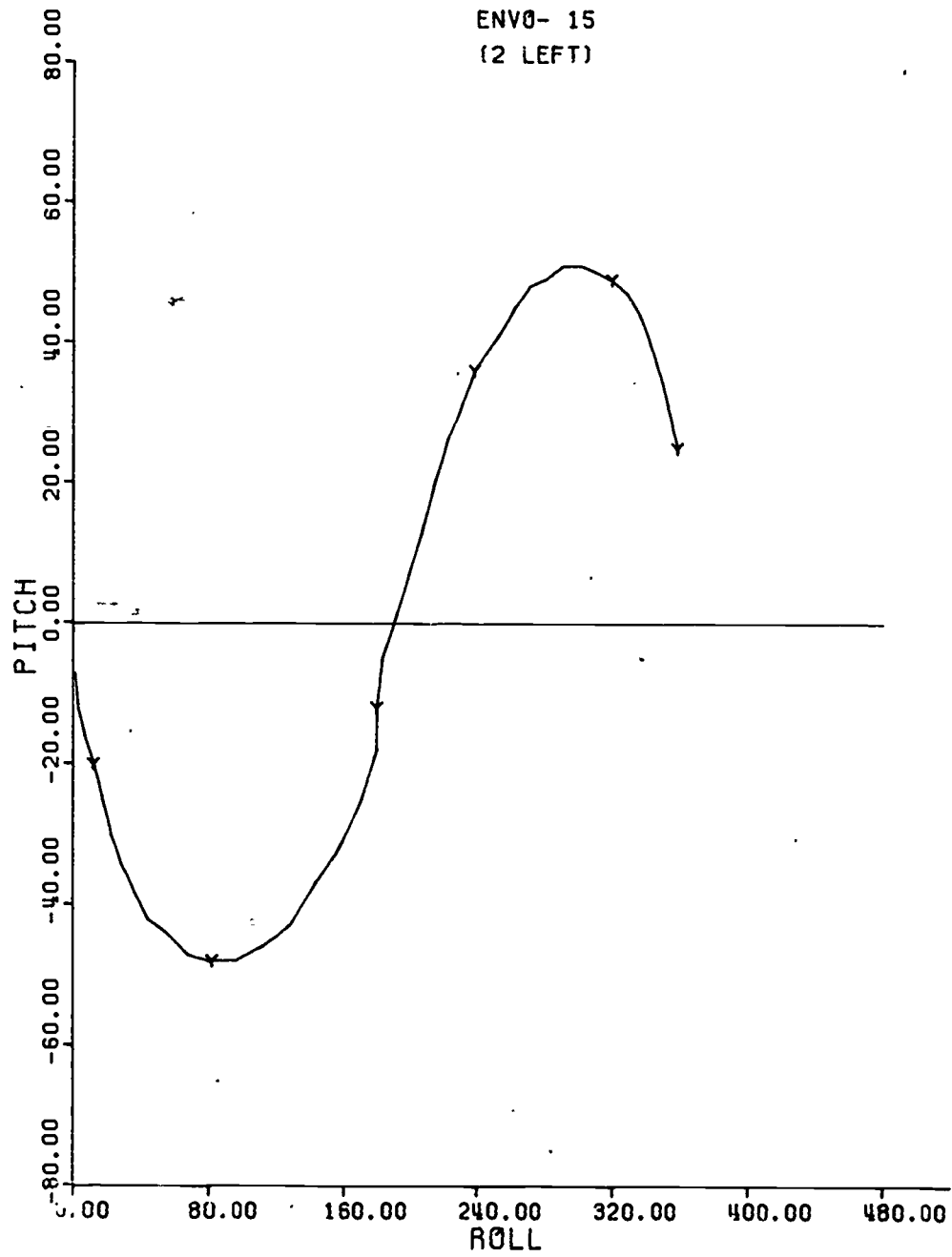

AFHRL-TR-72-6

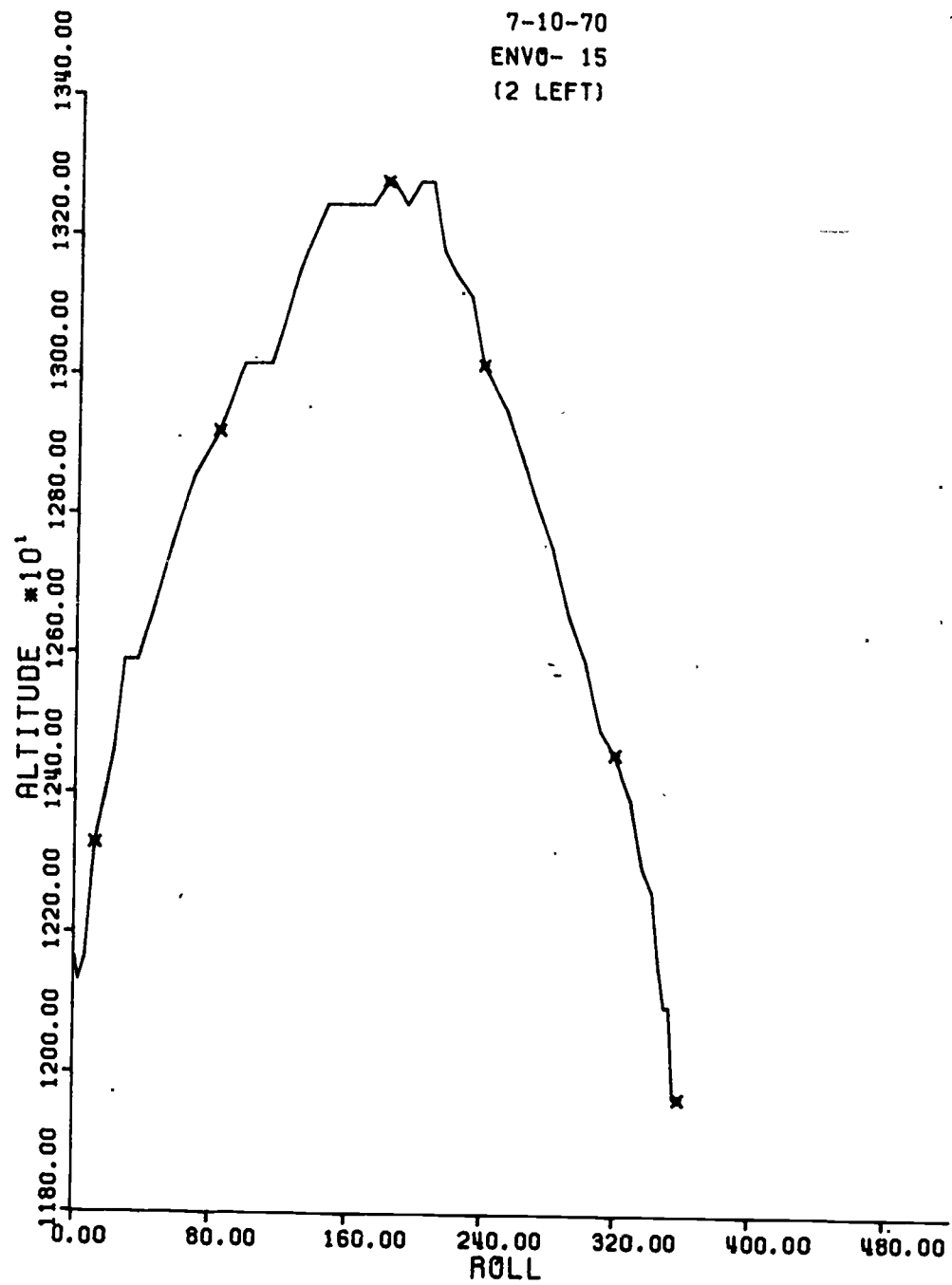

AFHRL-TR-72-6

7-10-70
ENVO- 15
(2 LEFT)

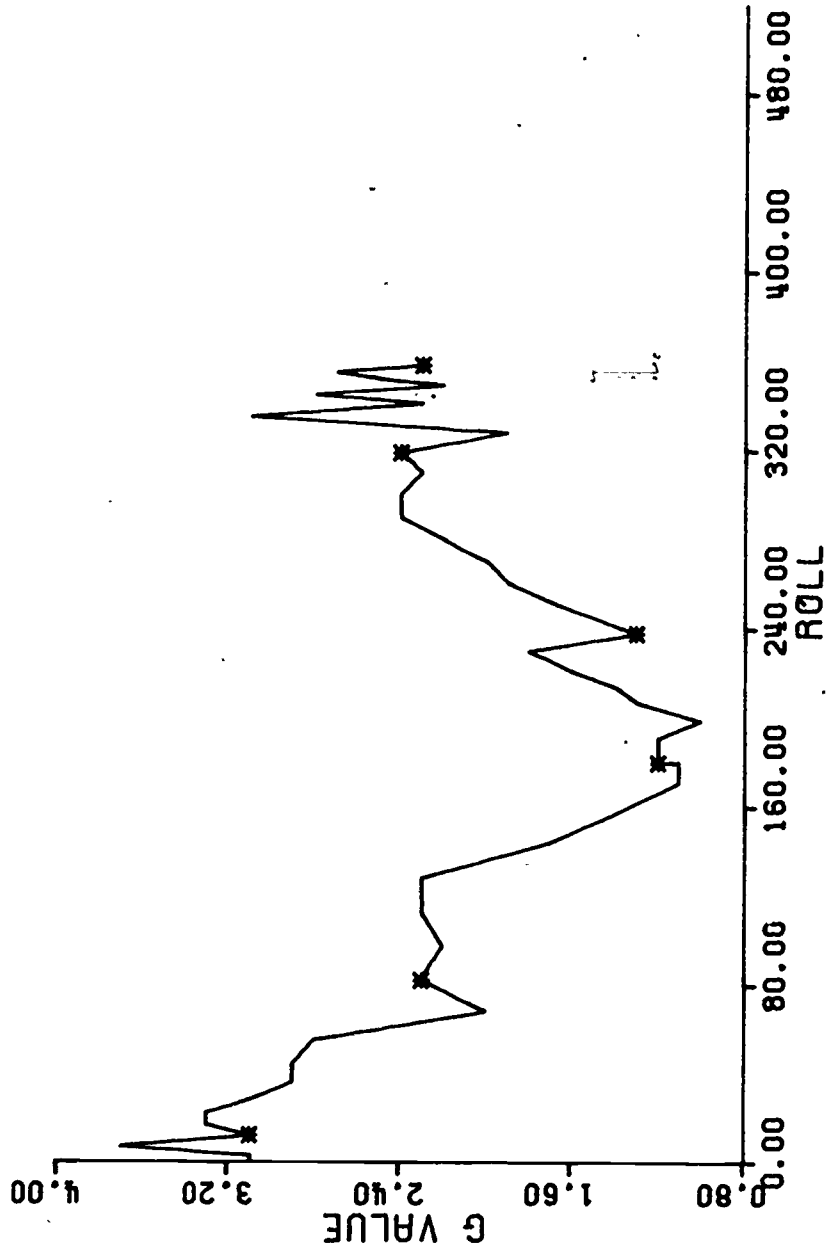

6-22-70
ENV0- 16
(3 LEFT)

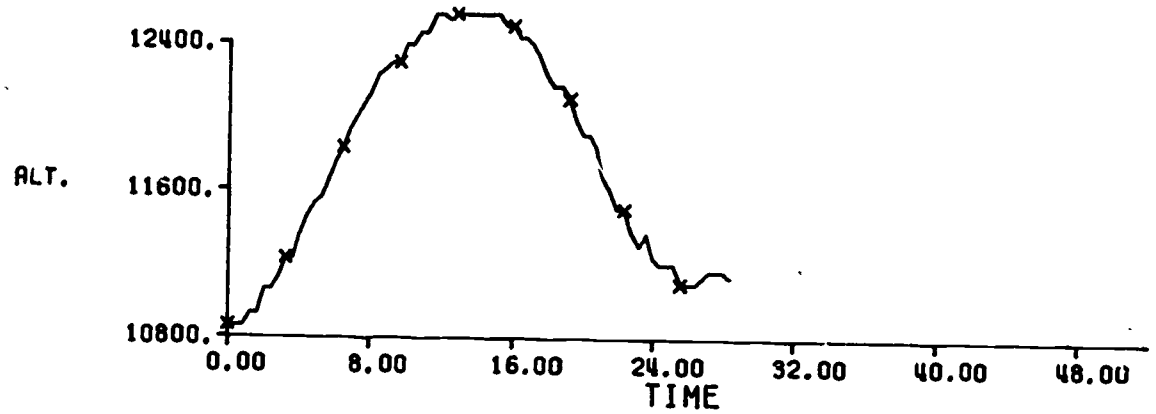
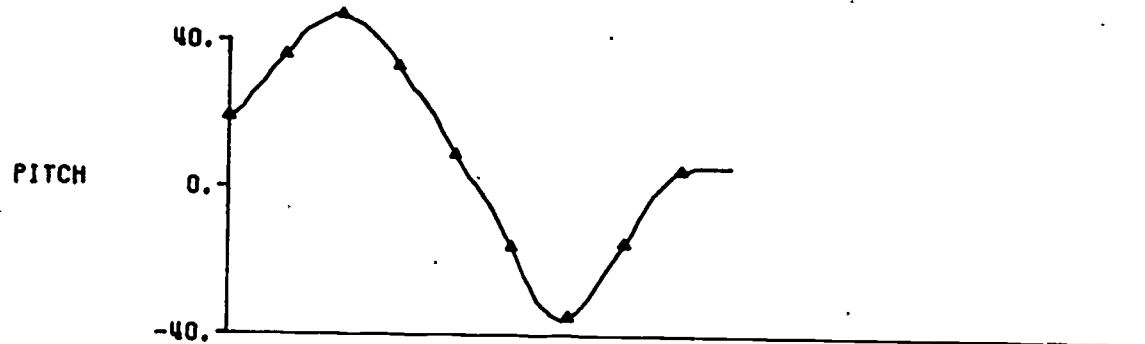
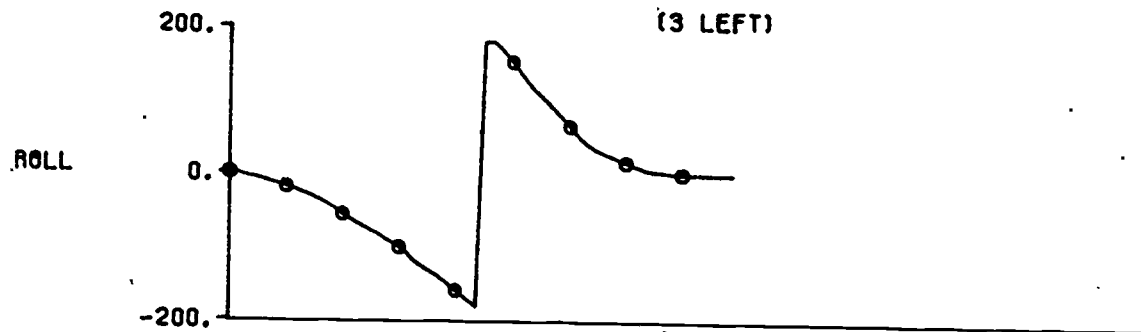

AFHRL-TR-72-6

6-22-70
ENV0- 16
(3 LEFT)

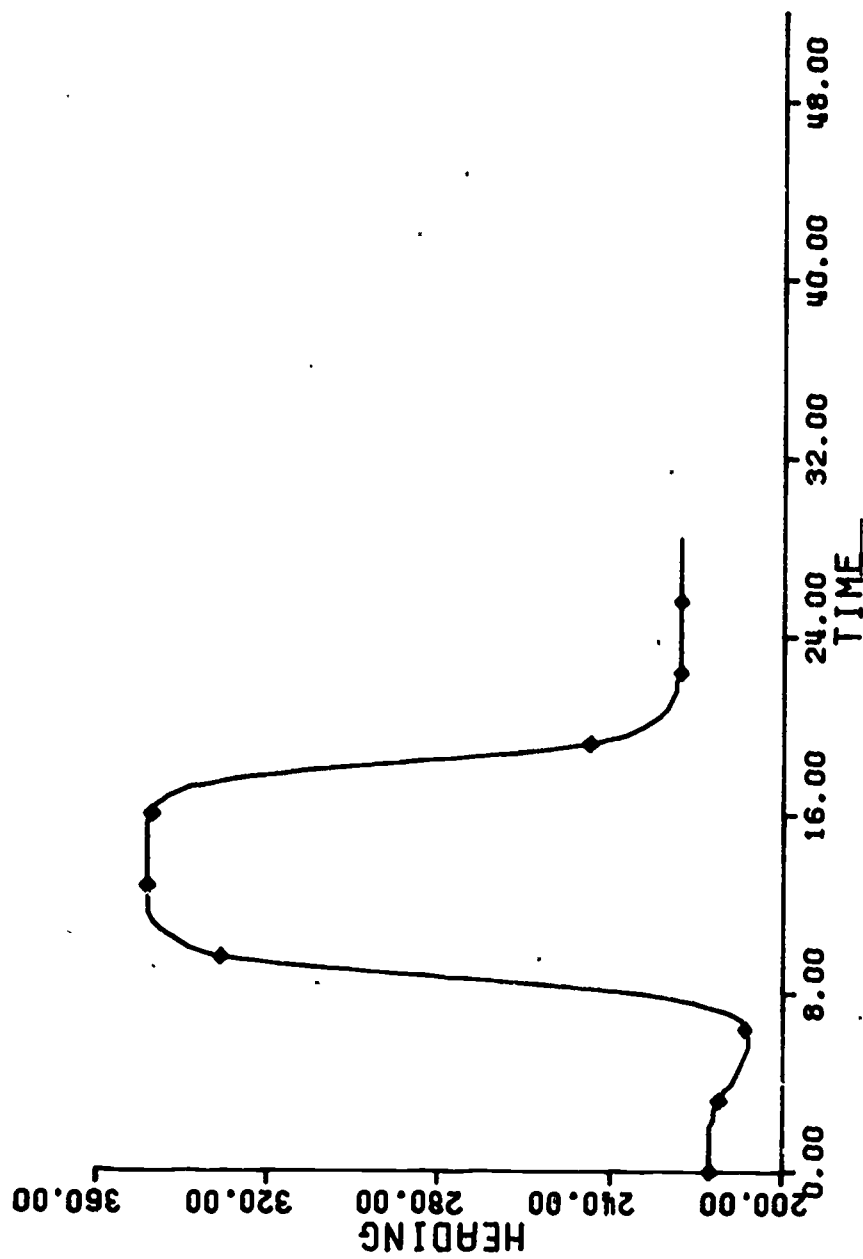

AFHRL-TR-72-6

6-22-70
ENV0- 16
(3 LEFT)

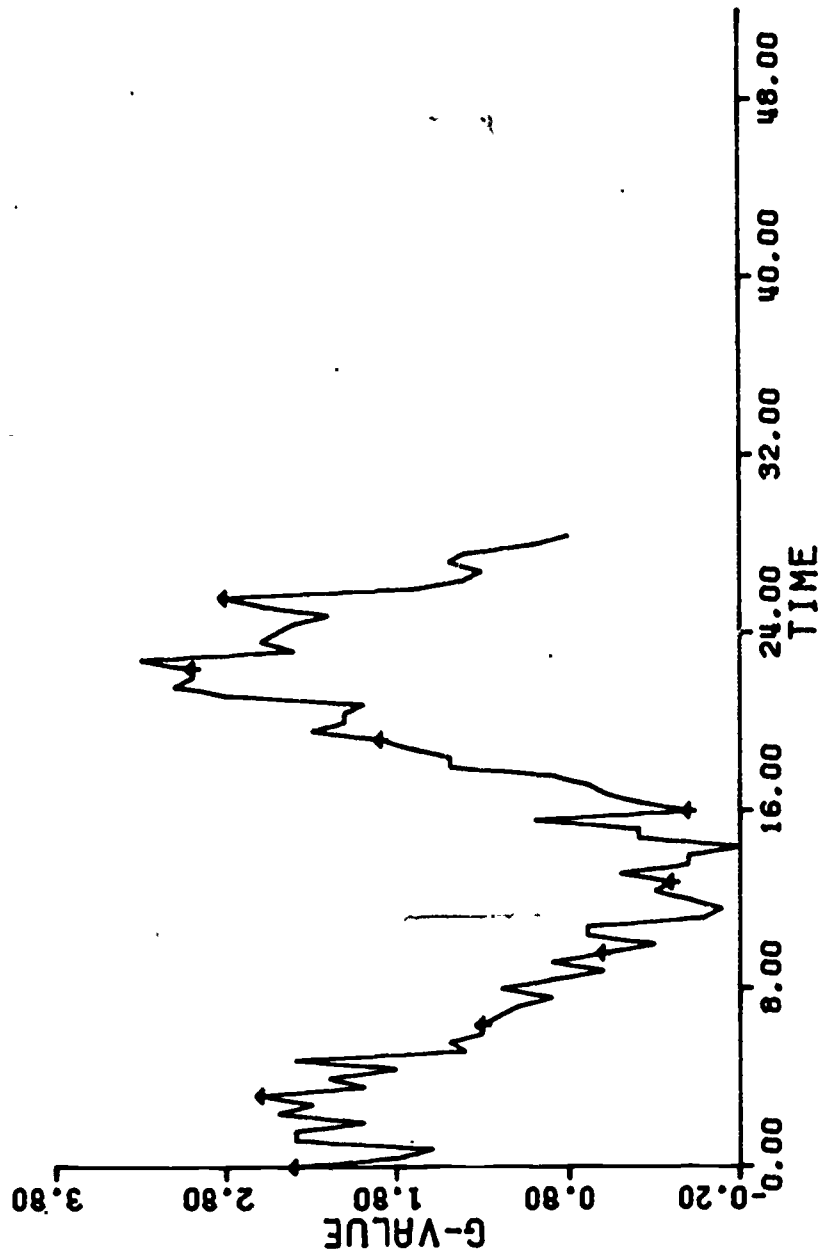

AFHRL-TR-72-6

6-22-70
ENV0- 16
(3 LEFT)

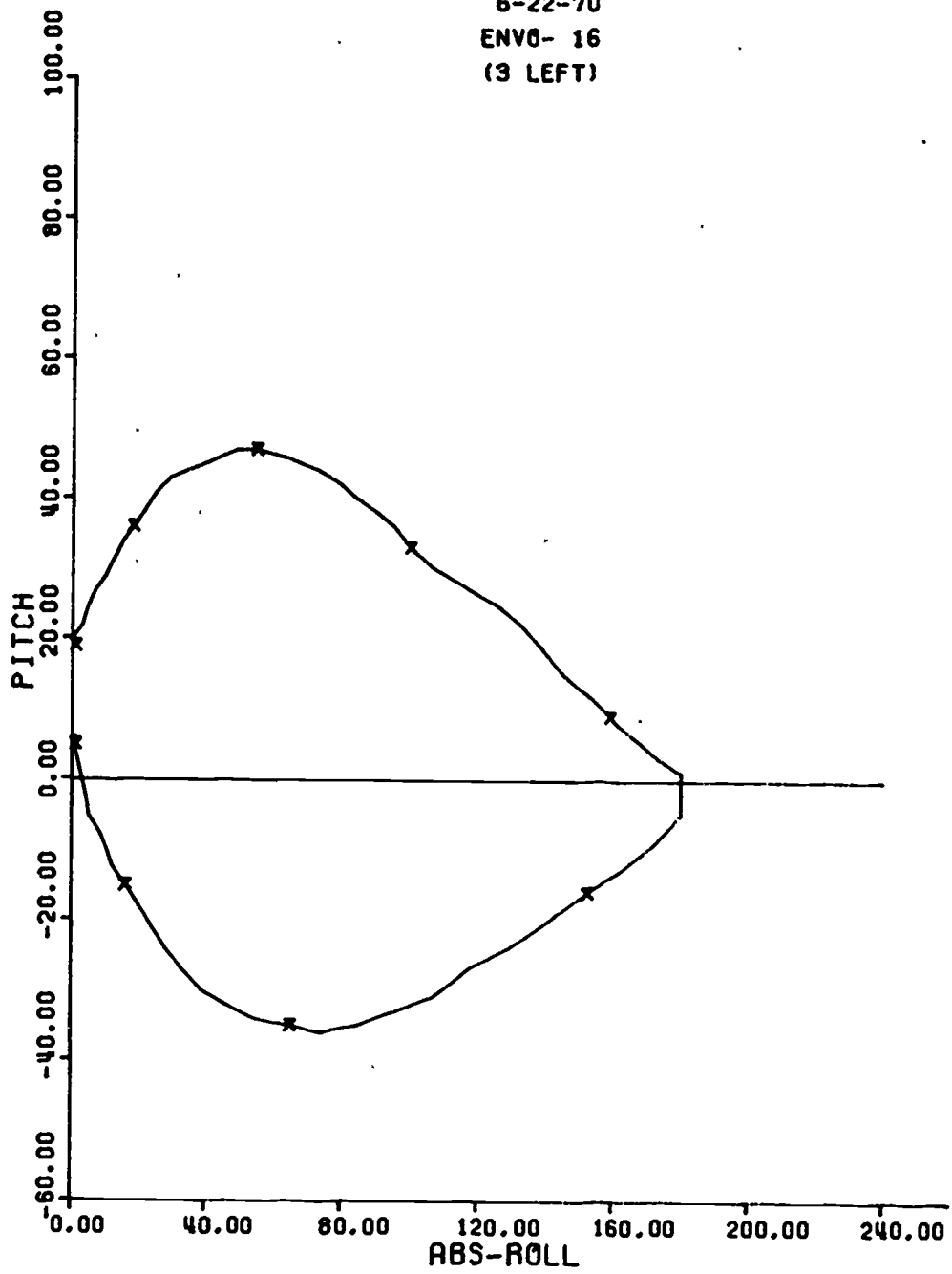

AFHRL-TR-72-6

6-22-70
ENVG- 16
(3 LEFT)

ROLL = 90

ROLL = 180

ROLL = 0

ROLL = -90

ROLL-PITCH PLOT

AFHRL-TR-72-6

6-22-70
ENV6- 18
(S LEFT)

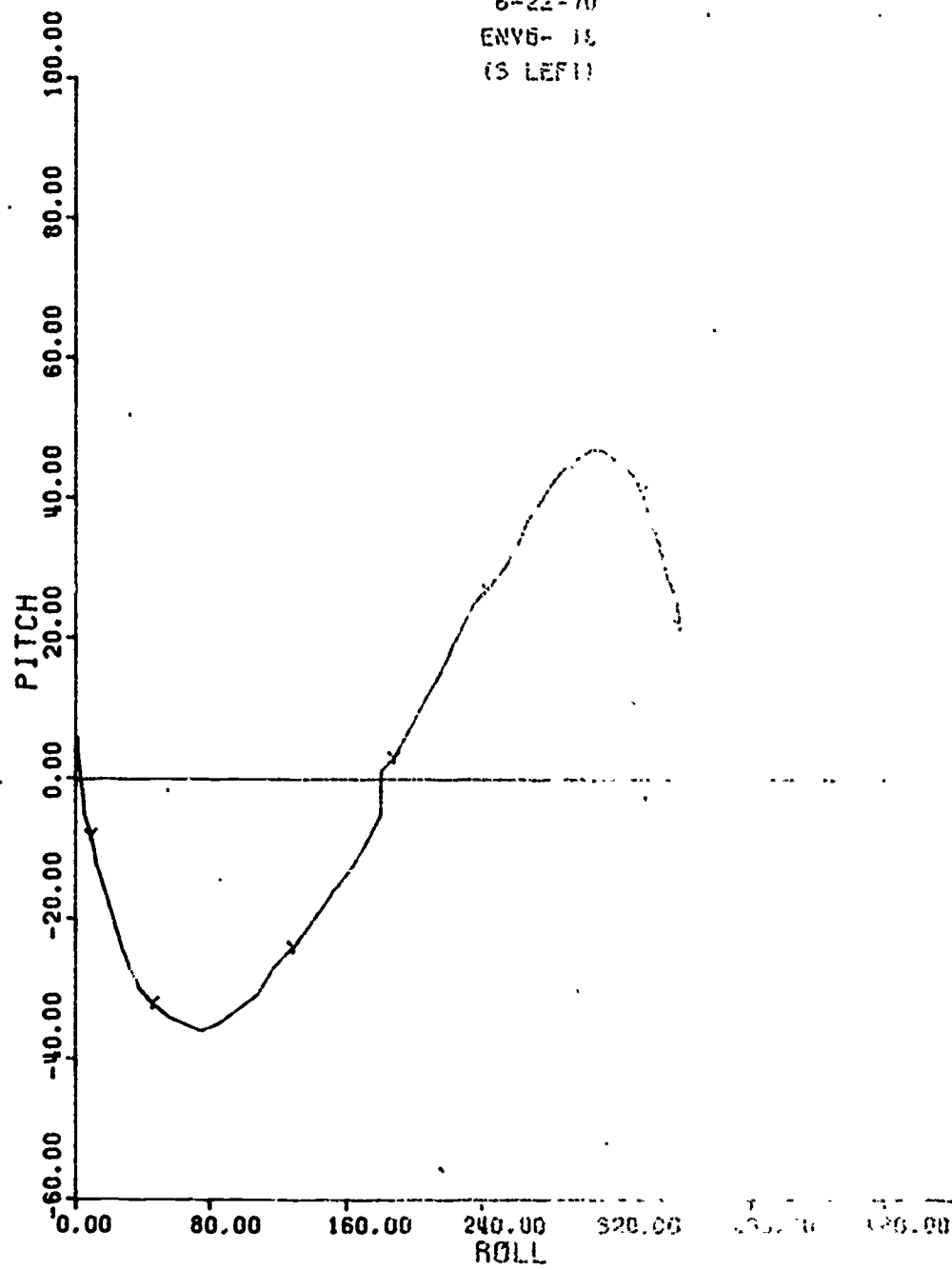

AFHRL-TR-72-6

6-22-70
ENV0- 16
(3 LEFT)

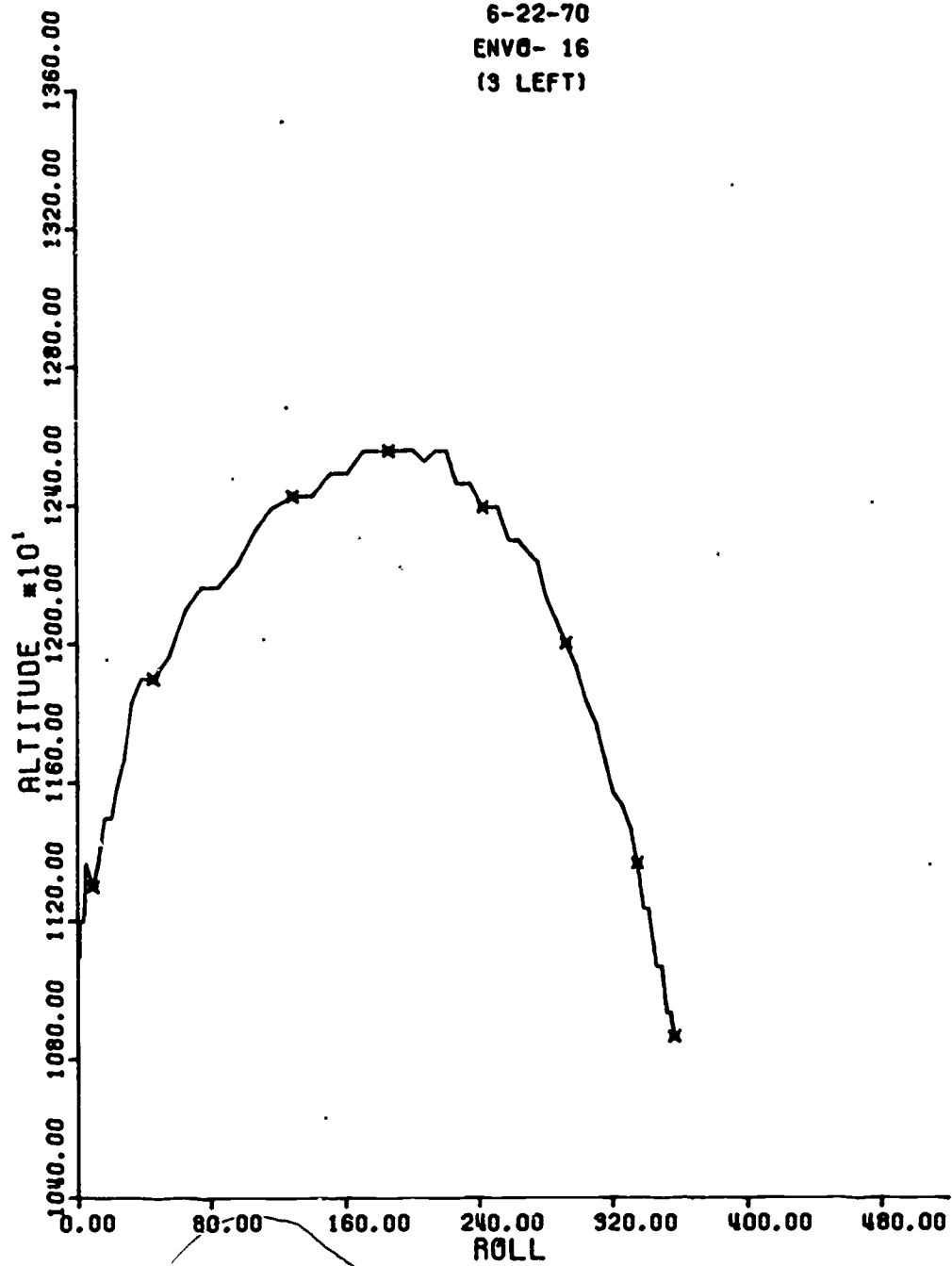

6-22-70
ENV0- 16
(3 LEFT)

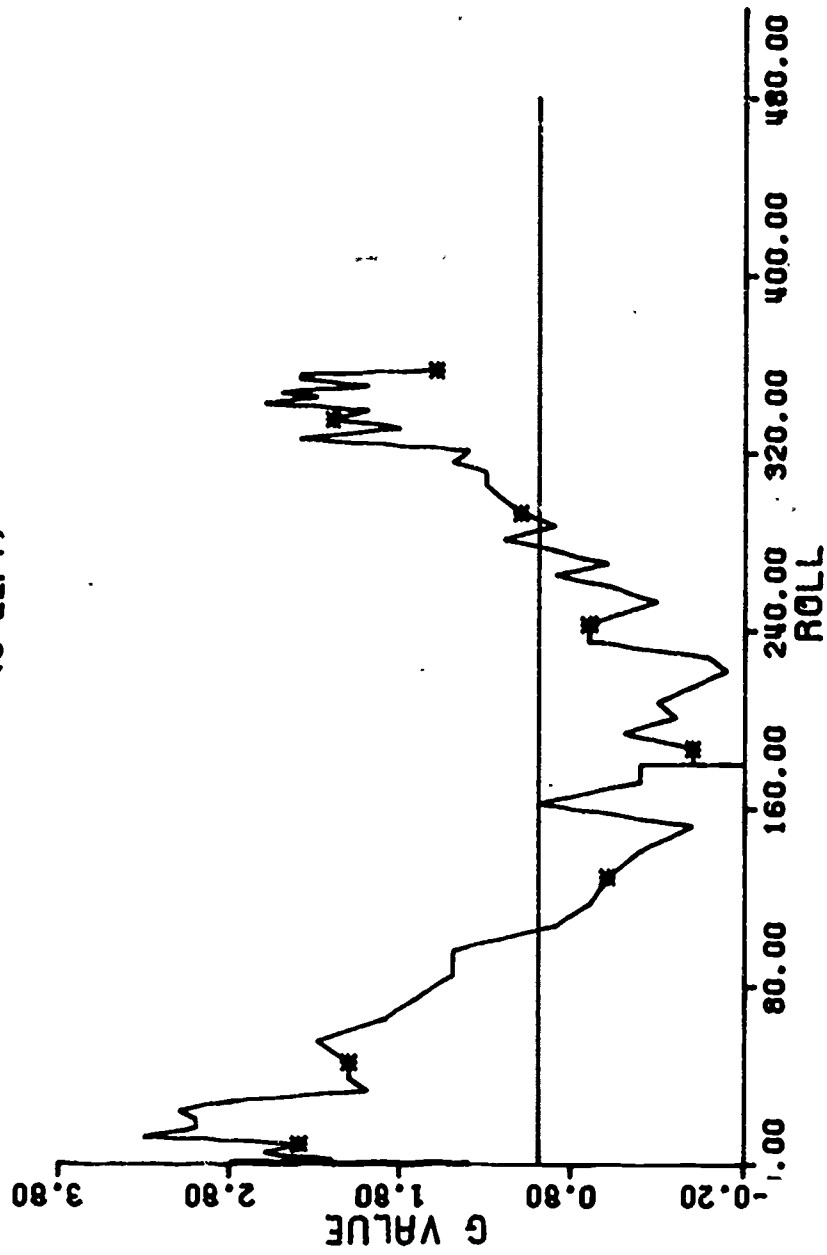

AFHRL-TR-72-6

APPENDIX XVIII
REPRESENTATIVE BARREL ROLL PLOTS

AFHRL-TR-72-6

(PILOT'S COMMENTS)

"This will be Barrel Roll No. 1, Event 36. The trouble in barrel rolls is essentially the same troubles as we have in lazy 8's. Student enters with the nose low, gets the proper parameters, starts his turn off, turns back up, is through straight and level flight with bank still in. Way too much pitch during this half of the maneuver. Not enough back pressure, too much bank. He is not very far off the point to the other side, rolls back up and is back to straight and level flight near his original point; however, if the whole maneuver were shifted up, that would be a fair maneuver."

AFHRL-TR-72-6

12-19-69
ENV0- 36
(2 LEFT)

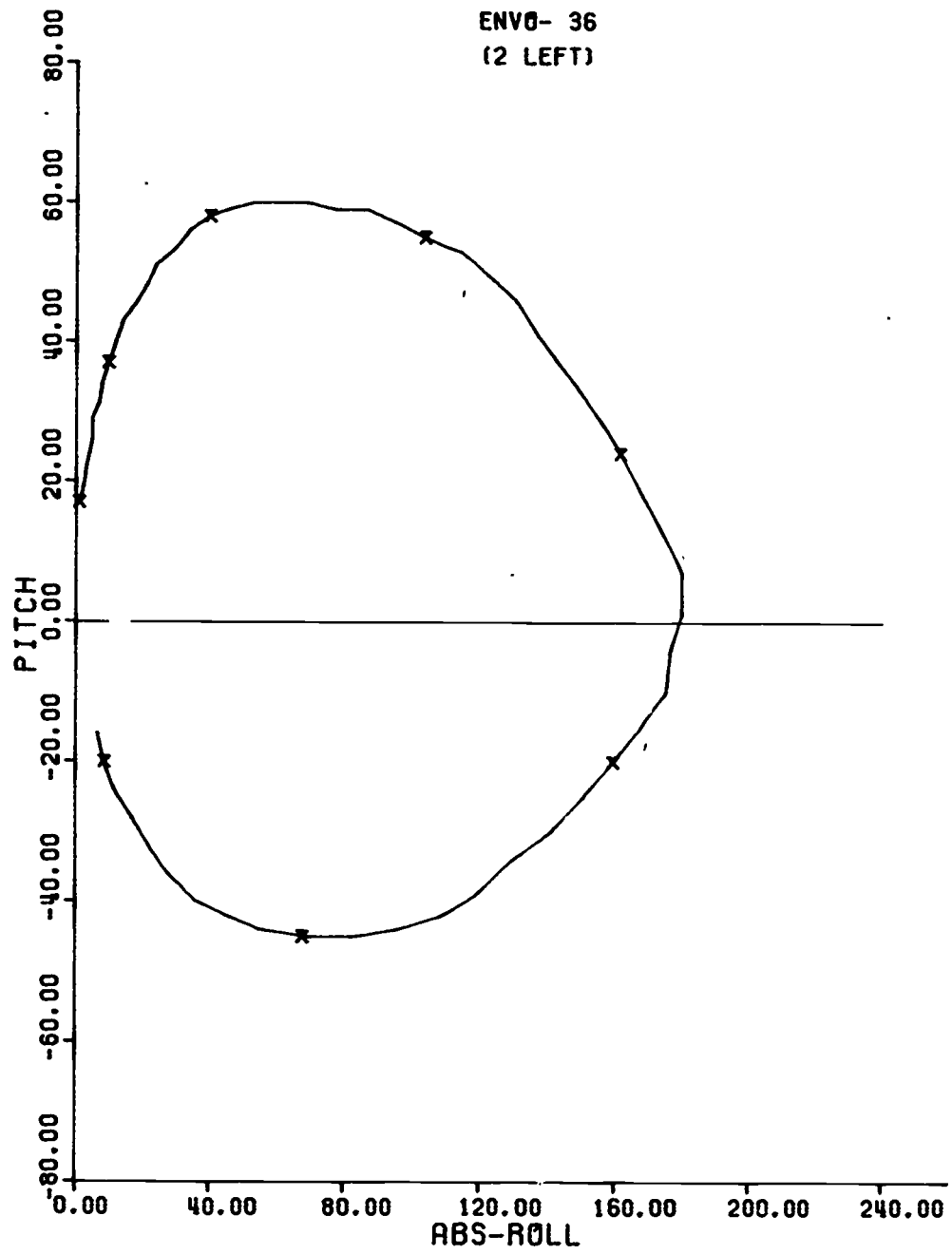

AFHRL-TR-72-6

12-19-69
ENV0- 36
(2 LEFT)

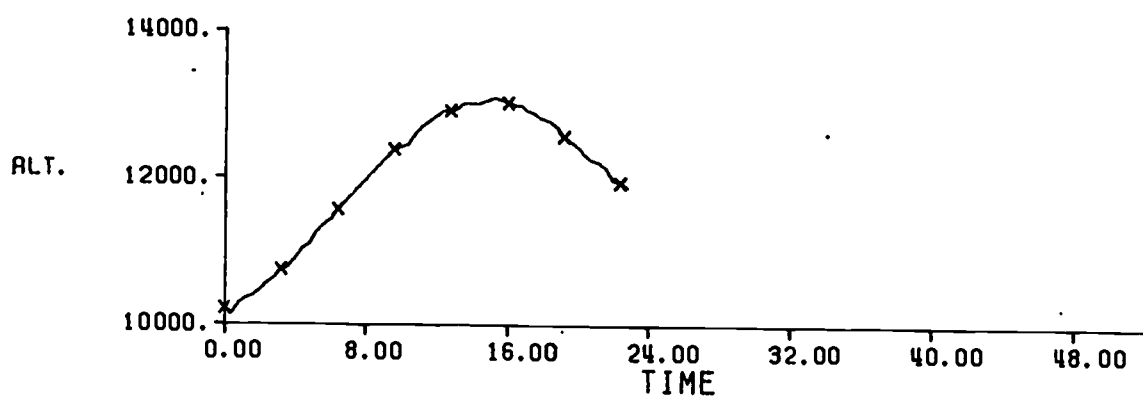
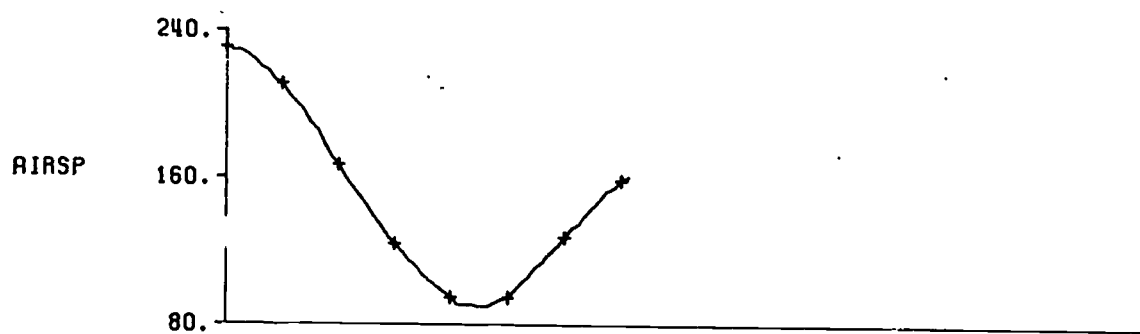
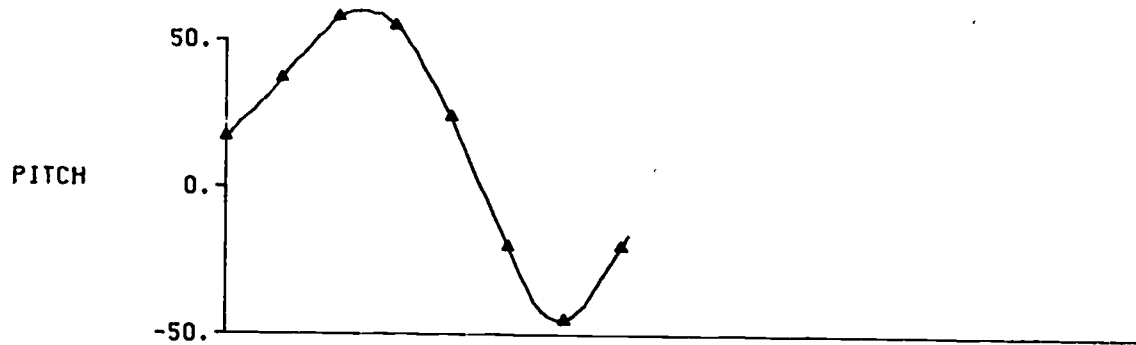
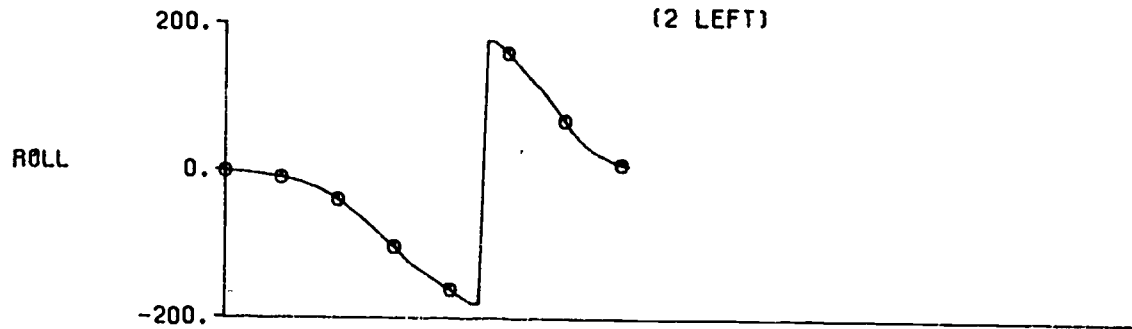

AFHRL-TR-72-6

(PILOT'S COMMENTS)

"Barrel Roll No. 6, event No. 59. The nose is below the point. Turn off. Our reference point about 20-30°. Begin the maneuver itself. This time, something that is fairly common for students to do is not to make allowance for the change of airspeed in the rate of roll that is required. Here I am not changing the aileron pressures; as a result the rate of roll is slowing down, and as we come out of the bottom of the maneuver the rate of roll increases and we wind up making a bigger maneuver than we should have and kind of dishing out at the bottom and that would have been a fair maneuver."

AFHRL-TR-72-6

12-19-69
ENV0- 59
(2 LEFT)

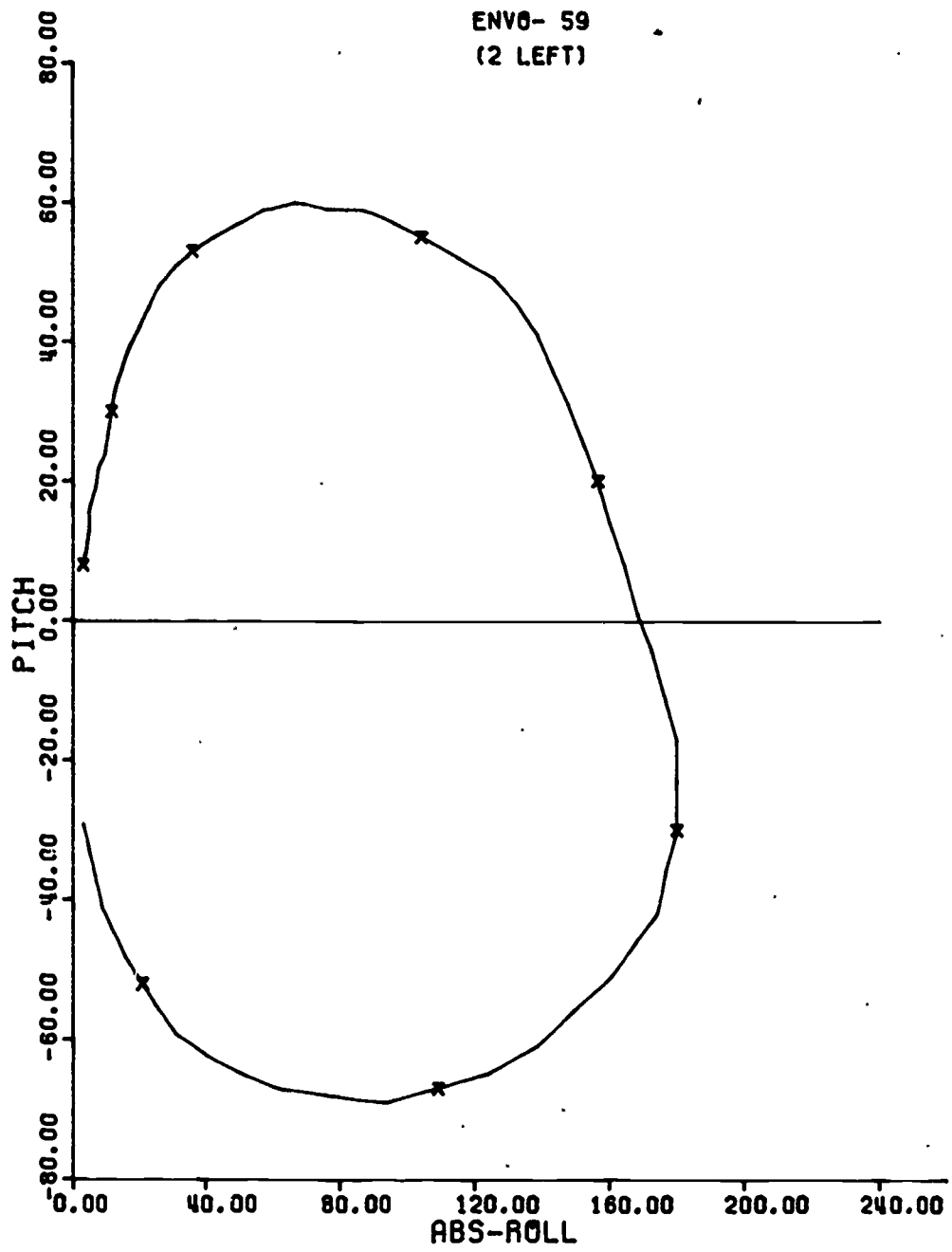

AFHRL-TR-72-6

12-19-69
ENV0- 59
(2 LEFT)

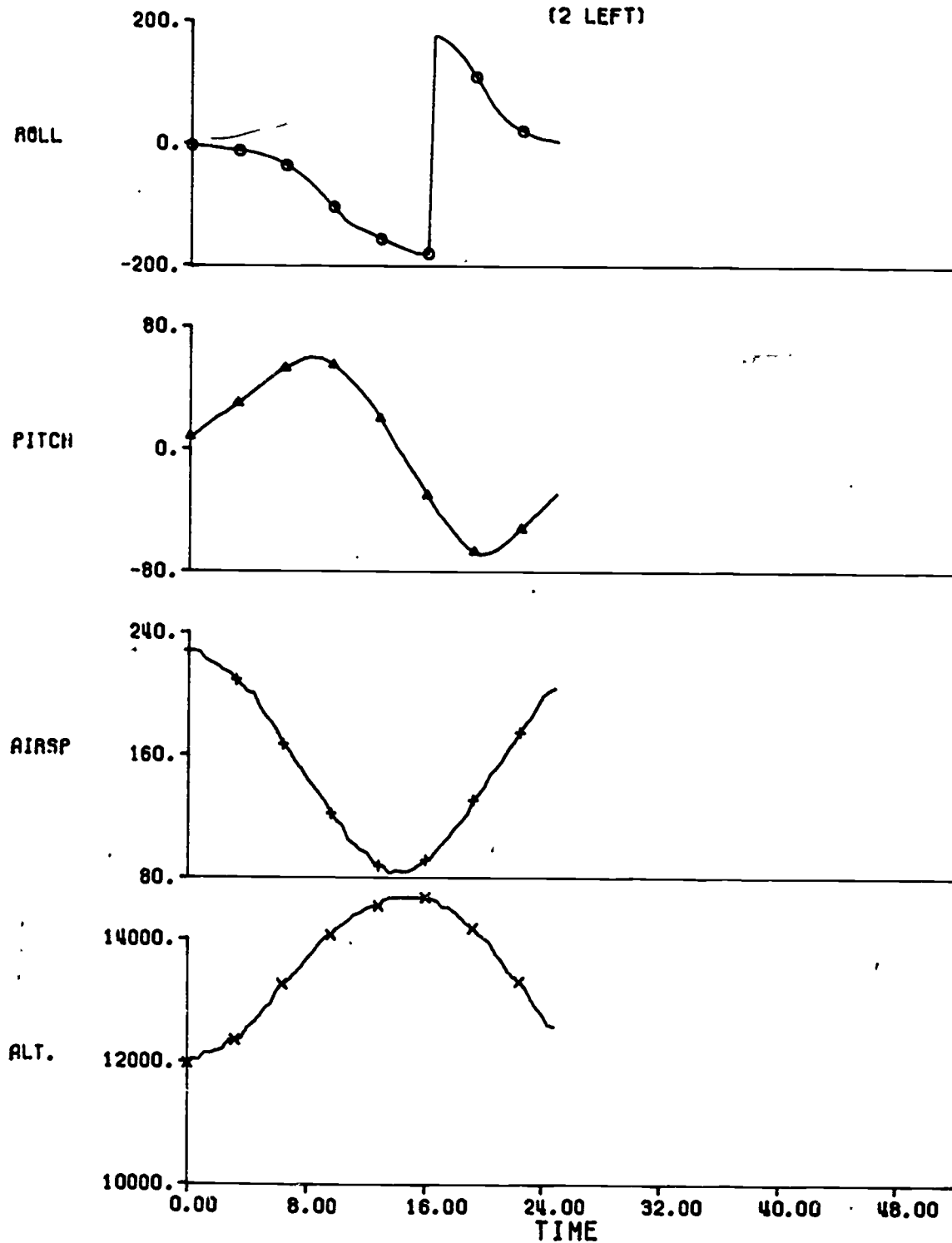

AFHRL-TR-72-6

(PILOT'S COMMENTS)

"This will be barrel roll 2, event No. 37. This one again has the nose below the point, turns off a given distance, comes through straight and level flight. Gets a pretty fair start of the thing, not enough back pressure during the first part, consequently the first half of the maneuver is flattened out; he has to roll much too rapidly to get his nose through at the proper attitude. He continues to roll too fast and winds up flattening out the bottom part of the maneuver. He has basic idea that he is flattening it out too much."

AFHRL-TR-72-6

12-19-69
ENV0- 37
(2 RIGHT)

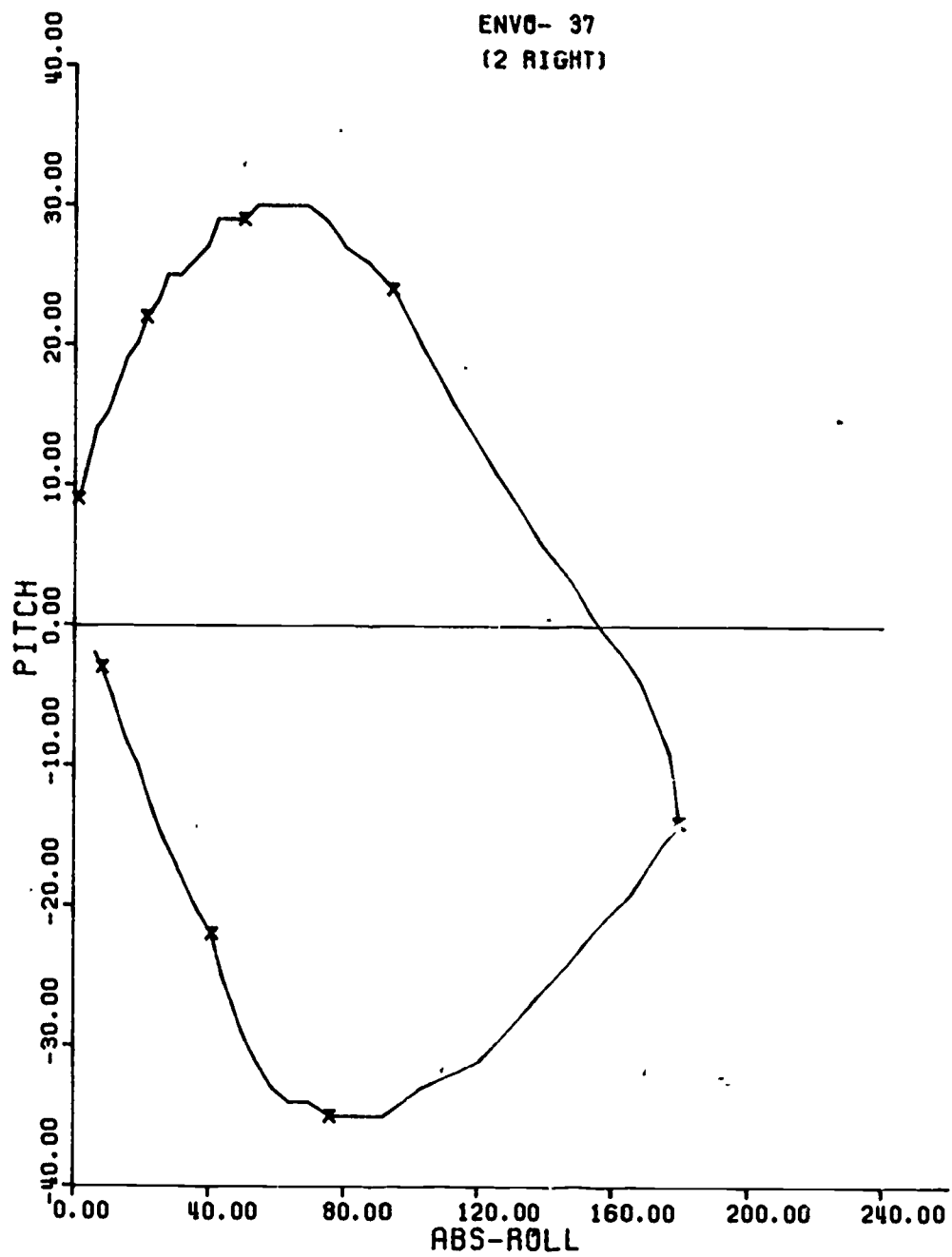

AFHRL-TR-72-6

12-19-69
ENV0- 37
(2 RIGHT)

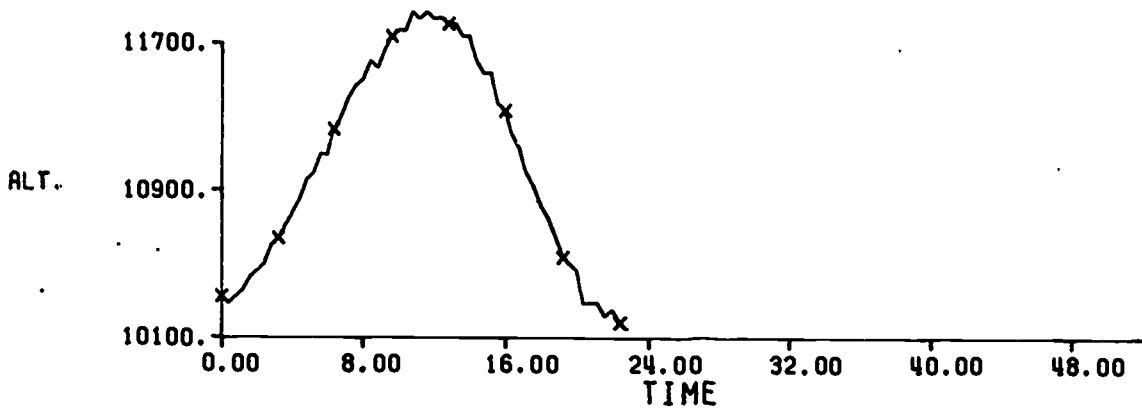
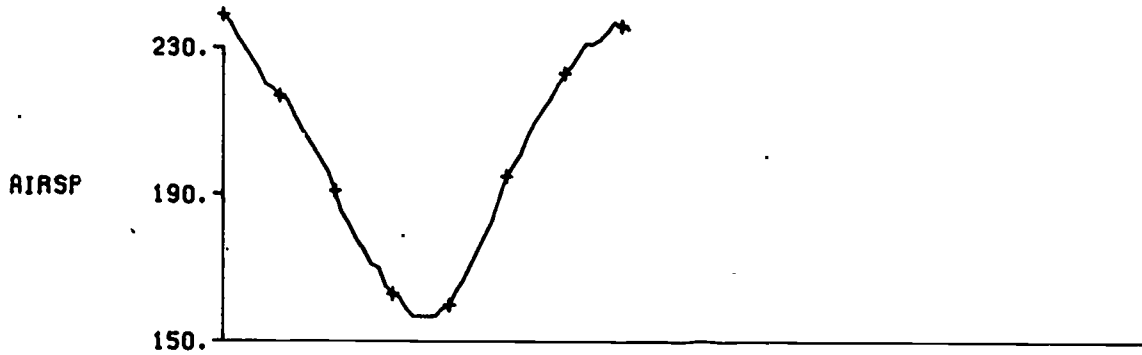
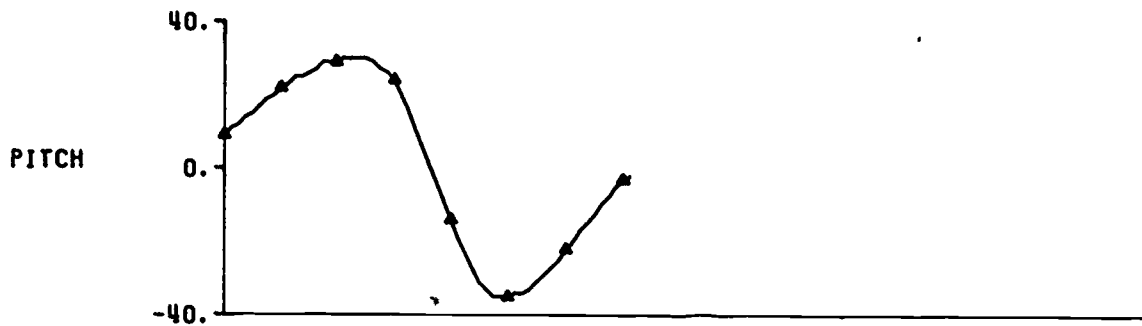
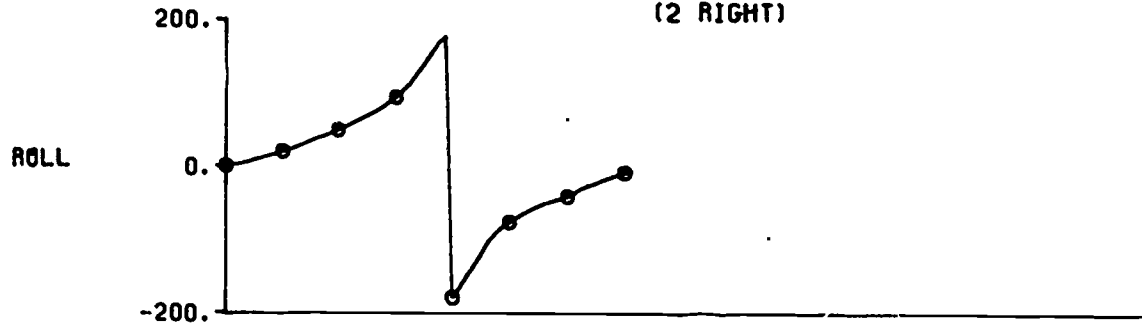

AFHRL-TR-72-6

(PILOT'S COMMENTS)

"Barrel roll 5, event No. 40. Nose below the point coming up on our entry airspeed; in this one again you have got the real tiger flying the airplane. Basically a little too aggressive with it. He is pretty smooth with the controls. But he flies a very tight, very aggressive barrel roll which is fine as far as aggressiveness goes but it does not quite look like a barrel roll is supposed to look, and that would be a fair maneuver."

AFHRL-TR-72-6

12-19-69
ENVG- 40
(2 RIGHT)

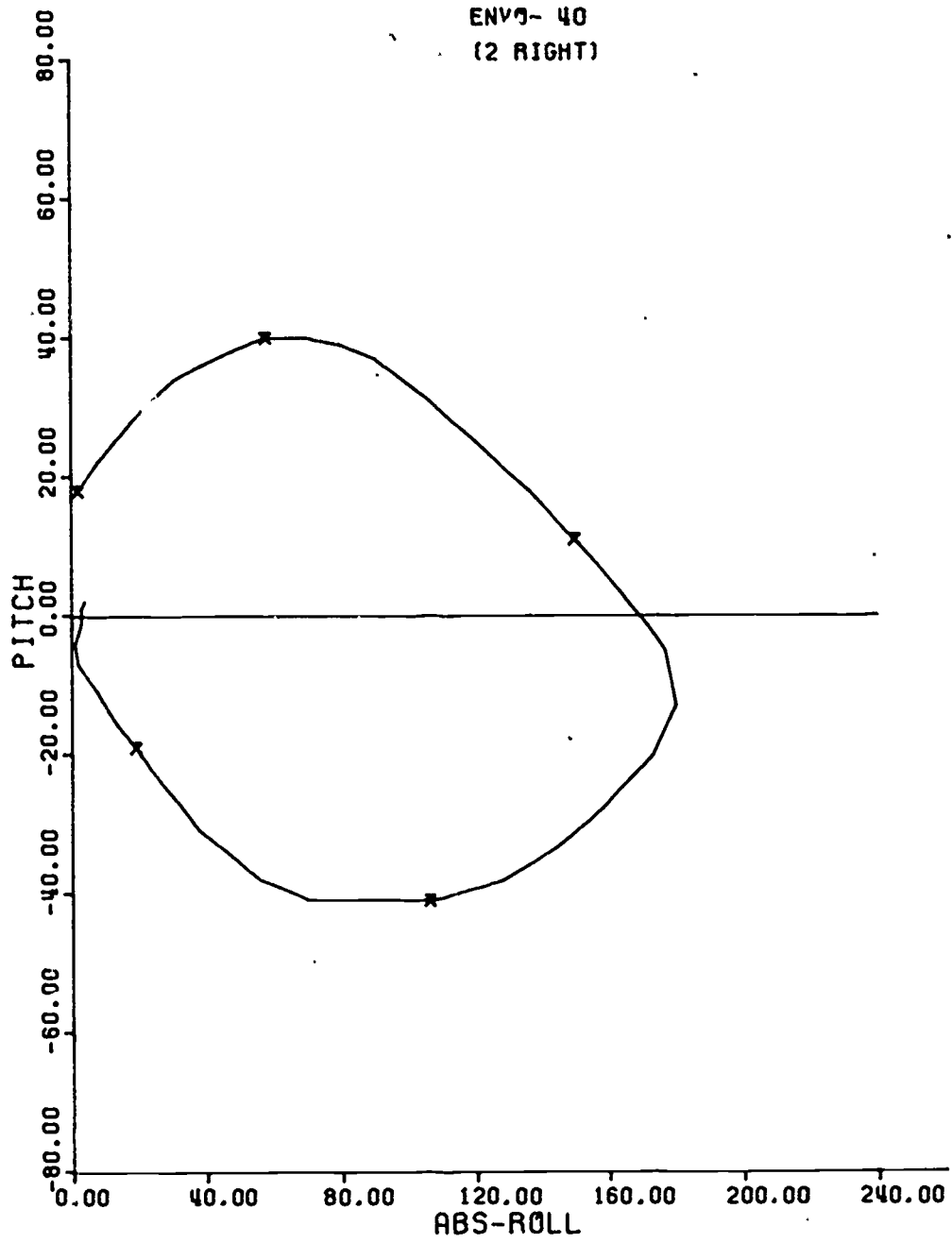

AFHRL-TR-72-6

12-19-69
ENV0- 40
(2 RIGHT)

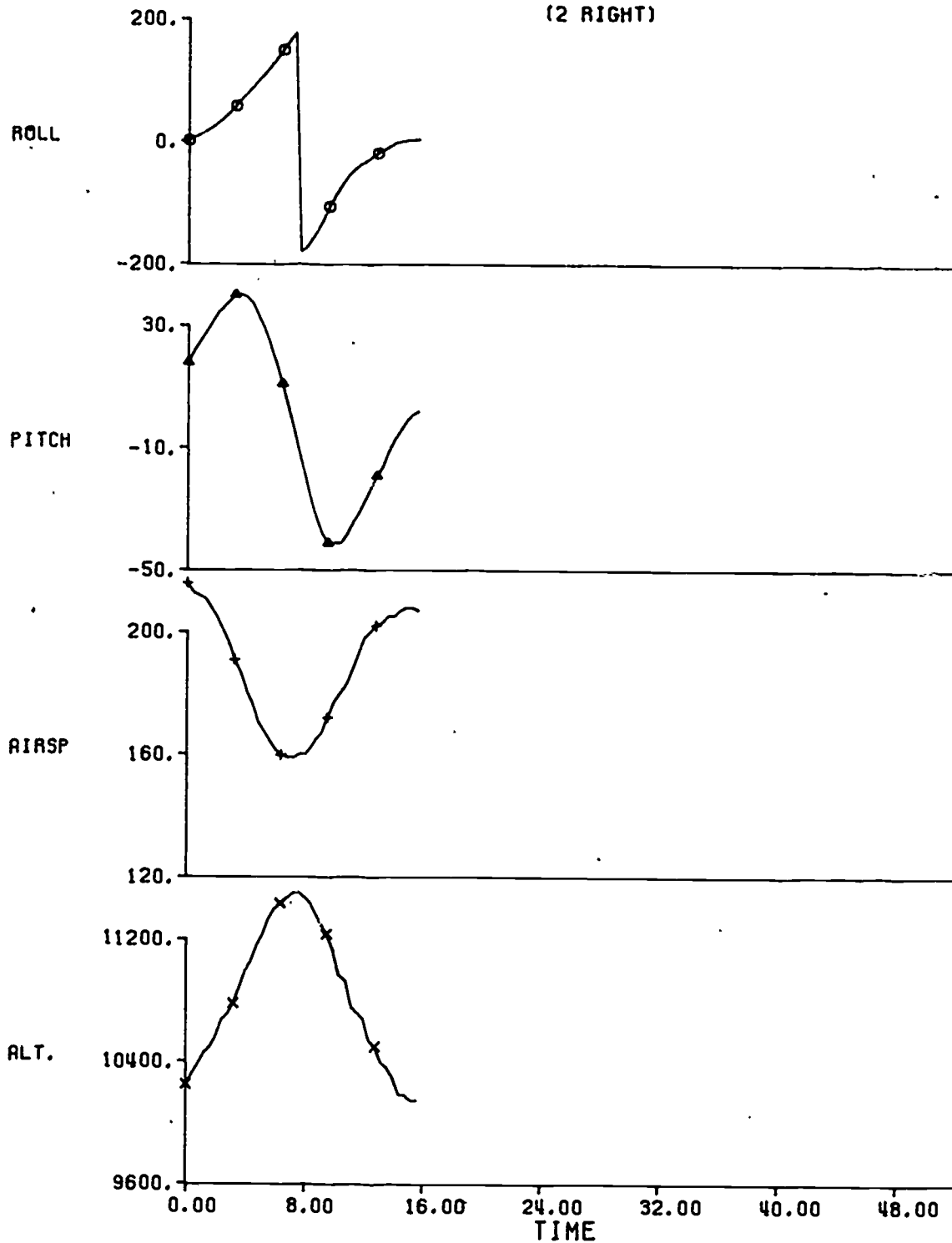

AFHRL-TR-72-6

(PILOT'S COMMENTS)

"Nose below the point entering, turns off much too far, back through not in straight and level flight, essentially winds up flying a loop around his point. The nose is much too far off the point; a little bit of burble on the top and we are back up. However we are about 60 or 70° off our point, and that would be an unsatisfactory maneuver also."

AFHRL-TR-72-6

12-19-69
ENV0- 41
(1 LEFT)

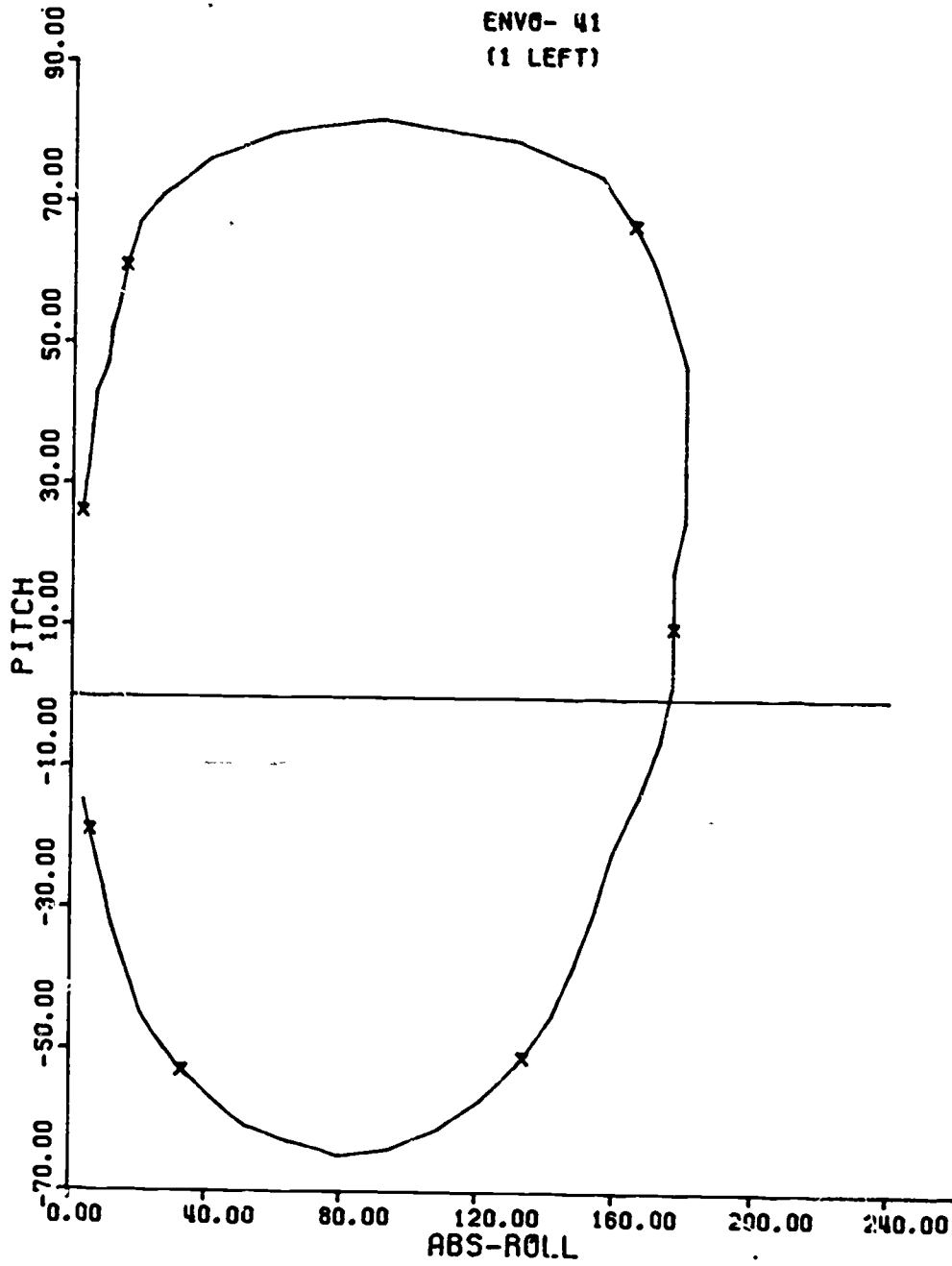

AFHRL-TR-72-6

12-19-69
ENV0- 41
(1 LEFT)

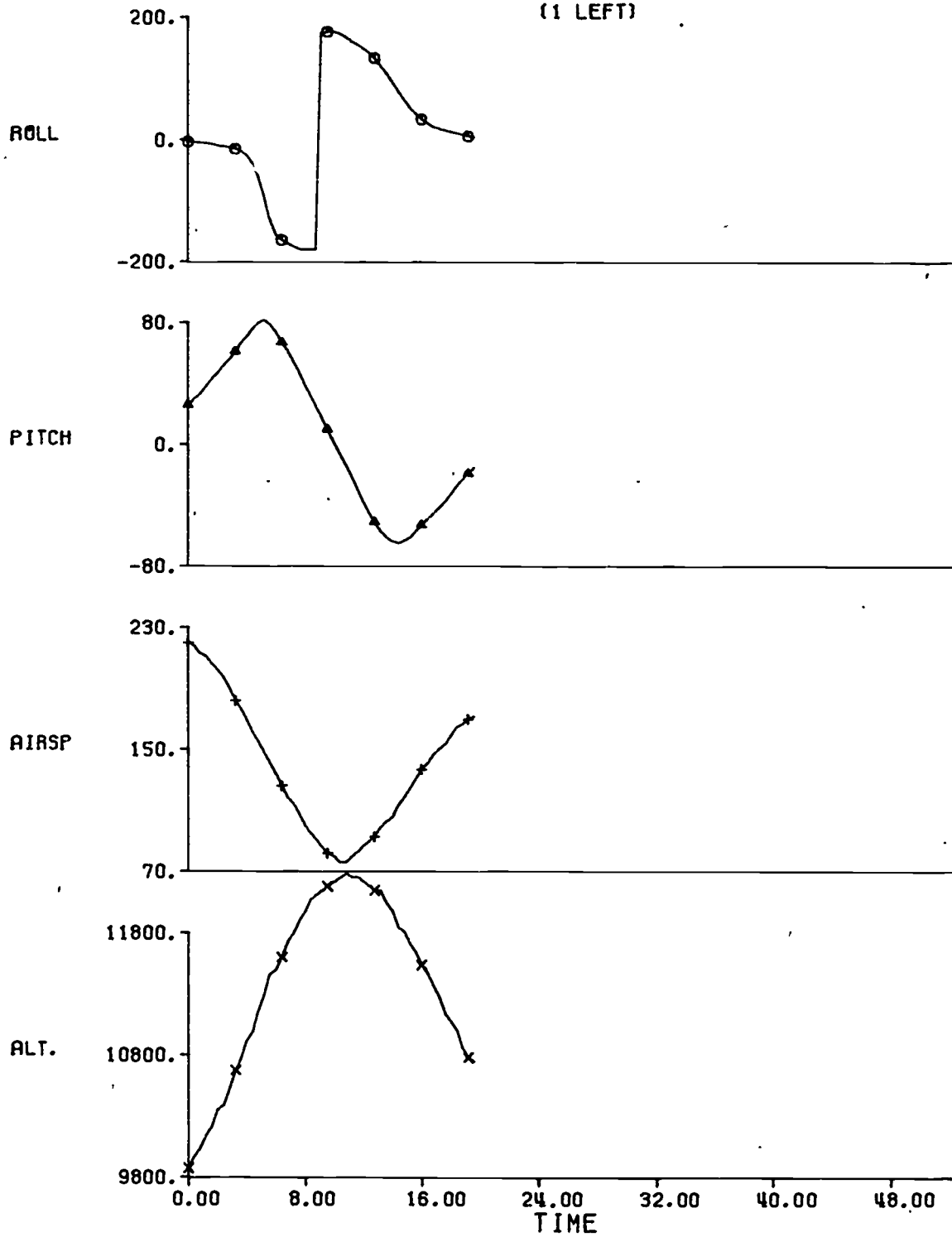

AFHRL-TR-72-6

(PILOT'S COMMENTS)

"Turn back around to the west. This will be barrel roll No. ^a, event No. 62. This is the student who makes a reasonably good entry for the maneuver. Rolls the nose around his point, turns off, and then starts to roll initially with way too much back pressure and then just rolls easing up on the back pressure. As a result the nose never quite gets back to the horizon at all and you wind up at the original entry point. However, you have never descended at all and never made the lower part of the maneuver look anything like it's supposed to look. That would have been an unsatisfactory."

AFHRL-TR-72-6

12-19-69
ENV0- 62
(1 LEFT)

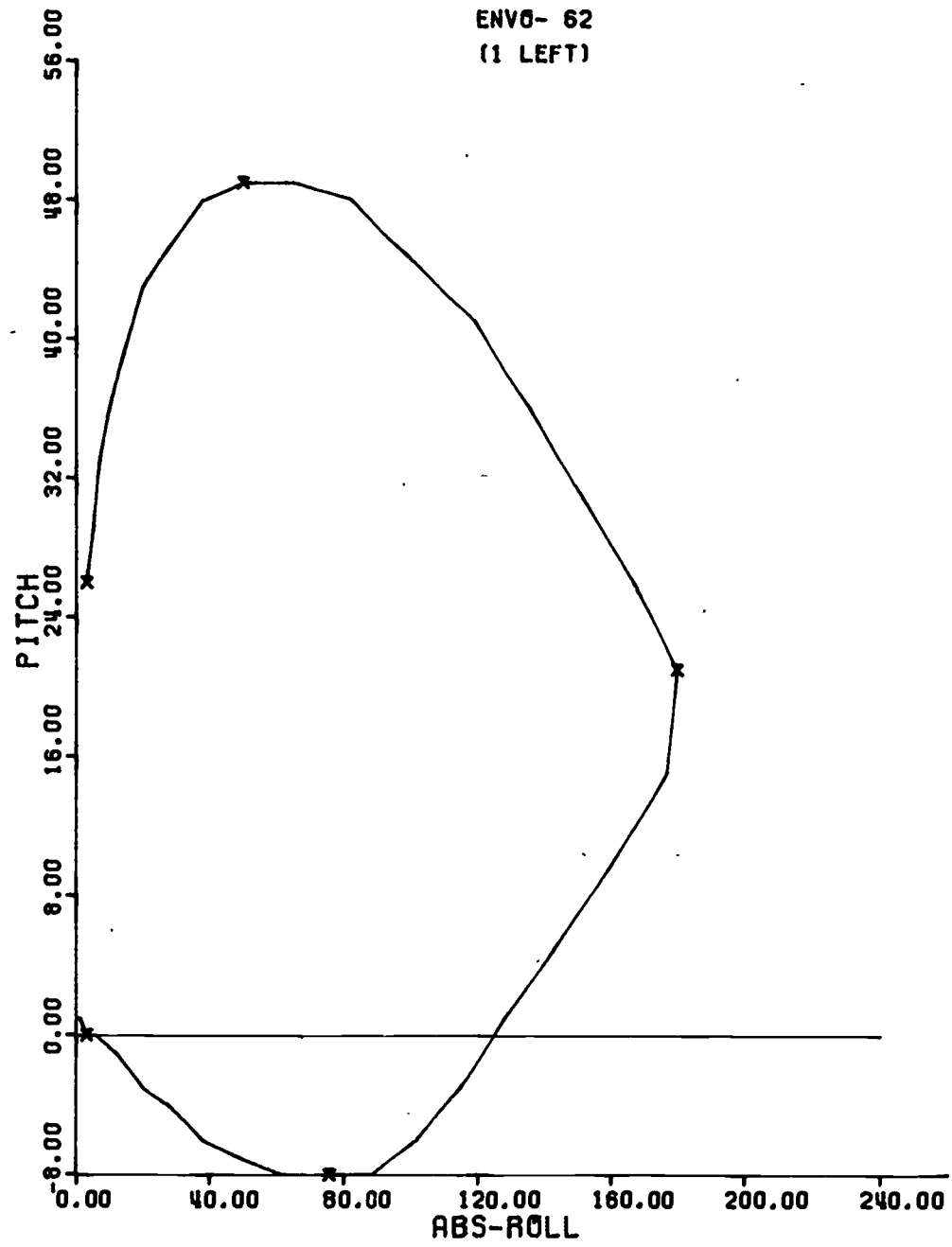

AFHRL-TR-72-6.

12-19-69
ENV0- 62
(1 LEFT)

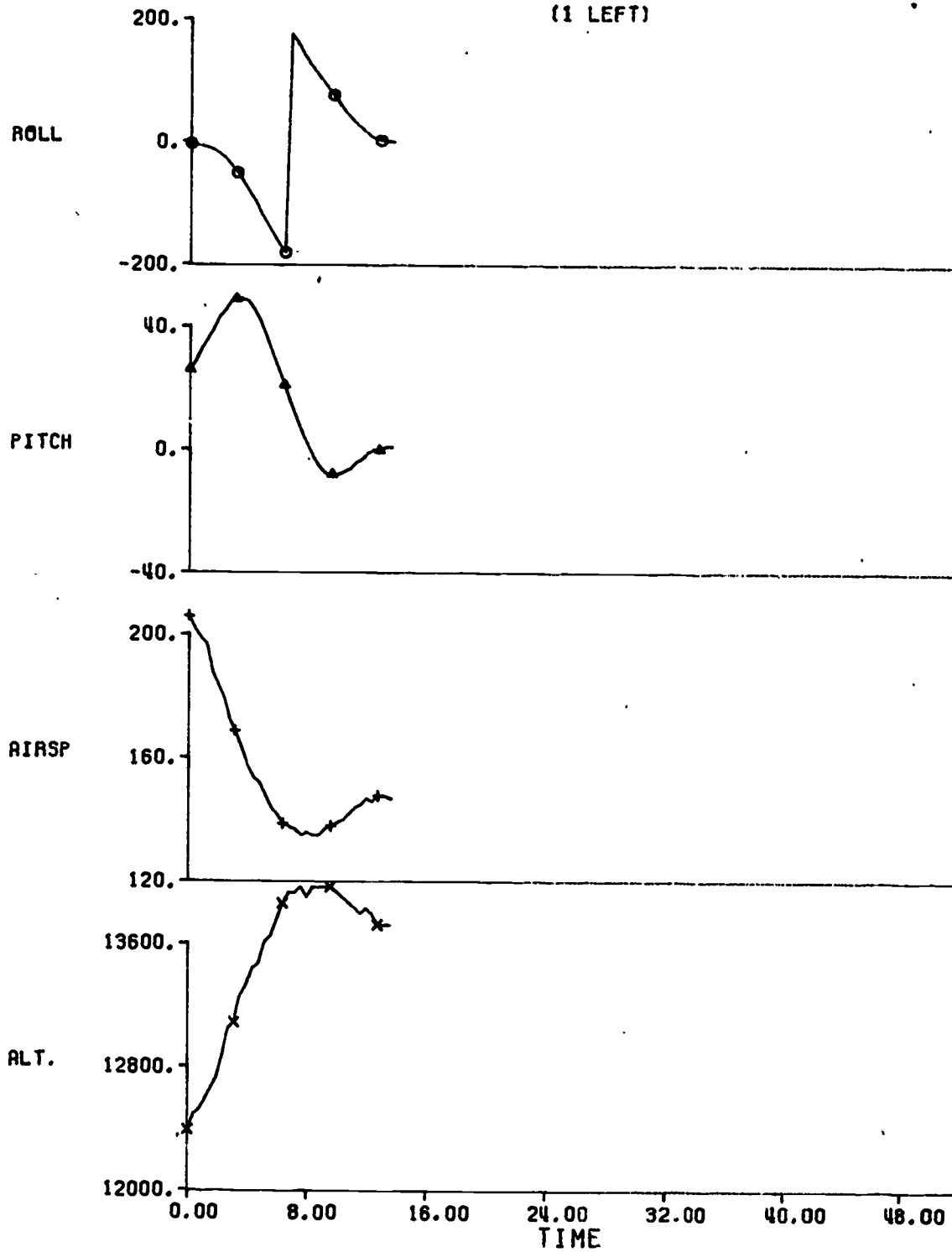

AFHRL-TR-72-6

(PILOT'S COMMENTS)

"This will be event No. 55, barrel roll 3. The nose is below the point. A lot of times when the student knows the maneuver he will turn off the point, do a pretty good job, look away for a minute and lose his reference point so that he winds up coming way over beyond the point coming through level flight with the bank indication, and because of this the nose comes well down below normal. He has to use a little higher rate of roll to come out at the bottom. Little more g's than necessary, way dished out. And that would have been an unsatisfactory barrel roll. Turn around and work back up toward the northwest momentarily."

AFHRL-TR-72-6

12-19-69
ENVG- 55
(1 LEFT)

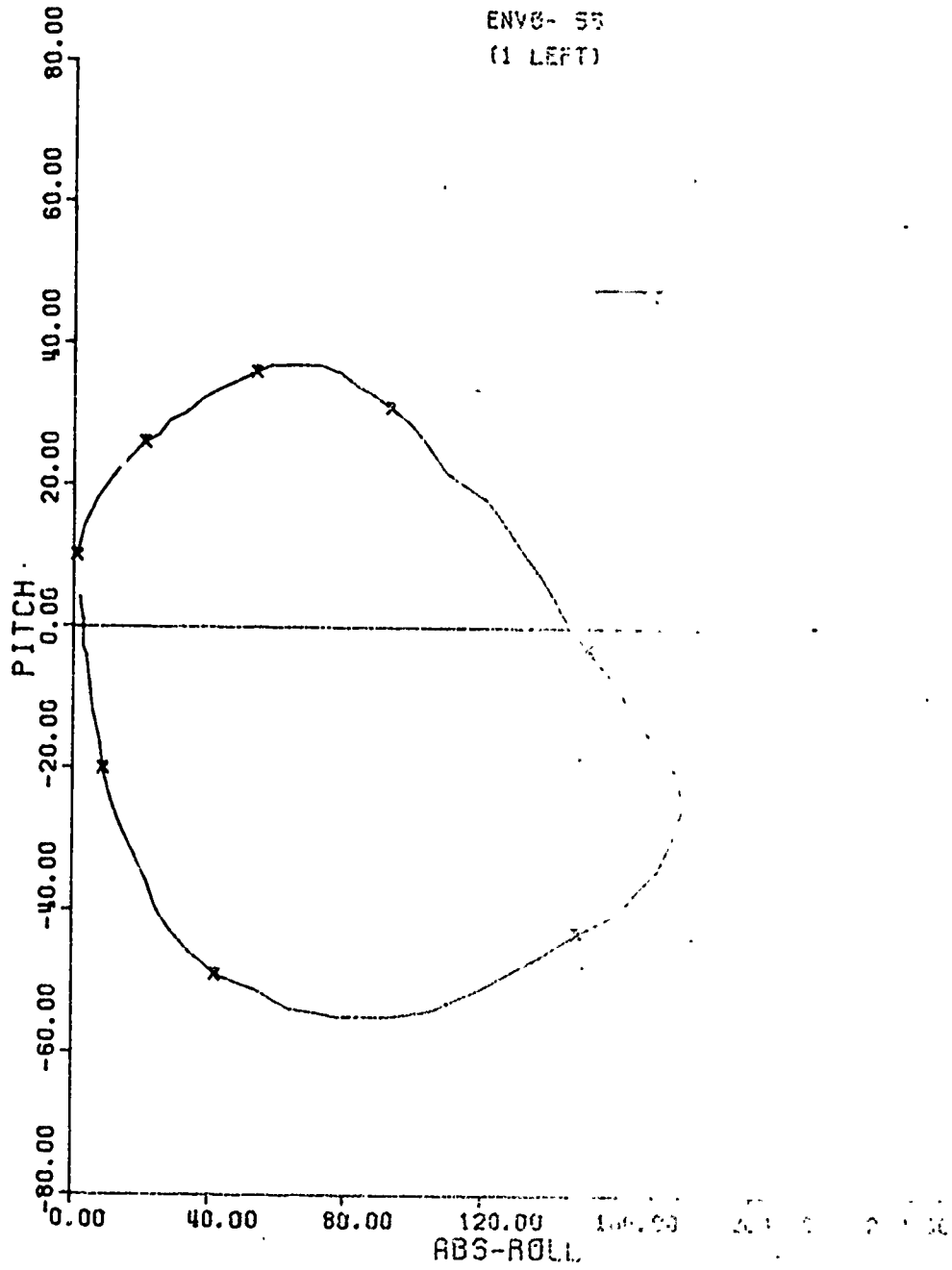

AFHRL-TR-72-6

12-19-69
ENV0- 55
(1 LEFT)

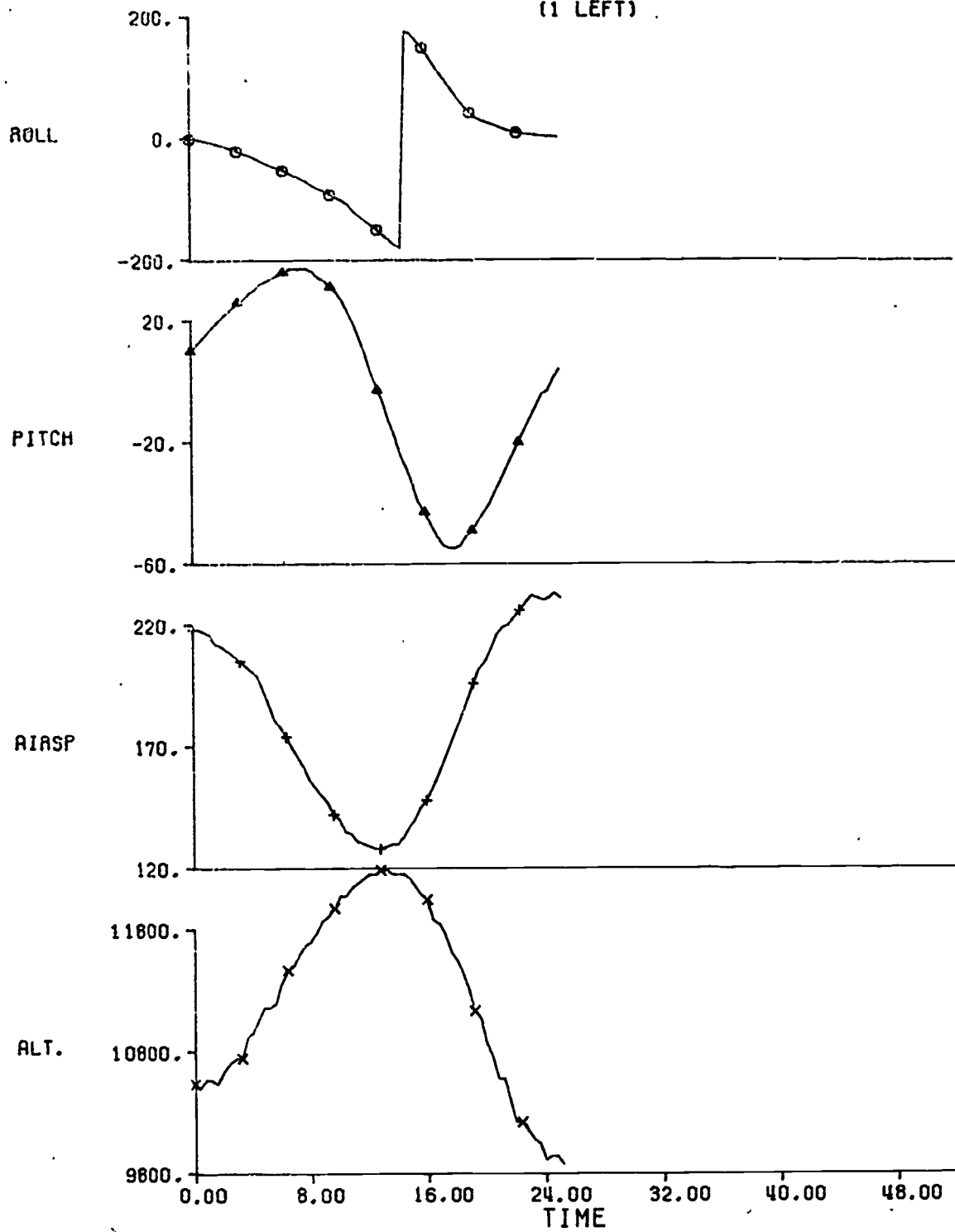

AFHRL-TR-72-6

(PILOT'S COMMENTS)

"This will be barrel roll No. 5, event 57. Nose below the point, off. This time he rolls much too fast to start with. He is flattening out the maneuver much too much across the top. The nose is off the far side about as far as it should be, however, in here he is not rolling off nearly fast enough and 9 times out of 10 cases, he will wind up what we consider to be a high speed dive recovery. That would have been unsatisfactory."

12-19-69
ENV6- 57
(1 LEFT)

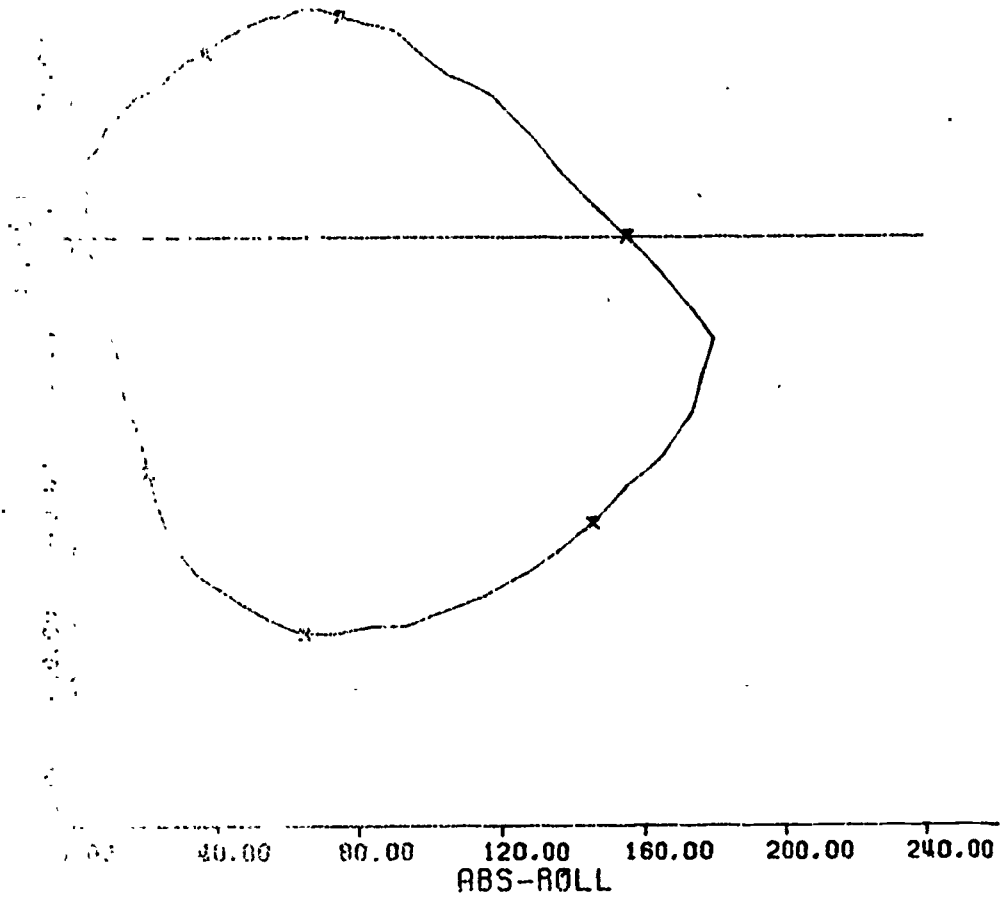

12-19-69
ENV0- 57
(1 LEFT)

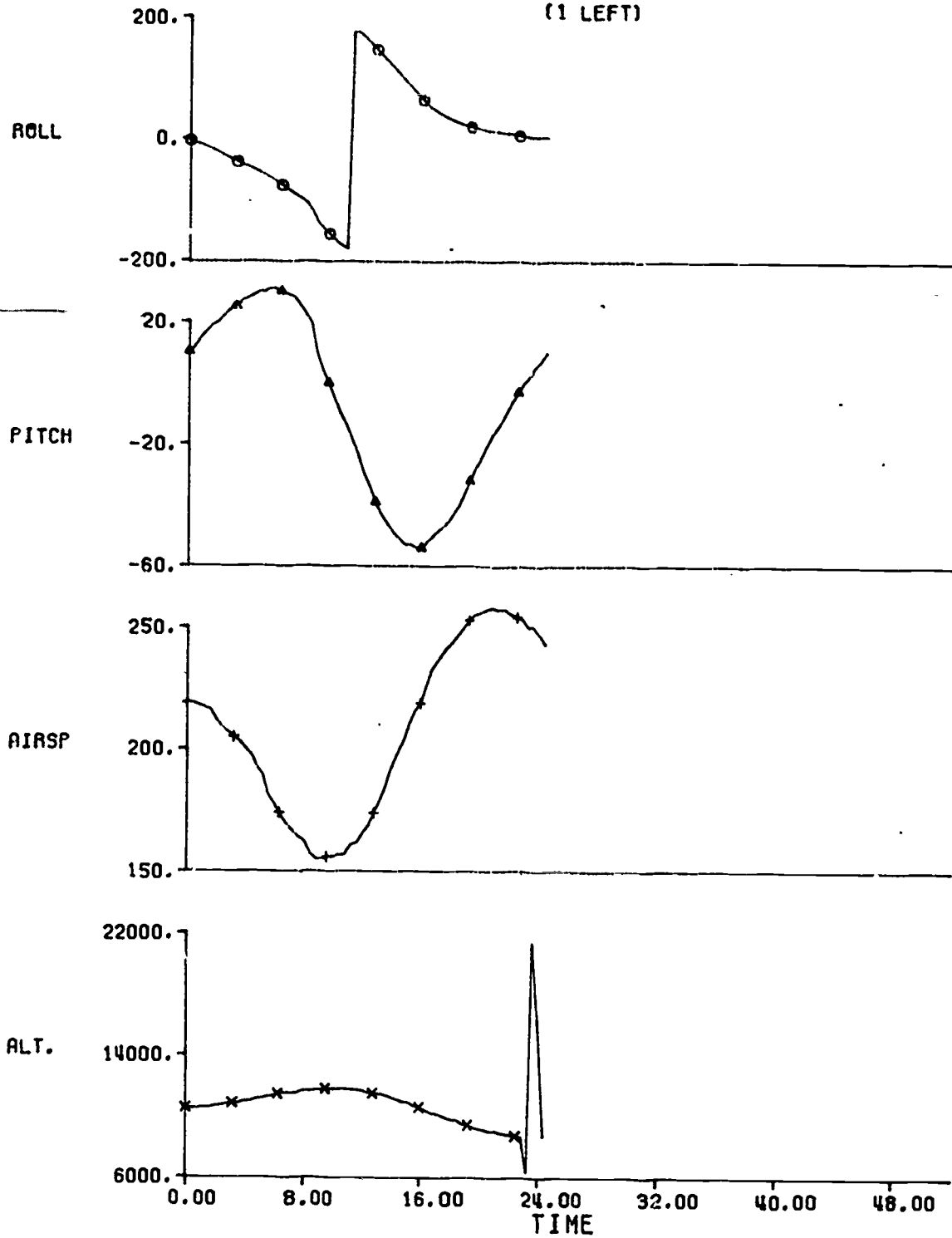

AFHRL-TR-72-6

(PILOT'S COMMENTS)

"The barrel roll is much easier to mess up on the entry than even this one is. This one will be barrel roll 10, event 69. Driving around he wants to do a barrel roll, again they just make up their mind. The airspeed is already 230 knots as a maximum entry airspeed. They pick out their point, lower the nose below the point. The airspeed is already 240. Then they lower the nose, start to do the maneuver, come up with much too much airspeed, 250, 260, 270, they worry about the airspeed, getting the nose way up too high. Generally disorganized. That would have been an unsatisfactory."

AFHRL-TR-72-6

12-19-69
ENV6- 69
(1 RIGHT)

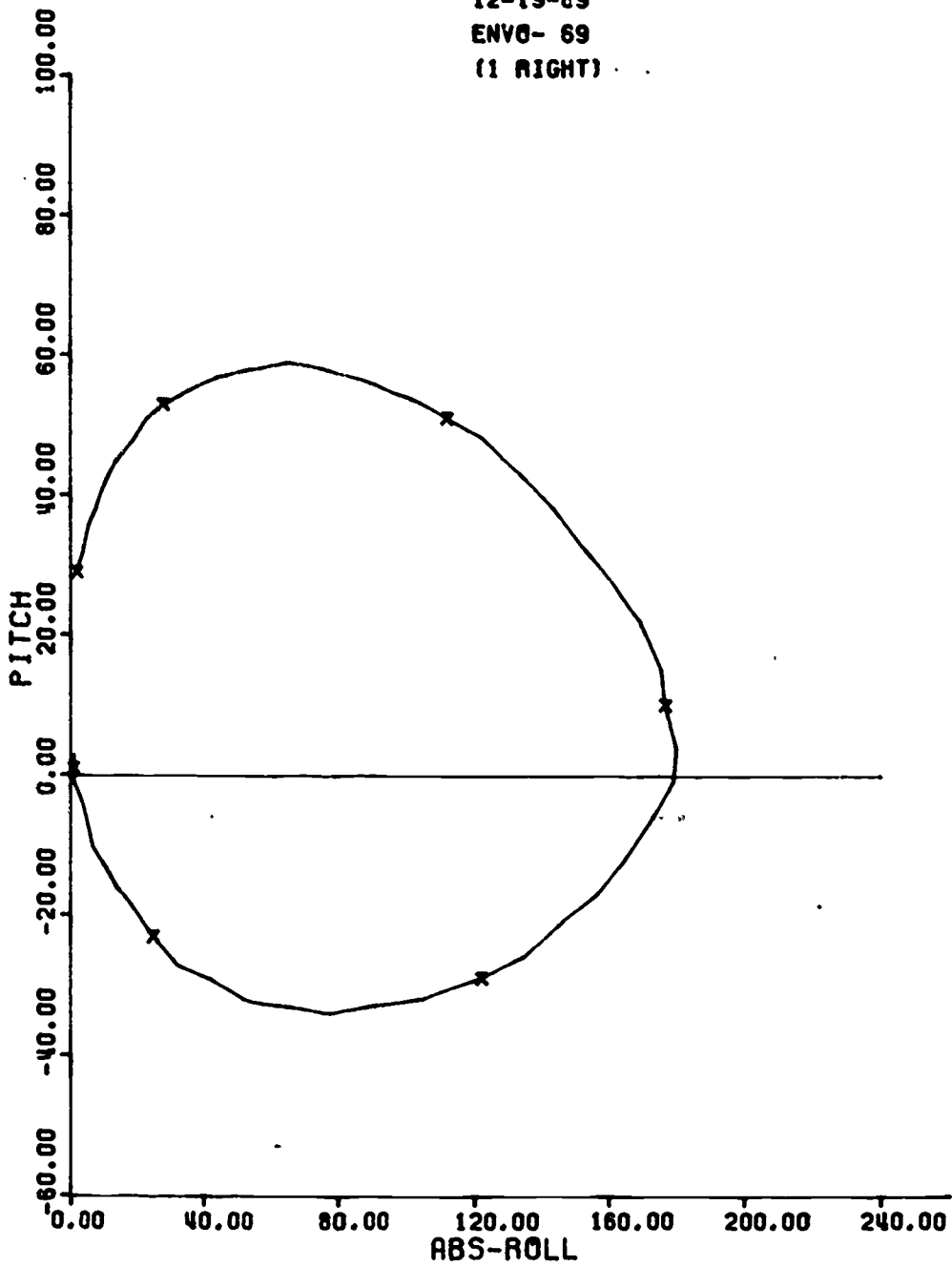

AFHRL-TR-72-6

12-19-69
ENVO- 69
(1 RIGHT)

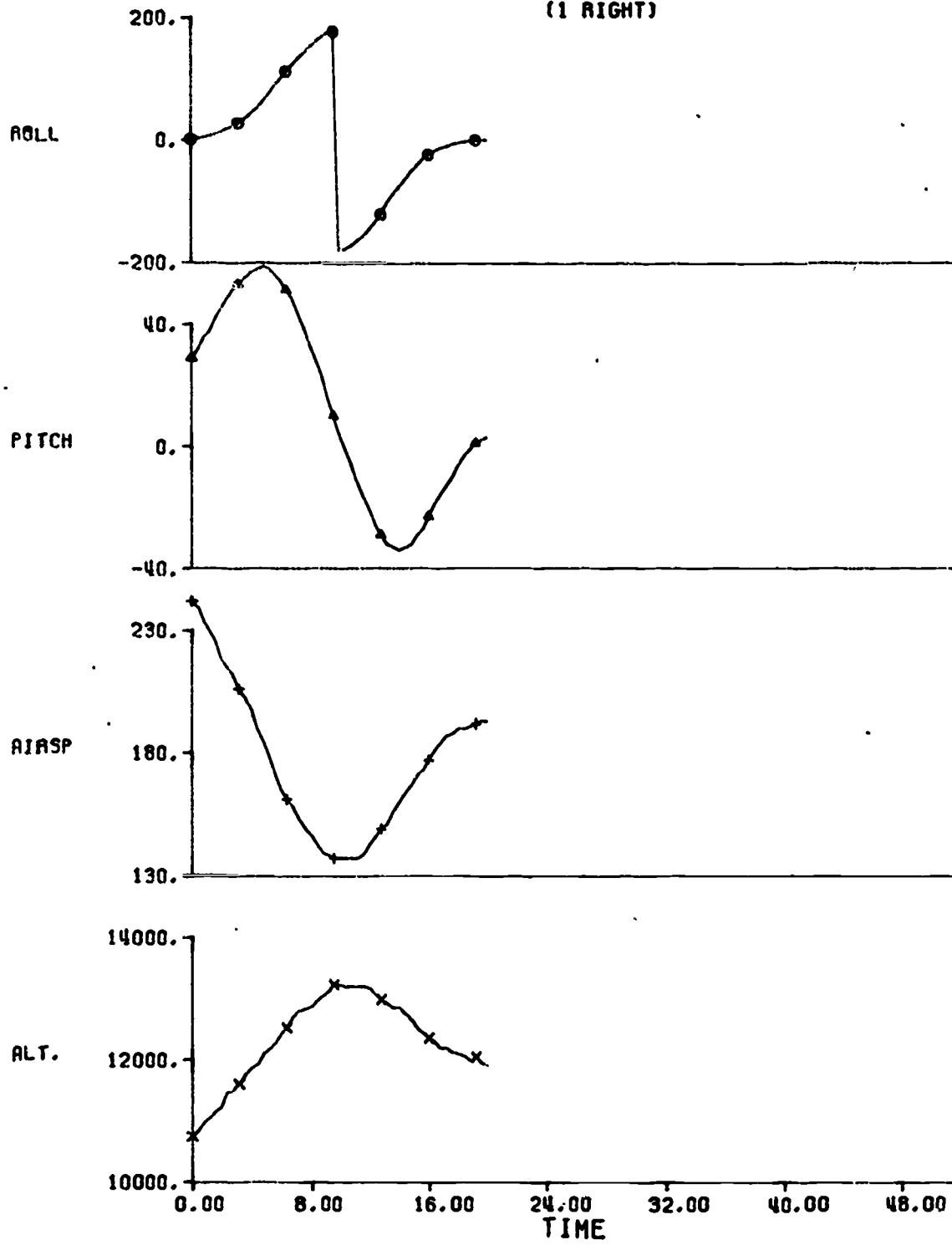

AFHRL-TR-72-6

(PILOT'S COMMENTS)

"The most common tendency on the barrel roll for an unsatisfactory maneuver is what we are about to do, barrel roll No. 8, event No. 61, and that is flattening out across the top like we have shown before, with the rate of roll a little too slow in the second quadrant, winding up coming through the horizon with bank still and the nose coming much too low. Winding up with essentially a high speed dive recovery. And I am getting myself into an area, headingwise, that I should not be in on those."

AFHRL-TR-72-6

12-19-69
ENV0- 61
(1 RIGHT)

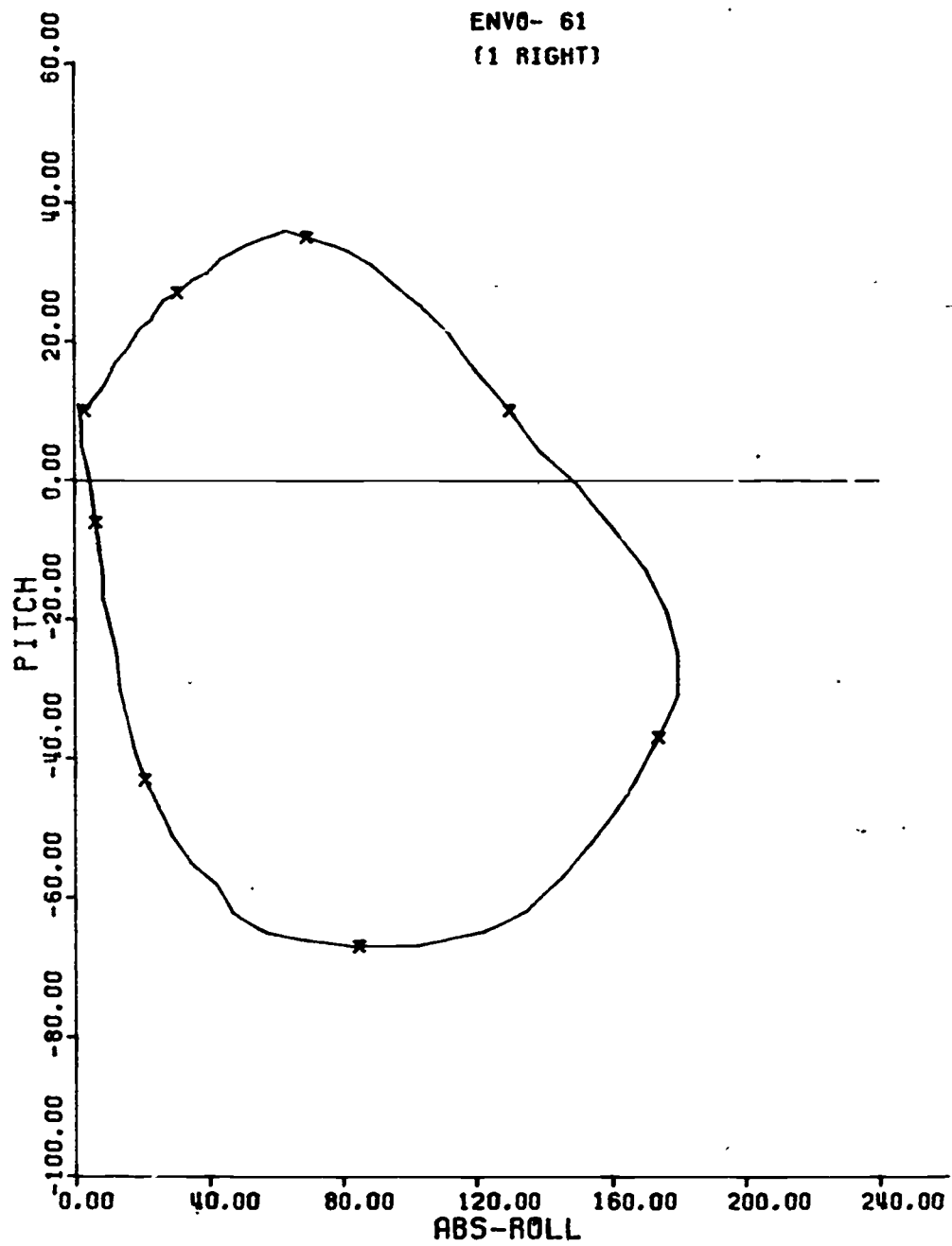

AFHRL-TR-72-6

12-19-69
ENV0- 61
(1 RIGHT)

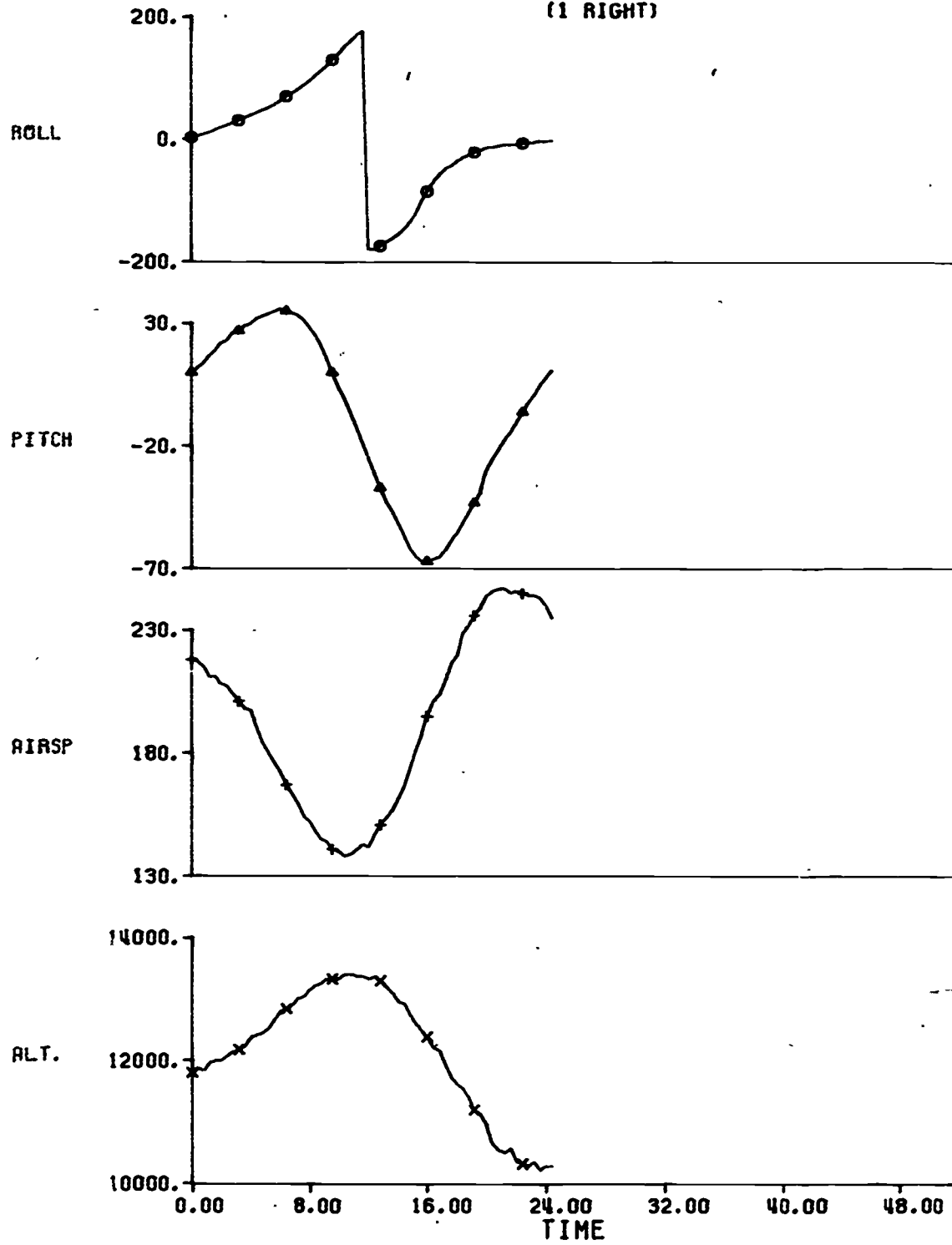

REFERENCES

1. Glaser, R., and Klaus, D. J., "Proficiency Measurement: Assessing Human Performance," (R. Gagne, Ed.), Psychological Principles in Systems Development, New York: Holt, Rinehart, and Winston, 419-476 (1963).
2. Brown Operation and Maintenance Manual For Pulse Code Modulation Data Acquisition System. Brown Engineering Company, Inc., Huntsville, Alabama.
3. Connelly, E. M., Schuler, A. R., Bourne, F. J., and Knoop, P. A. Application of Adaptive Mathematical Models to a T-37 Pilot Performance Measurement Problem, AFHRL-TR-70-45, Air Force Human Resources Laboratory, Wright-Patterson AFB, Ohio (1971).
4. Air Training Command, 1967. Primary Flying, Jet, ATC Manual 51-4, Headquarters Air Training Command, Randolph AFB, Texas (1967).
5. Connelly, E. M., Schuler, A. R., and Knoop, P. A., 1969. Study of Adaptive Mathematical Models for Deriving Automated Pilot Performance Measurement Techniques, AFHRL-TR-69-7, Volumes I and II, AFHRL, WPAFB, Ohio (1969).
6. Smith, J., Flexman, R., and Houston, R., Dec 1952. Development of an Objective Method of Recording Flight Performance, Technical Report 52-15, Human Resources Research Center, Air Training Command, Lackland AFB, Texas (Dec 1952).

UNCLASSIFIED

Security Classification

DOCUMENT CONTROL DATA - R & D		
<i>(Security classification of title, body of abstract and indexing annotation must be entered when the overall report is classified)</i>		
1. ORIGINATING ACTIVITY (Corporate author) Air Force Human Resources Laboratory Advanced Systems Division, AFHRL/AS Wright-Patterson AFB, Ohio 45433		2a. REPORT SECURITY CLASSIFICATION Unclassified
		2b. GROUP N/A
3. REPORT TITLE AUTOMATED PILOT PERFORMANCE ASSESSMENT IN THE T-37: A FEASIBILITY STUDY		
4. DESCRIPTIVE NOTES (Type of report and inclusive dates) Final (May 1968 - April 1971)		
5. AUTHOR(S) (First name, middle initial, last name) Patricia A. Knoop and William L. Welde		
6. REPORT DATE April 1973	7a. TOTAL NO. OF PAGES 463	7b. NO. OF REFS 6
8a. CONTRACT OR GRANT NO N/A	9a. ORIGINATOR'S REPORT NUMBER(S) AFHRL-TR-72-6	
b. PROJECT NO 6114 12 003		
c. 1710 10 001	9b. OTHER REPORT NO(S) (Any other numbers that may be assigned this report)	
d.		
10. DISTRIBUTION STATEMENT Approved for public release; distribution unlimited.		
11. SUPPLEMENTARY NOTES N/A	12. SPONSORING MILITARY ACTIVITY Air Force Human Resources Laboratory Air Force Systems Command Wright-Patterson AFB, Ohio	
13. ABSTRACT <p>Research was conducted to develop a capability for quantification and assessment of in-flight pilot performance for utilization in Undergraduate Pilot Training (UPT). This feasibility effort was directed to overcoming the disadvantages of the traditional subjective rating of a pilot trainee's performance by the instructor pilot. This was accomplished through the development of an automated, objective performance measurement system that possesses the characteristics of reliability, validity, and sensitivity. A T-37B was instrumented to digitally record 24 flight and engine parameters. An extensive computer software system was developed with which to reduce, calibrate, and analyze the recorded data from the lazy 8 and barrel roll maneuvers, and compute performance measures. Criterion values for the two maneuvers were developed by utilizing task analysis data, narrative descriptions, and recorded in-flight maneuver performance of a highly qualified Air Training Command instructor pilot. Utilizing recorded data from 16 students and 4 instructors, experimental performance measures were derived through an iterative analytic approach.</p> <p>Study results indicated that lazy 8 performance assessment can be accomplished using the flight parameters of roll angle, pitch angle, and airspeed in a single summary error measure. Barrel roll measurement is dependent upon roll and pitch angle, acceleration (g force), and roll rate. A definite relationship between roll and pitch was determined to be critical to measurement. Discussions of measurement validation methods, debriefing plots, a sampling rate study, instrumentation techniques, and problem areas are provided.</p>		

DD FORM 1 NOV 65 1473

UNCLASSIFIED

Security Classification

UNCLASSIFIED
Security Classification

14 KEY WORDS	LINK A		LINK B		LINK C	
	ROLE	WT	ROLE	WT	ROLE	WT
Pilot Performance Assessment						
Performance Measurement						
Proficiency Measurement						
T-37B						
In-flight Data Acquisition						
Flight Data Sensors						
Airborne Data Recorders						
Data Calibration/Reduction						
Lazy 8						
Barrel Roll						
Undergrate Pilot Training						