

DOCUMENT RESUME

ED 075 243

24

SE 016 072

TITLE Self-Paced Physics, Segments 19-23.
INSTITUTION Naval Academy, Annapolis, Md.; New York Inst. of
Tech., Old Westbury.
SPONS AGENCY Office of Education (DHEW), Washington, D.C. Bureau
of Research.
BUREAU NO BR-8-0446
PUB DATE 70
CONTRACT N00600-68-C-0749
NOTE 148p.

EDRS PRICE MF-\$0.65 HC-\$6.58
DESCRIPTORS College Science; Electricity; *Instructional
Materials; *Physics; *Problem Sets; Problem Solving;
*Remedial Programs; Science Education; *Self Help
Programs
IDENTIFIERS Self Paced Instruction

ABSTRACT

Five study segments of the Self-Paced Physics Course materials are presented in this fourth problems and solutions book used as a part of student course work. The subject matter is related to electric charges, insulators, Coulomb's law, electric fields, lines of force, solid angles, conductors, motion of charged particles, dipoles, electric flux, surface charge densities, charging processes, and Gauss's law. Contained in each segment are information panels, core problems enclosed in a box, core-primed questions, scrambled problem solutions, and true-false questions. Accompanying study guides are used to answer the true-false questions and to reveal directions for reaching solutions. When the core problem is answered incorrectly, the study guides require students to follow the remedial or enabling loop, leading to the solutions of core-primed questions. Also included is a sheet of problem numbers with corresponding page numbers which locate correct answers. (Related documents are SE 016 065 - SE 016 088 and ED 062 123 - ED 062 125.)
(CC)

U.S. DEPARTMENT OF HEALTH
EDUCATION & WELFARE
OFFICE OF EDUCATION
THIS DOCUMENT HAS BEEN REPRO-
DUCED EXACTLY AS RECEIVED FROM
THE PERSON OR ORGANIZATION OR-
IGINATING IT. POINTS OF VIEW OR OPIN-
IONS STATED DO NOT NECESSARILY
REPRESENT OFFICIAL OFFICE OF EDU-
CATION POSITION OR POLICY.

ED 075243



SEGMENTS 19-23

SE 016 072

DEVELOPED AND PRODUCED UNDER THE
U.S. OFFICE OF EDUCATION, BUREAU OF RESEARCH,
PROJECT #8-0446, FOR THE U.S. NAVAL ACADEMY
AT ANNAPOLIS. CONTRACT #N00600-68C-0749.

NEW YORK INSTITUTE OF TECHNOLOGY, OLD WESTBURY

FILMED FROM BEST AVAILABLE COPY

19211 - Self-Paced Physics

Original Document

PROBLEMS AND THEIR CORRECT-ANSWER PAGES

Segments 18, 20, 21, 22 and 23

Segment 18		Segment 20		Segment 21		Segment 22		Segment 23	
P #	Page	P #	Page	P #	Page	P #	Page	P #	Page
1	13a	1	18a	1	18a	1	25a	1	19a
2	13c	2	18b	2	18a	2	25a	2	19a
3	11b	3	19b	3	21a	3	25b	3	20a
4	12a	4	28a	4	16b	4	20a	4	21a
5	15b	5	18b	5	22a	5	16a	5	19a
6	13b	6	18b	6	13b	6	25d	6	14d
7	17b	7	17a	7	24a	7	24a	7	18a
8	12c	8	16b	8	15a	8	17b	8	16a
9	17c	9	25a	9	27a	9	19a	9	18b
10	11a	10	23a	10	19a	10	25b	10	18b
11	17a	11	27a	11	13a	11	21a	11	19a
12	15c	12	16a	12	17a	12	17a	12	20b
13	11c	13	30a	13	15b	13	16b	13	15b
14	18a	14	20a	14	25a	14	18b	14	15a
15	16a	15	26a	15	20a	15	25c	15	19b
16	15a	16	17a	16	23a	16	18a	16	23a
17	18b	17	24a	17	14a	17	24a	17	20a
18	12b	18	29a					18	15
19	14a	19	19a					19	19a
		20	22a					20	24a
								21	20a
								22	22a
								23	16a
								24	17b
								25	20a

Reading: *HR 26-1/26-7 SZ 24-1/24-6 SW 28	Reading: *HR 27-1/27-4 SW 28-2 SZ 25-1/25-3	Reading: *HR 27-4,27-5 *SW 28-2 SZ 25-1	Reading: *HR 27-4,27-6, 28-1 SW 28-8,29-1 SZ 26-7 AB 37-3
--	--	--	--

Reading: *HR 28-2/28-4 SW 29-2 SZ 25-4

P	STEP	NAME	P	STEP	SECTION	SEGMENT 19
1	0.1	Reading: *HR 26-1/26-7 SZ 24-1/24-6 SW 28	7			A B C D <input type="checkbox"/> <input type="checkbox"/> <input type="checkbox"/> <input type="checkbox"/>
	0.2	Information Panel, "The Electrical Charge"	8			A B C D <input type="checkbox"/> <input type="checkbox"/> <input type="checkbox"/> <input type="checkbox"/>
		<input type="checkbox"/> A <input type="checkbox"/> B <input type="checkbox"/> C <input type="checkbox"/> D <input type="checkbox"/> T <input type="checkbox"/> F	9			A B C D <input type="checkbox"/> <input type="checkbox"/> <input type="checkbox"/> <input type="checkbox"/>
		<input type="checkbox"/> <input type="checkbox"/> <input type="checkbox"/> <input type="checkbox"/> <input type="checkbox"/> T <input type="checkbox"/> F	10			A B C D T F <input type="checkbox"/> <input type="checkbox"/> <input type="checkbox"/> <input type="checkbox"/> <input type="checkbox"/> <input type="checkbox"/>
		<input type="checkbox"/> <input type="checkbox"/> <input type="checkbox"/> <input type="checkbox"/> <input type="checkbox"/> T <input type="checkbox"/> F (ans)	10.1			View single concept loops (Ealing) dealing with electrostatic fundamentals entitled "Introduction to Electrostatics", "Insulators and Conductors", "Electrostatic Induction"
	2.1	If correct, advance to Problem 5; if not, continue sequence.	10.2			Information Panel, "Coulomb's Law"
		<input type="checkbox"/> A <input type="checkbox"/> B <input type="checkbox"/> C <input type="checkbox"/> D <input type="checkbox"/> T <input type="checkbox"/> F	11			<input type="checkbox"/> <input type="checkbox"/> <input type="checkbox"/> <input type="checkbox"/> T F (ans)
		<input type="checkbox"/> <input type="checkbox"/> <input type="checkbox"/> <input type="checkbox"/> <input type="checkbox"/> T <input type="checkbox"/> F	11.1			If correct, advance to 14.1; if not, continue sequence.
		<input type="checkbox"/> A <input type="checkbox"/> B <input type="checkbox"/> C <input type="checkbox"/> D <input type="checkbox"/> T <input type="checkbox"/> F	12			A B C D <input type="checkbox"/> <input type="checkbox"/> <input type="checkbox"/> <input type="checkbox"/>
	5.1	Information Panel, "Conservation of Charge"	13			A B C D <input type="checkbox"/> <input type="checkbox"/> <input type="checkbox"/> <input type="checkbox"/>
		<input type="checkbox"/> A <input type="checkbox"/> B <input type="checkbox"/> C <input type="checkbox"/> D <input type="checkbox"/> T <input type="checkbox"/> F				
6.1	If first choice was correct, advance to 10.1; if not, continue sequence.					

P	STEP	NAME	P	STEP	SECTION	SEGMENT 19
14		<div style="border: 1px solid black; width: 200px; height: 30px; margin-bottom: 5px;"></div> <div style="display: inline-block; text-align: center; margin-right: 10px;">T <input type="checkbox"/></div> <div style="display: inline-block; text-align: center;">F <input type="checkbox"/></div> <p style="text-align: right;">(ans)</p>				
	14.1	Information Panel, "Applications of Coulomb's Law"				
15		<div style="border: 1px solid black; width: 200px; height: 30px; margin-bottom: 5px;"></div> <div style="display: inline-block; text-align: center; margin-right: 10px;">T <input type="checkbox"/></div> <div style="display: inline-block; text-align: center;">F <input type="checkbox"/></div> <p style="text-align: right;">(ans)</p>				
	15.1	If correct, advance to 19.1; if not, continue sequence				
16		<div style="display: flex; justify-content: space-around; margin-bottom: 5px;"> ABCD </div> <div style="display: flex; justify-content: space-around;"> <div style="border: 1px solid black; width: 30px; height: 30px; margin: 2px;"></div> <div style="border: 1px solid black; width: 30px; height: 30px; margin: 2px;"></div> <div style="border: 1px solid black; width: 30px; height: 30px; margin: 2px;"></div> <div style="border: 1px solid black; width: 30px; height: 30px; margin: 2px;"></div> </div>				
17		<div style="border: 1px solid black; width: 200px; height: 30px; margin-bottom: 5px;"></div> <p style="text-align: right;">(ans)</p>				
18		<div style="border: 1px solid black; width: 200px; height: 30px; margin-bottom: 5px;"></div> <p style="text-align: right;">(ans)</p>				
19		<div style="border: 1px solid black; width: 200px; height: 30px; margin-bottom: 5px;"></div> <div style="display: inline-block; text-align: center; margin-right: 10px;">T <input type="checkbox"/></div> <div style="display: inline-block; text-align: center;">F <input type="checkbox"/></div> <p style="text-align: right;">(ans)</p>				
	19.1	Homework: HR Problem 26-6				

STUDY GUIDE

SELF-PACED PHYSICS

P	STEP	NAME	P	STEP	SECTION	SEGMENT 20
	0.1	Reading: *HR 27-1/27-4 SW 28-2 SZ. 25-1/25-3	7			A B C D <input type="checkbox"/> <input type="checkbox"/> <input type="checkbox"/> <input type="checkbox"/>
1	0.2	Information Panel, "The Electric Field" <input type="text"/> (ans)	8			A B C D T F <input type="checkbox"/> <input type="checkbox"/> <input type="checkbox"/> <input type="checkbox"/> <input type="checkbox"/> <input type="checkbox"/>
2	1.1	If correct, advance to 4.1; if not, continue sequence. A B C D <input type="checkbox"/> <input type="checkbox"/> <input type="checkbox"/> <input type="checkbox"/>	9	8.1	Information Panel, The Electric Field Due to Point Charges" <input type="text"/> (ans)	T F <input type="checkbox"/> <input type="checkbox"/>
3		A B C D <input type="checkbox"/> <input type="checkbox"/> <input type="checkbox"/> <input type="checkbox"/>	10	9.1	If correct, advance to 12.1; if not, continue sequence. <input type="text"/> (ans)	
4		A B C D T F <input type="checkbox"/> <input type="checkbox"/> <input type="checkbox"/> <input type="checkbox"/> <input type="checkbox"/> <input type="checkbox"/>	11		<input type="text"/> (ans)	
5	4.1	Information Panel, "Lines of Force" A B C D T F <input type="checkbox"/> <input type="checkbox"/> <input type="checkbox"/> <input type="checkbox"/> <input type="checkbox"/> <input type="checkbox"/>	12	12.1	The following are optional. They amplify ideas already presented.	A B C D T F <input type="checkbox"/> <input type="checkbox"/> <input type="checkbox"/> <input type="checkbox"/> <input type="checkbox"/> <input type="checkbox"/>
6	5.1	If first choice was correct, advance to 8.1; if not, continue sequence. A B C D <input type="checkbox"/> <input type="checkbox"/> <input type="checkbox"/> <input type="checkbox"/>		12.2	Information Panel, "The Electric Field Due to Distributed Charges"	
				12.3	AV, CALCULATION OF \vec{E} FOR AN INFINITE UNIFORMLY CHARGED WIRE	

ACCESS Produced Under License from the Meredith Corporation

P	STEP	NAME	P	STEP	SECTION	SEGMENT 20
	<u>13</u>	<p>A B C D T F</p> <p><input type="checkbox"/> <input type="checkbox"/> <input type="checkbox"/> <input type="checkbox"/> <input type="checkbox"/> <input type="checkbox"/></p>		19	<p>A B C D</p> <p><input type="checkbox"/> <input type="checkbox"/> <input type="checkbox"/> <input type="checkbox"/></p>	
	13.1	If first choice was correct, advance to 17.1; if not continue sequence.		20	<p>A B C D T F</p> <p><input type="checkbox"/> <input type="checkbox"/> <input type="checkbox"/> <input type="checkbox"/> <input type="checkbox"/> <input type="checkbox"/></p>	
	<u>14</u>	<p>A B C D</p> <p><input type="checkbox"/> <input type="checkbox"/> <input type="checkbox"/> <input type="checkbox"/></p>		20.1	Homework: HR 27-7	
	<u>15</u>	<p>A B C D</p> <p><input type="checkbox"/> <input type="checkbox"/> <input type="checkbox"/> <input type="checkbox"/></p>				
	<u>16</u>	<p>A B C D</p> <p><input type="checkbox"/> <input type="checkbox"/> <input type="checkbox"/> <input type="checkbox"/></p>				
	<u>17</u>	<p>A B C D T F</p> <p><input type="checkbox"/> <input type="checkbox"/> <input type="checkbox"/> <input type="checkbox"/> <input type="checkbox"/> <input type="checkbox"/></p>				
	17.1	Information Panel, "The Solid Angle"				
	<u>18</u>	<p>A B C D T F</p> <p><input type="checkbox"/> <input type="checkbox"/> <input type="checkbox"/> <input type="checkbox"/> <input type="checkbox"/> <input type="checkbox"/></p>				
	18.1	If first choice was correct, advance to 20.1; if not, continue sequence.				

STUDY GUIDE

SELF-PACED PHYSICS

ACCESS - Produced under license from the Meredith Corporation

P	STEP	NAME	P	STEP	SECTION	SEGMENT 21
	0.1	Reading: *HR 27-4, 27-5 *SW 28-2 SZ 25-1	6		A B C D	<input type="checkbox"/> <input type="checkbox"/> <input type="checkbox"/> <input type="checkbox"/>
	0.2	Information Panel, "Electric Field Problems - Type 1"	7		A B C D	<input type="checkbox"/> <input type="checkbox"/> <input type="checkbox"/> <input type="checkbox"/>
1		<input type="checkbox"/> <input type="checkbox"/> <input type="checkbox"/> <input type="checkbox"/> (ans)	8		A B C D	<input type="checkbox"/> <input type="checkbox"/> <input type="checkbox"/> <input type="checkbox"/>
2	1.1	If correct, advance to 4.1; if not, continue sequence.	9			<input type="checkbox"/> <input type="checkbox"/> (ans)
		A B C D				
3		<input type="checkbox"/> <input type="checkbox"/> <input type="checkbox"/> <input type="checkbox"/>	9.1		Information Panel, "Motion of Charged Particles in an Electric Field"	<input type="checkbox"/> <input type="checkbox"/> (ans)
		<input type="checkbox"/> <input type="checkbox"/> <input type="checkbox"/> <input type="checkbox"/>				
4		<input type="checkbox"/> <input type="checkbox"/> <input type="checkbox"/> <input type="checkbox"/> (ans)	10			<input type="checkbox"/> <input type="checkbox"/> (ans)
		<input type="checkbox"/> <input type="checkbox"/> <input type="checkbox"/> <input type="checkbox"/>				
4	4.1	Audiovisual, CALCULATION OF E FOR AN INFINITE UNIFORMLY CHARGED WIRE	10.1		If correct, advance to 13.1; if not, continue sequence.	<input type="checkbox"/> <input type="checkbox"/> (ans)
5	4.2	Information Panel; "Electric Field Problems - Type 2"	11		A B C D	<input type="checkbox"/> <input type="checkbox"/> <input type="checkbox"/> <input type="checkbox"/>
		<input type="checkbox"/> <input type="checkbox"/> <input type="checkbox"/> <input type="checkbox"/> (ans)	12		A B C D	<input type="checkbox"/> <input type="checkbox"/> <input type="checkbox"/> <input type="checkbox"/>
		<input type="checkbox"/> <input type="checkbox"/> <input type="checkbox"/> <input type="checkbox"/>				
	5.1	If correct, advance to 9.1; if not, continue sequence.				

STUDY GUIDE

SELF-PACED PHYSICS

ACCESS - Produced under license from the Meredith Corporation

P	STEP	NAME	P	STEP	SECTION	SEGMENT 21
13		<p>A B C D T F</p> <p><input type="checkbox"/> <input type="checkbox"/> <input type="checkbox"/> <input type="checkbox"/> <input type="checkbox"/> <input type="checkbox"/></p> <p>13.1 Audiovisual, DEFLECTION OF AN ELECTRON IN AN ELECTRIC FIELD</p>				
14		<p><input type="checkbox"/> <input type="checkbox"/> T F</p> <p>_____ (ans)</p> <p>If correct, advance to 17.1; if not, continue sequence.</p>				
15		<p><input type="checkbox"/> _____ (ans)</p>				
16		<p>A B C D</p> <p><input type="checkbox"/> <input type="checkbox"/> <input type="checkbox"/> <input type="checkbox"/></p>				
17		<p>A B C D T F</p> <p><input type="checkbox"/> <input type="checkbox"/> <input type="checkbox"/> <input type="checkbox"/> <input type="checkbox"/> <input type="checkbox"/></p> <p>17.1 Homework: HR 27-28</p>				

P	STEP	NAME	P	STEP	SECTION	SEGMENT 22
1	0.1	Reading: *HR 27-4; 27-6; 28-1 SW 28-8; 29-1 SZ 26-7 AB 37-3	6		A B C D <input type="checkbox"/> <input type="checkbox"/> <input type="checkbox"/> <input type="checkbox"/>	
	0.2	Information Panel, "Dipoles and Dipole-Moments"	7		A B C D <input type="checkbox"/> <input type="checkbox"/> <input type="checkbox"/> <input type="checkbox"/>	
	1.1	If first choice was correct, advance to Problem 4; if not continue sequence.	8		A B C D T F <input type="checkbox"/> <input type="checkbox"/> <input type="checkbox"/> <input type="checkbox"/> <input type="checkbox"/> <input type="checkbox"/>	
	2		8.1		Information Panel, "Calculation of Electric Flux"	
	3		9		A B C D T F <input type="checkbox"/> <input type="checkbox"/> <input type="checkbox"/> <input type="checkbox"/> <input type="checkbox"/> <input type="checkbox"/>	
4			9.1		If first choice was correct, advance to Problem 14; if not continue sequence.	
	4.1	Information Panel, "Electric Flux"	10		A B C D <input type="checkbox"/> <input type="checkbox"/> <input type="checkbox"/> <input type="checkbox"/>	
	4.2	Audiovisual, FLUX	11		A B C D <input type="checkbox"/> <input type="checkbox"/> <input type="checkbox"/> <input type="checkbox"/>	
5			12		A B C D <input type="checkbox"/> <input type="checkbox"/> <input type="checkbox"/> <input type="checkbox"/>	
	5.1	If first choice was correct, advance to 8.1; if not, continue sequence				

P	STEP	NAME	P	STEP	SECTION	SEGMENT 2 2
13		<p style="text-align: center;"> A B C D T F </p> <div style="display: flex; justify-content: space-around; align-items: center;"> <div style="border: 1px solid black; width: 30px; height: 30px; margin: 0 5px;"></div> <div style="border: 1px solid black; width: 30px; height: 30px; margin: 0 5px;"></div> <div style="border: 1px solid black; width: 30px; height: 30px; margin: 0 5px;"></div> <div style="border: 1px solid black; width: 30px; height: 30px; margin: 0 5px;"></div> <div style="border: 1px solid black; width: 30px; height: 30px; margin: 0 5px;"></div> <div style="border: 1px solid black; width: 30px; height: 30px; margin: 0 5px;"></div> </div>				
14		<div style="border: 1px solid black; width: 200px; height: 30px; margin-bottom: 5px;"></div> <div style="display: flex; justify-content: flex-end; align-items: center; margin-bottom: 5px;"> <div style="border: 1px solid black; width: 30px; height: 30px; margin-right: 10px;"></div> <div style="border: 1px solid black; width: 30px; height: 30px;"></div> </div> <p style="text-align: right;">(ans)</p>				
14.1		<p>If correct, advance to 17.1; if not, continue sequence.</p>				
15		<p style="text-align: center;"> A B C D </p> <div style="display: flex; justify-content: space-around; align-items: center;"> <div style="border: 1px solid black; width: 30px; height: 30px; margin: 0 5px;"></div> <div style="border: 1px solid black; width: 30px; height: 30px; margin: 0 5px;"></div> <div style="border: 1px solid black; width: 30px; height: 30px; margin: 0 5px;"></div> <div style="border: 1px solid black; width: 30px; height: 30px; margin: 0 5px;"></div> </div>				
16		<div style="border: 1px solid black; width: 200px; height: 30px; margin-bottom: 5px;"></div> <p style="text-align: right;">(ans)</p>				
17		<div style="border: 1px solid black; width: 200px; height: 30px; margin-bottom: 5px;"></div> <div style="display: flex; justify-content: flex-end; align-items: center; margin-bottom: 5px;"> <div style="border: 1px solid black; width: 30px; height: 30px; margin-right: 10px;"></div> <div style="border: 1px solid black; width: 30px; height: 30px;"></div> </div> <p style="text-align: right;">(ans)</p>				
17.1		<p>Homework: HR 28-3</p>				

STUDY GUIDE

SELF-PACED PHYSICS

P	STEP	NAME	P	STEP	SECTION	SEGMENT 23
1	0.1	Reading: *HR 28-2/28-6 SW 29-2 SZ 25-4	7		A B C D	<input type="checkbox"/> <input type="checkbox"/> <input type="checkbox"/> <input type="checkbox"/>
	0.2	Information Panel, "Distribution of Charge in Conducting and Non-conducting Bodies"	8		A B C D T F	<input type="checkbox"/> <input type="checkbox"/> <input type="checkbox"/> <input type="checkbox"/> <input type="checkbox"/> <input type="checkbox"/>
	1.2	If first choice was correct, advance to 4.1; if not, continue sequence.	8.1		The following material on Gauss's Law is optional.	
			8.2		Audiovisual, CALCULATION OF \vec{E} USING GAUSS'S LAW	
	2		9		A B C D T F	<input type="checkbox"/> <input type="checkbox"/> <input type="checkbox"/> <input type="checkbox"/> <input type="checkbox"/> <input type="checkbox"/>
	3		9.1		If first choice was correct, advance to 16.1; if not, continue sequence.	
	4		10		A B C D	<input type="checkbox"/> <input type="checkbox"/> <input type="checkbox"/> <input type="checkbox"/>
	4.1	Information Panel, "Charging Processes"	11		A B C D	<input type="checkbox"/> <input type="checkbox"/> <input type="checkbox"/> <input type="checkbox"/>
	5.1	If first choice was correct, advance to 8.1; if not, continue sequence.	12		A B C D	<input type="checkbox"/> <input type="checkbox"/> <input type="checkbox"/> <input type="checkbox"/>
	6		13		A B C D	<input type="checkbox"/> <input type="checkbox"/> <input type="checkbox"/> <input type="checkbox"/>

STUDY GUIDE

SELF-PACED PHYSICS

P	STEP	NAME	P	STEP	SECTION	SEGMENT 23
14		<div style="border: 1px solid black; width: 200px; height: 20px; margin-bottom: 5px;"></div> _____ (ans)	20.1		Information Panel, "Further Applications of Gauss's Law"	
15		A <input type="checkbox"/> B <input type="checkbox"/> C <input type="checkbox"/> D <input type="checkbox"/>	21		A <input type="checkbox"/> B <input type="checkbox"/> C <input type="checkbox"/> D <input type="checkbox"/>	
16		A <input type="checkbox"/> B <input type="checkbox"/> C <input type="checkbox"/> D <input type="checkbox"/> T <input type="checkbox"/> F <input type="checkbox"/>	22		<div style="border: 1px solid black; width: 200px; height: 20px; margin-bottom: 5px;"></div> _____ (ans)	
16.1		Information Panel, "Simple Applications of Gauss's Law"	23		<div style="border: 1px solid black; width: 200px; height: 20px; margin-bottom: 5px;"></div> _____ (ans)	
17		A <input type="checkbox"/> B <input type="checkbox"/> C <input type="checkbox"/> D <input type="checkbox"/> T <input type="checkbox"/> F <input type="checkbox"/>	24		<div style="border: 1px solid black; width: 200px; height: 20px; margin-bottom: 5px;"></div> _____ (ans)	
17.1		If first choice was correct, advance to 20.1; if not, continue sequence.	25		A <input type="checkbox"/> B <input type="checkbox"/> C <input type="checkbox"/> D <input type="checkbox"/>	
18		A <input type="checkbox"/> B <input type="checkbox"/> C <input type="checkbox"/> D <input type="checkbox"/>	25.1		Homework	HR 28-11
19		A <input type="checkbox"/> B <input type="checkbox"/> C <input type="checkbox"/> D <input type="checkbox"/>				
20		<div style="border: 1px solid black; width: 200px; height: 20px; margin-bottom: 5px;"></div> _____ (ans)				

OBJECTIVE

To develop the concept of electrical charge and answer simple descriptive and numerical problems relating to it.

A given body in an isolated system of bodies is acted upon by a resultant gravitational force. As long as the masses in the system, and their relative positions and separation distances, do not change, this resultant gravitational force remains fixed in magnitude and direction. Should an observer in such a system detect a variation in the gravitational force vector, he would be justified in assuming that a mass transfer had occurred. Mass is the source or origin of the gravitational force.

Similarly, charge may be considered to be the source or origin of the electrical force in any system where such a force is detectable. But unlike the phenomenon of gravitation, the presence of charge does not necessarily or automatically signify that a resultant electrical force also exists. A neutral body contains equal positive (+) and negative (-) charge magnitudes and does not exert an external electrical force on neighboring bodies. Thus, the presence of a resultant electrical force signifies an *imbalance* of charge, either in the form of a positive-to-negative ratio other than unity, or in the form of unbalanced charge deployment, or both.

Electrical charge is *quantized*. The elementary negative charge is taken as that of an isolated electron; the elementary positive charge, numerically equal to the charge on electron, is the charge on an isolated proton. In the MKS system, the unit of charge magnitude is the *coulomb* (abbreviated "coul") and will be rigorously defined in a later segment. For present we shall have to be satisfied with the approximation that one coulomb of charge contains 6.25×10^{18} elementary charges as previously described. Conversely, the magnitude of charge on a single electron or a single proton is approximately

$$\frac{1}{6.25 \times 10^{18}} \text{ coul} = 1.60 \times 10^{-19} \text{ coul}$$

When a standard 100-watt incandescent lamp is operated in the average U.S. home, about 5/6 of a coulomb of charge passes through it each second. This will help you establish in your own mind the relative magnitude of the coulomb in more or less familiar terms.

next page

continued

You will find in this section questions relating to the

- (a) nature of charge
- (b) magnitude of the elementary charge;
- (c) relationship between the coulomb and the elementary charge;
- (d) nature of conductors and insulators.

PROBLEMS

1. Charge is

- A. a unit of electrical force.
- B. a source of electrical force.
- C. a unit of current.
- D. an electron.

2. Millikan's Oil Drop experiment suggests that charge is quantized. How many discrete electrons comprise a coulomb of charge?

3. Select the correct definition for *quantization* from the following list.

- A. A unit amount of physical property.
- B. The existence of a physical property in integral multiples of discrete, fixed amounts.
- C. The smallest value of a physical property.
- D. A very small quantity of a physical property.

4. The absolute value of the charge on an electron in the MKS system is

- A. 6×10^{18} coul
- B. 8.9×10^{-12} coul
- C. 9×10^9 coul
- D. 1.6×10^{-19} coul

5. In an *ideal* insulator
- A. charges are fixed at all times.
 - B. charges are free to move within the insulator.
 - C. charges tend to be displaced from their equilibrium positions under the action of applied electric fields.
 - D. charges tend to spread over the surface of the insulator rather than remain localized.

INFORMATION PANELConservation of Charge

OBJECTIVE

To recognize and apply the principle of conservation of charge to a number of relevant electrical phenomena.

All the experimental evidence relating to the nature and behavior of charged bodies strongly indicates that, in the charging and discharging process, charge is neither created nor destroyed but only transferred from one location to another. The principle of conservation of charge has withstood every test imposed upon it in the sub-atomic as well as the macroscopic world.

The process of charge transfer demands mobility on the part of elementary charges. In the usual electrostatic phenomena involving solid pieces of rubber, glass and similar materials, and in the utilization of current electricity in power applications, communication, and related activities, electric charges move from one place to another to provide the observed effects. In most solid materials (there are some important exceptions), the elementary negative charges are the mobile ones so that it is essentially correct to say that charge is transferred within a solid, or from one solid to another, by the motion of electrons rather than by shifting elementary positive charges.

Consider this very simple example: an initially neutral glass rod is stroked with neutral silk cloth. The glass is then found to be carrying a positive charge. In conformity with the conservation principle, we would then say that there has been a transfer of charge from one object to the other and, as noted above, mobile negative charges account for it. Thus, the glass rod has lost electrons to the silk cloth, the rod becomes positively charged, the cloth acquires an equal negative charge, and the total charge of the system remains unchanged. Alternatively, the cloth now carries an *excess* of electrons while the rod has a *deficiency* of electrons, compared to the initial state for each object.

next page

continued

The questions in this section require that you apply the principle of conservation of charge to various situations in which mobile charges are involved.

6. Two uncharged metal spheres are in contact. A hard rubber rod is stroked with fur and brought very near to one of the two metal spheres (no contact between rod and sphere). The spheres are then separated, and the rod removed from the vicinity. Which of the following can now be said about the metal spheres?

- A. The spheres will attract one another.
- B. The spheres will be negatively charged.
- C. The spheres will be positively charged.
- D. The spheres will repel one another.

7. The principle of conservation of charge can be stated as:

- A. charges always appear in pairs.
- B. like charges repel; unlike attract.
- C. the quantity of work done on a charge by an externally generated field is constant.
- D. the quantity of charge in a closed system does not change.

8. When a glass rod is charged by stroking with a silk cloth, what charge does the silk cloth develop?

- A. positive
- B. negative
- C. neutral
- D. none of these

9. An uncharged metal ball is attracted by a negatively charged rubber rod. Upon making contact with the rod, the ball moves away quickly. Why?
- A. The metal ball was inherently charged and therefore repelled by the rubber rod.
 - B. Upon contacting the rubber rod, the metal ball became negatively charged. The rod and ball are now both negatively charged and repel one another.
 - C. The ball and rod after making contact became oppositely charged. This causes the observed repulsion.
 - D. The rubber rod is a non-conductor while the metal ball is a conductor. When contact is made, the total charge is zero causing the ball and rod to collide. Since momentum is conserved, the ball and rod separate quickly.
10. Two uncharged conducting pith balls are touched by a glass rod that has been rubbed with silk. If the pith balls were in contact before being touched by the glass rod, what happens immediately afterwards?
- A. The pith balls remain uncharged.
 - B. The pith balls repel one another.
 - C. The pith balls are negatively charged.
 - D. One pith ball is negative and one is positive.

INFORMATION PANELCoulomb's Law

OBJECTIVE

To apply Coulomb's Law to the solution of problems which entail the explicit and implicit relationships stated by this law.

In its basic form, Coulomb's Law is written

$$F = k \frac{q_1 q_2}{r^2} \quad \text{for point charges}$$

next page

continued

It is essential that you recognize the proportionalities stated in this form, i.e., that the electric force is directly proportional to the product of the charge magnitudes and inversely proportional to the distance between the point charges. Clearly, k is a constant of proportionality.

To modify Coulomb's Law so that it is more convenient to use in deriving subsequent "working" equations, we replace the constant k with the expression $1/4\pi\epsilon_0$ so that

$$F = \frac{1}{4\pi\epsilon_0} \frac{q_1 q_2}{r^2}$$

The quantity ϵ_0 is a constant often called the *permittivity of a vacuum* and has the value (to 3 significant digits)

$$\epsilon_0 = 8.85 \times 10^{-12} \text{ coul}^2/\text{nt} \cdot \text{m}^2$$

in the MKS system. You are urged to check the dimensional accuracy of the last equation using newtons for force, coulombs for charge, and meters for separation distance.

To simplify numerical problem solutions you may use the fact that

$$k = \frac{1}{4\pi\epsilon_0} = \frac{1}{4 \times 3.14 \times 8.85 \times 10^{-12}}$$

so $k = 9.0 \times 10^9 \text{ nt} \cdot \text{m}^2/\text{coul}^2$

and thus $F = 9.0 \times 10^9 \frac{q_1 q_2}{r^2}$

becomes the final statement of Coulomb's Law to be used in solving problems.

The problems in this section are aimed at having you

- (a) determine the force between point charges of given magnitude and position;
- (b) state what happens to the magnitude of the electric force with given changes in charge and position;
- (c) calculate the way in which a given charge should be split for given positions in order to achieve the maximum electric force.

11. A certain charge Q is to be divided into two parts, q and $Q-q$. Find the ratio Q/q if the two parts, placed a given distance apart, are to display maximum electrostatic repulsion.

12. Charges of $+5$ and -6 μcoul are 3 m apart. What is the force between them?

- A. 3×10^{-2} nt, attractive
- B. 3×10^{-2} nt, repulsive
- C. 3.3×10^{-12} nt, repulsive
- D. 3.3×10^{-12} nt, attractive

13. Two small spheres carrying unequal positive charges repel each other with a force of 0.30 nt when r meters apart. If the charge on each sphere is doubled, and the distance between them is tripled, what is the force of repulsion?

- A. 0.07 nt
- B. 0.2 nt
- C. 0.4 nt
- D. 0.13 nt

14. Two charges $+q$ and $-q$ are a distance r apart. Imagine a third charge Q placed between the two charges on a line joining them. Where must Q be placed so the resultant force on it is a minimum?

INFORMATION PANEL

Applications of Coulomb's Law

OBJECTIVE

To apply Coulomb's Law to the solution of problems that include the electric force as one of several parameters.

continued

The electric force F as given by

$$F = 9.0 \times 10^9 \frac{q_1 q_2}{r^2}$$

often appears in problems which deal essentially with mechanics. The fact that the electric or "coulomb" force originates in charges, rather than masses or muscles, does not affect the way in which it is used in approaching force problems of any type.

Since Coulomb's Law is valid only for *point* charges it can be applied with good approximation to other bodies only if they are very small as compared with the distance separating them. In this portion of your work, you may assume that the conditions imposed by this constraint are met.

Suppose, for example, that you were asked to find how close the upper pith ball (see diagram) will finally come to rest above the lower one for the

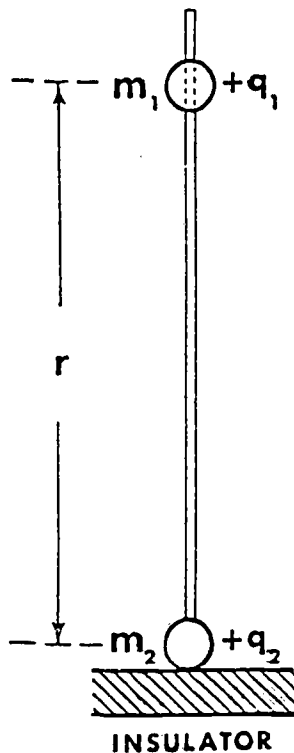

conditions shown. The upper ball slides frictionlessly on a nylon guide while the lower one rests on a perfect insulator. You might approach this problem in this way

(1) For the final rest condition (equilibrium), the weight mg of the upper ball must be equal in magnitude to the electric force of repulsion F , or $F = -mg$

(2) Since F is the coulomb force, then

$$k \frac{q_1 q_2}{r^2} = -mg$$

(3) Solving for r

$$r = \sqrt{-k \frac{q_1 q_2}{mg}}$$

(4) Substituting 9.0×10^9 for k and -9.8 for g

$$r = \sqrt{\frac{9.0 \times 10^9 \times q_1 q_2}{9.8 \times m}}$$

next page

continued

You will find the problems in this section to be of this and similar types in which the coulomb force is treated as any other force in its mechanical involvement.

15. In the accompanying diagram, two equally charged balls are suspended from a common point by (weightless) rods 0.40 meters long. When the balls come to rest, they are 0.40 meter apart. The magnitude of the charge in microcoulombs on the balls is approximately _____.

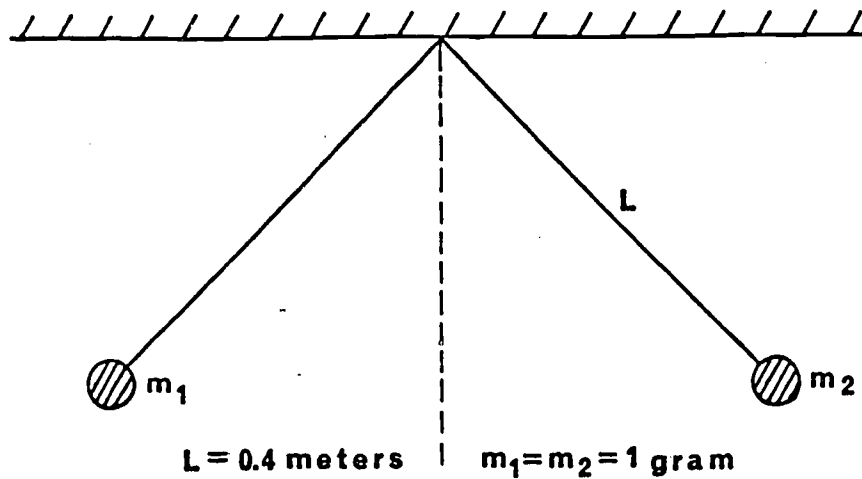

16. The value for the permittivity constant ϵ_0 in Coulomb's Law in the MKS system of units is

- A. 8.9×10^{-12} coul²/nt - m²
- B. 9×10^9 nt - m²/coul²
- C. 8.9×10^9 coul²/ nt - m²
- D. 9×10^{-12} nt - m²/coul²

17. Two pith balls are suspended from the same point by weightless, inextensible, insulated strings and receive equal charges of -3×10^{-6} coul. The coulomb force causes them to separate a distance of 0.2 meter. What is the magnitude of the coulomb force each ball experiences when equilibrium is reached?

18. How far apart must two electrons be if the force of electrostatic repulsion on each electron is just equal in magnitude to the weight of the electron? (The electron mass is 9.1×10^{-31} kg).

19. Four equal positive charges, each of magnitude $q = 1.00 \times 10^{-7}$ coul are placed at the corners of a square of side $a = 0.500$ m. Find the magnitude of the resultant force acting on any one of them.

[a] CORRECT ANSWER: B

The pith balls are lightweight, conducting spheres. When the positively-charged glass rod touches either pith ball, the excess positive charge on the glass rod removes electrons from *both* pith balls. Both spheres are then positively charged and since they are free to move, they repel one another so that they move apart.

TRUE OR FALSE? When the experiment described above is repeated with small metal balls instead of pith balls, the end result is an attractive force between the spheres.

[b] CORRECT ANSWER: B

When a physical property such as charge exists in discrete "packets" rather than in continuous amounts, the property is said to be quantized. Mass contains quantized packets such as the electron and proton.

[c] CORRECT ANSWER: D

The initial configuration gives

$$F_1 = \frac{1}{4\pi\epsilon_0} \frac{q_1 q_2}{r^2}$$

The new configuration calls for doubling both q_1 and q_2 and tripling r , hence

$$F_2 = \frac{1}{4\pi\epsilon_0} \frac{(2q_1 \times 2q_2)}{(3r)^2} = \frac{1}{4\pi\epsilon_0} \frac{(4q_1 q_2)}{(3r)^2}$$

Therefore

$$F_2 = \frac{4}{9} F_1$$

so that

$$\frac{4}{9} \times 0.30 = 0.13 \text{ nt}$$

[a] CORRECT ANSWER: D

Since one coulomb is the combined charge of 6.25×10^{18} elementary charges, each elementary charge (electron or proton) must have a magnitude of

$$\frac{1}{6.25 \times 10^{18}} = 1.6 \times 10^{-19} \text{ coul of charge.}$$

TRUE OR FALSE? The charge on a *proton* equals 1.6×10^{19} coul.

[b] CORRECT ANSWER: 5.1 m

The magnitude of the electrostatic force F on each electron due to the presence of two electrons each of charge $e = 1.6 \times 10^{-19}$ coul, a distance R apart is

$$F = \frac{e^2}{4\pi\epsilon_0 R^2}$$

and the weight of the electron is mg . Therefore for the given condition equality we obtain

$$\frac{e^2}{4\pi\epsilon_0 R^2} = mg, \text{ where } m = 9.1 \times 10^{-31} \text{ kg.}$$

or

$$\begin{aligned} R &= e \sqrt{\frac{1}{4\pi\epsilon_0 mg}} \\ &= 1.6 \times 10^{-19} \sqrt{\frac{9 \times 10^9}{9.1 \times 10^{-31} \times 9.8}} \\ &= 5.1 \text{ m} \end{aligned}$$

[c] CORRECT ANSWER: B

When a glass rod and silk cloth are brought into close contact, the cloth is able to attract some electrons from the rod. Upon separation, the rod is deficient in electrons, and thus positively charged, while the cloth now has an excess of electrons and is negatively charged. Since electrons are merely *transferred* from the rod to the cloth the *total* number of charges in the cloth-rod system does not change and charge is conserved.

[a] CORRECT ANSWER: B

Electrical charge is a difficult phenomenon to define. The fact that electrical forces are always associated with charge makes our definition operational in nature. This choice should hardly be considered final, but will encourage precise extension as our understanding of electrical forces improves.

TRUE OR FALSE? As the work in electricity proceeds, a new and more rigorous definition of charge will be developed.

[b] CORRECT ANSWER: A

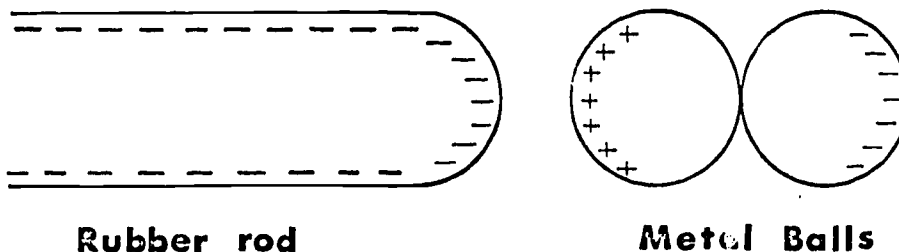

The presence of the negatively charged rubber rod near the left metal sphere causes electrons to migrate away from the left sphere and concentrate on the right sphere, leaving excess positive charge on the left sphere. If the spheres are now separated, they will be oppositely charged, and therefore attract one another.

TRUE OR FALSE? If both spheres had been perfect insulators, no migration of charge would have occurred, hence the spheres would not have attracted one another after separation.

[c] CORRECT ANSWER: 6.25×10^{18}

The charge of an electron is a very small but definite negative quantity of magnitude 1.60206×10^{-19} coulombs. The important item to remember is that all charge is an integral multiple of the charge on an electron. One coulomb is the sum of the charges on 6.25×10^{18} electrons.

TRUE OR FALSE? Certain rare sub-atomic particles are known to have a charge equal to 2.5 electronic charges.

[a] CORRECT ANSWER: $6.90 \times 10^{-4} \text{ nt}$

Let the corners of the square be labeled as A, B, C, and D as shown in the diagram. The force acting on charge q at A due to charge q at B is

$$F_{AB} = \frac{q^2}{4\pi\epsilon_0 a^2}$$

and its direction is shown in the diagram. Similarly

$$F_{AD} = \frac{q^2}{4\pi\epsilon_0 a^2}$$

and

$$F_{AC} = \frac{q^2}{4\pi\epsilon_0 2a^2}$$

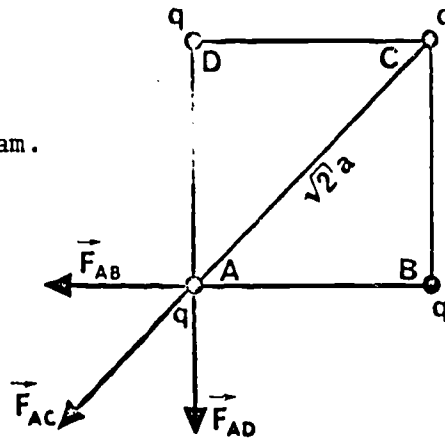

The total (resultant) force acting on the charge at A is

$$\vec{F} = \vec{F}_{AB} + \vec{F}_{AD} + \vec{F}_{AC}$$

From geometry we find

$$\begin{aligned} F &= \sqrt{F_{AB}^2 + F_{AD}^2} + F_{AC} \\ &= \sqrt{2} \frac{q^2}{4\pi\epsilon_0 a^2} + \frac{q^2}{4\pi\epsilon_0 2a^2} \\ &= \left(\sqrt{2} + \frac{1}{2} \right) \left(\frac{q^2}{4\pi\epsilon_0 a^2} \right) \\ &= \left(1.41 + \frac{1}{2} \right) \left(\frac{9 \times 10^9 \times 1 \times 10^{-14}}{.25} \right) \end{aligned}$$

$$= 6.90 \times 10^{-4} \text{ nt}$$

TRUE OR FALSE? In all of the equations above, q^2 represents the product of two equal charges.

[a] CORRECT ANSWER: A

Notice that the permittivity constant ϵ_0 has this particular value for a vacuum. In a dielectric material (insulator), other values of the permittivity constant are possible.

For direct insertion into Coulomb's Law, it will be useful to remember that $1/4\pi\epsilon_0$ has the value of 9×10^9 nt m²/coul².

[b] CORRECT ANSWER: A

In reality all materials will conduct charge. Those which offer little resistance to the movement of charge are called conductors, while those which exhibit large conduction resistance are called non-conductors or insulators. Although there are no perfect insulators, the ability of quartz to insulate charge is about 10^{25} times as great as that of copper, so that for many practical purposes some materials behave as if they were perfect insulators.

TRUE OR FALSE? There are no perfect insulators!

[c] CORRECT ANSWER: A

According to Coulomb's Law, the force between two charges q_1 and q_2 at a distance r apart is given by

$$F_1 = \frac{1}{4\pi\epsilon_0} \frac{q_1 q_2}{r^2}$$

Substituting the numerical data given, we find

$$F = \frac{(9 \times 10^9) (5 \times 10^{-6}) (-6 \times 10^{-6})}{r^2}$$

$$F = -3 \times 10^{-2} \text{ nt}$$

Thus, the force between them is 3×10^{-2} nt and is attractive

[a] CORRECT ANSWER: 0.32 μcoul

A diagram of the forces acting on one of the balls would be as follows:

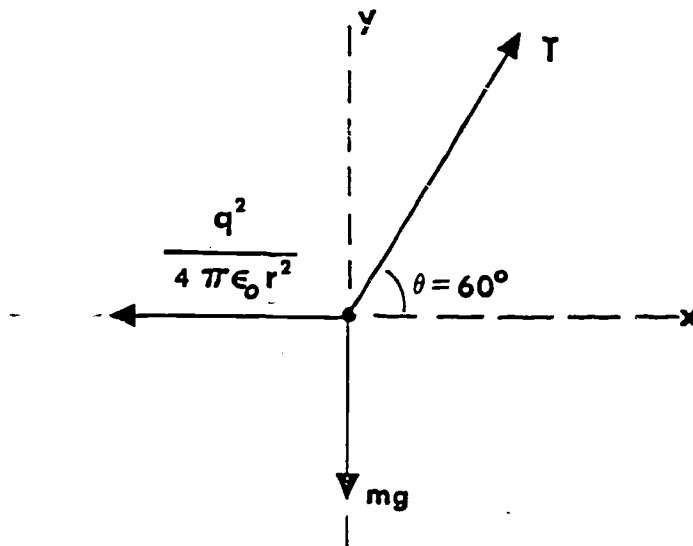

The ball is stationary and thus we can write

$$T \cos\theta - \frac{q^2}{4\pi\epsilon_0 r^2} = 0$$

$$T \sin(\theta) - mg = 0.$$

Solving for q yields

$$q = \pm \sqrt{4\pi\epsilon_0 r^2 mg \cot\theta}$$

Substituting the data given:

$$q = \pm \sqrt{\frac{0.16 \times 1.0 \times 10^{-3} \times 9.8 \times 0.577}{9 \times 10^9}}$$

$$q = \pm 0.32 \times 10^{-6} \text{ coul}$$

$$q = \pm 0.32 \mu\text{coul}$$

TRUE OR FALSE: The horizontal vector in the diagram represents the coulomb force between the charged spheres.

CORRECT ANSWER: 2

Let the distance between point charges Q and $Q-q$ be R . The magnitude of the coulomb force of repulsion \vec{F} (like charges) is

$$F = \frac{1}{4\pi\epsilon_0} \frac{Q(Q-q)}{R^2} \quad (1)$$

Equation (1) gives the force as a function of q , since all other quantities, namely, Q , R , and ϵ_0 are constants. Hence, in order to maximize the function, we differentiate F with respect to q and equate to zero. Thus

$$\frac{dF}{dq} = \frac{Q}{4\pi\epsilon_0 R^2} - \frac{2q}{4\pi\epsilon_0 R^2} = 0$$

Therefore

$$\frac{Q}{q} = 2 \text{ for maximum electrostatic repulsion.}$$

TRUE OR FALSE? In the right-hand term of equation (1), only q is considered a variable.

[b] CORRECT ANSWER: D

This principle is often loosely stated as "charge cannot be created or destroyed, but only transferred from one point to another."

[c] CORRECT ANSWER: B

The negative rod has an excess of electrons while the metal (conducting) ball is neutral--neither excess nor deficiency of electrons. Upon contact, some excess electrons transfer to the ball and spread out on the conducting surface leaving both bodies negatively charged. The result is repulsion between bodies of like charge.

[a] CORRECT ANSWER:

If we place the charge Q between two charges then the forces from both charges will be in the same direction and thus, the resultant force will be a minimum at some point between them. Let x be the distance of the charge Q from $+q$, then the force on Q is

$$F = \frac{1}{4\pi\epsilon_0} \left[\frac{qQ}{x^2} + \frac{qQ}{(r-x)^2} \right]$$

To find a point where F is minimum, differentiate F with respect to x and equate to zero.

$$\frac{dF}{dx} = \frac{1}{4\pi\epsilon_0} \left[\frac{-2qQ}{x^3} - \frac{2qQ}{(r-x)^3} \right] = 0$$

or

$$x = \frac{r}{2}$$

Thus the force on the charge Q is minimum when Q is midway between the charges. We can satisfy ourselves that this is a minimum rather than a maximum by noting that the force approaches infinity as Q approaches either charge.

TRUE OR FALSE? As it turns out, Q must lie on the same straight line as the other two charges in order for the forces to add algebraically.

[b] CORRECT ANSWER: 2 nt

Data from this problem can be substituted directly into Coulomb's Law

$$F = \frac{1}{4\pi\epsilon_0} \frac{q_1 q_2}{r^2}$$

$$= \frac{(9 \times 10^9) (-3 \times 10^{-6}) (-3 \times 10^{-6})}{0.04^2}$$

$$F = \frac{81 \times 10^{-3}}{4 \times 10^{-2}} = 2 \text{ nt}$$

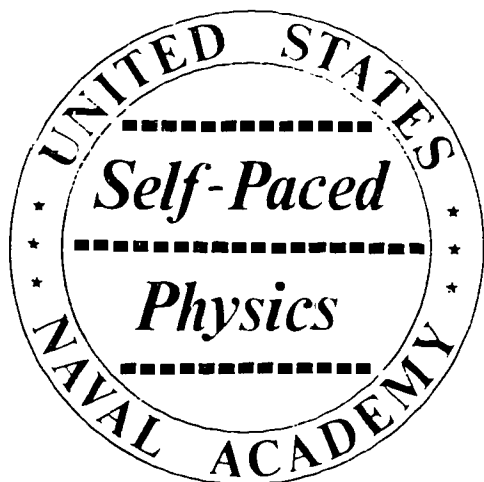

SEGMENT SEPARATOR

note

ALL WRITTEN MATERIAL APPLICABLE TO
THE FOLLOWING SEGMENT IS CONTAINED
IN THE PAGES BETWEEN THIS COLORED
SHEET AND THE NEXT.

INFORMATION PANELElectric Field

OBJECTIVE

To develop the concept of the electric field; to apply field theory to fundamental questions and problems in which this concept is a useful tool.

Although Coulomb's law enables us to calculate the force that one charged body exerts on another, it does not pretend to describe the mechanism by means of which this force is applied. A pair of charged bodies exert forces on one another--this is an experimental fact--but no one can *explain why* this force exists. We know it is there and we know how to calculate its magnitude, but neither Nature nor reason provides the insight needed to isolate the cause of the phenomenon.

This apparent impasse does not prevent us from speculating about the mechanism of force action, however. We may not be able to *explain* but we can still *describe*. To do this, we need to set up a workable mechanism that is fully compatible with the experimental evidence available to us.

Thus in physics we find it most helpful to approach electric phenomena via the concept of the *electric field*. In the most general sense, a field is considered as a region of space having certain physical properties. An electric field in particular is characterized by the ability to exert forces on charged particles within it; these forces are independent of any gravitational forces that may be present. An uncharged particle experiences no force in an electric field.

Essentially, the field concept deemphasizes the charges that are the origin of the field and emphasizes instead the space itself. It is of interest that this shift of emphasis is often considered to have paved the way for Clerk Maxwell's mathematical analysis of electric fields. The importance and significance of the field approach may be gathered from the quotation below taken from the classic book by Einstein and Infeld:

"In the beginning, the field concept was no more than a means of facilitating the understanding of phenomena from the mechanical point of view. In the new field language it is the description of the field between two charges, and not the charges themselves, which is essential for an understanding of their action. The recognition of the new concepts grew steadily, until substance was overshadowed by the field. It was realized that something

next page

continued

of great importance was happening in physics. A new reality was created, a new concept for which there was no place in the mechanical description. Slowly and by a struggle the field concept established for itself a leading place in physics and has remained one of the basic physical concepts. The electromagnetic field is, for the modern physicist, as real as the chair on which he sits."

Now imagine a point charge which demonstrates by its observed behavior that it is being subjected to a force of one newton. Instead of seeking some other charge which can account for this force, we merely say that our first charge is located in an electric field capable of bringing to bear on it a force of one newton. At this point we need to establish the meaning of *field intensity* or field strength. This is readily done when it is recognized that the force acting on a unit charge is really what we mean by the intensity of the field. So, if the charge in question were exactly one coulomb and the force one newton, we could then say that the field intensity is one newton per coulomb. Symbolically,

$$E = F/q$$

where E is the magnitude of the electric field (or field intensity), F is the magnitude of the force, and q is the magnitude of the charge on which the force acts. Since force is a vector quantity and charge is scalar, the definition of field intensity is better written

$$\vec{E} = \vec{F}/q_0$$

where q_0 = the charge on a small positive test body. The direction of \vec{E} is the direction of \vec{F} . The direction of the electric intensity, then, is normally determined by the direction in which a *positive* test charge would move if it were free to do so in the field. The unit of field intensity in the MKS system is, as indicated, the newton per coulomb (nat/coul).

The problems in this section require that you

- (a) recognize the correct definition of an electric field;
- (b) be able to state how the direction of an electric field is determined;
- (c) solve a problem involving the equilibrium of a particle of given mass in an electric field of given intensity.

PROBLEM

1. What must be the charge on a particle of mass 2.00 gm if it is to remain stationary in the laboratory when placed in a downward-directed electric field of intensity 500 nt/coul?

2. We define electric field strength as
- A. the number of lines of force leaving the source of the field
 - B. the force per unit charge acting on a charge placed in the field
 - C. the number of lines of force per unit area passing through an imaginary sphere surrounding the source of the field
 - D. the force exerted on a single electron placed in the field.
3. Select the statement which most fully expresses the concept of electric field direction.
- A. The electric field is in the direction of the force experienced by a small charged particle placed in the field.
 - B. The electric field points toward or away from the charges generating it.
 - C. The electric field direction is chosen to be the direction in which a positive charge would tend to move if placed in the field.
 - D. The electric field is a scalar field.

4. A uniform (constant) electric field exists in the region between two oppositely charged plane parallel plates. A 1.0 gm particle having a charge $q = -9.8 \times 10^{-7}$ coul is observed to move horizontally with a constant velocity. The electric field in the region must therefore be

- A. 10^4 nt/coul upward
- B. 10^4 nt/coul downward
- C. 10^7 nt/coul upward
- D. 10^{-7} nt/coul downward

INFORMATION PANEL

Lines of Force

OBJECTIVE

To recognize and analyze the effect of an electric field on neighboring charged particles using the lines of force concept.

Since the introduction of Faraday's model of the electric field--a model associated with imaginary lines of force--a number of conventions have been accepted and are now used more or less universally. In any given region in an electric field, the way in which the lines of force are represented provides the following information:

(1) The direction of the field intensity vector \vec{E} is indicated by an arrowhead on the lines through the point or region under examination. This is the direction in which a *positive* test charge tends to move under the influence of the field.

(2) The electric field around an isolated spherical charged body is radial. If the body is positive, the line direction is outward; if negative, the line direction is inward.

(3) The spacing between lines of force indicates the magnitude of the field intensity in that region. The density of the lines, i.e., the number of lines passing through the area under consideration, is proportional to the intensity.

(4) The direction of a given line of force at a given point is the direction of the tangent drawn through that point.

next page

continued

(5) When a lines-of-force diagram involving two or more charged bodies is drawn, each line must be shown originating on a positively charged body and terminating on a negatively charged body.

(6) A negatively charged body in a field tends to move in a direction opposite that of the intensity vector at that point.

The questions that follow emphasize

(a) the analysis of lines-of-force diagrams to determine their most likely source or sources;

(b) the observations required to determine relative intensities in different parts of an electric field; similarly, observations to determine field direction.

5. A portion of an electric field line diagram (below) has been erased. Of the four choices given below, which is most likely responsible for the illustrated field?

- A. two positive charges
- B. two negative charges
- C. a single positive charge
- D. a single negative charge

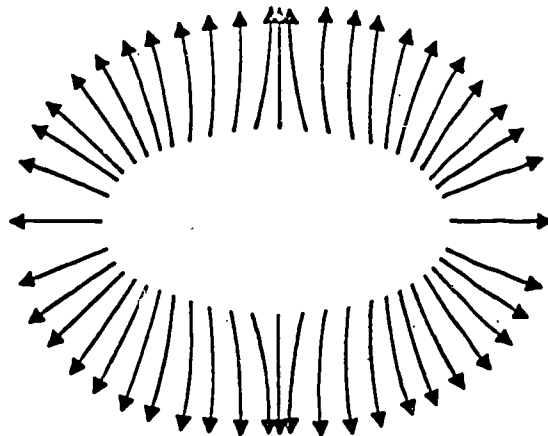

6. In the figure below, a positive charge is most likely located at which of the following positions?

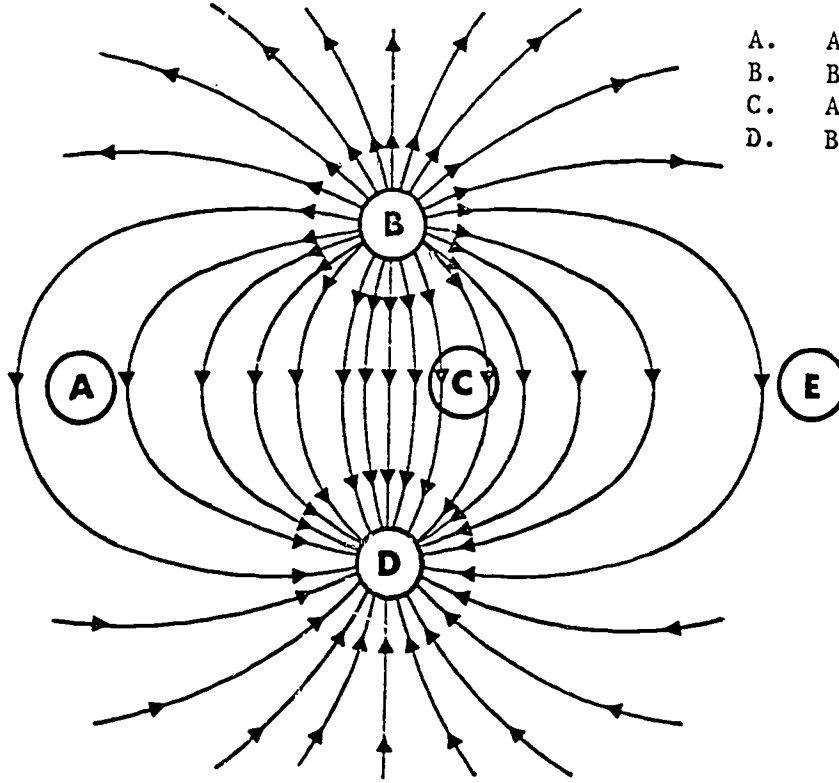

- A. A and B
- B. B and D
- C. A, C, and E
- D. B only

LINES OF FORCE

7. Charges are embedded in insulators to produce the electric field depicted below. Where is the electric field intensity highest?

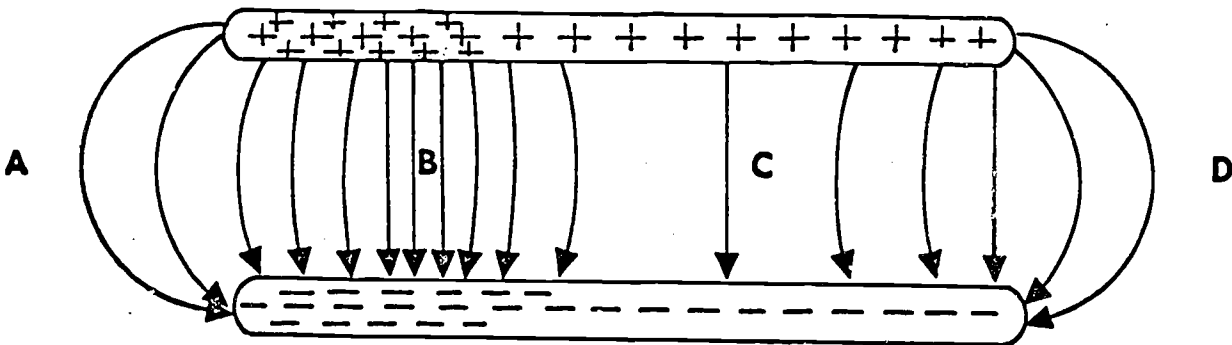

- A. At point A.
- B. At point B.
- C. At point C.
- D. At point D.

8. Refer to the electric field lines drawn below. What observation can be made about the electric field at point P?

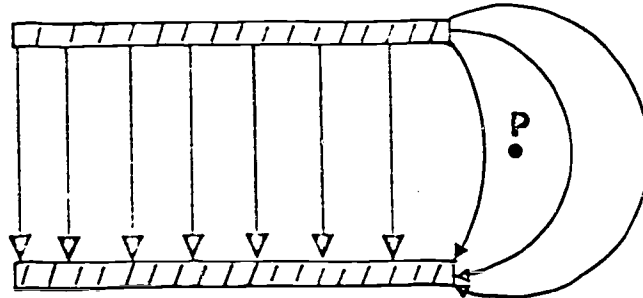

- A. There is no electric field at this point since no line of force passes through this point.
- B. The electric field at this point is curved similar to the nearby lines with intensity approximately twice that of the field within the gap.
- C. The electric field points downward with intensity smaller than that of the electric field within the gap.
- D. The electric field at this point is curved similar to the nearby lines with intensity approximately one-half that of the field within the gap.

INFORMATION PANEL

Electric Field Due to Point Charges

OBJECTIVE

To solve problems involving the intensity and direction of the resultant field due to two or more charges.

As you move more deeply into field theory and applications of the electric field concept, it becomes more possible to tie up some of the loose ends we still have with us.

next page

continued

A more rigorous definition of *charge* can now be stated: electric charges are the *sources* and *sinks* of electric fields. This definition implies that electric fields originate and terminate on electric charges (see item e in the Information Panel, "Lines of Force".) By convention, the charges on which electric fields originate are *positive* and are called *sources*; those on which fields terminate are *negative* and are called *sinks*. Charges produce a field which in turn applies a force on another charge immersed in it. We consider that charges do not influence each other directly but only through the field they produce which acts as an intermediary, even in a vacuum.

The resultant electric field due to two or more point charges is the vector sum of the individual fields at the point where the resultant is to be determined. That is

$$E = \vec{E}_1 + \vec{E}_2 + \dots \vec{E}_n$$

If the particles lie on the same straight line, their magnitudes may be added directly without resorting to vector methods. The magnitude of an electric field (electric intensity) due to a point charge q is given by

$$E = q/4\pi\epsilon_0 r^2$$

in which r is the distance between the source of the field and the point at which the intensity is to be determined. For many problems in this area, where vector addition is required, the x - and y -components of the field due to each particle at the point of interest are determined, and the resultant found using the relation

$$|E| = \sqrt{E_x^2 + E_y^2}$$

where E is the magnitude of the resultant field intensity.

The direction of the resultant field is, of course, readily obtained from the trigonometric relationships in the problem.

The fundamental requirements of the problems in this section are that you be able to

- (a) calculate the ratio of point charges, given the magnitudes of the charges, the required distances, and the field intensity at a point in space resulting from the presence of these charges;

next page

continued

(b) determine the resultant field intensity due to several point charges not located on the same line;

(c) find the magnitude of the electric field intensity at a given point on the same line on which the point charges are placed.

9. Two point charges q_1 and q_2 are one meter apart. The electric field intensity at a point one meter to the right of q_2 and on a line joining q_1 and q_2 is zero. What is the ratio q_1/q_2 ?

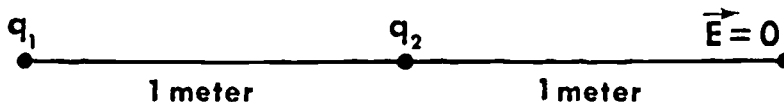

10. Two positive charges are located at $(0,1)$ and $(2,0)$ and produce electric field intensities of magnitudes 5 nt/coul and 12 nt/coul, respectively, at the origin. What is the magnitude of the resultant field intensity?

11. Three equal charges each of $+4.00 \mu\text{coul}$ are located at three corners of a square 2.00 meters on an edge. What is the magnitude of the electric field intensity E at the fourth corner?

12. What is the magnitude of the electric field at the point x in the diagram?



- A. $\frac{10}{9} \frac{q}{4\pi\epsilon_0 r^2}$
- B. $\frac{2}{3} \frac{q}{4\pi\epsilon_0 r^2}$
- C. $\frac{2}{9} \frac{q}{4\pi\epsilon_0 r^2}$
- D. $\frac{8}{9} \frac{q}{4\pi\epsilon_0 r^2}$

INFORMATION PANEL

Electric Field Due to Distributed Charges

OBJECTIVE

To solve problems in which the resultant electric field intensity at a specified point in space is to be found when the source is a regular geometric body carrying uniformly distributed charges.

The determination of resultant field intensity due to distributed charges of bodies of various types is somewhat more complex than the same process for point charges. Nevertheless, it is possible to follow a general pattern which applies equally well to a number of special cases, especially those in which symmetry may be utilized.

When the charge distribution is continuous, the body is visualized as being divided into individual point charges, each of which carries the charge dq and produces an element of electric intensity $d\vec{E}$. The electric intensity due to each "point charge" is then given by

next page

continued

$$d\vec{E} = dq/4\pi\epsilon_0 r^2$$

in which r is the distance separating the charge element dq from the point at which the resultant field is to be calculated. The resultant field at this point is then obtained by integrating the field contributions of all the elements so that

$$\vec{E} = \int d\vec{E}$$

This integration is, of course, a vector process and must be so handled. You are urged to study (not merely read) the problem examples presented in your reading to develop the strategies used in performing this integration for bodies of different shapes. The problems presented in the pages that follow include the determination of resultant fields for charged rings, and for rods of finite and infinite lengths. Before you tackle these seriously, be sure you understand the development in the examples mentioned above.

13. The electric field \vec{E} for a point on the axis of a uniformly charged ring (see diagram) with total charge q and radius a at a distance x from its center is

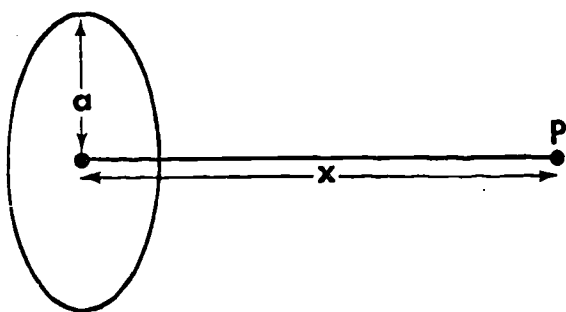

- A. $E = \frac{1}{4\pi\epsilon_0} \frac{qx}{(a^2 + x^2)^{3/2}}$
normal to the axis
- B. $E = \frac{1}{4\pi\epsilon_0} \frac{qx}{(a^2 + x^2)^{3/2}}$
along the axis
- C. $E = \frac{1}{4\pi\epsilon_0} \frac{q}{a^2 + x^2}$
normal to the axis
- D. $E = \frac{1}{4\pi\epsilon_0} \frac{q}{a^2 + x^2}$
along the axis

14. A thin non-conducting rod of finite length ℓ carries a total charge q , distributed uniformly along it. The magnitude of the electric field at point P on the perpendicular bisector as shown in the figure is

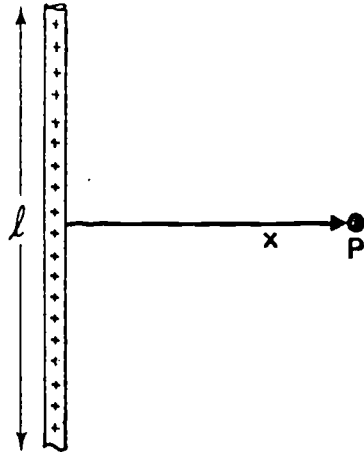

- A. $E = \frac{q}{4\pi\epsilon_0} \frac{1}{\sqrt{\ell^2 + x^2}}$
- B. $E = \frac{q}{2\pi\epsilon_0 x}$
- C. $E = \frac{q}{4\pi\epsilon_0} \frac{x}{\sqrt{\ell^2 + 4x^2}}$
- D. $E = \frac{q}{2\pi\epsilon_0 x} \frac{1}{\sqrt{\ell^2 + 4x^2}}$

15. The electric field at point P a distance R from an infinitely long wire having a uniform line charge density λ coul/m is

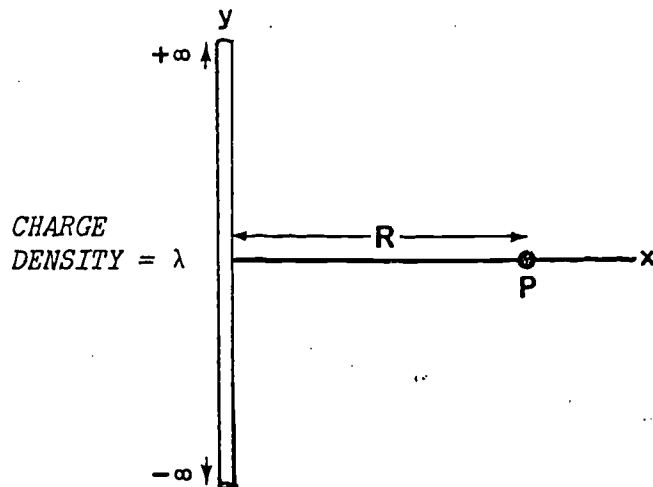

- A. $\frac{\lambda}{4\pi\epsilon_0 R}$ in the x direction
- B. ∞ in the x direction
- C. $\frac{\lambda R}{2\pi\epsilon_0}$ in the x direction
- D. $\frac{\lambda}{2\pi\epsilon_0 R}$ in the x direction

16. A segment of wire, with uniform charge-per-unit-length λ , is bent into a semi-circle of radius R. The magnitude of the electric field at the midpoint of the diameter which joins the ends of the semi-circle is:

- A. $\lambda/\pi\epsilon_0 R$
- B. $\lambda/2\pi\epsilon_0 R$
- C. $\lambda/3\pi\epsilon_0 R$
- D. $2\lambda/3\pi\epsilon_0 R$

17. A charged ring with radius a has a total charge of q . Charge q_1 is distributed uniformly over half the circumference of the ring and charge q_2 is distributed uniformly over the other half ($q_1 + q_2 = q$).

The component of the electric field E_y at point P is

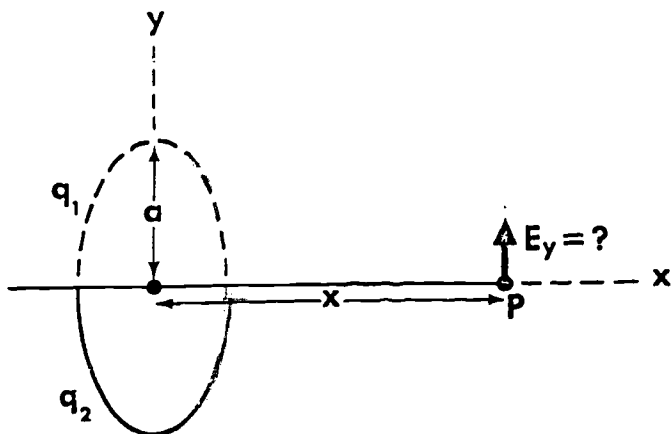

- A. $E_y = \frac{1}{2\pi^2\epsilon_0} \frac{(q_2 - q_1)a}{(x^2 + a^2)^{3/2}}$
- B. $E_y = \frac{1}{2\pi^2\epsilon_0} \frac{(q_2 + q_1)a}{(x^2 + a^2)^{3/2}}$
- C. $E_y = \frac{1}{4\pi\epsilon_0} \frac{(q_2 - q_1)a}{(x^2 + a^2)^{1/2}}$
- D. $E_y = 0$

INFORMATION PANEL

The Solid Angle

OBJECTIVE

To solve problems involving electric field intensities near charged planes and inside charged spheres.

The core problem in the following section deals with the field inside a hollow, charged, conducting sphere. The solution requires some understanding of the nature and characteristics of solid angles.

The definition of a solid angle parallels that of an angle in a plane to a great extent. Let's review the latter briefly. As illustrated in

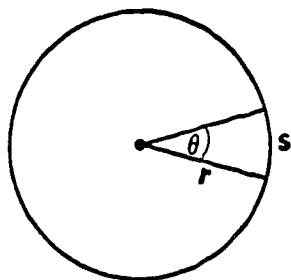

Figure 1

Figure 1 at the left, the angle θ is defined as the intercepted arc length divided by the radius of the circle, or

$$\theta = s/r$$

Since s and r are both lengths, then the ratio s/r is dimensionless. The unit of angle measure is, of course, the radian.

next page

continued

To define the solid angle in similar terms, we first picture a section of a sphere of radius r containing an inscribed cone as shown in Figure 2, with the apex of the cone at the center of the sphere. The cone cuts an area A on the surface of the sphere and since this area is proportional to the square of the radius, that is

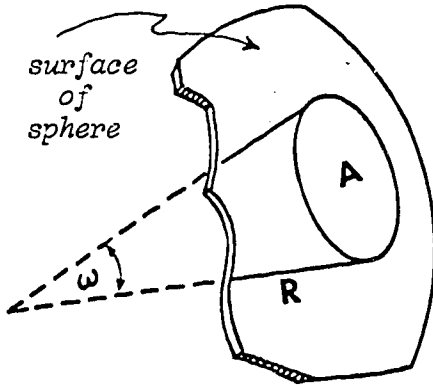

Figure 2

$$A \propto R^2$$

then the ratio A/R^2 is dimensionless and may be conveniently used as the measure of the solid angle ω . Thus,

$$\omega = A/R^2$$

and, if A and R^2 are in the same units, the angle magnitude is then in steradians. (In popular usage, the steradian is sometimes referred to simply as a "radian".

Based on this definition, the solid angle subtended by the surface of the entire sphere is the total surface area $4\pi R^2$ divided by R^2 , or simply 4π steradians.

For an irregularly shaped surface, the solid angle subtended at the center by a area element dA is defined as

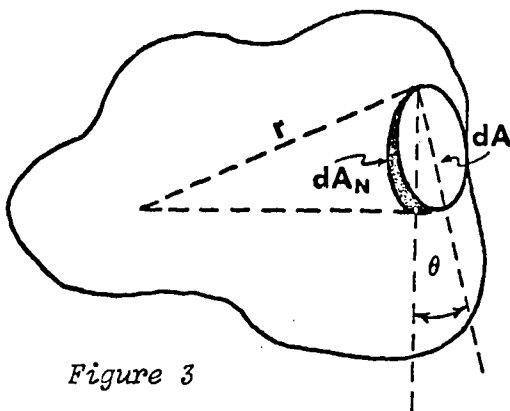

Figure 3

$$d\omega = dA_N/r^2 = dA \cos\theta/r^2$$

As Figure 3 indicates, the element dA_N is the normal projection of dA , and θ is the angle between the planes of the two elements of area.

This section contains problems in which you will be asked to

- (a) find the field inside a hollow, spherical charged conductor;
- (b) determine the magnitude of the component of E parallel to an infinite, uniformly charged plane, given the charge density and the position of the point where the component is to be found;
- (c) the perpendicular component of the electric field at a given point with relation to an infinite charged plane, given the charge density on its surface.

18. What is the electric field inside a hollow charged spherical conductor of radius R , surface area A , and total charge Q , distributed so that the charge density is σ ?

- A. $\frac{\sigma A}{4\pi\epsilon_0 R^2}$
- B. $\frac{\sigma A}{2\pi\epsilon_0 R^2}$
- C. $4\pi\epsilon_0 R^2 Q$
- D. ~~none~~ of these

19. At a point near the surface of an infinite, uniformly charged plane with charge density σ , the magnitude of the electric field E *parallel* to the plane is

- A. $\sigma/2\epsilon_0$
- B. 0
- C. $\sqrt{y} \sigma/2\epsilon_0$
- D. σ/ϵ_0

20. The y component of the electric field at point p at a distance y from an infinite plane having uniform surface charge density σ is

(Hint: The infinite plane may be imagined to be composed of an infinite number of concentric annuli.)

- A. $\sigma/2\epsilon_0$
- B. 0
- C. $\sigma/2\epsilon_0\sqrt{y}$
- D. $\sqrt{y}/2\epsilon_0$

[a] CORRECT ANSWER: D

Both charges produce a field at the point x. The fields are along the same axis, but oppositely directed. We want the magnitude of \vec{E} , where

$$\vec{E} = \vec{E}_1 + \vec{E}_2$$

$$\vec{E}_1 = \frac{q}{4\pi\epsilon_0 r^2} \text{ to the right}$$

$$\vec{E}_2 = \frac{q}{4\pi\epsilon_0 (3r)^2} \text{ to the left.}$$

Adding these vectors yields

$$\vec{E} = \frac{q}{4\pi\epsilon_0 r^2} - \frac{q}{36\pi\epsilon_0 r^2} \text{ to the right}$$

$$\vec{E} = \frac{2}{9} \frac{q}{\pi\epsilon_0 r^2} \text{ to the right.}$$

TRUE OR FALSE? At point x, the resultant electric field is taken as directed to the right because $3r$ is a larger quantity than r .

[b] CORRECT ANSWER: C

Even though lines of force are imaginary, they do help us get the picture of what's happening. The relationship between the lines of force and the electric field strength vector is as follows:

- (1) *Direction* of E is the same as the tangent to the line of force at that point.
- (2) *Magnitude* of E is proportional to the density of the lines of force. The lines at P are further apart than those within the gap, indicating less density, hence a field with less intensity.

TRUE OR FALSE? The field contained within the gap is essentially uniform in intensity.

[a] CORRECT ANSWER: B

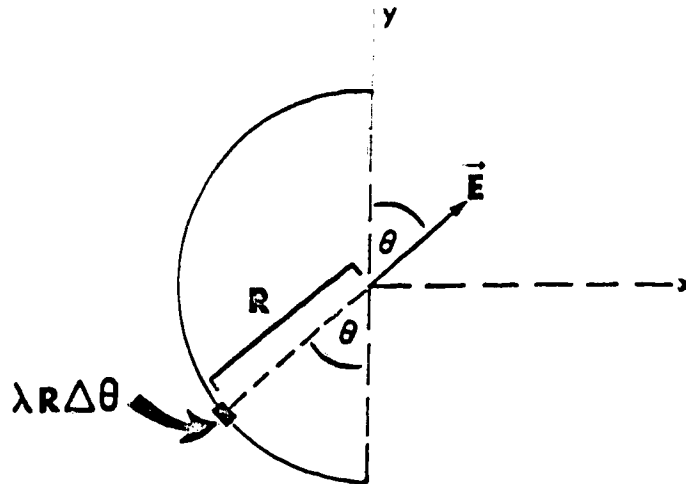

Each segment of wire of length $R\Delta\theta$ contributes an amount

$$\frac{\lambda R}{4\pi\epsilon_0 R^2} \sin\theta \Delta\theta \text{ to } E_x.$$

The total x-component of \vec{E} is given by an infinite sum of such contributions:

$$E_x = \text{Limit}_{\Delta\theta \rightarrow 0} \sum \frac{\lambda}{4\pi\epsilon_0 R} \sin\theta \Delta\theta \equiv \int_0^\pi \frac{\lambda}{4\pi\epsilon_0 R} \sin\theta \, d\theta.$$

Note that the integration limits are chosen so that θ sweeps over the entire semi-circle; that is, over all charged segments of the wire. We have

$$E_x = \frac{\lambda}{4\pi\epsilon_0 R} \int_0^\pi \sin\theta \, d\theta = \frac{\lambda}{4\pi\epsilon_0 R} [-\cos\theta]_0^\pi = -\frac{\lambda}{4\pi\epsilon_0 R} [(-1) - 1] = \frac{\lambda}{2\pi\epsilon_0 R}.$$

The component E_y may be evaluated in a similar manner. However, for every component of \vec{E} that is up, there is another component of \vec{E} that is down. The sum of all of these components will be zero.

[a] CORRECT ANSWER: -3.92×10^{-5} coul

We are told that the particle is stationary, therefore, the sum of the forces acting on the particle is zero. The forces acting on the particle are its weight and the electrostatic force \vec{F}_e due to the presence of electric field. Therefore

$$\begin{aligned}\vec{F}_e + \vec{w} &= 0 \\ \vec{F}_e &= -\vec{w} \quad (1)\end{aligned}$$

or, where

$$w = mg.$$

In order to have an electrostatic force acting upward on a charged particle in an electric field that acts downward, the charge on the particle must be negative. The magnitude of the charge is obtained by substituting the expression for F_e and w in equation (1). Thus

$$-qE = mg$$

or

$$-q = \frac{mg}{E}$$

$$q = - \frac{(2 \times 10^{-3} \text{ kg}) (9.8 \text{ m/sec}^2)}{500 \text{ nt/coul}}$$

$$q = -3.92 \times 10^{-5} \text{ coul}$$

TRUE OR FALSE? The product $-qE$ represents an electric force acting upward on a negative particle in an electric field that also acts upward.

[b] CORRECT ANSWER: A

Lines of force give a vivid picture of the way in which E varies throughout a given region of space. In order to obtain an intuitive picture of nature, man often builds these conceptual models with which further predictions can often be made. A single (+) or (-) charge would produce a line pattern which would resemble the spokes of a perfectly circular wheel rather than the pattern shown. Two (-) charges would yield a configuration similar to that shown, but the direction of each force line would be inward instead of outward.

TRUE OR FALSE? This pattern could be made to represent the field around a single negative charge merely by reversing the directions of all the lines of force.

[a] CORRECT ANSWER: B

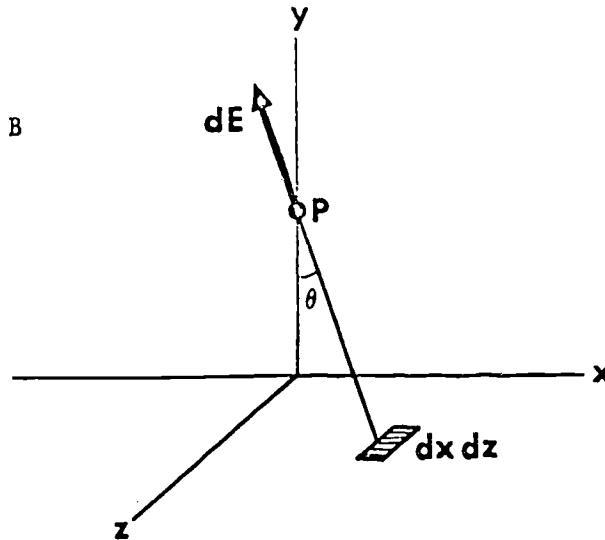

The contribution to the field strength dE at P from an area element $dx dz$ is

$$dE = \frac{1}{4\pi\epsilon_0} \frac{dq}{(x^2 + y^2 + z^2)}$$

where

$$dq = \sigma dx dz$$

The x -component of the field is

$$dE_x = dE \sin\theta = dE \frac{\sqrt{x^2 + z^2}}{\sqrt{x^2 + y^2 + z^2}}$$

Let us now take another element of area dA' at the same distance from the y -axis in the negative x and z directions. The x -component of the field at p due to this element is exactly the same in the magnitude but opposite in the direction to that of the first one. Therefore, the total contributions at p due to these two area elements cancel out. Since the contributions from the remaining charges can be paired off in a similar manner, the x -component of the field at a point near the surface of an infinite, uniformly charged plane is zero.

[b] CORRECT ANSWER: C

This statement is merely a re-wording of the definition of electric field. The important item to remember is that the test charge must be *positive*. When in doubt about the direction of the electric field at a point, simply imagine your positive test charge placed at the point in question. Now decide the direction in which the charge will move.

[a] CORRECT ANSWER: D

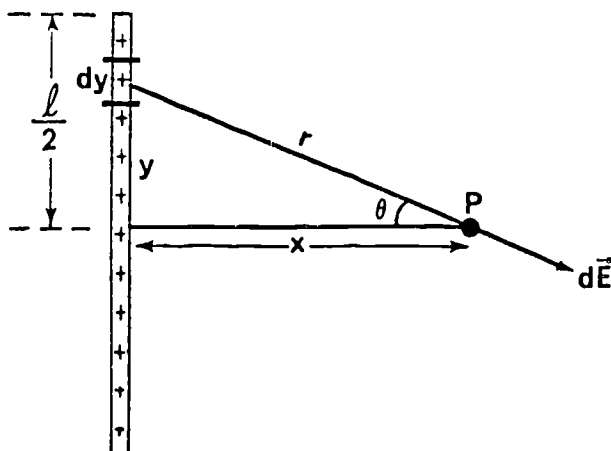

The magnitude of the field dE due to the charge element $dq = \frac{q}{l} dy$ is

$$dE = \frac{1}{4\pi\epsilon_0} \frac{dq}{r^2} = \frac{1}{4\pi\epsilon_0} \cdot \frac{q}{l} \cdot \frac{dy}{(y^2 + x^2)} \quad (1)$$

The resultant field E can be obtained by integrating over the entire rod. The y -component of the field vanishes because every charge element on the upper half of the rod has a corresponding element on the lower half such that their field contributions in the y -direction cancel. Thus \vec{E} points entirely in the x -direction. Integrating (1) over the entire rod, we have

$$E = E_x = \frac{1}{4\pi\epsilon_0} \frac{q}{l} \int_{-\frac{l}{2}}^{\frac{l}{2}} \frac{dy}{y^2 + x^2} \cos\theta = \frac{1}{4\pi\epsilon_0} \frac{q}{l} \int_{-\frac{l}{2}}^{\frac{l}{2}} \frac{xdy}{(y^2 + x^2)^{3/2}}$$

where

$$\cos\theta = \frac{x}{r} = \frac{x}{\sqrt{y^2 + x^2}}$$

has been substituted. Therefore

$$E = \frac{1}{4\pi\epsilon_0} \frac{q}{l} \frac{x}{x^2} \frac{y}{\sqrt{y^2 + x^2}} \Big|_{-\frac{l}{2}}^{\frac{l}{2}}$$

$$E = \frac{q}{2\pi\epsilon_0 x} \frac{1}{\sqrt{l^2 + 4x^2}}$$

[a] CORRECT ANSWER: B

Recall that by convention, that is, by agreement among physicists, lines of force are drawn close together where the electric field is intense and, conversely, further apart where the field is less intense.

There is, however, no agreement on how many lines to draw in order to represent a given electric field intensity. Generally, we draw enough lines to make the field configuration clear, but not so many that the diagram is crowded.

For example, if a typical field intensity for some charge distribution is 100 nt/coul, we might choose to draw lines separated by 1/2 cm to represent this intensity. Then on the diagram (as below) regions where the lines are closer together, say 1/4 cm apart, would be representing electric field intensities of 200 nt/coul.

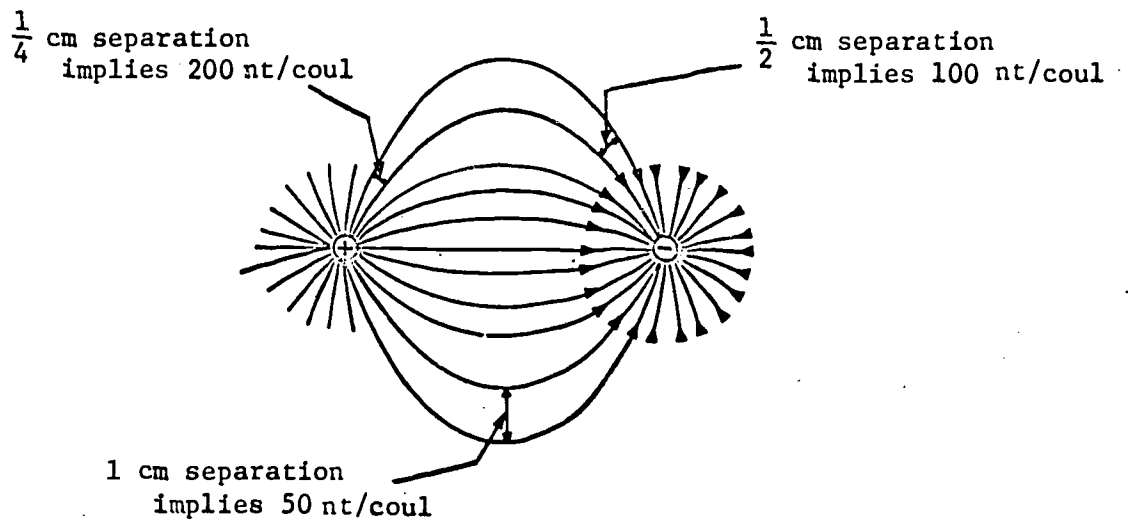

[a] CORRECT ANSWER: A

Let us first write down the contribution to dE_y due to an annulus of inner and outer radii r and $r + dr$, respectively. The total charge included is $dq = \sigma dA = \sigma 2\pi r dr$ and the field strength is

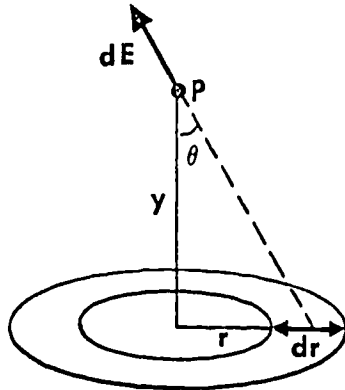

$$dE = \frac{dq}{4\pi\epsilon_0(r^2 + y^2)} = \frac{\sigma r dr}{2\epsilon_0(r^2 + y^2)} \quad (1)$$

and the y -component of the field strength is

$$dE_y = dE \cos\theta = dE \frac{y}{\sqrt{r^2 + y^2}} \quad (2)$$

Substituting the expression for dE from (1), we have

$$dE_y = \frac{\sigma r y dr}{2\epsilon_0(r^2 + y^2)^{3/2}} \quad (3)$$

Now if we integrate over r from zero to infinity, we get the required result

$$E_y = \int_0^{\infty} \frac{\sigma y r dr}{2\epsilon_0(r^2 + y^2)^{3/2}} = \frac{\sigma}{2\epsilon_0}$$

TRUE OR FALSE? The area of a given annulus with radius r is $r dr$.

[b] CORRECT ANSWER: B

The operational measurement of the field strength at a point might proceed as follows:

Place a charge q_0 at the point in space where the field strength is to be measured. Use a spring balance to measure the force F on the charge q_0 . Then the electric field strength becomes:

$$|E| = \frac{F}{q_0}$$

Although this method might be conceptually sound and quite appropriate to our present thinking, you probably can imagine the difficulty of attaching the spring balance to a charged particle. A more practical method of measuring $|E|$ will be discussed later.

[a] CORRECT ANSWER: 13 nt/coul

Notice that this problem emphasizes the important aspects of superposition. When two vector fields overlap at a point (in this problem at the origin), the fields can be superimposed giving a resultant field. If the quantities are scalar, they may be added directly. However, since the quantities of the field are vectors, then vector addition is necessary. In our problem the following diagram tells the story:

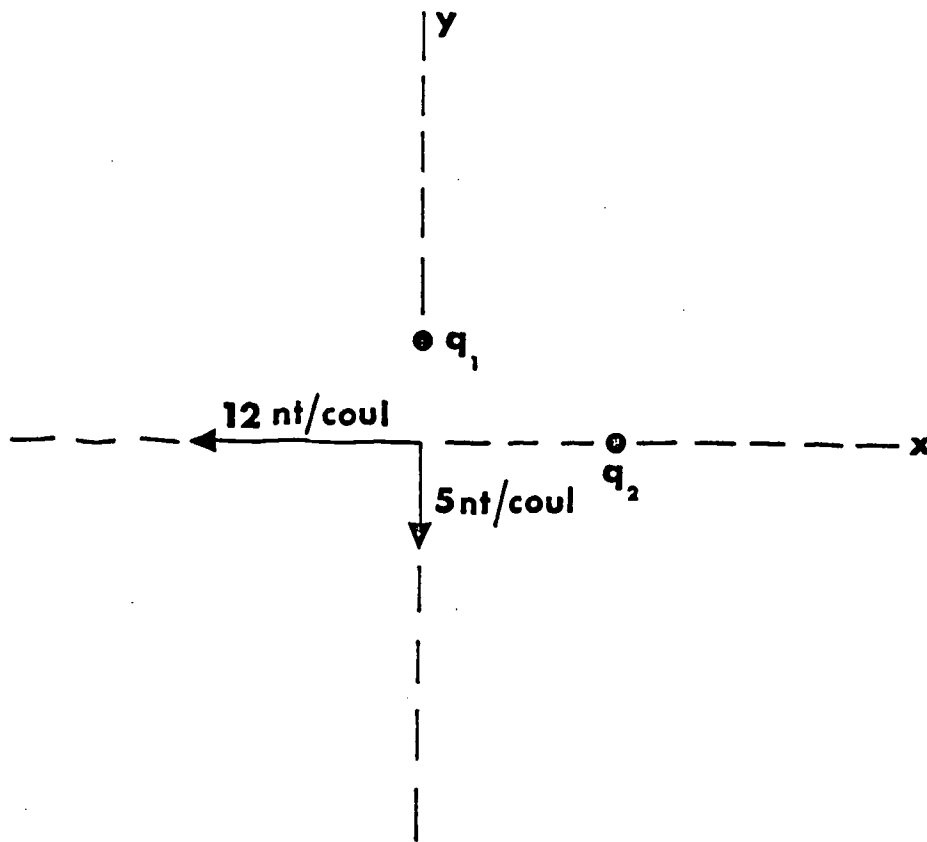

Notice that the direction of the field due to each positive charge is away from the individual charges. The resultant electric field can be found by:

$$E_R = \sqrt{E_1^2 + E_2^2} .$$

$$E_R = \sqrt{(5)^2 + (12)^2} = 13 \text{ nt/coul}$$

[a] CORRECT ANSWER: A

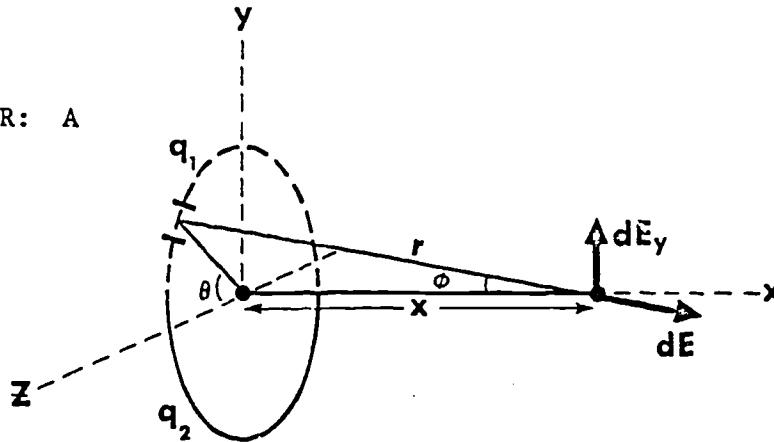

We can consider the ring to consist of two half rings carrying charges q_1 and q_2 , respectively. The resultant field can be found by adding the contributions from each half-ring vectorially. The component of the field dE_{1y} due to the charge element dq_1 can be expressed as

$$dE_{1y} = \frac{1}{4\pi\epsilon_0} \frac{dq_1}{r^2} \sin\phi = \frac{1}{4\pi\epsilon_0} \frac{dq_1}{x^2 + a^2} \sin\phi$$

where

$$dq_1 = \frac{q_1}{\pi a} ds = \frac{q_1}{\pi a} a d\theta$$

and

$$\sin\phi = \frac{a \sin\theta}{r} = \frac{a \sin\theta}{\sqrt{x^2 + a^2}}$$

Thus

$$dE_{1y} = \frac{1}{4\pi\epsilon_0} \frac{q_1}{\pi(x^2 + a^2)} \frac{a \sin\theta}{\sqrt{x^2 + a^2}} d\theta$$

Integrating over θ from 0 to π , we obtain the total contribution to E_{1y} :

$$\begin{aligned} E_{1y} &= \frac{1}{4\pi\epsilon_0} \frac{q_1}{\pi} \frac{a}{(x^2 + a^2)^{3/2}} \int_0^\pi \sin\theta d\theta \\ &= \frac{1}{2\pi^2\epsilon_0} \frac{q_1 a}{(x^2 + a^2)^{3/2}} \end{aligned}$$

The total contribution from the other half ring can be obtained in a similar manner:

$$E_{2y} = \frac{1}{2\pi^2\epsilon_0} \frac{q_2 a}{(x^2 + a^2)^{3/2}}$$

next page

continued

Thus, the net component of the resultant field in the y-direction is:

$$E_y = E_2 y - E_1 y = \frac{1}{2\pi^2\epsilon_0} \frac{(q_2 - q_1)a}{(x^2 + a^2)^{3/2}}$$

TRUE OR FALSE? For the conditions described above, dE_x has not been calculated.

[a] CORRECT ANSWER: -4

Again we have superimposed two electric fields at a point and this time the resultant field is zero. We can restate the information of this problem in equation form by writing:

$$\vec{E}_1 + \vec{E}_2 = 0 \text{ (at the point in question).}$$

Since both vectors are on the x-axis, we can add their magnitudes directly. Thus,

$$\frac{q_1}{4\pi\epsilon_0 r_1^2} + \frac{q_2}{4\pi\epsilon_0 r_2^2} = 0.$$

Solving this equation for the desired ratio yields

$$\frac{q_1}{q_2} = \frac{-r_1^2}{r_2^2}.$$

But, we can see that $r_1 = 2 r_2$ and by substituting back into the above equation we obtain

$$\frac{q_1}{q_2} = -4.$$

Notice that either charge could be negative.

TRUE OR FALSE? There is no point *between* q_1 and q_2 on the line joining them where $\vec{E} = 0$ in this problem.

[a] CORRECT ANSWER: D

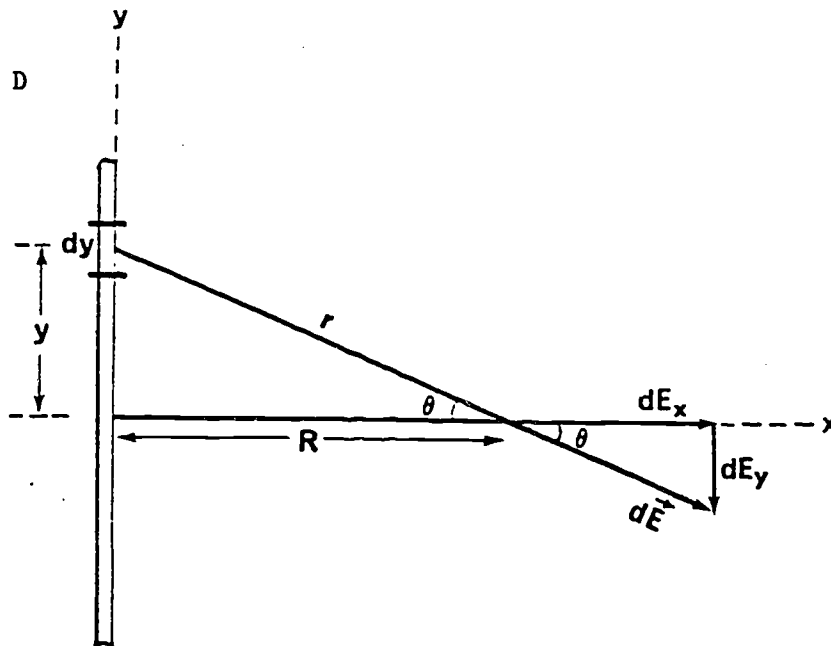

The magnitude of the field dE due to charge element $dq = \lambda dy$ distributed over dy is

$$\begin{aligned} dE &= \frac{1}{4\pi\epsilon_0} \frac{dq}{r^2} \\ &= \frac{1}{4\pi\epsilon_0} \frac{\lambda dy}{(R^2 + y^2)} \end{aligned} \quad (1)$$

The resultant field \vec{E} can be obtained by integrating over the entire wire. As before, the y -component of the field E_y vanishes because every charge element on the upper half of the wire has a corresponding element on the lower half such that their field contributions in the y -direction cancel. Thus \vec{E} points entirely in the x -direction.

Integrating equation (1) over the entire wire, we have

$$\begin{aligned} E &= E_x = \int dE_x = \int dE \cos\theta \\ &= \int \frac{R dE}{\sqrt{R^2 + y^2}} \end{aligned} \quad (2)$$

Substituting the value of dE from equation (1) we have

$$\begin{aligned} E &= \int_{-\infty}^{+\infty} \frac{\lambda R dy}{4\pi\epsilon_0 (R^2 + y^2)^{3/2}} \\ E &= \frac{\lambda}{2\pi\epsilon_0 R} \end{aligned}$$

and points in the positive x -direction.

[a] CORRECT ANSWER: 17.2×10^3 nt/coul

This diagram should be helpful.

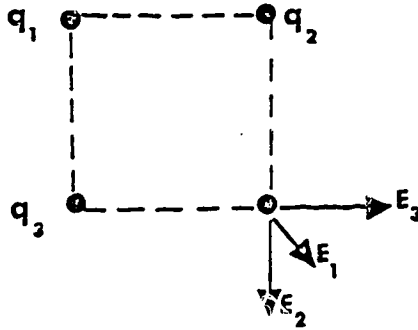

We want to find the magnitude of the resultant electric field at the corner of the square shown above. In equation form, this electric field is

$$\vec{E} = \vec{E}_1 + \vec{E}_2 + \vec{E}_3.$$

From the diagram we can see that the x-component of the resultant electric field will be

$$\begin{aligned} E_x &= |E_3| + |E_1| \cos 45^\circ \\ &= \frac{q_3}{4\pi\epsilon_0 r^2} + \frac{(\sqrt{2}/2) q_1}{4\pi\epsilon_0 (\sqrt{2}r)^2} \end{aligned}$$

Realizing that $q_1 = q_3$ we can reduce this expression to

$$E_x = \frac{q}{4\pi\epsilon_0 r^2} \left[1 + \frac{\sqrt{2}}{4} \right].$$

The y-component of the resultant electric field is in the negative direction but has the same magnitude as the x-component. Finally, the magnitude of the resultant electric field is

$$\begin{aligned} |E| &= \sqrt{E_x^2 + E_y^2} \\ |E| &= \frac{q}{4\pi\epsilon_0 r^2} (1.915) = 17.2 \times 10^3 \text{ nt/coul.} \end{aligned}$$

[a] CORRECT ANSWER: B

We are told that the particle is moving with a constant velocity, therefore the sum of the forces acting on the particle is zero. The forces acting on the particle are its weight and the electrostatic force \vec{F}_e due to the presence of the electric field. Therefore

$$\vec{F}_e + \vec{w} = 0$$

$$\vec{F}_e = -\vec{w} \quad (1)$$

or

where $w = mg$

In order to have an electrostatic force acting upward on a negatively-charged particle, the electric field must be acting *downward*. The magnitude of the electric field is obtained by substituting the expression for F_e and w in equation (1). Thus

$$qE = mg$$

or

$$E = \frac{mg}{q}$$

$$E = \frac{(1 \times 10^{-3} \text{ kg}) (9.8 \text{ m/sec}^2)}{9.8 \times 10^{-7} \text{ coul}} = 10^4 \text{ nt/coul}$$

and its direction is downward.

TRUE OR FALSE? The resultant force acting on the particle described above is zero.

[b] CORRECT ANSWER: D

The lines of force around a positive charge point outward and their density indicates the strength of the electric field in that region. The symmetry of the pattern implies that there are *no* charges present at A, C, or E. The charge at D cannot be positive because the lines are directed *toward* that point.

[a] CORRECT ANSWER: D

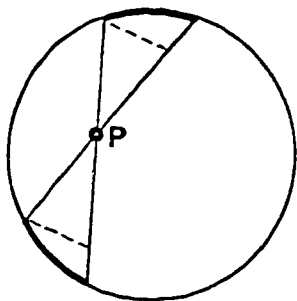

Let us construct two narrow cones with their vertices at some arbitrary point P. Both cones include the same solid angle ω and they intercept areas A_1 and A_2 on the surface of the sphere. Let σ be the charge per unit area so that

$$\sigma = \frac{Q}{4\pi R^2}$$

The magnitudes of the electric field E_1 and E_2 due to charges σA_1 and σA_2 at P are

$$E_1 = \frac{\sigma A_1}{4\pi\epsilon_0 r_1^2} \quad (1)$$

and

$$E_2 = \frac{\sigma A_2}{4\pi\epsilon_0 r_2^2} \quad (2)$$

and they are oppositely directed. The projections of these areas normal to the axes of the cones are $A_1 \cos\theta$ and $A_2 \cos\theta$ respectively and hence

$$\omega = \frac{A_1 \cos\theta}{r_1^2} = \frac{A_2 \cos\theta}{r_2^2}$$

or

$$\frac{A_1}{r_1^2} = \frac{A_2}{r_2^2} \quad (3)$$

From (3), (1), and (2), we have

$$E_1 = E_2$$

and since they are oppositely directed, we may write

$$\vec{E}_1 + \vec{E}_2 = 0.$$

The contributions from the remaining charges on the surface may be paired off in a similar manner. Consequently, the field at an arbitrary point inside a hollow, charged, conducting sphere is zero.

TRUE OR FALSE? If P had been at the geometric center of the sphere, it would not have been necessary to project the subtended areas normal to the cone axes.

[a] CORRECT ANSWER: B

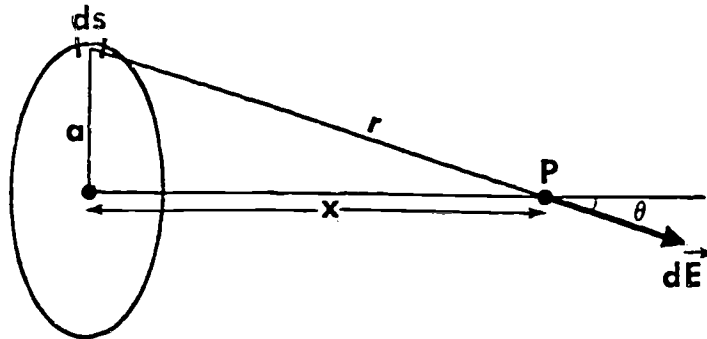

Let us first consider the field $d\vec{E}$ at p due to a differential line element ds of the ring:

$$dE = \frac{1}{4\pi\epsilon_0} \frac{dq}{r^2} = \frac{1}{4\pi\epsilon_0} \frac{dq}{x^2 + a^2}$$

where

$$dq = \frac{q}{2\pi a} ds$$

and the direction of $d\vec{E}$ is along the line connecting ds and p as shown.

The resultant field \vec{E} at p due to the entire ring can be obtained by adding all the contributions from these differential elements, i.e., integrating over the ring. From the symmetry of the ring, it is easy to see that the total contributions to the field component *perpendicular* to the axis cancel out and only the component along the axis will remain after the integration. Thus

$$\begin{aligned} E &= \int dE \cos\theta = \frac{1}{4\pi\epsilon_0} \int \frac{dq}{x^2 + a^2} \frac{x}{\sqrt{a^2 + x^2}} \\ &= \frac{1}{4\pi\epsilon_0} \frac{x}{(x^2 + a^2)^{3/2}} \frac{q}{2\pi a} \int ds \end{aligned}$$

and since

$$\int ds = 2\pi a,$$

then

$$E = \frac{1}{4\pi\epsilon_0} \frac{qx}{(x^2 + a^2)^{3/2}}$$

TRUE OR FALSE? In the second equation, the term $q/2\pi a$ might be described as the force per unit length of the ring.

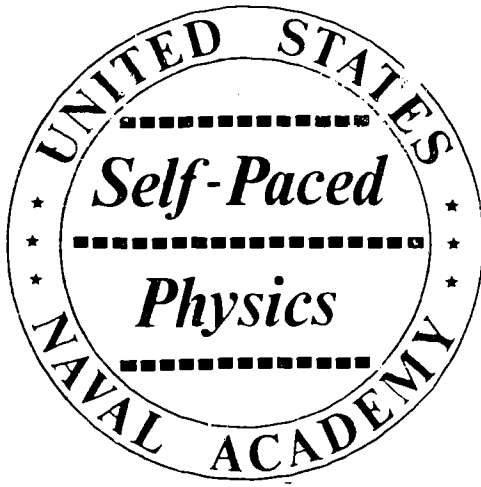

SEGMENT SEPARATOR

note

ALL WRITTEN MATERIAL APPLICABLE TO
THE FOLLOWING SEGMENT IS CONTAINED
IN THE PAGES BETWEEN THIS COLORED
SHEET AND THE NEXT.

INFORMATION PANELElectric Field Problems - Type 1

OBJECTIVE

To solve basic problems involving the electric field around certain specific charged bodies, and the force exerted by this field on neighboring charges.

The electric field produced around certain configurations of charges is relatively easy to evaluate. For example, an infinitely long line of charges--typified by an infinite wire to a very close approximation--gives rise to a field whose intensity can be written as:

$$E = \frac{\lambda}{2\pi\epsilon_0 r} \quad (1)$$

in which λ is the charge per unit length in coul/meter, and r is the perpendicular distance between the line of charge and the point at which the intensity of the field is to be determined.

If there is a point charge at the point for which the magnitude of the field intensity has been calculated, the magnitude of the electric force exerted on this charge due to its presence in the field is given by:

$$F = Eq \quad (2)$$

in which q is the magnitude of the charge. Thus, to find the force on a point charge q located at some distance r from a line of charge having a charge density λ , equation (1) is substituted into equation (2) and the resulting equation solved for F . It is also clear that a charge located in a field-free region, i.e., in a region where the field intensity is zero, is not subjected to any electric force at all.

Suppose, however, that it is desired to find the resultant field somewhere *between* a given line of charge and a given point charge. In this event it would be necessary to determine the vector sum of the fields due to both charged bodies, or:

$$\vec{E} = \vec{E}_1 + \vec{E}_2 \quad (3)$$

giving careful attention to the direction of each field as well as to their relative magnitudes.

In the problems that follow you will be asked to determine

(a) how a charge embedded in an infinitely long wire carrying a certain charge density of its own can produce a field of zero intensity at a given distance from the wire;

continued

(b) the magnitude of the force acting on a charged particle at the center of a hollow charged spherical conductor;

(c) the magnitude of the force on a charged particle at a given distance from an infinitely long charged wire;

(d) the field intensity at a point between a charged infinite wire and a charged particle near it.

1. An infinitely long wire has a uniform charge density of $\lambda = +3.0 \times 10^{-6}$ coul/m. When a point charge Q is embedded in this wire, the electric field is measured to be zero at all points on a circle of radius 2.0 meters perpendicular to the axis of the wire. If Q is on the wire and at the center of the circle, what is the value of the charge Q ?

2. What is the force acting on a charge $q = 10$ μ coul placed at the center of a hollow charged spherical conductor of radius R and total charge Q ? Note: The table in the INFORMATION PANEL on page 3 may be helpful.

A. $\frac{20\pi q}{QR}$

B. $\frac{20\pi Q}{qR}$

C. $\frac{40\pi Q}{qR}$

D. zero

3. Find the magnitude of the electric force acting on a charge $q = 2.0 \times 10^{-6}$ coul placed at a distance $r = 2.0$ m from an infinitely long wire having a uniform line charge density $\lambda = 3.0 \times 10^{-6}$ coul/m.

4. A point charge $q = 8.0 \times 10^{-6}$ coul is placed at distance $d = 4$ m from an infinitely long wire having a uniform line charge density $\lambda = 2.0 \times 10^{-6}$ coul/m. Find the electric field at point P midway between the point charge and the infinite wire.

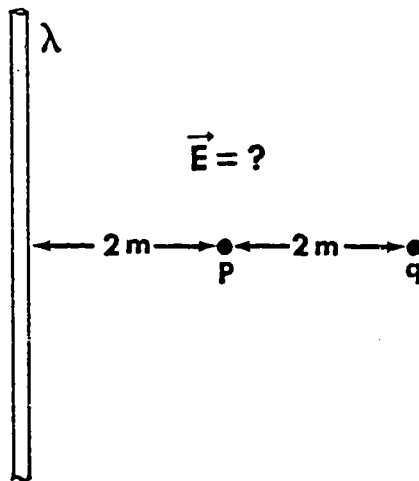

INFORMATION PANELElectric Field Problems - Type 2

OBJECTIVE

To solve problems relating to the electric field and the force produced by such fields on charged particles near large parallel conducting plates carrying a charge, uniformly charged rings, uniformly charged spheres, and point charges.

next page

continued

To assist you in solving the forthcoming problems in this section, you may refer to the chart below where we have summarized the relationships needed.

Charge Distribution Causing Electric Field	Distance from Charges	Magnitude of the E-Field
Point charge q	r	$E = \frac{1}{4\pi\epsilon_0} \frac{q}{r^2}$
Charge q uniformly distributed on the surface of conducting sphere of radius R	$r < R$	$E = 0$
	$r \geq R$	$E = \frac{1}{4\pi\epsilon_0} \frac{q}{r^2}$
Infinite (very long) wire having line charge density λ	r	$E = \frac{1}{2\pi\epsilon_0} \frac{\lambda}{r}$
Infinite charged surface having surface charge density σ Note: If the surface is a conductor, the field inside the material is zero and E outside is twice as great, that is, $E = \sigma/\epsilon_0$	r	$E = \frac{\sigma}{2\epsilon_0}$
Ring of conducting material with uniform line charge λ and radius a	x (distance from center of ring along axis)	$E = \frac{1}{4\pi\epsilon_0} \frac{qx}{(a^2 + x^2)^{3/2}}$ (field along axis of ring)

In addition to the above information, it will help you to remember that, in dealing with problems involving atomic nuclei, the *atomic number* is equivalent to the total number of *protons* in the nucleus. A proton carries the same magnitude of charge as the electron but is positive.

next page

continued

To solve the problems that follow in this section successfully, it will be necessary for you to

(a) apply the relevant electric field equations to parallel charged plates to find the force they exert on a charged particle between them;

(b) use the field equation for a sphere of charge to determine the force acting on a proton on the surface of the sphere;

(c) apply vector methods to calculate the field due to two charges and the force acting on a third charge on a line between them;

(d) apply the field equation for a ring of charge in order to calculate the electric field at some point on the axis of the ring.

5. Two large parallel metal plates adjacent to one another carry uniform surface charge densities $+\sigma$ and $-\sigma$, respectively, on their inner surfaces. The magnitude of σ is 10 coul/m^2 . A charge, $q = 3.0 \times 10^{-6} \text{ coul}$, is placed between these two plates. What is the magnitude of the electric force on it?

6. Ernest Rutherford in 1911 found that the nucleus contains all the positive charge of an atom. His experiment indicated that the nucleus of the gold atom had a radius of about 10^{-14} meter. If gold has an atomic number of 79, what is the repulsive force on a proton located on the "surface" of the nucleus? Assume that the charge due to the protons is uniformly distributed over the surface of the nucleus, and solve the problem to one significant digit.

- A. $2 \times 10^{-3} \text{ nt}$
- B. 200 nt
- C. $3 \times 10^{-15} \text{ nt}$
- D. $4 \times 10^{-34} \text{ nt}$

7. Two charges q_1 and q_2 are separated by a distance L as in the figure where $q_1 = 4q_2$ and $L = 1.0$ m. At what point on the line joining q_1 and q_2 should one place a third charge Q such that the electric force on Q is zero?

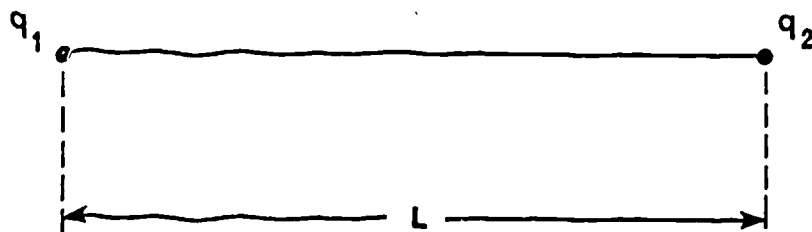

- A. 50 cm to the left of q_2
- B. 67 cm to the right of q_1
- C. 25 cm to the right of q_1
- D. 75 cm to the right of q_1

8. In the diagram are two large parallel plates, with surface charge densities of 10.0 coul/m² and -10.0 coul/m². What are the magnitude and direction of the electric field at point A?

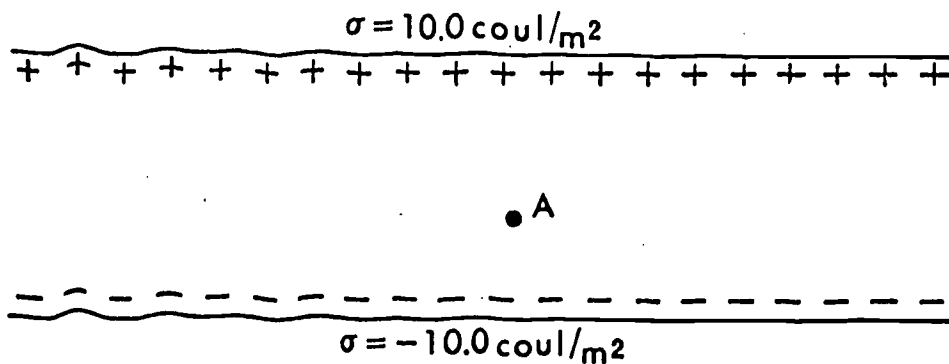

- A. 1.13×10^{12} nt/coul vertically down
- B. 1.17×10^2 coul/m vertically up
- C. 1.28×10^2 nt/coul vertically up
- D. 5.60×10^{11} nt/coul vertically down

9. A circular ring has a uniform charge of 10 coul and a radius of 25 cm. A charge of -20 coul is located at its center as shown in the diagram. What is the force on an electron located at point P, 1.0 m away, on the axis of the circular ring?

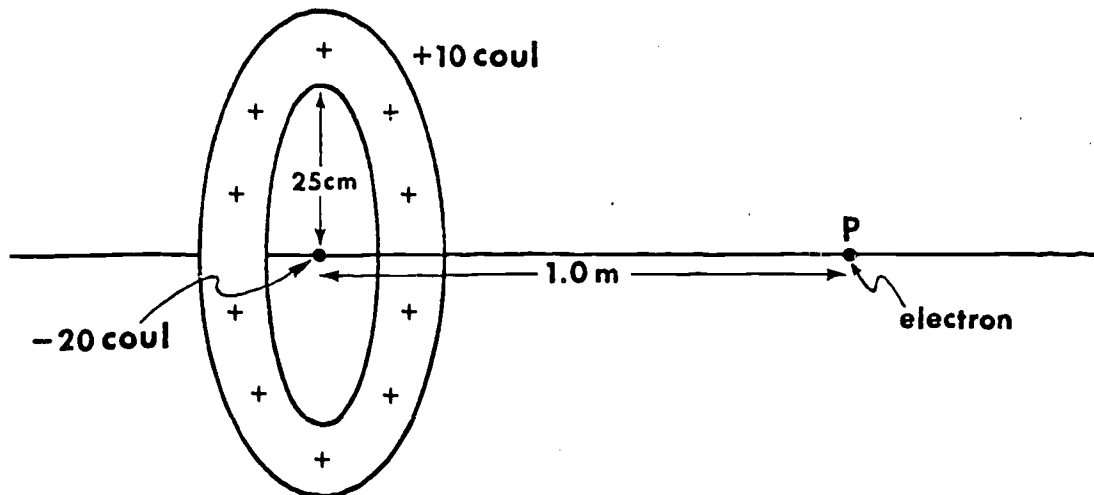
INFORMATION PANELMotion of a Charged Particle in an Electric Field

OBJECTIVE

To combine the principles of dynamics with those of electric fields in solving problems in which these principles are interrelated.

It may be assumed, in dealing with situations where the influence of the electric field between two large, parallel, charged conducting plates is to be evaluated, that the field is uniform throughout the space between the plates. The magnitude of this electric field in general is:

$$E = \frac{\sigma}{\epsilon_0}$$

and when there is a charged particle between the plates, the force acting on it is given by:

$$\vec{F} = Eq$$

If the particle is an electron or a proton, the magnitude of the force is:

$$F = Ee$$

where e is the elementary charge (a proton and electron have equal and opposite charges).

next page

continued

A few familiar facts linking dynamics and kinematics to electric forces bear repetition here:

(1) A positive particle held between two charged parallel plates has no kinetic energy. When released, it will accelerate in the direction of the field, the magnitude of its acceleration being:

$$a = \frac{qE}{m}$$

where m is the mass of the particle and q is its charge. The same equation holds for a negative particle, but the acceleration will occur in a direction opposite that of the field.

(2) Conservation of kinetic energy may be assumed unless otherwise noted. That is, the final kinetic energy of a particle released in a uniform electric field is equal to the work done on the particle by the field or:

$$\frac{1}{2} mv^2 = qEd$$

where d is the distance traversed by the particle throughout the time that the force acts.

(3) A charged particle projected at right angles to a uniform field will have a trajectory similar to that of a projectile in a gravitational field. For example, when a charged particle is projected horizontally (ignoring gravitational effects) through a *uniform* vertical electric field its horizontal velocity remains uniform while its vertical motion is uniformly accelerated. Thus, an electron projected horizontally between a pair of parallel charged plates lying in horizontal planes undergoes a vertical deflection y which can be determined from the relationship:

$$y = y_0 + v_{oy}t + \frac{at^2}{2}$$

and since $a = qE/m$, then:

$$y = y_0 + v_{oy}t + \frac{Eq}{2m} t^2$$

It is important to note that the horizontal component of the velocity of the particle does not influence the deflection y . We might add that in many problems the x -axis is taken to be that of the initial path of the particle so that $y_0 = 0$; furthermore, if the particle starts its

next page

continued

vertical motion on the x-axis, $v_{oy} = 0$, too. Hence, for this special but not unusual case:

$$y = \frac{Eq}{2m} t^2$$

(4) A charged particle projected *parallel* to an electric field (ignoring gravitational effects) will be either accelerated or decelerated depending on the nature of the charge and the direction of the field. The magnitude of the acceleration is:

$$a = \frac{qE}{m}$$

so that any of the pertinent equations of kinematics or dynamics may be readily applied.

The problems in the succeeding section are varied in nature. To solve them, you are expected to be able to calculate

- (a) the acceleration of a charged particle moving through an electric field;
- (b) the kinetic energy acquired by a charged particle moving through an electric field;
- (c) the deflection of a charged particle moving at right angles to an electric field (uniform);
- (d) the net change of velocity of a charged particle moving parallel to an electric field.

10. Two oppositely charged metal plates are placed parallel to one another separated by a distance of 1.0×10^{-3} m. The uniform electric field between the plates has an intensity of 1.0×10^3 nt/coul. If a proton is released very close to the positive plate, what will be its kinetic energy at the instant it collides with the negative plate?

11. A particle with charge q and mass m is projected horizontally with velocity v_0 at right angles to a uniform electric field of magnitude E . Which of the following is the correct expression for the vertical deflection y during elapsed time t ?

A. $y = \frac{qE}{mv_0} t^2$

B. $y = \frac{Eq}{2m} t^2$

C. $y = \frac{mv_0}{qE} t^2$

D. $y = \frac{qE}{3m} t^2$

12. A uniform electric field E acts upon a particle of mass m and charge q . If the velocity of the particle at $t = 0$ is equal to zero, what is the general expression of the velocity of the particle as a function of time? (No other fields or forces are present.)

A. $v(t) = \frac{qEt}{m}$

B. $v(t) = \frac{qEt}{2m}$

C. $v(t) = \frac{mqt}{E}$

D. $v(t) = \frac{mqt}{2E}$

13. A uniform electric field $E = 1.0$ nt/coul is directed along the positive x-axis. An electron is shot along the positive x-axis with an initial velocity of $+100$ m/sec. If the initial x-displacement of the electron is equal to 2.0 m, what is the x-displacement after 30 seconds?

- A. 1.8×10^3 cm
- B. 7.9×10^{13} cm
- C. -1.8×10^3 cm
- D. -7.9×10^{13} cm

14. The figure below shows an electron projected with speed $v_0 = 1.00 \times 10^7$ m/sec at right angles to a uniform field E . Find the deflection of the beam on the screen when the length l of the plate is 2.00 cm, the distance d from the end of the plates to the screen is 29.0 cm, and $E = 1.50 \times 10^4$ nt/coul. (Neglect the gravitational effect.)

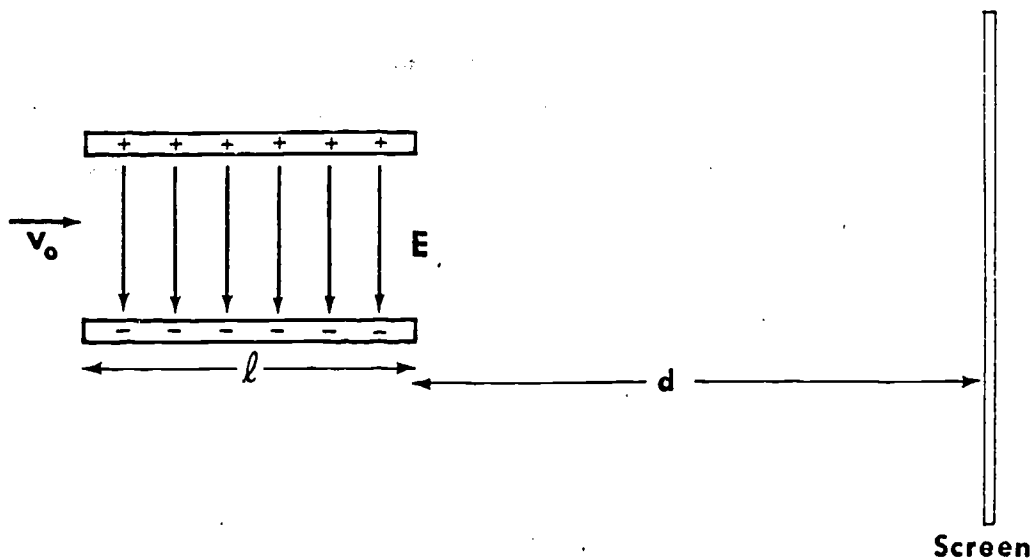

15. An electron is shot with a speed of 5.00×10^8 cm/sec parallel to uniform electric field of strength 1.00×10^3 nt/coul, arranged so as to retard its motion. How far will the electron travel in the field before coming (momentarily) to rest?

16. An electron is shot horizontally with a speed of 10.0 m/sec between two flat, charged plates each of which is 1.00 meter long. If the electric field intensity between the plates is 1.00×10^{-3} nt/coul, what is the y-velocity of the electron as it leaves the plates on the other side?

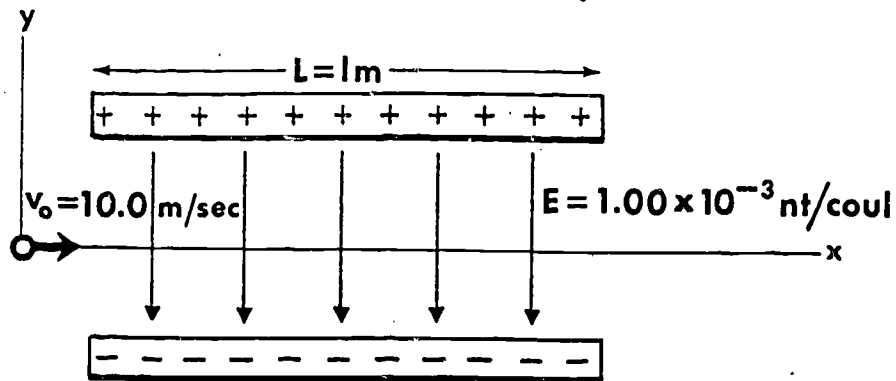

- A. 20 m/sec up
- B. 1.76×10^7 m/sec up
- C. 3.77×10^2 m/sec up
- D. 38.6 m/sec down

17. Two parallel plates are one meter apart. The electric field between the plates is 10.0 nt/coul. If a proton enters the field midway between the plates with a horizontal velocity of 100 m/sec, how far will it travel in the horizontal direction before hitting one of the plates?

- A. 3.23×10^{-4} m
- B. 6.26×10^{-1} m
- C. 3.23×10^{-3} m
- D. 3.23×10^2 m

[a] CORRECT ANSWER: B

The force acting on the charged particle in the y-direction is

$$F = Eq \quad (\text{assuming the field is vertically upward}).$$

The y-acceleration can be determined from Newton's second law,

$$a = \frac{F}{m} = \frac{Eq}{m}$$

Since the field is uniform, the force on the charge is constant throughout the field of motion. For a constant force, we may use the following expression for displacement:

$$y = y_0 + v_{oy}t + \frac{a}{2} t^2$$

Since $v_{oy} = 0$ and $y_0 = 0$, we may write

$$y = \frac{Eq}{2m} t^2$$

Notice that the horizontal component of velocity v_0 does not influence the deflection y .

[b] CORRECT ANSWER: B

The atomic number indicates the number of protons in an atom. Since the protons are evenly distributed over the surface of a sphere of radius 10^{-14} meter, the field at the surface will be

$$E = \frac{79e}{4\pi\epsilon_0 r^2}$$

where e is the charge on a proton. The force on a proton at the surface can be found from

$$F = Eq = \frac{79e^2}{4\pi\epsilon_0 r^2}$$

Substituting, we find

$$F = \frac{79(1.6 \times 10^{-19})^2}{4\pi\epsilon_0 (10^{-14})^2}$$

$F = 200$ nt to one significant digit.

a) CORRECT ANSWER: C

This looks very much like the old projectile problem again, and in fact it is very similar. The following items must be considered:

- (1) the x-velocity remains at $v_x = 100$ m/sec,
- (2) the y-displacement at the time of impact is $y_f = 0.5$ meters,
- (3) the y-acceleration is

$$a_y = \frac{Eq}{m} \text{ upward, and}$$

- (4) the initial y-velocity is zero.

Now to combine these observations we can write

$$y_f = \frac{a_y}{2} t^2$$

so that the time of flight is

$$t = \sqrt{\frac{2y_f}{a_y}}$$

The x-displacement at this time interval would be

$$x_{\max} = v_x t = v_x \sqrt{\frac{2y_f}{a_y}}$$

Substituting for the acceleration yields

$$x_{\max} = v_x \sqrt{\frac{2y_f m}{Eq}}$$

TRUE OR FALSE? The acceleration a_y as given above is $\frac{Eq}{m}$.

[a] CORRECT ANSWER: D

The force \vec{F} on a charge q placed at a point where the field \vec{E} is given by $\vec{F} = q\vec{E}$. The field at the center of a hollow charged spherical conductor is zero, hence $\vec{F} = 0$.

[b] CORRECT ANSWER: D

The force on the electron at all times in the electric field can be expressed as

$$\vec{F} = \vec{F}_q$$

and thus the acceleration is

$$a = \frac{Eq}{m}$$

Notice that the force on a charge is *constant* in a uniform electric field. Since the acceleration is also constant, we may write

$$x = x_0 + v_0 t + \frac{a}{2} t^2$$

Substituting the proper values we obtain

$$x = 2 + 100 \times 30 + \frac{1(-1.6 \times 10^{-19})}{2(9.11 \times 10^{-31})} (30)^2$$

$$x = -7.9 \times 10^{13} \text{ m}$$

TRUE OR FALSE? The expression $x = x_0 + v_0 t + \frac{a}{2} t^2$ is valid for either a uniform or non-uniform field.

[a] CORRECT ANSWER: A

The electric field near a large, charged surface is independent of the distance from the surface. We found that the magnitude of the field near a plate with surface charge density σ is

$$E = \frac{\sigma}{2\epsilon_0}$$

Now we have two parallel plates and must add the effect of each plate at the point A. Thus

$$\vec{E}_A = \vec{E}_1 + \vec{E}_2$$

Both \vec{E}_1 and \vec{E}_2 will have a vertically downward direction. (Check this with a positive test charge.) Adding the two vectors, we obtain

$$E_A = \frac{\sigma}{2\epsilon_0} + \frac{\sigma}{2\epsilon_0} \text{ downward}$$

$$E_A = \frac{\sigma}{\epsilon_0} \text{ downward}$$

Notice that the field at A is independent of position.

[b] CORRECT ANSWER: $\vec{E} = 0$

Let \vec{E}_1 and \vec{E}_2 be the electric fields due to the line charge λ and point charge q respectively at point P. The resultant field at point P is

$$\vec{E} = \vec{E}_1 + \vec{E}_2$$

where

$$E_1 = \frac{\lambda}{2\pi\epsilon_0(d/2)} = \frac{2.0 \times 10^{-6} \times 18 \times 10^9}{2} = 1.8 \times 10^4 \text{ nt/coul}$$

and

$$E_2 = \frac{q}{4\pi\epsilon_0(d/2)^2} = \frac{8.0 \times 10^{-6} \times 9 \times 10^9}{2^2} = 1.8 \times 10^4 \text{ nt/coul}$$

next page

continued

and their directions are shown in the diagram

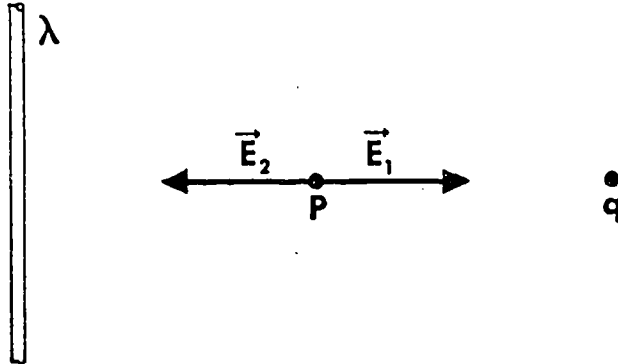

thus, $\vec{E} = \vec{E}_1 + \vec{E}_2 = 0$

TRUE OR FALSE? The electric field intensity at P due to the infinitely long wire is symbolized by \vec{E}_2 .

[a] CORRECT ANSWER: A

GIVEN: (1) uniform electric field E
(2) at $t = 0$, $v = 0$

FIND: $v(t)$ = velocity as function of time.

If the acceleration was known as a function of time, we can solve for the velocity. The force acting on the charged particle is

$$\sum \vec{F} = q\vec{E} = m\vec{a}$$

$$a = \frac{qE}{m}$$

Since

$$a = dv/dt$$

$$v(t) = \int_0^t a dt = \int_0^t \frac{qE}{m} dt$$

$$v(t) = \frac{qEt}{m} + C$$

Using our initial condition for the velocity, $v = 0$ at $t = 0$ yields

$$v(t) = \frac{qEt}{m}$$

[a] CORRECT ANSWER: $-12 \mu\text{coul}$

The accompanying diagram shows the long wire and the circle of points where the electric field is found to be zero. The electric field of the charge Q is shown (\vec{E}_2) as well as the electric field of the line (\vec{E}_1). To put all the given information into symbols, we might say,

$$\vec{E}_1 + \vec{E}_2 = 0$$

(at $r = 2.0 \text{ m}$)

For a line of charges,

$$E_1 = \frac{\lambda}{2\pi\epsilon_0 r}$$

For a point charge Q ,

$$E_2 = \frac{Q}{4\pi\epsilon_0 r^2}$$

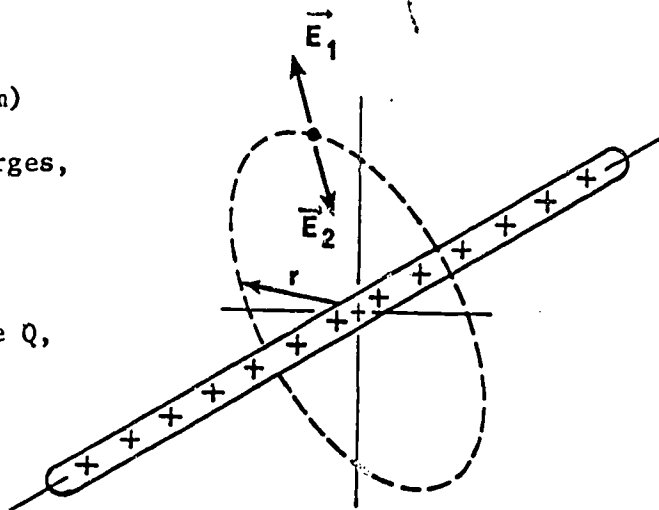

$\vec{E}_1 + \vec{E}_2 = 0$
for all points
on circle radius
 r .

Since both of these vectors are in the radial direction, we may add their magnitudes directly. Therefore, we require that

$$\frac{\lambda}{2\pi\epsilon_0 r} + \frac{Q}{4\pi\epsilon_0 r^2} = 0$$

Solving for Q yields

$$Q = -2 r\lambda$$

$$Q = -12 \mu\text{coul}$$

TRUE OR FALSE? When $Q = -12 \mu\text{coul}$, $\vec{E}_1 + \vec{E}_2 = 0$ at $r = 2 \text{ m}$.

[a] CORRECT ANSWER: 1.6×10^{-19} j

The kinetic energy of the proton just before it crashes into the negative plate is

$$K = \frac{1}{2} m_p v^2$$

v may be found from the equation of kinematics

$$v^2 = 2ad$$

where d is the distance between the plates.

Since the initial speed of the proton is zero and a is given by the expression:

$$a = \frac{eE}{m_p}$$

Therefore we obtain

$$\frac{1}{2} m_p v^2 = eEd = 1.6 \times 10^{-19} \text{ joule}$$

TRUE OR FALSE? The expression $a = \frac{eE}{m_p}$ is a restatement of Newton's second law.

[a] CORRECT ANSWER: 0.071 m

The word uniform immediately alerts us that the electric field will be constant throughout the distance traveled by the electron. The retarding force on the electron can be found by the relationship

$$F_x = Eq = ma$$

assuming that both the field and the velocity of the electron are directed along the positive x-direction. Both the charge and mass of the electron are given on the inside of the cover of HR. The acceleration is, therefore

$$a = \frac{Eq}{m}$$

Since the acceleration is constant, we may write

$$v_f^2 = v_i^2 + 2 ax$$

where the final velocity is equal to zero.

Solving for x, we obtain

$$x = \frac{-v_i^2}{2a} = \frac{-v_i^2 m}{2Eq}$$

Inserting the given values,

$$x = - \frac{(5 \times 10^6)^2 (9.11 \times 10^{-31})}{2(1 \times 10^3) (-1.6 \times 10^{-19})}$$

$$x = .071 \text{ m}$$

This problem could also be solved by energy considerations. You may have used such a technique.

[a] CORRECT ANSWER: 5.4×10^{-2} nt

The force \vec{F} on a charge q in a field \vec{E} is given by

$$\vec{F} = q\vec{E}$$

The magnitude of the field \vec{E} at a distance r from the infinitely charged wire is

$$E = \frac{\lambda}{2\pi\epsilon_0 r}$$

and its direction is shown in the diagram. Therefore,

$$\begin{aligned} F &= \frac{q\lambda}{2\pi\epsilon_0 r} \\ &= \frac{(2.0 \times 10^{-6}) (3.0 \times 10^{-6}) (18 \times 10^9)}{2} \end{aligned}$$

$$F = 5.4 \times 10^{-2} \text{ nt}$$

and it is directed away from the wire.

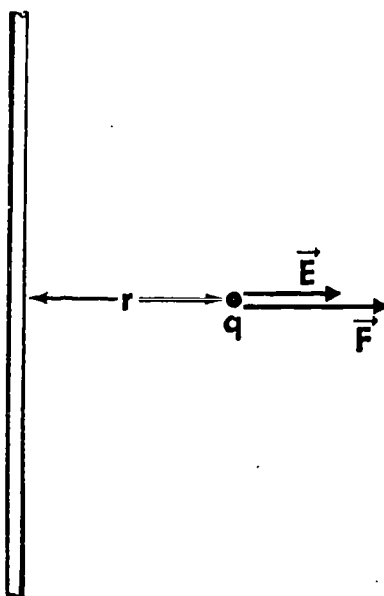

[a] CORRECT ANSWER: 3.4×10^6 nt

The force on the charge may be obtained by first calculating the field at that point and then using the equation

$$F = qE$$

The electric field near a large, charged surface is independent of the distance from the surface and is given by

$$E = \frac{\sigma}{2\epsilon_0}$$

Since we have two parallel plates, the resultant field is obtained by adding the effect of each plate at the point

$$\vec{E} = \vec{E}_1 + \vec{E}_2$$

Both \vec{E}_1 and \vec{E}_2 will be directed vertically downward. Thus,

$$E = \frac{\sigma}{2\epsilon_0} + \frac{\sigma}{2\epsilon_0} = \frac{\sigma}{\epsilon_0} \text{ downward}$$

Therefore

$$F = qE = q \frac{\sigma}{\epsilon_0} = 3.4 \times 10^6 \text{ nt vertically downward}$$

TRUE OR FALSE? The expression $E = \frac{\sigma}{2\epsilon_0}$ above shows that the force acting on a charged particle when it is near a large charged plate is larger than it is when the particle is slightly further away.

[a] CORRECT ANSWER: B

The only force experienced by the electron as it travels between the two plates is the force due to the electric field. The electric field is directed vertically down, so we write

$$F_y = -Eq = m a_y$$

thus

$$a_y = \frac{-Eq}{m} \quad (1)$$

Both m and q refer to an electron, and the values of these quantities can be obtained on the inside cover of HR. The y -velocity of the electron after passing between the plates would be found from

$$v_y = v_{oy} + a_y t \quad (2)$$

where $v_{oy} = 0$, and t is the time required to travel a horizontal distance equal to 1 meter. Since the horizontal velocity does not change,

$$L = v_{ox} t, \quad \text{or} \quad t = \frac{L}{v_{ox}} \quad (3)$$

Substituting the results of (1) and (3) into (2), we obtain

$$v_y = \frac{-Eq L}{m v_{ox}}$$

Substituting the known values yields

$$v_y = \frac{-10^{-3}(-1.6 \times 10^{-19}) (1)}{(9.11 \times 10^{-31}) (10)}$$

$$v_y = 1.76 \times 10^7 \text{ m/sec}$$

Notice how the signs take care of the final direction of the electron's travel. You should have expected that a negative charge would go up in an electric field that is directed downward.

[a] CORRECT ANSWER: B

If the total force on charge Q is zero, then

$$\vec{F} = Q\vec{E} = 0$$

Thus, we must look for a point where the resultant field \vec{E} is given by

$$\vec{E} = \vec{E}_1 + \vec{E}_2 = 0$$

or

$$\vec{E}_1 = -\vec{E}_2$$

This tells us that the fields must be oppositely directed. Now we can equate the magnitudes

$$\frac{q_1}{4\pi\epsilon_0 x^2} = \frac{q_2}{4\pi\epsilon_0 (L - x)^2}$$

where x is measured to the right of q_1 .

Letting $q_1 = 4q_2$, we have

$$\frac{4}{x^2} = \frac{1}{(L - x)^2}$$

or

$$2(L - x) = \pm x$$

and this yields

$$x = \frac{2}{3}L \quad \text{or} \quad x = 2L$$

The latter solution will not give $\vec{E} = 0$; only the former is the physically acceptable solution for this case.

Thus

$$x = \frac{2}{3}L = 67 \text{ cm to the right of } q_1$$

[a] CORRECT ANSWER: $y = 15.8 \text{ cm}$

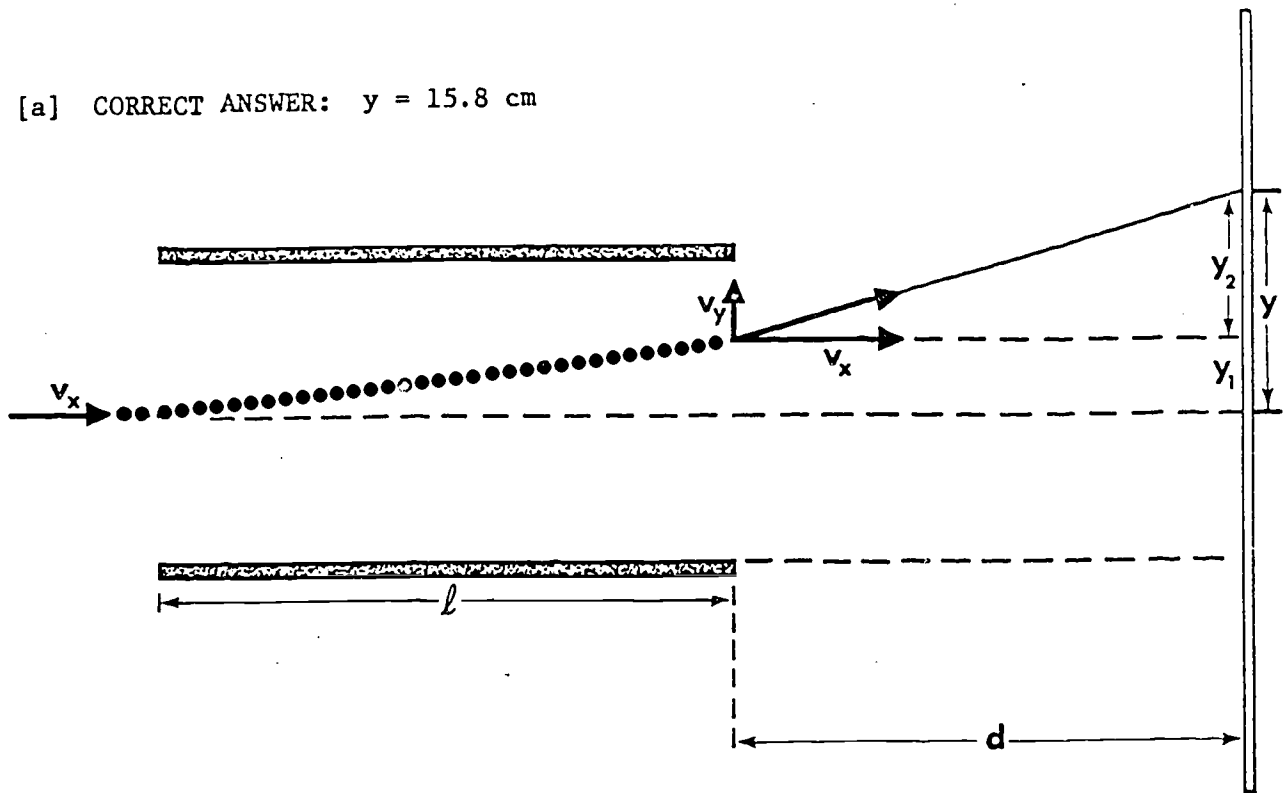

Since the electron is initially moving horizontally and the electric force acts vertically, the horizontal component of the electron's velocity remains constant: $v_x = 10^7 \text{ m/sec}$. The time t_1 that the electron spends in the uniform field between the deflecting plates is therefore, $t_1 = l/v_x$, and the time t_2 required for the electron to traverse the distance d from the end of the deflecting plates to the screen is $t_2 = d/v_x$.

During the passage through the uniform field between the deflecting plates, the electron experiences a constant upward force $F_y = eE$ and hence

$$a_y = \frac{F_y}{m} = \frac{eE}{m}$$

where m is the electron mass.

The upward displacement y_1 of the electron as it leaves the electric field is

$$y_1 = \frac{1}{2} a_y t_1^2 = \frac{1}{2} \frac{eE}{m} \left(\frac{l}{v_x} \right)^2$$

and the y -component of the electron velocity at that point is

$$v_y = a_y t_1 = \frac{eE}{m} \frac{l}{v_x}$$

next page

continued

The upward displacement y_2 of the electron in the field-free region is

$$y_2 = v_y t_2$$

$$y_2 = \frac{eE}{mv_x} \frac{d}{v_x}$$

Therefore, the total displacement is

$$y = y_1 + y_2 = \frac{1}{2} \frac{eE}{m} \frac{\ell^2}{v_x^2} + \frac{eE\ell}{mv_x^2} d = \frac{eE\ell}{mv_x^2} (d + \ell/2)$$

TRUE OR FALSE? The vertical component of the velocity of the electron is constant throughout its path.

[a] CORRECT ANSWER: 1.6×10^{-17} N

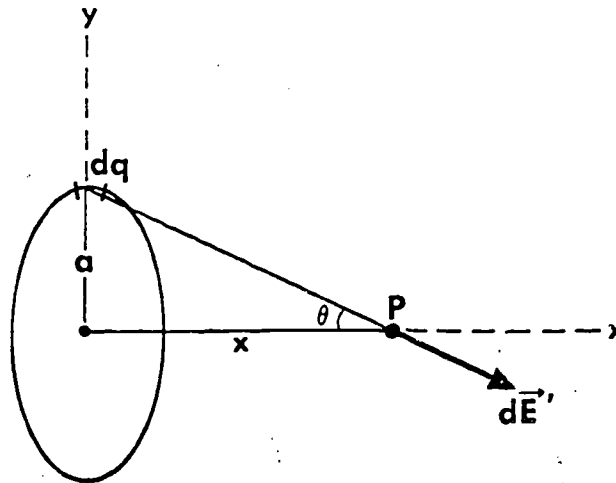

First calculate the resultant field at P due to the charged ring and the point charge, and then use the equation

$$F = qE$$

to obtain the force F acting on the electron.

The total field \vec{E} is

$$\vec{E} = \vec{E}_1 + \vec{E}_2$$

where

$$E_1 = \frac{Q}{4\pi\epsilon_0 x^2} \text{ where } Q = \text{charge on central particle}$$

and

$$E_2 = \frac{1}{4\pi\epsilon_0} \frac{qx}{(a^2 + x^2)^{3/2}} \text{ where } q = \text{charge on ring}$$

The latter is obtained in the following manner:

The contribution to the electric field at P from a charge element dq of the ring is

$$d\vec{E}' = \frac{1}{4\pi\epsilon_0} \frac{dq}{(x^2 + a^2)}$$

next page

continued

The resultant field at P is found by integrating the effect of all the elements of the ring. It is clear from the symmetry of the ring that the resultant field must lie along the ring axis. Thus only the component of $d\vec{E}'$ parallel to the axis contributes to the final result.

$$E_2 = \int dE' \cos\theta$$

where

$$\cos\theta = \frac{x}{\sqrt{x^2 + a^2}}$$

Thus

$$E_2 = \int dE' \cos\theta = \frac{1}{4\pi\epsilon_0} \int \frac{x dq}{(x^2 + a^2)^{3/2}} = \frac{qx}{4\pi\epsilon_0(x^2 + a^2)^{3/2}}$$

The two vectors \vec{E}_1 and \vec{E}_2 are in opposite directions along the x-axis, thus the resultant field is

$$E = -\frac{Q}{4\pi\epsilon_0 x^2} + \frac{qx}{4\pi\epsilon_0(x^2 + a^2)^{3/2}}$$

Substituting numerical values, we obtain

$$E = -9.8 \times 10^{10} \text{ nt/coul}$$

and

$$F = eE = 1.6 \times 10^{-8} \text{ nt}$$

TRUE OR FALSE? In this solution it is shown that both resultant fields acting on the electron lie along the x-axis.

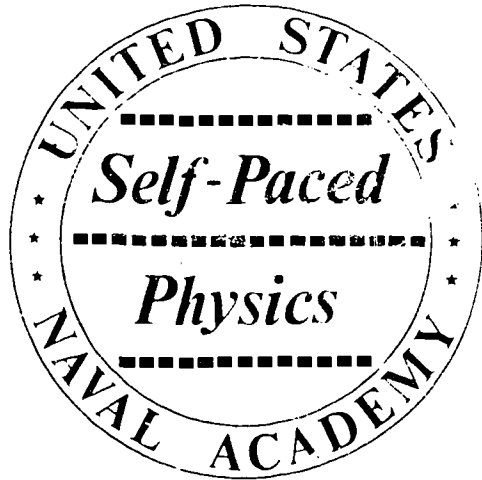

SEGMENT SEPARATOR

note

ALL WRITTEN MATERIAL APPLICABLE TO
THE FOLLOWING SEGMENT IS CONTAINED
IN THE PAGES BETWEEN THIS COLORED
SHEET AND THE NEXT.

INFORMATION PANELDipole and Dipole-Moments

OBJECTIVE

To define a dipole and the dipole axis; to solve a basic problem involving the dipole moment.

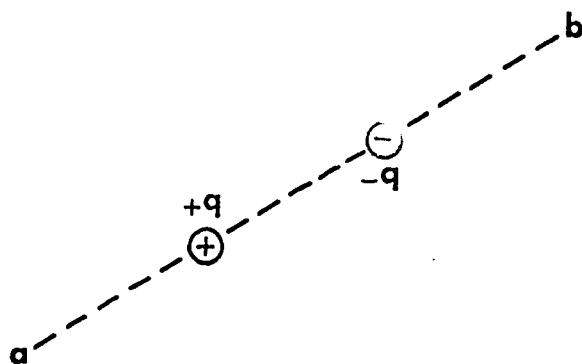

In the most general terms, an *electric dipole* is made up of a pair of charges of equal magnitude but opposite sign as illustrated at the left. From a practical point of view, electric dipoles are most significant in the study of atomic and molecular physics. The hydrogen atom, for example, is a true electric dipole since it comprises a single electron and a single proton--a pair of

equal charges of opposite sign--located relatively close to one another. For the same reason, a molecule of hydrogen chloride (HCl) also exhibits the properties of an electric dipole.

The *dipole axis* is defined as a line of indefinite length passing through the electrical center of both charges. The indefinitely long line ab in the drawing above is the dipole axis.

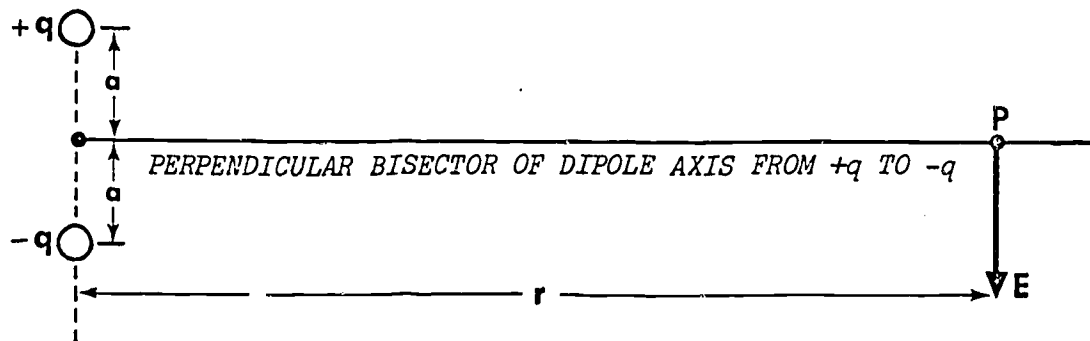

When the charges forming the dipole are separated by a *very short* distance compared to the distance along the perpendicular bisector of the line joining them where the resultant electric field is to be determined (point P in the diagram above), it can be shown that the resultant electric field intensity is:

(magnitude)

$$E = \frac{1}{4\pi\epsilon_0} \frac{2aq}{r^3}$$

(direction)

parallel to the dipole axis, from (+) to (-)

continued

The characteristics of the charge distribution is given by the product $2aq$, where a is the distance from the charge to the perpendicular bisector and q is the charge magnitude. Regardless of the method used to study E at various distances from the dipole, it is never possible to determine a and q separately; only the product $2aq$ can be deduced from such analyses. Thus, $2aq$ appears to have the characteristics of an entity that is worth describing as such. This product is called the *dipole-moment*, usually symbolized by p , so that:

$$\text{dipole moment} = p = 2aq \quad (\text{magnitude})$$

The dipole-moment vector is directed from the (-) toward the (+) charge along the dipole axis.

It is important to remember that the equation for the magnitude of the electric intensity given on the previous page is valid only when the distance to point P is very much greater than a .

In the questions that follow, you will be asked to

- (a) recognize and describe the dipole axis;
- (b) recognize and describe the dipole-moment;
- (c) solve a problem involving the dipole-moment vector.

PROBLEMS

1. Which of the following choices is the direction of the axis of an electric dipole?

- A. An imaginary line drawn perpendicular to the line joining the two charges with the positive charge to the left of this perpendicular line.
- B. The direction defined by an imaginary straight line drawn from the negative to the positive charge forming the dipole.
- C. The direction defined by an imaginary line drawn from the positive to the negative charge forming the dipole.
- D. The direction defined by an imaginary line drawn perpendicular to the line joining the two charges that form the dipole, with the positive charge to the right of this line.

2. For the dipole configuration shown in the figure, the *axis* of the dipole is parallel to the:

- A. x axis
- B. y axis
- C. z axis
- D. -y axis

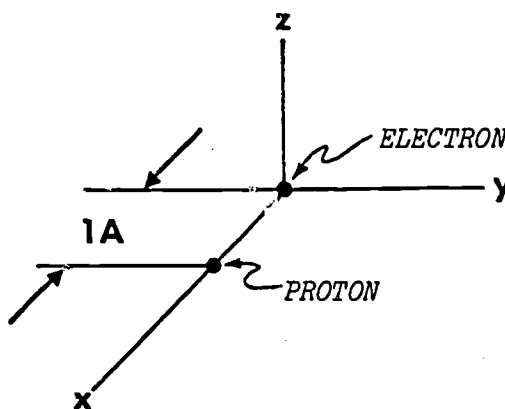

3. For the electric dipole shown in the previous diagram, what is the direction of the dipole moment vector?

- A. +x axis
- B. -x axis
- C. +z axis
- D. -z axis

4.

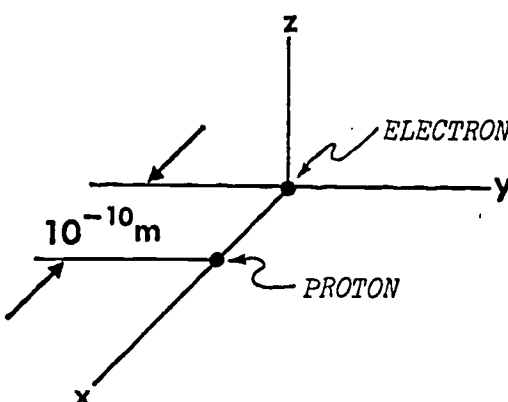

The electric dipole-moment, \vec{p} , of the configuration is

- A. 3.2×10^{-29} coul-m; -z axis
- B. 1.6×10^{-29} coul-m; +x axis
- C. 1.6×10^{-29} coul-m; +z axis
- D. 3.2×10^{-29} coul-m; -x axis

INFORMATION PANELElectric Flux

OBJECTIVE

To describe and define the flux of an electric field.

Flux is a general term, applying to any vector field and a surface that is immersed in the field. Descriptively, one may envision lines of electric force due to an electric field cutting through any hypothetical surface within the field; the *flux* is measured by the number of lines of force that cut through the surface. Quantitatively, the flux ϕ is defined as the

surface integral of the dot product $\vec{E} \cdot d\vec{S}$ (scalar) all over the surface through which the lines of force pass. That is

$$\phi = \int \vec{E} \cdot d\vec{S}$$

The use of the surface integral implies that the surface under consideration is to be divided into infinitesimal elements of area $d\vec{S}$ and that the scalar product $\vec{E} \cdot d\vec{S}$ be evaluated for each element of area and the sum be taken for the entire surface area.

For closed surfaces (spheres, cylinders, cubes, etc.), the flux ϕ is taken as *positive* if the lines of force point *outward* for a given element, and *negative* if they point *inward*. It is also to be noted that the vector direction of an *area* or surface vector is *perpendicular to the surface*.

In this section you will be asked to

- (a) calculate the flux through a surface of given dimensions immersed in a given electric field;
- (b) recognize the definitions of electric flux and the vector direction of an area vector;
- (c) recognize the semi-quantative definition of electric flux.

5. The vector field \vec{A} shown in the diagram has a constant magnitude and direction at every point in space. The direction of \vec{A} is always parallel to the x-axis. What is the *flux* of the vector \vec{A} through the surface S shown in the diagram?

- A. $210 \vec{j}$
- B. 176
- C. $435 \vec{k}$
- D. 500

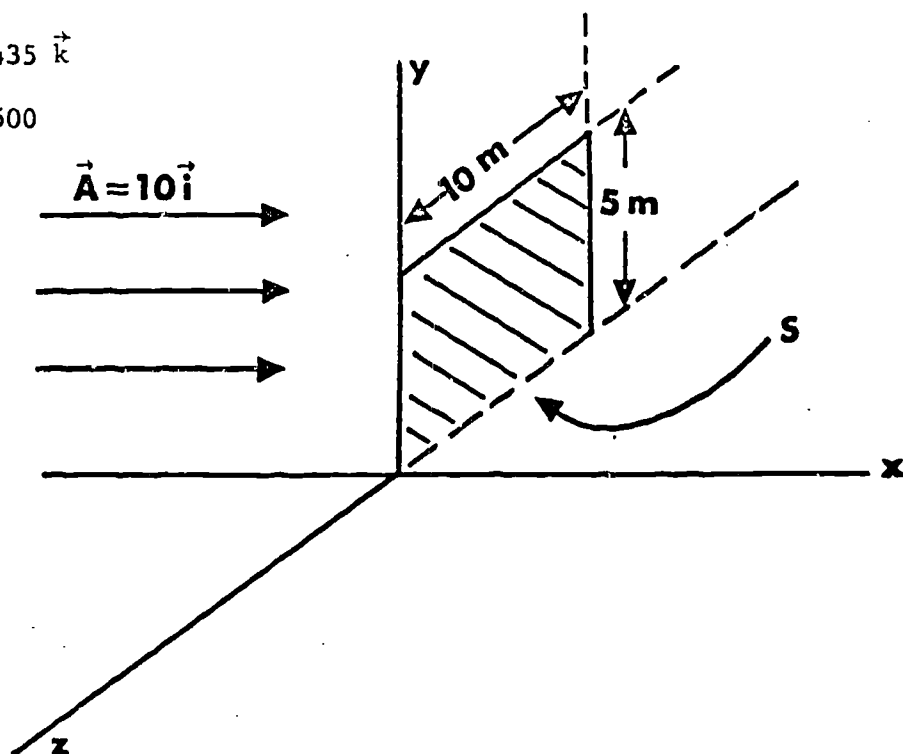

6. The vector direction of a surface (area vector) has been defined as:

- A. the direction of a line tangent to the surface at the point in question.
- B. the "average" direction of the lines emanating from the surface.
- C. the direction of a vector perpendicular to a surface.
- D. a surface cannot have a direction.

7. Electric flux is a measure of
- the field strength of a field at a unit distance from the surface.
 - the number of lines of force that cut through any hypothetical surface.
 - the number of electrons passing through a closed surface that surrounds a charge.
 - the magnitude of the electrical force that is exerted on a unit charge placed in a electric field.

8. In a "semi-quantitative" way, the electric flux may be defined analytically as:

- | | | |
|----|--|---|
| A. | $\phi = \sum \vec{E} \cdot \Delta \vec{S}$ | $\Delta \vec{S}$ = element of surface cut by the electric lines of force representing \vec{E} |
| B. | $\phi = \sum Q \vec{E}$ | ϕ = electric flux |
| C. | $\phi = \sum Q \vec{E} \cdot \Delta S$ | \vec{E} = electric field strength |
| D. | $\phi = \sum E \cdot E$ | Q = charge |

INFORMATION PANELCalculation of Electric Flux

OBJECTIVE

To deal with problems involving the total flux passing through various types of surfaces having various orientations to the electric field.

It has been shown that flux ϕ is defined by the relation

$$\phi = \int \vec{E} \cdot d\vec{s}$$

Problems requiring the calculation of ϕ may take on a great variety of forms but we have limited our presentation to a few of the simpler types. The information that follows should assist you in recognizing the individual characteristics of each of these.

(1) *Flux through a plane perpendicular to the electric field.* In this case, all of the lines of force in the field are perpendicular to the surface so that the total number of lines passing through the surface is equal to E . Since the angle θ between the area vector and the field vector is everywhere zero degrees, the total flux is given simply by

$$\phi = ES$$

(2) *Flux through a plane parallel to the electric field.* Here, the field vector is perpendicular to the area vector, the angle θ is 90° , and no lines of force pass through the surface. Thus,

$$\phi = 0$$

(3) *Flux through a plane inclined at an angle θ to the electric field.*

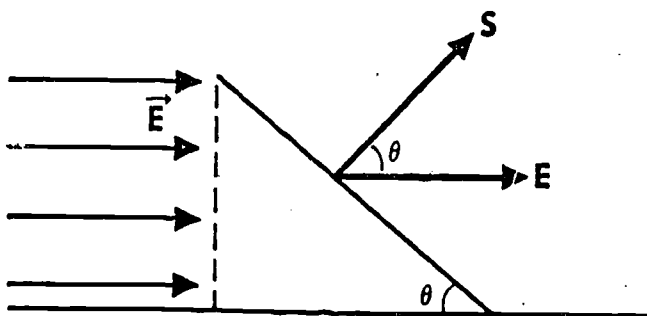

In the diagram at the left, the surface is a plane inclined to the field at an angle θ . Clearly, the number of lines of the field E that pass through this plane is equal to the number that pass through the projection of the plane *perpendicular* to the field vector. Thus, the number of lines per unit area is

$$E_s = E \cos\theta$$

next page

continued

so that the total flux may be obtained from

$$\phi = \int (E \cos\theta) dS$$

and since the surface is a plane for which all elements of area have the same vector direction, then

$$\phi = ES \cos\theta$$

(4) *Flux through curved surfaces.* In this variety of problem, the relationship between the field intensity and the surface area through which the lines of force pass must be established in such a way as to make the integration possible. As a basic first step, you should select the differential elements of area with a view to keeping the perpendicular component of \vec{E} the same for all of them. If you have difficulty with the first core problem of this group, you would be well advised to study the solution with a great deal of care.

(5) *Flux through closed surfaces.* The solutions to the problems involving the flux through a cubical box immersed in a uniform electric field indicate a very important aspect of this subject: in general, if a closed surface does not contain an internal charge of its own, the total flux passing through it while in an electric field is zero. This follows from the fact that there are as many lines of force leaving the surface (assigned a positive sign) as there are entering it (negative), hence the net flux is taken as zero. However, you are urged to study the solutions carefully since they tackle the problems from a basic point of view in order to show that, in the absence of sources or sinks, the total flux through a closed surface is zero.

9. In the accompanying figure, a shell is shown which consists only of half a cylinder with no end surfaces. What is the value of ϕ_E ?

- A. 360 nt-m²/coul
- B. 420 nt-m²/coul
- C. 785 nt-m²/coul
- D. 500 nt-m²/coul

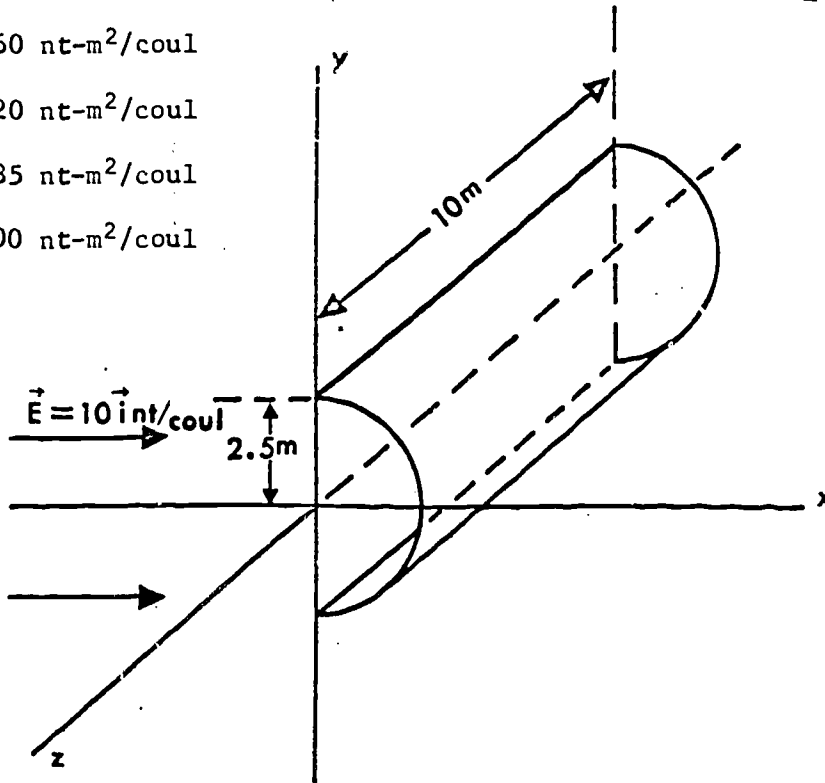

10. In the accompanying diagram, a \vec{D} -field is shown parallel to the x-axis. What is the flux of the vector \vec{D} through the surface shown in the diagram?

- A. Zero
- B. 500
- C. 317
- D. 176

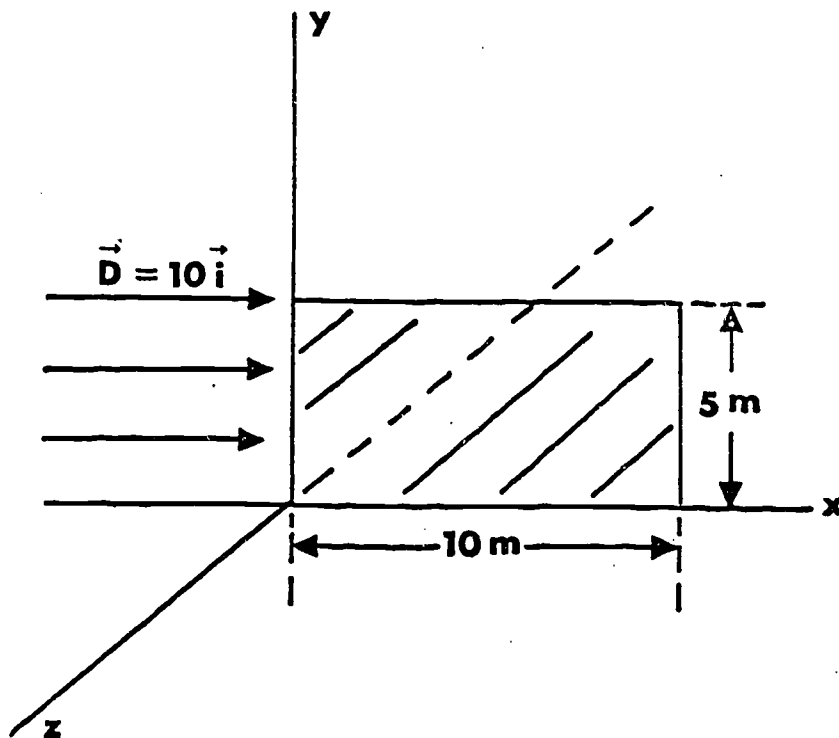

11. An electric field $\vec{E} = 10 \text{ nt/coul}$ in the x-direction is shown in the diagram below. What is the flux (ϕ_E) of \vec{E} through the surface?

- A. 500 nt/coul
- B. 353 nt-m²/coul
- C. 276 nt-m²/coul
- D. 363 nt-m²/coul

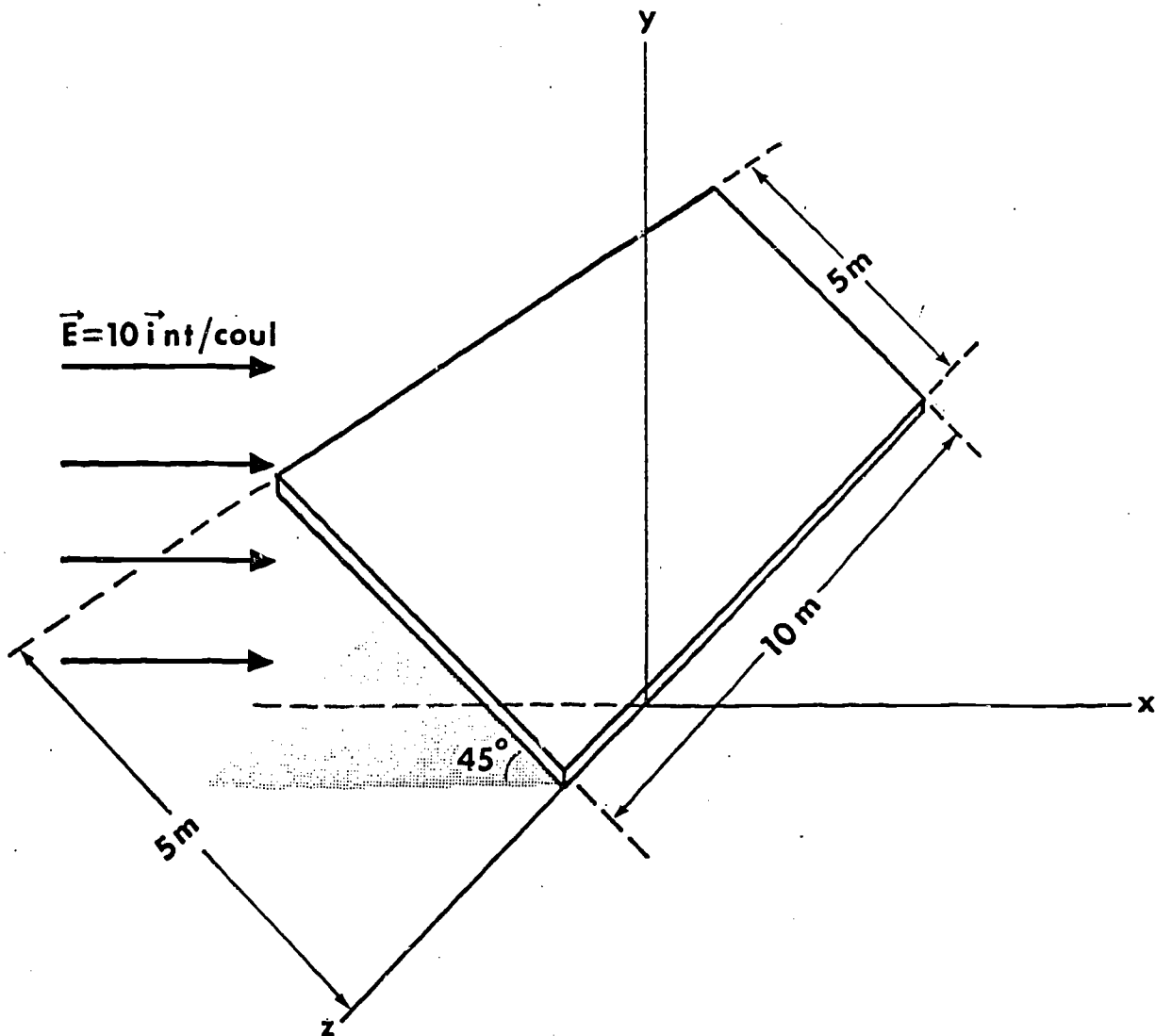

12. A vector field \vec{B} as shown in the diagram is parallel to the x-axis. A surface S consists of two parts: S_1 parallel to the yz-plane, and S_2 parallel to the xz-plane. What is the flux of the vector \vec{B} through the surface S ?

- A. 2000
- B. 500
- C. 300
- D. 700

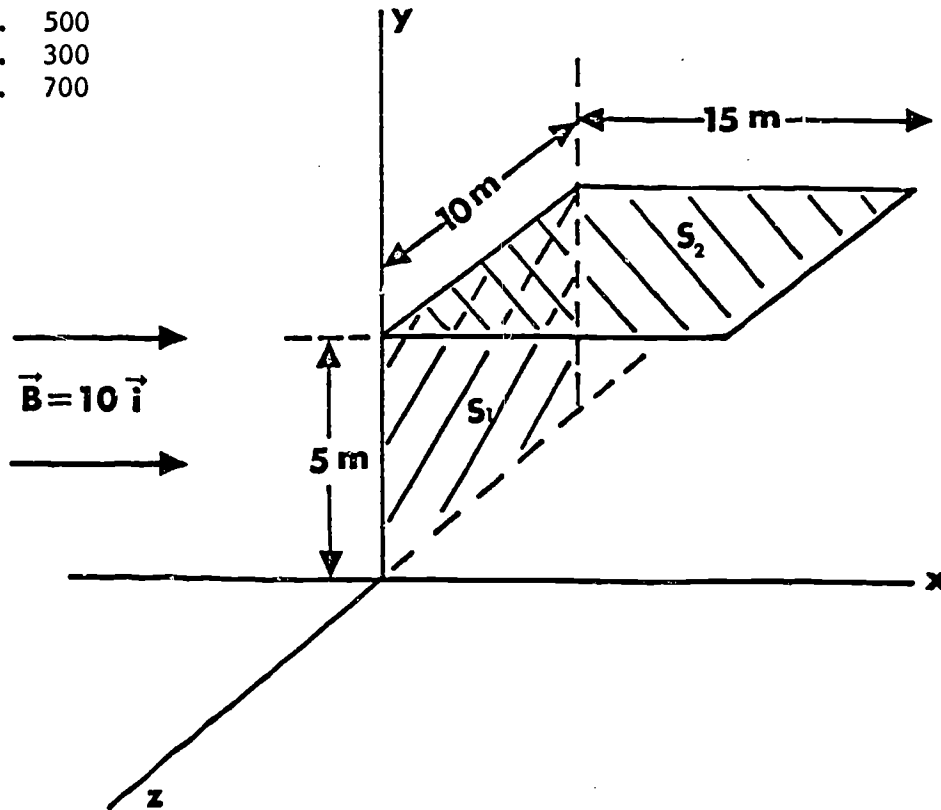

13. A hemispherical shell with a radius of 2 meters has its edge on the xz-plane. An electric field exists throughout the space in which the shell is located and has a magnitude of 10 nt/coul parallel to the y-axis. What is the flux, ϕ_E , through the spherical shell? The shell consists *only* of the spherical surface.

- A. 62.8 nt-m²/coul
- B. 502.4 nt-m²/coul
- C. 251.2 nt-m²/coul
- D. 125.6 nt-m²/coul

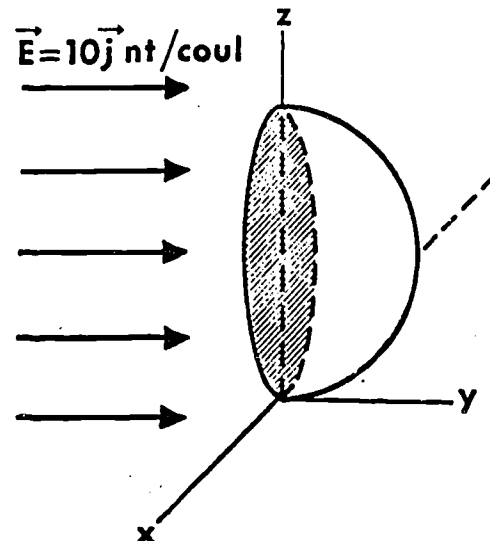

14. A cubical surface 5 meters on edge is shown in the diagram. What is the value of the electric flux ϕ_E through the cubical surface?

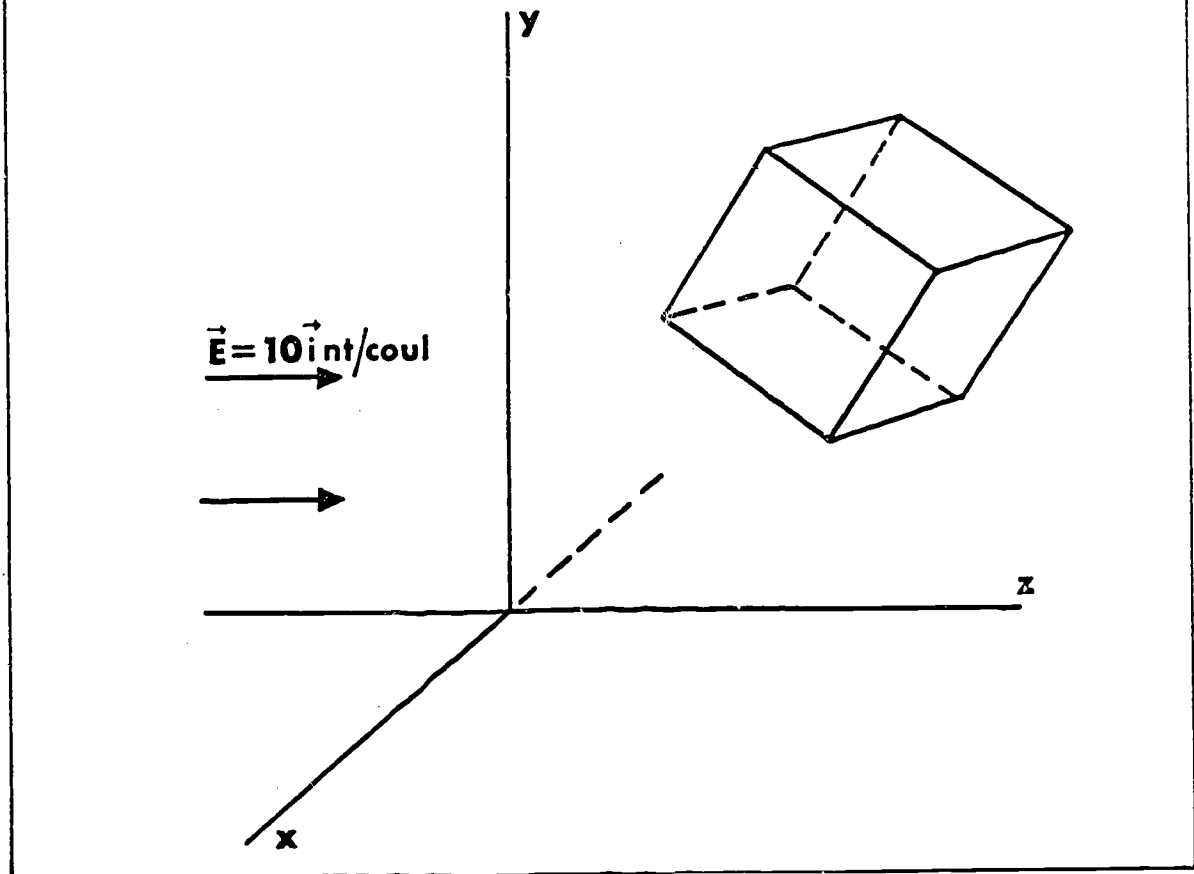

15. For a closed surface, which of the following is true?

- A. The flux is considered positive if the lines of force point everywhere outward (are emergent) and negative if all the lines of force are pointing inward.
- B. Even though the charge that produces the lines of force remains constant, the lines of flux may move about the closed imaginary surface surrounding the charge.
- C. The number of lines of flux emanating from a source may vary even though the source of the lines is stationary.
- D. Doubling the charge enclosed by it will not result in a doubling of the number of lines of flux emanating from it.

16. In the diagram two electric fields exist simultaneously in space. Both fields are parallel to the x-axis, but are oppositely directed as shown. What is the total ϕ_E through a 4×5 meter surface which lies completely in the yz-plane?

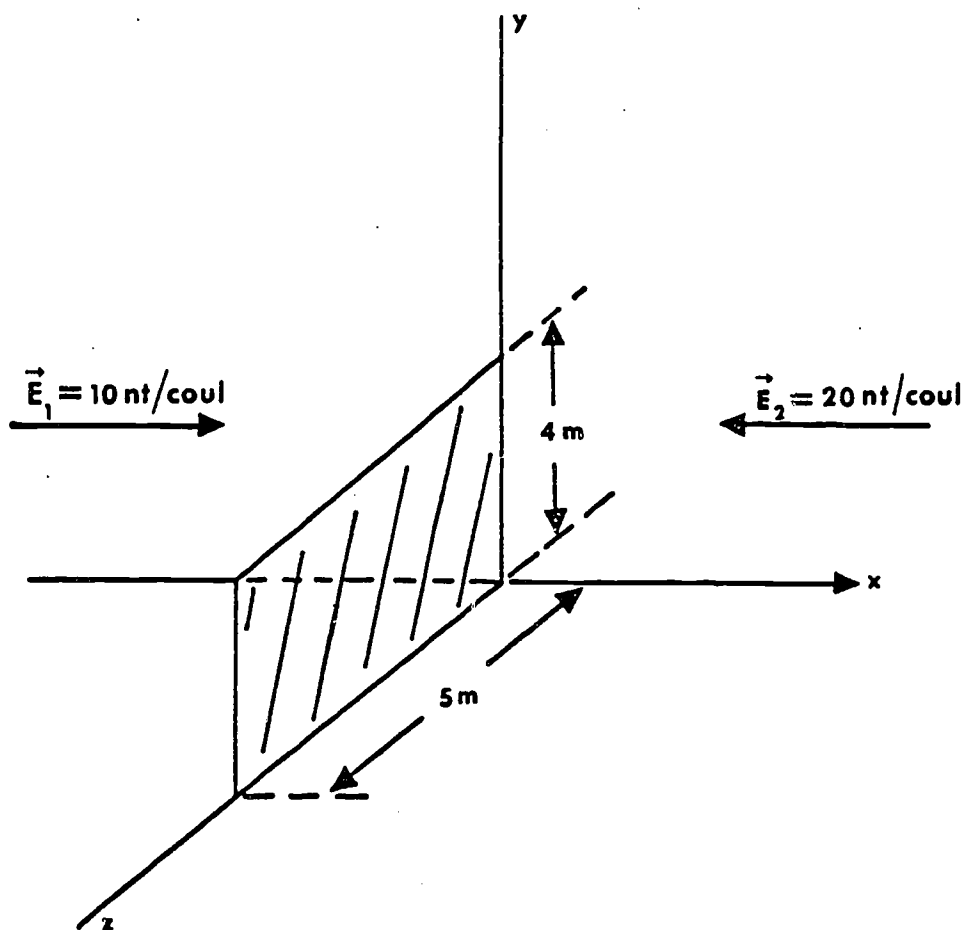

17. A cubical surface 5 meters on edge is placed in an electric field. What is the value of ϕ_E through the cubical surface?

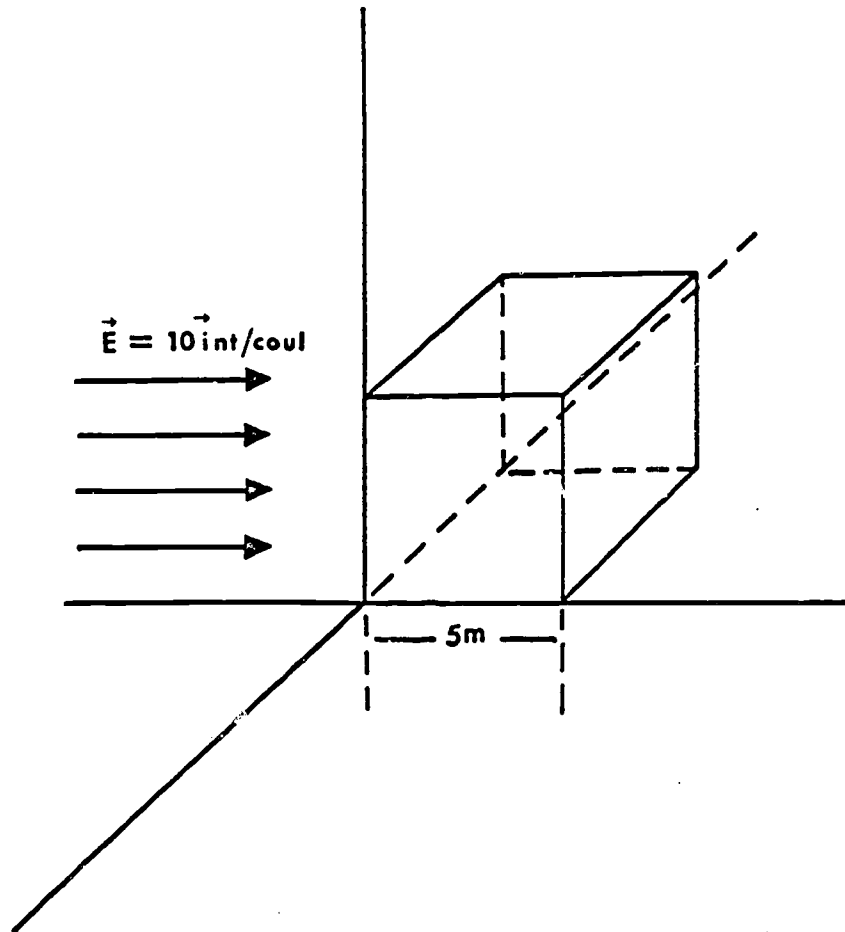

[a] CORRECT ANSWER: D

The flux of any field vector \vec{A} is equal to the term $\vec{A} \cdot d\vec{S}$ integrated over the total surface, S. That is,

$$\phi_A = \int A \, dS \, \cos\theta$$

where θ is the angle between \vec{A} and $d\vec{S}$. In this problem the magnitude of A is constant, and the angle $\theta = 0$. Therefore, the integral becomes

$$\phi_A = A \int dS = AS$$

$$\phi_A = 500 \quad (\text{scalar quantity})$$

TRUE OR FALSE? In this solution, the angle between the field vector and surface vector is zero over the entire surface.

[b] CORRECT ANSWER: D

You could solve this problem by computing the flux which goes through the spherical shell directly. However, that involves using spherical coordinates and their attendant complexities. Therefore, let us evaluate the flux in the following manner: The flux which comes out of the spherical surface must go through the flat opening of the spherical shell first. Thus,

$$\phi_E = \phi|_{\text{spherical shell}} = \phi|_{\text{flat face of spherical shell}}$$

Thus, we obtain

$$\phi_E = \int_{\text{flat face of spherical shell}} \vec{E} \cdot d\vec{S} = E\pi r^2 = 125.6 \text{ nt}\cdot\text{m}^2/\text{coul}$$

TRUE OR FALSE? The spherical shell described above is a closed surface.

[a] CORRECT ANSWER: B

In finding the flux of a vector through a surface, we are free to divide the surface into convenient parts if necessary. In this problem we might best consider

$$\phi_B = \phi_1 + \phi_2$$

where

$$\phi_1 = \oint \vec{B} \cdot d\vec{S}_1$$

and

$$\phi_2 = \oint \vec{B} \cdot d\vec{S}_2$$

For the first surface, we see that the vectors \vec{B} and $d\vec{S}_1$ are in the same direction. Therefore,

$$\phi_1 = BS_1$$

For the second surface, we see that \vec{B} is perpendicular to the area vector $d\vec{S}_2$; therefore,

$$\phi_2 = 0$$

Finally,

$$\phi_B = BS_1 + 0$$

and

$$\phi_B = 500$$

[b] CORRECT ANSWER: A

The electric flux is equal to the component of the electric field perpendicular to the element of surface area ΔS times the magnitude of the element of surface area ΔS and this product is *summed* for all elements of surface area. That is,

$$\phi = \sum \vec{E} \cdot \Delta \vec{S}$$

In effect, this says symbolically what the previous sentence says in words.

TRUE OR FALSE? The semi-quantitative expression $\phi = \sum \vec{E} \cdot \Delta \vec{S}$ may be made fully quantitative by writing it as

$$\phi = \oint \vec{E} \cdot d\vec{S}$$

[a] CORRECT ANSWER: $-200 \text{ nt-m}^2/\text{coul}$

This problem, for the first time, highlights the question of positive or negative direction of the surface area vector $d\vec{S}$. For a flat plane as shown in the figure accompanying the problem, we will assume $d\vec{S}$ points along the positive x-direction. When a *closed* surface is involved, we will specify that the area vector always points outward. Some examples of closed surfaces are an empty box with six sides, a cylindrical shell with ends covered, or a spherical shell.

In the problem discussed here we can divide the task into two steps.

$$\phi_E = \phi_1 + \phi_2$$

$$\phi_1 = E_1 S \cos 0^\circ = E_1 S$$

$$\phi_2 = E_2 S \cos 180^\circ = -E_2 S$$

Therefore,

$$\phi_E = E_1 S - E_2 S$$

Alternatively, the vector fields \vec{E}_1 and \vec{E}_2 can be added

$$\vec{E} = \vec{E}_1 + \vec{E}_2$$

and the resulting field can be used in the expression

$$\phi_E = \vec{E} \cdot \vec{S}$$

[b] CORRECT ANSWER: Zero

In the absence of sources or sinks, the flux through any *closed* surface must be zero. This really says that for continuous flow "what goes in the closed surface must come out."

TRUE OR FALSE? Regardless of the orientation of the cubical box, as long as it is immersed in the field the total flux through it is zero.

[a] CORRECT ANSWER: r

Let us look at this problem closely by studying a side view.

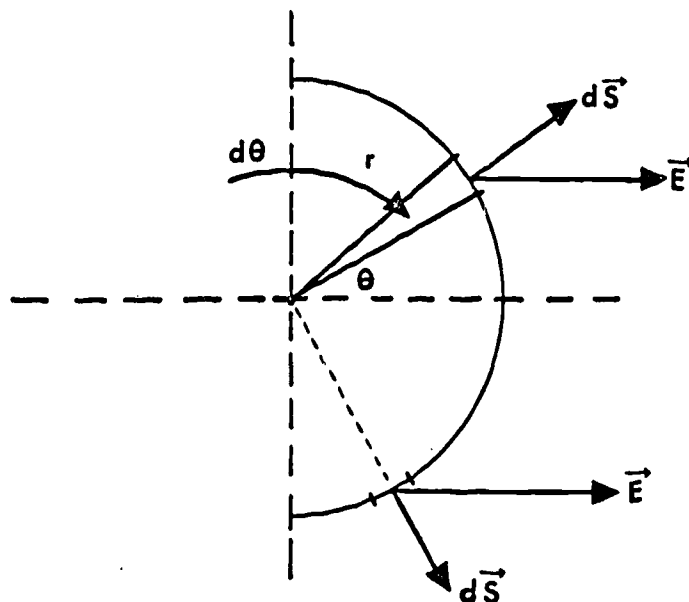

Notice carefully that \vec{E} and $d\vec{S}$ have a different angle between them for nearly all positions on the cylindrical shell. We must choose differential elements of area over which the perpendicular component of \vec{E} will be a constant. Strips of width $r d\theta$ and as long as the cylindrical shell (say L) have this desired property. Then,

$$dS = (r d\theta) L$$

The relationship for flux,

$$\phi_E = \oint \vec{E} \cdot d\vec{S}$$

becomes,

$$\phi_E = \int_{-\pi/2}^{\pi/2} E r L \cos\theta d\theta$$

Since E , r , and L are all constants, this becomes,

$$\phi_E = E r L \sin\theta \Big|_{-\pi/2}^{\pi/2}$$

next page

continued

or

$$L = 500 \text{ nt-m}^2/\text{coul}$$

One thing you should notice immediately is that $E(2rL)$ is really the axial cross-sectional area of the cylinder times the vector magnitude of E . Of course, the conclusion would be that the flux through the vertical plane in the above diagram is *equal* to the flux through the curved, cylindrical shell.

TRUE OR FALSE? The axial cross-sectional area of this cylinder is equal to $2\pi rL$.

[a] CORRECT ANSWER: B

The magnitude of the charge on an electron and a proton is 1.6×10^{-19} coul, and from the figure we see that the charges are 10^{-10} m apart. Therefore, the electric dipole-moment is

$$\begin{aligned} p &= 2aq = 2\left(\frac{1}{2} \times 10^{-10} \text{ m}\right)(1.6 \times 10^{-19} \text{ coul}) \\ &= 1.6 \times 10^{-29} \text{ coul-m} \end{aligned}$$

and is in the direction of the +x-axis.

TRUE OR FALSE? In the expression for dipole moment, $p = 2aq$, a is the distance between the two charges.

[b] CORRECT ANSWER: B

This direction of the axis is also the direction of the electric dipole moment vector \vec{p} .

TRUE OR FALSE? A separate (+) charge placed on the dipole axis would tend to move at right angles to the axis.

[a] CORRECT ANSWER: B

Notice that E could be any field vector which is everywhere parallel to the x -axis. The surface S is placed at an angle of 45° with one edge parallel to the z -axis. Let's view the set-up from the side.

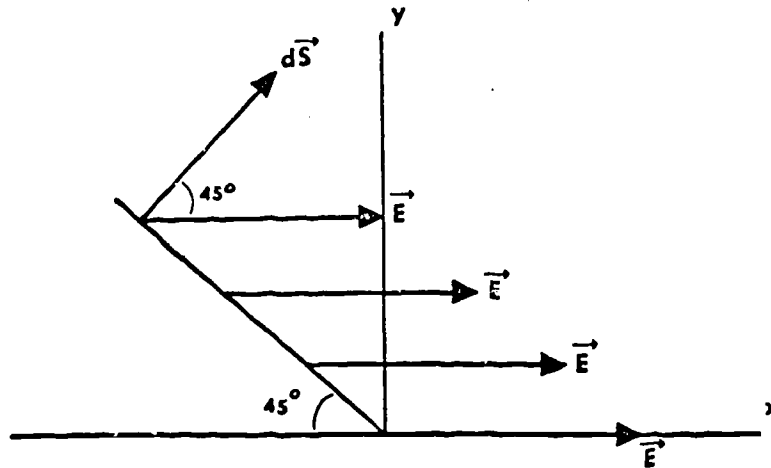

The surface area is flat; therefore, one vector $d\vec{S}$ perpendicular to the surface will be perpendicular at all points. The E -vectors are constant in magnitude and at 45° to the surface at all points. The flux of the E -vector becomes

$$\phi = \oint \vec{E} \cdot d\vec{S}$$

where \oint indicates the integral of dS over the whole surface. Therefore,

$$\phi = \oint E dS \cos 45^\circ$$

Since E is a constant and the integral of dS is simply the total area, this becomes

$$\phi = E S \cos 45^\circ$$

You can see that $E \cos 45^\circ$ is the component of E perpendicular to the surface S .

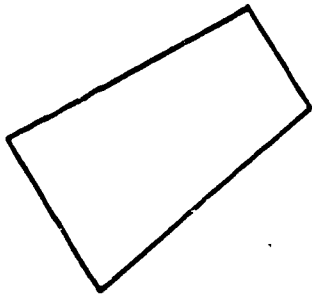
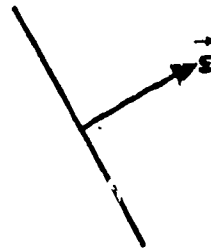
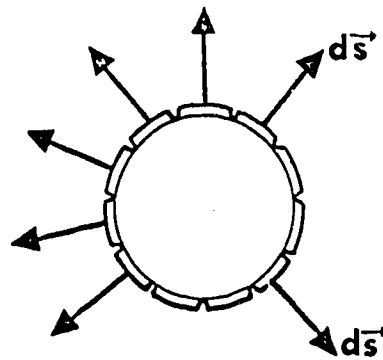
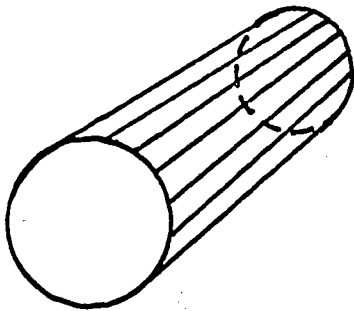
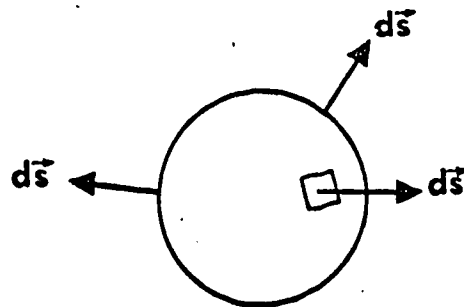
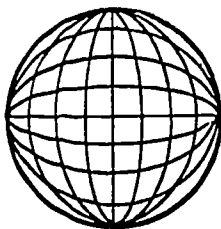
FLAT SURFACE**THREE DIMENSIONAL****SIDE VIEW****CYLINDRICAL SURFACE****SPHERICAL SURFACE**

[a] CORRECT ANSWER: B

Flux might better be introduced as the result of a mathematical property of vectors. Let us discuss the vectors that are involved in this manipulation. One vector that is *always* involved in flux is the surface area vector, usually noted as \vec{S} .

We define this area vector as a vector with direction perpendicular to the surface and with magnitude equal to the surface area. If the surface is curved, we must divide it into elements of a size small enough so that the vector representing the area is perpendicular at all points on the element of area. For instance, consider the surfaces on the opposite page. For a flat surface, there is, of course, need for only one vector to represent the total area. For the cylindrical area we must divide the surface into many small (differential) "strips." Notice that the area vector (now a differential element of area) will be constant along the entire strip. For a spherical area, differential "strips" will not be good enough; therefore, we divide the surface into small (differential) squares.

Again, an area vector must have magnitude and direction. The magnitude of the area vector is the actual numerical value of the area involved, and the direction is perpendicular to the surface area.

The other vector involved in flux calculations can really be any vector quantity that has a specific value at every point in space. This is the definition of a vector field. Good examples of this type of vector field would be the velocity field of a moving fluid, or the electric field that we have been studying.

Now that we have established the two vectors involved in flux, the mathematical expression for flux ϕ of vector field \vec{E} through area S is

$$\phi = \int \vec{E} \cdot d\vec{S}$$

where the integration is taken over the whole surface S . Notice that flux is a scalar quantity.

[a] CORRECT ANSWER: Zero

The cube shown in the problem is a *closed* surface. We could easily consider the problem in six steps by saying

$$\phi_E = \phi_1 + \phi_2 + \phi_3 + \phi_4 + \phi_5 + \phi_6$$

where

ϕ_1 = flux through the side facing the E-field

$\phi_2, \phi_3, \phi_4, \phi_5$ = flux through the sides with edges parallel to the x-axis

and

ϕ_6 = flux through the side on the back of the cube from the E-field

The area vector $d\vec{S}$ is pointing outward from all the surfaces and consequently we can see the surfaces 2, 3, 4, and 5 all have area vectors perpendicular to the electric field. Therefore,

$$\phi_2 = \phi_3 = \phi_4 = \phi_5 = 0$$

Through side one,

$$\phi_1 = ES \cos 180^\circ$$

or

$$\phi_1 = -ES$$

Through side six,

$$\phi_6 = ES \cos 0^\circ$$

or

$$\phi_6 = ES$$

Finally,

$$\phi_E = -ES + 0 + ES$$

or

$$\phi_E = 0$$

We know that in the absence of sources or sinks, the total flux through any closed surface will be zero.

TRUE OR FALSE? This solution makes use of the fact that, when the field vector is perpendicular to the area vector, the flux through the surface is ~~is~~ maximum.

[a] CORRECT ANSWER: A

The axis is defined as the line joining the two charges of the dipole.

[b] CORRECT ANSWER: A

If we look closely at the diagram we will see that \vec{D} is perpendicular to the area vector $d\vec{S}$ at all points. Since the $\cos 90^\circ$ is zero, $\vec{D} \cdot d\vec{S}$ will be zero at all points on the surface. Therefore, there is no flux of the vector \vec{D} through the surface.

[c] CORRECT ANSWER: A

Remember that a *line of force* is an imaginary line drawn in such a way that its direction at any point (i.e., the direction of its tangent) is the same as the direction of the field at that point. Consequently, a *sign* is now being attached to the meaning of flux in such a manner that, if the field vector at the surface points outward, the flux is positive. If the electric field vector at the surface points inward, the flux is negative.

[d] CORRECT ANSWER: C

Another helpful way to describe the direction of the area vector is to say that it is direction of the "outward normal" to the surface.

[e] CORRECT ANSWER: A

The dipole moment vector \vec{p} is always drawn ~~from~~ from the negative charge to the positive charge.

TRUE OR FALSE? The position of the dipole axis depends upon the magnitudes of the dipole charges.

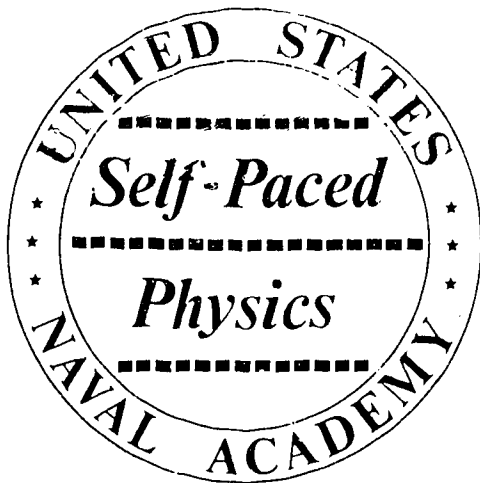

SEGMENT SEPARATOR

note

ALL WRITTEN MATERIAL APPLICABLE TO
THE FOLLOWING SEGMENT IS CONTAINED
IN THE PAGES BETWEEN THIS COLORED
SHEET AND THE NEXT.

INFORMATION PANELDistribution of Charge in Conducting and
Non-conducting Bodies

OBJECTIVE

To answer questions relating to surface charge density and electric field intensity for conductors and non-conductors carrying charges.

Surface Charge Density

When a non-conducting body is given an electric charge, the charges tend to remain where they have initially been placed. For a solid object, the charges may be found scattered throughout the substance in various concentrations depending upon the original charging process. Charges transferred to a *conducting* body, however, will be found to distribute themselves on the surface of the object if it is solid. The surface charge density on a conducting solid sphere, for example, is uniform over the entire surface and is given by the expression:

$$\sigma = q/4\pi r^2$$

Most real conducting bodies do not display uniform charge density on their surfaces, however. Certain geometries such as spheres, long cylinders, and large flat plates may be considered to carry uniform charge densities but, in general, charge density varies from point to point when the object in question is asymmetrical.

Internal Charges

As a consequence of the freedom of motion of charges in a conducting material, they tend to concentrate on the outside surfaces due to coulomb force repulsion. When electrostatic equilibrium is established, the electric field E is zero everywhere inside the conducting body. On the other hand, assuming that the initial charging process placed charges uniformly throughout a body made of a perfect *dielectric* (non-conductor), the internal charge distribution will remain uniform. For instance, if a non-conducting sphere is given a uniform charge, the charge density within it is:

$$\rho = \frac{\text{total charge (q)}}{\text{total volume}} = 3q/4\pi R^3$$

in which R is the radius of the sphere.

next page

continued

The questions in this section call for responses which indicate understanding of

(a) the nature of the surface charge on conducting and non-conducting bodies;

(b) the electric field within a conductor in electrostatic equilibrium.

1. A non-conducting uniformly charged sphere ($\rho = +3 \text{ coul/m}^3$) has a radius of one meter. The sphere is plunged into a very cold solution (temperature = 1° K) and becomes a conductor. What is the surface charge, σ , of the sphere?

- A. 1 coul/m^2
- B. 3.78 coul/m^2
- C. 0.025 coul/m^2
- D. 3 coul/m^3

2. The surface charge density on a conductor

- A is constant at any point of the conductor's surface
- B. is not a meaningful quantity since the charge is distributed throughout the conductor
- C. is constant for any given conductor of given *total* charge
- D. may vary from point to point depending on the shape of the surface of the conductor

3. For a charged, insulated conductor in electrostatic equilibrium,
- A. there is an electric field both inside and outside the conductor
 - B. the electric field intensity is zero everywhere outside the conductor
 - C. the electric field inside the conductor is less than (excluding zero) the electric field outside the conductor
 - D. the electric field is zero everywhere inside the conductor

4. Two uniformly charged spheres A and B each carrying a total charge q have identical radii. If sphere A is made of a conducting material and sphere B of a non-conducting material, the charge densities associated with spheres A and B are

- A. $\rho = \frac{3q}{4\pi R^3}$ and $\sigma = \frac{q}{4\pi R^2}$ respectively
- B. $\sigma = \frac{q}{4\pi R^2}$ and $\sigma = \frac{q}{4\pi R^2}$ respectively
- C. $\rho = \frac{3q}{4\pi R^3}$ and $\rho = \frac{3q}{4\pi R^3}$ respectively
- D. $\sigma = \frac{q}{4\pi R^2}$ and $\rho = \frac{3q}{4\pi R^3}$ respectively

INFORMATION PANEL

Charging Processes

OBJECTIVE

To describe the nature of the charge transferred from a charged body to an uncharged body by *contact*; by *induction*.

next page

continued

Charging by Contact

When a charged conductor is touched to the surface of a second uncharged conductor, charges are directly transferred so that the second conductor assumes a charge of like sign. (This assumes that the conductors are insulated from any discharge paths that may exist). Thus, a negatively-charged rod touched to an uncharged metal sphere will cause the sphere to assume a negative charge; mobile electrons flow from one body to the other as a direct consequence of the coulomb force that exists between like charges. A positively-charged rod touched to the same metal sphere "draws" electrons from the sphere, leaving the latter with a deficiency of electrons--hence a net positive charge.

Charging by Induction

In the process of charging by induction, the charged body is merely brought close enough to the neutral body to disturb its charge distribution. The two diagrams below will help to establish the descriptive

CHARGING BODY

NEUTRAL BODY

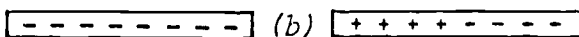
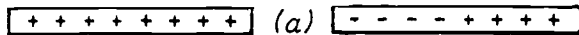

relationship. In (a), an insulated uniformly charged positive rod is laid near an initially neutral bar of metal (insulated from its surroundings.) Electrons move from the far end of the bar to the near end, making this end negative and leaving the far end positive.

When the charged rod is removed the charges in the bar redistribute themselves to re-establish neutrality.

In (b), the negatively charged rod repels the electrons in the initially neutral bar to the remote end, leaving the near end positive. Thus, in the induction process, that portion of the body being charged always takes on a charge *opposite* that of the adjacent portion of the charging body. The questions that follow require that you recognize the difference between the two charging processes and apply this knowledge to specific experiments.

5. The aluminum foil of a negatively charged electroscope is observed to have a deflection of 45° . Imagine that you have been walking on a rug on a dry winter day and then bring your hand near the knob of this electroscope, causing the angle of deflection to drop to 10° . Which of the following is true about the charge on your hand?

- A. Positively charged
- B. Negatively charged
- C. Not charged
- D. It depends on whether you have rubber soled shoes or not

6. The charge from a previously charged metal ball touched to the inside surface of a large conducting can

- A. will transfer to the outside surface of the can by virtue of Coulomb's law
- B. will essentially disappear since a charge cannot reside on the inside of a conductor
- C. will not be transferred to the can because a charge cannot reside inside the surface of a conductor
- D. will remain totally with the metal ball

7. A metal ball (uncharged) introduced into a charged conducting pail will

- A. be repelled from the inner surface of the pail
- B. be attracted to the inner surface of the pail
- C. have no electrical forces acting upon it
- D. become charged

8. A negatively charged rod is brought near the knob of the negatively charged electroscope. What happens to the leaves of the electroscope?

- A. There is no effect
- B. The leaves spread further apart
- C. The leaves come closer together
- D. The leaves drop to the zero deflection.

9. The net charge enclosed in a Gaussian surface is q . The general form of Gauss's law is

- A. $\phi = q \oint \vec{E} \cdot d\vec{S}$
- B. $q = \frac{1}{4\pi\epsilon_0} \oint \vec{E} \cdot d\vec{S}$
- C. $\oint \vec{E} \cdot d\vec{S} = \frac{q}{\epsilon_0}$
- D. $q = \frac{1}{\epsilon_0} \oint \vec{E} \cdot d\vec{S}$

10. A Gaussian surface is best defined as any

- A. surface near a charge
- B. real surface enclosing a charge
- C. hypothetical surface enclosing a net charge
- D. closed hypothetical surface, whether or not there is a charge present

11. The relationship between the flux ϕ_E through a closed surface and the net charge enclosed within the surface is given by

A. $\epsilon_0 qE$

B. $\frac{q}{4\pi\epsilon_0}$

C. $\frac{q}{\epsilon_0}$

D. $\epsilon_0 q$

12. In the equation for Gauss's law, the q term indicates

A. charge exterior to the Gaussian surface

B. the net charge enclosed by the Gaussian surface

C. the net charge enclosed by the Gaussian surface and any other charges in proximity to the Gaussian surface

D. the absolute value of the net charge enclosed by the Gaussian surface

13. For a spherical Gaussian surface surrounding a point charge at its center,

A. the Gaussian surface acts as a source of electric field lines

B. the magnitude of the electric field strength is constant everywhere on the surface

C. the outward flux from a positive point charge through the surface is taken in the negative sense

D. the Gaussian surface acts as a sink of electric field lines

A positive charge of 2 coulombs is placed at the origin of the coordinate system shown in the diagram. If a spherical surface ($r = 1$ m) has its center at the origin, what is the electric flux ϕ_E through the surface in $\text{nt} \cdot \text{m}^2/\text{coul}$?

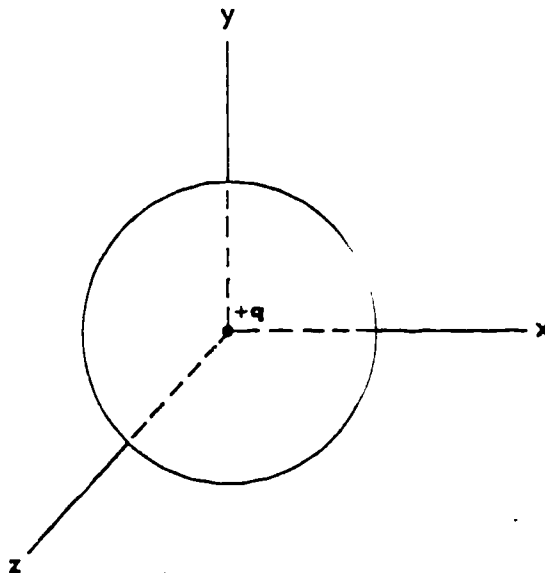

15. For a Gaussian surface centered around a spherically symmetric charge distribution, the electric field E has
- the same value as it would if all the charge were concentrated at the center of the distribution
 - a larger value than it would if the charge were concentrated at the center, since concentrating the charge at the center of the charge distribution would make some of the charge more distant from the surface
 - a smaller value than it would if the charge were concentrated at the center of the charge distribution because in the latter case, the charge has a greater "average distance" from the reference point.
 - no connection with the size of the surface area

16. An alpha particle ($q_\alpha = +2e = 3.2 \times 10^{-19}$ coul) is located at the center of a spherical Gaussian surface of radius $r = 2$ m. Use Gauss's law to find the magnitude of the electric field at the surface of the sphere.

- A. 4.5×10^9 nt/coul
- B. 1.6×10^{-10} nt/coul
- C. 1.2×10^{-10} nt/coul
- D. 1.5×10^{-10} nt/coul

INFORMATION PANEL

Simple Applications of Gauss's Law

OBJECTIVE

To apply Gauss's law to the solution of fundamental problems in which this law is a key tool.

Gauss's law applies to any closed surface and is used to provide the relationship between the flux ϕ_E through that surface and the net charge enclosed inside the surface. The law states that

$$\epsilon_0 \phi_E = q \tag{1}$$

But since it has also been shown that

$$\phi_E = \oint \vec{E} \cdot d\vec{S} \tag{2}$$

then equations (1) and (2) can be combined to yield the most useful form of Gauss's law:

$$\epsilon_0 \oint \vec{E} \cdot d\vec{S} = q \tag{3}$$

next page

continued

Among the more significant of the descriptive outcomes of Gauss's law is the following:

The total flux passing outward through any closed surface equals $1/\epsilon_0$ times the net electric charge inside the closed surface.

In the questions that follow, you will be expected to

- (a) answer descriptive questions relating to the interpretation of Gauss's law as applied to specific examples;
- (b) solve fundamental problems in which Gauss's law serves as a tool for determining electric intensity inside and outside charged bodies.

17. The diagram below shows the magnitude of the electric field plotted as a function of distance. Which of the following objects could produce such an electric field?

- A. A uniformly charged, non-conducting sphere
- B. An infinitely large, charged plate
- C. A charged conducting cylinder
- D. An infinite line of charge

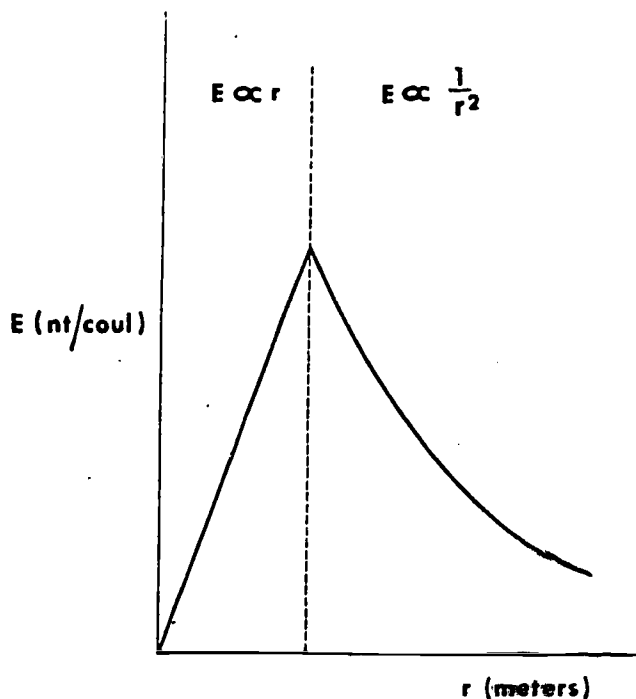

18. A spherical conductor (radius = r_s) carries an excess charge of Q coulombs. What is the magnitude of the electric field for points $r > r_s$?

- A. Zero
- B. $\frac{Q}{4\pi\epsilon_0 r} - \frac{Q}{4\pi\epsilon_0 r_s}$
- C. $\frac{Q}{4\pi\epsilon_0 r^2}$
- D. $\frac{Q^2}{4\pi\epsilon_0 r^2}$

19. Look at the diagram below and determine what effect a spherically symmetric shell of charge between R_1 and R_2 would have on the electric field intensity E at a point $r < R_1$.

- A. \vec{E} is a function of r
- B. \vec{E} is a constant but not zero
- C. \vec{E} is zero and hence will be the same with or without the shell
- D. The correct answer would depend upon knowing whether or not the charge is positive or negative. This is because one may act as a sink of the electric field.

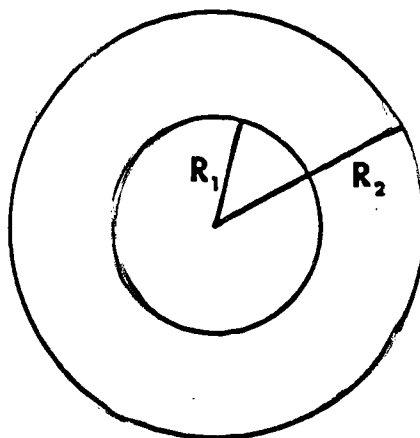

**spherically symmetric
charge distribution**

23. A non-conducting sphere of radius 2 m contains a total charge 8 coul which is uniformly distributed throughout the sphere. Use Gauss's law to calculate the magnitude of \vec{E} at distance 1 m from the center of the sphere.

INFORMATION PANEL

Further Applications of Gauss's Law

OBJECTIVE

To apply Gauss's law to the solution of problems involving the determination of the intensity of the electric field outside and between a number of differently shaped conductors.

In this course in physics, we shall attempt to apply Gauss's law only to objects of high symmetry for which the evaluation of the surface integral is reasonably simple. In general, you should find it possible to solve the problems that follow by adhering to a straightforward pattern of approach which includes the following steps:

(a) Sketch or imagine a *closed* Gaussian surface such that the electric field in which you are interested (E) is *constant* at all points on the surface.

(b) Choose the nature and orientation of the Gaussian surface so that the electric field is *either perpendicular or parallel* to the surface at all points.

(c) Consider only the charge *enclosed* within the Gaussian surface as having any effect on the flux through the surface.

(d) Note that the effect of (a) above is to enable you to place \vec{E} outside the integral sign thus:

$$q = \epsilon_0 \vec{E} \oint d\vec{S}$$

so that you are left with the simpler problem of expressing the surface area in terms of the given quantities. Thus it is usually possible to write the flux through the Gaussian surface as simply:

$$ES = q/\epsilon_0$$

next page

continued

You will find the requirements of the problems in this section to be the determination of electric intensity \vec{E} (or the force on a charge in such a field) for

- (a) the outside of an infinitely long wire conductor;
- (b) the outside of a large conducting plate;
- (c) the space between two large conducting plates;
- (d) the space between two hollow conducting spheres;
- (e) the space between two hollow concentric cylinders of metal.

21. Consider an infinitely long straight wire of radius "a". Apply Gauss's law to find the magnitude of the electric field E at a distance r , where $r > a$. The linear charge density is λ coul/m.

A. $E = \frac{\lambda}{2\pi\epsilon_0 a}$

B. $E = \frac{\lambda}{4\pi\epsilon_0 r^2}$

C. $E = \frac{\lambda}{2\pi\epsilon_0}$

D. $E = \frac{\lambda}{2\pi\epsilon_0 r}$

22. A thick, flat plate is constructed of copper (a good conductor). The surface dimensions of the plate are $10 \text{ m} \times 10 \text{ m}$. If a charge of four coulombs is placed on the plate, what is the electric field strength one meter from the flat surface of the plate in N/coul ?

23. Two large sheets of copper are shown in the diagram. The sheets are *very* thin and are oppositely charged. ($\sigma = 3$ coulombs per square meter of the copper sheet.) Using Gauss's law, what is the magnitude of E midway between the two plates in nt/coul?

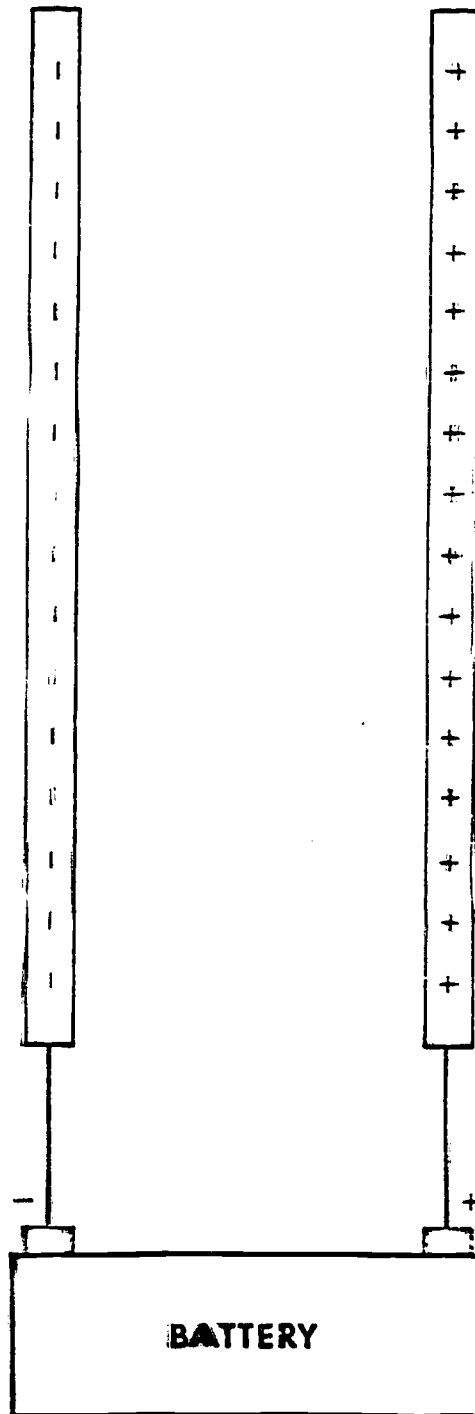

24. An electron is placed midway between the two concentric spheres as shown at right. What is the magnitude of the force in newtons on the electron if the distance from the center of the concentric spheres is 1.5 m, and each sphere has a charge of +10 coulomb distributed over its surface?

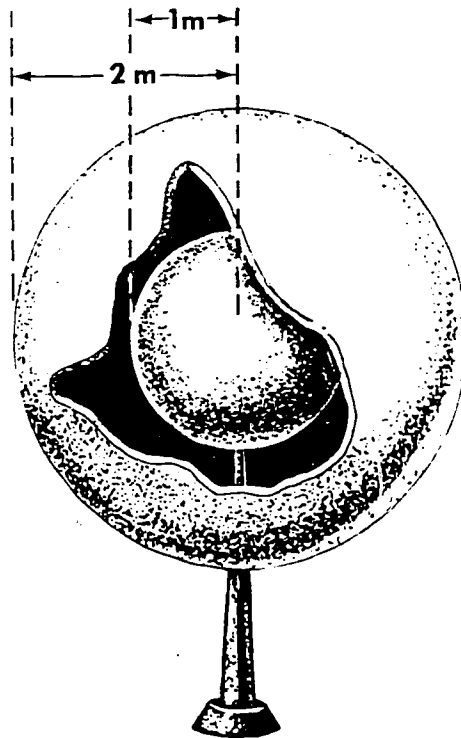

25. Two coaxial hollow metal cylinders of length L with radii a and b ($b > a$) carry charges $+q$ and $-q$ respectively. The magnitude of the electric field (neglecting edge effects) at a point $a < r < b$, measured from the common axis is

A. $\frac{qL}{4\pi\epsilon_0 r^2}$

B. $\frac{q}{2\pi\epsilon_0 rL}$

C. $\frac{qL}{2\pi\epsilon_0}$

D. $\frac{qr}{2\pi\epsilon_0 L}$

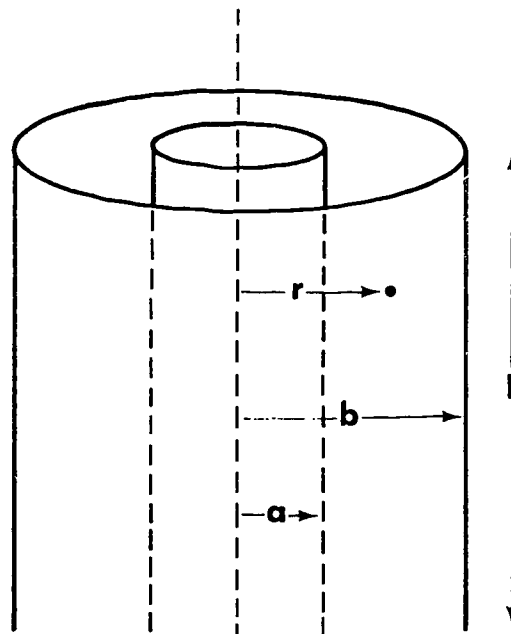

[a] CORRECT ANSWER: 22.6×10^{10}

To calculate the flux through the sphere we write

$$\phi_E = \oint \vec{E} \cdot d\vec{S}$$

The vectors \vec{E} and $d\vec{S}$ are parallel at all points on the sphere since \vec{E} and $d\vec{S}$ are both radially outward. From the symmetry it is obvious that the magnitude of \vec{E} is constant and found from Coulomb's law to be

$$E = \frac{q}{4\pi\epsilon_0 r^2}$$

Therefore

$$\phi_E = \frac{q}{4\pi\epsilon_0 r^2} \int dS$$

For a sphere, the surface area is found from

$$S = 4\pi r^2$$

Substituting, we find that

$$\phi_E = \frac{q}{\epsilon_0} = \frac{2}{8.85 \times 10^{-12}} = 22.6 \times 10^{10}$$

Notice how the flux is related to the magnitude of the charge enclosed within the surface. This says, in effect, that the *flow* is directly related to the strength of the *source*.

[b] CORRECT ANSWER: B

When the negatively charged rod is held close to the negatively charged knob, the negative charges in the knob move downward toward the leaves. The leaves then repel one another with more force and therefore spread further apart.

TRUE OR FALSE? The motion of charges described above is made possible by the conducting material of the knob and leaves.

[a] CORRECT ANSWER: D

Since charges are able to move about freely in a conductor, there is a tendency due to the mutual repulsion, for any excess number of charges (either positive or negative) to move to the *surface*. At equilibrium all the excess charges are spaced in such a manner that no *net* force acts on any one charge. The *shape* of the surface of the conductor is very important. You might imagine that on symmetrical objects such as spheres, long cylinders, and large flat plates the charges will be distributed evenly and the surface charge density, σ , will be *constant* over the entire surface. For non-symmetrical surfaces, the charge density will *not* be constant.

[b] CORRECT ANSWER: 6.4×10^{-10} nt

Let's construct a spherical Gaussian surface concentric to both spheres and with a radius of 1.5 m. Notice how Gauss's law is used frequently to find the magnitude of the E-field. Once we determine the E-field, we can calculate the force on the electron located midway between the spheres. The flux through the Gaussian surface can be written as

$$ES = \frac{q}{\epsilon_0}$$

where q is the net charge on the *inner* sphere. Substituting the value of the surface area of the Gaussian sphere yields

$$E = \frac{q}{4\pi\epsilon_0 r^2}$$

The force on the electron then becomes

$$F = \frac{q q_e}{4\pi\epsilon_0 r^2} = \frac{10 \times 1.6 \times 10^{-19}}{4\pi(8.85 \times 10^{-12})(1.5)^2} = 6.4 \times 10^{-10}$$

where

$$q_e = 1.6 \times 10^{-19} \text{ coul}$$

[a] CORRECT ANSWER: A

When the material becomes a conductor, *all* the charges will distribute themselves *evenly* on the surface. Therefore

$$\sigma = \frac{q}{4\pi r^2}$$

In this case, q is the total charge that was initially spread throughout the total volume of the dielectric (non-conducting) sphere. Therefore,

$$q = \frac{4}{3} \pi r^3 \rho$$

The surface charge density then becomes

$$\sigma = \frac{(4/3)\pi r^3 \rho}{4\pi r^2} = \frac{\rho r}{3}$$

TRUE OR FALSE? The symbol " ρ " in this problem is charge per unit area.

[b] CORRECT ANSWER: C

You can derive Gauss's law from the relationship between charge and flux. Charge is proportional to flux,

$$q = \epsilon_0 \phi \quad (1)$$

but from the definition of flux,

$$\phi = \oint \vec{E} \cdot d\vec{S} \quad (2)$$

Combining (2) with (1), we obtain

$$q = \epsilon_0 \oint \vec{E} \cdot d\vec{S}$$

which is Gauss's law.

TRUE OR FALSE? We may rewrite equation (1) above as $q = \phi \epsilon_0$ in which ϕ is a constant of proportionality.

[a] CORRECT ANSWER: C

A uniformly charged spherical shell does not contribute to the electric field in the interior of the shell. This can be seen by applying Gauss's law.

Use these guidelines:

- (1) A closed Gaussian surface is necessary.
- (2) The Gaussian surface is chosen such that $|\vec{E}|$ is constant at all points on the surface.
- (3) The Gaussian surface is chosen such that \vec{E} is either perpendicular or parallel to the surface at all points.
- (4) *Only* the charge enclosed by the Gaussian surface has any effect on the total flux through the surface.

Thus

$$q = \epsilon_0 \oint \vec{E} \cdot d\vec{S} = \epsilon_0 E \int dS$$

$$q = \epsilon_0 4\pi r^2 E$$

Since $q = 0$ inside a spherical Gaussian surface of radius $r < R$, we obtain $E = 0$.

[b] CORRECT ANSWER: A

From Gauss's law, one can show that the electric field outside of a uniformly charged sphere could be represented by

$$E = \frac{Q}{4\pi\epsilon_0 r^2}$$

where Q is the total charge, and r is the distance from the center of the sphere. This means that for all points outside of the charged sphere, the electric field decreases as $1/r^2$. This same expression would be used if all charge were concentrated at the center.

[a] CORRECT ANSWER: B

Construct a coaxial cylindrical Gaussian surface of length L with radius $a < r < b$. The magnitude of the electric field may be obtained by using Gauss's law. Thus,

$$q = \epsilon_0 \oint \vec{E} \cdot d\vec{S} \quad (1)$$

because the sum of the charges enclosed by the Gaussian surface is $+q$. From symmetry, it is clear that the magnitude of \vec{E} is constant at all points on the curved Gaussian surface (neglecting edge effects). The direction of the electric field is from the inner cylinder carrying $+q$ charges to the outer cylinder carrying $-q$ charges. The area of the curved Gaussian surface is $2\pi rL$. The contribution to the integral in equation (1) due to the top and bottom parts of the Gaussian surface is zero because the vectors \vec{E} and $d\vec{S}$ are perpendicular to one another. Substituting the above results in equation (1) we find

$$\begin{aligned} q &= \epsilon_0 \cdot E \int_{\text{curved surface}} dS \\ &= \epsilon_0 \cdot E \cdot 2\pi rL \end{aligned}$$

Therefore

$$E = \frac{q}{2\pi\epsilon_0 rL}$$

[b] CORRECT ANSWER: B

It is important always to determine the *total* charge enclosed by the Gaussian surface while being careful to maintain all signs of positive and negative charges.

[a] CORRECT ANSWER: D

All the excess charge on a conductor resides on the surface and thus the surface charge density σ is associated with the conducting sphere A. The magnitude of σ is

$$\begin{aligned}\sigma &= \frac{\text{total charge}}{\text{surface area}} \\ &= \frac{q}{4\pi R^2}\end{aligned}$$

In a dielectric (non-conductor) the excess charge remains embedded wherever it is placed. In the dielectric sphere B the charge is uniformly distributed throughout the volume of the sphere. Hence, the volume charge density ρ is associated with the dielectric sphere B and is given by

$$\begin{aligned}\rho &= \frac{\text{total charge}}{\text{total volume}} \\ &= \frac{3q}{4\pi R^3}\end{aligned}$$

TRUE OR FALSE? The quantity $\frac{q}{4\pi R^2}$ is measured in coul/m².

[b] CORRECT ANSWER: C

Choosing a spherical Gaussian surface of radius r , we write

$$\frac{Q}{\epsilon_0} = \oint \vec{E} \cdot d\vec{S}$$

In this case \vec{E} and $d\vec{S}$ are parallel, and from symmetry, E , the magnitude of the electric field is constant at every point on the Gaussian surface. Therefore,

$$\phi_E = \frac{Q}{\epsilon_0} = ES$$

We know that for a sphere

$$S = 4\pi r^2$$

Therefore

$$E = \frac{Q}{4\pi\epsilon_0 r^2}$$

It is important to observe that an electric field due to spherical charge distribution acts as if all the charge were located at the center for $r > r_s$.

[a] CORRECT ANSWER: 2.26×10^9

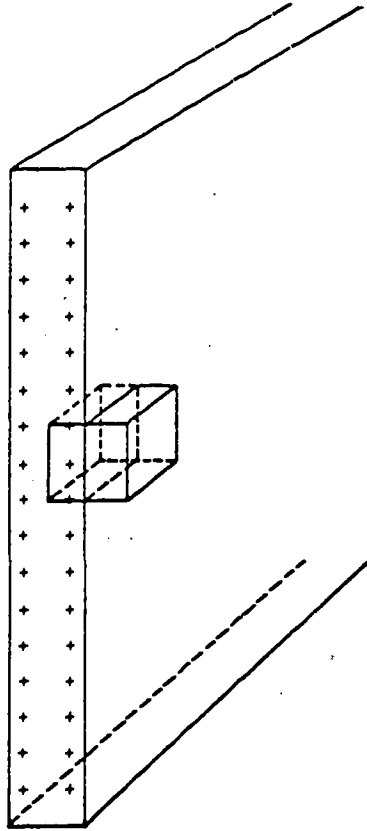

The four coulombs will spread evenly over the surface of the plate (see figure). The surface charge σ on each side of the plate is

$$\sigma = \frac{4}{2(10 \times 10)} = 0.02 \text{ coul/m}^2$$

Notice that the factor of 2 in the denominator comes from the fact that there are two surfaces of the thick plate over which the four coulombs will spread. In order to determine the electric field at points away from the surface of the flat plate we construct a Gaussian cube as shown. There is *no* field *inside* the conducting plate. Outside, the field is perpendicular to the plate so that we may write

$$\phi_E = \begin{matrix} 0 \\ \text{inside} \end{matrix} + \begin{matrix} ES \\ \text{outside} \end{matrix} = \frac{q}{\epsilon_0}$$

next page

continued

The total charge enclosed by the Gaussian cube is

$$q = \sigma S$$

Therefore we can write that

$$ES = \frac{\sigma S}{\epsilon_0}$$

or

$$E = \frac{\sigma}{\epsilon_0} = \frac{.02}{8.85 \times 10^{-12}} = 2.26 \times 10^9$$

[a] CORRECT ANSWER: D

In a conductor, charges are free to move under the influence of forces. If an excess of charge is placed on a conductor, the charges will repel each other resulting in a distribution of charge *on the surface* of the conductor and electrostatic equilibrium will be established. At electrostatic equilibrium, the electric field \vec{E} is zero everywhere inside the conductor.

[b] CORRECT ANSWER: C

This equation is a statement of Gauss's law. The flux through any *closed* surfaces is related to the algebraic sum of the sources (positive charges) and sinks (negative charges) which are located within the closed surface.

[a] CORRECT ANSWER: 9×10^9 nt/coul

Using a Gaussian surface with radius r inside the non-conducting sphere, we may write Gauss's law as

$$\epsilon_0 \oint \vec{E} \cdot d\vec{S} = q$$

$$\epsilon_0 4\pi r^2 E = q = \rho \frac{4\pi}{3} r^3$$

and

$$E = \frac{\rho r}{3\epsilon_0} \quad (1)$$

where ρ is the charge density. This charge density can be expressed in terms of the total charge q and the radius R as

$$\rho = \frac{q}{(4\pi/3)R^3} \quad (2)$$

From (1) and (2), we obtain

$$E = \frac{qr}{4\pi\epsilon_0 R^3}$$

and substitution of the given data yields the answer:

$$E = \frac{qr}{4\pi\epsilon_0 R^3} = 9 \times 10^9 \text{ nt/coul}$$

TRUE OR FALSE? Knowledge of the actual radius of this non-conducting sphere is *not* necessary to solve this problem.

[b] CORRECT ANSWER: A

Like charges, because of the repelling forces, have a tendency to move as far away from each other as possible. The movement of charges from the metal ball to the can allows the charges to increase their separation distance.

[a] CORRECT ANSWER: C

The flux on the surface of the sphere will be

$$\phi_E = \frac{+2e}{\epsilon_0}$$

where

e = magnitude of the charge on an electron.

The flux through the spherical surface may be written in terms of the electric field as follows:

$$\phi_E = \oint \vec{E} \cdot d\vec{S}$$

For a point charge at the center of the sphere, \vec{E} and $d\vec{S}$ are parallel, and from symmetry, the magnitude of the electric field E is constant at every point on the Gaussian surface. The integral over the surface yields the area of a sphere. Therefore,

$$\phi_E = ES = E(4\pi r^2)$$

and

$$E(4\pi r^2) = 2e/\epsilon_0$$

Solving for E yields

$$E = \frac{2e}{4\pi\epsilon_0 r^2}$$

Substituting the values known,

$$E = 7.2 \times 10^{-10} \text{ nt/coul}$$

TRUE OR FALSE? In the last symbolic equation above, the only variable on the right hand side is e .

[b] CORRECT ANSWER: B

Lines of \vec{E} emanate radially from an isolated point charge. The magnitude of \vec{E} is dependent upon distance ($|\vec{E}| \propto 1/r^2$). When the distance r is constant, \vec{E} is constant also.

[a] CORRECT ANSWER: 3.39×10^{11}

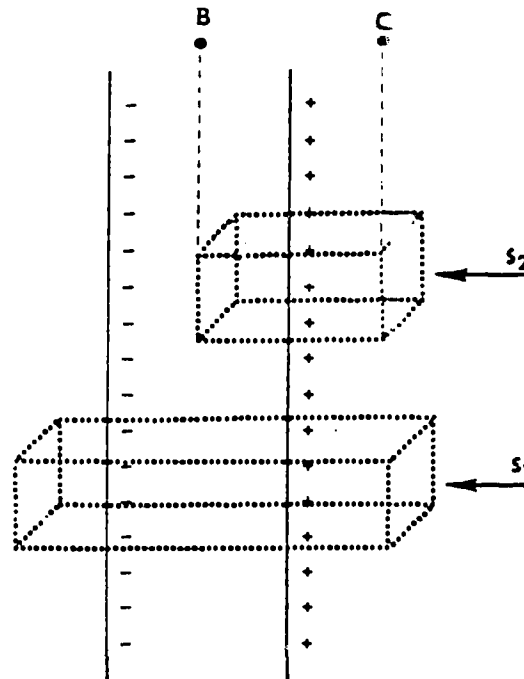

In the diagram, a long symmetric Gaussian surface S_1 in the form of a right parallelogram is shown. The electric field \vec{E} at the long parallel edges of the Gaussian surface is perpendicular to the surface. Therefore, the contribution to the integral, $\oint \vec{E} \cdot d\vec{S}$, due to the four long parallel sub-surfaces is zero. For the end surfaces we can write

$$\int_{\text{end surfaces}} \vec{E} \cdot d\vec{S} = \frac{q}{\epsilon_0} \quad (1)$$

However, the total charge enclosed by the parallelogram is

$$\begin{aligned} q &= \sigma S_1 + (-\sigma)S_1 \\ &= 0 \end{aligned} \quad (2)$$

Substituting equation (2) in equation (1), we find

$$\int_{\text{end surfaces}} \vec{E} \cdot d\vec{S} = 0 \quad (3)$$

From the symmetry of the chosen Gaussian surface, the electric field \vec{E} at the end surfaces (if it exists) should be constant; therefore, the only conclusion is that the \vec{E} field is zero outside the charged parallel plates.

next page

continued

In order to find the magnitude of the electric field at a point B midway between the plates we construct a Gaussian surface in the form of a right parallelogram S_2 . As we have seen before, the electric flux through the long sides of the parallelogram is zero. For the ends of the parallelogram we may write

$$E_B S_1 \left| \begin{array}{c} | \\ B \end{array} \right| - 0 \left| \begin{array}{c} | \\ C \end{array} \right| = \frac{q}{\epsilon_0}$$

where the lines indicate the end surface. Notice that we have used the information from the first part of the solution, i.e., that the flux at C is zero. Therefore,

$$E_B S_1 = \frac{\sigma S_1}{\epsilon_0}$$

or

$$E_B = \frac{\sigma}{\epsilon_0}$$

This same result could be obtained by adding the electric fields at point B due to each plate.

$$\vec{E}_B = \vec{E}_+ + \vec{E}_-$$

The fields due to the positive and negative plates are both in the same direction and equal to $\sigma/2\epsilon_0$. Therefore,

$$E_B = \frac{\sigma}{2\epsilon_0} + \frac{\sigma}{2\epsilon_0}$$

or

$$E_B = \frac{\sigma}{\epsilon_0}$$

The E-field between two parallel plates of opposite but equal charge is just twice the field due to the individual plates.

[a] CORRECT ANSWER: A

When the deflection decreases, we can conclude that each leaf has less negative charge than before. The negative charge must have been "pulled" into the knob. The presence of a positively charged hand would cause the negative charges to move to the knob.

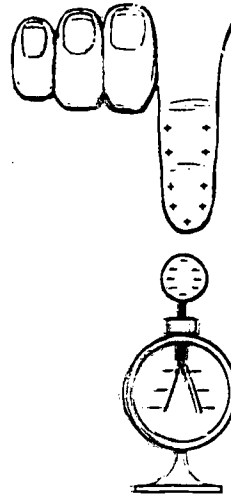

TRUE OR FALSE? When the hand is removed, the deflection of the leaves will be restored to its original angle.

[b] CORRECT ANSWER: D

Gauss's law states that the flux of a vector through a closed surface depends upon the magnitude of the *source* or *sink* enclosed within the surface. Gauss's law relates specifically to the electric field vector, and any closed surface will suffice in applying Gauss's law. We will see later that certain surfaces are more convenient than other surfaces.

[c] CORRECT ANSWER: C

Since all the charge is located on the surface of the conducting can, there will be no electric field inside the can. The uncharged metal ball will not experience any electric forces.

[a] CORRECT ANSWER: D

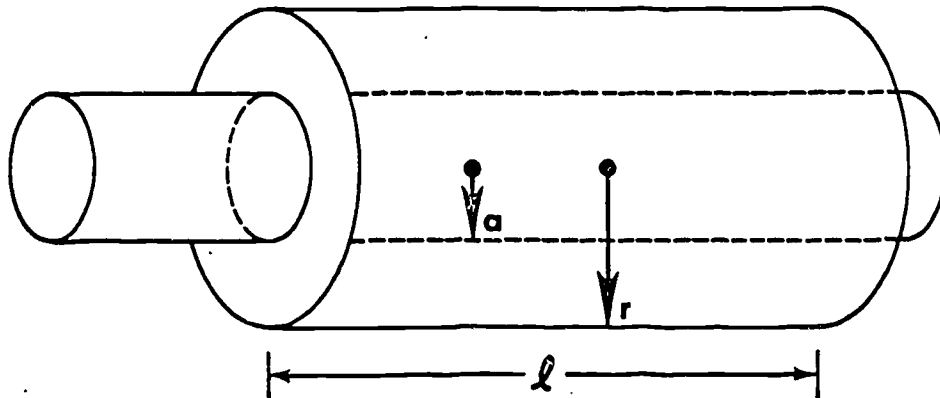

A sample solution of the problem is given below. In the diagram, we have sketched a Gaussian surface of radius r . We may write

$$\phi_E = \oint \vec{E} \cdot d\vec{S} = \frac{q}{\epsilon_0} \quad (1)$$

Now λ is the charge per unit length on the wire. Therefore,

$$\lambda = q/l$$

or

$$q = \lambda l$$

Substituting this into equation (1) yields

$$\lambda l = \epsilon_0 \oint \vec{E} \cdot d\vec{S} \quad (2)$$

Since our Gaussian surface is a cylinder, the area of the curved surface is

$$S = 2\pi r l$$

because of symmetry, E is constant on the curved surface, so that the integral in equation (2) becomes

$$\lambda l = \epsilon_0 E 2\pi r l$$

Solving this expression for E gives the desired result.

[a] CORRECT ANSWER: A

For E inside the sphere, we use a Gaussian spherical surface with radius $r < R$. Applying Gauss's law, we may write

$$\epsilon_0 \oint \vec{E} \cdot d\vec{S} = q$$

or

$$\epsilon_0 E(4\pi r^2) = \rho(4/3\pi r^3)$$

where ρ is the charge density. Solving for E we obtain

$$E = \frac{\rho r}{3\epsilon_0} \quad r < R$$

For E outside the sphere, we use a Gaussian spherical surface with radius $r > R$. Again applying Gauss's law

$$\epsilon_0 \oint \vec{E} \cdot d\vec{S} = q$$

yields

$$\epsilon_0 E 4\pi r^2 = q$$

or

$$E = \frac{q}{4\pi\epsilon_0 r^2} \quad r > R$$

where q is the total charge on the non-conducting sphere.

TRUE OR FALSE? The same two equations for E (when $r < R$ and when $r > R$) are obtained for a uniformly charged conducting sphere.