

DOCUMENT RESUME

ED 073 369

AC 014 252

AUTHOR Sticht, Thomas G.; And Others
TITLE HumRRC's Literacy Research for the U.S. Army:
Progress and Prospects.
INSTITUTION Human Resources Research Organization, Alexandria,
Va.
SPONS AGENCY Office of the Chief of Research and Development
(Army), Washington, D.C.
REPORT NO HumRRO-PP-2-73
PUB DATE Jan 73
NOTE 31p.; Paper presented at U.S. Continental Army
Command, October 1972

EDRS PRICE MF-\$0.65 HC-\$3.29
DESCRIPTORS Adult Basic Education; Adult Education Programs;
Adult Literacy; *Adult Reading Programs; Enlisted
Men; *Literacy Education; *Military Training;
*Reading Research; Technical Reports

ABSTRACT

This report summarizes literacy research performed in HumRRO Work Units REALISTIC, READNEED, and FLIT. Data are reported that show reading demands of various Army jobs and reading ability levels of personnel prior to, during, and after Project 100,000. Research and development of a new job-related, functional literacy training program for the army is described. (Author)

ED 073369

Professional
Paper
2-73

HumRRO-PP-2-73

U.S. DEPARTMENT OF HEALTH
EDUCATION & WELFARE
OFFICE OF EDUCATION
MAY 1973
REPRODUCTION FROM
HUMAN RESOURCES RESEARCH ORGANIZATION
PUBLICATIONS
NOT NECESSARILY
APPROVED BY THE OFFICE OF EDUCATION

HumRRO

FILMED FROM BEST AVAILABLE COPY

HumRRO's Literacy Research for the U.S. Army: Progress and Prospects

Thomas G. Sticht, John S. Caylor, Lynn C. Fox, Robert N. Hauke,
James H. James, Steven S. Snyder, and Richard P. Kern

Presented at
U.S. Continental Army Command
October 1972

HUMAN RESOURCES RESEARCH ORGANIZATION
300 North Washington Street • Alexandria, Virginia 22314

January 1973

AKC14252

Prepared for
Office of the Chief of Research and Development
Department of the Army
Washington, D.C. 20310

The Human Resources Research Organization (HumRRO) is a non-profit corporation established in 1969 to conduct research in the field of training and education. It is a continuation of The George Washington University Human Resources Research Office. HumRRO's general purpose is to improve human performance, particularly in organizational settings, through behavioral and social science research, development, and consultation. HumRRO's mission in work performed under contract with the Department of the Army is to conduct research in the fields of training, motivation and leadership.

The contents of this paper are not to be construed as an official Department of the Army position, unless so designated by other authorized documents.

Published
January 1973
by
HUMAN RESOURCES RESEARCH ORGANIZATION
300 North Washington Street
Alexandria, Virginia 22314

Prefatory Note

This paper was presented by Dr. Sticht at a briefing for the Deputy Chief of Staff for Individual Training, U.S. Continental Army Command, on 25 October 1972.

The paper summarizes some of the HumRRO literacy research and development performed for the U.S. Army since 1968 under Work Units REALISTIC (Determination of Reading, Listening, and Arithmetic Skills Required for Major Military Occupational Specialties), READNEED (Methodology for Evaluating Reading Requirements of Army Jobs), and FLIT (Development of a Prototype Job-Functional Army Literacy Training Program). Under the first two Work Units, literacy needs for several Army MOSs were identified and methodology was developed for evaluating them. Under the current effort, FLIT, an experimental training program is being designed to provide a level of functional literacy appropriate to minimal MOS requirements.

Members of the literacy research staff at Division No. 3 are Thomas G. Sticht, Leader; John S. Caylor, Lynn C. Fox, Robert N. Hauke, Richard P. Kern, SP5 James H. James, SP5 Steven S. Snyder, Nina A. McGiveran, and William H. Burckhartt.

HUMRRO's LITERACY RESEARCH FOR THE U.S. ARMY: PROGRESS AND PROSPECTS

Literacy research and development projects have been conducted by HumRRO since 1968 under sponsorship of the Department of Defense, Office of Manpower and Reserve Affairs, and of the Department of Army, U.S. Continental Army Command. This research represents, so far as I know, the longest sustained, intense program of literacy research and development ever undertaken by the military, or for that matter, any large organization.

This series of research and development projects has had two major objectives: first, to determine the nature of the literacy problem in the Army by studying the literacy demands of Army jobs and the literacy skills of Army personnel, and second, to develop a literacy training program to provide job-related, functional literacy skills.

DEFINING THE LITERACY PROBLEM

Literacy Demands of Army Jobs

Research to define the literacy problem was conducted under HumRRO Work Units REALISTIC¹ (Determination of Reading, Listening, and Arithmetic Skills Required for Major Military Occupational Specialties), and READNEED² (Methodology for Evaluating Reading Requirements of Army Jobs). In these projects, we studied the literacy demands of Army jobs by a variety of methods. In one, we developed a special formula that permits an estimation of the reading grade level of ability needed to read and comprehend Army job manuals.¹ This "readability" formula was applied to samples of reading materials from seven Military Occupational Specialties (MOSs) into which larger numbers of marginally literate men might be assigned.

The average reading difficulty level of materials in seven MOSs is shown in Figure 1. Also shown are the average reading ability levels of three groups of Army personnel: Army Preparatory Training (APT) graduates for FYs 1968, 1969, and 1970, and Category IV and non-Category IV job incumbents studied³ in HumRRO Work Units REALISTIC and UTILITY (Study of Soldiers in Lower Mental Categories: Job Performance and the Identification of Potentially Successful and Potentially Unsuccessful Men). The Figure shows considerable disparity between the reading ability of personnel, and the readability levels of job printed materials, which range from 10+ to 12th grade.

¹Thomas G. Sticht, John S. Caylor, Richard P. Kern, and Lynn C. Fox. *Determination of Literacy Skill Requirements in Four Military Occupational Specialties*. HumRRO Technical Report 71-23, November 1971.

²John S. Caylor, Thomas G. Sticht, Lynn C. Fox, and J. Patrick Ford. "Methodologies for Determining Reading Requirements of Military Occupational Specialties," Technical Report in preparation.

³Robert Vineberg, Thomas G. Sticht, Elaine N. Taylor, and John S. Caylor. *Effects of Aptitude (AFQT), Job Experience, and Literacy on Job Performance Summary of HumRRO Work Units UTILITY and REALISTIC*. HumRRO Technical Report 71-1, February 1971.

Average Reading Difficult Level of Materials in Seven MOSs

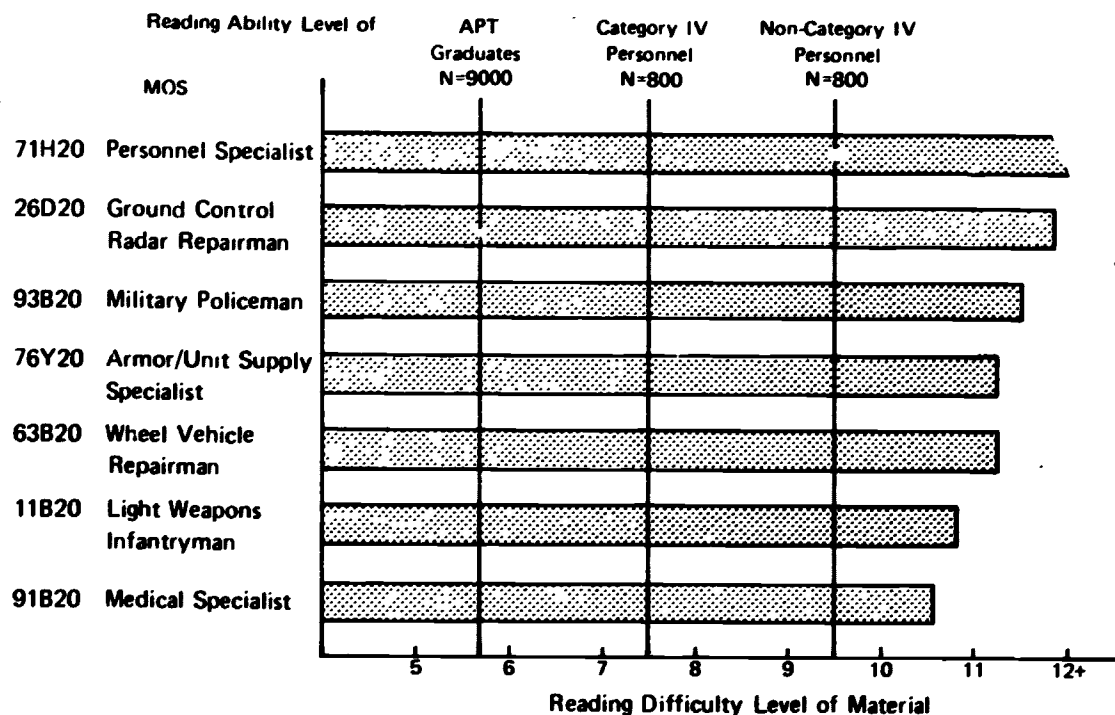

Figure 1

The readability technique offers a low-cost method for estimating the reading demands of job materials. However, it does not provide a direct indication of how well people can read and comprehend job materials; for this information we need to test people on samples of job reading materials.

As a first step, structured interviews were conducted with men of different reading ability levels who were working as mechanics, supply clerks, and cooks. The interview was conducted at the man's job location and he was asked to provide the following:

- (1) Personal data (Name, Unit, etc.)
- (2) A description of his typical work day
- (3) Five examples of his use of information sources other than printed materials
- (4) Five examples of his use of printed materials (obtain the materials and locate the exact page referred to)
- (5) Five examples of duties or tasks performed not involving use of printed materials
- (6) Five examples of the use of arithmetic
- (7) Ways to modify printed materials to make them easier to use

Figure 2 shows the extent to which men of differing reading levels reported the use of job materials. Since each man could give, at the most, five citations of the use of reading materials, five citations is 100% of the maximum possible; four citations would be 80% of the maximum possible, and so forth. As shown in the figure, for Supply Clerks and Mechanics, the higher the reading level the greater the reported use of job

Reading Ability and Use of Job Reading Materials

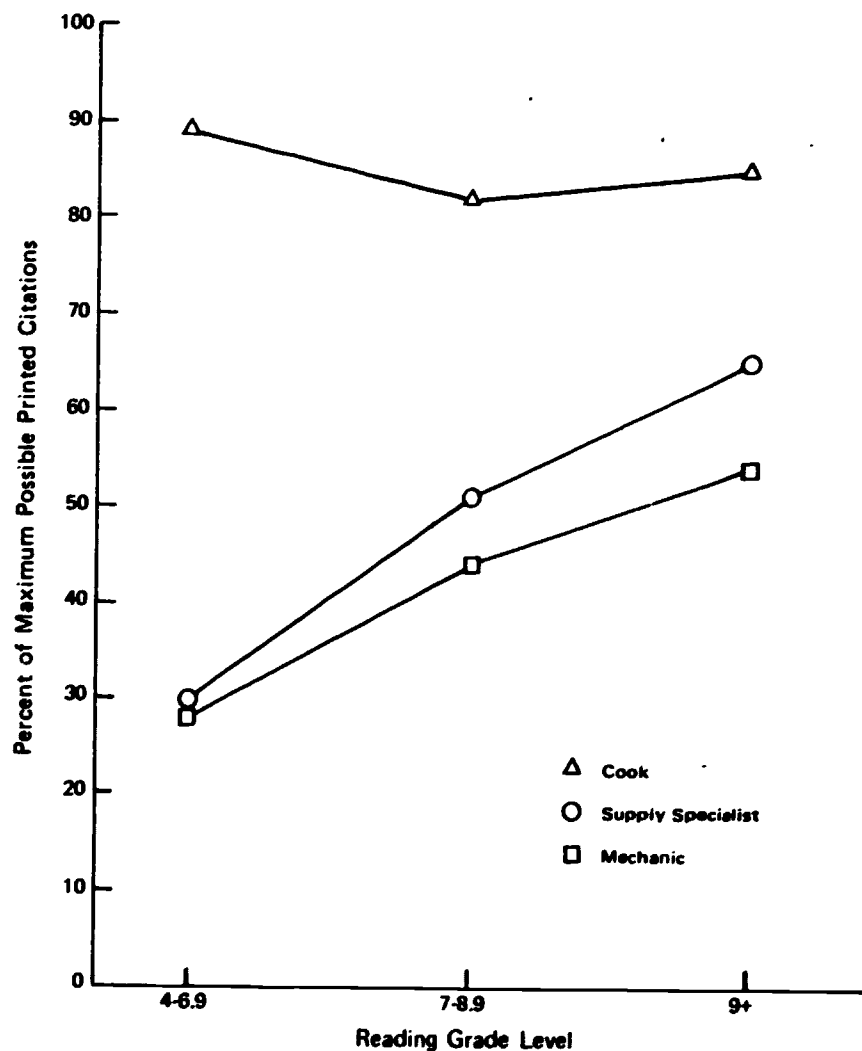

Figure 2

reading materials. For Cooks, there was a high reported usage of materials, mostly recipe cards. In general, however, the importance of these data is that they suggest that men who have higher literacy skills will use job reading materials more frequently.

The main purpose of the structured interview was to obtain samples of job reading materials actually used by job incumbents. With the materials in hand, we constructed reading tests using photocopied samples of actual job reading material, and asked questions to determine how well people could locate and extract information from the job reading materials. We administered the Job Reading Task Tests (JRTT) for Mechanic's, Supply Clerk's, and Cook's reading material to several hundred men at the Fort Ord reception station. We also administered a standardized reading test, so we could see how performance on the JRTT varied as a function of general reading ability.

Data for men tested on the Cook's, Repairman's, and Supply Clerk's job reading task tests are shown in Figure 3, which gives the percentage of men at each reading grade

Men at Each Reading Grade Level Reaching Different Criterion Levels on Reading Task Test (percent)

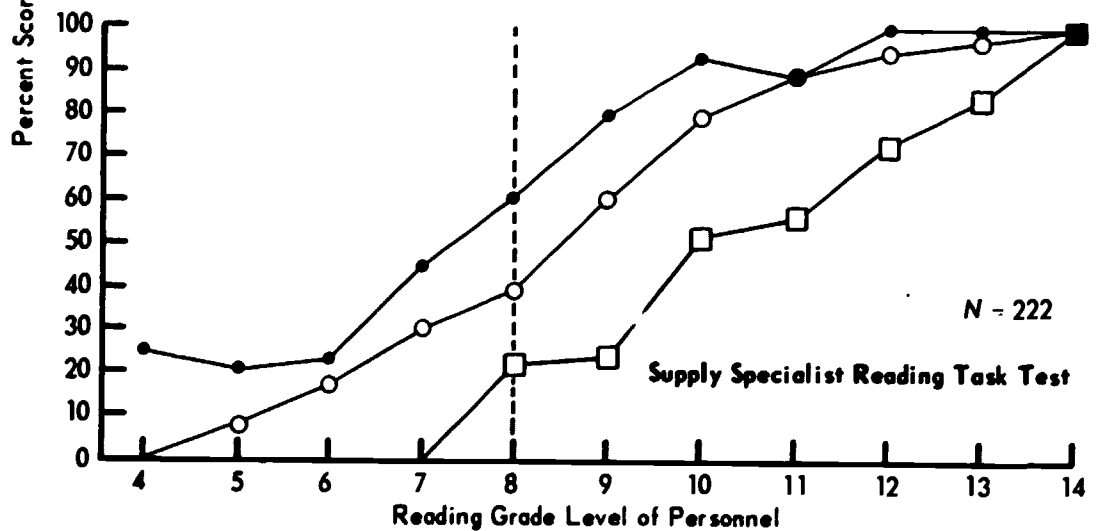
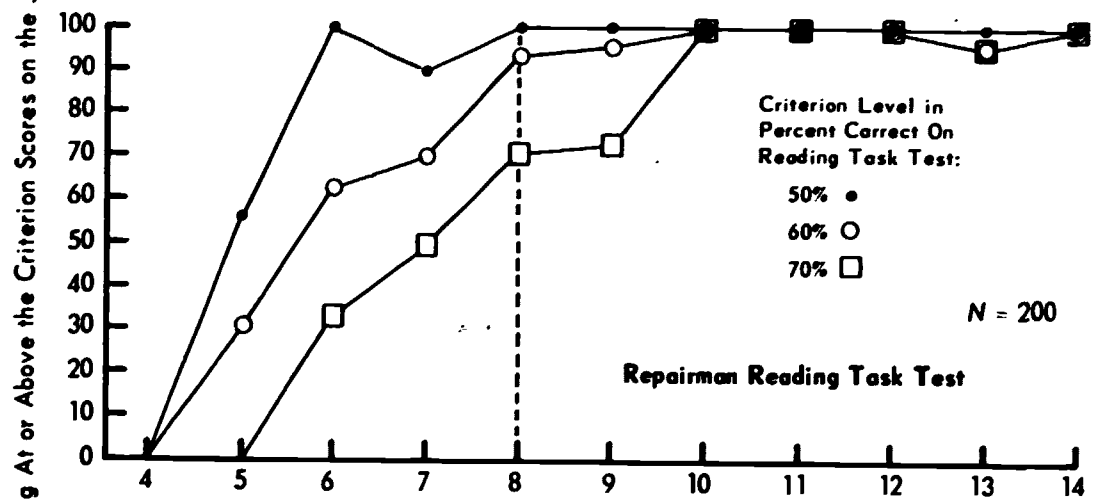
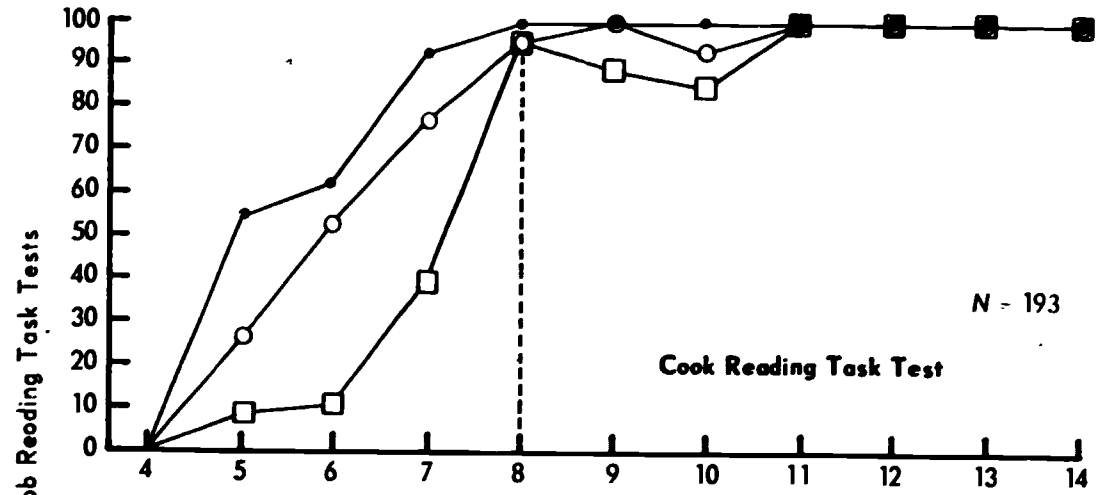

Figure 3

level who achieved either 50, 60, or 70% correct on the JRTT. Thus, for the Repairman's test, some 70% of the men who read at the eighth grade level achieved 70% correct. For Supply Specialists, only 20% of the men reading at the eighth grade level scored 70% correct or better on the Supply Clerk's JRTT. These curves clearly show that the Cook's job reading materials are easier than the Repairman's, which, in turn, are easier than the Supply Clerk's materials.

If management wanted literacy training to provide reading training up to the point where 70% of the men could get 70% correct on the JRTT (the 70/70 criterion typically used in the Army and other services), the minimal literacy level for the Cook's field would be 7 to 8, for Repairmen it would be 8, and for the Supply Clerks it would be 12.0! This clearly exceeds the current APT goal of 5.0. Even the generous objective of 70/50 would suggest a minimum targeted level of 6.0.

As a final approach to the problem of defining literacy demands of Army jobs, we studied job incumbents in the Armor, Mechanic, Supply, and Cook's jobs and compared their performance on literacy tests and on three measures of job proficiency. In the present paper, only data concerning the relationship of reading to job sample and job knowledge test performance will be considered. Complete reports, as previously noted, are available from HumRRO concerning the remaining relationships.

For this research, 400 men were tested in each job. The job sample tests are 4 to 5-hour individually administered tests in which men performed actual job tasks. Figure 4 shows a mechanic repairing a vehicle while the test administrator looks on. In Figure 5 a cook is shown performing a job sample test, while Figure 6 shows an Armor Crewman responding to Arm and Hand Signals in the Armor Crewman's job sample test. A Supply Clerk works in a simulated office performing a job sample test in Figure 7. As illustrated in the four figures, the job sample tests are actual hands-on job tasks.

The job knowledge tests were paper-and-pencil tests, constructed under the supervision of HumRRO research personnel in conjunction with Army content experts. The tests were designed to include questions about information actually needed to do the jobs.

The percentages of Cooks, Mechanics, and Supply Clerks at various reading grade levels who scored 50% or better on the job sample and job knowledge tests are shown in Figure 8. As with the job reading task tests, it is clear that reading ability is related to both of these measures of job proficiency, although, as expected, the relationship is strongest for the paper-and-pencil job knowledge test.

In the job sample data, the solid line is the average of the three jobs. If we choose the not-too-exacting criterion of literacy at which 70% get 50% correct on the job sample test, the minimal literacy level would fall in the seventh grade. It would be much higher for job knowledge, somewhere in the vicinity of the 12th grade!

Another way to consider the job proficiency and reading ability data is to see how well men perform relative to others in their job. Figure 9 shows data for Armor Crewmen. Here we have divided all the Armor Crewmen who took the job sample and job knowledge tests into four groups: the top 25% of performers, the next 25%, the next to bottom 25%, and the bottom 25%. For each reading ability level, we have presented the percentage of men in each quartile of proficiency. At the bottom of the figure is the pattern—that is, the proportion of men in each quarter—that we would expect to find if reading ability was not related to job proficiency—there would be 25% of all who took the test in each quartile. Over- or under-representation in each quartile occurs when there is a correlation between reading and job proficiency.

Because of this correlation we see that, for the job knowledge data, 59% of the readers in the 4 to 5.9 grade level were among the bottom of 25% of job performers. For the job sample data, 38% of the 4 to 5.9 grade level readers were in the bottom quarter of job performers.



**Repairman Test:
Wheelbearing Adjustment Problem**

Figure 4



**Cook Test:
Job Skill Demonstration**

Figure 5



**Armor Crewman Test:
Arm and Hand Signals**

Figure 6



**Supply Specialist Test:
Set-up for Problem**

Figure 7

Reading Ability and Job Proficiency

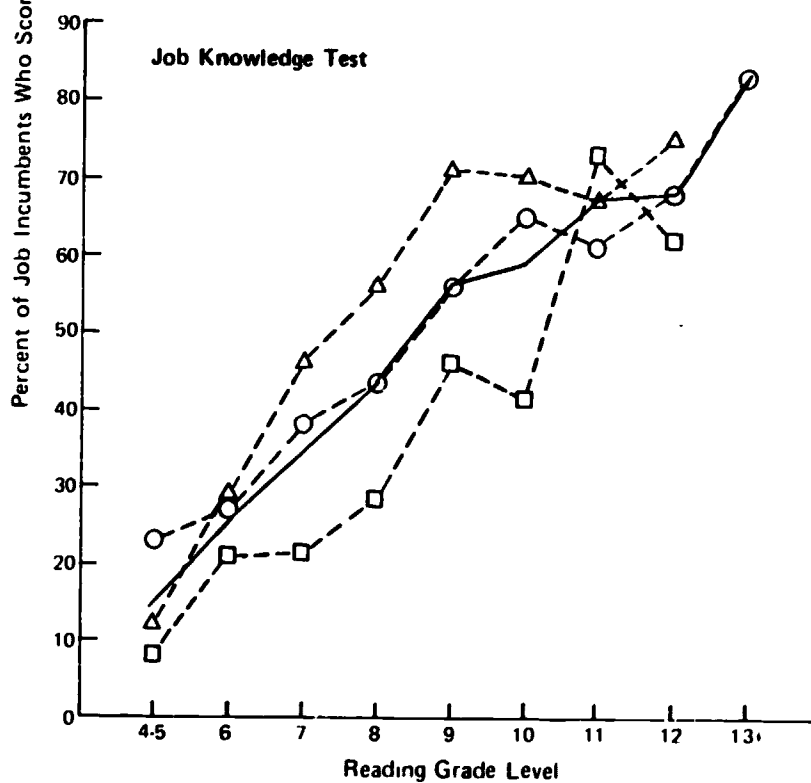
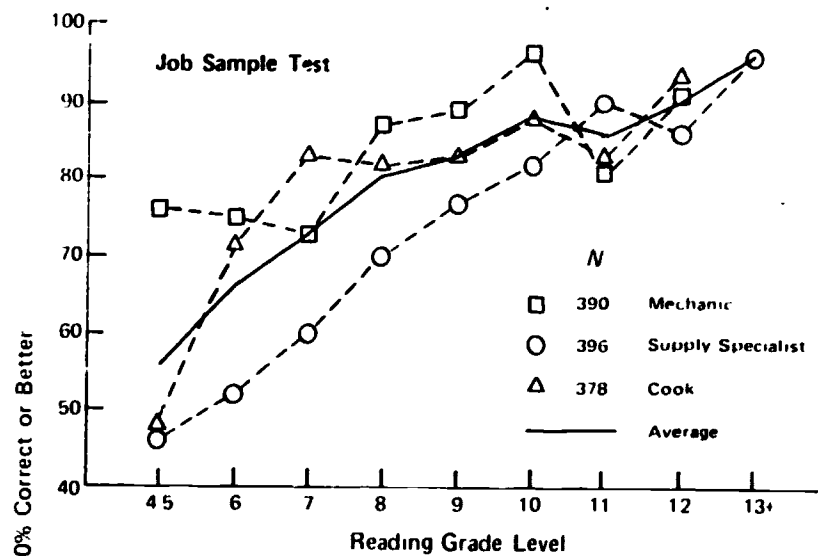

Figure 8

Quarter Distributions of Job Knowledge and Performance
by Reading Grade Level: Armor Crewman (MOS 11E)

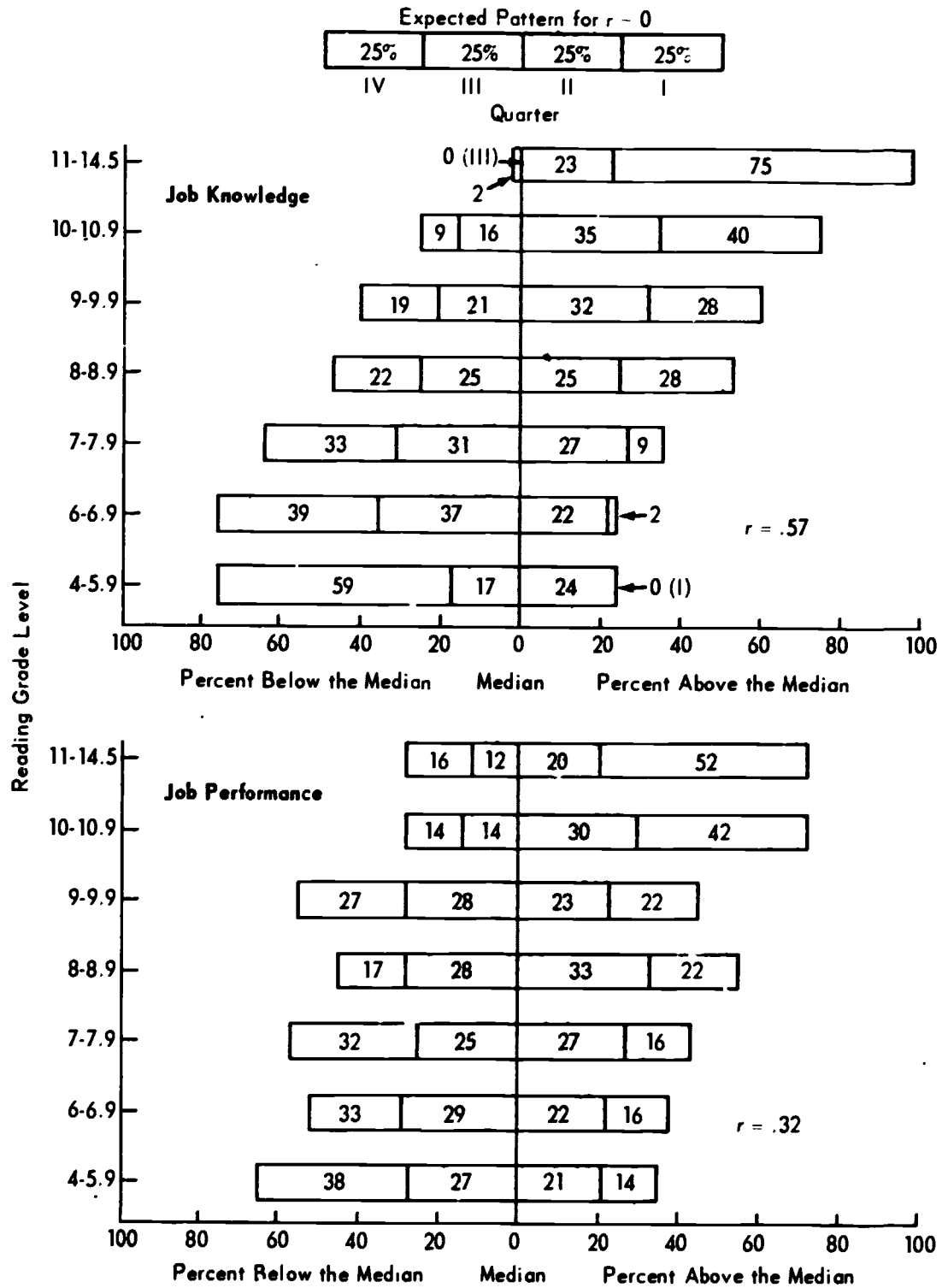

Figure 9

A similar finding holds for all four jobs, as the "visual impact" figure (Figure 10) shows.

To illustrate how these data establish the general minimal level of literacy for Army jobs, I will use the job sample data (Figure 11). What we did was to choose a decision rule stating that the lowest level of literacy that should be used to establish goals for literacy training is the level at which men would not be expected to be over-represented in the bottom quartile of performers. Looking at the Cook's job knowledge data, we see that only at the 7-7.9 level does representation in the bottom quarter fall equal to or below the expected 25%. Similarly, for the job sample data, the 7-7.9 level is the one at which people are not over-represented in the bottom quarter of performers. Thus, for both types of data, a seventh grade level of reading proficiency seems desirable.

Similar analyses applied to the Armor Crewman and Mechanic data suggest minimal levels of 8.0, while the Supply Clerk's job would be best provided for by a literacy program targeted to ninth grade reading ability.

These analyses, coupled with the extensive data on job reading task test performance and on the readability of Army materials, suggest the conclusion that the *minimum* functional literacy level for the Army is seventh grade reading ability. Thus, remedial literacy training ought to be targeted to this level as a *minimum*.

Reading Ability of Army Personnel

Up to this point I have discussed HumRRO research that has focused on the reading demands of Army Jobs. The other side of the Army's literacy problem concerns the reading ability levels of the personnel available to do the jobs. We have obtained several estimates of the reading ability levels of Army personnel.

One set of data (Table 1) comes from Work Units REALISTIC and UTILITY, and show the reading ability levels of personnel just after Project 100,000 began. About 15% of the total Category IV sample were members of Project 100,000. As shown in the table, about 40% of the Mental Category IV personnel read below the 7.0 grade level, compared to only 8% of the non-Category IV men.

Table 1
Reading Ability Levels for
Army Job Holders—
UTILITY-REALISTIC Data
(percent)

Reading Grade Level	Mental Category IV (N=762)	Non-Category IV (N=774)
13+	0	7
12-12.9	0	10
11-11.9	0	7
10-10.9	3	19
9-9.9	12	23
8-8.9	17	14
7-7.9	28	12
6-6.9	24	6
5-5.9	12	2
4-4.9	4	0
Total	100	100

} 40 } 8

Quarter Distributions of Job Knowledge and Performance by Reading Grade Level:

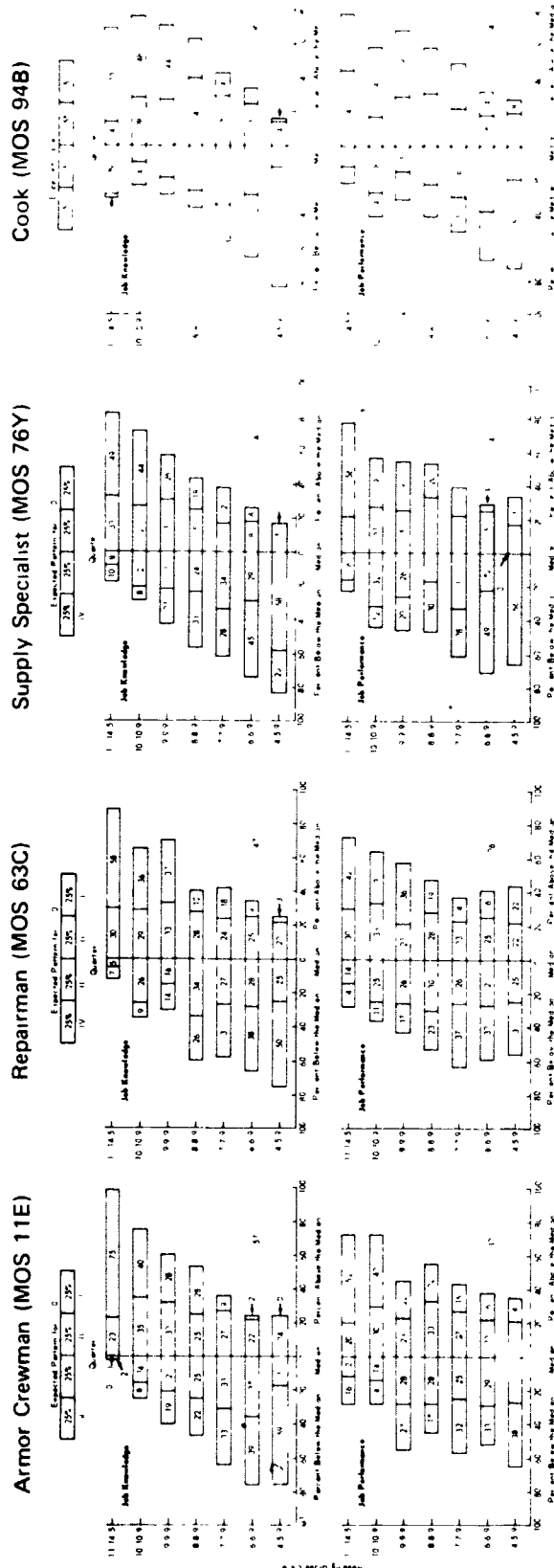

Figure 10

Quarter Distributions of Job Knowledge and Performance
by Reading Grade Level: Cook (MOS 94B)

Expected Pattern for $r = 0$

25%	25%	25%	25%
IV	III	II	I

Quarter

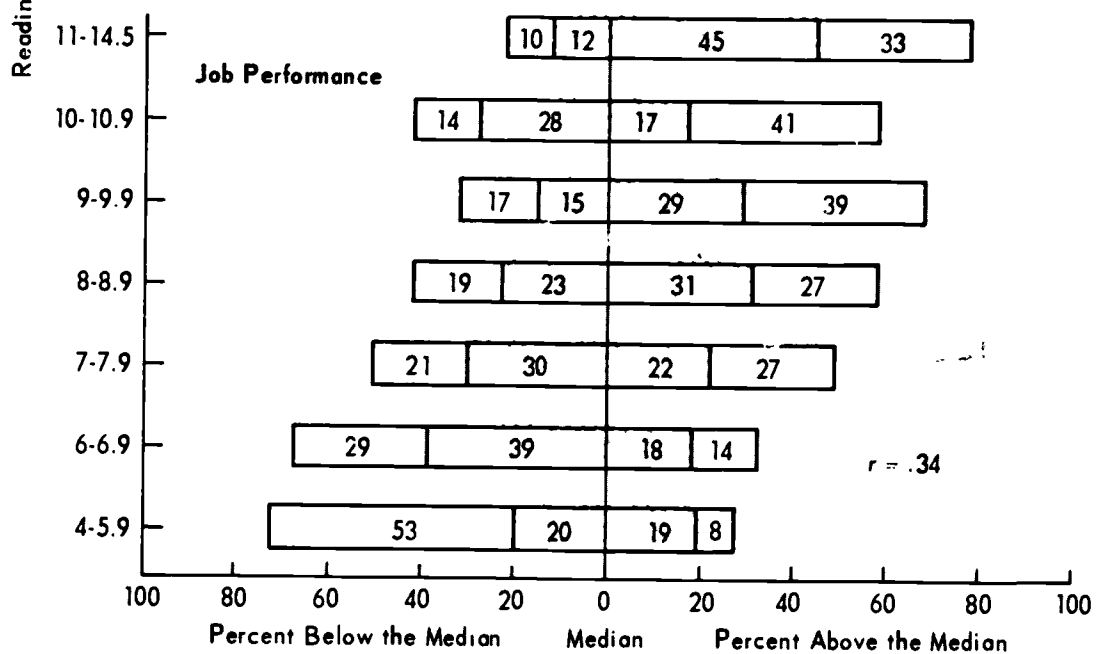
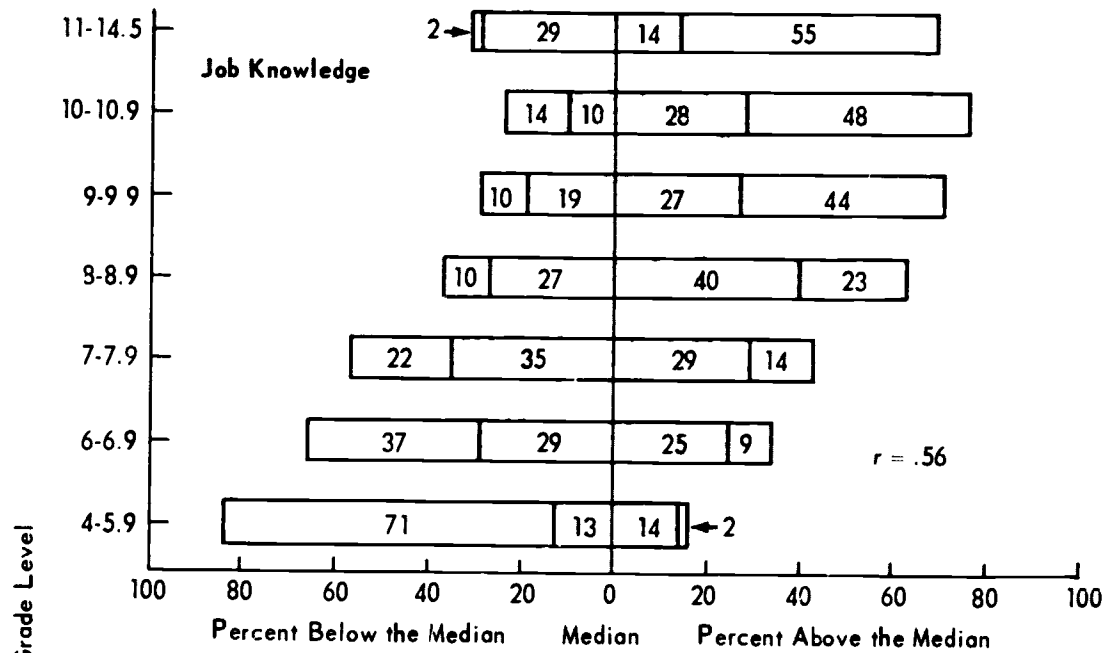

Figure 11

These data represent, to a large part, pre-Project 100,000 distributions of reading ability levels. Table 2 data were obtained at Fort Ord in September 1970 and September 1971 in conjunction with the development of Job Reading Task Tests on Work Unit READNEED, while Project 100,000 was in full swing. The table shows the percentage of men in each Armed Forces Qualification Test (AFQT) decile who scored below the three reading grade levels. The last column indicates that as many as 12% of those with AFQTs of 40-49 may read below the seventh grade level, and that the proportion increases as AFQT decreases.

Table 2
AFQT and Reading Ability
(percent)

AFQT	Reading Grade Level (N=2,300)		
	5	6	7
90-99	0	0	0
80-89	0	1	3
70-79	0	0	0
60-69	2	8	12
50-59	2	2	2
40-49	5	8	12
30-39	3	10	22
20-29	9	24	37
10-19	3	26	53

Our most recent data on the reading levels of Army personnel were obtained in February and March 1972 when we monitored the reading testing of Category IV men at all Army APTs. During this period, CONARC reviewed the continued need for APT after Project 100,000 was discontinued and entry requirements for Category IV men were raised. These data are for post-Project 100,000 personnel. Data from five APTs concerning the numbers and percentages of Category IV men scoring at various reading grade levels are presented in Table 3. The last column shows the cumulative percentage of men, and indicates that 11% of men scored below the 5.0 level, the target level for the current APT program. Thirty-three percent fall below the 7.0 level recommended by HumRRO on the basis of the data reviewed earlier.

From these data, we can make estimates of the continued need for remedial literacy training in the Army. If the current APT target of 5.0 is maintained, 11% of Category IV personnel fall below this level. Rounding a little, we can say that some 10% of Category IV men will qualify for APT. Since, by DoD quota directives, Category IV men can be expected to make up at least 20% of the Army's input, some 10% of 20% of all recruits will qualify for APT. If the Army input in a year is 100,000 men, 20,000 will be Category IV men, of whom 2,000 will qualify for APT under present standards.

If the standards are raised to 7.0, then 33% of the new, higher quality Category IV men, or roughly 6,500 men per year (based upon 100,000 input), are predicted to qualify for remedial literacy training.

Table 3
**Reading Levels of Category IV
 Men Screened for APT^a**
 (N=1,625)

Reading Grade	Number	Percent	Cumulative Percent
2.0-2.9	6	0	0
3.0-3.4	14	1	1
3.5-3.9	28	2	3
4.0-4.4	39	2	5
4.5-4.9	91	6	11
5.0-5.4	89	5	16
5.5-5.9	97	6	22
6.0-6.4	114	7	29
6.5-6.9	71	4	33
7.0-7.9	288	18	51
8.0-8.9	242	15	66
9.0-9.9	191	12	78
10.0-10.9	147	9	87
11.0-11.9	141	9	96
12.0-12.6	67	4	100

^aTest Period, Feb-Mar 1972, Forts Ord, Jackson, Leonard Wood, Dix, and Knox

Summary of HumRRO's Work on Defining the Literacy Problem

At this point, I would like to briefly summarize what I think we have learned about the Army's literacy problem. We have seen that (a) by a variety of methods, the reading demands of Army jobs, even the less complex ones, far exceed the reading ability levels of many personnel; (b) there is a positive relation between reading ability and job proficiency; (c) the present goal of Army remedial literacy training falls considerably short of the reading demands of the jobs; and (d) even with the higher mental aptitude enlistment standards, there is a continued need for remedial literacy training, whether the objective is fifth grade ability or the more realistic minimal objective of seventh grade ability. This need will most likely grow as the Army moves toward an all volunteer force.

DEVELOPING JOB-RELATED, FUNCTIONAL LITERACY TRAINING

Work Unit FLIT: Objectives and Procedures

I now want to turn to HumRRO's present, CONARC-sponsored literacy research—Work Unit FLIT (*F*unctional *L*iteracy). This Work Unit was initiated in September 1971 as a result of discussions between HumRRO and CONARC regarding the apparent discrepancies between the literacy demands of jobs, as described above, and the current objectives of Army Preparatory Training.

The general objective of FLIT is to develop a prototype literacy training program for the Army that will provide a level of functional literacy appropriate to present *minimal* MOS reading requirements. The program developmental effort operates under two major constraints: The program is not to exceed the present APT duration of six

weeks, and it is not to lower current APT standards (i.e., grade 5.0 achievement). Within these constraints, the FLIT developmental effort is concerned with the total set of components in an instructional system, including selection of students and instructional staff, development of instructional curriculum, materials, and methods, and program evaluation.

The developmental program got under way around 1 October 1971, and is presently scheduled for completion 30 June 1973. If desired by the Army, an implementation-dissemination phase will be undertaken during FY 71.

In planning for the FLIT experimental program, visits were made to APTs at Forts Dix, Jackson, Polk, Lewis, and Ord, as well as the Air Force literacy school and the large Job Corps center at San Marcos, Texas, in order to locate exemplary practices for possible inclusion in the FLIT program. Site visits to the APT schools showed that a wide variety of programs were in effect, but nothing of an exemplary nature. Both civilian and military personnel were found as instructors; administrators were always civilian; and there were no consistently applied criteria for selecting instructors—most had college degrees, but many had had no experience in adult basic education. In some cases, school administrators had no training either in reading or in education administration.

Materials differed from one APT to another, and ranged from an almost totally programmed, mechanized, expensive system especially designed for young adults to a heavy reliance on the "Private Pete" series developed in World War I, reinforced by some more current workbooks from United States Armed Forces Institute (USAFI). Information about the success rates of the APT schools for FY 1970 and 71 was obtained from CONARC. Table 4 shows the number of men processed through each of eight APTs and the percentage of men who achieved the 5.0 level or above, in either Week 1, Week 3, or Week 6, the final week of APT.

The percentage of men who achieved 5.0 in the first week varies from none at Fort Ord to 70% at Fort Knox, with the overall average for CONARC at about 25%. The variation among APTs reflects the fact that testing in Week 1 of APT is not mandatory in CONARC directives; rather, teachers are permitted to recommend for retesting those whom they feel are qualified in the first week. Data obtained from the Fort Ord APT during special testing conducted during Week 1 indicated that about 50% of the people qualified for graduation within two days of their arrival at APT. A basic conclusion from these data is that much of APT success can be attributed to testing artifacts, not the least of which is the hectic pace of the reception station testing.

Additional activities during the planning phase of FLIT involved the collection of data from the APT school at Fort Ord and the Air Force literacy program. The data provide a standard to which the FLIT achievement data may be compared relative to other military programs.

As a consequence of our visits to the APT schools and a survey of literature on the ineffectiveness of previous Army, Navy, and Air Force attempts at literacy training, we concluded that (a) past achievement data reflect large amounts of testing artifact, (b) the fifth grade reading level is inadequate for Army career fields, and (c) if a literacy training program of six weeks' duration is to have any direct effect on a man's subsequent job performance—either in job training or on the job—the literacy training should deal directly with the kinds of reading tasks the students encounter in AIT and on the job.

With these considerations in mind, we have developed a literacy program that differs considerably from the current APT program. Both APT and FLIT are six weeks in duration—beyond this there is not much similarity.⁴ The objective of APT is grade level

⁴ Actually, FLIT is only 26 days rather than 30 days, because we must test men on Tuesday of the last week to get orders for AIT/CST by the end of the week, and to let men out-process

Table 4
Achievement Data for Army APT,
FY 1970, and 1971

APT	Percent Who Achieved 5 0 Level				Percent Below 5 0	Percent Administrative Drop	N
	Total	Week					
		1	3	6			
Fort Polk	86	8	66	13	10	4	1,917
Fort Campbell	86	2	73	12	10	4	2,333
Fort Knox	83	70	9	4	12	5	3,068
Fort Dix	78	29	28	21	13	10	2,514
Fort Jackson	75	20	40	16	20	4	2,006
Fort Lewis	73	10	41	23	19	8	1,168
Fort Ord	70	0	49	22	18	12	1,062
Fort Leonard Wood	70	16	46	8	19	11	468
CONARC	80	26	40	15	14	6	17,035

5.0 in general reading, while the objective of FLIT is to provide students with the ability to use their job reading materials with the competency of a person having at least 7.0 general reading ability. However, as the data presented earlier show, the Mechanic could use training up to a minimum of 8.0, while the Supply Clerk's job requirements are higher at 9.0. Thus, while the FLIT program tries to reach these higher levels, we know that there is a limit to what can be accomplished, therefore our official minimum goal is the 7.0 level.

The curriculum under the APT program is a General Education Development (GED) program consisting of six hours daily of reading, writing, English grammar, arithmetic, and social studies. In planning the FLIT program, we took note of the fact that all previous attempts to improve job proficiency through GED training have failed and also that the GED curriculum has little direct bearing on job reading tasks. For this reason, the FLIT program uses the six weeks available to train men explicitly in reading and extracting information from job reading materials. Although we also include a general reading program, which provides literature and practical information about consumerism, citizenship duties, and other information relevant to life management, our primary emphasis is upon job-related reading. Much behavioral science research has indicated that learning is more likely to transfer from the school to the job situation when the school tasks closely resemble the job tasks.

In order to focus reading training directly on a student's job reading materials, we must know what his job is going to be. Since this information isn't available until several weeks into Basic Combat Training, (BCT) we have scheduled the FLIT program *after* BCT. Our survey of the reading demands of BCT showed very little need for reading, especially under the new performance-oriented program.

Thus, by placing the FLIT program after BCT, the reading training can be focused directly on a man's MOS reading materials. Also, time and money are saved by not providing literacy training to men who cannot complete BCT. Of 185 men who qualified for FLIT at the reception station testing, 24 (13%) were discharged during BCT. Thus, the post-BCT location for FLIT training effects some immediate cost savings for literacy training.

The last two differences between the APT and FLIT programs, Instructors and Directorate, are interrelated. APT is now under the Director of Personnel and Community Activities (DPCA) and operated by the Education Office. For the most part, the Education Office hires civilian instructors, although military personnel may supplement the civilian instructional staff. The FLIT program, however, has been placed in the regular training pipeline between BCT and Advanced Individual Training (AIT) or Combat Support Training (CST). Being job-oriented, pre-MOS preparation, it is part of regular Army training, rather than an activity outside the training program for general educational development, which may, but probably will not, make the men more able job performers—especially in only six weeks of remedial GED. Since the FLIT program is considered an integral part of the Army training sequence, it is under the Director of Plans and Training (DPT), and uses military instructors (currently these instructors are research assistants from the U.S. Army Human Research Unit, Presidio of Monterey, California.) The FLIT experimental school is being conducted at Fort Ord.

The FLIT Instructional Program

An overview of the FLIT instructional program in job reading as of October 1972 is presented in Figure 12. This figure shows the flow of students through the FLIT job reading program. First, men are tested at the reception station using the present APT screening test, the USAFI Intermediate Achievement Test, Form D. Since we are aiming at 7.0 proficiency, we have raised the entry cutoff score from 4.9, the current APT cutoff score, to 6.1—.9 of a grade unit difference below the target goal of 7.0. This difference has been introduced to try to reduce the numbers of people who might erroneously be sent to FLIT, because of testing artifacts of the kind mentioned earlier (i.e., some 50 to 70% of present APT success might result from testing artifact). Present APT accepts people reading at 4.9 and sends them out at 5.0. As I will show later, testing artifacts may produce as much as .9 of a year's gain, so we have introduced this difference between selection and target grade levels.

If a man scores higher than 6.1, he goes directly to BCT; if he scores below 6.1, he is tagged for FLIT and then sent to BCT. If a man fails to complete BCT, he is no longer in the program. If he completes BCT and is not tagged for FLIT, he goes directly to AIT/CST; if tagged for FLIT, he is sent to the school and on the day of entry is administered the job reading task test for his MOS cluster, and the USAFI. If he performs well on both of these tests—about 7.5 averaged over the two tests—we initiate action to move him along to AIT/CST. If he does not do well, he is entered in the job reading program.

In the job reading program, he enters Module 1, where he studies tables of content from manuals in his MOS. He completes worksheets, both printed and audio, which resemble the job task. The worksheets deal with both the structure and the content of tables of content. At the end of Module 1, he takes a proficiency check consisting of a sample of the more difficult worksheets. If he passes the proficiency check with 90% correct in less than 10 minutes, he proceeds to the module on indexes.

This sequence of modules and proficiency checks proceeds through extracting information from the body of manuals, following procedural directions, filling out MOS and general Department of the Army (DA) forms, and extracting information from tables and graphs.

FLIT Job Reading Program as of October 72

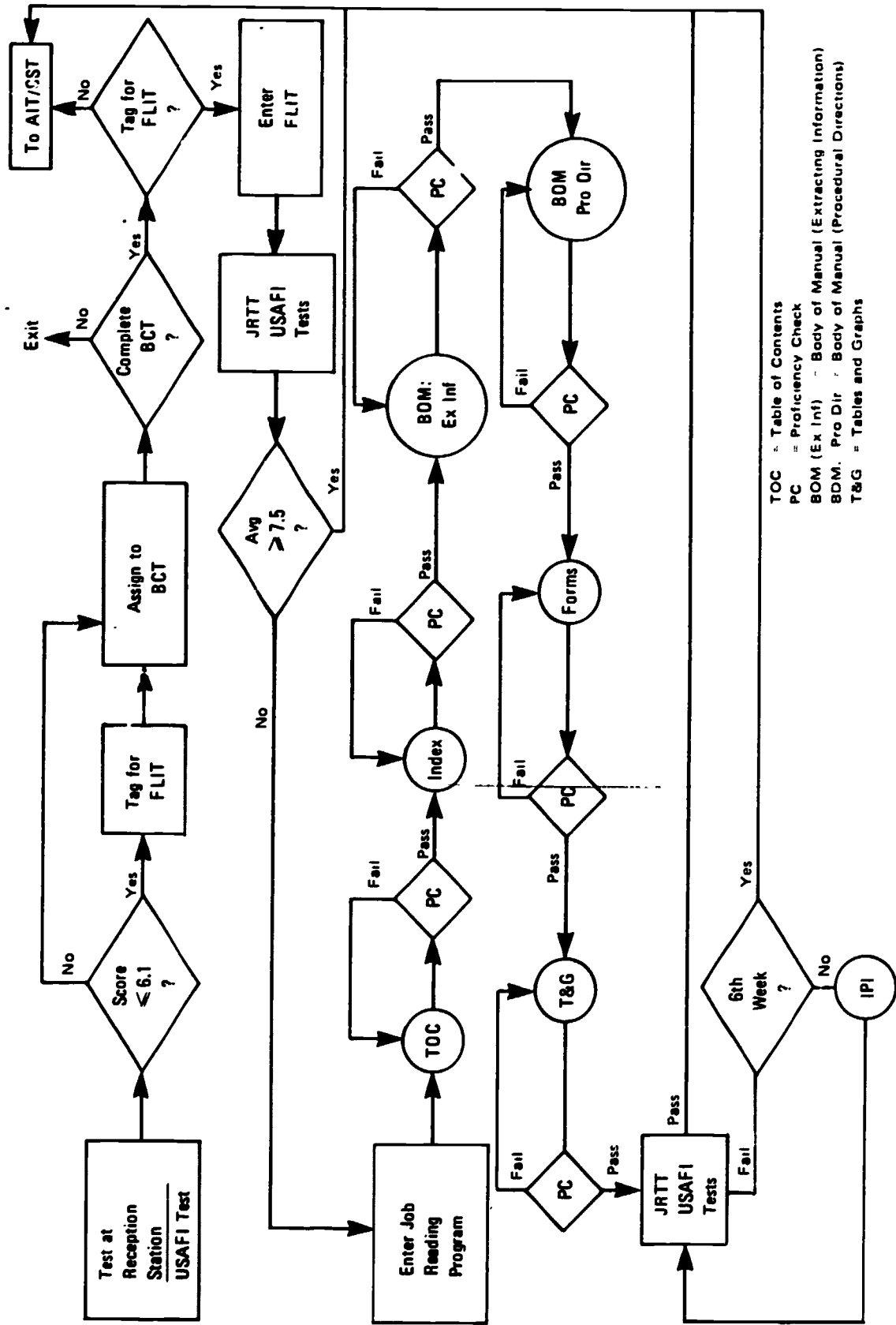

TOC = Table of Contents
 PC = Proficiency Check
 BOM (Ex Inf) = Body of Manual (Extracting Information)
 BDM, Pro Dir = Body of Manual (Procedural Directions)
 T&G = Tables and Graphs

Figure 12



At the end of this sequence, the man is retested on his JR TT and an alternate form of the USAFI test. If he passes both, or averages above the 7.0 level, he is released from FLIT with orders to AIT/CST. If he fails the end of program tests and is in the sixth week, he is sent along to AIT/CST. If he is not in the sixth week, his JR TT test scores are examined to see where he needs more training and an individually prescribed instructional sequence is made up for him. He continues this cycle until he passes the tests or six weeks are up, and is then sent along to AIT/CST.

The job reading program just described is currently in use with materials for six career clusters: Combat, Medic, Cook, Communication, Clerical, and Mechanical. The job reading materials for the Combat, Medic, Cook, and Communication Clusters are shown in Table 5, while Table 6 shows the materials for the Clerical and Mechanical clusters, as well as the various DA forms that are taught.

Table 5
Job Reading Materials for
Combat, Medic, Cook, and Communication Clusters

Combat	Medic	Cook	Communication
FM 7-11	FM 8-10	TM 10-405	TM 11-5805-201-12
FM 22-5	FM 8-35	TM 10-415	TM 11-381
FM 23-8	FM 8-50	TM 10-419	TM 11-2134
FM 23-11	TM 8-230	AR 30-1	TM 11-5805-262-12
FM 23-12		TM 10-412	TM 11-5820-401-10
FM 23-16			TM 11-5820-520-12
FM 23-67			FM 24-20
FM 23-90			TM 11-381
TM 9-1005-224-10			TM 11-5820-398-12
TM 9-1345-200			
FM 21-6			
FM 5-20			
FM 23-71			
FM 23-9			

The following series of figures (Figures 13 through 27) illustrate the FLIT Job Reading Program flow chart presented in Figure 12. The photographs show the progress of a man through the program, beginning with a picture of the FLIT school (a converted mess hall) and ending with a picture of a man who has successfully completed the USAFI and JR TT being presented with a certificate (ready to go on to AIT/CST).

In Figure 17, the reading worksheet packet assigned to the student will be for a table of contents, if it is the student's first week. In selecting an instructional guide (Figure 18) the student is receiving incidental training in filing skills. The instructional guides are photocopied parts of technical manuals that permit the student to focus on one part of the manual at a time. An advanced student uses manuals rather than instructional guides (Figure 19). After the USAFI and JR TT tests, if a man needs more instruction he is recycled through additional job reading.

This is the current job reading component of FLIT. As the developmental effort continues, we expect to modify this component and add job reading training that will emphasize basic word attack skills, higher level comprehension skills, and job concepts

Table 6
**Job Reading Materials for
 Clerical and Mechanical Clusters**

Clerical	Mechanical	DA Forms
AR 725-50	TM 9-2320-218-20	2765
AR 210-130	TM 21-305	2402
AR 735-11	TM 9-2320-209-10	2408
AR 700-84	TM 9-8000	2408-1
AR 710-2	TM 9-2320-209-20	2400
AR 710-1	TM 9-2320-218-10	2408-7
AR 735-5	TM 9-8024	2408-8
CTA 50-901	TM 9-243	2404
TM 38-750	TM 9-2320-244-20	2765-1
DA PAM 310-1	TM 21-300	2407
DA PAM 310-7	TM 38-750	DA-1
AR 680-1	FM 20-22	173
DA PAM 310-2		3034
FM 21-6		3327
		314
		2062
		201
		2867

and principles. The current materials that we are using for word attack and comprehension are non-job related and make up the other major component of the FLIT curriculum—the developmental, or general reading, component. The students usually divide their time between three hours of job reading and three hours of general reading per day.

The general reading is conducted in a manner similar to the job reading: A student receives a general reading work assignment sheet, then picks materials from one of the kits of graded difficulty level, or he may work on a graded novel with accompanying worksheets. After getting his materials, the student gets a starting time score, then works on his materials either independently or in a group listening to a selection. When he finishes his worksheet, a peer-scorer corrects it, and the man goes on to his next assignment.

In addition to this experimental core curriculum, we have reading, writing, and discussion activities over which instructors have discretionary control. In designing the FLIT program, we are careful to leave some discretionary time to the instructors, so as not to stifle their creativity and interest.

Characteristics of FLIT Students

For the first 16 classes, 170 men entered the FLIT program. Detailed descriptive data were obtained from an extensive questionnaire administered individually to the first six classes. This practice was halted because of the length of time required for the interview. The questionnaire was later reinstated as a take-home item, so we have data for about 130 of the 170 men. In the tables that follow, numbers fluctuate because of missing information.



Figure 13 *The FLIT school that a man enters after BCT—a converted Mess Hall.*



Figure 14 *A man taking the JRTT on his first day in the school.*



Figure 15 *A man taking the USAFI on his first day in FLIT.*



Figure 16 *After testing, the man enters the FLIT classroom and meets his instructor.*

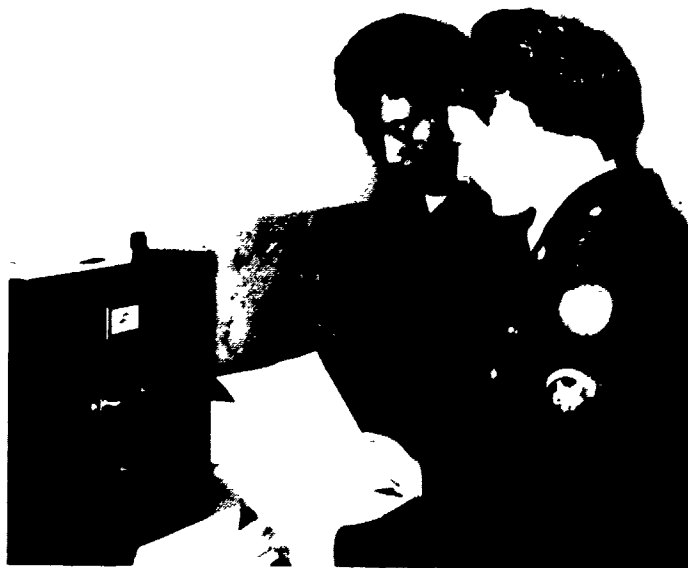

Figure 17 *The instructor assigns the student a job reading worksheet packet.*



Figure 18 *The student selects an instructional guide from a file cabinet*



Figure 19 *An advanced student selects his job manual.*



Figure 20 *After getting his worksheets and job manual, the student's starting time is recorded by a peer timer/scorer.*



Figure 21 *Students work on job reading worksheets.*

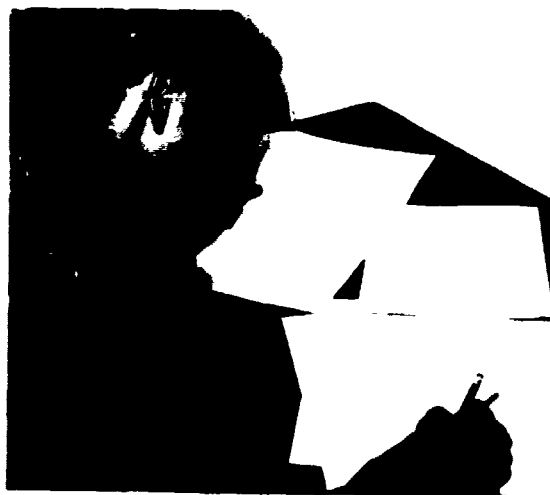

Figure 22 *Student working on forms module.*



Figure 23 *Student working on Cook's menu cards.*

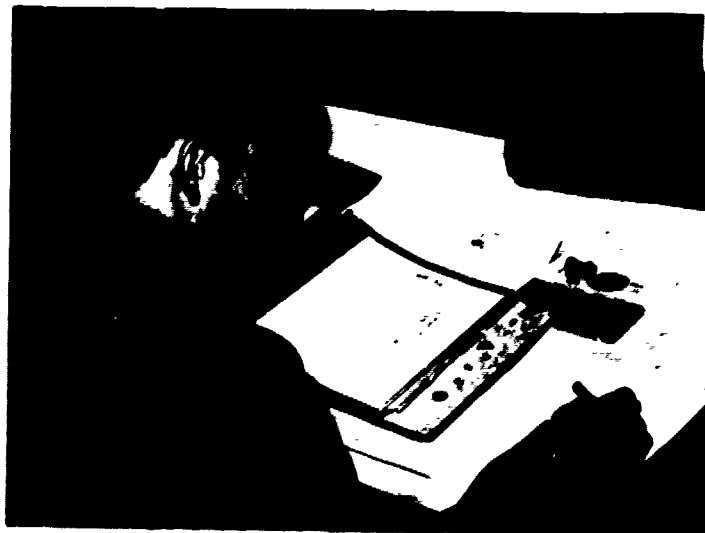

Figure 24 *Peer-scorer records accuracy and time scores on student's job reading records sheet.*



Figure 25 *Student taking proficiency check test at end of a module.*



Figure 26 *After the last proficiency check for the tables and graphs module, the man is administered the USAFI and JRTT tests.*



Figure 27 *Man who successfully completed the USAFI and JRTT is given a certificate.*

The ages and education levels of students in the first 16 FLIT classes are shown in Table 7. The median age is 19, and median years of education completed is 12. Eighty-five out of 130 (over 60%) reported having a high school diploma or GED equivalency, which contrasts sharply with the mean entry reading grade level of 6.0 in the data for the men in the first 12 classes.

The ethnic groups represented in the FLIT program offer quite a variety, as Table 8 shows. Some 2/3 of the men are non-Anglo-American. About 25% of the men in the FLIT program up to now have been foreign born, with more than one-half these men having lived in this country for one year or less.

Table 7

**Age and Education Level of
FLIT Students—16 Classes**

Age	N	Education	N
17	9	7	3
18	15	8	5
19	40	9	14
20	44	10	17
21	7	11	10
22	3	12	69
23	5	13	7
24	2	14	2
25+	4	15+	4
Total	129	Total	131
		High School Diploma	81
		GED	4
		No High School Diploma	45
		Total	130

Table 8

**Ethnic Group and Foreign Born
FLIT Students—16 Classes**

Ethnic Group	N	Foreign Born	
		Time in USA (Months)	N
Anglo-American	49	1-3	10
Negro	17	4-6	2
Oriental	10	7-12	6
Spanish-American	23	24	4
Polynesian	27	36	3
American Indian	3	48	1
Total	129	60+	6
		Total	32
			(25%)

The large range of ethnic groups and number of foreign born individuals imply considerable language variation, which Table 9 confirms. Here we see that, although English is the primary language for more than 60% of the sample, many of the men have a primary language other than English, with Spanish the next most common language.

It is clear from these data that much of the literacy problem at the FLIT school goes beyond students having inadequate reading, decoding, or word-attack skills; much of the problem is a language problem. In the FLIT job reading program, the man with marginal English language skills is provided practice in using these skills in working with job reading materials.

Effectiveness of the Training Program

We are still in the earlier stages of our developmental work, so we have not yet constructed fully operational job reading task tests for the Combat, Communications, and Medic clusters. Therefore, I will present data only for the Cook, Mechanical, and Clerical clusters, for which we have operational JRTT, and for general reading achievement measured by the USAFI for everyone.

General reading data for men in the first 12 classes of FLIT are presented in Table 10. For comparison purposes, we also show data obtained from an Air Force report on the effectiveness of the general literacy program at Lackland Air Force Base, and data for 9,000 men who completed Army APT during FYs 1968 and 1969.

As Table 10 shows, 90 men participated in the first 12 classes of the FLIT program. Tested at the reception station, they had an average reading grade level of 5.1. After

Table 9

Language Background of FLIT Students—16 Classes

Language	Students' Primary Language	Language Spoken in Home
English	86	70
Tagalog	7	6
Spanish	11	26
Samoan	8	7
Japanese	2	2
Chinese	2	2
Korean	2	3
Guamanian	6	5
Eskimo	1	1
Micronesian	1	1
American Indian	2	2
Total	128	125

BCT, and on the first day in the FLIT school, they were retested on general reading, and scored 6.0, .9 of a grade unit above their reception station score. This is the gain I was talking about earlier when I said that .9 of a grade level gain can be attributed simply to testing artifacts.

The average exit score from FLIT was 7.2, a gain of 2.1 years if we compute gain in the FLIT program as the difference between the reception station and exit week scores,

Table 10

**General Reading: FLIT, Air Force, and
Army APT Literacy Programs**

Literacy Program	N	Average Grade Level			Unadjusted Gain	Adjusted Gain
		Reception Center	Week 1	Exit Week		
FLIT	90	5.1	6.0	7.2	2.1	1.2
Air Force	277	-	5.2	6.7	1.5	1.5
APT	8,999	4.0	-	5.6	1.6	.7

as is the policy in APT. The contrast with the Air Force and APT programs can be seen in the "Unadjusted Gain" column. In the "Adjusted Gain" column we have subtracted the .9 gain due to testing artifacts. We see that on general reading, the FLIT gain is 1.2 years, which is .3 below the Air Force and .5 above the current APT. With regard to the FLIT and Air Force differences I should point out that, unlike the FLIT program, which is oriented toward job-related reading, the Air Force program is explicitly geared to general reading, and in addition it is 13 weeks long, while the FLIT and APT programs are less than half that, at six weeks.

FLIT achievement scores on job reading task tests for Mechanic, Clerical, and Cook MOSs are shown in Table 11. These data are for men in the FLIT school who are going to be in one of these career fields, and who have received job-related reading training. The entry week scores are for the first week in the school, not for the reception station.

We note first that the men scored considerably higher on the JRTT than they did on the USAFI test during the first day in school. This may reflect the fact that the JRTTs are tapping special aptitudes for MOS-related reading, and that these men have special aptitudes for these MOSs, which is presumably why they were given the MOS.

Table 11

**Job Reading: FLIT, Air Force, and
Army APT Literacy Programs**

Literacy Program	N	Grade Level		
		Enter	Exit	Gain
Mechanics				
FLIT	14	7.6	10.0	2.4
Air Force	11	6.6	7.1	0.5
Clerical				
FLIT	16	7.3	10.0	2.7
Air Force	19	5.7	6.6	0.9
Cooks				
FLIT	6	5.2	7.3	2.1
Air Force	26	6.1	6.6	0.5
APT	47	4.6	5.7	1.1

Thus the *average* score for Mechanic is above the 7.0 minimum competency level, but still below the eighth grade level which the research described earlier indicates would be desirable for Mechanics. Similarly, the Clerical average entry score of 7.3 exceeds the 7.0 minimum, but is well below the ninth grade level suggested as minimal for the Clerical field.

The small number of Cooks surprised us a little, as we expected many more marginally literate men to be assigned to the Cook's field. At any rate, their entry reading level is well below the 7.0 minimum estimated for Cooks.

Exit scores are fairly uniformly 2 to 2.5 grade units above the entry level scores.

Again, we have some basis for evaluating the FLIT program by comparing FLIT data to data obtained from small numbers of Air Force personnel who took the JRTTs on their first and last weeks in the Air Force general reading program. The differences in gain are substantial.

For the Cook's test, we also have data on APT students tested at Fort Ord during FY 1971. Their gain is better than the Air Force's gain, but still a year below the FLIT gain.

Table 12 shows the percentage of men in the FLIT school who scored at the minimum of 7.0 on the USAFI and one of the JRTT at entry and exit from the program. On general reading, none of the men scored above 7.0 at the reception station—this was by definition, since 6.1 was our cutoff score. On the first day in FLIT, however, 27% scored above the 7.0 level, while at the exit week, 58% obtained the 7.0 level, for a 31% gain in numbers achieving the seventh grade level in general reading.

We see comparable percentage gains for Mechanical, Clerical, and Cook personnel who achieved 7.0 on the JRTT. Again we note that more than half of the Mechanics and Clerks were above the 7.0 level on the entry week tests, with more than 90% achieving 7.0 level at the end of their training. Cooks went from 17% to 50% above the 7.0 level, although with only six students these percentage changes must be regarded with caution.

Table 12
FLIT Program
Percent Achieving Grade Level 7.0

Testing	Reading Test							
	General		Mechanics		Supply		Cooks	
	N	%	N	%	N	%	N	%
Reception Station	90	0
Entry Week	90	27	14	57	16	57	6	17
Exit Week	90	58	14	93	16	94	6	50
Gain		31		36		37		33

This, then, is the program, the people, and the progress of the FLIT developmental effort after 16 weeks of input, or about one-third of the way through the operational phase of developmental effort. We believe that the data obtained so far offer encouragement for continued effort.

As in the past, the FLIT developmental effort will continue to be guided by these principles which have proven successful in a wide variety of training contexts:

(1) Functional Training. Through the use of actual job reading material, the man sees the purpose for the reading training in concrete terms of job proficiency, not in general educational development, which they have failed many times in the past.

(2) Performance Orientation. This training permits the men to perform the kinds of reading tasks they will encounter in job training and out on the job; thus there is a direct transfer of skills learned in FLIT to the AIT/CST and job.

(3) Individualization. Individualized training permits men to work at the rate suitable for them, and with materials oriented toward *their* jobs.

(4) Student Assistance. Students participate as instructional aides and peer-instructors to relieve pressures on teachers and to help "stamp in" what they learn in FLIT.

(5) Quality-Control. During training, quality control in the form of modular instructional units with end-of-module proficiency checks aims to provide students and instructors with immediate feedback about learning achievements and deficiencies, so that corrective action can be taken.

(6) Follow-Up. Questionnaires to follow up FLIT graduates provide feedback for making the FLIT job reading program faithful to the AIT/CST reading demands. To date we have sent out 50 follow-up questionnaires, and have had 10 (or 20%) returned. Eight out of 10 felt that one or more of the FLIT activities helped them in their MOS training, and three have suggested additional material to be included in the FLIT school. We believe that with this continued interaction between the development staff and FLIT graduates, gaps between job reading demands, job reading training, and personnel reading skills will continue to be closed.

Unclassified

Security Classification

DOCUMENT CONTROL DATA - R & D		
<i>(Security classification of title, body of abstract and indexing annotation must be entered when the overall report is classified)</i>		
1 ORIGINATING ACTIVITY (Corporate author) Human Resources Research Organization (HumRRO) 300 North Washington Street Alexandria, Virginia 22314		2a REPORT SECURITY CLASSIFICATION Unclassified
		2b GROUP
3 REPORT TITLE HumRRO's LITERACY RESEARCH FOR THE U.S. ARMY: PROGRESS AND PROSPECTS		
4 DESCRIPTIVE NOTES (Type of report and inclusive dates) Professional Paper		
5 AUTHOR(S) (First name, middle initial, last name) Thomas G. Sticht, John S. Caylor, Lynn C. Fox, Robert N. Hauke, James H. James, Steven S. Snyder, and Richard Kern		
6 REPORT DATE January 1973	7a TOTAL NO OF PAGES 31	7b NO OF REFS 3
8a CONTRACT OR GRANT NO DAHC-C-73-0004	8b. ORIGINATOR'S REPORT NUMBER(S) HumRRO-PP-2-73	
b. PROJECT NO 2Q062107A745		
c.		
d.	9b OTHER REPORT NO (S) (Any other numbers that may be assigned this report)	
10 DISTRIBUTION STATEMENT Approved for public release; distribution unlimited.		
11 SUPPLEMENTARY NOTES Div. No. 3, Presidio of Monterey, Calif.	12 SPONSORING MILITARY ACTIVITY Office, Chief of Research and Development Department of the Army Washington, D.C. 20310	
13 ABSTRACT This report summarizes literacy research performed in HumRRO Work Units REALISTIC, READNEED, and FLIT. Data are reported that show reading demands of various Army jobs, and reading ability levels of personnel prior to, during, and after Project 100,000. Research and development of a new job-related, functional literacy training program for the Army is described.		

DD FORM 1473
1 NOV 66

Unclassified

Security Classification

Unclassified

Security Classification

14 KEY WORDS	LINK A		LINK B		LINK C	
	ROLE	WT	ROLE	WT	ROLE	WT
Army training Comprehension of reading Literacy training MOS training Readability						

ERIC Clearinghouse
MAR 27 1973
on Adult Education

Unclassified

Security Classification