

DOCUMENT RESUME

ED 072 299

VT 018 805

AUTHOR Raudenbush, David B.
TITLE Automotive Pollution Control.
INSTITUTION Deptford Township Area Vocational School, N.J.; New Jersey State Dept. of Education, Trenton. Div. of Vocational Education.; Rutgers, The State Univ., New Brunswick, N.J. Curriculum Lab.
PUB DATE Apr 73
NOTE 86p.
AVAILABLE FROM David B. Raudenbush, Automotive Pollution Control, N. J. Voc-Tech Curriculum Laboratory, Building 4103, Kilmer Campus, New Brunswick, N. J. 08903
EDRS PRICE MF-\$0.65 HC Not Available from EDRS.
DESCRIPTORS *Air Pollution Control; *Auto Mechanics; Learning Activities; Lesson Plans; *Manuals; Secondary Grades; *Supplementary Textbooks; Visual Aids; Vocational Development; *Vocational Education
IDENTIFIERS *New Jersey

ABSTRACT

Intended for a 1- or 2-month curriculum in auto mechanics, this student manual on automotive pollution control was developed by a subject matter specialist at an area vocational school and tested in a vocational auto shop. Intended either for use in an integrated curriculum or for use in teaching pollution control as a separate course, these 12 instructional units contain lessons covering the design, functioning, and service procedures for devices used to control crankcase emissions, exhaust emissions, and fuel evaporation in automobiles. For each lesson, a behavioral objective precedes topical reading materials and questions useful for review or assignment purposes. Working diagrams illustrate the text, which includes introductory teaching suggestions. (AG)

ED 072299

STATE OF NEW JERSEY
DEPARTMENT OF EDUCATION
DIVISION OF VOCATIONAL EDUCATION

AUTOMOTIVE

POLLUTION

CONTROL

DAVID B. RAUDENBUSH, INSTRUCTOR
DEPTFORD TOWNSHIP AREA VOCATIONAL SCHOOL
DEPTFORD, NEW JERSEY

VT018805

MEMORANDUM

Revised 5/69

TO: The ERIC Clearinghouse on Vocational and Technical Education
The Ohio State University
1900 Kenny Road
Columbus, Ohio 43210

FROM: (Person) Benjamin Shapiro, Director (Agency) N.J. Voc-Tech Curriculum Lab
(Address) Building 4103 - Kilmer Campus, New Brunswick, N.J. 08903

DATE: January 5, 1974

RE: (Author, Title, Publisher, Date) David B. Raudenbush, AUTOMOTIVE POLLUTION CONTROL,
N.J. Voc-Tech Curriculum Laboratory, April 1973, (available now)

Supplementary Information on Instructional Material

Provide information below which is not included in the publication. Mark N/A in each blank for which information is not available or not applicable. Mark P when information is included in the publication. See reverse side for further instructions.

(1) Source of Available Copies:

Agency N.J. Voc-Tech Curriculum Laboratory, Rutgers University
Address Building 4103 - Kilmer Campus, New Brunswick, N.J. 08903
Limitation on Available Copies NO LIMITS Price/Unit \$2.00
(quantity prices) _____

(2) Means Used to Develop Material:

Development Group Individual authorship by subject matter specialist
Level of Group Regional
Method of Design, Testing, and Trial Designed by subject matter specialist
and tested in vocational auto shop

(3) Utilization of Material:

Appropriate Educational Setting Vocational High School
Type of Program High school class
Occupational Focus Auto mechanics
Geographic Adaptability Variable depending upon state legislation
Uses of Material Student workbook
Users of Material Students

(4) Requirements for Using Material:

Teacher Competency Subject matter certification
Student or Trainee Selection Criteria Auto mechanics student
Time Allotment Variable - 1-2 months

Supplemental Media --
Necessary _____ } (Check Which)
Desirable _____ }

Describe _____
Source (agency) _____
(address) _____

ED 072299

U.S. DEPARTMENT OF HEALTH,
EDUCATION & WELFARE
OFFICE OF EDUCATION
THIS DOCUMENT HAS BEEN REPRO-
DUCED EXACTLY AS RECEIVED FROM
THE PERSON OR ORGANIZATION ORIG-
INATING IT. POINTS OF VIEW OR OPIN-
IONS STATED DO NOT NECESSARILY
REPRESENT OFFICIAL OFFICE OF EDU-
CATION POSITION OR POLICY.

State of New Jersey
Department of Education
Division of Vocational Education

AUTOMOTIVE POLLUTION CONTROL

Prepared by:
David B. Raudenbush, Instructor

Thomas Glasgow, Director
Deptford Township Area Vocational School
Deptford, New Jersey

Vocational-Technical
Curriculum Laboratory
Rutgers - The State University
Building 4103 - Kilmer Campus
New Brunswick, New Jersey

April 1973

**DIVISION OF VOCATIONAL EDUCATION
STEPHEN POLIACIK, ASSISTANT COMMISSIONER
MORTON MARGULES, ASSOCIATE DIRECTOR**

**CURRICULUM LABORATORY
RUTGERS - THE STATE UNIVERSITY
BUILDING 4103 - KILMER CAMPUS
NEW BRUNSWICK, NEW JERSEY**

ACKNOWLEDGMENTS

I would like to express my appreciation to the many people who have made this manual possible. I am especially indebted to the members of the Board of Education, Superintendent Mario Grippi, Principal Alfred Teodoro, former Director of Vocational Education Joseph English and Director Thomas Glasgow, all of the Deptford Township Area Vocational School, for their sponsorship and encouragement of this project. I would also like to thank Benjamin Shapiro and Everett Warzecha of the Vocational-Technical Curriculum Laboratory and Dr. Joseph Kelly of the Division of Vocational Education for their assistance.

My thanks go also to the following sources for the use of materials and illustrations:

- American Motors Corporation
- Chrysler Corporation
- Ford Motor Company
- General Motors Corporation
- National Automotive Service, Glenn-Mitchell Manuals Inc.*
- Automotive Smog-Control Manual, Harold T. Glenn*
- Chilton's Auto Repair Manual*
- Motor's Auto Repair Manual*
- Sun Electric Corporation

David B. Raudenbush

TO THE INSTRUCTOR

The instructor may use this manual to supplement existing course material or to teach Pollution-Control Devices as a separate course.

The text includes the three sources of automotive pollution: crankcase emissions, exhaust emissions, and fuel evaporation. Under each source area, for each type of equipment, separate lessons cover the design, functioning, and service procedures for the devices used. Complete information for each system and its service requirements is covered in a simple manner so that the student can easily understand the operating principles and service requirements of modern-day pollution-control devices.

At the end of most lessons there is a suggested assignment, which may be helpful in the review of material covered by the lesson. In order to encourage the student to use other resources (shop manuals), some of the suggested assignment questions may require the use of other resource materials.

TABLE OF CONTENTS

	Page
To the Instructor	ii
Unit I – Introduction	
Lesson 1 – Automotive Air Pollution	1
Lesson 2 – Automotive Pollution-Control Legislation	3
Chart – Automotive Pollution Laws and Their Effective Dates	5
Unit II – Crankcase Emissions	
Lesson 1 – Open-Type Positive Crankcase-Vent System	7
Lesson 2 – Closed-Type Positive Crankcase-Vent System	9
Lesson 3 – Dual-Action Positive Crankcase-Vent System	11
Unit III – Air-Injection Systems	
Lesson 1 – Operating Principles	13
Lesson 2 – Testing Air-Injection Systems	16
Lesson 3 – Air-Injection System Maintenance	20
Lesson 4 – Trouble-Shooting	22
Unit IV – The Clean Air System (C.A.S.) – Chrysler Corporation	
Lesson 1 – Principles of the Clean Air System	23
Lesson 2 – Testing the Components	28
Lesson 3 – Tune-Up Adjustments	32
Unit V – The Combustion-Control System (C.C.S.) – General Motors	
Lesson 1 – Principles	33
Lesson 2 – Testing the Components	38
Lesson 3 – Tune-Up Adjustments	42
Unit VI – The Climatic Combustion-Control System (C.C.C.) – General Motors	
Lesson 1 – Principles	44
Lesson 2 – Testing the Components	46
Unit VII – The Improved Combustion Exhaust-Emission-Control System (IMCO) – The Ford Motor Co.	
Lesson 1 – Principles	47
Lesson 2 – Testing the Components	53
Lesson 3 – Tune-Up Adjustments	56

	Page
Unit VIII – The “Engine Mod” System – American Motors	
Lesson 1 – Principles	57
Lesson 2 – Testing the Components	60
Lesson 3 – Tune-Up Adjustments	62
Unit IX – The Vapor-Saver System (V.S.S.) – Chrysler Corporation	
Lesson 1 – Operating Principles	64
Lesson 2 – Maintenance	67
Unit X – The Evaporation-Control System (E.C.S.) – General Motors	
Lesson 1 – Operating Principles	69
Lesson 2 – Maintenance	73
Unit XI – The Fuel Evaporative Emission-Control System (F.E.E.C.) – Ford Motor Company	
Lesson 1 – Operating Principles	74
Lesson 2 – Maintenance	76
Unit XII – The Evaporative Emission-Control System (E.E.C.) – American Motors	
Lesson 1 – Operating Principles	77
Lesson 2 – Maintenance	79

UNIT I – INTRODUCTION

Automotive Air Pollution

Lesson 1

OBJECTIVE: To become familiar with the automobile contaminants that pollute the air.

INFORMATION:

The automotive internal combustion engine is known to be the principal source of the major ingredients of air pollution, namely, hydrocarbons, carbon monoxide, and nitrogen oxides. A single automobile without antipollution devices will emit about 1.25 pounds of pollutants per day of driving. This quantity is insignificant by itself, but when multiplied by 108 million vehicles on the road (1970 U.S. census), we find that 67,500 tons of pollutants are emitted into the atmosphere *each day*, concentrated in the urban areas.

If absolutely pure gasoline (or diesel fuel) were to burn completely in an engine, the only products they would give off would be carbon dioxide and water, and there would be no problems of air pollution from vehicles.

But there are other substances in our fuels, and there is never absolutely complete combustion (burning). The result is that pollutants are given off in large quantities. These products produce the burning sensations in your eyes and nose that you experience when driving in very heavy traffic. Even if you aren't conscious of them, their accumulation in the air is harmful to people's health and they damage crops and other growing things.

Carbon monoxide is the best known of these products. It results from incomplete combustion due to too little air. You recognize it as a real killer. People commit suicide by running cars in closed garages. In lesser doses it may cause headache, nausea, dizziness, drowsiness, confusion, or lapse of attention. Carbon monoxide is particularly dangerous to man because it is odorless, so that a person may breathe it in without knowing it. However, it is usually combined with other gases that do have odors.

All pure petroleum products consist of the elements carbon and hydrogen, joined together in various proportions. That is why they are called *hydrocarbons*. Unburned hydrocarbon vapors in sufficient quantity are also capable of poisoning people and are suspected of causing cancer.

Other products of incomplete combustion include the *nitrogen oxides*. Nitrogen dioxide and nitric oxide are both poisonous gases; nitrous oxide is used medically as an anesthetic, and some dentists still use it as "laughing gas" – although people have been killed by it.

These are the most dangerous pollutants, perhaps, but not the only ones. Sulfur dioxide, carbon particles (soot), lead compounds, and other pollutants all contribute to damaging our health and our environment.

Smog, from the words "fog" and "smoke", may cause irritation of the eyes, ears, and throat of humans, and damage to various crops as well, if allowed to become concentrated in an area. Smog is fog made dark and irritating by the emissions from large numbers of vehicles, aggravated by lack of wind or trapped by an *inversion layer* (an overlay of warmer air above cooler air).

There are two types of smog, London smog and Los Angeles smog. The London Smog consists mainly of sulfur compounds, aerosols (fine solid or liquid particles) and carbon monoxide. A principal cause is the burning of soft coal. Bad smogs caused many deaths, particularly from respiratory causes, in the past, but London has at least partly corrected the situation in recent years.

Los Angeles - type smog is induced by the photochemical action of sunlight on the pollutants in the air. It consists mainly of organic compounds (hydrocarbons), nitrogen oxides, and carbon monoxide. It too is a great danger to health, particularly to the old people or those already ill.

Because the automobile has been responsible for about 60% of the air pollution in the United States, legislation (the Clean Air Act of 1963 and The Air Quality Act of 1967 - revised in 1970) has been enacted to limit emissions from the automobile crankcase, exhaust, and fuel vents. (Lesson 2 will discuss this legislation.)

ASSIGNMENT:

1. What are the major ingredients of photochemical smog?
2. Which was the first state to develop significant legislation on automotive air pollution?
3. What percent of air pollution has the automobile been responsible for?
4. Name the three most important pollutants given off by vehicles.
5. What effects do pollutants have on man and his environment?

UNIT I - INTRODUCTION

Automotive Pollution-Control Legislation

Lesson 2

OBJECTIVE: To become familiar with legislation concerning motor-vehicle pollution control.

INFORMATION:

Because of the smog problem in the Los Angeles area, the state of California was the leader in developing effective pollution-control legislation for motor vehicles. In 1961 all cars sold in the State of California were required to have approved *crankcase emission-control devices* (PCV). As a result of the crankcase vent system, pollution in the Los Angeles area remained constant between 1960 and 1967 despite an increase in vehicle registration of about 1 million autos. Voluntarily, the U.S. auto manufacturers installed positive crankcase-vent (PCV) systems on all 1963 vehicles. In 1968 legislation passed by Congress became effective. All new cars sold in the U.S. from that date had to be equipped with positive crankcase-vent systems.

It took longer to develop effective *exhaust emission-control devices*. However, California legislators set exhaust emission standards for motor vehicles sold in that state from 1966 on at a maximum of 275 parts per million (PPM) for unburned hydrocarbons and a 1.5% level (by volume) as the concentration of carbon monoxide. The same regulations were adopted nationally and became effective on all 1968 vehicles sold in the United States.

The Federal Government changed its standards of measurement from parts per million (English) to grams per mile (metric) and adopted more stringent exhaust emission requirements for all 1970 and later U.S. and imported cars. These standards required that exhaust emissions from any car or light truck (under 6000 lb.) not exceed 2.2 *grams per mile* (approximately 180 PPM) for hydrocarbons and 23 grams per mile (approximately 1%) for carbon monoxide. This is about a 33% decrease in permitted exhaust emissions. The new gram-per-mile standard takes into consideration that emissions level is related to vehicle weight, and allows higher levels of pollutants for heavy vehicles.

California now also requires that all new vehicles sold (beginning with 1970 models) be equipped with an approved device to control *fuel evaporation emissions* at the carburetor and fuel tank. In 1970 the Federal Government passed similar legislation (effective on all 1971 cars) to limit fuel-evaporation emissions to 2 grams per soak period on all vehicles imported into or manufactured in the United States.

The proposed 1975 Federal regulation for particulate matter is 0.1 gram per mile. California has not yet set any limit on these emissions because they do not contribute to photochemical smog, California's problem.

California has proposed a standard for nitrogen oxides emissions for 1975 vehicles of 1.0 gram per mile and has reduced other emission standards to 0.5 gram per mile for hydrocarbons and 12.0 grams per mile for carbon monoxide. The Federal Government will probably follow closely to these standards for hydrocarbons, carbon monoxide and nitrogen oxides in the near future, as it has done in the past.

The chart on the next page summarizes the various standards imposed by California and by the Federal Government for the car model years indicated.

AUTOMOTIVE POLLUTION LAWS AND THEIR EFFECTIVE DATES

CALIFORNIA

FEDERAL GOVERNMENT

1961	Positive crankcase emission-control devices (PVC) (All cars sold in California)	
1963		U.S. auto manufacturers voluntarily installed positive crankcase emission-control devices on all their cars.
1966	Exhaust emissions limited to 275 parts per million (PPM) unburned hydrocarbons, 1.5% carbon monoxide.	
1968		Positive crankcase ventilation system on all cars sold in U.S. Exhaust emissions limited to 275 parts per million of hydrocarbons and 1.5% carbon monoxide.
1970	Approved fuel-evaporation control devices on all cars sold in California. Evaporation emissions limited to 2.0 grams per soak period.	Approximately 33% reduction in exhaust emissions on all cars sold in U.S. Change in measurement system from parts per million to grams per mile. Hydrocarbons limited to 2.2 grams per mile (180 PPM) and carbon monoxide to 23 grams per mile (1%).
1971		Fuel-evaporation emissions limited on all cars sold in U.S. to 2.0 grams per soak period.
Proposed for 1975	Nitrogen oxides emission limited to 1.0 gram per mile (GPM) Hydrocarbon emission 0.5 GPM. Carbon monoxide emission 12.0 GPM	Particulate matter in exhaust emission limited to 0.1 gram per mile. Other standards likely to follow California's.

ASSIGNMENT:

1. What were the initial California and U.S. standards for hydrocarbon emissions?
2. What were the initial California and U.S. standards for carbon monoxide emissions?
3. What were the 1970 national standards for hydrocarbon and carbon monoxide emissions?
4. To how many grams per hot soak have evaporative emissions been limited?
5. List the standards that have been proposed for 1975 cars.

UNIT II - CRANKCASE EMISSIONS

Open-Type Positive Crankcase-Vent Systems

Lesson 1

OBJECTIVE: To learn the purpose of and service requirement on the open-type positive crankcase-vent (PCV) system.

EQUIPMENT:

- PCV solvent
- PCV valve and hose
- Oil breather cap
- Mechanics wire

INFORMATION:

Uncontrolled crankcase emission, consisting of blow-by gases, make up about 25% of the total unburned hydrocarbons allowed to escape to the atmosphere. The purpose of the positive crankcase ventilation system is to route the blow-by gases back to the combustion chambers, where they are consumed in the normal combustion process. (See figure below)

Fresh air entering through the oil-filter cap joins the blow-by gases in the crankcase. After passing through the PCV valve and related tubing, it goes back to the intake manifold for recycling.

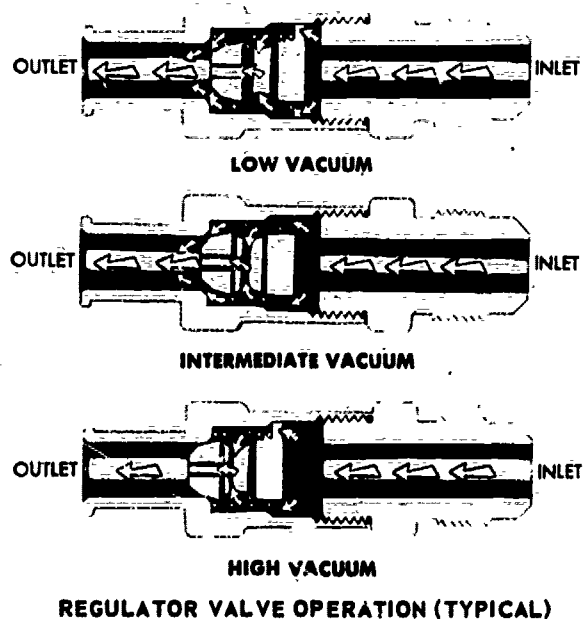
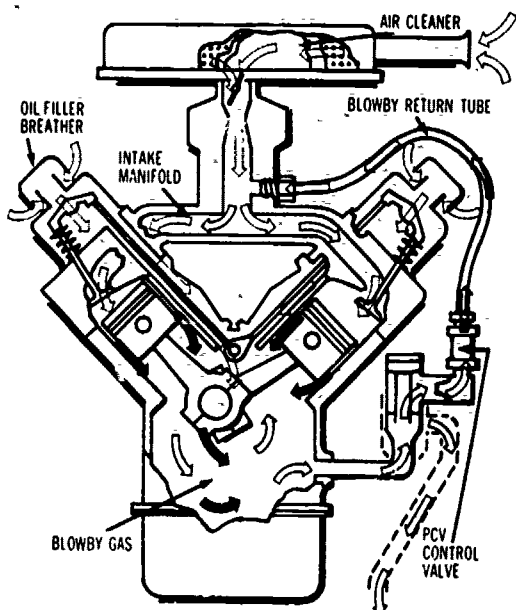

The recommended service is to clean the oil-filter breather cap and the PCV valve and hose every 6,000 miles, and replace the PCV valve every 12,000 miles.

SERVICE PROCEDURE:

1. Test the PCV system, using special test equipment and following equipment maker's procedure. As an alternate method:
 - a. Remove breather cap and place the palm of your hand over breather hole. A strong suction should be felt.
 - b. Pinch PCV hose. RPM should drop.
2. Clean the open-type PCV system by removing PCV valve, oil-filter breather, and PCV hose. Place components in suitable solvent and agitate until clean. Allow solvent to drain off and lightly oil breather mesh. Replace components and test system.



*Oil Fill Cap with Filter Element:
Clean and lightly re-oil. Replace
cap if filter element is clogged.*

ASSIGNMENT:

1. Name at least three different types of PCV valves.
2. Where will excessive blow-by gases be vented in the open-type PCV system?
3. What is the major pollutant emitted from the crankcase?

UNIT II - CRANKCASE EMISSIONS

Closed-Type Positive Crankcase-Vent System

Lesson 2

OBJECTIVE: To learn the purpose and service requirements of the closed-type positive crankcase-vent (PCV) system.

EQUIPMENT:

- Air filter assembly
- Oil filter cap and hose
- PCV valve and connecting tubing
- PCV solvent

INFORMATION:

The closed-type positive crankcase-vent system is very similar to the open PCV system except that the closed system includes a hose from the oil-filter cap to the air cleaner to take care of the excess blow-by generated during severe acceleration, by worn engines, or by PCV systems in need of service.

Each component of the PCV system should be removed, cleaned, and tested every 6,000 miles, and the PCV valve replaced every 12,000 miles.

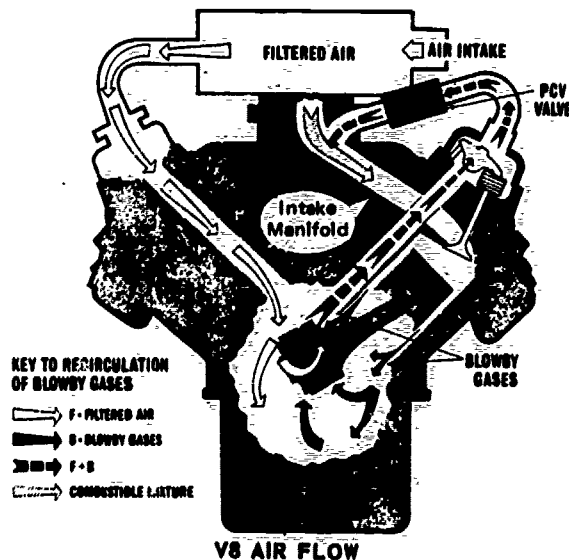

SERVICE PROCEDURE:

1. Test the PCV system, using special test equipment and following equipment maker's procedure.
 - a. A quick check is to connect tachometer to engine, start engine, and clamp PCV valve hose. Engine should show a drop of 50-60 RPM. Also, a strong vacuum can be felt at oil-filter cap opening.

2. Clean filter, PCV valve and hose in suitable solvent and blow off with compressed air. Re-oil breather-cap filter, if used, with 10W30 oil and replace components. Test system.

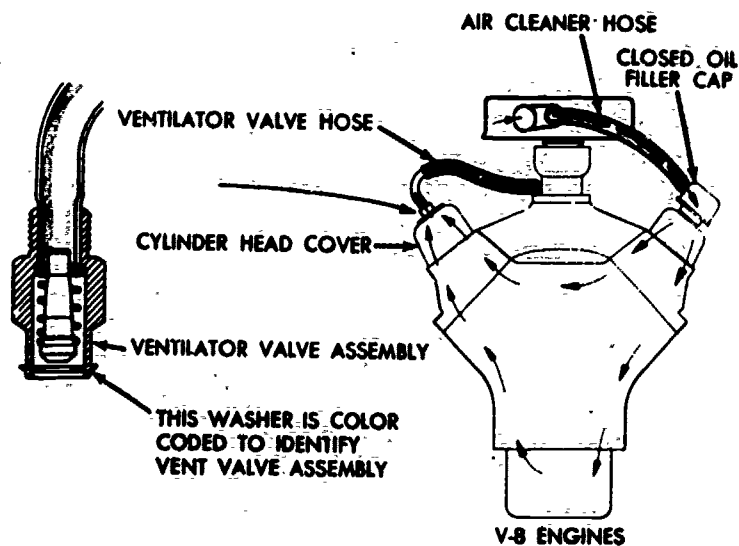

ASSIGNMENT:

1. Student should perform above service procedure on live vehicle equipped with closed-type positive crankcase vent system.
2. If the PCV valve becomes plugged, what effect will this have on the carburetor air-filter systems?
3. What noticeable effect will there be to the engine if the oil-filter breather becomes plugged?

UNIT II - CRANKCASE EMISSIONS

Dual-Action-Type Positive Crankcase - Vent System

Lesson 3

OBJECTIVE: To learn the purpose, function, and service requirement of the dual-flow positive crankcase-vent system.

EQUIPMENT:

- Dual-flow PCV valve
- Connecting tubing
- Air filter
- PCV solvent
- 1/16 drill bit
- Carburetor

INFORMATION:

The dual-flow PCV valve gives positive control of crankcase emissions. Fresh air enters the oil-filter breather cap and mixes with blow-by gases in the crankcase. During idle and low speeds, the crankcase vapors are drawn by manifold vacuum through the base of the valve and hose connected to a fixed orifice fitting in the base of the carburetor. During high-speed operation or under heavy load crankcase vapors are allowed to pass by the diaphragm in the valve and into the air-cleaner snorkel to mix with fresh air entering the carburetor.

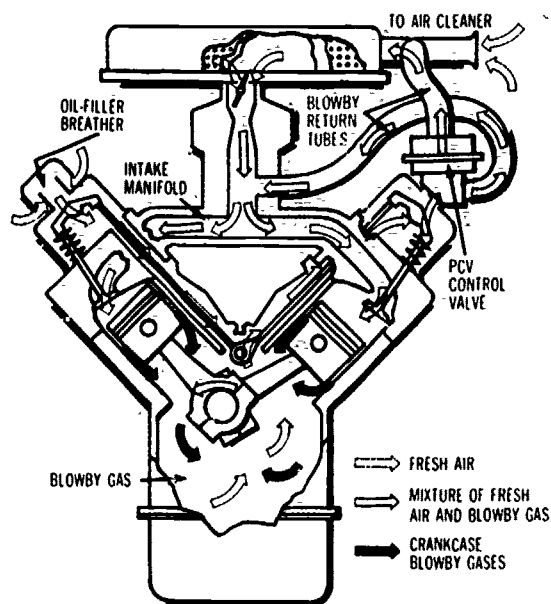

SERVICE PROCEDURE:

1. Remove both hoses and valve.
2. Clean hoses and valve in appropriate solvent; blow air through hose and valve small tube (only).
3. Clean fixed orifice fitting at carburetor with 1/16th-inch drill bit.
4. Re-install valve and hoses; inspect air filter and service if necessary.
5. Wash oil-fill cup in solvent; shake and allow to dry; oil filter lightly and re-install.
6. Test system. With vehicle engine running, pinch small PCV hose; engine R.P.M. should drop.

ASSIGNMENT:

1. What noticeable effect to the engine would there be if the fixed orifice in the dual-flow PCV system were plugged?
2. List at least two possible causes of the air cleaner's becoming saturated with oil in the dual-flow PCV system.

UNIT III - AIR-INJECTION SYSTEMS

Operating Principles

Lesson 1

OBJECTIVE: To become familiar with the purpose and operation of the air-injection system.

INFORMATION:

The purpose of the air injection system is to force air into each exhaust port immediately next to each exhaust valve. Since the exhaust gases contain an excess of hydrocarbons and are at about kindling temperature, the injection of oxygen starts the mixture burning and so consumes the hydrocarbons that normally would be expelled into the atmosphere.

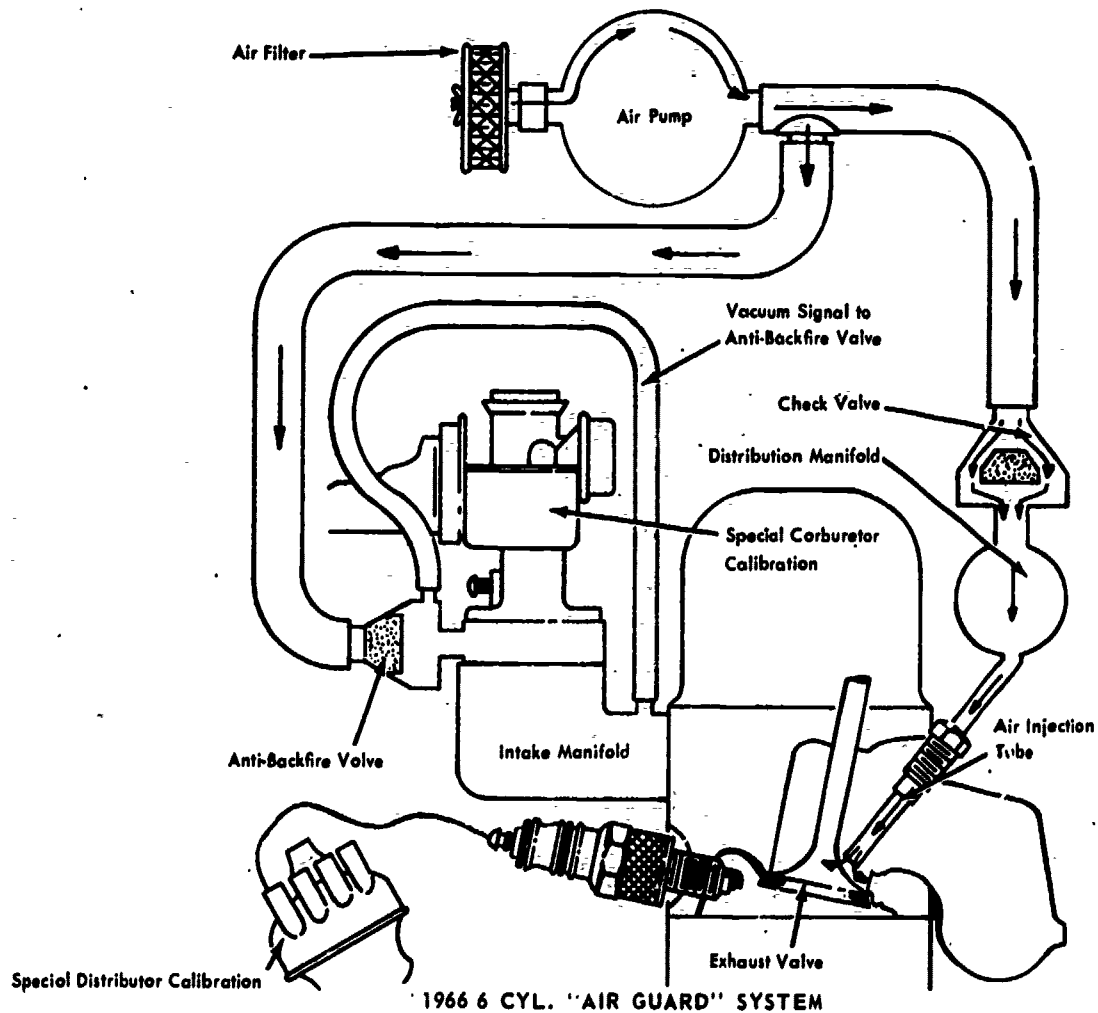

In operation, air enters the system through an air filter connected to the air pump. The pump compresses the air (2-6 psi approximately) and directs it through connecting hoses to a check valve, then to a steel distribution manifold (two on V-8's) into stainless steel injection tubes in each exhaust port.

Check valve. - The check valve prevents reverse flow of exhaust gases if the pump should become inoperative or exhaust pressure should exceed pump pressure.

Anti-backfire valve. - There are two types of anti-backfire valves in the injection system: the air gulp used in 1966-67, and the by-pass type used from 1966 to the present. The purpose of the anti-backfire valve is to eliminate a backfire upon deceleration.

The air-gulp-type valve is used to provide a "gulp" of air into the engine induction system during rapid throttle closure. The gulp of air enters the carburetor below the throttle plate and leans out the normally even-rich fuel mixture inducted into the combustion chamber during deceleration. Thus more complete combustion takes place. The gases expelled into the exhaust manifold have no excess hydrocarbons, and therefore backfire does not occur.

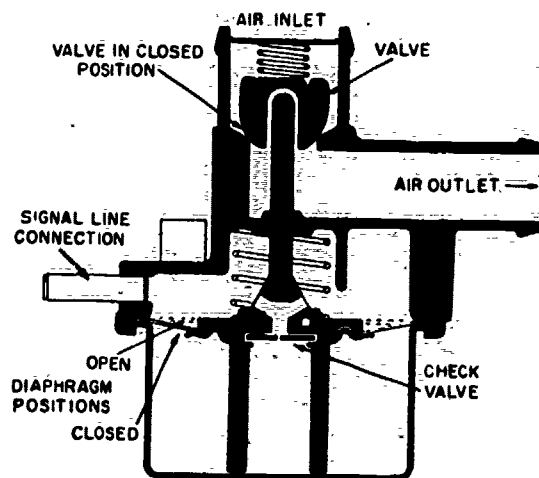

INTAKE AIR BLEED VALVE

The by-pass-type valve is normally in the closed position, allowing pump air to discharge freely through valve fittings to the exhaust manifold. When the throttle is closed rapidly and engine manifold vacuum rises, the valve diaphragm moves against the valve to the open position. Now the pump air is dumped or by-passed to the atmosphere through a muffler or air cleaner, which acts as a silencer. With no oxygen supply to the exhaust manifold, no backfire can take place.

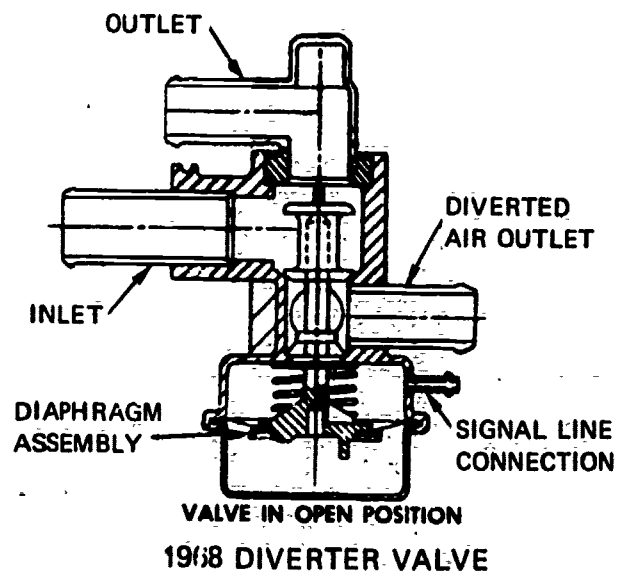

ASSIGNMENT:

1. List the names of all the domestic car manufacturers of air injection systems.
2. Will a leaky exhaust manifold gasket have any effect on operation of the air injection system? Why?
- 3; Why is belt tension important on the air pump?

UNIT III – AIR-INJECTION SYSTEMS

Testing Air-Injection Systems

Lesson 2

OBJECTIVE: To learn testing methods for the air-injection types of pollution-control systems.

EQUIPMENT:

Low-pressure gage (fuel pump)
Air-pump gage adapter
Hand tools
R.P.M. gage

INFORMATION:

The following tests should be included with tune-up procedures on cars with air-injection emission-control systems.

PROCEDURES:

1. **Air-supply pump test.** – Assemble a test gage and adapter and install it in the air-supply hose to the manifold ahead of the check valve. If there are two check valves, close off one with a suitable plug in the end of hose. Insert open-pipe end of test gage adapter in other air-supply hose and clamp securely. Install a tachometer on engine.

Start engine and slowly increase engine speed to 1500 RPM. Observe the pressure; it should be one psi or more. If pressure does not meet or surpass the above pressure, disconnect and plug hose to anti-backfire valve. Repeat pressure test. If pump fails to meet pressure requirements, replace pump.

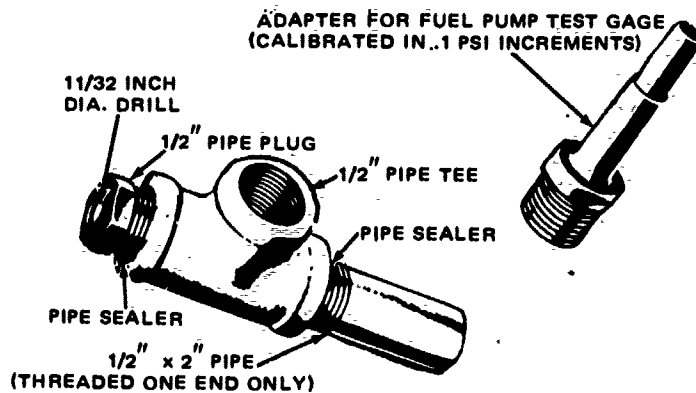

AIR-SUPPLY PUMP TEST GAGE ADAPTER

2. Check-valve test. — Disconnect hose from air supply at check valve. Visually inspect valve plate inside valve body. Insert probe into valve and open and release valve plate; it should return with light pressure against its seat. Start engine and run at 1500 RPM. There should be no leakage at check valve. Note valve flutter at idle, due to exhaust pulsation. If valve tests OK replace supply hose.

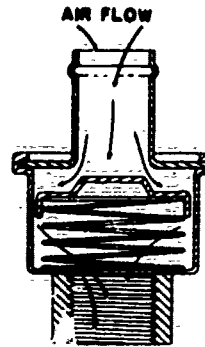

**CHECK VALVE
OPEN POSITION**

3. Anti-backfire valve. — If the idle speed is rough or it is impossible to reduce the engine idle speed to specified RPM, disconnect the following:

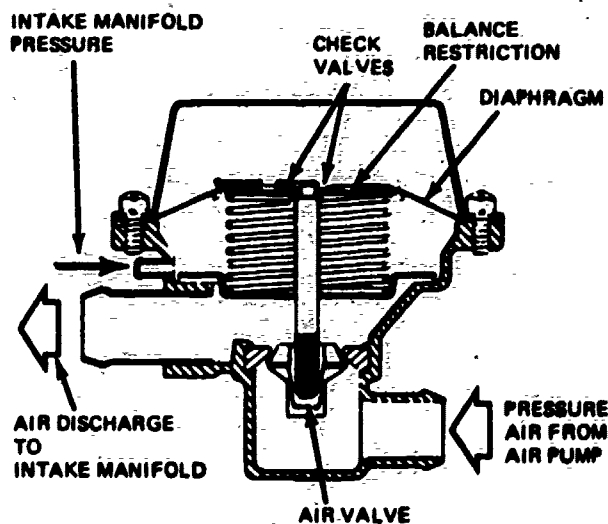

**ANTI BACK-FIRE VALVE
AIR GULP TYPE**

- a. On the "gulp" system, disconnect the vacuum-sensing tube at the valve and plug the tube end. Disconnect the hose connecting the intake manifold to the backfire-suppressor valve at the valve end and plug the hose. If the idle can now be smoothed or the specified RPM achieved, the valve is defective.

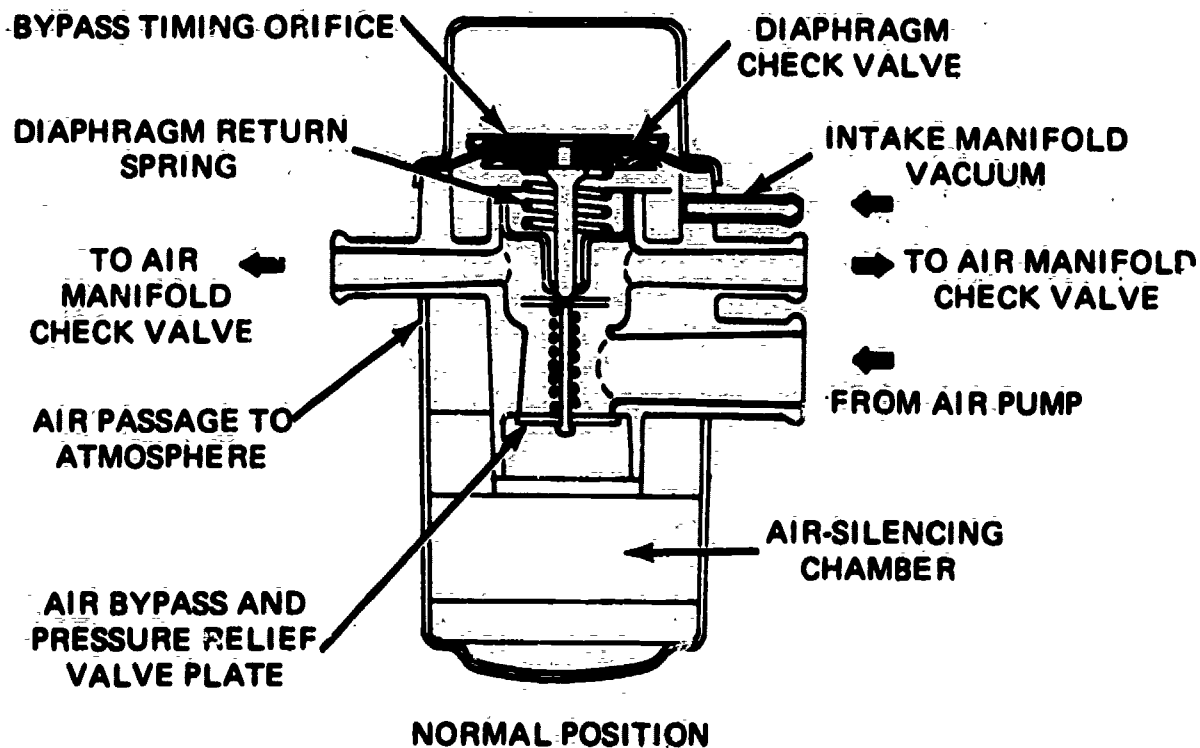

**ANTI BACK-FIRE VALVE
AIR BYPASS TYPE (FORD TYPE)**

- b. On the air-bypass system, disconnect the vacuum-sensing tube at the valve and plug the tube end. If the idle can now be smoothed or the specified RPM achieved, the valve is defective.

To test the function of the "gulp" valve, disconnect the rubber hose connecting air pump to the backfire-suppressor valve at valve. Open and close throttle rapidly. A loud sucking noise should be heard if valve is functioning properly.

For the air-bypass valve, disconnect rubber hose connecting the backfire-suppressor valve to carburetor air cleaner or listen to muffler mounted on bypass valve. Open and close throttle rapidly; the noise of escaping compressed air should be heard from valve on deceleration.

If either valve fails to pass the function test, it should be replaced.

ASSIGNMENT:

Perform the above-listed tests for the air-injection emission-control system on a working model or live automobile.

UNIT III - AIR INJECTION SYSTEMS

Air-Injection System Maintenance

Lesson 3

OBJECTIVE: To learn periodic maintenance of the air-injection system.

EQUIPMENT:

Belt-tension gage
Hand tools

INFORMATION:

As a regular tune-up procedure (approximately 12,000 miles), vehicles equipped with an air-injection system should be tested as outlined in lesson 2 of this unit and maintained as outlined in this lesson.

PERIODIC MAINTENANCE:

1. Drive belt. - Inspect for deterioration and replace if required. Adjust tension to 125 lbs. for a new belt or 75 lbs. for a used belt. Caution: Do not pry on pump housing.

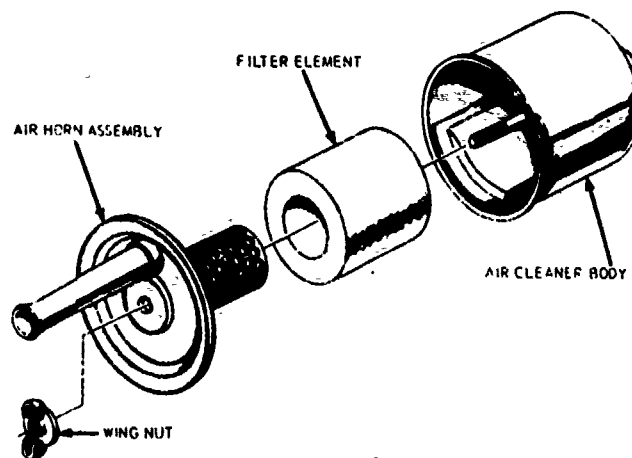

1966-67 THERMACTOR AIR PUMP AIR CLEANER

2. Pump filter. - If pump external filter is used, replace at 12,000-mile intervals.

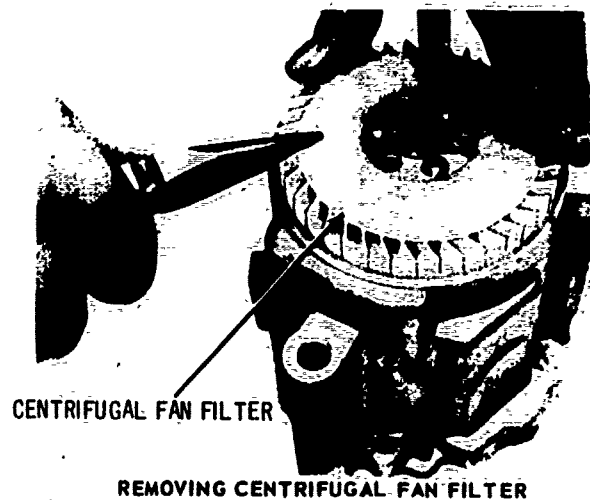

CENTRIFUGAL FAN FILTER

REMOVING CENTRIFUGAL FAN FILTER

If centrifugal filter is used, replace at 12,000 miles. Remove pulley and pry out fan disc.

Note: Care should be taken to prevent fragments from entering the air-intake hole. Install new filter by drawing it on with pulley bolts. Do not hammer or press on.

3. On models with relief valve on pump, replace valve only if it is making excessive noise. Pressure-relief valve can be removed by using small slide hammer, and installed with bushing driver and hammer.
4. Hoses and tubing should be inspected and replaced as necessary.

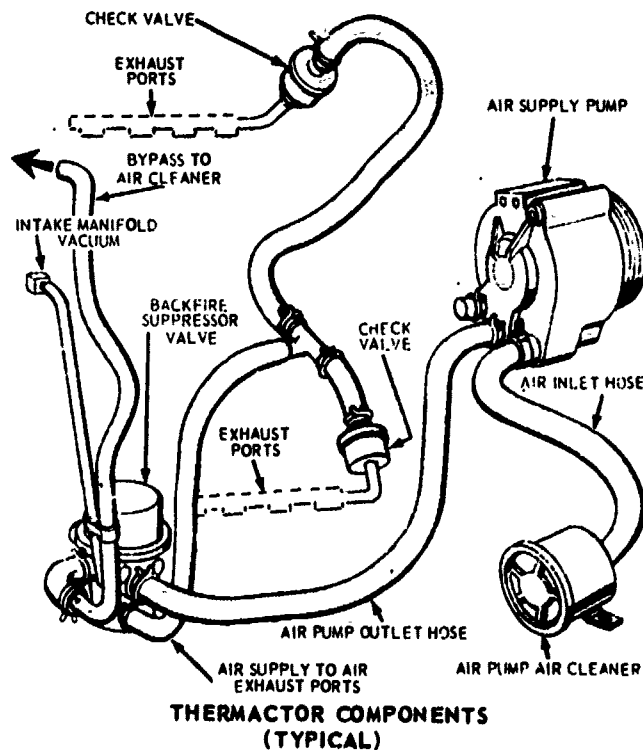

THERMACTOR COMPONENTS
(TYPICAL)

UNIT III -- AIR-INJECTION SYSTEM

Trouble-Shooting

Lesson 4

OBJECTIVE: To become familiar with possible problems and their causes in the air-injection system.

Problem	Cause
Excessive backfire in exhaust system	Anti-backfire-valve vacuum line collapsed, plugged, disconnected, or leaking. Defective or malfunctioning anti-backfire valve.
Excessive hesitation on acceleration (above 20 MPH)	Intake vacuum leaks at anti-backfire valve, vacuum line, or air outlet. Defective anti-backfire valve.
Air-supply hoses burned	Defective check valve on air-supply manifold.
Noisy air-pump drive belt	Drive belt improperly adjusted. Seized or failing air pump. Misaligned or defective pulleys.
Rough engine idle	Improper carburetor and/or initial timing adjustments. Intake vacuum leak at anti-backfire valve, vacuum or air-inlet hose. Anti-backfire valve defective or stuck open.
Engine surge at all speeds	Anti-backfire valve defective or stuck open. Improper carburetor adjustment.

ASSIGNMENT:

1. Why would a leaky intake manifold hose cause the engine to surge?
2. What noticeable effect would there be if the air-pump drive belt were loose?
3. If the diverter or bypass type of anti-backfire valve were stuck open, what might the customer's complaint be?

UNIT IV – CLEAN AIR SYSTEM (C.A.S.), CHRYSLER CORP.

Principles of Chrysler Clean Air System

Lesson 1

OBJECTIVE: To become familiar with the exhaust-emission-control components which may be found on Chrysler Corp. vehicles from 1966 to 1971.

INFORMATION:

Chrysler Corporation cars use the Clean Air System to reduce hydrocarbon and carbon monoxide emissions from the exhaust. (This was formerly known as the Clean Air Package, or C.A.P.) The system consists of a special carburetor, distributor systems, and other special control devices as follows:

Carburetion. – The carburetor has been calibrated leaner for cruise and idle conditions. This leaner carburetion reduces hydrocarbon and carbon monoxide emission from the exhaust.

Distributor. – The distributor is more finely calibrated than in previous models and incorporates a centrifugal advance mechanism which allows basic timing to be slightly retarded yet recover to normal advance at slightly above idle.

Anti-icing device. – In order to prevent carburetor icing, all 1966–69 6-cylinder engines and some 318" V-8 engines are equipped with a heat tube in the exhaust manifold. A hose connected to the air filter allows cold, filtered air to enter the heat tube. Another hose leads from the heat tube to the carburetor base to heat the throttle area.

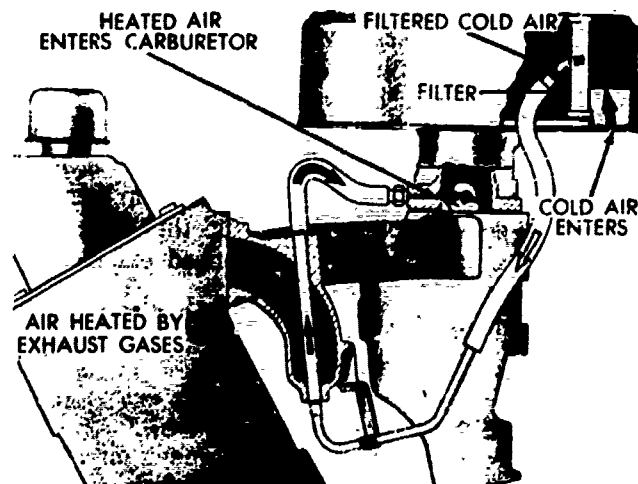

ANTI-ICING DEVICE

Solenoid speed control. -- Used on high-performance engines (340", .440", and 426" HEMI.) to maintain idle speeds of 800 -1000 RPM during idle and deceleration. To prevent "after-running" with such high idle speeds, these engines have an electrical solenoid throttle stop which holds throttle at correct idle position when energized. When ignition is turned off, solenoid de-energizes, permitting throttle valves to close further.

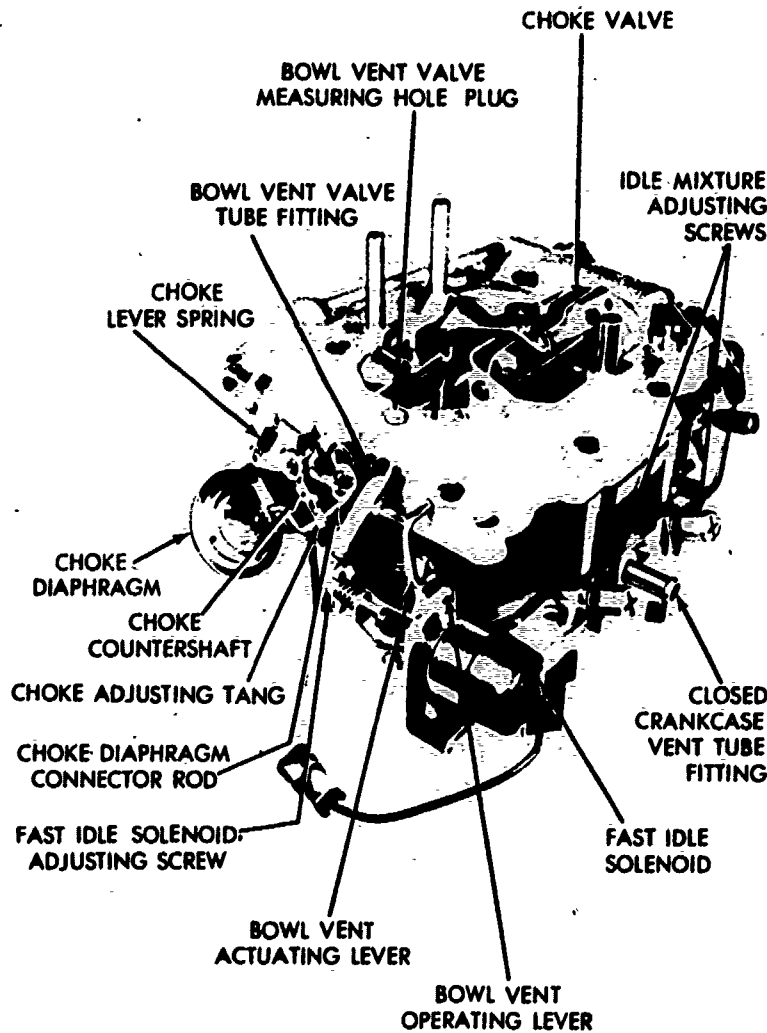

CARTER THERMO-QUAD CARBURETOR

Thermostatic-controlled air cleaner. -- Used on 1970 and 1971 engines (except high-performance). The system provides heated air to the carburetor (from the stove on the exhaust manifold) with progressive mixing of this air with underhood air to maintain an intake air temperature of 95°F. - 105°F. for efficient combustion and emission control.

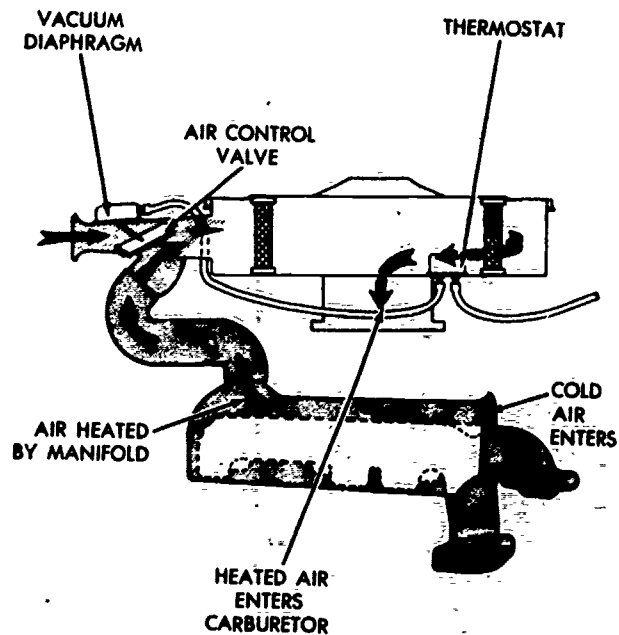

THERMOSTATIC CONTROLLED AIR CLEANER

Vacuum-control valve. — This valve provides for distributor vacuum advance during deceleration for better burning of fuel. When intake manifold vacuum rises to approximately 16" of mercury under a deceleration condition, the valve diaphragm moves, opening a port and applying full intake manifold vacuum to the distributor to move the distributor to full advance position. This aids in better burning of the fuel mixture during deceleration periods.

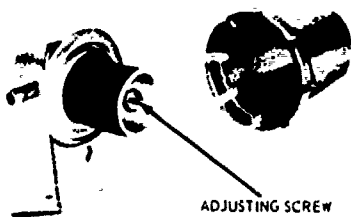

DISTRIBUTOR VACUUM DECELERATION VALVE

Distributor-modulator solenoid. — Used on 383" and 440" engines. Consists of a distributor vacuum-unit solenoid control which retards timing approximately 5°-6° for closed-throttle idling. The solenoid is controlled by a ground switch incorporated in the carburetor throttle lever and is closed only in closed-throttle position.

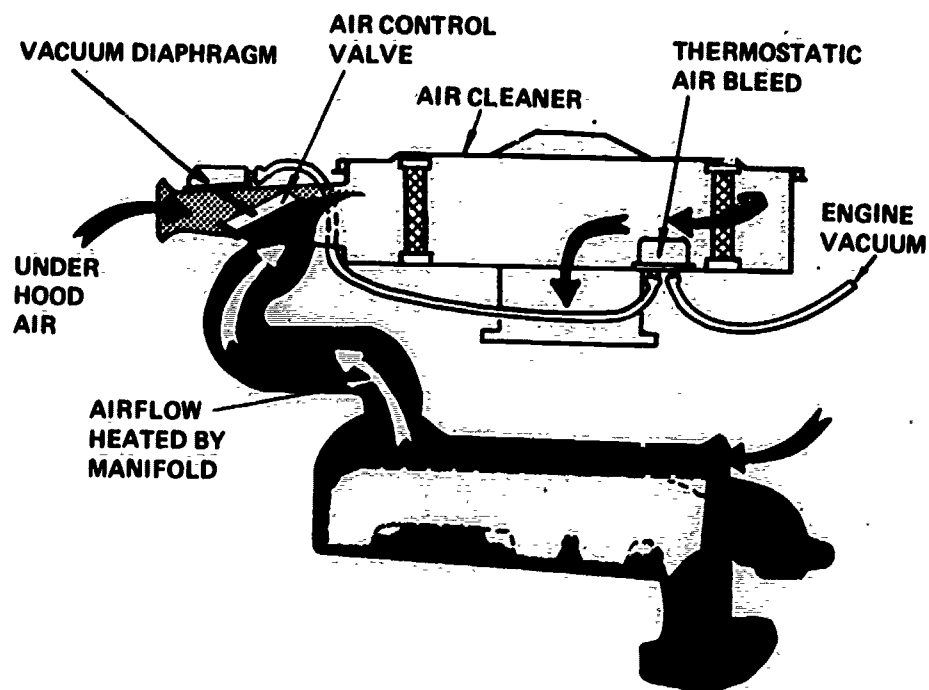

BASIC CHRYSLER HEATED AIR INLET SYSTEM

Transmission-controlled spark (NOx System Corp.). — The NOx system is designed to reduce emission of nitrous oxide to the atmosphere by eliminating distributor vacuum advance in the lower gear ranges. The NOx system consists of a special camshaft (with increased overlap), a 185° coolant thermostat, a solenoid vacuum valve, and — depending on transmission used — a speed switch mounted in the speedometer cable on automatic transmissions or a transmission switch mounted on the transmission housing (manual transmission) to control the solenoid vacuum valve.

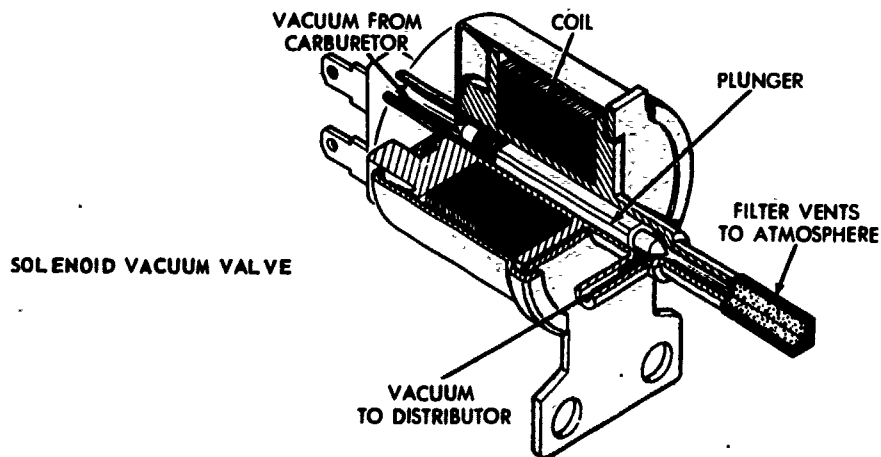
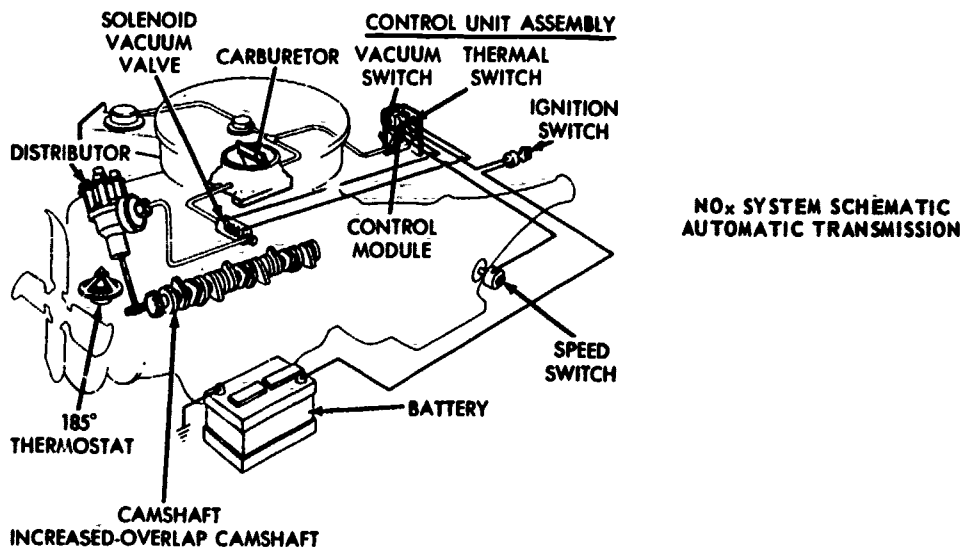

ASSIGNMENT:

1. Why is ignition timing retarded during idle on CAS-equipped cars?
2. Name two methods of consuming free hydrocarbons in the exhaust system.
3. What does CAS mean?
4. At what speed ranges are emissions-control devices most necessary?

UNIT IV - CLEAN AIR SYSTEM

Testing the Components of C.A.S.

Lesson 2

OBJECTIVE: To learn the test methods for components of the clean air system (Chrysler).

EQUIPMENT:

- Vacuum-gage tachometer
- Jumper wire
- RPM gage
- Hand tools
- Timing light

INFORMATION:

All C.A.S.-equipped cars require tests of several components in addition to those covered in a normal tune-up; solenoid idle-speed control, thermostatic-controlled air cleaner, vacuum-control valve, distributor-modulator solenoid, transmission-controlled spark system.

PROCEDURE:

Solenoid idle speed control. - The solenoid control may be considered OK if, with engine at normal idle, the solenoid wire is removed and engine RPM drops.

Thermostatic controlled air cleaner. - With air cleaner and duct assembly installed on vehicle, engine cold (less than 100°F.) and running, the air-control valve should be lifted (heated air open). If air-control valve is not lifting, the valve plate may be sticking, vacuum diaphragm assembly or link faulty, or no vacuum available at the diaphragm due to a faulty sensor or hose. Use a vacuum gage, "T" connected at the diaphragm, to check for vacuum.

As throttle is snapped open, the air-control valve should drop (close the hot-air passage).

As engine compartment temperature rises (to 90° - 110°F.) the air-control valve should gradually drop to close the hot-air passage and completely open the snorkel passage.

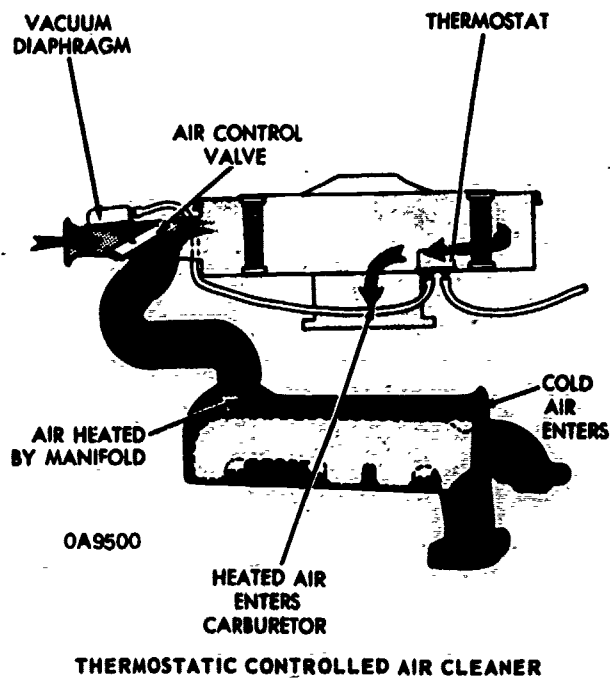

Vacuum-control valve. — With engine at normal operating temperature, ignition timing and hot-idle correctly set, and dashpot not touching throttle lever, proceed as follows: Connect tachometer to engine; connect vacuum gage to distributor vacuum tube at control valve; and clamp vacuum hose between valve and manifold. Start engine. Vacuum reading should be less than 6" of mercury. If not, timing and idle are incorrect.

Remove clamp from vacuum hose. With transmission in neutral, hold engine RPM at 2000 for 5 seconds, then release throttle and observe distributor vacuum. When throttle is released, vacuum should increase above 16" of mercury and remain there for at least 1 second. Within 3 seconds after throttle is released, vacuum should fall below 6" mercury. If control valve is not adjusted properly (time release), it may be adjusted by turning adjusting screw under cover in end of valve (See next lesson).

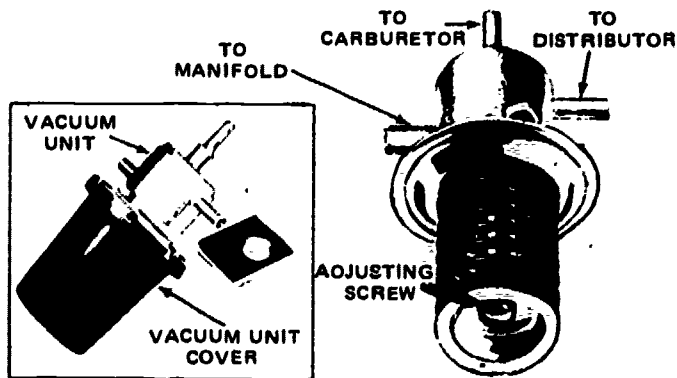

VACUUM CONTROL VALVE ADJUSTMENT

Distributor modulator. — Disconnect vacuum hose at distributor vacuum unit, start engine and allow it to idle with throttle valves fully closed. With timing light directed at timing mark on engine front cover, disconnect distributor solenoid ground lead at carburetor. Timing should advance at least $5\frac{1}{2}^{\circ}$ above basic setting and engine speed should increase. If no advance is noted, check for current at solenoid ignition terminal. If feed circuit tests OK, solenoid is defective.

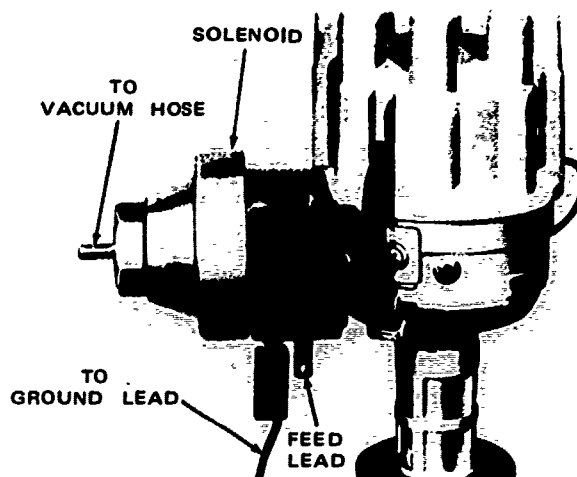

CHRYSLER CORP. SOLENOID RETARD DISTRIBUTOR

Transmission-controlled spark (NO_x System). —

Manual transmission: Ambient temperature must be above 70°F. Place transmission in neutral and turn ignition on. Disconnect wire from B+ terminal of ballast resistor while holding solenoid vacuum valve. You should feel valve de-energize. Reconnect wire and you should feel solenoid energize. Place transmission in high gear. Solenoid should not energize when wire is disconnected or connected. If system does not function correctly, check the following:

A. Remove electrical connector from solenoid vacuum valve. Place a jumper from the piggy-back connector on ballast resistor to one of the solenoid vacuum-valve terminals. Place a second jumper from the remaining vacuum-valve terminal to ground. With ignition switch on, solenoid should energize. If not, replace solenoid vacuum valve.

B. Remove electrical connector from thermal switch. Using a short wire, jump electrical connector. Place transmission in neutral and turn ignition on. Solenoid vacuum valve should energize. If temperature is above 70° and solenoid vacuum valve does not energize when thermal switch is connected but does energize when plug is jumped, thermal switch is defective and should be replaced.

- C. Place transmission in neutral and turn ignition switch on. Remove electrical connector from transmission switch and connect to ground. If solenoid vacuum valve functions when this is done; replace transmission switch.

Automatic transmission: Ambient temperature must be above 70°F. Test the following:

A. Using a T-fitting, place a vacuum gage between distributor and solenoid vacuum valve. Raise rear wheels. Disconnect and plug vacuum line at vacuum switch on control-unit assembly. Start engine and run at fast idle (above 850 RPM). Vacuum gage should read zero. Remove electrical lead from control-unit T-connector. Vacuum gage should indicate vacuum. Reconnect wire and gage should drop to zero.

B. Unplug and reconnect vacuum line to vacuum switch and disconnect single-wire lead from control unit to speed switch. Gage should indicate vacuum. A sharp acceleration will cause vacuum gage to drop to zero sharply. As engine RPM stabilizes, vacuum should be restored and gage should indicate vacuum advance. Reconnect speed-switch lead.

C. Disconnect and plug vacuum line at vacuum switch. Vacuum reading should be zero. Accelerate engine to above 30 MPH. Vacuum gage should indicate normal vacuum advance when speed reaches above 30 MPH.

If no solenoid action occurred in the foregoing procedure, replace the control-unit assembly. Repeat tests to be sure the temperature-switch malfunction has been corrected. Reconnect vacuum lines as before test and be sure all wires are securely connected.

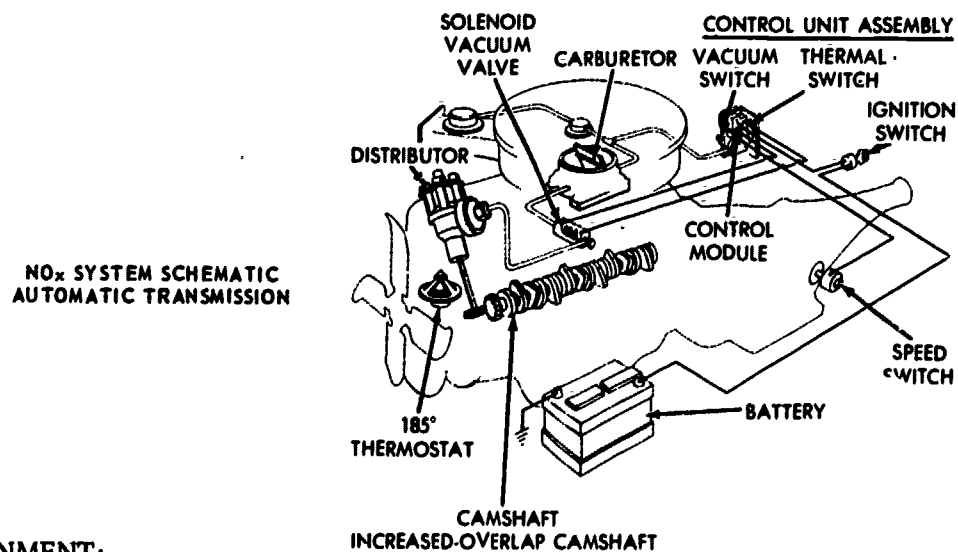

ASSIGNMENT:

The student should practice each of the foregoing tests to become familiar with each component and its proper operation.

UNIT IV - CLEAN AIR SYSTEM

Tune-up Adjustments

Lesson 3

OBJECTIVE: To learn tune-up procedures for C.A.S. or C.A.P. equipped vehicles.

EQUIPMENT:

Vacuum gage
RPM gage
Combustion analyzer
Hand tools

INFORMATION:

In addition to C.A.S. component tests in lesson 2, and after usual ignition and carburetor tune-up service, the following adjustment procedure must be observed to insure that the engine is balanced and operating within emission standards.

PROCEDURE:

1. Check and adjust ignition timing to specification. Note: vacuum-control valve to manifold line must be clamped if so equipped.
2. Check and adjust warm-idle speed, using tachometer. Adjustment is made by speed screw or solenoid plunger. The air cleaner must be in place, transmission in neutral, and air conditioner off. Back-off dashpot so plunger does not contact throttle lever. Adjust air-fuel ratio to 14.0-14.2 by first balancing each adjustment screw to highest idle and then turning 1/6th turn at a time until specification is reached.
3. Check and adjust distributor vacuum-control valve if necessary on vehicles so equipped. Note: One turn will change setting 1/2" mercury. If valve cannot be adjusted properly, replace it.
4. Move throttle to obtain 2000 RPM and adjust dashpot so stem is just contacting but not pressing on throttle-actuating tab.

SUGGESTED ASSIGNMENT:

The student should practice tuning at least one C.A.S.-equipped car to become familiar with special tune-up procedure.

**UNIT V – THE COMBUSTION-CONTROL SYSTEM (CCS)
GENERAL MOTORS**

Principles of the Combustion Control System

Lesson 1

OBJECTIVE: To become familiar with the exhaust-emission control components which may be found on General Motors vehicles from 1966 to 1971.

INFORMATION:

General Motors vehicles use a variety of equipment to reduce exhaust emissions by controlling combustion. The system, regardless of vehicular use, is called the Combustion-Control System, or C.C.S. The system consists of a specially calibrated carburetor and distributor system and other special control equipment as follows:

Carburetor. – Carburetors have been calibrated to run much leaner than in previous models due to air-temperature control, fast-acting automatic choke, and idle-adjustment limitation.

Distributor. – The distributor is more finely calibrated than in previous models and incorporates a centrifugal advance mechanism which allows basic timing to be set slightly retarded (at idle), yet recover to normal advance at slightly above idle.

Thermostatic air cleaner. – System consists of an air cleaner with an integral damper assembly and vacuum motor, hot-air pipe and shrouding from exhaust manifold, and a temperature sensor controlling the vacuum motor. The motor is connected by linkage to the damper assembly in the air-cleaner snorkel tube.

With engine compartment temperature below 85°F., the temperature sensor is closed, the damper is closed to outside air, and air is drawn from around shroud through hot-air pipe at exhaust manifold, and into air cleaner. When the temperature in air cleaner reaches about 100°F., sensor bleeds off vacuum to vacuum motor, causing damper to open to outside air until air in engine compartment reaches about 100°F. At compartment temperature of 100° F. or more, damper is completely open to engine-compartment air, and completely closed to hot air from hot-air pipe.

Under full throttle or below 6"–8" of mercury, the vacuum motor no longer holds the valve open to hot air, and only engine-compartment air enters carburetor.

**THERMOSTATICALLY
CONTROLLED AIR-
CLEANER ASSEMBLY**

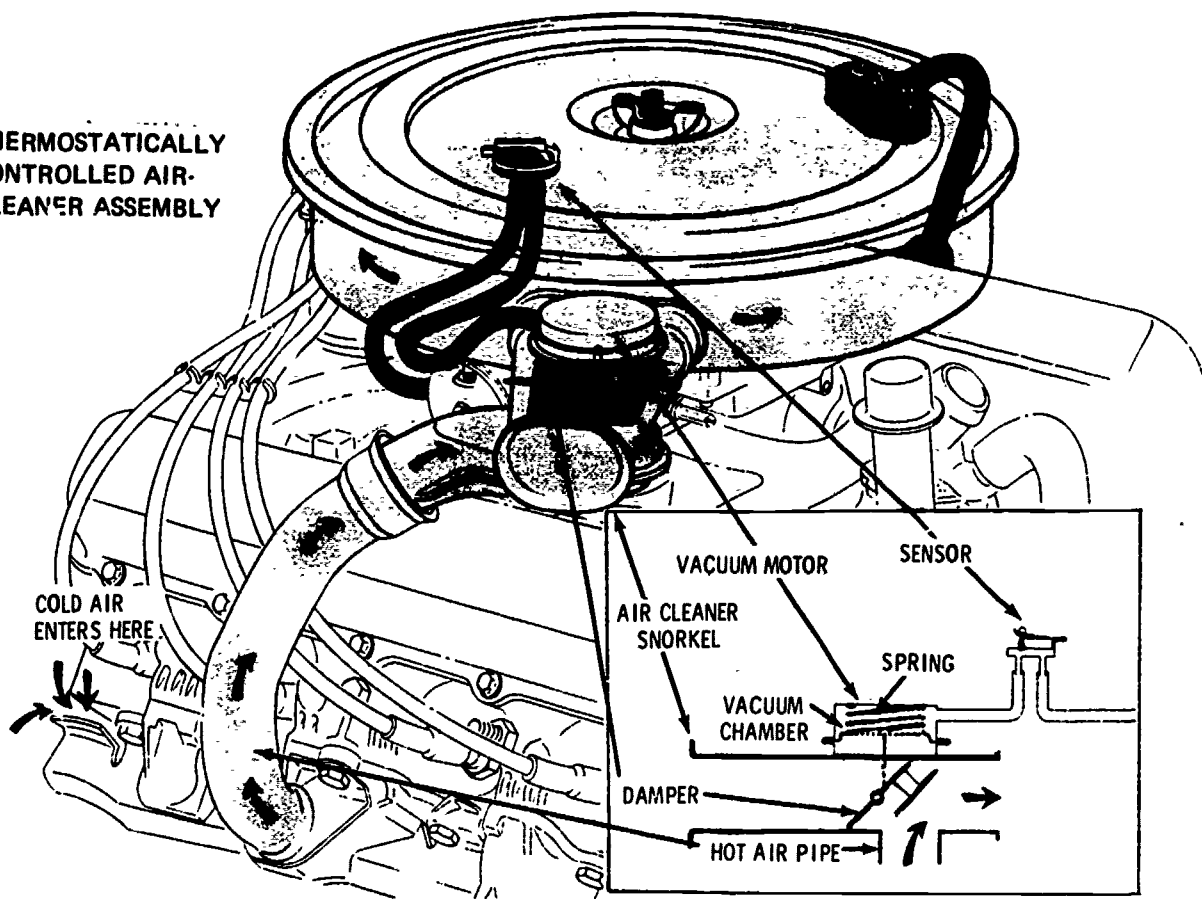

Throttle-control solenoid. – To prevent engine after-run, some G.M. vehicles are equipped with a throttle-control solenoid. When energized, throttle is held in correct position by solenoid plunger. When ignition switch is turned off, solenoid de-energizes, permitting throttle to almost close (about 400 engine RPM's), thus preventing after-run or dieseling.

**TYPICAL
IDLE SOLENOID ADJUSTMENT**

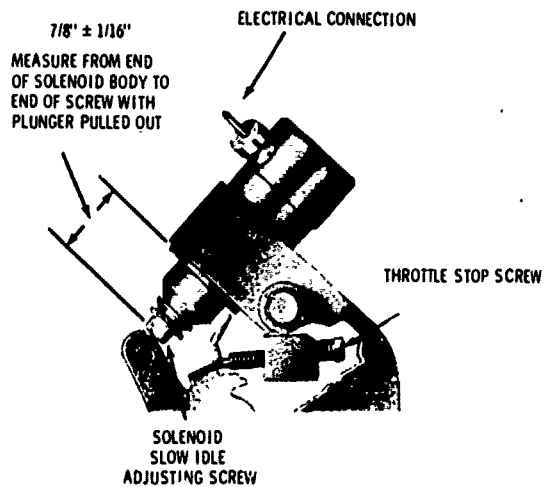

Transmission-controlled spark (T.C.S.). – Most General Motors cars (1970 on) are equipped with a transmission-controlled vacuum-advance control system which eliminates vacuum advance in the lower gear range. The purpose is to retard timing, making it necessary to open the throttle slightly more to maintain the same idle speed. This gives better mixture distribution and permits more efficient combustion, aiding in the control of emissions.

The T.C.S. system consists of a solenoid valve inserted in the vacuum line leading to the vacuum-advance unit, a switch located in the transmission, and an electrical harness connecting these control units. There are two types of transmission switches – an oil-pressure-operated switch used on automatic transmissions, and a mechanical switch operated by contact with the shift lever on manual transmissions.

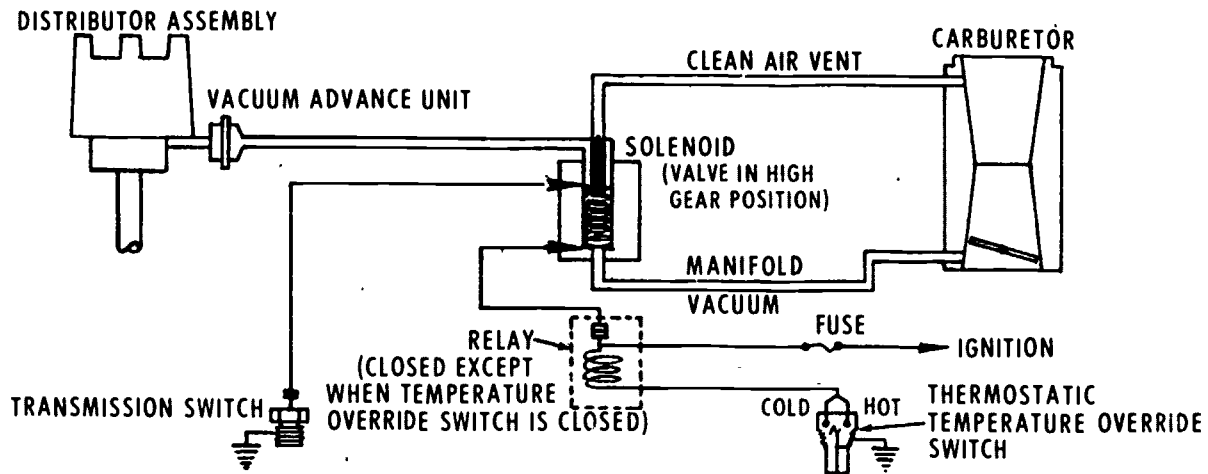

LAYOUT OF TYPICAL TRANSMISSION CONTROL SYSTEM
(TEMPERATURE OVERRIDE SWITCH AND RELAY ON CHEVROLET, PONTIAC AND OLDSMOBILE ONLY)

The transmission switch remains closed in the lower gear ranges, thereby energizing the solenoid and closing off vacuum. A vent bleeds off any vacuum in the hose leading to the distributor-advance unit. Spark advance is retarded. In high gear, the transmission switch opens and the solenoid de-energizes, closing the vent port and opening the vacuum line to the distributor. The vacuum advance then starts to operate normally.

A temperature-override switch is used on some vehicles (Chevrolet, Pontiac, Oldsmobile, Vega). The circuit provides full vacuum in all gears when the engine is cold. A thermostatic water-temperature switch located in the block provides the signal which energizes a normally closed relay, opening the circuit to the solenoid vacuum valve and providing full vacuum. Some vehicles also have a hot-override switch which provides full vacuum to increase engine cooling.

Combination emission control (C.E.C.). – Used on 1971 Chevrolet 6-cylinder and V-8 engines and all other General Motors 6-cylinder engines. The C.E.C. valve combines the function of the T.C.S. (transmission-controlled spark) solenoid and the action of a throttle-return check. Two separate throttle settings are possible – one for curb idle, and one for control of hydrocarbons on deceleration. The C.E.C. valve is serviced as a unit, by replacement only.

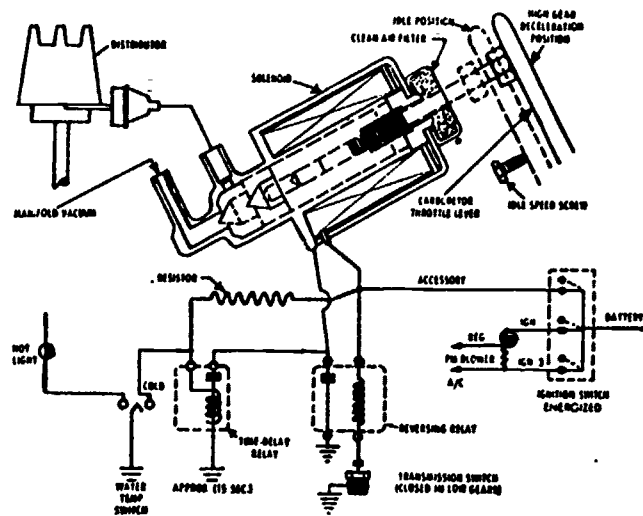

COMBINATION EMISSION CONTROL (C.E.C.) SYSTEM

The solenoid vacuum switch at transmission controls vacuum advance. When the solenoid is energized, the vacuum port is uncovered and the distributor receives vacuum. When the solenoid is de-energized, vacuum to distributor is shut off. The C.E.C. solenoid is controlled by two switches and a time-delay relay. The solenoid energizes in high forward gears and reverse on automatic transmissions by the transmission switch. A thermostatic switch is used to provide thermal override below 82°F. A time-delay relay energizes the C.E.C. solenoid for approximately 15 seconds after ignition is turned on, giving full vacuum to the distributor independent of engine temperature at start. A reversing relay is used to open the solenoid circuit (de-energize solenoid) when the transmission switch is closed (low gear) and close the solenoid circuit (energizing solenoid) when the transmission switch is open.

Control of engine dieseling is achieved by using a lower throttle-blade opening, resulting in a lower curb idle speed.

Thermo-vacuum valve. — Used on some General Motors vehicles from 1967 on. A three-outlet valve is designed to eliminate overheating at prolonged idle. By permitting full vacuum advance at idle, engine speed is increased, thus improving performance of cooling fan and water pump.

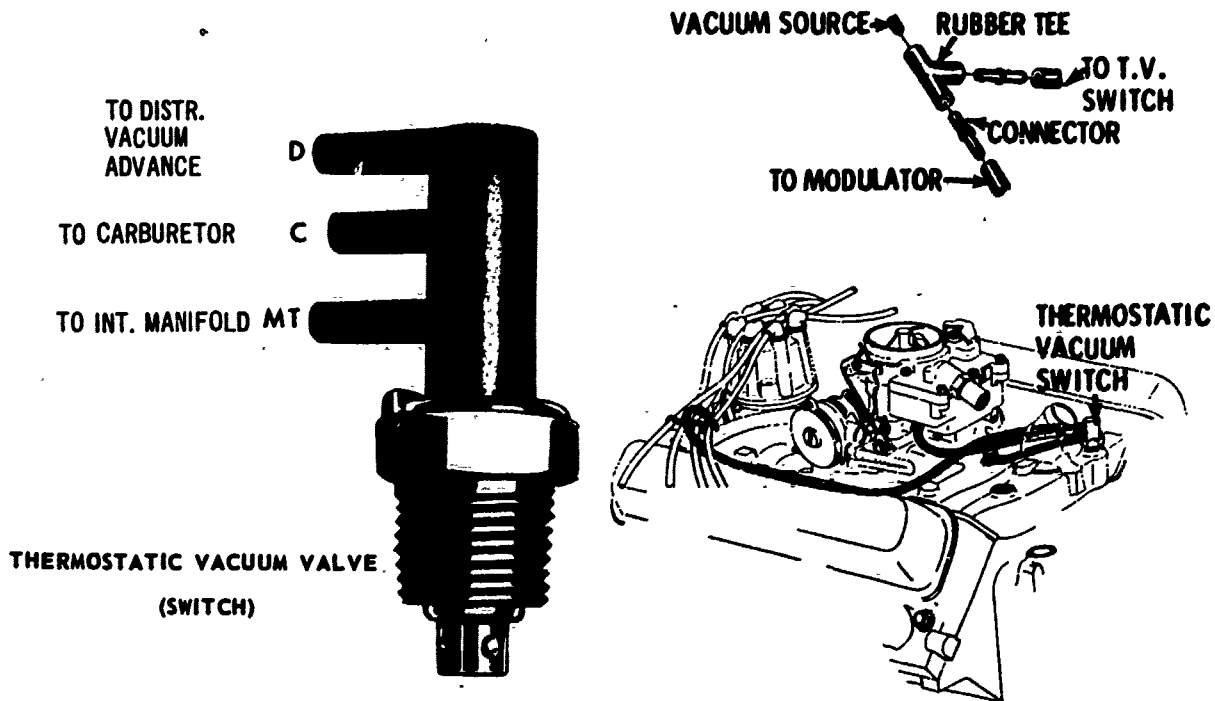

THERMOSTATIC VACUUM VALVE HOSE ROUTING
(TYPICAL)

When coolant temperature reaches 220°F., the thermo-vacuum valve is activated. The valve will then move to permit "MT" (manifold vacuum) to activate distributor vacuum-advance unit, allowing engine to run cooler.

ASSIGNMENT:

1. Describe two methods of limiting the carburetor-idle mixture control.
2. What is the purpose of controlling the temperature of the air entering the carburetor?
3. What is the purpose of the throttle-control solenoid on a 350" Buick engine?
4. What substances are emitted from the exhaust? Does the T.C.S. system control them?

UNIT V - THE COMBUSTION-CONTROL SYSTEM

Testing the Components

Lesson 2

OBJECTIVE: To learn the test methods for components of the Combustion-Control System (General Motors).

EQUIPMENT:

Vacuum gage
RPM gage
Jumper wire

INFORMATION:

The following components of the Combustion-Control System require tests in addition to those covered in a normal tune-up: thermostatic air cleaner, throttle-control solenoid, transmission-controlled spark system, combustion-emission control system, thermo-vacuum valve.

PROCEDURE:

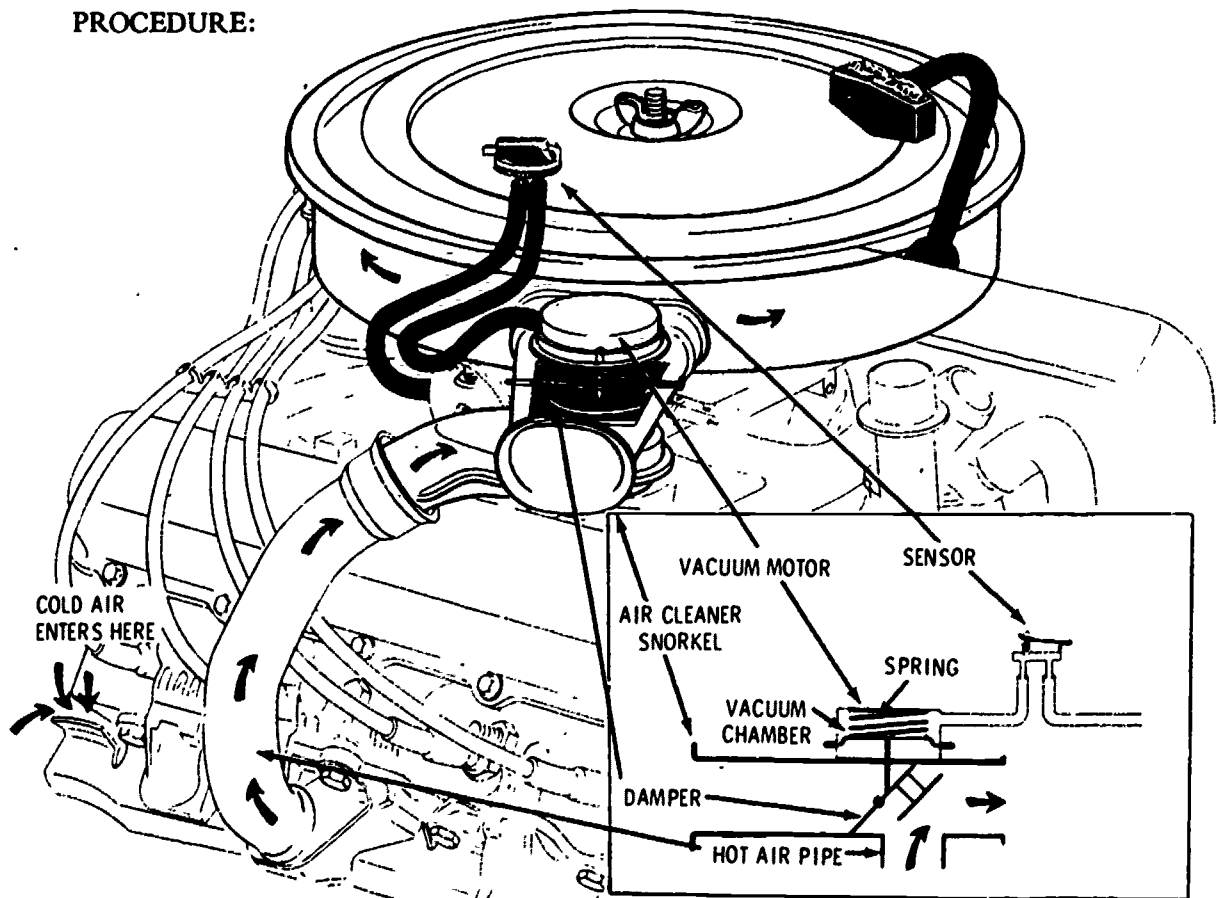

THERMOSTATICALLY CONTROLLED AIR CLEANER ASSEMBLY

Thermostatic air cleaner. — Tape a thermometer in air cleaner next to temperature sensor. Engine compartment must be less than 80°F. Install a tie-in vacuum line at vacuum motor and connect a vacuum gage in the line. With engine off, damper should be open. (Check it.) Install cover on air cleaner and start engine. With engine at idle and ambient temperature below 85°F., damper should close. With engine-idling temperature above 85°F., damper should open. Note: It should be completely open at 128°F.

When damper in snorkel begins to move, quickly remove cover on air cleaner and check thermometer next to sensor and vacuum gage. Vacuum at motor should be 5"–9" mercury when damper assembly is closed to outside air.

If temperature is within specifications, system is operating correctly. If temperature is out of specification, but vacuum is correct (5"–9"), replace sensor. If both temperature and vacuum are out of specification, replace vacuum motor.

Throttle-control solenoid. — If solenoid energizes when ignition switch is turned on and throttle is depressed slightly and releases throttle when deenergized, solenoid may be considered as operating correctly.

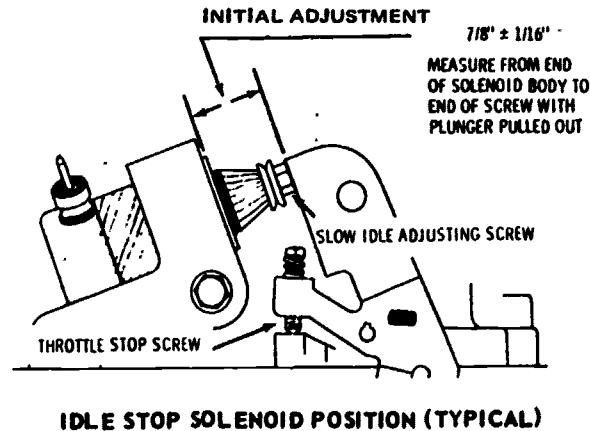

Transmission-controlled spark. —

T.C.S. solenoid test: Disconnect hoses and electrical connector. Connect a hose to the distributor vacuum port on the solenoid and blow into it. Air should come out of the vacuum port that was connected to the vacuum source. Plugging this port should shut off air through the solenoid. Connect a jumper from one terminal to ground. Connect other terminal to a 2-volt source. An audible click should be heard, and air should now come out of the vent port. Plugging the vent port should shut off the air flow through the solenoid.

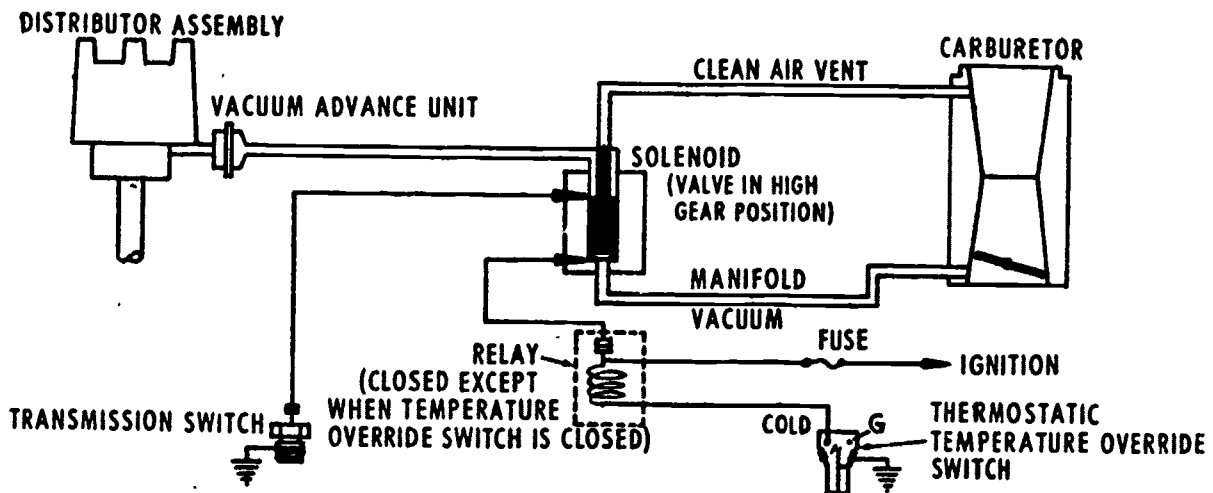

TYPICAL T.C.S. SYSTEM (OVERRIDE RELAY AND SWITCH ON VEGA ONLY)

Transmission-switch test: Disconnect connector from switch on side of transmission and connect an 0.8 ampere or less test lamp from T.C.S. switch terminal to a 12-volt source. Test light should be *off* when transmission is in reverse (engine running) and *on* when transmission is in drive, park, neutral, and low.

Temperature-override switch relay test: Disconnect relay; connect 12-volt source to No.1 terminal. Connect test light to No.2 terminal and to ground. Test light should be *on*. Replace relay if light is off. Connect No.3 terminal to ground. Test light should go *off*. Replace if relay light remains on.

Temperature-override switch: Disconnect switch and connect 12-volt test light from "G" terminal of switch to 12-volt source. Note: engine must be cold. Start engine; test light should be on and go off, same as green light on dash.

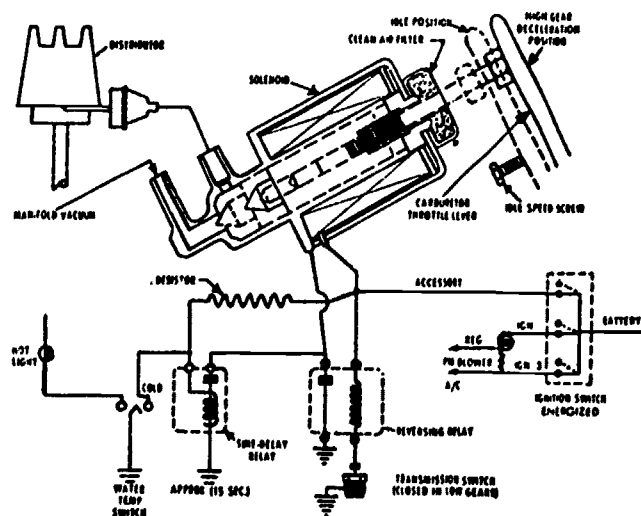

COMBINATION EMISSION CONTROL (C.E.C.) SYSTEM

Combination emission control.— Failure of the C.E.C. valve will result in no vacuum advance and no high-gear-deceleration throttle position. Note: the C.E.C. valve is serviced as a unit, by replacement only.

Thermo-vacuum valve. — When overheating occurs at idle (red light), disconnect outlet “D” and attach a vacuum gage to the outlet. If indication shows full vacuum, valve is operating properly. When normal coolant temperatures exist, there should be approximately 2”–5” vacuum at “D” outlet.

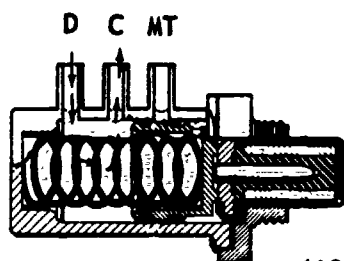

1A9519

D - TO DISTRIBUTOR VACUUM ADVANCE
C - TO CARBURETOR
MT - TO INTAKE MANIFOLD
THERMO VACUUM VALVE (TYPICAL)

ASSIGNMENT:

The student should practice each of the foregoing tests to become familiar with each component and its proper operation.

UNIT V -- COMBUSTION CONTROL SYSTEM

Tune-up Adjustments

Lesson 3

OBJECTIVE: To learn additional tune-up steps required of C.C.S.-equipped vehicles.

EQUIPMENT:

Vacuum gage
RPM gage
Combustion analyzer
Hand tools

INFORMATION:

In addition to test and unit replacement as outlined in lesson 2, the following adjustments may become necessary on C.C.S.-equipped vehicles. Note: Follow sticker procedure (found under hood of all G.M. vehicles) for timing and carburetor adjustments.

Throttle-control solenoid. -- Adjust solenoid plunger to obtain hot-idle specification. Disconnect wire at solenoid and adjust carburetor speed screw to obtain ignition-off throttle position (usually 400 RPM). Reconnect wire.

Transmission-controlled spark. -- The T.C.S. system must be functional-tested at each engine tune-up (as outlined in lesson 2) in order to limit NOx emission and provide proper vacuum advance for fuel economy.

Combination emission control. -- (Note: adjustment necessary only after valve adjustments have been upset -- as, for example, during carburetor overhaul.)

With engine running and transmission in neutral for manual or drive for automatic, air conditioner off, distributor vacuum hose removed and plugged, and fuel-tank hose from vapor canister disconnected, perform the following:

1. Manually extend the C.E.C. valve plunger to contact throttle lever.
2. Adjust plunger length to obtain idle speeds as required.

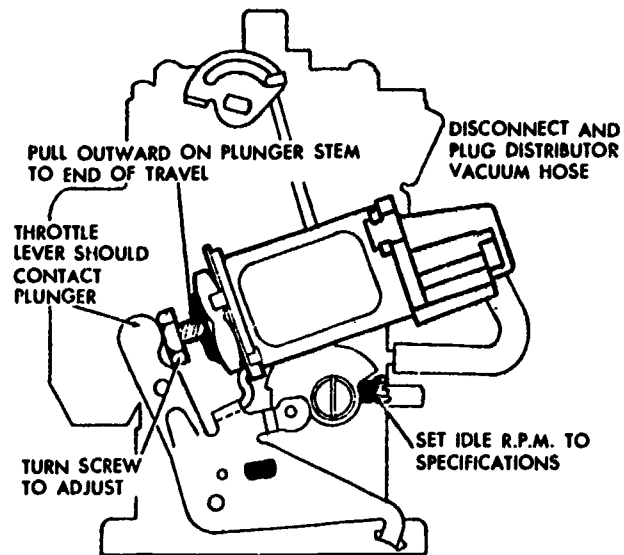

C.E.C. VALVE ADJUSTMENT (TYPICAL)

ASSIGNMENT:

The student should practice performing tune-up adjustments on C.C.S.-equipped vehicles.

UNIT VI - CLIMATIC COMBUSTION-CONTROL SYSTEM (C.C.C.)

Principles of the Climatic Combustion-Control System

Lesson 1

OBJECTIVE: To learn the operating principles of the climatic combustion-control system (General Motors).

INFORMATION:

The Climatic Combustion-Control system was used on 1967 Oldsmobile 2- and 4-barrel 330", 400", and 425" engines. The system centers around a thermostatically controlled air cleaner. The air-cleaner assembly is designed to keep air entering the carburetor at approximately 100°F. when the underhood temperature is less than 100°F. By keeping the temperature at 100°F. or above, the carburetor can be calibrated to operate more efficiently without affecting engine performance, provide improved fuel economy, eliminate carburetor icing, and improve engine warm-up.

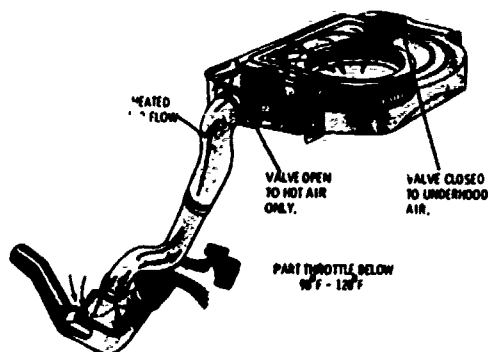

**THERMOSTATIC AIR CLEANER
BELOW 90-120°F.**

During the engine warm-up period, with engine compartment temperatures below 90° to 120°F., the temperature sensor is closed. This allows engine vacuum to be directed to the vacuum motor, closing the valve plate to the outside air. With the valve closed, the cool air will flow through the holes in the left side of shroud, where it is heated.

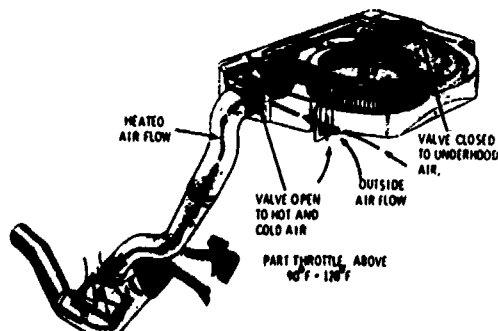

**THERMOSTATIC AIR CLEANER
ABOVE 90-120°F.**

The heated air then flows up through the hot-air pipe and through the connector into air cleaner. As the temperature inside the air cleaner reaches approximately 100°F., the bi-metal temperature sensor bleeds off vacuum to the right vacuum motor, causing the valve to open. This allows underhood air to be mixed with heated air as needed to keep the air temperature at approximately 100°F. Under wide-open throttle or below 6" to 8" of vacuum, the vacuum motor will no longer hold the valve open to hot air; therefore the hot-air pipe is closed off, allowing only underhood air to enter air cleaner.

ASSIGNMENT:

1. What does C.C.C. mean?
2. What is the purpose of the C.C.C.?
3. At what temperature does the air cleaner regulate air entering carburetor?

UNIT VI - CLIMATIC COMBUSTION CONTROL

Testing the Components

Lesson 2

OBJECTIVE: To learn the method for testing the climatic combustion control.

PROCEDURE:

Remove air cleaner and allow it to cool down to 75° F. Install air cleaner on carburetor and attach hot-air hose connector and vacuum line. With air filter in position, tape a thermometer in air cleaner. Install cover on air cleaner and start engine. Observe valve plate in right snorkel. When valve plate begins to move toward the open position, quickly remove cover on air cleaner and record reading on thermometer. The thermometer should read between 90°F. and 120°F. If system is not functioning properly, replace temperature sensor and/or vacuum motor.

ASSIGNMENT:

1. At what temperature should right-hand snorkel (CCC) start to open?
2. Under what condition should *left* hand snorkel open?

UNIT VII – THE IMPROVED COMBUSTION EXHAUST-EMISSION-CONTROL SYSTEM (IMCO) – FORD

Principles of the Improved Combustion Exhaust-Emission-Control System

Lesson 1

OBJECTIVE: To become familiar with components of the Improved Combustion System (IMCO) and their operations.

INFORMATION:

The Improved Combustion System used by Ford Motor Company consists of specially designed distributor and carburetor systems which reduce exhaust contaminants by burning them more completely within the combustion chamber.

The component of the IMCO system and their operation are detailed below.

Carburetor. – Carburetors have been calibrated to run much leaner than on previous models due to air-temperature control, the fast-acting automatic choke, and idle-adjustment limitation.

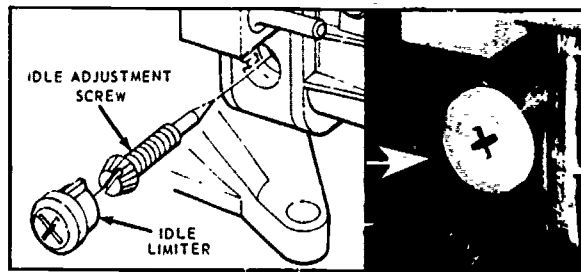

**HOLLEY COBRA JET CARBURETORS IDLE
MIXTURE SCREWS & LIMITER STOPS**

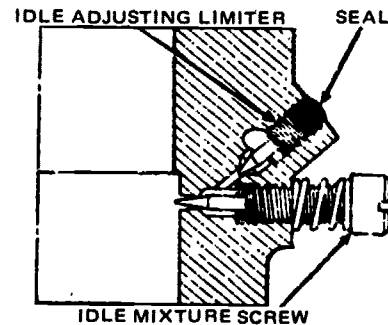

**CARTER CARBURETORS IDLE MIXTURE
SCREW, LIMITER & SEAL**

Distributor. – The distributor is more finely calibrated than on previous models and incorporates a centrifugal advance mechanism which allows basic timing to be set slightly retarded yet recover to normal advance at slightly above idle.

Distributor vacuum-control valve. – This is a temperature-sensing valve designed to eliminate engine overheating at prolonged idle. The valve accomplishes this by controlling engine timing. When coolant temperature rises to 220°–230°F., the distributor vacuum valve is actuated. The valve will now move to allow full engine vacuum to be directed to the distributor, to advance timing and allow engine to run cooler.



DISTRIBUTOR VACUUM-CONTROL VALVE

Note: Hookups of this system will vary considerably, depending upon type of carburetor, whether diaphragm distributor is single or dual, and whether or not a filter is employed on the valve.

Distributor vacuum-advance control valve. — The vacuum-advance control valve (deceleration valve) is used to control the distributor vacuum-advance unit during periods of deceleration. It is connected in the vacuum line to the distributor vacuum unit and has two vacuum import lines (one line from carburetor vacuum-port fitting and a second line from intake manifold), so the vacuum source can be switched from carburetor to manifold as required.

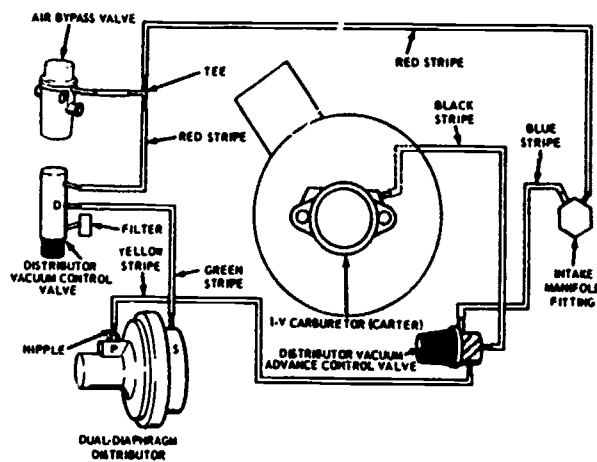

In operation, the outer (advance) diaphragm is connected to the carburetor source for conventional advance. During deceleration, when throttle valve is closed, the valve connects the vacuum-advance unit to the intake manifold vacuum momentarily. This provides maximum ignition timing advance, which gives the fuel mixture additional time to burn while in the cylinders, thus limiting the amount of unburned hydrocarbons in the exhaust.

Distributor vacuum unit—dual diaphragm.— Used on most Ford Motor Company engines. Retard (inner) chamber of vacuum unit is connected directly to the intake manifold and will retard timing for closed-throttle idling.

Electronic distributor modulator. — Used on most 6- and 8-cylinder models equipped with automatic transmission. The system consists of four major components: a speed sensor, a thermal switch, an electronic control amplifier, and a three-way solenoid valve

that controls the vacuum applied to the distributor. The modulator operates to prevent spark advance below a specified speed when accelerating, and also prevents advance below a specified value on deceleration. The vacuum-advance line is connected through a temperature-sensing control valve which advances tuning if engine overheats.

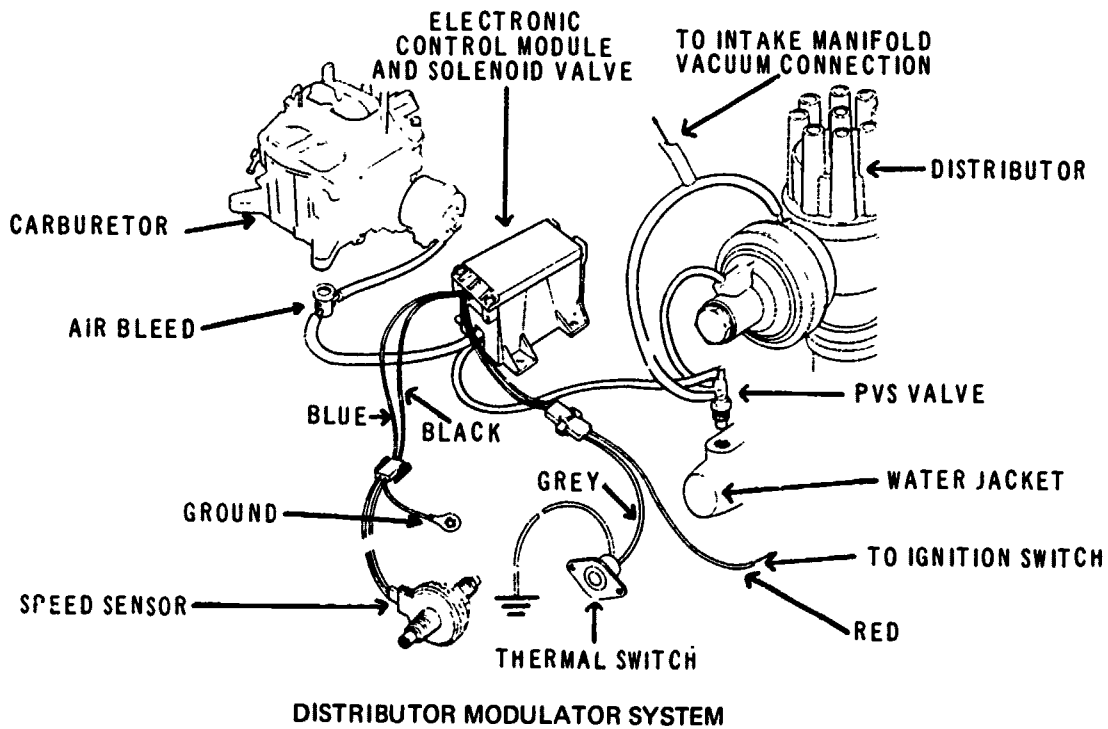

Distributor Modulator Specifications

Thermal Switch	Open	68 Max. (°F.)
	Close	58 Min. (°F.)
Speed Sensor	Resistance	40-60 ohms @ Room Temperature
	Coil Resistance to Case	Open Circuit
System Operating Limits		
ENGINE	TRANSMISSION	VACUUM ADVANCE CUT-IN SPEED ON ACCELERATION
200-1V	Auto.	23 ± 2.3 mph
240-1V	Auto.	23 ± 2.3 mph
250-1V	Auto.	23 ± 2.3 mph
390-2V	Auto.	23 ± 2.3 mph
429-4V	Auto.	28 ± 2.8 mph
460-4V	Auto.	28 ± 2.8 mph
On deceleration, the vacuum advance cut-out speed for all of the above engines is approximately 18 mph.		

Electronic RPM limiter. – Used on high-performance engines to prevent the engine from overrun, the Electronic RPM Limiter is connected into the ignition system at the distributor. It is designed to short out cylinders as the engine RPM goes over 6000. Shorting out of cylinders limits the RPM smoothly. The engine acts as though the plugs were fouling out. This prevents an inadvertent overspeed condition that could cause damage to the engine.

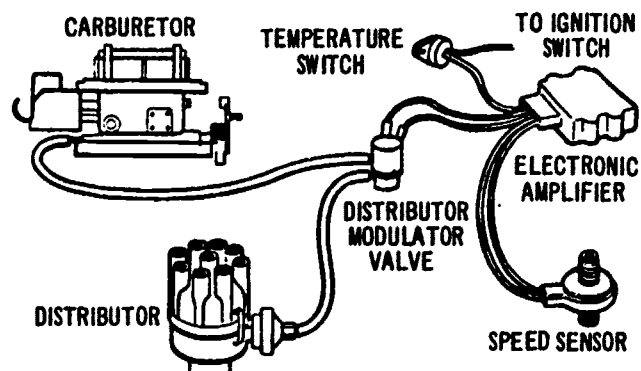

ELECTRONIC SPARK CONTROL SYSTEM (ESC)

Thermostatic air cleaner. – A thermostatically controlled air cleaner is used on Ford Motor Company vehicles to regulate the temperature of the air entering the carburetor.

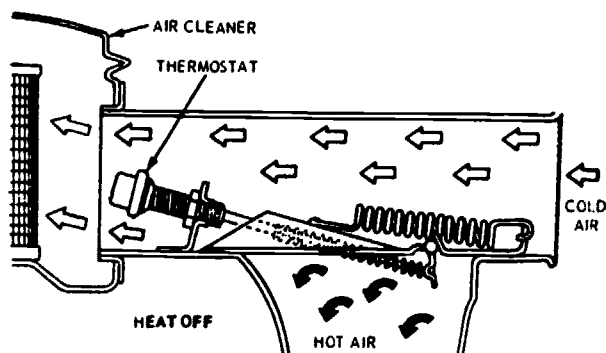

DUCT AND VALVE ASSEMBLY

A thermostatic built-in air duct is exposed to incoming air. A spring-loaded valve plate is connected to the thermostatic bulb through linkages. The valve-plate spring holds the valve in the closed position (heat on) until the thermostatic bulb overcomes the valve-spring tension. As the temperature rises, the bulb will overcome spring tension and open valve plate.

A later version of the thermostatic air cleaner consists of a vacuum-operated duct valve and temperature sensor (bi-metal switch).

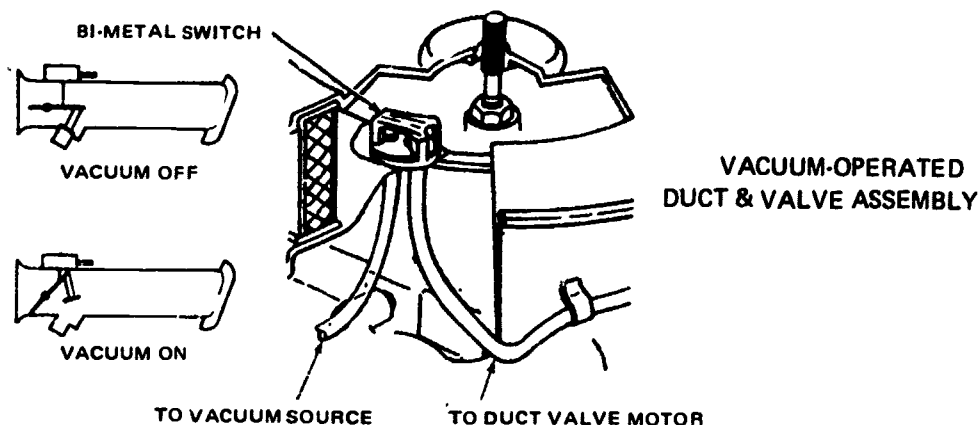

When engine compartment temperature is below approximately 80°F., the bi-metal switch is closed, allowing vacuum to pass through switch and close door to engine-compartment air. Warm air is then drawn from the shroud around the exhaust manifold. When the temperature inside the air cleaner rises above 80°F., the bi-metal sensor switch begins to bleed off vacuum, allowing duct to open to underhood air. Thus temperature of air entering carburetor is regulated to 80°F. or more, allowing much finer calibration of the carburetor.

Decel valve. — Used on Pinto models only. The decel valve is located on the intake manifold. Its purpose is to supply an additional air-fuel mixture to the engine during periods of deceleration (high intake manifold vacuum). The decel valve consists of a valve controlled by two springs and operated by a diaphragm. The diaphragm is subjected to atmospheric pressure on one side and manifold vacuum on the other. A small tube connects the valve to a system of fuel- and air-bleed jets in the carburetor.

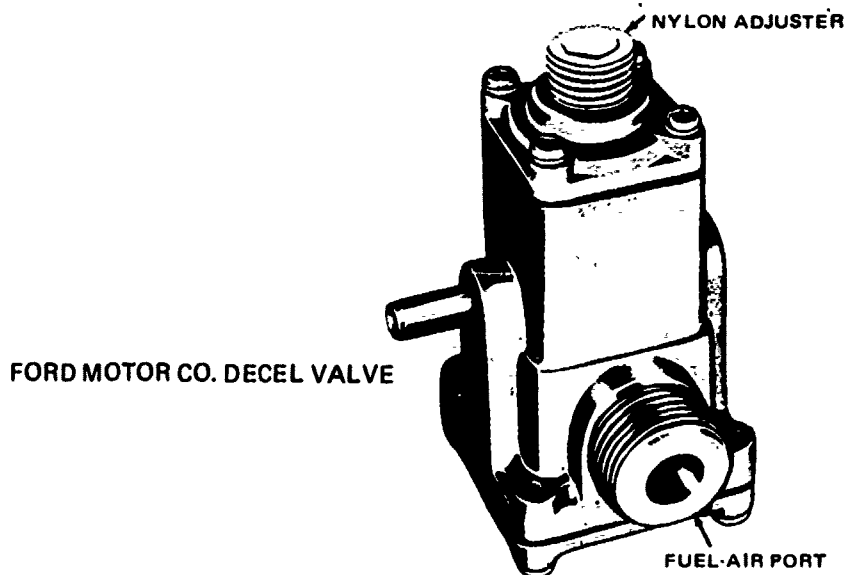

When caused to operate by high intake vacuum, an additional air-fuel mixture is drawn into the engine. This additional volume of combustible mixture, when compressed, results in a more rapid and complete burning of the fuel mixture, thereby reducing emission of hydrocarbons and carbon monoxide.

UNIT VII – IMPROVED COMBUSTION SYSTEM

Testing the Components

Lesson 2

OBJECTIVE: To learn to test the components of the Improved Combustion Exhaust Emission System (IMCO).

EQUIPMENT:

- Tachometer
- Thermometer
- Vacuum gage
- Stop watch
- Timing light
- Aerosol oil spray

INFORMATION:

The following components of IMCO-equipped vehicles require tests in addition to those performed in a normal tune-up: distributor vacuum-control valve (temperature), distributor vacuum-advance control valve (decel advance), distributor dual-diaphragm vacuum unit, electronic distributor modulator, electronic RPM limiter, thermostatic-controlled air cleaner, decel valve.

PROCEDURE:

Distributor Vacuum-Control Valve (temperature). – Connect an RPM gage to engine, cover radiator, and start engine. Allow to idle (hot-slow) until temperature light comes on or gage reading is abnormally high. If idle speed has increased 100 RPM or more, valve is functioning properly; if not, replace valve. Note: Do not excessively overheat engine.

Distributor vacuum-advance control valve. – With RPM gage connected to engine, adjust hot-slow idle to specifications. Open throttle to increase engine speed to 2000 RPM, hold speed for approximately 5 seconds, then close throttle. If valve is working properly, engine speed will come back to normal idle speed within 4 seconds (Use stop watch). If valve does not work within the proper time interval, refer to the next lesson in this unit.

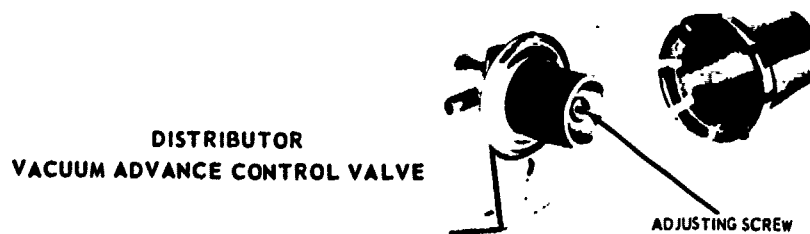

Distributor dual-diaphragm vacuum unit. — With engine running at hot-slow idle, remove manifold vacuum line on retard (inside) diaphragm. Engine speed should increase, and timing should advance approximately 6°. (Note use of RPM gage and timing light.) If diaphragm does not operate properly, the entire diaphragm must be replaced.

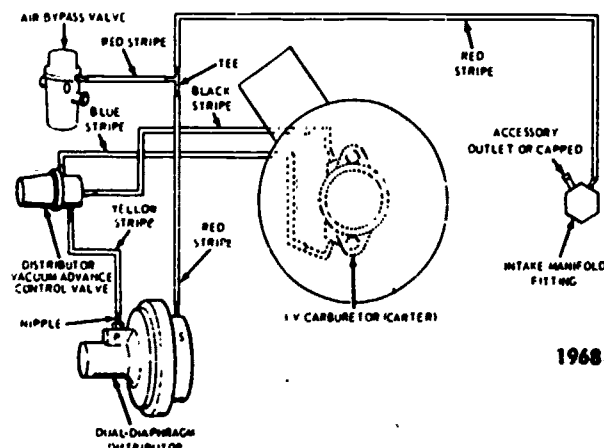

1968-240¹ THERMACTOR EMISSION

Electronic distributor modulator. — (System check.) This system should be tested when loss of engine performance is noted. Symptoms are similar to those of retarded ignition timing. To test the modulator system, connect a vacuum gage in the large hose on module. Raise rear wheels of vehicle and start engine. Vacuum gage should read zero. Place transmission in gear and *slowly* accelerate to 30 MPH. Vacuum gage should indicate at least 6" vacuum by 25 MPH. Allow vehicle to coast, at between 25-15 MPH. Vacuum should drop to zero. Chill thermal switch with aerosol oil spray or similar device. Raise engine speed to approximately 1500 RPM. There should be a vacuum reading. If system fails to pass the above functional test, refer to specific vehicle model shop manual for module test.

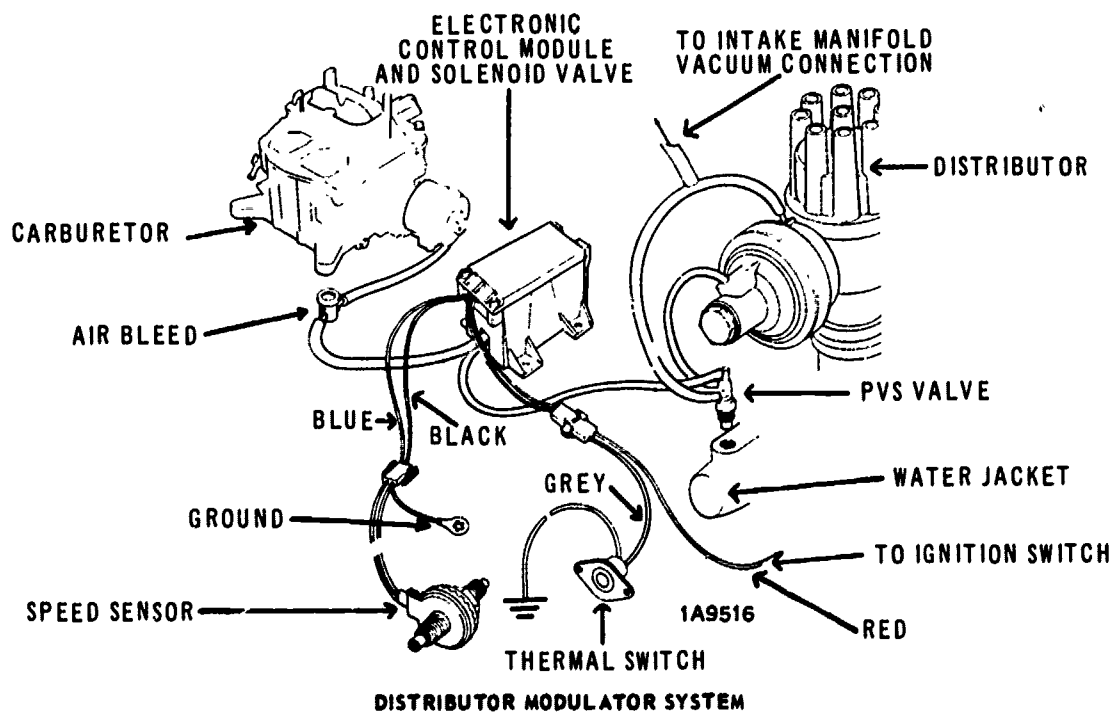

Electronic RPM limiter (Governor). — Improper operation of the governor usually results in an engine-won't-start condition, misfiring, or loss in RPM-limiting action. To check this system, if one of the above conditions exists, disconnect RPM limiter at coil and recheck condition. Note: Dwell angle is critical to this system and must be within 3° of proper setting. If engine still fails to operate properly, test coil, condenser, primary wiring, and fuel system for proper operation. If system fails to limit RPM to 6000, replace governor. If engine operates properly (start, misfire, etc.) with system disconnected, replace governor.

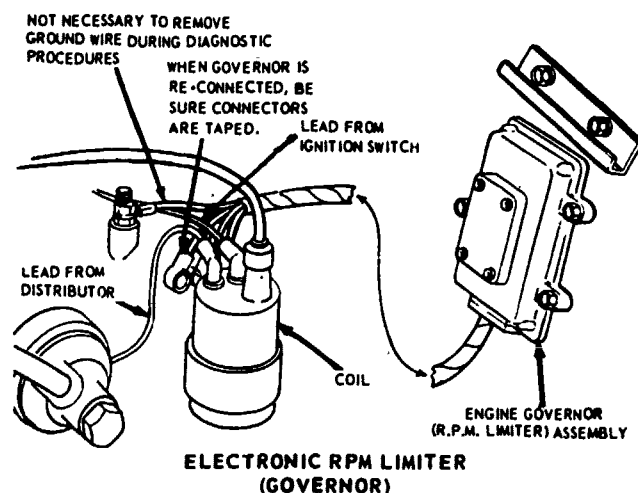

Thermostatic air cleaner. —

Thermostatic Bulb Type: Place duct assembly in water. Heat water to 100°F. Valve should be in *heat-on* position. Increase temperature to 135°F. Valve should move to *heat-off* position. Note: Allow 5 minutes for temperature to stabilize. If valve operation is unsatisfactory, and there is no plate and duct interference and the jam nut cannot be adjusted, then duct and valve assembly must be replaced.

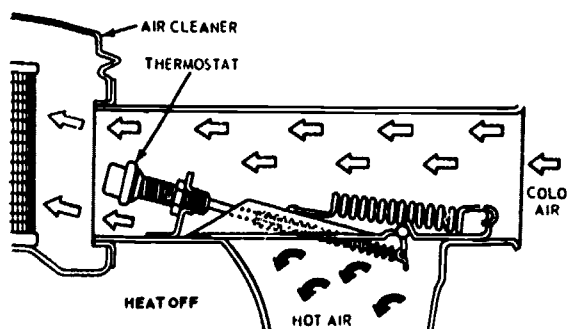

TEMPERATURE OPERATED DUCT & VALVE ASSEMBLY

Vacuum-Operated Type: Tape thermometer inside air cleaner and start engine. When valve in duct starts to open, quickly remove air-cleaner lid and observe temperature. Temperature should be approximately 80°F. If temperature is incorrect, replace temperature sensor. If duct valve fails to operate, check diaphragm and hose for leak and replace if necessary.

Some air cleaners have an auxiliary air-inlet valve for wide-open throttle operation. To test valve, start engine and observe valve. Valve should be closed with vacuum line connected and open with vacuum line disconnected. If valve fails to operate, replace valve.

Decel valve. — Run engine at idle speed for five minutes. Connect RPM gage. Remove air/fuel-mixture hose from decel valve and connect a vacuum gage, using a T-fitting so valve remains operational. Raise engine speed to 3000 RPM, hold for at least two seconds, and release throttle. A vacuum reading should be indicated for no more than 5 seconds. (Use stopwatch.) If valve fails to operate, replace valve. If valve-operating time is wrong, adjust valve by turning nylon adjuster ½ turn in or out, and retest time lapse.

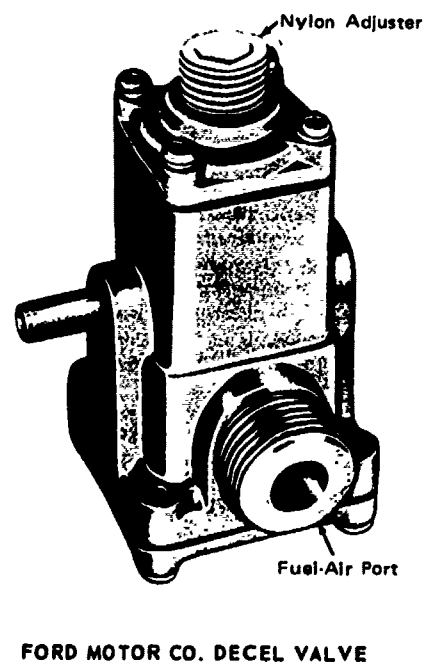
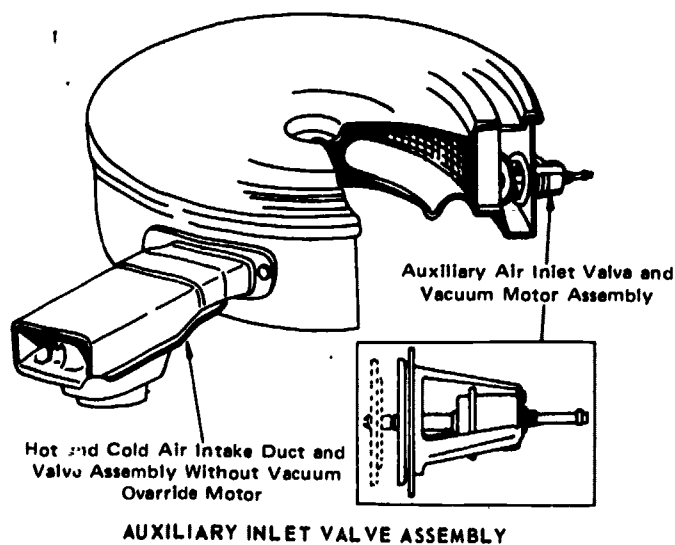

UNIT VII – IMPROVED COMBUSTION SYSTEM

Tune-Up Adjustments

Lesson 3

OBJECTIVE: To learn tune-up adjustments in addition to usual carburetor and ignition tune-up which may be necessary in IMCO-equipped vehicles.

EQUIPMENT:

RPM gage
Vacuum gage
Stopwatch

INFORMATION:

In addition to the IMCO components tests in lesson 2, and after usual ignition and carburetor tune-up service, the following adjustment procedures must be observed to insure that the engine is balanced and operating within emission standards.

PROCEDURE:

Distributor vacuum-advance control valve. – When vacuum control valve does not pass the time-interval test (lesson 2), remove plastic cover from valve and turn adjusting screw $\frac{1}{4}$ turn at a time, repeating test. (Speed RPM to 2000 for 5 seconds and then close throttle). Engine speed should drop to normal idle within 4 seconds (use stopwatch).

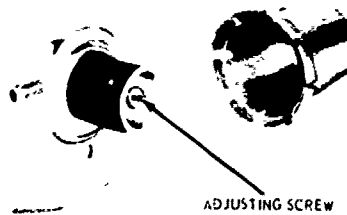

DISTRIBUTOR VACUUM DECELERATION VALVE

Thermostatic air cleaner. – On the thermostatic bulb-type air cleaner, the duct-valve temperature setting can be changed by loosening the jam nut and turning the thermostatic bulb assembly in or out as required. Note: Air cleaner should be retested after each change in adjustment.

No adjustments are provided on other units of the IMCO emission-control system.

SUGGESTED ASSIGNMENT:

The student should practice making all tune-up tests and adjustments on at least one IMCO-equipped vehicle.

UNIT VIII – “ENGINE MOD” SYSTEM (American Motors)

Principles of “Engine Mod”

Lesson 1

OBJECTIVE: To become familiar with the exhaust-emission control equipment used on American Motors engines.

INFORMATION:

American Motors vehicles use a combination of accessory equipment and engine design modification to reduce hydrocarbons, carbon monoxide, and oxides of nitrogen exhaust emissions. A description of engine modifications and emission-reducing equipment follows:

Engine design. – American Motors 6-cylinder and V-8 engines have combustion chambers designed to reduce the quench action which takes place when the combustion flame front reaches the edge of the combustion chamber. This design also reduces the compression ratio of the engine.

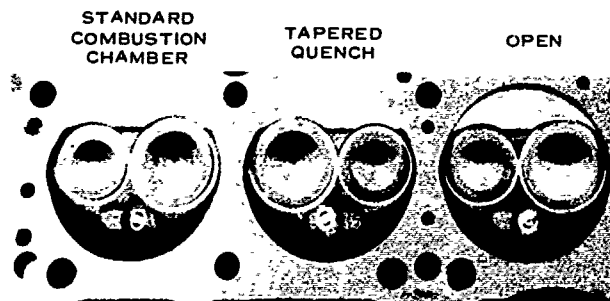

Carburetion. – Carburetor has been calibrated to run much leaner than on previous models, due to incoming-air-temperature control, fast-acting automatic choke, and idle adjustment or enrichment limitation.

Distributors. – Distributors are more finely calibrated and incorporate a means of spark retard during idle.

Thermostatically controlled air cleaner. – The air-cleaner assembly consists of a thermostatically controlled valve, snorkel, and hot-air duct. The valve is calibrated to control carburetor incoming air temperature to between 110° F. and 130°F.

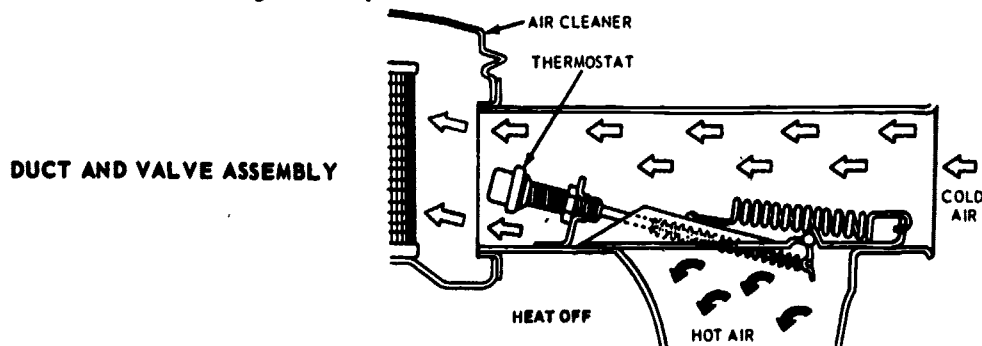

Distributor vacuum unit—dual diaphragm.— The dual-diaphragm vacuum advance is designed so that ignition timing is retarded at idle (above 9" vacuum). With timing retarded at idle, a greater throttle opening is necessary to maintain correct engine speed. With greater throttle opening, more air is allowed to enter the engine, thus raising combustion efficiency at idle. Ignition timing is advanced normally above idle.

Deceleration valve. — The decel valve is used to advanced ignition timing during periods of deceleration. When intake manifold vacuum rises above a specific value, the decel valve closes off vacuum to the carburetor spark port and supplies intake manifold vacuum to the advance side of the distributor vacuum unit, providing full-vacuum advance timing. As manifold vacuum falls below the specific value, the decel valve closes off intake manifold vacuum and restores carburetor spark-port vacuum to the advance side of the vacuum unit.

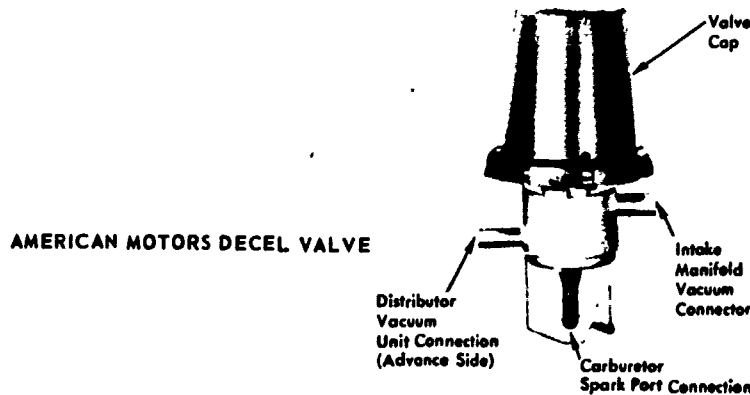

Transmission-controlled spark. — The T.C.S. system consists of a solenoid vacuum valve inserted in the vacuum line leading to the vacuum-advance control unit; a temperature-override switch located at the front upper cross-member; a switch located in the transmission; and an electrical harness connecting these units. The system is designed to eliminate spark advance in the lower gear ranges. Its purpose is to reduce the emission of nitrogen oxide by lowering peak combustion pressure and temperature during the power stroke.

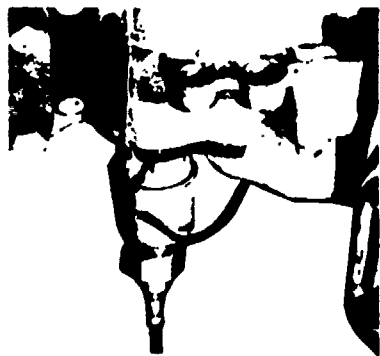

**TYPICAL SOLENOID CONTROL SWITCH
(AUTOMATIC TRANSMISSION)**

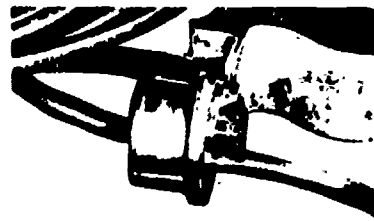

SOLENOID VACUUM VALVE

In operation, the solenoid vacuum valve, when energized, vents distributor vacuum to the atmosphere, and when de-energized, vacuum passes through the valve to the distributor advance unit, resulting in normal vacuum advance. The solenoid valve is controlled by a transmission switch which only de-energizes solenoid in high gear, and a temperature-override switch which provides full vacuum in all gears when ambient temperature is below 63°F. The override switch completes the circuit to the battery, and the solenoid vacuum valve is controlled by the solenoid control switch.

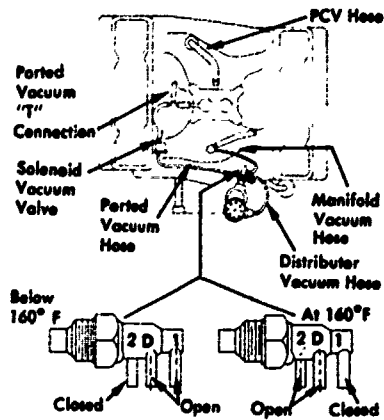

COOLANT TEMPERATURE OVERRIDE SWITCH

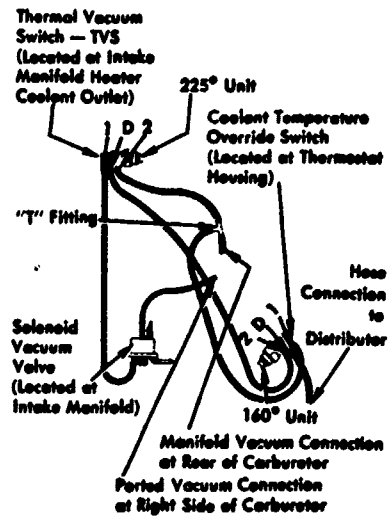

JEEP THERMAL VACUUM SWITCH HOSE ROUTING

ASSIGNMENT:

1. What does "Engine Mod" mean?
2. How does a retarded spark at idle reduce emissions?
3. Name two designs of combustion chambers which reduce quench area.

UNIT VIII - ENGINE MOD SYSTEM

Testing the Components

Lesson 2

OBJECTIVE: To learn to test components of the Engine Mod emission-control system.

EQUIPMENT:

- RPM gage
- Voltmeter (12V)
- Timing light
- Vacuum gage
- Stopwatch

INFORMATION:

The following components of Engine Mod emission-control system require tests in addition to those performed during a normal tune-up: Dual vacuum control, decel valve, and the transmission-controlled spark system.

Distributor dual-diaphragm vacuum-control valve. - With engine idling at hot-slow idle speed, remove manifold vacuum line on distributor vacuum unit. Engine speed should increase and timing should advance. Note: Use RPM gage and timing light. If diaphragm does not operate properly, the complete distributor vacuum unit must be replaced.

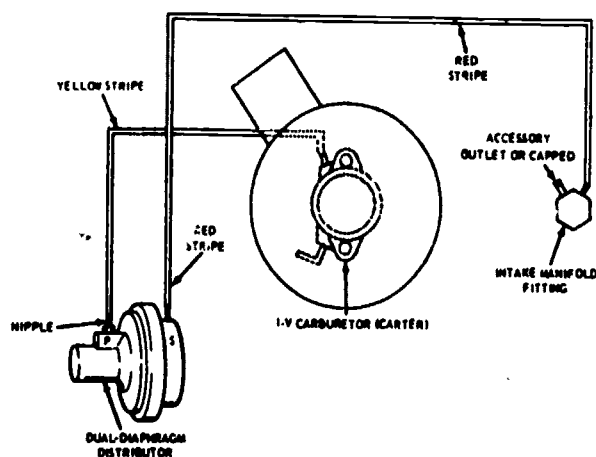

Deceleration valve. - Install a T-fitting and vacuum gage in the distributor vacuum advance hose. With engine at hot-slow idle speed, vacuum should be less than 4" of mercury. If vacuum is above 4", check timing, idle speed, and idle-mixture adjustment.

Raise engine speed to 2000 RPM for 10 seconds. Release the throttle and observe the vacuum gage. Vacuum should increase to at least 20" for a minimum of 1 second and fall to idle level (less than 4" Hg) within 5 seconds after releasing throttle. If decel valve fails to operate, it must be replaced. If decel valve is out of calibration, remove plastic cover and turn adjusting screw to adjust to proper operating specifications.

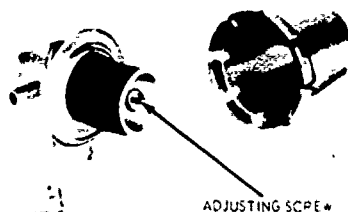

DISTRIBUTOR VACUUM DECELERATION VALVE

Transmission-controlled spark (T.C.S.). — Install vacuum gage in distributor vacuum-advance hose. Raise rear wheels of vehicle. Start engine and place transmission in drive position. Accelerate to 50 MPH and observe vacuum gage. When transmission shifts into high range, normal vacuum reading should be indicated on vacuum gage. If no reading is indicated, check for electrical continuity through transmission and temperature switches and at solenoid valve. Replace unit if defective.

SUGGESTED ASSIGNMENT:

1. Student should practice above tests on Engine-Mod-equipped vehicle.
2. Have student road-test an Engine-Mod - equipped vehicle with T.C.S. disconnected in order to understand the operating characteristics of a malfunctioning T.C.S. system.

UNIT VIII – ENGINE MOD SYSTEM

Tune-Up Adjustments

Lesson 3

OBJECTIVE: To learn tune-up procedures in addition to those performed in a usual carburetor and ignition tune-up.

EQUIPMENT:

RPM gage
Combustion analyzer
Hand tools

INFORMATION:

In addition to the Engine Mod tests and unit replacement suggestions outlined in lesson 2, the following methods of carburetor adjustment are suggested by American Motors Corporation to be performed during tune-up.

PROCEDURE:

Idle-limiter cap(s). – Remove idle-limiter cap(s) by inserting a sheet-metal screw in center of cap and turning clockwise. After removal, discard cap and adjust idle mixture by one of the below-listed procedures:

1. **Tachometer procedure.** – With engine running on hot-slow idle RPM, turn mixture screw(s) counterclockwise (richer) until a loss of engine RPM is indicated, then turn mixture screw(s) clockwise (leaner) until engine RPM increases; continue turning until RPM decreases. Now turn mixture screw(s) counterclockwise until the highest RPM reading is indicated – at a “lean best idle” setting. If carburetor has two mixture screws, turn both equally, unless engine demands otherwise. If idle speed changed more than 30 RPM during this adjustment, reset to specified idle speed and repeat this adjustment.

2. **Combustion analyzer procedure.** –

Note: Connect combustion analyzer by following instructions of particular manufacturer.

Start engine and allow sufficient time for engine analyzer to stabilize. Turn mixture screw(s) counterclockwise (richer) until a definite indication of richness

is noted. Turn mixture screw(s) clockwise (leaner) 1/16th turn at a time, until obtaining specified air/fuel ratio $14:1 \pm 0.2$. Allow 10 seconds for meter to stabilize after each adjustment. If idle speed changed more than 30 RPM, readjust and repeat mixture adjustment until specified air/fuel ratio is obtained. Adjust final curb-idle speed to specifications. Install new idle-limiter cap(s) over idle-mixture screw(s) with ear(s) positioned against full-rich stop(s). Press cap firmly and squarely into place.

CAUTION: Be careful not to disturb mixture setting while installing cap(s).

SUGGESTED ASSIGNMENT:

Student should practice making carburetor adjustments, following one of the above procedures.

UNIT IX – VAPOR-SAVER SYSTEM (V.S.S.) – CHRYSLER CORPORATION
(FUEL-EVAPORATION EMISSION CONTROL)

Operating Principles of the Vapor-Saver System

Lesson 1

OBJECTIVE: To learn the purpose and operating principles of the Vapor-Saver System for fuel-evaporation emission control.

INFORMATION:

Previous to 1971 (1970 in California), vehicles were equipped with gas tanks and carburetors which were vented to the outside air to allow pressure to equalize and to make use of atmospheric pressure in carburetor design. Unfortunately, this design permitted fuel vapors to leave the vehicle during two conditions.

(1) Fuel vapors left the carburetor vent during the “soak” period which follows hot-engine shutoff. Engine heat can cause the temperature of the fuel bowl to rise to as high as 200°F. At this temperature fuel will vaporize at a rate of from 2 to 28 grams per soak period. The 1971 limit has been set at 2 grams per soak period.

(2) Fuel vapors leave the fuel tank during the daily temperature rise or when the vehicle is parked on a heat-reflecting surface.

The Vapor Saver System is designed to reduce fuel vaporation to the atmosphere through the use of a closed system in which fuel-evaporation emission from the gas tank and carburetor flow through a vent line to the oil-filter breather cap (part of the Positive Crankcase Vent System). With engine not running, these fumes are collected in the engine crankcase. With engine running, these fumes are purged from the crankcase together with normal crankcase vapors through the regular crankcase ventilation hose extending to the carburetor base. Fumes are then drawn into the intake manifold and burned in the engine.

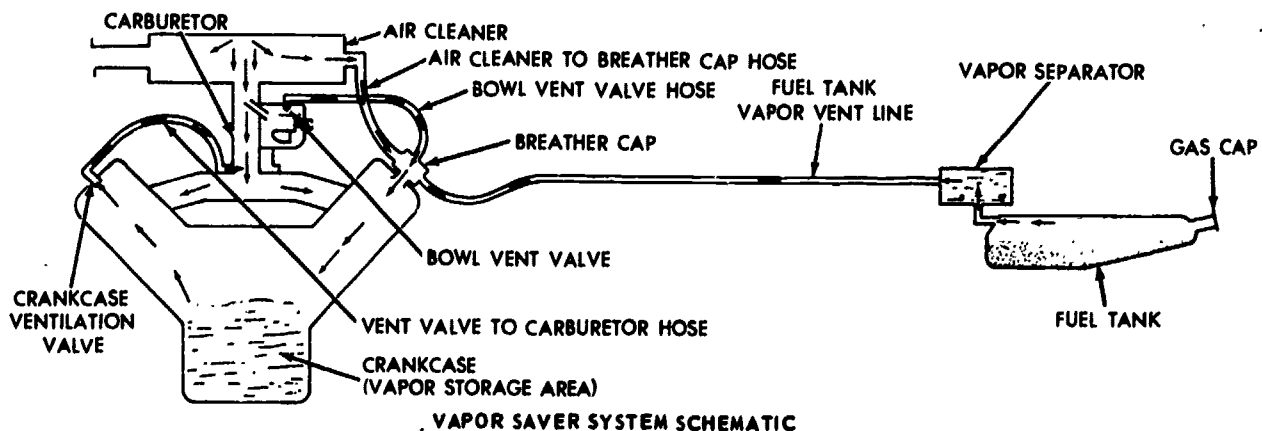

The components of the Vapor-Saver System and the operation are as follows:

Fuel tank and filler cap. — Filler cap is identified by the term “Pressure-Vacuum” and normally seals the tank. (psi setting $\frac{1}{2}$ ”–1” or $\frac{1}{4}$ ” – $\frac{1}{2}$ ” vacuum.) The fuel tank has four vent lines connected to a vapor-liquid separator tube. It also has a 1.4-gallon overfill tank located on top of the main tank. This limiter tank is closed except for a small inlet hole in the bottom. It remains essentially empty when the main tank is filled. It provides for thermal expansion of the fuel due to temperature changes.

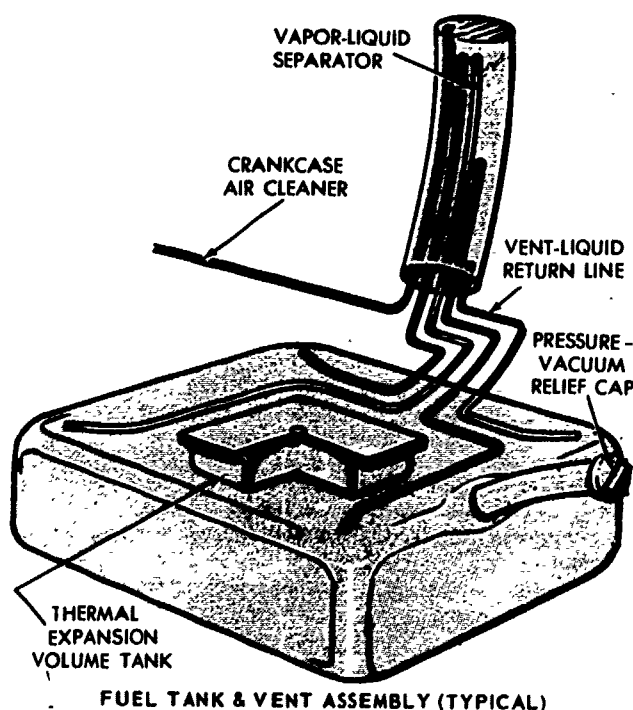

Vapor-liquid separator and vent lines. — The separator consists of an angle-mounted steel tube within the trunk. Vent tubes (one from each corner of the tank) extend into the separator at different heights to provide positive venting regardless of vehicle position. The shortest line is a return for liquid fuel or condensate within the separator. The vent line to the crankcase air cleaner ends at the highest point in separator and has a small orifice to minimize the transfer of liquid fuel to the crankcase.

Carburetor bowl vent. — Carburetors used with the V.S.S. have a hose connected at the bowl vent outlet to control fuel vapors from the carburetor bowl. These hoses are connected differently on 6- and V-8 engines, as follows: 6-cylinder engine has a hose connected into the crankcase via a connecting nipple on the fuel pump. V-8 engines use a hose connected to a separate fitting on the crankcase breather cap.

ASSIGNMENT:

1. To what temperature could the fuel in the carburetor rise during a "hot soak" period?
2. What is 1971 standard for limiting evaporative emissions?
3. What percent of hydrocarbon loss is due to evaporation in cars without evaporation-emission controls?

UNIT IX – THE VAPOR-SAVER SYSTEM

Maintenance

Lesson 2

OBJECTIVE: To learn to diagnose malfunctions and test components of the Vapor-Saver System.

INFORMATION:

The Vapor-Saver System should not require any maintenance in normal service other than regular checks and maintenance to the Positive Crankcase System, as outlined in Unit II. However, the system should be visually inspected during each tune-up (12,000 miles) to insure proper operation of the system.

PROCEDURE:

Loss of fuel or escape of fuel vapors through tank filler cap as detected by a hydrocarbon meter or visual observation indicates one or more of the following:

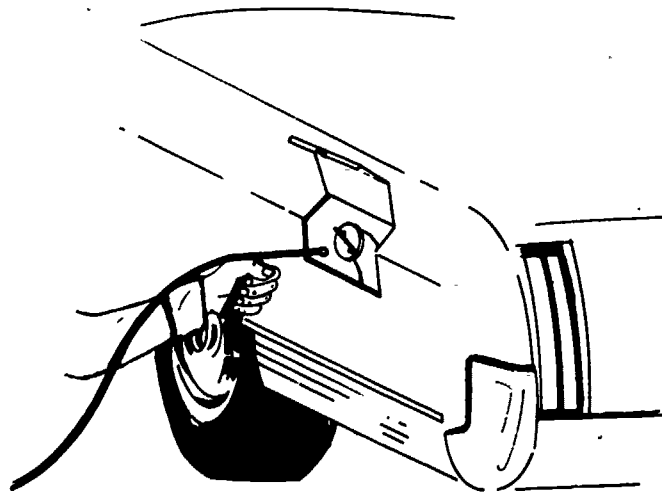

1. Defective seal on filler cap
2. Defective release valve in tank filler cap.

Note – in either case, replace cap.

3. Plugged vent lines between fuel tank and vapor separator; plugged vent line between vapor separator and crankcase air-inlet cleaner; or plugged limiter tank inlet hole (in fuel tank). Disconnect and blow compressed air through each line. Note: If fuel tank requires purging, remove plug in access hole at top of limiter tank and purge expansion chamber separately through this hole.

SUGGESTED ASSIGNMENT:

The student should visually inspect a vehicle equipped with the Vapor Savor System for possible malfunction.

UNIT X – EVAPORATION-CONTROL SYSTEM (E.C.S.) – GENERAL MOTORS

Operating Principles of the Evaporation-Control System

Lesson 1

OBJECTIVE: To learn the purpose and operating principles of the Evaporation-Control System (E.C.S.) used on General Motors vehicles.

INFORMATION:

The Evaporation-Control System (E.C.S.) is designed to prevent fuel vapors from entering the atmosphere. The fuel system is closed with a normally sealed fuel-tank filler cap. A vent system is provided through which fuel vapors are conducted through a vent line to the engine compartment, where they are burned through normal engine combustion. The E.C.S. consists of the following components:

Fuel tank. – The fuel tank is designed with an air chamber to allow for fuel expansion. Tank venting is accomplished by three vent lines, one in the rear and two in the front of the tank, which lead to a liquid-vapor separator. A single vent line leads from the liquid-vapor separator to an activated-charcoal collection canister where raw fuel vapors are stored until they can be drawn into the engine and burned.

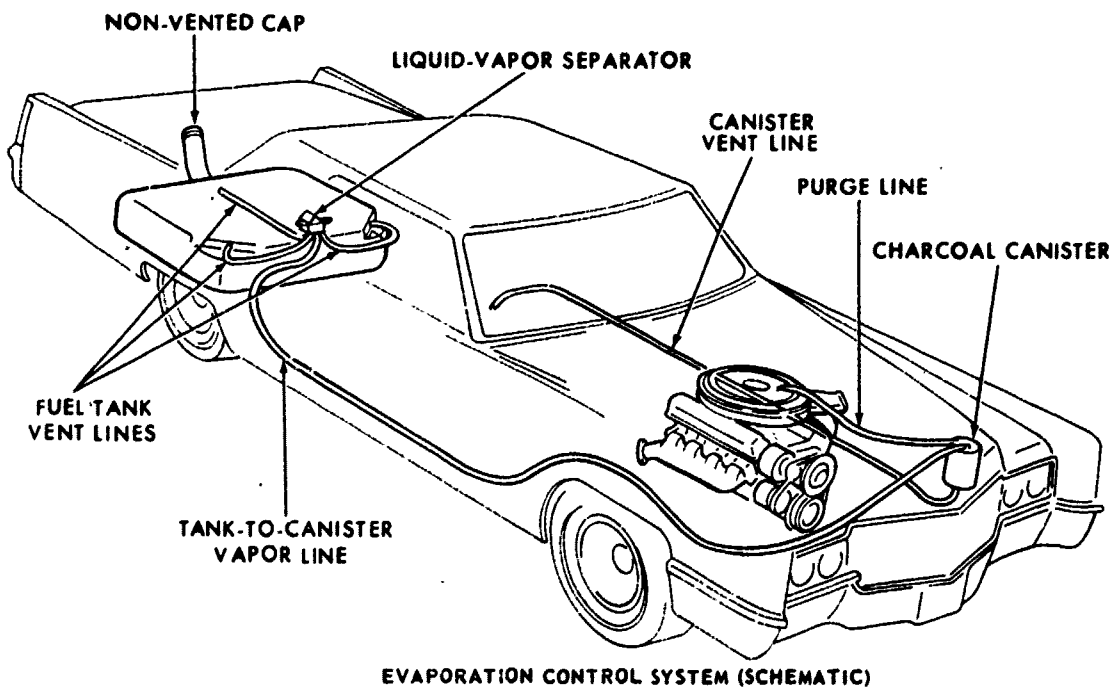

Fuel tank filler cap. – A pressure-vacuum relief valve is incorporated in the cap to vent the tank under conditions of excessive pressure or vacuum.

Liquid-vapor separator. — The liquid-vapor separator is located behind the rear seat, above the fuel tank. The vent lines from the tank lead into the separator, and one line leads from the separator to the charcoal canister. The lines are placed at different heights inside the separator so the tank will be vented regardless of vehicle position. The separator catches liquid fuel and returns it to the main fuel tank, while allowing vapors to pass through into the line connected to the charcoal canister.

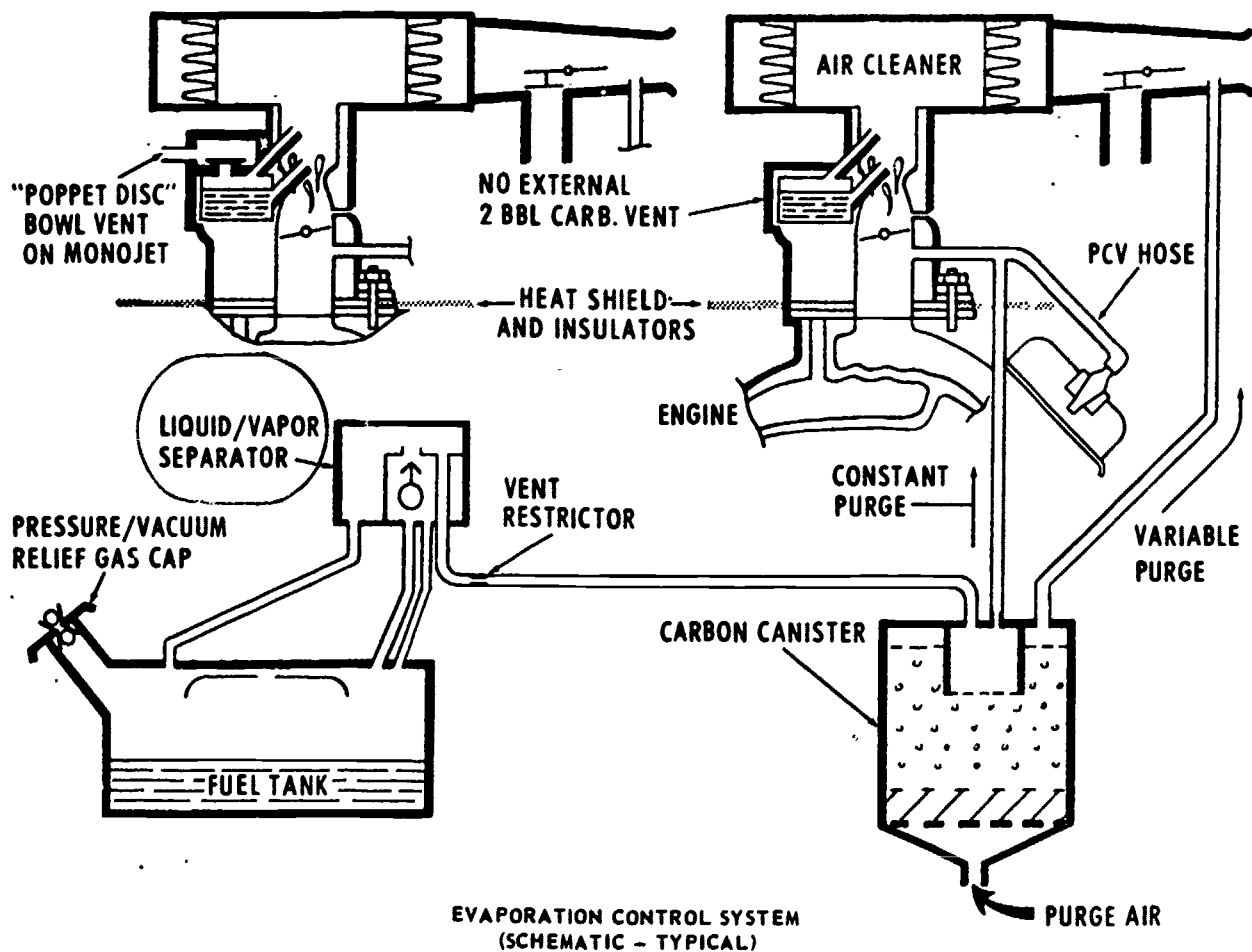

Charcoal canister. — The canister is filled with activated charcoal, which absorbs and stores fuel vapors when the engine is not running. Three different versions of charcoal canisters are used. Applications and descriptions are as follows:

1. **Two-tube type.** — Used on most General Motors V-8 engine applications. When the engine is running, air is drawn in through the bottom of the canister. The air picks up vapors which are being held by the charcoal and carries them through the carburetor into the engine to be burned. This action purges and renews the absorption capacity of the charcoal.

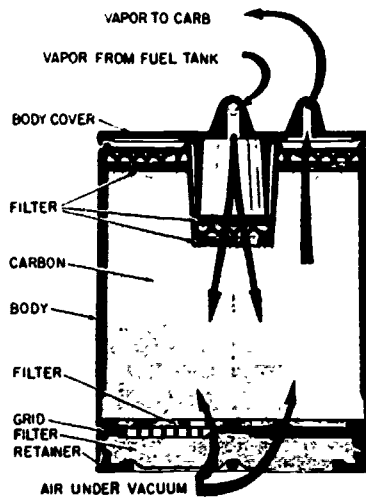

TWO TUBE CANISTER

2. **Three-tube purge-valve type.** — Used on all G.M. 6-cylinder engines and all Chevrolet engines except Vega. The three-tube operation is similar to the two-tube type; however, a purge valve is added which is an integral part of the canister. The purge valve controls the flow of vapor from canister to carburetor intake manifold. The purge valve consists of a body, a spring-loaded diaphragm, a diaphragm cover, and metered purge restrictions.

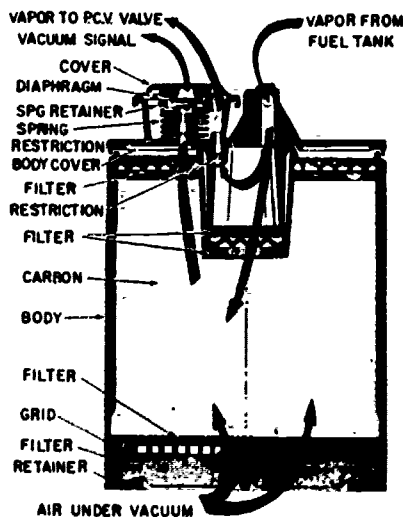

THREE TUBE PURGE VALVE CANISTER

The purge valve limits the flow of vapors to the carburetor or manifold at idle, but allows maximum vapor purge during higher carburetor air flows. This is accomplished through use of a vacuum signal from the carburetor spark port, which unseats the diaphragm. A minimum amount of canister purge can be maintained at idle because of the smaller constant-bleed restriction. At higher speeds, where more fuel vapor can be tolerated, the spark port in the carburetor is uncovered, and vacuum is applied to purge the valve diaphragm. This lifts the diaphragm off its seat and allows additional vapor to be pulled through the larger restriction, thereby completely purging the vapor canister.

3. **Four-tube purge-valve type.** — Used on Chevrolet Vega models only. Operation of the four-tube-type canister is identical to that of the three-tube, except that an extra vent tube connects to the carburetor float-bowl vent valve located on the air horn. This vent tube will be connected only on those models that are shipped vertically. On all other models, connection will be capped at the canister.

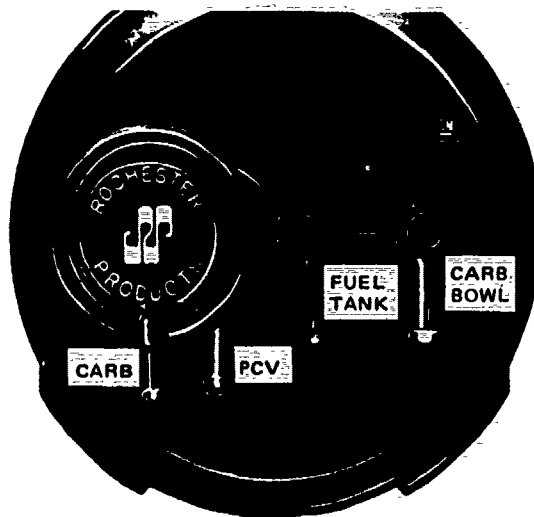

FOUR-TUBE PURGE VALVE CANISTER

ASSIGNMENT:

1. What is the purpose of having three vent tubes in different locations in the fuel tank?
2. What is the purpose of the charcoal in the canister of the E.C.S. system?
3. What is a liquid-vapor separator?

UNIT X - THE EVAPORATION CONTROL SYSTEM

Maintenance

Lesson 2

OBJECTIVE: To become familiar with the maintenance requirements and service procedures on the G.M. Evaporation-Control System.

MAINTENANCE INFORMATION:

Replace the charcoal-canister filter at 12,000 miles or 12-month intervals (more often in dusty areas). This is the only regular maintenance service required.

PROCEDURE:

Canister filter replacement. - Disconnect hoses from top of canister and remove canister from mounting bracket. Remove cover from bottom of canister by pulling it down to disengage clips. Remove and discard filter element by squeezing element out from under retainer bar. Install new filter by squeezing the element under retainer bar and positioning it evenly around the entire bottom of canister, with edges tucked under the canister lip. Snap bottom cover in place, reinstall canister on bracket, and reconnect hoses.

CAUTION: Hoses are of a special type, and only hose marked "EVAP" should be used for replacement.

SUGGESTED ASSIGNMENT:

The student should visually inspect the E.C.S. system to become familiar with the components, hose routing, and type of connections. He should remove and replace a canister filter on an E.C.S.-equipped vehicle.

**UNIT XI – FUEL EVAPORATIVE EMISSION-CONTROL SYSTEM
(F.E.E.C.) – FORD MOTOR CO.**

Operating Principles of Fuel Evaporative Emission-Control System

Lesson 1

OBJECTIVE: To learn the operating principles of the Fuel Evaporative Emission-Control (FEEC) system.

INFORMATION:

The Fuel Evaporative Emission-Control system is a closed-vent system designed to prevent fuel vapors from being emitted to the atmosphere. The F.E.E.C. consists of a two-way vented filler cap, a specially designed fuel tank, a fuel-vapor separator, a carbon-filled canister, and various fuel-vapor vent lines. A brief description of the major components follows:

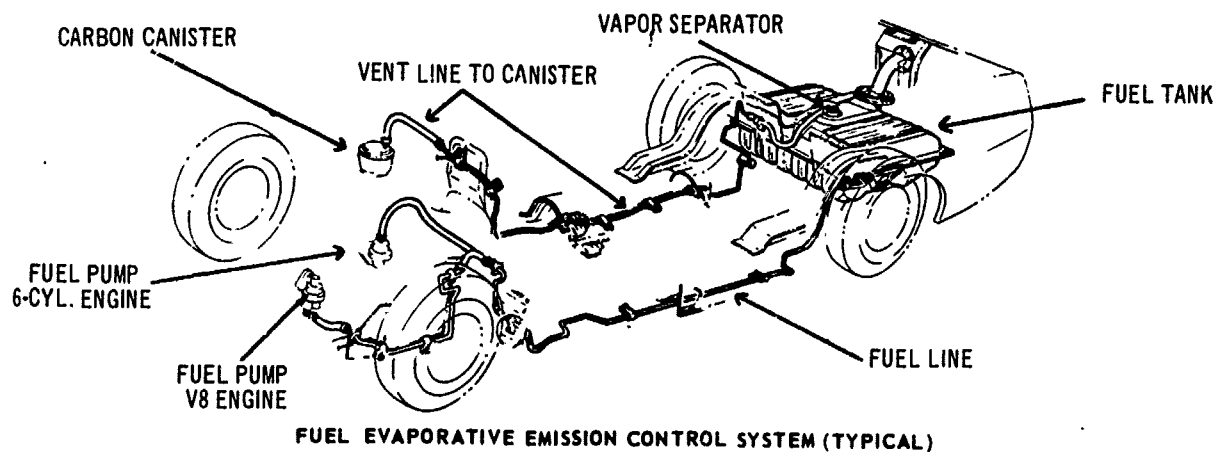

Fuel tank filler cap.— The filler cap is sealed with a built-in pressure-vacuum relief valve. Cap valve releases under pressure of .75–1.25 psi or vacuum of .25". Under normal operating conditions, the cap operates as a check valve, allowing air to enter the tank as the fuel is used, while preventing vapors from escaping through the cap.

Fuel tank. — Fill-limiting is accomplished through the filler-neck configuration and/or internal vent lines within the filler neck and tank. This system is designed to permit approximately 10% – 12% air space when tank is filled to capacity. This space provides for thermal expansion and adequate breathing space for the vapor separator.

Vapor separator. — An orifice-type vapor-separator assembly mounts directly to the fuel tank, using the same type of cam-lock ring as fuel sending units. The separator assembly is filled with a foam material that acts as a multiple-baffle system to separate raw fuel and vapor and prevent raw fuel from entering the vapor line.

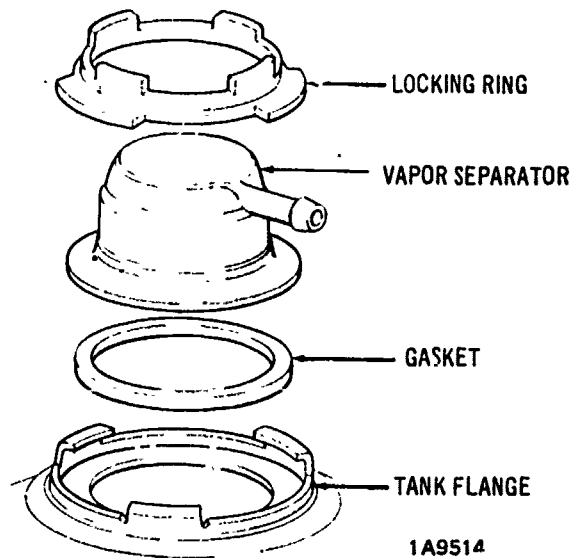

**VAPOR SEPARATOR ASSEMBLY
(EXC. TORINO & MONTEGO)**

Carbon canister. — The fuel-tank vent line (from vapor separator) is connected to a canister filled with activated carbon, located in the engine compartment.

In operation, the fuel vapors trapped in the sealed fuel tank are vented through the orifice vapor-separator assembly in the top of the tank. Vapors leave the separator assembly through a single vapor line and continue to the carbon canister, where they are absorbed by activated carbon until such time as the engine is operated. Fuel vapors are then purged from the canister through a hose connected from the canister to the air cleaner, and burned in the engine by the normal combustion process.

ASSIGNMENT:

1. What is the purpose of the foam material in the vapor separator?
2. What type of hose is used in the F.E.E.C. system?
3. At what psi will the tank filler cap release?
4. What does F.E.E.C. mean, and to which automobile manufacturer does it refer?

UNIT XI - FUEL EVAPORATIVE EMISSION-CONTROL SYSTEM

Maintenance

Lesson 2

OBJECTIVE: To become familiar with the maintenance requirements and service procedures on the Fuel Evaporative Emission-Control System.

MAINTENANCE INFORMATION:

The Fuel Evaporative Emission-Control System requires only visual inspection every 12,000 miles or 12 months. Replacement of the carbon canister is required if the canister becomes contaminated by oil, water, or pain. Component parts of this system cannot be repaired and must be replaced if damaged or inoperative.

CAUTION: Damage to fuel filler cap or contamination that renders pressure-vacuum valve inoperative may result in deformation of the fuel tank.

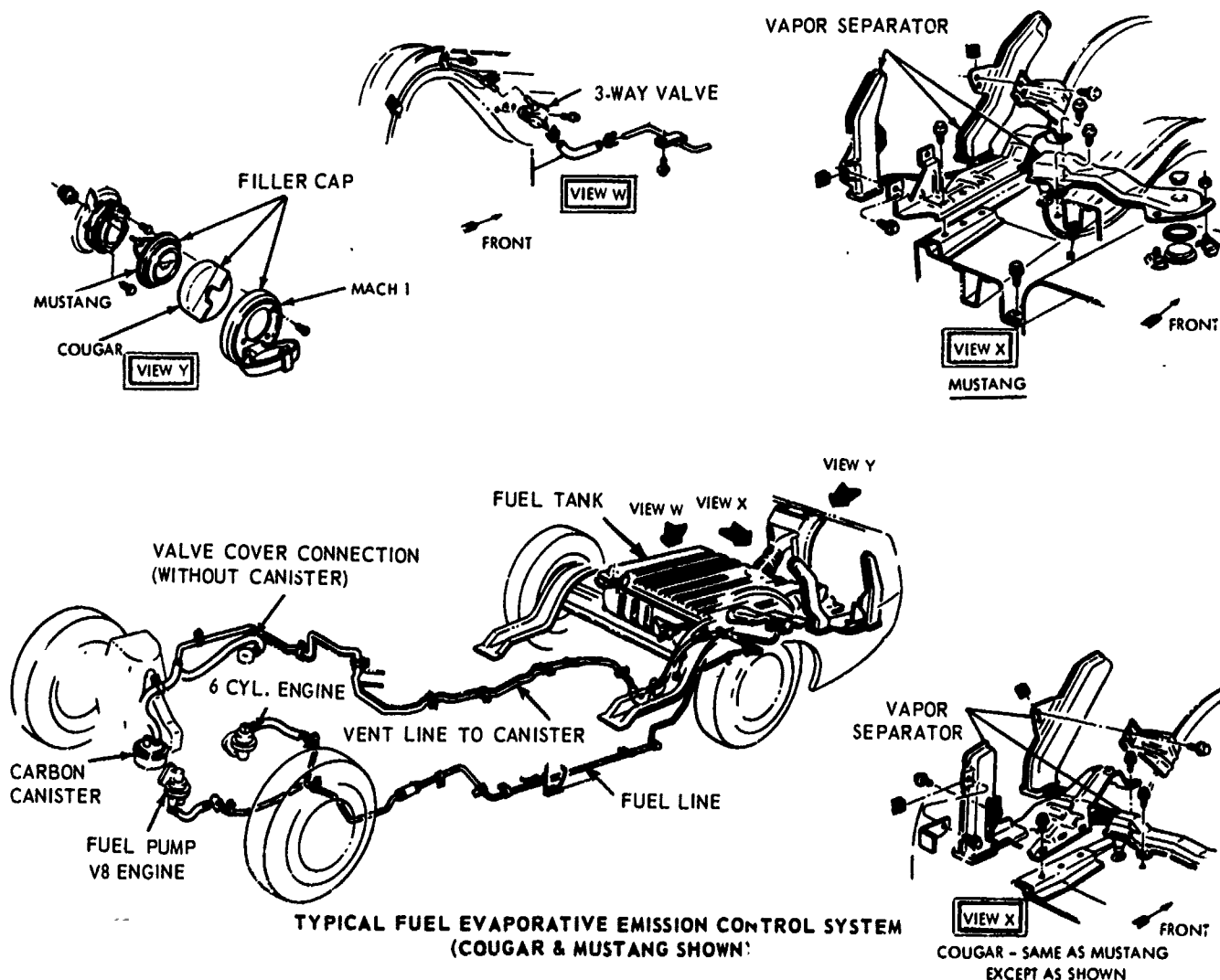

UNIT XII — EVAPORATIVE EMISSION-CONTROL SYSTEM (EEC)—AMERICAN MOTORS

Operating Principles of the Evaporative Emission-Control System

Lesson 1

OBJECTIVE: To learn the purpose and operating principles of the Evaporative Emission Control (EEC) used on American Motors vehicles.

INFORMATION:

The Evaporative Emission-Control System is designed to prevent fuel vapors from being discharged into the atmosphere. Through the use of a closed system in which fuel vapors from the fuel tank flow through a vent line to a charcoal canister (V-8 engines, automatic) or to the cylinder-head cover (all 6-cylinder and V-8 standard transmission engines). With engine not running, vapors are collected in the crankcase (6-cylinder and V-8 standard transmissions) or in the charcoal canister (V-8 automatic). With engine running, fuel vapors are drawn into the regular crankcase ventilation system and burned in the engine through normal combustion.

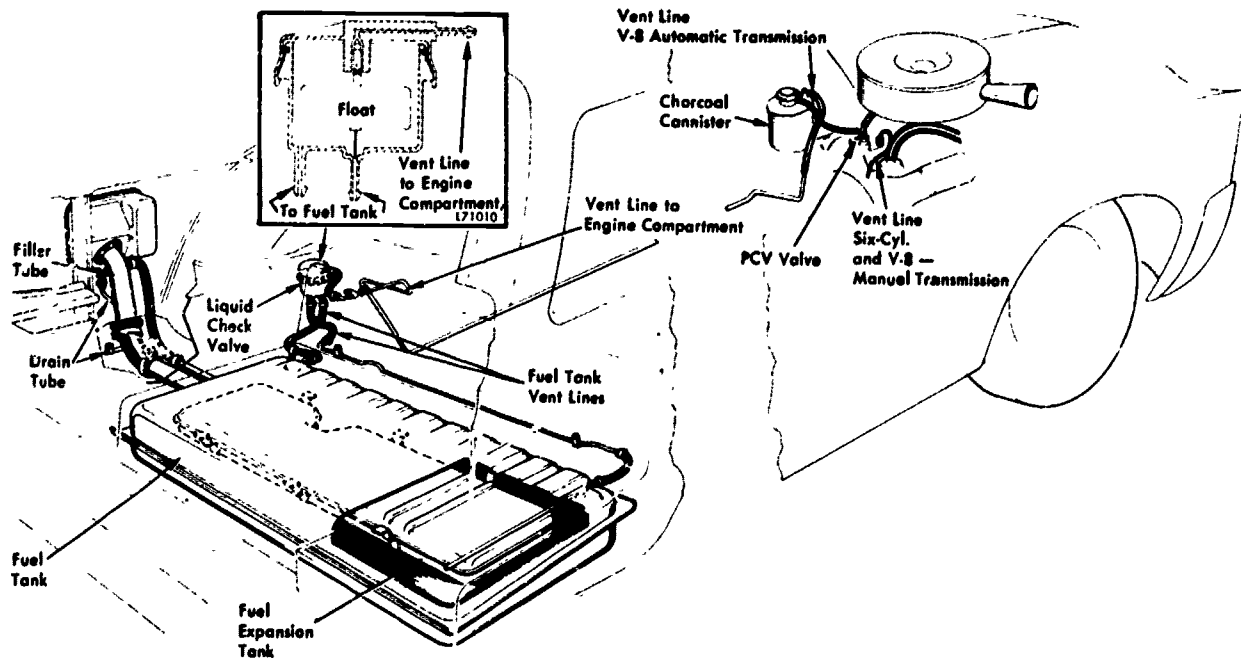

EVAPORATIVE EMISSION CONTROL SYSTEM (TYPICAL)

Fuel-tank filler cap. — The fuel-tank filler cap incorporates a two-way relief valve which closes the tank to the atmosphere under normal operating conditions. The relief valve is calibrated to open only when a pressure of 0.5–1.0 psi or a vacuum of .25"–.5" occurs. NOTE: It is normal to occasionally encounter an air-pressure release when removing filler cap.

Fuel tank. — The fuel tank on all models except Gremlin incorporates an integral air-expansion tank to provide an air-displacement area for normal fuel expansion due to temperature changes. The fuel tank on Gremlin models is designed to provide an adequate air displacement area for fuel expansion.

Check valve. — (Not used on Gremlin.) The vent lines from the tank terminate in the check-valve assembly (located above tank). The check valve consists of a filtered needle valve which prevents liquid fuel from flowing through the vent line to the canister or crankcase under any condition.

Charcoal canister. — (Used on V-8 automatic only.) The fuel-tank vent line is connected to a canister filled with activated carbon and located in the engine compartment. With the engine not running, fuel vapors are stored in this canister. The canister is also connected to the crankcase vent system (P.C.V.) and with engine running, fuel vapors are drawn into the engine and burned in the normal combustion process. This action clears the canister and renews its storage capacity.

ASSIGNMENT:

1. What percent of hydrocarbons is emitted by the vent system in a pre-control automobile?
2. What might a deformed gas tank indicate?
3. Briefly explain the operation of the E.E.C.

UNIT XII — EVAPORATIVE EMISSION-CONTROL SYSTEM

Maintenance

Lesson 2

OBJECTIVE: To become familiar with the maintenance requirements on the Evaporative Emission-Control System.

MAINTENANCE INFORMATION:

The Evaporative Emission-Control System should be visually inspected every 12,000 miles and the charcoal-canister filler (V-8 automatic) replaced. The Positive Crankcase Vent System should also be serviced at this time, as the two systems are interconnected. Hoses which are found to be cracked or otherwise deteriorated should be replaced with hose marked "EVAP" only. Any deformation of the gas tank would indicate a filler-cap malfunction and possible replacement.