

DOCUMENT RESUME

ED 070 572

SE 014 119

TITLE Introduction to Sonar, Navy Training Course.
INSTITUTION Bureau of Naval Personnel, Washington, D. C.; Naval Personnel Program Support Activity, Washington, D. C.
REPORT NO NAVPERS-10130-B
PUB DATE 68
NOTE 186p.; Revised 1968
EDRS PRICE MF-\$0.65 HC-\$6.58
DESCRIPTORS *Acoustics; Instructional Materials; *Job Training; *Military Personnel; Military Science; Military Training; Physics; *Post Secondary Education; *Supplementary Textbooks

ABSTRACT

Fundamentals of sonar systems are presented in this book, prepared for both regular navy and naval reserve personnel who are seeking advancement in rating. An introductory description is first made of submarines and antisubmarine units. Determination of underwater targets is analyzed from the background of true and relative bearings, true and relative motion, and computation of target angles. Then, applications of both active and passive sonars are explained in connection with bathythermographs, fathometers, tape recorders, fire control techniques, internal and external communications systems, maintenance actions, test methods and equipment, and safety precautions. Basic principles of sound and temperature effects on wave propagation are also discussed. Illustrations for explanation use, information on training films and the sonar technician rating structure are also provided. (CC)

ED 070572

U.S. DEPARTMENT OF HEALTH,
EDUCATION & WELFARE
OFFICE OF EDUCATION
THIS DOCUMENT HAS BEEN REPRO-
DUCED EXACTLY AS RECEIVED FROM
THE PERSON OR ORGANIZATION ORIG-
INATING IT. POINTS OF VIEW OR OPIN-
IONS STATED DO NOT NECESSARILY
REPRESENT OFFICIAL OFFICE OF EDU-
CATION POSITION OR POLICY.



INTRODUCTION TO SONAR

BUREAU OF NAVAL PERSONNEL

NAVY TRAINING COURSE NAVPERS 10130-B

PREFACE

This book is written for the men of the U. S. Navy and Naval Reserve who are seeking advancement in the Sonar Technician rating.

At this writing the general rating of Sonar Technician includes the service ratings of Surface Sonar Technician (STG) and Submarine Sonar Technician (STS) at the Third and Second Class levels. The general rating of Sonar Technician is at the First Class level and above. Although the Surface and Submarine Sonar Technicians may operate different equipment, certain practical factors and knowledge factors apply to all Sonar Technicians. This book covers many of the factors common to both ratings.

The scope of this training course does not permit inclusion of the fundamentals of mathematics, electricity, and electronics. If you need such information, you should study the appropriate training courses that appear in the reading list. Because of security classification, some common sonar subjects cannot be included in this training course, but may be found in classified courses and other publications.

As one of the Navy Training Courses, this book was prepared by the Training Publications Division, Naval Personnel Program Support Activity, Washington, D. C., for the Bureau of Naval Personnel.

First edition 1960

Second edition 1963

Revised 1968

Stock Ordering No.
0500-036-0100

THE UNITED STATES NAVY

GUARDIAN OF OUR COUNTRY

The United States Navy is responsible for maintaining control of the sea and is a ready force on watch at home and overseas, capable of strong action to preserve the peace or of instant offensive action to win in war.

It is upon the maintenance of this control that our country's glorious future depends; the United States Navy exists to make it so.

WE SERVE WITH HONOR

Tradition, valor, and victory are the Navy's heritage from the past. To these may be added dedication, discipline, and vigilance as the watchwords of the present and the future.

At home or on distant stations we serve with pride, confident in the respect of our country, our shipmates, and our families.

Our responsibilities sober us; our adversities strengthen us.

Service to God and Country is our special privilege. We serve with honor.

THE FUTURE OF THE NAVY

The Navy will always employ new weapons, new techniques, and greater power to protect and defend the United States on the sea, under the sea, and in the air.

Now and in the future, control of the sea gives the United States her greatest advantage for the maintenance of peace and for victory in war.

Mobility, surprise, dispersal, and offensive power are the keynotes of the new Navy. The roots of the Navy lie in a strong belief in the future, in continued dedication to our tasks, and in reflection on our heritage from the past.

Never have our opportunities and our responsibilities been greater.

CONTENTS

CHAPTER	Page
1. The sonar technician	1
2. Submarines and antisubmarine units.	9
3. Bearings and motion	20
4. Physics of sound	34
5. Bathythermograph	57
6. Principles of sonar.	91
7. Basic fire control	110
8. Communications	132
9. Maintenance	146
10. Safety; test equipment; test methods.	154
APPENDIX	
I. Training film list.	176
INDEX	178

4

READING LIST

NAVY TRAINING COURSES

Basic Electricity, NavPers 10086
Introduction to Electronics (chapters 1-6, 9), NavPers 10084
Basic Electronics, NavPers 10087 (chapters 1-11, 17, appendix II)
Sonar Technician G 3 & 2, NavPers 10131
Sonar Technician S 3 & 2, NavPers 10132
Basic Handtools, NavPers 10085

OTHER NAVY PUBLICATIONS

Handbook of Test Methods and Practices (sections 1, 2, and 4.5),
NavShips 0967—000—0130
NavShips Technical Manual (chapter 9670), NavShips 0901—000—0013
Maintenance and Material Management (3-M) Manual (chapters 1, 2, 3),
OpNav 43P2
Application of Oceanography to ASW (chapters 2 and 3), H. O. 781
Antisubmarine Classification Manual, NWIP 24-1(A) (chapters 1, 2,
3 STG); (chapters 1, 2, 5 STS)

USAFI TEXTS

United States Armed Forces Institute (USAFI) courses for additional reading and study are available through your information and education officer.* A partial list of those courses applicable to your rate follows.

CORRESPONDENCE COURSES

Number	Title
C 885	Fundamentals of Radio
B 887	Intermediate Radio
A 788	Introduction to Electronics, Part I
A 789	Introduction to Electronics, Part II
D 290	Physics, Part I
D 291	Physics, Part II

*"Members of the United States Armed Forces Reserve components, when on active duty, are eligible to enroll for USAFI courses, services, and materials, if the orders calling them to active duty specify a period of 120 days or more, or if they have been on active duty for a period of 120 days or more, regardless of the time specified in the active duty orders."

CHAPTER I

THE SONAR TECHNICIAN

A substantial force of conventional and nuclear-powered submarines, many of them capable of launching nuclear missiles, represents a potential threat to our country's security and a continuing challenge to our Navy's antisubmarine forces.

To meet this challenge, U. S. Navy ships and submarines continually conduct exercises in anti-submarine warfare (ASW) operations, revising tactics and evaluating new methods and equipment used for detecting and destroying enemy underwater craft. Destroyers are our main antisubmarine (A/S) surface vessels. They provide protection against submarines for major surface ships by forming a sonar screen around the ship. Upon detection of a submarine trying to penetrate the screen, the destroyer initiates an attack, and the main body turns away from the contact area. Destroyers also operate in special A/S forces called hunter-killer groups, whose function is to actively seek out and destroy enemy submarines. Our own submarines — particularly nuclear-powered types with their generally superior detection equipment — play an equally important role in ASW. They are capable of selecting the depth that provides the best underwater detection conditions. Additionally, they have the endurance to conduct surveillance operations over wide ocean areas.

The Sonar Technician, whether aboard ship or submarine is a vital member of the Navy's ASW team. All Sonar Technicians must learn to operate the sonar equipment installed in their ship. This requirement includes not only manipulating controls, but also interpreting data derived from sonar, fire control, and associated equipment. Sonar Technicians also must be able to maintain the sonar in good working condition.

This text is a self-study training course designed to help you meet the professional

qualifications required for advancement to Third Class Sonar Technician. Although this course is limited to unclassified material, much of your work will deal with classified equipment and information. You should never discuss with strangers details of your work, nor reveal information concerning equipment characteristics and capabilities. These restrictions apply also to shipmates who have no need to know the information. Violation of security regulations can result in punishment by court-martial.

The remainder of this chapter gives information on the enlisted rating structure, the Sonar Technician rating, requirements and procedures for advancement in rating, and references to help you work for advancement and to perform your duties as a Sonar Technician. Also included are suggestions on how to make the best use of Navy Training Courses. Before you begin studying the rest of this course, therefore, you should study the remainder of this chapter very carefully.

ENLISTED RATING STRUCTURE

The two main types of ratings in the present enlisted rating structure, are general ratings and service ratings.

GENERAL RATINGS identify broad occupational fields of related duties and functions. Some general ratings include service ratings; others do not. Both Regular Navy and Naval Reserve personnel may hold general ratings.

SERVICE RATINGS identify subdivisions or specialties within a general rating. Although service ratings can exist at any petty officer level, they are most common at the PO3 and PO2 levels. Both Regular Navy and Naval Reserve personnel may hold service ratings.

INTRODUCTION TO SONAR

SONAR TECHNICIAN RATING

The Sonar Technician rating is a general rating in the deck group (group I). The fundamental task of all Sonar Technicians is to provide underwater data for operational use. Sonar Technicians operate and maintain sonar equipment, perform duties required as members of antisubmarine (A/S) attack teams, and interpret target and oceanographic data. At the third and second class petty officer levels there are two service ratings—one for men assigned to surface ships and one for men assigned to submarine duty.

SONAR TECHNICIAN G (SURFACE) (STG)

Surface Sonar Technicians operate shipboard antisubmarine equipment. This equipment includes sonars and underwater fire control systems used in solving ASW problems. Equipment operation at the third and second class levels usually is limited to manipulating dials and interpreting received data. As an STG you must also be able to perform operational, preventive, and technical maintenance on sonar, underwater fire control, and associated equipment.

SONAR TECHNICIAN S (SUBMARINE) (STS)

Submarine Sonar Technicians operate submarine sonar and oceanographic equipment, and interpret data received from passive and active sonars, submarine fire control equipment, and associated auxiliary sonar equipment. As an STS you also must be able to construct and interpret submarine sonar plots, and perform operational, preventive, and technical maintenance on submarine sonar and associated equipment, excluding fire control equipment.

DUTY ASSIGNMENTS

The majority of sea duty assignments for Submarine Sonar Technicians are in submarines and aboard submarine tenders. Most Surface Sonar Technicians are assigned to destroyer-type ships. Other sea duty billets include destroyer tenders, antisubmarine aircraft carriers, minesweepers, and certain cruisers. Some of the locations of shore duty assignments, which usually consist of instructor billets, are: U.S. Fleet Sonar School, Key West, Florida; U.S. Fleet Antisubmarine Warfare School, San Diego,

California; U.S. Navy Submarine School, New London, Connecticut; and Fleet Training Centers. Shore duty billets of a general nature, common to all ratings, are also open to Sonar Technicians.

Wherever you are stationed, one quality that all petty officers must exhibit is leadership. As you advance in rate, you will have more and more responsibility, authority, and control over other men. You must strive always to set a good example for the men under you by maintaining high standards of personal conduct, as well as professional and military competency. In other words, be a good Navyman. General Order #11 outlines the leadership qualities expected of all persons in the Navy in a position of authority.

ADVANCEMENT IN RATING

Some of the rewards of advancement in rating are easy to see. You get more pay. Your job assignments become more interesting and more challenging. You are regarded with greater respect by officers and enlisted personnel. You enjoy the satisfaction of getting ahead in your chosen Navy career.

But the advantages of advancing in rating are not yours alone. The Navy also profits. Highly trained personnel are essential to the functioning of the Navy. By each advancement in rating, you increase your value to the Navy in two ways. First, you become more valuable as a specialist in your own rating. And second, you become more valuable as a person who can train others and thus make far-reaching contributions to the entire Navy.

HOW TO QUALIFY FOR ADVANCEMENT

What must you do to qualify for advancement in rating? The requirements may change from time to time, but usually you must:

1. Have a certain amount of time in your present grade.
2. Complete the required military and occupational training courses.
3. Demonstrate your ability to perform all the PRACTICAL requirements for advancement by completing the Record of Practical Factors, NavPers 1414/1. In some cases the Record of Practical Factors may contain the old form number, NavPers 760.
4. Be recommended by your commanding officer, after the petty officers and officers super-

Chapter 1 — THE SONAR TECHNICIAN

vising your work have indicated that they consider you capable of performing the duties of the next higher rate.

5. Demonstrate your KNOWLEDGE by passing written examinations on the occupational and military qualification standards for advancement in rating.

Some of these general requirements may be modified in certain ways. Figure 1-1 gives a more detailed view of the requirements for advancement of active duty personnel; figure 1-2 gives this information for inactive duty personnel.

Remember that the qualifications for advancement can change. Check with your division officer or training officer to be sure that you know the most recent qualifications.

Advancement in rate is not automatic. Even though you have met all the requirements, including passing the written examinations, you may not be able to "sew on the crow" or "add a stripe." The number of men in each rate and rating is controlled on a Navy-wide basis. Therefore, the number of men that may be advanced is limited by the number of vacancies that exist. When the number of men passing the examination exceeds the number of vacancies, some system must be used to determine which men may be advanced and which may not. The system used is the "final multiple" and is a combination of three types of advancement systems.

Merit rating system
Personnel testing system
Longevity, or seniority, system

The Navy's system provides credit for performance, knowledge, and seniority, and, while it cannot guarantee that any one person will be advanced, it does guarantee that all men within a particular rating will have equal advancement opportunity.

The following factors are considered in computing the final multiple:

Factor	Maximum Credit
Examination score	80
Performance factor (Performance evaluation)	50
Length of service (years x 1)	20
Service in pay grade (years x 2)	20
Medals and awards	15
	185

All of the above information (except the examination score) is submitted to the Naval Examining Center with your examination answer sheet. After grading, the examination scores, for those passing, are added to the other factors to arrive at the final multiple. A precedence list, which is based on final multiples, is then prepared for each pay grade within each rating. Advancement authorizations are then issued, beginning at the top of the list, for the number of men needed to fill the existing vacancies.

HOW TO PREPARE FOR ADVANCEMENT

What must you do to prepare for advancement in rating? You must study the qualifications for advancement, work on the practical factors, study the required Navy Training Courses, and study other material that is required for advancement in your rating. To prepare for advancement, you will need to be familiar with (1) the Quals Manual, (2) the Record of Practical Factors, (3) a NavPers publication called Training Publications for Advancement in Rating, NavPers 10052, and (4) applicable Navy Training Courses. The following sections describe them and give you some practical suggestions on how to use them in preparing for advancement.

The Quals Manual

The Manual of Qualifications for Advancement in Rating, NavPers 18068-B (with changes), gives the minimum occupational and military qualification standards for advancement to each rate within each rating. This manual is usually called the "Quals Manual," and the qualifications themselves are often called "quals." The qualification standards are of two general types: (1) military qualification standards and (2) occupational qualification standards.

MILITARY STANDARDS are requirements that apply to all ratings rather than to any one particular rating. Military requirements for advancement to third class and second class petty officer rates deal with military conduct, naval organization, military justice, security, watch standing, and other subjects which are required of petty officers in all ratings.

OCCUPATIONAL STANDARDS are requirements that are directly related to the work of each rating.

Both the military requirements and the occupational qualification standards are divided into subject matter groups; then, within each subject

INTRODUCTION TO SONAR

REQUIREMENTS *	E1 to E2	E2 to E3	#† E3 to E4	# E4 to E5	† E5 to E6	† E6 to E7	† E7 to E8	† E8 to E9
SERVICE	4 mos. service—or completion of recruit training.	6 mos. as E-2.	6 mos. as E-3.	12 mos. as E-4.	24 mos. as E-5.	36 mos. as E-6. 8 years total enlisted service.	36 mos. as E-7. 8 of 11 years total service must be enlisted.	24 mos. as E-8. 10 of 13 years total service must be enlisted.
SCHOOL	Recruit Training.		Class A for FR3, DT3, PT3, AME 3, HM 3			Class B for AGC MUC, MNC.		
PRACTICAL FACTORS	Locally prepared check-offs.	Records of Practical Factors, NavPers 1414/1, must be completed for E-3 and all PO advancements.						
PERFORMANCE TEST		Specified ratings must complete applicable performance tests before taking examinations.						
ENLISTED PERFORMANCE EVALUATION	As used by CO when approving advancement.	Counts toward performance factor credit in advancement multiple.						
EXAMINATIONS**	Locally prepared tests.	See below.	Navy-wide examinations required for all PO advancements.				Navy-wide, selection board.	
NAVY TRAINING COURSE (INCLUDING MILITARY REQUIREMENTS)		Required for E-3 and all PO advancements unless waived because of school completion, but need not be repeated if identical course has already been completed. See NavPers 10052 (current edition).					Correspondence courses and recommended reading. See NavPers 10052 (current edition).	
AUTHORIZATION	Commanding Officer	U.S. Naval Examining Center			Bureau of Naval Personnel			

* All advancements require commanding officer's recommendation.

† 1 year obligated service required for E-5 and E-6; 2 years for E-6, E-7, E-8 and E-9.

Military leadership exam required for E-4 and E-5.

** For E-2 to E-3, NAVEXAMCEN exams or locally prepared tests may be used.

Figure 1-1.— Active duty advancement requirements.

Chapter 1 — THE SONAR TECHNICIAN

REQUIREMENTS *	E1 to E2	E2 to E3	E3 to E4	E4 to E5	E5 to E6	E6 to E7	E8	E9
TOTAL TIME IN GRADE	4 mos.	6 mos.	15 mos.	18 mos.	24 mos.	36 mos.	36 mos.	24 mos.
TOTAL TRAINING DUTY IN GRADE †	14 days	14 days	14 days	14 days	28 days	42 days	42 days	28 days
PERFORMANCE TESTS	Specified ratings must complete applicable performance tests before taking examination.							
DRILL PARTICIPATION	Satisfactory participation as a member of a drill unit.							
PRACTICAL FACTORS (INCLUDING MILITARY REQUIREMENTS)	Record of Practical Factors, NavPers 1414/1, must be completed for all advancements.							
NAVY TRAINING COURSE (INCLUDING MILITARY REQUIREMENTS)	Completion of applicable course or courses must be entered in service record.							
EXAMINATION	Standard Exam	Standard Exam or Rating Training.	Standard Exam required for all PO Advancements.				Standard Exam, Selection Board. Also pass Mil. Leadership Exam for E-4 and E-5.	
AUTHORIZATION	Commanding Officer		U.S. Naval Examining Center			Bureau of Naval Personnel		

* Recommendation by commanding officer required for all advancements.

† Active duty periods may be substituted for training duty.

Figure 1-2.—Inactive duty advancement requirements.

INTRODUCTION TO SONAR

matter group, they are divided into PRACTICAL FACTORS and KNOWLEDGE FACTORS. Practical factors are things you must be able to DO. Knowledge factors are things you must KNOW in order to perform the duties of your rating.

In most subject matter areas, you will find both practical factor and knowledge factor qualifications. In some subject matter areas, you may find only one or the other. It is important to remember that there are some knowledge aspects to all practical factors, and some practical aspects to most knowledge factors. Therefore, even if the Quals Manual indicates that there are no knowledge factors for a given subject matter area, you may still expect to find examination questions dealing with the knowledge aspects of the practical factors listed in that subject matter area.

You are required to pass a Navywide military/leadership examination for E-4 or E-5, as appropriate, before you take the occupational examinations. The military/leadership examinations are administered on a schedule determined by your commanding officer. Candidates are required to pass the applicable military/leadership examination only once. Each of these examinations consists of 100 questions based on information contained in Military Requirements for Petty Officers 3 and 2, NavPers 10056 and in other publications listed in Training Publications for Advancement in Rating, NavPers 10052.

The Navywide occupational examinations for pay grades E-4 and E-5 will contain 150 questions related to occupational areas of your rating.

If you are working for advancement to second class, remember that you may be examined on third class qualifications as well as on second class qualifications.

The Quals Manual is kept current by means of changes. The occupational qualifications for your rating, covered in this training course, were current at the time the course was printed. By the time you are studying this course, however, the quals for your rating may have been changed. Never trust any set of quals until you have checked it against an UP-TO-DATE copy in the Quals Manual.

Record of Practical Factors

Before you can take the servicewide examination for advancement in rating, there must be an entry in your service record to show that you have qualified in the practical factors of both the military qualifications and the occupational qualifications. The record of practical factors, men-

tioned earlier, is used to keep a record of your practical factor qualifications. This form is available for each rating. The form lists all practical factors, both military and occupational. As you demonstrate your ability to perform each practical factor, appropriate entries are made in the DATE and INITIALS columns.

Changes are made periodically to the Manual of Qualifications for Advancement in Rating, and revised forms of NavPers 1414/1 are provided when necessary. Extra space is allowed on the Record of Practical Factors for entering additional practical factors as they are published in changes to the Quals Manual. The Record of Practical Factors also provides space for recording demonstrated proficiency in skills which are within the general scope of the rating but which are not identified as minimum qualifications for advancement.

Until completed, the NavPers 1414/1 is usually held by your division officer; after completion, it is forwarded to the personnel office for insertion in your service record. If you are transferred before qualifying in all practical factors, the incomplete form should be forwarded with your service record to your next duty station. You can save yourself a lot of trouble by making sure that this form is actually inserted in your service record before you are transferred. If the form is not in your service record, you may be required to start all over again and re-qualify in the practical factors which have already been checked off.

NavPers 10052

Training Publications for Advancement in Rating, NavPers 10052 (revised), is a very important publication for anyone preparing for advancement in rating. This bibliography lists required and recommended Navy Training Courses and other reference material to be used by personnel working for advancement in rating. The NavPers 10052 is revised and issued once each year by the Bureau of Naval Personnel. Each revised edition is identified by a letter following the NavPers number. When using this publication, be SURE that you have the most recent edition.

If extensive changes in qualifications occur in any rating between the annual revisions of NavPers 10052, a supplementary list of study material may be issued in the form of a BuPers Notice. When you are preparing for advancement, check to see whether changes have been made in the qualifications for your rating. If changes

Chapter 1 — THE SONAR TECHNICIAN

have been made, see if a BuPers Notice has been issued to supplement NavPers 10052 for your rating.

The required and recommended references are listed by rate level in NavPers 10052. If you are working for advancement to third class, study the material that is listed for third class. If you are working for advancement to second class, study the material that is listed for second class; but remember that you are also responsible for the references listed at the third class level.

In using NavPers 10052, you will notice that some Navy Training Courses are marked with an asterisk (*). Any course marked in this way is **MANDATORY**—that is, it must be completed at the indicated rate level before you can be eligible to take the servicewide examination for advancement in rating. Each mandatory course may be completed by (1) passing the appropriate enlisted correspondence course that is based on the mandatory training course; (2) passing locally prepared tests based on the information given in the training course; or (3) in some cases, successfully completing an appropriate Class A course.

Do not overlook the section of NavPers 10052 which lists the required and recommended references relating to the military qualification standards for advancement. Personnel of ALL ratings must complete the mandatory military requirements training course for the appropriate rate level before they can be eligible to advance in rating.

The references in NavPers 10052 which are recommended but not mandatory should also be studied carefully. ALL references listed in NavPers 10052 may be used as source material for the written examinations, at the appropriate rate levels.

Navy Training Courses

There are two general types of Navy Training Courses. **RATING COURSES** (such as this one) are prepared for most enlisted ratings. A rating training course gives information that is directly related to the occupational qualifications of ONE rating. **SUBJECT MATTER COURSES** or **BASIC COURSES** give information that applies to more than one rating.

Navy Training Courses are revised from time to time to keep them up to date technically. The revision of a Navy Training Course is identified by a letter following the NavPers number. You can tell whether any particular copy of a Navy Training Course is the latest

edition by checking the NavPers number and the letter following this number in the most recent edition of List of Training Manuals and Correspondence Courses, NavPers 10061. (NavPers 10061 is actually a catalog that lists all current training courses and correspondence courses; you will find this catalog useful in planning your study program.)

Navy Training Courses are designed to help you prepare for advancement in rating. The following suggestions may help you to make the best use of this course and other Navy training publications when you are preparing for advancement in rating.

1. Study the military qualifications and the occupational qualifications for your rating before you study the training course. Remember, you are studying the training course primarily in order to meet these quals.

2. Set up a regular study plan. It will probably be easier for you to stick to a schedule if you can plan to study at the same time each day. If possible, schedule your studying for a time of day when you will not have too many interruptions or distractions.

3. Before you begin to study any part of the training course intensively, become familiar with the entire book. Read the preface and the table of contents. Check through the index. Look at the appendixes. Thumb through the book without any particular plan, looking at the illustrations and reading bits here and there as you see things that interest you.

4. Look at the training course in more detail, to see how it is organized. Look at the table of contents again. Then, chapter by chapter, read the introduction, the headings, and the subheadings. This method will give you a pretty clear picture of the scope and content of the book. As you look through the book in this way, ask yourself some questions:

What do I need to learn about this?

What do I already know about this?

How is this information related to information given in other chapters?

How is this information related to the qualifications for advancement in rating?

5. When you have a general idea of what is in the training course and how it is organized, fill in the details by intensive study. In each study period, try to cover a complete unit—it may be a chapter, a section of a chapter, or a subsection. The amount of material that you can cover at one time will vary. If you know the subject well, or if the material is easy, you can cover quite a

INTRODUCTION TO SONAR

lot at one time. Difficult or unfamiliar material will require more study time.

6. In studying any one unit—chapter, section, or subsection—write down the questions that occur to you. Many people find it helpful to make a written outline of the unit as they study, or at least to write down the important ideas.

7. As you study, relate the information in the training course to the knowledge you already have. When you read about a process, a skill, or a situation, try to see how this information ties in with your own past experience.

8. When you have finished studying a unit, take time out to see what you have learned. Look back over your notes and questions. Maybe some of your questions have been answered, but perhaps you still have some that are not answered. Without looking at the training course, write down the main ideas that you have gotten from studying this unit. Don't just quote the book. If you can't give these ideas in your own words, the chances are that you have not really mastered the information.

9. Use Enlisted Correspondence Courses whenever you can. The correspondence courses are based on Navy Training Courses or on other appropriate texts. As mentioned before, completion of a mandatory Navy Training Course can be accomplished by passing an Enlisted Correspondence Course based on the Navy Training Course. You will probably find it helpful to take other correspondence courses, as well as those based on mandatory training courses. Taking a correspondence course helps you to master the information given in the training course, and also helps you see how much you have learned.

10. Think of your future as you study Navy Training Courses. You are working for advancement to third class or second class right now, but someday you will be working toward higher rates. Anything extra that you can learn now will help you both now and later.

SOURCES OF INFORMATION

One of the most useful things you can learn about a subject is how to find out more about it. No single publication can give you all the information you need to perform the duties of your rating. You should learn where to look for accurate, authoritative, up-to-date information on all subjects related to the military requirements for advancement and the professional qualifications of your rating.

Some of the publications described here are subject to change or revision from time to time—some at regular intervals, others as the need arises. When using any publication that is subject to change or revision, be sure that you have the effective (latest) edition. When using any publication that is kept current by means of changes, be sure you have a copy in which all official changes have been made. Studying canceled or obsolete information will not help you to do your work or to advance in rating; it is likely to be a waste of time, and may even be seriously misleading.

PUBLICATIONS

In addition to the material presented in the reading list at the front of this book, many other publications are available for you to study to further your knowledge and aid you in advancement. Taking a correspondence course, for example, is a very good method of learning a subject.

Other sources of information are the technical manuals for each piece of equipment. These manuals usually are published by the equipment manufacturer, and consist of several sections giving a general description of the equipment, installation and operation instructions, and preventive and corrective maintenance procedures.

Tactical doctrines, which also must be studied, consist of Naval Warfare Publications (NWP) and Allied Tactical Publications (ATPs). Of great interest to Sonar Technicians is NWP 24, Antisubmarine Operations, which sets forth anti-submarine doctrine and tactical instructions for surface ships, aircraft, and submarines. Many NWP have supplements, known as Naval Warfare Information Publications (NWIPs), which give detailed technical instructions on how to carry out the doctrine found in the NWP. Some examples are: NWIP 24-1, Antisubmarine Classification Manual; and NWIP 23-8, Submarine Approach and Attack Manual. Also of interest is ATP 1, Vol. I, Allied Naval Maneuvering Instructions.

TRAINING AIDS

Most ships and stations carry a supply of training films that are a valuable source of supplementary information on many technical and operational subjects. A selected list of training films is given in Appendix I to this training course. Magnetic tapes also are available for training in sound recognition, target classification, and other aspects of sonar operations.

CHAPTER 2

SUBMARINES AND ANTISUBMARINE UNITS

During World War II, submarines sent millions of tons of shipping to the bottom. Early in the war, England's lifelines were nearly strangled by German submarines. American submarines played a large role in the defeat of Japan by sinking nearly all her merchant marine. Obviously, the submarine is a potent weapon, requiring equally effective countermeasures. The United States and Great Britain were successful in developing equipment, weapons, and tactics that enabled the destruction of the German submarine force. Japan, however, never was able to develop an effective defense against our submarines.

Since World War II the submerged endurance of the submarine has become sufficient to cause difficulty in locating it. The problem increases as the submarine goes constantly faster, deeper, and stays down longer. To cope with the modern submarine, we now have better detection devices, more modern weapons, and newer ships, but the battle for supremacy is a never-ending one.

THE SUBMARINE

All Sonar Technicians are concerned with the hunt for and destruction of enemy submarines. It is of especial importance, therefore, that you know the capabilities of enemy submarines, and know them well. Innumerable questions will come to you over a period of time or after a course of events in antisubmarine warfare (ASW) operations: How fast can a submarine dive or turn? How does the submarine use depth? What is the submarine's top speed when submerged? Because this text is unclassified, many of the answers are of a general nature. In your studies, though, you will learn many details about submarine characteristics and tactics. Such knowledge makes it easier for you to detect submarines and hold contact after detection. Most of this text concerns our own submarines, but foreign navies usually have submarines of comparable ability.

HISTORY AND DEVELOPMENT

The first successful submarine was built in 1620 by Cornelius Van Drebel, a Dutch physician. During repeated trials in the Thames River, he maneuvered his craft successfully at depths of 12 to 15 feet beneath the surface.

Various other European designers of that time constructed submersible craft also, but they failed to arouse the interest of any navy in an age when the potentialities of submarine warfare were inconceivable.

Most of the early craft were of wooden frames, covered with greased leather or similar material, and propelled by oars. Different methods of submerging were thought of and some were even tried. One inventor's design consisted of a number of goatskin bags built into the hull, each connected to an aperture in the bottom. He planned to submerge the craft by filling the skins with water, and to surface it by forcing the water out of the skins with a "twisting rod." Although his vessel was never built, it seems that this design was the first approach to the modern ballast tank. Another inventor actually submerged his craft by reducing its volume as a result of contracting the sides through the use of hand vises.

Ideas were plentiful, some of them fanciful and grotesque, but some contained elements capable of practical application. Lack of full understanding of the physical and mechanical principles involved, coupled with the well-nigh universal conviction that underwater navigation was impossible and of no practical value, kept postponing the attempt to utilize a submarine in naval warfare during the early period.

A submarine was first used as an offensive weapon during the American Revolutionary War. The Turtle, a one-man submersible designed by an American inventor named David Bushnell and hand operated by a screw propeller, attempted to sink a British man-of-war in New York Harbor. The plan was to attach a charge of gunpowder to the ship's bottom with screws and explode it with

INTRODUCTION TO SONAR

a time fuze. After repeated failures to force the screws through the copper sheathing of the hull of HMS Eagle, the submarine gave up and withdrew, exploding its powder a short distance from the Eagle. Although the attack was unsuccessful, it caused the British to move their blockading ships from the harbor to the outer bay.

On 17 February 1864, a Confederate craft, a hand-propelled submersible, carrying a crew of eight men, sank a Federal corvette that was blockading Charleston Harbor. The hit was accomplished by a torpedo suspended ahead of the Confederate Hunley as she ramméd the Union frigate Housatonic, and is the first recorded instance of a submarine sinking a warship.

The submarine first became a major component in naval warfare during World War I, when Germany demonstrated its full potentialities. Wholesale sinking of Allied shipping by the German U-boats almost swung the war in favor of the Central Powers. Then, as now, the submarine's greatest advantage was that it could operate beneath the ocean surface where detection was difficult. Sinking a submarine was comparatively easy, once it was found—but finding it before it could attack was another matter.

During the closing months of World War I, the Allied Submarine Devices Investigation Committee was formed to obtain from science and technology more effective underwater detection equipment. The committee developed a reasonably

accurate device for locating a submerged submarine. This device was a trainable hydrophone, which was attached to the bottom of the ASW ship, and used to detect screw noises and other sounds that came from a submarine. Although the committee disbanded after World War I, the British made improvements on the locating device, during the interval between then and World War II, and named it asdic after the committee.

American scientists further improved on the device, calling it sonar, a name derived from the underlined initials of the words sound navigation and ranging.

At the end of World War II, the United States improved the snorkel (a device for bringing air to the crew and engines when operating submerged on diesels) and developed the Guppy (short for greater underwater propulsion power) is a conversion of the fleet-type submarine of World War II fame. A Guppy submarine is shown in figure 2-1. The superstructure was changed by reducing the surface area, streamlining every protruding object, and enclosing the periscope shears in a streamlined metal fairing. Performance increased greatly with improved electronic equipment, additional battery capacity, and the addition of the snorkel.

The world's pioneer nuclear-powered submarine is the USS Nautilus (SS(N) 571). (See fig. 2-2.) The Nautilus, commissioned in September 1954, is 320 feet in length, with a

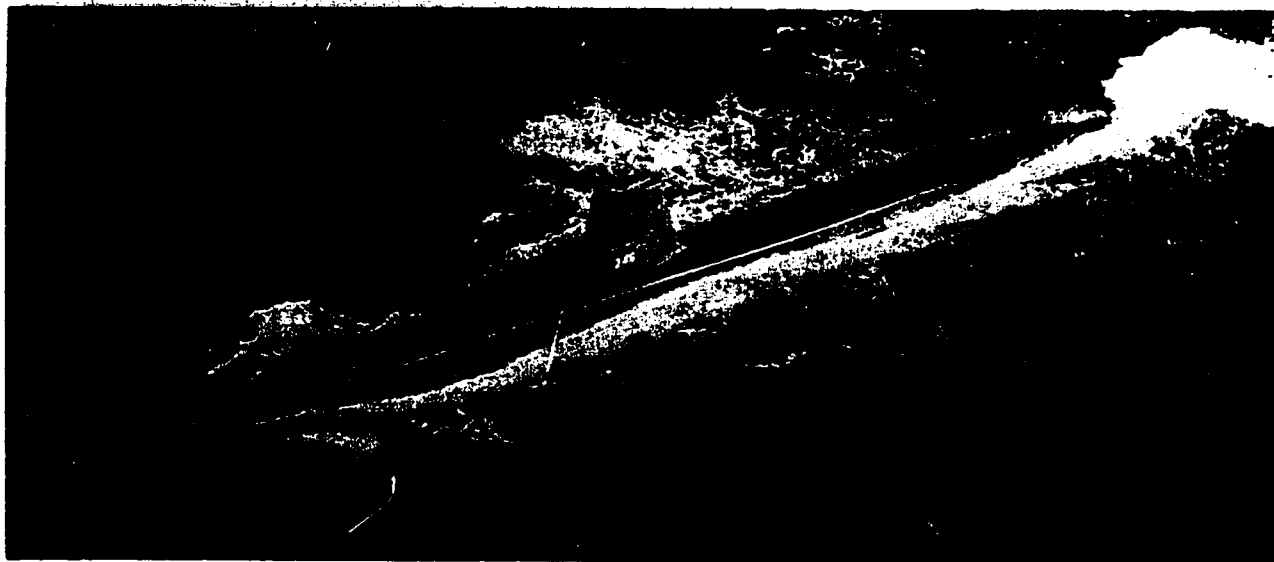

71.1(346)
Figure 2-1.—Guppy submarine.

Chapter 2 — SUBMARINES AND ANTISUBMARINE UNITS

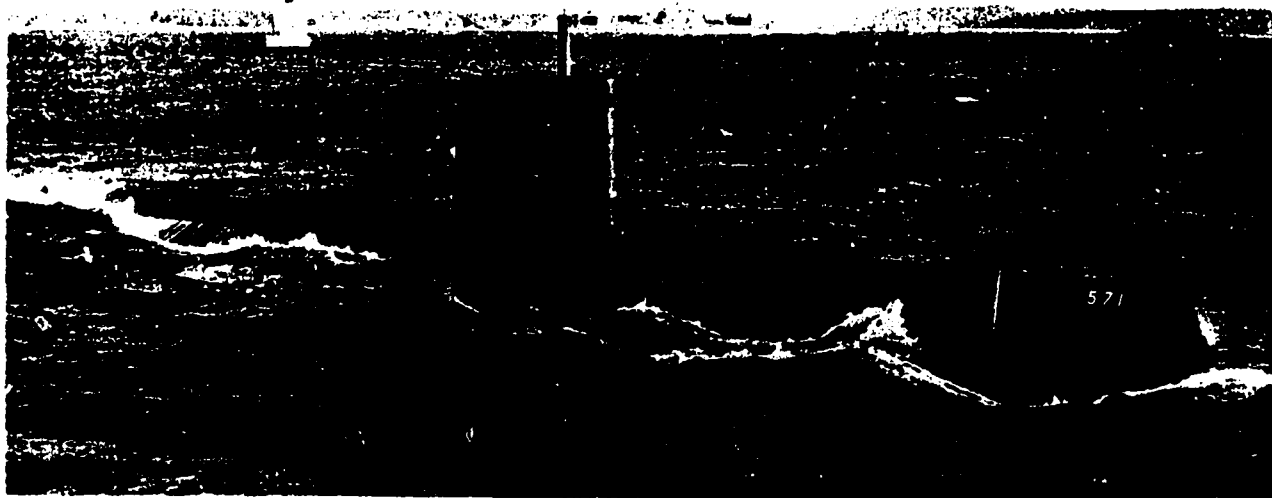

71.1
Figure 2-2.— USS Nautilus (SSN 571).



71.1
Figure 2-3.— USS Mariano Vallejo (SSB(N) 658).

INTRODUCTION TO SONAR

standard surface displacement (ssd) of 3180 tons, and is designed for traveling faster under the water than on the surface.

An intensive building program for nuclear submarines has been in effect for several years, and many new ships have joined the fleet. The USS George Washington (SSB(N) 598) was the first submarine designed to launch, while submerged, the Polaris missile. The USS Mariano Vallejo (SSB(N) 658), shown in figure 2-3, is the 40th, out of a programmed 41, fleet ballistic missile submarine to be commissioned. Her speed is in excess of 20 knots, and she can dive below 400 feet.

One of our fastest submarines is the USS Skipjack (SS(N) 585) (fig. 2-4), whose hull is a radical departure from the conventional idea of submarine hulls. Her diving planes are on the sail, resulting in increased maneuverability.

SUBMARINES IN GENERAL

A submarine ranges in length from about 50 feet to more than 400 feet. Diving is accomplished by controlled flooding of ballast

tanks. To surface the submarine, compressed air expels the water from the tanks.

Probably the smallest submarines in the world belong to the ex-German Seahound class (now in Russian possession). They are 49 feet long and displace only 15 tons. Somewhat heavier, but still in the midget submarine class, are the U. S. Navy's X-1 and the British Shrimp class. The X-1 is less than 50 feet long and displaces 25 tons. Boats of the Shrimp class are slightly longer and displace 30 to 35 tons.

At the other extreme are the bulk of the U. S. Navy's submarines. Included are the latest nuclear-powered submarines. Some of these ships are over 400 feet long and displace more than 7000 tons (ssd). Others, designed for speed and maneuverability, are not quite as long, and displace less tonnage.

Some submarines can cruise in excess of 20 knots submerged. A type of diesel submarine used by the Germans in World War II, and now a part of the Russian fleet, can dive at a rate of 1 1/2 feet per second, and can turn 90° in a little over 1 minute, using full rudder and 5 knots of speed.



71.1
Figure 2-4.— USS Skipjack (SSN 585).

Chapter 2—SUBMARINES AND ANTISUBMARINE UNITS

PROPULSION

Conventional submarines use diesel engines for propulsion when surfaced, and batteries when submerged. Nuclear-powered submarines get their propulsion from atomic reactors.

Conventional Submarines

When on the surface, a submarine's twin screws are turned by electric propulsion motors powered by generators driven by diesel engines. Upon submerging on snorkel, virtually the same performance can be had, but depth of submergence is limited to the length of the snorkel mast. Submerged to greater depths, the submarine relies on large banks of storage batteries to drive its electric propulsion motors because combustion engines require far more air than is available. Here, endurance is limited strictly to the condition of the batteries. Theoretically, if batteries are well charged, a speed of 1 knot can be maintained for about 50 or 60 hours. At full speed, however, the batteries are exhausted after approximately 1 hour.

One way of forcing a battery-powered submarine to the surface is to outwait its staying power. The submarine eventually must use its snorkel, or surface, to recharge batteries and replace air.

Nuclear Submarines

Atomic power has brought close to reality the dream of having a true submarine, that is, one of unlimited submerged endurance and range. The Nautilus refueled for the first time over 1 year after she commenced operating. The Triton circumnavigated the world completely submerged. The Nautilus and Skate pioneered exploration of the north polar seas beneath the icecap, all made possible only by nuclear energy. The human factor, and the quantity of supplies that can be carried, are the main limitations to the endurance of modern submarines.

SUBMARINE ARMAMENT

Armament of a submarine depends on its design and mission. The attack-type submarines normally carry only torpedoes, but they may be employed as minelayers. Fleet ballistic missile submarines carry 16 Polaris missiles, and they have 4 torpedo tubes forward.

Torpedoes

The torpedo is a self-propelled underwater weapon having either a high-explosive or a nuclear warhead. Conventional warheads are loaded with up to 1000 pounds of HBX explosive.

Underwater explosion of the torpedo warhead increases its destructive effect. When a projectile explodes, a part of its force is absorbed by the surrounding air. Upon explosion of the torpedo warhead, the water transfers almost the full force of the explosion to the hull of the target ship.

Fleet-type and Guppy submarines are fitted with 10 tubes, 6 in the bow and 4 in the stern. Spare torpedoes are carried in ready racks near the tubes. On war patrol, a submarine of this type usually puts to sea with a load of 28 torpedoes aboard.

Torpedoes are propelled by gas turbines or electric motors. Turbine types have maximum speeds of 30 to 45 knots, with a maximum effective range of as much as 7 1/2 miles. Electric torpedoes usually have less speed and range than turbine types, but from the submariner's point of view, they have the advantage of leaving no visible wake.

Torpedoes are of the straight-running, acoustic homing, or wire-guided types. The straight-running torpedo has automatic control devices that hold it on a preset course at a preset depth, whereas the acoustic homing type can steer itself toward its target. It may be either active or passive. The active acoustic torpedo sends out pulses of sound and homes on the echoes that return from the target. Passive types home on the noises emanated by the target. The wire-guided type of torpedo is directed to the target by signals sent through the wire from the launching submarine.

Two new submarine weapons are Astor and SUBROC. Astor is an electric-propelled Mk 45 torpedo with a nuclear warhead. It is wire-guided to the target, and has a range of over 10 miles. The SUBROC is an antisubmarine rocket with either a conventional or a nuclear warhead, and has a range of over 20 miles.

After it is launched from the submerged submarine, SUBROC's solid-fuel motor ignites, and the rocket enters the air. At some point in its trajectory the rocket motor separates from the missile. The missile, which is directed to its target by an inertial guidance system, makes a supersonic reentry into the water, sinks to a predetermined depth, and explodes.

INTRODUCTION TO SONAR

Mines

Navy mines are thin-cased underwater weapons with a heavy load of high explosives. They may be laid by both aircraft and surface craft, but submarines are employed for mine laying when secrecy is required, or when the area to be mined is beyond the range of aircraft. Mines may be of the bottom, moored, or drifting type. Bottom mines rest on the ocean floor, and are highly effective in shallow water. Moored mines are positively buoyant. A cable, attached to an anchor on the sea bottom, holds the mine at a predetermined depth beneath the surface. Drifting mines float freely at or near the surface. Mines may be actuated by contact with a vessel, by a vessel's magnetic field, by noise, or by pressure differences created when a vessel passes over the mine. Acoustic-, pressure-, and magnetic-influenced mines may be set to permit the passage of several ships, then explode under the next one to pass over.

Missiles

Specially designed fleet ballistic missile submarines, as mentioned earlier, carry the Polaris missile, adding tremendous striking power to the submarine fleet. The latest Polaris model, the A3, has a 1-megaton nuclear warhead, with a range of 2500 miles. An improved Polaris, called the Poseidon, will have the same range as Polaris, but double the payload, with multiple warheads to confuse enemy defense systems.

MANEUVERABILITY

Modern nuclear submarines present a serious problem to antisubmarine (A/S) forces. Holddown tactics used to force conventional submarines to surface or snorkel to recharge batteries, are ineffective against nuclear submarines because they do not use batteries for submerged operations. They can remain submerged on nuclear power for indefinite lengths of time. The attack-type submarines are faster when submerged than on the surface. Moreover, they exceed the speeds of many types of surface ships. Their sail-mounted diving planes permit radical maneuvers, almost like those of an airplane. Actual operating depths are classified, but the modern submarine can go considerably deeper than the World War II types.

ANTISUBMARINE UNITS

Antisubmarine (A/S) forces are composed of special design ships, aircraft, and submarines. Their purpose is to seek out and destroy enemy submarines. Aircraft carriers of the CVS type (with fixed-wing aircraft and helicopters embarked), together with a number of destroyers, form hunter-killer (H/K) groups, whose primary mission is to deny an enemy the effective use of his submarines. Guided missile destroyers, whose chief function is defense against air attack, also have A/S capabilities. Nuclear attack submarines are also assigned to H/K groups. The SSNs are especially effective in A/S operations because of their ability to select the depth providing the best sonar conditions, their long endurance and maneuvering capabilities, and the type of weapons they carry. Elements of a typical hunter-killer group are shown in figure 2-5.

SHIPS

The destroyer-type ships (DDs) are the prime submarine hunter-killers. They operate in H/K groups, screen convoys, carriers, and other naval vessels against submarine attacks, and provide protection against air attack.

Destroyers range in size from 2100 tons to nearly 8000 tons displacement. From about 5000 tons up they usually are designated frigates (DLs). Destroyer escorts (DEs) are somewhat smaller than regular destroyers, although the latest type of escort is larger than many World War II destroyers. Ships with guided missile capability have the letter G added to their designation (DDG, DLG, DEG).

Antisubmarine armament carried by frigates of the type shown in figure 2-6 consists of ASROC (antisubmarine rocket), located behind the forward missile launcher, and A/S homing torpedoes amidships on each side. Some of the latest DLGs fire ASROC and Terrier missiles from the same launcher.

Guided missile destroyers have essentially the same A/S armament as frigates. The arrangement varies between classes. Some DDGs have the ASROC launcher forward, behind the 5"/54 gun; others have it amidships, as seen in figure 2-7.

Conventional destroyers (DDs) that have undergone the fleet rehabilitation and modernization (FRAM) program have either ASROC or DASH, in addition to their A/S torpedoes. (The

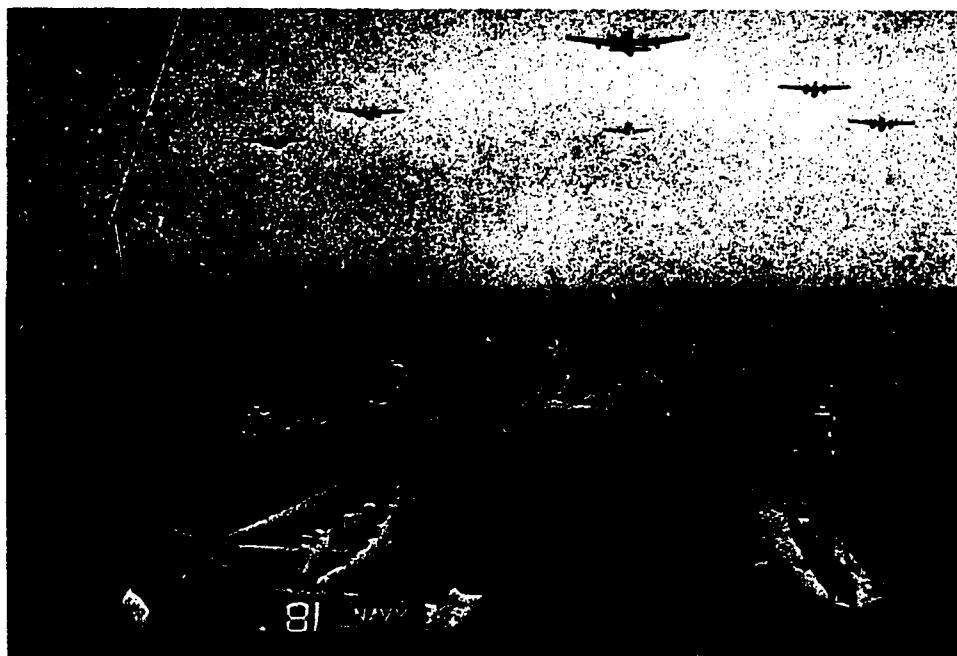

134.102(71)
Figure 2-5.— A typical ASW hunter-killer group.

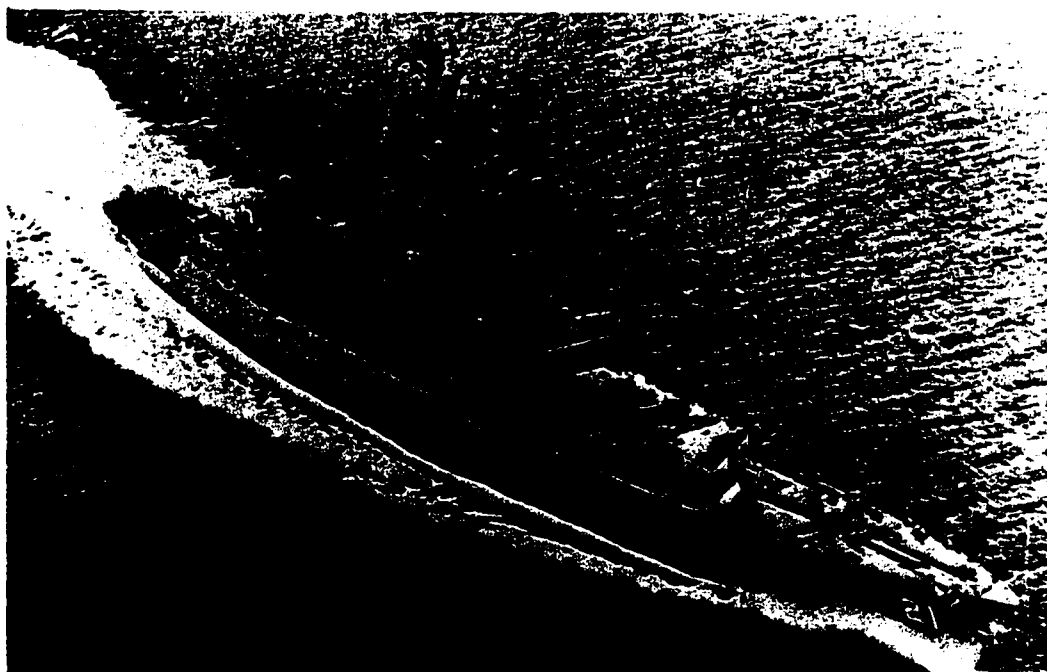

134.84
Figure 2-6.— USS Gridley (DLG 21).

INTRODUCTION TO SONAR



33.272

Figure 2-7.—ASROC launch from USS Henry B. Wilson (DDG 7).



3.130

Figure 2-8.—DASH taking off from a destroyer.

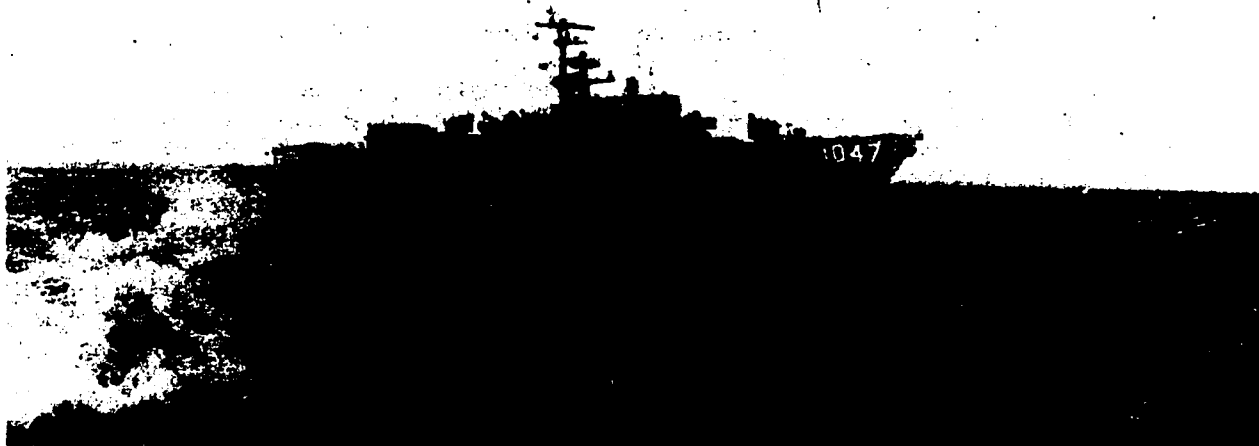

134.87(1047)
Figure 2-9.— USS Voge (DE 1047).



3.115
Figure 2-10.— ASW helicopter using dipping sonar.

INTRODUCTION TO SONAR

word dash is formed from the underlined letters of the term drone antisubmarine helicopter.) (See fig. 2-8.) It is a pilotless, remotely controlled helicopter, capable of carrying 2 homing torpedoes or a nuclear depth charge to a target several miles away.

The ASROC is the shipboard counterpart of the submarine's SUBROC. It is a solid-fuel rocket that carries either a homing torpedo or a nuclear depth charge to a range of 5 miles. Like the SUBROC, it is unguided during flight. When the torpedo is used, a parachute slows its descent to the surface. On contact with the sea, the parachute separates and the torpedo begins its active acoustical search.

The destroyer escort USS Voge (DE 1047), shown in figure 2-9, is one of the newest ships in the modern design DE 1040 class. She carries ASROC and A/S torpedoes, and will evaluate

a new naval tactical data system (NTDS) for antisubmarine warfare (ASW) application.

All the destroyer-type ships mentioned have the latest sonar equipment compatible with the type of ship. The newer ships have bow-mounted sonars. Some ships also have variable-depth sonar (VDS) installed on the stern.

Practically all destroyer-type ships are conventionally powered, the exception being the few ships in the USS Bainbridge (DLGN 5), which have nuclear-powered propulsion systems. The Navy of the future, however, will doubtless have a greater proportion of nuclear-powered surface ships, just as our submarine force has today. Conventional destroyers must refuel every few days, restricting their freedom of movement. In contrast, the Bainbridge, in company with USS Enterprise (CVAN 65) and USS Long Beach (CGN 9), made a 30,000-mile voyage around the world without refueling or replenishing supplies.



Figure 2-11.—S-2 Tracker, A/S search and attack aircraft, with MAD probe extended.

134.95.5

Chapter 2—SUBMARINES AND ANTISUBMARINE UNITS

AIRCRAFT

The use of aircraft in conjunction with ships and submarines adds greater capability and versatility to ASW. Areas of surveillance can be enlarged, ranges extended for detection and attack, and a diversified use of weapons utilized. Two types of aircraft are used in ASW: the helicopter for close ranges, and the fixed-wing aircraft for long ranges. The helicopter uses a dipping sonar; that is, one that may be lowered from the aircraft for searching, as shown in figure 2-10, and retracted for flight. Fixed-wing aircraft use magnetic anomaly detection (MAD) equipment whereby they detect the submarine

by variations in the earth's magnetic lines of force.

Aircraft also use other devices for detecting the presence of submarines. One of these devices is the sonobuoy, which is dropped into the water by the aircraft and then monitored by radio. Sonobuoys are described in chapter 6.

The aircraft also can be used as a tactical device to carry a weapon to the submarine. Among the weapons that can be launched from an aircraft are the homing torpedo and the nuclear depth charge. Figure 2-11 shows an aircraft of the type carried aboard a CVS. Another type of aircraft used in ASW is the P3 Orion, which is land-based. The Orion is a long-range patrol plane, and carries highly sophisticated electronic detection equipment.

CHAPTER 3

BEARINGS AND MOTION

In studying bearings and motion, you must remember that they are of two types. The two types of bearings are true bearing, which uses true north as a reference, and relative bearing, which uses ship's head as a reference. True motion is the movement of an object across the earth. Relative motion is the movement of one object in relation to another object.

This chapter discusses both types of bearings and both types of motion. It shows how they are applied in determining the location and movement of an underwater target, such as a submarine.

With modern sonar, it is possible to locate and track a submarine with dependable accuracy. In order to make full use of precision equipment, it is necessary to evaluate bearings and motion correctly and thus avoid setting erroneous values into the equipment computers.

REQUIREMENTS FOR LOCATING SUBMARINES

Many landmarks and familiar objects on land can be utilized for establishing a position and determining the location of a particular point. In civilian life we were accustomed to such descriptive terms as "The third house on the right," or "Just a mile down the highway at the big signboard." At sea, though, we must adjust ourselves to doing without the convenience of familiar objects and use other means at our disposal for locating a target. Targets visible on the surface or in the air can be pointed out, but an unseen underwater object must be located in a manner that is both clear and accurate. This method of location is accomplished by using sonar to determine the object's direction and distance from the sound transmitting ship.

In chapter 4 you will read about the numerous variables affecting the travel of sound beams in water. These variables greatly affect the precision with which the exact location of an underwater target can be determined. With present-day

equipment we are able to compensate for many of the variables and obtain exact positioning information. Electromechanical computers are utilized in solving many of the problems of target bearing and motion. It must be borne in mind, however, that direction and distance must be obtained first, then reported by the operator before the computer can be set up to produce a correct solution. Thus, the ability to determine and report the correct bearing and range as speedily as possible is of the utmost importance to the entire attack problem.

SONAR INFORMATION

Sonar provides the two items of information—direction and distance—from which we derive all subsequent data. Direction and distance are referred to as bearing and range. Correct interpretation and transmittal of bearing and range information are deciding factors in successfully conducting any attack.

Bearing

The direction of the echo from the sound transmission source is called the bearing. Bearing is measured clockwise in degrees of azimuth in three figures from 000° through 360°. Azimuth is defined as a horizontal arc of measurement of the horizon in degrees. One quarter of a circle is 90° and a full circle is 360°.

Until a few years ago, an allowance of 2-1/2° for error in bearing was considered within limits of tolerance in antisubmarine attacks. Today, this standard of tolerance has been reduced to approximately 1°. A bearing error of 2-1/2° at 100 yards amounts to a position error of 4.36 yards; at 2000 yards this error is 87.2 yards. With a bearing error of 1°, we are off target only 1.75 yards at 100 yards, and 35 yards off at 2000 yards. As you can see, modern equipment has provided greater bearing accuracy. No doubt future sonars will give even better accuracy,

Chapter 3—BEARINGS AND MOTION

but remember that the finest equipment will always need a competent operator.

Range

The distance from the sound source to the target is called range. In sonar, range always is expressed in yards. With modern sonar equipment, range detection varies from less than 100 yards to thousands of yards. Ranges can be measured to an accuracy of 1 percent of the range scale in use. To achieve this accuracy you must have up-to-date knowledge of water conditions and be able to make adjustments to the equipment to compensate for variations in the velocity of sound.

Range is reported in thousands and hundreds of yards. Some sample ranges, and the manner in which they are reported, are listed here for your information.

- 3000—"Range three thousand, closing."
- 2500—"Range two five hundred."
- 1750—"Range one seven five zero."
- 1100—"Range one one hundred."
- 1000—"Range one thousand."
- 800—"Range eight hundred."
- 660—"Range six six zero."
- 150—"Range one five zero."
- 400—"Range four hundred, opening."

It should be noted that the word "yards" is never included in a report, because ranges always are given in yards.

One range report by itself is insufficient to conduct an attack, although such information as whether the range is opening, closing, or constant is of vital significance. A succession of both bearing and range reports is required to determine target location and motion.

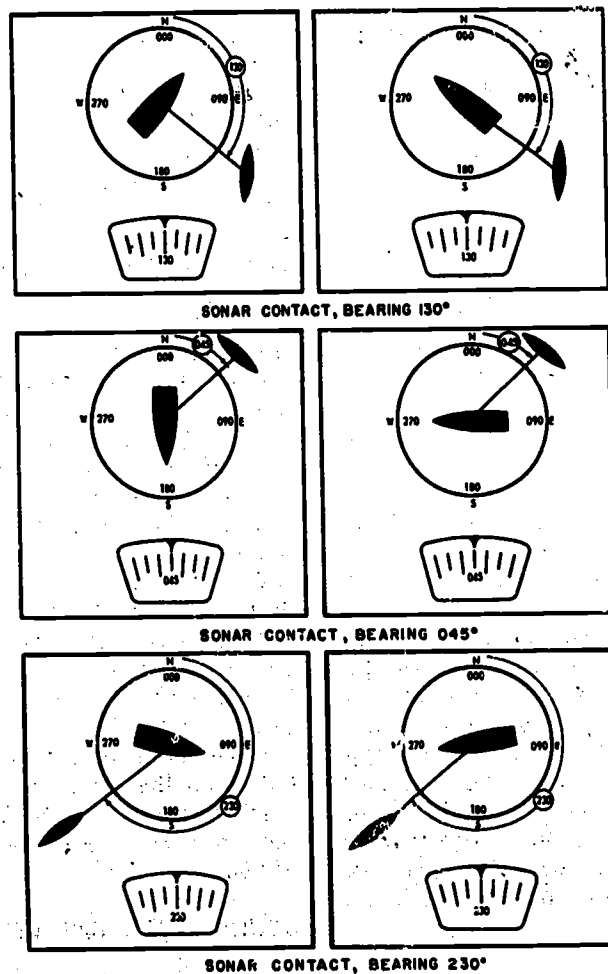

71.3
Figure 3-1.— True bearings are independent of ship's head.

INTRODUCTION TO SONAR

BEARINGS

In establishing a bearing, we invariably must have a reference point to ensure that the direction is always the same. True bearing is referenced to true north regardless of the direction or motion of the ship. Relative bearing is always referenced to the ship's bow. In all instances, bearings are reported in degrees and are read clockwise.

Sonar bearings are reported in three figures, and you say "zero" instead of "oh." A sonar contact due east of your ship is reported as "Sonar contact, bearing zero niner zero." If the contact were due west, it would be reported as "Sonar contact, bearing two seven zero."

Notice in the foregoing examples that the word "true" is not used. Unless stated otherwise, always assume that bearings are reported as true bearings. If a gyro failure occurs, relative bearings must be used, and the sonar operator will add the word "relative" to his bearing report. If he wishes, the operator can avoid saying "relative" after each report by stating "All bearings will be relative until further notice."

TRUE BEARINGS

To illustrate that true bearings are independent of the ship's heading, figure 3-1 shows three different bearings. The ship and the contact have been drawn in to show that, although the ship has a different course, the true bearing of the contact remains the same. In the illustration, compare the examples on the left with the examples on the right.

All shipboard and submarine sonar sets utilize a gyrocompass repeater to provide true target bearing by reading the sonar bearing marker against the dial. Figure 3-2 shows this dial as it is in a standard shipboard sonar set. The section enclosed within the dotted lines is the area visible to the sonar operator through the glass window. The marker at the top, which can be seen through the transparent bearing dial, indicates the bearing to which the operator has trained the cursor on the scope. Because the cursor normally is positioned in the middle of the target presentation, the dial marker indicates the center bearing of the contact.

RELATIVE BEARINGS

True bearings are the ones of principal concern to Sonar Technicians because standard

operating procedures are based on true bearings. You need to understand relative bearings, however, inasmuch as casualties to the gyrocompass necessitate shifting to relative bearing procedures.

Relative bearings are read in degrees clockwise from the ship's bow, which is always 000°. If a contact is broad on your ship's port quarter, the relative bearing is 225°. If a contact is on your starboard beam, the relative bearing is 090°. Figure 3-3 diagrams these two examples, illustrating how relative bearings are determined.

When the ship changes course, the relative bearing of a target changes. In figure 3-4 the ship changes course 60° to the right. This course change causes the relative bearing of the target to change from 090° relative to 030° relative.

Relative bearings can be read on the sonar console from the same dial that gives true bearings, although not at the same time. If a complete gyro failure should occur, this dial automatically indicates relative bearing. Occasionally, the gyro may act erratically for a few moments, causing the picture on the scope to jump, making it difficult for the operator to track the target. To obtain a presentation with more stability, the operator can control the equipment so that a relative picture is presented on the scope, the dial indicating relative bearing.

Figure 3-5 typifies a bearing indicator from which true and relative bearings may be read simultaneously. This type of indicator, used in earlier sonars, is a good example for showing the comparison of true and relative bearings.

The outer dial, which is fixed, indicates relative bearing. The inner dial is free to rotate. When connected electrically to the ship's master gyrocompass, it acts as a gyro repeater and shows ship's course and true bearing. The diamond-shaped pointer between the two dials indicates the direction in which the sound receiver is trained. Both relative bearing and true bearing are read by observing the position of the pointer.

True course is read on the inner dial opposite 000°R on the outer dial. As shown in figure 3-5, ship's course is 045°, and a contact broad on the starboard bow (045°R) has a true bearing of 090°.

STERN LINE INDICATOR

With modern scanning sonars, the sonar operator has an ideal picture of antisubmarine action. He not only receives the audio response,

Chapter 3—BEARINGS AND MOTION



45.29(71)A

Figure 3-2.—Bearing dial assembly.

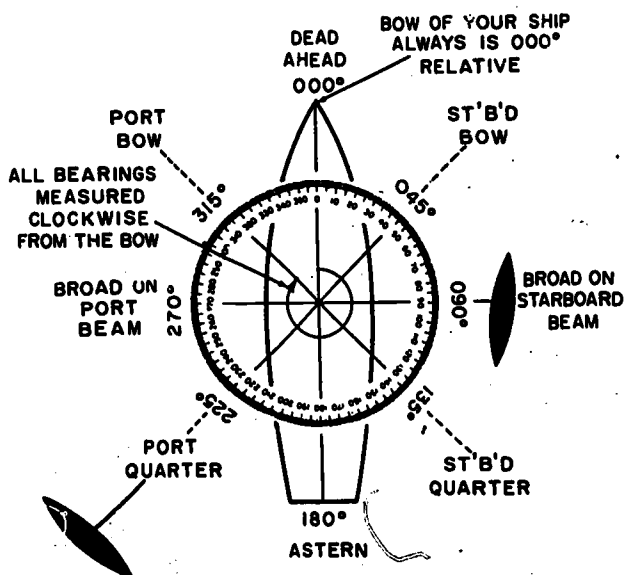

45.29(71)B

Figure 3-3.—Relative bearings.

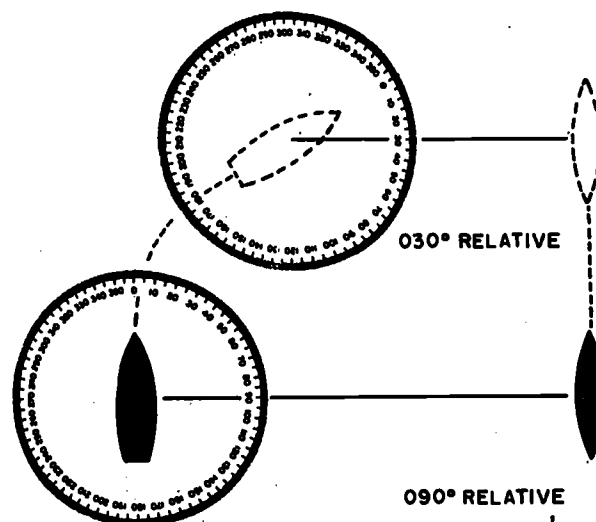

45.29(71)C

Figure 3-4.—Relative bearing change.

INTRODUCTION TO SONAR

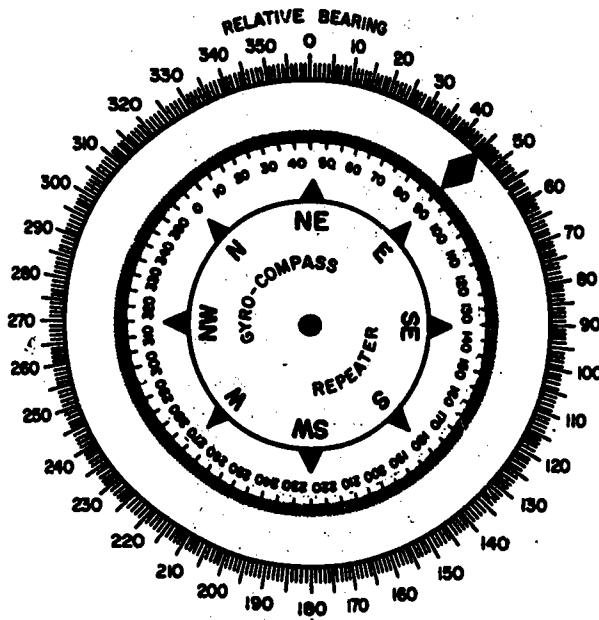

45.29(71)K
Figure 3-5.— Bearing and course indicator.

but is aided by a video presentation 360° in azimuth. The presentation is a true picture of the area surrounding the ship, and, (with exceptions noted later in the text) it does not change with alterations in ship's course.

Although the video presentation is independent of ship's heading, the Sonar Technician needs to be constantly aware of the ship's course for purposes of conducting search arcs, performing control manipulations, and reporting sonar information. Ship's course information is provided in the form of a stern line on the face of the scope. The stern line, illustrated in figure 3-6, is presented as an illuminated broken line, which, as its name implies, indicates the direction of the ship's stern. If this line indicated the bow of the ship, it would be much easier to interpret ship's course. Because most sonar information comes from forward, however, the addition of the stern line indicator in that direction would tend to clutter the scope unnecessarily.

Normally, with the ship's gyro operating, own ship's movement does not appreciably alter the presentation on the scope. Only the stern line indicator shows when the ship is turning or if a course change has occurred. When turning right, the stern line moves clockwise; when turning left, it moves counterclockwise. Movement of the stern line alerts the operator

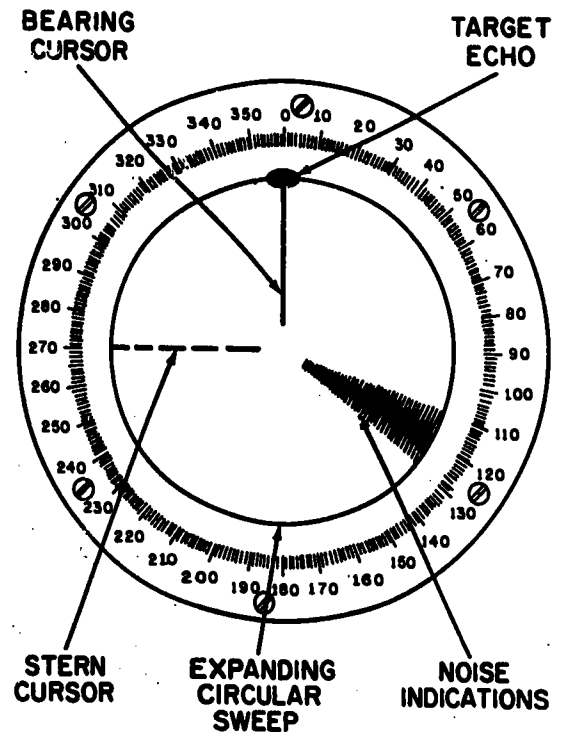

45.29(71)J
Figure 3-6.— Stern line indicator.

to course changes, so that he then can be prepared to make adjustments to keep the bearing cursor on target.

When looking at the scope, it is best to picture the ship as in the center of a small segment of the ocean, with the ocean always oriented to true north at the top of the scope. The ship turns in the center, and its direction is shown by the stern line to indicate the reciprocal of the true course.

GYRO FAILURE

When the gyro is operating, the top of the scope is north (000° true). When the gyro is inoperative, the top of the scope is 000° relative (ship's head).

The first indication of a gyro casualty is the erratic movement of the stern line or the illumination of the red GYRO OFF light on the sonar console. Any failure of gyro input to the sonar causes the stern line to swing to 180° relative, where it remains as long as the gyro inputs are cut off. If the ship is headed for a target when the gyro fails, the target echo moves to 000° relative. Thus, the ship may

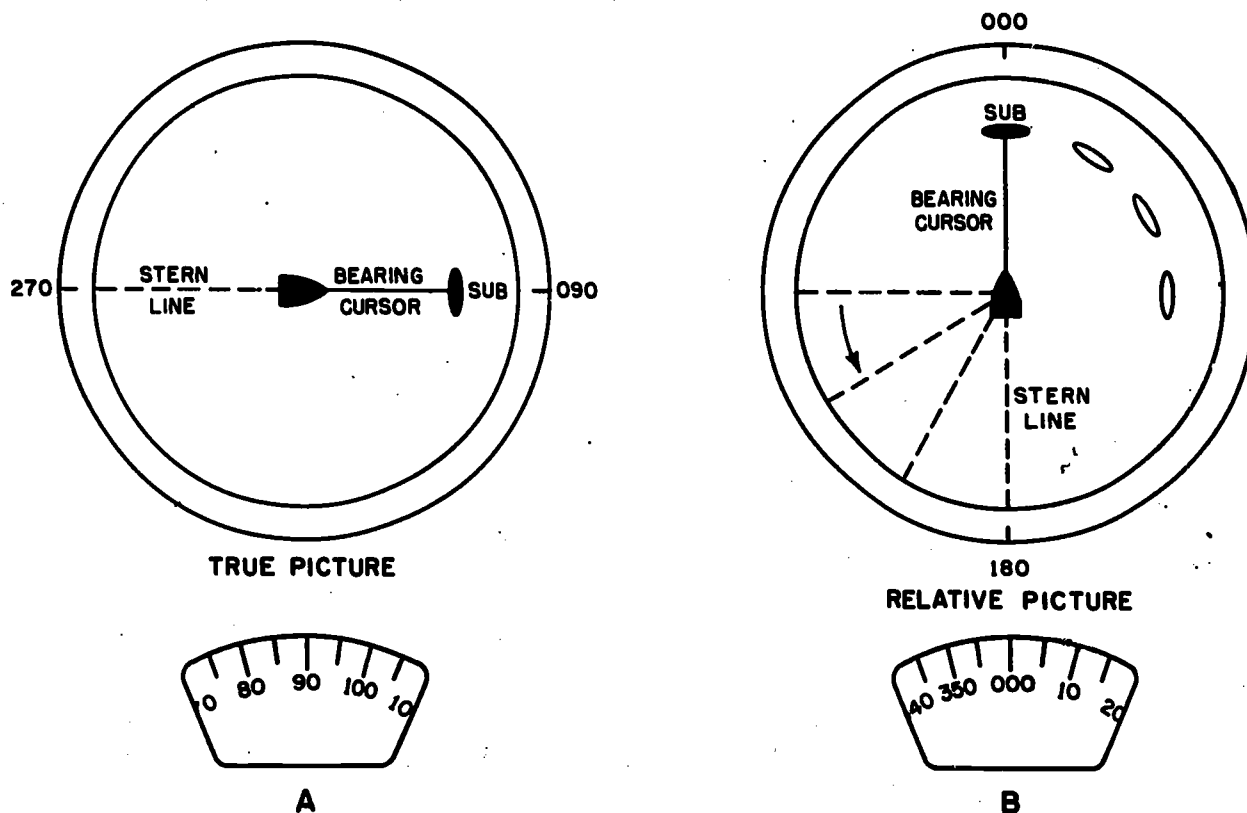

Figure 3-7.—Effect of gyro failure.

71.4

be heading for a target bearing 090° true, but the target echo is presented at the top of the scope.

The effect of gyro failure is illustrated in figure 3-7. Part A shows the scope with normal gyro input. The submarine is located to the right of center. The stern line is at 270° and indicates that the ship is on course 090° true and headed for the contact.

With a gyro casualty, the stern line will swing 90° counterclockwise. The entire video presentation will change a like amount in the same direction as shown in part B of the illustration. To remain on target, the bearing cursor must also be trained 90° counterclockwise. The dials below the scopes in the illustration indicate the direction in which the bearing cursor is trained to maintain contact.

CONVERTING TRUE AND RELATIVE BEARINGS

Even though you lose gyro input to the sonar, you can easily determine the true bearing of the target if you know your ship's course and the relative bearing of the target. If the relative

bearing is 029° and the ship's course is 027° true, for instance, as in figure 3-8, you can see that the true bearing of the target is 056°. The true bearing is obtained by adding the ship's course and the target's relative bearing. Thus, by the formula we have:

$$027^{\circ}T + 029^{\circ}R = 056^{\circ}T.$$

Now examine figure 3-9. The ship is on a course of 180° true, and the target is at 251° relative. Again, it is easy to determine true target bearing by applying the formula as before:

$$180^{\circ}T + 251^{\circ}R = 431^{\circ}T.$$

This time the bearing is greater than 360°. When the answer exceeds 360°, you must subtract this figure to obtain the correct answer. Thus:

$$180^{\circ}T + 251^{\circ}R = 431^{\circ}T - 360^{\circ}T = 071^{\circ}T.$$

RULES FOR CONVERSION

Certain rules are established for converting true and relative bearings. After each rule is

INTRODUCTION TO SONAR

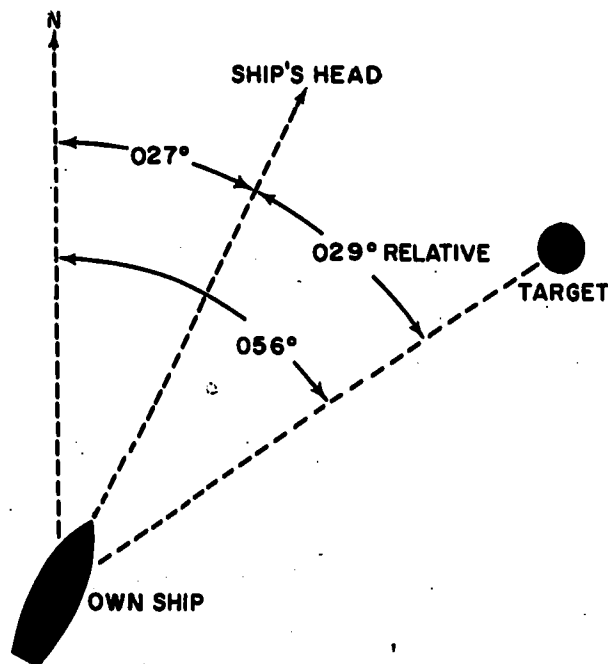

45.29(71)F.2
Figure 3-8.—Target at 056° true.

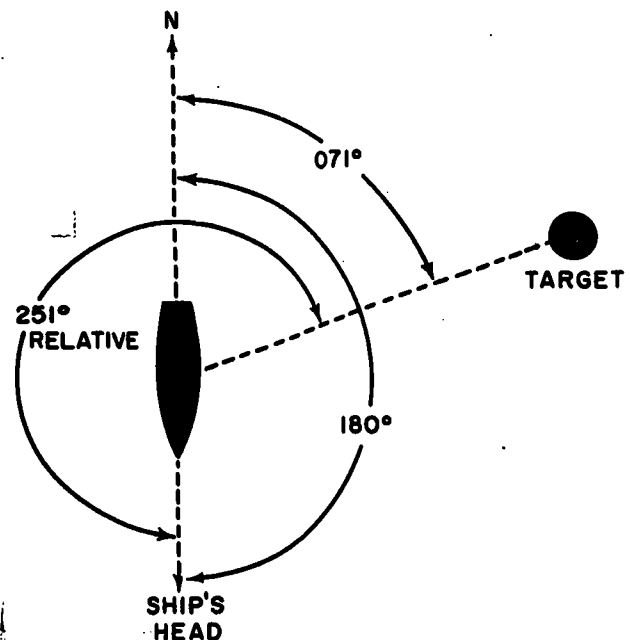

45.29(71)G.2
Figure 3-9.—Target at 071° true.

stated, the mathematical formula representing the rule is given. The formulas are expressed in fire control symbols. By means of these symbols we avoid detailed explanations of the values or measurements. Following are the fire control symbols used in these formulas.

- By— True target bearing.
- B— Relative target bearing.
- Co— Own ship's course.

True target bearing equals relative target bearing plus own ship's course. In formula, this rule is expressed thus:

$$By = B + Co$$

If the true bearing, as computed, is greater than 360°, that value must be subtracted from the total. Our rule now is: True target bearing equals relative target bearing plus own ship's course minus 360°.

$$By = B + Co - 360°$$

If you know your course and the true target bearing, the formula may be worked in reverse to obtain the relative target bearing. Relative target bearing equals true target bearing minus own ship's course.

$$B = By - Co$$

If the true bearing is less than the ship's course, 360° must be added to the true bearing before subtracting ship's course. Relative target bearing equals true target bearing plus 360° minus own ship's course.

$$B = By + 360° - Co$$

If the true target bearing is 045°T and ship's course is 270° true, for example, we find the target's relative bearing thus:

$$045°T + 360° = 405° - 270° = 135°R$$

MOTION

As mentioned at the beginning of this chapter, the two types of motion are true and relative. The Sonar Technician must have a thorough understanding of both types of motion in order to interpret target movement correctly and to give assistance in making an attack.

TRUE MOTION

True motion is the movement of an object across the earth, using true (geographic) north as the reference point.

RELATIVE MOTION

Relative motion is the apparent movement of an object in relation to another object. Do not confuse the concept of relative motion with relative bearing. Relative motion is measured as a true direction of apparent movement.

You may have been unaware at the time, but on many occasions you have witnessed the solution of relative movement problems. When a baseball player races to catch a high fly ball, or when a football quarterback throws downfield to a receiver, the players are estimating relative movement. As an example, assume your ship is on a course of 000° at a speed of 20 knots. You are overtaking and will pass close aboard a ship that is also on course 000° , but whose speed is only 10 knots. As you close the ship, the bearings to him draw aft. Eventually you pass him and he falls further and further behind. His relative movement from you is approximately 180° , but his true movement is 000° .

Following are three rules pertaining to relative motion you must remember when making an attack on a submarine. Figure 3-10 illustrates these relative motion situations.

1. If range is closing and the bearings are drawing toward the bow, your ship will pass astern of the submarine.
2. If range is closing and the bearing remains steady, the ship will pass directly over the submarine. (If the submarine were on the surface, a collision would result.)
3. If range is closing and the bearings are drawing aft, the ship will pass ahead of the submarine.

ADVANCE AND TRANSFER

When a ship changes course to head for a new bearing, she does not move as a car does on land. Water is a fluid substance, and it does not allow the ship the advantage of good traction. As rudder is applied to a ship, a short period ensues before the rudder takes hold in the water. During the turn, the stern of the ship actually slides through the water. As it slides, the ship tends to advance in the same direction of her original course. The distance the ship moves in the original direction until she is on the new course is called advance. The amount of advance depends on ship's speed, amount of turn, and amount of rudder angle applied.

During the change in course, the ship also moves at right angles to the original course. The distance the ship moves at right angles to the original course during the turn is called transfer. The amount of transfer, as with advance, depends on the amount of turn, ship's speed, and amount of rudder angle.

Advance and transfer vary with each type of ship, and even with ships of the same type. Each ship, therefore, makes her own advance and transfer tables for various rudder angles and at different speeds.

As you can imagine, advance and transfer will affect target bearings during a turn. All possible situations cannot be explained here because there are almost unlimited combinations of target and attacker relative movements. If the target is on your port beam, for example, and has the same course and speed you have, when you turn left to head for him, his bearing will change to the right. Figure 3-11 illustrates the effect of advance and transfer on bearing when the target is stationary, or nearly so.

BEARING DRIFT

When the sonar operator detects an underwater target, he reports the bearing and range. The conning officer then turns the ship to head for the reported target. As the ship turns, the bearing cursor is trained back and forth across the target to check for bearing width, and the target is classified. The operator then places the cursor in the center of the target pip. The cursor shows direction of sound reception. Its length indicates range when the cursor line is adjusted to touch the target echo. With the ship headed for the target on a steady course, and at a constant speed, with the cursor bisecting the echo, any change in target bearing results from target movement. If the target moves to the right, the operator must train his cursor to the right in order to remain on target, reporting "Bearing drift right." If the target moves to the left, he must train his cursor to the left to remain on target, and reports "Bearing drift left."

In an attempt to evade the attacking ship, the submarine will maneuver. The attacking ship, in turn, changes course as necessary to reach optimum weapon firing position while maintaining sonar contact. Regardless of the number of course changes of the ship, or maneuvers by the submarine, the job of the operator is to keep the cursor on the target. Correct bearings, ranges, audio response, and other

INTRODUCTION TO SONAR

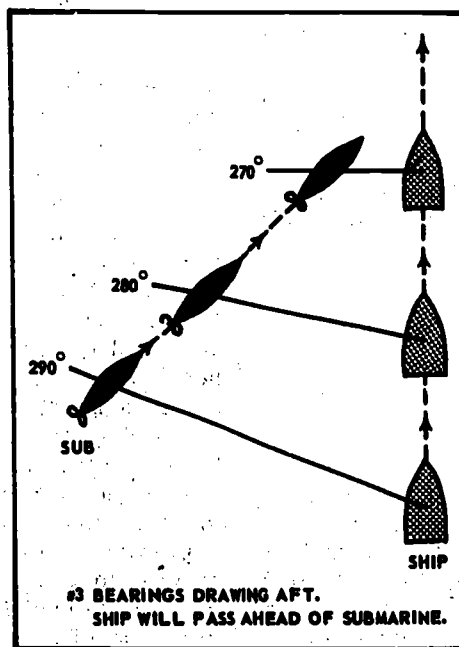
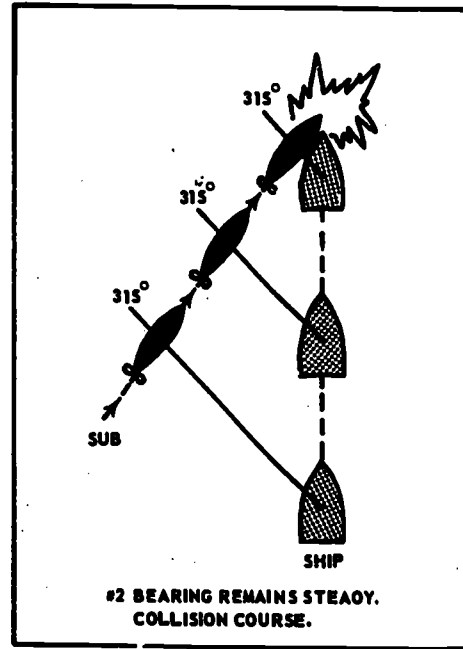
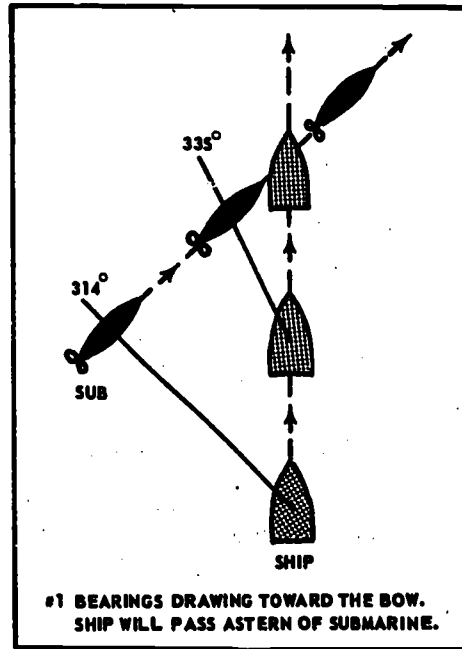

71.5

Figure 2-10. — Relative motion situations.

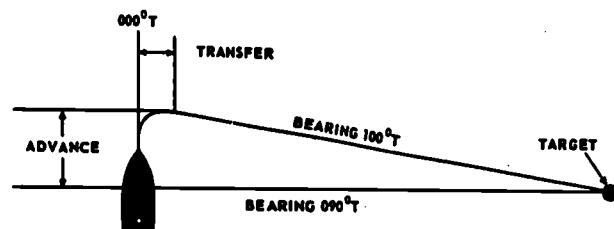

71.6

Figure 3-11.—Effect of advance and transfer on bearing.

target data can be obtained only when the cursor is kept positioned properly on the target echo.

ATTACK LEAD

Once target movement is determined, the conning officer turns the ship to point the bow ahead of the target. This maneuver is called the collision lead. If the proper amount of lead is taken, the target bearing ceases its drifting movement and remains steady. The amount of lead depends on the type of attack and the weapon used. Depending on the speed and maneuvers of the target, it may become necessary to increase or decrease the lead so as to maintain a steady bearing during the approach phase of the attack. Drift may be determined correctly only if the cursor is positioned properly to bisect the target echo at all times. The following example should help clarify bearing drift and attack lead.

Assume that you (the sonar operator) gain contact on a submarine bearing 090° true. (The submarine's course is 180°.) The ship turns to head for the target and steadies on course 090°. This maneuver is apparent when the stern line steadies on 270°. Noticing that the bearing is drifting to the right (caused by advance and transfer during the turn and target movement), you move the cursor to the right to remain on target, and report "Bearing drift right." Thereupon, the conning officer changes course to the right to establish a collision lead. With collision lead established, there is no bearing drift, relative movement of the target on the scope is directly toward the ship as the ship closes the target, and a true movement in the direction of 180° (course of submarine) can be determined from the video presentation on the scope by observation of the target traces. (NOTE: Remember that true bearing drift can be determined accurately only when the ship is headed

directly at the target.) In this illustrative case, assuming a depth charge attack, additional lead is applied at 700 yards. This maneuver is called attack lead. The amount of lead depends on target aspect, target speed, and the sinking time of the depth charges. As this final attack lead is applied to the right, the bearings commence to drift left and aft, down the port side, until contact is lost at short range. At this stage of the attack, the operator must train the cursor rapidly aft so as to regain contact as the attacking ship clears the submarine.

In almost every depth charge attack, you will follow the same procedure, once you detect a target on the scope. The cursor is trained on the target and adjusted for range. You continue to bisect the target, tracking the submarine movements until contact is lost during the final stages of the attack. For an attack using ahead-thrown weapons, the procedures are basically the same, except that contact is not normally lost. The sonar operator must be alert for rapidly changing bearings at short range.







DOPPLER AND TARGET ASPECT

When contact is made on an underwater object, these questions require answers: (1) What is it? (2) Is it moving? (3) In which direction is it moving?

Classification steps, when executed properly, give the answer to the first question. Doppler helps to answer all questions. Doppler, an acoustic phenomenon, is explained fully in chapter 4. At this time it is enough to know that doppler up means the target is headed toward you; doppler down means the target is headed away from you; and no doppler means the target is either broadside to you and neither coming toward you nor headed away, or it is stationary. Assume that you have contact with a submarine. It has doppler, so it must be moving—but in which direction? By this time the ship has turned to head for the target, enabling you to arrive at the answer to the third question. If doppler is up, the target is moving toward the ship. If doppler is down, the target is moving away from the ship.

The operator's job is to determine the direction of target movement and report it. If the submarine is headed directly at the ship, the target aspect will be direct bow and doppler will be up. If you are headed at the target, and the target has bearing drift to the right with no doppler, the target aspect is starboard beam.

INTRODUCTION TO SONAR

SUBMARINE						
ASPECT	DIRECT BOW	STBD BOW PORT BOW	STBD BEAM ----- PORT BEAM	PORT QTR STBD QTR	DIRECT STERN	
BEARING DRIFT	NONE	RIGHT LEFT	RIGHT ----- LEFT	LEFT RIGHT	NONE	
DOPPLER	UP	MODERATE UP	NO	MODERATE DOWN	DOWN	

71.7
Figure 3-12.—Target aspect.

Figure 3-12 shows the five basic target aspects and their associated doppler. The degree of doppler is dependent on target speed. For example: Doppler of a direct bow target with a high closing speed would be reported as "marked up."

Target aspect is best described as the relative position of the submarine with respect to the sound beam. Perhaps the easiest way of deciding which aspect the submarine is presenting is to visualize it in the center of four quadrants and, by the process of elimination, solve for the proper quadrant. This procedure gives a rough aspect, and doppler and bearing drift will further define the exact aspect. Look at figure 3-13 to see how this solution is accomplished. Assume that your ship is headed for the target, and that initially you have a steady bearing with high up doppler, which indicates that the ship and the submarine are headed directly for each other. Next, you detect a bearing drift to the right, with slight up doppler. Quadrants A and B are eliminated because a target in either quadrant would have down doppler. A target in quadrant C will have up doppler, but the bearing drift will be to the left. Therefore, you would report "Starboard bow aspect."

As the ship attacks, she makes minor course and speed changes, but these changes have little or no effect on target aspect or doppler. If the ship circles the submarine, however, or if the submarine makes a change in course, target aspect will change. A change in doppler is the first indication that the submarine is changing course, and this change must be reported immediately. As soon as the new aspect can be determined, it also must be reported. During an antisubmarine attack (or series of attacks), aspect changes often. The sonar operator's job is to detect, evaluate, and report each change as it occurs.

COMPUTING TARGET ANGLE

Target angle, which is a relative bearing, gives more precise information on the course of a ship or submarine than does target aspect, but target angle is more difficult to obtain than is target aspect. In considering a destroyer making an attack on a submarine, target angle is the relative bearing of the destroyer from the submarine.

Chapter 3 — BEARINGS AND MOTION

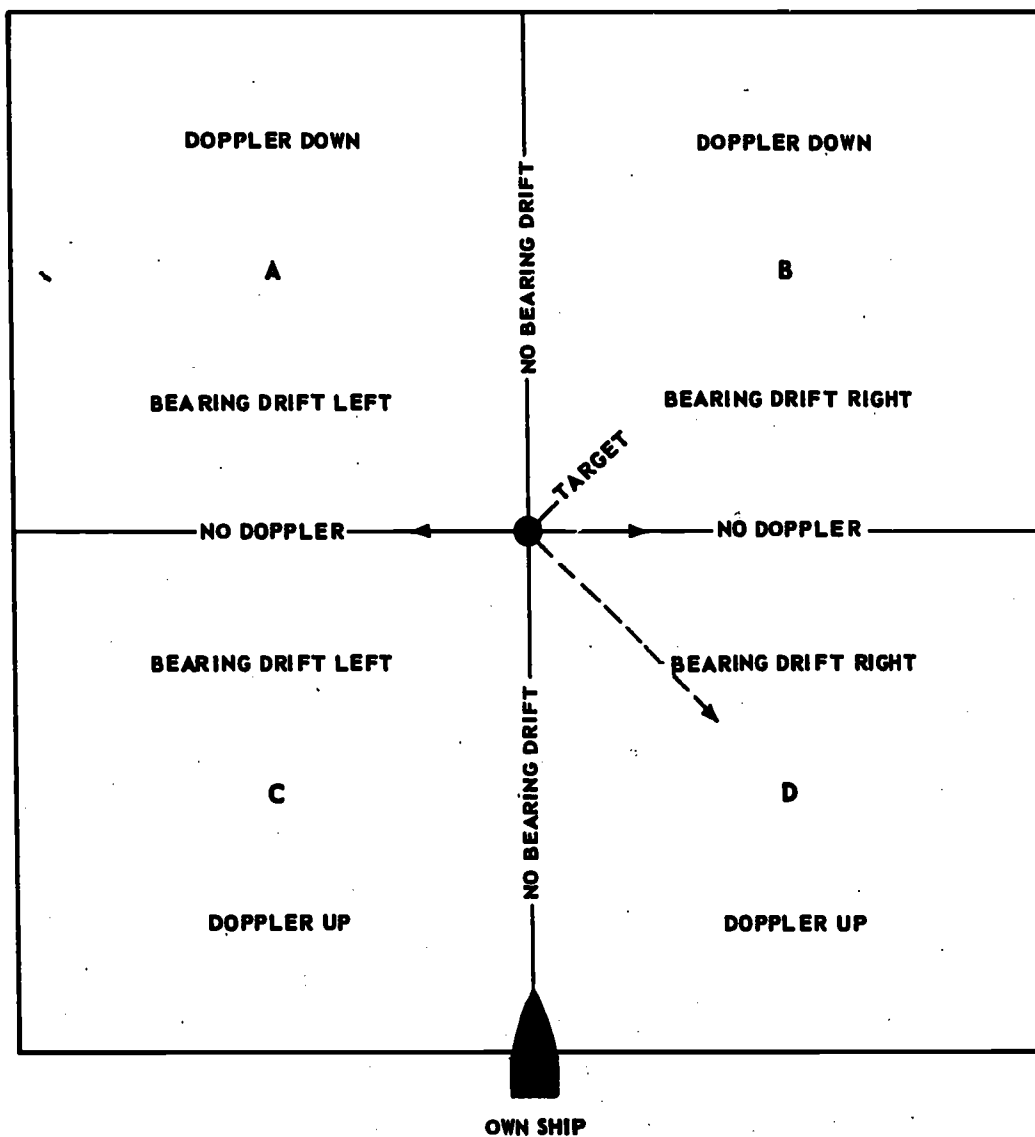

71.8

Figure 3-13. — Solving target aspect.

Imagine that you are on board a submarine looking at an approaching destroyer. The relative bearing of the destroyer is 090° , which indicates it is approaching on the submarine's starboard beam. As viewed from the destroyer, the submarine's target angle is 090° , because target angle is the relative bearing of the ship from the target, measured in the horizontal plane from the bow of the target clockwise from 000° to 360° . Like target aspect, target angle depends on the target's heading. When

the submarine changes course, target angle changes accordingly.

Figure 3-14 illustrates several target angles. Also shown are angles on the bow (discussed later) and related doppler. Notice that no matter in which direction the ship is heading, the course of the submarine governs target angle.

You may be curious why target aspect is so important when target angle provides more accurate information. Aspect is given as a general indication and can be reported after only four

INTRODUCTION TO SONAR

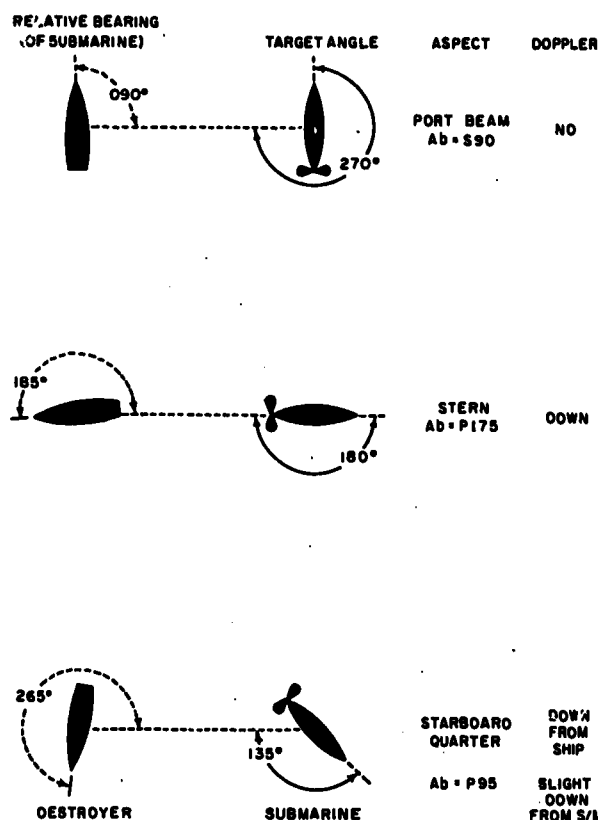

71.9

Figure 3-14. — Target angle.

or five transmissions, based on doppler and the first indication of bearing drift. Target angle, on the other hand, is derived from more precise data. It is necessary to know the submarine's course, which can be determined only by tracking the submarine for several minutes. In many attacks, it is difficult to report an accurate target angle because of radical maneuvers by the submarine or because of insufficient time to determine target angle. In such instances, target aspect information necessarily must suffice for the conning officer to estimate the target angle and adjust the attack lead accordingly.

In antisubmarine warfare, there is little time between detection and attack. Target aspect thus affords a means of reporting reliable information quickly.

Aboard a submarine, target angle is derived by a method known as angle on the bow (Ab). Whereas the ship uses 360° for computing target

angle, the submarine uses only 180°, specifying port or starboard side. To illustrate, a destroyer has a submarine bearing 070°R. Aboard the submarine the target angle would be reported as "Angle on the bow, starboard 70." A relative bearing of 345° from ship to target is reported on the submarine as "Angle on the bow, port 15." Figure 3-14 illustrates some angles on the bow.

Target angle is not all guesswork. It can be computed accurately by using the formula: target angle equals true bearing plus 180° minus target course. Expressed in fire control symbols, the formula reads: $Bts = By + 180 - C$, where—

Bts = target angle.
 By = true bearing.
 C = target course.

Assume that you are on a ship and tracking a submarine bearing 270°, course 135°. Find the target angle by applying the preceding formula. Thus:

$Bts = 270° + 180° - 135°$
 $Bts = 450° - 135°$
 $Bts = 315°$

An example of computing this target angle is seen in figure 3-15. In effect, the +180° in the formula allows the viewer to change places so that he may see his own relative bearing from the target. Compare the relative bearing of the destroyer from the submarine with the value computed for target angle.

If the product of $By + 180°$ is less than target course, 360° must be added to the equation before subtracting target course. Example: A target is on course 270°, bearing 010°.

$Bts = 010° + 180°$
 $Bts = 190° + 360°$
 $Bts = 550° - 270°$
 $Bts = 280°$

Angle on the bow (Ab) may be computed in the same manner as target angle, with one exception. Because the answer is in degrees of relative bearing, it must be converted to degrees port or starboard. Referring again to figure 3-15, you see that the destroyer bears 090°T and is on course 240°.

$Ab = 090° + 180° - 240°$
 $Ab = 270° - 240°$
 $Ab = 030°$ or starboard 30.

If the answer is greater than 180°, subtract the answer from 360° to obtain angle on the bow to port.

Chapter 3—BEARINGS AND MOTION

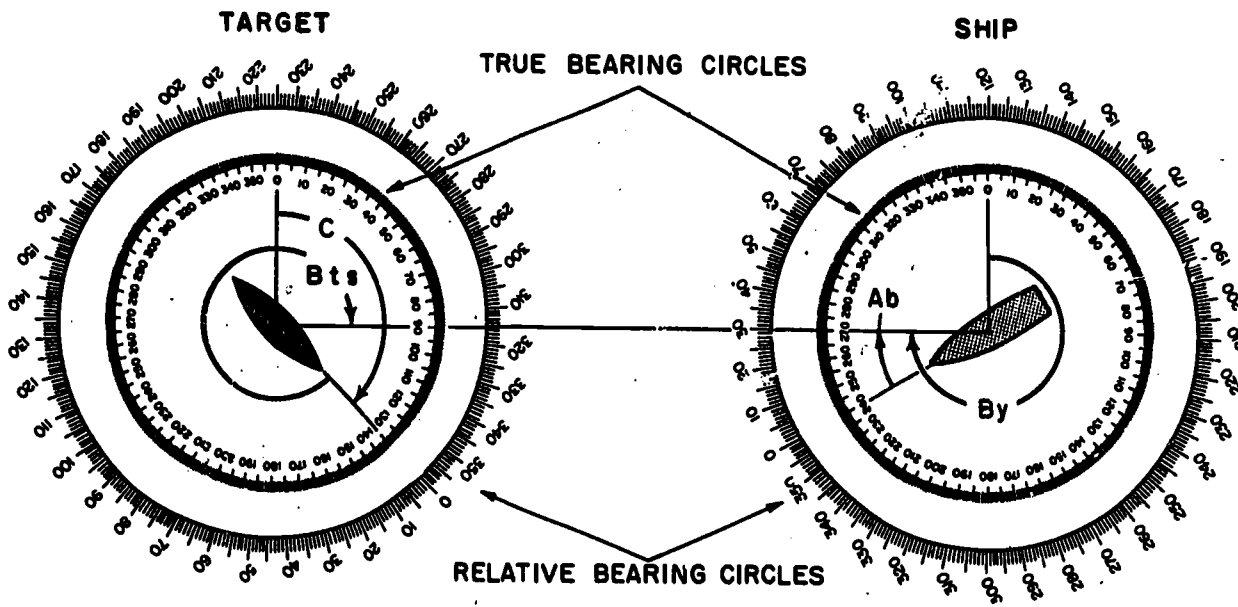

45.29(71)H

Figure 3-15.—Computing target angle.

Target course can be determined by the formula $C = By \pm (180 - Ab)$. If Ab is to port, the resultant of the figures in parentheses is

subtracted from By . Conversely, if Ab is to starboard, the solution within parentheses is added to true bearing.

CHAPTER 4

PHYSICS OF SOUND

Sonar is an electronic device that utilizes sound energy as a means of locating submerged objects, such as submarines. The equipment may be either active or passive. Sonar of an active nature transmits the sound energy into the water and must depend on the returning echoes bouncing off the target to provide bearing and range information. Passive sonar depends for bearing information on sounds originated by the target (such as screw cavitation, machinery noises, and so forth).

This chapter, then, deals with sound and its behavior in sea water.

WHAT SOUND IS

Sound is the physical cause of your sensation of hearing. Anything that you hear is a sound.

Sound travels in the form of waves, which vary in length according to their frequency. A sound having a long wavelength is heard at a low pitch; one with a short wavelength is heard at a high pitch. A complete wavelength is called a cycle, and the number of cycles per second is the sound's frequency. Frequencies are now measured in the Hertz system, 1 hertz (Hz) being equal to 1 cycle per second. Frequencies of 1000 cps or more are measured in kilohertz (kHz). Normally, sounds below 20 Hz or above 15 kHz are beyond the human hearing range. Between these two frequencies is the average human audible range. More information on the characteristics of sound is given in the next section of this chapter.

REQUIREMENTS FOR SOUND

Before sound can be produced, three basic elements must be present. (See fig. 4-1.) These elements are a source of sound, a medium to transmit the sound, and a detector to hear it. If there is no source to generate a noise, then there can be no sound. The same theory holds true for the other required elements.

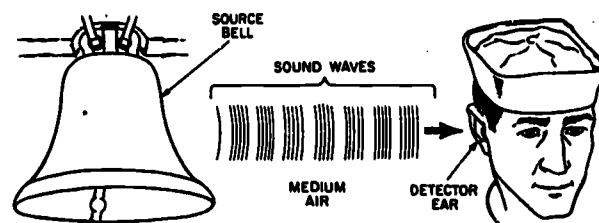

71.18
Figure 4-1.—The three elements of sound.

You may recall the experiment in which a bell was placed inside a jar containing a vacuum. You could see the bell ringing, but you could hear nothing because there was no medium to transmit sound from the bell to you. What about the third element, the detector? You may see a source (such as an explosion) apparently producing a sound, and you know the medium (air) is present, but you are too far away to hear the noise. So far as you are concerned, there was no detector and, therefore, no sound. For purposes of this text, we must assume that sound can exist only when an auditory vibration is caused by a source, is transmitted through a medium, and is heard by a detector. Figure 4-1 illustrates this assumption. The bell vibrates on being struck, thus acting as a sound source. The vibrating bell moves the particles of air—the medium—in contact with it. And the sound waves travel to the ear, which acts as the detector.

Source

Any object that moves rapidly to and fro, or vibrates and thus disturbs the medium around it, may become a sound source. Bells, radio loudspeaker diaphragms, and stringed instruments are familiar sound sources.

Medium

Sound waves are passed along by particles of the material through which they travel. The elasticity of the medium determines the ease, distance, and speed of sound transmission. The greater the elasticity, the greater the speed of sound. The speed of sound in water is about four times that in air, for example; in steel, it is about 15 times greater than in air.

Detector

The detector acts as the receiver of the sound wave. Because it doesn't surround the source of the sound wave, the detector absorbs only part of the wave's energy, thereby usually requiring an amplifier to boost the signal's energy to permit reception of weak signals.

THE EAR AS A SOUND DETECTOR

The limits of human hearing are determined by two interacting physical variables, frequency and intensity, and several other conditions that are dependent on the individual variables (including age, state of health, attention, and prior exposure). The limits of hearing, however, are normally between 20 and 20,000 hertz for young, healthy persons, provided the upper and lower frequencies are sufficiently intense. For healthy, middle-aged persons, however, the upper limit may lie between 12 and 16 kHz, the low-frequency threshold remaining about 20 Hz. For purposes of this text, sounds capable of being heard are called sonics. Sounds below 20 Hz are called subsonics, and those above 15 kHz are known as ultrasonics or supersonics. The term "ultrasonic" merely refers to acoustic phenomena above the level of human hearing. A 15-kHz vibration might be "ultrasonic" for the average 60-year old person.

Early active sonar equipments transmitted ultrasonic sounds through the water. Along with other sounds, they received echoes of these ultrasonic sounds and converted them into audible ones. Modern active sonars transmit sounds within the audible range. Because these transmissions are very high tones, however, the equipment converts them into lower ones better suited for listening.

The human ear is a good sound detector. It can detect a wide range of frequencies, but does not respond equally well to all of them. Figure 4-2 illustrates the variation in the amount of power that is barely audible to the average

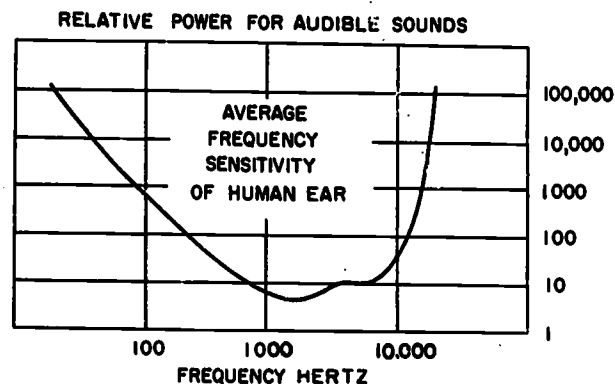

71.46
Figure 4-2.— Frequency sensitivity of the human ear.

ear at different frequencies. It is evident from this chart that the ear is most sensitive to frequencies in the range from about 1000 Hz to 2000 Hz. The average person finds an 800-Hz note a rather pleasant one to listen to for long periods of time. In underwater echo ranging equipment, the echo frequency commonly is converted to an 800-Hz note.

Never turn up the volume on sonar equipment so that echo sounds are louder than necessary. One reason is that the ear is not a sensitive detector of relative changes in sound intensity. An increase or decrease of about one-fourth of the total power must take place before the ear notices any difference.

An intensely loud sound slightly paralyzes the ear, reducing its ability to hear low-intensity sounds that follow immediately. This effect is similar to one you probably have experienced with light. If you look into a very strong light, your eyes are blinded momentarily.

The ear is a sensitive detector of change in pitch. An average person can tell when sounds differ a few cycles in pitch, even though they cannot detect the change in intensity. This faculty is known as pitch discrimination. It is a great help in selecting from a background of reverberations a submarine echo of slightly different pitch, that is, one with doppler.

Here's a summary of your ear's characteristics:

1. Your ear does not readily detect small relative changes in sound intensity. It is not sensitive to high and low audible frequencies.

INTRODUCTION TO SONAR

2. Your ear is sensitive to the 800-Hz note for which sonar equipment is designed. Your ear temporarily is paralyzed by very loud signals so that you may not hear the weaker signals that follow.

3. Your ear has the property of pitch discrimination. This characteristic will aid you in selecting an echo from the background of noise and reverberation.

Heavy gunfire may cause permanent deafness or other injury to your ears. Use ear protectors or cotton when near gunfire, and take every possible precaution to protect your hearing. As a Sonar Technician, you are essential to the successful fighting of your ship. Your ability to operate the sonar depends on the effectiveness of your hearing.

WAVES IN GENERAL

Waves may be classified by types as transverse and longitudinal. A transverse wave is one wherein the particles of the medium through which the wave is passing move at right angles vertically to the wave's direction. In a longitudinal wave the particles move back and forth along the wave's direction of travel, resulting in compression and rarefaction of the wave. An example of a transverse wave is a water wave.

Throw a stone into a pool. A series of circular waves travels away from the disturbance. In figure 4-3 such waves are diagramed as though seen in cross section. Observe that the waves are a succession of crests and troughs. The wavelength (1 cycle) is the distance from the crest of one wave to the crest of the next wave.

The amplitude of a transverse wave is half the distance, measured vertically from crest to trough, and serves to indicate the intensity of the wave motion.

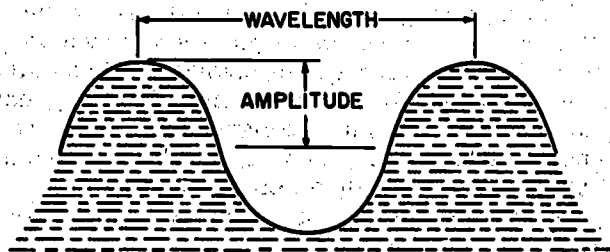

71.19

Figure 4-3.—Elements of a wave.

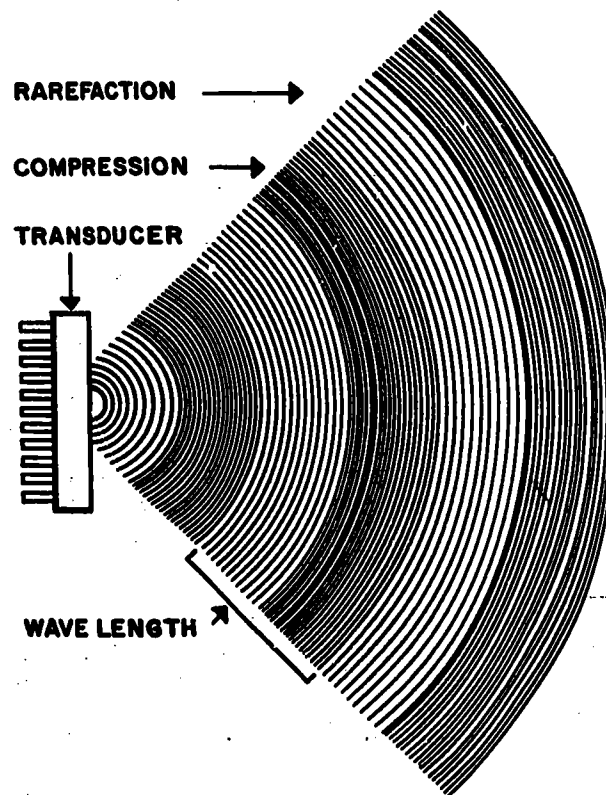

4.221

Figure 4-4.—Longitudinal waves.

SOUND WAVES

Sound waves are longitudinal or compression waves, set up by some vibrating object such as a sonar transducer. In its forward movement, the vibrating transducer pushes the water particles lying against it, producing an area of high pressure, or compression.

On the backward movement of the transducer, the water particles return to the area from which they were displaced during compression and travel beyond, producing an area of low pressure, or a rarefaction. The compression moves outward by pushing the water particles immediately in front of the compressed particles. The rarefaction follows the compression, transferring the pull produced by the backward movement to the particles immediately ahead. The next forward movement of the transducer produces another compression and so on. In figure 4-4 the compressions are represented

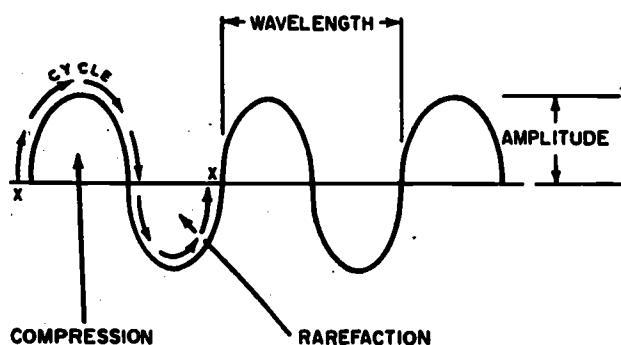

71.21

Figure 4-5.— The sound wave.

by dark rings. As the sound waves spread out, their energy simultaneously spreads through an increasingly large area. Thus the wave energy becomes weaker as distance increases.

Another way of representing the actions of a sound wave is illustrated in figure 4-5. Compressions are shown as hills above the reference line, and rarefactions as valleys below it. The wavelength is the distance from one point on a wave to the next point of similar compression. The change occurring in compression and rarefaction in the space of 1 wavelength is called a cycle.

Frequency

The frequency of a sound wave is the number of vibrations per second produced by the sound source. A sonar transducer, for example, may transmit on a frequency of 5 kHz, or 5000 vibrations per second. Motion is imparted to the sound wave by the back-and-forth movement of the particles of the medium, in effect passing the wave along, although the particles themselves have very little actual movement. The wave, however, may travel great distances at a high rate of speed.

Density

Perhaps you've heard people speak of a heavy fog as being "thick as pea soup." This murky condition would be a dense fog caused by the atmosphere being filled with small particles of water called vapor condensation. A fog-filled atmosphere is heavier (because of the weight of the water particles in it) than a clear atmosphere. The measure for this "thickness" of a

substance is called density, and is defined as "weight per unit volume." In the study of general physics, density of any substance is a comparison of its weight to the weight of an equal volume of pure water. Because of the salt content (salinity) of sea water, it has a density greater than that of fresh water.

Density is also an indication of the sound transmission characteristics of a substance, or medium. When a sound wave passes through a medium, it is transmitted from particle to particle. If the particles are loosely packed (as they are in fresh water as compared with sea water), they have a greater distance to move to transmit the sound energy. In so doing time is consumed, and the overall result is a slower speed of sound in a less dense medium.

Density and elasticity are the basic factors that determine sound velocity. The formula for determining velocity is:

$$c = \sqrt{\frac{E}{p}}$$

where c equals velocity, E equals the medium's elasticity, and p equals the medium's density. Variations in the basic velocity of sound in the sea are caused by changes in water temperature, pressure, and density, as will be seen in the section on sound propagation. In fresh water of 65°F, sound velocity is approximately 4790 feet per second (fps). In sea water, velocity depends on pressure and temperature in addition to salinity. For all practical purposes, you can assume that sound travels at a speed of 4800 fps in sea water of 39°F.

Wavelength

If a sonar transducer vibrates at the rate of 25,000 vibrations per second, and if the temperature is 39°F, the first wave will be 4800 feet away at the end of the first second. Between the transducer and the front of this wave there will be 25,000 compressions. Thus, the wavelength, that is, the distance between points of similar compression, must be $4800 \div 25,000$ or 0.192 foot, because there are 25,000 compressions extending through a distance of 4800 feet. The wavelength always can be found if the frequency and the velocity are known. Formula:

$$\text{Wavelength} = \frac{\text{Velocity}}{\text{Frequency}}$$

INTRODUCTION TO SONAR

Suppose the wavelength is 0.4 foot and the frequency is 12 kHz. What is the velocity?

$$0.4 = \frac{\text{Velocity}}{12,000}$$

Expressed another way, velocity = $0.4 \times 12,000 = 4800$ fps. If the wave length and the velocity are known, the frequency can be found in a similar manner.

$$0.4 = \frac{4800}{\text{Frequency}}$$

Or, frequency = $4800 \div 0.4 = 12$ kHz.

CHARACTERISTICS OF SOUND

Sound has three basic characteristics: pitch, intensity, and quality. Together they make up the tone of a sound. With the proper combination of characteristics, the tone is pleasant. With the wrong combination the sound quality degenerates into noise.

PITCH

An object that vibrates many times per second produces a sound with a high pitch, as in the instance of a whistle. The slower vibrations of the heavier wires within a piano cause a low-pitched sound. Thus, the frequency of vibration determines pitch. When the frequency is low, sound waves are long; when it is high, the waves are short.

INTENSITY

Intensity and loudness often are mistaken as having the same meaning. Although they are related, they actually are not the same. Intensity is a measure of a sound's energy. Loudness is the effect of intensity on an individual, in the same manner that pitch is the effect of frequency. Increasing the intensity causes an increase in loudness, but not in a direct proportion. To double the loudness of a sound requires about a tenfold increase in the sound's intensity.

QUALITY

The quality of a sound depends on the complexity of its sound waves. Most sounds consist of a fundamental frequency (called the first harmonic), plus several other frequencies that are exact multiples of the fundamental. The fundamental is the lowest frequency component of the sound wave. By combining different fundamentals in suitable proportions, a tone can be built up to a desired quality. Musical tones are produced by regular vibrations of the source; when the source vibrates irregularly, the sound is called noise. By sounding together the proper organ pipes, any vowel sound can be imitated. On the other hand, drawing a fingernail across a blackboard creates a noise of a different sort.

DECIBELS

Throughout your Navy career as a Sonar Technician, you will be using decibels as an indicator of equipment performance. Power output and reception sensitivity of a sonar equipment are measured in decibels, which are used to express large power ratios.

In the decibel system, the reference level is zero decibel (0 db), which is the threshold of hearing. The pressure level, or signal strength, of underwater sounds is compared to the 0 db level, and is given either a positive or a negative value. Sonar receivers are capable of detecting sounds having a signal strength below the 0 db level. In such instances, the signal is given a minus db value.

The reason for using the decibel system when expressing signal strength may be seen in table 4-1. It is much easier to say that a source level has increased 50 db, for example, than it is to say the power output has increased 100,000 times. The amount of power increase or decrease from a reference level is the determining factor—not the reference level itself. Whether power output is increased from 1 watt to 100 watts, or from 1000 watts to 100,000 watts, it still is a 20-db increase. (See table 4-1).

Examine table 4-1 again, and take particular note of the power ratios for source levels of 3 db and 6 db (also 7 and 10 db). It can be seen that to increase a sonar's source level by 3 db, it is necessary to double the output power. As a typical example, if the sonar source level drops from 140 db to 137 db, the sonar has lost half its power. Any 3-db loss, no matter what the source level, means loss of half the former power.

Table 4-1.—Decibel Power Ratio Equivalents

Source Level (db)		Power Ratio
1	=	1.3
3	=	2.0
5	=	3.2
6	=	4.0
7	=	5.0
10	=	10
20	=	100
30	=	1000
40	=	10,000
50	=	100,000
60	=	1,000,000 = 10^6
70	=	10,000,000 = 10^7
100	=	10^{10}
110	=	10^{11}
140	=	10^{14}

Now let's see what is required to increase a sonar's range. To double the range of a sonar requires a source level increase of approximately 27 db. This power increase is equivalent to about 500 times, which obviously is impractical. By another method, such as increasing receiver sensitivity, the range can be increased fairly easily, although it may not be doubled.

So far we have discussed the decibel mainly in relation to power output, but the decibel also is used to determine receiver sensitivity. Receiver sensitivity is measured in minus numbers, which represent the number of decibels below a reference level that a signal can be detected by the receiver. The larger the negative number, the better the sensitivity. Although the range would not be doubled, it is more practical, for instance, to increase a receiver's sensitivity from 112 db to 115 db than it is to double the output power of the sonar transmitter. Also, it is not always necessary to increase the sensitivity of the receiver itself. An effective increase of several decibels may be achieved if local noise levels can be reduced in such sources as machinery, flow noise, crew noise, etc.

NOISE

The most complex sound wave is one in which the sound consists of numerous frequencies

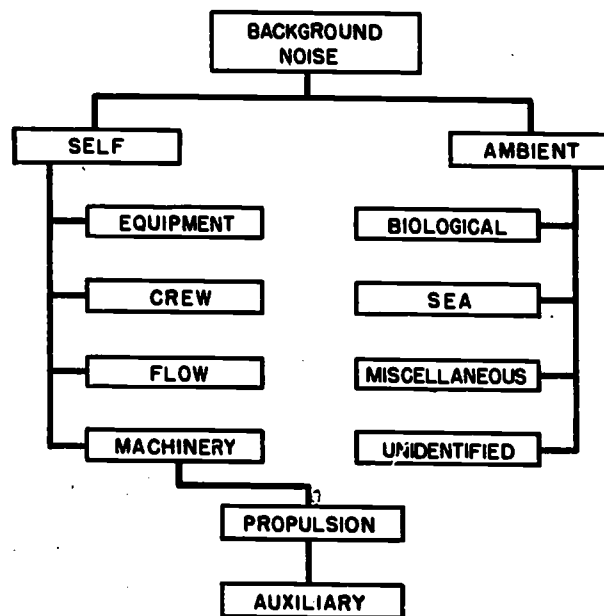

71.116

Figure 4-6.— Noise sources.

across a wide band. Such a form of sound is called noise because it has no tonal quality. The source of several types of noises may be identified easily, however, because of the standard sound patterns of the noises. Ship noise, for instance, consists of many different sounds mixed together. You may be unable to distinguish a particular sound, but, on the whole you could recognize the sound source as a ship. Some noise sources are shown in figure 4-6. The sources of many noises detected by sonar have not yet been identified. Explanations of some kinds of noises that have an adverse effect on a sonar operator follow.

Ambient Noise

Ambient noise is background noise in the sea that is due to natural causes. Different phenomena contribute to the ambient background noise. Many of the sources are known and their effects are predictable, but many still are unknown. From this unwanted background noise, the sonar operator must be able to separate weak or intermittent target noises. In general, the average operator requires a target signal strength of 4 db above background noise.

INTRODUCTION TO SONAR

● **Thermal noise:** The absolute minimum noise in the ocean is called thermal noise. As the name implies, it is a function of temperature. This noise is created by the motion of the molecules of the liquid itself and is difficult to measure.

● **Residual minimum:** The lowest noise level that normally is measurable is called residual minimum. Different unknown phenomena undoubtedly contribute to the minimum observable value. The point of interest, however, is that you are never likely to encounter ambient noise levels below the residual minimum.

● **Surface agitation:** For a sizable region above the residual minimum noise, the ambient noise levels appear to be related to the surface agitation. Usually, agitation of the surface of the sea is measured as sea state. Surface windspeed, however, ordinarily is a more reliable measure of expected ambient noise than sea state. As the wind rises, the surface becomes more and more agitated, causing the ambient noise level to rise. Normally noise levels in this region are associated with what is called sea noise to distinguish them from other noises, which really are not caused by the sea itself. A heavy rain, for instance, will add greatly to the ambient noise.

Flow Noise

As an object moves through water, there is a relative flow between the object and the medium. This flow is easiest to understand by assuming that the object is stationary and that the water is moving past the object. If the object is reasonably streamlined and its surface is smooth, and if it is moving very slowly, a flow pattern known as laminar flow is set up. Such a pattern is shown in view A in figure 4-7, where the lines represent the paths followed by the water as it flows around the object. If the flow is laminar, all lines are smooth. Although laminar flow produces little, if any noise, it occurs only at very low speeds—perhaps less than 1 or 2 knots.

If the speed of the water is increased, whorls and eddies begin to appear in the flow pattern, as seen in part B in figure 4-7, and the phenomenon is called turbulent flow. Within these eddies occur points where the pressure is widely different from the static pressure in the medium. Thus we have, in effect, a noise field. If a hydrophone is placed in such a region, violent

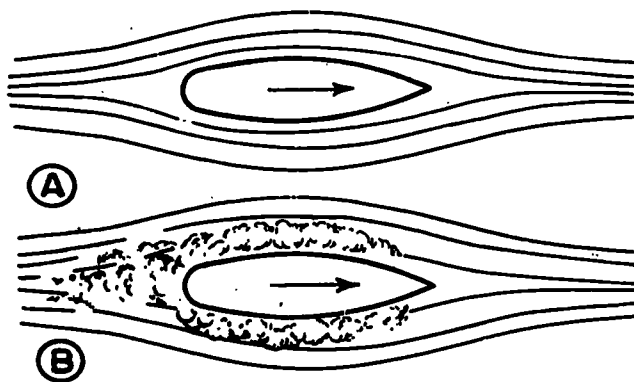

71.22

Figure 4-7.—Patterns of flow noise.
A—Laminar flow; B—Turbulent flow.

fluctuations of pressure will occur on its face, and what is called flow noise will be observed in the system.

As pressures fluctuate violently at any one point within the eddy, they also fluctuate violently from point to point inside the eddy. Moreover, at any given instant, the average pressure of the eddy as a whole differs but slightly from the static pressure. Thus, very little noise is radiated outside the area of turbulence. Hence, although a ship-mounted hydrophone may be in an intense flow noise field, another hydrophone at some distance from the ship may be unable to detect the noise at all. Flow noise, then, is almost exclusively a self-noise problem.

Actually, not much information is known about flow noise, but these general statements may be made about its effect on a shipborne hydrophone: (1) It is a function of speed with a sharp threshold. At very low speeds there is no observable flow noise. A slight increase in speed changes the flow pattern from laminar to turbulent, and strong flow noise is observed immediately. Further increases in speed step up the intensity of the noise. (2) It is essentially a low-frequency noise. (3) It has very high levels within the area of turbulence, but low levels in the radiated field. In general, the noise field is strongest at the surface of the moving body, decreasing rapidly as you move away from the surface.

As the speed of the ship or object is increased still further, the local pressure drops low enough at some points to allow the formation of gas bubbles. This decrease in pressure

Chapter 4—PHYSICS OF SOUND

represents the onset of cavitation. The noise associated with this phenomenon differs from flow noise.

Cavitation

Cavitation is produced whenever a solid object moves through the water at a speed great enough to create air bubbles. After a short life, most of the bubbles collapse. The sudden collapse of the bubbles causes the acoustic signal known as cavitation noise. Each bubble, as it collapses, produces a sharp noise signal.

Because the onset of cavitation is related to the speed of the object, it is logical that cavitation first appears at the tips of the propeller blades, inasmuch as the speed of the blade tips is considerably greater than the propeller hub. This phenomenon, known as blade tip cavitation is illustrated in figure 4-8.

As the propeller speed increases, a greater portion of the propeller's surface is moving fast enough to cause cavitation, and the cavitating area begins to move down the trailing edge of the blade. As the speed increases further, the entire back face of the blade commences cavitating, producing what is known as sheet cavitation. This form of cavitation is shown in figure 4-9. Cavitation noise is referred to as hydrophone effects.

The amplitude and frequency of cavitation noise are affected considerably by changing speeds. Cavitation noise versus speed at a constant depth is diagramed in figure 4-10. The curves shown are idealized; they do not

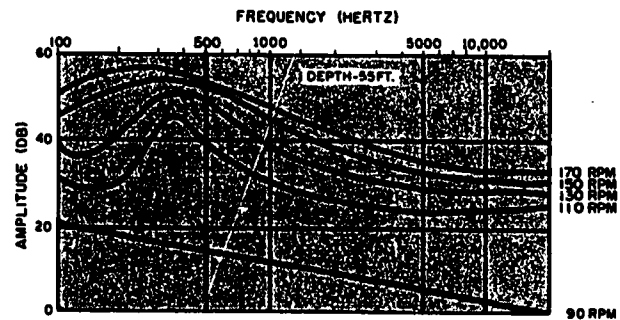

71.24
Figure 4-9.—Sheet cavitation.

represent any particular submarine. Note the great difference in noise level caused by the addition of only 20 turns, from 90 rpm to 110 rpm. At 90 rpm there is no cavitation; the noise level is due to flow noise and background noise. At 110 rpm cavitation has started, and the noise level has gone up many decibels, with a peak amplitude at about 400 Hz. As speed is increased further, the amplitude peak tends to move toward the lower frequencies. The amplitude increases at a lesser rate, but covers a broader frequency band. The curves are also characteristic of a submarine on the surface and of surface warships, although the amplitude levels may be different.

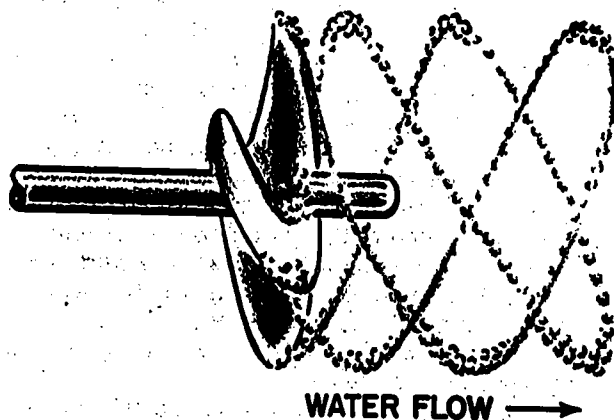

71.23
Figure 4-8.—Blade tip cavitation.

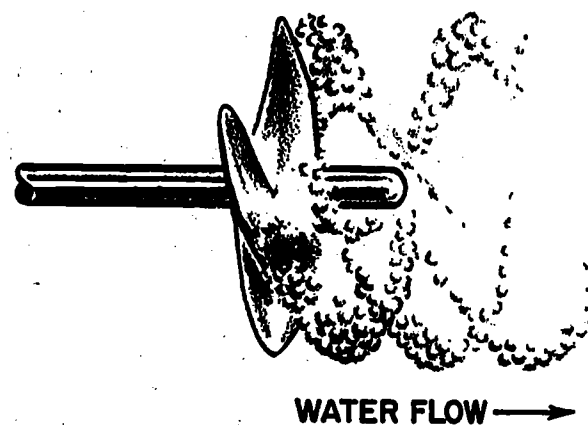

35.50
Figure 4-10.—Speed effect on cavitation noise.

INTRODUCTION TO SONAR

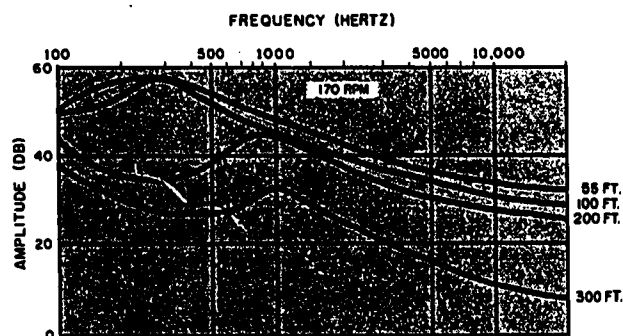

35.51

Figure 4-11.—Depth effect on cavitation noise.

Cavitation noise versus depth at a constant speed (170 rpm) is shown in figure 4-11. The upper curve is the same as the upper curve in figure 4-10. As the submarine goes deeper, the cavitation noise decreases and moves to the higher frequency end of the spectrum in much the same manner as though speed had been decreased. This decrease in noise is caused by the increased pressure with depth, which tends to compress cavitation noise. The curves are not exactly the same as those shown in figure 4-10, but the similarity is readily apparent.

Machinery Noise

Machinery noise is produced aboard ship by the main propulsion machinery and by any or all of a large number of auxiliary machines that may or may not be connected with the main propulsion system. Machinery noise usually is produced by rotating or reciprocating machines. Most noise of this type is generated by dynamic imbalance of the rotating portion of the machinery that causes a vibration within the machine. Such a vibration may then be transmitted through the machine mounts to the hull, from where it is radiated into the water as acoustic energy.

Shipboard Noise

In addition to the machinery discussed so far, there are many other shipboard noise sources over which you probably will not have any control. Some of the noise sources are fire and flushing pumps, air compressors, refrigeration machinery, air conditioning systems, diesel

generators, gasoline pumps, blower motors, and portable power tools. Any (or all) of the aforementioned equipment may be operating at any one time, adding greatly to the noise radiated by the ship, and therefore entering the sonar receiver. If the combination of these noises becomes too great for effective sonar search, ask your watch supervisor to request the OOD to secure all nonessential equipment. Another noise source is circuit noise, generated within the sonar equipment itself. This noise may be in the form of a 60-hertz hum, staticlike noises from electric cables due to improper cable shielding, or leakage currents from other sources entering the receiver stages. Unlike ambient noise, however, this type of generated noise may be controlled.

Marine Life

A sonar operator may hear many strange sounds during his time on watch. He may have to listen to (and try to identify) the source of whistles, shrieks, buzzes, pings, knocks, cracklings, and other weird noises not ordinarily associated with the sea. Most of these noises probably come from different species of fish, but only a few have been identified positively. Following are descriptions of a few marine life noises.

Porpoises give out a whistling sound and sometimes a sound like a chuckle. (Submarine hydroplanes and rudders sometimes also give off a whistling sound.) These mammals are found in all ocean areas of the world.

Snapping shrimp are common around the world between latitudes 45°N and 45°S, usually in waters less than 30 fathoms deep. As you approach a bed of snapping shrimp, you hear a buzzing sound. As you go closer, the sound resembles fat sizzling on a fire, then becomes similar to that given off by burning brush.

Whales, which are found in all oceans, give off a variety of sounds, including knocks, groans, pings, and one resembling a swinging rusty gate. The knocking sound of the sperm whale resembles the noise of hammering. Sperm whales and other large species seldom are heard in waters shallower than 100 fathoms. Blackfish, which are similar to whales, emit a whistling sound like a porpoise, but clearer in tone.

The preceding examples of marine life noises are just a few that you will encounter. Do not let the strange sounds mislead or distract you. A valid target may be just beyond the whale you are listening to. Available tapes and films

Chapter 4—PHYSICS OF SOUND

describe many biologic noises. All Sonar Technicians should review these tapes and films periodically to maintain proficiency in their recognition of sounds.

UNDERWATER SOUND TRANSMISSION LOSSES

Now that you know something of the theory of sound, you are ready to take a closer look at what happens to an underwater sound pulse.

To gain the full benefit of echo ranging sonar equipment, you must be able to transmit an underwater sound pulse and recognize the returning echo from a target. Detection of the echo depends on its quality and relative strength, compared with the strength and character of other sounds that tend to mask it.

Sonar Technicians must know (1) what can weaken sound as it travels through water, (2) what conditions in the sea determine the path and speed of sound, and (3) what objects affect the strength and character of the echo.

When a sound wave travels through water, it encounters elements that reduce its strength. Any signal strength lost in this manner is known as a transmission loss.

TRANSMISSION LOSSES

As a sound pulse travels outward from its source, it becomes more and more weakened. Much of its energy is lost because of sea conditions and distance. Three factors directly related to sound transmission losses are divergence, absorption, and scattering. The latter two are referred to as attenuation loss, and are dependent on transmission frequency. Divergence loss is independent of frequency.

Divergence

When a sound wave is projected from a point source, it assumes a spherical shape, spreading equally in all directions. This spreading is called divergence, and the further the wave travels, the more energy it loses. The energy lost by a sound wave due to spherical divergence is inversely proportional to the square of the distance from its source, or 6 db each time the range doubles.

In shallow water areas, the surface and bottom are boundaries that limit the vertical divergence of the sound wave. Consequently, the expanding wavefront is cylindrical, rather than spherical, in shape. Cylindrical spreading

loss is only half that of a sphere, or 3 db each time the distance is doubled. Spreading loss at close range is very high, but beyond about 2000 yards the loss becomes less significant.

Absorption

In the topic on sound waves, you learned how a sound pulse moves through water. The repeated compressions and rarefactions of the sound wave cause the water molecules to move back and forth, thus passing the sound wave along. An old saying goes: "You can't get something for nothing." In our illustrative case, energy is lost (in the form of heat) by the sound pulse in its efforts to compress the water. Energy lost to the medium in this manner is called absorption loss.

Scattering

Besides losses caused by divergence and absorption, a sound wave loses energy due to the composition of the medium through which it passes. Composition of the sea naturally varies from place to place, and from time to time. In general, however, sea water contains large amounts of minute particles of foreign matter and many kinds of marine life of all shapes and sizes. Each time the sound wave meets one of these particles, a small amount of the sound is reflected away from its direction of movement and is lost. The reflection losses to the water are known as scattering losses. Some of the scattered energy is reflected back to the sonar receiver and is then called volume reverberation (discussed later in this section).

REFLECTIONS

When a sound wave strikes the boundary between two mediums of different densities, the wave will be reflected, just as light is reflected by a mirror. Some of the energy will be lost, but most of it will be reflected at an angle equal to the angle of incidence. The angle of incidence is the angle, with respect to the perpendicular, at which the wave strikes the boundary. According to the physics law of regular reflection (reflection from a smooth surface) the angle of reflection equals the angle of incidence.

INTRODUCTION TO SONAR

Reflection takes place whenever the sound hits the boundary between sea and air (sea surface) and between sea and bottom, and when it hits a solid object, such as a submarine. The amount of energy reflected depends on the object's density, size, shape, and aspect. More energy is reflected by a submarine broadside to the sound beam than by one that is bow on.

Surface Effect

Because the density of water is several hundred times that of air, practically all of a sound wave is reflected downward when it strikes the surface boundary. This effect is true only when the surface is quite smooth, however. When the surface is rough, scattering takes place.

Bottom Effect

The bottom of the sea reflects sound waves, too. In deep water, this aspect need not be considered, but in waters of less than 100 fathoms, the sound may be unwantedly reflected from the bottom. Other considerations being equal, transmission loss is least over soft mud. Over rough and rocky bottoms, the sound is scattered, resulting in strong bottom reverberations.

REVERBERATIONS

You probably are acquainted with the effect in an empty room where your voice seems to echo all around you as you talk. After you stop talking, the sound continues to bounce around the room from wall to wall until it finally is absorbed by the walls and the air. The sound level in the room while you are talking is higher than normal because of the reverberation effects. The same effects can also be observed in the ocean. Reverberation in the ocean usually is divided into three categories. They are reverberations from the mass of water, from the surface, and from the bottom.

The following discussion on reverberations may seem like a repetition of the topic on reflections, but the two phenomena are not the same. Although reverberations are reflections, all reflections do not become reverberations. All the processes contributing to reverberation are random in nature, with the result that reverberation amplitudes vary over wide limits.

Moreover, reverberation level is proportional to source level and to pulse length. Another point to remember is that when you are in company with another ship, you may hear reverberation effects from her sonar in addition to your own.

From Mass of Water

Reverberation from the mass of water is called volume reverberation, which was mentioned in the discussion on scattering. Suppose a short pulse of sound is sent out from a stationary underwater source, which is immediately replaced by a listening hydrophone. As the pulse of sound travels through the water, it encounters various particles that reflect and scatter the sound. Because almost all of these particles are much smaller than a wavelength of the sound, they do not reflect the sound as a flat mirror reflects light. Instead, they absorb energy from the sound wave and reradiate this energy in all directions. Some reradiated energy from each particle returns to the hydrophone at the source location and is heard as a gradually fading tone at the same frequency as the source.

From the Surface

Some of the sound energy from the source strikes the surface, the point of impingement moving farther and farther from the source as the sound travels. If the surface were perfectly flat, this sound energy would be reflected as though from a mirror, and would bounce away from the source in accordance with the laws of reflection. But the surface is not perfectly smooth, and each wavelet tends to reflect the sound in all directions. Some reflected sound returns to the hydrophone, adding to the reverberation.

From the Bottom

In general, reverberation effects from both the mass of water and the surface are small compared to bottom reverberation. The bottom is usually much rougher than the surface. Thus, more of the sound is reflected in other directions than those expected of a reflecting mirror. If the water is fairly deep, no bottom reverberation occurs for quite some time after the pulse, because the sound must be given time to reach the bottom and be reflected. Normally, a sharp rise eventually occurs in the reverberation level after the source is cut off.

REFRACTION

If there were no temperature differences in the sea, the sound wave would travel approximately in a straight line, because the speed of sound would be roughly the same at all depths. As indicated in figure 4-12, the sound would spread and become weakened by attenuation at a relatively constant rate.

Unfortunately, however, the speed of sound is not the same at all depths. The velocity of sound in sea water increases from 4700 feet per second to 5300 feet per second as the temperature increases from 30° to 85°F. As will be seen later in the chapter, salinity and pressure also affect sound speed, but their effects usually are small in relation to the large effects commonly produced by temperature changes. Because of the varying temperature differences in the sea, the sound does not travel in a straight line. Instead, it follows curved paths, resulting in bending, splitting, and distortion of the sound beam.

When a beam of sound passes from one medium in which its speed is high (such as warm water) into one in which its speed is low (such as cool water), the beam is refracted (bent). A sound beam bends away from levels of high temperature and high sound velocity, and bends toward levels of low temperature and low sound velocity. Figure 4-13 illustrates the refraction of a sound beam. As a result of refraction, the range at which a submarine can

be detected by sound may be reduced to less than 1000 yards. This range may change sharply with changing submarine depth.

QUENCHING

In strong winds and heavy seas, the roll and pitch of the echo ranging ship make it difficult to keep the sound directed on the target. Additionally, the turbulence produces air bubbles in the water, weakening the sound waves. Occasionally this envelope of air bubbles blankets the sound emitted by the transducer. Sonar operators can tell, by a dull thudding sound, when the sound beam is being sent out into air. This action is known as quenching.

PROPAGATION OF SOUND
IN THE SEA

We have discussed the various basic phenomena that cause power loss in transmitting sound: divergence, attenuation (absorption, and scattering), reflections, reverberations, refraction (bending), and quenching. Now, we must consider the structure of the sea as an acoustic medium, and learn the effects of this structure on the transmission of sound.

Of the many conditions affecting sound wave travel through the water, the following factors influence its speed.

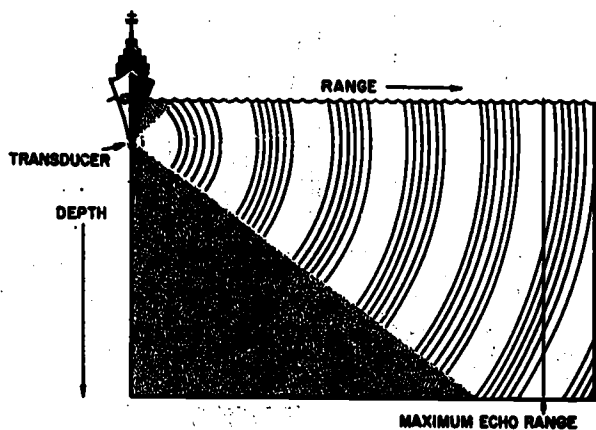

71.26
Figure 4-12.—Sound travel in water of constant temperature.

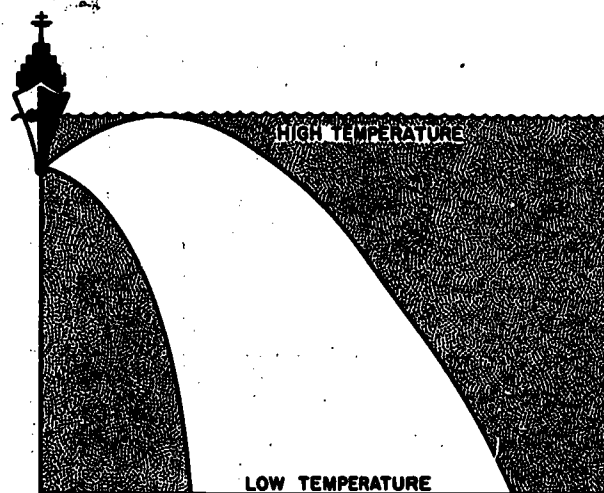

71.27
Figure 4-13.—A refracted sound beam.

INTRODUCTION TO SONAR

CONTROLLING FACTORS

The speed of sound wave travel through the water is controlled by three conditions of the sea. They are: temperature, which takes the form of slopes and gradients; pressure, caused by increased depth; and salinity, or the salt content of the water.

Temperature

With presently operational sonars, temperature is by far the most important of the factors affecting the speed of sound in water. Depending on the temperature, the speed of sound increases with increasing temperature at the rate of 4 to 8 feet per second per degree of change. Inasmuch as the temperature of the sea varies from freezing in the polar seas to more than 85°F in the tropics, and may decrease by more than 30°F from the surface to a depth of 450 feet, it is clear that temperature has a great effect on the speed of sound. Remember: The speed of sound increases when the temperature of water increases.

Pressure

Sound travels faster in water under pressure. Pressure increases as depth increases, so the deeper a sound wave travels, the faster it travels. Pressure effect on transmitted sound, although rather small in comparison to temperature effects, cannot be neglected. The speed of sound increases about 2 feet per second each 100 feet of depth.

Salinity

Sea water has a high mineral content. Salt content is spoken of as the salinity of the water. The weight of the higher density sea water is about 64 pounds per cubic foot; that of fresh water is about 62.4 pounds per cubic foot. This variation is the result of the salt content in the sea water.

The overall effect of increasing the salinity of water is to increase the speed of the sound, which means that when sound passes through water that varies in salinity, it travels faster in the saltier water. In the open ocean, the values of salinity normally lie between 30 and 35 parts per thousand. In the region of rivers

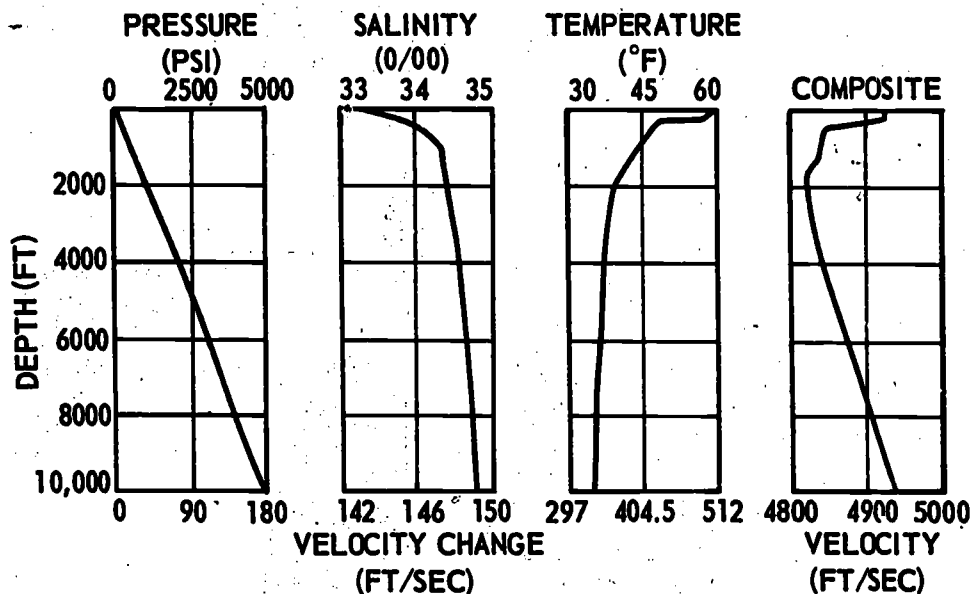

35.5(71)

Figure 4-14.—Normal curves for pressure, salinity, and temperature.

and other fresh water sources, the salinity values may fall to levels approaching zero. The speed of sound increases about 4 feet per second for each part per thousand increase in salinity. Salinity has a lesser effect on the speed of sound than does temperature, but its effect is greater than that of pressure.

Composite

Figure 4-14 shows reasonably normal curves for temperature, salinity, and pressure as a function of depth in the Pacific Ocean and also the resulting velocity structure. It should be noted that the salinity variation plays a minor part in the form of the depth-velocity curve. This effect is almost entirely evident in the first 500 feet below the surface. The temperature curve also shows wide variations in the top 500 feet. From 2000 feet, downward, the temperature is nearly uniform as the water approaches the maximum density point at about 40°F. The pressure effect is represented by a straight line as the velocity increases linearly with depth.

On the composite curve, it easily can be seen that the velocity in the top 2000 feet is a somewhat skewed replica of the temperature curve. Below 2000 feet it follows closely the straight line gradient of the pressure curve.

DEPTH AND TEMPERATURE

Except at the mouths of great rivers, where salinity may be a determinant, the path followed by sound is governed by the water temperature and the pressure effect of depth.

The pressure effect is always present and always acts in the same manner, tending to bend the sound upward. Figure 4-15 illustrates the situation when the temperature does not change with depth. Even though the temperature does not change, the speed of sound increases with depth, due entirely to the effect of pressure, and the sound bends upward.

Figure 4-16 shows what happens when temperature increases steadily with depth. When the surface of the sea is cooler than layers beneath it, the water has a positive thermal gradient. Although this condition is unusual, it does happen, and causes the sound to be refracted sharply upward. In certain areas of the Red Sea, between Africa and Arabia, temperatures of well over 100°F have been recorded in depths exceeding 1 mile. Moreover, the salinity of the water in those areas approaches 30 percent, compared to between 3 and 4 percent in most ocean areas.

When the sea grows cooler as the depth increases, the water is said to have a negative

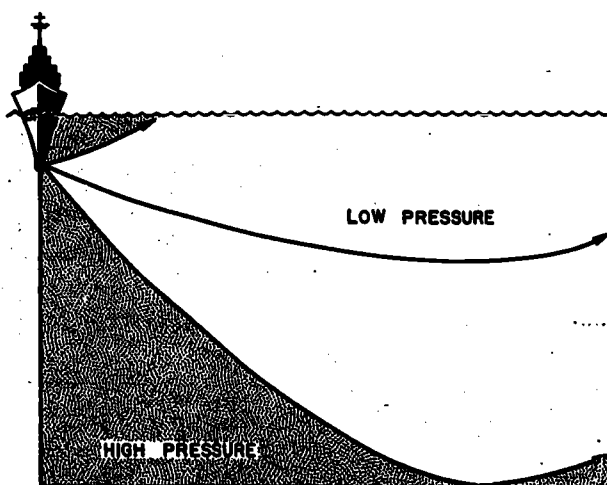

71.29
Figure 4-15.— Pressure tends to bend the sound beam upward.

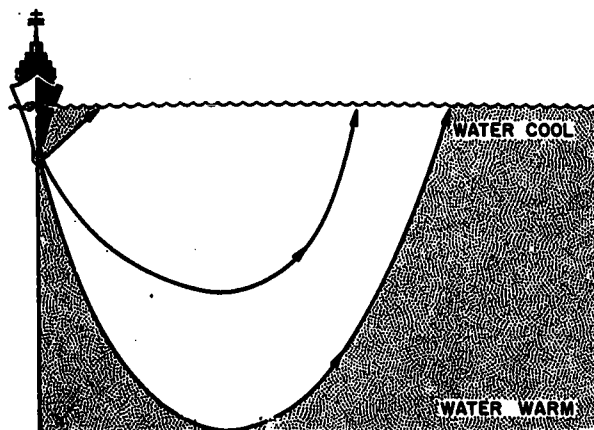

71.30
Figure 4-16.— Positive thermal gradient tends to bend the sound wave upward.

INTRODUCTION TO SONAR

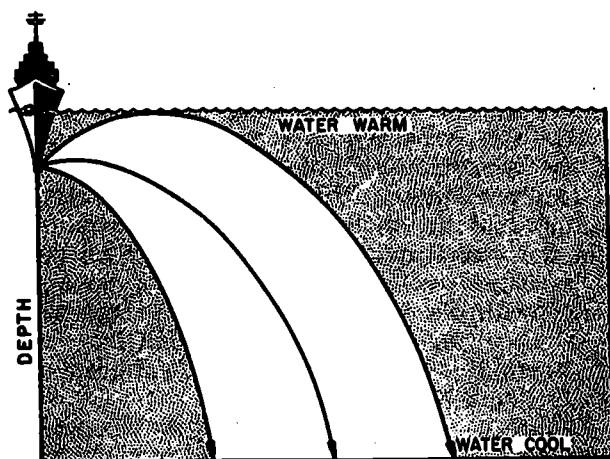

71.31
Figure 4-17.—Negative thermal gradient tends to bend sound downward.

thermal gradient. Here the effect of temperature greatly outweighs the effect of depth, and the sound is refracted downward. This common condition is illustrated in figure 4-17.

If the temperature is the same throughout the water, the temperature gradient is isothermal (uniform temperature). In figure 4-18 the upper

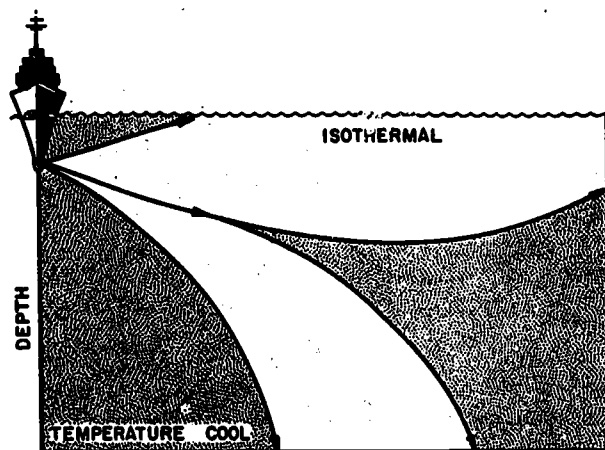

71.32
Figure 4-18.—Sound wave splits when temperature is uniform at surface and cool at bottom.

layer of water is isothermal; beneath this layer the temperature decreases with depth. This temperature change causes the transmitted sound to split and bend upward in the isothermal layer and downward below it.

Don't forget: When no temperature difference exists, the sound beam bends upward. When the temperature changes with depth, the sound beam bends away from the warmer water.

Under ordinary conditions the sea has a temperature structure similar to that in figure 4-19. This temperature structure consists of three parts: a surface layer of varying thickness, with uniform temperature (isothermal) or a relatively slight temperature gradient; the thermocline, a region of relatively rapid decrease in temperature; and the rest of the ocean, with slowly decreasing temperature down to the bottom. If this structure changes, the path of a beam of sound through the water also changes.

Layer Depth

Layer depth is the depth from the surface to the top of a sharp negative gradient. Under positive gradient conditions the layer depth is at the depth of maximum temperature. Above layer depth, the temperature may be uniform. If it is not uniform, a positive or weak negative gradient may be present.

SEA SURFACE	
TEMPERATURE UNIFORM OR CHANGING SLIGHTLY WITH DEPTH	SURFACE LAYER ISOTHERMAL OR "MIXED LAYER" WHEN TEMPERATURE UNIFORM
TEMPERATURE DECREASING RAPIDLY	THERMOCLINE
TEMPERATURE DECREASING SLOWLY	REGION BELOW THE THERMOCLINE
SEA BOTTOM	

71.33
Figure 4-19.—Typical layers of the sea.

Layer Effect

Layer effect is the partial protection from echo ranging and listening detection a submarine gains when it submerges below layer depth. Sometimes a submarine, diving through a sharp thermocline while taking evasive action, loses the screw noises of the enemy ASW ship. Although usually the pinging can still be heard, it is as a low intensity signal. On the ASW ship, ranges on submarines are reduced greatly when the submarine dives below a sharp thermocline. Often, the echoes received are weak and mushy.

Shallow Water Effect

Echo ranging is difficult in shallow water because the sound is reflected from the bottom. When the ship is in shallow water, and the ocean floor is smooth, the sound bends down from the surface to the bottom, then back up to the surface, and again down to the bottom. When the transmitted sound acts in this manner, there are spaces empty of sonar coverage into which a submarine can pass and be undetected. In figure 4-20 you will notice how a sonar contact on a submarine can be lost when the submarine enters the shaded area.

The shaded spaces in figure 4-20 are called shadow zones. Contact is regained when the submarine enters the wave path again. As shown in the illustration, contact is made at long range (point A), it is lost (point B), and regained at short range (point C). Note, however, that without the reflection, the maximum range would have been the short range at which the contact was regained (point C).

The reason for the loss of contact at short range is shown at point D, where the submarine passes beneath the sound. The distance at which contact is lost at short range depends on the depth of the submarine. Here is a rule of thumb for estimating a submarine's depth:

• The range in yards at loss of contact is roughly equal to the depth of the submarine in feet. A contact lost at 300 yards would thus be presumed to be about 300 feet deep.

Once the behavior of sound in sea water is known, it is possible to predict sound conditions in the sea. From the temperature gradient of the water, an experienced person can judge the maximum range to expect. A new Sonar Technician is not expected to know how to

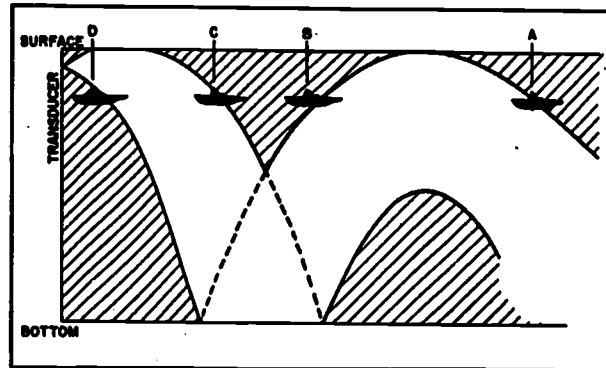

71.28
Figure 4-20.—Shallow water effect on transmitted sound.

predict sound conditions, but he should understand why results are poor one day and good another day. He should know what is meant by shadow zones, and the reasons why sound does not travel in a straight line. He also should be able to distinguish between poor equipment adjustment and poor sound conditions.

Following are some general conditions for hearing echoes.

1. Usually poor near coasts (50 miles) as compared to sea conditions farther out. Conditions for hearing are particularly poor at the mouths of rivers.
2. Better in winter than in summer.
3. Better at night than in the middle of the day, especially in spring and summer.
4. Better in morning than in afternoon, in spring and summer, but little change if whitecaps are present. In many localities, however, conditions are better in the afternoon than in the morning, because of the effect of prevailing winds that freshen in the afternoon.

DEEP WATER SOUND PROPAGATION

From the preceding discussions, it can be concluded that the behavior of the sound wave is influenced considerably by the structure of the sea. Most of our discussion so far has pointed out the adverse effects on a sound beam in comparatively shallow water—say 100 fathoms or less. Now, let's examine some of the phenomena that take place in very deep water.

INTRODUCTION TO SONAR

Direct Path

Theoretically, if the sound waves were not affected by velocity gradients, all the sound waves would be straight lines, and would travel in a direct path at whatever angle they left the source. In actual practice, however, the sound beam follows a path, or paths, as determined by the sea condition at the time.

Sound Channel

Figure 4-21 illustrates a combination of two gradients of equal slope, one negative and one positive. Their junction is a point of minimum velocity. If a sound source transmits at this depth of minimum velocity, all of the sound beams that start in an upward direction will be bent back down, and those that start downward will be bent back up. When such a condition occurs, we have what is called a sound channel. The depth of minimum velocity is called the axis of the channel. In this symmetrical situation, a beam that starts out downward will rise as high above the channel axis as it went below it, and then will be bent downward again. Sound will remain in the channel as far as the channel exists, and will suffer very little loss as it progresses through the channel.

Sound channels are a rarity in shallow water (under 100 fathoms), but are always present in the deep water areas of the world. The depth of the axis of the channel is about 350 fathoms in the central Pacific and somewhat over 500 fathoms in the Atlantic. In the polar regions, where the surface water is materially colder, the axis of the channel lies nearer the surface.

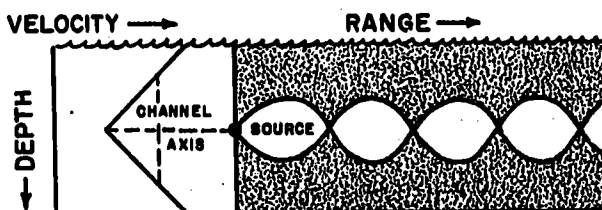

71.34
Figure 4-21.—Strong negative and strong positive gradients forming a sound channel.

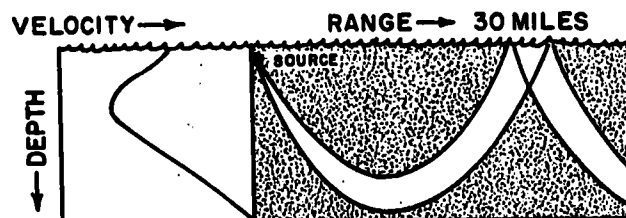

51.8
Figure 4-22.—Convergence zone.

Convergence Zone

Another effect that is closely related to the deep sound channel is called the convergence zone effect. The convergence zone effect is now applied to long-range active sonar, but this effect long has been used by submarine sonar operators. If the sound source is placed near the surface instead of near the axis of the sound channel, the path followed by the sound beam looks somewhat like that in figure 4-22.

Sound energy from a shallow source travels downward in deep water. At a depth of several thousand feet, the signal is refracted due to pressure, and returns to the surface at a range of about 30 miles. The surface zone is from 3 to 5 miles wide.

The sound that reaches the surface in the first convergence zone is reflected or refracted at the surface, and goes through the same pattern again. It produces a zone approximately 6 miles wide at 60 miles, and another 9 miles wide at about 90 miles. Experienced Sonar Technicians are familiar with this convergence zone effect. Often they have picked up strong noise signals from targets that appear suddenly, show up strongly for a few minutes, and then disappear.

A surface or near-surface contact detected in the first convergence zone will have about the same signal strength as a target detected at 3 miles when no zone is present. Minimum depth required along the path of the sound beam is about 1000 fathoms. The usual requirement is 2000 fathoms for conducting convergence zone searches. The minimum depth required is related to the surface velocity of the sound, and increases as the velocity increases.

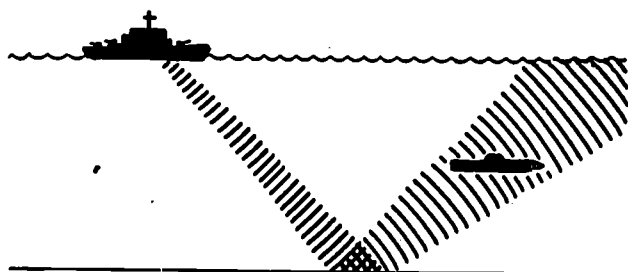

51.7
Figure 4-23.—Bottom bounce effect.

Bottom Bounce

For long-range search in water depths over 1000 fathoms, newer sonar equipment may operate in what is called the bottom bounce mode. The transducer is tilted downward at an angle so that the sound beam strikes the bottom and is reflected back to the surface, as shown in figure 4-23.

Because of the depression angle (15° to 45°) the sound beam is affected less by velocity changes than are sound pulses transmitted in the normal mode. At great depths, however (2500 fathoms and greater), the sound beam usually will be refracted before reaching the bottom, thus producing a convergence zone effect.

DOPPLER

You probably are familiar with the changing pitch of a train whistle as the train passes near you at high speed. As the train approaches, the whistle has a high frequency. As the train goes by, the frequency drops abruptly and becomes a long, drawnout sound. The apparent change in frequency of a signal resulting from relative motion between the source and the receiver is known as doppler effect. Figure 4-24 illustrates doppler effect.

Each sound wave produced by the whistle is given an extra "push" by the motion of the train. As the train comes toward you, the resultant effect is an increase in pitch, caused by compression of the waves. As the train moves away from you, the sound waves are spread further apart, resulting in a lower pitch.

Because doppler effect varies inversely with the velocity of sound, the effect is much less marked in the sea than it is in the air. Doppler

can, however, be noted by the Sonar Technician if he listens carefully.

Although a stationary receiver was used for illustrative purposes, the same effects can be observed if the receiver is moving toward a stationary source.

DOPPLER AND REVERBERATIONS

Earlier in this chapter you learned that as a sound pulse moves through the water it loses some of its energy to the water particles. The particles reradiate the energy in all directions. Part of the reradiated sound is returned to the sonar receiver, and the effect known as reverberation is heard. The water particles become sound sources and, as your ship moves through the water, doppler effect is noticed. The following example should help clarify doppler effect for you.

Your ship is underway at a speed of 15 knots; sound velocity is 4800 feet per second; sound frequency is 12 kHz. The sonar is keyed, and 1 second later it is keyed again. During the 1-second interval, the first pulse travels 4800 feet. When the second pulse is transmitted, it is only 4775 feet from the first one because the ship has traveled 25 feet. Using the formulas given in connection with wavelength, you can easily determine that the apparent frequency of the reverberations from ahead of you is approximately 12.1 kHz whereas those from behind your ship have a frequency of about 11.9 kHz. Reverberations from the beam will have the same frequency as the transmitted pulse, because the ship is neither going toward the particles nor away from them. The doppler effect of reverberations is illustrated in figure 4-25. To determine echo doppler, the Sonar Technician compares the tone of a target echo to the tone of the reverberations.



71.37
Figure 4-24.—Doppler effect.

INTRODUCTION TO SONAR

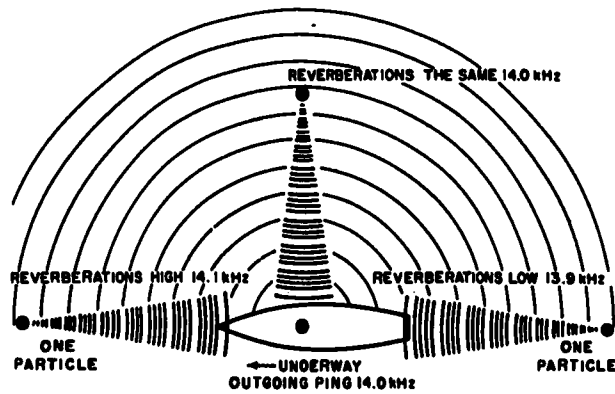

71.39
Figure 4-25.— Illustration of doppler.

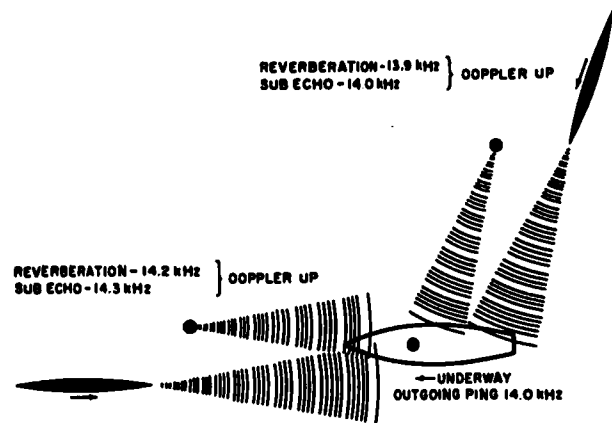

71.41
Figure 4-27.— Doppler up.

No Doppler

Consider the echo from a submarine that is neither going away from nor toward the sound beam. It either is stopped or is crossing the sound beam at a right angle. If the submarine is in either of these situations, it reflects the same sound as the particles in the water, and its echo has exactly the same pitch as the reverberations, which means the submarine echo has no doppler. Whenever the pitch of the submarine echo is the same as the pitch of the reverberations, therefore, you know that the submarine is stopped or that you are echoing off its beam, and you would report "No doppler." Figure 4-26 illustrates a "no doppler" situation.

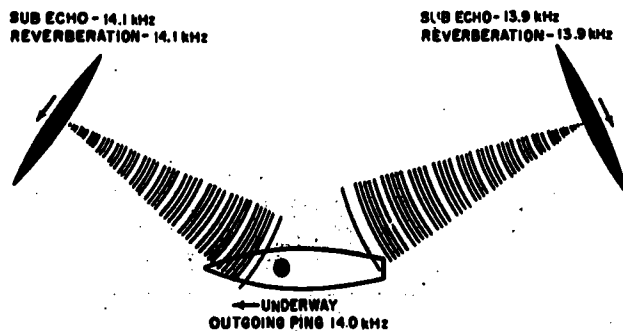

71.40
Figure 4-26.— No doppler.

Doppler Up

Suppose the submarine is coming toward the echo ranging ship. In this situation, it is as though the submarine were a train approaching a car at a crossing. The sound transmission reflected from the approaching submarine is heard at a higher pitch than the reverberations. When the echo from the oncoming submarine is higher than the reverberations, report "Doppler up." When making this report, you are telling the conning officer that the submarine is heading toward your ship and making way through the water. This form of doppler is illustrated in figure 4-27. Notice in the illustration that the echo frequency of the submarine on the ship's starboard quarter is the same as the ship's sonar frequency, yet it has up doppler. Remember, doppler is determined by comparing the tone of the target echo and the tone of the reverberations.

Doppler Down

Just as the tone of a train's whistle decreases in pitch as the train moves away from you, so does the doppler of a submarine moving away from your ship. No matter where the submarine is located in relation to your ship, if he is heading away from you, the tone of his returning echo will be lower in pitch than the tone of the reverberations. Figure 4-28 illustrates two situations when you would report "Doppler down" to the conning officer.

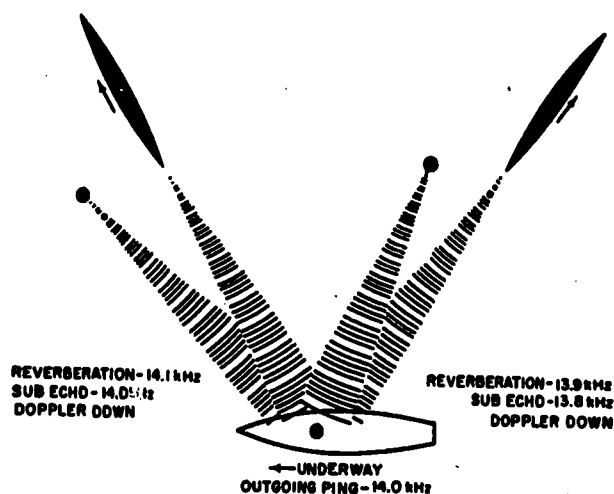

71.42

Figure 4-28.—Doppler down.

DOPPLER REPORTS

To summarize what you have just learned about doppler: Doppler is the difference in pitch between the reverberations and the echo. When the echo is higher than the reverberations, you will sing out "Doppler up". If it's the same as the reverberations, report "No doppler." If the echo is lower than the reverberations, say "Doppler down."

When you become a really skilled operator, you will be able to give the degree of doppler, that is, how high or low it is. For instance, a submarine coming directly toward your ship at 6 knots returns a higher echo than a submarine coming directly toward the ship at 2 knots. Also, a submarine coming directly toward the ship at 6 knots returns a higher echo than a 6-knot submarine that is heading only slightly toward the ship.

The importance of prompt and accurate reports cannot be overemphasized. Two details count: how much speed the submarine is making, plus how much it is heading toward or away from the ship. The combination of these two considerations is spoken of as the component of the submarine's speed toward or away from the ship. If the submarine's speed component is more than 6 knots, report "Doppler marked, up (or down)." When it is 3 to 6 knots, inclusive, report "Doppler moderate, up (or down)." If less than 3 knots, then call it "Doppler slight, up (or down)." (See fig. 4-29.)

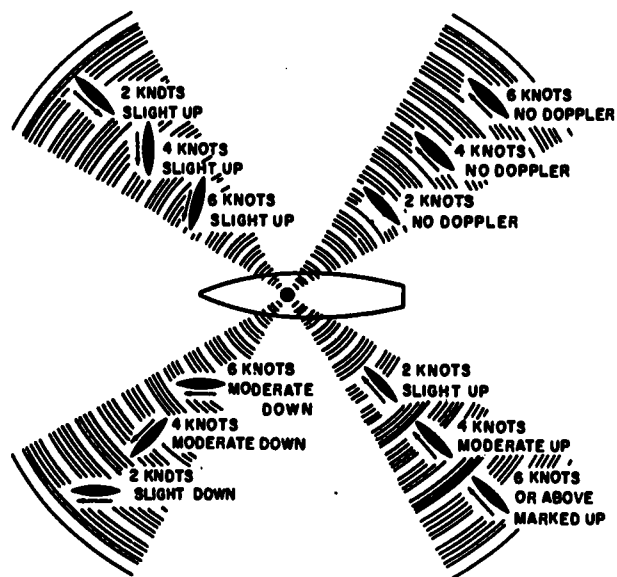

71.43

Figure 4-29.—Doppler conditions.

You now realize how important it is to give an accurate report of doppler to the conning officer. It tells whether the submarine is coming toward or going away from your ship, and gives the component of the submarine's motion. Remember that any contact that does have doppler must be moving in the water; if it is not a surface ship, chances are that it is a submarine or a large fish. Figure 4-30 gives an idea of the value of doppler.

HOW TO RECOGNIZE ECHOES

Sonar Technicians learn to recognize one echo from another by listening to recordings of reverberations and echoes and by practicing with the sonar aboard ship. The following topics contain remarks intended to serve as helpful hints, but they cannot take the place of actual practice.

TWO TYPES OF ECHOES

Echoes are of two types: those with doppler and those without doppler. If an echo has doppler, you can assume that it is a submarine or a large fish or mammal—perhaps a whale.

INTRODUCTION TO SONAR

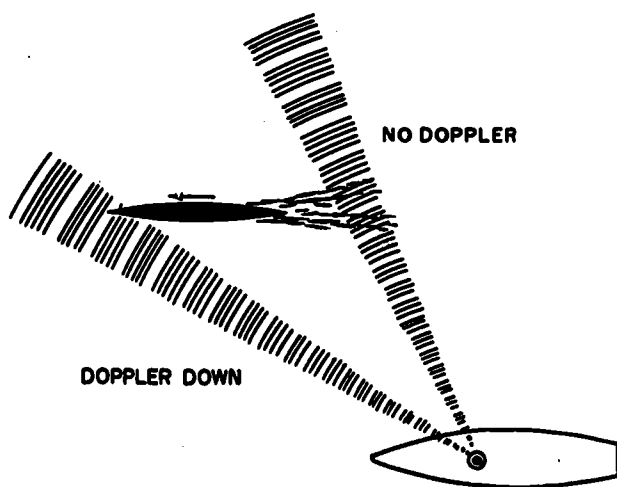

71.44
Figure 4-30.— Value of doppler.

If the echo has no doppler, it is from the beam of a submarine, from a stopped submarine, from the submarine's wake, or it is not from a submarine. If an echo without doppler is from the beam of a submarine, it will be sharp and clear, because the side of a submarine presents a large reflecting surface.

Sharp, loud echoes, without doppler, are received from any large, solid surface. The larger the area of the target, the greater the strength of the echo.

A weak, mushy echo, without doppler, is heard from such objects as riptides, kelp beds, schools of small fish, and wakes that are breaking up. The weak, mushy sound is caused by the numerous small reflections that combine in random fashion to form an irregular echo wave.

Often, you will receive the worst type of echoes from the stern of a submarine. The target area is small and is broken into multiple surfaces by the screws, the wake, and the like, so that there is a combination of reduced power and interference. Don't dismiss weak, poor-sounding echoes as nonsubmarine. Experienced sonar operators will tell you that although an echo from dead astern of the target is hardest for an operator to identify, it can be done with a little perseverance.

The strength of the echo depends on the power of the incoming wave. This power depends on the sound output of the transducer, the size,

position, and movement of the target, and the conditions of sound transmission in the sea.

You probably will hear a lot of different sounds while echo ranging. A stationary object near the surface produces good echoes, but there will be no doppler. (Once in a while, a strong current or tide will cause an echo to have a doppler effect, but such an occurrence is unusual.) A whale may have echo characteristics closely resembling those of a submarine. Echoes also may be heard from large fish, such as blackfish. Schools of herring or other small fish sometimes run large enough to reflect a strong echo. In shallow water, as along the Continental Shelf on the eastern coast of the United States, hulls of long-sunken ships may return a very convincing echo. Because Nazi U-boats were so effective in this area during World War II, the shelf is littered with dead ships capable of hoaxing the unsuspecting sonar operator into believing his contact is actually a submarine.

Often you will hear strange chuckling and whistling sounds in an area abounding in porpoises or dolphins. If the water is shallow and the bottom is hard, rocky, or covered with coral heads, sound waves are reflected strongly. Often these reflections return as loud and clear as echoes from a target, but they have no doppler.

From time to time, you may pick up strange sounds that are difficult to identify. Submarine hydroplanes and rudders frequently give off a noticeable whistling sound. Submarine pumps and other machinery can be heard rattling or thumping if the machines are not silenced. You also can hear a torpedo.

Torpedo noise is distinct from all others. When a torpedo is fired from a submarine, the first indication might be the sound of escaping air, quickly followed by a sound like a propeller noise. The rhythm is too rapid for the beats to be counted (as you can count those of a ship's propeller), and it increases swiftly in intensity as it approaches, resembling the whine of a jet engine, but not as high-pitched.

ARTIFICIAL TARGETS

Submarines are capable of putting artificial targets into the water to confuse the tracking ship. They are of two general types: targets that are self-propelled, which can return an echo with doppler; and targets that are stationary, providing excellent sound-reflective qualities, but usually without doppler. Practice

and experience in recognition are the best insurance in countering these artificial targets.

Some of the self-propelled kind receive the ping of the echo ranging sonar, amplify it and give it a change in doppler, then retransmit it. They also may be programed to simulate submarine movements. Usually the returning signal is stronger than the returning echo from the submarine, so it is easy for the inexperienced sonar operator to shift from the actual target to the artificial one.

The stationary type also returns a strong echo, which often is more pronounced than that from a submarine. This type of target comes in several forms.

One form of stationary target is a "pill" of chemicals, which reacts with water to form bubbles of carbon dioxide gas. The action is much the same as bicarbonate of soda in water. The pill dissolves, creating millions of bubbles of the gas, which, because they are grouped together, return a strong echo.

Another target of the bubble type is produced when the submarine releases a quantity of air. A few moments are required for the air to rise to the surface, and while it is doing so, it provides excellent sound-reflective characteristics. Like the pill, the echo returned is often stronger than that obtainable from a submarine.

Similar to the air bubble released by a submarine is the knuckle, which is a mixture of air and water created by a submarine making a sharp turn. Although it is not in general use by a submarine commander during an attack, because it slows him down, he may have to make a hard, high-speed turn in an attempt to avoid a weapon. The knuckle can produce a clear, sharp signal upon which an inexperienced operator may concentrate while the submarine escapes.

Stationary false targets do not affect the pitch of the echo. This characteristic means that a stationary target does not give a doppler change except under very unusual conditions. This unchanged doppler characteristic is an important clue in recognition of a false target.

When tracking a target, for example, an abrupt change from doppler up (or down) to no doppler may well be an indication that the target has ejected a bubble to throw you off guard, which may result in your making an attack on the false target. You must, therefore, be suspicious of any drastic change in doppler.

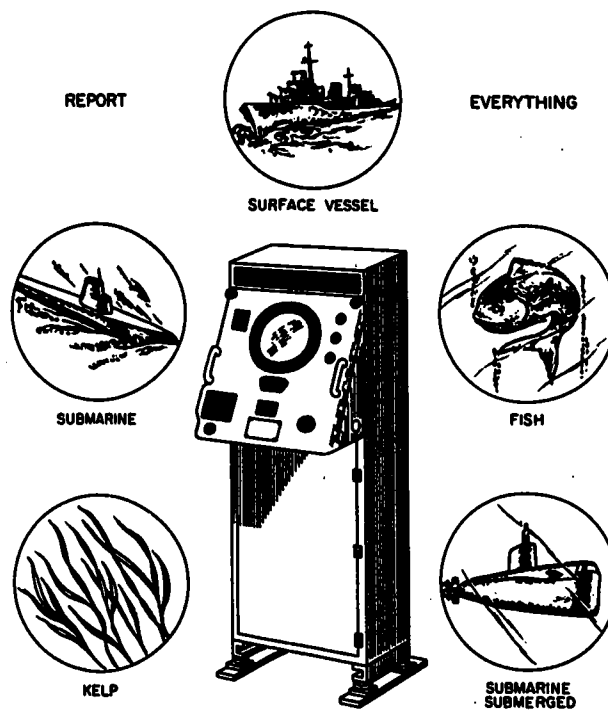

71.45
Figure 4-31.— Report everything you hear.

Furthermore, you must be suspicious of echoes that change suddenly from weak or mushy to clear and sharp. Such an echo may be a self-propelled target leading you away from your quarry.

Electronic and mechanical jammers are also used by submarines. The electronic type usually operates on one of several selectable sonar frequencies, acting as a screen by overloading the ship's sonar receiver. The mechanical type of jammer releases a series of explosions that jam the sonar receiver because of their wide bandspread of noise. The mechanical type is especially effective in shallow water because of repeated reverberations from the bottom.

You must remember that doppler can tell you considerably more about target motion than simply whether it is going toward or away from you. You must practice to achieve the near-perfect discrimination demanded of a good Sonar Technician. To achieve this goal, you must listen and concentrate on echoes.

INTRODUCTION TO SONAR

REPORT EVERYTHING YOU HEAR

One of the Sonar Technician's most important tasks is to distinguish the target echoes from other noises that tend to mask them. Sonar operators hear many kinds of echoes. Rocks, shoals, buoys, mines, surface craft, whales, schools of fish, wakes of surface craft and submarines, as well as the submarines themselves, can reflect sound.

Report every sound you hear, regardless of whether you can identify the echo. Figure 4-31 illustrates a few of the many objects that may return an echo or emit a sound. Do not delay making your report while you try to determine what you have detected. By the time you decide it's a submarine, it may be too late. Don't be afraid to make a report that may turn out to be nonsubmarine. The safety of your ship and the lives of your shipmates are worth more than the time spent or the ordnance expended on a false contact.

CHAPTER 5

BATHYTHERMOGRAPH

The travel of sound waves in the sea was discussed in the preceding chapter. To interpret correctly the information displayed by sonar equipment, Sonar Technicians must have a thorough knowledge of the factors affecting sound wave travel in water. Because thermal conditions of the sea are of the utmost importance to Sonar Technicians, a means must be available for measuring water temperatures at various depths. The measuring device used is the bathythermograph, called BT. Use of the bathythermograph enables the submarine hunter to determine the layer depth and to estimate sonar detection ranges at various depths. By determining layer depth, an estimate can be made of the probable depth the submarine captain will employ to escape detection. The submarine captain uses the BT to determine the best depth to avoid detection.

Much of the data used in conjunction with BT information for determining sonar detection ranges cannot be included in this text because of the classified nature of the subject matter. Sonar range prediction methods are presented in other publications, such as Sonar Technician G 3 & 2, NavPers 10131 and Sonar Technician S 3 & 2, NavPers 10132.

Before proceeding to our discussion of the BT and its use, a brief review of the temperature effects on sound travel is appropriate.

TEMPERATURE

As explained in chapter 4, the conditions that affect sound travel in water are pressure, salinity, and temperature. Increases in pressure speed up the velocity of sound, making the speed of sound higher at extreme depths. An increase in salinity also increases the velocity of sound. The effects of pressure and salinity are not nearly as great, however, as are those caused by changes in temperature—particularly abrupt changes. Information obtained about the

ocean temperature at a given time can be used to predict what will happen to the transmitted sound as it travels through the water.

As a result of knowing the temperature of the water at various depths, we can arrive at fairly accurate conclusions regarding the maximum range at which a submarine may be detected, as well as the most favorable depth for the submarine to avoid detection. These two fundamentals are important considerations in anti-submarine warfare. They influence the types of screens used for convoys, and aid in determining the spacing of ships in the screen.

EFFECT OF TEMPERATURE

The speed of sound through water increases at the rate of between 4 and 8 feet per second for each 1° rise in temperature. This 4- to 8-fps change depends on the temperature range of the water. At water temperatures in the 30° range, for instance, a 1° rise increases the rate of travel differently than does a 1° rise in the 70° range.

Ships and submarines of the U. S. Navy operate in all sea temperatures—from near freezing in the polar regions to the upper 80s in the tropics. To provide accurate range data, sonar equipment must be adjusted to the changes in sound velocity.

Under some conditions, a pulse transmitted by sonar equipment may travel easily through water that varies greatly in temperature. Under different conditions, the pulse transmitted may be unable to penetrate a 5° temperature change layer at all, because it is reflected and scattered instead.

LAYERS

A pulse of acoustical power may provide sonar reception out to several thousand yards of range. The same pulse, if transmitted into a layer of water (such as a sound channel that tends to keep the pulse confined within it), may

INTRODUCTION TO SONAR

be able to provide sonar data on contacts many miles distant.

Sound has a natural tendency to seek paths toward the cooler layers of the sea. Because the temperature of the sea normally decreases with depth, the path of a transmitted pulse of sound usually is in a downward direction.

If a cross section or a profile of the sea's temperatures were taken, a normal condition might show a layer of water of uniform temperature (less than $1/2^\circ$ temperature change) from the surface to varying depths. This condition is called isothermal. Next, there would be a region of water in which the temperature decreased rapidly with depth. Such an area is known as a thermocline. Finally, for the remainder of the measured depth, the temperature would decrease only slightly with depth.

THERMOCLINES

The thermocline can play havoc with a pulse of acoustical energy. As the transmitted sound pulse reaches the thermocline, one of two effects is apparent.

First, the thermocline can prevent passage of the pulse, reflecting it back to the surface. Targets beneath the thermocline may possibly be undetected. This possibility is one of the reasons submarine commanding officers seek the cover of such thermoclines, thus hoping to evade detection by surface ships or aircraft.

Second, the thermocline can allow passage of the sound pulse but alter its direction considerably in so doing. This effect is called refraction. If a sound pulse enters a thermocline at, for instance, a 30° angle from the sea's surface, it is possible for the angle to be altered to 70° or more while traveling through the thermocline, and change again as it emerges. The result of this refraction can be a distorted path of sound travel that affects the accuracy of target presentation at the sonar console.

SUBMARINE BATHYTHERMOGRAPH

More information is required from a submarine BT than from its shipboard counterpart. Because salinity, temperature, and pressure affect the ability of a submarine to maintain desired operating depth, knowledge of these conditions and their effect on buoyancy is necessary so that the diving officer can maintain trim of the submarine. The AN/BSH-2D and the AN/BQH-1A (which is replacing the AN/BSH-2D)

are the types of BTs that provide the necessary data.

AN/BSH-2D

The AN/BSH-2D is designed for use in all types of submarines. It indicates changes in sound velocity with depth, and shows direction of buoyancy change. It can measure and indicate temperatures between 40°F and 90°F , salinity content from 20 to 40 parts per thousand parts of water, depths between 0 and 800 feet, and buoyancy from 0 to 100,000 pounds. Whenever a change occurs in salinity, temperature, or depth, their new values are indicated within a few seconds.

The AN/BSH-2D consists of five units: two salinity-temperature elements (one on the periscope shears and one on the hull below the waterline), an amplifier computer, a recorder, and a switch for selecting a salinity-temperature element.

The selector switch chooses one of the salinity-temperature elements and connects it to the amplifier computer. Changes in salinity and temperature cause the element to change its electrical resistance characteristics. The amplifier computer converts the change in electrical resistance into corresponding voltage changes, amplifies the signal, computes the sound velocity and buoyancy changes, and transmits the information to the recorder unit. This unit then displays the data on a card. Accuracy of the AN/BSH-2D is ± 8 feet in depth, ± 6 feet per second in sound velocity, and 2-1/2 percent of the change in buoyancy.

DEPTH-SOUND SPEED MEASURING SET AN/BQH-1A

The AN/BQH-1A is a completely transistorized device used to provide accurate information concerning sound ranging conditions in the surrounding water and buoyancy during diving operations.

The equipment is capable of measuring sound velocity in sea water over a range of 4600 to 5100 fps. Accurate depth measurement is provided by a depth element and its associated circuitry. Velocity of sound and depth of the sensing element, which measures this velocity, are displayed on a two-channel (pen and drum) servomechanism recorder (fig. 5-1).

Maintaining the trim of a moving submarine is aided greatly by indicating on the recorder chart a series of isoballast lines. These lines

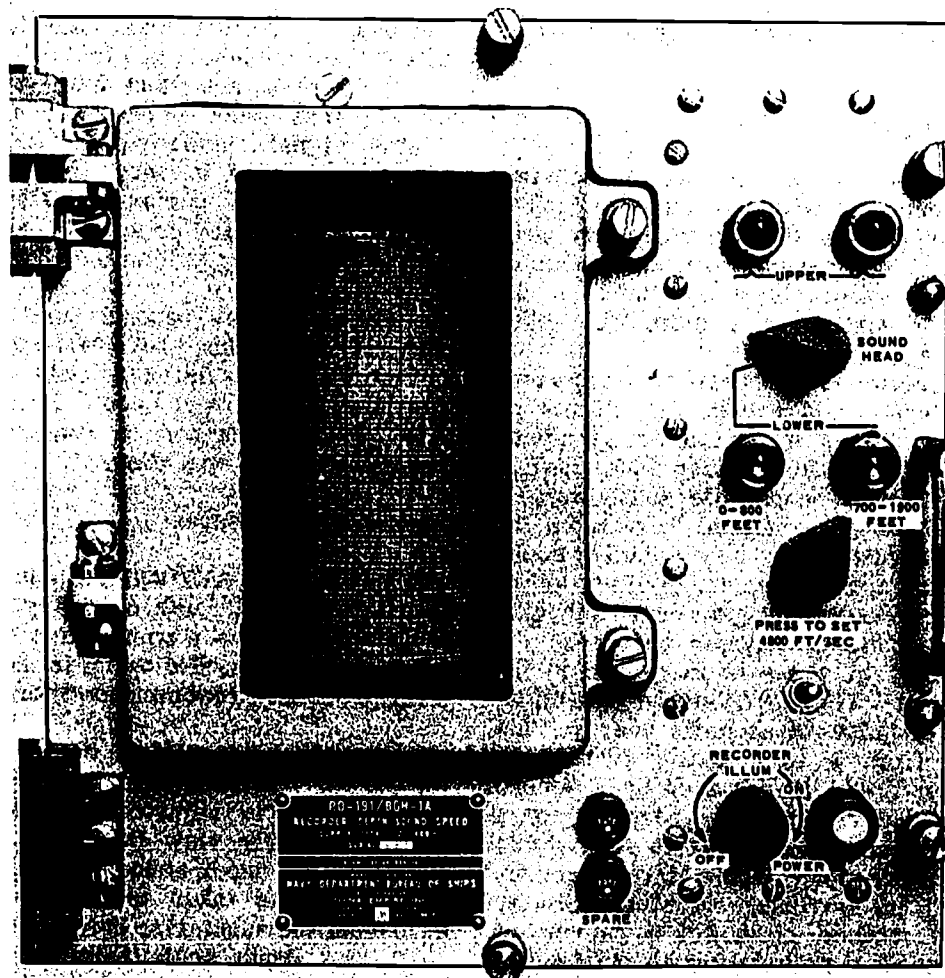

35.156

Figure 5-1.— Depth-sound speed measuring set AN/BQH-1A.

are precalculated for various classes of submarines. Charts must be selected with isoballast lines printed for that particular class of submarine. In indicating a trace that crosses the isoballast lines, action of the pen and drum gives the amount of water to pump or flood in order to maintain the submarine's trim.

Buoyancy changes, indicated by crossings of isoballast lines, may be related to submarine depth and also to velocity of sound in water. Both submarine buoyancy (upon which trim depends) and velocity of sound in water are definite functions of salinity, temperature, and pressure, inasmuch as a moving submarine encounters

changing conditions of salinity, temperature, and pressure, the AN/BQH-1A recording equipment must measure these changes in terms of absolute values of velocity of sound in water. Sensitivity of the velocity-measuring portion of this equipment is sufficient to indicate changes in sound velocity of 1 fps when passing through a thermal gradient. Equipment pressure circuits are capable of indicating changes in depth of approximately 1 foot. This measurement represents the minimum readable definition of the recorder chart's pressure portion.

Isoballast curves are calculated in such a way that individual curves pass through all points

INTRODUCTION TO SONAR

where a loss in buoyancy with depth exactly equals any gain in buoyancy resulting from a decrease in water temperature or increase of salinity.

Functional Operation

To measure sound velocity and to ascertain velocity gradients in the surrounding water, two transducer assemblies (sound heads) are provided with each depth-sound speed measuring equipment. One assembly is mounted on the upper (or sail) portion of a ship. The other device is mounted at the keel.

To obtain accurate information concerning changing gradients and subsequent effects on buoyancy during diving operations, it is advisable to use the lower sound head while diving, and the upper sound head while ascending. By following this pattern, radiated heat from the skin of the ship will wash away from the sound head. Radiated heat, consequently, will not interfere with measurements of gradients and indications of corresponding buoyancy changes.

Sound velocity in water is measured in the following manner: The AN/BQH-1A transmits into the water a pulse of acoustic energy. This pulse travels from a transmitting transducer through the water and is received by a second receiving transducer. The time required for a pulse to travel from transmitter to receiver is measured by means of electronic timing circuits. Thus, a direct measurement of sound velocity is made. This method of direct measurement eliminates the need for correlating various factors of the ocean: salt content, density, and temperature, plus pressure corresponding to depth at which velocity is measured.

Description of Controls

Operating controls of the AN/BQH-1A depth-sound speed measuring set are described for the recorder and repeater. Refer to figure 5-1.

● **Recorder:** Following are the major operating control switches on the recorder.

1. **Power on/off recorder illumination control:** This control applies 400-cycle primary power to the recorder. It varies the brightness of the internal chart illumination.

2. **Sound head select:** A two-position switch that permits an operator to select either the upper or lower sound head for displaying sound velocity on the recorder drum.

3. **Depth scale select:** A two-position switch that permits an operator to select either of two overlapping depth scales. One depth scale is 0 to 800 feet; the other, 700 to 1500 feet.

4. **Press-to-set 4800 fps:** A spring-loaded switch, that, when depressed, applies a calibrating signal internally generated in the particular sound head in use. The switch acts as a system check of performance and accuracy of sound velocity indication. It also assists in proper positioning of new recorder charts.

● **Repeater:** The repeater unit is identical to the recorder unit, but the repeater has no operational controls. The only control on the repeater is the power on/off illumination switch. The repeater cannot be operated unless the recorder is also operating.

Operating Procedures

Because the AN/BQH-1A and its associated sound heads and depth circuitry are completely transistorized, no warmup time is required for proper operation. Following is the normal operating procedure recommended for the set.

1. After lighting off the equipment and selecting the desired sound head, the recorder illumination control is adjusted to provide sufficient light to clearly view the chart. (NOTE: When surfaced, the upper sound head is not immersed. Care must be taken to avoid energizing this head until the submarine completely submerges.)

2. The depth scale select switch is set to the desired depth setting (0-800 feet or 700-1500 feet). The equipment is now ready for normal operation.

3. The press-to-set 4800 fps switch is depressed and held until the velocity indicating drum reaches a steady position. Indicated velocity position should be 4800 fps. (NOTE: For each sound head the absolute value of the 4800-foot calibrate velocity varies slightly. Test data sheets supplied for the sound head in use should be consulted for exact calibrated readings.)

4. In the preceding step, when the drum steadies, the press-to-set switch is released. The drum should rotate and indicate the sound velocity in the water at the sound head in use.

5. When both sound heads are immersed, the sound head select switch may be rotated to select first one, then the other, sound head. Each time the select switch is changed, the drum should rotate to a position that shows the velocity of sound at the sound head selected.

Chapter 5—BATHYTHERMOGRAPH

When shifting from one head to the other, the recorder also indicates the difference in depth between the two sound heads.

6. The press-to-set 4800 fps switch is depressed. When the drum rotates to a velocity reading of 4800 fps, the switch is released. The drum then will rotate and begin to give a continuous record of velocity and depth for the sound head in use.

Checks and Adjustments

Minimum front panel controls and adjusting knobs are contained on the AN/BQH-1A. Periodically, the operator should depress the press-to-set switch and verify that the initial calibration accuracy of the equipment is maintained throughout an operating period.

Emergency Use

Because the velocity display and depth display on the AN/BQH-1A are independent of each other, the recorder is capable of emergency operation on either independent channel. If failure of the depth circuitry occurs, an operator may continue to supply useful velocity information by manually positioning the depth pen to a readable portion of the chart. In the event of failure in the sound heads or drum circuitry, depth information may still be supplied independently.

71.113

Table 5-1.—BT Series Designations

Series No.	Name	Design depth
OC-1/S	Shallow	0 to 200 feet
OC-1A/S		
OC-1B/S		
OC-1C/S		
OC-2/S	Medium	0 to 450 feet
OC-2A/S		
OC-2B/S		
OC-2C/S		
OC-3/S	Deep	0 to 900 feet
OC-3A/S		
OC-3B/S		
OC-3C/S		

SHIPBOARD BATHYTHERMOGRAPHS

A surface ship is much less concerned with buoyancy and salinity data than is the submarine, consequently the shipboard BT is required to make only temperature versus depth measurements. Three types of mechanical BT are in general use aboard ships. One type is used for measuring shallow depths (200 feet), another for medium depths (450 feet), and the third for deep water (900 feet). The BT carries a coated glass slide on which is scribed temperature changes as the BT dives to its operating depth. Upon retrieval, the temperatures are read by placing the slide in a gridded viewer. Essentially, each BT is constructed the same, and each one operates in the same manner. Differences will be noted where applicable. Table 5-1 lists the various BTs in use and gives their designed operating depth. A new type, the expendable BT, is discussed later in the chapter.

DESCRIPTION OF UNITS

All three BT types use the same size slide for recording temperature and depth. To elaborate, the slide used in the deep model shows 4-1/3 times more data than the one used in the shallow model. The information taken by the deep BT is compressed, in comparison to the shallow recording. Because of this compression, it shows less detail and thereby makes it more difficult to read accurately. Lowering a deep-type BT in shallow water to obtain a recording is impractical because insufficient detail is gleaned from the slide to make accurate readings possible.

The deep BT differs slightly from the other two in that it does not have a stylus lifter. The stylus lifter on the shallower BTs lifts the stylus from the slide as the BT comes to within 70 to 50 feet of the surface while being retrieved. This action prevents double traces that would complicate the reading of surface temperature. Another difference is that the spring on the depth element is outside the bellows. Because the deep BT pressure element is smaller (to withstand the pressure of deep water), the spring cannot fit inside the bellows as it does in the depth elements of shallower BTs. Some old models of the deep BT may further be identified by a diving lug mounted just forward of the fin guards. The diving lug allows for very deep-angled dives to enable the BT to reach its designed depth in a minimum amount of time. Figure 5-2 shows a typical mechanical bathythermograph.



71.72

Figure 5-2.— The bathythermograph.

Except for the differences just noted, all three of the BTs are constructed the same. They consist of a thermal element, a depth element, a body tube, a nosepiece, and a tail guard. An auxiliary nose sleeve is available to aid the BT in diving. These units are shown in figure 5-3.

Thermal Assembly

The thermal assembly is the temperature-measuring element. The temperature reading represents the average temperature of the capillary tube assembly, which is located in the tail.

The tube assembly is wound in staggered fashion on a six-sided frame that extends beyond the body of the BT. This staggered winding ensures a flow of water around the capillary tubing. Breather holes in the body tube allow water to run freely in or out, thereby keeping the internal pressure equalized with the outside pressure. The Bourdon tube element has a bimetallic strip, and any difference in temperature between the water within the BT surrounding the Bourdon tube and the water flowing past the capillary tubing is offset by the action of the bimetallic compensator.

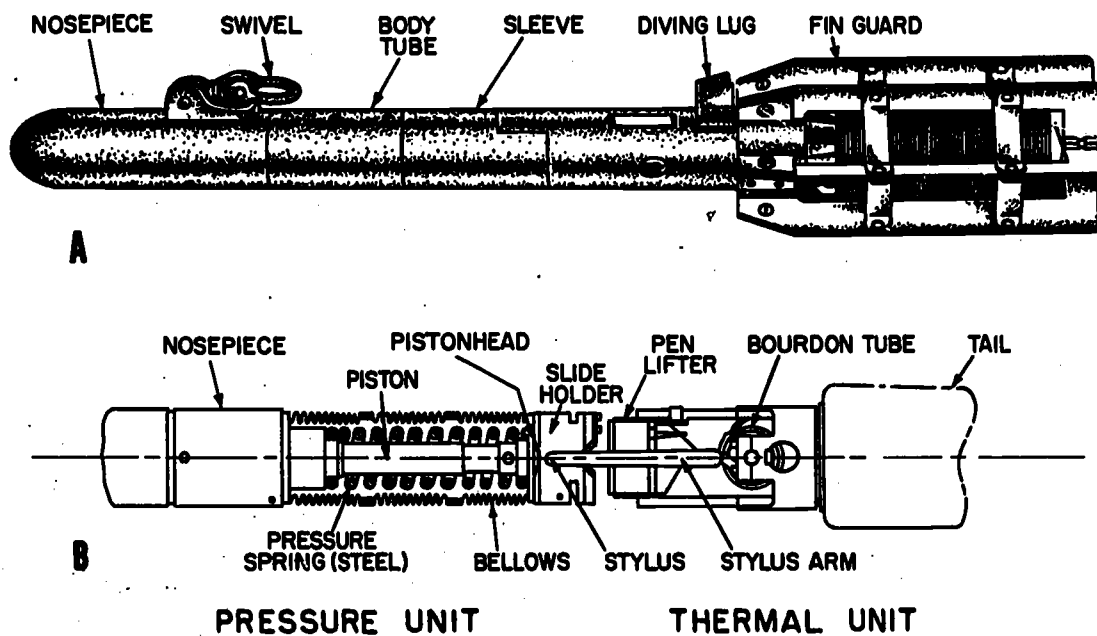

71.74

Figure 5-3.— The BT and its parts.

Depth Element

The depth element, located in the body tube, consists of a piston device with an accurately wound steel spring. An envelope, made up of three metallic bellows soldered together, surrounds the spring and keeps the water pressure off the spring and off the spring side of the pistonhead. In one type of BT, one end of the bellows assembly is soldered to the solid nose-piece, but in another type this end is soldered to the mounting base. In both types, the movable end is soldered to the spring side of the pistonhead. Increasing water pressure tends to collapse the bellows and compress the spring, causing the slide holder attached to the pistonhead to move forward, that is, toward the nose.

Body Tube

The body tube serves as the main support and protection case for the depth element and thermal assembly. The movable brass sleeve covers the slide ports next to the slide holder. The sleeve may be moved forward easily when it is necessary to get at the slide and slide holder. When the BT is to be lowered, push back the sleeve until it touches the forward end of the tail fins, thereby enabling the automatic stylus lifter to be activated. This action covers the slide ports and also releases the stylus lifter so that the stylus can write on the coated glass slide inserted in the slide holder.

Nosepiece

A large percentage of the approximately 25-pound weight of the BT is concentrated in the nosepiece. This weight makes the nose sink first during a BT lowering, if the towing cable is payed out freely. The nosepiece has an attached towing fin, swivel, and shackle where the towing cable may be attached easily.

Auxiliary Nose Sleeve

On vessels moving at high speeds, earlier models of the hydro bathythermograph often failed to dive to the depths from which information was desired. Two types of diving attachments have been added to overcome this difficulty.

One attachment is a heavy bronze sleeve, slipped over the nose of the instrument and secured by tightening two locking screws. This sleeve adds to the weight of the BT and increases diving speed. The ship can move at higher speed

71.114

Table 5-2.—Maximum Towing Speeds

BT type	Depth (feet)	Maximum speed	
		Without nose sleeve	With nose sleeve
OC-1B/S, OC-1C/S	200	15	22
OC-2B/S, OC-2C/S	450	10	13
OC-3B/S, OC-3C/S	900	3	6

and the BT still can reach full depth. Table 5-2, based on paying out 1000 feet of cable, shows the maximum ship speeds that can be used with and without the nose sleeve. Note, for instance, that to get the BT down to 900 feet without the nose sleeve, own ship's maximum speed would have to be 3 knots. With the nose sleeve, the speed could be as great as 6 knots.

The other device is a towing block attached well aft on the BT and used while lowering the instrument. This attachment causes the BT to dive at a steep angle because the towing point is well aft.

Tail Guard

The tailpiece assembly consists of the fin pieces strengthened with two tie strips. This assembly protects the capillary tubing and stabilizes the BT during the lowering, towing, and raising of the instrument.

THEORY OF OPERATION

The BT can be operated while the ship is underway at speeds up to 18 knots. It works most satisfactorily, however, at speeds of 12 knots or less.

The temperature element, corresponding to the mercury column in a glass thermometer, consists of about 45 to 50 feet of fine copper tubing filled with xylene. The tubing is wound around inside the tail fins of the BT and comes into direct contact with the sea water. One end of the tubing is fixed; the other end is attached

INTRODUCTION TO SONAR

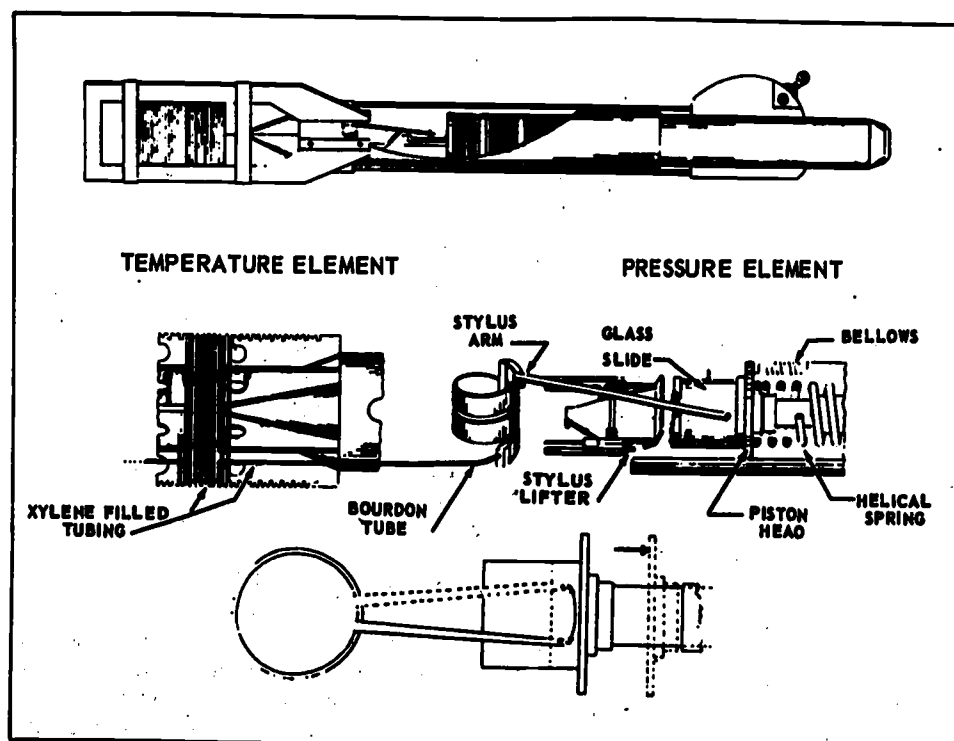

71.73

Figure 5-4. — BT temperature and pressure elements.

to a Bourdon tube. As the xylene expands or contracts with the changing water temperature, the tubing expands or contracts, causing the Bourdon to move. A stylus is attached to the free end of the tube. The stylus records the movements of the Bourdon, as it expands or contracts with changes of temperature, on a gold-colored, metallic-coated glass slide. The temperature range is from 28° to 90°F. The slide is held rigidly on the end of a coil spring enclosed in the copper bellows. Water pressure, which increases in proportion to water depth, compresses the bellows as the BT sinks.

Figure 5-4 illustrates the BT temperature and pressure elements. The dotted line drawings in the lower portion of the illustration show the action of the stylus moving left on the slide, with a decrease in temperature, and the bellows being compressed to the right (note arrow) as depth increases. Increase in depth pulls the slide toward the nose of the BT, at right angles to the direction in which the stylus moves to record temperature. When the BT is raised

toward the surface, the spring expands the bellows to its original shape. Thus, the trace scratched on the plated surface of the slide is a combined record of temperature and pressure. Pressure is directly proportional to depth.

Each instrument must be calibrated carefully by the manufacturer because external pressure slightly affects the internal pressure of the xylene in the Bourdon, and because temperature changes also influence the movement of the bellows.

A special grid is supplied with each instrument for converting the stylus trace to temperature and depth readings. These grids are not interchangeable. For correct readings the grid is constructed so that the temperature lines may not always be exactly straight and vertical, but vary slightly with increasing depth. The depth lines, likewise, are not exactly arcs of circles, with radius equal to the length of the stylus. Instead, they are calibrated to allow for thermal expansion of the bellows.

Chapter 5—BATHYTHERMOGRAPH

At a temperature of 105°F, the recording stylus moves against a stop pin. If this temperature is exceeded, the calibration of the instrument becomes ruined, perhaps permanently. For this reason, the BT must always be kept out of the sun and away from the vicinity of firerooms, steampipes, and other sources of heat. An instrument that has been overheated may have the stylus arm jammed by the pen lifter bar in the high-temperature position. If another BT is aboard, use it, and turn in the damaged instrument for adjustment. If a spare is unavailable, gently lift the stylus arm from the pen lifter bar and let the arm swing back toward the low-temperature side.

The temperature calibration henceforth will be in error as a result of deformation of the Bourdon. This information must be recorded on the bathythermograph logsheet. The BT logsheets

are special sheets, issued by the National Oceanographic Data Center, for recording the information obtained by lowering the BT. These logsheets are discussed later in this chapter.

When a BT has been damaged, turn in the instrument to the nearest repair facility at the first opportunity. The BT repair facilities are located at the San Francisco, Pearl Harbor, and Boston Naval Shipyards.

BT TOWING EQUIPMENT

Towing equipment required to operate the bathythermograph is described in the following list.

1. Hoist: The hoist has a drum with a capacity of 3000 feet of cable, an electric motor with controls and reduction gears, a control lever for



71.75
Figure 5-5.—BT towing equipment.

INTRODUCTION TO SONAR

operating the brake and clutch, and a drum revolution counter.

2. Boom: The boom should extend at least 8 feet and no more than 10 feet from the side of the ship, and it should be strong enough to withstand a force of 1500 pounds. A typical hoist and a boom are shown in figure 5-5. In the illustration the BT is suspended from the towing block and is ready for lowering.

3. Towing block: A small counterbalanced wheel that attaches to the end of the boom to allow cable to pay out with minimum friction.

4. Wire rope: The wire rope is of 3/32-inch diameter, 7 x 7 stainless steel aircraft control type, and is 3000 feet in length.

BT ACCESSORIES

Each BT comes supplied with the following accessories: (1) a grid and slide holder, for viewing the slides, (2) a box of slides, (3) a swivel for attaching the BT to the cable, (4) a pair of tongs for holding the slide to rinse it, and (5) a thermometer for taking bucket temperatures. These accessory items are described as this text progresses.

OPERATION OF THE BT

Personnel operating the BT at night and during rough sea conditions should wear life-jackets and use safety lines. For each lowering of the BT the succeeding steps must be followed.

Step 1—Determine Water Depth

Determine water depth in order to select the proper BT.

Step 2—Examine Wire and Connection to BT

Whenever possible, determine that the wire is hitched to the winch reel in such a manner that it cannot pull loose if all wire should pay off the drum. As an additional precaution, do not pay out the last layer of wire when lowering the BT. The wire should be wound on the drum so that it pays out and reels in at the top of the drum. For survey work, it is recommended that bare wire be used—not plastic-coated wire. If 900-foot-depth BTs are to be used, at least 2000 feet of 3/32-inch, 7 x 7 stainless steel wire should be used. The plastic-coated wire usually comes in 1200-foot lengths and cannot be spliced, hence it is not long enough for use with 900-foot BTs. Run the free end of the wire

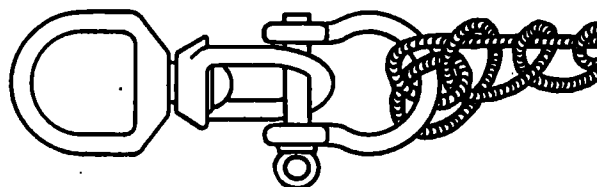

71.76

Figure 5-6.— BT cable hitch.

through the towing block at the end of the boom. This block is of a special counterbalanced design for BT use.

The type of cable hitch used to connect the BT to the wire differs slightly with various models. The instruction book accompanying each BT shows the method of attachment for that model. One such cable hitch is shown in figure 5-6. If the connection is frayed, rusted, kinked, or doubtful in any way, cut off the faulty part of the wire and make a new connection. Be sure to seize the hitch to prevent its coming free. Check the swivel carefully. On those models that use a Fiege-type swivel connector, make sure the Fiege sleeve is screwed into the socket as tightly as possible. More BTs are lost because of poor connections than from any other cause.

Step 3—Check Winch

The hand lever on the winch serves as both brake and clutch. It has three positions. When it is vertical, the winch is in neutral and the drum can be turned in either direction. When it is pushed outboard to the engaged (or hoist) position, the motor turns the drum and spools on the wire. When the lever is pulled inboard (or toward the operator) to the brake position, the drum is locked and cannot be rotated.

With the winch lever in neutral, turn on the motor to make sure power is available. The shaft bearings should be kept well lubricated according to the instructions provided with each model winch. The drum should turn freely.

The winch installation should be such that the wire passes across the top of the drum. The hand lever should move away from the operator to engage the motor, and toward the operator to set the brake. On some earlier model winches, the hand lever operation is just the reverse; that is, the brake is away,

Chapter 5—BATHYTHERMOGRAPH

and the clutch is toward the operator. Check these operating positions to make sure that the installation is correct and that the drum revolves freely in neutral.

Step 4—Put Slide in BT

Remove the waterproof cover from the box of glass slides and take out one slide at a time, holding the slide by the edges to avoid damaging the metallic film. Do not remove the waterproof cover from the box until actually ready to use the slides.

Insert the slide into the hole on the side of the BT as shown in figure 5-7 and push it into its bracket. The edge of the slide with the beveled corners goes in first, the longer bevel toward the nose of the BT. Make certain that the plated surface of the slide is toward the stylus. Push the slide in all the way against

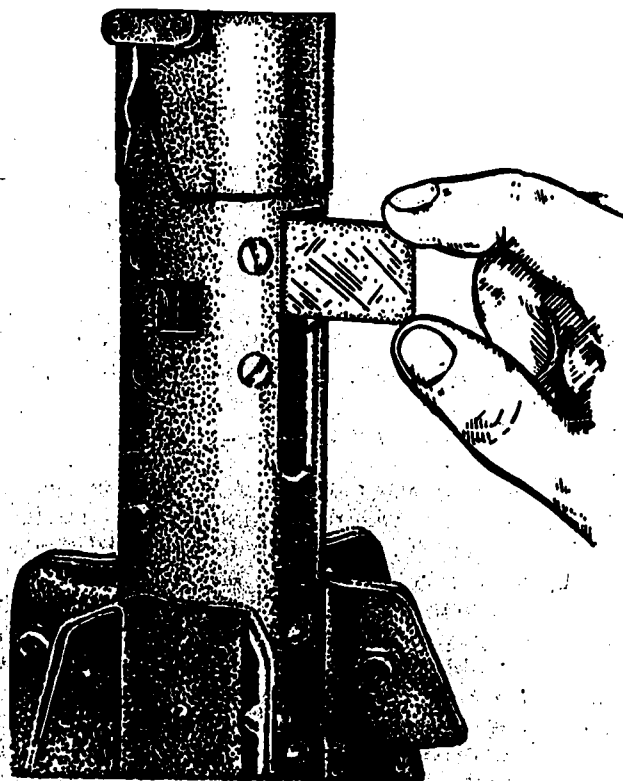

71.77

Figure 5-7.—Inserting the slide.

the stop pin. The slide must be fully in, otherwise the temperature recorded will be fictitiously low. Check the grooves of the slide holder to ensure that they are clean, free of glass chips, and that the spring holds the slide firmly against the opposite groove. With the slide fully in, the stylus is brought against the plated surface when the sleeve is moved back to cover the opening. To reduce extraneous scratches on the slide, do not move the sleeve back until the BT is ready to be put over the side.

Step 5—Put BT Over the Side

After obtaining permission from the OOD to make a lowering, pick up the BT and pull the sleeve down over the slide port. On the shallow and medium depth models, pull the sleeve down toward the tail as far as possible so as to engage the catch of the stylus lifter, then push the sleeve up toward the nose about 1 inch. This action leaves the port open enough for the catch to release when the BT is retrieved. On the 900-foot model, the sleeve should remain all the way back toward the tail. Set the winch lever in neutral. With one hand, hold the BT at the rail; with the other, take up the slack in the wire by rotating the drum. Set the brake when all slack is in.

When ready to commence lowering, set the winch lever to neutral and lower the BT into water to such a depth that it tows smoothly just below the surface. Put on the brake and hold the BT there for 1 minute to enable the thermal element to come to the temperature of the surface water. Set the winch counter at zero.

Step 6—Take Bucket Temperature

While the BT is being towed at the surface, take the bucket temperature of the surface water and record it on the bathythermograph log sheet. Special bucket thermometers are supplied for U.S. Navy surveys by the Oceanographic Office. These special bucket thermometers are more accurate than thermometers issued with the BT kits, and are to be used in lieu of the ones in the kits. The thermometers are read to the nearest 0.1°F.

A bucket can be made from a half-gallon can (obtained from the galley) and attaching a line to it. Attach the bitter end of the line to the lifeline or rail. Throw the can over the side and let it fill and empty several times before hauling a surface sample aboard. As soon as it is aboard, set it on deck and insert the

INTRODUCTION TO SONAR

thermometer into the bucket so that at least 3 inches of the bulb end is immersed in sea water. Stir the thermometer with a circular motion for 20 to 30 seconds and then read it with the stem still immersed in the water. Stir it once or twice more and check the reading.

The bucket sample must be taken while the BT is being towed. Make the temperature reading as soon as possible after the sample is on deck. If the sample is allowed to stand for more than 45 seconds, the temperature reading no longer is valid. It also is of importance to stir the thermometer to bring it to temperature more rapidly and accurately.

Step 7—Lower the BT

Move the winch lever to the neutral position and allow the wire to pay out freely. Success in reaching the maximum desired depth depends chiefly on two factors: (1) having the winch drum and towing block bearings well lubricated to minimize friction; and (2) getting the BT down below the ship's screw wash as soon as possible. With practice, it is possible to raise the BT slightly, after the surface towing is completed, skip it off the crest of a wave so that it swings forward, and then lower it rapidly. This method enables the BT to plunge into the water, and its momentum will carry it more rapidly past the turbulence of the wash, enabling it to reach a greater depth. This technique is especially useful with the 900-foot instrument. It takes practice, but, to the experienced operator, this method is easy to use and is more effective than the diving lug assembly attached to some of the old models.

When the ship is making more than 12 knots, there usually is enough drag on the wire while the BT is diving to ensure that it will not slacken and backlash. At lower speeds, and during heavy rolling, the wire may slack between the winch and the towing block. Slack in the wire may cause backlash on the winch drum or a kink at the towing block. The operator should provide himself with a round stick about 15 inches long for the purpose of gently slowing the drum when excessive slack appears. Do not apply too much pressure to the drum with the stick, because once the diving motion of the BT is arrested, it will not dive farther, regardless of the amount of wire payed out. Do not touch the wire with your hands when the drum is in motion; you may be injured seriously.

Step 8—Stop at Proper Depth

To reach a given depth, the amount of cable to be payed out depends on the speed of the ship, the type of BT, and whether the nose sleeve is attached. Table 5-2 provides a rough estimate of speeds at which full depth may be expected to be reached when using 1000 feet of wire.

The observer should take data on the length of wire payed out and the actual depths recorded by the BT. He then should plot a graph showing counter reading against depth for various ship speeds.

When the counter indicates that the proper length of wire is payed out, or when the last layer of wire on the drum is reached, the brake should be applied smoothly, allowing the drum to stop without a sudden jerk. An excessive jerk will part the wire. Now the BT will swim back up to near the surface far astern. Check to see that the wire leads properly for hauling in. If it does not lead from the towing block to the center of the drum, adjust the boom guys until it does.

Step 9—Haul in the BT

Move the hand lever smartly from the brake position to the hoist position. Do not pause while going through neutral, otherwise more wire will pay out. Guide the wire back and forth in even layers on the drum, using the stick. The end of an old swab handle will do. Do not use a metal guide. If kelp or seaweed fouls the wire, ease on the brake and clear the wire with a boathook. Haul in at full speed until the BT is close astern but still a safe distance from the ship's screws.

Step 10—Bring BT Aboard

When only about 100 feet of wire is out, the BT should be readily visible at the surface. As the wire is hauled in, the BT will reach a position nearly under the boom where it will begin to porpoise, breaking clear of the surface and swinging forward as the ship rolls or as wave crests pass. This action is the most critical point in the operation. To bring the BT alongside and raise it without too much swing requires practice. If the BT is brought in too fast, it may skip or swing forward of the boom, perhaps hitting the side of the ship or swinging completely over the boom. If the BT skips or swings forward of the boom, it is advisable to shift at once to neutral and allow the BT to sink freely until it passes

Chapter 5—BATHYTHERMOGRAPH

clear astern and it is safe to try again. The operator must learn the feel of his own winch.

With a little practice the BT can be brought safely to within 2 or 3 feet of the towing block. The winch motor should be turned off at this point, eliminating the possibility of accidentally jamming the BT against the towing block. Some winches have a handcrank, permitting manual rotation of the drum at this point. The BT can then be brought aboard in various ways, depending on how the boom is rigged.

With the standard gate boom, the use of a retrieving line and ring is recommended. This line consists of a metal ring from 1 to 1-1/2 inches in diameter through which the wire is passed between the towing block and the BT. To the ring is attached a retrieving line, which is secured to the lifeline or rail. With the proper amount of slack, the ring rides freely when the BT is being lowered and hoisted. By hauling in on the retrieving line while easing the brake, the BT can easily be brought to hand.

If a retrieving line is not used, it will be necessary to rig in the boom by casting off the after guy and swinging the boom in with the forward guy. Two men can pull it in with a boathook—one man on the hook and the other to slack the wire with the winch. If the boom tops up, the BT can be brought aboard by one man hauling in on the topping lift.

Step 11—Remove Slide and Secure Equipment

As soon as the BT is in hand, move the sleeve forward toward the nose to lift the stylus off the slide. This action prevents the upper portion of the trace from being affected by air temperature and becoming obscured as the instrument is handled.

Slack off the wire, place the BT in its deck rack, and set the brake. Notify the bridge that the BT is on deck. Partially eject the slide by pushing against its edge with the forefinger, the wire slide remover, or a pencil through the slide-ejecting port. Grip the slide carefully by the thumb and forefinger. Hold the slide only by the edges, being careful not to obscure the trace with smudges or fingerprints.

If another lowering is to be made soon and there is no danger of overheating the BT, it may be left in the deck rack connected to the wire. Otherwise, unshackle it and stow in a cool place.

CAUTION: Never let the temperature of the BT exceed 105°F (40.6°C). If this temperature is exceeded, the calibration of the instrument will be damaged. Never leave the BT on deck without protecting it from hot sun. Suitable protection to the thermal element can be effected by keeping it covered with wet cloths.

Step 12—Check Slide

As soon as the slide is removed from the BT, examine it to be sure that a suitable trace was obtained. If the trace is smudged or obliterated in any way, lower the BT again with a fresh slide.

Once a suitable slide is obtained, rinse it off in fresh water, and label it according to the directions given later in this text under the topic heading "Marking BT Slide."

PRECAUTIONS TO BE OBSERVED

To obtain the greatest accuracy and prolong the useful life of the BT, certain precautions must be observed. They are discussed in the ensuing topics.

Disassembling BT

Do not disassemble the BT. It is a precision instrument, with delicate internal mechanisms. Even with the greatest care possible, it is difficult to avoid damage if disassembling is attempted aboard ship.

If, for any reason, the BT fails to operate satisfactorily, it should be turned in for repair, with a report indicating the symptoms to aid the repair facility in correcting the trouble. Standard failure reports also should be submitted in accordance with current directives.

Maintenance of BT

The BT is an accurate measuring instrument and, although the construction is reasonably rugged, the internal mechanisms are delicate. Careful handling is essential to maintain the accuracy of the measuring elements.

After each period of use, the BT should be rinsed with fresh water. Never store a BT that is being withdrawn from use without first rinsing it thoroughly.

INTRODUCTION TO SONAR

The interior of the BT should be rinsed weekly with half a cupful of corrosion preventive compound (specification MIL-C-16173, grade 3 (stock number 8030-244-1296 for 1 gallon can)). Place the BT in a clean bucket with the tail fins down. Slide the sleeve forward toward the nose, pour in the compound, and close the sleeve. Cover the four openings in the body tube, shake the BT, and turn it over on its nose and back several times so that every part is rinsed thoroughly. Then let the compound drain out. The compound can be re-used several times. Do not oil the BT; fresh water or rust-preventive compound is the only lubrication necessary.

Inspecting New Slides

Do not remove the water and airtight cover from around the box of slides until ready to use the slides from that box. Samples of slides in a new box should be inspected before using. If the coated surface of a new slide is in bad condition, or if the surface shows spots after lowering the BT, all the slides in the box should be tested by holding each slide under a moderate stream of water. Do not use slides on which spotting or flaking of the coated surface appears. If more than 25 percent of the slides are unusable as a result of spotting or flaking, report the failure in accordance with current Naval Ship Systems Command instructions.

CHECKING CALIBRATION

Expected accuracy of the BT is 0.1°F for temperature and 10 feet or less for depth. If, for any reason, the instrument is suspected to be in error, the following emergency procedures can be used aboard ship to check its accuracy.

Temperature

To check the calibration of the thermal unit, insert a new slide in the BT and leave the sleeve up so that the stylus does not touch the slide. Immerse the BT, tail first, in a bucket containing water of about 40°F, and deep enough to cover the sleeve. Insert a bucket thermometer into the water and stir for 30 seconds. Push down the sleeve, engaging the stylus, and take the bucket temperature reading. Raise the sleeve and trip the stylus, leaving the BT in the water. Add hot water to bring

the bucket temperature up to about 60°F and repeat the measuring process, and again at a water temperature of 80°F. Next, subtract algebraically each bucket thermometer temperature reading from its corresponding BT temperature reading. Add all the differences and determine the average temperature difference. On future lowerings, apply the average difference to each temperature reading.

Depth

Immerse the BT thermal element, with the sleeve down, in a bucket of water of about 40°F, then in a bucket containing water of about 85°F. This temperature difference will cause a zero depth line to be drawn on the slide. Place the slide in a viewer and read the difference between the trace depth line and the zero depth line of the grid. For future slide readings, apply the depth error to each temperature change point to obtain correct depth at that point.

REPLACEMENT

Turn in the BT for recalibration or repair if any of the following conditions exist: BT temperature consistently differs 4°F or more from bucket thermometer temperature; depth error of more than 10 feet for the 200-foot model,

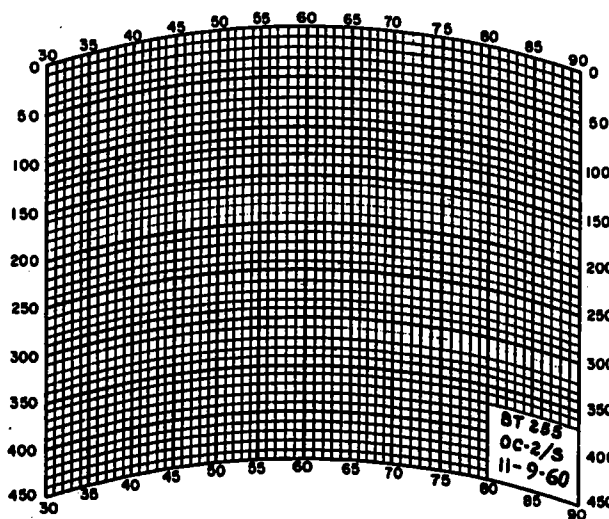

71.81
Figure 5-8.— BT grid.

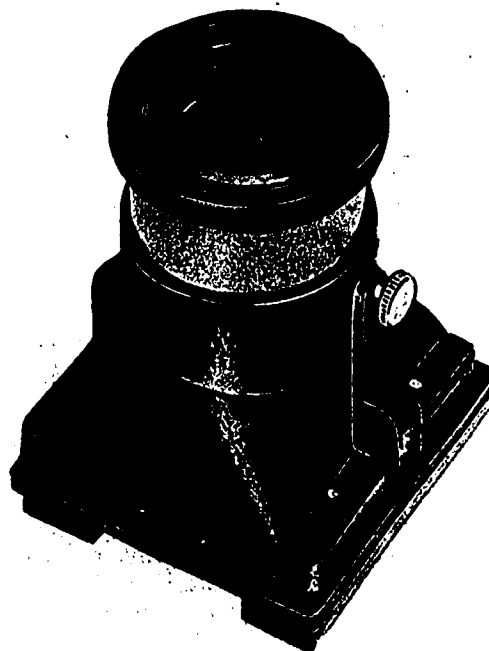
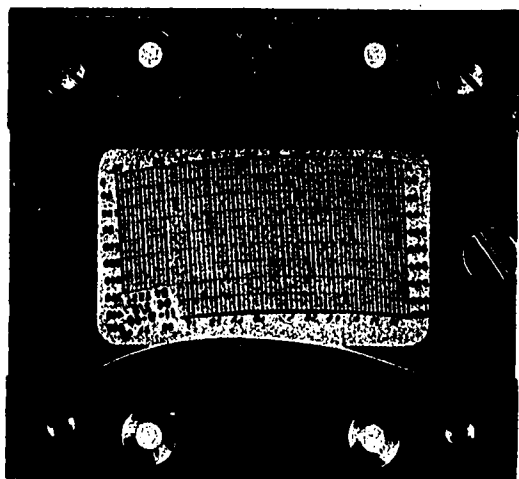

71.82

Figure 5-9.— Grid mount assembly and slide viewer.

20 feet for the 450-foot model, and 40 feet for the 900-foot model; the BT slide shows double traces over the entire trace length; more than 18 months have elapsed since last calibration.

BT SLIDES

To make proper use of information on the slide obtained by lowering the BT, an understanding of how to interpret the trace and its meaning is of as much importance as the lowering and raising process. To read the trace properly, two pieces of equipment are necessary. They are the BT grid and the slide viewer.

GRID AND VIEWER

Notice in figure 5-8 that the grid has a block in the lower right corner containing certain information. Included are the BT serial number, the type (OC-2/S, meaning that it is the medium, or 0- to 450-foot depth model), and the date of manufacture.

The grid is mounted in a grid mount assembly that attaches to a slide viewer. Both of these

items, needed for reading BT slides, appear in figure 5-9. The grid mount assembly in the illustration is a bottom view and shows the grid as it is mounted in the assembly. Putting it in as shown (backwards) allows it to be read correctly when viewed through the slide viewer. The BT slide fits behind it with the etched side toward the grid, and is held in place by a spring clamp.

Loading Slide into Grid Mount Assembly

To load the BT slide into the grid mount assembly, set the slide loosely in the holder. It should be positioned with the coated surface down and the beveled corners on the right side, just clearing the stop pin. Hold the assembly as shown in figure 5-10. With a thumb motion like that used in rolling a cigarette, push the slide against the spring until the slide drops flat against the grid. Then push the slide to the right firmly against the stop pin. The coated surface should lie smoothly against the grid.

The prescribed method prevents the grid from scratching or rubbing against the coated surface. When the holder and slide are placed

INTRODUCTION TO SONAR

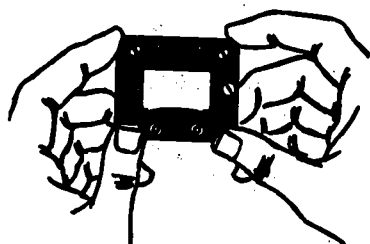

71.83.2
Figure 5-10.—Locking the BT slide in the grid mount assembly.

in the viewer, make sure that the slide is kept tight against both the stop pin and the groove opposite the spring. Otherwise, temperature and depth readings will be incorrect.

If the grid becomes loose in the holder, apply cement to the face of the grid. Check to see that the narrow edge of the grid is tight against the stop pin, and that the long edge (the zero pressure edge) is tight against the edge of the holder opposite the spring. The spring is narrow and is placed in such a position that the grid fits behind it. As a result, the spring bears on the slide and holds it snugly without pressing on the grid.

Reading Accuracy

The trace scratched by the stylus is a temperature-depth curve. Each point on the trace represents the temperature at a given depth. Temperature and depth values are read from the curve on the slide. Temperatures are read horizontally and should be read as close as possible to the nearest tenth (0.1) of a degree. Depths are read vertically and should be read to within 10 feet or better on the 900-foot BT, 5 feet or better on the 450-foot BT, and 2 feet on the 200-foot models.

When a BT slide is seen through the viewer, the trace is superimposed upon the grid for the particular BT that made the temperature recording. Figure 5-11 shows what a Sonar Technician sees as he views a BT slide.

Place the slide back of the transparent glass grid, which is ruled off in temperature and depth scales. The slide should be held back of the grid in the same position it had in the BT. The viewer's eyepiece may be adjusted to bring the

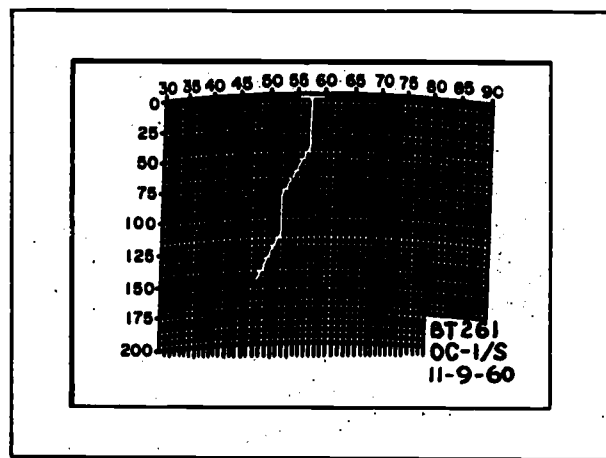

71.84
Figure 5-11.—BT slide as seen through the viewer.

trace and scales into proper focus. Handle the grid carefully to avoid scratching the grid or the slide. Each BT has three identical grids. Two are sent along with the BT, one of them to be used as a spare. The third grid is retained at the National Oceanographic Data Center.

HYSTERESIS EFFECTS

The stylus etches information while the BT sinks and also as it rises. If water conditions where it rises differ greatly from where it sinks, two distinctly different traces will be seen. Usually, however, differences in water conditions are negligible, so that, if two traces appear, they may be caused by hysteresis. This condition is a lag in the movement of one of the elements.

If it is suspected that hysteresis exists, insert a new slide in the BT and make a second lowering. A brief inspection of the slides will reveal if water conditions changed during the two lowerings. If water conditions are the same, and the BT is affected by hysteresis, each of the two slides will show two separate traces following each other. If the traces are essentially similar, a slight separation is negligible.

READING SURFACE TEMPERATURE

When the BT is on the deck, it usually has a different temperature than when put into the

Chapter 5—BATHYTHERMOGRAPH

water. The temperature element moves the stylus along the zero depth line of the surface water temperature position during the 30 seconds or more when the BT is towing at the surface. Consequently, the top of most traces is an almost horizontal line. This surface trace should fall along the zero depth line of the grid when the slide is viewed. If it appears more than 3 feet above or below, correct the depth readings by the amount of this error. Read surface temperature by noting the point at which the trace starts downward from the surface trace.

It's a good idea to make a comparison from time to time between the surface temperature as read from the slide, and the bucket surface temperature as read for the same lowering. On a series of slides taken from the same BT, the readings from the slide and the bucket thermometer should be about the same. If there is a difference, and if the difference continues for later lowerings, the calibration of the BT probably has shifted. A shift in calibration, sometimes called a shift in the zero points, usually does not change the accuracy of the BT. But, make a note on the BT logsheet showing the slide number and the time at which a shift in calibration was detected.

If the BT accidentally strikes either the ocean floor or an underwater object, the depth at which it struck can be determined by reading the depth of the horizontal line across the trace, made when the stylus arm vibrated with the shock.

READING BT TRACE

The bathythermograph, as already pointed out, provides a continuous visual record of the temperatures from the surface of the sea to a depth to which it is lowered. The temperatures of various ocean depths recorded on the slide by the BT are represented as a graph of temperature against depth when seen through the grid viewer. Figure 5-12 shows the portion of a BT grid immediately surrounding the trace.

In figure 5-12, the line marked "A" represents changes in temperature between the sea surface and a depth of 250 feet. Little change in temperature results until a depth of 50 feet is reached. At that point, the temperature of the water begins to cool quite rapidly to a depth of 145 feet. Below 145 feet, the water cools more slowly.

From the temperature curve, one can discover the sound pattern of the sea at the time

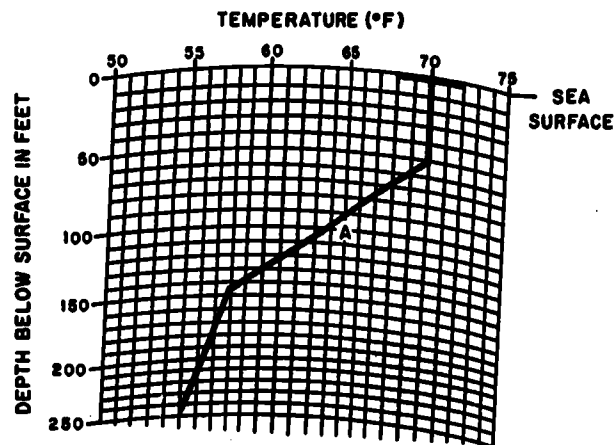

71.85
Figure 5-12.—Graphing the BT trace.

of the bathythermograph observation. It is from the sound pattern that an estimate of maximum sonar range can be made.

The variation of temperature with depth can be quite complicated. Many different conditions may be represented by the different bathythermograph slides. It is convenient to consider the water as layers. In each layer the temperature can change from top to bottom. Create a mental picture of the location of these layers from the appearance of the slide. Visualize, too, how the temperature is changing. Study the following examples until each kind of layer can be identified easily.

Negative Gradient

A negative gradient condition exists when the temperature of the water decreases with depth. A BT, lowered through a negative gradient, produces a slide with the etched trace sloping to the left as depth increases. Figure 5-13 represents a trace showing a negative gradient. This illustration depicts a particularly sharp gradient, which is quite common. Negative gradients spell trouble for sonar operators because they result in short sonar ranges.

Positive Gradient

Sometimes, layers are found in which the temperature increases with depth. The BT trace slopes to the right. Although usually observed

INTRODUCTION TO SONAR

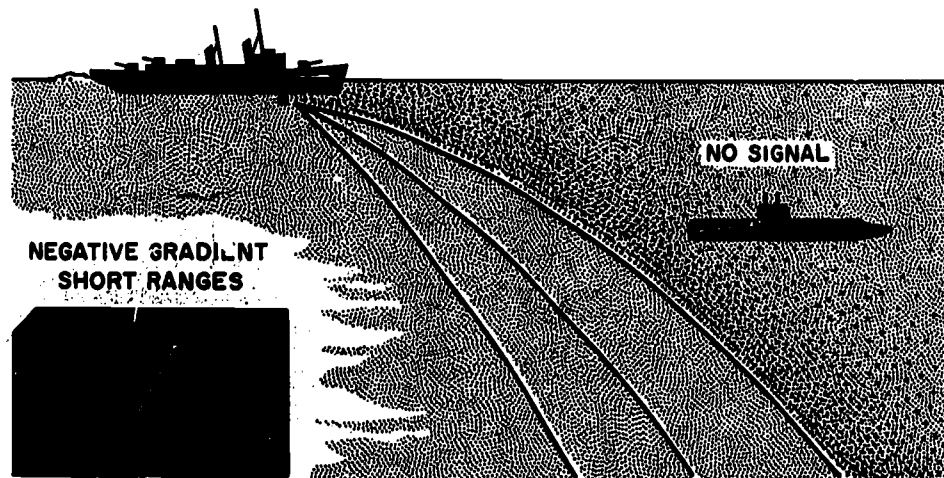

71.87

Figure 5-13.—Sound pulse travel through negative gradient.

in coastal waters, this condition may be found anywhere. In figure 5-14 a positive gradient is shown to exist down to a certain depth, beyond which a negative gradient is formed. Depending on the depth of the start (top) of the negative gradient, such a trace can also mean trouble for the Sonar Technician. As a result of this condition, the shipboard sonar operator observes

unusually long ranges to targets near the surface. Little of the pulse's power penetrates the negative gradient, however. The reason is that the higher temperatures in the lower part of the positive gradient bend the pulse back up toward the surface of the sea from which it is reflected downward again, and so on, forming a surface channel.

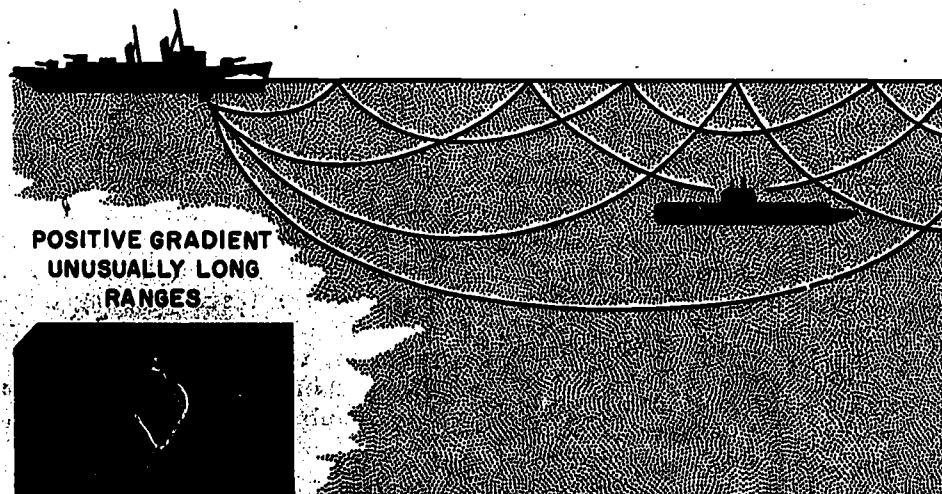

71.86

Figure 5-14.—Sound pulse travel through positive gradient.

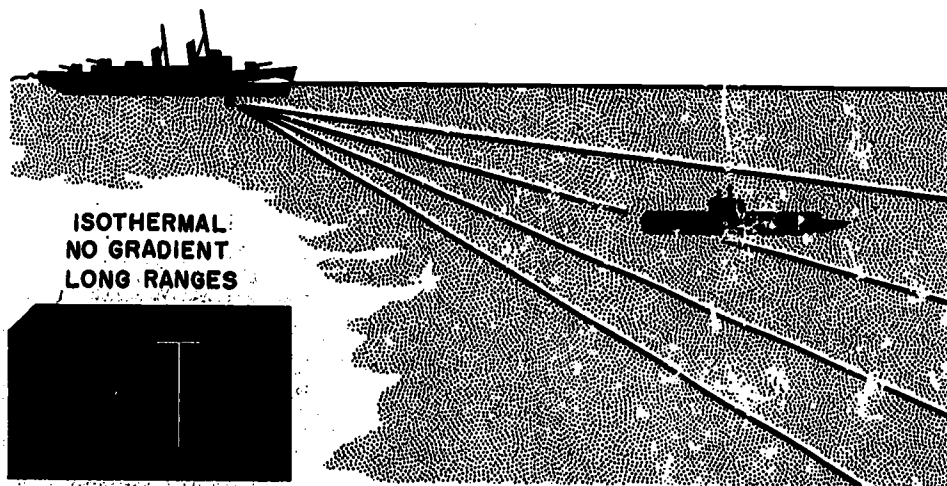

71.88

Figure 5-15. — Sound pulse travel through isothermal water conditions.

Any energy of the pulse that does pass through the negative gradient is reduced greatly, and the sound beam is bent sharply downward. Submarines operating 50 feet or more beneath the top of the negative gradient are difficult targets to detect. The shipboard Sonar Technician may get extremely long ranges on a submerged target near the surface (such as the underwater section of the hull of another screening ship), but he may be unable to detect a submarine just a few hundred yards away. Should the submarine enter the positive gradient, however, it probably would be detected.

Isothermal Layer

An isothermal layer of water is one of uniform or nearly uniform temperature throughout. This condition is not confined necessarily near the surface of the sea, but often is found between layers or gradients of markedly different temperatures. An isothermal condition can be caused by waters of two different temperatures mixing. In this respect, it sometimes is referred to as a mixed layer. Isothermal layers are of importance in predicting the path the sound pulse will follow. For this reason Sonar Technicians must be able to read accurately the top and bottom depths of such a layer. You are shown an isothermal condition in figure 5-15. Now look at figure 5-16 to see how isothermal layers sometimes are located in a

temperature profile of the sea. Notice that every time a straight, vertical BT trace is recorded, the layer of water between its limits is known to be isothermal.

DAILY HEATING

Daily heating of the surface water layer has a marked effect on sonar ranges. It produces a condition ASW men call afternoon effect.

When the surface is heated by the summer sun, and the winds are not strong enough to keep the surface water well mixed, the water close to the surface may be several degrees warmer than the water 20 to 30 feet down. This effect is maximum in the late afternoon,

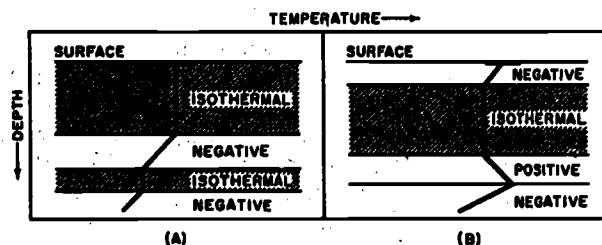

71.89

Figure 5-16. — Temperature profiles.

75
80

INTRODUCTION TO SONAR

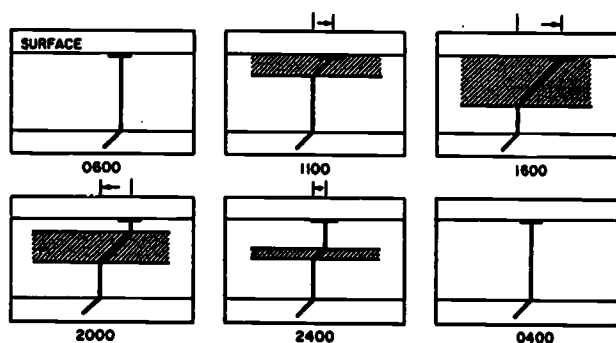

71.90

Figure 5-17.—Effect of daily heating.

and usually disappears at night as the surface cools off and water continues to mix. Figure 5-17 is a simplified illustration showing how traces on a series of slides may indicate daily heating or cooling near the surface.

An isothermal layer is seen at 0600 (local time) on a calm, clear day. From 0600 to 1600 the surface is shown gaining heat from the sun faster than it can dissipate the heat back into the atmosphere. The surface temperature increases, and a negative gradient layer, represented by the crossed lines, is established. This layer deepens as the heat penetrates, and diffuses downward by conduction during the time the surface is gaining heat.

After 1600 the surface cools off by evaporation faster than it receives heat from the declining sun. The cooler and denser surface water mixes and may destroy the negative gradient layer. Sufficient cooling may occur during the night to reestablish a single isothermal layer, as shown at 0400.

MARKING BT SLIDE

Immediately after the slide is removed from the BT, it must be marked as outlined herein. Use a sharp pencil, and be careful that you don't obscure or touch the temperature trace. Information on the slide and BT logsheet must agree. Figure 5-18 illustrates the information to be marked on the slide.

1. Line 1, Consecutive slide number and time group: Number the slides consecutively between ports. If 300 slides are used, they are numbered from 1 to 300. Use Greenwich

mean time (0000 to 2359), giving the hour and minute at which the bathythermograph entered the water. Draw a dash between the slide number and the time. Slide number 5, taken at 2240, for example, is marked 5-2240.

2. Line 2, Date: Day, month, and year are entered as numerals. Use Roman numerals for the month. For example, 29 November 1950 is written as 29-XI-50.

3. Line 3, BT instrument serial number: The serial number of the BT is stamped near the nose of the instrument. It is an important number, because the data center that processes your slides has over ten thousand grids, only one of which is a duplicate of yours. Always include any letter that precedes or follows the serial numbers; for example, BT 1216A or BTAA-1257. Without the proper instrument serial numbers, the information on your slide is worthless.

FURTHER USE OF BT SLIDES

In addition to providing immediately useful data on the temperature conditions of the sea, BT slides are used in compiling charts that give the ocean's average thermal conditions for each month of the year. These charts are published by the Navy Oceanographic Office in the form of an atlas. Atlases give the average thermal conditions and probable detection ranges for various types of operational search sonar equipments. The charts are used by planning

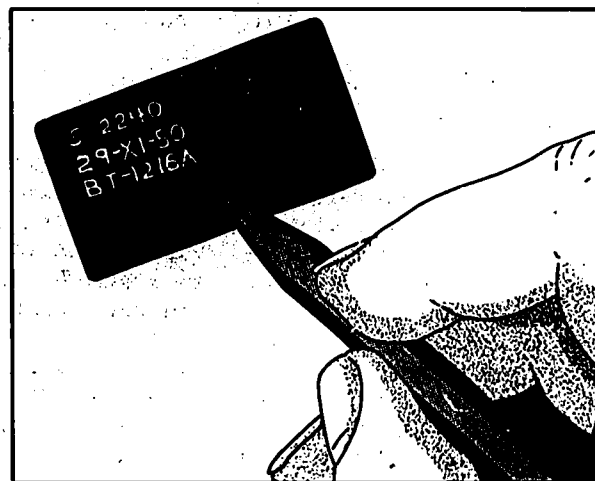

71.91

Figure 5-18.—Marking the BT slide.

Chapter 5—BATHYTHERMOGRAPH

personnel to select safe convoy routes. Another use is to estimate where the enemy might have his submarines deployed.

In wartime, routes of each convoy must be planned carefully. If an area in the ocean has consistently poor sonar conditions, the convoy escorts will have difficulty detecting submarines, so the convoy should stay clear. If the average detection ranges between two areas differ noticeably, it will be necessary to vary spacing of the escorts. The atlases show these conditions and, because they are available in advance of the actual operation, they can be used to estimate the number of escorts needed to provide adequate protection.

The atlases are prepared from the information contained on thousands of BT slides, which, for many years, have been forwarded by individual ships to the Oceanographic Office. At the Oceanographic Office, the slides are analyzed, and average monthly thermal conditions for areas of the ocean are plotted on ocean charts. The result is a monthly series of charts showing average condition thermal belts. The belts can be consulted to decide which are the dangerous and which are the relatively safe passage routes.

To guarantee that the slides arrive in good condition, they must be handled with utmost care. They must not be smudged, scratched, or broken. To be useful, they must retain all of the information required by the National Oceanographic Data Center, where the slides now are processed.

MAILING SLIDES AND LOGSHEETS

To avoid breakage and to ensure safe delivery of the BT slides, make certain that you carry out the following precautions before mailing the slides to the Oceanographic Office.

1. Put no material between slides.
2. Pad the box well, using the same box in which the slides were received.
3. Put in completed standard mailing label. Copies of this form (NODC-3167/11 (9-61)) may be obtained from the National Oceanographic Data Center (NODC).
4. Pack slides in a cardboard box.
5. Wrap the packages securely, and label clearly (type or print legibly) with the following data: ship's name, date of cruise, and sheet number of the BT logsheet. Be sure this information is on the duplicate standard label inside the box.

The foregoing procedure is to protect your slides so that NODC has the necessary information to process them. Fold and staple the BT logsheet so that the mailing format printed on the reverse side is displayed. Mail the BT slides, logsheets, and recorder charts to—

The National Oceanographic Data Center
Washington, D.C. 20390

OBTAINING ADDITIONAL LOGSHEETS AND SLIDES

Bathymograph logsheets may be obtained as follows:

1. All naval activities in the Atlantic area (including the Gulf of Mexico, Panama Canal Zone, European and Mediterranean areas) submit completed Form DD-1149 to—
The Oceanographic Distribution Office
U.S. Naval Supply Depot
5801 Tabor Avenue
Philadelphia, Pa. 19120
2. All naval activities in the Pacific area (including Antarctic and Indian Oceans) submit completed Form DD-1149 to—
The Oceanographic Distribution Office
U.S. Naval Supply Depot
Clearfield, Utah 84015
3. All other naval activities may request from—
The National Oceanographic Data Center
Washington, D.C. 20390

Bathymograph slides are a standard stock item in the electronic system and are obtained through any normal supply support channel. The stock number and description is: NS 6655-67-67-987, Slide Set, Metallic Coated. A set consists of molded plastic box, 50 slides, and telescoping box for shipping.

BT LOGS

All BT slides must be accompanied by a BT logsheet (NODC-EXP-3167/10 Rev. 3-66) when sent to the National Oceanographic Data Center. The completed form is essential for processing the BT slides. All items on the form must be filled in. The BT log is designed to provide a standard format for radio transmission of synoptic BT data. Its purpose also is to provide NODC with the information required for computer processing of BT data.

INTRODUCTION TO SONAR

NODC-EXP-3107/10 (REV. 3-86)

NATIONAL OCEANOGRAPHIC DATA CENTER
BATHYTHERMOGRAPH LOG

ENVIRONMENTAL DATA

VESSEL USS FRED T. BERRY DD85B COUNTRY U.S.A. SHEET NO. 1

INSTITUTE U.S. NAVY CRUISE NO. — STATION NO. —

1 BT INSTRUMENT NUMBER AND LETTER <small>(Prefix/Suffix)</small>	2 CONSECUTIVE SLIDE NUMBER	3 DATE (GMT)			4 TIME (GMT)		5 LATITUDE			6 LONGITUDE											
		DAY	MONTH	YEAR	HOUR	MIN.	DEG.	MIN.	N S	DEG.	MIN.	E W									
9027A	7	1	8	08	6	7	1	2	3	0	3	7	4	2	N	0	6	5	2	7	W

7 DEPTH TO BOTTOM	8 WIND		9 AIR TEMPERATURE		10 BAROMETRIC PRESSURE <small>(Inch.)</small>	11 CLOUD	12 WAVE		13 SEA SURFACE REF. TEMP.															
	<input checked="" type="checkbox"/> Fathoms <input type="checkbox"/> Meters	DIR.	SPEED (KNOTS)	DRY BULB			WET BULB	TYPE	AMT.	HEIGHT <small>(ft)</small>	PERIOD (SEC)	CODE	TEMPERATURE											
1650	1	1	08	7	2	7	6	9	8	9	0	5	1	8	3	0	8	0	6	X	X	6	8	6

CRUISE NO. — STATION NO. —

1 BT INSTRUMENT NUMBER AND LETTER <small>(Prefix/Suffix)</small>	2 CONSECUTIVE SLIDE NUMBER	3 DATE (GMT)			4 TIME (GMT)		5 LATITUDE			6 LONGITUDE														
		DAY	MONTH	YEAR	HOUR	MIN.	DEG.	MIN.	N S	DEG.	MIN.	E W												

7 DEPTH TO BOTTOM	8 WIND		9 AIR TEMPERATURE		10 BAROMETRIC PRESSURE <small>(Inch.)</small>	11 CLOUD	12 WAVE		13 SEA SURFACE REF. TEMP.															
	<input type="checkbox"/> Fathoms <input type="checkbox"/> Meters	DIR.	SPEED (KNOTS)	DRY BULB			WET BULB	TYPE	AMT.	HEIGHT <small>(ft)</small>	PERIOD (SEC)	CODE	TEMPERATURE											

CRUISE NO. — STATION NO. —

1 BT INSTRUMENT NUMBER AND LETTER <small>(Prefix/Suffix)</small>	2 CONSECUTIVE SLIDE NUMBER	3 DATE (GMT)			4 TIME (GMT)		5 LATITUDE			6 LONGITUDE														
		DAY	MONTH	YEAR	HOUR	MIN.	DEG.	MIN.	N S	DEG.	MIN.	E W												

7 DEPTH TO BOTTOM	8 WIND		9 AIR TEMPERATURE		10 BAROMETRIC PRESSURE <small>(Inch.)</small>	11 CLOUD	12 WAVE		13 SEA SURFACE REF. TEMP.															
	<input type="checkbox"/> Fathoms <input type="checkbox"/> Meters	DIR.	SPEED (KNOTS)	DRY BULB			WET BULB	TYPE	AMT.	HEIGHT <small>(ft)</small>	PERIOD (SEC)	CODE	TEMPERATURE											

Chapter 5—BATHYTHERMOGRAPH

REPLACES BATHYTHERMOGRAPH RADIO LOG PRINC-NODC 3167/10 (REV. 11-63)
AND ALL OTHER PREVIOUS RADIO LOGS

RADIO MESSAGE INFORMATION

VESSEL *USS FRED T. BERRY DD 858*

1 MESSAGE PREFIX	2 DAY OF WEEK	3 TIME HOUR MIN.	4 O 5 C T LATITUDE DEG. MIN.	6 LONGITUDE DEG. MIN.	7 SEA SURFACE REF. TEMP. CODE TEMP.
BATHY	3	1230	03742	06527	XX686

BATHYTHERMOGRAPH TRACE READINGS

DEPTH Z ₀ Z ₁ Z ₂ Z ₃ Z ₄	TEMP. T ₀ T ₁ T ₂ T ₃ T ₄	DEPTH Z Z T ₁ T ₂ T ₃ T ₄	DEPTH Z Z T ₁ T ₂ T ₃ T ₄	DEPTH Z Z T ₁ T ₂ T ₃ T ₄	DEPTH Z Z T ₁ T ₂ T ₃ T ₄	DEPTH Z Z T ₁ T ₂ T ₃ T ₄	MESSAGE SUFFIX
00647		14647	30694	40676	51619		
54563		73552	90492				19991

DATE / TIME GROUP
181406
MONTH-YEAR
08-67

1 MESSAGE PREFIX	2 DAY OF WEEK	3 TIME HOUR MIN.	4 O 5 C T LATITUDE DEG. MIN.	6 LONGITUDE DEG. MIN.	7 SEA SURFACE REF. TEMP. CODE TEMP.
BATHY					

BATHYTHERMOGRAPH TRACE READINGS

DEPTH Z ₀ Z ₁ Z ₂ Z ₃ Z ₄	TEMP. T ₀ T ₁ T ₂ T ₃ T ₄	DEPTH Z Z T ₁ T ₂ T ₃ T ₄	DEPTH Z Z T ₁ T ₂ T ₃ T ₄	DEPTH Z Z T ₁ T ₂ T ₃ T ₄	DEPTH Z Z T ₁ T ₂ T ₃ T ₄	DEPTH Z Z T ₁ T ₂ T ₃ T ₄	MESSAGE SUFFIX
00							19991

DATE / TIME GROUP
MONTH-YEAR

1 MESSAGE PREFIX	2 DAY OF WEEK	3 TIME HOUR MIN.	4 O 5 C T LATITUDE DEG. MIN.	6 LONGITUDE DEG. MIN.	7 SEA SURFACE REF. TEMP. CODE TEMP.
BATHY					

BATHYTHERMOGRAPH TRACE READINGS

DEPTH Z ₀ Z ₁ Z ₂ Z ₃ Z ₄	TEMP. T ₀ T ₁ T ₂ T ₃ T ₄	DEPTH Z Z T ₁ T ₂ T ₃ T ₄	DEPTH Z Z T ₁ T ₂ T ₃ T ₄	DEPTH Z Z T ₁ T ₂ T ₃ T ₄	DEPTH Z Z T ₁ T ₂ T ₃ T ₄	DEPTH Z Z T ₁ T ₂ T ₃ T ₄	MESSAGE SUFFIX
							19991

DATE / TIME GROUP
MONTH-YEAR

INTRODUCTION TO SONAR

A sample logsheet is illustrated in figure 5-19. Information pertaining to one BT drop is supplied on the form. The environmental half of the logsheet requires completion of 14 items. The radio message portion has 7 data units, plus spaces for the necessary trace readings.

ENVIRONMENTAL DATA ENTRIES

In the heading of the environmental data section, record your ship's name and hull number, country, sheet number, and sponsoring activity. Spaces for cruise and station numbers are for special assignments. If an apparent malfunction of the BT occurs, include pertinent information at the bottom of the sheet under "Remarks." Successive logsheets are numbered consecutively.

Item 1—BT Instrument Number

The number is stamped on the nose of the BT. Always include any letter used as a prefix or suffix to the number. Compare the number stamped on the BT with the number on the BT grid. The two numbers MUST agree.

Item 2—Slide Number

Number the slides consecutively, starting with number 1 for the first BT reading taken after leaving port.

Item 3—Date

Day and month are given according to Greenwich date. Record the last two digits of the year.

Item 4—Time

Record the GMT hour and minute at which the BT entered the water.

Items 5 and 6—Latitude and Longitude

Record the degrees, minutes, and hemisphere (N or S, E or W) at the time of lowering the BT. Prefix with zero when necessary to complete the degrees boxes. Example: Latitude 8° is recorded as 08; longitude 27° is recorded as 027.

Item 7—Water Depth

Enter depth obtained by sounding at time of lowering BT. Check appropriate box to indicate fathoms or meters.

Item 8—Wind

Enter true wind direction, to the nearest 10°, using the appropriate code from the accompanying list. Record the true wind speed in knots.

Item 9—Air Temperature

Record the dry and wet bulb air temperatures, to the nearest 0.1°, and check the appropriate box for °F or °C. If centigrade temperature is less than 0°, add 50.0 to the actual reading (-2°C is entered as 52.0). Enter a dash above the first (tens) digit to indicate Fahrenheit readings below 0°.

Item 10—Barometric Pressure

Use millibars, to the nearest tenth, to record barometric pressure, omitting the thousands and hundreds digits (1011.2 mb = 11.2). Table 5-3 is used in converting inches to millibars.

Item 11—Weather

Record present weather (WMO code 4501) as follows:

- 0 Clear (no cloud at any level).
- 1 Partly cloudy (scattered or broken).
- 2 Continuous layer(s) of cloud(s).
- 3 Sandstorm, duststorm, or blowing snow.
- 4 Fog, thick dust, or haze.
- 5 Drizzle.
- 6 Rain.
- 7 Snow, or rain and snow mixed.
- 8 Shower(s).
- 9 Thunderstorm(s).

00	Calm	20	195°—204°
01	5°—14°	21	205°—214°
02	15°—24°	22	215°—224°
03	25°—34°	23	225°—234°
04	35°—44°	24	235°—244°
05	45°—54°	25	245°—254°
06	55°—64°	26	255°—264°
07	65°—74°	27	265°—274°
08	75°—84°	28	275°—284°
09	85°—94°	29	285°—294°
10	95°—104°	30	295°—304°
11	105°—114°	31	305°—314°
12	115°—124°	32	315°—324°
13	125°—134°	33	325°—334°
14	135°—144°	34	335°—344°
15	145°—154°	35	345°—354°
16	155°—164°	36	355°—4°
17	165°—174°	99	Winds variable, or direction unknown.
18	175°—184°		
19	185°—194°		

Chapter 5—BATHYTHERMOGRAPH

112.76(71B)
Table 5-3.—Conversion Table, Inches To Millibars

In.	Milli-bars	In.	Milli-bars	In.	Milli-bars	In.	Milli-bars	In.	Milli-bars	In.	Milli-bars	In.	Milli-bars
27.30	931.3	28.00	948.2	28.50	965.1	29.00	982.1	29.50	999.0	30.00	1,015.9	30.50	1,032.9
27.51	931.6	28.01	948.5	28.51	965.5	29.01	982.4	29.51	999.3	30.01	1,016.3	30.51	1,033.2
27.52	931.9	28.02	948.9	28.52	965.8	29.02	982.7	29.52	999.7	30.02	1,016.6	30.52	1,033.5
27.53	932.3	28.03	949.2	28.53	966.1	29.03	983.1	29.53	1,000.0	30.03	1,016.9	30.53	1,033.9
27.54	932.6	28.04	949.5	28.54	966.5	29.04	983.4	29.54	1,000.3	30.04	1,017.3	30.54	1,034.2
27.55	933.0	28.05	949.9	28.55	966.8	29.05	983.7	29.55	1,000.7	30.05	1,017.6	30.55	1,034.5
27.56	933.3	28.06	950.2	28.56	967.2	29.06	984.1	29.56	1,001.0	30.06	1,018.0	30.56	1,034.9
27.57	933.6	28.07	950.6	28.57	967.5	29.07	984.4	29.57	1,001.4	30.07	1,018.3	30.57	1,035.2
27.58	934.0	28.08	950.9	28.58	967.8	29.08	984.8	29.58	1,001.7	30.08	1,018.6	30.58	1,035.6
27.59	934.3	28.09	951.2	28.59	968.2	29.09	985.1	29.59	1,002.0	30.09	1,019.0	30.59	1,035.9
27.60	934.6	28.10	951.6	28.60	968.5	29.10	985.4	29.60	1,002.4	30.10	1,019.3	30.60	1,036.2
27.61	935.0	28.11	951.9	28.61	968.8	29.11	985.8	29.61	1,002.7	30.11	1,019.6	30.61	1,036.6
27.62	935.3	28.12	952.3	28.62	969.2	29.12	986.1	29.62	1,003.1	30.12	1,020.0	30.62	1,036.9
27.63	935.7	28.13	952.6	28.63	969.5	29.13	986.5	29.63	1,003.4	30.13	1,020.3	30.63	1,037.3
27.64	936.0	28.14	952.9	28.64	969.9	29.14	986.8	29.64	1,003.7	30.14	1,020.7	30.64	1,037.6
27.65	936.3	28.15	953.3	28.65	970.2	29.15	987.1	29.65	1,004.1	30.15	1,021.0	30.65	1,037.9
27.66	936.7	28.16	953.6	28.66	970.5	29.16	987.5	29.66	1,004.4	30.16	1,021.3	30.66	1,038.3
27.67	937.0	28.17	953.9	28.67	970.9	29.17	987.8	29.67	1,004.7	30.17	1,021.7	30.67	1,038.6
27.68	937.4	28.18	954.3	28.68	971.2	29.18	988.2	29.68	1,005.1	30.18	1,022.0	30.68	1,038.9
27.69	937.7	28.19	954.6	28.69	971.6	29.19	988.5	29.69	1,005.4	30.19	1,022.4	30.69	1,039.3
27.70	938.0	28.20	955.0	28.70	971.9	29.20	988.8	29.70	1,005.8	30.20	1,022.7	30.70	1,039.6
27.71	938.4	28.21	955.3	28.71	972.2	29.21	989.2	29.71	1,006.1	30.21	1,023.0	30.71	1,040.0
27.72	938.7	28.22	955.6	28.72	972.6	29.22	989.5	29.72	1,006.4	30.22	1,023.4	30.72	1,040.3
27.73	939.0	28.23	956.0	28.73	972.9	29.23	989.8	29.73	1,006.8	30.23	1,023.7	30.73	1,040.6
27.74	939.4	28.24	956.3	28.74	973.2	29.24	990.2	29.74	1,007.1	30.24	1,024.0	30.74	1,041.0
27.75	939.7	28.25	956.7	28.75	973.6	29.25	990.5	29.75	1,007.5	30.25	1,024.4	30.75	1,041.3
27.76	940.1	28.26	957.0	28.76	973.9	29.26	990.9	29.76	1,007.8	30.26	1,024.7	30.76	1,041.7
27.77	940.4	28.27	957.3	28.77	974.3	29.27	991.2	29.77	1,008.1	30.27	1,025.1	30.77	1,042.0
27.78	940.7	28.28	957.7	28.78	974.6	29.28	991.5	29.78	1,008.5	30.28	1,025.4	30.78	1,042.3
27.79	941.1	28.29	958.0	28.79	974.9	29.29	991.9	29.79	1,008.8	30.29	1,025.7	30.79	1,042.7
27.80	941.4	28.30	958.3	28.80	975.3	29.30	992.2	29.80	1,009.1	30.30	1,026.1	30.80	1,043.0
27.81	941.8	28.31	958.7	28.81	975.6	29.31	992.6	29.81	1,009.5	30.31	1,026.4	30.81	1,043.3
27.82	942.1	28.32	959.0	28.82	976.0	29.32	992.9	29.82	1,009.8	30.32	1,026.8	30.82	1,043.7
27.83	942.4	28.33	959.4	28.83	976.3	29.33	993.2	29.83	1,010.2	30.33	1,027.1	30.83	1,044.0
27.84	942.8	28.34	959.7	28.84	976.6	29.34	993.6	29.84	1,010.5	30.34	1,027.4	30.84	1,044.4
27.85	943.1	28.35	960.0	28.85	977.0	29.35	993.9	29.85	1,010.8	30.35	1,027.8	30.85	1,044.7
27.86	943.4	28.36	960.4	28.86	977.3	29.36	994.2	29.86	1,011.2	30.36	1,028.1	30.86	1,045.0
27.87	943.8	28.37	960.7	28.87	977.7	29.37	994.6	29.87	1,011.5	30.37	1,028.4	30.87	1,045.4
27.88	944.1	28.38	961.1	28.88	978.0	29.38	994.9	29.88	1,011.9	30.38	1,028.8	30.88	1,045.7
27.89	944.5	28.39	961.4	28.89	978.3	29.39	995.3	29.89	1,012.2	30.39	1,029.1	30.89	1,046.1
27.90	944.8	28.40	961.7	28.90	978.7	29.40	995.6	29.90	1,012.5	30.40	1,029.5	30.90	1,046.4
27.91	945.1	28.41	962.1	28.91	979.0	29.41	995.9	29.91	1,012.9	30.41	1,029.8	30.91	1,046.7
27.92	945.5	28.42	962.4	28.92	979.3	29.42	996.3	29.92	1,013.2	30.42	1,030.1	30.92	1,047.1
27.93	945.8	28.43	962.8	28.93	979.7	29.43	996.6	29.93	1,013.5	30.43	1,030.5	30.93	1,047.4
27.94	946.2	28.44	963.1	28.94	980.0	29.44	997.0	29.94	1,013.9	30.44	1,030.8	30.94	1,047.8
27.95	946.5	28.45	963.4	28.95	980.4	29.45	997.3	29.95	1,014.2	30.45	1,031.2	30.95	1,048.1
27.96	946.8	28.46	963.8	28.96	980.7	29.46	997.6	29.96	1,014.6	30.46	1,031.5	30.96	1,048.4
27.97	947.2	28.47	964.1	28.97	981.0	29.47	998.0	29.97	1,014.9	30.47	1,031.8	30.97	1,048.8
27.98	947.5	28.48	964.4	28.98	981.4	29.48	998.3	29.98	1,015.2	30.48	1,032.2	30.98	1,049.1
27.99	947.9	28.49	964.8	28.99	981.7	29.49	998.6	29.99	1,015.6	30.49	1,032.5	30.99	1,049.5

INTRODUCTION TO SONAR

Item 12—Clouds

1. Type: Code the significant type of clouds (WMO code 0500).

- 0 Cirrus.
- 1 Cirrocumulus.
- 2 Cirrostratus.
- 3 Alto cumulus.
- 4 Altostratus.
- 5 Nimbostratus.
- 6 Stratocumulus.
- 7 Stratus.
- 8 Cumulus.
- 9 Cumulonimbus.
- x Cloud not visible because of darkness, fog, duststorm, sandstorm, or other phenomena.

2. Amount: Record the fraction of the celestial dome covered by clouds (in eighths) (WMO code 2700).

- 0 Zero.
- 1 One okta (eighth or less, but not zero).
- 2 Two oktas.
- 3 Three oktas.
- 4 Four oktas.
- 5 Five oktas.
- 6 Six oktas.
- 7 Seven oktas.
- 8 Eight oktas.
- 9 Sky obscured, or cloud amount cannot be estimated.

Item 13—Waves

Enter the mean height of the predominant waves. Check the appropriate box to indicate feet or meters. Record the period of the waves in seconds.

Item 14—Sea Surface Reference Temperature

Use the appropriate code from the accompanying list to indicate the instrument used to obtain the sea surface temperature, and in which system it was measured. Record temperature to the nearest tenth of a degree.

- XX °F Bucket thermometer.
- 99 °F Injection thermometer.
- 89 °F Injection thermistor (NSRT).
- YY °C Bucket thermometer.
- 98 °C Injection thermometer.
- 88 °C Injection thermistor (NSRT).

TRACE READOUT

Interpretation of the BT trace is necessary to obtain the required values for making up the sonar message and for radio transmission of BT information. The observer must insert the BT grid and slide in the viewer and read off the points for encoding where the BT trace changes direction. This procedure is in addition to reading surface and bottom values.

No adjustment is made for discrepancy between reference temperature and BT temperature. Any bias in depth (trace beginning above or below zero line) must, however, be adjusted visually before reading at any depth. Otherwise, the trace will be in error.

A sample BT trace readout is shown in figure 5-20 with the readout figures to the right. The arrows indicate points that should be reported. Do not routinely read points at 50 or 100 feet unless the trace changes direction at these points. When the trace is in a straight line, only two readings are necessary—a surface reading and a reading at the deepest depth of the BT trace.

RADIO MESSAGE INFORMATION

The radio, or BATHY, message should contain sufficient points so that the trace plotted by the addressee is identical to the original trace, except for minor wiggles. Provision is made on the BT log for entering the readings in the proper order for radio transmission. The observer should not interpret the number of spaces provided for this information to be a restriction on the number of points to be recorded. Use as many lines on the BT logsheet as required to describe the BT trace accurately.

The radio message portion of the BT logsheet shown in figure 5-19 is completed as described in the following itemization.

Item 1—Prefix

All BT messages are prefixed by the word BATHY, which is preprinted on the logsheets.

Item 2—Day

Enter the code number for the day of the week, starting with number 1 for Sunday.

Item 3—Time

Record the GMT hour and minute at which the BT entered the water.

Chapter 5—BATHYTHERMOGRAPH

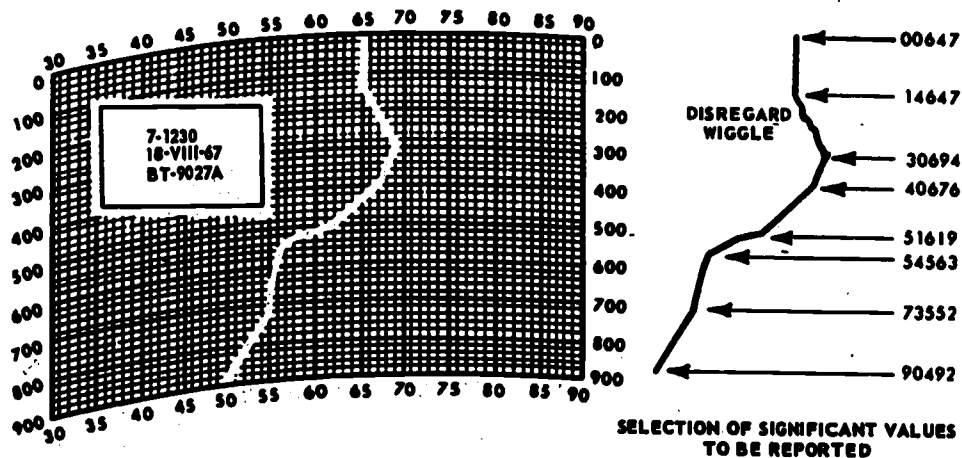

71.93
Figure 5-20.— Trace readout.

Item 4—Octant of Globe

Record the octant of the globe as follows:

North latitude

- 0 — 0° to 90°W.
- 1 — 90°W to 180°.
- 2 — 180° to 90°E.
- 3 — 90°E to 0°.

South latitude

- 5 — 0° to 90°W.
- 6 — 90°W to 180°.
- 7 — 180° to 90°E.
- 8 — 90°E to 0°.

Items 5 and 6—Position

Record the degrees and minutes of latitude and longitude, respectively. Prefix with zeroes when necessary to complete the degrees boxes. Example: Latitude 5°30' is recorded as 0530; longitude 9°45' is entered as 00945.

Item 7—Reference Temperature

Enter the code and figures that are recorded in item 14 of the environmental data section.

BT TRACE READINGS

When entering the depth-temperature readings, adhere to the following directions.

Symbol

ZZ Water depth in feet. Z₀Z₀ is the surface, preprinted as 00 on the logsheet. Depths of subsurface temperature changes are recorded in tens of feet; e.g., 140 feet is recorded as 14.

TTT Temperature. T₀T₀ is the surface temperature. Subsurface temperatures are symbolized by T_zT_zT_z. Record the temperature to the nearest 0.1°F or C.

All messages must terminate with message suffix figures 19991.

Along the right edge of the radio message section, record the GMT date-time group of the BT message, and the month and year the message was sent.

A sample BT radio message is shown in figure 5-21. It follows the information contained in the radio message section of figure 5-19. Note that the radio message is not sent to the National Oceanographic Data Center. Only the logsheets and slides are sent to NODC. The addressee for the BT message is governed by your ship's location.

INTRODUCTION TO SONAR

NAVAL MESSAGE									
OPNAV FORM 2110-28 (REV. 3-61) S/N 0107-705-4000									
RELEASED BY			DRAFTED BY			PHONE EXT NR		PAGE	PAGES
DATE		TOR/TOD		ROUTED BY		CHECKED BY		1	OF 1
18 August 19--		181445				HCS			
MESSAGE NR	DATE/TIME GROUP (GCT)	PRECEDENCE	FLASH	EMERGENCY	OPERATIONAL IMMEDIATE	PRIORITY	ROUTINE	DEFERRED	
9	181406Z						X		
		ACTION							
		INFO					X		

From: USS Fred T. Berry DD858
 To: FLEWEAFAC NORVA
 Info: CANMARCOM HALIFAX

BATHY 31230 03742 06527 XX686 00647 14647 30694 40676
 51619 54563 73552 90492 19991

DISTRIBUTION:
 (PAGE ONE ONLY)

UNCLASSIFIED

DATE/TIME GROUP (GCT)
 181406Z

31.47

Figure 5-21.— BT message.

SEA SURFACE TEMPERATURE REPORTS

In connection with the antisubmarine warfare environmental prediction system (ASWEPS), all ships of the U.S. Fleet are required to record the sea surface temperature (CTEM) every odd hour while at sea, commencing at 0100Z (or the first odd hour after leaving port) and ending at 2300Z (or the last odd hour before entering port). A radio message, containing the required data, is transmitted daily after the final observation at 2300Z. As with BT messages, the addressee for CTEM messages depends on your

ship's location. The message is sent unclassified, with a priority precedence.

Figure 5-22 illustrates the log on which to record the sea surface temperatures. It is filled in to represent the collective readings for a single day. The message format is similar to that used for a BATHY message.

LOGGING PROCEDURE

Information contained in the CTEM log is similar to that entered in the BT log. Two major differences are that only surface temperatures are recorded, and the temperatures must

SEA SURFACE TEMPERATURE LOG

SHIP'S NAME FRED T. BERRY HULL No. DD 858 DATE 28 AUG 67

CODE PREFIX		INSTRUMENT INDICATOR			DATE			POSITION			TIME (GMT)			END OF MESSAGE INDICATOR															
DAY	MONTH	YEAR	Q	L	L	L	L	L	L	L	HOUR	SEA SURFACE TEMPERATURE																	
C	T	E	M	J	D	D	M	M	Y	Q	L	L	L	L	L	L	L	L	L	6	6	T	T	T	1	9	9	9	1
C	T	E	M	J	2	8	0	8	7	2	2	1	2	3	1	2	1	2	8	0	1	2	0	1					
										2	2	1	1	1	1	2	0	5	5	0	3	2	0	8					
										2	2	1	0	0	1	2	0	1	8	0	5	2	1	2					
										2	2	0	4	6	1	1	9	4	6	0	7	2	1	7					
										2	2	0	3	6	1	1	9	1	4	0	9	2	2	1					
										2	2	0	2	4	1	1	8	3	8	1	1	2	2	6					
										2	2	0	1	2	1	1	8	0	5	1	3	X	X	X					
										2	1	9	5	7	1	1	7	3	0	1	5	2	4	4					
										2	1	9	4	6	1	1	6	5	9	1	7	2	4	0					
										2	1	9	3	0	1	1	6	2	7	1	9	2	3	2					
										2	1	9	1	7	1	1	5	5	4	2	1	2	2	5					
										2	1	9	0	6	1	1	5	2	2	2	3	2	0	6	1	9	9	9	1

BEGIN RADIO MESSAGE WITH CTEM

I.—ENTER THE FOLLOWING APPROPRIATE LETTER AS I, TO INDICATE INSTRUMENT USED FOR MEASURING SEA SURFACE TEMPERATURE.

- (N) INJECTION THERMISTOR (NSRT)
- (B) BUCKET THERMOMETER
- (J) INJECTION THERMOMETER
- (O) OTHER (SPECIFY)

TRANSMIT DATA ONLY FROM UNSHADED PORTION OF LOG.

END RADIO MESSAGE WITH 19991

CTEM LOG: NAVOCEANO-EXP-8167/71 (REV. 2-67)

INTRODUCTION TO SONAR

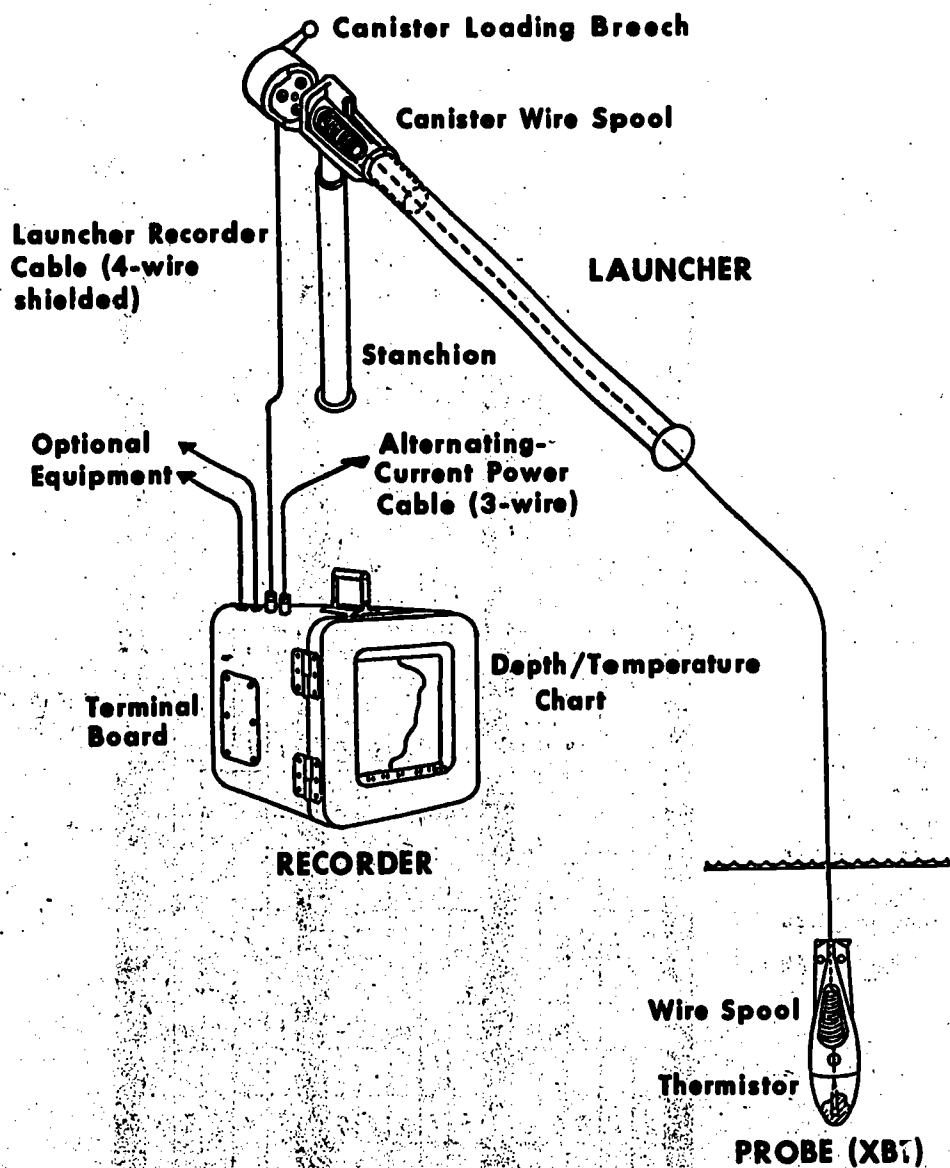

71.126
Figure 5-23. — Expendable BT system.

Chapter 5—BATHYTHERMOGRAPH

be in centigrade. If you have only a Fahrenheit thermometer, you can convert the readings to degrees centigrade by using the formula: $5/9 (F^{\circ}-32)$. If an observation is missed, insert XXX in the temperature space for that hour. Do not try to extrapolate.

Identification

Enter your ship's name and hull number, and the date at the top of the sheet.

Message Prefix

Each message contains the prefix CTEM, together with a code letter indicating the instrument used to measure the temperature. The code letters are: (N) injection thermistor; (B) bucket thermometer; (J) injection thermometer; (O) some other device, which must be specified. Instrument preference is in the order listed.

Date

Enter the day of the month, the month, and the year. The day and the month will contain two numerals each. Use only the last numeral for the year.

Position

Octant, latitude, and longitude are recorded for each reading. See items 4, 5, and 6 in the radio message section of the BT log for proper method of making entries. Each entry is to be the position of the ship at the exact time of taking the temperature reading.

Observation

Enter the GMT hour and the sea temperature to the nearest 0.1°C . When the temperature is below zero, add 50 to the absolute value.

Ending

The message must end with the numerals 19991.

EXPENDABLE BATHYTHERMOGRAPH

Many undesirable features are connected with the use of the mechanical BT and its associated equipment. The most unwelcome aspect is that the ship conducting a BT drop must maintain a slow speed and steady course. The deeper

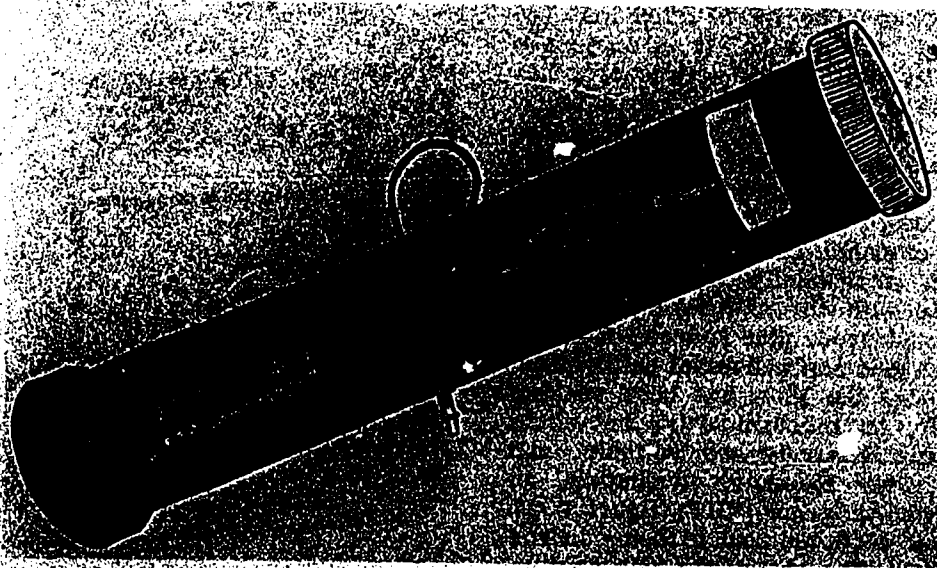
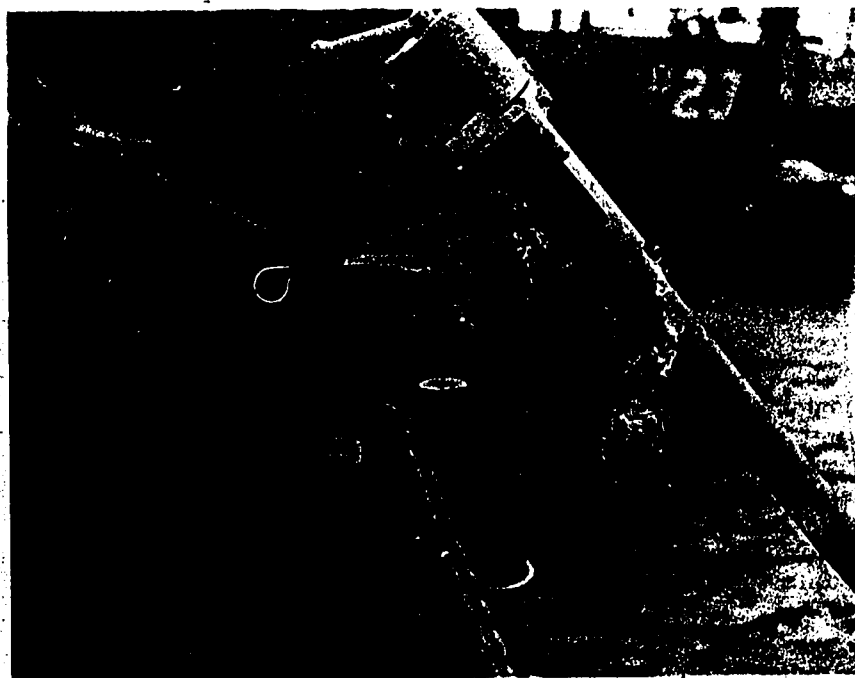

Figure 5-24.— Expendable BT probe in its cannister.

71.118

INTRODUCTION TO SONAR



71.127

Figure 5-25.—Expendable components and launcher.

the drop required, the slower the speed necessary. Thus, the ship is increasingly vulnerable to submarine attack. The BT is often lost because of parting of the wire. It is subject to damage caused by striking the bottom or other objects. Because of faulty slides, or a faulty stylus, several lowerings may be required before an acceptable trace can be obtained, thereby prolonging the ship's exposure to attack. Rough weather may produce such hazardous conditions for operating personnel that a lowering cannot be made at all. Additionally, the cost of providing each ship with three different types of BTs must be considered, plus spares—each one requiring its own grid and individual calibration.

For many years the Navy has been seeking a replacement for the mechanical BT that would be cheaper, more accurate and reliable, and safer to use. After extensive evaluation, an expendable bathythermograph (XBT), figure 5-23, system has been accepted and is being introduced into the fleet. The cost of the XBT system is considered reasonably low. The extra fuel consumed in maneuvers required for a mechanical BT lowering often costs more than the expendable components of the XBT. Also, the

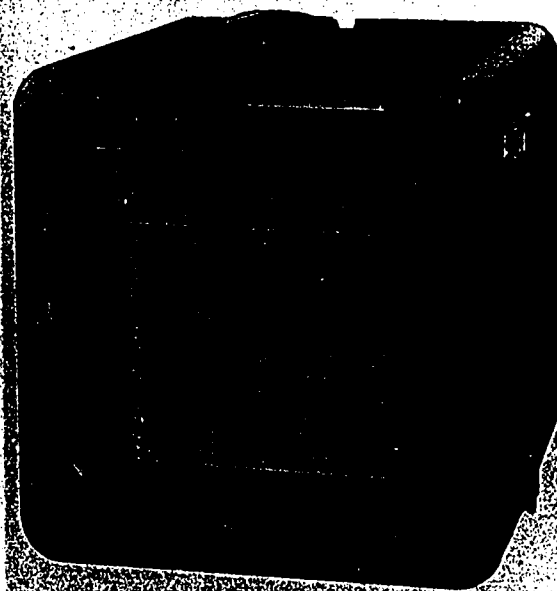

71.119

Figure 5-26.—BT recorder.

Chapter 5—BATHYTHERMOGRAPH

XBT is more accurate and has a greater depth range than the conventional BT. Moreover, its use removes speed restrictions on the ship. Readings can be obtained at speeds to 30 knots.

COMPONENTS

The expendable bathythermograph system is composed of a sensor probe, a cannister, a launch mechanism, and a temperature-depth recorder. The expendable portion of the system, consisting of the cannister and the probe, is seen in figure 5-24, and figure 5-25. The probe

weighs about 1 pound and is spin stabilized. It contains a thermistor, which senses temperature changes, and a reel of special wire. The cannister also contains a reel of wire, and holds the probe. The launcher is essentially a tube for holding the cannister. It can be installed to provide through-the-hull launching of the probe, eliminating the necessity for sonar personnel to be on deck in rough weather. The recorder (fig. 5-26) plots a track on a strip chart of temperature versus depth in real time. The strip chart is synchronized to the probe's rate of descent.

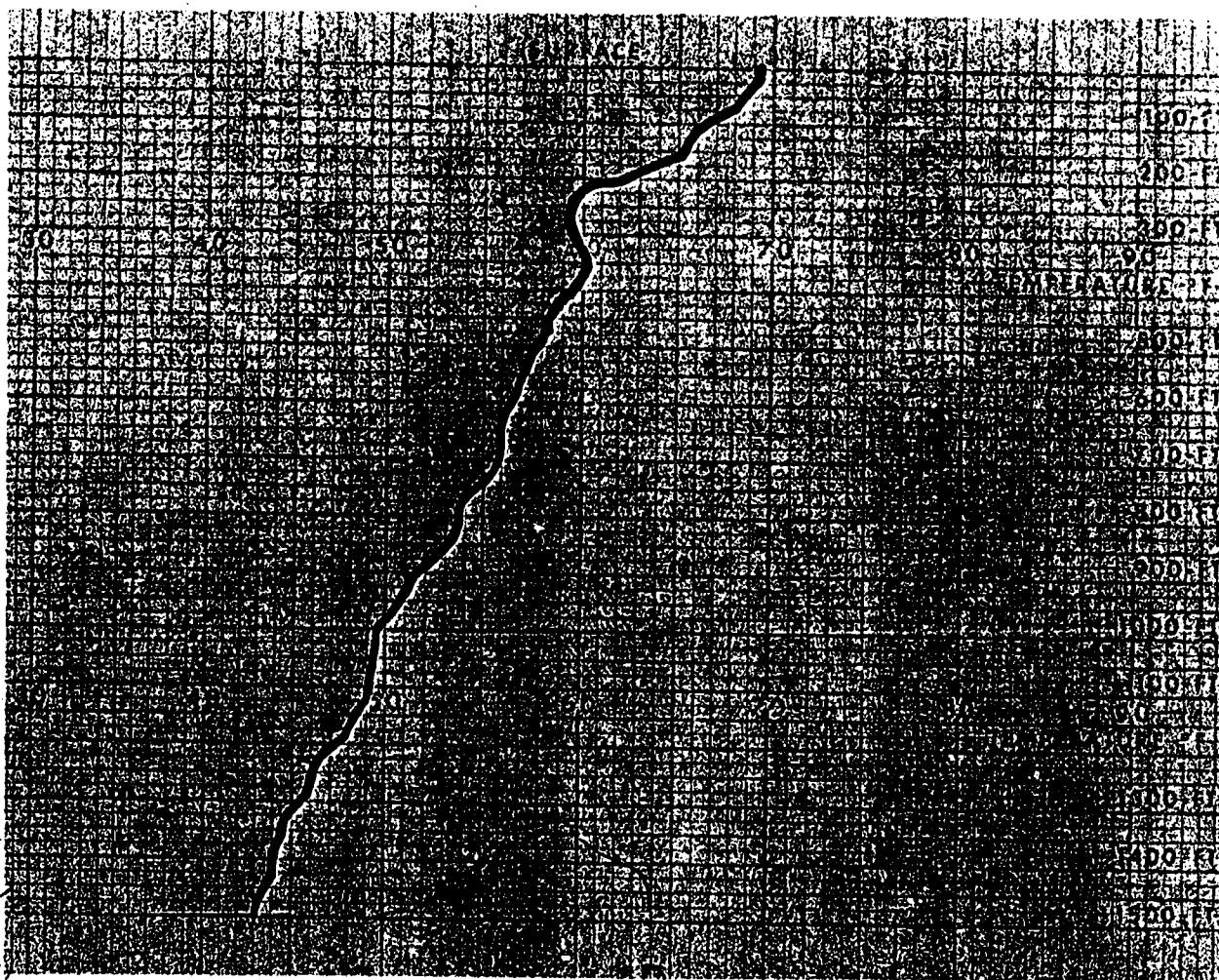

71.120

Figure 5-27.—Recorder chart.

INTRODUCTION TO SONAR

OPERATION

When you place the cannister in the launch tube, a watertight electrical connection is formed between the probe and the recorder, causing the recorder to run for 2 seconds. This action sets the automatic starting circuits, which are activated when the probe hits the water. The probe is held in position by a pin protruding from the launcher. Pulling the pin permits the probe to fall free of the cannister, into the water. (The cannister remains in the launcher.) As the probe starts its free fall, the wire commences unreeling from the probe and from the cannister. This double unreeling action allows the probe to sink straight down, and permits the ship to proceed unhindered.

When the probe strikes the water, an electrode triggers the recorder. The thermistor transmits temperature changes to the recorder, where they are plotted on the strip chart by a stylus. At a depth of 1500 feet, the probe's wire is exhausted and the recorder stops. A complete readout is obtained in 90 seconds from time of launch. Temperature range of the probe is 28°F to 96°F, with an accuracy of 0.4°F. Depth accuracy is 2 percent or 15 feet, whichever is greater.

Figure 5-27 shows a representative temperature-depth profile. Only 6 inches of chart paper are needed for each 1500-foot drop. Present plans call for the fleet to be completely equipped with the XBT system within 2 years.

CHAPTER 6

PRINCIPLES OF SONAR

The earliest sonar equipment was a passive device, a simple hydrophone lowered into the water and used to listen for noise created by a submarine. The only indication of a target was an audio tone. Bearing accuracy was doubtful, and ranges were strictly guesswork.

Today's sonar equipments provide highly accurate ranges and bearings. They present information both visually and aurally. Both active and passive types of equipment are used.

Although specific sonars and related equipments (except a fathometer and a tape recorder) are not covered in this chapter, basic principles of operation given herein are applicable to all sonar equipments.

SONAR SYSTEMS

Two general types of sonar systems are employed for the detection of targets. They are referred to as active and passive sonars.

The active type of sonar is capable of transmitting underwater sound pulses that strike targets and are returned in the form of echoes. Echoes returned indicate the range and bearing of the target.

Passive sonars do not transmit sound. They merely listen for sounds produced by the target in order to obtain accurate bearing and estimated range information.

Active sonar systems normally are associated with surface ships, whereas passive systems usually are associated with submarines. Newer surface ships, however, employ separate passive systems in addition to their active sonars. Submarines, although still relying primarily on passive systems, also employ active sonars.

ACTIVE SONAR

A simplified active sonar system is shown in figure 6-1. In this set the sonar transmitter consists of a high-frequency audio oscillator and

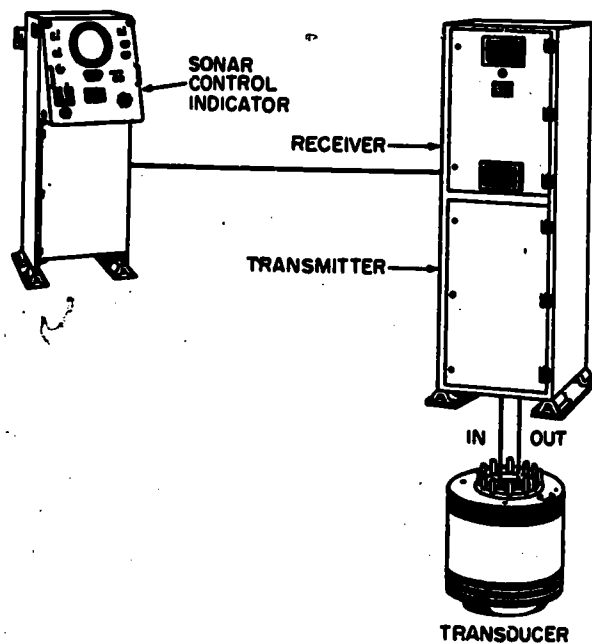

Figure 6-1.—Simplified active sonar system. 71.47

an amplifier. The transmitter feeds a short, powerful pulse to the transducer for transmission into the water. The signal is transmitted in 360° of azimuth.

A transducer is a device used to convert one form of energy into a different form. In a sonar set, the transducer converts electrical energy into acoustical energy and reconverts the sound echoes to an electrical signal, thus acting as both a loudspeaker and a microphone.

Just as important to the sonar system as the transmitter and transducer is the receiver. It functions on the superheterodyne principle. In this unit the small, high-frequency electrical

INTRODUCTION TO SONAR

signals resulting from the echo are amplified and converted to audio signals that can be heard through a loudspeaker or earphones. The receiver also feeds the amplified echo signal to the various video indicating devices, such as the cathode ray tube (CRT) on the control indicator.

Searchlight Sonar

Early active sonars utilized the searchlight principle for transmitting sounds. Like the searchlight, the transducer had to be trained to a particular bearing in order to transmit sound on that bearing. The sound beam was narrow in bearing width (about 5°), consequently the echoes were received from only a small sector of the surrounding sea. An arrangement of this type was necessary at that time because sufficient power for omnidirectional transmission could not be generated. The scanning sonars in widespread use today develop tremendous power—enough to be transmitted 360° in azimuth simultaneously.

Late modifications to active sonars allow the selection of directionally transmitted sonic pulses, somewhat related in principle to the earlier searchlight sonars. This feature, called rotating directional transmission, is discussed later.

The main disadvantage of the searchlight type of sonar was the length of time required to scan the area around the ship. Search procedures called for the operator to transmit, listen for echoes, train the transducer to a new bearing, transmit, listen, and so on, first on one side of the ship, then the other. It was possible for a submarine to slip by undetected on the port side, for example, while the operator was searching on the starboard side. Moreover, maintaining contact with a target that had a rapidly changing bearing required a high degree of proficiency on the part of the operator. Another disadvantage was that searchlight equipment had only an audio presentation, whereas today's scanning sonars provide both a video and an audio presentation.

Scanning Sonar

Modern submarines and ASW ships are equipped with scanning sonar, which transmits sound pulses of high energy in all directions simultaneously. One of the features of scanning sonar is a cathode ray tube (CRT) display of all underwater objects detected in the area surrounding the ship. Target echoes appear as

bright spots on the CRT, similar to the display of a radar's PPI.

Some of the data that you may learn from the CRT presentation are as follows:

1. The size of the target may be estimated from the size of the echo. Don't rely too heavily on this feature, though, because echo appearance depends on such factors as target aspect, range, and equipment performance.
2. The distance of the echo from the center of the CRT represents range to the object from your ship when the CRT is used in the ship center display (SCD) mode.
3. True bearing of the object can be determined directly on the scope.
4. Target movement can be determined from its scope presentation. Fixed objects such as reefs and sunken ships will move in a direction parallel to your ship's movement and in the opposite direction. Moving objects may have motion in any direction with respect to own ship.
5. The wake of a submarine often can be seen. By examining the wake, you may be able to establish a submarine's heading even before its movement can be determined by tracking.
6. Submarines that are too far away for detection by echo ranging may yet emit enough noise to be detected. Under these conditions, a small segment of the scope appears to be filled with a rippling pattern. The general direction of the noise source can be ascertained by taking a bearing to the center of the noise pattern.

TRANSDUCERS

Knowledge of the design and function of the transducer is the key to understanding the principles of sonar, whether of the scanning or the searchlight type. You already know that a transducer converts outgoing signals from electrical to acoustical energy, and converts incoming signals from acoustical to electrical energy. Signals are converted by the magnetostrictive, piezoelectric, or electrostrictive process.

Magnetostrictive Process

Magnetostriction is a process whereby changes occur in metals when they are subjected to a magnetic field. If a nickel tube is placed in a magnetic field, for example, its length is shortened as a result of the magnetostrictive effect. The effect is independent of the direction of the magnetic field.

Chapter 6—PRINCIPLES OF SONAR

In the searchlight type of sonar, several hundred nickel tubes are arranged in a circle and mounted on one side of a metal plate called a diaphragm. Each tube is wrapped with a coil of wire to prevent frequency doubling. When an alternating current is applied to the coil, the tubes shorten and lengthen at the rate of the alternating current. Each tube is polarized by a constant magnetic field, usually supplied by a permanent magnet. During one half cycle of the applied signal, the a-c voltage and the polarizing field add; during the next half cycle, they oppose each other, and the magnetic field is always in only one direction. The contractions of the tubes thus are fixed to the a-c frequency.

As the tubes contract and expand, the diaphragm vibrates and produces an acoustic signal of the same frequency as the applied alternating current. A magnetostrictive transducer used in searchlight sonars is shown in figure 6-2.

Transducers employed with some scanning sonars also operate on the principle of magnetostriction. Instead of nickel tubes, however, the

transducer elements have nickel laminations pressed in a thermoplastic material. Each element contains a permanent magnet for polarizing the nickel. Several elements are mounted vertically to form 1 stave, and 48 vertical staves are arranged circularly to form the transducer. A scanning transducer is shown in figure 6-3. An exploded view of a portion of a stave is seen in figure 6-4.

Many types of operational scanning sonar transducers are magnetostrictive. Except for variations in dimensions, they are similar in design. The type shown in figure 6-3 is a cylindrical unit approximately 19 inches in diameter and 27 inches long, and has an operating frequency of 20 kHz.

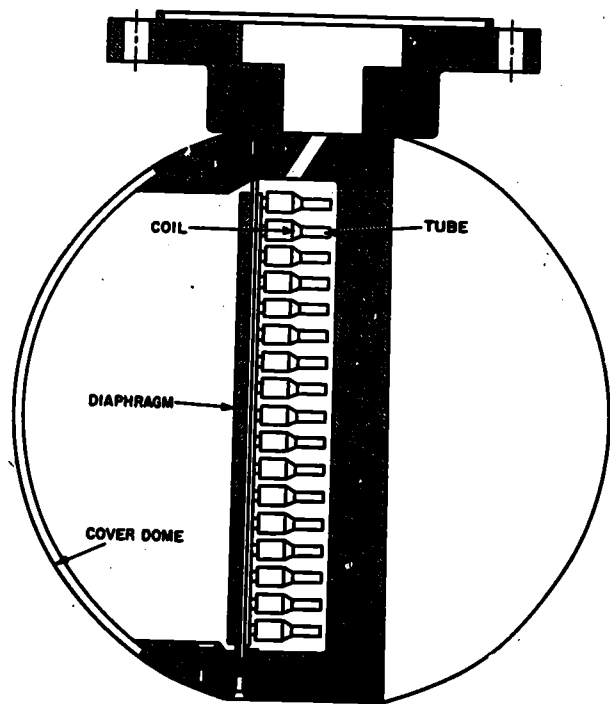

71.48
Figure 6-2.—Searchlight magnetostrictive transducer.



71.49
Figure 6-3.—Scanning magnetostrictive transducer.

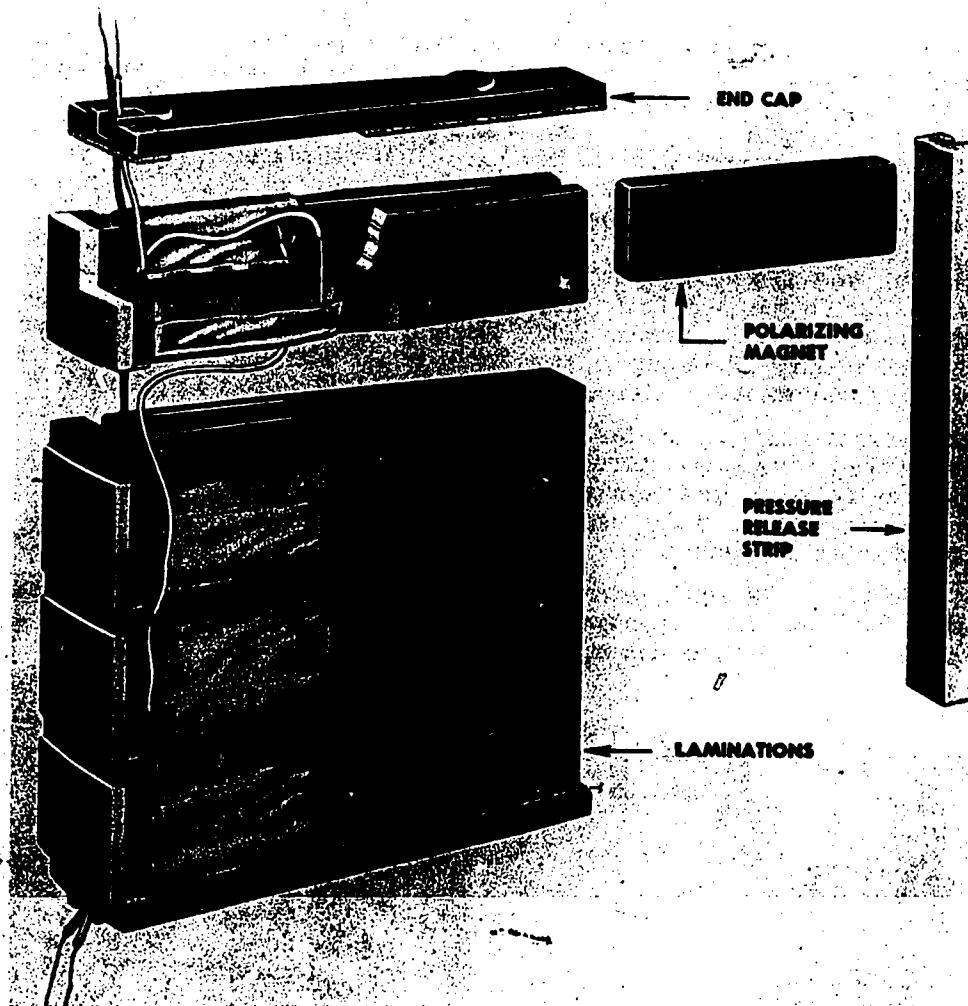

71.50
 Figure 6-4.— Exploded view of one scanning sonar transducer stave.

Electrically, the magnetostrictive scanning sonar unit acts as two independent transducers housed in a common container. One of the independent units is the search section. The other is the maintenance of close contact (MCC) section, located above the search elements.

The search section is made up of 48 vertical staves. Each stave consists of nickel laminations and a polarizing magnet. Electrically, the staves are independent of one another.

As its name implies, the MCC section is used to maintain contact on a close-in submarine. The MCC elements transmit in a delayed sequence from the top down, causing a

phase delay of the sound beam, which results in the top of the beam bending down toward the delayed portion of the beam. The effect resembles refraction. Transmission is at a downward angle of approximately 30°.

Because the elements are so placed that they can cover a 360° area, there is no need to rotate the transducer in scanning sonar. Such an arrangement provides video coverage simultaneously on all bearings. Audio coverage is afforded by training a cursor to the desired bearing. Most present-day magnetostrictive transducers are built along the same general lines. Physical dimensions vary according to the operating frequency and power output desired.

Piezoelectric Process

The piezoelectric transducer functions much like the magnetostrictive type. An exception is that crystals are used instead of nickel laminations. Various kinds of crystals have been employed, but the most commonly used type is ammonium dihydrogen phosphate (ADP).

The arrangement of the crystals on a diaphragm is similar to the method used in the magnetostrictive transducer. One end of the crystal is attached to a bakelite-covered steel plate, and the other end is allowed to vibrate freely. The free ends of the crystal block constitute the transmitting and receiving elements. The entire arrangement of crystals is connected electrically to give the effect of a single large crystal. The elements are housed in a chamber filled with castor oil, which has sound transmission qualities similar to sea water. The oil also protects the sensitive crystals from being damaged by exposure to water or moisture. When an electric current of the desired frequency is passed through the crystals, they change size as a unit, causing a vibration. Vibrations are passed by the castor oil, through the "window" of the sonar dome, into the sea water. When outside energy is received in the form of an echo, it exerts mechanical pressure on the crystals, which produce an electrical current

that is amplified and converted to visual and audible signals.

Nearly all transducers now being built are of the ceramic type. Ceramic compounds have high sensitivity, high stability with changing temperature and pressure, relatively low cost, and can be constructed in almost any reasonable shape or size.

Electrostrictive Process

The most commonly used ceramic compound is lead zirconate titanate. Such transducers are known as electrostrictive transducers yet behave in a piezoelectric manner, and now are more widely used in modern sonar systems. Although a ceramic material is essentially electrostrictive, it can be made to behave like a piezoelectric material by polarizing it permanently. Polarization is accomplished by impressing an extremely high voltage on the material for a period of several minutes to align the molecules. Once the molecules are aligned properly, the compound can be treated similarly to that used with a piezoelectric material.

MODERN ACTIVE SONAR THEORY

The theory of modern active sonar operation may best be understood by breaking it down into

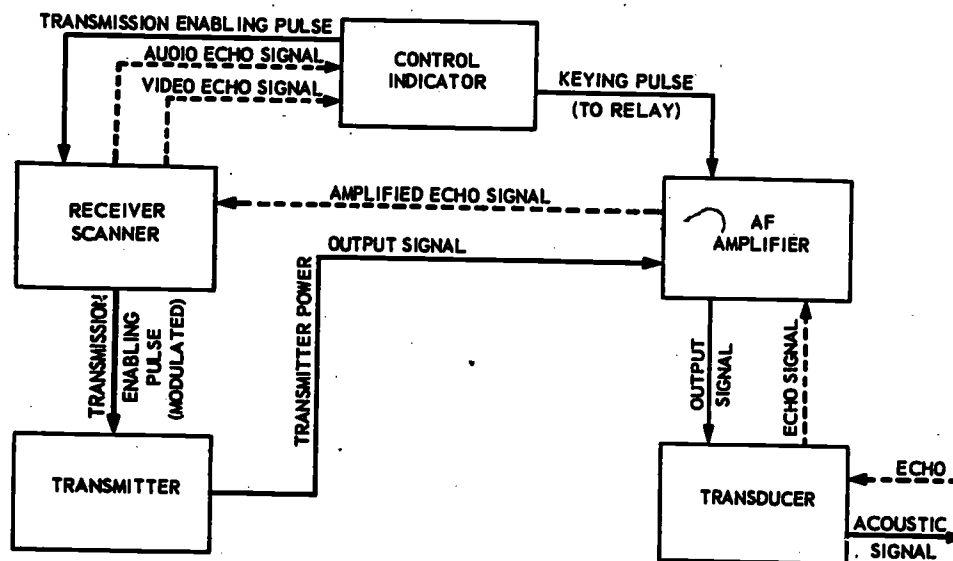

71.51
Figure 6-5.—Sonar system—block diagram.

INTRODUCTION TO SONAR

three basic functions: transmission, reception, and presentation. A block diagram of a representative sonar system is seen in figure 6-5. The diagram shows only the system's major units and main signal paths.

Transmission

Transmission of the sound pulse is initiated in the control-indicator, which contains the necessary keying circuits. Pulse length is also determined at the control-indicator by the sonar operator. The keying pulse from the control-indicator triggers the transmitter oscillator in the receiver-scanning system assembly and actuates the transmit-receive switch in the audio-frequency (a-f) amplifier. In the receiver-scanner the pulse is modulated to the equipment operating frequency, amplified, and delivered to the sonar transmitter, where it is further amplified to the power level required for transmission.

The output of the sonar transmitter is fed to the transmit-receive switch in the a-f amplifier, then to the transducer transfer switch where selection is made between NORMAL or MCC operation. The signal then goes to the transducer where it is converted to acoustical energy and propagated into the water. The shape of the transmitted signal resembles that of a hollow cylinder (or sphere, depending on the shape of the transducer), which expands in diameter as it travels outward. The thickness of the cylinder walls depends on the pulse length selected by the operator. (See fig. 6-6.)

Reception

If the transmitted sound wave strikes an object having sufficient reflective characteristics, a small portion of the signal is returned to the transducer. In the transducer, the acoustic signal is converted to an electrical signal by the piezoelectric effect of the receiving staves. Each of the 48 staves has its own preamplifier, located in the a-f amplifier. After preamplification the signal is sent to the video and audio scanning switches in the receiver-scanning switch assembly.

The video scanning switch rotates continuously, thereby sampling noise signals and echoes from all bearings. The audio scanning switch is positioned to any bearing selected by the sonar operator. Signals from the scanning switches are fed to the receiver section of the receiver-scanner where they are converted to suitable frequencies and amplified for presentation.

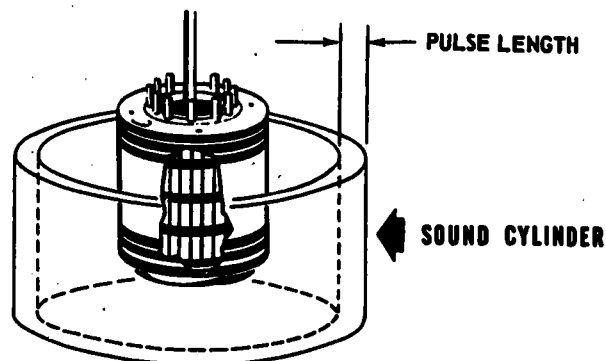

71.52
Figure 6-6.— Pulse length determines thickness of sound cylinder.

Presentation

For the returning echo to be of any value, it must be presented in such a manner that the sonar operator can interpret the information it represents. The echo is presented to the operator both visibly and audibly.

The manually positioned audio scanning switch feeds the signal to the audio portion of the receiver, which is of the superheterodyne type. Incorporated in the receiver audio circuits is a control for eliminating the effect of own ship's speed on the reverberation pitch. This control is called the own doppler nullifier (ODN). It removes own ship doppler effect from target echoes, greatly aiding the operator in target classification. From the receiver the audio signal is sent to a headset position at the control-indicator, and also can be fed to loudspeakers.

After the output of the video scanning switch is processed in the video portion of the receiver, it is displayed at the control-indicator on a cathode ray tube. The sweep on the CRT is a spiral scan, which is synchronized with the video scanning switch. (See fig. 6-7.)

One method of obtaining a spiral scan is to rotate the field of the deflection coils around the CRT, simultaneously applying a sawtooth voltage to the coils to cause displacement of the sweep with each succeeding rotation of the coil. For clarity of explanation, the coil yoke is mechanically connected to the video scanning switch. As the video scanner and deflection coil rotate, the sawtooth voltage causes the sweep to spiral outward from the center of the

Chapter 6— PRINCIPLES OF SONAR

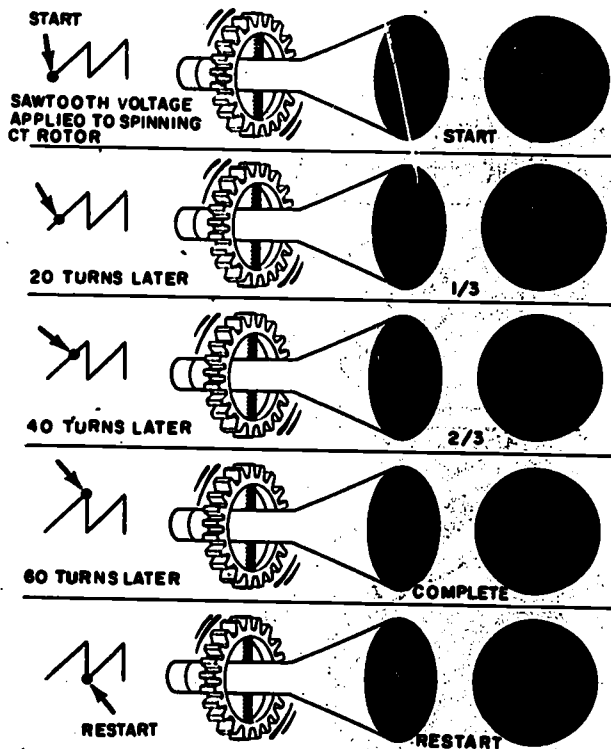

A STEP-BY-STEP GENERATION OF SPIRAL SCAN

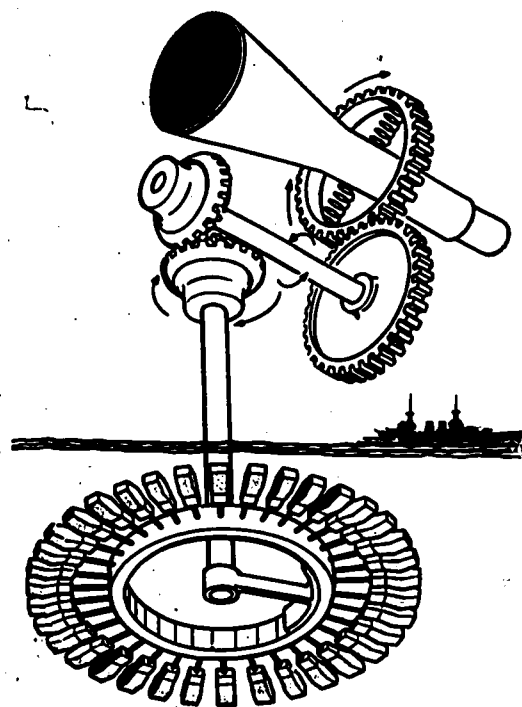

B SYNCHRONIZING THE SWEEP WITH THE SCANNING SWITCH

71.121

Figure 6-7.— Generation of spiral scan.

scope at a linear rate. On reaching the scope's outer edge, full deflection is achieved and the sweep is then cut off.

Rotation of the scanner is at such a speed that you don't see a spiral sweep, but what appears to be an expanding circular sweep. An echo is seen on the scope as a brightening of the sweep, at a distance from the scope center, and in a direction corresponding to the target's range and bearing.

During the interval between the end of one sweep and the beginning of the next, the cursor is electronically produced on the scope. Because of the long persistency of the CRT, the target echo remains visible for a short time, allowing the operator to determine accurately the target's range and bearing. Bisecting the echo with the cursor gives the bearing of the target. By adjusting the length of the cursor so that its

tip touches the echo, the target's range is determined.

Also located on the sonar control-indicator are various switches and controls. Their purpose is to give a better target presentation. These switches and controls, together with complete operating procedures, are explained in the manufacturer's technical manual supplied with each sonar system.

Rotating Directional Transmission

Conventional scanning sonars formerly were of the type just discussed; that is, only omnidirectional transmission was possible. Modern sonars have an operating feature called rotating directional transmission (RDT), which operates on a principle similar to the searchlight type of transmission. The RDT provides greater transmitted power than the conventional scanning

INTRODUCTION TO SONAR

type, affording improved sensitivity and detection range.

At any instant of RDT, the signal is the resultant of phased excitation of several contiguous transducer staves, resulting in a source level improvement that is characteristic of directional transmission. Excitation of the transducer staves is caused by the output of a transmit scanner, which operates much like the video scanning switch of a conventional scanning sonar. Transmission is accomplished in a sector (up to 300° wide), which is centered on the bow or on a selected bearing, depending on the type of operation chosen by the operator at the control unit.

PASSIVE SONAR

Passive sonar, as its name implies, depends entirely on the target's noise as the sound source instead of the returned echoes of a transmitted signal. Target detection is achieved at great ranges through the use of highly sensitive hydrophones.

Although passive sonar is usually associated with submarines, many surface ships now have a passive system that utilizes their active sonar transducers. During the interval between sound pulse transmissions, the transducer acts as a hydrophone, allowing the sonar operator to monitor a broader frequency spectrum than normally is possible. Passive reception does not interfere with the reception of pulse echoes. During transmission, however, the passive feature is interrupted.

Hydrophones

A hydrophone is a device used to listen for underwater sounds. In operation it is similar to the transducer of active sonar equipment when converting sound energy to electrical energy. Two general types of hydrophones may be employed—electrostrictive and magnetostrictive. Modern hydrophones are of the electrostrictive type, consisting of ceramic elements that operate on the piezoelectric principle. When the elements are struck by a sound wave, the vibrations set up are converted to an electrical signal, amplified, and displayed at the operating console.

Single Line Hydrophone

Knowledge of the single line type of hydrophone, although it is not in general use today, will aid you in understanding how modern hydrophones operate.

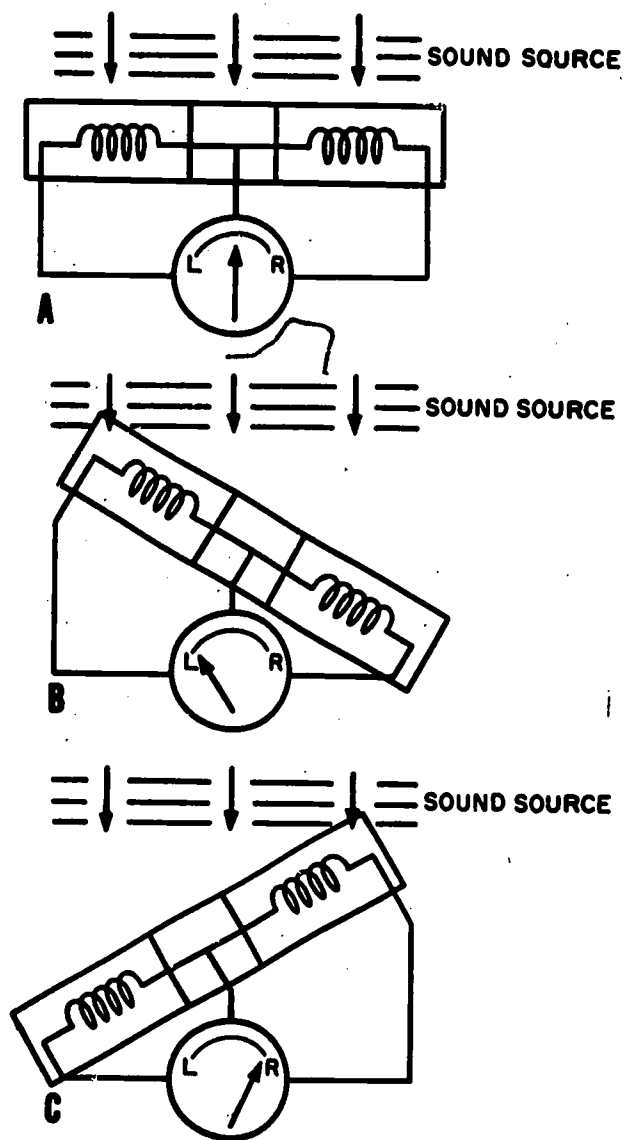

71.54
Figure 6-8.—Operation of the RLI.

A typical early type uses the magnetostrictive effect for sound detection. The hydrophone, which is trainable through 360°, is a line type whose nickel tubes are arranged horizontally in a line. It is divided electrically into right and left halves. Weak signals from the hydrophone are fed to an audio amplifier, then to bandpass filters that remove undesired frequencies from the

detected sound. A supersonic converter is used to increase the spectrum of detectable frequencies.

Accurate bearing is determined by training the hydrophone back and forth across the direction of the sound source. Outputs of the right and left halves of the hydrophone are fed to a right-left indicator (RLI). Any phase difference between the right and left signals causes the meter to deflect.

Operation of the RLI is diagrammed in figure 6-8. In part A of the illustration, the hydrophone is on target. Signals in both halves (right and left) produce a phase difference equal to zero. No deflection is indicated by the meter needle. In part B, the hydrophone is trained off the target to the right, and the meter needle is deflected in the "train left" direction. The meter indication informs the operator that he must train left to obtain a phase difference of zero. The hydrophone in part C is trained to a position left of the target. A right train is necessary to obtain the desired bearing.

The majority of passive sonar systems are equipped with the automatic target follower (ATF) feature. With the ATF feature, right and left signals are fed back into the training system, causing the hydrophone to follow the target automatically.

Array Sonar

Modern sonars utilize a hydrophone array, which is installed in one of two configurations. The conformal array is curved around the submarine's hull, with an open end aft. The circular array consists of a number of hydrophones arranged vertically in a circle and mounted in or under the submarine's bow.

MODERN PASSIVE SONAR THEORY

The theory of modern passive sonar consists of two basic steps: reception and presentation. Figure 6-9 is a simplified block diagram of an array type of passive sonar. The array cannot be trained physically. Instead, a compensator switch is added that, in effect, trains the system electronically.

Reception

Signals received in an array type of passive sonar system are converted to electrical energy

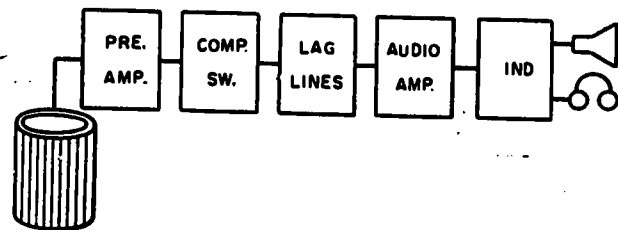

71.55
Figure 6-9.—Block diagram of an array-type passive sonar.

and then are fed to a preamplifier to be amplified to a usable level. There is one preamplifier for each hydrophone in the array. The output from each preamplifier is connected to a slipring in the compensator switch. The slipring couples the preamplifier output to a rotor plate.

One side of the rotor plate consists of an equal number of brushes and sliprings, each brush riding on a slipring. On the other side of the rotor plate, a set of brushes is arranged in a scale model of the hydrophone array. These latter brushes couple the rotor plate output to the stator plate. The stator plate has two sets of bars inlaid on the plate, one set on each half of the plate. Brushes on the rotor facing the stator plate make contact with the bars as the rotor is trained, and the signals present on the brushes are picked off by the bars. Half of the brushes on the rotor plate are always in contact with the stator plate, thereby utilizing half of the array at any given time. The center of the stator plate, being the reference point, makes it possible to determine the exact bearing of the target.

The arrangement of the hydrophones causes the signals to be out of phase with each other at the output of the preamplifiers. For the signals to be usable, they must be placed in phase with each other, hence, it is necessary to delay the signal. Each bar in the stator plate is connected to lag lines. The purpose of lag lines is to delay the first received signals a proportional amount until the last received signals can catch up.

Once the signals are in phase with each other, they are additive. As a result we have a strong signal to feed to the audio amplifier. There the signal is amplified and then is fed to an indicator.

INTRODUCTION TO SONAR

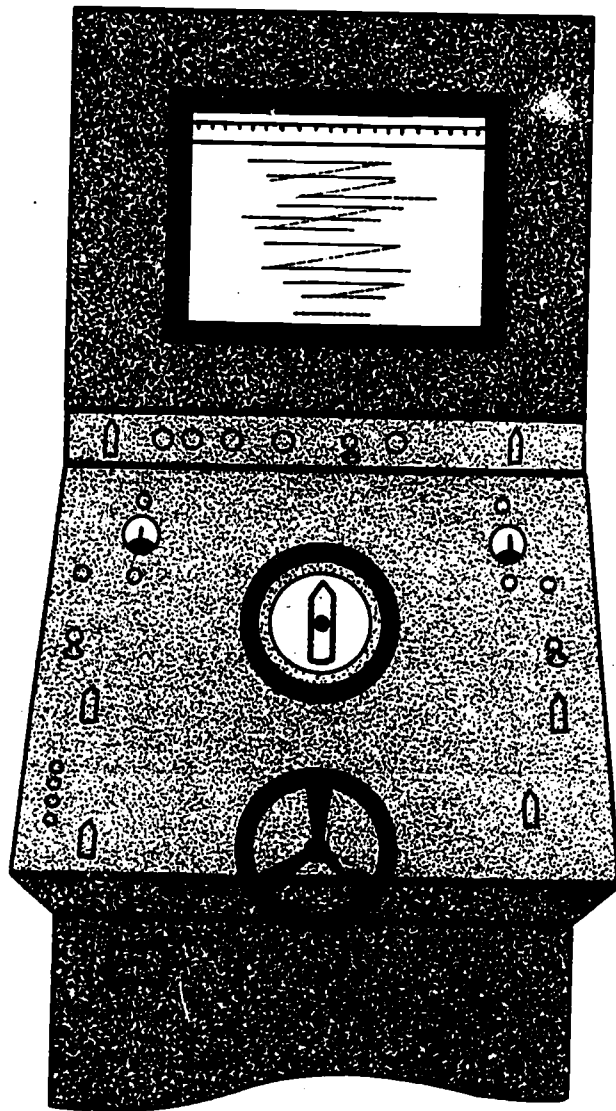

35.9
Figure 6-10.—Console of an array-type passive sonar.

Presentation

The console illustrated in figure 6-10 is representative of the indicators used with some types of array sonars. Target indications are presented continuously on a paper recorder and a CRT. They also are given audibly. The CRT is not located on the console itself, but

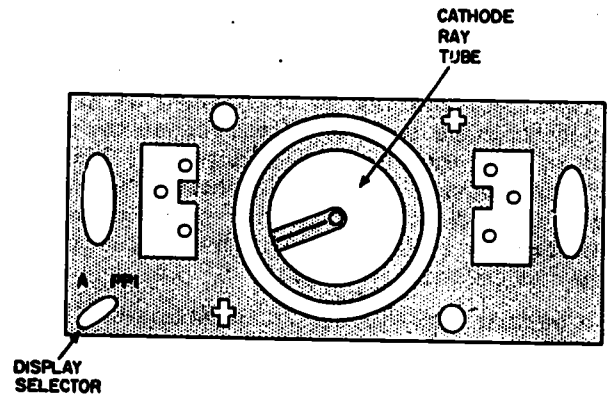

35.10
Figure 6-11.—Azimuth indicator of an array-type passive sonar.

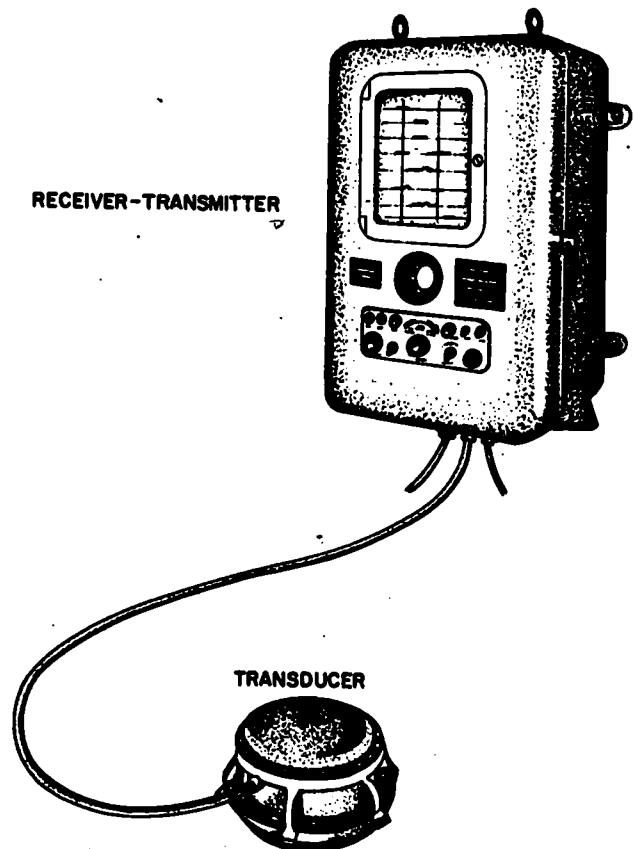

62.9
Figure 6-12.—Echo sounding equipment.

Chapter 6—PRINCIPLES OF SONAR

is a part of a separate unit—an azimuth indicator (fig. 6-11).

The paper recorder (on the upper portion of the console) plots the bearing of all noise. Operating in synchronization with the paper recorder is the CRT. It indicates the location of all noise-producing targets by inward deflections of the circular sweep. An audio channel, provided with each azimuth indicator, permits listening (with the aid of an external speaker) to this continuously scanning beam.

More detailed information on passive sonar systems is contained in Sonar Technician S 3&2, NavPers 10132. Also consult the manufacturer's technical manual supplied with each equipment.

FATHOMETER

Water depths can be measured in several ways. One method is to drop a weighted, distance-marked line (lead line) to the bottom and observe

the depth directly from the line. Chief disadvantages of this method are that its use is limited to very shallow water, and the operation is slow.

The use of sound is the more common method of measuring water depth. A sound pulse, directed toward the bottom, is transmitted, and its echo is received. The time between pulse transmission and echo reception is measured and, based on the speed of sound in water, the depth is thereby determined. Such an echosounding device is known as a sonar sounding set, called a fathometer. Basically the fathometer is a navigational instrument, but because it operates on the sonar principle, it usually is given to the Sonar Technician for upkeep.

One type of fathometer used aboard ships and submarines is the AN/UQN-1 sonar sounding set, shown in figure 6-12. Several models of the set are in use. In our discussion the AN/UQN-1C is representative of all the equipment modifications.

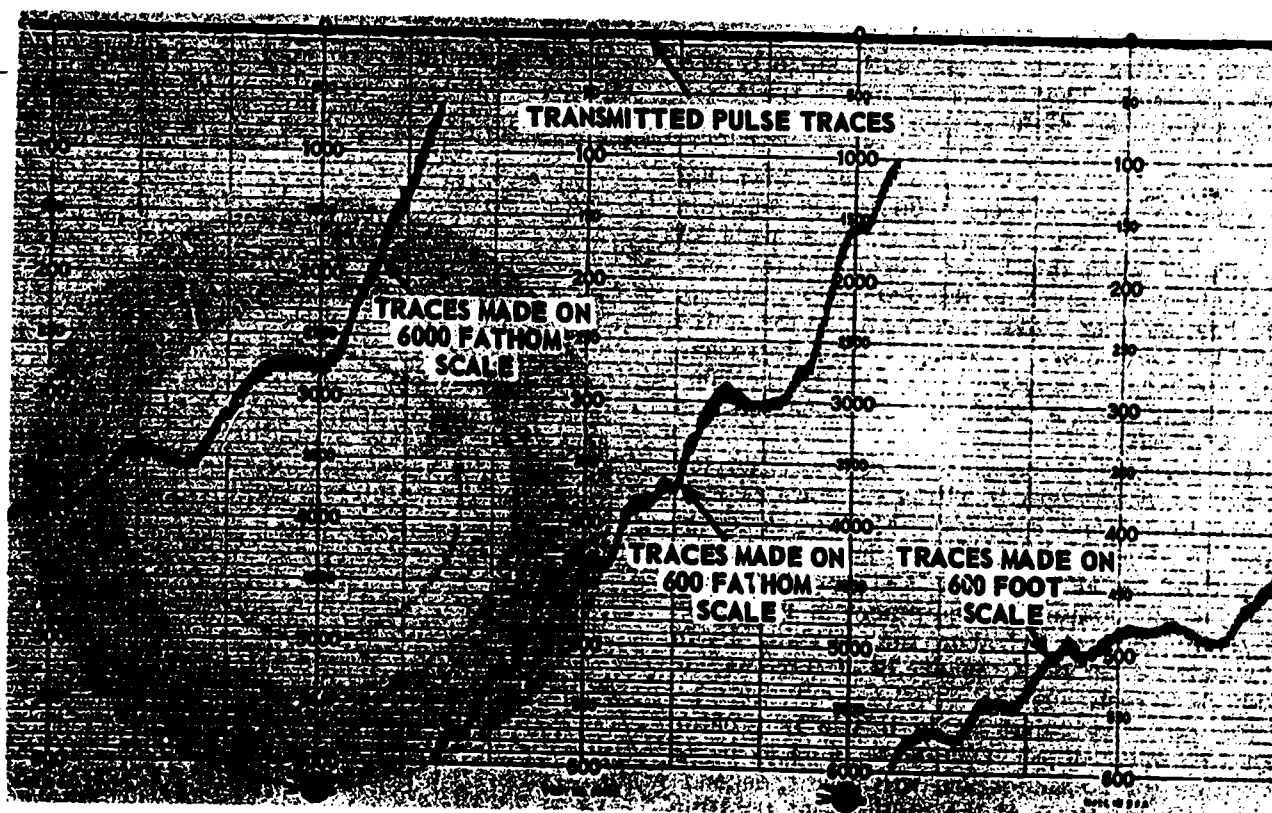

Figure 6-13.—Depth recording showing a steady decrease in depth. 62.10

INTRODUCTION TO SONAR

The AN/UQN-1C fathometer employs the hot stylus and sensitized paper method of recording depths. It also has a visual scope presentation for shallow depths. This fathometer is a compact unit, capable of giving accurate readings at a wide range of depths—from about 5 feet to 6000 fathoms. Three recorder ranges are provided on the AN/UQN-1C. They are 0 to 600 feet, 0 to 600 fathoms, and 0 to 6000 fathoms. The CRT ranges are 0 to 100 feet and 0 to 100 fathoms. The equipment may be keyed manually or automatically. (NOTE: All depths are measured from the ship's keel, not the water's surface.)

Two styluses are used, but they are spaced so that only one stylus records at a time. When the fathometer records, a stylus starts down the recorder chart simultaneously with the transmission pulse. The stylus moves at a constant velocity and marks the paper twice—once at the top of the chart when the pulse is transmitted, and again on the depth indication when the echo returns. A depth recording made by a fathometer of this type is seen in figure 6-13.

The recording illustrated was made from a ship sailing over a sea with steadily decreasing depth. The first part of the trace was recorded on the 6000-fathom scale. Inasmuch as the paper moves from right to left, you can see in the section of the paper shown that the depth decreased from 4000 to 600 fathoms. (Later depth information is to the right of the paper.) When depth was about 600 fathoms, the scale was shifted to the 600-fathom setting. (See how shifting makes use again of the entire width of the paper.) Because depth decreased still further, the scale was shifted to the 600-foot setting when a depth of about 100 fathoms was recorded.

The marking on the paper is downward (stylus motion is downward) in alternate rows printed from 0 to 600 and 0 to 6000. Marking the chart paper in this manner allows the same paper to be used for all recorder settings. You must check which scale the equipment is recording on to make sure whether the marking is in thousands of fathoms, hundreds of fathoms, or hundreds of feet.

Be sure the range scale in use is greater than the water depth. Otherwise, a false depth indication (or no indication) will result, depending on the position of the styluses at the time of echo return. If water depth actually is 120 feet, for instance, and you have selected the 100-foot range scale, a depth of 20 feet will be indicated.

Other false indications are multiple echoes and reverberations, both of which usually are caused by too high a gain setting. Multiple echoes are the result of the transmitted pulse being reflected back and forth several times between the bottom and the ship's keel. In shallow water a solid line may be recorded, making it impossible to read the depth. Both multiple echoes and reverberation effects can be reduced by decreasing the gain.

Visual indication is supplied by a circular sweep on the face of a CRT. Transmitted pulse and returning echo mark the sweeptrace radially. The visual indicator, pointing to a depth of 82 (feet or fathoms, depending on the scale setting) is shown in figure 6-14.

OPERATIONAL PROCEDURE

Following is a brief discussion on normal operation, security operation, and shutdown procedures. Refer to figure 6-15 while reading this description.

Normal Operation

For simplicity, it may be assumed that there is only one normal way of operating the

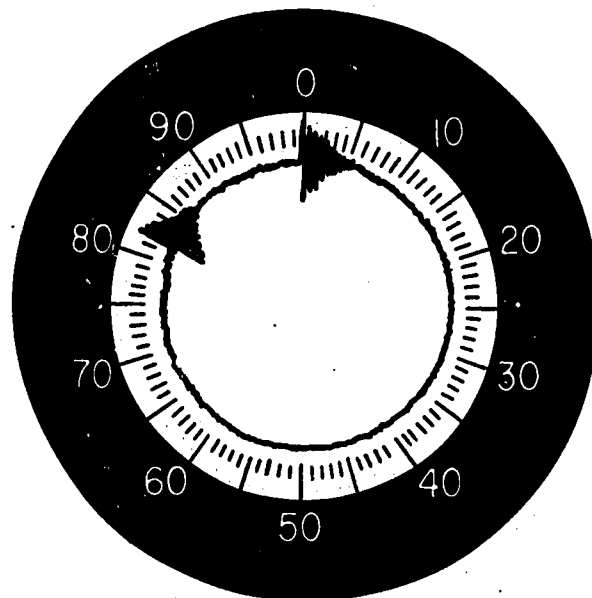

71.57
Figure 6-14.—Visual depth indicator.

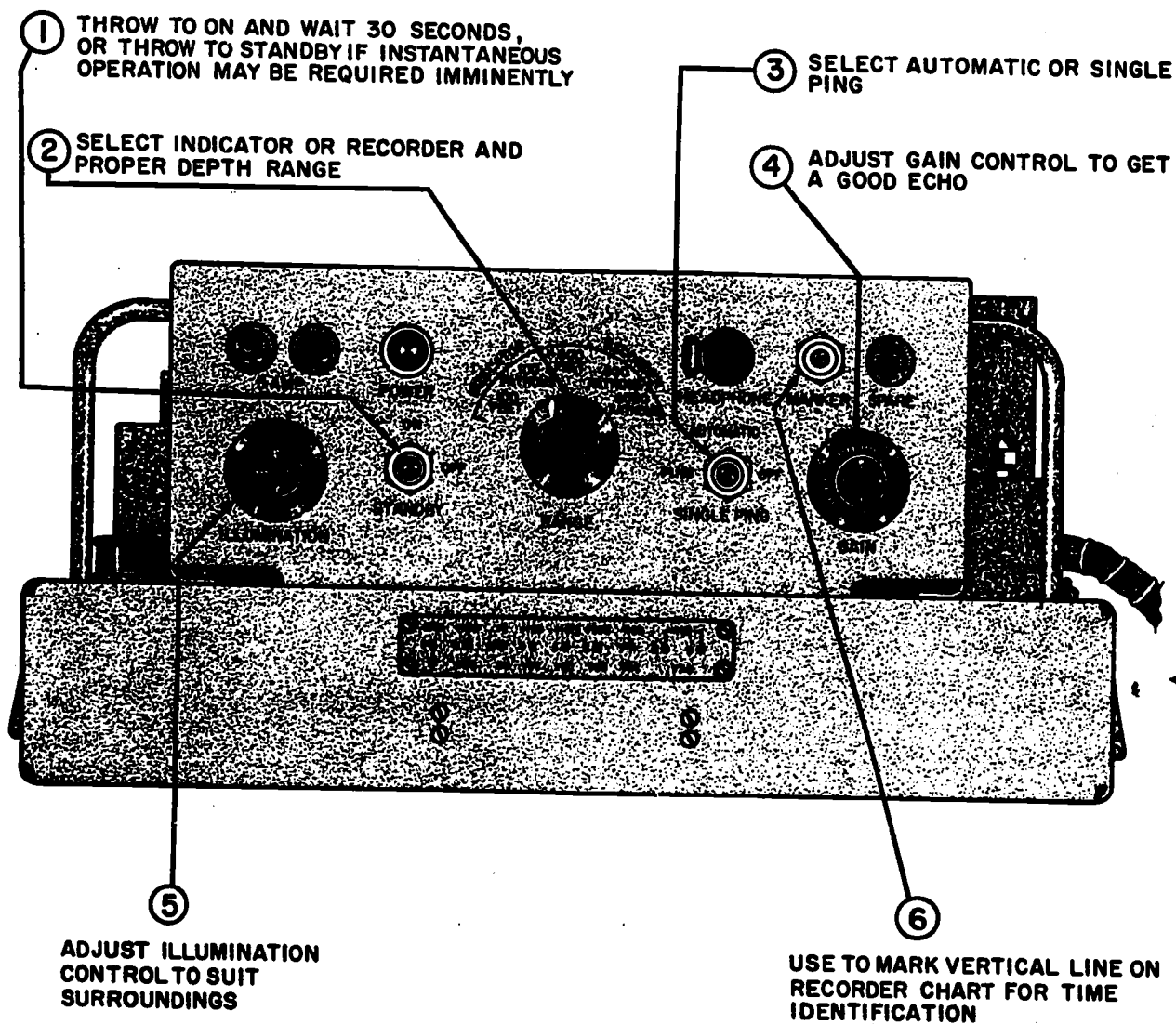

71.58
Figure 6-15.—Fathometer control panel.

fathometer. Deviations may be considered as expedients for conserving electrical energy, time, paper, or for maintaining sonar security.

1. Move power switch to STANDBY, wait about 30 seconds, then throw the switch to ON. This procedure prolongs the life of the keyer tube by allowing the filament to heat before applying plate voltage.

2. On the range switch select the proper range scale. On the indicator the scale is either

100 feet or 100 fathoms. On the recorder the scale is 600 feet, 600 fathoms, or 6000 fathoms.

3. Set the ping switch to AUTOMATIC.

4. Turn the gain control clockwise until a suitable echo mark is obtained.

5. Observe that both styluses attached to the revolving belt mark the paper from the zero line to 5 feet.

6. Check to see that the proper range marking is indicated on the top of the paper.

INTRODUCTION TO SONAR

7. Depress marker button. Observe that a straight line is drawn down the full length of the paper. This line should be straight from top to bottom, otherwise the stylus is out of adjustment.

Security Operation

If it is not desired to place pulsed energy in the water periodically, the fathometer may be operated as for normal operation, except that the ping switch is triggered downward to SINGLE PING, then is released. The circuitry is arranged to pulse the first time the keying contacts operate after triggering and then release immediately. The ping switch may be held down as long as desired without damage. The result is exactly the same as if this switch were in the AUTOMATIC position.

Shutdown

Put the ping switch to the OFF position. Throw the power switch to the OFF position (center). This action disconnects both sides of the 115-volt, 60-cycle supply from the equipment (except the service outlet).

ROUTINE MAINTENANCE

Routine maintenance as used here applies to functions, besides operation, that should be performed by the operator. When the operator checks out fathometer equipment before a run, he should be prepared (if necessary) to make minor adjustments, and replace lamps, tubes, styluses, or paper. Moreover, he should be satisfied that the equipment will render continuous satisfactory performance during the anticipated operating interval.

The manufacturer's technical manual that accompanies the particular fathometer aboard your ship lists a step-by-step procedure for accomplishing minor adjustments, replacing parts, and preventive maintenance requirements.

TAPE RECORDER

Sonar Technicians, particularly aboard submarines, must be able to make recordings of sonar echoes and of other sounds detected by the transducer or hydrophone. Such recordings are valuable aids in classifying sounds (determining the nature and/or source). All ships and submarines are supplied with the necessary

equipment to make such recordings. The most common installation is the AN/UNQ-7 recorder-reproducer sound set, familiarly known as a tape recorder.

The AN/UNQ-7 tape recorder is more sophisticated than many commercial types. It is a two-track recorder and reproducer, and is responsive to all frequencies in the audible range. Both tracks may be recorded either simultaneously or independently. Normally, track B is used to record signals directly from the sonar equipment. Track A is used for recording voice information.

When a recording reproduced by the equipment is played back, both tracks can be heard, or only one track, each channel having its own volume control. In short, the AN/UNQ-7 acts as a combination of two separate recorders that are capable of being coupled to allow superimposing two audio information channels upon each other. Figure 6-16 shows the front panel of the recorder. Later models, namely the -7B, -7C, and -7D, are transistorized and have a somewhat different

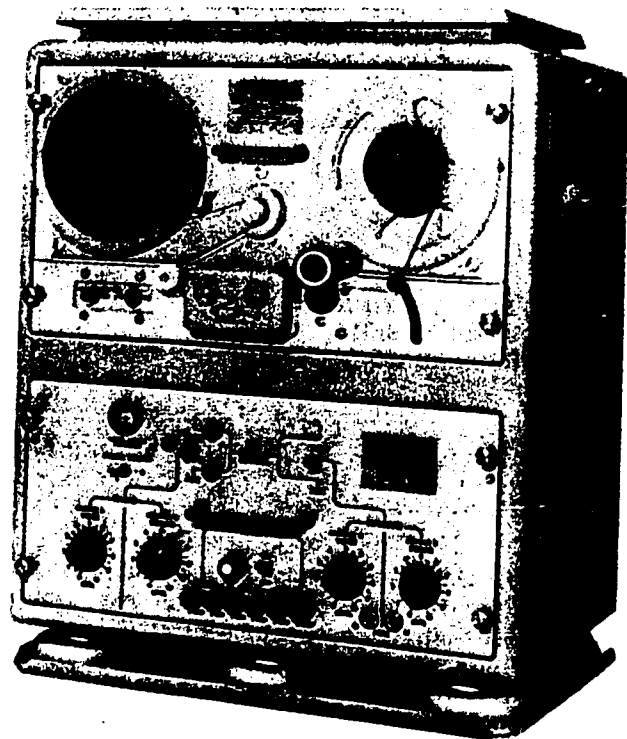

7.54
Figure 6-16.—Tape recorder AN/UNQ-7.

appearance, but their operating characteristics are the same as the basic model.

Originally the AN/UNQ-7 had recording speeds of 3-3/4 and 7-1/2 inches per second (ips). Field changes permitted an additional speed of 15 ips. All subsequent models, beginning with the AN/UNQ-7A, have the 15 ips feature built in. In general, the faster the recording speed, the more faithful is the sound reproduction.

The standard reel is 7 inches in diameter, holding 1200 feet of 1/4-inch tape. At a recording speed of 15 ips, 1200 feet of tape will last about 15 minutes.

OPERATING PRINCIPLES

Magnetic tape consists of finely ground iron-oxide particles deposited upon a plastic backing (tape). The particles, too small to be seen with the naked eye, are deposited in such a way that they are allowed to move or line up in an orderly fashion as a result of some force applied to them. The force having such an effect on the iron-oxide particles is a magnetic field. This magnetic field can be caused by a common magnet or by a temporary electromagnetic field. It results from passing an electrical current through a coil of wire.

MAGNETIC HEADS

A microphone contains a magnetic device that is capable of producing electrical energy representative of the sounds spoken into it. In a tape recorder, the microphones-produced electrical pattern causes a magnetic field to represent the pattern about a wire coil to which it is fed. The coil is wound on a core that has a gap in one side. Because the magnetic field is most intense at the gap, that is where the signal is placed on the tape. The narrower the gap, and the sharper the gap edges, the better is the high-frequency response. Figure 6-17 shows a typical magnetic head. The magnetic tape passes over the head, and the electrical pattern is reproduced upon the tape in the form of regular patterns of iron-oxide particles that line up in accordance with the signal passed through the coil.

The recorder has three heads. The device in the recorder about which the magnetic field is produced by the microphone is called the recording head. Another head, called the erase head, eliminates the magnetic pattern from the particles on the tape. A third head is for playback of the recorded signal and is called the

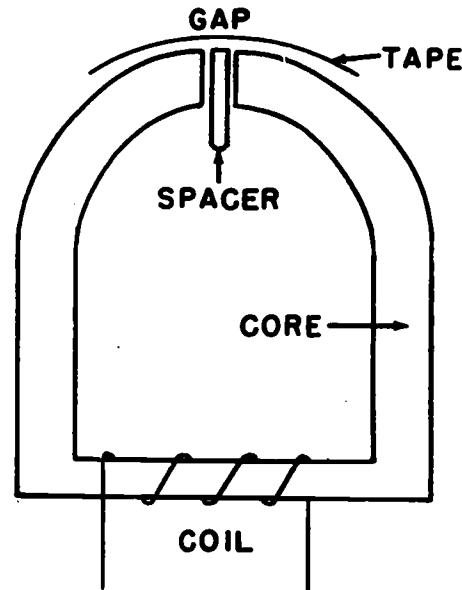

71.122

Figure 6-17.—Typical magnetic head.

reproduction head. The three heads are contained in a single housing.

Recording Head

The recording head is composed of a highly permeable material, which means that the core is easily magnetized, and just as easily demagnetized, by a current passing through the coil. High permeability is a necessity in order for the magnetic field to follow the fluctuations of the signal to be impressed on the tape.

In reality, the signal cannot be put "as is" directly onto the tape. It must be mixed with another signal for strength and linearity, that is, without distortion throughout the signal band. The bias signal with which the original signal is mixed is of very high frequency—too high to be heard. Electrically, it has unchanging, steady-strength characteristics. The a-c bias assures better acceptance by the tape of the signal to be recorded, and helps reduce distortion of strong signals.

Erase Head

Tape passes from the erase head to the recording head, and then to the reproduction

INTRODUCTION TO SONAR

head (in that order). The erase head demagnetizes both channels simultaneously. It is unnecessary to erase a tape individually before it is re-recorded, because when a tape is being used for recording, the erase head is energized so that a new recording cannot be ruined by superimposing it over an older one. Thus, tapes having recordings that no longer are needed for retention can be used directly. The machine simply is set to record, the old tape is put on, and, after it passes the erase head, it is "cleaned" of the earlier recording. It next passes the recording head, which puts a new magnetic pattern on it.

Reproduction Head

The reproduction head, which is next in line, is similar to the recording head in construction. That is, it has a broken ring of permeable material wound with wire coils. When the recorded tape passes over the gap, the permeable material is affected by changes in the tape's magnetic field, and an electric current is induced in the coils surrounding the ring. The induced signal is amplified and fed to phone jacks for audible presentation.

OPERATING THE EQUIPMENT

The top half of the tape recorder, as seen in figure 6-16, is the actual recorder and reproducer. The lower portion is the amplifier section. It includes controls and indicators that directly affect the recording and playback of the tapes.

Each recording track has a separate channel. On the equipment they are labeled channels A and B. Channel A is used for voice recording and reproduction; channel B, for sonar information. Both channels have separate controls for recording and reproduction. The recording controls are to the left of the amplifier section. Playback controls are at the right of the amplifier section.

Threading Tape

The roll of magnetic tape to be used for recording purposes is placed on the left reel-hold assembly on the upper section of the recorder. It is placed in such a way that, when the equipment is in operation (recording or reproducing), the reel rotates in a counterclockwise direction, and the magnetic tape leaves the reel from the bottom.

Other parts are on the upper section to guide the tape and to pull it through the head device. When the tape unwinds from the left reel, it is threaded around the guiding assemblies, fed through the head assembly, around the capstan (which actually pulls the tape through), and then it is taken up by the right reel. A pictorial diagram of the path followed by the tape from reel to reel is printed on the face of the head assembly. By adhering to the diagram, you will have no difficulty threading the equipment properly.

Recording

After the tape is threaded, the tape recorder is energized by turning the power switch to the ON position. You must wait for a short warmup period.

Next, select the speed at which recording is desired. As mentioned earlier, there is a choice of 3-3/4, 7-1/2, or 15 inches per second. Select the faster speed for critical recordings, during which the pitch of the echo may have an important part in later evaluation. A recording made at a higher speed can be studied more completely by reproducing it at the lower speed. (An 800-cps tone, recorded at 7-1/2 inches per second, is heard at 400-cps when reproduced at 3-3/4 inches per second.) Hence, recordings that may require later analysis should be made at the higher speed. The disadvantage of the higher recording speed is that the tape is used twice as fast as when operating at the next slower speed. Information on speeds to use for recording and playback are contained in the technical manual supplied with each recorder.

Although the higher speed provides the highest quality reproduction, differences in recordings made at each speed are not detected easily. Only when a critical analysis of the recording is made does the faster speed prove its worth over the slower one.

The recording level is selected next, and each channel's level must be adjusted individually. An indicator on the amplifier assembly is labeled record level indicator. Directly below it is a two-position toggle switch labeled channel selector. The positions of the switch are marked A and B, each representing a channel. Set the toggle switch to either channel, and observe the vertical amplitude on the face of the indicator. The record level controls, below the channel selector switch, are marked for channels A and B. Adjust the level control for the channel chosen until the signal peaks (shown in the level indicator) occupy the space between the upper

and lower horizontal lines. Next, select the other position on the switch and make the same adjustments for the other channel. The equipment is now ready to record on both channels.

To start the recording process, an unlabeled button to the right of the record level indicator is held to the left, and the tape recorder control (record section) is moved up to the No. 1 position. A light (indicator No. 1) glows as the equipment begins to record.

The unlabeled button is called the record safety interlock switch. Its function is to prevent accidental or inadvertent recording. To record, you must place the record switch in the No. 1 position, and simultaneously turn the record safety interlock switch to the left.

To stop recording, set the record switch to the neutral (middle) position. To start recording again, move the safety interlock once more to the left as the record switch is returned to the No. 1 position.

The other position of the record switch is labeled AUX (for auxiliary). This position is provided for use if an auxiliary recorder-reproducer is added to the system.

Recording from Remote Location

A device that allows some control of the assembly from remote locations is included with the tape recorder. A single operating control and two indicating lamps (labeled STANDBY and RECORD) are on the remote control unit. The single operating control is a two-position toggle switch that parallels the record switch on the amplifier section. Preliminary adjustments, such as tape threading and level control, must be set before using the remote control unit. The standby light indicates that power has been applied and that tape is threaded. It does not signify selection of the proper speed nor adjustment of the level controls. It does not light when no power is applied, when the tape is threaded improperly, nor when the equipment is used to reproduce a previously recorded tape.

The positions of the toggle switch are STANDBY and RECORD. The standby position corresponds to the neutral position of the record switch on the recorder proper. The record position takes precedence at both locations, meaning that if RECORD is selected on the remote control unit, the equipment will record even though the record switch on the equipment proper is in neutral. If RECORD is selected on the instrument proper, but STANDBY is set on the remote control unit, the equipment will

record again. Thus, a tape being reproduced on the recorder proper can be ruined (by the automatic erasure process during recording) if the switch at the remote control unit is set to the record position during playback. Consequently, the switch on the remote control unit must never be moved from the standby position unless the standby light is glowing.

When the machine is recording, the RECORD light on the remote control unit glows. When approximately 5 minutes of recording time remains on the tape, the RECORD lamp flashes to warn that the end of the reel is approaching. If the recorder cuts out (this feature is automatic when the tape reel is exhausted), the RECORD light goes out. When the tape recorder returns to a standby condition, the STANDBY light glows again.

Reproducing

To play a recording, thread the tape, turn on the power switch, allow for warmup, and choose the tape speed.

Next, place the REPRODUCE switch in the No. 1 position (it has the same positions as the RECORD switch). This setting actuates tape motion, and both channels are reproduced simultaneously.

Finally, adjust the reproduce level controls for both channels to the desired output of each of the headphones (if used) or the loudspeaker.

To stop the playback, simply return the reproduce switch to the neutral (middle) position. This stoppage may occur at will throughout the run of the reel. The equipment returns to the standby condition whenever the neutral position is selected. As in the recording mode, the tape motion stops automatically when the end of the reel is reached.

Remember that the switch on the remote control unit must not be set to record during the reproduction mode of operation. Otherwise, the recording will be ruined.

OTHER USES

The tape recorder allows simultaneous recording and reproducing of sounds. By this means, you can monitor what is being recorded as it is recorded. Steps to set the equipment to this mode of operation are included in the equipment instruction book, Technical Manual, Recorder-Reproducer Set, Sound, AN/UNQ-7, NavShips 365-2471.

INTRODUCTION TO SONAR

A switch on the upper section of the instrument allows rapid rewind and fast forward operation. Instructions and procedures for using the switch, as well as those for erasing and splicing the tape, are also included in the instruction book.

VARIABLE DEPTH SONAR

Thermal layers, as you know, reflect or refract the sonar beam, making it difficult to detect and maintain contact on a submarine operating below the layer. To overcome this detection problem, the variable depth sonar (VDS) was developed.

Modifications were made to existing sonars to permit them to transmit and receive signals through a transducer contained in a towed vehicle. Two current VDS systems are the AN/SQA-10, used in conjunction with the AN/SQS-29 and -30 sonar sets, and the AN/SQA-11, used with the AN/SQS-23 sonar set.

Modifications included the addition of a VDS transmit scanner, receiver scanner, a-f amplifier, and a relay-junction box. The shipboard

sonar can use either its hull-mounted or its towed transducer, or it can transmit on one and receive on the other. Either transducer may transmit an RDT beam. Received signals are presented in the normal manner at the master consoles.

Figure 6-18 shows the VDS transducer ready for lowering. The transducer may be towed at almost any speed and at depths to several hundred feet. To stow the towed vehicle, the boom is rotated so it faces forward and the transducer is lowered onto a deck cradle where it is securely fastened down.

SONOBUOYS

The sonobuoy is an expendable device dropped from an aircraft into the sea. It detects underwater sounds or echoes (depending on the type of unit) and transmits the detected information to the aircraft by means of a self-contained radio transmitter. Some surface ships are also equipped to receive the transmitted information.

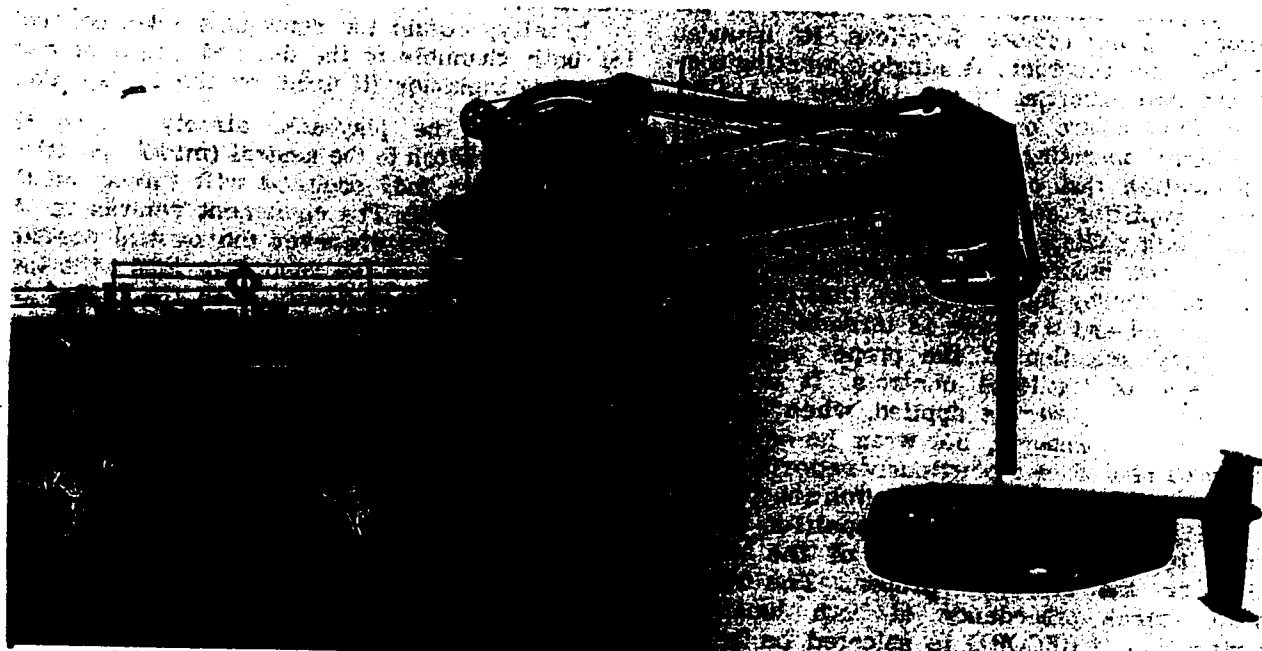

51.63
Figure 6-18.— VDS towed vehicle ready for lowering.

Chapter 6 — PRINCIPLES OF SONAR

Sonobuoys are used primarily by ASW units, but they also are employed in harbor defense installations. The three methods of detecting underwater targets are echo ranging, directional listening, and nondirectional listening.

The echo ranging type of sonobuoy uses a miniature transducer for transmitting sound pulses and receiving echoes. Operating depth is down to 200 feet. Received echoes are transmitted to the aircraft or ship in the form of range information only.

The directional type of sonobuoy provides bearing information on detected underwater sounds. The submerged unit rotates at a slow rate. Sounds detected by the hydrophone are amplified and frequency-modulated for radio transmission. The transmitting frequency is determined by the heading of a magnetic compass at the instant of sound reception.

The nondirectional type provides only detection information. Range and bearing of the sound source are unknown.

CHAPTER 7

BASIC FIRE CONTROL

Although the overall objective of all Sonar Technicians is to aid in destroying enemy submarines, the manner in which the task is accomplished varies with the individual branch of the rating. The shipboard Sonar Technician, for example, tries to maintain continuous contact through echo ranging sonar and aggressively enters the submarine/ship duel, using every available means to hold contact. The submariner has a tendency to sneak up on the target, gathering attack information from the noises produced by the target itself, perhaps making one sonar transmission just before firing. In each instance, the ultimate goal of the antisubmarine unit is destruction of the enemy submarine.

The system by which information is collected and translated into weapon firing data (including positioning of trainable weapon launchers) is called fire control.

UNDERWATER FIRE CONTROL

Fire control is defined as the technique by which weapons are directed to a selected target. It consists of the material, personnel, methods, communications, and organization necessary to destroy the enemy. Underwater fire control includes all of the foregoing components, with the added difficulty that the selected target is a submarine, capable of moving in three dimensions—in range, bearing, and depth.

WEAPONS

Some of the antisubmarine weapons controlled by underwater fire control equipment and used by ships and submarines against enemy submarines are described in the topics that follow. The discussion also points up some of the problems that must be overcome by the underwater fire control system to realize success. Not all weapons are discussed because of the nature of their classification.

Shipboard Antisubmarine Weapons

Aboard ship, several kinds of antisubmarine weapons are available. The principal one is the homing torpedo. Others include depth charges, hedgehogs, and rocket-propelled ordnance.

Figure 7-1 shows a Mk 32 torpedo tube mount used for launching homing torpedoes of the Mk 43, Mk 44, and Mk 46 types. The usual destroyer installation has one triple-tube mount on each side of the ship.

Homing torpedoes are of two types—active and passive. The active type transmits sound pulses and homes on the echoes reflected from the target. The passive type is guided to the target by noise emanating from the target itself.

Early antisubmarine torpedoes had two serious drawbacks. First the endurance or active period was relatively short—a matter of minutes. The second concerned their speed capability. Compared with speeds of many modern submarines, the homing torpedo was slow and could be outrun by a submarine. These drawbacks have been eliminated for the most part in modern high-speed torpedoes. The newer torpedo also is quite maneuverable, in contrast to the submarine, and has a tighter turning circle. Except for attempting to delude the torpedo with a decoy-type device, one of the best defenses the submarine skipper can provide against a modern antisubmarine torpedo is to call for all available power in an effort to clear the area at maximum speed. Modern torpedoes, however, normally are faster than the submarine. Inasmuch as the primary mission of an A/S escort vessel is to prevent the submarine from making an attack, causing the submarine to evade a torpedo and run from the area would accomplish the escort's mission.

When conducting an antisubmarine torpedo attack, the ship must maneuver into a favorable launching position. A typical homing torpedo runs in helical patterns while seeking a submarine. Once contact with the submarine is achieved,

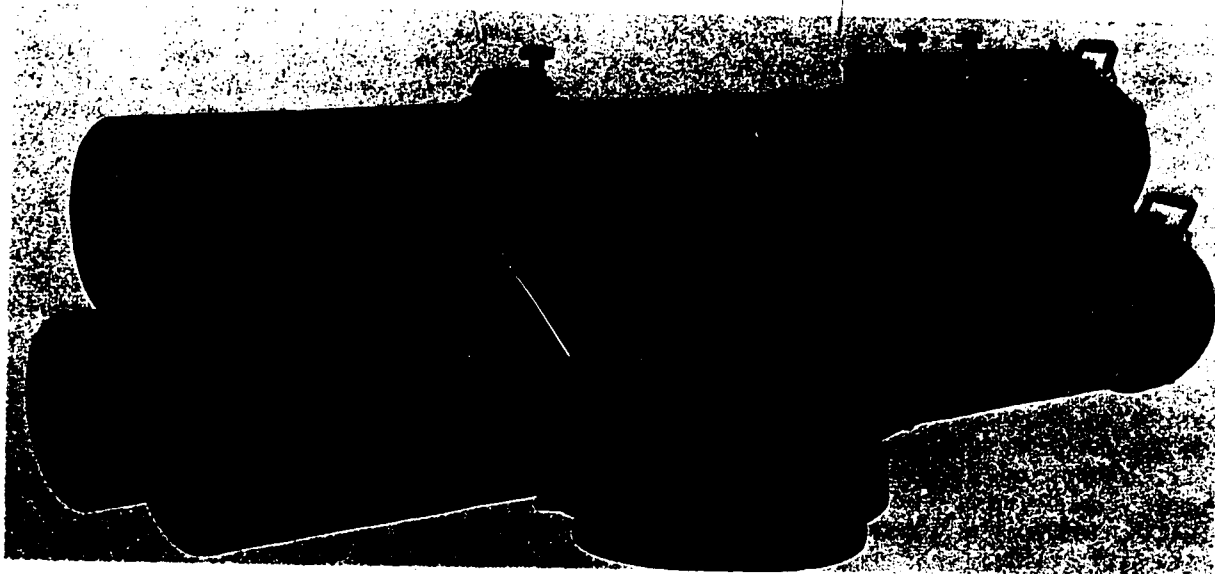

3.129
Figure 7-1.— Torpedo tube Mk 32.

the torpedo steers toward the target. If contact is lost, the torpedo searches for a short time in the general direction in which it is running, then resumes a helical search pattern if contact is not regained. Some types have a passive capability in conjunction with their active feature which enables them to detect a submarine that is beyond their active acoustic range.

The depth charge currently in use is the teardrop-shaped type, and is either influence-detonated or hydrostatically detonated. These depth charges are launched from racks on the ship's fantail. A direct hit is unnecessary for a kill, but to be effective the explosion must be quite close to the submarine. For this reason, depth charges are launched in patterns covering the submarine's position and the area into which he may maneuver. In general, it can be said that because of their slow sinking rate, depth charges are not too effective against modern submarines. Although depth charges are being phased out of operation, many reserve destroyers, as well as some active ships, still are equipped with them and with hedgehogs.

Hedgehogs are impulse-propelled charges. In order to explode, they must come in contact with a submarine. They usually are fired in a circular pattern. Two general types of hedgehog mounts are in operational use. One is fixed to the deck and has spigots (from which the hedgehogs are fired) that can be tilted to allow

for last-minute changes in the relative positions of the ship and the submarine. The other type, the trainable mount, can be rotated to the firing bearing. When a full pattern is fired from either mount, the charges fall into the water in a large circular pattern. Tilting the spigots causes a distortion in the pattern, however, so that it is advantageous to fire with zero tilt set on the spigots. In the trainable mount, pattern distortion does not occur because the entire mount is trained to the correct bearing at the time of firing.

Shipboard antisubmarine rockets are of several operational types. The earliest one, labeled Weapon A still is in operational use. It has a maximum range of nearly 1000 yards, contains several hundred pounds of explosive, and is detonated by a magnetic influence fuze.

Another shipboard rocket device is the anti-submarine rocket, better known as ASROC, discussed in chapter 2.

Submarine Antisubmarine Weapons

Today's submarine has a choice of many types of torpedoes, each designed for a specific purpose. The three main classes of torpedoes are straight-running, acoustic homing, and wire-guided.

Although the straight-running contact torpedoes are useful in certain tactical situations,

INTRODUCTION TO SONAR

they are not considered effective as antisubmarine weapons. These torpedoes are used chiefly against surface targets at fairly short ranges. They are noisy and thus are detected easily but are difficult to counter because of their high speed.

Acoustic homing torpedoes available to submarines have features for homing passively, actively, or a combination of the two.

Wire-guided torpedoes are a variation of the acoustic homing torpedo. They are guided to the target submarine's vicinity by signals sent over the wire by the launching submarine. After the target is acquired by the torpedo, it homes on the target without further guidance from the launching submarine.

The submarine also has a rocket-propelled weapon, containing a nuclear warhead, called SUBROC, which was described in chapter 2.

DETECTION-TO-DESTRUCTION PHASES

Theoretically, the fire control problem begins when a target is detected and ends with its destruction. In practice, though, the fire control problem starts well after initial detection. It commences after the initial classification and when target tracking is ordered.

Like all other fire control systems (anti-aircraft, surface-to-surface, and the like), the antisubmarine fire control system solves the problem in the following stages: (1) tracking the target; (2) analyzing target motion; and (3) computing ballistic solution.

Detecting a submarine is no easy matter. Neither is it a simple task, once a submarine contact is established, to carry out the successive phases mentioned here. Although fire control systems are capable of performing complicated tasks, such as predicting future positions, submarine hunting is subject to errors caused by human judgment. Training in proper operation of the equipment for maximum ASW effectiveness is a must for Sonar Technicians.

Because the same equipment often is used in detecting a submarine as in tracking it, detection is considered as a phase, even though in the strictest sense it may not be a part of the problem.

Detection Phase

A submarine may be detected in several ways, the most positive being visual sighting. If the submarine is seen to dive, classification is evident; there is no question about the positive nature of the contact. Once such a classification

is established, the next phase (tracking) can be initiated.

Detection also can be made by radar. If a radar contact suddenly disappears, there is a good chance that the echo was the return from a surfaced submarine and that the disappearance was caused by diving. If sonar contact also is held, it can be assumed the contact is a submarine. Most surface-search radars can receive a radar indication from a periscope. Hence, it is possible to track a submarine that is operating completely submerged except for its periscope. The radar method goes hand-in-hand with visual detection, because radar frequently provides the first indication, directing eyes to the location of the periscope, snorkel, sail, or hull of the submarine.

The sonar equipment aboard your ship or submarine is designed to detect and track the submarine, and feed computing devices with tactical data to achieve the destruction phase of the problem.

Tracking Phase

After detection, the contact must be tracked. Aboard a submarine, a graphic display of target bearings is made during this phase. From information furnished by this display, target motion is established. Normally, the submarine uses only passive sonar for tracking, because active sonar may disclose the presence and even the location of the tracker.

Shipboard Sonar Technicians track the target with active sonar, depending largely upon the strength and quality of the echo of the transmitted pulse for target information. Antisubmarine ships have fire control systems that incorporate automatic tracking features. Once the contact is established firmly, the automatic devices keep the sonar on the target, and compute the course to be steered so that the ship will arrive at the best firing position for the weapons selected for use.

Basically, establishment of relative rates of target motion is all that is desired from the tracking phase of the problem. The tracking phase sets up the pattern for the next phase—target motion analysis. It is from the relative rates that actual target motion is determined.

Target Motion Analysis Phase

The target motion analysis phase is a dynamic problem because both the attacking unit and the target usually are in motion continuously, and all

related factors change constantly. As a result of the target motion analysis phase, we can establish the true motion components of the target (course and speed). There are several ways of arriving at a course and speed solution. A discussion of the methods follows.

The target's true course and speed can be established on the dead-reckoning tracer (DRT) plot maintained in CIC by Radarmen from information supplied by the sonar operators over sound-powered telephone circuits. The DRT utilizes own ship's course and speed inputs to cause a lighted "bug" to follow own ship movements. Sonar target ranges and true bearings are plotted from the bug, thus establishing the submarine's position. Course and speed are then determined by the plotter. The DRT plot is used by the CIC officer to aid him in conning the ship when CIC has control of the attack, and to supply search arcs to the sonar operators whenever contact is lost.

A maneuvering board may also be used to determine contact course and speed, but this method is not so rapid nor so accurate as the DRT. The direction and distance of contact movement are transferred to a vector representing own ship's course and speed, thus establishing the target's course and speed vector. Another drawback to the maneuvering board method of plotting is that the target's plotted track shows only apparent movement (relative motion).

Target true course and speed also can be read from dials on the attack director (discussed later).

On surface ships the underwater fire control systems usually have to compute a horizontal sonar range from the measured slant range and estimated target depth information. This computation is necessary because the fire control system solves for target course and speed in the horizontal plane on the surface in which own ship operates. Slant range is transmitted to the attack director from the sonar console. Depth is set manually into the director.

The attacking submarine may use different methods to determine true direction of target motion. One method is by direct observation, when possible, of the angles on the bow. Angle on the bow was discussed in chapter 3.

Ballistic Solution Phase

It is difficult to say when one phase of solving a fire control problem ends and another begins. One phase usually overlaps another; often they are concurrent. The start of the

ballistic solution phase, for example, practically coincides with that of the tracking phase. An antiaircraft fire control system presently in use provides a solution in only 2 seconds, once the target is acquired by radar. Yet, during that time, the target is tracked, its motion is analyzed, and the ballistic solution is computed. Most underwater fire control systems, however, take longer to develop a solution. The reason is that certain inaccuracies in target information are provided by underwater sound. Additionally, range limitations of the weapons require the attacking unit to be at a definite point to launch nontrainable weapons, and within a specific area to fire its trainable weapons.

After determining the target's course, speed, and depth, two items must be considered in order to complete the problem. One is how to close the target. The other is when to fire.

To close the target, the course to steer for the optimum firing point must be known. In the fire control problem the course to steer is indicated as a correction to own course. Own ship's present course must be changed by the amount of correction necessary to intercept the target. The best intercept course is a collision course, which means the target is closing on a constant bearing. Computing course correction is an automatic process in underwater fire control systems.

The second consideration—when to fire—is a decision reached from a compilation of many items. If you use two different types of weapons in the same attack, one of them to be fired ahead and the other to be dropped astern, it stands to reason that the ahead-thrown weapon must be fired first. What the problem develops into is a calculation of two time periods: the time of explosion and the time to fire. The problem is solved by computing the time of explosion after the initial classification of the target, then subtracting (1) dead time (how long it takes, after the command to fire, to actually fire the weapon), (2) time of flight (the time required, after firing, for the weapons to strike the water), and (3) sinking time (length of time for the weapon, after striking the water, to reach the depth of the target). When these subtractions are made, you have the time to fire. The values subtracted have been calculated from testing weapons and from previous experience.

Assume that, after detecting a target, explosion time of 3 minutes is calculated. If the weapon used has a dead time of 5 seconds, a time of flight of 7 seconds, and a sinking time of 18 seconds, then a total of 30 seconds ($5 + 7 + 18 = 30$) is subtracted from the 3

INTRODUCTION TO SONAR

minutes to the time of explosion, leaving 2-1/2 minutes as the time to fire the weapon after the decision to fire is reached. Bear in mind that time to fire and time of explosion are individual items. Although the weapon will be fired in 2-1/2 minutes, it will explode in 3 minutes.

Destruction Phase

Destruction of the target is the ultimate goal of the submarine hunter. During this phase the computed ballistic solution is used so that the ordnance may effectively be fired on the target. Although the surface ship's primary A/S weapon is the homing torpedo, the methods of submarine destruction by surface ships are many and varied. Included are ramming, direct hits with hedgehogs, hull-rupturing near-misses with depth charges and depth bombs, and damage of less serious nature that forces the submarine to the surface where it can be finished off with gunfire. Anti-submarine submarines, of course, use their A/S torpedoes on their submarine targets. In short, the destructive phase includes action on the part of the attacking unit that leads to a kill—directly or indirectly.

FUNDAMENTAL PROBLEM

The fundamental problem of fire control is to deliver fire on the selected target. A direct hit is not required with some weapons. A depth charge, for example, can cause the destruction of a submarine if the charge explodes close enough to it. All attacks are made with the intention of hitting the target, but with some weapons, a near-miss is good enough.

Solving the fundamental problem is no easy matter. The difficulty is due to such factors as target speed, maneuvers, range and speed of the weapon, all of which play important roles in delivering fire on the selected target. The solution to the problem varies greatly with given situations. A duck hunter, for example, "leads" the duck along the path of flight. If the hunter aimed directly at the duck as he fired, the shot would pass through the area at which he aimed; but, because the duck is moving, it no longer would be at that spot when the shot reached there. Consequently, the hunter makes an estimate of the future position of the duck, aims for that spot, and fires his gun. If he estimated correctly, both the shot and the duck will arrive simultaneously at the predicted position. The fire control problem is similar to the duck hunter's problem, but on a much larger scale.

REFERENCE PLANES

Assume that a gun, rigidly fixed to a ship's deck, fires while the deck is level, and its projectile hits the target. The same gun, if fired at a time other than when the deck is level, will miss the target. If the gun is free to train (rotate) and elevate, however, compensation can be made for the ship's roll and pitch. The gun then will remain reasonably steady, thus improving the chances of hitting the target, regardless of the ship's motion. A fire control system, in conjunction with a stable element, attempts to make the necessary adjustments to keep the weapon steady.

Deviations from the level attitude are measured by a gyromechanism (the stable element), which transmits to a computer in the fire control system signals that indicate variation of the position of the deck with respect to the horizontal.

Based on signals from the stable element, the fire control system computes values of train and elevation for the weapons launchers to compensate for deviation from the level attitude. The various attitudes are measured with reference to flat, two-dimensional surfaces called planes. (See fig. 7-2.) An underwater fire control system computes solutions in the horizontal, deck, and vertical planes.

Horizontal Plane

A horizontal plane is tangent to the surface of the earth. Visualize this condition by laying a playing card on an orange. The card represents

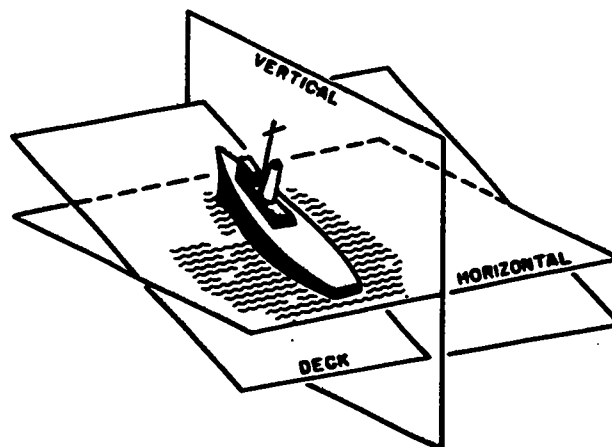

71.123

Figure 7-2.—Reference planes.

Chapter 7—BASIC FIRE CONTROL

the horizontal plane, the orange symbolizes the earth, and the point of contact between the two is the point of tangency. Every plane parallel to the horizontal plane is likewise a horizontal plane.

Deck Plane

The deck plane represents the level of the ship's gun mounts. (References to guns include similar weapons systems.) When the ship is level, the horizontal and deck planes coincide, but when the ship rolls and pitches, the deck plane deviates from the horizontal. The stable element measures the amount of angular deviation and transmits the information to the fire control system. The fire control computer compensates for deck tilt by computing a solution in the horizontal plane, then makes train and elevation corrections. What the system does, in effect, is bring the deck plane back to the horizontal.

Vertical Plane

A vertical plane is perpendicular to the horizontal plane, and is the reference from which bearings are measured. Relative bearing, for example, is measured in the horizontal plane clockwise from the vertical plane through own ship's centerline to the vertical plane through the line of sight.

The system of planes makes possible the design and construction of mechanical and electronic equipment to solve the fire control problem. These lines and planes are imaginary extensions of some characteristic of the ship or target, or of the relation in space between them.

FIRE CONTROL NOMENCLATURE

Fire control nomenclature provides a brief and accurate means of expressing quantities that otherwise would require extended descriptions.

Two systems of expressing fire control quantities presently are effective. The older of the two systems remains in use because some of the earlier fire control equipment, such as the Mk 105, still is in service. With the appearance of new weapons, the old system was found to be inadequate for expressing the fire control quantities for such ordnance as missiles. All new weapons systems (such as ASROC), therefore, use the new fire control nomenclature.

The entire nomenclature is too lengthy and detailed for inclusion in this text, but brief explanations of the two systems are provided so that you may better understand the meaning

and purpose of the fire control quantities and their symbols.

A compilation of the nomenclature used in the older antisubmarine fire control systems may be found in ordnance publication OD 3447 and in Sonar Technician G 3 & 2.

Old System

The older system of fire control nomenclature is made up of capital letters that represent basic quantities, and lowercase letters, numerals, the Greek delta (Δ), and the prime mark ('), used as modifiers to expand the meaning or function of the basic quantity. The capital letter C, for example, is the basic quantity for true course. Own ship is represented by the lowercase letter o; and the target is identified by the letter t. By adding the modifier to the basic quantity, own ship's course becomes Co, and target course is Ct.

Further expansion of the application of the basic quantity is provided by adding more than one modifier, and placing them both before and after the basic quantity. Thus, B (for bearing) can be modified first to become Br (relative bearing), further to cBr (generated relative bearing), and finally to Δ cBr (increments of generated relative bearing).

The prime modifier (') signifies that the quantity is measured with respect to the deck plane of the ship. Because guns and directors are fastened to the deck of a ship, Br can be measured only at the instant the deck is horizontal. Actual values of director train (angles measured in the deck plane are an indication of train, not bearing, in the language of fire control) consequently include a prime mark, signifying that the quantity is measured with respect to the deck plane. As a result, B'r is director train and represents the angle measured from the vertical plane through the fore-and-aft axis of own ship to the vertical plane through the line of sight in the deck plane clockwise from the bow of own ship.

The Greek delta (Δ) also is used as a modifier. It is placed before the quantity it modifies, and signifies a change in that quantity during some specific time. It is an increment of a quantity.

New System

Ordnance pamphlet OP 1700 has established and standardized the nomenclature used in describing fire control problems and their solutions for the control of guns, underwater weapons,

INTRODUCTION TO SONAR

and missiles. Volume 1 contains the nomenclature for the quantities applicable to solutions of the gun fire control problem. Volume 2 covers the nomenclature for underwater related quantities. Volume 3 has the standard nomenclature for missile related quantities.

The plan of the OP 1700 system follows the general pattern of the previous system, with modification to permit introduction of new quantities. It has greater flexibility and wider application to advanced fire control problems.

In some instances, quantities in the new system have different symbols than they do in the old system. True target bearing, for example, uses the capital letter B in the old system, but in the new system it is symbolized as B_y . Target course in the old system is represented by Ct, whereas in the new system the modifying letter t is omitted.

The geometrical quantities used in naval fire control are those quantities involved in the mathematical solution of the general fire control problem. Hence, the geometrical quantities fall into certain main classes of quantities. Each of the main classes of quantities is represented by a class name. In each class, other geometrical quantities, besides the basic quantity, are expressed by applying modifiers to the basic quantity, as in the old system. The modifiers express the way in which the quantity is measured.

To illustrate, a class of quantities for expressing present target position is linear distance between own ship and the target. This class of quantities is called ranges. The basic geometrical quantity in this class is the linear distance between own ship and the target, measured along the line of sight. It is expressed by the capital letter R. Another quantity in this class is the linear distance between own ship and the target, measured in the deck plane. This quantity is symbolized by applying the modifier d (meaning measured in the deck plane) to the basic range quantity R, forming quantity R_d .

The nomenclature assigned to represent the basic geometrical quantity in each class, and the letters and numerals used as modifiers are listed (as mentioned previously) in the three volumes of OP 1700. Extracts of Volume 2 of OP 1700 (underwater fire control nomenclature) are contained in Sonar Technician G 3 & 2.

SONAR POSITION QUANTITIES

When a target echo is received by a sonar transducer, the target actually is not at the

position indicated on the sonarscope, but at some other location. This difference in target positions is due to curvature of the sound beam and to target movement during echo return time.

The determination of actual target position requires the application of corrections to the sonar measurements. These corrections, which are computed in the underwater fire control system, consist of two position quantities: apparent target position and past target position. (Target course and speed also are considered in the problem.) Sonar position quantities are illustrated in figure 7-3. The quantities are expressed in the new fire control nomenclature.

Two class quantities, range (R) and bearing (B), are shown, together with the modifiers necessary to express the appropriate measurement. Quantities related to apparent target position are represented by the lowercase letter a; those related to past target position use the letter p. The modifier h means the measurement is in the horizontal plane; the modifier v refers to the vertical plane.

Apparent Target Position

Apparent target position is the point from which the sonar echo appears to come. It differs from present target position because of refraction of the sound beam, and because of target travel during the time required for the echo to return to own ship. The dotted lines in figure 7-3 represent apparent position measurements. The quantity B_a is apparent target relative bearing, and R_{ha} is apparent target range measured in the horizontal plane.

Past Target Position

Past target position is the location of the target when struck by the sound beam. In other words, it is the position from which the sonar echo actually comes. Past target position differs from apparent target position because of refraction of the sound beam. It differs from present target position because of target movement during the time it takes the sound pulse to return to own ship.

Present Target Position

Present target position is where the target actually is located when the sonar echo reaches own ship. It represents the distance traveled by the target during the time it takes the sound pulse to return to own ship from the target.

Chapter 7—BASIC FIRE CONTROL

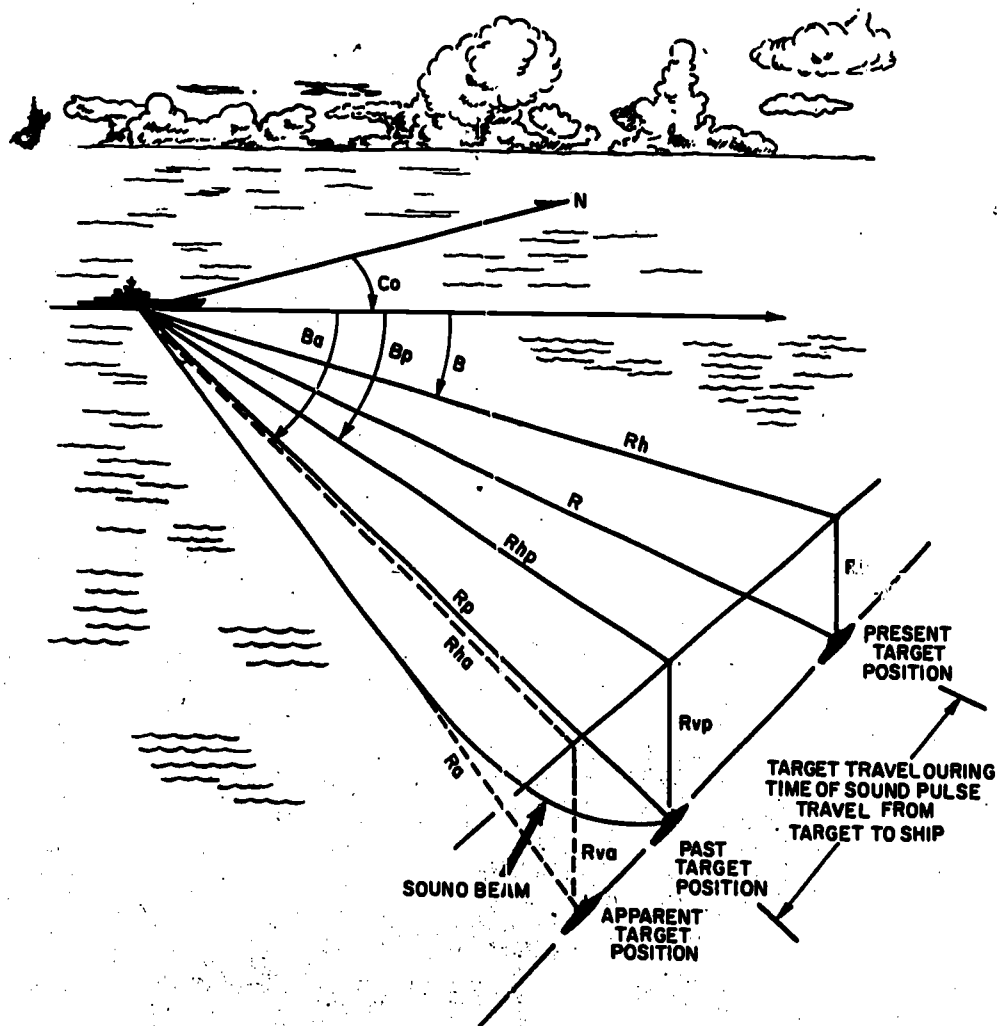

71.124

Figure 7-3.—Sonar position quantities.

As shown in figure 7-3, quantity B is the target's relative bearing at the time the echo is received. Target depth (Rv) and horizontal range (Rh) combine to produce actual target range (R).

NAVIGATIONAL PARALLAX

Two ships sometimes operate as a unit to solve the underwater fire control problem. One ship measures and computes position data and transmits the information to its assist ship, which makes the attack. When two ships operate in this manner, correction for parallax must be made. Correction for parallax must also be

made when conducting a DASH attack. Parallax is the apparent displacement of an object when seen from two different points.

The class of quantities used to express linear displacement between the computing ship and the assisting ship reference points is called navigational parallax (symbolized Pn), and is measured along the navigational parallax base-line.

Parallax corrections to a basic quantity, to account for displacement, are symbolized by lowercase letters pn, and precede or follow the basic quantity, which is enclosed in parentheses. To illustrate: Relative target bearing

INTRODUCTION TO SONAR

from the assist ship, as determined by the computing ship, is expressed $B + pn(B) = (B)pn$, where B equals relative target bearing from the computing ship, $pn(B)$ is the correction to be made to account for displacement between the two ships, and $(B)pn$ equals relative target bearing from the assist ship after correction is made for displacement between the computing ship and the assisting ship.

Another type of parallax correction is Pdo , which accounts for displacement of the weapon launcher from the reference point (the sonar transducer), measured in the deck plane along own ship's centerline.

EQUIPMENT

An underwater fire control system usually is designed to operate with a particular weapon system, although efforts are made to make the

system compatible with future weapons. One modern fire control system may be used with several weapon types. Regardless of the system, it serves only one purpose: the destruction of enemy submarines.

After target position is determined the basic problem for the system is to predict future target position, calculate the required attack course and firing time, and transmit the data to weapons and control stations.

Because most underwater fire control systems are of a classified nature, they cannot be included in this text. Certain concepts are discussed, however, to give you some basic knowledge of how a fire control system operates.

BASIC COMPUTING MECHANISMS

The purpose of the computer in a fire control system is to solve the problem of delivering a weapon on the target. Available information is

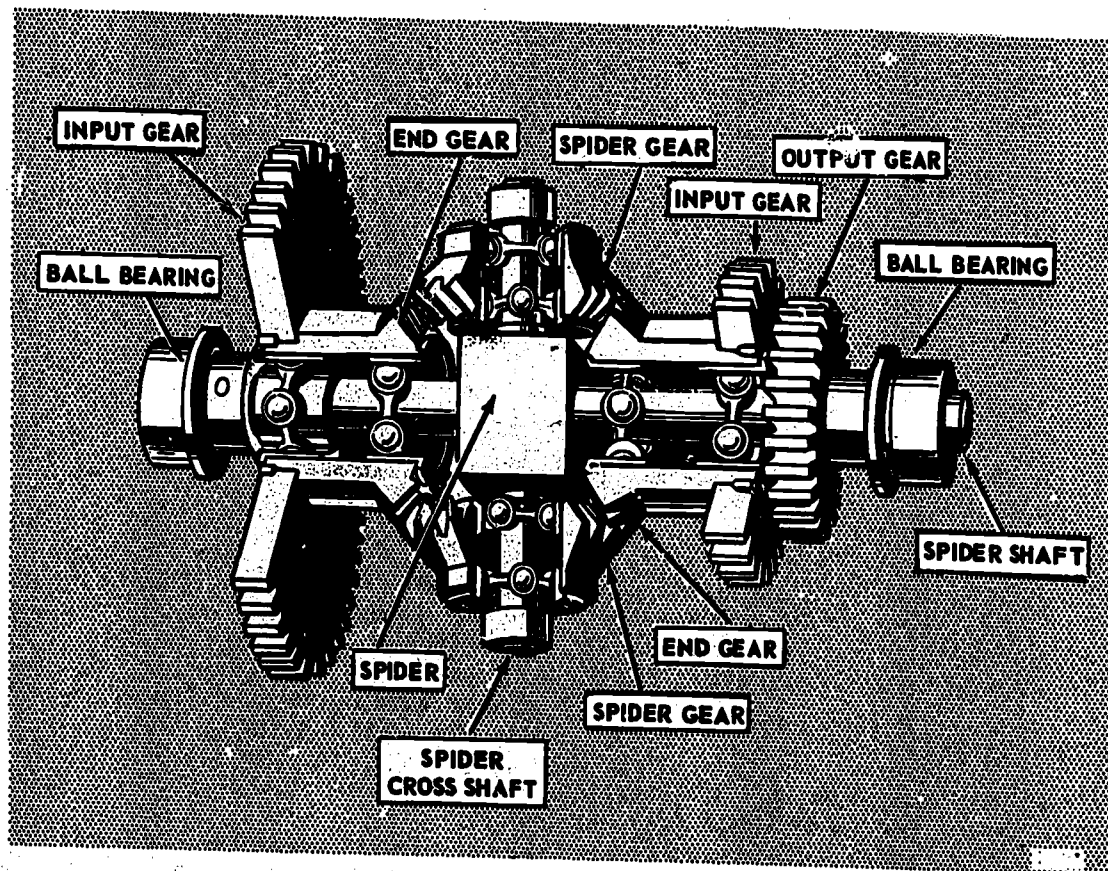

12.87
Figure 7-4. — Bevel gear differential.

fed into the computer. If the information is sufficient and correct, the computer tells how to get to firing position and when to fire. The electromechanical computer solves the problem by means of a maze of interconnecting machinery. Taken as a whole, the computer is complex and difficult to comprehend. Basically, however, the components are simple machines consisting of gears, levers, cams, springs, etc., that perform mathematical functions more rapidly than man could possibly do.

Mechanical Computing Devices

Of the many devices for computing fire control data, the easiest ones to understand are mechanical devices that perform basic mathematical operations.

Solving the trigonometric functions of a right triangle is an important mathematical operation because fire control computations are based on the right triangle. Three of the six natural functions of an angle in trigonometry enter into the fire control problem. They are the sine, cosine, and tangent. The remaining functions—secant, cosecant, and cotangent—seldom are used. Other mathematical computations performed by mechanical computing instruments include algebraic functions, simple addition, subtraction, and multiplication.

Mechanical computing devices depend on rotary and linear motion in solving problems. When an electrical signal is received by a synchro motor, for instance, the motor turns a shaft, providing an output of rotary motion. This motion is then transmitted along various shafts and through gear trains to some other point in the computer. As long as the path of motion is along shafts and gears, the motion is rotary. If the rotary motion is used as an input to a component such as a lever multiplier or lever differential, the rotary motion is converted to linear motion. Linear motion is transmitted by pushrods and links, and may be reconverted to rotary motion.

Figure 7-4 shows the parts of a bevel gear differential which combines two inputs into a single output that is either the sum or the difference of the inputs. Around the center of the mechanism are four bevel gears meshed together. Bevel gears on either side are called end gears; those above and below are called spider gears. The spider gears mesh with the end gears to perform the actual addition or subtraction. They

follow the rotation of the two end gears, turning the spider shaft a number of revolutions proportional to the sum or difference of the revolutions of the end gears.

Assume that the left side of the differential is rotated while the right side is held fast. The moving end gear drives the spider gears, making them rotate on the stationary end gear. This motion rotates the spider in the same direction as the input and turns the output shaft a number of revolutions proportional to the input. If the right side is rotated while the left side is held stationary, the same result occurs. When the two inputs rotate in the same direction, the differential adds; when they rotate in opposite directions, the differential subtracts. The output of a gear differential equals half the sum or difference of the inputs.

Another type of differential is the lever differential, shown in figure 7-5. This device performs the same functions as the gear differential—it adds and subtracts, and the output is proportional to the inputs—but the motion used in accomplishing the job is linear. The upper left drawing in figure 7-5 shows the lever differential receiving equal inputs. If both inputs push upward one-fourth inch, the output shaft also moves upward the same distance. The drawing in the lower left shows unequal inputs, and the triangle on the right represents the values entered on the lower left drawing. (When comparing the drawings, remember that none of the joints are anchored. The entire assembly is capable of moving.) In the lower left drawing, consider input A to be zero and

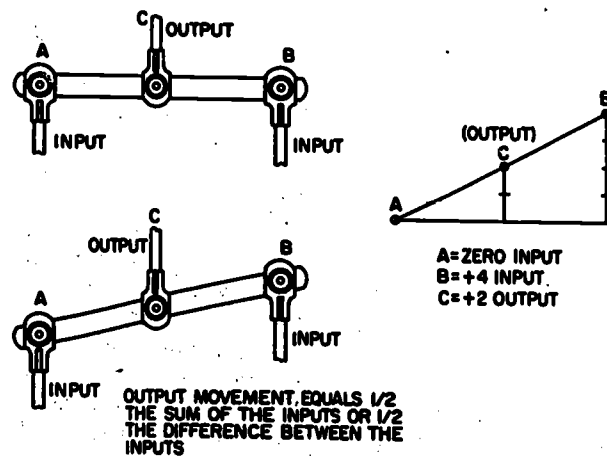

71.103

Figure 7-5.—Lever differential.

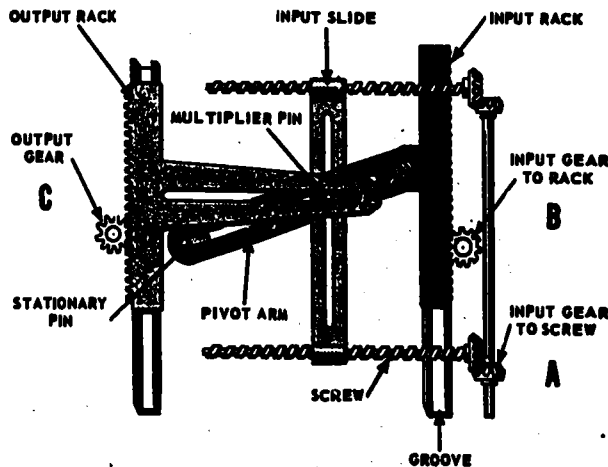

12.91
Figure 7-6.—Screw multiplier.

input B to have a value of 4. If B moves ahead a value of 4 and input A remains stationary, then the output value C is 2. If input A were -1, and input B were +4, then output C would be $+1-1/2$. For the type of lever differential shown in figure 7-5 the output equals half the algebraic sum of the inputs.

A mechanical multiplier commonly used is the screw type, shown in figure 7-6. It takes two constantly changing input values, and produces a single output that is the product of the two inputs. If the input to the screws (point A) is weapon time of flight, for example, and the input to the rack (point B) is range rate, then the output (point C) is predicted range.

A cam is a device that produces a mechanical output that has a nonlinear relation to its input. Cams usually convert a rotary motion into a linear output. Figure 7-7 shows a flat cam mounted on a rotating shaft. A cam follower rides on the outer edge of the cam, converting the rotary motion of the input to a linear output.

Other mechanical computing devices used in fire control systems include such mechanisms as integrators and component solvers. Integrators solve problems pertaining to time and motion, having two inputs and one output. One input may be elapsing time, for instance, and the other input range rate. The output of the integrator will be total change of range at any instant of time.

A component solver provides solutions to problems involving movement in relation to the target. The solver has two inputs (usually from

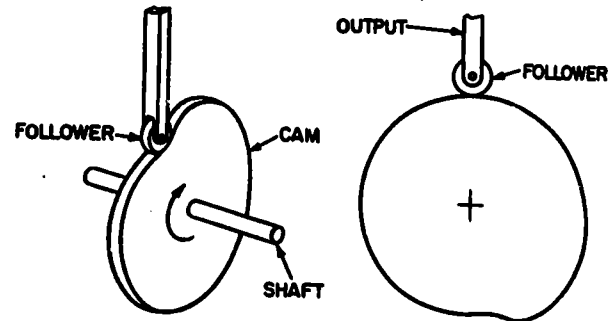

71.105
Figure 7-7.—Flat cam and cam follower.

differentials) and two outputs. When solving for own ship movement, for example, the inputs may be own ship speed and target relative bearing. The outputs are own ship's horizontal motion along and across the line of sight.

Mechanical Noncomputing Devices

In all types of computing instruments, certain values or quantities must be limited insofar as they pertain to minimum and maximum values. Some computing components must have a limit stop to protect them from too large or too small an input value. Limit stops are mechanical safety devices that prevent shafts from rotating farther than they should. Friction drives, overrides, and overdrives also are used to protect components.

A mechanical stop is shown in figure 7-8. Notice that rotation in the type illustrated is limited to about 90°. Rotation is halted when the shafts come in contact with the fixed block at the top of the device.

A friction drive absorbs the shock that otherwise could damage a computing component. If a motor overruns enough for the output to hit a limit stop, or a handcrank is turned with too much force, or the line driven by the crank hits a limit stop and the crank still turns, the friction drive slips and eases the strain on the mechanism.

A hunting tooth limit stop keeps values within specified computation limits. It has two gears. One is connected to the input shaft, and the other functions when the hunting tooth engages as a result of the quantities set on the input gear.

An override allows a computing mechanism to accept larger quantities than the design specifies. The override permits acceptance of only

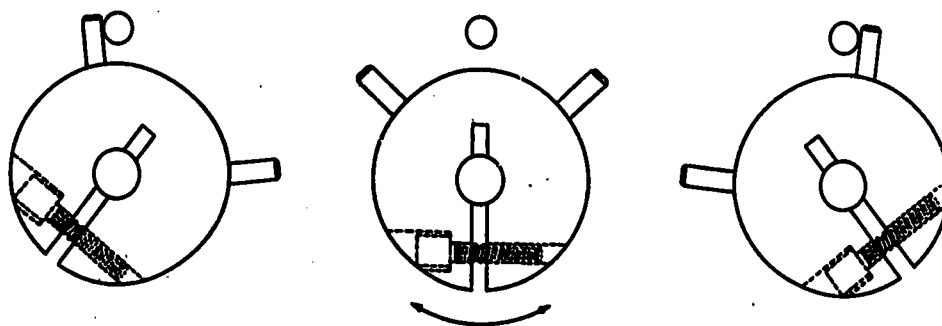

71.106
Figure 7-8.—Mechanical stop.

the maximum safe quantity limit, however. In other words, it allows the full value to be used by some components, but still protects others from accepting unsafe values.

Electromechanical Devices

Electromechanical devices combine two different types of action—electrical and mechanical. These devices, such as the magnetic brake and magnetic clutch, have wide usage and application in fire control computing components.

The magnetic brake can stop and hold a shaft at a given value when certain conditions are met. The magnetic brake is used to prevent a line of gearing from turning. When the current is off, no magnetic action takes place. In figure 7-9, an exploded view of a magnetic brake, notice that the spring washer holds the cap away

from the electromagnet, thus allowing the shaft to turn freely. When the current is turned on, the electromagnet exerts a force great enough to overcome the effect of the spring washer and pulls the cap tight against the electromagnet, thereby locking the shaft in place.

An electromagnetic clutch is used to engage and disengage a line of gearing. An exploded view of a magnetic clutch is shown in figure 7-10. When current is fed to the electromagnet, the friction plate assembly and cap assembly are in contact with each other, and the output line transmits input rotation. When current to the electromagnet is cut off, the friction plate assembly and cap assembly separate by spring action, losing contact with each other. The output line does not rotate or transmit any input to the clutch when these components are separated.

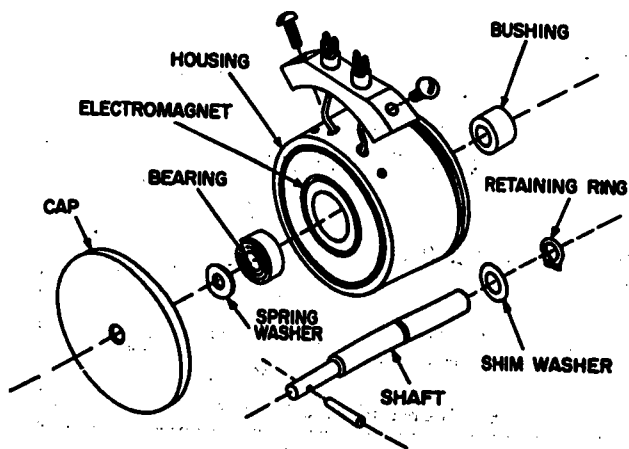

71.59
Figure 7-9.—Magnetic brake—exploded view.

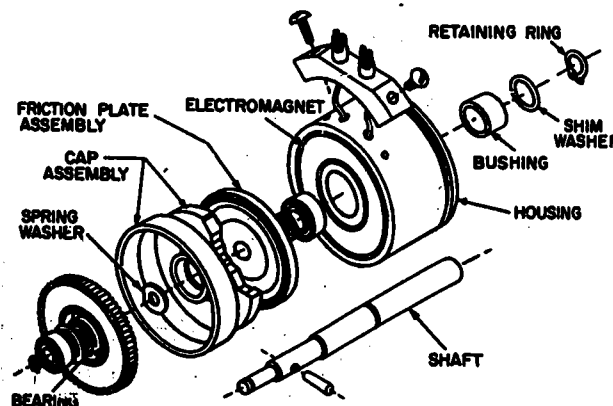

71.60
Figure 7-10.—Magnetic clutch—exploded view.

INTRODUCTION TO SONAR

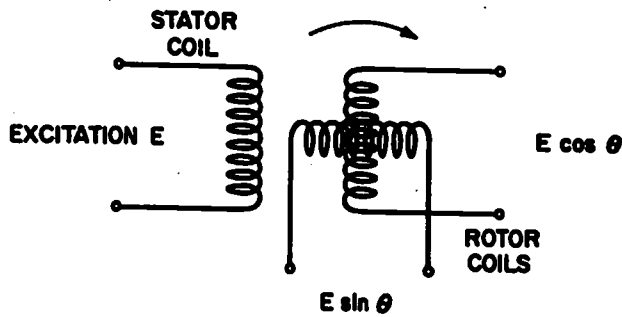

12.105(71)
Figure 7-11.— Electrical resolver—schematic symbol.

Another device that should be considered here, although it is an electrical assembly—not electromechanical—is the electrical resolver. The resolver is a computing device, and functions much like a transformer. It is capable of separating an electrical input vector into two right angle components. The resolver has a stator and a rotor, each part consisting of two separate coils wound at right angles to each other. Voltages induced on the stator coils by excitation of the rotor coils depend upon the displacement of the rotor with respect to the electrical zero reference axis of the resolver. In solving for a single vector, only one of the stator coils is connected electrically and represented on a schematic. Figure 7-11 shows the schematic symbol of an electrical resolver.

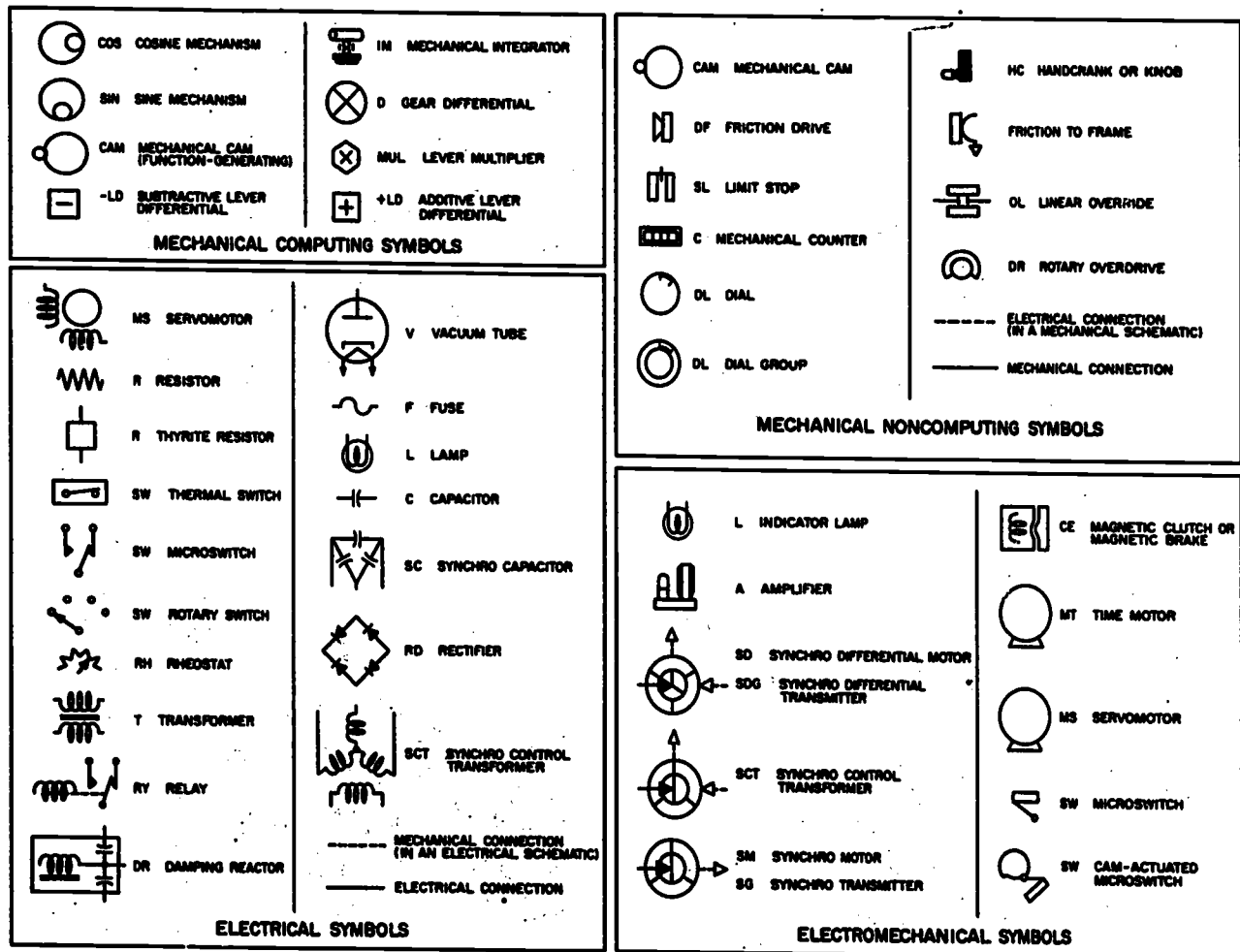

13.5(71)
Figure 7-12.— Identifying symbols and their abbreviations.

Chapter 7—BASIC FIRE CONTROL

When the resolver is zeroed electrically, the rotor coil clamped to the stator coil is called the cosine coil. The other rotor coil, at right angles to it, is called the sine coil. As the rotor rotates from 0° to 360°, the voltage induced across the cosine coil follows the cosine function of the excitation voltage. Similarly, the voltage induced across the sine coil follows the sine function of the excitation voltage.

Schematic Identification of System Components

In the maintenance publications for fire control systems, the devices described in this section are identified by standardized symbols. The identifying symbols and their abbreviations for system components are reproduced in figure 7-12. Usage of some of the component symbols in a sectional diagram may be seen in figure 7-13.

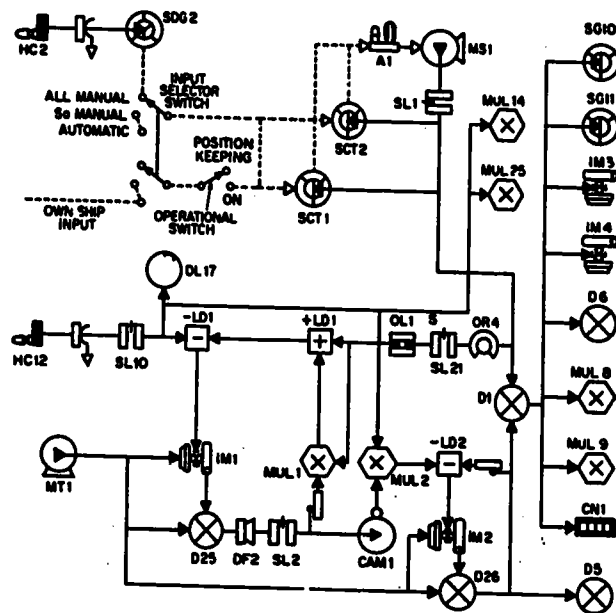

71.61
Figure 7-13.—Use of symbols in a sectional diagram.

UNDERWATER FIRE CONTROL SYSTEMS

A modern fire control system, as mentioned earlier, is tailored to the requirements of a particular weapon system. Aboard submarines, the weapon is the torpedo. Aboard ships, the weapon system usually consists of several types, such as A/S torpedoes, DASH, hedgehogs, and depth charges. Despite the type of fire control

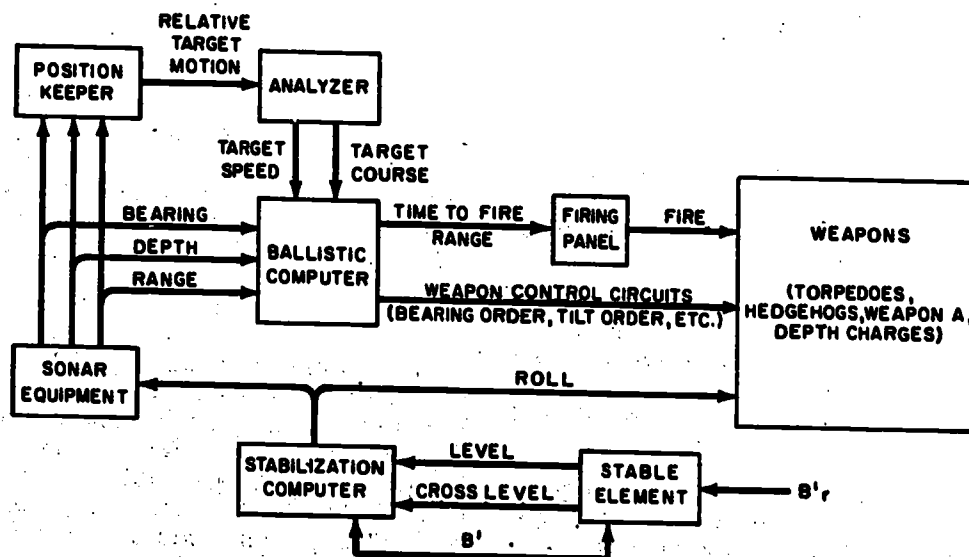

51.101
Figure 7-14.—Typical underwater fire control system.

INTRODUCTION TO SONAR

system used, each one has the same purpose—to direct fire to the target.

Shipboard System

A shipboard underwater fire control system (representative of the Mk 105) is illustrated in figure 7-14. The system performs the following functions:

1. Integrates associated fire control equipment with own ship components.
2. Computes sonar and weapon stabilization data, analyzes target motion, and provides a solution to the ASW fire control problem.
3. Provides ballistic control data for stern-dropped depth charges, hedgehogs (both fixed and trainable), A/S homing torpedoes, and trainable rockets (weapon A).

Target location information is supplied by the sonar to the ballistic computer (such as the Mk 5 attack director). The same information is furnished to the position keeper, which uses the data to track (dead reckon) the target. Target track information is fed to the analyzer, which computes target course and speed.

Target motion data from the analyzer, and target location information from the sonar, are combined in the ballistic computer, whose output is weapon control orders. To compensate for roll and pitch motion of the ship, the stabilization computer provides correction orders to the sonar and to the weapon mounts.

If sonar contact is lost, the position keeper continues to provide target track information. As long as the target does not change course or speed during lost contact time, the resulting weapon control orders will be valid.

The latest shipboard underwater fire control system is the Mk 114, which was designed for use with ASROC. The system also can be used with fixed and trainable hedgehog projectors, DASH, and the Mk 43, Mk 44, and Mk 46 A/S homing torpedoes.

The Mk 53 attack console is the data processing center for the system. It receives target position information from sonar or radar and combines it with own ship and ballistic data to produce weapon orders. Aided tracking and position keeping are also functions of the attack console.

Submarine System

Torpedo fire control on the surface is relatively simple. When the submarine is submerged, however firing torpedoes at a surface target becomes complicated. When the target is another submerged submarine, the fire control problem is even more complicated. The equipment used to solve the submariner's fire control problem is the torpedo data computer (TDC). It is illustrated in figure 7-15.

The TDC consists of three sections—position keeper, receiver, and angle solver. Target information from sonar (usually passive) is fed to the receiver section, along with own course and speed. Sonar bearing and target course and speed are manually set into the position keeper. The position keeper serves the same function as its counterpart in the Mk 105 shipboard system. The output of the position keeper is sent to the angle solver section of the TDC, which continuously computes the correct gyro angle for the type of torpedo used. The TDC then transmits this information to gyro angle indicator regulators located in the forward and after torpedo rooms. The indicator regulators automatically set the torpedo gyros to the ordered position. If computed target information is correct, the torpedo, after being fired, will come to the course set by the gyro angle indicator regulator and proceed to hit the target.

FIRE CONTROL SYSTEM TESTS

Certain transmission, computing, and rate tests must be performed in order to ascertain that the fire control solution is correct, and that values are received correctly at remote stations. Also, frequent operation of a system exercises servosystems, power drives, and computing networks, thereby bringing attention to any existing trouble.

Transmission Tests

Transmission tests are held to check the accuracy of automatically controlled devices at remote stations, and to check their response to changing signals. When running these tests, the first step is to establish voice communications between stations. Next, the man at the transmitting station must read the exact output value of the quantity being checked. In turn, the man at the receiving station must adjust the receiver to correspond to the reading from the transmitting station.

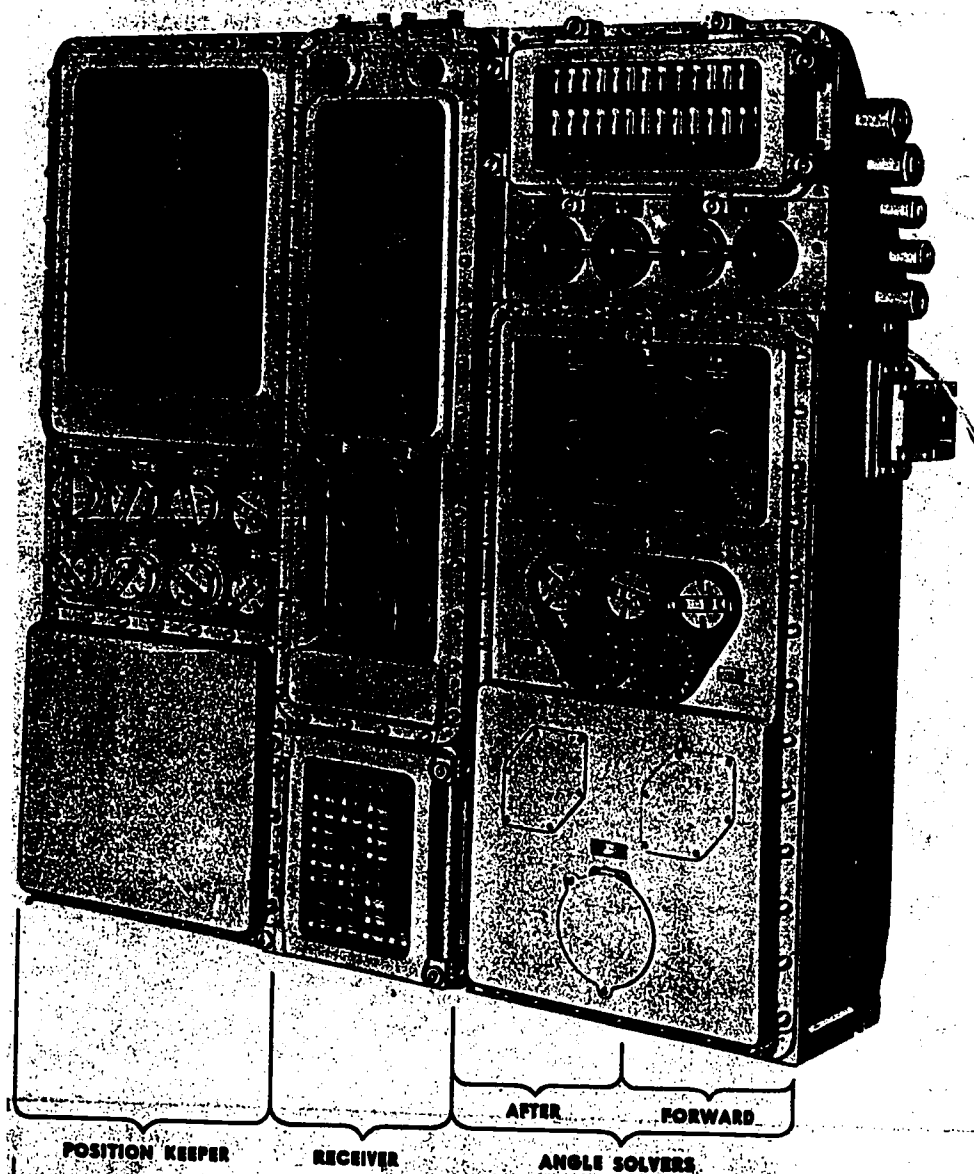

4.191
Figure 7-15.—Torpedo data computer Mk 4.

Computing Tests

As sonar tracks a moving target, constantly changing inputs are fed to the computer. Instantaneous values of these inputs are used by the computer to solve ballistic computations and to predict future target positions. The computer's solution is therefore based on an infinite number of static (still) problems. As relative

motion rates are integrated with time to generate computer changes in target position, the problem becomes dynamic. To test the computer's accuracy, consequently, both static and dynamic tests are run.

- Static tests: Static tests check the overall operation of the computing system in a stand-still condition. In this type of test, appropriate

INTRODUCTION TO SONAR

test values are inserted manually, and the problem is stopped at a fixed point. Input test quantities are thus of a constant value and produce fixed answers, which do not change with time. These fixed answers indicate whether the static portion of the fire control equipment is performing properly.

• **Dynamic tests:** Dynamic tests are run to check the computer's generation of bearing and range for specified time intervals against a mathematical solution whose answer contains correct amounts of change in quantities for like conditions. During the test, fixed values are

assigned to relative motion rates by manually setting inputs to the relative motion group. The time system of the computer is then moved, either manually or by the time motor, an amount equal to the test interval. Readings are then taken to ensure correctness of the solution.

Rate Tests

Rate control tests check the functioning of the rate control system. Mechanisms of this system correct values, such as target angle and target speed, so that computer target motion rates agree with actual rates of the target. In

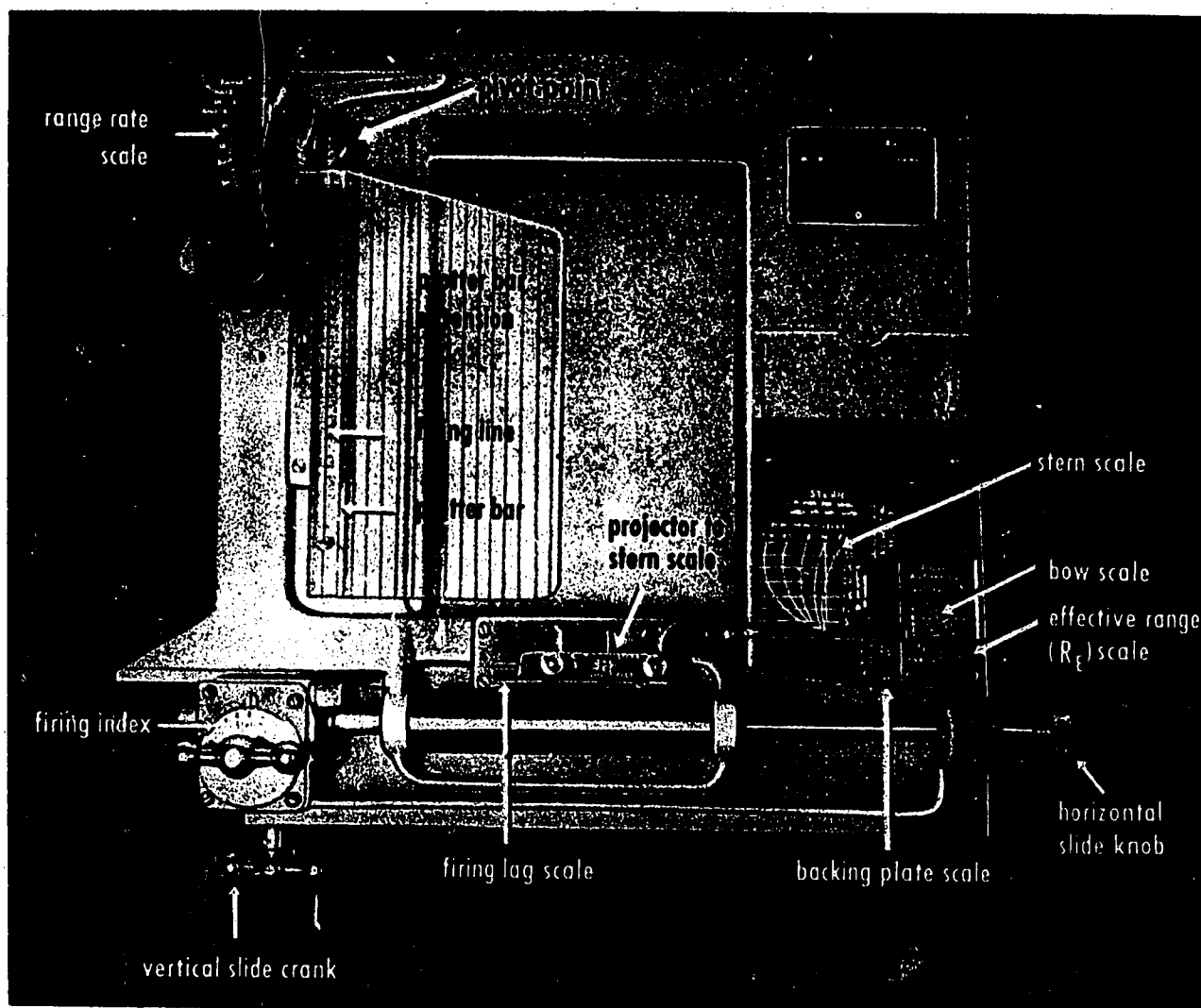

51.85

Figure 7-16.— Tactical range recorder.

Chapter 7—BASIC FIRE CONTROL

other words, this test determines the time required for the computer to arrive at correct relative motion rates. Time required must be small, but smoothness of tracking must also be considered. The rate control system is a compromise between these two factors.

Rate control tests consist of tracking a hypothetical motionless target with the computer set for a selected sensitivity of rate error detection. Sensitivity is controlled by the time constant input to the rate control system. Initially a large error is introduced and the time motor is started. Time required to reduce the error by a preselected percentage is timed by a stopwatch. This stopwatch reading is a measure of the actual time constant or sensitivity of the system. It is compared against the theoretical value for the test.

TACTICAL RANGE RECORDER

The tactical range recorder (TRR) shown in figure 7-16 is among the oldest underwater fire control instruments in the Navy. In the event of a casualty to the primary fire control system, the TRR is a fairly reliable auxiliary means of directing depth charge and hedgehog attacks. The introduction of newer fire control systems and such weapons as ASROC, however has resulted in a deemphasis on using the TRR as an aid in firing weapons. The TRR still is a useful aid, though, for classifying sonar contacts as submarine or nonsubmarine, and for determining target motion. Because of the broad scope of the subject of classification, only a brief discussion of the TRR is given here. More detailed information on the use of the TRR is contained in Sonar Technician G 3 & 2, NP 10131.

Range Rate

The traces on the recorder paper show target range versus time. From the traces you can determine range rate and target aspect. Range rate is the relative speed at which your ship is closing the target. Target aspect is the target's heading in relation to your ship.

The recorder paper moves downward at a constant rate, representing time. The stylus is synchronized with the sound pulse transmissions, and moves across the paper from left to right. When a target echo is received, the stylus burns a trace on the paper that represents target range, as illustrated in figure 7-17.

To determine range rate, turn the plotter bar until the parallel lines on the plotter bar

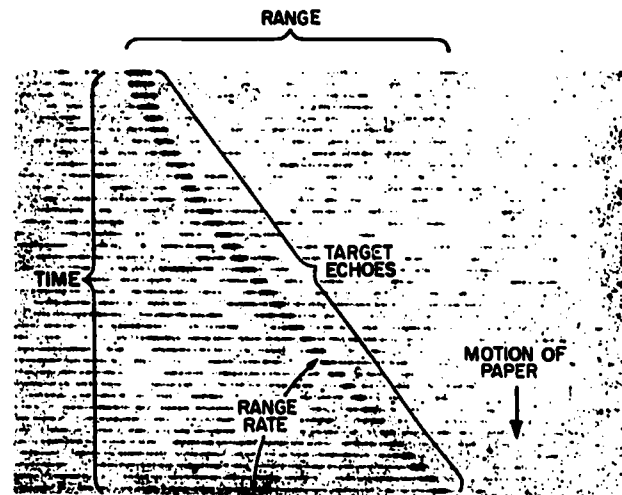

71.64
Figure 7-17.—TRR target traces.

extension match the slope of the traces, then read the speed on the range rate scale. When measuring range rate, use only the latest 200 yards of traces, that is, only those traces nearest the top of the paper. Refer to figure 7-18.

Because range rate is a clue to target aspect, which gives an indication of the target's heading, you may wonder about the reliability of range rate. For the greatest accuracy in determining range rate, you must know your ship's speed, and the ship must be headed at the target. Meeting these two conditions is not always possible, consequently you must have some other means of determining aspect.

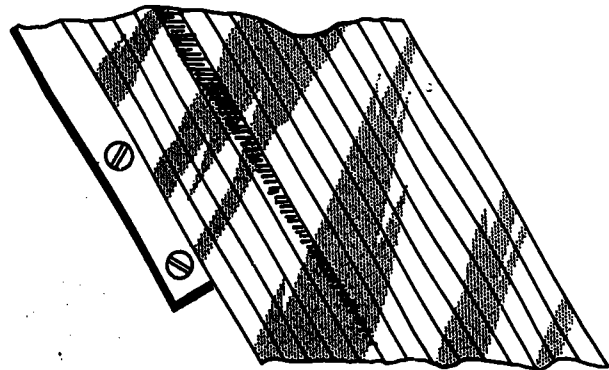

71.65
Figure 7-18.—Determining range rate.

INTRODUCTION TO SONAR

You learned in chapter 3 how to determine aspect from doppler effect. When you can also observe an echo indication at the same time you hear it, you can learn more about the target than you can from audio responses alone. A more reliable method of determining target aspect than that based on range rate alone is to compare the recorder traces with the doppler effect. Naturally, this method takes some practice and requires a knowledge of how the traces appear for different target aspects.

Doppler and Recorder Traces

Doppler and recorder traces work together in serving as a check on each other. That is why it is essential to use your eyes and ears simultaneously. When operating the recorder, look at the traces and listen to the doppler. If you hear no doppler, you have either a beam trace or one from a motionless target. (Doppler is a function of target motion. If a submarine is dead in the water, there is no doppler indication, but the traces will record the target in its proper aspect. Thus, traces for a stern-on target, which is dead in the water, are recorded as stern-on, but instead of having doppler down, you will have no doppler.)

For purposes of this text, assume that the target is in motion. This assumption allows simple comparison of doppler and recorder

traces. Thus, doppler up means a bow or direct-bow target; doppler down means a quarter or stern-on target.

Individual Echoes

Suppose a pulse of sound hits a submarine that is beam-on to the sound signal. All parts of the outgoing pulse strike the submarine at approximately the same time. All parts of the pulse are thus reflected and started on their return journey simultaneously. In figure 7-19 you can see that parts 1, 2, 3, and 4 start back together. These echoes hit the transducer simultaneously, and when the returning echo reaches the receiver, it is transformed into a short, dark line on the recorder paper. A beam trace is the same length as a recorded pulse length.

The beam trace has no doppler, but it has a definite "smack" as you hear it. It sounds short and sharp, and it appears on the paper very much as it sounds. Both edges of the trace are sharp and distinct, and the entire trace is solid and well defined. Because it is easy to recognize, it is the simplest of the recorder traces. Study figure 7-19 until you can recognize the trace easily.

Consider the quarter aspect target in figure 7-20. The stern of the submarine is nearer than the bow, so that portion of the transmitted pulse marked 1 hits the submarine first and starts back first. It is followed by the portion marked 2, and so on.

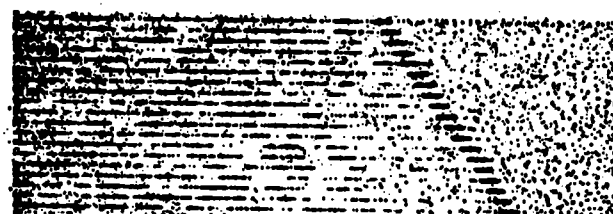
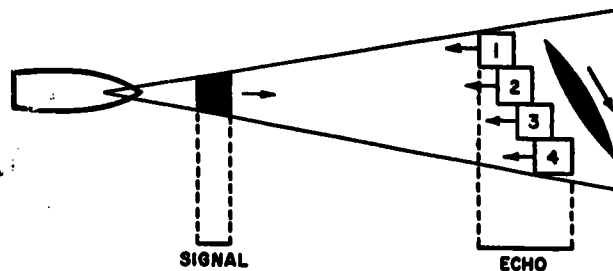
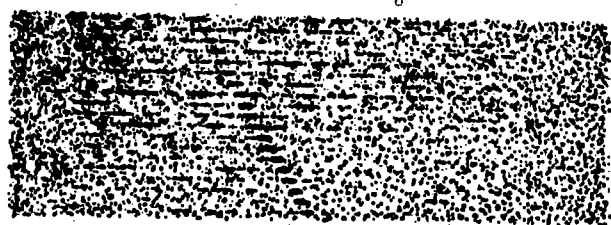
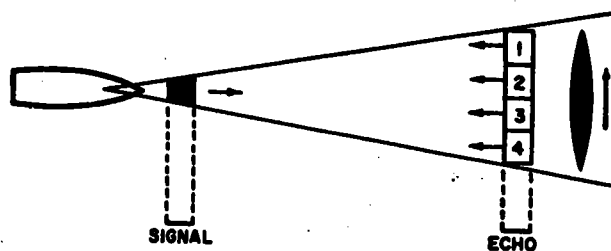

51.29(71)

Figure 7-19.—Beam aspect traces.

51.30(71)

Figure 7-20.—Quarter aspect traces.

Chapter 7—BASIC FIRE CONTROL

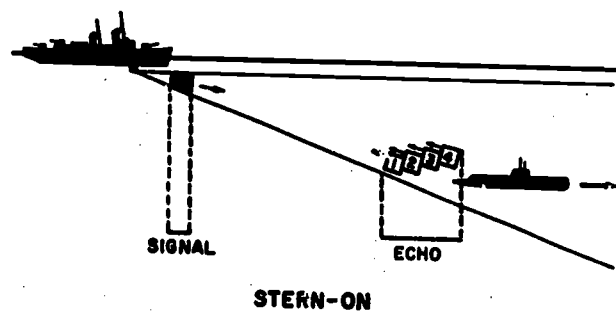

51.31(71)
Figure 7-21.— Direct stern traces.

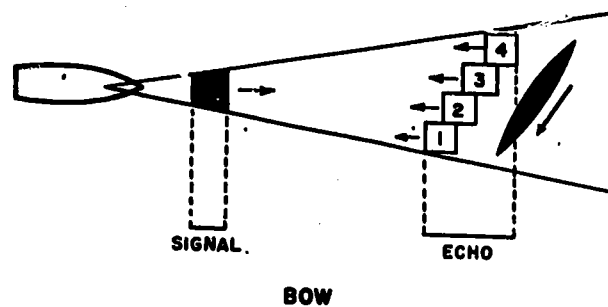

51.31(71)A
Figure 7-22.— Bow aspect traces.

As you can see, part 1 returns to the transducer sooner than part 4, hence the echo is recorded as a long trace. Because the trace is drawn out, it is not as clear as a beam trace. The ends are not clearly defined. At long range the trace may be weak, but you can distinguish it by the low doppler that accompanies it.

If you have a stern-on target, the trace is similar to a quarter trace. (See fig. 7-21.) On a stern target, however, some of the echo returns from the wake, some from the stern, some from the conning tower, and some possibly from the bow. This characteristic tends to make the echo even longer than the quarter target. It is not as solid as the quarter trace, but is quite long.

Stern traces also are irregular, and they may vary in shape and length from echo to echo. If the target is moving, doppler is down and the left edge of the trace may be particularly irregular because of the wake.

The bow target traces, shown in figure 7-22, are longer than beam traces. The portion of the sound pulse that hits the bow returns ahead of the part that hits the stern. The resulting echo is lengthened. Doppler from a moving bow aspect target is up.

If the submarine is coming directly toward your sound pulse, the trace is direct-bow, as it appears in figure 7-23. Again, the trace is long, because the echoes are returning at different

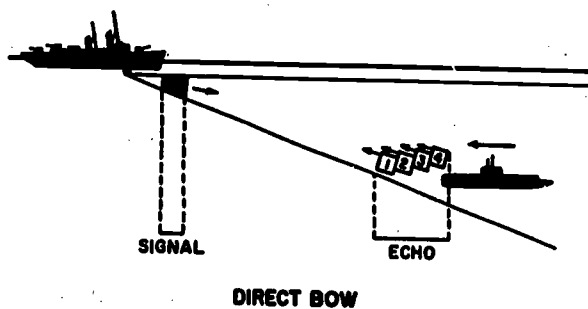

51.31(71)B
Figure 7-23.— Direct bow aspect traces.

INTRODUCTION TO SONAR

in stern traces, inasmuch as it is farther away than the submarine itself; doppler is high.

One of the best ways to identify a TRR trace is to decide whether it is a beam trace. Normally, a good look at the trace is all that is necessary to resolve this question, but you should also listen for doppler. If doppler is low, the target aspect is either quarter or stern-on. If high, the target is either bow or direct-bow. Remember, though, that doppler depends on motion as well as aspect of the target.

Sonar echoes also are returned from other submerged objects besides submarines. Usually nonsubmarine traces are recognized easily. Echoes returned from a wake, for example, ordinarily are not accompanied by doppler, the traces are quite long, and the entire series of traces consists of irregular waves.

Stationary targets, such as nonmobile countermeasures (a bubble is an example) are very sharp and regular in the series of traces, but there is no doppler, and the range rate equals own ship's speed.

INTERPRETING DIAL READINGS

Sonar Technicians must be able to interpret, and sometimes interpolate, sonar and fire control equipment dial settings. Information to be read from these dials includes such values as range, range rate, target course and speed, and many other fire control values. Normally, two types of dials are used. They are disc dials and ring dials.

A disc dial is simply a flat, circular plate secured to a shaft, and inscribed with values of the function it serves. A ring dial is circular-shaped also, but has a hollow center to permit placing a disc dial within it. An example of the use of these dials is shown in figure 7-24.

The top dial group displays target information. The bottom dial group shows own ship data. The counters between the two dial groups show horizontal sonar range. The dial to the left of the range counters indicates horizontal range rate.

Target Dial Group

Two concentric dials make up the target dial group. They are a ring outer dial and a disc inner dial. Both dials are graduated in 5° increments and are numbered at 10° intervals. Target angle (144°) is read on the inner dial against the fixed index at the bottom of the dials. Target course (072°) is

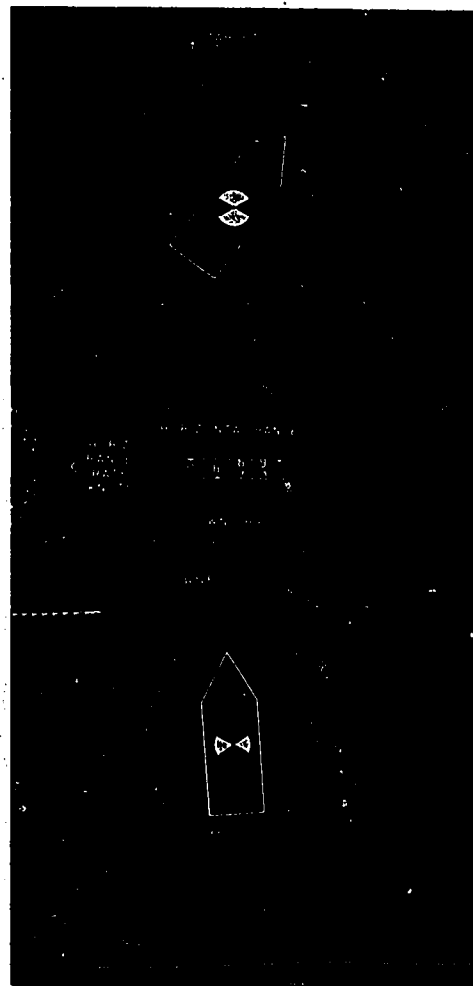

51.108

Figure 7-24.—Own ship and target dial groups.

read on the outer dial against the zero graduation of the inner dial.

Own Ship Dial Group

The own ship dial group consists of an inner disc dial, an inner ring dial, and an outer ring dial. The two inner dials are graduated in 5° increments and are numbered at 10° intervals. The outer dial has only a diamond marker and the words COURSE ORDER inscribed. The inner disc dial shows relative sonar bearing (002°) against a fixed index at the top of the dials. The inner ring dial shows own ship's course (032°) against the zero graduation of the inner disc dial. Course order (039°) is read on the inner

Chapter 7—BASIC FIRE CONTROL

ring dial against the diamond index on the outer ring dial.

Range Dials

The counters between the target and own ship dial groups show generated horizontal sonar range (870 yards). The dial to the left of the range counters indicates range rate (2 knots), which is the rate in knots at which horizontal range is changing.

The dials just discussed are only a few of the many that you must be able to interpret.

Of particular importance is the ability to interpolate (to "read between the lines") and to note direction of change of the dial readings.

Our discussion of the fire control problem, and of the equipment used to solve the problem, was necessarily restricted to fundamentals. Computer mechanisms, fire control nomenclature, antisubmarine weapons, and recorder traces were only briefly covered, serving to acquaint you with the problems involved in making attacks on enemy submarines. You need to study many technical manuals, and other training courses, to fully comprehend the duties of a Sonar Technician.

CHAPTER 8

COMMUNICATIONS

The main essential of communication between two persons is that the language they use must be understandable to both. Not only must one person be able to express himself clearly, but the other man must be able to comprehend what is communicated.

Realizing that many problems are encountered in communications, the Navy has adopted certain standard methods and practices to minimize errors and misunderstandings in message transmittal and reception. Many of these standard procedures are used by other allied services. They are invaluable in conducting joint international operations. The phonetic alphabet has been adopted by all allied forces for combined operations.

In this chapter you will become acquainted with some of the internal and external communication systems used aboard ship. Additionally, you will learn correct operating procedures for radiotelephone and underwater telephone communications. Because the phonetic alphabet and sound-powered telephone procedures are covered in Basic Military Requirements, NavPers 10054, they are not included in this text.

INTERNAL COMMUNICATIONS

Most men in the Navy, regardless of rate, are familiar with internal communications. Sonar Technicians, especially, have occasion to use several types of systems available for transmitting sonar information. It is almost impossible to conduct attacks on enemy submarines or ships without some method of internal communications. On a destroyer, sonar control may be located below decks, on the bridge level, or in some other section of the ship (depending on the type and class of ship). Because it is remote from the bridge, some means of communication must be established between the bridge and sonar control. This requisite is accomplished by utilizing one or more of the internal communication systems. Shipboard circuits include MC

(loudspeakers) circuits, sound-powered phones, and automatic devices. These devices are remote indicators, and are used to transmit bearings, ranges, course orders, firing orders, and other data.

When sonar contact is made, the bridge usually is informed over an MC system. By this method, all stations concerned are alerted, and sound-powered phones are then manned to eliminate excessive noise levels caused by the constant use of loudspeakers. The ASW officer is directed to make the attack. His course orders to the bridge are relayed by automatic electromechanical devices to direct the helmsman in maneuvering the ship to the firing position. As the ship reaches the firing point, signals or verbal instructions to fire must be transmitted to the weapons stations for firing weapons at the correct time.

SOUND-POWERED PHONES

The shipboard voice communication system used most extensively is the sound-powered telephone (S/P) network. It consists of primary battle circuits JA to JZ, with auxiliary and supplemental circuits for use if a primary circuit is damaged. The degree to which these circuits are manned varies. Few circuits are used under normal peacetime cruising conditions. During general quarters, when all battle stations are manned, all circuits may be used.

Of primary concern to the Sonar Technician are the JA, JP, and JS circuits. The JA, the captain's battle circuit, is used for transmitting orders to key control stations and exchanging vital information with those stations. Weapons control information is passed over the 8JP circuit. The other S/P circuit you will probably man is the 61JS. It normally is used as a one-way system to provide contact range and bearing, and other data to UB plot, CIC, and the

Chapter 8 — COMMUNICATIONS

bridge. The LJS circuit is the main antisubmarine attack team control circuit. It connects the bridge, CIC, and sonar control, and is used primarily for conning orders when sonar or CIC has control of an attack. Normally, the LJS is manned by officers in charge of the various stations.

Circuit discipline must be maintained at all times when you are wearing phones. Personal conversations with friends on the same circuit may cause a delay in the transmission of vital information, resulting in a delayed or missed attack. With the high speeds of modern submarines, such a delay could result in the loss of your ship or the ship you are trying to protect.

MC SYSTEMS

Although sound-powered phones are the most common means of internal communications, there are other methods, one of which is the MC (shipboard announcing) system. The MC system is an electronic speaker-type system, similar to an office-to-office intercommunication system, and is designed to provide amplified voice communication.

Sonar and CIC underway watch stations usually are not fully manned under normal cruising conditions aboard ASW ships. When a sonar contact is gained, the 29MC (sonar control and information) is used to alert CIC, UB plot, and the bridge. Contact information (such as ranges, bearings, and doppler reports) is passed over this circuit (a one-way system) until the contact is classified as nonsubmarine or until ASW stations can be fully manned. Submarines utilize the 27MC (sonar and radar control) system.

Another communication system found aboard most ships and submarines is the 21MC (captain's command system). It is a two-way system, with each intercommunicating unit capable of calling either 10 or 20 stations, depending on the type of ship in which it is installed. The essential components are a reproducer, amplifier, and controls necessary for operation. The reproducer acts as a microphone in the calling unit and as a loudspeaker in the unit called. Amplification takes place in the calling unit. The controls consist of the talk switch, pushbutton assembly, busy light, call light, volume and dimmer controls, and a microphone or handset jackbox.

To operate the 21MC, depress the pushbutton of the station desired. If the station is busy, the red BUSY light will flash. If the BUSY light does not flash, depress the TALK switch and speak

directly into the speaker grill. Release the TALK switch to listen. When your conversation is completed, depress the release button at the far left end of the row of station buttons to remove your intercom unit from the circuit. When you are called, the CALL light illuminates. It is unnecessary to depress the button of the station calling; merely use the TALK switch as described herein.

Despite its many advantages, when the MC system is used the noise level is increased greatly. This condition occurs because of its speaker-type output and the fact that it picks up background noise from the transmitting station. Because of the high noise level generated by operating the 21MC, it should be used only when absolutely necessary.

REMOTE INDICATORS

The fastest means of communicating information is to transfer it electrically. Through the use of electromechanical and electronic repeaters, sonar information is displayed at remote locations aboard ships and submarines without delay.

One type of display, an electronic azimuth-range indicator, shows bearing and range of a contact on a cathode ray tube. It duplicates audio and video information present at the sonar operator's console.

Another type of remote indicator displays sonar information electromechanically. Contact range and bearing are shown by counters similar to an automobile's mileage indicator. There is also an electromechanical order transmitter. In this unit, a moving pointer (indicating firing bearing) is matched by the operator at a weapons station. Another moving pointer (indicating course to steer during an attack (is matched on the bridge by the helmsman.

As you can see, electrical/electronic repeaters reduce the time required to transmit information, eliminate noise-producing transmissions, and reduce the volume of traffic over S/P phone circuits.

EXTERNAL COMMUNICATIONS

During antisubmarine operations (and, for that matter, all operations), it is imperative that communications between ASW units, such as ships and aircraft, be conducted smoothly and efficiently, and free of confusion, insofar as practicable. A faulty microphone switch of a sound-powered phone, frequently cutting out (a common

INTRODUCTION TO SONAR

failure), can prevent vital information from getting through just as effectively as if it were not reported at all.

Poorly trained or inattentive operators can cause confusion, delay, and mistakes, and may even create a dangerous situation.

RADIOTELEPHONE

Radiotelephone (R/T), commonly called voice radio, is a rapid means of exchanging information between ships, aircraft, and submarines. Voice radio usually is amplitude-modulated. A continuous-wave radiofrequency carrier has an audio signal impressed upon it, varying its amplitude in accordance with the audio variations. A handset or a carbon microphone is used to key the transmitter.

Although voice radio is a fast means of communication, speed without accuracy is more than worthless—it can be dangerous. When ships are operating together at high speeds and in close formation, a mistake or a delay in communications can cause a collision.

In antisubmarine operations, voice radio is used to exchange contact and tactical information between the CICs and bridges of the ships participating in the operation. The captain or the OOD mans the bridge radio circuit, used primarily to exchange tactical information. The CIC officer and the Radarmen handle the combat information (CI) net to exchange contact information between CICs. Contact information between CIC's is evaluated by the CIC evaluator and pertinent information is relayed to the captain and OOD on the bridge by use of sound-powered phones.

Because radiotelephone procedures are used with the underwater telephone, and because Sonar Technicians may be assigned CIC watches during normal cruising conditions, it is necessary for you to be familiar with proper radiotelephone procedures.

RADIOTELEPHONE PROCEDURES

Whenever you use a radiotelephone, your speech must be clear and slow. Speak the message by natural phrases—not in stilted, word-by-word fashion. Use a normal tone; don't shout. Pronounce each word clearly and distinctly, pausing at intervals. Think about what you are going to say, then say it. Keep the message as brief as possible.

Heading

The basic format of a military message consists of the heading, text, and ending. The message form is in plaindress, abbreviated plaindress, or codress. Codress is an encrypted message, with which a Sonar Technician normally is not concerned. Plaindress is used for radiotelegraph and teletype communications, as well as for radiotelephone administrative messages. A plaindress message usually has a complex heading, consisting of call, transmission instructions, precedence, date-time group, address, and other elements. The type of radiotelephone message you will use most, however, is the abbreviated plaindress, in which the heading includes only the station called and the station calling. In some instances, after communications are established, the heading contains only the station calling. An example of a typical heading is: FARMERBOY—THIS IS ISLAND QUEEN.

Text

The text of the message is the basic thought or idea the originator wishes to communicate. It follows the heading, and is separated from it by the word BREAK. Quite often radiotelephone messages, particularly those of a tactical nature, are coded. There are several reasons for coding messages. The first is obvious: so that the enemy will not know your intentions. If, for instance, you were ordered in plain language to commence a sonar listening sweep, and the message was intercepted by an enemy submarine, he could rig for silent running to reduce his noise output to a minimum, making your job all the more difficult. If the message is sent in code, however, chances of interpretation by the enemy are reduced even though he should intercept it. Another purpose is brevity. The less time on the air the better, for both security and practical reasons.

Signal codes are contained in communication publications known as signal books (of which there are several), each having a particular application. One signal book consists of two letters, or a combination of letters and numerals, that usually are used for tactical signals. (Members of NATO use this book, as well as the standard phonetic alphabet, for combined operations.) As an example, a certain two-letter and a numeral signal tells all ships to make oil fog and smoke. From his signal book, the captain of an Italian ship can read and understand the

Chapter 8—COMMUNICATIONS

meaning of the signal as quickly as the captain of a U.S. Navy destroyer. Two letters and a numeral thus overcome the language barrier and make a brief message as well.

Another means of reducing transmission time, and providing a degree of security, is through the use of brevity code words. In general, these code words are used to convey contact and related information. Communication publication ACP 165 contains the operational brevity code.

At the end of the text, the word **BREAK** is used again to separate the text from the ending.

Ending

The ending of a radiotelephone message consists of one of two words—**OVER** or **OUT**. When **OVER** is used, the sender is telling the receiver to go ahead and transmit, or "This is the end of my transmission to you and a response is necessary." With the use of **OUT**, the sender in effect is telling the receiver: "This is the end of my transmission to you and no response is required." In motion pictures and television productions, you are likely to see military personnel say "Over and out," but there is never a need for their combined use in this manner.

CALL SIGNS

In radiotelephone procedure, ships have call signs that are common, easily pronounced words or expressions. The radiotelephone call sign of one ship, for example, is **BLUE STAR**; another is **BEANSTALK**; still another is **EL TORO**. All U.S. Navy ships are assigned a voice call sign. If you need to know the voice call sign of any Navy ship, you can find it in the communication publication **JANAP 119**.

PROWORDS

Radiotelephone procedure also requires the use of standard procedural words, called prowords. Although prowords are not code words as such, they say a great deal with the utmost brevity. The words **OVER** and **OUT**, mentioned earlier, are prowords. Besides **OVER** and **OUT**, two other prowords that are never used together are **ROGER** and **WILCO**. **ROGER** is used as a

receipt. It merely means that you have received the message—not that you understand it or will carry out any orders contained in it. **WILCO** is the answer to the proword **ACKNOWLEDGE**, and means that you will comply with any instructions or orders contained in the message. For this reason, the proword **WILCO** must never be used without specific permission from a person having the authority to grant such permission.

Following is a list of the more common prowords, the meaning and usage of which you should memorize. This list is not complete, as are the ones in communication publications. It consists mainly of the prowords you are most likely to hear and use on the underwater telephone. Should you be interested in seeing a more complete list of prowords, check **DNC 5** or **ACP 125**.

<u>Proword</u>	<u>Meaning</u>
ALL AFTER	All after.
ALL BEFORE	All before.
BREAK	The text is separated at this point. Do not confuse the separated portions.
CORRECTION	An error in my transmission has been made. I now correct it.
DISREGARD	This entire transmission is in error. Disregard it.
THIS TRANSMISSION FIGURES	Figures or numerals follow.
FROM	This message is originated by _____.
I SAY AGAIN	I repeat the entire transmission (or portions indicated).
I SPELL	I shall spell the next word with the standard phonetic alphabet.
OUT	This is the end of my transmission. No receipt is required.
OVER	Go ahead with your transmission at this time. (Or, This is the end of my transmission for which a response is required.)
ROGER	I have received your last transmission satisfactorily.
SAY AGAIN	Repeat all (or portions indicated) of your message.
THAT IS CORRECT	You have repeated my message or have given information correctly.

INTRODUCTION TO SONAR

<u>Proword</u>	<u>Meaning</u>
THIS IS	This message is from ____.
TIME	What follows is the time or date-time group of this message.
TO	This message is for action by and is directed to ____.
WAIT	I must pause for a few seconds.
WAIT OUT	I must pause for longer than a few seconds.
WILCO	I have received and understood your message, and you have the assurance of the command that it will be complied with. (This type of answer requires CO's permission.)
WORD AFTER	The word after (word) is ____.
WORD BEFORE	The word before (word) is ____.
WRONG	Your last transmission was incorrect. The correct version follows.

mind. Go through the alphabet several times to get the feel of the sound of the dit-dah combinations.

The Code

In the pronunciation guide for the sounds of the characters in the accompanying list, the sounds are written out phonetically insofar as possible. The short sound "dit" actually takes on the sound "di." The "i" is very short and the "t" is dropped.

<u>Letter</u>	<u>Pronunciation</u>
A	di-DAH
B	DAH-di-di-dit
C	DAH-di-DAH-dit
D	DAH-di-dit
E	dit
F	di-di-DAH-dit
G	DAH-DAH-dit
H	di-di-di-dit
I	di-dit
J	di-DAH-DAH-DAH
K	DAH-di-DAH
L	di-DAH-di-dit
M	DAH-DAH
N	DAH-dit
O	DAH-DAH-DAH
P	di-DAH-DAH-dit
Q	DAH-DAH-di-DAH
R	di-DAH-dit
S	di-di-dit
T	DAH
U	di-di-DAH
V	di-di-di-DAH
W	di-DAH-DAH
X	DAH-di-di-DAH
Y	DAH-di-DAH-DAH
*Z	DAH-DAH-di-dit

INTERNATIONAL MORSE CODE

The international Morse code is a telegraphic alphabet, which is another way of saying that it is a dot and dash communication system. The code is pronounced by saying "dit" and "dah," not "dot" and "dash," so forget about dots and dashes and think only in terms of dits and dahs. The group of dits and dahs representing each character must be made as one unit, with a clear break between each dit and dah, and a much more distinct break between characters.

Never try to identify a character by counting dits and dahs. Don't let yourself get into this habit. It's a temptation at first, but you won't be able to count fast enough when the code speed picks up. Learn sound patterns instead. To understand what this requirement means, rap out the pattern beginning "Shave and a haircut." You recognize this ditty from its characteristic rhythm, not because it has a certain number of beats in it. You must learn code the same way. Each character has its own distinctive sound pattern. With study and drill you will learn to recognize each pattern as fast as you now recognize "Shave and a haircut." The accent always falls on dahs, and you should pronounce each rhythmical combination with that rule in

<u>Number</u>	<u>Pronunciation</u>
1	di-DAH-DAH-DAH-DAH
2	di-di-DAH-DAH-DAH

Chapter 8—COMMUNICATIONS

Number	Pronunciation
3	di-di-di-DAH-DAH
4	di-di-di-di-DAH
5	di-di-di-di-dit
6	DAH-di-di-di-dit
7	DAH-DAH-di-di-dit
8	DAH-DAH-DAH-di-dit
9	DAH-DAH-DAH-DAH-dit
**0	DAH-DAH-DAH-DAH-DAH

*Zulu is written as Z to avoid confusion with the number 2.

**Zero is written as Ø to avoid confusion with the letter O.

Study and Practice

If you have any trouble learning code, the following method may be helpful. Go through the three groupings of short, medium, and long sounds with their accompanying practice words. Make up words of your own if you wish further practice. Speak the practice words in code. Say "Tee: DAH dit dit; Mine: DAH-DAH di-dit DAH-dit dit."

If you can speak words rapidly and distinctly in code, you'll have an easy time of it when you learn to receive code, because the spoken code and transmitted code sounds are similar. Practice the figures in even groups: 11, 22, 33, 44, 55, 66, 77, 88, 99, etc. Learn each letter by overall sound. Never count the dits and dahs.

<u>Short Sounds</u>		<u>Practice Words</u>	<u>Long Sounds</u>		<u>Practice Words</u>
E	dit	TEE, ATE, EAT, TEA, MEAT, MEET	B	DAH-di-di-dit	BAT, BALL, BEAT, GLIB, GAB, JAB
T	DAH	MINE, TIME, MAINE, TEAM	C	DAH-di-DAH-dit	CUT, CAM, COAT, CODE, CALF
A	di-DAH	AIM, NITE, TAME, TEA, MATE	F	di-di-DAH-dit	FIVE, FAT, FUSS, FEET, EFFECT
I	di-dit	TAME, NAME, MITE, MIAMI	H	di-di-di-dit	ACHE, HUSH, HAVE, HOLD, HOT
M	DAH-DAH	MAMA, MEAN, MAN, MAT, EMIT	J	di-DAH-DAH-DAH	JERK, JIM, JAR, JAM, JAB
N	DAH-dit	MINT, MANE, TAN, ITEM, TINT	L	di-DAH-di-dit	LIKE, LAG, JELLY, LOVE, LATE
<u>Medium Sounds</u>			P	di-DAH-DAH-dit	PUSH, PAIR, POLE, PART, HAPPY
D	DAH-di-dit	MUST, SAME, MAMA, SUIT, AUTO	Q	DAH-DAH-di-DAH	QUAY, QUEBEC, QUEEN, QUIZ, QUIT
G	DAH-DAH-dit	MUSS, OUST, MUSE, MUTE, ATOM	V	di-di-di-DAH	VIM, VERY, VETCH, VAT, EVE
K	DAH-di-DAH	TAUT, MASS, MAST, SUET, SAM, WIND	X	DAH-di-di-DAH	WAX, XRAY, LYNX, SIX, EXAM
O	DAH-DAH-DAH	SEA, TUM, SAW, OAT, SUE, SAT, WED	F	DAH-di-DAH-DAH	YOUNG, YOKE, YAK, JERKY, YAM
R	di-DAH-dit	SUM, MUD, IOU, USE, SEAM, DARK	Z	DAH-DAH-di-dit	ZERO, BUZZ, FIZ-ZLE, QUILL, LYNX
S	di-di-dit	GEORGE, DOWN, KIND, SORT, MASK			
U	di-di-DAH	WORK, GROW, URGE, TUG, PULL			
W	di-DAH-DAH	WIGS, WORN, WET, WAKE, WALL			

INTRODUCTION TO SONAR

The only way to learn code is by practice—continuous practice. (Practice makes perfect.) The value of practice cannot be overemphasized, as you will learn when you test yourself, with the help of your shipmates, to find out how much you have learned through practicing by yourself.

If you have carried out the recommendations made up to this point, you are ready to receive code transmitted to you on a hand key. The ship or station to which you are attached has practice hand keys you can use.

Find a Radioman who will key code groups to you to help you in your training. The sound

produced by keying an oscillator resembles the sound of code from the sonar transmitter.

After you learn the sound of each character at a slow rate of speed, it is not difficult to reduce the time between characters and thus to copy at a much faster speed. But don't strive for speed before accuracy. Be a competent operator. Make every transmission and reception accurately. Accuracy is much easier if you learn the fundamentals well. Some code practice exercises that will help you are included for your convenience.

CODE PRACTICE

1. EEE TTT AAA NNN III SSS HHH RRR
MMM OOO EEE TTT AAA NNN III SSS
SSS HHH MMM RRR OOO EEE TTT III
TTT EEE TTT III NNN SSS OOO AAA
NNN EEE AAA NNN TTT OOO III SSS
2. UUU VVV DDD BBB KKK CCC WWW JJJ
PPP UUU VVV DDD BBB KKK CCC WWW
JJJ PPP VVV UUU BBB CCC KKK WWW
DDD KKK BBB CCC WWW UUU VVV JJJ
CCC WWW KKK PPP DDD VVV JJJ UUU
3. RRR LLL FFF GGG ZZZ XXX YYY QQQ
RRR LLL FFF GGG QQQ ZZZ YYY RRR
QQQ GGG ZZZ LLL YYY RRR FFF LLL
YYY QQQ RRR XXX ZZZ YYY LLL GGG
LLL QQQ YYY UUU ZZZ XXX RRR LLL
4. 111 222 333 444 555 666 777 888
999 000 111 222 333 444 555 666
777 888 999 000 123 456 789 000
113 344 225 577 668 800 992 220
123 456 789 012 345 678 905 599
5. VUI YQZ CXGRSLKJPQXZRIFCVB
WFK DSHQZALKFBVRS TUOTMEGY
ZXVEGNIWSLHMUA EVUA EWQGHV
CIXZLNRYUKVUWSXEDCRFVTGB
YHN UJMIKOLPQAZWSXEDCRFVT

Chapter 8—COMMUNICATIONS

CODE PRACTICE--Continued

6. E 8 Y 7 B 6 X 1 W 0 Z 2 A 3 C 5 S 4 I 2 F U 1 F
 5 D 8 Q 4 T 6 U 9 Q 2 E 0 S 5 U 1 Y G 2 J 4 S 3
 E 5 T 7 Z 8 K 6 M 9 R 1 A 2 R S 7 W 8 E 9 R 2 A
 3 Z 3 X 6 U 8 B 7 C 6 T E 8 Y 7 B 6 Y 0 F 1 W 4
 F 1 A 7 I 5 R 8 S 0 M 6 C 2 K 3 A 9 Z 3 Z 6 D 2
7. WI AN TY SX EC LV OD OZ SP TZ EC NU VA EH LM DQ
 BM ZS CD QA IU SD PQ OW IE UR YT LA KS JD HF GM
 ZN XB CV QZ WX EC RV TB YN UM IL OP AE SR DT FY
 HU JI KO LP ZS XD CF VG BH NJ MK SW XE CR VT BY
 NU MI LO PS DO FI GY BU IN JU HA XR TV TV YB NU
8. DE FT BY 72 VA 54 98 IM BT BT 11 34 66 CV VF TG
 62 84 QA WS RF 64 20 BY 77 GY AA YF UH LJ VD BK
 KK 99 25 56 83 25 LA KS JD CY BU IN EB QV QV ZZ
 22 00 TT 75 44 VY 53 VS CW MC WH 66 FS SS ER EE
 26 CG PL IA LE FG QY 85 RI 39 NF JE SI 25 37 AR
9. WNTAGR DTS ELY BFC UZX REH KCE HLJ AQE RNG TCV
 EPL ZSW QAH SHL GBT VRT GUK GYO DCM XSD ZAU YER
 DLN ARG VNB EDX BWS UTA RHI KTZ HBY ALK RDC TOC
 ESX IUP PKJ NYH GHT DFR VED SWN VBT XFZ RDA FUE
 NYH OLX RWH MKY ATA NWS RGU SKZ KDG OKL OIX GLM
10. OLVHM YBLUR XOHIZ OVICT FINXC
 XSHTY VIZNT UBLMQ ABLBE JNCYZ
 BZWCN JNC DU TLZKL ABDEF ZVNUW
 KFREQ LMXMV NHUWQ RNVUT KUXFC
 DEHLY HEDIP AZQWI ZYSKQ IQAWM
11. NWZIH ZXCKA DBTGW WNLIP WBUOX
 ADXFR JIQCA UTHAV NCBRF DSEDC
 XVHRW QIMNJ FSTRO TNBLU JHKNI
 OQJUY RGBNS VCXTR JTUBD CGFH5
 VXH7G 2JI9Y TX3S6 T148P BT0ZX

PROSIGNS

Procedural signals, called prosigns, are used by radiotelegraph operators for the same reason that prowords are used by radiotelephone talkers. Most prowords have an equivalent prosign, which, in several instances, is an abbreviation of the proword. You will notice in the accompanying list of prosigns that some of them are overscored. Overscoring means that the letters are to be

sent as one character, that is, without the normal pause between letters.

SENDING

Your ability to send code depends mainly on two considerations. First, you must know the correct sound of the character you are attempting to transmit. Second, you must know the correct method for keying. Practicing the code aloud,

INTRODUCTION TO SONAR

<u>Prosign</u>	<u>Proword</u>	<u>Meaning</u>	<u>Remarks</u>
AA	ALL AFTER	All after	} Used to identify portions of a transmission when requesting a repetition.
AB	ALL BEFORE	All before	
WA	WORD AFTER	Word after	
WB	WORD BEFORE	Word before	
K	OVER	Go ahead and transmit.	} Every transmission ends with one or the other of these prosigns.
\overline{AR}	OUT	End of transmission; no reply expected or desired.	
\overline{AS}	WAIT	I must pause for a few seconds.	
$\overline{AS} \overline{AR}$	WAIT OUT	I must pause longer than a few seconds.	
BT	BREAK	Long break	Separates text of message from heading and ending.
II		Separative sign	Used for all other separations in messages. Write it as a short dash.
DE	FROM	From	
EEEEEEEE	CORRECTION	I just made an error.	Corrected version is sent immediately.
EEEEEEE	\overline{AR}	DISREGARD THIS TRANSMISSION	
IMI	SAY AGAIN	Repeat	
R	ROGER	I have received all of your last transmission.	

as well as receiving it by oscillator, should give you a good knowledge of code sound. The proper method for keying is your next concern.

Probably the first key you'll encounter is the unshielded telegraph key, normally used on practice oscillators on shipboard and on station circuits. The key must be adjusted properly before you can transmit clear-out characters. A hand key, with parts labeled, is shown in figure 8-1.

A spring tension screw, behind the key button, controls the amount of upward tension on the key. The tension desired varies with operators. Too

much tension forces the key button up before the dahs are completely formed; spacing between characters is irregular, and dits are not clearly defined. If the spring tension is very weak, characters run together and the space between characters is too short.

The gap between the contacts, regulated by the space adjusting screw at the back of the key, should be set at one-sixteenth inch for beginners. This measurement does not apply to every key and operator; it is a matter of personal preference. Some operators like a closed key, others an open key. "Closed" and

Chapter 8—COMMUNICATIONS

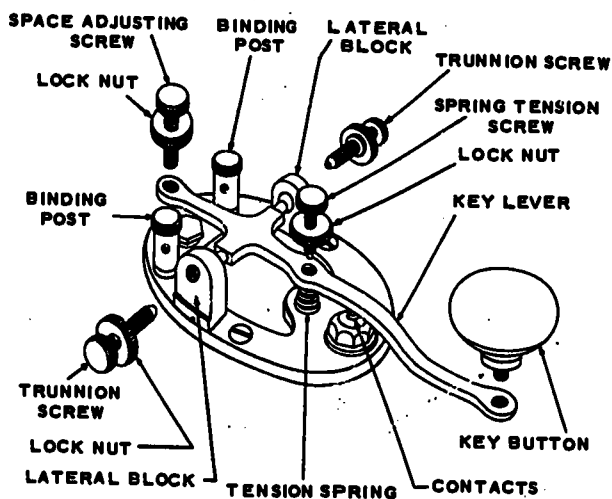

76.8A

Figure 8-1.—Hand key.

“open” are terms for a short and a long gap. As the student progresses, further gap adjustment may be made to suit his sending speed. Contacts that are too close have an effect similar to weak spring tension. Contacts that are spaced too far have the same effect as too much spring tension.

The final adjustment of the key is the side-wise alignment of the contact points. This alignment is controlled by the trunnion screws at either side of the key. If they are too tight, the key lever binds. If they are too loose, the contacts have sidewise play. Usually, when the sidewise alignment is correct, no further adjustment is required.

From the beginning you should learn the correct way to grasp the key. The following instructions, in the order listed, constitute the proper procedure for becoming a proficient operator: Do not hold the key tightly, but let your fingers rest lightly on the key knob. Your thumb rests against the side, your forefinger rests on top of the key; your third finger is bent and relaxed with the remaining two fingers.

Speed and accuracy of transmission depend, to a large extent, on acquiring the proper movements of your wrist and hand while operating the key. To close the key, your wrist moves upward and your hand rocks downward toward your fingertips. To open the key, these two movements are reversed—your wrist comes down and your hand rocks back. A dah should be about three times as long as a dit.

Conditions of the water have a bearing on the speed at which you will be able to transmit. At times you can transmit rapidly and your signals will be clearly audible. Other times you may have to go very slowly, otherwise your dits and dahs cannot be distinguished by the receiving operator.

UNDERWATER COMMUNICATIONS

For many reasons it is necessary for a ship and a submerged submarine to communicate with each other. Of paramount importance is the safety of the submarine and its crew. During exercise periods the ship can advise the submarine when it is safe to surface. Should an emergency arise aboard the submarine, the ship can be so informed. Exercises can be started and stopped, or one in progress can be modified, by using the underwater telephone. Attack accuracy can be signaled by the submarine to the attacking ship. Sonar Technicians must be proficient in radiotelephone procedures because those techniques are used for underwater voice communication. When CW (radiotelegraph) is used, you must be able to send and receive Morse code without causing delay or misunderstanding.

The most widely used underwater telephone installation is the AN/UQC-1 (and modifications) sonar set, commonly called Gertrude. Although intended for use by sonar control personnel, some installations provide remote voice operation from the bridge and from CIC. It operates as a single sideband suppressed carrier transceiver, with a modulated frequency of 8 to 11 kc. It has a microphone for voice transmission and a hand key for sending CW signals. Mounted on the front panel of the control unit (fig. 8-2) are a speaker, microphone, and earphone jacks, on-off and receiver-transmit switches, a telegraph key, and three neon glow lamps indicating output, plate voltage, and filament voltage.

When you wish to transmit by voice, set the toggle switch to VOICE & CW RECEIVE, plug in the microphone, and depress the microphone button. For CW transmission, set the toggle switch to CW TRANSMIT and use the hand key. (CAUTION: Do not operate in the CW mode for longer than 30 minutes at a time. Operation for longer periods causes excessive heating of the transducer.)

The range of transmission varies with water conditions, local noise level, and reverberation effects. Under normal sonar conditions, however, communication between ships should be possible

INTRODUCTION TO SONAR

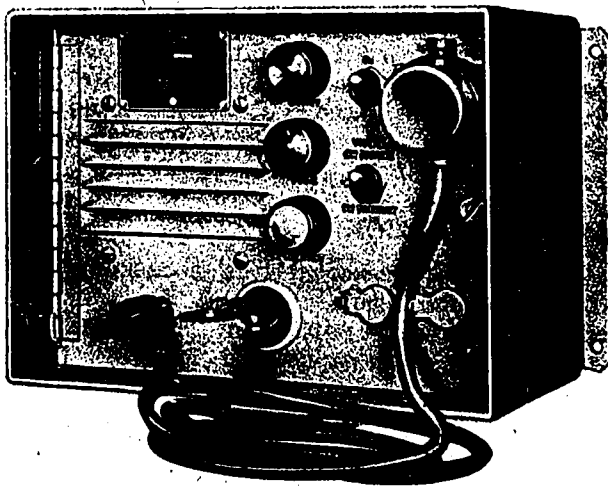

71.71
Figure 8-2.—AN/UQC-1 control unit.

at ranges out to 12,000 yards. Under the same conditions, submarines achieve a greater range. If the submarines are operating in a sound channel (described in chapter 4), the communication range may be many miles greater than that achieved by ships.

Local noise, caused by ship's movement through the water, machinery, screws, etc., can reduce the range to less than half the normal range. Severe reverberation effects may also cause a reduction in range, but you can overcome them by speaking slowly, pausing after each word to let the echoes die out. At very short ranges it may be impossible to reduce the receiving gain to a comfortable speaker output level. Then, you must speak softly, holding the microphone away from your lips.

VOICE PROCEDURE

As mentioned earlier, you will use the same voice procedures for underwater voice communication as for radiotelephone transmissions. In other words, you call the station for which you have a message, identify yourself, send your message, and end the transmission with either OVER or OUT.

Calling and Answering

Here is an example of a call from a submarine (call sign WEASEL) to an ASW ship (call sign LONGSHOT). Dashes shown are not actually

sent, but indicate pauses the operator makes so that his transmission can be understood more easily.

LONGSHOT—THIS IS WEASEL—OVER
WEASEL—THIS IS LONGSHOT—OVER

With communication established, WEASEL sends his message:

LONGSHOT—THIS IS WEASEL—BREAK—
AM READY—AT REQUIRED DEPTH—
SPEED—AND COURSE—BREAK—OVER

LONGSHOT gives a receipt, using an abbreviated call:

THIS IS LONGSHOT—ROGER—OUT

Following is an example of a related series of messages between ships conducting an ASW exercise.

DOUGHBOY—THIS IS BIG BEN—BREAK—
CEASE ECHO RANGING DURATION MY
ATTACK—BREAK—OVER
BIG BEN—THIS IS DOUGHBOY—ROGER—
BREAK—INFORM DOUGHBOY THIS CIR-
CUIT WHEN ATTACK COMPLETED—
OVER
DOUGHBOY—THIS IS BIG BEN—ROGER—
OUT

Correcting an Error

If you make an error in transmission, send the proword CORRECTION immediately. Go back to the last correctly sent word, repeat it, and continue with the correct version. Example:

WEASEL—THIS IS LONGSHOT—BREAK—
ALL HERE—CORRECTION—ALL CLEAR
SURFACE—BREAK—OVER

Waits

When an operator finds it necessary to delay transmission momentarily, he sends the proword WAIT. If the delay is for longer than a few moments, the transmission is WAIT OUT. A new call is made when communication is resumed.

Repetitions

The request for a repetition is SAY AGAIN, not "Repeat." Used alone, SAY AGAIN means

Chapter 8 — COMMUNICATIONS

"Repeat all of your last transmission." Followed by identification data, it means "Repeat the indicated portion of your transmission." The answer to SAY AGAIN is I SAY AGAIN, followed by the repetition requested. Example: WEASEL asks LONGSHOT to repeat all of his last transmission, and LONGSHOT complies.

THIS IS WEASEL—SAY AGAIN—OVER
THIS IS LONGSHOT—I SAY AGAIN—
WEASEL—THIS IS LONGSHOT—BREAK—
CHANGE BASE COURSE TO ZERO NINER
ZERO—MAINTAIN PRESENT DEPTH AND
SPEED—REPORT WHEN READY—BREAK

If WEASEL missed only the word PRESENT, he would frame his request as follows:

THIS IS WEASEL—SAY AGAIN—WORD AFTER
MAINTAIN—OVER

When WEASEL has the complete message, he sends a receipt.

Canceling a Message

To cancel a message in progress, cease sending immediately and transmit the proword DISREGARD THIS TRANSMISSION. Example: LONGSHOT'S operator begins a message, then is ordered to delay it.

WEASEL—THIS IS LONGSHOT—TAKE STA-
TION—DISREGARD THIS TRANSMISSION
—OUT

Once a message is receipted for, it cannot be canceled by means of the proword DISREGARD THIS TRANSMISSION. Instead, a new message must be sent.

UNDERWATER TELEGRAPH PROCEDURES

Knowledge of the Morse code itself will not enable you to send a correct message. You also must have a working knowledge of simple radio-telegraph procedure. You won't need to master all the details because sonar communications are kept to a bare minimum, and messages sent are in brief, plain style. If you learn the procedure given here, you will be able to handle any underwater message you are likely to encounter.

Underwater telegraph procedure closely parallels underwater telephone procedure. Construction of messages is the same, and so are principles of calling, receipting, correcting errors, waiting, and obtaining repetitions. You will notice two important differences, though: Instead of using voice calls, you will use the international call signs of the ships. Also, instead of prowords, you will use prosigns.

Call Signs

Call signs are letters or letter-number combinations. They are used chiefly for identification of a communication activity. By international agreement, the United States has the use of the first half of the A block (assigned to Army and Air Force units) and all of the K, N, and W blocks. You are already familiar with the K and W calls. They are assigned to commercial radio stations. Your concern here is with the N calls, assigned to the Navy, Marine Corps, and Coast Guard. Naturally, your primary interest is with U. S. Navy ship calls.

The Navy assigns a 4-letter call to each of its ships. Should the need arise, you can find the international call of any Navy ship in ACP 113, Call Sign Book For Ships. Following are a few examples.

<u>Ship</u>	<u>Call Sign</u>
USS Cony (DD 508).....	NILX
USS O'Bannon (DD 450).....	NUJC
USS DuPont (DD 941).....	NTIR
USS Seawolf (SSN 575).....	NBWX

Call

The call is a transmission directed to the station with which you wish to communicate, requesting that station to answer. Begin the transmission with the call sign of the station you are calling. Next, give the prosign DE (from), then the call sign of your own ship, and finally the prosign K. In the following example the USS Cony, a DD (call sign NILX), calls the submarine Catfish (call sign NJRV): Call: NJRV DE NILX K; reply: NILX DE NJRV K. Cony now repeats the call without the prosign K and proceeds with the text of the message.

After communication is established, further calling or answering incident to transmission of a message usually is handled by abbreviated calls. The abbreviated call omits the call sign of the station called. If there is a possibility

INTRODUCTION TO SONAR

of confusion, however, a full call should be used. Example: full call: NJRV DE NILX; abbreviated call: DE NILX.

Text

The call is followed by the text, which is the main part of the message. It is the basic idea or information that the originator (station with information to send) desires to communicate to the addressee (station receiving the message). The text may be sent in plain language or it may be sent coded. In addition to regular coded signals, Sonar Technicians use a special 3-letter code with meanings that cover most of the information sent or exchanged in underwater communications. This code is contained in FXP 1.

The 3-letter code sometimes is referred to as the "short signals." Use of short signals shortens the time required to exchange information. Even so, you will handle many underwater messages with plain language texts.

The heading and text of a message are separated by BT. Likewise, the text and ending are also separated by BT.

Ending

The ending marks the conclusion of the message. In underwater sound communications, the ending consists of the prosign K or AR, depending on whether a reply is required.

Challenging

In some situations the use of CW, rather than voice, is highly desirable. Here is an example: Your ship (or submarine) is on a routine patrol. You have a "probable" sonar contact. The captain wants to know its nationality, and orders you to challenge. One method is to use voice transmission:

UNKNOWN STATION—THIS IS (your ship's international call sign)—IDENTIFY YOURSELF—OVER

You could also tell the unknown station its bearing and range from you. He may not have an underwater telephone installation, however. Even though equipped with a telephone, if he is from a foreign nation he may not understand you. By using CW, you can transmit an international interrogation signal. This signal is AA (two di-dahs sent as a single group: di-dah-di-dah). The challenge is followed by the

letters DE (from) and the four letters of your ship's call sign, ending with K (over). If the contact is a submarine, and he decides to answer you, he will transmit his call letters. You then can look up his call sign in ACP 113 to obtain his name and country.

Many search sonars can be used to transmit CW signals. This usage puts a power drain on the equipment, however, causing it to heat up. Built-in overloads are provided to reduce power output before damage occurs to the equipment, resulting in reduction of range with the lesser power output. Thus, under normal conditions, CW transmission is not recommended for search sonars.

SUBMARINE COMMUNICATION METHODS

The AN/UQC underwater telephone is the submerged submarine's primary means of communicating with surface ships. For this reason, during exercise periods ships are required to man the UQC continuously. In addition to its required use for safety purposes, the UQC is used throughout an exercise by ships and submarines for sending attack signals, obtaining range checks, transmitting sonar short signals, and for several other purposes. Subject to equipment limitations, keyed sonar is the secondary means of underwater communications. Many submarine sonars do not have CW capability.

Emergency communication equipment carried by a submarine include a radio and a telephone. The radio is battery-powered and floats to the surface upon release through the signal ejector. Once on the surface it automatically transmits on emergency radiofrequencies.

The emergency telephone, designated AN/BQC-1A, is also battery-powered, and is portable. It has the same voice frequency characteristics as Gertrude, with a range of about 5000 yards. The usual installation provides one set in both the forward and after torpedo rooms. In addition to its voice transmission capability, the AN/BQC-1A can emit a 24.26 kHz continuous tone for homing purposes. Submarine rescue vessels have equipment capable of detecting and homing on the tone. With all batteries in good condition, 72 hours of continuous tone transmission is possible. Range of the homing signal is 2000 to 5000 yards.

Colored flares and smoke signals afford another means of communication. Black or green signals are used by the submarine to indicate the simulated firing of torpedoes and to mark

Chapter 8—COMMUNICATIONS

her position. A yellow flare or smoke signifies the submarine intends to surface. Ships must then clear the area and keep other shipping away. A designated ship notifies the submarine that the signal was sighted, and informs him when it is safe to surface. A red flare denotes trouble. It means the submarine is carrying out emergency surfacing procedures. If the flares are repeated, or if the submarine fails to surface within a reasonable length of time, it can be assumed he is disabled and requires immediate

assistance. You must make every effort to maintain sonar contact and establish communications by any means possible, but preferably by voice.

Detailed pyrotechnic, sonar, and explosive signal information is contained in FXP 1. All Sonar Technicians must become familiar with the signals in that publication. The rescue of a disabled submarine's crew could depend on your ability to establish and maintain reliable communications.

CHAPTER 9

MAINTENANCE

Any piece of machinery or precision equipment requires some type of care to keep it running efficiently. Proper upkeep of an automobile, for example, includes changing the oil at certain mileage intervals. The windshield must be kept clean; headlights and brakes must be adjusted every once in a while; and an occasional engine tuneup must be obtained. Sonar equipment also requires periodic upkeep, but in more detail and at more regular intervals than does an automobile. Aboard your ship or submarine you will assist in carrying out scheduled maintenance on the equipment to which you are assigned.

Various publications are available to assist you in carrying out a maintenance program. The manufacturer's technical manual for each piece of equipment is an invaluable aid. These books describe the components of the equipment, operating standards, and required maintenance. Other publications include the Naval Ships Technical Manual and Electronic Information Bulletins (EIBs).

TYPES OF MAINTENANCE

Maintenance is divided into three categories, according to their complexity and purpose. The three types of maintenance are operational, preventive, and corrective.

At first glance it may seem that preventive and operational maintenance are synonymous, but there is a good deal of difference between the two. Operational maintenance is confined to acts that can be performed by an operator while he is on watch, and usually is further confined to one component, such as the sonar console. Preventive maintenance is a systematic program covering the entire sonar system, and requires several men to carry out.

The Navy's operational and preventive maintenance program formerly was called POMSEE. Ships and stations today, however, utilize a

program known as the Standard Navy Maintenance and Material Management System, more familiarly called the 3-M System, which will be discussed later in the chapter, as will the POMSEE program.

OPERATIONAL MAINTENANCE

Operational maintenance is the elementary upkeep performed by the operator to keep his equipment in good operating condition. It consists mainly of proper operation of the equipment, such as starting, stopping, calibrating, and manipulating controls in the prescribed manner. At times, operational maintenance may also include inspection, cleaning, and lubrication of equipment, and replacement of minor parts, such as indicator lamps.

PREVENTIVE MAINTENANCE

Preventive maintenance is work done that is intended to forestall equipment failure. Comprising this category are inspection, cleaning, testing, and lubrication. It also includes minor adjustments and replacement of minor deteriorated parts (if no high degree of technical skill or internal alignment is required) which, if left uncorrected, might lead to equipment malfunction or part failure.

Inspecting

All electronic equipment should be inspected daily for such defects as broken meter glasses, loose control knobs, burned-out indicator lights, loose cable connections, and the many small items that may be checked with or without the equipment actually being energized. On units that utilize ventilation for cooling, the intake and outlet areas should be inspected to see that they are free of obstructions.

Many items can be inspected daily, weekly, and monthly to help maintain the equipment in

Chapter 9 — MAINTENANCE

serviceable condition, but they are too numerous to mention in detail here. In some instances these routine checks include electrical measurements to check individual units for malfunctioning circuitry. Technical manuals furnished by the manufacturer include lists of checks to be conducted at regular intervals and the desired reading or measurement required for peak performance of the specific equipment.

Cleaning

Cleaning is an important part of preventive maintenance. External surfaces of electronic units and the surrounding spaces should be cleaned daily. This daily routine reduces the amount of dirt and dust that enters the equipment through circulating air blower intakes. Some dust and dirt naturally will work their way in, hence the interiors of units should be cleaned carefully at least once a week with a soft cloth. If possible, a vacuum cleaner should be used. Avoid using blowers, bellows, or cleaning solvents, because they tend to push or wash dirt into inaccessible corners. If it becomes necessary to use a cleaning solvent, use only methyl chloroform. See NavShips Technical Manual, article 67.306 for safety precautions. Air filters should be cleaned at least once a week. Climate and operating conditions may require cleaning more often. Overheating due to clogged air filters often is a prime cause of equipment failure. Neglect in cleaning filters is, therefore, inexcusable.

Generators must be given a careful cleanliness check while the equipment is inoperative. Brushes and commutators should be cleaned frequently. Be careful not to blow or brush carbon dust and other foreign matter into the windings or bearings. When cleaning generators, ensure that the brushes slide freely in their holder and exert proper pressure on the slipping or commutator surface.

Lubrication

Electronic gear has many parts—such as motors, hoists, gears, and springs—that require regular lubrication. The manufacturer's technical manual should be followed to ascertain where, how often, and how much lubrication is needed. Use caution when lubricating the parts of any piece of equipment, and follow the instructions in the book pertaining to the individual type of equipment. Too much lubrication can be just as harmful as too little.

CORRECTIVE MAINTENANCE

Corrective maintenance is another name for repair, and is necessary only after equipment failure. Corrective maintenance usually calls for replacement of internal parts or alignment of electronic components requiring technically trained personnel. Some of this work is performed by operating personnel while assisting the technician. As you advance in rate you will perform more highly technical maintenance on your own.

MAINTENANCE AND MATERIAL MANAGEMENT SYSTEM

Reliability of electronic equipment depends on the quality of the preventive and operational maintenance received by the equipment. As equipment becomes more complex, the maintenance problem becomes ever greater.

In the past, many programs evolved that often were uncoordinated and sometimes unworkable. The lack of well-trained technicians, together with the large number of reports required by some programs, seriously hampered the maintenance effort. Overloaded bureaus, moreover, could not properly correlate the mass of information in the reports.

To alleviate these conditions, the Standard Navy Maintenance and Material Management (3-M) System was implemented. The 3-M system replaces all other maintenance programs. It prescribes standard maintenance procedures and provides a feedback report system that enables the program to be updated, and corrects errors and deficiencies.

Procedures for managing and reporting the maintenance program are contained in Maintenance and Material Management (3-M) Manual, OpNav 43P2.

Basic elements of the 3-M system are the Planned Maintenance Subsystem (PMS) and the Maintenance Data Collection Subsystem (MDCS). The PMS provides a uniform system of planned preventive maintenance. The MDCS provides a means of collecting necessary maintenance and supply data, in a form suitable for machine processing. A man-hour accounting system also is used aboard repair ships and tenders in conjunction with the MDCS. As a third class petty officer, you will be concerned with the Planned Maintenance Subsystem and certain portions of the Maintenance Data Collection Subsystem. The degree of equipment readiness,

INTRODUCTION TO SONAR

effectiveness, and reliability depends on how well you perform the required maintenance.

PLANNED MAINTENANCE SUBSYSTEM

Preventive maintenance, when properly carried out, reduces casualties and associated costs and equipment downtime required for major repairs. The PMS is designed to simplify maintenance procedures (insofar as possible) by defining the maintenance required, scheduling its performance, describing the tools and methods to be used, and providing for the detection and prevention of impending casualties.

In establishing minimum equipment maintenance requirements, the NavShips Technical Manual, manufacturers' technical manuals, and other applicable publications are reviewed critically. If planned maintenance requirements are found to be unrealistic or unclear, they are modified or completely revised before incorporation into the PMS.

It is possible that the planned maintenance specified in the PMS may differ from that prescribed in other documents. Should some variance become apparent, remember that, insofar as preventive maintenance is concerned, the PMS supersedes and takes precedence over existing requirements set forth in various technical publications.

Planned Maintenance Subsystem Manual

A master Planned Maintenance Subsystem Manual (OpNav 43P1) is tailored to each ship. It contains minimum planned maintenance requirements for each maintainable component installed in that particular ship. Normally, appropriate sections (engineering, electronics, weapons, etc.) of the master manual are kept in the office of the department concerned. Respective sections are used by department heads in planning and scheduling all maintenance requirements in their departments.

The departmental PMS manual contains a section for each division or maintenance group within a department. Each divisional section includes a table of contents and a maintenance index page (MIP) for each system, subsystem, or component. Applicable portions of the PMS manual are kept in the working space for the equipment to which they pertain. These portions serve as a ready reference to the required planned maintenance. Each MIP contains a brief description of maintenance requirements and the frequency with which they are to be effected.

The frequency code is: D—daily, W—weekly, M—monthly, Q—quarterly, S—semiannually, A—annually, C—overhaul cycle, and R—situation requirement. Frequency codes for daily, weekly, monthly, quarterly, semiannual, and annual planned maintenance actions are self-explanatory. Code C designates certain planned maintenance actions performed in a specified quarter (i.e. once) during the operational cycle between shipyard overhauls. Code R identifies planned maintenance actions that are to be performed before getting underway, after a specified number of hours of operation, or to meet other requirements that arise only during specific situations.

Figure 9-1 shows a maintenance index page from a typical PMS manual. Information entered on the MIP includes the system or component, a short description of each maintenance requirement, maintenance frequency code plus a consecutive number starting with numeral 1 for each frequency code assigned, rate(s) recommended to perform the maintenance, average time required to perform the maintenance, and related maintenance requirements. Related maintenance represents additional planned maintenance that can be completed before, in conjunction with, or immediately after a scheduled maintenance.

Shipboard application of the PMS varies slightly from one ship to another. Clarification is required, therefore, of information found on MIPs regarding rates recommended to perform maintenance and the average time required for the task. Actually, maintenance tasks are performed by personnel available and capable, regardless of the rate listed on the MIP. As listed on the MIP, average time required does not consider time required to assemble necessary tools and materials, to obtain permission to secure equipment, nor to clean the area and put away tools upon conclusion of a task. Always remember that no maintenance is complete until all tools and equipment are put away and the area is cleaned.

Scheduling Planned Maintenance

For each division or maintenance group, a cycle schedule that provides a visual display of planned maintenance requirements (based on the operational cycle of the ship between shipyard overhauls) is exhibited in the departmental office. Information supplied on a cycle schedule for any particular division or maintenance group includes the MIP number from the PMS manual, a listing of all equipment within that particular group for which planned maintenance is required, and the specific quarter in which the semiannual, annual,

Chapter 9—MAINTENANCE

System, Subsystem, or Component					Reference Publications	DATE			
AN/SQS-29B, 29C Sonar Detecting-Ranging Set						1 October 1965			
Bureau Card Control No.					Maintenance Requirement	M.R. No.	Rate Req'd	Man Hours	Related Maintenance
J2	01000000	AS	AESH	M	1. Measure noise level (hull equipment). 2. Compute ship and sea noise level.	M-13	STG2 STGSN	3.0 3.0	M-11
J2	01000000	AS	AESJ	M	1. Calculate AN/SQM-2 voltage attenuation factor. 2. Measure and observe transmitter output pulses.	M-14	ST1 STGSN	1.0 1.0	None
J2	01000000	AS	AESK	Q	1. Test hull and VDS receiving system noise. 2. Test hull own doppler nullifier circuit. 3. Test VDS own doppler nullifier circuit.	Q-1	STG3 STGSN	0.8 0.8	None
J2	01000000	AS	AESL	S	1. Clean and inspect sonar set.	S-1	STG3 STGSN	9.0 9.0	R-1
J2	01000000	AS	AESM	A	1. Calibrate sonar test set.	A-1	STG3 STGSN	0.4 0.4	None
J2	01000000	AS	AESN	C	1. Lubricate high-voltage motor generators after 3000 hours of operation or at 3 year intervals.	C-1R	STG3	1.5	None
J2	01000000	AS	AESP	R	1. Test operational readiness of equipment prior to getting underway.	R-1	STG3 STGSN	1.8 1.8	None
J2	01000000	AS	AESQ	R	1. Replace commutator brushes in high-voltage motor-generators.	R-2	STG2 STGSN	1.5 1.5	None
<p>These maintenance cards were prepared for this equipment in which the following field changes have been accomplished: AN/SQS-29, 29A-1 through 9, 11, 12, 15 through 17, 19, and 20. Of these, the following field changes affect the maintenance actions: AN/SQS-29, 29A-19 and 20</p> <p>New maintenance requirements cards and maintenance index pages will be made available as future field changes are accomplished that affect the prescribed planned maintenance.</p>									
(Page 2 of 2)									

MAINTENANCE INDEX PAGE
OPNAV FORM 4700-3 (7/65)

BUREAU PAGE CONTROL NUMBER 80-9/2-A5

98.171
Figure 9-1.—Maintenance index page.

154 149

INTRODUCTION TO SONAR

and overhaul cycle planned maintenance actions are to be performed. A cycle schedule also lists quarterly and situation requirement planned maintenance actions that must be scheduled, as well as monthly planned maintenance requirements.

Cycle schedules are utilized by department heads, in conjunction with their division officers and leading petty officers, to prepare quarterly planned maintenance schedules. A quarterly schedule is displayed in a holder, known as the maintenance control board, adjacent to the cycle schedule to which it pertains. A quarterly schedule gives a visual display of the ship's employment schedule and the planned maintenance to be performed during that particular quarter. A quarterly schedule has 13 columns, one for each week in the quarter, for scheduling maintenance throughout a 3-month period.

At the end of each week, the leading petty officer of a division or maintenance group updates the quarterly schedule by crossing out (with an X) the preventive maintenance performed. If a planned maintenance action is not completed during the week it is scheduled, the leading petty officer circles the action on the quarterly schedule. Uncompleted maintenance is then rescheduled for another week within the same quarter.

At the close of each quarter, the applicable quarterly schedule is removed from its holder and retained on board as a record of the planned maintenance completed. This record may be discarded at the beginning of the second quarter after the next shipyard overhaul.

A quarterly schedule also is used by a leading petty officer to arrange a weekly planned maintenance schedule for posting in an appropriate workspace. The weekly schedule of planned maintenance should not be considered as the total of all work for a given week. This weekly work covers only scheduled planned maintenance and is in addition to other routine work, upkeep, and corrective maintenance to be accomplished. The weekly schedule provides a list of components in the working area, appropriate page number of the PMS manual, and spaces for the leading PO to use in assigning planned maintenance tasks to specified personnel. Daily and weekly planned maintenance actions are pre-printed on the forms, and the other maintenance actions are written in by the leading PO as required. When the leading PO is assured that a maintenance task is completed, he crosses out the maintenance requirement number on the weekly schedule. If for some reason a task cannot be completed on the day scheduled, the

leading petty officer circles the maintenance requirement number and reschedules it for another day. Current status of scheduled maintenance is readily available by looking at the weekly schedule.

Maintenance Requirement Card

A maintenance requirement card (MRC) is a 5 by 8 inch card on which a planned maintenance task is defined sufficiently to enable assigned personnel to perform the task. (See fig. 9-2.) A master set of MRCs is maintained in the departmental office. Cards applicable to the equipment in which Sonar Technicians are interested are maintained in the workspace. If

SYSTEM ASW-U/W	COMPONENT AN/SQS-29B, 29C Sonar Detecting-Ranging Set	M. R. NUMBER SO-9 H-14	
SUB-SYSTEM Sonar	RELATED M.R. None EIC-J201000	RATES STI 1.0 STGSN 1.0	M/H 1.0 1.0
M.R. DESCRIPTION 1. Calculate AN/SQM-2 voltage attenuation factor. 2. Measure and observe transmitter output pulses.		TOTAL M/H 2.0 ELAPSED TIME: 1.0	
SAFETY PRECAUTIONS 1. Observe standard safety precautions. 2. Short across all terminals of 19D terminal board to electrical ground, using a shorting probe.			
TOOLS, PARTS, MATERIALS, TEST EQUIPMENT 1. Electronic multimeter (VTVM), ME-6 ()/U or equivalent 2. Audio oscillator, TS-382 ()/U or equivalent 3. Oscilloscope, AN/USH-105 or equivalent 4. 1/2" Open end wrench 5. Sound-powered phones (2) 6. Sound Measuring Set, AN/SQM-2 7. Shielded test lead (2) 8. Warning tags 9. 4' Jumper lead 10. Shorting probe			
PROCEDURE Voltage attenuation factor for AN/SQM-2 Serial _____ is _____.			
NOTE 1: Above factor is obtained by performing MR 1 of this MRC. After this factor has been obtained, subsequent accomplishment of this MRC will start with MR 2.			
Preliminary a. Turn OFF and tag both equipment POWER switches. b. Turn OFF and tag both voltage regulator switches. c. Turn OFF and tag bulkhead power switch.			
1. Calculate AN/SQM-2 Voltage Attenuation Factor. a. Remove cover on terminal side of hull relay and junction box. (Cable stuffing tubes are on right when facing terminal side.) (Cont'd on Page 2)			
LOCATION	DATE	PAGE 1 of 4	
	1 October 1965	J2 0100 000 JS	
		ASJ	

MAINTENANCE REQUIREMENTS CARD
OPNAV FORM 4700-1 (REV. 7/65)

98.176
Figure 9-2. — Maintenance requirement card.

Chapter 9 — MAINTENANCE

a card in the workspace becomes lost or mutilated, a new card may be made from the master set and can be used until a feedback report is sent in and a new card obtained.

A maintenance requirement card is one of the principal components of the PMS with which Sonar Technicians are concerned. Suppose that on a Monday morning an individual looks at the weekly schedule and finds that he is assigned the maintenance action identified as M-14. The weekly schedule indicates that this particular maintenance action is listed on page SO-9 of the PMS manual. The MRC that describes the task assigned is identified by the number combination SO-9, M-14 in the upper right corner. In preparation for performing the assigned task, MRC number SO-9, M-14 is selected from the set of cards in the workspace. An MRC identifies each component; gives the rate and time required to perform the maintenance; gives a brief description of maintenance required; cites safety precautions to be observed; and lists tools, parts, and materials needed to accomplish the task. This information is given to enable personnel to be completely ready to perform all prescribed maintenance before actually working on equipment authorized. The procedure described on the MRC is standardized, and is the best known method of performing that particular task. For purposes of time conservation, any related maintenance requirement included on the MRC should be done at the same time or in conjunction with the assigned task.

The 16-digit number on the lower right side of the MRC is the bureau card control number. This number also appears on the MIP. Each MRC has a bureau card number, which must be referred to in any correspondence concerning the card.

In some ships, two or more divisions may have identical equipment. When duplication occurs, each division retains separate (but identical) MRC cards for the equipment.

Feedback Report

A PMS feedback report, OpNav form 4700-7 (fig. 9-3) is designed for reporting any discrepancies or suggested improvements in the PMS as installed aboard ship. This report is to be filled out by the man who discovers a discrepancy or suggests an improvement. It is signed by a designee of the commanding officer, and is mailed via the type commander to an appropriate field office listed on the reverse side of the originator's copy of the form. Atlantic

INSTRUCTIONS ON BACK OF GREEN PAGE		
FROM: SS 39E	SERIAL #: 1	
TO: NAVY MAINTENANCE MANAGEMENT FIELD OFFICE San Diego California 92136	DATE: 10 July 1967	
VIA: ComLufPac		
SUBJECT: PLANNED MAINTENANCE SYSTEM FEEDBACK REPORT		
SYSTEM (Communications and Control)	COMPONENT AS/ECR-2P, 2C Sonar Listening Set	
SUB-SYSTEM Sonar Systems	M. R. NUMBER SC-15 C-2 CONTROL NO. C1 C62A 574 B3 .037 G	
DISCREPANCY:		
<input type="checkbox"/> M. R. Description	<input type="checkbox"/> Equipment Change	<input type="checkbox"/> Typographical
<input type="checkbox"/> Safety Precautions	<input type="checkbox"/> Missing Maintenance Index Page (MIP)	<input type="checkbox"/> Technical Publications
<input type="checkbox"/> Tools, Etc.	<input type="checkbox"/> Technical	<input type="checkbox"/> Miscellaneous
<input type="checkbox"/> Missing Maintenance Requirement Card (MRC)	<input checked="" type="checkbox"/> Procedure	
Recommend procedure e. be changed to read: Using a nonconducting nozzle, vacuum equipment to pick up loose dust and dirt.		
SIGNATURE		
THIS COPY FOR:		

OPNAV FORM 4700-7 (Rev. 8-64)

ADDRESSEE

40.101

Figure 9-3. — PMS feedback report.

Fleet ships use the Norfolk address; Pacific Fleet ships send reports to the San Diego address.

When submitting a feedback report, be sure it is filled out completely and legibly. If the purpose of submitting a feedback report is to correct a discrepancy, for example, on a maintenance requirement card, be sure the discrepancy is clearly identified, and that the recommended change is correct and readily understood. Instructions for preparing the report are listed on the back of the form.

MAINTENANCE DATA COLLECTION SUBSYSTEM

The Maintenance Data Collection Subsystem is intended to provide a means of recording

INTRODUCTION TO SONAR

maintenance actions in substantial detail so that a variety of information may be collected concerning maintenance actions and performance of equipment. In addition to the foregoing information, MDCS furnishes data on initial discovery of a malfunction, how equipment malfunctioned, how many man-hours were expended on its repair, equipment involved, repair parts and materials used, delays incurred, reasons for delay, and the technical specialty or work center that performed the maintenance.

In recording maintenance actions, codes must be used in order to convert information to a language that can be read by automatic data processing machines. Codes are listed in the equipment identification code (EIC) manual. Third class petty officers are required to prepare numerous maintenance forms, using appropriate EICs. These forms are sent to a data processing center where coded information is punched onto cards, which then are machine-processed to produce various reports for use in maintenance and material management.

Reports coming from the automatic data processing machines are accurate and useful only if information is entered clearly and correctly on maintenance forms. All codes supplied on the forms must therefore be accurate and clearly written.

The MDCS requires that coded entries be made on OpNav forms 4700-2B (shipboard maintenance action), OpNav form 4700-2C (work request), and OpNav form 4700-2D (deferred action). Detailed descriptions of entries for these forms appear in the EIC manual and in chapter 3 of the 3-M Manual, OpNav 43P2.

POMSEE PROGRAM

Although the 3-M system has been implemented in all major type commands, some ships do not yet have the system in operation, or only part of the system. Aboard ships that do not have any part of the 3-M system in operation, the old POMSEE program still must be carried out. The short title POMSEE is formed from the underlined letters of the term Performance, Operation, and Maintenance Standards for Electronic Equipment. This title is an accurate self-description of the contents of POMSEE publications. The POMSEE publications include Performance Standards Sheets and Maintenance Standards Books for electronic equipment.

Performance standards sheets are filled out by technicians when equipment is installed and

immediately after it is overhauled. A minimum value is set by the cognizant command for certain performance characteristics that must be obtained before the equipment is considered satisfactory.

Maintenance Standards Books provide methods for measuring the performance of a specific equipment. These books have space for recording the measurements, and give a preventive maintenance schedule for the equipment. The Maintenance Standards Books do not tell how to locate trouble in the equipment. The applicable technical manuals must be consulted for methods and practices of troubleshooting. Maintenance Standards Books are in two parts: Part I—Reference Standards Tests, and Part II—Preventive Maintenance Checkoff.

Part I contains itemized step-by-step procedures for making tests, enabling the person making the test to record significant operating values taken while the equipment is operating at peak efficiency. Upper and lower limits or tolerances are given so that an indication is immediately apparent if performance falls below the prescribed limits. Illustrations are included to show test point locations.

Part II contains maintenance steps that must be performed at regular intervals. These steps include tests on circuits and components, and they specify what and when other routine maintenance (such as lubrication) should be accomplished. Part II enables the operating personnel to perform checks and preventive maintenance in a systematic manner. In general, the steps outlined in part II are the same as those used in part I to establish the values representing equipment operation at peak efficiency. All checks should be performed by the operating personnel insofar as possible.

A distinction between performance standards and reference standards should be pointed out at this time.

Performance standards set forth in the performance standards sheets must be met when equipment is installed. When it is established that the equipment meets the performance standards, reference standards are taken by a qualified person and are entered in ink in the reference standard column in part I of the Maintenance Standards Book.

Upon completing each preventive maintenance check prescribed, results should be entered in the time schedule table accompanying each chart. Entries in these tables are of prime importance, because they indicate whether the equipment is performing at maximum efficiency. Comparison

Chapter 9—MAINTENANCE

of a given reading with readings obtained previously, and with the initial reference standard test indications (part I), will reveal any significant change. It is expected that from time to time readings will show some changes. Minor variations do not necessarily mean that the equipment is not operating properly. If, however, a particular step shows a reading that varies

progressively in the same direction every time the check is made, it is an indication that the equipment is not in top condition, that a failure may be about to occur, and that corrective measures should be taken. At such times the technician should refer to appropriate manufacturers' instruction books for service and repair procedures.

CHAPTER 10

SAFETY; TEST EQUIPMENT; TEST METHODS

Sonar Technicians must assist in the upkeep and repair of the sonar equipment aboard their ship or station. Consequently, you must become familiar with the types of test equipment, test methods, and safety precautions to be observed when using or working on electronic equipment. Naturally, a knowledge of electronics is required also. Information related to the electronics field can be found in Introduction to Electronics, NavPers 10084; Basic Electronics, NavPers 10087 and Basic Electricity, NavPers 10086. Information on the selection, care, and use of hand and portable power tools is contained in Basic Handtools, NavPers 10085.

SAFETY

Maintaining electrical and electronic equipment is a dangerous business. Every year, lives are lost aboard ship due to electric shock. Several cases of fatal shock have been recorded from using such equipment as portable drills and grinders, fans, movie projectors, and even coffee pots. In most instances, death would have been avoided by observing appropriate safety precautions. Most men will treat with extreme caution a circuit containing several thousand volts, but will act with indifference toward the common household variety. Yet, 115 volts a-c is the prime source of death from electric shock. You must continually be alert when working with electricity, and you must adhere strictly to all pertinent safety precautions.

Although some safety practices are given in this chapter, you should become familiar with the safety instructions contained in the following publications: Naval Ships Technical Manual, chapter 9870; Handbook of Test Methods and Practices, NavShips 0967-000-0130; and Safety Precautions for Shore Activities, NavSO P-2455. An index of Navy Department documents containing safety precautions applicable to the operating forces is contained in OpNav Notice 5100.

GENERAL SAFETY PRECAUTIONS

Whenever possible, deenergize the main power input to any equipment before you work on it. Remember, though, that there still may be power in the equipment from such external sources as synchros, remote indicator circuits, and stable elements. When you open the switch in the main supply line (or any other power switch), indicate the switch is open by attaching to it a tag reading: "This circuit was ordered open for repairs and shall not be closed except by direct order of (your name, or name of person in charge of repairs)."

If you must work on an energized circuit, observe the following safety precautions.

1. Never work alone. Have another man, qualified in first aid for electric shock, present at all times. He should also be instructed in how to secure the power.
2. Use insulating rubber matting. The matting must be kept clean and dry. Wear rubber gloves, if possible, and use insulated tools. Remove rings and watches.
3. Use only one hand whenever possible. Keep the other hand behind you or in your pocket.
4. Do not indiscriminately stick your hand into an enclosure.
5. Have ample illumination.
6. Never short out, tamper with, or bypass an interlock.

Before working on a deenergized component, discharge all capacitors in the unit. A capacitor is a device for temporarily storing electrical energy. Successive small charges are built up in the capacitor for later release. Sonar transmitting equipments utilize this feature by building up electrical energy in the equipment's capacitor bank between each ping. A trigger pulse then releases the energy in a single high-powered pulse. Nearly all types of electronic equipment use capacitors of varying sizes and types. Normally, the larger the capacitor, the higher the electrical charge it will hold for a greater length

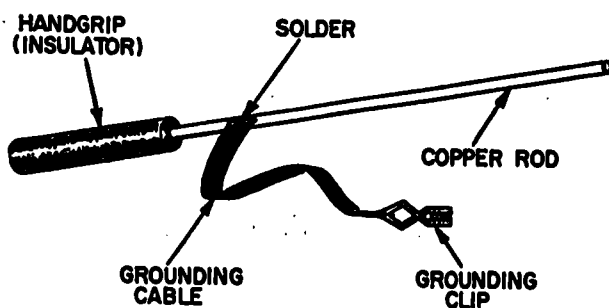

1.1(71)
Figure 10-1.—Shorting bar.

of time. On many electronic equipments, charges upwards of 14,000 volts are present. Usually, such large charges are discharged by mechanical means when the equipment is opened. Many other capacitors, however, must be discharged manually by the man working on the circuit.

To drain capacitor charges, the device you will use is the shorting bar, shown in figure 10-1. The shorting bar usually consists of a copper rod, which has an insulated grip on one end. A heavy braided cable is soldered to the rod near the grip. On the free end of the cable is a battery clip. When using the shorting bar, first secure power to the equipment, clamp the cable clip firmly to the frame or other good ground, then discharge each capacitor by holding the insulated handgrip and touching the terminals of the capacitors with the copper rod. Always ground the capacitor at least twice, because the capacitor's charge may not be completely drained by one application of the shorting bar.

Practically all electronic equipments have a metal grounding strap connecting the equipment chassis to the ship's hull. The purpose of the grounding strap is to place the equipment's frame and the hull at the same electrical potential, thus permitting personnel to touch the equipment without danger of receiving an electric shock. As you know, a difference in potential is what causes current to flow. If a component should develop a short to the chassis, the short-circuited power will bleed off to ground through the strap. If there is a faulty or open ground strap connection, however, a potential difference is established. Should you then come in contact with the equipment, you become the ground strap. In other words, the current passes from the equipment through you to ground, resulting in an electric shock—possibly a fatal one. You must ensure, therefore, that all ground connections are tight and free of

foreign matter, such as dirt, grease, or paint, that might interfere with the required metal-to-metal contact at the ground connection points.

Fuses are another source of potential danger to the careless Sonar Technician. The purpose of a fuse is to protect electric circuits and components. A fuse blows because more current than the fuse can handle tries to pass through it. The cause of the current overload may be a momentary surge in ship's power, or it may be a short circuit. Whatever the cause, two precautions must be observed when replacing fuses. First, use a fuse puller, even if power is secured. (Although it is desirable to secure power to the affected circuit, it is not always necessary or practical to do so.) If you were to use a screwdriver, pliers, or your bare fingers, great harm may be done if you contact adjacent live circuits. Second, always replace a fuse with one having the same rating. Substituting a higher rated fuse may cause serious damage to the equipment. If the circuit does not burn out, dangerous potentials may exist that normally would not be present, thus endangering servicing personnel.

Cathode ray tubes (CRT) are used in all sonar equipment. They are of rugged construction, and normally have a long life. They do require replacement from time to time, however, and a few precautions must be observed in handling them. A CRT must be handled gently to prevent breaking it and to avoid displacing its internal elements. Always place a CRT face down on cushioning material. If the tube is broken, don't handle the glass with bare hands because the tube's inner surface is coated with a toxic material. Gloves and special face masks are available for wear by personnel handling CRTs.

SAFETY WITH POWER TOOLS

Hazards associated with the use of portable electric power tools include electrical shock, bruises, cuts, falls, particles in the eyes, explosions, and the like. All Sonar Technicians should become familiar with the safety practices contained in NavShips Technical Manual, chapter 9600, section II. Following are some of the general safety precautions you should observe when working with power tools.

1. Ensure that the tools are grounded in accordance with articles 60-25 through 60-27 and 60-29 of the NavShips Technical Manual.
2. Avoid, if possible, using spliced cables.

INTRODUCTION TO SONAR

3. Carefully inspect the cord and plug. If the cord is frayed, or the plug appears damaged, replace them.
4. If an extension cord is used, connect the cord of the power tool into the extension cord, then connect the extension cord into the power receptacle. When your work is finished, unplug the extension cord from the power receptacle, then unplug the cord of the power tool.
5. Wear safety goggles for protection against particles that might strike your eyes.
6. See that the cables do not present a tripping hazard.

ELECTRIC SHOCK

Electric shock is a jarring, shaking sensation. You may feel as though someone hit you with a sledgehammer. Although usually associated with high voltage, fatal shocks often are received from 115 volts or less. If your skin resistance (which varies) becomes low enough, a current of 100 milliamperes (.100 ampere) at 115 volts, sustained for only a couple of seconds, is sufficient to cause death.

Symptoms and Effects

The victim of an electric shock is very pale; his skin is cold and clammy. His breathing (if he is breathing) is irregular, shallow, and rapid. He may sweat profusely, and his eye pupils will be dilated. In some cases he will be unconscious, and have an extremely weak pulse, or no pulse. In severe cases he will have no heartbeat. Vital organs in the path of the current may be damaged (usually due to heat) and nerves paralyzed.

Rescue and Treatment

The first thing to do for a victim of electric shock is to remove him from contact with the circuit. The best method is to open the switch, if you can do so without too much delay. If an ax is handy and the power cable is accessible, the cable can be cut, assuming that it would take too long to find the proper switch. If there are no ready means for cutting the power, use any dry nonconducting material to pull the man free; a belt, clothing, a piece of line, a wooden stick, or a sound-powered phone cord. Be extremely careful that you don't become a victim yourself.

The treatment to give a shock victim depends on his condition—whether he is breathing or not.

The following care is prescribed when the man is breathing.

1. Lay victim on his back, with his head lower than his feet. Loosen the clothing about his neck and abdomen so he can breathe freely. Keep him warm, but not hot. **SUMMON MEDICAL AID.**
2. Keep the man still. Electric shock weakens the heart, and any muscular activity on his part may cause the heart to stop functioning.
3. Normally, no liquids should be given. Never give stimulants nor sedatives.
4. If the necessary materials are available, apply a small amount of vasoline to his burns, and cover with a sterile dressing to prevent infection.

Resuscitation

If the shock victim is not breathing, immediate efforts must be made to revive him, even though he may appear to be dead. (Victims of severe electric shock sometimes appear as though rigor mortis has set in.) The effort must be continued until medical personnel can take over, or until a competent person declares the victim to be dead. Speed in beginning artificial respiration is of the utmost importance. Figure 10-2 shows that the victim's best chance of survival depends on beginning resuscitation within 5 minutes.

The mouth-to-mouth method of artificial respiration is preferred. Next in preference is the

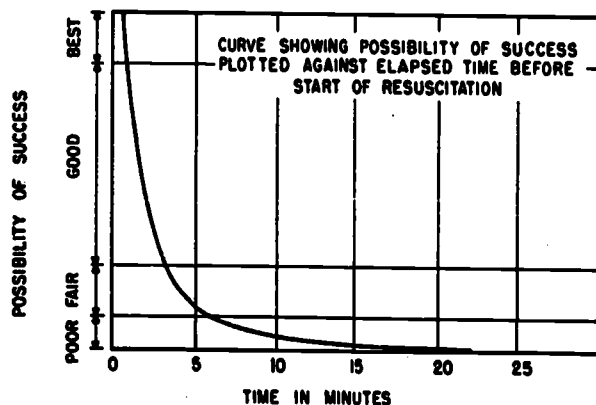

Figure 10-2.—Importance of speed in commencing artificial respiration.

71.101

back-pressure, arm-lift method. Detailed information on administering artificial respiration can be found in Standard First Aid Training Course, NavPers 10081, and in Handbook of Test Methods and Practices, section 1. Whichever method you use, the important objective is to start immediately.

TEST EQUIPMENT

Electrical equipment is designed to operate at certain efficiency levels. Technical instruction books and sheets containing optimum performance data—such as voltages and resistances—are prepared for each Navy equipment. The instructions are intended to aid the technician in maintaining the equipment.

As a Sonar Technician, you will work with ammeters, voltmeters, ohmmeters, and electron tube analyzers. You also may have occasion to use such equipment as wattmeters, power factor meters, capacitance-resistance-inductance bridges, oscilloscopes, signal generators, and other types of test equipment. Basic movements and construction of measuring devices are discussed in Basic Electricity.

GROUNDING TEST EQUIPMENT

Equipment that measures electrical values of component parts must never assume a ground level different from that of the chassis of the component. One reason is that measurement of an electrical value of a component, by an equipment having its own ground level value, would possibly reflect the difference in potential between the component and the test equipment. The other reason is that if the ground level of the test equipment differs from that of the component being measured, a condition of electrical hazard may result, and maintenance personnel may be shocked. For the ground levels of the test equipment and component parts to be the same, all electric and electronic test equipment must be grounded. Self-contained test equipment, such as multimeters, have two test probes and one grounding cable. When the grounding cable is attached to the component being tested, it is as though the test equipment were part of the chassis of the component. Touching the test equipment in one hand and the chassis of the component in the other does not, in itself, result in electric shock if the grounding cable is attached securely.

Externally powered equipment, such as a tube tester, is grounded to the frame of the ship through a standard three-wire electrical cord

and plug. A firm connection to the power receptacle is all that is needed to ground such equipment so that it will be safe to the touch. Other equipment—perhaps older or repaired test equipment—may not be equipped with the three-wire cord. If it is not so equipped, the test equipment should be grounded, with a separate cable running from its chassis or housing to the frame. Always check to see that the ground connection is firm and that it is sufficient to take any electrical load supplied to it.

VOLTMETER

The voltage of a circuit, or the voltage drop across part of a circuit, is measured with a voltmeter. Various voltage ranges are obtained by adding resistors of different values in series with the coil of the meter's movement. The voltmeter actually is a current-measuring instrument, but it indicates voltage through measurement of the current flow through a resistor of known value. When using a voltmeter, the following precautions must be observed to prevent damage to the meter:

1. Observe proper polarity in connecting the meter to the circuit.
2. Always connect the meter across (parallel to) the circuit component being tested.
3. Use a range (scale) large enough to prevent full-scale deflection of the needle.

The accuracy of the voltage readings depends on the sensitivity of the meter. Sensitivity is the meter's internal resistance, measured in ohms per volt. A low-sensitivity meter will indicate erroneous values when used in a high-resistance circuit due to the loading effect of the meter. Because the meter is connected in parallel, the total resistance of the circuit is reduced and the amount of current is increased. The following examples show how meter sensitivity affects accuracy.

• Figure 10-3 shows a series circuit. The value of resistor R1 is 50,000 ohms, that of R2, 100,000 ohms. Source voltage is 150 volts. The circuit has a current of .001 ampere, as determined by Ohm's law, which means that 50 volts is dropped across R1, and 100 volts is dropped across R2. When you place a voltmeter across R2, will it read 100 volts? Maybe. Assume the meter has a sensitivity rating of 1000 ohms per volt, and you use the 0-100-volt scale. The meter resistance is 100,000 ohms. When you connect the meter across R2, you have two 100,000-ohm resistors in parallel, and the equivalent resistance becomes 50,000 ohms. (The total resistance of two parallel

INTRODUCTION TO SONAR

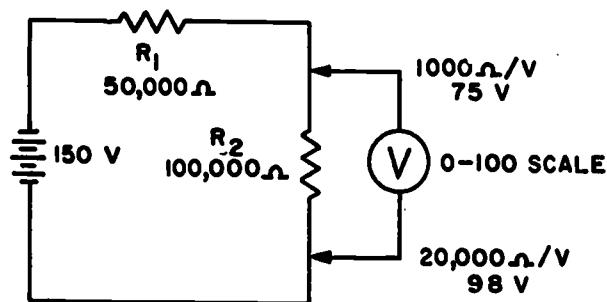

Figure 10-3.—Effect of sensitivity on meter accuracy. 71.125

resistors equals their product divided by their sum. It is always less than the value of the smallest resistor.) The total circuit resistance is no longer 150,000 ohms, but 100,000 ohms, and the total current flow is .0015 ampere. By applying Ohm's law you can see that the meter will read 75 volts. (If the meter had a 0-500-volt scale, you would get a reading of about 90 volts.)

- Now use a more sensitive meter, one rated at 20,000 ohms per volt. The internal resistance of the meter is 100 times 20,000 or 2,000,000 ohms. The equivalent resistance of R_2 is approximately 95,000 ohms, total circuit resistance is 145,000 ohms, and total current is .00103 ampere. The meter will now indicate about 98 volts across R_2 .

OHMMETER

The ohmmeter is used to measure resistance, check circuit continuity, and test for grounds. It has a self-contained voltage source. Because the ohmmeter is a resistance measuring device, you must deenergize the circuit under test before you connect the ohmmeter, otherwise serious damage will result to the meter.

The resistance measuring capabilities of the ohmmeter are controlled by fixed resistors of different values connected in series with the meter's movement. On some ohmmeters, scale selection is accomplished with a selector switch; on others, separate test lead jack connectors are used to obtain the desired scale.

To ensure an accurate reading, the meter must be zeroed to the scale used. Zeroing is accomplished by shorting the test leads together and adjusting the variable resistor labeled "ohms zero adjust" to align the pointer with the zero mark on the dial. Whenever you change scales, the meter must be zeroed again.

MEGOHMMETER

An ordinary ohmmeter is incapable of measuring resistance of millions of ohms, as found in conductor insulation. To test for insulation breakdown requires a much higher potential than is furnished by an ohmmeter. An instrument known as a megohmmeter (called megger) is used for these tests. The megger supplies the required high potential by means of a handcranked d-c generator. Meggers usually are rated at 500 volts, although higher rated types are available. To avoid excessive test voltage, the megger is equipped with a friction clutch between the handcrank and the generator. When the generator is cranked fast enough to exceed its rated value, the clutch slips. As with the ohmmeter, power must be removed from the circuit under test before connecting the megger.

MULTIMETER

The multimeter is a multipurpose meter that can measure resistances, a-c and d-c voltages, and d-c milliamps. Its versatility and portability eliminate the need for carrying several meters for test purposes. The usual precautions must be observed when making resistance and voltage measurements. When measuring d-c voltage, proper polarity must be observed. The face of the instrument has separate graduated scales to indicate the three values that can be measured. Be sure you read the proper scale.

TUBE TESTER

Electron tubes often are the cause of equipment failure. They may burn out, or their elements may become shorted or broken owing to vibration. Even new, unused tubes are subject to damage, so you should always test a tube before inserting it into a circuit. The test instrument you will use is the tube tester. Its usual application is to measure the mutual conductance of a tube, which is an indication of how well the grid can control plate current. The tube tester also can measure the emission of rectifier tubes, test for shorts, and tell if a tube has become gassy.

OSCILLOSCOPE

The oscilloscope is one of the most valuable pieces of test equipment available to the Sonar Technician. With the oscilloscope you can determine a signal's frequency, pulse width and amplitude, measure voltages and phase relations, and

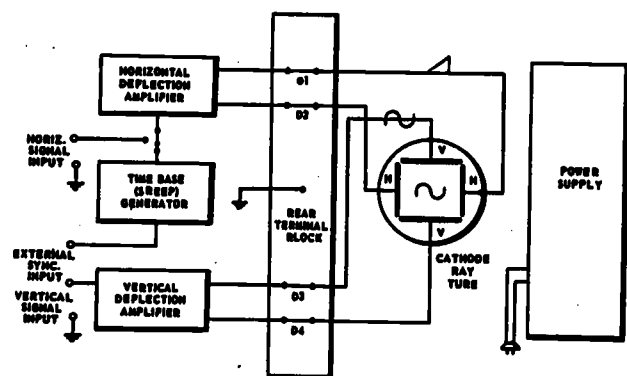

20,324
Figure 10-4.—Block diagram of a CRT oscilloscope.

observe signal waveforms. The latter use is particularly helpful, inasmuch as many technical manuals include (in their servicing block diagrams) waveforms at various test points.

The oscilloscope (fig. 10-4) consists of a cathode ray tube, vertical and horizontal beam deflecting circuits, sawtooth voltage sweep circuits, and necessary power supplies. The signal to be observed (a sine wave, for instance) is applied to the vertical deflection plates. If that were the only signal applied, all you would see on the scope would be a straight, vertical line. To have the sweep conform to the sine wave voltage on the vertical deflection plates, a sawtooth (linearly increasing) voltage is applied simultaneously to the horizontal deflection plates. The result is that the sweep moves across the scope at a uniform rate, following the fluctuations of the signal applied to the vertical plates. When the sawtooth signal reaches its cutoff point, the sweep returns rapidly to its starting point, to await the next sawtooth signal. The measurement of frequency, calibration, and other special situations requires the use of a synchroscope, which is an oscilloscope with special circuits added, such as sweep triggers and marker generators. The sweep commences only when a signal is received. Oscilloscopes and synchroscopes are explained in detail in Handbook of Test Methods and Practices, and Basic Electronics.

TEST METHODS

Whenever a piece of sonar equipment breaks down, it may be your job to locate the trouble and restore the faulty circuit to its proper operating

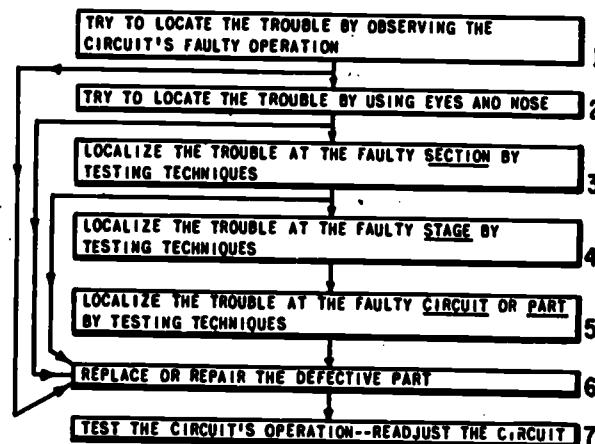

12,259(71)
Figure 10-5.—Troubleshooting procedure.

condition. The means by which you will find the faulty component is called troubleshooting, which consists of logical testing methods. Troubleshooting aids you will use are troubleshooting charts, servicing diagrams, and voltage and resistance charts.

Troubleshooting charts list various equipment malfunctions, their probable cause, and the necessary corrective action. Servicing diagrams show test points, desired waveforms, proper voltages, and other related servicing information. Voltage and resistance charts show the normal voltage and resistance values at the pins of connectors and tube sockets.

Although much of the equipment you are required to maintain is quite complex, and you may feel that it is beyond your capability to keep it operative, the job usually becomes much easier if it is first broken up into successive, logical steps. Figure 10-5 shows a general troubleshooting procedure. Steps 1 through 5 are to be followed in locating the trouble. Steps 6 and 7 are carried out in making repairs. Sometimes steps 2, 3, 4, and 5 may be eliminated, but never steps 6 and 7.

TERMINAL DESIGNATIONS

When carrying out your troubleshooting procedures, you will find that many test points are located on terminal boards. Wiring diagrams, which aid you in tracing a circuit from one unit to another, indicate the terminal connections of each circuit in each unit. You must understand, therefore the system used for marking terminal boards

INTRODUCTION TO SONAR

and conductors, as set forth in Dictionary of Standard Terminal Designations for Electronic Equipment, NavShips 900,186,

Terminal Boards

Terminal boards are marked with a 3- or 4-digit number preceded by the letters TB. The first 1 or 2 digits of the TB number represent the unit number in the equipment. This number is assigned by the manufacturer in a logical order. The last 2 digits represent the terminal board number in a unit, starting with 01, 02, 03, etc. Thus, terminal board TB 1003 indicates the 3rd terminal board in the 10th unit of the equipment.

Terminal Markings

Markings of terminals on terminal boards indicate a specific function for the following circuits; (1) common primary power circuits, (2) ground terminals, (3) common servo and synchro circuits, (4) video circuits, (5) trigger circuits, and (6) audio circuits. The breakdown of these categories into specific functions, with the terminal designation of each, is listed in NavShips 900,186. They are called rigidly assigned designations.

Terminals whose functions do not fall under the categories listed are assigned designations by the equipment manufacturer in accordance with NavShips 900,186. They are manufacturer-assigned designations. Only terminals that are connected together externally have exactly the same designation within any given equipment.

Conductor Marking

On the conductor lead, at the end near the point of connection to a terminal post, spaghetti sleeving is used as a marking material and insulator. The sleeving is engraved with indelible ink, or branded with identifying numbers and letters by a varitype machine, and slid over the conductor.

The order of marking is such that the first appearing set of numbers and letters, reading from left to right, is the designation corresponding to the terminal to which that end of the wire is connected. A dash follows the terminal designation, and then the number (without TB) of the terminal board to which the other end of the conductor is attached. There is another dash and the designation of the particular terminal to which the other end of the wire is connected.

Figure 10-6 shows how terminal boards, terminals, and conductors are marked. The lower

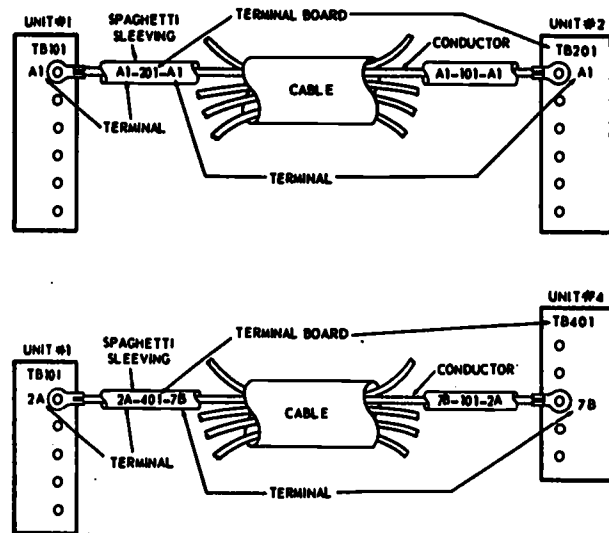

70.6

Figure 10-6.—Conductor and terminal markings.

portion of the illustration, for example, shows a conductor running from terminal 2A on TB101 to terminal 7B on TB401. The spaghetti sleeve on the conductor attached to TB101 is marked 2A-401-7B, indicating the other end of the conductor is attached to terminal 7B on TB401. The sleeve at terminal 7B of TB401 is marked 7B-101-2A, indicating the other end of the conductor is attached to terminal 2A on TB101. If you must remove a conductor from a terminal, the first set of letters and numbers tells you to which terminal it must be reconnected.

Cable Marking

When doing maintenance or repair work, you may have to trace a cable from one section of the ship to another, examining the cable for damage that might be the cause of equipment breakdown. Cables are identified by metal tags that give information on the cable's use. Tags are attached to the cable as close as practicable to each terminal connection, on both sides of decks and bulkheads, and at intervals of about 50 feet. Colored tags formerly were used to classify the necessity of the cable, and you may still see some of them. Red indicated a vital circuit, yellow a semivital circuit, and gray a nonvital circuit.

The cable designation information is a combination of letters and numbers, consisting of a service letter, circuit letters, and cable numbers. A typical cable designation is R-SK3. The service

letter (R) means the cable supplies electronic equipment; the circuit letters (SK) denote scanning sonar; and number 3 means it is the third cable in the scanning sonar circuit. A complete list of cable designations may be found in chapter 9600 of NavShips Technical Manual.

CABLES

Insulation resistance tests (ground tests) must be made periodically to determine the cable's condition. Tests also should be made when the cable sustains physical damage, when cables have been disconnected for circuit or equipment changes, after shipyard overhauls, and when the cable has been subjected to oil or saltwater. The 500-volt megger is used for making the tests. Following are the recommended test procedures.

1. Disconnect the cable from the equipment.
2. Measure the resistance between the cable armor and ground. A zero reading should be obtained.
3. Connect all conductors in the cable together, and simultaneously measure their resistance to ground. If the reading is at or above the acceptable minimum, no other readings need be taken. (Usually 10 megohms indicates an acceptable condition, but minimums vary according to cable type, length, and temperature; consult the appropriate instruction book for the equipment.) If the reading is below the accepted minimum, the conductors must be separated and tested individually to isolate the faulty conductor.

RESISTORS

A resistor is a device used to limit current flow. It is of either the fixed or variable type. Resistors are tested with an ohmmeter after the resistor is disconnected from the circuit. This action prevents damage to the meter from circuit voltage, and ensures that only the resistor being tested gives a reading on the meter. Before conducting the test, set the meter to the proper scale, touch the ends of the meter test leads together, and adjust the meter to obtain a zero reading.

Fixed Resistors

Fixed resistors may be made of wire, wound on a core and coated with ceramic, or they may be made of carbon. They have either axial or radial leads, and have a wattage rating according to the amount of heat they dissipate. In general,

Table 10-1.—Standard Color Code for Resistors

Color	Significant figure or number of zeros	Decimal multiplier	Resistance tolerance
Black	0	---	Percent ±
Brown	1	---	---
Red	2	---	---
Orange	3	---	---
Yellow	4	---	---
Green	5	---	---
Blue	6	---	---
Violet	7	---	---
Gray	8	---	---
White	9	---	---
Gold	---	0.1	5(J)*
Silver	---	---	10(K)*
No color . . .	---	---	20(M)*

*Symbol designation alternate for color.

20.373

carbon resistors are rated at 1/2 to 2 watts. Wire-wound resistors usually are rated above 2 watts.

Resistance value is indicated by colored markings on the resistor. The standard color code given in table 10-1 is used to interpret the resistor markings. With only slight effort you should be able to memorize the color code in a short time.

A resistor always has three (sometimes four) resistance value indicators. Two methods are used to color code fixed resistors. In figure 10-7, the axial lead type is shown to the left; the radial lead is shown on the right. Resistance value is determined as follows: color A indicates the first significant figure, color B the second significant figure, color C gives the multiplier (number of zeros), and color D is the percentage of tolerance. If there is no fourth color, the tolerance is 20 percent. Assume that an axial lead and a radial lead resistor each has the following color code marking: A—red, B—green, C—orange, and D—gold. Referring to table 10-1, you find that the first significant figure is 2, the second significant figure is 5, and the multiplier is 1000 (three zeros). The resistance value is 25,000 ohms, or 25K as it sometimes is marked on a schematic diagram. The tolerance is 5 percent.

A fixed resistor is tested by placing an ohmmeter lead on each resistor lead. For the resistor



INTRODUCTION TO SONAR

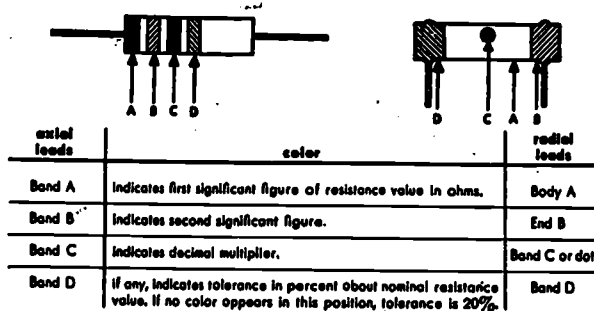

Note: Low-power insulated wire-wound resistors have axial leads and are color coded similar to the left-hand figure above except that band A is double width.

20.374

Figure 10-7.—Color code for axial-lead and radial-lead fixed composition resistors.

used in our example, a reading of 24K to 26K would be acceptable.

Low-power, wire-wound resistors have axial leads, and are color coded similar to the regular axial lead resistor, except that band A is double width.

Variable Resistors

Variable resistors are of two general types. They may be rheostats or potentiometers.

A rheostat normally is used to adjust the current in a circuit without opening the circuit. Some rheostats, however, are so constructed that the circuit may be opened also. In general, a rheostat has two terminals. One terminal is connected to one end of the resistance element; the other, to the sliding contact. As seen in figure 10-8, the resistance element is circular in shape and is made of resistance wire wound around an insulating form that usually is of a ceramic material. The resistance is decreased by rotating the wiper toward terminal 1.

To test a rheostat, you first must disconnect it from the circuit. An ohmmeter is used to measure the resistance between terminals 1 and 2 (refer to fig. 10-8), with the wiper rotated all the way to terminal 2. This action gives total resistance. Moving the wiper slowly back toward terminal 1 shows an ever-decreasing resistance until a reading of zero is obtained. If a reading of maximum shows on the meter during this phase of rotating the wiper toward terminal 1, it means the wiper is not making proper contact at that point.

The potentiometer (often called a "pot") is a control instrument used for varying the amount of voltage applied to an electrical device. The term

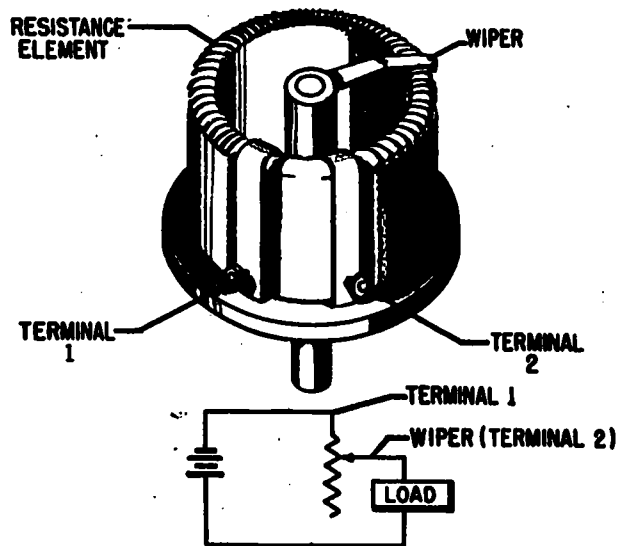

71.94

Figure 10-8.—Rheostat.

potentiometer customarily refers to any adjustable resistor having three terminals, two of which are connected to the ends of the resistance element and the third to the wiper contact. The potentiometer is illustrated in figure 10-9. By positioning the sliding contact, any desired voltage within the range of the potentiometer may be selected and used where needed. As a rule, potentiometers are constructed to carry smaller currents than rheostats.

Potentiometers are measured in much the same way as rheostats. When disconnected from the circuit, they may be tested with an ohmmeter by measuring for total resistance between terminals 1 and 2. Applying one lead to terminal 3 and the other lead to either terminal 1 or 2 and moving the wiper results in a smoothly increasing or decreasing variation in resistance.

COILS

Coils used in electronic circuitry are of many types. Among the types are the inductance coil, which is used to oppose changes in current or frequency; field and armature coils, as used in motors and generators; and solenoid coils, which are used in electromagnets.

All types of coils have one characteristic in common: They are made of varying lengths of wire, therefore an ohmmeter may be used to make a continuity test to determine if there are any opens,

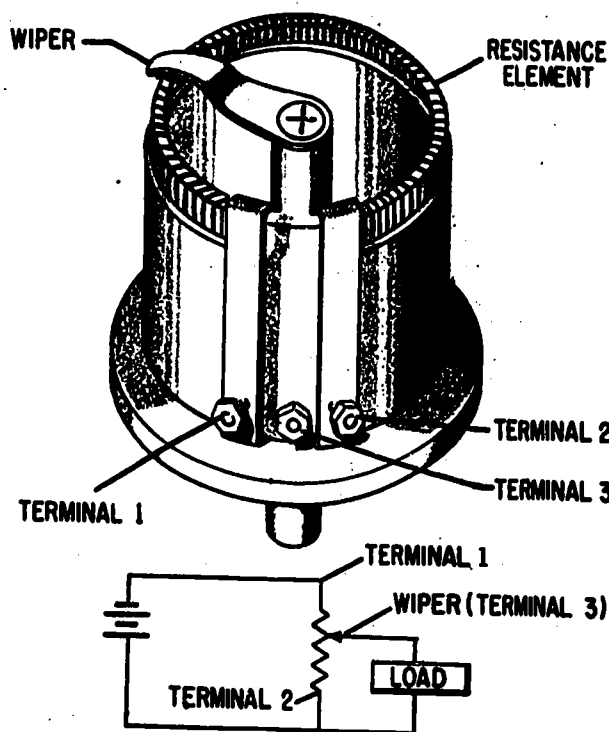

33.75(71)
Figure 10-9.— Potentiometer.

or breaks, in the wire. This continuity check is the simplest test for coils. Other tests for measuring the current flow and voltage can be made with various kinds of test equipment.

Direct current and alternating current work differently when there is a coil in the circuit. When a circuit containing a coil is energized with direct current, the coil's effect in the circuit is evident only at the instant the circuit is energized or deenergized. For instance, when the switch in figure 10-10 is placed in position 1, the inductance of coil L causes a delay in the time required for the lamps to attain normal brilliance. After they attain normal brilliance, the inductance has no effect on the circuit so long as the switch remains closed. When the switch is opened, an electric spark jumps across the opening switch contacts. The spark is caused by the collapsing magnetic field cutting the turns of the inductor.

When the inductive circuit is supplied with alternating current, however, the inductor's effect is continuous. For equally applied voltages, the current through the circuit is less when alternating current is applied than when direct current is applied and is allowed to reach its steady state.

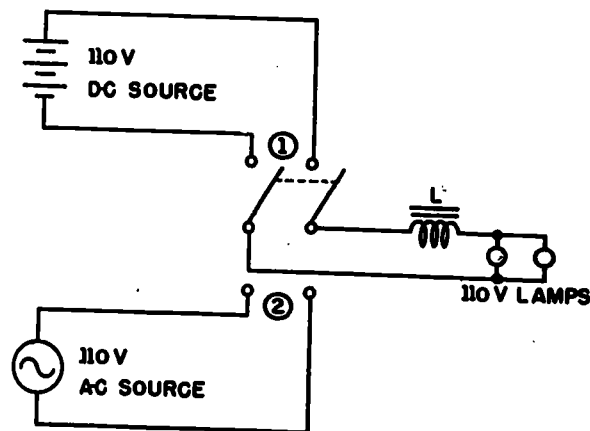

71.95
Figure 10-10.— Inductance in a-c and d-c circuits.

The alternating current is accompanied by an alternating magnetic field around the coil, which cuts through the turns of the coil. This action induces a voltage in the coil that always opposes the changing current. When the switch is in position 1, the lamps burn brightly on direct current. In position 2, although the effective value of the applied a-c voltage is equal to the d-c value, the lamps burn dimly because of the opposition developed across the inductor. Most of the applied voltage appears across coil L, with little remaining for the lamps.

An electromagnet is another device that uses a coil. The electric bell is one of the most common instruments employing an electromagnet. A simple electric bell is diagramed in figure 10-11. Its operation is explained as follows:

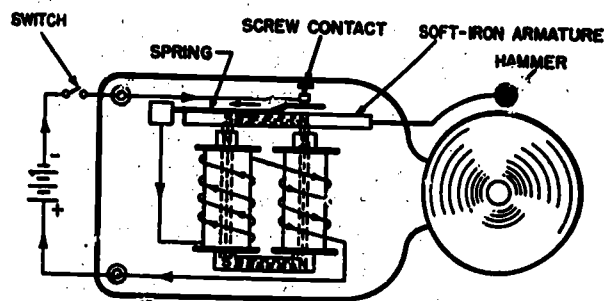

71.96
Figure 10-11.— Electric bell.

INTRODUCTION TO SONAR

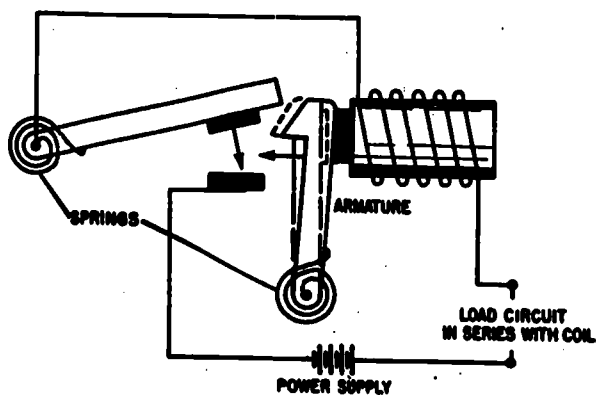

71.97
Figure 10-12.—Magnetic circuit breaker.

1. When the switch is closed, current flows from the negative terminal of the battery, through the contact points, the spring, the two coils, and back to the positive terminal of the battery.
2. The cores are magnetized, and the soft-iron armature (magnetized by induction) is pulled down, thus causing the hammer to strike the bell.
3. At the instant the armature is pulled down, the contact is broken, and the electromagnet loses its magnetism. The spring pulls the armature up so that contact is reestablished, causing the operation to be repeated. The speed with which the hammer is moved up and down depends on the stiffness of the spring and the mass of the moving element.

The magnetomotive forces of the two coils are in series aiding, therefore the magnetism of the core is increased over that produced by one coil alone.

Safety devices also utilize coils for their operation. A circuit breaker, like a fuse, protects a circuit against short circuits and overloading. In the circuit breaker, the winding of an electromagnet is connected in series with the load circuit to be protected and with the switch contact points. The principle of operation is illustrated in figure 10-12. Excessive current through the magnet winding causes the switch to be tripped, and the circuit to both breaker and load is opened by a spring. When the circuit fault is cleared, the circuit is closed again by resetting the circuit breaker manually.

Coils have many more applications and can be studied more thoroughly in Basic Electricity.

TRANSFORMERS

Transformers ordinarily are tested by checking for shorts, measuring resistance of the individual windings, and measuring voltage outputs of each winding.

1. Descriptions of transformers are contained in the technical manual for the equipment wherein the transformer is used. The manual specifies the terminals to test for each winding and tells what the measurement should read. Small power transformers, of the size used in electronic equipment, usually are color coded as shown in figure 10-13. In an untapped primary, both leads are black. If the primary is tapped, one lead is common and is colored black, the tap lead is black and yellow, and the other lead is black and red.

On the transformer secondary, the high-voltage winding has two red leads if untapped, or two red leads and a yellow and red tap lead if tapped. On the rectifier filament windings, yellow leads are used across the entire windings, and the tap lead is yellow and blue. If there are other filament windings, they may be green, brown, or slate. The tapped wire is yellow in combination with one of the colors just named; that is green and yellow, brown and yellow, or slate and yellow.

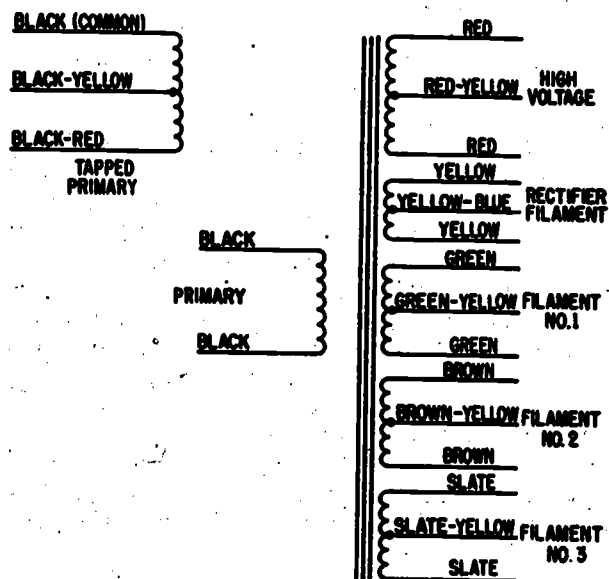

20.379(71)
Figure 10-13.—Color coding of small power transformer leads.

The easiest way to check a suspected malfunctioning transformer is to measure its voltage output. This test can be made by using a voltmeter to measure across the proper terminals, and comparing the reading obtained with the proper voltage, as indicated in the technical manual. If only one reading is in error, it indicates that only that winding is at fault. If all windings read in error, the trouble could possibly be the fault of either high- or low-input voltage. Consequently, it always is necessary to measure the input voltage as well as the output voltage.

If improper voltage is measured at any of the output windings, the next step is to measure the resistance of each winding. For this measurement, the connections to the terminals must be disconnected first. Power to the equipment must be secured in order to disconnect a transformer. Once the leads are free measure the resistance across each winding with an ohmmeter set to the proper scale. Check each winding carefully, including any center taps. Next, set the ohmmeter to a high scale and test for shorts between windings and between windings and ground.

If no faults are discovered in the voltage or resistance readings, or in the tests for shorts, the transformer is assumed to be in proper operating condition. It then can be connected back in the circuit.

If a replacement is required, use as the replacement only the one indicated in the manufacturer's technical manual. It is always good policy to test for a short and make a resistance check on a new transformer before installing it in the circuit.

CAPACITORS

Capacitance, inductance, and resistance are measured for precise accuracy by alternating current bridges. These bridges are composed of capacitors, inductors, and resistors in a wide variety of combinations. The bridges operate on the principle of the Wheatstone bridge, in which an unknown resistance is balanced against known resistances. The unknown resistance is calculated in terms of the known resistance after the bridge is balanced. One type of capacitance bridge circuit appears in simplified schematic form in figure 10-14. When the bridge is balanced by adjusting the two variable resistors, no a-c voltage is developed across the input of indicator tube V1, and the shadow angle is maximum. (V1 is a "magic eye" tube, commonly used as a radio receiver tuning indicator.) Any slight imbalance produces an a-c voltage, which, in turn, develops a grid-

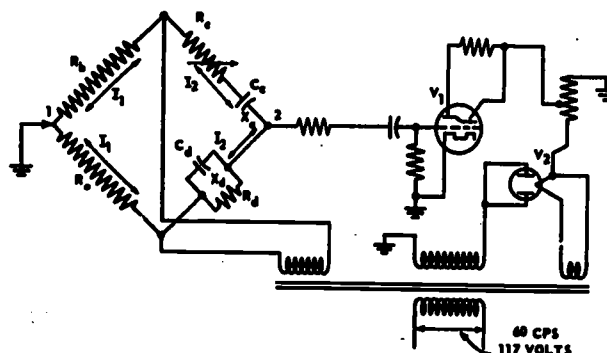

20.344

Figure 10-14.—Simplified schematic of capacity checker.

leak bias and lowers the plate current of V1, reducing the shadow angle.

In the basic Wheatstone bridge circuit using d-c voltages and simple resistances, the balance is obtained when the voltage drops are equal across the ratio arms. In the a-c capacity bridge, it is insufficient to have equality of voltage drops in the ratio arms. The phase angle between current and voltage in the two arms containing the capacitors also must be equal in order to obtain a balance. When a balance is obtained, the current is equal on both sides of the bridge circuit.

The capacitance-inductance-resistance bridge, type ZM-11/U, shown in figure 10-15, is widely used to measure capacitance, resistance, and inductance values in addition to special tests, such as the turns ratio of transformers and capacitance quality tests. It is a self-contained instrument, except for a source of line power. It has its own source of 1000-Hz bridge current with a sensitive bridge balance indicator, an adjustable source of direct current for electrolytic capacitor and insulation resistance testing, and a meter with suitable ranges for leakage current tests on electrolytic capacitors.

Many capacitors have their value printed on them, but some types use a color code system to indicate their value. The color code used is the same as that used for resistors, but the methods of marking the capacitors vary greatly. The method used for fixed mica capacitors is shown in figure 10-16.

A black dot in the upper left corner signifies that the capacitor has a mica dielectric. The center dot in the upper row indicates the first significant figure, and the upper right dot indicates the second significant figure of the capaci-

INTRODUCTION TO SONAR

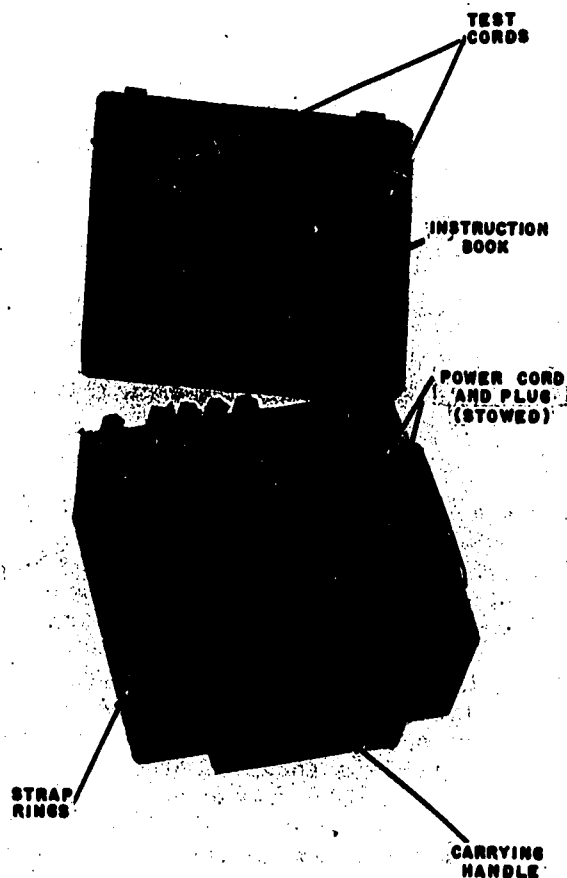

20,345

Figure 10-15.—Capacitance-inductance-resistance bridge, type ZM-11/U.

tance value in micromicrofarads ($\mu\mu\text{f}$). The right dot in the lower row indicates the decimal multiplier that determines the number of zeros to be added to the right of the two significant figures. The center dot (lower row) specifies the tolerance, which is the possible deviation of the actual capacitor value from that given by its dot markings. The left dot on the lower row deals with temperature coefficients and applications.

By way of explanation, a capacitor with upper-row dots colored black, red, and green (reading from left to right, according to the directional indicator) would mean a mica capacitor with the significant figures 2 and 5. The lower row of dots (reading from right to left) are brown, red, and red. The brown dot requires the addition of one

zero to the value 25, giving the result as 250 $\mu\mu\text{f}$. The red center dot indicates that the actual capacitor value may be greater or smaller than the 250 $\mu\mu\text{f}$ by plus or minus 2 percent. The left red dot means it is a bypass or silver mica capacitor. Some mica capacitors have only three dots, indicating the first and second significant figures and the multiplier. Their tolerance is 20 percent, and they have a 500-volt rating. Try reading some of the values of the mica capacitors you see in electronic equipment when they are exposed to view. Learning to read capacitor values is a matter of practice, much like reading resistor values.

TUBES

Electron tubes are essential components of electronic equipment. If the average tube is not overdriven, nor operated continuously at maximum rating, it can be expected to have a life of at least 2000 hours before the filament opens. Tubes do fail, however, before achieving their full life expectancy. Some of the more important conditions affecting the life expectancy of an electron tube are (1) the circuit function for which the tube is used; (2) deterioration of the cathode (emitter) coating; (3) decrease, with age, in emission of impregnated emitters in filament-type tubes; (4) defective seals, which permit air to leak into the envelope and oxidize the emitting surface; and (5) internal short circuits and open circuits caused by vibration or excessive voltage. Because of the attendant expansion and contraction of the tube elements during the process of heating and cooling, the electrodes may lean or sag, causing excessive noises (microphonics) to develop. Other electron tube defects are cathode-to-heater leakage and nonuniform electron emission of the cathode. The defects, of which only the most common are listed here, contribute to about 50 percent of all equipment failures. For this reason it is good practice, when you are troubleshooting the equipment, to eliminate immediately any tube that may have contributed to the equipment's failure, but avoid blind replacement of good tubes by fresh spares. In a glass envelope tube, visible evidence of a tube defect may be present when the filament is open, when the plate current is excessive, when the tube becomes gassy, or when arcing occurs between electrodes. When metal-encased tubes are warm to the touch, it is an indication that the heater is operating. A tube may be tapped lightly with the finger while operating in a particular circuit to provide an aural indication of loose elements or microphonics.

COLOR	CAPACITANCE		TOLERANCE	CHARACTERISTIC
	SIGNIFICANT FIGURE	DECIMAL MULTIPLIER		
BLACK	0	1	20 PERCENT	A B C D E F G
BROWN	1	10		
RED	2	100		
ORANGE	3	1,000		
YELLOW	4			
GREEN	5			
BLUE	6			
VIOLET	7		5 PERCENT	
GRAY	8			
WHITE	9			
GOLD		0.1	10 PERCENT	
SILVER		0.01		

BLACK DOT IDENTIFIES MICA CAPACITOR

DIRECTIONAL INDICATORS

1ST } SIGNIFICANT FIGURES OF CAPACITANCE IN $\mu\mu\text{f}$

2ND }

DECIMAL MULTIPLIER

CHARACTERISTIC CAPACITANCE TOLERANCE

CHARACTERISTICS

- A - ORDINARY MICA BYPASS
- B - SAME AS A-LOW LOSS CASE
- C - BYPASS OR SILVER MICA (± 200 PARTS/MILLION/C)
- D - SILVER MICA (± 100 PARTS/MILLION/C)
- E - SILVER MICA (0 TO +100 PARTS/MILLION/C)
- F - SILVER MICA (0 TO +50 PARTS/MILLION/C)
- G - SILVER MICA (0 TO - 50 PARTS/MILLION/C)

20.376(71)

Figure 10-16.—Color code for fixed mica capacitors.

Several types of tests may be conducted to determine the condition of a tube. The most common test is substituting a good tube for the suspect one. Other tests, requiring the use of a tube tester, are emission, transconductance, gas, short circuit, and noise tests.

Substitution Test

Substituting a tube known to be in good condition is the most reliable method of deciding the quality of a questionable tube. In high frequency circuits, tube substitution should be carried out carefully one at a time, noting the effect of differences in interelectrode capacitances of the substituted tubes on tuned (aligned) circuits. The substitution method of testing cannot be used to advantage to locate more than one faulty tube in a single circuit. If both an a-f amplifier tube and an i-f amplifier tube are defective in a receiver, replacing either one does not correct the trouble. If all the tubes are replaced, there is no way of knowing which tubes were defective. Under these or similar conditions, the use of test equipment designed for testing the quality of a tube saves valuable time.

Emission Test

An important indication of the condition of a tube is obtained by a comparative check of the cathode or filament emission. In most instances, a pronounced lower-than-normal emission, or a complete loss of emission, indicates that the tube has reached the end of its useful life. Both

multigrid and diode tubes are tested for cathode emission.

• **Multigrid tubes:** For a test of the emission of a multigrid tube, the tube is connected as a half-wave rectifier. (See fig. 10-17.) The plate and all the grids of the tube are connected together. A milliammeter and a variable resistor are placed in series with the tube, and the entire circuit is connected across a transformer secondary. Because of their common connection, the plate and all of the grids are at the same potential with respect to the cathode. As a result, the tube functions as a diode rectifier, conducting

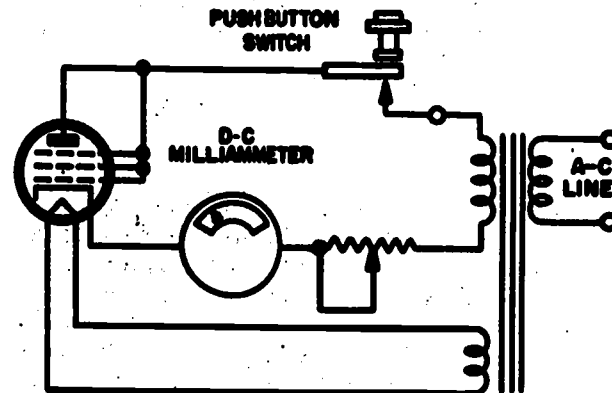

Figure 10-17.—Basic circuit used for emission test.

current only on the alternate half-cycles when the plate and grids are positive with respect to the cathode. The amount of current that flows indicates the condition of the cathode-emitting surface. On tube-testing equipment, the meter scale usually is calibrated by dividing the total pointer arc into three areas, which are labeled GOOD, WEAK (or FAIR), and BAD.

• Diode tubes: The emission test for diode and rectifier tubes and the diode part of multisection tubes is similar to the emission test used for multigrid tubes. The tube filament or heater is operated at the rated value, and an a-c voltage is applied to the test circuit consisting of the diode, a d-c milliammeter, and a variable resistor. A tapped secondary is utilized in some circuits to vary the amplitude of the test signal. The variable resistor limits the tube current to a safe value. The amount of current flowing through the resistance and the meter depends on the electron emission within the tube, and therefore indicates the emission quality of the tube.

Transconductance Test

The term transconductance (also called mutual conductance) expresses the effect of grid voltage upon the plate current of a tube. By measuring the transconductance of a tube, it is possible to evaluate the tube's ability to amplify a-c signals much more accurately than by measuring its cathode emission, because this test more closely approximates actual circuit conditions. Transconductance is expressed mathematically as the ratio of a change in plate current to a small change in control grid voltage, with all other electrode voltages held constant. Transconductance is measured in units of conductance called micromhos.

Gas Test

In all electron tubes, except some types of rectifier and regulator tubes, the presence of any appreciable amount of gas is extremely undesirable. When gas is present, the electrons emitted by the cathode collide with the molecules of gas. As a result of these collisions, electrons are dislodged (secondarily emitted) from the gas molecules, and positive gas ions are formed. Because the control grid is negatively biased, the positive gas ions are attracted to it, and they absorb electrons from the grid circuit in order to revert to a more stable condition (not ionized).

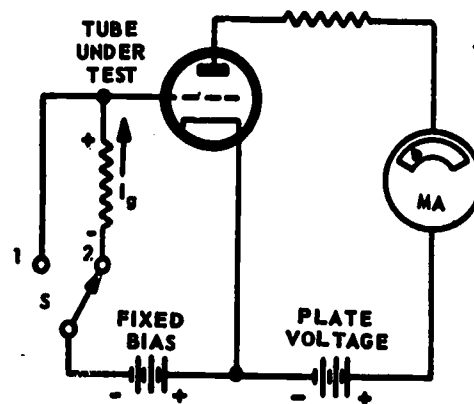

1.76
Figure 10-18.—Basic circuit used for gas test.

If the amount of gas in the tube is appreciable, the collisions between the numerous gas molecules and the cathode-emitted electrons release many secondarily emitted electrons, and the resulting flow of grid current is high. The basic circuit used for the gas test is shown in figure 10-18. With switch S set to position 1, a certain value of plate current is measured by the d-c milliammeter. If there is no gas (or a negligible amount) present in the tube, throwing switch S to position 2 does not change the plate current reading. If gas is present, current flows through the large value grid resistor, causing a voltage drop to develop with the polarity as shown. The net effect is to reduce the negative bias voltage on the grid of the tube, resulting in an increase in plate current. Small plate current increases are normal; large increases indicate excessive gas. In some circuits a neon light is substituted for the milliammeter and glows to show the presence of excessive gas.

Short Circuit and Noise Tests

The test for short-circuited elements must be applied to a tube of doubtful quality before any other tests are made. This procedure protects the meter (or any other indicator) from damage. Also, it follows logically, if a tube under test has elements that are short-circuited, there is no further need to apply additional tests to that tube. Short circuit tests usually are sensitive enough to indicate leakage resistance less than about 1/4 megohm. The proper heater voltage is applied in order to detect any tube elements that might short

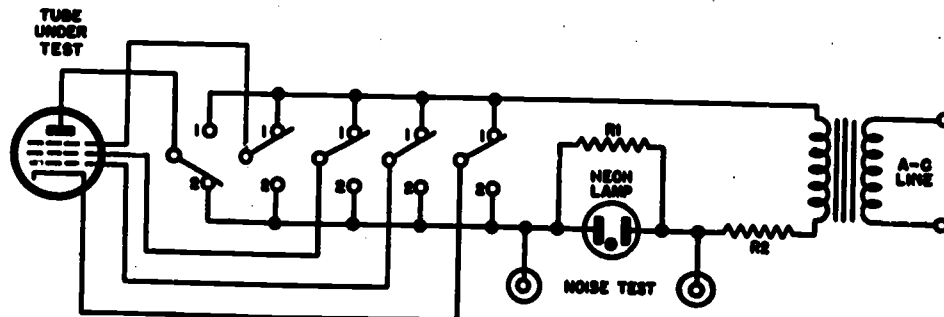

Figure 10-19.—Basic circuit used for short circuit and noise tests. 1.75

as a result of the heating process. The short circuit test is similar to the test for detecting noisy (microphonic) or loose elements. Because the only difference between the two tests is in the sensitivity of the device used as an indicator, the noise test is discussed as a part of the short circuit test.

Figure 10-19 shows a basic circuit used for detecting shorted elements within a tube. With the plate switch set to position 2, the plate of the tube under test is connected to the leg of the transformer secondary containing the neon lamp. All the other elements are connected through switches to the other leg of the secondary. If the plate of the tube is touching any other element within the tube, the a-c circuit of the secondary is completed and both plates of the neon lamp glow. If no short exists, no indication will be present, or only one plate of the neon lamp will glow. Each of the other elements is tested by means of the switching arrangement shown. Resistor R2 limits the current through the neon lamp to a safe value. Resistor R1 bypasses any small alternating currents in the circuit that might be caused by stray capacitance, thus preventing the neon lamp from indicating erroneously. Tapping the tube lightly is recommended to detect loose elements that might touch when the tube is vibrated.

The noise test is, in effect, no more than a very sensitive short circuit test. In figure 10-19 two leads are taken from either side of the neon lamp and brought to external receptacles labeled "noise test". A high-gain amplifier (with speaker) is connected to the receptacles. Perhaps the handiest amplifier for this test is an ordinary radio receiver. The antenna and ground terminals of the receiver are connected to the noise test jacks, and a normal short circuit test is made while tapping the tube. If tube elements are loose—but perhaps

not loose enough to indicate on the neon lamp—loud crashes of noise (or static), over and above the normal amount of noise that is present, are heard from the receiver. The noise test also may be made without the use of the high-gain amplifier merely by inserting the leads from a pair of headphones into the noise test receptacles. The latter check, of course, is not as sensitive as the test made with the amplifier, but ordinarily is more sensitive than the short circuit test made with the neon lamp as an indicator.

SEMICONDUCTORS

Semiconductors have been used in electric circuits for several years. Copper-oxide and selenium dry-disc rectifiers are two of the more familiar types. The outstanding characteristic of a dry-disc rectifier is that it will conduct current easily in one direction, but very little or no current in the opposite direction, thus acting like a vacuum tube diode. Dry-disc rectifiers are too bulky and heavy, however, for many modern electronic requirements. Experiments in nonconducting materials led to the development of the transistor, making possible the microminiaturization found in modern electronic equipment such as computers and missiles.

Transistors are constructed of semiconductor materials. The most widely used semiconducting elements are germanium and silicon. In their regular form, these substances are nonconductive. When impurities are added to them, however, they behave as conductors. Adding arsenic to germanium, for instance, results in the presence of a large amount of free electrons (negative charge). The material is then a semiconductor of the N-type with a negative current. When indium is added to

INTRODUCTION TO SONAR

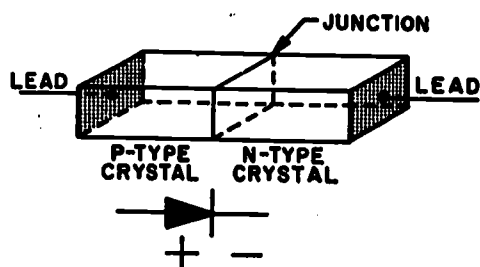

20.23:71.98

Figure 10-20.— Junction diode.

germanium, P-type material is formed, which produces the flow of positive (hole) current. (The theory of operation of semiconductors, which is too involved for this text, can be found in Introduction to Electronics, NavPers 10084.)

When N- and P-type materials are combined, they form what is called a junction diode, shown with its schematic symbol in figure 10-20. Because a diode will not amplify a signal, a third semiconductor section is added, forming a junction transistor, which acts like a vacuum tube triode. (Other transistor types include the tetrode and the power transistor.) The transistor actually is two junction diodes placed back to back, with the center element common to both junctions, and are of either the PNP or the NPN type. Internal current flow is the result of hole conduction in the PNP type, and of electron conduction in the NPN type. External current in a transistor circuit is always electron flow.

The elements of a transistor are called the emitter, base, and collector. They correspond respectively to a vacuum tube's cathode, control grid, and plate. Figure 10-21 shows the two types of transistors, their schematic symbols, and their relation to the triode. The primary difference between the operation of a vacuum tube and a transistor is that the tube is voltage-operated and the transistor is current-operated, resulting in low power requirements for transistors.

Transistors, like vacuum tubes, come in a variety of types, each with its own characteristics. Following are some of the data found on a transistor specification sheet published by the manufacturer.

1. The kind of semiconductor (PNP, NPN, diode, etc.), type of material used, and type of construction.
2. Common applications (audioamplifier, rectifier, etc.).

3. Absolute maximum ratings of voltages and collector current. These ratings must never be exceeded.
4. Collector power dissipation factor.
5. Beta (gain) of the transistor.
6. Collector cut-off (leakage) current.

You should know the semiconductor specifications before attempting quality tests.

Transistors normally are more rugged than electron tubes, and do not often require replacement. Their life expectancy is 40,000 hours or more. Should it become necessary for you to replace a transistor, however, certain precautions must be observed. Before removing the old transistor, note the orientation of the transistor's base, emitter, and collector leads to ensure proper insertion of the new device. Cut the leads of the new transistor to the proper length to prevent undue stress. When soldering the new transistor into the circuit, use the proper solder, soldering iron, and a heat sink. Transistors are very susceptible to heat, r-f radiation, and electric shock. One of the most frequent causes of damage to a transistor is the electrostatic discharge from the human body when the device is handled. Such damage may be avoided by discharging your body to the chassis before handling the transistor. Detailed information on how to replace a transistor, handling precautions, and transistor lead coding methods is given in Servicing Techniques

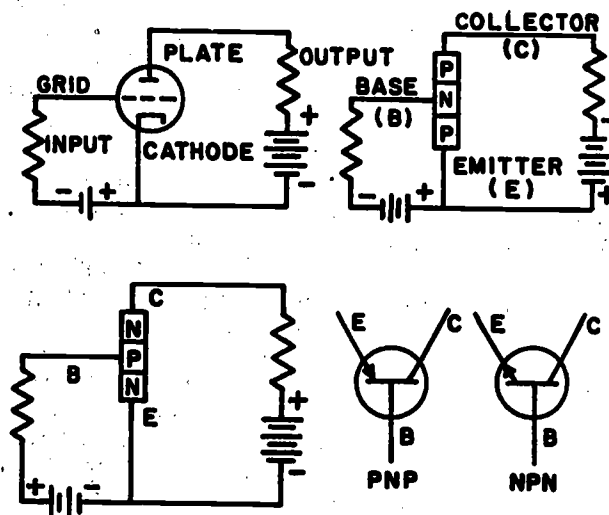

Figure 10-21.— Corresponding elements in triode and transistor.

1.280A(20A)

for Transistorized and Printed Circuits, NavShips 93394.

Four main failures are associated with transistors: (1) opens, caused by a break in the leads or a break in the emitter-base or collector-base junction; (2) shorts, caused by a rupture of the crystal through the base material; (3) high leakage current, caused by contamination building up on the emitter-base or the collector-base junction; and (4) low gain, caused by excessive heat or mal-treatment.

Before testing a transistor, first determine the type, whether PNP, NPN, or diode. Ground all test equipment to the chassis under test. If removal of the transistor from the circuit is necessary, use a low-wattage soldering iron (35 watts or less), use proper heat sinks, and ground the soldering iron tip to the chassis under test.

Two basic units of test equipment can be used to test transistors. The TS-1100/U transistor tester is designed to test the beta (gain) of a transistor while in the circuit, the ICO (collector leakage current), and shorts with the transistor removed from the circuit.

If the TS-1100/U test set is not available, any good multimeter or vacuum tube voltmeter (VTVM) may be used after first observing certain precautions. To avoid loading the circuit, the multimeter must have a sensitivity of at least 20,000 ohms per volt on all voltage ranges; the ohmmeter circuits must not pass a current exceeding 1 milliampere. The VTVM should have an input resistance of 11 megohms or more, and must have an isolation transformer between the meter and the powerline.

Diodes

Before testing a diode, its polarity must be determined. The diode usually is marked with a plus (+) or minus (-) sign. Connect the test leads to the diode in a forward bias condition, that is, the positive lead to the positive side of the diode and the negative lead to the negative side. Current will now flow easily, and if a reading of 1000 ohms or less is obtained, this part of the test is good. If a higher reading is obtained, the diode is open.

Connect the test leads to the diode in a reverse bias condition—the positive lead to the negative side of the diode and the negative lead to the positive side. Current will not flow readily, and a reading in excess of 10,000 ohms should be obtained. If a reading under 10,000 ohms is obtained, the diode is shorted.

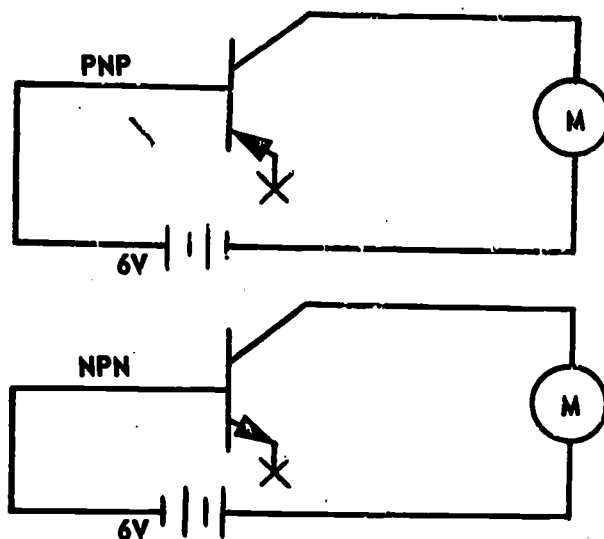

71.99
Figure 10-22.—Transistor leakage current test.

A general statement can thus be made: The front-to-back ratio must always be at least 10 to 1.

Transistors

Three tests can be accomplished on the transistor by using the multimeter. The transistor must be removed from the circuit for testing.

Determine the type of transistor, whether PNP or NPN. The same resistance test can be performed on the transistor as on the diode. The transistor has two junctions, the emitter-base and the collector-base. Because each junction can be treated as a diode, the same readings hold true.

When testing power transistors, the same ratio (10 to 1) holds true, except that the reverse resistance must be in excess of only 1000 ohms.

To perform the leakage current test, the manufacturer's specifications should be consulted to ascertain the allowable limits. Determine the type of transistor and set up one of the tests shown in figure 10-22, using a 6-volt battery and microammeter.

If the leakage current is twice as much as the specification sheet calls for, replace the transistor. If no specifications are available, use the following rule of thumb:

1. Silicon transistor—less than 1 microamp.

INTRODUCTION TO SONAR

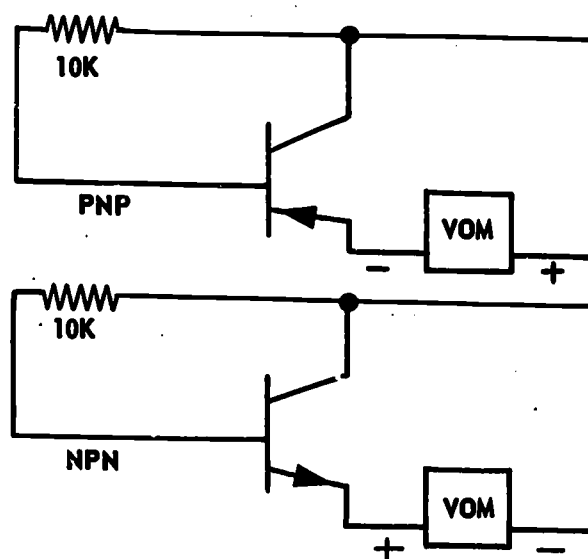

71.100

Figure 10-23.—Transistor gain test.

2. Small germanium transistor—less than 10 microamps.
3. Medium germanium transistor—less than 100 microamps.
4. Power transistors—less than 1 milliamperes.

The beta test can be accomplished by inserting a 10,000-ohm resistor between the collector-base junction and connecting the meter to the emitter and collector as shown in figure 10-23.

Once the resistance is obtained on the meter, use the following formula to figure the gain: $B = 1200 + R$. The letter B represents gain, 1200 is a constant, and R is the resistance read on the meter.

Check the manufacturer's specification for the gain of each transistor. If the specifications are not available, use the following rule of thumb:

1. Silicon transistors—5 times or more.
2. High-frequency transistors—10 times or more.
3. All other transistors—15 times or more.

CONTINUITY TESTS

The purpose of the continuity test is to ensure that a circuit is complete or continuous. An open circuit is one in which a break in the circuit (a broken lead, defective switch, burned out

resistor, and the like) prevents the flow of current. Before conducting the test, secure power and disconnect the circuit to be tested.

An ohmmeter normally is used to test for continuity on those parts of a circuit wherein resistance is low. An open circuit is indicated when the meter reads very high or infinite resistance.

When testing for circuit continuity, the ohmmeter should be set on the lowest scale. If a medium or high scale is used, the needle may indicate zero ohms, whereas the actual resistance could be as high as 500 ohms.

Occasionally, you may have to make a continuity test of a circuit whose ends are in different spaces. Several methods can be used to test a circuit from one compartment to another. (Always make sure the power is secured before you disconnect the circuit.) The following means of testing are accomplished more easily by two men.

1. Attach a jumper from one end of the circuit to ground. At the other end, connect the ohmmeter in series between ground and the conductor. A very high resistance reading indicates an open circuit.
2. If an ohmmeter is not available, a pair of sound-powered telephone handsets with alligator clips on their leads may be used. Connect the handset leads between the circuit and ground at each end of the circuit. If the circuit is open, communication is impossible.
3. A battery-powered test lamp also can be used. Ground one end of the circuit. Connect the lamp between the other end and ground. If the lamp does not light, the circuit is open.

Intermittently open circuits sometimes are encountered. These breaks usually are found in cables or wrapped multiple wiring. When the testing equipment indicates an open circuit, the cable or wiring can be flexed. Any momentary continuity of the circuit is apparent by an indication on the test equipment, and the location of the break is then known.

Grounds

Grounded circuits are caused by some part of the circuit making contact, either directly or indirectly, with the metallic structure of the ship.

Grounds have several causes, the two most common being frayed or worn insulation that allows bare wire to come into contact with the equipment's chassis or ship's structure, and

moisture-soaked insulation that provides current a leakage path to ground.

Usually, a ground is indicated by a blown fuse or tripped circuit breaker. A high resistance ground, however, may occur where insufficient current can flow to rupture the fuse or open the circuit breaker.

An ohmmeter is used in testing for grounds. By measuring the resistance to ground at any point in a circuit, it is possible to determine if that point is grounded. Before conducting this test, it is necessary to study the associated wiring diagrams for the presence of intentional grounds. These grounds must be disconnected before the circuit can be tested accurately. A zero, or very low, reading indicates the circuit is grounded.

Shorts

A short circuit is similar to a grounded one, except that it is between two or more conductors and usually has a greater tendency to blow fuses. Two conductors with frayed insulation may touch each other, short-circuiting the current path. Too much solder on the pin of a connector may cause a short circuit to an adjacent pin. Again, the test instrument used is the ohmmeter. Isolate the two suspected circuits and connect the meter to them. A high resistance reading indicates the circuits are satisfactory.

Shorts may occur in conductors besides those in cables or in the wiring in chassis. Components such as transformers, motor windings, and capacitors—to name a few—are also susceptible to short circuits. These components should be checked for a resistance reading, and this reading compared with the figure given for the component in the schematic or equipment technical manual.

VOLTAGE

The voltage test is accomplished only with power applied to the equipment. Prescribed safety precautions must be carefully observed, therefore, to prevent injury to personnel or damage to the equipment. The voltage test is used not only in isolating casualties to major units, but also in determining malfunctions of subassemblies and circuits. Before measuring the voltage of a circuit, a test should be made to ascertain that the power source is supplying the normal voltage required by the circuit being tested. In using the voltmeter for this test, make certain that the meter used is adjusted for the type of voltage

(a-c or d-c) to be measured and that the scale setting is set to the proper range. Because defective elements may cause higher-than-normal voltages to be present in the circuit, the highest voltmeter range should be used first. Once a reading is indicated, adjust the voltmeter scale progressively downward until the lowest scale appropriate to the actual voltage may be used. This system gives the most accurate measurement and avoids damage to the meter movement.

Many schematics indicate proper voltages at various test points. If a certain stage is suspected, the voltage can be measured by placing the test leads at the designated test points. The voltage reading obtained by the meter should be the same as that given on the schematic.

CURRENT

Current, expressed in amperes, is measured in much the same way as voltage except that the meter must be connected in series in the circuit being tested. The ammeter is a low-resistance instrument because, if it offered more than a minute amount of resistance, it would reduce the amount of current flow in the circuit and result in an erroneous measurement.

When the ammeter is connected in the circuit, it is used in the manner prescribed for the voltmeter. In other words, start with the higher scale and progressively adjust the scale used until a reading is obtained on the lowest scale that gives a meter indication.

If a circuit is disconnected or opened to insert the meter for a measurement, be sure and restore that part of the circuit before further testing.

Because of the time and effort expended in connecting an ammeter into a circuit, it usually is more advantageous to measure the voltage across a resistor of known value and calculate the current by using Ohm's law.

RESISTANCE

Usually the resistance of a circuit, portion of a circuit, or circuit element is measured with the ohmmeter. First, power must be secured to the circuit and the meter zeroed before connecting the meter into the circuit.

Selection of the proper scale is an important phase in making resistance measurements. To check a circuit of low resistance, use the lower range of the ohmmeter. If a high range is used, the meter may indicate zero, even though some resistance is present in the circuit. Conversely, to

INTRODUCTION TO SONAR

check a circuit with high resistance, select the high scale, because the low range scale may indicate infinity when actually the resistance is less than 1 megohm.

While conducting resistance tests, take into account that other circuits containing resistance and capacitance may be in parallel with the circuit tested. To obtain a correct reading, the circuit tested should be isolated from other parallel circuits.

When measuring a resistor, remember that most resistors have a tolerance of approximately 10 percent. If the measurement of a resistor falls within this tolerance, it usually is considered to meet requirements and need not be replaced unless the circuit calls for a critical value.

GENERATOR MAINTENANCE

Minor routine maintenance of generators is performed by the Sonar Technician to ensure a proper voltage supply to the associated sonar equipment. This part of the text is not intended to teach the methods of generator repair; only those procedures required as normal maintenance are discussed.

Commutators

The first requirement for good commutation is continuous, close contact between the commutator and the brushes. Successful commutation is not a function of the electric circuit, or the brush, or the commutator alone. It depends on all of these factors, and can be maintained only through proper inspection, cleaning, and maintenance.

• **Inspection:** Proper inspection of the commutator consists of the following steps.

1. Check the bars on the commutator for flat spots, burned condition, and looseness indicated by irregular high or low bars.
2. Check for streaks and grooves.
3. Check for dragged copper on the leading edges of the bars and for filled slots caused by the dragged copper.
4. Check the riser connections for thrown solder.
5. Check the mica for a pitted condition and the presence of oil, grease, dirt, and particles of carbon or copper embedded in the mica.

• **Cleaning and maintenance:** The following procedures should be observed to maintain the commutator in a good operating condition.

1. Clean commutators of dirt, oil, or grease with a lintless cloth moistened with a safety-type petroleum solvent.
2. Clean scratches and rough edges from the commutator bars by pressing a very fine sandpaper against the surface with a block of wood that has the same contour as the commutator. A piece of canvas is sometimes adequate for this purpose. The sandpaper or canvas should be moved back and forth across the surface, parallel to the shaft. Remove all grit after this operation by means of a lintless cloth. Under no circumstances should emery cloth be used for cleaning.
3. Clean high mica from between the commutator bars. This procedure consists of removing the mica protruding from the commutator slots, so that there is no contact between the mica and the brushes as the commutator revolves. This process, called undercutting, is accomplished by sawing or scraping the mica from the slots. An ideal tool for this purpose is a hacksaw blade that has been ground down to remove all teeth, so as to prevent burring of the commutator bars. For small commutators, a slotting file may be used to file and scrape out the mica. Care must be taken not to undercut too deeply. Although the square-shaped slot usually is preferable, the V-shaped slot may be more satisfactory where the slots are likely to collect dirt. After undercutting is completed, remove all burrs and polish the commutator. Do not use any lubricants when undercutting.

Sliprings

The principle of close electrical contact applies to the sliprings as well as to the commutator. With few minor exceptions, the procedure for inspecting, cleaning, or minor resurfacing of sliprings is identical to that for commutators.

Brushes

The brushes of a generator are the points of contact between the external circuit conductors and the commutator. These points "brush" the commutator so as to take off the generated voltage. The brushes ride on the surface of the commutator and are held in place by brush holders. Brushes usually are made of high-grade carbon. They are insulated from the frame, and are free

Chapter 10—SAFETY; TEST EQUIPMENT; TEST METHODS

to slide up and down in the holders so that they may follow irregularities in the surface of the commutator. A flexible braided-copper conductor, commonly called a pigtail, connects each brush to the external circuit. A spring forces each brush to bear on the commutator with from 1 1/2 to 10 pounds of pressure for every square inch of brush surface riding on the commutator. These springs ordinarily are mounted so that brush pressure is adjustable.

Brushes should be inspected periodically to see that proper spring tension is applied, that the brushes ride free in the brush holders, that the brushes are of adequate length, and that they make proper maximum contact with the commutator.

If brushes become worn to an extent where length is reduced considerably, the ability of the spring to exert proper pressure is affected. Failure of the brush to ride free in the holder has the same result. When these conditions occur, brush replacement is necessary.

To replace a brush, first secure all power to the generator, wait until the shaft has stopped, remove the defective brush, then place the new brush in the holder. Never attempt to replace a

brush on a generator while the armature still is turning. Residual magnetism may cause a generator output, even though all power is secured to the unit. If the brush does not slide freely in the holder, sand its sides with a medium-coarse grade of sandpaper until the sides make a close but free fit.

After the brush is fitted in the holder, fit it to the commutator by sanding it with a medium-coarse grade of sandpaper. Sand in the direction of commutator rotation by placing the sandpaper strip between the brush contact surface and the commutator, with the rough side of the sandpaper toward the brush.

Apply pressure to the brush and pull the sandpaper through the contact area. Repeat this process until the brush face makes a good fit with the commutator curvature.

After all brushes are replaced in this manner, blow the carbon dust away from the commutator and toward the outside of the generator.

After replacement of brushes and cleaning, power may be restored and the generator turned on. Watch the brushes for proper operation and possible excessive sparking. If sparking is excessive, some additional fitting may be required.

APPENDIX I

TRAINING FILM LIST

Certain training films that are directly related to the information presented in this training course are listed below under appropriate chapter numbers and titles. Unless otherwise specified, all films listed are black and white with sound, and are unclassified. For a description of these and other training films that may be of interest, see the United States Navy Film Catalog, NavWebs 10-1-777 and supplements thereto.

Chapter 1

THE SONAR TECHNICIAN

MN-10819 The Sonar Technician. (29 min.—color.)

Chapter 2

SUBMARINES AND ANTISUBMARINE UNITS

MC-10232A Dash. (30 min.—color.)

Chapter 4

PHYSICS OF SOUND

MN-8998F Physics of Underwater Sound—Part 1—Basic Principles. (20 min.)

MN-8998G Physics of Underwater Sound—Part 2—Velocity Profiles. (25 min.)

MN-8998H Physics of Underwater Sound—Part 3—Absorption and Scattering. (17 min.)

MN-10409 Marine Biology—Sounds in the Sea. (30 min.—color.)

Chapter 5

BATHYTHERMOGRAPH

MN-6832A Military Oceanography—Bathymograph Observations. (16 min.—color.)

Appendix I— TRAINING FILM LIST

Chapter 8

COMMUNICATIONS

MN-2621B Radio Operator Training— The Technique of Hand Sending.
(9 min.)

Chapter 9

MAINTENANCE

MN-10043A The Planned Maintenance System — Introduction. (20 min.)

Chapter 10

SAFETY; TEST EQUIPMENT; TEST METHODS

MA-7812B Circuit Testing With Meters and Multimeters — Practical
Application. (33 min.)

MN-9655 Printed Circuits and their Repair. (28 min.)

MN-10334 The Junction Transistor. (28 min. — color.)

Classified training tapes are available for use by Sonar Technicians to develop proficiency in the detection and classification of surface and underwater targets. The Acoustic Sensor Training Materials Catalog, NavPers 93790-A, with the SECRET supplement thereto lists the tapes available as well as procedures to follow for procurement of these sonar training aids.

182

INDEX

A

Active duty requirements, 4
Active sonar, 91
 theory, 95-98
Advance and transfer, 27
Advancement in rating, 2
Aircraft, ASW, 19
Ambient noise, 39
Ammeter, 173
AN/BQH-1A, 58
QN/BSH-2D, 58
Angle on the bow, 32
Antisubmarine units, 14-19
Antisubmarine weapons, 110-112
Armament, submarine, 13
Array-type passive sonar, 99
Artificial respiration, 156
Artificial targets, 54
ASROC, 18
Attack lead, 29

B

Basic computing mechanisms, fire control, 118
Basic courses, 7
Basic fire control, introduction, 110
BATHY message information, 82
Bathothermograph
 expendable, 86
 shipboard, 61
 submarine, 58
Bearing drift, 27
Bearing measurement, 20
Bearings, 22-26
Brushes, generator, 173
BT
 calibration, 70
 logs, 77-83
 maintenance, 69
 message, 84
 slides, 71

towing equipment, 65
towing operation, 66-69
trace readout, 82

C

Call signs, 135
Capacitors, 165
Cavitation, 41
Coils, electronic circuitry, 162-164
Collision lead, 29
Communications, introduction, 132
 emergency, 144
 pyrotechnic, 145
Commutators, 173
Conductor markings, 160
Continuity tests, 171
Convergence zone, 50
Conversion table, inches to millibars, 81
Converting true and relative bearings, 25
Corrective maintenance, 147
CRT oscilloscope, block diagram, 159
CTEM log, 84-87

D

Decibels, 38
Deep water sound propagation, 49-51
Detection-to-destruction phases,
 fire control, 112-114
Development of submarines, 9-12
Dial readings, fire control, 130
Divergence, sound wave, 43
Doppler, 29, 51, 128
Duty assignments, 2

E

Echoes, 53
Echo presentation, 96
Electric shock, 156

INDEX

- Electromechanical devices, fire control, 121
Electron tubes, 166-169
Electrostrictive process, 95
Enlisted rating structure, 1
Environmental data, BT log, 80
Equipment, underwater fire control, 118-131
Expendable bathythermograph, 87-90
External communications, 133
- F
- Fathometer, 101-104
Fire control
 computing mechanisms, 118-123
 detection to destruction phases, 112-114
 dials, 130
 nomenclature, 115
 reference planes, 114
 symbols and abbreviations, 122
 system tests, 124-127
Flow noise, 40
Frequency of sound wave, 37
Fundamental problem, fire control, 114-118
- G
- General ratings, 1
Generator maintenance, 173
Graphing the BT trace, 73
Grounding test equipment, 157
Gyro failure, 24
- H
- Hydrophones, 91-98
Hysteresis effects, BT 72
- I
- Inactive duty requirements, 5
Internal communications, 132
- L
- Layer depth, 49
Layers of temperature, 57
- M
- Magnetostrictive process, 92-94
- Mailing precautions, BT slides, 77
Maintenance, introduction, 146
Maintenance requirement card, 150
Manual of Qualifications for Advancement
 in Rating, 3, 6
Marine life noises, 42
Marking BT slide, 76
MC systems, 133
Mechanical computing devices,
 fire control, 119
Megohmmeter, 158
Mines, 14
Military standards, 3
Missiles, 14
Modern passive sonar theory, 99-101
Morse code, 136-139
Motion, 26-29
Multimeter, 158
- N
- Navy Training Courses, 7
Noise, 39-43
Noncomputing devices, fire control, 120
Normal curves for pressure, salinity,
 and temperature, 46
Nuclear submarines, 13
- O
- Occupational standards, 3
Ohmmeter, 158
Operational maintenance, 146
Oscilloscope, 158
- P
- Parallax, 117
Passive sonar, 98
 theory, 99-101
Piezoelectric process, 95
PMS feedback report, 151
POMSEE program, 152
Potentiometer, 162
Power tools, safety precautions, 155
Preparation for advancement, 3
Preventive maintenance, 146-152
Propagation of sound in the sea, 45-51
Prosigns, 139
Prowords, 135
Publications, 8
 Manual of Qualifications for
 Advancement in Rating, 3, 6

INTRODUCTION TO SONAR

Publications—continued

- Military Requirements for Petty Officers 3 & 2, 6
- Training Publications for Advancement in Rating, 3, 6
- List of Training Manuals and Correspondence Courses, 7
- Pulse length, 96

Q

- Qualification for advancement, 2
- Quals Manual, 3, 6
- Quenching, 45

R

- Range rate, 127
- Radiotelephone, 134
- Rating courses, 7
- Reading BT trace, 73-75
 - surface temperature, 72
- Record of Practical Factors, 2, 6
- Reflections, sound wave, 43
- Refraction, sound wave, 45
- Relative bearings, 22
- Relative motion, 27
- Remote indicators, 133
- Resistance, 173
- Resistors, 161
- Resuscitation, 156
- Reverberations, sound, 44
- Rheostat, 161
- RLI operation, 98
- Rotating directional transmission (RDT), 97

S

- Safety
 - precautions, general, 154
 - power tools, 155
- Scanning sonar, 92
- Searchlight sonar, 92
- Sea surface temperature reports, 84
- Semiconductors, 169-171
- Sending code, 139-141
- Service ratings, 1
- Shallow water effect on transmitted sound, 49
- Shipboard antisubmarine weapons, 110
- Shipboard bathythermographs, 61-71
- Ships, (A/S), 14
- Signal codes, 134
- Sliprings, 174

- Sonar information, 20
- Sonar position quantities, 116
- Sonar system, block diagram, 95
- Sonar Technician rating, 2
- Sonobuoys, 108

Sound

- audible range, 34
 - characteristics, 38
 - description, 34
 - propagation, 45
 - speed, 46
 - waves, 36-38
- Sound-powered phones, 132
 - Sound wave reception, 96
 - Stern line indicator, 22
 - Study methods, 7, 8
 - Subject matter courses, 7
- Submarine
 - armament, 13
 - antisubmarine weapons, 111
 - bathythermograph, 58
 - communication methods, 144
 - general characteristics, 12
 - history and development, 9
 - locating requirements, 20
 - propulsion, 13
- SUBROC, 13

T

- Tactical range recorder, 127-130
- Tape recorder, 104-108
- Target angle, 30
- Target aspect, 29
- Temperature effect, 46, 57
- Temperature profiles, 73-76
- Terminal designations, 159
- Test equipment, 157-159
- Test methods
 - cables, 161
 - capacitors, 165
 - coils, 162
 - continuity tests, 172
 - current, 173
 - resistance, 173
 - resistors, 161
 - semiconductors, 171
 - transformers, 164
 - tubes, 166-169
 - voltage, 173
- Thermoclines, 48, 58
- 3-M system, electronic equipment, 147
- Torpedoes, 13
- Training aids, 8
- Training courses, 7

INDEX

Training Publications for Advancement
in Rating, 3, 6

Transducers, 91-95

Transformers, 164

Transistors, 171

Transmission losses, sound pulse, 43

Troubleshooting procedure, test methods, 159

True bearings, 22

Tube tester, 158

Underwater fire control, 110-114
systems, 123

Underwater sound transmission losses, 43-45

V

Variable depth sonar, 108

Voltmeter, 157

U

Underwater communications, 141

telegraph procedures, 143

voice procedures, 142

W

Wavelength, 37

Weapons, antisubmarine, 110-112