

DOCUMENT RESUME

ED 067 898

EM 010 398

AUTHOR Schwartz, Elizabeth  
TITLE Film-Making and the Curriculum.  
INSTITUTION Ladue School District, Mo.  
PUB DATE 72  
NOTE 62p.  
AVAILABLE FROM School District of the City of Ladue, 9703 Conway Road, St. Louis, Missouri 63124

EDRS PRICE MF-\$0.65 HC Not Available from EDRS.  
DESCRIPTORS \*Animation; Enrichment Activities; Film Production; \*Films; Grade 4; Grade 5; Grade 6; \*Guides; Photographic Equipment; Photography; \*Production Techniques; Sound Effects; Student Developed Materials

ABSTRACT

A guide to filmmaking techniques and the use of class-made films in the curriculum covers techniques of both animated and live-action films. The purposes of single concept, documentary, interpretive, and time-lapse films are discussed briefly. Production techniques covered include organization of personnel, scripting, filming, directing, editing, and making a sound track. Possible film projects for grades four through six are listed, along with a glossary and brief bibliography. Written by a teacher for other teachers, this book takes a non-technical practical approach to its subject. (JK)

ED 067898

# Film-making

AND THE CURRICULUM

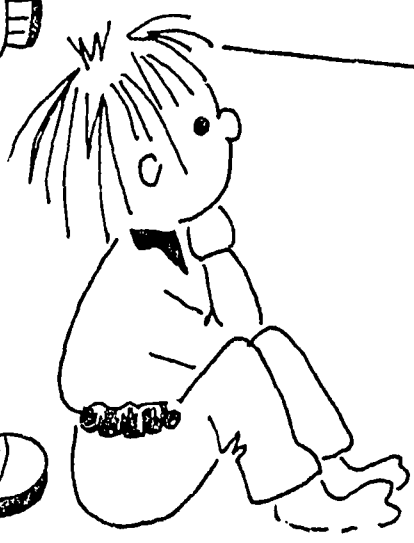
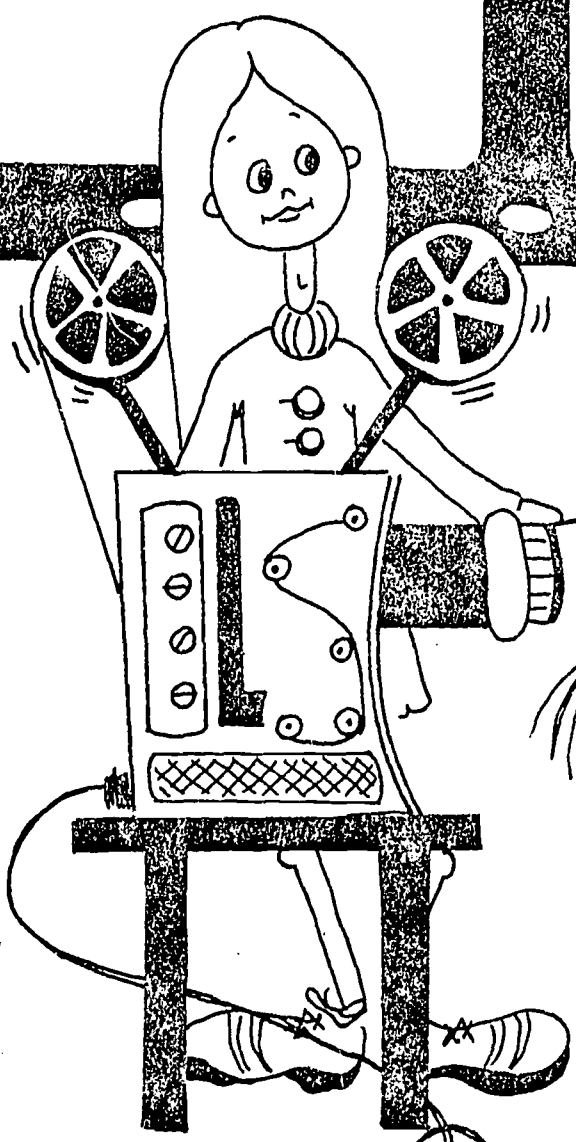

Written and illustrated by  
Elizabeth Schwartz

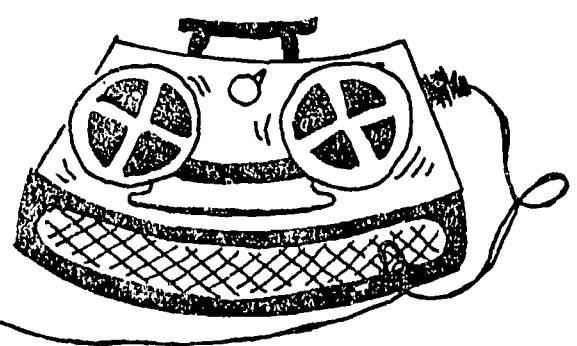

EM 010 398

ED 067898

School District of the City of Ladue  
St. Louis, Missouri, 63124

FILM-MAKING  
and  
THE CURRICULUM

Written and Illustrated  
by  
Elizabeth Schwartz

"PERMISSION TO REPRODUCE THIS COPY-  
RIGHTED MATERIAL BY MICROFICHE ONLY  
HAS BEEN GRANTED BY

Ladue School District  
TO ERIC AND ORGANIZATIONS OPERATING  
UNDER AGREEMENTS WITH THE U.S. OFFICE  
OF EDUCATION. FURTHER REPRODUCTION  
OUTSIDE THE ERIC SYSTEM REQUIRES PER-  
MISSION OF THE COPYRIGHT OWNER."

Dr. Charles D. McKenna, Superintendent

Dr. Franklin P. Morley, Assistant  
Superintendent for Instruction

© School District of the City of Ladue, 1972

## INTRODUCTION

With the advance of media technology, audio-visual materials are becoming the tools of the teacher. Today's pupils are media sophisticated, accustomed to modern communications of all types, and are eager to participate in their own audio-visual productions.

Many teachers are reluctant to make use of existing equipment for classroom productions because they believe they lack the know-how, technical abilities, or talent to effectively guide such an undertaking. Others doubt that children are capable of generating worthwhile films. Still others feel that the learning of skills and subject matter would be jeopardized, because a film or media program would be too time-consuming.

My own experience indicates the contrary. Film-making and other audio-visual work is simple, highly motivating for students, and extremely worthwhile. Classroom film productions unite basic studies with a fresh, new medium, stimulating students and encouraging meaningful learning from project inception to finished product.

For the teacher who has thought about film-making as a way of enhancing the curriculum, yet has been hesitant to begin, this book is intended.

## TABLE OF CONTENTS

I.	Advantages of Film-making within the Curriculum .....	1
II.	Live-Action Film Techniques .....	3
	A. One-idea Films .....	4
	B. Interpretations .....	6
	C. Documentaries .....	8
	D. Time-Lapse Photography .....	10
	E. The Film-maker's Crew and Other Personnel .....	12
	F. Scripting .....	14
	G. The Camera .....	16
	H. Diagram of Nikon Camera .....	18
	I. Diagram of Bolex Camera .....	19
	J. Film Stock .....	20
	K. A Word About Tripods .....	21
	L. Lighting .....	22
	M. Filming Your Production .....	24
	N. Directing .....	27
	O. Acting .....	30
	P. Editing .....	31
	Q. Cutting and Splicing .....	33
	R. Analyzing Your Work .....	35
	S. Soundtracks .....	36
III.	Animation .....	39
	A. What is Animation? .....	39
	B. Filming Figures That Move .....	40
	C. Positioning Flat Art for Animation .....	42

D.	Filming Figures That Don't Move .....	43
E.	Photographs and Magazine Pictures .....	44
F.	Titles and Credits .....	45
G.	Pop-ons, Split Screens, and Other Fun .....	46
IV.	Ideas for Possible Films in Grades 4, 5, and 6 .....	48
V.	Equipment and Books Currently Available in Ladue .....	50
VI.	The Producer's Language (Glossary) .....	52

Note: You may find it desirable to have your students read the technical information contained in these pages before discussing specific film-making assignments. Hence, simple language is used throughout.

## ADVANTAGES OF FILM-MAKING WITHIN THE CURRICULUM

Before advancing a few guidelines for making student-created films within the curriculum, some notes seem advisable about the value to students.

Subject matter, for the most part, is a static element in the learning process. Regardless of the instructional techniques a teacher employs, a certain body of material -- science, social studies, literature, etc. -- must be presented and mastered by the students. We know that children all too often adopt a passive role in this process. In sponge-like fashion they absorb the subject matter that's presented, and then replay it on demand in examinations. But they fail to relate to the subject material in a way that is meaningful to them and do not actively participate in the learning process.

Obviously the answer to this problem lies in motivation. The real challenge in teaching, beyond self-mastery of the subjects to be presented, is developing ways that make students want to learn. Many educators agree that the careful use of student produced audio-visuals is one of the most potent sources of motivation available to us today.

Our students are products of a vast communications explosion. As a result, even the slowest student responds readily to the challenge of developing a classroom film. It's fun, and it's something he feels he's as qualified to do as the brightest child in the class. So, from the outset, you have involvement -- involvement that becomes almost devotional as the project continues.

But that's just the beginning as far as teaching value is concerned. Within the parameters of the project, the children realize that they must master the subject matter in order to make their productions effective. In addition, they learn other important disciplines. Film-making requires patient attention to detail, and rewards the student who can think independently and function well in a team effort. There is much sharing of ideas and skills, good rapport in groups, and voluntary learning.

Film-making is, moreover, an excellent medium for self-expression. Children can observe their own growth and gain confidence in the worth of their own ideas. Each student is able to identify his own unique creative abilities and use them for the good of the group. As important, satisfaction and a sense of accomplishment are immediate. Students have visual proof that they have mastered the subject, and can communicate their expertise with others. My experience over the past few years convinces me that a production of premier quality is infinitely more meaningful than an high grade to the student, and that the subject matter learned in this manner is retained rather than forgotten immediately after a quiz. I have yet to see a child fail to be stimulated by the challenge of a classroom production, fail to optimize his own talents as the project proceeds, or fail to make a worthwhile contribution to the team effort.

Other interested educators throughout the nation have been exploring the visual literacy concept with extensive research and experiences for several years. Recently a symposium of these teachers was held at the University of Rochester and their findings were made public. Throughout their three hundred page report, effective use of film-making, photography, and other audio-visual techniques are encouraged as excellent approaches to learning.

Film-making is only one point on the visual learning spectrum. There is no perfect medium -- it all depends on you, the pupils you are teaching and their specific needs at the time. However, film-making just may be the tool you can use to enter a child's world -- the multisensory world of discovery.



LIVE-ACTION  
FILM  
TECHNIQUES

Before giving directions for making films in your classroom, let's first categorize film-making into two general sections--live-action and animation. Live-action films are those made with real people or things in true-to-life situations. For example, a film about your class's trip to Rockwoods Reservation or about a polluted stream would probably be done live-action. Animated films, on the other hand, are made with artwork or inanimate objects like toy cars or plastic dolls. These are photographed a frame at a time to give the illusion of motion or "life". For example, your class could make an animated film about the growth of a flowering plant by having the children make drawings of all stages from seedling to maturity. When photographed in sequence, their artwork would give the illusion of natural growth. There are other animated films done with thousands of separate drawings, such as the familiar Walt Disney productions, but this technique is much too difficult for general use.

Children can produce successfully either of the two types of films, but you and the children should be aware of the techniques involved for both, as they are quite different. In many situations, a combination of both techniques is the most interesting. It's up to you and the class to decide which type of film-making will work for your subject material, always remembering to let the subject be the main guide.

It would be a good idea to read the entire section on film-making before attempting a student-created film in your classroom. Let's begin by looking at the many kinds of live-action and animated films your classes can make with the Super 8mm camera.

## ONE-IDEA FILMS

One-idea films are exactly what the name implies....they are designed to convey one single idea or concept. For example, you as a teacher could make a film to show your pupils how to hold a pencil. A student could show the class how she baked a chocolate cake. These are the easiest films to make for they require very little equipment and time. They are only long enough to effectively explain the concept, usually from a few seconds to three or four minutes.

Suggested productions: How about filming a science experiment that takes three weeks to perform? The whole experiment can be presented on film in a matter of minutes. This, of course, can be a group-effort, an individual's presentation, or a complicated experiment done at home by the teacher. Here's what to do. Set up the experiment and film the changes made as the days pass. If you wish, you can show the passage of time by photographing titles between takes. When the experiment is finished, process the film, and show it to the class. Little or no editing is required. The film will be fun for everyone to watch, and will provide a permanent record of the experiment as well as a helpful review for an oncoming test.

The possibilities for subjects for one-ideas films are almost endless. Many children in Ladue have access to regular 8 or Super 8 cameras in their home; and once a child understands how to make these films, he can easily make his own to supplement an individual project. Maybe you're studying the socio-economic groups that live in St. Louis...a child could make a film on the types of housing these people occupy. Perhaps you're teaching historical sites and monuments. On a Sunday afternoon, a child probably could persuade his father to drive through all parts of the city and point out the locations of the things he may be studying. Without getting out of the car, the child could take a few frames of all he sees that pertains to the subject. A unique

experience could be shared with his classmates and heighten the awareness in the minds of all.

As a teacher, you can also bring many techniques and subjects to your classroom in this manner...ideas that are not available in library films or in books...or things your students may not have seen.

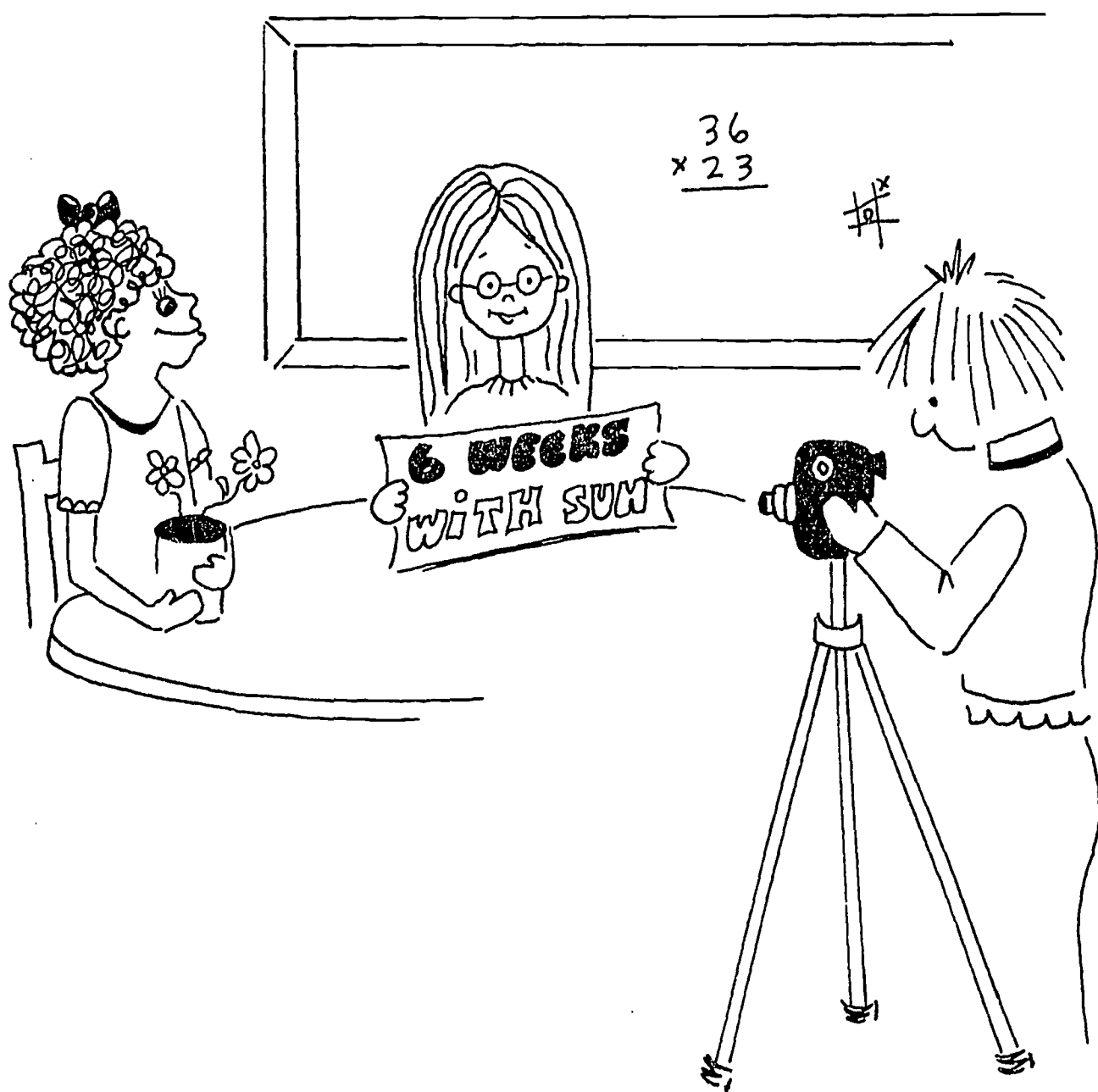

## INTERPRETATIONS

Interpretations are films that allow the film-maker to express his own personal ideas about the subject. Unlike one-idea films or documentaries, fact is not so important in an interpretation. For instance, a child may want to present his ideas about what life might be like if there were no changes in our weather. Or maybe another would like to tell what it feels like to win a race.

Interpretations can take any form. You may decide on an elaborate dramatization complete with actors and costumes, or a simple narrative using animation or live-action filming to tell your story. Any subject can be adapted to individual ideas, and then brought to realization with an effective film treatment.

Suggested productions: Perhaps your class is studying "Cultures in Conflict" and would like to do a film about prejudice. Why not do a dramatic interpretation? Have half of the class wear something yellow, some of the others wear something red, and a few wear something green. Have the children write a story that shows the conflicts between groups.....tell what it means to be different.....have your cast act out groundless hate and suspicion. The production might end with a scene where all the colors get together and discover what they have in common.

Interpretations of fiction can be equally as much fun. Maybe you'd like to express the feelings Tom Sawyer had while he was lost with Becky in the cave. Just thinking about what must have been going through Tom's head at the time gives one worlds of exciting ideas to develop. Maybe someone would like to write a story of an imaginary trip with Charlie in the Chocolate Factory.

History can be interpreted, too. What was it like to be with Washington at Valley Forge or with Neil Armstrong when man visited the moon?

What about the interpretation of a piece of music? What do you think the composer was picturing in his mind as he wrote "Dance Macabre"? Of course, classical music can lend to many exciting productions, but don't overlook contemporary songs, as well. Children are very fond of today's music and many of the current records are very good social commentaries.

As you can see, interpretations are a wonderful way to bring children's ideas to life. Oftentimes, a child sees things in a refreshing new way... it's great to let him portray his point-of-view.

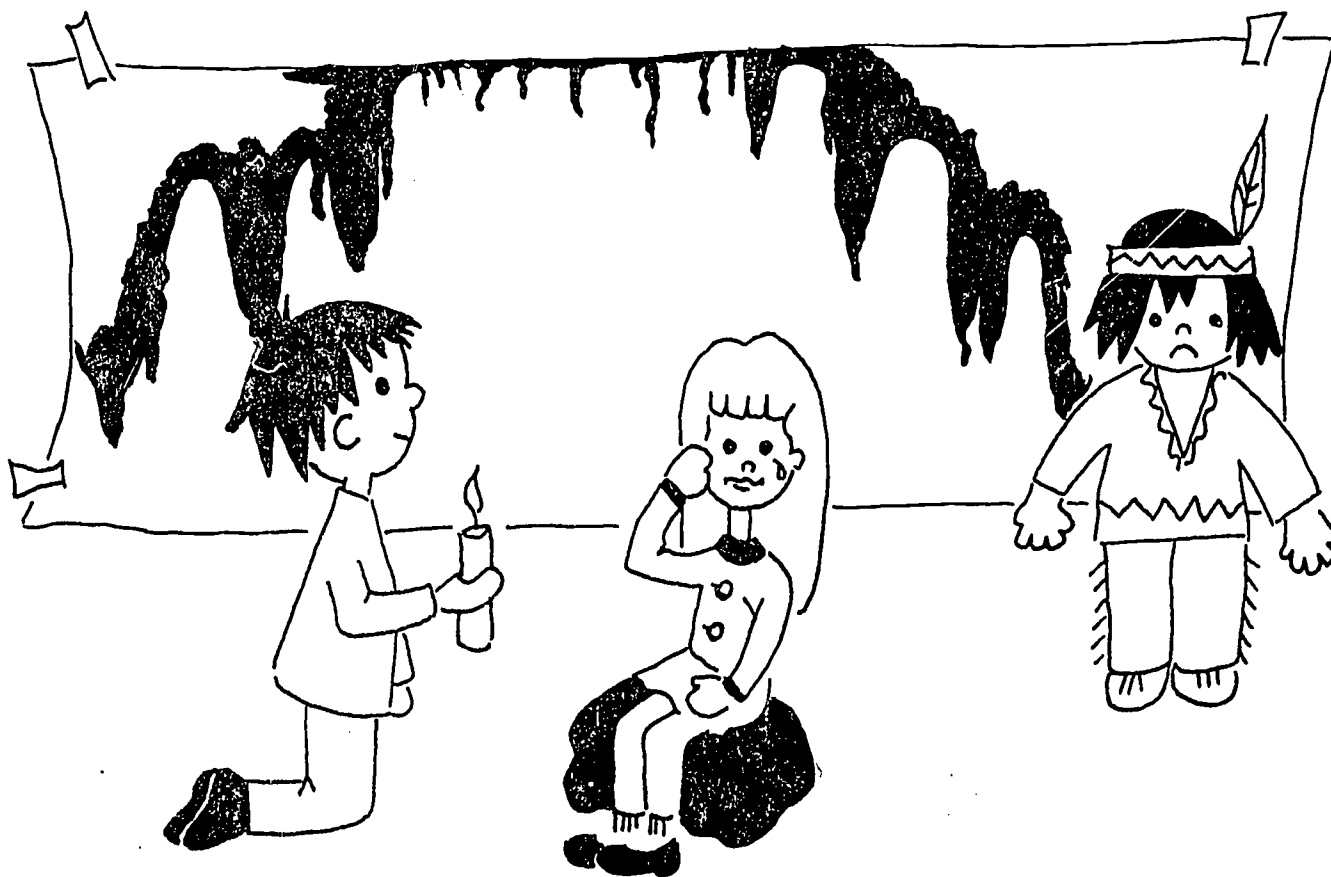

## DOCUMENTARIES

Simply stated, a documentary film is a record of fact. The fact can be a person, a situation, a process, or an event. Unlike one-idea films, documentaries are built on comparisons, different points-of-view, and in-depth reporting. As an example, you may want your class to make a documentary on a political election...presenting views of opposing candidates and taking a close look at campaign issues. Documentaries take time, so you can expect such a film to be at least seven minutes long.

Suggested productions: Perhaps your class will be taking a field trip to the Chrysler Plant. What about having the children interview an assembly-line worker, a designer, and an engineer on cassette tape, taking some on-the-scene film, and filling in later with stills from magazines to show the entire manufacturing process? When the class returns to school, play the cassette tape and discuss what has been said. Then have the children write some narration to complement the interviews and cover facts the workers may not have mentioned. Have the children read the narration to the class. What else needs to be told to give a true picture of the experience?

When recording the soundtrack, have a child operate the cassette and re-record the interviews along with the rest of the scripted narration and music. And since you may not get all you had hoped for on film, don't forget that you can film still pictures as well. Most places you visit on field trips give out free literature, complete with many photographs. (See the section on how to film still photographs and magazine pictures).

Subjects for documentary films are all around you. How about interviewing a farmer about his attempt at soil conservation or a policeman, a fireman, a doctor, and a lawyer about their roles in the community? Instruct the children that a documentary must be objective. Try not to let your

personal feelings or those of students get in the way. Others may not know what you do, or may not share your conclusions. Tell all the facts, be convincing, and let the viewers think for themselves.

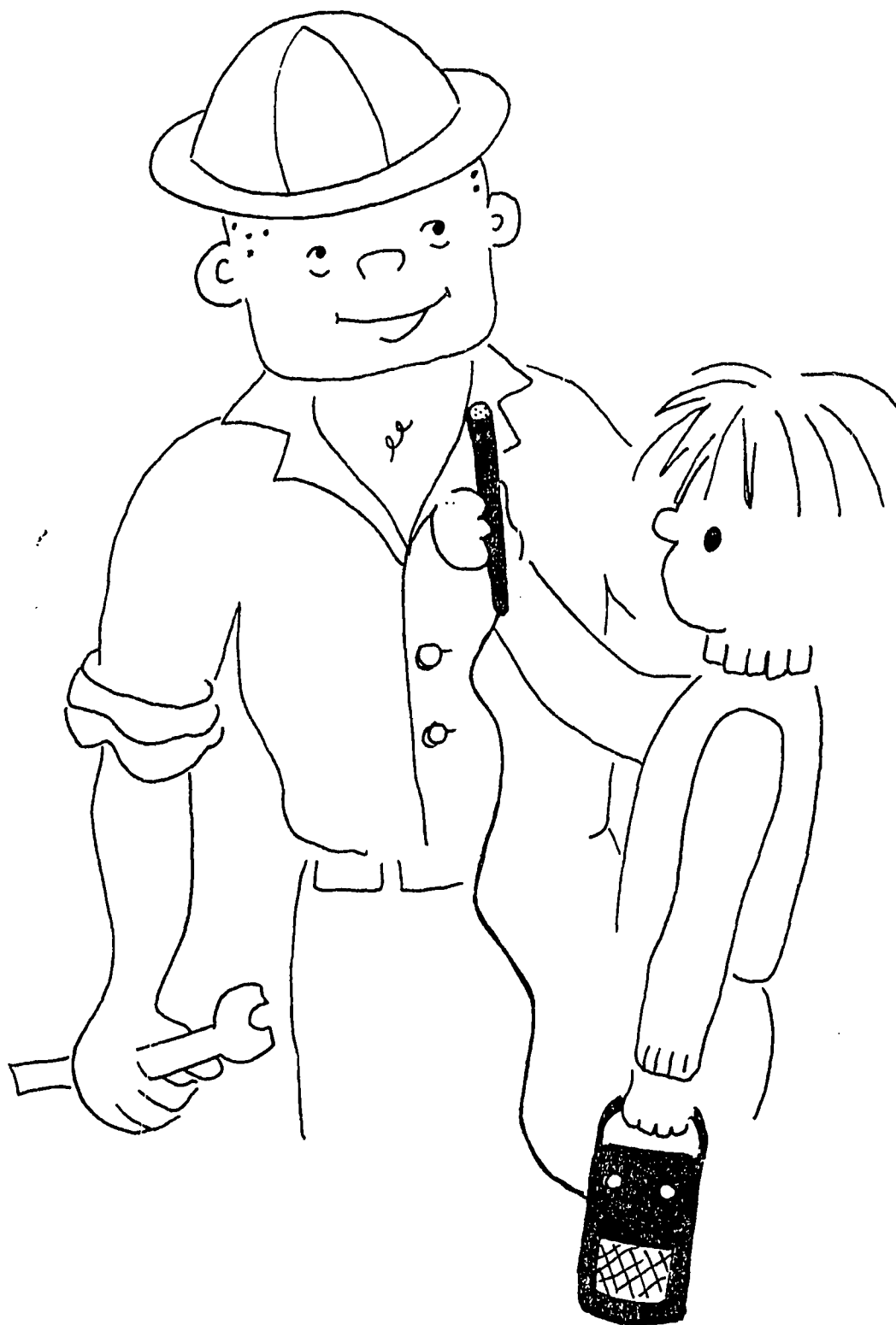



## SPECIAL EFFECTS

Time-lapse photography:

Nearly everyone has seen time-lapse photography showing a rose from bud to bloom or the moon rising and moving across the sky. The same effect can be accomplished by your class with a Super 8 camera. You first must determine how often a frame need be shot. There are eighteen frames per second in Super 8 running time, so if one frame were shot every three minutes, eighteen frames would give you a capsule of the action that took place over a fifty-four minute span of time. Imagine! Almost an hour compressed into one second of film. At the same filming rate, fifty-four hours would be covered in one minute of film time. Would this be enough time for the rose to bloom? Have your class work out the schedule mathematically before filming begins.

Obviously it is impossible to operate the camera manually during such long shooting schedules. You'll have to have a mechanical time-lapse device to do the shooting automatically. Such devices are available on the market today for Super 8 cameras, but if you can't buy one, why not make one? Building a time-lapse trigger would be a great science experiment!

Not long ago, a Horton Watkins student, Ken Bush, showed a film he had made with his own time-lapse invention. The film showed a whole day in passing, from sun-up to sun-set. Water evaporated from the sidewalks, clouds moved quickly across the sky, and shadows rose and fell swiftly. Ken's film was most exciting to view! His device consisted of an old electric clock with a bent-out second hand and a few assorted things found in his home workshop. As the second hand passed the same place each time, it struck a wheel which raised a lever setting off the single-framer on the camera. The same kind of thing has been done with electrodes. There are endless possibilities. A sixth grade boy working with electricity could invent such a device, use it himself, and then assist

the first graders in time-lapse filming of their chickens hatching!

Anything that changes is a natural for time-lapse photography, and what awareness your children will get from seeing things happen that are usually taken for granted!

To do time-lapse photography, you must use a tripod for stability. Once the camera is mounted, focus the subject sharply, and the device will do the filming.

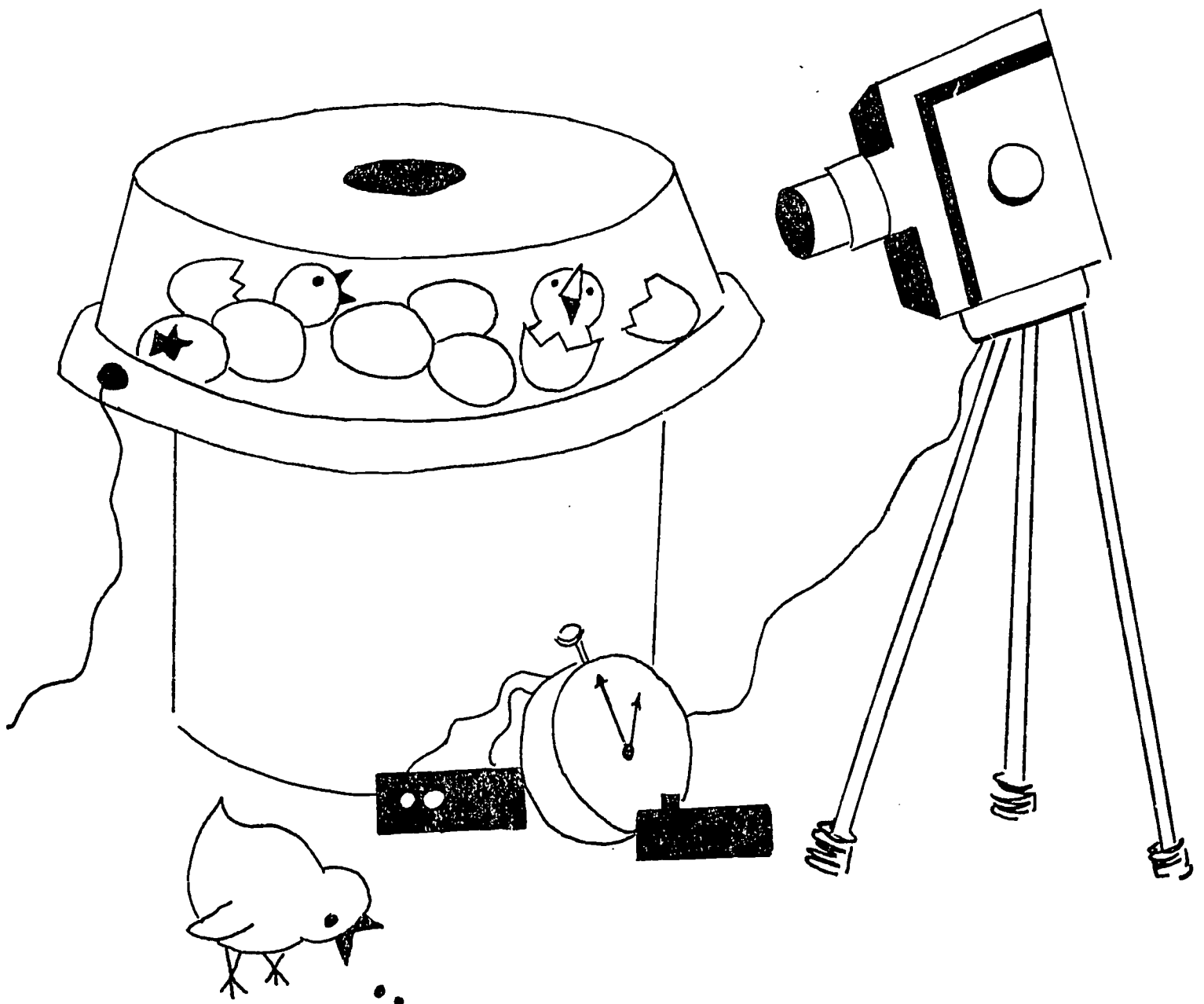

## THE FILM-MAKER'S CREW AND OTHER PERSONNEL

Every child likes a title and wants to feel that he has a very important job. In film-making, every job is important and must be done with care to insure a good show. Listed here are many of the key personnel in film-making, which can be expanded or simplified. Stress how each one's job will make the picture a whole and then give credits to each on the screen for a professional touch.

- Producer -- Has overall responsibility for the production. Selects and assigns the director, cameraman and all other personnel. He's the boss. As a teacher, you are the producer.
- Writer --- Prepares the script, working closely with the producer. Several writers may be involved if the script is lengthy or complicated.
- Director -- Takes his orders from the producer, but has overall responsibility for preparation, filming and editing. All the other members of the production take their orders from him, so he must know something about their jobs as well as his own. When filming, the director interprets the script, decides how each scene will be shot, coaches the actors, and makes sure everyone is doing his best to get the job done properly. After filming, he supervises the making of the sound track and editing. The director must make sure all elements of the production work together to tell the story.
- Assistant Director -- The "number two man" on the film-making team. His most important job is to coordinate film crew, actors, locations and props so that everything is ready for shooting on schedule. If the director is absent, the assistant director assumes his duties.
- Cameraman -- Responsible for the selection of proper film stock, lighting and exposure, and operation of the camera during filming. He must be thoroughly familiar with his equipment and with camera techniques so he can deliver the shots the director wants.
- Assistant Cameraman -- Helps the cameraman throughout the production. He's responsible for setting up the camera, loading the film, cleaning the lens, and assisting the cameraman with zooms, follow focus and rack focus. In addition, he prepares the slate and holds it in front of the camera at the beginning of each take.

- Grip ----- The handyman of every film. As directed by the cameraman, he strings extension cord, sets up and adjusts lights, carries equipment, arranges props, and does anything else that's necessary to keep the production running smoothly.
- Soundman -- Responsible for all sound recording, and the overall quality of the sound track. He may have assistants to help him with the sound equipment and hold the microphone, but the soundman always operates the tape recorder.
- Script Girl - Keeps the master script for the production. Makes note of the scene and take number, and gives these to the assistant cameraman to put on the slate. If changes in the script are made by the director during filming, she must take careful notes so that the editor will be able to follow the story.
- Editor --- Views the footage with the producer and director, selects the best takes of each scene, cuts, splices and assembles the show.
- Assistant Editor -- Helps the editor in assembling the show. He must take special care to store out-takes and trims in case these are needed later to revise the film.
- Music Arranger -- Selects music for the show from existing phonograph records, or composes new music. If new music is required, he supervises and directs the musicians.

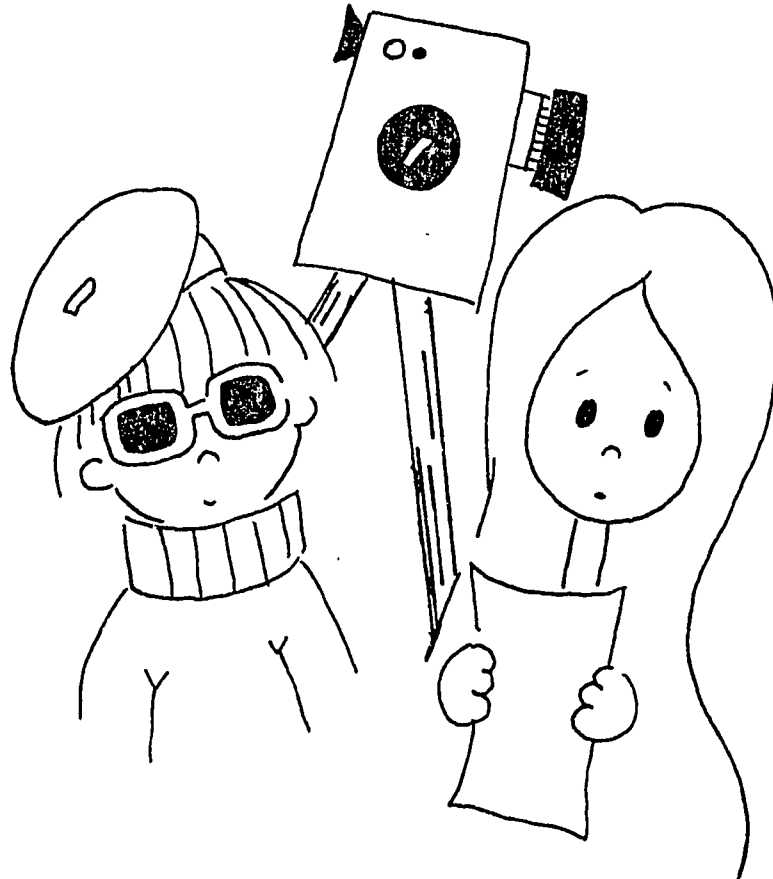

## SCRIPTING

Any production can be only as good as the script. Good pre-planning is a must if you want to use all time to a good advantage and **realize a good** product. Without knowing the specific subject, it would be difficult to say which would be the best way to write the script...that is, whether a select few should do all of the writing or let the class participate in the writing by the group method. The children must have a thorough knowledge of the subject matter, or be provided with a list of references to find material. Then, the writing part is accomplished much the same way any type of creative writing is done at school.

However, the children must be able to write what they want to visualize, and be able to visualize that which they write. The limitations of filming must be pointed out to them. For example, the class should not write a script about the scenery in the Alps, unless of course they wish to do the entire film with photographs and magazine pictures. If a particular location is needed to make the story ring true, they must be able to improvise, go there on a field trip, draw the scenery and use animation, or they should find another subject. Also, the script must be a narrative, rather than dialogue. Synchronous sound, which is necessary for dialogue, is rather ineffective in Super 8 and should not be attempted. However, a good narrative, blank verse, a lyrical poem, or a song can lend as much to a movie as dialogue.

In order to assist the children in thinking of sound and visuals as the whole, it is wise to provide them with a dittoed sheet, with corresponding sections for the audio-video. By giving the children a sheet like the one in the illustration, it will be much easier for them to see the movie in its entirety, each main part complimenting the other.

ILLUSTRATION OF SCRIPT FORMAT

NAME _____		DATE _____
TITLE _____		
AUDIO: WHAT YOU HEAR	VIDEO: WHAT YOU SEE	
		1
		2
		3
		4
		5

## THE CAMERA

At the present time, The School District of Ladue owns two types of Super 8mm cameras, the Bolex Macro-Zoom and the Nikon 8X Super Zoom. The cameras are two of the best on the market today and have more in the way of features than you'll probably need. The Bolex, with its macro-zoom, will allow you to focus subjects as close as one inch with no additional attachment. The Nikon will not focus sharply at distances less than three feet, but it is equipped with a power zoom, which is a manual feature on the Bolex. In all other respects, either cameras will do equally as fine a job. When using them, take time to read the instruction manual that comes with the camera. Have the children who will act as cameramen carefully read the manual, as well. The best cameramen have their equipment manual with them on location for quick reference, too.

In the event a student brings an older model to use in school and there are no instructions in the case, have the child write a letter to the manufacturer requesting the instruction booklet. Clearly state the camera's model numbers in the letter. The camera company will send the child an instruction booklet even for cameras they no longer make, such as the regular 8mm cameras, which have been on the market for years. Of course, it is nicer to have an excellent camera such as the Nikon or the Bolex, but good student films can be made with an inexpensive Kodak.

When reading the instruction manual, look for these things: proper loading procedures, exposure control, zooms (power-driven or hand-cranked), variable shutter speeds, and single-framing capabilities. As expressed, the Ladue-owned cameras provide most of the finest features, but you should know what to look for when a student brings his own camera to school.

AUTOMATIC exposure control is almost a must for children. Most 8's and Super 8's provide this feature, including the cameras in Ladue. The device

sets the proper exposure for you, or indicates that not enough light is available for filming. All you have to do is look in the camera, read the gauge in the viewfinder to see if you have enough light, and let the camera do the rest. As you film, the built-in exposure meter reads the intensity of the light and varies the lens opening (aperture) accordingly. You get good results everytime.

Here's what some of the other features will do for you. A single-framing device will allow you to do animation. Variable shutter speeds are necessary for slow-motion or fast-moving Chaplinesque action. A zoom lens allows you to move in quickly from a wide shot to a close-up, or the reverse.

Loading the camera, focusing the subject, and the location of all the various cranks and knobs will also be explained in the instruction manual. Since all cameras vary slightly, it's best for you to find the specific directions in your manual, rather than list them all here. However, you will discover that the operation of a Super 8 camera is as simple as can be.



DRAWING OF NIKON

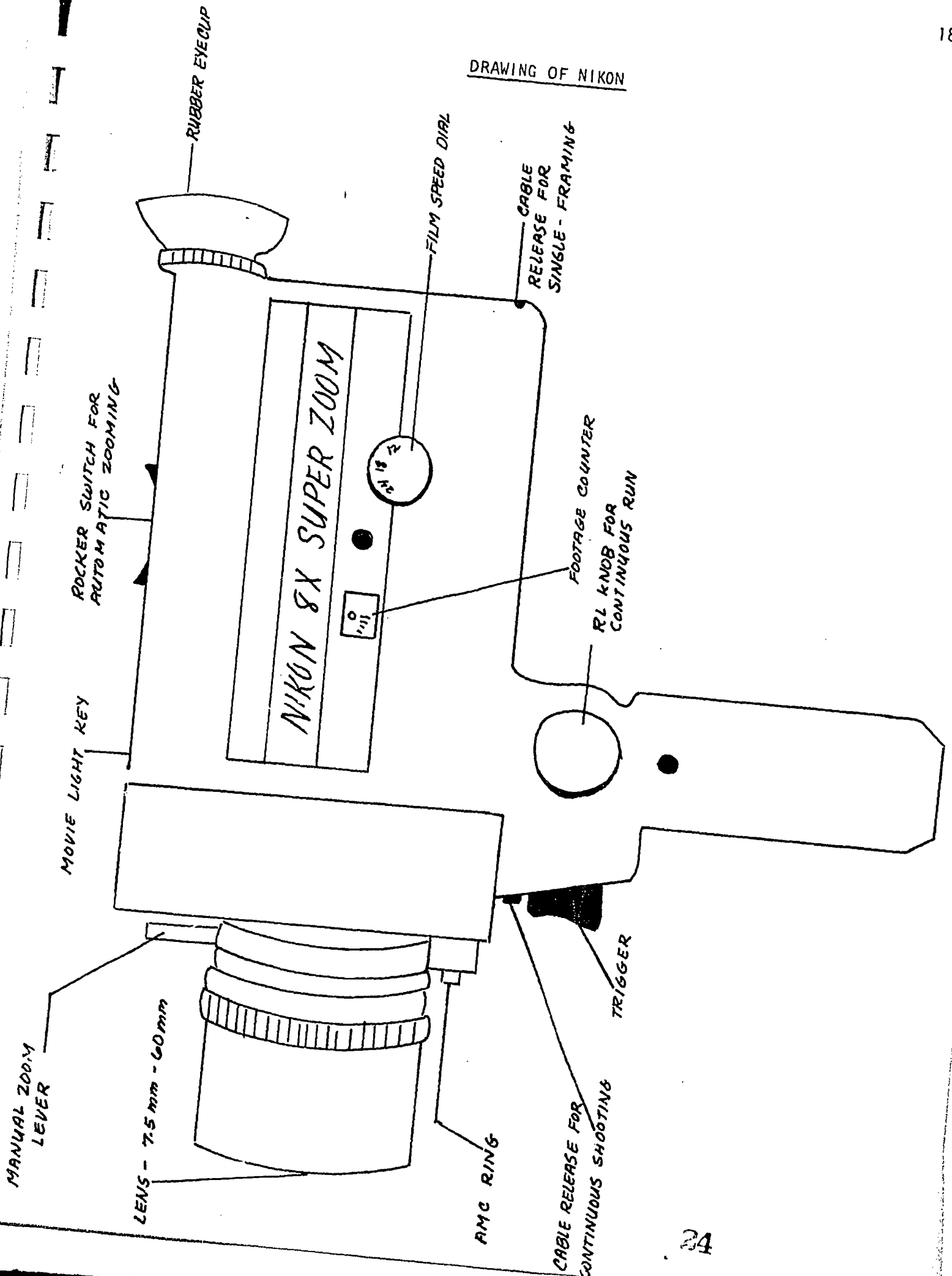

DRAWING OF BOLEX

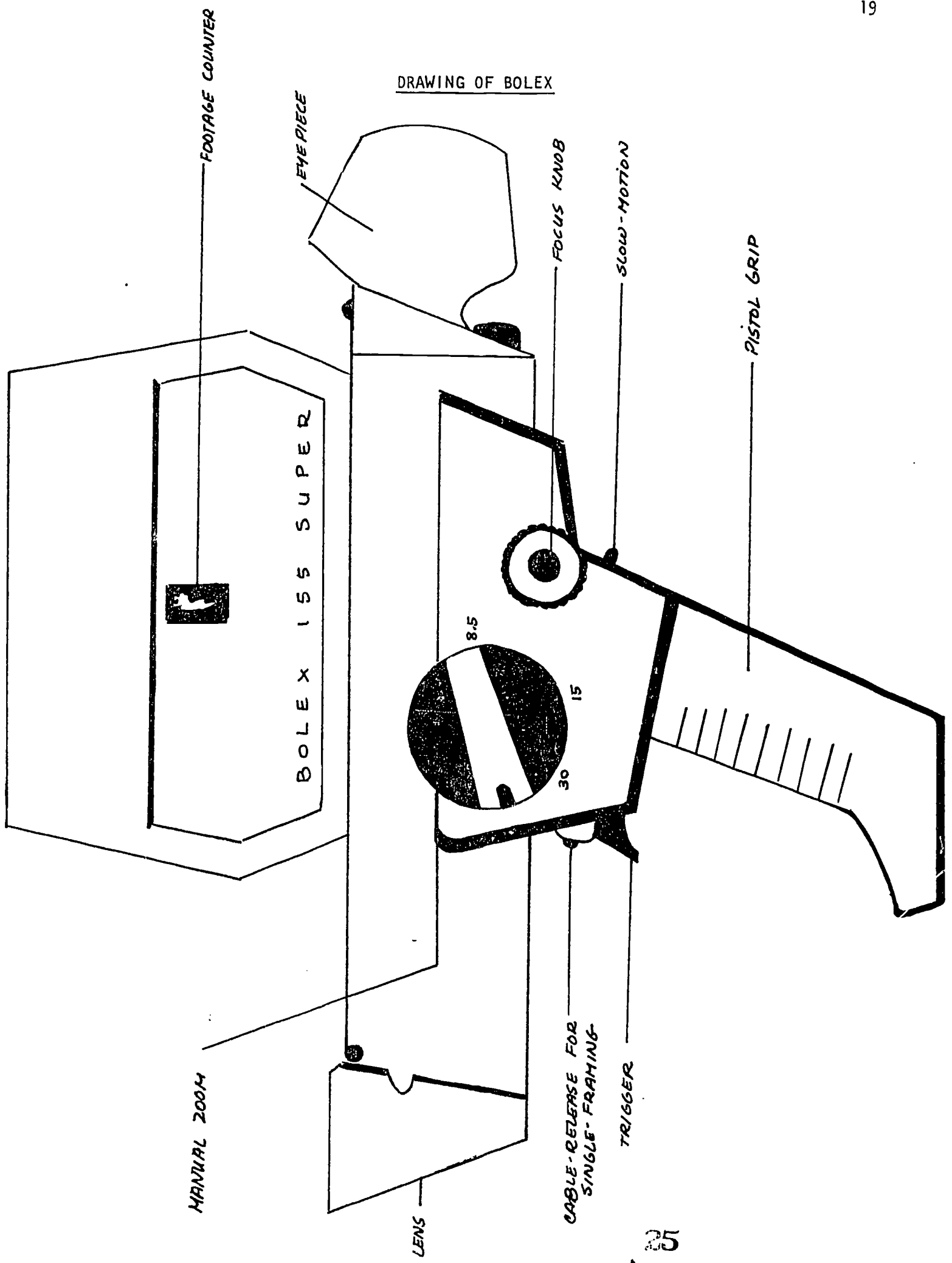

## FILM STOCK:

For the cameras in Ladue, as well as most Super 8 models, film is readily available in simple-to-use film cartridges. To load, you simply insert the cartridge in the camera's film compartment, close the lid, and you're ready to film. Notches on the cartridge itself automatically adjust the exposure control on the camera for the right film speed. Once Kodak made this type of notched cartridge-film available for Super 8, most leading manufacturers made their cameras to use Kodak's film.

There are four types of film available in Super 8 cartridges. You should know a few basics before buying a supply of cartridges, so follow the diagram below in making your choice.

### Color film:

- |                  |   |
|------------------|---|
| Kodachrome II    | * can be used indoors or out with good results. Inside you will need a #85 filter.  |
| Super Kodachrome | * for use indoors with photo lights. Good for animation and classroom photography. Not recommended for outdoor use, but you can use it in a pinch by adding a #85 filter to the lens. |

### Black and White film:

- |              |  |
|--------------|--|
| Kodak-Tri-X  | for use indoors. Requires little extra lighting. |
| Kodak Plus-X | for outdoor use in bright light.                 |

Children love to use color film, but remind them that some subjects are more effective in black and white. Unlike other types of film, black and white is rarely cheaper in Super 8 cartridges than color.

Pre-paid processing envelopes are available in which to mail your film. You can purchase them along with your film. When the film is developed, the laboratory mails it back to your home address.

\* an #85 filter is a standard built-in feature on the Nikon and Bolex.

## A WORD ABOUT TRIPODS

It is as difficult for a child to hand-hold an 8mm camera during filming as it would be for you to hand-hold a big 16mm professional camera. To solve the problem of jolts and jerks in your students' film, it is to your advantage to use a good tripod.

When setting up, make sure the tripod you use is heavy-duty and will not topple during camera movement. And be careful, too, that the camera is securely fastened to the tripod head.

A tripod is a necessity when filming animation and time-lapse photography. There is relatively no way to position art work or still objects exactly the same way twice if you do not have a steady platform for your camera.

Some live-action photography can be performed without a tripod, but use the tripod as much as you can. The slightest move made will be magnified when the film is shown on the screen.

Children have a tendency to become overly-anxious to use the camera. Allowing the time to set up the tripod seems also to insure better composition and fewer mistakes.

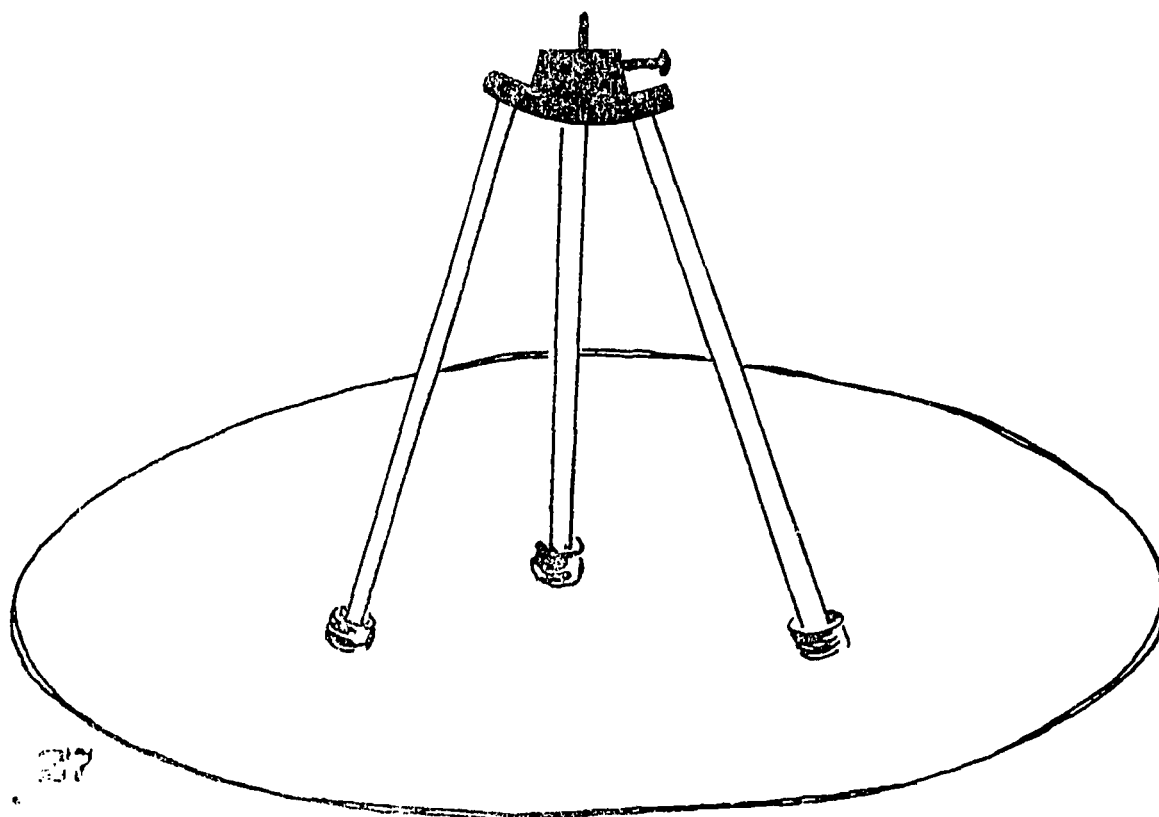

## LIGHTING

For proper exposure, all films require a good amount of light. The easiest source of light is the sun, so it's a wise idea to experiment with outdoor filming first. You may not wish to film an outdoor scene, but you can always set up a temporary shooting studio on the playground. If you don't want a backdrop of trees and flowers in a film about the signing of the Declaration of Independence, you can easily put a blanket down for the floor, string up a color sheet for a background, and add a table and some chairs.

If your classroom has large windows and good sunlight, you can probably shoot scenes inside. Check the built-in light meter in the camera and if it's safe to shoot, set up production as near the windows as is possible.

When there is not enough sunlight in the room, the simplest solution is to use a single movie light which attaches to the camera. This type of light is available with the cameras in Ladue. All subjects which are approximately the same distance from the camera will receive general illumination, and usually, this type of lighting will be enough. However, the single-light attachment often causes overexposure if you are filming closer than five feet to the subject.

In animation and other close-up photography, you will need additional lighting, unless you intend to film outdoors. For three-dimensional art work, you should use a movie light set at a 45 degree angle to the subject. This type of lighting will give detail to your art work, yet not cause double shadows. A movie light set on each side of the subject is best for flat art work or titles. Both lights should be set at 45 degree angles to the subject and should be of equal intensity.

All light has color. If you are shooting black and white film, this is of no concern. But if you're shooting color film, try not to mix light sources. For example, use either sunlight or artificial light on your subject -- but not both. Sunlight tends to be blue and artificial light is orange. If you mix the two, you won't like the results.

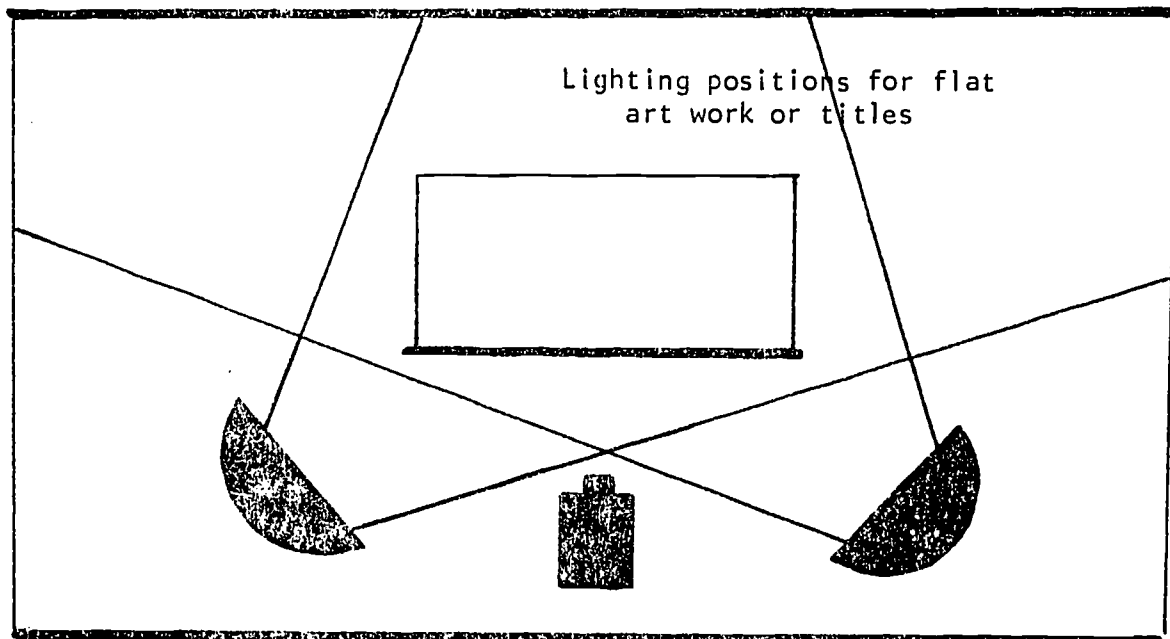
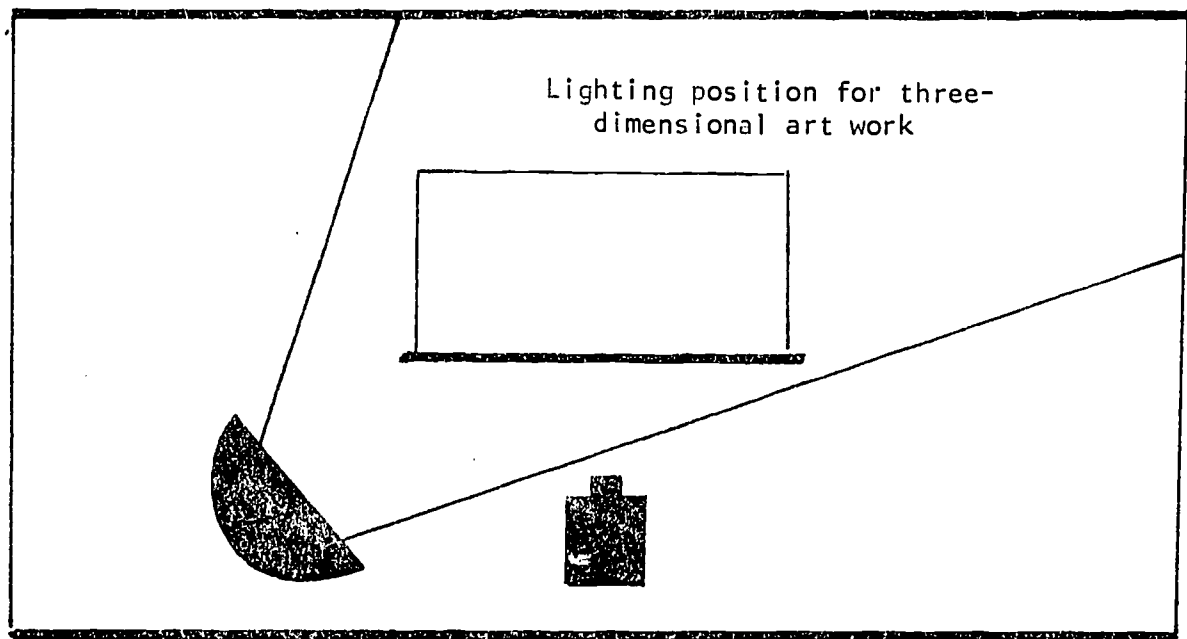

## FILMING YOUR PRODUCTION

With lighting established, the camera securely mounted on a tripod, and proper film selected, a cameraman or cameragal is ready to begin!

The director looks at the script (the director and cameraman can be the same person if you wish)....everything is ready for Scene 1....actors in place. The director calls for the shutter speed, depending on the effect required. The cameraman sets the dial for slow motion (24 frames per second), Chaplinesque (12 frames per second) or eighteen frames per second, which is normal speed for Super 8. Next, he carefully frames the scene or subject in the viewfinder. Once framing is completed, the cameraman sharply adjusts the focus. Most cameras have the distance in feet from the subject to the camera marked on the lens or focus knob. If not marked, simply move the focus until the subject is sharply in view. Now, the cameraman waits for further word from the director who will call "action" when the filming is to begin.

PANNING OR TILTING: These seem to be the most difficult manuevers for children. Panning is used to follow action side to side while keeping the subject in the viewfinder. Many new cameramen have a tendency to pan too quickly, which gives a distracting swish across the subject. The movement of the camera must be very slow....highly exaggerated. Tilting is following the up and down movement of the subject, and must also be done slowly. Make sure your tripod has a well lubricated head and that the movement can be done smoothly before attempting a pan or tilt. Have the cameraman practice the movement several times before actual shooting or you'll probably waste film.

If you are not following action, the children may want to use pans or tilts to show the full reaches of a stationary object, such as a tree. Slowly, slowly, slowly, rise up the trunk to the top, move vertically across

the tree to get the full breadth, and perhaps move slowly down the trunk again. Emphasis must be placed on the slow movement of the camera. The pan or tilt may seem like it's taking a long time to film, but on the screen it will look perfect.

ZOOMING: Zooming can be one of the most exciting techniques used in a film... that is, if you don't overdo it! Too many zooms make for tired eyes and an outlandish movie! Zooming refers to going toward or coming away from the subject, by continuously changing the image size. It may sound difficult, but if you have a camera with a zoom lens, such as the Bolex or Nikon, all you do is push a button or turn a knob and the lens does the rest. You can zoom in from a wide shot of your entire school building to a close up of the front door. Or you can start with a close up of a flower and zoom out to see the whole garden. If the camera has a manual zoom such as the Bolex, again work smoothly and slowly. The Nikon and other cameras with automatic zooms run at a set speed and make zooming very simple. Remember a practice run in zooming should always be made by the cameraman before actual filming.

FOLLOW FOCUS: If your subject moves from 60 feet to 6 feet away from the camera during filming, you'll need to adjust the focus. Rehearse the scene a couple of times with your assistant cameraman so he will know exactly when and how fast to move the lens or focusing knob. He may want to put grease pencil marks on the lens barrel or on the knob to mark the starting position, middle-of-the-scene position, and final position. His marks will take the guesswork out of following focus, and will give you perfect results. Remember, though, that follow focus is only necessary when your actors are moving considerable distances toward or away from the camera....for most scenes you can set your focus during rehearsal and leave it alone during filming.

RACK-FOCUS: Rack-focusing can be tricky, but highly effective if done correctly. Again, you will need an assistant cameraman to help with the



focusing while the cameraman is operating the camera. Perhaps you wish to focus on raindrops on a windowpane, then rack through the window to focus on the action inside the room. First the cameraman focuses on the raindrops... the inside of the room will be out of focus or blurred. After "action" is called and the cameraman is filming, the assistant turns the dial to the proper focus point for the interior subject. The filming does not stop. When the footage is viewed, it appears that the raindrops fade away while the interior action comes into sharp detail.

OUT-OF-SEQUENCE SHOOTING: In order to save time, it is usually better to shoot all scenes requiring the same basic setting at the same time, rather than going straight through the script, scene one, scene two, etc. As an example, if scene two and scene thirty-one call for exterior shots of a fish pond, film them at the same time so you won't have to go back later. The arrangement of the scenes in proper sequence will be done on the editing table. It's a good idea to film at least two "takes" of each scene so that you can select the version which works the best during the editing process.

MORE ELABORATE FILMING TECHNIQUES:

FADES: In the event you wish to indicate the passage of time, a fade-in or a fade-out might be in order. You can fake a fade by simply moving a piece of sooted glass in front of the camera's lens. As you slowly move the glass from the sooted area to the clear glass, you are fading in; from clear to sooted glass and you are fading out. You can also make ripple dissolves by using textured glass or another semi-transparent substance. Move the glass across the lens at the tail of Scene I and the head of Scene II. This effect is particularly nice between scenes that have no relationship to one another, or can be used to indicate a passage of time or flashback.

SWISH PANS: A very fast pan, blurring all in sight, can also provide a passage of time or flash-back effect.

## DIRECTING

All children have seen cartoons of a man wearing sunglasses and a beret, sitting in a canvas folding chair, and hollering for "lights, camera, action." They know immediately that this man is a movie director, but do they realize that calling these instructions to the film crew is the easiest and least important thing a director has to do?

The director's primary responsibilities are: (1) to interpret the script (2) to make the story make sense, and (3) to guarantee that the viewers take away from the film the exact feeling or message he is putting into it.

Before shooting can begin, the director has to decide what the writer had in mind when he wrote the scene. Did he intend for the scene to be funny, informative, full of suspense, sad, fast-moving....what was the writer trying to say?

When the director is sure of what the story is, he must find a way to tell it so that it makes sense to the audience. Let's say that the script calls for a boy to be lost in a forest. The director must be able to line up several shots which, when edited, allow the audience to understand the show. He might open with a wide shot of the forest itself, showing its size and complexity. Next he could shoot a closeup of the boy looking around, trying to find a way out. And finally he might follow the boy with a hand-held camera as he weaves around through the trees, getting nowhere at all.... perhaps ending up exactly where he began. Do these three shots make sense.... do they say "lost" to you? Would the scene make more sense to the audience if two or three additional shots were added or the order changed a bit?

The third thing a director must accomplish is to make sure the audience takes away from the film the exact message he is putting into it. When the projector is turned off, will the viewers be angry if he wanted them to be

angry? Will they be better informed about the subject he was trying to explain? Will they understand his ideas and the ideas of his script writer? A good way to illustrate this to children is to talk about shooting a film like building a house. Make sure all the parts are working together so that the house will stand strong and solid. Each scene might work by itself, but can all the scenes work together as a total unit? The last scene stands on the foundation you start building with the first scene. Keep the film moving along a straight line from start to finish so that you arrive at the place you're going. That's what the director's job is all about.

#### Directing Techniques:

Here are some techniques that the young director should be aware of. He may choose to use none or all of them, but he should know what he can do.

CAMERA MOVEMENT: Camera movement can make an interesting scene out of a dull one. If a shot has been chosen that has no life or movement, add action with a zoom, pan or tilt. For instance, a shot of the school building could be boring. Nothing happens...the building sits there. Action can be added with a nice slow zoom from a wide shot to a close-up of the front door. Remember, this is a movie, not a slide show. You've got a perfect opportunity to show movement and activity, so don't settle for a still shot. A good rule of thumb to follow is this: if there's plenty of action in the scene -- kids playing ball, planes flying overhead, actors moving about -- you're usually safe to set the camera on a tripod, turn it on, and leave it alone. But if the scene is lifeless -- a tree, a building, a statue -- add some interest with a camera move.

SHOOTING DIFFERENT ANGLES: If a shot stays on the screen too long, it can become dull regardless of how much action is going on. One way to solve this problem is to shoot the scene from different angles. For instance, if the scene is a basketball game, shoot some footage from the sidelines. Then, move

the camera under the basket to catch a different look at the action...perhaps a close-up of the ball zipping through the net, or a shot of players wrestling for the rebound. But be careful that the action in the two different angles matches. If the player missed the basket in the wide shot from the sidelines, don't shoot a picture of the ball going in the net from the second angle. That wouldn't make any sense at all. But a shot of the teams jumping for the rebound would be perfect.

CUTAWAYS AND INSERTS: Here are a couple of techniques that will make the film move along smoothly. A cutaway helps you get from one shot or angle to the next. Let's say that you want to film a scene of a car driving down the street. First you want a shot that shows the car coming directly toward the camera. Then you want a shot that shows the car going away from the camera and on down the street. If you splice the two shots together, the effect could be jolting and your audience might have a hard time deciding what's going on. So, shoot a cutaway -- an intermediate scene. In this case, a close-up of the car wheels rolling past the camera from a side angle would be effective. Put this shot between the other two, and you'll have a nice, smooth effect.

An insert is a scene that helps you draw your audience's attention to a particular part of the action you're filming. Perhaps the director wants to shoot one of his classmates making a model airplane. The first shot is wide to establish the boy working on the plane. As he moves to glue on one of the wings, shoot a close-up insert of his action, showing just his hands and the plane. Now go back to the wide shot, knowing that your audience got a good close view of exactly how to glue the wing. You can also shoot inserts of secondary actions taking place miles away from the primary action. In the example of the little boy lost in the forest, an insert of his mother anxiously looking out the window of their home might be very effective.

## ACTING

Children are quite uninhibited, so when it comes to acting, they have very little trouble. They must remember, though, that a realistic job of acting is necessary to make a good film. A great actor or actress must completely forget self while on camera, and assume the role as if he were, in fact, the fictitious person. A successful actor is not self-conscious and is able to do his job as if he were not acting at all.

The actors must listen to the director's instructions. He is in charge of interpreting the script and it's the actors job to deliver what he calls for. Once the director calls for the "action", the actor must try to forget all around and concentrate on the character he is trying to portray. The children should never look at the camera while acting, unless specifically told to do so. The director should rehearse the scene with the actors several times before actual filming so there will be no mistakes. Again, the actor must concentrate on his job....he wouldn't want a mistake of his to cause costly reshooting.

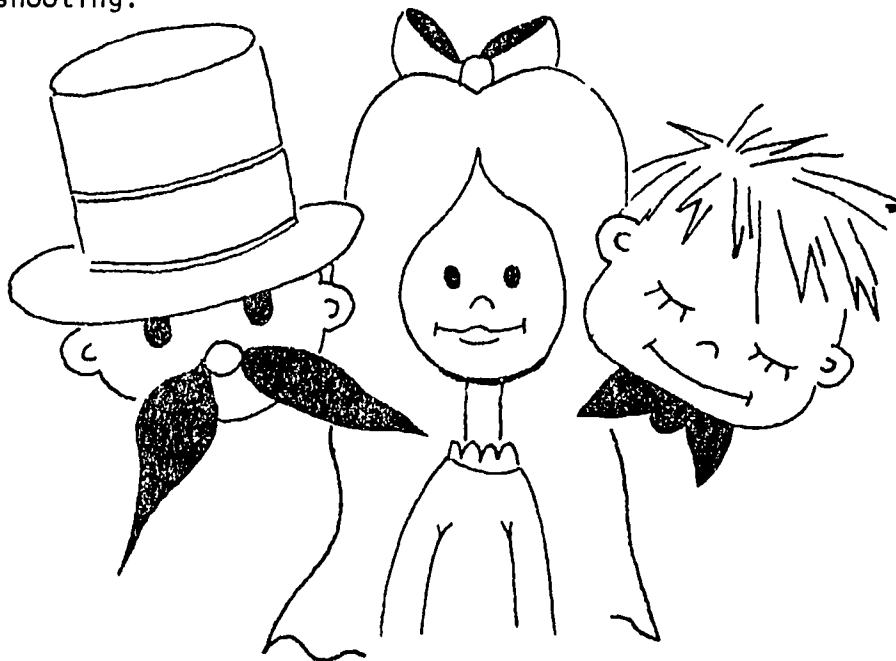

## EDITING

Don't hesitate to edit. In many an opinion, editing is what makes footage look like a production, rather than a home movie. Working with groups in available time needs the flexibility of shooting out-of-sequence. The editing is what puts each scene where it should be to make the story right. A scene that drags when viewing can be shortened. A scene that is too short can be lengthened with inserts. In the event the children shot one scene from several angles, editing can utilize one or all of the angles depending on the effect desired.

The editing equipment is simple to use. It consists of a viewer and two hand-cranked reels. Put the footage on the left hand reel, feed it through the viewer's sprockets and attach it to the right-hand reel. As you crank the right-hand reel, the footage is enlarged and shown on the viewer. The faster you crank, the faster it runs. You can slow the film down to analyze a frame at a time.

After viewing the footage and making the selections, prepare for cutting the footage apart. The editor has a lever that allows you to nick the edge of the footage while viewing, so that later you can cut the film at the original nicks. View each roll, select each scene, and make all nicks before removing the roll from the editor.

Make sure that you are extremely careful in handling the film. Fingerprints, scratches, and dust are very distracting in a movie when magnified by the projector. Wearing white gloves often helps.

If children are to edit: The process of editing is so simple, your class can easily do this if time allows. However, it would be wise to have a duplicate copy made of the original. Keep the original yourself and let the groups edit to their hearts' content. Children will have a difficult time keeping

the print clean, so don't expect their copy to look good on the screen. Their "work print" can easily be conformed to the original by you. Duplicate copies are available for a fraction of the cost of the original. Professional editing is never done on the original.

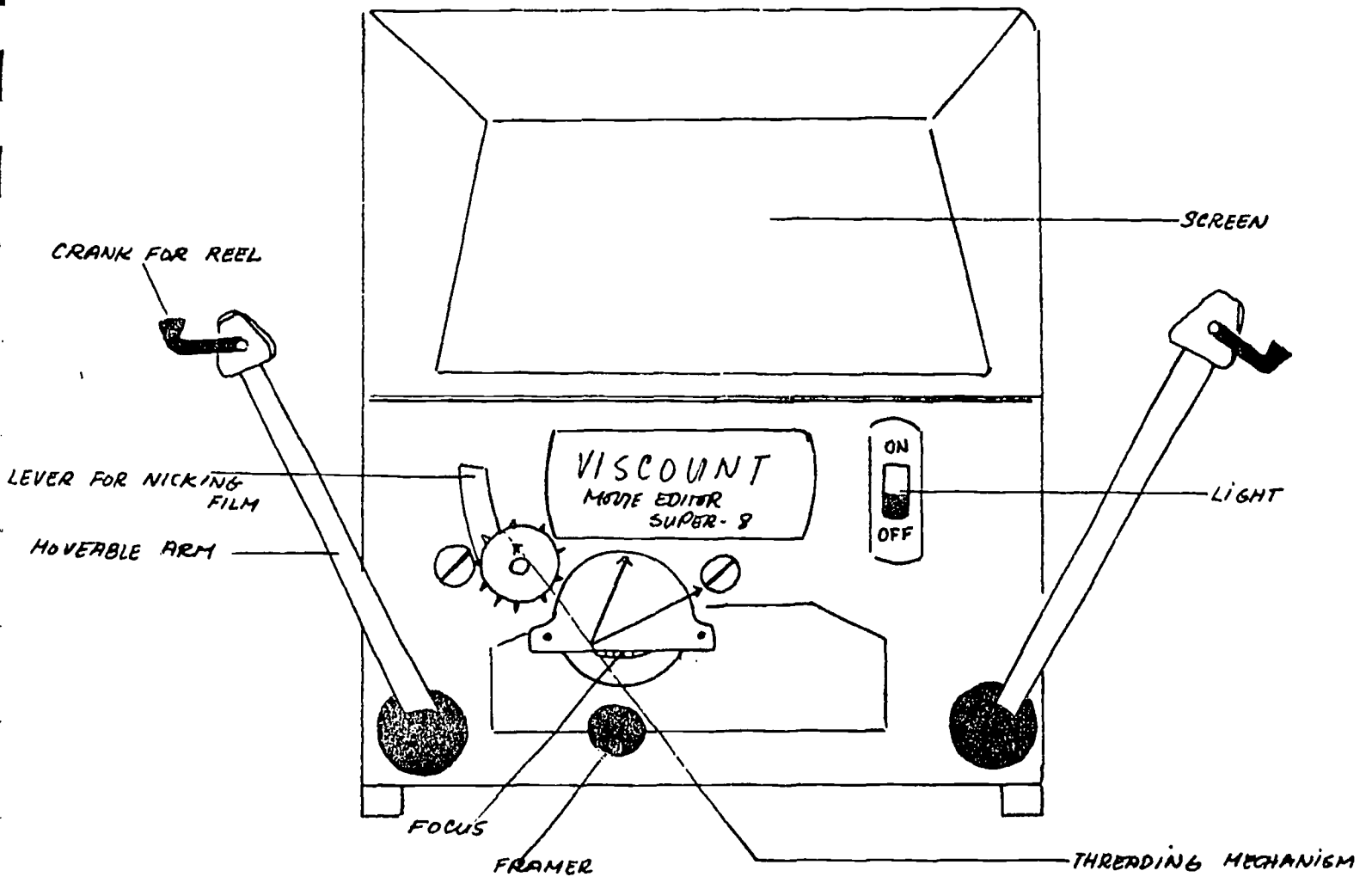

## CUTTING AND SPLICING

There are two types of splicers--tape and cement. Since tape splicing is easier for children to do, we will talk in terms of this type of splicer.

Once the roll of film is removed from the editing machine, locate the first nick you have made. Open the splicer and line up the nick with the blade. Place the splicer's pins in the sprocket holes to secure the footage. Bring down the blade. The cutting is accomplished with straight neat edges. Continue through the roll of film until you have removed all scenes that you wish to use. To avoid confusion later, I recommend slipping a pin through the top sprocket hole and pinning the footage to be used to a bulletin board where you have placed tags labeling each scene. As you remove each scene, place the footage under the appropriate label. Tape all unused film together and place it on an empty reel. You may wish to use some of this footage later.

After all scenes are removed to your satisfaction, you are ready to tape splice. Carefully place the tail of the first scene to the head of the second scene, on pins in the opened splicer. Press the blade down again to make sure all edges are perfect. Then, remove the backing from one side of the editing tape and match the tape's sprocket holes with those on the tail of Scene I. Smooth the tape out. Now pull the backing from the other side of the tape and repeat the procedure on the head of Scene II. This completes one side of your splice. Turn the film over and set the pins in the same sprockets. Tape again. Remove the footage from the splicer and rub the tape to make sure there are no air pockets between the tape and the film on either side.

Continue the same procedure until you have cut and spliced the entire film you have for the show. If you find a scene missing, you can fill in for



the moment with black or white leader. Also put about three feet of leader on the beginning of the film to enable you to thread the projector and add a few feet to the end for a tail.

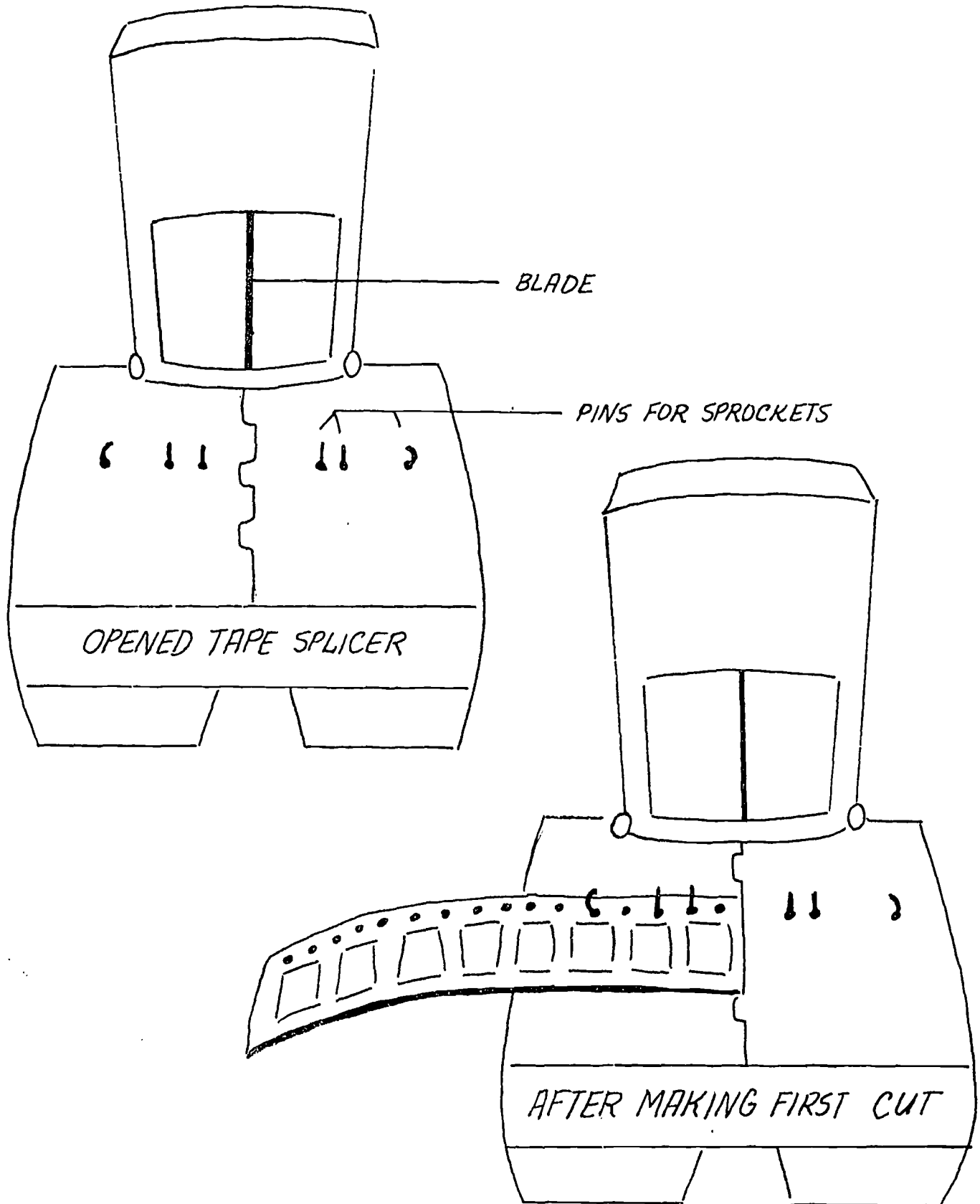

### ANALYZING YOUR WORK

Once the editing has been completed, show the class the film on the projector. They now can see the film running at the proper speed and in proper sequence. Encourage the class to be critical of their work, always keeping the audience in mind. Can others understand your story? Do the cuts seem to be in the right places for a smooth flow of action, or does the film jerk and jump along? Do you need to shoot more footage to fill in dead spots or make some scenes more understandable? Remember, you're looking at the first version of the film. More editing or a few additional scenes may be necessary to improve the production.

Sometimes time and expense will not allow the class to reshoot or re-edit all the things which they feel are not exactly as they had anticipated. However, the next time they make a film they will be more perceptive and benefit from their own mistakes if time is taken to carefully analyze their work.

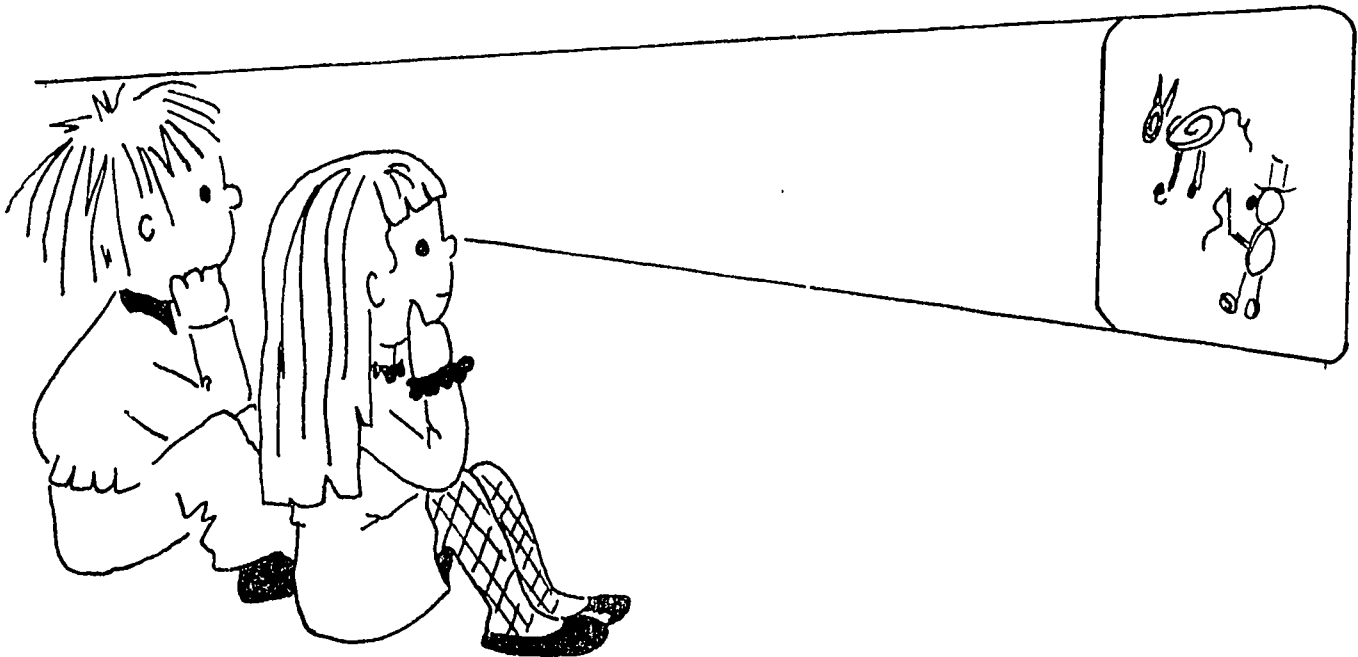

## SOUNDTRACKS

Soundtracks are what make the children's film a real movie! They have heard so many soundtracks in their few years that the components rarely need an explanation. Let the children decide what will enhance their production....sound effects, music, several narrators, or a combination of all? Sound effects can be as creative as there are many....children can find lots of things that will sound like wind blowing through the trees! Music is available on worlds of recordings. They can find a tape or a record perfectly suited for their film. If not, isn't there a musician in the group?

There are just a few tricks to recording a soundtrack in a manner that can be heard to the back of the classroom or to the last row in the auditorium. With the exception of some on-location interviews or special sound effects, always use the large tape recorder in your school, rather than a cassette. A cassette is fine for the children to practice on, but for the final recording, a large recorder will provide much better fidelity.

I usually tape the final recording and rarely have to tape more than twice. Have the children gather in a circle around you, no farther than an arm's length. Place the record player in the circle if music is to be used. After all is quiet, have a child start the recorder (you're holding the mike).. another child starts the projector...another the record player. Hold the mike near the record player for good music volume during the viewing of the titles. As the first narrator begins to speak, move the mike extremely close to him. The narrator is viewing the film as he reads his part to fit the action. When the child has finished, move the mike back to the record player for music. This technique gives the effect of the music fading as voices come up, etc. However, you never need touch the volume of the record player.

Remember, you cannot achieve true synchronous sound in this manner. But voice-over is just as effective in a movie--many professional films are made with no sync-sound. Be sure that your script is flexible enough that it can narrate the action even if the film is five frames ahead or behind what was originally intended.

If by chance you have a camera with a plug-in cassette (Bell and Howell makes one), you can do dialogue. However, you could not edit the film then, without some manner of editing the tape cassette also. The film would have to be shot in sequence with no margin for error.

ANIMATION

## ANIMATION

Animation is giving the illusion of movement to artwork or inanimate objects by filming slight progressive changes a frame at a time. The most frequently used artwork is disjointed paper characters; but don't forget that you can do much the same with toy soldiers, small dolls, clay figures, and other objects. The procedures for filming these subjects are the same as for flat disjointed art work, with the exception of camera placement.

Backgrounds: Before creating moving figures, the children should make the backgrounds for them. Draw the backgrounds (all stationary parts) on large construction paper or matt, which is 24" x 36". A background can be anything at all as long as it depicts where the characters are at a particular time.

After the children have made all backgrounds, they can begin the characters. Stress the importance of proportion. No one enjoys seeing a man ten times larger than his house.

If the character is to face the front, he can be made all in one piece, except for his arms, which the child may want to move. For walking, characters should be made from a side view, with moveable arms and legs.

For movement of birds, cars, boats, and the like, the subjects do not have to have moveable parts for simple animation. A thread can be taped to the bird and it can be pulled slowly across the background.

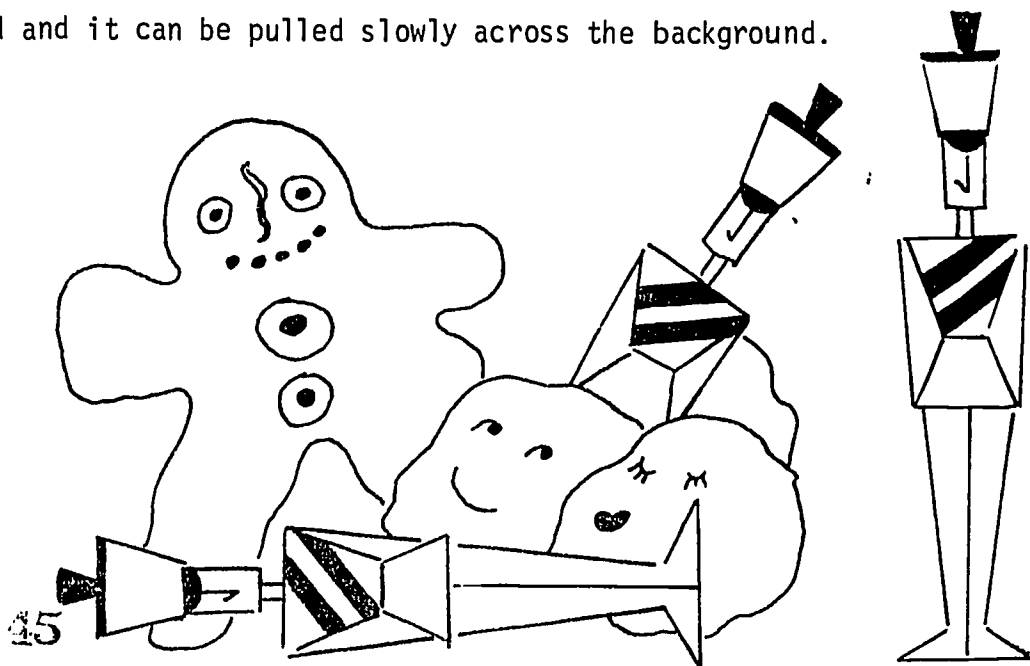

## FILMING FIGURES THAT MOVE

As stated earlier, you probably will need extra lighting for filming animation. Set two movie lights of equal intensity at forty-five degree angles to your flat art-work, which should be placed on the floor. Position the camera on the tripod with the lens pointed down to the floor. Look through the viewfinder to make sure you have enough distance between camera and artwork to allow proper focusing. The artwork must be fastened to the floor so it will not move during filming. Compose your shot so that the edges of the artwork or the floor will not show on the film, and focus sharply. Now all is ready to film your first scene.

When filming objects such as clay figures or dolls, you will have to set up your equipment differently. First you must set the camera in a horizontal position on the tripod. Your background should be mounted on a heavy piece of cardboard across the back of a table. The table will serve as your stage. Use one movie light placed at a 45 degree angle to your subject. The remainder of the filming is done exactly the same way as you would film flat art work.

Single-framing: If you are going to have moving figures, then you will have to use a camera with a single-framing device. This will allow you to shoot one frame each time the button is pressed. Since there are eighteen frames per second in normal Super 8 running time, you have to decide how many seconds it should take to complete the action you want to film.

For example, let's say the script calls for an animated girl to raise a spoon from a bowl of soup to her mouth. Have the children do the action themselves, and time the arm movement with a watch. It takes about two seconds to go from bowl to mouth....that amounts to 36 frames of Super 8mm film. I've found that shooting two frames for each move of the subject gives a good effect, so start by filming two frames of the girl with her spoon in the soup. Now

move her arm upwards just a little bit and shoot two more frames. Move her arm again, shoot two frames, move-shoot, move-shoot, move-shoot until finally she has her spoon at her mouth at the end of 36 frames. When all these individual frames are shown on the projector at normal speed, it will appear that the girl moved her arm all by herself. But remember, the key to good animation is to make moves gradually. Have one child move each part that you wish to animate. Another can operate the single-framer on the camera. It takes quite a lot of time to film animation, but if you rush the filming, the characters won't look real.

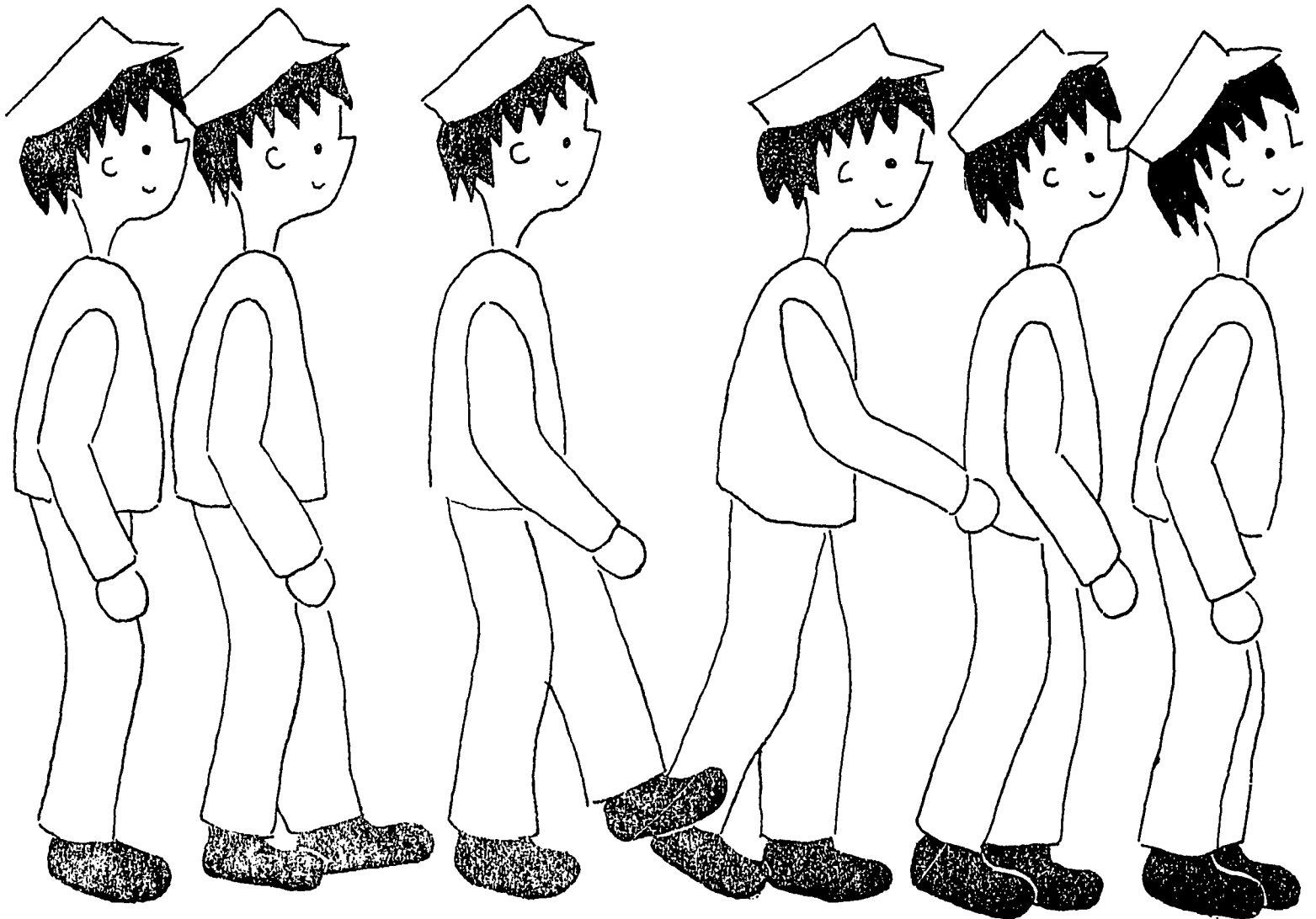

*The Walk*



POSITIONING FLAT ART FOR ANIMATION

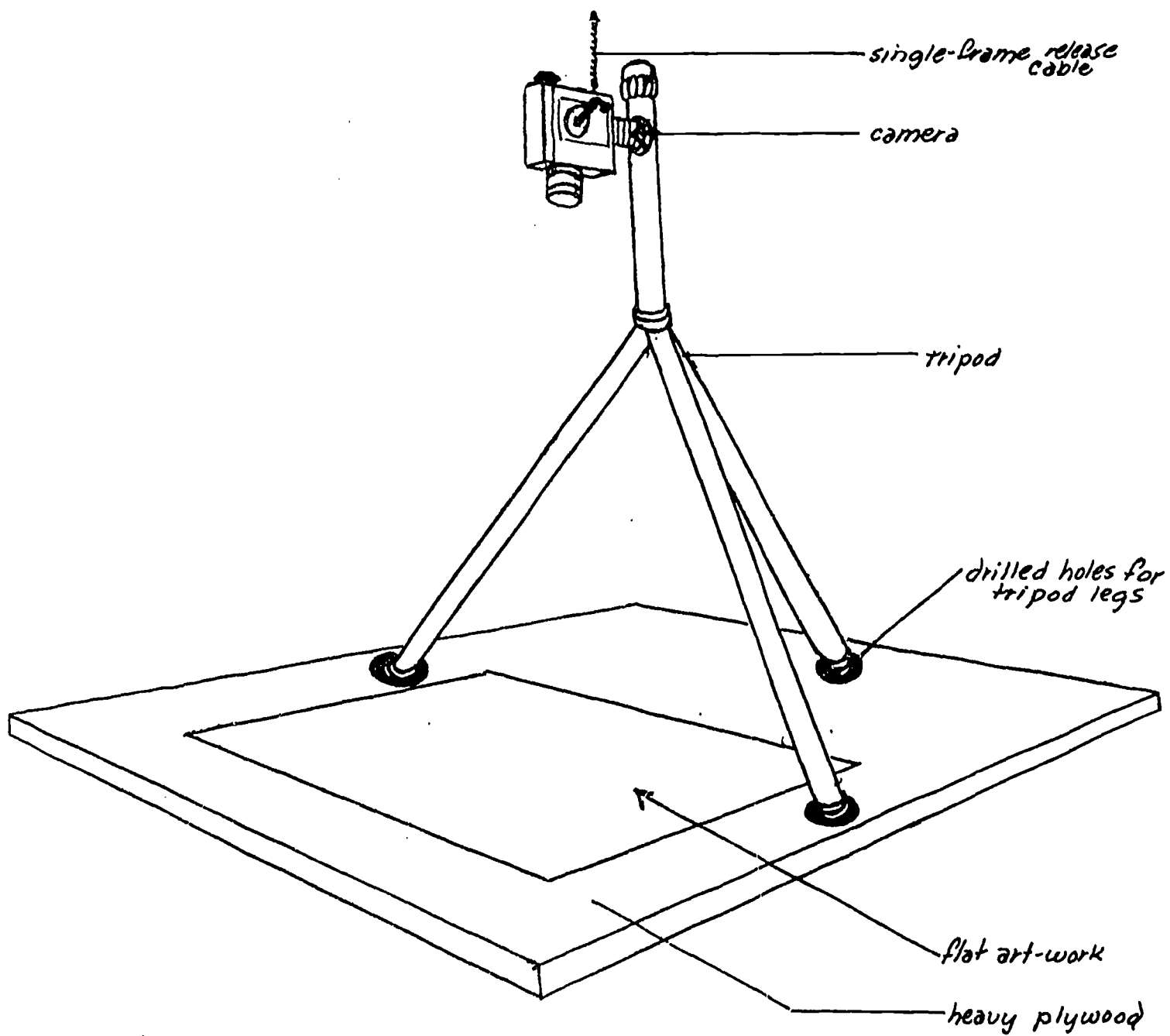

## FILMING FIGURES THAT DON'T MOVE

There are some artwork shows that don't require moving figures or frame by frame shooting. For instance, your students can make a super-size mural six to ten feet long with several situations on it. On the left hand side the children could draw the debtors in English prisons. Next to that you could have James Oglethorpe talking to the King of England about forming the colony of Georgia. In the middle of the poster, the children could draw ships crossing the Atlantic. A little further over you might have the people setting up the colony in Georgia, and at the right, you might see homes being built, farms planted, and people working together. Now, by panning, zooming and other camera techniques, the whole story of the founding of the Georgia colony can be captured on film. The camera is doing the moving rather than the figures themselves.

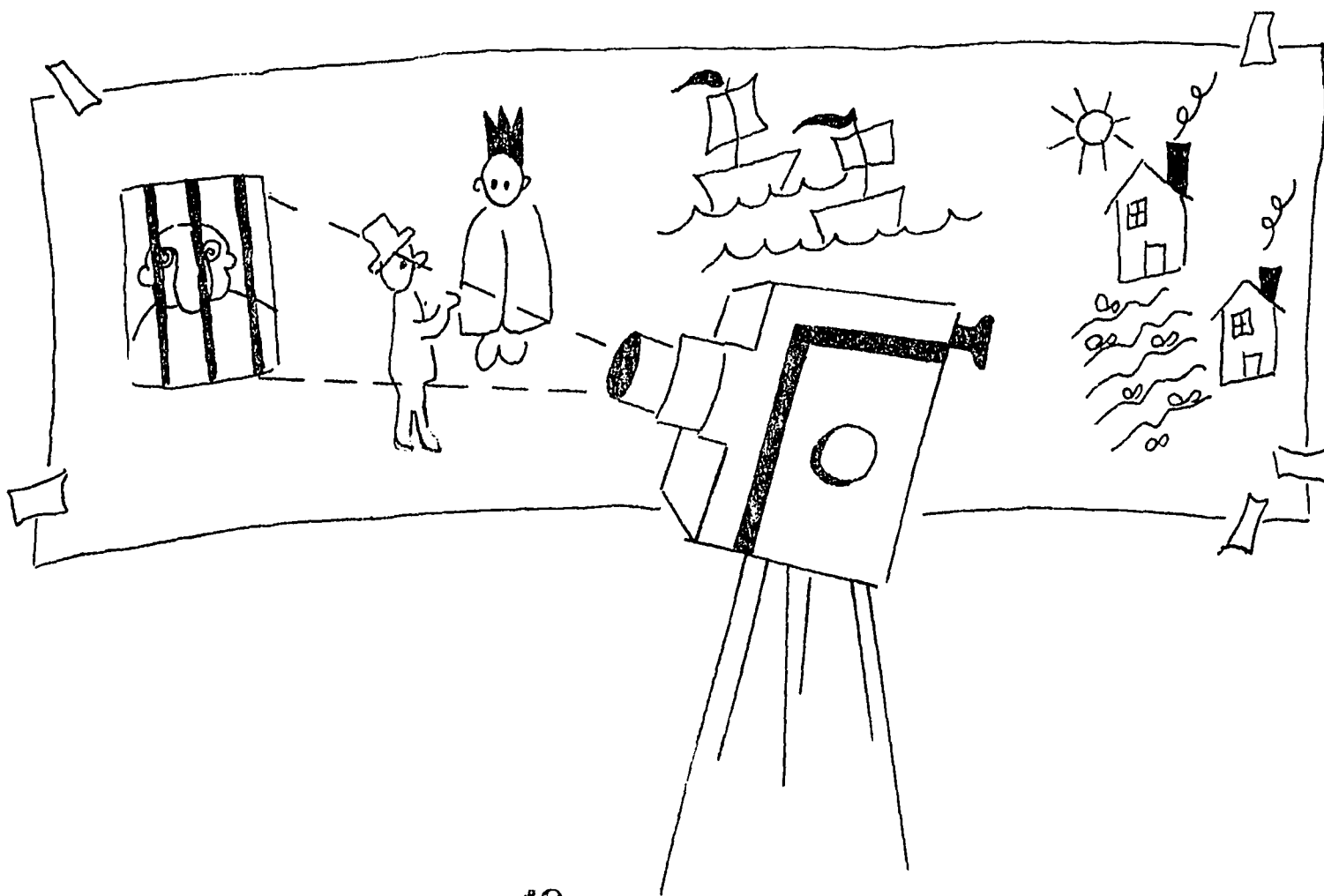

## PHOTOGRAPHS AND MAGAZINE PICTURES

Photographs and magazine pictures are invaluable to the classroom filmmaker. As in "Please Leave it Here for Me", you may need pictures of wild animals that cannot be filmed in live-action. Select all the pictures that will be needed from assorted magazines, cut out the pages, and film them exactly the same way you would for other art work.

The children, for example, could film a child running slow-motion through the thickest brush he could find in the park, and on the editing table cut in beautiful pictures of wild animals filmed from the pages of a magazine. A dream sequence could be filmed showing a child daydreaming under a tree and then cut in scenery from far-away lands.

Don't forget that movement can be added to the still pictures by zooming, panning, tilting, and other motion picture camera techniques.

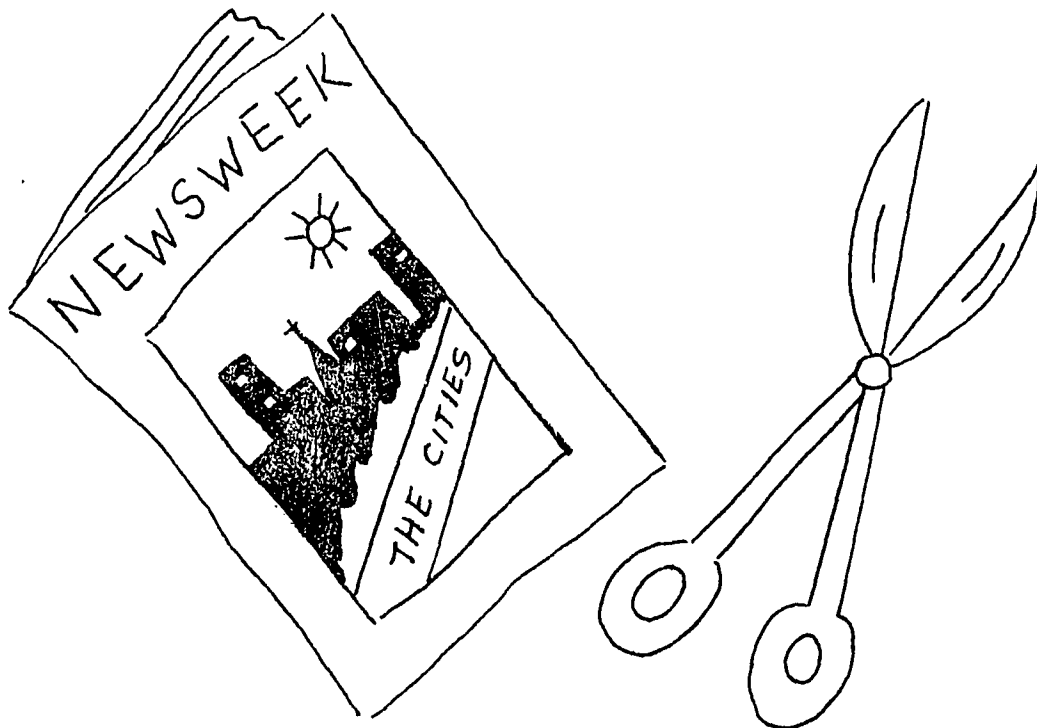

## TITLES AND CREDITS

Children of all ages seem to be as excited over the titles and credits in their movie as in the story itself. Be sure to give credit to everyone involved and for everything a child does. Let the children think of imaginative ways to display their achievements!

There are many ways to create titles and credits and they can be made as interesting as the rest of the show. The easiest method is to simply write the information on a piece of paper and film it. But you can also use letters cut from magazines and newspapers, stencil with pre-cut lettering devices, or make the title and each credit a part of an elaborate piece of art-work your students have designed. The main thing the children must do is make the lettering legible and easy to read.

Filming titles is done easily with cameras that have single-frame exposure buttons. Shoot enough frames to allow your audience to read the information twice. This will compensate for the fact that some people read slower than others. You can also film titles and credits by just running the camera long enough to give the viewer ample time to read the material. Always use a tripod to insure steadiness. Put your materials on the floor or a low table exactly as you would for art-work, set your lights, and begin filming. To avoid a lot of editing, film your titles and credits in the exact sequence they are to be shown in the final production.

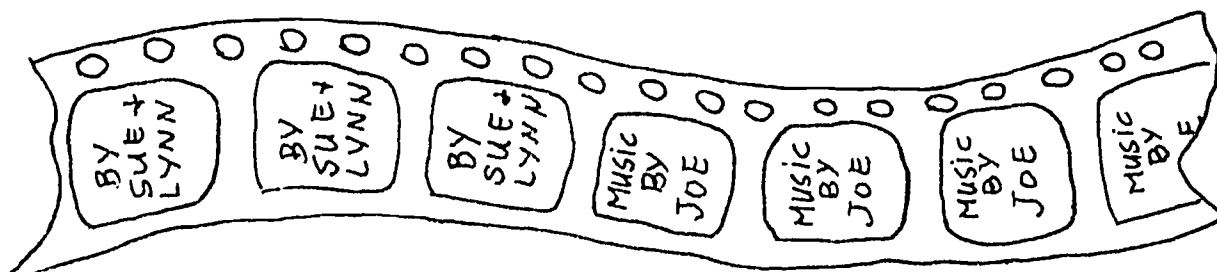

## POP-ONS, SPLIT SCREENS, AND OTHER FUN

Children love magic, so why not add a touch of magic to the show? The single frame device on the camera is good for a lot more than just filming animation. Have the children try some pop-ons or split screens for an exciting effect.

A young girl I know made a great film with pop-on titles...here's what she did. First she made a nice background of trees and flowers with a big blue sky overhead. Then she cut out individual paper letters for the title of her show. She began by filming several frames of only the background.... then she added one letter at a time across the sky, filming ten frames for each letter. When she was finished, it appeared that the title of the film spelled itself across the background. At the end of her show she used the same pop-on effect for her credits. The result was quite professional.

Split screens are a thrill to children, too. This technique allows you to present several ideas on the screen as a single unit. Let's say that the children want to show the life-giving effects of the sun. First, have the children select magazine pictures of the sun; a beautiful field of wheat, a budding rose, a tall tree, and a lawn of rich green grass. Arrange the photographs on a sheet of large black paper in a pleasing layout. Perhaps they'll want to put the sun in the middle, and group the pictures of growing things around the sides. Look in the camera's viewfinder and make sure all the pictures fit within the frame. Now, with the layout firmly fixed in everyone's mind, remove the pictures. Begin filming by shooting several frames of the black background. Stop the camera and put the picture of the sun in the middle of the layout. Shoot several frames of the sun and stop again. Now, without moving the picture of the sun, put your next picture in its proper place on the background. Shoot several more frames, and continue

the procedure until all the pictures surround the sun have been photographed. When projected, the film will first show the sun, then follow with all the marvelous things it makes grow.

Recently, I saw a live-action film showing a girl relaxing on a float in a swimming pool. Suddenly she disappeared, leaving an empty pool behind. Next was a scene of a rooftop, and just as quickly as she had vanished, the girl reappeared on the rooftop, still sitting on the rubber float! This film was made by a Horton Watkins high school boy who positioned his camera on a tripod at poolside, carefully framing his sister on the float. He shot a few seconds of film, then stopped the camera while the girl got out of the pool and the water settled. Then he shot a few more seconds of the empty pool, moved his camera to a new position and shot another scene of the rooftop. Again he stopped his camera while his sister climbed onto the roof and got on her float. A few more seconds of film completed the effect. You can imagine how my students enjoyed such antics on the screen.

These effects can all be duplicated with the Super 8mm cameras, but remember the effect won't work if you do not use a tripod and keep the camera absolutely still between takes.

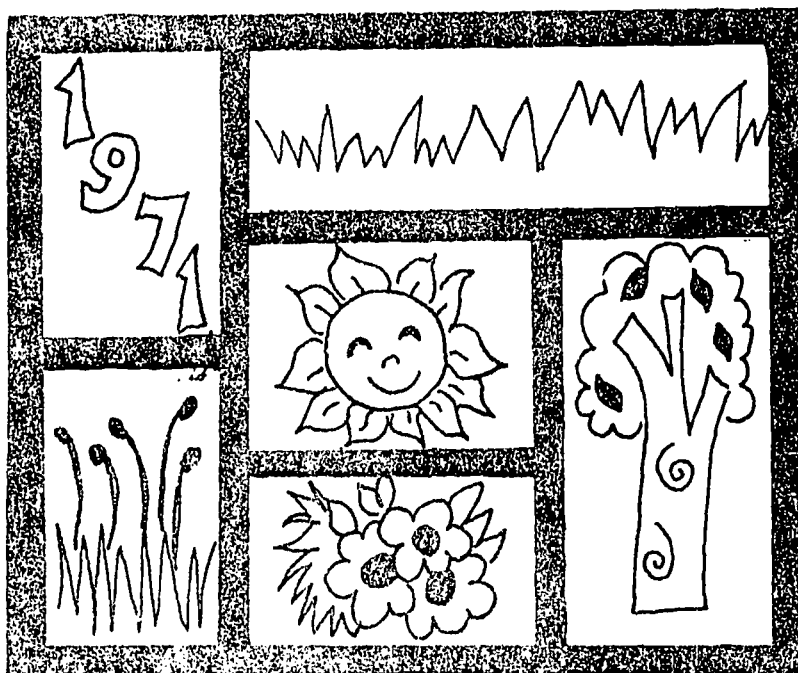

## IDEAS FOR POSSIBLE FILMS IN GRADES 4, 5, and 6

### GRADE FOUR:

#### Social Studies:

Social Science - situations filmed live-action as children role-play  
 Dignity, Status, and Rationality - interpretations of these  
 St. Louis - combination animated and live-action film showing the  
 growth and development of our city and county

#### Science:

Solar System - Animated film of the basic principles by which it  
 operates  
 Plants and Animals - Documentary of zoo and Climatron. Live-action  
 filming of specific plants and animals. Animated section on  
 extinct species  
 Chemical and Physical Changes - All manner of elaborate experiments  
 through one-idea films  
 Climate and Its Effect on Man - Animated film on climatic zones and  
 wind currents  
 Magnetism and Electricity - Animated film on how electricity is  
 produced. Documentary on power plant

#### Language:

Interpretations of fiction, creative-writing, drama  
 One-Concept films to illustrate specific points

#### Math:

Polygons - Film showing all types of polygons and relationship to  
 the real world  
 Measurement - Animated and live-action film showing how measurement  
 is used by all everyday

### GRADE FIVE:

#### Social Studies:

Cultures in Conflict - Interpretations of prejudice, discrimination,  
 cultural differences, etc.  
 Riverside, U. S. A. - Documentary on assembly line  
 American History - Animated or live-action enactments of many historical  
 happenings

#### Science:

Geology - Animation of the birth of the earth, rock formation  
 Weather - Time-lapse of a day in passing, animation of the causes of  
 the seasons, etc.  
 Conservation - Documentary on trip to farm or wildlife preserve.  
 Animated film on the balance of Nature. Live-action film showing  
 environmental pollution in St. Louis  
 Human Body - One-concept films for many experiments

**Language:**

Interpretations of fiction, creative-writing, drama  
 One-concept films to illustrate specific points in grammar

**Math:**

Experiments with fractions  
 Geometric figures  
 Enactment of complicated story problems

**GRADE SIX:****Social Studies:**

Urbanism - Live-action film on how urbanism affects us now and later.  
 Urban renewal, pros and cons  
 Political Geography - Animated film, containing many photographs and  
 magazine pictures, of a world-wide trip, emphasizing needs in  
 urban centers around the world

**Science:**

Man in Space - animated film exploring the Universe  
 Reproduction of Plants and Animals - live-action film showing spore-  
 reproduction, a sexual reproduction and other experiments  
 Molecules and Atoms - animated film on molecular theory

**Language:**

Interpretations of fiction, creative-writing, drama  
 One-concept films to illustrate specific points in grammar

**Math:**

Enactment of complicated story problems  
 Visualizing abstract problems  
 One-concept films on geometric constructions

Note: These Ideas are not given primarily as suggestions for actual pro-  
 ductions, but to illustrate how film-making can be incorporated into all  
 phases of the curriculum.



EQUIPMENT CURRENTLY AVAILABLE IN LADUE

- (1) KODAK-Instamatic (M-95) Movie Projector Super 8 or Reg. 8
- (1) VISCOUNT Movie Editor 45-A for Super 8 Film
- (1) DA-LITE Portable Screen 4' X 5'
- (1) BOLEX (155) Super 8 Movie Camera Manual Zoom  
Cable Release for Single Framing & Bolex-lite S2
- (1) STAR D Adjustable Tri-Pod
- (1) BOLEX Mini-Pod with Case
- (1) KODAK EKTAGRAPHIC Carousel Projector
- (1) KODAK Dissolve Unit (controls two projectors at once, manual, automatic  
and remote controls)
- (1) 141 CASSETTE Recorder
- (1) KODAK Presstape Universal Splicer
- (1) KODAK M-100 Super 8 Projector

BOOKS CURRENTLY AVAILABLE IN LADUE THROUGH THE INSTRUCTIONAL  
PLANNING CENTER

1. "Teaching Film Animation to Children,"  
(Anderson, Yvonne)
2. "Make Your Own Animated Movies,"  
(Anderson, Yvonne)
3. "How to Shoot a Movie Story,"  
(Gaskill, Arthur & Englander, David)
4. "All-in-One Movie Book,"  
(Petzold, Paul)
5. "Children As Film Makers,"  
(Lidstone, John & McIntosh, Don)
6. "Guide to Filmmaking,"  
(Pincus, Edward)
7. "The Technique of Film Editing,"  
(Reisz, Kavel & Gavin, Millar)
8. "Creative Film-making"  
(Smallman, Kirk)
9. "Filmmaking"-Folder:  
contains:
  - (a) Editing Your Movies
  - (b) Making an Outdoor Movie
  - (c) Your Programs from KODAK
  - (d) Sources of 2 x 2 inch Color Slides
  - (e) What happened to my Movies?
  - (f) Getting the Most Out of Your 8mm Film
  - (g) Close-up Movies
  - (h) Directory of Nontheatrical Film  
Producers and Distributors
  - (i) Movies with a purpose
  - (j) Slides with a purpose
  - (k) Suggestions For Conducting Film  
Competitions and Film Festivals
  - (l) An Incomplete Bibliography on Visual Literacy
  - (m) Motion Picture an AV Publications  
Selected References
  - (N) A filmography of Films About Movies  
And Movie-Making
  - (O) Elements of Visual Literacy
  - (P) Visuals Are a Language
  - (Q) Sources of Motion Pictures and Filmstrips
  - (R) Materials for Teaching Visual Literacy

## THE PRODUCER'S LANGUAGE

- animation -- the illusion of movement given to artwork or inanimate objects. Done with single-frame photography.
- audio-visuals -- the term used for productions employing both sight and sound. Can also be used to describe equipment needed for these productions.
- aperture -- the amount of lens opening required for correct exposure of the film. (See iris)
- automatic exposure control -- A built-in device in the camera that senses light and sets the correct aperture.
- cassette tape recorder -- small, light-weight recorder run on battery power. Ideal for on-location recording or making practice soundtracks. Fidelity is not as good as may be obtained with larger recorders.
- chaplinesque -- refers to quick, jerky movement of action on the screen. Done by shooting the camera at a slower speed than normal.
- cinema-verite -- an impressionistic style of making films popular with "underground" film-makers. No script is used. The story is made up as filming progresses.
- close-up -- (CU) a shot made from a camera position quite close to the subject. A face shot would be a CU.
- close-up lens -- an auxillary lens, put in front of the camera's normal lens for extreme close-up photography.
- credits -- a list of people involved in making an audio-visual production. Can appear either at the front or the back of your film or slide-show.
- cue -- a mark on your slide script to show where the projector must be advanced to the next picture. Also means setting your tape recorder and film projector so that they will start together at the correct place and time.
- cut -- a word used in the script to tell director and editor to move from one scene to the next. As in "cut to shot of boy walking up stairs...cut to shot of boy entering door." Also refers to physical cutting of film on the editing table. Directors will say "cut" when they want their cameramen to stop the camera.
- develop -- processing of film or slides at the laboratory.
- dissolve -- one scene fades out while another fades in...the two scenes overlap in the middle. Can only be done with specially equipped camera.

- emulsion -- the chemical substance on the film that allows images of light to be captured.
- fade-in -- the screen starts black, then slowly the scene is revealed.
- fade-out -- the scene slowly goes to black.
- film cartridge -- pre-packaged film used in most Super 8 cameras. No threading is required.
- film speed -- an expression of the amount of light required to expose the film emulsion. A film is "slow" if it requires lots of light for proper exposure. A "fast" film requires less light.
- filter -- a piece of colored glass placed in front of, or behind the lens. A number 85 filter is used to correct indoor film for outdoor shooting.
- focus -- to sharpen an image in the camera's viewfinder by adjusting the lens. Also means sharpening a scene on the screen by adjusting the projector's lens.
- footage -- exposed film.
- frame -- a single picture on a roll of movie film. There are 18 frames per second in normal Super 8 running time. Frame also means to compose your scene in the camera's viewfinder.
- f-stop -- a statement of the amount of aperture given your camera's lens. On most camera's, f22 means the iris in the lens is almost completely closed, allowing very little light to pass through. This would give the correct exposure in very bright sunlight. For exposure in very low light, you may have to adjust the f-stop to f2.8 so that the iris is opened up all the way, allowing as much light as possible to reach the film.
- iris -- a circular fan within the camera lens that can be adjusted manually or automatically to allow the proper amount of light to reach the film.
- leader -- black, white, or clear spocketed film used at the beginning or end of a film. Available at most camera stores, and necessary for editing.
- light meter -- a device for measuring light and determining f-stops. Necessary if you have a camera without automatic exposure control.
- live-action -- filming people or things in true-to-life situations.
- location -- the place where filming is to be done. There may be several locations for a single film.
- medium shot -- (MS) a shot made at a medium distance from the subject. A head, shoulders and waist shot would be a MS.

- movie light -- a light designed especially for film-making. Corrected for use with color film. Regular light bulbs will not give you the true colors of your subject.
- out takes -- scenes removed from the original footage by the editor. Will not be included in the final production.
- overexposure -- too much light on the subject or too big an iris opening causing the film to look washed out.
- pan -- to move the camera from side to side to follow action, or to give movement to still artwork or photographs.
- props -- any materials or objects needed to add realism to a scene, such as furniture, a bicycle or artificial snow.
- quick-cuts -- very short pieces of film spliced together to give a fast-moving choppy effect.
- rewinds -- hand cranked reels that allow the editor to run film back and forth through his viewer.
- ripple dissolve -- an effect achieved by moving a piece of rippled glass across the camera lens at the tail of one scene and the head of the next scene.
- running time -- the amount of time a scene will consume on the screen.
- script -- the blueprint for your production. Lists each scene in order along with the accompanying soundtrack.
- set -- if you can't find a location that suits your needs, you can make one. An artificial location is called a set.
- shutter -- a metal disk that revolves in front of the film inside your camera. At normal speed in Super 8mm, the shutter revolves 18 times per second, exposing 18 frames of film.
- shutter speed -- refers to the number of times the shutter revolves per second. 12 frames per second will give you a Chaplinisue effect, 18 frames will give you normal motion, and 24 frames will give you slow motion.
- slow motion -- refers to slow, exaggerated movement of action across the screen. Done by shooting the camera at a faster speed than normal.
- slate -- a small chalkboard used for identifying scene number and take number.
- splice -- to join two pieces of film together with tape or film cement. Tape splicing is easiest.
- splicer -- a device used to correctly align and join pieces of film together.

- sprocket holes -- the small holes along the film's edge which are used to pull the film through the camera and projector.
- stock -- unexposed film.
- swish pan -- a fast pan of the camera, blurring all in sight.
- sync sound -- sound-with-picture....sound that matches all lip movements and actions perfectly. Must be done with special equipment, and is not very satisfactory in Super 8mm.
- take -- a single attempt at filming a scene. At least two attempts or "takes" are usually necessary to get everything just right.
- threading -- looping film through a camera or projector.
- tilt -- to move the camera up and down to follow action, or add movement to still artwork or photographs.
- trims -- small sections of film from the head or tail of a scene not used in the final production. Always carefully save your trims so that you can lengthen the scene again if it seems to short on the screen.
- tripod -- a three-legged stand that gives stability to a camera while filming. The part of the tripod to which you attach your camera is called the "head".
- underexposure -- too little light on the subject, or too small an iris opening, causing the film to look dark.
- viewer -- an editing device which allows the editor to look at footage, fast or slow, or a frame at a time.
- viewfinder -- a rectangle through which the cameraman looks to frame his subject and focus.
- voice-over -- narration. The term means voice-over-picture rather than voice-with-picture as in sync sound.
- wide shot -- (WS) a shot taken some distance from the subject. A head-to-toe shot showing both background and foreground would be a WS.
- zoom lens -- a lens that enables the cameraman to shift from a close-up to a wide shot without stopping the camera. Most Super 8mm cameras are equipped with a zoom lens.

Published through the services  
of the Ladue Instructional Planning Center

Warren Green	Director
Sarah Leonard	Secretary
Charles Edwards	Printer
Betsy King	Ass't. Printer
Jackie Lichius	Media Assistant

Dr. Franklin P. Morley, Executive Director  
Assistant Superintendent in  
Charge of Instruction

Dr. Charles D. McKenna, Superintendent

© School District of the City of Ladue, 1971