

DOCUMENT RESUME

ED 066 920

EM 010 307

AUTHOR Kitzes, Esther; Knox, Helen
TITLE Britain's Open University; A Report to the Task Force on External Studies of the University of Pittsburgh.
INSTITUTION Pittsburgh Univ., Pa.
PUB DATE Jul 72
NOTE 97p.

EDRS PRICE MF-\$0.65 HC-\$3.29
DESCRIPTORS Adult Education; Colleges; Costs; *Educational Radio; Experimental Colleges; *Higher Education; Instructional Design; Instructional Media; Instructional Technology; *Instructional Television; *Multimedia Instruction; Operations Research; University Extension

IDENTIFIERS *Open University

ABSTRACT

The Open University (OU), an advanced multimedia instructional system, was established by the British government to provide university and professional education to those with the ability to continue their education by study in their own time, and particularly to those who could not otherwise obtain education at a university. This overview describes the purposes and methods of the OU in its introduction, and then concentrates on individual aspects of the university in subsequent sections. The first section describes the responsibilities and philosophy of the vice chancellor of the OU and provides some details about the students and administration. A chapter on television and radio discusses the OU's fairly extensive use of these media for instructional purposes, providing information on expenses, broadcasting schedules, and how students and faculty use these media. The objectives of the OU are defined in the next section, and then a section on course production in conjunction with the specified objectives is presented. The OU's study centers, library facilities, summer sessions, testing procedures, and costs are discussed in the next few sections, and a chapter on OU's students concludes the report. (SH)

ED 066920



THE OPEN UNIVERSITY

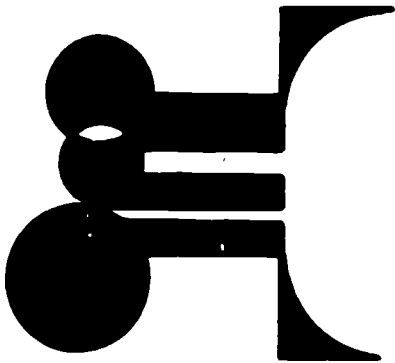

**A REPORT ON BRITAIN'S
NON-TRADITIONAL UNIVERSITY**

**Prepared for
The Task Force on External Studies
at the University of Pittsburgh**

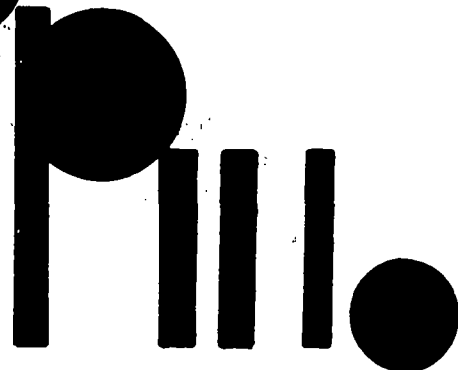
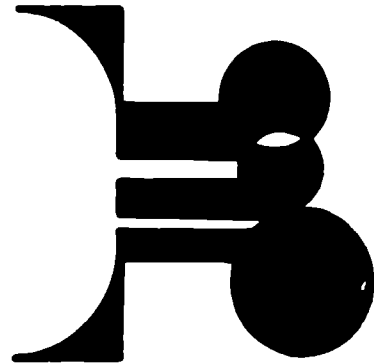

FILMED FROM BEST AVAILABLE COPY

EM 010 307

"We are dealing with an enormous number of people (students) who are as different as chalk and cheese"

--Perry

"The alumni of the Open University will provide the real push - but we don't have any of them yet."

--Perry



THE OPEN UNIVERSITY

"This is the first time in history that we've taken a bunch of first class academics and put them down in a situation where they have nothing else to do except devise the best teaching system that could be devised."

--Dr. Walter Perry
Vice Chancellor

"These people are so hungry for education they go until all hours cramming it in, gorging it,"

--Greville Rumble,
commenting on
summer sessions

"It is no longer necessary to argue that the broadcasting media, when imaginately used, are effective means of teaching."

--Planning
Committee, OU

"The study centers give our students a sense of belonging."

--Perry

"Higher Education is a basic human right"
--Planning Committee
The Open University

"The faculty made all my predictions (on academic standards) absolutely cockeyed." --Perry

"The first estimate was wildly optimistic." --Brian Lewis,
Curriculum Development

BRITAIN'S
OPEN UNIVERSITY

A Report to the Task Force
on External Studies
University of Pittsburgh
July 1972

U.S. DEPARTMENT OF HEALTH,
EDUCATION & WELFARE
OFFICE OF EDUCATION
THIS DOCUMENT HAS BEEN REPRO-
DUCED EXACTLY AS RECEIVED FROM
THE PERSON OR ORGANIZATION ORIG-
INATING IT. POINTS OF VIEW OR OPIN-
IONS STATED DO NOT NECESSARILY
REPRESENT OFFICIAL OFFICE OF EDU-
CATION POSITION OR POLICY

Esther Kitzes
Department of Educational
Communications and Technology
Room 233 D. Lawrence Hall

Helen Knox
Office of the Chancellor
107 Cathedral of Learning

The University of Pittsburgh
Pittsburgh, Pennsylvania 15213

BRITAIN'S OPEN UNIVERSITY

A Report to the Task Force on External Studies
at The University of Pittsburgh

CONTENTS

INTRODUCTION.....	1
HEADQUARTERS AND HEAD MAN Walton Hall and Dr. Walter Perry.....	7
TELEVISION AND RADIO One Out of Ten Study Hours.....	19
PHILOSOPHY BEHIND COURSE DESIGN.....	27
COURSE PRODUCTION AT THE OPEN UNIVERSITY.....	31
STUDY CENTERS Putting a Face to the University.....	42
LIBRARY FACILITIES Every Librarian Is an OU Librarian.....	45
SUMMER SESSIONS A Taste of Campus Life.....	47
TESTING AT OU The Computer and the Tutor.....	48
THE PRICE TAG A Quick Survey of Costs.....	49
STUDENTS As Different as Chalk and Cheese.....	53

INTRODUCTION

To answer some of the questions posed by a University of Pittsburgh task force on external studies, we included a visit to The Open University in a trip through the British Isles in May of this year.

The Open University (OU) was established by the British government "to provide university and professional education to those with the keenness and ability to continue their education by study in their own time, and particularly to those who could not otherwise obtain education at a university."¹

The instructional system being used by OU is generally accepted to be the most advanced and sophisticated multi-media instructional system for teaching large numbers of students at a distance.

OU is now in its second full year of operation with an estimated 37,000 plus students. Its 75-acre administrative campus is called Walton Hall for the structure which was on the site when OU took over and which now serves as the main administration building. The campus lies about 40 miles north of London, just outside of Bletchley in Buckinghamshire. There, OU generates such a blizzard of mail that it has its own branch of the post office. (Each student gets some nine major mailings a year, including units for 36 weeks of study, broadcast schedules and reading lists. All assignments come through Walton Hall at least once. Finally, OU answers between 1,500 and 3,000

¹Guide For Applicants For Undergraduate Courses 1973. The Open University, P. O. Box 48, Bletchley, Bucks, England.

inquires a week from prospective students.)

About 200 full-time faculty and a like number of staff are located at Walton Hall while another 4,500 part-time tutors and counselors run 300 study centers in 13 regions throughout the British Isles. Although it has no traditional campus, OU boards its 37,000 plus students on conventional campuses for a one or two week summer session.

This year, OU is offering 24 year-long courses in six broad areas: the humanities, science, technology, mathematics, social science, and educational studies.

It will log 540 hours of television and almost as many radio hours before its 1972 sessions are concluded.

The academic year is 10 months long, from January through October.

In 1973, OU will have an operating budget of \$26,500,000.

During our stay in Britian, we taped lengthy conversations with top OU officials, toured the Walton Hall campus, visited the British Broadcasting Corporation's OU production center outside of London, examined a sampling of the voluminous outpouring of printed correspondence materials, visited a study center, sampled student opinion, took in several BBC Open University "classes" and talked to other educators about the university.

Out of this ocean of material, four islands emerged which seemed to us to be most significant in insuring the workability of the institution.

(1) Academic Respectability. The initial plans for OU were greeted with a great deal of skepticism on the part of educators. The appointment of an academically star-studded planning committee set the stage. The resultant top academic

appointments put most fears to rest. Still, non-traditional though the university is, its leaders are at pains to be conventional in the types of subject matter offered. The faculty was chosen for academic suitability alone (broadcast or communications skills were not considerations). Even the BBC's OU staff members were selected primarily for academic credibility. The OU cut a wide swath around popular scientists or artists. As a result, Dr. Walter Perry, OU's Vice Chancellor (the position is equivalent to chancellor or president in the U.S.), says the faculty "made all my predictions absolutely cockeyed because they set standards so infinitely much higher than I would ever have dreamed...The standards are too high, if anything. They are flogging the students, poor dears."

(2) Single purpose. Long-distance instruction for adults is not a sideline at OU; it is the sole purpose and all energies are channeled toward making the system as effective as possible. Members of the faculty work almost exclusively on designing the material; they have virtually no other duties.* Teaching is limited to an occasional presentation on television. Vice Chancellor Perry says: "This is the first time in history that we've taken a bunch of first-class academics and put them down in a situation where they have nothing else to do except devise

*The exception is the Institute of Educational Technology which--in addition to curriculum building and course development--is engaged in the analysis of subject-matter competency, measurement of student achievement, analysis of student abilities, among other studies.

4

the best teaching system that can be devised." Dr. Perry believes that OU's greatest contribution (beyond providing thousands of people the means of obtaining a university education at home) will be the creation of an educational systems design that will make its impact on all of higher education. "What we do to bring up the standards of education in all the other institutions will be enormous," he said.

(3) Self-Improvement. The university is a self-improving system and has deliberate financial provisions for renewing courses. Some of the TV and radio broadcasts can be remade each year, and about a third of the printed matter must be revised yearly. The life of a course is four years, after which the whole of it may be rewritten.

(4) Special British Characteristics. (a) The size and population density of the British Isles have made it possible for The Open University to achieve an economy of scale; (b) Britain has the federally-financed BBC; (c) Britain provides direct federal support for higher education; (d) Britain has a national accreditation system.

In summary, we believe The Open University is viable because:

- * It has achieved academic respectability;
- * It has concentrated the efforts of all staff and faculty on a single purpose;

- * It has provided for its own improvement;
- * It has been able to capitalize on special physical and financial characteristics peculiar to Britain.

One additional element, however, has not been considered. Call it planning or luck, audacity or courage. Whatever the mysterious ingredient, it has caused many things to work when, by all rights, they should not. For example, what assurance did the planners have that academics who had no broadcasting experience could work out as effective communicators on the TV screen? What hope could anyone hold that a given 15 or 20 professors, many of whom were in clear disagreement, could work together to design an integrated course? What odds were being played by enrolling adult students without any prerequisites and submitting them to a rigorous undergraduate curriculum?

At times we got the feeling that the entire complicated system works simply because it must. We got the feeling that courses are produced in 18 months precisely because 18 months is not enough time.

In no way do we mean these comments to disparage the enormous amount of research that has led up to the OU system. It is a system design that carries out and evaluates the total learning and teaching process in terms of specific objectives. It is based on research in human learning and communication and incorporates the software and hardware born of the communications revolution. The Carnegie Commission on Higher Education repeatedly cites The Open University for its use of the new technology.²

²Carnegie Commission On Higher Education, Instructional Technology in Higher Education. Clark Kerr, Chairman. New York: McGraw Hill, 1972.

OU planners were on solid ground in most of their projections. Still, we were reminded of Italian physicist Enrico Fermi, who, after assuring the American government that an atomic bomb should work, had to admit that it might not. He capped the whole thing off by saying even if the project was unsuccessful it was worth undertaking anyway "just so we could know that an atomic bomb wasn't possible." Perhaps OU's architects had similar moments.

It is not our intent, however, to evaluate The Open University system. Further it is not our intent to determine whether all or part of The Open University system could be incorporated in the United States, by any of the states, or by any specific university.* We did, however, visit the OU Marketing Division so that we could bring back samples of the study materials for independent examination by The Task Force on External Studies at the University of Pittsburgh. We also have included in this report a detailed analysis of the curriculum development work of the course team in the hope that it may be of value to the task force.

The balance of the material is an account of what we saw and heard. The three-hour conversation we had with Dr. Perry was most helpful in correcting misinformation disseminated in the mass (and, yes, scholarly) media about The Open University.

*Four American institutions currently are studying the adaptability of parts of the OU system. They are Rutgers, Maryland, Houston and San Diego. Rutgers will undertake a one-year trial of some of the materials this September. The Educational Testing Service of Princeton, New Jersey, will evaluate the experiment.

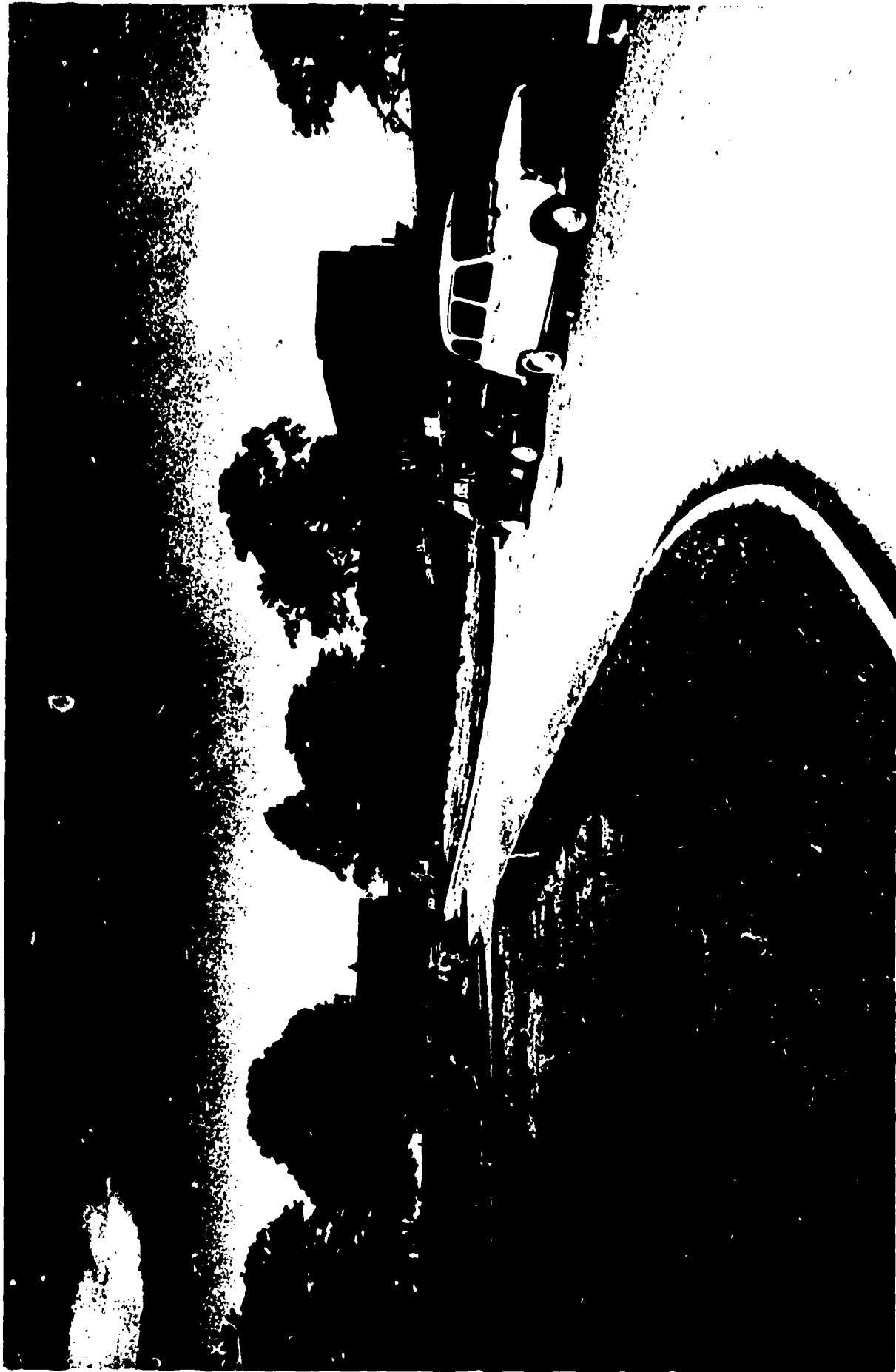

THE OPEN UNIVERSITY - Walton Hall
campus, outside of Bletchley, Bucks
England -- Photos by Esther Kitzes



Walton Hall, left. New extension
houses academic, administrative
functions. Photo by Kitzes



Walton Hall
Photo by Kitzes

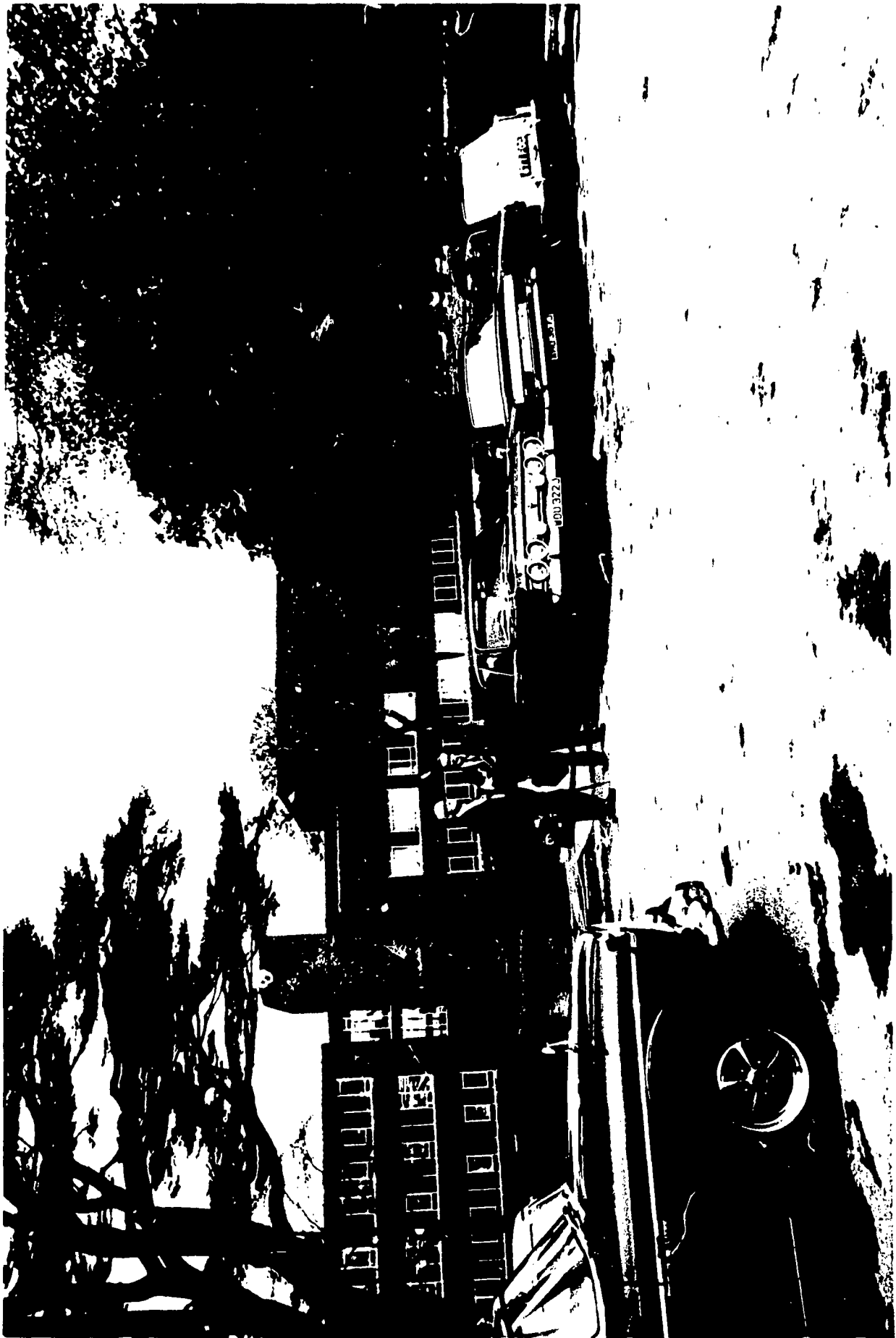

A campus without students
Photo by Kitzes



The Mount (Marketing Division)
Photo by Kitzes

© 1980 Kitzes



Signpost campus guide
Photo by Kitzes

HEADQUARTERS AND HEAD MAN
Walton Hall and Dr. Walter Perry

In Britain, the vice chancellor of a university is the chief academic and administrative officer, the individual responsible for the day to day operation of the institution. The Vice Chancellor of the Open University is Dr. Walter Perry, a physician and the former Deputy Vice Chancellor and Professor of Pharmacology at Edinburgh University.

"He could have stepped into the vice chancellorship of any university in the country," said John Greenall, the OU's Director of Information Services. "So when he accepted the position here, it became obvious that this university was not quite such a joke, not the institution that that cartoonists had made out."

In the 1960's, during the early planning years for a "University of the Air", the popular press could not resist poking fun at the proposed new university. One cartoon showed a commuting student driving home through London's horrendous traffic, all the while watching a televised lesson on a mini-screen in his car. "One of the Vice Chancellor's prime concerns from the beginning has been to insure that we've been accepted in academic circles as a full university in every sense of the word," Mr. Greenall said.

Both the caliber of the blue ribbon planning committee (under the chairmanship of Sir Peter Venables now Pro-Chancellor) and Dr. Perry's own qualifications proved to be powerful counter-balances to earlier skepticism. "For the first thirty senior posts -- the deans of faculty and senior lecturers and so on -- we had 1,200 applications, all from very

suitable people. The Vice Chancellor was quite amazed," Mr. Greenall said.

With all the emphasis on academic credibility, Mr. Greenall must have felt compelled to add that Dr. Perry "is just about the most un-stuffy academician you'll ever meet," and as if to underline those words, Dr. Perry himself popped into the room. "I'm perishing for a drink," he said. "I've been in committee meetings all morning."

Walter Perry is a confident, warm, articulate man -- stocky, slightly rumped, with thinning sandy hair. He told us he had been to the University of Pittsburgh once to meet Jonas Salk "because I was charged with insuring the safety of the Salk Vaccine in Britain." The Vice Chancellor has had one heart attack and is stubbornly restricting his work week to five days. Weekends he enjoys playing golf.

Dr. Perry disclaims having large social reasons for what he does. He took the OU position because "it was a gamble, a challenge, something worth doing. Of course it was a risk, if you weren't afraid things would go wrong, you would be stupid."

"Elitism was rampant in British education and it was denying an education to a hell of a lot of people...Certainly I was in sympathy with the sociological reasons (that were behind the establishment of the university) but I don't have a social purpose or a social drive in what I do... Political drive is important and that created the university, but it doesn't drive me. I'm an academic, not a politician."

During the three hours that followed, Dr. Perry methodically, often humorously, corrected a number of misconceptions about OU. He was unhappy with most of what the popular press has written about the university. He said a lot of the scholarly articles were now pretty well out of date.

OU is cited, time and again, by both the popular and scholarly press, for its use of television, yet a student spends only about 5% of his study time in front of his set, or 25 minutes out of a ten-hour study week.* The Vice Chancellor himself was carefully optimistic about the uses of television as a teaching and learning tool. At one point he said he believed a person could learn anything by watching television, no matter how complicated the subject. But he quickly added that a learner could just as quickly forget what had been learned unless the material was reinforced.

The reinforcement creates problems as well. "You put in front of any student vastly more material than you ever expect him to know. You wouldn't be a university professor if you didn't. But you say things to them in lectures, in seminars, in meetings -- 'You should read that,' or 'Why don't you just skim that?' or 'I'd skip that,' but you can't write that down. One of the biggest things they (OU students) have to learn is to be selective in what they read and even more selective in what they remember. You're sending out to these poor people hundreds and hundreds of pages of written material and references and there is no way of telling them or

*The ten hours, the faculty points out, is "notional not real." It has found that students in the science-based courses normally put in 15-16 hours a week of study and in the arts and social sciences, about 12 hours.

helping them decide for themselves how to choose. It is a terribly difficult lesson for them to learn. This is where teaching at a distance is difficult. We're trying to overcome it in the study centers.

"It's not the standard of material they're getting. That's very, very high, higher than in any of the conventional universities. It's the way in which they have to learn to be selective." (See "Course Production" section for further discussion)

The press cannot be unconditionally blamed for misconceptions about OU. The system is still evolving and Dr. Perry himself has had to revise his own thinking at times.

In OU's formative stages, he said he estimated the amount of material the faculty "would send out to students each week, and I designed store houses and print shops and (estimated) postal bills and staffing and everything else you can think of on that basis and I was off by a factor of somewhere between 8 and 16 fold."

The heart of the Open University's system is the course team, a combination of academics, administrators, TV and radio producers, and educational technologists who develop in concert, all the elements of a complete course.* None of the curriculum components is developed separately or independently, including the broadcast components.

*The Open University gives one credit for one successfully completed ten month (36 week) course. A one credit course might be roughly equivalent to five or six courses in a U.S. university and one credit at OU also might be said to equal about 18 U.S. credits. British universities do not use the credit system and students do not transfer from one university to another and receive recognition for their previous university work. OU is introducing a credit system and is pioneering in the transfer of credits by recognizing work done at another university or training college. For example, teachers in Britain are not required to receive degrees to teach. They can be certified at the end of three years at a training college (for which they receive no degree.) OU will allow teachers to count those three years as three credits toward its own degree. It takes six credits to receive a B.A. from OU; eight credits with honors.

Except for the actual TV and radio production, the team does its work at the Walton Hall campus. Open University people interchangeably refer to the campus either as Walton Hall or "the Milton Keynes headquarters." The mailing address is Bletchley, and the use of the three names is a source of some confusion. Milton Keynes is a new housing development going up near OU on the other side of Bletchley, the nearest town. A visitor might jump easily to the conclusion that the housing development is an offshoot of the OU or, at the very least, assume that a good number of the OU permanent staff would be planning to live there. "Not at all," said Dr. Perry, curing another misconception. The OU had nothing to do with the development. "And an Englishman will try to live as far away from his colleagues as possible."

Undergraduate students, of course, do not come to Walton Hall. A handful of graduate research assistants who are working full-time toward an advanced degree are on campus so that their research can be supervised by the faculty, but they take no course work (OU has not yet completed the development of advanced degree course work.)

Text material -- written by the course teams -- is not printed on campus. Make-up and design is done at Walton Hall by upwards of forty graphic artists. Dr. Perry also hopes to locate a BBC studio at Walton Hall in the not too distant future. He envisions an expansion of the campus' 75 acres to 110 acres.

Also on campus are limited research facilities but the faculty has had little time for research so far. One behavioral scientist, we noted, was studying the habits of monkeys at the nearby Woburn Abbey Wild Animal Park.

One of three OU computers is situated at Walton Hall (the others are in London and Newcastle.) The computers are linked to 100 terminals at study centers for students who take courses calling for up to ten hours on the computer. A considerable amount of administrative work also is handled by computer and OU is pioneering a system whereby the computer marks some assignments.

In times of national emergency Walton Hall is extremely vulnerable because of OU's dependence on utilities and public services. A mail strike created chaos during OU's first year of operation. This year, a power strike closed down the paper mills. OU ran out of manilla envelopes and had to delay a mailing.

Across the highway from Walton Hall and down a country lane is "The Mount", a white frame house whose front parlors now are filled with an assortment of academic print materials. "The Mount" is the headquarters for the Marketing Division, which is financially independent of OU. The sales of foundation course books (excluding those sold to OU students) had topped 100,000 in May, 1972. About 85 percent of these have been sold through 500 booksellers in the United Kingdom. Ernest Hunter, OU Director

of Marketing, says overseas sales and second level book sales have yet to make their full impact.

Although the texts were created for long-distance teaching, Mr. Hunter said some use was being made of them in conventional on-campus classrooms.

OU students use three kinds of reading material and the terminology can be confusing for an outsider. "Set materials" are standard texts or works (The Bible or Shakespeare's plays, for example) which the student must buy independently. Readers (paperback re-prints of chapters from standard texts) and reading lists are supplemental materials, suggested reading. "Texts" are produced at OU in units (there are up to 36 units in a course) and are soft-cover, magazine-size books of between 40 to 80 pages.

Science Foundation courses include home experiment kits of chemicals, glassware, and several unusual pieces of equipment, all designed especially for OU. An example is a plastic microscope which weighs only a few ounces. The technology kit includes a binary computing device, a "noise meter" and a small tape recorder. Students rent the kits equipment, but must pay for used materials and damage.

The general atmosphere at Walton Hall is reminiscent of an American University in August with most of the students gone, only a few professors at work (compared to hundreds in September) and a busy administrative staff.

The atmosphere at the mini-campuses or study centers can be quite another thing. Here again, Dr. Perry squelched a misconception that response to OU's study centers had been less than enthusiastic.

"Some study centers have formed committees of students and part-time tutoring staff and you can't tell them apart, they're the same age. They meet in each other's houses and listen to opera or discuss the Common Market -- this all happens but not 100% of the time. In some study centers you may well find the tutors are pulling more than in some others. In one, a math tutor may be giving a small group tutorial to 30 students. Another center will be dead. This all has to grow from the bottom. It depends on the students at a locality, on the tutors. Some of them have lively personalities, others don't. In ten to twenty years, all the centers will be lively. The alumni are going to furnish the real push and we don't have any of them yet, of course.

"The grass roots sense of belonging depends on the study center. There are a lot of students who don't want that grass roots feeling of belonging; they're quite happy to be all by themselves. But if they want to put a face to the university or a face to the fellow student, that's the only place they can go. If they want to talk to somebody, that's where they can talk to somebody who is also interested in what they're doing, in what the institution is doing.

It probably would be safe to say that roughly half of the students consider the study centers essential and the other half do not, just as in a conventional institution some students think lectures are a waste of time and others, of course, consider them essential. Student study habits always have differed. Some people learn by reading in the library or studying at home. Others find they need a university atmosphere, and the stimulus from their colleagues, the faculty and the staff.

The Open University is dealing with a large number of people who, as the Vice Chancellor said, "are as different as chalk and cheese." He doesn't expect all of them to turn up at the study centers, particularly since spending time at the centers is optional.

The Open University has been so deluged with requests from outsiders who want to come and study its methods that the Vice Chancellor tries to restrict visits to 48 hours. Dr. Perry and his staff have found that most outsiders are interested in pretty much the same things: finances, course production, student response, flaws in the system. The OU powers-that-be have become adept at briefing visiting firemen with relative dispatch.

Americans, they find, are particularly interested in finance. It appears to the OU people anyway that U.S. visitors think the British have found a way effectively to dispense quality education for a lot less than it costs back home. Given the financial difficulties of education in the states, Dr. Perry says it is easy to see why OU's system, calculated in its own terms to produce graduates for a third to a quarter of what it costs to produce graduates in a conventional university, is attractive to contemplate. Americans also seem to be looking for something quick and easy though academically solid and economical.

The truth is, of course, that there is nothing quick or easy or even very new in OU's system. The cost advantage comes in the economy of scale realized because the institution is dealing with a large population. An economy of scale is possible only if an institution can pull from a population of about 20 million, says Vice Chancellor Perry.

Existing U.S. institutions, or newly created ones, cannot exactly duplicate The Open University's system because, except in the densely populated states, there will not be enough students to gain an economy of scale. The Vice Chancellor conjectured that New York, Illinois and California might be big enough, but he couldn't see the sparsely populated states launching such a program even though they may consider external studies to be the answer to the spiraling costs of education. The Vice Chancellor warns, of course, that an external program is no answer at all if an economy of scale is not realized.

In addition to the size of the population, the proportion of population which has been educationally deprived is crucial. Again, this segment of the population is lower in the U.S. than it is in Britain. The U.S., with its system of state, private, teachers, and community colleges provides more physical facilities than England. Few states would have the equivalent of the British "forgotten million," to which OU has addressed itself. There is also the sociological perspective in the U.S. Americans are more education-oriented. A college degree in America is a passport to many more jobs than it is in England. The British have fewer college-trained personnel; jobs traditionally have been held by non-graduates.

A federally based external studies program in the U.S. is an even more remote possibility. The U.S. has no BBC, no direct federal

support of higher education, no national accreditation. The British have Royal Charters which permit them to act through the nominal head of state (the Queen) without the sanction of politicians. All of these things, says the Vice Chancellor, militate against the U.S. having an open university except in the very large states.

Americans -- at least as Open University administrators see them -- also seem to think external studies may fit the needs of certain deprived portions of the population. Americans, say their colleagues abroad, are taken with the idea of bringing education to the people. The Vice Chancellor, however, was stern in his warning that a new university dedicated to external studies should not cater to ethnic groups or to any specific grouping of people because these groupings will provide a far too restricted base for a long-term program.

The Open University in England would not have worked if it had started out by offering programs tailored for, say, the Welsh Nationalists or the West Indian immigrants. OU only can offer its programs because of its mass audience, the economy of scale again.

"There also is the question of status," the Vice Chancellor said. "We are a university. We live in Britain by the grace and favor of our academic colleagues. Oxford lives by the grace and favor of its academic colleagues. A university is a university because everybody accepts it as a university. Now, if you start offering courses, however much they are wanted and needed by people who are peculiarly deprived, either ethnically or sociologically, or in terms of occupation or what have you, you cease to be a university. Now you may be doing a thoroughly good job and there may be a very strong reason for having a non-university that is catering to the ethnically deprived groups but it is not a university."

Of course, an already established university can offer courses that cater to specific groups if it so pleases. Oxford is so unquestionably established that the Vice Chancellor said it could offer a course for Irish nannies and nobody would sneer. OU, however, is constrained to offering standard courses until its academic reputation is established beyond a shadow of doubt.

Dr. Perry does not think American state legislators are fully appreciative of how important academic respectability is for a program of this kind. There may be a temptation to have educators offer the sort of courses that serve sociological purposes. But a course tailored for the hillbillies in West Virginia might not be smiled upon by academicians at established universities and that could spell its doom, Dr. Perry believes.

"Respectability matters," said the Vice Chancellor. "I've been attacked in the press in Britain for making a cult of academic respectability. I am absolutely unrepentant because if we hadn't aimed first at getting that respectability -- you know, being the memory of a glorious failure never did the Irish Navy any good."

STUDYING AT THE OPEN UNIVERSITY

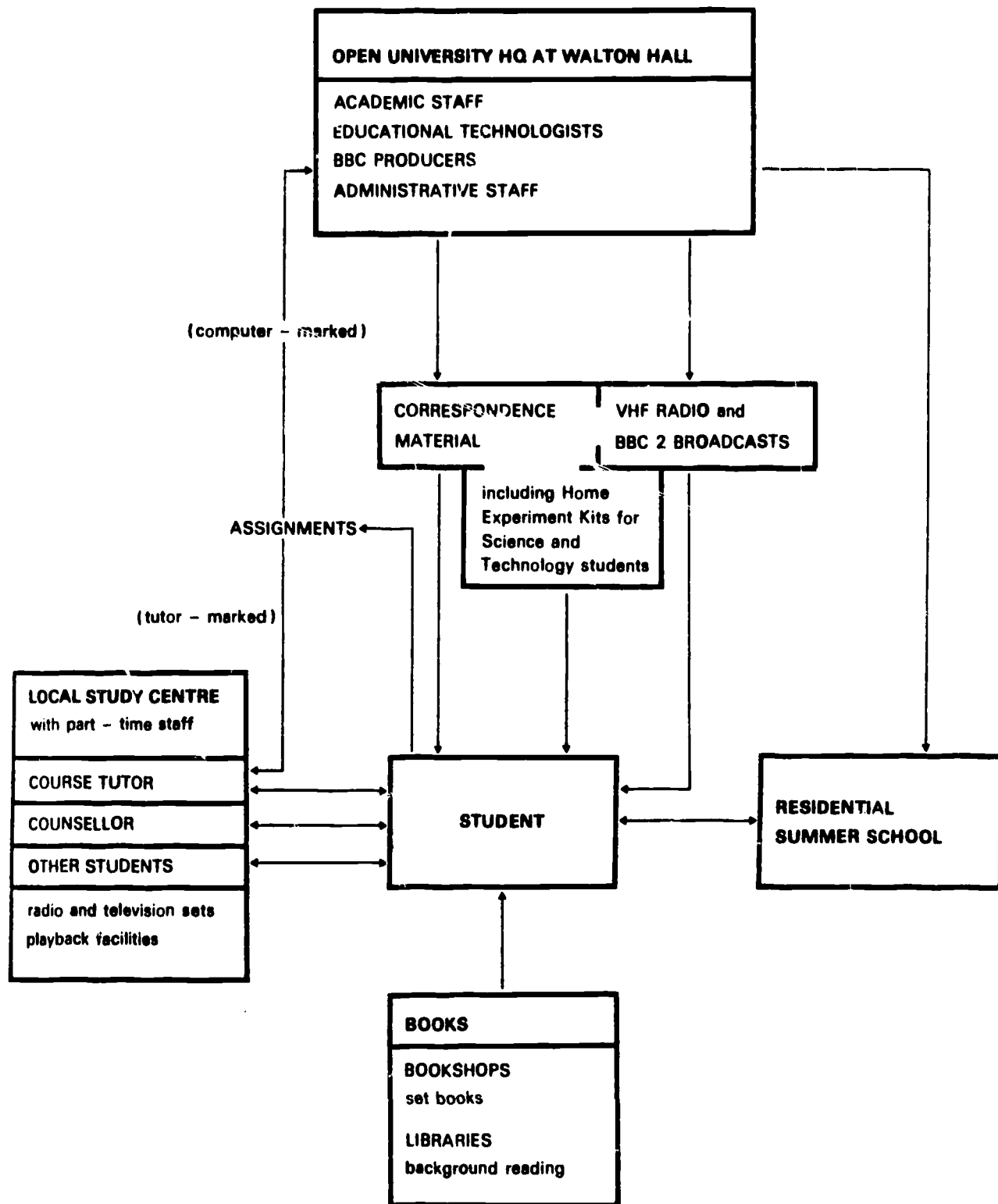

TELEVISION AND RADIO

"One Out of Ten Study Hours"

Probably the most common misconception about The Open University is that students spend a great deal of their time watching television and listening to the radio. This idea got its impetus from Prime Minister Harold Wilson who called the project "University of the Air" back in the middle 60s when the Labour Party's Jennie Lee first proposed an open university.

Actually, the student spends only 10 per cent of his study time on BBC television and radio broadcasts. However, this method of instruction is considered so important ("Vital" to the science courses) that 22 percent plus of the total Open University budget is allocated to it. This amounts to \$6,500,000 in U. S. currency.

BBC-2 carries roughly fifteen hours a week of television broadcasting and twelve hours on VHF Radio 3 and 4. Each program is repeated once during the week.

John Robinson, Chief Assistant (Open University) BBC, says he is continually asked: "Is it worth all that--paying nearly a quarter of your budget to provide one hour out of ten?" He replies: "So far, the University does not question this. Presumably, the quality of this one hour out of ten in terms of learning communication justifies spending nearly a quarter of our income."

Dr. David G. Hawkrige, director of OU's Institute of Educational Technology which is charged with course development and institutional research including evaluative studies of media such as radio and television, notes that "the influence of television and radio, should not be underestimated in spite

of the small percentage of viewing and listening time. Television probably provides the most powerful stimuli of all the learning resources." He feels that the telecasts provide valuable motivation to independent learners who are cut off in many ways from OU itself.

Members of the science faculty believe the television instruction is so essential they discourage students from taking the Science Foundation Course unless they have access to BBC-2 at their home. (Television playback equipment is available at study centers, but BBC's Robinson complains about the technical quality of the video copies--a result of limited funds).

Vice Chancellor Perry emphasized that all broadcasts are interwoven with the written unit texts. On camera, the instructor always refers back to the unit texts and vice versa. For example, we watched a 25 minute television show on Units 17 and 18 in the Humanities Foundation Course, "Which Was Socrates?" The professor and three students discussed the previous week's work which centered on various interpretations of Socrates' character. Then the conversation turned to a play by Aristophanes in which the leading character is a thinly-veiled caricature of Socrates. At this point, the television screen showed a dramatization of a portion of the play performed by professional actors, hired by BBC.

When students study Hamlet, they hear two radio lectures by Arnold Kettle, editor of Shakespeare in a Changing World, and G. Wilson Knight, author of Shakespearean Production. They also see a television dramatization of the closet scene and two interpretations of the nunnery scene. In the unit text there are photos of the television dramatizations.

For a science lecture on high energy physics, BBC film crews were dispatched to the European Organization for Nuclear Research labs (CERN) to see an experiment using the bubble chamber. Then students were sent photos

of bubble chamber tracks and asked to analyze them. (Dean and Director of Studies of the Faculty of Science is Michael Pentz who came to OU after a decade of research at CERN.)

BBC's Robinson pointed out that to augment the unit text's discussion of nuclear energy, BBC also filmed a sequence on the workings of a nuclear accelerator at the CERN facilities.

The science faculty uses television primarily for experiments involving visual movement, time-lapse photos, laboratory techniques, and electron microscope close-up pictures. Radio is used as "enrichment" or as Pentz said, to add "relevance, unity, coherence." An example is a biology unit dealing with the Krebs cycle. BBC taped a show with Hans Krebs in which he reminisced on the development of his idea of the cycle. Radio also is used for remedial work, and quite naturally, for music courses.

The OU faculty is not unaware that their television performance is a reflection of OU's academic image. Professors and students from other universities tune in. BBC's Robinson notes that OU's broadcasts attract a wide audience of non-students.

An indication of the caliber of staff that works on these BBC-OU television shows is OU's Assistant Head of Future Education, Peter Montagnon, a BBC staffer. He is head producer of the much acclaimed Kenneth Clark "Civilization" series. (We interviewed Robinson in Montagnon's office at BBC's OU production studios outside London).

During the first year of OU's existence, scheduling of radio and television time for four Foundation courses was relatively simple. Now that OU is offering 24 courses, produces 300 television shows a year, and a like number of radio shows, the scheduling task boggles the mind. (See attached Broadcast Schedule). In January 1973, five more courses will be offered

for post-experience students. Everyone says the biggest problem facing the University is the shortage of broadcasting slots.

OU has an agreement with BBC-2 for up to 30 hours a week of television broadcast time and 30 hours of radio. This academic year, BBC-2 carries 15 hours a week and 12 hours of VHF radio. Broadcast scheduling is set to accommodate the working students: between 4:30 and 7:30 p.m. weekdays and 9 to 1 on Saturdays and Sundays. Robinson says new slots will have to be after 11:30 p.m.

Each program goes out twice, once during the weekday and once at the weekend.

It will help to understand the transmission pattern as follows:

FOUNDATION COURSE		1 television per week 1 radio per week
SECOND LEVEL COURSES		
Arts	} full courses	{ 1 TV per fortnight 1 radio per week
Social Sciences		
Educational Studies	} Half courses	{ 1 TV per month 1 radio per fortnight
Science		
Maths	} full courses	{ 1 TV per week 9 radio per course
Technology		
Technology	half course	{ 1 TV per fortnight 5 radio per course

The schedule is printed in The Open University BA Degree Handbook 1972 and daily newspapers run it in their TV-radio schedules (see attached example).

To produce this staggering number of broadcasts, the OU/BBC staff works seven days a week on a shift system. There are sixty people on the BBC production staff.

Total personnel are:

Production staff	60
Administration	16
Supporting staff	165
Sec/Clerical	<u>70</u>
Total	<u>311</u>

One-third of the production staff was already employed by BBC in educational broadcasting, an area in which BBC has a long history, having produced the world's first educational broadcast in the 1930's. The other two-thirds were recruited through public advertisements and selected because of their academic qualifications, with an eye to how susceptible they might be to acquiring communications skills. BBC trained the newcomers in broadcasting. "They are not glorified technicians," Robinson emphasized, referring to their heavy academic orientation.

The BBC people work with the academic course team from the inception of course planning: in that way they can see how the unit text materials is progressing and can be interwoven with radio-TV offerings.

A survey of educational background of BBC educational staff members shows that Oxford, Cambridge, Glasgow, Liverpool, and London colleges and universities are represented. Robinson, for example, holds an M.A. from Oxford.

People who are the best communicators are used for on-camera performance. In a crunch, Dr. Perry adds his weight to make this ruling stick. Occasionally, BBC hires actors to produce segments of programs--dramatization of plays being obvious examples.

OU can draw on the vast film archives of BBC to flesh out its TV shows. This is an enormous money-saving treasure trove and adds tremendously to the scope and physical range of visual presentations, especially in the Humanities and Arts courses. For example, OU can borrow films from the "Civilization" series at no rental fee.

Some faculty are such dynamic performers they have been offered jobs in commercial television. These are the stars, but there are also "disasters," Robinson muses sadly. "But if someone is a disaster, one of his colleagues presents his material."

Ninety per cent of OU's 300 television programs are broadcast in black and white. The master print is on two-inch videotape. Some 60 programs are shot on film. Color film shows are reproduced in black and white by a commercial firm, Technicolor, and copies are made on 8 mm film with optical sound and placed in cassettes. Since 15 per cent of the British Isles cannot pick up BBC-2, copies of all OU television shows are filed at student centers in non-reception areas. BBC orders 70 copies of each program for this purpose. In this way, students outside the reception area of BBC-2 have access at the study centers to a complete set of all TV shows and radio broadcast tapes. (99 per cent can pick up the VHF radio transmission.)

Robinson is not happy with the technical quality of the reproduced television tapes, but OU will continue to go this route

until more funds are made available. Students who can see these shows only on videotape operate at a "disadvantage" says Robinson, because, in some cases "the sound is horrible and the reproduction quality is inadequate."

Students who do not own their own television sets, but live within NBC-2's transmission area can, of course, see the shows at the study center during the week or when it is repeated on week-ends.

Because the OU is committed to a policy of continuous improvement and constant monitoring of its courses, it turns to the broadcast media for remedial action. Special television and radio broadcasts are made when areas within a course are shown not to be teaching effectively. Feedback comes from analyses of assignment results, tutor-marked assignments and reports from course tutors. Another avenue of feedback is the newly founded student newspaper, Sesame.

BBC also runs a monthly television program, "Open Forum" and another program of the same name weekly on radio. These are magazine type programs and are intended to develop a wider view of the University than that available from a study of course material. The programs of discussion, reports and comments are planned by a University editorial group including OU and BBC staff as well as students. Students are invited to send in suggestions for programming. In a sense, this is an air-borne Student Union.

Five minute slots between television and radio programs are used for OU announcements and items of topical interest.

The decision of who gets how much of the \$6,500,000 allotted for broadcasting starts with the Council of the University, is modified by consultation with BBC, is reviewed by the Faculty Senate, is argued over by

the six faculty deans, and then is horse-traded by the individual faculty at the course team level.

The broad decision, what kind of courses are going to be offered, is settled by the top echelon, i.e., general degree program, post-experience courses, graduate degree course?

Once defined, the next question is how much should be allocated to each of the six faculties. Are they all going to have the same amount of broadcasting? Is science going to have the same as arts? Does science warrant a priori a greater share of television time than arts courses? And so on. In fact, in the second year offerings, science courses do have more television time than arts. On the other hand, the arts have more radio time than science.

The next level--the blood, sweat and tears level where individual course units are created--brings out the horse-traders. Extra money for the bubble chamber film at CERN or for an art film shot in Florence will result in a sacrifice somewhere else in the curriculum.

"There's great flexibility in this," said BBC's Robinson. "If the faculty decides to send a film crew out to Pittsburgh, then some other programs in the series will be pretty well cheaped."

A further comment on BBC's costs appears in the section called "The Price Tag."

Express Entertainment

Royal Flush of Emmy awards for B.B.C.



JACKSON AS ELIZABETH R



MICHELL AS HENRY

LED BY "Elizabeth R" actress Glenda Jackson, the B.B.C. scored a Royal Flush for Britain yesterday—by winning a record of nine Emmy awards. No European country has ever scooped up so many of America's top TV trophies, which are as prized as the Hollywood Oscar.

Britain's success was a double triumph for Miss Jackson, who won an Emmy as best actress in a drama series and another for the outstanding performance by an actress.

The award for the outstanding actor also went to Britain—to Keith Michell for his role in the B.B.C.'s "Six Wives of Henry VIII."

Actress Jenny Agutter took the prize for the outstanding supporting role with her part in the B.B.C. play "The Snow Goose."

But it was Elizabeth R which swept the board—

by also winning trophies for the best drama series, the best new series, and the best costumes.

Another B.B.C. winner was "Search for the Nile" which got the Emmy for the best drama documentary, and a special award for the writers. B.B.C. programme chief David Attenborough said last night: "It has taken a long, long time for our programmes to get this kind of recognition in America. But it has been worth waiting for."

TOP TEN

(Last week's placings in brackets)

- 1 ROCKET MAN Elton John (7)
- 2 COULD IT BE FOREVER David Cassidy (3)
- 3 A THING CALLED LOVE Johnny Cash (4)
- 4 METAL GURU T. Rex (-)
- 5 AMAZING GRACE Royal Scots Dragoon Guards (1)

RADIO

RADIO 1
5.0 a.m. As Radio 2. 7.0 Tony Blackburn. 8.0 Jimmy Young. 11.0 Dave Lee Travis. 1.0 p.m. Jennie Walker. 3.0 Alan Freeman. 5.0 What's New. 6.0 As Radio 2. 10.0 Sounds of the 70's: John Peel. (Also on VHF.) 12.0 to 2.2 a.m. As Radio 2.

RADIO 2
1.500 m. and VHF. 5.0 a.m. The Early Show. 7.3 Terry Wogan. (8.27 Racing Bulletin.) 8.55 Points For Thought. 9.2 Open House. 11.2 Morning Story. 11.15 Waggoners' Walk. 11.30 Tony Brandon. (1.30 Sports Desk.) 2.2 p.m. Woman's Hour. 4.15 Sports Desk. 4.40 Chester. 6.2 Afternoon Time. 8.0 Desk. 7.3 Afternoon Show. (7.20 Sports Desk.) 8.2 Record. 9.30 On The Lute. 10.2 Late Night. (Sports Desk at 10.15.) (Radio 2 on 1,500 m. and 200 m. only between 10.0 and 12.0.) 12.0 News. 12.5 a.m. Night Ride. 2.0-2.2 News. Weather.

RADIO 3
1.500 m. and VHF. 7.0 a.m. News. Weather. 7.5 Overture (S). 8.0 News. Weather. 8.5 Morning Concert (S). 9.0 News. Weather. 9.5 This Week's Composer (S). 10.45 Music Making (S). 11.45 Org. Recital. 12.15 p.m. Cardiff Midday Prom: Part 1. 1.0 News. Weather. 1.5 From Music Magazine (S). 1.20 Midday Prom: Part 2. 2.5 Haydn: Part 1 (S). 2.40 Interval: Talk. 2.55 Haydn: Part 2 (S). 3.30 Comedy. Poets. Lala (S). 4.20 Music In Our Time. (S). 5.15 Jazz Today (S). 5.45

Pied Piper. 6.5-7.30 Open University (VHF). 6.5 News. Weather. 6.10 Concert Calendar. 6.25 Programme News. Stock Market Report. 6.30-7.30 Study on 3. 7.30 Part Songs And Musicals (S). 8.0 Berlin Philharmonic Orchestra: Part 1 (S). 8.40 Music on The Air. 8.0 Berlin Philharmonic: Part 2 (S). 9.35 Tchaikovsky. 10.15 Bruckner And The Conductor. 11.0 Vivaldi: Part (S). 11.30-11.35 News. Weather.

S=Stereo

RADIO 4
330 or 200 m. and VHF. 6.25 Today. 6.45 Prayer For The Day. 6.50 Regional News. Weather. 7.40 Day. 8.0

TV, Radio Listing In Popular Press

11.0 For Schools. 12.0 You And Yours. 12.25 p.m. I'm Sorry I Haven't A Clue. 12.35 Weather. Preview and News. 1.0 The World At One. 1.30 The Archers. 1.45 Listen With Mother. 2.0 My Kind Of Music. 2.40 For Schools. 3.0 For, For The Mountain Peak. 4.0 Gardeners' Question Time. 4.30 Story Time. 5.0 P.M. Reports. 5.30-5.45 News. Weather and Preview. 6.0 News. 6.15 Fair Deal. 6.45 The Archers. 7.0 News Desk. 7.30 Roy Wood's Vintage Music Hall. 8.30 Is The Man Moving Into Britain? 8.0 The Guest For Gus. 8.50 Weather. 10.0 The World Tonight. 10.45 Today in Parliament. 11.0 A Good Night's Bedtime. 11.15 News. Weather. 11.31-11.36 Market Trends. 11.45-11.48 Constat Forecast.

● ELTON JOHN, 25-year-old former classical music student from Pinner, Middlesex, who has sold around five million record albums in the U.S., today gets the British seal of success. His "Rocket Man" has become his first No. 1 hit—soaring up past "The Rolling Stones' "Tumbling Dice," which has dropped to No. 7.

BBC 1

- 9.20 - 9.35 a.m. WATCH WITH MOTHER: The Herbs.
- 9.38 FOR SCHOOLS: Maths Today, Year 2.★ 10.0 Maths Workshop.★ 10.25-10.40 Words And Pictures.★ 11.0 Watch.★ 11.10 Going To Work.★ 11.40 Making Music.★ 12.5-12.30 p.m. New Horizons.★
- 12.55 - 1.25 AELWYD AC EIDDO.★
- 1.30 WATCH WITH MOTHER: Along The Trail.
- 1.45 - 1.53 NEWS. WEATHER.
- 2.5 - 2.25 FOR SCHOOLS★: Television Club.
- 4.15 PLAY SCHOOL.
- 4.40 JACKANORY.
- 4.55 ANIMAL MAGIC.
- 5.20 MOTOR MOUSE AND IT'S THE WOLF.
- 5.44 HECTOR'S HOUSE.
- 5.50 NEWS. WEATHER.
- 6.00 NATIONWIDE: Weather.★
- 6.45 TELEVISION TOP OF THE FORM.
- 7.5 TOMORROW'S WORLD.
- HOLLYWOOD PREMIERE: Shent Lonely Night. With Lloyd Shirlay Jones.★
- ★THEY

TODAY'S TV AND RADIO

BBC 2

- 11.0 - 11.25 a.m. PLAY SCHOOL.
- 5.35 - 6.30 p.m. OPEN UNIVERSITY.★
- 6.35-7.0 COMPUTERS IN BUSINESS: Models And The Boardroom.
- 7.5 OPEN UNIVERSITY.★
- 7.30 NEWS. WEATHER.
- 8.0 RICH MAN, POOR MAN: Food—the effects of modern food production on the land and in the sea.
- 8.50 WHEEL: ... covers the world.
- 9.20 T...
- MF

ITV

LONDON

- 10.20 a.m. FOR SCHOOLS. 10.20-10.45 You And The World. 11.0-11.15 Rules, Rules, Rules (repeat). 11.18-11.36 Meeting Our Needs. 11.40-12.0 The Messengers. 1.15-1.45 p.m. Time To Remember★ (repeat). 1.45-1.55 Stop, Look, Listen. 2.0-2.11 My World. 2.13 Just Look.
- 2.33 GOOD AFTERNOON: With Jill Tweedie.
- 3.00 HOUSEPARTY.
- 3.15 LET'S FACE IT: Polly Elwes talks to a skin specialist and a plastic surgeon and an electrolysis gives advice about facial hair.
- 3.45 DANGER MAN★ (repeat).
- 4.40 ONCE UPON A TIME: Alfred Marks tells the story of The Invisible Chimney Sweep.
- 4.55 JUNIOR SHOWTIME.
- 5.20 MAGPIE.
- 5.50 NEWS.
- 6.00 TODAY: With Eamonn Andrews.
- 6.30 CROSSROADS.
- 6.55 ALBERT: Blood Brothers. With Gregory Bewes.
- 7.2... the Doonee★ (1951)

1972 BROADCASTING SCHEDULE: DAILY PATTERN (WEEKDAY)

TV

MONDAY	TUESDAY	WEDNESDAY	THURSDAY	FRIDAY	TIMES	MONDAY	TUESDAY	WEDNESDAY	THURSDAY	FRIDAY
SDT 286 + S 223	E 281 + E 282 + E 283	MST 281 + MST 282	S 25—	D 283	17.35	—	—	—	—	—
S 232 + S 241	M 201	A 201 + A 202	TS 282	D 203 D 281 D 282	18.05	A 201	D 100	—	OPEN FORUM	Mathematics Second Level Programmes
S 100	—	A 100	—	—	18.35	A 100	D 203	Science and Technology Second Level Programmes	E 281 E 283	T 100
—	M 100	—	T 100	D 100	19.05	A 202	D 281 D 282	S 100	D 283 E 282	M 100

RADIO

Points to Remember

- 1 Most courses transmit their first TV programme at the weekend (repeat weekday) and their first radio programme during the week (repeat weekend).
- 2 No weekday transmissions during weeks 26-28. No weekend transmission during weeks 37-39 (except a few maths programmes). No broadcasts at all in weeks 35 and 36.
- 3 Principal exceptions to above daily pattern are:
 Week 22: No broadcasts at all on Monday.
 Weeks 23-25, 29-34: Irregular scheduling of some TV programmes because of Test Match broadcasts.

1972 BROADCASTING SCHEDULE. DAILY PATTERN (WEEKEND)

TELEVISION

Day	9.05-9.30	9.35-10.00	10.05-10.30	10.35-11.00	11.05-11.30	11.35-12.00	12.05-12.30	12.35-13.00
SATURDAY	TS 282	E 281 E 282 E 283	D 283	MST 281 M/ST 282	A 201 A 202	S 241 S 232	SDT 286 S 223	S 25- and OPEN FORUM
SUNDAY	OPEN FORUM (repeat)	D 100	A 100	D 203 D 281 D 282	M 100	T 100	S 100	M 201

RADIO

40

SATURDAY (mom.)	SATURDAY (aft.)	SATURDAY (aft. contd.)	SUNDAY (morn.)
10.30 to 10.55	14.00 to 14.20	15.00 to 15.20	9.00 to 9.25
M 100	A 201	OPEN FORUM (repeat)	D 100
10.55 to 11.15	14.20 to 14.40	15.20 to 15.40	9.25 to 9.45
Science and Technology Second Level Programmes	D 203	D 281 D 282	T 100
11.15 to 11.35	14.40 to 15.00	15.40 to 16.00	9.45 to 10.05
Mathematics Second Level Programmes	A 202	D 283 E 282	E 281 E 283
11.35 to 12.00	A 100		10.05 to 10.30
			S 100

1972 BROADCASTING SCHEDULES: weekly pattern illia

Week No.	1	2	3	4	5	6	7	8	9	10	11	12	13	14	15	16	17	18	19	20	21	22	
A	1-1	8-1	15-1	22-1	29-1	5-2	12-2	19-2	26-2	4-3	11-3	18-3	25-3	1-4	8-4	15-4	22-4	29-4	6-5	13-5	20-5	27-5	
TV	-	1	3	4	5	6	7	8	9	10	11	12	13	-	13	14	15	16	17	18	19	20	
R	-	0	1	2	3	4	5	6	7	8	9	10	11	-	11	12	13	14	15	16	17	18	
D	-	-	1	2	3	4	5	6	7	8	9	10	11	-	12	13	14	15	16	17	18	19	
TV	-	-	1	2	3	4	5	6	7	8	9	10	11	-	12	13	14	15	16	17	18	19	
R	-	-	1	2	3	4	5	6	7	8	9	10	11	-	12	13	14	15	16	17	18	19	
M	0*	1	2	3	4	5	6	7	8	9	10	11	12	-	13	14	15	16	17	18	25	19	
TV	-	-	1	2	3	4	5	6	7	8	9	10	11	-	12	13	14	15	16	17	18	25	19
R	-	-	1	2	3	4	5	6	7	8	9	10	11	-	12	13	14	15	16	17	18	25	19
S	0*	1	2	3	4	5	6	7	8	9	10	11	12	-	13	14	15	16	17	18	25	19	
TV	-	-	1	2	3	4	5	6	7	8	9	10	11	-	12	13	14	15	16	17	18	25	19
R	-	-	1	2	3	4	5	6	7	8	9	10	11	-	12	13	14	15	16	17	18	25	19
T	-	0	1	2	3	4	5	6	7	8	9	10	11	-	12	13	14	15	16	17	18	19	
TV	-	-	0	1	2	3	4	5	6	7	8	9	10	-	11	12	13	14	15	16	17	18	19
R	-	-	0	1	2	3	4	5	6	7	8	9	10	-	11	12	13	14	15	16	17	18	19
D	-	-	1	2	3	4	5	6	7	8	9	10	11	-	12	13	14	15	16	17	18	19	
TV	-	-	1	2	3	4	5	6	7	8	9	10	11	-	12	13	14	15	16	17	18	19	
R	-	-	1	2	3	4	5	6	7	8	9	10	11	-	12	13	14	15	16	17	18	19	
D	-	-	1	2	3	4	5	6	7	8	9	10	11	-	12	13	14	15	16	17	18	19	
TV	-	-	1	2	3	4	5	6	7	8	9	10	11	-	12	13	14	15	16	17	18	19	
R	-	-	1	2	3	4	5	6	7	8	9	10	11	-	12	13	14	15	16	17	18	19	
D	-	-	1	2	3	4	5	6	7	8	9	10	11	-	12	13	14	15	16	17	18	19	
TV	-	-	1	2	3	4	5	6	7	8	9	10	11	-	12	13	14	15	16	17	18	19	
R	-	-	1	2	3	4	5	6	7	8	9	10	11	-	12	13	14	15	16	17	18	19	

• Notes TV Wk 1: M100/0: Sun 12.05 Tue 18.05
 Wk 7: S100/0: Sun 12.35 Sat 10.05
 Wk 8: M100/C(1) Sat 10.05 M100/C(2) Sat 10.05
 Wk 8: Logic programme for A100: Tue 17.35
 Wk 9: Logic programme for A100: Sat 10.05
 Wk 22: S100/19 (rpt) to week 23: Sat 13.00
 RADIO Wk 22: A100/19 - Wed, 18.05

1972 BROADCASTING SCHEDULES: weekly pattern IIIb

Week No.	23	24	25	26	27	28	29	30	31	32	33	34	35	36	37	38	39	40	41	42	43	44				
Date	3-6	10-6	17-6	24-6	1-7	8-7	15-7	22-7	29-7	5-8	12-8	19-8	26-8	2-9	9-9	16-9	23-9	30-9	7-10	14-10	21-10	28-10				
A 100	TV 21	22	23	24	25	26	27	28	29	30	31	32	33	34	35	36	37	38	39	40	41	42	43	44		
D 100	R 19	20	21	22	23	24	25	26	27	28	29	30	31	32	33	34	35	36	37	38	39	40	41	42	43	44
M 100	TV 20	21	22	23	24	25	26	27	28	29	30	31	32	33	34	35	36	37	38	39	40	41	42	43	44	
S 100	R 19	20	21	22	23	24	25	26	27	28	29	30	31	32	33	34	35	36	37	38	39	40	41	42	43	44
T 100	TV 20	21	22	23	24	25	26	27	28	29	30	31	32	33	34	35	36	37	38	39	40	41	42	43	44	
D 203	R 19	20	21	22	23	24	25	26	27	28	29	30	31	32	33	34	35	36	37	38	39	40	41	42	43	44
D 281	TV 5	6	7	8	9	10	11	12	13	14	15	16	17	18	19	20	21	22	23	24	25	26	27	28	29	30
D 282	R 10	11	12	13	14	15	16	17	18	19	20	21	22	23	24	25	26	27	28	29	30	31	32	33	34	35
D 283	TV 7	8	9	10	11	12	13	14	15	16	17	18	19	20	21	22	23	24	25	26	27	28	29	30	31	32

• Notes

- TV Wk 23: S100/19 (rpt) - Sat, 13.00
- Wk 23/24: D282/5 (rpt) - wk 24, Sat, 10.05
- Wk 25: D283/7 (rpt) - wk 24, Sun, 13.05
- Wk 30: D281/6 (rpt) - Fri, 18.35
- D283/8 (rpt) - Wed, 19.05
- D282/6 (rpt) - Fri, 18.35
- D283/9 (rpt) - Wed, 19.05
- Wk 31: D203/14a - Sun, 09.05
- Fri, 18.35

Wk 32: D281/7 (rpt) - Fri, 18.35
 Wk 39: M100/32 - Sun, 12.05

1972 BROADCASTING SCHEDULES: weekly pattern IVa

Week No.	1	2	3	4	5	6	7	8	9	10	11	12	13	14	15	16	17	18	19	20	21	22
Date	1-1	8-1	15-1	22-1	29-1	5-2	12-2	19-2	26-2	4-3	11-3	18-3	25-3	1-4	8-4	15-4	22-4	29-4	6-5	13-5	20-5	27-5
A 201	TV		1	1	2	2	3	3	4	4	5	5	6	6	7	7	7	8	8	9	9	10
A 202	TV			1	2	3	4	5	6	7	8	9	10	11	12	13	14	15	16	17	18	19
E 281	TV	0*					2									3		4				6
E 282	TV		1		2		3		4		5		6		7		8		9		10	
E 283	TV					1				2												
M. 201	TV			1	2	3	4	5	6	7	8	9	10	11	12	13	14	15	16	17	18	19
MST 281	TV	0*	1		2		3		4		5		6		7		8		9		10	
MST 282	TV			1			2				3											

• Notes

TV Wk 2: Intro. prog. for Education Students: Sun, 12.35
MST 281/0 - Sun, 10.05
Fri, 19.05

RADIO
Wk 22: A 201/19: Thur, 18.05
A 202/19: Mon, 23.35

1972 BROADCASTING SCHEDULE: Weekly Pattern IVb

Week No.	23	24	25	26	27	28	29	30	31	32	33	34	35	36	37	38	39	40	41	42	43	44				
Date	3-6	10-6	17-6	24-6	1-7	8-7	15-7	22-7	29-7	5-8	12-8	19-8	26-8	2-9	9-9	16-9	23-9	30-9	7-10	14-10	21-0	28-10				
A 201	TV 10	19 20	20 21	22 22	23 23	24 24	25 25	26 26	27 27	28 28	29 29	30 30	31 31	32 32	33 33	34 34	35 35	36 36	37 37	38 38	39 39	40 40	41 41	42 42	43 43	44 44
A 202	TV 10	19 20	20 21	22 22	23 23	24 24	25 25	26 26	27 27	28 28	29 29	30 30	31 31	32 32	33 33	34 34	35 35	36 36	37 37	38 38	39 39	40 40	41 41	42 42	43 43	44 44
E 281	TV 10	19 20	20 21	22 22	23 23	24 24	25 25	26 26	27 27	28 28	29 29	30 30	31 31	32 32	33 33	34 34	35 35	36 36	37 37	38 38	39 39	40 40	41 41	42 42	43 43	44 44
E 282	TV 10	19 20	20 21	22 22	23 23	24 24	25 25	26 26	27 27	28 28	29 29	30 30	31 31	32 32	33 33	34 34	35 35	36 36	37 37	38 38	39 39	40 40	41 41	42 42	43 43	44 44
E 283	TV 10	19 20	20 21	22 22	23 23	24 24	25 25	26 26	27 27	28 28	29 29	30 30	31 31	32 32	33 33	34 34	35 35	36 36	37 37	38 38	39 39	40 40	41 41	42 42	43 43	44 44
M 201	TV 10	19 20	20 21	22 22	23 23	24 24	25 25	26 26	27 27	28 28	29 29	30 30	31 31	32 32	33 33	34 34	35 35	36 36	37 37	38 38	39 39	40 40	41 41	42 42	43 43	44 44
MST 281	TV 10	19 20	20 21	22 22	23 23	24 24	25 25	26 26	27 27	28 28	29 29	30 30	31 31	32 32	33 33	34 34	35 35	36 36	37 37	38 38	39 39	40 40	41 41	42 42	43 43	44 44
MST 282	TV 10	19 20	20 21	22 22	23 23	24 24	25 25	26 26	27 27	28 28	29 29	30 30	31 31	32 32	33 33	34 34	35 35	36 36	37 37	38 38	39 39	40 40	41 41	42 42	43 43	44 44

• Notes TV

- Wk 24: M201/21 (rpt) - Tue, 18.35
- Wk 25: E281/6 (rpt) - Sat, 09.35
- Wk 29: E283/6 (rpt) - Thur, 17.35
- Wk 31: M201/23 (rpt) - Tue, 18.35
- Wk 31: E281/7 (rpt) - Thur, 17.35
- Wk 31: M201/25 (rpt) - Tue, 18.35
- Wk 33: E281/8 (rpt) - Thur, 17.35
- Wk 33: M201/27 (rpt) - Tue, 18.35
- Wk 34: M201/28 (rpt) - Tue, 18.05
- Wk 34: M201/29 (rpt) - Fri, 18.35
- Wk 34: MST 281/15 (rpt) - Fri, 17.35
- Wks 37-39: M201 at 12.35 on Sun each wk.
- MST 281/282 at 12.05 on Sun (wks 37, 38)
- Wk 39: A201/17 - Wed, 19.05
- Wk 40: A201/16 (rpt) - Sat, 10.05
- Wk 40: A201/17 (rpt) - Sat, 11.05
- Radio
- Wk 29: M201/12 (rpt) - Wed, 18.35
- Wk 34: MST 281/8 (rpt) - Wed, 18.05
- Wk 39: MST 282/8 (rpt) - Wed, 18.05
- Wk 43: A201/35 (rpt) - Sat, 15.40
- Sun 09.45



1972 BROADCASTING SCHEDULES: weekly pattern Va

Week No.	1	2	3	4	5	6	7	8	9	10	11	12	13	14	15	16	17	18	19	20	21	22
Date	1-1	8-1	15-1	22-1	29-1	5-2	12-2	19-2	26-2	4-3	11-3	18-3	25-3	1-4	8-4	15-4	22-4	29-4	6-5	13-5	20-5	27-5
S 22-	TV	1	0	1	2	1	1	3	4	4	5	5	5	6	6	6	7	8	8	8	9	9
R	0	0	0	0	1	1	1	1	1	1	1	2	2	2	2	2	2	2	2	2	3	3
S 23-	TV	0	0	1	2	2	2	3	4	4	5	5	5	6	6	6	7	8	8	8	9	9
R	0	0	0	0	1	1	1	1	1	1	1	2	2	2	2	2	2	2	2	2	3	3
S 24-	TV	0	0	1	2	2	3	3	4	4	5	5	6	6	7	7	7	8	8	8	9	10
R	0	0	0	0	1	1	1	1	1	1	2	2	2	2	2	2	2	2	2	2	3	3
S 25-	TV	0	0	1	2	2	2	3	4	4	5	5	6	6	6	6	7	7	8	8	9	9
R	0	0	0	0	1	1	1	1	1	1	2	2	2	2	2	2	2	2	2	2	3	3
STD 286	TV	1	1	1	2	2	3	3	4	4	5	5	6	6	7	7	7	8	8	8	9	10
R	0	0	0	0	1	1	1	1	1	1	2	2	2	2	2	2	2	2	2	2	3	3
TS 282	TV	1	1	1	2	2	3	3	4	4	5	5	6	6	6	6	7	7	8	8	9	9
R	0	0	0	0	1	1	1	1	1	1	2	2	2	2	2	2	2	2	2	2	3	3
OPEN FORUM †	TV	1	1	1	2	2	3	3	4	4	5	5	6	6	6	6	7	7	8	8	9	9
R	0	0	0	0	1	1	1	1	1	1	2	2	2	2	2	2	2	2	2	2	3	3

* Notes

TV

Wk 1: Open Forum Sun, 1100-1200

Wk 2: Introductory programme for second level science students, Sun, 10.35

Wk 22: S241/10(rpt): to wk 23, Sun, 1300

STD 286/10 (rpt): Thur, 17.35

RADIO

Wk 2/3: Introductory programme for Biology based courses (SDT 286; S22.; S2-1) -Wed 18.35 wk 2 -Sat 10.55 wk 3

† As both transmissions of TV Open Forum take place at the weekend, the bold numbers refer to two weekend broadcasts and not (as would be normal) to one weekday and one weekend programme.

1972 BROADCASTING SCHEDULE: Weekly Pattern Vb

Week No.	23	24	25	26	27	28	29	30	31	32	33	34	35	36	37	38	39	40	41	42	43	44	
Date	3-6	10-6	17-6	24-6	1-7	8-7	15-7	22-7	29-7	5-8	12-8	19-8	26-8	2-9	9-9	16-9	23-9	30-9	7-10	14-10	21-10	28-10	
S 22-	TV 10		11		1		2		3	2	4	3				4		5		6			5 2-3
S 23-	R						2		3	2	4	3				4		5		6			5 2-2
S 24-	TV 10*	11	11*	1		2		3	2	4	3	2			4	2		5	6				5 2-1
S 25-	R						1		1								2						
SDT 286	TV 10	10*	11			13		14		15		16			15		16		17				
TS 282	R			4							5				5								
OPEN	TV 10	10*	11		12		13		14		15		16		15		16		17				
FORUM	R			7											17*								
	TV 21	22	23	24	25	26	27	28	29	30	31	32	33	34	35	36	37	38	39	39	39	39	39

NB. In week 26, S22-, S23-, and S24- are replaced by S2-3, S2-2, and S2-1.

• Notes

- TV
 Wk 23: S241/10 (rpt) - Sun, 13.05
 Wk 24: S25-/10 (rpt) - Sat, 12.35
 SDT 286/11 (rpt) - Thur, 17.35
 TS282/10 (rpt) - Sun, 09.05
 Wk 25: S24-/11 (rpt) - Sun, 13.05
 S25-/11 (rpt) - Mon, 19.05
 TS 282/11 (rpt) - Thur, 18.35
- Wk 29: S2-1/1 (rpt) - Mon, 19.05
 SDT286/12 (rpt) - Thur, 18.35
 Wk 30: TS282/12 (rpt) - Thur, 18.35
 Wk 31: S2-1/2 (rpt) - Mon, 19.05
 SDT286/13 (rpt) - Thur, 18.35
 Wk 32: TS282/13 (rpt) - Thur, 18.35
 Wk 33: S2-1/3 (rpt) - Mon, 19.05
 SDT286/14 (rpt) - Thurs, 18.35

THE PHILOSOPHY BEHIND THE COURSE DESIGN

Since the objectives of the Open University would indirectly be reflected in the type of curriculum offered, it is important, we believe, to restate the objectives of the OU before we examine the curriculum and see how it was designed. These objectives are clearly set forth in the OU Planning Committee's Report of 1969.

Pointing out that the opportunity to receive a higher education was now being accepted as a basic individual right, the Open University planners said the institution would attempt to provide this opportunity to the greatest number of people--not just the privileged few.

"Moreover, education generally, and higher education in particular is, at one and the same time, a necessary condition of a modern technological society and a defense against its abuses."³

The Planning Committee also felt the University had an unrivaled opportunity to rectify the long-continued imbalance "of providing educational opportunities currently denied to women as compared with men, and with this, occupational opportunities also."⁴

Having defined its objectives, the Planning Committee then set out to find what interest existed in the adult population for an Open University. Preliminary inquiries had been received which indicated there were significant groups of professional students -- other than certified

³Report of the Planning Committee to the Secretary for Education and Science. The Open University London, England. Her Majesty's Stationery Office. 1969. p.2

⁴Ibid. p. 5.

non-graduate teachers -- who had had no opportunity to take the Bachelor of Education degree or otherwise gain graduate status.

A nation-wide survey of the interest of the adult population in the Open University was carried out by the National Institute of Adult Education. A random sample of some 3,000 adults over 21 years of age was chosen from six areas; of the 3,000, some 70 percent returned the questionnaire. Compilation of results indicated there was good grounds for expecting a substantial number of candidates to enroll in the Open University.

As for persons under 21, "it is always preferable for those aged 16-21* years in employment . . . to take part-time courses" at technical and polytechnical universities and colleges. "We consider that only those whose circumstances make it impossible for them to do so should be enrolled in the courses of the OU."⁵

It was the decision, then, of the Planning Committee to focus its main work on the adult student.

Admission quotas were set to match the UK's averages for various occupational categories, percentage of adults in a given region, and sexes. (See Appendix "Analysis of Applications and Allocation of Places for 1972 Courses" and other section of this report entitled "Students").

Since the students at the OU would be coming from varying age groups and levels of attainment, it was decided that the first year courses would be designed to suit a wide variety of preparative backgrounds. Also,

*School leaving age in England is 15; it is projected this would be 16 by 1972-73.

⁵Ibid. p. 4.

no formal academic qualifications would be required to enroll. The degree the OU would offer would be a "general degree" in the sense that it would balance studies over a range of subjects rather than be confined to a single narrow speciality. This led to the concept of the Foundation Courses, designed as a means of familiarizing students with the modern concepts of the main "lines" of study. The Foundation Courses offered the first year were (1) Humanities, (2) Understanding Society: Social Sciences, (3) Mathematics and (4) Science. The following year 1972 two additional areas were added: Educational Studies and Technology.

In addition to this main emphasis on adults studies and the "general degree," the Planning Committee also declared that from the outset the University would aim to provide opportunities in higher education at the postgraduate level for two types of students: the graduate who desires to work for a higher degree by studying at a distance, and the graduate wishing to take courses for updating or refresher purposes. (Post-experience courses will begin in January 1973 and can lead, by credit stages, to a postgraduate degree).

As of this writing, the University is not yet in a position to offer course work leading to higher degrees. The limited number of graduate students currently enrolled are conducting research.

Having set these objectives, the Planning Committee then committed the University to a revolutionary multi-media system of higher education.

"It is no longer necessary to argue that the broadcasting media, where imaginatively used, are efficient means of instruction, since that has now been established by an adequate body of research."⁶

"Broadcasting, then, can most effectively be used as a component part of a fully integrated teaching system which also makes use of printed material, including specially written textbooks and directions for further reading; of correspondence tuition (teaching); of part-time face to face teaching, and of group discussion."⁷

Since the teaching methods of the OU would necessarily differ radically from those in use in other universities, the Planning Committee established a special group to provide the necessary expertise in the educational technologies associated with specialized course design, with the problems of programmed learning, and the assessment of student performance.

With its objectives clarified and its goal defined, the Planning Committee then turned over the design and development of the curriculum to its faculties.

⁶ Ibid. p. 6.

⁷ Ibid. p. 7.

COURSE PRODUCTION AT THE OPEN UNIVERSITY

It is interesting to look back at the planning committee's report and see how its original estimates worked out. The committee estimated it would take four full-time academic staff to provide service and revise the courses on each component subject and still be able to devote a significant portion of their time to private study and research. "This estimate was wildly optimistic," says Brian N. Lewis, deputy director of OU's Institute of Educational Technology.⁸

Experience has shown that it takes a dozen academics working virtually full-time for an academic year to produce one complete foundation course. ("And even then, they are too rushed to do a really good job," says Lewis. "It would indeed be more realistic to set the estimate of 18-20 academics for a one-year course.")⁹

All study materials are packaged and sent through the mail to students at intervals of about four to six weeks. Each package is a self-contained entity--complete with TV and radio broadcast schedules and questions tying in the broadcasts to the written correspondence texts.

The planning and writing of the correspondence material with the lists of objectives and key questions, study notes, self-assessment tests, computer-marked multiple tests, guide-lines for the study center tutors to evaluate the essay-type tests, was unlike anything the faculty had ever experienced.

The science faculty also designs home experiment kits and

⁸ Brian N. Lewis, "Course Production at the Open University I: Some Basic Problems." British Journal of Educational Technology No. 1 Vol. 2 Jan. 1971. p. 8.

⁹ Ibid. p. 8.

equipment. The course design teams of all the faculties also must write the radio and TV programs (one-a-week for the foundation courses), draw up auxiliary readings of books students can borrow or buy, briefing material for study center tutors, plus materials for short residential summer school sessions.

How is all this material produced? In a typical British understatement, Lewis says: "It is difficult for the outsider to appreciate just how abnormal are the problems that confront the Open University's academic and administrative members of the staff."¹⁰

BBC's John Robinson told us of some of these "abnormal" difficulties confronted by the course team when it was producing the TV and radio broadcasts.

"The big difference between the Open University method and almost any other is the attempt to bring the media together. Not only is this a course team, it is a multi-skilled course team in the sense that it has academic staff, it has radio producers and TV producers, and educational technologists on the team, the latter stressing the systematic design approach."

Many times, course teams are even more complicated when the courses are produced by two or three faculties. "We have people who are not only inter-disciplinary," said Robinson, "but also inter-faculty as well. For example, we have a course called "The Biological Basis of

¹⁰ Ibid. p. 5.

Behavior." On the course team we have psychologists from the Social Science Faculty, biologists from the Science Faculty and technologists from the Educational Technology Faculty concerned with systems design and systems development who ask: 'Are you going too fast? Have you really specified your objectives?' Then there will be radio and TV producers numbering three, four, six or eight, and so on. This team then, inevitably will split into smaller groups to tackle parts of the course. I want to stress once again, we will be meeting as a team, regularly over a period of eighteen months."

Robinson emphasized the informal way in which a broadcast idea emerges.

"Let's look at the curriculum for Unit Two in the new course offered by the Faculty of Social Sciences called "Decision Making In Britain."

(The course is described in the catalogue as follows: "Who makes the decisions that matter in Britain? Where are these decisions made and by whom? What are the constraints--economic, spatial, social and others that operate, and how are decisions implemented? Indeed, how far are changes or developments the result of decisions that are consciously made? This course is an exploration of the answers to these problems")

"Unit Two, the course team decides, will concentrate on how

decisions are developed in British labor relations in the last five years," Robinson continued.

"The course team selects a faculty member saying: 'Jim, you're an expert in this field; you take the main responsibility for this unit. Come back when you've got a draft of the unit. Come back and tell us what you are going to do with the radio and TV programs.'

"A few weeks later the team will have an outline from Jim and he will discuss his ideas with the TV producer and radio producer. At that stage it is impossible to say who produces the idea of how to do something, because it just emerges, it just evolves. The script will sort of emerge in a joint authorship. Basically, it will be the result of discussions over drinks at the bar in which the TV producers sort of fade ideas in."

Robinson pointed out that before the OU method of course team planning was developed, the usual method of planning a TV program was for an academic and a producer to meet about six weeks before the airing of the program--or even three weeks, or even three days and they would say: 'What are we going to do?'

"This just doesn't happen now with our Open University method. The idea--the seed of an idea--would have grown over weeks and months if this course team of people had been thinking about it over a period of a year or eighteen months. So as the team works there is a gradual development of ideas, the gradual working out of ideas."

We asked Robinson what was the alchemy, the ingredient that made this diverse, fiercely independent group of academics and professionals work together as a course team.

"The life span of the course team -- 18 months -- is the particular feature that makes this team concept work. They must get to know each other. They might hate each other like poison to begin with, but they just have to work together."

Brian Lewis, in his two papers on "Course Production at the Open University"¹¹ gives an incisive, humorous, no-holds barred description of the difficulties involved by the course teams; the personality clashes, the suspicions, and ego-trips of the academics.

"All team members are expected, in fact to learn something of educational technology. For example, the writing of correspondence units is not just a matter of converting ordinary lectures into print. In the ordinary lecturing situation, it is usually possible for students to question the lecturer on points of difficulty. In the case of correspondence materials, this safeguard is missing. Since the authors of correspondence will never be physically present for questioning, extra care must be taken to ensure that each unit is a sound piece of exposition."¹²

¹¹ Brian N. Lewis, "Course Production at the Open University I: Some Basic Problems." British Journal of Educational Technology, No. 1 Vol. 2 January 1971.

Brian N. Lewis, "Course Production at the Open University II: Some Basic Problems." British Journal of Educational Technology, No. 2 Vol. 2. May, 1971.

¹² Ibid. "Course Production I" p. 6.

Unfortunately, it is all too easy to be clear and accurate and, at the same time, intolerably dull, Lewis points out. Very few people can write this well and many academics are not even convinced it is necessary to go to so much trouble.

Authors "should turn the students on," Lewis insists. "Unless the author arouses in the student a sense of excitement and purpose, and explains why the knowledge is worth having and how it fits into the broader scheme of things, learning at a distance will tend to become a burden rather than a pleasure."¹³

David G. Hawkrige, director of the Open University's Institute of Educational Technology points out¹⁴ that because the student is learning at a distance he is deprived of honing the skill of what Snyder at M.I.T.* calls "selective negligence," the ability to identify and neglect what is unimportant in a lecture or reading material.

To highlight the important text material, OU curriculum designers build in to the written material a list of objectives, self-assessment questions that hit the highlights, and cross-reference questions to stimulate the student to search for important information.

Hawkrige's staff, who have been working with curriculum development, have found that some of the widely accepted teaching methods are not working. "The classical behavior objective is inadequate," Hawkrige states flatly, "although it is better than no objective at

¹³Ibid. "Course Production I" p. 6.

¹⁴David Hawkrige, "Educational Technology at the Open University." AV Communication Review, Vol. 20, No. 1 (Spring 1972), p. 7.

* Snyder, B. R. The Hidden Curriculum, New York; Knopf, 1971.

all in most circumstances. We cannot cope by using only the ideas of Mager* whose suggestions come from industrial training situations."¹⁴ On the other hand, the behavior objective research of Ausubel* has been encouraging to the IET staff.

Hawkrige also states that research by IET curriculum designers indicates that the neat hierarchy of concepts does not work in designing higher educational instructional materials. "Rather the complexity of the structure of knowledge aligns itself into a number of nodes of concepts. The subject matter could be entered from a number of directions and traversed by many routes. Some routes are more suitable to particular learning systems, such as holistic or serialist, inductive or deductive."

Samples of the curriculum design followed by the science foundation course team of writers are shown on the next four pages. These samples are from Unit I called "Science: Its Origins, Scales and Limitation." Each of the remaining 33 units in the year-long foundation course lists a "Statement of Objectives, a "List of Scientific Terms, and a conceptual chart or overview of the unit to be studied. The fourth sample is a page from Unit I showing how questions, attractive graphics and bold face type are used to improve learning. Note the list of suggested auxiliary readings at the bottom of the page.

Assessment of the instruction material is continually being made during the development and writing stage. Whenever possible, each

¹⁵ Ibid. p. 8.

* Mager, R. F. Preparing Instructional Objectives. Palo Alto, Calif. Fearon, 1962.

* Ausubel, D. B. The Psychology of Meaningful Verbal Learning. New York: Grune and Stratton, 1963.

MAN'S PROGRESS IN SCIENCE & TECHNOLOGY

PRE-HUMAN HUMAN

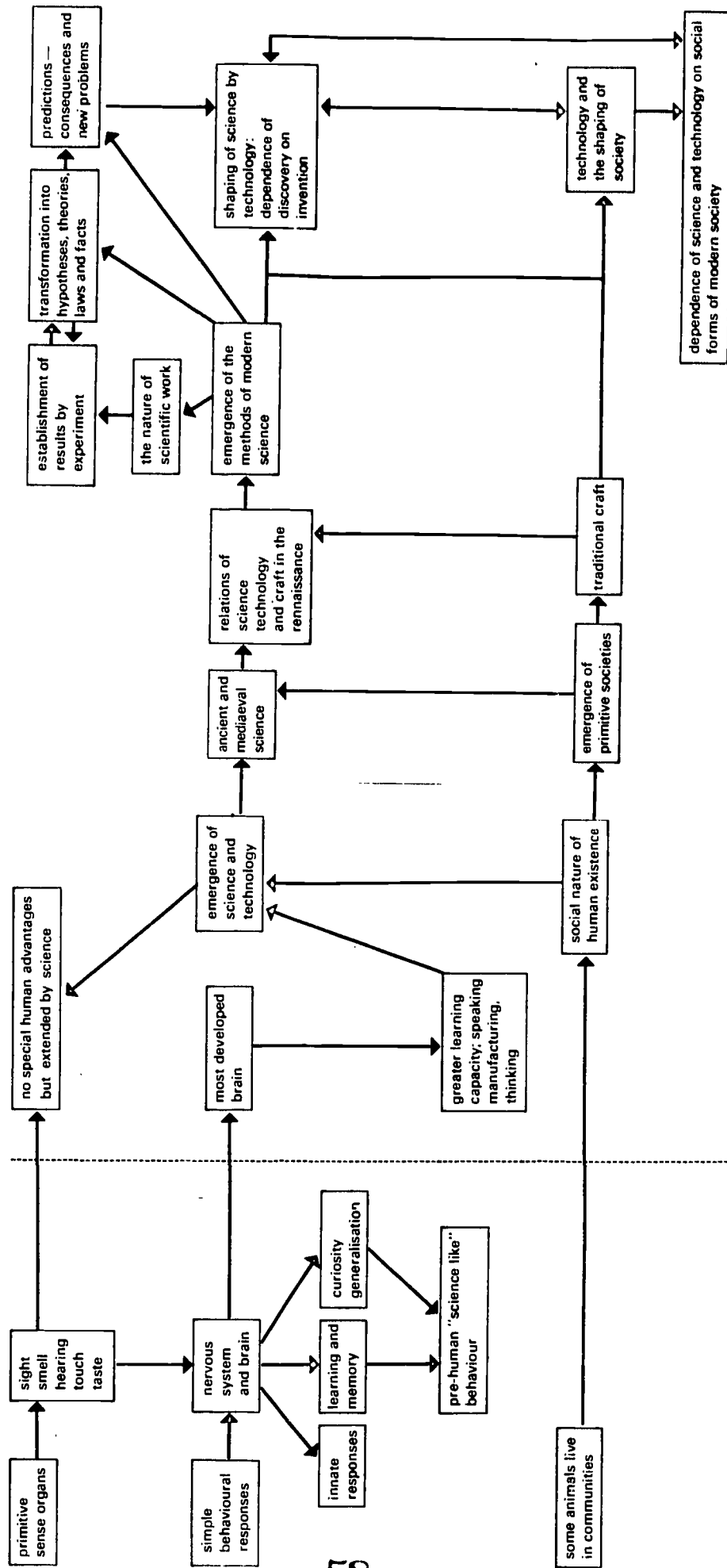

3-4000 million years ago

1 million years ago

3-4000 years ago

300 years ago

today

When you have completed this course unit you should be able to:

1. define in your own words or recognize valid definitions of the terms, concepts and principles listed in column 3 of Table A (p. 5), and recognize situations implicitly involving the ideas expressed by these terms, concepts and principles;
2. give six examples of the orders of magnitude by which man's technological capabilities have increased over the last century;
3. give at least three significant examples of, or select from a list of given examples, ways in which modern society has been, or is being, modified by science and technology;
4. illustrate in at least three separate contexts, the reciprocal interaction of science and technology by interrelating correctly groups of concepts, discoveries and technological achievements, producing your own examples;
5. give the names of at least five instruments or devices or techniques by means of which man has extended the range of his senses, and name the senses so extended. (The word 'extended' in this context includes bringing something into the limited range of man's senses by means of an instrument, device or technique;)
6. give, or recognize as valid, at least two examples which indicate that some form of brain information storage mechanism is necessary for the brain to interpret usefully (to the organism involved) signals about the environment received through its senses;
7. give, or recognize, at least two pieces of evidence that demonstrate the strength of an animal's drive to explore its environment;
8. name or select from a given list, three characteristic evolutionary features which distinguish the capabilities of man from all other organisms;
9. distinguish examples of scientific knowledge from those of craft knowledge;
10. given a simple experimental situation, list at least two-thirds of the factors (given also the total numbers of factors which could be expected) which might bias the final result unless reviewed;
11. give at least three reasons why (specify quantitative or qualitative) experimental data might be unreliable;
12. carry out simple experimental work given the necessary equipment and be able to identify sources of error within a given simple experimental set-up;
13. present the results of simple experimental work in a suitable form (i.e. conforming to current practice in scientific journals), including the use of graphs, bar charts etc. where appropriate;
14. select from given statements those which illustrate, or give at least three examples of, the transformation of scientific results with use;
15. identify, in an elementary way, terms or sentences in a text which have functions or natures or roles which illustrate the meanings of such concepts as: making and testing hypotheses; paradox; induction, deduction; argument by analogy; facts; principles;

Table A

A List of Scientific Terms, Concepts and Principles used in Unit 1*

Taken as prerequisites			Introduced in this Unit				
1	2	Unit No.	3	Page No.	4	Unit No.	
Assumed from general knowledge	Defined in a previous Unit		Defined and developed in this Unit or set book for this Unit		Developed in a later Unit		
sample bias statistics cell (biological) ratio brain velocity			<i>In Unit text</i>		extension of senses	2	
			science	1 f.	evolution	21	
			technology	1 f.	innate behavioural response	20	
			generalization	10	feedback loop	16	
			model	34 f.	energy	4	
			analogy	35	force	4	
			theory	34 f.	mass	3	
			hypothesis	35 f.	gravitation	4	
			correlation	35	conservation of energy	4	
			statistical probability	36	instantaneous velocity	3	
			induction	36	acceleration	3	
			deduction	36	electromagnetic radiation	2, 28	
			proof	34 f.	laws of thermodynamics	5	
			inference	36 f.	wave motion	2, 22	
			fact	37 ff.	radioactivity	6, 31	
			scientific method	36 f.			
				<i>In HED**</i>	Sect. No.		
				parallax	1.1		
				statistical error	2.2		
				mean value	2.2		
			constant of proportionality	2.7			
			direct and inverse proportionality	2.7			
			axis of a graph	2.8			
			'best curve'	2.10			
			significant figure	2.13			

* Any scientific terms used in this Unit but not listed are marked thus † and defined in the glossary.

** The Handling of Experimental Data (see p. 28).

1.2 Is human 'science' unique?

It is usual to set the emergence of 'modern science'* as occurring in Europe, in the sixteenth century and the development of science as proceeding with ever-increasing speed thereafter, particularly following the Industrial Revolution of the nineteenth century, in Britain, France and Germany, and rather later in the United States, Russia and Japan. But the activities described as science are the natural continuation of processes that had, indeed, been going on in earlier times in human societies. What is more, they are an extension of developments which we can trace not only in humans but even in the most primitive animal.

1.2.1 The senses and their development

The evolutionary path which has led to man and his society has been that of ever-increasing capacity to sense and react to the external world.

Man is commonly described as having five senses. Can you name them?

Sight, hearing, touch, taste, smell.

With these senses, primitive man must have explored the surrounding world, learned what was and what was not good to eat, what was to be feared and avoided as dangerous and what was not. Much of modern science has depended on the process of extending the range and precision of these senses, particularly those of sight, hearing and smell, making possible the detection of objects at a distance or with a degree of accuracy and clarity not otherwise possible, or of substances which would otherwise be outside the limits of detectability.

Name some scientific devices which extend the range of each of the three senses, sight, sound or smell. (Try to name at least one instrument which corresponds to each sense.)

Sight—telescope, microscope.
Sound—stethoscope, telephone.
Smell—breathalyser, smoke detector.

Maybe you got the first two right and not the third. The sense of smell depends on the presence in the nose of special detectors which respond, in ways we will describe in Unit 18, to small quantities of individual chemical substances in the air breathed in. The breathalyser, in measuring the amount of alcohol in breath, performs a similar job.

But the senses did not arise with man alone. More primitive animals possess them, often more fully developed than in man.

Name some animals which have better sight, hearing or smell than man.

You might have chosen from amongst many. For example, the ranges of sound that can be heard by the bat or the dog exceed that of man. The eyes of the owl are adapted to see quite well in a degree of darkness in

* If you would like to read more about this, see the relevant parts of *Ravetz and Bernal* (Vol. 2, Chapters 7, 8 and 9). We also suggest that you read Chapters 1 to 6 of *Rose and Rose over the course of the year*. We shall refer to these Chapters again in Units 33 and 34. The full details of these books are given in the Book List on p. 461

unit's draft is submitted to "guinea pig" students who are chosen because they are good error detectors and can comment articulately on how to improve the material. In addition to student assessors, scholars at other universities -- external assessors -- are asked to evaluate the unit's work. These external assessors are also used to help control standards in the examinations incorporated in the correspondence material, and the proctored examinations at the end of the year.

The test-revise-retest cycle of revising the original unit draft can be repeated as many times as necessary to satisfy the author and his course team colleagues. However, each new cycle adds at least three to four weeks to the overall production time.

In addition to the basic correspondence text, the authors must devise appropriate homework assignments. Some are marked by the computer; the written homework is marked by correspondence tutors.

As BBC's Robinson pointed out, the preparation of related radio and TV programs is no less difficult. Even the simplest show takes several weeks to plan, especially if it has to be carefully integrated with the correspondence materials or if there are special visual effects, such as time-lapse photography.

Lewis points out that "It might be thought that all the main difficulties and stresses and strains could be avoided by means of

appropriate forward planning techniques. But it is important to realize that the nature of the operation, and the time pressure under which everyone is working, are such that planning cannot possibly solve (or even foresee) all the problems that can arise.¹⁶

"Another fact of life is that different academics have different working methods, and different views of the educational enterprise in which they are involved. One member of the team might be enthusiastic about computer-marked objectives tests; whereas another might deplore them. One academic might prefer to write in a friendly and egalitarian manner, whereas others might adopt an impersonal approach. There are literally dozens of ways in which differences of approach and opinion can arise. If the differences happen to reflect strong underlying convictions, then the possibility of open conflict is never far away."¹⁷

Most academics are understandably suspicious of outside efforts to organize them more efficiently, Lewis says. It conjures up an image of a Big Brother organization whose business it is to make sure that the faculty is doing a competent job. Talk about production control or quality control "are likely to elicit a sharp reminder that the Open University is not a factory, and that course materials are not manufactured on an assembly line like bars of chocolate."¹⁸

¹⁶Lewis, "Course Production I". Ibid. p. 10.

¹⁷Lewis, "Course Production I". Ibid. p. 11.

¹⁸Lewis, "Course Production II". Ibid. p. 114.

As a consequence of this resistance, the University does not have a Total Systems Approach to its planning and production problems, says Lewis. However, insists Lewis, "because of the complexity and novelty of the OU system, good intentions and inspired guesses are no guarantee of success. Nothing less than a thorough-going Total Systems Approach to planning is really satisfactory."¹⁹

Consultants and staff of the IET drew up a specimen activity network chart. The original version with the pages joined end to end occupies a wall space about seven feet long and one foot deep. (Copy attached.)

Lewis says that its overwhelming physical size served one purpose - it impressed the academics with the enormousness of the task confronting them. Even more so, they saw what really has to go on to achieve it. Says Lewis: "The effects of studying this particular network has been salutatory enough to convert quite a few academic members of the staff to the systems thinking approach."²⁰

"As it actually worked out (and this may shock the purists) the main function of the network chart is to serve (a) as a memory jogger, and (b) as a starting point for further discussion."²¹

How effective is the instruction?

One of the main tasks of the Institute of Educational Technology headed by Dr. Hawkrige, is researching the answer to this question. In-depth studies are now underway to measure the validity of

¹⁹Lewis, "Course Production II". Ibid. p. 114.

²⁰Lewis, "Course Production II". Ibid. p. 116.

²¹Lewis, "Course Production II". Ibid. p. 116.

the objectives of the study units, the activities of the students while they study these units, and the tests used to measure students' achievement. The IET is waiting to tackle other studies in cost-effectiveness, course production scheduling and management, evaluative studies of such media as TV and radio, and the impact of OU-type institutions upon higher education, among others.

However, Dr. Hawkrige²² concludes, "Nobody at the University and least of all the members of the institute will claim that the courses are more than first approximations, first steps towards the ideal. On the other hand, there do seem to be good chances of being able to improve the courses."

²²Hawkrige, "Educational Technology". Ibid. p. 14.

START OF
PHASE 1A

COURSE PLANNING

COURSE PLANNING

Activities Network

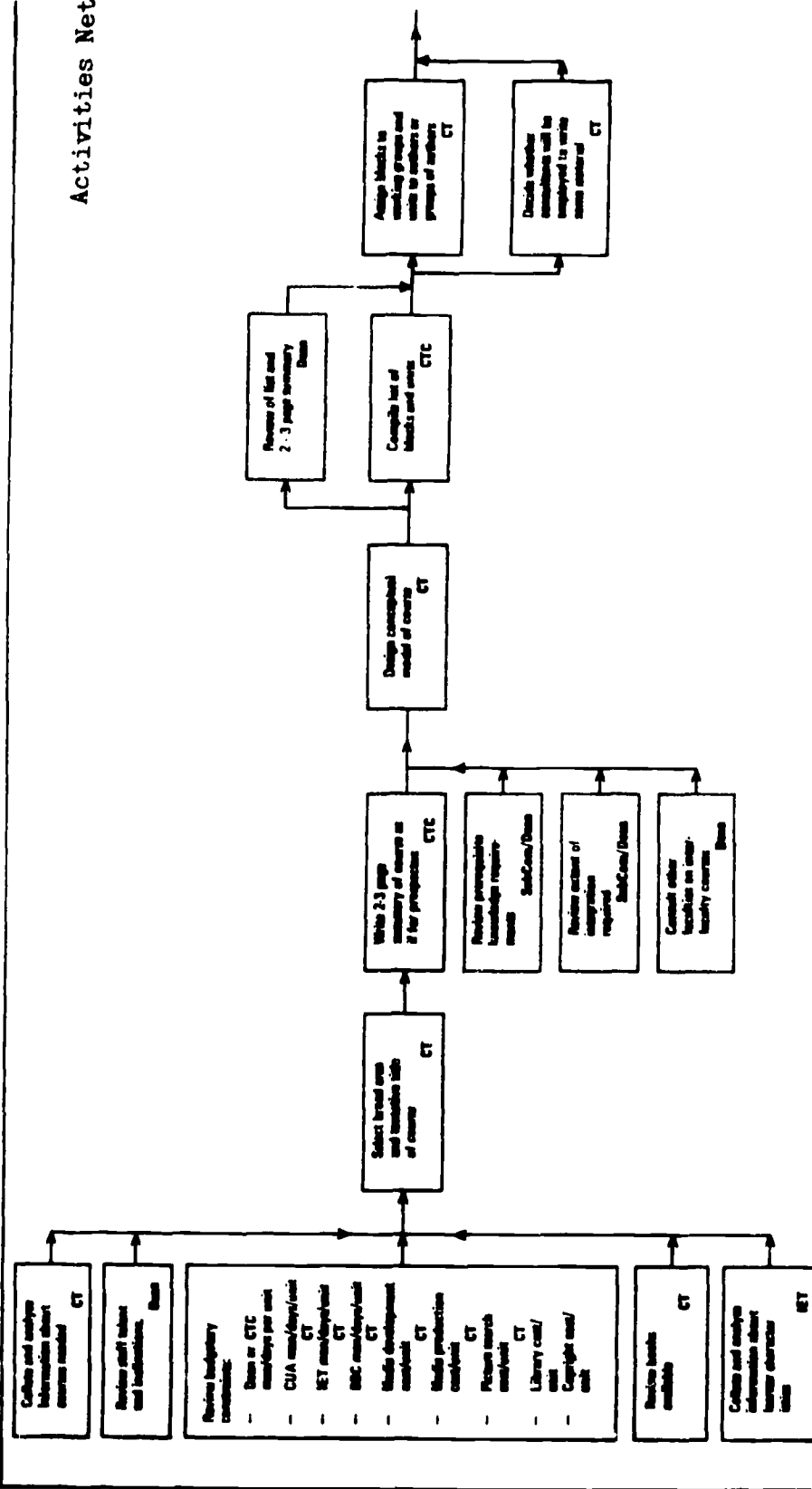

CT	Course Team	Editor
CTC	Course Team Chairman	IET
CUA	Course Unit Author	Inst. Ed. Technology
D1	Draft 1 of Unit	Media Evaluator
D2	Draft 2 of Unit	PO
D3	Draft 3 of Unit	SC
D4	Draft 4 of Unit	Sub/com
EA	External Assessor(s)	WG
		VC
		Working Group
		Vice-Chancellor

COURSE PLANNING

END OF PHASE 1A START OF PHASE 1B

UNIT PLANNING

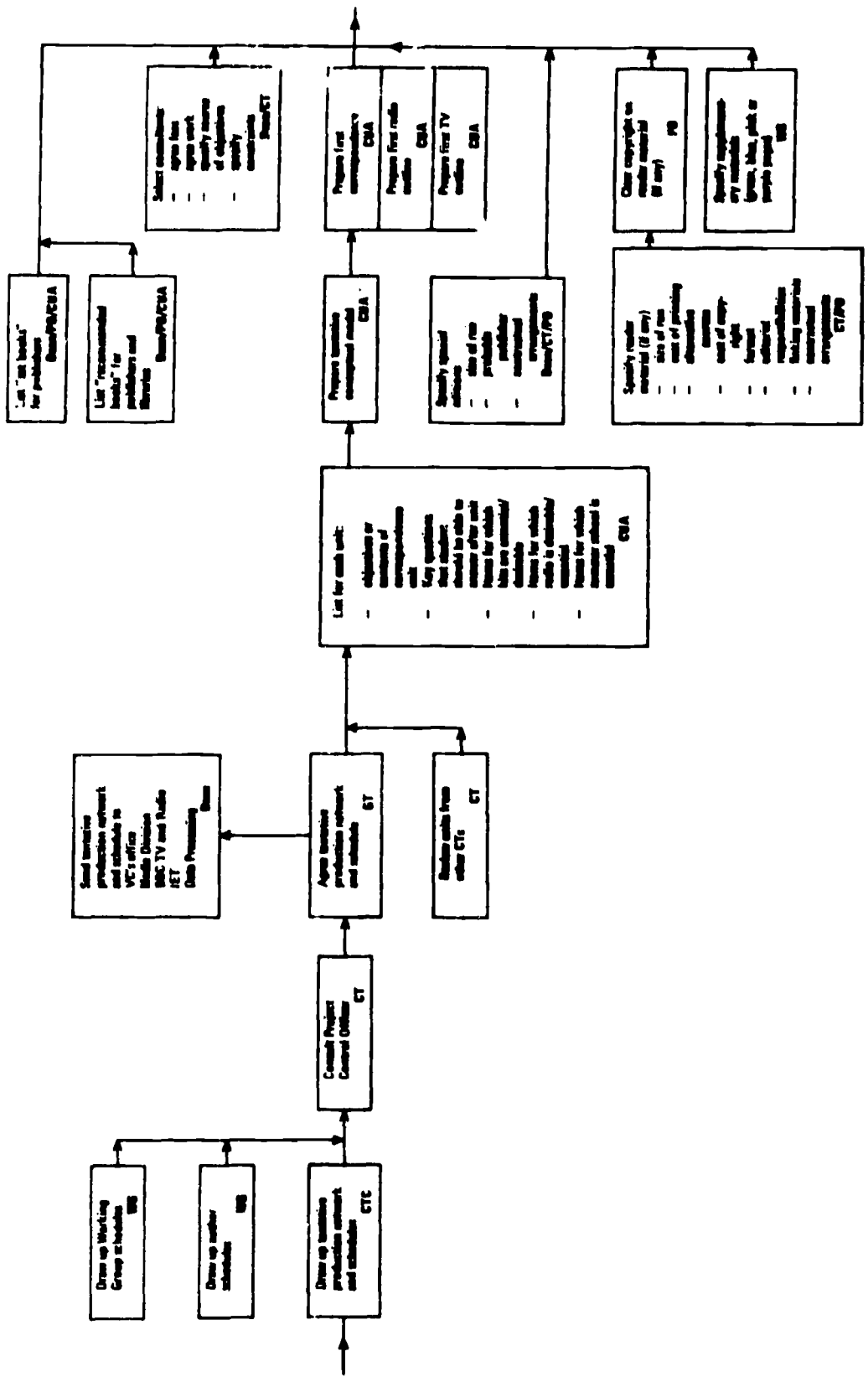

UNIT PLANNING END OF PHASE 1B START OF PHASE 2A UNIT WRITING

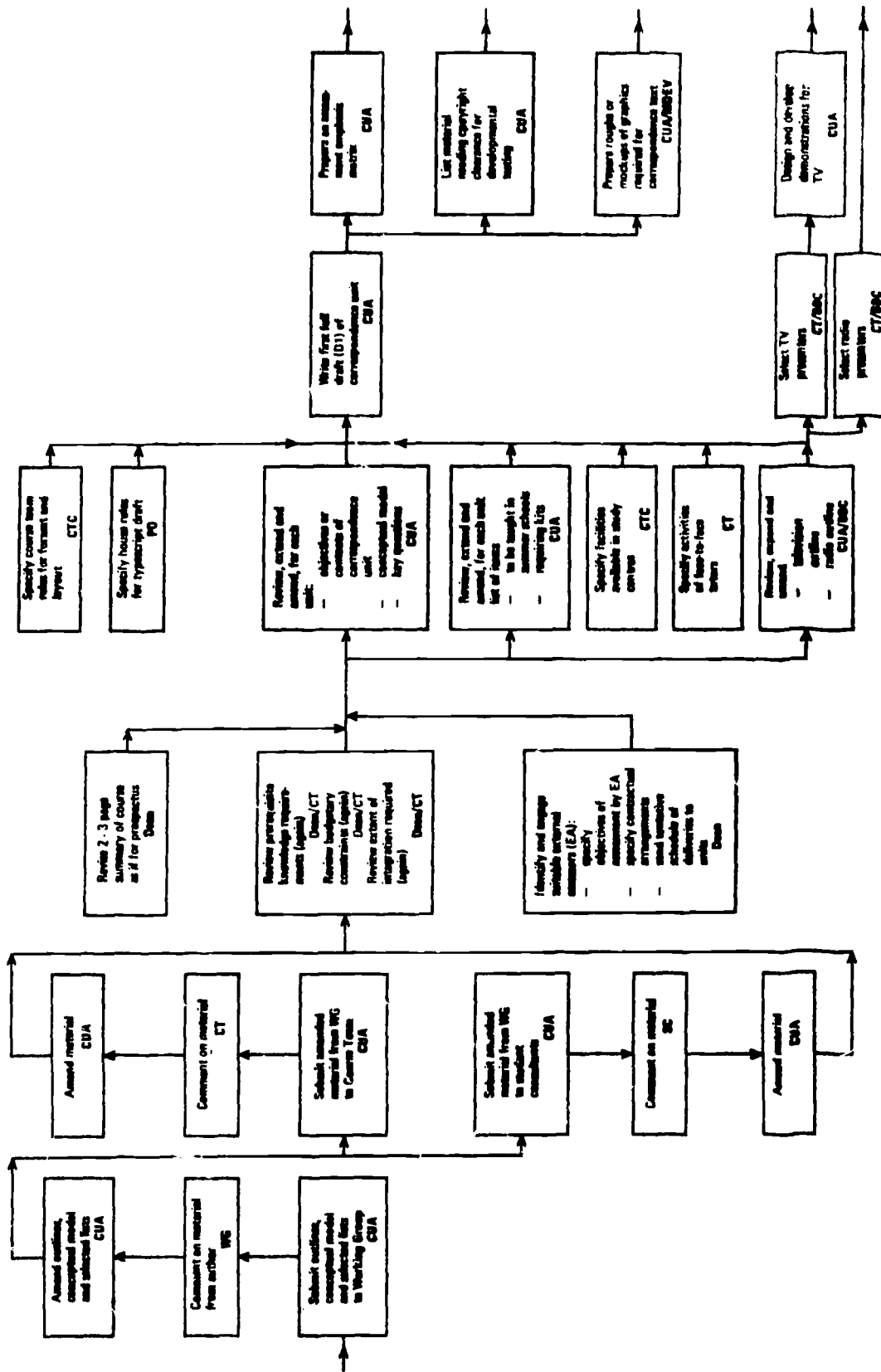

DEVELOPMENTAL TESTING

START OF PHASE 2B

END OF PHASE 2A

UNIT WRITING

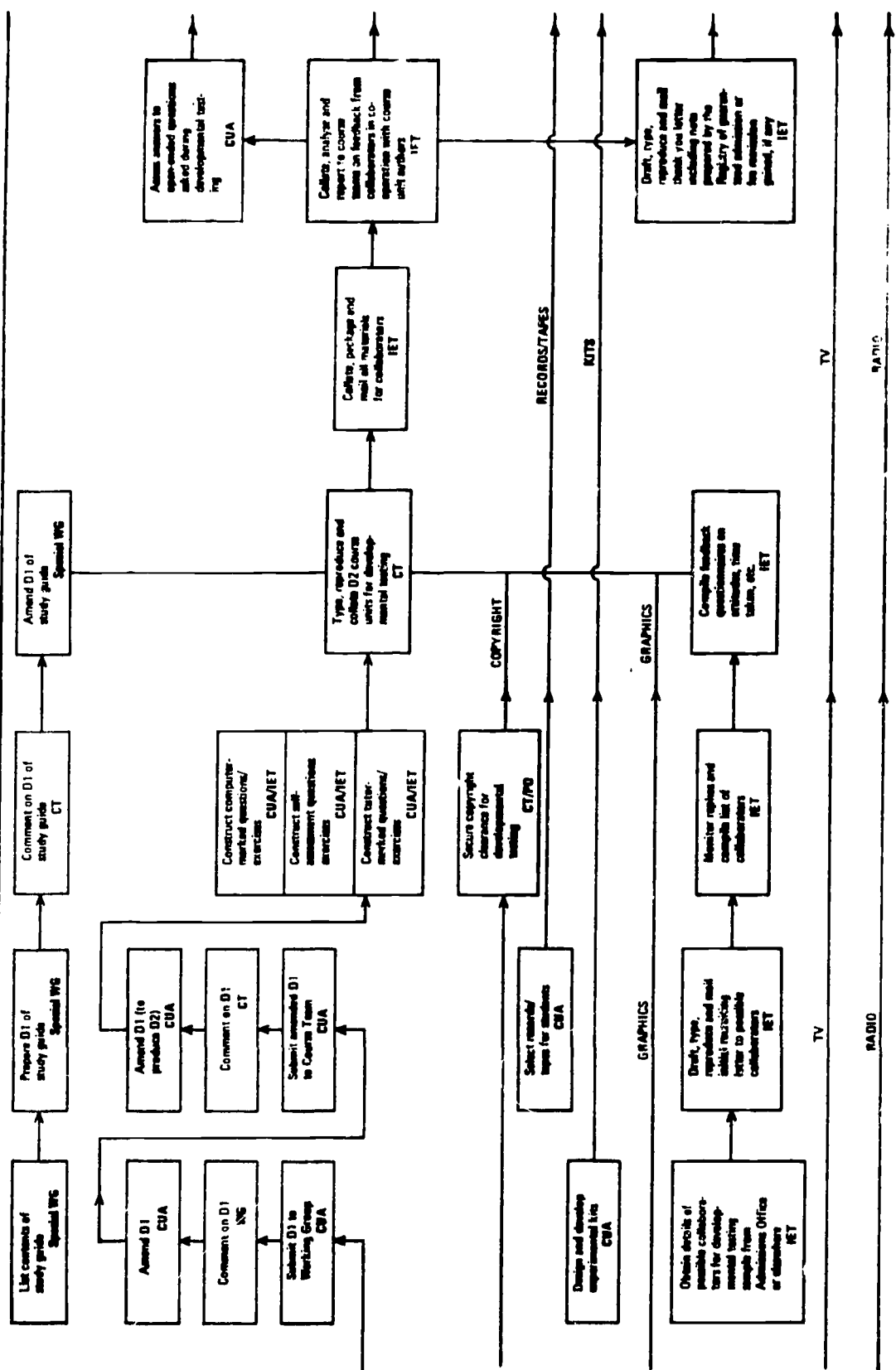

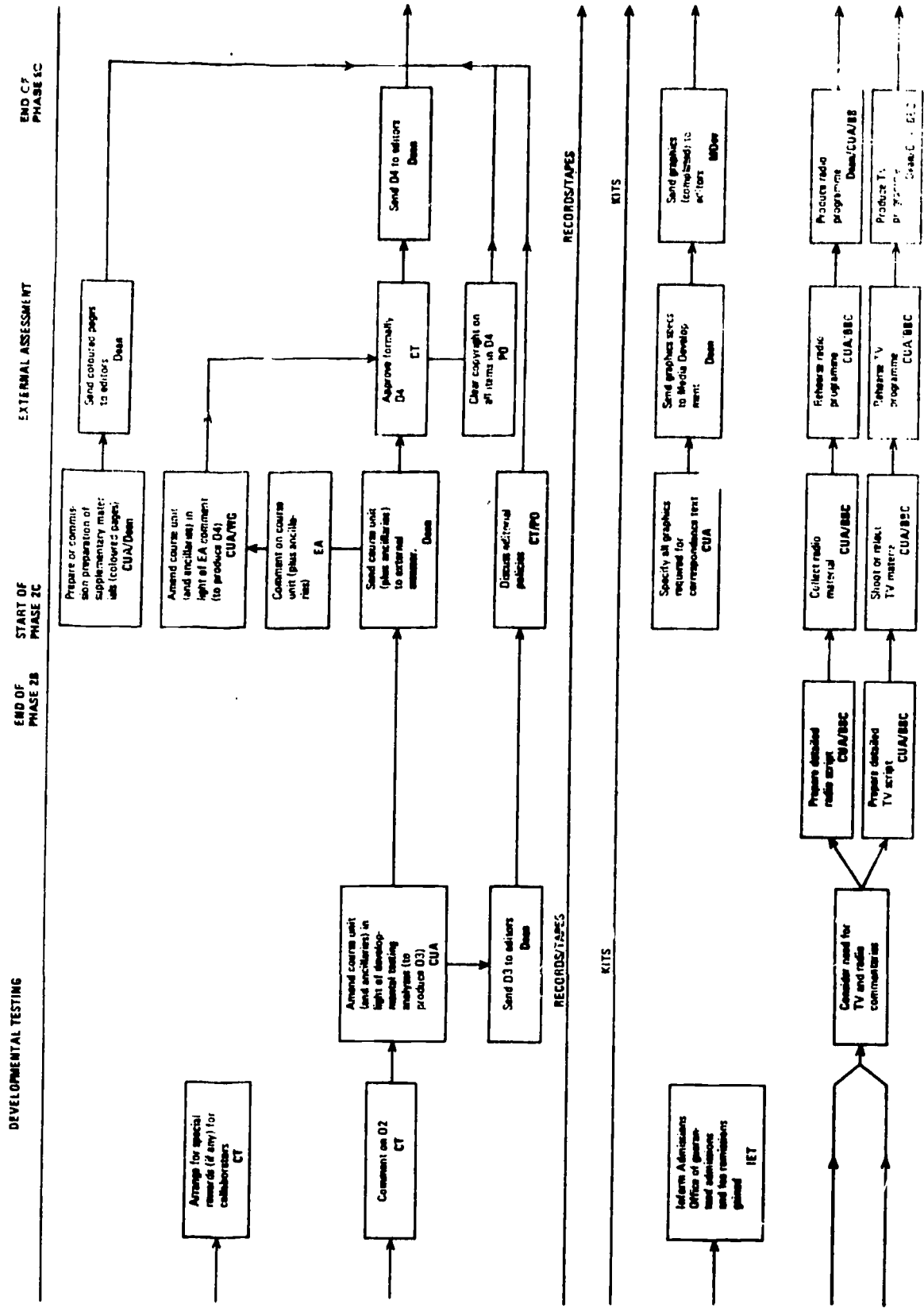

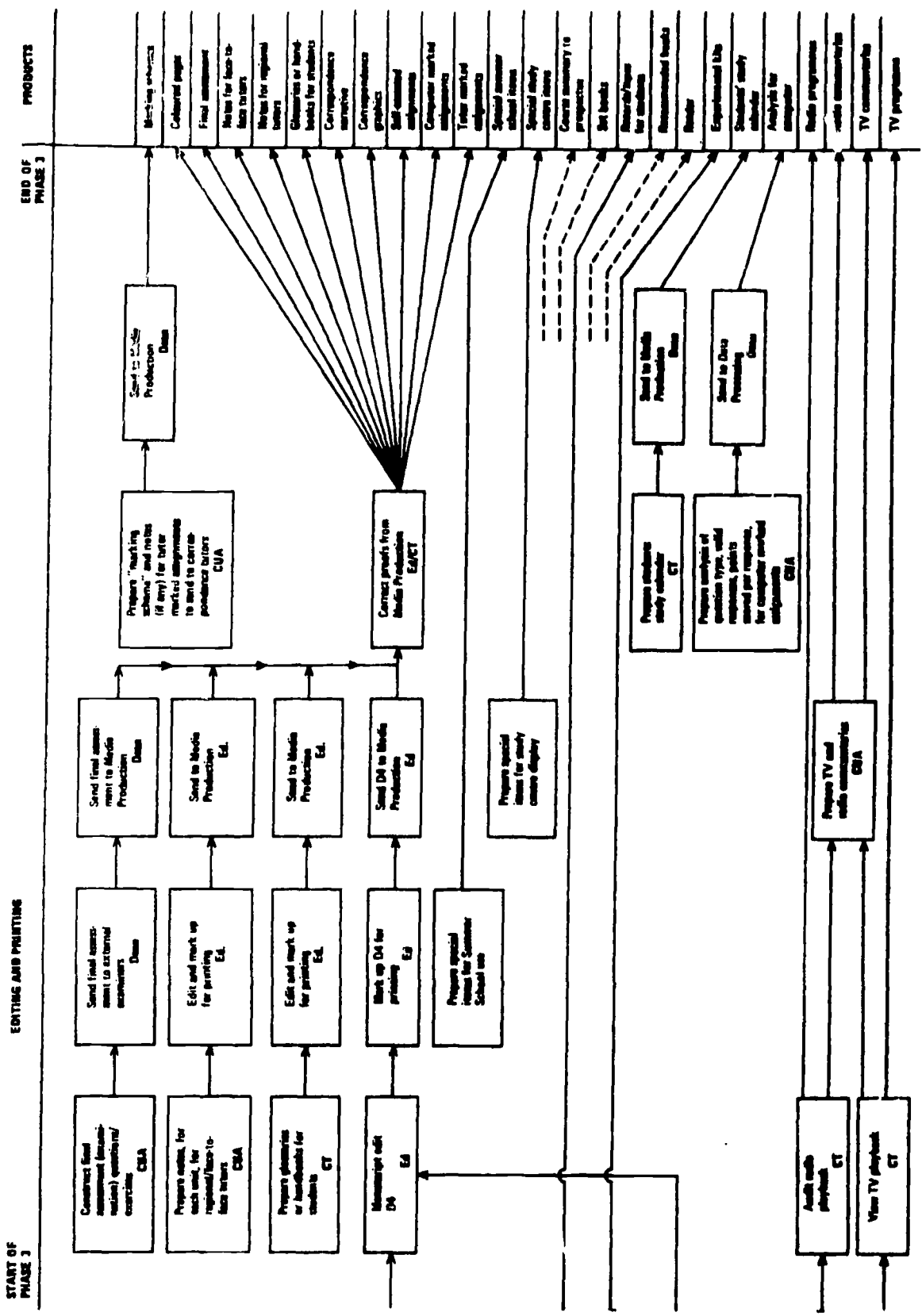

STUDY CENTERS

"Putting a Face to the University"

The College of Education in Bletchley, Buckinghamshire, a middle size college of between 1,500 and 2,000 students, is the site of the Milton Keynes Study Center, one of 300 study centers maintained by The Open University in 13 regions throughout the British Isles.

The Milton Keynes center is a typical one. The Open University has access to three rooms at the college during the hours of 5:30 to 9 p.m. five days a week. OU pays the college a facility fee (depending on their size, centers cost between 200 and 500 pounds--\$530-\$1,325-- a year) plus the cost of a janitor to keep it open.

Study centers accommodate from 60 to 200 students. In all cases the centers are located in existing structures: colleges, libraries, churches, schools. In North London, there is a study center at BBC's Alexandra Palace studios. There is even a Study Center at the Long Kesh Internment Center in embattled Northern Ireland. (Students there are ten internees who are taking foundation courses in the arts and social science.) At 100 strategically located centers, OU has computer terminals for math and technology students.

The Open University makes its agreements with a principal, or head master, or local librarian or whoever heads an institution in which it seeks shelter. OU asks for the evening hours, and if possible,

for access on Saturday and Sunday mornings, but doesn't insist on the weekend hours. It needs--besides the access to the rooms--some furniture, a blackboard, and a lockable cupboard for projectors, films, TV receivers and other equipment.

Regional Directors (there are 13 of them) manage about 25 centers each. Each has one or two full-time staff members--senior counselors who are responsible for counseling service in all of these centers. They are in turn responsible for the part-time people who are on duty in each of the centers every evening.

Most of the centers have one person on hand each evening, but in the larger centers as many as ten tutors and ten counselors may be on tap during a given evening. The tutors usually are recruited from some phase of adult education. They are paid on a sessional basis.

In a recruiting advertisement appearing in the London Sunday Times, May 21, 1972, the role of the course tutors and counselors are spelled out:

COURSE TUTORS are responsible for grading and commenting on students' written assignments, for replying to queries about students' work and for conducting face-to-face tutorials, normally at local study centres.

THE COUNSELOR'S main responsibilities are to give study advice to the students assigned to him (and in the case of Foundation Course students, tutorial support) and to help to organise discussion groups at a local study centre. The time needed for University duties varies according to individual contracts, but on the

average will occupy perhaps one evening per week for most of the year.

Appointments will normally be tenable for one year. Applicants should be graduates with recent teaching experience in adult or higher education.

Course tutors are not hired for a specific center unless 20 students using that center have enrolled for the course. Math and science tutors usually show up once a fortnight; art tutors every fourth week.

Counselors generally assume the role of father confessor and Vice Chancellor Perry says they end up listening to all sorts of problems; a common one is how to study with noisy children in the house.

Activity varies at the study centers. Some are dull. At others students have organized choral groups. As Vice Chancellor Perry says, the centers put a face to the university. Indeed, spirit is so high at two of the centers, that students held an open house for the community in April. Two hundred people showed up.

LIBRARY FACILITIES

Every Librarian is an Open University Librarian

The Open University Study Centers do not have any library facilities. The students have only the libraries available in the areas of their residence. "Largely through Carnegie (in Britain not U.S.), libraries are quite good, but, naturally, librarians vary in excellence," Dr. Perry said. Traveling libraries are available in localities where no formal library exists.

"What you cannot do," said Vice Chancellor Perry, "is browse."

Inter-library loan schemes can get any book listed in auxiliary reading lists, but the student must know which book he wants.

"The hard fact is (Vice Chancellor Perry again) that most undergraduates read only the set things anyway. I'm being sweeping. I always exaggerate, but students in first and second level courses read very little that isn't assigned to them. I'm not talking about final honors students, of course, or about graduate students.

"The librarians in this country were very scared about the increased demands that we would make on their resources, but after one year, most of them find they've overdone the provision of resources even at a very low rate. The demand for it is small."

All librarians are given the background reading lists about 18 months in advance.

Students who live near universities also use those libraries, but no previous arrangement was made with the universities.

Dr. Perry admits to being a pragmatist:

"If we'd have gone to their senates or councils back in 1969 or 1970 and asked for use of their libraries, we'd probably have got a very dusty answer. We'd probably still get a pretty dusty answer. It was far better to leave the students to turn up--librarians are far kinder than the powers that be."

SUMMER SESSIONS

A Taste of Campus Life

The Open University requires that each student in each course spend one week during the summer at a conventional university. For science students some of that time is spent in lab work. Humanities students take cultural tours. Mostly, though, the experience provides person-to-person contact and is OU's one chance to give its students a taste of the conventional, residential university experience.

Greville Rumble, Registrar of the Post Experience Courses, said being on hand for summer school was actually frightening. "These people are so hungry for education that they go until all hours cramming it in, gorging it. They average about two hours sleep a night. And when it is all over they say 'Now I see what I missed. This is what college was really like!' And, of course, that isn't what college is really like at all."

The cost of first level summer school, room and board, is 25 pounds per course; for second level, where specified, it is 35 pounds.

Courses which do not specify a week's stay on a campus do provide for person-to-person contact and a taste of campus life. This is arranged by holding two or three-day week-end seminars at established universities and colleges throughout the British Isles.

TESTING AT OU

The Computer and the Tutor

Students complete two kinds of assignments: tutor marked and computer marked. Final examinations are proctored. *

OU is currently undergoing a change. Last year, the students sent written material to the administrative campus. Walton Hall sent it out to the tutor, the tutor sent it back to Walton Hall and Walton Hall mailed it back to the student. Under that system, OU knew whether a student had written the work, or whether a tutor was sitting on it and hadn't marked it. The record was always right. "Of course," said Vice Chancellor Perry, "that system imposed a wonder of delay and turn around." The new system is a short-cut: student to tutor, tutor to Walton Hall, Walton Hall to the student. "We can't monitor whether the student originally did the work." There also is no way to tell whether a student is cribbing. However, every student undergoes a final examination with a proctor present. A rigid system of rules has been set up to prevent cheating.

A sample of the computer-marked test assignment is attached; also flow chart of the Data Processing Division's handling of computer-marked material and, an assignment form.

* Of those students who survived the first year and took the final exams, 92.5 per cent passed.

STUDENT

DATA PROCESSING DIVISION

CLERICAL OPERATIONS

COMPUTER OPERATIONS

CLERICAL OPERATIONS

DOCUMENT READING MACHINE

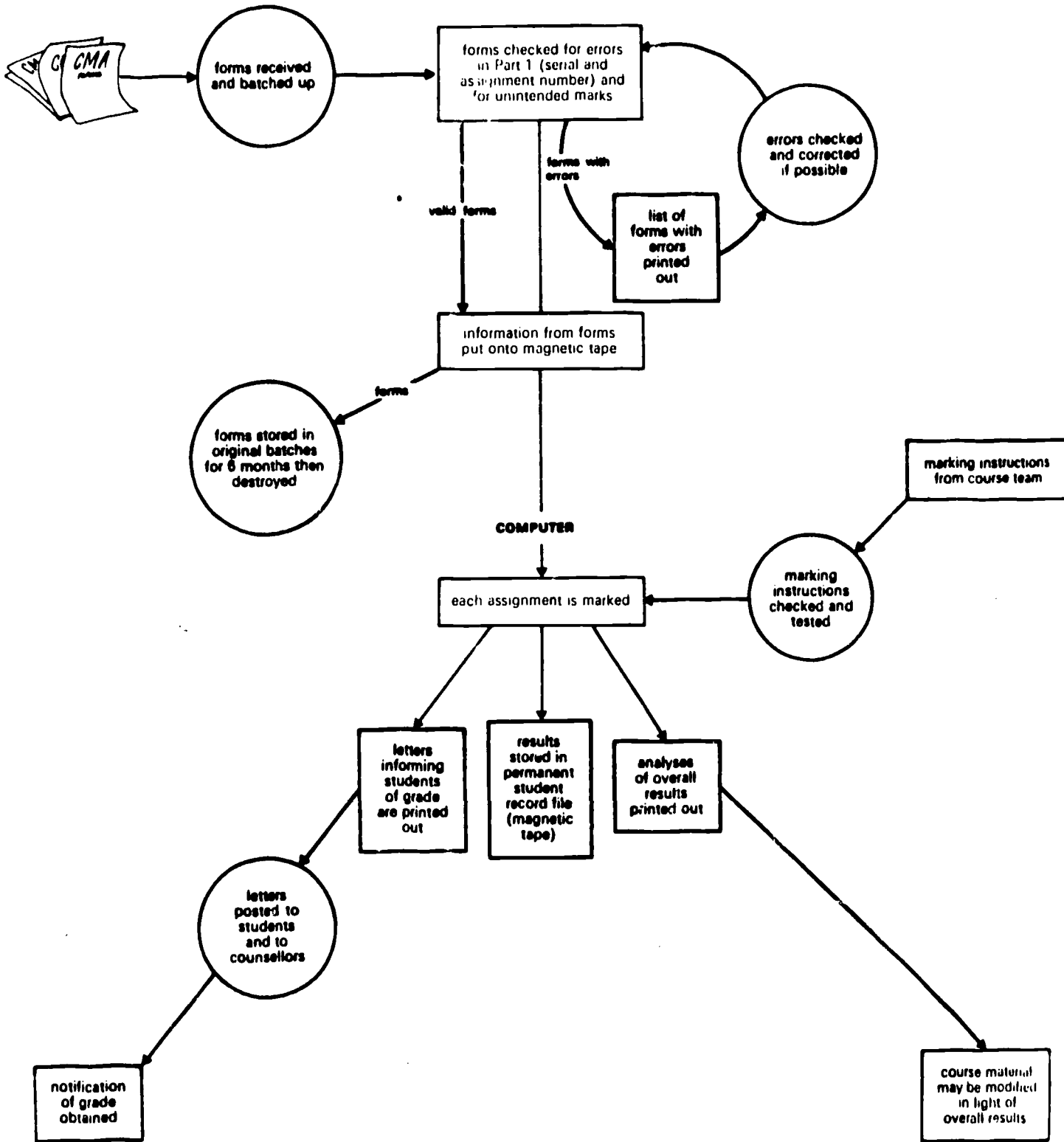

PART 1 PLEASE REMEMBER TO USE AN HB PENCIL

SERIAL NUMBER
ASSIGNMENT NUMBER
DATE SENT
NAME INITIALS AND ADDRESS

SERIAL NUMBER							
A	0	0	0	0	0	0	0
B	1	1	1	1	1	1	1
C	2	2	2	2	2	2	2
D	3	3	3	3	3	3	3
E	4	4	4	4	4	4	4
F	5	5	5	5	5	5	5
G	6	6	6	6	6	6	6
H	7	7	7	7	7	7	7
I	8	8	8	8	8	8	8
J	9	9	9	9	9	9	9

ASSIGNMENT NUMBER							
A	A	A	0	0	0	0	0
B	B	B	1	1	1	1	1
C	C	C	2	2	2	2	2
D	D	D	3	3	3	3	3
E	E	E	4	4	4	4	4
F	F	F	5	5	5	5	5
G	G	G	6	6	6	6	6
H	H	H	7	7	7	7	7
I	I	I	8	8	8	8	8
J	J	J	9	9	9	9	9

OFFICE USE ONLY	
0	
1	
2	
3	
4	
5	
6	
7	
8	
9	

PLEASE HANDLE THIS FORM WITH CARE.

BLOCK U														
ANSWER							COMMENT 1							
1	A	B	C	D	E	F	G	H	I	J	K	L	M	N
2	A	B	C	D	E	F	G	H	I	J	K	L	M	N
3	A	B	C	D	E	F	G	H	I	J	K	L	M	N
4	A	B	C	D	E	F	G	H	I	J	K	L	M	N
5	A	B	C	D	E	F	G	H	I	J	K	L	M	N
6	A	B	C	D	E	F	G	H	I	J	K	L	M	N
7	A	B	C	D	E	F	G	H	I	J	K	L	M	N
COMMENT 2							COMMENT 3							
	a	b	c	d	e	f	g	h	i	j	k	l	m	n

BLOCK V														
ANSWER							COMMENT 1							
1	A	B	C	D	E	F	G	H	I	J	K	L	M	N
2	A	B	C	D	E	F	G	H	I	J	K	L	M	N
3	A	B	C	D	E	F	G	H	I	J	K	L	M	N
4	A	B	C	D	E	F	G	H	I	J	K	L	M	N
5	A	B	C	D	E	F	G	H	I	J	K	L	M	N
6	A	B	C	D	E	F	G	H	I	J	K	L	M	N
7	A	B	C	D	E	F	G	H	I	J	K	L	M	N
COMMENT 2							COMMENT 3							
	a	b	c	d	e	f	g	h	i	j	k	l	m	n

PART 2

BLOCK W														
ANSWER							COMMENT 1							
1	A	B	C	D	E	F	G	H	I	J	K	L	M	N
2	A	B	C	D	E	F	G	H	I	J	K	L	M	N
3	A	B	C	D	E	F	G	H	I	J	K	L	M	N
4	A	B	C	D	E	F	G	H	I	J	K	L	M	N
5	A	B	C	D	E	F	G	H	I	J	K	L	M	N
6	A	B	C	D	E	F	G	H	I	J	K	L	M	N
7	A	B	C	D	E	F	G	H	I	J	K	L	M	N
COMMENT 2							COMMENT 3							
	a	b	c	d	e	f	g	h	i	j	k	l	m	n

BLOCK X														
ANSWER							COMMENT 1							
1	A	B	C	D	E	F	G	H	I	J	K	L	M	N
2	A	B	C	D	E	F	G	H	I	J	K	L	M	N
3	A	B	C	D	E	F	G	H	I	J	K	L	M	N
4	A	B	C	D	E	F	G	H	I	J	K	L	M	N
5	A	B	C	D	E	F	G	H	I	J	K	L	M	N
6	A	B	C	D	E	F	G	H	I	J	K	L	M	N
7	A	B	C	D	E	F	G	H	I	J	K	L	M	N
COMMENT 2							COMMENT 3							
	a	b	c	d	e	f	g	h	i	j	k	l	m	n

BLOCK Y														
ANSWER							COMMENT 1							
1	A	B	C	D	E	F	G	H	I	J	K	L	M	N
2	A	B	C	D	E	F	G	H	I	J	K	L	M	N
3	A	B	C	D	E	F	G	H	I	J	K	L	M	N
4	A	B	C	D	E	F	G	H	I	J	K	L	M	N
5	A	B	C	D	E	F	G	H	I	J	K	L	M	N
6	A	B	C	D	E	F	G	H	I	J	K	L	M	N
7	A	B	C	D	E	F	G	H	I	J	K	L	M	N
COMMENT 2							COMMENT 3							
	a	b	c	d	e	f	g	h	i	j	k	l	m	n

BLOCK Z														
ANSWER							COMMENT 1							
1	A	B	C	D	E	F	G	H	I	J	K	L	M	N
2	A	B	C	D	E	F	G	H	I	J	K	L	M	N
3	A	B	C	D	E	F	G	H	I	J	K	L	M	N
4	A	B	C	D	E	F	G	H	I	J	K	L	M	N
5	A	B	C	D	E	F	G	H	I	J	K	L	M	N
6	A	B	C	D	E	F	G	H	I	J	K	L	M	N
7	A	B	C	D	E	F	G	H	I	J	K	L	M	N
COMMENT 2							COMMENT 3							
	a	b	c	d	e	f	g	h	i	j	k	l	m	n

PART 3

4. VERY DIFFICULT TO FIND THIS ASSIGNMENT? VERY EASY

3	2	1	0	1	2	3
---	---	---	---	---	---	---

5. HOW INTERESTING DID YOU FIND THIS ASSIGNMENT? VERY INTERESTING VERY BOREDOM

3	2	1	0	1	2	3
---	---	---	---	---	---	---

6. HOW LONG DID YOU SPEND ON THIS ASSIGNMENT?

15 MIN TO 30 MIN	30 MIN TO 1 HR	1 HR TO 1 1/2 HRS	1 1/2 HRS TO 2 HRS	2 HRS TO 3 HRS	OVER 3 HRS

THE PRICE TAG
A Quick Survey of Costs

The total cost for the Open University for 1973 is estimated to be 10 million pounds or about \$26,000,000 (pegging the exchange at \$2.60). Student fees cover 15 per cent; the government subsidizes the remaining 85 per cent. Vice Chancellor Perry says subsidy may be compared with a 93 per cent government subsidy of other British universities.

Open University costs break down this way:

DIRECT STUDENT COSTS	50 per cent
OVERHEAD	50 per cent

Breakdown of OVERHEAD costs:

Production and transmission on BBC	50 per cent
Maintenance and regional administration	50 per cent

The full-time faculty is included in the OVERHEAD costs.

The part-time faculty (including 4,500 tutors) is part of DIRECT STUDENT COSTS.

It is difficult to make comparisons between U.S. and British educational costs because British faculty salaries are lower than those in the US. One math professor to whom we spoke told us he was hired at just over 3,000 pounds (a little less than \$8,000). We may assume that most senior academics make more than that, however.

An interesting figure: the cost of mailing one letter to every student is 1,200 pounds (\$3,120).

BBC

Twenty-two per cent plus of the annual budget is spent on the BBC broadcast component, or roughly \$6,500,000. BBC transmission costs are minimal in comparison to production costs: 100 pounds or \$260 an hour. In a year, counting re-runs, BBC airs about 540 hours. Total transmission cost is roughly \$140,000.

We received another figure, excluding academic salary costs of \$3,900,000 for the BBC component. That would allow \$520 per minute for production or about \$13,000 for each show. This \$3,900,000 figure, given by the Director of Post-Experience Courses, Greville Rumble, was part of the cost of course presentation and running of the student centers--a mixture of overhead and direct student costs. Mr. Rumble's figures would break down, in British pounds, as follows:

Administration -- 1,000,000 pounds
 Regional Admin. -- 1,000,000 pounds
 Academic Faculty -- 1,500,000 pounds
 BBC Component -- 1,500,000 pounds

The total BBC figure, however, would include part of the costs of the academic team.

Student Costs

Open University costs vary according to program, as might be expected. However, foundation courses cost students about 45 pounds a year (\$120) of which 25 pounds (\$66) is board and tuition for a week of on-campus study during the summer. An additional 10 to 15 pounds (\$26.50-\$40) must be spent for set books. Science students must also pay for breakage or damage to home experiment kits.

Public Relation Costs

An interesting figure is the first year expenditure for promotion and public relations: 60,000 pounds or \$159,000. The director of information services, John Greenall, says about a quarter of a million pounds (\$662,500) is what it costs to launch a new product in the British Isles.

He and the Vice Chancellor do not see eye-to-eye on publicity and promotion. Dr. Parry is concerned about academic respectability and "he has been most reluctant that we do anything at all which might tarnish our reputation as a university," Greenall said.

Advertising, as such, during the first year was confined to recruitment ads for personnel and low-key student recruitment promotion. Most of the promotion money went into massive leaflet campaign which saturated the civic and community organizations, libraries, trade unions, women and men's clubs, and industrial firms throughout the British Isles. In all, OU mailed a half million leaflets. It also maintained a press relations program. Greenall has two full-time former journalists in his department as well as a number of assistants. BBC publicized OU free of charge.

The Post-Experience Courses, six courses of various lengths to be offered in 1973, were launched by a press conference on April 25th of this year. Greenall said an intensive publicity campaign will include industrial and educational organizations as well as the media. Publicity will be addressed particularly to the employers of prospective students rather than to the students themselves, since it is hoped that employers in most cases will be paying a substantial part of the fees.

Marketing

The Open University's curriculum materials are now on sale to other institutions. The OU budget does not include income from marketing; it is listed in a separate budget. At the moment, all moneys received from marketing, which purchases the course sets from the OU and re-sells them at a profit, is ploughed back into further sales promotions.

Negotiations continue for the appointment of marketing agencies in various parts of the world. Already three agencies have been appointed in Australia, Ireland, and Norway.

A licensing system has been introduced whereby educational institutions may record OU TV and radio programs on payment of a fee for each recording. A copy of the recording licensing agreement form is available from the office of John Robinson, Chief Assistant (Open University) BBC.

Complete Financial Report Forthcoming

A complete financial statement which appeared in the Vice Chancellor's 1972 Report on the Open University was not available for distribution at the time of our visit to England in May 1972. Our request for a copy will be filled when copies are available.

THE STUDENTS

"As Different as Chalk and Cheese"

Of the first 24,000 students accepted in 1970 for the 1971 school year, some 15,000 successfully completed their work. In 1971, OU had another 35,000 applicants, offered 20,500 spaces which were taken up in January of 1972. For 1973, it already has 24,000 applications and plans to offer 20 per cent more spaces than it has available (to accommodate attrition). By 1974, OU anticipates a total enrollment of more than 45,000.

The applications for 1973 indicate some interesting trends. Of the first 17,000 of these applicants, teachers contribute a rather smaller percentage than in the first year--a decrease from 36.3 per cent to 31.6 per cent, while housewives have increased from 11 per cent to 13 per cent and technical and manual workers from 14.3 per cent, to 16 per cent.

The percentage of women increased from 33.7 per cent to 36.5 per cent. Admission officers believe the increase probably is due in part to specially directed publicity. Apparently, housewives have to overcome their inherent fear of being ridiculed for attempting a college degree. This fear is reflected in a popular Independent TV soap opera, "Coronation Street." The character, housewife Maggie Clegg, is secretly enrolled at the OU because, she says "it sounded a bit silly. Somebody my age. A woman as well." The reply from character Emily Pankhurst is: "there's nothing silly about education, Maggie Clegg. No matter how old you are. Or what sex. They'd still have us eating from soup kitchens if we'd not learned to read."

OU officials are happy to see more women enrolling. BBC's Robinson, re-iterating the University's policy to increase educational and

career opportunities for women, said: "It is good to see this perceptible movement towards greater social justice."

Because there are no entrance requirements, no age limits, the student body is composed of people "as different as chalk and cheese," the Vice Chancellor's colorful phrase.

Admission officers, however, are not getting a totally unknown commodity. The attached Application Form shows that much can be learned about the student: his academic level of achievement, his career successes--failures, and, in his added comments, his motivation and goals.

Admission Procedures

In general, admission is on a "first come, first served" basis. There are three major modifications to the "first come, first served" basis and one minor modification: "We try to advise people out of applying when we feel that, on the face of it, they do not seem to know what they are in for," said Information Director Greenall. "However, we make it perfectly clear that this is advice only." Only about 2 per cent of the applicants are so counseled. Those are people who have not shown any willingness to undertake any study or serious reading since they left school. "Terminal age of education is not a bar, but if a person left school 15 years ago and reads only The Daily Mirror and limits his cultural experiences to the light entertainment on the telly, we'd advise him to reconsider," Greenall said.

The three main modifications to the "first come" rule are:

1. Each part of the country has a quota. "If we had admitted people on a straight forward "first come" basis, certain things would have happened," Greenall continued. "There is a tendency

in this country for people in the south of the country to be rather more alert to what's going on than people in the north or outlying parts of the country. So by taking the first 25,000, we'd have a very high percentage of people from London and the Southeast and very low percentage from the north."

2. Quotas were set for qualified people. "Certain types of people are more aware, for example, teachers; also, those who tend to read the quality press rather than the popular press. So the second thing that would have happened, we would have a very high percentage of qualified people, shutting out the non-professionals, the very people we wanted to reach."

3. Quotas were set according to subject. "Most students want arts and social sciences, fewer want math and science, so we set quotas for the faculties. We decided to admit 25,000 students to 30,000 slots (5,000 would take two courses.) We limited 8,000 each to the arts and social sciences and 7,000 each to math and science."

In order to get a good distribution of students throughout the country, OU estimated what percentage of the adult population of England lived in each of its regions. It then compared this estimate with the number of applicants from each region and set the quota at a mid-point between the two.

As examples: London and the Southeastern part of the country had 17.9 per cent of the adult population; 18.5 per cent of OU's applications was from that area. In the south, with 8.9 per cent of the adult population and 11.3 per cent of the applications, OU offered 9.6 per cent of the places to people in that area.

Publicity was heavily concentrated on areas outside of London.

Drop-Outs

Causes for dropping out vary, but one of the most common is the difficulty of the course work. "The first publicity made it sound too easy," said a number of drop-outs in response to a questionnaire. Other causes: family problems, hysterectomies, divorces, job changes, and inability to find nursery facilities. One woman said she quit because of "excessive adiposity."

Ray Thomas, senior lecturer in economics in the Social Sciences faculty, asks whether the OU should institute some kind of pre-selection, self-assessment test so that applicants can find out for themselves whether they can hope to manage the foundation courses. Thomas believes that applicants from factories and blue collar workers would be the primary beneficiaries. At the moment, it would appear that OU officials believe it is better to have tried and failed than not to have tried at all. Besides, students who are uncertain about their inadequate academic background may enroll in preparatory courses, geared specifically for the type of OU home study curriculum. These prep courses are offered at established colleges throughout the British Isles.

Handicapped Students

This year OU has 300 disabled students enrolled; only 70 of them could make it to the week-long residential summer school. A full-time senior counselor has been appointed exclusively for the disabled students. Aides call on the student at home, counsel and tutor him, and administer the proctored year-end examination.

Student Activities

Students are now negotiating for a national student organization, which may be in operation this summer. At present, 40 student associations exist throughout the British Isles. The associations sponsor everything from social evenings, to cultural visits, to seminars. Also some pressure groups are campaigning for better libraries and sporting facilities, and more tutors.

Although the students have no common campus, they do seem to identify with the institution. There is a growing demand for school insignias and souvenir items--mugs, book-ends, and notebooks carrying the OJ emblem.

In May 1972, the first issue of the student-written-and-edited newspaper, Sesame, came off the press. It is a lively, well-written publication with repeated exhortations to the students to submit articles, gripes, and letters-to-the editor.

One amusing gripe: a letter from a student complaining that a package arrived in her mailbox in a plain brown wrapper. She opened it and found a polythene bag of "live squirming earthworms." Her plea: "May we have all parcels labelled in the future?"

Another was an article stressing the availability of professors. "I told a fellow student I had talked on the phone to Prof. Michael Drake, and she looked at me as if he didn't exist. I think it is television which emphasizes the remoteness of personalities. The fact is that Prof. Drake does exist and he is on the other end of the telephone."

In still another letter a student complained about the heavy reading load for a second level course in biology. The course team

professor wrote a detailed reply, explaining that in planning the course, care was taken that there would be no more than 20,000 words of reading material, including outside reading, per week. "My own guess," said the professor, "is that some of you are finding it heavy going because you don't believe us when we tell you to study a unit by looking at the objectives . . . and the unit guide, so as to discover what to learn and how to remember. . . those of you who still feel in difficulty are advised to contact your tutor, or write to us direct with queries."



The Open University

**Application for Registration for
Foundation Courses 1973**

For office use		Date received	Serial number
Vet check	To Enquiry Service Return		C
AD1	E		

Please type or use capital letters to complete this form; where possible answer in the boxes provided. The information supplied will be transferred to our computer records and legibility is very important. All information on this form will be strictly confidential to the Open University

Section A - personal information

A1 Title (Mr, Mrs, Miss etc) and initials of first names

A2 Surname

A3 Forenames

A4 Correspondence address

Enter your address as you would want us to put it on any letters to you. If this is not your permanent address in the U.K., please also complete section F6

A5 Sex
Enter M or F in box

A6 Date of birth
Enter your date of birth in box in figures only e.g. 03th November 1933 as

Day	Month	Year
00	11	33

A7 If you have previously applied to the Open University, enter here the full serial number given to you. If you applied for admission both in 1971 and 1972, give your 1972 serial number

A8 Marital Status Enter one of the following codes
S - Single; M - Married; W - Widowed, divorced etc.

Title

Initials

AO1

AO2

AO3

Section B - location

B1 Enter one code in each box to show whether you expect to have access to BBC2 television and VHF radio. The codes are 0 - not available in your area; 1 - available in area but not at home; 2 - available at home

B2 Examine the list of Study Centres on pages 31-34 of the Guide for Applicants. Can you attend a Study Centre regularly, travelling there and back in an evening? Answer Yes or No in the box

B3 If you answered Yes to question B2, examine the list again and enter here in order of preference the codes of the two Study Centres most convenient to you, irrespective of the Region to which they belong

B4 Using the Region codes on the same pages, enter the code of the Region to which your first choice Study Centre belongs. If you answered No to question B2, consult the map on page 30 of the Guide for Applicants and enter the code for the Region in which you would prefer to study.

BBC2

VHF

BBC2

VHF

BBC2

VHF

BBC2

VHF

Section C - occupation

C1 Using the list on the back of this form enter in the first box the code for the occupation group to which you feel you belong. In the other box please describe your occupation and the industry or other field in which you work.

Code 39 40	Job and industry
---------------	------------------

C2 If you are not currently employed or have recently changed your occupation enter the appropriate code for your last job. Give brief details if you wish.

Code	
------	--

C3 If you hope to change your occupation after university studies please enter the appropriate occupation code. Give brief details if you wish.

Code	
------	--

Section D - educational information

D1 Tick the appropriate box to show the age at which you completed full-time education (N.B. this can include a course of full-time study involving spending part of the time in employment).

15 or under	16	17	18	19	20	21 or over
A	B	C	D	E	F	G

D2 Examine the list on the back of this form. Then turn back to this page and tick each appropriate box.

A	B	C	D	E	F	G	H	J	K	L
---	---	---	---	---	---	---	---	---	---	---

D3 Use this space to enter full details of the qualifications referred to in question D2. 'Mode of Study' can mean full-time, part-time, evening, correspondence, day-release, sandwich etc.

Qualification	Major subject(s)	Awarding institution	Dates of study	Mode of study

Section E - course choice

E1 How many courses do you wish to follow in 1972, one or two? Write '1' or '2' in box (N.B. look carefully at pages 12-20 of the Guide for Applicants). If you plan to include course MST281 as one of your choices, you must write '2' in the box.

43

E2 Using the codes on page 12 of the Guide for Applicants, enter in order of preference the courses which you would be prepared to study in 1973. If places are not available for your first choice course you will be considered automatically for your other choice. The only second-level course for which you may apply at this stage is MST281.

44	50	57	58	64
1st choice	2nd choice	3rd choice*	*You should complete this box only if you are choosing to do two courses	

Section F - further information

F1 Do you wish to claim general credit exemptions? If yes, write Y in the box. We shall then send a claim form to you. We cannot undertake to revive an earlier claim or award unless you write Y in the box.

1	3 14
AO4	

F2 Do you expect to be living in the United Kingdom (including the Channel Islands) from 1st January 1973? Answer Y for Yes, N for No.

15

F3 If you are available by telephone during the day, please enter here your exchange and number.

16	40
----	----

Section F - further information (continued)

F4 What is your place of work? The information may be helpful to us in allocating tutors and counsellors to you. (NB we shall not contact your employer)

F5 Please enter here the number of children living at home in each age group, if any.

under 5 years	aged 5-10	aged 11-17
---------------	-----------	------------

F6 If the address given in section A4 is not your permanent address in the U.K. please enter your permanent address here

Section G - additional information to help us assess your application

G1 It would be helpful if you were to give brief details of any studies not given in section D. These may include courses not leading to qualifications or certificates, e.g. courses not completed, WEA, extra-mural, LEA, evening institute, preparatory courses etc. Please include any current courses.

courses/subjects	mode of study	Dates	
		From	To

G2 It is University policy to give special consideration wherever possible to those who due to disability or severe domestic difficulties are being prevented from following a degree course as a full-time student. In addition, it would be helpful to know if your particular situation will make it difficult for you to take advantage of our full range of facilities, e.g. Study Centre attendance, summer schools, examinations etc. Please give brief details or, if you wish, attach a letter for the attention of the University; do not write separately.

G3 Please give here any other information that you think might help us in considering your application. You may, if you wish, give details of any special interests or recreations.

Please check that you have correctly and clearly answered each question.

Signature :

Date :

Do not enclose any documents, certificates, letters or payment unless requested to do so.
Return as soon as possible to
Admissions Office, P.O. Box 48, Bletchley, Buckinghamshire, before 19 June 1972 at the latest.

Notes on questions C1, C2 and C3.

Please code occupation as follows:

Code Occupation group

- 01 Housewives**
Engaged on unpaid domestic duties or working in paid employment for less than 20 hours per week.
- 02 Armed forces**
British and foreign
- 03 Administrators and managers**
Central government, local government – administrative grades. Nationalised industries and private industry
- 04 Teachers and lecturers**
In primary, secondary, further and higher education. Training officers, instructors, educational advisers
- 05 The professions and the arts**
Doctors, dentists, pharmacists, pathologists, etc. All nurses (including nursery nurses) and medical auxiliaries. Authors, journalists, actors, musicians, artists, producers. Advertising, public relations, market research. Accountants, company secretaries, lawyers, clergy. Architects, surveyors, town planners. Librarians, all professional social workers
- 06 Qualified scientists and engineers**
Chemical, physical and biological scientists. Chartered engineers – civil, structural, mechanical, electrical, aeronautical, production, mining and work study engineers etc.
- 07 Technical personnel: including data processing, draughtsmen and technicians**
Draughtsmen, lab. assistants, technicians, Systems analysts, computer programmers, time & motion, O & M. Scientific, technical, engineering assistants and related workers.
- 08 Electrical, electronic, metal and machines, engineering and allied trades**
Electricians, electrical and electronic fitters and assemblers. Plumbers, welders, fitters, sheet metal workers, metal workers, machine tool-setters and operators, mechanics, tool-makers.
- 09 Farming, mining, construction and other manufacturing**
Farmers, forestry and fishermen, miners, quarrymen. Gas, coke and chemicals, glass and ceramics, furnace, forge, foundry and rolling mills, woodworkers, leather, textiles, clothing, Food, drink, tobacco; paper and printing. Builders, bricklayers, plasterers, painters. Warehousemen, packers, labourers, etc.
- 10 Communications, and transport: air, sea, road, and rail**
Drivers, railwaymen, porters, seamen, boatmen, pilots, navigators, traffic controllers, bus conductors, dockers, Telephonists, telegraph operators, postmen, messengers.
- 11 Clerical and office staff**
Typists, secretaries, clerks, cashiers, office machine operators. Central and local government, all executive and clerical grades.
- 12 Shopkeepers, sales, services, sport and recreation workers. Fire brigade and police**
Shop proprietors and managers, assistants, salesmen, travellers, insurance brokers, auctioneers, valuers, undertakers. Hotel and restaurant owners and workers, publicans, barmen, waiters, cooks, maids, cleaners, Chimney sweeps, caretakers, Hairdressers, laundries, garages, roundsmen, Hospital orderlies, ambulance men, Athletes, models, photographers.
- 13 Retired, independent means, not working (other than housewives), students**
- 14 In institutions, e.g. prison, chronic sick, etc.**

Note on question D2

Please examine this list and tick the appropriate box or boxes *overleaf* to indicate the qualifications that you hold, do *not* mark this page. A–K refer *only* to qualifications from institutions in the U.K.

- A** City and Guilds, R.S.A. or College of Preceptors
- B** G.C.E. 'O' Level, C.S.E., School Certificate, S.C.E. 'O' grade
- C** O.N.D. or O.N.C.
- D** G.C.E. 'A' Level, Higher School Certificate, S.C.E. 'H' grade, other university matriculation
- E** H.N.D. or H.N.C.
- F** University diploma or certificate not otherwise listed
- G** Professional qualifications
- H** Teacher's Certificate
- J** Degree
- K** Other qualifications
- L** Qualifications from institution outside the United Kingdom