

ED 066023

centre  
for  
educational  
research  
and  
innovation

# MULTIMEDIA COMPUTER-ASSISTED AND COMPUTER-MANAGED INSTRUCTION

technical report

OECD

ORGANISATION FOR ECONOMIC CO-OPERATION AND DEVELOPMENT

ORGANISATION FOR ECONOMIC  
CO-OPERATION AND DEVELOPMENT

Paris, 18th February, 1972

Or.Fr.

Centre for Educational Research  
and Innovation

CERI/CT/72.01

MULTIMEDIA COMPUTER-ASSISTED  
AND COMPUTER-MANAGED INSTRUCTION

by

A. JONES  
IMAGO Centre  
University of Louvain  
Belgium

U.S. DEPARTMENT OF HEALTH,  
EDUCATION & WELFARE  
OFFICE OF EDUCATION  
THIS DOCUMENT HAS BEEN REPRO-  
DUCED EXACTLY AS RECEIVED FROM  
THE PERSON OR ORGANIZATION ORIG-  
INATING IT. POINTS OF VIEW OR OPIN-  
IONS STATED DO NOT NECESSARILY  
REPRESENT OFFICIAL OFFICE OF EDU-  
CATION POSITION OR POLICY.

83.911

TABLE OF CONTENTS

	<u>Page</u>
FOREWORD . . . . .	5
1. - OBJECTIVES OF THE PROJECT . . . . .	9
2. - METHOD - GENERAL OUTLINE OF IMAGO SYSTEM . . . . .	15
3. - MEANS PROVIDED FOR THE VARIOUS TASKS . . . . .	33
4. - RESEARCH AND FUNCTIONAL PROGRAMMES . . . . .	65
5. - PRELIMINARY RESULTS . . . . .	75
6. - RESEARCH TEAM . . . . .	83
7. - BIBLIOGRAPHY AND PUBLICATIONS . . . . .	87
ANNEXES	
I - A praxeological basis . . . . .	91
II - A taxonomy . . . . .	97
III - References . . . . .	99

## FOREWORD

This technical report, the fourth of a series (\*) dealing with the new educational technology, i.e. the use of computers as a teaching medium, measures both the value and scope of such an approach. It is part of Joint Project CERI XI, whose primary objective has been to study "The Use of Computers in Higher Education". Five experiments have been associated with this Project, mainly thanks to support granted by interested national authorities. The general conclusions appear in a technical report based on views exchanged with the United States experts.

Professor Jones and his team were able to conduct their experiment at Louvain on the strength of support and aid provided by the Belgian Ministry of Education and Science Planning and Policy Department and by the Shell Company. Among other bodies which have contributed should be mentioned the Fonds de la Recherche Fondamentale Collective.

The report describes at length what a project on the use of computers as an educational medium really is. Anyone who attempts to study this as yet new type of technology in an educational context, i.e. experimentally, is of course bound to gain some knowledge of the steps needed to introduce it, the obstacles which are encountered, the constraints and what these imply and finally of the results obtained. The Centre for Educational Research and Innovation nevertheless felt that it might be well to show what actually does happen, as was earlier described in connection with another experiment associated with the Joint Project (see "Computer-Assisted Instruction: The Experiment of the Faculty of Science in Paris", OECD, CERI/CT/70.60, March, 1971).

A few preliminary remarks in regard to the present paper are called for:

- (i) The title may thus surprise those familiar with the term "Computer-Assisted Instruction". Here in fact we are dealing with "Multimedia Computer-Assisted and Computer-Managed

---

(\*) See "The Use of Computers in Higher Education: Perspectives and Policies". OECD, CERI/CT/70.64, June 1971.

Instruction System" which is a far cry from the first enthusiastic innocent vision of the computer as a panacea for the educational problems brought about by pedagogic, institutional and other changes. In this project the computer is but one of several media, which Chapter 3 of the report describes in ordered sequence, i.e. as an integrated system.

- (ii) The forms of computer utilisation vary considerably, according to the particular stage in the teaching and learning process. While sometimes used as a testing instrument, along the lines followed in the Paris Faculty of Science project, the computer can also serve as a valuable medium and aid for inventive stimulation exercises, thus opening up a novel and highly significant avenue of approach to the study in depth of a type of teaching practice which unfortunately is too often biased in favour of the tool's capacity rather than the end objectives of education.
- (iii) The importance attributed to the educational model should be noted, the word "model" being taken here in its scientific sense, i.e. as a "quantifiable exemplar". The "Human Operator" theory used in conjunction with this experiment provides a highly effective frame of reference. Such a theoretical study is all the more necessary since projects described as "experimental" yet which have little or nothing in common with a scientific approach are all too apt to be found. This of course does not mean that a "theory" is necessary or sufficient to warrant such an appellation, but merely that educational research must be closely reasoned, even though the subject cannot be formulated - or formalised - at all easily.

Much of the document deals with the question of evaluating and structuring educational information and with the various media in relation to each other.

In view of the interest aroused by the set of experiments covered by Joint Project CERI XI and because it in some way desired to promote them, the Centre for Educational Research and Innovation decided to consider establishing a Centre which could be used as a forum by anyone concerned with the use of computers in education. The consensus was that

a site near one of the experiments should be selected so that close, productive contacts with research activities could be maintained.

In line with this plan the Belgian Government has just agreed to the principle of setting up a Centre at the University of Louvain where Professor Jones and his team are conducting their experiment. CERI is of course highly gratified that the Joint Project should be sponsored in this way by the national authorities concerned.

The hope of CERI is that, just as the others in the same series, the present document will live up to the expectations of those concerned with educational renewal, including the various Research and Development teams engaged in the same kind of work as the Imago Centre.

## 1. OBJECTIVES OF THE PROJECT

The experiment described in this report covers the two spheres of:

higher education and  
continuing training.

Although the objectives may be different the principles governing our work are complementary.

After setting out the problem of transmitting knowledge in higher education and in the field of continuing training we will describe our guidelines and objectives.

### 1.1. The facts of the problem

#### 1.1.1. Higher education

(i) It is sometimes claimed that the quality of education is deteriorating because the number of students is increasing. While this may be regarded as a true or false statement according to the viewpoint adopted, a sounder argument is that accumulation of knowledge has compelled the rising generation to speed up the learning process, and that knowledge is now perhaps absorbed more slowly than it is transmitted.

(ii) Difficulties have also arisen on the teaching side, at least in higher education. Because of the attractions of research and the speeding up of such activities, whether willingly or not the profession has had to spend more time on research, often at the cost of much teaching time.

It has been argued that there should be a "symbiosis of research and teaching". Without denying the truth of this statement, it should be interpreted with considerable caution. However elegantly propounded, it is not always realistic, unless teaching itself is the goal of research.



(iii) Since the rate of teacher recruitment has not kept up with the continued increase in student numbers, a situation has arisen where a single teacher is responsible for training a great number of students. Retaining little or no contact with individual students, the teacher is unable to take various types of intelligence and speeds of learning into account.

Such a situation can but hinder the democratisation of education, and is probably the reason for increasing failure rates and the lack of interest in courses.

(iv) The student's behaviour has also radically changed. Living in a technically-advanced society, he is more demanding as to course quality and more critical of the teacher. But although technology has met and is increasingly meeting the requirements of the modern generation in many fields, this has not happened in education.

#### 1.1.2. Continuing education

(i) Continuing education is usually referred to in the occupational sense, i.e. in terms of updating knowledge. True, owing to the rapid growth of knowledge this aspect is of prime importance, yet the cultural side of education must not be neglected, one which, although less sharply delineated in a world bent on efficiency, clearly serves to round out the personality.

Increased leisure opens the way to the consumption of education. This new "consumer good" is therefore in urgent need of adequate preparation "if only to keep pace with progress and not be outmatched by supermachines nor programmed like them".(1)

(ii) The social institutions of several countries have requested, sometimes successfully, that continuing education schemes be set up (credit hours).

(iii) The introduction of continuing training into business and leisure activities involves problems which require various solutions

---

(1) Kaufmann A. and Pezé J. : Des Sous-Hommes et des Super-Machines. Albin-Michel, Paris 1970.



depending on each individual's occupation.

- For managerial staff the solution will depend on the size of the firm. A large enterprise may easily be able to release a staff member so that he can attend a residential seminar, while the smaller firm will naturally prefer training on the spot.
- For those in the liberal professions the individualisation of teaching would seem to be the only acceptable solution.
- As for teachers, it is unlikely that advantage can be taken of any continuing education scheme except during holidays.
- The problem of granting "credit hours" might be solved, at least in certain sectors, by holding courses during slack periods of the working day.

## 1.2. Objectives and basic choices

Two aspects will be singled out: individual attitudes and ways and means.

### 1.2.1. Attitudes

(i) Among the objectives to be achieved the following three are concerned with continuing education:

- Development of knowledge:  
maintaining, updating and adding to knowledge.
- Development of mental capacity:  
Since situations are becoming ever more complex any position of responsibility calls for increasingly difficult decisions requiring valid judgments and original solutions.
- Development of social personality:  
Situations are so complex as to call increasingly for group work, and each person must gain an awareness of the positive and negative sides of his human contacts.

(ii) An analysis of the situation leads to certain basic choices for renewing, adapting and adjusting "learning technology".

Let us begin by replacing the teaching approach by a learning approach.

By thus restating the whole problem we are confronted by a number of basic choices. The main working hypotheses are:

- to encourage the strong without discouraging the weak;
- to enable everyone to obtain the information he needs whenever he wants and for as long as he wants;
- to ensure that no one begins studies at a given level of difficulty unless he has acquired the prerequisite knowledge;
- to see that each individual learns to control his mental faculties and guide his mental processes just as an athlete is taught to guide his movements;
- to acquaint students with learning and working situations most closely resembling their future working situations.

#### 1.2.2. Ways and means

(i) The problem is therefore mainly one of continuity and of simultaneous "free" periods.

Among the possible solutions, the IMAGO Centre inclines towards the individualisation of education.

(ii) We believe that the only solution is to change our teaching methods so as to increase speed of assimilation, or what might be called educational "productivity".

(iii) In dealing with ways and means, the experiment's objectives are therefore:

- to make an inventory of teaching techniques;
- to ascertain the role of each technique in a given context, using the preparation of various pedagogic activities as a base.

Lectures, text books, magnetic tapes, television, group techniques and computer utilisation thus all enter into the picture.

1.3. The experimental framework

Computer-assisted and computer-managed instruction

The experimental course described in this paper concerns a general physics curriculum for physics and science education at junior university level.

For science students it merely provides a way of revising the course, enabling them during the year to monitor their real level of learning by means of a computer-assisted corrective test.

For physics students the experiment covers the quality of information, the learning process and the management of learning.

A new type of educational system called the "Instruction Multimedia Assisté et Géré par Ordinateur" (Multimedia Computer-Assisted and Computer-Managed Instruction) is used for the experiment.

In conjunction with continuing education the IMAGO method is now being used in two courses - one a "Financial Management" and the other a "Statistics" course.

## 2. METHOD - GENERAL OUTLINE OF IMAGO SYSTEM

### 2.1. Qualities required

Included in the basic choices given above are the main principles of programmed teaching and the Socratic method. A system founded on these choices requires that an educational model endowed with certain qualities and in which adequate ways and means planned in terms of objectives are available. The qualities required by the system include:

#### (i) Subject-matter

- The learning objectives must be specified.
- The concepts to be learnt must be arranged in the best possible sequence. Although this is particularly important in the exact sciences, especially physics, other sciences cannot be excluded a priori.
- In order that the learning process can be adapted to various speeds of working subject-matter must be divided into sequences. These must be short enough for a slow student to absorb them in less than an hour.
- The subject-matter must also be divided into sequences so that it can be adapted to various levels of knowledge and various aptitudes (abstract or concrete).

#### (ii) Relations with the student

- Access to the system must be flexible, and the student must feel personally involved; he must be a party to a dialogue.
- The subject-matter and exercises should be so presented that the student's active participation is frequently stimulated.
- A knowledge test should be made each time a new concept is absorbed, i.e. each subject-matter sequence.
- Any learning deficiency must immediately be corrected. The root of the mistake must be found and feedback provided.

- Decisions concerning the assessment of a student's studies must be objective.

(iii) The teacher

- The teacher must be available to answer the student's questions. This means that he must be largely freed from the task of transmitting information.
- The teacher's qualities of patience must have passed the test.

(iv) The learning system

- The process of interaction between the student's and the learning conditions should be devised to enable all efforts invested in a course to be optimised.
- The technical media must be chosen and adapted to the task, and owing to their variety may properly be said to form a multimedia system.

## 2.2. Educational model

The educational model on which the IMAGO method is at present based is described in Figure 1. The various tasks performed by the system are shown, and these will now be analysed in greater detail. The numbers appearing in the figure correspond to the various types of action to be undertaken. In some cases actual research is involved, while in others consumption factors or products are prepared and constructed.

### 2.2.1. The structuring of information for learning purposes

The structuring of information includes two distinct tasks, namely:

- (1) The formation of concept blocks and
- (2) the preparation of programmed remedial courses.

(i) Formation of "concept blocks"

The formation of these "blocks" consists of several phases as described below:

Figure 1  
EDUCATIONAL MODEL

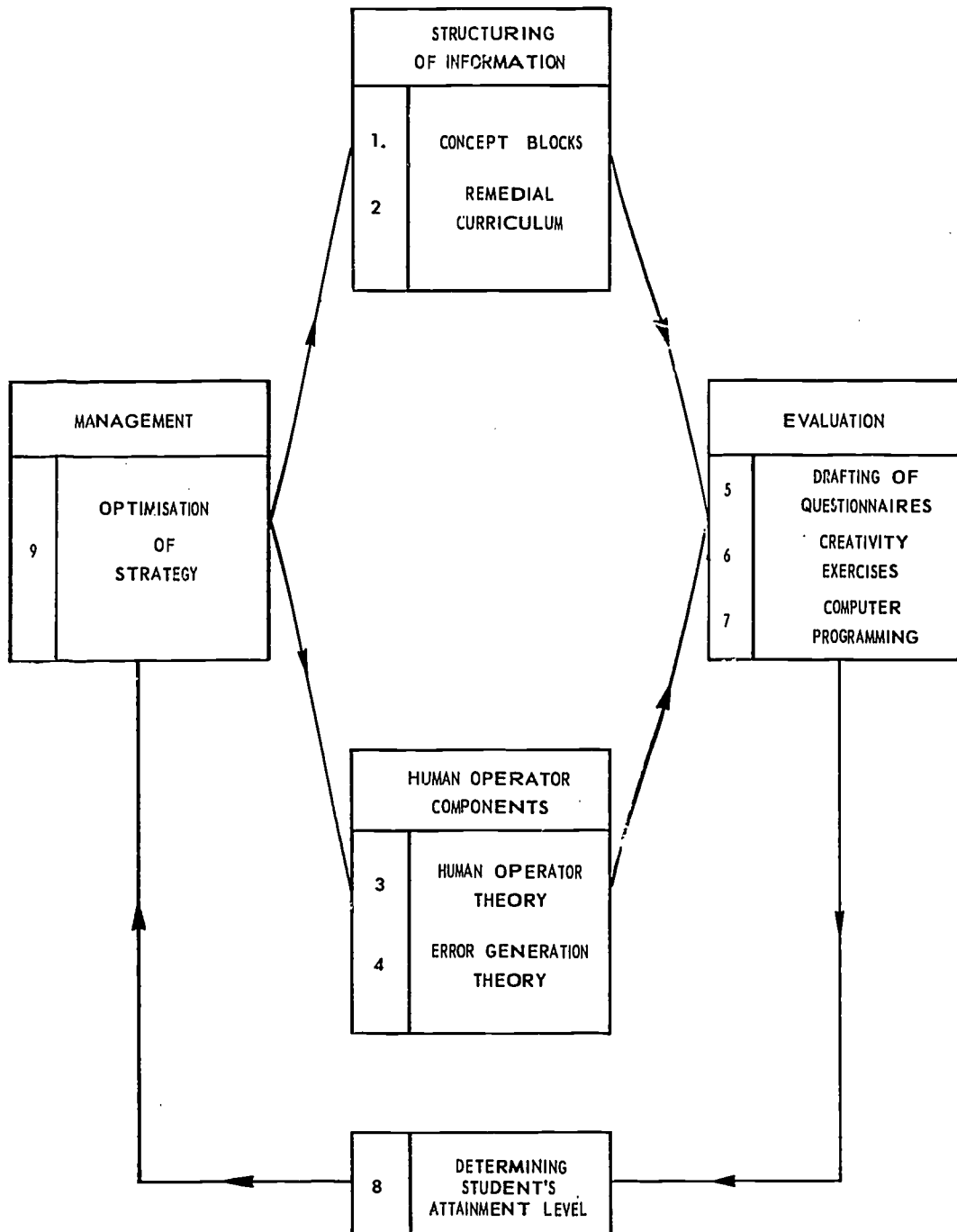

### Defining the objectives (Fig.2)

This has become a traditional step in all educational research. Several hierarchical classification schemes have been prepared, the best known being that of Bloom and his co-workers dealing with educational objectives in the cognitive (1), affective and psychomotor fields. Objectives are expressed in terms of identifiable and observable behaviour (this being essential for evaluating and testing the extent to which the subject achieves the objectives). "Performance", which might be the term used, takes place at the practical level of laboratory exercises and at higher thinking level.

### Organisation into strands (Fig.3)

By working back from the end objective, the teacher defines the intermediate stages until the entry level is reached, and educational "strands" are formed. The value of this sort of analysis will immediately be perceived, since it eliminates all redundant stages, whose sole raison d'être is apt to be academic elegance, while only those which help to achieve the ultimate objective are retained. The entry level is fixed in terms of knowledge of prerequisites or the expected level of capability.

### Organisation into "concept blocks" (Fig.4)

The objectives were used to define an educational content (or curriculum) which would enable the student to achieve them. The curriculum, developed by a reverse process of analysis, contains sequences of concepts and concept interrelationships. Each step in this arrangement corresponds to a level of knowledge and forms a "concept block". It very frequently is the equivalent of about one hour's learning by an average student.

To some extent the arrangement of these "blocks" can be adjusted to a specific thought approach either at the level of mental performance required or at the level of presentation.

For each of these various arrangements there is a "learning

---

(1) BLOOM, B.S. (Ed.) ENGLSEHART, M.D., FAUST, E.J., HILL, W.H. and KRATHWOHL, D.R., A taxonomy of educational objectives; Handbook I, The Cognitive Domain, New York, Longmans, Green, 1956.



Figure 2

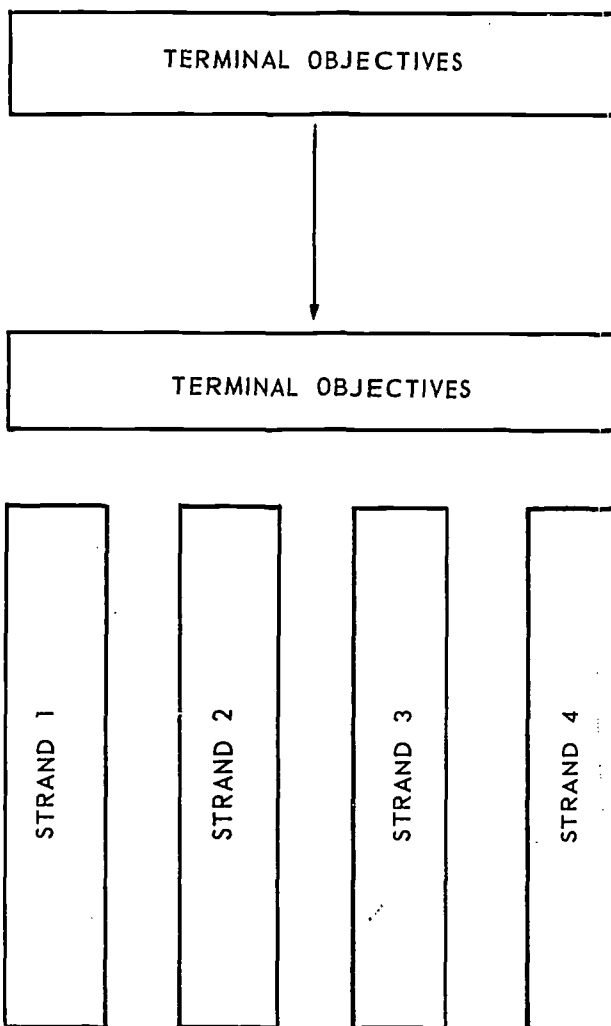

Figure 3

Figure 4

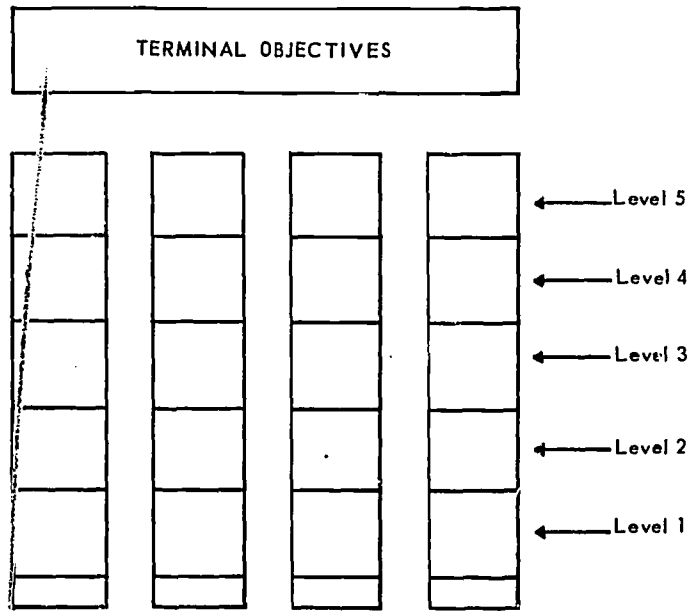
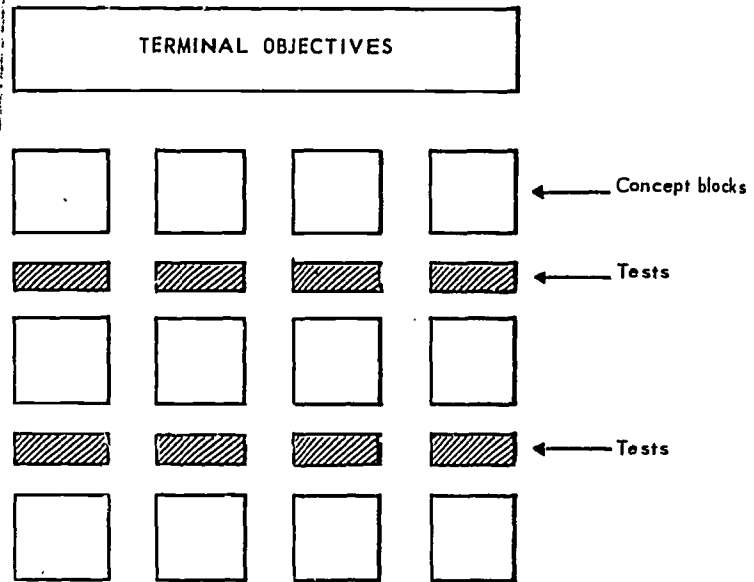

Figure 5



strand" reserved for the student which may vary from the "teaching strand". The fact that there are various "learning strands" means not only that the thought approaches may differ at the same level of achievement, but also that the levels of achievement are not necessarily of the same order of magnitude.

But the fact that a student can choose an approach in keeping with his way of thinking may result in a higher effective capacity than if the approach were forced on him. In the extreme case, the creation of these concept blocks should enable the student to plan his own computer-assisted curriculum (the computer informing him of certain necessary relations between blocks).

Each block includes:

- an information sequence, in which the leading component governs the other components of the block to which it belongs;
- learning requirements defining the form in which the information is presented (text books, television, magnetic tape);
- post-tests of knowledge acquired from the concept block: problems, exercises (paper and pencil).

(ii) The remedial course curriculum

As we have said, the entry level is fixed in terms of prerequisite knowledge or expected level of capability. This implies that the prerequisite capabilities should be effectively tested before the student tackles the curriculum. Thus in the humanities course a knowledge of logarithms, the elements of algebra and trigonometry, negative fractional exponents and roots were taken for granted. Owing to the teaching method used, it soon became apparent that most of this knowledge had been forgotten and often poorly grasped. These shortcomings were rapidly and effectively corrected by drawing up a series of programmed-lessons of the conventional type and by preparing individual data sheets recording the student's deficiencies.

### 2.2.2. Analysis of a human operator (HO)

For any meaningful assessment of a student's learning, evaluation standards must be defined as effectively as possible, and achievement and errors rated according to the mental aptitudes involved.

To provide this more solid basis for assessment the following two projects were undertaken:

- (3) a "Human Operator Theory",
- (4) a tentative "Error Generation Theory".

#### (i) The Human Operator Theory

When a person (here called a Human Operator or HO) tries to solve a problem a form of interaction occurs between him and his environment. Since human thought may also be said to progress along a path made up of ideas or images, further interaction occurs, but in a much more "abstract" manner. These two types of interaction, which might be called global apprehension and logical apprehension, are two essentially different faculties of the HO.

A restricted model of a "Human Operator and the Outside World" has been based on a study of these faculties and is described in further detail in Annex 1.

#### (ii) Tentative "Error Generation" Theory

By means of the "thinking aloud" method, errors, difficulties of understanding and explanations which have enabled the student to correct his own mistakes are noted during the paper-and-pencil exercises which are required at the end of each "concept block". This information and that yielded by analysis of the questionnaires later referred to is used to ascertain the reasoning process, the types of mistake and their causes, corrective information or procedures, and the student's preconceptions.

In classifying errors, basic types of mistake were found to exist in the logical relationships at the level of the reasoning process (transitivity). These were, for instance:

- the over-use of analogy,
- confusing a magnitude with its variation.

It should, in particular, be possible to derive certain learning algorithms from this study.

### 2.2.3. Evaluation (Fig.5)

On completion of each concept block the student should be subjected to a full set of tests, each covering a carefully specified aptitude for which the student is given a particular rating. All these ratings are included in the variables of the model which guides the student through the matrix of the concept blocks.

Included in the various aptitudes which must be tested and which are deduced from the "HO components" are:

- knowledge,
- the transitivity at the various levels,
- ability to proceed from the abstract to the concrete,
- creativity,
- motivation.

A specific test should be provided for each such aptitude. Although some tests are better when set orally (motivation) others (creativity and transfer from abstract to concrete) call for a written, oral and computer mix, and yet others (knowledge and transitivity) demand use of the computer.

So far the testing process has called for three types of project:

- (5) drafting questionnaires,
- (6) preparing creativity exercises,
- (7) computer programming.

The first two will now be described, the third being dealt with in connection with ways and means.

#### (i) Testing of knowledge and transitivity (drafting questionnaires)

##### (1) Objective

The objectives of the tests and of the resulting decision-making process may be said to lie at four levels:

##### At student level

- show the student result of his learning, i.e. inform him of what he

knows, does not know (up to the point where his knowledge stops), and especially correct his mistakes by providing him with appropriate information;

- motivate the student.

At information and learning level

- uncover any shortcomings,
- correct any item of largely "illegible" information.

At management level

- determine the value of the "knowledge" variable by means of the educational-psychology model,
- introduce this value into the management (decision-making process) model.

At the learning-process level

- uncover any preconceptions by the student,
- determine the line or process of reasoning most frequently followed.

(2) Preliminaries to drafting the questionnaires

When the objectives of testing have been defined, certain preliminary steps must be taken. Before any test questionnaire is prepared a three-phase study is required which we will describe using an example taken from a physics course: the concept of work.

First phase: Logical analysis of concept content (see Annex 1)

Among the concepts we propose to study are fundamental concepts whose number obviously will depend on what has already been tested in the learning process. The work concept thus may be said to imply the learning of three concepts:

- force,
- displacement,
- scalar product.

The work concept is at the intersection of these three concepts.

Without further expanding on the subject, by using Venn's diagrams, the work concept will be found at the intersection of the three conceptual sets

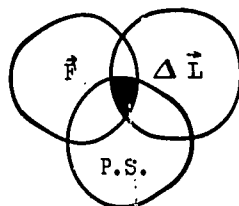

The elements being represented by  $\emptyset$ ,  $\{\vec{F}\}$ ,  $\{\Delta \vec{L}\}$ ,  $\{S.Q.\}$ , the set parts can be grouped together  $P(E)$  and numbered as follows:

0 for  $\emptyset$ ; 1 for  $\{\vec{F}\}$ ; 2 for  $\{\Delta \vec{L}\}$ ; 3 for  $\{\vec{F}, \Delta \vec{L}\}$ ; 4 for  $\{SP\}$ ;

5 for  $\{\vec{F}, SP\}$ ; 6 for  $\{\Delta \vec{L}, SP\}$ ; 7 for  $E = \{\vec{F}, \Delta \vec{L}, SP\}$ .

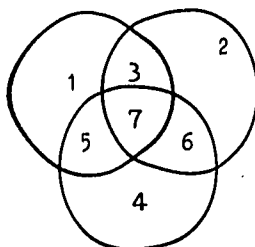

- It may, for instance, be asked what part  $3 = \{\vec{F}, \Delta \vec{L}\}$  represents. The answer is that the student should think of a force acting through a given distance in contrast to a force acting over a given time.
- Likewise, when element  $\{\vec{F}, SP\}$  of  $P(E)$  is considered, the force may be regarded as one exerted in a direction in which the body is free to move.

The inclusion relationship is then used to construct the grid shown below:

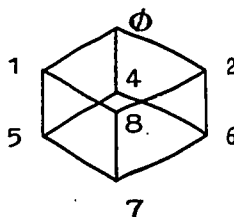



All possible ways of drafting a questionnaire appear on this grid. In addition, by assessing the content of each question it can be assigned a specific weight.

Second phase: Determination of objectives in terms of HO components  
(see Annex I).

The work concept can therefore be visualised at level 1 or level 2.

In the first case the questions will be used to verify how the message received agrees with the message taught. In the second case, where it is assumed that the message has not been taught, the student's ability to bring out the work concept by analysing situations put before him will be tested.

There will be a questionnaire for each of these objectives.

Third phase: Study of the student's thinking processes based on an analysis of mistakes

Included in the questionnaires on work concepts, for instance, will be questions which will test:

- whether the concept of force is clearly understood to be linked with acceleration,
- whether the student realises that any change in direction means a change in velocity (acceleration),
- whether he is aware of the vector concept of force,
- whether a force can be resolved in any two directions,
- if the concept of projection has been understood correctly,
- etc.

### (3) Conclusions

In conclusion, the various reasons given above argue in favour of:

- testing by means of branching questionnaires;
- the type of branching used;
- the expediency of branching. (Often based on the answer to a single question, this specific decision-making process may produce negative results).

Branching implies a highly diversified and adaptable test programme. Such a type of questionnaire is effective only if a computer is used.

Owing to the vast amount of data the computer can absorb and the speed of processing, a really effective feedback of the learning situation is provided.

(ii) Creativity tests

(1) The objectives

Creativity or inventive stimulation exercises are used to test innovative capacity. Innovation may concern one of the following components of what is called the O.C.L.E., namely:

- an Object
- a Concept
- a Law
- some new, complex Experiment

This stimulation in fact basically consists in challenging existing models and in building new ones.

- This test should supply a value for the "creativity" variable with the help of a formal model.
- The variable should be included in the management model.

(2) Preliminaries

Experience shows that creative activity depends on the extent of knowledge. It will therefore hinge on the result of knowledge tests.

2.2.4. Student attainment function

The variables or components of the human operator (HO) assessed by means of each test should be included in a model or "attainment function" of the student. The function's value will, therefore, depend on the results of each test and will be characteristic of the student. Consequently, in order to prepare the test, the validity of the components HO must first be checked. This work is the subject of Action No.8 in our programme.

#### 2.2.5. Management of learning

On the basis of the student's attainment level and the optimisation criteria it should be possible to guide him through the various concept blocks. The purpose of this management approach is to enable the student to achieve his highest performance rate as rapidly as possible. To obtain this result Action No.9 must be prepared.

#### 2.2.6. Conclusions

(i) In the model used the information collected helps to improve both the subject matter and HO components. The system is, therefore, continuously self-correcting.

(ii) The itinerary followed by the student through the set of "concept blocks" may vary considerably. A general outline of this itinerary is given in Figure 6.

Figure 6  
ORGANISATIONAL CHART OF LEARNING SYSTEM

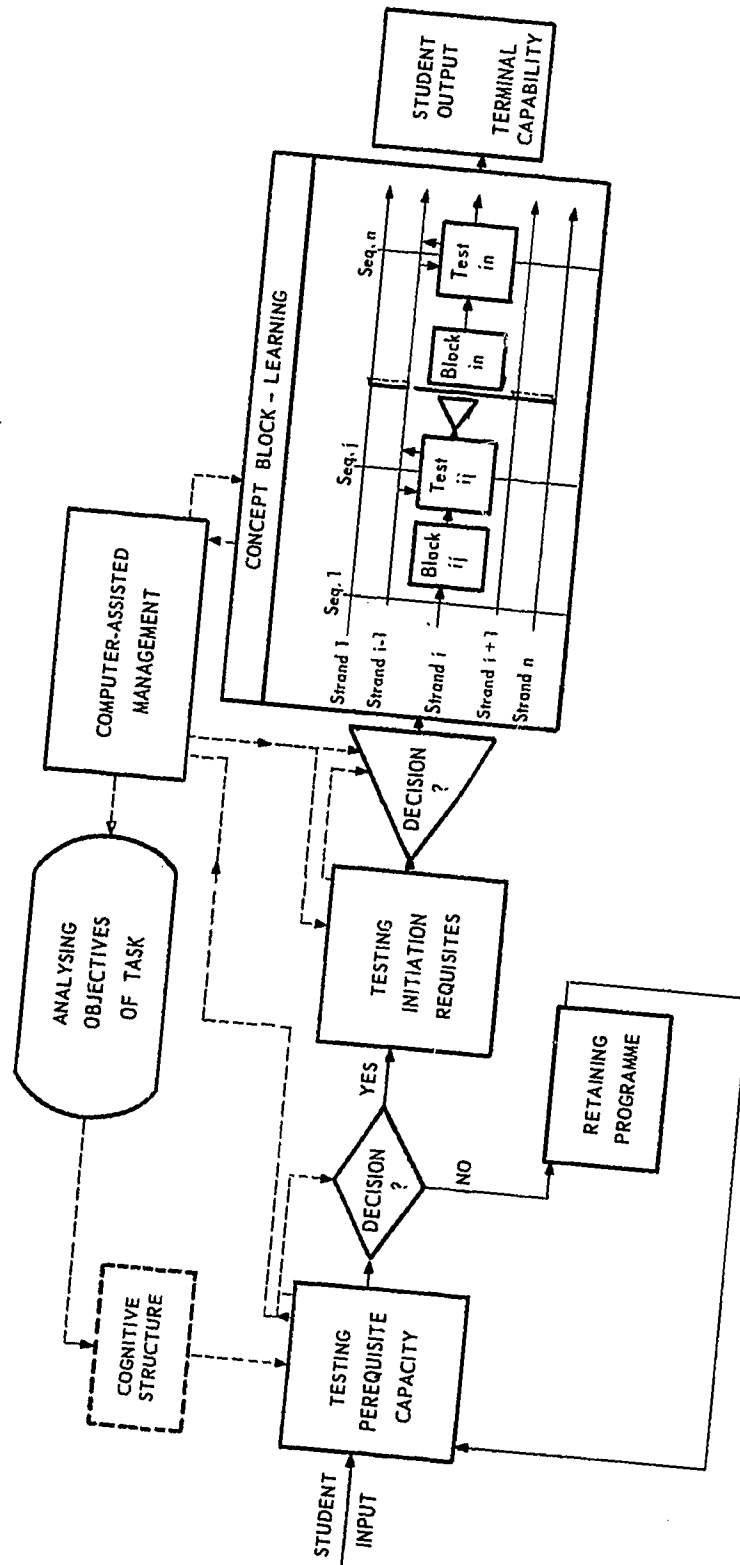

Figure 6A  
 DEFINITION OF TERMS AND SYMBOLS USED IN ORGANIGRAMME



Initial operation



Operations for testing, retraining, concept block and management of learning

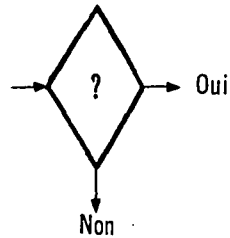

Decision-making process with two outputs

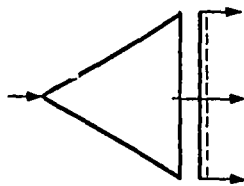

Decision-making process with n outputs

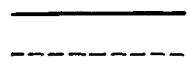

Student's itinerary  
 Transfer of information

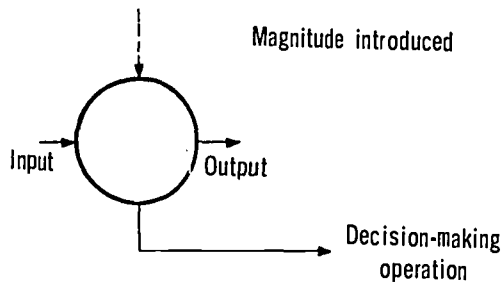

Magnitude depending on the magnitude introduced

Fig.6 B

Cognitive structure : student's preconceptions and cognitive approaches required by the task.

Testing prerequisite capacity : suitable behavioural requirements (at entry level).

Initiation requisites : profile of skills needed to begin learning strand.  
Requisites specific for each strand.

Information learning unit : includes - concept blocks arranged in strands.

- tests.

- learning strategies.

Computer-assisted management : use of an educational-psychology model in order to optimise teaching-learning process.

### 3. MEANS PROVIDED FOR THE VARIOUS TASKS

#### 3.1. Inventory of means

##### 3.1.1. Information and learning

The following media are used for this task:

3.1.1.1. A programmed syllabus (including sequences or concept blocks logically arranged according to learning objectives; test exercises or problems distributed as effectively as possible);

3.1.1.2. Magnetic tape on which "oral" information supplementing the programmed syllabus is recorded;

3.1.1.3. Later on a closed-circuit television system. A psychological study of learning processes shows that such a technical aid is essential. Students have trouble learning certain parts of the curriculum because physical phenomena are more difficult to understand without a dynamic visual aid. The choice of television therefore fills a need;

3.1.1.4. Lectures: these serve the purpose of motivation and synthesis before or after individualised learning of a set of concept blocks;

3.1.1.5. Practical work in the laboratory.

##### 3.1.2. Learning tests, consisting of:

3.1.2.1. Memory tests by means of computer-managed questionnaires;

3.1.2.2. Reasoning tests by the same method as memory tests;

3.1.2.3. Creativity tests by means of computer-assisted exercises stimulating inventiveness. The exercises are given either to individuals or groups.



### 3.1.3. The management of learning

An educational-psychology model for the management of learning is now being designed. Based on the results of the tests, this model will study the itinerary followed by the student so that his learning can be optimised. This work is mainly carried out by computer.

### 3.2. Detailed description of certain media

#### 3.2.1. The computer

Two ways of using the computer will be described, namely:

- questionnaires proposing to test
  - the knowledge of concepts
  - the students' reasoning capacity.
- inventive stimulation exercises.

#### 3.2.1.1. Hardware

The equipment used is the time-sharing commercial network of HONEYWELL-BULL at Louvain. The system consists of two central processing units (DATANET-30 and GE-235), a DSU-20 disk unit, a central console, numerous terminal consoles and a number of peripheral units. The space between the terminal consoles and processing units is only sufficient to provide access to telephonic or telegraphic lines. The configuration of the system described below is shown in Figure 7.

The DATANET-30 is a computer for recorded programmes with telecommunication capability. It manages the terminal consoles and the GE-235, by means of a main control programme.

The GE-235 with its 6 microseconds of cycle time and 16,000 words of memory is the most rapid calculator in the GE-200 series. Its main function is to compile and execute programmes. Very efficient floating point operations are obtainable with the rapid arithmetic unit.

The DSU-20 disk unit is a large-capacity immediate random-access store used to exchange information in both directions. The two central processing units have access to the 18 million characters stored in the disk unit. Accordingly, it not only acts as a buffer

Figure 7  
 CONFIGURATION OF THE TIME-SHARING SYSTEM

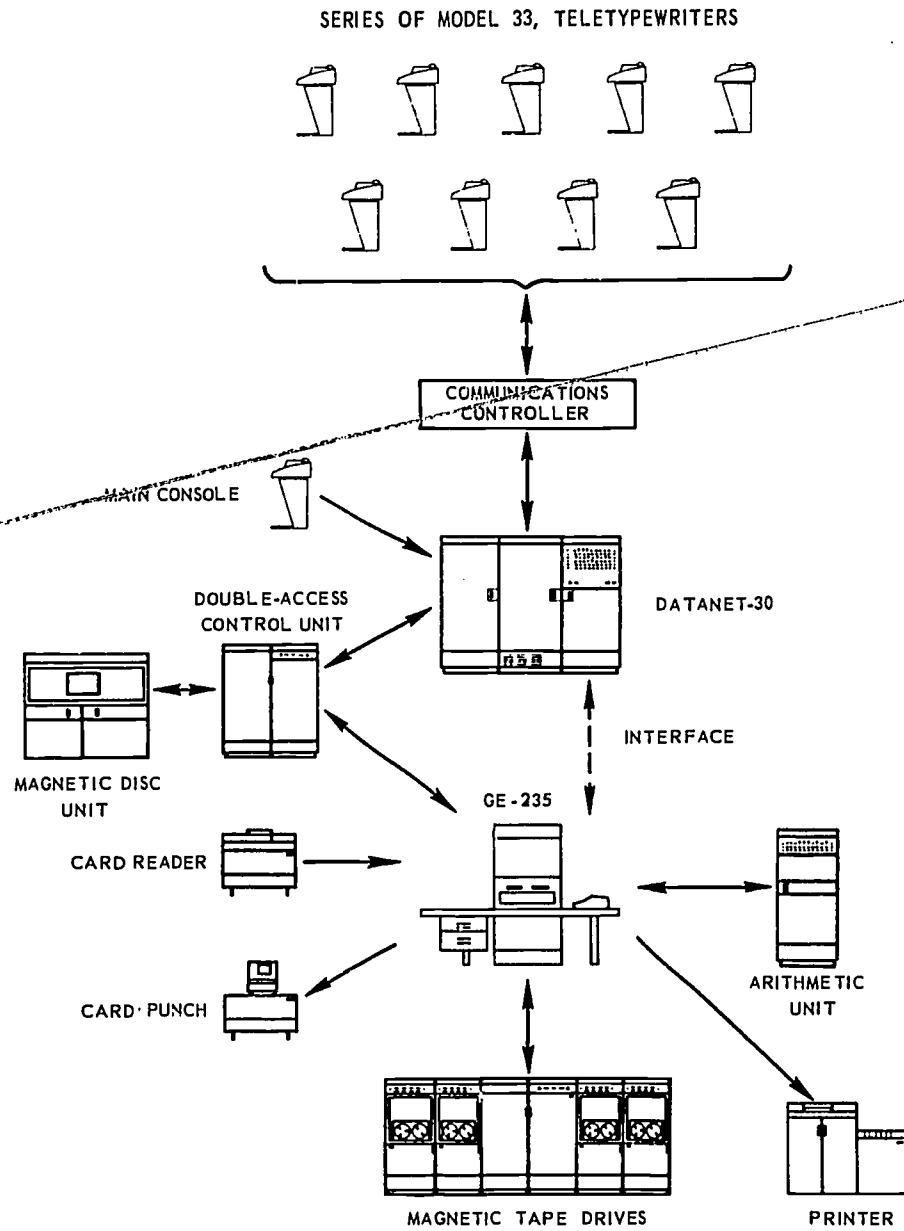

store between the GE-235 and the DATANET-30, but also serves to record programmes currently used or those in the library and for storing the compilers and operating systems described below.

The disk unit is divided into five areas:

(i) The area for current work containing the text of user programmes in the process of being written or of programmes asked for by the user.

(ii) The area of the user programme library; this area may contain from 2,000 to 7,000 programmes depending on their length.

(iii) The area of the library programme catalogue.

(iv) The area of the operating system and compilers.

(v) The area for receiving the programmes in execution pending further use.

The double-access control unit enables the GE-235 and DATANET-30 to use the disk unit successively. The two central processing units are permanently connected to this control unit, but cannot both use the disk unit simultaneously (see "DATANET-30" brochures).

The CIU-930 connection unit enables control data to be exchanged between the GE-235 and the DATANET-30 so that the latter can execute the programmes.

The consoles: A main console installed near the two central processing units is used for managing the whole system. It enables the DATANET-30 to be reloaded, the system to begin or stop execution and other maintenance operations to be carried out. The main and terminal consoles are usually TELETYPE units (Model 33). The terminal consoles are connected to the DATANET-30 by telephone lines which may be the private line of a user's installation with additional extensions or lines of a switched circuit.

The peripheral equipment, including magnetic tape drives, a high-speed line printer, a reader and card punch, complete the Bull-General Electric time-sharing system. Although the system uses this equipment to transcribe data from the disk memory to magnetic tape and to start off the operation, these machines are mainly intended for conventional handling when no time-sharing operation is in progress. The system's flexibility enables it even to be used simultaneously with time-sharing work of no great urgency.

The type of printing characters available on the seven terminal consoles installed at Louvain are unlike the original characters supplied by the manufacturer. They have been especially adapted to the subject of the Louvain experiment, which is physics, and are as follows:

26 capital letters:	ABCDEFGHIJKLMNOPQRSTUVWXYZ
10 figures:	1 2 3 4 5 6 7 8 9 0
3 small letters:	g t d
4 indices:	1 2 3 v
1 exponent:	2
2 Greek letters:	$\Theta$ $\pi$
6 punctuation marks:	: . , ) ( ' $\prime$
5 arithmetical signs:	+ - = / X

### 3.2.1.2. Description of questionnaires

#### (i) Method of testing

##### Form of test

The test consists of an interrogation in the form of a question-and-answer dialogue. The computer and the student communicate through a terminal console. The questions are printed automatically and the student has to type the answers. Theoretically the student is free to reply as he likes so long as the reply is concise and brief. Alphabetical letters or formulas can be used. An example of such a dialogue is given in Figure 8.

##### The flow chart

The questionnaire is prepared by a multidisciplinary team of teachers who use it to compose the flow chart in which the questions are set out in the order of the student's anticipated replies. An example of such a flow chart is given in Figure 9, showing the main core or sequence (questions Q 1 to Q 15) and branches (questions Q 16 to Q 27). The student who always answers correctly (marked 0 on the figure) will follow only the main sequence. If he makes a mistake he is guided into the branch corresponding to his type of mistake (marked 1, 2 or 3 on the figure).

Fig. 8

FORCE 17:02 TS-BRU 16/06/71

PLEASE TYPE YOUR NUMBER

? 99

CONCEPT OF FORCE

HERE ARE SOME TRIGONOMETRIC FUNCTIONS NEEDED IN THE QUESTIONNAIRE (ANGLES EXPRESSED IN DEGREES)

$$\cos 30 = \sin 60 = 0.865$$

$$\cos 45 = \sin 45 = 0.707$$

$$\cos 60 = \sin 30 = 0.500$$

GOOD LUCK...

GIVE THE NUMBER OF THE QUESTION YOU WOULD LIKE TO TAKE FIRST

Q 4

Q 4

A BALL ROLLING AT CONSTANT SPEED IN A HORIZONTAL PLANE REACHES THE BOTTOM OF A SLOPE (FIG.2). IT SLOWS DOWN.

IS THIS DUE TO FORCES? (OMIT FRICTION). REPLY YES OR NO.

?NO

INCORRECT.

IF A MOVING BODY CHANGES DIRECTION IT IS SUBJECT TO ACCELERATION. IF THERE IS ACCELERATION THERE IS FORCE IN THE PHYSICAL SENSE.

AS THE BALL PASSES FROM A HORIZONTAL TO A SLOPING PLANE IT CHANGES DIRECTION AND IS THEREFORE SUBJECT TO THE ACTION OF FORCES.

Q 5

WHAT ARE THESE FORCES?

? WEIGHT AND REACTION OF THE EARTH

CORRECT.

Q 6

A FORCE IS APPLIED TO A MOVING BODY IF THE LATTER HAS MASS AND ACCELERATION.

WHAT THREE CHARACTERISTICS ARE NEEDED IN ORDER TO KNOW THE FORCE?

? MAGNITUDE AND DIRECTION.

INCOMPLETE. THE TWO VALUES YOU HAVE GIVEN ARE NOT SUFFICIENT TO DETERMINE THE FORCE COMPLETELY.

THINK AGAIN AND GIVE A COMPLETE ANSWER.

Q 6

? MAGNITUDE, DIRECTION AND SENSE

CORRECT.

Fig. 8 A

Q 7  
CAN A FORCE BE RESOLVED IN ANY TWO NON-PARALLEL DIRECTIONS  
IN A PLANE ? (YES OR NO)

? YES  
CORRECT.

Q 8  
GIVE THE MAGNITUDE OF THE RESULTANT OF TWO FORCES OF 4 KG  
AND 3 KG FORMING AN ANGLE OF  $90^\circ$ .  
REPLY IN THE FORM  $R=...KG$

?  $R=7 KG$   
VECTORIAL ADDITION IS NOT AN ARITHMETICAL ADDITION.  
PROCEED...

Q 8

?  $R=25 KG$   
INCORRECT.  
HERE IS A QUESTION WHICH WILL HELP YOU TO FIND THE SOLUTION.

Q13

WHAT VECTORIAL OPERATION MUST YOU CARRY OUT HERE TO FIND  
THE RESULTANT FORCE ?

? ADDITION  
INCOMPLETE. DO NOT FORGET THAT THESE ARE VECTORS AND NOT  
SCALARS. TRY AGAIN.

Q13

? VECTORIAL ADDITION  
CORRECT.  
THINK IT OVER AND TRY TO ANSWER THE QUESTION CORRECTLY  
THIS TIME.

Q 8

?  $R=10 KG$

Q14

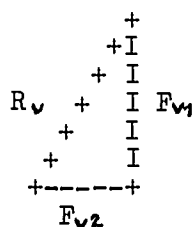

IN THE RIGHT TRIANGLE FORMED BY  
 $F_{v1}$ ,  $F_{v2}$  AND  $R_v$ , WHAT IS THE RELATIONSHIP  
BETWEEN THE MAGNITUDES OF THESE THREE  
SIDES ?

?  $R^2 = F_1^2 + F_2^2$   
CORRECT

YOU NOW HAVE ALL THE NECESSARY INFORMATION TO SOLVE QUESTION 8.

Q 8

?  $R=5 KG$   
CORRECT.

Fig. 8 B

Q 9  
LOOK AT FIGURE 3 AND GIVE THE VALUE OF THE ANGLE PRODUCED BY  
THE RESULTANT OF THE TWO FORCES WITH THE OX AXIS.  
REPLY IN THE FORM  $\theta = \dots$  DEGREES  
?  $\theta = 90$  DEGREES  
CORRECT.

Q10  
IS THE RESULTANT FORCE DIRECTED IN THE SENSE OF THE POSITIVE  
OR NEGATIVE Y'S ?  
? POSITIVE Y'S.  
CORRECT.

Q11  
WHAT IS THE MAGNITUDE OF THE RESULTANT FORCE ?  
REPLY IN THE FORM OF AN EQUATION  $R = \dots$  KG  
?  $R = 17.3$  KG  
CORRECT.

Q12  
LOOK AT FIGURE 4.  
WHAT IS THE MAGNITUDE OF THE PROJECTION ON OX OF THE RESULTANT  
OF FOUR FORCES APPLIED AT POINT O ?  
REPLY IN THE FORM  $R = \dots$  KG  
HERE ARE THE FIGURES...  $F_1 = 3$  KG  $F_2 = 4$  KG  $F_3 = 8$  KG  
 $\theta_1 = 45$  DEG  $\theta_2 = 60$  DEG.  
?  $R = 7.65$  KG  
INCORRECT.

Q17  
KNOWING THAT THE PROJECTION OF THE RESULTANT FORCE IS EQUAL TO  
THE SUM OF THE PROJECTIONS OF DIFFERENT FORCES TAKEN WITH THEIR  
SIGN, WRITE THE MATHEMATICAL RELATIONSHIP LINKING THE MAGNITUDE  
R OF THE RESULTANT AND THE PROJECTIONS OF FORCES  
 $F_{v1}$ ,  $F_{v3}$  AND THE TWO FORCES  $F_{v2}$ .  
REPLY IN THE FORM  $R = \dots$   
?  $R = F_1 - F_3 \cos \theta_2$   
CORRECT  
ALL YOU NOW HAVE TO DO TO ANSWER QUESTION 12 IS TO REPLACE  
THESE SIGNS BY THEIR NUMERICAL VALUES.

Q12  
?  $R = -1$   
CORRECT, BUT YOU HAVE FORGOTTEN TO NOTE THE UNITS. YOU WERE BEING  
CARELESS.....  $R = -1$  KG

THIS IS THE END OF THE QUESTIONNAIRE

GOODBYE TILL NEXT TIME.



Figure 9

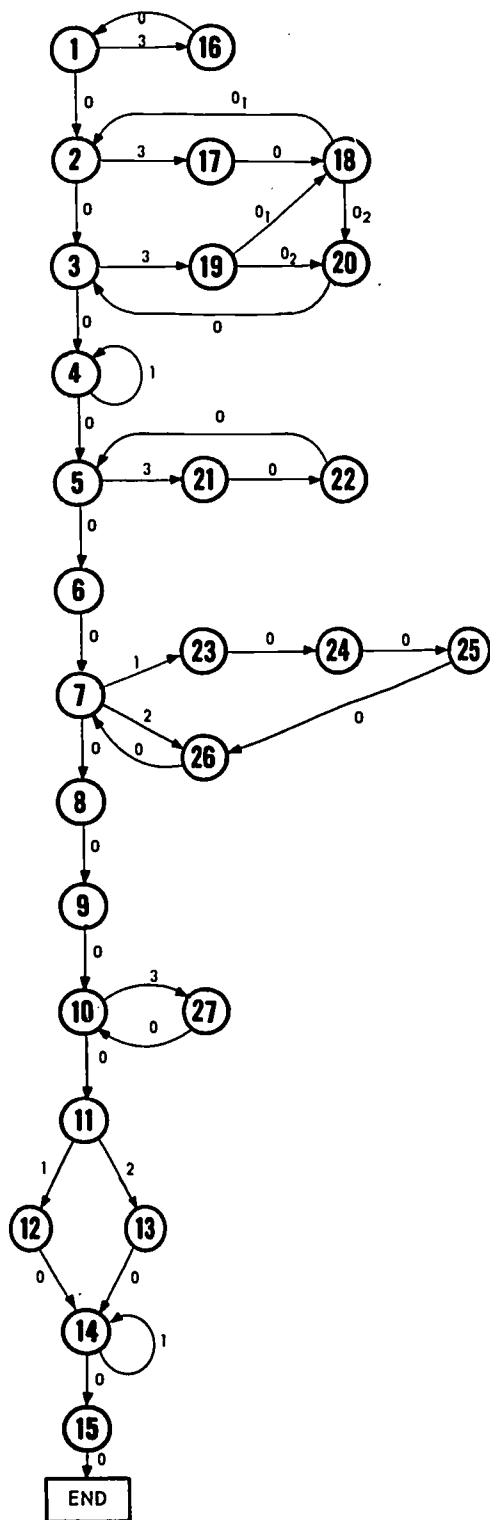

### Logic

An internal logic unit enables the system to work and provides the necessary flexibility. The "examiner's" imagination is only restricted in that:

- a question which has been replied to correctly will never be asked again;
- to avoid cycling no question is put more than twice in a row (three or more times would be possible).

If the student exhausts the "examiner's" patience, by not replying correctly to the branched questions provided, he will always get the reply at the end of the branching process. After receiving this additional information the student may, if the examiner so wishes, again be asked the questions wrongly answered. Some specific answer is the correct reply for the system's purposes, and an appropriate comment can be joined to each type of reply if the writer so wishes. The programming is sufficiently flexible for the system to be used by a teacher unfamiliar with computer technique.

### (ii) Description of programmes

#### Control programme

There are two control programmes at present. The first is used simply for managing interrogation by means of question and answer files, which will be described later on. The relevant instructions are included in the second programme, which, in addition, is used to store a set of data on the student's itinerary through the questionnaire.

#### Simple programme

The simple programme opens with the question, comment, introduction and DATA files.

- (1) § FILE I01/ I010, I02 / I020, I03 / I030,
- (2) + I04 / I040, I05 / I050, I06 / I060, I07 / I070,
- (3) + I08 / I080, I09 / I090, I10 / I100, INTRL
- (4) + DATA.
- (5) NQ = 10
- (6) § USE QUEST 1

Afterwards comes a definition of the variable NQ (total number of questions), and finally the link-up with the QUEST 1 management programme.

IO1 stands for the question file of the first question.

IO10 stands for the comment file of the first question.

INTRL stands for the introduction file of the questionnaire.

L will be the keyletter of the subject of the questionnaire.

#### Full programme

In the full programme we have arranged for some of the data relating to the itinerary of each student through the questionnaire to be stocked in two special files (WAY, REP).

WAY - itinerary through the questionnaire, or the sequence of questions asked;

- time taken to answer each question;

- truth value of the reply;

- number of questions asked;

- total interrogation time;

- mark obtained;

- student's number.

REP - for each question all replies of truth value 3 (not provided for).

The control programmes link up with general questionnaire management programmes, which are common to all the questionnaires.

The management programmes consist of two parts:

- the management programme proper, including, in addition, the alphabetical test: this programme manages the call for questions and the printing of comments and replies given by the computer.

- the formula test will be described below.

These programmes are linked together as shown in the attached outline (Figure 10).

Figure 10

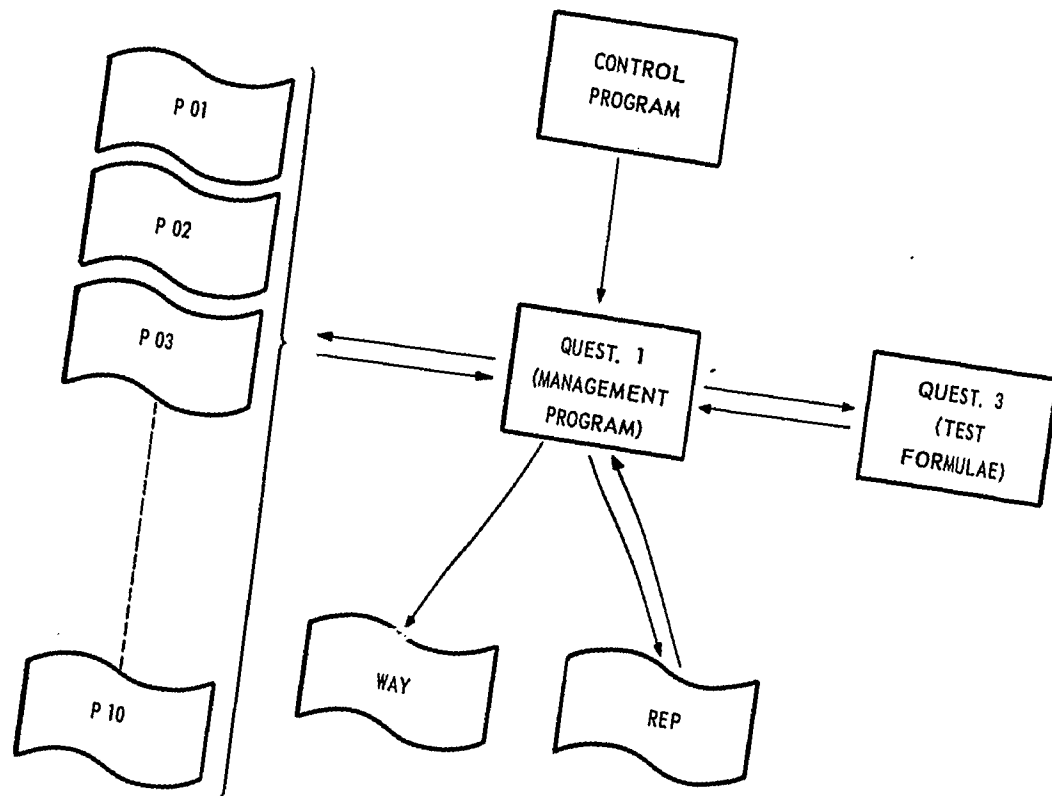

PROGRAMS  
(IN FORTRAN)

FILES

It is to be noted that the programmes QUEST 1 and QUEST 3 are stored on disks in compiled form. Storage on disks of question-and-answer files is all that is necessary to enter a questionnaire in the machine. No compilation is necessary as the files are generally punched on tape off-line, and then placed in the disk memory.

#### Alphabetical test

The alphabetical test is used to identify in the student's reply keywords or words that are significant in relation to the truth value of the reply.

It may be a word or its synonyms as, for instance,

force of gravity  
gravity  
gravitation or  
the earth's pull.

A synonym may consist of several words. It may consist of several words or synonyms, each one of which will have to be included in the reply for it to be meaningful.

The test may be applied only to the skeleton of the word to avoid spelling problems. For instance EAR - PULL will be tested instead of earth's pull.

#### Remarks

This test analyses all the words in the student's reply independently of the order in which they occur. When the required words are recognised the reply is considered to be correct. The student has a line of text (60 characters) for his reply.

#### Formula test

The formula test is used to examine the validity of a reply written as an equation. To work out this analysis, the control programme reduces the formula to a conventional form, which will be written in the appropriate file. The conventional form is presented as a sum of terms equal to 0. Each term consists of a numerical coefficient and several factors, a factor being defined as any character, excluding figures and the following signs: ( . = + - , ). Let us now consider the procedure for reducing the formula to its

conventional form. This consists in a series of operations which are carried out after the student's reply has been read, i.e.:

- (1) eliminating blanks;
- (2) identifying each term by means of the + - = signs;
- (3) defining the sign for each term;
- (4) defining each term's numerical coefficient;
- (5) defining each term's factors and classifying them according to their octal value in the central store;
- (6) changing the sign after the = sign;
- (7) reduction of similar terms;
- (8) classification of terms in the following order:
  - first, those which have the least number of factors;
  - where the factors are equal in number, similar factors will be compared, the term with a first factor of smallest octal value being placed first.
- (9) division of all terms by the coefficient of the first term with its sign. (Terms with an 0 coefficient are neglected).

A system of substitution is used to remedy any algebraic incompatibilities generated by this procedure. It is sufficient to substitute any two letters of the alphabet for a term or a series of terms. If a substitution has been programmed it is executed before the reduction to conventional form.

Such substitutions are also made in the case of brackets or denominators. Because of the limited storage capacity available, the first version of the formula test did not handle these parentheses and denominators. For the second version now being studied a TIME-SHARING CHB MKII system will be used, where the computer belongs to the GE-600 series and has a much larger memory capacity than the GE-235.

#### Constraints

- There may be at least 10 factors in the same term;
- two letters may be substituted for a maximum of 20 characters.

The limitations in these constraints have been introduced for practical purposes; there would be no objection to other values being assigned.

(iii) Editing of files

The information required for the management and printing of questionnaires is stored on files, there being a "question" and a "comment" file for each question. The writing of the question file varies according to whether the alphabetical or formula test is to be used. The editing system for the files is outlined below.

(1) Writing rules

Each line must be preceded by a line number, lines being recorded in ascending numerical order. If two or more lines have the same number only the last line will be taken into account. While certain lines alone are written in a strict form, a blank must be left after each line number. Each line contains 60 characters.

(2) Alphabetical test

9 Vector of subtracted points: 3-component vector

10 Branching vector: 8-component vector

20 Number of lines in question

21 Test of question

.

.

.

.

30 Number of keywords (maximum 10)

31 Number of characters in word followed by word itself

.

Format 3X, I<sub>3</sub>, 10 A<sub>1</sub>

.

.

(10 characters maximum)

.

50 Number of tests provided in reply

510 Number of keywords in first test and its truth value

511 Position of first keyword followed by its synonyms in list 31

32 ...

512 Number of keywords in second test and its truth value

521 Position

.  
. .  
. .

In line 9 we have three figures which are points subtracted when the truth value of the reply to the question is 1, 2 and 3. The questionnaire is marked on 20 points.

Example :

9 0.5,0.5,1

10 004, 120, 219, 319, 0, 0, 0, 0

20 3

21 NAME THE TWO FORCES WHICH ACT ON A BODY

22 PLACE IN A LIFT. DO NOT CONFUSE THEM

23 WITH THOSE EXERTED ON THE LIFT SHAFT.

30 9

31 008GRAVITY

32 004WGHT

33 005HEAVNS

34 008REACTION

35 009RESISTNCE

36 007THRUST

37 005RESPONSE

38 006ATTRACT

39 004EARTH'S

50 5

510 2,0

511 2,3

512 4,7

520 1,1

521 1,3

530 3,0

531 8,8

532 9,9

533 4,7

540 2,1

541 8,8

542 9,9

550 1,2

551 4,7



In the example chosen the correct reply should include a combination of the following two lists of synonyms :

Gravity	Reaction
Weight	Resistance
Heaviness	Thrust
Earth's attraction	Response

We are going to programme five tests :

Truth value 0	(1) Gravity	Reaction
	Weight	Resistance
	Heaviness	Thrust

or

(2) Earth's attraction	Reaction
	Resistance
	Thrust
	Response

Truth value 1 (The second force has been left out)	(3) Gravity
	Weight
	Heaviness
	(4) Earth's attraction
Truth value 2 (The first force has been left out)	(5) Reaction
	Resistance
	Thrust
	Response

For line 10 which gives the branching vector, we have the following sequence :

004 for truth value 0 move to Q.4  
120 for truth value 1 move to Q.20  
219 for truth value 2 move to Q.19  
319 for truth value 3 move to Q.19

(3) Formula Test

9. Vector of subtracted points  
10. Branching vector  
20. Number of lines in question  
21. Text of question  
22. . . .

- .
- .
- .
- 30. 0
- 40. Number of substitutions
- 41. Letters to be substituted, number of characters to be substituted, characters themselves. Format (3X, 2A1, 3X, I2, 3X, 20A1)
- 42. . . .
- .
- .
- .
- 60. Number of tests to be carried out
- 61. Truth value of test followed by the formula in conventional form. Format (3X, 51, 57A1)
- .
- .
- .

Example

SIN(A+B)=SINACOSB+SINBCOSA

9 0,0,1

10 002,302,6X0

20 2

21 WHAT IS THE VALUE OF SIN(A+B) ?

22 REPLY BY SIN(A+B)= ...

30 0

40 0

60 1

61 0B)+(AINS-2ABCINOSS

The stages for reducing to conventional form are:

1. Sin(A+B) = SIN A COS B + SIN B COSA
2. 3. 4. SIN (A B) SINA COS B SIN B COSA
5. (AINS B) ABC INOSS ABC INOSS
6. 7. (AINS B) -2 ABC INOSS
8. 9. B) + (AINS -2 ABC INOSS = 0

It should now be noticed that such a reply as

SIN(A+B) = 2SINA COS B will also pass this test.

It is therefore preferable to use two substitutions as follows:

9 0,0,1  
 10 002,302,6X0  
 20 2  
 21 WHAT IS THE VALUE OF SIN(A+B) ?  
 22 REPLY BY SIN(A+B)=...  
 30 0  
 40 4  
 41 PQ 08 SINACOSB  
 42 PQ 08 COSBSINA  
 43 XY 08 SINBCOSA  
 44 XY 08 COSASINB  
 60 1  
 61 1  
 61 0B)-PQ-XY+(AINS=0

(4) Comment files

As we have seen in the questions section, each text to be printed will be preceded by a line indicating the number of lines it contains.

Lines 10 to 19 will be reserved for the correct reply

20 to 29	for truth value 0
30 to 39	1
40 to 49	2
50 to 60	3
.	.
.	.
.	.

Take the example of the lift [elevator]:

10 3  
 11 THE TWO FORCES ARE THE WEIGHT OF THE BODY AND THE  
 12 REACTION EXERTED BY THE FLOOR OF THE LIFT ON THE  
 13 BODY  
 20 0  
 30 2  
 31 I ONLY RECOGNISE ONE OF THE TWO FORCES, THE WEIGHT  
 32 OF THE BODY  
 40 3  
 41 I ONLY RECOGNISE ONE OF THE

42 TWO FORCES IN YOUR REPLY.THE REACTION EXERTED BY THE FLOOR OF THE LIFT  
43 ON THE BODY  
50 1  
51 INCORRECT

(5) Introductory file

The heading of the questionnaire and all possible comments concerning it will be stored in this file.

Example :

10 3  
11 questionnaire on derivatives.  
12 .....  
13 the questionnaire consists of 10 questions.  
As usual the figure 3 represents the number of lines in the text to be printed.

(iv) Data recorded and their use

Data recorded

When testing knowledge or transitivity various data recorded are:

(1) for each student:

- sequence of questions,
- time taken to reply to each question,
- type of reply given to each question,
- number of questions asked,
- time taken to reply to questionnaire,
- mark obtained.

(2) for a specific questionnaire:

- unexpected replies,
- recurrence rate of various questions,
- average time per question.

### Use of data

The above data yield the following results (without the varying significance of the variables involved being taken into account).

(1) The analysis of itineraries shows their diversity

If the questionnaire is based on an educational-psychology model, the student's itinerary can be assimilated to a cognitive process.

(2) The analysis of marks obtained and types of replies show:

- the value of comments and branching questions,
- how the information phase of the learning situation should be amended.

(3) Result statistics and analysis

(4) Records of unexpected replies

- These are used to calculate a dispersion index of types of reply. This index is valuable.
- Show up any shortcomings in the course.

(5) Time taken to answer (average and individual)

- indicates how difficult it was to answer,
- determines length of interrogation sequence.

### 3.2.1.3. Inventive stimulation exercises

(i) Testing components

The "creativity game" involves the following three phases:

- (1) Construction of the "morphology" (generating sets, components of these sets) (Figure 11).
- (2) Composition of "r-arrangements" (Figure 12) for which the computer is used. The following three programmes are now in operation:
  - STIM 1 : use of free randomisation
  - STIM 2 : use of random itinerary
  - STIM 3 : deterministic sequencing of research.

Fig. 11

KINEMATIC MORPHOLOGY

SUBSTANCE OF MOVING BODY	:	WOOD, PLASTIC, METAL, STONE, POWDER, GAS, NEWTONIAN FLUID, VISCOUS FLUID, THIXOTROPIC VISCOUS FLUID
SHAPE OF MOVING BODY	:	BALL, TRUCK, RECEPTACLE, CYLINDER, CONE, TORUS, CUBE, PLATE, HUMAN BEING
CAUSE OF DISPLACEMENT VARIATION	:	GRAVITY, ELASTIC FORCES, VISCOSITY, DRY FRICTION
CONTACT	:	NO CONTACT, RAIL, KNIFE, AXIS, POINT, IMPACTION, WIRE, SPRING, DEFORMABLE PLASTIC CONTACT
TYPE OF DISPLACEMENT	:	AT REST, UNIFORM, UNIFORMLY ACCELERATED, PERIODIC
PATH	:	RECTANGULAR, CIRCULAR, ELLIPTICAL, CYCLOIDAL, FLAT, HELICOIDAL, SPIRAL
MEDIUM	:	VACUUM, WOOD, PLASTIC, STONE, METAL, POWDER, NEWTONIAN FLUID, VISCOUS FLUID, GAS, THIXOTROPIC FLUID
TESTING SYSTEM	:	PHOTOGRAPH, STROBOSCOPE, CHRONOMETER, PHOTOELECTRIC CELL, THERMOMETER, SCALES

Fig. 12

STIMI 11:38 TS-BRU 19/10/71

SUBSTANCE OF MOVING BODY  
SHAPE OF MOVING BODY  
CAUSE OF DISPLACEMENT VARIATION  
CONTACT  
DISPLACEMENT  
PATH  
MEDIUM  
TESTING BY

PLASTIC  
CYLINDER  
GRAVITY  
KNIFE  
UNIFORMLY ACCELERATED  
ELLIPTICAL  
GAS  
CHRONOMETER

SUBSTANCE OF MOVING BODY  
SHAPE OF MOVING BODY  
CAUSE OF DISPLACEMENT VARIATION  
CONTACT  
DISPLACEMENT  
PATH  
MEDIUM  
TESTING BY

STONE  
CYLINDER  
GRAVITY  
WIRE  
PERIODIC  
FLAT SPIRAL  
VISCIOUS FLUID  
PHOTOGRAPH

SUBSTANCE OF MOVING BODY  
SHAPE OF MOVING BODY  
CAUSE OF DISPLACEMENT VARIATION  
CONTACT  
DISPLACEMENT  
PATH  
MEDIUM  
TESTING BY

PLASTIC  
CUBE  
ELASTIC FORCES  
RAIL  
PERIODIC  
HELICOIDAL  
THIXOTROPIC FLUID  
THERMOMETER

SUBSTANCE OF MOVING BODY  
SHAPE OF MOVING BODY  
CAUSE OF DISPLACEMENT VARIATION  
CONTACT  
DISPLACEMENT  
PATH  
MEDIUM  
TESTING BY

VISCIOUS FLUID  
CONE  
VISCOSITY  
POINT  
UNIFORMLY ACCELERATED  
RECTANGULAR  
WOOD  
CHRONOMETER

SUBSTANCE OF MOVING BODY  
SHAPE OF MOVING BODY  
CAUSE OF DISPLACEMENT VARIATION  
CONTACT  
DISPLACEMENT  
PATH  
MEDIUM  
TESTING BY

WOOD  
HUMAN BEING  
DRY FRICTION  
NO CONTACT  
AT REST  
RECTANGULAR  
GAS  
STROBOSCOPE

SUBSTANCE OF MOVING BODY  
SHAPE OF MOVING BODY  
CAUSE OF DISPLACEMENT VARIATION  
CONTACT  
DISPLACEMENT  
PATH  
MEDIUM  
TESTING BY

POWDER  
TRUCK  
VISCOSITY  
SPRING  
PERIODIC  
FLAT SPIRAL  
METAL  
PHOTOELECTRIC CELL

(3) Inventive stimulation. In this phase the subject gets to know the components of an "r-arrangement" as a whole in order to try to pick out one of the constituents of the O.C.L.E.

(ii) Evaluation

The morphology and yield of the stimulation exercise will be evaluated:

(1) Morphology evaluation:

- richness,
- presence or absence of components and subsets in the generating units, number of times the morphology has to be revised to achieve the final result,
- distance between adopted and associated morphologies (HAMMING'S distance).

(2) Yield evaluation:

- operational feasibility (cost and accuracy),
- extensive quality (number of possible uses),
- intensive quality (value of possible uses),
- original quality (HAMMING'S distance).

These assessments will be made objectively and subjectively and the "inventor" may be called upon to give an opinion on the originality of his own invention.

3.2.2. Television as an educational medium

3.2.2.1. Preliminary remarks

This study is strongly influenced by the McLuhan theses. Although aware of the considerable controversy aroused by this Canadian writer, we are firmly on his side and shall leave to others the task of refutation. The medium, therefore, is the message. Television is a medium, a technical extension of man. The purpose of studying how to introduce television into the educational system is to find a new language inherent to the medium and which can supplement the usual (and familiar?) languages of the present system, rather than to seek technological solutions to mass communication. The study of television as applied to language is naturally a subject so vast in scope as to yield but general conclusions after a



mere year of research. Yet a series of concrete actions leading to a theoretical approach, perhaps heralding a new grammar, will have been possible.

3.2.2.2. Proposed procedure involving three preliminary assumptions:

(i) Sequences to be achieved purely by electronic means. Film would not be used for regular picture-editing or process shots. No animated cartoons to be used.

(ii) The main purpose of the television sequence is to provide the motivation rather than the means for understanding a subject.

(iii) Television is more suitable for showing processes than for presenting the carefully packaged product.

Why is this so?

(i) It is a purely electronic operation

- The fundamental quality of the cinema is entertainment.  
The fundamental quality of teaching by television is education.

The cinema is mechanical, linear and sequential. It is highly suitable for telling a story with a beginning and end and an action sequence made up of a series of pictures stuck end-to-end by the film editor.

Teaching is a non-linear system. It provides the student with a series of parallel concepts which he has to synthesise. The student can no longer be a passive looker-on, lulled by a lengthy continuous story, but must critically view the proceedings, constantly associating the message he receives with what he already knows. Television is better suited to education than the cinema, since the specific technique of taping by an electronic process (photography, editing and process shots) gives the sequence a clearly less linear and more synthesising structure than the mechanical film.

- Television is a less specialised medium than the cinema, and hence a "despecialising" medium.

Technically speaking television is easier to use than the cinema. Feedback takes place directly the picture is taken, and it is no longer necessary to go through the long, hazardous process of developing film in order to see the result. No more costly wasted

shooting, and editing is just as quick. In electronic process shots a more direct and more analytical technique is used than in film-making (the pictures are usually created by means of mathematical operations on the screen's scanning unit), and a comparatively simpler process is involved. Potentiometers and switches are used instead of heavy optical or mechanical devices.

Television language is thus not a specialist's language, and can more easily fit into an educational system where a person who has something to say has the preference over one who is merely glib and makes use of a specialised language.

(ii) Motivation sequence

Although Einstein's ideas are not difficult to understand, they require a complete reorganisation of the imagination. This is what motivation is - it means reorganising the student's imagination so that any and all new ideas which follow will immediately fit into his mental universe, not in any passive sense, but in a highly critical way in relation to past events, and as to the importance they should take. Motivation is in fact publicity, much like the sort of commercial advertising where the product is usually shown in a situation with which the consumer can easily identify himself (such as a picture of friends happily gathered round bottles of beer).

It is also such a kind of publicity as the review of a play or new film which summarises the plot and discusses its technical quality and any original aspects. The review thus enables the play-goer to choose what most appeals to him as set in an overall context. Even if a course and an entertainment are different the student must be able to sense a relationship between him and the course and between the course and a more global context if he is to understand it. As in commercial advertising he and the course must be "attuned" even if his imagination is not greatly stimulated; as in the case of a critical review, he must be prepared to apprehend the course not as entirely new information but as a message consisting of expected impressions and some measure of novelty.

Television is so comprehensive a medium as to be extremely effective as a motivating agent, and the pictures transmitted can be powerful enough to arouse the viewer's imagination. By means of pictures, television can also show situations with which the student

can easily identify himself, or it can suggest brief analyses or general syntheses of courses or subjects that the student can understand largely by intuition.

(iii) Processes rather than products

Television is a "cool" medium in which pictures are poorly defined.

A television picture is never very clear, or less so than a motion picture, which in turn is less sharp than a photograph, etc. Consequently the spectator has to add his own information to the picture; he must in some way participate (M.L.).

By definition a finished product is an absolute entity, which suffices unto itself. It is complete, self-contained and requires nothing to be added to it, taken away or changed. A finished product shows up badly on television, since in this medium it is suddenly confronted with participation from outside, something which is quite alien to it.

A process, on the other hand, always has an internal logic and must be studied in depth. Television, a medium favouring synthesis, which stimulates the imagination and calls for participation, is an ideal medium for it. In addition the presentation of a process, the whys and wherefores of a situation, the history of some investigative procedure, are often excellent motivations for understanding the final object.

3.2.2.3. Description of a formal response to these axioms

(i) An all-electronic operation

The scenario is thought out in terms of making optimal use of all possible and imaginable filming, editing and process shooting devices for television purposes. The sequence so thought out is then examined for technical feasibility, and as necessary is limited to the facilities available. In this way such uses of special effects have been found to acquire an intrinsic meaning. The effect becomes an easily identifiable code able to epitomise and cover the presentation or demonstration of an entire process. It can represent equivalence relationships, express the simultaneous quality of several situations, the summation of two physical magnitudes, the incompatibility of two hypotheses, the topological transformation

of an abstract configuration, the relation in space and time of several separate factors, etc.

(ii) Television as motivation

The motivation principle now used is to show the student a situation unconnected with the course, in which he can easily find his bearings and which he can use as a frame for the course.

For example: A physics lesson given to physical-training students on conservation of energy will show a pole vaulter and break down the jump in terms of the relevant physical law.

In the motivation sequence, the approach to the actual course is also critical. How far a physical law relates to a language, philosophy basic pragmatic axiom, etc., can thus be shown.

(iii) Presenting the process rather than the product

The sequence provides neither a lesson, proof of a physical law, formula, nor laboratory experiment, since these are finished products which the student cannot criticise; he can only accept or refuse them.

The sequence shows, instead, how starting with a motivation situation and a field specific to the student, the teacher turns the situation which is foreign to the student into one that concerns him personally, i.e. his course, and shows how he can then analyse the pole vault and what thought process will enable him to apply the law of energy conservation.

The sequence is hence a systematic progression from the concrete to the abstract. The student, starting with a familiar concrete situation, is drawn naturally into an area of abstract thought, as that of the course or of mathematical demonstration, and will therefore be more receptive to it.

3.2.2.4. Outline of a standard sequence

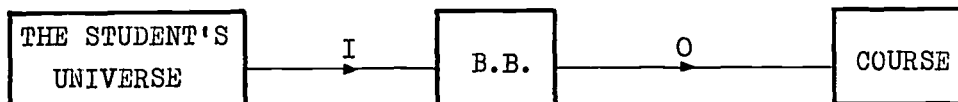

An analysis of the STUDENT'S UNIVERSE produces a series of pictures which are characteristic of the student, and can effectively be used to illustrate the course:

These concrete pictures taken in their basic state form Input (I) of the sequence.

The sequence itself or Black Box (B.B.) draws off the abstract course content from (I) and produces Output (O), i.e. a series of basic abstract pictures representing the teacher's analytical outline of pictures (I) and his own synthesis.

The Black Box contains various process shots and picture sequences according to a special code, showing equivalence or synthesis relationships between basic pictures (I) and basic pictures (O).

Finally, (O) is introduced into the course by tape-recorder, and the student acquires a true understanding of the subject.

#### Technical equipment

Individual magnetoscopes are used to present the sequence to the student enabling him to follow the proceedings at his own pace and level of knowledge.

Description of equipment: 8 Philips LDL 1000 Magnetoscopes yield fairly satisfactory technical results at very low cost.

1. The IVC 801 Magnetoscope for making master tapes; chosen for its adaptability and because studios have to be found outside Belgium, where they are largely lacking.

### 3.3. Cost of experiment

The research team referred to under section 6 was set up recently. A smaller team carried out the work mentioned in the research programmes and was responsible for the results.

For reasons apparent in the cost analysis, costs should be broken down into capital expenditure (preparation of course), operational expenditure (analysis of results) and research expenditure.

3.3.1. Capital expenditure

The audio-visual course devised is equivalent to a 60-hour lecture course. To these hours of information transmission should be added 18 hours of interrogation. The ratio between information and interrogation time is therefore about 3.3. The 78 hours covered a period of about 18 months.

The financing of this work is roughly broken down as follows:

Staff expenditure	Number	Amount (B.Frs)	
		(12 months)	(18 months)
Teaching staff	1 1/2	900,000	1,350,000
Scientific staff	2 1/2	875,000	1,315,000
Administrative staff	1/2	110,000	165,000
-----			
Equipment expenditure			
Magnetic tapes			85,000
Tape recorders			48,000
Programmed lessons			35,000
-----			
Computer expenditure			
Devising of software			475,000
		TOTAL :	3,290,000 B.Frs.

The cost of preparing such a course thus amounted to about B.Frs. 45,000 per hour of instruction.

It will be noted that computer time accounts for a comparatively small proportion of the cost of preparation, most of the outlay being on staff. Furthermore, since almost as many man-hours are needed for preparing one hour of "audio-visual" instruction as for preparing one hour of interrogation (some 200 m/h per lesson hour), lowering the ratio between information time and interrogation time would hence little affect the cost per hour of instruction.

### 3.3.2. Operational expenditure

The 18-month course may as a whole be said to have been attended by 45 students, operational expenditure breaking down as follows:

Staff expenditure	Number	Amount (B.Frs)	
		(12 months)	(18 months)
Teaching staff	1/2	300,000	450,000
Scientific staff	1/2	175,000	265,000
Administrative staff	-	-	-
Premises 200m <sup>2</sup> at B.Frs.1000 per m <sup>2</sup> per year		200,000	300,000
Computer expenditure		1,000,000	1,500,000
TOTAL (18 months)			2,515,000 B.Frs.

One hour's instruction therefore costs some B.Frs.500 per student.

Since here the computer is the most costly item, a reduction of the ratio between information and interrogation time will considerably affect operational expenditure.

### 3.3.3. Research expenditure

Research, based on data collected during operation of the system, takes up a fair amount of the teaching and scientific staff's time.

Expenditure is assessed as follows:

Staff expenditure Level	Number	Amount (B.Frs)	
		(12 months)	(18 months)
Teaching staff	1	600,000	900,000
Scientific staff	11/2	525,000	780,000
TOTAL (18 months)			1,680,000

#### 3.3.4. Conclusions

Although the costs are high the results prove that students who take the audio-visual course perform better than those receiving conventional instruction.

The students who had access to this system made use of it to varying degree. Total hours of attendance per student at this course (equivalent to 60 hours of lectures) ranged from 5 to 90 hours. A remarkable fact, however, is that those who spent at least 30 hours learning in this way were 93 per cent successful as against 39 per cent for the others.

For the comparison to be valid, however, the following research programme must be carried out. When evaluation in terms of performance becomes possible the cost of each information system must be compared in terms of information received at a certain skill level.



#### 4. RESEARCH AND FUNCTIONAL PROGRAMMES

##### 4.1. Research programmes

##### 4.1.1. Description of programmes

The programmes cover three of the University's physics courses:

- I.E.P. 118 : Physics and Elementary Mechanics
- PHYS. 116 : General Physics and Exercises (1st part)
- PHYS. 117 : General Physics and Exercises (2nd part)

##### (i) Programme 1: Evaluation of aptitudes by computer

The evaluation comprises three sub-programmes covering the evaluation of knowledge

- retentiveness,
- reasoning (transitivity) and
- creativity.

##### (ii) Programme 2: Computer-managed instruction

Learning can conceivably be managed on the basis of data obtained from Programme 1, which calls for the following sub-programmes:

- the definition of a series of standard training systems;
- the optimisation of itineraries.

##### (iii) Programme 3: Preparation of "concept blocks"

This includes three sub-programmes, following and corresponding to the three phases making up each "concept block".

1st phase: Stimulation by means of television.

2nd phase: Information by means of programmed textbooks and magnetic tape.

3rd phase: Self-testing of learning by means of televised exercises, the programmed textbook and laboratory handbook.

All activities under this programme concern course I.E.P. 118 alone.

(iv) Programme 4: Preparation of programmed remedial courses

The object of this programme is to standardise the knowledge required for course I.E.P. 118.

Action consists in writing linear programmed lessons in order to bridge the gaps in knowledge presumably acquired in the Humanities course.

All steps mentioned under these programmes are to be completed by 1971.

4.1.2. Present state of work

4.1.2.1. I.E.P. 118

This course is continuously available in the form described above to a class of 45 students.

(i) There is a 60-hour strand on magnetic tape accompanied by the programmed textbook. An example of a page of this book is given by Figure 13.

Student/teacher communication is introduced at the student's request; he calls on the teacher when he fails to find some answer or solution to a problem in the instructional system. Although at first, requests for additional explanations are frequent, after a few weeks the student acquires greater mastery and requests only occur when failure is certain.

The student chooses his own rate and time of learning. The system is available for use every day from 9 a.m. to 8 p.m., each student being responsible for organising his own timetable. Certain constraints, such as time limits for dealing with various parts of the programme might conceivably be introduced. In this system at least these would be justified because the less able students would then be able to test themselves and choose a learning rate matching their own capabilities.

(ii) The test questionnaires available on computers in 1970-1971 were as follows:

- Six questionnaires on infinitesimals including limits, derivatives, differentials and integrals.
- Thirteen questionnaires on physics including force, work, kinetic and potential energy, etc.

Figure 13

PARAGRAPH 1 THE LINEAR DISPLACEMENT OF A PARTICLE

FIRST ITEM : CONCEPT OF WORK

A. CONSTANT FORCE

- Consider that we wanted to push a car which has broken down ...

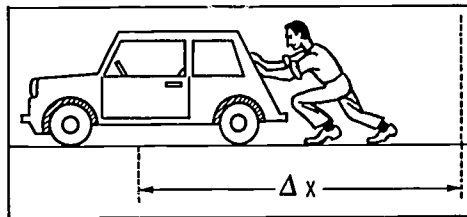

Fig 1

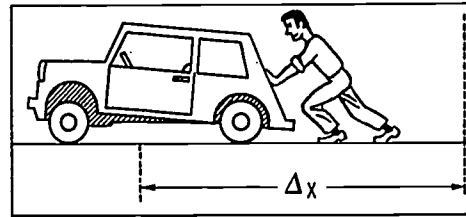

Fig 2

... they used the expression :

1.1  $T = F_x \Delta x$  to define the task.

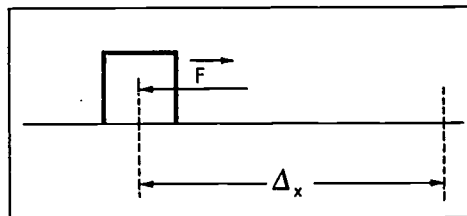

Fig 3

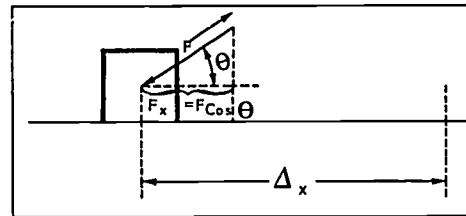

Fig 4

The effective part  $F_x$  is equivalent to :

1.3  $F_x = F \cos \theta$

The task is therefore :

1.4  $T = F_x \Delta x = F \cdot \Delta x \cdot \cos \theta$

1.5  $T = \vec{F} \cdot \vec{\Delta x}$



1.2  $T = F \cdot \Delta x$

(iii) The programmed remedial material consists of:

- a text on multiplication and power exponents,
- a text on negative exponents,
- a text on fractional exponents,
- two texts on logarithms,
- a text on trigonometric concepts.

#### 4.1.2.2. PHYS. 116

Questionnaires on this general physics course taught by conventional methods were drawn up for:

- vectors,
- Newton's law,
- uniformly accelerated motion,
- collisions,
- rotary motion,
- hydrodynamics.

#### 4.1.2.3. PHYS. 117

(i) Students taking this course, also taught by conventional methods, have access to the following questionnaires:

- three questionnaires on wave motion,
- three questionnaires on electrostatics,
- two questionnaires on direct currents,
- one questionnaire on alternating currents,
- one questionnaire on laws of induction.

(ii) Various exercises on creativity were attempted with students in this class. During one of them a student succeeded in re-inventing an optical experiment reproducing the Kerr effect, although he did not know it existed. The remarkable fact is that, with roughly the same knowledge of physics as that prevailing at the beginning of the 20th century, a student should have been able to

rediscover something found roughly at that time (the date of Kerr's discovery was 1875). Moreover, preparing the experiment enabled him to learn part of the physics course. Although in this case inventive stimulation did not result in any new experiment, it is nevertheless important from a teaching standpoint in that the student became aware of an inventive process by rediscovering it himself.

#### 4.2. Functional programmes

These programmes include activities undertaken by the IMAGO Centre in connection with continuing training, namely:

- The preparation of a financial management course using all the media used in the I.E.P. 118 course. Home instruction will be available about mid-October 1971.
- The preparation of a statistics course for private industry.

#### 4.3. Forthcoming programmes

The IMAGO Centre's various projects for the 1971-72 academic year are summarised below.

##### 4.3.1. Zoology course

###### - Objective:

To set up a modular information and testing system similar to that of the I.E.P. 118 course. This instruction is for second-year students of the first chemical science cycle.

###### - Action:

Steps required for carrying out this programme in 1971-72 will consist in:

- analysing the course content
- preparing the concept blocks
- preparing questionnaires.

##### 4.3.2. Evaluation of learning and aptitudes by computer (I.E.P. 118 - continued).

###### - Objectives:

Further information is to be gathered for constructing an

objective model for assessing the components of an HO, one based on definitions and logical links between concepts underlying the subject matter and on the originality of combinations.

- Action:

Many other steps are required for carrying out this programme started in 1970-71.

- (i) Separating the memory, reasoning and other components in each block;
- (ii) Drafting questionnaires for each component in each block;
- (iii) Analysing replies to the various questionnaires and revising them in the light of such information;
- (iv) Preparing strands which parallel existing strands, including the construction of blocks, the television sequence and questionnaires (for the study of "Statics").
- (v) Preparing educational tests (for each concept block) on objectives defined in behavioural terms, so that a preliminary analysis can be made of the course's and each student's shortcomings.

- Type: Paper and pencil test; multiple choice or closely allied questions; analysis and processing by computer.

- Advantages: Large number of items; tests take up less time and are quickly corrected.

- Three items for each objective.

- Criteria: 2/3 failures ———> student is deficient  
Over 75 per cent of students with 2/3 failures  
—————> teaching is deficient.

On the basis of results preparing:

- a profile of the course ——— teacher-student feedback
- a profile of each student ——— management oriented towards adjusted corrective test programme.

- (vi) In the light of the various possible profiles, preparing corrective test questionnaires leading back by successive steps to the origin of the mistake (more detailed diagnosis) and if the mistake is small, dealing with it, or otherwise, referring the student to suitable programmed handbooks.

Type of test: Questionnaires at level 1 and  
level 2

organising questions in order to check

- capacity to apply a formula to a concrete case,
- the real understanding of a question or
- reasoning capacity, etc.

Items: complicated questions with a low level of success the first time and a high level the second time.

Advantages: very limited objectives tested by numerous specifications.

#### 4.3.3. Continued study of HO components

- Objectives:

The first attempt to use J. Lombaerde's model was successful as a guide for drafting many of the questionnaires, although for some it proved rather difficult to apply. After investigation of the difficulties changes in the model were suggested.

These proposals are to be discussed and evaluated.

- Action:

The steps required to achieve the objectives therefore consist in:

- (i) redrafting existing questionnaires in terms of the improved model, and comparing the results obtained in both cases;
- (ii) preparing "concept blocks" in the light of these new factors.

#### 4.3.4. Testing of knowledge prerequisites

- Objectives:

Certain requisites must be met if the I.E.P. 118 course is to be tackled effectively. The testing of such requisites and the possibility of filling in any gaps noted must therefore be provided for.

- Action:

This programme, begun in 1970-71, revealed an unsuspected gap in knowledge presumably acquired during the Humanities course. It will now include the following activities:

- (i) Questionnaires will be improved and "illegible" questions removed;
- (ii) Secondary teachers will be made aware of the problem;
- (iii) Programmed remedial or initiation courses will be prepared on:
  - units of measurement and
  - the concept of mass and weight.
- (iv) The effectiveness of these changes throughout the I.E.P. 118 course will be tested.

#### 4.3.5. Development of "data processing"

- Objectives:

The extent to which answers are analysed and the way questionnaires are managed can be variously criticised, and the purpose of this programme is the gradual elimination of any such criticisms.

- Action:

The change from the present C.H.B. Mark I (GE-265 computer) to the C.H.B. Mark II (GE series 600 computer) will affect implementation of this programme. Priority is being given to the following types of action:

- (i) preparation of algorithms for processing replies of the formula type, giving added freedom of reply;



- (ii) preparation of algorithms for semantic analysis, enabling a one or two-line sentence to be recognised whatever the form of reply;
- (iii) improvement of the logic of the system of questionnaire management beyond the Markovian state.

4.3.6. Economic analysis

(Comparison of various educational systems)

As soon as performance can be evaluated, the final phase will be to incorporate costs in our estimates. This will consist in comparing the cost of a message received at some given level of capability in the various information systems.

## 5. PRELIMINARY RESULTS

### 5.1. Self-adjustment of the programme

Since various devices are introduced for the purpose of detecting learning, mistakes and mental attitudes associated with these mistakes are analysed from an educational psychology standpoint, the information and learning phase must be revised. The most frequently revised factors are the method of presenting and editing the subject-matter and any gaps.

This kind of management has the advantage of:

(i) keeping the student regularly informed of his learning attainments and enabling corrective methods to be promptly applied whenever the learning situation is deficient;

(ii) optimising the system (in terms of the objectives selected), while the many constraints (whether of a practical kind or relevant to the subject) are taken into account.

### 5.2. Individualisation of mass education

Individualisation in the multi-media system is achieved in the following way:

(i) The form in which the subject is presented is adjusted to the individual student's learning process and motivations. Each strand represents a specific approach to the objective;

(ii) Teacher/student relationships are generated by the student. When the student finds that the learning system does not provide an answer to a question or the solution to an exercise, he calls on the teacher;

(iii) The student chooses his own learning rate and time, learning time varying from 4 to 10 hours for the same sequence.

### 5.3. Student attitudes

#### 5.3.1. I.E.P. 118

For practical reasons, physics students could choose between the lecturing and the multi-media systems. Most students selecting the audio-visual method said that they had some trouble - whether real or apparent - with physics. Despite this self-diagnosis the performance of these students is of the same standard as that of fellow-students attending the lecture courses.

Although these two groups were not meant to serve any experimental purpose the following facts emerged:

(i) It is difficult for students who are used to a more directive type of educational system to set themselves a learning rate. Some therefore patterned their rate on the lecture rate (even missing out audio-visual sessions whenever they were a little ahead);

(ii) The reasons other students gave to justify their resumption of the lecture course showed the existence of a psychological problem, in that they preferred a sense of greater security rather than to take on responsibility for themselves.

#### 5.3.2. Computer-assisted tests

Computer-assisted tests are shown to be effective for revising the course and checking learning performance. Observation of the relationship between the student and the machine indicates that the student:

(i) Feels that he is testing his learning himself instead of being questioned in any conventional way;

(ii) May at first be put off by having to give an accurate reply before it is acknowledged by the computer;

(iii) Wants to converse with the computer; he wishes he were able to justify his reply when it is refused by the computer;

(iv) Expresses his reply more easily, even if he is not sure of its accuracy. This is an important psychological factor in computer-assisted testing. A teacher who questions a student may not always be able to pinpoint the student's reply, since the student can always go back on what he said according to how the teacher reacts.

#### 5.4. Analysis of questionnaire tests

##### 5.4.1. Error classification

Errors are broken down into several categories. For instance, there are those due to:

- inaccurate conceptualisation, resulting in mistakes in writing, the omission of indices or special signs;
- confusion of a magnitude and its variation;
- careless use of the analogy of form;
- inaccurate calculations, resulting in unit errors.

##### 5.4.2. Problems of questionnaire preparation

When corrective-test questionnaires intended for science candidates (PHYS. 116 and 117) were studied from the standpoint of design, improvements, and error analysis, various problems emerged:

(i) that of integrating corrective testing in the educational system. The PHYS. 116 and 117 courses are now given in lecture form. The fundamental question dealt with by the study was how the test could be integrated in the teaching system, since the corrective test as conceived could certainly not be used alongside conventional methods. These would have to be thoroughly gone into, while the objectives especially called for fresh thought.

(ii) Conflicting need for evaluation and individual treatment. The only possible way to assess a course, fully diagnose a student's shortcomings and provide individual treatment is to:

- define the objectives in behavioural terms;
- test three definitions for each objective; and
- decide on treatment when  
the student fails two out of three,  
75 per cent of all the students fail two out of the  
three definitions for a same objective.

Since the objectives had not been defined and the time available for testing was limited to one hour for a course given four hours per week, we chose to solve the problem by:

- noting the critical points in the subject-matter (i.e. those which on the basis of teaching experience were reputed to be difficult);
- questioning students on some of their definitions;
- selecting the number of definitions to be tested according to their importance;
- going back in successive stages to the origin of any shortcoming and dealing with it.

The effects of this compromise solution, as noted throughout the process of analysing the questionnaires, were:

- gaps in course evaluation questions were lacking in validity (over-complicated objectives);
- treatment was occasional (the student's shortcomings were not discovered systematically);
- treatment was superficial largely uncomprehensive (a comment or a branch question is not sufficient to correct a faulty mental process);
- corrective testing was little individualised (one standard for rejecting a question was a high percentage of correct replies, without allowing for the few students who had trouble in dealing with the question);

(iii) Problems of using the computer for corrective testing.

- difficulty of testing the student's ability to correlate the various subjects of study in the course.
- difficulty of testing "key solution" problems or involving overlong numerical calculations (the student either gives up too quickly and asks for the computer's help, or makes insufficient use of the computer, solving his problem with paper and pencil and occasionally sending in a signal to increase waiting time. Moreover, since an almost unlimited number of replies to these questions has to be provided, the treatment given is general and therefore little individualised). (This problem could be solved by providing a sub-routine for calculation available at the student's request).

- difficulty of asking the student to justify his answers (the present alphabetical test allows only very biased questions to be asked);
- problem of testing the knowledge of formulas (owing to typing difficulties and the possibility that the computer will refuse a correct but badly expressed answer). (Improvements to the formula test envisaged in connection with the adaptation of the questionnaires in the C.H.B. Mark II system would be a solution);
- difficulty of providing certain types of treatment or comment (those involving figures, such as the vectorial addition; those requiring overlong operations, such as extracting a square root);
- difficulty of any treatment in depth, since the student is not granted much time to grasp explanations of comments (these must be brief and limited to a minimum of information).

(iv) Partiality of evaluation

It is highly probable that the evaluation of our questionnaires is biased. A point thus strongly emphasised by Gagne is the danger of assigning the task of both preparing and assessing the questionnaires to the same people.

(v) We would also point out the shortcomings of the research on the PHYS. 116 and 117 courses as opposed to that undertaken on I.E.P. 116. The computer-assisted interrogations in the first case are not integrated in the learning process, while we feel that integration is one of the requisites for success.

5.5. Analysis of results of I.E.P. 118

5.5.1. Averaging of results

Whatever the method followed by the students, the results seem to average out the same, although for the multi-media course they seem to be distributed over a wider range.

This only shows that some students are unable to set themselves a learning rate. They attend the course seldom or not at all. We feel

that this is a positive outcome in that the multi-media system discourages those who are not motivated while encouraging those who are. The system in itself does not create motivation, which is why we started a television programme designed to increase the desire to study.

#### 5.5.2. Learning time

The most remarkable results are those achieved in terms of the time variable. The results of both the final examinations in July 1970 and the intermediate examinations in February 1971 confirm that all students using the multi-media system learnt more quickly. Thirty hours' attendance at the multi-media course were sufficient to produce at the end of the year a 95 per cent achievement rate in a subject; this would have taken sixty hours by the lecturing system. This result, while of the greatest intrinsic importance, is also significant owing to its sociological implications. In any event it shows that individualised instruction is helpful to students and is a way of saving resources.

#### 5.5.3. Conceptualisation levels

Results were roughly analysed for each type of conceptualisation, the general trend being shown in Figures 14 and 15 (85 students). For the first type of conceptualisation (Figure 14) the highest point of the curve is at 100 per cent.

Figure 14

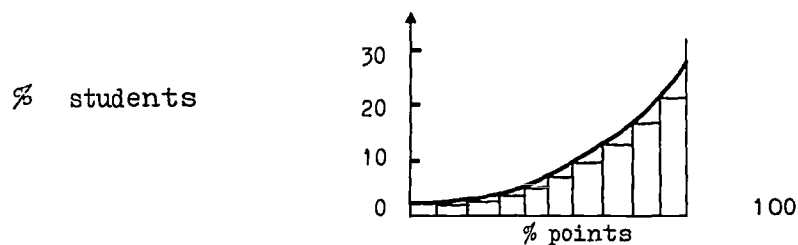

For the second type (Figure 15) the highest point is at about 40 per cent.

Figure 15

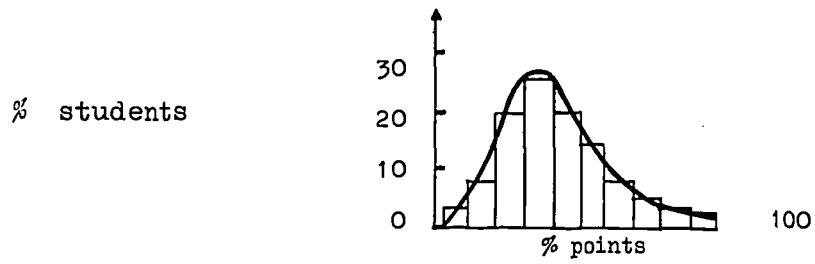



## 6. RESEARCH TEAM

### 6.1. Experimental Centre

IMAGO Centre  
University of Louvain  
Celestijnenlaan 200 C  
3030 - Héverlée  
Belgium

### 6.2. In charge of the experiment

Professor André JONES

### 6.3. Name and qualifications of assistants

A pluridisciplinary team is needed to deal with the technological, psychological and scientific aspects of the investigation. It consists of:

#### 6.3.1. Information Engineers

They have the fourfold task of:

(i) defining the logic and determining the analyses (the type of input) in terms of the system's teaching needs;

(ii) preparing a programme for managing the test questionnaires. This control programme is common to all questionnaires and, written in FORTRAN, determines the question or comment required by the student's reply;

(iii) introducing the questionnaires into the machine. A data sheet is prepared for each question, in which the question and comment, keywords or standard formulae used to analyse the student's reply and any addresses required by the reply;

(iv) analysing the input and processing it according to an educational-psychology model. At a later stage the application of research to learning management will enable new programmes to be written.

Staff assigned to this work:

J.M. ZELIS	Independent engineer: Assistant
J. LOMBAERDE	Independent engineer: Assistant
S. REGOUT	Independent engineer: Assistant
Ch. VANDERMEERSCH	First science degree: Assistant
Ch. LAPERCHE	Independent engineer: Assistant
P. SAENEN	Programmer

### 6.3.2. Teaching Staff

The teaching staff are the users of the system, and as such their assistance is needed in guiding research. Their task is to:

- (i) define learning objectives and decide on educational content. Objectives are determined by analysing requirements consistent with the student's future activity (further study, profession);
- (ii) set learning conditions; method of presenting the subject-matter, choice of media, etc.
- (iii) analyse the cognitive processes associated with learning in conjunction with the educational psychologists;
- (iv) define certain of the parameters of the management model.

Staff taking part in this work:

Professor A. JONES:	Doctor of Science
Professor A. MARTEGANI	Independent engineer
Mr. de SPOT	Independent engineer: Assistant
Mr. PETEAU	First Science Degree: Assistant

### 6.3.3. Educational Psychologists

Educational psychologists also have a fourfold task, which is to:

- (i) analyse the steps or mental processes of the student during learning. This psychological type of educational analysis determines the reasoning processes, types of error and their causes, information or corrective processes and the student's preconceived notions leading to distortions and errors in the acquisition of new ideas;

(ii) improve the teaching system by using information from the various kinds of feedback provided;

(iii) construct a psychological model of learning management;

(iv) test the extent to which students are satisfied with this method of learning.

The team of educational psychologists consists of:

Professor A. GILLE	Doctor of Educational Science
J.P. DENIS	First Educational Science Degree - Assistant
M.C. RAMBOUX	First Educational Science Degree - Assistant
Fr. DE CONINCK	First Educational Science Degree - Assistant
N. de ALMEIDA	Assistant

## 7. BIBLIOGRAPHY AND PUBLICATIONS

1. JONES A., L'Enseignement de la Physique aux U.S.A.  
Report to the "Fonds Perrin Galpin", 1967.
2. JONES A. and Techniques Modernes d'Enseignement.  
MARTEGANI A. Cahiers Galilée No.8, Louvain, October, 1968.
3. CARBONNEL J.R., On Man-Computer Interaction. A Model and Some  
Related Issues. I.E.E.E. Tr. on S.S.C., January,  
1969.
4. KAUFMANN A., L'Inventique. Entreprise Moderne d'Edition,  
FUSTIER M. and Paris, 1970.  
DREVET A.,
5. DENIS J.P., Une expérience pédagogique à Louvain.  
Informations universitaires, 6th year, No.4,  
Louvain, July, 1970.
6. HANSEN J.C., and "Etude de Résolutions de Problèmes".  
LOMBAERDE J., Thesis: Faculty of Applied Science, Louvain,  
September, 1970.
7. RAMBOUX M.C., "Contrôle correctif de l'apprentissage  
par ordinateur".  
Thesis for First Degree in Educational Science,  
Louvain, 1970.
8. DENIS J.P., and "L'Ordinateur et l'Enseignement". Record of Colloque  
MARTEGANI A., de l'Association Internationale de Pédagogie  
expérimentale de langue française, Educational  
Sciences (October 1971).
9. JONES A., "L'Instruction Assistée et Gérée par Ordinateur  
en Education Permanente". 28èmes Journées  
d'Information de L'ASSPA, Geneva, 15th-16th April,  
1971 (to be issued in Nouvelles Techniques, Zurich).

A N N E X E S

- I - A praxeological basis
- II - A taxonomy
- III - References

## I - A PRAXEOLOGICAL BASIS

Let there be a human being (1) or human operator (HO). Since the HO and his environment more or less continuously react with each other, it would be difficult to define this complementary factor of the universe in relation to the operator without first studying how far they depend upon each other. The difficulty of defining this complement (which we shall call the external or outside world W) is due to "under-development" of a science called praxeology (2).

We will therefore use but a simple type of praxeological basis, by showing when a "phenomenon" occurring in W (which therefore is given no specific definition here (3) will for an HO become a sign of the language which human thought is (for instance, when solving problems), i.e. when the phenomenon exerts some particular effect on the HO's behaviour.

We shall assume that a phenomenon generates a sign of human thought by an HO if he perceives it (4).

- 
- (1) Since we are not concerned with several human beings (i.e. the study does not deal with relations between humans) we refer to a "restricted" pragmatic approach.
  - (2) Praxeology (Kotarbinski, shortly before 1950) should provide a general theory of "action". The concept of action in the praxeological sense seems to correspond to consciousness on the part of the HO (possibly followed by action in the usual sense of the word): for instance, a person using a language makes use of a sign of that language whenever at certain times he reacts to this sign. "It is therefore impossible to say that someone uses signs without developing a theory of action, the sign's influence on the tendency to action determines its existence as a sign" (L. Apostel, p.303).
  - (3) In practice, for the HO the outside world will be equivalent to the total "reality" around him: experiences, objects, etc. A more detailed study is required in the field of praxeology.
  - (4) Because of the simplicity of this praxeological base, we will not deal here with the various methods of perception.

In this praxeology action is therefore reduced to the sense perception of a phenomenon:

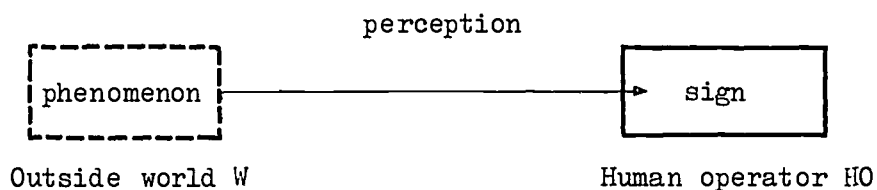

A RESTRICTED FORM OF PRAGMATISM

Definition of concepts

Having defined the sensory response to a phenomenon by an HO, we shall call the resulting sign in the HO "the concept". This gives us:

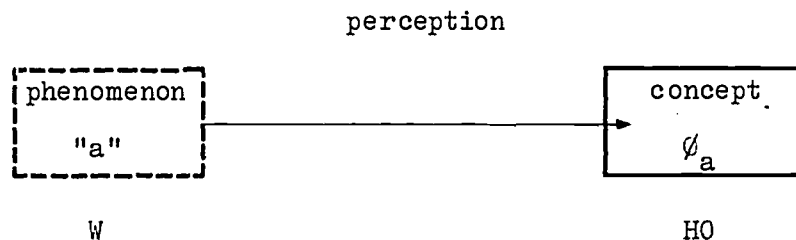

The concept  $\phi_a$  of a phenomenon "a" is therefore defined on the basis of an interaction (or action) between the HO and W.

Concepts of type 1 and 2 can be distinguished.

Example:

Let the phenomenon be "to close a book". An individual seeing someone close a book may retain an image of the operation as something being closed, or the image may be that of a closed book. The same phenomenon may give rise to two different types of concept, depending on the individual's perceptive action.

The first image is a type 2 concept, since the subject can, for instance, apply "to close" to such a phenomenon as "door", thus obtaining "the closed door". And these three phenomena yield the

following three concepts: (to close something), (door) and (closed door).

The concept  $\emptyset$  may thus be said to be of type 2 if  $\emptyset_a$  and concept  $\emptyset_b$  are such that a phenomenon yielding  $\emptyset$  by an action applied to a phenomenon yielding  $\emptyset_a$  by an action produces a new phenomenon yielding  $\emptyset_b$  by an action. Otherwise the concept  $\emptyset$  will be of type 1.

We have therefore defined concepts of type 2 as being the image of a phenomenon which enables some kind of application or transformation to be perceived in W.

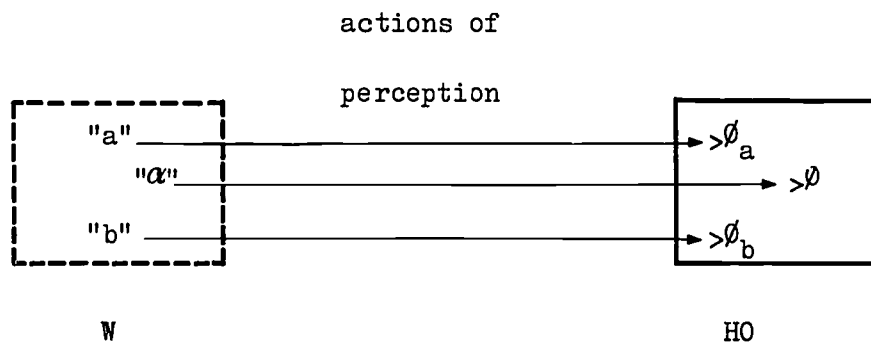

We may introduce the notation  $(\emptyset\emptyset_a) \triangleq \emptyset_b$  which is merely a writing convention.

Conception and decision.

We have seen the connection between a phenomenon and its mental image:

$$"a" \longrightarrow \emptyset_a$$

Since this mental image is produced by an action of perception, we shall call it a percept. The concept  $\emptyset_a$  may be a law for deciding whether a perceived phenomenon will have for the individual the same meaning or produce the same mental image as the phenomenon which produced  $\emptyset_a$ . (1)

---

(1) Here we get (but at the level of what we have defined as a percept) the definition of concept found in CHURCH's theory (Hunt and Howland, 1961).



An atomistic function of an individual variable (1)  $\phi_a$  "x" thereupon exists, defined by its truth table:

"x"	$\phi_a$ "x"
A	1
$\bar{A}$	0

This gives value 1 (i.e. the true value) for  $\phi_a$  "x", where "x" belongs to Set A of phenomena which, as perceived by the individual, yield the same mental image  $\phi_a$ ; the truth table gives value 0 (i.e. the untrue value (2)) for  $\phi_a$  "x" with "x" not belonging to Set A.(3)

Thus the HO will have percepts if the power to conceptualise (i.e. the existence of concepts) and the power to decide (i.e. the value of  $\phi_a$  "x" is 1 or 0 according to phenomenon "x") are attributed to him.

Specification and attribution. Implication. Comprehension in relation to a concept.

Example:

Let "bang the door" (or "a") be the phenomenon. If the individual has already perceived the phenomenon "close the door" (or "c"), he can reason as follows:  $\phi_a$  "a"  $\supset$   $\phi_c$  "a" which is true (4) (or  $\phi_i$  represents the concept derived from the perception of "i"), i.e. "to bang the door" is a specification of "close the door".

- (1) These concepts have been borrowed from RAMSEY.
- (2) (untrue) = false or meaningless.
- (3) The consideration of fuzzy sets (Zadeh, 1965) may be meaningful in relating phenomena to several percepts.
- (4) The implication  $\supset$  is defined by:

$p \supset q$  is true if p and q are true

$p \supset q$  is untrue if p is true and q is untrue

The concept  $\mu$  may therefore be considered as a specification of the concept  $\emptyset$  when the phenomenon "a" is such that  $\mu$  "a"  $\supset \emptyset$  "a" is true.

We can show the extensions of these concepts in W by Venn diagrams:

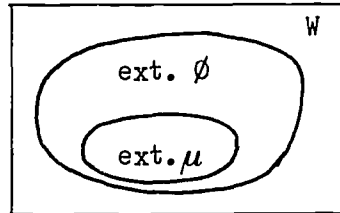

Accordingly, if we attribute to the HO the possibility of implication he can consider a concept as a specification of another concept.

We shall state two more definitions.

When concept  $\mu$  is a specification of concept  $\emptyset$ , we say that concept  $\emptyset$  is an attribute of  $\mu$ .

Example:

We say that the relationship between the concept (cat) and the concept (mammal) is understood by a given individual if he perceives a cat as belonging to a certain class of mammals. On the other hand, an individual does not have to understand the concept (cat) to be able to say, for instance, that a certain cat is black.

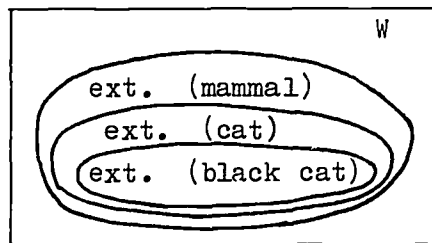

We may say, therefore, that a concept  $\mu$  is understood in relation to concept  $\emptyset$  when the concept  $\emptyset$  is an attribute of the concept  $\mu$ . The concept  $\mu$  is then a concept understood at level 1.

Comprehension at level 2. Abstraction.

If the HO now takes into consideration several concepts of type 1 understood at level 1 he may acquire a new mental image. This

is the concept understood at level 2. It would be fairly difficult to analyse the mental process involved in grasping such a concept; it might thus be a new type of action exerted by the HO on a set of concepts possessed by him (whereas we have only envisaged actions on W) or else an understanding at level 1 (i.e. reasoning based on conceptualisation, decision, implication and memorisation) leading to the new concept after a certain power of abstraction has been added by the HO.

Until a better praxeology is developed we can but assume the existence of this new concept, using the second viewpoint. Let us call this concept f.

We can still describe f as a truth table:

$\hat{D}$	f ( $\hat{D}$ )
$A_{\hat{D}}$	1
$\bar{A}_{\hat{D}}$	0

where  $\hat{D}$  designates the variable (with concepts as values) and  $A_{\hat{D}}$  the set of concepts for which f takes on value 1 (i.e. the true value). Thus we have an atomistic function f of an elementary function  $\hat{D}$  of an individual variable.

It is important to define accurately the field of the argument  $\hat{D}$ : it comprises all the concepts understood at level 1 (and therefore all the percepts).

We might also define the specification and attribution for concepts understood at level 2 (Chapter IV of Hansen and Lombaerde, 1970).

### Creativity

When the HO adds an attribute to a concept understood at level 2, this attribute may be a completely different concept from the concepts that the HO already possesses. Something has been created. We must, therefore, assume that the HO has a creative faculty.

## II - A TAXONOMY<sup>(1)</sup>

One of the most interesting uses of restricted pragmatism is in the preparation of a taxonomy for the characteristics of a HO. Questionnaires better adapted to the individual student and for testing may possibly be prepared if these characteristics can be separated. Research is at present taking place on this question.

Our restricted "Outside World - Human Operator", model yielded such HO characteristics (see Chapter VI of Hansen and Lombaerde) as:

- conceptualisation
- decision
- implication
- memorisation
- abstraction
- creativity.

Only practice can show whether these characteristics are capable of being measured or even observed, and therefore whether they can be of any use to us.

---

(1) Taxonomy is the science of classification.

### III - REFERENCES

- APOSTEL L., "Syntaxe, Sémantique et Pragmatique" dans Logique et connaissance scientifique. ("Semantic and Pragmatic Syntax" in Logic and scientific knowledge). J. PIAGET. Encyclopédie de la Pléiade. Gallimard, 1967.
- BRUNER J.S.,  
GOODNOW J.J. and  
AUSTIN G., A Study of Thinking, 1956.
- HANSEN J.C. and  
LOMBAERDE J., "Etude de résolutions de problèmes". Travail de fin d'études. (Solving problems. Terminal studies), Louvain, 1970.
- HUNT E.B. and  
HOWLAND C.I., "Programming a model of human concept formulation" in Readings in Math. Psychology, R.D. LUCE et al., 1961.
- KOTARBINSKI T., in "Synthèse". (Synthesis). Laren, 1948/1949.
- RAMSEY F., The foundation of mathematics, London, 1931.
- ZADEH L.A., "Fuzzy sets and systems". Proc. 1965. Symp. on Syst. Theny (Brooklyn, N.Y.).