

DOCUMENT RESUME

ED 065 735

AA 001 030

TITLE Authorized Courses of Study for the Quinmester Program. Curriculum Bulletin 10.  
INSTITUTION Dade County Public Schools, Miami, Fla.  
PUB DATE Apr 72  
NOTE 525p.  
EDRS PRICE MF-\$0.65 HC-\$19.74  
DESCRIPTORS \*Catalogs; \*Curriculum Guides; \*Extended School Year; \*High Schools; Year Round Schools  
IDENTIFIERS Florida; \*Quinmester Program

ABSTRACT

This master catalog lists and describes the nine-week courses of study basic to the curriculum structure for the quinmester extended year program. Most of the courses listed in this bulletin are designed to be nonsequential and nongraded. Prerequisites are indicated when they are essential for the successful completion of a course. Courses that carry credit in more than one area are listed under each subject area. A numeric code preceding the course titles represents a combination of the State accreditation and the local course identification numbers. The symbol to the left of a course title indicates that the course has been published. This catalog supersedes the edition published in March 1971 (ED 058 670).  
(Author/MH)

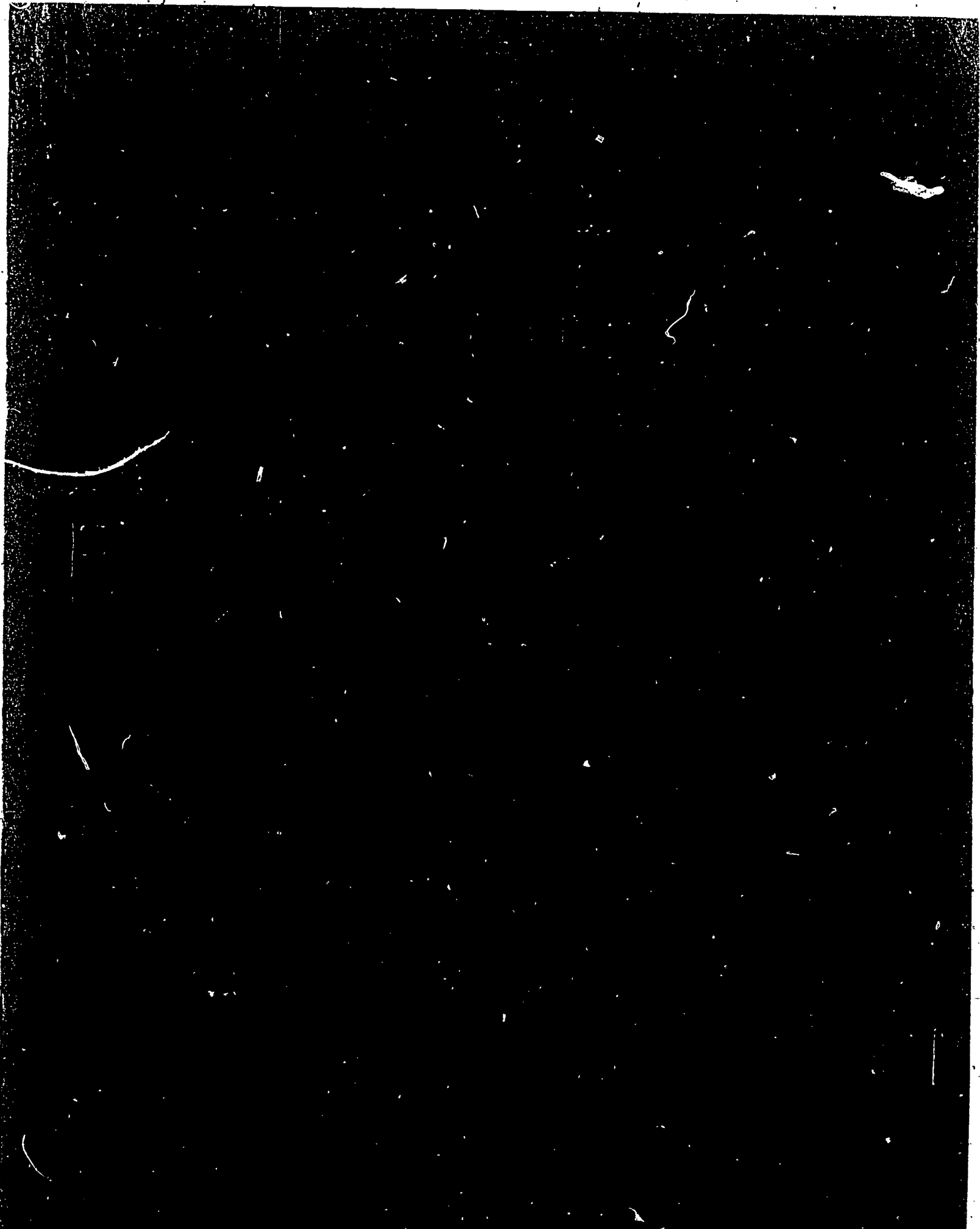

**AUTHORIZED COURSES OF STUDY  
FOR  
THE QUINMESTER PROGRAM**

**Curriculum Bulletin 10**

**April 1972**

**DIVISION OF INSTRUCTION  
Dade County Public Schools  
Miami, Florida**

DADE COUNTY SCHOOL BOARD

Mr. William Lehman, Chairman  
Mr. G. Holmes Braddock, Vice-Chairman  
Mrs. Ethel Beckham  
Mrs. Crutcher Harrison  
Mrs. Phyllis Miller  
Dr. Ben Sheppard  
Mr. William Turner

SUPERINTENDENT OF SCHOOLS

Dr. E. L. Whigham

Published by Dade County School Board

Copies of this catalog may be obtained through  
ERIC  
Document Reproduction Services  
P.O. Drawer 0  
Bethesda, Maryland 20014

Industrial Arts 5800-5999	447
Technical and Health Occupations 8000-8199	477
Trade and Industrial Education 9000-9999	481

APPENDIXES

Appendix A: Study Related to Effective Family Living	529
Appendix B: Education by Agreement	543

## INTRODUCTION

### *Authorized Program of Study*

The Florida statutes dealing with schools require each local school board to "authorize the assembling of all data and the making of school surveys essential to the development of a school program for the entire district and to adopt such a program as the basis for operating the schools" [F.S. 230.23(3)]. In addition, school boards are required to "adopt courses of study" [F.S. 230.23(7)(a)]. The official description of the adopted "school program" and the adopted "courses of study" is contained in *Program of Authorized Instructional Courses in Dade County Public Schools*, Curriculum Bulletin 1 (January 1972). Curriculum Bulletin 1Q supplements it, providing approved courses for schools and programs in the quinmester organization. In addition, Bulletin 1Q may be used by schools operating under the regular school organization that are authorized by their district superintendents to offer quinmester courses.

### *Curriculum Bulletin 1Q: Purposes*

This bulletin represents the catalog of authorized courses for the quinmester program in the Dade County Public Schools. Included are titles and descriptions of the nine-week courses of study that are the basis of the curriculum structure for the quinmester program. Each school implementing the quinmester program is expected to select the courses of study from this catalog that are appropriate for its student population.

### *Special Curriculum Information*

The majority of the secondary schools in the county system are currently functioning with a subdivision into grades seven, eight, and nine in the junior high school and ten, eleven, and twelve in the senior high school. At present a few schools follow the middle school organizational pattern, functioning with a subdivision that includes grades six, seven, and eight. The curriculum offerings are structured to meet the needs of these subdivisions. The required programs for grades seven, eight, and nine are explained on page 3. Graduation requirements, as established by state accreditation standards and approved by the Dade County School Board, are explained on page 4.

School staffs may refer to Curriculum Bulletin 1 for the following special information: Regular Program, Grades One through Six, page 3; General Information on Curriculum in Secondary Schools, page 6; Student Placement, including Exceptional Child Education and Bilingual Education, pages 7-8 and 10-11. When the quinmester program is extended to elementary schools, information relating to elementary courses of study will be added in subsequent editions of Bulletin 1Q.

### *Curriculum Bulletin 1Q: Utilization*

The courses described, which have been developed by groups of Dade County teaching personnel, are considered to be appropriate for instruction of students with varying achievement levels and interests. An interdisciplinary approach has been incorporated into these quinmester courses. Interdisciplinary courses are those in which credits may be given for alternate subject areas because the course content includes an interrelationship of concepts from those areas. Courses which may carry credits in more than one area are listed under each subject area.

## REQUIRED COURSES: GRADES SEVEN TO NINE

*Quinesters*

*Requirements*

- Each of the following for a full year or 4 quinquesters—in grades 7, 8, and 9:
  - 12 Language Arts (English SL should be taken by non-English-speaking students.)
  - 12 Mathematics
  - 12 Physical Education
- Each of the following for a full year or 4 quinquesters—in grades 7 and 8 only:
  - 8 Science
  - 8 Social Studies (Civics 7, American History 8)
- The following for 1 semester or 2 quinquesters—in grade 7, 8, or 9:
  - 2 Study related to effective family living (See Appendix A for list of courses available to meet this requirement.)
- Each of the following as a unit of instruction:
  - Drug abuse education—in all grades
  - Venereal disease education—in grade 7, 8, or 9
- One of the following for 1 semester or 2 quinquesters—in either grade 7, 8, or 9:
  - 2 {
    - Art
    - Foreign Language
    - Humanities
    - Music
- One of the following for 1 semester or 2 quinquesters—in either grade 7, 8, or 9:
  - 2 {
    - Agriculture
    - Business Education
    - Home and Family Education
    - Industrial Arts
    - Vocational courses (other)
    - Work Experience
- The remainder of the junior high school experience is to be comprised of courses selected from the following:
 

8 or more	{ <ul style="list-style-type: none"> <li>Agriculture</li> <li>Art</li> <li>Business Education</li> <li>Foreign Language (other than Spanish)</li> <li>Health Education</li> <li>Home and Family Education</li> <li>Humanities</li> <li>Industrial Arts</li> <li>Language Arts</li> </ul>	{ <ul style="list-style-type: none"> <li>Mathematics</li> <li>Music</li> <li>Reading</li> <li>Science</li> <li>Social Studies</li> <li>Spanish (FL or SL)</li> <li>Spanish-S</li> <li>Vocational courses (other)</li> <li>Work Experience</li> </ul>
-----------------	--	--

**REQUIRED PROGRAM FOR GRADUATION:  
GRADES TEN, ELEVEN, AND TWELVE**

At least sixty quinmester credits must be earned in grades ten through twelve for graduation. A quinmester credit is earned upon the satisfactory completion of each nine-week course of study. Each quinmester credit for interpretation purposes should be considered to be .25 or 1/4 of a Carnegie credit. Every pupil in grades ten through twelve should be scheduled for a minimum of twenty quinmester credits per year, except under unusual circumstances approved by the principal. These credits shall not include credit granted for athletic or extracurricular activities. No student shall be permitted to graduate with less than three full years in grades ten through twelve, except as provided under section 5.911 (2) of the Accreditation Standards for Florida Schools, 1963, State Department of Education or in accordance with temporary waivers authorized by the State Department of Education in connection with the quinmester twelve-month program.

The following quinmester credits are required for graduation:

<i>Subject</i>	<i>Quinmester Credits</i>	<i>Notes</i>
Language Arts	12	a
Mathematics	4	b
Physical Education	4	c
Science	4	d
Social Studies	8	e
Study related to effective family living	—	f
Study related to drug abuse	—	g

**NOTES:**

- a. Twelve quinmester credits of language arts are required. The last four quinmester credits may be waived by the principal, based on the school's assessment of the student's proficiency in the various language arts skills.
- b. Four quinmester credits in mathematics are required in grade ten, eleven, or twelve.
- c. Four quinmester credits of physical education are required in grades ten through twelve except for certified physical disability. This is exclusive of driver education, health, and first aid. (Marching bands, majorette and cheerleader groups, etc., are not construed to be physical education courses.)
- d. Four quinmester credits of science must be taken in grade ten, eleven, or twelve.
- e. Eight quinmester credits of social studies are required. Four of these, to be taken in grade eleven or twelve, must be in American history or American history and government; this shall include a quinmester course in Americanism vs. Communism.
- f. The requirement for one year (four quinesters) of study related to effective family living is effective in full for those students who are beginning seventh grade in the 1972-73 school year. Students who are in grade eight, nine, or ten in the 1972-73 school year must complete two quinesters before high school graduation. Students in grade eleven or twelve in the 1972-73 school year are not affected by this requirement. The requirement is subject to waiver for individual students by the principal. For a detailed list of courses to meet this requirement, see Appendix A.
- g. Instruction in drug abuse education is required by state law (Drug Abuse Education Act of 1970). This instruction is presented in every grade, seven through twelve, and may be a part of regular science, social studies, physical education, or health education.



#### *Exceptional Child Education Program*

This program includes children who, because of physical, mental, emotional, or learning disability, cannot be educated adequately in the public schools without the provision of special facilities or instructional services. Exceptional Child Education also includes the gifted pupil.

Exceptional children should be integrated into regular school programs to the extent their individual ability permits. While the severely impaired require self-contained classes and special school centers, the provision of resource classes in the regular school is preferred for the less handicapped. These resource classes provide specialized support on a part-time basis.

Children who are identified as gifted are provided for by special instructional programs. Basic needs are met through grouping and individual instruction in their own schools. In addition, there are special centers which these pupils may attend on a part-time basis. The programs at the centers are designed to provide for maximum development of academic talents, creativity and original thinking, and social responsibility, as well as for optimum self-realization. Another offering is the Elementary Mathematics Program, It/Figures; this accelerated program for high-achieving sixth-grade pupils utilizes a weekly television lesson, followed up by classroom activities with special worksheets and other locally prepared materials. Secondary pupils have the services of an itinerant resource person, special scheduling, and opportunities to participate in the following programs: Motivation in Depth Program for Gifted Science Students, Deep Accelerated Mathematics Program, and the Community Laboratory Research Program.

#### *Reading Program*

The special Reading Remediation Program in Dade County provides two major services. The first service consists of the corrective reading program, which operates at individual elementary and secondary school sites. The second service, also a supplement to the classroom program, is the remedial reading program which functions in reading centers at district-level sites and is designed to serve 3 to 5 percent of the pupil population with severe reading disabilities.

#### *Substance Abuse Education Program*

The program provides a special K-12, countywide, interdepartmental program for the prevention of drug misuse through education. The program, designed for the local needs of a large urban area, implements the state's Drug Abuse Education Act of 1970.

AUTHORIZED COURSES OF STUDY

## QUINMESTER COURSES

### *ADVANCED ART/INDIVIDUALIZED INSTRUCTION*

Advanced Arts Seminar I, II, III, IV . . . . . 24

### *ART AND THE AESTHETIC WORLD* (Drawing, painting, and art appreciation)

Advanced Arts Seminar I, II, III, IV	24
Advanced Drawing	25
Aesthetics and 20th Century Environment	24
American Black Art	13
Art and the Contemporary Scene	21
Art and the Press	21
Art within Reservations	14
Cartoon Carnival	14
Cartooning with Flick	22
Cinematography	23
Community Influences on Art	21
Contemporary Design	23
Design: Where It Starts	25
Drawing and Composition	25
Express Yourself	13
Found Art	16
Giants in Art	18
Industrial Design	22
Man and Nature	13
Microscopic Art	25
Nature and Life on Paper	19
Opaque Watercolor	17
Portfolio Presentation	21
Project Change	21
South of the Border	14
Transparent Water Color	17
Twentieth Century Painting	18

### *CERAMIC ARTS*

Advanced Arts Seminar	24
Ceramic Technology	19
Creative Ceramic Arts	19
Creative Ceramic Design	19
Creative Mold Making	20
Creative Mosaics	18
Potter's Wheel I	19
Potter's Wheel II, III	20
Relief Mosaics	26

### COMMERCIAL ART

Advanced Arts Seminar	24
Advertising Design	20
Art and the Press	21
Calligraphy	18
Cartoon Carnival	14
Cartooning with Flick	22
Cinematography	23
Container Design and Packaging	22
Contemporary Design	23
Industrial Design	22
Portfolio Presentation	21
Reel Thing, The	13
Serigraphs (Silk Screen Techniques)	16
Space Decorating and Displays	22
Stage Design	15
Stage Lighting	15
Transparencies	15

### CONSTRUCTIVE DESIGN/ASSEMBLAGE

Advanced Arts Seminar	24
Aesthetics and 20th Century Environment	24
Creative Design with Modern Materials	23
Design—Where It Starts	25
Found Art	16
Kinetic Sculpture	16
Metallic Formations (Sculpture)	17
Relief Mosaics	26
Stage Design	15
Stage Lighting	15
Stone Shapes (Sculpture)	16
Three-Dimensional Design (Sculpture)	17
Wooden Forms (Sculpture)	18

### CREATIVE ARTS CRAFTS

Advanced Arts Seminar	24
Advanced Gem Treasures (Lapidary)	26
Advanced Jewelry Design	20
Advanced Leather Working II, III	26
Aesthetics and 20th Century Environment	24
American Black Art	13
Art: Two from One—Casting	25
Art within Reservations	14
Creative Enameling Art	26
Creative Textile Design I	23
Creative Textile Design II	23
Design—Where It Starts	25
Gem Treasures (Lapidary) I	26
Jewelry Design I	20
Mod World of Leather, The	26
South of the Border	14

*FASHION DESIGN*

Advanced Arts Seminar	24
Creative Textile Design I, II	23
Costume Design	15
Portfolio Presentation	21

*FILM ARTS*

Advanced Arts Seminar	24
Aesthetics and 20th Century Environment	24
Cartooning with Flick	22
Cinematography	23
Contemporary Design	23
Portfolio Presentation	21
Principles of Photography	27
Reel Thing, The	13
Transparencies	15

*INTERIOR DESIGN*

Advanced Arts Seminar	24
Portfolio Presentation	21
Production and Display Workshop	22
Space Decorating and Displays	22
Stage Design	15
Stage Lighting	15

*PRINTMAKING*

Advanced Arts Seminar	24
Images and Imprints	14
Intaglio Design I	15
Intaglio Design 2	16
Portfolio Presentation	21
Relief in Design (Block Printing)	17
Serigraphs	16

AREA	ACCR. NO. FLA-DADE	COURSE TITLE AND DESCRIPTION
ART	6673.01 6671.04 6672.04 6674.07	<b>EXPRESS YOURSELF</b>  Provides an opportunity for students to learn that art is one of the most important means of self-expression, that each artist expresses himself in his own unique way and that each individual way is valid. Students select one subject area (e.g., landscape, still life, human forms, room interiors) and compare the handling of the subject matter by several artists (i.e., Van Gogh, Modigliani, Chagall, Roualt, Picasso, etc.). Activities include the creation of two- or three- dimensional work.
ART	6677.01 6673.02 6671.05 6672.05	<b>MAN AND NATURE</b>  A survey of the way nature affects the art of man, stressing his ever-present struggle for survival. Space exploration, undersea exploration, birds and animals, and plant life form the bases for study. Projects include drawing and painting from nature, both indoors and out, and using natural materials in collages, mosaics, assemblages, and sculpture.
ART	6677.02 6671.06 6672.06 6683.03 6681.04 6682.04	<b>AMERICAN BLACK ART</b>  A survey of black artists in America, their contribution to the American art scene, and the impact of the new black movements on trends in American art. Selected activities in this unit include murals, wood carving, and Afro trends in clothing and textiles.
ART	6681.01 6682.01 6693.01	<b>THE REEL THING</b>  An introduction to photography as a unique art form, including a brief history of creative and experimental photography and the evolution of the camera as an art tool. Activities present an opportunity to build a camera, make creative slides using color and positive/negative forms, photocaricatures, and photograms.
LANGUAGE ARTS	5111.26 5112.32 5113.73 5114.28 5115.139 5116.142	

AREA	ACCR. NO. FLA-DADE	COURSE TITLE AND DESCRIPTION	
ART	6671.01 6672.01 6693.02	<b>CARTOON CARNIVAL</b>  A survey of the history of cartooning, beginning as a means of social protest and evolving through contemporary cartooning. Activities present the student with an opportunity to develop his skills and translate his feelings in political cartoons, caricatures, and comic strips.	
LANGUAGE ARTS	5111.27 5112.33 5113.74 5114.190 5115.140 5116.143		
ART	6671.02 6672.02 6683.01 6681.02 6682.02		<b>ART WITHIN RESERVATIONS</b>  A study of the effects of western culture on the arts and crafts of the Navajo, Zuni, and Hopi Indians, stressing the important role of trading posts, western religions, and ancient Greek designs on Indian handiwork.  Western Indian art is compared with the art of the Florida Seminole Indian. A field trip to a Seminole reservation will give first-hand knowledge of the Seminole crafts. Students will design and execute crafts selected from the following areas: beadwork, leather, pottery, kachina dolls, jewelry, rugs, feather and bamboo tools and weapons.
ART	6671.03 6672.03 6683.02 6681.03 6682.03		<b>IMAGES AND IMPRINTS</b>  A survey of the development of print making as a fine art from the first accidental hand prints on clay cave walls to the multiple print methods used today. Students experiment with simple monoprint techniques, rubbings and stampings, progressing to more sophisticated multicolor designs in linoleum block and woodcuts.
ART	6677.04 6671.07 6672.09 6683.05 6681.06 6682.06 6478.16		<b>SOUTH OF THE BORDER</b>  A survey of the major post-Columbian movements and artists of South America and Mexico, stressing similarities and differences among geographical areas. Social protest painters, crafts, and mosaic works will be studied. Selected activities include art metal crafts, leather work, ceramics, and mosaics.
SOCIAL STUDIES			

AREA	ACCR. NO. FLA-DADE	COURSE TITLE AND DESCRIPTION
ART	6673.03 6693.03	<p>TRANSPARENCIES</p> <p>An exploratory course providing experiences in the development and design of transparencies that utilize various types of audiovisual equipment. The student will create 2" x 2" slides, filmstrips, overhead projector transparencies, and materials for the opaque projector. Emphasis will be placed on elements of design and creative effort.</p>
ART  LANGUAGE ARTS	6683.06 6693.03 6698.01 5184.13 5114.127 5115.142 5116.145	<p>STAGE DESIGN</p> <p>Study and application of design and construction as it relates to stage production. A multicurricular course planned in cooperation with the drama department.</p>
ART  LANGUAGE ARTS	6683.07 6693.04 6698.02 5184.14 5114.128 5115.143 5116.146	<p>STAGE LIGHTING</p> <p>Provides experiences in lumination and lighting for a drama production. The student will plan and set up a lighting system and develop a working knowledge of various tools and equipment required for this endeavor. A multicurricular course planned in cooperation with the drama department.</p>
ART HOME AND FAMILY ED. LANGUAGE ARTS	6697.01 6766.15  5184.10 5114.90 5115.90 5116.90	<p>COSTUME DESIGN</p> <p>Provides experiences in design and development of costumes for a dramatic production. The student will design and create costumes for use in dramatic productions. A multicurricular course planned in cooperation with drama and home and family living.</p>
ART	6675.01 6685.01	<p>INTAGLIO DESIGN 1</p> <p>An introductory course in advanced printmaking, using aquatint, etching, and engraving techniques. The student will create works in these mediums with emphasis placed on individual development of particular interests.</p>



AREA	ACCR. NO. FLA-DADE	COURSE TITLE AND DESCRIPTION
ART	6676.01 6686.01	<p>INTAGLIO DESIGN 2</p> <p>In-depth individualized study and application of intaglio printmaking methods and techniques.</p> <p>Mastery of skills described in Intaglio Design 1 is recommended.</p>
ART	6683.08 6681.07 6682.07	<p>STONE SHAPES (SCULPTURE)</p> <p>An exploratory course in the creation of shapes, using a variety of stones and techniques. Students cut, form, sand, carve, polish, smooth, and finish granite, marble, limestone, basalt, soapstone, and cast such materials as cement and plaster. A working knowledge of the various tools and processes is developed.</p>
ART	6683.09 6681.08 6682.08	<p>KINETIC SCULPTURE</p> <p>An exploratory course in the creation of 3-D forms that move in part or in whole. Students develop such sculptural styles as mobiles, stabiles, and other kinetic forms, using a wide variety of materials such as wood, metal, plastic, and glass.</p>
ART	6693.05 6671.10 6672.10	<p>SERIGRAPHS</p> <p>An introduction to serigraphy (silk screen) processes with exploration of personal interpretations through graphic media. The student uses a wide variety of techniques, including stencil, tusche, and film, and is involved in the construction of equipment. Composition and design are emphasized.</p>
ART	6677.05 6673.04 6671.09 6672.11 6682.24	<p>† FOUND ART</p> <p>A laboratory course to help students develop an awareness of the potentials of unusual art media and the utilization of their qualities. The student creates collage, montage, and constructions with emphasis on the creative possibilities of the media.</p>

ART  
16

AREA	ACCR. NO. FLA-DADE	COURSE TITLE AND DESCRIPTION
ART	6673.05 6671.10 6672.12	OPAQUE WATER COLOR  An introductory course providing experiences in opaque watercolor painting; concentrating on developing personal and individual qualities of design and composition through practice with tempera, gouache, casein, and acrylic paints. Matting and mounting techniques are taught.
ART	6673.07	TRANSPARENT WATER COLOR  An introductory course designed to develop skills and techniques in transparent water color. Drawing and composition will be emphasized. Students create, matt, and present paintings as a part of this course structure.
ART	6674.09 6683.10 6681.09 6682.09	† THREE DIMENSIONAL DESIGN (SCULPTURE)  An introductory course in sculptural formation investigating the techniques and processes of clay and plaster. Emphasis is placed upon designing forms in space, the effect of light, and shadow, and developing a working understanding of tools and their relationship to materials.
ART	6683.11 6681.10 6682.10	† RELIEF IN DESIGN (BLOCK PRINTING)  Exploration of basic printmaking processes and techniques, using a variety of media, including linoleum, wood, found materials, paper, and cardboard. Application of design to the media is emphasized and students work with the tools of printmaking.
ART	6683.12	† METALLIC FORMATIONS (SCULPTURE)  An exploratory course in the creation of shapes, using a variety of metals and techniques. Students cut, form, weld, rivet, cast, and finish such metals as steel, copper, aluminum, brass, pewter, and bronze. They develop a working knowledge of the various tools and processes, while gaining experience in three-dimensional design techniques.

AREA	ACCR. NO. FLA-DADE	COURSE TITLE AND DESCRIPTION
ART	6674.10 6683.13	† WOODEN FORMS (SCULPTURE)  An exploratory course in the creation of shapes, using a variety of woods and techniques. Students cut, form, sand, carve, gauge, chisel, smooth, and finish such woods as cherry, oak, ash, ebony, birch, chestnut, walnut, redwood, maple, beech, apple, gum, pear, pine, mahogany, rosewood, teak, and lignum vitae. They develop a working knowledge of the various tools and processes while gaining experience in three-dimensional design.
ART	6683.14 6681.11 6682.11 6687.01	† CREATIVE MOSAICS  A studio course designed to offer opportunities for experimentation in mosaic design by exploring uses of various techniques and materials. Emphasis is placed on the use of design in relation to creative compositions. Students design, glaze, fire, cut, and develop their own tiles, tessera, etc. to be utilized in mosaic projects.
ART	6674.01 6677.16	TWENTIETH CENTURY PAINTING  Study and application of painting from Cubism to the present in Europe and the United States. Opportunities are provided students to develop styles through the use of oil and acrylic paints, color, texture, spatial and value relationships. Art movement styles include Cubism, Surrealism, Abstract Expressionism, Op Art, Pop Art, and Representational.
ART	6693.06 6673.08 6671.11 6672.15	CALLIGRAPHY  An exploratory course in the creation of original lettering and design motifs, using advertising design as a source of techniques and processes. Particular emphasis is placed on developing the elements of design—line, shape, color, value, and texture—through the use of a wide variety of two-dimensional media.
ART  SOCIAL STUDIES	6677.08 6671.12 6672.16 6478.17 6414.22	† GIANTS IN ART  An introductory survey of art concepts from the beginning of recorded time to the present. The student investigates ideas of past civilizations and their relationship to our contemporary society.

ART  
18

AREA	ACCR. NO. FLA-DADE	COURSE TITLE AND DESCRIPTION
ART	6673.09 6681.12 6682.12	† NATURE AND LIFE ON PAPER  An exploratory course offering students opportunities to react kinesthetically to their surroundings through art materials, and to express their feelings visually in charcoal, pencil, conté, ink, crayons, pastels.
ART	6681.13 6682.13 6687.02	† CREATIVE CERAMIC ARTS  An exploratory course providing experience in the forming, decorating, glazing, and firing of pottery. Various methods such as pinch, coil, slab, and drape are presented. Students are encouraged to explore individual interest areas and develop sensitivity to the raw material, feeling for form, and concern for practicality or function.
ART	6688.01	† CREATIVE CERAMIC DESIGN  An opportunity for the student to develop further skill in forming larger and more complex hand-built pottery, requiring building in sections and combining.  Mastery of skills described in Creative Ceramic Arts is recommended.
ART	6688.02	CERAMIC TECHNOLOGY  A study of the preparation and development of clay bodies and ceramic glazes. Developing knowledge of properties of various ceramic materials; earth materials and metallic oxides—calculating batches and glaze formulas.  Mastery of skills described in Creative Ceramic Design is recommended.
ART	6683.15 6681.14 6682.14 6687.03	† POTTER'S WHEEL I  Students learn to form medium-sized pottery on the potter's wheel and develop skill to reproduce matching forms with emphasis on form, design, and function; glaze techniques and design application are covered.

ART  
19

AREA	ACCR: NO. FLA-DADE	COURSE TITLE AND DESCRIPTION
ART	6684.01 6687.05 6688.03	POTTER'S WHEEL II, III  An advanced course designed to further develop skills and techniques on the potter's wheel. The student learns how to form more complex and larger forms requiring more than one section, and welds two or more thrown larger sections together. Shape, form, surface decoration, glaze application, and exploration of materials is stressed. Mastery of skills described in Potter's Wheel I is recommended.
ART	6683.16 6681.15 6682.15 6687.04	CREATIVE MOLD MAKING  Experiences will be provided in making one-, two-, or three-piece original molds for either pressing or casting of useful or decorative objects. Molds will be individually produced by hand or on the potter's wheel.
ART	6683.17 6681.16 6682.16	JEWELRY DESIGN 1  A course providing experience in forming, pounding, saving, cutting, filing, soldering, and texturing. Students work in copper, brass, and aluminum. Emphasis is placed on sensitivity to material in developing functional and aesthetic objects.
ART	6684.02 6685.01 6686.01	ADVANCED JEWELRY DESIGN  The student develops further skills in forming more complex objects through advanced techniques and methods. Experience is provided in setting of stones and various other jewelry techniques such as forging, metal fusion, and charcoal block casting. Students work on an individual basis, using all facilities which fit a plan developed between student and instructor.
ART	6693.07 6697.02	ADVERTISING DESIGN  A survey course in commercial art, illustrating, and fashion design. Emphasis is placed on refined knowledge and skill of the basic techniques and procedures used in modern advertising art. A special unit exploring job opportunities is taught. Skill in the use of special commercial art techniques and materials is taught, including lettering types and specifications; art type, screens, key line, paste-up, color overlay, and other techniques used by contemporary advertising designers. Layout and consumer psychology are explored. Printing techniques, photography, and lithography are discussed and utilized when practical in the high school curriculum.

ART  
20

AREA	ACCR. NO. FLA-DADE	COURSE TITLE AND DESCRIPTION
ART	6676.01 6694.01	<p>PORTFOLIO PRESENTATION</p> <p>A course designed to provide experience in preparing a completed portfolio intended for the art-oriented student planning to pursue art as a career. Consideration of problems confronting the professional artist, including exploration, framing, matting, shipping, professional relations, and marketing as they relate to the artist.</p> <p>Mastery of skills described in Art Studio 3 is recommended.</p>
ART	6677.10 6673.11 6671.13 6672.18	<p>COMMUNITY INFLUENCES ON ART</p> <p>A survey course providing exploratory experiences developing student awareness of community influences as related to art and the artist. Comparison of factors relating to cultural and subcultural influences, environmental forces, and personal styles of the artist. Studio art projects.</p>
ART	6677.11 6673.12 6671.14 6672.19	<p>ART AND THE CONTEMPORARY SCENE</p> <p>A discussion and studio-oriented course designed to introduce the student to art as it is related to our contemporary society. Areas to be explored include hippie culture, drug culture, the theatre, lighting modulation, film art, etc. Studio art projects.</p>
ART LANGUAGE ARTS	6677.12 6693.08 5113.129 5114.220 5115.144 5116.147 5163.07	<p>ART AND THE PRESS</p> <p>An exploratory course in art as it applies to the press. Students will explore modern trends such as social protests, social commentary, etc., through field trips to the news media, guest speakers, local art critiques, student projects, political and amusement cartoons, translation of events into pictures and symbols, art production for the news media.</p>
ART	6677.13 6674.02 6675.02 6676.02	<p>PROJECT CHANGE</p> <p>An "Education by Agreement Course." After a brief orientation period, each student will agree, through an individualized contract scheme, to improve the visual appearance of his home, his school, or some part of his community.</p>

Education by Agreement is described in Appendix B.

AREA	ACCR. NO. FLA-DADE	COURSE TITLE AND DESCRIPTION
ART	6699.01	<p>PRODUCTION AND DISPLAY WORKSHOP</p> <p>Credit is given for performing artistic service to the school and the community. The art teacher will give assistance, evaluate the product, and determine the amount of credit that the service warrants. (Suitable guidelines will be written for credit-granting policy.)</p>
ART	6699.02	<p>SPACE DECORATING AND DISPLAYS</p> <p>An exploratory course dealing with design and display as it relates to window display, home, business, etc. A special unit exploring job opportunities is taught. Skill in the use of special commercial art and display tools and techniques is taught, including air brush art, graphic design, and TV art.</p>
ART	6693.11 6671.15 6672.21	<p>† CARTOONING WITH FLICK</p> <p>An exploratory course in film animation; students prepare animated cartoons by study and application of animation principles, scripting, and delineation.</p>
ART	6693.13 6694.02	<p>CONTAINER DESIGN AND PACKAGING</p> <p>An exploratory course in the fascinating, but highly technical, field of container and packaging design. Emphasis is placed on refined knowledge of the basic techniques used in preparing visuals, color comprehensives, and working drawings. Study of related information, such as consumer psychology, and color, layout, and lettering. Studio oriented course.</p>
ART	6693.14 6694.03	<p>INDUSTRIAL DESIGN</p> <p>To acquaint the student with principles of applied design as it relates to automobiles and modern household products, which are designed by an artist for possible manufacture by assembly line production. Special study and application of color, consumer psychology, tonal painting, experimental design, and specialized design. Job opportunities are taught; studio oriented course.</p>

ART  
22

AREA	ACCR. NO. FLA-DADE	COURSE TITLE AND DESCRIPTION
ART LANGUAGE ARTS	6677.15 6693.15 5113.75 5114.126 5115.141 5116.144	CINEMATOGRAPHY  Exploratory study of visual film arts, including visual expression through silent motion picture skills and lights. Art through color modulation and sound. Students who demonstrate mature competency in unit projects will be permitted to plan independent work.
ART	6693.16 6674.03 6671.16 6672.22	CONTEMPORARY DESIGN  Design as related to contemporary op art, experimental design, basic cinematography (visual expression through silent motion picture skills and lights). Student will experiment with illusionary color and compare psychological and illusionary effects of color to see how one color affects another.
ART	6674.11 6683.18 6681.17 6882.17	† CREATIVE DESIGN WITH MODERN MATERIALS  Comprehension and application of various techniques of sculpture and collage, using a contemporary point of view. Students will work with contemporary materials, such as wood, metals, plaster, plastics, styrofoam, cardboard, and other basic materials suitable for creative design products.
ART HOME AND FAMILY ED.	6683.19 6681.18 6682.18 6766.13	† CREATIVE TEXTILE DESIGN I  Exploratory experiences through creative expression in textile design. The student will develop imaginative designs through studio textile techniques; studio know-how is taught and application of textile design is made by using weaving processes and stitchery techniques; hooking and tufting.
ART HOME AND FAMILY ED.	6683.20 6681.19 6682.19 6766.14	CREATIVE TEXTILE DESIGN II  Exploratory application of design, color, and texture through <i>printed/dyed</i> textile design. The student will give creative expression to designs for wearing apparel, fabrics, decorative fabrics, and wallpapers for the home. Silk-screen techniques, dyeing, and resist processes (batik) are explored, and suitable projects are completed.  Mastery of skills described in Creative Textile Design I is recommended.



AREA	ACCR. NO. FLA-DADE	COURSE TITLE AND DESCRIPTION
ART	6675.05 6676.04 6685.04 6684.04 6677.17 6688.04 6694.04 6697.04 6698.03 6699.03	<p>ADVANCED ARTS SEMINAR I, II, III, IV</p> <p>Advanced study and techniques in student-selected area(s) for students who have shown competency in previous art classes. Students must demonstrate mature competency in unit projects, accompanied by a research project. Development of skill in researching library, community, and other resources is a must. Students work on an independent basis, using all art department and school facilities which fit a plan developed between student and instructor. Students prepare a research thesis, exhibit, and/or portfolio.</p> <p>Amount of credit earned depends on the students' goals and objectives; an education by agreement course (contract); i.e., an agreement between the student and school in which student agrees in writing to accept increased responsibility for his performance, and the school consents to relax its role of constant supervision.</p>
ART	6671.17 6672.32 6673.13 6674.08 6677.27	<p>AESTHETICS AND 20TH CENTURY ENVIRONMENT 1</p> <p>The student explores, expresses, and identifies environmental phenomena that characterize man's fight for survival with nature. Students work in groups, and/or on an independent basis, using all art department and school facilities which fit a plan developed between student and instructor. Activities include research, debate, writing, painting, sculpting, drawing, dramatizing any art form.</p>
ART	6674.05 6675.06 6677.28	<p>AESTHETICS AND 20TH CENTURY ENVIRONMENT SEMINAR 2, 3, 4</p> <p>A laboratory course to help students develop an awareness of physical and aesthetical phenomena regarding the condition of man-made and natural environment. Students work on an independent basis, using all art department, school, and community facilities which fit a plan developed between student and instructor. Students prepare a research thesis, critique, and other visual preparation necessary to complete projects.</p>

ART  
24

AREA	ACCR. NO. FLA-DADE	COURSE TITLE AND DESCRIPTION
ART	6671.18 6672.33 6673.14	† DESIGN—WHERE IT STARTS  An exploratory sampling of art media, techniques, and skills for two/three dimensional design and composition. Activities include sensitivity and skill practice in basic design principles; awareness of visual organization and spatial relationships of design; study of designs using line, form, space, texture, and color; appreciation for the creative processes and works of others.
ART	6681.20 6682.20 6683.21	ART: TWO FROM ONE—CASTING  Experimentation in basic casting techniques. Creating sand, plaster, rubber, oil-based clay molds to be cast with wax, plaster, cement, and plastic. The student learns the procedures for creating a mold in various media and the possibilities of the basic casting process.
ART	6671.19 6672.34 6673.14	MICROSCOPIC ART  An introductory drawing course with emphasis on design and composition. The areas of observation are the detailed examination of organic and man-made objects. These laboratory exercises are executed in pencil, pen and ink, and some color.
ART	6671.20 6672.35 6673.15	† DRAWING AND COMPOSITION  An introductory course in drawing concepts and composition. This course is a must for a student who wishes to pursue art further (painting, design, advertising, etc.). Studio course gives student an opportunity to explore such media as pencil. Emphasis is placed on good composition and aesthetic manipulation of media. Areas of concentration are landscaping, figure studies, still lifes, etc.
ART	6674.06 6675.07	† ADVANCED DRAWING  Students are encouraged to explore various drawing media such as conté, ink, and charcoal to develop methods for personal expression. Teaching emphasis is placed on composition and design with students developing individual curriculum according to their special interests.

AREA	ACCR. NO. FLA-DADE	COURSE TITLE AND DESCRIPTION
ART	6681.21 6682.21 6683.22	† THE MOD WORLD OF LEATHER  Exploratory application of basic leather design principles, texture, and color as applied to basic leathercraft. Leather skills and decorating techniques are explored. A studio course.
ART	6683.23 6684.03 6685.05	ADVANCED LEATHER WORKING II, III  Students create patterns for individual designs and projects in leathercraft. Techniques such as lacing, skiving, dyeing, and cutting are developed according to individual project requirements. Students work on an individual basis, using all facilities which fit a plan developed between student and instructor. Mastery of skills described in The Mod World of Leather is recommended.
ART	6683.24 6684.04 6687.06 6688.05	RELIEF MOSAICS  A course of study concentrating on bas relief techniques in ceramics. Creative ceramic techniques are used to develop unusual designs meant to be seen as hangings. Techniques such as casting, hand building, and throwing are combined to produce original sculptures.
ART	6681.22 6682.22 6683.25	† CREATIVE ENAMELING ART  Techniques in enameling are taught to facilitate the student's personal expression through the medium of creative art enameling.
ART	6681.23 6682.23 6683.26	† GEM TREASURES (LAPIDARY) I  Exploratory and creative techniques and processes in cutting, shaping, polishing, and setting precious and semiprecious rocks and gems. Useful and decorative objects are produced by students.
ART	6684.05 6685.06	ADVANCED GEM TREASURES (LAPIDARY)  Advanced techniques and processes in cutting, shaping, polishing, and setting precious and semiprecious rocks and gems. Useful and decorative objects are produced by the students. Mastery of skills described in Gem Treasures (Lapidary) I is recommended.

ART  
26

AREA	ACCR. NO. FLA-DADE	COURSE TITLE AND DESCRIPTION
ART	6681.24 6682.24 6693.17 5833.03	<p data-bbox="783 442 1231 472">PRINCIPLES OF PHOTOGRAPHY</p> <p data-bbox="783 503 1518 750">Trains student in basic procedures needed to take, develop, and print black-and-white pictures. The principles of the camera and lenses, theories of light as needed for photographers, darkroom developing and fixing of film, contact printing and enlarging, type of filters and papers, and the history of photography will be covered. Recommended for hobby photographers and publication staff photographers.</p>
INDUSTRIAL ARTS LANGUAGE ARTS	5114.124 5115.139 5116.142 5163.06	

ART  
27

## BILINGUAL EDUCATION

The quinesters in Bilingual Education include only two components of the Bilingual Education Program: English as a Second Language (ESL) and Spanish for Spanish Speakers (Spanish-S), a Spanish language and literature program.

English SL is to be offered to non-English language origin students who are at nonindependent and at intermediate levels of English proficiency and, therefore, cannot profit adequately from the regular English language arts courses. Independent non-English language origin students may choose to substitute English SL quins more appropriately for the regular English courses.

The bilingual teachers of Spanish SL, another component of the Bilingual Education Program, can use to advantage Spanish (foreign language) quins and some Spanish-S quins, if the students' proficiency in Spanish permits. These quins are appropriate for the language and literature phase of Spanish SL. For the multidisciplinary phase and for Curriculum Content in Spanish, the fourth component of Bilingual Education, the available quins written in English for the corresponding subject areas can also be used, provided that there are instructional materials available in Spanish. The suggested activities can be carried out in Spanish, and the Spanish resource materials listed in Section 5.8 of Bulletin 1C and those listed as part of the various Spanish-S quins may be used.

### *Code Numbers for Quinester Courses*

**English SL:** The code number 5110 identifies a quin as part of the language arts program at the junior high school level. Students who take these courses may get credit for English 7, 8, and 1 in the same manner as those students who take language arts quins numbered 5111, 5112, and 5113. The code number 5117 identifies a quin as part of the language arts program at the senior high school level. Students who take these courses may get credit for English 2, 3, and 4 in the same manner as those students who take language arts quins numbered 5114, 5115, and 5116. Three units in English as a maximum may be earned for English SL.

**Spanish-S:** The code numbers for these quins are included in the range of numbers designated for Spanish as a foreign language. Credit for Spanish-S quins, therefore, is to be given to students in Spanish. Though there is no fixed sequence, the quins numbered 7509.01 through 7509.05 are designed for seventh- and eighth-grade students. Each subsequent set of quins is designed to appeal to students in grades eight through twelve.

## QUINMESTER COURSES

### *ENGLISH SL (ENGLISH AS A SECOND LANGUAGE)*

#### *Nonindependent Level*

School and Home: Getting to Know What Our School Is All About	32
School, Home, and Neighborhood: Getting to Know More People and Places	32
Doing Your Own Thing In and Out of School: What You Are Doing Now and What You Do Regularly	32
What People Do—What People Did	33
It Takes All Kinds of People	33

#### *Intermediate Level*

How Much English Do You Know?	33
English through Current Literature	34
Writing What You Mean	34
Language and Culture	34
Job Opportunities through English	34
English for the Business World	34

#### *Independent Level*

Advanced Reading: English SL	35
Reading in Vocational Fields	35
Speech Round-Up	35
Speaking at Work	36
Advanced Composition	36
Writing in the Vocational Fields	36
If You're Going to Translate, Be Original	37

### *SPANISH-S (SPANISH LANGUAGE ARTS FOR SPANISH SPEAKERS)*

Visiting Central and South America	39
Stories of Yesterday and Today	39
What Do You Think?	39
Through Love and Adventure	39
Say What You Mean	40
The World Around Us	40
Friendly Letters	40
Short Stories and Fables	40
Mystery and Adventure	40
Is This What You Mean?	40

How Well Can You Listen? . . . . .	41
Do You Know What It Is? . . . . .	41
Speaking and Writing: An Art . . . . .	41
What's Your Line? Hobbies . . . . .	41
Do You Read Me? . . . . .	42
Understanding One Another . . . . .	42
Story Telling . . . . .	42
Facts and People: Where to Find Them . . . . .	42
Face to Face . . . . .	42
"Selling" a Book . . . . .	43
20th Century Latin American Short Stories . . . . .	43
Romanticism in Latin America . . . . .	43
Latin American Poetry Throughout the Ages . . . . .	43
Debating a Subject in Round Table Discussions . . . . .	44
The Birth of Spanish . . . . .	44
The Beginnings of the Spanish Theater . . . . .	44
The Spanish Theater in the Twentieth Century . . . . .	44
The Spanish Novel in the Twentieth Century . . . . .	45
Are You Tuned In? . . . . .	45
The Nature of Spanish . . . . .	45
Biographical Studies of Famous Latin Americans . . . . .	45
Spanish in the Business World . . . . .	46
Latin American Heritage . . . . .	46
Media Analysis . . . . .	46
News in Spanish . . . . .	46
Transferring the Skills . . . . .	46
Read On . . . . .	47
Vernacular Watchdog . . . . .	47
Fiesta . . . . .	47
Stepping into the Seventies . . . . .	47
Language and Nationality . . . . .	48
Humor in the Spanish Theater . . . . .	48
Love and Patriotism in Cuban Poetry . . . . .	48
Latin American History through Literature . . . . .	48
Our Times . . . . .	48
Cervantes and His Times . . . . .	49
The Golden Age of Spain . . . . .	49
Great Writers of Spain, Part I, The Nineteenth Century . . . . .	49
Great Writers of Spain, Part II, The Twentieth Century . . . . .	49
Great Writers of Hispanic America, Part I, The Nineteenth Century . . . . .	50
Great Writers of Hispanic America, Part II, The Twentieth Century . . . . .	50
Spanish Shorthand—Theory . . . . .	50
Spanish Shorthand—Speedbuilding . . . . .	50
Spanish Shorthand—Dictation and Transcription . . . . .	51
Spanish Business Communications . . . . .	51
Spanish Office Procedures . . . . .	51
If You're Going to Translate, Be Original . . . . .	51

AREA	ACCR. NO. FLA-DADE	COURSE TITLE AND DESCRIPTION
		ENGLISH SL
ENGLISH SL	5110.01 5117.01	† SCHOOL AND HOME: GETTING TO KNOW WHAT OUR SCHOOL IS ALL ABOUT  A course designed to present the students with simple English useful in school and family situations to enable them to understand and comply with school procedures and regulations. It also provides them with a background of general information about their immediate community through intensive listening, oral and written practices. The student will have practice with teaching machines, such as the language master, tape recorder, and record player. They will also carry on activities related to the holidays and important dates falling at the time of the specific quin.
ENGLISH SL	5110.02 5117.02	† SCHOOL, HOME AND NEIGHBORHOOD: GETTING TO KNOW MORE PEOPLE AND PLACES  A course designed to present students with a greater variety of useful questions, answers, and statements that will enable them to function effectively in some specific subject areas and in the community, through intensive oral and written practice. Students will participate in practices with teaching machines; will visit the library, nearby shopping center, police and fire departments, and theatres; and will make bulletin boards related to school activities, holidays, and experiences.
ENGLISH SL	5110.03 5117.03	† DOING YOUR OWN THING IN AND OUT OF SCHOOL: WHAT YOU ARE DOING NOW AND WHAT YOU DO REGULARLY  A course designed to acquaint students further with people in the school and in the community and what they contribute to society, with a view to the vocational orientation of the students themselves. Language practice is concentrated on contrasting verb forms for such situations (simple present, present continuous, "going to" future) so that students will be able to <i>discuss</i> with appropriate intonation and rhythm, <i>read</i> and <i>write</i> about these workers' and professionals' functions or duties, their distinctive characteristics (such as special dress and gear), their places of work, etc. The adequate use of the school library is given special attention.



AREA	ACCR. NO. FLA-DADE	COURSE TITLE AND DESCRIPTION
ENGLISH SL	5110.04 5117.04	<p data-bbox="820 447 1367 483"><b>WHAT PEOPLE DO-WHAT PEOPLE DID</b></p> <p data-bbox="820 506 1573 959">A course designed to enable students to function in various areas of the curriculum, especially history, science, and math, as they master the use of the simple past tense in questions, answers, negative and affirmative statements, in contrast with the present indefinite used in generalizations. Emphasis is on the sociocultural foundations of the United States of America and some resulting cultural patterns of North Americans that are in direct contrast with some Spanish American cultural patterns. Students will be able to ask and answer questions with <i>Who, What, Where, and When</i> and use the simple past tense in oral discussions and in writing. Further use of the library as source of information is emphasized and assistance is offered in making better and more economical use of books, both for study and for recreation.</p>
ENGLISH SL	5110.05 5117.05	<p data-bbox="784 1018 1295 1054">† <b>IT TAKES ALL KINDS OF PEOPLE</b></p> <p data-bbox="820 1078 1573 1482">A course designed to make students further understand cultural differences, to accept and adjust to environmental changes in conflict with their own culture without damage to their self image or that of their culturally different parents. Students <i>discuss, read, and write</i> about cultural differences and different culture groups in the community using controlled language patterns. They will be able to use orally and in writing simple present and simple past forms, present continuous and the forms "going to" and "will" as indicators of future time in questions, answers, and statements. Special pronunciation problems originating from present and preterit endings, as well as from pluralization, are given special attention.</p>
ENGLISH SL	5110.11, 5117.11	<p data-bbox="784 1637 1349 1673">† <b>HOW MUCH ENGLISH DO YOU KNOW?</b></p> <p data-bbox="820 1696 1573 2025">A course designed for the students who have completed the requirements of the first phase of ESL. Its function is to identify the needs of the students in the areas of comprehension, speech, reading, and writing in order to individually counsel the students in future quinmester selection. The student explores the social function of people within the family, school, and national and world community through speaking, reading, and writing. Fundamentals of county, state, and national government and citizenship are referential contact for further language growth.</p>

AREA	ACCR. NO. FLA-DADE	COURSE TITLE AND DESCRIPTION
ENGLISH SL	5110.12 5117.12	† ENGLISH THROUGH CURRENT LITERATURE  A course designed for students at the intermediate level to improve their vocabulary, reading, and comprehension skills. The students are expected to perform on the fifth grade reading level. They read, examine, and review current articles, essays, short stories, and musical lyrics as they master more complex grammatical structures, such as various types of modifying clauses and the perfect tenses.
ENGLISH SL	5110.13 5117.13	WRITING, WHAT YOU MEAN  A course designed to develop and practice the skills of writing as a means of communication. The students improve their reading skills and broaden their reading experience. They write sentences, paragraphs, essays, letters, and reports as they focus attention on more complex syntax and establish further sound-spelling relationships.
ENGLISH SL	5110.14 5117.14	† LANGUAGE AND CULTURE  A comparison of cultures through the study of history, religion, social structure, customs, holidays, and attitudes. The students are able to better adjust and perform within a multicultural society. They express themselves orally and comprehend English as used in mass-media, and formal and informal speech.
ENGLISH SL	5110.15 5117.15	† JOB OPPORTUNITIES THROUGH ENGLISH  A course to help students explore the various vocational opportunities in the community. They are able to determine which are pertinent to their needs and interests. Use is made of reading, oral and written reports, field trips, and interviews. Comprehension and the ability to use vocational terminology in accordance with their interests is emphasized.
ENGLISH SL	5110.16 5117.16	ENGLISH FOR THE BUSINESS WORLD  A course designed for students who wish to train for secretarial work, or as receptionists or office clerks. It enables them to understand and use orally and in writing the terminology and style of language used in most business occupations open to untrained young boys and girls seeking part-time employment in the business world.

AREA	ACCR. NO. FLA-DADE	COURSE TITLE AND DESCRIPTION
ENGLISH SL	5110.21 5117.21	† ADVANCED READING: ENGLISH SL  A course designed to improve reading skills and ability to interpret literature. It enables students to understand and use highly idiomatic vocabulary and grammatical structures of present-day English that interfere with comprehension. Excerpts from contemporary novels, short stories, newspaper articles, appropriate periodicals, and taped television and radio scripts will be examined and discussed. The students' oral and written expression will demonstrate their comprehension and acquisition of vocabulary and structures, as well as concepts and themes presented.
ENGLISH SL	5110.22 5117.22	† READING IN VOCATIONAL FIELDS  A course designed to acquaint the students with various occupations available to those with vocational interests. It enables them to understand and use the highly specialized vocabulary and structures needed in their chosen occupations. Excerpts from training manuals in various occupations, appropriate journals, and specialized periodicals and magazines are read and examined. The students demonstrate in oral and written expression their acquisition of grammatical structures and specialized vocabulary and their ability to follow instructions pertinent to the vocations of their choice.
ENGLISH SL	5110.23 5117.23	SPEECH ROUND-UP  A course designed to enable the students to achieve the highest possible level of oral comprehension and expression. The students will be able to understand and use the subtleties of spoken English, pronunciation, rhythm, and dramatization through activities specifically designed for Spanish speakers. These activities enable them to convey a thought clearly and concisely, change an opinion, present a logical argument, discuss in group situations, and develop self-confidence in public speaking situations.

AREA	ACCR. NO. FLA-DADE	COURSE TITLE AND DESCRIPTION
ENGLISH SL	5110.24 5117.24	<p data-bbox="816 460 1113 493"><b>SPEAKING AT WORK</b></p> <p data-bbox="816 524 1566 912">A course designed to enable the students to function successfully in all phases of oral communication in their chosen vocation. The student will be able to discriminate and produce the important vowel and consonant sounds, as well as grammatical structures that interfere with automatic comprehension and expression of spoken English. The students master other elements of effective speech, such as intonation, rhythm, and the use of vocabulary essential to their chosen fields. The students participate in activities that will enable them to choose a vocation wisely, sell themselves while seeking employment, and communicate with employees and employers, as well as with the public.</p>
ENGLISH SL	5110.25 5117.25	<p data-bbox="777 971 1188 1004">† <b>ADVANCED COMPOSITION</b></p> <p data-bbox="816 1034 1566 1394">A course designed for advanced students to enable them to express themselves in writing with native proficiency comparable to American students of similar educational levels by providing activities specifically geared to the elimination of those interfering features of language peculiar to Spanish speakers. The students will be able to produce outlines, paragraphs, compositions, themes, and term papers. Students prepare outlines based on reading selections, class notes, lectures, and reports; write expository, descriptive, and narrative paragraphs; expand writing skills in the area of compositions and themes; write a term paper.</p>
ENGLISH SL	5110.26 5117.26	<p data-bbox="816 1453 1368 1486"><b>WRITING IN THE VOCATIONAL FIELDS</b></p> <p data-bbox="816 1517 1566 1754">A course designed to enable the students to master the writing skills essential to seeking, obtaining, and advancing in their chosen fields. The students will be able to fill out job applications, write resumes of their personal and educational background, skills, and experience; write ads and letters for job application; and use appropriate vocabulary and writing skills pertinent to their individual occupations.</p>

AREA	ACCR. NO. FLA-DADE	COURSE TITLE AND DESCRIPTION
ENGLISH SL	5110.27	IF YOU'RE GOING TO TRANSLATE, BE ORIGINAL
SPANISH-S	5117.27	A course for bilingual students with literate mastery of both English and Spanish. It is designed to enable them to produce oral and written versions of expository or informative materials originally written in the other language. Translations appearing in widely accepted newspapers and magazines are critically analyzed in class. Communications between the school and the home are translated by the students. Individual students act as interpreters at PTA meetings and special school programs and assemblies.
	7509.84	

AREA	ACCR. NO. FLA-DADE	COURSE TITLE AND DESCRIPTION
		SPANISH-S
SPANISH-S	7509.01	† VISITING CENTRAL AND SOUTH AMERICA  A course designed to acquaint students with the Latin American countries and some of their characteristics. Short stories, pictures, maps, filmstrips, slides, and motion pictures are used to promote discussions. The students will read simple sentences with the proper intonation; write sentences, using correct punctuation; practice dividing words into syllables; and present in writing brief narratives and descriptions.
SPANISH-S FOREIGN LNG. SPANISH	7509.02  7506.27 7507.07	† STORIES OF YESTERDAY AND TODAY  A course designed to help students improve their oral and written expression, as well as their ability to summarize. Stories by Spanish and Spanish American writers are used. Students reinforce skills in recognizing the importance of writing as an efficient means of communication. Experiences are provided in paragraph building.
SPANISH-S	7509.03	WHAT DO YOU THINK?  A course designed to develop in the students the ability to find cause and effect relationships and to establish relationships between actions, characters, and feelings in the selected dialogues of the different fables selected. Some of these selections are in poetry in order to introduce students to the reading of poetry. Oral and written exercises facilitate the enrichment of vocabulary through the use of words that have the same origin, antonyms, and synonyms.
SPANISH-S FOREIGN LNG. SPANISH	7509.04  7506.28 7507.08	THROUGH LOVE AND ADVENTURE  A course enabling students to write brief descriptions and narratives. The selected literary works to be studied deal with interesting adventures and love stories in prose and verse. The students will be able to distinguish between historic facts and fiction. They are exposed to the three main tenses of verbs, descriptive adjectives, and the common and proper nouns. The concept and structure of paragraphs and other grammatical principles already studied are reviewed.

AREA	ACCR. NO. FLA-DADE	COURSE TITLE AND DESCRIPTION
SPANISH-S	7509.05	<p>SAY WHAT YOU MEAN</p> <p>A course designed to enable students to communicate to others what they really mean through the appropriate use of words and expressions. Activities include the analysis and discussion of current newspaper and magazine articles and speeches, quotations, writings, and famous sayings that illustrate effective use of language.</p>
SPANISH-S	7509.11	<p>† THE WORLD AROUND US</p> <p>By means of reading choice prose selections and watching pictures or filmstrips, the students use more appropriate words to describe persons, animals, or things orally and in writing.</p>
SPANISH-S	7509.12	<p>FRIENDLY LETTERS</p> <p>A course designed to enable the student to write informal letters to relatives and friends after letters of different types have been read in class. Differences and similarities of style between English and Spanish letter writing are stressed.</p>
SPANISH-S	7509.13	<p>† SHORT STORIES AND FABLES</p> <p>A course designed to develop the student's ability to listen carefully to short stories and fables read in class in order to identify the main idea and the characters.</p>
SPANISH-S	7509.14	<p>MYSTERY AND ADVENTURE</p> <p>A course designed to acquaint the student with the reading of mystery and adventure books. The student will be able to understand the vocabulary and to write narrative and descriptive compositions.</p>
SPANISH-S	7509.15	<p>IS THIS WHAT YOU MEAN?</p> <p>A course designed to help the students improve the practical aspects of oral communication and overcome the fear of speaking in public. The course enables the students to express themselves better in a job interview, a college interview, a telephone conversation, etc.</p>

AREA	ACCR. NO. FLA-DADE	COURSE TITLE AND DESCRIPTION
SPANISH-S	7509.21	<p>† HOW WELL CAN YOU LISTEN?</p> <p>A course designed to help students improve their ability to understand and produce oral language. The students are given practice in following and giving directions orally, reading and pronouncing words presenting difficulty, using capital and small letters correctly, and taking simple dictations.</p>
SPANISH-S	7509.22	<p>† DO YOU KNOW WHAT IT IS?</p> <p>A course designed to help the students improve their oral and writing ability. The course enables the students to describe persons, posters, and animals orally; identify and use synonyms in descriptions; avoid the repetition of connective words such as <i>and</i>, <i>then</i>, etc., in oral descriptions; read with great ease descriptive selections in prose; write various types of descriptions; and use the dictionary to enrich vocabulary, especially through use of synonyms.</p>
SPANISH-S	7509.23	<p>† SPEAKING AND WRITING, AN ART</p> <p>A course designed to enable the students to organize discussions and debates on topics of interest to the group, such as "How to Improve Some Television Programs," "A Festival of Folkloric Music," "Planning a Christmas Party," "Understanding Politics," etc. Students will reinforce skills in supporting a point of view calmly and dispassionately in evaluating and respecting opinions with which one does not agree, in expressing points of view with precision and coherence, avoiding digressions.</p>
SPANISH-S	7509.24	<p>WHAT'S YOUR LINE? HOBBIES</p> <p>A course designed to help the students improve their ability to speak and write correctly everyday Spanish as they discuss things they like to do. The course enables the students to avoid errors of agreement between the article and the noun, the adjective and the noun, and the subject and the verb; eliminate frequent grammatical errors in the usage of some verb forms such as <i>ande</i> for <i>anduve</i>, <i>traduci</i> for <i>trduje</i>; read fables and interpret the message they seek to convey; distinguish between the use of the hyphen and the dash in dialogues; recognize syllables consisting of two or more letters; use the diacritic (not written) accent correctly, as opposed to the orthographic or written accent.</p>



AREA	ACCR. NO. FLA-DADE	COURSE TITLE AND DESCRIPTION
SPANISH-S	7509.25	<p>DO YOU READ ME?</p> <p>A course enabling students to realize the importance of the various levels of language usage and the subtleties of idiomatic expressions. The student will function successfully in all phases of oral communication in several vocations of their choice.</p>
SPANISH-S	7509.31	<p>† UNDERSTANDING ONE ANOTHER</p> <p>A course designed to enable the students to communicate better with others orally. Students are given practice to improve their ability to listen, interpret and give oral information, directions, and explanations; and to summarize and relay information and messages. Common articulation problems that interfere with oral communication are identified for their elimination through oral practice.</p>
SPANISH-S	7509.32	<p>STORY TELLING</p> <p>A course designed to help the student develop the skill to narrate stories orally and in writing, to tell and write about his own experiences clearly and logically. Variety of sentence structure, word choice, and paragraph building within interesting contexts are emphasized.</p>
SPANISH-S	7509.33	<p>† FACTS AND PEOPLE: WHERE TO FIND THEM</p> <p>A course designed to enable students to locate useful facts and information about people. Library skills and research are emphasized as the students become familiar with their school and neighborhood libraries and the resources available to them.</p>
SPANISH-S	7509.34	<p>† FACE TO FACE</p> <p>A course designed to enable the students to participate in discussions and to use improvisational acting and speaking techniques for exploring problems affecting today's youth. The ability to listen to others and to respect widely differing opinions is stressed.</p>

AREA	ACCR. NO. FLA-DADE	COURSE TITLE AND DESCRIPTION
SPANISH-S	7509.35	<p>† "SELLING" A BOOK</p> <p>A course designed to enable the student to present and to listen to book reviews, following an outline which contains information about the author, the most important characters, an important incident, a criticism of the book, and recommendations to other readers. Skills in listening without interrupting, taking notes, and accepting each other's opinions are developed and reinforced throughout the course.</p>
SPANISH-S	7509.41	<p>20TH CENTURY LATIN AMERICAN SHORT STORIES</p> <p>A course designed to enable students to understand the art of short story writing and the varying philosophic trends of Latin American short story writers through the century. Emphasis is on contemporary conflicts and struggles pertinent to youth today. Students are stimulated to write their own stories through the study and discussion of selected works.</p>
SPANISH-S FOREIGN LNG. SPANISH	7509.42 7506.29 7507.09	<p>ROMANTICISM IN LATIN AMERICA</p> <p>A course designed to acquaint the students with the concepts and thoughts of Latin American Romantic authors. The students will be able to develop respect for other than modern styles of writings. Discussion, analysis, and comparison with contemporary realism will be stressed.</p>
SPANISH-S FOREIGN LNG. SPANISH	7509.43 7506.291 7507.091	<p>LATIN AMERICAN POETRY THROUGHOUT THE AGES</p> <p>A course designed to acquaint the students with the different styles of poetry throughout the ages. The student will be able to enjoy poetry, both old and new; identify and understand man's use of poetry as an expression of self throughout all time; and produce some poetry of his own.</p>

AREA	ACCR. NO. FLA-DADE	COURSE TITLE AND DESCRIPTION
SPANISH-S	7509.44	<p>DEBATING A SUBJECT IN ROUND TABLE DISCUSSIONS</p> <p>A course designed to enable the students to participate in round table or panel discussions on topics of general interest. Principles of argumentation and logical exposition are stressed, as well as strict adherence to "the rules of the game."</p>
SPANISH-S	7509.45	<p>THE BIRTH OF SPANISH</p> <p>A course designed to enable students to understand and appreciate the structure of the Spanish language through the study of its origin and evolution. Students apply skills in library research as they prepare oral and written reports on the most significant and interesting phases of the Spanish language and the most representative works of these phases.</p>
SPANISH-S FOREIGN LNG. SPANISH	7509.51 7506.292 7507.092	<p>THE BEGINNINGS OF THE SPANISH THEATER</p> <p>A course designed to acquaint students with the origin of the Spanish theater to Lópe de Vega. The students read the plays, using the correct intonation, and act out any one of the plays. Studies of character, setting, dialogue, and the author's use of a taste for good drama, while getting new insights into human conflict. Effective oral and written expression are stressed.</p>
SPANISH-S	7509.52	<p>THE SPANISH THEATER IN THE TWENTIETH CENTURY</p> <p>A course designed to continue the study of the Spanish theater. The students develop skills in recognizing human values, contemporary philosophy, and character portrayal. Effective oral and written expression, as well as dramatization, is stressed.</p>

AREA	ACCR. NO. FLA-DADE	COURSE TITLE AND DESCRIPTION
SPANISH-S	7509.53	<p>THE SPANISH NOVEL IN THE TWENTIETH CENTURY</p> <p>A course designed to acquaint the students with the newest literary trends. The students will be able to establish the difference between realism and naturalism and to recognize the similarities and differences between romanticism and "costumbrismo." Interpretative reading and study skills, as well as the development of critical judgment and of effective writing ability, are stressed.</p>
SPANISH-S	7509.54	<p>† ARE YOU TUNED IN?</p> <p>A course providing a number of listening experiences to help the student develop the skills necessary to interpret directions, information, and short explanations; to make judgments; to follow all points in a discussion, and to center attention upon significant details; to understand the relationship between voice inflection and the situation being portrayed by the speaker; to distinguish between fact and opinion; to recall the sequence of facts in a story and to be aware of important details of place, time, setting, and dialogue.</p>
SPANISH-S	7509.55	<p>THE NATURE OF SPANISH</p> <p>A course designed to enable students to identify the systems of Spanish and its most distinctive features. Students identify patterns of structure, spelling, pronunciation, and items of vocabulary that are most susceptible to incorrect usage because of English interference. Discussions of the various forms of "Spanglish" and of various dialects used by Spanish speakers in Dade County allow students to develop broadmindedness and attitudes of respect toward language and cultural differences.</p>
SPANISH-S SOCIAL STUDIES	7509.61 6493.05 6494.05	<p>BIOGRAPHICAL STUDIES OF FAMOUS LATIN AMERICANS</p> <p>A course designed to acquaint the students with the scientific and artistic contributions of prominent Latin Americans in the course of history. Biographies, written excerpts, novels, etc., are discussed and examined. Cultural values are stressed with a view to developing in the students pride in their own heritage and improving their self concept.</p>

AREA	ACCR. NO. FLA-DADE	COURSE-TITLE AND DESCRIPTION
SPANISH-S	7509.62	<p>SPANISH IN THE BUSINESS WORLD</p> <p>A course designed to enable the students to understand and to use the highly specialized vocabulary and structures needed in occupations of their choice. Participation in oral interviews; writing an adequate resume with educational background; filling out job applications for employment; writing business letters, telegrams, wires, etc.; ability to receive telephone and personal messages are stressed.</p>
SPANISH-S SOCIAL STUDIES	7509.63 6493.06 6494.06	<p>LATIN AMERICAN HERITAGE</p> <p>A course designed to acquaint the Spanish-speaking students with their cultural, historical, and geographical backgrounds. This course enables the students to obtain a better understanding of the multicultural society they live in. Various Spanish, Indian, and Negro influences in North American folklore are studied and discussed.</p>
SPANISH-S	7509.64	<p>MEDIA ANALYSIS</p> <p>A course designed to acquaint students with the critical reading of periodicals, newspapers, and magazines. The students will be able to form their own opinions and detect propaganda, gimmicks, and indoctrinating attempts in the news media. They use correct punctuation and capitalization in the writing of editorials and ads and generally identify newspaper style as being different from other prose writing.</p>
SPANISH-S	7509.65	<p>NEWS IN SPANISH</p> <p>This course is designed to train students in the basic principles of journalism as applied to interviewing; editorial writing; movie, theatre and book reviews; news; fashion features; etc.</p>
SPANISH-S	7509.70	<p>† TRANSFERRING THE SKILLS</p> <p>A course designed to assist the students who read in English but have had no reading instruction in Spanish. Students grasp sound-symbol correspondences in Spanish, syllabication, basic spelling patterns, and word formation. Emphasis is given to rapid reading drills. Differences in intonation, rhythm, and stress in both languages is clarified.</p>

AREA	ACCR. NO. FLA-DADE	COURSE TITLE AND DESCRIPTION
SPANISH-S	7509.71	<p><b>READ ON</b></p> <p>A course to further intensify and broaden the students' reading skills. Through selected readings in science, history, and world literature, the students increase their skills and abilities in making summaries, developing outlines, drawing conclusions, making generalizations, and using flexible and rich vocabulary.</p>
SPANISH-S	7509.72	<p><b>VERNACULAR WATCHDOG</b></p> <p>A course designed to establish the correct and proper usage of standard Spanish by means of a comparative study of "how it should be said" and "how we think it should be said." The students determine the proper usage, both orally and in writing. The use of the <i>Real Academia</i> dictionary and its influence on the evolution of Spanish will enable the students to identify expressions which are "incorrect" or not accepted as standard forms of Spanish. Semantic borrowings from English to Spanish, such as <i>application-aplicación</i>, direct borrowings, such as <i>nurse-nursa</i>, and forms of English syntax directly applied to Spanish, such as <i>llamame para atras-call me back</i>, are identified. More generally accepted language forms are practiced for use in their place.</p>
SPANISH-S	7509.73	<p><b>t. FIESTA</b></p> <p>A course designed to acquaint the students by means of multimedia resources (films, filmstrips, tapes, etc.) with the cultural differences among the various Latin American countries, relative to birthdays, weddings, national holidays, dances, songs, etc. Enrichment of vocabulary, idiomatic expressions, and colloquialism are stressed.</p>
SPANISH-S	7509.74	<p><b>STEPPING INTO THE SEVENTIES</b></p> <p>A course designed to acquaint the students with current problems, such as pollution, drug abuse, technological progress by means of critical reading and discussion of newspapers, magazines, and television and radio. Students do research and make oral and written reports and carry on panel discussions and debates on current topics.</p>

AREA	ACCR. NO. FLA-DADE	COURSE TITLE AND DESCRIPTION
SPANISH-S	7509.75	<p>LANGUAGE AND NATIONALITY</p> <p>The study of the historical background of Spanish, aimed to promote in the student a love for his culture and language. By means of the study of words, epic poems, folklore, stories and ballads, the students gain an insight into the origin, development, and practical use of Spanish.</p>
SPANISH-S FOREIGN LNG. SPANISH	7509.76 7506.293 7507.093	<p>HUMOR IN THE SPANISH THEATER</p> <p>A course designed to acquaint the students with Spanish dramatics and the use of a variety of dialects. The students identify typical examples of Spanish merriment throughout the development of Spanish drama. The characteristics of good humor are contrasted with the grotesque and vulgar.</p>
SPANISH-S	7509.77	<p>LOVE AND PATRIOTISM IN CUBAN POETRY</p> <p>A course designed to enable students to understand and interpret the patriotic and love poems of famous Cuban poets, such as José M. Heredia, Gertrudes G. de Avellaneda, Juan C. Zenea and José Martí. Contemporary exile poetry is studied comparatively for its literary, as well as for its social and historical, impact.</p>
SPANISH-S FOREIGN LNG. SPANISH SOCIAL STUDIES	7509.701 7506.23 6493.02	<p>LATIN AMERICAN HISTORY THROUGH LITERATURE</p> <p>The student learns about the growth, problems, etc. of Latin America by reading selections written by native authors. Lectures and discussions are in Spanish. The course is recommended for the student who has controlled the Spanish quins 7505.04 or 7505.14.</p>
SPANISH-S FOREIGN LNG. SPANISH	7509.702 7506.24 7507.21	<p>OUR TIMES</p> <p>This course is designed to acquaint students with Twentieth Century Spaniards and Iberoamericans from various fields including politics, literature, art, and music. Students explore their lives, deeds, writings, or other contributions to the modern Hispanic world. Extensive use is made of films, filmstrips, tapes, records, newspapers, and magazines. The class is conducted in Spanish.</p>

BILINGUAL EDUCATION  
48

AREA	ACCR. NO. FLA-DADE	COURSE TITLE AND DESCRIPTION
SPANISH-S LANGUAGE ARTS FOREIGN LNG. SPANISH	7509.703 5116.310  7506.25 7507.22	<b>CERVANTES AND HIS TIMES</b>  This course presents an accurate picture of the times, life, and works of the man who gave the world its first great novel. Students study the historical background while getting acquainted with Cervantes's main writings and style. Important literary and political figures of the Europe of the XVI and XVII centuries are considered. Emphasis is on guided discussion, free conversation, the writing of essays, and giving of reports. All class work is conducted in Spanish.
SPANISH-S LANGUAGE ARTS FOREIGN LNG. SPANISH	7509.704 5116.315  7506.26 7507.23	<b>THE GOLDEN AGE OF SPAIN</b>  The culture of the Golden Age of Spain is studied through readings, filmstrips, and tapes. The student gets acquainted with the life and work of the great masters in painting and literature. This course is recommended for the student who has controlled some of the 7506 courses.
SPANISH-S LANGUAGE ARTS FOREIGN LNG. SPANISH	7509.705 5116.311  7507.24	<b>GREAT WRITERS OF SPAIN, PART 1, THE NINETEENTH CENTURY</b>  Originals of the Romantic period and the most representative authors of the literary Spain of the Nineteenth Century are considered in this course. This is the first course of a block of four geared to students preparing to take the Advanced Placement Exam. Emphasis is maintained throughout the course on guided discussion and analysis, free conversation, and the writing of essays, and giving of reports. The class is conducted in Spanish.
SPANISH-S LANGUAGE ARTS FOREIGN LNG. SPANISH	7509.706 5116.312  7507.25	<b>GREAT WRITERS OF SPAIN, PART 2, THE TWENTIETH CENTURY</b>  Starting with the famous "Generación del 98," the works of the most representative authors of the literary Spain of the twentieth century are studied in this course. Emphasis is maintained throughout on guided discussion and analysis, free conversation, and the writing of essays and giving of reports. The class is conducted in Spanish. This course is geared to the very capable student interested in Advanced Placement.



AREA	ACCR. NO. FLA-DADE	COURSE TITLE AND DESCRIPTION
SPANISH-S LANGUAGE ARTS FOREIGN LNG. SPANISH	7509.707 5116.313  7507.26	GREAT WRITERS OF HISPANIC AMERICA, PART 1, THE NINETEENTH CENTURY  Works of the great writers of the Hispanic America of the nineteenth century are studied in this course, along with the literary movements of that time. Emphasis is on guided discussion and analysis, free conversation, the writing of essays, and the giving of reports. The class is conducted in Spanish. This course is geared to the very capable student interested in Advanced Placement.
SPANISH-S LANGUAGE ARTS FOREIGN LNG. SPANISH	7509.708 5116.314  7507.27	GREAT WRITERS OF HISPANIC AMERICA, PART 2, THE TWENTIETH CENTURY  The authors of today, the novelists and poets who constitute the literary elite of our century in Hispanic America, are studied in this course. Emphasis is on guided discussion and analysis, free conversation, the writing of essays, and giving of reports. The class is conducted in Spanish. This course is geared to the very capable student interested in Advanced Placement.
SPANISH-S BUSINESS EDUCATION FOREIGN LNG. SPANISH	7509.79 7707.12  7505.41	SPANISH SHORTHAND-THEORY  Integration of English shorthand skills with Spanish shorthand characters. Emphasis on Spanish brief forms, phrases, and abbreviations.  The student should have attained the objectives of Shorthand Dictation, Shorthand Basic Transcription, and a third-level course in Spanish prior to enrollment in this course.
SPANISH-S BUSINESS EDUCATION FOREIGN LNG. SPANISH	7509.80 7707.22  7505.42	SPANISH SHORTHAND-SPEEDBUILDING  Development of rapid writing skills with emphasis on spelling, vocabulary, Spanish business terms, punctuation, capitalization, and use of reference materials.  The student should have attained the objectives of Spanish Shorthand-Theory prior to enrollment in this course.

AREA	ACCR. NO. FLA-DADE	COURSE TITLE AND DESCRIPTION
SPANISH-S BUSINESS EDUCATION FOREIGN LNG. SPANISH	7509.81 7707.32  7505.43	<p>SPANISH SHORTHAND-DICTATION AND TRANSCRIPTION</p> <p>Application of skills and knowledge in transcribing Spanish dictation. The student will be able to distinguish between the proper term to be used in the translation and the mere verbatim translation of the written material. Includes related inquiry into opportunity for employment and the ethics of the secretary.</p> <p>The student should have attained the objectives of Spanish Shorthand-Speedbuilding prior to enrollment in this course.</p>
SPANISH-S BUSINESS EDUCATION FOREIGN LNG. SPANISH	7509.82 5128.32  7505.44	<p>SPANISH BUSINESS COMMUNICATIONS</p> <p>Emphasis on all types of communications currently used in Latin American business. Includes parts and styles of business letters and the preparation of various types of business communications, including letters, telegrams, and memorandums.</p> <p>The student should have attained the objectives of Effective Business Reports prior to enrollment in this course.</p>
SPANISH-S BUSINESS EDUCATION FOREIGN LNG. SPANISH	7509.83 7716.21  7505.45	<p>SPANISH OFFICE PROCEDURES</p> <p>Equips students with a knowledge of Spanish office procedures and other skills and attitudes required of bilingual secretaries. The student should have attained the objectives of The Office in Action prior to enrollment in this course.</p>
SPANISH-S ENGLISH SL	7509.84 5110.27 5117.27	<p>IF YOU'RE GOING TO TRANSLATE, BE ORIGINAL</p> <p>A course for bilingual students with literate mastery of both English and Spanish. It is designed to enable them to produce oral and written versions of expository or informative materials originally written in the other language. Translations appearing in widely accepted newspapers and magazines are critically analyzed in class. Communications between the school and the home are translated by the students. Individual students act as interpreters at PTA meetings and special school programs and assemblies.</p>

## BUSINESS EDUCATION

The quinmester courses of study described in this guide are designed to fulfill the requirements of a well-rounded business education curriculum for all students attending Dade County schools. Course titles in the index are arranged in sequence under each area. Flow charts following the index will assist counselors, administrators, and teachers in helping students plan their schedules. Arrows connecting courses indicate recommended sequences. A student may enroll in a course without taking the lower level course that precedes it if he can demonstrate ability to meet the objectives of the lower level course. It should be noted that many of the courses shown on these charts are not connected to other courses by lines or arrows. This omission indicates that the courses can stand by themselves and do not need to be taken in a sequence with other courses.

The first four digits of the code numbers that have been assigned to all the business education quinmester courses are the same as the numbers assigned to like courses in *The Accreditor* (Department of Education, Tallahassee, Florida). For example, Typing 1 in *The Accreditor* has the number 7704; all first-year typing quinmester courses have been assigned the same prefix number 7704. A decimal and two digits have been added to represent each quinmester course that is related to Typing 1. Thus, the four basic typing quinmester courses for senior high schools have been assigned these numbers: 7704.11, 7704.21, 7704.31, and 7704.41. The last two, or suffix, numbers designate the normal sequence of difficulty of the quinmester courses. However, there are other Typing 1 courses that may be given for enrichment and/or remedial purposes such as VariTyper (7704.22) and Typewriting Brushup (7704.42). Their numbers are also based on the sequence of difficulty.

QUINMESTER COURSES

FLOW CHARTS . . . . . 58-63

*BOOKKEEPING* . . . . . 77-80

- Introduction to Bookkeeping
- Special Journals and Ledgers
- Completing the Bookkeeping Cycle
- Special Bookkeeping Applications
- Data Processing in Bookkeeping
- Partnership Accounting
- Control Systems in Accounting
- Corporation Accounting
- Cost Accounting
- Special Accounting Applications

*BUSINESS ENGLISH* . . . . . 64-65

- Business Grammar in Good Taste
- Spell It Right
- Business Speech
- Effective Business Reports
- Effective Business Letters

*BUSINESS LAW* . . . . . 81-82

- The Law and the Establishment
- You and Your Security
- The "Ins" and "Outs" of Everyday Contracts
- Legal Problems in Family Life
- Legal Responsibility
- Paper That Passes for Money

*BUSINESS MANAGEMENT* . . . . . 87

- Small Business Management

*BUSINESS MATHEMATICS* . . . . . 65

- Business Math Fundamentals
- The Math of Business
- Arithmetic Applications

*BUSINESS TRAINING IN SPANISH* . . . . . 85-86

- Spanish Shorthand—Theory
- Spanish Shorthand—Speedbuilding
- Spanish Shorthand—Dictation and Transcription
- Spanish Business Communications
- Spanish Office Procedures

BUSINESS EDUCATION

*CONSUMER ECONOMICS* . . . . . 66-67

- In the Marketplace
- Taxes
- Bull and Bear: The Stock Market
- Choosing Your Home
- Trustworthy Americans
- Buying a Car
- Protection for the Consumer

*COOPERATIVE BUSINESS EDUCATION PROGRAM* . . . . . 92

*DATA PROCESSING* . . . . . 86-87

- Concepts of Business Data Processing
- Modern Business Data Processing

*FILING* . . . . . 84

- Filing and Finding

*GENERAL BUSINESS* . . . . . 80-81

- Our Business World
- Exploring Business Skills
- Tell It as It Is
- People and Products on the Move
- Banking Services
- As Other See You
- Preparation for Office Employment

*OFFICE CAREER OCCUPATIONS PROGRAM* . . . . . 91-92

- OCO No. 1
- OCO No. 2
- OCO No. 3
- OCO No. 4

*OFFICE MACHINES* . . . . . 83-84

- Preview of Computational Machines
- Talking Machines
- Duplicating Processes
- Bookkeeping Machines
- Key-Driven Calculators
- Electric Calculators
- Adding-Listing Machines (Ten-Key and Full-Key)
- Keypunch Operation

*OFFICE PRACTICE* . . . . . 85

- The Office in Action
- Receptionist Training

*RECORDKEEPING* . . . . . 76-77

- Welcome to Recordkeeping
- Money Records
- Dollars and Sense
- Payroll Records
- Both Sides of the Story—Buying and Selling

*SALESMANSHIP AND MERCHANDISING* . . . . . 66

- Salesmanship
- Merchandising

*SHORTHAND* . . . . . 72-76

- Rapid Writing (Theory)
- Rapid Writing (Application)
- Shorthand Theory (Introductory)
- Shorthand Theory (Intermediate)
- Shorthand Dictation
- Intensive Review of Shorthand Theory
- Introduction to Machine Shorthand Theory
- Intermediate Machine Shorthand Theory
- Machine Shorthand Dictation
- Intensive Review of Machine Shorthand Theory
- Shorthand Basic Transcription
- Shorthand Speedbuilding
- Shorthand Transcription
- Advanced Dictation and Transcription
- Office-Style Dictation and Transcription
- Legal Dictation and Transcription
- Medical Dictation and Transcription
- Technical Dictation and Transcription

*TYPEWRITING* . . . . . 67-72

- ABCs of Typewriting
- The Typewriter and You
- Developing Typewriting Skill
- Basic Typewriting Review
- E-Z Way to Type
- Personal Applications of Typewriting Skills
- Business Applications of Typewriting Skills
- VariTyper
- Typing Business Reports, Outlines, and Manuscripts
- Intermediate Typewriting Skills
- Typewriting Brush Up
- Clerical Typewriting
- Typewriting Machines with Many Faces
- Advanced Clerical Typewriting
- Advanced Typewriting Skill Building
- Medical Typewriting
- Statistical Typewriting
- Technical Typewriting
- Legal Typewriting

*BUSINESS EDUCATION*

56

*VOCATIONAL OFFICE EDUCATION PROGRAMS*

87-90

VOE Special Jobs, Clerical  
VOE Special Jobs, Secretarial  
VOE No. 1, Clerical  
VOE No. 1, Secretarial  
VOE No. 2, Clerical  
VOE No. 2, Secretarial  
VOE No. 3, Clerical  
VOE No. 3, Secretarial

BUSINESS EDUCATION  
57

**BUSINESS EDUCATION**  
**FLOW CHART FOR AREAS OF STUDY**

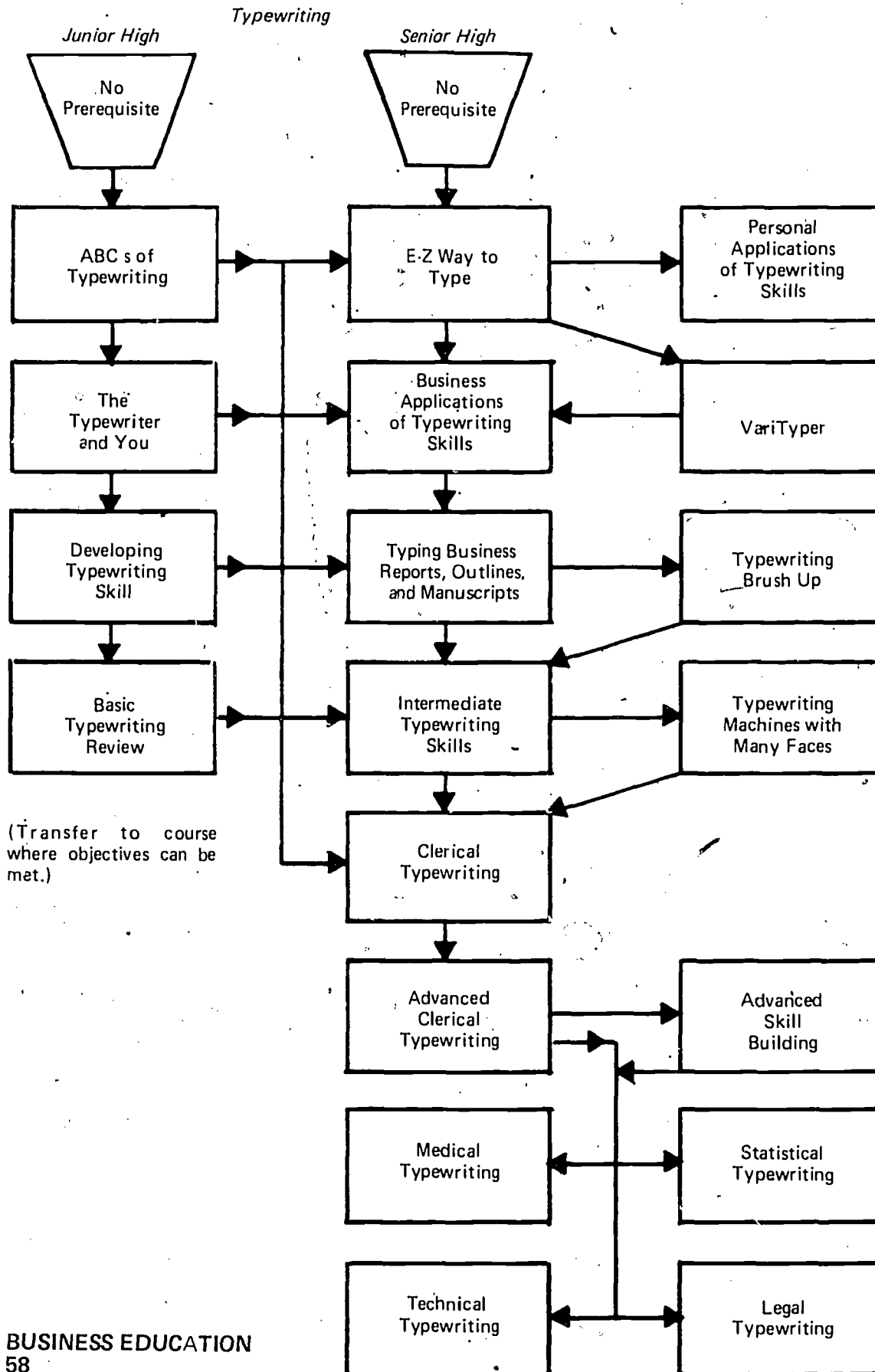



# BUSINESS EDUCATION

## FLOW CHART FOR AREAS OF STUDY

### Office Machines—Office Practice

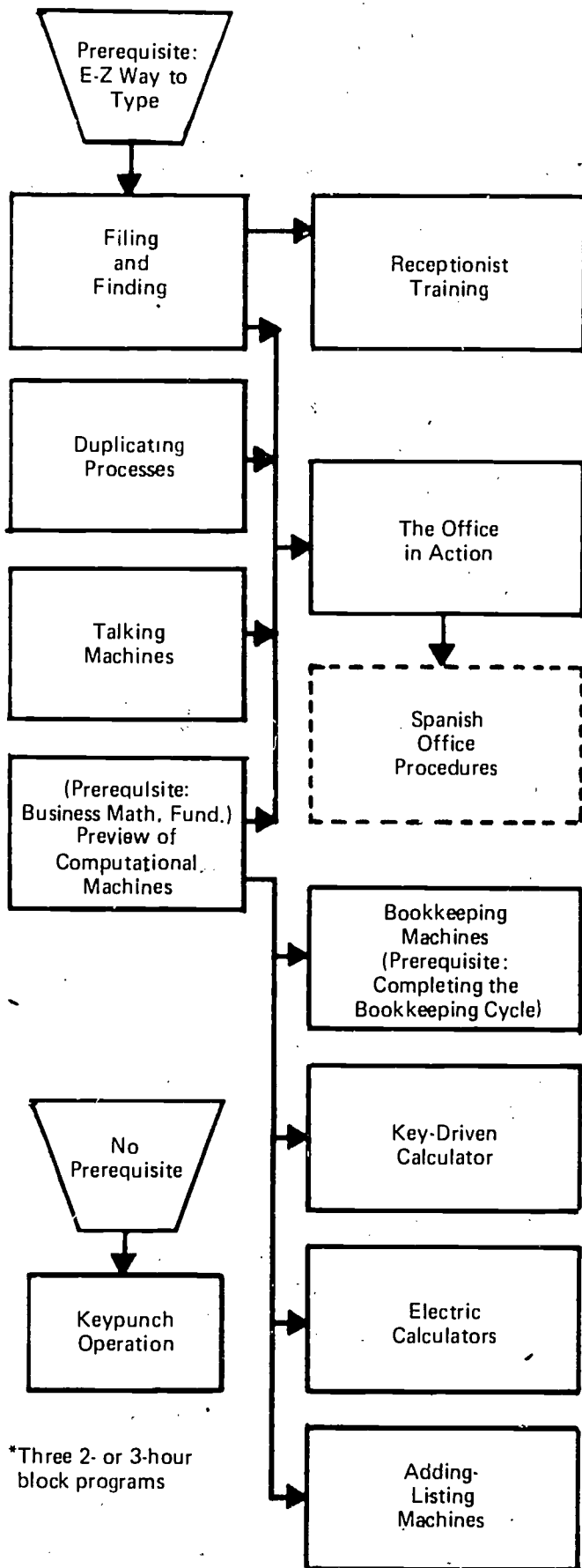

\*Three 2- or 3-hour block programs

### \*Vocational Office Education Programs VOE Clerical VOE Secretarial (Add to VOE Clerical)

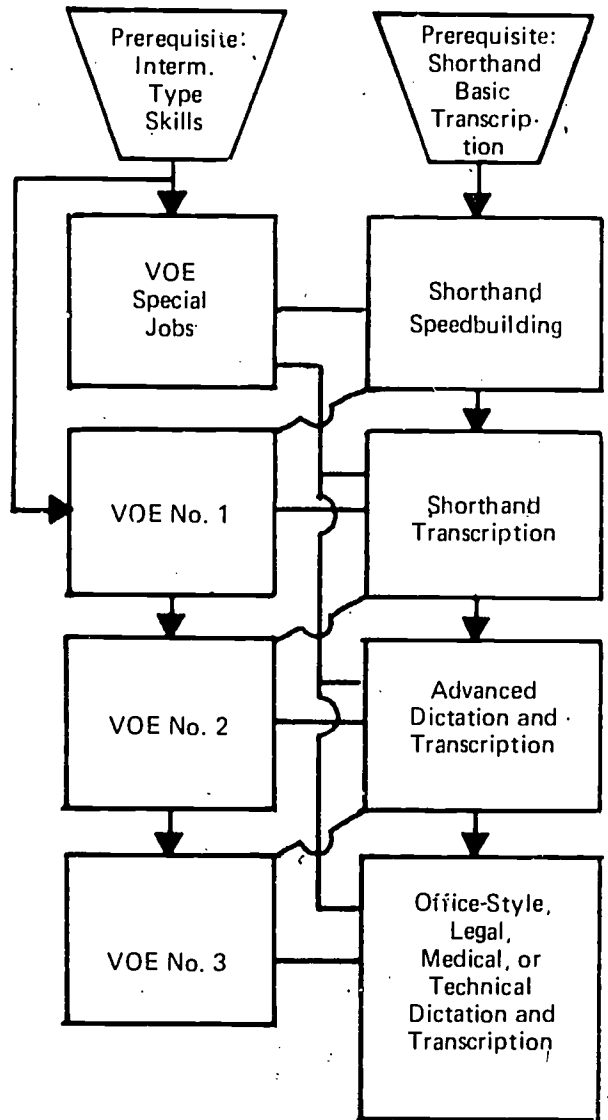

### Office Career Occupations (9th grade)

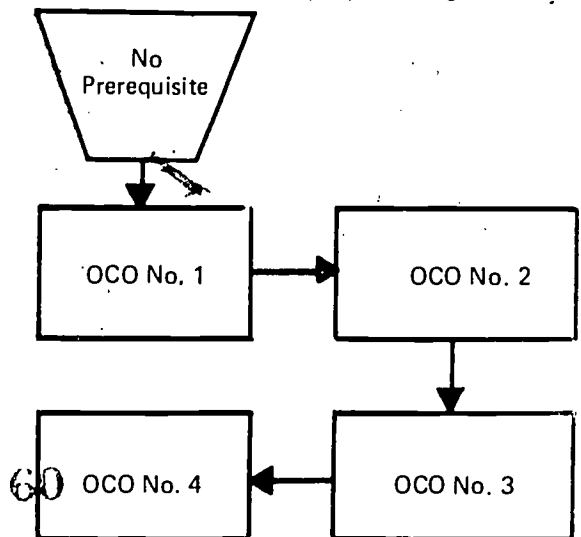

**BUSINESS EDUCATION**  
**FLOW CHART FOR AREAS OF STUDY**

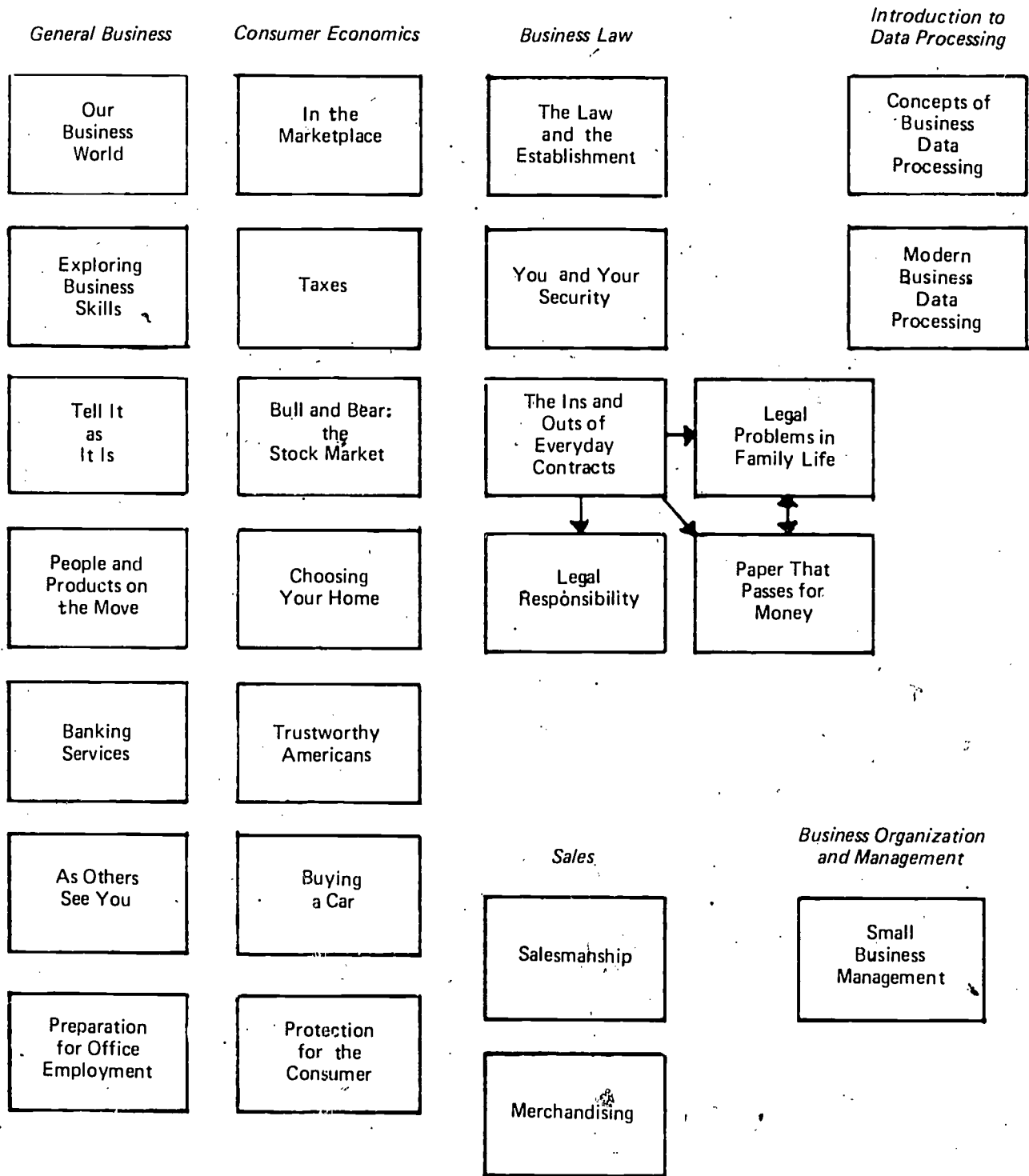
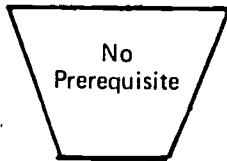

**BUSINESS EDUCATION**  
**FLOW CHART FOR AREAS OF STUDY**

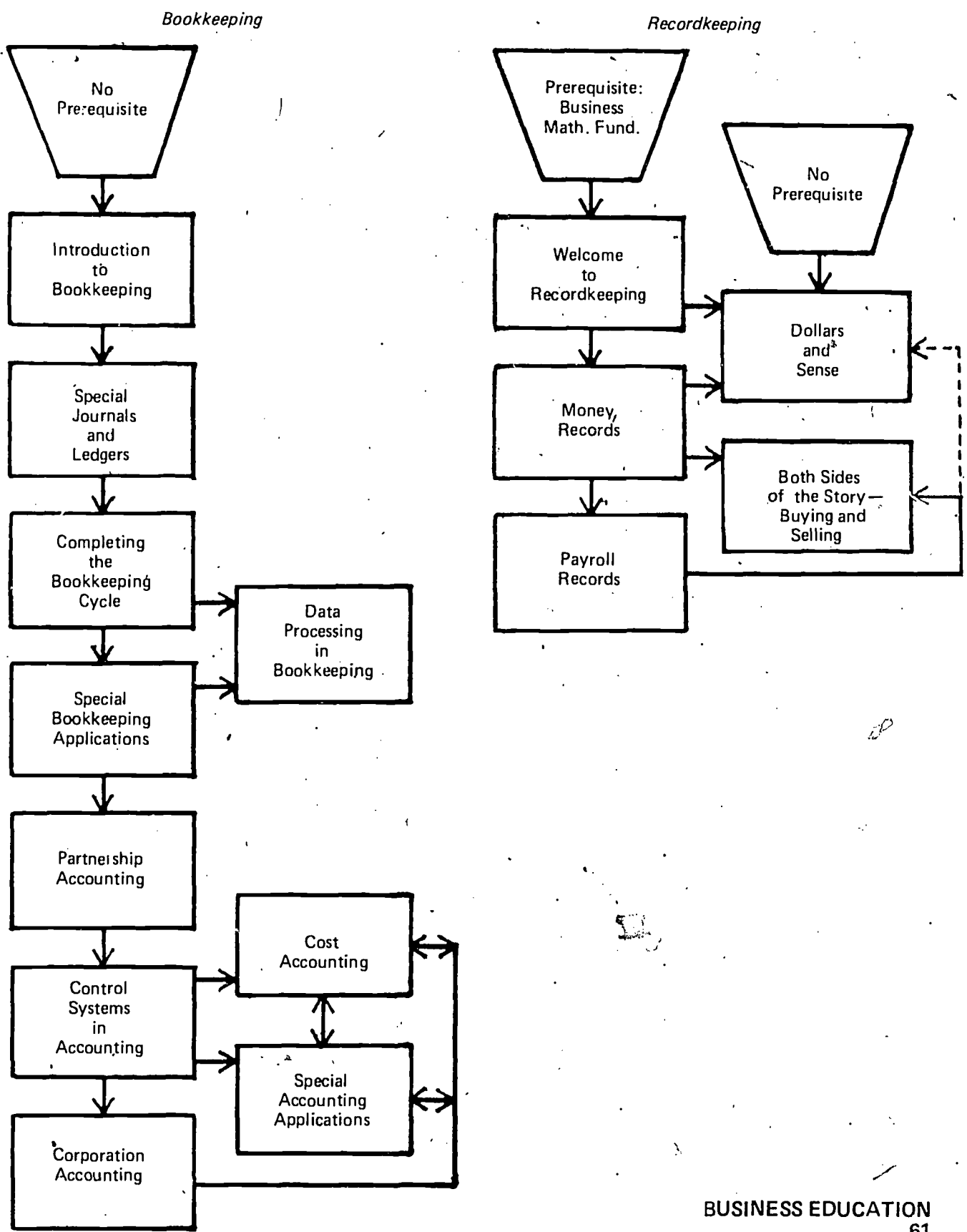

**BUSINESS EDUCATION  
FLOW CHART FOR AREAS OF STUDY**

*Business Math*

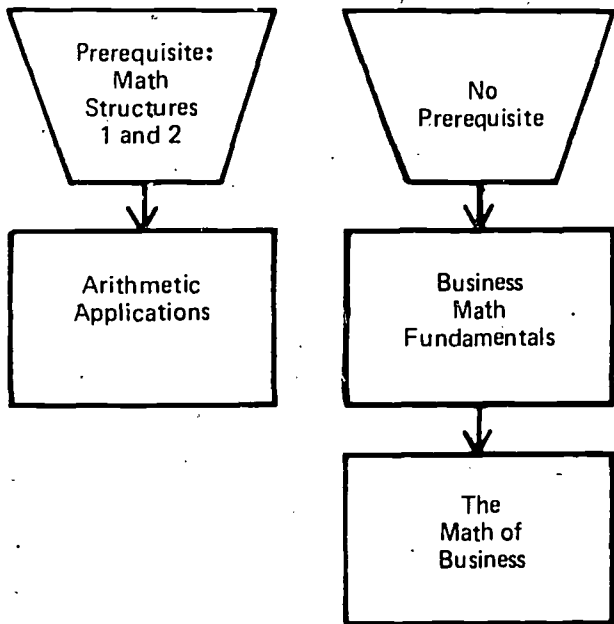

*Business English*

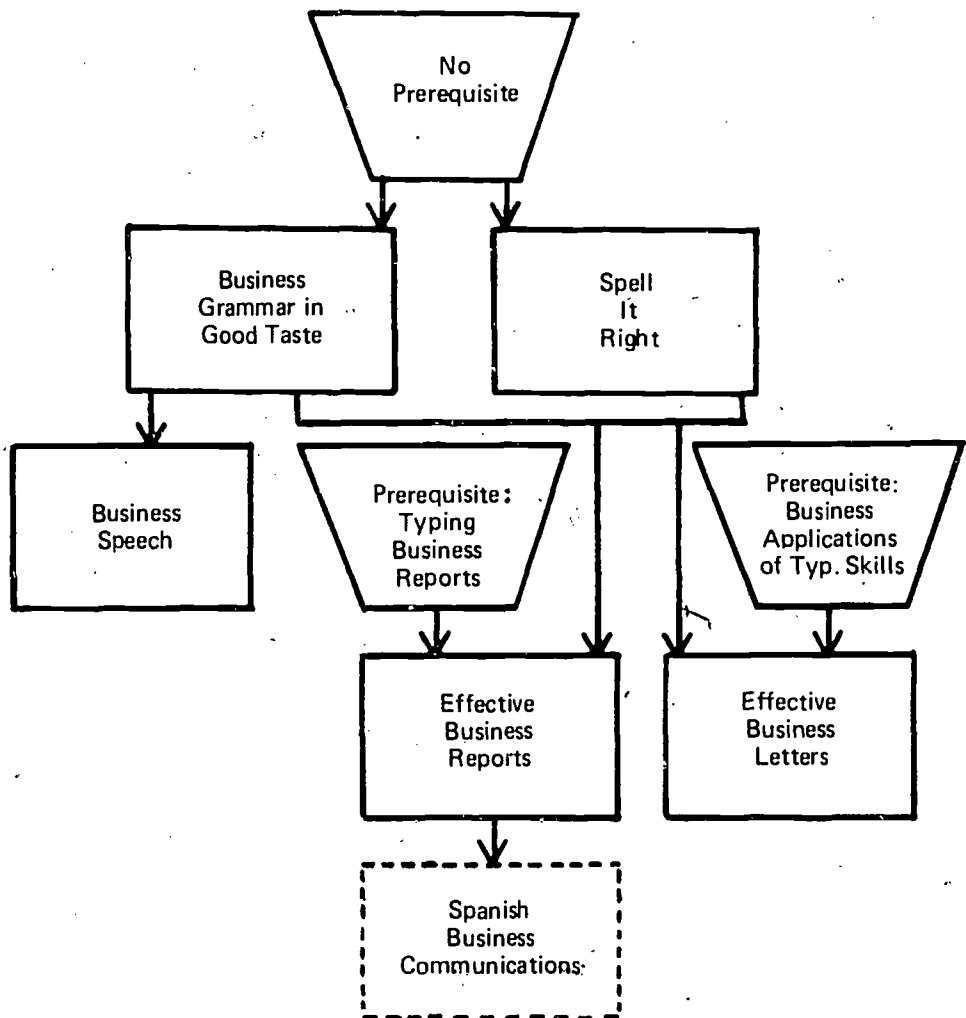

**BUSINESS EDUCATION**  
**FLOW CHART FOR AREAS OF STUDY**  
**SHCRTHAND**

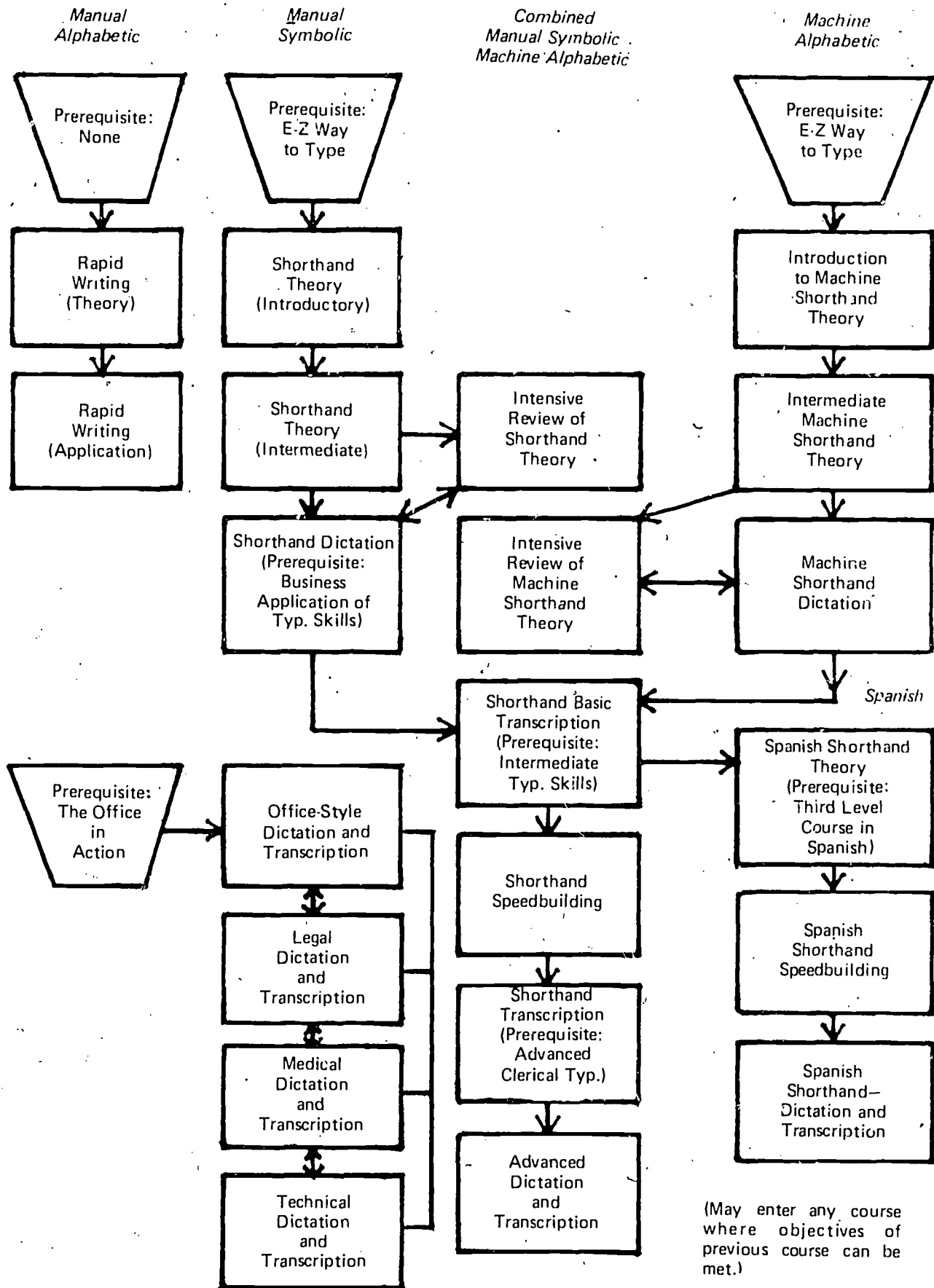

(May enter any course where objectives of previous course can be met.)

AREA	ACCR. NO. FLA-DADE	COURSE TITLE AND DESCRIPTION
BUSINESS EDUCATION	5128.11	BUSINESS GRAMMAR IN GOOD TASTE
LANGUAGE ARTS	5128.11	Equips students with the basic skill needed to apply grammar, punctuation, capitalization, abbreviations, and number style to simple business communications.
BUSINESS EDUCATION	5128.12	SPELL IT RIGHT
LANGUAGE ARTS	5128.12	Designed to help students achieve a high level of skill in vocabulary pertaining to business occupations. The course includes spelling rules, special aids in spelling, vocabulary and spelling drills consisting of general and specialized terms related to all phases of office occupations. Includes use of the dictionary and similar resource materials.
BUSINESS EDUCATION	5128.21	BUSINESS SPEECH
LANGUAGE ARTS	5128.21	Designed to help people in the business world. It includes preparing and delivering a speech and practicing simulated business situations that require skill in speaking; participating in a sales dialogue; leading committee and group discussions; conducting conferences and meetings; moderating programs; and oral reading of data, reports, and minutes of meetings. Emphasis is on the methods to use in preparing these forms of oral activities. Attention is given to pronunciation and vocabulary, enabling the student to use language which is clear, graphic, and persuasive.  The student should have attained the objectives of Business Grammar in Good Taste prior to enrollment in this course.
BUSINESS EDUCATION	5128.31	EFFECTIVE BUSINESS REPORTS
LANGUAGE ARTS	5128.31	Designed to provide students with the skill and knowledge needed to compose effective business reports, including format of a report, informal and formal reports, minutes of meetings, agendas, itineraries, news releases, and advertising copy.  The student should have attained the objectives of Business Grammar in Good Taste; Spell It Right; and Typing Business Reports, Outlines, and Manuscripts prior to enrollment in this course.

BUSINESS EDUCATION

64

AREA	ACCR. NO. FLA-DADE	COURSE TITLE AND DESCRIPTION
BUSINESS EDUCATION	5128.41	EFFECTIVE BUSINESS LETTERS
LANGUAGE ARTS	5128.41	<p>A review of business letter parts, placement, and punctuation; a study of qualities of effective business letters; application in the composition of business letters: remittance, order, acknowledgment, general response, claim and adjustment, credit and collection, sales, employment, public relations, and social-business letters, announcements, and invitations.</p> <p>The student should have attained the objectives of Business Grammar in Good Taste, Spell It Right, and Business Applications of Typewriting Skills prior to enrollment in this course.</p>
BUSINESS EDUCATION	5283.01	† BUSINESS MATH FUNDAMENTALS
MATH	5283.01	<p>Designed to reinforce skills in addition, subtraction, multiplication, division, percentages, decimals, fractions, whole and mixed numbers.</p>
BUSINESS EDUCATION	5283.11	† THE MATH OF BUSINESS
MATH	5283.11	<p>A fundamental review with emphasis on interest, markup, markdown, depreciation, discounts and commissions. The course includes shortcuts and rapid and mental calculations used in advanced business courses. The student should have attained the objectives of Business Math Fundamentals prior to enrollment in this course.</p>
BUSINESS EDUCATION	5283.21	ARITHMETIC APPLICATIONS
MATH	5211.63 5212.63 5213.63	<p>This is a practical course designed for the student who will not cover practical topics in other courses. Includes study of stocks and bonds, interest, installment buying, budget, credit cards, checking and savings accounts, travel, time, latitude and longitude, calendar patterns, etc.</p> <p>Designed for the student who has mastered the skills described in Math Structures 1 and 2.</p>

AREA	ACCR. NO. FLA-DADE	COURSE TITLE AND DESCRIPTION
BUSINESS EDUCATION	8737.01	<p><b>SALESMANSHIP</b></p> <p>Serves students who are planning to be salesmen, as well as those pupils interested in salesmanship from a consumer's point of view; includes a study of the general principles and techniques of selling, consideration of selling as a career, class discussions, oral and written reports, and sales talks.</p>
BUSINESS EDUCATION	8738.01	<p><b>MERCHANDISING</b></p> <p>A study of the techniques for making goods and services available to the consumer, with emphasis on retailing; guidance information as well as training for beginning retail workers. Includes a study of distribution of merchandise from retailer to consumer; basic discussion of the functions of recordkeeping and planning; government regulation of distribution; and information on job opportunities, potential for advancement, and personal qualifications.</p>
BUSINESS EDUCATION HOME AND FAMILY ED. MATH.	6463.01 5283.23 6765.03 5283.23	<p><b>IN THE MARKETPLACE</b></p> <p>Focuses on comparison shopping, store etiquette, impulse buying, reading labels, specials, loss leaders, standards in relation to need, installment or cash costs.</p>
BUSINESS EDUCATION SOCIAL STUDIES MATH	6463.02 5283.24 6463.02 6448.67 5283.24	<p><b>TAXES</b></p> <p>Explores questions of why we have taxes and how they benefit people; taxes at local, state, and federal levels; property, sales, income, excise, inheritance taxes.</p>
BUSINESS EDUCATION SOCIAL STUDIES	6463.03 6448.13 6446.17 6473.04 6463.03 6416.48	<p>† <b>BULL AND BEAR: THE STOCK MARKET</b></p> <p>Designed to provide students with an understanding of how the stock market works. Content includes investing; types of stocks, market fluctuations, influence of government on the market, reading the financial pages of the newspapers, and relationship of industry and business to market activity.</p>



AREA	ACCR. NO. FLA-DADE	COURSE TITLE AND DESCRIPTION
BUSINESS EDUCATION	6463.04	CHOOSING YOUR HOME
HOME AND FAMILY ED.	6764.02	Explores the choices available for selecting and financing a first home. Topics will include how people are housed, our heritage, housing values and their influence on behavior, types of housing available in the community, styles of architecture, buying vs. renting, and the factors to consider when landscaping and maintaining a home.
BUSINESS EDUCATION	6463.05	TRUSTWORTHY AMERICANS
		The extent of credit in the United States, its effect on individuals, on the national economy, and on business; types of credit plans; sources of credit.
BUSINESS EDUCATION	6463.06 5283.25	BUYING A CAR
		New or used? dollar value according to need; operating costs; financing; insurance; maintenance; storage. Designed for the pupil who needs motivation for learning economic concepts and simple recordkeeping.
BUSINESS EDUCATION	6463.07	PROTECTION FOR THE CONSUMER
		Federal and state regulation of industry operation and advertising; federal, state, and city agencies for consumer protection; private and business-sponsored organizations for consumer protection; and rights and responsibilities of the consumer.
BUSINESS EDUCATION	7701.01	† ABCs OF TYPEWRITING
		Designed to help junior high school students master touch typewriting, use operative parts of the machine, develop acceptable techniques and work habits, learn to listen and follow instructions, do simple centering and tabulation problems, practice word division, and gain speed and accuracy in straight-copy typewriting.

AREA

ACCR. NO.  
FLA-DADE

COURSE TITLE AND DESCRIPTION

BUSINESS  
EDUCATION

7701.02

THE TYPEWRITER AND YOU

The junior high student types postal cards, personal announcements, memorandums, personal notes, personal business letters, punctuation rules, envelopes, and learns the parts of letters, letter styles, folding of letters, proofreading, and erasing. The student will also learn to compose at the typewriter.

Students should have attained the objectives of ABCs of Typewriting prior to enrollment in this course.

BUSINESS  
EDUCATION

7701.03

DEVELOPING TYPEWRITING SKILL

The junior high student types reports and themes, title pages, footnotes, bibliographies, carbon copies, headings, and subheadings, and uses margins, pagination, and erasing. Emphasis is placed on speed and accuracy, the application of typewriting rules, and the advanced applications of typewriting skills.

Students should have attained the objectives of ABCs of Typewriting prior to enrollment in this course.

BUSINESS  
EDUCATION

7701.04

BASIC TYPEWRITING REVIEW

Designed as a review or reinforcement for junior high students who feel a need for additional help in mastering the basic skills required by a typist.

Students should have attained the objectives of ABCs of Typewriting prior to enrollment in this course.

BUSINESS  
EDUCATION

7704.11

† E-Z WAY TO TYPE

This course provides a strong foundation on which vocational or personal typewriting can be built. The student will develop ability to operate the typewriter by touch, center material horizontally and vertically, type simple tabulation problems, divide words correctly, apply typewriting rules, use proper typewriting techniques, and follow directions.

BUSINESS EDUCATION

68

69

AREA	ACCR. NO. FLA-DADE	COURSE TITLE AND DESCRIPTION
BUSINESS EDUCATION	7703.21	<p data-bbox="851 447 1591 506">PERSONAL APPLICATIONS OF TYPEWRITING SKILLS</p> <p data-bbox="851 537 1591 721">For students interested in using typewriting for personal use. Includes memorandums, postal cards, announcements, manuscripts, reports, personal business letters, envelopes, two letter styles, two punctuation styles, outlines, carbon copies, erasing techniques, proofreading symbols, rough draft typewriting, and composing at the typewriter.</p> <p data-bbox="851 752 1591 811">Students should have attained the objectives of E-Z Way to Type prior to enrollment in this course.</p>
BUSINESS EDUCATION	7704.21	<p data-bbox="851 875 1591 906">BUSINESS APPLICATIONS OF TYPEWRITING SKILLS</p> <p data-bbox="851 937 1591 1144">For the student interested in typewriting for vocational use. Includes carbon copies, envelopes, postal cards, announcements, memorandums, and two styles of business letters. Also includes activities such as proofreading, erasing, improvement of punctuation and capitalization skills, dictation, and composition at the typewriter, and preparation of stencils and masters for duplication.</p> <p data-bbox="851 1175 1591 1239">Students should have attained the objectives of E-Z Way to Type prior to enrollment in this course.</p>
BUSINESS EDUCATION	7704.22	<p data-bbox="851 1304 1591 1335">VARITYPER</p> <p data-bbox="851 1366 1591 1513">Individualized instruction for the student interested in learning to prepare material for reproduction. This is a specialized machine for automatic adjustment of margins; uses a variety of type styles. Typewriting speed is not required.</p> <p data-bbox="851 1544 1591 1601">The student should have attained the objectives of E-Z Way to Type prior to enrollment in this course.</p>
BUSINESS EDUCATION	7704.31	<p data-bbox="851 1661 1591 1720">TYPING BUSINESS REPORTS, OUTLINES, AND MANUSCRIPTS</p> <p data-bbox="851 1751 1591 1870">Vocational preparation for typing business reports, outlines, and manuscripts. Includes typing from rough drafts, using proofreading symbols, and setting up tabulated material with subheadings.</p> <p data-bbox="851 1901 1591 1982">The student should have attained the objectives of Business Applications of Typewriting Skills prior to enrollment in this course.</p>

BUSINESS EDUCATION  
69

AREA	ACCR. NO. FLA-DADE	COURSE TITLE AND DESCRIPTION
BUSINESS EDUCATION	7704.41	<p data-bbox="802 464 1354 495"><b>INTERMEDIATE TYPEWRITING SKILLS</b></p> <p data-bbox="802 525 1551 673">The student is expected to achieve minimum skill and knowledge needed for a beginning typist's position. He will be able to apply these skills to production problems. Emphasis is placed on building speed and accuracy, and the introduction of office techniques.</p> <p data-bbox="802 704 1551 792">The student should have attained the objectives of Typing Business Reports, Outlines, and Manuscripts prior to enrollment in this course.</p>
BUSINESS EDUCATION	7704.42	<p data-bbox="802 852 1161 882"><b>TYPEWRITING BRUSH UP</b></p> <p data-bbox="802 913 1551 1037">A review clinic for basic typing employability skills as a basis for further skill development. This course will be beneficial for students who have been trained in typewriting but have not used this skill recently.</p>
BUSINESS EDUCATION	7705.11	<p data-bbox="802 1097 1161 1128"><b>CLERICAL TYPEWRITING</b></p> <p data-bbox="802 1159 1551 1309">Continuation of skill development for greater occupational competency. Includes problems in typing advertising copy and news releases, agendas, minutes of meetings; tabulation problems with main, secondary, and columnar headings; itineraries; and financial statements.</p> <p data-bbox="802 1339 1551 1428">The student should have attained the objectives of Intermediate Typewriting Skills prior to enrollment in this course.</p>
BUSINESS EDUCATION	7705.12	<p data-bbox="802 1487 1458 1518"><b>TYPEWRITING MACHINES WITH MANY FACES</b></p> <p data-bbox="802 1549 1551 1699">The student operates three or more special typewriting machines: interchangeable type, nonmovable carriage, proportional-space, automatic margin justification, automatic typewriters, composing machines, and others that may be available.</p> <p data-bbox="802 1730 1551 1820">The student should have attained the objectives of Intermediate Typewriting Skills prior to enrollment in this course.</p>

AREA	ACCR. NO. FLA-DADE	COURSE TITLE AND DESCRIPTION
BUSINESS EDUCATION	7705.21	<p><b>ADVANCED CLERICAL TYPEWRITING</b></p> <p>Practical application of typewriting skills to forms used in offices. Emphasis on speed and accuracy in applying typewriting skills to production problems.</p> <p>The student should have attained the objectives of Clerical Typewriting prior to enrollment in this course.</p>
BUSINESS EDUCATION	7705.31	<p><b>ADVANCED TYPEWRITING SKILL BUILDING</b></p> <p>For the student interested in obtaining high speed with control. Includes drills that will enable the student to prepare more complex business forms and reports with a high degree of speed and accuracy. This is a culminating basic course for vocational competency; advanced courses are available for specialized applications.</p> <p>The student should have attained the objectives of Advanced Clerical Typewriting prior to enrollment in this course.</p>
BUSINESS EDUCATION	7705.32	<p><b>MEDICAL TYPEWRITING</b></p> <p>A course for the student interested in seeking employment as a medical records clerk in a medical office or a hospital. The course includes instruction enabling the student to prepare all types of medical forms and reports, spell and use medical terminology correctly, and transfer medical information from one form to another.</p> <p>The student should have attained the objectives of Advanced Clerical Typewriting prior to enrollment in this course.</p>
BUSINESS EDUCATION	7705.33	<p><b>STATISTICAL TYPEWRITING</b></p> <p>A course enabling the student to qualify for employment as a typist whose duties include typewriting of tabulated material, tables, and special problems consisting mainly of numbers, as in insurance, accounting, or brokerage offices.</p> <p>The student should have attained the objectives of Advanced Clerical Typewriting prior to enrollment in this course.</p>

BUSINESS EDUCATION

71

AREA.	ACCR. NO. FLA-DADE	COURSE TITLE AND DESCRIPTION
BUSINESS EDUCATION	7705.34	<p><b>TECHNICAL TYPEWRITING</b></p> <p>A course for the student who desires employment as a typist in a science-related office. Emphasis on rapid and correct typing of scientific expressions with correct spelling and use of scientific and technical terminology, as in electronics or marine science offices.</p> <p>The student should have attained the objectives of Advanced Clerical Typewriting prior to enrollment in this course.</p>
BUSINESS EDUCATION	7705.35	<p><b>LEGAL TYPEWRITING</b></p> <p>A course to help the student qualify for employment as a typist in a legal office. Instruction is given to enable the student to prepare all types of legal documents, spell and use legal terminology correctly, and transfer legal information from one document to another.</p> <p>The student should have attained the objectives of Advanced Clerical Typewriting prior to enrollment in this course.</p>
BUSINESS EDUCATION	7735.01	<p><b>RAPID WRITING (THEORY)</b></p> <p>The student will be introduced to the basic principles of a brief writing system based on the alphabet in preparation for abstracting notes from reading and listening.</p>
BUSINESS EDUCATION	7735.02	<p><b>RAPID WRITING (APPLICATION)</b></p> <p>Designed to help the student make application of his skill in rapid writing. It includes an extension of basic principles, exercises in taking notes from readings and lectures, and organization of material for research papers.</p> <p>The student should have attained the objectives of Rapid Writing (Theory) prior to enrollment in this course.</p>

AREA	ACCR. NO. FLA-DADE	COURSE TITLE AND DESCRIPTION
BUSINESS EDUCATION	7706.11	<p data-bbox="772 447 1351 478"><b>SHORTHAND THEORY (INTRODUCTORY)</b></p> <p data-bbox="772 509 1512 685">Symbolic manual shorthand in which the student reads and writes characters that represent sounds. This course includes reading from plates in the textbook, drill on basic brief forms, the formulation of characters in writing, transcription at the typewriter of isolated words and short phrases in the textbook, and oral spelling.</p> <p data-bbox="772 716 1512 835">The student should have attained the objectives of E-Z Way to Type prior to enrollment in this course. Grades in English that are average or better are important to success in Shorthand.</p>
BUSINESS EDUCATION	7706.21	<p data-bbox="772 899 1340 930"><b>SHORTHAND THEORY (INTERMEDIATE)</b></p> <p data-bbox="772 961 1512 1109">A continuation of Introductory Shorthand Theory with further emphasis on vocabulary development, spelling, and punctuation. The student will begin taking dictation on familiar material and transcribing his homework at the typewriter.</p>
BUSINESS EDUCATION	7706.31	<p data-bbox="772 1173 1130 1204"><b>SHORTHAND DICTATION</b></p> <p data-bbox="772 1235 1512 1323">This course reinforces shorthand theory and emphasizes speed and accuracy in dictation and transcription at the typewriter from class-dictated, but studied, material.</p> <p data-bbox="772 1354 1512 1466">The student should have attained the objectives of Shorthand Theory (Intermediate) and Business Applications of Typewriting Skills prior to enrollment in this course.</p>
BUSINESS EDUCATION	7706.32	<p data-bbox="772 1530 1422 1561"><b>INTENSIVE REVIEW OF SHORTHAND THEORY</b></p> <p data-bbox="772 1592 1512 1649">Designed for students who want to review shorthand theory to prepare for advanced courses.</p>
BUSINESS EDUCATION	7706.12	<p data-bbox="736 1708 1512 1763">† <b>INTRODUCTION TO MACHINE SHORTHAND THEORY</b></p> <p data-bbox="772 1794 1512 1882">Introduces the principles of expressing sounds by touch operation of a shorthand machine, and practice in spelling, reading, and transcribing machine-recorded notes.</p> <p data-bbox="772 1913 1512 2034">The student should have attained the objectives of E-Z Way to Type prior to enrollment in this course. Average or better grades in English are important to success in Machine Shorthand.</p>

BUSINESS EDUCATION

73

AREA	ACCR. NO. FLA-DADE	COURSE TITLE AND DESCRIPTION
BUSINESS EDUCATION	7706.22	<p><b>INTERMEDIATE MACHINE SHORTHAND THEORY</b></p> <p>A continuation of machine shorthand theory with emphasis on vocabulary development, spelling, punctuation, and application of principles of grammar.</p> <p>The student should have attained the objectives of Introduction to Machine Shorthand Theory prior to enrollment in this course.</p>
BUSINESS EDUCATION	7706.33	<p><b>MACHINE SHORTHAND DICTATION</b></p> <p>Designed to reinforce machine shorthand theory with emphasis on taking dictation with speed and accuracy.</p> <p>The student should have attained the objectives of Intermediate Machine Shorthand Theory prior to enrollment in this course.</p>
BUSINESS EDUCATION	7706.34	<p><b>INTENSIVE REVIEW OF MACHINE SHORTHAND THEORY</b></p> <p>Designed to review machine shorthand theory on an advanced basis for students who feel a need for further basic theory or additional skill building to prepare for advanced courses.</p> <p>The student should have attained the objectives of Intermediate Machine Shorthand Theory prior to enrollment in this course.</p>
BUSINESS EDUCATION	7706.41	<p><b>SHORTHAND BASIC TRANSCRIPTION</b></p> <p>A course to help students develop speed and accuracy in taking verbatim dictation, with emphasis on combining typewriting and shorthand skills in transcription of new matter dictation. The course is prescribed for manual and machine shorthand students who will apply individual methods of taking dictation with typewritten copies as the finished product.</p> <p>The student should have attained the objectives of Shorthand Dictation or Machine Shorthand Dictation and Intermediate Typewriting Skills prior to enrollment in this course.</p>



AREA	ACCR. NO. FLA-DADE	COURSE TITLE AND DESCRIPTION
BUSINESS EDUCATION	7707.11	<p><b>SHORTHAND SPEEDBUILDING</b></p> <p>For manual or machine shorthand students to develop further the ability to construct outlines under stress of dictation at 80-100 words a minute; to increase the student's ability in spelling, punctuating, and using proper grammar.</p> <p>The student should have attained the objectives of Shorthand Basic Transcription prior to enrollment in this course.</p>
BUSINESS EDUCATION	7707.21	<p><b>SHORTHAND TRANSCRIPTION</b></p> <p>For manual or machine shorthand student to develop efficient transcription techniques for producing mailable copies with speed and accuracy. There is continued emphasis on vocabulary building, proofreading, and making neat corrections.</p> <p>The student should have attained the objectives of Shorthand Speedbuilding and Advanced Clerical Typewriting prior to enrollment in this course.</p>
BUSINESS EDUCATION	7707.31	<p><b>ADVANCED DICTATION AND TRANSCRIPTION</b></p> <p>Further develops speed and accuracy in taking dictation and in transcribing notes; develops desirable personal traits and awareness of responsibility for proofreading and correcting errors before submitting typewritten transcripts for approval.</p> <p>The student should have attained the objectives of Shorthand Transcription prior to enrollment in this course.</p>
BUSINESS EDUCATION	7707.41	<p><b>OFFICE-STYLE DICTATION AND TRANSCRIPTION</b></p> <p>A specialized course in recording basic business terms in shorthand. An intensive practice in taking dictation and transcribing materials related to a variety of business transactions with a high degree of speed and accuracy. The course includes the spelling, pronunciation, and definitions of the most-used business terms, preparation of a variety of office forms, and the procedures and ethics of a good secretary.</p> <p>The student should have attained the objectives of Advanced Dictation and Transcription and The Office in Action prior to enrollment in this course.</p>

BUSINESS EDUCATION

75

AREA	ACCR. NO. FLA-DADE	COURSE TITLE AND DESCRIPTION
BUSINESS EDUCATION	7707.42	<p data-bbox="763 449 1354 479"><b>LEGAL DICTATION AND TRANSCRIPTION</b></p> <p data-bbox="763 508 1517 660">Intensive practice in taking dictation and transcribing dictation of materials related to the legal profession with a high degree of speed and accuracy. The course includes spelling, pronouncing, and defining the most-used legal terms, and the procedures and ethics of the legal secretary.</p> <p data-bbox="763 689 1517 778">The student should have attained the objectives of Advanced Dictation and Transcription prior to enrollment in this course.</p>
BUSINESS EDUCATION	7707.43	<p data-bbox="763 837 1394 867"><b>MEDICAL DICTATION AND TRANSCRIPTION</b></p> <p data-bbox="763 896 1517 1084">Intensive practice in taking dictation and transcribing materials related to the medical profession with a high degree of speed and accuracy. Includes spelling, pronouncing, and defining the most-used medical terms, preparation of a variety of medical forms, and the procedures and ethics of the medical secretary.</p> <p data-bbox="763 1112 1517 1201">The student should have attained the objectives of Advanced Dictation and Transcription prior to enrollment in this course.</p>
BUSINESS EDUCATION	7707.44	<p data-bbox="763 1260 1430 1291"><b>TECHNICAL DICTATION AND TRANSCRIPTION</b></p> <p data-bbox="763 1319 1517 1531">A specialized course in recording basic technical and scientific terms in shorthand. Intensive practice in taking dictation and transcribing materials related to these areas with a high degree of speed and accuracy. Includes spelling, pronouncing, and defining the most-used technical and scientific terms, also the role and ethics of a good secretary.</p> <p data-bbox="763 1559 1517 1648">The student should have attained the objectives of Advanced Dictation and Transcription prior to enrollment in this course.</p>
BUSINESS EDUCATION	7734.11	<p data-bbox="763 1707 1220 1738"><b>WELCOME TO RECORDKEEPING</b></p> <p data-bbox="763 1766 1517 1895">Concentrates on the fundamentals of single-entry recordkeeping, filing procedures, verification of names and numbers, introduction to forms and ruling, and improvement of penmanship.</p> <p data-bbox="763 1923 1517 2013">The student should have attained the objectives of Business Math Fundamentals prior to enrollment in this course.</p>

AREA	ACCR. NO. FLA-DADE	COURSE TITLE AND DESCRIPTION
BUSINESS EDUCATION	7734.21	<p><b>MONEY RECORDS</b></p> <p>Students will develop the ability to prepare receipts and vouchers, complete sales slips and credit slips, count and wrap money, prove cash, figure employee discounts, and determine refunds. Includes use of the autograph and cash registers and any other machines that require the preparation of money records.</p> <p>The student should have attained the objectives of Welcome to Recordkeeping prior to enrollment in this course.</p>
BUSINESS EDUCATION HOME AND FAMILY ED. MATH	7734.22 5283.22 6765.01 5283.22	<p>† <b>DOLLARS AND SENSE</b></p> <p>The student will plan the management of his or her money to get the most personal satisfaction from it. The course includes influence of teen-age spending on the economy, understanding and keeping money records, developing skill in decision making, and planning as a consumer.</p>
BUSINESS EDUCATION	7734.31	<p><b>PAYROLL RECORDS</b></p> <p>Acquaints students with different types of payroll records and gives them experience in preparing time cards, using charts to figure taxes, making appropriate deductions, and completing records for government requirements.</p> <p>The student should have attained the objectives of Money Records prior to enrollment in this course.</p>
BUSINESS EDUCATION	7734.32	<p><b>BOTH SIDES OF THE STORY—BUYING AND SELLING</b></p> <p>A study of records that deal with buying and selling at retail and wholesale levels. Includes invoices, statements, charge sales, cash sales, sales taxes, and returns.</p> <p>The student should have attained the objectives of Money Records prior to enrollment in this course.</p>
BUSINESS EDUCATION	7708.11	<p>† <b>INTRODUCTION TO BOOKKEEPING</b></p> <p>Beginning a double-entry bookkeeping system: assets, liabilities, and capital; expenses and income; balance sheet and income statements; journalizing and posting; trial balance and post-closing; trial balance; 6-column worksheet; closing entries; ruling and balancing accounts. Students who have not maintained a C or above average are encouraged to enroll in Welcome to Recordkeeping.</p>

78

AREA	ACCR. NO. FLA-DADE	COURSE TITLE AND DESCRIPTION
BUSINESS EDUCATION	7708.21	<p data-bbox="772 471 1274 502"><b>SPECIAL JOURNALS AND LEDGERS</b></p> <p data-bbox="772 530 1507 680">Designed to help students develop competence in the use of special journals and ledgers. Emphasis on cash receipts, cash payments, general purchases, and sales journals. Students will begin a practice set involving special journals and ledgers.</p> <p data-bbox="772 709 1507 799">The student should have attained the objectives of Introduction to Bookkeeping prior to enrollment in this course.</p>
BUSINESS EDUCATION	7708.31	<p data-bbox="772 863 1345 894"><b>COMPLETING THE BOOKKEEPING CYCLE</b></p> <p data-bbox="772 923 1507 1109">Preparation of payroll records, 8-column worksheet with adjustments (figuring income or loss, inventory and prepaid expenses), analyzing of profit or loss, financial reports from the worksheet, adjusting entries. Includes petty cash, returns, and discounts, completion of the practice set started in the preceding course.</p> <p data-bbox="772 1137 1507 1263">The student should have attained the objectives of Special Journals and Ledgers prior to enrollment in this course. It is recommended that the student attain the objectives of Payroll Records prior to enrollment in this course.</p>
BUSINESS EDUCATION	7708.41	<p data-bbox="772 1316 1327 1347"><b>SPECIAL BOOKKEEPING APPLICATIONS</b></p> <p data-bbox="772 1375 1507 1501">Various methods of handling, paying, and recording taxes; fixed assets and their disposal; depreciation; losses due to bad debts; various types of notes; and accrued interest and expense.</p> <p data-bbox="772 1530 1507 1620">The student should have attained the objectives of Completing the Bookkeeping Cycle prior to enrollment in this course.</p>
BUSINESS EDUCATION	7708.42	<p data-bbox="772 1673 1300 1704"><b>DATA PROCESSING IN BOOKKEEPING</b></p> <p data-bbox="772 1732 1507 1858">Introduction to manual data processing, including pegboard, keysort, bookkeeping machines, automated data processing, tabulating systems, and electric computer systems.</p> <p data-bbox="772 1887 1507 2042">The student should have attained the objectives of Completing the Bookkeeping Cycle prior to enrollment in this course. It is recommended that the student attain the objectives of Introduction to Data Processing prior to enrollment in this course.</p>

BUSINESS EDUCATION

AREA	ACCR. NO. FLA-DADE	COURSE TITLE AND DESCRIPTION
BUSINESS EDUCATION	7709.11	<p><b>PARTNERSHIP ACCOUNTING</b></p> <p>Provides students with an understanding of the financial activities of partnerships, division of income or loss, fiscal period reports, and federal income taxes. Students complete a partnership practice set.</p> <p>The student should have attained the objectives of Special Bookkeeping Applications prior to enrollment in this course.</p>
BUSINESS EDUCATION	7709.21	<p><b>CONTROL SYSTEMS IN ACCOUNTING</b></p> <p>Prepares the student to maintain voucher systems, inventory and budgetary controls; includes notes, drafts, and business taxes.</p> <p>The student should have attained the objectives of Partnership Accounting prior to enrollment in this course.</p>
BUSINESS EDUCATION	7709.31	<p><b>CORPORATION ACCOUNTING</b></p> <p>Students develop an understanding of the organization of corporations, corporate stock and bond transactions, fiscal reports, income tax returns, and dividends. Students also analyze financial statements and complete a corporation practice set.</p> <p>The student should have attained the objectives of Control Systems in Accounting prior to enrollment in this course.</p>
BUSINESS EDUCATION	7709.41	<p><b>COST ACCOUNTING</b></p> <p>Provides students with an understanding of cost accounting principles and procedures and sufficient background for applying factors of cost accounting to service and manufacturing businesses. Emphasis on overhead, materials, goods in process, and finished goods. Students complete a practice set for a manufacturing or similar business.</p> <p>The student should have attained the objectives of Control Systems in Accounting prior to enrollment in this course.</p>

BUSINESS EDUCATION

79

AREA	ACCR. NO. FLA-DADE	COURSE TITLE AND DESCRIPTION
BUSINESS EDUCATION	7709.42	<p>SPECIAL ACCOUNTING APPLICATIONS</p> <p>Sophisticated accounting procedures dealing with installment, C.O.D., and consignment sales; unit inventory control; electronic data processing; and the use of the computer for control. An appropriate practice set is recommended.</p> <p>The student should have attained the objectives of Control Systems in Accounting prior to enrollment in this course.</p>
BUSINESS EDUCATION	7711.01	<p>OUR BUSINESS WORLD</p> <p>An overview of the business world in which we live; characteristics of our free enterprise system (includes concept of profits); satisfaction of our wants and needs through production and distribution of goods and services; the organization of businesses (sole proprietorship, partnership, corporation, cooperative); effect of business activities on economic growth (includes use of natural resources and labor-management relations).</p>
BUSINESS EDUCATION	7713.11	<p>EXPLORING BUSINESS SKILLS</p> <p>Enables students to explore fields of work in the office occupations to determine their interests and aptitudes for shorthand, bookkeeping, salesmanship, and office procedures.</p>
BUSINESS EDUCATION LANGUAGE ARTS	7713.13 5113.131 5114.135 5115.150 5116.153	<p>TELL IT AS IT IS</p> <p>Designed to acquaint the student with the methods and art of business communications through oral, written, and visual means, including telephone techniques, letters, telegrams, telefax, posters, memos, and interpretation of business charts and graphs.</p>
BUSINESS EDUCATION	7713.14	<p>† PEOPLE AND PRODUCTS ON THE MOVE</p> <p>A study of the advantages and costs of various methods of travel and transportation for an individual, a businessman, and a product; includes time tables, shipping tables, maps, itineraries; transportation by auto, bus, train, plane, ship, truck, pipeline, and barge.</p>

AREA	ACCR. NO. FLA-DADE	COURSE TITLE AND DESCRIPTION
BUSINESS EDUCATION	7713.15	<b>BANKING SERVICES</b>  A course that gives students an insight into the personal and business services that banks provide. The course includes savings and checking accounts, loans, trusts, and safety deposit facilities.  It is recommended that the student attain the objectives of Money and Banking (Social Studies 6448.15) prior to enrollment in this course.
BUSINESS EDUCATION HEALTH	7713.49	<b>AS OTHERS SEE YOU</b>  Offers experiences in grooming and clothing selection and care to male and female students interested in self-improvement and good health. The relationship of personal well-being to success in personal, social, and occupational roles will be analyzed.
HOME AND FAMILY ED.	7391.05 7392.05 7393.05 7394.05 6763.04	
BUSINESS EDUCATION LANGUAGE ARTS	7713.50	<b>PREPARATION FOR OFFICE EMPLOYMENT</b>  A study of office employment opportunities in the local area and of the changing nature of employment and unemployment; types of office jobs and their requirements; steps for acquiring necessary skills; evaluation of personality characteristics needed for getting along with others in the working world; steps for securing a job (locating sources of information about jobs, writing a letter of application and a personal data sheet, preparing for employment tests and interviews, completing application forms); and an analysis of basic skills for civil service employment.  It is recommended that the student also attain the objectives of As Others See You.
BUSINESS EDUCATION	5113.133 5114.138 5115.153 5116.156	
BUSINESS EDUCATION	7715.01	<b>THE LAW AND THE ESTABLISHMENT</b>  An overview of the organization and operation of types of courts, the making of laws, the influence of administrative acts or individuals on legal procedures; includes laws concerning property, civil disobedience, employment, and vehicles.  It is recommended that the student also take Social Studies 6448.05 and 6448.06, The Supreme Court in American Life and Eye for an Eye: A History of Law.

AREA	ACCR. NO. FLA-DADE	COURSE TITLE AND DESCRIPTION
BUSINESS EDUCATION	7715.02	<p>YOU AND YOUR SECURITY</p> <p>The risks and realities of provisions for financial protection and future security; discusses the law and how it protects the individual; the contribution of state and federal governments to the rights and security of citizens; insurance: automobile, life, health and accident, and income; investment for future security.</p>
BUSINESS EDUCATION	7715.11	<p>THE "INS" AND "OUTS" OF EVERYDAY CONTRACTS</p> <p>A brief and comprehensive course covering the valid essentials of enforceable contracts; to be used as the basis for any future topics in the business law area.</p>
BUSINESS EDUCATION	7715.21	<p>LEGAL PROBLEMS IN FAMILY LIFE</p> <p>Acquaints students with the legal responsibilities connected with the family; relates these responsibilities to the laws of Florida; includes the relationship of laws to marriage, purchase, or rental of real property, debts, wills, and estates.</p> <p>The student should have attained the objectives of The "Ins" and "Outs" of Everyday Contracts, prior to enrollment in this course.</p>
BUSINESS EDUCATION	7715.22	<p>LEGAL RESPONSIBILITY</p> <p>Responsibility of the individual as it relates to others in regard to sales, warranties, employment, contracts, bailments, and agency relationships.</p> <p>The student should have attained the objectives of The "Ins" and "Outs" of Everyday Contracts prior to enrollment in this course.</p>
BUSINESS EDUCATION	7715.31	<p>PAPER THAT PASSES FOR MONEY</p> <p>Various kinds of papers (negotiable instruments) which are used in our economy to facilitate the circulation of funds for individuals and businesses.</p> <p>The student should have attained the objectives of The "Ins" and "Outs" of Everyday Contracts and also of Banking Services prior to enrollment in this course.</p>

BUSINESS EDUCATION

82



AREA	ACCR. NO. FLA-DADE	COURSE TITLE AND DESCRIPTION
BUSINESS EDUCATION	7718.01 5283.26	<p><b>PREVIEW OF COMPUTATIONAL MACHINES</b></p> <p>Acquaints students with the ten-key and full-key adding-listing machines; key-driven, rotary, printing, display calculators, and any other computational machines that may be available in the school's laboratory; however, there must be a minimum of four different types of computational machines. Emphasis is placed on basic operating procedures, use of special keys, and problems involving addition, subtraction, multiplication, and division.</p> <p>The student should have attained the objectives of Business Math Fundamentals prior to enrollment in this course.</p>
BUSINESS EDUCATION	7718.02	<p><b>TALKING MACHINES</b></p> <p>For students who desire special skills in the use of telephones, switchboards, intercoms, dictating machines, tape recorders, automatic answering services, and any special voice machines available in the school that do not require typewriters. Emphasis is placed on input.</p>
BUSINESS EDUCATION	7718.03	<p><b>DUPLICATING PROCESSES</b></p> <p>For students who desire special skills in the use of reproducing equipment. The special duplicating processes will include spirit, stencil, and thermal copier. Microfilm, offset, and other processes will also be studied. The student will use lettering devices, templates, and free-form drawing or tracing on stencils and masters. Typewriting skill is not required.</p> <p>For in-depth training in offset, Graphic Arts (Industrial Arts 5833.02) is recommended.</p>
BUSINESS EDUCATION	7718.04	<p><b>BOOKKEEPING MACHINES</b></p> <p>Students will use bookkeeping machines to make postings to accounts receivable, accounts payable, payroll, and other special applications for which the machine is suitable.</p> <p>The student should have attained the objectives of Preview of Computational Machines and Completing the Bookkeeping Cycle prior to enrollment in this course.</p>

AREA	ACCR. NO. FLA-DADE	COURSE TITLE AND DESCRIPTION
BUSINESS EDUCATION	7718.05	<p><b>KEY-DRIVEN CALCULATOR</b></p> <p>Designed to help students develop occupational proficiency in the use of the key-driven calculator to solve special business problems.</p> <p>The student should have attained the objectives of Preview of Computational Machines prior to enrollment in this course.</p>
BUSINESS EDUCATION	7718.06 5283.27	<p><b>ELECTRIC CALCULATORS</b></p> <p>Students will use printing, rotary, and electronic display calculators to solve special business problems with occupational proficiency.</p> <p>The student should have attained the objectives of Preview of Computational Machines prior to enrollment in this course.</p>
BUSINESS EDUCATION	7718.07 5283.28	<p><b>ADDING-LISTING MACHINES (TEN-KEY AND FULL-KEY)</b></p> <p>Students will develop mastery of the ten-key and full-key adding-listing machines in solving special business problems.</p> <p>The student should have attained the objectives of Preview of Computational Machines prior to enrollment in this course.</p>
BUSINESS EDUCATION	7718.08	<p><b>KEYPUNCH OPERATION</b></p> <p>Develops job-entry skills for position as keypunch operator. Good typing skills are required.</p> <p>The student should have attained the objectives of Intermediate Typewriting Skills prior to enrollment in this course.</p>
BUSINESS EDUCATION	7733.01	<p><b>FILING AND FINDING</b></p> <p>Includes aspects of filing, using alphabetic, subject, numeric, geographic, chronological systems; also includes organization and management of filing systems.</p> <p>The student should have attained the objectives of E-Z Way to Type or The Typewriter and You prior to enrollment in this course.</p>

AREA	ACCR. NO. FLA-DADE	COURSE TITLE AND DESCRIPTION
BUSINESS EDUCATION	7716.11	<p>THE OFFICE IN ACTION</p> <p>Provides students with an opportunity to apply acquired skills to various simulated office jobs.</p> <p>The student should have attained the objectives of Preview of Computational Machines, Talking Machines, Duplicating Processes, Filing and Finding, and Advanced Clerical Typewriting prior to enrollment in this course.</p>
BUSINESS EDUCATION	7716.12	<p>RECEPTIONIST TRAINING</p> <p>For students desiring knowledge and skill needed to perform basic reception duties. Includes instructions on handling telephone calls, petty cash, and simple typing jobs; making telephone calls, travel arrangements, and appointments; and receiving visitors.</p> <p>The student should have attained the objectives of Filing and Finding, and of Business Applications of Typewriting Skills (or Developing Typewriting Skill) prior to enrollment in this course. It is recommended that the student take As Others See You.</p>
BUSINESS EDUCATION FOREIGN LNG. SPANISH SPANISH-S	7707.12 7505.41 7509.79	<p>SPANISH SHORTHAND-THEORY</p> <p>Integration of English shorthand skills with Spanish shorthand characters; emphasis on Spanish brief forms, phrases, and abbreviations.</p> <p>The student should have attained the objectives of Shorthand Dictation, Shorthand Basic Transcription, and a third-level course in Spanish prior to enrollment in this course.</p>
BUSINESS EDUCATION FOREIGN LNG. SPANISH SPANISH-S	7707.22 7505.42 7509.80	<p>SPANISH SHORTHAND-SPEEDBUILDING</p> <p>Development of rapid writing skills with emphasis on spelling, vocabulary, Spanish business terms, punctuation, capitalization, and use of reference materials.</p> <p>The student should have attained the objectives of Spanish Shorthand-Theory prior to enrollment in this course.</p>

AREA	ACCR. NO. FLA-DADE	COURSE TITLE AND DESCRIPTION
BUSINESS EDUCATION FOREIGN LNG. SPANISH SPANISH-S	7707.32 7505.43 7509.81	<p>SPANISH SHORTHAND-DICTATION AND TRANSCRIPTION</p> <p>Application of skills and knowledge in transcribing Spanish dictation. The student will be able to distinguish between the proper term to be used in the translation and the mere verbatim translation of the written material. The course includes related inquiry into opportunity for employment and the ethics of the secretary.</p> <p>The student should have attained the objectives of Spanish Shorthand-Speedbuilding prior to enrollment in this course.</p>
BUSINESS EDUCATION FOREIGN LNG. SPANISH SPANISH-S	5128.32 7505.44 7509.82	<p>SPANISH BUSINESS COMMUNICATIONS</p> <p>Emphasis on all types of communications currently used in Latin American business. Includes parts and styles of business letters and the preparation of various types of business communications, including letters, telegrams, and memorandums.</p> <p>The student should have attained the objectives of Effective Business Reports prior to enrollment in this course.</p>
BUSINESS EDUCATION FOREIGN LNG. SPANISH SPANISH-S	7716.21 7505.45 7509.83	<p>SPANISH OFFICE PROCEDURES</p> <p>Equips students with a knowledge of Spanish office procedures and other skills and attitudes required of bilingual secretaries.</p> <p>The student should have attained the objectives of The Office in Action prior to enrollment in this course.</p>
BUSINESS EDUCATION	7743.01	<p>CONCEPTS OF BUSINESS DATA PROCESSING</p> <p>Familiarizes students with <i>manual</i> and <i>mechanical</i> data processing terminology, the cycle, the basic operations, and their relationship to these two systems; includes a familiarization with the various devices, equipment, media, and typical business applications for each system.</p>

AREA	ACCR. NO. FLA-DADE	COURSE TITLE AND DESCRIPTION
------	-----------------------	------------------------------

BUSINESS EDUCATION	7743.02	<p><b>MODERN BUSINESS DATA PROCESSING</b></p> <p>Familiarizes students with <i>punched-card</i> and <i>electronic</i> data processing terminology, the cycle, the basic operations, and their relationship to these two systems; includes a familiarization with the various devices, equipment, media, and typical business applications for each system; also includes introduction to languages used in data processing.</p>
-----------------------	---------	---

The student should have attained the objectives of Concepts of Business Data Processing prior to enrollment in this course. It is recommended that students continue to Math 5281.15, Use of the Computer in Problem Solving.

BUSINESS EDUCATION	7739.11	<p><b>SMALL BUSINESS MANAGEMENT</b></p> <p>A brief review of the relation of business to the community and an introduction to problems in organizing a small business. These problems include basic long-range decisions—type of organization, need for the business, method of financing—and the more immediate problems of location, housing, personnel, equipment, layout, records, and promotion of the business. Included also are ongoing operating problems: management, supervision, governmental obligations, finance, production, marketing, public relations, and survival factors.</p>
-----------------------	---------	--

#### VOCATIONAL OFFICE EDUCATION PROGRAM (Grade 12)

Advanced business education subjects are integrated in two programs: (1) a 3-hour secretarial block with business English, office procedures, and advanced shorthand; and (2) a 2-hour block with business English and office procedures. Both programs have a planned sequence of activities to provide the student with an understanding of the relationship of learning experiences to office occupations and also to refine skills so that the student can become a gainfully employed office worker immediately upon graduation.

The vocational business education programs that are funded as vocational units are listed in two sections of this bulletin—Business Education and Vocational Education.

AREA	ACCR. NO. FLA-DADE	COURSE TITLE AND DESCRIPTION
------	-----------------------	------------------------------

BUSINESS EDUCATION	7749.01	<p><b>VOE SPECIAL JOBS, CLERICAL (2 hours)</b></p> <p>Includes jobs on the proportional-space typewriter, the fluid duplicator, and the ink duplicator; two integrated jobs on a transcription machine; and one week as a receptionist. In the process of doing these jobs, the student should gain experience in composition at the typewriter, spelling, proofreading, setting up letters in two styles with two different styles of punctuation, and keeping bank records, a petty cash book, and a payroll. If some or all of the students are not currently enrolled in an office machines course, special jobs on machines that are available in the VOE classroom are included in this course of study. This quin includes limited specialized equipment requiring the rotation of student assignments. It is suggested that one-fourth of the class enrollment be assigned to this course of study while the other students are engaged in the work of a sequential VOE course of study—No. 1, 2, or 3.</p>
-----------------------	---------	---

Prior to enrollment in this course, the student should have attained the objectives of Intermediate Typewriting Skills (7704.41).

BUSINESS EDUCATION	7719.01	<p><b>VOE SPECIAL JOBS, SECRETARIAL (3 hours)</b></p> <p>Same as VOE Special Jobs, Clerical, but with the addition of training in one of the advanced shorthand quinmester courses which may be integrated with this instruction.</p> <p>Prior to enrollment in this course, the student should have attained the objectives of Shorthand Basic Transcription (7706.41).</p>
-----------------------	---------	--

AREA	ACCR. NO. FLA-DADE	COURSE TITLE AND DESCRIPTION
BUSINESS EDUCATION	7749.02	<p data-bbox="817 445 1247 479">VOE NO. 1, CLERICAL (2 hours)</p> <p data-bbox="817 507 1560 962">Includes three filing jobs and four sequential jobs. The filing jobs include a review of punctuation, capitalization, abbreviations, and the use of figures; the skills of inspecting, indexing, coding, and sorting letters according to alphabetic filing rules; and training in setting up an alphabetic index system with cross references and a numeric index system for a group of letters. The four sequential jobs include manuscript composition and typing, vocabulary building, proper use of the dictionary, good reading habits, and differentiating between acceptable and preferable spellings; a review of good sentence structure, word division, and tabulation; correcting and typing rough-draft letters; filling out an application for federal employment; and setting up an interoffice memorandum correctly from rough-draft copy.</p> <p data-bbox="817 989 1560 1081">Prior to enrollment in this course, the student should have attained the objectives of Intermediate Typewriting Skills (7704.41).</p>
BUSINESS EDUCATION	7719.02	<p data-bbox="817 1138 1300 1173">VOE NO. 1, SECRETARIAL (3 hours)</p> <p data-bbox="817 1200 1560 1292">Same as VOE No. 1, Clerical, but with the addition of training in one of the advanced shorthand quinmester courses which may be integrated with this instruction.</p> <p data-bbox="817 1320 1560 1412">Prior to enrollment in this course, the student should have attained the objectives of Shorthand Basic Transcription (7706.41).</p>
BUSINESS EDUCATION	7749.03	<p data-bbox="817 1471 1247 1506">VOE NO. 2, CLERICAL (2 hours)</p> <p data-bbox="817 1533 1560 1804">Includes seven sequential jobs. These jobs include a review of nouns, verbs, pronouns, adjectives, prepositions, and conjunctions; an introduction to simple business correspondence such as order letters, letters of transmittal, reservation letters, letters of cancellation, and letters of refusal; and experience in keeping an appointment book, using the telephone properly, making carbon copies, applying for a job, typing legal forms, and typing various types of credit memoranda and statements of account.</p> <p data-bbox="817 1832 1560 1894">Prior to enrollment in this course, the student should have attained the objectives of VOE No. 1, Clerical (7749.02).</p>

BUSINESS EDUCATION

89

AREA	ACCR. NO. FLA-DADE	COURSE TITLE AND DESCRIPTION
BUSINESS EDUCATION	7719.03	<p>VOE NO. 2, SECRETARIAL (3 hours)</p> <p>Same as VOE No. 2, Clerical, but with the addition of training in one of the advanced shorthand quinmester courses which may be integrated with this instruction.</p> <p>Prior to enrollment in this course, the student should have attained the objectives of VOE No. 1, Secretarial (7719.02).</p>
BUSINESS EDUCATION	7749.04	<p>VOE NO. 3, CLERICAL (2 hours)</p> <p>Includes seven or more sequential jobs. These jobs include more complex business letters, such as letters of credit refusal, follow-up collection letters, letters inviting credit, credit recommendations, letters of complaint, letters of apology, sales letters, and letters of application with personal data sheets; more complex business forms, such as inventory records, bills of lading, invoices and tabulated business reports with extensions to figure on office machines (optional), mailing forms, telegrams, and money orders; and other office techniques, such as the chain feeding of envelopes, weighing mail properly, and figuring costs of various classes of mail.</p> <p>Prior to enrollment in this course, the student should have attained the objectives of VOE No. 2, Clerical (7749.03).</p>
BUSINESS EDUCATION	7719.04	<p>VOE NO. 3, SECRETARIAL (3 hours)</p> <p>Same as VOE No. 3, Clerical, but with the addition of training in one of the advanced shorthand quinmester courses which may be integrated with this instruction.</p> <p>Prior to enrollment in this course, the student should have attained the objectives of VOE No. 2, Secretarial (7719.03).</p>



## OFFICE CAREER OCCUPATIONS PROGRAM (Grade 9)

Designed for students in ninth grade who are below grade level in reading, have an interest in office occupations, and are recommended by principal, counselor, and/or OCO teacher. The students will explore office skills and career opportunities in office occupations; will apply basic skills of communication and computation to office-related work; and experience opportunities for developing personality traits, grooming, and attitudes toward work.

The vocational business education programs that are funded as vocational units are listed in two sections of this bulletin—Business Education and Vocational Education.

AREA	ACCR. NO. FLA-DADE	COURSE TITLE AND DESCRIPTION
BUSINESS EDUCATION	7749.11	<p>OCO NO. 1 (2 hours)</p> <p>Includes the learning of the typewriter keyboard, basic composition at the typewriter, good work habits, and steps in finding a job; the recognition of one's own potential for office training and employment; and an introduction to alphabetic filing rules and a review of basic spelling rules.</p>
BUSINESS EDUCATION	7749.12	<p>OCO NO. 2 (2 hours)</p> <p>Includes the building of skill in typewriting, alphabetic and numeric filing, communication, spelling, and computation, the recognition of good personality traits, grooming habits, attitudes, and craftsmanship; an exploration of the broad field of selling; and preparation of material for fluid duplicating.</p> <p>Prior to enrollment in this course, the student should have attained the objectives of OCO No. 1 (7749.11).</p>
BUSINESS EDUCATION	7749.13	<p>OCO NO. 3 (2 hours)</p> <p>Includes further development of skills in typewriting, filing, and communication; the basic operation of full- and ten-key adding machines; and exploration of shorthand systems. The course also includes the recognition of business purposes and organization, of skills required in advanced business subjects, and of the need for continuing education.</p> <p>Prior to enrollment in this course, the student should have attained the objectives of OCO No. 2 (7749.12).</p>

AREA	ACCR. NO. FLA-DADE	COURSE TITLE AND DESCRIPTION
------	-----------------------	------------------------------

BUSINESS EDUCATION	7749.14	<p>OCO No. 4 (2 hours)</p> <p>Includes the further development of skills in filing, communication, and computation; a basic understanding of profit and loss, and fundamental terms and principles in bookkeeping procedures; preparation of materials for, and supervised operation of, ink and fluid duplicators; application problems for the full-key and ten-key adding machines; and the typing of simple business letters, application blanks, and personal data sheets.</p> <p>Prior to enrollment in this course, the student should have attained the objectives of OCO No. 3 (7749.13).</p>
-----------------------	---------	--

**COOPERATIVE BUSINESS EDUCATION PROGRAM (Grade 12)**

BUSINESS EDUCATION	7725.01 through 7725.11	(Refer to Cooperative Business Education courses listed in Vocational Education section.)
-----------------------	-------------------------------	---

## DRIVER EDUCATION

According to present driver licensing laws, an individual under the age of eighteen who wishes to be licensed must present evidence of having satisfactorily completed an approved driver education course. This recent legislation will result in an increase in the number of students who enroll in the quinmester course, Driver Education.

The quinmester plan enables schools to offer driver education five times each year, which will allow students considerable flexibility in scheduling.

AREA	ACCR. NO. FLA-DADE	COURSE TITLE AND DESCRIPTION
DRIVER EDUCATION	8573.01	DRIVER EDUCATION  / The course consists of 30 hours of classroom work and 6 hours of practice driving instruction. The classroom instruction stresses lawful motor vehicle operation, social responsibilities, development of wholesome attitudes, and economic maintenance. It includes instruction for driving in all types of traffic and under all kinds of weather and road conditions. Practice driving offers drill in the various maneuvers required of a competent and skillful driver.

## FOREIGN LANGUAGE

Quinmester courses in French, German, Hebrew, Latin, Russian, and Spanish are planned to satisfy three objectives: to provide direction for the standard academic program; to provide interesting and valuable alternate courses for students who want more than, or a change from, an academic block; to provide exploratory courses for students who plan to study a language for a brief experience. One of the goals of a language course is for the learner to experience personal satisfaction in his learning; this brief experience should prove rewarding and therefore lead to the development of positive attitudes and the desire to pursue further courses of study.

Each foreign language quin has specific objectives and sample test questions for each objective suitable for the evaluation of the course. The sections entitled "Suggested Procedures" and "Expansion of Materials" are explicit aids to the teacher. First and second level course outlines also include a syntactical and lexical inventory, which are valuable when the teacher wishes to create something original or serve an individual need of a student.

Each standard academic course uses a state-adopted text as its base. The alternates provide sufficient material so that, with the books in the average teacher's possession, the program can be satisfied. Additional resources, however, are recommended.

### *Recommendation to a School's Administration*

The nature of language being what it is, with its acquisition a cumulative process, great care has been exercised in developing the necessary sequence with alternate courses. Foreign language educators believe that every individual, regardless of his level of academic maturity, can learn a language and should be encouraged in its study. They believe, in addition, that each student has a different goal, some immediate and some long-range. In analyzing the flow chart of each language, therefore, thought should be given to the need to provide for the nonacademic, as well as the academic, and to offer alternatives as frequently as possible.

The Spanish flow chart serves as an aid in comprehending the philosophy of foreign language offerings. Many courses are offered at the beginning level. The courses entitled Buen Viaje, A Taste of Spanish, and Recreational Sports in Spanish can be offered as the first quin, as well as an academic Introductory Spanish, Part 1. If the learner proves to be adept and elects to pursue Spanish, he may go to Introductory Spanish, Part 2; but the average student will perform better if he moves from an alternate course to Part I of Introductory Spanish.

Practical Spanish is another option as a beginning quin. At the conclusion of Practical Spanish, Part I, the successful student can continue through the practical courses or change to an academic sequence. Care has been taken to provide as much semblance as possible in grammatical concepts among all quins of a comparable level.

### *Recommendation to a School's Counseling Staff*

Every student should be given the opportunity to study another language. Through such study, he will acquire new skills; he will improve his attitudes about foreigners; he will improve his self-concept. Students are to be encouraged to try a beginning quin.

Recommendations of the language teacher should be considered as to which quin courses will serve the individual student best.

#### *Junior High*

Junior high exploratory numbers 7500 and 7510 appear on certain quins in each language, making it possible for schools to offer these courses in a traditional organization.

#### *Senior High*

At the senior high school level, if a course is designated as Honors or Advanced Placement, students should be advised that four quins of such status are required.

#### *Code Numbers for Quinmester Courses*

An explanation of the numbering system for each foreign language precedes its course descriptions.

## QUINMESTER COURSES

<i>FRENCH</i>	103
Say It in French	107
Bon Voyage, Part 1	108
Le Français Courant, Part 1	108
Le Français Courant, Part 2	108
Le Français Courant, Part 3	109
Le Français Courant, Part 4	109
Bon Voyage, Part 2	109
Le Français D'Aujourd'hui, Part 1	110
Le Français D'Aujourd'hui, Part 2	110
Le Français D'Aujourd'hui, Part 3	110
Le Français D'Aujourd'hui, Part 4	111
En France	111
Le Français Moderne, Part 1	111
Le Français Moderne, Part 2	111
Le Français Vivant, Part 1	112
Le Français Vivant, Part 2	112
Le Français Vivant, Part 3	112
Le Français Vivant, Part 4	113
Advanced French Refresher	113
L'Esprit Français, Part 1	113
L'Esprit Français, Part 2	113
L'Esprit Français, Part 3	114
L'Esprit Français, Part 4	114
Aspects de la France, Part 1	114
Aspects de la France, Part 2	114
Le Français dans le Monde	115
Les Français Contemporains	115
Le Français Avancé, Part 1	115
Le Français Avancé, Part 2	115
Le Français Avancé, Part 3	115
Le Français Avancé, Part 4	116
Le Français Avancé, Part 5	116
 <i>GERMAN</i>	 117
German for Fun	119
German for Travel	119
Lernen Wir Deutsch! Part 1	120
Lernen Wir Deutsch! Part 2	120
Lernen Wir Deutsch! Part 3	120
Lernen Wir Deutsch! Part 4	121
Lernen Wir Deutsch! Part 5	121
Lernen Wir Mehr Deutsch! Part 1	121
Lernen Wir Mehr Deutsch! Part 2	122
Lernen Wir Mehr Deutsch! Part 3	122
Lernen Wir Mehr Deutsch! Part 4	122
Scientific German 1	123
Scientific German 2	123
Lernen Wir Noch Mehr Deutsch! Part 1	123

Lernen Wir Noch Mehr Deutsch! Part 2	123
Lernen Wir Noch Mehr Deutsch! Part 3	124
Lernen Wir Noch Mehr Deutsch! Part 4	124
German Culture and Civilization	124
Advanced German Refresher	124
Lernen Wir Deutsch! Part 9	125
Lernen Wir Deutsch! Part 10	125
Lernen Wir Deutsch! Part 13	125
Lernen Wir Deutsch! Part 14	126
Lernen Wir Deutsch! Part 15	126
Lernen Wir Deutsch! Part 16	126

*HEBREW* 127

Fun at the Kibbutz	127
Visit an Israeli Cafe	127
A Journey to Jerusalem	128
Enjoying a Movie	128
Up and Away to Israel	128
Visiting Grandparents	128
A Visit to an Israeli Doctor	128
Women's Lib Advances in Israel	129
Meeting an Old Friend	129
Early History through the Second Century	129
Historic Highlights beyond the Second Century	129
Journalistic and Spoken Hebrew	129
Hebrew Grammar	129
The Humanities and Hebrew, Part 1	130
The Humanities and Hebrew, Part 2	130
The Humanities and Hebrew, Part 3	130
The Humanities and Hebrew, Part 4	130
The Humanities and Hebrew, Part 5	130
The Humanities and Hebrew, Part 6	130
The Humanities and Hebrew, Part 7	130
The Humanities and Hebrew, Part 8	130

*LATIN* 131

Relationship of Languages, Part 1, History	134
Relationship of Languages, Part 2, English Grammar for the Foreign Language Student	134
Off to Rome	135
Roman Holiday	135
Schools, Animals, and Kids	135
An Introduction to Latin—Latin I, Part 1	135
Classical Myths in Today's World—Latin I, Part 2	136
Roman Heroes and Legends—Latin I, Part 3	136
Latin Potpourri—Latin I, Part 4	136
Programmed Latin, Part 1	136
Programmed Latin, Part 2	136
Programmed Latin, Part 3	136
Programmed Latin, Part 4	136
Programmed Latin, Part 5	137

**FOREIGN LANGUAGE**  
98

Programmed Latin, Part 6	137
Programmed Latin, Part 7	137
Programmed Latin, Part 8	137
Latin Revisited—Latin II, Part 1	137
Preparation for Study of Caesar—Latin II, Part 2	137
Study of Caesar—Latin II, Part 3	137
Caesar's Campaigns—Latin II, Part 4	138
Caesar's Campaigns—Latin II, Part 5	138
A Revolutionary: His Life and Trials, Part 1	138
A Revolutionary: His Life and Trials, Part 2	138
Roman Law and Cicero	138
Cicero and the Literate Life	139
Ovid's Poetry	139
Latin Literature	139
Readings from Cicero	139
Vergil, the Great Adventurer, Part 1	139
Vergil, the Great Adventurer, Part 2	139
Vergil, the Great Adventurer, Part 3	140
Vergil, the Great Adventurer, Part 4	140

*RUSSIAN* 141

Survey of Russian Society	143
Survive a Russian Party	143
Communicate in Russian, Part 1	144
A Traveler's Bag	144
Communicate in Russian, Part 2	144
Communicate in Russian, Part 3	145
The Russian Teen-Ager and You, Part 1	145
The Russian Teen-Ager and You, Part 2	145
The Russian Teen-Ager and You, Part 3	146
The Russian Teen-Ager and You, Part 4	146
Russian for the Science Minded	146
On the Russian Scene, Part 1	147
On the Russian Scene, Part 2	147
On the Russian Scene, Part 3	147
On the Russian Scene, Part 4	147
Advanced Russian, Part 1	148
Advanced Russian, Part 2	148
Advanced Russian, Part 3	148
Advanced Russian, Part 4	148
Russian and the Humanities, Part 1	149
Russian and the Humanities, Part 2	149

*SPANISH* 151

A Taste of Spanish	156
Buen Viaje, Part 1	156
Recreational Sports in Spanish	157
Practical Spanish, Part 1	157
Practical Spanish, Part 2	157
Practical Spanish, Part 3	158
Practical Spanish, Part 4	158
Introductory Spanish, Part 1	158
Introductory Spanish, Part 2	158
Introductory Spanish, Part 3	159
Introductory Spanish, Part 4	159

**FOREIGN LANGUAGE**



Introductory Spanish, Part 1	159
Introductory Spanish, Part 2	159
Introductory Spanish, Part 3	160
Introductory Spanish, Part 4	160
Introductory Spanish, Part 1	160
Introductory Spanish, Part 2	160
Introductory Spanish, Part 3	160
Introductory Spanish, Part 4	161
Buen Viaje, Part 2	161
Progressing in Spanish, Part 1	161
Progressing in Spanish, Part 2	161
Progressing in Spanish, Part 3	162
Progressing in Spanish, Part 4	162
Progressing in Spanish, Part 1	162
Progressing in Spanish, Part 2	162
Progressing in Spanish, Part 3	163
Progressing in Spanish, Part 4	163
Progressing in Spanish, Part 1	163
Progressing in Spanish, Part 2	163
Progressing in Spanish, Part 3	164
Progressing in Spanish, Part 4	164
Reassurance	164
Intermediate Spanish, Part 1	164
Intermediate Spanish, Part 2	165
Intermediate Spanish, Part 3	165
Intermediate Spanish, Part 4	165
Intermediate Spanish, Part 1	165
Intermediate Spanish, Part 2	166
Intermediate Spanish, Part 3	166
Intermediate Spanish, Part 4	166
Intermediate Spanish, Part 1	166
Progressing in Spanish, Part 3	167
Advanced Spanish Refresher	167
Spanish Shorthand—Theory	167
Spanish Shorthand—Speedbuilding	167
Spanish Shorthand—Dictation and Transcription	167
Spanish Business Communications	168
Spanish Office Procedures	168
Advanced Spanish, Part 1	168
Advanced Spanish, Part 2	168
Advanced Spanish, Part 3	169
Advanced Spanish, Part 4	169
Advanced Spanish, Part 1	169
Advanced Spanish, Part 2	169
Advanced Spanish, Part 3	170
Advanced Spanish, Part 4	170
Latin American History through Literature	170
Our Times	170
Cervantes and His Times	171
The Golden Age of Spain	171
Modern Spanish, Part 1	171
Modern Spanish, Part 2	171
Modern Spanish, Part 3	172
Modern Spanish, Part 4	172
Modern Spanish, Part 1	172

Modern Spanish, Part 2	172
Modern Spanish, Part 3	173
Modern Spanish, Part 4	173
Great Writers of Spain, Part 1, The Nineteenth Century	173
Great Writers of Spain, Part 2, The Twentieth Century	173
Great Writers of Hispanic America, Part 1, The Nineteenth Century	174
Great Writers of Hispanic America, Part 2, The Twentieth Century	174
Stories of Yesterday and Today	174
Through Love and Adventure	174
Romanticism in Latin America	175
Latin American Poetry throughout the Ages	175
The Beginnings of the Spanish Theater	175
Humor in the Spanish Theater	175

## FRENCH COURSES

7523 — LEVEL I  
7524 — LEVEL II

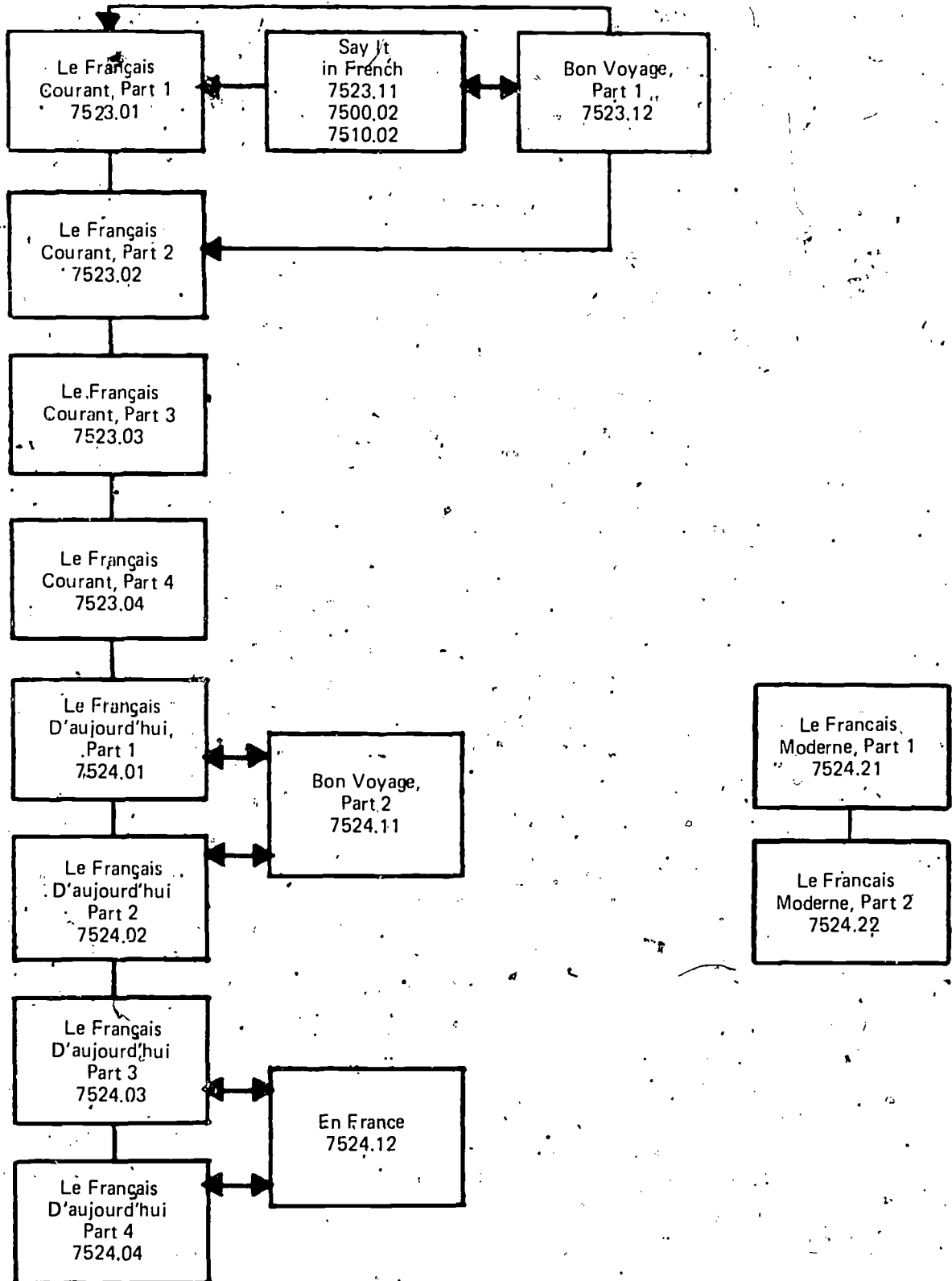

\* Course published but being phased out as new basic text for Le Français D'aujourd'hui becomes more available.

FRENCH COURSES

7525 - LEVEL III  
7526 - LEVEL IV  
7527 - LEVEL V

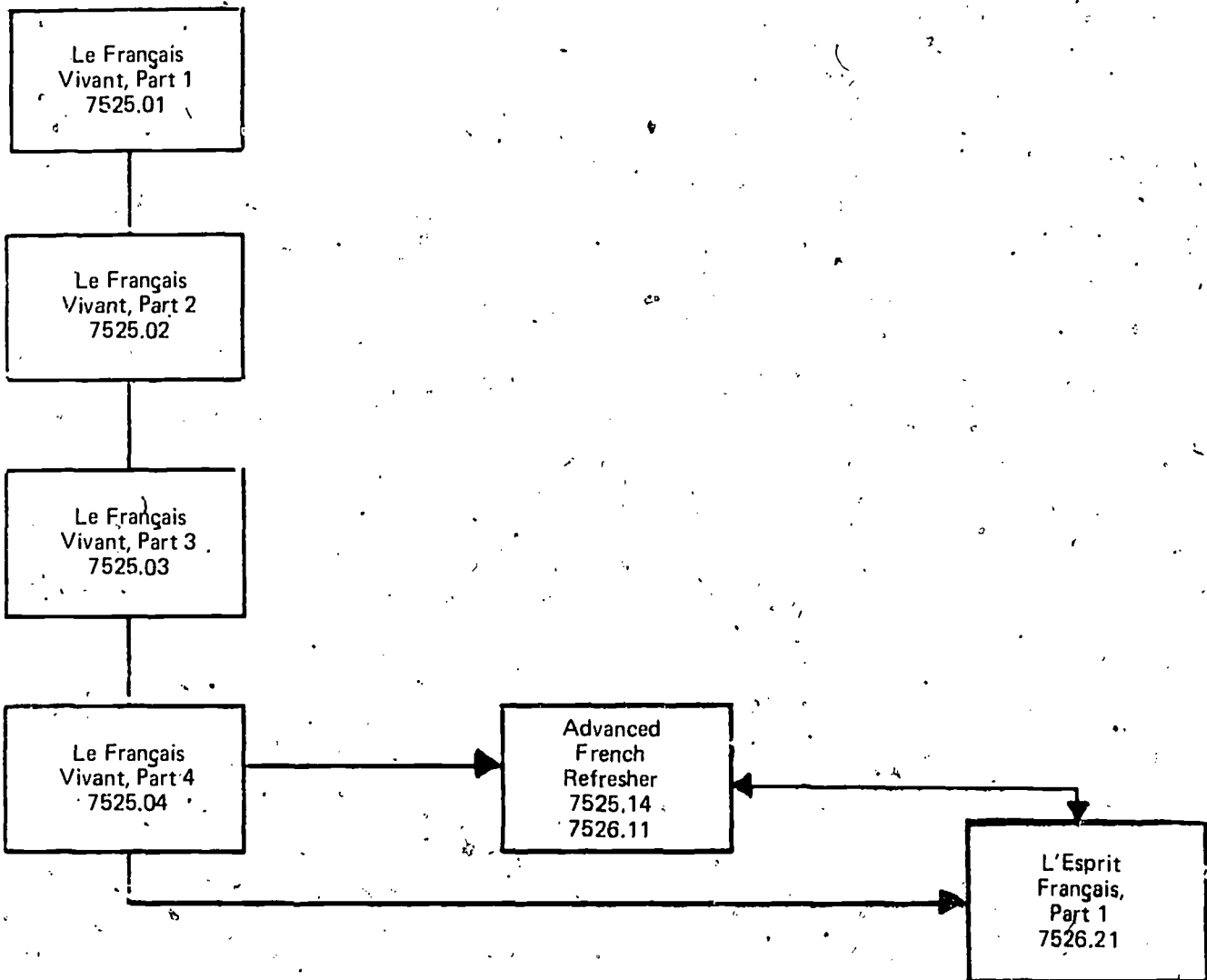

FRENCH COURSES

- 7525 - LEVEL III
- 7526 - LEVEL IV
- 7527 - LEVEL V

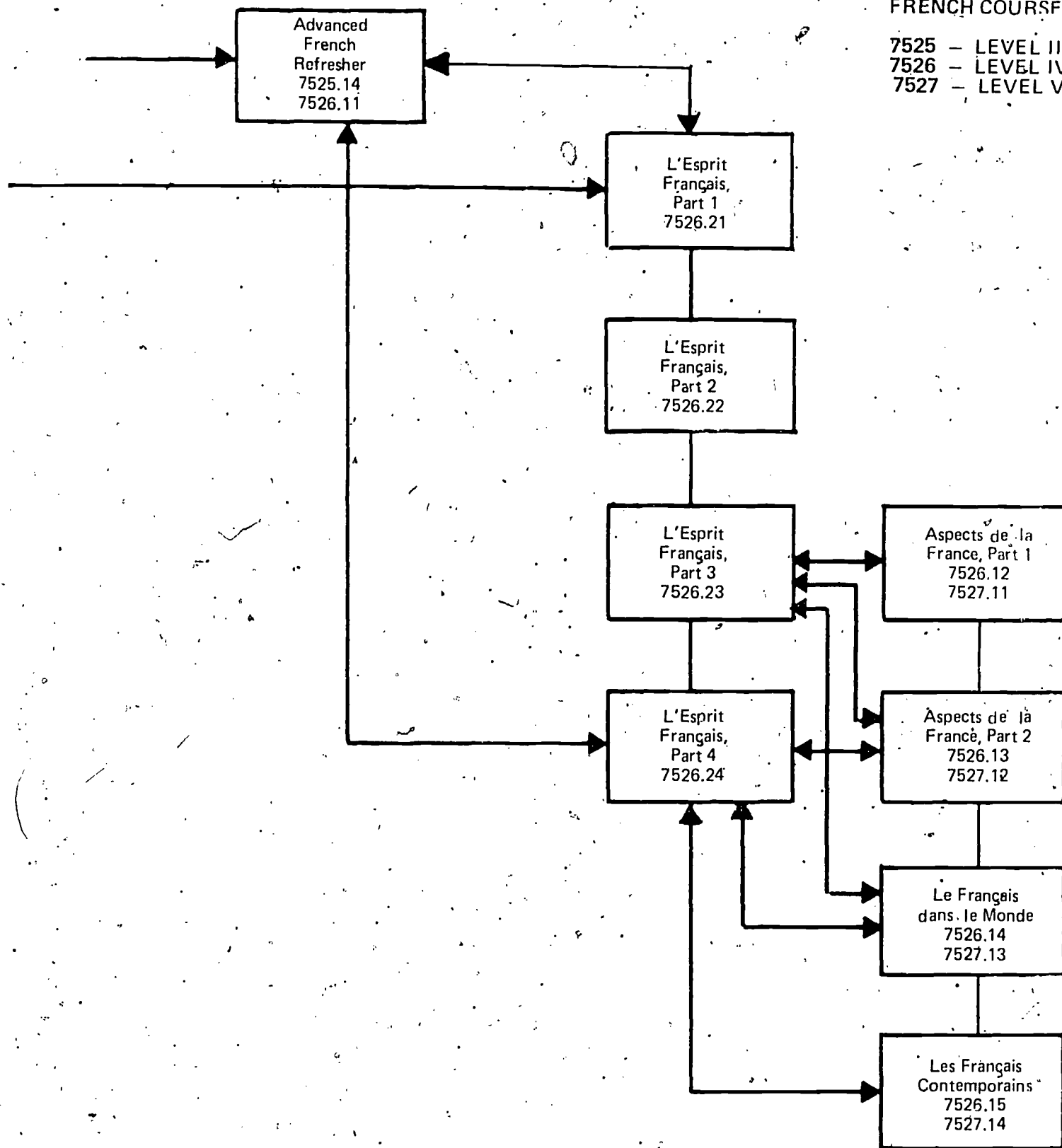

## FRENCH COURSES

7526 — LEVEL IV

7527 — LEVEL V

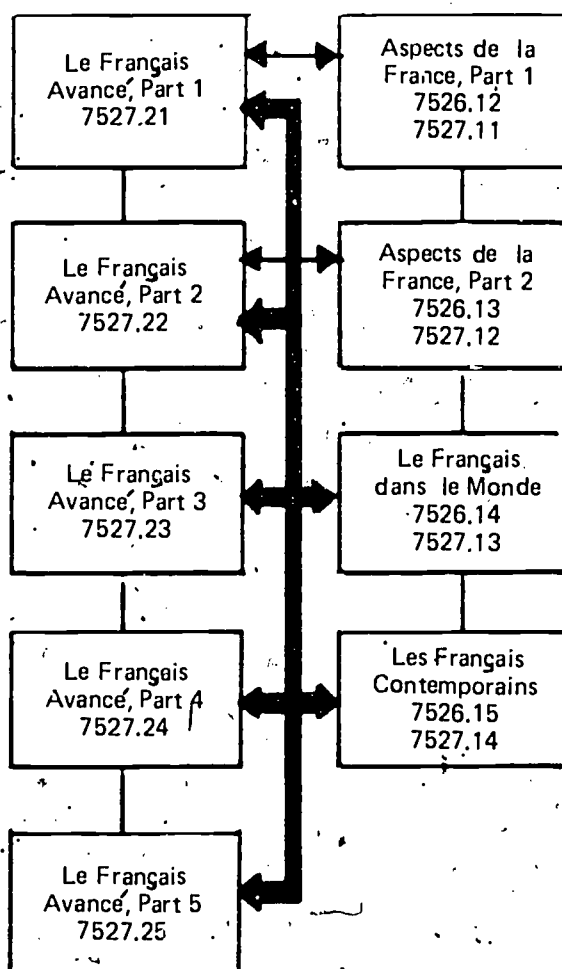

## CODE NUMBERS FOR FRENCH QUINMESTER COURSES

French courses are designated by state code numbers as follows:

- 7523 — Level I
- 7524 — Level II
- 7525 — Level III
- 7526 — Level IV
- 7527 — Level V

The standard academic course is further identified with .01, .02, etc. Each course takes its basic material from *ALM French*, Second Edition. The courses which take their core material from *ALM French*, First Edition are identified with .21, .22, etc. The alternate courses are marked .11, .12, etc.

To illustrate appropriate use of the code numbers, consider the student who has successfully completed six quins in the French program. He is then prepared to study 7524.03 but decides to study alternate quin 7524.12 instead. Later he chooses to take 7524.03. He will have studied the courses in the regular sequence and, in addition, experienced an alternate course.

The charts on pages 103-106 present the many alternates possible. Therein lies the flexibility of the French program.

AREA	ACCR. NO. FLA-DADE	COURSE TITLE AND DESCRIPTION
FRENCH	7523.11 7500.02 7510.02	† SAY IT IN FRENCH  This is a conversational course for the student who would like to learn some French but who is uncertain about his desire to pursue its formal study. Topics to be explored are basic greetings, school and classroom vocabulary, numbers 0-100, days of the week, months of the year, weather, time, the family, colors, French songs, and French games. 7523.01 or 7523.12 may be studied after this course; for the highly capable students, 7523.02 is appropriate.

AREA	ACCR. NO. FLA-DADE	COURSE TITLE AND DESCRIPTION
FRENCH	7523.12	† BON VOYAGE, PART 1  This is an introductory conversational course oriented to the potential traveler. It may be studied after 7523.11 Say It in French; or, if the student is particularly gifted, he may succeed in this with no previous contact with the French language. Emphasis is on oral control of useful everyday expressions, such as those used for passing through customs, securing transportation from the airport to the hotel, requesting a room, ordering food, making purchases, and visiting places of interest in Paris.
FRENCH	7523.01	† LE FRANÇAIS COURANT, PART 1  An opportunity to learn to speak contemporary French from the beginning is presented through short dialogues based on everyday teen-age experiences. Systematic treatment of pronunciation is designed to thoroughly familiarize the student with the sounds of French. Emphasis is on up-to-date vocabulary with present tense, affirmative and negative of some verbs, asking and answering questions, telling time, and counting. This is the first quin of the standard academic program. The basic content of this course is <i>ALM French</i> , Second Edition, units 1, 2, 3.
FRENCH	7523.02	† LE FRANÇAIS COURANT, PART 2  The content of the language manipulated is about movies and lunch and variations on these subjects. The vocabulary relative to the family, home, transportation, and foods. Emphasis is on the present tense of <i>avoir</i> , <i>faire</i> , <i>aller</i> ; concept of gender and number; commands; and possession. A gradual increase in reading and writing activities constitutes an important facet of the course. The basic material is from <i>ALM French</i> , Second Edition, units 4, 5, 6. French is the language used in the classroom. This course is designed for students who have controlled 7523.01 or equivalent material.



AREA	ACCR. NO. FLA-DADE	COURSE TITLE AND DESCRIPTION
FRENCH	7523.03	LE FRANÇAIS COURANT, PART 3  Conversation centers around shopping and getting acquainted with typical French personalities, as well as the weather and months of the year. The student begins to know <i>la belle France</i> through reading and writing activities. Structures include present tense of regular <i>ir</i> , and <i>re</i> , verbs, agreement of adjectives, and some direct object pronouns. The basic material is from <i>ALM French</i> , Second Edition, units 7, 8. French is the language used in the classroom. This course is designed for students who have controlled 7523.02 or equivalent material.
FRENCH	7523.04	LE FRANÇAIS COURANT, PART 4.  The learner, through these materials, interacts with a real French-speaking teen-ager and enjoys a quick tour of Paris. Additional vocabulary items include names of countries, nationalities, and languages. Structural elements studied include the irregular verbs <i>dormir</i> , <i>lire</i> , <i>dire</i> , and <i>écrire</i> ; further agreement of adjectives; and possessive adjectives. Longer narratives and writing of more complicated exercises are included. The basic material is from <i>ALM French</i> , Second Edition, units 9, 10. French is the language of the classroom. This course is designed for students who have controlled 7523.03 or equivalent material.
FRENCH	7524.11	BON VOYAGE, PART 2  This course offers further development of conversation designed for the American student/traveler. Where to go to see a real fashion show, how to call the doctor, how to explain a traffic problem to an officer are examples of course topics. Sufficient grammatical structure is presented to facilitate intelligent speech. A solid understanding of the 7523 courses or their equivalents would provide needed background, or this could be an alternate to 7524.01 or 7524.02.

AREA	ACCR. NO. FLA-DADE	COURSE TITLE AND DESCRIPTION
FRENCH	7524.01	† LE FRANÇAIS D'AUJOURD'HUI, PART 1  The basic numbering system is completed and previously learned structures are reviewed. New structural items include the present tense of the irregular verbs <i>vouloir</i> , <i>pouvoir</i> , and <i>venir</i> ; adjectives preceding the noun; object pronouns; and démonstrative adjectives. More emphasis is given to the reading and writing skills. The basic material is from <i>ALM French</i> , Second Edition, units 11, 12. French is the language of the classroom. This course is designed for students who have controlled the 7523 courses or equivalent material.
FRENCH	7524.02	† LE FRANÇAIS D'AUJOURD'HUI, PART 2.  Conversational topics permit the student to review his summer vacation. Principal elements of structure are expressions of quantity, more pronouns including those used independently of the verbs and <i>y</i> , <i>en</i> , the <i>passé composé</i> , agreement of the past participles, and the irregular present tense of <i>prendre</i> . Through his reading the student renews his acquaintance with typical French personalities. Writing activities include sentence expansion and paragraph rewriting. The basic material is from <i>ALM French</i> , Second Edition, units 13, 14, 15. This course is designed for students who have controlled 7524.01 or equivalent material.
FRENCH	7524.03	† LE FRANÇAIS D'AUJOURD'HUI, PART 3  The main structural items presented are key verb forms, verbs + <i>de</i> , or <i>a</i> + infinitive, reflexive verbs, and <i>passé composé</i> with <i>être</i> . Readings deal with topics of teen-age interest, including the famous bicycle race <i>Tour de France</i> . The basic material of this course is <i>ALM French</i> , Second Edition, units 15, 16, 17. French is the language of the classroom. The course is designed for students who have controlled 7524.02 or equivalent material.

AREA	ACCR. NO. FLA-DADE	COURSE TITLE AND DESCRIPTION
FRENCH	7524.04	<p>LE FRANÇAIS D'AUJOURD'HUI, PART 4</p> <p>Oral skills continue to be developed. Conversational activities center around a teen-age sister, a tape recorder, a picnic, and an open air market. Structures studied include interrogative pronouns, inversion form of questions, imperfect vs. <i>passé composé</i>, and comparisons of adjectives and adverbs. Through reading the student takes part in a questionnaire for young people and relives a childhood seashore vacation. The basic material is <i>ALM French</i>, Second Edition, units 18, 19, 20. French is the language of the classroom. This course is designed for students who have controlled 7524.03 or equivalent material.</p>
FRENCH	7524.12	<p>EN FRANCE</p> <p>This is a conversational course based on films on modern France as a basis for conversational activities. Students who have controlled 7524.03, or equivalent material, will succeed in this course, or perhaps they will prefer this as an alternate to 7524.03 or 7524.04.</p>
FRENCH	7524.21	<p>† LE FRANÇAIS MODERNE, PART 1</p> <p>Conversation centers on young people and their infraction of the law. Students review all previously learned structures. New items include the present tense of regular <i>ir</i> verbs; the present tense of the irregular verbs <i>lire, dire, écrire, mettre</i>; object pronouns; and the <i>passé composé</i> with <i>avoir</i>. Reading and writing skills are further expanded. The basic material is <i>ALM French</i>, First Edition, units 10, 11. French is the language of the classroom. Success in this course is indicated if the courses in the 7523 series or their equivalents have been controlled.</p>
FRENCH	7524.22	<p>† LE FRANÇAIS MODERNE, PART 2</p> <p>Shopping, meeting a train, and discussing vacation plans comprise the conversation manipulated in this course. The main structural elements studied are the <i>passé composé</i> of <i>être</i> and of some irregular <i>avoir</i> verbs, the irregular present tense of <i>sortir</i> and <i>venir</i>, demonstrative adjectives and adjectives, regular and irregular, which precede the noun. The basic material is <i>ALM French</i>, First Edition, units 12, 13, 14. French is the language used in the classroom. Success in this course is indicated if 7524.21 or equivalent material has been controlled.</p>

AREA	ACCR. NO. FLA-DADE	COURSE TITLE AND DESCRIPTION
FRENCH	7525.01	<p data-bbox="815 464 1263 495">LE FRANÇAIS VIVANT, PART 1</p> <p data-bbox="815 523 1576 892">Conversation centers around the eating habits of the French, a weekend hunting trip in Bologne, asking for directions to the chateaux area of the Loire, exploring archeological excavations, and the importance of the baccalaureate. The main structural items presented are the superlative of adjectives and adverbs, double object pronouns, stem changing <i>-er</i> verbs, and the future tense. Through his readings the student will strengthen the language learned orally. The basic material is <i>ALM French</i>, Second Edition, units 20, 21, 22. French is the language of the classroom. This course is designed for students who have controlled the 7524 courses or equivalent material.</p>
FRENCH	7525.02	<p data-bbox="815 940 1263 971">LE FRANÇAIS VIVANT, PART 2</p> <p data-bbox="815 999 1576 1392">Conversations center around a mother who breaks up a fight between her two sons and a tourist asking for directions in Tournon-les-Bains. New structural items introduced are the conditional tense <i>si</i> clauses; the reciprocal reflexive; <i>connaître</i> vs. <i>savoir</i>; the interrogative adjective <i>quel</i>; the interrogative pronoun <i>lequel</i>; and relative pronouns <i>qui</i> and <i>que</i>. Through reading selections the student learns about the French report card system and travels in the Pyrenees Mts. area. The basic material is <i>ALM French</i>, Second Edition, units 23, 24. French is the language used in the classroom. This course is designed for students who have controlled 7525.01 or equivalent material.</p>
FRENCH	7525.03	<p data-bbox="815 1451 1263 1482">LE FRANÇAIS VIVANT, PART 3</p> <p data-bbox="815 1511 1576 1880">Conversation is still much emphasized. Its content relates to a visit to the theatre and to a garage for repairs. Principal items of structure include demonstrative pronouns such as <i>celui</i>; adjective + <i>a</i>, or <i>de</i> + infinitive; the formation of the present subjunctive and use of the subjunctive after expressions of will and emotion. Through the reading selections, the student attends the Theatre Festival at Avignon and witnesses an automobile accident. The basic material is <i>ALM French</i>, Second Edition, units 25, 26. French is the language used in the classroom. This course is designed for students who have controlled 7525.02 or equivalent material.</p>

AREA	ACCR. NO. FLA-DADE	COURSE TITLE AND DESCRIPTION
FRENCH	7525.04	<p>LE FRANÇAIS VIVANT, PART 4</p> <p>Through this course the student acquaints himself with the occupations, preoccupations, and hopes of young French people, and reads a modern story dealing with personal ethics. Important structural elements taught are negative constructions, the clause relators <i>dont</i>, <i>ou</i>, and preposition † <i>qui</i> or <i>lequel</i>. The basic material is <i>ALM French</i>, Second Edition, units 27, 28. French is the language of the classroom. This course is designed for students who have controlled 7525.03 or equivalent material.</p>
FRENCH	7525.14 7526.11	<p>ADVANCED FRENCH REFRESHER</p> <p>This course is designed for the college-bound student who wants an intensive review of the essential elements of French grammar. Vocabulary is increased through varied reading and conversational activities. Attention is given to individual student problem areas. Third- and fourth-year students who desire to place well in college will find this quin profitable. This may be an alternate for 7526.21.</p>
FRENCH	7526.21	<p>L'ESPRIT FRANÇAIS, PART 1</p> <p>The reading centers on a small imaginary provincial town and the events which destroy its tranquility. After a thorough review of previously learned structure, new items are presented including superlatives of adjectives and adverbs, complex and simple forms of interrogative words, plus <i>quel</i> and <i>lequel</i>. Basic content of this course is <i>ALM French</i>, First Edition, units 26, 27. French is the language used in the classroom. This course is designed for students who have controlled the 7525 courses or equivalent material.</p>
FRENCH	7526.22	<p>L'ESPRIT FRANÇAIS, PART 2</p> <p>The mysteries surrounding a small town provide the source of reading and discussion. Main structural points include the formation and uses of remaining compound tenses, the past infinitive, and the position of adverbs with compound verbs. The basic content of this course is <i>ALM French</i>, First Edition, units 28, 29. French is the language of the classroom. This course is designed for students who have controlled 7526.21 or equivalent material.</p>

AREA	ACCR. NO. FLA-DADE	COURSE TITLE AND DESCRIPTION
FRENCH	7526.23	<p>L'ESPRIT FRANÇAIS, PART 3</p> <p>Readings include the unraveling of the mysteries in a small provincial town and a true story of mountain climbing in the Himalayas. New structural items are clause relaters including <i>ou</i>, <i>dont</i>, and <i>lequel</i>, and additional uses of the subjunctive. Basic content of this course is <i>ALM French</i>, First Edition, units 30, 31. French is the language of the classroom. This course is designed for students who have controlled 7526.22 or equivalent material.</p>
FRENCH	7526.24	<p>L'ESPRIT FRANÇAIS, PART 4.</p> <p>Readings include narratives and magazine articles written with the aim of acquainting the student with typical personalities in French society, such as the Paris traffic cop and the prefect. Continued structure drills make the student more adept in the uses of the subjunctive in oral and written French. Basic content of this course is <i>ALM French</i>, First Edition, units 32, 33. French is the language of the classroom. This course is designed for students who have controlled 7526.23 or equivalent material.</p>
FRENCH	7526.12 7527.11	<p>ASPECTS DE LA FRANCE, PART 1</p> <p>This course is of interest to the advanced student who wishes to learn more about famous men and events in French history. Some of the historical topics considered are Roman and Christian Gaul; Medieval France, including St. Louis and the Hundred Years War; the French Renaissance; the French Revolution; Napoleon Bonaparte; and the early nineteenth century, including Victor Hugo and the Romantics. These topics are read and discussed in French and use is made of films, filmstrips, and slides. Capsule grammar sessions are also a part of the course. The capable student may choose to substitute this course for 7526.23 or 7526.24.</p>
FRENCH	7526.13 7527.12	<p>ASPECTS DE LA FRANCE, PART 2</p> <p>This course develops topics relative to modern France, such as World Wars I and II, De Gaulle, modern culture, industry and government. All the material is read and discussed in French, and use is made of films, filmstrips, and slides. Capsule grammar sessions are a part of the course. The capable student may choose to substitute this course for 7526.23 or 7526.24.</p>

AREA	ACCR. NO. FLA-DADE	COURSE TITLE AND DESCRIPTION
FRENCH	7526.14 7527.13	<p>LE FRANÇAIS DANS LE MONDE</p> <p>This course is designed to make students familiar with the various countries throughout the world in which French is the official language or is widely used. It includes such culturally distinct areas as Canada, Haiti, Africa, Polynesia, and Southeast Asia. Students choose an area which interests them for intensive study. Class discussion is conducted in French. Extensive use is made of films, filmstrips, and tapes. This course may be an alternate to 7526.23 or 7526.24.</p>
FRENCH	7526.15 7527.14	<p>LES FRANÇAIS CONTEMPORAINS</p> <p>This course is designed to acquaint students with twentieth century Frenchmen from various fields such as politics, literature, art, music, films, fashion. Students will explore their lives, deeds, writings, or other contributions to modern France. Some personalities to be studied include: De Gaulle, Pompidou, Sartre, Camus, Malraux, Dior, Chanel, Bardot, Fernandel, Montand, Piaf. Extensive use is made of films, filmstrips, tapes, records, and magazines. Discussion is in French. This course may be an alternate for 7526.24 or a 7527 course.</p>
FRENCH	7527.21	<p>LE FRANÇAIS AVANCÉ, PART 1</p> <p>The student reads extensively magazine articles and short stories by well-known contemporary writers. The stories are all varied and interesting. There is much composition based on the readings. All class discussion is in French.</p>
FRENCH	7527.22	<p>LE FRANÇAIS AVANCÉ, PART 2</p> <p>An extensive reading course. Content is focused on early aviation, an analysis of the French character by a Frenchman, and French resistance in World War II. There is much composition based on the readings. All class discussion is in French.</p>
FRENCH	7527.23	<p>LE FRANÇAIS AVANCÉ, PART 3</p> <p>Extensive reading from an adaptation of a contemporary novel. There is much composition based on the readings. All class discussion is in French.</p>

AREA	ACCR. NO. FLA-DADE	COURSE TITLE AND DESCRIPTION
FRENCH	7527.24	<p>LE FRANÇAIS AVANCÉ, PART 4</p> <p>The student continues to read extensively from newspaper articles and short stories. He continues to write compositions and discuss in French.</p>
FRENCH	7527.25	<p>LE FRANÇAIS AVANCÉ, PART 5</p> <p>The student reads independently and freely from recognized contemporary and established lengthy writings in French. This course is for the very advanced student who has controlled the skills of the other 7527 courses or their equivalent.</p>





GERMAN COURSES

7533 - LEVEL I  
 7534 - LEVEL II  
 7535 - LEVEL III

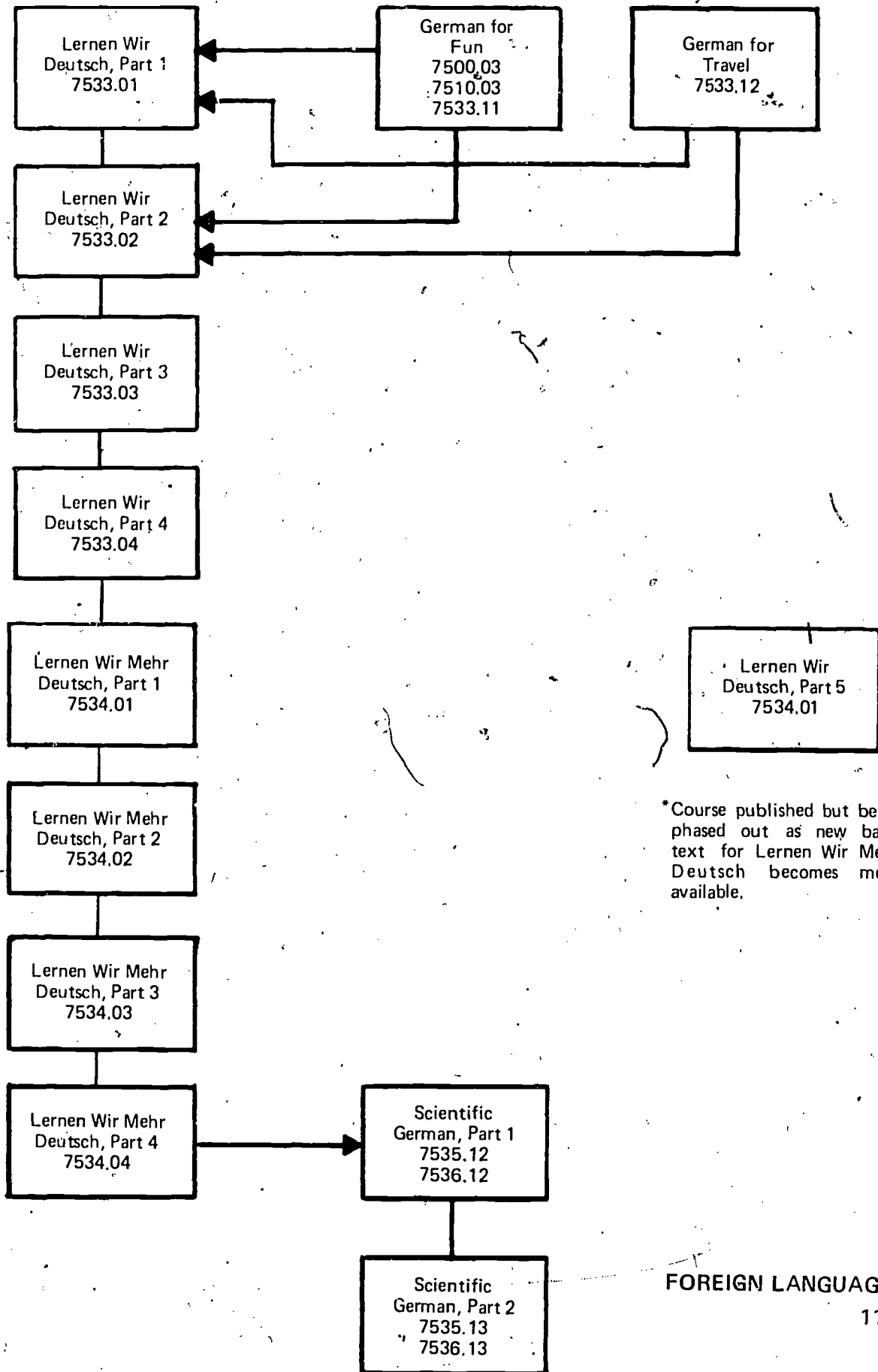

GERMAN COURSES

7535 — LEVEL III  
7536 — LEVEL IV

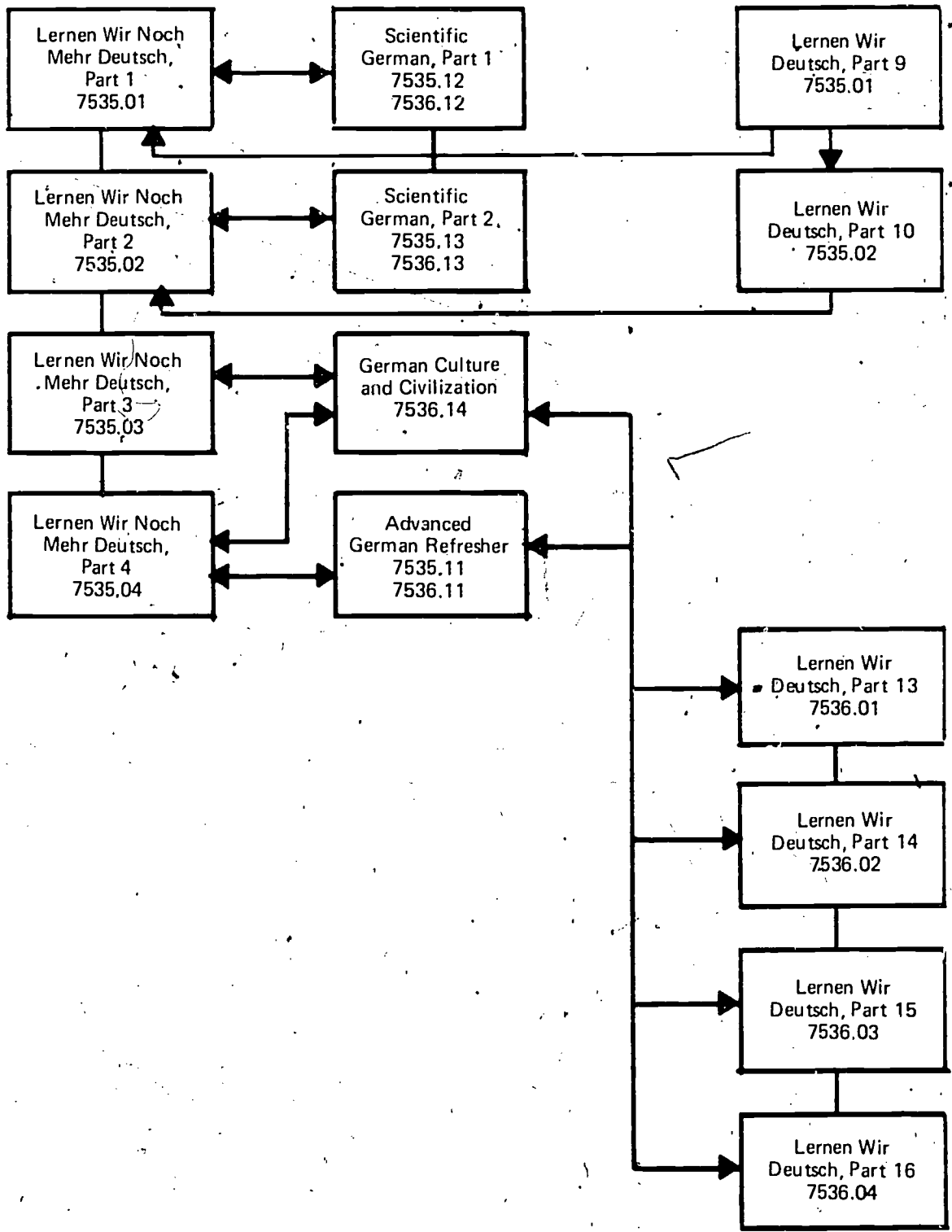

\*Course published but being phased out as new basic text for Lernen Wir Noch Mehr Deutsch becomes more available.



## CODE NUMBERS FOR GERMAN QUINMESTER COURSES

German courses are designated by state code numbers as follows:

- 7533 — Level I
- 7534 — Level II
- 7535 — Level III
- 7536 — Level IV

The standard academic courses are further designated with .01, .02, etc. Alternate courses carry the designation of .11, .12, etc.

The courses on the flow chart marked with an asterisk are being phased out and replaced by another course as the new basic text becomes available. That is, 7534.01 *Lernen Wir Mehr Deutsch! Part 1*, is based on *ALM German*, Second Edition and is designed to replace 7534.01 *Lernen Wir Deutsch! Part 5*.

AREA	ACCR. NO. FLA-DADE	COURSE TITLE AND DESCRIPTION
GERMAN	7500.03 7510.03 7533.11	† GERMAN FOR FUN  This is a course for the student who wants to learn German to speak it just for fun. This course teaches enough basic vocabulary and structures to do just that. Through games and songs, short dialogues and basic phrases or sentences, the student learns to tell time, to count, and to ask and answer various questions about the weather, school, family, friends, and special interests. German is spoken from the start. The student who decides to continue the study of German will follow with 7533.01. If he is exceptionally gifted, he may choose 7533.02.
GERMAN	7533.12	GERMAN FOR TRAVEL  This course is for the student who wants to know how to purchase a ticket; clear customs; get a taxi, train, or bus; find a hotel room; or the nearest pastry shop. Speech is emphasized, and he begins to feel like a traveler. Students learn enough basic vocabulary and structures to enable them to find their way around Germany, becoming familiar with various German customs and with the cities, villages, castles, and museums. Soon everyone will be wishing him <i>Gute Reise!</i>

AREA	ACCR. NO. FLA-DADE	COURSE TITLE AND DESCRIPTION
GERMAN	7533.01	† LERNEN WIR DEUTSCH! PART 1  The student can see through this beginning course of German the close relation between the English and German languages. He already knows more than he thinks! Content centers around a German family and from the start the student will speak German, using short dialogues and structured exercises. Although listening and speaking are emphasized, he begins to develop reading and writing skills through basic phrases and sentences. The basic material is <i>ALM German</i> , Second Edition, units 1, 2, 3. This is the first quin of the academic program.
GERMAN	7533.02	† LERNEN WIR DEUTSCH! PART 2  This course develops listening, speaking, reading, and writing skills on an elementary level. Through short dialogues and structured exercises, the student learns about the unusual and unique German post and school systems; visits quaint little shops and curiously modern department stores; and continues to work with such grammatical structures as nouns, pronouns, and verbs. Possessive determiners are introduced. The basic material is <i>ALM German</i> , Second Edition, units 4, 5. German is the language of the classroom. This course is designed for students who have controlled 7533.01 or equivalent material.
GERMAN	7533.03	LERNEN WIR DEUTSCH! PART 3  The content of this course centers around a visit to the beautiful old city of Hamburg and other topics of equal interest. Emphasis on oral communication is maintained while the other skills of language are developed. The accusative case, prepositions, the command, and the formation of one-syllable noun plurals are among the structures taught. The basic material is <i>ALM German</i> , Second Edition, units 6, 7. German is the language of the classroom. This course is designed for students who have controlled 7533.02 or equivalent material.

AREA	ACCR. NO. FLA-DADE	COURSE TITLE AND DESCRIPTION
GERMAN	7533.04	<p>LERNEN WIR DEUTSCH! PART 4</p> <p>Content centers on the slopes of Garmisch in the German Alps and on skiers. The student learns about other German sports, the seasons, weather, and foods. In the discussion of a German party, the student finds that German youth <i>tanzen</i> just like Americans. He continues to develop fundamental skills. Present tense of slightly irregular verbs and the formation of noun plurals of more than one syllable are introduced. Basic material is <i>ALM German</i>, Second Edition, units 8, 9, 10. German is the language of the classroom. This course is designed for students who have controlled 7533.03 or equivalent material.</p>
GERMAN	7534.01	<p>† LERNEN WIR DEUTSCH! PART 5</p> <p>Content centers around shopping, taking pictures, reading about a skiing trip, and activities on Mother's Day. The student learns to discuss, read, and write about these activities to suit his own needs. Structures studied are the use of the very important command forms of various verbs, verb phrases with <i>durfen</i> and <i>mogen</i>, and the present tense of verbs with separable prefixes. Basic content is that of <i>ALM German</i>, First Edition, units 11, 12. German is the language of the classroom. This course is designed for students who have controlled the 7533 courses or equivalent material.</p>
GERMAN	7534.01	<p>LERNEN WIR MEHR DEUTSCH! PART 1</p> <p>Through course content, the student takes a trip to the zoo, goes shopping for gifts for friends, and reads about a family excursion to a lake and about a shopping trip in search of a Mother's Day gift. The main structural points are irregular masculine nouns, the present tense and use of modals and <i>werden</i>, noun phrases, and third person pronouns as indirect objects in the dative case. The basic content is that of <i>ALM German</i>, Second Edition, units 10 (review), 11, 12. German is the language of the classroom. This course is designed for students who have controlled the 7533 courses or equivalent material.</p>

FOREIGN LANGUAGE  
121

AREA	ACCR. NO. FLA-DADE	COURSE TITLE AND DESCRIPTION
GERMAN	7534.02	LERNEN WIR MEHR DEUTSCH! PART 2  Through reading and oral work, the student learns to talk about mowing the lawn and related chores, and about a trip to the beach. He reads about a boy's visit with relatives on a farm and about a boy's discussion with his father concerning his allowance. Structural points include the dative case of first and second person pronouns, verbs which govern the dative, prepositions which govern the dative, and the order of objects. The basic content is <i>ALM German</i> , Second Edition, units 13, 14. German is the language of the classroom. Students who have controlled 7534.01 or equivalent material will succeed.
GERMAN	7534.03	LERNEN WIR MEHR DEUTSCH! PART 3  Content centers on the traditional afternoon coffee hour, German cars, automobile parts, and a minor accident. Additional readings include information about German license plates and how one can determine the name of the city in which the car owner resides. Main structural items are the conversational past tense of weak and strong verbs and adjective endings. The basic content is that of <i>ALM German</i> , Second Edition, units 15, 16. German will be the language of the classroom. Students who have controlled 7534.02 or equivalent material will succeed.
GERMAN	7534.04	LERNEN WIR MEHR DEUTSCH! PART 4  A dialogue teaches the student about a trip down the Rhine in a freighter. Readings refer to the capital, Bonn, and other places of interest; a famous poem; information about German waterways; and a story of a man's visit to New York, and the robbery which occurred in his home during his absence. As the student reads, he will constantly express himself orally. Structural items included in these units are the past tense of <i>haben</i> , <i>sein</i> , and <i>werden</i> ; the past tense of modals; the narrative past tense of weak verbs; and adjectives after numerals and other determiners of quantity. The basic content of this course is <i>ALM German</i> , Second Edition; units 17, 18. German is the language of the classroom. Students who have controlled the other 7534 courses or equivalent material will succeed.

AREA	ACCR. NO. FLA-DADE	COURSE TITLE AND DESCRIPTION
GERMAN	7535.12 7536.12	<p data-bbox="820 466 1238 495">SCIENTIFIC GERMAN, PART 1</p> <p data-bbox="820 530 1560 794">This is a basic course for students who wish to enter the fields of natural sciences and psychology in college. It is designed to equip students with an introduction to basic scientific vocabulary and grammatical structures. The student learns techniques in reading, writing, and translating scientific works and papers. Success will be more probable if 7534.04 or its equivalent has been controlled. This course will serve as an alternate for 7535.01.</p>
GERMAN	7535.13 7536.13	<p data-bbox="820 859 1238 887">SCIENTIFIC GERMAN, PART 2</p> <p data-bbox="820 923 1560 1011">This course will follow naturally Scientific German, Part 1. The readings become more specialized. This course will serve as an alternate for 7535.02.</p>
GERMAN	7535.01	<p data-bbox="820 1073 1453 1101">LERNEN WIR NOCH MEHR DEUTSCH! PART 1</p> <p data-bbox="820 1137 1560 1554">Through course content, the student learns about the Black Forest and its inhabitants, and that many of the farmers have moved into towns, their farmhouses taken over by city people as vacation homes. He also reads about a visit to the movies and sees copies of movie ads. He becomes acquainted with the city of Berlin and its famous Trümmerberg. Free discussion of these facts is encouraged. The main structural item is the narrative past tense of strong verbs. Other items are time expressions, the two-way prepositions and prepositional <i>da-</i> and <i>wo-</i> compounds. The basic content is that of <i>ALM German</i>, Second Edition, units 19, 20. German is the language of the classroom. Students who have controlled the 7534 courses or equivalent material will succeed.</p>
GERMAN	7535.02	<p data-bbox="820 1608 1453 1637">LERNEN WIR NOCH MEHR DEUTSCH! PART 2</p> <p data-bbox="820 1673 1560 2082">Through course content, the student learns that the question of one's future is just as important to young German people as to ours. He reads about an interesting Information Bureau in Munich where young people may ask questions about every conceivable facet of their lives, and he sees a page of Help Wanted ads from a local newspaper. Reading selections are discussed freely in class. The two structural points in these units are the accusative and dative reflexive verbs, and the comparison of adjectives and adverbs in all degrees. The basic content is that of <i>ALM German</i>, Second Edition, units 21, 22. German is the language of the classroom. Students who have controlled 7535.01 or equivalent material will succeed.</p>

FOREIGN LANGUAGE

123

AREA	ACCR. NO. FLA-DADE	COURSE TITLE AND DESCRIPTION
GERMAN	7535.03	LERNEN WIR NOCH MEHR DEUTSCH! PART 3  Reading content centers on school activities. A telephone and a letter serve as a means of conversation. A few poems and proverbs are also read. In addition an almost-true story of a downed plane on the Luneburger Heide is included. Structural items are the forms and usage of the genitive case, the interrogative <i>wessen</i> , relative pronouns and clauses, <i>wo-</i> compounds in relative clauses, and the past perfect tense. Controlled and free conversation continue to be emphasized. The basic content of this course is <i>ALM German</i> , Second Edition, units 23, 24. German is the language of the classroom. Students who have controlled 7535.02 or equivalent material will succeed.
GERMAN	7535.04	LERNEN WIR NOCH MEHR DEUTSCH! PART 4  Content centers around vacations, the Autobahn, Switzerland, the Oktoberfest in Munich, Munich itself, and one of its famous comedians, Karl Valentin. Structural items include the perfect forms of modals and of <i>helfen</i> , <i>horen</i> , <i>lassen</i> , and <i>sehen</i> ; the infinitive constructions with <i>zu</i> ; the present and perfect infinitive; and conditional sentences in real and unreal conditions. The basic content is that of <i>ALM German</i> , Second Edition, units 25, 26, 27. German is the language of the classroom. Students who have controlled 7535.03 or equivalent material will succeed.
GERMAN	7535.11 7536.11	ADVANCED GERMAN REFRESHER  Especially designed for college-bound students, this course offers a general review of grammar, conversation, and individualized reading. The reading selections include outstanding, contemporary German short stories. Third- and fourth-year students who desire to place well in college will find this quite very profitable.
GERMAN	7536.14	GERMAN CULTURE AND CIVILIZATION  This course is a guide to a realization and appreciation of the interesting differences in the German culture. The student acquires some information and understanding of the geography and history of Germany and learns about many famous Germans and their contributions in the fields of literature, science, art, and music. These understandings are gained through the use of oral and written German. This course is a profitable experience as an alternate or addition to 7535.03, 7535.04, or any other 7536 course.



AREA	ACCR. NO. FLA-DADE	COURSE TITLE AND DESCRIPTION
GERMAN	7535.01	<p data-bbox="790 478 1283 509">† LERNEN WIR DEUTSCH! PART 9</p> <p data-bbox="829 542 1573 906">The student reads about a beautiful castle built by Ludwig, the "Mad King of Bavaria"; Bonn, the capital of West Germany; and the German theater. Structural items include the past tense of weak and strong verbs, adjective endings after <i>der</i> words, the dative plural of the articles, and prepositions which govern the accusative. There will be extensive discussion in German of the readings. The writing of simple compositions is based upon a controlled vocabulary. Basic content is that of <i>ALM German</i>, First Edition, units 19, 20. Success in this course will be assured if the 7534 courses or their equivalents have been controlled. German is the language of the classroom.</p>
GERMAN	7535.02	<p data-bbox="790 966 1297 997">† LERNEN WIR DEUTSCH! PART 10</p> <p data-bbox="829 1030 1573 1447">Through readings, the student visits a German family, and finds out about its activities on an average Saturday, then learns from another family about the general economic situation of recent years. He discovers the things German boys and girls like to do in their spare time. Some interesting short stories are included. Points of structure include <i>da-</i> and <i>wo-</i> compounds, the use of the personal pronoun vs. prepositional compounds, the dative reflexive construction, and word order. Simple compositions are based on a controlled vocabulary. Basic content is that of <i>ALM German</i>, First Edition, units 21-22. German is the language of the classroom. Success in this course will be assured if 7535.01 or equivalent material has been controlled.</p>
GERMAN	7536.01	<p data-bbox="790 1506 1297 1537">† LERNEN WIR DEUTSCH! PART 13</p> <p data-bbox="829 1570 1573 1968">This course presents a vivid picture of life in postwar Germany. Additional readings are based upon individual interests. Structural items stressed are relative pronouns and clauses, adjectives not preceded by a determiner, <i>ein-</i> words used as pronouns, along with a comprehensive review of all declensional forms taught in preceding courses. Compositions are based upon free as well as controlled vocabulary and free conversation continues to be emphasized. The basic material of this course is that of <i>ALM German</i>, First Edition, units 27, 28. German is the language of the classroom. This course is designed for the advanced student who has mastered the 7535 courses or equivalent material.</p>

AREA	ACCR. NO. FLA-DADE	COURSE TITLE AND DESCRIPTION
GERMAN	7536.02	<p data-bbox="775 487 1241 511"><b>LERNEN WIR DEUTSCH! PART 14</b></p> <p data-bbox="775 542 1530 994">Emphasis is on readings in German, dealing with life in post war Germany. Additional readings are based upon individual interest. Items of structure include the perfect forms of modals and of <i>helfen, horen, lassen, and sehen</i> with infinitives in dependent and independent clauses; word order in subordinate clauses; the position of <i>nicht</i>; the position of adverbs of time, manner, and place; and the position of noun and pronoun objects, along with a comprehensive review of all verb forms taught in preceding courses. Compositions are increasingly based upon free vocabulary. The basic material of this course is that of <i>ALM German</i>, First Edition, units 29, 30. German is the language of the classroom. This course is designed for the student who has controlled 7536.01 or equivalent material.</p>
GERMAN	7536.03	<p data-bbox="775 1059 1241 1082"><b>LERNEN WIR DEUTSCH! PART 15</b></p> <p data-bbox="775 1113 1530 1480">Readings center on a selection describing the reactions of a young man suddenly called into military service and a modern selection presenting a kaleidoscope of characters. There are additional selections to suit individual interests. Structural points studied are conditional sentences; the simple subjunctive forms of <i>haben, sein</i>, strong and weak verbs; and the compound subjunctive. Free compositions stress the writing of letters, business and personal. The basic material of this course is that of <i>ALM German</i>, First Edition, units 31, 32. German is the language of the classroom. This course is designed for the student who has controlled 7536.02 or equivalent material.</p>
GERMAN	7536.04	<p data-bbox="775 1544 1241 1568"><b>LERNEN WIR DEUTSCH! PART 16</b></p> <p data-bbox="775 1599 1530 1965">Readings include a vivid, somewhat humorous, portrayal of life in Germany during the years immediately before Hitler came into power, as seen through the eyes of a high school student. Additional readings are continued on the basis of individual interests. Structural items include the simple quotative forms of <i>sein, haben</i>, strong and weak verbs, and modals. Free compositions continue to stress the writing of letters, business and personal. The basic material of this course is that of <i>ALM German</i>, First Edition, units 33, 34. German is the language of the classroom. This course is designed for the student who has controlled 7536.03 or equivalent material.</p>

## HEBREW COURSES

### CODE NUMBERS FOR HEBREW QUINMESTER COURSES

Hebrew courses are designated by state code numbers as follows:

7517 — Level I  
7574 — Level II  
7575.01 — Level III  
7575.40 — Level IV  
7575.50 — Level V

The code number 7575 is used for three levels because no other designation has been made available from the state; the distinguishing digits for the quins appear after the decimal.

AREA	ACCR. NO. FLA-DADE	COURSE TITLE AND DESCRIPTION
HEBREW	7517.01	<b>FUN AT THE KIBBUTZ</b>  Through content the student lives and breathes the fresh air of a modern Israeli kibbutz, or collective settlement, the backbone of the State of Israel. He learns to converse in simple affirmative, interrogative, and negative sentences. The aim of this quin is to converse in Hebrew—to speak the language of a modern people, woven with the golden thread of the ancient biblical tongue as spoken by Abraham and Moses.
HEBREW	7517.02	<b>VISIT AN ISRAELI CAFE</b>  Through course content the student sits and sips a cup of Israeli coffee as he chats with a friend at a typical sidewalk cafe in the bustling city of Tel Aviv. Although great stress is still placed on audio-lingual skills, this quin initiates and stresses the ability to read and write the ancient, yet modern, language of Hebrew. The student who has controlled the language of 7517.01 or its equivalent will succeed.

AREA	ACCR. NO. FLA-DADE	COURSE TITLE AND DESCRIPTION
HEBREW	7517.03	<p>A JOURNEY TO JERUSALEM</p> <p>Through his study the student can see the gleaming hills of Jerusalem appear in the brilliant sky as the streamliner powers its way up the same slopes trodden by pilgrims on their way to the Holy City. Audio-lingual skills are further developed by mastering the telling of time, numbers through 100, present tense, and agreement of adjectives with nouns in gender and number.</p>
HEBREW	7517.04	<p>ENJOYING A MOVIE</p> <p>The student pretends to join some friends as they prepare to leave for the movies and make the most of an evening out in the theatre. He learns about dressing and grooming himself—all in Hebrew. Future tense is introduced in this quin, along with conditional sentences and possessive forms. At the conclusion of this quin, the student may choose 7517.05 or 7574.01.</p>
HEBREW	7517.05	<p>UP AND AWAY TO ISRAEL</p> <p>The Mediterranean Sea greets the student as his plane takes him to the land of Israel. This quin enables him to take care of all tourist needs, such as getting directions to his destination or ordering from a menu. Accent is on audio-lingual skills, along with reading store window signs and headlines. His knowledge of Hebrew increases as he daily uses vocabulary that breathes with the adventure of experiences in the Holy Land. This quin is for the student who has completed 7517.03 or 7517.04.</p>
HEBREW	7574.01	<p>VISITING GRANDPARENTS</p> <p>The content centers on a twentieth century Israeli family which demonstrates typical family life as it experiences worldwide problems and then looks at its own family situations. Past tense is introduced in this quin, along with new formations of the imperative.</p>
HEBREW	7574.02	<p>A VISIT TO AN ISRAELI DOCTOR</p> <p>Oral work encourages the student to be able to tell how he feels. In Hebrew, of course! In this quin, he learns new uses for the infinitive in structure. The student who controls the language of 7574.01 or its equivalent will succeed.</p>

AREA	ACCR. NO. FLA-DADE	COURSE TITLE AND DESCRIPTION
HEBREW	7574.03	<p>WOMEN'S LIB ADVANCES IN ISRAEL</p> <p>Some contemporary problems are discovered through content. The pride of the Israeli father is most clearly demonstrated in his desire for his mate to stay at home—but to no avail. Women's liberation has arrived by necessity, if not through philosophy. More stress is placed on past tense, review of all usage of <i>kal</i> and introduction of the verb <i>haya</i>.</p>
HEBREW	7574.04	<p>MEETING AN OLD FRIEND</p> <p>The content centers on a chance meeting with an old friend. Old times have to be discussed, but with no time now for idle chatter, the sentimental review is continued over the phone. Stress on all tenses and structures with <i>rok</i> are found in this quin.</p>
HEBREW	7575.01	<p>EARLY HISTORY THROUGH THE SECOND CENTURY</p> <p>The development of the Hebrew language springs forth from the descriptions of early history. The student is acquainted with some philosophies of life and discovers a wealth of human intellect in the original tongue. Analysis of structure and oral work continues.</p>
HEBREW	7575.02	<p>HISTORIC HIGHLIGHTS' BEYOND THE SECOND CENTURY</p> <p>The student reads excerpts from the works of poets and writers prior to the fourteenth century. Basic ideals and virtues of social behavior expressed in these writings are studied. Discussion in Hebrew and language structure are vital parts of the course.</p>
HEBREW	7575.03	<p>JOURNALISTIC AND SPOKEN HEBREW</p> <p>The needs of the modern Israeli in the business world, as well as in his personal life, are clearly expressed through readings on progressive Israel. This quin has humor and discipline. Hebrew is the language of the classroom.</p>
HEBREW	7575.04	<p>HEBREW GRAMMAR</p> <p>This quin deals with specific grammar study in all seven conjugations, idioms and phrases, and a review of the basic structural areas of the language.</p>

FOREIGN LANGUAGE

129

AREA	ACCR. NO. FLA-DADE	COURSE TITLE AND DESCRIPTION
------	-----------------------	------------------------------

HEBREW	7575.40	THE HUMANITIES AND HEBREW, PART 1
--------	---------	-----------------------------------

The fate of man as it is presented by two outstanding literary figures is the subject of this course. The Hebrew writer Shalom Aleichem's *Fiddler on the Roof* and Ernest Hemingway's *Old Man and the Sea* are read and analyzed in Hebrew. The basic text is Book I, *Literary Selections* by Doovshanee. Hebrew is the language of the classroom.

HEBREW	7575.41	THE HUMANITIES AND HEBREW, PART 2
--------	---------	-----------------------------------

In this course the students compare and evaluate *Short Stories* by Schmucl Egnon and Dostoevsky's *Crime and Punishment* in Hebrew. The focus is the deterioration of man and the many forces that influence his actions for which he ultimately must be responsible. The basic text is Book II of Doovshanee's *Literary Selections*. Hebrew is the language of the classroom.

HEBREW	7575.42	THE HUMANITIES AND HEBREW, PART 3
--------	---------	-----------------------------------

The relationship of children to parents is the theme. It is illustrated in the *Hassidic Stories* of Y. L. Peretz and the French novelist Balzac's *Father Goriot*. There is oral discussion following the reading, as well as writing. The basic text is Book III of *Literary Selections* of Doovshanee. Hebrew is the language of the classroom.

HEBREW	7575.43	THE HUMANITIES AND HEBREW, PART 4
--------	---------	-----------------------------------

Three writers constitute the readings explored in this course. The character of man during the pressures of war and the tragedy of the consequences are depicted in these works: Martin Buber's *The Thinking of the Youth Today*; Rachel's *Selected Poetry*, and Tolstoy's *War and Peace*. Book IV of *Literary Selections* by Doovshanee is the basic text. Hebrew is the language of the classroom.

HEBREW	7575.50	THE HUMANITIES AND HEBREW, PART 5
	7575.51	THE HUMANITIES AND HEBREW, PART 6
	7575.52	THE HUMANITIES AND HEBREW, PART 7
	7575.53	THE HUMANITIES AND HEBREW, PART 8

These programs are individually prescribed by the teacher.

FOREIGN LANGUAGE  
130

LATIN COURSES

7513 — LEVEL I  
7514 — LEVEL II

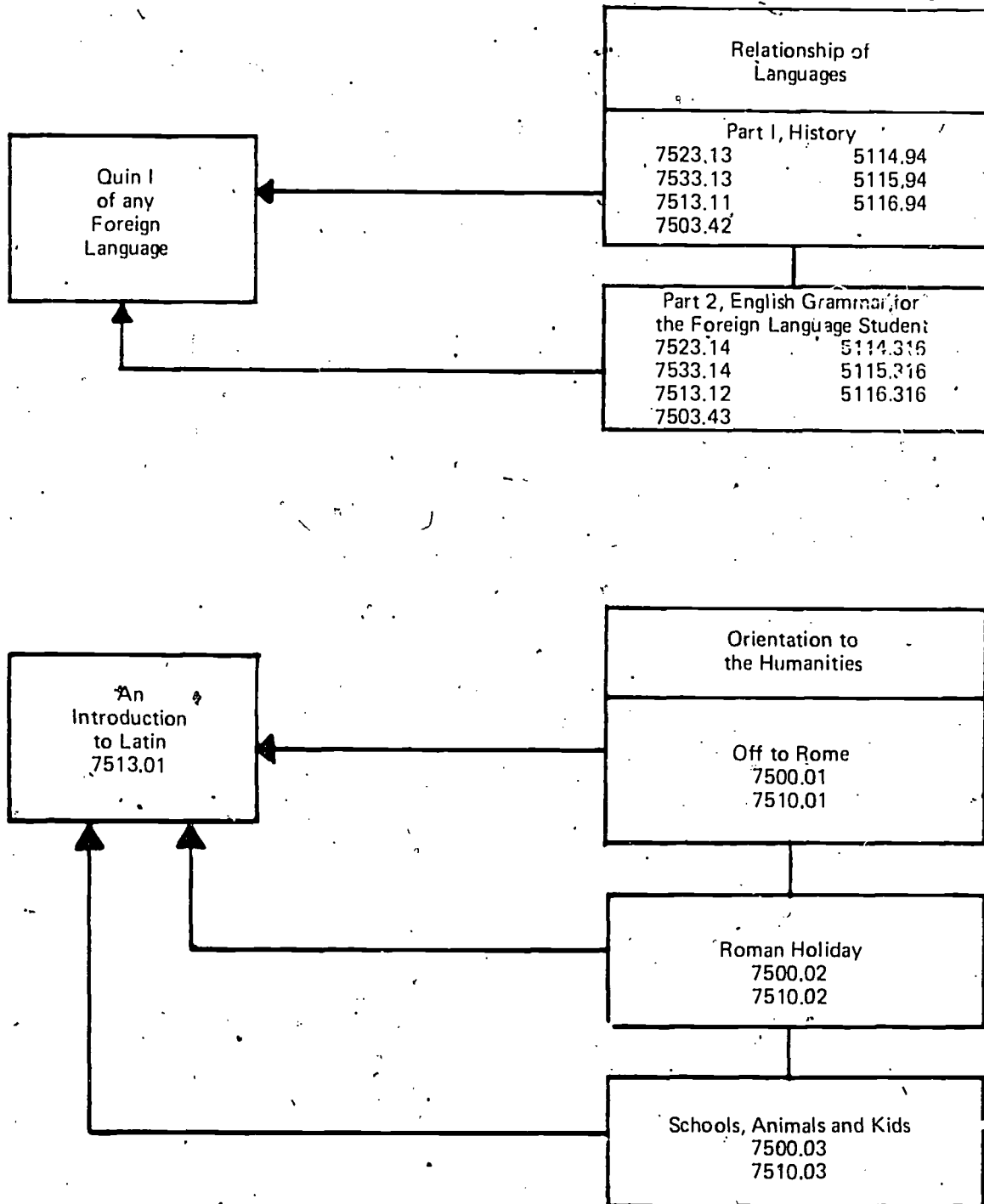

FOREIGN LANGUAGE  
131

LATIN COURSES

7513 — LEVEL I  
7314 — LEVEL II

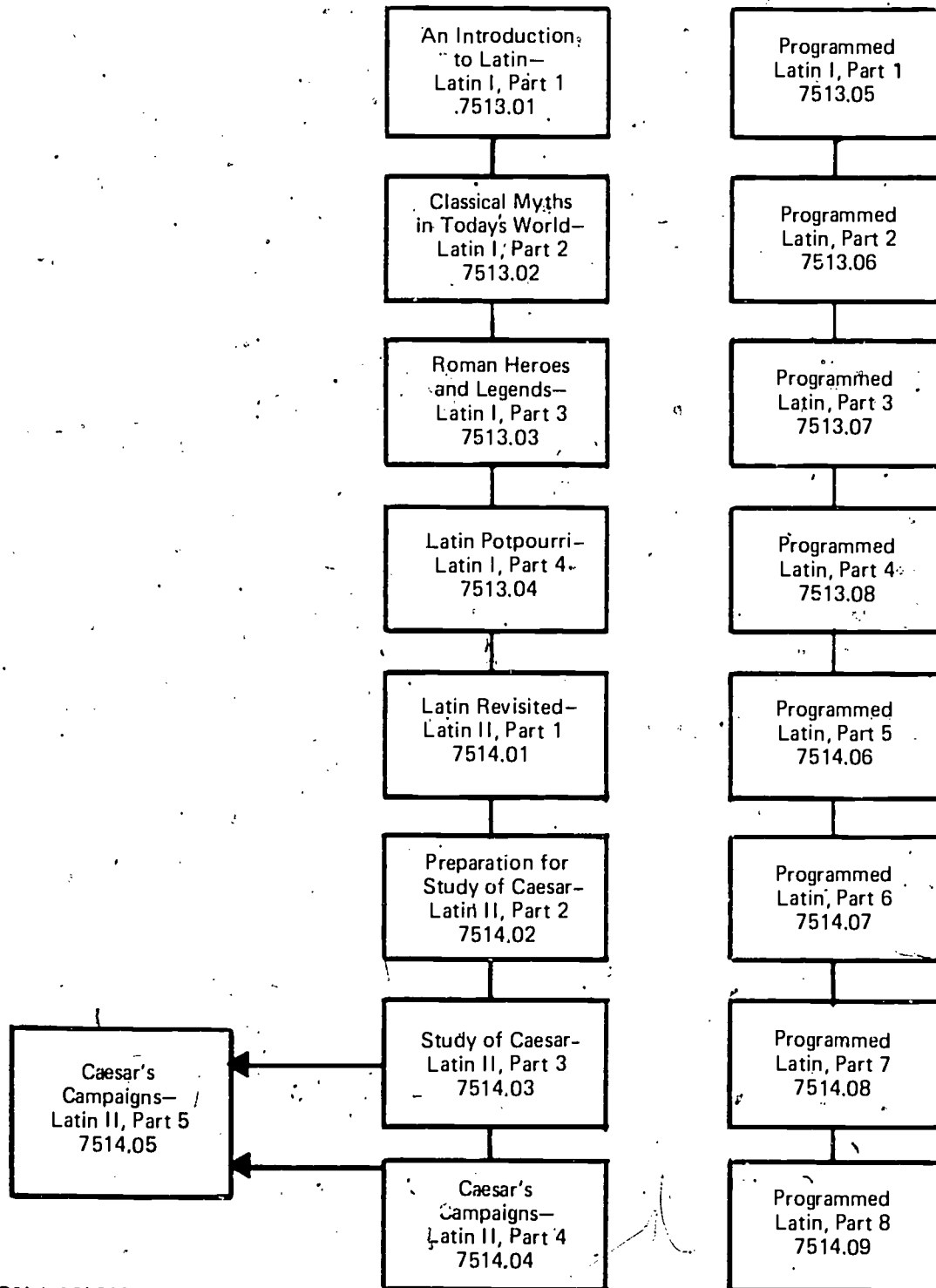



LATIN COURSES

7515 — LEVEL III  
7516 — LEVEL IV

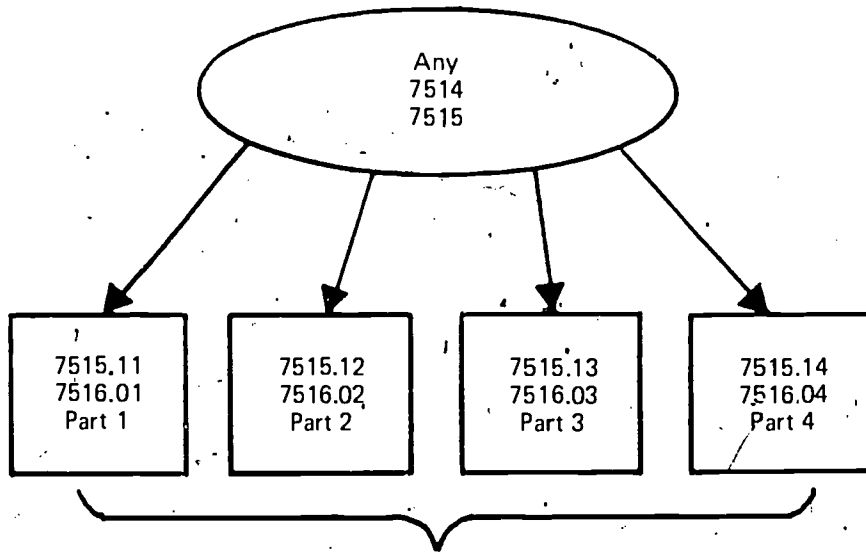
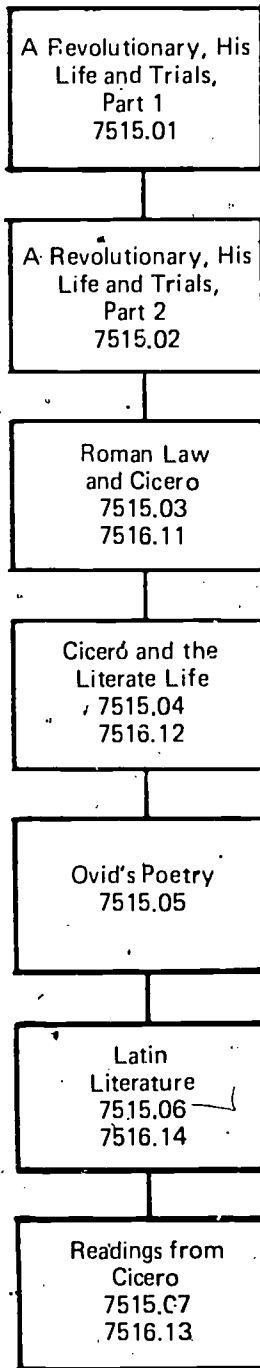

Vergil, The Great Adventurer

## CODE NUMBERS FOR LATIN QUINMESTER COURSES

The Latin chart reveals the variety of beginning courses, particularly exploratory courses such as the trilogy, Orientation to the Humanities.

Latin courses are designated by state code numbers as follows:

- 7513 - Level I
- 7514 - Level II
- 7515 - Level III
- 7516 - Level IV

The Latin program at levels I and II can be standard or programmed. At levels III and IV the varieties of possible offerings are numerous. Standard academic courses are designated by .01, .02, etc., and the alternates with .11, .12, etc.

The Relationship of Languages, Part 1 and Part 2, may be taken at the beginning of the study of any foreign language.

AREA	ACCR. NO. FLA-DADE	COURSE TITLE AND DESCRIPTION
FRENCH GERMAN LATIN SPANISH LANGUAGE ARTS	7523.13 7533.13 7513.11 7503.42 5114.94 5115.94 5116.94	RELATIONSHIP OF LANGUAGES, PART 1, HISTORY  This course traces the origin and history of the English language from the Anglo-Saxon period to the present. Influences from other languages on the vocabulary, structure (grammar), and syntax of English are stressed. In addition the student undertakes a brief comparative study of the foreign languages offered in his school in areas of vocabulary, idiom, word order, person, number, and structure. No prerequisite.
FRENCH GERMAN LATIN SPANISH LANGUAGE ARTS	7523.14 7533.14 7513.12 7503.43 5114.315 5115.316 5116.316	RELATIONSHIP OF LANGUAGES, PART 2, ENGLISH GRAMMAR FOR THE FOREIGN LANGUAGE STUDENT  This course is designed to strengthen students in English language skills preparatory to the study of a foreign language. It is NOT remedial grammar. Those elements of English grammar that are most commonly needed in foreign language study are stressed, for example, parts of speech, tense, conjugation, principal parts, cases. Structure is stressed with little emphasis on usage. No prerequisite.

FOREIGN LANGUAGE  
134

AREA	ACCR. NO. FLA-DADE	COURSE TITLE AND DESCRIPTION
------	-----------------------	------------------------------

A JOURNEY INTO OUR PAST: ORIENTATION TO THE HUMANITIES

This is a trilogy, consisting of the three courses that follow. Each one has eight units which focus on various aspects of the life of a Roman family in the first century A.D. The courses may be studied independently, but success in the second and third is more likely if the previous one has been studied. In general, each unit contains cultural background presented in English; Latin dialogue and expressions, including songs, games, and poems related to the theme of the unit; Latin mottoes and expressions common to English usage; English derivatives; some references to Roman and Greek mythology; and in particular an emphasis on the comparison between Roman and contemporary society.

LATIN	7500.01 7510.01	OFF TO ROME
-------	--------------------	-------------

Topics of study are the geographic location of the Roman Empire, the Romans, greetings, proper names, family structure, foods and eating customs.

LATIN	7500.02 7510.02	ROMAN HOLIDAY
-------	--------------------	---------------

Topics of study are clothing; significance of the Roman bath; architecture, especially houses, with attention to the influence on Spanish and contemporary houses; occupations; entertainment, and civic responsibilities.

LATIN	7500.03 7510.03	SCHOOLS, ANIMALS AND KIDS
-------	--------------------	---------------------------

The content of the course includes telling time by the day and year; information about schools; animals; and gladiatorial combat.

LATIN	7513.01	† AN INTRODUCTION TO LATIN-LATIN I, PART 1
-------	---------	--

This is the initial quin of a standard course of Latin—the language of the Romans. The course covers the use of Latin in daily life, including pronunciation, greetings, numbers and songs; introduction to Latin nouns, verbs, and their uses. There is also reading of simple Latin stories; Latin vocabulary with emphasis on English derivatives and orientation to classical mythology.

AREA	ACCR. NO. FLA-DADE	COURSE TITLE AND DESCRIPTION
LATIN	7513.02	<p>CLASSICAL MYTHS IN TODAY'S WORLD-LATIN I, PART 2</p> <p>This course offers further development of language skills. Reading of Latin stories is based on classical mythology. Latin vocabulary and English derivatives are studied and emphasis placed on Latin prepositions used as prefixes in English. The cultural topic studied is the way of Roman life.</p>
LATIN	7513.03	<p>ROMAN HEROES AND LEGENDS-LATIN I, PART 3</p> <p>This is a review of previously learned structures. Study includes pronoun forms and uses in both Latin and English. Latin readings are from mythology and the legendary history of Rome. Phrases, mottoes, and abbreviations used in English are presented. The cultural emphasis is on the legendary history of the early Romans.</p>
LATIN	7513.04	<p>LATIN POTPOURRI-LATIN I, PART 4</p> <p>The course begins with a review of forms and structures, and presents additional case uses and forms, particularly verbs. Latin readings are from mythology and Roman history. Vocabulary study continues to emphasize English derivatives in current use. There is more advanced study of classical mythology and Roman life.</p>
LATIN	7513.05 7513.06 7513.07 7513.08	<p>PROGRAMMED LATIN, PART 1 PROGRAMMED LATIN, PART 2 PROGRAMMED LATIN, PART 3 PROGRAMMED LATIN, PART 4</p> <p>The student moves at his own pace, advancing step-by-step toward comprehension of the structure and vocabulary. Content covered is small but well controlled and explanations and the use of correlating multi media add richness to the program. This is a desirable program for the highly motivated student who enjoys setting his own goals and possibly directing himself so that he can finish the complete course in less than the traditional time.</p>

AREA	ACCR. NO. FLA-DADE	COURSE TITLE AND DESCRIPTION
LATIN	7514.06 7514.07 7514.08 7514.09	PROGRAMMED LATIN, PART 5 PROGRAMMED LATIN, PART 6 PROGRAMMED LATIN, PART 7 PROGRAMMED LATIN, PART 8  Slowly but surely the student brings under his control the grammatical forms studied and begins to read. The primary purpose of the course is to provide the student with the ability to read and understand Latin literature without recourse to English. There is a modern linguistic analysis of the contrast in Latin and English structure and extensive use of audio-visual materials. It is not recommended that an average student move from a quin of programmed studies to one not programmed. The vocabulary and organization of material are vastly different.
LATIN	7514.01	LATIN REVISITED—LATIN II, PART 1  This course presents a thorough review of forms and structures previously studied, as well as new forms and structures. Latin vocabulary and English derivatives are studied and emphasis placed on the use of English derivatives in sentences. The student reads about the Trojan War or Roman life. Enrichment materials provide in-depth study of the War or daily activities of a typical Roman. Satisfactory completion of 7513 courses or their equivalent is recommended before pursuing this course.
LATIN	7514.02	PREPARATION FOR STUDY OF CAESAR—LATIN II, PART 2  The grammar of this course presents a thorough study of the subjunctive mood—forms and uses and additional forms and structures needed for the study of Caesar. The vocabulary study emphasizes -en suffixes. Readings are either on Hannibal or Roman life. Enrichment materials are based on the study of Roman history or Roman life.
LATIN	7514.03	STUDY OF CAESAR—LATIN II, PART 3  This course will provide a review of forms and structures as needed. The reading focuses on Caesar's campaign against the Helvetians. Emphasis continues on English derivatives. Caesar's life and times, and the Roman army are subjects for further reading. Upon successful completion of this course, the student may elect 7514.04 or 7514.05.

AREA	ACCR. NO. FLA-DADE	COURSE TITLE AND DESCRIPTION
LATIN	7514.04	<p>CAESAR'S CAMPAIGNS—LATIN II, PART 4</p> <p>The readings focus on Caesar's campaign against the Germans and Nervii. English derivatives continue to receive emphasis. Structural forms are reviewed as needed. Roman warfare and the life and customs of the Celts and Germans are cultural topics presented. After satisfactorily completing 7514.03, the student may elect this course or 7514.05.</p>
LATIN	7514.05	<p>CAESAR'S CAMPAIGNS—LATIN II, PART 5</p> <p>The reading consists of the first and second invasion of Britain. Emphasis continues on structure review and English derivatives. The cultural focus is on Roman ships and naval warfare, and life in Roman Britain. This course may be studied with success after completion of 7514.03 or 7514.04.</p>
LATIN	7515.01	<p>† A REVOLUTIONARY: HIS LIFE AND TRIALS, PART 1</p> <p>The study presents the background of the Catilinian Conspiracy and the First Oration against Catiline. It includes a review of grammar and syntax. It is expected that this course will follow the 7514 courses, but a student may study any 7515 quin in any sequence.</p>
LATIN	7515.02	<p>† A REVOLUTIONARY: HIS LIFE AND TRIALS, PART 2</p> <p>The student continues to study the Catilinian Conspiracy and the Third Oration against Catiline, including a review of grammar and syntax. This course logically follows 7515.01, but a student may study any 7515 quin in any sequence.</p>
LATIN	7515.03 7516.11	<p>ROMAN LAW AND CICE RO</p> <p>The student sees the evidence of mismanagement by a Roman governor through reading Cicero's oration against Verres and Cicero's letters. The teacher presents a review of grammar as the need arises. This course may be studied in any sequence.</p>

AREA	ACCR. NO. FLA-DADE	COURSE TITLE AND DESCRIPTION
LATIN	7515.04 7516.12	<p>CICERO AND THE LITERATE LIFE</p> <p>This course offers a praise of the literate life, including a defense of a Greek friend's citizenship. The teacher presents a review of grammar as the need arises. This course may be studied in any sequence.</p>
LATIN	7515.05	<p>OVID'S POETRY</p> <p>Readings are in mythology from Ovid's poetry. The teacher presents a review of grammar as the need arises. This course may be studied in any sequence.</p>
LATIN	7515.06 7516.14	<p>LATIN LITERATURE</p> <p>The student reads in Latin from works by various Roman writers. The teacher presents a review of grammar as the need arises. This course may be studied in any sequence.</p>
LATIN	7515.07 7516.13	<p>READINGS FROM CICERO</p> <p>The student discovers through readings from Cicero that ancient man's problems of everyday life are similar to problems that exist today. The teacher presents a review of grammar as the need arises. This course may be studied in any sequence.</p>
LATIN	7515.11 7516.01	<p>VERGIL, THE GREAT ADVENTURER, PART 1</p> <p>This sequence is based on the books of <i>The Aeneid</i>. The wanderings and exciting events of Aeneas and the Trojans are included with a study of the poetic devices used in the epic. A brief survey of Vergil's life and his other works are included. The translation of Book 1 is the basis of this course. The life of the author is briefly surveyed. These quins may be studied in any sequence following the 7514 and/or 7515 courses.</p>
LATIN	7515.12 7516.02	<p>VERGIL, THE GREAT ADVENTURER, PART 2</p> <p>This translation of Book II with supplements is the basis of this course. It may be studied in any sequence.</p>

AREA	ACCR. NO. FLA-DADE	COURSE TITLE AND DESCRIPTION
LATIN	7515.13 7516.03	<p>VERGIL, THE GREAT ADVENTURER, PART 3</p> <p>Book III in English and the translation of Book IV with supplements are the basis of this course. It may be studied in any sequence.</p>
LATIN	7515.14 7516.04	<p>VERGIL, THE GREAT ADVENTURER, PART 4</p> <p>Book V in English and the translation of Book VI with supplements are the basis of this course. It may be studied in any sequence.</p>



# RUSSIAN COURSES

7543 - LEVEL I  
7544 - LEVEL II

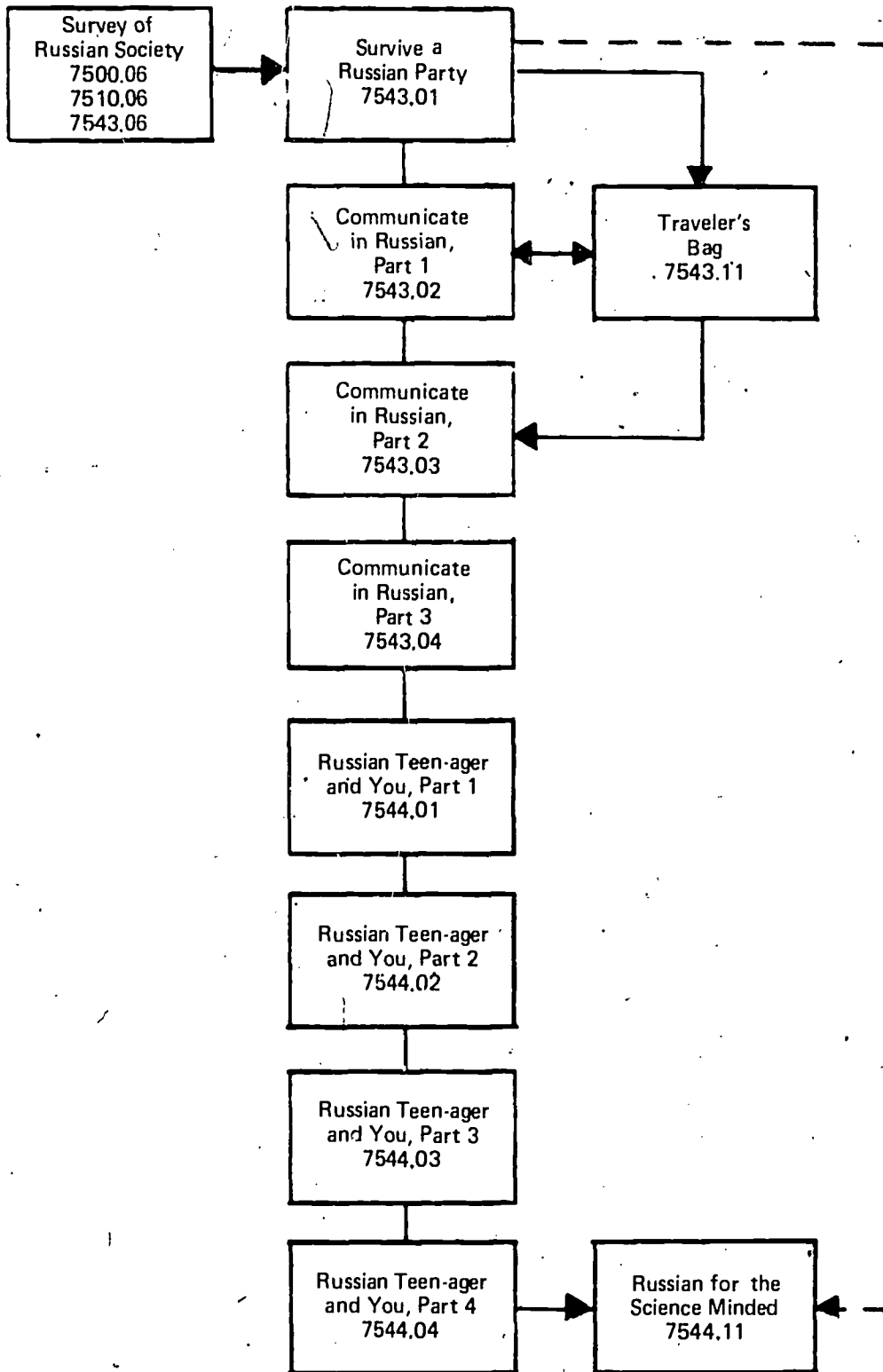

RUSSIAN COURSES

7545 - LEVEL III  
7546 - LEVEL IV

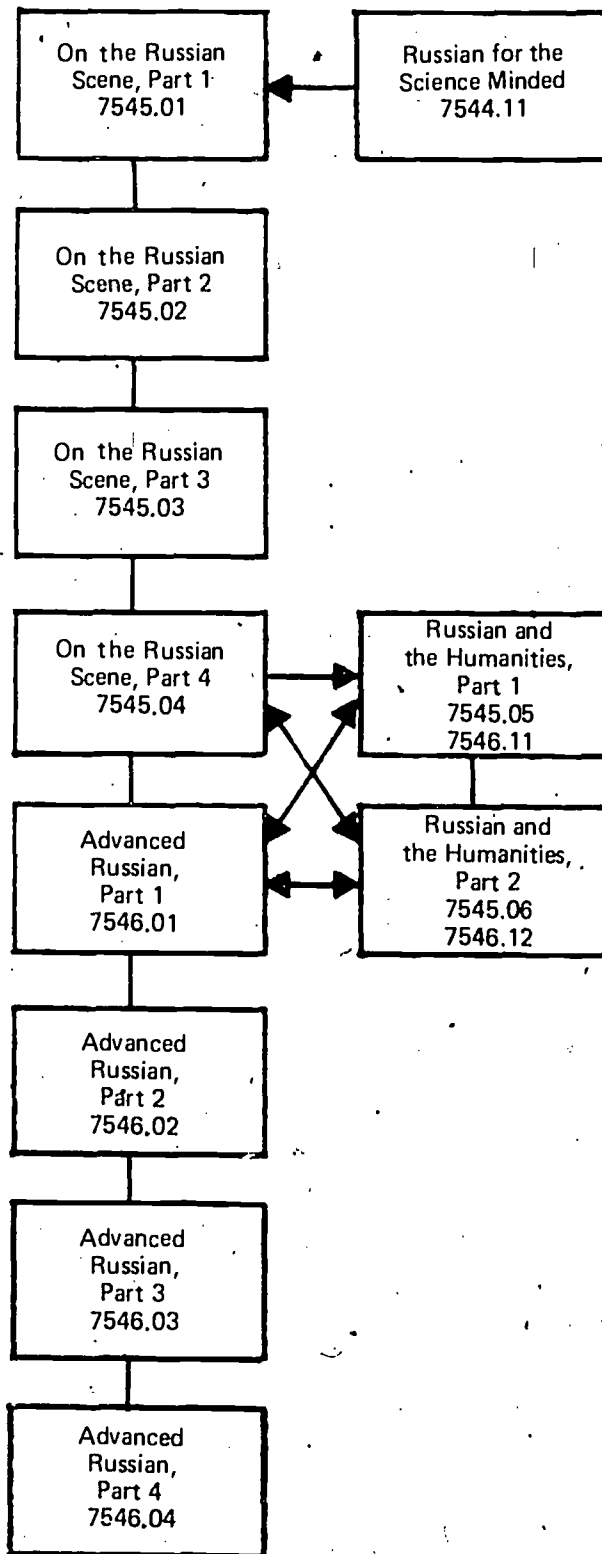

## CODE NUMBERS FOR RUSSIAN QUINMESTER COURSES

Russian courses are designated by state code numbers as follows:

- 7543 — Level I
- 7544 — Level II
- 7545 — Level III
- 7546 — Level IV

The standard or academic program is further designated with .01, .02, etc. The alternates are .11 or .12, etc.

AREA	ACCR. NO. FLA-DADE	COURSE TITLE AND DESCRIPTION
RUSSIAN	7500.06 7510.06 7543.06	† SURVEY OF RUSSIAN SOCIETY  The students survey aspects of Russian society in which they have an interest, such as censorship, collective farms, customs, education, espionage, government, language, law, labor camps, medicine, marriage, religion, secret police, sports, science and technology, youth, etc. Students who have some knowledge of the Russian language are encouraged to use Russian materials in their studies. Others are guided to English translations of Russian materials. Special speakers and events complement classroom activities.
RUSSIAN	7543.01	† SURVIVE A RUSSIAN PARTY  The student is able to survive the party! From greeting to parting, he communicates with his host and hostess in a typical Soviet apartment. The international language of music assists him. The student learns to write everything that he can say. All conversation is in the present tense. If a student wishes to study Russian, he must begin with this course. The basic content is that of <i>ALM Russian</i> , Second Edition, units 1, 2, 3, or equivalent material. The successful student of this course may advance to either 7543.02 or 7543.11.

AREA	ACCR. NO. FLA-DADE	COURSE TITLE AND DESCRIPTION
RUSSIAN	7543.02	<p>† COMMUNICATE IN RUSSIAN, PART 1</p> <p>Content teaches the student about such activities as conversation on the phone; discussion of everyday activities from writing to playing basketball; going on a picnic to the mountains—Russian style; taking a flight to Leningrad, the Venice of the North. Through the activities, the student learns to use critical structure of Russian, both orally and in writing. Among the basics are the use of nouns, pronouns, and verbs. The structural content of this course resembles that of 7543.11, but the vocabulary differs vastly and there is more emphasis on writing. The basic content is that of <i>ALM Russian</i>, Second Edition, units 4, 5, 6, or equivalent material. Russian is the language of the classroom. The only prerequisite is 7543.01 or equivalent material. The successful student of this course may continue with 7543.03 or 7543.11 according to his needs.</p>
RUSSIAN	7543.11	<p>† A TRAVELER'S BAG</p> <p>Through a visit to Moscow and Leningrad, the student learns vocabulary needed to get along in the Soviet Union—to take a taxi; order and buy a meal; ask for and understand directions; buy a balalaika; make the trip from Moscow to Leningrad, being sure the luggage gets there too; find his way in the hotel; visit a Russian family, a school, and a soccer game. Structural content of this course compares to 7543.02, but the vocabulary differs greatly. Emphasis is on oral language, not written language. The only prerequisite is 7543.01 or its equivalent.</p>
RUSSIAN	7543.03	<p>† COMMUNICATE IN RUSSIAN, PART 2</p> <p>More of the communication process of this language, including idiomatic expressions and the important aspect of the past tense, is learned. Content relates to a radio broadcast by cosmonauts and another visit to Moscow. Vocabulary grows, and the student begins to function in more complicated Russian. The basic content of this course is that of <i>ALM Russian</i>, Second Edition, units 7, 8, 9, or equivalent material. Russian is the language of the classroom. Success in this course depends upon the degree to which he controls the material of the preceding quins.</p>

AREA	ACCR. NO. FLA-DADE	COURSE TITLE AND DESCRIPTION
RUSSIAN	7543.04	<p data-bbox="799 454 1318 484">COMMUNICATE IN RUSSIAN, PART 3</p> <p data-bbox="799 518 1551 851">Content comprises the study of a visit to a trade exhibition and the activities of a Soviet summer camp. The student composes a dialogue; reads and writes letters, using words of description; discusses the calendar (the months and the activities they hold); learns to use the possessive, special endings with prepositions, and the objective case. The basic content of this course is <i>ALM Russian</i>, Second Edition, units 10, 11, 12 or equivalent material. Russian is the language of the classroom. Success in this course depends upon the degree to which the student controls the material of the previous quins.</p>
RUSSIAN	7544.01	<p data-bbox="799 913 1444 943">THE RUSSIAN TEEN-AGER AND YOU, PART 1</p> <p data-bbox="799 978 1551 1276">In this course the student begins to put everything he has learned in its place with the locative case. He learns his way around by locating people, places, and things. He makes a date, setting the time and day with confidence. He uses the past, present, and future tenses. Activity is centered in Leningrad during the first snows of the Russian autumn. The basic content is that of <i>ALM Russian</i>, Second Edition, units 12, 13. Russian is the language of the classroom. Students who have controlled the 7543 courses or equivalent material will succeed.</p>
RUSSIAN	7544.02	<p data-bbox="799 1333 1444 1363">THE RUSSIAN TEEN-AGER AND YOU, PART 2</p> <p data-bbox="799 1398 1551 1721">Through content the student visits the zoo and Gorki Park in Moscow, thus learning about the Russian dative and instrumental cases. He improves his use of the perfective aspect of Russian verbs. Russian poetry is introduced, and he can compose his own Russian verses. He becomes culturally acquainted with Russian street vendors and Russian pastimes. The basic content is that of <i>ALM Russian</i>, Second Edition, units 14, 15. Russian is the language of the classroom. This course is designed for students who have controlled 7544.01 or equivalent material.</p>

AREA	ACCR. NO. FLA-DADE	COURSE TITLE AND DESCRIPTION
RUSSIAN	7544.03	THE RUSSIAN TEEN-AGER AND YOU, PART 3  In this course, the student is introduced to Russians from various walks of life. Through oral manipulation he gains poise in making introductions and in carrying on a conversation. Interesting facts about Russian names and the derivations of some Russian words, including the regular and irregular declension, are presented. The basic content is that of <i>ALM Russian</i> , Second Edition, units 16, 17. Russian is the language of the classroom. This course is for students who have controlled 7544.02 or equivalent material.
RUSSIAN	7544.04	THE RUSSIAN TEEN-AGER AND YOU, PART 4  Content consists of study of the game of soccer, as waged upon by two friends, reported by Radio Moscow, and seen by a spectator at Dynamo Stadium. Grammar includes verbs of motion and telling time. Reading material also explains what a tenant thinks of his new Russian apartment. The study of special types of nouns, adjectives, and verbs is made interesting through an evening's visit to a Russian coffeehouse. Speech continues to be stressed. The basic content is that of <i>ALM Russian</i> , Second Edition, units 18, 19. Russian is the language of the classroom. The students who have controlled course 7544.03 or equivalent material will succeed here.
RUSSIAN	7544.11	RUSSIAN FOR THE SCIENCE MINDED  The student learns basic terminology and language structure which allow, with the help of a good dictionary, translation of limited scientific Russian material. Space technology needs students of Russian as translators in mathematics, chemistry, physical, and all areas of science related to national defense. This is not a course for those interested in oral language. The only prerequisite is 7543.01, but chances for success will increase with the more courses of Russian the student has taken.

AREA	ACCR. NO. FLA-DADE	COURSE TITLE AND DESCRIPTION
RUSSIAN	7545.01	<p>ON THE RUSSIAN SCENE, PART 1</p> <p>The Russian space program and the life of a Russian cosmonaut provide the opportunity to learn about the use of dates and the future tense of the verb <i>to be</i>. Through descriptions of the Russian winter and an Arctic radio station, the student has a chance to use comparative adjectives. The basic content is that of <i>ALM Russian</i>, Second Edition, units 20, 21. Conversation continues to be emphasized and, of course, Russian is the language of the classroom. The students who have controlled the 7544 courses or equivalent material will succeed.</p>
RUSSIAN	7545.02	<p>ON THE RUSSIAN SCENE, PART 2</p> <p>Through content relative to stamp collecting, the student learns in Russian about other countries. Study continues of irregular plurals of nouns, verb derivatives, and superlatives. A taxi ride around Moscow and a visit to the Bolshoi Ballet refines use of the verbs of motion, with their associated prepositions. The basic content is that of <i>ALM Russian</i>, Second Edition, units 22, 23. Russian is the language of the classroom. The students who have controlled 7545.01 or equivalent material will succeed.</p>
RUSSIAN	7545.03	<p>ON THE RUSSIAN SCENE, PART 3</p> <p>A visit to the world-famous Moscow Circus provides experience with some new verbs of motion- those of the performers in the circus ring. Verbal prefixes, diminutives, and partitive expressions are part of the continuing study of advanced grammar and word usage. Reading about Peter the Great and the city he founded, Leningrad, the student encounters the Russian participle. The basic content is that of <i>ALM Russian</i>, Second Edition, units 24, 25, 26. Russian is the language of the classroom. This course is designed for students who have controlled 7545.02 or equivalent material.</p>
RUSSIAN	7545.04	<p>ON THE RUSSIAN SCENE, PART 4</p> <p>History and geography dominate the reading material. Oral language development is emphasized in this course.</p>

AREA	ACCR. NO. FLA-DADE	COURSE TITLE AND DESCRIPTION
RUSSIAN	7546.01	<p data-bbox="784 454 1202 482">ADVANCED RUSSIAN, PART 1</p> <p data-bbox="784 514 1530 753">Modern Soviet prose and poetry on themes varying from travel to fishing to the Leningrad mail system offer advanced word study and opportunities for oral practice. Included in the study are root similarities, usage of suffixes, and additional practice with verbs of motion together with prefixes of direction. The basic text is <i>ALM Russian</i>, First Edition, units 26, 27. Russian is the language of the classroom.</p>
RUSSIAN	7546.02	<p data-bbox="784 817 1202 844">ADVANCED RUSSIAN, PART 2</p> <p data-bbox="784 877 1530 1148">Content centers on the cultural aspects of Moscow. There is continued advanced word study. Topics include many aspects of daily life in Moscow—transportation, time system, stores, and attractions. Additional prose and poetry provide work in irregular short-term comparatives, superlatives, and the genitive of comparison. The four skills continue to be emphasized. The basic text is <i>ALM Russian</i>, First Edition, units 28, 29. Russian is the language of the classroom.</p>
RUSSIAN	7546.03	<p data-bbox="784 1207 1202 1235">ADVANCED RUSSIAN, PART 3</p> <p data-bbox="784 1267 1530 1506">Readings become more diverse as an article on philology, a Russian story by Anton Chekhov, and a famous article by Ilf and Petrov are presented to give additional idiomatic and journalistic styles. Discussion, guided and free, takes place. Emphasis is on imperatives, prefixes, declension of numerals, and numeral usage in general. The basic text is <i>ALM Russian</i>, First Edition, units 30, 31, 32. Russian is the language of the classroom.</p>
RUSSIAN	7546.04	<p data-bbox="784 1570 1202 1598">ADVANCED RUSSIAN, PART 4</p> <p data-bbox="784 1630 1530 1841">Space, the press, women, geography, nature, military and daily life are the topics of prose and poetry by means of which the fine polishing process of language usage goes on, at the same time the cultural understanding of the Soviet people grows. The basic text is <i>ALM Russian</i>, First Edition, units 33, 34, 35. Russian is the language of the classroom.</p>



AREA	ACCR. NO. FLA-DADE	COURSE TITLE AND DESCRIPTION
RUSSIAN	7545.05 7546.11	<p data-bbox="813 461 1399 500">RUSSIAN AND THE HUMANITIES, PART 1</p> <p data-bbox="813 523 1571 684">The culture of the Russians is studied through readings, filmstrips, and tapes. The student becomes acquainted with the life and work of the great artists and writers of the past. Recommended for the students who have controlled the other 7545 courses.</p>
RUSSIAN	7545.06 7546.12	<p data-bbox="813 737 1399 776">RUSSIAN AND THE HUMANITIES, PART 2</p> <p data-bbox="813 799 1571 952">The culture of the Russians is studied further through readings, filmstrips, and tapes. The student becomes acquainted with the life and work of contemporary artists and writers. Recommended for the students who have controlled the previous 7545 courses.</p>

SPANISH COURSES  
 7503 - LEVEL I  
 7504 - LEVEL II

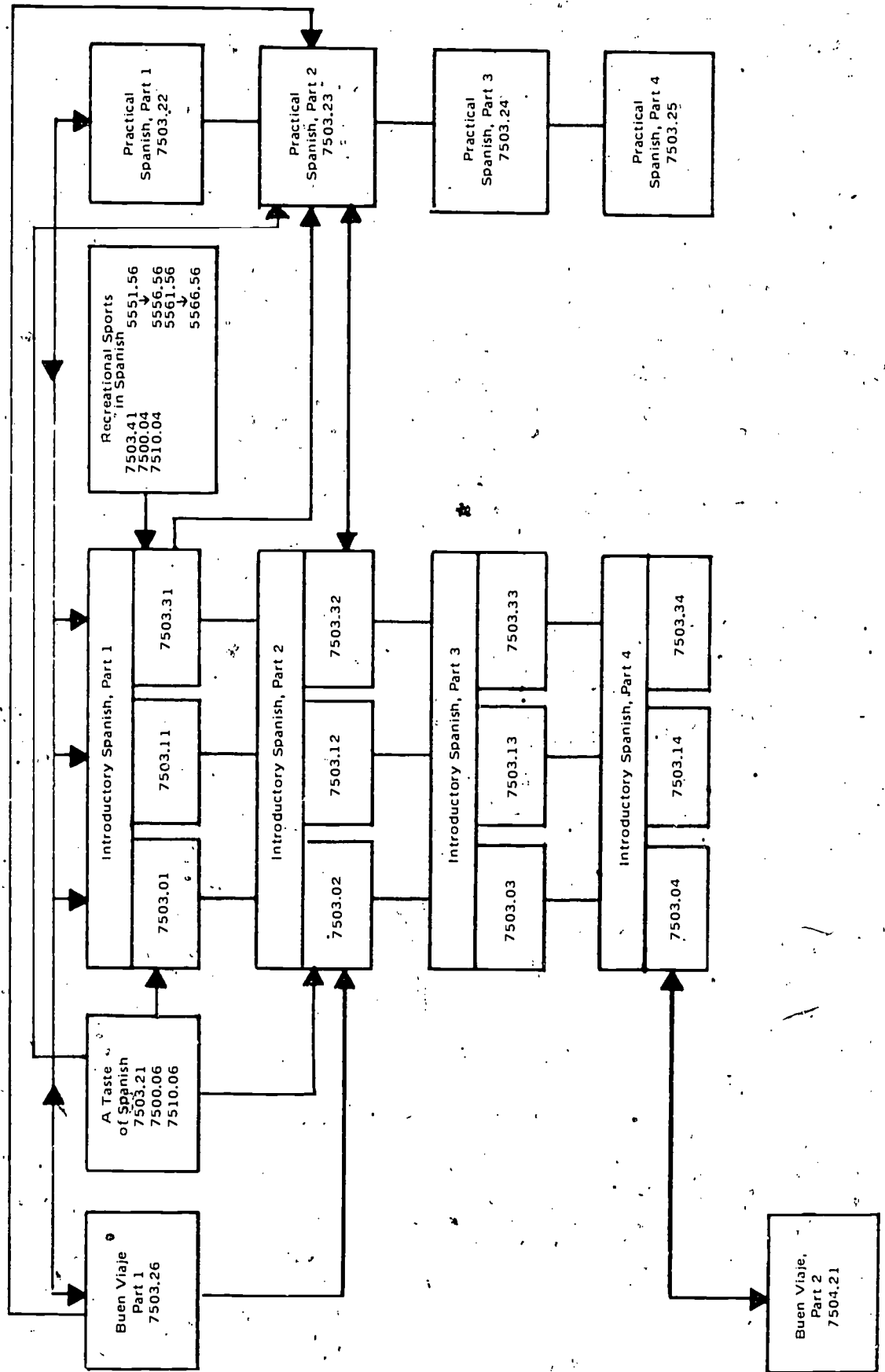

SPANISH COURSES  
7504 - LEVEL II

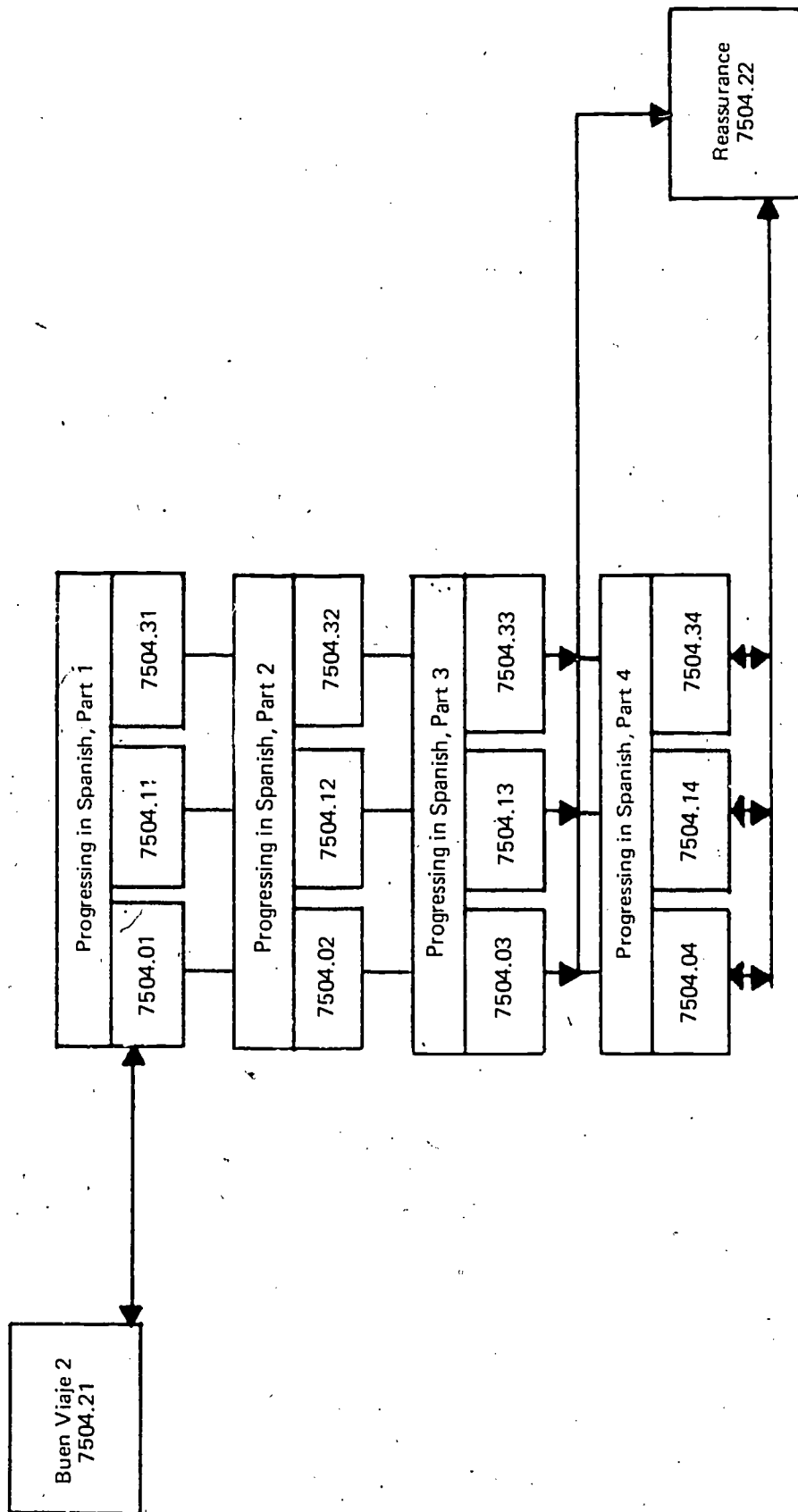

FOREIGN LANGUAGE  
152

SPANISH COURSES

7505 - LEVEL III  
7506 - LEVEL IV

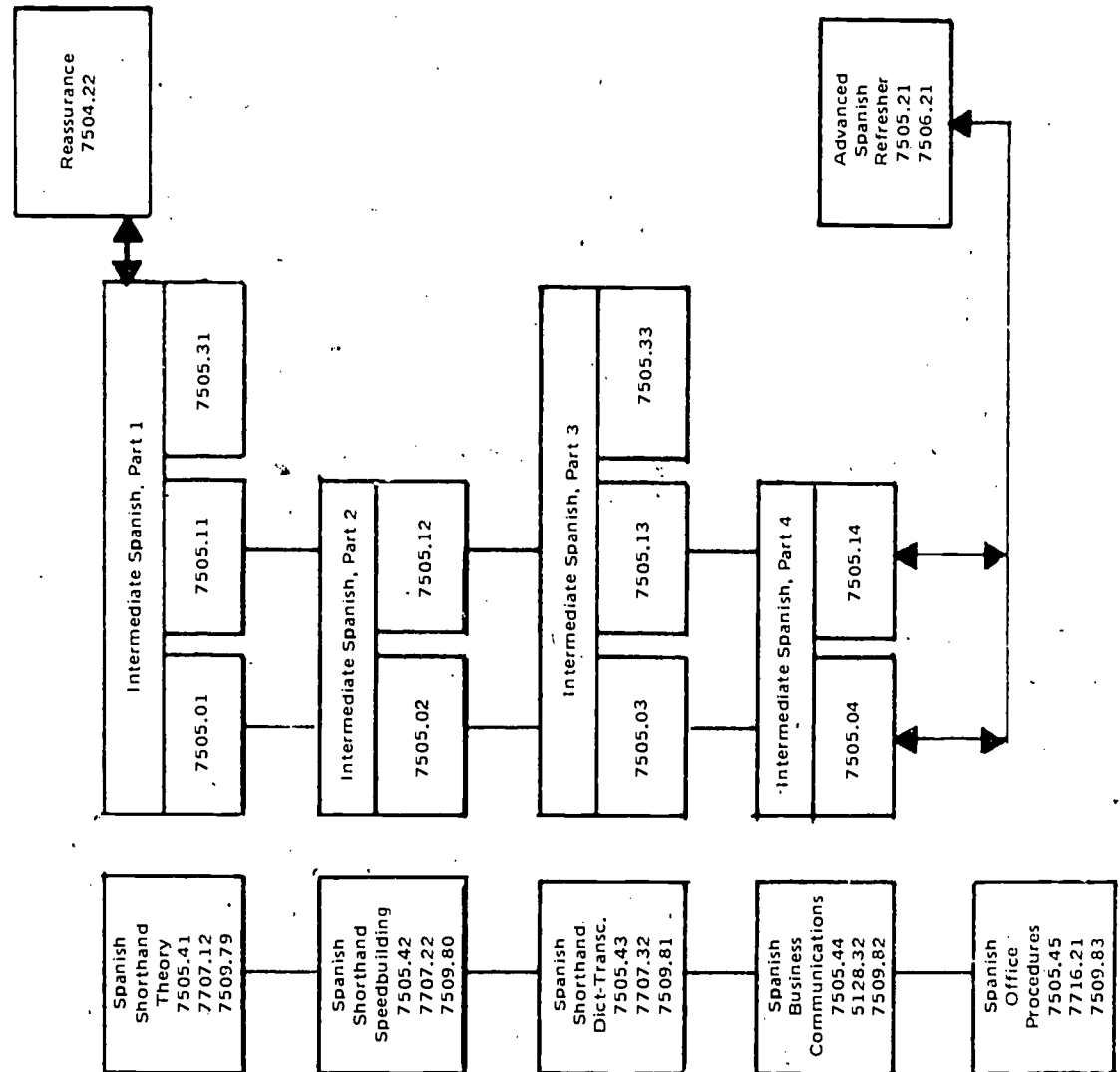

SPANISH COURSES  
7506 - LEVEL IV

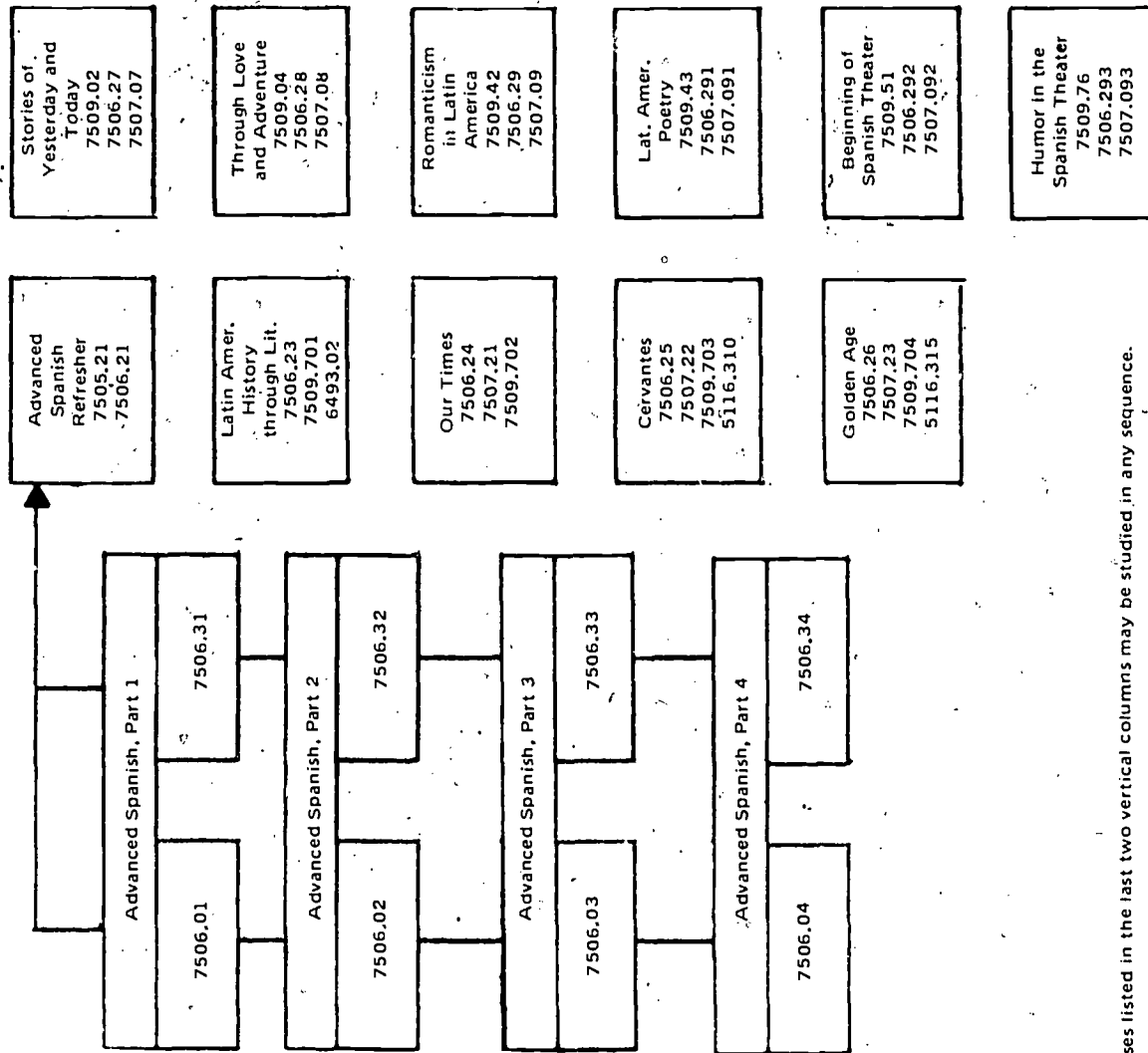

The alternate courses listed in the last two vertical columns may be studied in any sequence.

SPANISH COURSES

7506 -- LEVEL IV  
7507 -- LEVEL V

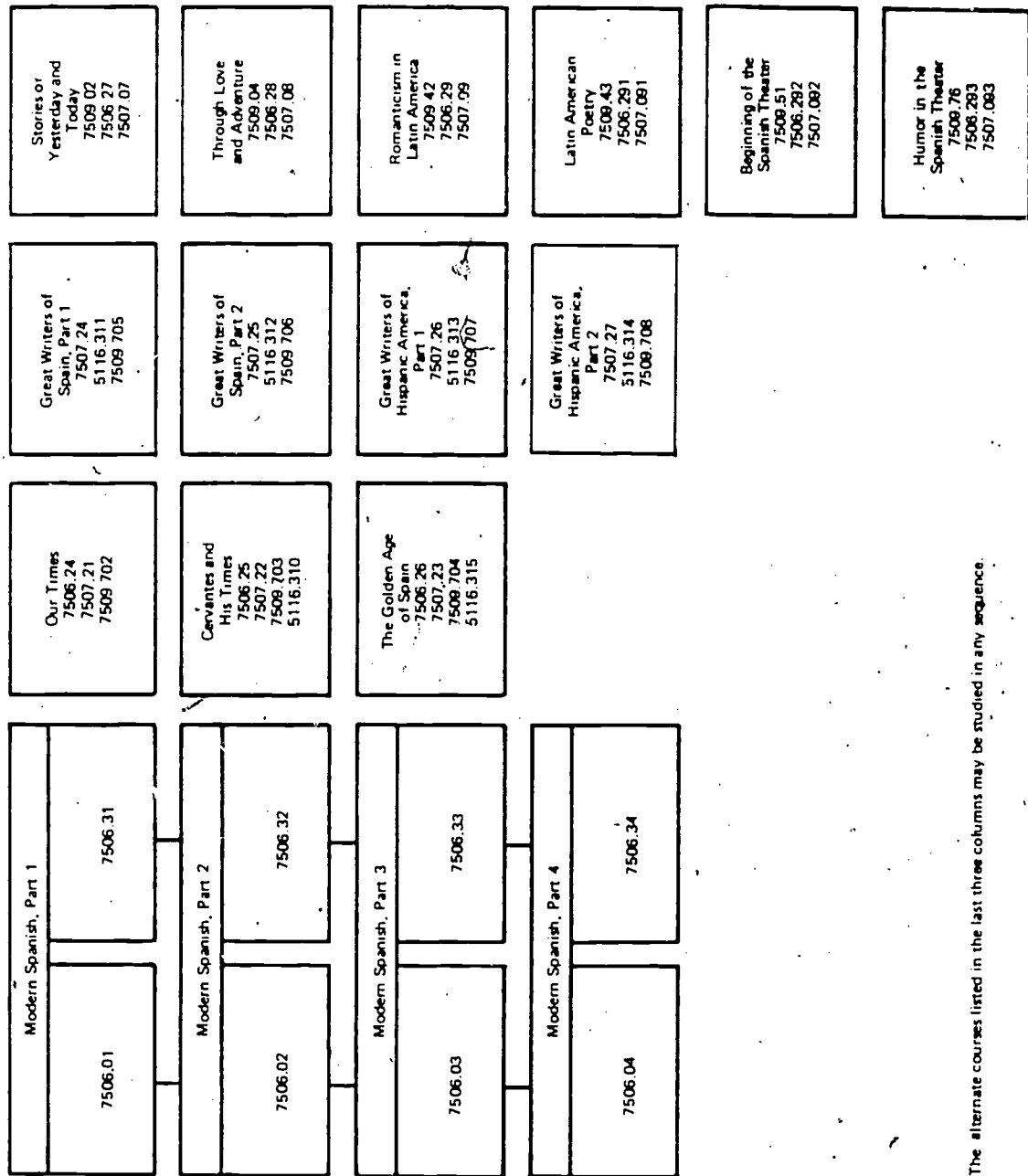

The alternate courses listed in the last three columns may be studied in any sequence.

## CODE NUMBERS FOR SPANISH QUINMESTER COURSES

Spanish courses are designated by state code numbers as follows:

- 7503 - Level I
- 7504 - Level II
- 7505 - Level III
- 7506 - Level IV
- 7507 - Level V

The coding of Spanish is more elaborate than that of other languages due to the fact that there are more offerings and more varieties of basic content. Each staff will have to decide on its own standard, academic program. Courses which relate primarily to *Learning Spanish the Modern Way* are designated by .01, .02, etc. Those relating to *ALM Spanish, Second Edition*, are coded with .11, .12, etc.; those relating to *ALM Spanish, First Edition*, are coded with .31, .32, etc. The latter group is being phased out as new basic texts become more available.

The alternates are labeled .21, .22, etc. There are courses in business education which are designated as .41, available as alternates at level III.

AREA	ACCR. NO. FLA-DADE	COURSE TITLE AND DESCRIPTION
SPANISH	7503.21 7500.06 7510.06	† A TASTE OF SPANISH  This is a look at the cultural events of the Spanish-speaking people and their language. An introductory conversational course, it appeals to the student who would like to learn some Spanish but is uncertain about his desire to continue its formal study. Some topics that are explored are greetings, numbers 0-100, days of the week, months of the year, weather, time, the family, colors, games, dances, and songs. If the student decides to continue language study, he can choose 7503.01, 7503.11, 7503.31, 7503.26, or 7503.23. A particularly talented and/or interested student can go to 7503.02, 7503.12, or 7503.32.
SPANISH	7503.26	BUEN VIAJE, PART 1  The content of this course centers upon passports, visas, immunization shots, customs, hotel accommodations, money exchange, etc. Spanish is the language used in the classroom. Logical sequence to this course is 7503.01, 7503.11, or 7503.31. A particularly talented and interested student could go to 7503.02, 7503.12, or 7503.32.

FOREIGN LANGUAGE  
156

AREA	ACCR. NO. FLA-DADE	COURSE TITLE AND DESCRIPTION
SPANISH	7503.41 7500.04 7510.04	RECREATIONAL SPORTS IN SPANISH
PHYSICAL EDUCATION	5551.56 through 5556.56 5561.56 through 5566.56	Two units are earned, one in Spanish and one in physical education, for this course. It is a two-hour block, allowing the student to participate in different games: shuffleboard, table tennis, horseshoes, deck tennis, and other similar activities. Rules are identified and applied by the student, and basic skills involved are practiced. The rudiments of Spanish structure are practiced in relation to playing the games.

### PRACTICAL SPANISH

The four courses entitled "Practical Spanish" provide instruction for the student who wants development in depth of the verbal skills of communication. In every course, the language presented enables the individual to function in different and important social and business situations. The nonverbal skills of language are emphasized to the degree necessary for students to make a meaningful whole out of their classroom activities, assuring understanding, retention, and the transfer of learning.

SPANISH	7503.22	PRACTICAL SPANISH, PART 1
		At the conclusion of this course, the student will function satisfactorily in everyday social and business situations such as introduction of self and others, identification of self and others, telephone conversations, and eating in restaurants. Among the structures taught are forms of address, personal titles, a class verbs including regular and some irregular (e → ie) forms, negations, days of the week, numbers, foods, and the all-important <i>ser</i> and <i>estar</i> verbs. Logical sequel to this course is 7503.24 but any student who chooses to do so can go to 7503.02, 7503.12, or 7503.32.

SPANISH	7503.23	PRACTICAL SPANISH, PART 2
		At the conclusion of this course the student will function satisfactorily in everyday social and business situations such as barbering and hairdressing. The classroom activities will review knowledge acquired in the preceding course, building upon it. Among the structures taught are the present indicatives of <i>tener</i> , <i>venir</i> , and <i>ir</i> , plus the direct object pronouns and adjectival agreement. This course is designed for students who have controlled 7503.23 or equivalent material. However, it may be studied after successful completion of 7503.21 or 7503.26.

FOREIGN LANGUAGE  
157



AREA	ACCR. NO. FLA-DADE	COURSE TITLE AND DESCRIPTION
SPANISH	7503.24	<p>PRACTICAL SPANISH, PART 3</p> <p>At the conclusion of this course, the student will function satisfactorily in everyday social and business situations such as those connected with retail services. The classroom activities will build upon knowledge acquired in the preceding courses, introducing new structures and expanding vocabulary. Among the grammatical points taught are common verbs that will be used in the past and future tenses. The logical sequel to this course is 7503.25.</p>
SPANISH	7503.25	<p>PRACTICAL SPANISH; PART 4</p> <p>At the conclusion of this course, the student will function satisfactorily in everyday social and business situations such as those connected with servicing and selling. Control of structure and expansion of vocabulary are maintained by the careful reviewing of material taught while building upon it. The student who successfully completes this Practical Spanish block of four courses can go to 7504.01, 7504.11, or 7504.34 if he chooses to continue his language study.</p>
SPANISH	7503.01	<p>† INTRODUCTORY SPANISH, PART 1</p> <p>The main objective of this course is the development of the speaking skill, utilizing materials taught. Content is of teen-age interest. Substantives and pronouns; the verbs <i>tener</i>, <i>estar</i>, and <i>ir</i> in the singular; the definite articles; the possessive adjective <i>su</i>; and the verb <i>ser</i> are among the grammatical points considered. The basic content is that of lesson 1 and 2 of <i>Learning Spanish the Modern Way</i>. The logical sequel to this course is 7503.02.</p>
SPANISH	7503.02	<p>† INTRODUCTORY SPANISH, PART 2</p> <p>Dialogues and short narratives provide oral practice. Continued emphasis is on speech. The present tense of the three conjugations; the irregular verbs <i>tener</i>, <i>venir</i>, and <i>ir</i>; and the direct object pronouns are presented. The basic material taught is that of lessons 3, 4, and 5 of <i>Learning Spanish the Modern Way</i>. Spanish is the language used in the classroom. This course is designed for students who have controlled 7503.01 or equivalent material.</p>

AREA	ACCR. NO. FLA-DADE	COURSE TITLE AND DESCRIPTION
SPANISH	7503.03	INTRODUCTORY SPANISH, PART 3  Some new common irregular verbs, reflexive verbs, a way to express future time, and indirect object pronouns are introduced. Gradual utilization of oral materials is emphasized. Reading and writing with understanding continues to be taught. The content centers briefly on a meal, bargaining in a market, and a telephone conversation. The basic material taught is that of lessons 6, 7, and 8 of <i>Learning Spanish the Modern Way</i> . Spanish is the language used in the classroom. This course is designed for students who have controlled 7503.02 or equivalent material.
SPANISH	7503.04	INTRODUCTORY SPANISH, PART 4  The multiple skills of language are expanded. Demonstrative adjectives and pronouns, commands, and the much-used past tense (preterito) are introduced. The basic content, is that of lesson 9, 10, and 11 of <i>Learning Spanish the Modern Way</i> . Spanish is the language of the classroom. The course is designed for students who have controlled 7503.03 or equivalent material.
SPANISH	7503.11	† INTRODUCTORY SPANISH, PART 1  This introductory course emphasizes oral work through the use of short dialogues. A verb in the present, interrogatives, and hints on how to read are introduced. The basic content is that of <i>ALM Spanish</i> , Second Edition, units 1, 2, 3. Logical sequel to this course is 7503.12.
SPANISH	7503.12	† INTRODUCTORY SPANISH, PART 2  Emphasis on oral work is maintained through this course with dialogues and a short narrative. Students will read and write the materials orally taught. Grammar consists of <i>ser</i> , <i>estar</i> , and adjectives. The basic content is that of <i>ALM Spanish</i> , Second Edition, units 4, 5, 6. Spanish is the language of the classroom. This course is designed for students who have controlled 7503.11 or equivalent material.

FOREIGN LANGUAGE  
159

AREA	ACCR. NO. FLA-DADE	COURSE TITLE AND DESCRIPTION
SPANISH	7503.13	<p>† INTRODUCTORY SPANISH, PART 3</p> <p>Vocabulary is increased while students progress in reading and writing ability. -E and -I verbs are taught, as well as some irregular ones like <i>conocer</i>, <i>poner</i>, <i>saber</i>, <i>salir</i>, <i>oir</i>, <i>tener</i>, and <i>venir</i>. The basic content is that of <i>ALM Spanish</i>, Second Edition, units 7, 8. Spanish is the language of the classroom. This course is designed for students who have controlled 7503.12 or equivalent material.</p>
SPANISH	7503.14	<p>INTRODUCTORY SPANISH, PART 4</p> <p>The oral work of this course involves planning a vacation and learning to use Spanish over the telephone. The structure focuses on indirect object pronouns and the past participle. Basic content is that of <i>ALM Spanish</i>, Second Edition, units 9, 10. Spanish is the language of the classroom. This course is designed for students who have controlled 7503.13 or equivalent material.</p>
SPANISH	7503.31	<p>† INTRODUCTORY SPANISH, PART 1</p> <p>This introductory course emphasizes oral work through the use of short dialogues. The grammar consists of the verb <i>estar</i>, two forms of <i>you</i>, subject pronouns, and gender. The basic content is that of <i>ALM Spanish</i>, First Edition, units 1, 2, 3. The logical sequel to this course is 7503.32.</p>
SPANISH	7503.32	<p>† INTRODUCTORY SPANISH, PART 2</p> <p>Emphasis on oral work is maintained throughout this course. -A verbs, indefinite articles, the verb <i>ser</i>, and agreement of adjectives are the structures presented. Basic content is that of <i>ALM Spanish</i>, First Edition, units 4, 5. Spanish is the language of the classroom. This course is designed for students who have controlled 7503.31 or equivalent material.</p>
SPANISH	7503.33	<p>† INTRODUCTORY SPANISH, PART 3</p> <p>The typical custom of eating the twelve grapes on New Year's Eve serves as one base for students to expand the multiple skills of language. The contractions <i>a/el</i>, <i>de/el</i>, personal <i>a</i>, and regular -A verbs in the present are presented. The basic content is that of <i>ALM Spanish</i>, First Edition, units 6, 7. Spanish is the language of the classroom. This course is designed for students who have controlled 7503.32 or equivalent material.</p>

AREA	ACCR. NO. FLA-DADE	COURSE TITLE AND DESCRIPTION
SPANISH	7503.34	<p>† INTRODUCTORY SPANISH, PART 4</p> <p>Common irregular verbs such as <i>tener</i>, <i>venir</i>, <i>ir</i>, and <i>dar</i>, and those that change e → ie are presented, along with additional uses of <i>ser</i> and <i>estar</i>. Emphasis is on oral work. Basic content is that of <i>ALM Spanish</i>, First Edition, units 8, 9. Spanish is the language of the classroom. This course is designed for students who have controlled 7503.33 or equivalent material.</p>
SPANISH	7504.21	<p>BUEN VIAJE, PART 2</p> <p>This course is a further development of conversation, designed for the American student traveler. How to get to that interesting spot or exciting event in a particular Spanish-speaking city, how to call the doctor, how to explain a traffic problem to the officer are examples of course topics. A solid understanding of the 7503 courses or their equivalents would provide needed background; or this could be an alternate to a beginning 7504 course.</p>
SPANISH	7504.01	<p>PROGRESSING IN SPANISH, PART 1</p> <p>The multiple skills of language are developed in this course while students read and discuss in Spanish a short narrative on Mexico. Knowledge of the preterit tense is expanded by learning common irregular verbs. The basic content is that of <i>Learning Spanish the Modern Way</i>, lessons 11, 12, 13. Spanish is the language of the classroom. This course is designed for students who have controlled 7503 courses or equivalent material. The logical sequel to it is 7504.02.</p>
SPANISH	7504.02	<p>PROGRESSING IN SPANISH, PART 2</p> <p>The beautiful cities of Ciudad Mexico and Madrid serve as topics of conversation; at the same time, other language skills are enhanced. Irregular verbs of the present tense, uses of <i>se</i>, and the comparison of adjectives are among the structures presented. The basic content is that of <i>Learning Spanish the Modern Way</i>, lessons 13 (review), 14, 15. Spanish is the language of the classroom. This course is designed for students who have controlled 7504.01 or equivalent material.</p>

FOREIGN LANGUAGE  
161

AREA	ACCR. NO. FLA-DADE	COURSE TITLE AND DESCRIPTION
SPANISH	7504.03	† PROGRESSING IN SPANISH, PART 3  A grammatical review (primarily oral) is provided in this course. The imperfect tense is among the new structures presented. Interesting narratives provide a basis for expansion of oral and written skills. The basic content is that of <i>Learning Spanish the Modern Way</i> , lessons 15 (review), 16, 17. Spanish is the language of the classroom. This course is designed for students who have controlled 7504.02 or equivalent material.
SPANISH	7504.04	PROGRESSING IN SPANISH, PART 4  Interesting narratives about Buenos Aires and rural Mexico and Spain contribute to the enhancement of reading and conversational skills. The structures considered include the present progressive, a review of the imperfect tense, possessives, and adjectival forms. The basic content is that of <i>Learning Spanish the Modern Way</i> , lessons 17 (review), 18. Spanish is the language of the classroom. The course is designed for students who have controlled 7504.03 or equivalent material.
SPANISH	7504.11	PROGRESSING IN SPANISH, PART 1  The multiple skills of language are developed with continued emphasis on enhancement of oral skills. The present progressive, direct object pronouns, and possessives are included in the grammar. The basic content is that of <i>ALM Spanish, Second Edition</i> , units 11, 12. Spanish is the language of the classroom. This course is designed for students who have completed the 7503 courses or equivalent material. The logical sequel to it is 7504.12.
SPANISH	7504.12	PROGRESSING IN SPANISH, PART 2  Irregular past participles and the reflexive pronouns are among the structures considered. Emphasis is on oral communication, while the other skills of language are also developed. Basic content is that of <i>ALM Spanish, Second Edition</i> , units 13, 14. Spanish is the language of the classroom. This course is designed for students who have controlled 7504.11 or equivalent material.

FOREIGN LANGUAGE  
162

AREA	ACCR. NO. FLA-DADE	COURSE TITLE AND DESCRIPTION
SPANISH	7504.13	<p>PROGRESSING IN SPANISH, PART 3</p> <p>The infinitives used as complements, adverbs, comparatives, the preterit, and the imperfect are the grammatical points considered in this course. Interesting narratives are also included. The basic material taught is that of <i>ALM Spanish</i>, Second Edition, units 15, 16, 17. Spanish is the language of the classroom. This course is designed for students who have controlled 7503.12 or equivalent material.</p>
SPANISH	7504.14	<p>PROGRESSING IN SPANISH, PART 4</p> <p>Verbs with irregular preterit stems and endings, the preterit forms of <i>ir</i> and <i>ser</i>, the prepositions <i>para</i> and <i>por</i>, and the demonstrative adjectives <i>aquel</i> and <i>aquello</i> are among the grammatical points to be taught. Some amusing narratives complete the course offerings. The basic material taught is that of <i>ALM Spanish</i>, Second Edition, units 17 (review), 18, 19. Spanish is the language of the classroom. This course is designed for students who have controlled 7504.13 or equivalent material.</p>
SPANISH	7504.31	<p>† PROGRESSING IN SPANISH, PART 1</p> <p>Through reading about and discussing pets and gifts, the emphasis on oral expression and communication is maintained. The structures include the present perfect, the direct object, and the demonstrative pronouns. Basic content is that of <i>ALM Spanish</i>, First Edition, units 10, 11. Spanish is the language of the classroom. This course is designed for students who have controlled the 7503 courses or equivalent material.</p>
SPANISH	7504.32	<p>PROGRESSING IN SPANISH, PART 2</p> <p>The multiple skills of language are developed in this course as students read and talk about a trip downtown and the bullfights. The present progressive and the indirect object pronouns are among the structures considered. Basic content is that of <i>ALM Spanish</i>, First Edition, units 12, 13. Class discussions are conducted in Spanish. This course is designed for students who have controlled 7504.31 or equivalent material.</p>

AREA	ACCR. NO. FLA-DADE	COURSE TITLE AND DESCRIPTION
SPANISH	7504.33	<p>PROGRESSING IN SPANISH, PART 3</p> <p>Interesting narratives serve as basis for guided discussions and free conversations. The imperfect tense and the reflexive pronouns are among the structures studied. Basic content is that of <i>ALM Spanish</i>, First Edition, units 14, 15. Class activities are conducted in Spanish. This course is designed for students who have controlled 7504.32 or equivalent material.</p>
SPANISH	7504.34	<p>PROGRESSING IN SPANISH, PART 4</p> <p>The narratives of this course are amusing and interesting. Typical Spanish customs are presented while students learn the contrast of preterit and imperfect. Emphasis on guided discussion and free conversation is maintained through the course. Writing skills are enhanced. Basic content is that of <i>ALM Spanish</i>, First Edition, units 16, 17. Class activities are conducted in Spanish. This course is designed for students who have controlled 7504.33 or equivalent material.</p>
SPANISH	7504.22	<p>REASSURANCE</p> <p>It is time to look at what was left behind. Rapid review of the main grammatical points already mastered are presented in new material. There are new readings, written exercises, and oral work conducted in Spanish.</p>
SPANISH	7505.01	<p>INTERMEDIATE SPANISH, PART 1</p> <p>The multiple skills of language are enhanced in this course. The readings are varied and include an excerpt from a contemporary Spanish novel. Discussions are conducted in Spanish. The structures involve a review of adjectives, adverbs, and the preterit. The important subjunctive tense is studied here. Basic content is that of <i>Learning Spanish the Modern Way</i>, lessons 19, 20. The class is conducted in Spanish. This course is designed for students who have controlled the 7504 courses or equivalent material. The logical sequel to it is 7505.02.</p>

AREA	ACCR. NO. FLA-DADE	COURSE TITLE AND DESCRIPTION
SPANISH	7505.02	<p>INTERMEDIATE SPANISH, PART 2</p> <p>Emphasis is on developing the four skills of language. The readings include descriptions of typical Mexican customs. A review of the imperative, the comparative, and the superlatives, plus the potential tense are among the structures studied. Basic content is that of <i>Learning Spanish the Modern Way</i>, lessons 21, 22. The class is conducted in Spanish. The course is designed for students who have controlled 7505.01 or equivalent material.</p>
SPANISH	7505.03	<p>† INTERMEDIATE SPANISH, PART 3</p> <p>Stories by contemporary authors and an excerpt from a magazine article provide the reading materials of this course. The article <i>lo</i>, the pluperfect, and the subjunctive are among the grammatical forms studied. Emphasis on the development of the four skills of language is maintained. Basic content is that of <i>Learning Spanish the Modern Way</i>, unit 23, and <i>Galería Hispánica</i>, Cuadros 1, 2. The class is conducted in Spanish. This course is designed for students who have controlled 7505.02 or equivalent material.</p>
SPANISH	7505.04	<p>INTERMEDIATE SPANISH, PART 4</p> <p>Interesting literary excerpts dealing with patriotic figures of Spain and Latin America, plus some charming legends of the Spanish-speaking world provide the reading of this course. Among the structures presented are adverbs, <i>modismos</i>, and the passive voice with <i>se</i>. The basic content is that of <i>Galería Hispánica</i>, Cuadros 3, 4. The class is conducted in Spanish.</p>
SPANISH	7505.11	<p>INTERMEDIATE SPANISH, PART 1</p> <p>Regular familiar commands, verbs with e→i, o→u; stem alternations in the preterit, stem alternation in the present participle, formal and indirect commands, and present subjunctive forms are the main grammatical points presented in this course. Interesting narratives are also included. Oral communication is continually emphasized. The basic material taught is that of <i>ALM Spanish</i>, Second Edition, units 20, 21. Spanish is the language of the classroom. This course is designed for students who have controlled the 7504 courses or equivalent material. The logical sequel to it is 7505.12.</p>



AREA	ACCR. NO. FLA-DADE	COURSE TITLE AND DESCRIPTION
SPANISH	7505.12	<p data-bbox="774 440 1259 471">INTERMEDIATE SPANISH, PART 2</p> <p data-bbox="774 502 1527 773">Irregular and negative familiar commands, the position of object pronouns in commands, compared adverbs with <i>lo</i>, and clause relaters are the main grammatical points to be considered in this course. Various narratives and discussions add interest to the daily work. The basic material taught is that of <i>ALM Spanish</i>, Second Edition, units 22, 23. Spanish is the language of the classroom. This course is designed for the students who have controlled 7505.11 or equivalent material.</p>
SPANISH	7505.13	<p data-bbox="774 828 1259 859">INTERMEDIATE SPANISH, PART 3</p> <p data-bbox="774 890 1527 1168">The subjunctive and the adjective clause, <i>hacer</i> with expressions of time, and adverbial conjunctions with the indicative or the subjunctive constitute most of the grammar of this course. The student reads contemporary short stories and orally manipulates content taught. The basic material taught is that of <i>ALM Spanish</i>, Second Edition, units 24, 25. Spanish is the language of the classroom. This course is designed for students who have controlled 7505.12 or equivalent material.</p>
SPANISH	7505.14	<p data-bbox="774 1223 1259 1254">INTERMEDIATE SPANISH, PART 4</p> <p data-bbox="774 1285 1527 1563">The conditional with its regular and irregular forms, the future, the past subjunctive, and the indicative and subjunctive in <i>si</i> clauses constitute the grammar studied in this course. Interesting narratives by contemporary writers provide reading and conversational matter. The material taught is that of <i>ALM Spanish</i>, Second Edition, units 26, 27. Spanish is the language of the classroom. This course is designed for students who have controlled 7505.13 or equivalent material.</p>
SPANISH	7505.31	<p data-bbox="774 1618 1259 1649">INTERMEDIATE SPANISH, PART 1</p> <p data-bbox="774 1680 1527 1927">Interesting readings dealing with the past and future of Latin America serve as a basis for guided discussions and free conversations. Preterit vs. imperfect, long form possessives, and the future tense are among the structures considered. Basic content is that of <i>ALM Spanish</i>, First Edition, units 17, 18. Class activities are conducted in Spanish. This course is designed for students who have controlled the 7504 courses or equivalent material.</p>

AREA	ACCR. NO. FLA-DADE	COURSE TITLE AND DESCRIPTION
SPANISH	7505.33	INTERMEDIATE SPANISH, PART 3  The indirect commands, relative pronouns <i>que</i> and <i>quien</i> , and the present subjunctive in noun clauses are among the structures considered in this course. Some interesting reading selections complete the offerings. Basic content is that of <i>ALM Spanish</i> , First Edition, units 21, 22. Class activities are conducted in Spanish. This course is designed for students who have controlled 7505.31 or equivalent material.
SPANISH	7505.21 7506.21	† ADVANCED SPANISH REFRESHER  Especially indicated for college-bound students, this course offers a general review of grammar, conversation, and individualized reading. Third- and fourth-year students who desire to place well in college will find this course profitable.
SPANISH BUSINESS EDUCATION SPANISH-S	7505.41 7707.12 7509.79	SPANISH SHORTHAND-THEORY  The course includes integration of English shorthand skills with Spanish shorthand characters. Emphasis on Spanish brief forms, phrases, and abbreviations. The student should have attained the objectives of Shorthand Dictation, Shorthand Basic Transcription, and a third level course in Spanish prior to enrollment in this course.
SPANISH BUSINESS EDUCATION SPANISH-S	7505.42 7707.22 7509.80	SPANISH SHORTHAND-SPEEDBUILDING  This course develops rapid writing skills, with emphasis on spelling, vocabulary, Spanish business terms, punctuation, capitalization, and use of reference materials. The student should have attained the objectives of Spanish Shorthand-Theory prior to enrollment in this course.
SPANISH BUSINESS EDUCATION SPANISH-S	7505.43 7707.32 7509.81	SPANISH SHORTHAND-DICATION AND TRANSCRIPTION  This course focuses on application of skills and knowledge in transcribing Spanish dictation. The student learns to distinguish between the proper term to be used in the translation and the mere verbatim translation of the written materials. It includes related inquiry into opportunity for employment and the ethics of the secretary. The student should have attained the objectives of Spanish Shorthand-Speedbuilding prior to enrollment in this course.

FOREIGN LANGUAGE  
167

AREA	ACCR. NO. FLA-DADE	COURSE TITLE AND DESCRIPTION
SPANISH BUSINESS EDUCATION SPANISH-S	7505.44 5128.32 7509.82	SPANISH BUSINESS COMMUNICATIONS  The emphasis is on all types of communications currently used in Latin American business. It includes parts and styles of business letters and the preparation of various types of business communications, including letters, telegrams, and memorandums. The student should have attained the objectives of Effective Business Reports prior to enrollment in this course.
SPANISH BUSINESS EDUCATION SPANISH-S	7505.45 7716.21 7509.83	SPANISH OFFICE PROCEDURES  The course equips students with a knowledge of Spanish office procedures and other skills and attitudes required of bilingual secretaries. The student should have attained the objectives of The Office in Action prior to enrollment in this course.
SPANISH	7506.01	ADVANCED SPANISH, PART I  The four skills of language continue to be developed in this course. The readings deal with common superstitions and some precepts geared to Spanish youth, though they prove interesting to all. The structures include the position of the indirect object pronoun in the sentence, the subjunctive mood, and the relative pronouns. Emphasis on oral expression and communication is maintained. Basic content is that of <i>Galería Hispánica</i> , Cuadros 5, 6. The class is conducted in Spanish.
SPANISH	7506.02	ADVANCED SPANISH, PART 2  Interesting excerpts from well-known Latin American writers comprise the readings. They deal with the Indians and the revolutionary movements against the Spanish Crown's rule. The structures include negative expressions, <i>modismos</i> , and the relative pronoun <i>cuyo</i> . Emphasis on oral expression and communication is maintained. Basic content is that of <i>Galería Hispánica</i> , Cuadros 7, 8. The class is conducted in Spanish.

AREA	ACCR. NO. FLA-DADE	COURSE TITLE AND DESCRIPTION
SPANISH	7506.03	<p data-bbox="772 442 1189 471">ADVANCED SPANISH, PART 3</p> <p data-bbox="772 502 1519 716">The readings deal with conflict and adventure in interesting and, at times, amusing ways. Among the structures are found the imperative mood and the subjunctive mood used with ¡ojalá! in the present, imperfect, and pluperfect tenses. The basic content is that of <i>Galería Hispánica</i>, Cuadros 9, 10. The class is conducted in Spanish.</p>
SPANISH	7506.04	<p data-bbox="772 775 1189 804">ADVANCED SPANISH, PART 4</p> <p data-bbox="772 835 1519 1049">Love, passions, and other feelings constitute the theme of the readings of this course. The present of <i>saber</i>, the gerund, and the subjunctive with impersonal expressions are among the structures. Emphasis is maintained on oral expression and communication. Basic content is that of <i>Galería Hispánica</i>, Cuadros 11, 12. The class is conducted in Spanish.</p>
SPANISH	7506.31	<p data-bbox="772 1109 1189 1137">ADVANCED SPANISH, PART 1</p> <p data-bbox="772 1168 1519 1561">The multiple skills of language are enhanced in this course with continued emphasis on guided discussion and free conversation. Nominalization with the definite, indefinite, and neuter articles is among the structures included. The readings center around such dissimilar figures as Pío Baroja and Miguel de Unamuno, both well-known writers of this century, and Isabel de Castilla and El Cid, who lived centuries ago. However, a main idea pervades through all the readings, giving them unity—that of patriotic love and concern for Spain's unity, grandeur, and freedom. Basic content is that of <i>ALM Spanish</i>, First Edition, units 24, 25, with numerous materials added. All class activities are conducted in Spanish.</p>
SPANISH	7506.32	<p data-bbox="772 1620 1189 1649">ADVANCED SPANISH, PART 2</p> <p data-bbox="772 1680 1519 1956">The conditional of probability, the past conditional, and future perfect are among the grammatical points considered. The readings serve as the basis for continued enhancement of oral skills. Written expression and communication are maintained throughout the course. Basic content is that of <i>ALM Spanish</i>, First Edition, units 26, 27. All class activities are conducted in Spanish. This course has been designed for students who have controlled 7506.31 or equivalent material.</p>

AREA	ACCR. NO. FLA-DADE	COURSE TITLE AND DESCRIPTION
SPANISH	7506.33	<p>ADVANCED SPANISH, PART 3</p> <p>The past subjunctive in noun and adverbial clauses, the past subjunctive and past perfect subjunctive in <i>si</i>-clauses are among the structures studied. Interesting readings complete the course's offerings. Basic content is that of <i>ALM Spanish</i>, First Edition, units 28, 29. All class activities are conducted in Spanish. This course has been designed for students who have controlled 7506.32 or equivalent material.</p>
SPANISH	7506.34	<p>ADVANCED SPANISH, PART 4</p> <p>Two short stories by Juan José Arreola and an excerpt from <i>Pobre feo</i>, by the well-known Chilean novelist Eduardo Barrios, comprise the readings of this course. Among the grammatical points considered, the indicative and subjunctive in adjective clauses and the meanings of <i>para</i> are the main ones. Basic content is that of <i>ALM Spanish</i>, First Edition, units 30, 31. All class activities are conducted in Spanish. This course is designed for students who have controlled 7506.33 or equivalent material.</p>
SPANISH SOCIAL STUDIES SPANISH-S	7506.23 6493.02 7509.701	<p>LATIN AMERICAN HISTORY THROUGH LITERATURE</p> <p>The student learns about the growth, problems, etc., of Latin America by reading selections written by native authors. Lectures and discussions are in Spanish. The course is recommended for the student who has controlled 7505.04 or 7505.14.</p>
SPANISH SPANISH-S	7506.24 7507.21 7509.702	<p>OUR TIMES</p> <p>This course is designed to acquaint students with twentieth century Spaniards and Iberoamericans from various fields including politics, literature, art, and music. Students explore their lives, deeds, writings or other contributions to the modern Hispanic World. Extensive use is made of films, filmstrips, tapes, records, newspapers, and magazines. The class is conducted in Spanish.</p>

FOREIGN LANGUAGE  
170

AREA	ACCR. NO. FLA-DADE	COURSE TITLE AND DESCRIPTION
SPANISH- LANGUAGE ARTS SPANISH-S	7506.25 7507.22 5116.310 7509.703	CERVANTES AND HIS TIMES  This course presents an accurate picture of the times, life, and works of the man who gave the world its first great novel. Students study the historical background while getting acquainted with Cervantes's main writings and style. Important literary and political figures of the Europe of the sixteenth and seventeenth centuries are considered. Emphasis is on guided discussion, free conversation, the writing of essays and giving of reports. All class work is conducted in Spanish.
SPANISH SPANISH-S LANGUAGE ARTS	7506.26 7507.23 7509.704 5116.315	THE GOLDEN AGE OF SPAIN  The culture of the Golden Age of Spain is studied through readings, filmstrips, and tapes. The student gets acquainted with the life and work of the great masters in painting and literature. This course is recommended for the student who has controlled some of the 7506 courses.
SPANISH	7507.01	MODERN SPANISH, PART 1  Typical customs of the Spanish world observed in the celebration of Christmas, Holy Week, and the carnival are included in the course's readings, along with excerpts taken from writings by Amado Nervo, Martin Luis Guzman, and Gregorio Lopez y Fuentes. The structures include a review of the pluperfect and the passive voice, <i>ser</i> + <i>participio</i> . Basic content is that of <i>Galería Hispánica</i> , Cuadros 13, 14. Emphasis is on guided discussion, free conversation, and written expression and communication. The class is conducted entirely in Spanish.
SPANISH	7507.02	MODERN SPANISH, PART 2  The readings of this course are so varied that they deal with death, fiestas, and foods. Among the structures considered are the present subjunctive, reflexive constructions, and the infinitive with prepositions. Basic content is that of <i>Galería Hispánica</i> , Cuadros 15, 16, 17. Emphasis is on guided discussion, free conversation, and written expression and communication. The class is conducted entirely in Spanish.

AREA	ACCR. NO. FLA-DADE	COURSE TITLE AND DESCRIPTION
SPANISH	7507.03	<p>MODERN SPANISH, PART 3</p> <p>The readings of this course include fables, short stories, and letters. The authors considered are well-known figures of the literary world such as Iriarte, Samaniego, Alarcón, Darío, Quiroga, Bécquer, and Ganivet. Emphasis is on guided discussion, free conversation, and written expression and communication. The class is conducted entirely in Spanish.</p>
SPANISH	7507.04	<p>MODERN SPANISH, PART 4</p> <p>The readings of this course include excerpts of novels that represent a development of literary concerns and styles across the centuries. Starting with <i>El Lazarillo de Tormes</i> and <i>Don Quijote de la Mancha</i>, some modern authors such as Benito Pérez Galdós and Rómulo Gallegos are also studied. Articles from well-known newspapers and magazines complete the offerings of this course. Emphasis is on guided discussion, free conversation, and written expression and communication. The class is conducted entirely in Spanish.</p>
SPANISH	7507.31	<p>MODERN SPANISH, PART 1</p> <p>The readings of this course are varied. They include magazine articles and poems from well-known poets such as Gustavo Adolfo Bécquer and Alfonsina Storni. The meanings of <i>por, para vs. por</i>, and a review of <i>ser</i> and <i>estar</i> with predicate adjective are among the structures considered. Emphasis is maintained on guided discussion, free conversation, and written expression and communication. The basic content is that of <i>ALM Spanish</i>, First Edition, units 32, 33. The class is conducted in Spanish.</p>
SPANISH	7507.32	<p>MODERN SPANISH, PART 2</p> <p>The readings of this course take the student to the times of Hernán Cortés the great "Conquistador" of Mexico. To assure variety of offerings some poems are included, like the famous "Madrigal" by Gutierre de Cetina and "Puentes" by Pablo Neruda. Nouns used in a generic sense and equivalents of <i>some</i> and <i>any</i> are among the structures considered. Emphasis is on guided discussion, free conversation, and written expression and communication. Basic content is that of <i>ALM Spanish</i>, First Edition, units 34, 35. The class is conducted in Spanish.</p>

AREA	ACCR. NO. FLA-DADE	COURSE TITLE AND DESCRIPTION
SPANISH	7507.33	<p>MODERN SPANISH, PART 3</p> <p>The readings of this course include excerpts from the novel <i>La parcela</i>, which presents the customs of rural Mexico at the end of the nineteenth century. The redundant pronouns, the uses of <i>quedar</i> vs. <i>quedarse</i>, and some idioms constitute the grammar. Emphasis is on guided discussion, free conversation, and written expression and communication. Basic content is that of <i>ALM Spanish</i>, First Edition, units 36, 37. The class is conducted in Spanish.</p>
SPANISH	7507.34	<p>MODERN SPANISH, PART 4</p> <p>The reading of excerpts of <i>La parcela</i> is completed in this course. One well-known poem by Luis de Góngora is also included in the readings. Further details on subject-verb agreement and meanings of the indirect object are among the structures studied. Emphasis is maintained on guided discussion, free conversation, and written expression and communication. Basic content is that of <i>ALM Spanish</i>, First Edition, units 38, 39, 40. The class is conducted in Spanish.</p>
SPANISH LANGUAGE ARTS SPANISH-S	7507.24 5116.311 7509.705	<p>† GREAT WRITERS OF SPAIN, PART 1, THE NINETEENTH CENTURY</p> <p>Originals of the Romantic period and the most representative authors of the literary Spain of the nineteenth century are considered in this course. This is the first course of a block of four geared to students preparing to take the Advanced Placement Exam. Emphasis is maintained throughout the course on guided discussion and analysis, free conversation, the writing of essays, and the giving of reports. The class is conducted in Spanish.</p>
SPANISH LANGUAGE ARTS SPANISH-S	7507.25 5116.312 7509.706	<p>GREAT WRITERS OF SPAIN, PART 2, THE TWENTIETH CENTURY</p> <p>Starting with the famous "Generación del 98," the works of the most representative authors of the literary Spain of the twentieth century are studied in this course. Emphasis is maintained throughout on guided discussion and analysis, free conversation, the writing of essays, and the giving of reports. The class is conducted in Spanish. This course is geared to the very capable student interested in Advanced Placement.</p>



AREA	ACCR. NO. FLA-DADE	COURSE TITLE AND DESCRIPTION
SPANISH LANGUAGE ARTS SPANISH-S	7507.26 5116.313 7509.707	GREAT WRITERS OF HISPANIC AMERICA, PART 1, THE NINETEENTH CENTURY  Works of the great writers of the Hispanic America of the nineteenth century are studied in this course, along with the literary movements of that time. Emphasis is on guided discussion and analysis, free conversation, the writing of essays, and the giving of reports. The class is conducted in Spanish. This course is geared to the very capable student interested in Advanced Placement.
SPANISH LANGUAGE ARTS SPANISH-S	7507.27 5116.314 7509.708	GREAT WRITERS OF HISPANIC AMERICA, PART 2, THE TWENTIETH CENTURY  The authors of today, the novelists and poets who constitute the literary elite of our century in Hispanic America, are studied in this course. Emphasis is on guided discussion and analysis, free conversation, the writing of essays, and the giving of reports. The class is conducted in Spanish. This course is geared to the very capable student interested in Advanced Placement.
SPANISH SPANISH-S	7506.27 7507.07 7509.02	† STORIES OF YESTERDAY AND TODAY  This course is designed to help students improve their oral and written expression, as well as their ability to summarize. Stories by Spanish and Spanish American writers are used. Students reinforce skills in recognizing the importance of writing as an efficient means of communication. Experience is provided in paragraph building.
SPANISH SPANISH-S	7506.28 7507.08 7509.04	THROUGH LOVE AND ADVENTURE  This course enables the student to write brief descriptions and narratives. The selected literary works to be studied deal with interesting adventures and love stories in prose and verse. The students become able to distinguish between historic facts and fiction. The three main tenses of verbs, descriptive adjectives, and the common and proper nouns are covered. The concept and structure of paragraphs and other grammatical principles already studied are reviewed.

AREA	ACCR. NO. FLA-DADE	COURSE TITLE AND DESCRIPTION
SPANISH	7506.29	ROMANTICISM IN LATIN AMERICA  This course is designed to acquaint the student with the concepts and thoughts of Latin American Romantic authors. The students develop respect for other than modern styles of writing. Discussion and analysis of Romanticism, as well as comparison with contemporary realism, are stressed.
	7507.09	
SPANISH-S	7509.42	
SPANISH	7506.291	LATIN AMERICAN POETRY THROUGHOUT THE AGES  This course is designed to acquaint the student with the different styles of poetry throughout the ages. The students learn to enjoy poetry, both old and new, identify and understand man's use of poetry as an expression of self, throughout all time, and produce some poetry of their own.
	7507.091	
SPANISH-S	7509.43	
SPANISH	7506.292	THE BEGINNINGS OF THE SPANISH THEATER  This course is designed to acquaint students with the Spanish theater from its origin to the time of Lope de Vega. Activities include reading plays with the correct intonation; acting out any one of the plays; and studying character, setting, dialogue, and the author's use of a taste for good drama, while getting new insights into human conflict. Effective oral and written expression are stressed.
	7507.092	
SPANISH-S	7509.51	
SPANISH	7506.293	HUMOR IN THE SPANISH THEATER  This course is designed to acquaint the students with Spanish dramatics and the use of a variety of dialects. The students identify typical examples of Spanish merriment throughout the development of Spanish drama. Characteristics of good humor are contrasted with the grotesque and vulgar.
	7507.093	
SPANISH-S	7509.76	

## GUIDANCE-ORIENTED PROGRAM

The guidance-oriented courses Project You and So You Want to Go to College are an integral part of the social studies discipline, having social studies code numbers. The courses were designed to help students plan careers in terms of educational preparation and vocational opportunities. Other guidance-oriented courses will be added to this section as they are developed.

AREA	ACCR. NO. FLA-DADE	COURSE TITLE AND DESCRIPTION
SOCIAL STUDIES	6470.42	<p>† PROJECT YOU</p> <p>A course of study designed to acquaint pupils with the world of work and the personal characteristics that will help them succeed in their career choices. High school curricular offerings will be examined as an intermediate step in planning. The course content will encompass study of various theories of career choice, the impact of youth in the labor force, job opportunities and requirements, personal appearance, job applications, and work relationships. Resource personnel from the business community, as well as tours to business sites, can be incorporated. Recommended for all junior high school students.</p>
SOCIAL STUDIES	6443.50	<p>† SO YOU WANT TO GO TO COLLEGE</p> <p>A course providing for the recognition and understanding of terms necessary to exploring college admission. Insight is gained concerning the relative importance of high school grades and activities, as well as high school testing and college entrance testing. The course will examine the junior college system, the senior college system, and their relationship to each other. It will also explore varying campus atmospheres and aspects of campus life. Practice in handling applications, including requesting transcripts and securing recommendations, will be provided. All sources of financial aid and general procedures for applying will be studied. Recommended for any senior high school student, whether or not college entrance is anticipated.</p>

GUIDANCE-ORIENTED PROGRAM

177

177

## HEALTH EDUCATION

Many health-related problems plague our community and may deter the school-age youngster from taking full advantage of the educational opportunities offered. To cope with the interferences to the individual and the threats to the community, an informed public can effectively attempt to resolve these critical health problems.

Several disciplines have coordinated their efforts to develop courses of study which fulfill the need for alerting and informing students of the current and potential health hazards and the technology necessary for their remediation. The developed units of study, which include instruction in venereal disease, narcotics and alcohol, and other abused drugs, will serve to satisfy county policies and state statutes.

The following represent the state code numbers for the quinmester courses listed below:

- 7391 Health 7 — Grade 7
- 7392 Health 8 — Grade 8
- 7393 Health 1 — Grades 10-12
- 7394 Health 2 — Grades 10-12

### QUINMESTER COURSES

Your S.T.A.N.D. on Health	180
Teen Changes	180
Safety in the Seventies	180
Drugs, Society, and You	180
As Others See You	180
Mood Modifiers—Drug Abuse	181
Boy-Girl Relationships	181
Girl Talk (or Program for Poise)	181
Bachelors Only	181

AREA	ACCR. NO. FLA-DADE	COURSE TITLE AND DESCRIPTION
HEALTH	7391.01	YOUR S.T.A.N.D. ON HEALTH  This quin provides for the study and discussion of the characteristics and effects of tobacco, alcohol, narcotics, and venereal disease. Safety precautions and first aid procedures will also be emphasized.
	7392.01	
SCIENCE	5311.47	
	5312.47	
	5313.47	
HEALTH	7391.02	TEEN CHANGES  An elective unit designed to provide an overview of mental health; personality development; body structure, function, and care. Emphasizes nutritional and health care needs of the teen-ager. The student will assess feelings and attitudes about growth and body changes.
	7392.02	
SCIENCE	5311.48	
	5312.48	
	5313.48	
HOME AND FAMILY ED.	6763.03	
HEALTH	7391.03	SAFETY IN THE SEVENTIES  An examination of safety in the areas of greatest concern to the individual and family. Students will identify the hazards and safeguards involved on the playground, in the water, on the highway, in the home, and other relevant situations. Additional instruction will be provided in the proper application of first aid in all of these areas. This is an elective unit.
	7392.03	
	7390.03	
	7393.03	
	7394.03	
HEALTH	7391.04	DRUGS, SOCIETY, AND YOU  The physical, mental, and social aspects of drugs and drug abuse. Designed to follow a basic health course about drugs. Emphasizes the social side of drug usage: the reasons people take drugs, the role of alienation, teen-agers and conformity, legal complications, drugs and crime.
	7392.04	
	7393.04	
	7394.04	
SOCIAL STUDIES	6470.07	
	6425.03	
	6471.08	
	6413.09	
HEALTH	7391.05	+ AS OTHERS SEE YOU  Offers experiences in grooming, and clothing selection and care to male and female students interested in self-improvement and good health. The relationship of personal well-being to success in personal, social, and occupational roles will be analyzed.
	7392.05	
	7393.05	
	7394.05	
HOME AND FAMILY ED.	6763.04	
BUSINESS EDUCATION	7713.49	

AREA	ACCR. NO. FLA-DADE	COURSE TITLE AND DESCRIPTION
HEALTH	7393.06 7394.06	† MOOD MODIFIERS-DRUG ABUSE  This quin provides students the opportunity to gain insights into the problems of all types of substance abuse. They will examine the detrimental effects upon the individual from the misuse and abuse of drugs, the motivations for substance abuse, and the need for rational decision making based on accurate information.
HEALTH  HOME AND FAMILY ED.	7393.07 7394.07 6763.09	BOY-GIRL RELATIONSHIPS  This course is not available at this time. See the courses entitled The Dating Years (junior high) and Becoming an Adult (senior high) described in the Home and Family Education section for alternate choices.
HEALTH  HOME AND FAMILY ED.	7391.09 7392.09 7393.09 7394.09 6763.02	† GIRL TALK (or PROGRAM FOR POISE)  This self-improvement course is designed as an interdisciplinary effort between Home and Family Education and Health Education. It provides students with the opportunity to analyze themselves, and plan and carry through a personal improvement program in the following areas: grooming, figure control, posture improvement, wardrobe planning, and clothing maintenance.
HEALTH  HOME AND FAMILY ED.	7391.10 7392.10 7393.10 7394.10 6763.10	BACHELORS ONLY  An elective course designed for boys, emphasizing physical conditioning, weight control, personal grooming, men's fashions, dating etiquette, consumer purchasing, budgeting, and social responsibilities.

## HOME AND FAMILY EDUCATION

The title of this area of study has been changed from Home Economics to Home and Family Education to better explain content and focus. It is recommended that courses be offered from each cluster to provide students with a variety of experiences in Personal, Family, and Social Relations; Child Development; Management and Family Economics; Housing and Home Furnishings; Textiles and Clothing; and Food and Nutrition. Many courses are multicurricular and it is recommended that, where possible, they be cooperatively planned and taught by an interdisciplinary team.

The first four digits of the code numbers reflect the State Accreditor numbers to be used in reporting course credit. The last two digits indicate, in most cases, the sequence of difficulty within that course category.

Any of the courses listed in this section may be taught on a Vocational Home Economics Unit provided the teacher has Vocational Home Economics certification and the application for a unit has been approved. The content of courses listed in "Personal, Home, and Family Living Preparation" emphasizes the vocational opportunities within the subject matter areas, as well as provides *useful* consumer and homemaking education. Courses listed under "Occupational Preparation" provide specific occupational education and training for *gainful* employment.

Home and Family Education is equally important for male and female students. Courses, with few exceptions, should be available to both sexes. Refer to Appendix A for courses which can be used to meet the graduation requirement of one year of study related to effective family living for all students in grades seven through twelve.

PERSONAL, FAMILY AND SOCIAL RELATIONS

Teen-age Living<sup>1</sup>  
(6763.01)  
(Social Studies 6470.16)

Girl Talk<sup>1</sup>  
(6763.02)  
(Health 7393.02)

Teen Changes<sup>1</sup>  
(6763.03)  
(Science 5311.48)  
(Health 7391.02)

The Dating Years<sup>1</sup>  
(6763.07)

As Others See You<sup>3</sup>  
(6763.04)  
(Bus. Ed. 7713.49)  
(Health 7391.05)

Bachelors Only<sup>3</sup>  
(6763.10)  
(Health 7391.10)

Becoming an Adult<sup>2</sup>  
(6763.05)

Understanding Individual Behavior<sup>2</sup>  
(6763.07)  
(Social Studies 6427.02)

Human Relations<sup>2</sup>  
(6763.08)  
(Social Studies 6425.04)

Boy-Girl Relationships<sup>2</sup>  
(6763.09)  
(Health 7393.07)

The New You<sup>2</sup>  
(6763.06)

Rings 'n Things<sup>2</sup>  
(6757.01)

Marriage Day by Day<sup>2</sup>  
(6757.02)  
(Social Studies 6425.15)

The Changing Family<sup>2</sup>  
(6757.05)  
(Social Studies 6425.15)

The Family and Crises<sup>2</sup>  
(6757.04)

HOME AND FAMILY EDUCATION—Personal, Home, and Family Living Preparation

CHILD DEVELOPMENT

As the Twig Is Bent:  
Birth to Age 23<sup>1</sup>  
(6758.02)

Trusting Threes to  
Fetching Fives<sup>3</sup>  
(6758.03)

Preface to a Life<sup>2</sup>  
(6758.01)

Off 'n Running:  
Ages 6-12<sup>2</sup>  
(6758.04)

Independent Study in  
Human Development<sup>2</sup>  
(6758.05)

Child Behavior<sup>2</sup>  
(6758.06)  
(Social Studies 6427.03)

Parentood<sup>2</sup>  
(6757.03)

MANAGEMENT AND FAMILY ECONOMICS

Dollars and Sense<sup>3</sup>  
(6765.01)  
(Bus. Ed. 7734.22)

S.O.S.—Spend or Save<sup>2</sup>  
(6765.02)

In the Marketplace<sup>3</sup>  
(6765.03)  
(Bus. Ed. 6463.01)

Intelligent Buyer and  
Repairer of Green Acres<sup>2</sup>  
(6765.04)  
(Industrial Arts 5803.01)

The Dual Role<sup>2</sup>  
(6754.01)

Decision Making for  
the Home<sup>2</sup>  
(6754.02)

HOUSING AND HOME FURNISHINGS

Interior Decorating  
for Teens<sup>1</sup>  
(6764.01)

Choosing Your Home<sup>2</sup>  
(6764.02)  
(Bus. Ed. 6463.04)

Decorating Your  
First Home<sup>2</sup>  
(6764.03)

Intelligent Buyer and  
Repairer of Green Acres<sup>2</sup>  
(6765.04)  
(Industrial Arts 5803.01)

Construction Planning<sup>2</sup>  
(6764.04)  
(Industrial Arts 5858.04)

Architectural Planning<sup>2</sup>  
(6764.05)  
(Industrial Arts 5807.01)

Architectural Appreciation  
Design<sup>2</sup>  
(6764.06)  
(Industrial Arts 5807.04)

TEXTILES AND CLOTHING

Handy Hobbies in  
Textiles<sup>1</sup>  
(6766.01)

Novice Knowledge  
in Sewing<sup>1</sup>  
(6766.02)

Fashion Dollar Why's<sup>3</sup>  
(6766.07)

Sew-So-Easy<sup>3</sup>  
(6766.03)

Sew-So-Well<sup>3</sup>  
(6766.04)

Sew-So-Smart<sup>2</sup>  
(6766.05)

Sew-So-New<sup>2</sup>  
(6766.06)

Fun with Fabrics<sup>2</sup>  
(6766.09)

Creative Fashions I<sup>2</sup>  
(6766.10)

Creative Fashions II<sup>2</sup>  
(6766.11)

Creative Fashions III<sup>2</sup>  
(6766.12)

Independent Study in  
Textiles and Clothing<sup>2</sup>  
(6766.13)

Creative Textile  
Design I and II<sup>2</sup>  
(6766.14)  
(Art 6581.18, 6681.19)

Costume Design<sup>2</sup>  
(6766.15)  
(Art 6697.01)  
(Language Arts 5184.10)

FOOD AND NUTRITION

Beginning to Cook<sup>1</sup>  
(6768.01)

Gourmet Chefs<sup>1</sup>  
(6768.12)

Menu Magic<sup>3</sup>  
(6768.02)

Creative Baking<sup>3</sup>  
(6768.03)

Creative Cooking<sup>2</sup>  
(6768.04)

Entertaining with  
a Flair<sup>3</sup>  
(6768.08)

Food with a  
Foreign Flavor<sup>3</sup>  
(6768.09)

Outdoor Cookery<sup>3</sup>  
(6768.10)

Cooking for Two<sup>2</sup>  
(6768.05)

Menus for  
Young Moderns<sup>2</sup>  
(6768.06)

Food Sense and Dollars<sup>2</sup>  
(6768.07)

Fashions in Food<sup>2</sup>  
(6768.11)

Independent Study in  
Food and Nutrition<sup>2</sup>  
(6768.13)

<sup>1</sup> Recommended for junior high  
<sup>2</sup> Recommended for senior high  
<sup>3</sup> Recommended for junior or senior high



## HOME AND FAMILY EDUCATION—Occupational Preparation

PERSONAL, FAMILY, AND SOCIAL RELATIONS	CHILD DEVELOPMENT	MANAGEMENT AND FAMILY ECONOMICS	HOUSING AND HOME FURNISHINGS	TEXTILES AND CLOTHING	FOOD AND NUTRITION
Orientation to Occupational Home Economics <sup>3</sup> (6775.01)	Sitting Safely <sup>1</sup> (6755.01)	Careers in Institutional and Home Management I <sup>2</sup> (6769.01)	Renovating Home Furnishings <sup>2</sup> (6767.01)	Sewing Professionally <sup>2</sup> (6756.01)	Awaken to the World of Food Service <sup>2</sup> (6773.01) (Trade & Ind. Ed. 9193.01)
	Child Care Services I <sup>2</sup> (6755.02)	Careers in Institutional and Home Management II <sup>2</sup> (6769.02)	Home Fashions <sup>2</sup> (6767.02)	Fashion Merchandising <sup>2</sup> (6756.02)	Nutritious Meal Planning <sup>2</sup> (6773.02) (Trade & Ind. Ed. 9193.02)
	Child Care Services II <sup>2</sup> (6755.03)	Careers in Institutional and Home Management III <sup>2</sup> (6769.03)	Interior Design Projects <sup>2</sup> (6767.03)	Careers in Clothing Services I <sup>2</sup> (6756.03)	Cooking Can Be Profitable <sup>2</sup> (6773.03) (Trade & Ind. Ed. 9193.03)
	Child Care Services III <sup>2</sup> (6755.04)	Careers in Institutional and Home Management IV <sup>2</sup> (6769.04)	Careers in Home Furnishings and Equipment I <sup>2</sup> (6767.04)	Careers in Clothing Services II <sup>2</sup> (6756.04)	A Chef-is Many Things <sup>2</sup> (6773.04) (Trade & Ind. Ed. 9193.04)
	Child Care Services IV <sup>2</sup> (6755.05)	Cooperative Institutional and Home Management I <sup>2</sup> (6791.01)	Careers in Home Furnishings and Equipment II <sup>2</sup> (6767.05)	Careers in Clothing Services III <sup>2</sup> (6756.05)	Party Foods <sup>2</sup> (6773.05) (Trade & Ind. Ed. 9193.05)
	Cooperative Child Care Services I <sup>2</sup> (6779.01)	Cooperative Institutional and Home Management II <sup>2</sup> (6791.02)	Careers in Home Furnishings and Equipment III <sup>2</sup> (6767.06)	Careers in Clothing Services IV <sup>2</sup> (6756.06)	Home Catering <sup>2</sup> (6773.06)
	Cooperative Child Care Services II <sup>2</sup> (6779.02)	Cooperative Institutional and Home Management III <sup>2</sup> (6791.03)	Careers in Home Furnishings and Equipment IV <sup>2</sup> (6767.07)	Cooperative Clothing Services I <sup>2</sup> (6786.01)	Cooperative Food Services I <sup>2</sup> (6789.01)
	Cooperative Child Care Services III <sup>2</sup> (6779.03)	Cooperative Institutional and Home Management IV <sup>2</sup> (6791.04)	Cooperative Home Furnishings, Equipment and Services I <sup>2</sup> (6793.01)	Cooperative Clothing Services II <sup>2</sup> (6786.02)	Cooperative Food Services II <sup>2</sup> (6789.02)
	Cooperative Child Care Services IV <sup>2</sup> (6779.04)		Cooperative Home Furnishings, Equipment and Services II <sup>2</sup> (6793.02)	Cooperative Clothing Services III <sup>2</sup> (6786.03)	Cooperative Food Services III <sup>2</sup> (6789.03)
			Cooperative Home Furnishings, Equipment and Services III <sup>2</sup> (6793.03)	Cooperative Clothing Services IV <sup>2</sup> (6786.04)	Cooperative Food Services IV <sup>2</sup> (6789.04)
			Cooperative Home Furnishings, Equipment and Services IV <sup>2</sup> (6793.04)		The Party Corps (6773.07)

<sup>1</sup> Recommended for junior high

<sup>2</sup> Recommended for senior high

<sup>3</sup> Recommended for junior or senior high

## QUINMESTER COURSES

Architectural Appreciation Design	196
Architectural Planning	196
As Other See You	188
As the Twig Is Bent: Birth to Age 2	191
Awaken to the World of Food Service	204
Bachelors Only	189
Becoming an Adult	189
Beginning to Cook	201
Boy-Girl Relationships	189
Careers in Clothing Services I	201
Careers in Clothing Services II	201
Careers in Clothing Services III	201
Careers in Clothing Services IV	201
Careers in Home Furnishings and Equipment I	197
Careers in Home Furnishings and Equipment II	197
Careers in Home Furnishings and Equipment III	197
Careers in Home Furnishings and Equipment IV	197
Careers in Institutional and Home Management I	195
Careers in Institutional and Home Management II	195
Careers in Institutional and Home Management III	195
Careers in Institutional and Home Management IV	195
Changing Family, The	190
Chef Is Many Things, A	204
Child Behavior	192
Child Care Services I	193
Child Care Services II	193
Child Care Services III	193
Child Care Services IV	193
Choosing Your Home	195
Construction Planning	196
Cooking Can Be Profitable	204
Cooking for Two	203
Cooperative Child Care Services I	193
Cooperative Child Care Services II	193
Cooperative Child Care Services III	193
Cooperative Child Care Services IV	193
Cooperative Clothing Services I	201
Cooperative Clothing Services II	201
Cooperative Clothing Services III	201
Cooperative Clothing Services IV	201
Cooperative Food Services I	205
Cooperative Food Services II	205
Cooperative Food Services III	205
Cooperative Food Services IV	205
Cooperative Home Furnishings, Equipment and Services I	197
Cooperative Home Furnishings, Equipment and Services II	197
Cooperative Home Furnishings, Equipment and Services III	197
Cooperative Home Furnishings, Equipment and Services IV	197
Cooperative Institutional and Home Management I	195
Cooperative Institutional and Home Management II	195
Cooperative Institutional and Home Management III	195
Cooperative Institutional and Home Management IV	195
Costume Design	200
Creative Baking	202

## HOME AND FAMILY EDUCATION

Creative Cooking	202
Creative Fashions I	199
Creative Fashions II	199
Creative Fashions III	199
Creative Textile Design I	200
Creative Textile Design II	200
Dating Years, The	188
Decision Making for the Home (or Appliance Ability)	194
Decorating Your First Home	196
Dollars and Sense	193
Dual Role, The	194
Entertaining with a Flair	202
Family and Crises, The	190
Fashion Dollar Why's (or Fashion Why's)	198
Fashion Merchandising	201
Fashions in Food	203
Food Sense and Dollars	203
Food with a Foreign Flavor	202
Fun with Fabrics (or Fascinating Fabrics)	199
Girl Talk (or Program for Poise)	188
Gourmet Chefs (or Bachelor Chefs)	201
Handy Hobbies in Textiles	198
Home Catering	205
Home Fashions	197
Human Relations	189
In the Marketplace	194
Independent Study in Food and Nutrition	204
Independent Study in Human Development	192
Independent Study in Textiles and Clothing	200
Intelligent Buyer and Repairer for Green Acres	194
Interior Decorating for Teens	195
Interior Design Projects	197
Marriage Day by Day	190
Menu Magic	202
Menus for Young Moderns	203
New You, The	189
Novice Knowledge in Sewing	198
Nutritious Meal Planning	204
Off 'n Running: Ages 6-12	191
Oriental to Occupational Home Economics	191
Outdoor Cookery	203
Parenthood	192
Party Corps, The	205
Party Foods	205
Preface to a Life	192
Renovating Home Furnishings	196
Rings 'n Things	190
Sewing Professionally	200
Sew-So-Easy	198
Sew-So-New	199
Sew-So-Smart	199
Sew-So-Well	198
Sitting Safely	193
S.O.S.—Spend or Save	194
Teen Changes	188
Teen-Age Living	188
Trusting Threes to Fetching Fives	191
Understanding Individual Behavior	189

AREA	ACCR. NO. FLA-DADE	COURSE TITLE AND DESCRIPTION
HOME AND FAMILY ED. SOCIAL STUDIES	6763.01 6470.16 6425.01 6412.23 6475.01	† TEEN-AGE LIVING  An examination of the changes and challenges confronting the young teen. Focuses on the factors influencing his attitudes, behavior, and relationships with others. Provides an opportunity for self-evaluation and clarification of personal values and goals.
HOME AND FAMILY ED. HEALTH	6763.02 7391.09 7392.09 7393.09 7394.09	† GIRL TALK (or PROGRAM FOR POISE)  This self-improvement course is designed as an interdisciplinary effort between Home and Family Education, and Health Education. It provides students with the opportunity to analyze themselves, and plan and carry through a personal improvement program in the following areas: grooming, figure control, posture improvement, wardrobe planning, and clothing maintenance.
HOME AND FAMILY ED. HEALTH SCIENCE	6763.03 7391.02 7392.02 5311.48 5312.48 5313.48	TEEN CHANGES  An elective unit designed to provide an overview of mental health; personality development; body structure, function, and care. Emphasizes nutritional and health care needs of the teen-ager. The student will assess feelings and attitudes about growth and body changes.
HOME AND FAMILY ED.	6763.07	† THE DATING YEARS  Examines the decisions facing the young teen-ager during the dating years. Such issues as the responsibilities and privileges that go with increasing maturity, family attitudes toward dating, living according to personal standards, and the contributions these years can make toward self-understanding and maturity will be discussed.
HOME FAMILY ED. BUSINESS EDUCATION HEALTH	6763.04 7713.49 7391.05 7392.05 7393.05 7394.05	† AS OTHERS SEE YOU  Offers experiences in grooming, and clothing selection and care to male and female students interested in self-improvement and good health. The relationship of personal well-being to success in personal, social, and occupational roles will be analyzed.

AREA	ACCR. NO. FLA-DADE	COURSE TITLE AND DESCRIPTION
HOME AND FAMILY ED. HEALTH	6763.10 7391.10 7392.10 7393.10 7394.10	BACHELORS ONLY  An elective course designed for boys, emphasizing physical conditioning, weight control, personal grooming, men's fashions, dating etiquette, consumer purchasing, budgeting, and social responsibilities.
HOME AND FAMILY ED.	6763.05	BECOMING AN ADULT  Enables the teen-ager to examine his or her present level of achievement of the developmental goals involved in the process of maturing toward adulthood. The factors involved in achieving sexual identity, emotional independence, effective social relationships, a positive self-concept, and a personal value system will be assessed.
HOME AND FAMILY ED. SOCIAL STUDIES	6763.07 6427.02 6448.47	† UNDERSTANDING INDIVIDUAL BEHAVIOR  A study of the causes of individual behavior through an analysis of the influence of heredity and environment on the individual.
HOME AND FAMILY ED. SOCIAL STUDIES	6763.08 6425.04 6448.52	† HUMAN RELATIONS  An analysis of the ways in which people behave toward each other. Includes group dynamics, ways people communicate, problems of interpersonal relations.
HOME AND FAMILY ED. HEALTH	6763.09 7393.07 7394.07	BOY-GIRL RELATIONSHIPS  This course is not available at this time. See the courses entitled The Dating Years (junior high) and Becoming an Adult (senior high) for alternate choices.
HOME AND FAMILY ED.	6763.06	THE NEW YOU  Designed to enable girls to improve their personal appearance through special projects in hair care and styling, skin care and makeup application, good health habits including diet, exercise, improvement of posture, charm and poise, voice control, manners, and the selection of clothes that look best on the specific figure.

AREA	ACCR. NO. FLA-DADE	COURSE TITLE AND DESCRIPTION
HOME AND FAMILY ED.	6757.01	RINGS 'N THINGS  Analyzes factors involved in choosing a husband or wife and the purposes of the engagement period. The influence on marital success of such factors as values and goals, life style, cultural background, age, religion, education, and attitude toward parenthood will be assessed.
HOME AND FAMILY ED.	6757.02	MARRIAGE DAY BY DAY  Designed to enable the student to develop realistic expectations of the marriage commitment in terms of his personal values and goals. Students will analyze typical marital adjustments, examine possible courses of action and determine their impact on family harmony. Topics will include realistic attitudes toward marriage, role expectations, common marital adjustments, importance of adaptability, family life styles, and the establishment of a relationship that encourages personal growth.
HOME AND FAMILY ED., SOCIAL STUDIES	6757.05 6425.15 6448.64	THE CHANGING FAMILY  Analyzes the changes occurring in the family unit in the United States and projected trends in family living. Topics will include the physical and psychological functions of a family, past and present; forms the family unit has taken in various cultures; the effect of the family unit on society; and the impact of social and technological changes on the family unit. Students will examine current issues affecting families.
HOME AND FAMILY ED.	6757.04	THE FAMILY AND CRISES  Examines situations that may lead to family crises and explores alternate courses of action. Topics will include single parents; adoption; emotionally, mentally, or physically handicapped family members. The laws which affect the family unit will be analyzed and the community agencies available to aid the family will be determined.

AREA	ACCR. NO. FLA-DADE	COURSE TITLE AND DESCRIPTION
HOME AND FAMILY ED.	6775.01	<p data-bbox="820 443 1560 500">ORIENTATION TO OCCUPATIONAL HOME ECONOMICS</p> <p data-bbox="820 534 1560 867">Analyzes the gainful employment possibilities in this field and identifies job titles and descriptions. Students will examine the problems connected with the dual role of working on the job and maintaining a home. The personal characteristics and attitudes of a successful employee will be appraised and experiences provided in developing these qualities. Practice will be provided in filling out job applications, being interviewed for a job, taking tests, analyzing job benefits, and managing income. This course is recommended to be taken previously to, or concurrently with, occupational offerings.</p>
HOME AND FAMILY ED.	6758.02	<p data-bbox="784 927 1560 962">† AS THE TWIG IS BENT: BIRTH TO AGE 2</p> <p data-bbox="820 989 1560 1166">Examines the social, emotional, physical, and intellectual development of children from birth through two years of age. Students will demonstrate the ability to provide for the effective care and guidance of these children. Competencies leading toward employment will be developed.</p>
HOME AND FAMILY ED.	6758.03	<p data-bbox="784 1226 1560 1260">† TRUSTING THREES TO FETCHING FIVES</p> <p data-bbox="820 1288 1560 1648">Identification of the stages of growth and development of the child at three, four, and five years of age will be the focus of this course. Emphasis will be placed on choosing appropriate play materials and activities, providing for the health and safety, and using desirable discipline and guidance techniques for children in this age group. The student will have an opportunity to plan and assist in an actual nursery school or to assist and/or observe in a local nursery school near the end of his course work. Employment opportunities and competencies leading toward the development of employable skills will be stressed.</p>
HOME AND FAMILY ED.	6758.04	<p data-bbox="820 1708 1560 1742">OFF 'N RUNNING: AGES 6-12</p> <p data-bbox="820 1770 1560 1951">Focuses on the social, emotional, physical, and intellectual development of the child from six to twelve years of age. The student will have the opportunity to observe and work with school-age children. It is recommended for those students who are considering vocational pursuits in the field of elementary education.</p>

AREA	ACCR. NO. FLA-DADE	COURSE TITLE AND DESCRIPTION
HOME AND FAMILY ED.	6758.01	† PREFACE TO A LIFE  Identifies the stages of development of a child from conception through birth. The student will develop an understanding of the process of human reproduction, prenatal development, and childbirth. Discussions will include family planning, responsibilities and adjustments of parenthood, and the many factors involved in providing for a new life. Medical and other professional community resource personnel participate in the presentation of this course.
HOME AND FAMILY ED.	6758.05	INDEPENDENT STUDY IN HUMAN DEVELOPMENT  Provides opportunity for the advanced student to do independent research on a topic from the area of Human Development for which he has secured prior approval. He or she will establish specific objectives, investigate available resources, and present findings in a manner agreed upon jointly by the student and teacher.
HOME AND FAMILY ED. SOCIAL STUDIES	6758.06 6427.03 6448.48	CHILD BEHAVIOR  An examination of the physical, mental, and emotional growth of children. Includes current theories of child rearing. Emphasis is on the effect of social environment on the development of the child's personality.
HOME AND FAMILY ED.	6757.03	† PARENTHOOD  Presentation of the responsibilities of parenthood and the satisfactions that can be derived from meeting these responsibilities in a manner which leads toward overall family harmony. Topics will include the assessment of a couple's readiness for parenthood; awareness of the effects of a child on the marriage relationship; prenatal development; needs of husbands and wives during pregnancy and as new parents; basic principles of child growth and development; providing for the physical, social, emotional and intellectual needs of children; and the development of a personal philosophy of "parenting."



AREA	ACCR. NO. FLA-DADE	COURSE TITLE AND DESCRIPTION
HOME AND FAMILY ED.	6755.01	SITTING SAFELY  Focuses on the privileges, responsibilities, and characteristics of an effective babysitter. Students will select appropriate activities and evaluate methods of child care based on knowledge of the basic needs of children at various age and developmental levels.
HOME AND FAMILY ED.	6755.02 6755.03 6755.04 6755.05	CHILD CARE SERVICES I CHILD CARE SERVICES II CHILD CARE SERVICES III CHILD CARE SERVICES IV  Focuses on the occupational preparation for a child care aide. It prepares students for employment as aides in child day care centers, Head Start programs, and kindergartens, or for self-employment. Students will identify the basic needs of children in a group and exhibit the ability to meet these needs, and will receive supervised work experience in a laboratory situation at their own school or in a nursery school or kindergarten in the community. It is recommended that students meet the objectives of the courses Orientation to Occupational Home Economics and Trusting Threes to Fetching Fives before enrollment. Specific course descriptions for each of the consecutive quins are in the process of development.
HOME AND FAMILY ED.	6779.01 6779.02 6779.03 6779.04	COOPERATIVE CHILD CARE SERVICES I (3 hours) COOPERATIVE CHILD CARE SERVICES II (3 hours) COOPERATIVE CHILD CARE SERVICES III (3 hours) COOPERATIVE CHILD CARE SERVICES IV (3 hours)  Basic instruction will be combined with supervised on-the-job experience in caring for children in nursery schools, day care centers, and kindergarten programs. Specific descriptions for each of the four consecutive quins are in the process of development.
HOME AND FAMILY ED. BUSINESS EDUCATION	6765.01 7734.22	† DOLLARS AND SENSE  The student plans the management of his or her money to get the most personal satisfaction from it. Includes influence of teen-age spending on the economy, understanding and keeping money records, developing skill in decision making, and planning as a consumer.

AREA	ACCR. NO. FLA-DADE	COURSE TITLE AND DESCRIPTION
HOME AND FAMILY ED.	6765.02	† S.O.S—SPEND OR SAVE  Offers experiences in the management of family money from the time it is earned or acquired until it is put to work to obtain family goals. Emphasis will be placed on methods of saving and investing, determining consumer values, the types and costs of credit, protecting the financial security of the family, and designing a plan for family spending.
HOME AND FAMILY ED.	6765.03	IN THE MARKETPLACE
BUSINESS EDUCATION	6463.01	Focuses on comparison shopping, store etiquette, impulse buying, reading labels, specials, loss leaders, standards in relation to needs, installment or cash costs.
HOME AND FAMILY ED.	6765.04	† INTELLIGENT BUYER AND REPAIRER FOR GREEN ACRES
INDUSTRIAL ARTS	5804.01	Experiences in making a variety of general home repairs, including repair of small appliances, plumbing repairs, painting simple wood products, patch plastering, etc. Topics will include consumer information concerning estimating and buying home materials and furnishings, and when a repair should not be attempted.
HOME AND FAMILY ED.	6754.01	THE DUAL ROLE  Designed to prepare the student for his or her homemaker-family member role and the dual role of homemaker and wage earner. Topics will include division of family responsibilities, efficient methods of housekeeping, providing for the care of children, the use of convenience foods, and consumer knowledge necessary to purchase goods and services for the family.
HOME AND FAMILY ED.	6754.02	DECISION MAKING FOR THE HOME (or APPLIANCE ABILITY)  The student will explore alternatives in the selection, maintenance, and arrangement of small and major equipment which will meet individual needs and conserve human resources. The use of electricity, gas, and water in the home to help maintain a safe, efficient, and pleasant environment for the family will be included.

AREA	ACCR. NO. FLA-DADE	COURSE TITLE AND DESCRIPTION
HOME AND FAMILY ED.	6769.01	CAREERS IN INSTITUTIONAL AND HOME MANAGEMENT I
	6769.02	CAREERS IN INSTITUTIONAL AND HOME MANAGEMENT II
	6769.03	CAREERS IN INSTITUTIONAL AND HOME MANAGEMENT III
	6769.04	CAREERS IN INSTITUTIONAL AND HOME MANAGEMENT IV
		Occupational preparation for gainful employment in institutional and home management and supportive services. Basic skills will be developed in the use and care of household equipment and supplies, housekeeping, laundry procedures, home management, and the care of the elderly and disabled. Specific course descriptions for each of the consecutive quins are in the process of development.
HOME AND FAMILY ED.	6791.01	COOPERATIVE INSTITUTIONAL AND HOME MANAGEMENT I (3 hours)
	6791.02	COOPERATIVE INSTITUTIONAL AND HOME MANAGEMENT II (3 hours)
	6791.03	COOPERATIVE INSTITUTIONAL AND HOME MANAGEMENT III (3 hours)
	6791.04	COOPERATIVE INSTITUTIONAL AND HOME MANAGEMENT IV (3 hours)
		Basic instruction will be combined with supervised on-the-job experience in areas of instructional and home management to include care of the elderly and disabled, housekeeping and home management, Specific course descriptions for each of the four consecutive quins are in the process of development.
HOME AND FAMILY ED.	6764.01	† INTERIOR DECORATING FOR TEENS
		An opportunity for the young teen to apply art principles and imagination when planning for the decoration of a room. Factors influencing the choice of home furnishings and their arrangement and care will be included.
HOME AND FAMILY ED.	6764.02	CHOOSING YOUR HOME
BUSINESS EDUCATION	6463.04	Explores the choices available when selecting and financing a home. Topics will include how people are housed, our housing heritage, housing values and their influence on behavior, types of housing available in the community, styles of architecture, buying vs. renting, and the factors to consider when landscaping and maintaining a home.

AREA	ACCR. NO. FLA-DADE	COURSE TITLE AND DESCRIPTION
HOME AND FAMILY ED.	6764.03	† DECORATING YOUR FIRST HOME  Emphasizes the decisions young people make when selecting furnishings and decorating their first home. Experience in using art principles when selecting and arranging furniture; treating backgrounds such as window, wall, and floor areas; and selecting the accessories will be included.
HOME AND FAMILY ED.	6764.04	CONSTRUCTION PLANNING
INDUSTRIAL ARTS	5857.04	Focuses on the methods of planning for a project. The student will go through the steps which are the responsibility of the owner, architect, and city planners when planning a house or a complete city. Involves financing and contracting, planning the living space, preparing the drawings, building a complete scale model of the designed house with landscaping, the developing of a city and regional planning chart covering a fifty-year period.
HOME AND FAMILY ED.	6764.05	ARCHITECTURAL PLANNING
INDUSTRIAL ARTS	5807.01	Includes the design and drawing of a floor plan, foundation and necessary wall sections of a single family residence. The logical relationship of the arrangement of living areas will be emphasized. Exterior designs will be studied in relationship to the natural surroundings and community. Material used in construction will be studied.
HOME AND FAMILY ED.	6764.06	ARCHITECTURAL APPRECIATION DESIGN
INDUSTRIAL ARTS	5807.04	A study of the history and development of architecture through the cultures of the world, utilization of space to meet family needs; design of single family residences, new building techniques, and local building codes.
HOME AND FAMILY ED.	6767.01	RENOVATING HOME FURNISHINGS  Affords practical experience in selecting materials and reupholstering furniture. Transfer of learnings to job opportunities will be discussed. Wood Finishing (Industrial Arts 5874.04) is a recommended extension of this course.

AREA	ACCR. NO. FLA-DADE	COURSE TITLE AND DESCRIPTION
HOME AND FAMILY ED.	6767.02	HOME FASHIONS  Application of interior design principles through the construction of various home accessories such as curtains, pillows, draperies, slipcovers, lamp shades. The selection and use of textiles and other materials will be included. The occupational application of these experiences will be discussed.
HOME AND FAMILY ED.	6767.03	INTERIOR DESIGN PROJECTS  Designed for the student with vocational aspirations in the field of interior design. It provides the student with an opportunity to apply previous learnings in this field and the related arts when designing special interest projects.
HOME AND FAMILY ED.	6767.04	CAREERS IN HOME FURNISHINGS AND EQUIPMENT
	6767.05	CAREERS IN HOME FURNISHINGS AND EQUIPMENT II
	6767.06	CAREERS IN HOME FURNISHINGS AND EQUIPMENT III
	6767.07	CAREERS IN HOME FURNISHINGS AND EQUIPMENT IV  Occupational preparation for gainful employment in home furnishings services. Topics will include characteristics and care of textiles, visual design, home decoration, drapery and slipcover making, merchandising of home furnishings and equipment. Specific course descriptions for each of the consecutive quins are in the process of development.
HOME AND FAMILY ED.	6793.01	COOPERATIVE HOME FURNISHINGS, EQUIPMENT AND SERVICES I (3 hours)
	6793.02	COOPERATIVE HOME FURNISHINGS, EQUIPMENT AND SERVICES II (3 hours)
	6793.03	COOPERATIVE HOME FURNISHINGS, EQUIPMENT AND SERVICES III (3 hours)
	6793.04	COOPERATIVE HOME FURNISHINGS, EQUIPMENT AND SERVICES IV (3 hours)  Basic instruction will be combined with supervised on-the-job experience in areas of home furnishings, such as drapery and slipcover making, upholstery, interior decorating, merchandising, and demonstration of home furnishings and equipment. Specific course descriptions for each of the four consecutive quins are in the process of development.

AREA	ACCR. NO: FLA-DADE	COURSE TITLE AND DESCRIPTION
HOME AND FAMILY ED.	6766.01	† HANDY HOBBIES IN TEXTILES  Students will explore a variety of textile hobbies, such as knitting, crocheting, embroidery, needlepoint, patchwork, quilting, and macrame. They will create practical and decorative articles for personal and home use, gifts, or possible money-making projects.
HOME AND FAMILY ED.	6766.02	† NOVICE KNOWLEDGE IN SEWING  The student who is interested in exploring the area of sewing at a young age will be given the opportunity to construct a simple project such as a cape, poncho, tie, scarf, chef's apron, or beach bag. Students will learn the basic techniques of pattern usage and clothing construction, but emphasis will be on the advantages of sewing and the satisfactions to be gained through clothing construction.
HOME AND FAMILY ED.	6766.07	† FASHION DOLLAR WHY'S (or FASHION WHY'S)  In order to get the most from their clothing dollars, students will examine credit buying, interpret fads vs. fashions, judge labels, and compare home-constructed garments to ready-made clothing. Experiences in recognizing suitable clothing for school, the world of work, and special occasions will be provided. They will apply their knowledge by planning and evaluating their personal wardrobe.
HOME AND FAMILY ED.	6766.03	† SEW-SO-EASY  Constructing a simple garment such as a jumper, skirt, or polo shirt will give the student experience in pattern selection and adjustment; selection and preparation of fabrics; and the basic techniques used in pressing, staystitching, interfacings, facings, darts, zippers, seams, and hems.
HOME AND FAMILY ED.	6766.04	† SEW-SO-WELL  The intermediate student will construct a garment which has a collar and set-in sleeves. Opportunities will be provided in the selection of fabric and pattern styles becoming to the individual.

AREA	ACCR. NO. FLA-DADE	COURSE TITLE AND DESCRIPTION
HOME AND FAMILY ED.	6766.05	† SEW-SO-SMART  The advanced sewing student will construct a coat or suit, using a simple pattern and woolen fabric. Techniques and skills in tailoring to include tailored buttonholes, linings, and underlinings will be emphasized.
HOME AND FAMILY ED.	6766.06	† SEW-SO-NEW  An update in the newest trends and techniques for individualized sewing. Students will demonstrate ability to construct various seam types and finishes, use machine attachments, apply various types of closures, and use decorative machine stitches for trimmings or monograms. The latest techniques for sewing on today's fabrics, such as knits, vinyls, and jerseys, will be demonstrated. The techniques demonstrated will be practiced through the construction of fabric samples and/or garments. This is an advanced course and may be taken before or after Sew-So-Smart.
HOME AND FAMILY ED.	6766.09	FUN WITH FABRICS (or FASCINATING FABRICS)  Includes experimentation in various methods of fabric design and construction, such as weaving, knitting, tie-dyeing, and batik. The student will identify and classify textiles and their characteristics in order to make wiser decisions when purchasing and caring for the many fabrics available on today's market. Career opportunities in the textile and clothing industry will be explored.
HOME AND FAMILY ED.	6766.10	CREATIVE FASHIONS I  After defining the art elements and design principles and using them to create original designs, the student will demonstrate ability to select clothing which is suitable for each figure type. The occupational field of fashion design and its history will be explored.
HOME AND FAMILY ED.	6766.11 6766.15	CREATIVE FASHIONS II CREATIVE FASHIONS III  The student will alter a basic commercial pattern to fit his or her individual measurements. The basic pattern will be used as a sloper to create an original design. Experience in designing necklines, armholes, and sleeves will be provided. These are advanced courses and may be taken for two consecutive quinesters after Creative Fashions I.

AREA	ACCR. NO. FLA-DADE	COURSE TITLE AND DESCRIPTION
HOME AND FAMILY ED.	6766.12	INDEPENDENT STUDY IN TEXTILES AND CLOTHING Opportunity is provided for the advanced student to do a special project in fashion design, clothing construction, or textile research. The objectives and project requirements are established by the teacher and student prior to enrollment.
HOME AND FAMILY ED. ART	6766.13 6683.19 6681.18 6682.18	† CREATIVE TEXTILE DESIGN I Exploratory experiences through creative expression in textile design. The student will develop imaginative designs through studio textile techniques; studio knowhow is taught and application of textile design is made by using weaving processes and stitchery techniques, hooking, and tufting.
HOME AND FAMILY ED. ART	6766.14 6683.20 6681.19 6682.19	CREATIVE TEXTILE DESIGN II Exploratory application of design, color, and texture through printed/dyed textile design. The student gives creative expression to designs for wearing apparel, fabrics, decorative fabrics, and wallpapers for the home. Silk screen techniques, dyeing, and resist processes (batik) are explored and suitable projects are completed. Previous mastery of skills described in Creative Textile Design I is recommended.
HOME AND FAMILY ED. ART LANGUAGE ARTS	6766.15 6697.01 5114.90 5115.90 5116.90 5184.12	COSTUME DESIGN A course planned to provide experiences in the design and the development of costumes for a dramatic production. The student will design and create costumes for use in dramatic productions. A multicurricular course planned in cooperation with Drama and Art.
HOME AND FAMILY ED.	6756.01	SEWING PROFESSIONALLY Provides opportunity for the student to develop skills necessary in altering ready-to-wear garments. Manufacturer's construction techniques, alterations and special sewing problems, pressing, working procedures, and employer-employee relationships will be studied to help the student develop salable skills.

HOME AND FAMILY EDUCATION  
200



AREA	ACCR. NO. FLA-DADE	COURSE TITLE AND DESCRIPTION
HOME AND FAMILY ED.	6756.02	FASHION MERCHANDISING  Areas of study will include career opportunities in merchandising and sales, socio-psychological effects of clothing, history of costume, famous designers, fibers and fabrics, grooming and wardrobe planning. Principles of merchandising, including advertising, receiving, sales, and product display, will be emphasized.
HOME AND FAMILY ED.	6756.03 6756.04 6756.05 6756.06	CAREERS IN CLOTHING SERVICES I CAREERS IN CLOTHING SERVICES II CAREERS IN CLOTHING SERVICES III CAREERS IN CLOTHING SERVICES IV  Provides students with basic knowledge, skills, and attitudes needed for entry level employment in a variety of clothing services. Opportunities will be provided for the development of skills in such areas as alterations, dressmaking, industrial sewing, clothing and textile merchandising, and clothing maintenance. Specific course descriptions for each consecutive quin are in the process of development.
HOME AND FAMILY ED.	6786.01 6786.02 6786.03 6786.04	COOPERATIVE CLOTHING SERVICES I (3 hours) COOPERATIVE CLOTHING SERVICES II (3 hours) COOPERATIVE CLOTHING SERVICES III (3 hours) COOPERATIVE CLOTHING SERVICES IV (3 hours)  Basic instruction will be combined with supervised on-the-job experience in areas of clothing management, production and services such as alterations, dressmaking, industrial sewing, clothing and textile merchandising, and clothing maintenance. Specific course descriptions for each of the four consecutive quins are in the process of development.
HOME AND FAMILY ED.	6768.01	† BEGINNING TO COOK  Opportunities for student to demonstrate his or her ability to perform basic skills in food preparation through a knowledge of vocabulary, measurements, kitchen equipment and appliances, and practical preparation techniques.
HOME AND FAMILY ED.	6768.12	† GOURMET CHEFS (or BACHELOR CHEFS)  Young men will perform basic skills in food preparation and service to include simple breakfasts, lunches, easy-to-prepare dinners, snacks, and party refreshments.

HOME AND FAMILY EDUCATION

201

AREA	ACCR. NO. FLA-DADE	COURSE TITLE AND DESCRIPTION
HOME AND FAMILY ED.	6768.02	† MENU MAGIC  Experiences will be offered in preparation and serving food, taking into consideration the nutritional needs of the teen-ager and his family. A knowledge of the Basic Four food groups will be applied to the planning and preparation of meals.
HOME AND FAMILY ED.	6768.03	† CREATIVE BAKING  The student will demonstrate his or her baking skills by preparing cakes, pies, pastries, and breads. An emphasis will be placed on creativity in decorating and designing attractive baked goods.
HOME AND FAMILY ED.	6768.04	CREATIVE COOKING  The application of imagination to developed food preparation skills is the theme of this course. The student will create a variety of interesting and attractively served dishes to include meats, casseroles, salads, fruits, vegetables, party foods, and desserts. Skill in preparing food properly to retain maximum quality, development of one's own recipes, and serving food attractively will be emphasized.
HOME AND FAMILY ED.	6768.08	† ENTERTAINING WITH A FLAIR  Students will develop the skills necessary to be successful hosts, hostesses, and guests. They will gain experience in planning and serving food for informal and formal occasions. Topics will include types of table service and appointments, etiquette, party management, and hospitality.
HOME AND FAMILY ED.	6768.09	† FOOD WITH A FOREIGN FLAVOR  Through a study of food customs and the preparation of dishes typical of many countries around the world, the student will be taking a cook's tour of other lands. This course will emphasize the pleasure in the discovery of new ideas, customs, people, and foods.

AREA	ACCR. NO. FLA-DADE	COURSE TITLE AND DESCRIPTION
HOME AND FAMILY ED.	6768.10	† OUTDOOR COOKERY  Experiences provided in the informal preparation of food outside the kitchen. Topics include barbequeing, camping, picnics, and outdoor parties.
HOME AND FAMILY ED.	6768.05	COOKING FOR TWO  Centers around preparation and serving of nutritious meals planned for two people. Experiences will include a review of concepts of basic nutrition, meal planning, food purchasing and preparation, as well as the use of convenience foods and the planning and organization of a basic kitchen.
HOME AND FAMILY ED.	6768.06	MENUS FOR YOUNG MODERNS  Opportunities for advanced student to plan, prepare, and serve meals which meet the nutritional needs of individual family members within various income levels. Experiences will include preparation of foods associated with various family backgrounds, a study of nutrients and how they can be preserved in foods, and the use of convenience foods.
HOME AND FAMILY ED.	6768.07	FOOD SENSE AND DOLLARS  A study of how the food dollar can be wisely spent by the consumer. Areas include food purchasing on various income levels; getting the most for the dollar, taking into consideration the number of family members; comparing convenience foods and foods made with raw products; becoming skillful at selecting foods; evaluating various types of food advertisements; and protection available to the consumer through laws and agencies.
HOME AND FAMILY ED.	6768.11	FASHIONS IN FOOD  An investigation of the latest developments in food in modern society for the student interested in the relationship of food to health, to science, and to the world around him. Explorations will be in such areas as space food, modern technology, ecology, nutrition, foods in the kitchens of the future, and what is happening in the food industry today.

AREA	ACCR. NO. FLA-DADE	COURSE TITLE AND DESCRIPTION
HOME AND FAMILY ED.	6768.13	INDEPENDENT STUDY IN FOOD AND NUTRITION  Explorations of student special interests in the world of food. Topics include experimental cookery, special dietary problems, occupations in food science and technology, consumer skills, and quantity food preparation.
HOME AND FAMILY ED.	6773.01	AWAKEN TO THE WORLD OF FOOD SERVICE
TRADE AND IND. ED.	9193.01	This course provides an exploratory experience in the field of commercial food service, the hotel and restaurant industry, and types of food service establishments. Food distribution and service are studied. The student will be able to answer the following: What is food? What industries are related to food service? What are the types and characteristics of food service units? This is a one- or two-quinmester credit course.
HOME AND FAMILY ED.	6773.02	NUTRITIOUS MEAL PLANNING
TRADE AND IND. ED.	9193.02	This course includes an introduction to the science and practice of nutrition in commercial food service establishments. Selecting, planning, preparing, and serving of foods which meet nutritional standards in institutional feeding are covered. This is a one or two quinmester credit course.
HOME AND FAMILY ED.	6773.03	COOKING CAN BE PROFITABLE
TRADE AND IND. ED.	9193.03	(Basic Cooking Procedures)  This course provides the opportunity for students to demonstrate their ability to perform basic skills in food planning preparation through knowledge of the use of basic equipment and tools, weights and measures, recipe interpretation, temperatures, and food cost and accounting. This is a one or two quinmester credit course.
HOME AND FAMILY ED.	6773.04	A CHEF IS MANY THINGS
TRADE AND IND. ED.	9193.04	This course enables the student to explore the career opportunities, responsibilities, and duties of food service personnel; and to prepare and serve foods, using industrial techniques. This is a one or two quinmester credit course.

HOME AND FAMILY EDUCATION  
204

AREA	ACCR. NO. FLA-DADE	COURSE TITLE AND DESCRIPTION
HOME AND FAMILY ED. TRADE AND IND. ED.	6773.05 9193.05	PARTY FOODS  This course includes planning, preparing, and serving foods for festive occasions (formal and informal); table setting and service; host-hostess skills; hospitality; catering and management techniques. This is a one or two quinmester credit course.
HOME AND FAMILY ED.	6773.06	HOME CATERING  Focuses on the use of equipment and appliances in the home to prepare food for catering as a business.
HOME AND FAMILY ED.	6789.01 6789.02 6789.03 6789.04	COOPERATIVE FOOD SERVICES I (3 hours) COOPERATIVE FOOD SERVICES II (3 hours) COOPERATIVE FOOD SERVICES III (3 hours) COOPERATIVE FOOD SERVICES IV (3 hours)  Basic instruction will be combined with supervised on-the-job experience in areas related to food management, production, and services. Specific course descriptions for each of the four consecutive quins are in the process of development.
HOME AND FAMILY ED.	6773.07	THE PARTY CORPS  This course is designed to train students for hourly employment as host and hostess helpers for social events. Students will learn the art of serving at a variety of social functions, preparing simple party foods and performing other tasks to be of assistance to persons who need help for special events but do not have regular employees or do not wish to hire professional caterers.

## HUMANITIES

The humanities represent an approach rather than a discipline. A group of quinmester courses are listed here in a humanities section. Chosen from various disciplines, the courses are included in the scope of humanities because their objectives appear to be particularly appropriate for application of a humanities approach. Any quinmester course in the humanities section may be used to attain one-quarter credit in the fulfillment of the humanities elective. Specific humanities code numbers have not been assigned to these courses; neither have they been cross-referenced within the other subject areas in which they may be found. For the purpose of recording credit in humanities, one or more of the following six designated code numbers should be used:

7186	HUMAN 1	Humanities 1
7187	HUMAN 2	Humanities 2
7188	HUMAN 3	Humanities 3
7189	HUMAN 4	Humanities 4
7181	HUMAN 7	Humanities 7
7182	HUMAN 8	Humanities 8

## QUINMESTER COURSES

Aesthetics and Twentieth Century Environment 1	209
Aesthetics and Twentieth Century Environment Seminar 2, 3, 4	209
American Biographies	209
American Black Art	209
American Culture	209
American Musical Theatre, The	210
Art and the Contemporary Scene	210
Art and the Press	210
Classical Civilization	210
Comparative World Religions	210
Contemporary Design	211
Community Influences on Art	211
Creative Ceramic Arts	211
Dawn: The Birth of Selected Civilizations	211
Design—Where It Starts	211
Directed Listening to Music	212
European Renaissance and Reformation	212
Expansion of Consciousness	212
Express Yourself	212
Exploring the Languages of Films	212

Giants in Art	213
Good Man, Good Life, and Good Society, The	213
Greek and Roman Mythology	213
Humanities	213
Ideas of Western Man: Classicism and Romanticism	213
Ideas of Western Man: Expressionism and Realism	214
Independent Study in Music Listening	214
Introduction to Eastern Philosophy	214
Introduction to Humanities	214
Introduction to Music Listening, An	214
Introduction to Philosophy	214
Language and Behavior	215
Man and His Environment: To Perceive and to React	215
Man and Nature	215
Man's Search	215
Media, Minds, and Masses	215
Modern Rock Poetry	216
Music Appreciation	216
Music History	216
Music Listening—Atonal	216
Music Listening—Baroque	216
Music Listening—Classic	216
Music Listening—Electronic	216
Music Listening—Ethnic	217
Music Listening—Jazz	217
Music Listening Laboratories	217
Music Listening—Renaissance	217
Music Listening—Romantic	217
Nature and Life on Paper	217
Novel of Initiation, The	218
Point of View	218
Project Change	218
Production and Display Workshop	218
Puritan Ethic, The	218
Quest for Utopia, The	219
Religion through the Ages in Literature	219
Revolutionary Black Theatre, The	219
South of the Border	219
Women in Literature	219
World History through Art and Music	220
Values	220

AREA	ACCR. NO. FLA-DADE	COURSE TITLE AND DESCRIPTION
ART	6671.17 6672.32 6673.13 6674.08 6677.27	AESTHETICS AND TWENTIETH CENTURY ENVIRONMENT 1  The student explores, expresses, and identifies environmental phenomena that characterize man's fight for survival with nature. Students work in groups and/or on an independent basis, using all art department and school facilities which fit a plan developed between student and instructor. Activities include research, debates; writing, painting, sculpting, drawing, dramatizing; any art form.
ART	6674.05 6675.06 6677.28	AESTHETICS AND TWENTIETH CENTURY ENVIRONMENT SEMINAR 2, 3, 4  A laboratory course to help students develop an awareness of physical and aesthetical phenomena regarding the condition of man-made and natural environments. Students work on an independent basis, using all art department, school, and community facilities which fit a plan developed between student and instructor. Students prepare a research thesis, critique, and other visual preparation necessary to complete projects.
LANGUAGE ARTS	5111.28 5112.34 5113.135	† AMERICAN BIOGRAPHIES  A study of selected Americans and their times. Aims include the understanding of the frame of reference of an individual in the context of his time, and how individuals can affect history.
SOCIAL STUDIES	6412.08 6411.08 6416.08	
ART	6677.02 6671.06 6672.06 6683.03 6681.04 6682.04	AMERICAN BLACK ART  A survey of black artists in America, their contribution to the American art scene, and the impact of the new black movements on trends in American art. Selected activities in this quin include murals, wood carving, and Afro trends in clothing and textiles.
LANGUAGE ARTS	5114.139 5115.154 5116.157	† AMERICAN CULTURE  A problem-centered analysis in depth of contemporary America. Utilizes an interdisciplinary approach, focusing on an analysis of art, literature, music, and philosophy to better understand contemporary culture.
SOCIAL STUDIES	6426.01 6416.34 6448.40	



AREA	ACCR. NO. FLA-DADE	COURSE TITLE AND DESCRIPTION
LANGUAGE ARTS	5114.97 5115.103 5116.103 5185.03	THE AMERICAN MUSICAL THEATRE  A study in depth of the musical art form from inception to the "now" scene. An analysis of music of America from burlesque to the present. The course places emphasis on the American musical contribution, including off-Broadway and the film industry.
ART	6677.11 6673.12 6671.14 6672.19	ART AND THE CONTEMPORARY SCENE  A discussion and studio-oriented course designed to introduce the student to art as it is related to our contemporary society. Areas to be explored include hippie culture, drug culture, the theatre, lighting modulation, film art, etc. Studio art projects.
ART LANGUAGE ARTS	6677.12 6693.08 5113.129 5114.220 5115.144 5116.147 5163.07	ART AND THE PRESS  An exploratory course in art as it applies to the press. Students will explore modern trends such as social protests, social commentary, etc., through field trips to the news media, guest speakers, local art critiques, student projects, political and amusement cartoons, translation of events into pictures and symbols, art production for the news media.
LANGUAGE ARTS  SOCIAL STUDIES	5114.67 5115.67 5116.67 5188.04 5148.05 6414.18 6448.57	† CLASSICAL CIVILIZATION  Includes the study of Greek mythology, philosophy, and drama, and an analysis of their effect on modern man and his ideas.
LANGUAGE ARTS SOCIAL STUDIES	5111.29 5112.35 5113.136 6478.08 6414.06 6470.36	† COMPARATIVE WORLD RELIGIONS  A study of selected world religions, focusing on religion as an institution in society. Includes effects of religion on people, governments, and international relations.

HUMANITIES  
210

AREA	ACCR. NO. FLA-DADE	COURSE TITLE AND DESCRIPTION
ART	6693.16 6674.03 6671.16 6672.22	CONTEMPORARY DESIGN  Design as related to contemporary op art, experimental design, basic cinematography (visual expression through silent motion picture skills and lights). Student will experiment with illusionary color, and compare psychological and illusionary effects of color to see how one color affects another.
ART	6677.10 6673.11 6671.13 6672.18	COMMUNITY INFLUENCES ON ART  A survey course providing exploratory experiences that develop student awareness of community influences as related to art and the artist. Comparison of factors relating to cultural and subcultural influences, environmental forces, and personal styles of the artist. Studio art projects.
ART	6681.13 6682.13 6687.02	† CREATIVE CERAMIC ARTS  An exploratory course providing experience in the forming, decorating, glazing, and firing of pottery. Various methods such as pinch, coil, slab, and drape are presented. Students are encouraged to explore individual interest areas and develop sensitivity to the raw material, feeling for form, and concern for practicality or function.
SOCIAL STUDIES	6478.01 6414.01 6445.01 6470.27	† DAWN: THE BIRTH OF SELECTED CIVILIZATIONS  Centering on the questions How did it all begin? and What is civilization? the students investigate selected past civilizations to discover how the people met and solved their problems. Components include (1) an examination of similarities and differences among the civilizations, (2) the role of cultural diffusion vs. isolation, (3) relation of the people to their environment, (4) comparison of their life style with present-day society.
ART	6671.18 6672.33 6673.14	† DESIGN—WHERE IT STARTS  An exploratory sampling of art media, techniques and skills for two/three-dimensional design and composition. Activities include sensitivity and skill practice in basic design principles; awareness of visual organization and spatial relationships of design; study of designs using line, form, space, texture, and color; appreciation for the creative processes and works of others.

AREA	ACCR. NO. FLA-DADE	COURSE TITLE AND DESCRIPTION
MUSIC	5634.59 5635.69	DIRECTED LISTENING TO MUSIC  Designed with emphasis on developing listening skill through study of music literature.
SOCIAL STUDIES	6414.12 6448.42	EUROPEAN RENAISSANCE AND REFORMATION  A survey course highlighting the changes manifested in Europe during the fourteenth-seventeenth centuries. The unifying concept is social change. Includes the influence of these periods on Western society.
LANGUAGE ARTS	5111.10 5112.10 5113.10 5114.10 5115.10 5116.10	† EXPANSION OF CONSCIOUSNESS  A course capitalizing on individual and group experiences and encouraging students to expand their powers of observation and discernment. Students analyze their thoughts and translate them into written responses.
ART	6673.01 6671.04 6672.04 6674.07	EXPRESS YOURSELF  Provides an opportunity for students to learn that art is one of the most important means of self-expression, that each artist expresses himself in his own unique way, and that each individual way is valid. Students select one subject area (e.g., landscape, still life, human forms, room interiors) and compare the handling of the subject matter by several artists (i.e., Van Gogh, Modigliani, Chagall, Roualt, Picasso, etc.). Activities include creating a two- or three-dimensional piece of work on the same subject.
LANGUAGE ARTS	5114.65 5115.65 5116.65	† EXPLORING THE LANGUAGES OF FILMS  A study of the techniques of motion pictures and their historical development. An analysis of the "language of pictures" (use of distance shots, angle shots, color, lighting, arrangement), the "language of motion" (camera movement, subject movement), and the "language of sound" (dialogue, narration, music, silence); an introduction to the optical and mechanical principles of motion picture operation; the advent of motion pictures, the silent era, the talkies, wide-screen processes, and the modern-day films. Short films, documentaries, and feature length films are viewed and analyzed.

HUMANITIES  
212

AREA	ACCR. NO. FLA-DADE	COURSE TITLE AND DESCRIPTION
ART	6677.08 6671.12 6672.16	† GIANTS IN ART An introductory survey of art concepts from the beginning of recorded time to the present. The student investigates ideas of past civilizations and their relationship to our contemporary society.
SOCIAL STUDIES	6478.17 6414.22	
LANGUAGE ARTS	5114.142 5115.157 5116.160	THE GOOD MAN, GOOD LIFE, AND GOOD SOCIETY Through comparative analysis of several societies, both past and present, student will be introduced to differing views about what constitutes the good life. A humanities approach is designed to help the student develop his own personal philosophy.
SOCIAL STUDIES	6448.17 6414.17 6499.02 6416.29	
LANGUAGE ARTS	5111.21 5112.26 5113.42 5114.43 5115.43 5116.43 5188.03	† GREEK AND ROMAN MYTHOLOGY A study of selected myths of Greece and Rome to help students understand mythological references in literature, art, music, science, and technology.
LANGUAGE ARTS	5114.53 5115.53 5116.53	HUMANITIES An introduction to the stylistic character and cultural climate of the important art epochs of Western civilization. Specifically it has three basic aims: (1) to develop a breadth of understanding and appreciation of the cultural pattern of the Western world, (2) to develop insight into actual works of music and art, (3) to develop a technique of general critical analysis by which the student can arrive at his own evaluation and judgment of works of art. Introducing the student to various kinds and periods of art may encourage him to seek more of the aesthetic experiences awaiting his participation.
LANGUAGE ARTS	5114.78 5115.78 5116.78	† IDEAS OF WESTERN MAN: CLASSICISM AND ROMANTICISM An analysis of some predominant schools of man's changing thought through the study of literature. A consideration of Classicism and Romanticism as they have affected contemporary American culture, the course focuses on philosophy and uses painting, sculpture, and music to illustrate each school of thought.

HUMANITIES  
213

AREA	ACCR. NO. FLA-DADE	COURSE TITLE AND DESCRIPTION
LANGUAGE ARTS	5114.781 5115.781 5116.781	† IDEAS OF WESTERN MAN: EXPRESSIONISM AND REALISM  An analysis of some predominant schools of man's changing thought through the study of literature. A consideration of Expressionism and Realism as they have affected contemporary American culture, the course focuses on philosophy and uses painting, sculpture, and music to illustrate each school of thought.
MUSIC	5635.591	INDEPENDENT STUDY IN MUSIC LISTENING  A continuation of listening experience with emphasis on a more in-depth study of music literature.
SOCIAL STUDIES	6414.23 6448.69	INTRODUCTION TO EASTERN PHILOSOPHY  A brief introduction to the ways of believing which have shaped Eastern thinking for thousands of years. Some systems of philosophy that will be studied are Hinduism, Buddhism, Confucianism, Taoism, Shinto.
MUSIC	5635.29 5635.39 5635.49 5635.59	† INTRODUCTION TO HUMANITIES  An exploratory course studying the interrelationships of the performing arts, the graphic arts, and the societies which produced them.
MUSIC	5634.19	AN INTRODUCTION TO MUSIC LISTENING  An introduction to music listening, exploring a variety of styles and periods and developing basic listening skills.
LANGUAGE ARTS  SOCIAL STUDIES	5114.75 5115.75 5116.75 6414.16 6499.01 6448.23 6416.28	INTRODUCTION TO PHILOSOPHY  This introduction to philosophy explores the great ideas of man throughout the ages and their influence on society in the realms of art, literature, economics, and government. The course involves extensive reading and individual study.

AREA	ACCR. NO. FLA-DADE	COURSE TITLE AND DESCRIPTION
LANGUAGE ARTS	5114.35 5115.35 5116.35 5187.07	LANGUAGE AND BEHAVIOR  An approach to language study dealing with the psychology, the process of abstraction, and the levels of meaning of language. Works to explore include Hall: <i>The Silent Language</i> ; McLuhan: <i>Understanding Media</i> ; and selections by Postman, Pei, Hayakawa, and others.
LANGUAGE ARTS	5111.13 5112.13 5113.13 5114.13 5115.13 5116.13	† MAN AND HIS ENVIRONMENT: TO PERCEIVE AND TO REACT  An investigation and appraisal of prose, poetry, and music which reflects the environment's effect on man or man's effect on his environment.
ART	6677.01 6673.02 6671.05 6672.05	MAN AND NATURE  A survey of the way nature affects the art of man, stressing his ever-present struggle for survival. Space exploration, undersea exploration, birds and animals, and plant life form the bases for study. Projects include drawing and painting from nature, both indoors and out, and using natural materials in collages, mosaics, assemblages, and sculpture.
LANGUAGE ARTS	5112.22 5113.22 5114.22 5115.22 5116.22 5188.02	† MAN'S SEARCH  An exploration of man's eternal search to understand himself and his world through the study of the mythology of the world.
LANGUAGE ARTS  SOCIAL STUDIES	5114.66 5115.66 5116.66 6416.21 6457.05 6443.06 6427.04 6448.26	† MEDIA, MINDS, AND MASSES  An examination of mass communication and its effect on American life. Emphasis on the types and techniques of propaganda, opinion polls, candidates, government and the media, freedom and responsibility of the press, effects of T V and radio on American values and life styles.

HUMANITIES  
215

200

AREA	ACCR. NO. FLA-DADE	COURSE TITLE AND DESCRIPTION
LANGUAGE ARTS	5113.40 5114.41 5115.41 5116.41	† MODERN ROCK POETRY  The opportunity to listen to selected lyrics of modern rock music and substantiate them as poetical. Excerpts from traditional poems will be used for comparison.
MUSIC	5634.39 5634.49	MUSIC APPRECIATION  A survey of music literature with emphasis on developing understandings and skills essential for intelligent listening to music.
MUSIC	5635.592 5635.692	MUSIC HISTORY  A continuation of the study of music literature with emphasis on developing understanding and skills essential for intelligent listening to music.
MUSIC	5635.891	MUSIC LISTENING-ATONAL  A survey of music of the Atonalists, c. 1900-present. The pupils conduct historical research, perform and listen to live and recorded performances, with emphasis on stylistic characteristics.
MUSIC	5635.792	MUSIC LISTENING-BAROQUE  A survey of music of the Baroque, c. 1600-1770. The pupil conducts historical research, performs and listens to live and recorded performances, with emphasis on stylistic characteristics.
MUSIC	5635.793	MUSIC LISTENING-CLASSIC  A survey of music of the Classic period, c. 1770-1825. The pupils conduct historical research, perform and listen to live and recorded performances, with emphasis on stylistic characteristics.
MUSIC	5635.892	MUSIC LISTENING-ELECTRONIC  A survey of music produced by electronic means, c. 1945-present. The pupils conduct historical research, perform and listen to live and recorded performances, with emphasis on stylistic characteristics.

HUMANITIES  
216

210

AREA	ACCR. NO. FLA-DADE	COURSE TITLE AND DESCRIPTION
MUSIC	5635.894	MUSIC LISTENING-ETHNIC  A survey of music from various ethnic backgrounds. The pupils conduct historical research, perform and listen to live and recorded performances, with emphasis on stylistic characteristics.
MUSIC	5635.893	MUSIC LISTENING-JAZZ  A survey of music in jazz idiom c. 1875-present. The pupils conduct historical research, perform and listen to live and recorded performances, with emphasis on stylistic characteristics.
MUSIC	5631.304 5632.304 5633.304 5634.304	MUSIC LISTENING LABORATORIES  Exploring a variety of styles and periods and developing basic listening skills.
MUSIC	5635.791	MUSIC LISTENING-RENAISSANCE  A survey of music prior to 1600. The students conduct historical research, perform and listen to live and recorded performances, with emphasis on stylistic characteristics.
MUSIC	5635.794	MUSIC LISTENING-ROMANTIC  A survey of music of the Romantic period, c. 1825-1900. The pupils conduct historical research, perform and listen to live and recorded performances, with emphasis on stylistic characteristics.
ART	6673.09 6681.12 6682.12	† NATURE AND LIFE ON PAPER  An exploratory course offering students opportunities to react kinesthetically to surroundings and to art materials; and to express their feelings visually in charcoal, pencil, conte, ink, crayons, pastels.



AREA	ACCR. NO. FLA-DADE	COURSE TITLE AND DESCRIPTION
LANGUAGE ARTS	5114.309 5115.309 5116.309	<p>THE NOVEL OF INITIATION</p> <p>This course will investigate novels which have as their principal purpose the initiation of their main characters into some basic mysteries of life: love, nature, war, religion, work, culture, politics, or travel. Such novels as <i>The Adventures of Huckleberry Finn</i>, <i>The Ordeal of Richard Feverell</i>, and <i>Candide</i> will be examined in order to give the student a clear idea of the importance of this type of novel in literature.</p>
LANGUAGE ARTS	5114.62 5115.62 5116.62 5167.03	<p>POINT OF VIEW</p> <p>A course designed to help students develop an understanding of point of view and to increase sensitivity to different points of view in their own writing, as well as in the writing of others.</p>
ART	6677.13 6674.02 6675.02 6676.02	<p>PROJECT CHANGE</p> <p>An Education by Agreement course. After a brief orientation period, each student will agree through an individualized contract scheme to improve the visual appearance of his home, his school, or some part of his community.</p> <p>Education by Agreement is an arrangement between a student and the school; it is described in Appendix B.</p>
ART	6699.01	<p>PRODUCTION AND DISPLAY WORKSHOP</p> <p>Credit is given for performing artistic service to the school and the community. The art teacher will give assistance, evaluate the product, and determine the amount of credit that the service warrants. (Suitable guidelines will be written for credit granting policy.)</p>
LANGUAGE ARTS	5114.61 5115.61 5116.61	<p>THE PURITAN ETHIC</p> <p>An examination through various genre of the lasting effects of the Puritan tradition on the life and literature of the American people.</p>

HUMANITIES  
218

AREA	ACCR. NO. FLA-DADE	COURSE TITLE AND DESCRIPTION
LANGUAGE ARTS	5114.71 5115.71 5116.71	† THE QUEST FOR UTOPIA  This course is designed to introduce the student to significant literature that illustrates the gulf between the vision of a perfect society and the realities of human nature. Works might include <i>Brave New World</i> by Huxley, <i>Notes from the Underground</i> by Dostoevski, and <i>Pincher Martin</i> by Golding.
SOCIAL STUDIES	6448.65 6414.20	
LANGUAGE ARTS	5114.81 5115.81 5116.81 5148.08	RELIGION THROUGH THE AGES IN LITERATURE  A course designed to reveal religious influences from different periods in literature. Selections include excerpts from Chaucer, portions of the Bible, <i>Idylls of the King</i> , <i>Beowulf</i> , early church plays, <i>Oedipus</i> , and <i>Antigone</i> .
LANGUAGE ARTS	5115.105 5116.105 5185.05	THE REVOLUTIONARY BLACK THEATRE  An in-depth study of plays and playwrights offering relevant themes. Contemporary writers such as Jones, Hansberry, and Baldwin are studied.
ART	6677.04 6671.07 6672.09 6683.05 6681.06 6682.06 6478.16	SOUTH OF THE BORDER  A survey of the major post-Columbian movements and artists of South America and Mexico stressing similarities and differences among geographical areas. Social protest painters, crafts, and mosaic works will be studied. Selected activities include art metal crafts, leather work, ceramics, and mosaics.
SOCIAL STUDIES		
LANGUAGE ARTS	5114.301 5115.301 5116.301 5148.09	WOMEN IN LITERATURE  A course designed to examine the diverse images of woman and the female mystique as represented by selected feminine protagonists in noted literary works: Helen of Troy, Penelope, Andromache, Sarah, Leah, Rachel, Bathsheba, Juliet, Cleopatra, Rosalind, Madame Bovary, Anna Karenina, Ma Joad, St. Joan, Eleanor of Aquitaine. Selected works of nonfiction about contemporary women of achievement may also be included.

HUMANITIES  
219

AREA	ACCR. NO. FLA-DADE	COURSE TITLE AND DESCRIPTION
SOCIAL STUDIES	6414.13	WORLD HISTORY THROUGH ART AND MUSIC  Making use of visual materials, students interested in the arts, but not necessarily music or art students, might pursue this survey of art and music through the ages. Emphasizes ways art and music reflect the society of the artist through his perceptions. The student explores attitudes and values of different periods and places in world history.
LANGUAGE ARTS	5111.17 5112.17 5113.17 5114.17 5115.17 5116.17	VALUES  An examination of literature designed to aid the student in identifying, understanding, and developing a system of values. Short stories, such as "The Man without a Country," and "I Am a Rock," and novels, such as <i>A Separate Peace</i> , are possible selections for exploration.

HUMANITIES  
220

## LANGUAGE ARTS

With the implementation of the quinmester plan, both teachers and students will have greater opportunities than ever before to develop and participate in truly meaningful learning experiences. If the quinmester is really to serve as a catalyst to bring about long needed changes in the approaches to placement of students in language arts courses, then every student should have maximum opportunity to study those particular facets of the language arts curriculum in which he is most interested and in which he is most likely to succeed.

Everyone has responsibility for the success of the plan. Each school has the obligation to offer a sufficient range of language arts courses to provide honest choices for every student. Students should have many opportunities to explore not only courses in literature and rhetoric, but also courses in such areas as film study, reading, the skills, and the performing arts. The chance to teach new and more relevant material will be a distinct advantage for teachers.

Students, as they confer with English teachers and guidance counselors, should be encouraged to evaluate themselves in terms of the general indicators of success and helped to analyze each course description in terms of their interests and talents.

### GENERAL INDICATORS FOR SUCCESS

1. Interest and enthusiasm
2. Inquiring mind
3. Responsibility
4. Persistence and drive
5. Reasoning ability
6. Academic achievement
7. Ability to communicate
8. Ability to work independently

For easy reference, the state code numbers used for the quinmester courses are listed below.

5111	ENGLISH 7	5187	VOCABULARY
5112	ENGLISH 8	5149	CONTEMPORARY LITERATURE
5113	ENGLISH 1	5148	WORLD LITERATURE
5114	ENGLISH 2	5188	MYTHOLOGY
5115	ENGLISH 3		
5116	ENGLISH 4	5196	DEBATE 1
		5197	DEBATE 2
5163	JOURNALISM 1	5198	DEBATE 3
5164	JOURNALISM 2		
5165	JOURNALISM 3	5173	SPEECH 1
5166	JOURNALISM 4	5174	SPEECH 2
5167	WRITING 1	5175	SPEECH 3
5168	WRITING 2		
		5183	DRAMA 1
5128	BUSINESS ENGLISH	5184	DRAMA 2
		5185	DRAMA 3
		5186	DRAMA 4

Every student is required to complete twelve quinmester courses in language arts in grades 7-9. In grades 10-12 each student is required to complete twelve quinmester courses in language arts in order to satisfy graduation requirements. The third unit (four quinmester courses) may be waived by the principal, based on the school's assessment of the student's proficiency in the various language art skills.

## QUINMESTER COURSES

Absurdist Vision, The	242
Acceleration (Reading)	243
Advanced Acting (Drama)	251
Advanced Competitive Forensics (Speech)	259
Advanced Oral Interpretation of Literature	257
Advanced Performance in Argumentation and Debate	260
Advanced Persuasive Speaking (Speech)	258
Adventures in Ecological Reading	242
Advertising and Business Management (Journalism)	263
Age of Milton, The	249
Alienation vs. Involvement	234
American Biographies	265
American Culture	265
American Humorists	250
American Musical Theatre, The (Drama)	254
American Mystics	249
Ancient Literature of the East	247
Approaches to Literary Criticism	235
Arthurian Legend, The	239
Art and the Press	267
Art of Satire, The	236
Basic Acting (Drama)	250
Behind the Curtain (Drama)	251
Bible as Literature, The	241
Black Novelist in America, The	236
Business Grammar in Good Taste	267
Business Speech	257
Cartoon Carnival	266
Cervantes and His Times	270
Children's Theatre	254
Cinematography	266
Civil War in Literature, The	241
Classical Civilization	238
Comedy	243
Commedia dell'Arte and the Actor (Drama)	253
Comparative Biography	246
Comparative Dialects	230
Comparative World Religions	265
Composition	237
Confrontation Debate	260
Costume Design	267
Craft of Poetry, The	242
Creative Journalism	262
Creative Writing: Free Style	247
Creative Writing: Informal Prose	248
Creative Writing: Poetry	248
Creative Writing: Short Stories	248
Critic, The (Drama)	252
Critical Thinking	231

## LANGUAGE ARTS

222

Designing the Set (Drama)	253
Developing the Art of Communication (CBE)	269
Developing Word Power	231
Developing Written Business Communication (CBE)	269
Dickens Family, The	249
Directing the Play	255
Discussion and Conference	233
Discussion and Debate	259
Do You Hear Me? (Listening)	228
Dramatic Interpretation	251
Dressing the Play (Drama—Costuming)	252
Effective Business Letters	268
Effective Business Reports	268
Elizabethan Acting	253
English on the Job	232
Enjoying Short Stories	228
Epic Hero, The	232
Epic Theatre and the Actor (Drama)	253
Evangelists, The	235
Everyday Communication	256
Everyday Reading and Writing	230
Existentialists, The	246
Expansion of Consciousness	228
Exploring the Languages of Films	238
Exploring Literature and Practicing Oral Communication (CBE)	269
Expository Writing	232
Faces for the Actor (Stage Makeup)	250
Facing Life	231
Facing the Test	228
Film as a Documentary	232
French Image, The	249
Fundamentals of Argumentation and Debate	258
Getting to Know Yourself through Acting	251
Glory That Was Greece (History of the Theatre), The	254
Golden Age of Spain, The	270
Good Man, Good Life, and Good Society, The	266
Great Writers of Hispanic America: Part I	271
Great Writers of Hispanic America: Part II	271
Great Writers of Spain: Part I	271
Great Writers of Spain: Part II	271
Greek and Roman Mythology	233
Harlem Renaissance, The	239
Henrik Ibsen—Critic of Society	243
Here's How! (Scenery Construction)	252
How to Make a Speech and Like It	256
How to Study	242
Humanities	235
Ideas of Western Man: Classicism and Romanticism	240
Ideas of Western Man: Expressionism and Realism	240
Illusion vs. Reality	237

Improving Sentence Structure and Variety	233
Individual and the State, The	239
Inductive-Deductive Logic	259
Inside-Outside (Composition)	227
Introduction to Logic	240
Introduction to Nonfiction, An	236
Introduction to the Novel	244
Introduction to Philosophy	240
Introduction to Plays	244
Introduction to Poetry	243
Introduction to Radio and Television	256
Introduction to Shakespeare	233
Irish Literature	247
Journalist and the Public, The	262
Language and Behavior	232
Language of Literature, The	236
Language of Persuasion, The	238
Learning Spot, The (Reading)	243
Legends and Heroes of the American West	246
Literature of Ecology, The	235
Literature of Science, The	240
Living Literature—From the Page to the Stage	255
Living Shakespeare	254
Man and His Environment: To Perceive and to React	229
Man and His Gods	236
Man between War and Peace	265
Man's Inner Struggle	234
Man's Search	230
Many Faces of Love, The	233
Mastering Decoding Skills	230
Masters of Lore, The	230
Media, Minds, and Masses	238
Meet the Photographer	267
Method as a School of Acting	253
Minority Groups in America	244
Modern Drama—A New Age	254
Modern Face of Love, The	234
Modern Rock Poetry	233
Mystery and Horror	244
Nation Divided against Itself, A	265
Nature of Language, The	229
Newspaper Editing	261
Newspaper Makeup	261
Newspaper Production	263
Newspaper Production: Editing	263
Nonfiction: The Newspaper, Periodicals, and Biography	231
Novel, The	236
Novel of Initiation, The	250

LANGUAGE ARTS  
224

Oral Decision Making	258
Oral Interpretation	256
Our Living Language	233
Outer Limits, The	231
Paragraph Building	227
Performance in Argumentation and Debate	259
Persuasive Speaking	257
Photojournalism	262
Pilgrims: Chaucerian and Renaissance	248
Point of View	237
Power of Words, The	234
Preparation for Office Employment	268
Principles of Photography	261
Promoting and Selling the Play (Drama)	255
Propaganda	264
Protest Drama	255
Psychology of Acting	253
Puritan Ethic, The	237
Quest for Utopia, The	239
Rags and Riches in Modern American Literature	245
Readers' Theatre	251
Reading for Meaning	229
Reading the Newspaper	260
Reel Thing, The	266
Reinforcing Knowledge of Grammar (CBE)	269
Relationship of Languages, Part 2, English Grammar for the Foreign Language Student	270
Relationship of Languages, Part 1, History	270
Religion through the Ages in Literature	241
Report Writing	241
Reporting Sports for the Media	261
Reviewing Capitalization and Punctuation, and Developing a Research Paper	269
Revolutionary Black Theatre, The	254
Righting Your Writing	227
Romantic Hero, The	246
Romantic Poets, The	240
Russian Novel, The	245
Seminar in Comedy (Drama)	252
Seminar in Ideas	258
Sentences: Are There Choices?	237
Shakespeare	241
Shakespearean Histories	246
Shakespearean Tragedies	246
Shaping Opinions	260
Shaw's Comedy	245
Short Story as an Art Form, The	234
So You Think You Are a Leader!	256
Sound and Color (Drama)	252
Special Occasion Speeches	258
Spell It Right	268



Stage Design	267
Stage Lighting	267
Stage without Words, The	251
Starting Place, The (Reading)	242
Suit the Speed to the Road (Reading)	229
Symbology	238
Tell It as It Is	269
Theatre of the Absurd, The	255
Three American Biographies	245
Tie It All Together (Composition)	227
To Hear a Different Drummer	245
Tools of Our Language	244
Top Ten	247
Tradition and Change in Non-Western Cultures	266
Tragedy and Theatre	254
Tragic Heroes	247
Tuning In (Listening)	257
TV and Radio Program Production	262
Values	229
Variations on Black Themes	228
Varsity Debate	260
Victorian Lace: Ladies, Lovers, and Lyrics	249
Voice of the American Indian	247
War as a Theme in Literature	234
What Do You Want to Know? (Independent Study)	227
What Is Language?	232
What Is This Thing Called Theatre?	250
Where The Books Are	227
Women in Literature	248
Words, Words, Words	229
World and the Stage, The	253
Writing a Research Paper	241
Writing for the Reader (Journalism)	261
Writing for Stage and Screen	255
Yearbook and Magazine Layout	263
Yearbook Editing	264
Yearbook Production	264
Yearbook Production: Editing	264
You, Too, Can Be a Legislator!	259

AREA	ACCR. NO. FLA-DADE	COURSE TITLE AND DESCRIPTION
LANGUAGE ARTS	5111.01 5112.01 5113.01 5114.01 5115.01 5116.01	† RIGHTING YOUR WRITING  Designed to enable the student to recognize the sentence and the non-sentence. The student practices writing, capitalizing, and punctuating sentences. Emphasis is on the writing of a variety of types of sentences and paragraphs.
LANGUAGE ARTS	5111.02 5112.02 5113.02 5114.02 5115.02 5116.02	† WHERE THE BOOKS ARE  Designed to provide students with the opportunity to acquire competencies in the utilization of various resources of the library, including the card catalogue, reference materials, and audio-visual resources. This course is a workshop in which the student practices library skills in his own program of study and may prepare current assignments for other classes.
LANGUAGE ARTS	5111.04 5112.04 5113.04 5114.04 5115.04 5116.04	† PARAGRAPH BUILDING  A course designed to help students develop various types of paragraphs. Experience in composing a variety of paragraphs orally and in writing is provided.
LANGUAGE ARTS	5111.05 5112.05 5113.05 5114.05 5115.05 5116.05	† TIE IT ALL TOGETHER (COMPOSITION)  Students read a variety of short expository pieces to discover inductively the structure of the sentences and paragraphs comprising the works and proceed to develop their own.
LANGUAGE ARTS	5111.06 5112.06 5113.06 5114.06 5115.06 5116.06 5167.06	† INSIDE-OUTSIDE  A course focusing on individual and group activities which enable students to become aware of their individual powers of seeing, hearing, smelling, touching, and tasting. The resulting experiences comprise the basis for writing.
LANGUAGE ARTS	5111.07 5112.07 5113.07 5114.07 5115.07 5116.07	† WHAT DO YOU WANT TO KNOW?  Each student plans an independent reading or research project identifying a theme, an area, or an author for an in-depth study. Writing assignments or other evaluative devices should be planned cooperatively by student and teacher.

LANGUAGE ARTS  
227

AREA	ACCR. NO. FLA-DADE	COURSE TITLE AND DESCRIPTION
LANGUAGE ARTS	5111.08 5112.08 5113.08 5114.08 5115.08 5116.08	† FACING THE TEST  Designed to help students apply the principles of effective study in a variety of testing situations. Emphasis is on developing such skills as planning wise use of allotted time, adapting reading rate to various types of test items, identifying types of analogous relationships, and word attack skills, including recognition of Greek and Latin roots and affixes.
LANGUAGE ARTS	5111.09 5112.09 5113.09 5114.09 5115.09 5116.09 5173.01	† DO YOU HEAR ME?  Provides a number of listening experiences to help the student understand the speaker's purpose and his own role as a listener, to make judgments, to follow instructions, to recall selectively ideas or information, and to take notes. Students have the opportunity to give formal speeches and participate in small group discussion.
LANGUAGE ARTS	5111.10 5112.10 5113.10 5114.10 5115.10 5116.10	† EXPANSION OF CONSCIOUSNESS  A course capitalizing on individual and group experiences and encouraging students to expand their powers of observation and discernment. Students analyze their thoughts and translate them into written responses.
LANGUAGE ARTS	5111.11 5112.11 5113.11 5114.11 5115.11 5116.11 5149.04	† VARIATIONS ON BLACK THEMES  Permits students to make cursory examination of the writings of many Black writers for the purpose of identifying major writers and recurring themes in the literature of Black Americans.
LANGUAGE ARTS	5111.12 5112.12 5113.12 5114.12 5115.12 5116.12	† ENJOYING SHORT STORIES  A study of the short story with emphasis on the student's enjoyment of the genre and his recognition of such elements of the short story as plot, character, and setting.

AREA	ACCR. NO. FLA-DADE	COURSE TITLE AND DESCRIPTION
LANGUAGE ARTS	5111.13 5112.13 5113.13 5114.13 5115.13 5116.13	† MAN AND HIS ENVIRONMENT: TO PERCEIVE AND TO REACT  An investigation and appraisal of prose, poetry, and music which reflects the environment's effect on man or man's effect on his environment.
LANGUAGE ARTS	5111.15 5112.15 5113.15 5114.15 5115.15 5116.15 5187.01	† WORDS, WORDS, WORDS  Presents the student with an opportunity to increase his word proficiency by investigating word origins, word histories, morphology, and phonology.
LANGUAGE ARTS	5111.16 5112.16 5113.16 5114.16 5115.16 5116.16 5187.02	† THE NATURE OF LANGUAGE  Leads the student to realize the importance of language to the individual and to the culture by exploring the possible origins of language, the causes and patterns of change, and the process through which language is learned.
LANGUAGE ARTS	5111.17 5112.17 5113.17 5114.17 5115.17 5116.17	† VALUES  An examination of literature designed to aid the student in identifying, understanding, and developing a system of values. Short stories such as "The Man without a Country," and "I Am a Rock," and novels such as <i>A Separate Peace</i> are possible selections for exploration.
LANGUAGE ARTS	5111.18 5112.18 5113.18 5114.18 5115.18 5116.18	† READING FOR MEANING  A skills development course designed to improve skills in reading for understanding via the identification of main and subordinate ideas, reading and listening for directions and purposes, and reading and listening for information.
LANGUAGE ARTS	5111.19 5112.19 5113.19 5114.19 5115.19 5116.19	† SUIT THE SPEED TO THE ROAD (READING)  Learn to read in different gears. Practice high speed reading for magazine stories. Learn to scan an article for a special need. Do close, careful reading to solve a math problem or do deep, thoughtful study of an inspiring poem. An effective reader has several reading rates and uses all of them.

LANGUAGE ARTS  
229

AREA	ACCR. NO. FLA-DADE	COURSE TITLE AND DESCRIPTION
LANGUAGE ARTS	5111.20 5112.20 5113.20 5114.20 5115.20 5116.20	† MASTERING DECODING SKILLS  A course designed to assist students who have not achieved mastery of decoding skills in relating phonemes (sounds) of the English language to graphemes and sequences of graphemes (letters) representing these phonemes; to deal systematically with the basic word patterns of English; to analyze the structure of word pairing, morphology, roots, prefixes, suffixes, and derived inflectional forms. Additional emphasis is given to instruction in the use of redundancies available in syntactic structures toward analysis and identification of previously unknown words, and to verify meanings as they are modified by context, including punctuation.
LANGUAGE ARTS	5112.21 5113.21 5114.21 5115.21 5116.21 5188.01	† THE MASTERS OF LORE  A course designed to provide the student with a means of examining the way a people relates to its environment as revealed in folklore. Consideration is given to the fable, parable, fairy tale, American tall tale and ballad, emphasizing how each form reflects a particular cultural developmental stage in the history of the world's people. Materials include selections from <i>Aesop's Fables</i> , the <i>Jataka Tales</i> , the Bible, <i>Grimm's Fairy Tales</i> , <i>Scandinavian Fairy Tales</i> , Bret Harte, <i>Canterbury Tales</i> , traditional and contemporary ballads.
LANGUAGE ARTS	5112.22 5113.22 5114.22 5115.22 5116.22 5188.02	† MAN'S SEARCH  An exploration of man's eternal search to understand himself and his world through the study of the mythology of the world.
LANGUAGE ARTS	5112.23 5113.23 5114.23 5115.23 5116.23 5187.03	† COMPARATIVE DIALECTS  A course designed to make students aware of the consistent patterns of various major dialects of American English. In his study the student observes alternative patterns.
LANGUAGE ARTS	5112.24 5113.24 5114.24 5115.24 5116.24	† EVERYDAY READING AND WRITING  A course designed to help students learn how to read, write, and understand letters, instructions, signs, maps, magazines, etc.

LANGUAGE ARTS  
230

AREA	ACCR. NO. FLA-DADE	COURSE TITLE AND DESCRIPTION
LANGUAGE ARTS	5112.25 5113.25 5114.25 5115.25 5116.25	† NONFICTION: THE NEWSPAPER, PERIODICALS, AND BIOGRAPHY  The student explores the forms of nonfiction. The course includes a study of the various elements of the newspaper, the news magazine, the special interest magazine, and biography.
LANGUAGE ARTS	5113.26 5114.26 5115.26 5116.26 5187.04	† CRITICAL THINKING  Designed to sensitize the student to both verbal and nonverbal clues to the levels of meaning from written and nonwritten communication. Practice is given in recognizing emotionally toned language, discriminating among reports, inferences, and judgments; making inferences, identifying propaganda devices, perceiving cause and effect relationships and fallacies in logic. Possible materials include <i>The Hidden Persuaders</i> , <i>The Ugly American</i> , and <i>The True Believer</i> .
LANGUAGE ARTS	5113.27 5114.27 5115.27 5116.27 5187.05	† DEVELOPING WORD POWER  A course to help the student develop word power. Included in the course will be training and practice in identifying various meanings of one word, finding meanings from context, interpreting nonliteral and figurative language, and analyzing the structure of words with emphasis on prefixes, suffixes, and roots.
LANGUAGE ARTS	5113.29 5114.29 5115.29 5116.29	† THE OUTER LIMITS  An exploration of unknown worlds, mental and physical, through fiction and nonfiction. Its purpose is to focus attention on the ongoing conquest of the frontiers of the mind, the physical world, and outer space.
LANGUAGE ARTS	5113.30 5114.30 5115.30 5116.30	† FACING LIFE  An investigation of literature, fiction and nonfiction, which deals with youth facing and overcoming the problems of life, stressing the novel and biography.

LANGUAGE ARTS  
231

205

AREA	ACCR. NO. FLA-DADE	COURSE TITLE AND DESCRIPTION
LANGUAGE ARTS	5113.31 5114.31 5115.31 5116.31	† ENGLISH ON THE JOB  Explores basic language and communication skills useful in choosing, finding, and working on a job. Content includes using the newspapers, completing job applications, speaking clearly, role-playing job interviews, reading career oriented fiction and articles, developing skills in listening, letter-writing, and language-usage.
LANGUAGE ARTS	5113.32 5114.32 5115.32 5116.32	† EXPOSITORY WRITING  Designed to aid students in developing competence in writing topic sentences and expository paragraphs incorporating the methods of cause and effect, comparison and contrast, illustration or example.
LANGUAGE ARTS	5113.33 5114.33 5115.33 5116.33 5148.01	† THE EPIC HERO  Allows the student to discover and analyze the characteristics of the epic hero as a nationalistic and cultural figure in literature; to identify the psychological dependence of peoples of various cultures in their search for identity and worth through the patriarchal figure or symbol. Such epic heroes as Beowulf, Ulysses, Roland, and El Cid are studied.
LANGUAGE ARTS	5113.34 5114.34 5115.34 5116.34	FILM AS DOCUMENTARY  An inquiry into the form and development of the motion picture and television film documentary, the preparation and production of individual or group student documentaries, and the evaluation of the documentary as social commentary and an art form.
LANGUAGE ARTS	5114.35 5115.35 5116.35 5187.07	LANGUAGE AND BEHAVIOR  An approach to language study dealing with the psychology, the process of abstraction, and the levels of meaning of language. Works to explore include: Hall, <i>The Silent Language</i> ; McLuhan, <i>Understanding Media</i> ; and selections by Postman, Pei, Hayakawa, and others.
LANGUAGE ARTS	5113.35 5114.36 5115.36 5116.36 5187.08	† WHAT IS LANGUAGE?  The study of the origin of language, language misconceptions, linguistics, semantics, communication, symbols, persuasion, and word manipulation.

LANGUAGE ARTS  
232

236

AREA	ACCR. NO. FLA-DADE	COURSE TITLE AND DESCRIPTION
LANGUAGE ARTS	5113.36 5114.37 5115.37 5116.37 5187.09	OUR LIVING LANGUAGE  A descriptive and historical study of language via linguistic analysis and comparison; language classification; language in its social and cultural setting.
LANGUAGE ARTS	5113.37 5114.38 5115.38 5116.38	IMPROVING SENTENCE STRUCTURE AND VARIETY  Learning to use sentence variety through a study of phrases, clauses, types of sentences, and transitional elements.
LANGUAGE ARTS	5113.38 5114.39 5115.39 5116.39 5173.02	DISCUSSION AND CONFERENCE  Development of skills in discussion as both a leader and a member of various groups. The student learns to be effective in various types of group situations, such as panel, round table, conference, and symposium.
LANGUAGE ARTS	5113.39 5114.40 5115.40 5116.40	† INTRODUCTION TO SHAKESPEARE  A careful study of a comedy and a tragedy by Shakespeare with emphasis upon language, development of character, and theme.
LANGUAGE ARTS	5113.40 5114.41 5115.41 5116.41	† MODERN ROCK POETRY  The opportunity to listen to selected lyrics of modern rock music and substantiate them as poetical. Excerpts from traditional poems will be used for comparison.
LANGUAGE ARTS	5113.41 5114.42 5115.42 5116.42 5149.02	† THE MANY FACES OF LOVE  Focuses on the theme of love and its many-faceted concerns as reflected through literary works of different times and cultural backgrounds.
LANGUAGE ARTS	5111.21 5112.26 5113.42 5114.43 5115.43 5116.43 5188.03	† GREEK AND ROMAN MYTHOLOGY  A study of selected myths of Greece and Rome to help students understand mythological references in literature, art, music, science, and technology.



AREA	ACCR. NO. FLA-DADE	COURSE TITLE AND DESCRIPTION
LANGUAGE ARTS	5113.43 5114.44 5115.44 5116.44	† MAN'S INNER STRUGGLE  Through the study of fiction students gain insights into some of the problems facing young people today. Students explore such questions as: Who am I? Where am I going? Why do I want to go? Can I make it? What's to stop me? Is this what I really want?
LANGUAGE ARTS	5113.44 5114.45 5115.45 5116.45 5187.10	† THE POWER OF WORDS  A course in semantics investigating verbal and nonverbal symbols and their denotations, emotional values, and levels of abstraction in an attempt to open the channels of communication between the students and those with whom they communicate.
LANGUAGE ARTS	5114.46 5115.46 5116.46 5148.12	WAR AS A THEME IN LITERATURE  An examination of literary works in which the major theme is war. Works to be studied include the short stories of Stephen Crane, Ernest Hemingway, and William Faulkner; novels such as <i>The Red Badge of Courage</i> , <i>All Quiet on the Western Front</i> ; and a variety of poems by writers of various countries.
LANGUAGE ARTS	5114.47 5115.47 5116.47	† THE MODERN FACE OF LOVE  An examination of the nature and kinds of love. A wide range of viewpoints touching on the force and morality of love are considered through various genres. Readings include <i>The Diary of a Young Girl</i> , <i>Ethan Frome</i> , <i>Love Story</i> , <i>Sons and Lovers</i> , <i>Scarlet Letter</i> , <i>Luv</i> , <i>Amen Corner</i> , <i>Butterflies Are Free</i> , <i>A Burnt Out Case</i> .
LANGUAGE ARTS	5114.48 5115.48 5116.48	ALIENATION VS. INVOLVEMENT  A discovery through literature that involvement offers a possible solution to the problems created by alienation.
LANGUAGE ARTS	5114.49 5115.49 5116.49	THE SHORT STORY AS AN ART FORM  A study of the control and discipline exerted by short story writers as they relate to art and form. Consideration is given to such concepts as style, theme, conflict, and setting, and how they are created, shaped, and maintained through the structure of the short story.

LANGUAGE ARTS  
234

238

AREA	ACCR. NO. FLA-DADE	COURSE TITLE AND DESCRIPTION
LANGUAGE ARTS	5114.50 5115.50 5116.50	<p>APPROACHES TO LITERARY CRITICISM</p> <p>An investigation of five major intellectual points of view from which literary works are analyzed and judged. A specific literary work (i.e., a novel, poem, short story, or other form) will be discussed and analyzed from these various points of view; essentially a work which lends itself to a particular approach (e.g., a sociological approach would be used in discussing London's <i>The Call of the Wild</i>). Areas of approach include moral, psychological, historical, biographical, sociological, and "new" criticism (a textual "creeping").</p>
LANGUAGE ARTS	5114.51 5115.51 5116.51	<p>THE EVANGELISTS</p> <p>A study of writers who have created their own system of values, codes of conduct, and means to achieve grace and salvation. The "religions" of these writers may be studied in relation to influences (traditional or otherwise) which affected them. Writers will include James, Hemingway, Hesse, Camus, Faulkner, Joyce, and Yeats.</p>
LANGUAGE ARTS SCIENCE	5114.52 5115.52 5116.52 5365.65	<p>† THE LITERATURE OF ECOLOGY</p> <p>A course designed to give the student a clearer understanding of the ecological problems that confront mankind. Readings in the course include, but are not limited to, <i>The Environmental Handbook</i>, <i>The Population Bomb</i>, <i>Defoliation</i>. The approach in this course will be from the viewpoint of the layman, not the scientist.</p>
LANGUAGE ARTS	5114.53 5115.53 5116.53	<p>HUMANITIES</p> <p>An introduction to the stylistic character and cultural climate of the important art epochs of Western civilization. Specifically, it has three basic aims: (1) to develop a breadth of understanding and appreciation of the cultural pattern of the Western world, (2) to develop insight into actual works of music and art, (3) to develop a technique of general critical analysis by which the student can arrive at his own evaluation and judgment of works of art. Introducing the student to various kinds and periods of art may encourage him to seek more of the aesthetic experiences awaiting his participation.</p>

AREA	ACCR. NO. FLA-DADE	COURSE TITLE AND DESCRIPTION
LANGUAGE ARTS	5114.54 5115.54 5116.54	† THE ART OF SATIRE  A study of the nature and purpose of satire: how it employs wit, humor, burlesque, parody, sarcasm, irony, or innuendo to ridicule what the artist sees as the vices and follies of man/society. Works to be studied range from those of Aristophanes to Evelyn Waugh.
LANGUAGE ARTS	5114.55 5115.55 5116.55	AN INTRODUCTION TO NONFICTION  An introduction to nonfiction as a form of writing dealing with truth, facts and ideas. Various classifications of nonfiction will be investigated including the biography (fictionalized biography, the biographical sketch and the autobiography), the essay (formal and informal), and true tales of great adventure with required readings in each.
LANGUAGE ARTS	5114.56 5115.56 5116.56 5148.03	THE NOVEL  A study of novels by representative writers of the eighteenth, nineteenth, and twentieth centuries. Emphasis is on the various forms in which a novel may be written.
LANGUAGE ARTS	5114.57 5115.57 5116.57 5149.01	THE BLACK NOVELIST IN AMERICA  An in-depth examination of the works of James Baldwin, Richard Wright, William Kelley, Gordon Parks, and others.
LANGUAGE ARTS	5114.58 5115.58 5116.58 5148.04	MAN AND HIS GODS  An examination of man's relation to his god—his fear, defiance, love, obedience to worship and imitation of god. Classical, Judaeo-Christian, and other outlooks are considered. Readings may include <i>Oedipus</i> , <i>The Odyssey</i> , <i>The New Testament</i> , <i>King Lear</i> , <i>Don Quixote</i> , <i>Paradise Lost</i> , <i>Faust</i> , <i>War and Peace</i> , and <i>The Brothers Karamazov</i> . Works by Montaigne, Kant, Locke, Augustine, Aquinas, Gibbons, and Tillich are other exploratory sources.
LANGUAGE ARTS	5114.59 5115.59 5116.59	THE LANGUAGE OF LITERATURE  A study of the stylistic elements found in fiction, including, but not limited to, plot-conflict, characterization, setting, tone-mood, and theme.

LANGUAGE ARTS  
236

AREA	ACCR. NO. FLA-DADE	COURSE TITLE AND DESCRIPTION
LANGUAGE ARTS	5114.60 5115.60 5116.60	† ILLUSION VS. REALITY  A study of significant literary works that deal with man's capacity for illusion and self-deception in his quest for identification and fulfillment. Sources for exploration: <i>Red Badge of Courage</i> and selected short stories by Stephen Crane, <i>Heart of Darkness</i> and <i>The Secret Sharer</i> by Joseph Conrad, <i>No Exit</i> by Jean Paul Sartre, and <i>The Cocktail Party</i> by T. S. Eliot.
LANGUAGE ARTS	5114.61 5115.61 5116.61	THE PURITAN ETHIC  An examination through various genres of the lasting effects of the Puritan tradition on the life and literature of the American people.
LANGUAGE ARTS	5114.62 5115.62 5116.62 5167.05	POINT OF VIEW  A course designed to help students develop an understanding of point of view and to increase sensitivity to different points of view in their own writing, as well as the writing of others.
LANGUAGE ARTS	5114.63 5115.63 5116.63	SENTENCES: ARE THERE CHOICES?  A study of the acceptable patterns of kernel sentences and transformation, identification of rhetorical styles in prose and poetry, and application of these principles to produce a variety of effective sentences.
LANGUAGE ARTS	5114.64 5115.64 5116.64	† COMPOSITION  Includes projects designed to foster invention and develop a sense of logical ordering. Techniques and characteristics of coherent composition through forms such as exposition, persuasion, narration, and inquiry are explored.

LANGUAGE ARTS

237

231

AREA	ACCR. NO. FLA-DADE	COURSE TITLE AND DESCRIPTION
LANGUAGE ARTS	5114.65 5115.65 5116.65	† EXPLORING THE LANGUAGES OF FILMS  A study of the techniques of motion pictures and their historical development. An analysis of the "language of pictures" (use of distance shots, angle shots, color, lighting, arrangement), the "language of motion" (camera movement, subject movement), and the "language of sound" (dialogue; narration, music, silence); an introduction to the optical and mechanical principles of motion picture operation; the advent of motion pictures, the silent era, the talkies, wide-screen processes, and the modern day films. Short films, documentaries, and feature length films are viewed and analyzed.
LANGUAGE ARTS  SOCIAL STUDIES	5114.66 5115.66 5116.66 6416.21 6457.05 6443.06 6427.04 6448.26	† MEDIA, MINDS, AND MASSES  A study of the workings of contemporary mass media: radio, television, newspapers and magazines, and movies. A study of the present status and power of media, as well as the history and development of media, will be included. The influence of media on life, in a community, and in a nation will be explored.
LANGUAGE ARTS  SOCIAL STUDIES	5114.67 5115.67 5116.67 5188.04 5148.05 6414.18 644B.57	† CLASSICAL CIVILIZATION  The study of Greek mythology, philosophy, and drama and their effect on modern man and his ideas.
LANGUAGE ARTS	5114.68 5115.68 5116.68 5187.11	THE LANGUAGE OF PERSUASION  A study of the speaker or writer as a persuader and identification of the logical and psychological tools of persuasion; an examination of the levels of abstraction, the techniques of propaganda, and the effective forces in advertising.
LANGUAGE ARTS	5114.69 5115.69 5116.69 5187.12	SYMBOLOLOGY  The study of nonverbal or graphic symbols in communication, of language as symbols, and symbols within language.

AREA	ACCR. NO. FLA-DADE	COURSE TITLE AND DESCRIPTION
LANGUAGE ARTS	5113.72 5114.70 5115.70 5116.70	THE INDIVIDUAL AND THE STATE  A study of questions of law and justice: Does justice have priority over considerations of order and peace? Is maintaining order more important than achieving perfect justice? Is civil disobedience a desirable or an effective way to redress current wrongs in our society? What is the moral responsibility of the citizen to resist laws or orders which are unjust? In protesting against social evils, is violence ever justified? Explorations include <i>Billy Budd</i> , Herman Melville; "Civil Disobedience," Henry David Thoreau; "The Case for Disobedience," Harold Laski; "The Case Against Disobedience," John Dickinson, <i>The Ox-Bow Incident</i> , Walter Van Tilburg Clark; "How Annandale Went Out," Edwin Arlington Robinson; <i>Where Do We Go from Here?</i> , Martin Luther King; "What We Want," Stokely Carmichael; <i>The Crucible</i> , Arthur Miller.
SOCIAL STUDIES	6448.56 6416.52	
LANGUAGE ARTS	5114.71 5115.71 5116.71	† THE QUEST FOR UTOPIA  Designed to introduce the student to significant literature that illustrates the gulf between the vision of a perfect society and the realities of human nature. Selected works include <i>Brave New World</i> by Huxley, <i>Notes from the Underground</i> by Dostoevski, <i>Pincher Martin</i> by Golding.
SOCIAL STUDIES	6448.65 6414.20	
LANGUAGE ARTS	5114.72 5115.72 5116.72	THE HARLEM RENAISSANCE  A study of the background and factors leading up to the Harlem Renaissance, the major literary figures of the period and their philosophies, and representative pieces of literature.
LANGUAGE ARTS	5114.73 5115.73 5116.73	THE ARTHURIAN LEGEND  A study of the early European English origins of the legend, Malory's <i>Le Morte D'Arthur</i> , the legend from Malory to the Victorians, Tennyson and the other Victorian Arthurian writers, and the twentieth century Arthurian literature of E. A. Robinson and T. H. White. Emphasis is placed on the manner in which the legend changes with each era.

AREA	ACCR. NO. FLA-DADE	COURSE TITLE AND DESCRIPTION
LANGUAGE ARTS	5114.74 5115.74 5116.74 5148.06 5149.02	THE LITERATURE OF SCIENCE  Emphasizes the link between the "hard" disciplines and the humanities through the study of such "scientific" writers as C. P. Snow, A. M. Whitehead, Darwin, Huxley, Bettelheim, Freud, Adler, May, Einstein, or others.
LANGUAGE ARTS  SOCIAL STUDIES	5114.75 5115.75 5116.75 6414.16 6499.01 6448.23 6416.28	INTRODUCTION TO PHILOSOPHY  This introduction to philosophy explores the great ideas of man throughout the ages and their influence on society in the realms of art, literature, economics, and government. The course involves extensive reading and individual study.
LANGUAGE ARTS	5114.76 5115.76 5116.76	THE ROMANTIC POETS  An intensive study of the works and life of one of the major Romantic poets: Wordsworth, Shelley, Keats, Byron, Coleridge, and others.
LANGUAGE ARTS	5114.77 5115.77 5116.77	INTRODUCTION TO LOGIC  A study of the art of clear thinking, including propositions and evidence, and the techniques of logic which determine validity and relevance. Application is made through the evaluation of fact, opinion, and propaganda.
LANGUAGE ARTS	5114.78 5115.78 5116.78	† IDEAS OF WESTERN MAN: CLASSICISM AND ROMANTICISM  An analysis of some predominant schools of man's changing thought through the study of literature. A consideration of Classicism and Romanticism as they have affected contemporary American culture, the course focuses on philosophy and uses painting, sculpture, and music to illustrate each school of thought.
LANGUAGE ARTS	5114.781 5115.781 5116.781	† IDEAS OF WESTERN MAN: EXPRESSIONISM AND REALISM  An analysis of some predominant schools of man's changing thought through the study of literature. A consideration of Expressionism and Realism as they have affected contemporary American culture, the course focuses on philosophy and uses painting, sculpture, and music to illustrate each school of thought.

AREA	ACCR. NO. FLA-DADE	COURSE TITLE AND DESCRIPTION
LANGUAGE ARTS	5114.79 5115.79 5116.79 5148.07	† THE BIBLE AS LITERATURE  An examination of selections from the historical and prophetic books of both the Old and New Testaments.
LANGUAGE ARTS	5114.80 5115.80 5116.80	† SHAKESPEARE  A course designed to bring out behavior patterns in characters revealed through the dialogue in the plays of Shakespeare. Selections include a comedy, a tragedy, a history, and some of the sonnets.
LANGUAGE ARTS	5114.81 5115.81 5116.81 5148.08	RELIGION THROUGH THE AGES IN LITERATURE  A course designed to reveal religious influences from different periods in literature. Selections include excerpts from Chaucer, portions of the Bible, <i>Idylls of the King</i> , <i>Beowulf</i> , early church plays, <i>Oedipus</i> , and <i>Antigone</i> .
LANGUAGE ARTS	5113.45 5114.82 5115.82 5116.82	† THE CIVIL WAR IN LITERATURE  The reading and discussion of literary works written during or about the Civil War, including <i>Jubilee</i> , <i>Gone with the Wind</i> , <i>Red Badge of Courage</i> , poetry by Walt Whitman, and the essays of Frederick Douglass.
LANGUAGE ARTS	5113.46 5114.83 5115.83 5116.83	REPORT WRITING  A study of methods of data collection, outlining, techniques of presenting structured and nonstructured data, writing a rough draft, and compiling a finished report.
LANGUAGE ARTS SOCIAL STUDIES SCIENCE	5114.84 5115.84 5116.84 6448.60 6416.54 6414.21 5387.01	† WRITING A RESEARCH PAPER  The writing of research papers as part of special projects in other content areas, such as science, mathematics, or social studies. The topic and content of the paper is determined by the student. Special emphasis is given to advanced research techniques, form, style, and clarity.



AREA	ACCR. NO. FLA-DADE	COURSE TITLE AND DESCRIPTION
LANGUAGE ARTS	5114.85 5115.85	ADVENTURES IN ECOLOGICAL READING
SCIENCE	5116.85 5365.02 5311.44 5312.44 5313.44	A reading and discussion course using some of Rachel Carson's writings and other similar books.
LANGUAGE ARTS	5111.32 5112.38 5113.76 5114.146 5115.161 5116.168	† HOW TO STUDY  A course designed to help the student learn the techniques of effective studying, including, among others, organizing time, planning a procedure, and completing the assignment. This course is a workshop in which the student practices these techniques in his own program of study. The student may prepare current assignments for classes other than language arts.
LANGUAGE ARTS	5114.147 5115.162 5116.169	THE CRAFT OF POETRY  An introduction to poetry as a form of writing. Emphasis is on mastery of the details of poetic effects in order that the student may pursue his interest in becoming more proficient in reading, evaluating, or writing poetry.
LANGUAGE ARTS	5114.148 5115.163 5116.170 5149.03	THE ABSURDIST VISION  The reading of plays and novels by contemporary European and American authors whose works expose the absurdity of conventional social and literary modes, but suggest certain positive human values. Works by Pirandello, Ionesco, Beckett, Ellison, Salinger, and Bellow are studied.
LANGUAGE ARTS	5111.33 5112.39 5113.77 5114.149 5115.164 5116.171	† THE STARTING PLACE  A reading laboratory with individual programs in reading speed and comprehension, study skills, visual efficiency, and auditory training, using multimedia materials on levels from grade three through junior high. Each student begins at a test-determined level and progresses as skill and efficiency increase. The basic purpose is to make the student more efficient in study and assigned reading, as well as recreational reading. Instruction includes techniques enabling the student to continue improvement of skills after course completion.

LANGUAGE ARTS  
242

AREA	ACCR. NO. FLA-DADE	COURSE TITLE AND DESCRIPTION
LANGUAGE ARTS	5111.34 5112.40 5113.78 5114.150 5115.165 5116.172	† ACCELERATION  An advanced reading laboratory, using multimodal materials from junior high to college, designed to improve reading speed and comprehension, visual and auditory efficiency, and study skills. Each student begins at a test-determined level and progresses as skill and efficiency increase. The basic purpose is to provide students with an opportunity to practice those reading skills which will be most helpful to them in reading the quantities of materials required in many content courses.
LANGUAGE ARTS	5111.35 5112.41 5113.79 5114.151 5115.166 5116.173	THE LEARNING SPOT  Reading for students needing individual or very small group instruction in reading skills. Each student is tested to identify difficulties, and a course is prescribed to remediate difficulties in perception, phonics, word attack skills, spelling, comprehension, interpretation, and reading-study skills.
LANGUAGE ARTS	5114.152 5115.167 5116.174	HENRIK IBSEN—CRITIC OF SOCIETY  An introduction to four great dramas which reveal that man's dream of perfection can sometimes lead to destruction, sterility, and estangement from life. Works to be studied include Henrik Ibsen's <i>Brand</i> , <i>The Wild Duck</i> , <i>Ghosts</i> , and <i>Hedda Gabler</i> .
LANGUAGE ARTS	5112.42 5113.80 5114.153 5115.168 5116.175	COMEDY  A study of the art and purpose of laughter in our society. Incorporated into the course is an examination of different types of comedy, such as slapstick, ethnic jokes, situation comedy, satire, and political cartoons. Records, films, periodicals, radio, and TV serve as sources for current material. Topics for discussion include: What makes people laugh? Is a sense of humor necessary? Can we laugh at ourselves?
LANGUAGE ARTS	5112.43 5113.81 5114.154 5115.169 5116.176	† INTRODUCTION TO POETRY  Emphasis is on the enjoyment of poetry. It includes an introduction to poetic language and a study of various types of poetry, such as the lyric and the narrative.

AREA	ACCR. NO. FLA-DADE	COURSE TITLE AND DESCRIPTION
LANGUAGE ARTS	5112.44 5113.82 5114.155 5115.170 5116.177	INTRODUCTION TO PLAYS  The study of several plays, introducing the student to the elements of the play and the theatrical terms necessary for understanding and enjoyment.
LANGUAGE ARTS	5112.45 5113.83 5114.156 5115.171 5116.178	INTRODUCTION TO THE NOVEL  The study of the novel as a literary form. Emphasis is placed on such aspects of the novel as plot, setting, character, theme, and style, as well as the enjoyment of the form.
LANGUAGE ARTS	5112.46 5113.84 5114.157 5115.172 5116.179	† MYSTERY AND HORROR  An exploration of various kinds of mysteries, including the detective story, the psychological mystery, and stories of the supernatural. Specific criteria for evaluating the mystery story are emphasized.
LANGUAGE ARTS	5112.47 5113.85 5114.158 5115.173 5116.180	MINORITY GROUPS IN AMERICA  A study of selections by white and nonwhite authors about life as a member of a minority group in the United States. Works of fiction, nonfiction, and poetry are studied to reveal problems such as prejudice, employment, housing, attitudes, and cultural adjustments.
LANGUAGE ARTS	5113.86 5114.159 5115.174 5116.181	TOOLS OF OUR LANGUAGE—GRAMMAR AND USAGE  The analysis of the basic structure of the English language, emphasizing accepted usage.

AREA	ACCR. NO. FLA-DADE	COURSE TITLE AND DESCRIPTION
LANGUAGE ARTS	5113.87 5114.160 5115.175 5116.182	TO HEAR A DIFFERENT DRUMMER  An examination of the types of individuals society declares to be "misfits." Readings include selections from the works of Thoreau, J. D. Salinger, Mark Twain.
LANGUAGE ARTS	5113.88 5114.161 5115.176 5116.183	THREE AMERICAN BIOGRAPHIES  A close study of three American biographies designed to acquaint students with the autobiographical and biographical forms as modes of expression and investigation. Materials may include Franklin's <i>Autobiography</i> , Sandburg's <i>Abraham Lincoln</i> , Herndon's <i>Life of Lincoln</i> , Helen Keller's <i>The Story of My Life</i> , Mizener's <i>The Far Side of Paradise</i> , and Schorer's <i>Sinclair Lewis</i> .
LANGUAGE ARTS	5113.89 5114.162 5115.177 5116.184	RAGS AND RICHES IN MODERN AMERICAN LITERATURE  A course designed to help the student view some of the many facets of American society as they are portrayed in literature. Materials may include <i>The Great Gatsby</i> ; <i>The Grapes of Wrath</i> ; <i>All My Sons</i> ; <i>They Shoot Horses, Don't They?</i>
LANGUAGE ARTS	5113.90 5114.163 5115.178 5116.185	SHAW'S COMEDY  An examination of five representative plays by George Bernard Shaw and comparison of his comedy with the comic art of Oscar Wilde, Richard Sheridan, Ben Jonson, and William Shakespeare.
LANGUAGE ARTS	5113.91 5114.164 5115.179 5116.186	THE RUSSIAN NOVEL  Primarily a comparison and contrast of the novels of Tolstoy and Dostoevski, through examination of such works as <i>War and Peace</i> , <i>Anna Karenina</i> , <i>Notes from the Underground</i> , <i>Crime and Punishment</i> , and <i>The Brothers Karamazov</i> .

AREA	ACCR. NO. FLA-DADE	COURSE TITLE AND DESCRIPTION
LANGUAGE ARTS	5113.92 5114.165 5115.180 5116.187	ROMANTIC HERO  A study of the characteristics of the romantic hero as he appears in various literary selections— <i>Cyrano de Bergerac</i> , <i>Don Juan</i> , <i>The Count of Monte Cristo</i> , <i>Three Musketeers</i> , <i>Don Quixote</i> , Frank Yerby novels, and C. H. Forester novels.
LANGUAGE ARTS	5113.93 5114.166 5115.181 5116.188	COMPARATIVE BIOGRAPHY  An examination of biography from <i>Plutarch's Lives</i> and Cellini's <i>Autobiography</i> to Nabokov's <i>Invitation of a Memory</i> . Special emphasis is placed on comparison of biographies of the same personality and the distinction between autobiography and biography.
LANGUAGE ARTS	5113.94 5114.167 5115.182 5116.189 5149.06	THE EXISTENTIALISTS  Emphasizes the philosophy and resulting life style of the Existentialist who sees his life as a series of choices. Introductory reading might include the essays of Sartre and Camus.
LANGUAGE ARTS	5113.95 5114.168 5115.183 5116.190	LEGENDS AND HEROES OF THE AMERICAN WEST  A course designed to separate facts from fiction associated with the old West. Study includes ballads, legends, and short stories dealing with not only the western hero and villain, but also the common frontiersman, his customs, and traditions.
LANGUAGE ARTS	5113.96 5114.169 5115.184 5116.191	† SHAKESPEAREAN TRAGEDIES  The study of two Shakespearean tragedies, possibly <i>Macbeth</i> and <i>Othello</i> , with concentration on the tragic hero, his development, tragic flaw, and eventual downfall.
LANGUAGE ARTS	5113.97 5114.170 5115.185 5116.192	SHAKESPEAREAN HISTORIES  A study of English history and historical figures through Shakespeare's plays. Materials might include <i>Henry IV</i> and <i>Richard III</i> . The student will be asked to compare the actual historical event or personality with Shakespeare's concept of it.

AREA	ACCR. NO. FLA-DADE	COURSE TITLE AND DESCRIPTION
LANGUAGE ARTS	5113.98 5114.171 5115.186 5116.193	VOICE OF THE AMERICAN INDIAN  An introduction to the American Indian cultural heritage and contributions to the American literary scene.
LANGUAGE ARTS	5113.99 5114.172 5115.187 5116.194	TRAGIC HEROES  An examination of a number of plays to study the actions of a hero in a particular situation, as well as the nature of the tragic view of man. Suggested reading: <i>Oedipus, the King; An Enemy of the People; The Cherry Orchard.</i>
LANGUAGE ARTS	5113.100 5114.173 5115.188 5116.195 5149.07	TOP TEN  A survey of the best selling contemporary, fiction and nonfiction. Yearly selection of titles is on a departmental basis.
LANGUAGE ARTS	5113.101 5114.174 5115.189 5116.196	ANCIENT LITERATURE OF THE EAST  A study of the major works of ancient Hebrew, Arabic, Iranian, Persian, Indian, Chinese, and Japanese literatures. <i>The Arabian Nights, Vedas, Buddhist scriptures, The Ramayana, the "Song of Solomon," and The Upanishads</i> are read for a fuller knowledge of the great cultural heritage of the East.
LANGUAGE ARTS	5113.102 5114.175 5115.190 5116.197	IRISH LITERATURE  An exploration of the customs, styles, and traditions of the people of Ireland through the eyes of great Irish writers of poetry, short stories, biography, and novels.
LANGUAGE ARTS	5111.03 5112.03 5113.03 5114.03 5115.03 5116.03 5167.01	† CREATIVE WRITING: FREE STYLE  A course for the student who wishes to share his experiences through the writing of short stories, poems, plays, and informal prose. The class is a workshop in all respects; students' written work will be read and heard, printed and read, rewritten and discussed by the whole class. Both content and style are emphasized.

AREA	ACCR. NO. FLA-DADE	COURSE TITLE AND DESCRIPTION
LANGUAGE ARTS	5111.36 5112.49 5113.104 5114.176 5115.191 5116.198 5167.02	† CREATIVE WRITING: SHORT STORIES  An opportunity to write short stories, including the vignette, the mood piece, and the full-length short story. Form, content, and style are stressed. Selections written in this class will be considered for publication in the school literary magazine.
LANGUAGE ARTS	5111.37 5112.50 5113.105 5114.177 5115.192 5116.199 5167.03	CREATIVE WRITING: POETRY  A workshop for students interested in writing poetry. Encouragement of individual writing styles is emphasized. Selections written in this class will be considered for publication in the school literary magazine.
LANGUAGE ARTS	5111.38 5112.51 5113.106 5114.178 5115.193 5116.200 5167.04	† CREATIVE WRITING: INFORMAL PROSE  A writing workshop for students interested in writing articles, biographies, and humorous essays, etc. Emphasis is on form and content with particular encouragement of individual styles. Selections written in this class will be considered for publication in the school literary magazine.
LANGUAGE ARTS	5114.301 5115.301 5116.301 5148.09	WOMEN IN LITERATURE  A course designed to examine the diverse images of woman and the female mystique as represented by selected feminine protagonists in noted literary works: Helen of Troy, Penelope, Andromache, Sarah, Leah, Rachel, Bathsheba, Juliet, Cleopatra, Rosalind, Madame Bovary, Anna Karenina, Ma Joad, St. Joan, Eleanor of Aquitaine. Selected works of nonfiction about contemporary women of achievement may also be included.
LANGUAGE ARTS	5114.302 5115.302 5116.302 5148.10	PILGRIMS: CHAUCERIAN AND RENAISSANCE  A course designed to investigate the "frame" motif of the pilgrimage in Chaucer's <i>Canterbury Tales</i> , Boccaccio's <i>Decameron</i> , Bunyan's <i>Pilgrim's Progress</i> . Period works of art exploring the same theme will also be investigated.

AREA	ACCR. NO. FLA-DADE	COURSE TITLE AND DESCRIPTION
LANGUAGE ARTS	5114.303 5115.303 5116.303	<p>THE AGE OF MILTON: PARADISE, METAPHYSICS, AND CHIVALRIC CODES</p> <p>A course of study designed to examine the dominant literary modes of thought during a period of lofty and exalted ideals expressed in Spenser's <i>The Faerie Queene</i>, Milton's <i>Comus</i>, <i>Paradise Lost</i>, and <i>Paradise Regained</i>, and John Donne's metaphysical poetry. Concomitant study will concentrate on period works of art and music.</p>
LANGUAGE ARTS	5114.304 5115.304 5116.304 5148.11	<p>THE FRENCH IMAGE</p> <p>A course of study designed to inform the student through thoughtful investigation of the wit, brilliance, satire, comedy, drama, intelligence, and impressionistic subtleties of fate which pervade the selected works of Hugo, Dumas, Maupassant, Moliere, Voltaire, Flaubert, Baudelaire, France, Camus, Sartre, and Proust.</p>
LANGUAGE ARTS	5114.305 5115.305 5116.305	<p>VICTORIAN LACE: LADIES, LOVERS, AND LYRICS</p> <p>A course of study designed to acquaint the student with the cultural mores of an age of artistic and delicate sensibilities. Emphasized are the love poems of the Brownings, the poetry of Christina Rossetti and Dante Gabriel Rossetti, the essays of John Ruskin, and the works of the Brontë sisters.</p>
LANGUAGE ARTS	5113.301 5114.306 5115.306 5116.306	<p>THE DICKENS FAMILY</p> <p>A course of study designed to familiarize the student with the starker aspects of Victorian England through the multiple works of the period's keenest recorder of human frailties, aspirations, cupidity, and misfortune. Works to be read and studied include <i>Oliver Twist</i>, <i>Tale of Two Cities</i>, <i>A Christmas Carol</i>, <i>Pickwick Papers</i>, <i>David Copperfield</i>, <i>Great Expectations</i>.</p>
LANGUAGE ARTS	5114.307 5115.307 5116.307	<p>AMERICAN MYSTICS</p> <p>A course of study designed to inform through reading and analysis of classical works of American transcendentalism: Emerson, Thoreau, and Whitman. The poems of Emily Dickinson may be studied as a clue to the spiritual life and thoughts of a sensitive recluse projecting herself beyond the physical bounds of house and time.</p>



AREA	ACCR. NO. FLA-DADE	COURSE TITLE AND DESCRIPTION
LANGUAGE ARTS	5114.308 5115.308 5116.308	<p>AMERICAN HUMORISTS</p> <p>A course of study designed to provide a knowledge of the evolution of the American version of comedy, wit, and satire in literary works, speeches, essays, plays, and the television medium. The contributions of the following men are investigated and analyzed: Mark Twain, Ogden Nash, James Thurber, Will Rogers. Significant works of other humorists may be included.</p>
LANGUAGE ARTS	5114.309 5115.309 5116.309	<p>THE NOVEL OF INITIATION</p> <p>This course will investigate novels which have as their principal purpose the initiation of their main characters into some basic mysteries of life: love, nature, war, religion, work, culture, politics, or travel. Such novels as <i>The Adventures of Huckleberry Finn</i>, <i>The Ordeal of Richard Feverell</i>, and <i>Candide</i> will be examined in order to give the student a clear idea of the importance of this type of novel in literature.</p>
LANGUAGE ARTS	5112.53 5113.47 5114.821 5115.821 5116.821 5183.01	<p>WHAT IS THIS THING CALLED THEATRE?</p> <p>An introductory course for the student interested in the theatre. Using the interdisciplinary approach, the content includes discussion of types and styles of drama; a brief history of drama; styles of acting and techniques of play production focusing on music, costume design, makeup, scenery, poster display, and theatre management.</p>
LANGUAGE ARTS	5112.54 5113.48 5114.831 5115.831 5116.831 5183.02	<p>BASIC ACTING</p> <p>A beginner's course in acting with emphasis on movement, characterization, voice, and diction.</p>
LANGUAGE ARTS	5113.49 5113.841 5115.841 5116.841 5183.03	<p>† FACES FOR THE ACTOR</p> <p>Straight and stylized theatrical makeup for thrust, proscenium, and arena staging; demonstration and practical application of modern makeup materials such as latex, collodion, plastics, and molded forms to create special character makeup; such as aging man, animals, birds, and stylized imaginative characters. Students create special makeup for a character in a well-known play. This class bears primary responsibility for the makeup of the play in rehearsal.</p>

LANGUAGE ARTS  
250

AREA	ACCR. NO. FLA-DADE	COURSE TITLE AND DESCRIPTION
LANGUAGE ARTS	5113.50	BEHIND THE CURTAIN  A unified study of all of the allies of the actor and the playwright. A study of the production staff that make the play possible, theatre management, set design, makeup, lights, and sound.
	5114.851	
	5115.851	
	5116.851	
	5183.04	
LANGUAGE ARTS	5113.51	THE STAGE WITHOUT WORDS  A building of the imagination through pantomime and mime. Progression moves from basic knowledge of movement to a mime theatre production.
	5114.861	
	5115.861	
	5116.861	
	5183.05	
LANGUAGE ARTS	5112.27	READERS' THEATRE  An opportunity for students to be resource personnel for other disciplines. If an English class is studying <i>Lord of the Flies</i> and a physics class is studying Galileo, the function of the drama class is to prepare Golding's <i>Lord of the Flies</i> and Brecht's <i>Galileo</i> for presentation to those classes.
	5113.52	
	5114.86	
	5115.86	
	5183.06	
LANGUAGE ARTS	5111.22	DRAMATIC INTERPRETATION  Oral interpretation of both prose and poetry, with specific emphasis on language, voice and diction, and dramatic presentation.
	5112.28	
	5113.53	
	5114.87	
	5115.87	
	5183.07	
LANGUAGE ARTS	5111.23	GETTING TO KNOW YOURSELF THROUGH ACTING  A study of improvisational acting techniques for exploring problems affecting today's youth. Role playing permits different and differing interpretations of characters. Stage concentration and acting techniques are stressed.
	5112.29	
	5113.54	
	5114.88	
	5115.88	
	5183.08	
LANGUAGE ARTS	5114.89	ADVANCED ACTING  A course designed for the student advanced in acting methods through post training or advanced motivation.
	5115.89	
	5116.89	
	5184.01	

LANGUAGE ARTS  
251

215

AREA	ACCR. NO. FLA-DADE	COURSE TITLE AND DESCRIPTION
LANGUAGE ARTS	5113.55 5114.90 5115.90 5116.90 5184.02	DRESSING THE PLAY  Consideration of period, style, setting, character relationships, and what is required of the costume. Stress relation of color and design to all of the above. Students will plot a play as to costume, showing progression of character when possible. This class will costume the play or plays in rehearsal during this quin.
LANGUAGE ARTS	5113.56 5114.91 5115.91 5116.91 5184.031 5184.032 5184.033 5184.034	HERE'S HOW! (SET CONSTRUCTION)  A practical course in which students learn the techniques of scene construction, including building various types of flats and other set pieces for a play. Students work with tools, stage hardware, and learn the value of using materials and supplies for set construction. This course may be elected for credit for four successive quinquesters.
LANGUAGE ARTS	5114.92 5115.92 5116.92 5184.04	THE CRITIC  A study of the role of the critic in the theatre, film, and television; a forum for the analysis, review, and criticism of the theatrical media in society today. Numerous field trips to legitimate theatre productions and films are required for students enrolled in this course.
LANGUAGE ARTS	5114.93 5115.93 5116.93 5184.05	A SEMINAR IN COMEDY  An evaluation of the comic, comedy, the art and purpose of laughter in our society.
LANGUAGE ARTS	5113.57 5114.179 5115.28 5116.201 5184.06	SOUND AND COLOR  A course designed to incorporate the underlying psychological and emotional concepts involved in use of lighting and sound. Students learn basic principles of designing and painting a set and relate sound to the colors used. They plot and cue a full-length play as to lights and sound.

AREA	ACCR. NO. FLA-DADE	COURSE TITLE AND DESCRIPTION
LANGUAGE ARTS	5115.95 5116.95 5184.071 5184.072 5184.073 5184.074	PSYCHOLOGY OF ACTING  Character analysis and character relationship analysis. Stanislavsky is the source for studying how the character functions. Characters are investigated through improvisations and scene work. This course may be elected for credit for four successive quinquesters.
LANGUAGE ARTS	5114.95 5115.96 5116.96 5184.08	THE WORLD AND THE STAGE  An introductory overview of the philosophy, history, and relationship of man and his environment to the stage.
LANGUAGE ARTS	5114.96 5115.97 5116.97 5184.09	COMMEDIA DELL'ARTE AND THE ACTOR  A study of the lightly stylized comedy technique of Harlequin, El Capitano, etc. Students work with the improvisational form of Commedia Dell'Arte, producing a play.
LANGUAGE ARTS	5115.98 5116.98 5184.10	METHOD AS A SCHOOL OF ACTING  An exploration of the method approach, using scene work from Ibsen to Miller.
LANGUAGE ARTS	5115.99 5116.99 5184.11	ELIZABETHAN ACTING  A workshop in which the students become actor apprentices, working with material from Shakespeare and other Elizabethan playwrights. Movement and vocal work are emphasized.
LANGUAGE ARTS	5115.100 5116.100 5184.20	EPIC THEATRE AND THE ACTOR  A study of techniques essential for Brecht, Fitch, Durrenmatt, and Wilder.
LANGUAGE ARTS	5115.101 5116.101 5185.011 5185.012 5185.013 5186.014	DESIGNING THE SET  A course providing opportunities for students to design a set for a play. The students become involved in script selection and procedures for scenic design, including perspective sketching and making of model sets. Vocabulary and the principles of color are emphasized. This course may be elected for credit for four successive quinquesters.

AREA	ACCR. NO. FLA-DADE	COURSE TITLE AND DESCRIPTION
LANGUAGE ARTS	5115.102 5116.102 5185.02	MODERN DRAMA—A NEW AGE  A study of the beginning of realism in the dramatic art form, the emergence of real man and real conflicts in modern world drama. Selected works of Ibsen, O'Neill, and Miller are included.
LANGUAGE ARTS	5114.97 5115.103 5116.103 5185.03	THE AMERICAN MUSICAL THEATRE  An in-depth study of the musical art form from inception to the now scene. An analysis of music of Americana from burlesque to the present. The course places emphasis on the American musical contribution, including off-Broadway and the film industry.
LANGUAGE ARTS	5115.104 5116.104 5185.04	TRAGEDY AND THEATRE  A study of the tragic hero from Oedipus to Willy Loman.
LANGUAGE ARTS	5115.105 5116.105 5185.05	THE REVOLUTIONARY BLACK THEATRE  An in-depth study of plays and playwrights offering relevant themes. Contemporary writers such as Jones, Hansberry, and Baldwin are studied.
LANGUAGE ARTS	5114.98 5115.106 5116.106 5185.06	LIVING SHAKESPEARE  An analysis of Shakespeare, the man, his life and times, his contemporaries, and his plays.
LANGUAGE ARTS	5115.107 5116.107 5185.07	THE GLORY THAT WAS GREECE  A study of selected plays by the Greek playwrights Aeschylus, Sophocles, Euripides, and Aristophanes.
LANGUAGE ARTS	5113.58 5114.99 5115.108 5116.108 5185.08	† CHILDREN'S THEATRE  The production of plays for and with children for presentation at elementary schools. This course involves choosing the play and mounting the production.

LANGUAGE ARTS  
254

AREA	ACCR. NO. FLA-DADE	COURSE TITLE AND DESCRIPTION
LANGUAGE ARTS	5115.109 5116.109 5186.01	<b>DIRECTING THE PLAY</b>  A course designed to involve the students in the fundamentals of play directing including rhythm, stylization, picturization, memorization, and other principles of directing. Students choose material and design the action for plays, which may be presented in interdisciplinary situations.
LANGUAGE ARTS	5115.110 5116.110 5186.02 5168.01	<b>WRITING FOR STAGE AND SCREEN</b>  An introduction to the creation of character development dialogue in a scenario and the one-act play.
LANGUAGE ARTS	5114.100 5115.111 5116.111 5186.03	<b>PROMOTING AND SELLING THE PLAY</b>  Basic study of expenses of production and ways and means of getting an audience and paying the bills. Emphasis on advertising the play—printing the tickets, printing the programs, payment of royalty, rentals, miscellaneous, and house management. Students draw up a production calendar for a full-length show and bear primary responsibility for promotion and ticket sales for the production.
LANGUAGE ARTS	5115.112 5116.112 5186.04	<b>LIVING LITERATURE—FROM THE PAGE TO THE STAGE</b>  A course designed to give living dimension to varied forms of literature. A study in interpretation and application of form and sound to literature from Red Riding Hood to Rod McKuen.
LANGUAGE ARTS	5116.113 5186.05	<b>PROTEST DRAMA</b>  The study of this form of drama in relation to today's life.
LANGUAGE ARTS	5115.113 5116.114 5186.06	<b>THE THEATER OF THE ABSURD</b>  Exploring the works of Albee, Pinter, Beckett, and Ionesco to work out acting techniques for absurdist drama.

LANGUAGE ARTS  
255

AREA	ACCR. NO. FLA-DADE	COURSE TITLE AND DESCRIPTION
LANGUAGE ARTS	5112.52 5113.59 5114.101 5115.114 5116.115 5173.03	† HOW TO MAKE A SPEECH AND LIKE IT  The theory and practice of speaking before an audience. Problems of preparation, content, research, organization, development of ideas, use of language, and effective delivery of extemporaneous speeches are studied. The major types of public speaking are studied with practice in each type before an audience. Some practical use of microphone techniques are practiced by the speakers.
LANGUAGE ARTS	5113.61 5114.102 5115.116 5116.117 5173.09	EVERYDAY COMMUNICATION  A course including practical aspects of oral communication with emphasis on job interview, college interview, telephone usage.
LANGUAGE ARTS	5113.198 5114.103 5116.118 5173.06	INTRODUCTION TO RADIO AND TELEVISION  A brief study of the history and development of radio and television with practice in script planning and writing, advertising production of simulated programs for both media. The place of mass media in political campaigns and molding of public opinion are included. The rules of the Federal Communications Commission are examined briefly.
LANGUAGE ARTS	5114.104 5115.118 5116.119	SO YOU THINK YOU ARE A LEADER!  An exploration of the specific qualities which make a leader. Outstanding leaders are studied and their special qualities of leadership examined. Practice in organizing, clear thinking, decision-making, parliamentary procedures, and leadership development are provided.
LANGUAGE ARTS	5114.105 5115.119 5116.120 5174.07	† ORAL INTERPRETATION  A study of communicating to an audience a work of prose or poetry. Emphasis is placed upon recreating the piece of literature through the use of paraphrasing, emphasis, variation of pitch and loudness. The student develops an awareness of the intellectual, emotional, and aesthetic entirety of the passage chosen by the student with his own interests and those of the audience in mind.

AREA	ACCR. NO. FLA-DADE	COURSE TITLE AND DESCRIPTION
LANGUAGE ARTS	5114.106 5115.120 5116.121 5174.08	PERSUASIVE SPEAKING  Practical application of logical and psychological bases of motivation used in oral communication. Emphasis is placed on ways of winning belief and action. Organization, the role of emotion, delivery, crowd and individual reactions, and the ethics of persuasion are included.
LANGUAGE ARTS	5128.21	BUSINESS SPEECH
BUSINESS EDUCATION	5128.21	A course designed to help people in the business world. It includes the preparation and delivery of a speech. It also includes other business situations which require skill in speaking—sales techniques, committee and group discussion, conducting conferences and meetings, moderating programs, and oral reading of data, reports, minutes of meetings, as well as the methods to use in preparing these forms of oral activities. Attention is given to pronunciation and vocabulary to enable the student to use language which is clear, graphic, and persuasive.
LANGUAGE ARTS	5114.108 5115.122 5116.123 5174.10	TUNING IN  A course designed to aid the student in developing effective skills for critical listening and listening for comprehension of ideas. The importance of listening for increased knowledge, for cultural growth, and social maturity is stressed. Clear articulation, effective voice production, acceptable pronunciation, pitch variation, and rhythm and phrasing are developed.
LANGUAGE ARTS	5114.109 5115.123 5116.124 5175.11	† ADVANCED ORAL INTERPRETATION OF LITERATURE  An emphasis upon further development of the use of voice, imagination, and emotion in creating word pictures for the audience. Included in the course are planning programs for performance; cutting selections; using music, movement, slides, and other multimedia devices to make the program enjoyable for the audience.

LANGUAGE ARTS  
257



AREA	ACCR. NO. FLA-DADE	COURSE TITLE AND DESCRIPTION
LANGUAGE ARTS	5114.110 5115.124 5116.125 5175.12	SEMINAR IN IDEAS  A seminar in which ideas of major social, economic, and political problems are brainstormed. Major ones are selected, researched, organized and discussed, and acted upon. Some of the discussions are taped for analysis. The student selecting this course should have interest in current affairs.
LANGUAGE ARTS	5114.111 5115.125 5116.126 5175.13	ORAL DECISION MAKING  A study of the nature and materials of oral decision making, including the understanding of group dynamics, finding and evaluating facts, steps in problem solving, and organizing for various forms of discussion. Through practice with current problems, students gain experience in leadership and participation in the process of discussion.
LANGUAGE ARTS	5114.112 5115.126 5116.127 5175.14	ADVANCED PERSUASIVE SPEAKING  An analysis of speeches from <i>Vital Speeches of the Day</i> , political speeches, TV commercials, and other types of speeches. Practical use of persuasive methods for school, community, county, state, and national campaigns in elections are emphasized.
LANGUAGE ARTS	5114.113 5115.127 5116.128 5175.15	SPECIAL OCCASION SPEECHES  The study and practice of the eulogy, tribute, after-dinner speech, introduction to a speaker, nomination, acceptance, campaign speeches. The welcome, storytelling, and master of ceremonies speech are also included.
LANGUAGE ARTS	5114.114 5115.128 5116.129 5196.01 5196.012	† FUNDAMENTALS OF ARGUMENTATION AND DEBATE  A study of the fundamentals of argumentative structure and formalized argument, including an introduction to research skills, evaluation of evidence, and the use of evidence and argument in the building of debate cases. Students are given practical experience in argumentative speaking in the classroom. This course may be elected for two successive quinquesters.

AREA	ACCR. NO. FLA-DADE	COURSE TITLE AND DESCRIPTION
LANGUAGE ARTS	5114.115 5115.129 5116.130 5196.02	† YOU, TOO, CAN BE A LEGISLATOR!  A course in which students become imaginary legislators. The classroom is the legislative house; elected students run the Congress under the rules of parliamentary procedure. Students write suggested pieces of legislation and employ congressional debate techniques in the ensuing debates. Students interested in public affairs and willing to give speeches enjoy this type of course.
SOCIAL STUDIES	6448.58 6416.53	
LANGUAGE ARTS	5115.130 5116.131 5197.01	† ADVANCED COMPETITIVE FORENSICS  An opportunity for students who have successfully auditioned for the course to continue in interscholastic competition. They pursue individual interests and skills in interpretative speaking, original oratory, extemporaneous speaking, and debate.
LANGUAGE ARTS	5113.62 5114.116 5118.131 5116.132 5196.04	INDUCTIVE-DEDUCTIVE LOGIC  A study of the principles underlying inductive and deductive reasoning. The students learn how to recognize the various kinds of fallacies, how to test fallacies, and how to counter fallacious reasoning.
LANGUAGE ARTS	5114.117 5115.132 5116.133 5196.03	DISCUSSION AND DEBATE  A classroom activity centering around the elements of good discussion and basic elements of informal debate. The class emphasizes the democratic process.
LANGUAGE ARTS	5114.118 5115.133 5116.134 5197.02	PERFORMANCE IN ARGUMENTATION AND DEBATE  A study in which students refine their understanding of the principles of argumentation and debate through participation in classroom debate. The course includes the structuring of a variety of case approaches, increased awareness of qualitative evaluation of evidence and stylistic factors of persuasion. For maximum success, students should have had Fundamentals of Argumentation and Debate.

LANGUAGE ARTS  
259

AREA	ACCR. NO. FLA-DADE	COURSE TITLE AND DESCRIPTION
LANGUAGE ARTS	5116.135 5197.03	CONFRONTATION DEBATE  A study of rational thinking, expertise in argument, self-discipline, and crowd psychology. Students are placed in an atmosphere of hostility outside the classroom where speeches generate opposing views and opinions from their audience.
LANGUAGE ARTS	5116.136 5197.041 5197.042 5197.043 5197.044	ADVANCED PERFORMANCE IN ARGUMENTATION  Continued development of the concepts learned in Performance in Argumentation and Debate. This class provides training for varsity debaters and may be elected for credit for four consecutive quinesters.
LANGUAGE ARTS	5116.310 5198.01 5198.02 5198.03 5198.04	VARSITY DEBATE  Designed for experienced and varsity debaters only, the emphasis in this class is on continuing performance of argumentation skills developed by the students in previous courses. This class may also serve as the official debating society/club of the school and may be elected for credit for four successive quinesters.
LANGUAGE ARTS	5111.25 5112.31 5113.63 5114.119 5115.134 5116.137 5163.01	† READING THE NEWSPAPER  A unit designed for reading and understanding the newspaper. Activities include a study of the structure of the newspaper, styles of writing found in newspapers, a detailed study of a story as it unfolds, writing assignments using different styles of writing.
LANGUAGE ARTS	5113.64 5114.120 5115.135 5116.138 5163.02	† SHAPING OPINIONS  A journalism writing course exploring serious techniques used in effective articles that mold opinion. Responsibility, good taste, the problems of censorship, crusading, and propaganda techniques will be studied. Extensive reading of editorials and columns, and practice in writing are included. This course is essential for those interested in newspaper work and is recommended for students interested in politics and law.

AREA	ACCR. NO. FLA-DADE	COURSE TITLE AND DESCRIPTION
LANGUAGE ARTS	5113.65 5114.121 5115.136 5116.139 5163.03	WRITING FOR THE READER  A journalism writing course to train students in techniques of newsgathering and reporting. Objectivity, accuracy, clarity, and journalistic style are emphasized. This course is essential for those interested in working on newspaper and yearbook staffs.
LANGUAGE ARTS	5113.66 5114.122 5115.137 5116.140 5163.04	† NEWSPAPER MAKEUP  Theory and practice in making up the front page, as well as inside pages, of the newspaper. Included are copyfitting, headline composition and fitting, typography and type specification, photo proportioning, and proofreading. Theories of offset and letterpress printing are covered.
LANGUAGE ARTS	5113.67 5114.123 5115.138 5116.141 5163.05	REPORTING SPORTS FOR THE MEDIA  A study of methods of interviewing, covering sports, developing sports features and human interest angles. Sports lingo, the informal writing style, objectivity, accuracy, caption writing, and sports photo editing are covered. This course is essential for sports editors and staff members of newspapers and yearbooks.
LANGUAGE ARTS	5114.124 5115.139 5116.142 5163.06	† PRINCIPLES OF PHOTOGRAPHY  A laboratory course to train students in basic procedures needed to take, develop, and print black-and-white pictures. The principles of the camera and lenses, theories of light as needed for photographers, darkroom developing and fixing of film, contact printing and enlarging, types of filters and papers, and the history of photography are covered. This course is recommended for hobby photographers and publication staff photographers.
ART	6681.24 6682.24 6693.17	
INDUSTRIAL ARTS	5833.03	
LANGUAGE ARTS	5114.125 5115.140 5116.143 5164.07	† NEWSPAPER EDITING  A course designed to groom editors for the newspaper. Editing copy, copyreading and proofreading, principles of headlining, responsibility of the press, libel and slander laws, and problems of censorship are included. Other areas to be explored: assigning staff, setting deadlines, dealing with the printer, developing beats, and effective methods of handling a staff. This course is essential for those interested in editing the newspaper.

LANGUAGE ARTS  
261

AREA	ACCR. NO. FLA-DADE	COURSE TITLE AND DESCRIPTION
LANGUAGE ARTS	5113.68 5114.126 5115.141 5116.144 5164.08	THE JOURNALIST AND THE PUBLIC An analysis of the various "publics" or audiences—both in school and out—which the journalist must identify and consider when writing. Methods of taking surveys and polls, interviewing techniques, "slanting" the story for an interest group, salesmanship, and the distinction between journalism and public relations are covered. This course is recommended for those interested in newspaper, advertising, politics, and merchandising.
LANGUAGE ARTS	5113.69 5114.127 5115.142 5116.145 5164.09	PHOTOJOURNALISM What makes a good storytelling photograph? Students learn about contrast, focus, subject matter, action, new angles, and other considerations of the photographer taking pictures. The principles of the camera and lenses, ways of cropping, enlarging and reducing photos, and some darkroom theory are included in this nonlaboratory course. This course is recommended for those interested in newspaper and yearbook and for beginning photographers.
LANGUAGE ARTS	5113.199 5114.199 5115.143 5116.146 5164.10 5165.10 5174.061	TV AND RADIO PROGRAM PRODUCTION A laboratory course in which students practice the techniques of writing scripts; and editing, producing, and broadcasting tapes and videotapes for TV, radio, and PA announcements. Students learn to operate audio-visual equipment.
LANGUAGE ARTS	5113.70 5114.128 5115.144 5116.147 5164.11	† CREATIVE JOURNALISM An application of the basic principles of journalism in writing columns, reviews, feature stories, human interest articles, fashion reporting, comics, personality interviews, and other types of entertaining writing for the newspaper.

AREA	ACCR. NO. FLA-DADE	COURSE TITLE AND DESCRIPTION
LANGUAGE ARTS	5115.145 5116.148 5164.121 5164.122 5164.123 5164.124	<p>NEWSPAPER PRODUCTION</p> <p>The production of the school newspaper at regular intervals; the students write all copy, sell advertising and subscriptions, and take all photographs. Success depends on the student's knowledge and use of techniques in journalistic writing; proofreading, copyreading, advertising and sales, headline writing, and page makeup. Extra time outside of class is expected of each student since deadlines must be met.</p> <p>It is recommended that students take other journalism courses prior to applying for this advanced class, which may be elected for credit for four successive quinquesters.</p>
LANGUAGE ARTS	5113.71 5114.129 5115.146 5116.149 5164.13	<p>† ADVERTISING AND BUSINESS MANAGEMENT (JOURNALISM)</p> <p>A course to train students in proper handling of school accounts—contracts, bookkeeping, business letters, the significance of the school audit, etc. Selling advertising and developing promotional ideas of a profitable and/or publicity-oriented nature is covered. Advertising layout and content is included. This course is essential to all club treasurers and business managers of publications.</p>
LANGUAGE ARTS	5115.147 5116.150 5165.141 5165.142 5165.143 5165.144	<p>NEWSPAPER PRODUCTION: EDITING</p> <p>Designed for newspaper editors and business staff. Positions of high responsibility are assigned to students with this course designation. The class meets at the same time and place as Newspaper Production and may be elected for credit during four successive quinquesters.</p>
LANGUAGE ARTS	5113.200 5114.200 5115.148 5116.151 5165.15	<p>YEARBOOK AND MAGAZINE LAYOUT</p> <p>A study of theory and practice in page layout, photo cropping and editing, use of color and special effects, copyfitting, headline writing and fitting, and principles of typography. Current magazines are studied for trends in layout, and methods of adapting magazine layout to school publications are developed.</p>

AREA	ACCR. NO. FLA-DADE	COURSE TITLE AND DESCRIPTION
LANGUAGE ARTS	5115.149 5116.152 5165.16	<p><b>YEARBOOK EDITING</b></p> <p>A course designed to groom editors for the yearbook. Future editors are trained in developing a plan for the book, emphasizing the importance of the yearbook as a permanent document. Students apply this philosophy in planning a theme and in insuring continuity, accuracy, and fully representative coverage of students, faculty, academic and extracurricular activities, and current attitudes. Methods of staff organization and scheduling, photography, and deadlines and included.</p>
LANGUAGE ARTS	5116.153 5166.171 5166.172 5166.173 5166.174	<p><b>YEARBOOK PRODUCTION</b></p> <p>The production of the annual yearbook. The staff assigns and supervises all photography, writes and edits all copy, sells advertising and subscriptions, and handles finances for this publication. Success depends on the student's knowledge and use of techniques in journalistic writing, proofreading, copyreading, advertising and sales, headline writing, photo editing, and layout. It is recommended that students take other journalism courses before applying for this advanced class, which may be elected for credit for four successive quinquesters.</p>
LANGUAGE ARTS	5115.150 5116.154 5166.181 5166.182 5166.183 5166.184	<p><b>YEARBOOK PRODUCTION: EDITING</b></p> <p>Designed as the second-year course for yearbook editors and business staff. Positions of high responsibility are assigned to students with this course designation. This course may be elected for credit for four successive quinquesters.</p>
LANGUAGE ARTS	5111.31 5112.37 5113.134	<p><b>PROPAGANDA</b></p> <p>Types and techniques of propaganda and its effects on American life. The course is designed to help students make decisions based on critical, objective thinking.</p>
SOCIAL STUDIES	6470.06 6413.08 6443.04 6471.07	

AREA	ACCR. NO. FLA-DADE	COURSE TITLE AND DESCRIPTION
LANGUAGE ARTS	5111.28 5112.34 5113.135	† AMERICAN BIOGRAPHIES  A study of selected Americans and their times. Aims include the understanding of the frame of reference of an individual in the context of his time and how individuals can affect history.
SOCIAL STUDIES	6412.08 6411.08 6416.08	
LANGUAGE ARTS	5111.29 5112.35 5113.136	† COMPARATIVE WORLD RELIGIONS  A study of selected world religions, focusing on religion as an institution in society. Includes effects of religion on people, governments, and international relations. Emphasis is placed on development of empathy for other cultures and customs through greater understanding of why people behave as they do.
SOCIAL STUDIES	6478.08 6414.06 6470.36	
LANGUAGE ARTS	5111.30 5112.36 5113.137	† A NATION DIVIDED AGAINST ITSELF  The events leading to the Civil War, the war years, and Reconstruction, and the importance of compromise.
SOCIAL STUDIES	6412.05 6411.05 6416.05	
LANGUAGE ARTS	5114.139 5115.154 5116.157	† AMERICAN CULTURE  A problem-centered, in-depth analysis of contemporary America. Utilizes an interdisciplinary approach, focusing on an analysis of art, literature, music, and philosophy to better understand contemporary culture.
SOCIAL STUDIES	6426.01 6416.34 6448.40	
LANGUAGE ARTS	5114.140 5115.155 5116.158	† MAN BETWEEN WAR AND PEACE  Incorporates the social science disciplines in an attempt to provide students with tools to deal with the complexities inherent in the issue: Why Men Wage War.
SOCIAL STUDIES	6448.16 6414.18 6416.27	



AREA	ACCR. NO. FLA-DADE	COURSE TITLE AND DESCRIPTION
LANGUAGE ARTS	5114.142 5115.157 5116.160	THE GOOD MAN, GOOD LIFE, AND GOOD SOCIETY.
SOCIAL STUDIES	6448.17 6414.17 6499.02 6416.29	Through comparative analysis of several societies, both past and present, students will be introduced to differing views about what constitutes the good life. A humanities approach is designed to help the student develop his own personal philosophy.
LANGUAGE ARTS	5114.144 5115.159 5116.162	TRADITION AND CHANGE IN NON-WESTERN CULTURES
SOCIAL STUDIES	6414.08 6478.10 6448.41	An examination of the problems and dilemma of non-Western countries, trying to preserve their own culture and national pride and yet attain the economic wealth of the West as represented by Europe and the United States.
LANGUAGE ARTS	5111.26 5112.32 5113.73 5114.28 5115.139 5116.142	THE REEL THING
ART	6681.01 6682.01 6693.01	An introduction to photography as a unique art form, including a brief history of creative and experimental photography and the evolution of the camera as an art tool. Activities in this course will present an opportunity to build a camera and make creative slides, using color and positive/negative forms, photocaricatures, and photograms.
LANGUAGE ARTS	5111.27 5112.33 5113.74 5114.190 5115.140 5116.143	† CARTOON CARNIVAL
ART	6671.01 6672.01 6693.02	A survey of the history of cartooning, beginning as a means of social protest (for example, the cartoons of the French artist Daumier) and evolving through contemporary cartooning. Activities in this course present the student with an opportunity to develop skills and translate feelings in political cartoons, caricatures, and comic strips.
LANGUAGE ARTS	5113.75 5114.126 5115.141 5116.144	CINEMATOGRAPHY
ART	6677.15 6693.15	An exploratory study of visual film arts, including visual expression through silent motion picture stills and lights, art through color modulation and sound. Students demonstrating mature competency in unit projects are permitted to plan independent work.

LANGUAGE ARTS  
266

AREA	ACCR. NO. FLA-DADE	COURSE TITLE AND DESCRIPTION
LANGUAGE ARTS	5111.14 5112.30 5113.138	† MEET THE PHOTOGRAPHER
INDUSTRIAL ARTS	5832.02	A study of the application of photography, its mechanics, and processes. The student will be involved with the taking of still and motion pictures, the processing of film, and the making of prints.
LANGUAGE ARTS	5114.127 5115.142 5116.145	STAGE DESIGN
ART	5184.13 6683.06 6693.03 6698.01	The study and application of design and construction as it relates to stage production.
LANGUAGE ARTS	5114.128 5115.143 5116.146	STAGE LIGHTING
ART	5184.14 6683.07 6693.04 6698.02	A course planned to provide experience in lamination and lighting for a drama production. The student plans and sets up a lighting system and develops a working knowledge of various tools and equipment required for this endeavor.
LANGUAGE ARTS	5114.90 5115.90 5116.90	COSTUME DESIGN
ART HOME AND FAMILY ED.	5184.12 6697.01 6766.15	A course planned to provide experiences in the design and the development of costumes for a dramatic production. The student designs and creates costumes for use in dramatic productions.
LANGUAGE ARTS	5113.129 5114.220 5115.144 5116.147	ART AND THE PRESS
ART	5163.07 6677.12 6693.08	An exploratory course to explore art as it applies to the press. Students explore modern trends such as social protest, social commentary, etc. Use is made of field trips to the news media; guest speakers; local art critiques; student projects; political and amusement cartoons; translating of events into pictures and symbols; art production for the news media and/or press.
LANGUAGE ARTS	5128.11	BUSINESS GRAMMAR IN GOOD TASTE
BUSINESS EDUCATION	5128.11	Equips students with the basic skills needed to apply grammar, punctuation, capitalization, abbreviations, and number style to simple business communications.

AREA	ACCR. NO. FLA-DADE	COURSE TITLE AND DESCRIPTION
LANGUAGE ARTS	5128.12	SPELL IT RIGHT
BUSINESS EDUCATION	5128.12	Designed to help students achieve a high level of skill in vocabulary pertaining to business occupations. The course includes spelling rules, special aids in spelling, vocabulary and spelling drills consisting of general and specialized terms related to all phases of office occupations. Includes use of the dictionary and similar resource materials.
LANGUAGE ARTS	5113.133 5114.138 5115.153 5116.156	PREPARATION FOR OFFICE EMPLOYMENT
BUSINESS EDUCATION	7713.50	Designed to help students develop ability to locate jobs, prepare for employment tests, standards, and interviews; complete employment applications; and evaluate personality traits and human relation skills. A review of basic skills for civil service employment will also be included.
LANGUAGE ARTS	5128.31	EFFECTIVE BUSINESS REPORTS
BUSINESS EDUCATION	5128.31	Designed to provide students with the skill and knowledge needed to compose effective business reports, including format of a report, informal and formal reports, minutes of meetings, agendas, itineraries, news releases, and advertising copy. The student should have attained the objectives of Business Grammar in Good Taste; Spell It Right; and Typing Business Reports, Outlines, and Manuscripts prior to enrollment in this course.
LANGUAGE ARTS	5128.41	EFFECTIVE BUSINESS LETTERS
BUSINESS EDUCATION	5128.41	A review of business letter parts, placement, and punctuation; a study of qualities of effective business letters; application in the composition of business letters: remittance, order, acknowledgment, general response, claim and adjustment, credit and collection, sales, employment, public relations, and social-business letters, announcements, and invitations. The student should have attained the objectives of Business Grammar in Good Taste, Spell It Right, and Business Applications of Typewriting Skills prior to enrollment in this course.

LANGUAGE ARTS  
268

AREA	ACCR. NO. FLA-DADE	COURSE TITLE AND DESCRIPTION
LANGUAGE ARTS	5113.131 5114.135 5115.150 5116.153	TELL IT AS IT IS  Designed to acquaint the student with the methods and art of business communications through oral, written, and visual means, including telephone techniques, letters, telegrams, telefax, posters, memos, and interpretation of business charts and graphs.
BUSINESS EDUCATION	7713.13	
LANGUAGE ARTS	5116.164	† DEVELOPING THE ART OF COMMUNICATION
CBE	7725.07	Reading, listening, comprehension, use of the dictionary. Vocabulary related to parliamentary procedure, vocational education, and business management. Applicant must be accepted by the teacher-coordinator.
LANGUAGE ARTS	5116.165	REINFORCING KNOWLEDGE OF GRAMMAR
CBE	7725.08	Complete grammar brushup. Vocabulary relating to personality development, office relationships, job finding and job success.
LANGUAGE ARTS	5116.166	REVIEWING CAPITALIZATION AND PUNCTUATION, AND DEVELOPING A RESEARCH PAPER
CBE	7725.09	Complete review of capitalization, punctuation, abbreviation, and the use of figures; fine points of writing; developing a research paper. Vocabulary related to budgeting, insurance, money and banking.
LANGUAGE ARTS	5116.167	DEVELOPING WRITTEN BUSINESS COMMUNICATIONS
CBE	7725.10	Complete coverage of all types of written business communications; original letter composition. Vocabulary related to business letters, communications media, mathematics, and filing.
LANGUAGE ARTS	5116.168	EXPLORING LITERATURE AND PRACTICING ORAL COMMUNICATION
CBE	7725.11	Special emphasis is placed on literature, both ancient and modern, and the development of the student's interest in reading for pleasure. Stress will be placed on speaking in the business world by covering everyday situations the student is apt to meet. Vocabulary and the use of the dictionary will be given emphasis.

LANGUAGE ARTS  
269

263

AREA	ACCR. NO. FLA-DADE	COURSE TITLE AND DESCRIPTION
LANGUAGE ARTS	5114.94 5115.94 5116.94	RELATIONSHIP OF LANGUAGES, PART 1, HISTORY
FOREIGN LNG. FRENCH GERMAN LATIN SPANISH	7523.13 7533.13 7513.11 7503.242	This course seeks to trace the origin and history of the English language from the Anglo-Saxon period to the present. Influences from other languages on the vocabulary, structure (grammar) and syntax of English are stressed. In addition the student undertakes a brief comparative study of the foreign languages offered in his school in areas of vocabulary, idiom, word order, person number, and structure. No prerequisite.
LANGUAGE ARTS	5114.316 5115.316 5116.316	RELATIONSHIP OF LANGUAGES, PART 2, ENGLISH GRAMMAR FOR THE FOREIGN LANGUAGE STUDENT
FOREIGN LNG. FRENCH GERMAN LATIN SPANISH	7523.14 7533.14 7513.12 7503.43	This course is designed to strengthen students in English language skills preparatory to the study of a foreign language. It is NOT remedial grammar. Those elements of English grammar most commonly misunderstood in foreign language study are stressed, for example, parts of speech, tense, conjugation, principal parts, cases. Structure is stressed with little emphasis on usage. No prerequisite.
LANGUAGE ARTS FOREIGN LNG. SPANISH	5116.310 7506.25 7507.22 7509.703	CERVANTES AND HIS TIMES
		This course presents an accurate picture of the times, life, and works of the man who gave the world its first great novel. Students study the historical background while getting acquainted with Cervantes's main writings and style. Important literary and political figures of the Europe of the sixteenth and seventeenth centuries are considered. Emphasis is on guided discussion, free conversation, the writing of essays, and giving of reports. All class work is conducted in Spanish.
LANGUAGE ARTS FOREIGN LNG. SPANISH	5116.315 7506.26 7507.23 7509.704	THE GOLDEN AGE OF SPAIN
		The culture of the Golden Age of Spain is studied through readings, filmstrips, and tapes. The student gets acquainted with the life and work of the great masters in painting and literature. This course is recommended for the student who has controlled some of the 7506 courses.

LANGUAGE ARTS  
270

AREA	ACCR. NO. FLA-DADE	COURSE TITLE AND DESCRIPTION
LANGUAGE ARTS FOREIGN LNG. SPANISH SPANISH-S	5116.311  7507.24 7509.705	† GREAT WRITERS OF SPAIN, PART 1, THE NINETEENTH CENTURY  Originals of the Romantic period and the most representative authors of the literary Spain of the nineteenth century are considered in this course. This is the first course of a block of four geared to students preparing to take the Advanced Placement Exam. Emphasis is maintained throughout the course on guided discussion and analysis, free conversation, and the writing of essays, and giving of reports. The class is conducted in Spanish.
LANGUAGE ARTS FOREIGN LNG. SPANISH SPANISH-S	5116.312  7507.25 7509.706	GREAT WRITERS OF SPAIN, PART 2, THE TWENTIETH CENTURY  Starting with the famous "Generacion del 98," the works of the most representative authors of the literary Spain of the twentieth century are studied in this course. Emphasis is maintained throughout on guided discussion and analysis, free conversation, and the writing of essays, and giving of reports. The class is conducted in Spanish. This course is geared to the very capable student interested in Advanced Placement.
LANGUAGE ARTS FOREIGN LNG. SPANISH SPANISH-S	5116.313  7507.26 7509.707	GREAT WRITERS OF HISPANIC AMERICA, PART 1, THE NINETEENTH CENTURY  Works of the great writers of the Hispanic America of the nineteenth century are studied in this course, along with the literary movements of that time. Emphasis is on guided discussion and analysis, free conversation, the writing of essays, and the giving of reports. The class is conducted in Spanish. This course is geared to the very capable student interested in Advanced Placement.
LANGUAGE ARTS FOREIGN LNG. SPANISH SPANISH-S	5116.314  7507.27 7509.708	GREAT WRITERS OF HISPANIC AMERICA, PART 2, THE TWENTIETH CENTURY  The authors of today, the novelists and poets who constitute the literary elite of our century in Hispanic America, are studied in this course. Emphasis is on guided discussion and analysis, free conversation, the writing of essays, and giving of reports. The class is conducted in Spanish. This course is geared to the very capable student interested in Advanced Placement.

LANGUAGE ARTS  
271

## MATHEMATICS

This section contains brief course descriptions of the mathematics quinmester courses. These courses include topics for virtually every type of secondary student and have been designed in such a way as to allow a student great freedom in the selection of his plan of study.

The first four digits of each course code number correspond to the state accreditation numbers. In the area of general mathematics (courses numbered 5211, 5212, 5213, and 5214), the two digits following the decimal point are to be interpreted in this manner:

- .01-.20 Basic work with whole numbers, decimals, and fractions
- .40-.45 Basic work with percent
- .46-.49 Further work with nonnegative rational numbers. . . after basic skills have been  
and acquired
- .70-.99

It is the purpose of the mathematics quins to give direction to both teacher and counselor. Each quin contains a set of performance objectives, a set of suggested teaching strategies, a cross-reference matrix for identifying texts and materials, a pretest, and a posttest.

The objectives which are clearly stated, usually in behavioristic terms, should be considered as minimum goals for a course. It is hoped that they, the courses and objectives, will provide for the teacher and counselor a description of a student's past mathematical background and a range of suggestions for his future endeavors.

The suggested teaching strategies and cross-references should in no way curtail teacher's presentation of any quin course. The teacher should feel free to select any text or teaching aid that may be necessary in order to achieve the objectives.

The pretest and posttest have been included in order to aid the teacher in identifying the entry and exit levels of each student.

## QUINMESTER COURSES

Activities with Decimals	288
Activities with Fractions	288
Activities with Percent	289
Activities with Whole Numbers	288
Algebra 1a	300
Algebra 1b	300
Algebra 1c	300
Algebra 1d	301
Algebra 1p	301
Algebra 1q	301
Algebra 1r	302
Algebra 1s	302
Algebra 1t	302
Algebra 1u	302
Algebra 2a	307
Algebra 2b	307
Algebra 2c	307
Algebra 2d	307
Algebra 2p	305
Algebra 2q	305
Algebra 2r	306
Algebra 2s	306
Algebra 2t	306
Algebra 2u	306
Analytic Geometry 1	309
Analytic Geometry 2	309
Arithmetic Applications	298
Business Math Fundamentals	291
Calculus 1	311
Calculus 2	312
Calculus 3	312
Calculus 4	312
Calculus 5	312
Career Geometry	304
Circular Functions 1	308
Circular Functions 2	309
Consumer Math 1	291
Consumer Math 2	291
Consumer Math 3	291
Consumer Math 4	291
CP Decimals	284
CP Fractions	283
CP General Math	281
CP Geometry	288
CP Measurement	287
CP Percent 1	286
CP Percent 2	286
CP Pre-Algebra	292
CP Pure Math 1	294
CP Pure Math 2	295
CP Pure Math 3	295
CP Pure Math 4	295

**MATHEMATICS**  
274



CP Ratio and Proportion	285
CP Statistics	288
CP Structures 1	292
CP Structures 2	293
CP Structures 3	293
CP Structures 4	293
CP Structures 5	293
CP Structures 6	294
CP Structures 7	294
CP Structures 8	294
CP Whole Numbers 1	282
CP Whole Numbers 2	282
CP Whole Numbers 3	282
CP Whole Numbers 4	282
Decimal Action	284
Decimals Revisited	290
Descriptive Geometry	305
Distributive Math and Recordkeeping	314
Dollars and Sense	292
Double-S Decimals	285
Double-S Fractions	284
Double-S Number Theory	283
Experiencing Decimals 1	284
Experiencing Decimals 2	284
Experiencing Fractions 1	283
Experiencing Fractions 2	283
Experiencing Percent 1	285
Experiencing Percent 2	285
Experiencing Whole Numbers 1	281
Experiencing Whole Numbers 2	281
Formalizing Coordinate Geometry	304
Fraction Action	283
Fractions Revisited	290
Geometry 1	303
Geometry 2	303
Geometry 3	304
Geometric Constructions	298
Geometric Game Strategy	303
In the Marketplace	292
Independent Study	297
Introduction to Motion Geometry	286
Introduction to Stretching Machines	282
Math for Electronics	315
Math of Business, The	315
Math Review	305
Mathematical Analysis 1	310
Mathematical Analysis 2	310
Mathematical Analysis 3	310
Mathematical Analysis 4	311
Mathematical Structures 1	295
Mathematical Structures 2	295

Mathematical Structures 3	296
Mathematical Structures 4	296
Mathematics for Recreation	298
Mathematics of Elementary Astronomy	314
Measurement Lab	287
Modern Algebra	313
Modern Geometry	305
Nature of Proof	304
Navigation	314
Our Mathematical Heritage	298
Patterns in Mathematics	299
Percent Action	285
Percent Revisited	290
Practical Probability	290
Practical Statistics	290
Practical Trigonometry	308
Pre-Algebra 1	299
Pre-Algebra 2	299
Pre-Algebra 3	299
Pre-Algebra 4	300
Probability	313
Probability and Statistics	297
Proofs in Geometry	303
Pure Mathematics 1	296
Pure Mathematics 2	296
Pure Mathematics 3	297
Rational Applications 1	289
Rational Applications 2	289
Rational Applications 3	289
Rational Applications 4	289
Scientific Mathematics	314
SFT Congruence	286
SFT Measurement and Construction	287
SFT Symmetry	287
Slide Rule	315
Statistics	313
Surveying Mathematics	315
Survey of Algebra 1	301
Symbolic Logic and Boolean Algebra	313
Taxes	315
Techniques of Differentiation and Integration	311
Transformations	297
Trigonometry 1	308
Trigonometry 2	308
Use of the Computer in Problem Solving	314
Vector Spaces	313
Whole Number Action	281
Whole Numbers Revisited	290

**MATHEMATICS**  
276

## SUGGESTED PATHS OF PROGRESS IN THE STUDY OF MATHEMATICS

The quins which follow are designed for the student whose arithmetic skills need reinforcing.

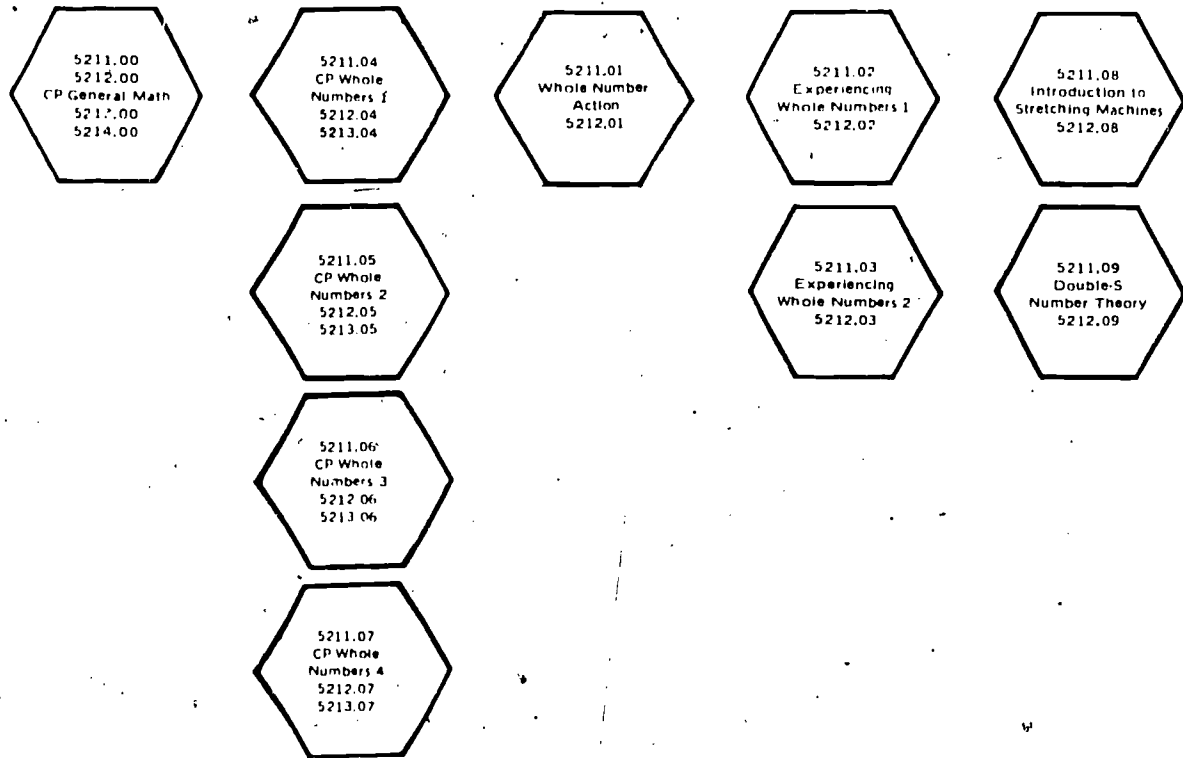

The quins which follow are designed for the student who has acquired basic computational skills with whole numbers.

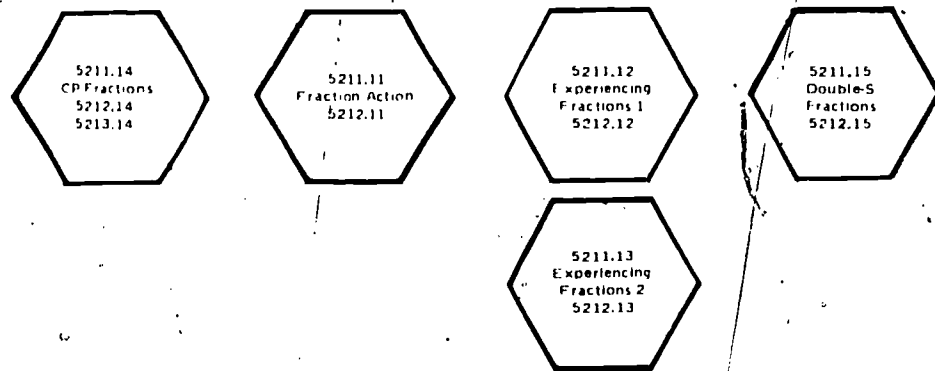

The quins which follow are designed for the student who has acquired basic computational skills with whole numbers and fractions.

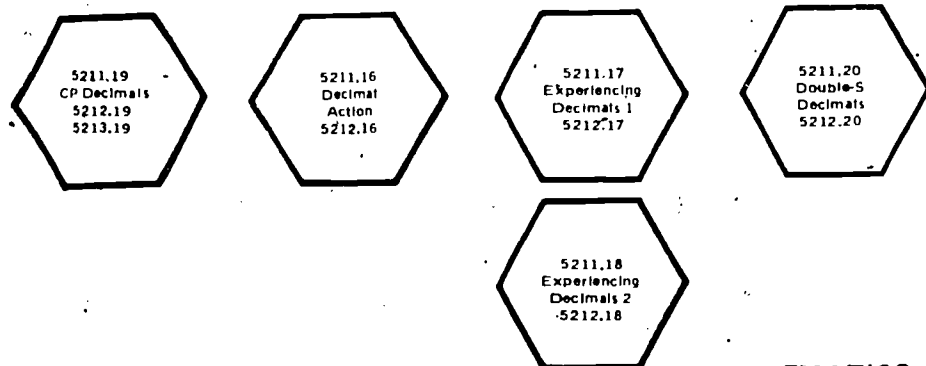

## SUGGESTED PATHS OF PROGRESS IN THE STUDY OF MATHEMATICS

The quins which follow are designed for the student who has acquired basic computational skills in whole numbers, fractions, and decimals

5212.43  
CP Ratio and Proportion  
5213.43  
5214.43

5211.40  
5212.40  
Percent Action  
5213.40

5212.41  
Experiencing Percent 1  
5213.41

5212.44  
CP Percent 1  
5213.44  
5214.44

5212.42  
Experiencing Percent 2  
5213.42

5212.45  
CP Percent 2  
5213.45  
5214.45

The quins which follow are designed for the student who has acquired basic computational skills with non negative rational numbers.

5213.70  
CP Measurement  
5214.70

5212.73  
Activities with Whole Numbers  
5213.73

5213.77  
Rational Applications 1  
5214.77

5285.21  
Consumer Math 1

5212.46  
Introduction to Motion Geometry  
5213.46

5213.71  
CP Geometry  
5214.71

5212.74  
Activities with Fractions  
5213.74

5213.78  
Rational Applications 2  
5214.78

5285.22  
Consumer Math 2

5212.47  
SFT Congruence  
5213.47

5213.72  
CP Statistics  
5214.72

5212.75  
Activities with Decimals  
5213.75

5213.79  
Rational Applications 3  
5214.79

5285.23  
Consumer Math 3

5212.48  
SFT Symmetry  
5213.48

5212.76  
Activities with Percent  
5213.76

5213.80  
Rational Applications 4  
5214.80

5285.24  
Consumer Math 4

5212.49  
SFT Measurement and Construction  
5213.49

5213.81  
Whole Numbers Revisited  
5214.81

5214.91  
Distributive Math and Recordkeeping  
8726.02

5213.82  
Fractions Revisited  
5214.82

5212.10  
Measurement Lab  
5213.10

5283.01  
Business Math Fundamentals (Business Education)

5213.83  
Decimals Revisited  
5214.83

5213.85  
Practical Statistics  
5214.85

5214.92  
Math for Electronics  
9323.04  
9783.04

5213.84  
Percent Revisited  
5214.84

5213.86  
Practical Probability  
5214.86

**MATHEMATICS**  
278

## SUGGESTED PATHS OF PROGRESS IN THE STUDY OF MATHEMATICS

The quins which follow are designed for the student who wishes to study Algebra in grade 8, 9, or 10.

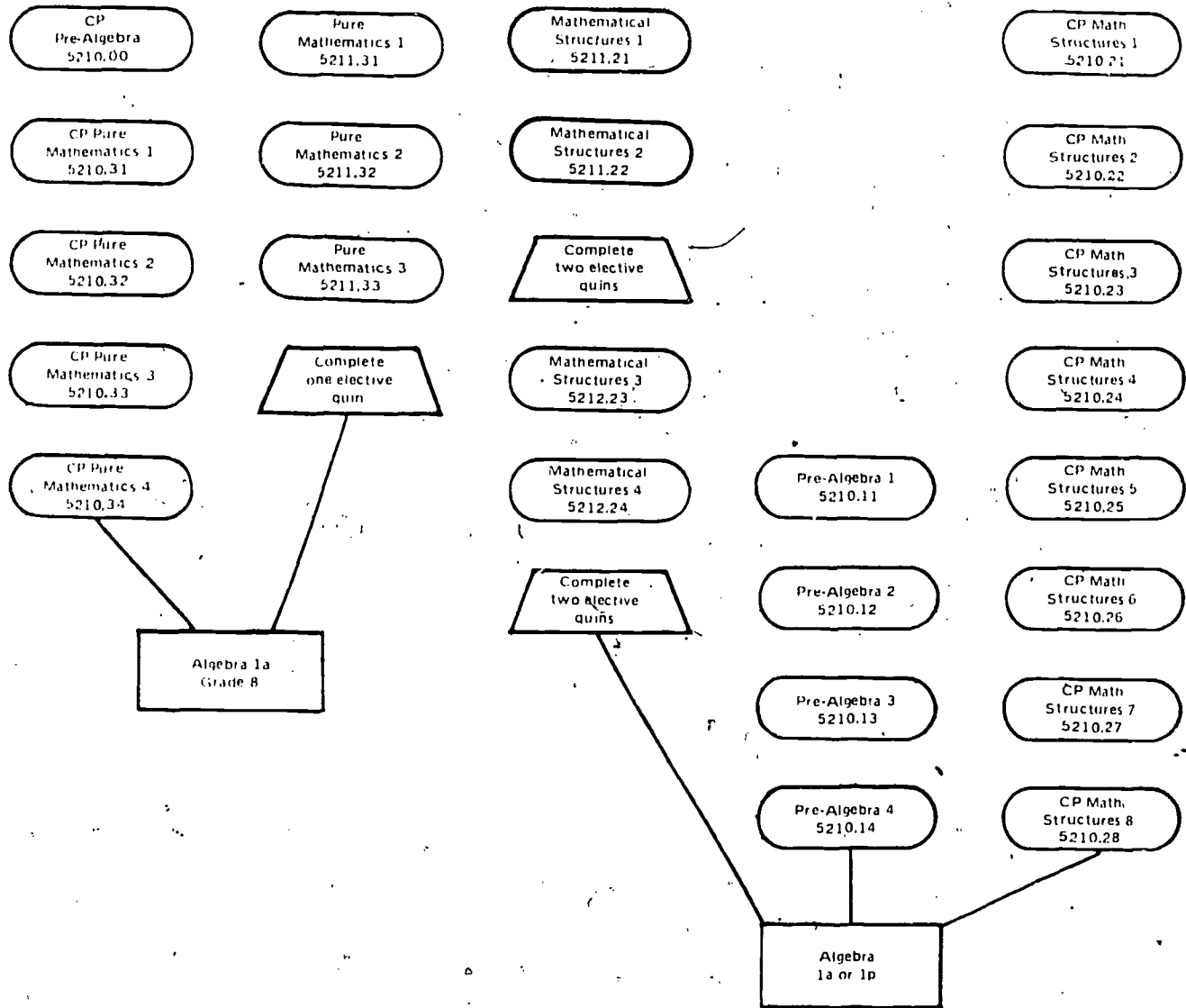

The quins that follow are elective quins.

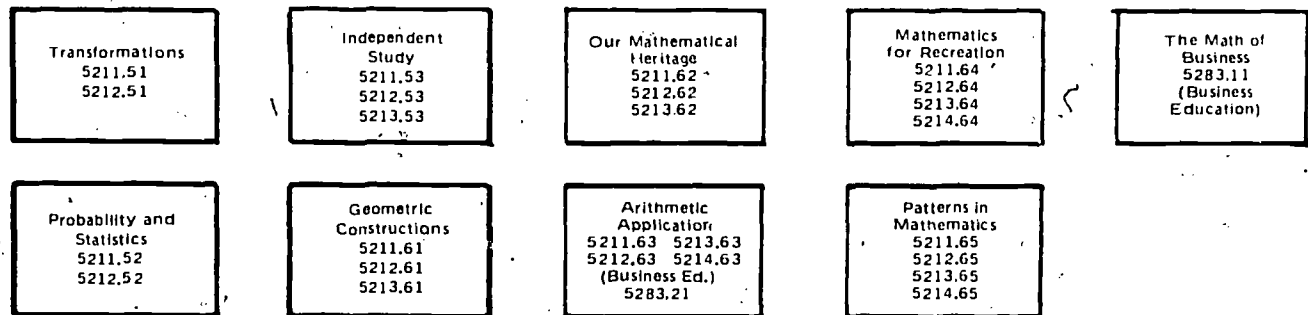



AREA	ACCR. NO. FLA-DADE	COURSE TITLE AND DESCRIPTION
MATH	5211.00 5212.00 5213.00 5214.00	<p data-bbox="835 478 1118 508">CP GENERAL MATH</p> <p data-bbox="835 539 1584 750">A course, included in a continuous progress program, whose objectives are a partial set of the objectives of one of the other CP quins numbered 5211, 5212, 5213, or 5214. Its purpose is to allow a student to earn one quin credit in mathematics if he makes satisfactory progress in the program even though he does not complete all of the objectives for the CP course on which he is working.</p> <p data-bbox="835 780 1584 959">A continuous progress (CP) program is defined to be a sequence of units or other materials which the student works through at his own pace without regard for the progress of other students in his class. Progress is considered to be satisfactory if the student is making progress that is commensurate with his ability.</p>
MATH	5211.01 5212.01	<p data-bbox="795 988 1193 1018">† WHOLE NUMBER ACTION</p> <p data-bbox="835 1050 1584 1140">A basic course in whole numbers with emphasis on activities that promote interest while improving computational skills.</p> <p data-bbox="835 1170 1584 1231">Designed for the student whose arithmetic skills need reinforcing.</p>
MATH	5211.02 5212.02	<p data-bbox="835 1290 1340 1319">EXPERIENCING WHOLE NUMBERS 1</p> <p data-bbox="835 1351 1584 1412">The first of two basic courses in whole numbers involving a laboratory approach.</p> <p data-bbox="835 1442 1584 1503">Designed for the student whose arithmetic skills need reinforcing.</p>
MATH	5211.03 5212.03	<p data-bbox="835 1562 1340 1592">EXPERIENCING WHOLE NUMBERS 2</p> <p data-bbox="835 1623 1584 1685">The second of two basic courses in whole numbers involving a laboratory approach.</p> <p data-bbox="835 1714 1584 1769">Designed for the student who has successfully completed Experiencing Whole Numbers 1.</p>

AREA	ACCR. NO. FLA-DADE	COURSE TITLE AND DESCRIPTION
MATH	5211.04 5212.04	<p>CP WHOLE NUMBERS 1</p> <p>A basic course in whole numbers with stress on place value, reading and writing numbers, rounding, estimating, and practical applications.</p> <p>Designed for the student whose arithmetic skills need reinforcing.</p>
MATH	5211.05 5212.05	<p>CP WHOLE NUMBERS 2</p> <p>A basic course in whole numbers with stress on addition, subtraction, and practical applications.</p> <p>Designed for the student who has successfully completed CP Whole Numbers 1.</p>
MATH	5211.06 5212.06	<p>CP WHOLE NUMBERS 3</p> <p>A basic course in whole numbers with stress on multiplication, division, and practical applications.</p> <p>Designed for the student who has successfully completed CP Whole Numbers 2.</p>
MATH	5211.07 5212.07	<p>CP WHOLE NUMBERS 4</p> <p>A basic course in whole numbers with stress on number theory, set theory, flow charting, and logic.</p> <p>Designed for the student who has successfully completed CP Whole Numbers 3.</p>
MATH	5211.08 5212.08	<p>INTRODUCTION TO STRETCHING MACHINES</p> <p>The first of four quins designed to develop computational skills with fractions, percents, and decimals, using the "stretcher and shrinker" approach developed by the University of Illinois Committee on School Mathematics. Includes factoring, equations, primes, exponents, and rearrangement (commutativity).</p> <p>Designed for the student who has competence in the basic computational skills with whole numbers.</p>



AREA	ACCR. NO. FLA-DADE	COURSE TITLE AND DESCRIPTION
MATH	5211.09 5212.09	<p>DOUBLE-S NUMBER THEORY</p> <p>The second of four quins designed to develop computational skills with fractions, percents, and decimals, using the "stretcher and shrinker" approach developed by the University of Illinois Committee on School Mathematics. Includes approximation, inverses, equations, factoring, and rearrangement.</p> <p>Designed for the student who has successfully completed Introduction to Stretching Machines, 5211.08.</p>
MATH	5211.11 5212.11	<p>FRACTION ACTION</p> <p>A basic course in fractions with emphasis on activities that promote interest while improving computational skills.</p> <p>Designed for the student who has acquired basic computational skills with whole numbers.</p>
MATH	5211.12 5212.12	<p>EXPERIENCING FRACTIONS 1</p> <p>The first of two basic courses in fractions involving a laboratory approach.</p> <p>Designed for the student who has acquired basic computational skills with whole numbers.</p>
MATH	5211.13 5212.13	<p>EXPERIENCING FRACTIONS 2</p> <p>The second of two basic courses in fractions involving a laboratory approach.</p> <p>Designed for the student who has successfully completed Experiencing Fractions 1.</p>
MATH	5212.14 5213.14	<p>CP FRACTIONS</p> <p>A basic course in fractions with stress on computational skills and practical applications.</p> <p>Designed for the student who has successfully completed CP Whole Numbers 4.</p>

AREA	ACCR. NO. FLA-DADE	COURSE TITLE AND DESCRIPTION
MATH	5211.15 5212.15	<p><b>DOUBLE-S FRACTIONS</b></p> <p>The third of four quins designed to develop computational skills with fractions, percents, and decimals, using the "stretcher and shrinker" approach developed by the University of Illinois Committee on School Mathematics. Includes the four operations with fractions and mixed numbers, and work with percent.</p> <p>Designed for the student who has successfully completed Double-S Number Theory, 5211.09.</p>
MATH	5211.16 5212.16	<p><b>DECIMAL ACTION</b></p> <p>A basic course in decimals with emphasis on activities that promote interest while improving computational skills. Includes review work to maintain and improve skills with whole numbers and fractions.</p> <p>Designed for the student who has acquired basic computational skills with whole numbers and fractions.</p>
MATH	5211.17 5212.17	<p><b>EXPERIENCING DECIMALS 1</b></p> <p>The first of two basic courses in decimals involving a laboratory approach.</p> <p>Designed for the student who has acquired basic computational skills in whole numbers and fractions.</p>
MATH	5211.18 5212.18	<p><b>EXPERIENCING DECIMALS 2</b></p> <p>The second of two basic courses in decimals involving a laboratory approach.</p> <p>Designed for the student who has successfully completed Experiencing Decimals 1.</p>
MATH	5212.19 5213.19	<p><b>CP DECIMALS</b></p> <p>A basic course in decimals with stress on computational skills and practical applications.</p> <p>Designed for the student who has successfully completed CP Fractions.</p>

AREA	ACCR. NO. FLA-DADE	COURSE TITLE AND DESCRIPTION
MATH	5211.20 5212.20	<p><b>DOUBLE-S DECIMALS</b></p> <p>The last of four quins designed to develop computational skills with fractions, percents, and decimals, using the "stretcher and shrinker" approach developed by the University of Illinois Committee on School Mathematics. Includes place value, the four operations with decimals, conversion between fractions and decimals, and applications.</p> <p>Designed for the student who has successfully completed Double-S Fractions, 5211.15.</p>
MATH	5211.40 5212.40 5213.40	<p><b>PERCENT ACTION</b></p> <p>A basic course in ratio, proportion, and percent with emphasis on activities that promote interest while improving computational skills.</p> <p>Designed for the student who has acquired basic computational skills with whole numbers, fractions, and decimals.</p>
MATH	5212.41 5213.41	<p><b>EXPERIENCING PERCENT 1</b></p> <p>The first of two basic courses in ratio, proportion, and percent involving a laboratory approach.</p> <p>Designed for the student who has acquired basic computational skills in whole numbers, fractions, and decimals.</p>
MATH	5212.42 5213.42	<p><b>EXPERIENCING PERCENT 2</b></p> <p>The second of two basic courses in ratio, proportion, and percent involving a laboratory approach.</p> <p>Designed for the student who has successfully completed Experiencing Percent 1.</p>
MATH	5212.43 5213.43	<p><b>CP RATIO AND PROPORTION</b></p> <p>A basic course in ratio and proportion with stress on the concepts involved, setting up and solving proportions, and the solution of simple practical word problems.</p> <p>Designed for the student who has successfully completed CP Decimals.</p>

AREA	ACCR. NO. FLA-DADE	COURSE TITLE AND DESCRIPTION
MATH	5212.44 5213.44	<p>CP PERCENT 1</p> <p>A basic course in percent with stress on the meaning of percent and its relationship to decimals and fractions.</p> <p>Designed for the student who has successfully completed CP Ratio and Proportion.</p>
MATH	5213.45 5214.45	<p>CP PERCENT 2</p> <p>A basic course in percent with stress on its application to problems of everyday living.</p> <p>Designed for the student who has successfully completed CP Percent 1.</p>
MATH	5212.46 5213.46	<p>INTRODUCTION TO MOTION GEOMETRY</p> <p>One of four quins designed to develop geometric concepts intuitively, using the "slides, flips, and turns" approach developed by the University of Illinois Committee on School Mathematics. Includes an introduction to the three basic motions of transformation and review work in computational skills.</p> <p>Designed for the student who has successfully completed work with whole numbers, fractions, decimals, and percent.</p>
MATH	5212.47 5213.47	<p>SFT. CONGRUENCE</p> <p>The second of four quins designed to develop geometric concepts intuitively, using the "slides, flips, and turns" approach developed by the University of Illinois Committee on School Mathematics. Includes development of the concept of congruence, basic geometric figures, and review work in computational skills.</p> <p>Designed for the student who has successfully completed Introduction to Motion Geometry, 5212.46.</p>

AREA	ACCR. NO. FLA-DADE	COURSE TITLE AND DESCRIPTION
MATH	5212.48 5213.48	<p data-bbox="776 471 1014 503">SFT SYMMETRY</p> <p data-bbox="776 539 1529 752">The third of four quins designed to develop geometric concepts intuitively, using the "slides, flips, and turns" approach developed by the University of Illinois Committee on School Mathematics. Includes the development of the concept of symmetry, triangle and quadrilateral classifications, parallel and perpendicular lines, and work with directed numbers.</p> <p data-bbox="776 782 1529 843">Designed for the student who has successfully completed SFT Congruence, 5212.47.</p>
MATH	5212.49 5213.49	<p data-bbox="776 895 1375 927">SFT MEASUREMENT AND CONSTRUCTION</p> <p data-bbox="776 963 1529 1145">The last of four quins designed to develop geometric concepts intuitively, using the "slides, flips, and turns" approach developed by the University of Illinois Committee on School Mathematics. Includes area; ratio; similarity; construction using ruler, compass, and protractor; and work with directed numbers.</p> <p data-bbox="776 1168 1529 1229">Designed for the student who has successfully completed SFT Symmetry, 5212.48.</p>
MATH	5212.10 5213.10	<p data-bbox="732 1281 1067 1313">† MEASUREMENT LAB</p> <p data-bbox="776 1349 1529 1530">A laboratory approach to introduce linear measurement, perimeter, circumference, area of square and rectangle, volume of rectangular solids, and fluid measurement. Applications include use of ruler, meter stick, thermometer, beaker, air gauge, geometric solids, and geoboards.</p> <p data-bbox="776 1553 1529 1628">Designed for the student who has acquired basic computational skills with nonnegative rational numbers.</p>
MATH	5213.70 5214.70	<p data-bbox="776 1680 1040 1712">CP MEASUREMENT</p> <p data-bbox="776 1748 1529 1871">A basic course in measurement with stress on linear measure, angle measure, use of ruler and protractor, adding and subtracting denominate numbers, and the metric system.</p> <p data-bbox="776 1893 1529 1945">Designed for the student who has successfully completed CP Percent 2.</p>

AREA	ACCR. NO. FLA-DADE	COURSE TITLE AND DESCRIPTION
MATH	5213.71 5214.71	<p>CP GEOMETRY</p> <p>A basic course in geometry with stress on recognition of geometric figures; finding perimeter, area, and volume of simple figures; and practical applications used in problem solving.</p> <p>Designed for the student who has successfully completed CP Measurement.</p>
MATH	5213.72 5214.72	<p>CP STATISTICS</p> <p>A basic course in statistics with stress on construction and interpretation of graphs as they relate to the practical problems of everyday living.</p> <p>Designed for the student who has successfully completed CP Geometry.</p>
MATH	5212.73 5213.73	<p>ACTIVITIES WITH WHOLE NUMBERS</p> <p>A course which will develop computational skills with nonnegative rational numbers through activities that promote interest. Emphasis is on whole numbers.</p> <p>Designed for the student who has acquired <i>basic</i> computational skills with nonnegative rational numbers.</p>
MATH	5212.74 5213.74	<p>ACTIVITIES WITH FRACTIONS</p> <p>A course which will develop computational skills with nonnegative rational numbers through activities that promote interest. Emphasis is on fractions.</p> <p>Designed for the student who has acquired <i>basic</i> computational skills with nonnegative rational numbers.</p>
MATH	5212.75 5213.75	<p>ACTIVITIES WITH DECIMALS</p> <p>A course which will develop computational skills with nonnegative rational numbers through activities that promote interest. Emphasis is on decimals.</p> <p>Designed for the student who has acquired <i>basic</i> computational skills with nonnegative rational numbers.</p>

AREA	ACCR. NO. FLA-DADE	COURSE TITLE AND DESCRIPTION
MATH	5212.76 5213.76	<p data-bbox="741 495 1136 525">ACTIVITIES WITH PERCENT</p> <p data-bbox="741 560 1492 652">A course which will develop computational skills with nonnegative rational numbers through activities that promote interest. Emphasis is on percent.</p> <p data-bbox="741 686 1492 743">Designed for the student who has acquired <i>basic</i> computational skills with nonnegative rational numbers.</p>
MATH	5213.77 5214.77	<p data-bbox="741 801 1136 831">RATIONAL APPLICATIONS 1</p> <p data-bbox="741 865 1492 957">One of four quins which will develop computational skills with nonnegative rational numbers through applications to business and industry.</p> <p data-bbox="741 991 1492 1049">Designed for the student who has acquired <i>basic</i> computational skills with nonnegative rational numbers.</p>
MATH	5213.78 5214.78	<p data-bbox="741 1106 1136 1136">RATIONAL APPLICATIONS 2</p> <p data-bbox="741 1170 1492 1262">One of four quins which will develop computational skills with nonnegative rational numbers through applications to business and industry.</p> <p data-bbox="741 1297 1492 1354">Designed for the student who has acquired <i>basic</i> computational skills with nonnegative rational numbers.</p>
MATH	5213.79 5214.79	<p data-bbox="741 1412 1136 1441">RATIONAL APPLICATIONS 3</p> <p data-bbox="741 1476 1492 1568">One of four quins which will develop computational skills with nonnegative rational numbers through applications to business and industry.</p> <p data-bbox="741 1602 1492 1660">Designed for the student who has acquired <i>basic</i> computational skills with nonnegative rational numbers.</p>
MATH	5213.80 5214.80	<p data-bbox="741 1717 1136 1747">RATIONAL APPLICATIONS 4</p> <p data-bbox="741 1781 1492 1873">One of four quins which will develop computational skills with nonnegative rational numbers through applications to business and industry.</p> <p data-bbox="741 1907 1492 1965">Designed for the student who has acquired <i>basic</i> computational skills with nonnegative rational numbers.</p>

AREA	ACCR. NO. FLA-DADE	COURSE TITLE AND DESCRIPTION
MATH	5213.81 5214.81	<p>WHOLE NUMBERS REVISITED</p> <p>One of four quins which will review skills with nonnegative rational numbers while presenting other topics in mathematics. Emphasis is on whole number review.</p> <p>Designed for the student who has acquired <i>basic</i> computational skills with nonnegative rational numbers.</p>
MATH	5213.82 5214.82	<p>FRACTIONS REVISITED</p> <p>One of four quins which will review skills with nonnegative rational numbers while presenting other topics in mathematics. Emphasis is on fraction review.</p> <p>Designed for the student who has acquired <i>basic</i> computational skills with nonnegative rational numbers.</p>
MATH	5213.83 5214.83	<p>DECIMALS REVISITED</p> <p>One of four quins which will review skills with nonnegative rational numbers while presenting other topics in mathematics. Emphasis is on decimal review.</p> <p>Designed for the student who has acquired <i>basic</i> computational skills with nonnegative rational numbers.</p>
MATH	5213.84 5214.84	<p>PERCENT REVISITED</p> <p>One of four quins which will review skills with nonnegative rational numbers while presenting other topics in mathematics. Emphasis is on percent review.</p> <p>Designed for the student who has acquired <i>basic</i> computational skills with nonnegative rational numbers.</p>
MATH	5212.85 5213.85 5214.85	<p>PRACTICAL STATISTICS</p> <p>A study of the uses of statistical data. Includes construction of graphs from data collected and organized by students. Emphasis is on project work.</p>
MATH	5213.86 5214.86	<p>PRACTICAL PROBABILITY</p> <p>Review of fractions using lab activities involving chance. Includes collecting and organizing data, Pascal's triangle, random sampling, permutations and combinations.</p>



AREA	ACCR. NO. FLA-DADE	COURSE TITLE AND DESCRIPTION
MATH	5285.21	<p>CONSUMER MATH 1</p> <p>One of four quins which will develop computational skills with nonnegative rational numbers through applications to daily living.</p> <p>Designed for the student who has acquired <i>basic</i> computational skills with nonnegative rational numbers.</p>
MATH	5285.22	<p>CONSUMER MATH 2</p> <p>One of four quins which will develop computational skills with nonnegative rational numbers through applications to daily living.</p> <p>Designed for the student who has acquired <i>basic</i> computational skills with nonnegative rational numbers.</p>
MATH	5285.23	<p>CONSUMER MATH 3</p> <p>One of four quins which will develop computational skills with nonnegative rational numbers through applications to daily living.</p> <p>Designed for the student who has acquired <i>basic</i> computational skills with nonnegative rational numbers.</p>
MATH	5285.24	<p>CONSUMER MATH 4</p> <p>One of four quins which will develop computational skills with nonnegative rational numbers through applications to daily living.</p> <p>Designed for the student who has acquired <i>basic</i> computational skills with nonnegative rational numbers.</p>
MATH BUSINESS EDUCATION	5283.01 5283.01	<p>† BUSINESS MATH FUNDAMENTALS</p> <p>Designed to reinforce skills in addition, subtraction, multiplication, division, percentages, decimals, fractions, whole and mixed numbers.</p>

AREA	ACCR. NO. FLA-DADE	COURSE TITLE AND DESCRIPTION
MATH	5283.22	† DOLLARS AND SENSE  The student will plan the management of his or her money to get the most personal satisfaction from it. The course includes influence of teen-age spending on the economy, understanding and keeping money records, developing skill in decision making, and planning as a consumer.
BUSINESS	7734.22	
EDUCATION	5283.22	
HOME AND	6765.01	
FAMILY ED.		
MATH	5283.23	IN THE MARKETPLACE  Focuses on comparison shopping store etiquette, impulse buying, reading labels, specials, loss leaders, standards in relation to need, installment or cash costs.
BUSINESS	6463.01	
EDUCATION	5283.23	
HOME AND FAMILY ED.	6765.03	
MATH	5210.00	CP PRE-ALGEBRA  A course, included in a continuous progress program, whose objectives are a partial set of the objectives of one of the other CP courses numbered 5210. Its purpose is to allow a student to earn one quin credit in mathematics each quinmester if he makes satisfactory progress in the program even though he does not complete all of the objectives for the CP course on which he is working.  A continuous progress (CP) program is defined to be a sequence of units or other materials which the student works through at his own pace without regard for the progress of other students in his class. Progress is considered to be satisfactory if the student is making progress that is commensurate with his ability.
MATH	5210.21	CP STRUCTURES 1  The first of eight CP quins which will prepare the students for success in algebra. Includes place value, reading and writing numbers, positive exponents, expanded notation, and elementary set theory.  Designed for the student who wishes to take algebra in either ninth or tenth grade.

AREA	ACCR. NO. FLA-DADE	COURSE TITLE AND DESCRIPTION
MATH	5210.22	<p data-bbox="761 470 1030 500">CP STRUCTURES 2</p> <p data-bbox="761 534 1512 661">The second of eight CP quins which will prepare the student for success in algebra. Includes computation with whole numbers, order relationships, number line, and properties of whole number operations.</p> <p data-bbox="761 688 1512 746">Designed for the student who has successfully completed CP Structures 1, 5210.21.</p>
MATH	5210.23	<p data-bbox="761 803 1030 833">CP STRUCTURES 3</p> <p data-bbox="761 870 1512 959">The third of eight CP quins which will prepare the student for success in algebra. Includes factors, multiples, primes, composites, LCM, and GCF.</p> <p data-bbox="761 987 1512 1051">Designed for the student who has successfully completed CP Structures 2, 5210.22.</p>
MATH	5210.24	<p data-bbox="761 1108 1030 1138">CP STRUCTURES 4</p> <p data-bbox="761 1173 1512 1322">The fourth of eight CP quins which will prepare the student for success in algebra. Includes operations with fractions, properties of operations with fractions, simplifying fractions, comparing fractions, and word problems.</p> <p data-bbox="761 1356 1512 1418">Designed for the student who has successfully completed CP Structures 3, 5210.23.</p>
MATH	5210.25	<p data-bbox="761 1476 1030 1506">CP STRUCTURES 5</p> <p data-bbox="761 1540 1512 1666">The fifth of eight CP quins which will prepare the student for success in algebra. Includes reading and writing decimals, computation with decimals, ratio, proportion, and word problems involving proportion.</p> <p data-bbox="761 1694 1512 1744">Designed for the student who has successfully completed CP Structures 4, 5210.24.</p>

AREA	ACCR. NO. FLA-DADE	COURSE TITLE AND DESCRIPTION
MATH	5210.26	<p data-bbox="795 484 1059 512">CP STRUCTURES 6</p> <p data-bbox="795 546 1533 695">The sixth of eight CP quins which will prepare the student for success in algebra. Includes meaning of percent; conversion among fractional, decimal, and percent forms; problem solving involving percent; integers; absolute value; and operations with integers.</p> <p data-bbox="795 730 1533 787">Designed for the student who has successfully completed CP Structures 5, 5210.25.</p>
MATH	5210.27	<p data-bbox="795 844 1059 872">CP STRUCTURES 7</p> <p data-bbox="795 906 1533 1056">The seventh of eight CP quins which will prepare the student for success in algebra. Includes solution of linear equations, using the properties of equality; metric and nonmetric geometry; square root; and the Pythagorean property.</p> <p data-bbox="795 1090 1533 1148">Designed for the student who has successfully completed CP Structures 6, 5210.26.</p>
MATH	5210.28	<p data-bbox="795 1205 1059 1232">CP STRUCTURES 8</p> <p data-bbox="795 1267 1533 1389">The last of eight CP quins which will prepare the student for success in algebra. Includes exponents, scientific notation, metric system, other number bases, graphing, and accuracy in measurement.</p> <p data-bbox="795 1423 1533 1480">Designed for the student who has successfully completed CP Structures 7, 5210.27.</p>
MATH	5210.31	<p data-bbox="795 1538 1035 1565">CP PURE MATH 1</p> <p data-bbox="795 1600 1533 1749">The first of four CP quins which will prepare the mathematically gifted Grade 7 student for success in algebra in Grade 8. Includes place value, set theory, computation with nonnegative rationals, properties, and word problems.</p> <p data-bbox="795 1783 1533 1868">Designed for the highly motivated, mathematically gifted Grade 7 student who has a thorough knowledge of elementary school mathematics.</p>

AREA	ACCR. NO. FLA-DADE	COURSE TITLE AND DESCRIPTION
MATH	5210.32	<p data-bbox="775 470 1017 500">CP PURE MATH 2</p> <p data-bbox="775 530 1530 654">The second of four CP quins which will prepare the mathematically gifted Grade 7 student for success in algebra in Grade 8. Includes ratio, proportion, percent, integers, and word problems.</p> <p data-bbox="775 684 1530 746">Designed for the student who has successfully completed CP Pure Math 1, 5210.31.</p>
MATH	5210.33	<p data-bbox="775 805 1017 835">CP PURE MATH 3</p> <p data-bbox="775 865 1530 989">The third of four CP quins which will prepare the mathematically gifted Grade 7 student for success in algebra in Grade 8. Includes solution of linear equations, metric geometry, and nonmetric geometry.</p> <p data-bbox="775 1019 1530 1081">Designed for the student who has successfully completed CP Pure Math 2, 5210.32.</p>
MATH	5210.34	<p data-bbox="775 1141 1017 1170">CP PURE MATH 4</p> <p data-bbox="775 1200 1530 1347">The last of four CP quins which will prepare the mathematically gifted Grade 7 student for success in algebra in Grade 8. Includes exponents, scientific notation, metric system, other number bases, graphing, and accuracy in measurement.</p> <p data-bbox="775 1377 1530 1439">Designed for the student who has successfully completed CP Pure Math 3, 5210.33.</p>
MATH	5211.21	<p data-bbox="775 1499 1241 1529">MATHEMATICAL STRUCTURES 1</p> <p data-bbox="775 1558 1530 1705">One of two quins in Grade 7 recommended to build fundamental concepts necessary for success in algebra. Includes numeration systems, other number bases with operations, properties of rational numbers, factors and primes.</p> <p data-bbox="775 1735 1462 1774">Designed for the highly motivated student in Grade 7.</p>
MATH	5211.22	<p data-bbox="775 1834 1241 1864">MATHEMATICAL STRUCTURES 2</p> <p data-bbox="775 1894 1530 2018">This is one of two quins recommended in Grade 7 in order to build fundamental concepts for success in algebra. Includes decimals, ratio and proportion, percent, and problem solving.</p> <p data-bbox="775 2048 1462 2068">Designed for the highly motivated student in Grade 7.</p>

AREA	ACCR. NO. FLA-DADE	COURSE TITLE AND DESCRIPTION
MATH	5212.23	<p><b>MATHEMATICAL STRUCTURES 3</b></p> <p>One of two quins in Grade 8 recommended to build fundamental concepts necessary for success in algebra. Includes integers and their operations, exponents and scientific notation, and metric system without conversions.</p> <p>Designed for the highly motivated student who has mastered the skills described in Math Structures 1 and 2.</p>
MATH	5212.24	<p><b>MATHEMATICAL STRUCTURES 4</b></p> <p>One of two quins in Grade 8 recommended to build fundamental concepts for success in algebra. Includes sets and their operation, open sentences, and graphing.</p> <p>Designed for the highly motivated student who has mastered the skills described in Math Structures 1 and 2.</p>
MATH	5211.31	<p><b>PURE MATHEMATICS 1</b></p> <p>The first of three quins designed for the mathematically gifted Grade 7 student who will begin algebra in Grade 8. Includes integers, sets, number properties, open sentences, and graphing. The pace will be rapid; concepts will be stressed.</p> <p>Designed for the highly motivated, mathematically gifted Grade 7 student; thorough knowledge of elementary school mathematics is necessary.</p>
MATH	5211.32	<p><b>PURE MATHEMATICS 2</b></p> <p>One of three quins which together prepare a Grade 7 student for algebra in Grade 8. Includes exponents, scientific notation, metric system, problem solving, decimal fractions, percent, and a review of ratio and proportion.</p> <p>Designed for the student who has mastered the skills described in Pure Math 1.</p>

AREA	ACCR. NO. FLA-DADE	COURSE TITLE AND DESCRIPTION
MATH	5211.33	<p>PURE MATHEMATICS 3</p> <p>One of three quins which together prepare a Grade 7 student for algebra in Grade 8. Includes number systems, factors, and primes, rational numbers, ratio and proportion.</p> <p>Designed for the student who has mastered the skills described in Pure Math 1.</p>
MATH	5211.51 5212.51	<p>TRANSFORMATIONS</p> <p>An optional quin designed for the serious student. A study of transformations in the plane through the use of <math>2 \times 2</math> matrix multiplication, 2-d vectors, and motion geometry. Will reinforce rational number operations, ratio and proportion, graphing in the Cartesian plane.</p> <p>Designed for the student who has mastered the skills and concepts in four Math Structures quins or three Pure Math quins.</p>
MATH	5211.52 5212.52	<p>PROBABILITY AND STATISTICS</p> <p>An optional quin designed for the serious math student. Includes basic ideas of probability and statistics, sequence and patterns, with emphasis on lab approach. Will reinforce rational number operations, ratio and proportion, and percent.</p> <p>Designed for the student who has mastered the skills and concepts in four Math Structures quins or three Pure Math quins.</p>
MATH	5211.53 5212.53 5213.53	<p>INDEPENDENT STUDY</p> <p>The content and direction of this course is left entirely to the teacher. Some product, such as a written report or project, will be expected. The student will keep a log of his activities.</p> <p>A student should be very creative and be able to work without constant direction.</p>

AREA	ACCR. NO. FLA-DADE	COURSE TITLE AND DESCRIPTION
MATH	5211.61 5212.61 5213.61	<p><b>GEOMETRIC CONSTRUCTIONS</b></p> <p>An optional quin to follow the study of Mathematical Structures which will reinforce ratio and proportion, fractions, problem solving, and decimals. Includes use of geometric tools, recognition of fundamental figures, geometric constructions, area, and volume.</p> <p>Designed for the student who has mastered the skills described in Math Structures 1 and 2.</p>
MATH	5211.62 5212.62 5213.62	<p><b>OUR MATHEMATICAL HERITAGE</b></p> <p>A study of the historical development of some mathematical concepts and men who contributed to mathematics as we know it today. Includes contributions of Pythagoras, Archimedes, Eratosthenes, Diophantus, Napier, Pascal, and others. Will reinforce fundamental skills with rational numbers.</p> <p>Designed for the student who has mastered the skills described in Math Structures 1 and 2.</p>
MATH BUSINESS EDUCATION	5211.63 5212.63 5213.63 5283.21	<p><b>ARITHMETIC APPLICATIONS</b></p> <p>This is a practical course designed for the student who will not cover practical topics in other courses. Includes study of stocks and bonds, interest, installment buying, budget, credit cards, checking and savings accounts, travel, time, latitude and longitude, calendar patterns, etc.</p> <p>Designed for the student who has mastered the skills described in Math Structures 1 and 2:</p>
MATH	5211.64 5212.64 5214.64	<p><b>MATHEMATICS FOR RECREATION</b></p> <p>This course explores the mathematics involved in games and puzzles. Activities are planned to reinforce whole numbers, factors and primes, fractions, decimals, geometric figures, and 2-d graphing.</p> <p>Designed for the student who has mastered the skills described in Math Structures 1 and 2.</p>



AREA	ACCR. NO: FLA-DADE	COURSE TITLE AND DESCRIPTION
MATH	5212.65 5214.65	<p data-bbox="790 472 1207 500">PATTERNS IN MATHEMATICS</p> <p data-bbox="790 534 1533 679">A nonrigorous investigation of the mathematics of patterns. Reinforces fundamental skills in computing with rational numbers. Includes sequences, series, Pascal's triangle, square numbers, magic squares, codes, decoding, and use of flow charts.</p> <p data-bbox="790 714 1533 771">Designed for the student who has mastered the skills described in Math Structures 1 and 2.</p>
MATH	5210.11	<p data-bbox="790 833 1023 860">† PRE-ALGEBRA 1</p> <p data-bbox="790 895 1533 1040">The first of four quins designed to strengthen fundamental concepts and skills which are basic preparation for Algebra 1. Includes number systems, properties of nonnegative rational numbers, simple open sentences, factorization of natural numbers, and problem solving.</p> <p data-bbox="790 1074 1533 1166">Designed for the student who has mastered the fundamental computational skills with nonnegative rational numbers.</p>
MATH	5210.12	<p data-bbox="790 1228 1023 1255">PRE-ALGEBRA 2</p> <p data-bbox="790 1290 1533 1435">The second of four quins designed to strengthen fundamental concepts which are basic preparation for Algebra 1. Includes an introduction to rational numbers, real number properties and operations, graphing in 1-d, and open sentences.</p> <p data-bbox="790 1469 1533 1526">Designed for the student who has mastered the skills and concepts of Pre-Algebra 1.</p>
MATH	5210.13	<p data-bbox="790 1588 1023 1616">PRE-ALGEBRA 3</p> <p data-bbox="790 1650 1533 1772">One of the four quins designed to strengthen fundamental concepts which are basic preparation for Algebra 1. Includes exponents, scientific notation, metric system, graphing in 2-d, and problem solving.</p> <p data-bbox="790 1806 1533 1852">Designed for the student who has mastered the skills and concepts in Pre-Algebra 1 and 2.</p>

AREA	ACCR. NO. FLA-DADE,	COURSE TITLE AND DESCRIPTION
MATH	5210.14	<p><b>PRE-ALGEBRA 4</b></p> <p>One of four quins designed to strengthen fundamental concepts which are basic preparation for Algebra 1. Includes open sentences, ratio and proportion, percent, problem solving, and simple geometric formulas.</p> <p>Designed for the student who has mastered the skills and concepts in Pre-Algebra 1 and 2.</p>
MATH	5215.21	<p><b>ALGEBRA 1a</b></p> <p>An introduction to the fundamental operations and properties of the real numbers, using sets as the basic language. Includes a review of the operations and properties of rational numbers, the development of set notation, the ordered field properties of the real number system, an introduction to algebraic expressions, the solution of linear equations and inequalities in one variable, and the solution of verbal problems.</p> <p>Designed for the student who has mastered the concepts and skills in the three Pure Math masters, the four Math Structures quins, or the four Pre-Algebra, quins, CP Structures 1 through 7, or CP Pure Math 1, 2, and 3.</p>
MATH	5215.22	<p><b>ALGEBRA 1b</b></p> <p>A continuation of the development of the concepts initiated in Algebra 1a. Includes further work in problem solving, work with integral exponents, operations with polynomials (including factbrization), and work with rational expressions.</p> <p>Designed for the student who has mastered the concepts and skills of Algebra 1a.</p>
MATH	5215.23	<p><b>ALGEBRA 1c</b></p> <p>A development of the concepts involved in the study of first and second degree equations and inequalities. Includes first degree equations involving absolute value, work with radicals, various approaches to solving quadratics, and problem solving.</p> <p>Designed for the student who has mastered the concepts and skills of Algebra 1b.</p>

AREA	ACCR. NO. FLA-DADE	COURSE TITLE AND DESCRIPTION
MATH	5215.24	<p data-bbox="784 454 969 489">ALGEBRA 1d</p> <p data-bbox="784 523 1528 672">A study of graphing in the Cartesian plane and other related topics. Includes the distance formula, slope, the slope-intercept form of the equation of a straight line, algebraic and graphic solutions to systems of equations, functions, and work with variation.</p> <p data-bbox="784 707 1528 764">Designed for the student who has mastered the concepts and skills of Algebra 1b.</p>
MATH	5215.25	<p data-bbox="741 821 1125 856">† SURVEY OF ALGEBRA 1</p> <p data-bbox="784 890 1528 948">A review of polynomials, factoring fractions, exponents, radicals, absolute value, linear and quadratic equations.</p> <p data-bbox="784 982 1528 1063">Designed for the student who has had experience with the material contained in the four quins of Algebra 1 but needs strengthening.</p>
MATH	5215.11	<p data-bbox="741 1120 969 1154">† ALGEBRA 1p.</p> <p data-bbox="784 1189 1528 1430">The first of six quins which together contain all the concepts and skills usually found in first-year algebra. An introduction to the fundamental operations of the real numbers, using sets as the basic language. Includes a review of the operations with rational numbers, the development of set notation, an introduction to algebraic expressions, and the solution of simple linear equations and inequalities in one variable.</p> <p data-bbox="784 1464 1528 1545">Designed for the student who has competence in the skills and concepts of the four Math Structures quins, the four Pre-Algebra quins, or the CP Structures 1 through 7.</p>
MATH	5215.12	<p data-bbox="784 1602 969 1637">ALGEBRA 1q</p> <p data-bbox="784 1671 1528 1912">A continuation of the development of the real number system and algebraic expressions and an introduction to problem solving. Includes the ordered field properties of the real number system, further work in the solution of linear equations and inequalities; an introduction to the solution of verbal problems, work with whole number exponents, and some work in the operations with polynomials.</p> <p data-bbox="784 1947 1528 1990">Designed for the student who has mastered the skills and concepts in Algebra 1p.</p>

AREA	ACCR. NO. FLA-DADE	COURSE TITLE AND DESCRIPTION
MATH	5215.13	<p data-bbox="809 464 991 499">ALGEBRA 1r</p> <p data-bbox="809 535 1565 690">A continuation of work with polynomials and the development of ability to work with rational expressions. Includes work with negative exponents; multiplication, division, and factoring of polynomials; and fundamental operations with rational expressions.</p> <p data-bbox="809 714 1565 785">Designed for the student who has mastered the skills and concepts of Algebra 1q.</p>
MATH	5215.14	<p data-bbox="809 821 991 856">ALGEBRA 1s</p> <p data-bbox="809 892 1565 1023">Further work in open sentences and problem solving and an introduction to radicals. Includes first degree equations involving absolute value, various approaches to solving quadratics, and problem solving involving quadratics.</p> <p data-bbox="809 1047 1565 1118">Designed for the student who has mastered the skills and concepts of Algebra 1r.</p>
MATH	5215.15	<p data-bbox="809 1154 991 1190">ALGEBRA 1t</p> <p data-bbox="809 1225 1565 1404">Further work in radicals and problem solving, and an introduction to graphing in the Cartesian plane. Includes operations with radicals, solution of equations involving radicals or rational expressions, the distance formula, slope; and the slope-intercept form of the equation of a line.</p> <p data-bbox="809 1428 1565 1511">Designed for the student who has mastered the skills and concepts of Algebra 1s.</p>
MATH	5215.16	<p data-bbox="809 1547 991 1582">ALGEBRA 1u</p> <p data-bbox="809 1618 1565 1725">Further work in solving equations and an introduction to functions. Includes the algebraic and graphic solutions to systems of equations, functions, and work with variation.</p> <p data-bbox="809 1749 1565 1811">Designed for the student who has mastered the skills and concepts of Algebra 1t.</p>

AREA	ACCR. NO. FLA-DADE	COURSE TITLE AND DESCRIPTION
MATH	5218.21	<p data-bbox="712 455 936 485">† GEOMETRY 1</p> <p data-bbox="751 517 1495 784">The first of a two-quin sequence which introduces the student to all of the theorems usually included in high school geometry. Emphasis is on the understanding and use of these theorems without proof. Develops concepts and skills relative to lines, angles, and triangles. Includes algebraic solution of some problems, sketching of 2-d and 3-d illustrations, interpreting data from illustrations, basic construction, and application of definitions, postulates, and theorems in problem solving.</p> <p data-bbox="751 814 1495 875">Designed for the student who has mastered the skills and concepts of Algebra 1b.</p>
MATH	5218.22	<p data-bbox="751 938 936 968">GEOMETRY 2</p> <p data-bbox="751 1000 1495 1238">The second of a two-quin sequence which introduces the student to all of the theorems usually included in high school geometry; emphasis is on understanding and use of these theorems without proof. Develops definitions and properties of plane and solid figures. Formulates methods for finding their linear measures, lateral and total area measures, and volume measures. Develops the Pythagorean theorem and special right triangle relationships.</p> <p data-bbox="751 1267 1495 1358">Designed for the student who has mastered the skills and concepts of Geometry 1, 5218.21, with a final average of low B or less.</p>
MATH	5218.23	<p data-bbox="751 1422 1077 1451">PROOFS IN GEOMETRY</p> <p data-bbox="751 1483 1495 1596">A study of the nature of proof, using Euclidean geometry as a model. The development of techniques of formal proof will be simplified through a liberal use of partially constructed proofs ready for completion.</p> <p data-bbox="751 1626 1495 1691">Designed for the student who has mastered the skills and concepts of Geometry 2 or 3.</p>
MATH	5209.55	<p data-bbox="751 1755 1183 1784">GEOMETRIC GAME STRATEGY</p> <p data-bbox="751 1816 1495 1930">An investigation of interesting and challenging mathematical activities which are not usually developed in other mathematics courses, including brainteasers, puzzles, and game theory.</p> <p data-bbox="751 1959 1495 2018">Designed for the student who has mastered the skills and concepts of Geometry 2.</p>

AREA	ACCR. NO. FLA-DADE	COURSE TITLE AND DESCRIPTION
MATH	5209.56	<p><b>CAREER GEOMETRY</b></p> <p>An introduction to the many uses of geometry in various careers designed to develop an appreciation for the versatility of geometric applications.</p> <p>Designed for the student who has mastered the skills and concepts of Geometry 2.</p>
MATH	5218.32 H	<p><b>GEOMETRY 3</b></p> <p>The second of a two-quin sequence which introduces the student to all of the theorems usually included in high school geometry; emphasis is on understanding and use of these theorems without proof. Develops definitions and properties of plane and solid figures. Formulates methods for finding their linear measures, lateral and total area measures, and volume measures.</p> <p>Develops an extensive view of the Pythagorean theorem and special right triangle relationships.</p> <p>This quin includes detailed development of the following new materials and enrichment activities not covered in 5218.22: application of metric measure, right triangle trigonometry, coordinate geometry, tangrams, tessellations, flexagons, projections, polyhedral models, topology, non-Euclidean geometry, suggested challenge problems, and architectural design applications.</p>
MATH	5228.33 H	<p><b>NATURE OF PROOF</b></p> <p>A study of the nature and methods of proof, using Euclidean geometry as a model. A more rigorous and formal course than 5218.23, Proofs in Geometry. Designed for the student who plans to study Advanced Mathematics.</p> <p>Designed for the student who has mastered the skills and concepts of Geometry 3.</p>
MATH	5228.34 H	<p><b>FORMALIZING COORDINATE GEOMETRY</b></p> <p>A study of proof, using the language of coordinate geometry and simple vector algebra.</p> <p>Designed for the student who has mastered the skills and concepts of Nature of Proof.</p>

AREA	ACCR. NO. FLA-DADE	COURSE TITLE AND DESCRIPTION
MATH	5228.36 H	<p>MODERN GEOMETRY</p> <p>An investigation of non-Euclidean geometry and extensions of Euclidean geometry.</p> <p>Designed for the student who has mastered the skills and concepts of Nature of Proof. Students should be interested in highly abstract geometry.</p>
MATH INDUSTRIAL ARTS	5228.37 5816.01	<p>† DESCRIPTIVE GEOMETRY</p> <p>A course in logical reasoning. Develops ability to draw and interpret the movement of a point, line, and a plane in space. Includes points, lines, plane surfaces, revolutions, polyhedrons, single curved surfaces, and simple intersections of surfaces.</p> <p>Designed for the student who displays the skills indicated in Drafting Techniques, 5813.02 and Analytic Geometry 1, 5295.23.</p>
MATH	5265.01	<p>MATH REVIEW</p> <p>A course designed for the students who have taken Algebra and Geometry and who need to strengthen their skills in problem solving and mathematics applications. Emphasis will be on the kinds of skills and procedures used in the college placement tests (SCAT, PSAT, etc.)</p>
MATH	5216.21	<p>ALGEBRA 2p</p> <p>The first of 6 quins which together contain all the concepts and skills usually found in second-year algebra. Includes a survey of the real and complex number system, and operations with polynomials of degree four and less.</p> <p>Designed for the student who has mastered the skills and concepts in all four quins of Algebra 1.</p>
MATH	5216.22	<p>ALGEBRA 2q</p> <p>A continuation of 5216.21, Algebra 2p. Emphasis is on operations and applications involving rational expressions and real exponents. Includes fractional and radical equations, inequalities, and relations between exponents and radicals.</p> <p>Designed for the student who has mastered the skills and concepts of Algebra 2p. May be taken concurrently with Algebra 2r.</p>

MATHEMATICS  
305

208

AREA	ACCR. NO. FLA-DADE	COURSE-TITLE AND DESCRIPTION
MATH	5216.23	<p><b>ALGEBRA 2r</b></p> <p>A review and extension of graphing in two-dimensions which was developed in 5215.24, Algebra 1d. Includes algebraic and graphic solutions of systems of equations, absolute value and inequalities, introduction to matrices and determinants.</p> <p>Designed for the student who has mastered the skills and concepts of Algebra 2p. May be taken concurrently with Algebra 2q.</p>
MATH	5216.24	<p><b>ALGEBRA 2s</b></p> <p>The fourth of 6 quins which together contain all of the concepts and skills usually found in second-year algebra. A further development of the concepts, notation, and graphing of functions and relations. Includes the quadratic formula, quadratic functions and their relation to the parabola, and applications of maxima and minima.</p> <p>Designed for the student who has mastered the skills and concepts of Algebra 2q and 2r.</p>
MATH	5216.25	<p><b>ALGEBRA 2t</b></p> <p>A further development of graphing in two-dimensions in addition to an introduction to logarithmic and exponential functions. Includes graphing of conic sections (circle, parabola, ellipse, and hyperbola), systems of first and second degree equations, quadratic inequalities, computing with common logarithms, applications, logarithms to any base, exponential equations.</p> <p>Designed for the student who has mastered the skills and concepts of Algebra 2s.</p>
MATH	5216.26	<p><b>ALGEBRA 2u</b></p> <p>An introduction to sequences, series, permutations, combinations, and probability. Includes arithmetic and geometric progressions, problems solved by counting, the binomial theorem, and factorials.</p> <p>Designed for the student who has mastered the skills and concepts of Algebra 2s.</p>



AREA	ACCR. NO. FLA-DADE	COURSE TITLE AND DESCRIPTION
MATH	5216.31 H	<p data-bbox="760 497 941 532">ALGEBRA 2a</p> <p data-bbox="760 560 1511 769">The first of four quins which together contain all the concepts and skills usually found in second-year algebra with emphasis on formal development as well as skills. Includes proofs involving properties of the real number field, a review of irrational numbers, introduction to complex numbers, and algebraic and graphic solutions of inequalities involving absolute value in 1-d.</p> <p data-bbox="760 797 1511 862">Designed for the student who has above-average mastery of the skills and concepts in first-year algebra.</p>
MATH	5216.32 H	<p data-bbox="760 920 941 955">ALBEGRA 2b</p> <p data-bbox="760 983 1511 1168">The second of four quins which together contain all the concepts and skills usually found in second-year algebra. A continuation of 5216.31, Algebra 2a. Includes further work in inequalities and absolute value in 1-d and 2-d, systems of linear functions and relations, fundamental operations with polynomials, and rational algebraic expressions.</p> <p data-bbox="760 1196 1511 1257">Designed for the student who has mastered the skills and concepts of Algebra 2a.</p>
MATH	5216.33 H	<p data-bbox="760 1315 941 1350">ALGEBRA 2c</p> <p data-bbox="760 1378 1511 1494">One of four quins which together contain all the concepts and skills usually found in second-year algebra. Includes exponential and logarithmic functions and equations, logarithmic computation, conic sections.</p> <p data-bbox="760 1522 1511 1617">Designed for the student who has mastered the skills and concepts of Algebra 2b, and may be taken concurrently with Algebra 2d.</p>
MATH	5216.34 H	<p data-bbox="760 1675 941 1710">ALGEBRA 2d</p> <p data-bbox="760 1738 1511 1889">One of four quins which together contain all the concepts and skills usually found in second-year algebra. Includes polynomial functions of degree greater than 2, sequences, series, combinations, permutations, probability, and an introduction to matrix algebra.</p> <p data-bbox="760 1917 1511 2003">Designed for the student who has mastered the skills and concepts of Algebra 2b, and may be taken concurrently with Algebra 2c.</p>

300

AREA	ACCR. NO. FLA-DADE	COURSE TITLE AND DESCRIPTION
MATH	5219.05	PRACTICAL TRIGONOMETRY  A course in applications of trigonometry. Emphasis is on computation; certain techniques of elementary algebra will be developed for use in problem solving; computation with base 10 logarithms will be introduced.  Designed for the student who has competence in general mathematics skills and who has interest in solving practical problems.
MATH	5219.11	TRIGONOMETRY 1  The first of a two-quin sequence designed for the serious student who has encountered difficulty in second-year algebra. An introduction to trigonometric functions of angles in standard position. Includes radian measure, angular velocity, fundamental identities, linear and quadratic trigonometric equations.  Designed for the student who has mastered the skills and concepts of Algebra 2p, q, r, s, t.
MATH	5219.12	TRIGONOMETRY 2  The second of a two-quin sequence designed for the serious student who has completed Trigonometry 1 or who has encountered difficulty in Circular Functions 1. Includes sum, difference, double-angle, and half-angle formulas, Law of Sines, Law of Cosines, applications, inverse trigonometric functions, DeMoivre's theorem.  Designed for the student who has mastered the skills and concepts of Trigonometry 1 or Circular Functions 1.  <i>NOTE:</i> Trigonometry 1 and 2 meet the minimum requirements for a course in trigonometry.
MATH	5219.21	CIRCULAR FUNCTIONS 1  The first of the two-quin sequence which is a systematic development of trigonometry through a study of circular functions. Includes a review of functions, graphing of circular functions and their inverses, arc length, angular and linear velocity.  Designed for the student who has mastered the skills and concepts of Algebra 2a, b, c, d.

AREA	ACCR. NO. FLA-DADE	COURSE TITLE AND DESCRIPTION
MATH	5219.22	<p data-bbox="746 466 1102 493"><b>CIRCULAR FUNCTIONS 2</b></p> <p data-bbox="746 530 1483 707">The second of a two-quin sequence which is a systematic development of trigonometry through a study of circular functions. Includes identities, trigonometric equations, applications to triangles, polar form of complex numbers, DeMoivre's theorem, and an introduction to vectors, matrices, and transformations.</p> <p data-bbox="746 737 1483 821">Designed for the student who has mastered the basic skills and concepts of Circular Functions 1 or Mathematical Analysis 1.</p> <p data-bbox="746 856 1483 913"><i>NOTE:</i> Circular Functions 1 and 2 fulfill the requirements for a standard course in trigonometry.</p>
MATH	5295.23	<p data-bbox="746 982 1102 1010"><b>ANALYTIC GEOMETRY 1</b></p> <p data-bbox="746 1042 1483 1249">The first of a two-quin sequence to complete the development of analytic geometry which was begun in second-year algebra. Emphasis in this course is on analysis of functions in the plane. Includes an introduction to vectors in a plane, detailed treatment of the line, families of lines, families of circles, conic sections, rotation and translation of axis.</p> <p data-bbox="746 1283 1483 1343">Designed for the student who has mastered the skills and concepts of Circular Functions 2.</p>
MATH	5295.24	<p data-bbox="746 1409 1102 1437"><b>ANALYTIC GEOMETRY 2</b></p> <p data-bbox="746 1469 1483 1614">The second of a two-quin sequence to complete the development of analytic geometry. Emphasis in this course is on curve sketching of algebraic and transcendental functions, polar coordinates, vectors in three space, and solid analytic geometry.</p> <p data-bbox="746 1648 1483 1703">Designed for the student who has mastered the skills and concepts of Analytic Geometry 1.</p>

AREA	ACCR. NO. FLA-DADE	COURSE TITLE AND DESCRIPTION
MATH	5286.31 H	<p data-bbox="775 468 1193 500"><b>MATHEMATICAL ANALYSIS 1</b></p> <p data-bbox="775 530 1528 741">The first of a four-quin sequence for the serious mathematics student. A rigorous presentation of trigonometry, using circular functions of real numbers as a defining basis. Includes identities, applications, trigonometric equations, inverse trigonometric functions, DeMoivre's theorem, and the polar form of complex numbers.</p> <p data-bbox="775 771 1528 863">Designed for the student who has above-average mastery of the skills and concepts of Algebra 2a, b, c, d, and the recommendation of instructor.</p> <p data-bbox="775 893 1528 952"><i>NOTE:</i> This course fulfills the requirements for a standard course in trigonometry.</p>
MATH	5286.32 H	<p data-bbox="775 1012 1193 1044"><b>MATHEMATICAL ANALYSIS 2</b></p> <p data-bbox="775 1074 1528 1189">The second of a four-quin sequence for the serious mathematics student. Includes detailed analytic geometry of the straight line, circle, and conic sections; use of vectors in two and three dimensions; parametric equations.</p> <p data-bbox="775 1219 1528 1311">Designed for the student who has mastered the skills and concepts of Mathematical Analysis 1 and has the recommendation of the teacher.</p>
MATH	5286.33 H	<p data-bbox="775 1370 1193 1402"><b>MATHEMATICAL ANALYSIS 3</b></p> <p data-bbox="775 1432 1528 1643">The third of a four-quin sequence for the serious mathematics student. Combines and elaborates on topics from trigonometry, analytic geometry, and advanced algebra. Includes graphs of algebraic functions in rectangular and polar form, exponential and logarithmic functions, polar coordinates, and an introduction to limit theory.</p> <p data-bbox="775 1673 1528 1765">Designed for the student who has mastered the skills and concepts of Mathematical Analysis 2 and has the recommendation of the teacher.</p>

AREA	ACCR. NO. FLA-DADE	COURSE TITLE AND DESCRIPTION
MATH	5286.34 H	<p data-bbox="826 461 1243 491"><b>MATHEMATICAL ANALYSIS 4</b></p> <p data-bbox="826 523 1566 707">The fourth of a four-quin sequence for the serious mathematics student. Continues the formal study of limit theory begun in Mathematical Analysis 3. Includes formal development of symbolic logic and Boolean algebra, an introduction to matrix algebra, and proofs by mathematical induction.</p> <p data-bbox="826 739 1566 828">Designed for the student who has mastered the skills and concepts of Mathematical Analysis 3 and has the recommendation of the teacher.</p>
MATH	5297.27	<p data-bbox="826 890 1566 950"><b>TECHNIQUES OF DIFFERENTIATION AND INTEGRATION</b></p> <p data-bbox="826 982 1566 1072">A short course in the basic techniques of calculus for the student who has need of these skills in other courses, such as beginning physics, economics, statistics, etc.</p> <p data-bbox="826 1104 1566 1189">Designed for the student who has mastered the skills and concepts of Analytic Geometry 2 or Mathematical Analysis 3.</p>
MATH	5297.41 H	<p data-bbox="826 1251 1005 1281"><b>CALCULUS 1</b></p> <p data-bbox="826 1313 1566 1517">This is the first of a four-quin sequence leading to the CEEB Advanced Placement AB Test in May. (A fifth quin may be added to complete the required experience for the BC Test.) Content includes a review and extension of advanced algebra, limit proofs involving sequences and algebraic functions, application of limits, and introduction to the derivative.</p> <p data-bbox="826 1549 1566 1726">Designed for the student who has a thorough knowledge of circular functions and analytic geometry, as well as considerable experience in symbolic logic, limit theory, matrix algebra, and mathematical induction. Recommendation by mathematics teacher is highly desirable.</p>

AREA	ACCR. NO. FLA-DADE	COURSE TITLE AND DESCRIPTION
MATH	5297.42 H	<p><b>CALCULUS 2</b></p> <p>The second of a four-quin sequence leading to the CEEB Advanced Placement AB Test in May. Emphasis is on theory and applications of the derivative and definite integral.</p> <p>Designed for the student who has mastered the skills and concepts of Calculus 1.</p>
MATH	5297.43 H	<p><b>CALCULUS 3</b></p> <p>The third of a four-quin sequence leading to CEEB Advanced Placement AB Test in May. Includes applications of the definite integral, derivation of Euler's number <math>e</math>; derivatives and integrals involving transcendental functions and their inverses.</p> <p>Designed for the student who has mastered the skills and concepts of Calculus 2.</p>
MATH	5297.44 H	<p><b>CALCULUS 4</b></p> <p>The fourth of a four-quin sequence leading to the CEEB Advanced Placement AB Test in May. Includes an introduction to differential equations; polynomial approximations of <math>\sin x</math>, <math>\cos x</math>, <math>e^x</math>, etc; formal integration.</p> <p>Designed for the student who has mastered the skills and concepts of Calculus 3.</p>
MATH	5297.45 H	<p><b>CALCULUS 5</b></p> <p>A continuation of the formal study of calculus leading to the CEEB Advanced Placement BC Test in May. Further develops basic properties of continuous and differentiable functions. Includes boundedness, Cauchy's formula, L'Hospital's rules, improper integrals, areas of surface of revolution, polar coordinates, infinite series, and elementary differential equations.</p> <p>Designed for the student who has mastered the skills and concepts of Calculus 4.</p>

AREA	ACCR. NO. FLA-DADE	COURSE TITLE AND DESCRIPTION
MATH	5293.35 H	<p><b>SYMBOLIC LOGIC AND BOOLEAN ALGEBRA</b></p> <p>A formal development of symbolic logic and the algebra of sets. Designed for those interested in higher mathematics.</p> <p>Designed for the student who has mastered the skills and concepts of Analytic Geometry 2 or Mathematical Analysis 3.</p>
MATH	5293.36 H	<p><b>MODERN ALGEBRA</b></p> <p>A formal development of beginning matrix algebra and the abstract algebra of groups, rings, fields, integral domains, etc. Designed for those interested in higher mathematics.</p> <p>Designed for the student who has mastered the skills and concepts of Analytic Geometry 2 or Mathematical Analysis 3.</p>
MATH	5293.37 H	<p><b>VECTOR SPACES</b></p> <p>A formal development of linear algebra as a vector space. Designed for those interested in higher mathematics.</p> <p>Designed for the student who has mastered the skills and concepts of Analytic Geometry 2 or Mathematical Analysis 3.</p>
MATH	5293.38 H	<p><b>PROBABILITY</b></p> <p>A study of the probability function and its application. The practical application of probability to game theory and voting power.</p> <p>Designed for the student who has interest in higher mathematics and has mastered the skills and concepts of Algebra 2a, b, c, d, with considerable experience in summation and factorial notation.</p>
MATH	5293.39 H	<p><b>STATISTICS</b></p> <p>Study of the methods of gathering, presenting, interpreting, and analyzing statistical data with stress on data distribution in applied situations.</p> <p>Designed for the student who has interest in higher mathematics and has mastered the skills and concepts of Algebra 2a, b, c, d, including the binomial theorem.</p>

AREA	ACCR. NO. FLA-DADE	COURSE TITLE AND DESCRIPTION
MATH	5281.15	<p><b>USE OF THE COMPUTER IN PROBLEM SOLVING</b></p> <p>An introduction to the use of an electronic computer. Includes flow charting, simple computer language, hands-on or simulated experiences on a computer, and solution of problems on selected topics through the use of a computer.</p> <p>Designed for the student who has competence in general mathematics skills.</p>
MATH SCIENCE	5266.16 5348.04 5347.04	<p><b>NAVIGATION</b></p> <p>A survey course in land, air, and water navigation. Includes vectors, manual computers, radio operation, chart and map reading.</p> <p>Designed for the student who has competence in general mathematics skills.</p>
MATH	5266.17	<p><b>MATHEMATICS OF ELEMENTARY ASTRONOMY</b></p> <p>An introduction to the mathematics needed in the study of astronomy. Includes use of scientific notation, ratios, decimals, formulas, and simple geometric facts.</p> <p>Designed for the student who has competence in general mathematics skills.</p>
MATH SCIENCE	5266.26 5344.01	<p><b>† SCIENTIFIC MATHEMATICS</b></p> <p>Includes scientific notation, metric system, graphing, ratios, and probability. It is recommended for students planning to take chemistry.</p>
MATH DISTRIBUTIVE EDUCATION	5214.91 8726.02	<p><b>DISTRIBUTIVE MATH AND RECORDKEEPING</b></p> <p>Teaches the basic skills of distributive math and recordkeeping which are basic requirements for employability.</p>



AREA	ACCR. NO. FLA-DADE	COURSE TITLE AND DESCRIPTION
MATH	5266.28	<p>SLIDE RULE</p> <p>A study of mathematical principles upon which the slide rule is based and its use in computations. The operations of multiplication, division, and roots will be emphasized.</p> <p>Designed for the student who is proficient in general mathematics skills and knowledgeable in logarithms and trigonometric functions.</p>
MATH INDUSTRIAL ARTS	5299.27 5858.03	<p>SURVEYING MATHEMATICS</p> <p>An introduction to the mathematics needed in surveying. Includes historical background, use of transit, scale drawing, and applications of elementary trigonometry.</p> <p>Designed for the student who has acquired the skills and concepts of Practical Trigonometry.</p>
MATH TRADE AND IND. ED.	5214.92 9323.04 9783.04	<p>MATH FOR ELECTRONICS</p> <p>Designed for the student interested in preparing for vocational electronics and related fields of electricity. It contains units in slide rule, powers of 10, basic algebra, basic trigonometry related to vector analysis, and logarithms related to decibels.</p>
MATH BUSINESS EDUCATION	5283.11 5283.11	<p>THE MATH OF BUSINESS</p> <p>A fundamental review with emphasis on interest, markup, markdown, depreciation, discounts, and commissions. The course includes shortcuts and rapid and mental calculations that will be used in advanced business courses.</p> <p>The student should have attained the objectives of Business Math Fundamentals prior to enrollment in this course.</p>
MATH BUSINESS EDUCATION SOCIAL STUDIES	5283.24 6463.02 5283.24 6463.02 6448.67	<p>TAXES</p> <p>Explores questions of why we have taxes and how they benefit people; taxes at local, state, and federal levels; property, sales, income, excise, inheritance taxes.</p>

## MUSIC

Courses are categorized in three groups according to achievement needed for success. Placement in courses is based on a pupil's (1) knowledge, (2) performance skills, and (3) motivation for study.

Pupils may have had opportunities and have developed skills needed for courses prior to entering a middle, junior high, or senior high school. If so, they should be placed in courses appropriate to their development. Many courses require unique performance skills. This is a consideration in placing pupils. For example, a pupil may be an advanced performer on a band or orchestral instrument. If he chooses to study a keyboard instrument, he might need to be placed in beginning keyboard laboratory.

### *GROUP I*

These courses are introductory courses in which pupils sing and listen to and perform on a variety of instruments to (1) determine their interest in specific ways of making music and (2) develop skills with music which will be useful in further study.

Music Laboratory I  
Music Laboratory II

### *GROUP II*

It is recommended that placement in the Group II courses be based on the skills described in Group I.

Music Laboratory III  
Keyboard Laboratory I  
Guitar Laboratory I

### *Music Listening*

An Introduction to Music Listening  
Introduction to Humanities  
Music Appreciation  
Directed Listening to Music  
Independent Study in Music Listening  
Music History  
Music Listening—Renaissance  
Music Listening—Baroque  
Music Listening—Classic  
Music Listening—Romantic  
Music Listening—Atonal  
Music Listening—Electronic  
Music Listening—Jazz  
Music Listening—Ethnic

*Instrumental Techniques*

Instrumental Techniques—Brass I  
Instrumental Techniques—Woodwind I  
Instrumental Techniques—Percussion I  
Instrumental Techniques—Strings I  
Instrumental Techniques—Band I  
Instrumental Techniques—Orchestra I

*Performing Organizations*

Band, Junior  
Band I  
Orchestra, Junior or Orchestra I  
Chorus, Junior  
Chorus, Male and Female I

*GROUP III*

It is recommended that placement in Group III courses be made on the basis of performance skills on specific instruments and/or the level of musicianship developed in Group II courses.

Music Laboratory IV  
Keyboard Laboratory II  
Guitar Laboratory II  
Music in American Society: Twentieth Century  
Music in Communications Media  
Musical Production  
Music Listening Laboratories  
Electronic Music Laboratory

*Music Theory*

These courses, as described, cover four quinesters. Placement is based on the level of knowledge and skill development.

Music Theory I  
Music Theory II  
Music Theory III  
Music Theory IV  
Composition

*Advanced Instrumental Techniques*

Instrumental Techniques—Brass II  
Instrumental Techniques—Woodwind II  
Instrumental Techniques—Percussion II  
Instrumental Techniques—Strings II  
Instrumental Techniques—Band II  
Instrumental Techniques—Orchestra II

*Band*

Instrumental Techniques—Band III  
Band, II  
Band, Marching  
Band, Concert

*Chorus*

Chorus, Male and Female II  
Chorus, Male and Female III  
Chorus, Male  
Chorus, Female

*Orchestra*

Instrumental Techniques—Orchestra, III  
Orchestra, Concert

*Individual and/or Small Groups*

Voice and/or Vocal Ensemble  
Instrumental Ensemble and/or Stage Band  
Instrumental Techniques—Solo  
Instrumental Techniques—Accompanying  
Conducting

*Code Numbers for Quinquimester Courses*

The code numbers assigned by the state for music have been used as the first four digits for each course. The first digit following the decimal point indicates degree of difficulty; i.e.,

- 1, 2, 3 beginning level courses
- 4, 5, 6 intermediate courses
- 7, 8, 9 advanced courses
- 9 college-level courses

The second digit following the decimal point indicates the area of study; i.e.,

- 0 all laboratory courses
- 1 brass instruments
- 2 woodwind instruments
- 3 percussion instruments
- 4 string instruments
- 5 band
- 6 orchestra
- 7 chorus
- 8 theory, conducting, composition, accompanying, and media production
- 9 music history, the humanities, appreciation, and listening

The third digit indicates a difference in approach; i.e.,

Music Laboratory III	5631.30
Keyboard Laboratory I	5631.301
Guitar Laboratory I	5631.302

## QUINMESTER COURSES

### LABORATORY COURSES

Music Laboratory I	322
Music Laboratory II	322
Music Laboratory III	322
Music Laboratory IV	322
Keyboard Laboratory I	322
Keyboard Laboratory II	323
Guitar Laboratory I	323
Guitar Laboratory II	323
Electronic Music Laboratory	323
Music Listening Laboratories	323

### LISTENING COURSES

An Introduction to Music Listening	323
Directed Listening to Music	324
Independent Study in Music Listening	324
Music Listening—Renaissance	324
Music Listening—Baroque	324
Music Listening—Classic	324
Music Listening—Romantic	324
Music Listening—Electronic	325
Music Listening—Atonal	324
Music Listening—Jazz	325
Music Listening—Ethnic	325
Music in American Society, Twentieth Century	325
Music Appreciation	325
Music History	325
Introduction to Humanities	326

### MUSIC THEORY

Music Theory I	326
Music Theory II	326
Music Theory III	326
Music Theory IV	327
Composition	327

## *INSTRUMENTAL TECHNIQUES*

Instrumental Techniques—Brass I	327
Instrumental Techniques—Brass II	327
Instrumental Techniques—Woodwind I	327
Instrumental Techniques—Woodwind II	328
Instrumental Techniques—Percussion I	328
Instrumental Techniques—Percussion II	328
Instrumental Techniques—Strings I	328
Instrumental Techniques—Strings II	328
Instrumental Techniques—Band I	329
Instrumental Techniques—Band II	329
Instrumental Techniques—Band III	329
Instrumental Techniques—Orchestra I	329
Instrumental Techniques—Orchestra II	329
Instrumental Techniques—Orchestra III	330
Instrumental Techniques—Accompanying	330
Instrumental Techniques—Solo	330

## *PERFORMING ORGANIZATIONS*

Band, Junior	330
Band I	330
Band II	331
Band, Marching	331
Band, Concert	331
Orchestra, Junior or Orchestra I	331
Orchestra, Concert	331
Chorus, Junior	332
Chorus, Male and Female I	332
Chorus, Male and Female II	332
Chorus, Male and Female III	332
Chorus, Male	332
Chorus, Female	333
Voice and/or Vocal Ensemble	333
Instrumental Ensemble and/or Stage Band	333
Conducting	333
Music in Communications Media	333
Musical Production	333

AREA	ACCR. NO. FLA-DADE	COURSE TITLE AND DESCRIPTION
MUSIC	5631.10	† MUSIC LABORATORY I  An introduction to music emphasizing identification of pitch and duration of tone. A laboratory approach in which students perform on instruments; sing; read, listen to, and compose music. (When ordering, request <i>A New Introduction to Music</i> , Level I, a state-adopted text.)
MUSIC	5631.20	† MUSIC LABORATORY II  An introduction to music emphasizing staff notation and music symbols. A laboratory approach in which pupils perform on instruments; sing; listen to, read, and compose music, with emphasis on developing skills for reading and writing music, using staff notation and music symbols. (When ordering, request <i>A New Introduction to Music</i> , Level II, a state-adopted text.)
MUSIC	5631.30	MUSIC LABORATORY III  An introduction to music emphasizing modes and forms. A laboratory approach in which the pupils perform on a variety of instruments; sing; listen to, read, and compose music, with emphasis on identification of elementary concepts of modes and forms. (When ordering, request <i>A New Introduction to Music</i> , Level III, a state-adopted text.)
MUSIC	5631.40	MUSIC LABORATORY IV  An introduction to music emphasizing harmony. A laboratory approach in which pupils perform on a variety of instruments; sing; listen to, read and compose music, with emphasis on identification of the ways in which harmony is used. (When ordering, request, <i>A New Introduction to Music</i> , Level IV, a state-adopted text.)
MUSIC	5631.301 5632.301 5633.301 5634.301	KEYBOARD LABORATORY I  An introduction to music emphasizing modes and forms. A laboratory approach in which pupils develop skills in playing keyboard instruments; sing; listen to, read, and compose music, with emphasis on elementary concepts of modes and forms.

AREA	ACCR. NO. FLA-DADE	COURSE TITLE AND DESCRIPTION
MUSIC	5631.401 5632.401 5633.401 5634.401	KEYBOARD LABORATORY II  An introduction to music emphasizing harmony. A laboratory approach in which the pupils develop playing skills on keyboard instruments; sing; listen to, read, and compose music, with emphasis on ways in which harmony is used.
MUSIC	5631.302 5632.302 5633.302 5634.302	GUITAR LABORATORY I  An introduction to music emphasizing modes and forms. A laboratory approach in which pupils develop skill in playing guitar; sing; listen to, read, and compose music, with emphasis on elementary concepts of modes and forms.
MUSIC	5631.402 5632.402 5633.402 5634.402	† GUITAR LABORATORY II  An introduction to music emphasizing harmony. A laboratory approach in which the pupils develop playing skills on guitar; sing; listen to, read, and compose music, with emphasis on ways in which harmony is used.
MUSIC	5631.303 5632.303 5633.303 5634.303	ELECTRONIC MUSIC LABORATORY  An introduction to music emphasizing modes and forms. A laboratory approach in which pupils develop skill in playing an electronic music synthesizer; sing; listen to, read, and compose music, with emphasis on identification of elementary concepts to modes and forms.
MUSIC	5631.304 5632.304 5633.304 5634.304	MUSIC LISTENING LABORATORIES  Exploring a variety of styles and periods and developing basic listening skills.
MUSIC	5634.19	AN INTRODUCTION TO MUSIC LISTENING  An introduction to music listening; exploring a variety of styles and periods and developing basic listening skills.

MUSIC  
323



AREA	ACCR. NO. FLA-DADE	COURSE TITLE AND DESCRIPTION
MUSIC	5634.59 5635.69	DIRECTED LISTENING TO MUSIC  Emphasis on developing listening skill through study of music literature.
MUSIC	5635.591	INDEPENDENT STUDY IN MUSIC LISTENING  A continuation of listening experience with an in-depth study of music literature.
MUSIC	5635.791	MUSIC LISTENING-RENAISSANCE  A survey of Renaissance music prior to 1600. The pupils conduct historical research, perform, and listen to live and recorded performances, with emphasis on stylistic characteristics.
MUSIC	5635.792	MUSIC LISTENING-BAROQUE  A survey of music of the Baroque, c. 1600-1770. The pupils conduct historical research, perform, and listen to live and recorded performances, with emphasis on stylistic characteristics.
MUSIC	5635.793	MUSIC LISTENING-CLASSIC  A survey of music of the Classic period, c. 1770-1825. The pupils conduct historical research, perform, and listen to live and recorded performances, with emphasis on stylistic characteristics.
MUSIC	5635.794	MUSIC LISTENING-ROMANTIC  A survey of music of the Romantic period, c. 1825-1900. The pupils conduct historical research, perform, and listen to live and recorded performances, with emphasis on stylistic characteristics.
MUSIC	5635.891	MUSIC LISTENING-ATONAL  A survey of music of the Atonalists, c 1900-present. The pupils conduct historical research, perform, and listen to live and recorded performances, with emphasis on stylistic characteristics.

AREA	ACCR. NO. FLA-DADE	COURSE TITLE AND DESCRIPTION
MUSIC	5635.892	MUSIC LISTENING-ELECTRONIC A survey of music produced by electronic means, c. 1945-present. The pupils conduct historical research, perform, and listen to live and recorded performances, with emphasis on stylistic characteristics.
MUSIC	5635.893	MUSIC LISTENING-JAZZ A survey of music in jazz idiom, c. 1875-present. The pupils conduct historical research, perform, and listen to live and recorded performances, with emphasis on stylistic characteristics.
MUSIC	5635.894	MUSIC LISTENING-ETHNIC A survey of music from various ethnic backgrounds. The pupils conduct historical research, perform, and listen to live and recorded performances, with emphasis on stylistic characteristics.
MUSIC	5635.99	+ MUSIC IN AMERICAN SOCIETY, TWENTIETH CENTURY A survey of music in the popular fields of this century. The pupils conduct historical research, perform and listen to live and recorded performances, with emphasis on social change as it is reflected in music. A study of the interaction of music and the American society of the twentieth century.
MUSIC	5634.39 5634.49	MUSIC APPRECIATION A survey of music literature, with emphasis on developing understandings and skills essential for literate listening to music.
MUSIC	5635.592 5635.692	MUSIC HISTORY A continuation of the study of music literature, with emphasis on developing understandings and skills essential for literate listening to music.

AREA	ACCR. NO. FLA-DADE	COURSE TITLE AND DESCRIPTION
MUSIC	5635.29 5635.39 5635.49 5635.59	† INTRODUCTION TO HUMANITIES  An exploratory course, studying the interrelationship of the performing arts, the graphic arts, and the societies which produced them.

### MUSIC THEORY

These courses, as described, will cover four semesters and need to be taken in sequence. Placement in these courses should be made on the level of knowledge and skill development for courses in Group III.

MUSIC	5636.18 5636.28 5636.38 5636.48	† MUSIC THEORY I  Presents the fundamentals of music through ear training, reading, and writing music, using the I, IV, V, and V <sub>7</sub> chords in major and minor modes.
-------	--	--

MUSIC	5637.18 H 5637.28 5637.38 5637.48	MUSIC THEORY II*  A continuation of study of fundamentals of music, including use of II, III, VI, VII Chords in major and minor keys, ear training, beginning melodic and harmonic dictation, and study of semi and full cadences in writing and at the keyboard.
-------	--	---

MUSIC	5638.58 H 5638.68 5638.78 5638.88	MUSIC THEORY III*  A continuation of study of fundamentals of music, including diminished and augmented chords, continued ear training, sight-singing, melodic and harmonic dictation, and beginning harmonic analysis of scores; harmonization of given bass and given treble and of original melodies; these to be written and performed vocally and at the keyboard.
-------	--	---

\*Note: These three years of theory are the equivalent of two years of college theory from which the student may be exempted by examination.

MUSIC  
326

3.8

AREA	ACCR. NO. FLA-DADE	COURSE TITLE AND DESCRIPTION
MUSIC	5639.58 H 5639.68 5639.78 5639.88	MUSIC THEORY IV*  Continuation of study of fundamentals of music, including basic stylistic analysis and introduction of atonal material. This year should provide greater depth than, and enrichment of, Theory. III, which will enable pupils to exempt the first two courses of theory in college.
MUSIC	5639.881 5639.98	COMPOSITION  Students will be able to compose, using materials from Theory I, II, III.
INSTRUMENTAL CLASSES		
MUSIC	5642.21 5642.31 5642.41 5642.51	† INSTRUMENTAL TECHNIQUES—BRASS I  An introduction to music emphasizing modes and forms. A laboratory approach in which pupils develop skill in playing brass instruments; sing; listen to, read, and compose music, with emphasis on identification of elementary concepts of modes and forms.
MUSIC	5644.41 5644.51 5644.61 5644.71	† INSTRUMENTAL TECHNIQUES—BRASS II  An introduction to music emphasizing harmony. A laboratory approach in which pupils develop skill in playing brass instruments; sing; listen to, read, and compose music, with emphasis on elementary concepts of harmony.
MUSIC	5642.22 5642.32 5642.42 5642.52	† INSTRUMENTAL TECHNIQUES—WOODWIND I  An introduction to music emphasizing modes and forms. A laboratory approach in which pupils develop skill in playing woodwind instruments; sing; listen to, read, and compose music, with emphasis on identification of elementary concepts of modes and forms.

\*Note: These three years of theory are the equivalent of two years of college theory from which the student may be exempted by examination.

AREA	ACCR. NO. FLA-DADE	COURSE TITLE AND DESCRIPTION
MUSIC	5644.42 5644.52 5644.62 5644.72	† INSTRUMENTAL TECHNIQUES—WOODWIND II  An introduction to music emphasizing harmony. A laboratory approach in which pupils develop skill in playing woodwind instruments; sing; listen to, read, and compose music, with emphasis on elementary concepts of harmony.
MUSIC	5642.23 5642.33 5642.43 5642.53	† INSTRUMENTAL TECHNIQUES—PERCUSSION I  An introduction to music emphasizing modes and forms. A laboratory approach in which pupils develop skill in playing percussion instruments; sing; listen to, read, and compose music, with emphasis on identification of elementary concepts of modes and forms.
MUSIC	5644.43 5644.53 5644.63 5644.73	† INSTRUMENTAL TECHNIQUES—PERCUSSION II  An introduction to music emphasizing harmony. A laboratory approach in which pupils develop skill in playing percussion instruments; sing; listen to, read, and compose music, with emphasis on elementary concepts of harmony.
MUSIC	5642.24 5642.34 5642.44 5642.54	† INSTRUMENTAL TECHNIQUES—STRINGS I  An introduction to music emphasizing modes and forms. A laboratory approach in which pupils develop skill in playing string instruments; sing; listen to, read, and compose music, with emphasis on identification of elementary concepts of modes and forms.
MUSIC	5644.44 5644.54 5644.64 5644.74	† INSTRUMENTAL TECHNIQUES—STRINGS II  An introduction to music emphasizing harmony. A laboratory approach in which pupils develop skill in playing orchestral string instruments; sing; listen to, read, and compose music, with emphasis on elementary concepts of harmony.

AREA	ACCR. NO. FLA-DADE	COURSE TITLE AND DESCRIPTION
MUSIC	5642.25 5642.35 5642.45 5642.55	INSTRUMENTAL TECHNIQUES—BAND I  An introduction to music emphasizing modes and forms. A laboratory approach in which pupils develop skill in playing band instruments in heterogeneous groupings, with emphasis on identification of elementary concepts of modes and forms.
MUSIC	5644.55 5644.65 5644.75 5644.85	† INSTRUMENTAL TECHNIQUES—BAND II  An introduction to music emphasizing harmony. A laboratory approach in which pupils develop skill in playing brass, woodwind, or percussion instruments in heterogeneous groupings; sing; listen to, read, and compose music, with emphasis on elementary concepts of harmony.
MUSIC	5646.35 5646.45 5646.55 5646.65	INSTRUMENTAL TECHNIQUES—BAND III  An introduction to music emphasizing harmony. A laboratory approach in which the pupils develop playing skills on brass, woodwind, or percussion instruments in heterogeneous groupings; sing; listen to, read and compose music, with emphasis on ways in which harmony is used.
MUSIC	5642.26 5642.36 5642.46 5642.56	INSTRUMENTAL TECHNIQUES—ORCHESTRA I  An introduction to music emphasizing modes and forms. A laboratory approach in which pupils develop skill in playing orchestral instruments in heterogeneous groupings, with emphasis on identification of elementary concepts of modes and forms.
MUSIC	5644.36 5644.46 5644.56 5644.66	† INSTRUMENTAL TECHNIQUES—ORCHESTRA II  An introduction to music emphasizing harmony. A laboratory approach in which the pupils develop playing skills on brass, woodwind, percussion, or orchestral string instruments in heterogeneous groupings; sing; listen to, read, and compose music, with emphasis on ways harmony is used.

AREA	ACCR. NO. FLA-DADE	COURSE TITLE AND DESCRIPTION
MUSIC	5646.36 5646.46 5646.56 5646.66	INSTRUMENTAL TECHNIQUES-ORCHESTRA III  An introduction to music emphasizing harmony. A laboratory approach in which pupils develop skill in playing brass, woodwind, percussion, or orchestral string instruments in heterogeneous groupings; sing, listen to, read, and compose music, with emphasis on elementary concepts of harmony.
MUSIC	5646.58 5646.68 5646.78 5646.88	INSTRUMENTAL TECHNIQUES-ACCOMPANYING  Designed for the qualified keyboard performer. Acquisition of skills and techniques for accompanying solo and ensemble performers, including transposition, open-score reading, and following a conductor.
MUSIC	5646.81 5646.82 5646.83 5646.84	INSTRUMENTAL TECHNIQUES-SOLO  A study of solo literature for the instrument, with emphasis on stylistic characteristics of the music and increased performance skill.

#### PERFORMING ORGANIZATIONS

MUSIC	5610.15 5610.25 5610.35 5610.45	† BAND, JUNIOR  A performing organization in which pupils develop increasing performance skills individually and in ensemble, with emphasis on stylistic characteristics of the music studied.
MUSIC	5613.15 5613.25 5613.35 5613.45	† BAND I  A performing organization in which pupils develop increasing performance skills individually and in ensemble, with emphasis on stylistic characteristics of the music studied.

AREA	ACCR. NO. FLA-DADE	COURSE TITLE AND DESCRIPTION
MUSIC	5613.55 5613.65 5613.75 5613.85	† BAND II  Instruction in performance of standard band literature of easy-to-medium difficulty. Emphasis is placed on intonation, phrasing, sight-reading, technical facility on the instruments, as well as responsibility of the individual to the total group. Opportunities are given for performance in concert. This program is for pupils who have had Band, Junior or Band I or who can demonstrate proficiency on an instrument that is satisfactory to the instructor.
MUSIC	5614.55 5614.65	† BAND, MARCHING  Instruction in street and field marching techniques and study of appropriate music. This organization participates in school and community events. Emphasis is placed on performance quality and individual and group responsibility.
MUSIC	5624.25 5624.35 5624.45 5624.55 5624.65 5624.75 5624.85 5624.95	† BAND, CONCERT  An advanced performing organization in which pupils develop increasing performance skills individually and in ensemble, with emphasis on stylistic characteristics of the music studied. Opportunities are given for performance.
MUSIC	5611.16 5611.26 5611.36 5611.46	† ORCHESTRA, JUNIOR or ORCHESTRA I  A performing organization in which pupils develop increasing performance skills individually and in ensemble, with emphasis on stylistic characteristics of music of easy-to-medium difficulty. Emphasis is placed on intonation, sight-reading, technical facility on the instrument, as well as responsibility of the individual to the total group. Opportunities are given for performance. Open to pupils who have had Instrumental Techniques-Orchestra, or who demonstrate proficiency on an instrument satisfactory to the instructor.
MUSIC	5615.27 5615.37 5615.47 5615.57 5615.67 5615.77 5615.87 5615.97	ORCHESTRA, CONCERT  An advanced performing organization in which pupils develop increasing performance skills individually and in ensemble, with emphasis on stylistic characteristics of the music studied. Opportunities are provided for performance.

MUSIC  
331

323



AREA	ACCR. NO. FLA-DADE	COURSE TITLE AND DESCRIPTION
MUSIC	5612.17 5612.27 5612.37 5612.47	† CHORUS, JUNIOR  An introduction to music emphasizing harmony. A laboratory approach in which the pupils develop skills in vocal production; listen to, read, and compose music, with emphasis on ways in which harmony is used. (Choral guide available in preliminary draft form at Music Office, Room 1601, Lindsey Hopkins.)
MUSIC	5612.57 5612.67 5612.77 5612.87	CHORUS, MALE AND FEMALE I  A performing organization in which pupils develop increasing performance skills individually and in ensemble, with emphasis on voice production in choral ensemble, intonation, phrasing, and general musicianship, as well as responsibilities of individuals to the group. A study of standard folk, patriotic, sacred, and secular music of easy-to-medium difficulty. (Choral guide available in preliminary draft form at Music Office, Room 1601, Lindsey Hopkins.)
MUSIC	5616.27 5616.37 5616.47 5616.57	CHORUS, MALE AND FEMALE II  A performing organization in which pupils develop increasing performance skills individually and in ensemble with emphasis on vocal production, tone quality, intonation, blend, and ensemble <i>esprit de corps</i> while developing a choral repertoire of standard literature of medium difficulty.
MUSIC	5617.17 5617.27 5617.37 5617.47 5617.57 5617.67 5617.77 5617.87	CHORUS, MALE AND FEMALE III  A laboratory approach, designed to study sacred and secular choral compositions. Emphasis will be placed on an advanced degree of musicianship and increased performance skills individually and in ensemble. Opportunities are provided for performance in the school and community and for student conductors to prepare ensembles for performance.
MUSIC	5618.17 5618.27 5618.37 5618.47	CHORUS, MALE  A laboratory approach, designed to study sacred and secular choral compositions of easy-to-medium difficulty. Emphasis is placed on voice production, intonation, phrasing, general musicianship, as well as responsibilities of individuals to the group.

MUSIC  
332

332

AREA	ACCR. NO. FLA-DADE	COURSE TITLE AND DESCRIPTION
MUSIC	5619.17 5619.27 5619.37 5619.47	CHORUS, FEMALE  A laboratory approach, designed to study sacred and secular choral compositions of easy-to-medium difficulty. Emphasis is placed on voice production, intonation, phrasing, general musicianship, as well as responsibilities of individuals to the group.
MUSIC	5626.17 5626.27 5626.37 5626.47 5626.57 5626.67 5626.77 5626.87	VOICE and/or VOCAL ENSEMBLE  A laboratory approach, designed to study and perform vocal literature for solo, duets, trios, quartets, and various other vocal combinations. Emphasis is placed on preparation of music for performance and critical analysis, and development of repertoire.
MUSIC	5645.25 5645.35 5645.45 5645.55 5645.65 5645.75 5645.85 5645.95	† INSTRUMENTAL ENSEMBLE and/or STAGE BAND  A study of literature for small ensembles. Emphasis is placed upon increased performing skill individually and in ensemble, and on stylistic characteristics of the music. This category includes stage band, and instrumental and vocal combination groups.
MUSIC	5646.58 5646.68 5646.78 5646.88	† CONDUCTING  A study of conducting techniques including score preparation, open reading, transposition, baton technique, and organization of rehearsals.
MUSIC	5630.68 5630.78 5630.88 5630.98	MUSIC IN COMMUNICATIONS MEDIA  A laboratory approach, involving microphone technique, tape and disc recordings, the audio function of television, and film making with sound or sound-dubbing. The science department is working on a similar course, and interdisciplinary cross-reference is planned.
MUSIC	5630.89	MUSICAL PRODUCTION  A laboratory course, using drama, instrumentalists, chorus, stage technicians, costuming, and scenery; results in a performance of a musical comedy or drama. It is interdisciplinary, using drama, music, shop, tailoring, and electronics pupils, and involving team-teaching.

MUSIC  
333

## PHYSICAL EDUCATION

The aim of physical education is to provide a well-balanced program of experiences to help boys and girls achieve the broad goals of education. The development and maintenance of physical fitness is the unique contribution and basic responsibility of physical education. The program strives for the maximum development of the potentiality of all students and is adjusted to their needs and abilities by assessing each individual's fitness status and level of achievement.

In addition, the values generated in the process of skill development in physical education are transmitted to the student's present activities and future pursuits. The values and their associated behaviors include the following:

<i>Value (Product Desired)</i>	<i>Method (Process Required)</i>
Indicates awareness of responsibility	Accountable for personal behavior and actions to others
Exhibits pride in sense of achievement	Practice and perfection of sports skills
Acknowledges feelings of acceptance	Member of a group striving for a common goal
Indicates respect for the worth and dignity of his peers	Game courtesy demonstrated towards opponents and playing relationships established with teammates
Exerts self-discipline	Adherence to rules of the game
Recognizes opportunities for creativity	Performance of skills individually improvised
Realizes need for conformity	Part of a team effort
Experiences situations containing incentives and the adventure of competition	Involvement in intraclass and interscholastic events—plaques, certificates, ribbons, patches, and trophies awarded

For easy reference, the state code numbers for the various quinmester courses are listed below:

5551 Phys. Ed., Female 7—Grade 7	5561 Phys. Ed., Male 7—Grade 7
5552 Phys. Ed., Female 8—Grade 8	5562 Phys. Ed., Male 8—Grade 8
5553 Phys. Ed., Female 1—Grade 9	5563 Phys. Ed., Male 1—Grade 9
5554 Phys. Ed., Female 2—Grades 10, 11	5564 Phys. Ed., Male 2—Grades 10, 11
5555 Phys. Ed., Female 3—Grades 11, 12	5565 Phys. Ed., Male 3—Grades 11, 12
5556 Phys. Ed., Female 4—Grade 12	5566 Phys. Ed., Male 4—Grade 12
5557 Varsity Sports, Female—Grades 10-12	5567 Varsity Sports, Male—Grades 10-12

The following represents the minimum number of quin units of credit recommended in each area of physical education for grades 7-12.

Team Sports	3
Lifetime Sports	2
Rhythmic Activities	1
Physical Conditioning	<u>0*</u>
Total Requirements	6
Total Electives	<u>10</u>
Total Phys. Ed. Quin Credits	16

\*NOTE: No specific course in the area of physical conditioning is required; however, the Advisory Council recommends that physical fitness tests be administered twice each year. The fitness tests may be combined with a unit chosen by the teacher which represents the best testing conditions for that school situation. Possible combinations for physical fitness testing would be soccer, football, track and field, and basketball.

## QUINMESTER COURSES

### TEAM SPORTS

Fundamental Touch Football  
Advanced Touch Football  
Girls Touch Football  
Beginning Basketball for Boys  
Beginning Basketball for Girls  
Advanced Basketball for Girls  
Fundamental Slow Pitch Softball  
Fast Pitch Softball  
Fundamental Volleyball  
Power Volleyball  
Beginning Speedball  
Speed-A-Way  
Fundamentals of Track and Field  
Advanced Track and Field  
Beginning Wrestling  
Advanced Wrestling  
Fundamental Field Hockey  
Advanced Field Hockey  
Beginning Gator Ball  
Officiating for Girls  
Officiating for Boys  
Deck Tennis  
Boundball  
Flicker Ball  
Independent Study in Physical Education

### PHYSICAL CONDITIONING

Weight Training for Boys  
Gymnastics for Girls  
Adapted Physical Education  
Physical Training

### LIFETIME SPORTS

Beginning Bowling  
Advanced Bowling  
Beginning Golf  
Advanced Golf  
Beginning Tennis  
Advanced Tennis  
Beginning Swimming  
Intermediate Swimming  
Advanced Swimming  
Beginning Archery  
Advanced Archery  
Beginning Badminton  
Advanced Badminton

### LIFETIME SPORTS (Continued)

Beginning Fencing  
Advanced Fencing  
Paddle Tennis  
Recreational Sports  
Recreational Sports in Spanish  
Beginning Gymnastics for Girls  
Intermediate Gymnastics for Girls  
Pocket Billiards  
Roller Skating  
Table and Quiet Games  
The Challenge of Leisure

### OUTDOOR LIFE SPORTS

Camping  
Hunting  
Hiking  
Horseback Riding  
Beginning Skin and Scuba Diving  
Beginning Water Skiing  
Fishing

### RHYTHMIC ACTIVITIES

Introduction to Dance  
Rhythm Movement Exploration  
Advanced Folk and Square Dance  
Advanced Social Dancing  
Beginning Modern Dance  
Advanced Modern Dance  
Interpretative Modern Dance

## QUINMESTER COURSES

Adapted Physical Education	350
Advanced Archery	346
Advanced Badminton	347
Advanced Basketball for Girls	341
Advanced Bowling	345
Advanced Fencing	347
Advanced Field Hockey	343
Advanced Folk and Square Dance	351
Advanced Golf	345
Advanced Modern Dance	352
Advanced Social Dancing	351
Advanced Swimming	346
Advanced Tennis	345
Advanced Touch Football	340
Advanced Track and Field	342
Advanced Wrestling	343
Beginning Archery	346
Beginning Badminton	346
Beginning Basketball for Boys	340
Beginning Basketball for Girls	340
Beginning Bowling	344
Beginning Fencing	347
Beginning Gator Ball	343
Beginning Golf	345
Beginning Gymnastics for Girls	348
Beginning Modern Dance	351
Beginning Skin and Scuba Diving	349
Beginning Speedball	342
Beginning Swimming	345
Beginning Tennis	345
Beginning Water Skiing	350
Beginning Wrestling	342
Boundball	344
Camping	349
Challenge of Leisure, The	349
Deck Tennis	344
Fast Pitch Softball	341
Fishing	350
Flicker Ball	344
Fundamental Field Hockey	343
Fundamental Slow Pitch Softball	341
Fundamental Touch Football	340
Fundamental Volleyball	341
Fundamentals of Track and Field	342
Girls Touch Football	340

Hiking	349
Horseback Riding	349
Hunting	349
Independent Study in Physical Education	344
Intermediate Gymnastics for Girls	348
Intermediate Swimming	346
Interpretative Modern Dance	352
Introduction to Dance	351
Officiating for Boys	343
Officiating for Girls	343
Paddle Tennis	347
Physical Training	350
Pocket Billiards	348
Power Volleyball	341
Recreational Sports	347
Recreational Sports in Spanish	348
Rhythm Movement Exploration	351
Roller Skating	348
Slimnastics for Girls	350
Speed-A-Way	342
Table and Quiet Games	348
Weight Training for Boys	350

AREA	ACCR. NO. FLA-DADE	COURSE TITLE AND DESCRIPTION
TEAM SPORTS		
PHYSICAL EDUCATION	5561.01 thru 5566.01	† FUNDAMENTAL TOUCH FOOTBALL  An outgrowth of regular football in which tackling and certain types of blocking have been replaced by tagging and screening. This game offers an opportunity to enjoy the activity and become knowledgeable in football. Actual participation develops coordination, power, and endurance.
PHYSICAL EDUCATION	5561.02 thru 5566.02	† ADVANCED TOUCH FOOTBALL  Offers advanced techniques and skills found in regular football, except for tackling and certain types of blocking. The game provides the opportunity to become competent in football and more physically fit by developing greater strength, endurance, and speed.
PHYSICAL EDUCATION	5551.03 thru 5556.03	† GIRLS TOUCH FOOTBALL  Offers girls the opportunity to become more knowledgeable in football by participating in a similar game which eliminates tackling and certain kinds of blocking that would prove injurious to girls. Basic football skills and rules are presented in such a way that girls can enjoy the physical activity involved, learn to appreciate football as a leisure-time spectator sport, and increase their overall fitness.
PHYSICAL EDUCATION	5561.04 thru 5566.04	† BEGINNING BASKETBALL FOR BOYS  Enables boys to learn the fundamental rules of basketball. Activities will emphasize team work and increase physical development in the areas of speed, endurance, and coordination.
PHYSICAL EDUCATION	5551.05 thru 5556.05	† BEGINNING BASKETBALL FOR GIRLS  Contributes to the student's physical fitness through the practice of basketball skills in game situations. It will encourage the acquisition of knowledge of the rules and will emphasize enjoyment of playing basketball.



AREA	ACCR. NO. FLA-DADE	COURSE TITLE AND DESCRIPTION
PHYSICAL EDUCATION	5551.07 thru 5556.07	† ADVANCED BASKETBALL FOR GIRLS  Increases effectiveness in fundamental basketball skills with emphasis upon acquiring advanced competencies. Students will gain insights into teamwork, increase proficiency in ability to play the game, and improve in the areas of coordination, fitness, confidence, and poise.
PHYSICAL EDUCATION	5551.08 thru 5556.08 5561.08 thru 5566.08	† FUNDAMENTAL SLOW PITCH SOFTBALL  Designed for either boys or girls or as a coeducational class. Students will acquire knowledge of the rules, improve physical fitness, and develop a sense of teamwork.
PHYSICAL EDUCATION	5551.10 thru 5556.10 5561.10 thru 5566.10	FAST PITCH SOFTBALL  Provides boys' or girls' classes with participation in advanced skills and tactics of fast pitch softball.
PHYSICAL EDUCATION	5551.11 thru 5556.11 5561.11 thru 5566.11	† FUNDAMENTAL VOLLEYBALL  Applies to coeducational classes. Students will participate in the fundamental skills of volleyball and will learn to identify and apply the rules of the game. The activities are designed to develop sufficient skills to enjoy volleyball and to improve flexibility and coordination.
PHYSICAL EDUCATION	5551.12 thru 5556.12 5561.12 thru 5566.12	† POWER VOLLEYBALL  Applies to either girls' or boys' classes and provides an opportunity to develop in-depth skills and knowledge of volleyball. Experiences in competition will be offered, accompanied by activities which promote overall fitness for each student.

AREA	ACCR. NO.- FLA-DADE	COURSE TITLE AND DESCRIPTION
PHYSICAL EDUCATION	5551.13 thru 5556.13	<b>BEGINNING SPEEDBALL</b>  A team sport played by girls' or boys' classes and is a combination of some of the basic skills in basketball, soccer, and football. It is an extremely valuable conditioning activity and emphasizes the passing and catching skills of basketball; the trapping, kicking, and dribbling skills of soccer; and the receiving and passing skills of football.
PHYSICAL EDUCATION	5551.14 thru 5556.14	<b>SPEED-A-WAY</b>  Applies to girls' classes and is a combination game of soccer, basketball, speedball, fieldball, and hockey, with the opportunity for players to run the ball as in touch football. The game is fast moving and challenging, and should make significant contributions to the student's physical fitness.
PHYSICAL EDUCATION	5551.15 thru 5556.15 5561.15 thru 5566.15	<b>FUNDAMENTALS OF TRACK AND FIELD</b>  Designed for girls' or boys' classes with an emphasis on running, jumping, and throwing activities. Participation in track and field activities can make outstanding contributions to physical conditioning.
PHYSICAL EDUCATION	5551.16 thru 5556.16 5561.16 thru 5566.16	<b>ADVANCED TRACK AND FIELD</b>  Designed for girls' or boys' classes to help students develop greater efficiency in running, jumping, and throwing events, as well as making significant contributions to physical conditioning.
PHYSICAL EDUCATION	5561.19 thru 5566.19	<b>† BEGINNING WRESTLING</b>  Presents boys' classes with the proper techniques of wrestling. Students will acquire knowledge of scoring and basic skills. The course provides challenging, strenuous, and competitive activities and makes a significant contribution to overall fitness.

AREA	ACCR. NO. FLA-DADE	COURSE TITLE AND DESCRIPTION
PHYSICAL EDUCATION	5561.20 thru 5566.20	† ADVANCED WRESTLING  Applies to boys' classes and provides an opportunity for students to develop their own styles, competencies, and skills in wrestling. The vigorous nature of this activity contributes to the development of strength and endurance.
PHYSICAL EDUCATION	5551.21 thru 5556.21	† FUNDAMENTAL FIELD HOCKEY  Designed for girls with emphasis on students acquiring basic skills and abilities to identify and apply the rules of the game. Student's participation in field hockey will assure significant gains in overall fitness.
PHYSICAL EDUCATION	5551.22 thru 5556.22	ADVANCED FIELD HOCKEY  Applies to girls and provides participation in advanced skills and strategies in field hockey. This vigorous and competitive sport makes a significant contribution to the development of endurance.
PHYSICAL EDUCATION	5551.24 thru 5556.24 5561.24 thru 5566.24	BEGINNING GATOR BALL  Designed for boys' or girls' classes and contains rules and skills from basketball, football, and soccer. Students will learn to identify and apply rules of play. This fast-moving game promotes teamwork, speed, endurance, and coordination.
PHYSICAL EDUCATION	5551.26 thru 5556.26	† OFFICIATING FOR GIRLS  Student must be recommended by the teacher to take this course. Girls will acquire knowledge of rules of various sports, be trained to observe and analyze plays, and apply the correct rule to the situation. Class tournaments and sports-day events will provide the opportunity to further develop officiating abilities.
PHYSICAL EDUCATION	5561.27 thru 5566.27	OFFICIATING FOR BOYS  Boys must be recommended by the teacher to take this course. Students will acquire knowledge of rules of particular sports, be trained to observe and spot game violations, and apply the correct rule to the situation. Class tournaments and sports-day events will enable the youngster to develop and practice officiating skills.

AREA	ACCR. NO. FLA-DADE	COURSE TITLE AND DESCRIPTION
PHYSICAL EDUCATION	5551.28 thru 5556.28 5561.28 thru 5566.28	† DECK TENNIS  Applies to separate classes or coeducational classes and can be played as a team sport in singles and doubles games. Students will develop sufficient knowledge of rules and adequate skills to enjoy the game as a recreational sport.
PHYSICAL EDUCATION	5551.29 thru 5556.29 5561.29 thru 5566.29	BOUNDBALL  Applies to boys', girls', and coeducational classes and is similar to the game of volleyball. Basic volleyball skills are practiced as they relate to boundball rules. This unit is challenging and fast moving as a team sport and can also be used as an excellent lead-up game to volleyball.
PHYSICAL EDUCATION	5551.34 thru 5556.34 5561.34 thru 5566.34	† FLICKER BALL  Can be played on a basketball court or outside across the width of a football field in boys' and girls' classes. Flicker ball equipment includes a goal similar to basketball and a football. The game is vigorous and exciting and should make significant contributions to the student's overall fitness.
PHYSICAL EDUCATION	5551.35 thru 5556.35 5561.35 thru 5566.35	† INDEPENDENT STUDY IN PHYSICAL EDUCATION  Provides an opportunity for the student and directing teacher to arrange on contractual basis a project for independent study. Areas of interest may include classroom leadership experiences, planned research study, curriculum writing activities, and/or additional skill development.
LIFETIME SPORTS		
PHYSICAL EDUCATION	5551.40 thru 5556.40 5561.40 thru 5566.40	† BEGINNING BOWLING  Designed for a coeducational class to provide the student with the opportunity to learn to score a bowling game correctly and to practice basic skills. Students will gain sufficient skill to enjoy bowling as a leisure-time sport and to experience activities which contribute to overall fitness.

AREA	ACCR. NO. FLA-DADE	COURSE TITLE AND DESCRIPTION
PHYSICAL EDUCATION	5551.41 thru 5556.41 5561.41 thru 5566.41	† ADVANCED BOWLING  A coeducational class emphasizing advanced skills and techniques of bowling. The student will increase his bowling competencies, develop an enjoyment of the game as a postschool activity, and experience exercises which promote physical fitness.
PHYSICAL EDUCATION	5551.42 thru 5556.42 5561.42 thru 5566.42	† BEGINNING GOLF  A coeducational class providing students the opportunity to identify golf terms and to practice basic skills. Student will acquire sufficient skill to enjoy golf as a leisure-time sport.
PHYSICAL EDUCATION	5551.43 thru 5556.43 5561.43 thru 5566.43	† ADVANCED GOLF  A coeducational class providing the student experiences to improve individual style and to increase effectiveness in skills and strategies. These activities will help to develop greater golf competencies, enjoy the sport as a postschool activity, and make desirable contributions to overall fitness.
PHYSICAL EDUCATION	5551.44 thru 5556.44 5561.44 thru 5566.44	† BEGINNING TENNIS  Designed to familiarize the student with tennis rules and regulations and to develop the basic skills. Tennis is a vigorous sport which promotes physical fitness and can become an enjoyable recreational activity.
PHYSICAL EDUCATION	5551.45 thru 5556.45 5561.45 thru 5566.45	ADVANCED TENNIS  A coeducational course helping students to gain insight into advanced skills and strategies. Tennis is an excellent postschool sport which contributes to the student's development of endurance, speed, coordination, and poise.
PHYSICAL EDUCATION	5551.46 thru 5556.46 5561.46 thru 5566.46	† BEGINNING SWIMMING  A coeducational unit designed for students who cannot swim. Basic techniques to be included are relaxing in water, submerging, rhythm breathing, front crawl, elementary back stroke, front and back float, and swimming underwater. Students identify and apply rules of water safety and experience growth in all-around body development.

AREA	ACCR. NO. FLA-DADE	COURSE TITLE AND DESCRIPTION
PHYSICAL EDUCATION	5551.47 thru 5556.47 5561.47 thru 5566.47	INTERMEDIATE SWIMMING  A unit designed to increase effectiveness in fundamental swimming skills with emphasis upon acquiring intermediate competencies. Students increase their endurance and versatility in the water and will develop sufficient skill to enjoy recreational swimming, and to benefit from the exercises contributing to all-around body development.
PHYSICAL EDUCATION	5551.48 thru 5556.48 5561.48 thru 5566.48	ADVANCED SWIMMING  A coeducational unit emphasizing the development of an all-around swimming capability. Additional strokes and miscellaneous water skills are developed so the student achieves the goal of being a versatile and all-around swimmer.
PHYSICAL EDUCATION	5551.49 thru 5556.49 5561.49 thru 5566.49	† BEGINNING ARCHERY  A coeducational class in which the student becomes familiar with archery equipment, safety precautions, archery etiquette, and scoring procedures. Opportunities will be provided to develop archery as a recreational activity.
PHYSICAL EDUCATION	5551.50 thru 5556.50 5561.50 thru 5566.50	† ADVANCED ARCHERY  A coeducational course designed to increase each student's competencies in archery by analyzing the individual's progress and correcting deficiencies caused by poor form. Activities will be introduced to review basic techniques of archery and improve precision by constant practice.
PHYSICAL EDUCATION	5551.51 thru 5556.51 5561.51 thru 5566.51	† BEGINNING BADMINTON  A coeducational class which provides students the opportunity to identify and apply rules of play and practice the basic skills of badminton. Participation in this unit aids physical fitness and helps students to become aware of badminton as a recreational activity.

AREA	ACCR. NO. FLA-DADE	COURSE TITLE AND DESCRIPTION
PHYSICAL EDUCATION	5551.52 thru 5556.52 5561.52 thru 5566.52	ADVANCED BADMINTON  A coeducational class designed to assist the student in acquiring advanced skills of badminton and strategy in singles and doubles play. As the student gains greater proficiency, his enjoyment of the game increases his desire to extend it into a lifetime sport.
PHYSICAL EDUCATION	5551.53 thru 5556.53 5561.53 thru 5566.53	BEGINNING FENCING  A coeducational unit in a competitive sport in which a beginning student will be introduced to scoring procedures, proper attire, equipment, etiquette, and safety. Participation in this course will help the student become aware of fencing as a recreational sport.
PHYSICAL EDUCATION	5551.54 thru 5556.54 5561.54 thru 5566.54	ADVANCED FENCING  A coeducational activity providing the opportunity for students to improve fencing skills in offensive and defensive attacks and counterattacks. Students will have the opportunity to develop competencies in speed and power, aggressiveness and control.
PHYSICAL EDUCATION	5551.55 thru 5556.55 5561.55 thru 5566.55	† PADDLE TENNIS  A coeducational course similar to tennis in scoring, terminology, and skills, but played with a wooden paddle, with sponge ball on a smaller court. Paddle tennis, like regular tennis, is vigorous and promotes physical fitness.
PHYSICAL EDUCATION	5551.56 thru 5556.56 5561.56 thru 5566.56	† RECREATIONAL SPORTS  A coeducational unit allowing the student to participate in different games: shuffleboard, table tennis, horseshoes, and deck tennis, and other similar activities. Rules will be identified and applied by the students, and basic skills involved in each of the four games will be practiced. Experiences in these areas are designed to carry over into recreational and postschool situations.

AREA	ACCR. NO. FLA-DADE	COURSE TITLE AND DESCRIPTION
PHYSICAL EDUCATION	5551.56 thru 5556.56 5561.56 thru 5566.56	RECREATIONAL SPORTS IN SPANISH  Two units are earned, one in Spanish and one in physical education, for this course. It is a two-hour block allowing the student to participate in different games: shuffleboard, table tennis, horseshoes, deck tennis, and other similar activities. Rules are identified and applied by the student, and basic skills involved are practiced. The rudiments of Spanish structure are practiced in relation to playing the games.
FOREIGN LNG. SPANISH	7503.41 7500.04 7510.04	
PHYSICAL EDUCATION	5551.58 thru 5556.58	† BEGINNING GYMNASTICS FOR GIRLS  A unit for girls designed to teach the principles and beginning techniques in gymnastics. The experiences provided will contribute to overall fitness and an aesthetic appreciation of the sport.
PHYSICAL EDUCATION	5551.59 thru 5556.59	INTERMEDIATE GYMNASTICS FOR GIRLS  An extension of the basic gymnastics unit, encompassing advanced movement on different pieces of apparatus. The program will provide experiences for leadership training, as well as physical fitness.
PHYSICAL EDUCATION	5551.71 thru 5556.71 5561.71 thru 5566.71	† POCKET BILLIARDS  A coeducational sport requiring increased motor coordination to attain proficiency in the game. Opportunities will be provided to develop sufficient skill to enjoy the game as a recreational activity.
PHYSICAL EDUCATION	5551.72 thru 5556.72 5561.72 thru 5566.72	ROLLER SKATING  A coeducational class, teaching safety procedures and basic techniques of balance on roller skates. As students become more competent, skating activities such as dancing, novelty events, and competition can be performed.
PHYSICAL EDUCATION	5551.74 thru 5556.74 5561.74 thru 5566.74	† TABLE AND QUIET GAMES  A coeducational unit, providing the student with the opportunity to learn and participate in a number of games. Activities will include checkers, chess, Chinese checkers, carrom, Nok-Hockey, skittles, Monopoly, Risk, and other recreational games.

PHYSICAL EDUCATION  
348



AREA	ACCR. NO. FLA-DADE	COURSE TITLE AND DESCRIPTION
PHYSICAL EDUCATION	5551.75 thru 5556.75 5561.75 thru 5566.75	THE CHALLENGE OF LEISURE  An introductory unit to lifetime sports containing definition and rationale for the lifetime sports unit. It emphasizes the selection of appropriate activities by the student and the proper method for improvement of skills.
OUTDOOR LIFE SPORTS		
PHYSICAL EDUCATION	5551.64 thru 5556.64 5561.64 thru 5566.64	† OUTDOOR LIFE-CAMPING  A coeducational unit designed to familiarize students with camping equipment and activities.
PHYSICAL EDUCATION	5551.65 thru 5556.65 5561.65 thru 5566.65	† OUTDOOR LIFE-HUNTING  A coeducational course providing the opportunity for students to learn the safety procedures, equipment, proper attire, and fundamental skills of hunting.
PHYSICAL EDUCATION	5551.66 thru 5556.66 5561.66 thru 5566.66	† OUTDOOR LIFE-HIKING  A coeducational unit helping students to become knowledgeable in techniques of hiking and to appreciate the overall contribution this activity makes to physical fitness.
PHYSICAL EDUCATION	5551.67 thru 5556.67 5561.67 thru 5566.67	OUTDOOR LIFE-HORSEBACK RIDING  A coeducational course presenting the basic fundamentals of horseback riding. It will provide experiences for participating in this sport for recreational purposes.
PHYSICAL EDUCATION	5551.69 thru 5556.69 5561.69 thru 5566.69	† OUTDOOR LIFE-BEGINNING SKIN AND SCUBA DIVING  A coeducational unit familiarizing the students with scuba equipment, the science of diving, and relevant safety procedure.

AREA	ACCR. NO. FLA-DADE	COURSE TITLE AND DESCRIPTION
PHYSICAL EDUCATION	5551.70 thru 5556.70 5561.70 thru 5566.70	† OUTDOOR LIFE-BEGINNING WATER SKIING  A coeducational sport providing the opportunity to learn the basic skills and safety procedures involved in water skiing.
PHYSICAL EDUCATION	5551.76 thru 5556.76 5561.76 thru 5566.76	OUTDOOR LIFE-FISHING  A coeducational unit providing the opportunity to learn safety procedures, equipment, and fundamental skills of fishing.
PHYSICAL CONDITIONING		
PHYSICAL EDUCATION	5561.80 thru 5566.80	† WEIGHT TRAINING FOR BOYS  Provides for a variety of activities from which each student should experience improvement in his physical strength, muscular development, and self-confidence.
PHYSICAL EDUCATION	5551.81 thru 5556.81	† SLIMNASTICS FOR GIRLS  Designed to help the student attain the level of fitness necessary for desirable figure proportions. It will be accomplished through analysis of present figure status, information concerning figure potential, methods of attaining this potential, and a figure-conditioning program.
PHYSICAL EDUCATION	5551.82 thru 5556.82 5561.82 thru 5566.82	† ADAPTED PHYSICAL EDUCATION  Designed to assist students who have disabilities and cannot successfully take part in the general physical education program. Students will be provided with the opportunity to participate in a variation of games, sports, and developmental activities which are designed to meet their own needs, interests, and limitations.
PHYSICAL EDUCATION	5551.83 thru 5556.83 5561.83 thru 5566.83	PHYSICAL TRAINING  Provides activities for individuals who wish to improve their physical fitness and for those who scored 40% or less on the physical fitness tests. Each student will be assisted in analyzing his own needs, identifying activities for remediation, and developing attainable goals to fulfill these needs.

PHYSICAL EDUCATION  
350

AREA	ACCR. NO. FLA-DADE	COURSE TITLE AND DESCRIPTION
RHYTHMIC ACTIVITIES		
PHYSICAL EDUCATION	5551.90 thru 5556.90 5561.90 thru 5566.90	† INTRODUCTION TO DANCE  A coeducational unit designed to acquaint the student with the fundamentals of folk, square, and social dancing. Activities in each area will provide the student with the opportunity to practice the basic dance movements, develop poise and confidence for enjoying dancing in social situations, and utilize adequate skills for participation in rhythmic activities.
PHYSICAL EDUCATION	5551.91 thru 5556.91 5561.91 thru 5566.91	RHYTHM MOVEMENT EXPLORATION  A course of study for a coeducational class in rhythmic activities other than dancing. Activities will include folk games, exercising to music, marching to music, and other rhythmic movements. These experiences will help students gain a greater appreciation for rhythm, develop creative expression, and acquire skill in rhythmic activities.
PHYSICAL EDUCATION	5551.92 thru 5556.92 5561.92 thru 5566.92	† ADVANCED FOLK AND SQUARE DANCE  A coeducational class providing an in-depth examination of folk and square dancing activities. Course is designed to familiarize students with more challenging step patterns and provide opportunities for creative expression and enjoyment of folk and square dancing in a postschool recreational atmosphere.
PHYSICAL EDUCATION	5551.93 thru 5556.93 5561.93 thru 5566.93	† ADVANCED SOCIAL DANCING  A coeducational class participating in traditional social dances, as well as contemporary dance forms. By practicing social dances to appropriate music, students will have opportunities to increase dancing proficiency, improve confidence and poise in social situations, and to develop an enjoyable activity in a postschool situation.
PHYSICAL EDUCATION	5551.94 thru 5556.94 5561.94 thru 5566.94	† BEGINNING MODERN DANCE  A history of dance. The program includes conditioning exercises and basic movement.

AREA	ACCR. NO. FLA-DADE	COURSE TITLE AND DESCRIPTION
PHYSICAL EDUCATION	5551.96 thru 5556.96 5561.96 thru 5566.96	† ADVANCED MODERN DANCE  Advanced principles and theory of movement, designed to give students a level of performance sufficient to enjoy the dance in class and in leisure-time activities.
PHYSICAL EDUCATION	5551.97 thru 5556.97 5561.97 thru 5566.97	INTERPRETATIVE MODERN DANCE  The interpretation of basic, axial, and locomotor movement leading to individual creative expression.

## SCIENCE

With the introduction of the quinmester plan, both teachers and students will have greater opportunities than ever before to develop and participate in truly meaningful learning experiences. Everyone who is involved has responsibility for the success of the plan. Each school should offer a sufficient range of science courses to provide honest choices for every student.

Students should have the chance to explore areas such as man's behavior and emotions, the effects of science on society, amateur radio, and cartography, as well as biology, physics, and chemistry. Opportunities should be provided for a student to study those particular facets of the curriculum in which he is most interested and in which he is most likely to succeed.

The chance to teach new and more relevant material will be a distinct advantage for teachers. It is assumed that the student will give thoughtful consideration to his needs and interests and will be guided in making wise selections by his parents, guidance counselors, and teachers.

### *Utilization of Science Quinmester Courses*

Each course contains a minimum set of performance objectives and a brief course outline, along with a great variety of suggested activities to accomplish each objective. What is emphasized and the method of teaching is up to the individual teacher. However, the student, at the end of nine weeks, should have accomplished the performance objectives and have been introduced to the material mentioned in the outline.

To make the quinmester courses most effective, the school should have available at least one copy of each textbook, laboratory manual, and the selected references (not the entire bibliography) which are listed within the course. After initial examination, class sets or individual texts may be selected, depending upon the needs of the individual students.

Performance objectives and related methods of teaching are numbered. There is a master sheet at the end of each science quinmester course. The performance objectives, the suggested methods of teaching, and related activities are cross-referenced. A variety of activities are suggested for each objective at various levels of sophistication. It would be impossible to complete all the activities within the nine-week period. The teachers should choose those methods and activities which are best adapted to the abilities of their students and which are compatible with the time schedules and facilities within the school.

Each science quin course is designed so that it can be taught using only one text or a variety of texts and other references and/or reprints. The courses are flexible due to the variety of materials and activities. Therefore, they can be adapted to various levels to meet the needs of the individual students. The courses are, in most cases, nonsequential with no prerequisite.

### *Suggestions for Student Placement*

#### *Explanation of Science Code Numbers*

.01-.39 regular courses

.40-.59 more difficult, some background would help

.60-.99 much more difficult, could be considered second-level caliber

#### *Junior High*

All courses are nonsequential and may be taken in any grade. Use the appropriate number: 5311 for seventh, 5312 for eighth, and 5313 for ninth grade. *Your S.T.A.N.D. on Health* (5311.47) includes narcotics, alcohol, and tobacco education, as required by state law, and first aid and venereal disease education, as recommended by Dade County. All students interested in taking high school chemistry or physics should take *Scientific Mathematics* (5344.01).

When accelerated students in the ninth grade desire to take biology quinmester courses 5314.10-5314.14, the recommendations as indicated in Curriculum Bulletin I, 1972 Edition, page 91 under course 5373, should be considered.

A number of the quins have multiple numbers indicating that they may be used in either junior or senior high school. Check ecology, marine science, and earth science for additional junior high course offerings.

#### *Biology*

Courses 5314.01-5314.09 are recommended for students whose interest and background in science are extremely limited. These courses emphasize high interest and individual student involvement.

Courses 5314.10-5314.14 form the basic biology block needed by serious biology students.

Courses 5363.01-5363.05 or 5346.01-5346.05 are anatomy and physiology and are recommended for second-year students. Either number may be used.

Check ecology and marine science for related biology offerings.

#### *Chemistry*

*Applied Chemistry I* (5316.03) and *Applied Chemistry II* (5316.04) are recommended for students needing science credit whose interest and background are limited.

*Introduction to Chemistry* (5316.01) and *Reactions of Atoms and Molecules* (5316.02) should be taken in sequence and are prerequisite to other chemistry offerings. If a student desires a full year's work in chemistry for one unit of credit, the other two courses may be selected from any of the available chemistry courses numbers 5316.05-5316.62. *Scientific Mathematics* (5344.01) should be completed before the student attempts *Reactions of Atoms and Molecules* (5316.02).

#### *Physics*

*Kinematics* (5318.01) and *Dynamics I* (5318.02) should be taken in sequence and prerequisite to other physics offerings. If a student desires a full year's work in physics for one unit of credit, the other two courses may be selected from any of the available physics courses numbers 5318.03-5318.60.

*Geometric and Applied Optics* (5318.04) does not need the above prerequisites.

*Physical Science (5348.01–5348.06)*

There is no sequence and a student may take any course listed. Check earth science, chemistry, and marine science for additional offerings.

*Earth Science (5343.01–5343.13)*

No sequence or prerequisites. All courses have multiple numbers and may be taken in junior or senior high. Use the appropriate number to indicate grade level. *Violent Florida Weather (5343.07)* is more meaningful if taught in September.

*Interdisciplinary*

Many courses have numbers of two or more subject areas. The student may take these courses and receive credit in either area. All courses carrying both science and agriculture code numbers are two periods in length and, therefore, are given two quinmester credits.

*Special Courses*

Courses 5334.01–5334.04 are selected topics in science for students whose interest and background in science are extremely limited.

If a student wishes to register for Advanced Placement Program Biology (5315.96–5315.99), A.P.P. Chemistry (5317.96–5317.99), A.P.P. Physics (5319.96–5319.99), Laboratory Research (5387.92–5387.99), or Science Research (5387.02–5387.05), he must agree to continue through four quinesters consecutively from September–June.

*Laboratory Orientation and Instrumentation (5387.06–5387.07)* is the fourth offering in the Motivation in Depth Program for gifted secondary science students. (Only students who have been in the Motivation in Depth Program are eligible to continue in its fourth offering.) Refer to Curriculum Bulletin I, 1972 Edition, page 96 for more details.

## QUINMESTER COURSES

Advanced Agricultural Science	378
Advanced Placement Program Biology	377
Advanced Placement Program Chemistry	377
Advanced Placement Program Physics	377
Adventures in Ecological Reading	371
Agricultural Biology	365
Amateur (Ham) Radio	363
Animal Behavior	362
Animal Clinic Technology	381
Animal Ecology in South Florida	371
Animal Life	361
Animal Structures and Functions	366
Animals from the Outside In	364
Applied Chemistry I (Living with Chemistry)	367
Applied Chemistry II	368
Applied Fundamentals of Agriculture	378
Applied Meteorology	370
Atmosphere	370
Atoms, Molecules, and Kinetic Theory	369
Atomic Physics	375
Basic Fundamentals of Agriculture	378
Basic Fundamentals of Ecology	371
Biochemistry	369
Career Orientation in Agriculture	379
Cartography	370
Cell Biology	366
Chemistry of Biology	366
Chemistry of Carbon and Its Compounds	368
Continuity of Life	365
Current Science	363
Dairy Herd Management	381
Design for Living, or Health, Nutrition and Exercise	362
Development of Agricultural Competencies	379
Digestion, Excretion, and Metabolism	367
Does It Have To Be a Dirty World?	365
Dynamic Nature of Atoms and Molecules	368
Dynamics I	374
Dynamics II	374
Ecology of Terrestrial Species of South Florida	372
Ecopolitics	372
Electronics in Action	363
Energy and Work	376
Energy: Light, Sound, and Heat	360
Energy: Machines	360
Energy of Atoms and Molecules	368
Environmental Crises—Man's Unbalancing of Nature's Balance	371
Everyday Chemistry	360
Everyday Measurements, or Living Things Can Be Measured	360



Four-Legged and Otherwise . . . . .	364
Freshwater Ecology of South Florida . . . . .	372
Freshwater Supplies of the Hydrosphere . . . . .	371
From Atmosphere to Space . . . . .	360
Fundamentals of Electricity and Electronics . . . . .	364
General Agricultural Concepts . . . . .	378
General Earth Science . . . . .	369
General Geology . . . . .	370
Genetics . . . . .	366
Geometric and Applied Optics . . . . .	374
Geomorphology . . . . .	370
Green Plant, The . . . . .	365
Growing Flowers . . . . .	381
Historical Geology . . . . .	371
History of Flight . . . . .	375
Human Ecology . . . . .	372
Human Reproduction . . . . .	367
Independent Study . . . . .	364
Industrial Chemistry . . . . .	368
Introduction to Aeronautics . . . . .	375
Introduction to Agricultural Science . . . . .	378
Introduction to Anatomy and Physiology . . . . .	367
Introduction to Biochemistry . . . . .	368
Introduction to Chemistry . . . . .	367
Introduction to Ecology of South Florida Species . . . . .	372
Introduction to Forestry . . . . .	379
Introduction to the Human Body . . . . .	362
Introduction to Life Science . . . . .	361
Introduction to Marine Science . . . . .	373
Introduction to the Plant World . . . . .	361
Invertebrate Marine Biology . . . . .	374
Investigating Intricacies of Life Science . . . . .	376
Kinematics . . . . .	374
Laboratory Orientation and Instrumentation . . . . .	377
Laboratory Research . . . . .	377
Lawn Maintenance . . . . .	381
Life in the Changing Biosphere . . . . .	362
Life in the Past—Biogeography . . . . .	366
Life Science through Field Experiences . . . . .	361
Light Theory . . . . .	374
Literature of Ecology, The . . . . .	373
Man and Disease . . . . .	365
Man and Nature . . . . .	365
Man and the Sea . . . . .	373
Man's Behavior and Emotions . . . . .	362
Man's Senses . . . . .	362
Marine Ecology of South Florida . . . . .	373
Marine Vertebrates and Plants . . . . .	373
Matter and Its Changes . . . . .	360

Mechanics of Motors and Machines	376
Microbiology	366
Mineralogy	369
Modern Physics	374
Navigation	375
Nervous System, The	367
Nuclear Chemistry	369
Nursery Management	380
Oceanography	373
Organic Chemistry	369
Ornamental Plant Maintenance	381
Our Solar System	370
Periodic Trends in Properties of the Elements	368
Perpetuating the Species	363
Physical Chemistry	375
Physical Laws of Space	375
Physiology of Plants	366
Plant Economics	365
Plant Life in the Backyard	361
Plant Propagation	379
Pollution	371
Poultry Production	380
Practical Agricultural Science	379
Practical Forestry	381
Prehistoric Life	361
Qualitative Analysis	369
Rain, Rocks, Rockets, and Reactions	376
Raising Young Dairy Animals	380
Reactions of Atoms and Molecules	367
Recreation and the Sea	373
Reproduction and Development	365
Respiratory and Circulatory Systems	367
Science and Society	372
Science Research	377
Scientific Approach to Solving Problems	360
Scientific Mathematics	364
Selected Courses in General Agriculture 1	378
Selected Courses in General Agriculture 2	379
Sensing Systems of Modern Aircraft	376
Solid State Physics	375
Soil Conservation	380
Space Science	370
Teen Changes	363
Theories of Evolution	366
Theory of Electricity and Magnetism	374
Types of Reactions	369
Urban Ecology	372

Violent Florida Weather	370
Water Conservation	380
What Makes Man Go?	376
Who Needs Plants?	364
Who's Who	361
Wildlife and Game Management	380
World of Animals, The	362
World of Matter, The	360
World of Plants, The	361
Writing a Research Paper	376
Your S.T.A.N.D. on Health	363
Your World and Welcome to It	364

SCIENCE  
359

AREA	ACCR. NO. FLA-DADE	COURSE TITLE AND DESCRIPTION
SCIENCE	5311.01 5312.01 <sup>9</sup> 5313.01	† SCIENTIFIC APPROACH TO SOLVING PROBLEMS  The student will study the work of scientists, become familiar with laboratory equipment, plan experiments, and use multiple forms of presenting data.
SCIENCE	5311.02 5312.02 5313.02	EVERYDAY MEASUREMENTS OF LIVING THINGS CAN BE MEASURED  Practice and experience in measuring and comparing factors connected with living organisms.
SCIENCE	5311.03 5312.03 5313.03	† ENERGY: MACHINES  An introductory course in energy involving six simple machines, electricity, magnetism, and motion.
SCIENCE	5311.04 5312.04 5313.04	† ENERGY: LIGHT, SOUND, AND HEAT  A basic course covering light, sound, and heat.
SCIENCE	5311.05 5312.05 5313.05	† FROM ATMOSPHERE TO SPACE  The aerodynamics of flight, rocketry, satellites, and man in space.
SCIENCE	5311.06 5312.06 5313.06	† MATTER AND ITS CHANGES  A survey course investigating the classification of matter, its physical and chemical properties, its changes, as well as acids, bases, and neutral solutions.
SCIENCE	5311.07 5312.07 5313.07	THE WORLD OF MATTER  A survey course exploring chemistry in industry and in the home.
SCIENCE	5311.08 5312.08 5313.08	EVERYDAY CHEMISTRY  A study of common chemicals found around the house and how chemical reactions affect everyday living.

SCIENCE  
360

351

AREA	ACCR. NO. FLA-DADE	COURSE TITLE AND DESCRIPTION
SCIENCE	5311.09 5312.09 5313.09	† WHO'S WHO  An introduction to famous people in science reviews, their contributions and accomplishments.
SCIENCE	5311.10 5312.10 5313.10	† INTRODUCTION TO LIFE SCIENCE  Explores the characteristics of living things, kingdoms, food webs, organisms, and typical cells.
SCIENCE	5311.11 5312.11 5313.11	† INTRODUCTION TO THE PLANT WORLD  Shows how plants are involved in every aspect of life; includes a study of edible, poisonous, disease-causing plants.
SCIENCE	5311.12 5312.12 5313.12	† PLANT LIFE IN THE BACKYARD  Study of basic plant types, including comparing their anatomy and physiology, importance and recognition.
SCIENCE	5311.13 5312.13 5313.13	† THE WORLD OF PLANTS  A survey course of the plant kingdom, including poisonous, ornamental, and edible plants of South Florida, their structures and functions.
SCIENCE	5311.14 5312.14 5313.14	LIFE SCIENCE THROUGH FIELD EXPERIENCES.  Identification and interrelationships of plants and animals.
SCIENCE	5311.15 5312.15 5313.15	PREHISTORIC LIFE  A survey course of the geological and biological history of the earth.
SCIENCE	5311.16 5312.16 5313.16	† ANIMAL LIFE  Activity oriented to show how animals are involved in all aspects of one's life. Topics include recognition and characteristics of harmful and beneficial animals.

SCIENCE  
361

AREA	ACCR. NO. FLA-DADE	COURSE TITLE AND DESCRIPTION
SCIENCE	5311.17 5312.17 5313.17	† THE WORLD OF ANIMALS A survey course of the animal kingdom, including basic structures and functions of each phyla, typical animals of South Florida, and unusual animals of the world.
SCIENCE	5311.18 5312.18 5313.18	ANIMAL BEHAVIOR A survey course studying reasons for the usual and unusual behavior of animals.
SCIENCE	5311.19 5312.19 5313.19	LIFE IN THE CHANGING BIOSPHERE Shows cause of variety in living things; explains classification systems and explores interaction.
SCIENCE	5311.20 5312.20 5313.20	† INTRODUCTION TO THE HUMAN BODY A survey course of the body systems, emphasizing structures and functions of the major organs, and organic malfunctions and/or diseases.
SCIENCE	5311.21 5312.21 5313.21	† DESIGN FOR LIVING, or HEALTH, NUTRITION AND EXERCISE A study of types of food, metabolism, nutritional deficiencies, food additives, and innovations in exercise.
SCIENCE	5311.22 5312.22 5313.22	† MAN'S BEHAVIOR AND EMOTIONS A study of the factors that influence an individual's behavior and adjustment.
SCIENCE	5311.23 5312.23 5313.23	† MAN'S SENSES A survey course of the human nervous system, with emphasis on the five senses and their importance to the individual.

SCIENCE  
362

AREA	ACCR. NO. FLA-DADE	COURSE TITLE AND DESCRIPTION
SCIENCE	5311.40 5312.40 5313.40	† PERPETUATING THE SPECIES  A survey course in the study of heredity, including asexual and sexual reproduction, probability, mitosis, meiosis, Mendel's laws, and mutations.
SCIENCE	5311.41 5312.41 5313.41	† CURRENT SCIENCE  Through the use of newspapers and magazines as textual materials, the student will be exposed to the latest science achievements.
SCIENCE  HEALTH	5311.47 5312.47 5313.47 7391.01 7392.01	YOUR S.T.A.N.D. ON HEALTH  This health quin provides for the study and discussion of the characteristics and effects of tobacco, alcohol, narcotics, and venereal disease. Safety precautions and first aid procedures will also be emphasized.
SCIENCE  HOME AND FAMILY ED. HEALTH	5311.48 5312.48 5313.48 6763.03 7391.02 7392.02	TEEN CHANGES  An elective unit designed to provide an overview of mental health; personality development; body structure, function, and care. Emphasizes nutritional and health care of the teen-ager. The student will assess feelings and attitudes about growth and body changes.
SCIENCE  INDUSTRIAL ARTS	5311.49 5312.49 5313.49 5822.03 5827.01	ELECTRONICS IN ACTION  An exposure to basic electronic components, their theory, identification, and use. This course of study will also develop an ability to understand and use schematics, chassis layout/construction, and wiring procedures.  The student will be able to display mastery of the fundamentals and skills indicated in Fundamentals of Electricity and Electronics, 5822.01, prior to entry into this course.
SCIENCE  INDUSTRIAL ARTS	5311.50 5312.50 5313.50 5822.04 5829.03	AMATEUR (HAM) RADIO  Prepares the student for his F.C.C. examination for an amateur radio license by acquainting him with equipment and techniques necessary in the field of amateur communications.

AREA	ACCR. NO. FLA-DADE	COURSE TITLE AND DESCRIPTION
SCIENCE	5311.51 5312.51 5313.51	† FUNDAMENTALS OF ELECTRICITY AND ELECTRONICS
INDUSTRIAL ARTS TRADE AND IND. ED.	5822.01 5823.01 9023.02 9323.01 9783.01	Provides an exploratory experience in the field of electricity and electronics. The student will be able to answer the following: What is electricity? How is electricity produced? How is electricity distributed? How is electricity used?
SCIENCE	5311.60 5312.60 5313.60	INDEPENDENT STUDY  The student will spend nine weeks on a research topic agreed upon by student and instructor.
SCIENCE MATH	5344.01 5266.26	† SCIENTIFIC MATHEMATICS  Includes scientific notation, metric system, graphing, ratios, and probability. Recommended for students planning to take chemistry.
SCIENCE	5314.01	ANIMALS FROM THE OUTSIDE IN  An introductory course in the structure and functions of animals, with a detailed study of one animal.
SCIENCE	5314.02	† FOUR-LEGGED AND OTHERWISE  Considers groups of animals in terms of life cycles, habitats, and environmental problems.
SCIENCE	5314.03	YOUR WORLD AND WELCOME TO IT  Begins with a study of cells and progresses to societies, including social behavior and man's influence on his environment.
SCIENCE	5314.04 5364.21	† WHO NEEDS PLANTS?  Introductory course in plants, with emphasis on useful and harmful Florida varieties.



AREA	ACCR. NO. FLA-DADE	COURSE TITLE AND DESCRIPTION
SCIENCE	5314.05	REPRODUCTION AND DEVELOPMENT Includes reproduction and development of plants, animals, and humans.
SCIENCE	5314.06	† MAN AND DISEASE The study of disease and man's efforts in fighting it through the ages.
SCIENCE	5314.07 5364.22	PLANT ECONOMICS Study of horticulture, landscaping, identification and treatment of plant diseases.
SCIENCE	5314.08	† DOES IT HAVE TO BE A DIRTY WORLD? A laboratory approach to the problems of pollution of the environment and the various methods of restoration and conservation.
SCIENCE	5314.09	AGRICULTURAL BIOLOGY Laboratory study of soils, plants, crop improvements, and pesticides. Fish farming, tropical fish, and careers in agriculture will be included.
SCIENCE	5314.10	† MAN AND NATURE Includes the scientific method, classification, evolution, populations, societies, communities, and environmental problems.
SCIENCE	5314.11	† CONTINUITY OF LIFE A study of reproduction, development, and genetics.
SCIENCE	5314.12 5364.23	† THE GREEN PLANT In-depth study of, the green plant covering the cell, structure, nutrition, growth, reproduction, behavior, and importance to man.

SCIENCE  
365

AREA	ACCR. NO. FLA-DADE	COURSE TITLE AND DESCRIPTION
SCIENCE	5314.13	† ANIMAL STRUCTURES AND FUNCTIONS A study of the structures and functions of animal systems.
SCIENCE	5314.14	† CELL BIOLOGY The chemical composition of the cell and its development.
SCIENCE	5314.15	1 CHEMISTRY OF BIOLOGY Covers the chemistry of carbohydrates, amino acids, fats, and nucleic acids. Some knowledge of math is needed.
SCIENCE	5314.16	LIFE IN THE PAST--BIOGEOGRAPHY History of man, animal, and plants. Isolation, adaptation, continental changes, and faunal regions will be studied.
SCIENCE	5314.17	MICROBIOLOGY A survey course of the identification and importance of the Protist Kingdom.
SCIENCE	5315.40	† GENETICS An in depth study of heredity. Prerequisite is four quarter courses of biology.
SCIENCE	5315.41 5364.24	PHYSIOLOGY OF PLANTS Prerequisite of four biology quarters. An in depth study of the functions of plants including photosynthesis, transpiration, transportation, reproduction, and growth.
SCIENCE	5315.42	THEORIES OF EVOLUTION Study of the various theories with attempt to explain the changes life has undergone.

SCIENCE  
300

AREA	ACCR. NO. FLA-DADE	COURSE TITLE AND DESCRIPTION
SCIENCE	5363.01 5346.01	† INTRODUCTION TO ANATOMY AND PHYSIOLOGY  An introductory course in anatomy and physiology, covering the structure and functions of the body; recommended before other anatomy and physiology courses.
SCIENCE	5363.02 5346.02	† THE NERVOUS SYSTEM  An in-depth study of the function and defects of the nervous system.
SCIENCE	5363.03 5346.03	DIGESTION, EXCRETION, AND METABOLISM  An in-depth study of the function and disorders of the digestive and excretory systems.
SCIENCE	5363.04 5346.04	RESPIRATORY AND CIRCULATORY SYSTEMS  An in-depth study of the transportation and exchange of materials in the human body.
SCIENCE	5363.05 5346.05	† HUMAN REPRODUCTION  Prerequisite: any four quins in the area of science; study of the physiology of reproduction.
SCIENCE	5316.01	† INTRODUCTION TO CHEMISTRY  Investigative approach to scientific phenomena, atomic theory, periodic table, and atomic structure.
SCIENCE	5316.02	† REACTIONS OF ATOMS AND MOLECULES  Introduces the mole concept through the use of experimentation; writing, balancing, and using equations; bonding and molecular structure.
SCIENCE	5316.03	† APPLIED CHEMISTRY I (LIVING WITH CHEMISTRY)  Uses of Introductory Physical Science materials, emphasizes common household products, classifies matter, develops concept of atomic structure and practical use of periodic table, and teaches the writing of formulas and equations through a study of our atmosphere.

AREA	ACCR. NO. FLA-DADE	COURSE TITLE AND DESCRIPTION
SCIENCE	5316.04	<p>APPLIED CHEMISTRY II-</p> <p>Study of chemical concepts, using foods, clothing, and "wonder products," i.e., plastics, rubber, alloys, etc.</p>
SCIENCE	5316.05	<p>ENERGY OF ATOMS AND MOLECULES</p> <p>Study of three phases of matter, solutions, and chemical reactions.</p>
SCIENCE	5316.06	<p>DYNAMIC NATURE OF ATOMS AND MOLECULES</p> <p>Recognizes physical and chemical systems in equilibrium, predicts products in solubility, acid-base, and oxidation-reduction reactions.</p>
SCIENCE	5316.07	<p>INDUSTRIAL CHEMISTRY</p> <p>Serves the function of vocational familiarization, and shows processes carried on daily in industry; includes the chemistry of petroleum, metals, plastics, coal tar derivatives, rubber, food processing, refrigeration and heating, sulfuric acid, ammonia, and power.</p>
SCIENCE	5316.40	<p>PERIODIC TRENDS IN PROPERTIES OF THE ELEMENTS</p> <p>Study in depth of the periodic tables by families.</p>
SCIENCE	5316.59	<p>CHEMISTRY OF CARBON AND ITS COMPOUNDS</p> <p>Adaptable for Chemistry I and Nursing; shows difference between organic and inorganic compounds, bonding habits and properties of carbon, nomenclature, reactions, and methods for preparation of hydrocarbons.</p>
SCIENCE	5316.60	<p>† INTRODUCTION TO BIOCHEMISTRY</p> <p>Adaptable for Chemistry I and Nursing; study of organic compounds associated with living things and the chemical reactions involved in the basic life processes.</p>

SCIENCE  
368

AREA	ACCR. NO. FLA-DADE	COURSE TITLE AND DESCRIPTION
SCIENCE	5316.61	† QUALITATIVE ANALYSIS  Study and recognition of cations in groups I, II, III, IV, V through laboratory investigation.
SCIENCE	5316.62	NUCLEAR CHEMISTRY  Study of the nucleus, including isotopes, decay schemes, radiation, and safe handling.
SCIENCE	5317.63	ATOMS, MOLECULES, AND KINETIC THEORY  Second-year mathematical approach, in-depth study of atomic structure, bonding, and the states of matter.
SCIENCE	5317.64	TYPES OF REACTIONS  Problem approach to stoichiometry, equilibrium, solutions, acidbase and oxidation-reduction reactions.
SCIENCE	5317.65	† ORGANIC CHEMISTRY  A mathematical approach to carbon chemistry.
SCIENCE	5317.66	BIOCHEMISTRY  A mathematical approach to the chemical reactions involved in life processes.
SCIENCE	5343.01 5311.26 5312.26 5313.26	† GENERAL EARTH SCIENCE  Survey course to motivate the student to take further studies in this field; includes astronomy, conservation, cartography, geology, meteorology, physiography, and topography.
SCIENCE	5343.02 5311.27 5312.27 5313.27	MINERALOGY  Study of minerals, their formation, structure, identification; includes formation of rocks.

SCIENCE  
369

AREA	ACCR. NO. FLA-DADE	COURSE TITLE AND DESCRIPTION
SCIENCE	5343.03 5311.28 5312.28 5313.28	† GENERAL GEOLOGY  Introductory course including land forms, minerals, rocks, earth's core, and steam development.
SCIENCE	5343.04 5311.29 5312.29 5313.29	† SPACE SCIENCE  A general study of the basic relationships that exist in the universe.
SCIENCE	5343.05 5311.30 5312.30 5313.30	† OUR SOLAR SYSTEM  A study of the interaction of the sun, and its family of planets and their moons.
SCIENCE	5343.06 5311.31 5312.31 5313.31	† APPLIED METEOROLOGY.  Study of instruments, weather maps, and forecasting of weather.
SCIENCE	5343.07 5311.32 5312.32 5313.32	VIOLENT FLORIDA WEATHER  Study of some of the more interesting aspects of violent weather, its detection, growth, effects, and possible alteration.
SCIENCE	5343.08 5311.33 5312.33 5313.33	ATMOSPHERE  Study of the total atmosphere by layers, with emphasis on physical characteristics.
SCIENCE	5343.09 5311.34 5312.34 5313.34	† GEOMORPHOLOGY  Study of external and internal forces resulting in landforms and soils.
SCIENCE	5343.10 5311.35 5312.35 5313.35	CARTOGRAPHY  Study of the earth's features through aerial photo analyses, map reading, and interpretations of map symbols as they apply to the earth sciences.
SOCIAL STUDIES	6478.15 6444.01 6445.05	

SCIENCE  
370

AREA	ACCR. NO. FLA-DADE	COURSE TITLE AND DESCRIPTION
SCIENCE	5343.11 5311.36 5312.36 5313.36	HISTORICAL GEOLOGY  Introductory course in the earth's developmental history, with emphasis on Florida.
SCIENCE	5343.12 5311.37 5312.37 5313.37	FRESHWATER SUPPLIES OF THE HYDROSPHERE  Study of surface and subsurface water supplies, including their development, chemistry, and movement.
SCIENCE	5343.13 5311.38 5312.38 5313.38	† POLLUTION  Study of causes, detection, and correction of air, water, and soil pollution, with emphasis on South Florida.
SCIENCE	5365.01 5313.45 5312.45 5311.45	† BASIC FUNDAMENTALS OF ECOLOGY  A basic survey course which includes the study of interrelationships of organisms in their environments; lab and field-study oriented.
SCIENCE	5365.02 5313.44 5312.44 5311.44	ADVENTURES IN ECOLOGICAL READING  A reading and discussion course using some of Rachel Carson's writings and other books.
LANGUAGE ARTS	5114.85 5115.85 5116.85	
SCIENCE	5365.03 5313.46 5312.46 5311.46	ANIMAL ECOLOGY IN SOUTH FLORIDA  Animal life in two major South Florida ecosystems will be considered.
SCIENCE	5365.04 5313.43 5312.43 5311.43	† ENVIRONMENTAL CRISES—MAN'S UNBALANCING OF NATURE'S BALANCE  Study of the results of man's interference in the balance of nature and possible solutions.

AREA	ACCR. NO. FLA-DADE	COURSE TITLE AND DESCRIPTION
SCIENCE SOCIAL STUDIES	5365.40 6416.51 6448.55	URBAN ECOLOGY  Study of urban environments, population densities, human reactions to crowded conditions, possible solutions.
SCIENCE	5365.41	INTRODUCTION TO ECOLOGY OF SOUTH FLORIDA SPECIES  An introductory survey course covering basic ecology of three major zones; includes research problems for the individual students.
SCIENCE SOCIAL STUDIES	5365.43 6425.14 6448.66 6416.57	SCIENCE AND SOCIETY  Investigates the impact of science on society. The effects of technology on the values, institutions, behavior, and health of a society will be explored.
SCIENCE SOCIAL STUDIES	5365.44 6448.09 6413.11 6418.02 6457.02 6446.15 6416.44	† ECOPOLITICS  A study of the politics of ecology. Includes an analysis of current local, national, and international issues.
SCIENCE	5365.60	HUMAN ECOLOGY  Deals with man's relationship to the natural environment and his manipulation of it.
SCIENCE	5365.61	FRESHWATER ECOLOGY OF SOUTH FLORIDA  Dynamics of South Florida freshwater ecology, using the Everglades, Big Cypress Swamp, and a freshwater pond.
SCIENCE	5365.62	ECOLOGY OF TERRESTRIAL SPECIES OF SOUTH FLORIDA  In-depth study of a hardwood hammock, pine and palmetto community, seastrand community, and a grassland prairie.



AREA	ACCR. NO. FLA-DADE	COURSE TITLE AND DESCRIPTION
SCIENCE	5365.63 5367.63	† MARINE ECOLOGY OF SOUTH FLORIDA  In-depth study of reef, mangrove, grass bed, sand and mud flats, and estuarine communities.
SCIENCE LANGUAGE ARTS	5365.65 5114.52 5115.52 5116.52	† THE LITERATURE OF ECOLOGY  Designed to give the student a clearer understanding of the ecological problems that confront mankind. Readings in the course will include, but not be limited to, <i>The Environmental Handbook</i> , <i>The Population Bomb</i> , <i>Defoliation</i> .
SCIENCE	5369.01 5313.25 5312.25 5311.25	† RECREATION AND THE SEA  Includes basic seamanship techniques, equipment maintenance, and safety; recreations such as fishing, snorkeling, and underwater photography will be explored.
SCIENCE	5369.02 5367.02 5313.42 5312.42 5311.42	† INTRODUCTION TO MARINE SCIENCE  A survey course that includes survey of local marine flora and fauna, tides, currents, waves, sea water chemistry, recreation, futures in marine science. May be used in junior high.
SCIENCE	5369.03	MAN AND THE SEA  Seminar approach with field trips, including history, marine institutes, techniques, commercial fisheries, and future developments.
SCIENCE	5369.60	† OCEANOGRAPHY  An introduction to the physical and chemical characteristics of the ocean; designed to acquaint the student with the oceans' forces which affect man and effect biological distribution.
SCIENCE	5367.40	MARINE VERTEBRATES AND PLANTS  Introduction to taxonomy and morphology of marine chordates and plants.

AREA	ACCR. NO. FLA-DADE	COURSE TITLE AND DESCRIPTION
SCIENCE	5367.41	† INVERTEBRATE MARINE BIOLOGY Introduction to local marine invertebrates; emphases on identification, taxonomy, and morphology.
SCIENCE	5318.01	† KINEMATICS A study of motion exclusive of mass and force.
SCIENCE	5318.02	† DYNAMICS I Time, space, matter, energy relationships in terms of force; K.E.; P.E.; collisions and Newton's Laws.
SCIENCE	5318.03	† DYNAMICS II Curvilinear and circular motion, torque, moment, angular motion, energy, and momentum.
SCIENCE	5318.04	GEOMETRIC AND APPLIED OPTICS Based on applied optics, includes lens systems, cameras, scopes, illumination, projected light, images, and parallax.
SCIENCE	5318.05	LIGHT THEORY Study of particle, wave, duality, and interference theories; includes an introduction to special relativity.
SCIENCE	5318.06	THEORY OF ELECTRICITY AND MAGNETISM Study of electron motion, electric circuits, magnetic field, electromagnetic induction, and waves.
SCIENCE	5318.07	MODERN PHYSICS Application of theoretical physics to modern living, atomic energy, radioactivity, pollution, lasers.

SCIENCE  
374

365

AREA	ACCR. NO: FLA-DADE	COURSE TITLE AND DESCRIPTION
SCIENCE	5318.08	<b>SOLID STATE PHYSICS</b>  Deals with the properties of solids at the atomic and molecular level: the nature of chemical bonds and their effects on the properties of solids.
SCIENCE	5318.42	<b>ATOMIC PHYSICS</b>  Study of the modern and classical concepts of the atom; the structure of the atom as a mass-energy relationship; practical uses of radioactivity, isotopes, etc.
SCIENCE	5318.60	† <b>PHYSICAL CHEMISTRY</b>  Study of physical properties of substances; especially the laws governing energy transformation, chemical interactions, periodicity of elements, electron configurations, molecular structure, and stereoisomerism.
SCIENCE	5348.01 5347.01	† <b>INTRODUCTION TO AERONAUTICS</b>  Basic study of aerodynamics, relative to fluid dynamics. Includes baby wind tunnel, supersonic travel, jetstreams and atmospheric "skipping."
SCIENCE	5348.02 5347.02	<b>HISTORY OF FLIGHT</b>  Overview of lighter-than-air craft, jets, rocketry, turbines, and satellites.
SCIENCE	5348.03	<b>PHYSICAL LAWS OF SPACE</b>  Non mathematical approach to kinematics; includes describing and measuring motion, Newton's three laws, falling objects, direction of motion, and special kinds of motion.
SCIENCE	5348.04 5347.04	<b>NAVIGATION</b>
MATH	5266.16	A survey course in land, air, and water navigation; vectors, manual computers, radio operation, chart and map reading.

SCIENCE  
375

AREA	ACCR. NO. FLA-DADE	COURSE TITLE AND DESCRIPTION
SCIENCE	5348.05	ENERGY AND WORK Measuring of work, power, and energy; forms of energy; conversion and conservation of energy; and types of machines.
SCIENCE	5348.06 5347.06	SENSING SYSTEMS OF MODERN AIRCRAFT Informative course describing the construction and operation of aircraft instruments.
SCIENCE	5334.01	WHAT MAKES MAN GO? A study of selected topics in biological science, presented through activity-centered study. Included are topics in environmental problems, human anatomy, human physiology, and heredity.
SCIENCE	5334.02	INVESTIGATING INTRICACIES OF LIFE SCIENCE A study of selected topics in biological science, presented through activity-centered study. Included are topics in microbiology, animal life, plant life, and ecology.
SCIENCE	5334.03	MECHANICS OF MOTORS AND MACHINES A study of selected topics in physical science, presented through activity-centered study. Included are topics in engines and motors, electricity, levers, and mechanical advantages.
SCIENCE	5334.04	RAIN, ROCKS, ROCKETS, AND REACTIONS This course will consist of selected topics in physical science, presented through activity-centered study. Included are topics in household chemistry, weather, geology, and space science.
SCIENCE LANGUAGE ARTS SOCIAL STUDIES	5387.01 5114.84 5115.84 5116.84 6448.60 6416.54 6414.21	† WRITING A RESEARCH PAPER Designed for the student who will write research papers as part of special projects in content areas, such as science, mathematics, or social studies. The topic and content of the paper will be determined by the student. Special emphasis will be given to advanced research techniques, form, styles, and clarity.

SCIENCE  
376

367

AREA	ACCR. NO. FLA-DADE	COURSE TITLE AND DESCRIPTION
SCIENCE	5315.96 H 5315.97 5315.98 5315.99	ADVANCED PLACEMENT PROGRAM BIOLOGY  Equivalent to college work as prescribed by the Advanced Placement Program. The student must register for four quinquesters consecutively from September-June.
SCIENCE	5317.96 H 5317.97 5317.98 5317.99	ADVANCED PLACEMENT PROGRAM CHEMISTRY  Equivalent to college work as prescribed by the Advanced Placement Program. The student must register for four quinquesters consecutively from September-June.
SCIENCE	5319.96 H 5319.97 5319.98 5319.99	ADVANCED PLACEMENT PROGRAM PHYSICS  Equivalent to college work as prescribed by the Advanced Placement Program. The student must register for four quinquesters consecutively from September-June.
SCIENCE	5387.92 H 5387.93 5387.94 5387.95 5387.96 5387.97 5387.98 5387.99	LABORATORY RESEARCH  Science investigations in research laboratories throughout the community. Participants are selected for this countywide program from nominations submitted by the senior high schools. The student must register for four quinquesters consecutively from September-June.
SCIENCE	5387.02 5387.03 5387.04 5387.05	SCIENCE RESEARCH  Designed for capable science students who have acquired a strong background in the basic sciences. Provides opportunity for individual investigations. May be taken for two to four consecutive quinquesters.
SCIENCE	5387.06 H 5387.07	LABORATORY ORIENTATION AND INSTRUMENTATION  This course completes the sequence of the Motivation In Depth Program for gifted science students. Only students who have been successful in the program are eligible.

AREA	ACCR. NO. FLA-DADE	COURSE TITLE AND DESCRIPTION
SCIENCE AGRICULTURE	5364.01 5709.01	<p><b>INTRODUCTION TO AGRICULTURAL SCIENCE</b></p> <p>An introductory course in agricultural science covering orientation to the policies, rules, and objectives of the agricultural department's programs. Basic training is given in regard to developing skills in the use and propagation of plants, agricultural management procedures, and leadership abilities. Two quinmester credits.</p>
SCIENCE AGRICULTURE	5364.02 5709.02	<p><b>GENERAL AGRICULTURAL CONCEPTS</b></p> <p>The development of basic agricultural knowledge in the fields of plant and animal science, agricultural mechanics, and human and natural resources. Two quinmester credits.</p>
SCIENCE AGRICULTURE	5364.03 5709.03	<p><b>BASIC FUNDAMENTALS OF AGRICULTURE</b></p> <p>The application of fundamental agriculture concepts in plant, animal, and soil science; the development of farm shop projects; and the reinforcement of leadership skills in regard to public speaking and parliamentary procedure. Two quinmester credits.</p>
SCIENCE AGRICULTURE	5364.04 5709.04	<p><b>APPLIED FUNDAMENTALS OF AGRICULTURE</b></p> <p>Principles and practices concerned with the plant processes, soil utilization, animal nutrition, agricultural management; and the development of farm shop skills. Two quinmester credits.</p>
SCIENCE AGRICULTURE	5364.05 5709.05	<p><b>SELECTED COURSES IN GENERAL AGRICULTURE 1</b></p> <p>Skill development and information courses regarding specific subjects in agricultural science. Subjects taught according to student demand. Designed to develop competencies for occupational entry. Two quinmester credits.</p>
SCIENCE AGRICULTURE	5364.06 5711.01	<p><b>ADVANCED AGRICULTURAL SCIENCE</b></p> <p>Advanced study and practical experience in the applied principles of agricultural science in the fields of livestock, crops, ornamental plants, ecology, and farm shop. Two quinmester credits.</p>

SCIENCE  
378

AREA	ACCR. NO. FLA-DADE	COURSE TITLE AND DESCRIPTION
SCIENCE AGRICULTURE	5364.07 5711.02	<p>DEVELOPMENT OF AGRICULTURAL COMPETENCIES</p> <p>The development of competencies and abilities in the areas of plant disease control, planting design, conservation of natural resources, animal disease control, and practical problems in farm shop skill development. Two quinmester credits.</p>
SCIENCE AGRICULTURE	5364.08 5711.03	<p>PRACTICAL AGRICULTURAL SCIENCE</p> <p>A combination of subject matter and practical experiences concerned with plant pests and their control, landscape practices, leadership decision making, farm shop projects, and environmental problems. Two quinmester credits.</p>
SCIENCE AGRICULTURE	5364.09 5711.04	<p>CAREER ORIENTATION IN AGRICULTURE</p> <p>Offers an opportunity for the student to select a number of vocations concerned with agricultural related occupations for further study and experience. Marketing and management knowledge is developed together with learning situations regarding human relations. Two quinmester credits.</p>
SCIENCE AGRICULTURE	5364.10 5711.05	<p>SELECTED COURSES IN GENERAL AGRICULTURE 2</p> <p>Skill development and information courses regarding specific subjects in agricultural science. Subjects taught according to student demand. Designed to develop competencies for occupational entry. Two quinmester credits.</p>
SCIENCE AGRICULTURE	5364.11 5793.01	<p>INTRODUCTION TO FORESTRY</p> <p>An introductory course to forestry as an occupation and the problems connected with forest conservation. Two quinmester credits.</p>
SCIENCE AGRICULTURE	5364.16 5791.01	<p>PLANT PROPAGATION</p> <p>Subject matter and experiences concerned with the production of plants for the purpose of propagation and transplantation. Two quinmester credits.</p>

SCIENCE  
379

AREA	ACCR. NO. FLA-DADE	COURSE TITLE AND DESCRIPTION
SCIENCE AGRICULTURE	5364.17 5791.02	<p><b>NURSERY MANAGEMENT</b></p> <p>Designed for the student preparing to enter the nursery business. Concerns fundamental nursery management, planning, maintenance, and environmental control.</p> <p>The student prior to entry in this course will demonstrate his achievement of the objectives set forth in Plant Propagation 5791.01. Two quinmester credits.</p>
SCIENCE AGRICULTURE	5366.03 5732.01	<p><b>POULTRY PRODUCTION</b></p> <p>An introduction to feeding principles and disease control methods used in the production of poultry, together with poultry improvement through selective breeding. Two quinmester credits.</p>
SCIENCE AGRICULTURE	5366.04 5771.01	<p><b>WILDLIFE AND GAME MANAGEMENT</b></p> <p>A study of the principles and practices involved in the conservation and improvement of wildlife such as game and fish. Two quinmester credits.</p>
SCIENCE AGRICULTURE	5365.05 5799.01	<p><b>SOIL CONSERVATION</b></p> <p>A combination of subject matter and practical experiences concerned with the maintaining of soil stability and productivity. Two quinmester credits.</p>
SCIENCE AGRICULTURE	5365.06 5799.02	<p><b>WATER CONSERVATION</b></p> <p>Provides an opportunity to learn and apply the principles involved in the conservation and management of water and water resources. Two quinmester credits.</p>
SCIENCE AGRICULTURE	5366.01 5730.01	<p><b>RAISING YOUNG DAIRY ANIMALS</b></p> <p>The development of competencies and abilities in the various areas of dairy cattle production concerning the selection, feeding, and management of young animals. Two quinmester credits.</p>



AREA	ACCR. NO. FLA-DADE	COURSE TITLE AND DESCRIPTION
SCIENCE AGRICULTURE	5366.02 5730.02	<p>DAIRY HERD MANAGEMENT</p> <p>The application of dairy cattle management techniques concerned with feeding, breeding, and disease control. Two quinmester credits.</p>
SCIENCE AGRICULTURE	5364.12 5793.02	<p>PRACTICAL FORESTRY</p> <p>A practical course in the propagation of forest trees and the principles and practices concerned with forest protection, mensuration, and management.</p> <p>The student, prior to entry in this course, will display his achievement of the objectives set forth in Introduction to Forestry 5793.01. Two quinmester credits.</p>
SCIENCE AGRICULTURE	5364.13 5789.01	<p>GROWING FLOWERS</p> <p>Learning experiences involved in the field and nursery production of flowers and the arrangement of such flowers for ornamental purposes. Two quinmester credits.</p>
SCIENCE AGRICULTURE	5364.14 5794.01	<p>LAWN MAINTENANCE</p> <p>Principles and practices involved in the proper care and use of lawn machinery and tools, the use of fertilizers and water, the control of lawn pests, and the methods used in reconditioning turf. Two quinmester credits.</p>
SCIENCE AGRICULTURE	5364.15 5794.02	<p>ORNAMENTAL PLANT MAINTENANCE</p> <p>Subject matter and practical experiences concerned with the pruning and trimming of plants, fertilizing, watering, and pest control of plants. Two quinmester credits.</p>
SCIENCE  AGRICULTURE	5366.05 5366.06 5366.07 5366.08 5366.09 5746.01 5746.02 5746.03 5746.04 5746.05	<p>ANIMAL CLINIC TECHNOLOGY</p> <p>Practical experience in selected veterinary clinics, acquainting the student with veterinary practices. Two quinmester credits for each quinmester.</p> <p>Four quinmesters of agriculture is the minimum requirement prior to enrollment in this program by senior students.</p>

## SOCIAL STUDIES

### *Rationale*

The social studies courses offered on the following pages focus on concepts from the social sciences to aid students in better understanding man in his social and physical settings. The objectives center on the achievement of skills the student needs to analyze issues and problems and make reasoned decisions in matters related to himself and the world around him.

The courses are not leveled or phased. They are generally nonsequential, although in some cases suggested or helpful prerequisite experiences are suggested. The courses are ungraded and classified as junior or senior high. The amount of student choice is great and it is assumed that each student, in consultation with his parents, guidance counselor, and teachers, will give thoughtful consideration to his individual needs and interests.

### *Requirements*

A minimum of eight social studies quins is required in junior high (7-9). It is recommended, however, that in keeping with the present policy of most Dade County junior high schools this number be increased to twelve quins. For graduation, a minimum of eight quins is required in senior high (10-12) of which four must be in American History or Government, to be taken in grade 11 or 12.

Social studies courses are grouped in five clusters: General Social Studies, American Studies, World Studies, Political-Economic Studies, and Behavioral Studies.

It is recommended that all students take the following program as a minimum:

#### Junior High

- A. Launch Pad: An Introduction to the Social Studies (6443.05) from the General Social Studies cluster.
- B. Two courses from the combined Behavioral Studies and General Social Studies clusters; one of these should be The Florida Story (6470.14) to comply with State Board of Education regulation 6A-6.22 calling for instruction in Florida history and government.
- C. Two courses each from the following clusters: World Studies, American Studies.
- D. One course from the Political-Economic Studies cluster.
- E. Two additional courses from any of the five clusters.

#### Senior High

- A. Americanism vs. Communism (6419.01) as required by Florida law in grade 11 or 12.
- B. Four courses from the combined clusters of Political-Economic and American Studies, as required for high school graduation in grade 11 or 12.

- C. One course each from the clusters World Studies, Behavioral Studies, General Social Studies in grades 10 through 12.

*Code Numbers for Quinmester Courses*

The code numbers assigned to the courses in this section indicate the accreditation category of the described course, as outlined in Curriculum Bulletin 1, *Program of Authorized Instructional Courses in Dade County Public Schools*, and *The Accreditor*, State Department of Education.

The first code number listed for a course should be considered its primary identification number. Where there are additional numbers, the first four digits of the number represent other social studies courses listed in *The Accreditor* that may be interpreted for credit in that course. The digits after the decimal are simply for the purpose of individual identification of a course. They do not imply sequence or prerequisites.

To illustrate the numbering system, refer to the course China: Awakening Giant in the junior high World Studies cluster. It has three identifying numbers: the primary one (6478.03) identifies it as a world cultures course; the two secondary numbers (6445.02 and 6414.02) from *The Accreditor* indicate that the course may be given credit in World Geography or World History 1 as well.

SOCIAL STUDIES  
JUNIOR HIGH SCHOOL

GENERAL SOCIAL STUDIES

- \*\*Launch Pad: An Introduction to the Social Studies (6470.13)
- Propaganda (6470.06)  
(Language Arts 5111.31)
- Ecology and Survival (6470.05)
- Changing Cities (6470.04)
- Black History and Culture (6412.10)
- Living in Dade County (6470.02)
- The Florida Story (6470.14)
- Cartography (6478.15)  
(Science 5343.10)

AMERICAN STUDIES

- \*The American Experience (6412.01)
- Minorities in American Society (6412.09)
- The American Indian (6412.07)
- American Biographies (6412.08)  
(Language Arts 5111.28)
- Forging a Nation (6412.03)
- Colonial America (6412.02)
- From Sea to Sea (6412.04)
- A Nation Divided against Itself (6412.05)  
(Language Arts 5111.30)
- Emergence of America as a World Power (6412.06)

WORLD STUDIES

- Dawn: The Birth of Selected Civilizations (6478.01)
- Regional Economic Development (6478.06)
- Peace in the Twentieth Century (6478.07)
- Life in the Soviet Union (6478.13)
- China: Awakening Giant (6478.03)
- Tribes and Nations: Emerging Africa (6478.04)
- Latin America: Struggle for Stability (6478.05)
- International Trouble Spots (6478.14)
- South of the Border (6478.16)  
(Art 6477.04)
- Empire to Commonwealth—The British Imprint (6478.18)
- Cuban History and Culture (6478.19)
- Japan, India, China: Which Direction? (6478.20)
- Giants in Art (6478.17)  
(Art 6677.08)
- Comparative World Cultures (6478.21)

POLITICAL AND ECONOMIC STUDIES

- \*Our Federal Government (6470.01)
- Our Living Bill of Rights (6470.10)
- The Law and You (6470.03)
- The Electoral Process (6470.11)
- Dissent and Change in America (6470.08)
- Consumer Education (6470.09)

BEHAVIORAL STUDIES

- Primitive Societies (6478.02)
- Teen-age Living (Home and Family Ed. 6763.01)
- Drugs, Society, and You (6470.07)
- Comparative World Religions (Language Arts 5111.29)
- The People of Dade County (6470.12)

\*\*Recommended prerequisite for courses in this cluster  
\*\*Recommended requirement for all students

SOCIAL STUDIES  
SENIOR HIGH SCHOOL

386  
SOCIAL STUDIES

GENERAL SOCIAL STUDIES

- Advanced Techniques in the Social Sciences (6425.11)
- Man Between War and Peace (Language Arts 5114.140)
- Introduction to Philosophy (Language Arts 5114.141)
- The Good Man, Good Life, and Good Society (Language Arts 5114.142)
- The Problem Is People (6425.07)
- Medic, Minds and Masses (Language Arts 5114.143)
- Seminar in Social Studies (6429.01)
- Cities in Crisis (6448.18)
- Modern Black History (6416.22)
- Current Affairs (6446.10)
- Urban Ecology (6416.51)
- Writing A Research Paper (Language Arts 5114.84)
- The Quest for Utopia (6448.65)
- The Individual and the State. (6448.56)
- (Language Arts 5114.70)
- Introduction to Eastern Philosophy (6414.23)

AMERICAN STUDIES

- America Since the Civil War (6416.09)
- Current Domestic Problems (6416.18)
- Protest and Change in American Society (6416.10)
- American Military History (6416.15)
- American Culture (6426.01)
- (Language Arts 5114.139)
- A Nation of Immigrants (6416.17)
- Great Debates in American History (6416.12)
- Impact of Reconstruction: Past and Present (6416.11)
- Industrial America (6416.13)
- Boom, Crash: A Domestic Dilemma (6416.14)
- U.S. in Asia: Past and Present (6416.16)
- American Foreign Policy (6416.58)
- American Values (6448.73)

WORLD STUDIES

- Tradition and Change in Non-Western Cultures (Language Arts 5114.144)
- Politics and Revolution (6448.19)
- International Relations (6448.20)
- Development of Europe—1000 B.C.—1000 A.D. (6414.11)
- European Renaissance and Reformation (6414.12)
- Race Relations Around the World (6425.10)
- World History through Art and Music (6414.13)
- Introduction to Archaeology (6414.07)
- Totalitarianism in the Twentieth Century (6448.21)
- Classical Civilization (6414.18)
- (Language Arts 5114.67)
- Global Village in Century 21 (6414.26)
- Biographical Studies of Famous Latin Americans (6493.05, 6494.05)
- (Spanish—S 7509.61)
- Latin American Heritage (6493.06, 6494.06)
- (Spanish—S 7509.63)
- Latin American History through Literature (6493.02)
- (Foreign Language 7506.23)
- (Spanish—S 7509.701)

POLITICAL AND ECONOMIC STUDIES

- Political
  - American Government (6448.01)
  - Politics and You (6448.02)
  - Congress in Action (6448.03)
  - The Changing American Presidency (6448.04)
  - The Supreme Court in American Life (6448.05)
  - Eye for an Eye: A History of Law (6448.06)
  - Americanism vs. Communism (6448.07)
  - Political Theory: Left to Right (6448.08)
  - Ecopolitics (Science 5365.44)
  - You, Too, Can Be A Legislator! (6448.58)
  - (Language Arts 5114.115)
  - Law and Society (6448.71)
  - Economic
    - Introduction to Economics (6448.10)
    - Your Buying Power (Business Education 6463.01)
    - Labor and Management (6448.12)
    - Bull and Bear: The Stock Market (6448.13)
    - (Business Education 6463.03)
    - Economics of Poverty (6448.14)
    - Money and Banking (6448.15)
    - Taxes (6448.67)
    - (6463.02)
    - (Business Education 6463.02)

BEHAVIORAL STUDIES

- Introduction to Psychology (6427.01)
- Understanding Individual Behavior (Home and Family Ed. 6763.02)
- Child Behavior (Home and Family Ed. 6758.06)
- Introduction to Sociology (6425.05)
- Prejudice in America (6416.23)
- Man and Society (6425.09)
- Human Relations (Home and Family Ed. 6763.08)
- Crime in America (6416.25)
- The Changing Family (Home and Family Ed. 6757.05)
- Introduction to Anthropology (6425.13)
- Science and Society (Science 5365.43)
- The Emergence of Modern Societies (6425.16)
- Changing Roles of Women (6425.17)

\* Required by law

## QUINMESTER COURSES

Advanced Techniques in the Social Studies	398
America Since the Civil War	401
American Biographies	392
American Culture	401
American Experience, The	391
American Foreign Policy	403
American Government	406
American Indian; The	392
American Military History	401
American Values	403
Americanism vs. Communism	407
Biographical Studies of Famous Latin Americans	405
Black History and Culture	390
Boom, Crash: A Domestic Dilemma	402
Bull and Bear: The Stock Market	408
Cartography	391
Changing American Presidency, The	406
Changing Cities	390
Changing Family, The	411
Changing Roles of Women	411
Child Behavior	409
China: Awakening Giant	394
Cities in Crisis	399
Classical Civilization	405
Colonial America	392
Comparative World Cultures	395
Comparative World Religions	397
Congress in Action	406
Consumer Education	397
Crime in America	410
Cuban History and Culture	395
Current Affairs	400
Current Domestic Problems	401
Dawn: The Birth of Selected Civilizations	393
Development of Europe, The: 1000 B.C.—1000 A.D.	404
Dissent and Change in America	396
Drugs, Society, and You	397
Ecology and Survival	390
Economics of Poverty	409
Ecopolitics	407
Electoral Process, The	396
Emergence of America as a World Power	393
Emergence of Modern Societies, The	411
Empire to Commonwealth—The British Imprint	395
European Renaissance and Reformation	404
Eye for an Eye: A History of Law	407
Florida Story, The	391
Forging a Nation	392
From Sea to Sea	392

Giants in Art	395
Global Village in Century 21	405
Good Man, Good Life, and Good Society, The	398
Great Debates in American History	402
Human Relations	410
Impact of Reconstruction: Past and Present	402
Individual and the State, The	400
Industrial America	402
International Relations	403
International Trouble Spots	394
Introduction to Anthropology	411
Introduction to Archaeology	404
Introduction to Eastern Philosophy	401
Introduction to Economics	408
Introduction to Philosophy	398
Introduction to Psychology	409
Introduction to Sociology	410
Japan, India, China: Which Direction?	395
Labor and Management	408
Latin America: Struggle for Stability	394
Latin American Heritage	405
Latin American History through Literature	406
Launch Pad: An Introduction to the Social Studies	390
Law and Society	408
Law and You, The	396
Life in the Soviet Union	394
Living in Dade County	391
Man and Society	410
Man Between War and Peace	398
Media, Minds, and Masses	399
Minorities in American Society	391
Modern Black History	399
Money and Banking	409
Nation Divided against Itself, A	393
Nation of Immigrants, A	402
Our Federal Government	396
Our Living Bill of Rights	396
Peace in the Twentieth Century	393
People of Dade County, The	398
Political Theory: Left to Right	407
Politics and Revolution	403
Politics and You	406
Prejudice in America	410
Primitive Societies	397
Problem Is People, The	399
Propaganda	390
Protest and Change in American Society	401

Quest for Utopia, The	400
Race Relations around the World	404
Regional Economic Development	393
Science and Society	411
Seminar in Social Studies	399
South of the Border	394
Supreme Court in American Life	407
Taxes	409
Teen-age Living	397
Totalitarianism in the Twentieth Century	405
Tradition and Change in Non-Western Cultures	403
Tribes and Nations: Emerging Africa	394
Understanding Individual Behavior	409
Urban Ecology	400
U.S. in Asia: Past and Present	403
World History through Art and Music	404
Writing a Research Paper	400
You, Too, Can Be a Legislator	407
Your Buying Power	408



AREA	ACCR. NO. FLA-DADE	COURSE TITLE AND DESCRIPTION
GENERAL SOCIAL STUDIES (JUNIOR HIGH)		
SOCIAL STUDIES	6470.13 6441.01 6442.01 6443.05 6412.11	<p>† LAUNCH PAD: AN INTRODUCTION TO THE SOCIAL STUDIES.</p> <p>A survey of the field of social studies, including an analysis of the different branches of social science: geography, anthropology, sociology, psychology, history, economics, and political science. Emphasis is placed on the basic skills of the social scientist: analyzing data; using maps, graphs; forming hypotheses; etc. The course is designed to aid the student in selecting and successfully applying social studies skills in his future social studies courses.</p>
SOCIAL STUDIES	6470.06 6413.08 6443.04 6471.07 6412.12	<p>PROPAGANDA</p> <p>Types and techniques of propaganda and its effects on American life. The course is designed to help students make decisions based on critical, objective thinking.</p>
LANGUAGE ARTS	5111.31 5112.37 5113.134	
SOCIAL STUDIES	6470.05 6471.06 6413.07 6412.13	<p>† ECOLOGY AND SURVIVAL</p> <p>A study of the political, economic, and social aspects of ecological problems in the community, state, and nation. The focus is on the causes and effects of pollution and alternate governmental and citizen actions. Students are encouraged to examine their own position and their personal responsibilities in the area of ecology.</p>
SOCIAL STUDIES	6470.04 6413.04 6471.04 6443.01 6412.14	<p>† CHANGING CITIES</p> <p>An introduction to urban life: its history; the attraction of the city; its growth; advantages, and problems. The condition of cities in America today is examined for the purpose of understanding the causes of their present condition and the steps that can be taken to save them.</p>
SOCIAL STUDIES	6412.10 6476.01 6470.17	<p>† BLACK HISTORY AND CULTURE</p> <p>A study of the contribution of the Blacks to our nation's development. This course surveys the black man's history in both Africa and the United States.</p>

AREA	ACCR. NO. FLA-DADE	COURSE TITLE AND DESCRIPTION
SOCIAL STUDIES	6470.02 6413.02 6471.02 6412.15	† LIVING IN DADE COUNTY  An examination of the student's immediate community and surrounding metropolitan area. Content includes community services, local government, Dade's economy, important people and places in Dade County, and the problems within the community, e.g., traffic, pollution, migrant workers. The course is designed to enhance the student's understanding of, and appreciation for, his local environment.
SOCIAL STUDIES	6470.14 6497.01 6412.16 6413.13	† THE FLORIDA STORY  A survey of Florida's history to include history, population centers, economy, government, current problems, ethnic groups, and future aspirations. The primary goal is for the students to become effective citizens in their own state.
SOCIAL STUDIES  SCIENCE	6478.15 6444.01 6445.05 5343.10 5311.35 5312.35 5313.35	CARTOGRAPHY  A study of the earth's features through aerial photo analyses and map reading.

#### AMERICAN STUDIES (JUNIOR HIGH)

SOCIAL STUDIES	6412.01 6411.01 6416.01 6470.18	† THE AMERICAN EXPERIENCE  A selective survey of America's history and development. Touches on the important historical concepts dealing with the American experience. Goals are to provide students with basic knowledge about this country's past and give them a content framework for their choices among other American studies course offerings.
SOCIAL STUDIES	6412.09 6416.19 6411.09 6425.02 6470.19	† MINORITIES IN AMERICAN SOCIETY  A historical review of the ethnic composition of our society, with emphasis on how minorities have contributed to the makeup of America. The concept that everyone is part of a minority is stressed.

AREA	ACCR. NO. FLA-DADE	COURSE TITLE AND DESCRIPTION
SOCIAL STUDIES	6412.07 6411.07 6416.07 6470.20	† THE AMERICAN INDIAN  A study of the variety of Indian cultures before the coming of the Europeans and their later history. Included are the contributions of Indians to our culture and their present status and problems. The development of American political policy toward the Indian is traced from early settlement to the present. Some attention is focused on Indians of Florida.
SOCIAL STUDIES  LANGUAGE ARTS	6412.08 6411.08 6416.08 6470.21 5111.28 5112.34 5113.135	† AMERICAN BIOGRAPHIES  A study of selected Americans and their times. Aims include the understanding of the frame of reference of an individual in the context of his time and the way individuals can affect history.
SOCIAL STUDIES	6412.03 6411.03 6416.03 6470.22	† FORGING A NATION  The American Revolution is used as a basis for studying conflict and change. Students examine different interpretations of the American Revolution. The second half of the course focuses on the aftermath of the war leading to the forming of a new nation.
SOCIAL STUDIES	6412.02 6411.02 6416.02 6470.23	† COLONIAL AMERICA  A study of the colonial period of American history. An analysis of the political organization, the social life, and economic structure in colonial society.
SOCIAL STUDIES	6412.04 6411.04 6416.04 6470.24	FROM SEA TO SEA  America's territorial and population growth from 1783 to the present. Focus is the concept of Manifest Destiny, its roots and results. The value implications of national expansion are explored. The Westward Movement is viewed from the points of view of the American Indian, Europeans, and the pioneer.

AREA	ACCR. NO. FLA-DÁDE	COURSE TITLE AND DESCRIPTION
SOCIAL STUDIES	6412.05 6411.05 6416.05 6470.25	† A NATION DIVIDED AGAINST ITSELF The events leading to the Civil War, the war years, and Reconstruction.
LANGUAGE ARTS	5111.30 5112.36 5113.137	
SOCIAL STUDIES	6412.06 6411.06 6416.06 6470.26	† EMERGENCE OF AMERICA AS A WORLD POWER The story of America as a world power, focusing on its development since 1898. Emphasis is on the concept of national power and its manifestation in national and foreign policy.

#### WORLD STUDIES (JUNIOR HIGH)

SOCIAL STUDIES	6478.01 6414.01 6445.01 6470.27	† DAWN: THE BIRTH OF SELECTED CIVILIZATIONS Centering on the questions How did it all begin? and What is civilization? the students investigate selected past civilizations to discover how the people met and solved their problems. Components include (1) an examination of similarities and differences among the civilizations, (2) the role of cultural diffusion vs. isolation, (3) relation of the people to their environment, (4) comparison of their life styles with present-day society.
SOCIAL STUDIES	6478.06 6445.05 6470.28	REGIONAL ECONOMIC DEVELOPMENT Examines the geographic, cultural, human, and change factors that influence the economic development of an area. Considers problems that exist today as a result of inequities in distribution of wealth.
SOCIAL STUDIES	6478.07 6414.05 6470.29	† PEACE IN THE TWENTIETH CENTURY A study of the efforts and failures to maintain world peace in this century. Encompasses the concept of nationalism and the role it plays in the decisions that lead to war, and organizations that have tried, and are trying, to preserve or bring about peace.

AREA	ACCR. NO. FLA-DADE	COURSE TITLE AND DESCRIPTION
SOCIAL STUDIES	6478.13 6470.30	† LIFE IN THE SOVIET UNION  Focuses on the national life style of the world's largest country and international Communist leader. Emphasizes the varied cultural background of the USSR and examines the influence of totalitarian government on a nation's institutions (religion, family, education, and economy) through an analysis of cultural characteristics.
SOCIAL STUDIES	6478.03 6445.02 6414.02 6470.31	† CHINA: AWAKENING GIANT  A comparison of the old culture with the new in China. China's tremendous cultural upheaval since the communist revolution of 1948 is studied in light of its traditional cultural patterns.
SOCIAL STUDIES	6478.04 6445.03 6495.02 6414.03 6470.32	† TRIBES AND NATIONS: EMERGING AFRICA  A historical study of the peoples and problems of sub-Saharan Africa, focusing on the conflicting allegiances of tribe and nation. Includes ancient kingdoms and current case studies.
SOCIAL STUDIES	6478.05 6445.04 6414.04 6493.01 6470.33	LATIN AMERICA: STRUGGLE FOR STABILITY  An analysis of past and present political power structure in Latin America. Focus is on strong man political power and instability, and the relationship of North America to Latin America.
SOCIAL STUDIES	6478.14 6474.01 6413.05 6443.02 6470.34	† INTERNATIONAL TROUBLE SPOTS  Case studies of current world trouble areas. The intent is to equip students to analyze current events. Selection of topics is determined by world events as they occur, with emphasis placed on understanding the complex, underlying political, economic, racial, and religious causes for large-scale conflict.
SOCIAL STUDIES ART	6478.16  6677.04 6671.07 6672.09 6683.05 6681.06 6682.06	SOUTH OF THE BORDER  A survey of the major post-Columbian movements and artists of South America and Mexico, stressing similarities and differences among geographical areas. Social protest painters, crafts, and mosaic works will be studied. Selected activities include art metal crafts, leather work, ceramics, and mosaics.

SOCIAL STUDIES  
394

AREA	ACCR. NO. FLA-DADE	COURSE TITLE AND DESCRIPTION
SOCIAL STUDIES	6478.18 6470.39	† EMPIRE TO COMMONWEALTH—THE BRITISH IMPRINT  A study of the basic elements developed in the English culture and their diffusion into various cultures around the world as these countries became a part of the British Empire. The British Isles, India, Kenya, Australia, New Zealand, and Canada should be studied, ending with the development of the American culture, providing the student with a deeper understanding of the factors that have helped to shape his own culture.
SOCIAL STUDIES	6478.19 6470.40	CUBAN HISTORY AND CULTURE  A study of the Cuban heritage; events leading to migration to United States; focuses on Cuban population in United States, its problems, contributions, and future.
SOCIAL STUDIES	6478.20 6470.41	JAPAN, INDIA, CHINA: WHICH DIRECTION?  A comparative study of these three Far Eastern countries facing and solving similar problems (overpopulation, industrialization, education of masses, etc.)—which is succeeding, which failing, and why; which is emerging as leader of Far East.
SOCIAL STUDIES ART	6478.17 6414.22 6677.08 6671.12 6672.16	† GIANTS IN ART  An introductory survey of art concepts from the beginning of recorded time to the present. The student investigates ideas of past civilizations and their relationship to our contemporary society.
SOCIAL STUDIES	6478.21 6445.06 6441.02 6442.02	COMPARATIVE WORLD CULTURES  A comparison of the values, attitudes, and beliefs of selected cultures throughout the world. The purpose is to provide the student with a basis for understanding cultural differences to aid him in better clarifying his own system of values.

AREA                      ACCR. NO.  
FLA-DADE                      COURSE TITLE AND DESCRIPTION

POLITICAL AND ECONOMIC STUDIES (JUNIOR HIGH)

SOCIAL STUDIES	6470.01 6413.01 6412.17	† OUR FEDERAL GOVERNMENT  Designed to provide the student with basic knowledge about our system of government and the way it works, and an understanding of the rights and responsibilities of each citizen in a democratic nation.
SOCIAL STUDIES	6470.10 6413.10 6471.09 6412.18	OUR LIVING BILL OF RIGHTS  An analysis of the Bill of Rights and its relationship to the individual. Utilizes selected Supreme Court decisions. The focus is on the meaning of, and the struggle for, human rights in this country.
SOCIAL STUDIES	6470.03 6413.03 6471.03	† THE LAW AND YOU  A study of laws and the reasons for them. Emphasis is on the relationship between youth and the law, and the way law really works in everyday life.
SOCIAL STUDIES	6470.11 6471.10 6413.15 6412.20	† THE ELECTORAL PROCESS  An analysis of procedures used in choosing national, state, and local leaders. Emphasis is on the pupils becoming more effective voters and citizens by analyzing the role of political parties, the role and habits of the electorate, the process of campaigning, polls and their possible effects on elections, factors other than campaign issues which may influence votes.
SOCIAL STUDIES	6470.08 6413.06 6471.05 6443.03	† DISSENT AND CHANGE IN AMERICA  An examination of means of effecting social change in America. Emphasis is placed on citizen responsibility in a democracy. Includes (1) the reasons for dissent and the methods people use to express it, (2) the ways various groups react to dissent and their motives, (3) the limits of dissent in a free society, (4) the means to control dissent, (5) the effectiveness of dissent in bringing about social change, and (6) the role of youth in dissent and change in America today.

SOCIAL STUDIES  
396

386

AREA	ACCR. NO. FLA-DADE	COURSE TITLE AND DESCRIPTION
SOCIAL STUDIES	6470.09 6471.08 6413.14 6443.08 6412.22	<p>† CONSUMER EDUCATION</p> <p>A look at the complex role of the individual as a consumer: the selection of goods and services, the processes of modern marketplace operations, sources of help, the recognition of unethical and fraudulent practices. The aim of the course is to help the student develop sound decision-making habits for functioning more effectively in the marketplace and best fulfilling his role as a consumer.</p>
BEHAVIORAL STUDIES (JUNIOR HIGH)		
SOCIAL STUDIES	6478.02 6470.35	<p>† PRIMITIVE SOCIETIES</p> <p>An examination of selected primitive societies from the anthropologist's point of view. The aim is to understand some of the elements common to all societies and man in general. Includes extinct societies, but focuses on existing primitive groups and the lessons we can learn from primitive peoples.</p>
SOCIAL STUDIES HOME AND FAMILY ED.	6412.23 6470.16 6475.01 6425.01 6763.01	<p>† TEEN-AGE LIVING</p> <p>An examination of the changes and challenges confronting the young teen. Focuses on the factors influencing his attitudes, behavior, and relationships with others. Provides an opportunity for self-evaluation and clarification of personal values and goals.</p>
SOCIAL STUDIES HEALTH	6470.07 6425.03 6471.08 6413.09 7391.04 7392.04 7393.04 7394.04	<p>† DRUGS, SOCIETY, AND YOU</p> <p>The physical, mental, and social aspects of drugs and drug abuse. Designed to follow a basic health course about drugs. Emphasizes the social side of drug usage: the reasons people take drugs, the role of alienation, teen-agers and conformity, legal complications, drugs and crime.</p>
SOCIAL STUDIES LANGUAGE ARTS	6478.08 6414.06 6470.36 5111.29 5112.35 5113.136	<p>† COMPARATIVE WORLD RELIGIONS</p> <p>A study of selected world religions, focusing on religion as an institution in society. Includes effects of religion on people, governments, and international relations.</p>

SOCIAL STUDIES  
397



AREA	ACCR. NO. FLA-DADE	COURSE TITLE AND DESCRIPTION
SOCIAL STUDIES	6470.12 6425.16 6412.24	THE PEOPLE OF DADE COUNTY  An examination of the many ethnic groups that make up Dade County. Focuses on the Cuban, black, Jewish, and white Anglo-Saxon groups and their interaction. Aims to increase understanding of the diverse cultural background within our community.

GENERAL SOCIAL STUDIES (SENIOR HIGH)

SOCIAL STUDIES	6425.11 6443.07 6453.01 6416.26 6448.22	† ADVANCED TECHNIQUES IN THE SOCIAL SCIENCES  Emphasizes methods of the social scientist, including research techniques, statistics, historiography, social sampling surveys, case studies, critical analysis of issues, etc. Students do independent work, applying the techniques.
----------------	---	--

SOCIAL STUDIES LANGUAGE ARTS	6448.16 6414.18 6416.27 5114.140 5115.155 5116.158	† MAN BETWEEN WAR AND PEACE  Incorporates the social science disciplines in an attempt to provide students with tools to deal with the complexities inherent in the issue Why Men Wage War.
---------------------------------	---	---

SOCIAL STUDIES LANGUAGE ARTS	6414.16 6499.01 6448.23 6416.28 5114.75 5115.75 5116.75	INTRODUCTION TO PHILOSOPHY  This introduction to philosophy explores the great ideas of man through the ages and their influence on society in the realms of art, literature, economics, and government. The course involves extensive reading and individual study.
---------------------------------	---	--

SOCIAL STUDIES LANGUAGE ARTS	6448.17 6414.17 6499.02 6416.29 5114.142 5115.157 5116.160	THE GOOD MAN, GOOD LIFE, AND GOOD SOCIETY  Through comparative analysis of several societies, both past and present, the student will be introduced to differing views about what constitutes the good life. A humanities approach is designed to help the student develop his own personal philosophy.
---------------------------------	--	---

AREA	ACCR. NO. FLA-DADE	COURSE TITLE AND DESCRIPTION
SOCIAL STUDIES	6425.07 6416.30	† THE PROBLEM IS PEOPLE  A study of the population explosion. Examines past and present theories (Malthus, Marx, Ehrlich). Emphasis is on understanding the realities of the present situation, cultural attitudes toward the problem, and the ecological consequences of overpopulation.
SOCIAL STUDIES	6416.21 6457.05 6443.06 6427.04 6448.26	† MEDIA, MINDS, AND MASSES  An examination of mass communication and its effect on American life. Emphasis on the types and techniques of propaganda, opinion polls, candidates, government and the media, freedom and responsibility of the press, effects of T V and radio on American values and life styles.
LANGUAGE ARTS	5114.66 5115.66 5116.66	
SOCIAL STUDIES	6429.01 6448.27 6416.31	† SEMINAR IN SOCIAL STUDIES  A highly individualized course to be structured by the instructor and students together, dealing with inquiry into social issues in depth. Requires permission of instructor. This course may be designated for students entering county competition in debate, extemporaneous speaking, the Social Studies Fair, and mock United Nations.
SOCIAL STUDIES	6448.18 6418.03 6413.12 6425.12 6416.32	† CITIES IN CRISIS  A study of urban problems with consideration of ways we as a nation can make the adjustments necessary to control the problems, relating to transportation, air and water pollution, jobs, housing, local politics, slums, noise, schools, crime, zoning practices, population patterns. Student will analyze alternative solutions to these problems through a consideration of ecology, city planning, model cities, and other factors in both the public and private sectors.
SOCIAL STUDIES	6416.22 6476.02 6448.28	MODERN BLACK HISTORY  A study of the black man and his role in American life. Focuses on the cultural, political, and economic role of the Black in America during the 20th century. Emphasis is placed on the civil rights movement.

SOCIAL STUDIES  
399

389

AREA	ACCR. NO. FLA-DADE	COURSE TITLE AND DESCRIPTION
SOCIAL STUDIES	6446.10 6474.03 6416.33 6448.29	CURRENT AFFAIRS  In-depth research, discussion, and analysis of selected national and international current issues, chosen on the basis of timeliness and relevance. The issues selected provide a variety of concepts for study.
SOCIAL STUDIES SCIENCE	6416.51 6448.55 5365.40	URBAN ECOLOGY  Study of urban environments, population densities, human reactions to crowded conditions, possible solutions.
SOCIAL STUDIES LANGUAGE ARTS SCIENCE	6448.60 6416.54 6414.21 5114.84 5115.84 5116.84 5387.01	† WRITING A RESEARCH PAPER  Designed for the student who will write research papers as part of special projects in other content areas, such as science, mathematics, or social studies. The topic and content of the paper will be determined by the student. Special emphasis will be given to advanced research techniques, form, style, and clarity.
SOCIAL STUDIES LANGUAGE ARTS	6448.65 6414.20 5114.71 5115.71 5116.71	† THE QUEST FOR UTOPIA  This course is designed to introduce the student to significant literature that illustrates the gulf between the vision of a perfect society and the realities of human nature. Works might include <i>Brave New World</i> by Huxley, <i>Notes from the Underground</i> by Dostoevski, <i>Pincher Martin</i> by Golding.
SOCIAL STUDIES LANGUAGE ARTS	6448.56 6416.52 5113.72 5114.70 5115.70 5116.70	THE INDIVIDUAL AND THE STATE  Deals with questions of law and justice. Does justice have priority over considerations of order and peace? Is maintaining order more important than achieving perfect justice? Is civil disobedience a desirable or an effective way to redress current wrongs in our society, such as racial inequality or commitment to war? What is the moral responsibility of the citizen to resist laws or orders which are unjust? In protesting against social evils, is violence ever justified? Such works as the following may be included in this unit: <i>Billy Budd</i> , Herman Melville; "Civil Disobedience," Henry David Thoreau; "The Case for Disobedience," Harold Laski; "The Case Against Disobedience," John Dickinson; <i>The Ox-Bow Incident</i> , Walter Van Tilburg Clark; "How Annandale Went Out," Edwin Arlington Robinson; <i>Where Do We Go from Here?</i> , Martin Luther King; "What We Want," Stokely Carmichael; <i>The Crucible</i> , Arthur Miller.

SOCIAL STUDIES  
400

AREA	ACCR. NO. FLA-DADE	COURSE TITLE AND DESCRIPTION
SOCIAL STUDIES	6414.23 6448.69	INTRODUCTION TO EASTERN PHILOSOPHY A brief introduction to the ways of believing which have shaped Eastern thinking for thousands of years. Some systems of philosophy which will be studied are Hinduism, Buddhism, Confucianism, Taoism, Shinto.
AMERICAN STUDIES (SENIOR HIGH)		
SOCIAL STUDIES	6416.09 6448.20	AMERICA SINCE THE CIVIL WAR A survey course in United States history with major emphasis placed on economic, social, and political development since the Civil War. Content includes industrialization, minority groups, reform movements, foreign affairs, and current problems.
SOCIAL STUDIES	6416.18 6418.01 6474.02 6448.31	CURRENT DOMESTIC PROBLEMS An intensive study of selected problems in America, such as pollution, civil rights, law and order. Newspapers or periodicals serve as textbooks for this course. Students should develop the ability to deal objectively with current issues.
SOCIAL STUDIES	6416.10 6448.32	† PROTEST AND CHANGE IN AMERICAN SOCIETY An analysis of social change and the role of protest in American history, with selected examples, types of protest, and its effectiveness in bringing about change.
SOCIAL STUDIES	6416.15 6448.33	AMERICAN MILITARY HISTORY A survey history of the American military. Encompasses the American idea of civilian authority, the role of the military in American history, and in-depth analysis of selected American wars and military campaigns.
SOCIAL STUDIES LANGUAGE ARTS	6426.01 6416.34 6448.40 5114.139 5115.154 5116.157	† AMERICAN CULTURE A problem-centered, in-depth analysis of contemporary America. Utilizes an interdisciplinary approach focusing on an analysis of art, literature, music, and philosophy to better understand contemporary culture.

SOCIAL STUDIES  
401

301

AREA	ACCR. NO. FLA-DADE	COURSE TITLE AND DESCRIPTION
SOCIAL STUDIES	6416.17 6448.34	A NATION OF IMMIGRANTS  An analysis of the "Great American Immigrations" and their effects on the development of America. Encompasses immigration laws, present policy, and the immigrant experience. The impact of immigration on the American culture is stressed.
SOCIAL STUDIES	6416:12	† GREAT DEBATES IN AMERICAN HISTORY  An analysis of selected debates or issues in America's past. Examples include the following: Tactics for Negro Advancement; Washington vs. DuBois; T.V.A.; Public Planning or Private Enterprise?; Should the U. S. Have Dropped the Atomic Bomb?; Hamiltonian vs. Jeffersonian Democracy. Students develop ability to examine differing views of controversial issues and rationally defend a position.
SOCIAL STUDIES	6416.11 6448.36	IMPACT OF RECONSTRUCTION: PAST AND PRESENT  A study of the Reconstruction Period (1865-1877) in American history and its consequences for America today. Emphasis is placed upon the social, political, and economic changes wrought by reconstruction in the United States. The changing role of the Black in American history is an important component.
SOCIAL STUDIES	6416.13 6448.37	INDUSTRIAL AMERICA  Encompasses the growth and expansion of American technology, the role of government, the place of the workingman, and the effects (benefits and hazards) of our rapid technological growth on the quality of life in America.
SOCIAL STUDIES	6416.14 6448.38	BOOM, CRASH: A DOMESTIC DILEMMA  A study of the political, economic, and social implications of the Jazz Age, stock market crash, the great depression, and the New Deal. Focus is on the complex interrelationships of events then and now.

SOCIAL STUDIES  
402

AREA	ACCR. NO. FLA-DADE	COURSE TITLE AND DESCRIPTION
SOCIAL STUDIES	6416.16 6448.39	† THE UNITED STATES IN ASIA: PAST AND PRESENT A study of the United States and Asia, from first contact to involvement today. Emphasis is on understanding the involvement of foreign policy and its implications for mutual development.
SOCIAL STUDIES	6416.58 6448.68	AMERICAN FOREIGN POLICY The study of American foreign policy with emphasis on this century, using specific examples in an attempt to analyze all the factors involved in policy making.
SOCIAL STUDIES	6448.73 6418.04 6429.02 6425.18	AMERICAN VALUES American beliefs, or values, that are embodied in our society, are studied. An analysis will be made from the inception of the American value system with the European Protestant tradition to the current challenge which is being levied against American values.
WORLD STUDIES (SENIOR HIGH)		
SOCIAL STUDIES LANGUAGE ARTS	6414.08 6478.10 6448.41 5114.144 5115.159 5116.162	TRADITION AND CHANGE IN NON-WESTERN CULTURES An examination of the problems and dilemma of non-Western countries trying to preserve their own culture and national pride and yet attain the economic wealth of the West, as represented by Europe and the United States.
SOCIAL STUDIES	6448.19 6414.10	† POLITICS AND REVOLUTION An analysis of the factors that go into making a political revolution. Focus is on the French Revolution as the basis for comparison with selected other major national upheavals, such as the Russian and American Revolutions and 20th century cases, such as Cuba and the Congo.
SOCIAL STUDIES	6448.20 6446.12 6457.03 6474.03 6416.35	INTERNATIONAL RELATIONS A study of international issues and the ways nations deal with mutual problems. Includes international organizations, treaties, and the Cold War, with a focus on interdependence in today's shrinking world.

SOCIAL STUDIES  
403

303

AREA	ACCR. NO. FLA-DADE	COURSE TITLE AND DESCRIPTION
SOCIAL STUDIES	6414.11 6448.45	† THE DEVELOPMENT OF EUROPE: 1000 B.C.—1000 A.D.  Examines the formation and evolution of Western society and includes the eras of the Greeks and Romans, and the emergence of medieval Europe. Contributions of these periods in politics, philosophy, architecture, and literature are considered.
SOCIAL STUDIES	6414.12 6448.42	EUROPEAN RENAISSANCE AND REFORMATION  A survey course highlighting the changes manifested in Europe during the 14-17th centuries. The unifying concept is social change. Includes the influence of these periods on Western society.
SOCIAL STUDIES	6425.10 6478.11 6448.43	RACE RELATIONS AROUND THE WORLD  A comparative study of race relations in selected areas of the world, e.g., the Union of South Africa and Brazil. Through an examination of the history, present institutions, and values of the countries, the students will generalize about the reasons for racial discrimination or the lack of it in any society and suggest alternatives for improving race relations.
SOCIAL STUDIES	6414.13	† WORLD HISTORY THROUGH ART AND MUSIC  Making use of visual materials, students interested in the arts, but not necessarily music or art students, might pursue this survey of art and music through the ages. Emphasizes ways art and music reflect the society of the artist through his perceptions. The student explores attitudes and values of different periods and places in world history.
SOCIAL STUDIES	6414.07 6478.09 6448.44	INTRODUCTION TO ARCHAEOLOGY  A study of past peoples with a view to identifying the elements that make up "culture." Students define culture and examine the archaeologist's task through one or more projects. Ancient world history and local history are utilized as content, with new archaeological findings included.

AREA	ACCR. NO. FLA-DADE	COURSE TITLE AND DESCRIPTION
SOCIAL STUDIES	6448.21 6446.13	† TOTALITARIANISM IN THE TWENTIETH CENTURY  An inductive analysis of the concept of totalitarianism. Encompasses the defining, analyzing, comparing, and evaluating of totalitarian systems.
SOCIAL STUDIES LANGUAGE ARTS	6414.18 6448.57 5114.67 5115.67 5116.67 5188.04 5148.05	† CLASSICAL CIVILIZATION  Includes the study of Greek mythology, philosophy, and drama and an analysis of their effect on modern man and his ideas.
SOCIAL STUDIES	6414.26	GLOBAL VILLAGE IN CENTURY 21  Analyzes political, economic, social, philosophical, scientific, technological, and psychological issues. The goal is to provide students with a framework to arrive at meaningful predictions about twenty-first century life.
SOCIAL STUDIES SPANISH-S	6493.05 6494.05 7509.61	BIOGRAPHICAL STUDIES OF FAMOUS LATIN AMERICANS  A course designed to acquaint the students with the scientific and artistic contributions of prominent Latin Americans in the course of history. Biographies, written excerpts, novels, etc., are discussed and examined. Cultural values are stressed with a view to developing in the students pride in their own heritage and improving their self concept.
SOCIAL STUDIES SPANISH-S	6493.06 6494.06 7509.63	LATIN AMERICAN HERITAGE  A course designed to acquaint the Spanish-speaking students with their cultural, historical, and geographical backgrounds. This course enables the students to obtain a better understanding of the multicultural society they live in. Various Spanish, Indian, and Negro influences in North American folklore are studied and discussed.

SOCIAL STUDIES  
405

385



AREA	ACCR. NO. FLA-DADE	COURSE TITLE AND DESCRIPTION
SOCIAL STUDIES FOREIGN LNG. SPANISH SPANISH-S	6493.02 7506.23 7509.701	LATIN AMERICAN HISTORY THROUGH LITERATURE  This course includes a study of the growth, problems, etc. of Latin America by reading selections written by native authors. Lectures and discussions will be in Spanish. Recommended for the student who has controlled 7505.34 at the least.
POLITICAL AND ECONOMIC STUDIES (SENIOR.HIGH)		
SOCIAL STUDIES	6448.01 6446.01 6416.36	† AMERICAN GOVERNMENT  A survey of the functioning of the Federal government. The student analyzes the fundamental concepts within the Constitution, the governing process, and effective citizenship participation in a representative democracy.
SOCIAL STUDIES	6448.02 6457.01 6446.11 6416.37	† POLITICS AND YOU  A study of the relationship between the citizen and political parties, American political parties, and their roles in shaping government, party platforms, the advantages and disadvantages of our two-party system, political ethics, voting procedures, and the examination of political trends.
SOCIAL STUDIES	6448.03 6446.02 6416.38	CONGRESS IN ACTION  An analysis of Congressional functions through a study of the evolution of the legislative branch of our government. An examination of actual current legislative actions and their influencing forces. The question, Is Congress responsive to the wishes of the people? is raised.
SOCIAL STUDIES	6448.04 6446.05 6416.39	THE CHANGING AMERICAN PRESIDENCY  An examination of the executive branch of our Federal government. Analysis of the evolution of the roles and functions of the American presidency. An in-depth study of selected presidents is included.

AREA	ACCR. NO. FLA-DADE	COURSE TITLE AND DESCRIPTION
SOCIAL STUDIES	6448.05 6446.03 6416.40	<p>THE SUPREME COURT IN AMERICAN LIFE</p> <p>The changing role of the Supreme Court from John Jay to the present, analyzed through selected major decisions. Includes a historical analysis of rulings and the impact of the Supreme Court on American life today.</p>
SOCIAL STUDIES	6448.06 6414.15 6416.41	<p>EYE FOR AN EYE: A HISTORY OF LAW</p> <p>The evolution of law from Babylonian times to the present. Focus is on the origins and evolution of our system of law.</p>
SOCIAL STUDIES	6448.07 6446.09 6419.01 6416.42	<p>† AMERICANISM VS. COMMUNISM</p> <p>A required in-depth study of communist systems and their comparison with capitalist systems. Includes the history of communism, and a survey of political, economic, and social life in communist countries today.</p>
SOCIAL STUDIES	6448.08 6446.14 6457.04 6416.43	<p>† POLITICAL THEORY: LEFT TO RIGHT</p> <p>Designed to aid students in understanding the rationale behind political decision making. An examination of common political terminology (liberal, conservative, radical, left, right, etc.) described within the context of the three spectrums of politics, social issues, and economics. Includes an identification of past and present domestic leaders and their philosophies.</p>
SOCIAL STUDIES	6448.09 6413.11 6418.02 6457.02 6446.15 6416.44	<p>† ECOPOLITICS</p> <p>A study of the politics of ecology. Includes an analysis of current local, national, and international issues.</p>
SCIENCE	5365.44	
SOCIAL STUDIES LANGUAGE ARTS	6448.58 6416.53 5114.115 5115.129 5116.130 5196.02	<p>† YOU, TOO, CAN BE A LEGISLATOR!</p> <p>Students become imaginary legislators; the classroom is the legislative house; elected students run the Congress under the rules of parliamentary procedure. All students write suggested pieces of legislation and employ congressional debate techniques in the ensuing debates.</p>

*NOTE:* Only students who are interested in public affairs and willing to give speeches should take the course.

SOCIAL STUDIES  
407

AREA	ACCR. NO. FLA-DADE	COURSE TITLE AND DESCRIPTION
SOCIAL STUDIES	6448.70 6416.60 6446.20 6414.28	LAW AND SOCIETY  A series of cases in which teen-agers might find themselves and how Florida law can affect their lives. The situations cover such problems as the draft, paternity suits, drugs, auto theft, shoplifting, loitering, and disturbing the peace. The aim is to help students develop critical thinking skills, using the concept of interpretation of statutory law as a vehicle.
SOCIAL STUDIES	6448.10 6446.07 6473.01 6416.45	† INTRODUCTION TO ECONOMICS  A study of the American system of private enterprise. Introduces basic economic principles.
SOCIAL STUDIES	6448.11 6446.16	YOUR BUYING POWER  Designed to develop economic understanding from a consumer point of view. Instruction is organized around actual activities in the life of each pupil, sources of consumer information, intelligent choice of goods and services, social and economic responsibilities of the student, development of a critical attitude toward advertising.
SOCIAL STUDIES	6448.12 6446.08 6473.03 6416.47	LABOR AND MANAGEMENT  A historical analysis of public policy concerning business, trade unions, and collective bargaining, with prime focus on the American labor movement. Causes and effects of labor-management disputes, public and private methods and agencies for dispute settlement.
SOCIAL STUDIES  BUSINESS EDUCATION	6448.13 6446.17 6473.04 6463.03 6416.48 6463.03	† BULL AND BEAR: THE STOCK MARKET  Designed to provide students with an understanding of how the stock market works. Content includes investing, types of stocks, market fluctuations, influence of government on the market, reading the financial pages of the newspaper, relationship of industry and business to market activity.

SOCIAL STUDIES  
408

AREA	ACCR. NO. FLA-DADE	COURSE TITLE AND DESCRIPTION
SOCIAL STUDIES	6448.14 6446.18 6473.02 6416.49	ECONOMICS OF POVERTY  A study of poverty in America, centering on these questions: Why are there millions of poor people in our wealthy nation? Who are they? Where are they? How can we as a nation eliminate poverty? Why are poor people poor? What are the dangers in trying to alleviate poverty or eliminate its causes? Should we have welfare?
SOCIAL STUDIES	6448.15 6446.19 6416.50	MONEY AND BANKING  Examines the nature, role, and scope of money in a capitalistic economy. Emphasis is placed on understanding the operation of government policies affecting banking with its subsequent influences on our national economy.
SOCIAL STUDIES BUSINESS EDUCATION MATH	6448.67 6463.02 6463.02 5283.24 5283.24	TAXES  Explores questions of why we have taxes and how they benefit people; taxes at local, state, and federal levels; property, sales, income, excise, inheritance taxes.
BEHAVIORAL STUDIES (SENIOR HIGH)		
SOCIAL STUDIES	6427.01 6448.46	† INTRODUCTION TO PSYCHOLOGY  A survey of psychology from prehistory to present day. A comparison of psychology with other methods of finding reasons for man's behavior. Examines the spectrum of current psychological methods and fields.
SOCIAL STUDIES HOME AND FAMILY ED.	6427.02 6448.47 6763.07	† UNDERSTANDING INDIVIDUAL BEHAVIOR  A study of the causes of individual behavior through an analysis of the influence of heredity and environment on the individual.
SOCIAL STUDIES HOME AND FAMILY ED.	6427.03 6448.48 6758.06	CHILD BEHAVIOR  An examination of the physical, mental, and emotional growth of children. Includes current theories of child rearing. Emphasis is on the effect of social environment on the development of the child's personality.

AREA	ACCR. NO. FLA-DADE	COURSE TITLE AND DESCRIPTION
SOCIAL STUDIES	6425.05 6448.49	† INTRODUCTION TO SOCIOLOGY  Deals with the body of knowledge concerning human groups, similarities and differences found among various human groups, and the patterns of interaction common to different human endeavors. The student is introduced to the basic techniques of the sociologist and to selected areas of sociological study: population, family, urban living, rural living, race relations, and crime.
SOCIAL STUDIES	6416.23 6425.06 6448.50	† PREJUDICE IN AMERICA  An examination of prejudice and discrimination in America, past and present. Includes types of prejudice, causes for prejudice, the costs of prejudice, where prejudice occurs. Focuses on behavior patterns that lead to prejudice and ways these patterns may be changed, using examples from history, from current events, and from within the pupils' immediate surroundings.
SOCIAL STUDIES	6425.09 6478.23 6448.51	MAN AND SOCIETY  This course is an examination of the ideas and tools by which patterns in human behavior may be recognized. Through the study of two simple societies, students should gain insight into the nature and development of humanness over the course of the last two million years of man's existence.
SOCIAL STUDIES HOME AND FAMILY ED.	6425.04 6448.52 6763.08	† HUMAN RELATIONS  An analysis of the ways in which people behave toward each other. Includes group dynamics, ways people communicate, problems of interpersonal relations.
SOCIAL STUDIES	6416.25 6418.04 6425.08 6448.53	† CRIME IN AMERICA  A study of crime in America, including the range of crime from physical assault to income tax evasion. Considers crime prevention and punishment, its cost to society, causes of crime, and the role of police and courts in dealing with crime.

SOCIAL STUDIES  
410

AREA	ACCR. NO, FLA-DADE	COURSE TITLE AND DESCRIPTION
SOCIAL STUDIES HOME AND FAMILY ED:	6425.15 6448.64 6757.05	<p>THE CHANGING FAMILY</p> <p>Analyzes the changes occurring in the family unit in the United States and projects trends in family living. Topics will include the physical and psychological functions of a family, past and present forms of the family unit in various cultures, the effect of the family unit on society, and the impact of social and technological changes on the family unit. Students will examine current issues affecting families.</p>
SOCIAL STUDIES	6425.13 6478.12 6448.54	<p>INTRODUCTION TO ANTHROPOLOGY</p> <p>A study to include the anthropological examination of the origin and evolution of man, his physical form and his culture; the processes by which cultures develop, and the structure and function of cultures.</p>
SOCIAL STUDIES, SCIENCE	6425.14 6448.66 6416.57 5365.43	<p>SCIENCE AND SOCIETY</p> <p>Investigates the impact of science on society. The effects of technology on the values, institutions, behavior, and health of American society will be investigated.</p>
SOCIAL STUDIES	6425.16 6478.22 6448.72	<p>THE EMERGENCE OF MODERN SOCIETIES</p> <p>An examination of the crucial issues involved in transforming simple societies into modern industrial nations. The purpose is to provide the student with an understanding that human adaptation involves contending with the social, as well as the physical, environment of man. The course is meant to be a follow-up to Man and Society (6425.09).</p>
SOCIAL STUDIES	6425.17 6427.04	<p>CHANGING ROLES OF WOMEN</p> <p>Analyzes the changes occurring in the roles of U.S. women. Areas of study will include the history of women, the psychology of being a woman, the various physical and emotional changes which women undergo, and an analysis of women's choices for a full life.</p>

## VOCATIONAL EDUCATION

### Programs and Quinmester Courses

INTRODUCTION	415
Agriculture	415
Business Education (Vocational)	416
Distributive Education	416
Diversified Education	417
Industrial Arts	417
Technical and Health Occupations	418
Trade and Industrial Education	418
Vocational Home Economics	421
AGRICULTURE 5700-5799	423
Agriculture Science 1	424
Agriculture Science 2	425
Agricultural Specialties	426
Cooperative Agriculture	430
BUSINESS EDUCATION (Vocational) 7700-7799	433
Cooperative Business Education	433
Office Career Occupations	435
Vocational Office Education	436
DISTRIBUTIVE EDUCATION 8700-8749	439
Marketing and Distribution	439
Cooperative Distributive Education I	439
Cooperative Distributive Education II	440
DIVERSIFIED EDUCATION 8750-8799	443
Diversified Cooperative Training	443
Work Experience (Junior High)	445
Work Experience (Senior High)	446
INDUSTRIAL ARTS 5800-5999	447
Construction	455
Drafting	456
Drafting, Architectural	458
Drafting, Naval	460
Drafting, Technical	461
Electricity	462
Electronics	463
General Industrial Arts	465
Graphic Arts	467
Graphic Communications	470
Industrial Technology	471
Manufacturing	471

Metals	472
Plastics	473
Woods	474
<b>TECHNICAL AND HEALTH OCCUPATIONS 8000-8199</b>	<b>477</b>
Health	
Health Service Aide	477
Cooperative Health Occupation Education	478
Technical	
Data Processing Technology (Pre-Technical)	480
<b>TRADE AND INDUSTRIAL EDUCATION 9000-9999</b>	<b>481</b>
Air-Conditioning and Heating Mechanics	481
Appliance Repair	485
Automotive Body Repair and Refinishing	489
Automotive Mechanics	493
Aviation Mechanics	497
Commercial Cooking and Baking	501
Cosmetology	505
Cosmetology Specialist	508
Graphic Arts (Printing)	510
Industrial Electronics	513
Quality Control	517
Radio and Television Service	519
Welding	523



## AGRICULTURE

Grades 9, 10, 11, 12  
2 units

The instructional program in agriculture places major emphasis on actual practice under supervision in as many of the instructional areas as can be arranged. Supervised practice coordinated with classroom instruction should result in well-rounded graduates who are knowledgeable and skillful in the field of agriculture.

Supervised occupational experience may be provided in several different ways, the most important of which traditionally has been the supervised farming program conducted on the home farm. Students who do not have adequate home facilities for agricultural projects may avail themselves of other opportunities provided for them. Facilities provided by the school in the form of land laboratories, school farms, forests, nurseries, and agricultural mechanics shops enable the student to achieve agricultural competencies denied him because of lack of facilities at home. In addition to using the school facilities, senior students may gain much needed experience by being placed on the job within established agricultural businesses, serving as aides to professional workers in agriculture, or by being placed on farms or ranches successfully involved in production agriculture.

The vocational agriculture courses consist of 90 instructional hours per quinmester, earning for the successful student two quinmester credits. Senior cooperative vocational students must have at least four quinesters of vocational agriculture prior to being placed in the program. The part-time cooperative student may work between 20 and 32 hours per week on the job for a total of eight quinmester credits for the school year.

Courses numbered 5709.01-5709.04 and 5711.01-5711.04 are vocational agriculture foundation courses, and it is to the advantage of the student to take the quinesters in sequence. If this is not possible, the instructor may then give his permission for the student to enroll in a particular quinmester, provided the objectives of the preceding quinesters have been achieved.

AGRICULTURAL SPECIALTIES consist of a series of quinmester courses (90 hours) designed to meet the specific interests of any student. The vocational student who has completed the foundation courses (Agriculture Science 1 and 2) "tracks off" to his interest area during his third year, thereby developing competencies and knowledge in several areas of agriculture which he may later choose as an occupation. During the fourth year of agriculture, the vocational student is then placed in the cooperative program for actual on-the-job training which should allow him to develop more easily in the vocation of his choosing.

AGRICULTURAL SPECIALTIES are also designed for the nonvocational student who has an interest in acquiring skills and knowledge in one or more agricultural areas but is not concerned with vocational training *per se*.

## BUSINESS EDUCATION

### *COOPERATIVE BUSINESS EDUCATION (CBE)*

Grade 12 (2-4 units)

A one-year program designed for the senior student wishing to pursue a career in an office occupation and receive supervised on-the-job training. CBE students are scheduled a minimum of two periods each day with the teacher-coordinator and receive CBE-related studies and Business English. An additional business subject is required. Where facilities permit, the CBE student takes Shorthand 2, Clerical Office Practice, or Bookkeeping 2 with the teacher-coordinator during the third hour. English or mathematics taught by the CBE coordinator will fulfill graduation requirements upon approval from the principal. The four quinquesters of the regular school year must be taken in sequence in order to obtain credit for the complete program.

### *OFFICE CAREER OCCUPATIONS (OCO)*

Grade 9 (2 units)

Designed for students in ninth grade who are below grade level in reading, have an interest in office occupations, and are recommended by principal, counselor, and/or OCO teacher. The students will explore office skills and career opportunities in office occupations; apply basic skills of communication and computation to office-related work; and experience opportunities for developing personality traits, grooming, and attitude toward work.

The vocational business education programs that are funded as vocational units are listed in two sections of this bulletin—Business Education and Vocational Education.

### *VOCATIONAL OFFICE EDUCATION (VOE)*

Grade 12 (2-3 units)

Advanced business education subjects are integrated in two programs: (1) a three-hour secretarial block with business English, office procedures, and advanced shorthand; and (2) a two-hour block with business English and office procedures. Both programs have a planned sequence of activities to provide the student with an understanding of the relationships of learning experiences to office occupations and to refine skills so that the student can become a gainfully employed office worker immediately upon graduation.

The vocational business education programs that are funded as vocational units are listed in two sections of this bulletin—Business Education and Vocational Education.

## DISTRIBUTIVE EDUCATION

### *MARKETING AND DISTRIBUTION*

Grades 10, 11 (1 unit)

These courses may be elected by any student who expresses an interest in them. They will be taught as elective courses by the Distributive Education teacher-coordinator and are recommended for those students who wish to pursue a career in sales and/or marketing and enter Cooperative Distributive Education.

### VOCATIONAL EDUCATION

416

405

*COOPERATIVE DISTRIBUTIVE EDUCATION (CDE) I & II*  
Grades 11, 12 (2-3 units)

A one- or two-year program designed for the student interested in pursuing a career in sales and/or marketing. The student is placed in a distributive occupation and receives supervised on-the-job training as part of his or her regular high school education. One or two hours daily of related classroom instruction is offered in 11th and 12th grades by the teacher-coordinator. A senior student entering the program will take two hours of related classroom instruction. The four quinquesters of the regular school year must be taken in sequence in order to obtain credit for the complete program.

DIVERSIFIED EDUCATION

*DIVERSIFIED COOPERATIVE TRAINING (DCT)*  
Grades 11, 12 (2-3 units)

Employment will be offered in community and industrial establishments of the student's choice. In the junior year, two hours of related classroom instruction is offered by the teacher-coordinator, together with supervised on-the-job training. In the senior year, the student continues his on-the-job training and takes one hour of related classroom instruction in addition to the other courses necessary for graduation. The four quinquesters of the regular school year must be taken in sequence in order to obtain credit for the complete program.

*WORK EXPERIENCE (WEP)*  
Grades 7, 8, 9, 10 (2-4 units)

The Work Experience Program (WEP) is preventive, individualized, and preparatory. It encourages staying in school; it is geared to individual student needs; it involves students in employment-finding procedures, employee-employer relationship discussions, and on-the-job experience.

In the Work Experience Program each student receives three or four hours of on-the-job training and three or four hours of classroom instruction. Each student in the WEP is eligible for placement in jobs that meet federal, state, and local employment laws. Job placement is based on individual interest and ability. The four quinquesters of the regular school year must be taken in sequence in order to obtain credit for the complete program.

INDUSTRIAL ARTS

Grades K-12  
1 unit

A series of industrial experiences designed to provide exploratory preparation which will enable the student to demonstrate an understanding of our man-made world. The student will explore various vocational or career interests to aid him in determining a future occupation.

## TECHNICAL AND HEALTH OCCUPATIONS

### *HEALTH SERVICE AIDE (HSA)*

Grades 10, 11 (1 unit)

These courses may be elected by any student who expresses an interest in them. They will be taught by the Cooperative Health Occupation teacher-coordinator and are recommended for those students who wish to pursue a career in a health-related occupation and/or enter the Cooperative Health Occupation Education Program.

### *COOPERATIVE HEALTH OCCUPATION EDUCATION (CHOE)*

Grade 12 (3 units)

A one-year program designed to provide the student with the knowledge and skills necessary to function as a nonprofessional employee in a health-related occupation. Student will obtain supervised on-the-job training at regular beginning wages and receive related classroom instruction with the teacher-coordinator two hours daily. It is recommended that the student take at least one Health Service Aide quinmester course before entering the program. The four quinesters of the regular school year must be taken in sequence in order to obtain credit for the complete program.

### *DATA PROCESSING TECHNOLOGY (Pre-Technical)*

Grades 9, 10, 11, 12 (1 unit)

These courses are open to any student who expresses an interest in them. The skills and knowledge taught are necessary for anyone who wishes to continue his education in Data Processing Technology. A knowledge of typing, office machines, and office procedures, including bookkeeping, is desirable but not mandatory.

## TRADE AND INDUSTRIAL EDUCATION

### *AIR-CONDITIONING AND HEATING MECHANICS*

Grades 10, 11, 12 (1-3 units)

The courses in this area are designed for the student who wishes to pursue a career in the air-conditioning, refrigeration, and heating area. Concentration will be on central air-conditioning units and commercial refrigeration. The courses are offered in the 10th, 11th, and 12th grades, with the opportunity to work in a cooperative program in the 12th grade.

In order to receive a trade competency certificate, it is required that the student complete 12 quins listed in the program of Air-Conditioning and Heating Mechanics.

## VOCATIONAL EDUCATION

418

### *APPLIANCE REPAIR*

Grades 10, 11, 12 (1-3 units)

The courses in this area are designed for the student who wishes to pursue a career as a major appliance repairman. The vocational industrial courses are offered in the 10th, 11th, and 12th grades, with the opportunity to work in a cooperative plan in the 12th grade.

In order to receive a trade competency certificate, it is required that the student complete 12 quins listed in this program of Appliance Repair.

### *AUTOMOTIVE BODY REPAIR AND REFINISHING*

#### *AUTOMOTIVE MECHANICS*

Grades 10, 11, 12 (1-3 units)

These courses in the trade area of automotive mechanics and automotive body repair and refinishing are designed for the student who wishes to pursue a career in the automotive field. The student will receive the general information, technical knowledge, basic skills, attitudes, and values that are required for job entry level.

Supervised instruction in conjunction with the manipulative skill is stressed throughout the course of programming. The applicant must have average ability in mechanical aptitude and no physical handicap that would impair coordination. Senior year students who display entry level skills will be placed in industry under the supervision of industry and the school-industry-education teacher-coordinator.

In order to receive a trade competency certificate, the student is required to complete 12 quins listed in the program of Automotive Mechanics, and Automotive Body Repair and Refinishing.

### *AVIATION MECHANICS*

Grades 10, 11, 12 (3 units)

Students attending any senior high school may be enrolled in the shop classes held at George T. Baker Aviation School. All classes meet for three hours a day at the Aviation School in this three-year program. Students may enter at any grade level after ninth grade.

### *COMMERCIAL COOKING AND BAKING*

Grades 10, 11, 12 (1-3 units)

The courses in this area are designed for the student who wishes to pursue a career in Commercial Food Services. The vocational industrial courses are offered in the 10th, 11th, and 12th grades with the opportunity to work in a cooperative plan in the 12th grade.

In order to receive a trade competency certificate, the student is required to complete 12 quins listed in the program of Commercial Cooking and Baking.

*COSMETOLOGY*  
*COSMETOLOGY SPECIALIST*  
Grades 11, 12 (3 units)

This two-year program is designed for the student interested in pursuing a career in cosmetology. The course prepares the student to pass the Florida State Board of Cosmetology examination and to become successfully employed in this area. Instruction will be provided in an environment similar to that encountered in the field of cosmetology. Related theory and practice in the required manipulative skills will be stressed. The course will consist of 1200 hours. The student must attend all quins necessary for meeting this requirement. All classes meet for three hours a day.

The Cosmetology Specialist course is a one-year program designed for the student interested in pursuing a career as a specialist. This course prepares the student to pass the Florida State Board Examination. The student must attend all quins necessary to complete the course which consists of 500 hours. All classes meet for three hours a day.

*GRAPHIC ARTS (PRINTING)*  
Grades 10, 11, 12 (1-3 units)

The courses in this area are designed for the student who wishes to pursue a career in the printing industry. The vocational industrial courses are offered in the 10th, 11th, and 12th grades, with the opportunity to work in a cooperative plan in the 12th grade.

In order to receive a trade competency certificate, it is required that the student complete 12 quins listed in this program of Graphic Arts (Printing).

*INDUSTRIAL ELECTRONICS*  
Grades 10, 11, 12 (1-3 units)

The courses in this area are designed for the student who wishes to pursue a career in an electronics field. The one-hour preparatory courses in 10th grade (Fundamentals of Electricity and Electronics, Alternating Current Fundamentals, Transistors) are taught in conjunction with the Industrial Arts Department. Math for Electronics is a vocational course which is taken before entering the Industrial Electronics program.

The Vocational Industrial Electronics courses are offered in three-hour blocks in the 11th and 12th grades with the opportunity to work in a cooperative plan in the 12th grade.

*QUALITY CONTROL*  
Grades 11, 12 (3 units)

Students attending any senior high school may be enrolled in the shop classes held at the George T. Baker Aviation School. All classes meet for three hours a day at the Aviation School in this two-year program. Students may enter at any grade level after the tenth grade.

### *RADIO AND TELEVISION SERVICE*

Grades 10, 11, 12 (1-3 units)

The courses in this area are designed for the student who wishes to pursue a career in Radio and Television Repair. The one-hour preparatory courses in the 10th grade (Fundamentals of Electricity and Electronics, Alternating Current Fundamentals, Transistors) are taught in conjunction with the Industrial Arts Department.

The Radio and TV Service courses are offered for two or three quinmester credits in the 11th and 12th grade with the opportunity to work in a cooperative plan in the 12th grade.

In order to receive a trade competency certificate, it is required that the student complete 12 quins listed in the program of Radio and Television Service.

### *WELDING*

Grades 11, 12 (3 units)

Students attending any senior high school may be enrolled in the welding classes held at the George T. Baker Aviation School. All classes meet for three hours a day at the Aviation School in this two-year program. Students may enter at any grade level after the tenth grade.

### VOCATIONAL HOME ECONOMICS

Grades K-12

Any of the courses listed in the HOME AND FAMILY EDUCATION section may be taught on a Vocational Home Economics unit provided the teacher has Vocational Home Economics certification and the application for a unit has been approved. The content of courses listed in "Personal, Home, and Family Living Preparation" emphasizes the vocational opportunities within the subject matter areas, as well as provides useful consumer and homemaking education. Courses listed under "Occupational Preparation" provide specific occupational education and training for gainful employment.

See the section on HOME AND FAMILY EDUCATION (pages 183-206) for a detailed description of the quinmester courses of study.

# AGRICULTURE

## GENERAL AGRICULTURE (JUNIOR AND SENIOR HIGH)

### AGRICULTURE SCIENCE 1 - 5709 (Vocational Students)

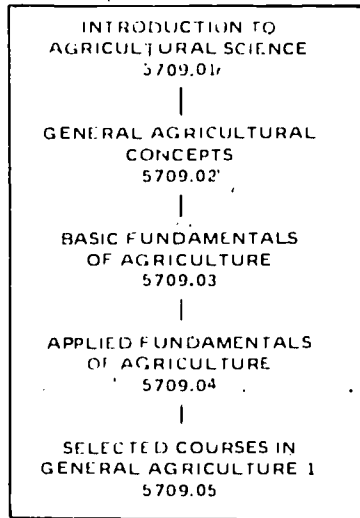

### AGRICULTURE SCIENCE 2 - 5711 (Vocational Students)

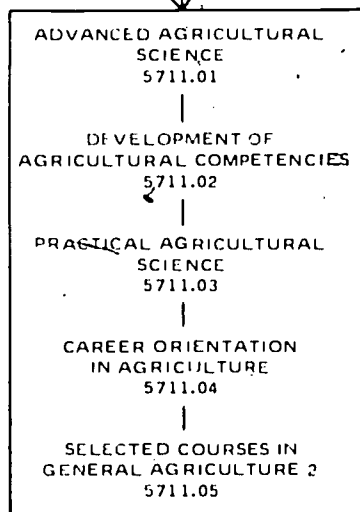

### COOPERATIVE AGRICULTURE

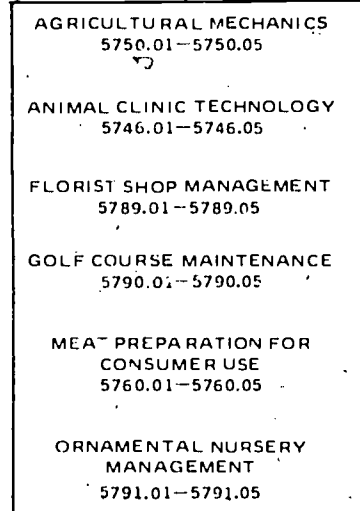

### AGRICULTURAL SPECIALTIES (Vocational and Nonvocational Students)

FARM MANAGEMENT	5798.01
SUBTROPICAL FRUIT PRODUCTION	5738.01
SOIL CONSERVATION	5799.01
WATER CONSERVATION	5799.02
RAISING YOUNG DAIRY ANIMALS	5730.01
↓	
DAIRY HERD MANAGEMENT	5730.02
LANDSCAPE DESIGN	5795.01
↓	
PRACTICAL LANDSCAPING	5795.02
GENERAL FARM ANIMAL PROD.	5728.01
GENERAL SHOP PRACTICES	5750.01
↓	
GENERAL AGRICULTURAL MECHANICS	5750.02
INTRODUCTION TO FORESTRY	5793.01
↓	
PRACTICAL FORESTRY	5793.02
GROWING FLOWERS	5789.01
LAWN MAINTENANCE	5794.01
ORNAMENTAL PLANT MAINTENANCE	5794.02
MEAT SELECTION AND PREP.	5760.01
PLANT PROPAGATION	5791.01
↓	
NURSERY MANAGEMENT	5791.02
POULTRY PRODUCTION	5732.01
↓	
THE POULTRY BUSINESS	5732.02
LAND USES FOR RECREATION	5769.01
INTRO. TO FISHPOND PROD.	5775.01
↓	
FARM FISHPOND PRODUCTION	5775.02
VEGETABLE GROWING	5764.01
↓	
VEGETABLE PRODUCTION TECHNIQUES	5764.02
WILDLIFE AND GAME MANAGEMENT	5771.01



AREA	ACCR. NO. FLA-DADE	COURSE TITLE AND DESCRIPTION
AGRICULTURE SCIENCE I		
AGRICULTURE SCIENCE	5709.01	INTRODUCTION TO AGRICULTURAL SCIENCE
SCIENCE	5364.01	An introductory course in agricultural science covering orientation to the policies, rules, and objectives of the agricultural department's programs. Basic training is given in regard to developing skills in the use and propagation of plants, agricultural management procedures, and leadership abilities. Two quinmester credits.
AGRICULTURE SCIENCE	5709.02	GENERAL AGRICULTURAL CONCEPTS
SCIENCE	5364.02	The development of basic agricultural knowledge in the fields of plant and animal science, agricultural mechanics, and human and natural resources. Two quinmester credits.
AGRICULTURE SCIENCE	5709.03	BASIC FUNDAMENTALS OF AGRICULTURE
SCIENCE	5364.03	The application of fundamental agricultural concepts in plant, animal, and soil science; the development of farm shop projects; and the reinforcement of leadership skills in regard to public speaking and parliamentary procedures. Two quinmester credits.
AGRICULTURAL SCIENCE	5709.04	APPLIED FUNDAMENTALS OF AGRICULTURE
SCIENCE	5364.04	Principles and practices concerned with the plant processes; soil utilization, animal nutrition, agricultural management; and the development of farm shop skills. Two quinmester credits.
AGRICULTURE SCIENCE	5709.05	SELECTED COURSES IN GENERAL AGRICULTURE 1
SCIENCE	5364.05	Skill development and information courses regarding specific subjects in agricultural science. Subjects taught according to student demand. Designed to develop competencies for occupational entry. Two quinmester credits.

VOCATIONAL EDUCATION  
AGRICULTURE  
424

AREA	ACCR. NO. FLA-DADE	COURSE TITLE AND DESCRIPTION
AGRICULTURE SCIENCE 2		
AGRICULTURE SCIENCE	5711.01	ADVANCED AGRICULTURAL SCIENCE
SCIENCE	5364.06	Advanced study and practical experience in the applied principles of agricultural science in the fields of livestock, crops, ornamental plants, ecology, and farm shop. Two quinmester credits.
AGRICULTURE SCIENCE	5711.02	DEVELOPMENT OF AGRICULTURAL COMPETENCIES
SCIENCE	5364.07	The development of competencies and abilities in the areas of plant disease control, planting design, conservation of natural resources, animal disease control, and practical problems in farm shop skill development. Two quinmester credits.
AGRICULTURE SCIENCE	5711.03	PRACTICAL AGRICULTURAL SCIENCE
SCIENCE	5364.08	A combination of subject matter and practical experiences concerned with plant pests and their control, landscape practices, leadership decision making, farm shop projects, and environmental problems. Two quinmester credits.
AGRICULTURE SCIENCE	5711.04	CAREER ORIENTATION IN AGRICULTURE
SCIENCE	5364.09	Offers an opportunity for the student to select a number of vocations concerned with agricultural related occupations for further study and experience. Marketing and management knowledge is developed, together with learning situations regarding human relations. Two quinmester credits.
AGRICULTURE SCIENCE	5711.05	SELECTED COURSES IN GENERAL AGRICULTURE 2
SCIENCE	5364.10	Skill development and information courses regarding specific subjects in agricultural science. Subjects taught according to student demand. Designed to develop competencies for occupational entry. Two quinmester credits.

AREA	ACCR. NO. FLA-DADE	COURSE TITLE AND DESCRIPTION
AGRICULTURAL SPECIALTIES		
FARM BUSINESS MANAGEMENT	5798.01	FARM MANAGEMENT  The principles and practices involved in the establishment of an agricultural enterprise. Two quinmester credits.
SMALL FRUIT, BERRY & NUT PRODUCTION	5738.01	SUBTROPICAL FRUIT PRODUCTION  Fundamentals and practices involved in the culture and production of subtropical fruits grown in the area, with special emphasis on backyard production. Two quinmester credits.
CONSERVATION SCIENCE	5799.01 5365.05	SOIL CONSERVATION  A combination of subject matter and practical experiences concerned with the maintaining of soil stability and productivity. Two quinmester credits.
CONSERVATION SCIENCE	5799.02 5365.06	WATER CONSERVATION  Provides an opportunity to learn and apply the principles involved in the conservation and management of water and water resources. Two quinmester credits.
DAIRY PRODUCTION SCIENCE	5730.01 5366.01	RAISING YOUNG DAIRY ANIMALS  The development of competencies and abilities in the various areas of dairy cattle production concerning the selection, feeding, and management of young animals. Two quinmester credits.
DAIRY PRODUCTION SCIENCE	5730.02 5366.02	DAIRY HERD MANAGEMENT  The application of dairy cattle management techniques concerned with feeding, breeding, and disease control. Two quinmester credits.
LANDSCAPE OPERATIONS	5795.01	LANDSCAPE DESIGN  Organized subject matter and practical experiences concerned with landscape design and plant use. Two quinmester credits.

VOCATIONAL EDUCATION  
AGRICULTURE  
426

AREA	ACCR. NO. FLA-DADE	COURSE TITLE AND DESCRIPTION
LANDSCAPE OPERATIONS	5795.02	<p>PRACTICAL LANDSCAPING</p> <p>Activities concerned with the establishment of plants and other devices for the beautification of home grounds and other areas of human habitation and recreation.</p> <p>Prior to enrolling in this course the student should first achieve the objectives in Landscape Design 5795.01. Two quinmester credits.</p>
LIVESTOCK PRODUCTION	5728.01	<p>GENERAL FARM ANIMAL PRODUCTION</p> <p>The principles and practices involved in the production, management, and marketing of general livestock. Two quinmester credits.</p>
DIVERSIFIED AGRICULT'L MECHANICS	5750.01	<p>GENERAL SHOP PRACTICES</p> <p>The planning, construction, and caring for small buildings and the development of skills regarding simple repairs around the home or farm. Two quinmester credits.</p>
DIVERSIFIED AGRICULT'L MECHANICS	5750.02	<p>GENERAL AGRICULTURAL MECHANICS</p> <p>The maintenance and repair of small gas engines and field equipment, together with skill development in welding, electrification, and the establishment of water systems.</p> <p>It would be to the advantage of the student enrolling in this course to first enroll in General Shop Practices 5750.01. Two quinmester credits.</p>
DIVERSIFIED FORESTRY SCIENCE	5793.01 5364.11	<p>INTRODUCTION TO FORESTRY</p> <p>An introductory course in forestry as an occupation and the problems connected with forest conservation. Two quinmester credits.</p>
DIVERSIFIED FORESTRY SCIENCE	5793.02 5364.12	<p>PRACTICAL FORESTRY</p> <p>A practical course in the propagation of forest trees and the principles and practices concerned with forest protection, mensuration, and management.</p> <p>The student, prior to entry in this course, will display his achievement of the objectives set forth in Introduction to Forestry 5793.01. Two quinmester credits.</p>

AREA	ACCR. NO. FLA-DADE	COURSE TITLE AND DESCRIPTION
FLORICULTURE SCIENCE	5789.01 5364.13	GROWING FLOWERS  Learning experiences involved in the field and nursery production of flowers and the arrangement of such flowers for ornamental purposes. Two quinmester credits.
LANDSCAPE MAINT. SCIENCE	5794.01 5364.14	LAWN MAINTENANCE  Principles and practices involved in the proper care and use of lawn machinery and tools, the use of fertilizers and water, the control of lawn pests, and the methods used in reconditioning turf. Two quinmester credits.
LANDSCAPE MAINT. SCIENCE	5794.02 5364.15	ORNAMENTAL PLANT MAINTENANCE  Subject matter and practical experiences concerned with the pruning and trimming of plants, fertilizing, watering, and pest control of plants. Two quinmester credits.
MEAT PROCESSING & MARKETING	5760.01	MEAT SELECTION AND PREPARATION  An introductory course for the student preparing for the meat processing and marketing occupations. The course is designed to develop the competencies in the classification, grading, preparation, and marketing of meat and meat products. Two quinmester credits.
NURSERY OPERATIONS SCIENCE	5791.01 5364.16	PLANT PROPAGATION  Subject matter and experiences concerned with the production of plants for the purpose of propagation and transplantation. Two quinmester credits.
NURSERY OPERATIONS SCIENCE	5791.02 5364.17	NURSERY MANAGEMENT  Designed for the student preparing to enter the nursery business. Concerns fundamental nursery management, planning, maintenance, and environmental control.  The student prior to entry in this course will demonstrate his achievement of the objectives set forth in Plant Propagation 5791.01. Two quinmester credits.

AREA	ACCR. NO. FLA-DADE	COURSE TITLE AND DESCRIPTION
POULTRY PRODUCTION SCIENCE	5732.01 5366.03	POULTRY PRODUCTION  An introduction to feeding principles and disease control methods used in the production of poultry, together with poultry improvement through selective breeding. Two quinmester credits.
POULTRY PRODUCTION	5732.02	THE POULTRY BUSINESS  General poultry management in regard to breeding, rearing, record keeping, and marketing.  The student should achieve the objectives of Poultry Production 5732.01 prior to enrolling in this course. Two quinmester credits.
RECREATION	5769.01	LAND USE FOR RECREATION  The study of recreation as one of the multiple uses of land and an introduction to the establishment of various recreational activities, such as fishing, hunting, camping, and nature study. Two quinmester credits.
FISH PRODUCTION & MANAGEMT.	5775.01	INTRODUCTION TO FISHPOND PRODUCTION  An introductory course in fishpond production. Concerned with pond design, fish reproduction, and feeding. Two quinmester credits.
FISH PRODUCTION & MANAGEMT.	5775.02	FARM FISHPOND PRODUCTION  Application of the principles of farm fishpond production, with an emphasis on catfish and bluegill varieties.  Prior to the enrollment in this course the student should be able to demonstrate his achievement of the objectives set forth in Introduction to Fishpond Production 5775.01. Two quinmester credits.
VEGETABLE CROP PRODUCTION	5764.01	VEGETABLE GROWING  The principles and operations involved in the production of vegetables commonly grown in the area. Two quinmester credits.

AREA	ACCR. NO. FLA-DADE	COURSE TITLE AND DESCRIPTION
VEGETABLE CROP PRODUCTION	5764.02	<p>VEGETABLE PRODUCTION TECHNIQUES</p> <p>An advanced practical course in the growing and marketing of vegetables commonly grown in the area.</p> <p>Prior to enrollment in this course the student will demonstrate his achievement of the objectives set forth in Vegetable Growing 5764.01. Two quinmester credits.</p>
WILDLIFE AND GAME MANAGEMENT SCIENCE	5771.01 5366.04	<p>WILDLIFE AND GAME MANAGEMENT</p> <p>A study of the principles and practices involved in the conservation and improvement of wildlife such as game and fish. Two quinmester credits.</p>

#### COOPERATIVE AGRICULTURE

Four quinesters of agriculture is the minimum requirement for senior students prior to enrollment in Cooperative Agriculture. Students in this program will remain in one of the six Cooperative Agriculture areas for a full year. For reporting purposes, a sequence of quin code numbers is used, one number for each quinmester's work.

DIVERSIFIED AGRICULT'L MECHANICS	5750.01 5750.02 5750.03 5750.04 5750.05	<p>AGRICULTURAL MECHANICS</p> <p>Training may be offered in any of the various areas having to do with the maintenance and repair of farm machinery and equipment. Two quinmester credits for each quinmester.</p>
ANIMAL SCIENCE TECHNOLOGY SCIENCE	5746.01 5746.02 5746.03 5746.04 5746.05 5366.05 5366.06 5366.07 5366.08 5366.09	<p>ANIMAL CLINIC TECHNOLOGY</p> <p>Practical experience in selected veterinary clinics, acquainting the student with veterinary practices. Two quinmester credits for each quinmester.</p>

AREA	ACCR. NO. FLA-DADE	COURSE TITLE AND DESCRIPTION
FLORICULTURE	5789.01 5789.02 5789.03 5789.04 5789.05	FLORIST SHOP MANAGEMENT  Training offered by selected florists for the student desiring to learn the florist business. Two quinmester credits for each quinmester.
GOLF COURSE OPERATIONS	5790.01 5790.02 5790.03 5790.04 5790.05	GOLF COURSE MAINTENANCE  Training provided by local golf courses for the student desiring training in any of the phases of golf course operation. Two quinmester credits for each quinmester.
MEAT PROCESSING & MARKETING	5760.01 5760.02 5760.03 5760.04 5760.05	MEAT PREPARATION FOR CONSUMER USE  Practical experience in meat cutting and marketing. Training is provided by local meat markets for those students desiring training as meat cutters or meat market managers. Two quinmester credits for each quinmester.
NURSERY OPERATIONS	5791.01 5791.02 5791.03 5791.04 5791.05	ORNAMENTAL NURSERY MANAGEMENT  Practical training in nursery practices and mangement. Two quinmester credits for each quinmester.



## BUSINESS EDUCATION

AREA	ACCR. NO. FLA-DADE	COURSE TITLE AND DESCRIPTION
COOPERATIVE BUSINESS EDUCATION (CBE)		
CBE	7725.01	† LOOKING INTO THE WORLD OF BUSINESS  Orientation toward cooperative vocational education; philosophy and history of vocational education; daily forms for CBE; club organization; and parliamentary procedure. Applicant must be accepted by the teacher-coordinator.
CBE CHOE	7725.02 8009.04	RELATING TO ENVIRONMENT  Environment in school, business, and outside relationships; good grooming; social skills; personality development; employer-employee relationships; and job finding and job success.
CBE CHOE DCT	7725.03 8009.03 8753.03	† EXPLORING MONEY, TAXES, AND INSURANCE  The vocational cooperative student explores money, taxes, and insurance: individual budgeting, social security, unemployment insurance, workmen's compensation, income tax, all types of insurance, and money and banking.
CBE	7725.04	REINFORCING COMMUNICATIONS AND CLERICAL TECHNIQUES  The CBE student reinforces his communications and clerical techniques; telephone, telegraph, and other types of communication media; brushup on mathematics; filing; and occupational monograph.
CBE	7725.05	DEVELOPING CLERICAL, BUSINESS, AND ORAL COMMUNICATION SKILLS  The CBE student develops clerical, business, and oral communication skills. Complete clerical brushup; general brushup information relating to recordkeeping, payroll, etc., oral communication in public speaking.

AREA	ACCR. NO. FLA-DADE	COURSE TITLE AND DESCRIPTION
CBE CDE CHOE DCT	7725.06 8727.05 8009.06 8753.05	EMPLOYABILITY SKILLS FOR THE VOCATIONAL COOPERATIVE EDUCATION STUDENT  Employability skills training will be given to students qualifying for vocational cooperative training. An individual training plan will be developed between the coordinator, the training sponsor, and the student when the student is judged to be job ready. Before entering this course, students must obtain the approval of each subject area teacher-coordinator.
CBE LANGUAGE ARTS	7725.07 5116.164	† DEVELOPING THE ART OF COMMUNICATION  Reading, listening, comprehension, use of the dictionary. Vocabulary related to parliamentary procedure, vocational education, and business management. Applicant must be accepted by the teacher-coordinator.
CBE LANGUAGE ARTS	7725.08 5116.165	REINFORCING KNOWLEDGE OF GRAMMAR  Complete grammar brushup. Vocabulary relating to personality development, office relationships, job finding, and job success.
CBE LANGUAGE ARTS	7725.09 5116.166	REVIEWING CAPITALIZATION AND PUNCTUATION, AND DEVELOPING A RESEARCH PAPER  Complete review of capitalization, punctuation, abbreviation, and the use of figures; fine points of writing; developing a research paper. Vocabulary related to budgeting, insurance, money and banking.
CBE LANGUAGE ARTS	7725.10 5116.167	DEVELOPING WRITTEN BUSINESS COMMUNICATIONS  Complete coverage of all types of written business communications; original letter composition. Vocabulary related to business letters, communications media, mathematics, and filing.
CBE LANGUAGE ARTS	7725.11 5116.168	EXPLORING LITERATURE AND PRACTICING ORAL COMMUNICATION  Special emphasis is placed on literature, both ancient and modern, and the development of the student's interest in reading for pleasure. Stress will be placed on speaking in the business world by covering everyday situations the student is apt to meet. Vocabulary and the use of the dictionary will be given emphasis.

VOCATIONAL EDUCATION  
BUSINESS EDUCATION

AREA

ACCR. NO.  
FLA-DADE

COURSE TITLE AND DESCRIPTION

OFFICE CAREER OCCUPATIONS (OCO)

BUSINESS  
EDUCATION

7749.11

OCO NO. 1 (2 hours)

Includes the learning of the typewriter keyboard, basic composition at the typewriter, good work habits, and steps in finding a job; the recognition of one's own potential for office training and employment; and an introduction to alphabetic filing rules and a review of basic spelling rules.

BUSINESS  
EDUCATION

7749.12

OCO NO. 2 (2 hours)

Includes the building of skill in typewriting, alphabetic and numeric filing, communication, spelling, and computation; the recognition of good personality traits, grooming habits, attitudes, and craftsmanship; an exploration of the broad field of selling; and preparation of material for fluid duplicating.

Prior to enrollment in this course, the student should have attained the objectives of OCO NO. 1 (7749.11).

BUSINESS  
EDUCATION

7749.13

OCO NO. 3 (2 hours)

Includes further development of skills in typewriting, filing, and communication; the basic operation of full- and ten-key adding machines; and exploration of shorthand systems. The course also includes the recognition of business purposes and organization of skills required in advanced business subjects, and of the need for continuing education.

Prior to enrollment in this course, the student should have attained the objectives of OCO NO. 2 (7749.12).

BUSINESS  
EDUCATION

7749.14

OCO NO. 4 (2 hours)

Includes the further development of skills in filing, communication, and computation; a basic understanding of profit and loss, and fundamental terms and principles in bookkeeping procedures; preparation of materials for, and supervised operation of, ink and fluid duplicators; application problems for the full and ten-key adding machines; and the typing of simple business letters, application blanks, and personal data sheets.

Prior to enrollment in this course, the student should have attained the objectives of OCO NO. 3 (7749.13).

VOCATIONAL EDUCATION  
BUSINESS EDUCATION  
435

435

AREA	ACCR. NO. FLA-DADE	COURSE TITLE AND DESCRIPTION
------	-----------------------	------------------------------

VOCATIONAL OFFICE EDUCATION (VOE)

BUSINESS EDUCATION	7749.01	<p>VOE SPECIAL JOBS, CLERICAL (2 hours)</p> <p>Includes jobs on the proportional-space typewriter, the fluid duplicator, and the ink duplicator; two integrated jobs on a transcription machine; and one week as a receptionist. In the process of doing these jobs, the student should gain experience in composition at the typewriter; spelling; proofreading; setting up letters in two styles with two-different styles of punctuation; and keeping bank records, a petty cash book, and a payroll. If some or all of the students are not currently enrolled in an office machines course, special jobs on machines that are available in the VOE classroom are included in this course of study. This quin includes limited specialized equipment requiring the rotation of student assignments. It is suggested that one-fourth of the class enrollment be assigned to this course of study while the other students are engaged in the work of a sequential VOE course of study—No. 1, 2, or 3.</p> <p>Prior to enrollment in this course, the student should have attained the objectives of Intermediate Typewriting Skills (7704.41).</p>
-----------------------	---------	---

BUSINESS EDUCATION	7719.01	<p>VOE SPECIAL JOBS, SECRETARIAL (3 hours)</p> <p>Same as VOE Special Jobs, Clerical, but with the addition of training in one of the advanced shorthand, quinmester courses which may be integrated with this instruction.</p> <p>Prior to enrollment in this course, the student should have attained the objectives of Shorthand Basic Transcription (7706.41).</p>
-----------------------	---------	--

AREA	ACCR. NO. FLA-DADE	COURSE TITLE AND DESCRIPTION
BUSINESS EDUCATION	7749.02	<p>VOE NO. 1, CLERICAL (2 hours)</p> <p>Includes three filing jobs and four sequential jobs. The filing jobs include a review of punctuation, capitalization, abbreviations, and the use of figures; the skills of inspecting, indexing, coding, and sorting letters according to alphabetic filing rules; and training in setting up an alphabetic index system with cross-references and a numeric index system for a group of letters. The four sequential jobs include manuscript composition and typing, vocabulary building, proper use of the dictionary, good reading habits, and differentiating between acceptable and preferable spellings; a review of good sentence structure, word division, and tabulation; correcting and typing rough-draft letters; filling out an application for federal employment; and setting up an interoffice memorandum correctly from rough-draft copy.</p> <p>Prior to enrollment in this course, the student should have attained the objectives of Intermediate Typewriting Skills (7704.41).</p>
BUSINESS EDUCATION	7719.02	<p>VOE NO. 1, SECRETARIAL (3 hours)</p> <p>Same as VOE No. 1, Clerical, but with the addition of training in one of the advanced shorthand quarter courses which may be integrated with this instruction.</p> <p>Prior to enrollment in this course, the student should have attained the objectives of Shorthand Basic Transcription (7706.41).</p>
BUSINESS EDUCATION	7749.03	<p>VOE NO. 2, CLERICAL (2 hours)</p> <p>Includes seven sequential jobs. These jobs include a review of nouns, verbs, pronouns, adjectives, prepositions, and conjunctions; an introduction to simple business correspondence, such as order letters, letters of transmittal, reservation letters, letters of cancellation, and letters of refusal; and experience in keeping an appointment book, using the telephone properly, making carbon copies, applying for a job, typing legal forms, and typing various types of credit memoranda and statements of account.</p> <p>Prior to enrollment in this course, the student should have attained the objectives of VOE No. 1, Clerical (7749.02):</p>



AREA

ACCR. NO.  
FLA-DADE

COURSE TITLE AND DESCRIPTION

BUSINESS  
EDUCATION

7719.03

VOE NO. 2, SECRETARIAL (3 hours)

Same as VOE No. 2, Clerical, but with the addition of training in one of the advanced shorthand quinmester courses which may be integrated with this instruction.

Prior to enrollment in this course, the student should have attained the objectives of VOE No. 1, Secretarial (7719.02).

BUSINESS  
EDUCATION

7749.04

VOE NO. 3, CLERICAL (2 hours)

Includes seven or more sequential jobs. These jobs include more complex business letters such as letters of credit refusal, follow-up collection letters, letters inviting credit, credit recommendations, letters of complaint, letters of apology, sales letters, and letters of application with personal data sheets; more complex business forms such as inventory records, bills of lading, invoices, and tabulated business reports with extensions to figure on office machines (optional), mailing forms, telegrams, and money orders; and other office techniques such as the chain feeding of envelopes, weighing mail properly, and figuring costs of various classes of mail.

Prior to enrollment in this course, the student should have attained the objectives of VOE No. 2, Clerical (7749.03).

BUSINESS  
EDUCATION

7719.04

VOE NO. 3, SECRETARIAL (3 hours)

Same as VOE No. 3, Clerical, but with the addition of training in one of the advanced shorthand quinmester courses which may be integrated with this instruction.

Prior to enrollment in this course, the student should have attained the objectives of VOE No. 2, Secretarial (7719.03).

DISTRIBUTIVE EDUCATION (DE)

AREA	ACCR. NO. FLA-DADE	COURSE TITLE AND DESCRIPTION
MARKETING AND DISTRIBUTION		
DE	8726.01	<p>† EXPLORING CAREERS IN MARKETING AND DISTRIBUTION</p> <p>Surveys distributive occupations in the South Florida area. This course is designed to interest students initially in careers in marketing and distribution.</p>
DE MATH	8726.02 5214.91	<p>DISTRIBUTIVE MATH AND RECORDKEEPING</p> <p>Teaches the basic skills of distributive math and recordkeeping, which are basic requirements for employability.</p>
DE	8726.03	<p>COMMUNICATION SKILLS RELATING TO MARKETING AND DISTRIBUTION</p> <p>Presents to the student broader meaning and understanding of communications in the business world necessary for employability. Develops the ability to write various types of business letters and prepare a speech.</p>
DE	8726.04	<p>PSYCHOLOGY AND HUMAN RELATIONS IN THE DISTRIBUTIVE WORLD</p> <p>Develops the social skills necessary in the business world relating to employer-employee, employee-employee, and employee-consumer relationships.</p>

COOPERATIVE DISTRIBUTIVE EDUCATION I (CDE)

CDE	8727.01	<p>† PREPARING FOR THE JOB AND SALESMANSHIP TRAINING</p> <p>Designed to prepare CDE students for the job and to teach them the skills, attitudes, and techniques of selling. Application writing, job interview, and job placement are stressed. Applicant must be accepted by the teacher-coordinator.</p>
-----	---------	---

AREA	ACCR. NO. FLA-DADE	COURSE TITLE AND DESCRIPTION
CDE	8727.02	ADVERTISING, LAYOUT AND DISPLAY  Acquaints CDE students with the purpose and scope of advertising and sales promotion, with emphasis on developing competencies in technical skills in this area.
CDE	8727.03	† ORGANIZATION OF A SMALL BUSINESS  The student develops a manual for better understanding of the nature of different business organizations and as an aid to understand the business requirements of the entrepreneur.
CDE	8727.04	MARKETING MANAGEMENT  The organization, operation, and control of a business, including government regulations that influence management decisions.
CDE CBE CHOE DCT	8727.05 7725.06 8009.06 8753.05	EMPLOYABILITY SKILLS FOR THE VOCATIONAL COOPERATIVE EDUCATION STUDENT  Employability skills training will be given to students qualifying for vocational cooperative training. An individual training plan will be developed between the coordinator, the training sponsor, and the student when the student is judged to be job ready. Before entering this course, students must obtain the approval of each subject area teacher-coordinator.

COOPERATIVE DISTRIBUTIVE EDUCATION II (CDE)

CDE	8728.01	† MERCHANDISING LABORATORY  This course is designed to give experience in research, selected, and organization of information to the Cooperative Distributive Education student, with the guidance of the training sponsor and the teacher-coordinator, for practical use on a specific item of merchandise or a service. Applicant must be accepted by the teacher-coordinator.
-----	---------	--



AREA	ACCR. NO. FLA-DADE	COURSE TITLE AND DESCRIPTION
CDE	8728.02	<p><b>AREA OF DISTRIBUTION LABORATORY</b></p> <p>Affords the CDE student experience in research, selection, and organization of information for practical use in one area or phase of marketing, such as supermarket operation, regional shopping areas, or an activity within one of these broad areas, such as fashion, credit, personnel, and advertising.</p>
CDE	8728.03	<p><b>STUDIES IN MARKETING LABORATORY</b></p> <p>Studies in marketing are conducted by the individual CDE students in the following areas: department store merchandising, specialty store merchandising, food industry, home furnishings industry, variety store merchandising, and service industry. Students select the area of study based on their career objective, conduct an investigation, and prepare a documental report.</p>
CDE	8728.04	<p><b>CREATIVE MARKETING LABORATORY</b></p> <p>The CDE students as a group complete an activity or research project which results in a measurable improvement in the economy of the local community, state, and/or nation by finding new markets for local products, promoting the community's resources, increasing sales, developing better services, or any other like improvement. The students through their cooperative efforts, with local businessmen acting as an advisory committee, grow and develop in their understanding of the marketing concept.</p>

## DIVERSIFIED EDUCATION

AREA	ACCR. NO. FLA-DADE	COURSE TITLE AND DESCRIPTION
DIVERSIFIED COOPERATIVE TRAINING (DCT)		
DCT	8753.01	† ORIENTATION AND JOB READINESS  Introduces the vocational cooperative student to the history and concepts of vocational cooperative education. The steps necessary in preparation for applying for a job are discussed and practiced. This is the first of all general related courses in DCT. Applicant must be accepted by the teacher-coordinator.
DCT	8753.02	† EMPLOYER-EMPLOYEE RELATIONS AND PERSONALITY DEVELOPMENT  Explains the role and responsibilities of the employer and employee in the success of the job and the business. The student is shown the need for developing his own personality and its importance in relationship to social and business situations.
DCT CBE CHOE	8753.03 7725.03 8009.03	† EXPLORING MONEY, TAXES, AND INSURANCE  The vocational cooperative student explores money, taxes, and insurance. Individual budgeting, social security, unemployment insurance, workmen's compensation, income tax, all types of insurance, money and banking are areas which will be covered.
DCT	8753.04	ORAL AND WRITTEN COMMUNICATIONS FOR BUSINESS  Explores the use of informational materials relating to the telephone, telegraph, and other communication instruments. The student is introduced to business forms and letters, and the importance of proper grammar and correct spelling in the business world. Correct delivery techniques of speech are practiced.

AREA	ACCR. NO. FLA-DADE	COURSE TITLE AND DESCRIPTION
DCT CBE CDE CHOE	8753.05 7725.06 8727.05 8009.06	EMPLOYABILITY SKILLS FOR THE VOCATIONAL COOPERATIVE EDUCATION STUDENT  Employability skills training will be given to students qualifying for vocational cooperative training. An individual training plan will be developed between the coordinator, the training sponsor, and the student when the student is judged to be job ready. Before entering this course, students must obtain the approval of each subject area teacher-coordinator.
DCT	8754.01	† EXPLORING BUSINESS AND INDUSTRY OCCUPATIONS  An overview of occupations in business or industry for the individual DCT student. This includes business ownership, management and operation of the business or industry, and the occupations which the students have selected as career objectives. Applicant must be accepted by the teacher-coordinator.
DCT	8754.02	† OCCUPATIONAL SKILLS  The development and understanding of the techniques and skills needed for the specific occupations of the DCT student.
DCT	8754.03	GOVERNMENT, BUSINESS, AND LABOR RELATIONS  Focuses attention on the expanding role of government in our free enterprise system with an overview of organized labor as it relates to the occupation of the individual cooperative student.
DCT	8754.04	CAREER INFORMATION AND CAREER PLANNING  A course of study in which the student develops the techniques necessary for securing and interpreting career information. The development of these skills will assist him or her in making realistic choices in planning for his future.

AREA	ACCR. NO. FLA-DADE	COURSE TITLE AND DESCRIPTION
WORK EXPERIENCE (JUNIOR HIGH)		
WORK EXPERIENCE	8769.01	(JR. HIGH)—INTRODUCTION TO THE WORK EXPERIENCE PROGRAM  An explanation and understanding of the goals, advantages, requirements, and the generally accepted standards for becoming successful employees.
WORK EXPERIENCE	8769.02	† (JR. HIGH)—THE LAW AND THE WORLD OF WORK  Acquaints students with the laws related to employment, the wide variety of occupations available to them upon completion of certain requirements, and the general characteristics of desirable employees.
WORK EXPERIENCE	8769.03	† (JR. HIGH)—EMPLOYER-EMPLOYEE RELATIONSHIPS  Designed to make students aware of those things necessary for developing good employer-employee relationships, as well as the need for growth and development on the job.
WORK EXPERIENCE	8769.04	(JR. HIGH)—MONEY MANAGEMENT AND SOCIAL INVOLVEMENT  Focuses on making the students aware of the need for personal social involvements, the need for self-appraisal, and the importance of wise money management.
WORK EXPERIENCE	8769.05 (optional)	† (JR. HIGH)—A CAREER CHOICE FOR THE INDIVIDUAL STUDENT  A choice of one of the many vocational programs offered in Dade County would be made during this quinmester. Plans are worked out with the teacher-coordinator.

AREA	ACCR. NO. FLA-DADE	COURSE TITLE AND DESCRIPTION
WORK EXPERIENCE (SENIOR HIGH)		
WORK EXPERIENCE	8769.06	<p>† (SR. HIGH)-INTRODUCTION TO THE SENIOR HIGH WORK EXPERIENCE PROGRAM</p> <p>Provides an opportunity for students at the senior high school level to become oriented to the specifics required for immediate employment. The instruction received should aid the students in making personal and social adjustments to school and society.</p>
WORK EXPERIENCE	8769.07	<p>† (SR. HIGH)-YOU AND YOUR OCCUPATION</p> <p>Acquaints students with the various career and occupational opportunities available to them and the requirements necessary for becoming a desirable employee.</p>
WORK EXPERIENCE	8769.08	<p>† (SR. HIGH)-GETTING YOUR MONEY'S WORTH</p> <p>Provides opportunity for practical application of the principles of wise money management and for gaining knowledge of the American economic system.</p>
WORK EXPERIENCE	8769.09	<p>(SR. HIGH)-OUTLOOK FOR THE FUTURE</p> <p>Designed to help students improve self concepts, set goals for the future, and acquaint them with various avenues for advancement or promotion their present jobs. It serves as a vehicle for exploring future occupational choices.</p>
WORK EXPERIENCE	8769.10	<p>(SR. HIGH)-OCCUPATIONAL EXPLORATIONS</p> <p>Serves as a pre-employment period designed to acquaint students with the myriad of occupations included in the world of work. Students observe employers on the job or undertake different work activities in order to increase their understanding of various occupations. Students have the opportunity to enroll in courses that can increase their skills and abilities so that they may be better qualified for the world of work.</p>

## INDUSTRIAL ARTS K-12

A primary purpose of American education is to prepare youth to function effectively in society. The culture of the American and international scene is heavily influenced by industrial technology and the products and environments accruing from them. It is, therefore, essential that educational programs purposefully portray realism and examine the elements which produce and maintain our man-made world. Industry is defined as the element of the economic institution which substantially changes the form of materials to satisfy human wants for material goods and services. Industrial technology is defined as those efficient and effective management, production, and personnel practices employed to change the forms of materials.

Industrial arts is the study of our man-made world, of industry and industrial technology. Industrial arts courses are offered at the elementary, and junior and senior high school levels. Through these various programs of industrial arts, the student will obtain knowledge, appreciation, and abilities for living and becoming a contributing member in our technological society.

Quinmester courses of study possessing two or more numbers are of such a nature that it may be impossible for a student to complete his or her intended experiences in one nine-week period of time. The additional higher number(s) permit the student to continue in the particular unit of study to complete or gain more in-depth experiences.

**INDUSTRIAL ARTS**  
**DRAFTING (SENIOR HIGH)**

448

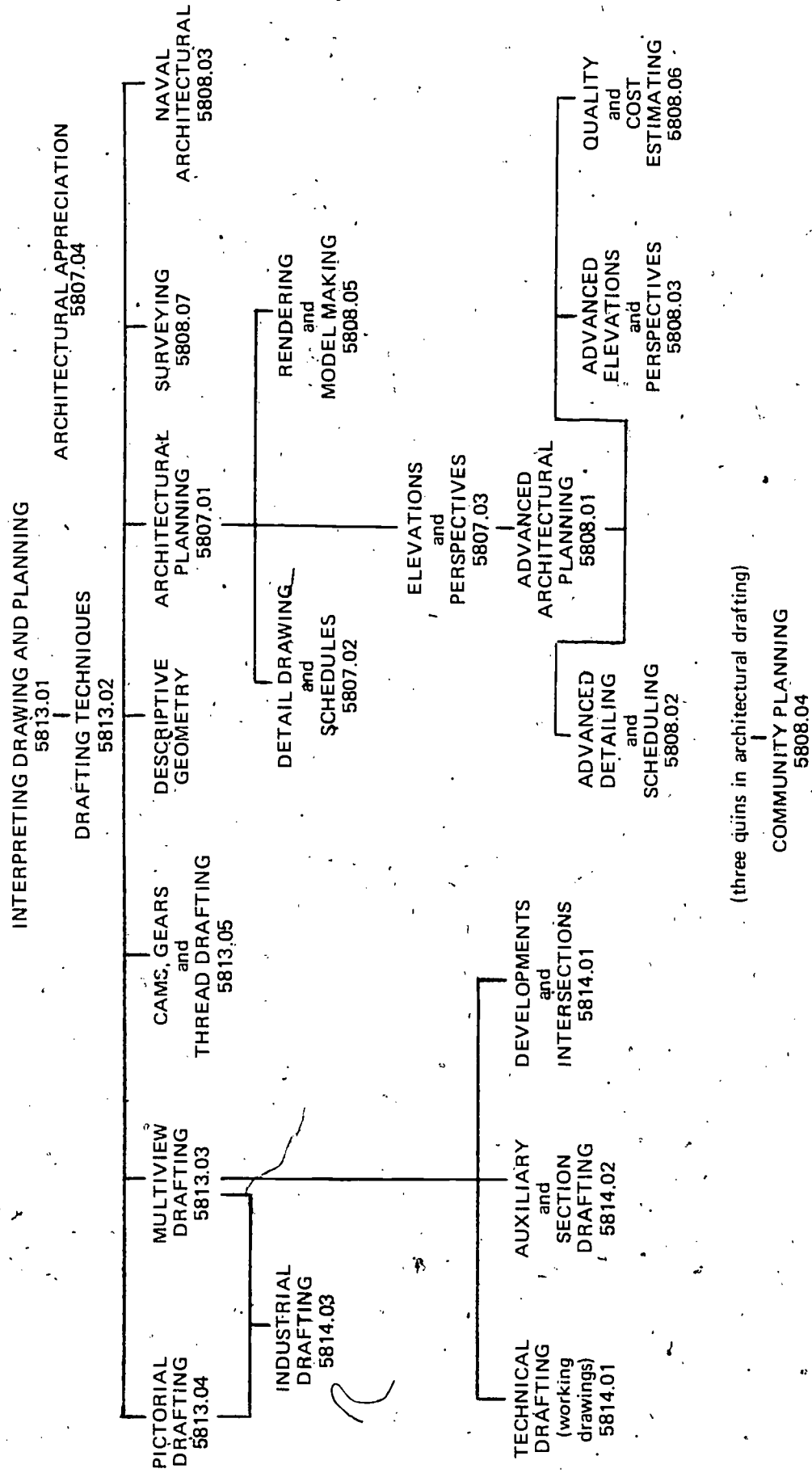

INDUSTRIAL ARTS  
ELECTRICITY (JUNIOR HIGH)

FUNDAMENTALS OF  
ELECTRICITY AND ELECTRONICS

5822.01  
5823.01  
(Science)  
5311.51  
5312.51  
5313.51

ELECTRICITY AS  
WE USE IT

5822.02  
5823.02

AMATEUR

(HAM)  
RADIO  
5822.04  
5829.03  
(Science)  
5311.50  
5312.50  
5313.50

ELECTRO MECHANICS

5823.04  
(Trade and Ind. Ed.)  
9323.05

ELECTRONICS  
IN ACTION

5822.03  
5827.01  
(Science)  
5311.49  
5312.49  
5313.49

ALTERNATING  
CURRENT FUNDAMENTALS

5823.03  
(Trade and Ind. Ed.)  
9323.02

VOCATIONAL EDUCATION  
INDUSTRIAL ARTS

449

435



**INDUSTRIAL ARTS**  
**ELECTRICITY (SENIOR HIGH)**

FUNDAMENTALS OF  
ELECTRICITY AND ELECTRONICS  
5322.01  
5823.01

ELECTRICITY AS WE USE IT  
5822.02  
5823.02

ELECTRONICS  
IN ACTION  
5822.03  
5827.01

ELECTRONIC LOGIC  
5829.01

ELECTRO MECHANICS  
5823.04

ALTERNATING CURRENT  
FUNDAMENTALS  
5828.CJ  
(Trade and Ind. Ed.)  
(9323.02)

VACUUM TUBE  
5827.02

TRANSISTORS  
5827.03

ELECTRONIC GADGETRY  
5828.01

ELECTRONIC TEST  
EQUIPMENT  
5828.02

ADVANCED  
SEMI CONDUCTORS  
5828.03

VOCATIONAL EDUCATION  
INDUSTRIAL ARTS  
450

INDUSTRIAL ARTS  
GRAPHIC ARTS (SENIOR HIGH)

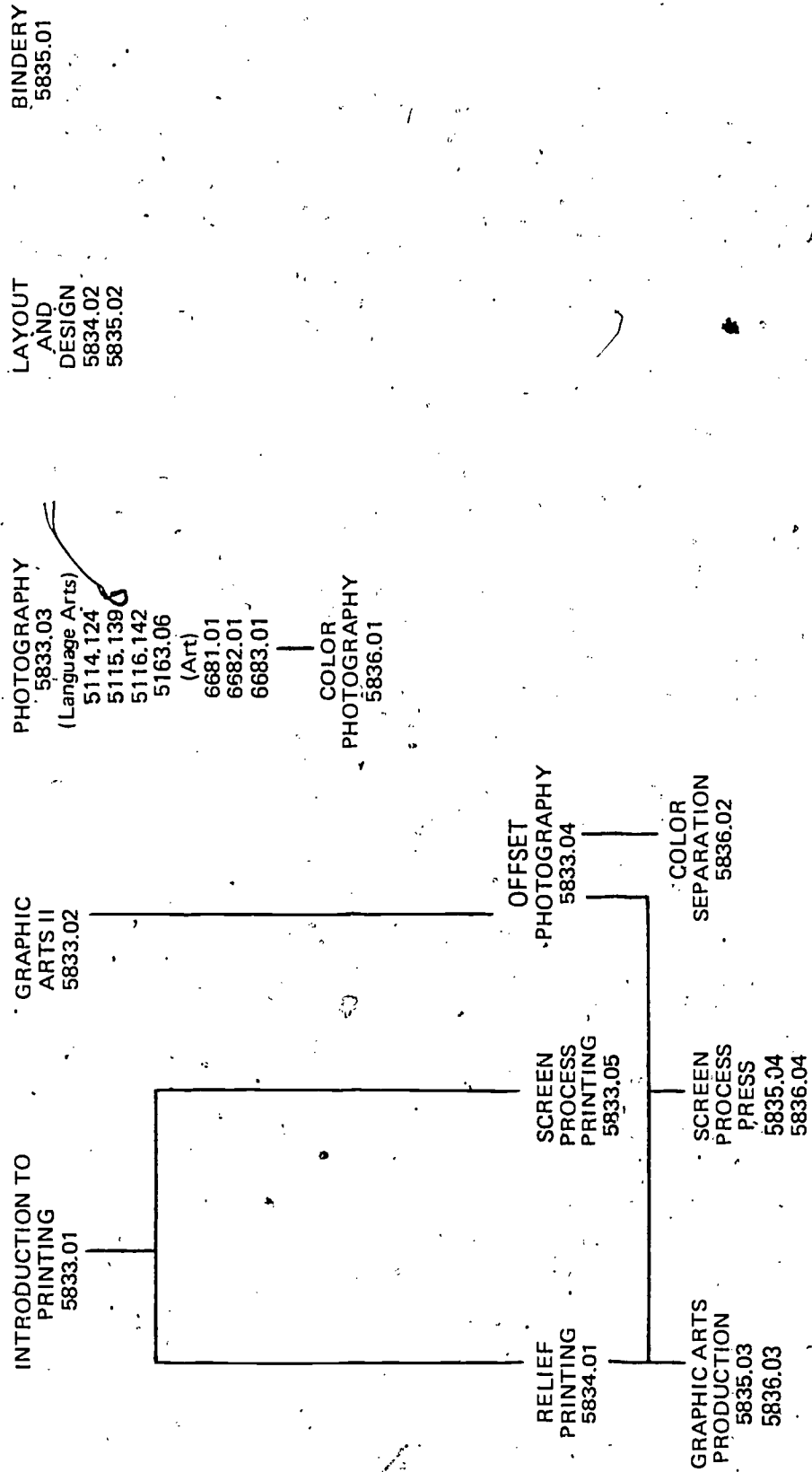

INDUSTRIAL ARTS  
GRAPHIC COMMUNICATIONS (JUNIOR HIGH)

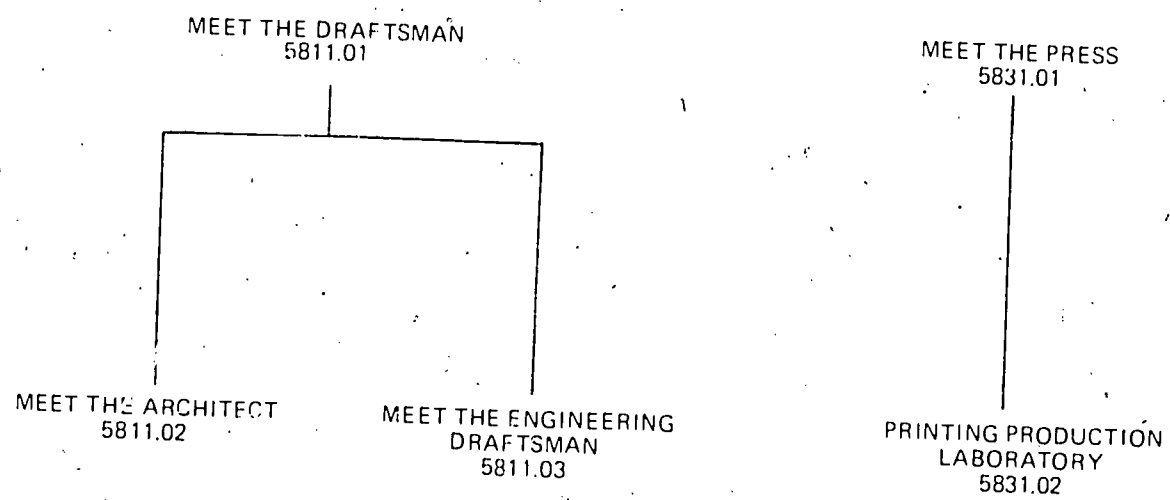

MEET THE GRAPHIC DESIGNER  
5832.01

MEET THE PHOTOGRAPHER  
5832.02

VOCATIONAL EDUCATION  
INDUSTRIAL ARTS  
452

INDUSTRIAL ARTS  
METALS (SENIOR HIGH)

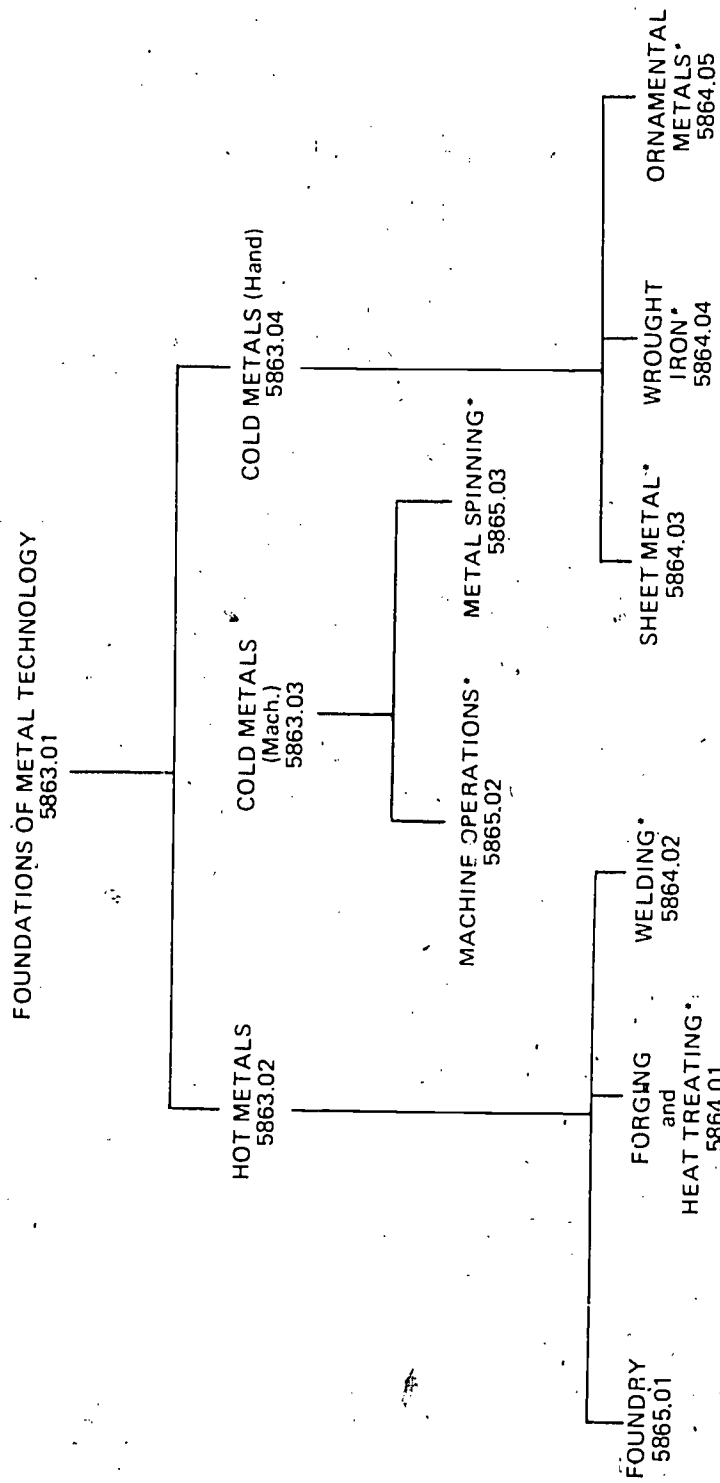

\*Under development.

INDUSTRIAL ARTS  
WOODS (SENIOR HIGH)

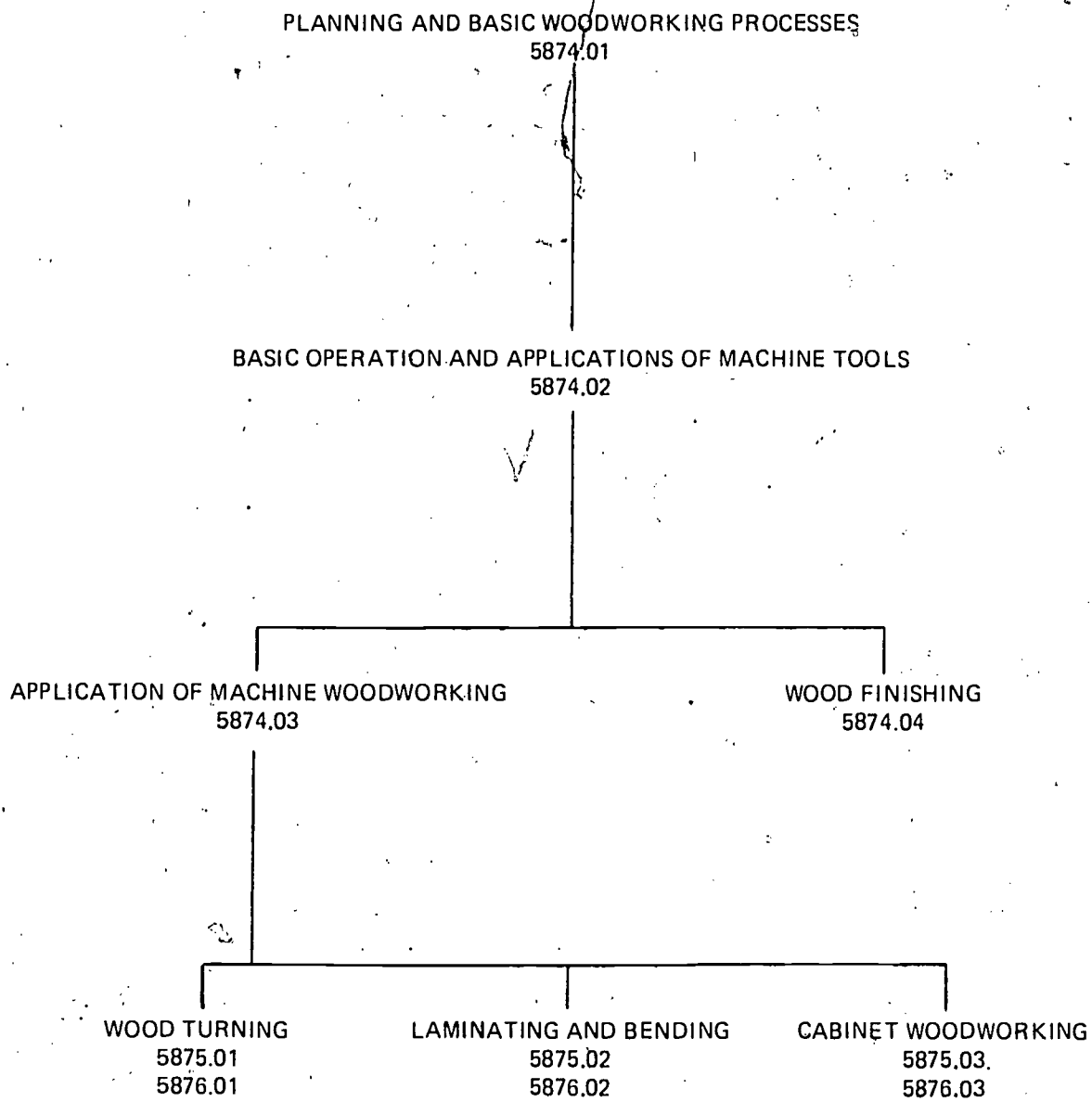

VOCATIONAL EDUCATION  
INDUSTRIAL ARTS  
454

440

AREA	ACCR. NO. FLA-DADE	COURSE TITLE AND DESCRIPTION
CONSTRUCTION 8	5857.01	<p>† MANAGING CONSTRUCTION</p> <p>Provides the student with a learning situation covering the building industry. The student will develop skills through simulated construction techniques, i.e., selecting a site, surveying, developing drawings, and career progression in the construction industry.</p>
CONSTRUCTION 8	5857.02	<p>† WORKING AS A CONTRACTOR</p> <p>Relates in depth to a contractor's operation in the building of various projects: roads, bridges, dams, and various buildings—from clearing the site to locating the structure; moving the earth; stabilizing earth and structures; classifying structures; mixing, placing, and finishing concrete; erecting steel frames; erecting concrete frames; building wood frames in a half scale wall section to culminate this sequence.</p>
CONSTRUCTION 8	5857.03	<p>THE BUILDING TRADES AT WORK</p> <p>Focuses on that part of the construction industry dealing with building techniques used in completing the structures; installing ventilating, plumbing, and electrical systems; enclosing exterior walls; insulating; applying wall material, ceiling materials, and floor materials; painting; decoration; completing the site; transferring of the project; and servicing the property.</p> <p>The student, prior to entry in this course of study, will be able to display mastery in Working as a Contractor 5857.02.</p>
CONSTRUCTION 8	5857.04	CONSTRUCTION PLANNING
HOME AND FAMILY ED.	6764.04	<p>Focuses on the methods of planning for a project. The student will go through the steps which are the responsibility of the owner, architect, and city planners when planning a house or a complete city. Involves financing and contracting, planning the living space, preparing the drawings, building a complete scale model of the house designed with landscaping, the developing of a city and regional planning chart covering a fifty-year period.</p>

VOCATIONAL EDUCATION  
INDUSTRIAL ARTS  
455

AREA	ACCR. NO. FLA-DADE	COURSE TITLE AND DESCRIPTION
CONSTRUCTION 1	5858.01	<p><b>WORKING AS AN ELECTRICIAN</b></p> <p>A realistic study of the duties performed by the electrician. The student studies the basics of electricity through the history, production, transmission, usage, and safety of it. The basics needed to wire a house from reading and making electrical drawings, wire size, parts of the systems, wiring combinations to the actual installation of electrical system from pole to switch.</p>
CONSTRUCTION 1	5858.02	<p><b>WORKING AS A PLUMBER</b></p> <p>Involves the student in the practice of plumbing and will refer to the various systems of pipes and tubes that carry liquids or gases from a source to a building, as well as sewage systems. The students will participate in activities of installation and servicing, the care and upkeep of plumbing, safe practices, and code regulations.</p>
CONSTRUCTION 1 MATH	5858.03 5299.27	<p><b>SURVEYING MATHEMATICS</b></p> <p>An introduction to the mathematics needed in surveying. Includes historical background, use of transit, scale drawing, and application of elementary trigonometry.</p>
DRAFTING	5813.01	<p><b>† INTERPRETING DRAWING AND PLANNING</b></p> <p>Interpretation of all types of drawing from the simple sketch to the complicated drawing in the mechanical, architectural, and engineering areas. The student will learn to make sketches of objects and dimension the same. He will learn to make a bill of materials and do a cost analysis of objects such as those constructed in school or home shops. Elementary architectural drawing procedures will be learned. Construction procedures of small objects and buildings will be explored.</p>

AREA	ACCR. NO. FLA-DADE	COURSE TITLE AND DESCRIPTION
DRAFTING	5813.02	<p><b>DRAFTING TECHNIQUES</b></p> <p>Covers the basic techniques of drafting and the use of tools and equipment used in drafting. The scope and uses of drafting will be explored. The student will learn the use of basic line values, lettering, and the use of drafting tools and equipment, including basic drafting tools, templates, underlays, reproduction equipment, etc. The use of the basic drafting symbols in architectural, mechanical, electronic, and marine drafting will be learned. The field of computer drafting will be explored. The basic techniques of sketching will be performed.</p> <p>The student, prior to entry into this course of study, will display mastery of the skills indicated in interpreting Drawing and Planning 5813.01.</p>
DRAFTING	5813.03	<p><b>MULTIVIEW DRAFTING</b></p> <p>Focuses on orthographic projection (multiview drawing), dimensions (size description), and geometric construction. Emphasis on line quality and accuracy of work will be stressed. The use of drafting as a universal language will be explored. The student should produce a series of his drawings to quality comparison.</p> <p>The student, prior to entry into this course of study, will display mastery of the skills indicated in Drafting Techniques 5813.02.</p>
DRAFTING	5813.04	<p><b>PICTORIAL DRAFTING</b></p> <p>The processes of isometric, oblique, and perspective drawing through sketching and instrument drawings. Various shading techniques and pencil renderings will be stressed. Perspective drawing will be limited to one and two point. The use of illustrations should be stressed.</p> <p>The student, prior to entry into this course of study, will display mastery of the skills indicated in Drafting Techniques 5813.02.</p>



AREA	ACCR. NO. FLA-DADE	COURSE TITLE AND DESCRIPTION
DRAFTING	5813.05	CAMs, GEARS, AND THREAD DRAFTING  Basic fundamentals of designing and drafting cams, gears, and threads. A study of the development of these will be made through student research and reports. The use of technical tables and fits and tolerances will be stressed.  The student, prior to entry into this course of study, will display mastery of the skills indicated in Drafting Techniques 5813.02.
DRAFTING, ARCHITECT'L HOME AND FAMILY ED.	5807.01	ARCHITECTURAL PLANNING  Includes the design and drawing of a floor plan, foundation, and necessary wall sections of a single family residence. The logical relationship of the arrangement of living areas will be emphasized. Exterior designs will be studied in relationship to the natural surrounding and community. Material used in construction will be studied.  The student, prior to entry into this course of study, will display mastery of the skills indicated in Drafting Techniques 5813.02.
DRAFTING, ARCHITECT'L	5807.02	DETAIL DRAWING AND SCHEDULES  Includes the design and drawing of window details, bath elevations, kitchen elevations, built-ins, fireplaces, closet detailing, structural detailing other than wall sections. Mechanical lettering and other special details will be emphasized.  The student, prior to entry into this course of study, will display mastery of the skills indicated in Architectural Planning 5807.01.
DRAFTING, ARCHITECT'L	5807.03	ELEVATIONS AND PERSPECTIVES  The study of the styles of architecture, roof designs, types of wall construction and exterior treatments and materials used. The designing and drawing of the necessary elevations and plot plan for the floor plan designed in grid structural elements will be completed. A study of locating the house on the property in order to obtain the best aesthetic and functional values will be made. A plot plan will be drawn and a perspective of the house will be drawn.  The student, prior to entry into this course of study, will display mastery of the skills indicated in Architectural Planning 5807.01.

VOCATIONAL EDUCATION  
INDUSTRIAL ARTS  
458

441

AREA	ACCR. NO. FLA-DADE	COURSE TITLE AND DESCRIPTION
DRAFTING, ARCHITECT'L HOME AND FAMILY ED.	5807.04 6764.06	ARCHITECTURAL APPRECIATION DESIGN  A study of the history and development of architecture developed through the cultures of the world, utilization of space to meet family needs, design of single family residences, new building techniques, and local building codes.
DRAFTING, ARCHITECT'L	5808.01	ADVANCED ARCHITECTURAL PLANNING  Includes advanced design in floor plans, wall structures, and foundations. Design and study will be limited to large and unusual residence and commercial buildings.  The student, prior to entry into this course of study, will display mastery of the skills indicated in Elevations and Perspectives 5807.03.
DRAFTING, ARCHITECT'L	5808.02	ADVANCED DETAILING AND SCHEDULING  This is the equivalent of a part of the second year in architectural drawing. The course involves some of the principles and activities in Advanced Elevations and Perspective, and Advanced Architectural Planning, with major emphasis on detailing and scheduling at an advanced level.  The student, prior to entry into this course of study, will display mastery of the skills indicated in Advanced Architectural Planning 5808.01.
DRAFTING, ARCHITECT'L	5808.03	ADVANCED ELEVATIONS AND PERSPECTIVE  This is the equivalent of a part of the second year in architectural drawing. The course involves some of the principles and activities in Advanced Architectural Planning, and Advanced Detailing and Scheduling, with major emphasis on elevations and perspective at an advanced level.  The student, prior to entry into this course of study, will display mastery of the skills indicated in Advanced Architectural Planning 5808.01.

VOCATIONAL EDUCATION  
INDUSTRIAL ARTS  
459

AREA	ACCR. NO. FLA-DADE	COURSE TITLE AND DESCRIPTION
DRAFTING, ARCHITEC'L	5808.04	<p>COMMUNITY PLANNING</p> <p>A study development of plans for a small community which will include residential and commercial building.</p> <p>The student, prior to entry into this course of study, will display mastery of the skills indicated in Elevations and Perspectives 5807.03.</p>
DRAFTING, ARCHITEC'L	5808.05	<p>RENDERING AND MODEL MAKING</p> <p>This quin includes work in the principles of color rendering and the building of architectural models.</p> <p>The student, prior to entry into this course of study, will display mastery of the skills indicated in Architectural Planning 5807.01.</p>
DRAFTING, ARCHITEC'L	5808.06	<p>QUALITY AND COST ESTIMATING</p> <p>A study of building specifications, estimating quantities of materials, and cost analysis. Manufacturing specifications such as Sweet's Construction Catalogue will be studied. How to write specifications will be included.</p>
DRAFTING, ARCHITEC'L	5808.07	<p>SURVEYING</p> <p>Includes plot planning, sight planning, and elementary surveying techniques.</p> <p>The student, prior to entry into this course of study, will display mastery of skills indicated in Drafting Techniques 5813.02.</p>
DRAFTING, NAVAL	5808.08	<p>NAVAL ARCHITECTURE</p> <p>An introduction to boat design, drafting techniques, and lofting.</p> <p>The student, prior to entry into this course of study, will display mastery of skills indicated in Drafting Techniques 5813.02.</p>

VOCATIONAL EDUCATION  
INDUSTRIAL ARTS  
460

AREA	ACCR. NO. FLA-DADE	COURSE TITLE AND DESCRIPTION
DRAFTING, TECHNICAL	5814.01	<p data-bbox="737 447 1312 478"><b>TECHNICAL DRAFTING (working drawings)</b></p> <p data-bbox="737 509 1471 628">An advancement of multiview drawings. The student will learn the purpose and processes involved in multiview-view (assembly) drawings, exploded views, parts lists, and parts descriptions.</p> <p data-bbox="737 659 1471 747">The student, prior to entry into this course of study, will display mastery of the skills indicated in Multiview Drafting 5813.03.</p>
DRAFTING, TECHNICAL	5814.02	<p data-bbox="737 811 1271 842"><b>AUXILIARY AND SECTION DRAFTING</b></p> <p data-bbox="737 873 1471 992">The use and process of the development of auxiliary views and section views as related to multiview and isometric drafting. Full and partial auxiliary will be developed. A full range of section views will be developed.</p> <p data-bbox="737 1023 1471 1111">The student, prior to entry into this course of study, will display mastery of the skills indicated in Multiview Drafting 5813.03.</p>
DRAFTING, TECHNICAL	5814.03	<p data-bbox="702 1175 1160 1206">† <b>INDUSTRIAL ILLUSTRATIONS</b></p> <p data-bbox="737 1237 1471 1380">Advanced techniques in pictorial illustrations, including cutaways, exploded pictorials, assembly pictorials, air brush techniques, color work, etc. Emphasis will be placed on the use of the illustrations in conjunction with written copy.</p> <p data-bbox="737 1411 1471 1501">The student, prior to entry into this course of study, will display mastery of the skills indicated in Pictorial Drafting 5813.04.</p>
DRAFTING, TECHNICAL	5814.04	<p data-bbox="737 1566 1266 1596"><b>DEVELOPMENT AND INTERSECTIONS</b></p> <p data-bbox="737 1627 1471 1715">Includes the fundamentals of sheet metal layout; development of cones, cylinders, and rectangular solids; intersections of cones, cylinders, and rectangles.</p> <p data-bbox="737 1746 1471 1834">The student, prior to entry into this course of study, will display mastery of the skills indicated in Multiview Drafting 5813.03.</p>

AREA	ACCR. NO. FLA-DADE	COURSE TITLE AND DESCRIPTION
DRAFTING, TECHNICAL	5816.01	<p>† DESCRIPTIVE GEOMETRY</p> <p>A course in logical reasoning which develops ability to draw and interpret the movement of a point, line, and a plane in space. Includes points, lines, plane surfaces, revolutions, polyhedrons, and single curved surfaces and simple intersections of surfaces.</p> <p>The student, prior to entry into this course of study, will display the skills indicated in Drafting Techniques 5813.02 and Analytic Geometry 5295.23.</p>
ELECTRICITY SCIENCE	5822.01 5823.01 5311.51 5312.51 5313.51	<p>† FUNDAMENTALS OF ELECTRICITY AND ELECTRONICS</p> <p>Provides an exploratory experience in the field of electricity and electronics. The student will be able to answer the following: What is electricity? How is electricity produced? How is electricity distributed? How is electricity used?</p>
TRADE AND INDUSTRIAL EDUCATION	9023.02 9323.01 9783.01	
ELECTRICITY	5822.02 5823.02	<p>† ELECTRICITY AS WE USE IT</p> <p>An activity-oriented course of study in basic house wiring and basic electro-magnetic devices. This will include safety and the applicable tools.</p>
ELECTRICITY TRADE AND INDUSTRIAL EDUCATION	5823.03 9323.02 9783.02	<p>ALTERNATING CURRENT FUNDAMENTALS</p> <p>Provides experimentation in and experiences with wave generation, R/C, L/C, phase relationships, and AC measurements. Students will receive practical application through the design and construction of a power supply unit.</p> <p>The student will be able to display mastery of the skills and fundamentals indicated in Electronics in Action prior to entry into this course of study.</p>

VOCATIONAL EDUCATION  
INDUSTRIAL ARTS  
462

AREA	ACCR. NO. FLA-DADE	COURSE TITLE AND DESCRIPTION
ELECTRICITY TRADE AND INDUSTRIAL EDUCATION	5823.04 9323.05	<p><b>ELECTRO MECHANICS</b></p> <p>A study of rotating electrical devices (motors, generators, alternators) and their control circuitry. Some emphasis will be placed on consumer products, with heavy emphasis on the associated controlling devices.</p> <p>The student will be able to display mastery of the fundamentals and skills indicated in Fundamentals of Electricity and Electronics 5822.01 and Electricity As We Use It 5822.02 prior to entry into this course of study.</p>
ELECTRONICS SCIENCE	5822.03 5827.01 5311.49 5312.49 5313.49	<p><b>ELECTRONICS IN ACTION</b></p> <p>An exposure to basic electronic components, their theory, identification, and use. This course of study will also develop an ability to understand and use schematics, chassis layout/construction, and wiring procedures.</p> <p>The student will be able to display mastery of the fundamentals and skills indicated in Fundamentals of Electricity and Electronics 5822.01 prior to entry into this course of study.</p>
ELECTRONICS SCIENCE	5822.04 5829.03 5311.50 5312.50 5313.50	<p><b>AMATEUR (HAM) RADIO</b></p> <p>Prepares the student for his F.C.C. examination for an amateur radio license by acquainting him with equipment and techniques necessary in the field of amateur communications.</p>
ELECTRONICS	5827.02	<p><b>VACUUM TUBE</b></p> <p>A course of study designed to give an in-depth study of the principles, theory, and application of vacuum tubes to amplifiers (R F, I F, and A F) and oscillators.</p> <p>The student, prior to entry into this course of study, will be able to display mastery of the skills indicated in Alternating Current Fundamentals 5823.03.)</p>

VOCATIONAL EDUCATION  
INDUSTRIAL ARTS  
463

AREA	ACCR. NO. FLA-DADE	COURSE TITLE AND DESCRIPTION
ELECTRONICS TRADE AND INDUSTRIAL EDUCATION	5827.03 9323.03 9783.03	<p><b>TRANSISTORS</b></p> <p>A study of the principles, theory, and application of transistors to amplifiers (R F, I F, and A F) and oscillators; an introduction to an experimentation with printed circuit techniques.</p> <p>The student, prior to entry into this course of study, will be able to display mastery of the skills indicated in Vacuum Tube 5827.02.</p>
ELECTRONICS	5828.01	<p><b>ELECTRONIC GADGETRY</b></p> <p>A course of study to relate components and circuits previously studied; to complete devices; to include, but not limited to, radios, televisions, stereos, transmitters, and devices such as burglar alarms, garage door openers, metal locators, etc.</p> <p>The student, prior to entry into this course of study, will be able to display mastery of the skills indicated in Transistors 5827.03.</p>
ELECTRONICS	5828.02	<p><b>ELECTRONIC TEST EQUIPMENT</b></p> <p>An activity oriented course of study to include the design, repair, and use of electronic test equipment (i.e., VOM, VTVM, AF and RF, generators, regulators, and variable power supplies.)</p> <p>The student, prior to entry into this course of study, will be able to display mastery of the skills indicated in Transistors 5827.03.</p>
ELECTRONICS	5828.03	<p><b>ADVANCED SEMI CONDUCTORS</b></p> <p>A course of study devoted to the principles of operation, application, and manufacturing of semiconductor devices.</p> <p>The student, prior to entry into this course of study, will be able to display mastery of the skills indicated in Transistors 5827.03.</p>

VOCATIONAL EDUCATION  
INDUSTRIAL ARTS  
464

AREA	ACCR. NO. FLA-DADE	COURSE TITLE AND DESCRIPTION
ELECTRONICS	5829.01	<p><b>ELECTRONIC LOGIC</b></p> <p>A course of study covering the math concepts of binary numbers and the logic circuitry dealing with control and computing devices.</p> <p>The student, prior to entry into this course of study, will be able to display mastery of the skills indicated in Fundamentals of Electricity and Electronics 5823.01 and Algebra 1d (Math 5215.24).</p>
ELECTRONICS	5829.02	<p><b>PLANNING AND DESIGN OF ELECTRONIC HOME ENTERTAINMENT CENTERS</b></p> <p>Construction-oriented course of study dealing with the basic operation, specifications, and use of home entertainment equipment.</p>
GENERAL INDUSTRIAL ARTS	5803.01	<p>† <b>USE AND CARE OF HAND TOOLS</b></p> <p>Teaches safe use and proper care of basic hand and power hand tools in woods and metals work. Two selected projects, using hand tools in construction of a wood and metal project, are required. These projects should come from the variety selected to accomplish the purposes.</p> <p>The student will be able to display mastery of the skills indicated in Planning Procedures for General Industrial Arts 5862.01 or 5872.01 prior to entry in this course of study.</p>
GENERAL INDUSTRIAL ARTS	5803.02	<p><b>BE AN OPERATOR (of woodworking machines)</b></p> <p>Method and practice in operation of woodworking machines to accomplish a specific purpose, including safe operation of machines, selection of materials, construction of and finishing a project.</p> <p>The student will be able to display mastery of the skills indicated in Use and Care of Hand Tools 5803.01 prior to entry in this course of study.</p>

VOCATIONAL EDUCATION  
INDUSTRIAL ARTS  
465

451



AREA	ACCR. NO. FLA-DADE	COURSE TITLE AND DESCRIPTION
GENERAL INDUSTRIAL ARTS	5803.03	ADVENTURE IN WELDING  Use of arc and gas welding equipment, including running of beads; all position welds; cutting and brazing of common metals, including cast iron; joining of wrought iron by use of rivets and welding; the properties, application, and use of common metals. All phases of soldering and spot welding of sheet metal are covered.
GENERAL INDUSTRIAL ARTS	5803.04	† EXPERIENCE IN SHEET METAL WORK  Explores all metal working machines and equipment in the shop; includes safe operations peculiar to particular machines, properties of common metals, application and use of common metals, soldering, riveting, and spot welding of metals.
GENERAL INDUSTRIAL ARTS	5803.05	PLASTICS  This course in plastics provides basic instruction in fabricating the type of plastics best suited for making of projects in the school shop and home workshop, the acrylics. It describes cutting, sanding, polishing, heat forming, casting, and machining procedures. It supplies constructional details on a variety of attractive craft projects. This course is intended also to acquaint the student with the use of plastics in industry. It describes the principal commercially available families of plastics and some of the major areas of application.
GENERAL INDUSTRIAL ARTS	5803.06	CERAMICS  This course of study will acquaint the student with many terms, tools, and procedures used in ceramics. In exploring the area of ceramics, the student will find that many of the procedures used in class work are duplicated on a larger scale by industrial processes.
GENERAL INDUSTRIAL ARTS	5803.07	LEATHERCRAFT  This course in leathercraft will acquaint the student with the tools, terms, and procedures of carving and stamping leather. Leathercraft will help the student to develop safe work habits; it will assist him in designing and creating his own projects.  In exploring the industrial areas, the student may find that the work interests him to the extent that he may wish to pursue it as his future livelihood or as a hobby.
VOCATIONAL EDUCATION INDUSTRIAL ARTS	466	

AREA	ACCR. NO. FLA-DADE	COURSE TITLE AND DESCRIPTION
GENERAL INDUSTRIAL ARTS	5803.08	ART METALS  This is an exploratory course. It provides manipulative experiences that will develop basic skills in the use of hand tools. It provides students with an opportunity to become familiar with various metals and to develop an appreciation of safe practices in metal work and an understanding of how raw materials are converted into finished products.
GENERAL INDUSTRIAL ARTS	5804.01	† INTELLIGENT BUYER AND REPAIRER FOR GREEN ACRES
HOME AND FAMILY ED.	6765.04	Experiences in making a variety of general home repairs, including repair of small appliances, plumbing repairs, painting simple wood products, patch plastering, etc.; consumer information concerning estimating and buying home materials and furnishings; when <i>not</i> to attempt a repair, as well as when to go ahead with a repair.
GRAPHIC ARTS	5833.01	† INTRODUCTION TO PRINTING  An exploratory experience in the area of letter press, rubber stamp making, hot stamp, bindery, and screen process printing.
GRAPHIC ARTS	5833.02	GRAPHIC ARTS
TRADE AND INDUSTRIAL EDUCATION	9573.02	Provides an exploratory experience in offset printing, photography, design and layout, paper selection, and cutting.
GRAPHIC ARTS	5833.03	† PRINCIPLES OF PHOTOGRAPHY
ART	6681.24 6682.24 6693.17	Trains student in basic procedures needed to take, develop, and print black-and-white pictures. The principles of the camera and lenses, theories of light as needed for photographers, darkroom developing and fixing of film, contact printing and enlarging, type of filters and papers, and the history of photography will be covered. Recommended for hobby photographers and publication staff photographers.
LANGUAGE ARTS	5114.124	
	5115.139	
	5116.142 5163.06	

AREA	ACCR. NO. FLA-DADE	COURSE TITLE AND DESCRIPTION
GRAPHIC ARTS	5833.04	<p>† OFFSET PHOTOGRAPHY</p> <p>A study of line copy and halftone process photography, process camera operation, camera technology, and plate making.</p> <p>The student, prior to entry into this course of study, will be able to display mastery of the skills indicated in Graphic Arts 5833.02.</p>
GRAPHIC ARTS	5833.05	<p>SCREEN PROCESS PRINTING</p> <p>A study of the fundamentals of screen process printing, multicolor operation, stencils, and photographic stencils.</p> <p>The student, prior to entry into this course of study, will be able to display mastery of the skills indicated in Introduction to Printing 5833.01.</p>
GRAPHIC ARTS TRADE AND INDUSTRIAL EDUCATION	5834.02 5835.02 9753.04	<p>LAYOUT AND DESIGN</p> <p>The fundamentals of design related to printed materials, layout, and paste-up. The designs created will not be limited to any one printing process, with the exception that only cold processes are used.</p>
GRAPHIC ARTS	5834.01	<p>† RELIEF PRINTING</p> <p>A study including hand composition, imposing, presswork, embossing, and proofing. Related materials as needed for a well-rounded program will be included.</p> <p>The student, prior to entry into this course of study, will be able to display mastery in the skills indicated in Offset Photography 5833.04.</p>
GRAPHIC ARTS TRADE AND INDUSTRIAL EDUCATION	5835.01 9753.03	<p>† BINDERY</p> <p>A study including pad making, bookbinding, plastic binding, cutting, drilling, jogging, types of materials and equipment, and related information.</p>

VOCATIONAL EDUCATION  
INDUSTRIAL ARTS  
468

AREA	ACCR. NO. FLA-DADE	COURSE TITLE AND DESCRIPTION
GRAPHIC ARTS	5835.03 5836.03	<p><b>GRAPHIC ARTS PRODUCTION</b></p> <p>Designed to give the student advanced experience in production work, including offset press work, paper selection and handling, billing, paper cutting, padding, bookbinding, and related printing activities.</p> <p>The student, prior to entry into this course of study, will be able to display mastery in the skills indicated in Offset Photography 5833.04 and Relief Printing 5834.01.</p>
GRAPHIC ARTS	5836.01	<p><b>COLOR PHOTOGRAPHY</b></p> <p>Study includes taking and developing continuous tone color; developing negatives, slides; and printing color pictures.</p> <p>The student, prior to entry into this course of study, will be able to display mastery in the skills indicated in Principles of Photography 5833.03.</p>
GRAPHIC ARTS	5836.02	<p><b>COLOR SEPARATION</b></p> <p>The basic process and information on color separation, (mechanical and photographic), camera work, stripping, plate making, and production.</p> <p>The student, prior to entry into this course of study, will be able to display mastery in the skills indicated in Offset Photography 5833.04.</p>
GRAPHIC ARTS	5835.04 5836.04	<p><b>SCREEN PROCESS PRESS</b></p> <p>The study of the development and techniques involved in the application of the automatic screen process presses employed in the industry.</p> <p>The student, prior to entry into this course of study, will be able to display mastery in the skills indicated in Screen Process Printing 5833.05 and Offset Photography 5833.04.</p>

AREA	ACCR. NO. FLA-DADE	COURSE TITLE AND DESCRIPTION
GRAPHIC COMMUNIC.	5811.01	<p>† MEET THE DRAFTSMAN</p> <p>Involves those operations used by a draftsman in the solving of basic problems in design, product planning, and engineering. Through the use of lettering, measuring, shape description, illustration, instrumentation, blueprint reading, and model making, the student will experience the skills and practices useful in the occupational world of the draftsman.</p>
GRAPHIC COMMUNIC.	5811.02	<p>† MEET THE ARCHITECT</p> <p>Focuses on the role of the architect in planning, designing, and solving basic architectural problems.</p> <p>Prior to entry, the student will display mastery of the skills indicated in Meet the Draftsman 5811.01.</p>
GRAPHIC COMMUNIC.	5811.03	<p>† MEET THE ENGINEERING DRAFTSMAN</p> <p>Involves the techniques and processes used by the engineering draftsman. Includes precision measurement, terminology, and specialized drafting instruments.</p> <p>The student, prior to entry in this course of study, will be able to display mastery of the skills indicated in Meet the Draftsman 5811.01.</p>
GRAPHIC COMMUNIC.	5831.01	<p>† MEET THE PRESS</p> <p>A study of the history and development of technology in printing and mass media communications. Included are printing methods in laboratory activities such as photography, composition, design, journalistic procedures, typesetting, plate making, and press work.</p>
GRAPHIC COMMUNIC.	5831.02	<p>† PRINTING PRODUCTION LABORATORY</p> <p>An opportunity for student to select independent study and research projects; includes relief printing, planographing, intaglio printing, and stencils.</p> <p>The student will be able to display mastery of skills indicated in Meet the Draftsman 5811.01.</p>

VOCATIONAL EDUCATION  
INDUSTRIAL ARTS  
470

AREA	ACCR. NO. FLA-DADE	COURSE TITLE AND DESCRIPTION
GRAPHIC COMMUNIC.	5832.01	† MEET THE GRAPHIC DESIGNER  The student will be involved with the processes of the graphic designer; the use of design elements and design medium; the role of the graphic designer in visual communication, advertising, and package design.
GRAPHIC COMMUNIC. LANGUAGE ARTS	5832.02 5111.14 5112.30 5113.138	† MEET THE PHOTOGRAPHER  A study of the application of photography, its mechanics and processes. The student will be involved with the taking of still and motion pictures, the processing of film, and the making of prints.
INDUSTRIAL TECH.	5893.01	† INDUSTRIAL FIELD TRIPS  Allows students to visit, observe, and draw inferences from various and related industrial facilities. Students will be made aware of various industries through the use of audio-visual materials, guest speakers, and applied research prior to the on-site study. As a follow-up, students will draw inferences through class analysis of what was observed.
INDUSTRIAL TECH.	5862.01 5872.01	PLANNING PROCEDURES FOR GENERAL INDUSTRIAL ARTS  Teaches the student to express and communicate ideas on paper. Consists of basic sketching, including dimensioning. Procedures for construction and computing costs of materials are covered.
MANUFAC- TURING 1	5867.01	† DESIGNING AND ENGINEERING THE PRODUCT  An introduction to manufacturing, with emphasis placed on designing and engineering regardless of manufactured product. The student is introduced to designing and engineering manufactured products and performs research and development activities as a base for further study. The student will become familiar with the designing process through the manipulatory activities of making sketches, drawings, and mockups. Engineering processes are covered through student activities of designing power elements, making working drawings, and building and testing the production prototype.

AREA	ACCR. NO. FLA-DADE	COURSE TITLE AND DESCRIPTION
MANUFACTURING 1	5867.02	<p>DESIGNING AND ENGINEERING THE PROCESS</p> <p>An introduction to manufacturing, with emphasis placed on the manufacturing process. The student is introduced to concepts of methods analysis, time and motion study, production control, and tooling. The student will become familiar with these concepts by actually performing simple operations.</p>
MANUFACTURING 1	5867.03	<p>† PRODUCTION PRACTICES</p> <p>An introduction to manufacturing, with emphasis placed on production practices regardless of product. The student is introduced to these practices through the manipulative activities: (1) <i>forming</i> by casting or molding, compressing and stretching, and conditioning; (2) <i>separating</i> by shearing, chip removal, and other methods; (3) <i>combining</i> by mechanical fastening, bonding, coating, and mixing.</p>
MANUFACTURING 1	5867.04	<p>† THE MASS PRODUCED PRODUCT</p> <p>An introduction to manufacturing with emphasis placed on the corporation and mass production. The student explores research and development, designing and engineering the product, designing and engineering the process; and studies production practices through the manipulative activities of actual production.</p>
METALS	5863.01	<p>† FOUNDATIONS OF METAL TECHNOLOGY</p> <p>Enables student to interpret various types of drawings, make a working drawing, and develop a plan of procedure, including the materials required, process indicated, and a cost analysis. Theory and practical experience in the use of layout tools and materials are emphasized.</p>
METALS	5863.02	<p>† HOT METALS</p> <p>Designed to give the student experiences and exploration into the areas of foundry, forging, heat treating, welding, and finishing.</p> <p>The student, prior to entry into this course of study, will be able to display mastery of the skills indicated in Foundations of Metal Technology 5863.01.</p>

VOCATIONAL EDUCATION  
INDUSTRIAL ARTS  
472

AREA	ACCR. NO. FLA-DADE	COURSE TITLE AND DESCRIPTION
METALS	5863.03	<p>† COLD METALS (MACHINE)</p> <p>Designed to give the student experiences and exploration into the areas of machine technology and spinning.</p> <p>The student, prior to entry into this course of study, will be able to display mastery of the skills indicated in Foundations of Metal Technology 5863.01.</p>
METALS	5863.04	<p>† COLD METALS (HAND)</p> <p>This course is designed to give the student experiences and exploration in the area of sheet metal, wrought iron, and art metal.</p> <p>The student, prior to entry into this course of study, will be able to display mastery in the skills indicated in Foundations of Metal Technology 5863.01.</p>
METALS	5865.01	<p>† FOUNDRY</p> <p>Provides experiences and exploration in the area of advanced pattern making, surface and machine finishing.</p> <p>The student, prior to entry into this course of study, will be able to display mastery in the skills indicated in Hot Metals 5863.02.</p>
PLASTICS	5882.01	<p>PLASTIC AND LAMINATES</p> <p>Forming, shaping, and machining of fiberglass and plastic laminates. Includes patching and repairing of metal panels by use of plastic, bonding of fiberglass to a variety of materials, and exploring the wide use of plastics and laminates used in the world today and tomorrow.</p> <p>The student will be able to display mastery of the skills indicated in Be an Operator 5803.02 prior to entry in this course of study.</p>



AREA	ACCR. NO. FLA-DADE	COURSE TITLE AND DESCRIPTION
WOODS	5874.01	<p>† PLANNING AND BASIC WOODWORKING PROCESSES</p> <p>Gives the student basic knowledge of the woodworking industry. Planning processes such as sketching, orthographic projection, and dimensioning as applied to project plans are covered. Project design includes the compiling of a bill of materials. Identification and use of basic woodworking hand tools and layout tools; plus a complete plan of procedure for an assigned task is prepared.</p>
WOODS	5874.02	<p>† BASIC OPERATION OF MACHINE TOOLS</p> <p>Designed to acquaint the student with the basic operation, safety measures, and proper application of power woodworking equipment through the project approach to learning.</p> <p>The student, prior to entry in this course of study, will display mastery of skills as indicated in Planning and Basic Woodworking Processes 5874.01.</p>
WOODS	5874.03	<p>APPLICATION OF MACHINE WOODWORKING</p> <p>Application of the basic concepts covered in 5874.02.</p> <p>The student, prior to entry in this course of study, will display mastery of the skills as indicated in Basic Operation of Machine Tools 5874.02.</p>
WOODS	5874.04	<p>WOOD FINISHING</p> <p>This course of study is designed to relate to the student the basic fundamentals of wood finishing by (1) brushing and/or (2) spraying all materials.</p>
WOODS	5875.01 5876.01	<p>WOOD TURNING</p> <p>This course will provide the student with an exploratory experience in the various methods of turning on the wood lathe. Spindle and faceplate turning are required experiences.</p> <p>The student, prior to entry into this course of study, will be able to display mastery of the skills indicated in Application of Machine Woodworking (5874.03).</p>

AREA	ACCR. NO. FLA-DADE	COURSE TITLE AND DESCRIPTION
WOODS	5875.02 5876.02	<p>LAMINATING AND BENDING</p> <p>This course will provide the student with experiences that are widely used in furniture manufacturing and construction.</p> <p>The student, prior to entry into this course of study, will be able to display mastery of the skills indicated in Application of Machine Woodworking (5874.03).</p>
WOODS	5875.03 5876.03	<p>CABINET WOODWORKING.</p> <p>Permits free choice of project. Cabinet work, use of all machines and tools, all items and devices necessary to complete projects within ability of students are included.</p> <p>The student will be able to display mastery of the skills indicated in Application of Machine Woodworking 5874.03 prior to entry into this course of study.</p>

## TECHNICAL AND HEALTH OCCUPATIONS

AREA	ACCR. NO. FLA-DADE	COURSE TITLE AND DESCRIPTION
HEALTH: HEALTH SERVICE AIDE (HSA)		
HSA	8007.01	<p>† MAINTAINING FITNESS IN AN AFFLUENT SOCIETY</p> <p>Includes the study of dangers of alcohol, smoking, drug abuse, obesity, and the problems of declining physical fitness in our present society. Good health habits and exercise will be included.</p>
HSA	8007.02	<p>FIRST AID: SAFETY AND SURVIVAL</p> <p>Includes safety, first aid, disaster and care of disaster patients. Common emergency procedures and medical self help will be included.</p>
HSA	8007.03	<p>HUMAN ECOLOGY AND THE HEALTH DANGERS</p> <p>Includes communicable disease, prevention of diseases, and the optimal environment (pure food, water, air, waste disposal methods, pesticides, radioactivity, and the effects the laws governing each one have on our lives).</p>
HSA	8007.04	<p>BASIC SKILLS FOR HEALTH OCCUPATIONS</p> <p>Development of selected skills common to many health occupations. Course will include fundamental and manipulative skills, such as those required of the nurse aide.</p>
HSA	8007.05	<p>† SURVEY OF THE HEALTH SERVICE FIELD</p> <p>Explores preparation needed, job opportunities, salaries, and fringe benefits for health occupations. Activities include guest speakers, field trips to a variety of health agencies, student conducted studies, interviews with various health personnel, with oral reports on many job opportunities.</p>

AREA	ACCR. NO. FLA-DADE	COURSE TITLE AND DESCRIPTION
------	-----------------------	------------------------------

HEALTH: COOPERATIVE HEALTH OCCUPATION EDUCATION (CHOE)

CHOE	8009.01	† THE COOPERATIVE STUDENT DEVELOPS HIS SCHOOL AND CAREER GOALS
------	---------	--

Introduces the cooperative health student to the goals expected in the course, school and job requirements, work forms, and an overview of the health career field. Organization of the cooperative education club and parliamentary procedure are included. Job opportunities and skills analysis are emphasized. Applicant must be accepted by the teacher-coordinator.

CHOE	8009.02	† PHYSICAL ADDICTIONS AND THE EFFECTS ON THE PERSONALITY
------	---------	--

A study of alcohol, drugs, tobacco, and any addiction that would affect the body as a whole. The concept of individual, worth handling of stress, anxieties, and defense mechanisms will be included.

CHOE CBE DCT	8009.03 7725.03 8753.03	† EXPLORING MONEY, TAXES, AND INSURANCE
--------------------	-------------------------------	---

The vocational cooperative student explores money, taxes, and insurance. Individual budgeting, social security, unemployment insurance, workmen's compensation, income tax, all types of insurance, money and banking are areas which will be covered.

CHOE CBE	8009.04 7725.02	RELATING TO ENVIRONMENT
-------------	--------------------	-------------------------

Environment in school, business, and outside relationships; good grooming; social skills; personality development; employer-employee relationships; and job finding and job success.

CHOE	8009.05	OPPORTUNITIES IN HEALTH SERVICE OCCUPATIONS
------	---------	---

Includes philosophy of the health field, advantages and disadvantages of health careers, compensations, nature of the work, and an occupational monograph on a specific health career.

AREA	ACCR. NO. FLA-DADE	COURSE TITLE AND DESCRIPTION
CHOE CBE CDE DCT	8009.06 7725.06 8727.05 8753.05	EMPLOYABILITY SKILLS FOR THE VOCATIONAL COOPERATIVE EDUCATION STUDENT  Employability skills training will be given to students qualifying for vocational cooperative training. An individual training plan will be developed between the coordinator, the training sponsor, and the student when the student is judged to be job ready. Before entering this course, students must obtain the approval of each subject area teacher-coordinator.
CHOE	8009.07	† FEATURES OF THE HEALTH SERVICE ENVIRONMENT  Includes orientation to community health agencies, institutional health team, office health team, students as a health team member, and preparation for health occupations. The laboratory experiments will include fundamental observational and manipulative skills. Applicant must be accepted by the teacher-coordinator.
CHOE	8009.08	BODY STRUCTURE AND FUNCTION I  This quinmester course includes the organization, composition, and systems of the human body. Laboratory experiments related to first aid will be covered. This is the first part of a two-part course of study.
CHOE	8009.09	BODY STRUCTURE AND FUNCTION II  This quinmester course of study is the second part of Body Structure and Function. It continues with the organization, composition, and systems of the human body. Related laboratory experiments will be included.
CHOE	8009.10	THE LIFE SPAN AND COMMUNITY HEALTH  A study of the growing years, reproductive years, general factors influencing human development, and diseases related to the different life spans and manners of dealing with them.

AREA	ACCR. NO. FLA-DADE	COURSE TITLE AND DESCRIPTION
------	-----------------------	------------------------------

TECHNICAL: DATA PROCESSING TECHNOLOGY (PRE-TECHNICAL) (DATA TK)

DATA TK	8120.01	<p>KEYPUNCH AND VERIFIER</p> <p>A historical introduction or review of data processing is given. The students are then introduced to the Hollerith Code, data processing vocabulary, operation of the IBM 024, 026, and 029 keypunches, and the 056-059 card verifier.</p>
DATA TK	8120.02	<p>SORTER AND ADVANCED KEYPUNCH</p> <p>Key punching principles are reviewed. The student then learns to operate the sorter in all modes of operation, including alpha sorting, numeric sorting, block sorting, selection, and other sorting techniques. The student also masters the keypunches with more advanced material under job conditions.</p>
DATA TK	8120.03	<p>COLLATOR OPERATION</p> <p>The student will learn operations of the collator and the principles of control panel wiring.</p>
DATA TK	8120.04	<p>UNIT RECORD EQUIPMENT</p> <p>Punch card principles are reviewed. The student then learns the purpose, operation, and principles of the following machines: interpreter, reproducing punch, accounting machines, verifier, calculators, sorter, and collator.</p>
DATA TK	8120.05	<p>INTRODUCTION TO COMPUTER PROGRAMMING</p> <p>Data processing principles are reviewed. The student then learns flowcharting techniques, logic principles, machine description, various memory/storage devices, binary arithmetic, and input/output devices.</p>
DATA TK	8120.06	<p>COMPUTER OPERATIONS</p> <p>The student will explore basic operating principles, procedures, and systems maintenance.</p>

VOCATIONAL EDUCATION  
TECHNICAL AND HEALTH OCCUPATIONS  
480

## TRADE AND INDUSTRIAL EDUCATION

AREA	ACCR. NO FLA-DADE	COURSE TITLE AND DESCRIPTION
------	----------------------	------------------------------

### AIR-CONDITIONING AND HEATING MECHANICS

AIR CND  
APPL REPAIR

9013.01  
9025.05

#### FUNDAMENTALS OF REFRIGERATION

This course will provide the student with an introduction to refrigeration and an understanding of trade terminology, heat and temperature, transfer of heat, refrigeration components, and the principle of the basic refrigeration cycle. It will also provide an understanding of the tools necessary to function in this field and will include the flaring, bending, swaging, soldering, and flaring of refrigeration tubing. This is a one, two or three quinmester course.

AIR CND

9013.02

#### REFRIGERANTS

The student will study refrigerants and their characteristics. Proper use of equipment for checking leaks and charging systems is practiced. Understanding moisture, installation of dryers and filters is learned. Also the use of line taps and quick coupled units.

Prior to entry into this course, the vocational student will display mastery of the skills indicated in Fundamentals of Refrigeration (9013.01).

AIR CND

9013.03

#### EVAPORATORS, CONDENSERS, AND RECEIVERS

Extending the student's knowledge of the components that deal with changing the state of a liquid by boiling off or condensing. This involves the evaporator, condenser, and storage of refrigerant in the receiver. The student will learn of the different types and calculate the sizes of these components.

Prior to entry into this course, the vocational student will display mastery of the skills indicated in Refrigerants (9013.02).

AREA	ACCR. NO. FLA-DADE	COURSE TITLE AND DESCRIPTION
AIR COND	9013.04	<p data-bbox="826 460 1121 495"><b>METERING DEVICES</b></p> <p data-bbox="826 525 1577 706">The student will understand, replace, and analyze the different types of metering devices which control the flow of refrigerant into the evaporator. He will learn how to adjust these controls, diagnose the effect on the capacity of the operating load through temperature and pressures. This is a one or two quinmester credit course.</p> <p data-bbox="826 736 1577 827">Prior to entry into this course, the vocational student will display mastery of the skills indicated in Evaporators, Condensers, and Receivers (9013.03).</p>
AIR COND	9013.05	<p data-bbox="826 885 1577 943"><b>SERVICE ANALYSIS AND CUSTOMER RELATIONSHIPS</b></p> <p data-bbox="826 973 1577 1243">Training experience providing skills in the use of tools and procedures for the determining factors involved in checking and starting a newly completed installation, step-by-step analyzing of field problems in the air-conditioning and refrigeration field. The course will also include customer relationships involving the mechanic's appearance, voice, knowledge of field, and temperament. This is a one or two quinmester credit course.</p> <p data-bbox="826 1273 1577 1368">Prior to entry into this course, the vocational student will display mastery of the skills indicated in Metering Devices (9013.04).</p>
AIR COND	9015.01	<p data-bbox="826 1426 1577 1485"><b>COMPRESSORS, SERVICE REPAIRS AND OPERATION</b></p> <p data-bbox="826 1492 1577 1791">The student will repair and replace an open-type, semihermetic, and welded hermetic compressor. He will also identify a reciprocating, rotary, centrifugal, and screw type compressor. Upon assembling a compressor, the student will also learn the selecting and adding of oil to a compressor. This course involves the student in sizing and installation of tubing, testing, and starting the systems, cleaning sealed units, repairing medium and low temperature equipment. This is a one or two quinmester credit course.</p> <p data-bbox="826 1822 1577 1910">Prior to entry into this course, the vocational student will display mastery of the skills indicated in Metering Devices (9013.04).</p>



AREA	ACCR. NO. FLA-DADE	COURSE TITLE AND DESCRIPTION
AIR CND	9015.02	<p data-bbox="737 461 1509 523">† FUNDAMENTALS OF ELECTRICITY, ELECTRONIC AND ELECTRICAL MATHEMATICS</p> <p data-bbox="769 553 1509 792">Provides the student with experiences in the field of electricity and electronics. It will answer questions on what electricity is, how it is produced, where it is used. This unit will give the air-conditioning student a better understanding of its use in the field. He will also study the mathematics necessary to complete his knowledge of electricity and electronics. This is a one or two quinmester credit course.</p> <p data-bbox="769 821 1509 913">Prior to entry into this course, the vocational student will display mastery of the skills indicated in Compressors, Service Repairs and Operation (9015.01).</p>
AIR CND	9015.03	<p data-bbox="769 973 1509 1035">ELECTROMAGNETISM, INDUCTANCE, AND CAPACITANCE</p> <p data-bbox="769 1065 1509 1219">A foundation course in the theory of electricity. The student will learn the Electron Theory of Magnetism; strength of electromagnets; alternating current; theory of inductance and capacitance, its definition, function, and formulas. This is a two or three quinmester credit course.</p> <p data-bbox="769 1249 1509 1373">Prior to entry into this course, the vocational student will display mastery of the skills indicated in Fundamentals of Electricity, Electronic and Electrical Mathematics (9015.02).</p>
AIR CND	9015.04	<p data-bbox="769 1432 1509 1464">ELECTRIC CIRCUITS</p> <p data-bbox="769 1494 1509 1579">This course will involve the student in series, circuits, parallel circuits, and combination of electrical terms. This is a two or three quinmester credit course.</p> <p data-bbox="769 1609 1509 1724">Prior to entry into this course, the vocational student will display mastery of the skills indicated in Electromagnetism, Inductance, and Capacitance (9015.03).</p>

AREA	ACCR. NO. FLA-DADE	COURSE TITLE AND DESCRIPTION
AIR CND	9015.05	<p data-bbox="761 445 1517 507"><b>REFRIGERATION AND AIR-CONDITIONING SYSTEM CONTROLS</b></p> <p data-bbox="761 537 1517 720">Provides the student with the understanding of the characteristics of controlled systems, pressure and temperature operated controls, low voltage thermostats and line voltage thermostats and controls. A unit of pneumatic controlled systems will be discussed. This is a two or three quinmester credit course.</p> <p data-bbox="761 750 1517 840">Prior to entry into this course, the vocational student will display mastery of the skills indicated in Electric Circuits (9015.04).</p>
AIR CND	9017.01	<p data-bbox="761 897 1517 959"><b>ELECTRIC MOTORS, STARTERS, RELAYS, AND PROTECTIVE DEVICES</b></p> <p data-bbox="761 989 1517 1265">This course is designed so that the student will recognize and understand the operation of capacitor start, split phase, shaded pole, polyphase, and repulsion induction electric motors. He will identify an open type of hermetic constructed motor and also test sealed unit relays of potential or current type. This unit will also identify magnetic starters and thermal overload protective devices, installing and testing these devices. This is a two or three quinmester credit course.</p> <p data-bbox="761 1294 1517 1384">Prior to entry into this course, the vocational student will display mastery of the skills indicated in Electric Circuits (9015.04).</p>
AIR CND	9017.02	<p data-bbox="761 1441 1517 1503"><b>DRAWING, READING, INTERPRETING MECHANICAL AND ELECTRICAL DIAGRAMS</b></p> <p data-bbox="761 1533 1517 1717">This course instructs in the reading and interpreting of manufacturer's diagrams, both mechanical and electrical. It will also include air-conditioning diagrams and specifications, automatic ice machines, and commercial refrigeration equipment. This is a two or three quinmester credit course.</p> <p data-bbox="761 1747 1517 1836">Prior to entry into this course, the vocational student will display mastery of the skills indicated in Electric Motors, Starters, Relays, and Protective Devices (9017.01).</p>

AREA	ACCR. NO. FLA-DADE	COURSE TITLE AND DESCRIPTION
AIR CND	9017.03	AIR CONDITIONING, RESIDENTIAL AND COMMERCIAL

The course spans the whole area of air-conditioning comfort conditioning. It includes the definition, use of the psychrometric chart, relative humidity, dew point, and use of load sheets. It will also cover duct design, installation, and precautions. This course will give the student the skills needed in repairing handles, hinges on domestic and commercial equipment. It includes the servicing and installing of window air-conditioning cabinets. Reverse cycle air conditioning will be explored, and its operation will be discussed. This is a two or three quinmester credit course.

Prior to entry into this course, the vocational student will display mastery of the skills indicated in Drawing, Reading, Interpreting Mechanical and Electrical Diagrams (9017.02).

AIR CND	9017.04	HEATING
---------	---------	---------

Designed to give the student the necessary skills to learn about fuel combustion and automatic burning equipment. It will also provide the student with the knowledge of boilers, furnaces, gravity and forced warm air systems. Hot water and steam systems using convectors, panels, and unit heaters will be included. Heating system controls will conclude the course. This is a two or three quinmester credit course.

Prior to entry into this course, the vocational student will display mastery of the skills indicated in Air Conditioning, Residential and Commercial (9017.03).

#### APPLIANCE REPAIR

APPL REPAIR	9023.01	ORIENTATION, SHOP TOOLS AND EQUIPMENT
-------------	---------	---------------------------------------

This course includes introduction to shop rules and safety regulations, the proper use of tools and equipment pertaining to the trade. Career opportunities in the major appliance field, customer relations, and writing out service orders and estimating job costs are all covered, as well as shop related jobs. This is a one or two quinmester credit course.

AREA	ACCR. NO. FLA-DADE	COURSE TITLE AND DESCRIPTION
APPL REPAIR IND. ELEC- TRONICS RADIO TV INDUSTRIAL ARTS SCIENCE	9023.02 9323.01 9783.01 5822.01 5823.01 5311.51 5312.51 5313.51	<p>† FUNDAMENTALS OF ELECTRICITY AND ELECTRONICS</p> <p>Provides an exploratory experience in the field of electricity and electronics. The student will be able to answer the following: What is electricity? How is electricity produced? How is electricity distributed? How is electricity used? One quinmester credit.</p> <p>Prior to entry into this course, the vocational student will display mastery of the skills indicated in Orientation, Shop Tools and Equipment (9023.01).</p>
APPL REPAIR	9023.03	<p>ELECTRICAL COMPONENTS AND APPLIANCE CIRCUITRY</p> <p>This course includes operations of electrical control devices and electrically operated components in major appliances. It also includes schematic interpretation, basic appliance circuits, and the use of circuit testing devices in appliance trouble-shooting. This is a one or two quinmester credit course.</p> <p>Prior to entry into this course, the vocational student will display mastery of the skills indicated in Fundamentals of Electricity and Electronics (9023.02).</p>
APPL REPAIR	9023.04	<p>WATER HEATERS AND DISHWASHERS</p> <p>This course includes installation of water heaters (gas and electric), water heater malfunctions and repairs, operation and troubleshooting repairs to dishwashers. Shop related jobs will also be included. This is a one or two quinmester credit course.</p> <p>Prior to entry into this course, the vocational student will display mastery of the skills indicated in Electrical Components and Appliance Circuitry (9023.03).</p>
APPL REPAIR	9023.05	<p>RANGES</p> <p>This course includes installation of electric and gas ranges, gas burners, and automatic pilot systems, electrical circuit tracing, malfunctions, troubleshooting, and repairs. Shop related jobs will also be included. This is a one or two quinmester credit course.</p> <p>Prior to entry into this course, the vocational student will display mastery of the skills indicated in Water Heaters and Dishwashers (9023.04).</p>

AREA	ACCR. NO. FLA-DADE	COURSE TITLE AND DESCRIPTION
APPL REPAIR	9025.01	<p><b>AUTOMATIC DRYERS: COMPONENTS AND OPERATIONS</b></p> <p>This course includes removing and replacing dryer components, operations and functions of dryer components, identifying component malfunctions, and gas and electric dryer installation procedures. This is a two or three quinmester credit course.</p> <p>Prior to entry into this course, the vocational student will display mastery of the skills indicated in Ranges (9023.05) or Water Heaters and Dishwashers (9023.04).</p>
APPL REPAIR	9025.02	<p><b>AUTOMATIC DRYERS: CIRCUITRY AND TROUBLE ANALYSIS</b></p> <p>This course includes dryer cycles of operations; principles of drying; analyzing electrical and mechanical malfunctions; circuit-tracing simple and complex dryer circuits, using appliance test equipment and meters. This is a two or three quinmester credit course.</p> <p>Prior to entry into this course, the vocational student will display mastery of the skills indicated in Automatic Dryers: Components and Operations (9025.01).</p>
APPL REPAIR	9025.03	<p><b>WASHING MACHINES: COMPONENTS AND OPERATIONS</b></p> <p>This course includes removing, rebuilding, and replacing washer components, operations and functions of components, identifying component malfunctions, and washing machine installation procedures. This is a two or three quinmester credit course.</p> <p>Prior to entry into this course, the vocational student will display mastery of the skills indicated in Automatic Dryers: Circuitry and Trouble Analysis (9025.02).</p>
APPL REPAIR	9025.04	<p><b>WASHING MACHINES: CIRCUITRY AND TROUBLE ANALYSIS</b></p> <p>This course includes washing machine cycle of operations; principles of washing; analyzing electrical and mechanical malfunctions; circuit-tracing simple and complex washer circuits, using appliance test equipment and meters. This is a two or three quinmester credit course.</p> <p>Prior to entry into this course, the vocational student will display mastery of the skills indicated in Washing Machines: Components and Operations (9025.03).</p>

AREA	ACCR. NO. FLA-DADE	COURSE TITLE AND DESCRIPTION
APPL REPAIR AIR COND	9025.05 9013.01	<p><b>FUNDAMENTALS OF REFRIGERATION.</b></p> <p>This course will provide the student with an introduction to refrigeration and an understanding of trade terminology, heat and temperature, transfer of heat, refrigeration components, and the principle of the basic refrigeration cycle. It will also provide an understanding of the tools necessary to function in this field and will include the flaring, bending, swaging, soldering, and flaring of refrigeration tubing. This is a one, two, or three quinmester course.</p>
APPL REPAIR	9027.01	<p><b>THE REFRIGERATION SYSTEM</b></p> <p>This course includes refrigeration components such as the evaporator; compressor and condenser; refrigeration tubing, including bending, swaging, flaring and soldering techniques. The course also includes basic evacuation and charging procedures. This is a two or three quinmester credit course.</p> <p>Prior to entry into this course, the vocational student will display mastery of the skills indicated in Fundamentals of Refrigeration (9025.05) or Washing Machines: Circuitry and Trouble Analysis (9025.04).</p>
APPL REPAIR	9027.02	<p><b>REFRIGERATION CONTROLS: ELECTRICAL AND MECHANICAL</b></p> <p>This course includes refrigerant metering devices, temperature controls, defrost heaters and thermostats, and air circulation fans. This course also includes basic electrical control circuitry and circuit tracing procedures. This is a two or three quinmester credit course.</p> <p>Prior to entry into this course, the vocational students will display mastery of the skills indicated in The Refrigeration System (9027.01).</p>
APPL REPAIR	9027.03	<p><b>DOMESTIC REFRIGERATORS</b></p> <p>This course includes installation, electrical and mechanical servicing, malfunctions, troubleshooting and repair, discharge, pump-down and recharging the system. This is a two or three quinmester course.</p> <p>Prior to entry into this course, the vocational student will display mastery of the skills indicated in Refrigeration Controls: Electrical and Mechanical (9027.02).</p>

AREA	ACCR. NO. FLA-DADE	COURSE TITLE AND DESCRIPTION
------	-----------------------	------------------------------

APPL REPAIR	9027.04	ROOM AIR CONDITIONERS
-------------	---------	-----------------------

This course includes installations, electrical and mechanical servicing, reverse cycle air conditioning, malfunctions, troubleshooting and repair, discharge, pump-down and recharging the system. Shop related jobs will also be included. Senior students will be eligible for the cooperative program. They will be placed in industry on a cooperative basis to receive on-the-job training. This is a two or three quinmester credit course.

Prior to entry into this course, the vocational student will display mastery of the skills indicated in Domestic Refrigerators (9027.03).

#### AUTOMOTIVE BODY REPAIR AND REFINISHING.

AUTO BODY	9033.01	INTRODUCTION TO AUTO BODY AND REFINISHING
-----------	---------	---

Teaches safe use and proper care of basic hand and power hand tools in the automotive body repair and refinishing trade. Human relations and shop safety will be stressed, together with basic problems in product design and engineering. This is a one or two quinmester credit course.

AUTO BODY	9033.02	BODY CONSTRUCTION AND TRIM
-----------	---------	----------------------------

A realistic study of automotive body and frame construction exploring all areas in design, so that the student may become familiar with these components. Replacement of trim panels and glass will be performed, as well as a variety of selected projects. This is a one or two quinmester credit course.

Prior to entry into this course, the vocational student will display mastery of the skills indicated in introduction to Auto Body and Refinishing (9033.01).

AREA	ACCR. NO. FLA-DADE	COURSE TITLE AND DESCRIPTION
AUTO BODY	9033.03	<p data-bbox="730 438 1065 470">AUTO BODY WELDING I</p> <p data-bbox="730 500 1476 684">Uses of gas welding equipment including running of beads, position welding, cutting, brazing, and joining common metals, including sheet metal, steel, and iron used in the automotive industry. All phases of soldering and spot welding of sheet metal are covered. This is a one or two quinmester credit course.</p> <p data-bbox="730 714 1476 805">Prior to entry into this course, the vocational student will display mastery of the skills indicated in Body Construction and Trim (9033.02).</p>
AUTO BODY	9033.04	<p data-bbox="730 858 1077 890">AUTO BODY WELDING II</p> <p data-bbox="730 920 1476 989">This is an advanced course in automotive welding techniques. It is offered for one or two quinmester credits.</p> <p data-bbox="730 1019 1476 1104">Prior to entry into this course, the vocational student will display mastery of the skills indicated in Auto Body Welding I (9033.03).</p>
AUTO BODY	9033.05	<p data-bbox="730 1157 1476 1212">AUTOMOTIVE BODY SHEET METAL MAINTENANCE I</p> <p data-bbox="730 1258 1476 1441">Explores the use of all sheet metal working and equipment common to this trade area. Diagnosis of damage and the proper techniques of repair are included. Emphasis is on the proper use of tools and fabrication methods used in automotive body maintenance and repair. This is a one or two quinmester credit course.</p> <p data-bbox="730 1471 1476 1563">Prior to entry into this course, the vocational student will display mastery of the skills indicated in Auto Body Welding II (9033.04).</p>
AUTO BODY	9035.01	<p data-bbox="730 1616 1476 1671">AUTOMOTIVE BODY SHEET METAL MAINTENANCE II</p> <p data-bbox="730 1717 1476 1901">An advanced course in sheet metal techniques. Emphasis is on the perfection of skills in sheet metal repair and fabrication techniques. Various types of problems will be utilized to advance the learner's skill through a variety of experiences. This is a two or three quinmester credit course.</p> <p data-bbox="730 1930 1476 2036">Prior to entry into this course, the vocational student will display mastery of the skills indicated in Automotive Body Sheet Metal Maintenance I (9033.05) or Auto Body Welding II (9033.04).</p>



AREA	ACCR. NO. FLA-DADE	COURSE TITLE AND DESCRIPTION
AUTO BODY	9035.02	<p data-bbox="808 454 1184 484"><b>BODY SHELL ALIGNMENT</b></p> <p data-bbox="808 514 1555 695">Training experiences provide skills in the use of tools and procedures for the alignment of automotive body damage. Manufacturer's manuals are utilized in all practical applications to insure the usage of correct tools and measurements relating to repair. This is a two or three quinmester credit course.</p> <p data-bbox="808 725 1555 817">Prior to entry into this course, the vocational student will display mastery of the skills indicated in Automotive Body Sheet Metal Maintenance II (9035.01).</p>
AUTO BODY	9035.03	<p data-bbox="808 879 1232 909"><b>AUTOMOTIVE BODY FILLERS</b></p> <p data-bbox="808 939 1555 1063">Practice in the use of auto body fillers, including body solder, and plastic materials. Methods of shaping and reforming contours are studied. This is a two or three quinmester credit course.</p> <p data-bbox="808 1092 1555 1184">Prior to entry into this course, the vocational student will display mastery of the skills indicated in Body Shell Alignment (9035.02).</p>
AUTO BODY	9035.04	<p data-bbox="808 1246 1232 1276"><b>AUTOMOTIVE REFINISHING I</b></p> <p data-bbox="808 1306 1555 1430">Foundation course of metal preparation prior to painting. Training provides experiences in metal preparation, masking, and priming. This is a two or three quinmester credit course.</p> <p data-bbox="808 1460 1555 1552">Prior to entry into this course, the vocational student will display mastery of the skills indicated in Automotive Body Fillers (9035.03).</p>
AUTO BODY	9035.05	<p data-bbox="808 1614 1238 1643"><b>AUTOMOTIVE REFINISHING II</b></p> <p data-bbox="808 1673 1555 1843">A continuation of Automotive Refinishing I (Course 9035.04) with emphasis on the practical application of color coating and sheet metal refinishing. Includes overall refinishing with enamels, lacquers, and acrylics. Spot repair painting and color matching are also emphasized. This is a two or three quinmester credit course.</p> <p data-bbox="808 1873 1555 1963">Prior to entry into this course, the vocational student will display mastery of the skills indicated in Automotive Refinishing I (9035.04).</p>

AREA	ACCR. NO. FLA-DADE	COURSE TITLE AND DESCRIPTION
AUTO BODY	9037.01	<p data-bbox="713 447 1467 507">UNIBODY CONSTRUCTION AND FRAME ALIGNMENT</p> <p data-bbox="713 534 1467 688">The main objective of this course is to familiarize the student with the basic concepts of unibody construction and frame alignment required to perform the operation in a shop environment which will simulate industry practices. This is a two or three quinmester credit course.</p> <p data-bbox="713 716 1467 838">Prior to entry into this course, the vocational student will display mastery of the skills indicated in Automotive Refinishing II (9035.05) or Automotive Refinishing I (9035.04).</p>
AUTO BODY	9037.02	<p data-bbox="713 897 1467 957">AUTOMOTIVE MECHANICS AS APPLIED TO AUTO BODY</p> <p data-bbox="713 984 1467 1196">Designed to familiarize the student with the basic mechanics of the automobile concerning the identification of parts, operation, and inspection related to collision damage. Minor repair and adjustments will be emphasized. Front end alignment, cooling systems, electrical systems, and air conditioning are covered. This is a two or three quinmester credit course.</p> <p data-bbox="713 1223 1467 1320">Prior to entry into this course, the vocational student will display mastery of the skills indicated in Unibody Construction and Frame Alignment (9037.01).</p>
AUTO BODY	9037.03	<p data-bbox="713 1379 1467 1409">COST ESTIMATING COLLISION DAMAGE</p> <p data-bbox="713 1437 1467 1591">Designed for the student to perform basic collision damage estimates. Emphasis is on the utilization of manufacturer's manuals in all practical application to learn the correct procedures used in the automotive body and refinishing trade. This is a two or three quinmester credit course.</p> <p data-bbox="713 1618 1467 1712">Prior to entry into this course, the vocational student will display mastery of the skills indicated in Automotive Mechanics as Applied to Auto Body (9037.02).</p>

AREA	ACCR. NO. FLA-DADE	COURSE TITLE AND DESCRIPTION
AUTO BODY	9037.04	<p><b>BODY SHOP MANAGEMENT</b></p> <p>To familiarize the student with the management operation of an automotive body shop. The senior student will be placed in industry on a cooperative basis in order to learn about shop management on the job. This is a two or three quinmester credit course.</p> <p>Prior to entry into this course, the vocational student will display mastery of the skills indicated in Cost Estimating Collision Damage (9037.03).</p>

#### AUTOMOTIVE MECHANICS

AUTO MECHANICS	9043.01	<p><b>AUTOMOTIVE HISTORY AND DEVELOPMENT OF THE AUTOMOBILE</b></p>
-------------------	---------	--

The main objective of this course is to familiarize the beginning student with the history and development of the automobile with basic concepts common to the automobile industry, and general information that is required for successful advancement in the automotive mechanics field. This is a one or two quinmester course.

AUTO MECHANICS	9043.02	<p><b>AUTOMOTIVE CHASSIS</b></p>
-------------------	---------	----------------------------------

This course will develop the student's understanding of the principles and theory relating to the brakes and suspension systems, and will acquaint him with the nomenclature of each type and application for each design. This is a one or two quinmester course.

Prior to entry into this course the vocational student will display mastery of the skills indicated in Automotive History and Development of the Automobile (9043.01).

AUTO MECHANICS	9043.03	<p><b>AUTOMOTIVE ENGINES</b></p>
-------------------	---------	----------------------------------

The theory and principles of operation of the automotive four-stroke cycle engine are studied and demonstrated. The student will develop an understanding of those systems necessary to make the engine perform as designed, such as cooling, fuel, ignition, and lubrication. Demonstrations to be made by the instructor when necessary. This is a one or two quinmester credit course.

Prior to entry into this course, the vocational student will display mastery of the skills indicated in Automotive Chassis (9043.02).

VOCATIONAL EDUCATION  
TRADE AND INDUSTRIAL EDUCATION

AREA	ACCR. NO. FLA-DADE	COURSE TITLE AND DESCRIPTION
AUTO MECHANICS	9043.04	<p><b>AUTOMOTIVE POWER FLOW SYSTEMS</b></p> <p>A foundation course in the theory of operation of the standard and automatic transmissions, clutch assemblies, drive line and rear axle assemblies. Demonstration to be given by the instructor when necessary. This is a one or two quinmester credit course.</p> <p>Prior to entry into this course, the vocational student will display mastery of the skills indicated in Automotive Engines (9043.03).</p>
AUTO MECHANICS	9043.05	<p><b>AUTOMOTIVE MINOR TUNE-UP,</b></p> <p>An introduction to engine tune-up and its related systems. Nomenclature and principles of operation and design of each system. Tune-up and diagnosis procedure demonstrated by the instructor; students will practice simple diagnosis and tune-up service techniques; proper maintenance and adjustments procedures will be defined and included. This is a one or two quinmester credit course.</p> <p>Prior to entry into this course, the vocational student will display mastery of the skills indicated in Automotive Power Flow Systems (9043.04).</p>
AUTO MECHANICS	9045.01	<p><b>AUTOMOTIVE MECHANICS POWER PLANT</b></p> <p>This course is designed to provide the student with general information, technical knowledge, and basic manipulative skills to perform maintenance of and repair to the engine. Basic overhaul procedures regarding the cylinder block, cylinder head and valve assembly, crankshaft and piston and rod assembly. Automotive lubrication, cooling, and basic operation of the ignition system are included. This is a two or three quinmester-credit course.</p> <p>Prior to entry into this course, the vocational student will display mastery of the skills indicated in Automotive Minor Tune-Up (9043.05) or Automotive Power Flow Systems (9043.04).</p>

AREA	ACCR. NO. FLA-DADE	COURSE TITLE AND DESCRIPTION
AUTO MECHANICS	9045.02	AUTOMOTIVE SUSPENSION, ALIGNMENT, AND BRAKES  The student will learn the operational theory, manipulative skills required to perform maintenance service and repair of the automobile suspension system, covering ball joints, springs, torsion bars, control arms, and other component parts. Automotive front end alignment procedures will be emphasized as per manufacturers' specifications throughout the course. Hydraulic principles relating to the brake system will be stressed; manipulative skills to perform brake maintenance and repair will be employed. The student will perform all operations necessary for gainful employment in the automotive trade area. This is a two or three quinmester credit course.  Prior to entry into this course, the vocational student will display mastery of the skills indicated in Automotive Mechanics Power Plant (9045.01).
AUTO MECHANICS	9045.03	AUTOMOTIVE ELECTRICAL AND ELECTRONIC SYSTEM I  This quinmester course covers basic electrical theory as applied to the automobile. Elementary physics of electricity, electrical terms and units, measurements, Ohm's law, magnetism, meters, and DC circuit analysis. Laboratory experiments relating to the text material will be covered. This is a two or three quinmester credit course.  Prior to entry into this course, the vocational student will display mastery of the skills indicated in Automotive Suspension, Alignment, and Brakes (9045.02).
AUTO MECHANICS	9045.04	AUTOMOTIVE ELECTRICAL AND ELECTRONIC SYSTEM II  This course is designed for the student who has completed Automotive Electrical and Electronic System I (9045.03). The objective is to further instruct the student in manipulative skills or maintenance and repair, related to the automobile's generator, voltage regulator, starting motor, and drive motors. All phases of electrical troubleshooting and repair used in the automobile will be emphasized. This is a two or three quinmester credit course.  Prior to entry into this course, the vocational student will display mastery of the skills indicated in Automotive Electrical and Electronic System I (9045.03).

AREA	ACCR: NO. FLA-DADE	COURSE TITLE AND DESCRIPTION
AUTO MECHANICS	9045.05	<p><b>AUTOMOTIVE BODY TRIM AND GLASS</b></p> <p>To familiarize the student with the manipulative skills and knowledge concerning general repair and adjustment of body trim items, including moldings, bumpers, trim panels, doors, hood and trunk assemblies, glass alignment and adjustment will be covered, as well as body and glass sealings. The student will perform the various operations in a shop environment. This is a two or three quinmester credit course.</p> <p>Prior to entry into this course the vocational student will display mastery of the skills indicated in Automotive Electrical and Electronic System II (9045.04).</p>
AUTO MECHANICS	9047.01	<p><b>AUTOMOTIVE FUEL AND CARBURETION</b></p> <p>This course is an introduction to the automobile fuel and carburetion systems. Basic manipulative skills relating to carburetor, maintenance and overhaul, together with adjustments of linkages and fuel indicating circuits will be included, using test equipment in a shop environment. This is a two or three quinmester credit course.</p> <p>Prior to entry into this course, the vocational student will display mastery of the skills indicated in Automotive Electrical and Electronic System II (9045.04).</p>
AUTO MECHANICS	9047.02	<p><b>AUTOMOTIVE TUNE-UP AND PERFORMANCE</b></p> <p>A complete course in automotive engine tune-up. The student will study in depth the troubleshooting components, using electronic testing equipment. Fuel metering, timing, and emission control system maintenance will be performed in a shop environment which simulates industry. This is a two or three quinmester credit course.</p> <p>Prior to entry into this course, the vocational student will display mastery of the skills indicated in Automotive Fuel and Carburetion (9047.01).</p>

AREA	ACCR. NO. FLA-DADE	COURSE TITLE AND DESCRIPTION
AUTO MECHANICS	9047.03	<p data-bbox="816 459 1365 486"><b>AUTOMOTIVE POWER FLOW SYSTEM II</b></p> <p data-bbox="816 523 1559 794">This course enables the student to diagnose and repair components relating to the power flow system. Manipulative skills will be stressed to perform proper maintenance on automotive clutch assemblies, standard and automatic transmissions, drive lines, differentials and rear axles. The instruction will be carried out following manufacturers' procedures in a shop environment which simulates industry. This is a two or three quinmester credit course.</p> <p data-bbox="816 821 1559 918">Prior to entry into this course, the vocational student will display mastery of the skills indicated in Automotive Tune-up and Performance (9047.02).</p>
AUTO MECHANICS	9047.04	<p data-bbox="816 973 1513 1001"><b>AUTOMOTIVE AIR CONDITIONING AND HEATING</b></p> <p data-bbox="816 1037 1559 1216">This course includes elementary physics of air conditioning and heating. Comprehensive laboratory experiments relating to the text will be covered. The manipulative skills of testing, diagnosis, repair and maintenance of automotive air conditioning will be stressed. This is a two or three quinmester credit course.</p> <p data-bbox="816 1244 1559 1340">Prior to entry into this course, the vocational student will display mastery of the skills indicated in Automotive Power Flow System II (9047.03).</p>
<b>AVIATION MECHANICS</b>		
AVIATION MECHANICS	9073.01	<p data-bbox="816 1616 1559 1676"><b>AIRCRAFT MATERIALS, PROCESSES, CLEANING, AND CORROSION CONTROL</b></p> <p data-bbox="816 1712 1559 1859">The main objective of this course is to familiarize the beginning students with the basic concepts common to aircraft materials and process. Included are the requirements of proper cleaning and corrosion control as outlined by the Federal Aviation Agency.</p>

AREA	ACCR. NO. FLA-DADE	COURSE TITLE AND DESCRIPTION
AVIATION MECHANICS	9073.02	<p><b>AIRCRAFT GROUND OPERATION, SERVICING, FLUID LINES AND FITTINGS, MECHANICS PRIVILEGES AND LIMITATIONS, AND MAINTENANCE PUBLICATIONS, FORMS AND RECORDS</b></p> <p>A basic course in the aircraft maintenance technician program, providing a foundation in the proper ground operation and servicing of aircraft, the fabrication of fluid lines and fittings, and Federal Aviation Agency requirements for mechanics, privileges and limitations, maintenance forms and records, and the use of maintenance publications.</p>
AVIATION MECHANICS	9073.03	<p><b>AIRCRAFT WEIGHT AND BALANCE WITH MATHEMATICS AND SHOP DRAWING</b></p> <p>A basic course in the aircraft maintenance technician program, providing a foundation in aircraft weight and balance control and computation. Basic shop drawing techniques, including lettering, geometric construction, orthographic and pictorial sketching and drawing. Review of basic mathematics is emphasized in the course.</p>
AVIATION MECHANICS	9073.04	<p><b>BASIC ELECTRICITY WITH PHYSICS</b></p> <p>A basic course in the aircraft maintenance technician program, providing a foundation in the proper ground operation and servicing of A/C, the fabrication of fluid lines and fittings, and Federal Aviation Agency requirements for mechanics. Privileges and limitations, maintenance forms and records, and the use of maintenance publications.</p>
AVIATION MECHANICS	9065.01	<p><b>AIRCRAFT WOOD STRUCTURES, COVERING AND FINISHING METHODS</b></p> <p>A study of related and manipulated aircraft wood structures with emphasis on the F.A.A. requirements, such as identification of defects on wood samples, defining terms used on wood structure, inspecting wood structure, servicing and repair of wood structure. Includes fabric cover; selecting and applying fabric and plastic covering material; inspecting testing and repairing fabric; identifying and selecting aircraft finish materials, such as dope and paint; application of and inspecting/finish; and identifying defects on finished materials.</p>

VOCATIONAL EDUCATION  
TRADE AND INDUSTRIAL EDUCATION

498



AREA	ACCR. NO. FLA-DADE	COURSE TITLE AND DESCRIPTION
AVIATION MECHANICS	9065.02	<b>AIRFRAME ASSEMBLY, RIGGING, AND INSPECTION</b>  To familiarize the student with the manipulative skills and basic knowledge concerning airframe assembly, rigging, and inspection, in accordance with F.A.A. regulations.
AVIATION MECHANICS	9065.03	<b>AIRCRAFT WELDING AND SHEET METAL STRUCTURES I</b>  A foundation course in aircraft welding and sheet metal techniques. Emphasis is on the proper use of tools, repair, and fabrication methods used in aircraft maintenance. Particular attention is given to Federal Aviation Agency requirements.
AVIATION MECHANICS	9065.04	<b>AIRCRAFT WELDING AND SHEET METAL STRUCTURES II</b>  An advanced course in welding and sheet metal techniques. Emphasis is on the perfection of skills in welding and sheet metal repair and fabrication techniques. Repairs on aircraft structures of various types are utilized to advance skills and provide a variety of experiences.
AVIATION MECHANICS	9067.01	<b>AIRCRAFT FUEL, HYDRAULIC AND PNEUMATIC SYSTEMS</b>  To familiarize the student with the operation, inspection, and repair of aircraft fuel systems—hydraulic and pneumatic.
AVIATION MECHANICS	9067.02	<b>AIRCRAFT LANDING GEAR, ICE AND RAIN CONTROL SYSTEMS</b>  To familiarize the student with the operation, inspection and repair of the aircraft landing gear, ice and rain control systems.
AVIATION MECHANICS	9067.03	<b>AIRCRAFT ELECTRICAL SYSTEMS</b>  Designed for high school students who are entering their third year of instruction in aviation mechanics. Objective is to familiarize the student with manipulative and related information concerning all phases of electricity as used in aircraft electrical systems.

AREA	ACCR. NO. FLA-DADE	COURSE TITLE AND DESCRIPTION
AVIATION MECHANICS	9067.04	AIRCRAFT INSTRUMENT, FIRE PROTECTION, WARNING, COMMUNICATION, NAVIGATION, AND CABIN ATMOSPHERE CONTROL SYSTEMS  To familiarize the student with manipulative skills and theoretical knowledge concerning aircraft instrument systems, such as major flight and engine instruments; fire protection and fire fighting systems; warning, communication, and navigation systems; aircraft cabin control systems, such as heating and pressurization, in accordance with Federal Aviation Agency (F.A.A.) standards.
AVIATION MECHANICS	9055.01	OVERHAUL, INSPECTION, AND REPAIR OF RECIPROCATING ENGINES I  Basic theory of reciprocating aircraft engine design, construction, and operation. Special emphasis is placed on inspection, repair, and overhaul requirements and practices.
AVIATION MECHANICS	9055.02	OVERHAUL, INSPECTION, AND REPAIR OF RECIPROCATING ENGINES-II  A continuation of course 9055.01, with emphasis on the practical application of theories presented.
AVIATION, MECHANICS	9055.03	† TURBINE ENGINE THEORY AND ENGINE INSPECTION  A foundation in the principles of operation, design, and construction of various turbine engines. Consideration is also given to engine accessories, systems, and inspection techniques.
AVIATION MECHANICS	9055.04	† INSTALLATION, REMOVAL, AND INSPECTION OF RECIPROCATING ENGINES  Training experiences providing skills in the use of tools and procedures for the installation, removal, and inspection of reciprocating engines. Manufacturers' manuals are utilized in all practical applications to insure the use of correct tools and procedures for adjusting, timing, and inspecting reciprocating engines.

AREA	ACCR. NO. FLA-DADE	COURSE TITLE AND DESCRIPTION
AVIATION MECHANICS	9057.01	† AIRCRAFT PROPELLERS AND COOLING SYSTEMS  A foundation course in the theory of operation of various aircraft propellers and cooling systems. Special emphasis is on maintenance and troubleshooting techniques.
AVIATION MECHANICS	9057.02	AIRCRAFT FUEL, FUEL METERING, INDUCTION AND EXHAUST SYSTEMS  A foundation course in the theory of operation of various fuel systems, fuel metering, induction system, and exhaust systems components. Emphasizes troubleshooting, maintenance and repair methods.
AVIATION MECHANICS	9057.03	† AIRCRAFT ENGINE IGNITION AND INSTRUMENT SYSTEMS  A foundation course in aircraft magnetos and engine ignition and instrument systems. Troubleshooting and maintenance procedures are emphasized.
AVIATION MECHANICS	9057.04	† AIRCRAFT ENGINE ELECTRICAL, FIRE PROTECTION AND LUBRICATION SYSTEMS  A foundation course in aircraft engine electrical systems including starters, generators, and regulators. Engine fire protection and lubrication are also included.

#### COMMERCIAL COOKING AND BAKING

CM COOK HOME AND FAMILY ED.	9193.01 6773.01	AWAKEN TO THE WORLD OF FOOD SERVICE  This course provides an exploratory experience in the field of commercial food service, the hotel and restaurant industry, and types of food service establishments. Food distribution and service are studied. The student will be able to answer the following: What is food? What industries are related to food service? What are the types and characteristics of food service units? This is a one or two quinmester credit course.
-----------------------------------	--------------------	--

VOCATIONAL EDUCATION  
TRADE AND INDUSTRIAL EDUCATION  
501

AREA	ACCR. NO. FLA-DADE	COURSE TITLE AND DESCRIPTION
CM COOK HOME AND FAMILY ED.	9193.02 6773.02	<p><b>NUTRITIOUS MEAL PLANNING</b></p> <p>This course includes an introduction to the science and practice of nutrition in commercial food service establishments. Selecting, planning, preparing, and serving of foods which meet nutritional standards in institutional feeding are covered. This is a one or two quinmester credit course.</p> <p>Prior to entry into this course, the vocational student will display mastery of the skills indicated in Awaken to the World of Food Service (9193.01).</p>
CM COOK HOME AND FAMILY ED.	9193.03 6773.03	<p><b>COOKING CAN BE PROFITABLE</b> (Basic Cooking Procedures)</p> <p>This course provides the opportunity for students to demonstrate their ability to perform basic skills in food planning preparation through use of basic equipment and tools, use of weights and measures, use of temperatures, reading and interpreting recipes, and food cost and accounting. This is a one or two quinmester credit course.</p> <p>Prior to entry into this course, the vocational student will display mastery of the skills indicated in Nutritious Meal Planning (9193.02).</p>
CM COOK HOME AND FAMILY ED.	9193.04 6773.04	<p><b>A CHEF IS MANY THINGS</b></p> <p>This course enables the student to explore the career opportunities, responsibilities, and duties of food service personnel, and to prepare and serve foods using industrial techniques. This is a one or two quinmester credit course.</p> <p>Prior to entry into this course, the vocational student will display mastery of the skills indicated in Cooking Can Be Profitable (9193.03).</p>
CM COOK HOME AND FAMILY ED.	9193.05 6773.05	<p><b>PARTY FOODS</b></p> <p>This course includes planning, preparing, and serving foods for festive occasions (formal and informal), table setting and service, host-hostess skills, hospitality, catering, and management techniques. This is a one or two quinmester credit course.</p> <p>Prior to entry into this course, the vocational student will display mastery of the skills indicated in A Chef Is Many Things (9193.04).</p>

VOCATIONAL EDUCATION  
TRADE AND INDUSTRIAL EDUCATION  
502

AREA	ACCR. NO. FLA-DADE	COURSE TITLE AND DESCRIPTION
------	-----------------------	------------------------------

CM COOK	9195.01	FOOD SERVICE EQUIPMENT SPECIALTY
---------	---------	----------------------------------

This course includes care and operation of kitchen and bake shop equipment, proper selection, specifications, and layout in commercial food service establishments. This is a two or three quinmester credit course.

Prior to entry into this course, the vocational student will display mastery of the skills indicated in A Chef Is Many Things (9193.04) or Party Foods (9193.05).

CM COOK	9195.02	FOOD SERVICE WITH A FLAIR
---------	---------	---------------------------

This course develops good work habits, both mental and physical. Waiter-waitress service, tray service, arm service, buffet service, banquet service, dining room arrangement and its relationship to personnel, employee-customer relations, and personal hygiene and grooming are covered. This is a two or three quinmester credit course.

Prior to entry into this course, the vocational student will display mastery of the skills indicated in Food Service Equipment Specialty (9195.01).

CM COOK	9195.03	INSPECTION, CARE, AND STORAGE OF FOODS
---------	---------	--

This course provides an opportunity for the student to practice proper industrial techniques of food inspection, storage, and care, including dry stores and perishables. Maintenance of perpetual inventory and food cost accounting are covered. This is a two or three quinmester credit course.

Prior to entry into this course, the vocational student will display mastery of the skills indicated in Food Service with a Flair (9195.02).

CM COOK	9195.04	CREATIVE FOOD PREPARATION
---------	---------	---------------------------

This course provides experiences of meal planning and preparation in a real-life commercial restaurant situation. This includes preparing a variety of appetizers, beverages, meats, vegetables, salads, breads, desserts, and pastries. This is a two or three quinmester credit course.

Prior to entry into this course, the vocational student will display mastery of the skills indicated in Inspection, Care, and Storage of Foods (9195.03).

VOCATIONAL EDUCATION  
TRADE AND INDUSTRIAL EDUCATION  
503

AREA	ACCR. NO. FLA-DADE	COURSE TITLE AND DESCRIPTION
CM COOK	9195.05	HOTEL AND RESTAURANT FOOD OPERATIONS  This course stresses the methods of production for high quality foods and the basic concepts and principles of food production. The meaning of quality and standards as it applies to the hotel-restaurant industry is discussed. This is a two or three quinmester credit course.  Prior to entry into this course, the vocational student will display mastery of the skills indicated in Creative Food Preparation (9195.04).
CM COOK	9197.01	SALES AND SANITATION OCCUPATIONS  This course explores employment opportunities and practices, on an advanced level, in suggestive selling, customer relations, advertising and display, harmonious working relations, and the importance of hygiene and sanitation occupations in food service operations. This is a two or three quinmester credit course.  Prior to entry into this course, the vocational student will display mastery of the skills indicated in Hotel and Restaurant Food Operations (9195.05) or Creative Food Preparation (9195.04).
CM COOK	9197.02	FOOD PREPARATION OCCUPATIONS  This course covers advanced terminology and preparation in the following areas: <ul style="list-style-type: none"> <li>Techniques in Menu Planning</li> <li>Techniques for Successful Salads and Salad Dressings</li> <li>Techniques for Soups and Sauce Cookery</li> <li>Planning and Preparing Successful Desserts</li> <li>Quantity Baking Techniques and Practices</li> <li>Food Service Safety and Sanitation</li> <li>Employability Skills</li> </ul> This is a two or three quinmester credit course.  Prior to entry into this course, the vocational student will display mastery of the skills indicated in Sales and Sanitation Occupations (9197.01).

AREA ACCR. NO. COURSE TITLE AND DESCRIPTION  
FLA-DADE

CM.COOK 9197.03

#### RECEIVING AND STORING OCCUPATIONS

This course provides an opportunity for advanced work in the techniques and responsibilities involved in purchasing, receiving, issuing, storing, cost and portion control, and inventory procedures used in industry. This is a two or three quinmester credit course.

Prior to entry into this course, the vocational student will display mastery of the skills indicated in Food Preparation Occupations (9197:02).

CM COOK 9197.04

#### MANAGERIAL OCCUPATIONS

This course is especially designed for students who show management potential. It is designed to teach effective management and control of that area of a food service establishment commonly referred to as the "back of the house." Emphasis is placed on labor control, supplies other than food, utilities, laundry, uniforms, equipment repair, replacement and depreciation, departmental relations, and effective sanitation practices. This is a two or three quinmester credit course.

Prior to entry into this course, the vocational student will display mastery of the skills indicated in Receiving and Storing Occupations (9197:03).

COSMETOLOGY 9205.01

#### COSMETOLOGY

#### COSMETOLOGY—A PROFITABLE CAREER FOR MEN AND WOMEN

This course introduces the cosmetology student to the goals and organization of the cosmetology program. The student will acquire knowledge of hygiene, ethics, sanitation, law, and safety rules. Manipulative skills and related technology of shampooing will be utilized. The student will learn the proper manipulations of fingerwaving, as well as acquire skill in constructing pin curls. With practice, the introduced techniques will continually improve. This is a three quinmester credit course.

VOCATIONAL EDUCATION  
TRADE AND INDUSTRIAL EDUCATION

505

400

AREA	ACCR. NO. FLA-DADE	COURSE TITLE AND DESCRIPTION
------	-----------------------	------------------------------

COSMETOLOGY 9205.02

CREATIVE COIFFURES

Through participation in this unit, the student will develop skills in setting hair with mechanical aids and will develop the technique for setting appropriate styles for all facial types. Hair pressing will be introduced, along with developing skill in using the curling iron. The students will work on each other and on patrons in the atmosphere of a styling salon. This is a three quinmester credit course.

Prior to entry into this course, the vocational student will display mastery of the skills indicated in Cosmetology—A Profitable Career for Men and Women (9205.01).

COSMETOLOGY 9205.03

SHAPING AND CONDITIONING HAIR

The student will gain knowledge and acquire the skill of basic cutting and shaping of hair and will develop skill in manipulating cutting and shaping tools. This unit will also include the study of scalp and hair structure, covering the recognition of scalp and hair problems and the skills necessary to treat them. Development will be accomplished by performing these skills on other students, mannequins, and patrons in a shop atmosphere. This is a three quinmester credit course.

Prior to entry into this course, the vocational student will display mastery of the skills indicated in Creative Coiffures (9205.02).

COSMETOLOGY 9205.04

HAIR—CURVY OR STRAIGHT

The student will demonstrate a knowledge of hair analysis, shampooing and shaping of hair; he or she will learn the different types of cold waving lotions and their effects on various kinds of hair, as well as acquire skill in all cold wave techniques. Practice on mannequins and patrons will be stressed. The student learns safe, correct techniques for straightening curly hair, using different chemical hair relaxers on all types of hair. This is a three quinmester credit course.

Prior to entry into this course, the vocational student will display mastery of the skills indicated in Shaping and Conditioning Hair (9205.03).

VOCATIONAL EDUCATION  
TRADE AND INDUSTRIAL EDUCATION  
506

451



AREA	ACCR. NO. FLA-DADE	COURSE TITLE AND DESCRIPTION
------	-----------------------	------------------------------

COSMETOLOGY 9205.05

**COLOR TECHNOLOGY**

The student will learn the theory of hair coloring and its related anatomy, physiology, and chemistry, which will include different types of hair colors and their effects on all kinds of hair. Selecting, mixing, and applying hair color and bleaches will be part of this course. Practice is done on mannequins and patrons in a salon atmosphere. This is a three quinmester credit course.

Prior to entry into this course, the vocational student will display mastery of the skills indicated in Hair-Curvy or Straight (9205.04).

COSMETOLOGY 9207.01

**CARE OF THE NAILS**

In this course, emphasis will be placed on the development of skills that were learned in the preceding quins. The student will work on mannequins and patrons. Through participation and discussion, the student will learn about the proper use of materials, equipment, and implements used in the procedure of manicuring and pedicuring. Methods and techniques of these skills will be developed. This is a three quinmester credit course.

Prior to entry into this course, the vocational student will display mastery of the skills indicated in Color Technology (9205.05).

COSMETOLOGY 9207.02

**COMPLEXION CARE**

The student will develop skills that were learned in the preceding quins by working on other students, mannequins, or patrons in a shop atmosphere. The purpose of facial treatments and the related anatomy and physiology will be learned, along with the development of skill in-giving facial treatments, massage manipulations, tinting brows and lashes, and applying facial makeup. The composition and function of all cosmetics will be included. This is a three quinmester credit course.

Prior to entry into this course, the vocational student will display mastery of the skills indicated in Care of the Nails (9207.01).

AREA	ACCR. NO. FLA-DADE	COURSE TITLE AND DESCRIPTION
COSMETOLOGY	9207.03	<p><b>WIGOLOGY</b></p> <p>Developing skills that were learned in the preceding quins, the students will work on each other, mannequins, and patrons in a shop atmosphere. The students will also acquire knowledge of the different types of wig construction and learn how to measure, shape, and style all wigs and hairpieces. This is a three quinmester credit course.</p> <p>Prior to entry into this course, the vocational student will display mastery of the skills indicated in Complexion-Care (9207.02).</p>
COSMETOLOGY	9207.04	<p><b>THE PROFITABLE BUSINESS OF COSMETOLOGY</b></p> <p>The student will learn the economic, financial, and location requirements of the beauty salon operator who is preparing to enter into business. Techniques of selling, advertising, display, and recordkeeping will be practiced. This is a three quinmester credit course.</p> <p>Prior to entry into this course, the vocational student will display mastery of the skills indicated in, Wigology (9207.03).</p>
<b>COSMETOLOGY SPECIALIST</b>		
COSMETOLOGY SPECIALIST	9457.01	<p><b>A CAREER AS A COSMETOLOGY SPECIALIST</b></p> <p>This is an orientation course for the student interested in being a specialist. Emphasis will be placed on hygiene, ethics, sanitation, law, and safety rules. The student will be introduced to the related technology of shampoos. Manipulative skills will be practiced. This is a three quinmester credit course.</p>

AREA	ACCR. NO. FLA-DADE	COURSE TITLE AND DESCRIPTION
COSMETOLOGY SPECIALIST	9457.02	<p data-bbox="790 512 1243 548"><b>MANICURING AND PEDICURING</b></p> <p data-bbox="790 578 1533 818">The theory of manicuring and pedicuring will be taught, which will include the anatomy and physiology of nails, nail disorders and treatment, proper use of materials, equipment and implements used in the procedure of a manicure and a pedicure. The student will develop skill in all manicuring techniques in an environment which will simulate shop practices. This is a three quinmester credit course.</p> <p data-bbox="790 849 1533 936">Prior to entry into this course, the vocational student will display mastery of the skills indicated in A Career as a Cosmetology Specialist (9457.01).</p>
COSMETOLOGY SPECIALIST	9457.03	<p data-bbox="790 994 987 1030"><b>SKIN BEAUTY</b></p> <p data-bbox="790 1060 1533 1241">This quin will teach the purpose of facial treatments and of the related anatomy and physiology. It also provides the student with the knowledge of the materials and implements needed for facial treatments, and includes all massage manipulations on patrons in a shop environment. This is a three quinmester credit course.</p> <p data-bbox="790 1272 1533 1359">Prior to entry into this course, the vocational student will display mastery of the skills indicated in Manicuring and Pedicuring (9457.02).</p>
COSMETOLOGY SPECIALIST	9457.04	<p data-bbox="790 1418 1184 1453"><b>THE ARTISTRY OF MAKEUP</b></p> <p data-bbox="790 1484 1533 1665">The purpose of facial makeup, the implements and materials needed for applying makeup, as well as the composition of all cosmetics, will be taught. Applying makeup, arching and tinting brows and lashes will be emphasized in an environment which will simulate shop practices. This is a three quinmester credit course.</p> <p data-bbox="790 1695 1533 1782">Prior to entry into this course, the vocational student will display mastery of the skills indicated in Skin Beauty (9457.03).</p>

AREA	ACCR. NO. FLA-DADE	COURSE TITLE AND DESCRIPTION
GRAPHIC ARTS (PRINTING)		
GRAPHIC ARTS (PRINT)	9753.01	<p>INTRODUCTION TO GRAPHIC COMMUNICATIONS</p> <p>To acquaint the student with the history of graphic communications, required manipulative skills, various types of equipment, opportunities available in the printing industry, related information concerning elementary composition, proofing, lockup, and operation of the (hand-fed) platen press. This is a one or two credit quinmester course.</p>
GRAPHIC ARTS (PRINT)	9753.02	<p>GRAPHIC ARTS</p> <p>Provides an exploratory experience in offset printing, photography, design and layout, paper selection, and cutting. This is a one or two quinmester credit course.</p> <p>Prior to entry into this course, the vocational student will display mastery of the skills indicated in Introduction to Graphic Communications (9753.01).</p>
INDUSTRIAL ARTS	5833.02	
GRAPHIC ARTS (PRINT)	9753.03	<p>† BINDERY</p> <p>A study including pad making, bookbinding, plastic binding, cutting, drilling, jogging, types of materials and equipment, and related information. This is a one or two credit quinmester course.</p> <p>Prior to entry into this course, the vocational student will display mastery of the skills indicated in the course Graphic Arts (9753.02).</p>
INDUSTRIAL ARTS	5835.01	
GRAPHIC ARTS (PRINT)	9753.04	<p>LAYOUT AND DESIGN</p> <p>The fundamentals of design related to printed materials, layout, and paste-up. The designs created will not be limited to any one printing process; with the exception that only cold processes are used. This is a one or two quinmester credit course.</p> <p>Prior to entry into this course, the vocational student will display mastery of the skills indicated in the course Bindery (9753.03).</p>
INDUSTRIAL ARTS	5834.02 5835.02	

AREA	ACCR. NO. FLA-DADE	COURSE TITLE AND DESCRIPTION
GRAPHIC ARTS (PRINT)	9753.05	SPECIAL IN-SHOP STUDENT PROJECT  This course is offered to give the student an opportunity to explore a specific area of interest. It will assist him in determining his career objectives so that he may pursue the area in depth. This is a one or two quinmester credit course.  Prior to entry into this course, the vocational student will display mastery of the skills indicated in Layout and Design (9753.04).
GRAPHIC ARTS (PRINT)	9755.01	COMPOSITION  This course includes shop safety and the manipulative signs and related information in the following areas: hand composition, spacing materials, composing stick, typesetting, proofing, proofreading, correcting, imposition, and lockup. This is a two or three quinmester credit course.  Prior to entry into this course, the vocational student will display mastery of the skills indicated in Layout and Design (9753.04).
GRAPHIC ARTS (PRINT)	9755.02	PROCESS CAMERA  This course covers the different types of process cameras used in the printing industry. Special emphasis is placed on manipulative skills, theory, the principles of the process camera, film processing, and exposure related to line and half-tone copy. This is a two or three credit quinmester course.  Prior to entry into this course, the vocational student will display mastery of the skills indicated in Composition (9755.01).
GRAPHIC ARTS (PRINT)	9755.03	LITHOGRAPHIC STRIPPING  This course includes the theory and manipulative skills required for preparing negatives, making the layout, marking the plate, imposing negatives, and opaquing. This is a two or three quinmester credit course.  Prior to entry into this course, the vocational student will display mastery of the skills indicated in Process Camera (9755.02).

AREA	ACCR. NO. FLA-DADE	COURSE TITLE AND DESCRIPTION
GRAPHIC ARTS (PRINT)	9755.04	<p><b>PLATEMAKING</b></p> <p>This course includes the various types of press plates that have been developed for the printing industry and its use. The student will learn film imposition, plate preparation, exposure and development for the production of lithographic plates. This is a two or three quinmester credit course.</p> <p>Prior to entry into this course, the vocational student will display mastery of Lithographic Stripping (9755.03).</p>
GRAPHIC ARTS (PRINT)	9755.05	<p><b>GRAPHIC ARTS PRODUCTION WORKSHOP</b></p> <p>This course is designed to give the student advanced experience in production work, including offset press work, paper selection and handling, billing, paper cutting, padding, bookbinding, and related printing activities. This is a two or three quinmester credit course.</p> <p>Prior to entry into this course, the vocational student will display mastery in the skills indicated in Platemaking (9755.04).</p>
GRAPHIC ARTS (PRINT)	9757.01	<p><b>PRESS OPERATION</b></p> <p>This course includes the different types of presses and their use in the printing industry. The student will obtain a working knowledge of letterpress (platen and cylinder) and lithography. This is a two or three quinmester credit course.</p> <p>Prior to entry into this course, the vocational student will display mastery in the skills indicated in Platemaking (9755.04) or Graphic Arts Production Workshop (9755.05).</p>
GRAPHIC ARTS (PRINT)	9757.02	<p><b>ADVANCED BINDERY</b></p> <p>This course is a study of the manipulative skills and related information required in the operation of bindery equipment. This will include safety, cutting, perforating, scoring, creasing, round cornering, punching, drilling, bookbinding operations, and automatic folding. This is a two or three quinmester credit course.</p> <p>Prior to entry into this course, the vocational student will display mastery of Press Operation (9757.01).</p>

VOCATIONAL EDUCATION  
TRADE AND INDUSTRIAL EDUCATION  
512

457

AREA	ACCR. NO. FLA-DADE	COURSE TITLE AND DESCRIPTION
GRAPHIC ARTS (PRINT)	9757.03	<p><b>PAPER AND INK TECHNOLOGY</b></p> <p>In this course, the student will learn the use and application of various papers and inks in the printing industry. Also included are the history of paper, manufacturing, kinds of paper, paper weights, types of inks and their relationship to presswork. This is a two or three quinmester credit course.</p> <p>Prior to entry into this course, the vocational student will display mastery of Advanced Bindery (9757.02).</p>
GRAPHIC ARTS (PRINT)	9757.04	<p><b>GRAPHIC COMMUNICATIONS—SALES AND PRODUCTION</b></p> <p>This course is designed to familiarize the student with front office procedures as it refers to advertising, sales, estimating, preparing job orders, processing of jobs through the plant, shipping, and billing. This is a two or three quinmester credit course.</p> <p>Prior to entry into this course, the vocational student will display mastery in the skills indicated in Paper and Ink Technology (9757.03).</p>

#### INDUSTRIAL ELECTRONICS

IND. ELEC- TRONICS	9323.01	† FUNDAMENTALS OF ELECTRICITY AND ELECTRONICS.
APPL REPAIR	9023.02	
RADIO TV	9783.01	
INDUSTRIAL	5822.01	
ARTS	5823.01	
SCIENCE	5311.51	
	5312.51	
	5313.51	

Provides an exploratory experience in the field of electricity and electronics. The student will be able to answer the following: What is electricity? How is electricity produced? How is electricity distributed? How is electricity used? One quinmester credit.

AREA	ACCR. NO. FLA-DADE	COURSE TITLE AND DESCRIPTION
IND. ELEC- TRONICS RADIO TV INDUSTRIAL ARTS	9323.02 9783.02 5823.03	<p>ALTERNATING CURRENT FUNDAMENTALS</p> <p>Experimentation in, and experience with, wave generation, R/C, L/C, phase relationships, and AC measurements. The student will receive practical application through the design and construction of a power supply unit. One quinmester credit.</p> <p>The industrial arts student will be able to display mastery of the skills and fundamentals indicated in Electricity in Action (5823.02) prior to entry into this course of study.</p> <p>The vocational student will be able to display mastery of the skills and fundamentals indicated in Fundamentals of Electricity and Electronics (9323.01).</p>
IND. ELEC- TRONICS RADIO TV INDUSTRIAL ARTS	9323.03 9783.03 5827.03	<p>TRANSISTORS</p> <p>A study of the principles, theory, and application of transistors to amplifiers (R F, I F, and A F) and oscillators; an introduction to an experimentation with printed circuit techniques. One quinmester credit.</p> <p>The industrial arts student, prior to entry into this course of study, will be able to display mastery of the skills indicated in Vacuum Tube (5827.02).</p> <p>The vocational student will be able to display mastery of the skills and fundamentals indicated in Alternating Current Fundamentals (9323.02).</p>
IND. ELEC- TRONICS RADIO TV MATH	9323.04 9783.04 5214.92	<p>MATH FOR ELECTRONICS</p> <p>Designed for the student interested in preparing for vocational electronics and related fields of electricity. It contains units in slide rule, powers of 10, basic algebra, basic trigonometry related to vector analysis, and logarithms related to decibels. One quinmester credit.</p>
IND. ELEC- TRONICS INDUSTRIAL ARTS	9323.05 5823.04	<p>ELECTRO MECHANICS</p> <p>A study of rotating (motors, generators, alternators) electrical devices and their control circuitry. Some emphasis on consumer product, but heavy emphasis on the associated controlling devices. One quinmester credit.</p> <p>The vocational student will be able to display mastery of the fundamentals and skills indicated in Fundamentals of Electricity and Electronics (9323.01) prior to entry into this course of study.</p>



AREA	ACCR. NO. FLA-DADE	COURSE TITLE AND DESCRIPTION
IND. ELEC- TRONICS	9325.01	† BASIC ELECTRICAL CONCEPTS AND DC CIRCUITS  This course includes elementary physics of electricity, electrical terms and units, measurements, Ohm's law, magnetism, meters, and DC circuit analysis. Comprehensive laboratory experiments relating to the text material will be covered. This is a two or three quinmester credit course.  Prior to entry into this course, the vocational student will display mastery of the skills indicated in Math for Electronics (9323.04).
IND. ELEC- TRONICS	9325.02	† DC CIRCUITS AND INTRODUCTION TO AC  This course of study includes batteries, inductance, capacitance, AC principles, vectors and phase relationships, inductive and capacitive reactance, and impedance. Comprehensive laboratory experiments relating to the text material will be covered. This is a two or three quinmester credit course.  Prior to entry into this course, the vocational student will display mastery of the skills indicated in Basic Electrical Concepts and DC Circuits (9325.01).
IND. ELEC- TRONICS	9325.03	RESONANT CIRCUITS AND INTRODUCTION TO VACUUM TUBES  This course includes AC circuit analysis, series and parallel resonance, transformers, vacuum tube fundamentals, diodes, triodes, tetrodes, pentodes, beam power, multigrid and special purpose tubes. The laboratory experiments relating to the text material will be covered. This is a two or three quinmester credit course.  Prior to entry into this course, the vocational student will display mastery of the skills indicated in DC Circuits and Introduction to AC (9325.02).
IND. ELEC- TRONICS	9325.04	SEMICONDUCTORS (4)  This course includes semiconductor fundamentals, diodes, triodes, tetrodes, power and special purpose transistors, interpreting specifications for vacuum tubes, and semiconductors. The laboratory experiments relating to the text material will be covered. This is a two or three quinmester credit course.  Prior to entry into this course, the vocational student will display mastery of the skills indicated in Resonant Circuits and Introduction to Vacuum Tubes (9325.03).

AREA	ACCR. NO. FLA-DADE	COURSE TITLE AND DESCRIPTION
IND. ELEC- TRONICS	9325.05	<p>† INDEPENDENT STUDY IN ELECTRONICS</p> <p>A study course open to any student who desires to specialize in one particular area of electronics upon approval of his instructor. This is a one, two or three quinmester credit course.</p> <p>Before entry into this quinmester course, the student should have the approval of the industrial electronics instructor.</p>
IND. ELEC- TRONICS	9327.01	<p>† BASIC ELECTRONIC CIRCUITS</p> <p>This course includes electrical and electronic fundamentals, introduction to radio circuits and systems, power supply circuits, mathematics for amplifier circuits, basic amplifiers, transducers, and oscillators. The laboratory experiments relating to the text material will be covered. This is a two or three quinmester credit course.</p> <p>Prior to entry into this course, the vocational student will display mastery of the skills indicated in Semiconductors (4) (9325.04).</p>
IND. ELEC- TRONICS	9327.02	<p>† BASIC ELECTRONIC SYSTEMS</p> <p>This course includes radio frequency amplifiers, AM and FM transmitters, antennas and transmission lines, AM receivers, and comparison of AM and FM. The laboratory experiments relating to the text material will be covered. This is a two or three quinmester credit course.</p> <p>Prior to entry into this course, the vocational student will display mastery of the skills indicated in Basic Electronic Circuits (9327.01).</p>
IND. ELEC- TRONICS	9327.03	<p>ADVANCED ELECTRONIC SYSTEMS I</p> <p>This course includes FM receivers, transistor circuits and systems, single sideband systems, troubleshooting, FCC license preparation, high frequency techniques, nonsinusoidal waves, and special oscillators. The laboratory experiments relating to the text material will be covered. This is a two or three quinmester credit course.</p> <p>Prior to entry into this course, the vocational student will display mastery of the skills indicated in Basic Electronic Systems (9327.02)</p>

AREA	ACCR. NO. FLA-DADE	COURSE TITLE AND DESCRIPTION
IND. ELEC- TRONICS	9327.04	<p>† ADVANCED ELECTRONIC SYSTEMS II</p> <p>This course includes wave shaping, limiters, clamping circuits, counters, sweep circuits, special power supplies, test equipment, advanced transistor circuits, and TV transmission and reception. The laboratory experiments relating to the text material will be covered. This is a two or three quinmester credit course.</p> <p>Prior to entry into this course, the vocational student will display mastery of the skills indicated in Advanced Electronic Systems I (9327.03).</p>
		QUALITY CONTROL
QUALITY CONTROL	9225.01	<p>INTRODUCTION TO MEASUREMENT AND THE USE OF SCALED INSTRUMENTS</p> <p>Explains the need for correct measurement and language of measurement; techniques used in reading and using various scaled and vernier instruments. Three quinmester credits.</p>
QUALITY CONTROL	9225.02	<p>MICROMETER INSTRUMENTS</p> <p>History and principles of the micrometer; techniques in reading and using the micrometer; checking, adjusting, and calibrating the micrometer. Three quinmester credits.</p>
QUALITY CONTROL	9225.03	<p>USING GAGE BLOCKS AS MEASURING STANDARDS</p> <p>Evolution of standards and the history of gage blocks; correct nomenclature, used with gage blocks; techniques in the use and care of gage blocks. Three quinmester credits.</p>
QUALITY CONTROL	9225.04	<p>DIAL INDICATIONS AND HIGH AMPLIFICATION INSTRUMENTS</p> <p>An introduction to comparison measurement; methods of amplification types of instruments and scale selections; care and calibration of these instruments. Three quinmester credits.</p>

AREA	ACCR. NO. FLA-DADE	COURSE TITLE AND DESCRIPTION
QUALITY CONTROL	9225.05	<p>CALIBRATION OF INSTRUMENTS, OPTICAL FLATS, SURFACE AND ANGLE MEASUREMENT</p> <p>Type of measurement errors and the interaction of these errors; the theory of waveform and light waves in measuring; application of the optical flat for measurement; reading the results when using optical flats; definition of reference plane and flatness; types of surface plates and proper care of these plates; understanding geometric angles and bubble levels; techniques in using the universal level and protractor and sine bar. Three quinmester credits.</p>
QUALITY CONTROL	9227.01	<p>METALLURGY, VISUAL INSPECTION, HARDNESS AND LIQUID PENETRANT TESTING</p> <p>This course covers the basic and simple methods of testing; fundamentals of metallurgy which are necessary for all testing of metals; hardness testing by mechanical and electrical means. Three quinmester credits.</p>
QUALITY CONTROL	9227.02	<p>RADIOGRAPHIC AND THERMAL TESTING</p> <p>Theory and principles of radiography and infrared rays; equipment used in these methods; standards used; interpretation of x-ray film and films used in radiography; advantages and limitations of these methods; care of the equipment, safety and work precautions. Three quinmester credits.</p>
QUALITY CONTROL	9227.03	<p>ULTRASONIC TESTING</p> <p>This course covers the theory of sound; calibrating the equipment and the use of standards; methods and interpretation of indications; operating and care of the equipment; safety work precautions. Three quinmester credits.</p>
QUALITY CONTROL	9227.04	<p>EDDY CURRENT AND MAGNETIC PARTICLE TESTING</p> <p>This course includes the principles of eddy current and magnetic particle testing; hardness testing; heat treat condition and alloy identification; use of standards for analyzing test results; techniques of operating equipment; interpretation of indications; advantages and limitations of this method of testing; care and calibration of equipment; safety and work precautions. Three quinmester credits.</p>

AREA	ACCR. NO. FLA-DADE	COURSE TITLE AND DESCRIPTION
<b>RADIO AND TELEVISION SERVICE</b>		
RADIO TV APPL REPAIR IND. ELEC- TRONICS INDUSTRIAL ARTS SCIENCE	9783.01 9023.02 9323.01 5822.01 5823.01 5311.51 5312.51 5313.51	<p>† FUNDAMENTALS OF ELECTRICITY AND ELECTRONICS</p> <p>Provides an exploratory experience in the field of electricity and electronics. The student will be able to answer the following: What is electricity? How is electricity produced? How is electricity distributed? How is electricity used? One quinmester credit.</p>
RADIO TV IND. ELEC- TRONICS INDUSTRIAL ARTS	9783.02 9323.02 5823.03	<p>ALTERNATING CURRENT FUNDAMENTALS</p> <p>Experimentation in, and experience with, wave generation, R/C, L/C, phase relationships, and AC measurements. The student will receive practical application through the design and construction of a power supply unit. One quinmester credit.</p> <p>The industrial arts student will be able to display mastery of the skills and fundamentals indicated in Electricity in Action (5823.02) prior to entry into this course of study.</p> <p>The vocational student will be able to display mastery of the skills and fundamentals indicated in Fundamentals of Electricity and Electronics (9323.01).</p>
RADIO TV IND. ELEC- TRONICS INDUSTRIAL ARTS	9783.03 9323.03 5827.03	<p>TRANSISTORS</p> <p>A study of the principles, theory, and application of transistors to amplifiers (R.F., I.F., and A.F.) and oscillators; an introduction to an experimentation with printed circuit techniques. One quinmester credit.</p> <p>The industrial arts student, prior to entry into this course of study, will be able to display mastery of the skills indicated in Vacuum Tube (5827.02).</p> <p>The vocational student will be able to display mastery of the skills and fundamentals indicated in Alternating Current Fundamentals (9323.02).</p>

VOCATIONAL EDUCATION  
TRADE AND INDUSTRIAL EDUCATION  
519

504

AREA	ACCR. NO. FLA-DADE	COURSE TITLE AND DESCRIPTION
RADIO TV IND. ELEC. TRONICS MATH	9783.04 9323.04 5214.92	<b>MATH FOR ELECTRONICS</b>  Designed for the student interested in preparing for vocational electronics and related fields of electricity. It contains units in slide rule, powers of 10, basic algebra, basic trigonometry related to vector analysis, and logarithms related to decibels. One quinmester credit.
RADIO TV	9783.05	<b>INDEPENDENT STUDY IN RADIO/TV SERVICE</b>  This quin is offered to give the student an opportunity to increase his competency by engaging in selected construction and troubleshooting projects on an individual study basis. This is a one or two quinmester credit course.  Prior to entry into this course, the vocational student will display mastery of the skills indicated in Math for Electronics (9783.04).
RADIO TV	9785.01	<b>FUNDAMENTAL ELECTRICAL PRINCIPLES</b>  A study in depth of basic electron theory, electrical units and measurements, Ohm's and Watt's laws, series and parallel circuits, magnetism, and introduction to A.C. Laboratory experiments relating to the text material will be covered. This is a two or three quinmester credit course.  Prior to entry into this course, the vocational student will display mastery of the skills indicated in Independent Study in Radio/TV Service (9783.05) or Math for Electronics (9783.04).
RADIO TV	9785.02	<b>A C CIRCUITS AND ACTIVE DEVICES</b>  A study in depth of inductance, capacitance, transformers, A C circuit analysis, vacuum tube fundamentals, semiconductor physics, and transistor fundamentals. Laboratory experiments relating to the text material will be covered. This is a two or three quinmester credit course.  Prior to entry into this course the vocational student will display mastery of the skills indicated in Fundamental Electrical Principles (9785.01).

VOCATIONAL EDUCATION  
TRADE AND INDUSTRIAL EDUCATION  
520

505

AREA	ACCR. NO. FLA-DADE	COURSE TITLE AND DESCRIPTION
RADIO TV	9785.03	<p><b>BASIC RADIO CIRCUITS AND VACUUM TUBE A.M. TROUBLESHOOTING</b></p> <p>A study in depth of basic circuits found in radio receivers. Also included is a study of complete vacuum tube radio receivers, including troubleshooting. Laboratory experiments, construction projects, and live production work supplement the related text material. This is a two or three quinmester credit course.</p> <p>Prior to entry into this course, the vocational student will display mastery of the skills indicated in A C Circuits and Active Devices (9785.02).</p>
RADIO TV	9785.04	<p><b>TRANSISTOR RADIO RECEIVERS</b></p> <p>This course covers all types of transistor receivers, including A M, F M, auto radio, and F M multiplex stereo. The related text material is supplemented by laboratory experiments, construction projects, and live production jobs. This is a two or three quinmester course.</p> <p>Prior to entry into this course, the vocational student will display mastery of the skills indicated in Basic Radio Circuits and Vacuum Tube A-M Troubleshooting (9785.03).</p>
RADIO TV	9785.05	<p><b>RADIO REPAIR WORKSHOP</b></p> <p>Designed for the student to upgrade his skills and broaden his knowledge of the overall industry. Activities will consist of selected production jobs, construction projects, and field trips. This is a two or three quinmester credit course.</p> <p>Prior to entry into this course, the vocational student will display mastery of the skills indicated in Transistor Radio Receivers (9785.04).</p>
RADIO TV	9787.01	<p><b>INTRODUCTION TO TELEVISION</b></p> <p>This course includes a study of television transmission and reception, antenna and receiver installation, types and uses of test equipment, and power supply circuits. Laboratory experiments relating to the text material will be covered. This is a two or three credit course.</p> <p>Prior to entry into this course, the vocational student will display mastery of the skills indicated in Radio Repair Workshop (9785.05) or Transistor Radio Receivers (9785.04).</p>

AREA	ACCR. NO. FLA-DADE	COURSE TITLE AND DESCRIPTION
RADIO TV	9787.02	TELEVISION SWEEP CIRCUITS AND PICTURE SIGNAL PATH  A study of the horizontal, vertical, synchronization, tuner, picture IF, video, and AGC circuits of a black and white television receiver. Laboratory experiments relating to the text material will be covered. This is a two or three quinmester credit course.  Prior to entry into this course, the vocational student will display mastery of the skills indicated in Introduction to Television (9787.01).
RADIO TV	9787.03	THE COMPLETE BLACK AND WHITE TELEVISION RECEIVER AND INTRODUCTION TO COLOR  A study of the sound signal path, black and white picture tube, alignment procedures, remote control systems, and theory of color receiver circuits. Laboratory experiments and live production work on black and white television receivers supplement the related text material. This is a two or three quinmester credit course.  Prior to entry into this course, the vocational student will display mastery of the skills indicated in Television Sweep Circuits and Picture Signal Path (9787.02).
RADIO TV	9787.04	THE COLOR TV  A study of color signal demodulation and matrix circuits, the color picture tube, alignment and troubleshooting of a color television receiver. Laboratory experiments and live production work on color television receivers supplement the related text material. This is a two or three quinmester credit course.  Prior to entry into this course, the vocational student will display mastery of the skills indicated in The Complete Black and White Television Receiver and Introduction to Color (9787.03).



AREA	ACCR. NO. FLA-DADE	COURSE TITLE AND DESCRIPTION
		<b>WELDING</b>
WELDING	9945.01	<b>BASIC ARC WELDING</b>  A foundation course in the basic principles of arc welding procedures, including safety orientation, theory, and practical applications. Three quinmester credits.
WELDING	9945.02	<b>ADVANCED ARC WELDING</b>  Basic Arc Welding (9945.01) required for this course. This course will provide the student with the practical exercises necessary to achieve proficiency in all positions of welding and the uses of different welding positions relating to industry. It also includes preparation of plate and oxyacetylene cutting. Three quinmester credits.
WELDING	9945.03	<b>ARC WELDING PIPE</b>  This course provides for the oxyacetylene cutting and beveling of pipe, both hand and semiautomatic equipment. Included is welding pipe from 6"-12" sch. 80 inclusive, by uphand and downhand methods, in 1G-2G-5G positions. The course is provided for students who have completed Basic and Advanced Arc Welding (9945.01, 9945.02). Three quinmester credits.
WELDING	9945.04	<b>GAS METAL ARC WELDING (MIG)</b>  There are four methods included in this course to "round" out a wire welder. <ol style="list-style-type: none"> <li>1. Small wire (MICRO WIRE)</li> <li>2. CO<sub>2</sub> large wire</li> <li>3. Inert gas shielding</li> <li>4. Flux cored wire</li> </ol> These methods involve practice and theory for each process. Completion of Basic Arc Welding, Advanced Arc Welding, and Arc Welding Pipe (9945.01, 9945.02, 9945.03) is required.  MICRO WIRE Pipe Welding is the second section of the course, intended to furnish welders with pipe welding proficiency, using micro wire equipment. It will encompass all positions of pipe, 1G-2G-5G, and include instruction in fit up and alignment of pipe. Three quinmester credits.



AREA	ACCR. NO. FLA-DADE	COURSE TITLE AND DESCRIPTION
WELDING	9945.05	<p><b>GAS TUNGSTEN ARC WELDING (TIG)</b></p> <p>The nature of TIG processes makes it desirable that Basic Arc Welding (9945.01) and Gas Metal Arc Welding (9945.04) be taken for this phase of welding. This welding is widely used in all industry; the course would encompass instruction in welding aluminum and stainless steel, in addition to other metals.</p> <p>Automatic Welding is the second phase of this course. Used in industry, automatic welding would utilize such equipment as:</p> <ol style="list-style-type: none"> <li>1. Submerged arc—Heavy plate</li> <li>2. Submerged arc—Light gage.</li> <li>3. Gas Metal (MICRO WIRE)</li> <li>4. Semiautomatic flux cored arc welding</li> </ol> <p>Basic, Advanced, and Gas Metal Arc Welding (MIG) (9945.01, 9945.02, 9945.04) are required for this section. Three quinmester credits.</p>
WELDING	9947.01	<p><b>BASIC GAS WELDING</b></p> <p>A foundation course to instruct the student in safety, practical applications, theory, and materials and tools used in the welding shop. Course includes instruction in light and heavy gage metal, and groove and fillet welding. Three quinmester credits.</p>
WELDING	9947.02	<p><b>ADVANCED GAS WELDING</b></p> <p>To meet requirements of industry, this course will provide instruction in the joining of dissimilar metals, silver soldering, brazing, and welding and brazing of similar metals. Basic Gas Welding (9947.01) is required before entry into this course. Three quinmester credits.</p>
WELDING	9947.03	<p><b>GAS WELDING PIPE AND PIPE TEMPLATE LAYOUT</b></p> <p>Course includes layout of pipe fittings, pipe branches, and the welding techniques necessary to assemble them. Use of contour markers and other related tools are examined. Basic Gas Welding (9947.01) is required before entry into this course. Three quinmester credits.</p>

AREA	ACCR. NO. FLA-DADE	COURSE TITLE AND DESCRIPTION
WELDING	9947.04	WELDING SYMBOLS-BLUEPRINT READING FOR WELDERS, PIPE TEMPLATE LAYOUT

This course is for students who wish to advance to the level that industry requires of foremen or leading men in the welding field. It will impart the basic knowledge necessary to read plans and convert them to material construction. Three quinmester credits.

WELDING	9947.05	UNDERWATER WELDING AND CUTTING
---------	---------	--------------------------------

Designed for students interested in underwater salvage or marine work and certain other industrial applications. This course will consist of safety, theory, and practical exercise needed to create a skilled underwater mechanic or diver. Basic and Advanced Arc Welding (9945.01 and 9945.02) and Basic and Advanced Gas Welding (9947.01 and 9947.02) are required before entry into this course. Three quinmester credits.

APPENDIXES

## APPENDIX A:

### STUDY RELATED TO EFFECTIVE FAMILY LIVING

The courses listed in this section have been approved to fulfill the requirement for two semesters, or four quinesters, of study related to effective family living (Revised Board Regulation 5127, Graduation Requirements). This study must be completed by all students, both boys and girls, between grades seven and twelve. The requirement is effective in full for those students who are beginning seventh grade in the 1972-73 school year. Students who are in grades eight, nine, or ten in the 1972-73 school year must complete one semester (two quinesters) before high school graduation. Students in grades eleven or twelve in the 1972-73 school year are not affected by this requirement. This requirement is subject to waiver for individual students by the principal.

Six major themes have been identified as being appropriate bases for instructional experiences related to the study of effective family living:

1. Family Economics and Management
2. Personal, Family, and Social Relationships
3. Human Development and the Family
4. The Home Environment
5. Food and Nutrition for the Family
6. Clothing for the Family

Existing courses designed to meet the requirement are listed in this appendix in categories related to their appropriate themes.

The junior high school will provide eighteen weeks of instruction appropriate for junior high school students related to any two of the six themes. The senior high school will provide eighteen weeks of instruction appropriate for senior high school students related to any two of the six themes. The way in which schools will meet the eighteen weeks requirement must be on file in the district office and in the Division of Instruction. It is the responsibility of the district office, in reviewing school plans for providing this program of study, to assure that a variety of themes are dealt with within grades seven through twelve. Quinester courses indicated as interdisciplinary that are selected to meet the requirements for study relating to effective family living may be used to satisfy other graduation requirements, e.g., in social studies.

The themes and the courses of study for each are as follows.

1. Family Economics and Management

*Regular courses*  
Family Economics

*Quinester Courses*  
Dollars and Sense  
S.O.S.—Spend or Save  
In the Marketplace  
The Dual Role  
Decision Making for the Home  
(or Appliance Ability)

2. Personal, Family, and Social Relationships

*Regular Courses*

Sociology  
Sociology (Human Relations)  
Home and Family Education 8  
Comprehensive Home and  
Family Education  
Personal, Family, and Social Relations  
Family Living

*Quinmester Courses*

Introduction to Sociology  
Teen-age Living  
Teen Changes  
The Dating Years  
As Others See You  
Becoming an Adult  
Understanding Individual Behavior  
Human Relations  
The Changing Family

3. Human Development, and the Family

*Regular Courses*

Psychology  
Child Development

*Quinmester Courses*

Rings 'n Things  
Marriage Day by Day  
The Family and Crises  
As the Twig Is Bent: Birth to Age 2  
Trusting Threes to Fetching Fives  
Preface to a Life  
Off 'n Running: Ages 6-12  
Child Behavior  
Parenthood  
Sitting Safely

4. The Home Environment (design, maintenance, repair)

*Regular Courses*

Housing and Home Furnishings

*Quinmester Courses*

Intelligent Buyer and Repairer for  
Green Acres  
Interior Decorating for Teens  
Choosing Your Home  
Decorating Your First Home  
Architectural Planning  
Architectural Appreciation Design

5. Food and Nutrition for the Family

*Regular Courses*

*Quinmester Courses*

Beginning to Cook  
Menu Magic  
Creative Baking  
Creative Cooking  
Entertaining with a Flair  
Food with a Foreign Flavor  
Outdoor Cookery  
Cooking for Two  
Menus for Young Moderns  
Food Sense and Dollars

6. Clothing for the Family

*Regular Courses*

*Quinmester Courses*

Novice Knowledge in Sewing  
Fashion Dollar Why's (or Fashion Why's)  
Sew-So-Easy  
Sew-So-Well  
Fun with Fabrics (or Fascinating Fabrics)  
Creative Fashions I

COURSES APPROVED FOR  
STUDY RELATED TO EFFECTIVE FAMILY LIVING

The following are regular courses for schools operating on the regular school organizational plan (two-semester academic year).

NUMBER	COURSE TITLE AND NOTES	DESCRIPTION
6425	Sociology Grade 12 1/2 unit Prerequisite: None (SOC)	Deals with a body of knowledge concerning the similarities and uniformities found in various human groups and the patterns of interaction common to different human endeavors. The student is introduced to the basic techniques of the sociologist and to selected areas of sociologic study: population, family, urban life, rural life, stratification, industrial problems, race relations, and crime and delinquency.
6427	Psychology Grade 12 1/2 unit Prerequisite: None (PSYCH)	Designed to assist students in understanding themselves and others through a systematic study of human behavior. Attempts to introduce students to the psychological concepts of: learning, perception, growth and development, communication, thinking, emotions, frustration, personality, and abnormal behavior. Examines issues and problems from the standpoint of a psychologist.
6425	Sociology (Human Relations) Grades 11, 12 1 unit Prerequisite: None (SOC)	Designed to teach pupils to become more understanding of each other, regardless of race, creed, or national origin. Encompassing elements of the disciplines of psychology and sociology, the course examines concepts of personality, perception of others, individual and group conflict, and effective communication.
6752	Home and Family Education 8 Grades 6, 7, 8 (1 year) Prerequisite: None (HOME EC 8)	A course in personal development for boys and girls which may include the development of a positive self-concept; changes in family life; new roles of the teen-ager; understanding of dependence-independence relationship with family; consumer education; working toward economic independence; development of skills for sensitivity in interpersonal relationships; preparation for family living; continued development of a workable philosophy of life.

NUMBER	COURSE TITLE AND NOTED	DESCRIPTION
6753	Comprehensive Home and Family Education Grades 8*, 9*, 10, 11 1 unit Prerequisite: None (HOME EC 1)	A comprehensive course providing boys and girls with exploratory experiences in the various areas of home and family education to include personal, family, and social relationships; child development; consumer education, textiles and clothing; housing and home furnishings; and food and nutrition.
6765	Family Economics Grades 9*, 10, 11, 12 1/2 unit Prerequisite: None (FM EC)	Management by individuals and families, reflecting differences in values, goals, and standards; basic principles of economics; ways in which our economic system affects, and is affected by, the family; factors which determine levels of family income; alternative uses of family income; use of credit to supplement family income; agencies and organizations concerned with family security; occupational and professional opportunities in family economics.
6764	Housing and Home Furnishings Grades 9*, 10, 11, 12 1/2 unit Prerequisite: None (HS&HM FURN)	Cultural aspects of housing in the United States and throughout the world; effects of societal changes on housing; financial aspects of housing; effects of housing on family and interpersonal relations; factors which influence one's choice of housing; achievement of housing essentials by families of varying circumstances; application of principles of aesthetics and management to housing; personal and community responsibility involved in housing; occupational and professional opportunities in housing and home furnishings.
6758	Child Development Grades 9*, 10, 11, 12 1/2 unit Prerequisite: None (CHILD DEV)	Intellectual, physical, emotional, and social development of children from conception to puberty; privileges and responsibilities of parenthood; effects of heredity and environment on children; legislation and social agencies concerned with the welfare of children; characteristics and needs of the exceptional child; community and family responsibilities to children; occupational and professional opportunities in child development.
6763	Personal, Family and Social Relations Grades 9*, 10, 11, 12 1/2 unit Prerequisite: None (PER FM REL)	Understanding and accepting self; extending friendships, changes in family life during last decade; new roles of the older teen-ager; achievement of mature dependence-independence relationship with family; establishment of economic independence; intellectual skills and social sensitivities for civic competence; preparation for marriage and family life, continued development of a workable philosophy of life.

\*No unit toward graduation granted in grade 8 or 9.

APPENDIX A

532

5.5



NUMBER	COURSE TITLE AND NOTES	DESCRIPTION
6757	Family Living Grades 11, 12. 1/2 or 1 unit Prerequisite: None (FM LIV)	Values and attitudes pertaining to human sexuality in home and family living; preparation for marriage; physical, social, emotional, and intellectual growth of children from conception through adolescence; management of the dual role of wage earner and homemaker; identification and differentiation of family roles; crises of families and coping factors; family values, life cycle, and goal setting; management of family resources; feeding, clothing, and housing families; agencies which affect the family; the family as a consuming unit, including consumer education, family economics, and use of consumer services; and recreation.

The following courses are quinmester courses for schools operating on the quinmester plan or for regular school organizations using quinmester curricular materials.

AREA	ACCR. NO. FLA-DADE	COURSE TITLE AND DESCRIPTION
SOCIAL STUDIES	6425.05 6448.49	INTRODUCTION TO SOCIOLOGY  Deals with the body of knowledge concerning human groups, similarities and differences found among various human groups, and the patterns of interaction common to different human endeavors. The student is introduced to the basic techniques of the sociologist and to selected areas of sociological study: population, family, urban living, rural living, race relations, and crime.
HOME AND FAMILY ED. SOCIAL STUDIES,	6763.01 6470.16 6425.01 6412.23 6475.01	TEEN-AGE LIVING  An examination of the changes and challenges confronting the young teen. Focuses on the factors influencing his attitudes, behavior, and relationships with others. Provides an opportunity for self-evaluation and clarification of personal values and goals.
HOME AND FAMILY ED. HEALTH SCIENCE	6763.03 7391.02 7392.02 5311.48 5312.48 5313.48	TEEN CHANGES  An elective unit designed to provide an overview of mental health; personality development; body structure, function, and care. Emphasizes nutritional and health care needs of the teen-ager. The student will assess feelings and attitudes about growth and body changes.

AREA	ACCR. NO. FLA-DADE	COURSE TITLE AND DESCRIPTION
HOME AND FAMILY ED.	6763.07	<p>THE DATING YEARS</p> <p>Examines the decisions facing the young teen-ager during the dating years. Such issues as the responsibilities and privileges that go with increasing maturity, family attitudes toward dating, living according to personal standards, and the contributions these years can make toward self-understanding and maturity will be discussed.</p>
HOME AND FAMILY ED.	6763.04	AS OTHERS SEE YOU
BUSINESS	7713.49	Offers experiences in grooming, and clothing selection and care to male and female students interested in self-improvement and good health. The relationship of personal well-being to success in personal, social, and occupational roles will be analyzed.
EDUCATION	7391.05	
HEALTH	7392.05	
	7393.05 7394.05	
HOME AND FAMILY ED.	6763.05	<p>BECOMING AN ADULT</p> <p>Enables the teen-ager to examine his or her present level of achievement of the developmental goals involved in the process of maturing toward adulthood. The factors involved in achieving sexual identity, emotional independence, effective social relationships, a positive self-concept, and a personal value system will be assessed.</p>
HOME AND FAMILY ED.	6763.07	UNDERSTANDING INDIVIDUAL BEHAVIOR
SOCIAL STUDIES	6427.02 6448.47	A study of the causes of individual behavior through an analysis of the influence of heredity and environment on the individual.
HOME AND FAMILY ED.	6763.08	HUMAN RELATIONS
SOCIAL STUDIES	6425.04 6448.52	An analysis of the ways in which people behave toward each other. Includes group dynamics, ways people communicate, problems of interpersonal relations.
HOME AND FAMILY ED.	6757.01	<p>RINGS 'N THINGS</p> <p>Analyzes factors involved in choosing a husband or wife and the purposes of the engagement period. The influence on marital success of such factors as values and goals, life style, cultural background, age, religion, education, and attitude toward parenthood will be assessed.</p>

AREA	ACCR. NO. FLA-DADE	COURSE TITLE AND DESCRIPTION
HOME AND FAMILY ED.	6757.02	<p><b>MARRIAGE DAY BY DAY</b></p> <p>Designed to enable the student to develop realistic expectations of the marriage commitment in terms of his personal values and goals. Students will analyze typical marital adjustments, examine possible courses of action and determine their impact on family harmony. Topics will include realistic attitudes toward marriage, role expectations, common marital adjustments, importance of adaptability, family life styles, and the establishment of a relationship that encourages personal growth.</p>
HOME AND FAMILY ED. SOCIAL STUDIES	6757.05 6425.15 6448.64	<p><b>THE CHANGING FAMILY</b></p> <p>Analyzes the changes occurring in the family unit in the United States and projects trends in family living. Topics will include the physical and psychological functions of a family, past and present; forms the family unit has taken in various cultures; the effect of the family unit on society; and the impact of social and technological changes on the family unit. Students will examine current issues affecting families.</p>
HOME AND FAMILY ED.	6757.04	<p><b>THE FAMILY AND CRISES</b></p> <p>Examines situations that may lead to family crises and explores alternate courses of action. Topics will include single parents; adoption; emotionally, mentally, or physically handicapped family members. The laws which affect the family unit will be analyzed and the community agencies available to aid the family will be determined.</p>
HOME AND FAMILY ED.	6758.02	<p><b>AS THE TWIG IS BENT: BIRTH TO AGE 2</b></p> <p>Examines the social, emotional, physical, and intellectual development of children from birth through two years of age. Students will demonstrate the ability to provide for the effective care and guidance of these children. Competencies leading toward employment will be developed.</p>

AREA	ACCR. NO. FLA-DADE	COURSE TITLE AND DESCRIPTION
HOME AND FAMILY ED.	6758.03	<p data-bbox="763 447 1333 475"><b>TRUSTING THREES TO FETCHING FIVES</b></p> <p data-bbox="763 512 1511 874">Identification of the stages of growth and development of the child at three, four, and five years of age will be the focus of this course. Emphasis will be placed on choosing appropriate play materials and activities, providing for the health and safety, and using desirable discipline and guidance techniques for children in this age group. The student will have an opportunity to plan and assist in an actual nursery school or to assist and/or observe in a local nursery school near the end of his course work. Employment opportunities and competencies leading toward the development of employable skills will be stressed.</p>
HOME AND FAMILY ED.	6758.01	<p data-bbox="763 932 1046 959"><b>PREFACE TO A LIFE</b></p> <p data-bbox="763 996 1511 1265">Identifies the stages of development of a child from conception through birth. The student will develop an understanding of the process of human reproduction, prenatal development, and childbirth. Discussions will include family planning, responsibilities and adjustments of parenthood, and the many factors involved in providing for a new life. Medical and other professional community resource personnel participate in the presentation of this course.</p>
HOME AND FAMILY ED.	6758.04	<p data-bbox="763 1322 1162 1350"><b>OFF 'N RUNNING: AGES 6-12</b></p> <p data-bbox="763 1386 1511 1575">Focuses on the social, emotional, physical, and intellectual development of the child from six to twelve years of age. The student will have the opportunity to observe and work with school-age children. It is recommended for those students who are considering vocational pursuits in the field of elementary education.</p>
HOME AND FAMILY ED. SOCIAL STUDIES	6758.06 6427.03 6448.48	<p data-bbox="763 1627 1010 1655"><b>CHILD BEHAVIOR</b></p> <p data-bbox="763 1692 1511 1816">An examination of the physical, mental, and emotional growth of children. Includes current theories of child rearing. Emphasis is on the effect of social environment on the development of the child's personality.</p>

AREA	ACCR. NO. FLA-DADE	COURSE TITLE AND DESCRIPTION
HOME AND FAMILY ED.	6757.03	<b>PARENTHOOD</b>  Presentation of the responsibilities of parenthood and the satisfactions that can be derived from meeting these responsibilities in a manner which leads toward overall family harmony. Topics will include the assessment of a couple's readiness for parenthood; awareness of the effects of a child on the marriage relationship; prenatal development; needs of husbands and wives during pregnancy and as new parents; basic principles of child growth and development; providing for the physical, social, emotional, and intellectual needs of children; and the development of a personal philosophy of "parenting."
HOME AND FAMILY ED.	6755.01	<b>SITTING SAFELY</b>  Focuses on the privileges, responsibilities, and characteristics of an effective babysitter. Students will select appropriate activities and evaluate methods of child care based on knowledge of the basic needs of children at various age and developmental levels.
HOME AND FAMILY ED. BUSINESS EDUCATION	6765.01 7734.22 5283.22	<b>DOLLARS AND SENSE</b>  The student plans the management of his or her money to get the most personal satisfaction from it. Includes influence of teen-age spending on the economy, understanding and keeping money records, developing skill in decision making, and planning as a consumer.
HOME AND FAMILY ED.	6765.02	<b>S.O.S.—SPEND OR SAVE</b>  Offers experiences in the management of family money from the time it is earned or acquired until it is put to work to obtain family goals. Emphasis will be placed on methods of saving and investing, determining consumer values, the types and costs of credit, protecting the financial security of the family, and designing a plan for family spending.
HOME AND FAMILY ED. BUSINESS EDUCATION	6765.03 6463.01 5283.23	<b>IN THE MARKETPLACE</b>  Focuses on comparison shopping, store etiquette, impulse buying, reading labels, specials, loss leaders, standards in relation to needs, installment or cash costs.

AREA	ACCR. NO. FLA-DADE	COURSE TITLE AND DESCRIPTION
HOME AND FAMILY ED. INDUSTRIAL ARTS	6765.04 5804.01	INTELLIGENT BUYER AND REPAIRER FOR GREEN ACRES  Experiences in making a variety of general home repairs, including repair of small appliances, plumbing repairs, painting simple wood products, patch plastering, etc. Topics will include consumer information concerning estimating and buying home materials and furnishings, and when a repair should not be attempted.
HOME AND FAMILY ED.	6754.01	THE DUAL ROLE  Designed to prepare the student for his or her homemaking-family member role and the dual role of homemaker and wage earner. Topics will include division of family responsibilities, efficient methods of housekeeping, providing for the care of children, the use of convenience foods, and consumer knowledge necessary to purchase goods and services for the family.
HOME AND FAMILY ED.	6754.02	DECISION MAKING FOR THE HOME (or APPLIANCE ABILITY)  The student will explore alternatives in the selection, maintenance, and arrangement of small and major equipment which will meet individual needs and conserve human resources. The use of electricity, gas, and water in the home to help maintain a safe, efficient, and pleasant environment for the family will be included.
HOME AND FAMILY ED.	6764.01	INTERIOR DECORATING FOR TEENS  An opportunity for the young teen to apply art principles and imagination when planning for the decoration of a room. Factors influencing the choice of home furnishings and their arrangement and care will be included.
HOME AND FAMILY ED. BUSINESS EDUCATION	6764.02 6463.04	CHOOSING YOUR HOME  Explores the choices available when selecting and financing a home. Topics will include how people are housed, our housing heritage, housing values and their influence on behavior, types of housing available in the community, styles of architecture, buying vs. renting, and the factors to consider when landscaping and maintaining a home.

AREA	ACCR. NO. FLA-DADE	COURSE TITLE AND DESCRIPTION
HOME AND FAMILY ED.	6764.03	DECORATING YOUR FIRST HOME  Emphasizes the decisions young people make when selecting furnishings and decorating their first home. Experience in using art principles when selecting and arranging furniture; treating backgrounds such as window, wall, and floor areas; and selecting the accessories will be included.
HOME AND FAMILY ED. INDUSTRIAL ARTS	6764.05 5807.01	ARCHITECTURAL PLANNING  Includes the design and drawing of a floor plan, foundation and necessary wall sections of a single family residence. The logical relationship of the arrangement of living areas will be emphasized. Exterior designs will be studied in relationship to the natural surroundings and community. Material used in construction will be studied.
HOME AND FAMILY ED. INDUSTRIAL ARTS	6764.06 5807.04	ARCHITECTURAL APPRECIATION DESIGN  A study of the history and development of architecture through the cultures of the world, utilization of space to meet family needs, design of single family residences, new building techniques, and local building codes.
HOME AND FAMILY ED.	6766.02	NOVICE KNOWLEDGE IN SEWING  The student who is interested in exploring the area of sewing at a young age will be given the opportunity to construct a simple project such as a cape, poncho, tie, scarf, chef's apron, or beach bag. Students will learn the basic techniques of pattern usage and clothing construction, but emphasis will be on the advantages of sewing and the satisfactions to be gained through clothing construction.
HOME AND FAMILY ED.	6766.07	FASHION DOLLAR WHY'S (or FASHION WHY'S)  In order to get the most from their clothing dollars, students will examine credit buying, interpret fads vs. fashions, judge labels, and compare home-constructed garments to ready-made clothing. Experiences in recognizing suitable clothing for school, the world of work, and special occasions will be provided. They will apply their knowledge by planning and evaluating their personal wardrobe.

AREA	ACCR. NO. FLA-DADE	COURSE TITLE AND DESCRIPTION
HOME AND FAMILY ED.	6766.03	<p><b>SEW-SO-EASY</b></p> <p>Constructing a simple garment such as a jumper, skirt, or polo shirt will give the student experience in pattern selection and adjustment; selection and preparation of fabrics; and the basic techniques used in pressing, staystitching, interfacings, facings, darts, zippers, seams, and hems.</p>
HOME AND FAMILY ED.	6766.04	<p><b>SEW-SO-WELL</b></p> <p>The intermediate student will construct a garment which has a collar and set-in sleeves. Opportunities will be provided in the selection of fabric and pattern styles becoming to the individual.</p>
HOME AND FAMILY ED.	6766.09	<p><b>FUN WITH FABRICS (or FASCINATING FABRICS)</b></p> <p>Includes experimentation in various methods of fabric design and construction such as weaving, knitting, tie-dyeing, and batik. The student will identify and classify textiles and their characteristics in order to make wiser decisions when purchasing and caring for the many fabrics available on today's market. Career opportunities in the textile and clothing industry will be explored.</p>
HOME AND FAMILY ED.	6766.10	<p><b>CREATIVE FASHIONS I</b></p> <p>After defining the art elements and design principles and using them to create original designs, the student will demonstrate ability to select clothing which is suitable for each figure type. The occupational field of fashion design and its history will be explored.</p>
HOME AND FAMILY ED.	6768.01	<p><b>BEGINNING TO COOK</b></p> <p>Opportunities for students to demonstrate his or her ability to perform basic skills in food preparation through a knowledge of vocabulary, measurements, kitchen equipment and appliances, and practical preparation techniques.</p>



AREA	ACCR. NO. FLA-DADE	COURSE TITLE AND DESCRIPTION
HOME AND FAMILY ED.	6768.02	<p><b>MENU MAGIC</b></p> <p>Experiences will be offered in preparation and serving food, taking into consideration the nutritional needs of the teen-ager and his family. A knowledge of the Basic Four food groups will be applied to the planning and preparation of meals.</p>
HOME AND FAMILY ED.	6768.03	<p><b>CREATIVE BAKING</b></p> <p>The student will demonstrate his or her baking skills by preparing cakes, pies, pastries, and breads. An emphasis will be placed on creativity in decorating and designing attractive baked goods.</p>
HOME AND FAMILY ED.	6768.04	<p><b>CREATIVE COOKING</b></p> <p>The application of imagination to developed food preparation skills is the theme of this course. The student will create a variety of interesting and attractively served dishes to include meats, casseroles, salads, fruits, vegetables, party foods, and desserts. Skill in preparing food properly to retain maximum quality, development of one's own recipes, and serving food attractively will be emphasized.</p>
HOME AND FAMILY ED.	6768.08	<p><b>ENTERTAINING WITH A FLAIR</b></p> <p>Students will develop the skills necessary to be successful hosts, hostesses, and guests. They will gain experience in planning and serving food for informal and formal occasions. Topics will include types of table service and appointments, etiquette, party management, and hospitality.</p>
HOME AND FAMILY ED.	6768.09	<p><b>FOOD WITH A FOREIGN FLAVOR</b></p> <p>Through a study of food customs and the preparation of dishes typical of many countries around the world, the student will be taking a cook's tour of other lands. This course will emphasize the pleasure in the discovery of new ideas, customs, people, and foods.</p>

AREA	ACCR. NO. FLA-DADE	COURSE TITLE AND DESCRIPTION
HOME AND FAMILY ED.	6768.10	<b>OUTDOOR COOKERY</b> Experiences provided in the informal preparation of food outside the kitchen. Topics include barbequeing, camping, picnics, and outdoor parties.
HOME AND FAMILY ED.	6768.05	<b>COOKING FOR TWO</b> Centers around preparation and serving of nutritious meals planned for two people. Experiences will include a review of concepts of basic nutrition, meal planning, food purchasing and preparation, as well as the use of convenience foods and the planning and organization of a basic kitchen.
HOME AND FAMILY ED.	6768.06	<b>MENUS FOR YOUNG MODERNS</b> Opportunities for advanced student to plan, prepare, and serve meals which meet the nutritional needs of individual family members within various income levels. Experiences will include preparation of foods associated with various family backgrounds, a study of nutrients and how they can be preserved in foods, and the use of convenience foods.
HOME AND FAMILY ED.	6768.07	<b>FOOD SENSE AND DOLLARS</b> A study of how the food dollar can be wisely spent by the consumer. Areas include food purchasing on various income levels; getting the most for the dollar, taking into consideration the number of family members; comparing convenience foods and foods made with raw products; becoming skillful at selecting foods; evaluating various types of food advertisements; and protection available to the consumer through laws and agencies.