

DOCUMENT RESUME

ED 064 044

SE 012 721

TITLE Primary Science Curriculum Guide, C. Branching Out.

INSTITUTION Victoria Education Dept. (Australia).

PUB DATE 69

NOTE 152p.

EDRS PRICE MF-\$0.65 HC-\$6.58

DESCRIPTORS Biology; *Curriculum; *Elementary School Science; General Science; Instruction; *Interdisciplinary Approach; Physical Sciences; *Science Activities; *Teaching Guides

IDENTIFIERS Australia

ABSTRACT

Examples of reports from children in grades 4-6 of Education Department of Victoria schools are used to illustrate the suggestions made for teaching the topics included in the science course. Emphasis is given to methods of inter-relating science and other activities, including social studies, mathematics, writing and history. Teachers are encouraged to provide children with extensive manipulative and experimental experiences. The topics discussed in the section on "Matter" concern the nature of liquids, diffusion, separation of materials, corrosion, the production of gas, and other examples of chemical and physical changes in household materials. "Energy" includes studies of heating and cooling, electricity and magnetism, light, sound, and movement. In "Life" the topics are primarily concerned with behavior, ecological principles, and growth.

(AL)

U.S. DEPARTMENT OF HEALTH,
EDUCATION & WELFARE
OFFICE OF EDUCATION
THIS DOCUMENT HAS BEEN REPRO-
DUCED EXACTLY AS RECEIVED FROM
THE PERSON OR ORGANIZATION ORIG-
INATING IT. POINTS OF VIEW OR OPIN-
IONS STATED DO NOT NECESSARILY
REPRESENT OFFICIAL OFFICE OF EDU-
CATION POSITION OR POLICY

ED 004047

EXPERIENCE

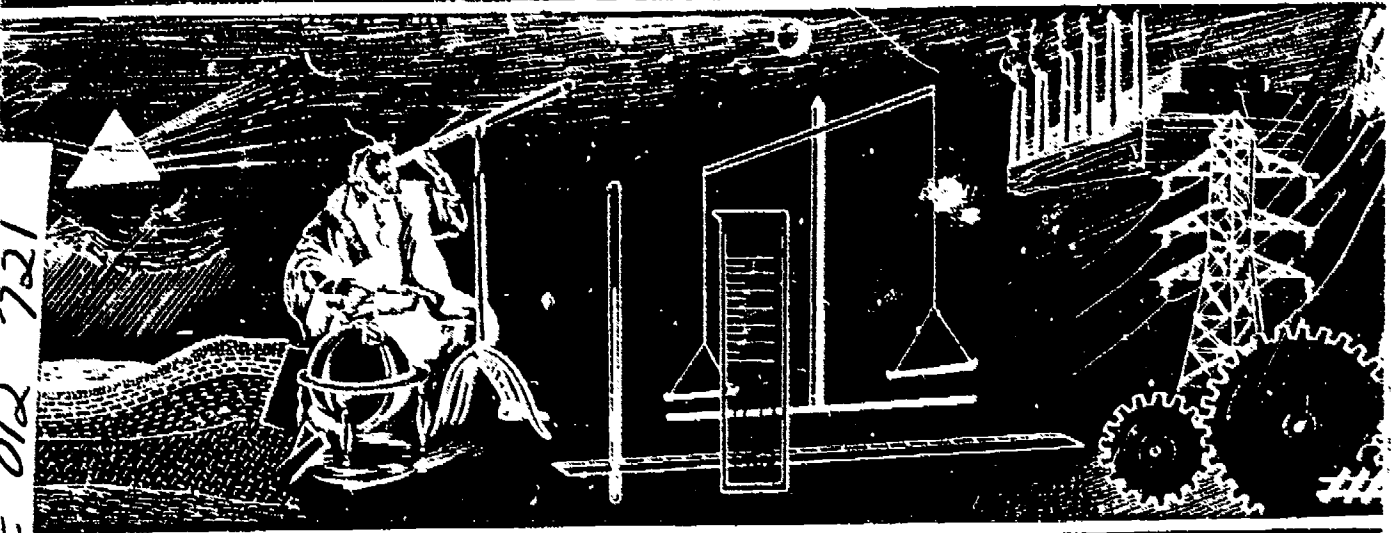

128 P10 721

CURRICULUM GUIDE

PRIMARY SCIENCE

C. BRANCHING OUT

PERMISSION TO REPRODUCE THIS COPY-
RIGHTED MATERIAL HAS BEEN GRANTED
BY

G. McK. Brown

TO ERIC AND ORGANIZATIONS OPERATING
UNDER AGREEMENTS WITH THE U.S. OFFICE
OF EDUCATION FURTHER REPRODUCTION
OUTSIDE THE ERIC SYSTEM REQUIRES PER-
MISSION OF THE COPYRIGHT OWNER

EDUCATION DEPARTMENT OF VICTORIA

2274/69.



CONTENTS

	PAGE
Notes on Using the Curriculum Guide	5
How to Begin—An Introduction to the Curriculum Guide ..	5
Developing Abilities	5

PART I: MATTER

A. Nature of Materials

Comparisons of Liquids	9
Diffusion through Liquids	14
Separating Materials	15
Rising Liquids	17
Chromatography	20
Hardness, Brittleness, and Elasticity	24
Threads and Fibres	29
Glass, Bricks, Pots, and a Kiln	36

B. Bringing About Change

Corrosion	38
The Results of Change	41
Boiling an Egg	44
Making Coal-gas	46
The Souring of Milk	49
Household Chemicals and Change	52

PART II: ENERGY

Fire	57
Heating and Cooling	61
Evaporation and Cooling	63
Thermometers	65
Expanding and Contracting	68
Things Getting Hot	69
Keeping Heat Out, and In	70
Magnets	71
Electricity	74
Static Electricity	80
Experiences with Light	82
Working with Sound	89
Making Objects Move	96
Galileo—the Solar System and Beyond	103
Happenings at a Distance	108

PART III : LIFE

	PAGE
Collecting and Caring	115
Groupings and Communities	115
Some Communities	116
A Possible Classroom Approach	117
Notes on Sample Communities	118
A Tree	118
The School-ground	119
A Vacant Allotment	119
Hay Infusions	121
Conservation	122
Behaviours	123
Growing Old.. .. .	123
Structure	127
Food and Feeding	129
Response to Stimuli	130
Slaters	134
Slugs and Snails	137
Life Stories	141
Growth of Populations	141
A Garden of Moulds	143
Incubating Eggs : The Development of an Embryo	145
Birth, Development, and Care of Young Animals	147
Patterns of Care among People	148
Men and Science	152

NOTES ON USING THE CURRICULUM GUIDE

The Curriculum Guide contains many suggestions on methods of approach. It is suggested that the aims of the course are most likely to be achieved if children's interests are developed. A method that emphasizes instruction is not desirable. *The Curriculum Guide should be regarded simply as source material showing how ideas might be followed up. The units in the Guide should under no circumstances be regarded as outlines for class lessons.* Nor should the units be regarded as a complete description of possible activities. If work in science arises out of children's interests, and if the children are encouraged to develop their own lines of inquiry, it is to be expected that unit barriers (and subject barriers) will be broken down. For example, an investigation arising out of an interest in magnets might widen into what may appear to be, at first glance, a quite unrelated topic. Work with magnets might lead to an interest in electricity, which in turn might lead to investigations into heating and cooling, then into the making of coal-gas, a study of air, and, perhaps, might finish with a study of the breathing of animals. In this way work in the three main sections of the course—matter, energy, and life—can often arise naturally from one starting-point.

Such a flexible approach to the teaching of science is most desirable, particularly when it follows the natural interests of the children. For the aims of the course, refer to the *Course of Study for Primary Schools, Science*. The Course of Study also includes introductory remarks to the sections on matter, energy, and life.

HOW TO BEGIN

AN INTRODUCTION TO THE CURRICULUM GUIDE

Refer to the primary science Curriculum Guide A—*Beginning Science*.

DEVELOPING ABILITIES

The developing of abilities is a vital part of primary science at all levels. It is necessary, therefore, that reference be made to Developing Abilities in the primary science Curriculum Guide B—*Following On*, before commencing work on the following units.

5/6

PART I
MATTER

7

7

CHROMATOGRAPHY

(Separating Colours)

We drew some red yellow orange and purple squares in terna and dipped the paper in methylated spirits. The yellow made a thin layer over the red and orange.

Bird
The methylated spirits has lifted the colours green and orange food dye the orange has separated.

We drew a black band in terna. We then dipped the piece of paper in methylated spirits. We think the black is made up of the colours that ran.

We obtained some red and blue ink and mixed it together. The blue ink separated and settled on the top.



PART I: MATTER

For a full understanding of the material that follows it is essential to refer to the introductory remarks on matter in the *Course of Study for Primary Schools, Science*.

A. NATURE OF MATERIALS COMPARISONS OF LIQUIDS

The activities in this unit have been designed to develop children's awareness of the differences in the structure and the behaviour of various liquids. Most of the activities deal with surface tension, but this term need not be used, nor should the teacher feel that he has to teach facts about surface tension. Children should be helped to organize their activities and encouraged to formulate their own theories and to test them.

The work should be done at a leisurely pace, and at the same time interest in other science projects should continue. The teacher should note any development in the children's initiative and also any improvement in their ability to organize and discuss findings. The free, written accounts made by children will show this improvement, if it occurs.

Introducing the Topic

This topic might arise naturally from observation of raindrops on a window, or of milk, ink, or water spilt on the floor or a desk.

Floating Razor Blades

Children may experiment by attempting to float needles, razor blades, and other suitable materials that they themselves suggest, on the surface of water. They should carefully observe the floating razor blades, using magnifying glasses if they so wish, and note the conditions in which the razor blades will rest on the surface.

Some children will notice only that the razor blades rest or float on the water, but there is more than this to observe. They should be encouraged to look from the side and to report even the slightest detail of what they see. It is hoped that the children will note that the razor blades seem to be resting in depressions in the surface of the water.

Note.—Care should be taken when handling razor blades. Blunted blades could be used.

Drops

Children should be asked to bring to school eye-droppers, a variety of liquids (such as water, oil, detergent, methylated spirits), and a variety of materials (such as waxed lunch-wrap paper, aluminium foil, glass, and scraps of vinyl or plastic) on which drops of the liquids may be placed.

Children might be interested in comparing the size of drops of different liquids. (This is not the same thing as comparing shape or heaping-up drops, which is mentioned later.) This can be done by putting a number of drops (say 50 or 100) of a liquid into a test-tube,

junket-tablet tube, or pill tube, and measuring against the same number of drops of various other liquids put into tubes of similar shape and size.

Children may note the shape of one drop of a chosen liquid on a particular surface, and then note any changes as they make their drop grow by adding more drops.

Children should compare drops of one liquid with drops of other liquids. They should become aware of the fact that water-drops are bigger, stronger, and more heaped-up than oil drops.

At this stage, children may experiment with their own, using any or all of the materials on hand. Droppers that have held one type of liquid should not be used for other liquids. If a dropper is first used for a detergent and then used for water, the drops will not heap up so readily. To overcome this problem a supply of milk straws should be on hand to replace the eye-droppers. Some preliminary experiences with eye-droppers are advisable, however, because with the eye-droppers the shape and the size of the drops that adhere to them can be more readily examined.

Children will find that for these experiments some surfaces give better results than others. Glass, for example, does not permit the development of really strong, heaped-up drops.

If small drinking glasses or even tin lids are available, the following experiment could be performed and children asked to forecast which liquid would overflow out of its container first. Each container should be filled to the brim and drops added until the container overflows. The number of additional drops needed to cause the liquid to overflow would have to be counted. Alternatively, paper-clips may be dropped into the brimful containers, and counted.

Resting Razor Blades on a Variety of Liquid Surfaces

Razor blades could be rested on a variety of liquids and children encouraged to look for differences. They could be asked to find out how much weight would be needed to sink a razor blade resting on water. For weights, they may suggest using pins, wire staples, or small paper-clips. The weights must be placed carefully on the blade, and each weight dropped on in the same way and from the same height.

Children should be asked to forecast the probable results if blades are floated on other liquid surfaces, and then sunk. Would more or fewer weights be needed?

Hanging Drops

Obtain several jam jars with screw-on lids and have a variety of liquids such as water (very hot, and also cold), soapy water, water and detergent, oil, methylated spirits, and kerosene on hand. Not all of these are essential, and children may suggest others that are equally suitable.

A small nail-hole may be made in the lid of a jam jar. The children may be asked to forecast what would happen if the jar was filled with water, the lid screwed on, and the jar inverted. After discussion, in

which the children may suggest that the water would drip out, let them set up the experiment to find out. (Probably, the water would remain in the jar, with a drop of water hanging from the hole.)

What would happen if we kept on enlarging the hole in the lid? Children can readily handle this task by using whatever tools are on hand and increasing the diameter of the hole to about three-eighths of an inch. A rough hole of this size can be made with a nail-punch, or a cleaner hole may be drilled. It should be emphasized that these are jobs for the children, not for the teacher.

When a hole of this size has been made and the jar filled with cold water and inverted, a very large drop will hang from the lid; this should provoke discussion about the strength of the drop, and its surface. If some sort of frame or stand is made by the children, observations will be more satisfactory. When the inverted jar is held by hand, slight movements will cause the drop to be detached. A suitable frame could be made from a wooden box with a series of 3-inch nails driven in to provide support for the jars.

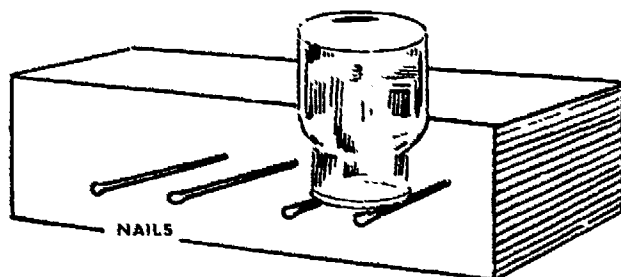

The children should exercise their own ingenuity and inventiveness. This is almost as valuable a part of the activity as the work with the liquids themselves.

Would other liquids make similar drops? Holes should be drilled in the lids of other jars, so that comparisons can be more easily made. If very hot water is used in one jar, some difference may be noted and the drop may detach itself. However, the contraction of cooling air in the jar may be a disturbing factor here, and this would provide an opportunity to emphasize the need for caution in observing results.

Note.—Care should be taken if hot water is poured into a glass jar.

When soapy water is used, the drop breaks easily and water should drip from the jar at a steady rate. Other liquids will behave differently. Observations made during previous activities should enable children to forecast likely results. If a stop-watch (or a watch with a second-hand) is available, the rates of emptying could be measured and compared.

Measuring the Strength of Surfaces with a Milk-straw Balance and a Plastic Floater

The teacher might initiate interest in this activity by asking children to lower the end of a pencil carefully towards the surface of a jar or a saucer of water until the pencil and the water are in contact. Children

should then raise their pencils carefully and note and describe the result. The water seems to stick (adhere) to the pencils, and is lifted considerably.

The teacher could suggest that if a balance were used it might be possible to measure how strong this sticking power was. Here is a balance that children could make as part of their science work :

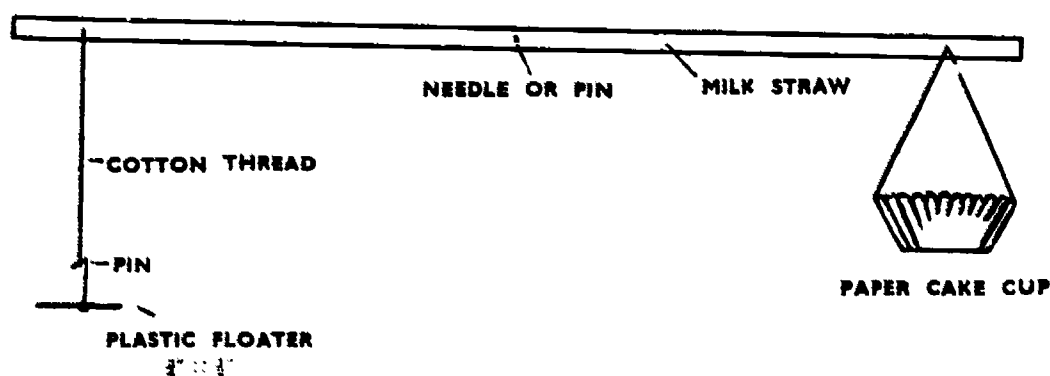

A needle should be passed through the centre of the straw and the balance supported between two pieces of wooden lath.

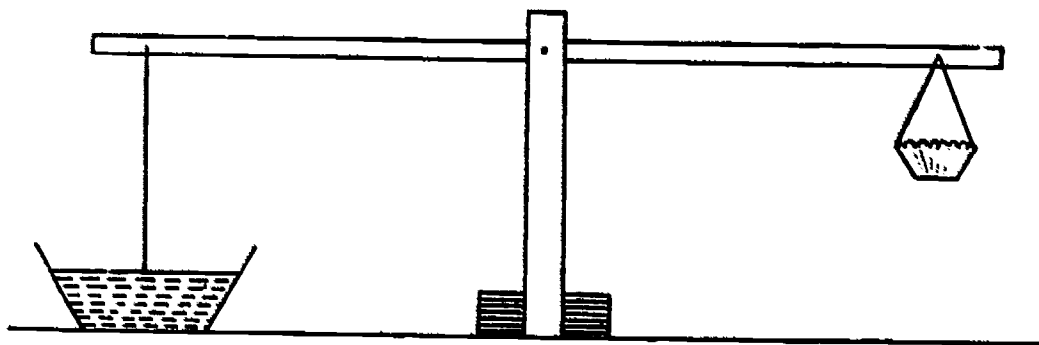

It does not matter if the paper-cake-cup side of the balance is slightly heavier than the other side. Generally, when the plastic floater rests on the surface of the water, the whole system works satisfactorily. The plastic floater should be thin, and the plastic from containers in which ice-cream is often sold in supermarkets is ideal material to use.

Pins placed in the paper cake cup provide suitable weights, and probably ten or twelve will be needed to lift the plastic floater from the surface. Children may then find how many pins are needed when oil, soapy water, and other liquids are used. They should be warned that before each liquid is tried, the floater should be washed clean and dried very carefully.

Liquid Films

As a result of their earlier work, children should be aware of a number of differences between liquids, and talk of some being "stronger" in their surfaces than others. They may now be interested in discussing the likely result when a weaker liquid is placed on a stronger liquid on

which some object, such as a razor blade, a cotton loop, or a match-stick, has been placed. Let the children place a drop of oil or methylated spirits near the object, and observe the result. (It is important in this activity that the children's equipment is clean, and, once several drops have been placed on the water, the container must be thoroughly washed and rinsed before being used again.)

The object will move. Children may say that when the drop was placed near it the object was "pushed" across the surface, but if they are reminded that the liquid in the drop is weaker than the water, and that the activity with the balance showed that water will "tug" more than the other liquids, some of the children may then suggest that the object was not "pushed" but was "tugged" by the stronger water. General discussion and agreement at this stage should be fruitful.

Killing Mosquito Larvae

Whether this activity is undertaken will depend on the season and the availability of larvae. Children may become interested in the activity as a result of discussion about Sir Ronald Ross and malaria control, or Walter Reed and the Panama Canal. They may like to experiment with liquids to find the most suitable ones to apply to water, that is, those which spread most readily. A further problem to investigate would concern the minimum number of drops necessary to kill the larvae. If this activity is undertaken, it is important that the jars containing water and larvae should have an equal surface area.

Viscosity

The "stickiness" of liquids is another property children may care to investigate. This would involve collecting other liquids such as honey, treacle, golden syrup, and oils (thin and heavy), as well as water. These might be compared by allowing them to run down a sheet of glass. This could be followed by comparing the rates of descent of marbles dropped into jars containing these liquids.

The effect of temperature on the viscosity of liquids could also be investigated.

Information for the Teacher

All of the above activities depend upon the fact that in the liquids used the forces of attraction vary between the molecules of the liquids. Molecules of water are more strongly attracted to each other than are molecules of oil or methylated spirits. This is particularly noticeable at the surface, as the above activities show.

The fact that the surface appears to possess a "skin" is due to the fact that the top layer of molecules is more tense, being attracted by the molecules alongside and below. They thus tend to be dragged down and are "tighter" than molecules within the liquid, which are attracted by molecules above as well. *It is not recommended that these facts be taught to children.*

Viscosity is the property of a fluid that causes it to resist flowing. It is an important factor in engine oils.

DIFFUSION THROUGH LIQUIDS

This unit is concerned with comparing the manner in which one substance becomes "mixed-up" with another liquid substance. The process can be seen as a drop of ink spreads through water. Why doesn't the drop stay a drop? Where does a grain of salt go when placed in a tumbler of water?

It is hoped that the unit will encourage children to search for possible explanations, and at the same time to develop abilities, particularly in handling and controlling the factors involved in the activities that are attempted.

Introducing the Topic

This topic may arise naturally from work in other units on liquids, or during an art period when paint is being mixed. The mixing of paint powders, pastes, or blocks with water should enable the children to observe that different materials spread differently through water.

Diffusion of Materials through Water

Children may now be interested in mixing various materials, solid or liquid, with water and observing the results. For example, a drop of ink could be introduced into a jar of cold water, the path it makes through the water observed, and the time it takes to completely diffuse recorded.

A further experiment might involve setting up several jars of water at different temperatures and introducing a drop of ink into each. The differences in the movements of the ink particles should be observed and the rates of diffusion compared. (This experiment also provides an opportunity for work with the thermometer.) The results that children obtain from such an experiment, and the ideas they formulate, should encourage them to perform further experiments in which they may test their ideas by setting up controls and varying the factors involved. This involves using a variety of materials. The children should try other materials such as water in oil, oil in water, orange juice and water, alcohol (methylated spirits) and water.

If half a pint of orange juice was added to half a pint of water, what volume of liquid would you expect to have? The children should mix carefully measured amounts of the liquids, and then measure the total volume.

Children will be surprised at the result of mixing equal volumes of water and alcohol (methylated spirits). After some speculation by the children, they may then mix measured volumes of salt and water and sugar and water, each time measuring the total volume obtained.

Perhaps children will suggest that there is space within water. This explanation might be illustrated by adding sand to pebbles, salt to sugar or pebbles, and so on. It is sufficient that children realize that this illustration *might* provide them with *part* of the answer. *No definite statement is possible at this stage.*

Other suitable materials might include—

- a few crystals of potassium permanganate (Condy's crystals) in water ;
- a spot of ball-point pen fluid in alcohol ;
- tea-leaves in water ;
- coffee beans (whole, ground) in water (*not* "instant" coffee).

In each case factors such as the temperature of the water or the turbulence of the water can be varied and the children encouraged to organize their experiments, use controls, measure, and attempt to offer *possible* explanations.

Solutions

- In work with solutions, questions such as the following might arise :
- Which solids dissolve completely in water ?
 - Which do not dissolve or only partly dissolve ?
 - What is the effect of using heat during the experiment ?
 - What is the effect of shaking the solution ?

Materials suitable for use in these experiments are sugar, sand, clay, loam, coal, chalk, salt, starch, tea-leaves, coffee grounds, instant coffee, food colouring, baking soda, flour, talc, etc.

Much of the work here may have been covered in earlier experiments and need not be repeated. Children's experiences in this section should be valuable in broadening the ideas already formed. The children should realize that the answers to some of their questions will vary, depending on the factors involved. For example, if a teaspoon of salt is mixed with one pint of water, it will dissolve completely. But what would happen if the amount of salt were increased, or the amount of water decreased ?

Diffusion through Gases

Perhaps the work on solutions may lead to an interest in diffusion through gases, in particular, the diffusion of smoke and perfume through air (see the unit Making Perfume, in *Following On*).

SEPARATING MATERIALS

Introducing the Topic

This unit follows naturally from the previous unit, Diffusion through Liquids. Having mixed a large variety of liquids and other materials during their work on diffusion, children might ask if there are any means by which they can recover the original materials from the mixtures.

Refer to the unit Separating Materials, in *Following On*. Some of the ideas developed there offer a natural starting point for work in this unit. This unit, however, is concerned mainly with liquids.

Simple Separating Processes

Evaporation.—Solutions such as salt and water, sugar and water, and water-colour may be separated by evaporation. However, only the salt, the sugar, or the water-colour would be recovered.

Sedimentation.—Mixtures such as dirt and water may be separated by allowing the mixture to stand until the dirt settles to the bottom of the container. The water can then be decanted (poured off). Children might discover which of the mixtures they have made can be separated by this means.

Skimming.—During social studies discussions, the problem of separating cream from milk might arise. The old method of allowing the milk to stand until the cream has risen to the top, and then skimming the cream from the milk with a spoon, could be applied to mixtures where two definite layers are formed, for example, oil and water.

Sieving.—Mixtures such as dirt and water might be partly separated by pouring through a sieve or a piece of fly wire.

Children will probably find that none of the above methods is completely satisfactory. However, these methods provide a starting-point for experiences with filtering and distillation. It is hoped that the children might suggest and attempt their own methods of filtering and distilling.

Filtering.—A paper towel, folded as in the diagrams, can be used as a filter. This method will separate some liquids from solids.

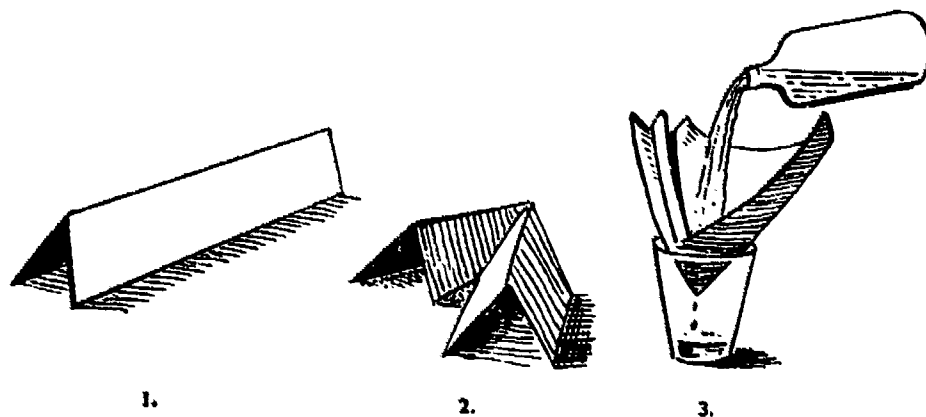

Distillation.—Other mixtures of solids and liquids may be separated by distillation. (See opposite page.)

At the end of the distillation be sure the tin does not boil dry. As soon as the lamp is removed, lever up the lid carefully—*beware of steam*—and drain all the liquid in the tubing into the water container.

In all of the above activities, the children should be developing a better understanding of the nature of materials. Further work on separating materials will be found in the units *Rising Liquids* and *Chromatography*.

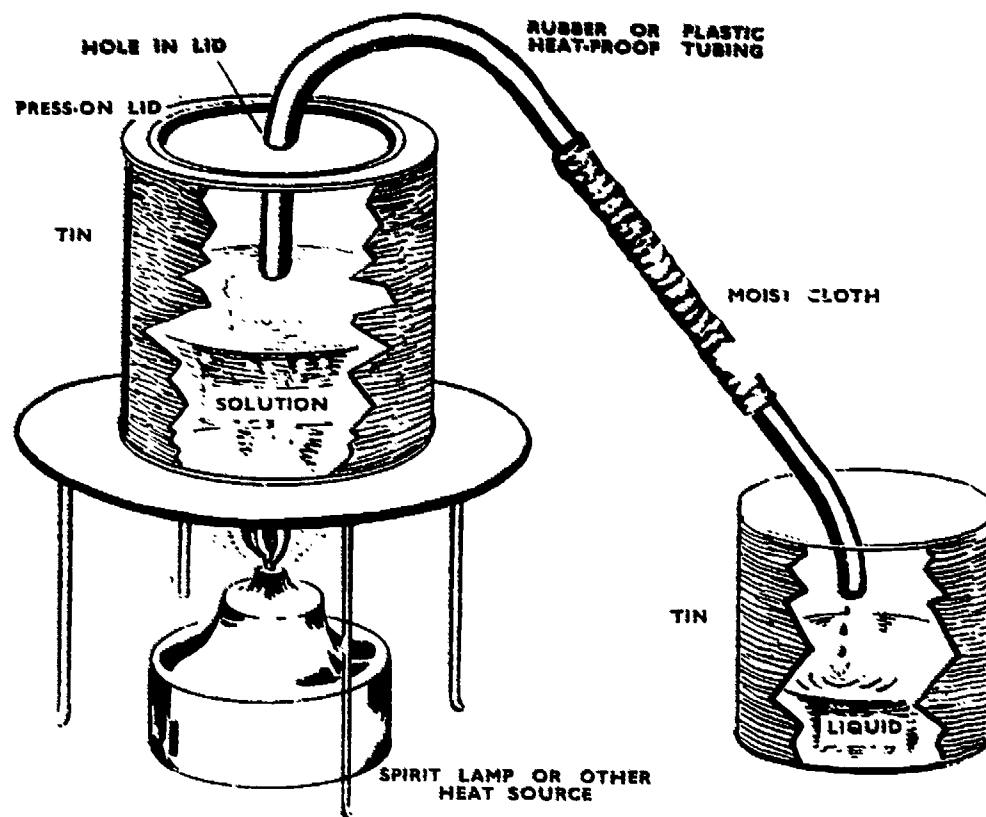

RISING LIQUIDS

Introducing the Topic

Capillary action plays a part in every child's school-life. Every time a child dries a blot of ink, whether with a sheet of blotting-paper, a stick of chalk, or his sleeve, he observes capillary action. The teacher can use this familiar occurrence to start a discussion that will lead the children to suggest a wider investigation. Speculation might arise as to how or why the blotting-paper absorbs the ink, and what happens if different materials and liquids are used.

Collecting Materials

Collect a variety of materials such as blotting-paper, paper towelling, newspaper, pages from magazines, a sponge, pieces of cardboard, chalk, string, wool, cotton, wooden strips (old rulers), and balsa; and various liquids such as water, milk, ink (various colours), oil, detergent, and alcohol (methylated spirits).

Planning the Activities

The children should plan and set up experiments to discover what happens when different materials and liquids are used. This planning may be done by the class as a whole, in groups, or individually, depending on classroom conditions and organization. Much of the planning and experimentation could be continued at home, since this topic is simple and interesting, and the results are self-recording to some extent, in that the strips of paper and other materials, when dry, can be used in place of sketches or graphs.

Strips of blotting-paper may be pinned to a ledge, a chair, a desk, a stand, or a box, and the lower end of the strips allowed to hang into containers holding various liquids.

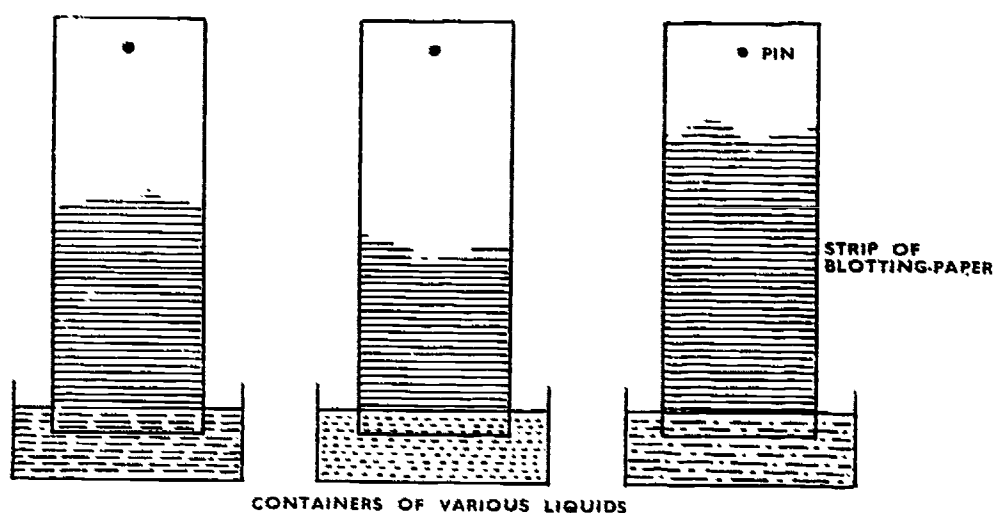

Suitable liquids are alcohol, oil, soapy water, detergent and other household cleaners, milk, inks, food dyes, water colour, tea, soft drinks, drinking chocolate, cocoa, instant coffee, ground coffee, beetroot juice, tomato juice, pineapple juice, orange juice, and cider.

Some of the factors to be considered are—

- rate of rise (calibrate the strips, which should be of the same length) ;
- width of strips ;
- proportion of constituents in the mixture ;
- different dilutions in water ;
- different papers ;
- rate of evaporation (controlled in some way—for example, by covering the strips with plastic) ;
- temperature.

The children should observe the rate at which the various liquids travel up the strips. Do some of the liquids travel further or faster than others? (The experiment should be left for about 24 hours or longer before this question is answered.) It is hoped that the children will attempt to vary and control the factors involved.

Using a Microscope or a Hand Lens

The children should examine the paper, the liquids, and the other materials used under a microscope or a hand lens. This will give them a better idea of the structure of the materials they are using.

At this stage some explanations might be suggested and the demonstration of capillary action that follows might help to decide whether these are reasonable, or it might suggest explanations.

Demonstrating Capillary Action

1. Take two sheets of glass and fix them firmly together with a couple of strong rubber bands. Insert a strip of cardboard or a very thin wooden or plastic strip along one edge between the sheets of glass. Lower into some coloured water.

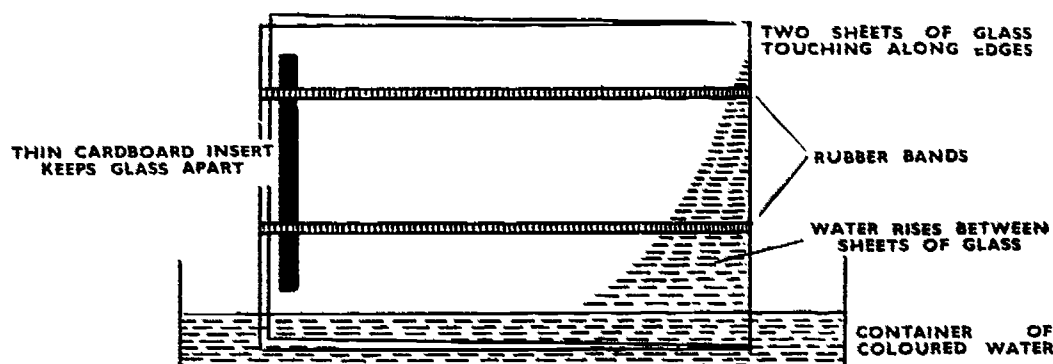

After the ensuing discussion, children may wish to re-examine the blotting-paper and other materials (used in the earlier experiments) under a microscope or a hand lens.

Capillary Action in Soil

The examination of capillary action in soil will provide an opportunity to connect science and the school garden. Try watering a pot plant by standing it in a few inches of water. After some time it will be noticed that the water has risen through the soil.

This might lead to an examination of capillary action in different types of soils. Lengths of wide, clear plastic hose, glass tubes open at both ends, or lamp-chimneys packed with different types of soil, such as clay, loam, or sand, and stood in a container of water, would serve the purpose. The children should organize the experiment in their own way.

Children may see a connexion between the capillary action in soil and in a stick of chalk.

This is not the way in which water normally rises in soil. In these experiments the soil is in contact with free water, and this is not usually so in nature. The class might discuss this, and try an experiment with dry soil over moist soil.

Capillary Action in Plants

A vase of flowers in the room offers an opportunity to introduce the idea of capillarity in plants. Most teachers and children have at some time stood plant cuttings in ink, or in ink and water, and observed the colour change in the cutting.

Suitable plants are snowdrop, white camellia, celery, and chinchinchee (refer to L. H. Brunning, *The Australian Gardener*, indexed under Chinchinchee, Star of Bethlehem, or Ornithogalum).

Capillary action is only one of the factors involved in the movement of water up the stems of plants, and the problem of how water can rise to the tops of trees 200 feet or more high might be worth discussing. *No completely satisfactory explanation exists.*

Note.—The process depends on the relationship between the surface tension of the liquid and a number of other factors. Where the cohesion of water molecules to each other is less than the adhesion of water to glass or paper, the water creeps upward.

CHROMATOGRAPHY

What Is Chromatography ?

Chromatography is a process for analysing or separating mixtures of dissolved chemical substances. The process is based on adsorption, that is, the adhesion to solid surfaces of substances contained in solutions.

This unit is mainly concerned with *paper chromatography*. One end of a strip of absorbent paper is placed in a solution containing a mixture of (usually different-coloured) substances such as a mixture of red ink and blue ink. As was discovered in the unit, *Rising Liquids*, the solution moves along the paper strip. It will be found that the solutes (dissolved substances) will separate out at different levels. Particles of the slower-moving substance, which are more strongly attracted to the paper, separate from the solution and are deposited in a band across the strip of paper. Particles of the other substances with less adhesion to the paper continue on until they, too, separate from the solution and form a band.

It is not desired that the above information be taught to the children. They should suggest explanations based on their observations. Such explanations will be more meaningful to the children, and more likely to lead them to further activities based on their own ideas.

Both teacher and children are likely to become deeply involved in speculation about the results, and the children might develop some idea of small particles separating from the solution as they adhere to ("stick to" or "grab at") the paper, while those components of the mixture which hold with less strength are washed further along the paper.

The simplicity of the work in this unit makes it suitable for children to work in small groups or individually, and the experiments may be performed both at school and at home.

Introducing the Topic

During work on *Rising Liquids*, a child might discover that the liquid solution with which he is experimenting has changed colour on the paper, or that, whereas he had a liquid of one colour in a jar, he now has a piece of paper on which he can see two or more colours.

Speculation on this unusual happening should lead to the planning of experiments, using strips of filter-paper, blotting-paper, or paper towelling (as in Rising Liquids), and a variety of coloured liquid solutions.

Further interest can be generated in art periods, when children ask questions such as, "Which colours should we mix to make purple (brown, orange, etc.)?" Chromatography provides one way of finding an answer.

Collecting Equipment

Once initial interest has been created, the children will quickly set about collecting equipment to use in their experiments. This unit requires only the simplest of equipment, such as the following :

- Drawing pins, saucers or similar containers, eye-droppers ;
- blotting-paper, filter-paper, paper towelling, face tissue, chalk, plants listed in Rising Liquids ;
- water, alcohol (methylated spirits), petrol, kerosene, oils (mineral and vegetable), and other available solvents ;
- ink of various colours, ball-point pens, paints from art supplies, food dyes, marking or spirit pens, ir delible pencils.

Points To Remember

The children should be developing the ability to vary and control the factors involved in their experiments. Introducing new factors can add extra interest to the experiments.

Sample Activities

Note.—It is not intended that these activities should be followed step by step. They are included in the Curriculum Guide only to give the teacher an idea of the great variety of work that is possible with chromatography. This unit will be most successful if the children are able to experiment freely and so develop their own ideas.

1. Pour a mixture of red ink and blue ink into a saucer or some other suitable container. Following the procedure suggested in Rising Liquids, hang a strip of paper so that one end is immersed in the liquid.

Factors to consider are—

- time taken for separation to commence ;
- distance the mixture travels before separation commences ;
- different dilutions in water ;
- proportion of constituents in the mixture ;
- different types of paper ;
- adding more colours to the mixture.

The children might be expected to vary the experiments in several ways, some of which are listed below. In each case, the same factors may be considered.

2. Repeat the above experiment but, when the liquid has risen a few inches, replace the saucer of ink with a saucer of water.
3. Repeat either of the above experiments. When the liquid has risen to about two-thirds the length of the paper, remove the saucer of liquid. Allow a few minutes for the liquid to stop dripping from the paper. Hang the paper so that the other end is now in the saucer of liquid (either the ink mixture or plain water).
4. Vary the experiments by drawing a line of ink mixture (the width of line will be found by experience) near the lower end of a paper strip. Place the end of the paper in plain water and allow the water to rise up through the line of ink.

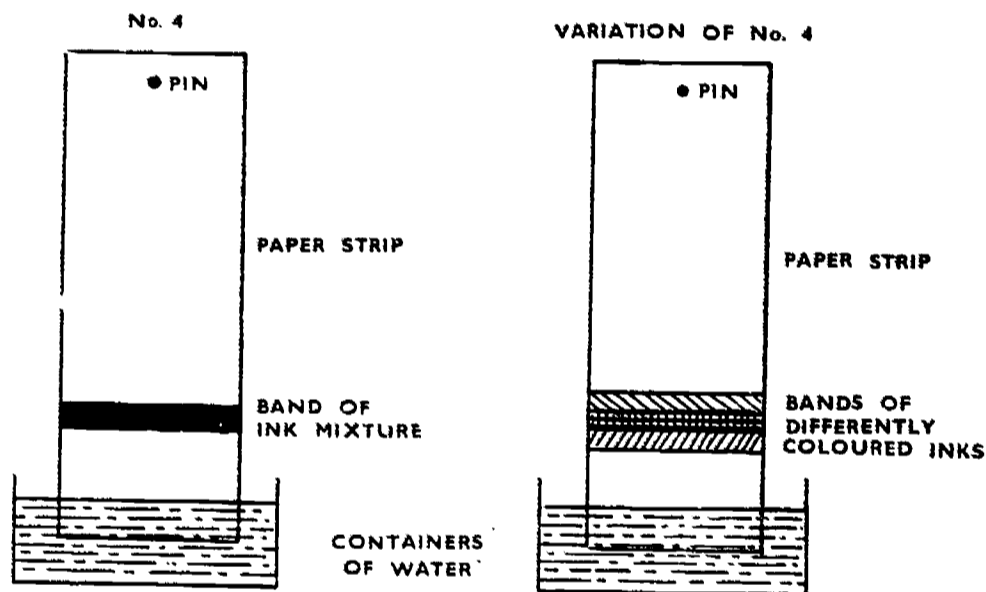

When the children wish to go on to an investigation of ball-point pen inks, food dyes, powder paints, and so on, they will be presented with the problem of having to dissolve these substances in a suitable solvent. The children should develop their own methods of dissolving the colours if they have not already done so during their work on diffusion.

5. Having discovered how to dissolve food dyes and powder paints, the children will be able to use chromatography to separate colours from a mixture. This will simply involve applying the methods they have developed with ink mixtures to the other solutions they have made.
6. When attempting to separate the colours in ball-point pen ink, the children will probably find it best to use the method suggested in activity No. 4 above. It is not suggested that the ink from different ball-point pens be mixed together on the paper; each colour may be treated separately (see illustrations opposite).

Note.—The children should discover for themselves which solvent they should use.

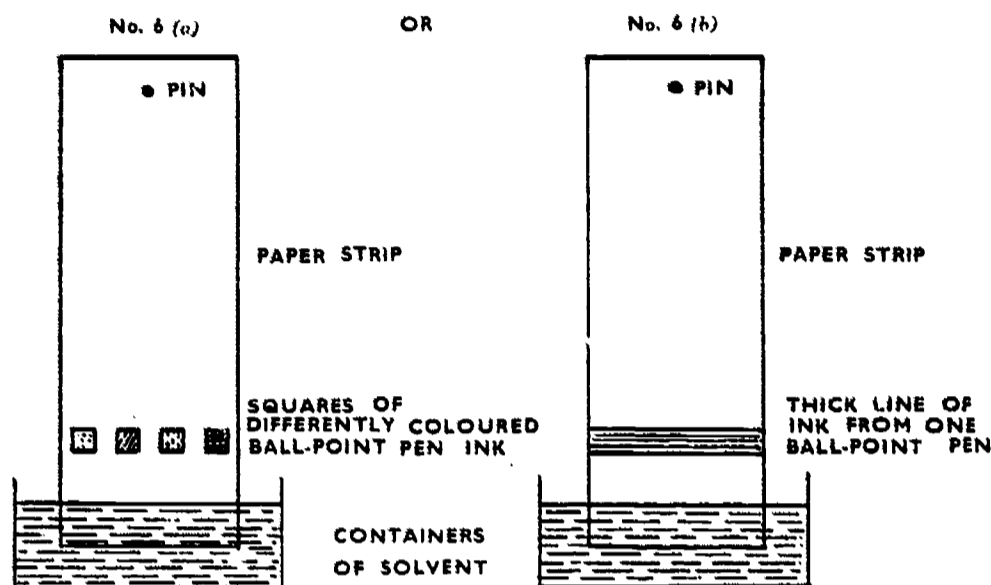

7. Investigations of the components of marking-pen fluids and the lead of indelible pencils would probably follow naturally from work with ball-point pens.
8. A less convenient form of chromatography can be carried out by placing drops of a mixture of differently coloured inks, etc., onto the centre of a piece of absorbent paper. This may be done with an eye-dropper or with a burette set so that the drops fall at regular intervals.
9. Can a stick of white chalk be substituted for the paper strips in some of the experiments?
10. Will the solutes (dissolved substances) separate in plants? (See the section on capillary action in plants in the unit *Rising Liquids*.)

These sample activities are included only to enable the teacher to obtain a picture of the way the children might develop the topic. The children need not be expected to cover all of the variations mentioned in this unit, and they should be free to develop the experiments in keeping with their own ideas.

Recording Results

The strips of paper can be dried and used in place of sketches as a basis for recording. The children may attach the strips to their written descriptions (excellent motivation for written-expression periods) or use them to illustrate talks to the grade.

A Final Note for the Teacher

Work in this unit might be spread over several weeks, perhaps running parallel with work in other topics. Short discussion periods may be arranged to allow children to share their discoveries and plan further activities. Since the equipment needed for chromatography is so simple, children should be able to plan and perform many of the experiments in their spare moments during the day, or even at home. In some

cases, once the children have planned an investigation, an experiment can be set up in the morning and observations made at convenient times throughout the day.

A Final Note on Liquids

It is neither necessary nor desirable to treat any unit in isolation. One way of combining work from several units is illustrated by the following brief report, which was made by a teacher who drew upon the suggestions from the four units Rising Liquids, Diffusion through Liquids, Comparison of Liquids, and Chromatography.

"The children in this class commenced by observing what happened when a razor blade was floated on a saucer of water. Using glider clips as weights, they experimented to find out how much weight the blade would support. During a previous experiment they had discovered that it was more difficult to sink a button in salty water than in fresh water, and so it was decided to try different liquids to see if this would have any effect on the weight the razor blade would support. Detergents, oils, methylated spirits, and other readily available liquids were tried both in their pure state and when mixed with water.

"While experimenting, children noticed other effects produced by variations, for example, a drop of oil on the water. They noticed the difference in appearance and that their razor blade moved. The children could offer no suggestions as to why the various events took place.

"Experiments on piling up drops, the effects of various kinds of surfaces, measuring the strength of surfaces, and observing hanging drops of various liquids followed, during which the children were encouraged to use their own initiative in constructing suitable apparatus and in conducting their own experiments.

"Discussion of experiments conducted and observations made during the development of this topic have led naturally to further investigation and suggestions. Other topics considered were the effect of depth on water pressure, chromatography, suitable solvents for various materials, and capillary action.

"These investigations, which have been developed over a period of weeks, will be continued for some time yet."

HARDNESS, BRITTLINESS, AND ELASTICITY

In this unit, which begins by investigating the hardness of materials, the children will have the opportunity to increase their understanding of the nature of materials, particularly solids; to plan simple experiments which will increase their understanding of the hardness, brittleness, and elasticity of materials; and to organize the data they gather in a way meaningful to themselves.

An investigation of hardness should lead naturally to the subjects of brittleness and elasticity. Teachers will find that hardness, brittleness, and elasticity are too closely related for each to be treated in isolation.

An elastic material may be defined as one which "spontaneously resumes its normal shape after distortion", and a brittle material as one which is "apt to break; fragile". Some materials are both elastic and brittle. For example, a sheet of glass, which is apt to break, is also elastic—it can be bent to some extent, and will return to its normal shape. A further illustration of elasticity of glass is the bouncing of a glass marble.

Introducing the Topic

The subject of hardness may arise in an art or a craft period, or at any time when it is necessary to cut or shape material. Discussion might lead to an interest in comparing the relative hardness of materials.

Collecting Materials and Equipment

Collect a wide range of materials, including some which the children might describe as "soft", since the terms "hard" and "soft" are relative, and when comparing the hardness of materials any statement such as "A is *harder* than B" implies that "B is *softer* than A". The inclusion of some soft materials in the collection is a natural way to bring this point to the notice of the children. Include rocks, various metals, several varieties of wood (for example, balsa, pine, and several hardwoods), metal cutters, metal tubes, centre-punches, rubber balls, marbles, plastics, rubber bands, bicycle pumps, cloth, threads, wooden rulers, plasticine, sponge, paper, cardboard.

Handling the Materials

The children should be allowed to handle the materials and to comment freely on anything that they observe. If they wish to compare the materials or to organize them in any way, they should be allowed to do so. Eventually the question of which material is the hardest should arise, and the children will be confronted with the problem of devising a suitable method of determining the relative degrees of hardness of the materials.

Planning Experiments

When planning the experiments, the children might decide to compare a variety of quite different materials (such as rubber, paper, iron, rock, leather, and glass) or a number of similar materials (such as iron, copper, lead, and aluminium) or different types of rocks, timbers, or plastics.

At first the children's tests may be rather inaccurate, but it is hoped that they will be able to see the shortcomings of their methods and refine them accordingly. The teacher's main task will not be to suggest suitable procedures to the children, or to criticize the procedures they adopt, but rather to encourage the children to examine their own work critically and to realize its possibilities and its limitations. The teacher may find that the children will devise tests similar to those below.

Some Tests for Hardness

Scratch Test.—This test is suitable for many materials, including rocks, metals, and wood. For example, try to scratch lead with the corner of a strip of iron. Then try to scratch the iron with the lead.

Encourage the children to go further into the problem by testing more metals. Eventually they might attempt to arrange the metals and/or other materials in order of hardness.

Punch Test.—Obtain a metal tube through which a centre-punch will slide freely. Stand the tube upright on the material to be tested. Allow the punch to fall down the tube. The children may use a hand lens to examine the mark that the punch makes in the material.

Bounce Test.—Drop a rubber ball onto the material from a measured height, and observe the height to which the ball bounces. A reasonably accurate result may be obtained by standing a measuring rod—a chalkboard ruler or a rod calibrated by the children—on the material, dropping the ball from a chosen mark on the rod, and measuring the height of bounce against the calibrations on the rod.

The children should realize that there are several factors involved in this experiment (as is true of all experiments). The results will be affected by the elasticity of the ball, the thickness of the material, the nature of the surface on which the material is resting, the height from which the ball falls, and so on. Consider the difference between dropping a ball onto a *single* sheet of paper resting on a solid wooden surface, and dropping the ball onto a *pile* of paper sheets on the same surface. If the children are unable to come to a definite conclusion (as will probably be the case) their attempts to control these factors and the speculation that may be expected will still be very valuable experiences for them.

The experiments may be varied by using different kinds of rubber balls, marbles, or ball-bearings. Comparison of the results of the different tests should provide an interesting subject for discussion.

Investigating Elasticity

The activities that follow deal mainly with elasticity, but hardness and brittleness will continue to be factors which need to be considered.

General Observations.—At first the children might examine the elasticity of many materials by bending them with their hands, bouncing, hitting, poking, or stretching. In addition to the collection of materials made at the beginning of the unit, the children should handle more obviously elastic materials such as garter elastic, rubber bands, bicycle tubes, rubber balls, rubber erasers, rubber toys, balloons, dough, plasticine, metal springs, sponges, plastics, strips of wood (rulers, laths), and strips of metal (hack-saw blades).

It must not be forgotten, however, that metals, glass, and other seemingly inelastic materials also have a certain degree of elasticity. This is evident in the bounce test when, for example, a glass marble rebounds when dropped onto a glass surface, or a metal ball-bearing rebounds from a sheet of metal.

After the children have had some time to handle the materials freely, they may be expected to attempt to organize their activities and to commence a more orderly investigation of the materials.

Bounce Test.—Refer to the bounce test mentioned earlier. Activities, and speculation on the results, might now begin to be centred on elasticity as one of the important factors.

Elasticity of Air.—This may be illustrated by blocking the outlet hole of a bicycle pump with the forefinger and depressing the plunger which, on being released, will spring out again. Elasticity of air is also observed when rubber air-filled balls or balloons are bounced or released from compression. It should be noted, however, that in these two examples the elasticity of the rubber is also an important factor.

Football or basket-balls having different pressures of air are also illustrative of the elasticity of air. If a pump with a pressure-gauge is available from the school sports equipment, children should be able to design bounce tests to compare the effect of different pressures of air in the balls. (If a pump with a gauge is not available, the number of strokes of the pump plunger can be counted as a rough but reasonably satisfactory method.)

Consider also what happens to a table-tennis ball if the air is released through a pin-hole.

Other things that could be considered are bicycle and car tyres, and air-filled cushions.

Elasticity of Wood.—Many children will not have thought of wood as being elastic. The idea may be introduced by telling the story of Robin Hood's search for a suitably elastic or "springy" wood for his bow. A kite, too, needs to be made from light, strong, *elastic* wood, and the problem of selecting a suitable wood might serve to introduce the topic.

Place a length of wood—a ruler, a lath from a trellis fence or wooden venetian blind, or a thin limb from a tree—so that it overhangs the edge of a box or the table (see Figure 1 below) and is held in position by a heavy weight or a nail. The elasticity may be tested by exerting pressure on the overhanging end of the wood.

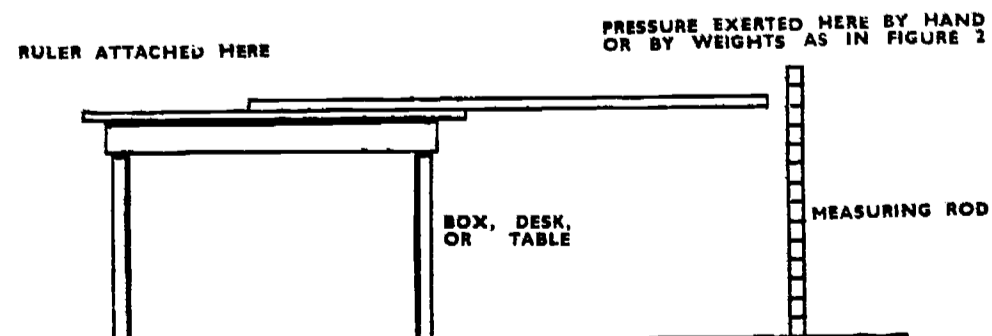

FIGURE 1

A more satisfactory and accurate test could be made by adding weights to the end of the wood. From this experiment, children might

go on to make a simple weight-measuring scale. (See Figure 2 below.)

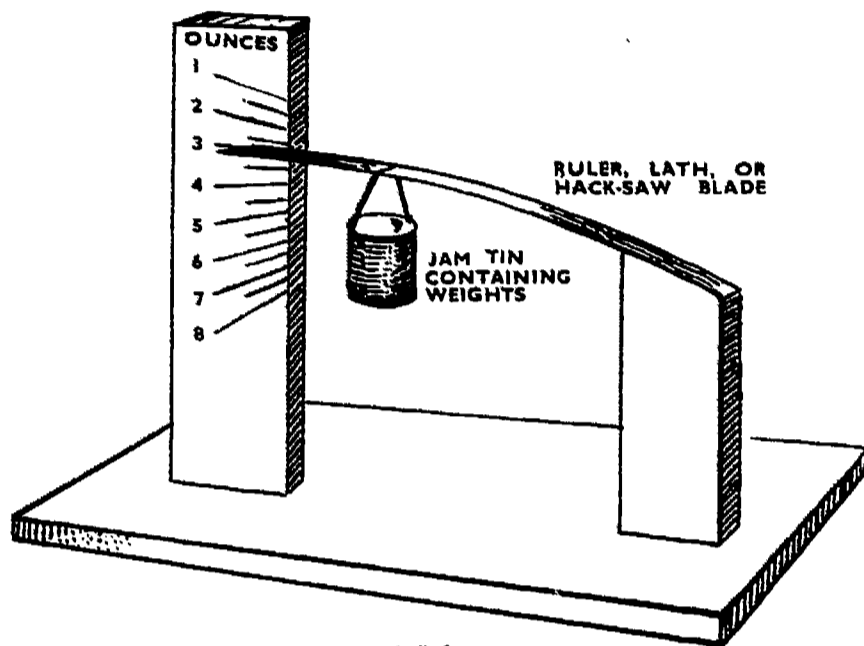

FIGURE 2

Other kinds of simple scales can be made by suspending weights from bicycle tubes, garter elastic, etc. Once again, children should be alert to discover factors that might affect the results, for example, the suspension point of the weights.

Elasticity of Metals and Plastics.—Elasticity or “springiness” of metal saw-blades, springs, and lengths of plastic (plastic rulers) may be investigated, using much the same methods as suggested for wood.

Children could also investigate the effect of twisting a ruler; how model boats or planes are powered by rubber bands (refer to the unit *Moving, in Following On*); clock springs; and the history of catapults.

Brittleness of Materials.—The brittleness of materials may be investigated by using tests similar to those used for elasticity, for example—

- by dropping the material from a measured height;
- by dropping a weight onto the material from a measured height;
- by adding weights or exerting pressure in some way.

Some materials suitable for experiences with brittleness (in addition to those mentioned earlier in the work on hardness and elasticity) are glass, china, potato crisps, fresh bread, stale bread, toast, green plant stems, dry plant stems, green leaves, dry leaves, pastry dough, baked pastry, and chalk.

A comparison of fresh bread, stale bread, and toast (and similar groups of materials) might prove interesting, and will provide a link with the unit on the effects of heat, and also with the unit *Water in Food, in Following On*.

THREADS AND FIBRES

In this unit the children will have the opportunity to—

- collect, handle, and compare a wide variety of threads and fibres ;
- use a hand lens or a microscope ;
- design and perform experiments to test the strength of threads ;
- design and perform experiments to study the effects of household chemicals, water, heat, and weather on different fibres ;
- use weights, scales, and balances ;
- relate their experiences orally and in writing ;
- record results in the form of written descriptions, tables, and graphs.

In all their activities, the children should be alert to discover and control factors that might influence the results of their experiments. They should understand the need to attempt to verify their conclusions.

The teacher will find that much of the material in this unit can be correlated with health, social studies, and craft courses.

Introducing the Topic

The problem of choosing a suitable rope, cord, string, wire, or thread for mountain climbing, tying parcels, hanging pictures, leashing a pet dog, or sewing on buttons, will serve to introduce this topic.

Collecting Materials

After the problem has been presented in the introductory discussion, a collection of a wide variety of threads and fibres could be made—for example, baling twine, string of varying thickness, and ropes of different materials and varying gauges ; cotton thread (machine thread, button thread, embroidery cotton) and terylene sewing thread ; picture wire ; knitting wools of different ply-ratings ; venetian-blind cord (cotton and nylon) ; reels of fishing-line on which the claimed breaking-strain is marked ; silk thread (much of the "silk" thread sold in shops is cotton with a shiny finish) ; unprocessed sheep's wool, cotton fibre, and coconut fibre.

The class will also need weighing apparatus—kitchen scales or spring balances.

It might also be wise to warn the children to take care not to tangle the threads.

Free Handling and Observation

It is desirable at this stage to allow the children to satisfy their curiosity about the materials. The threads and the fibres can be left on a bench or a table for a few days, and the children allowed to handle the materials and examine them under a microscope or a hand lens. The children should be encouraged to report their observations, either orally or in writing.

Organizing the Experiments

The children will face several problems when attempting to plan experiments to test and compare the strengths of the many threads and fibres. They should realize that pulling at the threads is a very unsatisfactory test for strength. When discussing the problem, children might suggest suspending the thread and attaching weights to the other end until the thread breaks. In several classes where children suggested this method, it became obvious that the tying of the weights to the end of the thread presented another problem. This was overcome by tying one end of the thread to a wooden rod, and the other end to a suitable container—a jam tin with a handle, a bucket, or a rubbish bin—in which the weights were placed.

The following extracts show how some of the children described their first attempts to measure the strength of cotton, knitting wool, and hayband.

- (a) "Tie the cotton to the stick and the other end to the handle of the bucket. Lift up the piece of wood so that the bucket is not touching anything. Start putting things in the bucket carefully. When the cotton breaks, weigh the bucket and what was put in it. Repeat this with other cottons and terylene. The results were—"

Material	Broke at
Cotton 50	1 lb.
Cotton 40	2 lb. 1 oz.
Terylene thread	7 lb. 5 oz.
Embroidery cotton	5 lb. 7 oz.

- (b) "First we organized ourselves into a group of six. Kerry was the leader in our group. We wanted to test how many pounds and ounces it took to break various plies of wool. Here you will see how we set it out.

Wool	Colour	Weight
3 ply	brown	5 lb.
3 ply	red	5 lb. 14 oz.
4 ply	yellow	6 lb. 1 oz.
4 ply	green	6 lb. 6½ oz.
8 ply	black	20 lb.

"In the weight column you will see how much weight it took to break the wool. We found this out by bringing tins from home to put the weights in. We fixed the wool onto the tin and wound the other end of the wool around rulers. We dropped the weights in one at a time until the wool broke and then we counted the weights and wrote it all down. We also did it another way, by doing it with dirt. All we had to do was weigh it."

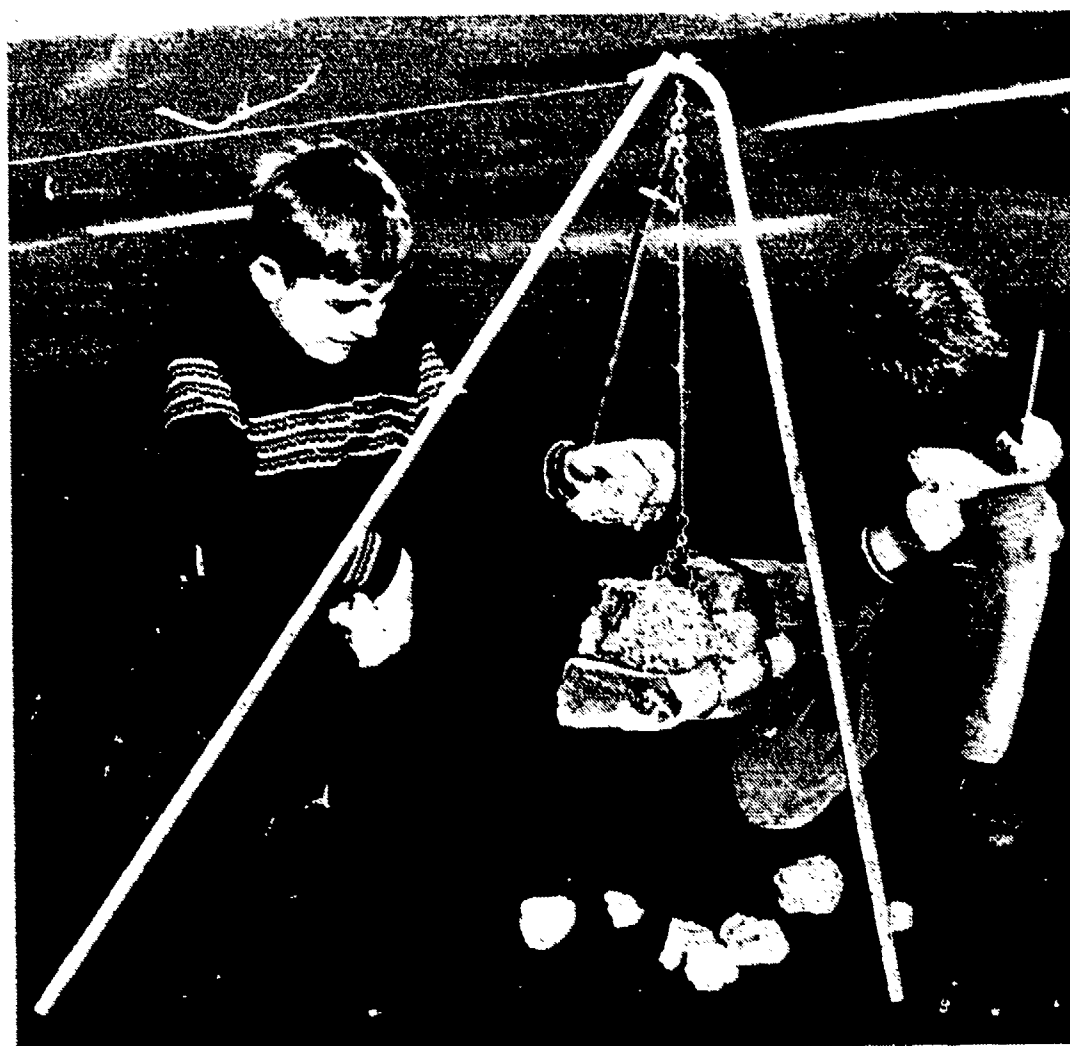

(c) "We put dirt in buckets with the hayband tied to it. The other end was tied to a stick. We held the bucket up by the hayband until it broke. But it didn't break. Then we used a rubbish tin, but when it broke it fell on my toe. We filled the bin up with bricks and gravel. We did the same for all the other experiments, but they didn't need rubbish bins. When it snapped we weighed it."

Material	Broke at
Hayband	84 lb.
String	24 lb.

Verifying the Results

Children should devise their own methods of carrying out the experiments and recording the results. The extracts that follow show that children are capable of recognizing faults in the methods they devise. If the teacher studies the children's written reports, he will find many points which, through discussion, might encourage children to plan further experiments to test their results.

"We had to do our experiments again because we forgot to set the scales at nought."

"Kerry and Jan said we shouldn't have *dropped* the weights in the tin but we said it didn't matter."

"Four-ply wool broke at six pounds weight when dropped in roughly. But when the weights were carefully placed in, it broke at 7lb. 2oz. weight."

"I think that the longer the wool is, the harder it should be to break because when it is short it can't stretch much and therefore it breaks."

"A long piece of wool should break before a short piece because it is heavier."

"The different cottons and wools seemed to break strand by strand rather than all at once."

"When we used nylon V.B. (venetian-blind) cord it took six stone six pounds to break it. When the nylon V.B. cord was breaking we could hear the threads breaking, too. They were making a tingling noise. They went ping, ping, ping, ping, ping."

"The cord seemed to get weaker the longer we left the weights on it."

"At one time we thought the line had broken when the knot had only slipped."

" but the bin handles cut the string when we placed only one brick in the bin so we tied it around the bin itself and it held two bricks before it broke."

"The last thing we put in the bucket was a whole brick. Then the cord broke. We weighed the bucket of bricks. I said our answer might be wrong because it might have broken if the last thing we had put in was only a bit of a brick. It would have broken if we had put an elephant in the bucket, too, but that wouldn't give the right answer."

A Summary of Some Factors That Might Be Considered

Were the scales used correctly?

Did the thread break because it was jerked? Were the weights placed or dropped into the container?

Does the length of thread make any significant difference?

Is time a factor? Does the thread weaken gradually under pressure, until it snaps?

Was suitable equipment used? Was the thread accidentally cut by sharp edges on the equipment?

Does temperature affect the result—particularly with synthetics, for example, nylon fishing-line?

Is it sufficient to test each thread only once?

Effects of Household Chemicals

It might be of interest and some practical use to investigate the effects of common household chemicals on some of the more common threads. Some bleaches and cleaners are not recommended for use on synthetic fibres. The children should be able to devise simple experiments to discover why these chemicals are not suitable for all materials. Several kinds of threads could be placed in the chemicals for some time—perhaps for a few hours or even days—and then studied under a microscope or a hand lens. The threads might be tested for strength and compared with untreated materials.

Effects of Water—Rotting

Simple experiments may be devised to study the effects of water on different materials. This would be a long-term experiment in which the threads would have to be left in water, and examined and tested at intervals.

Effects of Weather

Which threads are the most suitable for use out of doors in all weather conditions? (For example, for tying plants in the garden.) Here is an opportunity for another long-term experiment, somewhat similar to the one above, in which threads that have been left outside over a long period are examined and tested from time to time, and comments made on any changes that are observed.

Effects of Heat

This activity might take the form of an investigation into the reaction of different threads and fibres that come into direct contact with fire, with heat, and with boiling water. Such an investigation would add interest and meaning to a study of safety-first and clothing. (Refer also to the topic Fire.)

Discovering Threads and Fibres in Nature

Investigation into natural fibres might start when pupils study animal hair under a microscope or a hand lens, and feel its texture. This might be followed by a study of threads and fibres in plants—for example, bark of trees, wood (particularly plywood), leaves (palm), stems of plants, coconut fibre, grass, flax, bamboo, fibrous roots, cotton, palm fibre, banana skin, celery, and French beans.

Children might attempt some classification activities, using their own classifications.

Spinning Thread from Fibres

If a quantity of raw wool is available, as it may be in a country area, children could attempt to spin it. First they would need to card it, making a rough, unspun thread; then they would need to spin it between their fingers. This process is aided if a spindle can be made. Basically, this is a fairly weighty object—a large iron bolt or nut would be suitable—which will spin with sufficient momentum and weight to keep the wool taut.

Children can manage to produce a yard or two, either twisting with their fingers or with a primitive spindle, and this will be sufficient for testing and to initiate investigation into spinning and weaving, both ancient and modern.

The following notes were made by a teacher whose grade attempted to spin thread from fibres :

“ Raw materials which could be used include fleece (preferably a coarse type), long dog hair, (Samoyed, sheep dog), long cat hair (Persian), and Angora rabbit fur. The fibres should be at least $2\frac{1}{2}$ inches long.

“ The fibres can be prepared either by teasing and fluffing out with the fingers or by combing with a steel dog comb, about six to eight teeth to the inch. This should result in a fluffy mass of separated fibres free from tangles, hay seeds, and plant material.

“ Spindles suitable for children can be made very easily and cheaply, and by the children themselves. Some examples are shown below.

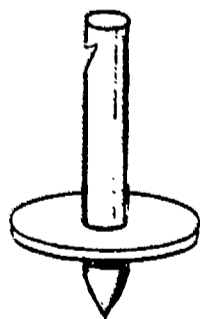

JAM-JAR LID AND
OLD PENCIL



STONE TIED
TO A STICK



COTTON REEL
AND DOWEL

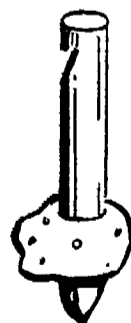

POTATO AND PENCIL
(NOT PERMANENT)

“ To use the spindle, tie about 18 inches of softly spun commercial yarn to the spindle as shown in Figure 1 below, and untwist the end.

“ Using a clockwise twist, twist the top of the spindle, and when it is revolving overlap some of the fibres of the commercial yarn with some of the fibres that are held in the hand; pull down a few of these fibres and as the fingers are sliding up over them they will twist together

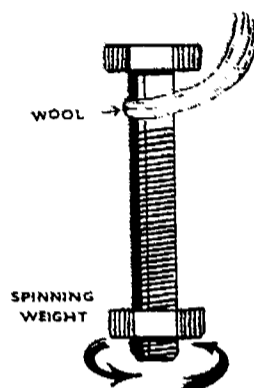

and make a yarn (see Figure 2). When a length has been spun, unhook the yarn, wind onto the spindle above the base, hook onto the top again, and recommence spinning."

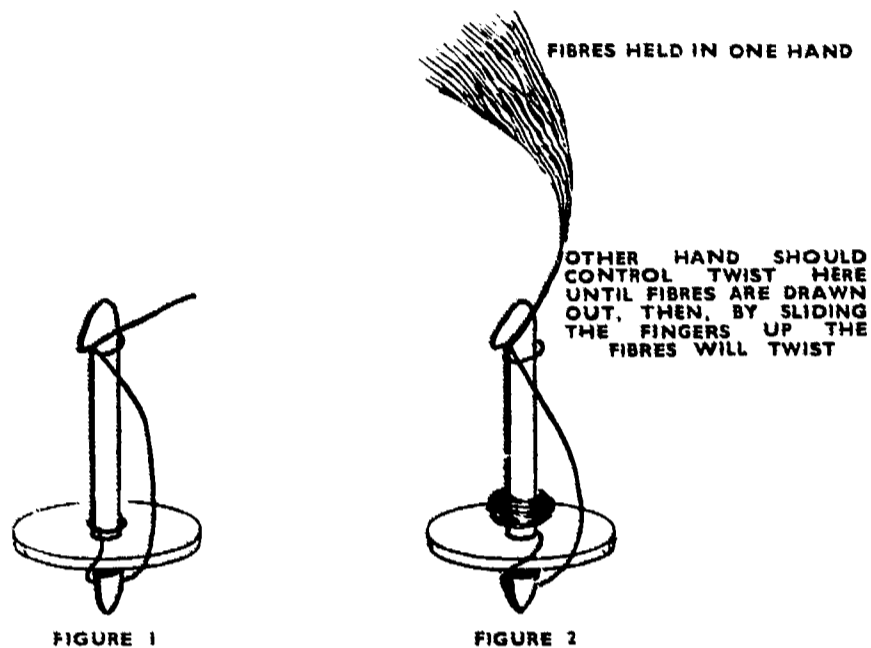

Dyeing

Extracting dye from plants can be an absorbing activity. Children could attempt to make dye by boiling plants. The leaves would be the most likely source of dye, but other parts of the plants could also be tried (beetroot, fruit such as plums and onions, grass).

Leaves of eucalypts, particularly *E. ficifolia* (red flowering gum) and *E. globulus* (Tasmanian blue gum), yield a wide variety of dye colours. The dye may be extracted by gently boiling the leaves in water for about two hours, adding a little water if evaporation is too great. The teacher needs to take safety precautions in any experiment involving boiling water, but the children can play an active part in collecting and measuring the materials, and planning experiments.

It will be found that dyes will bond to cloth (or threads) more readily and evenly if the cloth is clean. A firmer bond and a greater variety of colours are obtained by soaking the wet cloth in a mordant immediately after cleaning. Many substances can serve as a mordant—for example, ammonia, vinegar, or salt. Other common mordanting agents are alum (potassium aluminium sulphate), cream of tartar, stannous chloride, ferrous sulphate, copper sulphate, and potassium bichromate. All of these substances are obtainable from grocery stores or from nurserymen. The usual care should be taken in storing and using these materials, and the *dangers of tasting should be stressed*. The mordanting is carried out by simmering the cloth in the mordant solution for about half an hour. (Note.—Contact with metal of any kind will have an adverse effect on the mordant.) Experiment will reveal the most suitable proportions of constituents in the mordants.

Each mordant should produce a different colour, and mixtures of mordants will add even further to the range of colours obtained.

The mordanted cloth is dyed by being gently boiled in the dye extract. (Note—Containers should be thoroughly cleaned after use.)

The teacher will probably find that he has to tell the children about the need for a mordant. However, it is advisable to first allow the children to attempt to dye the cloth without using a mordant, so that they may observe the difference in results.

The idea of mixing mordants may well come from the children, and they should be free to vary the experiments according to their own ideas. The formulae the children use to obtain the different colours may be recorded. Collecting materials, measuring, varying the materials, planning experiments, discussing problems, speculating, and describing processes and results will all form a part of the work in this topic.

The links with social studies and art and craft are obvious. Some further ideas on threads and fibres will be found on page 35 of the *Curriculum Guide, Art and Craft, Primary*.

GLASS, BRICKS, POTS, AND A KILN

At the conclusion of this unit it is expected that children will show a better understanding of the effect of heat on certain materials, involving, in this case, partial melting and fusing of previously disparate particles. This unit might be regarded as a part of the unit Heating and Cooling, but here our attention is directed to the materials themselves rather than to the heat energy which produces change. By the time they tackle this unit, many children will be familiar with the terms "atoms" and "molecules", and they may enjoy discussing the observed changes in terms of the atoms and the molecules of which the materials are made up. Their discussions will be merely speculative, of course, but they may be interested to know that what happens during the process of fusing and hardening is by no means fully understood yet.

It is expected that these activities will also give children an opportunity to further the development of their abilities, especially in the planning and the execution of a project of some complexity.

How the Activity Might Be Introduced

It has been observed that interest can be aroused during the rather prosaic task of cleaning out the school incinerator. Often, broken bottles are raked out, twisted and mis-shapen by intense heat. This experience sometimes prompts children to attempt to melt glass and other materials by placing them in the incinerator for several days.

Interest might also arise out of art activities such as modelling in clay. At some point the desirability for a kiln to facilitate further investigations will become evident.

Making a Kiln

In the country, where wood is plentiful, it may be possible to place some clay pots or bricks under a heap of wood, which can then be set alight. This is a very primitive process, and many breakages must be expected. If some ordinary household bricks can be obtained, it is possible to build a kiln from which better results may be expected. About one hundred bricks would be needed. The kiln is built as follows :

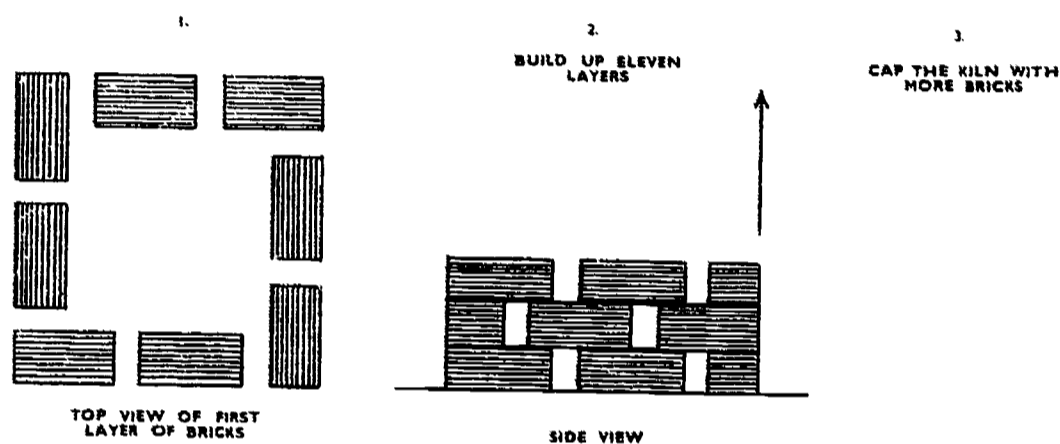

—(With acknowledgements, Nuffield Foundation Science Teaching Project.)

Place several bucketfuls of coke in the kiln ; place the bricks or the pots on this, with the lighter objects on the top to minimize breakages. Place dry sawdust in the kiln until it reaches the eighth or the ninth layer. Light the sawdust at the top by lighting screwed-up papers, first having sprinkled the surface of the sawdust with kerosene.

Further Developments

Either before or after the first firing, children may be interested in studying the properties of various earths and clays (if these are available locally) to determine their suitability for making bricks or small pots. Firing a number of articles made from different raw materials will provide more information.

Some children may be interested in discovering by how much bricks differ from the standard size (9in. x 4½in. x 3in.).

Other children may attempt to estimate the number of bricks used for walls in the locality, or for the external cladding of a large city building.

Another activity may have to do with the porosity of different types of bricks. Some bricks absorb more water than others, and children may attempt to devise a method of measuring the amount of water absorbed. This could be done by weighing the brick before and after immersion in water, and then determining what volume of water would account for the change in weight.

If there is a brickworks in the vicinity, an excursion to it would be valuable and probably lead to further activities, depending on the interest the children show.

B. BRINGING ABOUT CHANGE

In these units, the changes children observe will include many chemical changes in which new materials are formed with properties that differ from the original properties. These changes involve combining the original material with other substances, and, for the process to occur, energy will either be needed or will be produced. At times this will occur to a noticeable extent, for instance, when vinegar and bicarbonate of soda are mixed and carbon dioxide is given off. In this case there is a noticeable amount of heat produced. In other cases, for instance in rusting, the energy component will not be detectable.

The investigations children undertake may deal with—

- tarnishing and rusting of metals ;
- plating metals ;
- burning wood, steel wool, and other materials ;
- bleaching and stains ;
- souring of milk ;
- heating the white of eggs ;
- making coal-gas ;
- making other gases.

The work should provide opportunities for children to develop an understanding of what constitutes a valid experiment ; to recognize factors operating in a situation and to be interested in the possible effects of varying some of the factors ; and to develop the ability to make inferences and to draw conclusions consistent with the data obtained.

It is not expected that all of the topics mentioned in these units will be treated. Those chosen will depend largely on the children's interests. It may happen that interest in one topic, for example, making coal-gas, will lead to interest in other changes, but on the other hand interest may lapse for a time, to be aroused later during discussion or investigation in another area. It should be emphasized that some of these activities, in which many of the investigations will be carried on informally, may be done by children working in small groups. If there is a formal class lesson, it may be devoted to discussion and reports in which plans for further activities can be formulated and details of organization decided upon.

CORROSION

Rust forms on iron ; tarnish on silver. When copper is exposed to air a green coat or patina forms on the surface. These are three common examples of corrosion, a process that involves a chemical reaction of a metal with its environment. The process is so common and so amenable to experimentation that it provides a suitable introduction to the study of change at the senior level.

During their activities, children's discussion should be directed towards the idea of changes occurring in the materials. At the same time new materials may be formed due to some process of combination occurring between the original materials. The process is gradual and evidently involves very small particles of the materials.

The experiences themselves should be used to develop children's understanding of the fact that often a number of factors are involved in change, and that, in studying change, efforts must be made to isolate or sort out the factors that may be involved. At the conclusion of the activities, children should be able to give some account of the conditions favouring rusting and of the conditions that inhibit rusting.

The activities should also provide children with opportunities to develop their abilities to devise and carry out suitable experiments, and to draw valid conclusions on the basis of the data collected.

Changing the Conditions

In order to study the process of rusting, a systematic series of experiments must be carried out. The planning of these experiments should be done by the children. Sets of materials will be required, and the number of items in each set will depend on the number of experimental situations children suggest. Children are unlikely to suggest many at the outset; nor are they likely to offer the range of suggestions given below. First, they will probably need to observe a more loosely organized experiment. This might follow a question such as: "How could we make something rust?" Children may suggest placing some water in a fruit tin, wetting some steel wool, or placing some nails in a jar containing a small quantity of water. Observations and discussions that follow should provide the children with opportunities to organize some carefully controlled experiments, using the materials suggested below, to discover which combination of object, air, and liquid will produce rust most rapidly.

At the conclusion of these activities children should be encouraged to organize the information they have obtained, and to draw conclusions from it.

Materials

The materials children collect might include pins, nails, coffee-powder tins or fruit tins, pieces of steel wool, small pieces of galvanized iron, small pieces of copper, aluminium, lead, and stainless-steel strip, the zinc casing of old dry cells from flash-lights, and silver-plated teaspoons.

Children may suggest putting all of these in water, but there are many other problems that could be investigated, involving other factors that might be involved in corrosion—for example:

- Is tap-water the only liquid we could investigate?
- Does the air have anything to do with the process?
- Is there any air in tap-water?
- How could we get rid of it?
- Is there any connexion between the discolouration of a rusting nail, copper, and a spoon used in eating a boiled egg?
- How long should the investigation continue?
- At what intervals should observations be made?
- Would rusting make things lighter or heavier, or would there be no change in weight?

We do not expect that all of these problems will be investigated, but they do show the range of activities that small groups of children could undertake. (If change in weight is being studied, the balance described in the unit on liquids might be useful for comparing the weight of an unrusted tin with that of a badly rusted tin.)

The following liquids would be useful for these experiments :

tap-water, salty water, boiled water, moisture (either a small quantity of water sufficient to provide dampness in a covered container, or a piece of damp cloth) ;

vinegar, lemon juice ;

oil ;

egg-white and egg-yolk ;

methylated spirits ;

detergent, soap powder, washing soda, household bleaches and cleaners.

A variation of the method of experimentation would involve sealing the containers, perhaps with a layer of oil or by filling brimful and covering with a sheet of plastic, so that there was no air-space at the surface. Glass baby-food jars might make suitable containers for this work.

Observations should be made at regular intervals, and the data organized by the children for inclusion in a class Interest Book. Encourage the children to draw conclusions and to discuss their validity.

Prevention of Corrosion

Having observed a number of changes, and discussed methods of rust prevention as used in industry—coating with paint or some material less susceptible to corrosion, such as tin, zinc (galvanized iron), nickel, or chrome ; or covering with a film of oil or grease—children may wish to compare (experimentally) methods of rust prevention. This might involve selecting a combination of metal and the associated condition that causes the rapid formation of rust, and then applying whatever coatings are possible, including various types of paints and greases. Metallic coatings are harder to apply, but some children may be interested in applying a coating of copper to an iron key, and then comparing the susceptibility to rust of the plated key with that of another unplated key. It is possible to apply a coating of copper to a nail or a key by placing it in a solution of copper sulphate. A thicker coating can be applied in the following way.

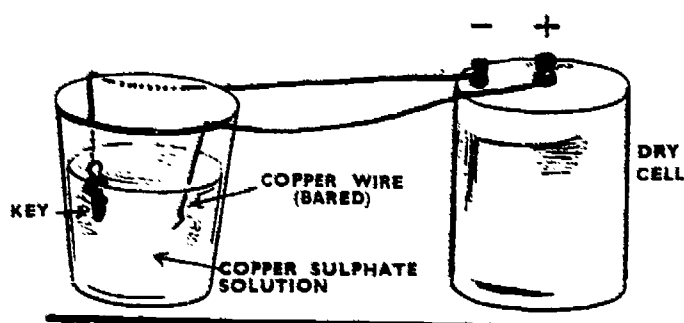

Dissolve a tablespoonful of copper sulphate (obtainable from a hardware store) in a glass of hot water. Connect the copper wires and the key to a dry cell, as shown in the diagram. A coating of copper will be deposited gradually on the key. Allow this process to continue for as long as possible before removing the key from the solution.

Note (a) Children should wash their hands after handling the copper sulphate.

(b) The key should be cleaned with sand-paper and washed carefully before being placed in the solution.

The times taken for the plated key and an unplated key to rust should now be compared. Not only is this an interesting activity associated with rusting, but it is also likely to provoke discussion about the plating process itself, and whether other objects could be used instead of the key.

Changes in Air Associated with Rusting

It is expected that children will notice that rust forms more rapidly when air is present. They may notice that when a nail is half immersed in water the rust often forms at the surface of the water first. Moistened steel wool or a nail kept damp rusts more quickly than steel wool or a nail immersed in boiled water (from which air has been driven off).

This might be an appropriate time to suggest that a small piece of moistened steel wool be placed in a test tube or a plastic pill tube, which is then inverted and placed in water (see diagram).

The water level in the tube will rise as the rusting occurs, suggesting that some of the air is used up. If a lighted match is lowered into the tube, it will go out more rapidly than a match lowered into a tube of fresh air, suggesting that the air has been changed. *On the basis of this evidence alone, a statement that the oxygen has been used up would not be scientifically sound; it can be said that the air has been changed.*



It might be of interest to speculate as to what would happen to another small piece of moistened steel wool inserted in the same tube of "used air". Would the steel wool rust? If it did rust, would it take longer for the rust to appear? If children do attempt to answer these questions, they would need to insert the fresh piece of steel wool carefully, so that no more air entered the inverted tube. This could be done if the steel wool was placed on the end of a straightened paper-clip or a piece of wire and then pushed into the tube while the mouth of the tube was kept under water.

THE RESULTS OF CHANGE

In this unit it is expected that children will study changes associated with the burning of a number of materials, from wood to wool, and as a result it is hoped that they will appreciate something of the law of conservation of matter, which states that under ordinary circumstances matter is neither created nor destroyed. At this stage, this idea will not

be formulated precisely nor proved experimentally. It is sufficient that **at the conclusion of their activities children will be able to understand that a given quantity of material undergoing change may be replaced by a variety of other substances, and that a number of these can be identified.**

The idea of conservation itself may be expressed by children in a form similar to : "You can't get rid of anything ; you only turn it into other things."

The unit also provides a number of opportunities for developing the abilities set down in the introduction to this set of units.

Introducing the Topic

Interest may be aroused during observation of flames produced by a lighted match, a candle, a hurricane lamp, and a methylated-spirits burner. All of these have interesting and characteristic flames. In this unit, however, we are also concerned with the changes and the products of this process of combustion. Children working in small groups may study each of the burning materials mentioned above, but in this section we will concentrate on one, the candle.

What changes can be noted ?

1. The wick turns black, and the tip bends over and is burnt away. (Wicks are made to do this to obviate the need for constant trimming.)
2. The wax melts.
3. The flame has a number of regions and colours. (Observation of colours produced when other substances burn, such as salt or steel wool, suggests that perhaps in each region different substances are burning.)
4. If the flame is held near a dry, empty tin or a milk bottle, water mist can be seen forming. Does the water mist come from the surrounding air ? Does it come from the candle ? Is it a result of a product of the burning process ? These are questions that might be asked, but not necessarily answered, at this stage.
5. Black soot is deposited on the glass or the tin.

Are these the only products ? We cannot be sure. There may be others, but they cannot be detected by direct observation under these conditions. Finally the candle will burn down and go out, leaving a quantity of wax.

This may suggest another question : How does the weight of the residue compare with the weight of the whole candle ? Of course it is too late to find the answer to the question as it applies to the original candle, but the experiment could now be repeated. The candle should be weighed before doing the experiment. (It is better to work this way rather than to suggest weighing the candle at the beginning of the activity,

when the point of such an exercise would be lost on the children.) A suitable balance for the work is described in the unit Comparisons of Liquids. If one of these is not available, the type of balance used for work in applied number in the infant school may be useful.

Other changes can be detected if a lighted candle is placed in a pan of water and covered with an inverted jar. The flame goes out and the water rises inside the jar, suggesting that some of the air has been used up. Children readily repeat the old dogmas about this—that the flame goes out because the oxygen is used up ; that oxygen constitutes one-fifth of the air and, therefore, the water rises one-fifth of the way up the inside of the jar. *These statements are not justified on this evidence.* In fact, not all of the oxygen will be used up (a white mouse will survive untroubled inside the jar for many minutes), and the water rarely rises one-fifth of the height.

Extending the Ideas

Wood and Steel Wool. Attempts might be made to compare the weight of a piece of wood with the weight of ash to which it can be reduced. If this is done successfully, similar comparisons could be made using other materials, including steel wool. Steel wool can be burnt using a methylated-spirits burner or solid-fuel tablets. Blow gently on the burning steel-wool pad until it glows. Allow it to cool and re-weigh.

Encourage children to list the conclusions that could be drawn from these activities. Sample conclusions might be :

When wood is burnt a light ash is produced, so some of the wood material has disappeared or gone somewhere.

When steel wool is burnt the ash is heavier, so some other substance has been obtained from elsewhere.

Perhaps some of the wood has turned into water-vapour or gas or soot. Perhaps the steel-wool ash has some air or gas from the air "mixed in" with it.

Any suggested conclusion should be discussed and, in some cases, checked by further experiments. But it is good science if some doubts are left as to how final these conclusions are.

Rubber, Plastics, and Fibres. When these materials are burnt it is desirable that children be encouraged to record the data they collect in some systematic form of their own choosing, so that the facts they discover are readily available, for example :

	Burn	Melt	Time taken to burn away	Smell	Substance remaining
Item A . .	Yes	Yes	5 sec.	Smells like burning hair	Soft and black
Item B . .	Yes	No	4 sec.	No smell	Grey ash
Item C . .	Yes	Yes	4 sec.	Smell of celery	Tarry bead

If plastics are examined, small samples only should be used—perhaps one inch square—to reduce the danger from highly inflammable varieties.

From the experiments and the information gathered, children should be encouraged to develop some ideas about the conditions necessary for burning, factors affecting rate of burning, and changes that occur as a result of burning.

It would be a natural consequence of these activities to compare the inflammability of various clothing materials—cotton, wool, rayon, and nylon. In this way, important safety ideas can be introduced. Other activities with fibres are suggested in the unit Threads and Fibres.

BOILING AN EGG

Most children know how to boil an egg. They know it takes from three to four minutes for the egg to coagulate satisfactorily in boiling water, but perhaps, because it is such a prosaic event, it is worth investigating further, with suitable excursions into interesting side issues that arise.

At the conclusion of the activities it is expected that children should be able to describe the methods they have devised and the results they have obtained in one or more areas of investigation, depending on which of the following topics have been studied: relationship between grade, weight, volume, and price of eggs; interaction between shell, egg-yolk, and egg-white and simple household chemicals; use of egg-white as a binder for pigment; observations of rate of coagulation and temperature; effect of simple household chemicals on coagulation. At the same time each activity should provide opportunities to develop abilities, including the planning of experiments and the forecasting of results.

Introducing the Topic

The foregoing comments make it clear that there are a number of experiments, other than boiling, that may be carried out with eggs; these may be introduced in a number of ways. In this unit it will be assumed that a general interest has been aroused, and that it has been decided to start with observations of eggs, but it is not necessary that every class should start this way or undertake all the activities set out here.

Grade, Weight, Volume, and Price

This heading should, by itself, suggest the type of activities that might be tackled. The starting-point could be a question such as: "Is the cheapest grade of egg really the best buy?" The average weight of a number of eggs in each grade could be ascertained and then used, in conjunction with prices, to determine the answer.

Some children may be interested in attempting to determine the relationship between weight and volume, and in this case the problem would be to find a method of determining volume. This is a problem they should attempt themselves with a minimum of assistance, but, if necessary, the teacher could suggest immersing an egg in a jar of water and noting the rise in water level. This rise could then be expressed as being equal to a certain number of teaspoonfuls of water, or some other suitable unit.

Egg-shells

Egg-shells are considered to be very fragile, yet in some ways they possess great strength. In one school, the theory that birds in early times laid their eggs in flight was being discussed, and it was decided to test the practicability of such a theory. It was spring, and the vacant ground next to the school was soft and covered with long grass. Thirty-six eggs were thrown over the school building on to the vacant ground, and only three were damaged. It might not be possible or desirable to carry out a similar experiment, but there is a less expensive activity that could be attempted. Obtain half of an empty egg-shell, trim it neatly, and place it on a piece of cloth (to absorb any irregularities) and then stack books on the egg-shell, as shown in the diagram below, to determine the weight the dome shape of the shell can withstand.

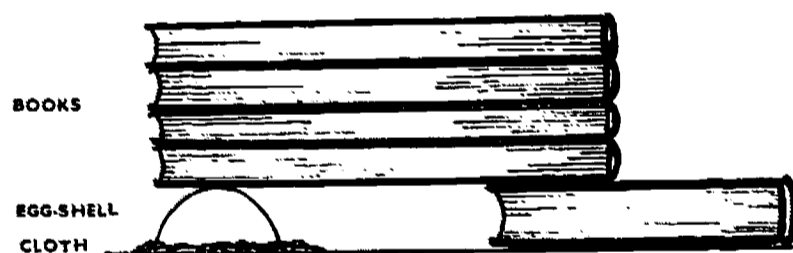

This may lead some children to investigate in detail the interesting relationships between shape and strength that are of such importance in architecture and many branches of engineering.

Library books dealing with these subjects could provide many ideas for model-making activities.

Eggs and Household Chemicals

It is not always realized that there are a number of chemicals that can be obtained from the home and used for simple investigations into chemical reactions between substances. These chemicals include vinegar, lemon juice, and household cleaners. Some children may investigate the possibility of producing reactions between some of these chemicals and small quantities of egg-shell and egg-white. For example, they may note that egg-shell is changed during immersion in vinegar. Streams of tiny bubbles can be seen rising from the shell, and the gas produced may be tested with a lighted match. Results may be inconclusive, but at times the match will be extinguished. (This may lead to discussion of other reactions that lead to a similar result—for example, when baking soda is added to vinegar or lemon juice.) After

some days of immersion in the vinegar, the shell will soften and tend to break up, but this result should not be attributed to the vinegar at this stage; the effect of placing egg-shell in other liquids, including water, would need to be investigated before making any conclusions.

Coagulation

The availability of several test-tubes, thermometers, and suitable heat sources would permit children in a small group to undertake some investigations of the process of coagulation. One egg provides sufficient material for many experiments. Break the egg and separate the white and the yolk carefully. Small quantities of egg-white or egg-yolk can be withdrawn with a milk straw and placed in test-tubes with water, and heated. The time taken for coagulation can then be measured. During this work, it might be instructive to discover if there is any significant relationship between temperature and the rate of coagulation. Will eggs coagulate at temperatures lower than boiling-point? If an egg coagulates in three minutes at 212 °F, how long would it take at half this temperature?

If a thermometer is available, it may be possible to experiment with egg-white at temperatures between 100 °F and 212 °F. Temperatures can be kept reasonably stable if the test-tubes of egg-white and water are placed in tins of warm water at the desired temperatures. Encourage the children to keep careful records of their findings, which they should later present to the class.

Finally, the effect of adding household chemicals to the egg-white and water before heating may also be studied.

Incubation

It is not proposed to outline suggestions for this topic here, since this is dealt with in the Life section of the Curriculum Guide. It is sufficient to say that attempts to hatch eggs may provide a natural extension of the studies undertaken in this unit.

MAKING COAL-GAS

How the Topic Might Arise

In many cases, work in science is closely associated with social studies. Any investigation in social studies on coal-fields, types of coal, or town studies could provide a natural introduction to this unit.

At the conclusion of their activities, children should understand that when a substance such as coal is heated it may be converted into a number of other substances.

During their activities children should develop further their abilities in weighing, timing, constructing apparatus, organizing tables of results, and drawing conclusions consistent with the evidence collected. It is hoped that they will also appreciate the fact that modern society depends to a large extent on the application of science and technology to problems associated with the use of the raw materials available.

Materials

Pieces of black coal, brown coal, briquettes, coke, wood shavings of the type found in rotary pencil sharpeners, dry gum-tree twigs, charcoal.

A heat source. This does not present a problem in any school where there are still open fire-places in the classrooms. A fire for heating the various substances can be lit in the fire-place. Where this is not possible, old kerosene tins set up in the playground would be quite suitable. A small group of responsible boys and girls should be elected to undertake this task.

Some small tins of the type in which powdered coffee is sold. Two holes should be pierced with a one-inch nail in the press-on lid of each tin. Before the children start work, they should be warned that the tins are likely to get very hot. They may need pliers or thick cloths to enable them to pick up the tins at the appropriate time. Strict supervision by the teacher will be necessary.

Solid-fuel burners that could be set up in the classroom on a suitably covered table would be useful at a later stage of the activity.

Introductory Activities

Children should first observe and examine the materials collected in order to determine some of their properties—colour, texture, hardness, smell (if any), weight. Some children may be satisfied with rough comparisons of weight. (It is unlikely that pieces of the same size can be obtained.) However, there may be some children who are not satisfied and who become intrigued with the problem of how more accurate comparisons could be made. The arguments and the activities undertaken to solve such a problem could be as valuable as any other activity suggested here. The children should solve the problem in their own way. Allow plenty of time for this. It may be a topic that crops up periodically during morning discussion over a period of several weeks, depending on the level of interest. The following hints, dropped at the right time, may help to sustain interest. A piece of black coal could be dropped into a graduated jug of water and the rise in the water level noted; the same procedure could be repeated with other materials. The next problem would be that of weighing. If sufficient small weights are not available, nails could be used as weights. A balance can be made from an 18-inch piece of lath, with a fruit tin hanging from each end. This apparently crude balance may be more accurate than many sets of scales found in schools. Infant-room balances can also be used, but making a balance is in itself a worth-while task.

These activities would provide raw data. It would then be necessary to standardize the figures. Once these are set out in a tabular form, the children should be able to suggest ways of standardizing them.

If it is possible to set the materials alight by lighting small fires in fruit tins pierced with holes, or by placing the materials over a suitable heat source, useful observations could be made on the nature of the different flames.

Making Gas

If the children are fortunate, gas may be obtained from several of the materials suggested above, but black coal is the most likely source.

The materials should be placed in the coffee-powder tins and heated over a hot fire. After some time, smoke will begin to appear from the holes in the lids. Apply a lighted match to the holes, and the gas given off may ignite. If this does not occur at first, continue heating the materials and test again.

When gas can be detected, the tins should be transferred to the smaller heaters set up in the classroom, and the heating and the testing continued. Most children find this a very exciting activity. It is possible that they may be successful in producing gas from two or three of the substances tested. On the other hand they may get gas only from the black coal. In writing up their experiences and supplying conclusions, they may tend to state categorically that "you can get gas from black coal, but not from brown coal", or write something similar. *Children should be encouraged to discuss whether or not a statement of this type is valid.* A growing reluctance to make generalizations on the basis of a limited set of experimental results should be a feature of children's thinking at this level.

Opportunities for timing the experiments should not be overlooked during this activity.

Products of Decomposition

Let us consider black coal first. Encourage the children to note down all the products they can observe from heating the material—smoke, a powerful "gassy" tarry smell, a watery liquid (this may be noticed in the early stages of heating), a sticky tarry residue, and, if heating is continued long enough, a coke-like substance may be formed. Children may call this "a kind of charcoal". The idea that all of these substances were somehow "in" the coal should be discussed; there may also have been other products that the children could not observe.

Other substances should be examined in the same way so that children gain some idea of the complex nature of many common materials.

A valuable investigation arising from this work would involve heating other common substances, such as salt and sugar, to determine whether decomposition occurs in every case, and whether similar products can be observed.

Note.—In any science activity involving heat, it is reasonable to expect that the teacher will take suitable precautionary measures. The position of the nearest fire-extinguisher should be known. No fire should be lit out of doors during restricted periods. A 2-ft. by 2-ft. piece of asbestos "Hardiflex" makes a safe base when any burner is being used in the classroom.

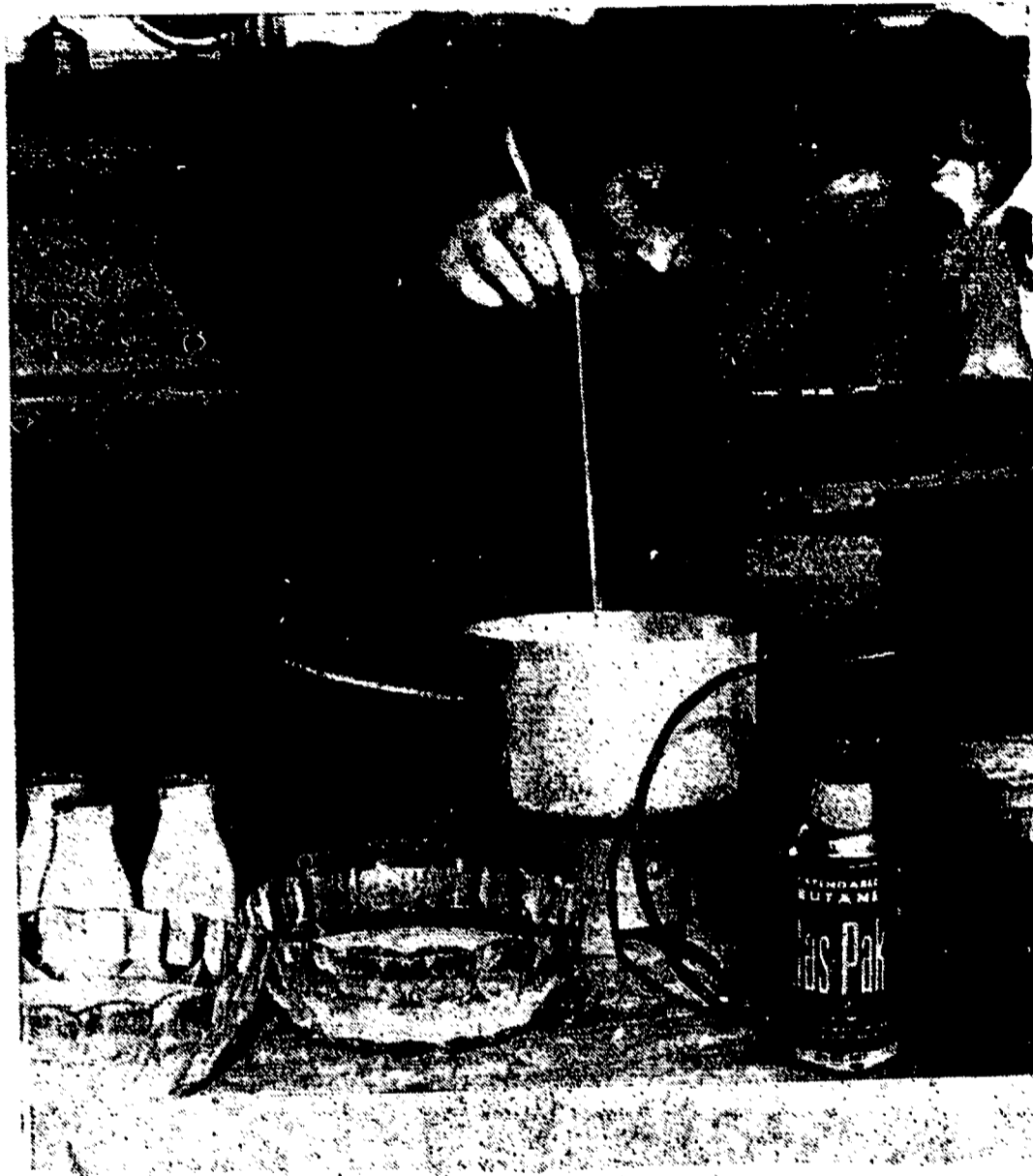

THE SOURING OF MILK

This unit is of much the same nature as the junior-level unit Bread, Toffee, Honeycomb, Ginger Beer, and Cheese. It is recommended, therefore, that teachers read the junior-level unit in *Following On*, and consider using some of the activities listed there in conjunction with those suggested in this unit. This applies particularly to the section on cheese in the junior-level unit.

It is expected that children will develop an understanding of the causes and the characteristics of physical and chemical changes, particularly those brought about by living things. This should be done by the children through their own observation and experimentation. In carrying out activities in this unit, opportunities will be provided for children to observe reactions and changes, to organize and record information, to measure, and to plan and perform simple experiments. Senior children can be expected to show a higher level of skill and understanding, and to give more consideration to the variety of factors involved.

This unit is closely linked with social studies, English language, and applied number. The topic might arise from work done in social studies, or from a discussion of the problem of keeping milk fresh at school.

Activities might commence with an investigation of the causes of milk turning sour. Statements such as "the warm weather made the milk turn sour" should be treated with caution. Warm weather is only partly responsible; it helps to create conditions suitable for the rapid growth of bacteria. However, environmental factors are important, and attempts to control and vary the environment can form the basis of many activities.

Changes in Milk Due to Environmental Factors

If containers of milk are placed in a number of places having different temperatures, a study can be made of the effect of temperature on the time it takes for milk to turn sour. The information obtained in this way can be arranged in table form, and then used to make a graph. It can be expected that the graph will show a pattern that will indicate the effect of temperature on the souring of milk. The use of thermometers would increase the accuracy of the experiment.

Interactions between Milk and Various Household Chemicals

Household chemicals, such as the following, may be added to milk in order to observe the interactions that take place: vinegar, detergent, methylated spirits, turpentine, lemon juice, orange juice and other fruit juices, bleach, salad-oil, soap, rennet or junket tablets, and ink.

Children should be warned of the danger of tasting some of these household chemicals. Every opportunity should be taken to reinforce safety consciousness, and it is desirable that children should be able to recognize the common household chemicals.

Activities should involve careful measuring of liquids, close observation, timing, and recording of results. Oral discussions and written descriptions of what took place would form a valuable part of this work.

Observations of Milk under a Microscope

Note.—If a microscope is not available, many of these observations can be made with the naked eye or with a hand lens.

Whole milk smeared on a glass slide can be studied under a microscope and comparisons made with other kinds of milk and with other white liquids. For example, comparisons could be made between fresh milk and sour milk; milk soured by different chemicals; the yoghurt mixture at regular intervals before, during, and after fermentation; cottage cheese; full-cream milk, skim milk, cream, evaporated milk, powdered milk (full cream and skim); milk and other white liquids such as milk of magnesia, white paint, and the sap of various plants such as the dandelion.

Comparison can be facilitated by smearing two different liquids side by side on the one slide, which can then be moved sideways under the lens.

Since work with a microscope can take quite a long time, most of these activities would need to be spread over a period of several days, or even weeks, usually taking up a few minutes here and there throughout the day as individual children have time to spare from other work.

Making Yoghurt

Yoghurt is the Turkish name for fermented milk. A particular type of bacteria changes fresh milk into yoghurt. The fermentation acts as a preservative. Cultures of bacteria are added to fresh milk that has been concentrated to two-thirds of its original volume. The mixture is then loosely covered and placed in a warm place (108 °F to 120 °F) for about three hours, or until the curd has developed. It is then cooled quickly to below 40 °F and refrigerated. The following recipe should be suitable for use in the classroom.

Ingredients : 2 pints of milk.
1 pint of water.
6 heaped tablespoons of skim-milk powder.
2 tablespoons of yoghurt.

Mix milk and water. Heat to between 108 °F and 120 °F.

Stir in skim-milk powder until fully dissolved.

Add 2 tablespoons of yoghurt.

Place in a jar and stand in a box containing crushed paper (to retain heat) until the desired curd has developed—this may be as long as eight hours.

Success is not always certain, so the value of this activity lies in the opportunity it provides for children to attempt to control and vary the factors involved. Opportunity will also be found to measure liquids, to weigh, and to use a thermometer.

It might be found that a better quality of yoghurt can be obtained by increasing or decreasing the proportion of water or skim-milk powder, or by varying the temperature.

In a Fifth Grade in a Melbourne school, The Souring of Milk was followed by Comparison of Liquids. That the two units can be naturally interwoven can be seen from the following extracts from reports written by one of the boys. It is worth noting that he does not go beyond the stage of describing what he observes. However, this was his first experience with science in the primary school. What he wrote provided the teacher with an insight into the level of the boy's thinking. It was then left to the *teacher to guide* the boy (and other interested members of the class) beyond the stage of random observation to where he was able to plan tests with a particular aim in mind. These are the observations the boy recorded :

" For this experiment I needed a bottle of milk. After two days the milk was gradually turning creamy." [" Creamy " was the boy's way of describing the thickening of the milk as the curds began to form.]

"The taste was sour. Under a microscope it had spots, circles, and lines. It had a thick layer of cream on top. After several days it had colours in it. Today it is green, pink, and yellow. It has a terrible smell and has a liquid like water."

At this stage the teacher could ask if there was any way of slowing down the rate of souring, or he might say, "I wonder if it would make any difference if we stood the milk in a warm spot" or "I suppose the sour milk must look different from fresh milk under a microscope."

When the boy was trying some of the activities suggested in Comparison of Liquids, milk was one of the liquids he used:

"We dropped a pin in each liquid. It turned out that the pin sank quickly in water, vinegar, and lemonade. In detergent, oil, milk, and paint it went slowly. This was probably because the last four liquids were thicker than the first ones."

Note that he has gone a little beyond observation. It would be hoped that the next step in his development might be to plan further experiments to prove or disprove his inferences. *Such a development in skills comes slowly, and is often the result of gentle guidance by the teacher.*

A still firmer link between the two units would occur if the boy (possibly at the teacher's suggestion in the above case) had applied the pin test to milk at different stages of fermentation.

Research into the work of Louis Pasteur might follow.

HOUSEHOLD CHEMICALS AND CHANGE

In *Beginning Science*, there is a section devoted to Discrimination and Classification, where activities that will help to develop children's abilities to discriminate and to classify objects and events in their environment are suggested. Not only do these activities involve valuable sensory training, they also introduce a notion that is of great importance in science, and in fact in all branches of learning—the grouping of ideas in patterns, categories, and hierarchies to make easier the task of handling the vast supply of raw data that the world provides. Therefore, the task begun in the infant school does not end there, but continues throughout school-life, and beyond. Indeed most of the science activities suggested in these guides should facilitate the processes of grouping, both in the immediate circumstances and later.

Any activities having to do with bringing about change are natural extensions of this idea of classification, and should be treated in such a fashion as will extend the abilities of children at the upper primary-school level. To assist in this process, it may be desirable to make a collection of common chemical reagents that will enable more sophisticated groupings to be made than were possible with younger children. These reagents need not be purchased from a chemical-supply house. There are sufficient materials available in the home or locally to enable a wide variety of investigations to be undertaken. Not only are these

investigations likely to appeal to upper primary-school children, anxious to emulate their older brothers and sisters, but they also provide practice in careful, methodical procedures, assembling large numbers of observations, drawing conclusions, and extending classification systems—all of which are of real value in themselves. A list of suitable materials is given below :

Vinegar (white vinegar is preferable)	kerosene
lemon juice	iodine
cream of tartar	Condy's crystals (potassium permanganate)
aspirin	starch
ascorbic acid tablets	soap flakes
	sugar
ammonia	salt
"Limil"	copper sulphate
washing soda	superphosphate
baking soda	fats—butter, margarine, paraffin wax, vaseline
	detergent
beetroot juice	iron
red-cabbage juice	iron coated with tin (food cans)
turmeric powder	iron coated with zinc (galvanized iron)
	aluminium (milk-bottle tops)
hydrogen peroxide	copper
household bleach	brass
	nickel plating
nail-polish remover (acetone solvent)	chromium plating
mineral turpentine	lead
methylated spirits	zinc (from torch batteries)
glycerine	carbon (rods from batteries)
water	

Large quantities of the materials are not necessary ; glass baby-food jars make suitable containers. When a collection has been made it should be stored, if possible, near a table or a ledge where observations can be made.

It will be noted that certain groupings have been made in the list printed above. It is not desirable that children be told about these ; it is better that they should make groupings on the basis of observations and investigations they themselves make. Similarly, it is not necessary that chemical names be known ; however, it is possible that children will begin to enjoy using the scientific names after they have discovered some of the characteristics of the various materials.

The following notes may be of some use to the teacher :

Initial Groupings

Groupings on the basis of readily observed characteristics—powders, crystals, solids, liquids, colours, smell—can be made, and these will be similar to the groupings made by younger children, except that the groups may be more complex and involve a more developed vocabulary.

Solubility Groupings

Comparisons should be made, using water and other liquids such as kerosene. Possibly this work may lead to a further grouping, where the dissolving of a substance is associated with some obvious change, for example, where vinegar is used and gas is given off.

Colour-change Groupings

Beetroot juice, red-cabbage juice, and turmeric change colour when certain substances are added. The juices may be obtained by boiling the materials in a small quantity of water. Red-cabbage juice will turn green when a little baking soda is added. If a small quantity of the green liquid is mixed with a few drops of vinegar, the green liquid changes to red.

If vinegar is added to the original red juice there will be no colour change, but if a few drops of liquid soap are added, the red juice will turn green.

Bleaching and non-bleaching groupings could result from adding bleaching agents to cabbage juice or beetroot juice, to coloured cloths, and to coloured flower petals.

Corrosion Groupings

These have been discussed in another unit.

Cleaning Groupings

Several of the liquids remove dirt or grease, and after testing a number of substances further groupings could follow.

The activities with household chemicals will probably extend over a long period. Children should be encouraged to make a record of their findings for other children to check. It is important that the children make up their own tests and their own groupings, using all of the materials or a selection of these, combining them in various ways to discover their properties. Before they start, the need for methodical procedures, records, and valid conclusions should be emphasized.

In many ways the procedures children adopt can provide a valuable means of evaluating progress and the level of responsibility and maturity the children have attained.

PART II

ENERGY



PART II : ENERGY

For a full understanding of the material that follows it is essential to refer to the introductory remarks on energy in the *Course of Study for Primary Schools, Science*.

FIRE

Fires and flames seem to be perennially interesting to mankind; especially, it might be said, to men. Witness the pleasure men get through burning rubbish in the backyard, or watching a bonfire. Perhaps this is a survival of primitive man's interest in a mysterious, awe-inspiring phenomenon with a frightening potential for harm. It is a phenomenon that demonstrates a strange process. Matter is converted into other matter and, at the same time, something else is produced—something intangible but no less real—which we call energy.

Children will think about energy and fire in their own way, but their ideas of change and of bringing about change should develop further as a result of their activities at both the junior and the senior levels.

Activities at the senior level are likely to be diverse and closely related to work in other topics. Some suggestions are given in this unit for the following areas :

- Inflammable Materials
- Comparisons of Fuels
- Flames
- Associated Topics.

A Note about Safety

Activities suggested here should be used to develop desirable safety attitudes. These attitudes are likely to be undermined if the teacher's classroom organization does not reflect the same attitude to safety. No hard and fast rules can be stated here, since measures to be adopted will depend on the class, its size, and the maturity of the individual children. Points that teachers should consider include the following :

Materials To Be Used.—Some heat sources such as candles and solid-fuel tablets may be used by children; other heat sources such as liquid gas and methylated spirits should be for the exclusive use of the teacher, with the children as onlookers.

Size of Groups.—There is no optimum size of a group. It may consist of one or two individuals or of the whole class. A large number of groups should not work with simple heat sources, such as candles, in a limited area.

Place for Work.—If the classroom space is cramped, the shelter-shed may prove more satisfactory. On the other hand, there will be times when the classroom is perfectly satisfactory. Draught and wind conditions should be considered. Metal trays or asbestos mats may be advisable.

In general, work should be done with the smallest heat source that is useful, and with small quantities of the materials. Of course, the teacher should be present at all times when inflammable materials are being used.

Inflammable Materials

Ignition Temperatures

Some materials will not burn until they are raised to a high temperature; others catch fire relatively easily. For example, rags soaked with paint or turpentine may burst into flame of their own accord if packed into a box. The volatile material in the rag combines with oxygen in the air, and this raises the temperature to the point at which a flame is kindled.

Children may be interested in sorting materials according to the temperature at which they catch fire. Encourage them to work out their own way of doing this. A possible method is indicated below :

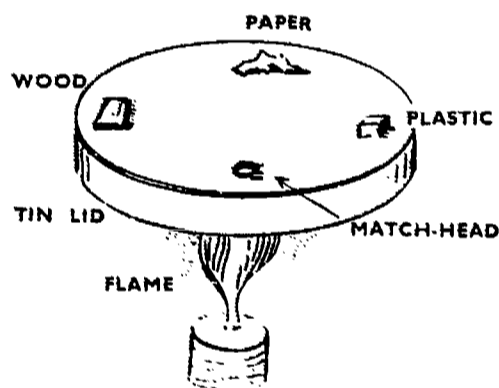

Other materials that could be examined include photographic negative film, brown coal, black coal, a variety of types of wood, pieces of leaf (compare tea-tree or eucalypt and camellia), pieces of cloth, sulphur.

It will be found that the match-head catches fire very readily, whereas the wood may only char. If a lighted match is passed over the materials as they begin to char, some will begin to burn even though the flame of the match does not touch the charring material.

Comparing Clothes

In one class, the children made clothes-peg dolls and dressed them in a variety of materials, including wool, cotton, rayon, nylon, linen, and flannel, and noted what happened when the materials were lit with a match. Work on this topic could be linked with activities noted in the Matter unit Results of Change, and also with the activities in the Fire unit for the junior level. The main difference at the senior level is that when children undertake these activities they will be expected to attack problems more systematically and be more ready to draw conclusions, if these are possible.

Comparison of Fuels

It may be possible for children to boil a small quantity of water in a tin lid, using a candle as a heat source. The question of the efficiency of

other kinds of heaters, compared with the candle, might be raised. Encourage the children to devise their own ways of making comparisons. One method might involve using a small candle as a standard, and timing how long it takes to heat a given quantity of water to boiling point (or, if a thermometer is available, to raise the temperature, say, ten or twenty degrees). The experiment would then have to be repeated, using other sources of heat, including—

- a methylated-spirits burner,
 - a kerosene burner (the lower part of a hurricane lamp),
 - a solid-fuel tablet (obtainable from hardware stores),
 - a fire-kindler,
 - a gas ring or an electric hot-plate, if these are available,
- and comparing the time taken with that of the candle.

If it is intended that water should be boiled, the activity might best be performed by a small group under the supervision of the teacher, with the rest of the class as onlookers.

Children should be warned of the dangers of using highly volatile liquids such as petrol and methylated spirits.

Flames

It can be instructive and pleasurable simply to look at flames, but children may wish to do more, and some suggestions for activities follow.

- (i) *Comparing the flames of various burning materials, such as candles, methylated spirits, kerosene, coal, briquettes, wood.*
- (ii) *Noting the different parts of individual flames.*
- (iii) *Investigating the colours of the flames of various materials.—* Different elements produce distinctive colours as they burn. However, because the materials and the flames that children work with contain impurities, they will not be able to come to any firm conclusions. Nevertheless, they will be interested to discover that different materials do produce flames that show differences in their colours. In these experiments the children should use a relatively clear, pale flame, for example, from methylated spirits. The end of a straightened-out paper-clip could be moistened in water, dipped in the material to be tested, and then held in the flame. Salt burns with a yellow flame; copper sulphate produces an emerald-green flame; potassium permanganate produces a lilac flame (try placing a very small quantity in a spoon, and sprinkle over the flame); boric acid (boracic, from the chemist) produces a green flame. Under the supervision of the teacher, other chemicals found in children's chemical sets may be tried.

Small quantities only should be used, and the dangers of working with unknown materials, which may be dangerous, should be emphasized.

- (iv) *Comparing temperatures of flame regions.*—If a suitable thermometer is available, temperatures of flame regions can be compared. A thermometer measuring up to 240 degrees Fahrenheit can be used. Place it in the side of the flame and note how long it takes to rise from 100 degrees to 200 degrees. When the thermometer reading returns to 100 degrees, place the bulb of the thermometer in the uppermost position of the flame and time the rise in temperature. If flames are compared, the data gained could be organized in some way. For example,

Flame	Time to rise 100 degrees (in secs.)	
	Side of flame (touching wick)	Top of flame
Methylated Spirits ..	6	3
Birthday Candle ..	12	4
Larger Candle ..	13	4

Children often forecast that the larger candle will be the hotter.

A decision would have to be made about the exact part of the flame to be tested, and a number of readings taken in order to ensure accuracy. The need for caution in interpreting results should be emphasized.

Note.—It is possible to insert a match-head into the centre of a methylated-spirits flame so that the wood begins to burn before the match-head ignites. The inner regions of the flame are cooler than the outer regions.

- (v) *Lighting an extinguished fuel.*—With practice, children will find that they can relight a flame after it has been extinguished, without actually touching the wick. They should bring a lighted match close to the wick immediately after the flame has been extinguished. Encourage them to discuss what happens and to put forward possible explanations. (Volatile gases form around the wick, and these ignite.)
- (vi) *Noting the effect of cold objects on a flame.*—Note what happens when a cold object (scissors, knife, coin) is placed in a flame. It will be noted that the flame does not appear to touch the object. Heat is conducted away from the gas region by the metal.
- (vii) *Flame and gauze.*—If a piece of metal gauze (insect screen) is placed on a flame, some interesting observations can be made. The flame does not pass through the gauze, which conducts heat away. On the other hand, the flame can be made to burn above the gauze if the gases that have passed through are lit with a match.

Work with gauze could be linked to the story of Davy's safety lamp, which was used in coal mines where there were dangers of explosions from dust and dangerous gases.

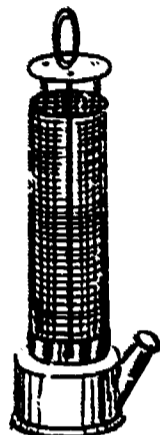

SIR HUMPHRY DAVY'S
SAFETY LAMP

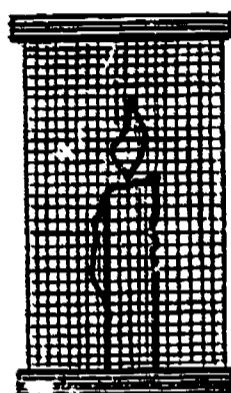

A MODEL THAT
CHILDREN COULD MAKE

Associated Topics

It is not expected that work on Fire will of necessity be treated as a self-contained unit. As with other units, the activities are grouped here for the teacher's convenience. The work children actually do may move from one unit to another, and even at times from science to English or to social studies.

The activities suggested above may be associated with the following themes :

Clothes

Safety

The Industrial Revolution
Great Inventions

(These two themes might be associated with investigations of fuels for steam-engines, motor-cars, and aeroplanes.)

Mining (Davy's safety lamp.)

Writing Poems (In this case, about fire or bush-fires.)

HEATING AND COOLING

In general, the aim of these units is to expand ideas that children may have on heat and its role as a form of energy for change and for work, and on the applications man makes of the knowledge he has gathered about it.

Evaporation and Cooling.—At the conclusion of their activities, children should be able to suggest and demonstrate methods of cooling ; they should also show some understanding of the fact that evaporation requires an input of heat energy, causing cooling in the surrounding material.

Thermometers.—Children should be able to construct and calibrate a thermometer, and be aware that there is a distinction between the

hotness, as measured by a thermometer, and the quantity of heat, which is dependent on the quantity of matter.

Expanding and Contracting.—Children should be able to demonstrate their ability to make comparisons, organize data, and discuss their findings. Some understanding should be apparent of the fact that the input of heat energy causes expansion to occur.

Things Getting Hot.—These activities should give further practice in the development of the abilities mentioned above, and lead to some understanding that the transfer of heat energy may occur as conduction, convection, and radiation.

Note.—It is not expected that children at this level will be able to express their understanding in the words used above. The level of verbalization the teacher should expect is the level that the children themselves use.

Introductory Activities

The suggestions contained in this section may be used to introduce the topic; they may also be used as activities that continue over a longer period, tying several sections together and maintaining interest in the topic. In either case, these activities should lead to an appreciation of the fact that man can apply his knowledge to serve some useful end, and that heat energy is used to bring about change and to do work.

Water Purifiers

The energy of the sun is sometimes sufficient to evaporate salt water in a bottle or a dish, and the evaporated water may then be condensed as pure water. Alternatively, salty water can be heated in a kettle, and the children encouraged to suggest methods of collecting the water-vapour. This work may lead to a discussion of methods being developed by scientists to purify water, using solar or atomic energy.

Two simple models are illustrated below:

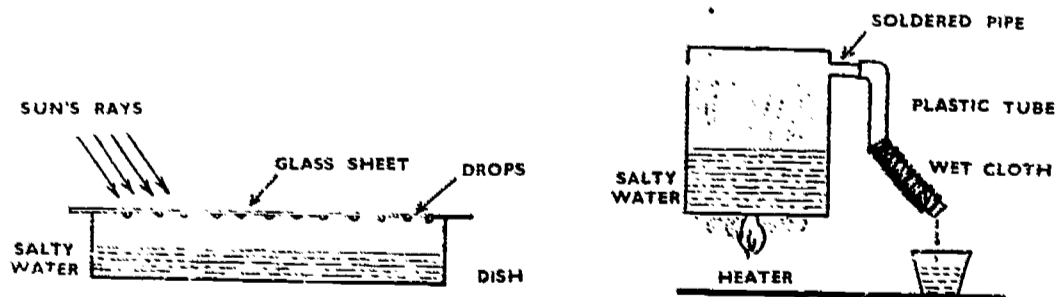

A Mobile Steam-engine

Children enjoy organizing displays of donkey-engines, which provide opportunities for telling the stories of Watt and Stephenson, as well as opportunities for writing descriptions of how the engines work. If a suitable engine is available, a group of children may attempt to make it mobile, using meccano pieces. This is more difficult than it may seem at first, but even if they do not succeed, children are likely to find that the attempt itself is enjoyable. It may also lead to a greater appreciation of the problems that the early inventors faced, and overcame.

Steam-turbines

Older children are quite capable of making simple steam-turbines, and this activity can lead to the telling of stories about Sir Charles Parsons and the *Turbinia*, as well as to an investigation of the present-day uses of steam-turbines in generating electricity and in driving ships.

Many books contain instructions for making steam-turbines out of jam tins. It is advisable for the children to try to make their own before looking at books. The basic requirement for a turbine is a heat source and a tin with a press-on lid, such as a golden-syrup tin or something similar. If a small hole is pierced in the lid, a jet of steam will gush out, and the problem then is to devise a system of blades capable of being turned by the steam jet.

Note.—These activities suggest a number of possible links with history and social studies. In many cases, stories can provide a very good introduction to a new science topic and at the same time arouse interest in other subject areas, which may perhaps lead to the writing of class or individual Interest Books. These books, in turn, suggest how science can provide valuable material for language activities at this level.

Evaporation and Cooling

The activities suggested here follow on from those associated with changes of state as set out in *Following On*. If the children have not carried out the activities outlined there, it may be advisable to begin by undertaking some of them or, at least, by organizing a discussion to ensure that children have some general ideas about changes of state.

Materials required for these activities are water, methylated spirits, and oil; a thermometer; pieces of cloth (towelling is particularly suitable); a water-bag; plastic bags without ventilation holes; and several bricks.

Interest in the topic may be aroused as a result of careful observation of the differences between water and methylated spirits, when children are likely to note that methylated spirits feels colder. Subsequently, if small amounts of methylated spirits are dabbed on the skin, children can attempt to describe the sensation produced and to suggest reasons for the feeling of coldness. Someone may suggest that methylated spirits is colder than water. A check, using a thermometer, will show the temperature of each to be the same (assuming the bottle of methylated spirits and the bottle of water have been kept in similar conditions). If no further suggestions are made, the children should be asked if they noticed anything else about the water and the methylated spirits. Equal amounts of methylated spirits and water should be poured onto the hands of several children. They should be asked to observe closely, and to describe what happens. This time it should certainly be noticed that the methylated spirits not only has a cooling effect, but that it evaporates more quickly.

A comparison might then be made with oil. It will be found that oil feels warmer than either the methylated spirits or the water. Also, the oil evaporates much more slowly than either of the others. It might even be necessary to put a drop or two of oil in a tin lid and to heat over a candle, in order to evaporate the oil.

Comparisons made by using a thermometer will establish that the actual temperatures of the three liquids are the same. It is the process of evaporation that produces the cooling effect in the surroundings. This could lead to other evaporation activities, such as the following :—

Wrap a cloth soaked in methylated spirits around a thermometer, and note any fall in temperature. For a control, another thermometer wrapped in a piece of dry cloth would be needed. This activity could be extended by comparing the fall in temperature resulting from wrapping a thermometer in a cloth soaked in water with the fall in temperature of a thermometer wrapped in a cloth soaked in methylated spirits.

Hang a filled water-bag in a sunny spot where air moves freely about it. After some hours, note the temperature of the water and compare it with the temperature of a similar volume of water in a plastic bag that has also been hanging beside it in the sun.

Wrap a piece of butter in greaseproof paper and a wet cloth. Wrap another piece in greaseproof paper and a dry cloth. Place both in a sunny spot ; leave for a while, and then compare.

Place a number of pieces of wet cloth in a variety of situations— in the sun, in shade, in a jar without a lid, in a jar with a lid, in front of a fan—and compare the rates of drying.

Make a Coolgardie safe. This would provide opportunities for links with social studies. The principle of the safe is simple.

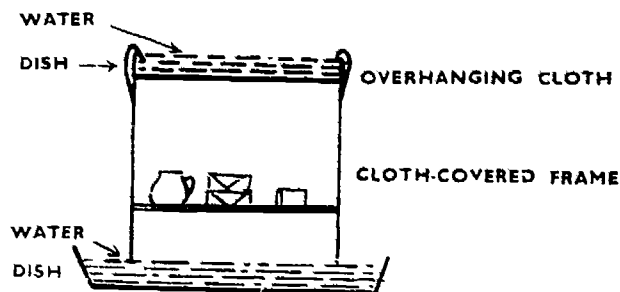

It consists of a frame surmounted by a tray of water, and standing in another tray. The frame is covered with some absorbent material such as towelling. Strips of towelling hang down from the upper tray and touch the sides, supplying sufficient water to keep the sides wet. When the cloth is soaked in water, the water evaporates, cooling the interior of the safe. The evaporated water is replaced by water soaked up by the immersed ends. The temperature inside the safe and outside the safe should be compared.

These activities lead naturally to a discussion of evaporation as it applies to the human body and to animals :

Why do we sweat when we get hot? What effect does the evaporation of sweat have on our bodies? Sweating occurs all the time, but it is only in hot, humid conditions that sweat is observed on the skin. Sweat also carries with it salt and waste products of the body's chemical activities. Washing is therefore essential.

Discuss how the panting of a dog could help it lose heat. The children might be able to suggest a possible answer, with some help. The moisture on the surface of the tongue evaporates, cooling the blood which is being pumped rapidly through the tongue. Cats sweat from pads on the feet.

Thermometers

Activities suggested for the unit Evaporation and Cooling may provide an introduction to work with thermometers. On the other hand, an examination of various types of thermometers may arise naturally, if they are made available to the class, and from this initial interest activities such as those suggested in the previous section might follow. Alternatively, work in both sections might proceed concurrently. A free treatment of the topic, rather than a rigid adherence to ideas set down here, is advisable.

Experiences Measuring Temperature

A wide variety of experiences is necessary to develop children's abilities to read temperatures accurately. At the same time a large amount of data will be collected, and this will provide opportunities for organizing information efficiently in the form of either tables or graphs. Children should be encouraged to write about their experiences, interpret the data collected, and draw valid conclusions.

If several suggestions are provided similar to those given below, children should have no difficulty in extending observation on their own initiative.

Some Suggested Activities

Measuring the temperature of melting ice, boiling water (only a very small quantity is needed and the teacher should take responsibility for this work), salt and ice, other substances and ice ; finding the melting point of paraffin wax or butter (place the butter in a small jar inside a larger jar of hot water).

Finding the body temperature of boys, girls, and adults—before and after exercise, on hot days and on cold days ; finding the body temperature of pet animals (this could prove difficult, but children might try placing a thermometer under the wing of a pet pigeon, and holding the bird carefully for a minute or two).

Noting and graphing temperature variations throughout the day or over a period of days ; finding average temperatures ; comparing times at which maximum temperatures are reached.

Comparing the temperature of soil taken on the surface, an inch or two below the surface, and two feet below the surface on a hot day. A hole could be driven into the soil and a thermometer lowered into this, and the temperature compared with that of the soil removed from the hole (the soil would probably be heated by the sun). These temperatures could be compared with the temperature of the asphalt in the playground.

Taping thermometers to cards and placing them in positions as shown below :

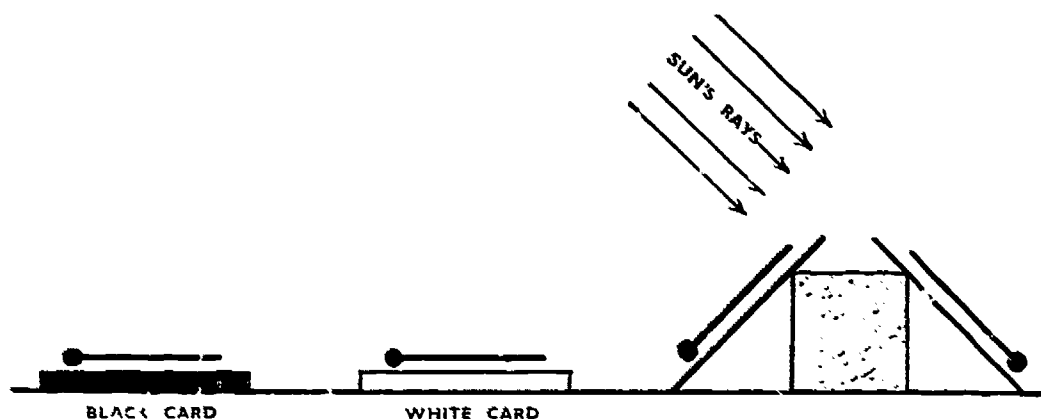

Quite noticeable differences can be detected over short periods, say ten minutes, and graphs can be plotted to show rises in temperature, with readings taken at one-minute or two-minute intervals.

Noting differences in the cooling rates of various liquids and solutions—water, a strong solution of salt and water or sugar and water, honey, flour and water (very thick paste), thick porridge. Only small quantities are needed, and these could be heated over solid-fuel tablets or other suitable heat sources. This is a small group activity. Children may find that equal volumes of the materials take different times to reach the heat-level decided upon. The porridge, or whatever semi-solid is used, should take the longest to cool down. This should lead to some idea of the distinction between the "hotness", which is measured by the thermometer, and the quantity of heat, which is dependent on the quantity of matter.

Making Thermometers

The neatest-looking articles are made from glass flasks, rubber stoppers with a hole, and lengths of glass tubing, but equally useful thermometers can be made from bottles, plasticine, and milk straws.

The children will note that the liquid in the thermometer expands when heated. This should lead naturally to an investigation of various liquids and their behaviour when heated. The diagrams show a typical experimental set-up :

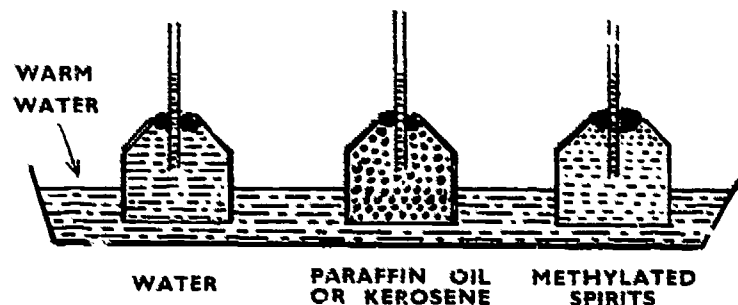

Children will observe that the liquids expand at different rates. The bottles and the liquids they contain could be used as thermometers if the tubes were backed with white card and marked to indicate the rise and the fall of the liquid more accurately. Evaporation of water and

methylated spirits would be a problem, but this could be overcome if the surface of the liquid was covered with a drop of oil.

Making a Scale

When designing his scale for a thermometer, Gabriel Fahrenheit (1686-1736) tried a number of alternatives before settling for a scale that called the lowest temperature he could get 0° , and human body temperature 100° . Boiling point on this scale then became 212° .

What is known as the centigrade scale has been renamed the Celsius Scale in honour of its originator Anders Celsius (1701-1744). Celsius at first suggested 100 as the freezing point of water and 0 as the boiling point, but this order was subsequently reversed.

Children may care to suggest their own scales, and the class thermometers could be calibrated by marking the cards used as backing for the tubes. If body temperature was taken as 0, temperatures above and below this figure could be labelled as "plus degrees" or "minus degrees", or degrees above or below zero. Absolute zero, the condition of minimum movement of the atomic particle, is known as 0° K (for Lord Kelvin). This temperature has almost, but not quite, been attained. (These facts are not to be taught or learned. They are included for the information of teachers.)

Air Thermometers

If some work has already been done on the behaviour of heated air, children may suggest making an air or a gas thermometer.

The upper bottle should be heated to drive out some of the air. On cooling, water will rise up the tube and measurements can be made of the movement of the water level in the tube.

This is a good thermometer in some ways, but it has its limitations. Small variations in temperature cause big changes in the water level. However, there is another factor involved—change in air pressure. This device can therefore act as a barometer too, and thus its use is limited. As a thermometer it is useful only over a short period or when barometric pressure is stable. The scale would need constant adjustment.

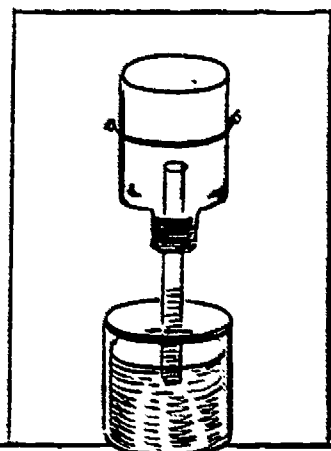

However, the fact that several factors are involved suggests its real value, particularly if the children have some knowledge of air pressure. At this level, the sorting out of the factors involved in an experimental situation and the development of a critical attitude are important. It is far better for the children to discover the disadvantages of air thermometers for themselves rather than to be told about them. Observations made over some weeks may lead children to note some discrepancies. If this is the result of making a thermometer of this type it will be a valuable exercise.

Expanding and Contracting

Work with thermometers provides a natural introduction to expansion and contraction, because, in their activities, children will discover that the principle of the thermometer is dependent on the expansion and contraction of the liquid in the thermometer.

Liquids

The same experimental set-up described in the previous section would be useful if children decided to make a chart to show the expansion and contraction of a number of liquids. This would provide a good opportunity for developing abilities in designing an experiment, measuring, organizing data, and drawing conclusions on the basis of the evidence obtained.

Contraction can also be detected if hot (not boiling) water is carefully poured into a narrow, long-necked soft-drink bottle. Mark the level. Allow the water to cool and check the level again.

Gases

Children may wish to investigate expansion in gases and to devise methods of observing this. One method has already been suggested in the previous unit Thermometers. A second method would be to tie a balloon over the mouth of a jar and then to heat the jar, but this may present difficulties. One safe method of doing this would be to place the jar in a bucket of hot water to heat the air.

Another method would involve the use of a tin with a small screw-on lid. The balloon could be fitted over the opening and the tin heated over a suitable heat source.

If glass or clear plastic tube is available, there are two other possibilities :

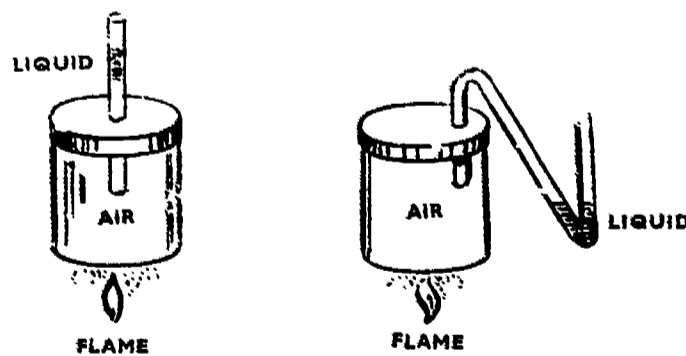

Observations could be made of the changes noted when heat is applied for a fixed time, perhaps for two or three minutes. The heat could come from a child's hands held around the container, a candle flame, a solid-fuel tablet, or a small methylated-spirits burner. This could also provide an opportunity for comparing the heat output of various materials.

Solids

Other children may wish to discover if solids expand. With certain materials their results are likely to be inconclusive, especially if they

desire to make comparisons. The materials decided upon must be held firmly at one end, and any expansion can then be detected at the other end. Children will probably try to heat thin pipes, rods, or steel knitting-needles, and attempt to measure changes in length with a ruler. They are unlikely to be successful in this, but it is advisable to let them try and to attempt to overcome the difficulty for themselves. The following diagram illustrates a possible solution :

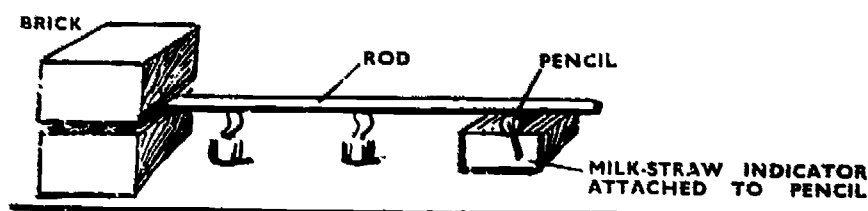

If a small vice is available, the heated rod could be fitted between the jaws and allowed to cool.

If the children wish to explore the subject further, they could attempt to make comparisons between metals, and for this purpose thin wire of copper or steel would be useful. Braided wire (picture-wire) may not produce satisfactory results, but would be worth using for the sake of comparison. A somewhat similar set-up to that used with rods would be required ; measurements could be made either by comparing the movement of milk-straw indicators or by measuring the changes in the length of the wire. The wires would need to be stretched tightly before heating, and full stretch could be achieved by hanging a weight on the end of the wire. The distance between the weight and the floor could then be measured.

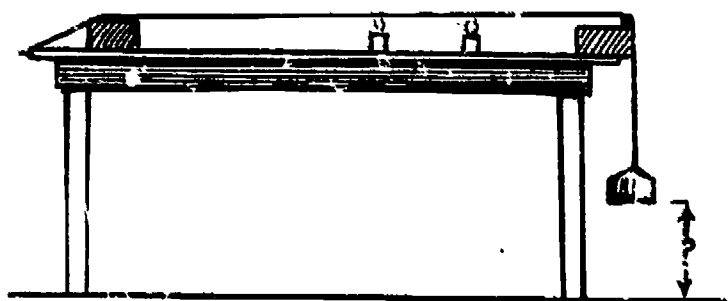

Things Getting Hot

Many children will be aware that the handle of a poker gets hot when the other end of the poker is left for a time in a fire. They will also be aware that objects placed in front of a radiator get hot, although they will probably not be aware that a different process is involved. Children should be encouraged to investigate heating, using solid objects, water, and air to give a wide background for later formulation of ideas on conduction, convection, and radiation. These terms need not trouble primary-school children, who should be more concerned with devising a variety of experimental activities, recording results, and discussing them in an attempt to come to some conclusions that are in accord with the facts observed.

Their investigations may involve activities similar to those outlined below :—

Heating one end of a steel knitting-needle and noting the time taken for the other end to get hot to the touch.

Attaching pins to metal strips or rods, by using candle-grease, then heating one end of each rod and noting the time it takes for the pins to drop off.

Placing the ends of strips or rods of aluminium, copper, stainless steel, glass, and wood in hot water and comparing the feel of each after some minutes.

Drinking hot liquid from cups made of plastic, china, enamel, and aluminium.

Observing the behaviour of a drop of ink in a glass of warm water and comparing this with the behaviour of a drop of ink in cold water.

Observing the behaviour of a pinch of tea-leaves or sawdust in a pyrex jar or a tin of water heated over some suitable heat source.

Observing the movement of a sheet of tissue-paper over a lighted candle, radiator, or other suitable heat source.

Noting the temperature in different parts of the classroom, especially when the heaters are working.

Discussing the sun. Most of the facts will come from books, but discussion should also be concerned with how the sun's heat manages to reach the earth. In all the cases considered so far, there has been some medium, either solid, liquid, or gas, to facilitate the transfer of heat. But between the sun and the earth's atmosphere there is virtually empty space. In this case the heating effect is produced by infra-red radiation. Infra-red rays emitted by the sun are not hot themselves, but they produce heat when they strike and excite the molecules of substances. It is not necessary that children should know this ; it is sufficient that they become aware that heat is radiated from the sun through cold, almost empty space.

Keeping Heat Out, and In

At some point during the work outlined in the previous section, interest may be aroused in the problem of insulation. For example, there is an obvious connexion between the effects of heating a metal rod and the fact that saucepans frequently have plastic handles. This could lead to a number of investigations aimed at discovering what materials are best for retarding heat flow.

If thermometers are not available, observations are still possible— noting the rate at which pats of butter or ice-cubes melt, or even testing the temperature of water with a finger.

Children will suggest many materials that may be insulators, and their effectiveness should be compared—crumpled or shredded paper, sawdust, plastic foam, sand, aluminium foil. These could be used to encase ice-cubes, butter, or tins of water, which should then be heated, either on a sunny window-ledge or over some suitable heat source.

It will be found that aluminium foil is a very good insulator because its shiny surface reflects heat. This may lead to an investigation of the effectiveness of other surfaces—for example, white paper and black paper. Children should be encouraged to design their own experiments, but the following procedure may be useful. Thermometers could be wrapped in foil, black paper, and white paper and placed in front of a radiator for a suitable period of time. The results obtained should add more meaning and purpose to any subsequent examination of a Dewar (vacuum) flask.

These activities should provide many opportunities to develop children's abilities in measurement and organization of data, on which valid conclusions can be based.

MAGNETS

Most children in Grades V and VI, like those of other age-groups, and adults too, enjoy playing with magnets. There is no reason why they should not repeat some of the studies that have been made earlier—classifying materials into those that are attracted by magnets and those that are not attracted; finding out how far a magnet will exert its force; discovering the materials through which magnetic forces will act; finding the relationship, if any, between size, shape, and strength; and so on. Perhaps the children can carry out more systematic experiments than they did in their earlier years, and record their results more efficiently. Suggestions for further activities follow.

Making Magnets

When a magnet is attached to a piece of iron, such as a pin or a nail, this also becomes a magnet. But when the magnet is removed, the nail loses its magnetism, or most of it. It might still noticeably attract small materials such as iron filings. If the nail is replaced by a piece of a hack-saw blade, which is hardened steel, more magnetism is retained.

If the hack-saw blade is stroked with a magnet, the effect is stronger. The stroking must be in one direction only, and with one end of the magnet.

Magnets, nails, pins, pieces of used hack-saw blades, and, perhaps, iron filings should be made available to the children. The teacher might suggest problems that could be investigated, such as the following:

As a magnet, how strong is the hack-saw blade when compared with the original magnet?

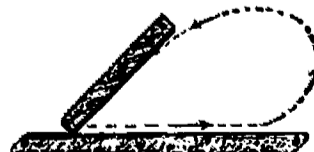
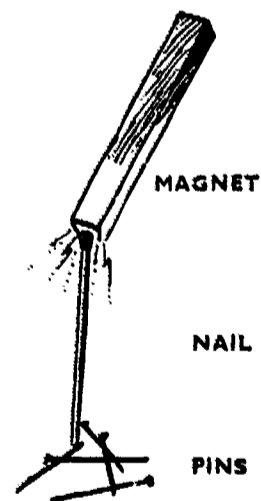



Does the number of strokes given make any difference?
What other things can be made into magnets?
How long do these home-made magnets retain their magnetism?
Are there other ways of making magnets?

It is probable that, during discussion, various other lines of investigation will be suggested.

Magnets and Forces

One of the intriguing things about magnets is that they exert forces at a distance from themselves. Perhaps children could find out how far these forces are exerted and discover the shape of the field of force by sprinkling small pins or iron filings around a magnet. During discussion this can be related to the way other forces are exerted, such as when we push or pull, or how the earth attracts things towards it. The unit *Happenings at a Distance* should be referred to here.

Magnets in History

There are several books on the discovery of the magnetic properties of a certain kind of iron ore. *The Stone That Loves Iron*, by Harley Carter (Wheaton), has a chapter on this, relating how natural magnets were found by the Greeks and the Chinese many years ago. Perhaps a story of the discovery of these magnets could lead to activities such as suspending a bar magnet from a piece of string or cotton, or floating a small magnet on a cork in water, to see how easy or how difficult it would be to find direction with a magnet. Children might also see problems—for example: How would a magnetic compass work on an iron ship? What precautions are needed in using a compass? Some children might like to imagine that they are lost, and work out or write an account of how they could find their way, using a compass.

There is also an opportunity to speculate on why a magnet points north and south. It depends on the Earth's own magnetism. By contrast, the moon has no magnetic field or, at least, only a very weak one, so on the moon a new way of finding direction would be needed. Children are not likely to know of the Earth's magnetic field. One way to introduce the idea might be to discuss what would happen if the Earth contained a magnet.

Electromagnetism

If there were facilities in the school for making an electric current, an interesting experiment could be done involving the making of a coil, perhaps by winding wire around a pencil. If a large nail was placed in the coil and the current switched on, the nail would act as a magnet, and the usual tests of magnetism could be made. If a hack-saw blade was put in the coil, it would become magnetized, but this time the magnetism would be retained when the current was switched off. *Mains power should never be used.*

Link with Social Studies

Library research into the history of magnets might interest many children. The story of the development and the use of the compass provides a natural link with the study of explorers. How did early mariners fare without a compass? What advantages did the compass give to later explorers? Can children use a compass to plan an "explorer's route" around the school-ground?

Some Problems To Put to the Class

After some work on magnetism, the teacher could suggest problems such as the following:

If salt, sand, and iron filings were mixed, how could the ingredients be separated? (This would require more than the use of a magnet.)

In a flour-mill, pieces of steel from the grinding mechanism sometimes get mixed with the flour. How could the flour be cleansed of this impurity?

What are some of the ways in which magnetic force is different from gravitational force (assuming that the class has done the

uni* Galileo—the Solar System and Beyond). (Answers might include the fact that magnets both “push” and “pull” other magnets, whereas the Earth only pulls.)

How could you make a horseshoe magnet, using an electric current? (A practical exercise.)

What happens when a hack-saw-blade magnet is broken in half? Are the pieces half-magnets, two separate magnets, or not magnets at all?

ELECTRICITY

In this unit, the following questions are considered :

What are some materials that are good conductors of electricity ?

What is there in a battery that produces a current ?

How does a hand generator produce a current ?

Does a current have any effect on a compass needle ?

How could we make a “current tester” ?

What effect does a current have on a steel knitting-needle and a nail ?

How could we make a telegraph transmitter and receiver ?

What forms of energy can be used to make electrical energy ?

What other forms of energy can be produced from electrical energy ?

It must be emphasized that activities other than those suggested in this unit may be just as interesting to the children. Many teachers may have difficulty in obtaining some of the equipment, particularly the hand generator, but this should not deter them from attempting the many other activities that are possible with more readily available materials.

Teachers are advised to read the unit Batteries, Bulbs, and Wires, in *Following On* before proceeding with this unit.

No matter what material is mentioned below, it is better that the children, rather than the teacher, should obtain it. Fathers, older brothers, the man next door, use them all. The triumph of being involved in a successful hunt heightens interest and causes the children to become involved, so that they become full of curiosity to know what is going to happen next.

Materials

A hand generator, available at disposals stores and hobby shops or from an old wall telephone. A generator is not essential ; if one is not available a good introduction to electricity can be made using torch batteries as a starting-point. However, the purchase of a generator is recommended because the novelty of it helps to introduce the unit very naturally.

A bicycle fitted with a dynamo. (In some activities a dynamo can be used in place of a hand generator.)

An assortment of magnets. In addition to those brought by children (a very powerful round magnet may be obtained from a radio and TV repair shop), it is advisable to buy a pair of powerful "alnico" magnets. These are made from an alloy of iron, aluminium, cobalt, and nickel.

Enamelled wire (20-30 gauge). This may be purchased very cheaply from an electrical wire manufacturer (see pink pages) or an electrical engineer, or may be obtained for nothing by unwinding it from old parts that are readily obtainable from radio repairers or electricians.

Small pieces of copper sheet, about 1 in. by $\frac{1}{2}$ in. The local plumber can supply these.

Six or seven yards of plastic-coated bell-wire.

Torch batteries, including some that are spent.

Torch-globe sockets, available from a radio-parts supplier, or improvised from wooden, spring clothes-pegs.

A $1\frac{1}{2}$ -volt battery. This is not essential, but useful.

A steel knitting-needle.

A compass.

The rest of the material can be made from odds and ends.

Introductory Activities

To create an atmosphere out of which questions are likely to develop naturally, it is advisable to place the material on the science table without comment, and to leave it there for some days. The material should include a hand generator, batteries, a torch, a torch globe and socket, short lengths of bell-wire, a compass, a spent torch battery cut in half with a hack-saw (children can do this), an old electric bell, bolts, a steel knitting-needle, pieces of plastic, rubber, cork, glass, hairpins, library books (the "Ladybird" book *Electricity and Magnets* is very popular).

The significance of much of this material will not be apparent to the children at first, but it is sufficient that they examine it informally, with no direction from the teacher.

After some time, interest should be developed further by informal questioning, discussion, and activities in which the teacher or interested children will take a leading part:

What happens if you hold the terminals of the generator while the handle is being turned? The mild shock children receive is quite harmless.

What do you notice if you place wires from the torch battery on your tongue? Children will be aware of a sour taste. *They should be warned against trying this activity with the hand generator or a more powerful battery.*

Would the current from the generator pass through more than one person? This activity can be extended until the current is passed through a chain of children holding hands, or even the whole class. A slightly modified version of this activity could be attempted with a torch battery, using the taste test.

These activities should be followed by an investigation to find substances that are conductors of electricity. Let the children suggest ways of carrying out the investigation, using the generator or the battery. In the case of the battery, a globe that lights up when current flows will indicate that a current is being conducted by the test material. Materials to be tested should include metals of various types, plastic, rubber, cork, glass, tap water, and tap water to which a spoonful of salt has been added.

Safety talks on the dangers of electricity and the uses of conductors and insulators should be instituted during these activities.

It is not desirable to provide children with generalizations and summaries of what they have discovered. They should make notes and diagrams, and summarize their own findings at their own level of ability.

How Does a Hand Generator Produce Electricity ?

If the children examine the hand battery on the science table, they will see that it contains a rod of hard material in the centre, some black powder or chemicals, and a metal case (the metal is zinc). The children may realize that the electricity is produced during some unspecified chemical reaction between these materials. But how does the hand generator produce electricity? Allow a group of children to examine the generator carefully. They will probably note that it consists of a coil of copper wire, which turns between the poles of a large magnet or magnets. If previous work with magnets is recalled, the children should be able to offer some description of what happens, in terms of magnetic lines of force, or the field of the magnets. They may make statements such as "The copper wire coil turns in the magnetic field, and electricity is produced" or "When the coil of wire turns, it cuts the mysterious lines of force from the poles of the magnet" or "The power of the magnet does something inside the wires and a current starts."

A bicycle fitted with a dynamo may also be used. If the bicycle is turned upside down, the dynamo can be operated by turning the pedal by hand.

Does a Current Have Any Effect on a Compass Needle ?

The previous activity should establish in children's minds a relationship between magnets and current. A magnet and its field produces an effect in a wire; would the current in a wire produce an effect in a magnet? The children should investigate this problem with different arrangements of a battery, a wire through which current is flowing, and a magnet (in this case, a compass). When the wire is placed above and parallel with the compass needle, and the current flows, the compass needle will be deflected. Children should not be led to this directly. If a group (or groups) of children are allowed to experiment freely, without instruction from the teacher, it is hoped that they will discover this for themselves.

The activity should lead children to see that when current flows through a wire, the wire is surrounded by lines of force that are similar to those around a magnet.

How Could a "Current Tester" Be Made?

This activity could be introduced by the teacher asking the children for their opinion as to whether a coil of wire would cause more deflection to the needle than the single wire did in the previous activity. The following experiment could be done to answer the question.

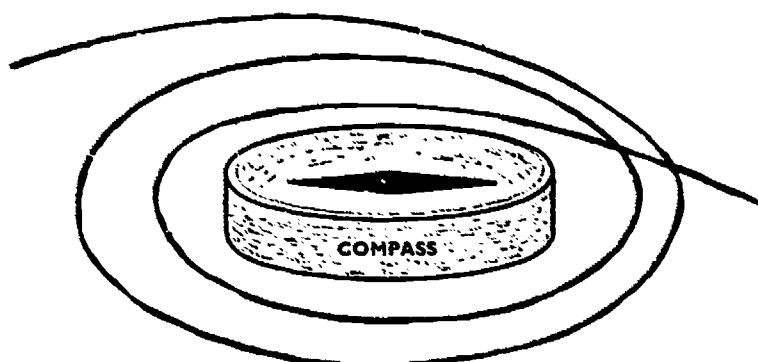

COMPASS IN COIL OF WIRE

Children could be asked to suggest ways of making a very sensitive compass. (Refer to the unit Magnets, where the method of making a magnet by stroking steel with a magnet is described.) By using two magnetized needles, the compass illustrated below could be made.

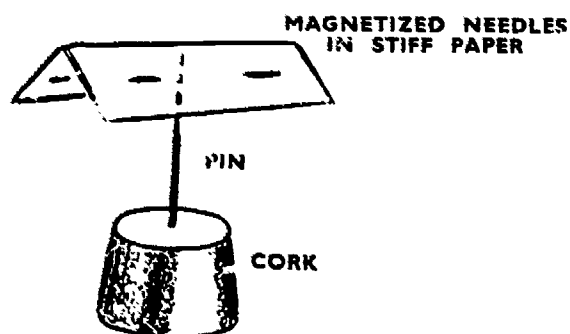

Set this compass in a coil of fine, enamelled wire (between 20 and 30 gauge is the most suitable).

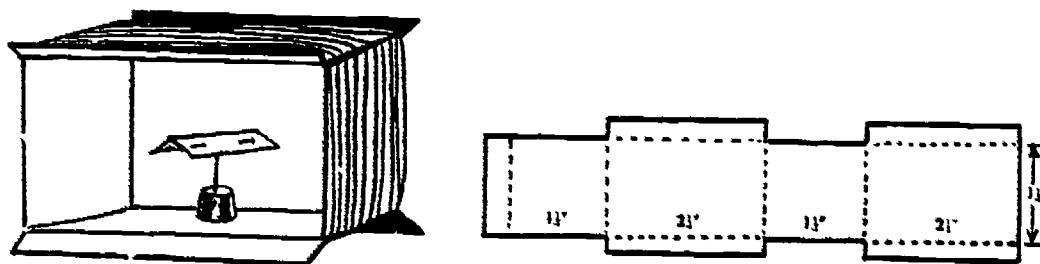

To make the coil, wind about 200 turns around a cardboard framework (for instructions, see diagrams) and place the needle compass inside the coil. Making this current tester is an ideal handwork activity for a group of interested girls and boys. The current tester may also be termed a galvanometer, a name that seems to appeal to children of this age, perhaps because it sounds very scientific.

With it, very faint currents can be detected, though it may be necessary to place the galvanometer under a large glass jar to protect it from draughts. For example, current produced by chemical means can be detected, as in the following case :

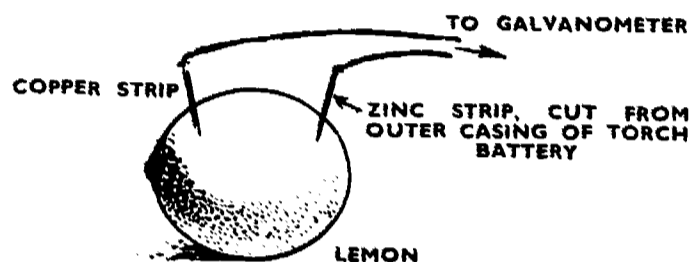

The needle of the galvanometer should be deflected every time the circuit is completed. The passage of current will also be detected as a sour taste if the ends of the wires are placed on the tongue. The lemon may be replaced by a jar of lemon juice or vinegar.

Current produced by means of a magnet can also be detected.

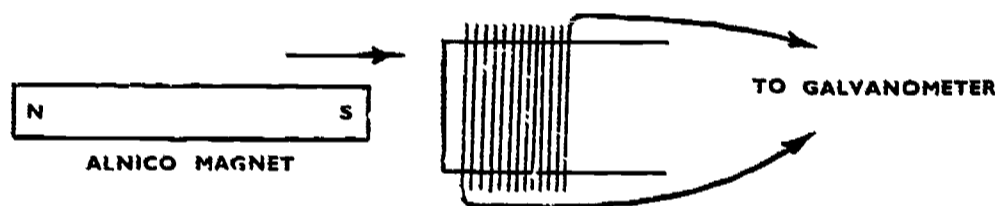

Wind about 50 turns of fine wire around a cardboard tube, such as is found in the centre of a roll of grease-proof paper. When the magnet is moved into this coil, the wires cut the lines of magnetic force and a current is produced. The children should discover how far their current tester must be placed from the magnet and wire coil. If it is too close, the magnet will affect the compass needle (whether or not it is moved in and out of the coil).

The point of these activities is to re-emphasize the ways in which current may be produced—

- (a) by chemical action,
- (b) by cutting the lines of force surrounding a magnet, and, in the case of the second activity, to stress the relationship between magnets and electricity.

In both cases the activities derive their original impetus from the teacher, but the children will play a leading part if they make the equipment themselves and are encouraged to answer the problems that arise as the activities proceed.

What Effect Does a Current Have on a Steel Knitting-needle ?

Both in the unit Magnets and in this unit, the activities should have made the children aware that the magnetic field surrounding a magnet can affect another piece of iron or steel. Also, by this time they should be aware that the field around a wire that carries current can affect a magnet (it deflected the compass).

The children could be asked what might happen if an unmagnetized piece of steel were used instead of a compass. A knitting-needle could be used. The children should first check the needle to ensure that it is not already magnetized.

If the knitting-needle is suspended on a thread, and the wire held above or near it, it is unlikely that any change in the knitting-needle will be noted. But if the effect of the magnetic field is multiplied by winding the wire around the needle before passing current through, there will be a great difference. The knitting-needle will become magnetized permanently.

If children experiment with a nail or a bolt made of soft iron, they will make a temporary magnet that works as such only while in the coil, and while current is flowing. This is a temporary electromagnet.

How Could We Make a Telegraph Transmitter and Receiver ?

The story of Samuel Morse, who used the principle of the temporary electromagnet to make the electric telegraph, may be of interest to children at this point.

The children should attempt to invent their own transmitters and receivers. An odds-and-ends box should be available containing 1 in. to 3 in. nails and bolts, some yards of plastic-coated wire, empty fruit tins (to provide metal strips for "senders" and "clickers", terms commonly used by children in this work), a pair of tin-snips, and some scraps of masonite or wooden off-cuts. The children should be left with this material in order to challenge their creative abilities. It is possible that no one will achieve success, but *it is important that the opportunity for creative activity be present always* in science at this level. It is not intended to include a picture of a model that will work, as this may influence teacher and children unduly. In any case, there are many books that give information on this work.

What Forms of Energy Can Be Used To Make Electrical Energy ?

Children should become aware that their own energy has to be applied to the hand generator before it can produce a current. For passing a magnet by hand through a coil of wire requires the use of some energy. Similarly, some energy must be involved in the chemical reactions that produce currents, otherwise the battery, for instance, would not become "worn out". Children readily comprehend the aptness of the term "energy" when they feel a current passing.

What Other Forms of Energy Can Be Produced by Electrical Energy ?

From their observations of electric-light bulbs and radiators, children will readily understand that electrical energy produces heat and light.

Children can also note that electrical energy produces sound when it causes a telegraph receiver to click loudly.

At this stage, the meaning of the term "energy" need not be investigated. It is sufficient that the word becomes familiar in this context, since the concept of energy will occur frequently in children's activities at a higher level.

At all stages it is suggested that children be encouraged to write freely about their activities and to make Activity Books on the subject. This writing will give the teacher some means of evaluating the level of understanding reached ; also, the effort of organizing experiences and summarizing findings will help children to understand significant facts.

Finally it is suggested that work on electricity proceed at a leisurely pace, interspersed with work in other topics. Handled in this fashion, there is sufficient work outlined here for two or three months' work. The work carried out at this stage should match the abilities and the interests of the class, and represents the upper limit of what should be done in the primary school.

STATIC ELECTRICITY

All the experiments suggested in this unit will work best on a cold dry winter day or on a day in summer when thunder is threatening. It will be worth while drying out the apparatus in front of a radiator before starting the activities.

The study of static electricity provides many opportunities to arouse the active interest of children, and to further develop skills such as observing, planning experiments, making inferences, and testing ideas. Group discussion should play an important part in work of this kind, and children may be expected to write accounts of their problems, investigations, and findings.

In any investigation into the nature of electricity (see previous unit Electricity) the subject of static electricity may arise.

It may be that the children have read about static electricity, or that they have heard the term and wish to know something about it. Most children have at some time picked up paper with a comb that they have rubbed on their clothes or have heard a nylon shirt crackle or, perhaps, even undergone the eerie experience of having their hair rise just before a thunder-storm.

One teacher recalled an incident in his own childhood when, as dark clouds gathered together and the atmosphere gradually approached the point where a violent thunder-storm seemed imminent, the children found that their hair began to rise as if they had all seen a ghost.

Although it is not likely that many teachers will find such a dramatic starting-point, it is worth emphasizing the desirability of an incidental introduction to ensure the active interest of the children.

Once the subject has been raised, children are usually quick to suggest simple activities involving static electricity. A number of suitable activities are discussed below.

If an inflated balloon is rubbed with a nylon cloth, and released near a wall, the balloon will probably stick to the wall. Will other things stick to the wall? A piece of newspaper can be placed against the wall. If rubbed with a brush, a ruler, or a pencil, or even the hand, it will probably stick. If one corner of the paper is pulled away, it may be attracted back to the wall. Other objects can also be tried. If the newspaper fails to stick to the wall, children may be able to carry out

further investigations in an attempt to discover why. For example, will the paper stick if it is first dried in front of a radiator? Will it stick to a wall made from a different material?

Rub a comb on a sleeve. The comb will usually attract small pieces of paper and the children's hair. Some experiments might be planned to determine whether the material from which the comb is made, or the type of cloth or paper, has any effect on the results. For example, try different kinds of combs, pens, rulers; rub these on various types of cloth, fur, human hair. The force exerted can be tested not only on bits of paper but also on hair, small pieces of aluminium (milk-bottle tops), a pin suspended on a thread, a thin stream of water running from a tap or from a hole in a can, wood shavings, and so on.

Teachers are advised not to attempt to give explanations based on atomic structure, although if some children have read or heard about this there is no objection to some incidental discussion. About the only general statement that can be arrived at at this stage is that rubbing sometimes produces a force that is able to attract light objects. This was known in 600 B.C. by the Greeks. The Greeks found that the substance amber (a solid resin) became affected by rubbing with fur; the Greek word for amber is *elektron*, and this is the origin of our word electricity.

Perhaps discussion will lead to the question of what happens when two charged objects are brought close to each other. Try this with two balloons that have been charged by rubbing with woollen material. Place them fairly close to each other. Probably, most children will expect that they will attract each other; instead they are forced apart. Apparently the force is not always attractive. Ask children to look more closely at the comb and paper experiment. The pieces of paper are first attracted, but then jump off again; the pieces of paper become charged by the comb, and are then repelled.

The principle of repulsion between bodies that are similarly charged can be used to develop an instrument to detect charge. How do we know that an object is charged? Up to now we have used the fact that light objects can be attracted by charged objects. An instrument that is more sensitive can be made from a piece of wire about 18 inches long, tissue-paper, and sealing-wax or paraffin wax. Make a loop in each end of the wire. Cut six to eight strips of tissue-paper about a quarter of an inch wide and 12 inches long. Push these through one loop and squeeze the sides of the loop so that the strips are held firmly at the middle. The wire must be given an insulated handle; a good way is to use a stick of sealing-wax. Test the instrument by charging a balloon and touching it to the free loop.

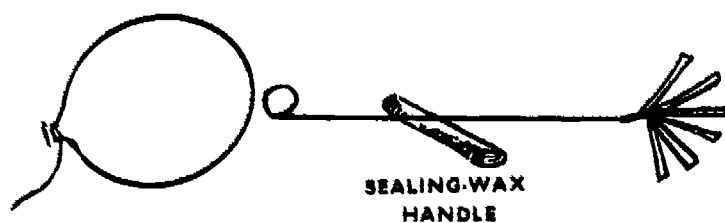

No doubt children will be able to explain how the instrument works. The instrument is an electroscope. What happens when the wire is touched? Why? (The charge runs through the person touching it to the earth, but is so small that he does not feel it.)

Sometimes static electricity is thought to be different from ordinary electricity; in fact the only difference is that it is not moving. But it can move along the wire in our instrument, or through our bodies, because these conduct electricity.

Enough electricity can sometimes be collected to make a spark that can be seen. Take a tin lid of the type that is pressed on (not the type that fits over the top) and attach it to the end of a stick of sealing-wax. Charge a balloon as before and press the metal disc onto the charged surface of the balloon. Bring a finger or a knuckle near to the disc, and a spark of about a quarter of an inch will jump across. Take the disc away and test it on the electroscope. Note that in this case the metal disc has become charged. Discuss why the metal became charged this time but not in the earlier experiment when it was rubbed with cloth.

An American scientist, Benjamin Franklin, experimented with static electricity. By flying a kite in a thunder-storm he showed for the first time that lightning was electricity. The flash that ran down the string of the kite behaved like man-made electricity. *The experiment is dangerous*, and a Polish scientist who repeated the experiment later was *killed*. Children must not be permitted to carry out this kind of experiment. The production of electricity in storm-clouds is not completely understood, but probably it is caused by friction between water-droplets and air.

Static electricity is sometimes produced on the outside of cars through friction with the air. Petrol-tankers drag a chain so that the electricity runs to earth and thus cannot build up to the point where a spark is formed, which could ignite the petrol.

EXPERIENCES WITH LIGHT

This unit should provide opportunities for observation, measurement, design and execution of experiments, and clear reporting.

It should lead towards some further understanding of the idea that light is an energy source, that white light is made up of other colours, that the reflection of light rays can be measured accurately, that light rays can be bent and their movements plotted.

Materials

Most of the materials, such as mirrors, pins, magnifying glasses cardboard, paints, and oil pastels, are readily available. In addition, there are several items that may need to be obtained beforehand. They are not essential, but would be useful if available. These items are—

a box-camera, films, a developing tank, and chemicals (a child's box-camera and developing kit would be suitable);

a variety of lenses;

an exposure meter ;

a light-sensitive resister (these are obtainable quite cheaply and one could possibly be ordered from the local radio-repair shop).

Reflection

These activities should enable children to understand and to give some account of the relationship between the angle of incidence and the angle of reflection. The following drawing illustrates one of the fundamental laws of reflection :

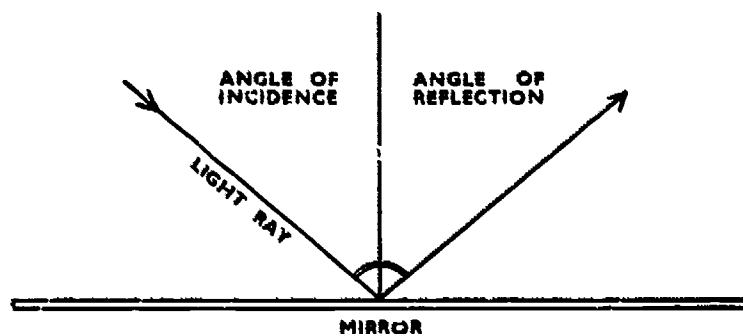

The angle from the vertical made by the ray of light hitting the mirror (the angle of incidence) is equal to the angle from the vertical of the ray of light reflected from the mirror (the angle of reflection). Children should not be told this. Instead, they should be provided with the necessary equipment to make discoveries in this field for themselves. Interest may originate through the type of activity mentioned in earlier units on light, where children make reflections on walls with mirrors. Once children are reminded of this pastime, they might try some experiments on the angles at which light strikes an object and is reflected, and then organize the facts that emerge. Because of the nature of the work, these activities may be best handled by a small group of interested children, while other work is going on. If children are supplied with a torch, a fibrastrip projector, some small mirrors, a comb, sheets of white paper, a protractor, some pins, and some small pieces of thick card to be used as masks for the projector, they will be stimulated to carry out further activities with reflection.

If children wish to get a thin beam of light from the projector, a piece of card shaped as shown, and the size of a colour slide, should be placed in the slide carrier. Children could experiment with slits and round holes of various sizes in the card to find the one that best suits their requirements.



With this equipment and a protractor it should be possible for children to measure the angle at which a ray of light approaches the mirror, and also to measure the angle of reflection. Pins or dots placed on the line of the beam may be used until the equipment is removed and lines can be drawn.

Instead of a cardboard mask in the projector, a comb placed in the full beam of light produces interesting effects, and a number of parallel rays can be reflected from the mirror. In all experiments, the beam of light should pass over a flat surface so that the beam is seen as a line on the surface.

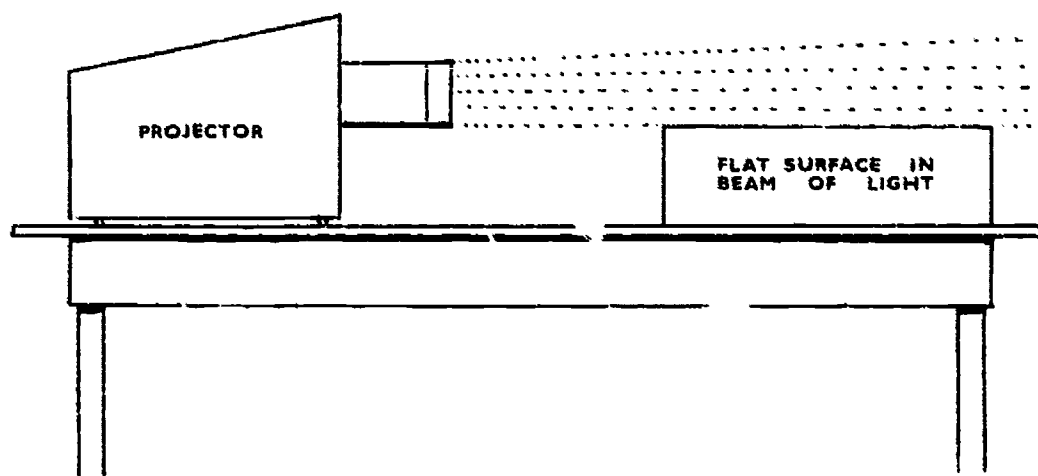

After this work some children may wish to make a periscope. Instructions for this are found in many children's books.

White Light and Colours

After work in this field, children should be able to give an account of their work that shows their understanding of the fact that white light can be produced by mingling colours, and also that white light can be broken up into these colours.

This work could also be undertaken as a group activity. Work in previous grades should have made children familiar with the fact that white light can be broken up into the colours of the rainbow. They may have observed rainbows or seen a spectrum of colour when sunlight passed through the fish-tank or a glass of water on a window-ledge. In the upper grades, a glass prism is useful and can be used in conjunction with the projector to produce a spectrum. If a prism is not available, a square or three-sided bottle filled with water may be used.

The children could be asked what they thought would happen if, instead of passing white light from the projector through the prism or its substitute, they passed light of another colour through. Pieces of coloured cellophane can be used to make filters for the projector. The room would need to be darkened. This work may produce other suggestions for activities. In any case, ensure that all findings are tabulated in some fashion.

The reverse of these activities is to produce white by mixing colours. Colour-mixing is made easier if a small electric hobby motor is used. Many boys have these. Cardboard colour-wheels combining two or more colours can be attached to the axle of the motor and made to spin rapidly. Colours in the following combination will blend to produce white when a disc is viewed revolving rapidly on the axle. Variations on this combination should be tried.

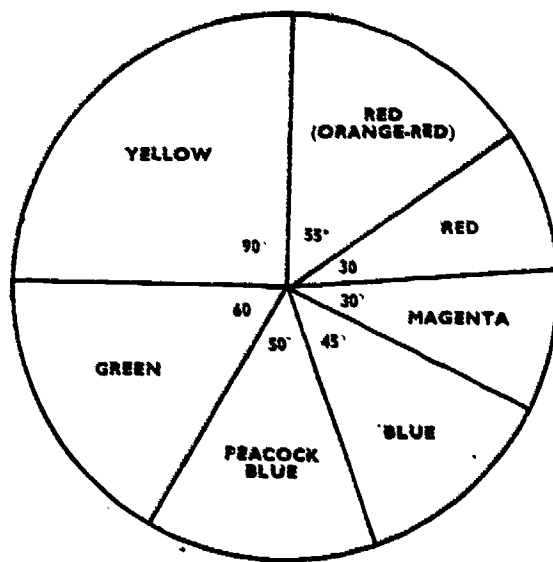

The quality of the white produced depends on the purity of the colours and the proportions in which they are used.

A simpler colour-wheel, using equal proportions of red, blue, and green, may also produce white, or an approximation to it. Children may like to experiment to see the effect when other colours are combined—for example. (a) crimson-red, yellow, and blue; (b) red and green; (c) yellow and blue.

Bending Light Rays

After work in this field, children should be able to show some understanding of the fact that light rays which, under everyday conditions are seen to travel in straight lines, can be bent. Children should also be able to describe their experiences clearly, both verbally and in writing, and to illustrate them with accurate diagrams.

(i) Light Rays

Many children do not realize that light rays are invisible unless dust or other material in the beam reflects the light. The rays of light from the sun are invisible. We see them only when they pass through dust or water in the atmosphere. When the projector is switched on, children see a patch of light on the wall and rarely consider what is going on between the projector and the patch. They can make the path of the beam visible if they blow chalk dust across it. They will also note that the ray is not bent. The idea of mysterious invisible light rays being emitted by the sun and travelling at an incredible speed through space is of great interest to many children. Their interest is likely to deepen when they are told that the nature of light is still not fully understood.

(ii) A Box-camera

Suggest to the children that they remove the back of a box-camera and stretch a sheet of tissue-paper across the area where the film normally goes. If the children point the camera at the window they will see a dim, inverted image on the tissue-paper. Some sort of cardboard hood to shut out light around the tissue-paper may help to make the image brighter. Suggest to the group that they light a candle, place it in front

of the camera—and note the image on the tissue-paper. It is almost certain that the children will ask why the image is inverted. The teacher could suggest that a diagram might be drawn and used to explain how the image became inverted.

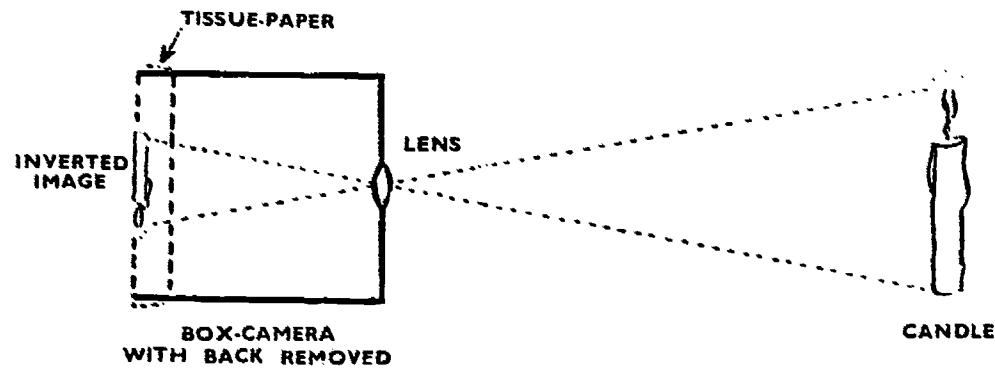

Children must not be presented with a drawing such as shown above. The teacher should note their efforts carefully, and encourage discussion and any attempts to refine what has already been done. Some children may feel that the lens caused the image to be inverted. It should be suggested that a camera without a lens could be made and experimented with. This could be made from a jam or fruit tin about 6 in. x 4 in., or larger. A hole must be made with a small nail in the bottom of the tin and tissue-paper stretched over the open end. A hood of stiff paper or card will be necessary.

(iii) Magnifying Glasses

If possible, a variety of magnifying lenses should be provided. If these are placed on the science table, the children, during informal activities, might focus the sun's rays and burn holes in paper. The teacher could ask the children to try to draw the sun's rays to show them passing through the lens and burning a hole. A typical diagram might look like this.

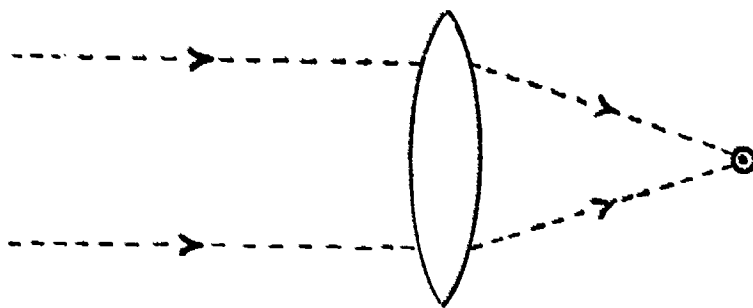

The children should measure the distance between the lens and the point of focus. Measurements with other lenses could also be made. These measurements should be compared with others made to show the distances at which the various lenses must be held above the table-top to obtain the sharpest definition and the greatest magnification. The distance between the point of focus and the lens is called the *focal length*.



Two magnifying glasses can be used to make a telescope. A telescope sufficiently powerful to see such things as the mountains on the moon and the moons around Jupiter can be made if a one-inch focal-length lens (for the eyepiece) and a fifty-inch focal-length lens (0.75 diopter) were obtained and fixed in cardboard tubes. The work in this topic could be related to that of the sixteenth-century Italian, Galileo Galilei. (Refer also to the units Galileo—the Solar System and Beyond and Men and Science.)

Energy

Work in this area with upper primary children is in some ways akin to some of the work done by beginners. For example, very young children need to build up a store of experiences with magnets, although clearly stated ideas of attraction and repulsion do not come until later. Similarly, children in the upper school, while they may be developing ideas about magnetism and electricity, talking about polarity and fields of force, and gaining insights into the nature of currents, will, in their turn, be building up a store of experiences leading to a later formulation of more abstract concepts such as energy. In other words, the idea of "light energy" need not be stated, and the experiences suggested below should be enjoyed for their own sake, although the teacher needs to be aware of the ideas underlying them. At this point, it may be appropriate to recall that energy is defined as a capacity to do work. Work is done whenever something is moved. Whenever a flower opens in response to sunlight, work is being done. Light thus has a capacity for doing work, and is a form of energy.

The activities listed below give experience in this area :

Noting behaviour of certain plants and flowers—for example, wattles, clover, sourgrass, gazanias, cape weed, marigolds, and sunflowers. Some of this work is mentioned in *Following On*, but it is expected that more precise observations will be possible here.

Fading of colours—materials and poster colours in sunlight. Here there is no obvious movement. The work done takes the form of a chemical change.

Effect of light on photographic film and printing paper. This would involve taking and developing films under a variety of conditions.

Using light to deflect a compass needle. Where the teacher and the children are particularly interested, and some work has been done on electric currents and electromagnets, this may prove an interesting activity, although it is not essential. A light-dependent resistor is needed.

The resistor needs to be wired into a single circuit. (For information on the resistor see under Materials at the beginning of this unit.)

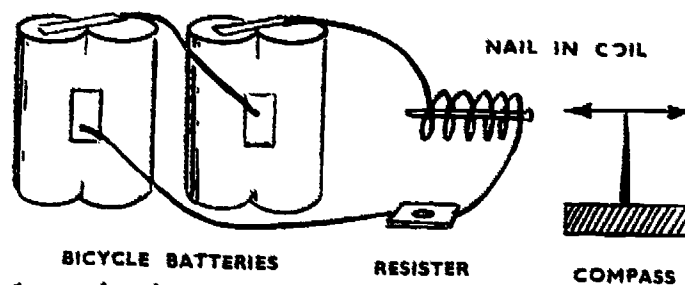

Wire the batteries in series as shown in the diagram. Two double batteries (as used in torches) should provide an adequate power source. Children may try a nail as the core of the electromagnet, but possibly a piece of a jam tin (about 9 in. by 4 in., rolled and flattened) may work better. It should be placed beside one end of the compass. The compass could be made from two magnetized needles (see the unit Electricity). When current flows and the face of the resistor is covered to prevent the entry of light, there will be no deflection. When the resistor is uncovered, deflection will occur.

A Photographic Exposure Meter

Someone interested in photography may possess a light-meter, and children will enjoy studying it. The working of the light-meter depends on the fact that when light strikes metals it throws out electrons. It does this more readily with some metals than others. Under the bubble glass of the light-meter there is usually a layer of selenium and another of lead, separated by a metallic film. Electrons flow when light strikes the selenium, and a current is set up in the circuit.

This unit only gives an outline of some of the work that may be done in this field. There are many other entertaining and instructive activities possible. For ideas on these, consult books in the school library.

WORKING WITH SOUND

This unit provides children with experiences in making, modifying, transmitting, measuring, and hearing sound.

Children should acquire—

experience in making sounds and sound-producing instruments ;
a knowledge of how sound is produced, that is, that sound is produced by vibration, and that energy is always involved ;
experience in modifying sounds—making sounds louder and softer ; varying pitch ; harmony and discord ; reverberation (echoing) ;
the knowledge that some materials transmit sound more readily than others.

Opportunity should arise for developing abilities in—

observing and measuring ; and
organizing and recording data in the form of graphs, tables, and sketches.

Organization of the Unit

This unit is divided into two main sections. The first section is the more important, since it encourages the type of child activity that is a vital part of the primary science course. Although set out under sub-headings, the activities in the first section are closely interwoven and, in actual practice, are very difficult to separate. Grouping the activities has been found convenient in writing the unit, but it is neither desirable nor practical to restrict the children in this way. Making, transmitting, modifying, and hearing sounds are all inseparable, for work with any one invariably involves the others.

The second section contains examples of work that can be expected from children. It is *not* to be taken as a collection of experiments to be conducted either by the teacher or by the children. Rather, it gives samples of the various types of activities children might suggest. Many of the examples have actually been suggested and carried out by children in primary schools in Victoria.

Before introducing this topic, teachers are advised to read the unit *Making Sounds in Following On*. It is probable that in carrying out the activities suggested in that unit, children will have made some discoveries about the transmission and the modification of sound. If these topics have not been covered in the middle school, or if the teacher believes revision and expansion of the topics are desirable, some time should be spent on a modified version of the topic before proceeding with this unit.

Equipment similar to that suggested in *Making Sounds* should be collected and the children permitted to design and make a variety of sound-producing instruments.

The following items may be added to the collection of equipment :
lengths of string, wire, nylon cord, and rope of various thicknesses ;
jam tins with their tops removed, biscuit tins ;

lengths of garden hose, tubes (rubber, cardboard, plastic), and pipes ;

sheets of cardboard and paper.

The children should be allowed to handle the equipment freely and to make instruments of their own design. This should lead to the construction of simple sound-producing, transmitting, and amplifying instruments.

Through their experiences in making the instruments, children will discover ways of modifying sound. Experiences may involve experiments in changing the pitch ; tuning instruments to the same pitch ; making pleasant and unpleasant sounds, harmony and discord ; reverberation (echoing) ; amplification ; directing sound ; and deadening sound (sound insulation).

Children should be encouraged to make careful observations, to plan and record their work accurately, and to make further tests of their conclusions.

This report from a teacher shows the type of work children might attempt with a minimum of direction from the teacher.

"Several children had suggested that different notes could be produced on a violin by 'making the strings longer or shorter'. They decided to test this idea with several stringed instruments. These included a violin, a guitar, a banjo, a ukulele, and several instruments the children had made, using rubber bands, strings, and wire. In each case the children were able to change the pitch by varying the length of the strings."

Further work involved investigation of tension (the children used the terms "tightness" and "looseness"), materials from which the strings were made, and thickness of the strings.

The children then planned to make an instrument that could produce a musical scale. They made a "bottle xylophone" (described later). Several groups measured the amount of water needed to produce each note, and recorded this carefully so that (i) other groups could compare results, and (ii) the "xylophone" could be set up again quickly by following the set of instructions. At a later date some children recorded information about other instruments they had made.

Children will be aware that sounds vary in volume. They may try to discover why some sounds are louder than others. Children should measure the volume of sound produced by various instruments. The following is a description of how one grade approached the problem.

The children took a number of instruments and measured the distance over which the sound from each instrument could be heard. The results were recorded in many different ways. Some children wrote only a short sentence, others a paragraph, while some attempted a much fuller description of the experiment.

Other children used figures and graphs, with varying degrees of success. The examples below show how children may be expected to develop their approach to recorded work.

SHARON

Guitar	100 ft.
Recorder	150 ft.
Straw whistle	70 ft.
Milk bottle	90 ft.
Triangle	60 ft.

MICHELLE

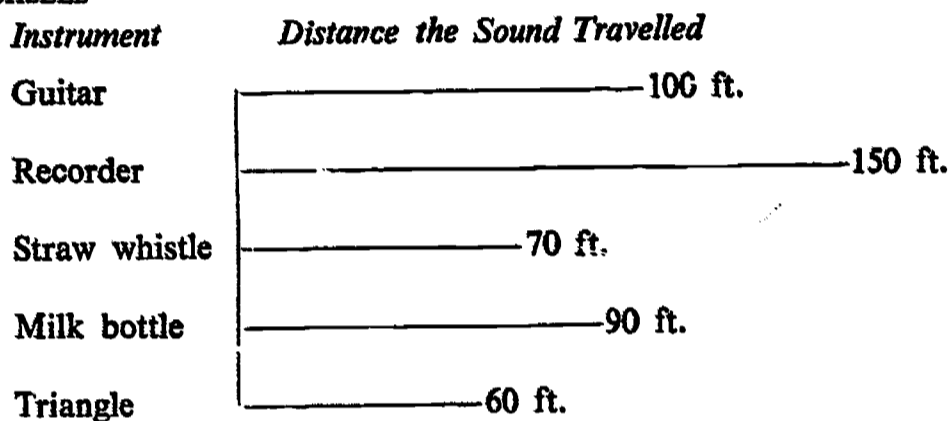

ROBYN

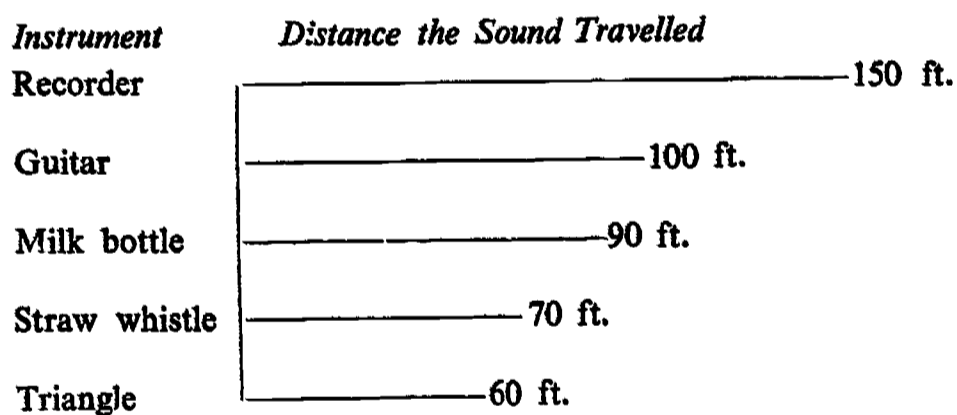

There was no wind.

Children should be able to discover ways to vary the volume of sound produced by the instruments. Further investigation might include experiences in making sounds louder by means of instruments such as megaphones, and making sounds softer by sound-insulation.

Sound is transmitted through gases, liquids, and solids. The sound-transmitting properties of substances vary greatly. Certain materials are therefore valuable for sound insulation (sound proofing), while others will transmit sound over much greater distances.

Activities involve measuring the distance that certain materials will transmit a sound, grading materials according to their transmitting or sound-proofing qualities, and using the knowledge thus gained when making or modifying sound-producing instruments.

Some examples of the kind of work that can be expected from children are included here. This is not a list of experiments for children to copy or for the teacher to demonstrate. These activities are only included to give the teacher an idea of the type of work that the children might undertake.

Megaphone

A megaphone can be made by rolling a piece of strong paper or thin card into a trumpet shape. This can be used as a megaphone or as an ear trumpet.

Model Stethoscope

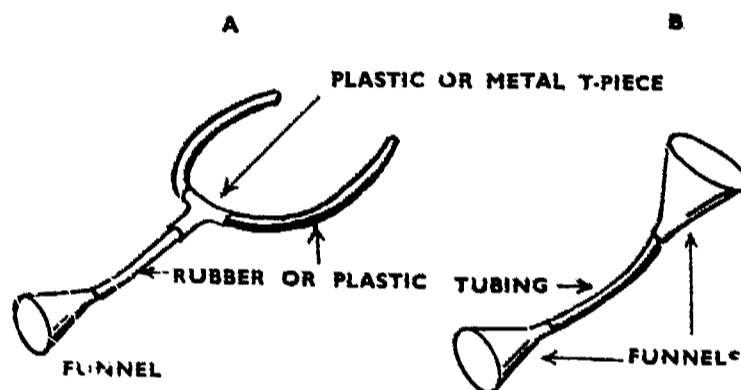

Pin or Wire Xylophone

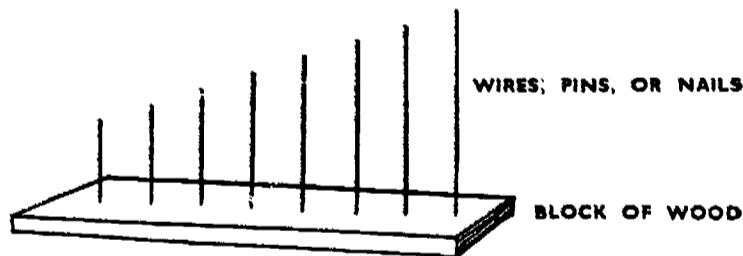

Bottle Xylophone

Take eight or more identical bottles and add water, filling to different levels, thus "tuning" the bottles to form a musical scale. The bottles may be stood on a bench or suspended by pieces of string.

Other Xylophones

Other xylophones can be made by suspending spoons, forks, rods, tubes, iron piping, etc. by string or thin wire.

Maracas

Partly fill cans with things such as wheat, dried peas, gravel, stones, sand, etc. Shake the cans. Modify the sounds by using different types of containers and varying the contents.

Rhythm Sticks

Pieces of dowelling rod varying in length and thickness produce different notes when struck together.

The Tin-can Telephone

Obtain two tin cans and punch a hole through the bottom of each. Thread about twenty feet of string through the holes and secure it at each end by using a match-stick. If two children hold the tins to their ears, and a vibrating tuning-fork is allowed to touch the string, the sound will travel along the string to the tins. It will be noted that the sound is greatly magnified. One child may speak into one of the cans while another child holds the other can to his ear. Can the sound be modified by using different materials ?

Spoon Chimes

Attach a spoon to the centre of a piece of string. By holding the ends of the string to the ears and striking the spoon, a chime will be heard. To vary the sound, several spoons may be tied together and struck or shaken.

Straw Pipes

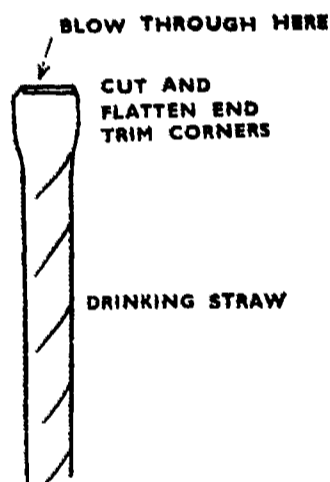

Bottle-and-straw Trombone

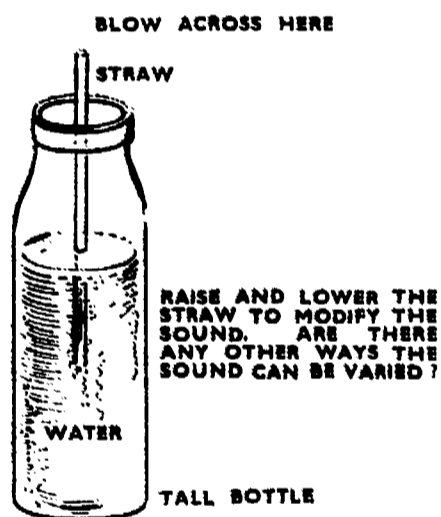

Fingernail Pick-up

Set an old record rotating on a turn-table and use a fingernail as a needle.

Needle-and-cup Pick-up

Make a pick-up from a needle and cardboard drinking cup, as illustrated.

This may be varied by using—
a needle only ;
a needle attached to a piece of paper or cardboard ;
a needle and a matchbox.

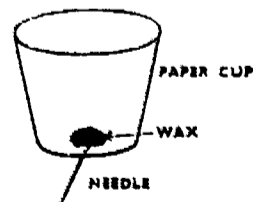

A Model Gramophone

If a meccano set is available, the children could attempt to design and make their own turn-table.

Water Transmits Sound

This may be illustrated incidentally during a swimming lesson.

During activities in making and modifying sounds, it is to be expected that the subject of hearing sounds will arise. In actual practice, hearing and making sounds will be found to be inseparable. The activities that follow, however, place emphasis on hearing sounds. These activities may be used as a follow-up to work on making and modifying sounds, or as starting-points to a general study of sound, or they may be interwoven with other activities on sound. The activities should help to make children more aware of hearing, and thus contribute to greater interest being taken in human physiology and well-being.

At the conclusion of this unit, children should have a better understanding of the sensitivity of the ear to vibrations, and of the differences between the hearing organs of various animals.

How Well Do You Hear ?

Children should suggest ways of measuring the ability to hear sound. If an alarm clock, a tuning-fork, a wrist watch, and a long tape measure are available, they might prove useful. The tape measure could be used to measure the distance at which the ticking of the clock or the vibrations of the tuning-fork prongs become inaudible to the listener, measuring distances in front of, at the sides of, and behind the listener.

Both ears may not be equally acute. It is difficult to block up one ear completely but, by using cotton-wool or a finger, a series of measurements could be taken to determine the acuteness of hearing in each ear.

When a child's eyes are closed and the clock is placed near enough to be heard clearly, it may prove difficult for the child to pin-point the direction from which the sound comes if one of his ears is blocked. This may provoke discussion and suggestions as to the reason why two ears are better than one.

During this work a mass of data will be accumulated, and discussion should follow as to how this could be presented. Children should look for significant details, such as the average distance over which they can hear sounds, or whether the position of the clock in front of or behind the listener is of importance.

Improving the Hearing

As a result of the activities described above, children may become interested in improving their ability to hear. They could suggest ways in which this might be done, such as using plastic funnels or "ear-trumpets" made from stiff paper bent into a conical shape; similar cones could be placed near the object emitting the sound. Children could also try listening through a solid object. If a watch or a clock is placed on a length of timber, a table-top, or some metal object such as a shelf of the standard metal bookshelf used in schools, children could measure the distances over which the ticking can be heard.

If the opportunity arises, an examination of hearing aids might be profitable. There are two types—the first conducts sounds directly through the air into the ear; the second type fits outside the ear and

conducts sounds to the inner ear through the bone. This could lead children to investigate the possibility of hearing through their own bones. They could try holding a watch or a tuning-fork between their teeth or against their forehead or chin, while covering their ears. One early form of hearing aid consisted of a fan-shaped piece of hard material (similar to plastic) held between the teeth and directed towards the sound source ; some children might try this for themselves. However, results are likely to be inconclusive since it is difficult to prevent the sounds from being heard in other ways.

Hearing in Animals

Many children like to compile Interest Books from the information they gather by personal observation of household pets such as dogs, cats, white mice, and rabbits, and other animals such as horses and sheep.

Children should note details such as the shape of the animal's ears, the observed range of movement of the ears, and the acuteness of hearing. In one class, this work developed when a terrier was brought to school for general observation work. The children noticed that the dog cocked its head whenever it heard its master's voice. The dog was taken out of the room by a child, and observers noted the distance that the dog had to be taken before it ceased to react to the voice.

Birds, Frogs, and Worms

Some children think that birds cannot hear because there are no ears visible. In this case, observation of a hen or a pet bird would be worth while.

Frogs do not have ear openings, but the brown patches behind the eyes indicate the position of the ear-drums.

The problem is more difficult in the case of worms. No ears are visible. If children experiment by ringing a bell, banging a drum, or making some other sound close to a worm on the surface of a pot of soil, the worm may not react. On the other hand, if the pot itself is vibrated (it could be placed on a drum) the worm may start to burrow.

This could lead to a discussion of whether it is correct to say that worms "hear", or whether it would be more correct to talk of them being sensitive to vibrations, which is not quite the same thing.

Do We Hear All the Sounds around Us ?

This topic arises quite dramatically if a tape recorder is used. When a normal classroom activity is recorded, it will be found that the machine picks up sounds that the children have been unaware of. The advantages and the disadvantages of this selectivity towards sounds might prove a fruitful subject for discussion.

A unit of this type lends itself to a variety of language activities. It also impinges on a number of other science topics—animal studies ; sound and sensory organs in general. If the right teaching moment occurs, this topic might be used as a springboard into other areas of interest. For example, this may be an appropriate time to discuss care of the ears.



MAKING OBJECTS MOVE

This unit is an extension of the junior-level unit Moving. It is recommended that teachers read Moving and consider using the activities in it as an introduction to those suggested in this unit.

The objectives for this unit are much the same as for Moving, except that senior children can be expected to operate with more complex material.

Interest in this unit might arise from children's interest in rockets or model engines, from social studies topics such as Transport, or from excursions to an aerodrome, a railway, or a garage.

Exploring the Relationship between Force and Mass

The words "force" and "mass" will occur frequently in discussions arising out of the activities in this unit. No attempt should be made, at this level, to explore in a formal way the notions of force and mass. By the use of the words in appropriate contexts, an understanding of what is meant by force and mass should develop progressively. A full understanding must wait until later years.

Activities might involve rolling balls down slopes (a board with one end resting on a brick would be suitable). Factors could be varied as follows :

- different angle of slope ;
- different length of slope ;
- different size of ball ;
- different weight of ball.

The tests might be to see how far the moving ball will roll on a horizontal surface or up an incline, and what effect varying the factors mentioned above will have on the distance travelled by the ball.

It is worth noting that children often think that the weight of a ball depends solely on its size—for example, that a basket-ball or a volley-ball is heavier than a cricket ball because it is bigger. Some weighing activities may settle this argument.

If a ball is placed at the foot of the slope and struck by a ball rolling down the slope, how far will the two balls roll ?

The factors listed above will need to be considered. Other considerations are the surface over which the balls are rolled and the effect of wind (particularly in the case of a table-tennis ball or a volley-ball). (See the notes on inertia on page 99.)

In recording the results of these experiments *the children will need to be aware of the need for accuracy and credibility in their reports.* For example, the Grade VI girl who wrote the following report soon received some critical remarks from her classmates : “ We rolled a ball down a slope and it rolled 13 ft. 4 in. Cricket-balls roll 8 ft. and marbles roll 11 ft. 3½ in.”

Comments from other children included :

“ What kind of ball was it that rolled 13 ft. 4 in. ? ”

“ Why didn't you measure the slope ? ”

“ How do you know that cricket-balls always roll 8 ft. ? Did you try it more than once ? ”

“ It would probably roll further if the slope was steeper or if you did it on the asphalt instead of on the gravel.”

At this stage the teacher broke into the discussion and suggested that children who were interested might help the girl plan some further experiments and write a more satisfactory report. Soon several groups were at work in the playground. The following is an extract from what one group wrote :

“ We were trying to find out how far balls will roll along the ground if you start them off by rolling them down a piece of sloping wood. The important thing was not how far the balls rolled, but to find out if a steeper slope makes them roll further. This is what we did. We put one end of a four-foot plank of wood on a brick. We rolled a tennis-ball down the plank and measured how far it rolled. We did this five times. The next morning in mathematics our teacher let us work out the average of how far the ball rolled.

Two days later : At lunch-time today some of us did our experiment again, but we put the end of the plank on two bricks instead of one brick. The balls rolled further.

Next day : We worked out the averages for our last experiment. Then we did it again with three bricks, and worked out that average.

This week we made graphs of how far the balls rolled.”

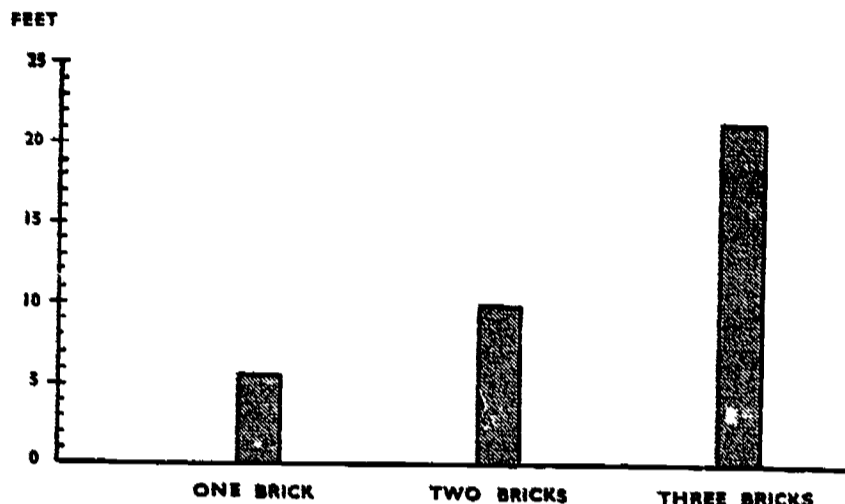

Other children experimented with different kinds of balls, while others rolled the balls over different kinds of surfaces.

The children in a Grade IV also attempted some of this work. Their teacher reported that the topic was particularly valuable since it provided motivation for language work and mathematics, and gave more meaning to the applied number period. He also found that the activities provided an opportunity for co-operation between the two grades. This is evident in the following report by one of the Grade IV children.

"We had a four-foot long piece of wood and three bricks. We hammered two pieces of wood on either side of it. First we put one brick under the wood and rolled a ball down the aisle. Then we measured the distance it had rolled. After we did that we did the same with two bricks, then three bricks. Every time we added a brick the ball rolled faster and farther. Grade VI did it too. Their average was different from ours. Our average was, for one brick, 4 ft. 8 in. ; for two bricks, 12 ft. 4 in. ; and for three bricks, 23 ft. 10 in. The average for Grade VI was for one brick, 5 ft. 3 in. ; two bricks, 11 ft. 5 in. ; and for three bricks, 21 ft. 6½ in."

Measuring

No. of roll	1 brick	2 bricks	3 bricks
1	4' 9"	13' 0"	25' 9"
2	4' 10½"	13' 5"	24' 9"
3	4' 9"	15' 7"	23' 2½"
4	4' 6"	11' 8"	23' 11½"
5	4' 10½"	13' 5"	22' 11"
6	4' 4½"	12' 9½"	22' 6"
Average	4' 8"	13' 4"	23' 10"

"We decided that if we had taken more measurements, we would get a more accurate average."

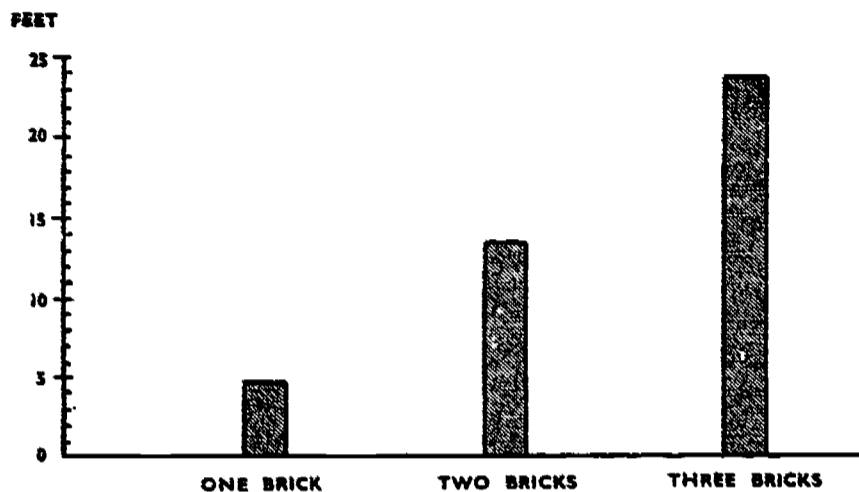

NOTE.—During discussion, the children showed that they were aware of the problems involved in keeping the ball rolling straight down the plank ; they repeated some of the experiments because “the ball had bounced from side to side all the way down the plank”.

Overcoming Inertia

For the purposes of this unit, the activities detailed above give experience in overcoming inertia. The children will see that a body at rest needs a push or a pull to start it moving. Furthermore, once it is moving it needs another force to stop it or to change its direction. (This might be friction, an obstacle in the path of the moving object, wind resistance, or some form of braking system.) Children will have experienced their own inertia when travelling on a bus—they are thrown backwards when the bus accelerates, forwards when it brakes, and sideways when it turns a corner. A pencil placed on a sheet of paper on a table will remain behind if the paper is jerked away from under it.

Model Engines (Petrol and Steam)

If model petrol or steam engines are available, children may be interested to examine and operate these, to try to discover how they work, and to use them to drive toys or construction-kit models. Further activities might include library research, the making of Interest Books, and excursions to garages, power-houses, and milking sheds.

The Institute of Applied Science has many working models. Excursions may be arranged through the Education Officer, Institute of Applied Science, 304–328 Swanston Street, Melbourne.

This may be an appropriate time to investigate other types of engines, including electric motors, and to follow the practical experience with some library research into the history and the use of engines.

Trains, Cars, and Planes

Activities with trains, cars, and planes would include examinations of model trains and model railway systems, and excursions to the railway yards ; examination of cars and excursions to garages and car-assembly plants ; examination of model planes and gliders, and excursions to aerodromes and air displays.

Interest Books could be made on topics such as "How Cars Are Made", "The History of Trains", "The History of Planes", "Transport".

Opportunity should arise to deal with road safety. Visits from police and railway or air-force personnel would add further interest to the topic.

While the main emphasis is on the engines that make these things move, children might become interested in the making of model gliders and paper aeroplanes. Suitable shapes and materials would have to be considered. Children might attempt to find the most suitable paper from which to make a paper aeroplane—such paper would need to be both light and strong, but this is best left for the children to discover for themselves.

In one school, the children made planes from many different kinds of paper, each child experimenting until he found what he thought was the most suitable material and design. The next week, "The Great Aeroplane Competition" was held. There were two sections—the plane that flew the furthest, and the plane that stayed in the air for the longest time. Girls won both sections.

This was followed by a model parachute competition. The teacher reported that the children's investigations provided excellent motivation for language work, both oral and written.

Rockets

Most children are interested in rockets. The ideas that follow should help to develop the children's understanding of force and motion, and should prove to be of particular interest to anyone interested in space travel. The idea of rocket propulsion is difficult for children to fully understand. Therefore the activities are of a simple, non-technical nature.

When a child stands on a roller skate, skate-board, or scooter and attempts to make a forward motion, this motion is associated with a backward motion of the skate. Similar observations can be made—

- (a) when a child steps from the back of a billy-cart,
- (b) when a brick is thrown from the back of the billy-cart (a skate-board or tricycle could be used instead of a billy-cart).

In each case there is a tendency for the cart to move forward. This motion might be slight, but it should result in some interesting discussion and speculation.

A number of activities that illustrate rocket propulsion follow. Children will probably be able to see that the mode of action of a rocket has some similarities to that shown in the experiments mentioned above. Most children are aware of the behaviour of an inflated balloon that is released. The balloon flies off erratically. Why does the balloon move forward as the air streams out behind? Many children imagine erroneously that the balloon is pushed forward by the escaping air pressing on the air behind the balloon. The compressed air in the

balloon may be compared with a compressed spring, or with throwing a brick from a billy-cart, so that children see that the balloon moves forward as a reaction to the force of the air escaping in the opposite direction.

A Rocket Car.—Children may investigate ways of attaching an inflated balloon to a toy car, perhaps with sticky tape, so that the car is propelled forward.

A Plastic-bag Rocket.—If two paper-clips are fastened to a plastic bag and hooked on a length of tightly stretched thread, and a long balloon is inflated and placed in the bag, when released, the "rocket" will travel rather erratically along the thread.

A Balloon Rocket.—If a length of strong thread is passed through a milk straw and stretched tightly, and a long balloon inflated and fixed to the straw with sticky tape, when released, the rocket should shoot along the thread. This is a very efficient little rocket, and it should travel at a smart pace at least thirty feet up an inclined thread.

Vinegar and Baking Soda.—Obtain a test-tube or a junket-tablet tube and a cork. The "fit" of the cork is important. During the course of the activity it will be found that, if the cork is inserted too tightly, the experiment may not work as well as it should. The experiment requires a certain knack and timing, which children soon develop.

Wrap a level teaspoon of baking soda lightly in a piece of tissue-paper. Then pour some vinegar into the test-tube until it is about one-third to one-half full and insert the baking soda into the tube so that it does not touch the vinegar. Cork the tube and quickly place it horizontally on two or three pencils.

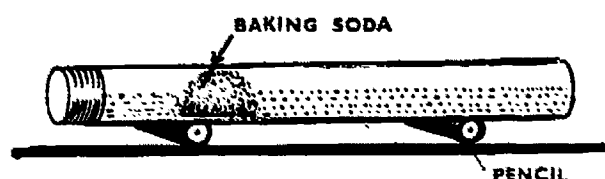

The chemical action between the baking soda and the vinegar produces gas (carbon dioxide), and the cork should be blown out of the tube. This action produces a reaction, and the test-tube will shoot forward on the pencils.

Fireworks Rockets, Air-and-water Rockets.—Little need be said about fireworks rockets except to advise caution in their use by children. Air-and-water rockets are available at many toyshops and may be of interest to some children and teachers.

A Carbon-dioxide Rocket.—These highly spectacular rockets provide boys and girls with opportunities to design their own rockets—an opportunity for creative handwork that should not be overlooked. The propellant is the capsule of compressed gas used in a soda-water bottle, and is obtainable at hardware stores. It is interesting for children to compare the amount of gas compressed in these containers with that compressed in an inflated balloon. This may be done if the gas is collected

in a large jar that has been filled with water and then inverted in a bucket of water. A hole may be pierced in the end of the capsule with a pair of compasses or dividers.

The rocket can be made from a block of balsa, carved to a suitable shape, with a hole at the back in which the capsule can be inserted. The rocket can be strung on a tightly stretched wire or length of strong nylon fishing-line, and the capsule pierced. These rockets attain a high speed, and their use must be carefully organized and controlled. They may travel one hundred yards or more.

It would be easy throughout these activities for the teacher to play the leading role and demonstrate a succession of entertaining devices. He should limit himself to making suggestions, extending discussion, and encouraging children to test their own ideas, where possible, and to write accounts of their experiences.

Firing Projectiles.—Children could work with marbles and jets of water to explore relationships between angle of elevation, distance travelled, and propelling force.

Medieval gunners believed that a cannon-ball travelled in a straight line until the driving force was exhausted, and then plunged in a straight line to the earth. Galileo is credited with disproving this idea. Artillery gunners today know that a projectile describes a curved path, and they are provided with tables indicating the distance the projectile travels when it is fired at any given angle.

Children may perform their own experiments with angle of elevation, distance travelled, and propelling force. A clear example is seen when a garden hose is pointed into the air at different angles. The stream of water is seen as a curve, and it is a simple matter to discover the angle at which the hose must be set to obtain the greatest range. This can be done by cutting a circle from plywood or card, and dividing it into segments.

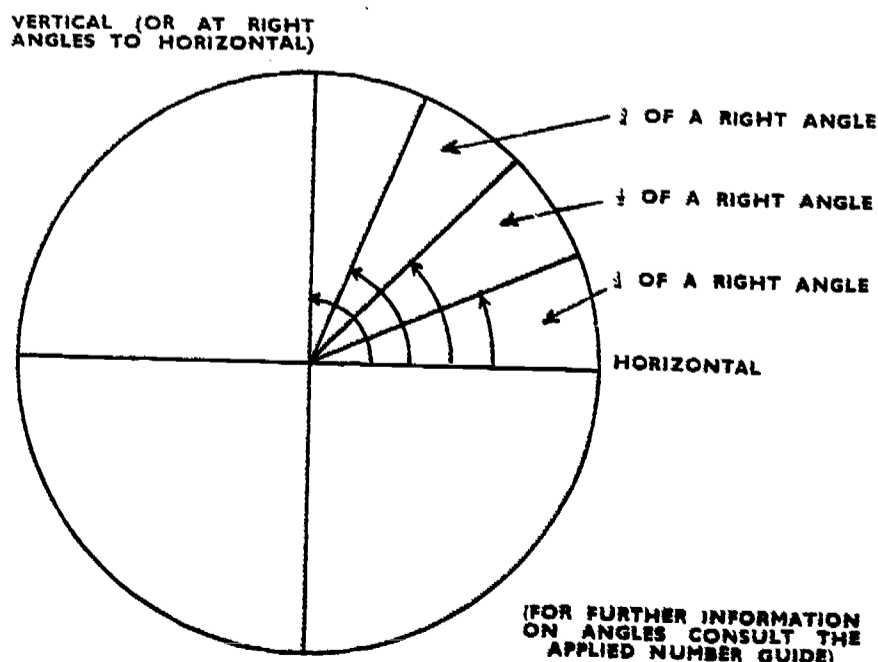

The hose can then be placed along each of the lines in turn, and the distance to where the water strikes the ground measured with a tape. For ease of operation, the circle of plywood may be cut in half (or in four to form a quadrant) so that the straight edge can be rested on the ground or other suitable horizontal surface. Variation of range can be obtained by altering the water pressure. Does this affect the relationship between the angle of elevation and the distance travelled?

Marbles can be used as projectiles. They can be propelled up short sloping planks of wood by an elastic band. Variations can be made to the angle of the wooden plank or to the propelling force (e.g. the elastic band can be stretched further), and in each case the distance travelled can be measured to establish any relationship among the three factors.

Children can be left to their own ingenuity to devise ways to regulate the angle and the propelling force. Due care and precautions need to be taken in any activities involving projectiles. Further refinements may be made by using a plumb-line to establish the vertical position, and a builder's level to set the horizontal position. Some children may be able to go further, using compasses, protractors, and set squares.

This work with angles will lead naturally to activities associated with the solar system.

GALILEO—THE SOLAR SYSTEM AND BEYOND

This unit has been presented as a case history, showing how, in a particular situation, a number of activities developed. In a different situation, work might proceed differently, covering more than or less than what is described below, depending on the interests and the abilities of the children. It is unwise to indicate too definite a learning path if, by so doing, the teacher's own creative talents are inhibited. Similarly, teachers are unlikely to produce children with initiative and independence if they make them all follow the same well-marked learning path.

Nevertheless certain objectives can be kept in mind and should underlie any work that develops. The work should provide children with opportunities to—

- make accurate observations and measurements ;
- organize the data they collect ;
- make apparatus that enables them to collect relatively accurate data ;
- look for patterns in their data ;
- search for relevant information that interests them ;
- learn something of the way scientists operate, by studying the life of one of the greatest of them.

How the Topic Arose

In this case the topic arose during a lull in proceedings. Work children had been engaged in was completed and, as sometimes happens, no other topic seemed likely to arise naturally out of the children's interests. As the teacher cast around in his mind for a likely starting-point, he noticed on his table a musket-ball that had been made by the

father of one of the children. The father was a gun enthusiast, who apparently had an old muzzle-loader, and the boy had brought to the school a ball that the father had moulded himself. The teacher remembered that Galileo had used just such a ball in his experiments, and he therefore decided to tell the story of Galileo in the hope that this would arouse some interest.

Pendulums

He began by telling the children that Galileo was a famous scientist who had used musket-balls in his experiments. He suggested that perhaps they could try out some of Galileo's experiments for themselves. But before telling about the musket-ball experiments, the teacher described the occasion when the young Galileo was in church, watching the swinging oil-lamps that hung on long chains from the roof of the church. Galileo timed the swing of a lamp by counting the beats of his pulse.

In the classroom the lights hung on long chains, and very soon the lights were set swinging and the children watched them. The level of interest was high, and the teacher suggested that the children should make pendulums, like the swinging lamps, and time them, using whatever means they decided on. (Many of them found difficulty in counting pulse-beats.) The teacher suggested that they should time the swings immediately the pendulums were set swinging, and again later. Many of the children assumed that the later swings would take longer, "because the pendulum would be going slower then". They were surprised to find that this was not so, and that the time the swings took remained constant. They attempted to make a pendulum that took one second to swing from one side across to the other side and back. With this pendulum they were able to time events fairly accurately to one-quarter of a second (half a swing from one side to the other).

The children made notes of their investigations, reported their group findings to the class, and began work on Interest Books. Some children became interested in grandfather clocks and other clocks, and the teacher encouraged them to follow this interest in their free time and to incorporate the information in their own Interest Books.

Inclined Planes and Musket-balls

All of this took time, and a lengthy period passed before an opportunity arose to pursue the general topic further. Eventually the teacher found time, and began by remarking that one of the stories about Galileo that the children had found in their books was probably untrue. He retold the story concerning the leaning bell-tower of Pisa, from which Galileo is said to have dropped unequal weights that behaved contrary to the expectations of a learned gathering at the foot of the tower. The children set to work in the playground to check Galileo's discoveries, using a variety of materials as weights. Some of the children wanted to time the rate of descent of the weights, but found that they fell too rapidly in vertical descent. Several children used the school slide to roll things down, because, they said, they moved more slowly and could be timed.

Later, children organized their findings and made notes for their Interest Books. The following extracts were typical :

"If you weighed round about five and a half stone it would take you $1\frac{1}{2}$ -2 seconds to come down a twelve-foot-long slide. We know because we tried it."

"I found out that when I took a basket-ball and a piece of chalk and dropped them together they would hit the ground together. The basket-ball was heavier, bigger, and had air in it. The chalk had nothing in it and was lighter. But the chalk and the basket-ball hit the ground together."

"I have discovered that if you jump and let a stone go at the same time, you and the stone will hit the ground together. I know because Don Matthews and I tried it."

"First of all I found a milk-bottle top and a straw. I held them up at eye-level and dropped them. The straw hit the ground first. Then I screwed up the bottle-top and I left the straw as it was. I held them up again and dropped them. They landed on the ground together. Then I screwed up the straw and left the bottle-top as it was. I held them up again and dropped them. They both landed on the ground together."

It is worth noting that in this last extract the child shows signs of becoming aware that previously unsuspected factors can affect experiments. The teacher seized on this point when group reports were being considered, and later some additional activities were undertaken to obtain further information.

The fact that one group had used a slide to slow down the rate of descent provided the teacher with an opportunity to get back to the musket-ball, which was still lying on his table. He explained to the class that Galileo had difficulty timing the rate of descent of objects, and constructed a "groove" of wood lined with polished parchment down which he rolled a variety of objects, including a musket-ball. It seemed natural to follow Galileo's example, but to construct a groove lined with polished parchment was obviously beyond the abilities of the class. A number of alternatives were suggested, including drain pipes, roof guttering, and corrugated iron. However, because none of these materials were readily available, a group of boys set to work to make a substitute "groove" from several pieces of light timber about ten feet in length.

The "groove" or inclined plane was set up with one end raised about six inches above the other. It became a popular plaything, and a variety of objects—marbles, ball-bearings—were rolled down the slope. The children noted that the objects gathered speed as they rolled down. The question of timing these objects now arose. In successive fixed periods of time the objects covered greater distances as they accelerated.

The inclined plane was therefore adjusted so that the object would cover the first foot in one second. The side of the inclined plane was marked in feet, and the children set to work to discover how far the

object would roll in two seconds, three seconds, and so on. The information gained was set out as follows :

1 distance	4 distances	9 distances	? distances
1 second	2 seconds	3 seconds	4 seconds

At this point work done squaring numbers in mathematics bore fruit, and a number of children realized simultaneously the nature of the relationship that existed—the distance travelled varied as the square of the time. The relationship also appeared to be constant, but this could not be proved by the children because their inclined plane was not long enough.

Accordingly, two boys strung up a length of wire across the room and ran a pulley from a meccano set down it. Unfortunately, they had difficulty in drawing the wire taut, but they still managed to gather some additional information.

The work with the inclined plane continued off and on for many weeks. The teacher suspected that this was partly due to the fact that the ball rolling down the inclined plane produced a very satisfactory sound but, happily, more valuable outcomes were also noted. Work of this nature needs to be leisurely, and every child needs plenty of practical experience if topics such as this are to be worth while. Some children speculated on how fast a person would be falling when he hit the ground if he had fallen from an aeroplane many thousands of feet up. It was a disappointment for them when they learned that eventually a falling body would attain a constant speed, due to increasing air resistance. Maximum speed would be about 120 m.p.h.

Graphs and Numbers

Later in the year, when the subject of graphs arose in mathematics, the children returned to their figures. Graphing "time" against "distance" they joined the points in various ways, some producing a satisfying curved line that they used to estimate things such as the distance travelled in $1\frac{1}{2}$ seconds.

Telescopes

Work had continued for many weeks and still the story of Galileo's life had not been completed. It was taken up again when one of the children brought along a picture of Galileo looking through a telescope. When the teacher suggested that it might be possible to make a telescope, several boys became interested, and began to make a collection of lenses. Their hit-and-miss methods did not prove very satisfactory, but at length two lenses were found that did give some magnification when used together. One lens was small, and it was fitted into a large cork float from a fishing-net. The cork was then fitted into one end of a tube of thin card. The second lens was fitted into the other end of the cardboard tube. The children were intrigued to discover that the image seen through the telescope was inverted.

The teacher told how Galileo with his telescope discovered moons circling Jupiter, and on a clear night later in the year, many of the children in the class saw these moons with a telescope brought by one of the boys.

Rather better telescopes than the one described above can be made from paired lenses, available cheaply from optical-supply houses that cater for amateur astronomers.

However, in the mean time other interests developed, including a study of the phases of the moon and of the moon's path. This in turn lead to observations over an extended period of the sun's path across the sky. Work on this topic began in mid-winter, and observations were made at midday over a period of many weeks, when the weather was suitable. The diagram shows how this was done.

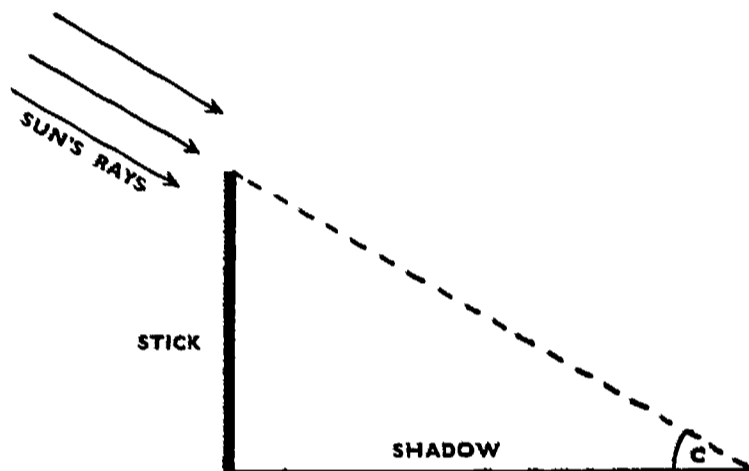

A stick was placed vertically in the ground and the length of the shadow marked. Later a scaled-down drawing of the stick and the shadow was made, and the angle at point C was determined with a protractor. This work tied in nicely with work in mathematics. Over a period of months changes in the angle were easily detected.

Note.—Children should be warned against looking at the sun. Coloured glass and similar materials do not protect the eye from the sun's direct rays. It is worth mentioning that Galileo eventually went blind, possibly because he was tempted to look at the sun.

More Work with Angles

Later, in discussion, the teacher mentioned the possibility of finding the heights of objects by using angles, and when a picture of an "angle measurer" was found in the Unesco Source Book, a group of children set to work to make their own. It looked like this :

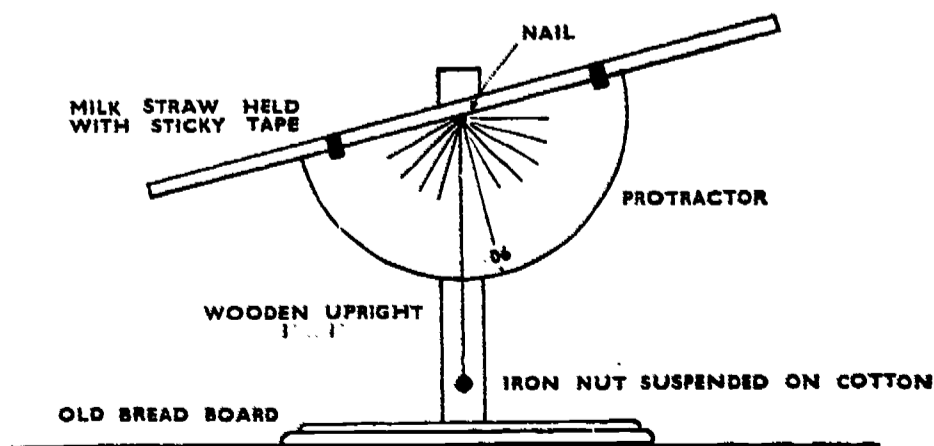

Through the straw the children could sight at the top of a tall object. The angle of elevation could then be read from the protractor. The distance between the "angle measurer" and the object was measured, and a scaled-down drawing made so that the height of the object could be calculated.

Interest was very high, and a large number of these instruments were constructed. Many hours were spent using them, making drawings and calculations and writing accounts of how the instruments were made and used.

The Solar System and Beyond

While all of these activities were going on, interest in the sun, the moon, and the satellites of Jupiter was developed further through prepared talks, displays of library books, and the compilation of Interest Books by children who had developed particular interests in astronomical matters. This became a theme that never really died, but which provoked many hours of discussion and speculation throughout the year.

Information on when the sun, the moon, and the planets rise and set can be found in the weather sections of daily newspapers. The planets will rise or set within eight degrees of either side of the point on the horizon where the sun rises or sets.

Both the children and the teacher *shared* interests in a way that made any suggestions that the teacher made natural outcomes of a common interest in things, not formal directions initiating the next task to be performed.

It was significant that the slower children had no real difficulty with this work. Little of it required facility with figures and knowledge of earlier work in mathematics. It was noticeable that these children regained confidence in their own abilities, which carried over to other work.

HAPPENINGS AT A DISTANCE

Junior and senior level activities suggested in the topics Moving and Making Objects Move provide children with experiences leading to some basic ideas about energy—that it is associated with change, with bringing about change, and, in general, with a capacity to do something or to make something happen. (Here the ideas are expressed in terms that children might use themselves.)

The source of energy may be regarded (depending on circumstances) as being a human being, a twisted rubber band, a battery, a candle, an object such as a marble raised above its surroundings, food, fuel, or perhaps the sun.

A feature of energy is that it can be transmitted ; something occurring in one place can cause something else to happen in another place, and it is this feature that introduces the element of delight in many children's games and pastimes, including such things as—

games played with marbles or number rods ;
certain activities with skipping-ropes, fishing-lines, and "slinky" springs ;

making tidal waves in the bath ;
 causing small torch-lights to light up by joining wires through which current flows ;
 producing an electric-magnetic effect with wires, batteries, and nails or bolts ;
 sending messages on home-made telegraph sets ;
 talking through a tin-can telephone ;
 producing certain effects with transistor radios (this will be explained later, in some detail).

This unit suggests a number of activities that are related because they embody the idea of something happening in one place producing an effect somewhere else. It is suggested that this idea, rather than some formal notion or definition of energy, should provide the starting-point.

Marbles and Number Rods

A suitable occasion for introducing the idea might occur during the marble season or when rods are being used in mathematics. Sometimes, when a marble is fired at a cluster or line of marbles, the first marble to be hit may not move much, but another marble against which it rests is moved considerably. The more this phenomenon is considered, the stranger it may appear to be. Children often take it for granted ; the teacher, however, can seize on the opportunity to show that there is something extraordinary underlying the very ordinary event. The following refinement of the child's activity makes this clearer :

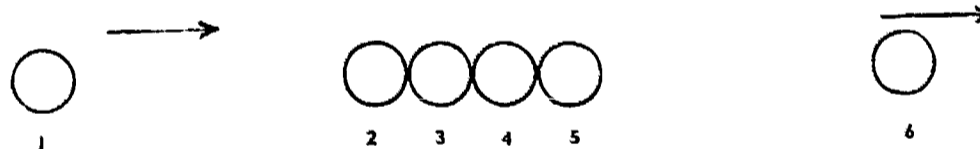

When a marble is rolled towards a group of marbles, all of which are touching, note what happens. They all stay still except the marble on the far end, which rolls away. Without any contact taking place between them, the first marble causes the sixth marble to move. Children should attempt in their own way to explain what occurs.

They may also care to set up number rods and bring about a somewhat similar result, causing one rod to fall so that its motion is transmitted to a rod from which it is far removed.

Children may also care to explore the effect of rolling more than one marble towards a line of marbles, and to set up other experiments with rods, tennis-balls, beach balls, or other materials they have on hand.

Working with Skipping-ropes, Springs, Ponds, and Pipes

Children often make "snakes" with long skipping-ropes, and this activity can be related to the ones described above, because here also something happening in one place causes something to happen elsewhere. The energy the child puts into the rope travels down the rope, producing a wavy, snake-like motion until the farther end of the rope, or something

tied to it, is affected. Some children may suggest timing the "waves", and they need little encouragement to explore variations of the basic activity.

Long, slack springs are also useful. Sometimes these springs are available from toyshops. When an input of energy (a jerk or a push) is applied at one end of the spring, a wave or ripple can be seen travelling to the other end of the spring.

Related activities are also possible if children have access to a fishpond or a fish-tank. It is customary for children to think that when they make a wave on water, the wave is a unit, a body of water that moves along. If so, they may imagine that a floating object would move along with the wave. Observation will show that this is not strictly true. The wave travels through the water; the water itself moves forward only to a very limited extent.

Further observation of this can be made by placing a drop of ink on the water and watching the effect of a wave on the ink.

A related activity is for a child to tap one end of a pipe while another child listens at the far end.

Where one of the above activities arises naturally, the children may be asked to describe what happens, and to relate this to what happens in other cases that they suggest.

Working with Electricity

In many activities with batteries, light globes, and wire—in fact with electricity generally—what happens is analogous to the happenings in the activities described above—something done in one place causes something to happen elsewhere. A piece of wire in a circuit is connected to a battery, and a globe lights up; a home-made telegraph key is depressed, and a piece of metal in the receiver taps the head of a nail and produces a sound.

Electricity is particularly useful as a form of energy that can be used to transmit a "happening" from one place to another. Children should need little encouragement to begin searching for examples of this use, and then to make for themselves pieces of apparatus that demonstrate it. The unit on Electricity should be consulted if necessary. The apparatus might include—

- model streets with electric-light circuits;
- signal transmitters using torch globes or "clickers" (see the unit Electricity);
- model electromagnets for lifting small objects—the electromagnet might be part of a larger meccano model;
- model trains, cars, or aeroplanes that work by remote control;
- a radio broadcasting station.

When the last suggestion was made to a class, one boy, a keen radio hobbyist, was genuinely horrified and objected that such an activity would be offensive to the Post-master General, but the nature of the station makes this extremely unlikely. The following diagram indicates how the station was made:

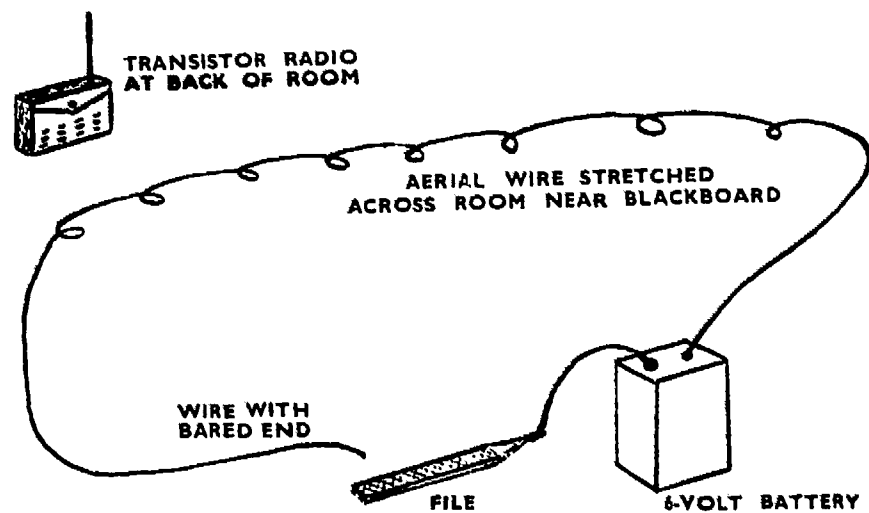

The battery, plastic-covered aerial wire, and the file were set up at the front of the room, and the transistor radio, tuned to a silent place between 3AR and 3LO, was placed in the back corner of the room. When the bared end of the wire was scraped along the file, static was produced on the radio. Messages were sent by varying the contact between the file and the bared wire, thus producing variations in the static.

The same effect could be produced on an ordinary radio, but work with a battery-powered transistor radio is more dramatic. There are no wires attached to the transistor set. Children tend to think that with a radio connected to mains electricity, the radio sounds actually travel through the wire. With the set-up described above, they come to understand that no wires are needed to transmit the signals; by making something happen at the file, something is made to happen elsewhere, the energy being transmitted through space. (The air plays no part in the proceedings.)

In one class, the children experimented to discover how far they could transmit their signals, and they moved the little radio out into the passage. They also saw a similarity to the mysterious powers of a magnet that could also make something happen at a distance. They knew that the magnet worked through paper, wood, and other materials; they speculated whether this radio power (someone soon started using the term "radio waves") would also penetrate materials. A group of children huddled round the radio, and the bared wire was scraped on the file. The static was heard clearly, the radio waves having passed through their bodies. The children cheered. This is what one boy wrote, in a rather breathless style :

"Today we made a broadcasting station and a receiver. We made the broadcasting station with a file, a battery, and some wire. First of all we threw the wire over the girders in our room, then we attached one wire to a 6-volt battery terminal and another wire to the other terminal, the other end of that wire we attached to a file, the wire that was thrown through the girders was attached to a battery terminal, but the other end of it was left free. Skin about $\frac{1}{2}$ inch of the wire. Now for the receiver. The receiver is a

transistor which you should tune between 3LO and 3AR. Put it at the back of the room and turn it on. Put the volume up and when someone at the "broadcasting station" scrapes the free wire across the file you should hear static coming from the transistor. The energy used is electrical energy and muscle energy and heat energy caused by the sparks you will see on the file when working it. The static has been transmitted through space by radio waves and will go through almost everything."

The father of one girl in the class was an airlines pilot, and he was invited to speak to the children about radar. His talk aroused great interest, and the children set to work to make class books, posters, and a big display on the work they had done.

A boy from another class, the keen radio hobbyist mentioned earlier, came up to the teacher one day and rather condescendingly offered to tell the class how to make a radio. His offer was accepted, but the highly technical nature of the talk left the children and the teacher equally mystified at the end. One girl wrote later: "It was a very interesting talk, but I still don't know how to make a radio." Neither did the teacher.

However, several days later some boys announced that they intended to make a radio out of bits they had scrounged from a local electrical retailer. Others began work on a crystal set. The girls, not to be outdone, started up in competition. Someone brought an electric soldering iron, and before long the room was festooned with soldered wires. It was interesting to note that the girls showed more dexterity in the use of the soldering iron than did the boys.

- Note :*
- (i) Experience has shown that it is not advisable to begin activities such as these with definitions of energy. *The early emphasis on verbalisms only hinders children's thinking later.*
 - (ii) Girls were as interested in the work as the boys ; so was the teacher, who was a middle-aged woman.
 - (iii) Finally, the important idea that began to develop dealt with "action at a distance", with the transmission of energy in a variety of ways. But the most important aspect of the work was that it provided children with opportunities to gain power over their environment and to bring about change in a variety of novel, yet significant, ways.

PART III

LIFE



A garden of moulds.

PART III : LIFE

For a full understanding of the material that follows it is essential to refer to the introductory remarks on life in the *Course of Study for Primary Schools, Science*.

COLLECTING AND CARING

Refer to Appendix I, Collecting and Caring, in the Curriculum Guide A—*Beginning Science*. This unit is important at all levels.

GROUPINGS AND COMMUNITIES

This unit should provide children with opportunities to study communities of living things, thereby gaining some understanding of the relationships existing between various forms of life and their environment. Evidence of the development of understanding could be gained from observation of the way children attempt to create a community of plants and animals, and their ability to identify relationships in communities studied. Children should also develop an understanding of the role played by human beings in communities of living things, and this should be reflected in their activities and descriptions.

This unit is basically an introduction to the ideas of **Ecology**. The quotations that follow give some indication of what ecology is :

Ecology is a modernization of the old field of natural history . . . an attempt to fit each living thing in its place in the world—as an individual, as a member of a constantly changing community, and as a possible ancestor of new generations that will evolve by becoming adapted to their environmental conditions.
—*International Encyclopedia of Science*.

. . . organisms are in constant communication with their whole environment ; this results in the balance of nature where the activities of the entire community of animals and plants interlock and are interdependent. In fact it is in this ecological setting that we catch the evolutionary mechanism in operation. The whole of life is in a sense a unit, for changes in any part affect all other parts.

—Bonner, John Tyler,—*The Ideas of Biology*, University Paperbacks, Methuen, London, 1965, p. 13.

The most significant feature of man's ecology is that to a large extent he can alter it to suit (or sometimes damage) his own purposes. He wants to live longer, so he improves his medical care. He is cold, so he builds a house, lights a furnace, and puts on his longer winter underwear. In this way he has been able to do all the things animals have taken millions of years of selection and evolution to do. He can live in the tropics, in the arctic, in the desert, or in the rain forest, or anywhere in between these extremes. He can fly ; he can travel on or under water ; he can move rivers to make power ; he can mould the environment about him to suit his whims, his greed, his common sense, and his humanity. All these remarkable aspects come from extended embryonic development and increase in brain size.

Some animals can also modify their environment. The beaver needs high water for protection, house building, and winter feeding, so he builds a dam. Bird nests are insulated and serve as a useful isolation device against the raw environment. The difference, as before, is a matter of degree ; man is so much better at it. He is so because he has the ability of invention and imagination, and once the new idea has spawned it can be carried down directly to the next generation. The beaver's dam-building behaviour is to a far greater extent genetically determined and, therefore, rigid and slow to progress. This would be even more the case with insect nests, such as some of the large termite nests that are beautifully constructed to control the temperature and humidity for the colony inside . . .

Another striking way man keeps altering his environment is by altering his relation with other animals and plants. In the first place he is waging a constant war against his parasites. As civilization advances, the number of communities that live in quiet resignation and balance with their bacterial, protozoan, and worm parasites steadily decreases. The variety of specific medical tricks to combat these enemies becomes more formidable every day. The danger lies only in the fact that, with fewer parasites, we have fewer immunities and that with mutation among micro-organisms we must be ever vigilant for a sudden epidemic spread of new virulence . . .

Besides modifying his parasites, man has also done extraordinary things in the modification of animals and plants to provide more abundant food. The domestication of animals and then the selective breeding of animals and plants to produce a higher yield have been steadily rewarding processes for centuries. Even recently, the discovery by G. H. Shull and E. M. East—that if two pure-bred (homozygous) strains of corn were cross-bred, the first generation would show a marked hybrid vigour—has meant an incredible gain in the yield of corn. The amount of milk per cow, eggs per chicken, meat per pig, etc., seems to rise steadily as the science of agriculture advances.

But man's relation to wild animals and plants is not so happy. The urge to shoot, saw down, and plunder his natural environment until it is almost beyond repair seems to be a persistent characteristic of man. It is the frontier spirit, which is all very well when one man is free to take his food from millions of acres of wilderness; but the tide is turning, at first slowly, then rapidly, and soon there will be many men on one acre, and all the birds, the plants, and the mammals are bound to suffer. Admittedly to some extent our worries about the loss are sentimental, but then there is no sin to such a sentiment; it deserves respect even though it may have no meaning in terms of money.

Conservation has practical meaning, too. Certain commodities on the surface of the earth are limited in their supply. Minerals, oils, coal, in fact everything that is brought up out of the soil is finite in quantity. Even the crops that can be replenished, such as woodland or arable soil, can be lost if care is not taken to restore what is taken. Mostly the proper care is not exerted, although our consciousness of it and all these problems is steadily increasing . . .

—Bonner, *op.cit.*, pp. 207-210.

In this section it is probable that activities will arise naturally from a study of the living material in and around the classroom. The work will probably involve, first, *careful observation of the material in its environment or the community*, and second, *a study of the effect of altering the environment in some way*. If these two ideas, are kept in mind, the work is unlikely to present many difficulties. It should be clear, of course, that although a community may appear to be simple—for example, a plant growing in a pot of soil—it can be complex beyond the understanding of a primary school child, except when considered in very broad terms. There may be many aspects of the situation about which children may be ignorant, but this need not detract from the value of the studies that they are able to undertake.

Some Communities

1. A rotting log.
2. Under a plant, a bag, or a stone—either damp or dry.
3. On a tree-trunk (for example, a black wattle).
4. A lawn, or several lawns compared.
5. Near a south (shaded) wall.
6. Near a north (sunny) wall.
7. Under a pile of leaves.
8. Water standing in a paddock.
9. A fish-tank.

10. A jar of pond-water and weed.
11. Hay infusions.
12. A classroom (from children in their desks to silver-fish in the cupboard).
13. A suburban house and block of land.
14. A farm-house and environs.
15. A piece of bush-land.
16. A vegetable plot at school—the effect of introducing new species for example, grass or weeds.
17. A plot of waste ground, vacant allotment, or paddock. An extension of this investigation might involve a study of what happens when a house is erected on this piece of land.
18. Pond, creek bank, sea-shore.
19. A plant growing in a classroom and one growing out of doors.
20. Human beings in arctic, tropic, temperate, and desert regions.
21. Around the school (including a study of mice, stray dogs, birds, insects, the school garden, trees, etc.).
22. The world from the point of view of a fly, a silver-fish, a sparrow, or a fish.
23. The white mouse's community (or other class pet).
24. A garden-bed or a rockery.

A Possible Classroom Approach

Children may wish to select their own subjects for investigation, and carry out extended studies, working in groups of two or three. On the other hand, study of one area—for example, a piece of waste ground—might interest the class as a whole, in which case a large number of studies might develop from this one area. In any case, exploring particular interests may be more rewarding than exploring what the teacher may, at the outset, feel are the important features of the situation. If the wasteland is rich in rusty cans, and this leads to a study of corrosion rather than a study of the community, this may be as worth while as what was originally planned.

Work on Life will continue throughout the year, but possibly the work will be more intensive during the third term, when weather conditions make life-studies easier. Indeed Life may be the major theme for the term. In this case the studies of communities might go on largely out of school-hours, with some time taken each week for the making of Interest Books in which studies of the various communities are gathered together. During school-hours, the lives of great men and women, such as Pasteur, Lister, and famous nurses, might be studied. This may lead to work with microscopes, the study of diseases, or investigations into community health, as well as experiments with particular plants and animals, both in and out of the classroom.

After initial interest has been aroused, an investigation into the relationships between the living things in the classroom might begin. The children should attempt to "map" these relationships in a way

of their own choosing—possibly through diagrams and written descriptions. This particular study may involve—

the children, the amount of food they eat, the air they require, and the sources and the availability of these (which could lead to an investigation of ventilation and quite an amount of mathematical calculation pertaining to both food and air) ;

flies, spiders, silver-fish, earwigs, and other small creatures (it may be impossible to count these individually but an estimation of their numbers could be made) ;

plants (including, perhaps, the invisible moulds that descend invariably on the discarded apple-core or crust which at some time or other is discovered in a child's desk).

Identifying and enumerating the classroom inhabitants would be the first task ; it could be followed by an examination of the relationships, if any, that exist between them—for example, between the mould and the apple, where the mould assists in the decomposition of the material ; or between the children, their books, and the silver-fish in the cupboard, where the silver-fish are agents in decomposition of another kind. The effect of removing one item might then be considered—if the books were removed, the silver-fish population would diminish ; if the human beings were removed, the population of smaller forms of life would increase enormously, but some plants would die from lack of care.

Notes on Sample Communities

A Tree

A tree is itself part of a larger community, but it may also constitute a community in itself. Its growth is related to the soil and the climate—the wind, the rain, the sunshine, and in some areas, the degree of atmospheric pollution. In a school-ground, growth may also depend on the frequency and ferocity of attacks on it by children. A tree may also be a home for countless small forms of life—lichens, fungi, green algae, spiders, insects, wood grubs, and birds.

But trees vary in the richness of life they support (this itself could become an interesting study). Acacias are among the most suitable for study, but any tree in the school-ground, or nearby, could be studied. Some possible activities might be—

1. A count of the birds using the tree :

Types.

What they do—Do they roost ? Do they hunt for insect life ?

Are there more of them at certain times of the year or in certain weather ?

2. Insect and spider counts :

Types.

Places found.

Possible food materials.

3. Making a diagram to show the chain of relationships existing between the tree and its environment, both living and inanimate.



The School-ground

The following is an outline of activities provided by a suburban school first opened in the 1870s and enlarged progressively since then. The garden and the brick building, with solid bluestone foundations and a high-pitched slate roof, provided shelter for an extensive community. Human beings, while exerting overwhelming influence in this community, and numbering about 700, formed only a minority of the animal population. These included stray dogs, rats, mice, pigeons, starlings, blackbirds, mynahs, sparrows, and a number of itinerant or seasonal visitors such as magpies and swallows, plus a huge variety of smaller forms of life. Each species seemed to fit into a particular niche in the community. The dogs were few in number, tending to appear at

lunch-time to scavenge among the food bins and around the incinerator. They were persistent, resisting attempts to drive them off. Strenuous efforts to reduce the food-scrap problem caused a decline in the number of scavenging dogs. This was an occurrence that could have been represented in graphical form. The mice and the rats were furtive inhabitants, and rarely sighted, but their presence could be detected at times and their possible living quarters determined with some accuracy. The birds were easier to study, and here a different pattern could be determined for each bird, based on their roosting and nesting places, food supplies, flight patterns, and flock characteristics. Similar information could be gathered about the other forms of life, both animal and plant. To compile the data was a task for the whole class, working in groups, and this was not the end of the matter, for the data then had to be presented. This was done in a number of ways—through the construction of a scale model, the drawing of an accurate map, and the writing of detailed reports of group findings in which the relationships between the members of the community were explored in detail appropriate to the age-level and the abilities of the participating children.

A Vacant Allotment in a Bayside Suburb

A vacant allotment in a bayside suburb would most likely consist of grasses and weeds on fairly open ground, or be covered with small scrubby bushes, thickets of tea-tree, and scattered heaps of various materials. An area such as this could provide the basis for an entire term's work. The first visit would be for children to discover possible fields for investigation, but on subsequent visits clearly defined tasks would be essential. Broken crockery might provide a link with archaeological investigations and the uncovering of ancient civilizations, a topic that could be followed up with profit in the school library. Other materials could be sorted systematically, and a table of data compiled or a graph drawn to show the results. The presence of rusty cans and other metals that have not corroded could lead to an investigation of corrosion.

The plants could also be sorted, the frequency of certain species established, and maps drawn to show their particular habitats and relationships with each other. If an umbrella was opened and placed upside down under a small bush, which was then shaken vigorously, various kinds of living material would be deposited in the umbrella. On returning to school the umbrella could be up-ended over some sheets of white paper, and the living matter sorted.

Other work might involve measuring or estimating the height of various trees and bushes, attempting to follow root growth of selected plants or trees, collecting soil samples by driving fruit tins into the ground in different areas, trying to sort out the above-and-below ground populations, and attempting (the word is used advisedly) to estimate the populations of various living species in the area.

The possibilities mentioned above represent a foundation on which children can build as they wish, in accordance with the characteristics of the particular area they study.

Hay Infusions

Infusions can be made by putting a handful of vegetable substance, such as hay, in a jam jar of water and leaving it for about ten days. In addition to hay, grass, and even pepper corns, can be used successfully. In fact, comparisons between a number of infusions made with different materials would be both interesting and valuable.

In a short time the jar will be alive with protozoa of various kinds, including the species paramecium which are good subjects for study because of their relatively large size. The cheap students' microscopes many children now own are quite suitable for this work. Take a piece of rotting hay from the jar and scrape it gently with the edge of a spare slide so that a drop of water and any animals close to the hay are deposited on the slide that is to be viewed. Populations are usually larger near the plant stems; however, in a well-established infusion, which is not too diluted with water, animal life will abound anywhere in the liquid.

The great charm of work with infusions is that for no apparent reason both the habitat and the population undergo change. Sometimes the liquid itself may change colour; sometimes the number of paramecium will be reduced drastically, as if by a plague or other natural catastrophe then, later, the population will once again explode dramatically.

Small quantities of the original infusion may be drawn off and tinkered with in various ways—for example, by adding small quantities of salt, antiseptic, rotting fruit, or pieces of ice, or by placing it in a warm environment or a completely darkened environment. The inhabitants can be compared with those found in the fish-tank, especially along the leaves of water-plants. The leaves should be gently scraped to obtain a sample of their population.

Not only can the relationship existing between the living material and the environment be studied, but also analogies can be drawn between these inhabitants and human life, particularly in relation to population and environment.

All of this work can be treated in association with a study of the lives of Leeuwenhoek, Pasteur, Ross, and others who used microscopes with great effectiveness. For example, the story of Pasteur's life and work tends to make children very "microscope conscious", and the problem is then usually one of trying to cope with the interest aroused. If possible, obtain a simple guide to microscopy (the *How-and-Why Book on Microscopes* is suitable, but there are others available that should also be considered for purchase). It is not advisable to have the children queuing up all the time to look through the microscope (or microscopes if more than one is available). It is perhaps better to develop a more fluid, informal arrangement with three or four children acting as chief investigators. Girls are often very interested in this work. They are also likely to be patient and more adept at handling slides than many of the boys. If it is possible for children to use the classroom during recess times, all children who are interested in microscope work can be catered for and taught the fundamentals of the craft by the leaders. This practice has been found to work well with responsible senior children.

One final hint may be useful. Paramecium are fast swimmers and it may be difficult to keep them in view. Reduce the amount of water and use scraps of cotton wool or paper tissue on the slide, to act as traps to slow down the hunted animals.

The suggestions given above will, it is hoped, provide ideas for studying other communities. If possible, extend the work beyond collection, estimation, measurement, and mapping. Encourage children to ask why certain communities are as they are, and to undertake simple experiments to prove or disprove the hypotheses they suggest.

Conservation

Some knowledge of the interrelationships between living things and their environment, particularly between man and his environment, can provide a basis for investigation of conservation problems. Initially, these can be introduced through the study of local problems, which exist everywhere.

In a coastal industrial city these might include air pollution from factories and motor-cars. Often, factory chimneys belching black smoke can be seen, and in some areas soot can be collected from the roofs of parked cars and from window-ledges. Car exhaust might also be studied, and certain products collected by covering the pipe for a few moments with cloth or a jam tin. Of course this will not trap all of the gases, such as the poisonous carbon monoxide. In discussion with children it might be useful to know the number of motor vehicles in Victoria. There are over one million, and approximately 60 per cent of these are in Melbourne. The combined capacity of these for polluting the air can be imagined.

Other forms of pollution from cities include water pollution, both of streams and of bayside areas. Water samples drawn from different areas would show this. City areas are also defaced and damaged by rubbish dumping and urban development, which may affect parks and gardens, roadside trees, and the ground itself where quarrying is not carefully controlled.

Children in bayside suburbs can observe the destruction of beaches and the coastal tea-tree fringe, and note the effects of building roads, car parks, boat harbours, and esplanades. This is not to deny the necessity of these, but simply to point out that, when these are constructed, the long-term effects have to be balanced against the short-term benefits, and this is not always easy.

Other topics that could be investigated if the school environment is suitable might involve :

1. Agricultural land and soil conservation.
2. Water harvesting, both for agriculture and urban use.
3. Forests and man.
4. Animal grazing. Animals in this context might include rabbits as well as sheep and cattle.
5. The land and the wild life, both bird and animal.
6. Water and fisheries.

Most teachers are aware of the effect of rabbit plagues, prickly-pear infestation, spread of Mallee desert lands, bush-fires, water erosion, and the shooting of kangaroos in various parts of Australia. A book that all teachers should read is *The Great Extermination*, by the late Professor A. J. (Jock) Marshall, Heinemann, Melbourne, 1966.

BEHAVIOURS

This unit has been designed to provide suggestions for use in classrooms where children are interested in living things. Suggestions for activities have been grouped under the following headings :

Growing Old

Structure

Food and Feeding

Response to Stimuli.

The activities children undertake should help to develop their understanding of the following general ideas :

Living things exhibit great variety, but underlying the differences there are fundamental similarities which they share.

Living things interact with their surroundings.

In the course of interaction with the environment living things undergo change.

Systematic knowledge of life has been gathered during man's interaction with the environment, and often this knowledge has been used by man to his advantage.

Note that the above ideas have been expressed in adult terms, not in language children would use. Also, these ideas do not constitute a list of the characteristics of living things, but simply a general background, useful in that it provides some perspective for viewing behaviour.

It is also expected that children will find opportunities to observe, to design experiments, to critically assess their work, to organize their ideas systematically, to apply mathematical techniques where this would be useful, and to express their ideas and conclusions with growing force and clarity.

Growing Old

All the world's a stage,
And all the men and women merely players ;
They have their exits and their entrances ;
And one man in his time plays many parts,
His acts being seven ages. At first the infant,
Mewling and puking in the nurse's arms ;
Then the whining school-boy, with his satchel
And shining morning face, creeping like snail
Unwillingly to school. And then the lover,
Sighing like furnace, with a woeful ballad
Made to his mistress' eyebrow. Then a soldier,
Full of strange oaths, and bearded like the pard,
Jealous in honour, sudden and quick in quarrel,
Seeking the bubble reputation
Even in the cannon's mouth. And then the justice,
In fair round belly with good capon lin'd,
With eyes severe and beard of formal cut,
Full of wise saws and modern instances ;

And so he plays his part. The sixth age shifts
Into the lean and slipper'd pantaloon,
With spectacles on nose and pouch on side,
His youthful hose, well sav'd, a world too wide
For his shrunk shank ; and his big manly voice,
Turning again toward childish treble, pipes
And whistles in his sound. Last scene of all,
That ends this strange eventful history,
Is second childishness and mere oblivion ;
Sans teeth, sans eyes, sans taste, sans every thing.

At first sight it may seem incongruous to find Shakespeare in this guide, but the passage has been quoted in full to emphasize that science and English may often blend to produce a natural flow of thought and activity. Many children in Grade VI like to look at this poem and hear it read, and at times it can lead to discussions, about growing up, and some of the differences between children and adults, not only in size, but also in what they say and do. It is only a short step from here to the consideration of changes in other living things.

Children may decide to find out more about growth and development among humans, and then extend their investigations.

Growth

In studying growth of animals and plants, the following activities might be undertaken :

(a) Finding the average weight or height of children of different ages. The problem of obtaining an adequate sample is likely to arise, and discussion on this should be encouraged. Information obtained should be presented in some systematic way, perhaps by graphing.

This activity could be extended to the study of animals such as caterpillars, chickens, rabbits, tadpoles, mice, and household pets (kittens, pups).

(b) Germinating plants, grasses, jonquils, daffodils, and plants with a number of leaves. Growth could be measured by counting and marking with a felt pen the new shoots on a small branch and, using this number as a base, estimating the total number of new shoots on the whole plant.

A feature of any work on growth should be the comparisons that are made between animals and plants, and it is hoped that these comparisons will lead to a realization that it is useful to look for patterns or similarities in the rate of growth of all living things studied.

One starting-point might be found in studying the growth rate of human babies. Some mothers of children in the class may still have record cards showing increases in the weights of babies measured at the Infant Welfare Centre. If not, girls might like to visit the Centre to ask for information. If all else fails, the following table may be useful. The information could be graphed as part of the work in mathematics. The shape of the graph should be compared with the shapes of graphs that children make after studying other living things.

<i>Birth</i>	<i>4 weeks</i>	<i>8 weeks</i>	<i>12 weeks</i>	<i>16 weeks</i>
7 lb. 4 oz.	8 lb. 3 oz.	9 lb. 12 oz.	11 lb.	12 lb. 12 oz.
<i>20 weeks</i>	<i>24 weeks</i>	<i>28 weeks</i>	<i>32 weeks</i>	<i>36 weeks</i>
14 lb.	15 lb. 2 oz.	16 lb. 2 oz.	17 lb.	17 lb. 8 oz.
<i>40 weeks</i>	<i>44 weeks</i>	<i>48 weeks</i>	<i>52 weeks</i>	
18 lb. 2 oz.	18 lb. 12 oz.	19 lb. 8 oz.	20 lb. 8 oz.	

Encourage children to draw conclusions from the evidence they have collected and to speculate on the probable directions their graphs would take.

The rate of growth of parts of the body could also be measured, for example—

- human hair (let children suggest ways of measuring the growth) ;
- finger nails (make a small indelible mark or a nick near the base of the nail and measure the distance the mark moves in a week—a number of children and adults could be compared in this regard) ;
- the length of feet and hands of children of various ages.

Why Do Animals Stop Growing ?

An examination of growth-rate graphs will show that they always flatten out. Ask the children why they think this happens. The discussion that develops could be fruitful. The teacher should not expect all of the questions to be answered, and children should not imagine that all questions in science have answers.

It may be of some interest to note that in *Gulliver's Travels* the giants of Brobdingnag were twelve times the height of Gulliver. It has been calculated, taking into account the length and the width of the giant's bones, that their bones would have been 144 times as strong as Gulliver's. However, the volume and the weight of flesh and bone would have been 1,728 times as great as Gulliver's. To support their own weight would have been as difficult for the giants as it would be for a man to carry eleven men on his back. Physical laws govern the structure of human beings and set limits to size (and the size attained), thus presenting a balance between the strength of the skeleton, the volume and the weight of flesh and muscle covering, and the food and energy requirements necessary to keep the organism functioning efficiently. What applies to human beings applies equally to other living things.

Change and Development

This section began with a passage from Shakespeare about the process of ageing, and it ends with a consideration of the possibilities for investigating the changes that plants and animals other than humans undergo as they grow older.

A distinction can be made here between development, which involves changes such as are noted in the life-cycle of animals and in the process of ageing, and growth. Children will probably not be aware of the distinction, and it is not necessary that it should be pointed out to them at this stage. Further ideas on development are treated in Life Stories.

Activities

Activities children may undertake include the following :

Collecting and comparing the bark of saplings, mature trees, and dead trees.

Pulling up seedlings and mature plants to compare root growth and growth of other parts.

Comparing dead and decaying fallen tree-trunks with healthy wood.

Collecting snake skins and other shed skins, and comparing the process of shedding the skin with moulting in cats and dogs and the shedding of bark by trees.

Studying the life-cycle of a moth.

Noting the differences between a kitten or a puppy and an aged cat or a dog, not only in appearance and size, but also in movements and behaviour.

Noting changes in grasshoppers. These moult, but apart from the fact that they lack wings, the young (nymphs) are similar in appearance to the mature ones.

Studying creatures such as ants that go through a larval stage, pupate, and then emerge in the mature state.

One can imagine how a general topic of this kind could be used in a class as the basis of a display. After all, the proper place for children's work is not in their desks, but around them, creating a learning environment where each child can benefit from the experience of others. It is worth noting in passing, too, how much more willingly children work at writing, painting, and model-making when they realize that the fruits of their work will be shared, not hidden from sight. Displays that are created by the children themselves, and changed frequently, tend to generate more activity and interest.

If science begins with art and poetry, and ends with it, so much the better.

They're slowly plodding up the hill,
Horse and man.
Who can think thoughts, or dream dreams
As they can ?
They have time enough to spare,
Horse and man.
A sort of sympathy is shared
Between them ;
Much wisdom in each grey head.
Now and then
The horse's ears twitch happily—
Just old men.

Jean (aged 11)

Structure

In a very important sense, the structure of an animal is an outward sign of the behaviour of a piece of living material. It is evidence of a particular response to the problems presented by the environment in which the living material finds itself. Therefore investigations and discussion could be usefully centred on the question: How does a particular structure assist the animal or the plant to survive?

At the junior level, children were encouraged to study structures of living things and, on the basis of the information they could gather, to make groupings showing similarities and differences. At the senior level, work might proceed initially on similar lines, with more emphasis being placed on the relation of the living material to its environment. Care should be taken to ensure that children do not interpret structural adaptations as being the gifts of far-seeing Mother Nature. Statements such as: "The spines on an echidna and the prickles on a rose-bush are Nature's way of protecting them," should be avoided. Such a statement obscures questions that might be asked, for example: "How did such structures get there?" and "What function do they have?"

Children should discover that the answer to the first question is not at all clear, although, sometimes, bits of evidence that suggest lines of fruitful investigation become available. The answers to a question about function may be settled by observation, or it may not, but children should be encouraged to look, and to base their own tentative theories on the evidence that they collect.

The Galapagos Finches

The celebrated Galapagos finches provide examples of evolutionary adaptations. The story of these birds may be of interest to the children, and it gives some insight into the process itself.

There are fourteen species of these finches on the islands, all distinctly different. The birds are sometimes called Darwin's finches, for it was he who first suspected their scientific importance. John Gould, the ornithologist, had pointed out to Darwin that the birds were unique, with no close relatives elsewhere.

The following summary of their characteristics is taken from David Lack's essay in *First Book of Animals*, by the editors of "Scientific American", published by Simon and Schuster, New York, 1955.

Darwin's Finches

(a) *Ground-finches*. There are six species, mainly eating seeds they find on the ground. These birds live in arid coastal areas. Three species have different-sized beaks, suitable for eating different-sized seeds. A fourth species has a longer, pointed beak suitable for eating prickly pear. The fifth and sixth species differ in that one is small and one is large, that both eat seeds and cactus, and their beaks are suitably modified for this.

(b) *Tree-finches*. There are six species, mainly eaters of insects in trees. They live in moist forest areas. Three species are similar and differ mainly in body and beak size, probably because the insects they eat differ in size. A fourth species eats insects in mangrove swamps. A fifth species, although a tree-dweller, does not eat insects, and its parrot-like beak is suited to its diet of buds and fruits. The sixth species is one of the most amazing birds anywhere. It is like a woodpecker, with a chisel-shaped beak, but with no long woodpecker's tongue to extract insects from under the bark.

The finch carries a cactus spine or a twig in its beak which it inserts in a likely crevice to dislodge the insect. It then drops the "tool" and eats the insect.

(c) *Warbler-like Finch*. There is one species, which eats small insects on bushes and lives in both arid and humid areas. Its beak is thin and pointed.

(d) *Cocos Island Finch*. This island is isolated and the bird is different to the others.

A Possible Explanation

In the case of each bird, the beaks seem to be adapted to different diets. The birds do not inter-breed, probably because of differences in appearance. Appearance plays a decisive role in bird-mating.

For differences to become established, it seems necessary for a form of life to be isolated. Probably, after the original species arrived at Galapagos, available environmental niches on the individual islands were filled. Slight inheritable differences, to be found in any population, were sufficiently important in these circumstances to enable certain birds with differing beak structures to obtain certain foods more easily, and these birds tended to survive. Subsequently, perhaps as the competition for available foods grew, the now diverse species spread from island to island, and the present situation was established wherein different species live side by side. In the case of the Cocos Island finch, access to the other islands was much more difficult, and its finch now remains there in solitary state.

Note.—This information has been included for interested teachers. Parts of it may also be of interest to the children.

Activities

Activities children may undertake include the following :

Pressing flowers and plants. Such work may lead naturally to other activities not closely connected with comparisons of structures. If girls wish to use their pressed and dried flowers in art-craft activities, such as making gift or greeting cards, this should be encouraged.

Observing plant structures and sections with a hand lens or a microscope (for example, onion skin, thin slivers of bottle cork, stems, leaves).

Studying the roots of carrots, radishes, and parsnips. The tip should be cut off and stood in a dish of red ink. Cut thin cross-sections with a sharp knife.

Studying the structure of leaves.

Cutting sections of suitable flowers to show parts of the flower.

Collecting bones and skulls.

Mounting small bones on stiff paper or card. A chicken's wing, vertebrae and skulls of fish, and the bones of a rabbit are suitable.

Where a number of small bones are being mounted to show the structure of a limb, model-aircraft cement will be found useful.

Placing bones in various household chemicals, such as vinegar, hydrogen peroxide, or laundry bleach, and noting any reaction. Bones may need to be immersed for several days.

Collecting and comparing the teeth of human beings and various animals.

Studying and comparing organs, for example, a bullock's heart and the hearts of a chicken, a sheep, and a rabbit. If a piece of lung-tissue is placed in water, children will note that it floats. From this they may conclude that it contains tiny air-sacs. Other organs that should be examined are eyes, kidneys, and brains.

Food and Feeding

This topic is mentioned in *Following On*, and what was said there need not be elaborated here. Experiments on feeding are suitable for both junior and senior levels. If children are interested in the topic, they should be encouraged to design their own experiments and follow up their own lines of inquiry. At this level, more sophisticated experiments will be possible, and children should be encouraged to seek out possible factors that would influence their results.

It would be most undesirable for children to carry out any experiments that could harm their pets, and all of their activities should be carefully supervised by the teacher. With reasonable precautions, short-term experiments may be undertaken. Several weeks are probably sufficient for an experiment of this type. Even if no clear-cut result can be noted, the work may still be worth while if the planning and the observation work are of a high order. Also, many children tend to think that deficiencies in diet show up quickly. They argue: "I eat fish and chips and sweets daily, and I'm fit, therefore there is nothing really wrong with my diet, no matter what the teacher says." Experiments in this field, even if they are inconclusive, may encourage them to suspend judgment, rather than jump to conclusions on the negative results of a short-term trial.

TO WHAT EXTENT DOES THE AMOUNT OF FOOD AVAILABLE AFFECT THE ANIMAL'S GROWTH ?

After discussing this problem, the children should be asked to put forward ideas that could be tested by experiment. As far as possible the children's plans should be followed, and they could be encouraged to think about the following questions :

What is a desirable diet for the particular animal being kept ?
(Books available at pet stores will give advice on this point.)

How can the effect of the diet be measured ?

What is the best time to carry out experiments on diet ? (Just after weaning is a good time. Growth is rapid and the litter can be divided, different animals being fed on different amounts of food. One group could be fed a recommended, balanced diet ; a second group could be given more than adequate supplies of food ; and a third group could be given a supply of food that is deficient in some way. Behaviour should be noted carefully and a weighing program undertaken. Under no circumstances should any activity be undertaken that endangers the animal.

DOES THE ANIMAL NEED A BALANCED DIET ?

DOES THE ANIMAL NEED A VARIETY OF FOODS ?

Children may suggest a variety of foods. Some possibilities for use with white mice are corn flakes and water for one group, corn flakes and milk for another, and corn flakes, milk, and carrot or lettuce for a third group. A balanced diet for white mice contains moisture, fats, carbohydrates, proteins, minerals, and vitamins. The children would need to study behaviour, changes in weight (if these can be detected), and appearance (glossiness of coat, brightness of eye, etc.).

IS THE COLOUR OF THE FOOD IMPORTANT TO THE ANIMALS ?

Children could be asked to suggest experiments to test whether the colour of the food has any bearing on animals' feeding habits. As far as possible, children's ideas should be followed, but, if necessary, the teacher can assist by suggesting colouring materials. For example, cochineal, green food colouring used in cake icing, laundry blue, ink, powder colours, and powdered food dyes could be used. Children should treat their findings with caution, since the colouring matter may change the smell of the food, causing the animal to reject it. Small cubes of bread would be easy to colour, if dipped in coloured solutions.

On the basis of an experiment of this type, children are prone to jump to unwarranted conclusions. For example :

(a) If mice seem to show a colour preference, it is possible that they really are aware of different colours, or that the changed smell of the food has affected their choice.

(b) If mice do not seem to show a colour preference, it is possible that they may be aware of the colour of the food but this does not affect the attractiveness of the food, or, perhaps, they may be colour-blind.

Children should not be told these possible explanations but should draw their own conclusions from the experiments.

If birds are available, the work could be extended, and similar experiments undertaken with the birds as subjects.

Response to Stimuli

The relevant material suggested in *Following On* should be studied since it may be appropriate for this level also. However, a number of additional activities could also be tackled :

Plants

Plant wheat seeds in two saucers. When they have germinated, place each saucer in a shoe-box from which one end has been removed. Cut the tips off the seedlings in one saucer and observe if this has any effect on the inclination of the shoots.

Children are aware that many shoots grow towards the light. Would roots also grow towards the light or away from it? Children should attempt to devise a method of finding out. One method would involve suspending a small plant over a glass of water so that the root was immersed. The plant would then need to be covered by a box from which one end had been removed to allow light to enter.

Germinate seeds in a glass jar so that the roots can be observed growing down. Then place the jar on its side and note the direction of root growth.

Animals

A number of suggestions are to be found in *Slaters* (page 134) and *Slugs and Snails* (page 137). With any small animals, experiments could be undertaken to discover their reactions to

warmth, cold, touch, light, darkness (often darkness can be simulated by covering the container with dark-red cellophane), moisture, food, and gravity.

Children should be encouraged to extend their observations to include themselves and other human things. These could include the following :

Taste : (i) Small pieces of apple, onion, celery, and carrot could be used. Children should work in pairs. The taster should be blindfolded and his nose closed with a peg. Plugging the nostrils is not an acceptable alternative. Responses should be recorded and compared.

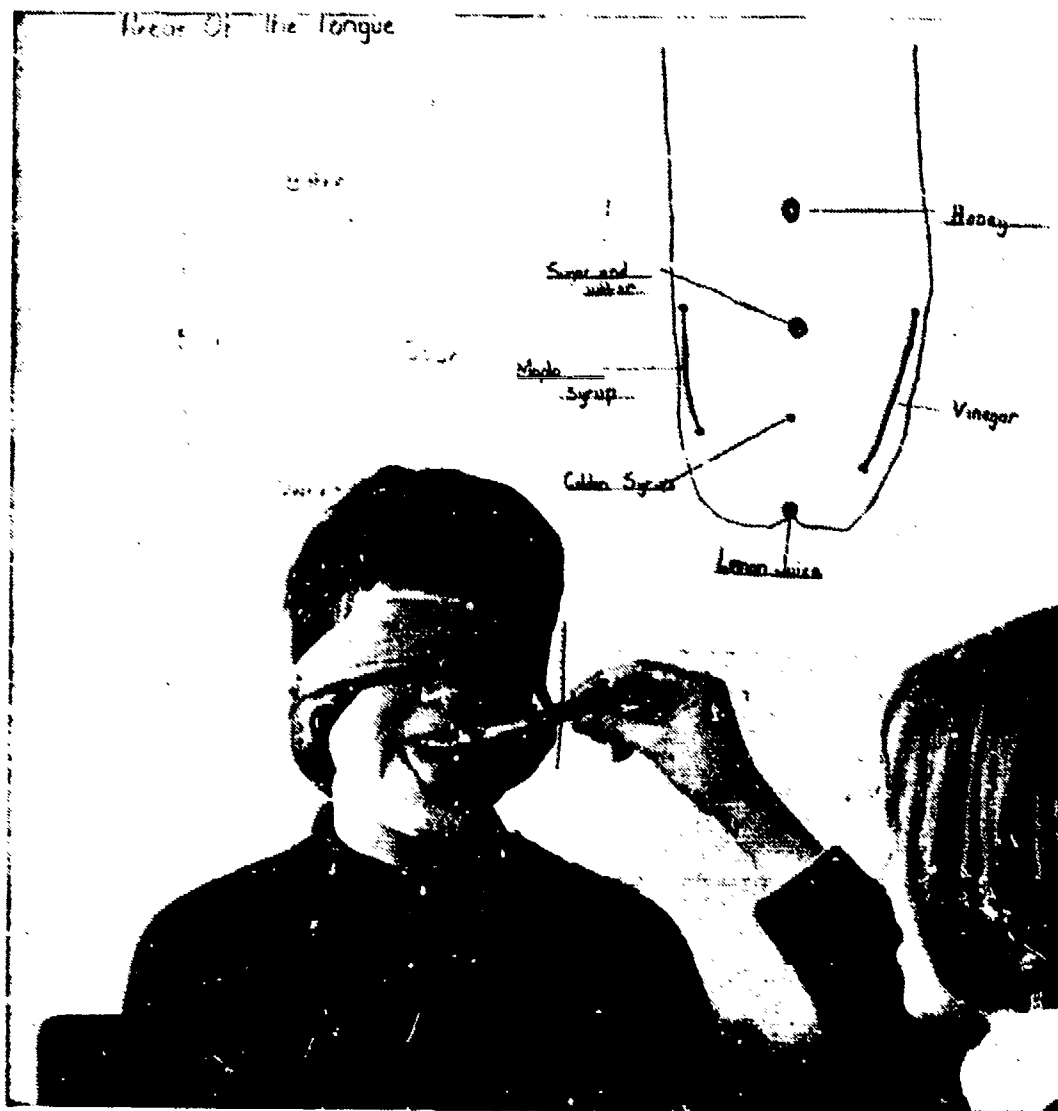

(ii) Sugar, salt, aspirin, and vinegar could be used to map the taste areas of the tongue. Children will need to devise ways of placing tiny quantities of the materials used on the front, the sides, and the back of the tongue. With care, they may discover that sour and salty sensations are detected on the sides, bitter sensations at the back, and sweet sensations at the front of the tongue. The use of an eye-dropper and solutions might be suggested.

Sight : If a collection of green dress materials and blue dress materials is made, children may attempt to group them as "greens" or "blues". They will probably find that disputes arise as to whether some materials are in their correct groups.

Touch : The sensitivity of body parts (the palm of the hand, the side of a finger, the back of the hand, the forehead) can be discovered by dropping small pieces of paper onto these parts. Children should work in pairs, using smaller and smaller pieces of paper until the paper cannot be felt alighting on, say, the palm of the hand. The person being tested should work with his eyes closed.

Learning

Through observation of their pets, children will be able to obtain information about learned behaviour, and their ideas could be extended through experiments and observations of small mammals kept at school.

1. Obtain two food containers that can be left partly closed to hide the contents. Matchboxes would be suitable if mice are being studied. Place the containers in adjacent corners of a cage holding a mouse, with the food in only one of the boxes. Do this daily for a week or a fortnight, and then place the food supply in the other box. It is necessary to remove both boxes when renewing the food supply so that the animal does not see the food being placed in the box.
2. Obtain a small sheet of glass and set it up at one end of the cage. Access to the area behind the glass should be possible only at one end. Before carrying out the experiment the children should be asked how they think the animal will behave when it can see food but cannot obtain it easily.

Observations could take place when food is placed behind the glass, and hungry animals, such as white mice, are placed on the other side of the glass. Questions might be : Do the mice make a purposeful search for a way to reach the food ? Do they find a way to the food by chance ? Do they remember how to reach the food next day ? How could we tell if they are learning a path ? (Some of the children may suggest timing the mice.)

3. Another experiment where reasoning power in a specific situation can be measured is to tie the hungry animal to a peg. The leash used (string or cotton) is then passed around another peg and the food placed just out of the animal's reach. Note the reaction. To reach

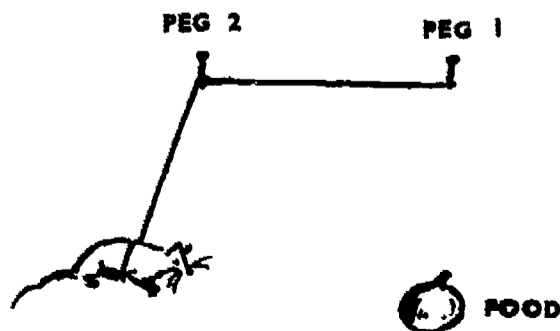

the food the animal must go back around the second peg. This experiment could also be tried with dogs or cats, but care should be taken to see the animal used is not kept from its food for too long.

The limitations of these experiments should be emphasized. An animal may have intelligence that an experiment of this type does not measure.

4. Children may care to discover if gold-fish can learn. The tank could be tapped in one corner just before feeding, and at no other time, and the food placed in the tank at that corner only.
5. Habit. If children write their own name as quickly as possible for a minute, the number of times the name has been written could be noted and compared with the number of times they are able to write their name backwards in one minute.
Speed of writing with the left hand and with the right hand could also be compared.
Some children may care to make lists of their own habits, classifying them as "useful habits" or "other habits".
6. Trial and error learning could be measured by using children's puzzles. The times taken for first performances could be compared with the times taken for subsequent performances. If no puzzles are available, children could make their own, perhaps by cutting up letters made of cardboard :

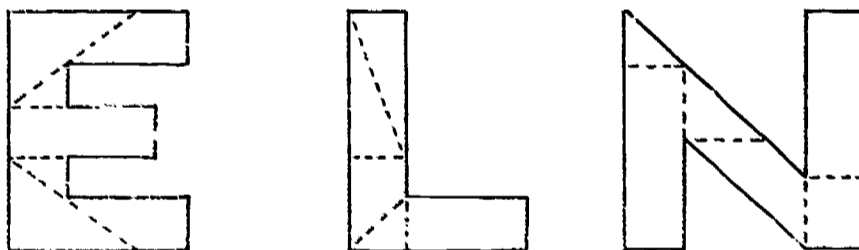

7. The significance of meaning can be discovered if children attempt to learn lists of letters and words :

zab	set	fat
czs	hat	old
leb	top	bob
usp	net	top
tok	hut	sat

Results could be timed, averaged, and graphed.

8. Learning in babies and young children could also be studied. From a variety of sources, children can gather information about the approximate ages at which babies open their eyes, follow people with their eyes, play with rattles, sit up, crawl, walk, utter words, feed themselves, dress themselves, tie shoe-laces and neck-ties, and perform other tasks. Care should be taken to ensure that unfortunate comparisons are not drawn.

To conclude this unit, activities with slaters and activities with slugs and snails are described in some detail. Such activities can be adapted easily for use with other animals. It will be seen that the activities may range widely, covering a number of topics and going beyond the confines of the units into which the section on Life has been divided. It is desirable to follow children's interests rather than follow a prearranged program.

Slaters (also called wood-lice or sow-bugs in some books)

Activities such as those described below would be useful in giving children opportunities to examine how the behaviour and the anatomy of an animal fit it for survival in a particular environment.

At the same time opportunities would occur for children to formulate explanations of behaviour, to devise experiments to test these explanations, and to observe carefully, perhaps with a hand lens.

Introductory

The children could be encouraged to find slaters and to bring them to school. The following questions could be discussed :

Where are slaters found ?

How can slaters be kept alive in captivity ?

What do slaters eat ?

Are slaters insects ?

Are slaters pests ? (A dogmatic affirmative answer to this may have to be modified later.)

Slaters can be kept in a small tank or a large jar containing a mixture of moist peat (available from gardening-supply shops) or leaf mould, and pieces of rotting wood and dead leaves. It is advisable to have a loose cover on the container to maintain a damp environment. If a piece of slate or a flat piece of rock is included, the slaters will often congregate beneath it.

Encourage close observations of structure. Hand lenses are useful for this work. Gill-like structures attached to the abdomen may be seen, and perhaps this will suggest why the slater shows a preference for damp places. It may also encourage speculation about the slater's origins.

Behaviour

Obtain cardboard shoe-boxes or, better still, pie-dishes with curved sides and place a few slaters in each. The children should observe the behaviour of the slaters and make general comments. A clump of grass and earth should be placed in one corner of a box containing slaters, and observations made. Where do the slaters go ? Why ? Various answers will be suggested—perhaps "they want food" or "they don't like the light" or "they are reacting to drying up".

Some children might like to try some experiments at home on the behaviour of slaters under different circumstances. The children should be encouraged to write about their activities and their findings.

Theories of behaviour should be discussed. Probably someone will say that slaters don't like light. What evidence is there for saying this ? It should be remembered that generalizations cannot be made from one example.

How can a theory that has been put forward be tested? It may be necessary to decide which theories are to be tested if it is impossible to test them all, but at least the most popular or the most promising should be tested. *The teacher should resist any temptation to impose a particular theory as the important one to be tried out.*

The following notes offer suggestions for further activities.

SLATERS DON'T LIKE LIGHT

How can we discover if it is the light that the slaters are escaping from? Perhaps they look for shelter when light falls on them. Someone might suggest investigating their behaviour in the dark. If the floor of a dark box is sprinkled with powder, the slaters' movements may be recorded. It will probably be random. An alternative would be to cover the box with red cellophane. Many creatures are insensitive to red light and behave as they would in the dark. This, of course, suggests that other coloured cellophane could be used to obtain comparisons and further information.

Someone may suggest shining a strong light between the slaters and the shelter.



Slaters probably do react negatively to a light stimulus.

PERHAPS SLATERS ARE AFTER FOOD THAT IS TO BE FOUND IN DARK PLACES

This will raise the question of what slaters eat. How can this be tested? Probably the best way is to leave some slaters on a damp cloth in a box (darkened) with a few tiny food samples to discover their preferences.

This experiment could be repeated with several boxes of slaters, each being given a particular food sample—meat, dead plants, live plants, paper, wood.

WHAT SORT OF LIVING PLACE WOULD SLATERS CHOOSE IF THEY WERE OFFERED A CHOICE?

Some children may raise this question; if not, the teacher could. Children may suggest ways of testing this. The illustration below shows one possible test.

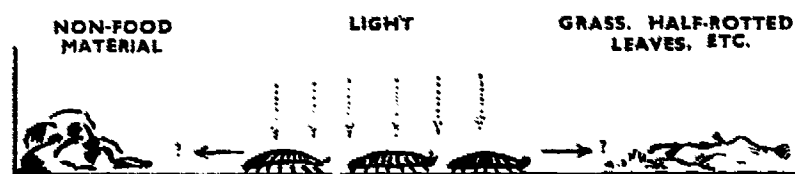

(When slaters head away from light, do they show a preference? Do they head for shelter under food material or are they satisfied to head for shelter which provides no food? In other words, is their motion random, away from light, or directed towards a food or a shelter goal? This could be an important test since it would tend to show whether slaters use their senses to help them locate food, or whether it is coincidental that the slaters' dislike of light or open, dry conditions leads them to sheltered spots where food may also be present. This information is for the teacher's enlightenment, not necessarily for the children.)

Where do slaters go? In what numbers? In discussion the point should be made that a large number of slaters would be needed to make any generalization worth while. Results from all of the experiments carried out should be compared before drawing any conclusion, if one is possible. Perhaps someone may suggest leaving the experimental box set up overnight as a further check. Questions dealing with random movement should be framed in the following way: How do slaters know where to go? Do they know where they are going?

ARE SLATERS AFFECTED BY HEAT?

If this question arises it should also be tested. One way is to put a light globe under one end of a box, the top of which is darkened, perhaps by red cellophane.

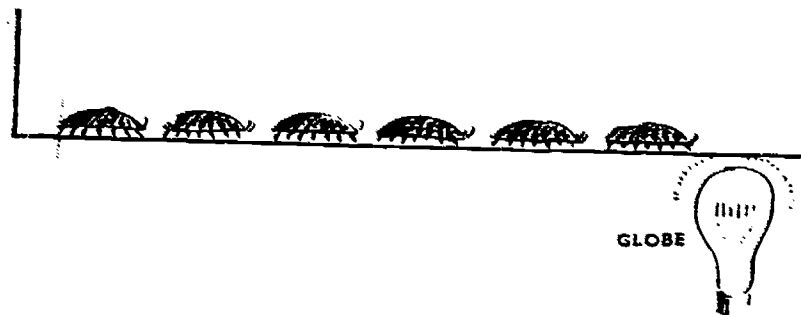

After inspection the children should decide whether the distribution of the slaters is random or whether it has been affected by the heat.

DO SLATERS SEEK MOISTURE?

This question may be provoked by the fact that some slaters die from drying out (dehydration). A test to discover whether slaters seek moisture might be as illustrated.



Once again the results observed, say, after two hours and overnight, should be recorded. Note also differences, if any, between the slaters' behaviour in a darkened box and in one which is open to light.

A monitor might carry out observations every five minutes to note if the movement of the slaters is random or whether it is directly towards the moister area.

DO SLATERS PREFER TO GO UPHILL OR DOWNHILL?

Someone may notice a tendency to move in one direction. One test would be to put slaters in a glass tube containing a damp paper strip as a pathway. Alternatively, try putting the paper strip on a sheet of glass and tilting the glass. Note any reaction by the slaters.

What proportions of slaters show a tendency, if any, to move up, down, or sideways? Where do they finally settle down?

Note.—These are only some of the possible lines of inquiry. Many others could be followed up. This unit is not intended as a full account of the habits of slaters, nor is it recommended that a full and exhaustive treatment is desirable. The teacher should be guided by the interests of the children in deciding where to begin and where to end.

What is important is that certain abilities essential in the study of science, are being encouraged. At the same time an important concept—that living things respond to their environment—is being illustrated.

The class may not be able to find answers to all of their questions. Some children may read further, but references are few. It is hoped that children will come to realize that at the end of their studies there will still be much to be discovered about slaters, or any other subject that they investigate.

At all stages children should be encouraged to write accounts of their activities—what they did, why they tried out their experiments, and what they observed. These could become part of a class Interest Book on slaters.

Slugs and Snails

It is expected that the activities suggested below will provide children with opportunities to develop skills in observation and to suggest and design their own experiments. At the same time, situations are likely to arise in which some specific knowledge will be gained about methods of locomotion; reaction to light, heat, or other stimuli; food preferences; and the reactions of slugs and snails to the environment in which they live. The following notes offer suggestions for experiments and procedures in this area.

Initiating Interest

It is not necessary that all activities should start spontaneously. If this one should, so much the better; but in most classes where this does not occur, a remark that slugs and snails seem to be plentiful and, if collected, could be used for experiments may be sufficient to arouse interest. Some teachers are disappointed if such an introduction leads nowhere. Possibly it will unless it is followed by something more specific. The teacher should call for volunteer collectors and bring up the problem of classroom "homes" for the snails. Probably, large jars and small fish-tanks will be most suitable, but let the children themselves come to this conclusion and provide the containers.

At this stage some informal remarks could be made about slugs and snails and the stage in the evolutionary development of life they represent.

Snails are related to marine shell-fish, but they possess the ability to live with less moisture than their relatives on the sea-shore and under the sea. To children, snails may be more interesting and of more significance as descendants of the early forms of life that first emerged from the sea, than as garden pests. Other shelled creatures found an existence along the tide-lines, nourished by the regular flow of salt-water organisms that washed over them. Today, some snails are still more at home in water than on land. Some examples of these are the water-snails often kept in fish-tanks. Some ancestors of the garden snails and slugs moved further and further from deep water, needing only moist conditions for survival. Possibly, as the waters covering the earth subsided, some species of shell-fish were able to take advantage of the mutations and the physical differences that distinguished them from others, and managed to survive where others could not.

Information of this nature may be supplied informally, and it may help to get the work off to a better start. What follows represents the wide range of activities that are possible. This unit contains material for children at both the middle and the upper school levels, and much of it may not be suitable for some children—their span of interest may be short; their abilities may be limited. Therefore, the teacher should be selective in choosing ideas from the unit, which, after all, is only meant as a guide, not as a firm program to be taught.

Environmental Studies

A number of different slugs and snails may be collected by children. There are thought to be over 400 species of snails native to Australia, although there are only a few native species of slugs. About ten slug species have been introduced from elsewhere. The garden pests are nearly all introduced species. The following is a list of the more common slugs and snails:

Snails: the common brown garden snail, the white garden-snail (the shell of this species is brown interspersed with white), the pointed snail (this species has a dark-brown, pointed, cone-like shell about a quarter of an inch long), the cellar snail (this species has a flat round shell about a quarter of an inch across).

Slugs: the yellow slug (which is not yellow, but a light shade of brown), the black garden slug (which is about the same length as the yellow slug, that is, two inches long, but somewhat darker in colour), and the giant grey slug (which is dark in colour and often about four inches long).

Children are likely to bring the ordinary garden snail in a variety of sizes. This might start an argument about whether the sizes indicate different species, and, if it is decided on the basis of close observation that they are of the same species, further questions may arise about how fast snails grow. Similar arguments are likely about slugs. Small light-brown slugs, about an inch long, are common, and there may be arguments about whether these are baby slugs of one of the species mentioned above or a separate species. Arguments of this type need not be settled by the teacher. The children should be asked to think of ways to settle the matter. In other words, the children should, at all

times, be encouraged to plan and carry out their own experiments to prove or disprove their theories. Even if their experiments fail, there are occasions when they should be content with a suspended judgment.

Water-snails were mentioned earlier. If it is possible to keep some in a fish-tank, a comparison of their habits with the habits of land-snails may prove interesting.

Discussion about the places where the creatures were found may lead to speculation concerning suitable and unsuitable homes for the children's new "pets". Using large jars, children could quite easily create environments similar to those in which the slugs and the snails were found. However, the possible effects of altering these environments, in which sheltered, moist conditions are provided and food supplies readily available, should be discussed. The following list gives some alternative living environments for children to investigate. It should be emphasized that it should not be expected that children will suggest all of these, nor is it necessary for the teacher to supply them.

Dry all over, sandy and rocky.

Dry, with one moist area (perhaps the moist area could be a piece of damp plastic sponge).

Slightly moist (damp sand or damp blotting-paper could be used to make a "floor").

Deep water.

Rather dry, with liquids other than water present, perhaps in shallow press-on-type tin lids.

Any or all of the above conditions could be varied by placing the homes in shade, in direct sunshine, under electric light, behind red cellophane which would simulate night-time conditions, with or without hiding places, and with rough surfaces or smooth surfaces. The surfaces could be created out of coarse sand-paper, thorny twigs, razor blades, dry glass, oiled glass, or glass smeared with vaseline. The effect of introducing salt or ashes could also be noted. On contact with these substances snails tend to produce slime to the point of exhaustion, and they die.

Children should be encouraged to observe behaviour in all of these environments. Observations need to be close and accurate. Some children may like to use magnifying glasses in this work, and all observations should be recorded briefly. Out of these observations another problem will almost certainly arise: How can the mass of information be handled so that significant details are not lost? This is a problem all adult scientists must meet and overcome. The children should suggest answers to the problem and accept the methods that are satisfying to them, without too much refining on the teacher's part. Possibly, there are procedures that can be adopted to prove to children the importance of careful observation and collation of material.

Food Studies

Many experiments could be devised by children to determine food preferences of slugs and snails. It has been said that one type of slug will eat butter, milk, cream, bacon fat, and meat scraps. It might be

possible to discover if this is true for any of the slugs and the snails the children find. Slugs commonly eat fresh and decaying vegetable matter. In one sense they play a valuable role in breaking down material and creating humus but, at the same time, they destroy material prized by humans.

It may be that some slugs or snails prefer decaying material to fresh. Frequently they do show a preference for certain types of fresh leaves. If they showed a preference for lettuce leaves rather than the leaves of a nasturtium, could any tentative conclusions be drawn from this about the protective mechanisms some plants possess? If children compare the taste of a lettuce leaf with that of a nasturtium leaf they may gain some helpful information. *Any generalized conclusion must be tentative.* An investigation need not be rounded-off patly with the "correct" answer. It would be far more valuable for children to become aware that other unknown factors may have influenced their results.

With the co-operation of a local nurseryman it might be possible to obtain seedlings of a number of different plants that could be set in soil in a fish-tank or a large jar. If a snail were introduced, some information about preferences might be gained. This activity could be duplicated with other species of slugs or snails.

The activities described need not be the activities the children actually undertake. Their own ideas must be encouraged. However, if they have difficulty in suggesting feeding experiments, the ones suggested here, or others similar to them, may be used to stimulate their thinking. If they have been stimulated effectively, it should become apparent in any subsequent series of feeding experiments the class undertakes, perhaps with worms, caterpillars, budgerigars, or white mice.

Observations of Structure

Little need be said about this. Armed with a magnifying glass, a pencil, and paper, children should be allowed plenty of time for close observation. At the end of the period of observation it may be profitable to check the accuracy and the closeness of the children's observations. Their written work and diagrams should be kept so that any future development in skills can be noted.

Children may suggest a number of activities to test the sensitivity of feelers and eye-stalks. Observations should be made of the rippling movement of the muscular foot as the snail moves forward, the mouth parts, the shell, and the breathing-hole beneath the shell.

Estimating Populations

For older children this activity could open up a larger field of work. Population sampling is an important scientific technique, and once children have acquired some skill they can apply it in a variety of situations involving many forms of life, both plant and animal.

Slugs and snails are pests. How many of these pests infest our gardens, our suburbs, and our cities? The very immensity of such a question intrigues children and they respond readily and with imagination to the challenge of finding some answer. The question may arise either directly from the teacher, or indirectly out of some comment such as :

"Sir, there are *millions* of snails at our place." Plenty of time should be allowed for children to suggest methods of finding out, and to argue the problem among themselves. If a number of likely methods of discovering the snail population in a given area arise, the children should proceed with them and later compare their methods and results.

In any sampling of population, the population of a small area is first ascertained, and from this an estimate of the total population is made. In finding the snail population of a home garden, the problem is made difficult by the fact that only parts of the whole area are snail infested. The first step would probably be to make a scale map of a garden (a good link with maths) on graph paper. The snail areas might then be shaded and some estimate made of the population of a number of small sections. These figures would need to be averaged so that the average population of a section could be gauged. From here on it would be a simple matter to estimate the total snail population of the garden, and even of bigger areas. The figures gained are likely to be of astronomical proportions.

The teacher will probably find as the activity proceeds that many fifth-grade and sixth-grade children develop a good eye for the flaws and the traps that can appear in this work. The development of this ability is of course one of the main aims of undertaking the activity. The teacher should note carefully any development in this skill, as well as in the ability to suggest methods, plan procedures, and carry them through. All of these things are far more important than knowing just how many snails there are in the garden.

All of the children's activities should provide valuable opportunities for language work. The making of individual or class books is an integral part of the whole activity in this as in every other unit.

LIFE STORIES

This unit provides a miscellany of activities on :

Growth of Populations

A Garden of Moulds

Incubating Eggs ; the Development of an Embryo

Birth, Development, and Care of Young Animals

Patterns of Care among People.

Although much of this work will involve observation and experimentation, a good deal of discussion, reference reading, and making of individual or group Interest Books should occur.

The main purpose of this unit is to arouse and maintain *interest*, *curiosity*, and *discussion*.

Growth of Populations

Some living things produce large numbers of their own kind, others produce very few. A multitude of checks and balances operate to limit the growth of population. These checks may have to do with availability of food, competition with other forms of life, climatic variation, possibilities for dispersion, disease, and, in animals, care-requirements of the young.

Many investigations should arise naturally from activities described in the unit *Collecting and Caring*.

White Mice

The average litter is eight, and white mice are capable of reproduction every sixty days. The children may attempt to calculate how many white mice they could have after twelve months, if they began with just one pair. This provides a nice problem in mathematics, and it should emphasize the need for care in setting-out the basic data. If children have difficulty in arriving at a satisfactory result, setting-out the facts in the following way may prove helpful.

Days	Start	60	120	180	240
No. of pairs (i.e. parents)	1	5	25	125

In a year there would be 15,625 pairs. Results could be graphed and the pattern of geometrical progression noted informally, without any technical language. Encourage speculation about the means by which this population explosion is limited in the classroom as well as outside. Comparisons could be made with other pets that children keep, either at school or at home.

Egg-laying Moths

The gum emperor moth, the painted apple moth, and the silkworm moth are sometimes observed laying eggs. It may be possible for children to estimate the number of eggs laid by one moth, and then to consider the number that could be laid by a large colony of moths. Once again the means by which the numbers of caterpillars and moths are limited should be discussed.

Thistles and Other Plants

It would not be possible for children to count the number of seeds produced by a single thistle plant, but a group of children could attempt to count the seeds produced by one flower, and then, using this figure as a starting point, estimate the total seed production of a plant.

Other plants could be treated in a similar fashion and questions of weed infestation and control could then be investigated. Natural limitations on the spread of plants could also be discussed.

Microscopic Organisms

Some information on hay infusions will be found in the section *Groupings and Communities*. Pieces of raw potato, handfuls of straw or dry grass, lima beans, or peas should be placed in small quantities of water and exposed to the air for several days. The containers should then be closed and left in a warm place for a few more days. Drops of the water should then be drawn off and examined under a microscope. Micro-organisms such as paramecium will probably be noted. The

colony is likely to multiply. The effect of adding other materials should be investigated (see Groupings and Communities). Factors that might limit the growth of the colony could be discussed and comparisons made with populations of other living things.



A Garden of Moulds

Perhaps activities may arise from an interest in mushrooms or other fungi (most of which fruit in the autumn) or from the finding of a mouldy piece of food. Some activities are indicated below :

The Function of a Mushroom or a Toadstool

If it is a plant, what does it grow from? Does it produce seeds like other plants? Does it have roots? These questions should lead to investigations such as cutting the mushroom up and digging about in the soil where mushrooms are found to try to find the answers. Children could proceed in the following ways :

Cut off the stalk of the mushroom or the toadstool and place the cap, gills down, on a sheet of paper. After a few days the spores, which are not seeds but carry out the function of seeds, should fall out on the paper.

Dig up a spadeful of forest soil. This should disclose a network of grey or white threads which make up the bulk of the fungus, the mushroom being only the fruiting body. Discuss the function of these threads. (They are not roots but are absorbing food material from decaying material.)

Growing Fungi

It is possible to grow some fungi, particularly moulds, in the classroom. Some bacteria may be grown in numbers large enough to enable children to see a colony of them without using a microscope. The starting-point for the activity may arise from the finding of a mouldy apple-core, an orange with green or blue mould on its skin, or any food that has gone bad. This will also provide ideas on suitable materials on which to grow these fungi. Some suggestions are pieces of fruit, cream or cottage cheese spread over the bottom of a bowl, pieces of moistened (not soaked) stale bread, rich soil (95 per cent) and cornflour (5 per cent) mixed with water to produce a dough-like consistency, crushed grapes and a little water, dried apricots and water. There are many other substances that act as a medium for the growth of moulds and bacteria, and suggestions from the class should be tried.

The best containers for growing moulds are small dishes that can be covered by pieces of glass. The materials used should be placed in the dishes and left open for a day or two before covering. The cover is not absolutely necessary, but without it the fungi may form spores that will contaminate other dishes, and the same type of fungus is then likely to be found in each dish. The dishes are best kept in a warm and fairly dark place, but not in direct sunlight.

The children should keep records of their daily observations, perhaps in the following form :

Bowl 1. Pieces of Apple

Day	Appearance
1st Day	Nothing visible
6th Day	Patches of white, furry growth

Two main types of growth will be seen—

- (a) Moulds, which are fungi—these are made up of small threads and are easily seen through a hand lens.
- (b) Bacteria colonies—more compact patches of various colours with no visible threads.

In discussion a number of questions may arise :

- Where did the fungi or the bacteria come from ?
- Are they really plants ?
- Why can they grow in the dark ?
- Are they poisonous ?

Some of the above experiments can be followed by further investigation if the class remains interested. For example, several dishes can be set up with one suitable medium, and the medium "seeded" with a breath or a sneeze, dirty hands, dust from a shelf, or soil. For good results it is necessary to sterilize the dishes, the lids, and the medium before the experiment begins. Small jars and their lids can be sterilized in a saucepan of boiling water in the way that a baby's utensils are sterilized. The lid must be kept on the saucepan while the apparatus cools, and the lid put on the jar afterwards. The jar can be opened briefly to put in the medium (which must also be boiled and kept covered) and for the seeding process.

Another experiment might be to observe growth under various conditions, such as in dark cupboards, on window-sills, and elsewhere.

After the above activities have been carried out, discuss why food does or does not go bad. Perhaps the class will try some likely bacteria-growing substances both in the refrigerator and out of the refrigerator—for example, bread slightly moist and dry bread; dried apricots and moistened or undried fruits. This work should lead to some ideas on the conditions necessary for preserving food. (See the section on decay and preservation in the unit Life Stories in *Following On*.)

It is important that children should not get the idea that all bacteria and fungi are harmful. Some cause decay of foods and a few cause diseases, but most fulfil a useful function in nature. Discuss how dead plants and animals are returned to the soil. Children may read about the work of Fleming and Florey in the discovery of penicillin, and discuss this in class.

Incubating Eggs ; the Development of an Embryo

An activity of this nature might develop from any one of a number of starting-points :

- Talks about birds nesting in the locality ;
- how hens are kept at home ;
- finding dead fledgelings on the ground after a storm ;
- work with thermometers ;
- controlling temperatures with various forms of insulation ;
- a visit to a poultry farm ;
- discussion about reproduction ;
- investigations of the properties of eggs.

The following is an account of how one class attempted to hatch eggs :

The starting-point was not clear, even to the teacher, and it seemed to arise out of a mixed bag of interests. There was a poultry farm near by ; children had been observing some effects of heat ; insulation was investigated briefly ; and the pair of budgerigars that were being kept in the classroom had produced an egg which did not hatch. When the egg was opened the children expected to see a dead bird, but instead

they found a curdled mess that gave off an offensive odour. The school cleaner, a bird fancier, gave advice on what should be done next time an egg was laid, and a group of children visited the poultry-man to see how he hatched eggs in an incubator. The teacher found a picture of a home-made incubator in a book and, as interest was very high, it was decided to attempt to hatch eggs in the classroom.

The incubator was made from two cardboard soap-boxes fitted one inside the other, as shown in the diagram.

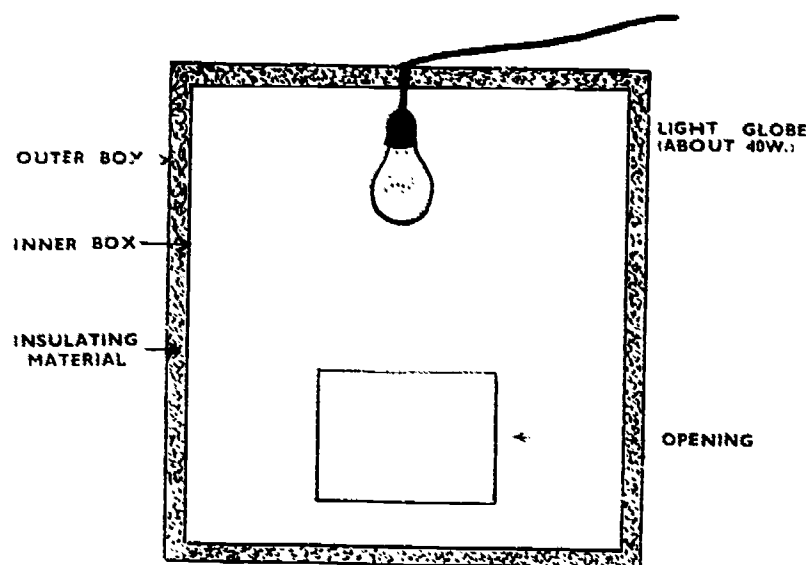

An inspection opening was cut in one side and fitted with a piece of glass that could be raised to allow some ventilation. A thermometer was placed inside, and the globe switched on. After some days spent in trying a variety of globes, a fairly constant temperature of about 100 degrees was attained. Aluminium foil, paper, and sawdust were tried as insulators, and the foil was found to be satisfactory.

A dozen fertile eggs were then obtained and placed in the incubator, along with a jar of water to provide some moisture in the atmosphere. The eggs were turned daily. The children had found out that the period of incubation was twenty-one days, and they decided to open an egg every three days to see what changes were taking place.

However, interest was so great that an egg was broken open every day for the first few days, and changes were noted almost immediately. The teacher was struck by the great interest the girls showed in the work. After ten days or so, considerable development could be seen in the embryos. Rudimentary legs and wings were noted as well as the eyes and a beak. In fact, the changes the children observed on the tenth day were viewed in awed silence. One girl expressed the opinion that to open any more eggs "would be murder". Some boys objected, but the class voted overwhelmingly in favour of not opening any more eggs.

Great care was taken by self-appointed thermometer watchers, who endeavoured to ensure that the temperature did not rise too high, but a series of hot days played havoc with temperature regulation.

At this point the librarian produced a book, *A Bird Is Born*, by E. Bosiger and J. Guilcher, World of Nature series, No. 4. Oliver and Boyd, London, 1960, which could not have arrived at a better moment.

On the due hatching day no eggs hatched. The children were disappointed but decided to wait a few days before opening the eggs. Several eggs were added, some showed a degree of development, and one egg contained an embryo on which feathers were beginning to appear. In one sense the activity had been a failure. But in another sense it had proved very worth while. The children's appreciation and respect for natural processes were both evident and deep. The word "biology" had taken on real meaning.

Some teachers have actually succeeded in hatching eggs in this way, but the problems of maintaining suitable conditions are great. Possibly late autumn or August are the most suitable times for this work to be undertaken as temperature control seems easier then. The incubator needs ventilation and moisture, and the eggs should be turned. However, the main value of the work is not to be found in the end result, but all along the way, in the attitude to life that children develop as they watch a wonderful process begin and unfold.

Birth, Development, and Care of Young Animals

An activity such as the one described on the previous pages would provide a natural introduction to the activities described below. However, an occasion when a classroom pet or a child's pet at home produces young could provide an equally good starting-point.

Birth and care in animals show differences that are related to the conditions under which animals live. One idea children may develop as a result of their observations is that care is largely an instinctive process which, except in humans, is not something that must be learned. Even in human beings, of course, the instinctive processes are important and show themselves in feeding and mothering generally.

The following investigations may be undertaken by children :

How Young Ones Are Born

This would involve studies of the animals referred to in *Collecting and Caring*, or any other animals that children are able to study. In addition, the use of reference books available in the library would provide further information and enlarge the range of the children's interests.

Development

This would involve a study of changes that can be observed in living things and, as such, it might develop from activities of the type described in *Behaviours*.

Where children have pets at home, they may set to work to record their observations on the birth and development of young ones. These observations could then become part of a group or an individual Interest Book entitled "The Baby Guinea-pig", "Young Pets", or some similar topic.

Care of the Young

Investigations into how animals care for their young would be a natural extension of this work. Reference reading on animals such as the stickleback, the digger wasp, the dolphin, the mallee fowl, the kangaroo, spiders, ants, and bees would probably increase the children's interest in patterns of care among common animals. At the same time it could provide background for discussion on the relationships between environment, structure, number of offspring, level of development at birth, and the care provided.

Patterns of Care among People

The patterns of care among humans are immensely more complex than those of animals because man is a social being. Care for the young is only part of the general pattern of caring, or social welfare, that influences the life of all members of the community.

The tiger in the jungle fends for itself. In the asphalt jungle of the city man co-operates to preserve life by attempting to reduce accidents and eradicate slums. He also builds hospitals and infant-welfare centres, combats infectious diseases, provides sanitation and community water supplies, and, in general, attempts to control the environment and to organize life in order to maintain it. He does not always succeed, and often the collective nature of life poses its own threats to his survival.

This is a vast topic which is not the preserve of science alone in schools. In fact, it emphasizes that science has no longer any clear boundaries in the school, or anywhere else for that matter. In the classroom, health, social studies, and science may be combined naturally and effectively in many investigations, but nowhere is this more true than in investigations of topics such as :

- Infant Welfare Centres
- Hospitals and Medical Care
- Infectious Diseases
- Housing, Sanitation, and Water Supply
- Care of Aged People
- Traffic and Road Safety
- The Troubles of Cities
- Surveys of the Local Community.

In some of these topics, work could develop as a result of excursions. In others, such as Traffic and Road Safety, first-hand observation may be linked with the study of factual material, tables of data, and graphs. In other topics much of the raw material will be found in Year-books, and yet it, too, may be regarded as a part of science.

Traffic and Road Safety

Work might begin when children make a traffic survey as part of their social studies activities, noting such things as—

- the rate of traffic flow over half-hour intervals, starting at 8.00 a.m. ;
- the direction of the flow ;
- the busiest streets ;
- the type of traffic.

This data would need to be organized and the implications examined for road safety. Other work might cover the types of accidents that have occurred in the school-ground and the "danger spots" around the school.

The Australian Road Safety Council is a valuable source of data concerning accidents, and a number of booklets are available which would be of use. Children should be encouraged to draw conclusions from the tables they obtain. The following data were found in the Council's publication, *Road Safety* (Current Affairs Bulletin Reprint).

NUMBER OF FATALITIES BY MONTH
(During a certain year)

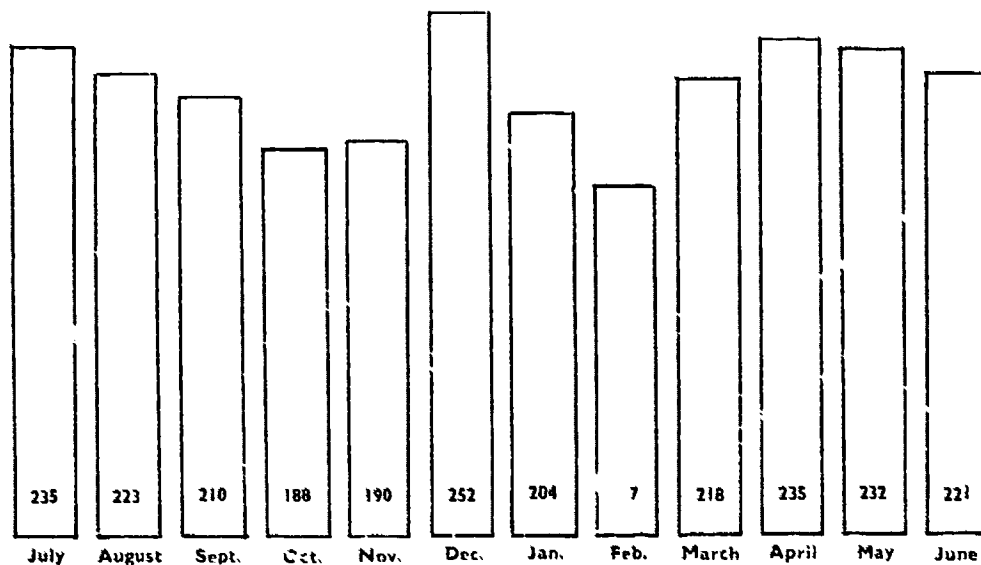

NUMBER OF FATALITIES BY DAY

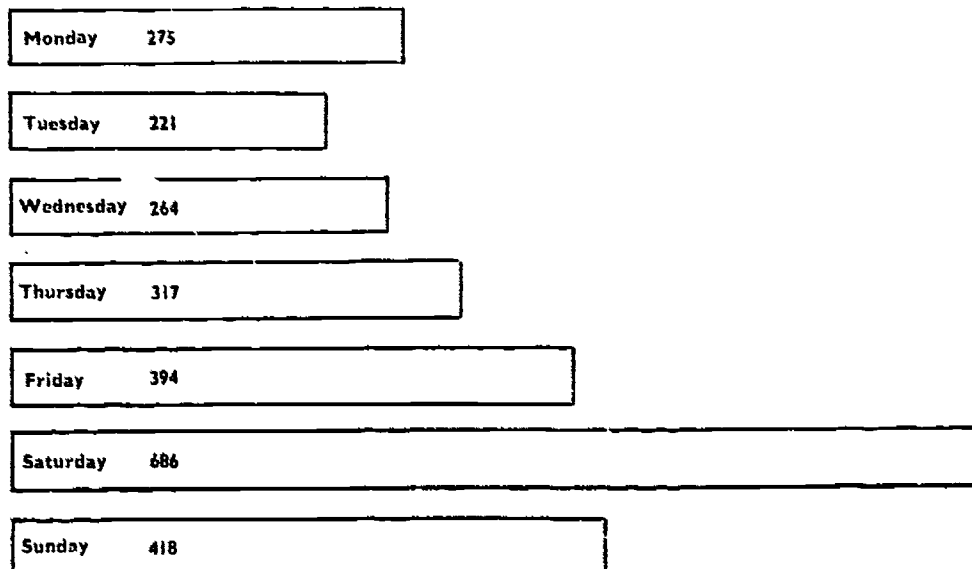

NUMBER OF FATALITIES BY HOURS

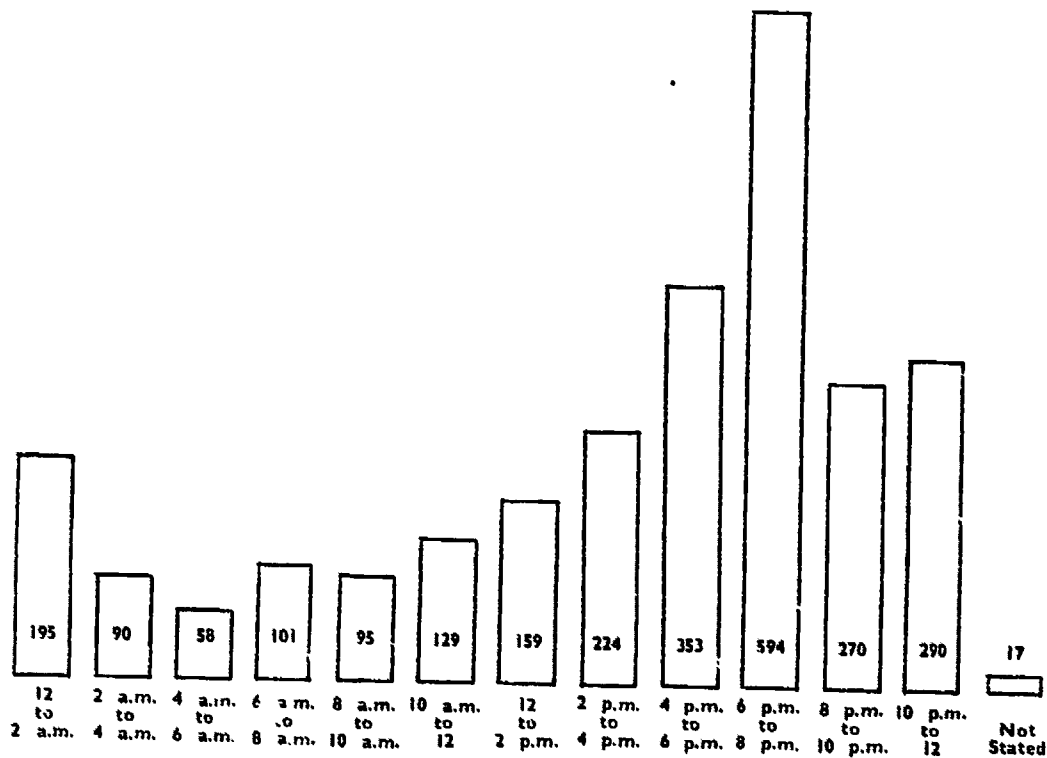

Questions that might arise include :

Why are April, May, June, July, August, and December high accident months ?

Why do so many accidents occur on Saturdays ?

Why do so many accidents occur between 6 p.m. and 8 p.m. ?

(This table is for a year before 10 o'clock closing was introduced. It would be interesting to compare it with the table for a later year.)

It is hoped that children will realize that their conclusions can only be tentative, and that many factors may be involved.

Infectious Diseases

Ideally, work on diseases should be carried out by groups of children or individuals who follow up particular topics or interests. This means that a good deal of written material should be available.

It is hoped that from time to time books will become available on the major diseases, their nature, treatment, history, incidence, and control. In the mean time the following publications would be useful:

World Health, the magazine of the World Health Organization, Hunter Publications, 23 McKillop Street, Melbourne, 3000.

Health Bulletin, published by the Department of Health, Victoria, 295 Queen Street, Melbourne, 3000.

Some information will also be found in State and Commonwealth Year-books.

Raw data, that is, figures, are extremely valuable. One of the aims of this course is to enable children to organize facts so that they can be understood and conclusions drawn. When such material is available, the figures should not be interpreted for the children who should be encouraged to make graphs or tables for themselves. Figures could be rounded off for this purpose. The following figures may indicate some of the possibilities :

RAW DATA ON INFECTIOUS DISEASES IN VICTORIA
(with acknowledgements to Department of Health, Victoria)

<i>Year</i>	<i>Diphtheria Cases</i>	<i>Poliomyelitis Cases</i>	<i>Malaria Cases</i>
1931	5,423	277	8
1932	7,322	27	1
1933	6,564	16	9
1934	5,478	183	3
1935	4,309	66	9
1936	5,218	7	5
1937	3,020	1,372	2
1938	1,746	794	2
1939	1,618	42	3
1940	1,369	20	2
1941	2,704	51	4
1942	1,307	23	9
1943	1,333	9	6
1944	1,245	9	195
1945	898	238	621
1946	494	247	3,413
1947	405	124	1,608
1948	364	55	79
1949	401	760	4
1950	326	202	7
1951	190	420	3
1952	246	297	2
1953	201	283	3
1954	107	569	25
1955	170	235	12
1956	103	251	11
1957	74	12	9
1958	35	60	7
1959	14	30	12
1960	5	23	7
1961	2	68	8
1962	27	20	18
1963	180	21	19
1964	71	5	16
1965	28	..	17
1966	20

- Notes :
1. Mass immunization against diphtheria began in 1932 and the campaign against the disease built up during the ensuing years. The outbreak of 1963 is thought to have resulted from complacency. Mothers neglected to get booster injections for their children. The disease is always present and could break out again.
 2. Polio immunization began in 1956.
 3. Malaria is not a real problem in Victoria, but the rise in the number of cases after the war, when soldiers returned from tropical areas may interest children.

If tuberculosis was being discussed, the graph below might prove useful. If the children seem likely to profit by it, the data contained in the graph could be given to them in the form of a table, and they could make their own graphs and discuss the reasons for the two peaks.

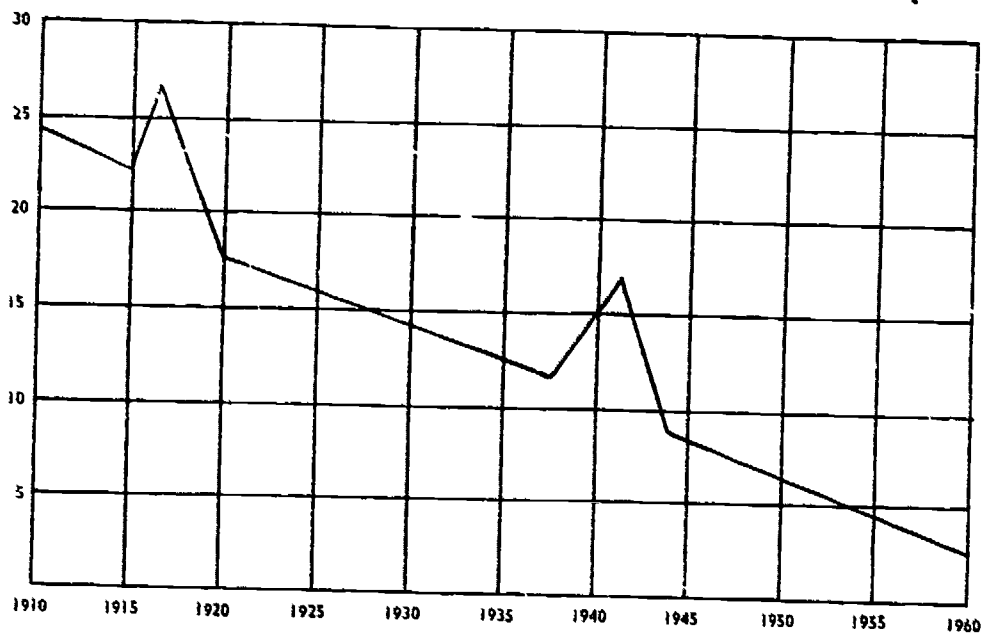

T.B. MORTALITY RATE PER 10,000 INHABITANTS OF FRANCE

—with acknowledgements to *The Human Machine—Disorders*, the Living Universe series, Thos. Nelson, London, 1965.

Reference reading in the library should be encouraged and points, such as those given in the notes above, introduced when the time seems opportune.

It is expected that work of this nature would be carried on partly in mathematics periods. It could form part of a study that would span most subjects in the primary school, especially social studies, mathematics, and English, as well as science. For example, figures on malaria could lead to the making of an Interest Book which treats topics such as :

- Description of the Disease
- Treatment
- Early Thoughts on Causes
- Digging the Panama Canal
- Dr. Walter Reed and Yellow Fever
- Dr. Ronald Ross
- Quinine and the Cinchona Tree
- Malaria Control Today.

MEN AND SCIENCE

Refer to the Curriculum Guide B—*Following On*.

A. C. BROOKS, Government Printer, Melbourne.