

DOCUMENT RESUME

ED 058 678

EC 040 894

AUTHOR Waligura, Randolph L.; And Others
TITLE Environmental Criteria: MR Preschool Day Care Facilities.
INSTITUTION Texas A and M Univ., College Station. School of Architecture.
SPONS AGENCY Rehabilitation Services Administration (DHEW), Washington, D.C.
PUB DATE 71
NOTE 109p.
EDRS PRICE MF-\$0.65 HC-\$6.58
DESCRIPTORS Building Design; *Child Care Centers; *Classroom Environment; Disadvantaged Youth; *Environmental Influences; Environmental Research; *Exceptional Child Services; Facilities; *Mentally Handicapped; Preschool Children

ABSTRACT

Contributions of the physical environment to the learning process and environmental needs of preschool children are evaluated. Guidelines for the planning and design of preschool day care facilities, especially for mentally retarded and other children with developmental disabilities, are established. The current status and trends in day care services are summarized and the background, learning characteristics, and curriculum objectives for retarded, culturally deprived, and normal children are described. Methods and activities used to achieve these objectives, and the implications they have for the supporting physical environment, are identified. Component parts of the physical environment (color, light, acoustics, climate control, interior surfaces, space, flexibility) are discussed individually and in their relationship with each other and various psychological variables. Suggested detailed planning and design requirements for the preschool facility cover the education/training area, ancillary area, administrative area, storage, furniture, and safety. The planning and design process necessary for utilization of these guidelines is illustrated by four hypothetical case studies in which facilities are designed for different day care situations.

(KW)

Environmental Criteria

MR

Preschool Day Care Facilities

ED 058678

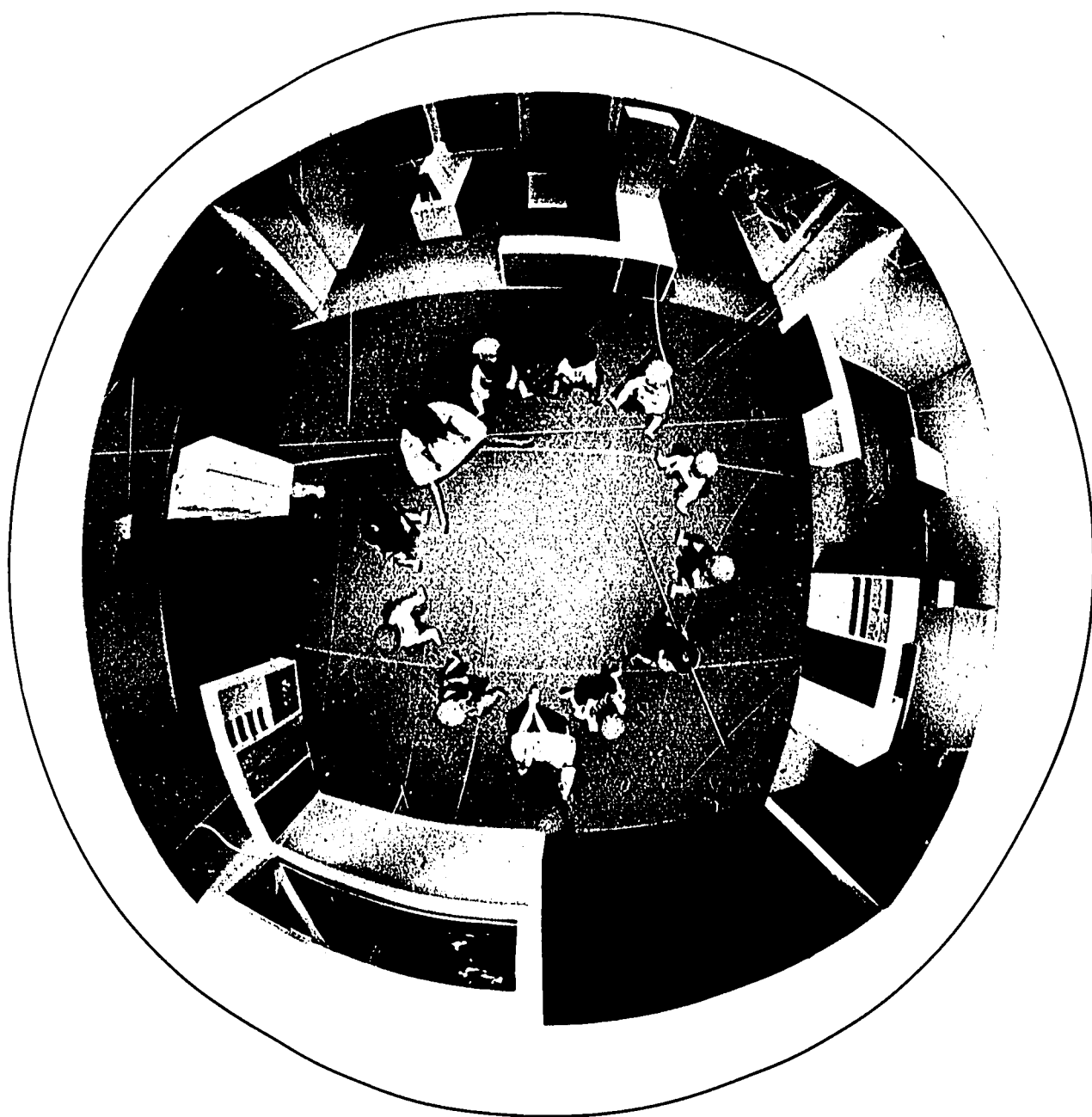

EC 040 894E

ED 058678

**Environmental Criteria:
MR Preschool Day Care Facilities**

conducted by:
Research Center
College of Architecture & Environmental
Design
Texas A&M University
College Station, Texas 77843

sponsored by:
Grant RD-1-MR 07000
Department of Health, Education, & Welfare
Social and Rehabilitation Service
Rehabilitation Services Administration
Division of Mental Retardation
Washington, D.C.

U.S. DEPARTMENT OF HEALTH,
EDUCATION & WELFARE
OFFICE OF EDUCATION
THIS DOCUMENT HAS BEEN REPRO-
DUCED EXACTLY AS RECEIVED FROM
THE PERSON OR ORGANIZATION ORIG-
INATING IT. POINTS OF VIEW OR OPIN-
IONS STATED DO NOT NECESSARILY
REPRESENT OFFICIAL OFFICE OF EDU-
CATION POSITION OR POLICY.

Acknowledgements

As is almost always the case with projects of this scope and duration, the final product is the result of the dedicated efforts of many persons.

Research Team:

Randolph L. Wallgura, principal investigator
Mary Martha Thompson, research associate
Robert Bradley, research assistant
Jim Brinkley, graduate assistant
Pat Caporina, graduate assistant
Jan Edwards, graduate assistant
Terrence Gent, graduate assistant
David Martino, graduate assistant
Charles Toperzer, graduate assistant
Ralph Hilton, undergraduate assistant
Rand Silvermann, undergraduate assistant
Arie Schinnar, undergraduate assistant
Bill Volgt, undergraduate assistant
Mike Wester, undergraduate assistant
Judy Henderson, librarian
Linda Escamilla, secretary
Linda Jamison, secretary
Lucinda Kerley, secretary

Technical and photographic assistance was furnished by Gunter Schmitz, Director of Project Development and by Russell Stogsdill, Research Architect.

Administrative support and encouragement was furnished by James Patterson and George J. Mann, past and present Directors of the Research Center, and by Edward J. Romieniec, Dean of the College of Architecture and Environmental Design.

Advisory Team:

Stuart Fisher, M.P.H., Director
Planning and Programming Development
Department of Mental Health/Mental Retardation
Austin, Texas

Mary Jernigan
Supervisor of Special Education
Bryan Public Schools
Bryan, Texas

Marjory Kirkland
Social Work Consultant, CSB
Department of Health, Education, and Welfare
Social and Rehabilitation Service
Rehabilitation Services Administration
Division of Mental Retardation
Washington, D.C.

Robert B. Kugel, M.D., Dean
College of Medicine
University of Nebraska
Omaha, Nebraska

Darrell J. Mase, PH.D., Dean
J. Hillis Miller Health Center
College of Health Related Professions
University of Florida
Gainesville, Florida

A. Rorke Vanston, Architect
Chief of Architectural & Engineering Unit
Department of Health, Education, & Welfare
Social and Rehabilitation Service
Rehabilitation Services Administration
Division of Mental Retardation
Washington, D.C.

Walter A. Varvel PH.D.
Professor
Department of Psychology
Texas A&M University
College Station, Texas

Raymond W. Vowell
Vice Chancellor for Public Affairs
University of Texas Austin, Texas

Consultants:

John Bartram, M.D.
Mary Martin, Director of Nursing School
St. Christopher's Hospital for Children
Philadelphia, Pennsylvania

Frank Borreca, Executive Director
Harris County Center for the Mentally Retarded
Houston, Texas

Max Christensen, Rector
Mildren Gillaspay, Principal
St. James' Episcopal Church Nursery School
and Kindergarten
San Francisco, California

Edward Curley, Director
Community Facilities Planning
Department of Mental Hygiene
State of New York

Louis Fields, Director
Cooperative School for Handicapped Children
Vienna, Virginia

H. Carl Haywood, Assistant Director
John F. Kennedy Center
George Peabody College for Teachers

Helen Huggins, Director
Aid Retarded Children Preschool Program
San Francisco, California

Marie Hughes, Director
Mary Coxon, Research Associate
Center for Early Childhood Education
University of Arizona

William Kelliett, Jr., Assistant Professor
College of Architecture & Environmental Design
Texas A&M University
College Station, Texas

Walter Kroner, Research Associate
Center for Architecture Research
Rensselaer Polytechnic Institute

Clifford Lockyer, Director
Sue Walpol, Principal
Jim Bohannah, Director of Education
Bridgeport Regional Center
Bridgeport, Connecticut

Gaines Mann, Assistant Director
Demonstration & Research Center for Early Education
George Peabody College for Teachers

Peter Manning, Director
School of Architecture
Nova Scotia Technical College

Jerome Medrick, Medical Director
Rochelle Meyers, Director of Nursery School
Children's Hospital — Child Development Center
San Francisco, California

Hyman Pleasure, M.D.,
Deputy Commissioner for Local Services
Department of Mental Hygiene
State of New York

Sally Provence, M.D., Director
June Patterson, Director of Nursery School
Child Development Unit
Yale University
New Haven, Connecticut

Katherine Reno, Director
School of the Chimes, Inc.
Baltimore, Maryland

Grady Rogers, Director
Richard Webster, Project Architect
Irene Wortham Day Care Center
Ashville, North Carolina

Arnold Rosner, Associate Professor
College of Architecture & Urban Planning
University of Washington
Seattle, Washington

H. David Sokoloff, Architect
Lackey-Sokoloff-Hamilton-Blewett
San Francisco, California

Norma Stone, President
Texas Association for the Education of Young Children
Houston, Texas

Robert Utzinger, Assistant Professor
Architecture Research Laboratory
University of Michigan
Ann Arbor, Michigan

Sylvia Zucker, Executive Director
Sarah B. Hudgins Regional Center
Hampton, Virginia

Special Credits:

Appreciation is extended to the following individuals for allowing us the use of their information, photos, and publications as reference sources for our project.

The Metropolitan Toronto School Board

SEF E1

Education Specifications and User Requirements for Elementary (K-6) Schools

Richard Datner, AIA

Design for Play

Paul Friedberg, ASLA

Ledermann and Trachsel

Creative Playgrounds and Recreation Centers

Special thanks to Don Sweeney and H.C. Cairncross for their fine job of reviewing and editing.

Finally, we must acknowledge our debt to the Department of Health, Education, and Welfare, Rehabilitation Services Administration, Division of Mental Retardation, for their financial assistance, for their encouragement, and for their spirit of objective inquiry. Their willingness to support a project of this scope indicated the high degree of concern felt for early childhood education and training. Special thanks to Dr. Jaslow and his staff, and especially to A. Rorke Vanston, who served as project liaison officer and whose enthusiasm and expert advice and criticism contributed enormously to the success of this project.

Preface

All children exist simultaneously in many "environments." They live in a physical environment, in a socio-economic, in intellectual and emotional environments, to name a few. Each environment contributes to a child's behavior in proportions which vary with the circumstances. Effective early education should provide the diverse experiences conducive to a child's sound growth toward the assumption of a meaningful adult role which best fulfills his potential.

The part played by the physical environment in the learning process is poorly understood and until recently has been virtually ignored. There is steadily growing recognition that the physical environment can not only provide the basic levels of comfort but also the stimulation needed for maximum physical, social, emotional, and intellectual development. The importance of this developmental stimulation can be determined only after its potential contributions are understood and evaluated.

Many authorities in the field — educators, child development specialists, architects — feel that the physical environment plays a significant role in the learning-living cycle. It is difficult to substantiate this feeling because of inadequate measuring and evaluation methods and the newness of the field of environmental science, but serious efforts are being made to study the relationship between man and his environment.

The task, therefore, of studying the environmental needs of preschool children and of developing environmental criteria which would not only enhance the learning experience of young children but also make an effective contribution to the field of environmental studies, was undertaken as a view towards establishing a set of guidelines for persons concerned with the planning and design of day care facilities for preschool children.

Although it was determined that the guidelines were applicable to all preschool facilities, special emphasis is placed on facilities for those mentally retarded children who can effectively benefit from a structured preschool program.

A more comprehensive application would be for children with "developmental disabilities". Developmental disabilities being defined as "a disability attributable to mental retardation, cerebral palsy, epilepsy, or another neurological condition of an individual found to be closely related to mental retardation or to require treatment similar to that required for mentally retarded individuals, which disability originates before such individual

attains age eighteen, which has continued or can be expected to continue indefinitely, and which constitutes a substantial handicap to such individual".

Information throughout this publication, whenever categorized as being for the mentally retarded, should be thought of as pertaining to children with developmental disabilities as previously defined.

In developing these guidelines we have accepted certain premises. The views expressed herein contain the thoughts, theories, and results of practical applications of many people, properly documented, of course. Hopefully, however, the synthesis has resulted in the promulgation of new ideas which are attributable to and the responsibility of the research team.

- The physical facility is thought of as a catalytic agent in the learning process. It provides basic human comfort, necessary equipment and furniture, supplies, and creates an optimum setting for physical, social, and emotional development.
- The physical facility can also suggest and stimulate behavior.
- A certain small percentage of learning and behavior modifications may be attributed to the effects of the physical environment.
- A larger percentage can be attributed to the nature of the activity that is being performed.
- Although individual children perceive their environment differently, generalizations have been made concerning the physical and psychological responses to environmental stimulation that are widely accepted.
- The ability, enthusiasm, and creativeness of the preschool teacher will largely determine the success of the educational program.
- The enthusiasm and creativeness of the teaching staff can be greatly influenced by the physical environment.

This report has been developed in six parts.

Part 1 discusses the current status and trends in day care services.

Part 2 provides general orientation to early childhood development and preschool program objective followed by a more detailed discussion of the background and learning characteristics of retarded, culturally deprived, and "normal" children. Curriculum objectives for each of these groups are presented separately and their similarities noted.

Part 3 combines the educational objectives of programs for mentally retarded, culturally deprived and normal children in a discussion of the methods and activities used to achieve these objectives, and the implications they have for the supporting physical environment.

Part 4 emphasizes the role that the component parts of the physical environment play in providing direction, suggestions, stimulations and basic comfort necessary for optimum learning experiences. These component parts are discussed individually and in their relationship with each other and various psychological variables.

Part 5 suggests detailed planning and design requirements for the preschool facility. Specific spaces are presented in terms of environmental components, relationships, furnishings and the role they have on specific educational activities.

Storage requirements for each space in the preschool facility are discussed and specific information is presented for effective utilization.

Equipment/furniture is carefully analyzed with projections being made for future development.

Guidelines are summarized into charts and matrices for actual usage by practicing educators and architects.

Part 6 illustrates the planning and design process essential for effective utilization of the above derived guidelines. The process is presented in the form of four hypothetical case studies in which facilities are designed to fit four different day care conditions. Specific solutions are illustrated by architectural designers as their individual interpretation of the guidelines.

This report is intended to be a working document for educators, administrators, architects, and designers who are developing preschool day care facilities for mentally retarded, culturally deprived, and normal children. It provides planning and design guidelines for the creation of a physical environment which will effectively implement the preschool program. Only through its usage and continuous feedback of information will effective evaluation and continuous updating and revisions be possible. This realistic experimentation will provide substantial and meaningful refinements toward enhancing our present "state-of-the-arts".

Table of Contents

Introduction Need Purpose	6
1 Day Care Services Current Status Component Parts Educational Trends	8
2 Day Care Programs Mentally Retarded Children Culturally Deprived Children Normal Children	12
3 Program Implications Orientation Educational Trends Curriculum Influence	20
4 Environmental Implications Definition of Environment Color Light Acoustics Climate Control Interior Surfaces Space Flexibility Psychological Variables Summary	26
5 The Day Care Facility Basic Planning Considerations Education/Training Area Ancillary Area Administrative Area Storage Furniture Safety Relationship Matrices	40
6 Case Studies Design Process Design Applications	84
Observations/Recommendations	104

Introduction



Need

This country has lagged far behind Russia and Western European countries in providing day care facilities for children and until recently has steadfastly refused to confront its obligations in this area. When day care turned out to be a focal point of Federal programs designed to provide training and jobs for the underemployed and the unemployed, the attention of many was directed to a fact which has been known to working mothers for years — there are not enough day care facilities. Attention was also directed to the fact that the services which were available fell short of making the vital contribution to the growth of children that current learning theory indicated was possible. Advantage was not being taken of those years during which the child was most malleable and opportunities were being lost to provide children with the stimulating and growth fulfilling experiences so vital for normal development. Children living in low income and welfare families were bearing the brunt of this neglect.

Gradually it has become apparent that day care services offer an unparalleled opportunity to do two humane and profitable things at one time: (1) release many women from child care responsibilities so that they can work, improve their standards of living, and, in many cases, go off "relief"; and (2) at the same time provide their children with better care and greater opportunities for growth than they could receive in their homes.

With an understanding of the value of educational day care and an acceptance of responsibility to provide such services, the Federal Government has provided financial incentive for the organization of day care centers and created standards for their operation. In addition, the business community has realized that day care for preschool children is both public spirited and profitable. Likewise, many industrial firms now recognize day care as a fringe benefit for workers from which the company too receives benefits such as an expanded labor pool, reduced absenteeism and fewer family related anxieties.

Children from culturally deprived backgrounds and children of working mothers are not the only ones benefiting from stimulating day care. It has become an acknowledged educational force for handicapped children — the mentally retarded, the deaf and hard of hearing and the visually and orthopedically handicapped — and its potential for guiding children toward creative growth is being used to advantage by an increasing number of parents who are enrolling their children in preschool and

Purpose

nursery school programs. Lillian Katz notes that "In the five years since Head Start began, the enrollment of children in preschool classes has just about doubled. In 1969 nearly a million children were enrolled in pre-primary classes. This figure includes enrollment in Head Start projects, day care centers, private and cooperative nursery schools, laboratory schools, and public and parochial preschool programs including kindergartens." (13:42)

There seems to be little doubt that large sums of private and public money will be spent in the coordination and renovation of various kinds of day care facilities and in the maintenance and evaluation of day care programs. It is important that this money be spent wisely in order to develop day care facilities which increase the impact of the educational program and which respond to changing program needs. Buildings should stimulate teacher creativity, help the teacher-child relationship to become more meaningful and broaden the child's opportunity to make significant and lasting contacts with the world around him. This is especially true for children with developmental disabilities.

Little information is available to provide guidelines for the construction of day care centers for either full day care or preschool programs. While some highly specialized facilities will be constructed, such as those connected with medical and graduate schools, the majority of day care centers will be service oriented. Most will represent the good faith efforts of communities to provide services responsive to the needs of their citizens. However, the sponsors may have little information about how such facilities should be planned, and the architects may have limited knowledge of the programs which will take place in the building they are hired to plan. They may be equally lacking in knowledge concerning the behavior and development of young children.

It was the purpose of this project to prepare guidelines for those who build or renovate day care centers. The project as originally conceived was limited to day care facilities for the retarded, particularly the mild and moderate retarded preschoolers, mainly because they represent the largest group of the retarded population that can effectively benefit from structured group learning processes. The scope was later enlarged to include facilities for preschool culturally deprived children from whose ranks come a disproportionately large number of the retarded. As the project progressed, the conviction grew that the guidelines would be useful to anyone considering the construction of any kind of day care facility for preschool children, normal or handicapped. **The similar physical, social, emotional and intellectual characteristics which children share as children are greater than their individual differences.** Their educational needs are the same, although the means by which they are realized vary as do their expectations concerning the extent of their ultimate development.

This report presents the results of an investigation into the requirements for a physical setting which would complement the program objectives of day care facilities for children from two through seven years of age.

The research reported herein was performed pursuant to a grant with Rehabilitation Services Administration, U.S. Department of Health, Education and Welfare. Contractors undertaking such projects under government sponsorship are encouraged to express freely their professional judgment in the conduct of the project. Points of view or opinion stated do not therefore necessarily represent official Rehabilitation Services Administration position or policy.

The project has utilized an interdisciplinary team of psychologists, nurses, planners, educators, and architects.

Day Care Services

1

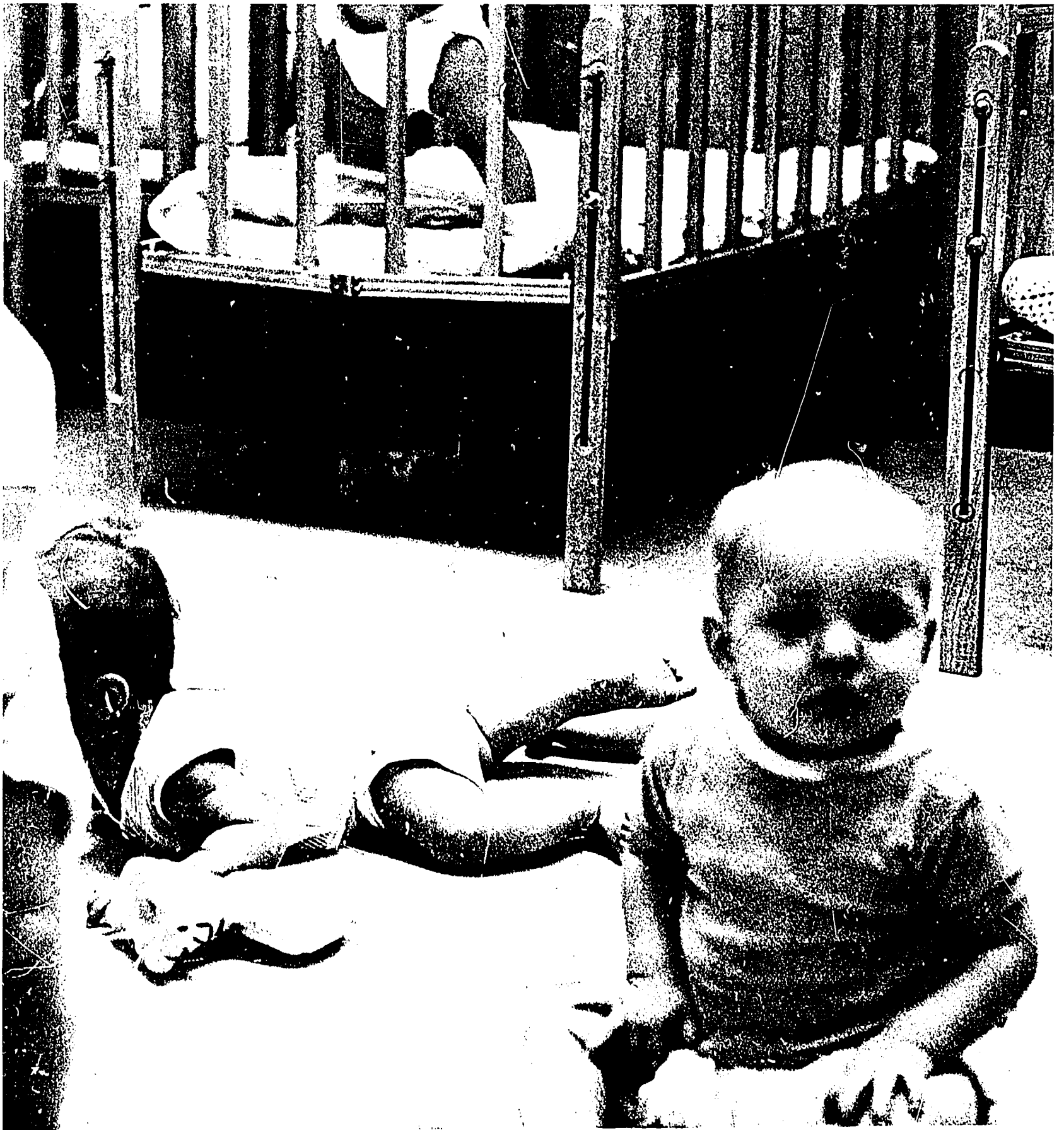

Current Status

A day care center is defined as any facility for the care of children for less than 24 hours a day. Preschools, nursery schools, day nurseries, centers offering full day care for the preschool children of working mothers, and homes offering similar care are all considered day care facilities.

While this project was primarily concerned with facilities for preschool retarded and culturally deprived children, the results have relevance for all day care facilities for young children between the ages of 2 to 7 years of age. "Regardless of why a child comes to the center, or the number of hours he is there, his needs are the same. Children, because they are children, must be served in a group by the same professional insight and skills and by the same basic facilities and curricular process." (28:4)

Nursery schools offering group experiences for children under five years of age were established in this country after World War I, but it was not until World War II, when women became a vital part of the labor force, that day care centers for the children of working mothers received governmental support. When the war was over, the federally sponsored programs disappeared, although many women continued to work, providing for the care of their children as best they could. The number of working women increased steadily to over nine million by 1964. Of these, three and a half million had children under six years of age and two million had children under three years of age. (6:5) Recently, the **Wall Street Journal** reported that, in 1969, there were 4.2 million working mothers with preschool children. It was also estimated that the proportion of working mothers, who have children living at home will rise from 60% to 70% during the 1970's compared with 42% in 1960 and only 10% in 1940. (2) What proportion of these mothers have one or more children with a developmental disability is not known.

In Russia and many European countries, day care has long been recognized as important and has been provided for by the government. Only with the advent of the "poverty program," however, did the United States begin to recognize the importance of day care as a resource for the welfare of young children, even though it had been demonstrated earlier through the rapid growth in the '50's of preschool programs for handicapped children, particularly retarded children.

Day care for children is necessary if mothers must work, and work is highly desirable for

mothers in many families receiving welfare. Both of these facts have been recognized in a legislative proposal, The Family Assistance Act, for a new federally supported day care program which was sent to Congress in October, 1969, by H. E. W. Secretary Robert Finch. The Family Assistance Act, which would replace Aid to Families of Dependent Children, includes a work-training provision which is mandatory for all welfare recipients except those with preschool age children, for whom work-training is voluntary. Under the Act, the Federal Government would be obligated to provide comprehensive day care services for all families participating in the plan. Secretary Finch asked Congress for \$386 million to cover the cost of providing day care for approximately 450,000 children in the first year of the program. The cost would be approximately \$1600 a year for a preschool child and \$400 a year for a school age child. He stated that, "Beyond the value of day care to the working parent, there are enormous benefits which accrue to the child enrolled in a comprehensive child development program. We know that the child of poverty needs far more than custodial care if developmental deficits are to be overcome." (23:2) The Act was later amended to provide money for the construction of day care facilities. While it seems unlikely that this proposal will pass in 1970, the fact that it was even proposed seems predictive of things to come.

While the federal government sponsors programs to improve the employment potential of low income and welfare families by providing training and jobs for women as well as men, another important group is surging into the labor market — the middle class mother. Rudeman points out that, "In recent years the largest group of maternal employment has occurred in middle class families. One of the strongest correlations in this field is between employment and education: the more education the mother has the more likely she is to work" (6:21) Educated women have long supported preschool experience for their children. As they join the labor force, many prefer day care services to home care. They also demand high quality care for their children. In addition, an increasing number of parents have felt that preschool experience can make a valuable contribution to the development of their children even when the mother is at home, and consequently, such parents have enrolled their children in private nursery schools. These preschool

programs for children from middle class families served as models for many of the early programs for handicapped children and for the Head Start programs.

As a result of such developments, prejudice against day care for even very young children is giving way. Also disappearing is the notion that if a child is in a day care center there is something abnormal about the family situation. Federal funds have become available and pilot and experimental projects in infant group care are being undertaken. Bettye Caldwell and Julius Richmond at Syracuse University were among the first to demonstrate that infants could develop satisfactorily under proper day care conditions.

Since few communities have allocated public funds to provide adequate day care facilities, private resources for child care have mushroomed. The Children's Bureau reported that licensed day care facilities in the fifty states, Puerto Rico, the Virgin Islands and the District of Columbia increased from 23,707 in March, 1965 to 38,400 in March, 1968. The number of children being cared for in these facilities increased during that period from 310,000 to 531,000. It estimated that 90% of all children in day care are in such private homes and centers. How many are being cared for in their own homes by maids, relatives and siblings, or in unlicensed centers is not known. A study done by the Census Bureau for the Children's Bureau indicated that 400,000 children under the age of twelve were looking after themselves while their mothers worked. (6:6)

An interesting and promising development in expanding and improving the day care services offered by communities is now in its initial phase. The federally sponsored 4-C program — Community Coordinated Child Care is an outgrowth of the Federal Panel on Early Childhood. As the 4-C Manual states its objective: "The 4-C idea is deceptively simple. In any community there is a spectrum of agencies and of child care services, which, when put together, form a whole, meant to meet the child care needs of the members of that community. If one put all of the available services together in any community one would probably find huge gaps, some duplication and harmful competition for scarce resources in the child care service spectrum. It is the GOAL of 4-C to meet and work to eliminate these problems through community wide planning and provision of child care services." The Office of Economic Opportunity is under contract with the Day Care and Child Development Council of

Component Parts

America, to provide technical assistance to communities interested in exploring this concept of coordination.

Also, private industry has begun to provide day care services as a fringe benefit to employees with industry realizing benefits at the same time. Industrial concerns considering day care centers now realize such services tend to increase job applications from qualified women and cut down on absenteeism. In March 1970, a Conference on Industry and Day Care was held in Chicago. People actively involved in day care programs discussed costs, funding, program goals and evaluation, community relations, franchising, licensing, and pending Federal legislation with representatives of industry and franchising companies. Representatives of fifty companies attended the conference, which was sponsored by the Urban Research Corporation.

A comprehensive day care program involves cooperation between and among parents and three professional groups: health workers, educators and social workers. The proportional contribution of the three groups depends on the nature of the service being offered and the local population. A program for under-privileged children, for example, may need full emphasis in all three areas, while a nursery school for the retarded children of middle class parents may require only training for the children and casework for the parents. A preschool for normal children may provide only educational experiences.

In planning a day care program, major consideration should be given to the basic services which the facility will provide, e.g., full or part day care, health, community and social services, the nature of the population served, etc. Attention should also be given to the ease with which the program can tolerate change particularly during a time when the goals and methods of education are being scrutinized and challenged and changed. Knowledge of the direction of such changes can be helpful in planning a facility which is flexible enough to accept change gracefully and to encourage innovation as well. With this in mind, the following section discusses educational trends now influencing day care services.

Educational Trends

Demand

Appropriate early stimulation improves the quality of the developmental process in young children, and this effect has focused attention on the vital role which preschool education plays in human growth. This, coupled with the need for care for the children of working mothers, has led to an increasing demand for educational day care facilities. This demand is being met by both governmental and privately sponsored facilities.

Early Involvement

Day care planning is tending to include children at an increasingly early age. Many communities, for example, are exploring the possibility of developing programs for two and three year olds, and especially for the handicapped two and three year olds, because of the hope that early stimulation and training can prevent the development of functional retardation in culturally deprived children and help the retarded child function up to his potential.

There is at present a re-evaluation by professional people of the potential of day care centers for infants, e.g. the work of Caldwell & Richmond. (4) While there have always been infants in day care centers and day care homes, professional people have tended to disapprove and have maintained that infants should remain in their own homes. The re-evaluation of the possibilities of day care for infants should lead to wider acceptance and the development of standards for optimal infant care. At present the Children's Bureau is sponsoring five studies which are seeking the most effective ways of using mother substitutes, comparing development in children experiencing different care situations, and exploring the possibility of training women from disadvantaged backgrounds as non-professional assistants. (22:7)

New Teaching Approaches

Many approaches are being tried in an effort to produce more effective teaching methods to apply to realistic and relevant subject matter. For example, the approaches of Montessori and others while not new are being re-evaluated in light of new learning theories. Other approaches, such as the "talking typewriter" of O. K. Moore and the "pressure cooker" of Bereliter and Engelmann, are new and controversial. Maya Pines in

her book, **Revolution in Learning — The Years from Birth to Six**, presents a useful discussion of these various approaches and others as well. (14)

The work of four men — Bruner at Yale, Hunt at Illinois, Bloom at Chicago, and Piaget in Geneva — has provided new psychological insights into the learning process. These insights, with their emphasis on relevancy, the sequential nature of learning, critical periods in growth, and the surprising capacity of children for learning are producing modifications in school curricula.

New Methods Of Delivering Services

Concurrent with the search for improved curricula is the search for new methods of delivering services. Methods of delivery are being tailored to the recipient just as with the program. In some cases, the child comes to the program and in other cases the program is brought to the child, either directly or indirectly through the training of his mother in educational skills and child care practices. Ira Gordon in Florida and Earl Schaffer in Washington, D.C. are among the pioneers in the attempt to establish a more effective home learning environment. People from different professional backgrounds provide a variety of services. The visiting nurse and home economist, for example, have been particularly welcome in many low income families who looked with suspicion on other "do good" approaches.

Since the business community has become sensitive to the advantages of having day care services available for the children of their employees, day care programs are being set up in areas adjacent to industrial plants and in office and hospital complexes. (7:110) Mobile units are being used in some states to provide outlying areas with educational and diagnostic services for young children as well as for other age groups.

Redefined Teacher's Role

The shortage of special education teachers has forced the public schools into a re-examination of the role of the teacher in the classroom. It is especially important therefore that the energy of the gifted teacher be channeled into teaching and not drained off into a variety of activities which could be done as well by another with less training. School systems are experimenting with master

teachers, team teaching, and the use of teacher aides. More specialty teachers are being employed.

Non-Professional Assistant

The non-professional worker is increasingly being accorded a position in the educational hierarchy. This is no new concept to day care, where the teacher-helper or assistant has long been utilized. Such staff personnel often assist in the instruction of the children under the supervision of the teacher, and in addition, carry out routine duties such as seeing that the children get to the bathroom. The use of non-professional personnel in day care centers has been accelerated by the establishment of programs designed to train unskilled adults for better employment. Examples are the New Careers program of the Department of Labor as well as the University of Florida program mentioned earlier. Both programs emphasize the development of non-professionals as parent educators and effective participants in the classroom teaching process.

Audio-Visual Technology

Appearing on the market are an increasing number of audio-visual aids and teaching devices which many educators believe will revolutionize teaching methods. Young children respond well to films, filmstrips, tape recorders, and phonograph records. Television programmers are becoming interested in producing material which is both relevant and instructive for the intended viewers. **Sesame Street**, which focuses on widening the life experiences of the disadvantaged child, is an excellent beginning in this direction. Also, closed circuit television and videotape are proving useful in university teacher-training programs and in demonstration and experimental schools.

Comprehensive Services

The trend toward more comprehensive services is conspicuous in day care programs involving children from low income welfare families. Such children require the full spectrum of health and social work services, since they, more than other children, are likely to have mental, physical, and sensory defects which need care. The Head Start programs have required that these services be available as a condition precedent to sponsorship.

Parental/Community Involvement

Most of the federally sponsored day care programs are for the children of poverty. These programs require that parents be involved in all phases of planning, and those which have succeeded have been those to which the parents have been most committed. Parent understanding and support of school programs — and hopefully reinforcement at home — give the programs meaning and validity to the children. At the same time, involvement in the school can be an educational force in the life of the parents.

Increased community involvement is apparent from the number of people of all ages and social backgrounds who are working as volunteers. Service groups have fund raising projects. Many individuals are feeling an increased responsibility for the welfare of others and actively trying to improve the status quo.

Day Care Programs

2

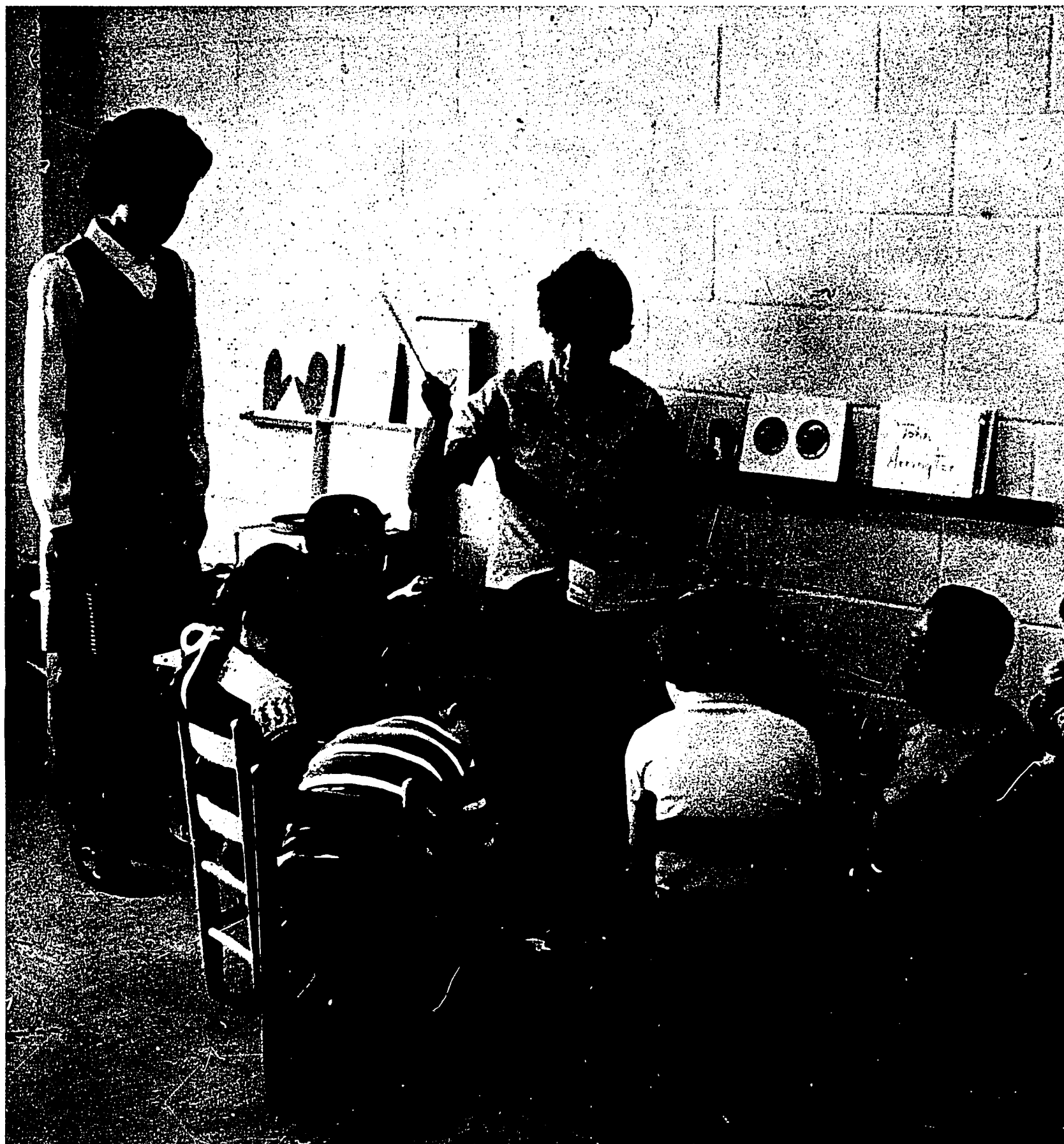

Mentally Retarded Children

General Information

The definition of mental retardation which currently has the widest acceptance is that of the American Association of Mental Deficiency: "Mental retardation refers to sub-average general intellectual functioning which originates during the developmental period and is associated with impairment of adaptive behavior." (65:3) This definition is flexible, yet definitive, and stresses that intelligence test scores must be evaluated in conjunction with other information related to adaptive behavior. Its developmental approach allows a comparison between specific behavior patterns of individuals and standards appropriate for contemporaries. Since it is a functional definition it avoids the problem of etiology. It challenges the previously held criterion of the permanence of the condition: "Mental retardation is a term descriptive of the current status of the individual with respect of intellectual functioning and adaptive behavior." (65:4)

The AAMD classification describes five levels or degrees of mental retardation:

- Level V Borderline retardation
I.Q. between 84 and 68 on the Stanford-Binet
- Level IV Mild retardation
I.Q. between 67 and 52
- Level III Moderate retardation
I.Q. between 51 and 36
- Level II Severe retardation
I.Q. between 35 and 20
- Level I Profound retardation
I.Q. below 20

In the application of this classification, persons falling in Level V are not designated members of the retarded population. This position has been taken because to include this group would greatly increase the number of persons stigmatized as mentally retarded and serve no compensating useful function. The 3% of the population generally referred to as mentally retarded are those whose I.Q.'s fall below 70.

There are estimated to be about 5,500,000 retarded individuals in the United States. This figure is based on an incidence of 3% in an estimated population of 185,000,000. A HEW report points out that this "Figure has never been reached in any study where rigorous criteria of mental retardation were employed." (66:14) The report further states that the retarded population, "... is sufficiently greater than the approximate one percent now known to all agencies to suggest that it is greater

than 3% among the lower socio-economic class. It may be less than 1% in high socio-economic areas."

It is difficult to identify mildly retarded children before school age when they are placed in competition with their peers. Children who are identified as retarded before this time are usually those who are moderately or severely retarded. There is an increase in incidence of those diagnosed as retarded over the school years with a spurt of reported cases at adolescence. Once the period of school attendance is over many of the mildly retarded are assimilated into society, living for the most part in the lower socio-economic group.

For purposes of assignment to special school classes, retarded children are classified as educable (mildly retarded) or trainable (moderately retarded).

About 85% of the mentally retarded are educable and they make up 2% to 2½% of the school age population. These children have a rate of intellectual development of approximately one-half to three-fourths that expected of an average child and an I.Q. of approximately 50 to 70 or 75. They can be expected to achieve a fourth or fifth grade level in academic subjects, they have adequate communication and social skills for ordinary situations, and most can develop occupational skills (unskilled and semi-skilled work) which will provide a measure of economic independence in adulthood. This group contains many culturally deprived persons toward whom early childhood programs to prevent mental retardation are directed.

Estimates vary widely, but the figure four in a thousand of the school age population (.4%) approximates the proportion of children classified as trainable mentally retarded. Kirk proposes that a community program for the trainable plan for one child in a thousand school children initially, and increase the scope of the program to two per thousand as it becomes established. (62:126)

Trainable mentally retarded children show a rate of intellectual development which is approximately one-fourth to one-half that of the average child. Their I.Q. will be between 25 or 30 and 50. Many of these children have physically identifying characteristics such as mongolism or microcephaly. Motor development is usually poor. They have limited speech and language ability, but can make their wants known. The academic skills they are capable of acquiring are insufficient to be useful except for the recognition of some words and phrases.



They can learn the basic self-care routines, some homemaking skills, and routine tasks if they are properly trained. Some can work in a sheltered workshop environment.

Severely and profoundly retarded children are generally not considered the responsibility of public school systems. However, there is an increasing demand for day care facilities for such children as well as for severely retarded adults. Probably many could reside in their communities if day care programs were available.

Although this report concerns itself mainly with programs and facilities for the mild and moderate retarded preschool child, it is recognized that day care facilities for the severe and profoundly retarded will be needed in the future. These children, because of the greater number of associated handicapping conditions, both physical and behavioral, would warrant special considerations in the development of programs, staffing patterns, and facility design criteria.

It is possible to assign a specific cause in only 15% to 20% of the cases of mental retardation. The majority of the remaining 80% to 85% are mildly retarded persons who show no gross brain abnormality. These individuals are concentrated in high population density areas. To what extent their retardation is due to environmental deprivation is not precisely known.

The HEW pamphlet, **An Introduction to Mental Retardation: Problems, Plan and Program**, provides a useful classification of the causes of mental retardation. (78) (For a more technical and detailed classification see the AJMD "Manual on Terminology and Classification in Mental Retardation.") The HEW pamphlet divides mental retardation into three broad categories according to etiology:

1. Mental retardation due to uncertain cause with impaired learning ability the one manifestation. By and large, these persons are mildly retarded and most of them are the children of the more disadvantaged classes of society.
2. Mental retardation associated with a number of specifically identified conditions or diseases. The conditions or diseases may be due to infection, to poisoning from a variety of sources, to the results of a wound or surgery, to disorders or metabolism, growth or nutrition, to conditions due to new growths and to unknown prenatal influences.
3. Mental retardation associated with conditions due to uncertain or unknown cause with obvious physical manifestations. The more severely and profoundly retarded usually have physical or sensory handicaps.



Family Characteristics

The child who is identified as retarded during his preschool years is usually moderately to severely retarded. Even at a very early age, his slow and deviant development distinguishes him from other children.

Immature and deviant behavior can serve as a constant reminder to the parents of the child's abnormality and as a reproach to them for their own real and imagined inadequacies. These stresses can be reduced if counseling is available to parents and if the community, by providing day care facilities, assumes some responsibility for guiding the development of the retarded. The support and relief provided by these services can make it possible for many retarded children to remain in their own homes and can help strengthen family ties weakened by the stress of daily living.

The retarded child has the same growth fulfilling needs as all children. Not only does he have the same needs, he shows the same behavior reactions and employs the same defense mechanisms. The retarded child's personality may fail to develop normally through a combination of circumstances involving his perceptual and intellectual deficits and because of the reactions of those

who care for him to these deficits. Controls do not develop in the usual time and serious management problems arise because the child pushes for immediate gratification of his wishes. The adjustment problems faced by the retarded child in infancy and early childhood and the way their resolution molds his personality are discussed with insight by Hutt and Gibby. (68)

Infancy and early childhood are periods of biological dependency for all children, but they are periods of particular significance for retarded children. Because such children develop so slowly, unwelcome behavior has a longer time to become established, and consequently requires a longer period for eradication. An example is the 'negative period' which is commonly encountered with normal children at about two years of age but which appears later and customarily lasts longer in retarded children. Another such example is the child's tendency to repeat the speech or imitate the gestures of adults. There are additional difficulties in establishing feeding and toilet routines, and these difficulties may be compounded by the parents' understandable frustrations with the situation.

According to Hutt and Gibby, "It may be stated categorically that all parents of mentally retarded children are likely to show some

undesirable personality reactions to the fact that their child is retarded." (68:292) Most parents go through a series of stages in their attempt to face the knowledge that their child is mentally retarded. Their initial reaction may be one of shocked disbelief, which serves as a basic kind of self-protection. This initial disbelief may be of short duration and the parents may then move toward realistic planning, even though their emotional acceptance may lag behind their intellectual understanding. With some parents the disbelief hardens into denial.

It is a rare parent who will confess that he rejects his retarded child. Such feelings are unworthy and are pushed as far out of consciousness as possible. The parent may unconsciously look for methods of treating the child which will allow him to repudiate the idea of rejection. One method which is employed often, especially in middle class families, is that of overprotecting the child, of doing things for the child that he needs to be taught to do for himself. The defenses the parent employs in dealing with his feelings about his retarded child will be those which have evolved into his life adjustment pattern. As individual tensions increase, relations between the parents may grow more strained and the whole family structure become increasingly unstable.

Adjustment is improved if parents are aware of the nature of their emotional relationship with their retarded child. Their needs are threatened and they are justified in feeling that they also matter. With counseling, it may be possible to work out means by which neither the parent nor the retarded child will suffer unnecessarily.

The assistance required by parents generally falls into two categories: educational and psychotherapeutic. The educational process involves relaying information concerning growth patterns, training periods, discipline procedures, problems faced by the other children in the family, and community resources. Parent workshops can provide this information and also give parents the opportunity to share common problems and help one another toward solutions. The psychotherapeutic process involves emotional rather than intellectual learning and can be carried on in both individual and group sessions.

Learning Characteristics

Retarded children differ most from normal children in those variables which are most involved in complex intellectual processes. "One of the most fundamental ways in which retarded children differ from normal children of the same age is the slowness and inefficiency with which they acquire knowledge and skills. Intelligence is, in fact, defined by some writers as the ability to learn." (75:317) Generally, they are least retarded in physical development. The extent of social and emotional development will be a product of the child's mental and physical development as well as his life experiences. There is a higher incidence of emotional disturbance among mentally retarded children than among normal children. (72)

In spite of the emphasis on the importance of early counseling with the parents of retarded children and early training and stimulation for the children themselves, little has been written on the learning characteristics of the preschool retarded child. He is assumed to have those

characteristics which are associated with his general developmental level but in actual practice this is not quite true. Very early, the retarded child will indicate on intelligence tests his failure to develop a basis for conceptual thinking. The test items on which he will do best are concrete and practical, while nonretarded children will do equally well or better on those items which involve some abstract thinking. (52:488-494) This is particularly obvious in the mongoloid child but is apparent probably in all trainable children. (80:148)

In addition to deficient conceptual and abstracting abilities, mentally retarded children also manifest poor recall and distractibility. Over-learning of a task is of significant value in retention.

More has been written on the learning characteristics of the school age child. Christine P. Ingram, for example, presents an excellent summary of various age levels of the educable mentally retarded child in **Education of the Slow Learning Child**. (69) Other information sources are suggested in the bibliography.

Educational Objectives

Hopefully the time will come when most mental retardation will be preventable. In the meantime, programs are being designed to improve the opportunities of the retarded through suitable education and training. These educational programs are also "preventive" in that they serve to check the increase in the degree of retardation that is, a cumulative mental deficit, by stimulating the child to use the abilities he possesses. This cumulative deficit can occur in both the organically retarded child and the culturally deprived child.

The broad goal of the educational process for the mentally retarded is identical with that for all children: the preparation of the individual for a productive life — productive in satisfaction for himself and in contributions to society. While all individuals cannot produce equally, almost all can make some contribution.

More specific long range goals depend on the individual, on the degree of his retardation and on his ability to utilize whatever resources he may have. For a preschool child showing signs of retardation due to environmental deprivation, the educational and occupational goals would be similar to those for the majority of children. For a moderately retarded preschool mongoloid child, the goal would be the partial independence of a sheltered workshop and a halfway house.



Unlike educators of the culturally deprived, educators of the retarded are in general agreement concerning priorities among different learning objectives. There is essential agreement on a developmental approach to the "whole" child, which means devising a curriculum which offers the retarded child the opportunity to develop both the physical and mental skills his maturational level has equipped him to handle. The educational goals listed below are presented by educators of retarded children and are fundamentally the same as those for culturally deprived and normal children, although the mentally retarded child is at a more immature level of development and requires goal-directed methods appropriate to his lower level:

1. The guidance of the child in the management of his attention as a prelude to the establishment of orderly purposeful behavior.
2. The development of accurate sensory recognition and discrimination to provide the foundation for concept development.
3. The improvement of fine and gross motor coordination.
4. The establishment of a good relationship with peers and adults.
5. The acquisition of a positive self-image and a desire to learn.
6. The stimulation of speech and language development.



While broad educational goals may be the same for all children, the expectations of the teacher concerning the performance of the retarded child differ from those for deprived and normal children. The teacher knows that her methods must match the retarded child's requirements, that it will take a much longer time for him to learn certain skills, and that he may never achieve them to the fullest degree. She accommodates her teaching methods to his need for much repetition and for the varied concrete methods of presentation necessary to the establishment of concepts. She realizes his need for direct guidance and a structured program. She makes allowances for his short span of attention and his distractibility at the same time seeking methods to overcome them.

Early training for the retarded is directed toward the establishment of those fundamental perceptions, attitudes and skills upon which later learning is built. The preschool curriculum does not represent a dilution of the school program, but rather a direct and concentrated approach to reinforcing the emerging maturational skills.

Educational objectives for preschool mentally retarded and culturally deprived children will be discussed further in Part 2. The program objectives and the methods and materials used to achieve these objectives have major implications for facility planning.

Culturally Deprived Children

General Information

Only in recent years has attention turned to educational programs for handicapped children, the first group to receive such attention being the mentally retarded. The largest group consists of socially disadvantaged or culturally deprived children.

There is no hard and fast causal relationship between socio-economic status and social disadvantage for the child, as Havighurst points out. (50) While there is a statistical relationship between socio-economic status and school achievement, there are so many individual exceptions that socio-economic status cannot be considered the decisive criterion. Havighurst also points out that of the total child population, the approximate 65% whose parents belong to the working class are no more likely to be culturally deprived than the children of "white collar" parents.

Nevertheless, the overwhelming majority of children demonstrating certain types of school problems do come from poverty-stricken families. Havighurst concludes that the deprived, who he estimates represent about 15% of the United States population and 20% of the child population, come from groups which have the following characteristics in common:

1. Lowest income level in America;
2. Rural background;
3. Discriminated against socially and economically;
4. Most visible in the big cities, although present in all except high income communities; many in rural areas. (50:26-27)

So defined, the deprived are about evenly divided between whites and non-whites. However, more than 90% of the programs for disadvantaged young people service groups that consist primarily of blacks. (44:100)

The federal government has acted by providing programs to meet the special needs of low income families. In 1966, for example, money was allocated under Title I, Elementary and Secondary School Act, Education of Children of Low Income Families. Before the passage of this Act, the Office of Economic Opportunity had made grants to programs for preschool children in the Head Start programs. Head Start anticipated an enrollment of 259,000 children in the 1970 fiscal year, an increase of 46,500 over 1969. The program was budgeted to receive \$338,000,000. (21:3)

Family Characteristics

The "deprived" groups in our country have been segregated by racial discrimination and other socio-economic conditions into self-perpetuating sub-cultures which are self-defeating in terms of equipping individuals to enter the main stream of American life. Fatigue, defeat and depression produced by poor nutrition, ill health, discrimination and little or no education, are endemic in these sub-cultures, and the associated isolation, deprivation and sense of futility are passed along to the children.

Conditions under which these families live vary according to racial and geographical background, but they have in common a continuing struggle to survive. Puerto Rican and Mexican American families usually have both a father and a mother present, but in a high proportion of the black families only a mother is present. Generally, the families are large (60% of the Head Start families were reported to contain six or more people). Approximately one quarter of the Head Start families received AFDC and many existed solely on this meager income.

The mother, especially the black mother, may work, but her pay is so poor and her child care arrangements so inadequate that the overall situation may well be made worse rather than better by her attempt to supplement the family income. Her children are either left without adequate supervision or are under the care of a sibling who is kept out of school. In addition, the mother may be physically and emotionally unable to handle the dual role of breadwinner and mother. As products of a deprived environment themselves, such parents may not have the emotional reservoir from which to supply their children with the warmth and attention they need. Whitney Young describes them as "emotionally unavailable" to their children. (51:25)

Many of the women have borne large numbers of children without adequate medical care. Diets are inadequate. Housing is poor. Plumbing is substandard or nonexistent. Crowding produces not only lack of privacy, but a confusing over-stimulation which may in turn prevent the development of the ordered approach to the environment which middle class families provide for their children and which seems to be important for school success. Speech is simple, demanding and direct. It is not used to describe or explain and the children are not exposed to language which gives them relational terms, presents accurate grammar, or enriches their vocabulary.

Children are exposed to violence and aggression and to overwhelming sights and sounds both in their homes and in the streets where they play. External danger is real. Punishment may be harsh and inconsistent and meted out by an assortment of people.

On the positive side, many deprived people, adults as well as children, show great ingenuity and resourcefulness in dealing with difficult life situations and display a high level of intra-group loyalty and morality. Young says, "Despite the realities of existence in the slums of our cities and in the dilapidated shacks of rural poor, many a 'deprived' child is remarkably healthy and well equipped to cope with life. It may not be a reality we would wish on him, but it is his reality, and in relation to it, he often functions with an intelligence and a ready exercise of natural wit that would leave the child of the white middle class, temporarily put in similar circumstances, hopelessly outclassed." (51:27)

Learning Characteristics

Studies show that children from low income families earn I.Q. scores five to fifteen points below average on standardized intelligence tests. "Such a deficit places the average of the group on what is now coming to be considered the borderline of mental deficiency, so that roughly half of the children in such groups fall into the mentally retarded range." (35:4) Furthermore, the scores drop with age. While it is no longer accepted that the I.Q. represents innate intelligence uninfluenced by environmental factors, scores do indicate whether or not a child has acquired certain methods of thinking, vocabulary content and language style, and basic information which he needs if he is to succeed in school. In this respect, the low intelligence test scores accurately predict academic learning difficulties.

The most pervasive aspect of the intellectual retardation of the culturally deprived child is in the area of language development, especially with respect to the abstract dimension of verbal functioning. Bereiter and Engelmann comment that, "Compared to the overall average of three to nine months retardation, disadvantaged children of preschool age are typically at least a year behind in language development . . . in vocabulary size, sentence length and use of grammatical structure." (35:4)

Partly as a consequence of their language inadequacy, deprived children demonstrate poor acquisition of conceptual thinking. Because these two abilities are major factors in

academic achievement, disadvantaged children are retarded most in the areas that count the most. (35:5)

Reissman among others has noted that the approach of deprived children is physical rather than mental, visual rather than aural, externally oriented rather than introspective, and problem rather than abstract centered. They are alert to stimulations which have immediate relevance for them and inattentive to stimulations not relevant to their immediate needs, e.g., the teacher's directions and material may seem totally irrelevant to them. Their work habits are under-developed, they ignore difficult problems and they have a poor self-image. They are, however, proficient in skills which their environment rewards.

Reissman concludes:

"These (characteristics) translate into a physical style which offers valuable suggestions for a teaching approach.

1. They often appear to do better on performance tests of intelligence.
2. They like to draw.
3. Role playing is an attractive technique to them.
4. They often use their fingers when counting and move their lips when reading.
5. They like to participate in sports and are game oriented.
6. They employ physical forms of discipline.
7. They appear to think in spatial terms rather than in temporal terms (they often have poor time perspective)." (48:261)

Educational Objectives

There is reason to believe that if intervention in the life of the culturally deprived child takes place early enough, the effects of environmental deprivation can be avoided. Wilkerson states that, "The hypothesis that appropriate experience can minimize, if not fully overcome, the learning handicaps with which most slum children come to school is well grounded in behavioral theory and supported by considerable experience." (44:27) The preschool or day care program offers an opportunity for such intervention. It may be designed both to anticipate and check the effects of stimulus deprivation and to help the child catch up in areas such as language and cognitive development, where his deficiencies may produce cumulative educational and intellectual retardation.

New educational techniques are needed for the disadvantaged learner. Methods and curricula which have been directed toward children from the middle segment of American life are largely unsuccessful with disadvantaged learners. For them educational methods must reflect more cognizance of the learner and his problems. Methods must be more dynamic and curricula must be more carefully designed to emphasize the sequential and integrated learning of essential content. For those interested in the new forms of education which are being tried the bibliography contains pertinent references.

The "new form of education" needed for the deprived child is not significantly different in its broad aspects from the new approach to education that is being sought for all children, in that it seeks to incorporate relevancy, enthusiasm, individualization and knowledge concerning growth and learning into the child's learning experience. In **Educating Disadvantaged Children Under Six**, Macintosh, Gore and Lewis list areas in which these children need strengthening. (43) The areas listed are essentially the same as those listed in the Iowa pamphlet **Nursery Education**, mentioned earlier, as target areas for preschool programs for normal children.

Listed below are educational objectives for day care programs for deprived children. The list includes objectives identified by various writers in the field. The objectives are neither mutually exclusive nor presented in the order of their importance.

1. Establishment of orderly purposeful behavior
2. Stimulation of language development
3. Encouragement of skillful eye-hand and gross motor coordination
4. Acquisition of a positive self image and motivation for learning
5. Encouragement of mutually satisfactory relationships with peers and adults
6. Development of a cognitive style which will facilitate later school learning

At this point a comment is in order about the importance of determining the health status of the child. A child whose diet is inadequate or one who is suffering from any debilitating physical condition, is not going to be able to respond in an optimal fashion to any day care program no matter how stimulating its curriculum or supporting its physical environment. Any facility offering a truly total child care development approach needs to deal with the child's physiological condition and needs as well as his physical and psychological needs. Nowhere is this more important than in the day care services for the culturally deprived child.



Normal Children

General Information

Mental health and personal adjustment are generally thought to be learned patterns of behavior. Research findings in child growth and development indicate that if the need for early stimulation is met and constructively channeled, the child will enjoy growing and be absorbed and exhilarated by the experience. (9:15) At least two things are necessary for growth to take place — a healthy self-respect and the opportunity to confront a variety of experiences on which to establish and test this emerging self.

Nursery School, a publication of the Iowa State Department of Public Instruction, summarizes the characteristics of normally developing preschool children and the educational goals to be met in planning day care programs for them. (28) This summary is presented as a synthesis to the previous discussion of preschool mentally retarded and culturally deprived children. It presents the normal developmental process and, thus, also sets the goals which educators are striving to at least approximate for children with developmental disabilities.

Educational Objectives

The preschool child is in the process of achieving "selfhood" and developing ways of relating to others. Program planning encourages the emergence of age appropriate characteristics by offering the child the opportunity to try for autonomy in a variety of situations involving mastery of personal relationships and materials. Although some failure may be desirable and is certainly inevitable, guidance should assure that it will not be overwhelming.

The preschool child is in the process of adding dimension and depth to his concepts of the world. Experiences should be geared to help him acquire facts and develop the skills necessary to store and process the facts effectively.

The preschool child is acquiring language to be used as a tool for further learning and as a means of communication. Language is acquired by imitation and fluent language results from an environment rich in experiences associated with words and ideas. One of the goals of the nursery school should be to help provide such an environment. A preschool child rapidly gains control over his body, has a great deal of energy, fatigues easily and recovers rapidly. He cannot sit still very long. His increasing mastery of his body helps the

growth of his self-confidence and presents him with new opportunities for exploration and manipulation. During this time he needs to learn habits of respect for his body through good personal hygiene.

The preschool curriculum is designed to strengthen significant aspects of the child's ongoing developmental pattern. To properly plan a program, the teacher must have knowledge of early childhood developmental patterns and information concerning the background and characteristics of each child. It is important, also, to realize that children vary greatly in their development and that therefore programs must be individualized. Because it is difficult to communicate with preschool children as a group, planning for them must be on an individual or very small group basis.

Some of the many excellent books available on child development are listed in the selected bibliography.



Program Implications

3



Orientation

This section presents the interface between the total program and the physical environment in which it takes place and states the design requirements of the facility if the program is to operate in an optimum fashion.

Specifically, Part 3 considers: the general orientation of the total day care program, current trends in day care services and the curricula in terms of their implication for designing the physical environment.

In designing an educational facility, an architect must consider the nature of the services offered and the relationship of these services to one another. These considerations dictate the basic layout of the facility.

Specifically, the architect must know if the facility is to be a total day care facility or a nursery school, how its services are oriented, whether its only function is to offer a day care program, or whether it has obligations for teacher training, medical research, curriculum experimentation, after school care for school age children, broad community, recreation or health programs, or other activities. Each of these obligations places demands on the design of the facility by indicating what areas or rooms are required and how they should be related to one another. In addition, the nature of the services to be provided in the rooms defines proper building technology, i.e., the size and shape of the rooms, color and texture, lighting, temperature control, acoustics and other factors.

There are three fundamental types of services to be provided for in planning a facility: Education/Training, Administration, and Ancillary Services. Consideration of the interrelationship of the three services is essential in planning the basic layout. The solution to this problem will determine the convenience and lack of confusion with which different aspects of the program will function and will relate to one another.

Educational Trends

The educational and social trends considered in Part 1, have implications for the planning of any type of day care facility. Careful consideration of the trends toward accepting increasingly younger children for day care, developing new approaches in teaching and in delivering educational services, increasing the comprehensiveness of services, and recognizing the increased involvement of parents may mean the difference between building a center or school which is soon outdated and one which will remain functional for many years because of its adaptability to a variety of changing demands.

A day care center should be planned to allow for expansion, which may take the form of increased enrollment or increased comprehensiveness of services. Increased enrollment may mean a larger number of the same age children, or an extension of the program to include younger children or after-school care for school age children.

The field of early childhood development and preschool education is expanding so rapidly that it is not possible to say with assurance what a program will require in a few years. This consideration indicates a need for adjustability, flexibility and expandability in the physical environment.

Curriculum Influence

In Part 2, educational objectives for three different groups of preschool children — normal, culturally deprived, and mentally retarded — were stated in broad terms. It was noted that the objectives were fundamentally the same for all three groups, emphasizing the need for stimulation of young children toward maximum physical, social, emotional and intellectual development within the individually appropriate developmental framework.

The present section restates the curriculum goals, integrating the individual goals for the three groups into one set applicable to all preschool children. Methods and representative activities for achieving these goals and the implications of goals, methods, and activities for classroom and total facility planning are discussed. This lumping together of methods and activities employed in teaching all preschool children does not imply that the teaching methods, equipment, materials and activities are identical for normal, mentally retarded and culturally deprived preschoolers. What it does imply is that the environmental criteria associated with the development of the curricular goals are similar in all major aspects and vary only in relatively minor details. This is analogous to saying that it is possible to plan an excellent program for four year olds, but that the program will consider the individual characteristics of the children within this group.

The curricular objectives have been classified into two groups — skill objectives and attitude-behavior objectives — according to whether they exert specific and direct or more general influence on the planning of the physical environment.

Most programs are planned around the teaching of skills and it is the way these skills are taught that provides the child with the opportunity to work toward meeting the attitude-behavior goals. While assigned periods of time are devoted to teaching something definite, the more pervasive attitude and personal-social skills are being continuously taught by precept and example. There is no hard and fast line between skill and attitude-behavior goals, or between the different goals within these two groups. Activities designed to implement one objective may also promote development in other areas. Activities should promote development toward as many goals as possible.

For the purpose of environmental planning, the two groups of curriculum goals require different considerations. Aside from those aspects of the environment which contribute to general well being, the attitude-behavior goals require no special spatial considerations. However,

achievement of attitude-behavior goals depends on careful planning for the skill objectives because it is in an atmosphere of well planned, happy activity that the attitude-behavior goals are best achieved. The "skill" goals do require spatial consideration. The activities associated with them require, for example, space to work in, equipment to work on, and space for the storage of materials.

In the following discussion, the three attitude-behavior goals are considered together. The four skill goals are dealt with separately because each has definite environmental requirements.

Attitude/Behavioral Objectives

The three attitude/behavioral objectives are: **the establishment of orderly purposeful behavior, the encouragement of wholesome relations with peers and adults, and the acquisition of a positive self image and the desire to learn.**

In order to learn, children need an environment which supports them. It is axiomatic for all children that, until some routine has been established and the children have begun to handle materials and enter into activities purposefully, little can be taught. The teacher has a particularly challenging problem in establishing such a routine with culturally deprived and mentally retarded children. The culturally deprived child may come from a chaotic family background, where a physical reaction to a situation is the expected response and little verbal communication takes place. Consequently, he does not respond to verbal directions, and physical demonstrations play an important part in teaching him. Likewise mentally retarded children rely heavily on demonstration for learning and may also need training in focusing their attention.

Deprived and retarded children who experience a group situation for the first time may run about wildly, hide, kick, scream and defy authority. Conversely, they may be unusually subdued and withdrawn. Such behavior is most constructively perceived not as pathological, but as a learning situation where naive children need to be taught how to behave appropriately.

Reissman states that, "On the average, it is the old-style, highly structured teacher who appears to be the most popular and effective with underprivileged children." (48:265) He goes on to say, "What is needed is a perfect marriage of the traditional and the progressive. The traditionalist contributes structure, rules, discipline, authority, rote, order, organization and strong external demands for achievement.

He fights to win the child to a higher level of conceptual achievement.

The progressive places the emphasis on motivation: the down-to-earth learning by doing; examples drawn from the experience of the child — beginning in the present and moving toward the broad, the abstract, the cultural heritage." (48:266)

Betty Levy says, "A few words about classroom order, control and discipline are in order . . . A firm, structured, and highly regulated class environment is not only necessary in order to teach, but is also . . . desirable for the children's own growth . . . It is essential to establish clear rules and definite limits and to insist that they are obeyed." (49:433)

During the day's activities the alert teacher finds innumerable opportunities to encourage wholesome peer and authority figure relationships. The teacher sets an example by being respectful and considerate in her attitude and in her behavior toward her charges. She expects aides and other personnel working with the children to be the same.

It is important for a child to see himself as a valued and worthwhile individual. If he thinks of himself as capable and accepted, he will likely behave in a capable and adequate fashion. If he feels that he is incapable of carrying out a task, he may not even attempt it. It is also important that a child see a situation as having relevance to his need, because it is hard to become involved in a task when one sees no point in doing it.

The teacher can most effectively aid in the development of the child's self esteem by believing in him and expecting him to learn. The importance of the teacher's attitude in stimulating learning has been ably documented in the work of Rosenthal and Jacobson. (37:219)

When a child feels "right" and comfortable at his "school," he has already begun to have a good feeling about himself. When he is directed toward activities which interest him and tasks which he can accomplish, he realizes that learning is an exhilarating experience.

Kathryn Werlin presents an excellent discussion of the relationship between learning and room arrangement, class routines and the organization of staff responsibilities. (24:2) She points out that organization of space in a room structures a program by defining the child's and adult's use of the room and that the physical environment has a critical effect on children's behavior. Too fluid an arrangement does not provide the necessary supportive framework in which children can learn to control themselves.

Methods

Methods to encourage development toward the educational goals of orderly behavior, wholesome interpersonal relations and a positive self image include the following:

- Careful lesson planning, which involves a slow and explicit introduction to the activity routines.
- Allowance should be made for repeated demonstrations to accompany verbal directions. Variations in the routine should be introduced only after it is understood and the child is functioning within its framework.
- Tight program planning to minimize the necessity of disciplinary action by keeping pupils busy and interested. There is need for a variety of activities so that substitutions can be made when a counted on activity falls flat or when children become bored and begin to look for something to do.
- Simple rules of conduct which are clearly stated and enforced.
- Motivation through activities which are appropriate to the developmental level of each child and have relevance for him.
- Activities which encourage and facilitate independence in the self care area.
- Activities which assist the child in determining who he is.
- Alertness on the part of the teacher to the emotional and social needs of the individual children so that she can help them learn acceptable and gratifying behavior.
- Frequent opportunities for the children to experience success and approval. This is especially important when the child is first entering the group or when he has had few successful experiences and has a low opinion of his ability and acceptance.

Design Considerations

To assist in achieving the attitude-behavior curriculum goals, the physical environment should be of a size and shape that permits either a variety of activities to take place simultaneously or for the total group to be engaged in the same activity. It should also provide for both quiet and energetic activities, and should allow for easy inconspicuous supervision.

A comfortable environment requires careful planning for lighting, climate control and acoustics. Supplies should be readily available, as well as a personal storage area for individual children which enhances a sense of personal possessions. The arrangement should make order, i.e. pickup, storage and clean up, both fun and instructional. The following are also

important:

- Windows from which children can look.
- A classroom removed from areas where activity would be distracting to others or where activities of others would be distracting to the children.
- Activity areas which are clearly delineated, but with movable dividers to provide flexibility.
- Bathrooms which are readily available.
- Ready access to the outdoors.
- A staff lounge for the comfort of adults.
- Furniture the appropriate size for children.
- Closed storage space for equipment and supplies which are seasonal or to which the children should not have access.
- Clearly defined open storage area.

The physical environment must be ordered and uncluttered, including carefully delineated activity areas, systematic storage of materials, and well defined routines.

Skills Objectives: Precognitive/Cognitive

Rich and varied environmental experiences are essential to the development of the early sensory motor intelligence which precedes cognitive development. In a middle class home this stimulation is ordinarily available so that the middle class child enters school with a wide range of experiences, and a feeling of involvement in the learning process. This may not be true of culturally deprived children whose experiences, by definition, are limited, or of mentally retarded children, who may also have been deprived of experiences because their parents have not felt they could profit from them.

Impetus for this environmental approach to mental development comes from the work of T. McVickers Hunt. Hunt takes the model of developmental stages proposed by Piaget and emphasizes the importance of achieving "a match," — that is, a close correspondence between the child's developmental level and the experiences to which he is exposed — so that cognitive development is fostered. A brief presentation of Hunt's work is contained in **Social Class, Race, and Psychological Development** by Deutsch, Katz and Jensen. (37:293)

The achieving of a "match" is important in teaching all children, but especially in teaching mentally retarded children. To achieve it, the teacher must have knowledge of the child's level in specific developmental areas as well as the child's overall developmental level provided

by a psychometric evaluation. In planning activities appropriate for learning at one developmental level, the teacher lays the foundation for learning at the next level to which the child will advance. She should be sensitive to the child's readiness to take this step so that he remains motivated and does not become bored. However, with retarded children, overlearning is important for the retention of the material.

Methods

Perceptual discrimination and early concept formation are usually taught through the use of standardized equipment, graded for difficulty and presented in sequence, but there is ample opportunity for the exercise of the teacher's creative ability in the production of materials. Formal activities selected to promote perceptual discrimination and early classification usually take place with children seated around a table, but they can also take place with the children seated on the floor.

Connor and Talbot in **An Experimental Curriculum for Young Mentally Retarded Children** list eighteen types of activities which they think contribute to intellectual development. (57) They are: listening to oral language, using books, handling books, participation in group activities, singing, visual, auditory, gustatory, olfactory, tactile discrimination activities, color recognition, matching, quantity and time concepts, nature study, problem solving, self-concept activities and the obeying of rules. This book also lists teaching procedures for various developmental levels.

There are many opportunities to reinforce formal learning and give it practical application and relevance. For example, there are games which require spatial orientation and sensory discrimination. Also, food offers opportunities for sensory learning and later for the development of classification skills. Nature study, homemaking activities, music and handicrafts can all be oriented toward stimulating cognitive development. Intellectual development is closely related to the development of speech and language.

Design Considerations

Design considerations for encouraging the development of precognitive and cognitive skills are similar to those discussed in the previous section. This goal also has, however, some specific requirements for the physical environment. They are:

- Interest areas in which a variety of activities can take place involving different numbers of children
- Adequate, comfortable seating arrangements
- Good equipment and imaginative supplies
- Available supplies
- Display space
- Chalk boards
- Floor areas which children can sit on
- Floors which can be marked on
- Space for simple food preparation
- Space for indoor garden
- Adequate convenient storage

Skills Objectives: Speech/Language

Psychologists are becoming increasingly cognizant of the relationship between verbal behavior and the development of the thinking process. A lack of verbal ability may have consequences beyond its effect on social communication by determining a thinking pattern which is not amenable to the development of conceptual thinking.

Piaget's observations of young children indicate that language develops only after images — the central process representing objects and events — have been produced by repeated encounters with these objects and events. The child must also have a person after whom to model his speech. When one or both of these factors is absent, or only minimally present, the child's language does not develop fully, which restricts later cognitive development. The absence of encounters with the environment and a good speech model contribute to poor cognitive development of culturally deprived children through early curtailment of language development.

A majority of the people who work with deprived children place the highest priority on overcoming the language handicap of such children. And, since the insidious withholding of necessary environmental stimulations begins at birth and is most devastating during the time when early speech is being acquired, intervention early in the child's life is essential.

With many retarded children, speech lags behind other areas of development, which is probably both a result and a continuing cause of the retarded mental development.

Methods

The effects of cultural deprivation on both the deprived and the retarded may best be counteracted by providing the child

opportunities to encounter a wide variety of objects and pictures and by exposing the child to appropriate behavior. The physical environment should encourage the child to scrutinize and manipulate new objects as long as he is interested. Such varied experiences would foster the development of representative imagery which in turn could provide referents first for spoken words and later for written language and cognitive development. Jensen says, "The child must learn to 'see' and sensory experiences must become integrated for the child to become capable of form discrimination, size constancy, distance judgement, figure-ground distinctions and the like." (37:120)

The following suggestions are based on the approaches of Jensen and Deutsch among others. (37)

1. Presentation of a good speech model by the teacher and others.
2. Building up of an ever increasing number of images and ideas through exposure to a variety of objects and situations. This can be accomplished by, for example, the use of verbally stimulating material and equipment, walks to see the school and its surroundings, visits to inspect community activities, the reinforcement of these experiences in play, in looking at pictures, in role playing and in discussion.
3. Encouragement in the labeling of persons, objects and activities and the transfer of the labels from the objects themselves to pictures and then to words. "Verbal bombardment" and encouragement in verbal expression are reinforced with attention getting devices and audio-visual aids which evoke interest and attention.
4. Encouragement in increasing verbal fluency by requesting the use of sentences, supplying adjectives, relational words, etc.
5. Requesting a child to say what he is doing and when the occasion is appropriate, to evaluate it. Ask for verbal explanations.
6. Exploiting the language potential which is inherent in any activity.
7. Consider the use of the Bereiter-Englemann method.
8. Choral singing, puppets, etc.

There is a great deal of material available which is designed to stimulate speech and language development. For example, **Peabody Language Development Kits** are available for various developmental levels, and books such as **Language Motivating Experiences for Young Children** by Rose C. Engel contain many

stimulating ideas. (27) Also, there is standard equipment such as the record player, tape recorder and the Bell and Howell Language Master.

The stimulation of speech and language development is a curriculum objective which may have a specific period and specific equipment assigned to it, but it is also a continuous process related to all other activities.

Design Considerations

Design considerations of this curriculum objective are closely related to those of the skill goals because speech needs to be about something. Special environmental considerations are raised when specific methods such as the Bereiter-Englemann method are used. (83) Easily accessible storage space is necessary for audio-visual equipment, and spaces must be allotted for flexible use of such equipment. Interest centers for small group activities encourage communication. Plant growing, an aquarium, and animals (when possible) all delight children. The classroom should contain ample display areas for the children's work and for things they bring to school or gather on excursions. Windows that the children can look out of stimulate observation.

Skills Objectives: Manipulative

Early learning takes place through the senses. The young child manipulates many objects and becomes aware of their distinguishing characteristics, such as weight, texture, loudness and taste. Slowly he begins to compare and classify. He learns how to "handle" his environment by seeing, hearing, smelling and touching the many objects with which he comes in contact. He learns the names of objects, spatial relationships, and the relationship between cause and effect.

Children gain independence as they learn to do things for themselves. Children like to cut, print, paste, button and build. They need material with which to work. Culturally deprived children have had limited experience with toys and materials and therefore limited opportunity to learn with such materials. When first presented with toys, many culturally deprived children do not know what to do with them. By providing these children with the material with which to experiment and learn and by guiding them in the process, day care programs can help compensate for the lack of stimulation in

their environment.

Eye-hand coordination is also promoted by the teaching of self help skills, an area in which it is important for retarded children to receive specific training. The child is trained in self help skills whenever it is appropriate in the ongoing daily routine. Toilet training, including zipping, handwashing and the adjustment of clothing are taught in the bathroom setting. Taking off and putting on outer garments and clothing care are part of the school routine. Learning to wipe one's nose involves considerable manual dexterity and is a social necessity. Training in self help skills benefits the child doubly — in increased independence and in increased skill.

Given the opportunity and motivation, deprived preschool children usually acquire manipulative skills rapidly. However, the moderately retarded child with poor eye-hand coordination may need extended training before he masters some of the basic manipulative skills and the more seriously handicapped child may never do so.

Methods

The teaching of manipulative skills involves a careful selection of material appropriate to the child's developmental level. In day care programs for preschool children, the activities usually involve cutting, brush and finger painting, pasting, clay, drawing, manipulating paper and string, bead stringing, puzzles, and peg boards. As the children become older these activities become incorporated into hand crafts. Most of these activities take place seated at a table, and are done either individually or by small groups of children.

Hammering, sawing, sanding and using a screw driver are activities enjoyed especially by small boys. Large and small blocks, and other construction materials, toy cars, airplanes, and such also have their place in any program.

Design Considerations

Design considerations of this program objective involve:

- An area with working space and convenient storage for supplies. Working surface can consist of both tables and hard floor surface.
- Workshop activities should have a permanent area of their own because they have special equipment requirements. Tables and floors should be indestructible. Workshop activities are also noisy and should be placed where they will not interfere with other activities.
- Personal storage and hygiene are as should

be considered training areas as well as functional areas.

- All surfaces need to be easy to clean.
- Material and supplies should be of good quality.
- Areas for the display of work are important and should be provided.

Skills Objectives: Physical Coordination

Exercise is fun for children and vital to their physical and mental well being. They acquire confidence in themselves as they acquire control over their bodies. Given the opportunity, healthy children will get plenty of exercise without urging.

Reissman has pointed out that culturally deprived children are especially responsive to learning presented in the form of games. Active games offer an excellent opportunity to teach cooperation, respect for rules, and the acceptance of different roles at the same time that physical development is advanced.

Many retarded children do not get enough exercise. Their general health as well as sleeping and eating patterns would improve with more exercise. Brief periods of calisthenics during the class period can improve the alertness of children. The mildly retarded child may have normal physical coordination, while the moderately retarded child is usually poorly coordinated.

Physical education programs should include both indoor and outdoor activities. Activities should range from exercises to develop coordination and timing to creative movement activities set to music. They should involve children both in simple rule governed games and in spontaneous activities organized by the children themselves. Verbal communication may be improved by providing the children with words which label their activities and encouraging them to both describe what they are doing and express their feelings.

Methods

The list of physical activities which young children enjoy is endless. Connor and Talbot list the following activities as contributing to motor development: walking, running, marching, jumping, hopping, skipping, dancing, use of stairs, jumping rope, sliding, ball playing, and the use of various kinds of vehicles. (57:27)

Design Considerations

Design considerations in planning for physical and recreational activities require attention to outdoor play area, covered outdoor play area, gym or multi-purpose room, and the classroom itself.

- The outdoor play area should be easily accessible from the classroom. Whenever possible, it should contain some natural features such as a tree or sloping ground. Both hard and soft surfaces are desirable.
- There should be adequate space for vehicles, a sand box, and a place for water play.
- A drinking fountain and bathroom should be available.
- Ample storage space for outdoor play and maintenance equipment is needed.
- Equipment should be as safe as possible and should encourage a variety of uses.
- The covered play area should be contiguous with the building. This area is usually small but can be very valuable, especially in unusually hot or rainy climates.
- It is usually possible to provide a gym or swimming pool only when the day care center is part of a larger facility. They are both highly desirable, and the swimming pool particularly offers wonderful opportunities for retarded and deprived children. These facilities require adjacent dressing, shower, toilet and storage areas. Both the gym and the swimming pool should be at a distance from the classroom because of noise and ventilation.
- In most day care centers many energetic activities will be conducted in the classroom or in a multi-purpose room, so enough space must be provided for children to exercise, dance, use walking and balancing boards, etc. In some indoor room. Hard and easily cleaned floor and wall surfaces allow the teacher to relax during an indoor play period.

Environmental Implications

4



Definition of Environment

Webster defines environment as "all the conditions, circumstances, and influences surrounding and affecting the development of an organism." For this publication, concerned with the planning, design and construction of preschool day care facilities, three aspects of the environment are considered.

First, the "organism" involved — the children, staff, parents and community members; second, the "development of the organism" — the program designed to promote the development of the children by providing the best in care, education, and training; and third, the "surrounding conditions and influences" — the physical setting in which the program takes place. This includes the interior and exterior spaces and the equipment and supplies which make these spaces responsive to the people and the program.

The people involved in day care programs and the programs themselves have been discussed in previous sections. An understanding of people and programs is necessary for a determination of the characteristics which an educationally enhancing physical environment should possess. In other words, in order to design appropriately, it is necessary for the designer to have a clear cut idea of what will happen in the building he is designing and the characteristics of the people who will use it. As Lecaze says, "Architecture is the art of producing beautifully what is useful." (117:94)

This statement might be extended to say, "Architecture is the art of producing beautifully what is useful so that it becomes applicable."

The young child is constantly being exposed to new people, objects and events. His response to them is more direct and energetic than an adult's, whose responses are tempered by past experiences which gives them meaning extrinsic to themselves. In exploring his environment, the child utilizes the most concrete tools he has — his five senses, vision, hearing, smell, touch, and taste.

In a physical setting thoughtfully designed for preschool education, the physical components of the environment can provide direction, suggestion, stimulation, protection, comfort, and many other things. The environment can create an atmosphere in which learning is natural and conducive to the learning process. Even the doors, walls, and floor surfaces can enhance the learning process and serve as effective assistants to the staff. Design can illustrate spatial and temporal concepts. It can create a sense of privacy or a sense of community. It can be relaxed or stimulating. It can encourage independence and offer security. It can be adaptable, versatile, flexible and orderly; and in so being, it can encourage these characteristics in the people who live and work therein. It can also be simple and beautiful.

In trying to create a meaningful educational environment for preschool children which will meet these general design objectives and the more specific ones which have been mentioned previously, consideration will next be given to the following physical environmental variables:

- color
- light
- acoustics
- climate control
- interior surfaces
- space
- flexibility
- psychological variables

Color

Color can not only contribute to the beauty of a day care center, it can produce a psychological effect on the behavior of children. "Paint and especially carefully planned color schemes appear to influence the scholastic achievement of elementary school children, and especially those of kindergarten age." (105:430)

While the response to color is highly individualized and since it has not so far been possible to correlate specific color reactions to particular behavior processes, there are general responses to color which are widely accepted. Empirical studies have led to some interesting observations about color which are useful in understanding how color may affect the behavior of young children.

Design Considerations

There is evidence of increased activity, alertness, and outward orientation in the presence of warm and luminous colors, thus creating an environment which is conducive to muscular effort, action, and a cheerful feeling. (86:133) Red produced tension, excitement, and a feeling of warmth in controlled laboratory experiments, while blue resulted in a feeling of well-being, calmness, coolness, less anxiety or hostility, and less awareness or concern for outside noise. (84:31) "Behavior is increased or relaxed according to the type of color stimulation. Red and related colors activate; blues, violets, and green calm. Light colors activate; deep colors produce passive moods. Beyond this the exact hue or tone of color is fairly optional." (105:40)

"Young children are said to enjoy strong primary colors properly used. Children react strongly to color psychology and colors should be chosen purposefully. Color treatments should also be based on the use of the room as well as the length of time it will be used." (117:94) It might also be stated that the size of the surface area to be colored needs consideration — large surface areas being the pastel and soft hues with small surface areas being the strong bright colors.

Kenneth Bayes, reporting on experiments carried out by Oser, Brian, Goodenough, and others, indicates that perception of color over form is dominant in early childhood, with a general change in emphasis until form is dominant in maturity. Dominance of color awareness increases until four and a half years, after which age there is increasing recognition of shape. (84:38)

Color	Psychological Response	Advantageous Usage in Curriculum
Red	exciting stimulating defiant contrary hostile hot passionate active fierce intense happy sometimes irritating	outdoor play equipment indoor or outdoor gross motor activity cognition activities which require stimulation
Orange	welcoming jovial lively energetic forceful exuberant hilarious disturbing distressful	entrance to a facility and/or classroom gross motor activity
Green	calm peaceful serene quiet refreshing restful	reading corner nap area eating area isolation room (if it is to be used as a "quiet room")
Blue	calm peaceful soothing tender secure comfortable melancholic contemplative subduing serene sad dignified restful	reading corner nap area eating area isolation room (if it is to be used as a "quiet room")
Black	despondent dejected ominous unhappy powerful defiant hostile strong	not recommended to be used in large amounts may be effectively used as accents in areas in which a child is to express himself
White	cool pure clean frank youthful	reading corner eating area health area isolation room administrative area

Color	Psychological Response	Advantageous Usage in Curriculum
Yellow	cheerful joyful inspiring vital	gross motor activity music corner art corner
Purple	stately dignified mournful mystical	reading corner may be effectively used as accents in study area
Gray	neutral non-respondent soothing	used as complement to other colors use as accents

Contrary to what might be expected, there is reason to believe that with maladjusted children, excitable individuals respond more therapeutically to stimulating colors and withdrawn children to cool colors. (84:36) In other words, children respond best to colors which are in sympathy with their own emotional condition.

The chart sums up the accepted psychological responses to colors and suggests their advantageous use in educational facility planning.

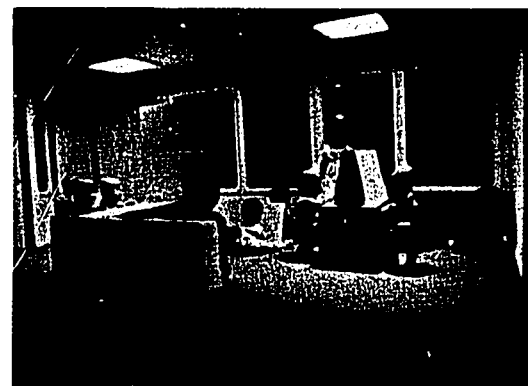
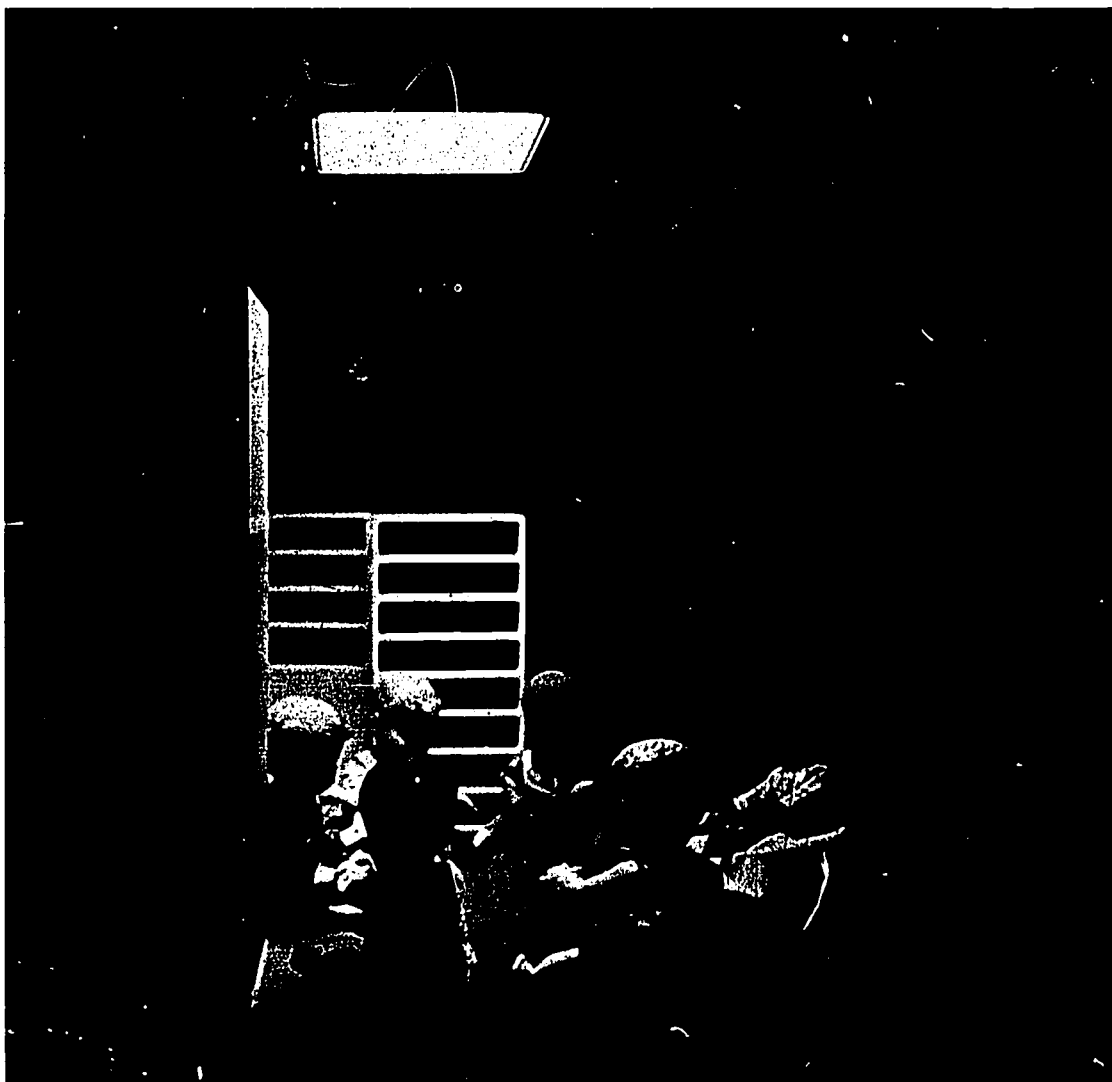

Conclusions

Colors produce responses in children which need to be taken into consideration in the selection of colors for day care centers. Color selection should be based on the children's responses to color, the purpose for which the area will be used, the nature of the children using the area, and the size, light exposure, and other physical characteristics of the area. Personal color preference should also be considered, especially in spaces that are occupied for long periods of time by one person. This is particularly applicable in offices or similar spaces. Color can be used as a means of identifying a child's personal property, e.g., his storage space, his chair, his glass, etc.

Light

It is difficult to overestimate the importance of good lighting. A publication by the National Council on Schoolhouse Construction states, "... research has produced irrefutable evidence that a properly designed luminous environment can help students and teachers and contributes to the conservation of energy for physiological growth and developmental needs and the maintenance of a tension-reduced instructional climate." (117)

A good lighting environment encourages good housekeeping practices and orderliness and lessens discipline problems. It also helps create a positive and aesthetically pleasing surrounding for teaching-learning activities and certainly increases the safety factor of facilities by decreasing the chances for accidents.

"Perhaps one of the most overlooked advantages of a good visual environment is that it helps equalize education opportunity for those with substandard vision. This is true because a person with substandard vision benefits more than a person with a standard vision as the visual environment is improved. Since studies have shown that approximately twenty percent of pupils attending the elementary grades have substandard vision, the need for providing better than the minimum quality visual environment is apparent." (117:122)

Preschool facilities have some illumination requirements which differ from schools for older children. Older children sit in one place and work at a well established desk level. The activities of preschool children are more diversified. They take place in various subdivisions of the room and at floor, table and standing level.

Terminology

The difference between quality and quantity of light needs stressing. A sufficient quantity of light is important, but other factors such as glare, light distribution, and source brightness play an important role in good visual environment.

Although still a highly important factor, the foot candle (the measure of quantity of light) is no longer the recognized measure of lighting efficiency because foot candles alone do not determine how well one sees. The National Council of Schoolhouse Construction states that the concept of brightness-balance has been adopted as the informed approach to the design of an acceptable visual environment for schools. "The concept of brightness-balance stresses the correlation of values of brightness difference and brightness patterns with values of lighting levels and varying tasks." (117:121)

The brightness of a surface results from the light it reflects to the eye. Glare is excessively high brightness and is of two types, direct and reflected. Direct glare, resulting in distractions, discomfort or a reduction in visibility, is commonly caused by windows and lighting fixtures. It is light which the eye sees directly. Reflected glare is brightness which the eye sees reflected from a surface. Reflected glare is at a minimum when the area producing light is maximum or when the brightness difference between the ceiling and the luminaire is minimum.

The following chart presents the recommended levels of illumination for areas within the day care center.

"Most visual tasks are seen by reflected light; depending upon the character of the task, reflected glare may or may not be a problem." (117:128)

Since the eye adapts when it fixes on a task, any change in the brightness level requires a readaption of the eye. For this reason, the brightness relationships of the various surfaces in the entire visual field should be kept within recommended limits. It is usually desirable to limit the brightness of light sources exposed toward the work so that seeing is not hindered by reflection from the detail of the task, nor from the background. Recommendations concerning levels of illumination (quantity in terms of foot candles) must be related to the visual tasks to be performed and the design of the lighting system.

ROOM	FOOT-CANDLES	
	Detail	General
Classroom/Playroom	30	70
total group activity	30	50
arts/crafts	50	70
book center	50	70
blocks center	30	50
housekeeping/dramatic play	30	50
nature study/science	50	70
Tutoring/quiet	50	70
Infant Care	30	50
Observation	2	20
Music	30	50
Indoor Recreation	15	
Bathroom (Children)	30	
Multipurpose	30	50
Teachers Office	50	100
Material Preparation	50	100
Kitchen	50	70
Dining	15	30
Exec. Dir. Office	50	100
Educ. Dir. Office	50	100
Secretary/Clerical	100	150
Conference/Board	30	50
Staff Lounge	15	30
Medical/First Aid	50	100
Health Personnel	50	100
Parent/Community	30	50
Psychologist Office	50	100
Speech Therapist Office	50	100
Social Worker Office	50	100
Lobby/Reception	15	30
Student Work Room/Univ. Affiliated	50	100
Volunteer Auxilliary	30	50
Mechanical	10	
Janitorial	20	
Corridor	10	
Bathroom (general)	20	
Storage (classroom)	20	
Storage (general)	10	

As mentioned previously, foot candle recommendations cannot be divorced from the type and layout of the related lighting system. Under optimum conditions for visual comfort and efficiency, the brightness of the surroundings should be uniform and slightly lower than the brightness of the task, but this is often difficult to achieve.

Some of the accepted methods of achieving brightness balance are:

- Ceilings, walls, woodwork, etc., painted for high light reflection
- Paint finishes matte rather than glossy
- Light colored furniture and equipment
- Light colored tack and chalk boards
- Light colored floors
- Multi-source daylight
- Continuous windows
- Window heads flush with ceiling
- Minimum width window mullions

Design Considerations

Daylighting

The same criteria for good lighting should be applied to daylighting as to artificial illumination. Actually, a greater variety of conditions prevail in daylighting than in artificial lighting because of the wide variety of fenestration material and the many ways in which the materials are used.

Glazed areas are provided in classrooms and playrooms for two purposes: to admit daylight into the room and to permit occupants to see out. In considering the latter purpose, EFL reports, "In planning the number and placement of windows, consideration ought to be given to the view outside the window. Where the school setting affords a pleasant, changing view, windows might be included as integral parts of the classroom. Windows should be low enough for the children to see through. When windows would expose the monotony of a brick wall, the space traditionally given them might be better used as space for classroom display." (115:7)

Glazed areas designed to admit daylight must exclude direct viewing of the sky and maintain a favorable brightness-balance in the room. Daylight can be provided through the use of windows, the glazing of inner walls toward corridor, clerestory windows, and skylights.

A new unit of measurement of light is currently being developed which takes into account all the factors for proper illumination that have previously been discussed. It is called "visual performance index" (VPI) and will replace the

typical foot-candle charts in the near future. It is recommended that VPI figures be adopted as soon as they are available.

Regulation of the presentation of light and heat can be achieved through a variety of methods, the most satisfactory probably being the orientation of the building. Classrooms facing north provide the most even distribution of light. However, experiences have shown that in temperate zones, school room wings should face southeast to receive early morning sunlight. (120:58)

Daylight can also be controlled by the use of roof overhangs or canopies above the windows. How far they should project and the extent of their perforation needs to be determined carefully. The use of louvers inside the room, including the relatively inexpensive venetian blind, offers effective light control when properly operated. Tinted glass and the humble window shade are also means of light control. When the exclusion of most of the light is desired for the use of visual aid equipment, black shades may be advisable.

Artificial Lighting

To attain a balanced visual system concerned with comfort and efficiency, it is necessary to design both the electric lighting and the day lighting against the same criteria. The goal in both cases is the production of a glare free visual environment where the brightness-balance is appropriate to the activity performed.

A good rule-of-thumb to follow concerning illumination for a preschool facility is to provide a proper artificial lighting system as if no other lighting source was available.

A glare-free system of illumination is one which distributes the light to the task from all angles and in equal amounts. In the use of artificial lighting system, this means:

- a luminous ceiling or wall designed semi-indirect system that produces uniform ceiling and side wall brightness is optimum.
- the least desirable systems are those in which the source of light is of small physical dimensions and is coupled with dark ceiling areas between light sources
- systems of large surface area, low-brightness luminaires with wide lighting distribution characteristics and minimum brightness at angles which produce reflected glare, will produce the highest contrasts in the table
- direct lighting systems are improved with the use of a good polarizing panel instead of lenses or simple diffusers

- in small rooms, conventional ceiling light sources are generally satisfactory for providing adequate lighting levels
- fluorescent lighting is preferred to incandescent when the lamp is exposed to the task as in louvered-bottom direct lighting systems.
- lighting systems which have diffusing or refracting material below the lamps, such as semi-direct fixtures or luminous ceilings, are best fluorescent lighting systems are the most practical way to provide recommended lighting levels for classroom.
- if incandescent lamps are used for general lighting, indirect luminaires provide the most suitable quality.
- illumination levels for incandescent lighting systems are usually limited to about 30 foot candles due to the heat produced.

Conclusions

There is not one definite or optimal way to design a proper visual environment for the preschool child. The design principles established for the visual environment, however, should not and need not be compromised in favor of other considerations. Within the design limits, there is flexibility for creating a great many reasonable, practical and attractive solutions.

Acoustics

Good preschool programs are often identified by the sounds of busy activities being carried on simultaneously. Acoustical control in the playroom is important because, while certain sounds can be comforting and interesting, excessive noise produces irritation, distraction, and fatigue in teacher and children. In the playroom, sound can be used to heighten the interest in many kinds of activities, and to relate activities to space, e.g., a quiet space for resting, an acoustically alive space for physical activity. Psychoacoustics seeks to determine the nature of human response to sound and to apply this information to securing a sonic environment which is optimal for given activities or conditions.

However, it is not easy to determine what constitutes a satisfactory acoustical environment. It differs for children and adults and is influenced by the mood and background of the listener. Noise which makes adults flinch, is often interesting and enjoyable to children, who are naturally curious about sounds. In bad acoustical conditions, the teacher is often more miserable than the children. However, under these conditions, while the children may be enjoying themselves, they are not concentrating on the learning materials as well as they could otherwise.

Barnett and Erickson write, "As in most areas of psychology, one is impressed by the tremendous scope of individual differences. In many instances, there appears to be little common ground, and consequently the average or mean values obtained from psychoacoustical experiments do not seem immediately interpretable in criteria." (106:153)

There is limited ability to translate responses such as "annoying," "bothersome," "stimulating," and "soothing" into a physical description of the sounds producing them and to generalize about the effects of sounds on different people.

With this in mind, the following generalizations on acoustical environment are presented:

- the level at which a constant background noise is acceptable is usually defined as that level which is consistent with the ability to hear normal speech easily
- continuous, featureless noise seems to have very little effect on performance unless the noise level is high
- extreme quiet does not provide an appropriate environment for many learning activities
- intermittent or irregular sounds are more annoying and distracting than steady sounds, which do not elicit numerous shifts or attention

- noise which is familiar or unavoidable is less annoying than strange or unnecessary sound
- high pitched noise is more fatiguing and irritating than low pitched noise

Design Consideration

The National Council on Schoolhouse Construction calls attention to the fact that sound as a factor in schoolbuilding design has both a positive and a negative aspect. The positive aspect consists of providing an environment in which wanted sounds can be comfortably and effectively heard. The negative aspect involves the control, dissipation or absorption of interfering, unwanted sounds. Problems to be coped with in achieving this double goal are: the reverberation of sound through a space, and the amount of sound transmitted into one space from another. (117)

To be effective, any sound barrier must be airtight. Even the smallest openings, such as open joints or cracks, electrical outlet boxes back to back, or keyholes, will greatly reduce the sound isolating value of a partition or wall. Air ducts are a common source of sound transmission from one space to another and should be given serious design considerations.

One basic design recommendation for the planning of a day care facility is that whenever possible a site be selected in an area which has a low noise level. If a noisy site is unavoidable, provision should be made for sound interception in exterior walls and for landscaping to provide sound barriers.

Interior design should be such that noisy activities are grouped together. This recommendation has particular relevance for day care facilities giving services to infants and very young children as well as to the general arrangement of interest centers within the play area.

The characteristics of sounds are frequently more important in the solution of sonic problems than the actual decibel level. Equal decibel levels related to sound pressure are not equal levels when different pitches or frequencies are involved. Loudness is a function of both volume (decibel) and pitch. It is the way that sound is experienced and the use to which the space is put that should determine the definition and solution of acoustical problems.

The control of reverberation — that is, the persistence of sound in a room — is an important aspect of sound control. It is directly related to the ease with which speech can be understood in areas in which a variety of loud activities are being carried on at the same

time — this situation being characteristic in day care centers. Reverberation is a function of the volume and emptiness of space.

Many day care center designs will be similar to the open classroom in a school facility. Open plan schools are reported to work well acoustically. The situation produces a certain amount of background noise which is expected and easily adjusted to. This background hum may effectively mask distracting sounds. In some situations, a featureless background sound may be deliberately introduced to mask other noises and secure privacy.

In discussing the planning of open schools, the EFL report, **Schools Without Walls**, states, "Of the two horizontal surfaces in the room, floor and ceiling, treat only one acoustically — the floor. Treatment of both may have a deadening effect on the space. An acoustically absorptive (i.e., carpet) floor stops unwanted sound where it starts; a hard ceiling reflects wanted sounds to where they are wanted." (103:31)

The dimensions of the room should be large enough so that there can be adequate separation between work groups, and the population within the room should not exceed the number for which planned.

Traditionally, ceilings have provided the main source of sound control through the use of acoustical tile. Recently, there has been a trend away from this surface as the sole source of control.

"... It should be noted that in most cases the ceiling is the **last** place to treat for effective results, rather than the only location for application of acoustical material." (117:138)

"Many classrooms today are fully covered with acoustical absorption, but this coverage is seldom needed and is actually a detriment to effective communication." (96:28)

Hard flooring on which a great deal of noise is produced by footsteps, moving furniture, etc., causes sound reverberation and should be avoided. Softer flooring, such as carpet, rubber, linoleum, asphalt, is preferable.

Conclusions

The control of sounds within a play area and of sounds entering the area is an important feature in the design of a day care facility. Sound control can be achieved through a combination of methods involving initial site selection, the relationship of different areas within the facility, and the use of materials which have sound absorbing properties.

Climate Control

Human beings can exist only within a fairly narrow range of temperatures. Of all the components of the environment, the thermal unit may be the most vital. Yet, it is less significant than other components in its effect on human behavior so long as conditions close to those required for human comfort prevail. Thermal comfort is not a luxury; it is a physical and mental requirement for the effective use of a classroom. Classroom discomfort means inattention, restlessness, fatigue and irritation for teacher and children. The best heating, cooling and ventilating systems for playrooms and classrooms are those which function unnoticed, but which contribute through their appropriate and inconspicuous functioning to the alertness, productivity, and relaxation of the persons living and working within the area.

"An optimum thermal condition in which most students are at their greatest efficiency is the object of a good thermal environment. These thermal conditions will set the sensitive body mechanism at their minimum stress point and promote the greatest possible alertness over the longest period of time. The four prime factors which control efficient body comfort are radiant temperature, air temperature, air velocity and humidity control." (117:115)

There are other factors which influence comfort, but which are not directly concerned with the production or removal of heat. These include odors, dust, dirt and such atmospheric contaminants as smoke and exhaust fumes. They need to be eliminated to the greatest possible extent in the interests of health as well as of comfort.

Design Considerations

A great deal of technical information on the design of the thermal environment of schools is available. Most of this information is applicable to preschool day care conditions. However, the activities of preschool children and the nature of preschool programs do pose some special problems in preschool thermal environment design. Waechter and Waechter consider some of these problems in **Schools for the Very Young**. (125)

- In a preschool, young children contribute radiant body heat, just as larger children do, but there is more space for each child and a greater variety in space distribution as compared with a typical classroom
- the problem of exposure to the radiant temperature which may occur near windows is less grave than in classrooms for older children because pre-schoolers constantly move around

- very young children love to play on the floors, requiring warm floors and favoring radiant floor panel heating or carpeting
- preschools, particularly those with a half day program, have a relatively short heating period and the system used must be capable of quickly warming or cooling the building
- since the children are so small physically, the thermostats in the classrooms should be placed no higher than their heads so that the system will be responsive to conditions at the child's level
- In day care centers serving infants, special consideration needs to be given to the thermal climate of the infant care area

Performance Criteria

It is well to remember that optimum thermal conditions vary according to the individual's age, sex, health, activity level, and other factors, and that no two researchers agree on exact combinations of radiant temperature, air temperature, relative humidity, and air movement that constitutes the optimum. However, there is agreement in general:

Radiant temperature — the average temperature of surrounding surfaces should be the same as air temperature; a floor temperature that is warm to the touch, 79° F optimum.

Air temperature — 65° F to 70° F is optimal for vigorous activities; 72° F to 75° F is optimal for sedentary activities

Air movement — 20 to 40 lineal feet per minute measured at approximately 30 inches above floor level.

Relative humidity — 40% to 60%

Outside air — 15 to 30 cubic feet per person; 0.3 to 0.8 cubic feet per minute per square foot Heating is most easily and economically secured in buildings which have proper wall and roof insulation and solar radiation protection. This last point is very important where large areas of glass are used. The use of glass for natural lighting may conflict with effective thermal control. Heat loads produced by daylight and electric light systems represent a big design concern in large school buildings, but may not be of much concern in small day care centers.

The type of heating and ventilating which should be installed in preschool day care facilities depends upon many factors: original cost, operating cost, maintenance services available, the size of the facility, and state and local building standards. Each system has advantages and disadvantages. Some of the common systems include:

Direct radiation — best is provided by radiators or convectors located in the room under the window or along the window wall. Ventilation and cooling are often by open window, but may be supplied by mechanical means.

Panel heating — A radiant temperature which warms the room by means of a flat ceiling or wall heated above room temperature by hot water piping, warm air ducts, or electric heaters. Ventilation and cooling may be by open windows or mechanical means.

Unit ventilators — Fan units equipped with a heating element, outside air and recirculated air dampers, and fresh air intake. Located in each classroom, they supply heating and cooling in accordance with the demands of the classroom.

Warm air furnaces — Heat absorbed by air is forced through ducts into room. Cooling is usually by open windows; however, cold air can be introduced into a warm air duct system to provide air-conditioning.

Central fan or blast system — Air is driven over banks of hot water or steam heated radiators or coils, and delivered through ducts by a fan. This type system may also be equipped for cooling.

Split systems — Usually radiation or panel heating combined with a fan system for cooling, ventilating air, and extra heat for a quick warm up.

Air conditioning has become practically mandatory in climates where cooling is of equal if not more importance than heating. Day care centers which are in operation throughout the year should consider the possibility of a dual heating and cooling system even in parts of the country where summer is of short duration. Educators believe that air conditioning both directly and indirectly improves the educational process.

Conclusions

The problems of designing a good day care center atmospheric environment are similar to those of designing a school. Local climatic conditions will dictate the final solutions to the problem. The goal is to provide the healthiest conditions possible. Technical advances made during the last few years make it essential that expert assistance be secured in the early planning stages of a properly integrated system.

Technical information relating to climate control from this and the following chapter was taken from: **SEF E1, Educational Specifications and User Requirements for Elementary (K-6) Schools** (116)

Interior Surfaces

Interior surfaces are an aspect of the environment which is rarely considered. One notices walls, floors, and ceilings, but seldom the materials from which they are made. Interior surfaces stimulate vision and the sense of touch. Of these two, perhaps the tactile sense is the most important for the preschool children, especially the very young and the retarded.

"The sense of touch is constantly in use but sadly neglected. Even though the human being may cut himself off temporarily from sight or hearing by closing the eyes or plugging the ears, he can never in normal conditions be free of tactile sensation of the body on the surface which support it. Yet except when the cruder aspects of physical comfort or discomfort are involved, there is little consciousness of the sensations of touching the chair seat or the bed, or the desk on which the arms rest. The sensual life could be far richer if man became only slightly more aware of the tactile sense and, as a corollary of this, if architects more often used texture consciously as a design element — as a tactile experience and not just, as at present, visually." (84:41)

Design Considerations

Walls

The walls of a day care facility are used for many things besides defining the limits of the rooms. The purposes for which the walls are to be used should be kept in mind when the material for them is selected. It should also be kept in mind that material or equipment being used in the program and placed on walls should be placed at child's eye level. This is true of windows as well as chalk boards and tack boards. A wall that is to be "worked" on should have a texture that is appropriate to its use and that has low maintenance and high durability. Unused wall surfaces require less maintenance and allow more freedom for textural expression.

There should be many sorts of wall treatment in a preschool facility: smooth, rough, soft, and hard, each selected with as many purposes in mind as possible.

- preschool facility walls need not have blackboards or bulletin boards, but there should be provisions for writing, drawing, and mounting of information on the wall surfaces
- walls should provide a pleasing background for children's work, much of which will be vividly colored
- tackboard walls and chalkboard walls permit teacher and children to utilize many areas for education and training purposes
- working walls should be selected for durability and ease of maintenance qualities
- walls and doors should be easily and inexpensively maintained, especially the parts that are within the children's reach
- the baseboard should match the wall to eliminate a strong band of brightness — difference at a location that falls well within the visual range of preschool children
- glossy surfaces should be avoided, both in natural materials or applied surfaces in order to avoid disturbing highlights
- trim may be used as an accent to wall surfaces, but should retain about the same reflection factor values to avoid objectionable brightness-difference
- paint finishes should be flat or matte on all large interior surface areas
- semigloss finishes are permissible on trim surfaces for accents and for areas where frequent cleaning is necessary

Floors

Floors also deserve careful consideration because preschool children spend much time sitting or working on the floor. In addition to such characteristics as smoothness, easy maintenance, warmth, resilience, and water resistance, the floor material should also be considered for its acoustical properties.

The following observations may be helpful in selecting floor materials:

- floor surfaces in art and craft areas should be easily washable and water resistant
- floor surfaces in play areas should be resilient
- bare concrete and terrazzo floors should be avoided because of hardness, coldness, and noisiness
- wood flooring should be avoided because of maintenance and the hazard of splinters
- carpet as a floor surface offers the following qualities: it is comfortable to sit and walk on, resilient, and an effective noise preventer and absorber. However, some activities should be carried on where the floor surface is more readily mopped and scrubbed. Area carpets or rugs are frequently more satisfactory than wall-to-wall carpeting because they are more easily cleaned and allow for more flexibility in the arrangement of the area. Both functional and maintenance aspects of the different types of floor surfaces should be considered before a choice is made for a particular area.

Ceilings

Although ceilings do not come into direct physical contact with the occupant of the preschool facility, they are important in the learning environment.

- ceilings may be more textured than walls and floors because they do not come into direct physical contact with the occupants
- ceilings should be used mainly for sound distribution
- the effectiveness of ceilings as a light-reflecting agent may be compromised to a degree when acoustic materials are needed and applied to it
- acoustic plaster and perforated fiber boards lose less of their acoustical properties when painted than do the non-perforated materials
- materials should be selected mainly for sound distribution and light reflecting qualities, two considerations which may not be complementary

Other Surfaces

Other surfaces which deserve consideration are a large part of the room's interior surface occupied by storage walls, built-in equipment and furniture, windows, doors, and sliding partitions. Chalkboards and tackboards and viewing screens are included in this group if they are applied to the wall and are not an integral part of a working wall design.

- conventional blackboards should be coverable with lighter colored surfaces when a high level of reflectance is required
- high reflection chalkboards (20-25%) are only practical when a high level of illumination compensates for the reduced brightness-difference between the white chalk and the light-colored board
- bulletin boards, tackboards, etc., should complement the wall color scheme
- semigloss finishes should be used on trim, doors, woodwork, and other areas where frequent cleaning is necessary
- desk tops and frames should have a flat non-glossy finish
- desk and equipment finishes should have a 30 to 50% reflection factor range. This includes all case work, shelving, supplementary furniture, machines, lockers, filing, cabinets and the like

Conclusions

Since interior surfaces play a large part in the educational value of the environment, it is important for the architect to carefully consider this area when designing a preschool facility.

It is advisable for the architect to list all the materials which might be used against these requirements: workability, availability and cost. Only then may a sound evaluation be achieved with regard to hygienic qualities, color, light reflection, acoustical qualities, textural qualities, insulation value, and initial and maintenance costs.



Space

Space is where things happen. The way space is enclosed, that is, the size and shape including the height of the room, plays an important part in the efficiency, enthusiasm, and discipline with which the activities are carried on in a preschool day care center. Children respond more impulsively to their environment than do adults. Space suggests certain activities to them. A high spot is a place from which to survey the world and command attention. Long corridors or wide open space invite running, tunnels invite crawling through, and closets invite hiding. Size can be forbidding, frightening, restricting, inviting or any number of other things. It can produce behavior related to these feelings.

Research in learning indicates that room size, form, and scale have a definite bearing on the effectiveness of the information transferred to the child.

The following comments apply directly to the arrangement of space and its contents in the preschool day care facility:

"The classroom's arrangement should contribute to the child's concepts of order and space. A perceptually clear and distinct room environment, achieved through uncluttered equipment and furniture arranged in an orderly fashion, helps the child focus his attention on the curriculum instead of distracting him with irrelevant stimuli. Daily contact with an uncluttered, structurally simple environment helps teach time and space organization. Tidiness is a secondary benefit." (115:4)

Design Considerations

Space is defined by its size, form (shape and volume), and scale.

Size

A space can be too large or too small for a given activity. The optimal size of any space should be determined by the nature of the activity or activities which will take place in the area, the number of children and adults who will be involved, and the furniture, equipment, and supplies which are needed. Even with this information, it is impossible on the basis of available data to give a definite prescription for the size required for an area.

Because of changing requirements, it is very difficult to exactly determine the required size. Therefore, we can only approximate the minimum and maximum area needed to effectively conduct the activity or activities it houses. The optimum size of any space lies somewhere between the minimum and maximum area.

Form

The housed activities also dictate the form of the space involved. In addition to the activities of the children, there are teacher activities which influence the form of a room. The most important of these is probably the supervision of the children by the teacher. The shape of the room should be such that easy casual supervision is possible. Square or nearly square rooms are preferred by many teachers because they offer ease of supervision plus flexibility in the arrangements of interest and play centers. However, a box, which ignores the three dimensional possibilities of space and produces boredom, is not advisable.

It is well to remember that booming big spaces with high ceilings invite boisterous uninhibited play. Lower ceilings tend to create a more subdued atmosphere. Attention can be focused on an activity by lowering the ceiling, raising the floor of the area, or creating an alcove where the activity takes place.

Scale

Children's space should be friendly and pleasant — a space which children readily recognize as their own because the things in it are scaled to their size and stimulating to their interests.

Scale is the relationship between the human body and its environment. Before planning spaces and designing equipment for preschool children, it is necessary to understand the characteristics of their physical growth. Further discussion of this topic will be found in the forthcoming section of "Furniture." This provides basis for scaling children spaces to their size. Proper scale is achieved by giving informed consideration to such items as the interior proportions of space, the size and shape of furniture, equipment, fixtures, and other operative products, the height of operating hardware, blackboards, shelf windows, stair rails, electrical switches and the like.

Scale and form appropriately blended can produce an atmosphere of order and beauty indefinitely but definitely related to learning.

Conclusions

The size and shape of the space for the activities of preschool children need to receive careful consideration because of the influence these parameters have on the behavior of children.

Flexibility

We have come to realize that the only certainty in preschool education is change. In facilities where there is constant change and improvement in materials, methods, and techniques, it is essential that building flexibility be provided. Many administrators and architects do not have a specific program or specification for flexibility; they are only aware of the criticism they may receive if they can not claim to have such capability in their facility.

Flexibility should not be confused with freedom of movement — it is much more. It is a prescribed system for optimizing daily needs by correct planning resulting from an exact knowledge of requirements. Flexibility is not all encompassing, but follows a certain set of rules and standards based on rational "decision making" towards fulfilling the given requirements. It performs most efficiently when it follows its prescribed path; deviation from this path limits performance and increases the cost.

It should be kept in mind who the real users of flexibility are: not the architect, the contractor, or the manufacturer who supplies the building components, but the children and the personnel of the facility — especially the children's teachers. Flexibility can be used as an educational tool: children love to change their physical environment. But the main users and creators of flexibility are the teachers.

If, however, a facility's flexibility is too difficult to realize, either because it takes too much time or effort, they will not make intended use of built-in flexibility unless they are forced to do so. The flexibility features must be convenient and simple to operate.

Design Considerations

The concept of flexibility can be described as a function of at least four contributive parameters. A facility is flexible to the extent that it incorporates these parameters:

expansibility — the ability for exterior growth, enlargement, or change
adaptability — multifunctional space; it has to accommodate changing needs
convertibility — the ability to internally change a space into a totally different space or spaces quickly, efficiently, and economically
useability — the utility of a facility and its environmental components, furniture, equipment and fixtures

Motivators for flexibility:

- children
- staff
- community patterns (social, political, cultural, and economical)
- educational objectives
- educational program
- educational activities

Means of achieving flexibility:

- multi-use equipment/furniture
- portable equipment/furniture
- partitions/dividers
- changeable wall, floor, ceiling surfaces
- electrical and mechanical systems
- non-load bearing walls
- large spans
- audio-visual technology
- prefabrication
- modular coordination
- systems approach

Conclusions

Flexibility, therefore, becomes an integral component of the physical environment. If facilities could be tailor-made and disposable to meet every possible situation, flexibility would not be needed. But the reality of life forces us to economize — disposable, tailor-made facilities are not economical. One space has to do many things: accommodate changing educational objectives and needs, changing community patterns, changing children and teachers, newly developing audio-visual technology, etc. We need a variety of spaces to satisfy many conditions but yet costs require us to compromise.

The built environment must house a specific program with an individualistic teacher in charge of a number of different children. Not only do specific programs require inherent flexibility, but the teachers themselves require the opportunity to structure the built environment to their own particular teaching preferences.

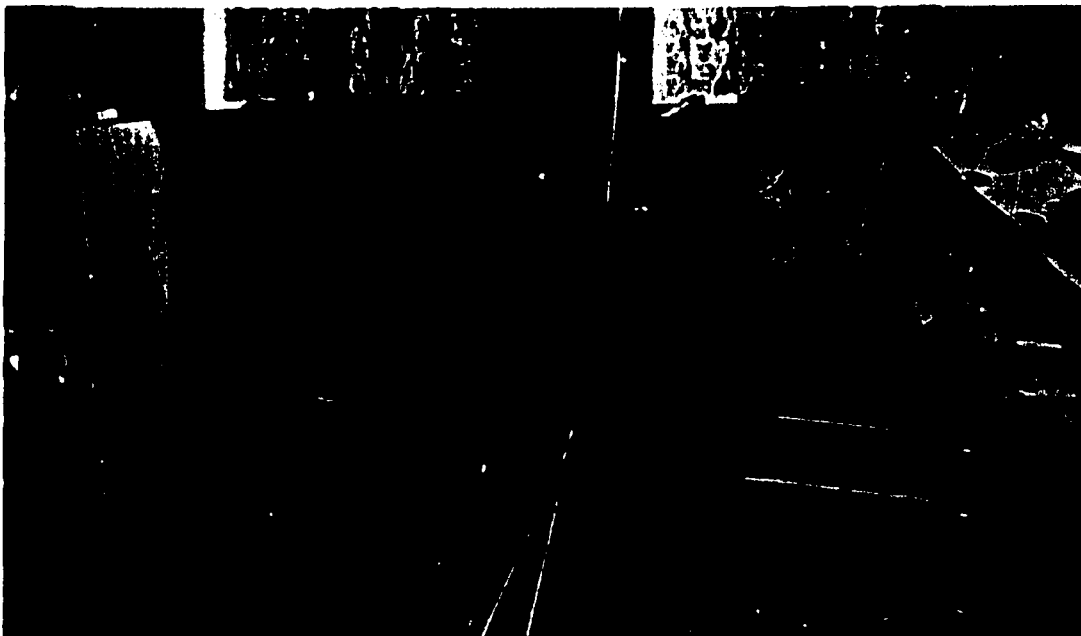

Psychological Variables

Throughout the text, several psychological variables have been indicated relating to the preschool child. The usual concept of the psychological world of the child comprises things he knows about, the objects he is aware of, the things he notices and keeps in mind as he goes about his daily life. But this description is restrictive as it only includes objects of which the child is conscious. We really do not have a good idea as to what is on his level of consciousness except as determined by his behavior patterns and by what the child can tell us.

We know that the child's psychological state cannot be isolated from the physiological one. A healthy body makes for an alert attentive mind. It is necessary to provide food and health services, along with psychological and social services, whenever they are needed. Specific inclusion of these services within the preschool facility will depend on individual need and availability of resources to that particular facility.

There are hidden problems that result from poor nutrition at initial stages of development. Under-nutrition and malnutrition interfere with the learning by preschool age children; these years are irreversibly lost. This is in addition to the possibility of irreversible damage to both physical and mental development.

We know that environmental stimulation can initiate and accelerate or even retard maturation — a process of growth and development of mind and body; learning is dependent upon a certain stage of maturation.

We also know that he learns by past experiences and that behavior is affected and modified by these experiences. Most of his experiences and learning have come through his few self-chosen activities.

Since the preschooler has very little experience with life and therefore does not know how to further expand these activities, it is then up to the concerned adults to steer him into constructive creative learning experiences.

Therefore, it is essential that the environment of young children must be adjusted to both their physical and mental power. Not only must we provide adjustable tables and chairs, for example, but also problems and opportunities adjusted to the thinking and feelings they are experiencing.

Since the psychological aspects of the child's learning ability has been adequately covered throughout the previous sections of this report, an in-depth study is not considered necessary at this time. It is only mentioned here as a reminder and to stress the importance that the psychological variable has upon the total learning environment.

Summary

The physical environment provides not only the basic levels of comfort but also helps to alter, modify, and construct attitudes, behavioral patterns, and other psychological responses. This "therapeutic" level of environmental design is discussed in Bednar and Haviland's **The Role of the Physical Environment in the Education of Children with Learning Disabilities.** (85) Their chapter on conceptualizations is especially worthy of note and reference should be made to it by everyone contemplating the construction of a preschool facility.

This section has looked at the environmental variables as single concerns. The obvious fact is that they are very closely interrelated.

Vision has psychological qualities through its relationship to light, color and texture.

- A crate painted dark blue was experienced as heavier than an identical one of yellow. (84:32)
- Weights are judged as being heavier under red light and lighter under green light.
- We feel textures with our eyes. We see rough buildings, and slick ones, sharp corners, and soft spaces.

Sound can be used to heighten environmental sensations and help relate activities and behavior to space.

- A quiet place for resting
- Soft music for dining
- Lively sounds for physical activity
- Noise sounds loudest in a white room and quietest in a purple one. (84:32)
- Sensitivity to red colors is lowered by the influence of sound, while sensitivity to green colors is increased. (90:109-118)
- Low notes tend to make colors appear as deeper hues and vice versa. (90:109)

Because of so many of the variables are interrelated, future research is needed to determine not only what influences the isolated variables have on learning ability, but what effect the total environment has on learning ability. Once the variables have been isolated and evaluated, the interactions and relationships among the variables can be plotted to achieve meaningful and realistic results for effective evaluation of the total learning environment.

The Day Care Facility

5

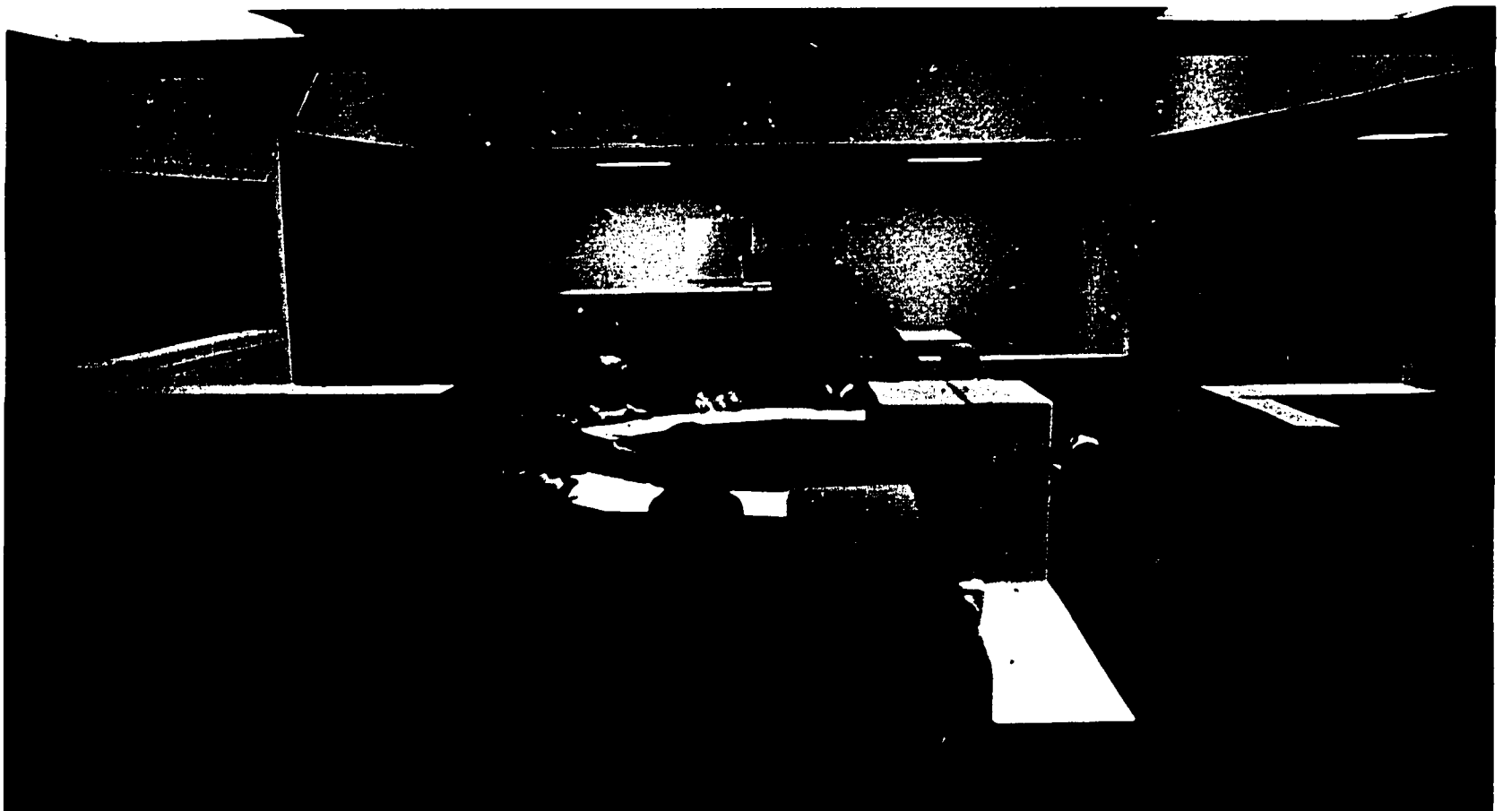

Basic Planning Considerations

This chapter on the Day Care Facility suggests detailed planning and design requirements for the preschool facility. Specific spaces are presented in terms of environmental components, relationships, furnishings and the role they have in specific educational activities. This information is derived from the preceding two chapters.

Certain preliminary aspects of planning a day care facility need careful consideration. These include: site selection, location of a facility on site, codes, zoning, safety and sanitary standards, and ordinances — local, state, and national.

Site Selection

- the site should be easily accessible to the center of the community services and activities.
- the site should be located in a quiet zone within a convenient distance of the homes of the children or of the mother's place of work.
- the site should be free from dust, noise, fumes, and airport traffic patterns.
- the site should offer easy access by foot, car, bus, etc.
- the site should be planned for future needs — part of a coordinated community plan.
- the site should be adequate to provide sufficient well-drained outdoor activity and play areas.
- the site should be selected for its natural amenities (plant life, animals, water, earth forms, etc. — trees, bushes, and shrubs on and around the site will reduce noise).
- the size of the facility is only partially related to total required area of the site — consider adequate parking, deliveries, safe loading and drop-off zones, pedestrian/auto circulation, future building expansion, and adequate playground/recreation space.
- select sites near existing elementary schools if possible because public school systems are beginning to incorporate early childhood education into their elementary school plans.

Location

- locate the facility at some distance from arterial streets and roads, railroads, and other type of hazards and noise.
- when noisy sites must be utilized, greater sound insulation in the facility must be provided.
- locate the facilities' noisy activities nearest the outside noise source — in this way, the room housing the noisy activities can shield to some degree the quieter activities.
- provide easy, safe access to the classroom.
- roads, walks, and on-site parking should be located to minimize hazards to pedestrians, but permit ease of traffic movement for staff, visitors, and deliveries.
- locate facility with consideration of sun orientation.
- locate facility in consideration of prevailing breeze and other natural amenities.

Codes, Ordinances, Zoning

- check and comply with local standards.
- every facility should have at least two fire exits immediately accessible to all rooms used by children.
- all outside doors should open outward.
- facilities should be designed to make them accessible to and usable by all physically handicapped, including public, staff, and children.
- provide low firm railing easily usable by children in hazardous locations.
- classrooms, if not established by code, are preferred on the ground floor.
- provide ramps if handicapped children are involved.

The component parts of a day care center will be considered under three main headings which correspond with its functional organization:

**Education/Training
Ancillary Service
Administration**

The anticipated and planned interaction among these three groups should determine the general spatial layout of the facility. Analysis of these inter-group relationships reveals that interaction is most dynamic between the educational training and ancillary service groups. Interaction among ancillary service and administration is second in degree of activity, while the least contact of this kind occurs between the administration and education/training groups. Spatial planning should reflect these relationships. The spaces allocated for education/training should, of course, be closely located to each other for optimal intra-group activities and should as a whole be located near those spaces noted for supporting ancillary services. The ancillary service spaces should also relate to the administration area(s), whereas contact between administrative and education/training spaces should be minimal if at all.

The spatial layout of the center should facilitate meaningful interaction and help provide a continuous learning experience for all participating persons. With careful planning this can be accomplished.

Education/Training Area

This area consists of the classroom/playroom and other spaces directly associated with the education and care programs for the children. The care activities include bathroom, naps and food service. Special educational activities might include a music room, a tutoring/isolation room, a multipurpose room or other rooms appropriate to the center's program. In most day care centers these activities will take place in the playroom and provision for them will be a part of playroom planning. Consequently the requirements of special activity rooms will be touched on only briefly, following the discussion of the classroom.

Classroom/Playroom

The classroom/playroom is the most important space in any preschool facility. The activities which take place there provide the means for achieving the education and training goals of the child care activities mentioned previously. Therefore, the classroom/playroom must provide for a variety of activities. This room is composed of two kinds of spaces: a relatively large open space for activities which will involve the whole group of children and smaller more structured spaces where specific activities take place. The interior arrangement of classroom/playroom should be flexible, involving few or no fixed partitions and providing multi-functional furniture and storage units which can double as partitions. Moveable partitions or backdrops can also provide extra flexibility for structuring group activities.

This situation is usually handled by the creation of "interest centers" within the play area.

Interest centers are clusters of functionally related materials. Some are located around large or relatively permanent objects such as a sink, work bench, play house or piano. Others, consisting mainly of easily portable and storable objects, such as puzzles, blocks, and drawing equipment, require only storage space and floor or table space. Though a center of interest is arranged to stimulate direct experiences, each child is free to use the center in his own way.

The interest centers are adjacent to the larger group activity space, and activities can overflow into this larger space whenever necessary. This has the advantage of allowing a variety of activities to go on at the same time. However, another solution, primarily applicable to large facilities containing a number of classrooms or playrooms, is to equip each room for one activity rather than a variety. This has the disadvantage of limiting the children's choice at any given time, but with careful planning could have advantages through the specialization of teachers.

Interest centers which have environmental requirements in common should be set up near each other. This is especially true of noisy and quiet activities. Circulation and traffic patterns should be clearly defined. Satisfying environmental requirements can be done through the skillful manipulation of the texture and light and acoustical properties mentioned earlier.

Since stimulating interest centers are based on children's interests and motivity, the contents and nature of the centers should differ for children with different backgrounds and life experiences. Careful consideration of the relevancy of interest centers is vital in providing enriching experiences to deprived children and retarded children.

Some possible interest centers are described on the following pages. In each, the material and supplies should be appropriate for the children's maturity levels and backgrounds.

The arrangement of the play area should promote the program objectives discussed in Section 2. The achievement of the attitude-behavior objective requires that the space be organized in an orderly and convenient way, that it suggest and make easy purposeful play and care of materials, and that it encourage cooperative play and facilitate unobtrusive supervision by adults. The part played by the environmental variables in achieving this goal has been discussed in the previous section.

The total playroom/classroom area is considered to consist of two distinct types of spaces: (1) the space for total group activities, and (2) spaces for interest centers.

1 Total Group Activity Space

This is the hub of the classroom around which the different interest centers are arranged and into which they can expand when necessary. Some of the activities which will take place in this subspace of the playroom are listed below. The list is followed by a discussion of the part played by the physical environmental variables in producing an optimal environment for these and similar activities.

activities:

- musical activities such as singing, dancing, listening to records
- story telling
- dramatic play
- indoor physical activities
- eating
- resting on the floor

groupings:

- large (6-15 children)
- small (2-5 children)
- large group activities are prevalent in this space, with ability to be subdivided into smaller groups when needed

atmosphere:

- active, lively, cheerful

color scheme:

- warm color range
 - pastels for large surfaces (walls, floor, ceiling)
 - primaries for accents, trim, and emphasis

interior surfaces:

- floor
 - resilient
 - easily maintained/cleaned
 - durable
 - non-slip
 - smooth
 - since this is a high activity space, floor surface should have sound absorption qualities to eliminate scraping of tables, chairs, shuffling of feet, and high-pitched loud voices
 - floor should be free of drafts, and warm and comfortable to the touch
 - if floor is not carpeted, a rug would be desirable
- walls
 - smooth
 - easily maintained/cleaned
 - walls and doors, within reach of children, should be easily washable
 - walls should be designed to serve as working surfaces (writing and display)

- baseboard should complement the walls in order to eliminate a strong band of brightness difference at a location that often falls well within the visual field of the children
- doors should be safe and easy for children to use
- all corners should be rounded for safety
- ceilings
 - light reflective surface for overall uniform lighting
 - sound distribution for good tonal qualities
 - avoid vaulted or domed ceilings
- other
 - permanent and built-in equipment and furniture should complement wall finishes
 - glossy finishes should be eliminated in order to avoid disturbing highlights

space configuration:

- size
 - min. 40 sq. ft./child
 - max. 60 sq. ft./child
- square or nearly a square shape is desirable for ease of supervision and control plus flexibility in group arrangements
- high ceiling, in comparison to adjoining spaces, may be used for sound reduction and to help create an active, lively atmosphere

relationships:

- necessary to
 - observation
 - bathroom
 - outdoor recreation
 - storage
- desirable to
 - arts/crafts center
 - housekeeping/dramatic play center
 - nature study/science center
 - book center
 - block center
 - tutoring/quiet
 - music
 - indoor recreation
 - multi-purpose
 - maintenance
 - teacher
- undesirable to
 - napping/resting
 - infant care
 - staff lounge
 - mechanical
 - executive director
 - secretary
 - conference/board
- provide separate entrance for preschool children when it is part of a larger complex where older children are involved

furniture/equipment:

- open shelf storage
- closed shelf storage
- personal storage units (1 per child)
- desk (1 per child)
- chalkboard
- audio-visual equipment
- cots/mats (1 per child)
- musical equipment
- chairs (1 per child and 3 or 4 extra)
- display boards
- teacher desk and chair optional, but teacher needs some private space
- electrical services should be readily available to all parts of the classroom for audio-visual equipment

lighting:

- quantity
 - 30 ft. candles/general
 - 50 ft. candles/detail
- a good artificial lighting system that provides overall uniform illumination is recommended
- natural light can be introduced where possible
- rheostat-controlled lighting level is recommended during rest periods, use of audio-visual equipment, and other applicable activities
- provide windows for visual link with outdoors; shield for glare and reflection
- use shielded warm white fluorescent lamps

acoustics:

- surface treatment in small spaces has relatively little effect on hearing conditions; consider treatment of floor to reduce activity generated noise
- sound reverberation within space should be avoided
- sound insulation between adjacent classrooms and spaces

climate control:

- temperature
 - 72° to 78°
- humidity
 - 30% to 50%
- outside air
 - 0.5 to 0.8 cfm/sq. ft.
 - 15 to 30 cfm/person
- air changes
 - 6 to 8/hour
- air movement
 - 25 to 80 fpm
- avoid floor drafts

2 Arts/Crafts Center

The arts and crafts center provides material with which children can make things. The young child is creative when he works with uncommitted material like water, sand, clay, finger paint, paste, etc. Teachers curtail some of the activities because they are messy, but disorder can be reduced to a minimum if space is carefully designed and appropriate storage and floor and table surfaces are provided. Special attention should be given to the selection of floor and wall materials. Activities may be done on the floor, desk, work table or easel.

activities:

- sand play
- water play
- drawing
- painting
- clay modelling
- manipulation of paper
- cutting paper
- pasting

groupings:

- small (2 - 5 children)
- individual
- occasionally all of class will participate in arts/crafts activities

atmosphere:

- active, lively, stimulating

color scheme:

- warm color range
 - pastels for large surfaces (walls, floor, ceiling)
 - primaries for accents, trim, and emphasis

interior surfaces:

- floor
 - easily maintained/cleaned
 - moisture proof
 - resilient
 - durable
 - may be equipped with a floor drain
 - vinyl-asbestos tile is recommended near sink and clean up area
- walls
 - easily maintained/cleaned
 - washable within reach of children
 - walls should be designed as writing and display surfaces
- ceiling
 - should be light reflective for overall uniform illumination
 - acoustical treatment of ceiling is recommended

space configuration:

- size
 - min. 30 sq. ft./child 150 total sq. ft.
 - max. 50 sq. ft./child 250 total sq. ft.
- when all of class are involved, approximately 250 sq. ft. of additional space is required (flexible arrangement would allow this additional space to be shared with the total group activity space)

relationships:

- necessary to
 - observation
 - outdoor recreation
 - storage
- desirable to
 - total group activity
 - housekeeping/dramatic play center
 - nature study/science center
 - book center
 - block center
 - tutoring/quiet
 - indoor recreation
 - bathroom
 - maintenance
- undesirable to
 - infant care
 - staff lounge
 - mechanical
 - executive director
 - educational director
 - secretary
 - conference/board room

furniture/equipment:

- children's sink
- teacher's sink
- counter space
- open shelf storage
- closed shelf storage
- easels
- desks
- work table
- bulletin boards or suitable wall space for displays
- waste baskets
- chairs

lighting:

- quantity
 - 50 ft. candles/general
 - 70 ft. candles/detail
- cool white shielded fluorescent lamps are recommended
- overall uniform illumination with incandescent spotlighting for accent and emphasis
- natural daylighting can be introduced to enhance art work

acoustics:

- avoid all hard surfaces to prevent sound reverberation
- sound produced in this space should not disturb persons in adjacent areas
- acoustical treatment of walls and ceiling
- avoid vaulted or domed ceilings

climate control:

- temperature
 - 72° to 78°
- humidity
 - 30% to 50%
- outside air
 - 0.5 to 0.8 cfm/sq. ft.
 - 15 to 30 cfm/person
- air changes
 - 6 to 8/hour
- air movement
 - 25 to 40 fpm
- avoid floor drafts

3 Housekeeping/Dramatic Play Center

A center for housekeeping and dramatic play is recognized by the home-like, child sized furniture and housekeeping essentials. The young child is a natural inventor of dramatic situations in which he imitates human beings who puzzle or delight him. The center for dramatic play is especially valuable because role-playing enables a child to find the personal courage to release negative and ambivalent as well as positive feelings. It stimulates him to find the words to express these feelings and to communicate them increasingly.

This center is probably the most popular in day care facilities, and few teachers would care to be without one. Sensitive teachers feel that this is a place where children imitate, interpret and assimilate the roles and customs of their culture.

activities:

- sharing
- role playing
- dressing
- housekeeping
- preparing food

groupings:

- small (2-5 children)
- individual

atmosphere:

- active, cheerful, warm

color scheme:

- warm color range
 - pastels for large surfaces (walls, floor, ceiling)
 - primaries for accents, trim, and emphasis

interior surfaces:

- floor
 - should be free of drafts and warm to the touch
 - contribute to sound control
 - comfortable sitting surface
 - carpet is recommended
 - easily maintained/cleaned
- walls
 - should be designed to serve as writing and display surfaces
 - easily maintained/cleaned
 - washable within reach of children
- ceiling
 - sound absorbent
 - light reflective

space configuration:

- size
 - min. 15 sq. ft./child 75 total sq. ft.
 - max. 25 sq. ft./child 125 total sq. ft.
- space flexibility should provide for a home-like arrangement (kitchen, dining, living, and bedroom)

relationships:

- necessary to
 - observation
 - outdoor recreation
 - storage
- desirable to
 - total group activity
 - arts/crafts center
 - nature study/science center
 - book center
 - block center
 - tutoring/quiet
 - indoor recreation
 - bathroom
 - maintenance
- undesirable to
 - infant care
 - staff lounge
 - mechanical
 - executive director
 - educational director
 - secretary
 - conference/board
- consider adjacent relationship to block center for cooperative activities

furniture/equipment:

- open shelf storage
- closed shelf storage
- pegboard
- bulletin board
- full length mirror
- table
- 2 or 4 chairs
- stove, refrigerator, cupboard, beds, buggies, (child-scaled)
- housekeeping accessories
- dress-up clothes and accessories

lighting:

- quantity
 - 30 ft. candles/general
 - 50 ft. candles/detail

acoustics:

- acoustical treatment of floors to prevent noise such as shuffling of feet, scraping of furniture and blocks

climate control:

- temperature
 - 72° to 78°
- humidity
 - 30% to 50%
- outside air
 - 0.5 to 0.8 cfm/sq. ft.
 - 15 to 30 cfm/person
- air changes
 - 6 to 8/hour
- air movement
 - 25 to 40 fpm
- avoid floor drafts

4 Nature Study/Science Center

Nature study or science centers promote the child's interest in living things. Children have insatiable curiosities about the world around them. This area should provide space for an aquarium, bird and animal cages, a terrarium, and potted plants—hopefully, not all at one time. The needed services of direct sunlighting, water and soil preparation can be provided by utilizing a small outdoor study area directly accessible through or included within the indoor area. If the teacher is interested in nature and gifted in communicating with children this can be a most exciting center.

activities:

- listening and talking
- nature study
- taking care of animals
- taking care of plants
- collection of rocks, leaves, etc.
- study of seasonal changes
- study of current scientific events

groupings:

- small (2 to 5 children)
- individual

atmosphere:

- passive, quiet, interesting

color scheme:

- cool color range
 - pastels for large surfaces (walls, floor, ceiling)
 - primaries for accents, trim, and emphasis

interior surfaces:

- floor
 - soft, comfortable, and warm to the touch
 - easily maintained/cleaned
 - carpet or area rug recommended
 - should contribute to sound control
- walls
 - easily maintained/cleaned
 - light reflective
 - walls should be designed to serve as working surfaces
- ceiling
 - light reflective
 - sound absorbent

space configuration:

- size
 - min. 15 sq. ft./child 75 total sq. ft.
 - max. 25 sq. ft./child 125 total sq. ft.
- low ceiling may be used to create quiet, relaxed atmosphere
- flexible space arrangements would allow separate areas for varied nature study activities

relationships:

- necessary to
 - observation
 - outdoor recreation
 - storage
- desirable to
 - total group activity
 - arts/crafts center
 - housekeeping/dramatic play center
 - book center
 - block center
 - tutoring/quiet
 - indoor recreation
 - bathroom
 - maintenance
- undesirable to
 - infant care
 - staff lounge
 - mechanical
 - executive director
 - educational director
 - secretary
 - conference/board

furniture/equipment:

- aquarium
- terrarium
- animal cages
- planting beds
- bulletin board
- chalkboard
- closed shelf storage
- table
- chairs (2 to 4)

lighting:

- quantity
 - 30 ft. candles/general
 - 50 ft. candles/detail
- use shielded cool white fluorescent fixtures
- uniform illumination with incandescent spotlighting for emphasis
- should have natural sunlighting for the nature areas

acoustics:

- acoustically treated floors and ceilings

climate control:

- temperature
 - 72° to 78°
- humidity
 - 30% to 50%
- outside air
 - 0.5 to 0.8 cfm/sq. ft.
 - 15 to 30 cfm/person
- air changes
 - 6 to 8/hour
- air movement
 - 25 to 40 fpm
- avoid floor drafts
- need air circulation for odor control, especially in areas where animals are kept

5 Book Center

The book center should be a comfortable and intimate space. Space for individual activities and frequent small group activities of 2 to 5 children is needed. Space for quiet and exploring activities by children sitting or lying on the floor should be located away from traffic perhaps set apart by movable dividers and screens.

activities:

- handling books
- paging through books
- listening to stories, tapes, and records
- browsing
- viewing slides, filmstrips

groupings:

- small (2 - 5 children)
- individual
- total group may utilize this area at times

atmosphere:

- passive, quiet, relaxed

color scheme:

- cool color range
 - pastels for large surface areas
 - primaries for accents, trim, and emphasis

interior surfaces:

- floor
 - soft, comfortable, and warm to the touch
 - easily maintained/cleaned
 - carpet or area rug recommended
- walls
 - easily maintained/cleaned
 - light reflective
 - sound absorptive
 - walls should be designed to serve as working surfaces
- ceiling
 - light reflective
 - sound absorptive

space configuration:

- size
 - min. 10 sq. ft./child 50 total sq. ft.
 - max. 20 sq. ft./child 100 total sq. ft.
- low ceiling can be used to help create a quiet intimate atmosphere

relationships:

- necessary to
 - observation
 - outdoor recreation
 - storage
- desirable to
 - total group activity
 - arts/crafts center
 - housekeeping/dramatic play center
 - nature study/science center
 - block center
 - tutoring/quiet
 - indoor recreation
 - bathroom
 - maintenance
- undesirable to
 - infant care
 - staff lounge
 - mechanical
 - executive director
 - education director
 - secretary
 - conference/board

furniture/equipment:

- table
- 4 or 5 chairs
- open shelf storage
- closed shelf storage
- tackboard
- chalkboard
- audio-visual — same as main activity space

lighting:

- quantity
 - 50 ft. candles/general
 - 70 ft. candles/detail
- uniform illumination
- cool white shielded fluorescent fixtures
- rheostat control for use of audio-visual equipment
- illumination should be without glare and reflections
- avoid natural light because it is difficult to control

acoustics:

- acoustical privacy
- elimination of sound interference
- sound insulation from other spaces
- acoustical treatment of floors and ceiling is recommended

climate control:

- temperature
 - 72° to 78°
- humidity
 - 30% to 50%
- outside air
 - 0.5 to 0.8 cfm/sq. ft.
 - 15 to 30 cfm/person
- air changes
 - 6 to 8/hour
- air movement
 - 25 to 40 fpm
- avoid floor drafts

6 Block Center

Block building usually takes place on the floor and requires an open space located away from traffic. The blocks and other toys should be conveniently stored nearby. This activity occurs spontaneously and aids in developing motor and manipulative skills. Building is a natural activity for young children and structures are a natural way for them to express ideas. With a center sufficiently isolated and room enough to permit structures to remain assembled after the session is over, children can return to reconstruct, elaborate, or rearrange the blocks. As interests shift during the course of the year, floor space will grow and shrink to accommodate the children involved. When certain props, such as toys, or puppets are added, the block construction space then becomes a play center involving more floor space.

activities:

- visual and tactile discrimination
- block construction
- manipulating small toys

groupings:

- small (2-5 children)
- individual

atmosphere:

- active, cheerful, inspiring

color scheme:

- warm color range
 - pastels for large surfaces (walls, floor, ceiling)
 - primaries for accents, trim, and emphasis

interior surfaces:

- floor
 - high impact
 - soft, comfortable, and durable
 - should be free of drafts and warm to the touch
 - carpet is recommended
 - comfortable sitting surface
- walls
 - should be smooth
 - easily maintained/cleaned
 - should have working wall surface
 - high impact
- ceiling
 - sound distribution for good tonal qualities

space configuration:

- size
 - min. 10 sq. ft./child 50 total sq. ft.
 - max. 20 sq. ft./child 100 total sq. ft.
- when all of class are involved approximately 50 to 100 sq. ft. of additional space is required. (flexible arrangements would allow this additional space to be shared with the total group activity space or similar space)

relationships:

- necessary to
 - observation
 - outdoor recreation
 - storage
- desirable to
 - total group activity
 - arts/crafts center
 - housekeeping/dramatic play center
 - nature study/science center
 - book center
 - tutoring/quiet
 - indoor recreation
 - bathroom
 - maintenance
- undesirable to
 - infant care
 - staff lounge
 - mechanical room
 - executive director
 - educational director
 - secretary
 - conference/board

furniture/equipment:

- open shelf storage
- closed shelf storage
- chalkboard
- bulletin board
- block cart
- solid hardwood unit blocks
- supplementary play material

lighting:

- quantity
 - 30 ft. candles/general
 - 50 ft. candles/detail
- shielded warm white fluorescent lamps
- uniform illumination with incandescent spotlight for emphasis
- rheostat control for reducing lighting level to create atmosphere and mood

acoustics:

- impact noise is critical
- acoustical treatment of floors to prevent noise such as shuffling of feet, scraping of furniture and blocks

climate control:

- temperature
 - 72° to 78°
- humidity
 - 30% to 50%
- outside air
 - 0.5 to 0.8 cfm/sq. ft.
 - 15 to 30 cfm/person
- air changes
 - 6 to 8/hour
- air movement
 - 25 to 40 fpm
- avoid floor drafts

Supportive Spaces

7 Tutoring/Quiet

This small space can be used for many purposes. It can serve as a quiet area for the overactive child, a place for psychological testing, a space for individual counseling or instruction, a small teacher's office, and a space for individual or small group study for children who learn more easily when separated from the group.

This space should be located adjacent to the children's classroom so that it may be viewed easily by the teacher.

The area should provide an intimate environment, acoustically isolated, that is enclosed and free from distractions. The enclosed space, or tutoring room, enables a child or small group of children to be free of distractions while working with a teacher or with specialized teaching equipment.

activities:

- individual work
- individual study
- isolation
- testing

groupings:

- individual
- small (2 to 5 children)

atmosphere:

- quiet, passive, peaceful

color scheme:

- cool color range
 - cool pastels for large surfaces (walls, floors, and ceiling)
 - cool primaries for accents, trim, and emphasis

interior surfaces:

- floors
 - soft and comfortable
 - inviting to lie and sit upon
 - carpet is recommended
- walls
 - should be designed to serve as working surfaces
 - easily maintained/cleaned
 - sound absorptive
- ceiling
 - should be light reflective and sound absorber.

space configuration:

- size
 - min. 15 sq. ft./child 75 total sq. ft.
 - max. 20 sq. ft./child 100 total sq. ft.
- low ceiling recommended

relationships:

- necessary to
 - observation
 - storage
- desirable to
 - total group activity
 - arts/crafts center
 - housekeeping/dramatic play center
 - nature study/science center
 - book center
 - block center
 - bathroom
 - maintenance
 - teacher
- undesirable to
 - infant care
 - staff lounge
 - mechanical
 - executive director
 - educational director
 - secretary
 - conference/board

lighting:

- quantity
 - 50 ft. candles/general
 - 70 ft. candles/detail
- glare free artificial illumination

acoustics:

- sound insulation from other spaces
- reduce activity generated sounds
- acoustical treatment of floor and ceiling is recommended

climate control:

- temperature
 - 72° to 78°
- humidity
 - 30% to 50%
- outside air
 - 0.5 to 0.8 cfm/sq. ft.
 - 15 to 30 cfm/person
- air changes
 - 6 to 8/hour
- air movement
 - 25 to 40 fpm
- avoid floor drafts

8 Napping/Resting

Preschool children at a day care center for more than a half day need a nap. Napping on cots or mats usually takes place in the classroom because the small group and familiar surroundings create a calmer atmosphere. Space should be large enough to accommodate the cots or mats with an appropriate distance between them. Tables, chairs, and other furniture and equipment will probably have to be moved to one side or stacked in order to provide the necessary space. If napping takes place in the playroom, storage space must be provided for the cots or pads.

A few preschool facilities continue the luxury of a separate nap room because it makes less work for the staff and provides a faster transition, although this is usually considered an extravagant use of valuable space. Napping may also take place in the multi-purpose room if a separate space, excluding the classroom, is needed.

activities:

- resting
- sleeping

grouping:

- large (total class)

atmosphere:

- passive, calm, quiet, intimate

color scheme

- cool color range
 - pastels for large surfaces (walls, floor, ceiling)
 - primaries for accents, trim, and emphasis

interior surfaces:

- floor
 - soft, inviting to lie upon
 - comfortable
 - carpet is recommended
- walls
 - should be sound absorptive
- ceiling
 - sound absorbent

space configuration:

- size
 - min. 15 sq. ft./child 225 total sq. ft.
 - max 20 sq. ft./child 300 total sq. ft.
- low ceiling may be used to create quiet relaxed atmosphere

relationships:

- desirable to
 - multipurpose
 - bathroom
 - medical/first aid
 - storage
 - teacher
- undesirable to
 - total group activity
 - music
 - indoor recreation
 - infant care
 - staff lounge
 - kitchen
 - dining
 - mechanical
 - executive director
 - educational director
 - secretary
 - conference/board

furniture/equipment:

- cots or mats
- record player (optional)

lighting:

- quantity
 - 30 ft. candles/general
- rheostat control to dim or turn out artificial light sources
- screen or shield natural light sources

acoustics:

- need soft sound environment
- sound insulation from other spaces
- acoustical privacy
- treatment of floor, wall and ceiling is recommended

climate control:

- temperature
 - 72° to 78°
- humidity
 - 30% to 50%
- outside air
 - 0.5 to 0.8 cfm/sq. ft.
 - 15 to 30 cfm/person
- air changes
 - 6 to 8/hour
- air movement
 - 25 to 40 fpm
- avoid floor drafts

9 Music

A fully developed music room is not considered essential to the preschool program. To create an optimal environment for the children's exposure to music, the main activity space of the classroom may be utilized. The multipurpose room can also be used as a music room when a separate room is not deemed feasible.

If a separate music room is provided, it should be accessible from the classrooms yet not immediately adjacent to them. Because of the expected sound and possible distraction, the room should be planned to include proper acoustics and high ceilings and spatial separation. Uniformity of sound throughout the room is necessary so that the children can benefit equally from their experiences with listening to music, creating and discovering new sounds, etc.

Provisions should be made for location of audio equipment with electrical outlets spaced conveniently throughout the room.

activities:

- listening to music
- dancing
- singing
- rhythm band

groupings:

- large (10-15 children)

atmosphere:

- active, lively, cheerful

color scheme:

- warm color range
 - warm pastels for large surfaces (walls, floor, ceiling)
 - warm primaries for accents, trim, and emphasis

interior surfaces:

- floor
 - flat/resilient
 - comfortable and inviting to sit upon
 - should contribute to sound control by eliminating scuffing of feet, chairs, and high pitched noises
 - if carpet is not used an area rug would be desirable
- walls
 - reflection and absorption of sound
 - easily maintained/cleaned
 - windows not required
- ceiling
 - sound distribution
 - light reflective

space configuration:

- size
 - min. 30 sq. ft./child 300 total sq. ft.
 - max. 50 sq. ft./child 500 total sq. ft.
- high ceiling is required

relationships:

- necessary to
 - observation
 - storage
- desirable to
 - total group activity
 - indoor recreation
 - bathroom
 - maintenance
- undesirable to
 - napping/resting
 - staff lounge
 - mechanical
 - executive director
 - educational director
 - secretary
 - conference/board

furniture/equipment:

- chairs
- musical instruments
- piano
- record player
- closed shelf storage

lighting:

- quantity
 - 30 ft. candles/general
 - 50 ft. candles/detail
- overall uniform illumination
- shielded incandescent lamps are recommended
- if fluorescent lighting is used consider remote mounted ballasts

acoustics:

- acoustical privacy
- extraneous noise should be minimized
- sound insulation from outside sources
- avoid vaulted or domed ceilings

climate control:

- temperature
 - 72° to 78°
- humidity
 - 30% to 50%
- outside air
 - 0.5 to 0.8 cfm/sq. ft.
 - 15 to 30 cfm/person
- air changes
 - 6 to 8/hour
- air movement
 - 25 to 40 fpm
- avoid floor drafts

10 Indoor Recreation

This space is utilized primarily for active indoor play, but it can also be used for special events such as Christmas parties, movies, puppet shows, etc. As recreational activities are of a noisy nature, special consideration should be given so as not to disturb adjoining spaces. Furniture and equipment should be appropriate to the development of physical dexterity, coordination and motor skills. This space, if used for indoor play exclusively, can be tailored to fit the needs of the children. An example of this is "The Magruder Environmental Therapy Complex", an adaptive playground for physically disabled children. (127) Children whose growth experiences have been normal and those who have been restricted by mental, emotional or cultural limitations can also benefit from this type of specialized play area.

Usually the indoor recreational space is multi-functional supporting other activities such as dining, music, dancing, and community meetings. If it is scheduled for a variety of activities, it should have the characteristics of the "multi-purpose space." If this space is used for community functions, it should be accessible to the exterior or entrance lobby and should have accessible toilet facilities.

activities:

- wheeled toys
- walking, running, crawling
- climbing
- jumping, bouncing
- ball playing

grouping:

- small (2-5 children)
- large (6-15 children)
- larger groups for special events

atmosphere:

- active, cheerful, stimulating

color scheme:

- warm color range
 - warm pastels for large surface areas
 - warm primaries for accents

interior surfaces:

- floor
 - easily maintained/cleaned
 - resilient
 - sound absorptive
 - non-skid
- walls
 - easily maintained/cleaned
 - light reflective
 - all corners rounded for safety
- ceilings
 - light reflective
 - sound absorbent

space configuration:

- size
 - min. 100 sq. ft./child 1500 total sq. ft.
 - max. 150 sq. ft./child 2250 total sq. ft.
- a high ceiling is recommended for acoustical reasons and also to encourage exuberance and freedom of child's play

relationships:

- necessary to
 - bathroom
 - maintenance
 - storage
- desirable to
 - total group activity
 - arts/crafts center
 - housekeeping/dramatic play center
 - nature study/science center
 - book center
 - block center
 - music
 - outdoor recreation
 - mechanical
- undesirable to
 - napping/resting
 - infant care
 - staff lounge
 - material preparation
 - kitchen
 - health personnel
 - psychologist
 - speech therapist
 - social worker
 - parents
 - volunteer auxiliary
 - lobby
 - receptionist
 - executive director
 - educational director
 - teachers
 - secretary
 - conference/board

furniture equipment:

- stairs
- slopes
- slides
- tunnels
- balancing boards
- bouncing boards
- climbing towers
- rope ladder
- toys
- audio-visual
- open shelf storage
- closed shelf storage

lighting:

- quantity
 - 30 ft. candles/general
 - 50 ft. candles/detail
- uniform illumination
- warm white shielded fluorescent lamps
- rheostat control for use of audio-visual equipment

acoustics:

- acoustical treatment of floor and ceiling is recommended
- elimination of sound reverberation within space
- acoustical separation from adjoining spaces

climate control:

- temperature
 - 68° to 72°
- humidity
 - 30% to 50%
- outside air
 - 0.3 to 0.8 cfm/sq. ft.
 - 30 to 40 cfm/person
- air changes
 - 6 to 8 per hour
- air movement
 - 25 to 40 fpm
- more fresh air is needed for removal of body odors due to high physical activities
- avoid floor drafts

11 Multipurpose

Some believe that a multipurpose room is really a no purpose room; others that it is a real asset to a center. What it turns out to be depends on the care with which it is planned.

The functions of this area are dependent upon the type of program offered, the number of children served, and the extent of other special spaces located in the facility. The space is probably most beneficial to small preschool facilities. The multipurpose room can provide space for group activities such as music, dancing, indoor play, dining, and community/parent meeting.

The location of this room depends upon the purposes for which it will be used. It should be adjacent to the kitchen if used as dining and near the lobby if used for parent/community activities. Storage room(s) and toilet facilities should be immediately accessible to the multipurpose room. These storage facilities must provide for a variety of equipment and furniture that will be used at various time periods. In addition, if the room is to be used for indoor play and/or parent community functions, it should be directly accessible from the outdoors.

activities:

- dining
- parent/community meetings
- school-day group activities: music, etc.
- indoor play

groupings:

- these are dependent upon the types of activities for which the space will be utilized as related to the preschool program

atmosphere

- active, cheerful, stimulating

color scheme:

- warm color range
 - warm pastels for large surface areas (floor, wall, and ceiling)
 - warm primaries for accents

interior surfaces:

- floor
 - easily maintained/cleaned
 - resilient
 - smooth
 - moisture proof
 - sound absorbent to eliminate scraping sounds of tables, etc.

walls:

- easily maintained/cleaned
- moisture proof
- light reflective
- walls should be designed to serve as working surfaces
- all corners rounded for safety

ceiling:

- light reflective
- sound absorbent

space configuration:

- size
 - min. 50 sq. ft./child 1000 total sq. ft.
 - max 100 sq. ft./child 1500 total sq. ft.

relationships:

- necessary to
 - bathroom
 - storage
- desirable to
 - total group activity
 - napping/resting
 - observation
 - infant care
 - outdoor recreation
 - kitchen
 - dining
 - parent
 - maintenance
- undesirable to
 - staff lounge
 - medical/first aid
 - mechanical
 - executive director
 - educational director
 - secretary
 - conference/board

furniture/equipment:

- chairs
- tables
- play equipment
- bulletin board
- chalk board
- audio and visual equipment
- musical equipment
- instructional aids
- open shelf storage
- closed shelf storage

lighting:

- quantity
 - 30 ft. candles/general
 - 50 ft. candles/detail
- uniform illumination
- warm white shielded fluorescent lamps (especially in dining area)
- rheostat control

acoustics:

- acoustical treatment of floor and ceiling is recommended
- elimination of sound interference
- sound produced within the space should not be allowed to disturb persons in other areas

climate control:

- temperature
 - 72° to 78°
- humidity
 - 30% to 50%
- outside air
 - 0.5 to 0.8 cfm/sq. ft.
 - 15 to 30 cfm/person
- air changes
 - 6 to 8/hour
- air movement
 - 25 to 40 fpm
- avoid floor drafts

12 Observation

The observation room is a separate space providing a means for observing children activity spaces without being seen.

This room is used mostly in facilities which are university oriented, where teacher-training is of major concern.

The observation room should be contiguous to the areas to be observed, e.g. classroom/playrooms, interest center, psychological testing rooms. It should be accessible directly from the corridor to allow unnoticeable entrance and should be located as to be able to view 80% of adjoining space with a good line of sight. One way glass is recommended because of visual requirements. Closed circuit television can be used for inaccessible areas.

Audio requirements suggest a sound controlled room so as to not distract children or teacher. The use of the intercom system or microphones and earphones provide a means for listening to the observed activity.

The observation room should be inviting and informal. Table or shelf space for sitting and writing should be provided for recording observations. It may be used for a limited amount of storage.

activities:

- observation
- consultation
- meetings

groupings:

- appropriate to the group it will serve

atmosphere

- passive, quiet, intimate setting

color scheme:

- cool range
- deeper hues are recommended to help darken room for prevention of "see-through image" reversal

interior surfaces:

- floors, walls, ceiling are to be acoustically treated
- carpet recommended on floor

space configuration:

• size

- min. 60 total sq. ft.
- max. 100 total sq. ft.

• low ceiling is recommended

- form depending on requirements for proper visual coverage and sight lines

relationships:

- total group activity
- arts/crafts center
- housekeeping/dramatic play center
- nature study/science center
- book center
- block center
- tutoring/quiet
- music
- psychologist

• desirable to

- multipurpose
 - infant
 - dining
- undesirable to
 - staff lounge
 - material preparation
 - kitchen
 - medical/first aid
 - parent
 - volunteer auxiliary
 - mechanical
 - maintenance
 - storage
 - lobby
 - receptionist
 - executive director
 - educational director
 - secretary
 - conference/board

furniture/equipment:

- table or writing shelves
- chairs
- audio equipment (intercom/microphones, earphones)
- limited storage

lighting:

- quantity
 - 2 ft. c./general
 - 20 ft. c./detail
- direct detailed lighting is needed for recording
- observations — light sources should be close to writing surface
- incandescent lamps are recommended

acoustics:

- sound insulation
- special attention to prevent transmission of sound from observation room to adjoining room
- doors, air registers, back-to-back electrical receptacles are sound transmitters.

climate control:

- temperature
 - 72° to 78°
- humidity
 - 30% to 50%
- outside air
 - 0.5 to 0.8 cfm/sq. ft.
 - 15 to 30 cfm/person
- air changes
 - 6 to 8/hour
- air movement
 - 25 to 40 fpm
- avoid floor drafts

13 Bathroom

In addition to its primary function, the toilet room provides a space for training in toilet habits to develop self-help grooming and self reliance. This space should be directly accessible to the teacher and the children.

The toilet areas should be scattered throughout the facility, one bathroom for each classroom rather than centrally located. They should be accessible from the outdoor and indoor play areas, as well as the classroom.

One water closet and one wash basin is recommended per 8 to 10 children. This space should provide enough room for one teacher and 3 to 4 children at one time. Separate toilet rooms, boys and girls, are not necessary for preschool children. A bathtub or shower in centers serving underprivileged children is highly desirable. There should be mirrors placed at child height, and adequate storage for supplies, clothing, towels, and so forth.

Fixtures and furnishings should be scaled to the children's height with special attention being given to efficient manipulation of fixture hardware by the children.

In a converted building where some adult-size toilets and washbowls must be used by children, low steps or platforms should be placed in front so that the children can reach them.

activities:

- dressing
- personal hygiene
- toilet education
- grooming

groupings:

- individual
- small (2 to 5 children)

atmosphere:

- passive, quiet, relaxed

color scheme:

- cool color range
 - pastels for large surfaces (walls, floor, ceiling)
 - primaries for accents, trim, and emphasis

interior surfaces:

- floor
 - easily maintained/cleaned
 - non-slip
 - durable
- resilient floor surfacing such as vinyl and asbestos tile is recommended
- walls
 - moisture proof
 - easily maintained/cleaned
 - washable
 - light reflective
 - all corners rounded for safety
- ceiling
 - high humidity considerations
 - moisture proof
 - light reflective

space configuration:

- size
 - min. 50 total sq. ft.
 - max. 100 total sq. ft.

relationships:

- necessary to
 - total group activity
 - indoor recreation
 - multipurpose
 - infant care
 - dining
 - lobby
- desirable to
 - arts/crafts center
 - housekeeping/dramatic play center
 - nature study/science center
 - book center
 - block center
 - tutoring/quiet
 - napping/resting
 - music
 - outdoor recreation
 - staff lounge
 - medical/first aid
 - parent community
 - volunteer auxiliary room

furniture/equipment:

- water closet
- wash basin
- bath tub
- mirror
- closed shelf storage
- closed children's personal storage
- chair
- wall heater

lighting:

- quantity
 - 30 ft. candles/general
- shielded incandescent lamps are recommended for overall uniform illumination
- special lighting consideration in grooming areas

acoustics:

- same consideration as typical residential bath facilities

climate control:

- air changes
 - 12 to 20 per hour
- outside air
 - 2 cfm/sq. ft. minimum
- humidity
 - 30% to 50%
- air movement
 - 25 to 40 fpm
- avoid floor drafts
- warm temperatures should be maintained to prevent chilling if this space is used for bathing
- exhaust fan to remove high moisture content and odors

14 Infant Care

An increasing number of infants will be cared for in day care centers in the future. For this reason, the inclusion of an infant care area should be considered even if infant care is not already a part of the program.

The area provided for infants should be separate from that for older children and operable as a self contained unit. It should be oriented for natural daylighting at certain times during the day. Its atmosphere and furnishings should encourage mothering by the staff and stimulate curiosity and activity on the part of the babies and toddlers. It should be well ventilated, but not drafty, and subject to good climate control. All materials should be easily cleaned/washable.

The size of this area is dependent upon the number of infants to be cared for. Its arrangement should provide for three different kinds of activities: the activities of the babies and toddlers, food services, and the bathing and diaper routine.

While baby beds may appear to dominate the area, the room should be of sufficient size to hold several pieces of home type furniture, e.g., a rocking chair(s) and an upholstered chair(s), and provide sufficient floor space for crawling and walking practice. A play pen(s) is also desirable. Babies need to see the world from as many vantage points as possible: sitting propped in chairs, maneuvering on the floor, lying in various positions on their beds. Things to look at and reach for need to be around. Music and talk programs on radio and TV can be stimulating. A table or counter of convenient adult height for changing diapers, dressing and bathing should be located adjacent to plumbing facilities. Plumbing facilities consist of a toilet or flushing device and a sink of the proper area and depth for bathing infants and very young children. Diaper supply shelves and diaper disposal containers should be within arm's reach. Also within arm's reach should be necessary bathing and dressing supplies. Ample storage space should be provided for bedding and for the individualized storage of personal clothing.

The food preparation and storage area is in a separate adjoining space. Equipment consists of a stove or warming equipment, refrigerator, and washing and sterilizing equipment.

activities:

- sleeping
- floor play
- playing in play pens
- bathing

- changing diapers
- preparing food and feeding infants
- rocking

groupings:

- individual
- small (2-5 children; toddlers may be put in small groups but their play activities are individualistic)

atmosphere:

- active, bright, cheerful

color scheme:

- warm color range
 - warm pastels for large areas (floor, walls, and ceiling)
 - warm primaries for accents, trim, and emphasis

interior surfaces:

- floor
 - flat
 - resilient
 - warm and comfortable to the touch
 - non-slip
 - easily maintained/cleaned
 - washable
 - rug would be desirable
- walls
 - easily maintained/cleaned
 - washable
 - all corners rounded for safety
- ceiling
 - sound absorbent

space configuration:

- size
 - min. 35 sq. ft./infant
 - max. 50 sq. ft./infant
- sleeping area should be separated from play area

relationships:

- necessary to
 - bathroom
 - kitchen
 - storage
 - teacher
- desirable to
 - multipurpose
 - observation
 - outdoor recreation
 - dining
 - medical/first aid
 - health personnel
 - maintenance
- undesirable to
 - total group activity
 - arts/crafts center
 - housekeeping/dramatic play center
 - book center
 - block center
 - tutoring/quiet

- napping/resting
- indoor recreation
- staff lounge
- material preparation
- parent
- volunteer auxiliary
- mechanical
- receptionist
- executive director
- educational director
- secretary
- conference/board

furniture/equipment

- toilet, water closet, and sink
- washer and dryer
- closed shelf storage
- baby beds
- play pens
- comfortable chairs
- rocking chairs
- diaper pail
- infant toys
- radio and record player
- refrigeration
- stove or warming equipment
- sterilizing equipment

lighting:

- quantity
 - 30 ft. candles/general
 - 50 ft. candles/detail
- shielded incandescent lamps
- natural lighting is recommended
- rheostat control for reducing lighting level and darkening space
- windows are recommended to provide visual link to the outdoors

acoustics:

- sound insulation from other spaces
- acoustical privacy
- acoustical treatment of ceiling is recommended
- avoid vaulted or domed ceilings

climate control:

- temperature
 - 72° to 78°
- humidity
 - 30% to 50%
- outside air
 - 0.5 to 0.8 cfm/sq. ft.
 - 15 to 30 cfm/person
- air changes
 - 6 to 8/hour
- air movement
 - 25 to 40 fpm
- avoid floor drafts
- ventilation of diaper change area and infant food preparation space
- separate climate control system may be warranted for this area

15 Outdoor Recreation

In the past the site and the outdoor play areas have not been thoroughly integrated into the preschool learning environment. Major concern has been with the building and its interior spaces. Educators have usually been more interested in the durability of standard equipment than in the creation of an environment conducive to child play and learning. However, creative playground concepts were inflated during the 1940's, and important principles have been developed and refined during the past decade. The following material is intended to illustrate these principles as they apply to the preschool of today.

Dattner, (128) in *Design for Play*, reveals that although work and play are in reality complex overlapping terms, the two activities are most often thought of as opposites. Adult play is most simply described as freely chosen recreation in which one participates to refresh the senses during the nonworking hours. Dattner indicates that in work we are interested in the results, while "it is the process of play, not the product, that gives us satisfaction. (128:9) He believes that the creative play of children bears close resemblance to the creative endeavors of artists and scientists because mastering new activities and processes are very important rewards to both groups, while their completed projects are less meaningful to them.

Many studies reveal that play is an important way in which children gain knowledge and insight. To achieve these gains Ledermann and Trachsel believe that children need flexible play items which stimulate their imagination by suggesting a variety of approaches to their use. (130:10) During the preschool years children are interested in exploring their environment and in finding out how they can manipulate it. They like to create and to build. They also enjoy fantasy and project themselves into the roles of parents, animals, and even objects. They are also learning to play in groups and participate in various games which require a give and take relationship with other children. They require play equipment which encourages creative growth.

The outdoor area and playgrounds for the preschool facility should be an expansion of the classroom by providing an atmosphere for well rounded mental and physical development. The area should provide security for the child, but it should also provide imaginative features that promote self-realization, independence and cooperation. In addition to the outdoor play area, a covered area for use during inclement weather is very desirable.

Ideally, there should be direct access to the play areas from all classrooms. Functional spaces should be provided for certain activities rather than large open spaces which encourage overlapping and perhaps conflicting activities. When play areas are used by older children as well as those in the preschool, the areas should be separated by fences of natural materials. Such traditional equipment as swings, correctly designed, are welcome, but major emphasis should be placed on providing more creative and imaginative items.

design considerations:

1. The outdoor play area should not be so small that it is crowded nor so large that it cannot be properly managed. The size recommendations are 200 to 300 sq. ft./child. No more than two classes of 15 children each should use space at any one time.
2. Advantage should be taken of site characteristics such as variable ground levels, trees, earth mounds, areas of sun and shade, etc.
3. An adequate drainage system should be provided so that play areas dry rapidly.
4. A variety of play surfaces: soft grass, sand and dirt, and hard surfaces, are advisable.
5. The play area should provide an extensive range of features and materials that children may utilize to develop a more complete awareness of the world: objects with a variety of weights, colors, textures, shapes and sounds.
6. Specific areas for sand boxes, sand mounds, and water play are desirable. These areas should be separated from the traffic lanes of wheeled equipment.
7. Certain areas should be relatively unstructured so that children can use materials to develop their own environment.
8. Natural materials of a general form should be utilized when possible rather than detailed, artificial, and highly mechanical equipment.
9. Imaginative play equipment should be provided: wendy houses, large boxes, and other materials which can be used for construction.
10. A space for growing plants is desirable and should be in a protected sunny part of the play yard.
11. Equipment for climbing, swinging and balancing should consist of simple materials, e.g., wood beams and old tires.
12. A fence should be provided around the entire outdoor area, and boundaries should be provided between the various functional spaces.
13. An outdoor shed should be provided for storage of portable equipment if not provided as a part of the main building.
14. A drinking fountain and convenient water faucets are recommended.
15. Special attention should be given to safety factors.

design examples:

The following playgrounds, generally acclaimed as excellent examples of outdoor recreation spaces, are presented here in order to illustrate the above design considerations.

Playground for small children at the "Helligfeld" housing estate, Zurich-Helligfeld, Switzerland.

Designed by the Municipal Building Department at Zurich (Alfred Trachsel) in collaboration with the Pro Juventute Foundation, Zurich.

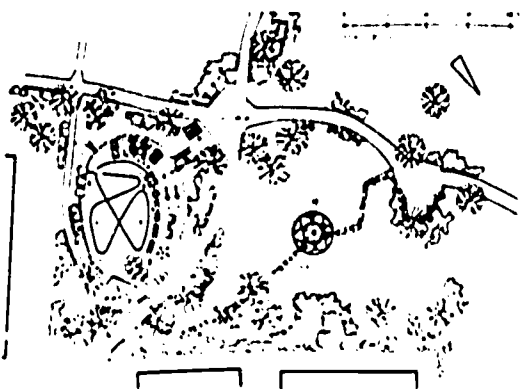

1

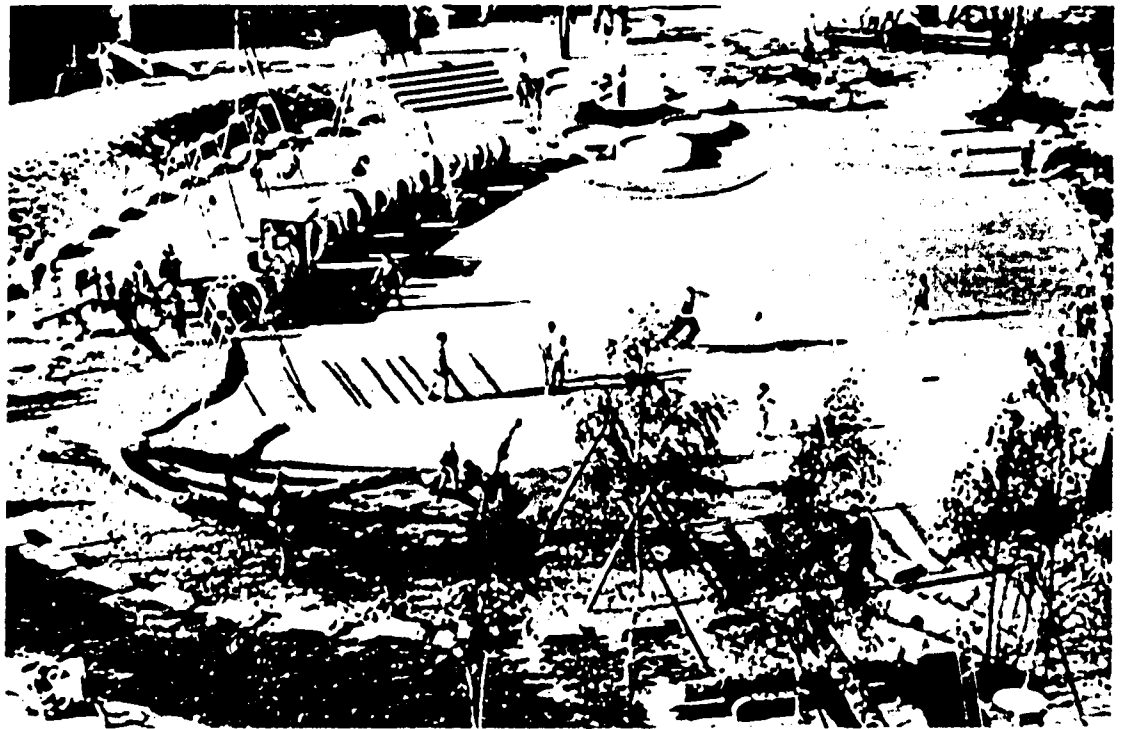

2

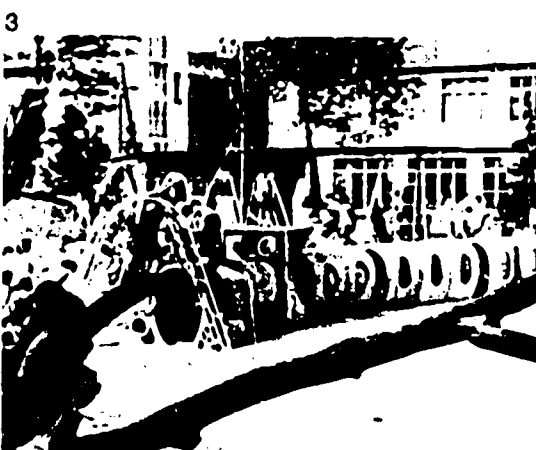

3



4

1. Site plan: hard surface (1), sandpit (2), paddling pool (3), belt of sand with climbing trees and swings (4), train of concrete ducts (5), tubular climbing arch (6), railway station of concrete ducts (7), aeroplane of tree trunks (8), wendy houses (9), slide (10), toilets (11), hill with pergola-like pavilion (12).

2. The playground from the south. In the center is the hard-surface area for street games. On the left the belt of sand with equipment. In the background paddling pool and sandpit.

3. The train consists of simple concrete elements.

4. The aeroplane is made of tree trunks.

5. Climbing tree for games requiring courage. In the background is the slide.

6. The paddling pool consists of brightly colored concrete basins of different heights. The water level is 4 inches in each basin.



5



6

"Sonnengarten" playground at the Zurich-Triemli housing estate, Switzerland

Designed by Alfred Trachsel, Zurich, in collaboration with the Pro Juventute Foundation, Zurich

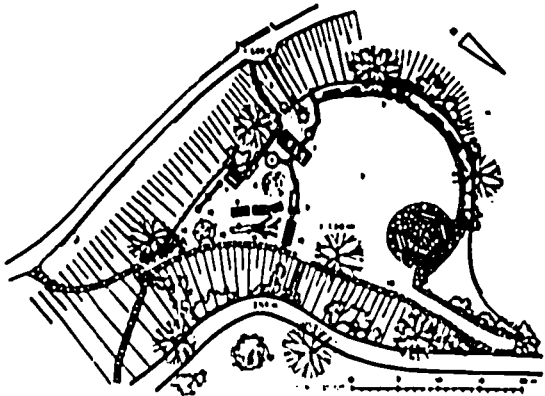

1



2

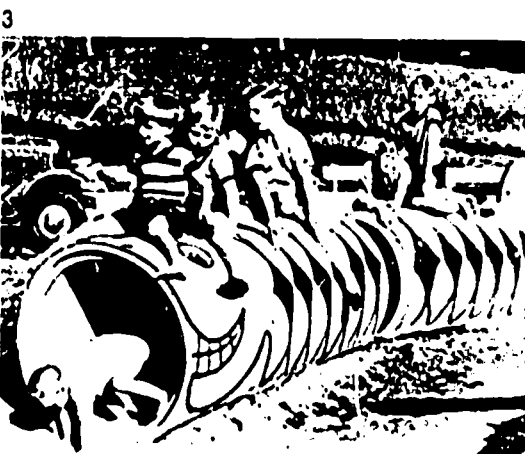

3



4

1. Site plan: hard surface with pavilion (1), small paddling pool (2), slide situated on the slope (3), disused lorry (4), concrete drum in upright position (5), sand heap on extensive sand area (6), concrete ducts (7-10), climbing tree (11), see-saw (12), climbing tower (13), aeroplane of tree trunks (14), concrete elements forming the bank of the slope (15).
2. The playground from the south-east. In the foreground is the sand area, with the hard surface and the pavilion behind. Quite simple elements such as concrete drums on angular castings and tree trunks form the play equipment.



5



6

3. Concrete ducts for crawling and climbing.
4. This cart with a barrel is especially popular because the children can crawl into the barrel through a small opening.
5. The south-east corner of the playground.
6. A spring which is lined with stones has been made into a small paddling pool.

**Adventure playground in Central Park,
New York City**

Designed by Richard Dattner, New York

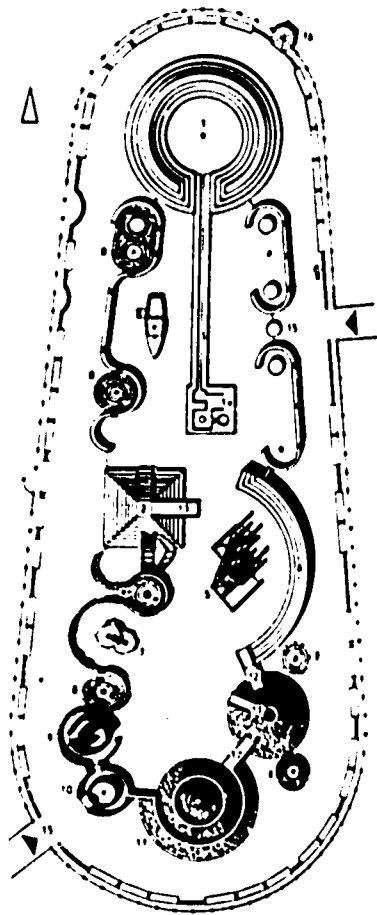

1



2

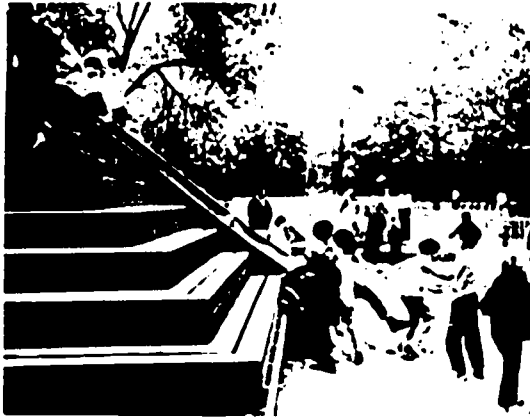

3

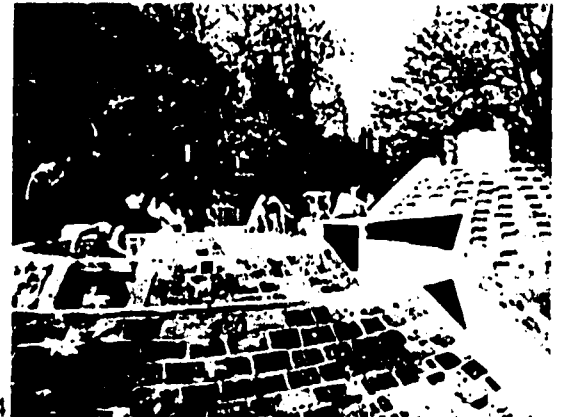

4

1. Site plan: splashing pool (1), climbing pyramid (2), water channel (3), boat (4), climbing structures (5), amphitheatre (6), tree houses (7), tree "pit" (8), castle (9), "stronghold" with tower (10), hill-in-a-hill (11), tunnel (12), slide (13), wading pool (14), entrance (15), pump house (16).

2. General view of the northern half of the playground with its water area.

3. Climbing pyramid and slide of wood planks.

4. The hill-in-a-hill.

5. Castle and stronghold with tower.



5

Vest Pocket Park, Quincy Street, Bedford-Stuyvesant Area of Brooklyn, New York

Designed by M. Paul Friedberg and Associates, New York

1-3. Very simple building materials, such as timbers and metal piping, were used to make sand boxes, things for sitting-on and climbing, swings, see-saws.



2

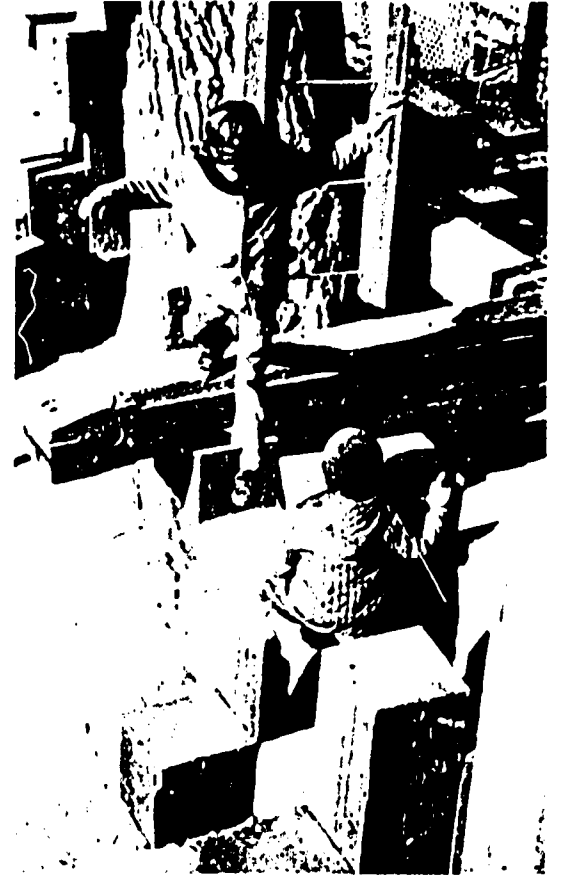

3

Simple playground equipment

4-6. These illustrations show how play elements can be created at comparatively small costs, and because of their simplicity, leave the greatest scope for a child's imagination.

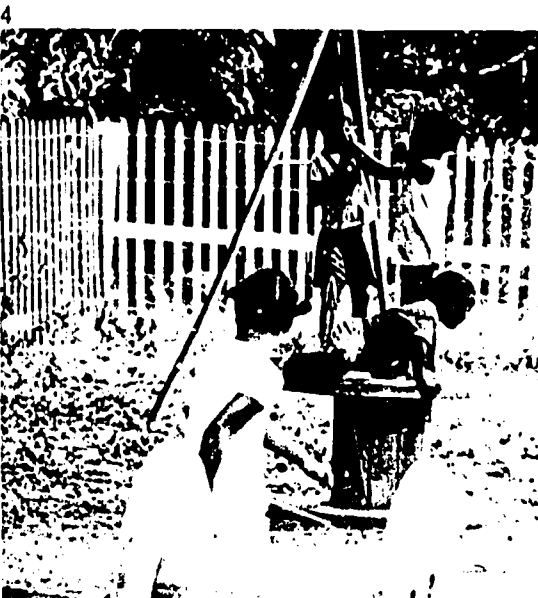

4



5



6

Ancillary Area

The space necessary for ancillary services is dependent on the breadth of the services offered to children and parents and will vary widely from one center to another.

In considering the spatial layout of ancillary spaces it is convenient to classify them under six headings based on the nature of the services offered. The more direct this service is to the children, the more desirable it is that these spaces be close to the education/training area.

Professional

- psychologist
- speech therapist
- social worker

Health

- personnel
- medical/first aid

Food

- kitchen
- dining

Staff

- lounge
- material preparation
- student/university affiliated

Community

- parent
- volunteer auxiliary

Building

- mechanical
- maintenance
- storage

Staff

Even a small day care center needs a private room where the staff can relax. In addition to needed relaxation, the informal conferences, information exchange and planning sessions which spontaneously take place when staff get together can make a valuable contribution to the program.

16 Staff Lounge

This room should have a relaxed, comfortable atmosphere. It should contain an area for coffee making and, in some cases where there is no kitchen, should provide for simple food preparation. A small prefabricated kitchen unit behind closed doors is a good answer to the food preparation problem. The lounges should have shelves for professional books and periodicals. A bathroom should adjoin or be nearby.

The lounge should be apart from the other areas of the building, but not to such an extent that it is isolated.

space configuration:

- size
 - min. 150 total sq. ft.
 - max. 200 total sq. ft.

furniture/equipment:

- sofa and/or 3 to 5 lounge chairs
- low tables for magazines, etc.
- coffee-snack counter
- work table
- personal storage
- open shelf storage
- telephone

environment:

- restful and quiet atmosphere
- cheerful and attractive decor that relates to the administrative offices
- sound produced within the space should not be allowed to disturb persons in other areas
- 15 to 30 ft. c. of uniform incandescent lighting are recommended for general and detailed work respectively.
- good ventilation and climate control is needed

17 Material Preparation

The material preparation area should be convenient to the teaching area and the lounge. Working surface should be ample for the use of the duplicating machine and for making posters and other kinds of instructional material. A typewriter is an asset. There should be ample space for the storage of supplies and portable teaching aids. Its arrangement should encourage order.

space configuration:

- size
 - min. 90 total sq. ft.
 - max. 120 total sq. ft.

furniture/equipment:

- work table for material preparation
- sink
- closed shelf storage
- chairs
- duplicating equipment
- typewriter

environment:

- quiet and efficient atmosphere
- sound produced within the space should not be allowed to disturb persons in other areas
- 50 to 100 ft. c. of uniform incandescent lighting are recommended for general and detailed work respectively
- good ventilation and climate control is needed

Those preschool facilities affiliated with a university may provide a separate space for use by student teachers and similar personnel. If this is considered desirable the requirements would be identical to those of the staff lounge and material preparation space.

Food

Any center which offers full day care must prepare and serve at least one hot meal. For this a kitchen is necessary. For a preschool facility a snack bar may be adequate unless the center is to be used for other activities in which food preparation is involved. However, the inclusion of a kitchen should be considered for any type center because it allows future broadening of the scope of the program without expensive additions.

The educational value for preschool children of taking part in kitchen activities should not be overlooked. This is especially true for children whose home exposure to food preparation may be very limited. The varieties of foods — their different colors, shapes, textures, smells and tastes — provide excellent sensory and discriminatory experiences.

18 Kitchen

The kitchen is usually placed apart from other areas and connected with them only through the dining space. The kitchen space differs in only a few particulars from the ordinary home kitchen. It should include a large pantry and freezer (for a week or two weeks supply), so that economical quantity purchases can be made and stored. A home type kitchen range, refrigerator, double sink and garbage disposal are adequate unless meals are being prepared for over a hundred children. Two home type dish washers make it possible for time to be used more economically by kitchen help. The day care kitchen needs only limited storage space in the form of the standard kitchen cabinets.

The kitchen should have a separate service entrance with the pantry and freezer located near by. A covered outdoor container for garbage cans should be located conveniently to the service door, but made as inconspicuous as possible. A washroom should be convenient to the kitchen.

In a large center where a cook or dietitian plans the meals and does the ordering, a small planning area is desirable. This may consist of a desk with filing drawers.

space configurations:

- size
 - min. 150 total sq. ft.
 - max. 300 total sq. ft.

furniture/equipment:

- 2 dishwashers
- double sink with greater depth in one side
- food preparation counter
- large storage pantry
- deep freeze
- residential type refrigerator
- residential type stove and food warmer
- utensil storage
- food carts

environment:

- cheerful and efficient atmosphere
- room materials should be washable: easily cleaned and maintained
- special attention should be given to ventilation: control of odor and dust
- 50 to 70 ft. c. of uniform incandescent or warm white fluorescent lighting are recommended for general and detailed work respectively
- climate control should permit lower than average temperatures (65° to 70°), especially during food preparation time

19 Dining

The dining area should adjoin the kitchen. It is very convenient to have a low counter pass-thru between the kitchen and dining area. The older children can receive and return their plates to this window. A convenient source of drinking water should be available in the dining area.

A separate dining area is desirable, but since it is used for a limited period of time. It is often considered an extravagant use of space. About 20 square feet is needed for each child. Because of noise and confusion, it is not advisable for large groups of children (probably over 30, although it depends upon their age and other conditions) to eat at the same time, so that the dining room would not have to seat all the children simultaneously.

Alternate solutions to the separate dining area are the multipurpose room and eating in the classroom. Each solution to the problems of where the children are to eat has assets and drawbacks. The final solution is determined by the weighing of personal considerations and the adoption of the best answer for the individual facility.

space configuration:

- size
 - min. 900 total sq. ft.
 - max. 1200 total sq. ft.

furniture/equipment:

- appropriately scaled tables and chairs for adults and children
- high chairs for infants

environment:

- cheerful atmosphere
- sensitive blending of colors that relate to the dining function
- easily maintained and cleanable wall and floor materials
- acoustical treatment of ceiling and walls is required
- 15 to 30 ft. c. of uniform incandescent or warm white fluorescent lighting are recommended to complement correct food and warm color tones
- good ventilation and climate control is needed

Health

This area has two functions: one, it provides office, examination, and treatment space for medical and dental personnel associated with the program; two, it provides space for the routine health care and first aid which are part of pre-school programs.

20 Medical/First Aid

It is possible to be more definitive concerning the first aid space. This space consists of the examination area, first aid room, a toilet and lavatory, and a semi-secluded area where children who have become ill can lie down, isolated from others. The space will also need a desk for the nurse or attendant, and health record storage.

In addition to first aid and routine health inspections, screening for auditory or visual defects may be part of the health program. Ample storage space should be provided for necessary equipment and supplies. It is especially important that first aid supplies be close to a convenient water supply.

This space should be convenient to the education/training area, but not in a high traffic area.

space configuration:

- size
 - min. 80 total sq. ft.
 - max. 100 total sq. ft.
- bathroom not included in the figure

furniture/equipment:

- screen(s) or partition(s)
- equipment and supply storage
- table
- scales
- work counter and sink
- electrical and telephone outlets
- toilet and lavatory (a shower is also desirable)
- 1 bed or cot
- tackboard and display space on walls
- auditory and visual screening equipment
- desk and files

environment:

- atmosphere should be quiet and free from distracting elements
- the space should suggest a cheerful, healthy, atmosphere
- the furnishings should not suggest a hospital environment
- 50 to 100 ft. c. of uniform incandescent lighting are recommended for general and detailed work respectively
- rheostat control is required for eye examination space
- good ventilation and climate control

21 Health Personnel

The extent to which space for medical and dental personnel is required varies widely with the orientation of the program. For this reason the size and layout of this area is a highly individualized problem and should be planned in consultation with the professional personnel who will be using it. If extensive use is made of a nurse, pediatrician, or dentist, space is needed for desk, filing and storage.

space configuration:

- size
 - min. 50 sq. ft./medical attendant
 - max. 80 sq. ft./medical attendant

furniture/equipment

- office desks according to personnel
- equipment storage and files
- office chairs and seating for visitors
- tackboard and display space
- appropriate equipment which may include auditory and visual screening equipment

environment:

- atmosphere should be quiet and efficient decor and furnishings should reflect the role of the occupant as well as relate to the other administrative offices
- 50 to 100 ft. c. of uniform incandescent lighting are recommended for general and detailed work respectively
- good ventilation and climate control

Professional

22 Psychologist

The psychologist can make a valuable contribution in working toward the behavior modification of the children in the classroom situation and in working with parents toward a greater understanding of their child's behavior at home. He can make suggestions for appropriate discipline, training, and stimulation of the retarded child, and help the parents toward understanding and working with their own feelings and frustrations.

An ideal arrangement for this area consists of two rooms with an observation window between. One room is for the testing of children and the other for observation, conferences, and paper work. If only one room is possible, it should be large enough to have separate areas allotted to testing and other working so that it will not be necessary to rearrange the office for a change in activities. The area should include ample closed storage space for test equipment and supplies and shelves for books. It should be close to a bathroom. If the psychologist works directly with the children, the office should have easy access to the education/training area, but it should also be easily approached from the outside.

space configuration:

- size
 - min. 200 total sq. ft.
 - max. 250 total sq. ft.
- this includes a space for testing

furniture/equipment

- office desk
- 3 to 4 adult chairs
- low table for testing
- 1 to 2 chairs for children
- tackboard
- file or desk file
- audio equipment if needed with observation of testing in adjoining room
- closed circuit TV may be used in certain situations instead of a one-way glass window
- closed shelf storage

environment:

- atmosphere should be quiet and efficient
- testing area should be free of distracting elements
- decor should relate to other administrative offices
- 50 to 100 ft. c. of uniform incandescent lighting are recommended for general and detailed work respectively.
- good ventilation and climate control

23 Speech Therapist

A speech therapist works to stimulate the development of language skills in children. She may work with the children individually or in a small group. The kind and amount of equipment needed will depend on the characteristics of the children involved. The therapist will also have consultations with parents and other staff members.

This space should be readily accessible from the education/training area and also convenient to the public entrance. It is important that it be quiet either by acoustical control or because of its location. It should be provided with closed storage for equipment and supplies.

Like the space assigned to the psychologist, that assigned to the speech therapist would be more efficient if it consisted of two rooms. This would be particularly appropriate if the speech therapist were a full time staff member.

space configuration:

- size
 - min. 200 total sq. ft.
 - max. 250 total sq. ft.
- this includes space for testing
- furniture/equipment:**
 - desk and chair
 - large low table
 - 2 to 3 adult chairs
 - 5 small chairs for children
 - large mirror
 - tape recorder, language master, ear phones and other
 - file or desk file
 - many electric outlets
 - closed shelf storage

environment:

- atmosphere should be quiet and efficient
- a sound and acoustical control is needed
- decor should relate to other administrative offices
- 30 to 50 ft. c. of incandescent lighting are recommended for general and detailed work respectively
- good ventilation and climate control

24 Social Worker

A full time or part time social worker will, as a rule, have more contact with parents and staff members than she will with the children. She may conduct the initial intake interview with the parents and be consulted about family or child care problems. For this reason, her office should be reached easily from the public entrance while its proximity to the education/training area is relatively unimportant.

The office does not usually have any special requirements similar to those of the psychologist or speech therapist. However, one consideration is worth thinking about — the office should contain a small play area for children who often must accompany parents to interviews. The office should contain comfortable chairs and provide privacy for interviews.

space configuration:

- size
 - min. 100 total sq. ft.
 - max. 150 total sq. ft.

furniture/equipment:

- desk and chair
- book storage
- 2-3 chairs for adults and children
- file or desk file

environment:

- warm, friendly, and relaxed atmosphere
- cheerful and attractive decor should relate to other administrative offices
- 50 to 100 ft. c. of uniform incandescent lighting are recommended for general and detailed work respectively
- acoustical privacy
- good climate control

Community

25 Parent

Communication with parents is an important aspect of a day care program. Part of this communication may be through parent meetings. It is important for a day care center to have an area large enough to contain a parents meeting, or any other meetings.

This area may be a separate room (see conference/board room under "Administrative Area") or it may be one of the functions of the multipurpose rooms (see multipurpose room under "Education/Training Areas").

Whatever its designation, the meeting room should provide comfortable seating and be furnished so that audio-visual presentations as well as group discussions and lectures are possible.

The meeting space should be easily approached from the public entrance to the building and should have convenient access to kitchen and bathroom.

space configuration:

- size
 - min. 150 total sq. ft.
 - max. 200 total sq. ft.

furniture/equipment:

- comfortable chairs
- conference-type table
- wall display space and/or chalkboards
- audio-visual equipment including viewing screen
- numerous electrical outlets are important
- open shelf storage

environment:

- warm, friendly, and relaxed atmosphere
- cheerful and attractive decor relating to the administrative offices
- acoustical treatment is recommended
- 30 to 50 ft. c. of uniform incandescent lighting are recommended for general and detailed work respectively
- good ventilation and climate control is needed

26 Voluntary Auxiliary

A separate space for volunteer workers may be desirable in large preschool facility, but in most centers the parent room or other similar spaces will also be used by the volunteer auxiliary. If a space is provided it should have identical requirements as the parent room.

Building

27 Mechanical

It is difficult to recommend specific mechanical equipment because of the unknown factors involved such as the preschool location, climate and cost considerations. The equipment selected, however, should perform to the preschool needs and requirements that have been established in this publication.

Approximately one square foot of mechanical space per 15 square feet of total preschool space is recommended. In a large facility this mechanical area may be centrally located, for efficient performance assuming that proper consideration is given to the overall environmental requirements. A small 1 or 2 classroom unit may have the mechanical space located away from the facility to prevent unwanted disturbances. Special considerations for sound insulation, convenient screening, and location for efficient performance are warranted.

28 Maintenance

Provision for the convenience and efficiency of the caretaking staff is often forgotten in the planning of buildings. Maintenance space should be carefully planned in relation to the maintenance services which will be required in the different activity areas. Even facilities which intend to use commercial maintenance firms need to provide janitor closets and space for the storage of maintenance supplies. Each child activity area should contain the necessary supplies for a quick clean up.

In addition to the storage of cleaning supplies and equipment, space (80-100 total sq. ft.) needs to be provided for a workshop where equipment and toys can be repaired and where tools, paint, etc., for simple building maintenance can be kept. This area can be located separate from the main building and perhaps in an outside building which houses outdoor maintenance and playground equipment.

29 Storage

Because of the importance of this subject, a special section (beginning on page 73) has been allotted to storage requirements for a preschool facility.

Detailed requirements for functional areas and individual spaces within the facility are summarized for effective utilization by architects and planners.

Administrative Area

The requirements for the administrative area of a day care center are similar to those for any administrative area. The number, size and spatial relationship of the offices should be determined by the size and function of the staff. The furnishings are typical of normal office requirements. A small facility may require office space for only its director with perhaps, additional room for a part-time receptionist-clerk-typist. A large facility employing ancillary personnel, consulting services or programs with other community agencies, will require more extended administrative space.

Since the administration regulates the organization of the school as well as provide a link with visitors and the outside, an attractive and efficient office arrangement is essential. The administrative office(s) as a whole should create an atmosphere of warmth and friendliness and provide a smooth circulation pattern for staff and visitors.

In a large facility the link between the education/training area and the administrative area is relatively weak so that the administrative offices can be placed as far away from the education/training area as the total space permits. This has advantages for both activities.

The administrative area provides two basic services to the day care facility: reception and management. Specific spaces includes: receptionist, lobby, executive director, educational director, teacher, secretary, and conference/board. Other offices necessary should reflect their normal functions.

Reception

30 Lobby

The entrance to the day care center should welcome and reassure. Unless it is used for other activities, e.g. receptionist, meetings, it can be very small. If it is to provide space for a receptionist-clerk-typist it will, of course, need to be larger. If not it should be situated so that it is visible from the office of the director or secretary. This provides an opportunity for the receptionist or director to observe the arrival of visitors and, in some cases, also to observe the relationship between parent and child. It should have direct access to a bathroom and, of course, to the main entrance of the center. If the center contains a conference/board room or any meeting room to be used by the public, it is desirable to have it close to the entrance of the building.

It is not advisable for the children to enter through the reception and administrative area. A separate and more direct entrance to the playrooms should be provided.

space configuration:

- size
 - min. 100 total sq. ft.
 - max. 200 total sq. ft.

furniture/equipment:

- lounge chairs/sofa
- low table
- display area
- open shelf storage
- water fountain

environment:

- first impression person forms when entering facility transition space
- warm, friendly, and relaxed atmosphere
- cheerful and attractive decor
- mixture and sensitive blending of colors
- 15 to 30 ft. c. of uniform incandescent lighting are recommended for general and detailed work respectively
- special lighting consideration for display area
- windows are desirable for visual link to outdoors
- good ventilation and climate control is needed

31 Receptionist

If the preschool provides a receptionist space, it should be located to assist all disciplines and provide information, direction and control over the reception and lobby area. The receptionist should be easily accessible to the administrative office and should have visual access to all persons entering the building.

space configuration:

- size
 - min. 50 total sq. ft.
 - max. 80 total sq. ft.

furniture/equipment:

- desk
- chair
- personal storage
- files
- telephone

environment

- warm, friendly, and relaxed atmosphere
- should create a pleasing impression for persons entering the preschool
- decor should relate to lobby and administrative spaces
- 50 to 100 ft. c. uniform incandescent lighting are recommended for general and detailed work respectively
- good ventilation and climate control is needed

Management

32 Executive Director

The office of the director is similar in size and furnishing to the office of any comparable administrator. The director coordinates the personnel, supervises the program, and maintains contact with the public. The director meets and consults with staff, parents, and members of the community individually and in small groups. In a small center the director may do just about everything, including working with the children and planning the meals. In a large facility he may have no direct contact with the children and only indirect supervision over the program.

The office should be conveniently located for visitors, but away from the main line of traffic. It should be adjacent to secretarial services, conference area, and convenient to any other administrative personnel with whom the director has continual contact.

space configuration:

- size
 - min. 100 total sq. ft.
 - max. 150 total sq. ft.

furniture/equipment:

- desk or desk unit
- chair
- filing
- personal storage
- sofa and/or 2 - 3 chairs
- telephone
- dictaphone
- tackboard
- individual room accents

environment:

- furniture, accessories, and color should be appropriate and reflect the occupant's position
- atmosphere of an executive office and pleasant study
- 50 to 100 ft. c. of uniform incandescent lighting are recommended for general and detailed work respectively
- direct lighting for detailed work space
- acoustical treatment of floor and ceiling is recommended
- climate control is required

33 Educational Director

In a large facility an educational director may coordinate the education/training program. The office requirements for this position are similar to those for the administrative director. However, it is desirable that the office of the educational director be located close to the classroom/playroom for ease in supervision.

34 Teacher

This space provides a home base for the teacher whether located in the classroom, the staff lounge, material preparation space, or a separately designated office. The space should provide for material preparation and storage as well as for educational meetings and consultation with parents and staff.

space configurations:

- size
 - min. 50 sq. ft./teacher
 - max. 80 sq. ft./teacher

furniture/equipment:

- desk
- files
- chairs
- personal storage
- storage of educational materials

environment:

- atmosphere should be quiet and efficient
- decor should relate to other administrative offices
- 50 to 100 ft. c. of uniform incandescent lighting are recommended for general and detailed work respectively
- good ventilation and climate control is needed

35 Secretary

The number of secretarial staff employed will depend on the size of the center and the nature of its program. The secretarial area(s) should be located so that they are accessible to the staff members who need their services. This area should serve as the center for school communications and should be convenient to file and storage areas. Included in this area is a storage workroom space for duplicating procedures, equipment, and supplies. It should be directly accessible to the secretary(s).

space configuration:

- size
 - min. 80 total sq. ft.
 - max. 100 total sq. ft.
- this includes space for both secretary and storage

furniture/equipment:

- desk
- office chair (1 or 2)
- file cabinet and storage
- work table
- typewriter
- telephone and intercom
- duplicating machines

environment:

- should be harmonious and complimentary to the administrative atmosphere
- 100 to 150 ft. c. of incandescent lighting are recommended for general and detailed work respectively
- acoustical treatment in work room should prevent duplicating procedures from disturbing others in the administrative area

36 Conference/Board

The uses to which this room will be put should be carefully analyzed during the planning stages. It may be used for board meetings, staff meetings, group counseling, parent or community meetings, and a variety of other things. It should be located near the administrative offices and may provide for the use of audio-visual equipment and a library. Provision should be made for at least 10 adults to sit comfortably during discussion without disturbing adjacent spaces.

space configuration:

- size
 - min. 150 total sq. ft.
 - max. 200 total sq. ft.

furniture/equipment:

- conference table
- comfortable chairs
- wall display space and/or boards
- audio-visual equipment
- shelves
- open shelf storage

environment:

- should compliment the administrative offices
- provide an atmosphere for direct problem solving and free flow of ideas
- 30 to 50 ft. c. of uniform incandescent lighting is recommended for general and detailed work respectively
- good ventilation and climate control is needed
- acoustical privacy is needed to avoid disturbing adjacent areas

Storage

For child's safety, for convenience, and for good housekeeping, every facility must have adequate storage of the right type and in the right places. The types of storage, depends upon the various supplies, materials, furniture, and equipment, to be stored and should be planned for during the beginning phase of building design. Enough cannot be said about the provision of adequate storage for preschool facilities. In almost all the instances during our site surveys, the teachers and staff expressed their personal preferences for more storage space. Although storage requirements have been discussed in the requirements for each individual space, the importance of this subject warrants further consideration.



There is basically two different types of storage: **1) Enclosed Storage Space**, examples of which include closets, storerooms, and walk-in storage rooms, to allow for reserves of supplies and materials bought in large quantities. This space is also utilized for supplies and materials, equipment that has seasonal or occasional usage and those items which should be kept away from the children because they are dangerous or because they should not be used without supervision. **2) Storage Unit**, examples of which include filing cabinets, cupboard, bins, and all type of shelving to allow for supplies and materials that are readily available and necessary for everyday usage by the children and the staff. They can be either open or closed, or a combination of both. Storage units are defined as being of two varieties: **a) fixed**, either permanently or temporarily, to the floor, wall, or ceiling, and **b) moveable**, that which allows freedom of movement either the space or from one space to another space.

Except in a few exceptional cases, the bathroom, janitor closet, and other specialized spaces for example, permanently built-in storage is not recommended. Temporarily attached and moveable units are more desirable, not only to permit storage when and where it is needed but also to increase the flexibility of space arrangements. An example of this kind of moveable storage units is illustrated in the section on Furniture.

A combination of both enclosed storage space and storage units are needed in the Education/ Training Area. Also needed is a centrally located enclosed maintenance or janitorial closet.

The Ancillary area contains spaces for such a variety of activities that storage requirements will be considered individually for each space. However, a centralized enclosed janitorial closet should be provided.

In the Administrative Area office supplies are usually stored most efficiently in centrally located space convenient to the secretarial space. Storage requirements for each space will be considered individually.

The following information summarizes storage requirement for areas and spaces of a preschool facility.

Classroom/Playroom

Storage requirements for a typical classroom/ playroom arrangement, where the group activity space and the interest center spaces are contained in one room are as follows:

enclosed storage: 80-120 cu. ft./child

- for all reserve teaching supplies, materials, equipment, and furniture
- for supplies and equipment that should be kept away from the children

storage units: 12-24 cu. ft./child

- for all open and closed shelving, cabinets, files, and bin storage for supplies and materials pertinent to everyday usage by the children and teachers
- for child and teacher personal storage
- teachers not only use those units for storage but also to form interest centers. Since different interest centers are likely to be found in different classrooms because of teacher preference these units must be flexible enough to accommodate not only a variety of teaching, supplies, and materials but also to allow for changing interests and moods of the occupants.

When the total group activity space and the interest center spaces are separate independent rooms, they will require specific enclosed storage and storage unit consideration. These are as follows:

Total Group Activity

enclosed storage: 55-75 cu. ft./child

storage units: 4-8 cu. ft./child

Arts/Crafts Center

enclosed storage: 32-56 cu. ft./child

storage units: 4-8 cu. ft./child

Housekeeping/Dramatic Play Center

enclosed storage: 6-12 cu. ft./child

storage units: 2-4 cu. ft./child

Nature Study/Science Center

enclosed storage: 12-24 cu. ft./child

storage units: 4-8 cu. ft./child

Book Center

enclosed storage: none

storage units: 3-6 cu. ft./child

Block Center

enclosed storage: none

storage units: 3-5 cu. ft./child

Supportive

Tutoring/Quiet

enclosed storage: none

storage units: according to specific use

Napping/Resting

enclosed storage: 5-10 cu. ft./child

- for cots, mats, and pallets
- for audio equipment

storage units: none

Music

enclosed storage: 4-8 cu. ft./child

- for equipment that should be kept away from the children
- for instruments, records, and supplies

storage units: 2-4 cu. ft./child

Indoor Recreation

enclosed storage: 48-60 cu. ft./child

- for large wheeled toys, jumping, and bouncing boards, mats, climbing, towers, and other assorted large play equipment

storage units: 2-4 cu. ft./child

- for balls, small toys, and other numerous play items

Observation

enclosed storage: none

storage units: according to specific use

Bathroom

enclosed storage: none

storage units: 30-50 total cu. ft.

- for supplies, towels, and children's personal items and extra clothing

Multipurpose

(a) enclosed storage: 45-55 cu. ft./child

- for dining and meeting chairs and tables

(b) enclosed storage: 48-60 cu. ft./child

- for indoor recreation equipment and supplies
- for audio-visual equipment and accessories

storage units: 4-6 cu. ft./child

- for supplies and materials pertinent to activity being performed

Infant Care

enclosed storage: 40-60 cu. ft./child

- for food storage and preparation if desired
- for washing and sterilizing equipment

storage units: 4-6 cu. ft./child

- for bedding, diapers, personal clothing and assorted infant supplies

Outdoor Recreation

enclosed storage: 600-800 total cu. ft.

- for large and small outdoor play equipment

storage units: none

Staff

Staff Lounge

enclosed storage: none

storage units: 40-60 total cu. ft.

- for cutlery and cookery, and dry goods
- only when a small kitchenette is utilized
- for magazines and books
- for coats and personal storage

Material Preparation

enclosed storage: none

storage units: 30-50 total cu. ft.

- for duplicating equipment, teaching aids, materials and supplies

Professional

Psychologist

enclosed storage: none

storage units: 10-20 total cu. ft.

- for testing equipment and supplies
- for records, and personal storage

Speech Therapist

enclosed storage: none

storage units: 10-20 total cu. ft.

- for testing equipment and supplies
- for records, and personal storage

Social Worker

enclosed storage: none

storage units: 6-10 total cu. ft.

- for records and personal storage

Community

Parent

enclosed storage: 100-180 total cu. ft.

- for extra furniture and audio-visual equipment

storage units: 10-20 total cu. ft.

- for display and book storage

Auxiliary Volunteer

enclosed storage: 100-180 total cu. ft.

- for extra furniture and audio-visual equipment

storage units: 10-20 total cu. ft.

- for display and book storage

Building

Mechanical

enclosed storage: (see maintenance)

storage units: none

Maintenance

(a) enclosed storage: 120-200 total cu. ft.

- for a maintenance workshop
- for equipment, furniture, and material repairs
- for building supply storage
- for mechanical supply storage

(a) storage units: 60-100 total cu. ft.

(b) enclosed storage: 200-300 cu. ft./each

- for janitorial and maintenance closets
- for supplies and equipment convenient to the education/training area, the ancillary area, and the administrative area

(b) storage units: none

Health

Medical/First Aid

enclosed storage: none

storage units: 20-40 total cu. ft.

- for medical equipment and supplies
- for auditory/screening equipment

Health Personnel

enclosed storage: none

storage units: 6-10 cu. ft./user

- for health records, and personal storage

Reception

Lobby

enclosed storage: none

storage units: 75-100 total cu. ft.

- for magazine and book display
- for coat storage

Receptionist

enclosed storage: none

storage units: 6-10 total cu. ft.

- for filing and personal storage

Management

Executive Director

enclosed storage: none

storage units: 10-20 total cu. ft.

- for files and personal storage
- for files and personal storage
- for books and publication display
- for books and publication display

Educational Director

(same as "executive director")

Teacher

enclosed space: none

storage units: 10-20 cu. ft./user

- for files and personal storage
- for educational materials

Secretary

enclosed storage: 400-600 total cu. ft.

- for other supplies and materials
- for duplicating equipment

storage units: 20-50 cu. ft./user

- for files and record storage

Conference/Board

enclosed storage: 100-180 total cu. ft.

- for extra furniture and audio-visual equipment

storage units: 10-20 total cu. ft.

- for display and book storage

Furniture

It is a generally well known and accepted fact that the utility of the preschool facility will largely determine its success.

Too often the frustrations and anxieties caused by poorly furnished facilities have jeopardized the educational potential of the preschool program. Because we as humans adapt so easily to our environment we have learned to live with furniture and hardware which in many cases is uncomfortable, inappropriate, irritating, and on occasion downright ridiculous. Maynard H. Lyndon, "Design for Children", **Architectural and Engineering News**, states that: "Most children grow up and accept the same silent dilemma of their parents. They learn to live with the same door that hinges on the least logical side, the shower faucets under the stream of water, the coat hook that is inaccessible, or the door knob that is so decorative it is irritating to the hand. Why should they question such things if their parents haven't?"

To provide adequate furnishings for a preschool child we need to know all we possibly can about child growth and development: their needs, interests, and capabilities. Preschool children have specific physical needs which in the past have been neglected in lieu of consideration of school age children and adult needs.

Anthropometry

This growing concern to fit the things people touch to their physical and psychological needs is known by a variety of names (anthropometry, biometrics, biomechanics, and human engineering) the most common of which is anthropometry.

The objective of anthropometric design is to combine the concept of measuring life or growth with its proper design function. Knowledge about child development and growth will greatly help the educator, designer, and manufacturer determine their decisions about furnishing for preschool children. Limited data are available on the physical development of the preschool child. Dreyfuss, whose publication, **The Measure of Man-Human Factors in Design**, is the major work in this field, gives information on individuals from four years of age to adulthood only.

In determining physical criteria for children under 4 years of age, the research team extrapolated the Dreyfuss data and developed measurements for children between the ages of 2 and 4. The following charts, for children between the ages of 2 and 7, represent a combination of both Dreyfuss' data and the extrapolated data.

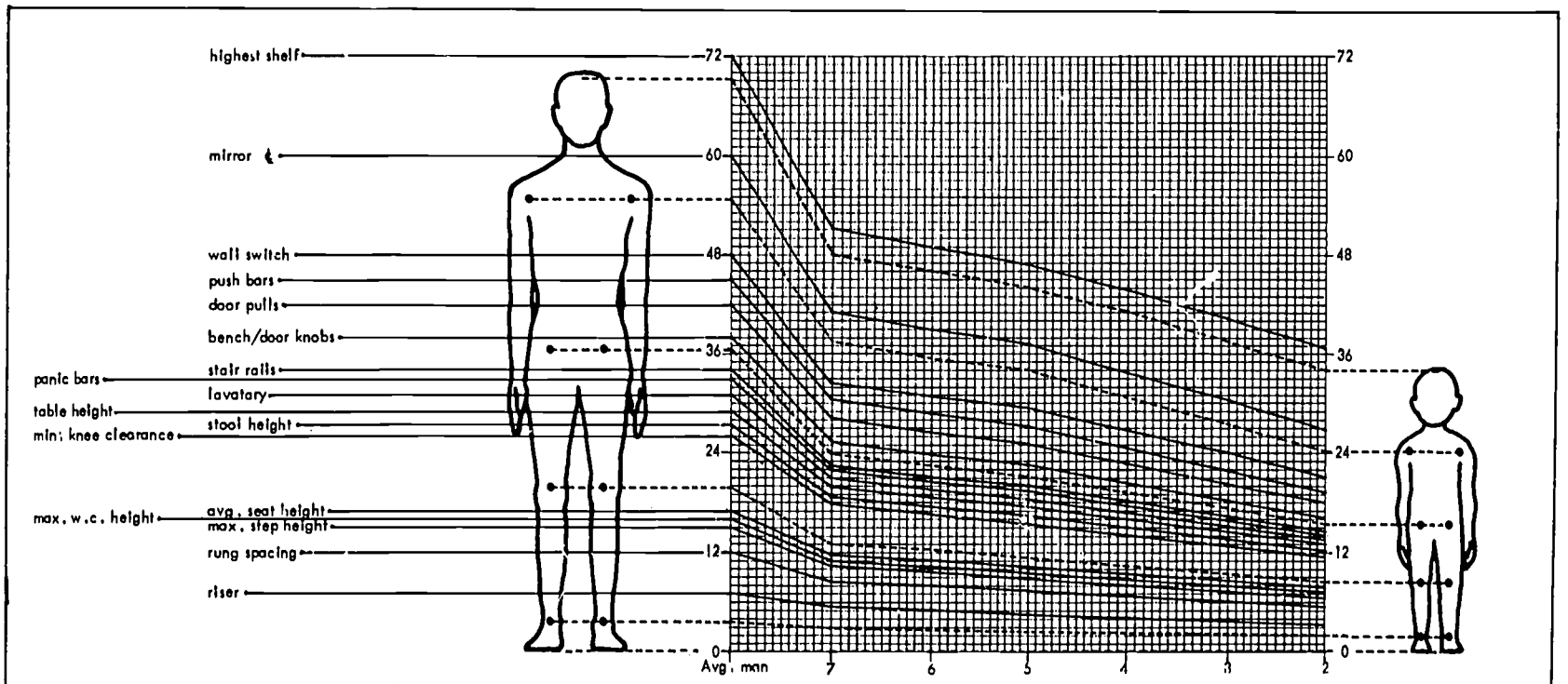
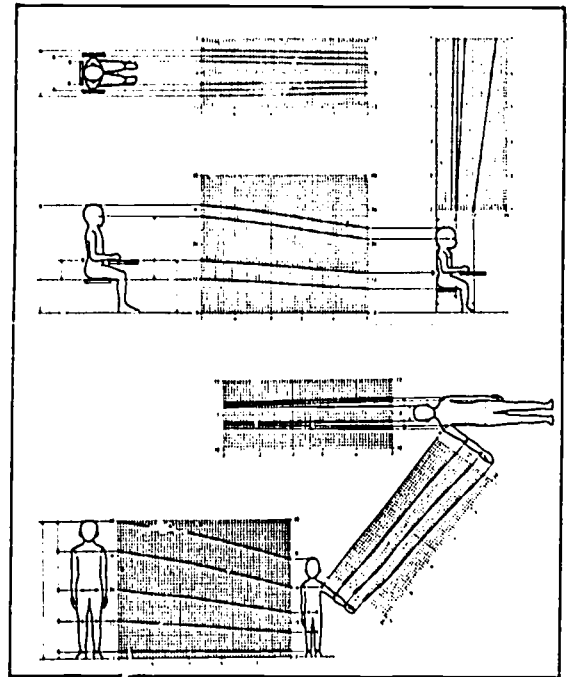

Market Survey

Using this information, together with other comparative factors of utility (maintenance, flexibility, adaptability), an analysis of commercially available furniture and equipment was conducted to determine the appropriateness of furnishings for a preschool facility. This analysis indicated that very little concern has been given for the preschooler's needs, largely because the market potential for this age range is very small in comparison with that of school age children.

It is believed that the present and increasing future emphasis on early childhood education will provide the necessary impetus for designers and manufacturers to become cognizant of this growing market and provide the needed furnishing for optimum learning situations.

Design Objectives

Not only is more involvement needed but a reevaluation of types of furnishings for preschoolers as well.

Together with the demands placed by the physical and mental capabilities of the children, the inherent nature of the educational programs poses certain considerations which are unique. These demands, easily translated into design objectives, include the following:

- multipurpose
- durable
- safety constructed
- easily maintained
- easily used by children
- easily used by teacher
- appropriately scaled
- safely finished
- stimulating
- attractive
- adaptable
- flexible

Probably the most appropriate design objective comes directly from Henry Dreyfuss' creed, "We bear in mind that the object we are working on is going to be ridden in, sat upon, looked at, talked into, activated, operated, or in some way used by people. If the point of contact between the product and the people becomes a point of friction, then the industrial designer has failed. On the other hand, if people are made safer, more efficient, more comfortable or just plain happier by contact with the product, then the designer has succeeded."

Design Examples

The examples which follow are provided to illustrate current design philosophy for furniture for preschool facilities. It is hoped that they may stimulate designers and manufacturers to reconsider and reevaluate what is currently being provided for the preschool child as well as for the school age child.

Basic preschool furniture includes: desk/chair and storage units. A variety of materials can be effectively used to construct this very simple basic furniture.

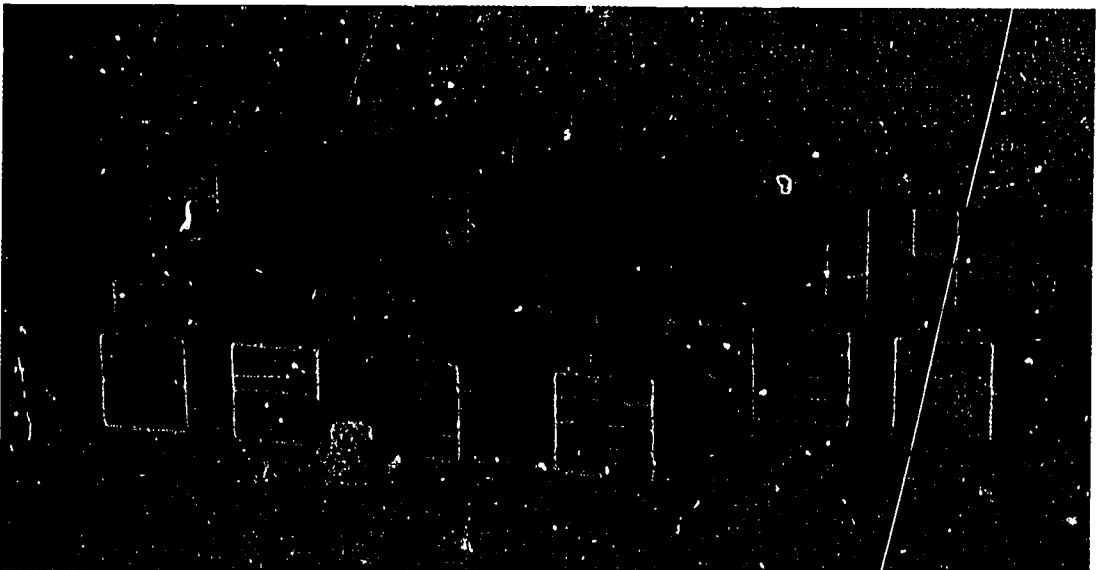
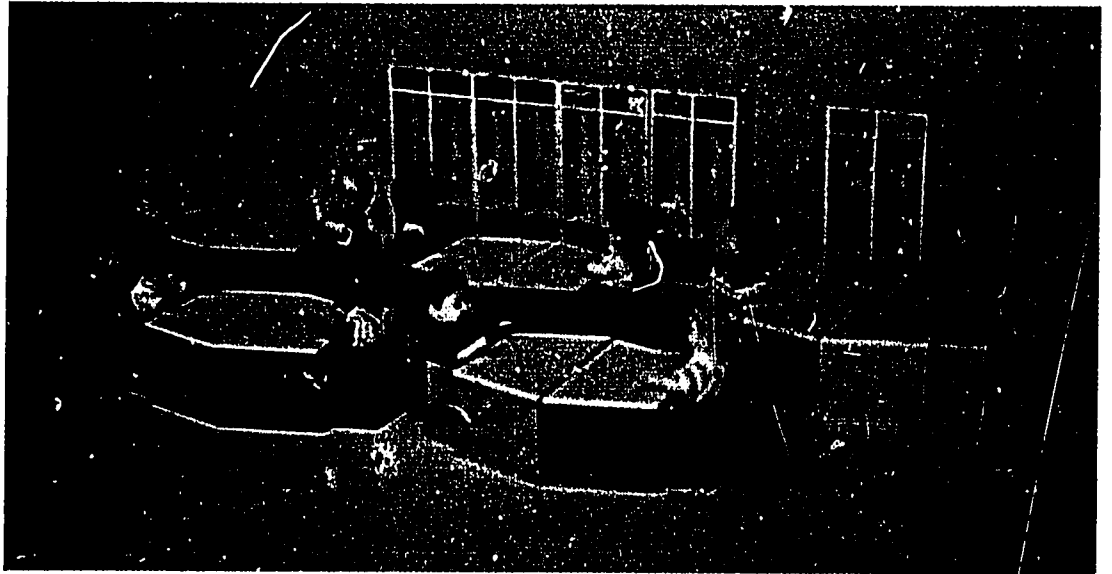
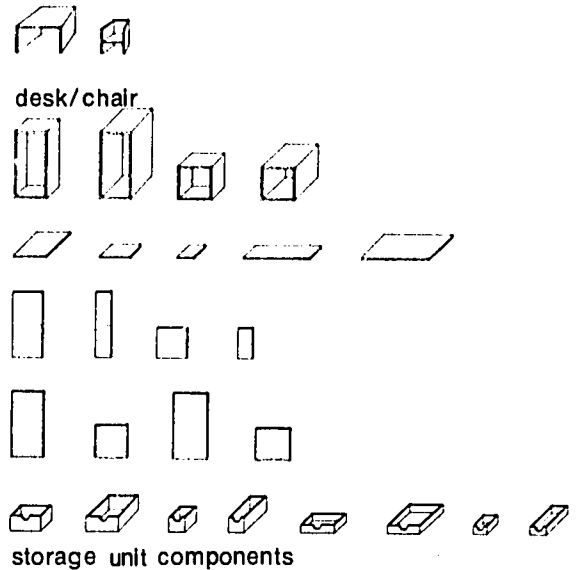

The chairs provide two seating heights, 8½ and 11 inches, simply by turning them over. Other imaginative functions, educational and recreational, can also be performed.

The desks offer various flexible arrangements to accommodate changing curriculum needs. Both are color coded, along with the personal storage units, to identify a child's personal property.

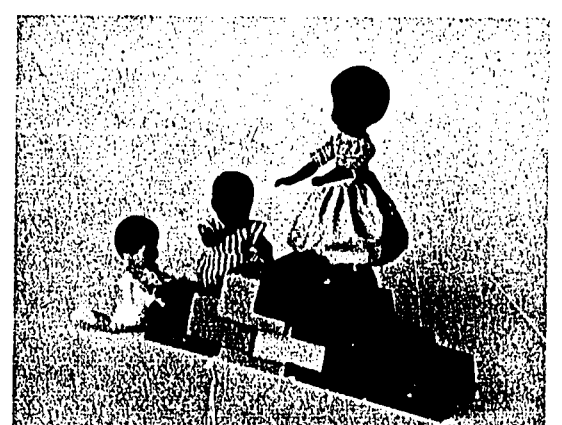
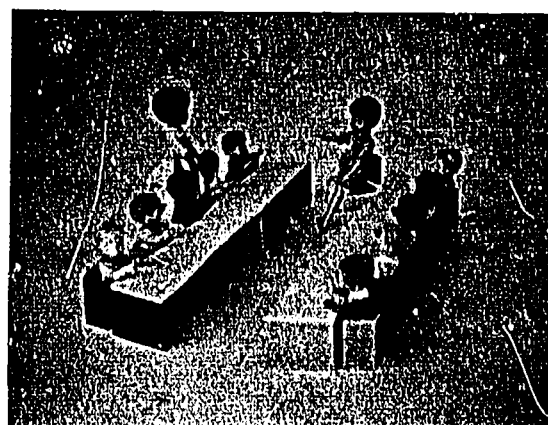
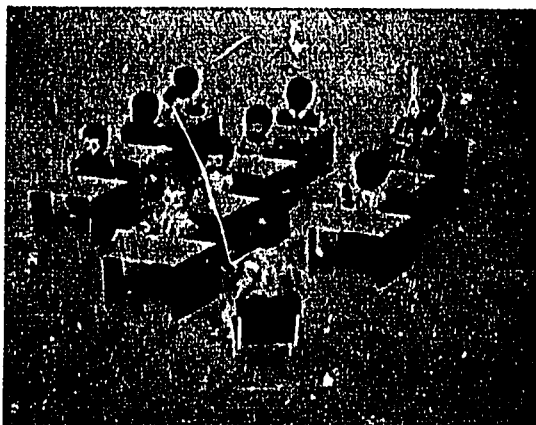
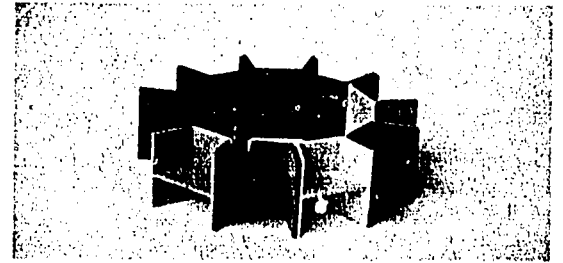
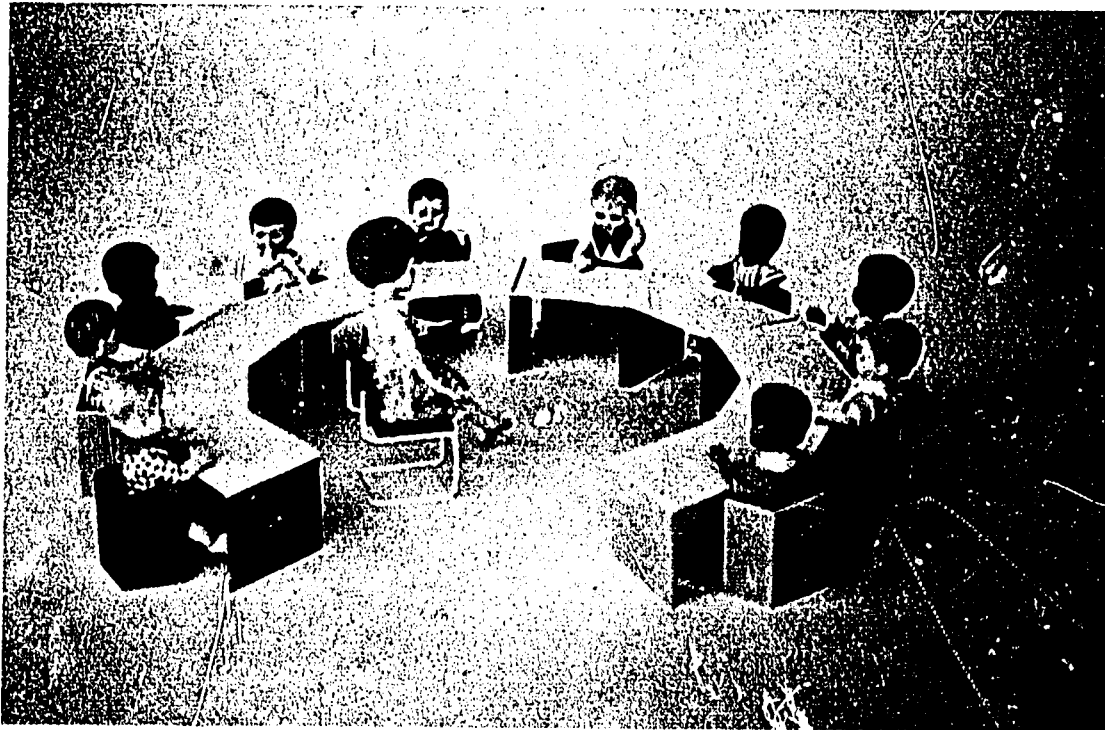
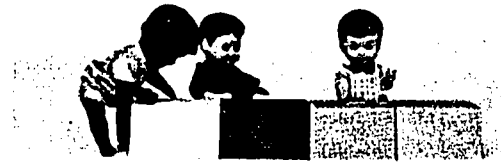
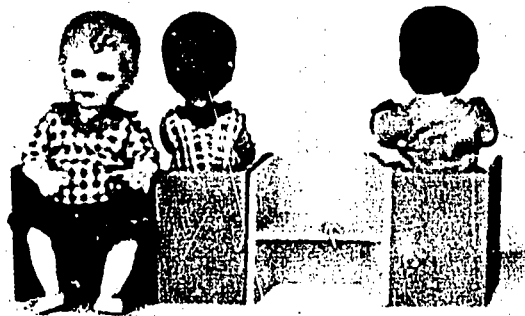

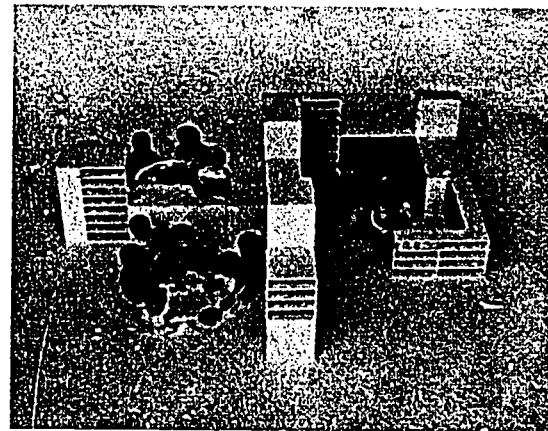
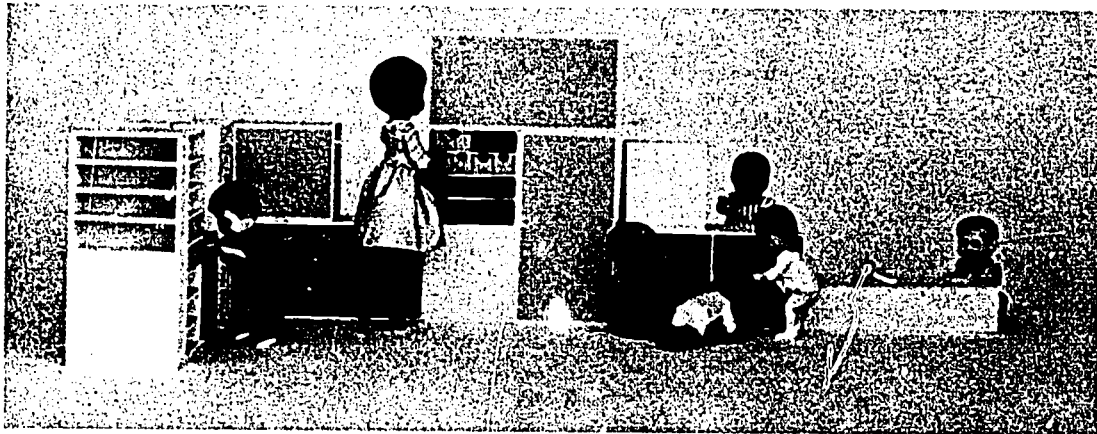

Moveable storage units can be used to create a variety of arrangements within a larger space. Storage can be provided when and where it is needed, simply by adding or removing shelves. Doors can be added to provide closure. Chalk and display surfaces are attachable. The stackable units provide various working surfaces at the appropriate heights.

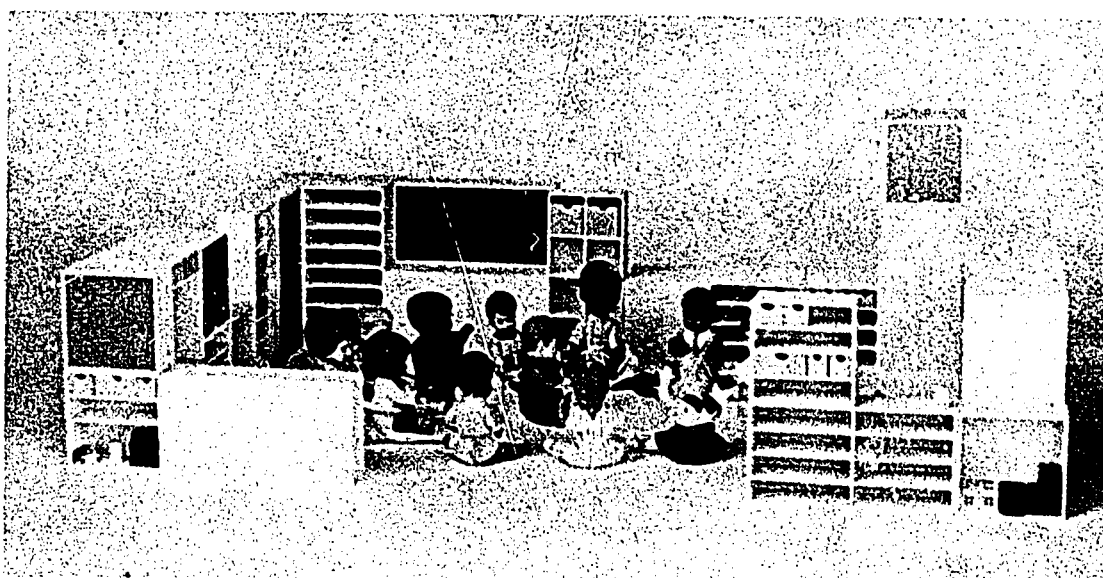
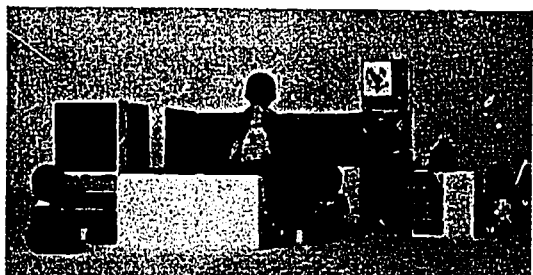
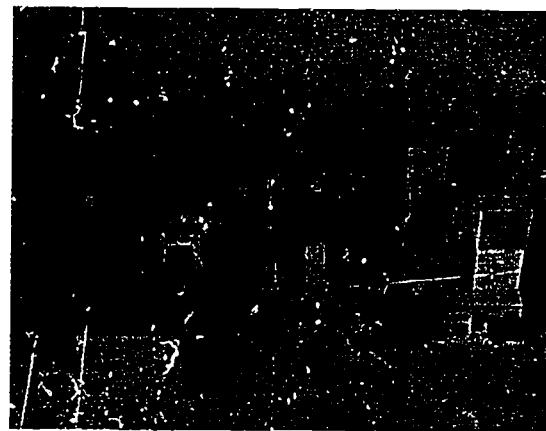

Safety

Preschool children are not able to fully differentiate between safety and danger. Therefore, people who have the responsibility for their care need to be alert to avoid settings and situations which provide universal and unnecessary hazards. It is of course, necessary that all local building, fire and safety regulations be strictly adhered to. Although these regulations provide basic safety measures, there are many special features for small children that should be considered.

Fire

- all classrooms should have at least two means of egress
- every floor of the facility should have at least two separate outdoor exits
- classroom doors and facility exits should open out
- fire extinguishers should be appropriately spaced in all parts of the facility
- fire escapes should be properly constructed for small children usage
- a fire-alarm system is recommended for large facilities
- children should be instructed in proper safety procedures
- fire exits should be properly marked and distinguishable by children

Facility Interior Surfaces

- avoid highly textured and slippery floors
- floors should be splinter proof and free of protruding edges
- changes in floor levels should be properly marked and distinguishable (ramps are better)
- carpeted surfaces should be static-electricity proof
- avoid heavily textured wall surfaces that may cause abrasions
- wall surfaces should be free of sharp and protruding edges and mouldings
- rounded wall corners and edges are recommended
- full length, floor-to-ceiling glass should be shielded to prevent children from running through it

Doors

- all doors should open out
- avoid self-closing automatic and spring operated doors
- swinging doors should allow visual access to other side
- door hardware should be child operable
- child-proof locks and bolts should be located out of reach of children and operable from both sides

Furniture/Equipment

- all furniture should be free of splinters, sharp corners and edges
- furniture, equipment, and toys should have nontoxic finishes
- flimsy, fragile furnishings that break easily should be avoided
- furniture and equipment that may tip-over should be avoided

Electrical

- electrical outlets should be child-proof
- locate outlets out of child's reach
- exposed electric wiring systems should be prohibited

Heating/Cooling Equipment

- room heaters, fans, and other potentially dangerous equipment should be located out of child's reach (ceiling or high on wall) or screened from child's touch

Stairs/Ramps

- locate all rooms used by children on ground floor when possible
- stairs should be well lighted with appropriate child height bannisters
- close off all open stairwells and child-proof all terraces, windows, and exits other than door
- ramp should be provided in place of stairs or in combination with stairs

Outdoor Equipment

- all playground equipment should be safely constructed
- materials should be used that are sturdy, durable and splinter-proof
- avoid sharp corners and protruding pointed objects
- hazardous equipment such as swings should be located away from major flow of traffic and equipped with soft seats
- surfaces under jumping, climbing, skating and swinging equipment should be soft; sand, grass or padded material is recommended

Architectural Barriers

Although preschool children in general need special consideration to avoid settings and situations that are hazardous and dangerous; additional considerations are needed for those preschoolers, especially the mentally retarded, who may have associated physical handicaps that would affect their use of the facility.

Architects and others, whose decisions affect building design, need information concerning the elimination of architectural barriers in preschool day care facilities. Besides the many special precautions already mentioned other information sources are currently available and can be studied to advantage by anyone planning a preschool facility. These include:

- **Public Law 90-480**, Elimination of Architectural Barriers
- **Making Facilities Accessible to the Physically Handicapped**, The State University of New York
- **ANSI A117.1**, American National Standards Institute
- **Housing for the Physically Impaired**, HUD
- **State and Local Efforts to Eliminate Architectural Barriers for the Handicapped**, National League of Cities, Department of Urban Studies, Washington, D. C.
- **Outdoor Recreation for the Physically Handicapped**, Department of Conservation, State of New York
- **Travel Barriers**, Department of Transportation, Washington, D.C.

The space requirement chart reflects the min/max amount of physical size (sq. ft.) and the min/max amount of storage (cu. ft.) needed for each particular space within any preschool facility. A min/max range is given

only because optimum space requirements should be determined independently for each preschool facility; based on that particular facility's needs. The optimum condition would, therefore, fall somewhere between the given min/max range.

Spaces	Size □ 1 sq. ft.	Storage Requirements @ 1 cu. ft.	
		enclosed storage	movable storage
Classroom • typical area includes total group activity space, arts/craft center, housekeeping/dramatic play center, nature study/science center, book center, and block center	80-120/child	80-120/child	12-24/child
total group activity • 10 children typical • 15 children maximum	40-60/child	55-75/child	4-c/child
arts and craft center • 1-5 children typical • 15 children maximum	30-50/child	32-56/child	4-6/child
housekeeping and dramatic play center • 1-5 children typical • 15 children maximum	15-25/child	6-12/child	2-4/child
nature study/science center • 1-5 children typical • 15 children maximum	15-25/child	12-24/child	4-8/child
book center • 1-5 children typical • 15 children maximum	10-20/child	none	3-6/child
block center • 1-5 children typical • 15 children maximum	11-20/child	none	3-6/child
tutoring/quiet • 1-5 children	15-20/child	none	according to specific use
napping/resting • 15 children maximum	15-20/child	5-10/child	none
music • 15 children maximum	30-50/child	4-8/child	2-4/child
indoor recreation • 15 children maximum	100-150/child	48-60/child	2-4/child
multipurpose (dining, recreation, assembly) • separate enclosed storage for recreation equipment/supplies • separate enclosed storage for dining/assembly furniture	50-100/child	93-115/child	4-6/child
observation	60-100 total	none	according to specific use

Spaces	Size □ 1 sq. ft.	Storage Requirements @ 1 cu. ft.	
		enclosed storage	movable storage
bathroom	50-100 total	none	30-50 total
infant care	40-60/infant	40-60/infant	4-6/child
outdoor recreation • 2 classes maximum at any one time • 30 children	200-300/child	600-800 total	none
staff lounge	150-200 total	none	40-60 total
material preparation	80-120 total	none	30-50 total
kitchen	150-300 total	200-300 total	100-150 total
dining	15-20/child	none	none
medical/first aid	80-100 total	none	20-40 total
health personnel	50-80 total	none	6-10/user
psychologist • includes testing and observation space	175-225 total	none	10-20 total
speech therapist • includes testing space	175-225 total	none	10-20 total
social worker	100-150 total	none	6-10 total
parent • 5-10 parents typical	150-200 total	100-180 total	10-20 total

Spaces	Size □ 1 sq. ft.	Storage Requirements @ 1 cu. ft.	
		enclosed storage	movable storage
volunteer auxiliary • 5-10 parents typical	150-200 total	100-180 total	10-20 total
mechanical	1 sq. ft./15 sq. ft. of building space	none	none
maintenance • workshop	80-100 total	120-200 total	60-100 total
janitorial closets	none	200-300 each	none
lobby	100-200 total	none	75-100 total
receptionist	50-80 total	none	4-10 total
executive director	100-150 total	none	10-20 total
educational director	180-150 total	none	10-20 total
teacher	50-80/user	none	10-20/user
secretary	80-100/user	400-600 total	20-50/user
conference board	150-200 total	100-180 total	10-20 total

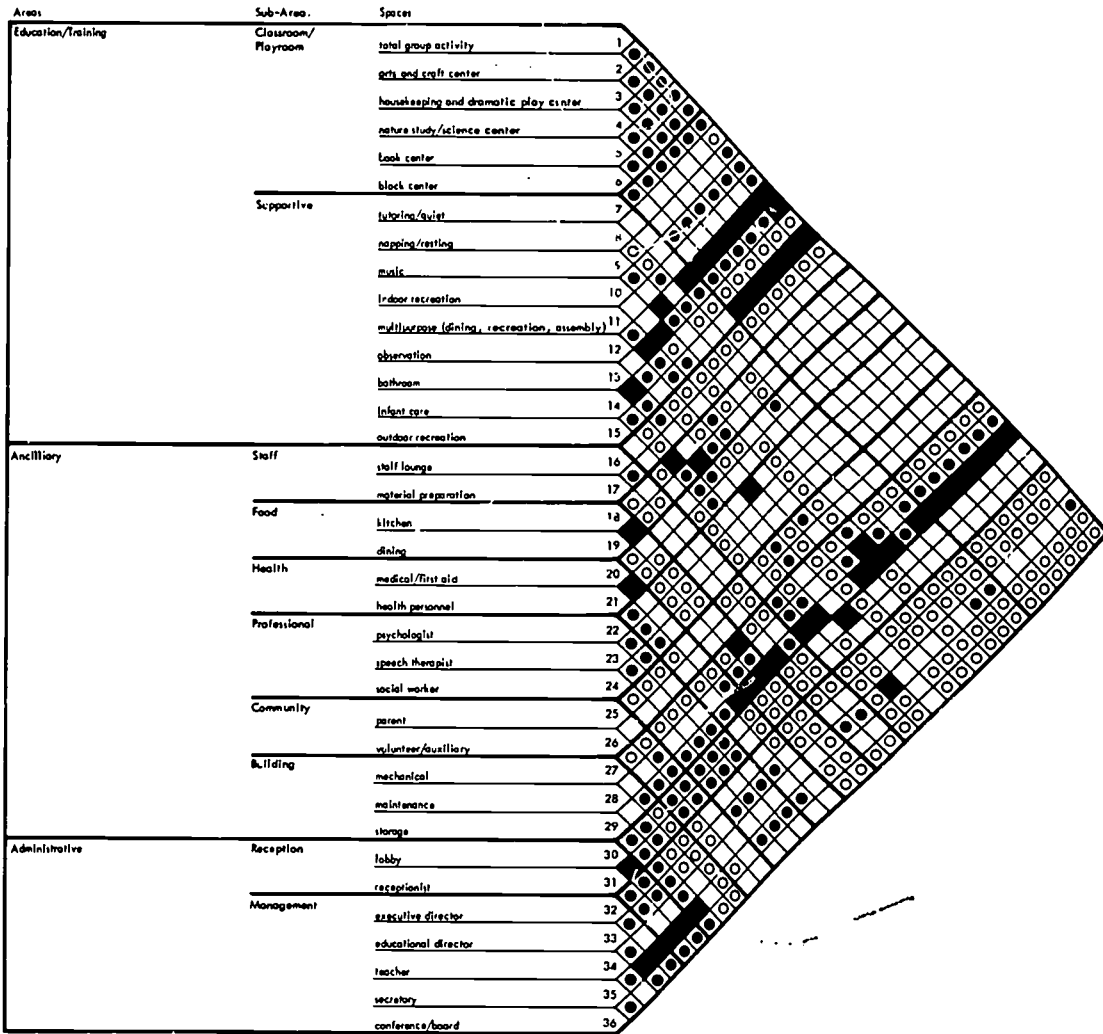

The space relationship chart lists all the spaces within a preschool facility and reflects the particular relationship they share with each other. This relationship was determined by objective and subjective assessment and based on several criteria: efficiency of circulation, common service needs, administrative convenience, teaching convenience, and other functional aspects. This criteria is specified by the architect, client, and consultant.

A value was assigned for each space relationship; necessary, desirable, unimportant, undesirable; and represents the relative strength of the relationship between spaces; (for example the relationship between the total group activity space and the bathroom is necessary).

It is likely that some spaces will coincide with all the criteria in many cases; in others, spaces needing to be close for one reason, may require no contact for the others. Therefore, the relationship coinciding with all the criteria would receive the highest ranking.

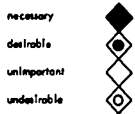

Case Studies

6



Design Process

The purpose of this section is to explain the design process and illustrate its use in the planning of preschool day care facilities. Four case studies are presented. Each takes a specific day care program, determines the design criteria by analyzing program goals, and presents one or more solutions to the resulting design problem.

It will be helpful to the educator to have some understanding of the design process as it is used by the architect. It is the organization process through which a project passes from its inception to its conclusion. It consists of six phases in this chronological order:

- Criteria development
- Criteria synthesis
- Schematic design
- Design development
- Construction documents development
- Construction administration

It is with the first four phases of the design process that this report is concerned.

Criteria Development

Criteria development is the most critical and influential phase of the design process. It is during this time that the designer and educator work in close collaboration. It is the educator's responsibility to give the designer a clear cut explanation of three factors which will determine the facility design: first, the general orientation and objectives of the day care program; second, a description of the educational/training objectives and the services which support them; and, third, the specific activities which will be carried on within the center to achieve these objectives. Together the architect and educator consider the design implications inherent in the general goals and curriculum and establish priorities among them. As much time needs to be devoted to this phase as is necessary to produce clear cut criteria which are understood and accepted by both architect and client.

To assist in criteria development, Part I of this report presented a brief survey of present day care programs and social and educational trends in preschool education, with special emphasis on the needs of culturally deprived and mentally retarded children. Then, Part II considered the implications of the program for the design of the physical environment in which it takes place. Using the information in Part I as a guideline, the educator analyses his own unique program and then considers, with the designer, the design implications presented in Part II.

This is the time to establish priorities because it is seldom possible to satisfy all desires. If, at a later time in the design process, there is a fund shortage or costs become excessive, the less important goals are de-emphasized. This procedure can help ease critical decision making when financial problems arise.

This is also the time to consider the establishment of a long range master plan if program expansion is anticipated.

Criteria Synthesis

During this phase, all data on design implications for all activities are consolidated. The data is organized in such a manner that the following environmental characteristics are apparent:

- Necessary relationship between areas
- Relative size of spaces
- Characteristics common areas
- Characteristics specific to areas

Schematic Design

On the basis of information secured during the criteria synthesis, the designer prepares sketches illustrating possible approaches to the design of the facility. The sketches, cost data, and other information are presented to the client for constructive evaluation. A thorough evaluation of the project is vital at this time because the final design will follow the fundamental principle established in the schematic design. Any proposed changes should be made during the schematic design phase before the project has developed into accurate drawings.

Design Development

In this phase, the concepts established in the schematic design are developed in the form of accurate drawings showing plans, elevations, sections and special details. Upon completion of these drawings, a project review is held with the client for additional evaluation prior to finalization of the drawings. A more accurate cash estimate will also be prepared for careful consideration.

Construction Document Development

Final documents (drawings, specifications, and contract formats) are prepared during this phase. These documents are of a technical and legal nature and are not easily understood by those outside the design and construction professions. Special attention is given to detailed drawings and specifications which describe the final product and how it is to be constructed. When these documents are completed, there is a final review with the client. This will be the last opportunity for changes to be made without adding to the cost of the contract. After the contract document has been signed and a contractor selected to construct the facility for a certain amount of money (his bid), all changes become additions to the initial contract price and must be paid for by the client.

Construction Administration

Immediately after the selection of the contractor, actual construction on the project will begin. During the construction process, the architect visits the job site to survey progress of the work. He works closely with the contractor to select proper colors and finishes and makes on-the-spot decisions as the need arises. Any questions or comments which the client may have during the construction phase should be directed to the architect.

When construction is complete, the facility usually receives final inspection, final fee portions are paid, and the client moves in. Under certain conditions, the client may occupy certain portions of the facility prior to complete finalization of the construction. This procedure, however, is not normally recommended due to the legal problems which may arise concerning liability for the incomplete structure. Patience should be exercised to avoid legal involvement and possible additional construction costs.

The design and construction processes are lengthy, technical and sometimes trying for all concerned — the architect, contractor, and educator. Active participation by the client who will carry out the program is vital during all phases of the process. Just as the designer must rely completely on the client to provide valid basic program criteria, the client must rely on the architect to provide a valid design based on this criteria.

Design Applications

Preschool for Retarded Children Projected Program

This preschool has been in operation for about ten years and is well established in the community. It offers four morning and four afternoon educational/training sessions for retarded children between the ages of four and eight. The present enrollment is eighty. The majority of the children are classified as trainable mentally retarded, but some of the older ones are more severely handicapped. The only admission requirement is that the child be ambulatory and thought to be able to profit from group training. Transportation is provided by the parents.

The curriculum is directed toward achieving the objectives outlined in Part 2. Instruction emphasis training in the self-help areas, speech and language stimulation, mental development through sensory discrimination and early concept formation, and improvement in fine and gross motor coordination.

The present staff consists of:

- 4 teachers
- 4 teacher aides
- 1 educational supervisor
- 1 social worker
- 1 psychologist (50% of the time)
- 1 executive director
- 1 secretary
- 1 receptionist/clerk typist
- 1 maintenance man

There is an active parent organization and a volunteer auxiliary associated with the center.

At present the center occupies a large old house in a centrally located area which has been rezoned for apartment buildings. It is financed by the local United Fund, student tuition and donations.

One and a half acres have been donated for building the new center. The site is accessible by freeways from all parts of the city. The land is flat and contains three large trees. The center will be financed by state and matching local funds.

The present waiting list indicates that an increase in enrollment of about 50% can be anticipated during the first few years of operation in the new center. In addition to preparing for the anticipated increase, the center would like to expand its services in two directions:

First, the addition of a program for children over seven years of age who are so severely retarded that they are not eligible for public school special class. No upper age limit would be set for admission to this program.

Second, the provision of space for weekend and evening recreational activities for retarded adolescents and adults and for meetings of community groups.

Increased involvement with the teacher training program at the university level has been requested by the Special Education Department, but no investment in research or experimental programs is foreseen.

The only curriculum changes planned involve the use of audio-visual equipment and the establishment of the program for the older more severely retarded group.

The projected staff consists of:

- 6 preschool teachers
- 6 teacher aides
- 1 teacher for older pupils
- 1 teacher aide for older pupils
- 1 school principal
- 2 social workers
- 1 psychologist
- 1 executive director
- 1 secretary
- 2 receptionist/clerk typist
- 1 bookkeeper 50% of the time
- 1 maintenance man

Since this is a school rather than a total day care center, no preparation of complete meals is necessary. However, a kitchen facility will be needed for the preparation of refreshments for social events.

In line with present trends, there is a possibility that in the future the school will admit children at a younger age than four. If this takes place, space will be needed for working with the mothers in early child management as well as with the younger children themselves.

Design Objectives

The designer and client — in this case, the executive director of the preschool — met many times to discuss the general and specific program objectives. The architect visited the center and watched the interaction between the children and the teachers and came to understand the role of the ancillary personnel. He was interested in the children, and did some independent reading. He understood the curriculum goals and the methods by which they were achieved.

Through the application of the design process, the architect and client determined that the design objectives were as follows:

- 1) To provide education/training area for twelve half day preschool classes of about 10 children each
- 2) To provide education/training area for one class of about 15 severely retarded children over seven years of age.
- 3) To design the above education/training areas in such a way that the physical environment made a positive contribution to the program
- 4) To integrate an outdoor play area into the training/educational setting
- 5) To provide for easy pick up of the children by their parents
- 6) To design spaces for the ancillary personnel which reflected their individual involvement with the program
- 7) To design an administrative area which would promote efficient supervision of the total program and enable the center to project a good public image
- 8) To provide a recreational and meeting space, easily accessible to the public and possibly to separate from the educational/training and administrative areas
- 9) To provide adequate off-street parking.

Spaces Needed

The specific spaces needed for this case study includes: total group activity, arts/craft center, nature study/science center, block center, multipurpose, observation, bathroom, outdoor recreation, staff lounge, kitchen, medical/first-aid and health personnel, psychologist, social worker, parent, volunteer auxiliary, mechanical, maintenance, storage, lobby and receptionist, executive director, educational director, teacher, secretary, conference/board.

Solution

The plan of each unit is a simple cross. Any wing of the cross can be extended to provide additional space for new equipment or other future program needs. Future trends do not call for the teacher student ratio to exceed 1 per 10, therefore, provisions are not specifically made to enlarge the classroom to accommodate more children per class. The class could conceivably accommodate 15 children, but exceeding this number is not recommended.

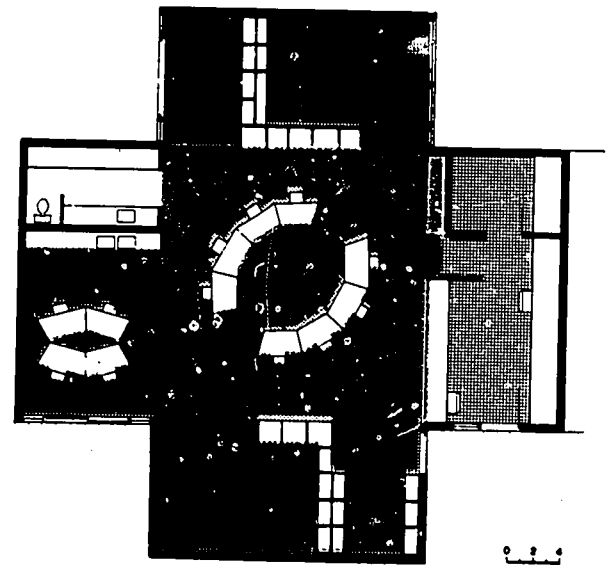
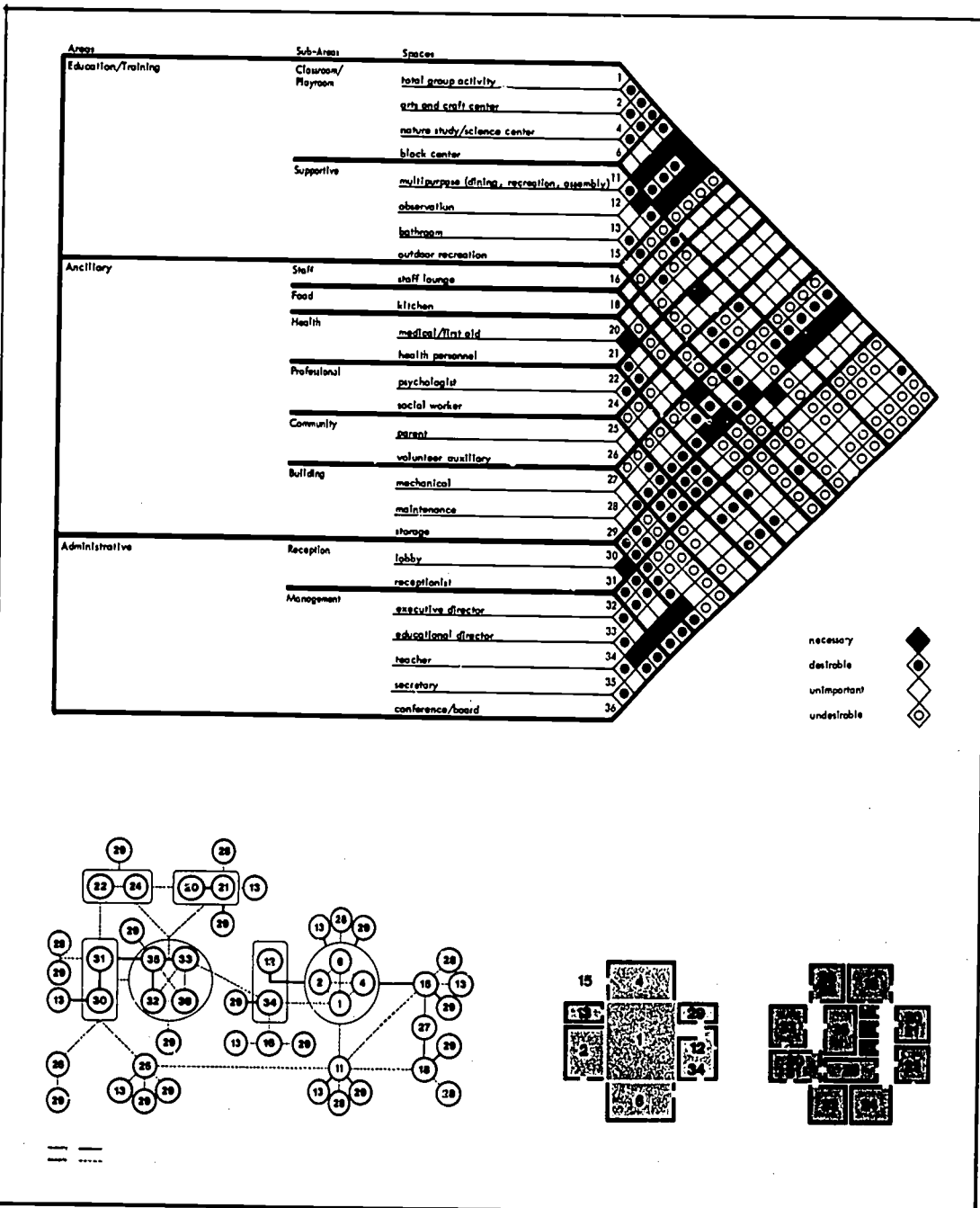

relationship chart, relationship graph, schematic preschool unit and administrative unit plan

The classroom is designed to provide centers of activity in the "arms" of the cross plan. All art supplies, wash basins, and work counters, for example, are located in a specific "arm" of the cross. However, the art activity can extend toward the center of the plan which acts as an overflow area shared by all activities. In this way, the children become oriented toward certain activity centers but can actually utilize much more space than is specifically designated for each individual activity. Separate spaces were not provided for isolation or resting. Isolation can be accomplished by sending an unruly child to an inactive space which is closed off by the use of movable storage units. Rest can be accommodated, using mats and cots, in the total group activity space.

This scheme conserves space and allows multi-use of equipment and facilities yet eliminates the impersonal megastructure feeling of some versatile, adaptable, multi-use buildings. The smaller activity centers also relate more to the scale of the child than a large open expanse of space which is required to facilitate all the activity needs.

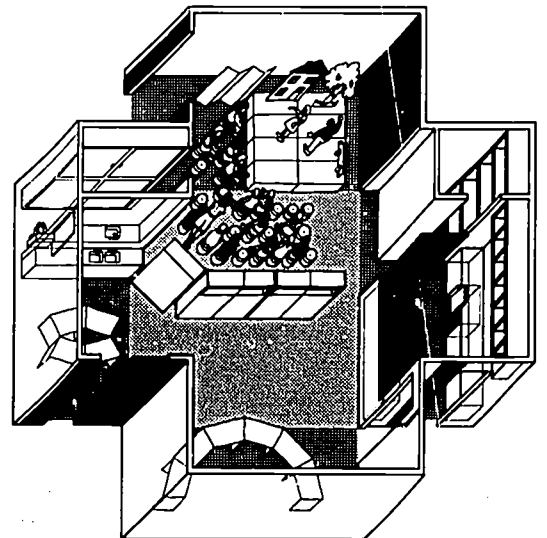
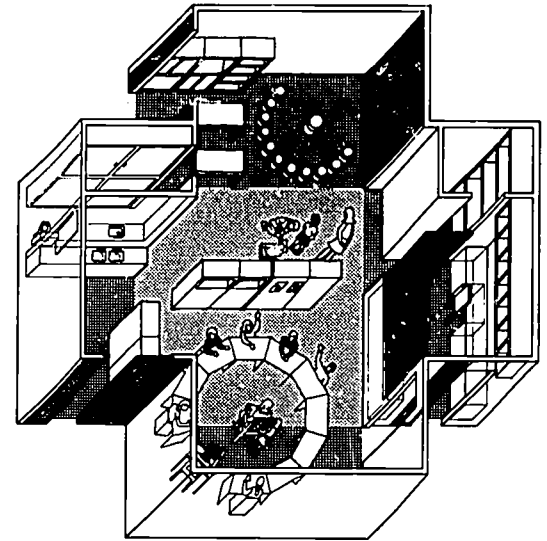
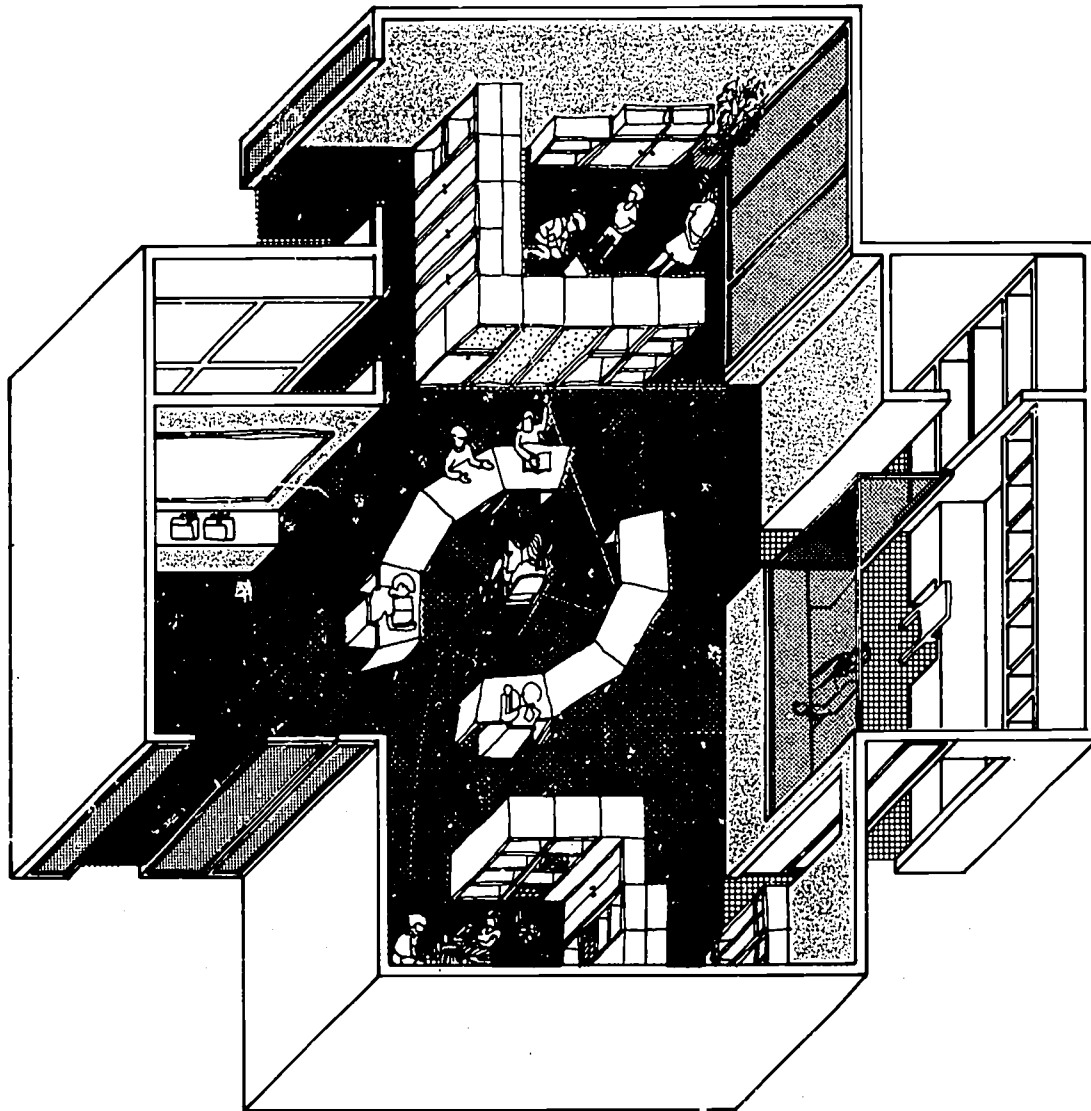
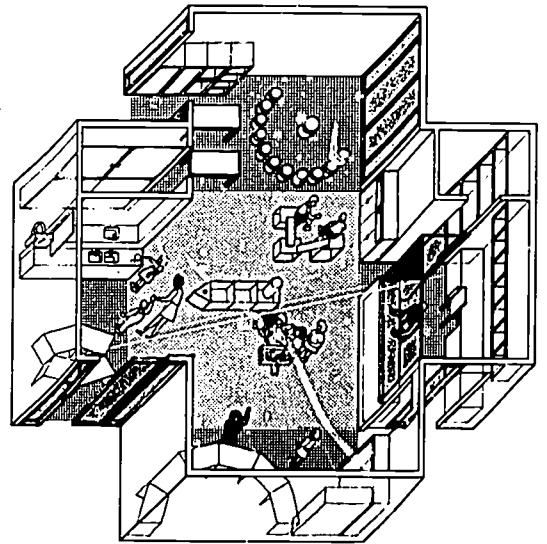

The basic design concept is limited to a single story structure. The site plan shows six classroom units plus three additional units: the administrative unit, the multipurpose unit, and a unit for the older retarded. Each of the six classroom units houses 10 children, one teacher and one teacher's aide. These classrooms are designed for 120 children per day (60 children per 1/2 day shift). The unit for the older retarded is designed for 10 children per 1/2 day shift. The multipurpose unit provides (1) a recreation facility for the older retarded to use at nights and on weekends, for such activities as dances, T.V., movies, games, and meetings; (2) a center for community use when the older retarded or other children are not scheduled to use it; and (3) multipurpose space for use by the younger children at various times during the day.

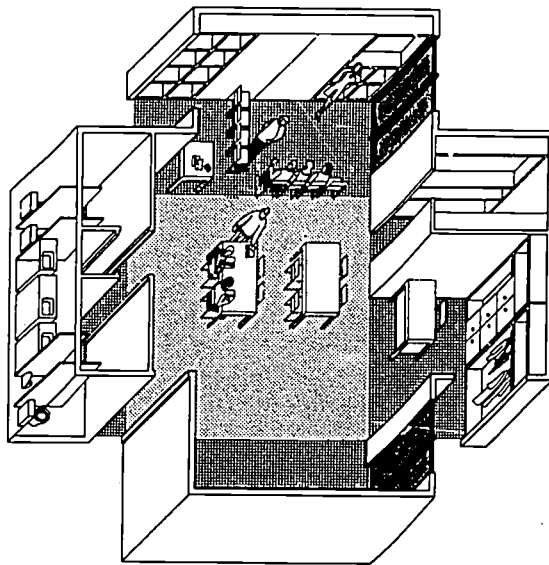

older retarded unit

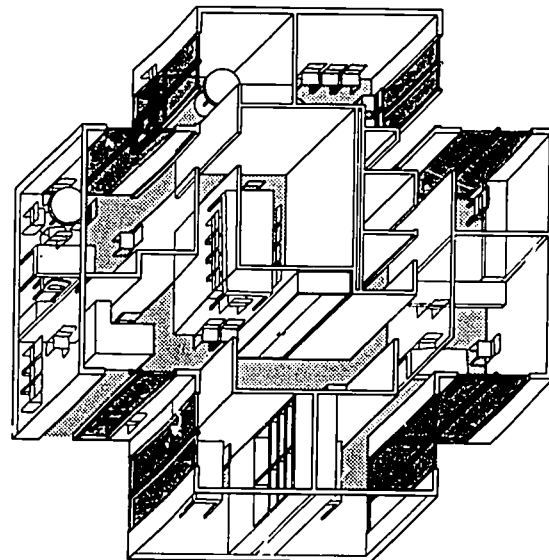

administrative unit

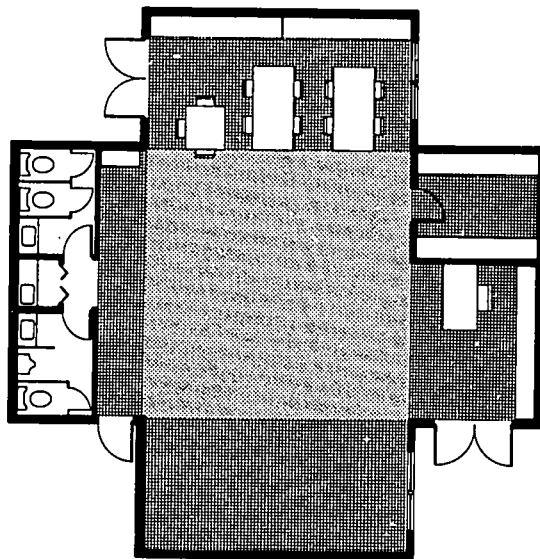
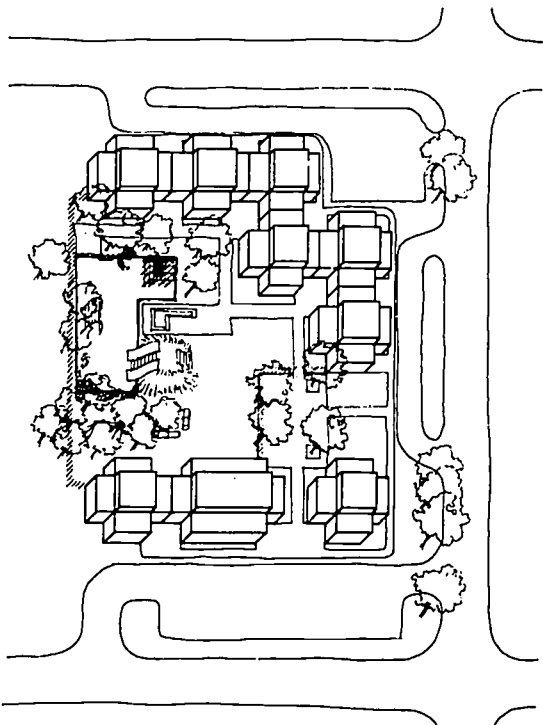

multipurpose unit

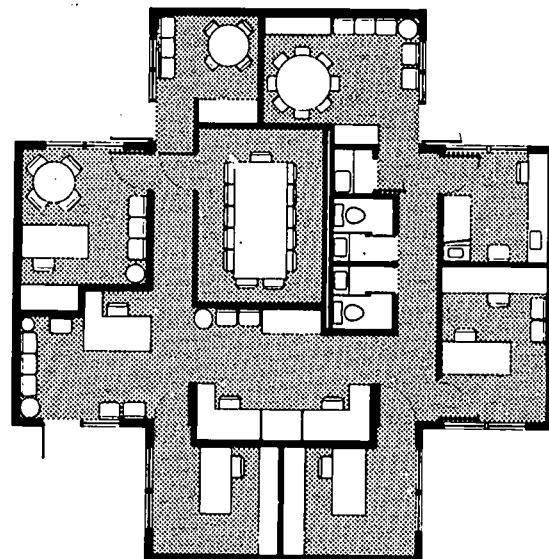

0 2 4

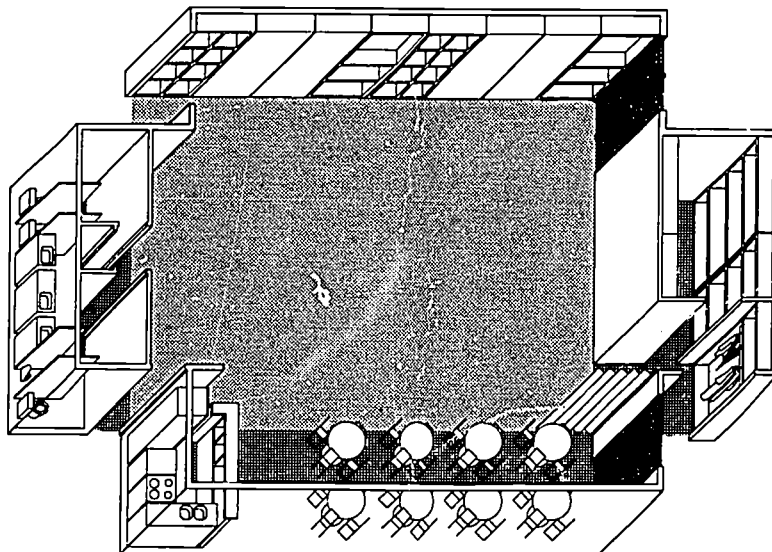

Day Care Center for Culturally Deprived Children

This day care center is still in the planning stage. It is part of a Model Cities Comprehensive Plan for a city of about 60,000 which involves planning in six program areas: manpower, education, housing, physical facilities, health and social services.

The center is to be located in proximity to three hospitals and a box plant which together employ an estimated 700 women. The site consists of 4 acres.

Most of the mothers of the children who will attend the day care center are employed in low skilled or unskilled jobs. Many of the families have been welfare recipients at one time or another. A few mothers will be employed as nurses or in technical or professional positions. They live in the adjoining residential area.

Projected Program

The center will provide total day care services for two shifts of ninety children and ten infants each. The hours will coincide with the shifts at the hospital. No plans for the expansion of services are considered necessary because the area being served is considered to have a stable population.

The comprehensive educational program will be designed to compensate for cultural deprivation. The curriculum goals and methods are those discussed in Part 1, "Culturally Deprived Children" and Part 2, "The Curriculum Implications". The curriculum goals include the establishment of orderly purposeful behavior, the encouragement of wholesome behavior, the encouragement of wholesome interpersonal relations, the acquisition of a positive self-image, the development of precognitive and cognitive skills, the stimulation of language development, and the development of manipulative skills and physical coordination.

In addition to the educational program the center will offer those supportive health and social work services necessary to encourage wholesome child development. These services include health inspections with referral to clinics for needed therapy, careful fulfillment of nutritional requirements, availability of case work services for the family, and developmental and psychological examinations.

Inservice staff education will be continuous. Training will be offered to women in the community who are qualified to become teacher aides or community outreach workers. Due to the fact that the mothers will be working, only limited parent education will be feasible. A Parent Advisory Board will reflect the needs of the community.

The staff will consist of:

- executive director
- educational director
- social worker
- psychologist
- 6 teachers for the day session
- 6 teacher aides for the day session
- 6 teachers for the evening session
- 6 teacher aides for the evening session
- secretary
- receptionist
- janitor
- maid
- cook
- cook assistant

Design Objectives

- 1) To provide an innovative day care center for a total enrollment of 90 culturally deprived preschool children
- 2) To provide an infant care area for 10 infants
- 3) To provide an outdoor recreation area to supplement the education/training area
- 4) To provide specialized education/training spaces for the testing and evaluation of new methods of delivering educational services
- 5) To provide a stimulating environment to compliment the proposed new education/training program
- 6) To provide maximum flexibility of space arrangements within the education/training area for present and future program developments.

Spaces Needed

The particular spaces needed for this case study include: total group activity space, arts/crafts center, housekeeping/dramatic play center, nature study/sciences center, book center, block center, multipurpose (recreation, assembly), bathrooms, infant care, outdoor recreation, staff lounge, material preparation, kitchen, dining, medical/first aid, health personnel, psychologist, social worker, parent, mechanical, maintenance, storage, lobby, receptionist, executive director, educational director, secretary, conference/board.

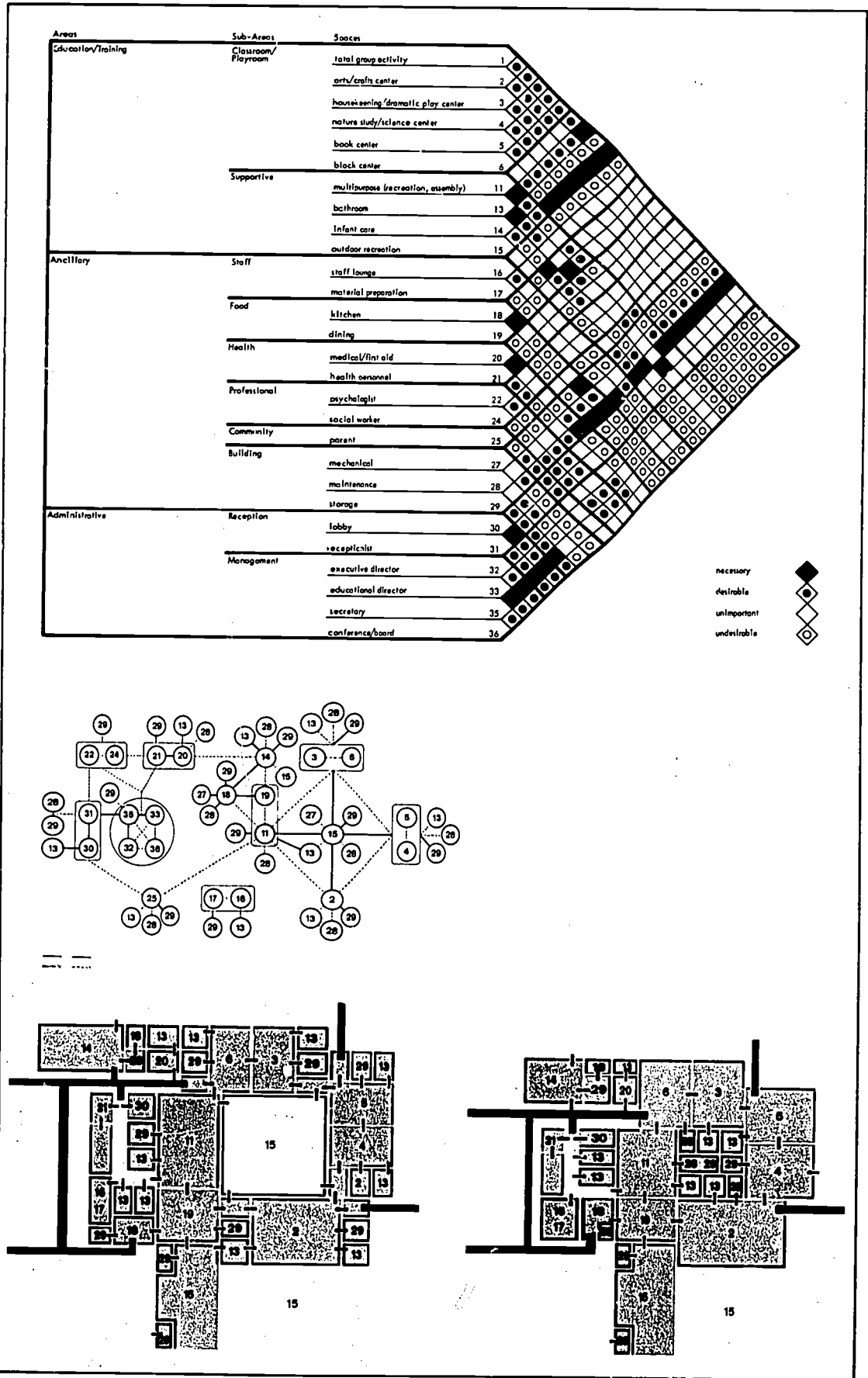

Solution

The design objectives suggested that a unique type of preschool facility was needed to compliment the new education/training program. Environments, particular to arts/crafts activities, housekeeping/dramatic play activities, block play activities, and other similar educational activities, were provided for in separate spaces. Instead of having a group of 15 children in one classroom for the duration of the day care program, all the children rotate through the specialized spaces on a time sharing basis. This affords specialization of teaching skills by the staff and avoids over duplication of teaching supplies and equipment. Although time scheduling of activities is the unique feature of this concept, the advantages inherent in this solution warrants its investigation for future development.

Two variations of this solution are presented for review.

relationship chart, relationship graph, schematic plans (solution no. 1/solution no. 2.)

Solution No. 1

This solution is an inward oriented scheme in which the specialized education/training spaces are arranged around an open courtyard. The courtyard not only provides visual relief and a point of orientation, but also has the functional aspect of being a useable space for arts/crafts activities and especially for nature study/science center activities. An aviary, a shallow pond for aquatic life, and earth beds for plant life are indigenous to this area.

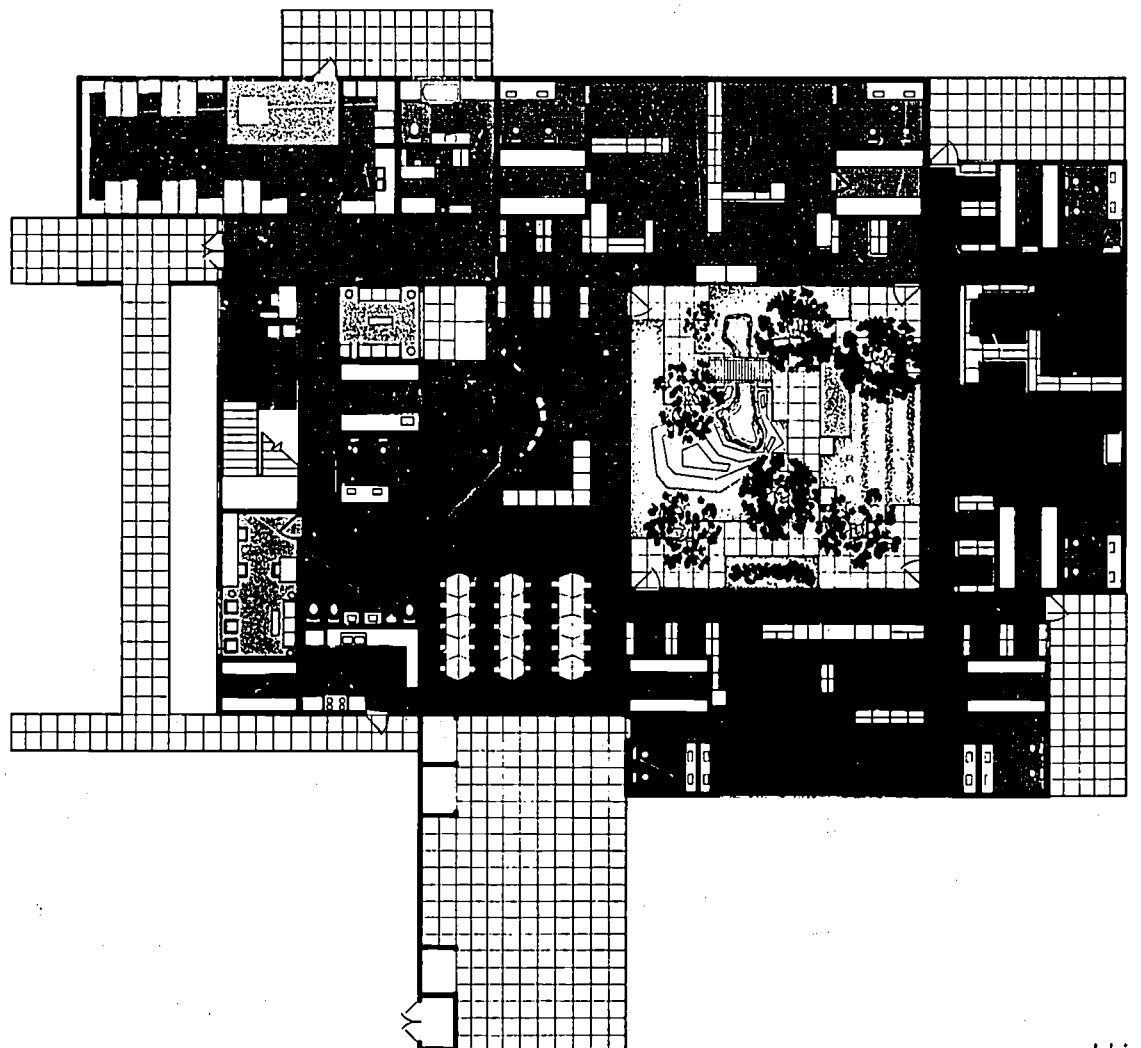
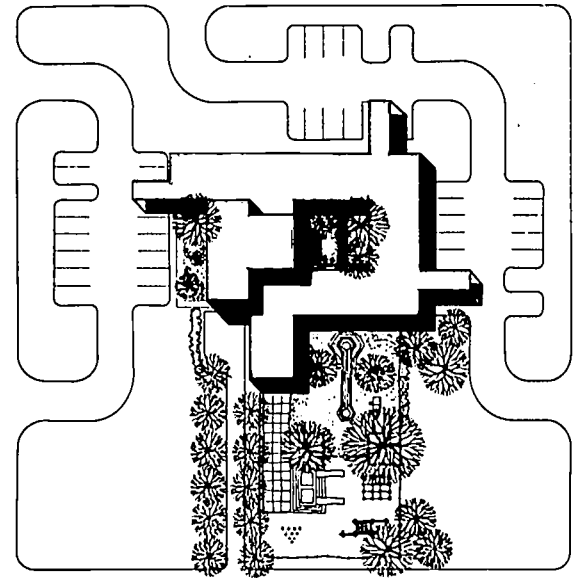

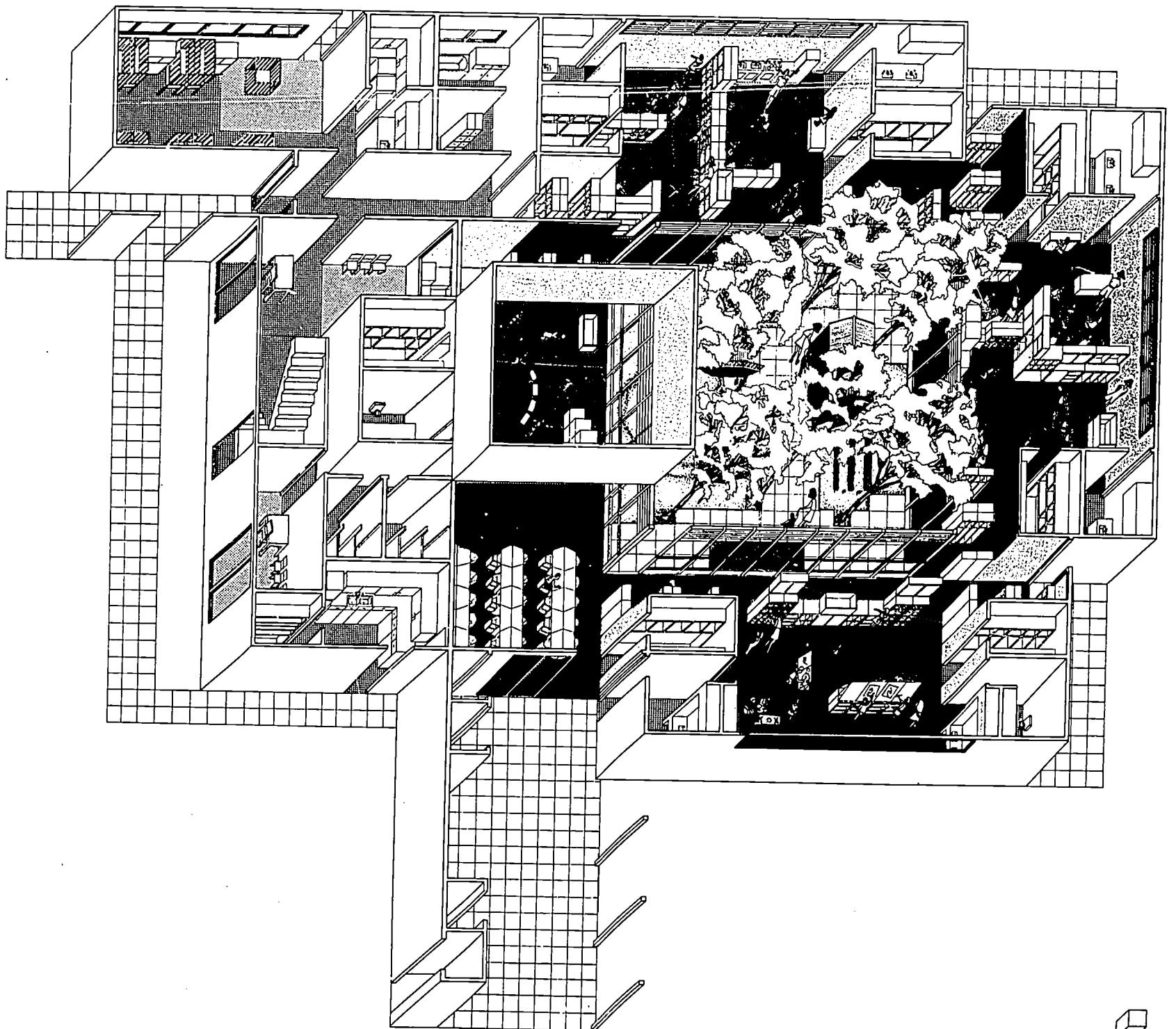

Solution No. 2

This solution is an outward oriented scheme in which the education/training spaces are arranged around a service core of bathrooms, storage and maintenance spaces, and a mechanical space. This scheme offers compact space arrangements with visual relief and orientation being provided for by windows opening to the surrounding outdoors.

In both solutions the education/training spaces are located on the ground floor only with administrative and ancillary spaces occupying 2 levels. Also notice that interior surfaces are useable and working surfaces, and that the new furniture concept has been used extensively to create appropriate activity groupings.

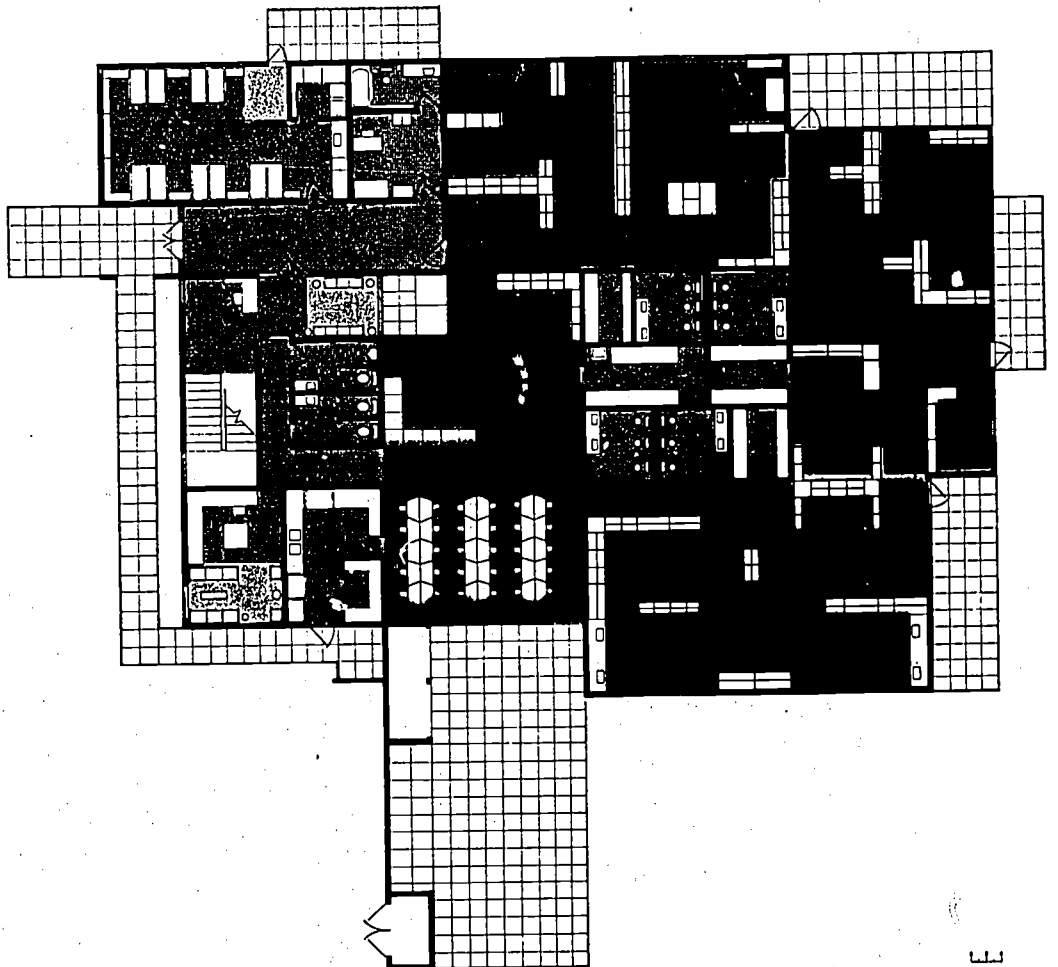

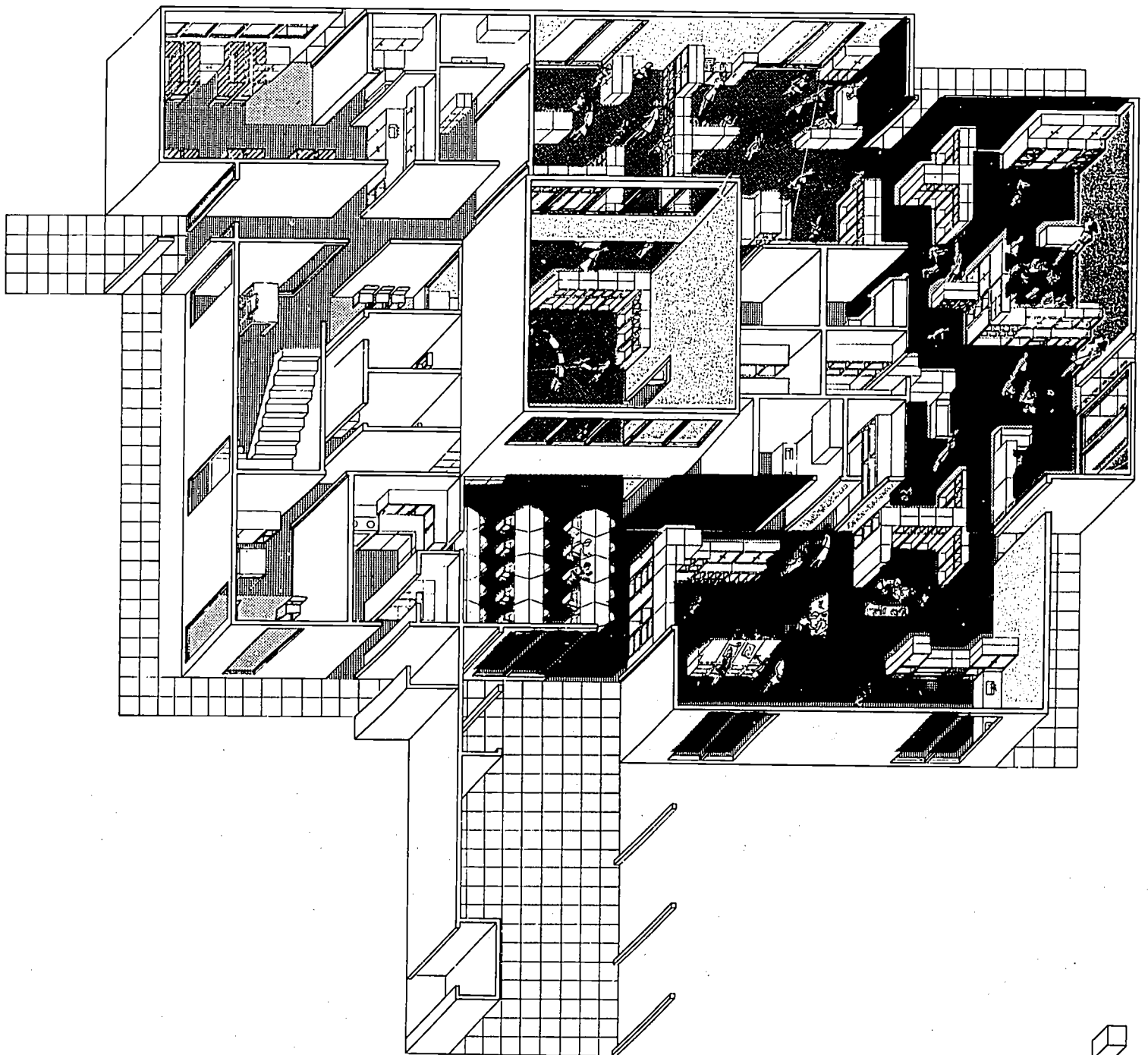

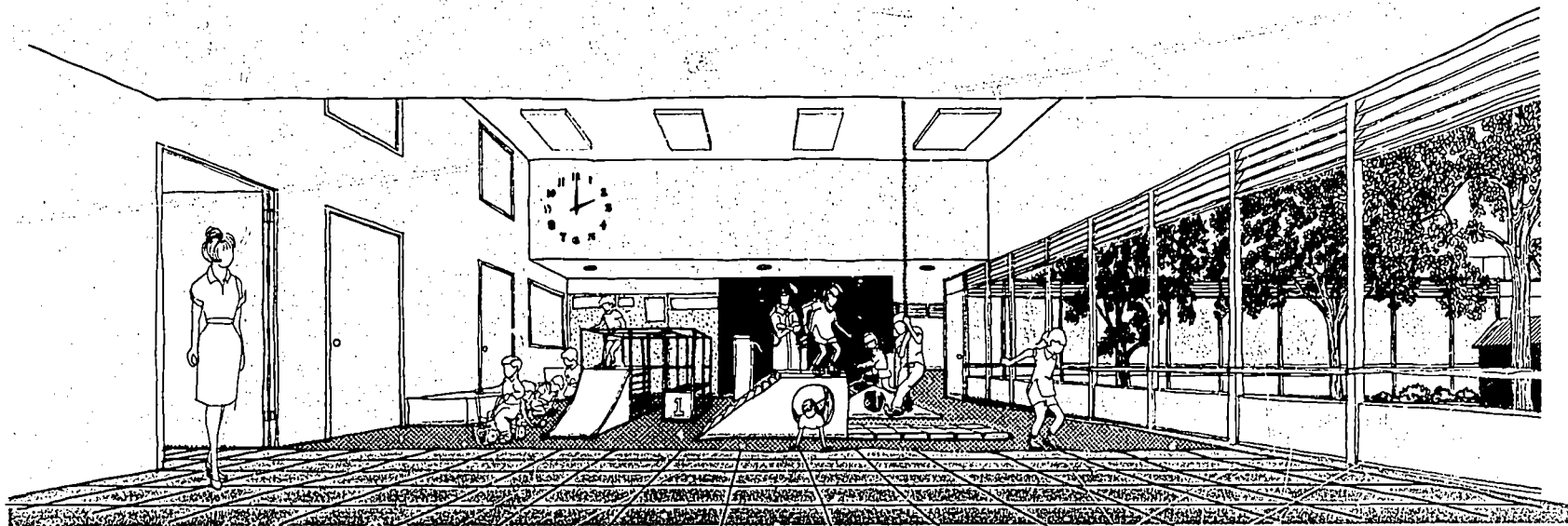

multipurpose space (solution no. 1)

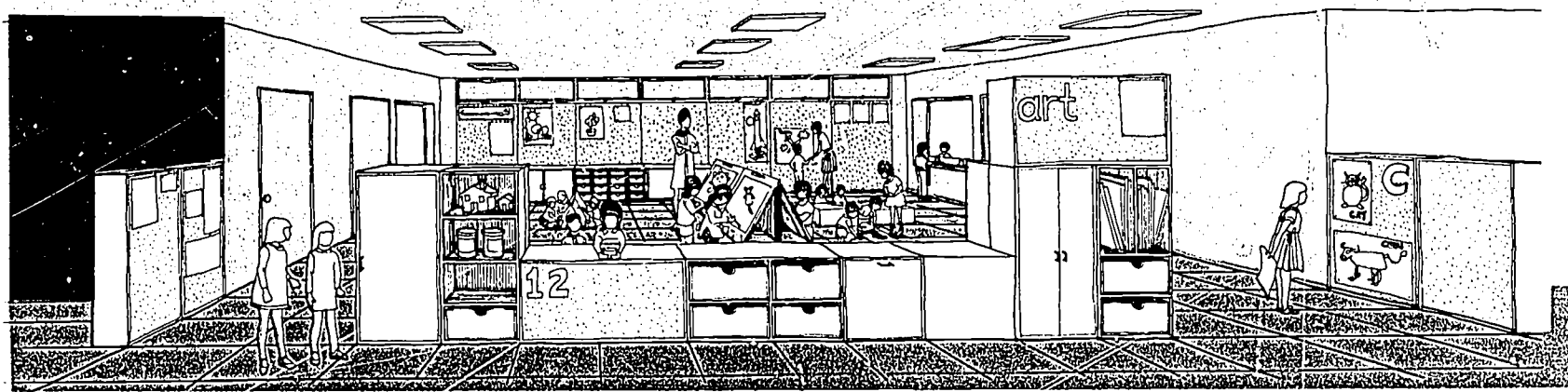

arts/crafts center (solution no. 1)

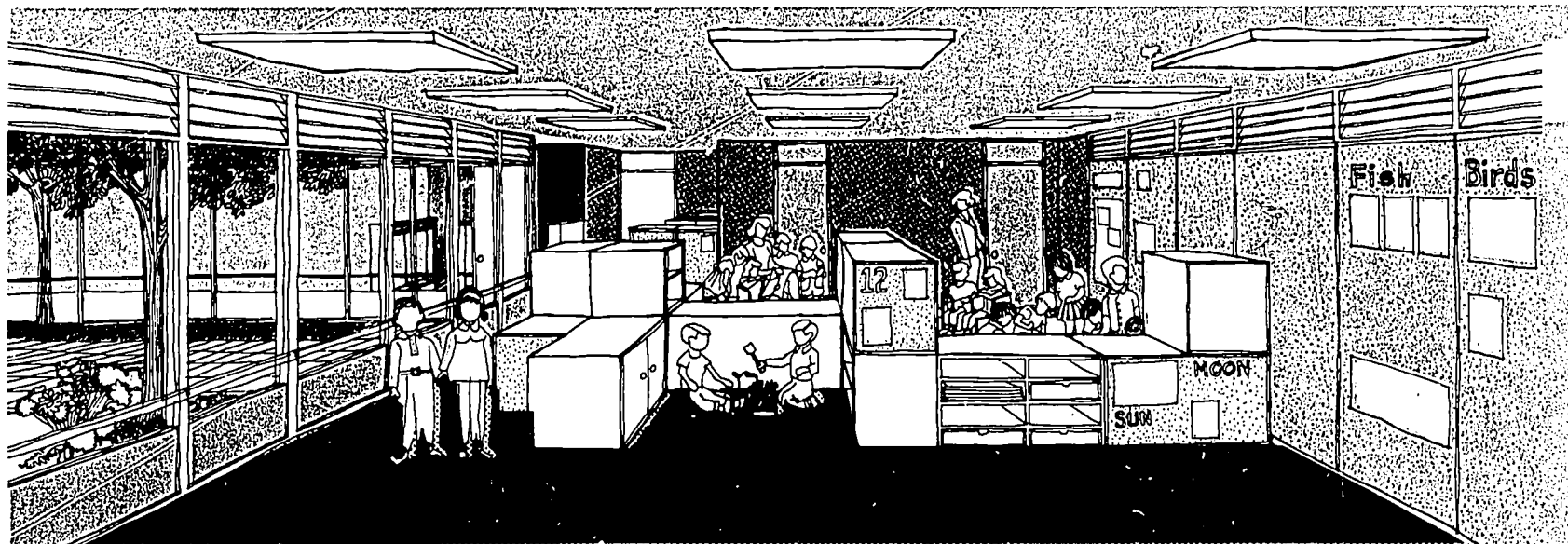

book/nature center (solution no. 1)

Mobile Day Care Unit for Migrant Workers

There are an estimated 275,000 migrant farm workers in the United States. No one knows how many children accompany their parents on seasonal migrations to cultivate and harvest crops. Estimates run from 100,000 to 600,000 with the most frequently quoted figure being 150,000. The work force is predominately male with half being under twenty-five years of age.

There are three main streams of migrant movement in the United States. The Atlantic Coast Streams consist mostly of Negroes whose home base is Florida. The Central and Pacific Streams consist primarily of Mexican-Americans whose home bases are Southern California, and Texas.

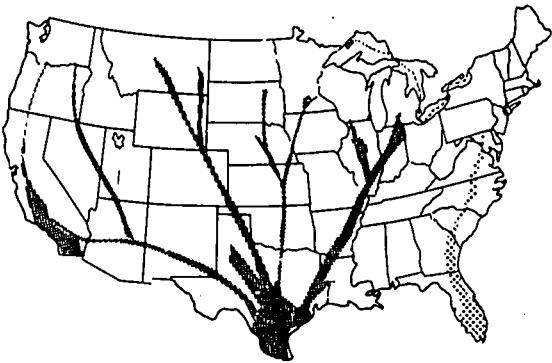

The families live in camps provided by the firms for which they work. The houses usually have electricity and water, but are run down and dilapidated. The children's attendance in school is irregular and many of them work in the fields when they should be attending classes, even though it is illegal. School age children and older women may remain in the camp to look after the infants and young children. Some children "live" in automobiles parked by the fields in which their parents are working.

The migrants look with suspicion on school and day care programs. The few attempts to reach their children through these services have had slight effect. Colorado started special summer school programs and reached only 300 of an estimated 3,000 in the state.

In a day care center operating in the basement of an Arkansas church, the children were observed to be enthusiastic about an activity for short periods of time, but unable to settle down and work purposefully. The young children are friendly, spontaneous and self-reliant. They have few toys to play with, limited exposure to pictures and books, and no opportunity to acquire the speech patterns and basic concepts needed in school. Their diet and eating habits are poor. Little dental and medical care is available. The children age rapidly.

Projected Program

The group of migrant workers with which this case study is concerned winters in the Rio Grande Valley. In May they move north to begin seasonal agricultural work in Colorado, Wyoming, and as far north as Montana, returning to Texas in the fall. The group is predominantly Mexican-American. The educational level of the adults is about fourth grade, but few perform at this high a level. The language spoken is "Tex-Mex". Even at a young age the men drink heavily, are careless and hostile, even violent at times. They want no free hand outs.

By becoming a part of their daily lives, a mobile day care unit would offer the migrant community an opportunity to gain confidence in the child care workers and to understand the value of the services which are offered. The objectives of the program would be two fold: (1) to offer young children basic learning experiences and give them good supervisory care; and (2) to offer training to the women in better child care and homemaking practices. As a fringe benefit, it might be able to provide some evening recreational experiences and a modest library of magazines for the adults.

The program would be patterned after those for culturally deprived children, but its content should have special relevance to the life style of the migrant family, which actually is rich in many experiences offering interesting learning opportunities. Emphasis would be placed on organized purposeful behavior, the completion of tasks, and language stimulation.

The mothers of children would serve as paid aides in the day care program. They would receive continuous in-service training in meeting the needs of developing children. Instruction in nutrition and domestic skills would also be a part of the program.

The initial program would provide for fifteen infants and young children. The unit in which it is housed should contain more than adequate sanitary facilities, a washer and dryer, if possible, and an efficient compact cooking space. It will need to be designed with all the efficiency of a pullman compartment.

The staff should consist of one trained preschool teacher who understands the cultural background of the children, and two teachers aides who are members of the migrant group. Contributing staff, e.g., county nurse, county demonstration, and the like, would be secured from the district in which the migrant group is working.

Design Objectives

- 1) Providing space for a basic day care program for (15) children and a limited number of infants (max. of 5).
- 2) Unit must be able to travel with the migrant workers and be reasonably easy to erect and dismantle.
- 3) Unit should contain adequate sanitary facilities, a washer and dryer, if possible, and an efficient compact cooking area.
- 4) It will need efficiently designed storage for equipment and supplies.
- 5) Unit must conform to the standard 8 ft. width when traveling on the highway.

Spaces Needed

This is a basic day care unit and since space will be limited, the unit must be flexible enough to provide space for total group activities, small group activities, and supporting ancillary services. The specific spaces needed are: total group activity space, arts/crafts center, housekeeping/dramatic play center, book center, block center, infant care, bathroom, kitchen, maintenance and storage. Outdoor recreation is provided outside the mobile unit depending on the specific location. Mechanical services (electrical, water and waste) are supplied and hooked up in the conventional way.

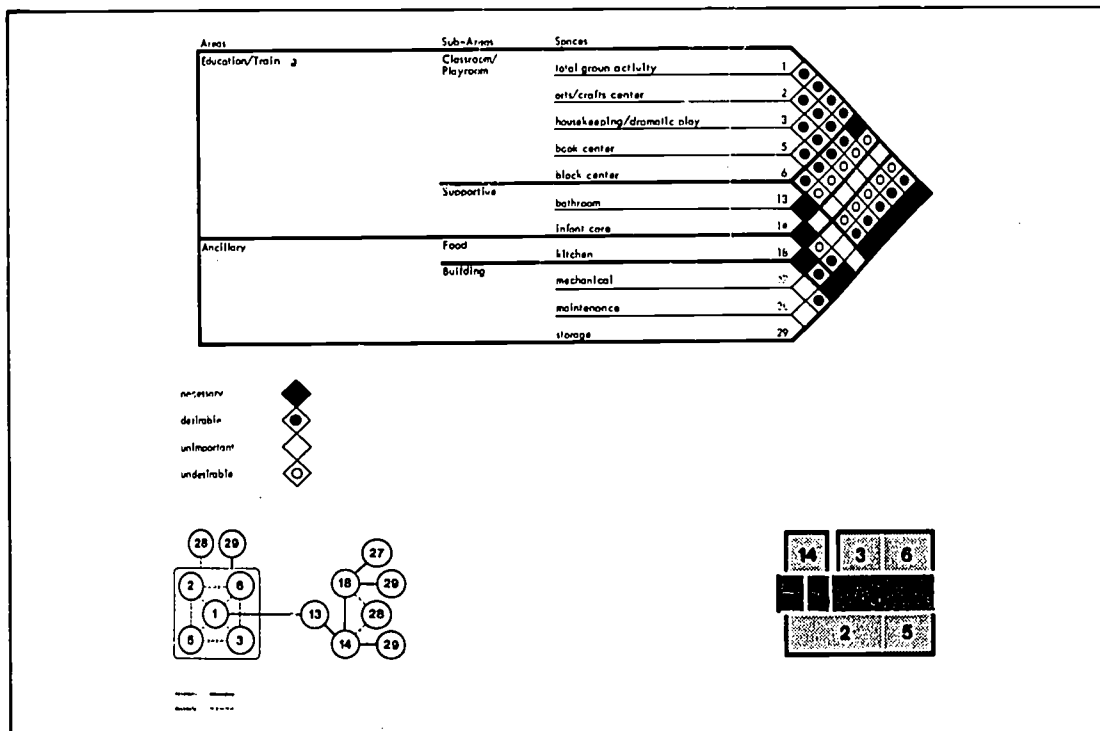

relationship chart, relationship graph, schematic plan

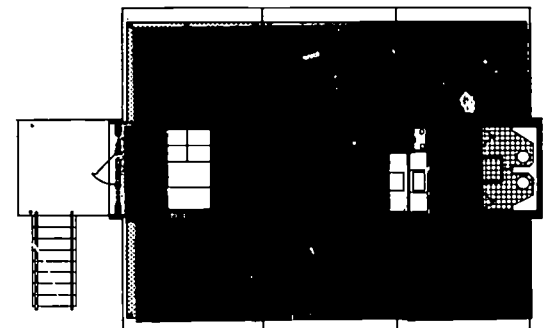

0 2 4

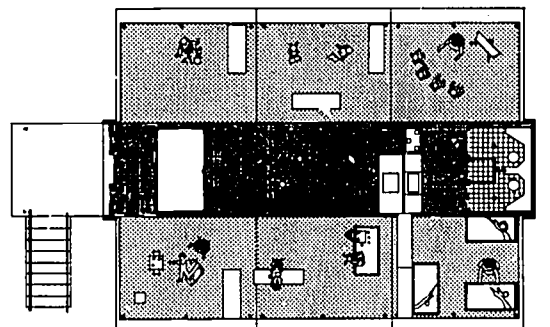

0 2 4

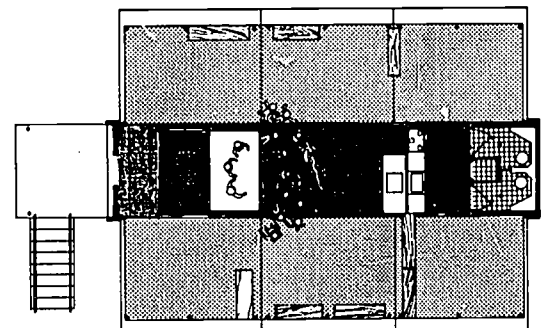

0 2 4

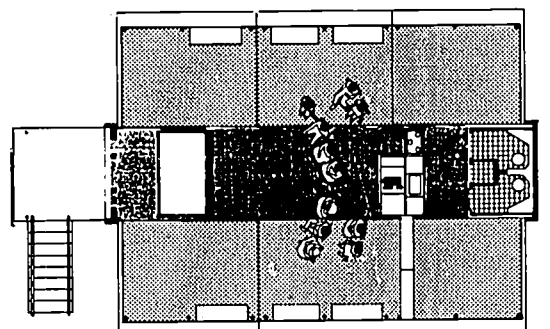

0 2 4

Possible Solutions

The design parameters, suggested either a trailer, a collapsible structure such as a tent, or a combination of the two.

The trailer concept gave the mobility required, but, to achieve the necessary square footage, while adhering to the highway width of eight feet, it became necessary to connect two or more units together.

A collapsible structure was found to provide the necessary square footage, but fell short of the desired mobility as it was found that too much time would have to be spent erecting and dismantling such a structure.

A trailer-tent solution was found to come nearest to meeting the two major requirements. By using the trailer's sides as a floor, and a tent structure to cover it, both the desired mobility and square footage requirements could be achieved.

Solution

In the final solution, a modified 8' x 9' x 32' freight trailer was used as it can be easily obtained and easily moved. The floor area is increased by lowering the three hinged wall panels on each side of the trailer and folding out the tent-like walls and roof within.

Although the minimum square footage necessary for these spaces is approximately 1200 sq. ft., the unit has been compacted to 800 sq. ft. In order to meet the design objectives. By scheduling activities such as arts/crafts, blocks, housekeeping/dramatic play, etc. independently of each other, optimum spacial requirements can be obtained.

The interior arrangement of kitchen, bathrooms, and storage unit was determined by the need for structural stability and the need to keep plumbing lines close together and toward one end of the trailer.

Molded polyurethane foam storage cabinets are stored in a rack opposite the kitchen and toilet during transit and used as area dividers when the day care unit is in use. The empty storage rack could then become a climbing structure for the children.

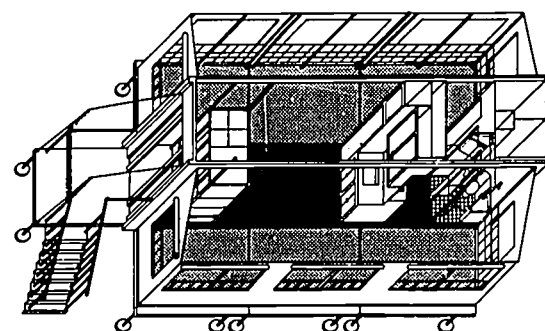
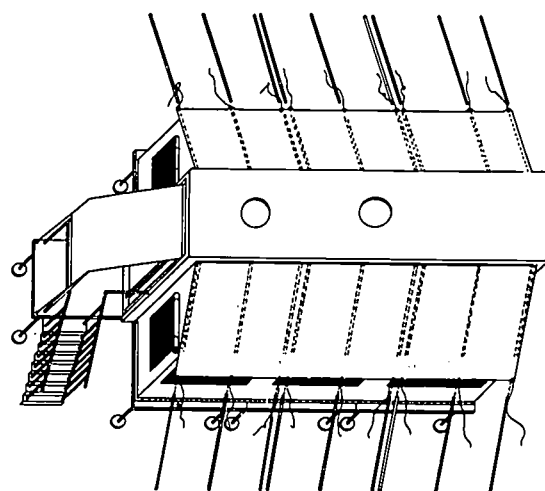
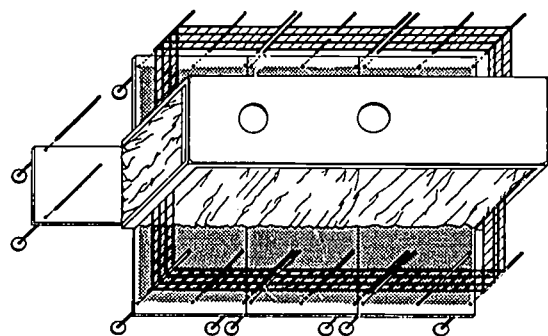
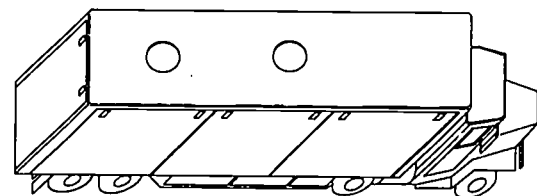
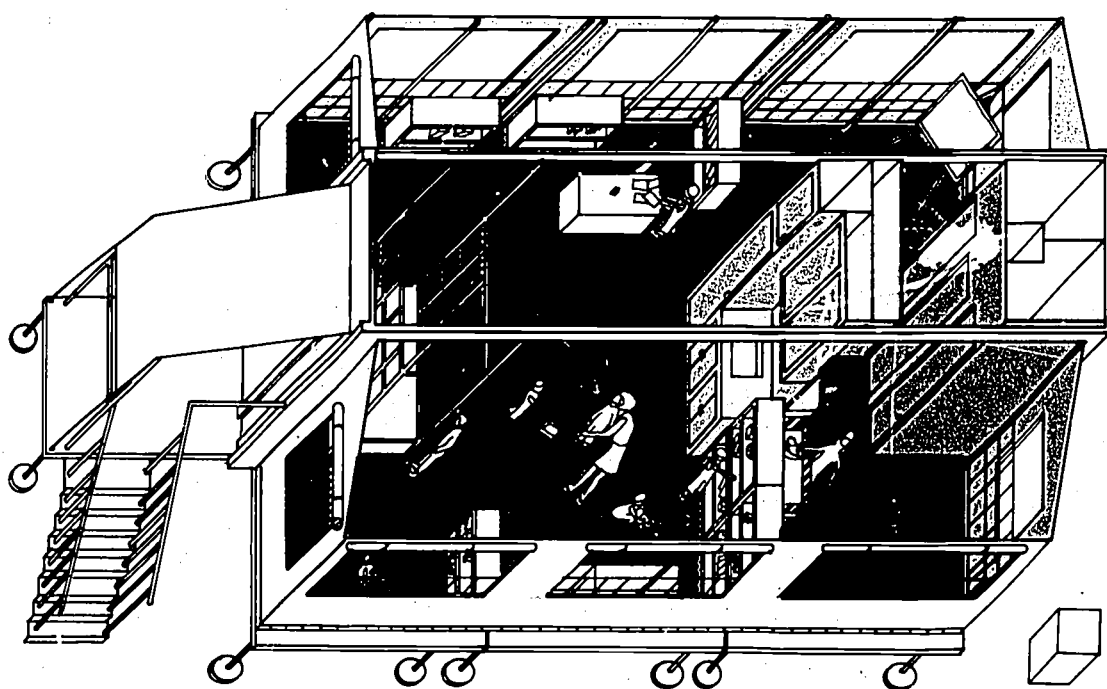

2x2x2

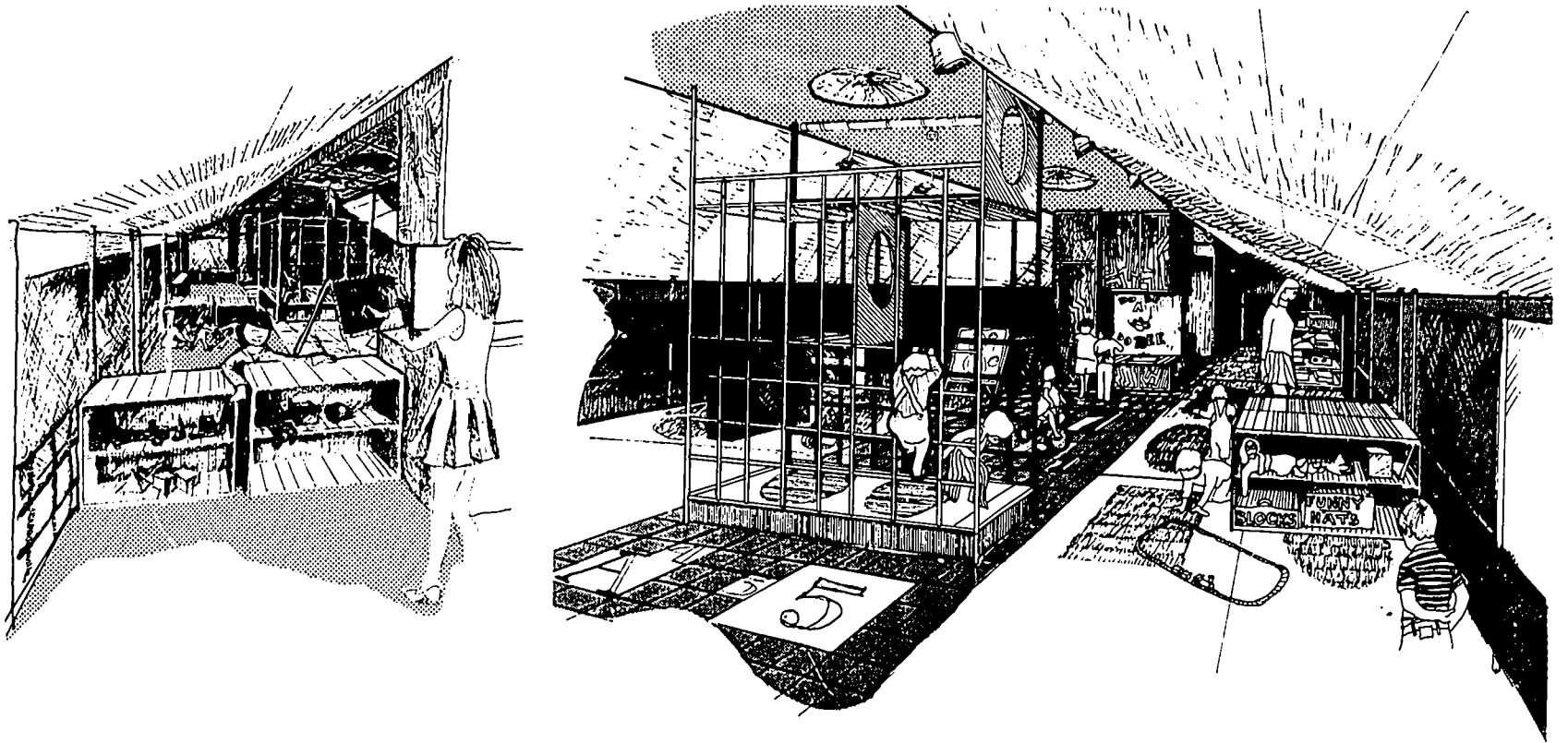

Neighborhood School Addition

The public school system has received a state mandate to provide services for three and four year old children who are considered physically, mentally, or culturally handicapped. The local school has decided to construct classrooms on the sites of existing elementary schools. Where space allows the classrooms will be in an independent building with an enclosed play area.

The school selected for the first building project is in the central city where the school age population is declining. The school is forty years old, but has been well maintained. It is a one story structure with an enrollment of about 900 children, kindergarten through the sixth grade. The majority of the students are from low income families. Play ground space is adequate, but not extensive. The school enjoys an excellent relationship with the parents in the neighborhood, who turn out for parent-teacher meetings and use the school cafeteria for community activities.

Projected Program

All services available to the elementary school may be utilized by the preschool unit. A school counselor will be assigned to the program, but will have her office in the school area which houses the ancillary services, i.e. the school nurse who does auditory and visual screening as well as routine health inspection and first-aid, the school psychologist and two elementary school counselors. Special teachers for music, crafts, and physical activities will be available once a week. Supervision of the teachers will be supplied by the central school administration. The existing school contains a teacher's lounge and material preparation center, and a cafeteria. Community volunteers will be used as teacher's aides.

The preschool building is to consist of two classrooms. Each will contain a morning and an afternoon session consisting of ten to fifteen children depending on the composition of the group. The program will provide for a maximum of 60 children, with a maximum of 30 in attendance at any one session.

The program is to be a structured program with its contents relevant to the neighborhood culture. The existing kindergarten staff has incorporated the Bereiter-Engleman (83) program into the curriculum and feel that it has made a contribution. The education supervisor would like to see this program extended to a lower age group on a trial basis.

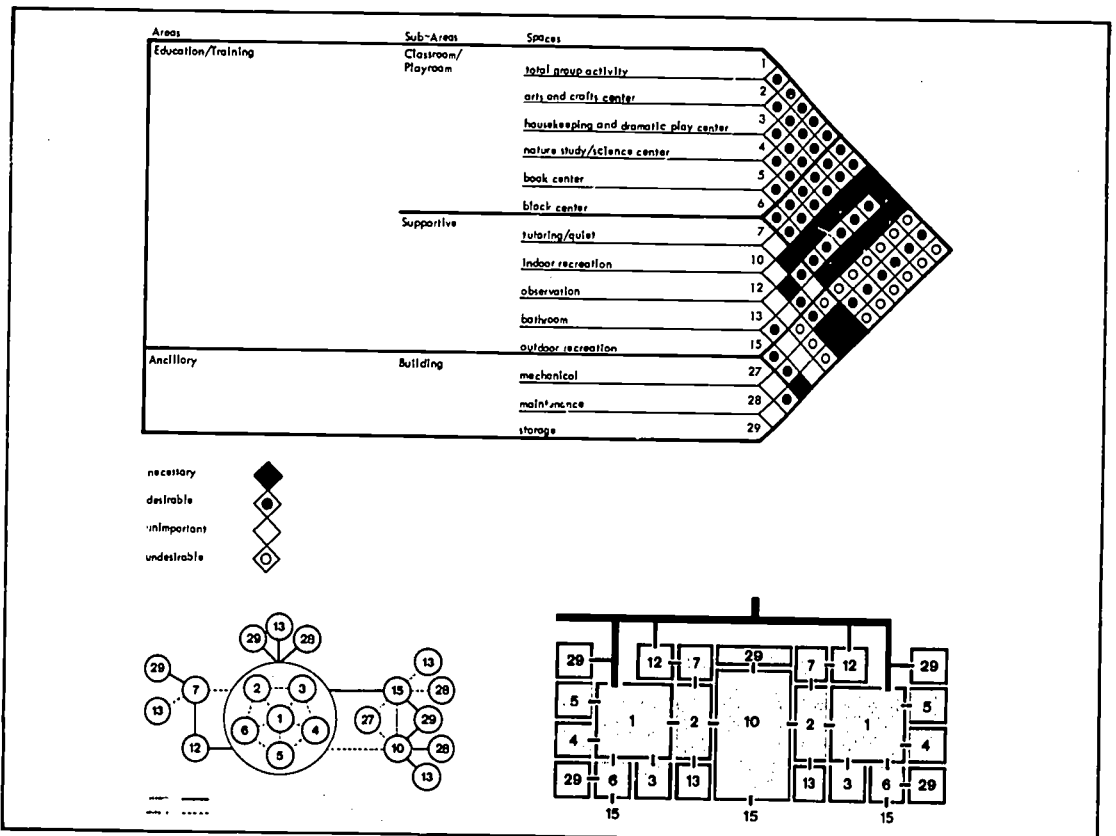

relationship chart, relationship graph, schematic plan

The projected staff consists of:

- 2 teachers
- 2 teacher aides
- 1 counselor — to be in existing building
- parent volunteers

Design Objectives

- 1) To provide an optimum environment for the achievement of the proposed program objectives
- 2) To provide a separate preschool facility for 30 children, ancillary and administrative services will be provided for in the existing elementary school
- 3) To provide a separate outdoor recreational area to supplement the education/training program
- 4) To obtain maximum flexibility within the classroom/playroom by utilizing the "new furniture" concept as space creators
- 5) To provide a facility that is complimentary to the innovative nature of the proposed program
- 6) To provide a minimum facility for maximum learning experiences
- 7) To provide for easy delivery/pick up of the children by their parents.

Spaces Needed

The specific spaces needed for this case study include: total group activity, arts/crafts center, housekeeping/dramatic play center, nature study/science center, book center, block center, tutoring/quiet, indoor recreation, observation, bathroom, outdoor recreation, storage.

Solutions

There were three possible solutions considered for this case study:

- No. 1 Two independent classrooms sharing a indoor recreation space.
- No. 2 Two independent classrooms sharing storage, observation, and tutoring/quiet spaces.
- No. 3 Open school plan for 30 children sharing observation and bathroom spaces.

The two classrooms sharing the indoor recreation space, is the only solution shown in floor plan and site plan along with additional floor plan arrangements to illustrate flexibility of the new furniture concept. However, all three solutions are shown in isometrics.

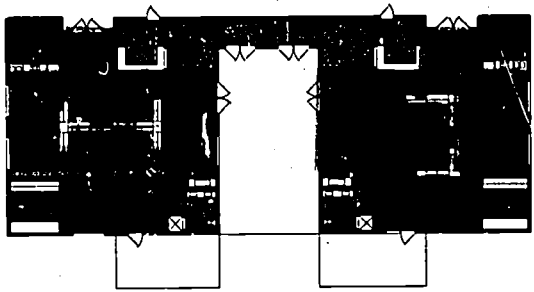

Solution No. 1

The two independent classrooms which share the indoor recreational space provides one possibility for an addition to a neighborhood school. The preschool facility is separated from the existing neighborhood school, providing easier pick up/delivery of children. All ancillary services are located in the existing school. The preschool facility in all three solutions, has its own outdoor recreational area which supplements the education/training areas.

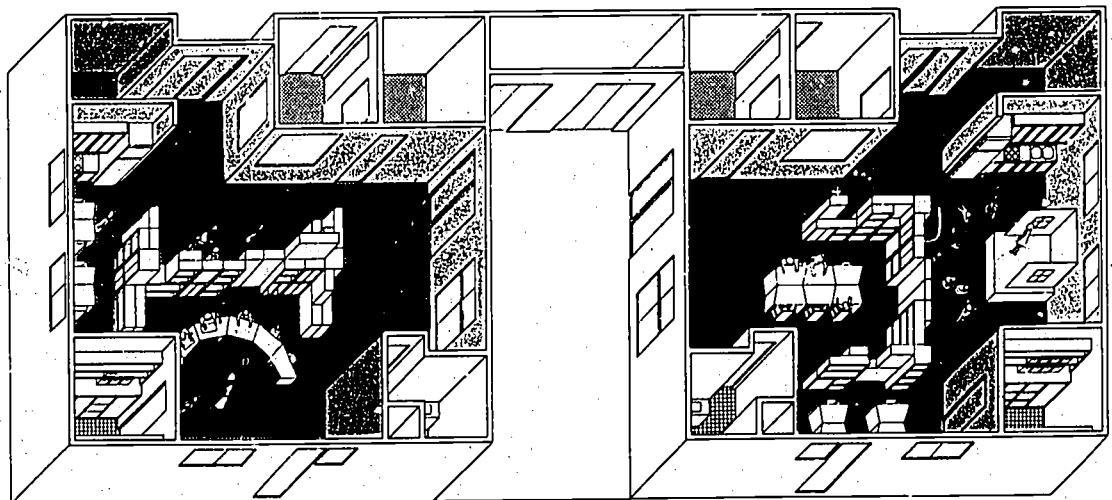
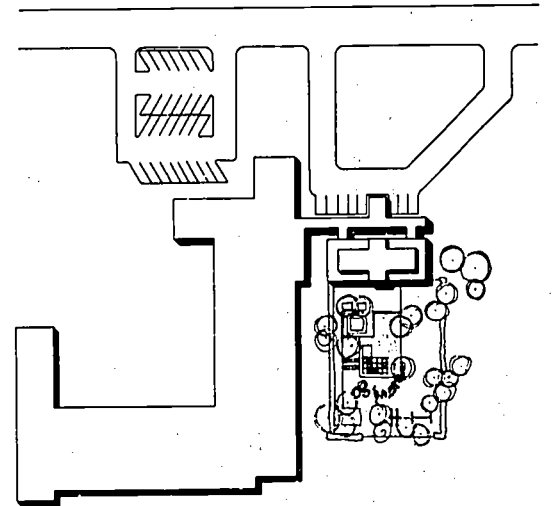
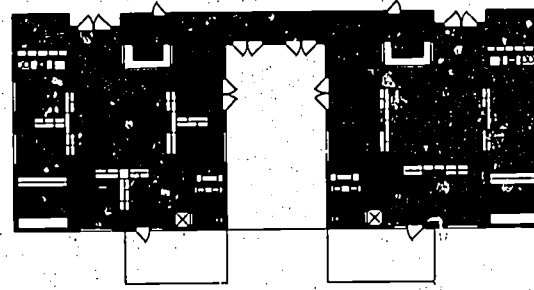
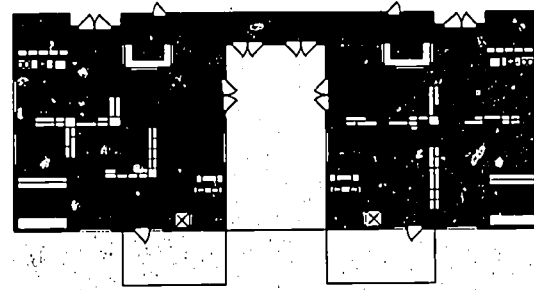
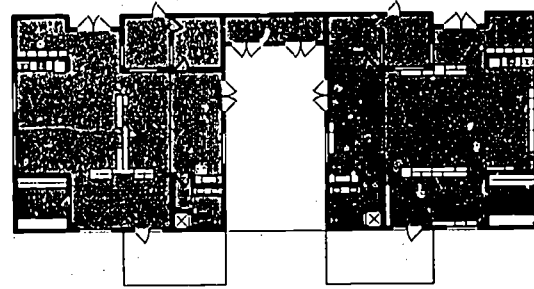
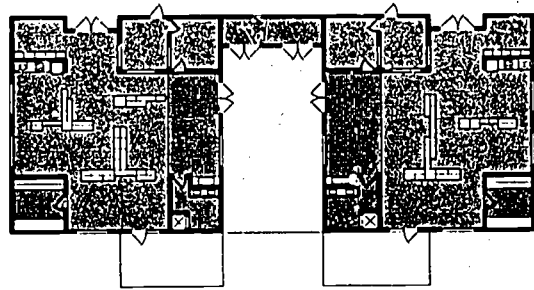

Solution No. 2

This solution is a slight variation of solution No. 1. These two independent classrooms share the observation, tutoring/quiet, and storage space in order to illustrate how costs can be economized and yet let the facility maintain maximum versatility. Notice that this solution omits the indoor space in order to share the above mentioned spaces. indoor recreation is scheduled to occur within the classroom itself.

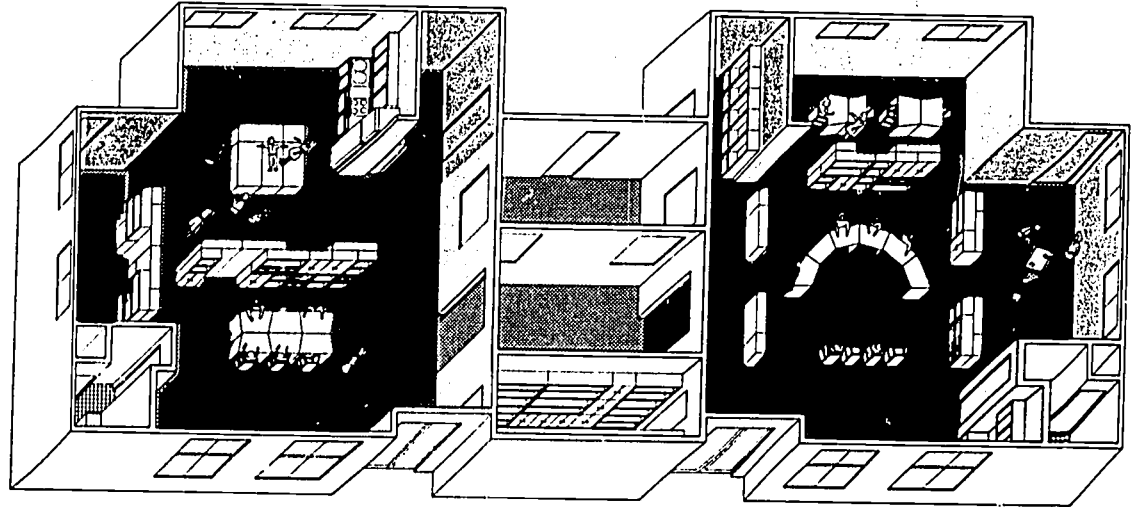

Solution No. 3

The open plan allows maximum flexibility of the education/training area. The interest centers are located around the total group activity space which allows them to expand or contract depending on the activity desired. The "new furniture" system provides the tools in which to shape the interior space desired for a particular activity. Observation and bathroom spaces are shared to economize on construction costs. This solution offers a larger open floor space in which large group activities such as indoor recreation, dining, etc., can easily be accommodated.

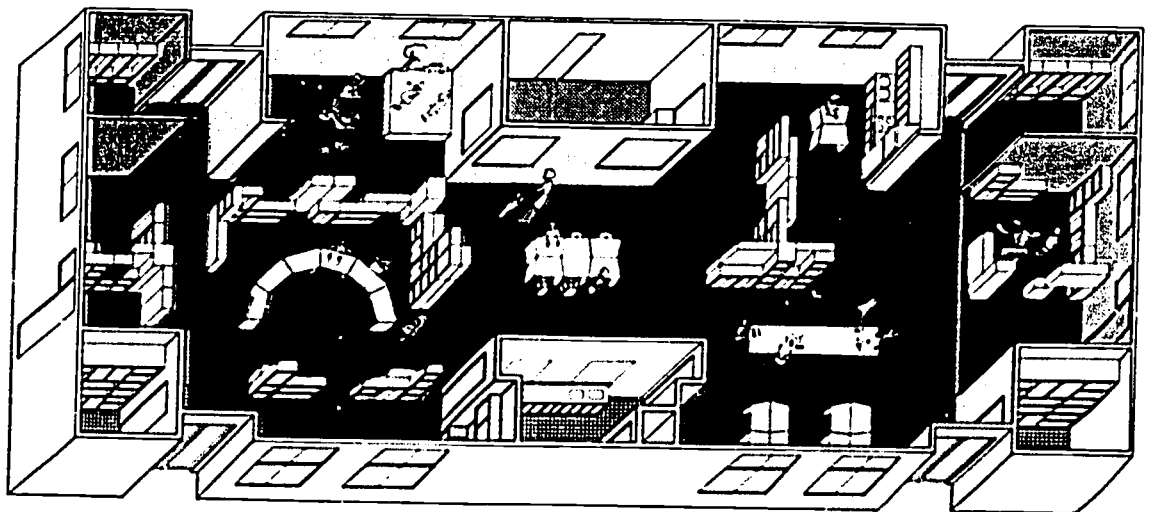

Observations/Recommendations



This publication represents a serious attempt to provide educators and architects with the much needed information for the planning and design of a preschool facility. Although emphasis has been placed on facilities for the retarded child, the "guidelines" are applicable to all preschool children because first of all "children are basically children". The similar characteristics they share as children are much greater than their individual differences.

Special consideration should indeed be given to the handicapped child, especially physically handicapped children, who make use of wheelchairs, grab bars, and other locomotive devices.

A good rule of thumb to follow when planning any type of facility would be to remove all physical barriers that would limit the facilities use by any one, child or adult.

Preschool day care is a much needed educational service in the U.S. Recent emphasis by state and federal agencies plus the growing national public concern provides the necessary incentive for structuring early childhood education. Although we have lagged far behind the Western European countries in providing comprehensive education for our young children, the time is not too late to rectify this situation and take the necessary action to become the leading force for early childhood education.

This basic service should be available to everyone, regardless of race, creed, and color, or their financial ability to pay. It is one of the necessary ingredients to insure a continually growing prosperous nation. But preschool education should be more than a baby sitting service, which in many instances it has been in the past. It should represent an integral part of the total educational spectrum; "the beginning of the formal learning process".

This philosophy of progressive education should be rightfully reflected in the facilities that house the programs. A creative facility that provides the necessary stimulation and furnishing for maximum educational growth is seriously needed. There have been too many instances in which poorly designed and furnished facilities have caused anxieties and frustrations towards depriving the children of maximum learning situations.

Some general observations concerning this work include the following:

- preschool facilities should be planned to take advantage of existing community resources and natural amenities.
- parental and community involvement is needed and space should be provided for these community groups to effectively contribute to the overall program objectives.
- provisions should be made to allow post-school children (6 years and up) to utilize the facility before and after regularly scheduled preschool hours.
- preschool facilities can take many different forms, there is no single best solution.
- preschool facilities should reflect their own environment, they should not be institutional in appearance or look like a second home.
- preschool facilities should contain a variety of spaces; for large group, small group, and individual activities.
- spaces should allow flexible arrangements by the children in order to create their own learning environment.
- preschool facilities should provide the basic comforts (lighting, acoustical control, and climate control) necessary for healthy productive child growth.
- preschool facilities should be flexible to allow for expansion or contraction on the site; management of interior and exterior spaces; multiple use of spaces; because the only certainty in education is change.
- preschool facilities should be designed to be used by the children and their teachers. Interior surfaces should be useable; wall surfaces for writing, painting, coloring, and for displays (bulletin boards, tack and magnetic surfaces, felt boards, chalk boards, and taping surfaces); floor surfaces should be warm and free of drafts such as carpeting or area rugs for spaces where a small child spends most of the time on the floor and soft sponge vinyl for high activity spaces and where spaces require high maintenance such as arts/crafts, and water play; ceilings should basically be used for light and sound reflectance and absorption, they can also be used for color emphasis and for hanging screens, mobiles and so forth.
- too many interior surfaces inhibit use by the children and their teachers and are provided only for visual relief.
- furniture and equipment should be child scaled, safety constructed and be small and light enough to be easily moved.

- fixtures and hardware, such as door knobs, light switches, lavatories, water closets, drinking fountains, mirrors, windows, etc., should be of appropriate height, scale, and location to be effectively utilized by the children.
- colors should be used purposefully to create atmosphere, stimulation, and for individual recognition of ownership.
- infant care should be realized as a growing necessary service to be provided for by day care facilities in the future.
- the outdoor play areas are an integral part of the educational program and should receive thorough consideration when planning the facility.

This publication is presented as a working document for utilization by educators, and architects. Our intention was not to tell how it should be done but only to suggest performance criteria necessary for effective planning and design. Optimum condition should be determined independently for each facility; depending on individual location, program, size, budget, and the available resources of the community and staff.

The effective usage and feedback of this information by educators and architects will provide a long range evaluation, essential for continued improvement and development. A quicker testing and evaluation period could be initiated by actual construction of a preschool facility for the specific purpose of testing and evaluation.

In both cases, only after optimization and evaluation of this information can realistic and meaningful conclusions be formulated, that are necessary for establishing the kind of facility needed for a growing, progressive educational attitude now apparent in the U.S.

Bibliography

Day Care Programs for Children Under Six

- 1 Boguslowski, D. B. **Guide for Establishing and Operating Day Care Centers for Young Children**, New York Child Welfare League of America, Inc. 1968.
- 2 Bray, T. J., "Mother's Helper: Day Care Centers Find Favor as More Women Flock into Work Force" **Wall Street Journal**, Vol. XLV, No. 70, 1970.
- 3 Caldwell, B. M. and J. B. Richmond, Programmed Day Care for the Very Young Child — A Preliminary Report," **Journal of the Child Welfare League of America, Inc.**, Vol. XLIV, No. 3, 1965.
- 4 **Child Welfare League of America Standards for Day Care Service**, New York: Child Welfare League of America, Inc., 1968.
- 5 Chittenden, G. E., M. N. Murphy, and B. Williams, **Essentials of Nursery Education**, New York: National Association for the Education of Young Children, no date given.
- 6 **Day Care — An Expanding Resource for Children**, New York: Child Welfare League of America, Inc., 1965.
- 7 "Day Care: Its a Lot More Than Child's Play," **Business Week**, March 21, 1970, p. 110.
- 8 Fisher, D. C., **The Montessori Manual for Teachers and Parents**, Cambridge, Massachusetts: Robert Bentley, Inc., 1966.
- 9 Graham, W., **Toward Better Kindergartens**, Washington, D. C.: Association for Childhood Education International, 1965-66.
- 10 Headley, N. E., **Education in the Kindergarten**, 4th edition, New York: American Book Company, 1966.
- 11 Hechinger, F. M., **Pre-School Education Today**, Garden City, New York: Doubleday and Company, 1966.
- 12 Holitor, G. H., **A Curriculum for the Pre-School Child**, Educational Resources Information Center, January, 1967.
- 13 Katz, L. G., "Teaching in Preschools: Roles and Goals," **Children**, Vol. 17, No. 2, 1970.
- 14 Pines, M., **Revolution in Learning: The Years from Birth to Six**, New York: Harper and Row, 1967.
- 15 **Preschool Education**, Washington, D.C.: The CEC Information Center on Exceptional Children, The Council on Exceptional Children, October, 1968.
- 16 Rasmussen, M., editor, **Play — Children's Business**, Washington, D.C.: Association for Childhood Education International, 1963.
- 17 Rieger, E., **Science Adventures in Children's Play**, New York: Play Schools Association, Inc., 1968.
- 18 Shoemaker, R., **All in Play**, New York: Play Schools Association, Inc., 1958.
- 19 Sunderlin, S., editor, **Bits and Pieces**, Washington, D.C.: Association for Childhood Education International, 1967.
- 20 Sunderlin, S., editor, **Physical Education for Children's Healthful Living**, Washington, D. C.: Association for Childhood Education International, 1966-68.
- 21 **Voice for Children**, Day Care and Child Development Council of America, Vol. 2, No. 4, 1969.
- 22 **Voice for Children**, Day Care and Child Development Council of America, Vol. 2, No. 7, 1969.
- 23 **Voice for Children**, Day Care and Child Development Council of America, Vol 2, No. 9, 1969.
- 24 Werlin, K., "Classroom Dynamics: Preschool Communication and Structure," **Teaching Exceptional Children**, Vol. 2, No. 1, 1969.

Child Development

- 25 Bloom, B., **Stability and Change in Human Characteristics**, New York: Wiley, Inc., 1964.
- 26 Bruner, J. S., **The Process of Education**, Cambridge: Harvard University Press, 1960.
- 27 Engel, R. C., **Language Motivating Experiences for Young Children**, Van Nuys, California: DFA Publishers, 1968.
- 28 **A First Step in Education . . . Nursery School**, Des Moines: Iowa State Department of Public Instruction, 1968.
- 29 Hunt, J. McV., **Intelligence and Experience**, New York: Ronald Press, 1961.
- 30 McCandless B. R., **Children — Behavior and Development**, 2nd edition, New York: Holt, Rinehart and Winston, 1967.
- 31 Mussen, P. H., **The Psychological Development of the Child**, Englewood Cliffs, N. J.: Prentice-Hall, Inc., 1965.

- 32 Ramussen, M., editor, **Early Childhood, Crucial Years for Learning**, Washington, D.C.: Association for Childhood Education International, 1966.
- 33 Stone, L. J., and J. Church, **Childhood and Adolescence**, New York: Random House, 1957.

Culturally Deprived Children and Their Education

- 34 Beery, K., **Preschool Prediction and Prevention of Learning Disabilities**, Educational Resources Information Center, March, 1967.
- 35 Bereiter, C. and S. Engelmann, **Teaching Disadvantaged Children in the Preschool**, Englewood Cliffs, N.J.: Prentice-Hall, 1966.
- 36 Biber, B., **Young Deprived Children and Their Educational Needs**, Washington, D.C.: Association for Childhood Education International, 1967.
- 37 Deutsch, M., I. Katz, and A. R. Jensen, **Social Class, Race and Psychological Development**, New York: Holt, Rinehart and Winston, Inc., 1968.
- 38 **Education of the Deprived and Segregated**, New York: Bank Street College of Education, 1965.
- 39 Gray, S. W., R. A. Klaus, J. O. Miller and B. J. Forrester, **Before First Grade**, New York: Teachers College Press, 1966.
- 40 Haywood, H. C., and J. T. Tapp, "Experience and the Development of Adaptive Behavior," **International Review of Research in Mental Retardation**, E. R. Ellis, editor, New York: Academic Press, 1966.
- 41 Kugel, R. B., and M. H. Parsons, **Children of Deprivation**, U. S. Department of Health, Education, and Welfare, Children's Bureau Publication #440, 1967.
- 42 Mackintosh, H., L. Gore, and G. M. Lewis, **Educating Disadvantaged Children in the Primary Years**, U.S. Department of Health, Education, and Welfare, 1965.
- 43 Mackintosh, H., L. Gore, and G. M. Lewis, **Educating Disadvantaged Children Under Six**, U.S. Department of Health, Education, and Welfare, 1965.
- 44 Miller, H. L., editor, **Education for the Disadvantaged**, Toronto: The Free Press, 1967.

45 **Project Head Start: Evaluation and Research, 1965-1967**, Division of Research and Evaluation, Project Head Start, Washington, D.C.

46 Rlessman, F., **The Culturally Deprived Child**, New York: Harper and Row, 1962.

47 Sachse, J., **Dubnoff Preschool Compensatory Program**, Dubnoff School, Los Angeles, 1967.

48 Webster, S. W., editor, **Understanding the Educational Problems of the Disadvantaged Learner, Part II of The Disadvantaged Learner**, San Francisco: Chandler Publishing Co., 1966.

49 Webster, S. W., editor, **Educating the Disadvantaged Learner, Part III of The Disadvantaged Learner**, San Francisco: Chandler Publishing Co., 1966.

50 Webster, S. W., editor, **Knowing the Disadvantaged, Part I of The Disadvantaged Learner**, San Francisco: Chandler Publishing Co., 1966.

51 Young, W. M., Jr., "Poverty, Intelligence and Life in the Inner City," **Mental Retardation**, Vol. 7, No. 2, 1969.

59 Durbin, M. L., **Teaching Techniques for Retarded and Pre-Reading Students**, Springfield, Illinois: Charles C. Thomas, 1967.

60 Ebersole, M., N. C. Kephart, and J. B. Ebersole, **Steps to Achievement for the Slow Learner**, Columbus: Charles E. Merrill Publishing Co., 1968.

61 Erickson, M. J., **The Mentally Retarded Child in the Classroom**, New York: The Macmillan Company, 1965.

62 Gardner, W. I., and H. W. Nisonger, **A Manual on Program Development in Mental Retardation**, monograph supplement to **American Journal of Mental Deficiency**, Vol. 66, No. 4, 1962.

63 Getman, G. N., E. R. Kane, M. R. Halgren, and G. R. McKee, **Teacher's Manual — Developing Learning Readiness**, New York: Webster Division, McGraw-Hill Book Co., 1968.

64 Hanson, F. M., F. M. Daly, and L. W. Campbell, **Programs for the Trainable Mentally Retarded in California Public Schools**, Sacramento: California State Department of Education, 1966.

65 Heber, R., **A Manual on Terminology and Classification in Mental Retardation**, monograph supplement to the **American Journal of Mental Deficiency**, 1961.

66 Heber, R., **Vocational Rehabilitation of the Mentally Retarded**, U.S. Department of Health, Education, and Welfare, Vocational Rehabilitation Administration, December, 1965.

67 Hudson, M., **Procedures for Teaching Trainable Children**, CEC Research Monograph, Series A, No. 2, 1960.

68 Hutt, M. L. and R. G. Gibby, **The Mentally Retarded Child**, 2nd edition, Boston: Allyn and Bacon, Inc., 1968.

69 Ingram, C. P., **Education of the Slow Learning Child**, New York: The Ronald Press Company, 1960.

70 Kirk, S. A., **Early Education of the Mentally Retarded**, Urbana: University of Illinois Press, 1958.

71 Kirk, S. A., M. B. Karnes, and W. D. Kirk, **You and Your Retarded Child**, New York: The Macmillan Company, 1958.

72 Menascino, F. J., "Psychiatric Aspects of Mental Retardation in Children Under Eight," **American Journal of Orthopsychiatry**, Vol. 35, No. 4, p. 852, 1965.

73 **Mental Retardation Publication of the Department of Health, Education and Welfare**, U.S. Department of Health, Education, and Welfare, January, 1968.

74 **A Proposed Program for National Action to Combat Mental Retardation**, President's Panel on Mental Retardation, Washington, D.C.: U.S. Government Printing Office, 1962.

75 Robinson, H. B., and N. M. Robinson, **The Mentally Retarded Child, a psychological approach**, New York: McGraw-Hill Book Company, 1965.

76 Rostnweil, L. E., and J. Long, **Understanding and Teaching the Dependent Retarded Child**, Darien, Conn.: The Educational Publishing Corporation, 1960.

77 Rothstein, J. H., editor, **Mental Retardation, Readings and Resources**, New York: Holt, Rinehart and Winston, 1961.

78 Secretary's Committee on Mental Retardation, **An Introduction to Mental Retardation, Problems, Plans and Programs**, Washington, D.C.: U.S. Government Printing Office, 1965.

79 Secretary's Committee on Mental Retardation, **Financial Assistance Programs in Mental Retardation of the Department of Health, Education and Welfare**, Washington, D.C.: U.S. Government Printing Office, 1966.

80 Thompson, M. M., "Psychological Characteristics Relevant to the Education of the Pre-school Mongoloid Child" **Mental Retardation**, Vol. 1, No. 3, p. 148, 1963.

81 **Trainable Mentally Retarded (T.M.R.) — Course of Study and Curriculum Guide**, Division of Special Education, San Mateo County Schools System, California, 1968.

82 Van Witsen, B. **Perceptual Training Activities Handbook**, New York: Teachers College Press, 1967.

83 Younle, W. J., **Instructional Approaches to Slow Learning**, New York: Teachers College Press, 1967.

Planning the Day Care Facility Environmental Variables

84 Bayes, K. **The Therapeutic Effect of Environment on Emotionally Disturbed and Mentally Subnormal Children**, Surrey, England: The Gresham Press, 1967.

Mentally Retarded Children and Their Education

52 Achenback, T. M., "Comparison of Stanford-Binet Performance of Nonretarded and Retarded Persons Matched for MA and Sex," **American Journal of Mental Deficiency**, Vol. 74, No. 4, 1970.

53 Baumgartner, B., **Guiding the Retarded Child**, New York: The John Day Company, 1965.

54 Bensberg, G. J., **Teaching the Mentally Retarded**, Atlanta: Southern Regional Education Board, 1965.

55 **The Care of the Retarded Child: Therapy and Prognosis**, U.S. Department of Health, Education and Welfare, Children's Bureau, 1964.

56 **Community Day Centers for the Mentally Retarded in Illinois**, Illinois Department of Mental Health, Springfield, 1966.

57 Conner, F. P. and M. E. Talbot, **An Experimental Curriculum for Young Mentally Retarded Children**, New York: Teachers College Press, 1966.

58 **Day Care Center Curriculum Guide**, Louisiana State Department of Hospitals, Division of Mental Retardation, Baton Rouge, Louisiana, no date given.