

## DOCUMENT RESUME

ED 057 609

EN 009 458

**AUTHOR** Smith, Jordan J.  
**TITLE** Interactive Television: A Mass Medium for Individuals.

**INSTITUTION** Interuniversity Communications Council (EDUCOM), Boston, Mass.

**SPONS AGENCY** Corporation for Public Broadcasting, Washington, D. C.

**Pub DATE** Oct 69  
**NOTE** 75p.

**EDRS PRICE** MF-10.65 HC-11.75

**DESCRIPTORS** Communication (Thought Transfer); \*Computers; Individualized Instruction; \*Information Centers; Information Dissemination; \*Information Networks; Information Retrieval; Information Services; Information Storage; \*Information Systems; Input Output Devices; Television

**IDENTIFIERS** \*SYSTEM 3

**ABSTRACT**

A one-to-one network of communication, labeled SYSTEM-3, will come into being as a result of the demands of the public for information. In general, this form of communication system serves an asymmetric communication need--the user supplies a group of control signals that modulates the automatic flow of large amounts of information from a central store. SYSTEM-3 will be able to collect data from many identified points and to direct information from the center to some specified subset of the connected terminals. This paper describes SYSTEM-3 and considers some of its applications: individualized instruction and education, special information and inquiry centers, two-way files generated by the user population, public distribution of materials, interactive entertainment to increase involvement, creative interaction and experimentation, provision of computer access to the individual citizen, polling, and interactive advertising. Following the discussion of applications, the receiver-terminal and the interconnection of SYSTEM-3 centers to form a network are described in greater detail, and a final section considers the organizational, regulatory, and technological activities which must be undertaken for SYSTEM-3 to be realized.

(5M)

ED057609

**INTERACTIVE TELEVISION:  
A MASS MEDIUM FOR INDIVIDUALS  
OCTOBER 1969**

**U.S. GOVERNMENT PRINTING OFFICE: 1969  
O-348-742**

**JORDAN J. BARUCH**

**PREPARED FOR THE  
PUBLIC BROADCASTING  
CORPORATION**

TABLE OF CONTENTS

	<u>Page</u>
Foreward	1
I. Prologue: An Overview	3
II. SYSTEM-3: An Introduction	10
III. Applications: Raison D'etre	17
IV. SYSTEM-3 Revisited: A Closer Look	44
V. Activities: What Must Be Done	59

### ACKNOWLEDGEMENT

The author wishes to express his gratitude to the many colleagues whose involvement helped to shape this paper. While their number is large, certain ones must be individually thanked. Joseph Becker for his help with the background material. Dr. J.C.R. Licklider, Dr. Ruth Davis, Dr. Donald Lindberg and Dr. David Tiedeman for their extensive reviews. To the many others my sincerest gratitude.

Special thanks go to Dr. Rhoda Baruch of the Harvard Graduate School of Education. She has shaped many of the author's views on education by her teaching, and introduced him to the tradition/change dichotomy. Most importantly, her view of the role of personal participation in the development of a sense of autonomy really forms the foundation for this paper.

## FOREWARD

This paper is an outgrowth of a request made in October 1968 by R. Killian, Jr., that EDUCOM deal with the non-radio/non-video uses of the facilities of the Corporation for Public Broadcasting. Of particular concern to the corporation was the potential for interaction between the developing Public Broadcasting System and the growing worlds of interactive computation and interactive educational programming.

From our base in the use of interactive information technology, we examined P.L. 90-129 and the book "Public Television" (1) containing the report of the Carnegie Commission that gave rise to the Act. Additional material (2,3) was reviewed and our initial views were drafted and reviewed with many of our colleagues.

The Corporation for Public Broadcasting (The Corporation) established under Public Law 90-129 by the 90th Congress in 1967, has wide responsibilities. Under Section 396 of that Act -- the Congressional Declaration of Policy, we read:

"SEC. 396 (a) (1) THAT IT IS IN THE PUBLIC INTEREST TO ENCOURAGE THE GROWTH AND DEVELOPMENT OF NON-COMMERCIAL EDUCATIONAL RADIO AND TELEVISION BROADCASTING, INCLUDING THE USE OF SUCH MEDIA FOR INSTRUCTIONAL PURPOSES:"

Section 301, Title II, of this same act, makes it clear that Congress visualized a wide diversity of activities to be subsumed under the heading of "Instructional Purposes."

"INSTRUCTIONAL TELEVISION AND RADIO (INCLUDING BROADCAST, CLOSED CIRCUIT, COMMUNITY ANTENNA TELEVISION AND INSTRUCTIONAL TELEVISION FIXED SERVICES, AND TWO-WAY COMMUNICATION OF DATA LINKS AND COMPUTERS.)"

To implement these Congressional charges, the Corporation will "establish and maintain a library and archives", "arrange...for interconnection facilities..." and "will conduct (directly or through grants or contracts) research, demonstrations or training in matters related to non-commercial educational television or radio broadcasting." Further, while it is specifically barred from owning any interconnection or production facility, the Corporation will "contract with. or make grants to, program production entities..."

Congress' clear recognition of the wide scope of modern public broadcasting and its charges to the Corporation could make P.L. 90-129 one of this nation's most significant pieces of communication legislation since the establishment of the Federal Communications Commission. This potential for impact was at variance with our initial draft that dealt largely with the didactic use of the medium. It was generally felt that an expansion of that view was in order. The passage of time, the rapidity of developments in technology and in the nation's needs has shaped this new result. It is an action-oriented document that deals with one view of our future communication environment. It is very different from the first draft.

Boston, Mass.  
October 1969

## 1. PROLOGUE: AN OVERVIEW

Our society needs and is ready for a third type of national communications system. This state is a reflection of the "I am I" cry of our students and of the problems of being an individual in the ghetto. It is a reflection of the student programming at a computer console in Massachusetts and practicing math at one in Mississippi. It reflects a baby burned with lye in New York and a cop trying to get a "make" in Illinois. It reflects the need for the individual to communicate with the system and a demand that the system recognize the individual. Many commercial and governmental agencies are examining this demand. We believe that it rests with the Public Broadcasting Corporation to lead in its development and to represent the public in its management and utilization.

This paper posits the existence of such a third system. For convenience we call it SYSTEM-3, or extended broadcasting. The receiver/terminals on SYSTEM-3 have buttons on them that send data back to the transmitting center - data about how the viewer feels, what he thinks, what he wants. Two-way channels - largely on community cables carry this data back to the center. No hang-ups, no busy signals, no bureaucrats - data to center - and the center responds. Back to homes and offices and hospitals and police-stations and schools come words and pictures and stories and music. And the viewer reacts, and the center reacts, and the story changes. And extended broadcasting isn't to the viewer, or at the viewer, but it's with the viewer and it's got to be hotter than the media men ever thought it could be.

But we're getting ahead of ourselves. First we have to see where we are and where we've been to know where we're

going and how we're going to get there.

The vast majority of the communications activity in our society is carried on two kinds of systems, distinguished from each other by their connection patterns.

One pattern is typical of the common carrier or point to point communication. The postal service, the telephone network and the telegraph system fall into this category. The stations served by such a system can generally take on the role of either sender or receiver. One node chooses another node with which to communicate and any technology that intervenes does so in order to bring about private point-to-point communication.

Because no one knows who will call whom next, a major cost of running such a system lies in the apparatus and organization required to establish the connections. A large,  $N$ -station network requires roughly  $N^2/2$  possible connections.

Philosophically, the role of the organization that manages a common-carrier network is to connect the nodes to each other, and to do so as intimately as possible. Because of this philosophy, privacy is a vital characteristic. Any intervener functions as a common carrier. He neither adds to, subtracts from, nor modifies the intelligence being transmitted nor does he sit in judgment of its content. He is truly one who carries.

Because of their special role, the common carriers are closely regulated. Matters of privacy are regulated by legislation covering wire tapping, disclosure of information by the carriers, and the use of transmitted information entrusted to the carrier's care. Bookies and lovers,



priests, lawyers and doctors rely both on the essential privacy of such point to point, one to one connections, and on the assurance that their messages will undergo no modification. The importance of such a point to point network in our nation cannot be overemphasized. The Federal control over the postal system and over the rates and the practices of the common carriers is a clear indication of the importance that Congress assigns to the carrier's operation.

The second national system is the one we dedicate to broadcasting. The term itself is descriptive of the activity. From yesterday's town crier to the modern television station, broadcasting involves a broadcaster, a central node sending out its information to any and all who will take the trouble to listen or watch. The relationship of the broadcaster to his public is a statistical one. That which goes out from the station does so publicly, unaffected by the individual listener's identity or his level of attention. Feedback to the broadcaster is generally a long-term phenomenon, statistical in nature, having only a slow effect on the character of the program material.

The broadcaster is responsible for the information that he transmits. Whether he generates it, purchases it, or contracts to receive it from some other source, its content and quality are his ultimate responsibility. Because Congress recognized the finite nature of the spectrum that all broadcasters share, they are treated by the law as guardians of a public asset. Because the public has little influence over what is carried, Congress has appointed the FCC to guard their interests. More and more the FCC requires broadcasters to be responsive to the needs of the community that they serve and indeed to be part of that community. The listener or viewer dealing with our

broadcast system is extremely limited in the selection of materials from which he can choose. A handful of radio and television stations are within the reach of his receiver and, because of network activities, a fair degree of program redundancy exists even among these in dense urban areas.

Economic considerations dictate that the technologies and the organizations of the two communication systems closely reflect their functions. That fact, however, severely limits the ease with which society can extend the function of either system. The common carrier system is represented by a network of lines mediated by the world's most complex and effective switching system. The lines (analogous to information pipes) used by the carriers have widely different capacities that can be subdivided in order to satisfy the needs of multiple simultaneous users. The rate structure and organization of the common carriers reflect their point to point nature. A myriad of central offices exists to perform the switching and interconnection function and the carriers make maximum use of local and state by state legislation to optimize their operational freedom.

The major operational effort of the carriers deals with their role as interconnectors. The facility with which they make connections, the accuracy with which they can predict usage and with which they can reflect those statistics in the allocation of switching equipment has much to do with their profits. One equipment design will be optimum, for example, if a telephone company predicts that only one local line out of 12 will be in use at any one time and that the average duration of a connection will be four minutes. If, however, a change in phone activity dictates that as many as 30% of the local users will demand simultaneous connection and that the average duration

of that connection will be 40 minutes, a very different design will be required. Either a major change must then be made in the switching system or the company will find that its efforts to meet the new requirements by the first system will result in markedly uneconomical facilities utilization. Such changing use does exist, is ill-served by the common carriers, and represents a major pressure for SYSTEM-3.

In broadcasting, technology and organization again reflect system use. Characteristically we find large transmitters each capable of reaching large numbers of receivers. Since the financial return to a broadcaster is largely proportional to the number of receivers he reaches, geographical radiation patterns and program content are both generally geared to maximizing that number. In order to preserve the locally responsive nature of the station, however, the FCC regulates the pattern and requires a reasonable amount of local content. To further insure a reflection of local needs, the FCC has declared that the owners of such stations should be members of the community and be active in the management and operation of the station.

The feedback that results from public pressure on station management is extremely slow. The changes it produces are often perceptible only over months and years. Those stations that seek to be responsive on a shorter time scale (generally for educational purposes) have instituted such innovations as telephone feedback from the listener. Such systems quickly strangle, however. A station capable of addressing a million receivers will be coupled to its viewers through a switchboard capable of handling three or four

simultaneous calls. The recognition of the need for a better match between the number who hear and the number who can be heard constitutes another pressure for the establishment of SYSTEM-3.

While it is poor engineering to describe a proposed solution and then to discuss the needs that that proposed solution is intended to meet, our joint role of soothsayer and designer gives us that prerogative. The problems for which SYSTEM-3 holds promise, and hence the uses to which it is likely to be put, have as their major common factor only the kind of demand that they place on a communication system. By presenting in Section II a brief preview of SYSTEM-3, we will have a common context for Section III in which we discuss the various applications. In Section IV we will attempt to refine and extend our description of SYSTEM-3 permitting the engineer ascendancy over the seer. We can then, in Section V, deal with the organizational, regulatory and technical problems that must be overcome in order to bring SYSTEM-3 and its attendant applications to a common stage of development. The final section will then briefly discuss a possible collaborative role for EDUCOM in this development.

In all of these sections, the distinction between Public and Private sector is far smaller than the distinction between "now" and "then". SYSTEM-3 will develop - is developing - as a collaborative effort between the Public and Private Sectors. We take the position that the representative of the Public Sector will be the Public Broadcasting Corporation. We further take the position that the Public Broadcasting Corporation will be partner to, and shareholder in, whatever Private entity develops. Thus, these following sections assume many shared facilities,

shared intellectual investments and shared commitments. There may well be separate Public and Private channels, Public and Private satellites, and even Public and Private computers; but the major distinction will be whose interest is served and who is the guardian. Thus it is not until Section V that we really discuss the role of the Corporation with any specificity. Before that we are busy describing a world in which it will live.

## II. SYSTEM-3: AN INTRODUCTION

Since the 1950's, a new style of communication has grown so rapidly that our existing communication systems have been severely strained in their efforts to meet its needs. Characteristically this style is typified by a main, central node in a two-way communication with many satellite nodes. We shall call this communication style one-to-many-to-one. In complex configurations, some of the satellites may serve as central nodes to other, lower level satellites. In terms of information flow, although not necessarily in terms of structure, such a communication network looks much like a tree, with communication flowing in both directions along the trunk, branches and twigs. Because neither of the two existing forms of communication system is readily transformable to such a network, we have called the system that will serve its needs "SYSTEM-3."

It is our thesis that SYSTEM-3 will come into being as a result of the demands of those who would use its facilities. In a recent survey conducted by EDUCOM for the U.S. Office of Education, a catalog was developed that listed and described 82 separate functioning United States networks concerned solely with the transmission of digital data. Everyone of them was a one-to-many-to-one system.

In other studies performed for the legislative background of the "Networks for Knowledge Act," it was possible to identify similar non-profit network configurations dealing with

- . Interlibrary loan
- . Computer use in research

- . Bibliographic file exchanges
- . Computer aided instruction
- . Poison control information
- . Problem solving

Among the disciplines and activities represented in the networks then receiving federal financial support were

- . Biomedicine
- . Command and Control
- . Transportation
- . Research Reports
- . Toxicology
- . Biology
- . Urban Renewal
- . Civil Defense
- . Water Resources
- . Oceanography
- . Nuclear Energy
- . Engineering
- . Agriculture
- . Chemistry

and some 50 others.

The major national libraries- The Library of Congress, the National Library of Medicine, and the National Agricultural Library have a joint task force addressing the problem of a national library network. EDUCOM, and various small groups have undertaken the interconnection of institutions of higher education in multimedia networks.

This proliferation of network activities is too active a phenomenon to arise simply out of desires for organi-

zational aggrandizement. It seems clear that it reflects a major need on the part of many groups within the public sector.

In general, this form of communication system serves an asymmetric communication need. By and large, the amount of information sent to a user node from the center is very much larger than the amount transmitted inward from user to center. In Poison Control Center, for example, the user supplies a poison name, an amount and perhaps an age figure. In return he gets a large mass of information on contents, therapy, precautions, etc. In Computer Aided Instruction, the user supplies a few bits of information indicating a choice among a limited set. In return he gets text, instructions, illustrations, etc. In an Interactive Television Program a student calls in a question and he and the rest of the audience get explanations, illustrations, etc. In a Library System, a subject heading from the user generates citations and loses a flow of text and other material.

In each case, the user supplies what is essentially a group of control signals that modulates the the automatic flow of large amounts of information from a central store. Such is the general nature of the communication style that will be served by SYSTEM-3. Central to the task of mediating this automatic response is the digital computer. Central to the task of displaying the large amounts of data that result is the television transmitter/receiver. This satyr-like hybrid of the two technologies forms the core of SYSTEM-3.

This hybrid core requires two capabilities of the communication system that links it to its terminals. First,



the core must be able to receive bursts of data from each individual terminal. Those data must be identified as to their terminal of origin. The data may, in the case of television, represent audience response signals; they may, in the case of information request systems be requests for specific information. In each situation they will have a different semantic content closely related to the display. In each case, however, they have the common characteristic of being identifiable as to their origin. Suddenly the audience has faces. Suddenly it is composed of individuals whose responses are individually collected. We shall call this characteristic of SYSTEM-3, this ability to collect data from many identified points, BROADGATHERING.

The second feature that the core requires of the communications system is the ability to direct information to a given terminal or to any group of terminals connected to the center. In a television program, for example, the same program might initially be seen by all the viewers tuned to that channel. After some action has been taken by the viewers, some might see one end to their drama and others might see quite a different ending. In the case of an information request system, of course, each individual requesting information will expect his own information privately displayed on his terminal. In the case of a teacher, the data he supplies might well control the display on an entire set of terminals that he designates. This feature of SYSTEM-3, this ability to direct information from the center to some specified subset of the connected terminals we shall call NARROWCASTING.

Clearly the concepts of both narrowcasting and broad-gathering require that the individual terminals or receivers connected to SYSTEM-3 have labels- or, in the current jargon, addresses. A receiver's address may generally be provided either by having each receiver connected to the center by a specific line, or it may be provided electronically with the receivers connected to a single cable or partly line. For more than a very few receivers attached to a single center, the party line solution is more economical. Both the modern intracity cable transmission system and the direct broadcast two-way satellite are examples of party lines capable of handling the information required by SYSTEM-3.

Needless to say, the receiver/terminals on such a party-line are special units. Neglecting for now what goes on inside them, we can describe their external appearance. First and foremost they look like ordinary color TV sets. Only 14 pushbuttons and a light distinguish the simplest terminals from such sets. Twelve of the buttons are arranged along the bottom and right side of the picture tube. Seven divide the horizontal axis and five the vertical. Below them both is the light that lights up "READY" and the green and red buttons that permit or prohibit interrogation of the terminal by the SYSTEM-3 center.

Conservative calculations indicate that the center should be able to poll 750 active sets out of a population of one million sets, receive and store from each one 12 bits of data, and use less than 1/30 of a second to do so. Because the receivers are equipped for narrowcasting, each can be shut off for this 30th of

a second with no more preceptable image interference than that occasioned by the blink of an eye. This fraction,  $1/30$  second will recur frequently. It represents the time to transmit one complete TV picture or frame. Actually, such frames are transmitted as two interlaced halves, so we shall sometimes refer to  $1/60$  second as a "half-frame time."

We shall see in Section IV that the transmission of a 37-bit string from the center over the party line is sufficient to control the reception of any one among one-million receivers connected to the party line. Over a single video channel we can conservatively transmit somewhat in excess of 1,000 such control commands during each frame-time.

The use of a digital computer for the collection and transmission of control signals at such speed is anything but far-fetched. Modern digital computer frequently have channels that operate more than 10 times this rapidly. Similarly, the bandwidth required is not inconsistent with that of a single medium-quality television channel. At least that bandwidth may be on either satellite or cable. The redundancy of three provided for in our calculation will cope with any expected noise. It should be noted that the blocks of data to be received from each of the terminals can contain as few as 12 bits from the simplest home terminal to 600 bits representing a full line of text from the most complex terminal. The range of audience response that we are equipped to handle with such a system can be very wide indeed.

Figure I shows a rough block diagram of a SYSTEM-3

communication system. The center transmits both picture and terminal-control signals over an outbound channel while it receives data from the connected terminals over an inbound channel. It is assumed that our terminal can store one frame and display it continuously. As a result, the center can transmit a single image to a terminal and have that terminal store that image without using channel capacity for regeneration. While image storage tubes, discs, and other local storage devices still range in cost from \$1,000 up, such cost figures will drop rapidly in a growing market.

The SYSTEM-3 center contains equipment for generating images, deciding who gets what, manipulating slides and films and even for calling for help. It is a display management center with library, file and computation capability equal to its task.

In summary the, SYSTEM-3 contains a center capable of broadgathering data from many terminals and capable of narrowcasting images over one or more video channels to its associated terminals. This combination of narrowcasting and broadgathering we combine under the heading of "EXTENDED BROADCASTING." It is the business of SYSTEM-3 and is central to the applications described in the next section.

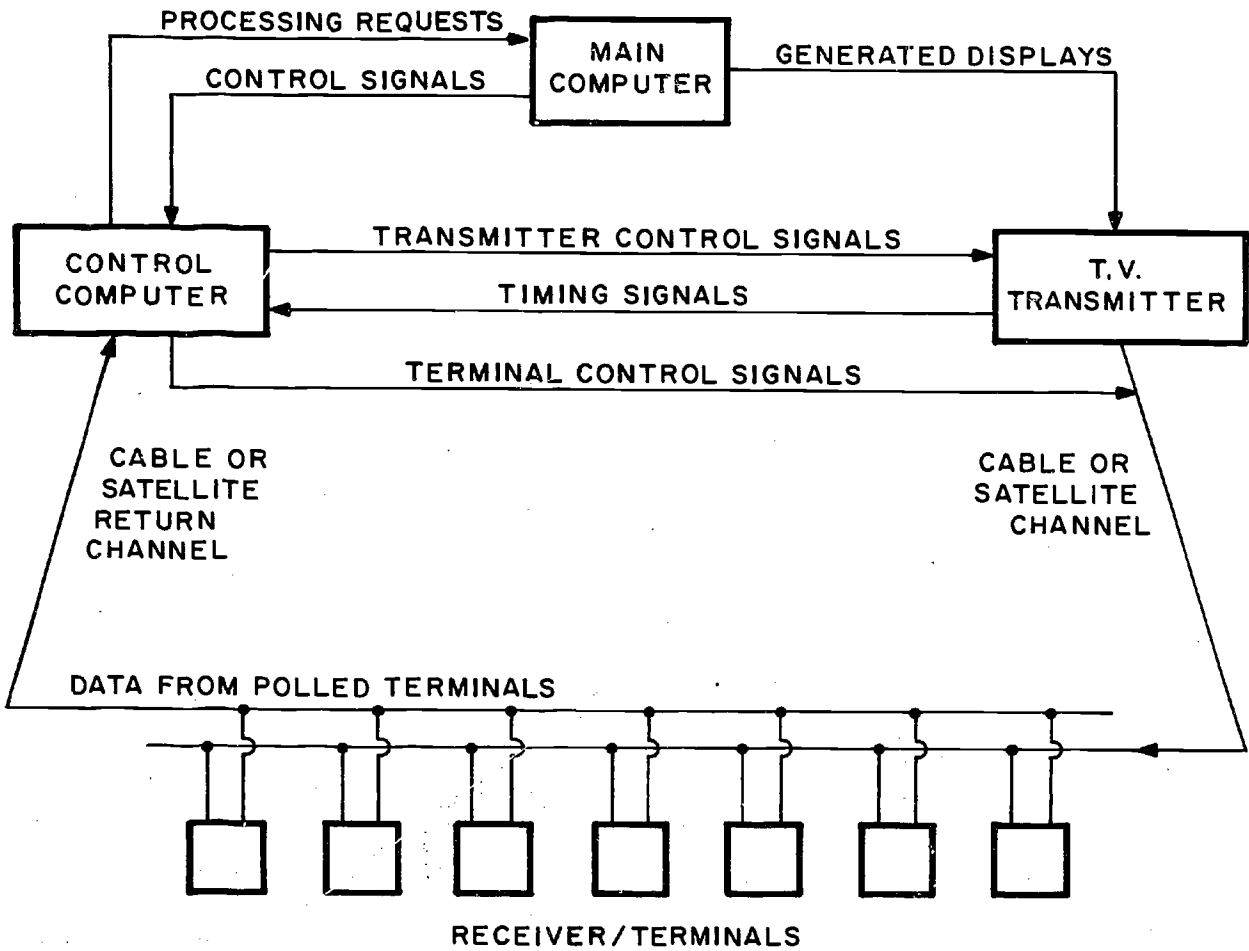

FIG.1 A SYSTEM-3 CONFIGURATION

### III. APPLICATIONS: RAISON D'ETRE

Broadly speaking, both Public and Commercial applications require SYSTEM-3. The Public applications are those normally considered in the public domain: medical, library, instructional, public safety and other service activities. In the Private domain lie the commercial computational service, direct home marketing and other functions normally conducted for profit. We shall include in this section a detailed description of the Public applications and some brief remarks on the others. The reader must be cognizant of both if he is to understand the ontogeny of extended broadcasting and hence the development of SYSTEM-3.

#### A. Instruction: Buy, sell, borrow or cut-back?

It is our belief that a major driving function in the development of SYSTEM-3 will be its use for instruction. It has the potential to provide reasonably individualized participatory instruction at a distance: at home, in the community and in other non-school locations. Indeed, we believe that the instructional use of SYSTEM-3 will not only foster the development of extended broadcasting but, in true regenerative fashion, will foster the development of education. Indeed, we doubt that vital education can take place without the kind of responsiveness that SYSTEM-3 can provide.

One of the basic responsibilities of public education is the review, examination, and transmission of our past, our traditions. Much of education is concerned with passing on past experience and accumulated skills from generation to generation. This transmission takes place everywhere, in the arts, the social sciences, and science; it pervades the whole gamut of educational

activity. It is this aspect of education that provides the stability for civilization and for society. It is within this aspect that education provides the tools and the training that we need in order to function within society. When the system does this part of its job too well, however, conservatism rules, students riot and the system loses vitality. Change is needed to temper stability.

The other responsibility of education, the one diametrically opposed to the first, but essential to its survival, is that of facilitating change. Developing the individual's critical perception, his identification of himself as a change agent, his courage and the skills for producing change, are needed to provide for the continuing development of society.

Educational television is, at present, a powerful tool for transmitting tradition. As such it has had a significant impact in the arts, in lectures, in seminars, in debates, and in the record that broadcasting makes of history as it happens. News, commentary, and reviews summarize our place in the present and our path through the past; the arts help display this summary in a form whose attractiveness and appeal has to be experienced to be appreciated.

Educational television is also a powerful aid in training, in the teaching of skills. Through its powers, we can watch skilled craftsmen, examine in detail the most complicated of processes, capture a fleeting phenomenon, join masters as they work and discuss their work, and have the vast range of human knowledge and behavior laid out for us. Little that can be learned through watching and listening does not benefit from such presentation.

Despite the obvious contribution of educational television--of the broadcasting system in this field, despite the fact that educators have not yet learned to use these facilities to anywhere near their full potential, we cannot help but agree with Licklider's comments in his article TELEVISTAS<sup>(8)</sup> "Educational television is too conservative in its estimation of the feasibility of selective, interactive, and intercommunicational television systems, and of the achievability, with the aid of such systems, of a significant breakthrough in education."

While such interaction is being recognized as important in the educational areas of tradition and skills, timely interaction is fundamental and vital to the second task, that aspect of education involved with change.

That is not to say that conventional broadcasting has no role to play in education for change. Educational television, has presented program on program showing the need for change in the human condition in our country. Certainly, televised riots and confrontations have served to educate elements of our population in the potential, and limitations of such means for producing change. Because it lacks his participation, however, broadcasting cannot deal with the extremely personal problem of the individual recognizing himself as an effective agent for change.

We have learned to see others as such change agents. Through the medium of dramatic presentation, we often see an individual as an effective learner/doer, perceiving the need for change and development and producing it. We have come to know our civilization's heroes and legends with an intimacy never before achievable. We meet them, relive their work, understand their rewards



and their struggles, and identify with them. This same medium of dramatic presentation opens to us the world of the possible. We observe other individuals taking effective action to influence their future and society's. But they're heroes, larger than life, I am only I.

Powerful as this use of television may be then, it still cries out for augmentation. The final step, that of transferring the concept of some general individual as an effective change agent to ME as that agent requires personal participation. Traditionally, work experiences, laboratory experiences, group interactions, interpersonal relations with the teacher, and even the "exercises in the back of the book" produce that flexing of muscle, that exercise of agency, that sense of competence and autonomy that rarely seems to arise without such participation. We see, then, as a major demand of education, today and tomorrow, a demand for participation. While some participation is now possible through gross-sampling techniques via the telephone, or by mail, neither truly constitutes a form of participation suitable for education's need. To meet that need, we will require those rapid responses from identified users and those means to modify each individual users video environment that are characteristic of a SYSTEM-3 communication network.

In order to facilitate our discussion of the instructional application of extended broadcasting, let us define the term "slide-show" that will be central to that discussion. A slide-show is a succession of images projected more slowly than those that make up a motion picture. While the time interval between slides may vary widely, depending on the content of the accompanying audio, we shall assume an average interval between images of four seconds.

The storage unit in the receiver holds each image until the next change. Each show also has a unique audio channel associated with its sequence of images. Approximately 100 simultaneous slide shows can be transmitted in the bandwidth required for one video channel of SYSTEM-3. The control capability of SYSTEM-3 makes it possible to switch any receiver or group of receivers from one such slide show to another at will. SYSTEM-3 is therefore potentially a valuable medium for the future development of computer-aided instruction.

Now that we've described the slide-show, let's imagine its use in a business school instructional session. Rather than a case study observed from a distance, we can make the student take the role of an operating decision maker in the business under study. For that we require that the simultaneous slide-shows on the channel represent alternate worlds of possibility. The student leaves one and enters the other as a result of his decisions. For example, there might be six decision points in a one-hour program. At each of these points he might be required to choose among two to five decisions. Allowing for redundancy, dead ends, and closures in the decision tree, what starts out as a single world--a common starting point--shown in a normal video presentation may well branch out to as many as 100 slide-shows representing alternate worlds--outgrowths of alternate decisions--during the session.

During our hypothetical case study, there might be one decision involving inventory, one involving dropping sales, and one involving a shortage of capital. In fact, of course, there would be many such decisions--each depending on what that individual had done before. At the end of the case, however, each student--the student who bought and the student who sold, the student

who decided to cut back on production and the one who decided to increase the sales force, the one who decided to diversify the line and the one who decided to start a new advertising campaign, the student who decided to borrow capital, and the one who decided to seek equity financing--each student would have moved through a set of experiences clearly of his own making. This is the experience of doing, the experience of "ME" as an agent of change.

Clearly, business is not the only area amenable to such instructional techniques. Branching programs of one sort or another are being used from third grade through medical school. With the aid of extended broadcasting, however, they can take on a new vitality and realism. In the medical program the results of test, examination and therapy decisions would not be simple text descriptions as they now are, but the display of tissue-slides, stethoscope sounds, ECG and other graphic representations, and even patient interviews. Rarely will a problem be complex enough to exceed our limit of 100 possible alternate worlds. Rarely will the medical student or doctor get more involved with a case study.

We do not, however, believe that the public use of SYSTEM-3 in education will be restricted to computer-aided instruction. Because SYSTEM-3 can function as an extensive inquiry system with a single terminal requesting and examining information, reacting to it and getting a new display, we believe that extended broadcasting will be applied to such educational tasks as individual self-evaluation, for monitoring one's own progress in a subject area and for area exploration. In this type of use, the number of terminals that can be individually serviced by a single video channel is

very large. Where the study time devoted to a specific display is in the order of minutes, the number of terminals that may be simultaneously served will be in the order of thousands. These applications, and the use of adjunct materials will allow extended broadcasting to play a significant role in computer managed instruction.

B. The Information/Inquiry Center: It was a blue bottle...

As society's activities have become more complex, special information centers have become more common. We are all familiar with "directory assistance" and some of us are familiar with the marine and pilot weather information centers, and others, public and private, of an even more esoteric nature. In the public area, an information center representative of the entire genus is the Poison Control Center. Current Poison Control Centers require that the physician who has a poisoning case on his hands, call a special number. He will then be connected with an individual who will discuss the case with him. He will be asked such questions as the name of the poison, how much was taken, the age of the patient, etc. The attendant at the Poison Control Center will search his files for the appropriate measures to be taken. A frequent suggestion that arises is the use of a computer-managed data bank to be used by the attendant at the control center. The advantages of such a computer-managed data bank are many, the most significant medically being its exhaustiveness, its ease of updating, its speed of its response, and its multiple cross-indexing.

Even with such an automated data base, the use of the telephone and an intervening human between the inquirer and the data combine to produce a traffic bottleneck. In fact, many Poison Control Centers can only handle one inquiry at a time. The development of direct access

computation techniques has led many people to suggest the elimination of the attendant and the substitution of direct inquiry by the inquirer. The use of special terminals in hospital settings or in the doctor's office, and the use of touchtone telephones with voice answer back from the computer over the common carrier network are the most generally suggested approaches. Such approaches could be satisfactory as long as the inquiry flow rate stayed small and as long as the information to be displayed could be restricted to words. Where traffic requirements are high, or where non-discursive display is required as in the display of physical things like labels, bottle shapes, physical signs, etc. direct access inquiry can be better handled over SYSTEM-3.

We can visualize a physician called to a home where a child has swallowed a portion of the contents of an unlabeled bottle. If the home has a SYSTEM-3 receiver/terminal in it (and it will when they are as popular as TV sets) we can envision our physician switching to Channel 97, the emergency medical channel and requesting help. Using the first of the seven horizontal buttons and the first of the five vertical buttons he presses the 1-1 combination to signal an emergency inquiry. The screen lights up with a matrix seven columns wide and five rows high. Each of the 35 cells offers the physician a choice--a decision as to the kind of help he needs. Our physician now presses the combination 2-4 to indicate "POISON". Successive matrices, each offering him many choices pass in response to his actions. When he requests a display of unlabelled containers, he may be faced by a smaller matrix in which each cell shows a stylized container in much the same fashion that airline baggage damage sheets show an array of stylized

luggage shakes. Our physician picks the one most nearly like the one in the house and is faced with another more detailed group, all of that category. Fortunately, one is an exact match. Indicating that one, he is told its contents and its manufacturer and may then be given a recommendation or may again be asked questions about the patient's age, etc.

This ill-developed scenario is not intended to bias the design of a SYSTEM-3 Poison Control Center. We wish to indicate how effectively a video display system coupled with a small array of buttons can serve to act as the input/output terminal for a moderately complex information/inquiry center. For the many centers that cannot rely on discursive text, for those whose information must be available from the home, for those whose inquiry rate is too high to justify the cost of using the switched network system, and for those who must transfer answers back at video rates because of the amount of data involved, such an example is probably appropriate. Fingerprint and facial comparisons; geographic information such as the location of people, things, and places; artistic displays in general; the whole world of graphical inquiries; and inquiry systems that feed another SYSTEM-3 center will all find that SYSTEM-3 frees them to develop in ways not now feasible.

Needless to say, each SYSTEM-3 center cannot contain all of the information represented by the union of such information centers. They do not have to. SYSTEM-3 centers themselves can be inquiry stations on other SYSTEM-3 networks. This interconnection pattern will permit the existence of substantively organized centers. One will deal with poisons and another with art treasures. Each will use local, geographically organized, SYSTEM-3 networks for their general information distribution function.

Two interesting developments from the concept of an information/inquiry center on SYSTEM-3 are the concepts of a distribution center and of a two-way file. We shall now consider each of these in turn.

C. Two-way files:...a small ovoid mass...

In each of the two previous examples, in education and in the information/inquiry system, we considered the user response to be of only transient interest, its role restricted to controlling the information output of narrowcasting. It is obvious, of course, that the center's computer could record the broadgathered data were it valuable. Presumably, if a student sought certification in an area, he could request that his performance on a given problem or in a given situation become a matter of record.

In our two previous applications the main corpus of information originated with a small group of input agents. It was stored for subsequent distribution to a much larger group of information consumers. There is another class of information store, however, where the generators of the information and the consumers of the information are largely the same people. These files are basically our social memory. They are perhaps best exemplified by the medical record. A patient's medical record is composed of bits and pieces of information entered into it by the very same people who are concerned with the examination of that record. Whether the record is considered in its entirety or whether it is fragmented into a radiological record, a pathology record, a financial record, etc. is irrelevant. By and large it represents a collation of the information generated by the user population.



While various other such two-way files come to mind, let us again revert to medicine for our example. We can visualize our physician either calling from someone's home or utilizing the SYSTEM-3 terminal in his office. This time he is calling the medical record "library" in order to review and update the information concerning his current patient. First, however, he must establish his identity and that of his patient. Using the 12 push buttons now in a remember configuration to generate 12-bit numbers, our physician is able to identify himself from a population of a million physicians by two sequential transmissions.

After the center has displayed the doctor's name and patient's name for verification, it is in a position to provide the physician at a distance with a most useable medical record. Text, graphs, x-rays, color photographs of slides, color photographs of physical signs etc. are all entities that can be displayed for his examination. Indeed, it is interesting to note that a single 4"x6" microfiche can hold about 2,000 images, each in full color, and having a greater resolution than can be displayed on a color T.V. tube. High-speed selectors now exist - at reasonable cost - capable of selecting a specific image out of such a matrix in less than a second under digital control. We have little doubt that such image selectors will play a major part in a SYSTEM-3 center.

Back to our physician, however. Having reviewed his patient's case, he now signals the computer that he wishes to update the record. Because he does not have a text keyboard, he asks for the kind of branching inquiry program now being experimentally used for that



purpose. He might, for example, indicate "MEDICATION" on the first matrix, and in only half a dozen choices pin it down as to name, route, dosage, frequency, etc. This action serves to update the record but to give the center an opportunity to check for contraindication. In any case, his input becomes a new part of the file for that patient and thus becomes part of the continuing social medical memory of that community.

Frequently, of course, a freer form of text entry will be needed in medicine. Many SYSTEM-3 terminals will have more complex input devices. Some may have keyboards and internal storage registers capable of holding one or more lines of type. Such terminals will, because of cost, be less widely distributed than the home type terminal and their use will consequently be restricted to special locations such as physician's offices, hospitals and other professional places where their additional cost is warranted by their additional utility.

We do not fall back on medicine for our examples because it is all that exists, but rather because of its probable familiarity to the reader. Indeed such activities as the Social Science Data Archive, EDUCOM's file resource sharing program and the proposed Project Cambridge all recognize the public need for two way files. Most exciting among these developments is the concept of the two-way library. Many of our special interest libraries have author populations that seriously overlap their reader populations. We are recognizing that such libraries should contain not only the literature, but the corpus of commentary on that literature. SYSTEM-3's two-way files operating in conjunction with the distribution center we will discuss net may well bring about the two-way library.

D. Distribution Center: Mail it, please, by next week.

Networks for the distribution of material things are frequently homeomorphic with those for the distribution of information. Control information (such as inquiries and orders) flows from many individuals to a center which then ships out the required material and frequently also ships out information such as invoices and bills. This construction would lead one to expect that the SYSTEM-3 network might serve as a mediating factor in goods distribution. While we will deal with the subject more fully as a commercial application of SYSTEM-3, there are certain public distribution functions that fall within the purview of the Public Broadcasting Corporation.

An obvious public distribution system likely to grow out of the information/inquiry function is that of the public library. It is clear that many inquiries and requests for information can best be responded to by means other than direct display. In those cases where a single request would initiate the flow of very large amounts of text or illustrative material, it is unlikely that the transmission of such quantities over the party line would make sense. The user can neither absorb them at a rate that warrants tying up the line, nor, in general, can he absorb them at a single reading. As a result, it is often desirable that the information be transmitted to him in some non-fugitive form. The same situation arises in the public library. Books, films, records and other such material represent massive responses to small inquiries.

In the public library, such inquiries are made either

after direct reference to a catalog or after the intervening activity of the librarian. Direct catalog referencce is an information/inquiry activity. In fact, the catalog is the information center for the contents of the collection. Here again the direct intervention of a human agent, in this case the librarian, represents a limiting factor in the number of inquiries that can be handled. If suitable catalog information were contained in a directly accessible file, and if users were taught how to conduct probing, effective, exploratory and relevant searches within that file, we could expect many simultaneous users to arrive at decisions. Once such a decision has been made, our SYSTEM-3 user should be able to determine whether the material is available and to order it delivered. Whether the material is delivered by mail, or by delayed electrical means, whether it is delivered in microform or as the original, whether it is a disc or tape or some other recording is irrelevant to our discussion. Whether the material is delivered for his retention or to be subsequently returned, whether it is delivered free or whether there is a charge for the service, is also unimportant. In each case the center's computer can record the order and display it for action. Similarly, material distribution network can notify the center of its compliance with the order so that a record of the complete transaction can be maintained.

One can easily visualize a frequent merging of the information/inquiry center function and library distribution function. A housewife searching for a seafood souffle recipe may scan through several titles and finally display several complete recipes. She may either copy one or "freeze it" on the screen of the

terminal while she prepares that night's dinner. She may also request from the center the cookbook from which it was taken or some other collection of which it formed a part. This added material is required on a much slower time schedule and can be forwarded to her by mail or other delivery system. Indeed, it is this natural transition from the information/inquiry center to the library center that makes this such an attractive public application of SYSTEM-3.

A closely related distribution function, that of news dissemination involves more blurred boundaries between the commercial and public sector. Presumably one might sift through the day's news much as our housewife sifted through recipes, reading abstracts and even full news stories of those items that interested us. It is unlikely, however, that public or private services would exist (as they now do), whose main function was to assemble a continuing commentary on the news. Thus, the individual after pursuing one or more news stories might order a groups of such commentaries tailored to his interest, delivered to him on a one-shot or subscription basis. Such "news-magazines" would again presumably be delivered by mail or by some material distribution system.

We shall stop here in our consideration of delivery systems, primarily because there are few "free goods" in our society. We shall take up the matter again under the heading of "MARKETING."

E. Interactive Entertainment: Take the money and run.

Not all public broadcasting is aimed at bread; part is reserved for circuses. It is clear that the techniques that we used for our business school example might just as well have been applied to a mystery story with the viewer taking the role of the detective (or of the criminal). This kind of involvement, this sharing the decision-making function with the character in the story rather than observing him going through the decision making function will introduce a totally-new dimension into television entertainment. Even the Czechoslovakian attempt at the Montreal World's Fair produced heightened reaction, although it introduced only one decision point into the program and only reacted to a poll of the audience.

We can visualize the involvement on the viewers part as he decides whether to follow the butler or to keep watch at the front door or to phone for help. How one resolves the conflicts between members of the family is hard to guess. Perhaps viewing will not only become interactive but competitive, with each member of the family using his own receiver to see who comes out best. It is fun to move from detective stories to political dramas and a whole new form of pseudoautobiography - where a personal drama gives each viewer a chance to live his life among 100 worlds of his own choosing.

With this kind of interaction and involvement, one hesitates to use the word "entertainment." How different is such an opportunity to explore various life styles from the kind of "life simulation" activities advocated by modern guidance professionals. If Arrowsmith caused

a rash of doctors, how many would have been affected by participating rather than watching. Even the Brave New World maintained passivity when if offered feelies. Which will have more appeal - five sense passive dramas or two-sense interactive ones?

We are particularly intrigued with the use of computer-mediated entertainment material for the very young. Children's stories that involve children in rski-taking, decision-making, and their natural consequences, cannot help but produce the transition between entertainment and education that is so often espoused and so rarely achieved by modern writers and educators.

In particular, we are impressed with the potential role of this form of entertainment in the development of the child's values and psychology. Such things as need Achievement apparently have major influence on societal development and can probably be developed in the individual by techniques similar to those of computer mediated entertainment. Indeed, this kind of interactive program material may be just what is urgently needed by those who would deal with many of our basic urban and social problems.

But interactive entertainment need not all be in the theater arts. Certainly such participation will awaken new forms in music, dance and the graphic arts as well. In these, it may well be only the degree of pre-programming that distinguishes the interacting viewer from the creative artist.

F. The Creative Arts

One rarely thinks of the television receiver as a tool for the creative artist. The interactive television receiver, however, the SYSTEM-3 terminal, obviously is just such a tool. We visualize the SYSTEM-3 user employing his terminal over a wide range of artistic activities. Those who have seen the Kaleidoscopic and marvelously intricate moving patterns generated by a digital computer are aware of the power and beauty of such displays. Those few who have sat at a terminal and manipulated such patterns with a few stitches are aware of the intoxication that accompanies such activity. We consider this kind of "play" activity as being wonderfully suited to children of all ages. The experimentation with abstract design by random intervention on the part of the very young child will gradually develop into a more ordered interventive process as the child matures. With time, the desire to preserve pleasant experiences will result in the assembly of files of such switch settings for storage and later replay. One can visualize that certain members of the community will become more skilled at this activity than others, and that they will make their intervention files available for replay by other members of the community. Thus, will the SYSTEM-3 artist be born along with the SYSTEM-3 art show.

It is not only in the field of abstract design, however, that such activities will develop, but there will be a parallel development in music and in authorship. It is, I am sure, clear that the task of writing a scenario that contains intervention points and that involves the viewer through sharing as well as observing is a sig-



nificantly different art form from that performed by present day playwrights and authors. Just as new playwrights evolve to handle the minor transition from stage to screen to tube, a whole new class of interventive playwrights will evolve to handle the much larger step from passive to interactive scenarios. The medium will not only be their good, however, it will also be their tool. The computer and the interactive terminal will be essential to the playwright's craft. It will no longer be possible, for example, to represent a script as a simple one-dimensional flow of text and events. The script for an interventive play is a much more complex topological figure and its representation will require the file manipulation, management and display characteristics of a central computer. It is most likely, therefore, that our playwright will use the same sort of terminal as does a computer programmer or problem solver connected to SYSTEM-3.



G. Problem Solving: If a man and a half digs a...

One of the most complex applications of SYSTEM-3 in the public domain is the provision of computer access to the individual citizen as a matter of public policy. It is clear that the provision of such access is appropriate in conjunction with many educational activities, and it is clear that such access is appropriate for those individuals who are serving in the public's interest. In the latter group we will find those who are writing the applications programs that permit educators, doctors, and other to use SYSTEM-3 effectively. In the first group we will find student, in the professional schools and children in the elementary grades. The former may be engaged in sophisticated simulation and the latter in curricula involving data manipulation and logic constructs.

Regardless of the use, however, it is unlikely that SYSTEM-3 communication will set the limits on who shall use the system. The limits will be set by the sheer economics of supplying computational capability across a wide spectrum of users as a public service. Even in the case of the complex terminals that contain an entire keyboard, we shall find that line by line polling can serve several thousand simultaneous users with no communication-induced queing. If, as in the case of the information/inquiry centers we assume a fanning out from the SYSTEM-3 center to a hierarchy of computers providing computer access, we may indeed start to approach Fano's ideal of making computer access and the didactic material to insure its intelligent use available in every home.

We shall not dwell on the specifics of using the SYSTEM-3 center or its computer in this mode, since enough has been already written in the literature regarding the wonders of time-shared and direct-access computation. Suffice to say that it could produce a significant change in society's present view of computation.

## H. Polling

The last public application of SYSTEM-3 that we wish to discuss is that of polling. And there we stop more from a feeling of having exhausted our reader's patience than our subject.

Clearly, any communication system that provides for the rapid transmission of wide-band information from a center to a large number of receivers and for broad-gathering data from each of these receivers can become a new political factor. Much has been said in the press and in our professional societies of the advantages of bringing to a politician an instantaneous picture of the desires of his constituency. An almost equal amount has been written about the dangers of impetuous action and the loss of deliberation that such a system might foster. Whether such a system would foster demogogery or democracy, whether the people would rule as a body politic or as a body hysteric or whether we would evolve some new concept such as public advice and consent, it seems clear that the advent of public SYSTEM-3 communication would initiate a new era in political evolution.

New stars would arise, new rules would become established for the game, new Luddites might emerge, and whole new structures might develop. The marked change in the role of the president and other elected officials since the advent of mass instantaneous communication media would, we believe, be a minute change compared to that occasioned by the advent of instantaneous two-way mass communication.

But polling in the public domain is not restricted to political activity in the normal sense. Polling of

wide audiences would introduce a new concept of program "ratings"; matters of public taste could be explored, as could the level of public information on vital questions. In any case responsiveness would become the keynote. The advent of interactive public broadcasting will, we believe, bring public broadcasting one step nearer to being an activity of the public rather than and activity aimed at the public.

This then is a selection of potential public applications of SYSTEM-3. This is the broad shape of tomorrow's Public Broadcasting. As exciting as they are, they are unlikely to happen by themselves. Each one assumes the existence of a well-equipped center and inexpensive widely distributed terminals. To provide that wide distribution will require pressure from the public and private sector. Characteristically, in our economy, public pressure is by far the slower of the two, and so it behooves us to examine the possible commercial application of SYSTEM-3. In that way we may be able to assess the time frame over which the development of SYSTEM-3 is likely to take place.

## I. Marketing: Size 26 in ecru and...

Just as television in the United States secured its major impetus from advertising, it is possible that SYSTEM-3 communication will secure a major part of its support from what might be called interactive advertising. Interactive advertising is not a new concept, it is, what happens with most point-of-sale displays; it is what happens at our supermarkets. The buyer is offered a large number of alternatives from which he makes a choice and to which choice he makes an immediate commitment. While direct selling is rarely expressed in those terms, they will help to understand the use of SYSTEM-3 as a marketing tool. In most of our previous applications the viewer was given a sequence of choices with which he could interact if he chose. By interacting he could make choices and indeed indicated commitment to those choices. Identifying codes like those used by the doctor for security and the unique address of each terminal could form basis for a reasonably secure system for charge purchases.

One can imagine that after a particularly entertaining and involving drama, White's Department Store or Black's Emporium might find it easy to involve the viewer in continuing to make choices right through the "commercial message." Such commercial messages would be far less likely to engage in long-term image building than in direct selling. A 60-second commercial might display notice of several classes of merchandise currently offered under "particularly favorable terms." By responding, our user could request a frame containing information on one specific class of goods. He might even continue to the next station break. During that

break he might go further in his inquiries or he might actually place an order.

If we realize that there will be a very large number of channels available over any future intracity cable (current estimates say 80 in a few years) we can expect that one or more of the channels will be dedicated wholly to such sales. We shall have catalogs of the air. Indeed, as in the case of the catalog for the library, information/inquiry centers and catalogs are indistinguishable. It is to be expected then that much effort will be devoted to updating such catalogs and providing closely linked "serendipitous" information with the users inquiry. We must expect that these catalogs will be referenced by the commercials associated with the entertainment programs.

In general, fewer than four or five responses would be necessary to locate any item in a Sear's catalog or some other similar compendium and one more to place the order. If Sear's uses SYSTEM-3 for marketing, must not anyone else in the community who wishes to be competitive in the home market? If they all do - or any reasonable number of them does - does it not take a very small percentage of the sales flow to support not only SYSTEM-3, but to provide the impetus and means for securing wide distribution of responsive receivers?

Needless to say, the commercial end of SYSTEM-3 takes on a major credit management function under these conditions, for if the user makes a commitment via his terminal, and if the supplier honors that commitment, isn't the SYSTEM-3 management in the ideal position to provide a banking function to both? Again, doesn't it

take a rather small percentage of such activity to both emphasize the impetus and reinforce the means for securing widespread distribution of receivers on SYSTEM-3. One cannot help but wonder, given such commercial utilization of SYSTEM-3, whether future entrepreneurs engaged in providing cable or satellite connection may not provide that connection free in exchange for the other prerequisites provided then.

In addition to marketing there is a private or commercial version of each of the activities we discussed from Section A thru H.

The training that is done free in the public education system is done at great expense, albeit for more specialized ends, in every major industry.

Baron Rothschild's legendary preoccupation with information as the foundation for business makes one realize the commercial value of information/inquiry centers dedicated to that end.

Each of the others, not even excluding the creative arts, will offer to some entrepreneur, the chance to construct a business enterprise for gain.

We will someday find SYSTEM-3 carrying bit strings representing private and public, commercial and philanthropic, community and corporate applications. The technology, the organization, the hardware, the software and the communications capabilities required by each sector is required by both. It is likely, therefore, that the two economic sectors will function synergistically, each helping to bring about the other. In

Section V we shall discuss the organizational regulatory and technical events that must take place, the processes that must be initiated for this synergism to produce a viable system.



#### IV. SYSTEM-3 REVISITED: A CLOSER LOOK

This section is a return to the more usual organizational schema. Having discussed a group of applications, we can now discuss the structure of a system capable of implementing those applications. A broad description of the system was introduced in Section II. This section is intended to present enough detail to demonstrate a reasonable degree of feasibility and to serve as the context for the activities that we will cover in the next section. In many presentations, the present material would be covered in an appendix, but the author's loyalty to engineering as a profession militates against its relegation to such a subsidiary position. We shall split our discussion into two parts. First, we shall discuss the receiver itself, and second we shall discuss the SYSTEM-3 center with particular attention to the interconnection of such centers to form SYSTEM-3 network.

The proposed solutions offered in this section are illustrative. No doubt other engineers will have more elegant, more cost-effective, and simpler solutions. The illustrations are offered here largely as an existence proof rather than as design blueprint for further development.

##### A. The Receiver/Terminal

To aid in our calculations, we have assumed that a SYSTEM-3 center would serve a maximum of one million receivers (a reasonable maximum population on a single cable, for example). We have assumed that the center can address any individual receiver, and within that receiver the center can enable the receipt and storage of the next image frame or disable such receipt. We have further assumed that the transmitter can query an addressed receiver, requiring

it to transmit the string of bits stored in its data buffer register if that register is ready for transmission and that it can subsequently clear that buffer.

In order to facilitate the frequent transmission of slide-show presentations, we assume that the center can:

- (1) Direct the receiver to display the Nth frame (called a time slice) out of every four-second series of 120 frames until instructed otherwise; and
- (2) select one audio channel out of a possible 120 such channels being broadcast.

In addition to being able to issue these commands to individually addressed receiver/terminals, we consider it desirable that the center be able simultaneously to control all units connected to a specific time-slice. This group of receiver/terminals should be further divisible into those units that are enabled (receiving images) and those that are disabled (holding an image without receiving others).

For query purposes, we assume that a local oscillator in each set, much like the present heterodyne oscillator, will be modulated by the stored bit string. The query data can be returned either over the same frequency-division channel as that to which the receiver is tuned or over some other channel depending on the traffic.

All commands to the receiver/terminals - all control signals - we visualize as consisting of bit strings transmitted in the infra-black on the channel to which the receiver is tuned or on a dedicated channel. In either

case, no confusion with the display signal will be occasioned.

The digital command string that we have chosen consists of a 36-bit word, preceded by a start pulse, for a total of 37 transmitted bits. Their definition might be as follows:

Bit	Meaning
∅	Start pulse, triggers clock
1	∅--This is a station address
1	1--This is a time-slice address
2-21	20-bit station address if bit 1 is a zero
13-21	9 bit time-slice address if bit 1 is a one The first two bits indicating the state of the units addressed: ∅1=disabled units only 1∅=enabled units only 11=all units The last 7 bits being the time-slice addressed.
22-29	8-bit operation code (see below)
30-36	7-bit time slice or channel modifier (N) to the operation code. N may equal ∅, the null condition.

The operation codes are (in octal)

001	Connect unit to Audio Channel N
002	Connect unit to Time-Slice N
004	Clear Data Buffer
*010	Disable receipt of images
*020	Enable receipt of images
**040	Power off
100	Transmit Data (station address only)

For economy we have assumed that the operation codes can be logically added together to form more complex commands, but only one starred command may appear in such a set. The double starred command may not be included. Thus, the operation code 117 means "Disable receipt of images, transmit data, clear the data buffer and connect the unit to both audio channel N and time-slice N." That translation also indicates the execution order.

We assume that there is also a need for the center to control certain additional peripherals through the receiver. The first bit of the operation code is, therefore, reserved to the use of these control activities and a "one" in that place disables all regular receiver response to the operation code. The code series 200 to 377 is, therefore, reserved for the control of peripherals.

The 040 command is included as the ultimate courtesy. We assume that the center will transmit it when it has finished its home-broadcast schedule for the benefit of those who fell asleep during the late hours. It shuts off the receiver.

In addition to the control logic, the receiver that we have hypothesized requires:

- (1) A 120-frequency beat-frequency oscillator -- for single-sideband use -- followed by a good steep audio mixer/filter.
- (2) A 120-position electronic commutator advanced by the frame-synch pulses and synched on Position 1 every four seconds by a control signal superimposed on the broad-pulse, frame-synch at that time. Its position defines the time slice. At each position, it serves to connect the incoming video signal to

- (3) a 120-switch, double-pole bank opened and closed by the address portion of the time-slice setting commands. When closed, one side passes the video signal on to
- (4) a double-pole switch for enabling/disabling the receipt of images. One side of this switch completes the video path.
- (5) A manually-set buffer that is read out three times as a bit-string with a redundancy of three on receipt of the 100 control command. The normal reset position of the buffer is alternate ones and zeros. The receipt of this or any non-zero pattern indicates that the set is "on" and willing to be interrogated. This buffer will vary from a simple 12-button/12-bit register in the home receiver to alternate 70 character registers in the most complex receiver.
- (6) A 20-bit, hard-wired shift register used for address decoding.
- (7) An 8-bit decoding matrix, operating in conjunction with the remaining pole of (3) and (4) above for time-slice addressing.
- (8) A storage tube or electromechanical method of storing and continuously displaying a single frame.

Depending on regulations, the half-megahertz band required for the 120 audio channels may be obtained by cutting back on the bandwidth of the video channel used during multichannel audio work -- with some loss of horizontal resolution -- or from added spectrum space. We believe, however, that some skirt sharpening will provide the added bandwidth without either loss of horizontal resolution from today's levels or the exceeding of FCC spectrum requirements.

Querying the receiver in station-address mode is a frequent operation in both special inquiry use and in course work. Its economic use in that mode will require storing, in the center's computer, the list of all active receivers to be addressed. For special inquiry use, no problem is envisioned. In course work, station addressing is used only where individual responses are required. To poll the entire population of one million receivers to determine which are active would take 42 seconds of black time (37 bits of inquiry, 37 bits of response, 10 bits of turnaround, 1 million receivers, 2 megabit per second bandwidth each way). If the course required preregistration, of course, this time would be unnecessary, since the list of registrants would be used as sufficiently accurate for response requests.

The most frequent use of the control signals will be in polling for viewer responses. Using the same figures as were used above, we can poll 750 receivers in a single frame time. If, as in political polls, the audience is larger, more time will be required. The frames required need not, however, be successive. Indeed, if 10,000 viewers were to be polled, we would require 12 frames and would probably spread the polling time over 30 or more frames, using the alternating interlace positions on alternate frames or on every third frame to produce minimal image degradation. What degradation did occur would last for only a second.

Station-address mode for control will be used whenever unique material is to be shown to a single receiver. This mode is probably the most important one we have since it permits the center to use SYSTEM-3 the narrowest form of narrowcasting. Here the transmitted digital command chain will have the form:

$\emptyset A \emptyset 23N$       Station A enable and connect time slice and  
                          audio channel N  
                          (Frame of information for Station A)  
 $\emptyset A \emptyset 1 \emptyset$       Station A disable

Note that 37 bits are required before and after the frame to be displayed. At a two-megabit rate, each such bit string would require only 19 microseconds. The FCC standards provide 50-microsecond "broad-pulses" in each half-frame synch train or more than enough time for two such 37-bit trains. By superimposing our 37 bits on half the infra-black crown of one such pulse, we would have no difficulty securing sufficient control bandwidth. For such single-frame presentation at a rapid rate, our command chain would be:

	$\emptyset A \emptyset 1 \emptyset$	Station A disable
Time-Slice (N-1)	$\emptyset B \emptyset 23N$	Station B enable and connect time-slice and audio channel N
		Frame of information for Station B
	$\emptyset B \emptyset 1 \emptyset$	Station B disable
Time-Slice N	$\emptyset C \emptyset 23(N+1)$	Station C enable and connect time slice and audio channel (N+1)

The ability to send out many enable and disable signals rapidly is important in any case where receivers are handled in groups. A programmed course using multiple slide-shows is an example of such a circumstance. Here we might have 1,000 students and 10 possible branches -- with 200 or more students due to be shown the next frame of one such segment. During the half-frame time preceding

that display frame the center has more than sufficient time to send out the 200 enabling commands. Because the commands are in the infra-black, no hash appears on the screens. Following the display frame, the receivers can be disabled with a single command by addressing it to all enabled receivers in that time-slice. The command would be 1 - 10N010 - .

A possible usage of the receiver will be to permit the simultaneous transmission of up to 120 simultaneous uncorrelated slide shows over a single video channel. Such a capability would permit the simultaneous transmission of more illustrated lectures than go on in even our largest and dullest universities. In a parallel set of slide-shows, each time-slice has associated with it its own audio channel. At any time before that time-slice comes up, we can transmit the command:

Units on time-slice A enable

followed by the frame information and the command:

Units on time-slice A disable

issued at any time before that slice reoccurs. This string changes the "slide". Thus, the slides can easily be changed at times separated by four seconds.

The use of the 002 command (connect unit to time-slice N) permits added image time slices to be used in that slide tape presentation if it is desired to use more frequent changes. The cost of doing so, of course, is more computation. By having the computer establish a queue, the center can change slides as rapidly as desired as long as the ensemble average doesn't get shorter than four seconds.



It should be noted, as implied in the previous section, that slide-show presentations need not be illustrated lectures. Twelve, 10-alternative presentations can be given simultaneously in a 120 time-slice system. Up to 750 students per time-slice could be polled as to their answers in a single frame time. These polling frames count as slide changes in computing the ensemble average. Each such 10-alternative course might serve 3,000 students, and the group of 12 such presentations - might serve up to 36,000 students with only a loss of 40 frames to polling at each decision point.

The codes from 200 to 377 can be used, along with suitable decoding matrices and relays to operate a wide range of auxiliary equipment connected to any receiver. Thus, for example, a receiver equipped with a video tape recorder could request that that recorder be turned on, that a program be transmitted, and that the recorder then be turned off. When we discuss the hierarchical organization of SYSTEM-3, we will see that this same set of codes is used to transfer control among the various levels of the hierarchy.

#### B. The SYSTEM-3 Center

While Figure 1 served as a good working diagram for the discussion of SYSTEM-3 applications, it is insufficient in detail for our present purposes. The diagram, for example, shows the SYSTEM-3 center as being isolated, transmitting to its little collection of receivers, but with no way of receiving information from the outside. Were this the case, SYSTEM-3's would be extremely limited. Let us examine that center in more detail so that we can uncover those elements of its structure that permit of networking.

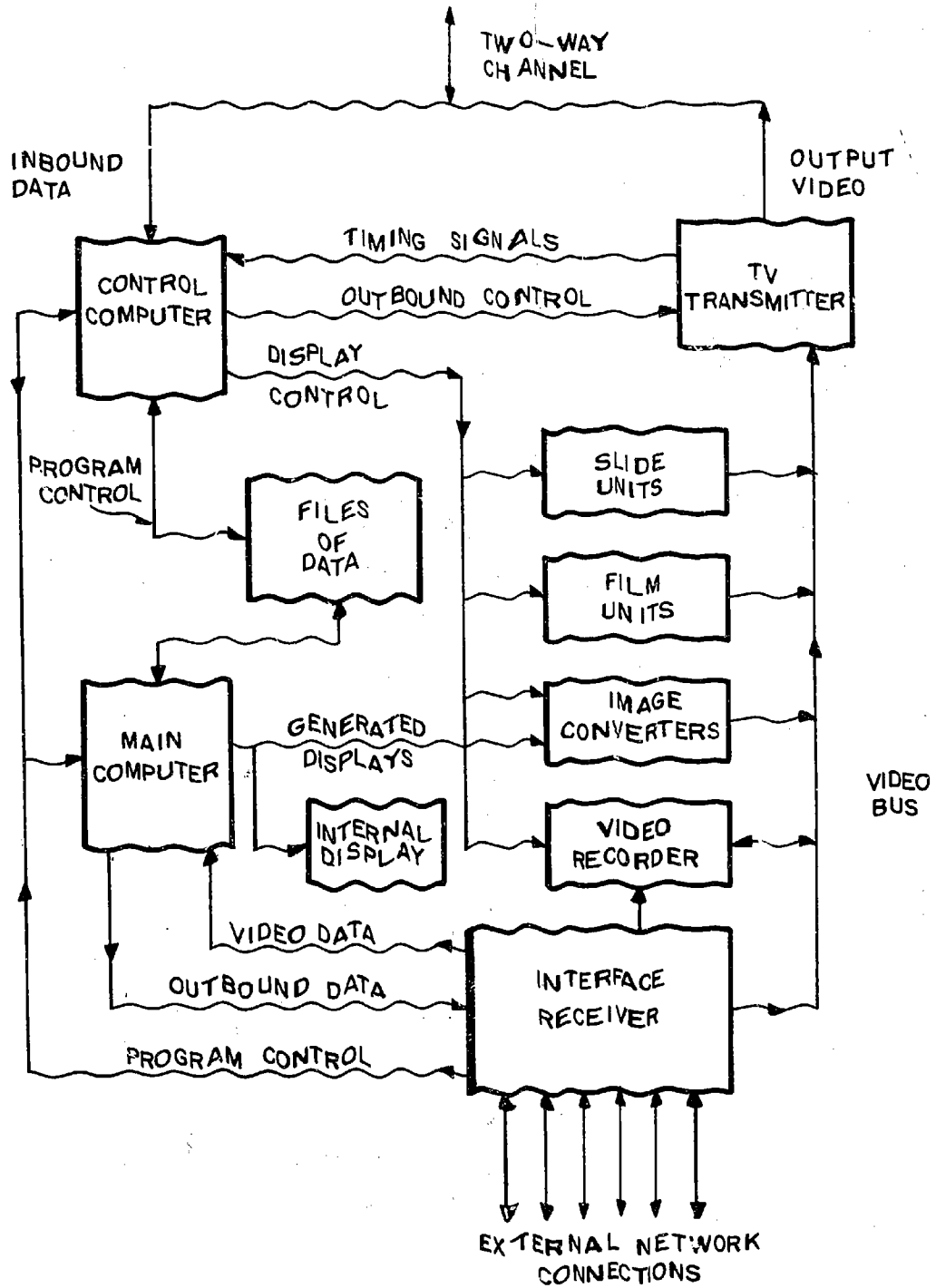

FIG. 2 DETAIL OF SYSTEM-3 CENTER

Figure 2 is a detailed diagram of the inside of a SYSTEM-3 center. As in the case with most recursive structures, its two ends (shown at the top and bottom of the figure) are identical, both being connections to a two-way channel. At the top of the page we assume a network of receivers and at the bottom of the page we assume connection to other SYSTEM-3 networks.

Starting with the T.V. transmitter, we see that the transmitter generates both the outbound video signal for the channel that the center serves, and a set of timing signals for the control computer. These timing signals are necessary in order to permit the interlace of the outbound control information with the outbound picture information and to synchronize the control of display units. By routing the outbound control signal through the T.V. transmitter, it may be handled like any of the other signals on the video bus. The other signals on the video bus derive from slide units capable of handling microfiche or other visible images, from film units for handling motion pictures and from image converters. These image converters serve to convert the graphic displays generated by the main computer to suitable rosters for transmission on the video bus. Also hung on the video bus is a video recorder which is subject to control by the output of the control computer or as a peripheral of the interface receiver.

The control computer feeds the transmitter with outbound control signals whose function is to set the state of the receivers connected to the center's channel or to poll those receivers. It also receives the poll data from the center's channel and does the computation necessary to make the decisions reflected by the outbound control signals, by the display control signals, and by the program control signals leading to the main computer.

By and large both the display control signals and the program control signals are of the same nature. The display control signals are designed to select and display items of information that are present either in the video recorder, on the image converters, in the film unit, or in the slide units. The program control signals serve to secure such information if it is not present in one of those locations. They control the program running in the main computer which then either secures the information from the data files, secures it as a result of calculation, or seeks it outside the center by means of the interface receiver. It will be noted that the data files are assumed to be shared by both the control and the main computers. In that way, incoming data from polls can be stored on the files for future use and the files can serve as an adjunct memory to the control computer.

The recursive nature of the center is secured by the interface receive. For those activities where data is to be obtained from other networks, the main computer is assumed to manipulate the interface receiver in the same way that the user of an ordinary receiver manipulates his. Outbound data is entered into the interface receiver buffer by the main computer in a fashion completely analogous to the push-button operation of that buffer by the human user. The same outbound data is used to determine which of the external networks is to serve the interface receiver - an activity closely analogous to the channel tuning performed by the human user. Incoming data on the interface receiver can be routed directly to the video bus (which replaces the picture tube). If one or more frames represent digital data for the center than display material, the external network can (through the use of the control signals between 200 and 377) route that video data to the main computer. Other control codes

in the range from 200 to 377 serve as program control inputs to the main computer and complete the center's complement of activities.

It should be noted that no difference exists in the signals required at either end of the center and hence, SYSTEM-3 centers can serve as receivers on one or more SYSTEM-3 channels. This characteristic makes it possible to nest such channels to any depth and provides for the interconnection of such channels into one or more major national networks.

We shall see in the next section that the external network connections may be to networks organized on a geographical basis or on a substantive basis. Further, the channels represented at both ends of the center may be coaxial cable, direct broadcast satellite, microwave or other video bandwidth two-way channels.

In terms of information interchange, one important feature has been neglected in the above description. The contents of a full video channel, such as a dozen programmed courses or some other admixture of information can be recorded on video tape. Such prerecordings would carry all of the time-slice addressed commands, but no station poll or other station addressed commands. In place of these commands it would carry a black segment preceded by a control code between 200 and 377. This control code would act as a program control signal to the control computer to conduct its own internal poll or to transmit the other station addressed commands during the time allowed in the black frame. Thus, information can be supplied in pre-recorded form to the SYSTEM-3 center by supplying the center with a video tape and a computer program tape that contains the branching logic for it. Thus, the video

recorder also serves to provide an intersection between the center and any other SYSTEM-3 network. Each center so equipped can accept video and program tape combinations or generate such combinations.

It should be noted that while the control computer and the main computer are shown as separate units in this diagram, it is likely that most small centers will combine the two into a single computer. We expect that only in very large centers where either a great deal of computation is being done (necessitating a separate main computer) or where many receivers are being serviced (necessitating a separate control computer) will be units be separate. Indeed, we expect that some very small centers will come into existence with many of the display elements also left out. For example, we expect that single schools will have a center consisting of an interface receiver, video recorder, small combined control and main computer, and a local T.V. transmitter. As the school grows in the use of the center, of course, one would expect the gradual addition of image converters, slide units, data files, etc. Some scientists and others may well have "centers" consisting only of a control receiver and a computer - with the manual input being to the computer.

Missing from Figure II, but of fundamental importance, is the studio and program preparation equipment. Many SYSTEM-3 centers will initiate program material as well as rebroadcasting that secured from outside. In the case of political broadcasts or live programs in which audience participation, either on an individual or a statistical basis, is important, the internal display connected to the main computer serves as the feedback to the live performers. Such feedback can be a graphical representation of viewer response, it can be a text representation of

EDUCOM

single viewer response, or it can be a quite complex video display. The same display also serves to notify the operating staff in the center when slides, films, etc. are to be changed, or when other human intervention is necessary. Needless to say, an ordinary SYSTEM-3 receiver can serve as the internal display if it is connected to the output of the T.V. transmitter rather than to the main computer. Narrowcasting makes this use of a SYSTEM-3 receiver very simple.

It should be apparent that two SYSTEM-3 centers, each equipped with live program preparation equipment and response display equipment can be interconnected to establish what becomes a geographically distributed meeting. Individuals along either SYSTEM-3 channel can also become part of such a meeting although their response can be represented only in the form of data rather than in the form of a video signal. We expect that professional and other learned societies will take advantage of this facility - particularly if center-facilities are located in some of our universities.

We anticipate that future meetings of these learned societies may well take place in comfortable meeting rooms located at such centers with small groups at various other centers. Video presentations given in one such meeting room could be augmented by audio-visual material drawn from the local video library or any other library in, or attached to, the network. They would be transmitted over the normal professional channel to all interested receivers. Such a meeting would be recorded and an immediate video proceeding would result.

There would be a marked reduction in the travel of the participants, since each would now be travelling only to his local center. Note also that any other inter-

ested centers could both observe and secure an immediate recording of the proceedings for local viewers who are interested but unable to attend at the scheduled times.

Implied by the diagram of Figure 2, but again not made specific, is the large store of rapidly accessible visible material to be used for transmission purposes. We visualize this large store to consist of films, video tapes, microfiche, slides, books and other illustrative material. The configuration, content, and extent of such a library will, however, be a matter that is highly individual to the particular SYSTEM-3 center.



## V. ACTIVITIES: WHAT MUST BE DONE

The applications that we have described, the facilities that make them possible, the financial and social rewards associated with them, and the anticipated blossoming of our information environment do not exist today. They will not exist tomorrow unless we make a national commitment that they will exist and unless that commitment is translated into a program of activities. These activities must bridge the gap between our present capabilities and those needed for the full realization of the potentials of SYSTEM-3. Broadly speaking, they can be broken down into three areas: organizational, regulatory and technological. Let us consider each in turn.

### A. Organization: With People

Commercial television became a feasible activity in this country not because of the allocation of appropriate bandwidth, not because of the development of the image orthicon, not because of the development of electromagnetic deflection, but primarily because an enormous reservoir of old motion picture films was available as program material. As a matter of fact, that reservoir gave the medium something to market in its early days without heavy production costs and the normal flow of commercial interest took over from there.

As the commercial activity grew, it became possible for public television to ride its coat tails into existence. A miniscule portion of television's annual budget is even now devoted to public television and the percentage is unlikely to approach anything representing a partnership in the foreseeable future.

In extended broadcasting, neither of those two phenomena is likely to be duplicated. No store of interactive mystery films, of participation westerns, or of responsive comedy films exists. Indeed, nowhere do we even have studios equipped to generate such material or writers trained to write it. There will be no major commercial coat tail to ride. Quite the contrary, we believe that extended broadcasting can only come into being through the concerted collaborative efforts of the public and private sectors. Indeed, Congress' charge to the corporation to establish archives and to arrange for interconnection, to conduct research demonstrations and training related to public broadcasting and to contract with program production entities could not have been better made had extended broadcasting been specifically envisioned by the framers of the bill.

It is most likely that the early development of extended broadcasting will take place via applications that do not involve what we now call television programs. Information/inquiry centers, as exemplified by the Poison Control Center, two-way files as exemplified by the central medical record, the use of SYSTEM-3 by programmers and other problem solvers, and the library network all require the orderly consolidation of information and the organization of user populations to interact with that information rather than scripts. Such professional networks as the Lister Hill Center for Biomedical Communications and the National Agricultural Library; such secondary and tertiary publishing activities as Chemical Abstracts and the Library of Congress MARC-II System represent foci for such activities. It is they who have the stored up material ready to be released by extended broadcasting. These special interest groups are, in these areas, the analog to Warner Bros., Paramount, etc.

Much of the information in such special interest groups is highly dynamic. It can't be distributed in cans or on video-tape. Such groups are establishing, even now, centers of their own. As SYSTEM-3 develops, such centers will be connected to the geographic SYSTEM-3 centers to form special interest networks. The Lister Hill Center at the National Library of Medicine, for example, might establish such a network. It would use a combination of cable, microwave, satellite and video tape to disseminate such materials as poison information, medical practice information, medical didactic information, and other bio-medical information. Because of its close ties with the profession, with the National Library of Medicine, and with the medical schools, it would be in an ideal position to collate such information and to contract for its generation and its structuring. We assume that such contracting might be jointly sponsored by the Lister Hill Center and the Corporation. Alternatively the Corporation might restrict itself and concentrate on more general materials.

Presumably, it would be uneconomical for each such special interest network to reach the individual users for whom its information is intended. It would, therefore, be the local SYSTEM-3 distribution center that would make such information available to the interested individuals in its area. We can visualize a patient hospital record network, a public-safety information network, a motor-vehicle registration network, and other similar substantive networks functioning primarily as information wholesalers. Distribution would be through the local SYSTEM-3 public broadcasting channel. In the early days, when the information to be marketed is largely of this kind, interactive but not really of a program nature, the Public Broadcasting Corporation will be needed to coordinate the activities of the special interest networks, to set

up the governing mechanisms and to ensure an appropriate division of the limited public broadcasting bandwidth in a geographic area among the many needs.

As SYSTEM-3 develops, however, there will be a greater and greater demand for the preparation of new program material specifically suited for extended broadcasting. Computer-aided instruction, interactive television programs, and the creative arts activities will all be part of this demand by Congressional directive, it falls to the Public Broadcasting Corporation to train and equip people capable of meeting that demand. Support for courses in interactive playwrighting and the maintenance of filming and editing facilities will become an important part of the Corporation's organizational task. We have no doubt that some of the special interest networks and other information wholesalers as well as some of the more forward looking commercial publishers will develop and maintain program origination capabilities. Despite this fact, the general body of such material will be difficult and expensive to produce and will require a form of national financing.

In part C of this section, we will discuss the importance of the academic community to the preparation of such material. Organizationally, it will take a major joint effort on the part of the Corporation and the Office of Education to manage the creative activity that will be required.

But software organization is just one of the Corporation's problems. If the use of SYSTEM-3 is to be economical, then the center cost per subscriber and the receiver costs must be driven down. That need calls for collaboration between the Corporation and the commercial interests.

A glance at the chart shown in Figure 11 will make it clear that very few commercial C.A.T.V. franchise holders now in business have either the capital or the personnel to incorporate SYSTEM-3 communication into their cable system. Even if they owned such a center, however, it is unlikely that they could exploit. The lack of appropriate program material and the lack of appropriate direct marketing material on a local basis makes such exploitation impossible.

We believe that organizations analogous to the Public Broadcasting Corporation will come into being in the private sector. Broader in scope than the now existing program distribution networks, we believe that these organizations will provide the nucleus for the commercial exploitation of extended broadcasting. They may rent centers or supply them on a franchise basis, they will distribute SYSTEM-3 program material, both with and without associated interactive sales segments, they will provide centrally coordinated credit banking, and they will perform the commercial equivalent of the organizational functions of the Public Broadcasting Corporation. The financial return to such a commercial organization will take place not only through normal advertising revenue, but through direct participation in the commercial sales made in association with their material. This latter will also, we believe, be the major source of revenue to the local SYSTEM-3 operator, although his cable interconnection and operation fees may in fact continue.

Because no similar source of revenue exists for the Public Broadcasting Corporation, and because we do not believe that one can come into existence without the other, we strongly believe that either the Public Broadcasting Corporation or some other non-profit entity committed to extended broadcasting should participate in the establish-

ment of the commercial corporations that will serve extended broadcasting. Such an equity participation from the start will provide the capital base and the ongoing income to insure that the strength of public broadcasting remains proportional to that of commercial broadcasting. Such a partnership activity could be a particularly healthy one considering the impact that SYSTEM-3 communication will have on the community as a whole. Having established such a joint relationship, we believe that the natural melding of public and private interest will lead to a rapid development of the technical and regulatory actions required to bring SYSTEM-3 communications about.

#### **B. Regulation: With Government**

The primary regulatory problems facing the development of extended broadcasting lie with the Federal Communication Commission. Neither fish nor fowl, neither common carrier nor broadcasting, SYSTEM-3 communication must challenge both and demands either the establishment of a new bureau or a new agency. Because SYSTEM-3 does not provide point to point communication in the sense of a common carrier, and because it does not provide broadcast communication in the sense of a broadcaster, the FCC must recognize that the development of SYSTEM-3 does not challenge the present markets of either of those, although it certainly challenges what both would like to visualize as a future market. We cannot restrict the development of SYSTEM-3 communication in order to preserve some future hypothetical market for existing interests.

Specifically, we believe that the Federal Communications Commission must maintain its jurisdiction over community cable systems, must reserve a significant portion of each such systems for public use, and must permit - nay foster -

experimentation in the two-way use of such cable systems. Such experimentation can initially be carried on entirely in the education area. While these experiments do not require the use of community cables, without the commitment of the FCC, there is no assurance that their successful completion will see permission for SYSTEM-3 cable use. We feel that the early educational experiments should grow into other public experiments, in the information/inquiry area, in library use, etc. and that general experiments should follow as rapidly as early successes allow. These initial experiments will not only provide for software experimentation but for working out many of the technical and communication problems involved. It is imperative that, at an early stage, the FCC recognize that for SYSTEM-3 communication to be viable and to have the impact that it should on our society, two-way microwave or wire interconnection of community cables is essential. Only by such interconnection can any kind of major information/inquiry and distribution activity be carried on economically. The real-time interconnection will be largely used for transferring data rather than program material. The program material generally of interest to extended broadcasting will largely be prerecorded since only that kind can take on the complexity required by user interaction. As a result, any interconnection system will be paralleled by a tape distribution system for more general program material.

In addition to the Federal Communication Commission it is most likely that either the Department of Commerce, the Federal Banking Commission or some other federal agency will be vitally concerned with the credit control necessary for the smooth operation of the commercial aspects of extended broadcasting. As early plans develop in joint public and commercial areas, Congressional activity will be required to define the regulatory jurisdiction over

this realm of extended broadcasting activity.

### C. Technical: With Things

To the organizational and regulatory activities that are prerequisite to the establishment of SYSTEM-3, we must add a group of technical developments. It is almost certain that the burden of sponsoring these development activities will fall heavily to the Public Broadcasting Corporation either in collaboration with such agencies as the United States Office of Education or in collaboration with commercial broadcasting interests.

One such required development is the SYSTEM-3 receiver. Incorporating a fair degree of logical hardware as well as the other features described in Section IV, the receiver development will require the collaboration of people skilled both in digital logic and television communication. Corporations such as RCA, Westinghouse and others, as well as many of our engineering schools, are logical sites for such development activity. Whether the early receivers actually incorporate any large scale integrated circuitry, or whether they are simply designed with the eventual use of such circuitry in mind, is relatively unimportant. The first few thousand prototypes will be expensive in any case and will require subsidy, probably from both the commercial and public sector.

A far more complex development program is involved in the development of the SYSTEM-3 center, although that development program is much more amenable to a gradual phased approach than is the receiver development. The basic SYSTEM-3 center will consist of a computer, random access data files, a small set of image converters, and a television transmitter. The single, small computer will be used both for polling and for file manipulation while the



image converters will handle the display for video transmission. Such a center will be capable of providing restricted services in information inquiry, library distribution, two-way files, problem-solving, or the creative arts.

In the early experimental stages, such a center can be established in association an ETV station, an academic computer group and a community cable. The center will serve as a test-bed for solving the basic problems of synchronizing the transmitter time signals with the computer control, of integrating the display control and the transmission, and all of the problems of polling and controlling the receiver/terminals. Once these basic problems have been solved, slide units and film units can be added. These will require the same kind of frame by frame mixing equipment now used by T.V. stations, as well as synchronized flying spot scanners and multiple single-sideband audio playbacks. Here the problem will be to cope with the growing saturation of the control computer and to synchronize the various elements of the video transmission system.

With the advent of image manipulation equipment, bibliographic problems will arise. It will be necessary to use sophisticated bibliographic management techniques to manage the center's library and to mesh in an interactive environment. It is they who will form the authorship nucleus for SYSTEM-3 program material. We expect that not only will didactic material flow from this community, but that their close association with interactive environments and their close involvement with the development of interactive systems will make the educational community a logical source for much of the entertainment material in the early days of extended broadcasting.

It will also fall to the community of educators to evaluate the impact of such programming on the users. Is learning enhanced? Do need arousal and involvement occur? Can achievement be measured? All of these are questions that the educational community must answer both for itself and for public broadcasting as a whole. More esoteric questions, such as the sociological impact of polling as part of the political process, and the economic effects of this new marketing channel will also fall to the scholars in the educational community. We believe that this community of educators, and particularly those in higher education, will be central to the development of SYSTEM-3 and extended broadcasting.

In addition to the substantive software development program, a major system software development program faces the Corporation. The complex real-time control operation represented by a SYSTEM-3 center is no more complex than many now handled by digital computers. It nonetheless represents a sizable software development activity. Polling, inquiry handling, the management of controllers, and of terminals, the synchronization of display units, and interaction with the interface receiver represent a modestly complex process control problem.

In addition to the control programming, there is another set of system programs that require development. For a playwright or other substantive program author to work efficiently, he needs a set of information management programs that will allow him to manipulate his files, his script and display the topology of his scenario as he works on it. The development of good scenarios is going to require all of the discursive skills of the author and all of the spatial skills of the sculptor. The individual or team tackling such a problem will require all of the technical augmentation it can muster. The development of

system programs to provide such technical augmentation will be an early task of SYSTEM-3 development.

While the foregoing developments are extensive, they need not be frightening. No major breakthroughs are required in order to bring about even an advanced stage of SYSTEM-3 communication, and extended broadcasting can begin after only a very few initial achievements .

#### D. EDUCOM: An Existing Resource

Because of its commitment to information and communication technology in higher education, EDUCOM would like to work with the Corporation for Public Broadcasting on the development of SYSTEM-3. We recognize that the Corporation's commitments to public broadcasting range over an enormous spectrum, and that the development of SYSTEM-3 can only occupy a small part of its attention. EDUCOM, on the other hand, has the organizational structure that will permit it to involve a wide range of members of the higher education community, to call upon a wide range of technical and organizational disciplines, and to coordinate the initial development activities required.

Using our staff and others drawn from the academic community, we would like to consider, with the corporation, a program involving the development of several hundred prototype receivers, two basic SYSTEM-3 centers, and the supporting software necessary to permit a set of extended broadcasting activities. These experiments would be conducted using a combination of existing ETV facilities, auxiliary computer equipment, a private cable, and allocated space on a community television cable. We would aim at target populations of both students and community members.

From the earliest stages, EDUCOM would propose to involve the information and communication industry and the regulatory agencies in this activity. Our experiences to date with both segments indicate that such early involvement can prevent the polarization that has frequently interfered with developments in the past.

The program would require three to five years before an operating SYSTEM-3 local network would be ready for evaluation. During that time, however, many of the basic technical, regulatory and organizational problems should have been solved and extended broadcasting should be ready for a period of growth. Such a program will cost the order of six million dollars over a five-year period including cable charges, equipment costs and personnel costs. We would expect this money to come half from government or the Corporation and half from the information/communication industry.