

DOCUMENT RESUME

ED 057 069

24

TM 000 699

AUTHOR Scheuerer, Daniel T.; And Others
 TITLE The Placement of Students in Viable Learning Situations Through the Use of Achievement Tests and Systems Engineering Rather than Through Annual Promotion and Retention. Volume II of II. Final Report.

INSTITUTION Melbourne High School, Fla.
 SPONS AGENCY Office of Education (DHEW), Washington, D.C.
 BUREAU NO BR-6-1568
 PUB DATE Jun 70
 CONTRACT OEC-2-6-061568-0982
 NOTE 313p.
 AVAILABLE FROM Materials copyrighted by BSCS available from Biological Sciences Curriculum Study, University of Colorado, P.O. Box 930, Boulder, Colorado 80302; Those from ETS, Test Development, Educational Testing Service, Princeton, N.J. 08540

EDRS PRICE MF-\$0.65 HC Not Available from EDRS.
 DESCRIPTORS *Achievement Tests; Administrator Role; American History; Biology; Educational Objectives; English; High School Curriculum; Learning Experience; Learning Processes; Management Systems; Mathematical Concepts; Models; Multiple Choice Tests; *Nongraded System; Norms; Program Evaluation; *Secondary Schools; *Student Placement; Student Promotion; *Summative Evaluation; Systems Approach; Tests

IDENTIFIERS Brevard County; Florida; *Melbourne High School

ABSTRACT This document, the second of two volumes of a final report on a nongraded, phased, secondary school, presents the achievement instruments specifically developed for the operations research undertaken in that project. An intent of the project was to establish an acceptable procedure for developing instrumentation to support student placement and movement through a nongraded system. The instruments themselves should be considered placement measures not specific achievement measures. The tests developed were intended for use only in the school investigated in this report, and were normed on the population of that school. Attempts to apply them in other educational situations may be both misleading and unreliable. See also TM 000 698. (CK)

ED057069

PA 24

THE PLACEMENT OF STUDENTS
IN VIABLE LEARNING SITUATIONS
THROUGH THE USE OF
ACHIEVEMENT TESTS AND SYSTEMS ENGINEERING
RATHER THAN THROUGH
ANNUAL PROMOTION AND RETENTION

COOPERATIVE RESEARCH PROJECT #6-1568

GRANT/CONTRACT #OEC-2-6-061568-0982

The Brevard County (Florida) School System

June, 1970

U.S. DEPARTMENT OF HEALTH,
EDUCATION & WELFARE
OFFICE OF EDUCATION
THIS DOCUMENT HAS BEEN REPRO-
DUCED EXACTLY AS RECEIVED FROM
THE PERSON OR ORGANIZATION ORIG-
INATING IT. POINTS OF VIEW OR OPIN-
IONS STATED DO NOT NECESSARILY
REPRESENT OFFICIAL OFFICE OF EDU-
CATION POSITION OR POLICY

The research reported herein was supported by the Cooperative
Research Program of the Office of Education, U. S. Department
of Health, Education, and Welfare.

VOLUME II OF II

PLACEMENT MODELS AND INSTRUMENTATIONS

PERMISSION TO REPRODUCE THIS COPY
RIGHTED MATERIAL BY MICROFICHE ONLY
HAS BEEN GRANTED BY

BSCS

TO ERIC AND ORGANIZATIONS OPERATING
UNDER AGREEMENTS WITH THE U.S. OFFICE
OF EDUCATION. FURTHER REPRODUCTION
OUTSIDE THE ERIC SYSTEM REQUIRES PER-
MISSION OF THE COPYRIGHT OWNER.

TM 000 699

ERIC

ERIC
Full Text Provided by ERIC

FINAL REPORT

Project Number G-1568

Contract Number OHC-2-6-061568-0082

THE PLACEMENT OF STUDENTS IN VIABLE LEARNING SITUATIONS
THROUGH THE USE OF ACHIEVEMENT TESTS AND SYSTEMS ENGINEERING
RATHER THAN THROUGH ANNUAL PROMOTION AND RETENTION

Daniel T. Scheuerer

with the assistance of

Dr. B. Frank Brown
Richard L. Gillespie
James L. Scogggs
Kenneth D. Jenkins
Robert A. Mennella
Donald A. Treisman
Thomas S. Barrows
Dr. Bertram Spector

June, 1970

VOLUME II

PLACEMENT MODELS AND INSTRUMENTATION

The research reported herein was performed pursuant to a contract with the Office of Education, U. S. Department of Health, Education, and Welfare. Contractors undertaking such projects under Government sponsorship are encouraged to express freely their professional judgment in the conduct of the project. Points of view or opinions stated do not, therefore, necessarily represent official Office of Education position or policy.

U. S. DEPARTMENT OF
HEALTH, EDUCATION, AND WELFAREOffice of Education
Bureau of Research

PLACEMENT MODELS
AND
INSTRUMENTATION

Introduction

This is the second of two volumes prepared as components of the final report on USOE Cooperative Research Project 6-1568. Volume I set forth the scope of the project and described various models which may be used to support the development of a nongraded, phased, secondary school. Volume II was designed to display the measuring instruments developed specifically as a part of the operations research undertaken in the above project.

At the outset, several points should be emphasized to prevent misunderstanding and/or misinterpretation.

1. The instruments developed for the above projects and displayed in this volume were intended for use in a single school and were normed on the population of that school. Any attempt to apply them in other educational situations may be both misleading and unreliable.

The purpose for the project, insofar as the instruments displayed in this volume are concerned, was to establish an acceptable procedure for developing instrumentation to support student placement and/or movement through a nongraded system. The instruments themselves should be considered as placement measures, not measures of achievement of specific skills.

2. The objectives set forth in Volume I are not keyed to the instrumentation shown in Volume II of this report. Instrumentation

developed will reflect certain of these objectives, but was, of necessity, designed before these objectives were fully developed. It was assumed that a commonality existed between the two components. This assumption was consensually validated by review of the instruments by teaching personnel. In cases where such validation could not be obtained, tests were modified or dropped. A prime example of this was found in the American History courses/phases. Since commonality of objectives was absent, no consensual validation by teaching personnel could be obtained. Instrumentation was therefore impossible to develop/select which could be validated by teacher consensus. This area was consequently dropped from the testing segment of the project.

In order for this volume to serve as a separate unit if so desired, the information set forth in Chapter III of Volume I is repeated herein.

The contents of this, Volume II, were substantially prepared by Donald A. Gillman and Thomas S. Barrows of Educational Testing Services, Princeton, N. J. Their sincere efforts to provide the best possible support is greatly appreciated.

TABLE OF CONTENTS

	<u>Page</u>
Melbourne High School	1
Purpose of the Project	2
Phase Placement Models	3
Progress Test Development	6
Progress Tests	8
Math Concepts, Phase 2	8
Biology I, Phases 2-4	10
English, Phases 2-4	13
American History, Phases 3 and 4	19
Item Analyses	21
End-of-Course Tests	21
Score Reports and Local Norms	22
Suggested Phase Placements	23
Effectiveness of Phase Placements	35
Summary and Recommendations for Further Research	45
Administrative Control Elements	48

APPENDICES:

- A. Test Booklets
- B. Proposed Student Profile

LIST OF FIGURES

<u>Figure</u>		<u>Page</u>
3-1	Phase Placement, Parallel Regression Lines	3
3-2	Phase Placement, Crossing Regression Lines	4
3-3	Phase Placement, Non-parallel, Non-crossing Regression Lines	4
3-4	Phase Placement Form	27
3-5	Phase Shift Frequencies for 1967-1968 and 1968-1969 - Biology I	37
3-6	Phase Shift Frequencies for 1967-1968 and 1968-1969 - English	38
3-7	Phase Shift Frequencies for 1967-1968 and 1968-1969 - American History	39
3-8	Phase Shift Frequencies for 1968-1969 - Mathematical Concepts	40
3-9	Phase Shift Frequencies for 1967-1968 and 1968-1969 - Combined Across Course and Initiator	41

LIST OF TABLES

<u>Table</u>	<u>Page</u>
3-1	Mathematics Progress Test Characteristics 9
3-2	Biology Progress Test Characteristics 12
3-3	Revised Biology Progress Test Characteristics 13
3-4	English Progress Test Formats 16
3-5	English Progress Test Characteristics, by Part 17
3-6	English Progress Test Characteristics, by Section 18
3-7	American History Progress Test Characteristics 20
3-8	American History Progress Test Means and Standard Deviations--Melbourne Population 21
3-9	End-of-Course Test Characteristics 22
3-10	Reduced Predictor Batteries: Discriminant Function Coefficients and Multivariate F Ratios for Males 32
3-11	Reduced Predictor Batteries: Discriminant Function Coefficients and Multivariate F Ratios for Females 33
3-12	Multiple Regression Reduced Predictor Batteries: Zero Order and Multiple Correlation Coefficients for Males 34
3-13	Multiple Regression Reduced Predictor Batteries: Zero Order and Multiple Correlation Coefficients for Females 34
3-14	Fall 1968 Registration Percentages 44

PHASE PLACEMENT RECOMMENDATIONS

In order for the nongraded, multiphased system to work efficiently, accurate phase placement recommendations were needed. The development of specialized achievement tests to be used in conjunction with other measures for initial placement and/or as a part of an information collection and feedback system at intermediate points during the school year was an important part of this project.

This chapter describes the section of the project carried out by Educational Testing Service (ETS) for the Brevard County, Florida, Public School System (Brevard). The work was accomplished during the period September 1966 through February 1970. While initial plans for the project included all of Brevard's high schools, the majority of the work was carried out in cooperation with only one, Melbourne High School, and the four junior high schools which send their graduates to it - Central, Herbert Hoover, Southwest, and Stone. This reduction in project scope was made at the request of Brevard project direction staff, and was necessitated by the fact that Brevard County high schools differed widely with respect to curricula and methods for placing students within curricula.

Melbourne High School

Melbourne High School has a student population of approximately two thousand students who would normally be considered 10th, 11th, and 12th graders. Melbourne is, however, "nongraded" and "multi-phased."²

2

For a more detailed description, see Brown, B. Frank, The Appropriate Placement School: A Sophisticated Nongraded Curriculum. West Nyack, N.Y.: Parker Publishing Company, Inc., 1965.

Each Melbourne course is offered in one or more (up to five) optional versions, or 'phases.' These phases may differ with respect to content, materials, rate of curriculum coverage, depth of coverage, and/or achievement levels of the students enrolled in them. (Phase 5 is most advanced, Phase 1 least advanced.) Students are allowed to select that phase of a course which they feel is most appropriate to their background, ability, interests, academic motivation, or other characteristics. Phase placement recommendations, based on prior achievement, are furnished to students at the time of Fall registration. However, freedom to select phases other than those recommended and to change phase at any time during the school year is a critical feature of the Melbourne system. This freedom is constrained only by the prohibition of underphasing oneself into remedial work or by logistic factors such as filled class sections.

Purpose of the Project

The Melbourne phasing system allows each student considerable freedom of choice, and as a consequence places upon him more than the usual burden of responsibility for making wise decisions. Acting upon the premise that the informed choice is most apt to be the best choice, the purpose of this project was to furnish to students and staff information relevant to the decisions of phase choice. Two separate but related elements were the focus of this effort: (a) the initial placement of students into phases at the time of Fall registration and (b) the development of a system of information collection and feedback at intermediate points throughout the school year. Only the combination of these two approaches could the flexibility of the Melbourne system be capitalized upon to the fullest extent.

It should be made clear that this project was not an evaluation study. It was not intended to produce data relevant to questions of the worth or effectiveness of ungraded schools or course phasing. Rather it took as its starting point the structure and function of Melbourne High School, and attempted to develop procedures for the improvement and facilitation of this structure and function. There was no attempt to control any aspect of the school environment, and in fact every effort was made to interfere as little as possible with the normal operation of the school. The project was conceived and carried out in the spirit of operations research, rather than experimental investigation.

Phase Placement Models

Three different procedures for placing students in appropriate phases were considered. The first, and perhaps most obvious, might be called the maximized payoff model. It requires, very simply, that each student be placed in that phase for which his predicted criterion score is highest. To develop this model requires a criterion common across all the phase options within a course, one or more predictors of this criterion, and separate within-phase prediction equations. Three possible results of such an analysis are shown in Figures 3-1 - 3 below.

Figure 3-1 - Phase Placement,
Parallel Regression Lines

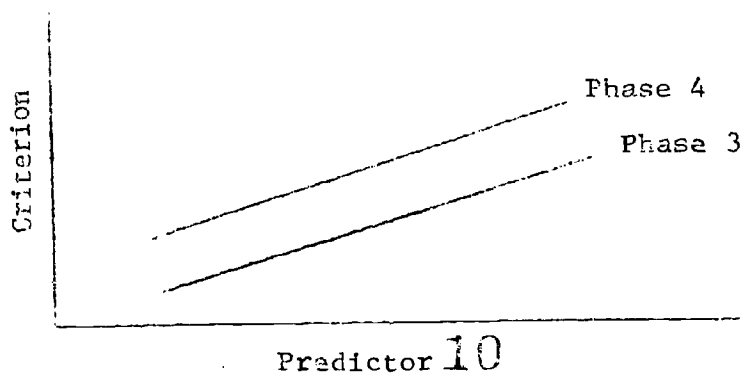

Figure 3-2 - Phase Placement,
Crossing Regression Lines

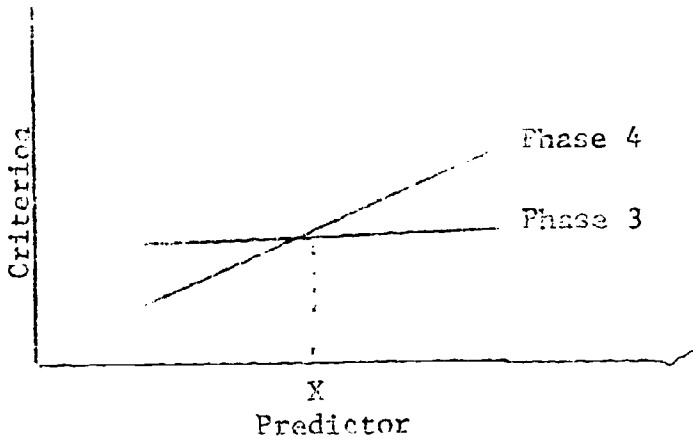

Figure 3-3 - Phase Placement, Non-Crossing,
Non-Crossing Regression Lines

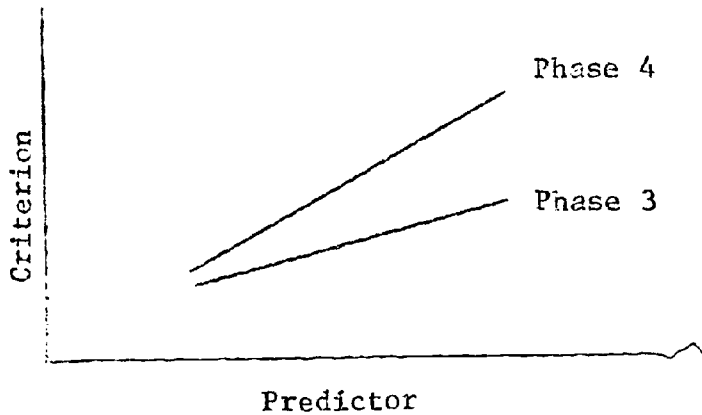

Figure 3-1 shows the situation in which, no matter what the value of the predictor, phase 4 always results in better achievement than phase 3. Such a result suggests discontinuation of the less effective phase and assignment of all students to the more effective phase. Figure 3-2 shows that phase 4 is more effective only for those students whose predictor score exceeds some cutoff, "X." Here the placement decision would be to assign all students with placement scores below "X" to phase 3, and all those above "X" to phase 4. Figure 3-3 shows a situation in

which the lines are clearly not parallel, but a single phase is superior for all students for whom data are available. In this case, the placement decision would be the same as that indicated by Figure 3-1.

A second placement model to receive consideration might be called the group membership model. It assumes that the present student constitution of phase groups is meaningful, and that the placement problem is simply one of continuing to form phase groups "like these." This model does not depend upon the prediction of course achievement, and therefore does not require any end-of-course criterion measure. As does the maximized payoff model, it requires one or more predictor variables. In the group membership model, however, the function of these variables is to predict phase membership rather than course achievement. The group membership model was worthy of consideration, especially in the Melbourne High School situation, for two reasons. First, students were already being placed in homogeneous phase groups through a rational, even if somewhat informal, procedure and it is widely believed that homogeneous groups can be taught more effectively. Second, and perhaps more important, the freedom to select and shift phases allowed a corrective mechanism to operate on initial phase placements throughout the school year. By using phase membership at the end of the school year to develop placement equations, it was possible to incorporate in the group membership model some of the experience and wisdom that individual students and staff members normally gained during the year, and to provide registration recommendations based on this experience and wisdom.

The third phase placement model to be considered was one which combined features of each of the two previously mentioned. There were

certain difficulties in applying each of the first two models which suggested the approach of combining aspects of both. For example, the maximized payoff model required the development of within-phase equations, but the homogeneity of existing phase groups, a result of the prior Melbourne phase placement procedures, made within-phase prediction extremely poor. However, the predictor-criterion relationships obtained using data from all phases of a course were sufficiently high to be of use. The group membership model had the disadvantage of assigning a student to a group whose members he was most like, even if his predicted achievement varied substantially from that of the group. Therefore a combined model was developed which first assigned students on the basis of group membership, but allowed modification of this initial placement if the student's predicted achievement varied markedly from the group average. A more detailed description of this model is given in the section of this report on Suggested Phase Placements.

Both the group membership and combined group membership/maximized payoff models were used in this project. In addition, as a service to Melbourne High School, phase placements based on their previous procedure were developed. A complete description of which models were applied to the various courses appears in the section on Suggested Phase Placements.

Progress Test Development

A prime requirement of a system of information feedback throughout the school year was recognized to be a set of achievement measures custom-made for the particular content of those Melbourne courses selected for study. It was necessary that these measures (hereafter called "progress tests") be appropriate across all phases (or at least as many as possible)

of each course studied, in order that the resulting score scale be comparable across phases. Thus a student could interpret his score relative not only to his current phase membership, but also with respect to standards of achievement in phases to which he might consider shifting.

In March of 1967, four concurrent two-day workshops were held in Brevard County for the purpose of analyzing courses in four major subject matter areas - English, Mathematics, Science, and Social Studies. Participating in these workshops were approximately fifty representatives of three Brevard County high schools (Melbourne, Cocoa Beach, and Satellite), and an ETS test development specialist in each of the areas. The objectives of these workshops were to select a group of courses for which progress tests would be developed and to analyze the chosen courses in terms of required student behaviors and desired course outcomes.

For two days prior to the workshops, the ETS personnel visited classes in each of the three high schools in each of the four subject areas. These visits were primarily to estimate from first hand observation the ability and achievement levels of students in the various phases. This was necessary in order that the progress tests to be developed be appropriate with respect to difficulty as well as content.

As a result of the workshop discussions, the following courses were selected:

1. English (phases 2, 3, and 4)
2. Biology I (phases 2, 3, and 4)
3. American History (phases 3 and 4)
4. Mathematical Concepts (phases 1 and 2)

Although other phases were offered in certain of these courses, the phases

listed above were those whose content could be appropriately covered by tests developed within the constraints of project resources.

The scope of English curriculum content spanned by phases 2, 3, and 4 proved to be too broad for adequate treatment during the two-day workshop. Therefore, a second two-day session was held in April 1967. In addition, Melbourne Biology staff and the ETS test development specialist met during the Summer of 1967 for a final review of proposed Biology test items.

Progress Tests

One of the objectives of the workshops was the identification and description of course content in terms sufficiently specific to allow the construction of custom made achievement tests. These tests were intended to assess course achievement at each of four intermediate points during the school year. Since circumstances dictated a somewhat different approach in each of the four chosen subject areas, each will be treated separately.

Math Concepts, Phase 2 "This course is designed to allow the student to attain a working knowledge of the basic mathematical operations applied to whole numbers, fractions, decimals, percents, ratio, and proportion."³ It was decided to develop a series of four 50 item, 40 minute progress tests, to be administered at approximately equal intervals throughout the school year.⁴ The four tests covered, respectively, the

³ Scheuerer, Daniel T. (Ed.), Melbourne High School Curriculum Profile, 1968-1969, p. 12.

⁴ Test booklets are contained in Volume II of this report.

following topics:

- I - Whole Numbers
- II - Fractions
- III - Decimals and Percent
- IV - Measurement, Denominate Numbers, and Geometry

Following the first administration of these tests during the 1967-1968 school year, each was subjected to an analysis to determine the characteristics of its constituent items and of the test as a whole. Each analysis was based on all available cases, reduced by random sampling to a total N equal to the highest possible multiple of five. Statistics were obtained describing test reliability, error of measurement, difficulty, speededness, and item discrimination. These statistics are given in Table 3-1 below.

Table 3-1 - Mathematics Progress Test Characteristics

Test	N	N of Items	Mean	S.D.	Rel. (KR20)	S.E. Meas.	% Comp. ¹	% Comp. 75% ²	Mean Δ ³	Mean r bis
I (#30)	160	50	32.9	8.7	.89	2.3	79	98	11.1	.53
II (#31)	155	50	22.8	8.4	.86	3.1	86	98	13.4	.43
III (#32)	145	50	19.9	7.0	.81	3.1	88	96	14.1	.38
IV (#33)	160	50	13.8	4.4	.53	3.0	69	86	15.4	.22

¹The percent of examinees completing the entire test

²The percent of examinees completing 75% of the test items

³Mean delta is an index of test difficulty. Delta is defined as the normal deviate, expressed in terms of a scale with a mean of 13 and a standard deviation of 4, which corresponds to the proportion of candidates reaching the item who answers it correctly. A low delta describes an easy item; a high delta, a difficult one. For 4-choice items (all progress tests developed for Melbourne were made up of 4-choice items), a test of middle difficulty would have a mean delta of approximately 11.7.

Inspection of Table 3-1 shows that, during the 1967-1968 school year, the Mathematics progress tests became progressively more difficult for the examinees who took them. This suggests that less class time was spent on the topics covered by the later tests, even though these topics

were stated as course objectives by Melbourne Mathematics faculty at the workshops. The progressively decreasing reliabilities may indicate that the later tests are dealing with content which is unfamiliar to the examinees, or may simply be a result of the decreasing variability of the sample. Still another explanation is that the later tests are actually more heterogeneous in content.

Biology I, Phases 2-4. "Basic-phased (phase 3) Biology is based on special materials entitled Patterns and Processes adopted by the BSCS for students who may have difficulty with reading, language, and mathematics. These special materials are made up of units (ecology, evolution, cell energy processes, reproduction, genetics, and man and his environment) prepared in those areas of biology which seem most difficult."⁵

"This BSCS (Blue Version) course (phases 3 and 4) is designed for those students with average abilities in science. It is an approach in which evolutionary aspects of biology are interpreted in the light of recent advances in genetics and physiology."⁶

The above descriptions highlight a basic problem in the construction of the Biology progress tests. The differences in course objectives, content, and materials across phases are sufficiently great to preclude the development of a single test maximally appropriate to all phases. This problem was solved in the following way. For each of the first two Biology progress test administrations, three tests were developed. Of

⁵ Scheuerer, Daniel T. (Ed.), op. cit., p. 5.

⁶ Ibid.

these, one was custom made for the phase 2 course, and a second for phases 3 and 4. These tests provided scores which were maximally appropriate for determining achievement within phase. The third test was based on content common to all three phases. It therefore yielded scores which were comparable across all phases. These scores, together with the local norms based on them could be used by students and staff in making decisions regarding shifts between phases 2 and 3.

It was decided at the workshops by Melbourne Biology faculty that it would be more useful to schedule all progress test administrations during the first semester. In particular, it was felt that information relevant to comparative standing across phases would be most appropriately early in the first semester. Therefore, only two progress tests were developed for each of the third and fourth administrations - one custom made for phase 2, and the other for phases 3 and 4.

Analyses were performed on the data from the 1967-1968 administrations. Table 3-2 shows the characteristics of the entire set of ten 40 minute tests.⁷ It should be noted that the test used in the fourth administration for phase 2 was not specially developed for this project, since an existing instrument (Biological Science: Patterns and Processes, Achievement Test 4, published by the Psychological Corporation) was judged to be suitable. The tests custom made for phases 3 and 4 were in part constructed from item collections published by the Biological Sciences Curriculum Study and were used with the permission of that organization.

7

Test booklets are contained in Volume II.

Table 3-2 - Biology Progress Test Characteristics

Test	Phase	N	N of Items	Mean	S.D.	Rel. (KR20)	S.E. Meas.	% Comp.	% Comp. 75%	Mean Δ	Mean r bis
I (#22)	2	110	30	14.6	6.0	.84	2.4	88	96	13.2	.48
I (#23)	3,4	475	30	17.0	5.0	.73	2.3	99	100	12.2	.48
I (#21)	2-4	535	30	19.4	4.6	.76	2.3	99	100	11.3	.50
II (#25)	2	100	30	16.5	5.0	.78	2.4	100	100	12.4	.45
II (#26)	3,4	455	30	15.1	4.5	.69	2.5	99	100	13.0	.59
II (#24)	2-4	575	30	18.0	4.9	.78	2.3	99	99	11.8	.51
III (#27)	2	95	30	12.5	4.0	.64	2.4	100	100	13.9	.46
III (#28)	3,4	440	30	12.1	4.9	.75	2.5	96	99	14.1	.42
IV (20)	2*	81	50	22.2	6.4	.82**	3.1**	--	--	--	--
IV (#29)	3,4	445	30	16.2	4.7	.73	2.5	99	99	12.6	.43

*

Biological Science: Patterns and Processes, Achievement Test 4

**

Reliability and standard error of measurement reported by publisher, based on a sample of 740 cases, drawn from students in grades 9 through 12. This test was not item analyzed by ETS.

Melbourne faculty comments on all progress tests were obtained by questionnaire. Biology teachers indicated that most students had completed the progress tests in less than the allotted forty minutes, and this was confirmed by the item analysis data (see the % Completed column in Table 3-2). It was judged that each test could be lengthened and still retain the desired characteristic of unspeededness. Therefore, revised forms of all Biology tests (except Test IV, phase 2) were developed, consisting of the 1967-1968 form plus an additional ten items appearing in the number 31-40 positions. Table 3-3 shows the characteristic of these revised forms, which were administered during the 1968-1969 school year.

Table 3-3 - Revised Biology Progress Test Characteristics

Test	Phase	N	N of Items	Mean	S.D.	Rel. (KR20) Coeff.	S.E. Mean	% Comp.	% Comp. 75%	Mean	Mean r bis
I (#72)	2	105	40	21.2	5.9	.78	2.8	97	100	12.7	.41
I (#73)	3,4	525	40	22.8	6.3	.82	2.7	97	100	12.1	.46
I (#71)	2-4	675	40	25.4	6.2	.82	2.7	98	100	11.4	.48
II (#75)	2	110	40	21.9	6.4	.81	2.8	98	100	12.5	.44
II (#76)	3,4	550	40	20.8	6.0	.77	2.9	97	99	12.8	.40
II (#74)	2-4	690	40	24.1	6.5	.84	2.6	98	100	11.8	.50
III (#77)	2	110	40	15.6	5.6	.74	2.8	97	98	14.3	.33
III (#78)	3,4	530	40	14.8	5.1	.69	2.8	94	99	14.5	.33
IV (#79)	3,4	510	40	21.4	5.8	.77	2.8	94	99	12.6	.40

Comparison of Tables 3-2 and 3-3 shows that the revised tests had higher reliabilities, with the exception of Test I (phase 2) and Test III (phases 3 and 4). In the case of each exception, the lower reliability may be a result of greater sample homogeneity (standard deviations for 1968-1969 scores based on the first 30 items were 4.5 for Test I (phase 2) and 4.0 for Test III (phases 3 and 4)). The addition of ten items did not substantially affect test difficulty, but the mean item r_{bis} was reduced in several instances, indicating that some of the added items were measuring new dimensions of biology. The speededness indices were not markedly affected by the revisions, and the tests remained virtually unspeeded.

English, Phases 2-4. "Phase 2 Communication Skills concentrates on individual improvement in basic reading and communication skills. Students are guided toward vocabulary enrichment, expanded comprehension, and increased reading speed, although improved written and oral expression may naturally arise from improved reading ability."⁸

8

Scheuerer, Daniel T. (Ed.), op. cit., pp. 18-19.

"Phase 3 English is designed to develop and improve the student's English skills in language, written and oral composition, listening, reading, and literature interpretation."

"Designed for the competent student, Phase 4 English focuses on important aspects of the American character as they are revealed in our literature.... Students will also explore the structure and nature of the English language and methods of clear oral and written expressions."¹⁰

The English and Biology areas shared a common problem. Differences across phases were too great to allow a single progress test appropriate to all phases. Unlike Biology, however, a somewhat different solution to this problem was adopted for English. Four progress tests unique to each phase were developed, to be administered at approximately equal intervals throughout the school year. However, there was sufficient similarity among phases to allow a common core of items within tests for adjacent phases. Each test thus could be subscored to yield a score which was common also to the test for the adjacent phase. Two such subscores could be obtained for the phase 3 test - one in common with phase 2 and another with phase 4. These subscores were used as criterion data in the development of phase placement recommendations, to be described in a later section of this report. Because of their relatively small number of items, these subscores had reliabilities which were considered too low for individual score reporting.

The English tests were constructed in several separately paced sections, corresponding to bodies of subject content of major importance,

⁹
Ibid.

¹⁰
Ibid.

as identified at the workshops. Since many of these sections were too short to yield reliable scores, some were combined to produce part scores. Table 3-4 shows the format of the English progress tests and the scores they yield.¹¹

The English tests were different from progress tests in the other three areas in that they measured the development of proficiency in the same skills throughout the school year. Thus it can be noted in Table 3-4 that all four progress tests within each phase have sections bearing the same name. This is in contrast to the sequence of progress tests in each of the other three subject areas, which cover different material as the year progresses. For this reason, it was judged that the fourth English progress test in each phase could also serve as an end-of-course test. The selection of end-of-course tests in Biology, Mathematics, and American History will be discussed in a later section of this report. Analyses were performed on the data from the 1967-1968 administrations. Tables 5 and 6 show the characteristics of the entire set of twelve 40 minute English tests.

10

Ibid.

11

Test booklets are contained in Volume II.

Table 3-4 - English Progress Test Formats

<u>Test</u>	<u>Phase</u>	<u>Section</u>	<u>Items</u>	<u>Time</u>	<u>Score</u>
I (#34)	2	Spelling	20	5'	Items 1-20 (Part I)
		Language	5	5')	
		English Expression	20	15')	Items 21-60 (Part II)
		Reading	15	15')	
II (#37)	2	Spelling	20	5'	Items 1-20 (Part I)
		Language	10	10')	
		English Expression	20	10')	Items 21-65 (Part II)
		Reading	15	15')	
III (#40)	2	Spelling	20	5'	Items 1-20 (Part I)
		Language	10	10')	
		English Expression	15	10')	Items 21-60 (Part II)
		Reading	15	15')	
IV (#43)	2	Spelling	20	5'	Items 1-20 (Part I)
		Language	15	10')	
		English Expression	15	10')	Items 21-65 (Part II)
		Reading	15	15')	
I (#35)	3	Spelling	20	5'	Items 1-20 (Part I)
		Language	5	5')	
		English Expression	20	15')	Items 21-65 (Part II)
		Literature	20	15')	
II (#38), III (#41)	3	Spelling	20	5'	Items 1-20 (Part I)
		Language	10	10')	
		English Expression	20	10')	Items 21-65 (Part II)
		Literature	15	15')	
IV (#44)	3	Spelling	20	5'	Items 1-20 (Part I)
		Language	15	10')	
		English Expression	20	10')	Items 21-70 (Part II)
		Literature	15	15')	
I (#36)	4	Language	10	10')	Items 1-55 (Total)
		English Expression	20	10')	
		Literature	25	20')	
II (#39)	4	Language	10	10')	Items 1-55 (Total)
		English Expression	25	15')	
		Literature	20	15')	
III (#42)	4	Language	15	15')	Items 1-50 (Total)
		English Expression	20	10')	
		Literature	15	15')	
IV (#45)	4	Language	20	15')	Items 1-55 (Total)
		English Expression	20	10')	
		Literature	15	15')	

Table 3-5 lists characteristics of the parts of the English progress tests for which scores were reported. It should be noted that the Part I reliabilities are not low for a part consisting of only twenty items and requiring only five minutes of testing time. Table 3-6 below lists speededness, difficulty, and mean item discrimination indices for each section (see Table 3-4) of the same tests. In interpreting the speededness indices, it should be noted that they refer to paced sections. That is, each section was separately timed, but examinees were allowed to proceed immediately to the next section if they completed the preceding section before the announced time limit.

Table 3-5 - English Progress Test Characteristics, By Part

Test	Phase	Part*	N	N of Items	Mean	S.D.	Rel. (KR 20)	S.E. Meas.
I	2	I	390	20	7.6	2.8	.52	1.9
		II	390	40	19.2	5.1	.72	2.7
I	3	I	855	20	8.8	3.0	.54	2.1
		II	855	45	20.2	5.0	.64	3.0
I	4	Total	375	55	28.4	6.3	.73	3.3
II	2	I	230	20	9.9	3.4	.67	2.0
		II	230	45	22.0	7.7	.86	2.8
II	3	I	910	20	10.0	3.4	.66	2.0
		II	910	45	26.5	6.6	.81	2.9
II	4	Total	325	55	36.8	6.3	.78	3.0
III	2	I	280	20	12.4	3.5	.72	1.9
		II	280	40	20.5	6.2	.80	2.8
III	3	I	920	20	13.4	3.4	.70	1.9
		II	920	45	25.3	6.8	.82	2.9
III	4	Total	320	50	33.6	6.3	.79	2.9
IV	2	I	280	20	11.4	3.8	.75	1.9
		II	280	45	21.7	6.9	.82	2.9
IV	3	I	885	20	13.7	3.4	.71	1.9
		II	885	50	24.2	6.8	.80	3.1
IV	4	Total	305	55	33.5	7.0	.80	3.1

*See Table 3-4, "Score" column for definition

Table 3-6 - English Progress Test Characteristics By Section

Test	Phase	Section	N	N of Items	% Comp.	% Comp. 75%	Mean Δ	Mean r bis
I	2	Spelling	390	20	95	99	14.4	.40
		Language	390	5	99	99	12.6	.40
		English Expression	390	20	99	99	14.4	.29
		Reading	390	15	98	99	11.9	.46
I	3	Spelling	855	20	92	96	13.7	.38
		Language	855	5	99	99	14.0	.26
		English Expression	855	20	98	99	14.0	.32
		Literature	855	20	92	98	13.0	.30
I	4	Language	375	10	99	99	12.8	.34
		English Expression	375	20	97	99	13.3	.31
		Literature	375	25	90	98	12.5	.34
II	2	Spelling	230	20	93	97	13.0	.46
		Language	230	10	90	94	13.1	.50
		English Expression	230	20	98	99	13.7	.40
		Reading	230	15	83	92	11.9	.59
II	3	Spelling	910	20	98	99	13.1	.46
		Language	910	10	98	99	12.8	.36
		English Expression	910	20	99	99	12.4	.40
		Literature	910	15	95	99	10.9	.49
II	4	Language	305	10	99	100	11.5	.32
		English Expression	325	25	99	99	11.0	.39
		Literature	325	20	98	99	10.6	.41
III	2	Spelling	280	20	95	99	11.6	.52
		Language	280	10	95	98	12.7	.40
		English Expression	280	15	99	99	13.6	.36
		Reading	280	15	96	99	12.2	.48
III	3	Spelling	920	20	99	99	11.1	.51
		Language	920	10	98	99	12.3	.34
		English Expression	920	20	99	99	12.8	.44
		Literature	920	15	94	99	11.6	.49
III	4	Language	320	15	98	99	11.5	.40
		English Expression	320	20	99	99	10.6	.47
		Literature	320	15	98	100	10.8	.37
IV	2	Spelling	280	20	98	99	12.1	.53
		Language	280	15	98	99	14.1	.28
		English Expression	280	15	99	99	13.6	.39
		Reading	280	15	96	99	11.9	.57
IV	3	Spelling	885	20	99	99	10.9	.53
		Language	885	15	96	98	13.3	.35
		English Expression	885	20	99	99	13.3	.40
		Literature	885	15	97	99	12.9	.42
IV	4	Language	305	20	99	100	11.5	.41
		English Expression	305	20	99	100	11.9	.36
		Literature	305	15	96	99	11.8	.40

American History, Phases 3 and 4. Phase 3 "... is designed to help students become more fully aware of America's social, economic and political development. Particular emphasis is given to the individual's responsibility of citizenship in a democratic society. Special attention is given to the following: The American Constitution, Diplomatic History, Industrialization, Growth of Capitalism, Sectionalism vs. Nationalism, Social and Intellectual Change, and a required six weeks' study of Communism."¹²

Phase 4, "... centered around problems in American History, utilizes a thorough investigation and analytical approach to causal factors of significant occurrences in the continuum of the nation's history. Quest study and research techniques receive maximum emphasis."¹³

The workshop sessions with Brevard American History faculty brought to light a serious problem. Instructional approaches of individual teachers to the same course, within as well as across phases, differed greatly. In fact, there was serious question whether any set of progress tests could be appropriate to such a wide range of instructional practices. It was therefore decided to select progress tests which would stress the application of knowledge in generalizing principles and concepts. The Cooperative Topical Tests in American History were judged to meet this requirement. The entire battery includes eight tests, organized chronologically from exploration and colonization to the present. The tests were scheduled to be administered in pairs, at approximately equal

12

Scheuerer, Daniel T. (Ed.) op. cit., p. 1.

13

Scheuerer, Daniel T. (Ed.) op. cit., p. 2.

intervals throughout the 1967-1968 school year. In fact, however, only the first four tests were administered:¹⁴

Test I - Exploration, Colonization, and Independence, 1450 - 1783

Test II - Foundations of American Government, 1781 - 1801

Test III - Growth of Nationalism and Democracy, 1801 - 1840

Test IV - Expansion, Civil War, and Reconstruction, 1840 - 1877

By the time the above four tests had been administered, it was apparent from faculty evaluation of the tests that they considered them to be inappropriate. In addition to the course content differences noted at the workshops, there also were serious differences among teachers with regard to the rate, sequence, and emphasis which characterized their treatment of various topics. It was therefore decided not to administer the remaining four tests in the series, and not to administer any American History progress tests during the 1968-1969 school year.

Since the selected History progress tests were part of a standardized battery, the characteristics of which were already known, it was decided not to perform item analyses on these tests. Table 3-7 shows the statistical characteristics reported in the publisher's manual for the four tests administered.¹⁵

Table 3-7 - American History Progress Test Characteristics

Test	N	N of Items	Mean	S.D.	Rel. (KR 20)	S.E. Meas.	% Comp.	% Comp. 75%	Mean r bis
I	265	60	42.5	9.3	.89	3.1	99	100	.51
II	260	60	36.8	10.3	.89	3.4	94	98	.44
III	260	60	38.4	10.9	.91	3.2	98	99	.53
IV	225	60	43.7	9.7	.90	3.0	99	100	.53

14

Test booklets are contained in Volume II

15

Handbook for Cooperative Topical Tests in American History. Cooperative Test Division, Educational Testing Service, Princeton, N. J., 1965, p. 25.

Table 3-8 shows means and standard deviations for the administrations of these tests to Melbourne students during the 1967-1968 school year. Comparison of these means to those reported in Table 3-7 lends some support to the judged inappropriateness of these tests for Melbourne American History students, especially at the phase 3 level.

Table 3-8 - American History Progress Test Means and Standard Deviations - Melbourne Population

<u>Test</u>	<u>Phase</u>	<u>N</u>	<u>Mean</u>	<u>S.D.</u>
I	3	436	25.4	7.3
	4	53	35.6	8.1
II	3	400	22.8	6.9
	4	47	31.3	8.0
III	3	354	23.2	8.1
	4	47	29.4	6.0
IV	3	405	25.4	8.5
	4	40	33.8	7.9

Item Analyses. Detailed information regarding the numbers and achievement levels of examinees choosing each option of each progress test item is presented in Appendix C.

End-Of-Course Tests

In addition to the custom made progress tests, it was decided to select an existing standardized end-of-course test in each subject area (as described previously, the final progress test for each of English phases 2-4 served also as an end-of-course test). These tests covered the total material presented in these classes during the school year, although they were of necessity less specifically appropriate to Melbourne curricula. The tests selected by ETS test development specialists were:

BSCS Comprehensive Final Examination, Form J. Published for the Biological Sciences Curriculum Study by the Psychological Corporation, New York, N. Y., 1966.

American School Achievement Tests, Form D, Advanced Battery, Part II, Arithmetic Computation and Arithmetic Problems. Published by Bobbs-Merrill Company, Inc., Indianapolis, Indiana, 1955.

Cooperative Social Studies Tests, American History (Senior High School), Form A. Published by Educational Testing Service, Princeton, N. J., 1955.

Table 3-9 shows the characteristics of these end-of-course tests.

Reliabilities are those reported by the publishers.

Table 3-9 - End-of-Course Test Characteristics

<u>Test</u>	<u>Form</u>	<u>N of Items</u>	<u>Time Limit</u>	<u>Scores</u>	<u>Rel.</u>	<u>Type of Rel.</u>
ESCS Comprehensive	J	50	45'	Total	.82	KR20
American School Ach. Test	D	43	25'	Arith. Comp.	.80	Correlation between parallel forms
		24	25'	Arith Comp.	.73	Correlation between parallel forms
Coop. Amer. Hist. (Sr. High)	A	70	40'	Total	.90	KR20

The selected end-of-course tests were appropriate for all phases within Biology, Mathematics, and American History respectively. The test administrations in each area were conducted near the end of the second semester.

Score Reports and Local Norms

It was judged desirable to evaluate thoroughly the characteristics of the newly developed progress tests before making scores available to students and faculty. Therefore, score reports during the 1967-1968 school year were not furnished for several months following the various test administrations. They were therefore of minimal use to

students and staff. However, score reporting during 1968-1969 was accomplished promptly, for use on an optional basis by Melbourne faculty and students. Score reports were sent to the local project director, and were presumably made available to teachers and students. Certain score reports were withheld for financial reasons, but these delays came late in the second semester and probably had little effect.

Local (Melbourne) norms were developed by phase for all progress and end-of-course tests. Raw scores were reported by class roster to Melbourne in both 1967-1968 and 1968-1969, and could be converted to percentile ranks by reference to the appropriate local norms table. These tables are contained in Appendix C. In those situations where a common test across phases was administered, students could determine not only their standing within phase but also with respect to students in adjoining phases. In order to guard against over-interpretation of scores, users were provided with an index number for each progress test and advised to consider each score as being somewhere within the range created by adding and subtracting this index number from the reported score. In effect, this meant that individual scores were reported as bands of plus and minus one standard error of measurement around the obtained score.

Suggested Phase Placements

Progress test scores supplied students with feedback upon which to base their phase change decisions during the 1968-1969 school year. However, the school had available to it additional data which could be used to develop suggested phase placements for students at the time of Fall 1968 registration. Melbourne High School utilized an open course registration of the college type. Prior to the 1968-1969 school year, the

school had provided students with suggested phase placements in four general areas--English, Mathematics, Science, and History. These phase placements were derived from the results of achievement tests administered during the Spring. If, for example, placement was to be made among four available phases, each student achievement score was classified according to the national norms quartile range into which it fell. Placement was then suggested for the corresponding phase. The instruments used for this procedure were the Stanford Achievement Test battery for Fall 1967 placement and the Sequential Tests of Educational Progress for Fall 1966 placement. Placement in each area was based on data from a single test, chosen on the basis of judged relevance to the area.

A new system of placement was sought which would make use of more information about each student than a single achievement test score, and which would utilize the relationships of these predictor data to an objective criterion of success common to all phases of a given course. Since Melbourne faculty did not have departmental exams, the selected end-of-course tests served as criterion measures in three of the four courses chosen for study--Biology I, American History, and Mathematical concepts (see Table 3-9). In English, the progress tests were so spaced that the fourth one was administered at the end of the second semester and served as the end-of-course criterion measure.

As noted above, differences among phases within English were sufficiently great to preclude the use of a single criterion instrument across all phases into which placement was desired. However, it was possible to embed overlapping sets of items in the instruments for adjacent phases, thus producing a sub-score common to phases two and three,

and another common to phases three and four. These subscores were used as the criterion measures.

In addition to the end-of-course criterion measures, a short satisfaction questionnaire was developed and administered concurrently with each progress and final test. This questionnaire consisted of four items concerned with student attitudes toward particular courses, phases, the subject regardless of course and phase, and the marks received. However, item intercorrelations were low and prediction of the satisfaction total score was poor. Therefore, the satisfaction variable was not used as a criterion in the development of phase placements.

The sending junior high schools for Melbourne High School had, for some years prior to the 1967-1968 school year, participated in the Florida Ninth Grade State Testing Program. This battery was examined, and it was concluded that it would serve well as the nucleus of a set of predictor instruments. It comprised the following tests:

School and College Ability Test, Form 3B, published by Educational Testing Service, Princeton, N. J., 1957: Verbal, Quantitative and Total scores

Metropolitan Achievement Tests, Advanced Battery, Form EM, published by Harcourt, Brace and World, Inc., New York, 1961: Reading, Language, Arithmetic Computation, Arithmetic Problem Solving and Concepts, Social Studies Information, and Science

This battery was administered statewide each Fall through 1966 (a new battery was adopted in Fall 1967) to all ninth grade students, and scores were thus available in time to develop predictions for Sophomore phase placements the following Fall and subsequent high school years.

In addition to these academic ability and achievement measures, it was decided to include in the predictor battery measures of student

interest in various subject matter areas. The instrument chosen for this purpose was the Academic Interest Measures (AIM), published by Educational Testing Service,¹⁶ which yields interest scores for biological sciences, English, fine arts, mathematics, social sciences, secretarial, physical sciences, foreign languages, music, engineering, home economics, and executive. This instrument was administered to all ninth grade students in the sending junior high schools in the Spring preceding their entry into Melbourne High School.

Phase placement recommendations were developed for eleven different subject matter areas (see Figure 3-4). In American History (phases 3 and 4) and English (phases 2-4) a two stage decision rule was employed. The first stage involved determination of the degree to which each student was similar to those who had been enrolled in the various phases in the past. This degree of likeness was determined in terms of the predictor variables described previously. The second stage involved the prediction of an end-of-course criterion score for each student, using the same predictor variables. A multiple decision rule was applied in order to combine the two predictions (phase membership and criterion score):

1. Assign for each student that phase for which he is most like previous student enrollees (at the end of the school year) except that--
2. If a student's predicted criterion score falls below the mean score of the next lower phase, or above the mean of the next higher phase, the phase placement will be altered down or up one phase accordingly. Alteration of more than one phase in either direction will not be allowed.

16

See Halpern, G. "Development of An Interest Test: Academic Interest Measures." Research Memorandum, 66-13. Educational Testing Service, Princeton, N. J., 1966.

Figure 3-4 - Phase Placement Form

EDUCATIONAL TESTING SERVICE

GRAD 1971
FROM CENTRAL JR HS

MELBOURNE HIGH SCHOOL FALL 1968 REGISTRATION

AT THE BOTTOM OF THIS PAGE ARE SUGGESTED PHASE PLACEMENTS FOR SEVERAL SUBJECTS. YOU MAY ENTER EITHER A HIGHER OR LOWER PHASE THAN THE ONE SUGGESTED, WITH THE EXCEPTION THAT IF YOUR RECOMMENDED PHASE IS 3 OR HIGHER, YOU MAY NOT ENROLL IN PHASES 1 OR 2 FOR THAT SUBJECT.

PLEASE BEAR IN MIND THAT THESE SUGGESTED PHASE PLACEMENTS ARE NOT PERFECT. THEY ARE ONLY ONE OF THE THINGS YOU SHOULD CONSIDER IN CHOOSING THE BEST PHASE FOR YOU.

THE NUMBER FOLLOWING EACH COURSE IS THE SUGGESTED PHASE PLACEMENT. IF A PHASE IS RECOMMENDED IN A COURSE YOU HAVE ALREADY TAKEN, PLEASE DISREGARD IT. AN ASTERISK (*) INSTEAD OF A NUMBER INDICATES THAT THERE WAS NOT ENOUGH INFORMATION TO ESTIMATE A PHASE PLACEMENT FOR YOU IN THAT COURSE. IN SUCH CASES, SEE THE COUNSELOR STAFF FOR HELP IN PLANNING YOUR SCHEDULE.

ENGLISH	3
AMERICAN HISTORY	2
ALGEBRA I	4
ALGEBRA II	3
PLANE GEOMETRY	3
CHEMISTRY I	3
BIOLOGY I	3
BIOLOGY II	3
PHYSICAL SCIENCE (OTHER THAN CHEMISTRY I)	2
MATH. (OTHER THAN PLANE GEO. AND ALG. I/II)	4
HISTORY (OTHER THAN AMERICAN HISTORY)	3

This procedure had the advantage of capitalizing upon the experience of previous students in placing themselves in appropriate phases, yet allowed for modification in cases where the probability of extremely deviant achievement in either direction was great.

The technique of multiple group discriminant analysis was used to predict phase membership.¹⁷ Discriminating functions were developed, separately for males and females, using data from students enrolled during the 1967-1968 school year. Phase membership was determined at the end of the year, in order that the predictions would reflect the outcomes of the natural phase selection process which took place throughout the school year. Such a selection process could occur only under the conditions of free choice characteristic of a school like Melbourne High School.

Since the number of available predictors was quite large, it was desirable to reduce the number actually used for each prediction, in order both to prevent excessive degradation of the precision of prediction for subsequent groups of students, and to obviate the necessity of collecting large amounts of data in subsequent years.

All test data were initially examined (separately by sex) with the expectation that most variables would not be useful, but that the useless variables might obscure the functional variables in the first multivariate tests. For this reason, all available data were analyzed initially, with little note being given to the multivariate F ratios. Attention was centered upon the univariate statistics and the predictive

¹⁷

See Rao, C. R., Advanced Statistical Methods in Biometric Research. New York: Wiley and Sons, 1953, pp. 257 ff.

efficiency of each single variable. Even when the multivariate F test suggested that no significant prediction was available, a few of the variables sometimes had significant univariate F ratios. Thus, at the first attempt to predict, all variables were used and that single variable with the largest univariate F ratio was selected, provided that the univariate F had a probability of less than .05. This initially selected variable was then treated as a covariate and the discriminant analysis was rerun.

Of the remaining variables, that one with the largest univariate F ratio having a probability of less than .05 was selected. This variable was then added to the first as a covariate and the analysis rerun.

Successive variables were selected, successive covariate analyses were performed, and variables added to the set of useful predictors until none of the remaining variables had a univariate F with a probability of less than .05. The final set of useful predictors constituted the reduced battery. The final phase prediction discriminant function was determined by rerunning the analysis using only the selected variables. The multivariate F ratios obtained from this analysis described the usefulness of the selected variables in predicting phase. The procedure is a generalization of the Wherry-Doolittle method of battery reduction in multiple correlation.

Because academic interest (AIM) data were not available for substantial numbers of students, two sets of discriminant functions for each sex were developed--with and without interest scores as predictor variables. The availability of AIM data determined which function was used for each student.

The second stage of the placement decision rule employed for American History and English involved the prediction of final test scores. Standard techniques of multiple regression were used. The Wherry-Doolittle battery reduction procedure was directly applicable, and was followed without modification.¹⁸ As in the development of discriminant functions, two sets of regression equations for each sex were developed and used for students with and without academic interest scores.

Examination of within-phase scatterplots of the various predictor variables versus the criterion revealed that predictability of final test score within phase was rather low. Because the predictor and criterion means varied systematically across phases, prediction for the total group was considerably better. For this reason, a common regression equation across phases within course was employed.

In Biology I, Plane Geometry, Algebra I, Algebra II, Chemistry I, English (phase 5 only), and American History (phase 2 only), phase placements were developed on the basis of group membership alone (stage one of the previously described decision rule). In the case of each course except Biology I, this was necessary because no common criterion measure existed. Although a final test for Biology I was selected and administered, the data were not in usable form at the required time and were not used in the placement process. Techniques of battery reduction and phase prediction were identical to those described for English (phases 2-4) and American History (phases 3 and 4).

For Mathematics (other than Plane Geometry, Algebra I, and Algebra II), phases 1-5; History (other than American History), phases 2-5

¹⁸

See Garret, H. E., Statistics in Psychology and Education. New York: David McKay Co., 1966.

Biology II, phases 2-5; and Physical Science, phases 1-5, the procedure used by Melbourne High School to develop phase placements for the Fall 1967 registration was duplicated. For each course offered in four phases, each student score on a designated Stanford Achievement Test was classified according to the national norms quartile range into which it fell, and placement was recommended in the corresponding phase. For courses offered in five phases, the scores were classified by national norms quintile ranges and phase placement recommendations were developed in similar manner.

Progress tests were developed and a final test was selected for Mathematical Concepts. Although these measures were administered and scores were reported, no phase placement recommendations were developed because this course was offered at only one phase level (phase 2) during the 1967-1968 school year.

Tables 3-10 and 3-11 give multivariate F ratios and discriminant function coefficients for the various reduced predictor batteries.

The interest variables which were of use in predicting phase membership in English (males and females), American History (males only), and Chemistry (males only), are shown in Tables 3-10 and 3-11. An interesting situation arose in Algebra I and II, where the Metropolitan Language test was the only predictor retained in the reduced battery for males, while the Metropolitan Arithmetic Problems test was retained for females. A possible explanation for this phenomenon might lie in the greater expectations or pressures for higher education focused on males. The Metropolitan Language test is probably a good general ability measure. It may well be that the higher ability, college destined males

Table 3-10 - Reduced Predictor Batteries: Discriminant Function Coefficients and Multivariate F Ratios for Males

Course	Phase	Predictors	Without AIM		Predictors	With AIM	
			Disc. Func. Coeff.			Disc. Func. Coeff.	
			f ₁	f ₂		f ₁	f ₂
English	2-5	Metropolitan Read.	-.03	1.22	Metropolitan Read.	.05	1.41
		Metropolitan			SCAT Verbal	.47	-.48
		Social Studies	.34	.02			
		SCAT Verbal	.43	-.30	SCAT Mathematical	.56	-.66
		SCAT Mathematical	.49	-.85	AIM English	.28	-.23
		F=24.21(12,920); Pr<.001			F=18.61(12,744); Pr<.001		
American History	2-4	Metropolitan			Metropolitan		
		Social Studies	.70	--	Social Studies	.53	--
		SCAT Mathematical	.49	--	SCAT Mathematical	.58	--
		F=31.54(4,350); Pr<.001			AIM English	.34	--
					F=19.57(6,268); Pr<.001		
Biology I	2-4	Metropolitan			No AIM Variables		
		Language	-.13	1.25	In Reduced Battery		
		Metro. Arith. Problems	.58	-.27			
		Metro. Science	.68	-.57			
		F=23.89(6,466); Pr<.001					
Plane Geometry	3-4	Metro. Arith. Problems	--	--	No AIM Variables		
					In Reduced Battery		
		F=15.83(1.41); Pr<.001					
Algebra I	2-4	Metro. Language	--	--	No AIM Variables		
					In Reduced Battery		
		F=6.09(2,32); Pr=.006					
Algebra II	3-4	Metro Language	--	--	No AIM Variables		
					In Reduced Battery		
		F=18.39(1,84); Pr<.001					
Chemistry I	3-4	SCAT Verbal	--	--	SCAT Verbal	.86	--
					AIM Engineering	-.64	--
		F=7.70(1.71); Pr=.007			F=5.19(2,64); Pr=.008		

Table 3-11 - Reduced Predictor Batteries: Discriminant Function Coefficients and Multivariate F Ratios for Females

Course	Phase	Predictors	Without AIM		Predictors	With AIM	
			Disc. Func. Coeff.			Disc. Func. Coeff.	
			f ₁	f ₂		f ₁	f ₂
English	2-5	Metro. Reading	-.10	1.33	Metro. Reading	-.01	1.35
		Metro. Language	.46	.35	Metro Language	.49	.11
		Metro Social Studies	.42	-.51	Metro Social Studies	.35	-.44
		SCAT Verbal	.30	-.62	SCAT Verbal	.23	-.52
		SCAT Mathematical	.19	-.57	SCAT Mathematical	.15	-.63
		F=20.57(15,895); Pr<.001			AIM Social Studies	.29	.08
American History	2-4	Metro. Arithmetic Problems	.69	.87	No AIM Variables In Reduced Battery		
		SCAT Verbal	.53	.21			
		SCAT Mathematical	-.11	-1.50			
Biology I	2-4	Metro. Language	.77	-.62	No AIM Variables In Reduced Battery		
		Metro. Arithmetic Problems	.37	.04			
		Metro. Science	-.06	1.15			
Plane Geometry	3-4	Metro. Language	.63	--	No AIM Variables In Reduced Battery		
		SCAT Mathematical	.62	--			
Algebra I	2-4	Metro. Arithmetic Problems	--	--	No AIM Variables In Reduced Battery		
		F=14.66(2,29) ; Pr<.001					
Algebra II	3-4	Metro Arithmetic Problems	--	--	No AIM Variables In Reduced Battery		
		F=27.38(1,66) ; Pr<.001					
Chemistry I	3-4	Metro Social Studies	--	--	No AIM Variables In Reduced Battery		
		F=11.68(1,32) ; Pr=.002					

feel they must choose the higher phases in Algebra I and II, regardless of their mathematics achievement levels. The females, under less pressure, are free to phase themselves on the basis of more suitable criteria.

Tables 3-12 and 3-13 give zero order and multiple correlation coefficients for the various multiple regression reduced predictor batteries. Note that only courses with end-of-course criterion instruments are included.

Table 3-12 - Multiple Regression Reduced Predictor Batteries: Zero Order and Multiple Correlation Coefficients for Males

Course	Phase	Without AIM		With AIM	
		Predictors	r	Predictors	r
English	2-3	Metro. Reading	.63	No AIM Variables In Reduced Battery	
		Metro. Language	.60		
		R = .68			
English	3-4	Metro. Language	.61	No AIM Variables In Reduced Battery	
		SCAT Verbal	.61		
		SCAT Mathematical	.55		
		R = .68			
American History	3-4	Metro. Social Studies	.74	Metro. Social Studies	.70
		SCAT Mathematical	.53	SCAT Mathematical	.56
		R = .77		AIM English	.28
				R = .58	

Table 3-13 - Multiple Regression Reduced Predictor Batteries: Zero Order and Multiple Correlation Coefficients for Females

Course	Phase	Without AIM		With AIM	
		Predictors	r	Predictors	r
English	2-3	Metro. Language	.64	No AIM Variables In Reduced Battery	
		Metro. Arith. Problems	.54		
		R = .68			
English	3-4	Metro. Language	.62	Metro. Language	.60
		SCAT Verbal	.58	SCAT Verbal	.61
		R = .67		AIM Social Studies	.24
				R = .69	
American History	3-4	Metro. Social Studies	.70	Metro. Social Studies	.69
		SCAT Mathematical	.50	SCAT Mathematical	.49
		R = .73		AIM Foreign Language	.37
				R = .73	

Inspection of Tables 3-12 and 3-13 shows that interest variables were retained in the reduced batteries for American History (males and females), and English (females only). There seemed to be few systematic differences between males and females in terms of achievement variables retained in the reduced predictor batteries. Application of a standard shrinkage formula¹⁹ to the obtained multiple correlations shows that correlations of virtually equal magnitude might be expected in similar student samples.

Effectiveness of Phase Placements

As stated earlier, the study carried out by ETS was more in the spirit of operations research than experimental research. It represented an attempt to improve the information available to students and staff of Melbourne High School in order that they might make better decisions with respect to initial phase placement and subsequent phase shifting. The study was carried out under the usual operating conditions of the school, with no attempt to exert experimental control over any of the forms of information feedback. As described previously, phase placement predictions were developed using final test data from the 1967-1968 school year, and these equations were used to provide phase placement recommendations for the 1968-1969 school year. Although progress tests were administered during 1967-1968, detailed analysis of test and item characteristics had to be performed before it could be determined that these newly constructed instruments were appropriate and useful to the groups for whom they were constructed. For this reason, progress test scores were purposely not

¹⁹

See Guilford, J. P., Fundamental Statistics in Psychology and Education. N. Y.: McGraw-Hill Book Company, Inc., 1956, p. 399.

reported to the school during 1967-1968 until far later than the time at which they could have had any effect upon student decisions to shift phase. Thus, with the exception of the administration (but not reporting) of the progress and final tests, the 1967-1968 school year at Melbourne High School was unaffected by the activities of the study. Therefore, the introduction in Fall 1968 of a partially new system of generating phase placement recommendations, plus the impact of progress test scores reported to students and staff throughout the 1968-1969 school year, might be expected to have had considerable impact upon the incidence and kinds of phase shifting behavior.

During both the 1967-1968 and 1968-1969 school years, records were kept of phase shifting within the courses for which progress tests were developed--Biology I, English, American History, and Mathematical Concepts. The initiator (school or student) of each phase shift was also recorded. Figures 3-5 to 3-9 show the data for both years, separately by course and combined. Shifts between two classes of the same phase are not included, since they were considered not to represent a true curricular change.

The results shown in Figures 3-5 to 3-9 are at most suggestive, and the urge to overinterpret them must be strongly resisted. Although the emphasis of this project was on information feedback, there were many other influences acting upon students in Melbourne High School during the 1967-1968 and 1968-1969 school years. It would be difficult for someone familiar with the local situation to suggest additional factors which might be responsible for changes in phase shift behavior between the two years. Differences in the student body, faculty, administration, and curriculum all might be expected to have effects, which would be confounded with the

Figure 3-9- Phase shift frequencies for
1967-1968 and 1968-1969 - Biology I

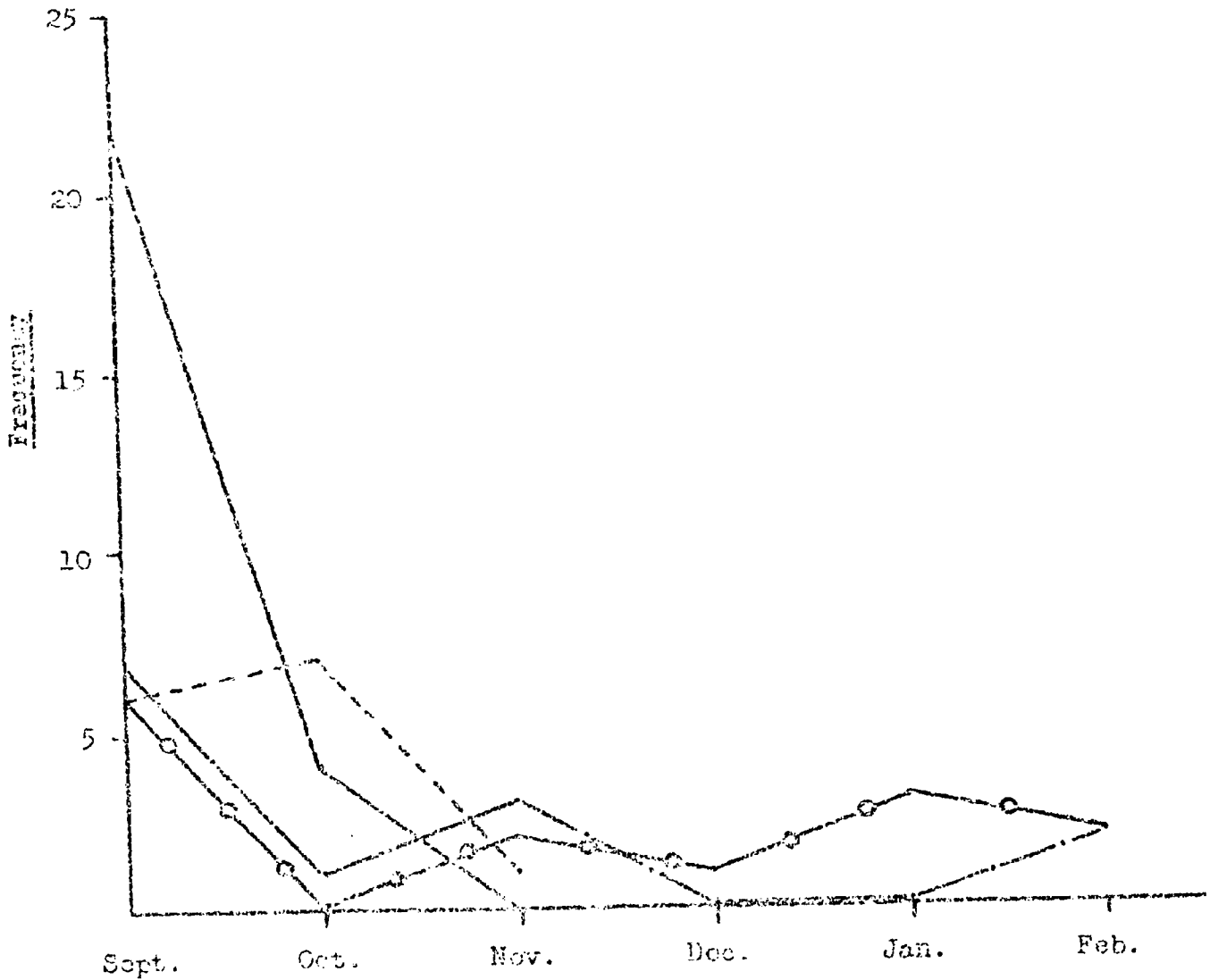

----- '67-'68 School initiated
----- '67-'68 Student initiated
-.-.-.-.- '68-'69 School initiated
o---o---o '68-'69 Student initiated

Figure 3-6- Phase shift frequencies for
1967-1968 and 1968-1969 - English

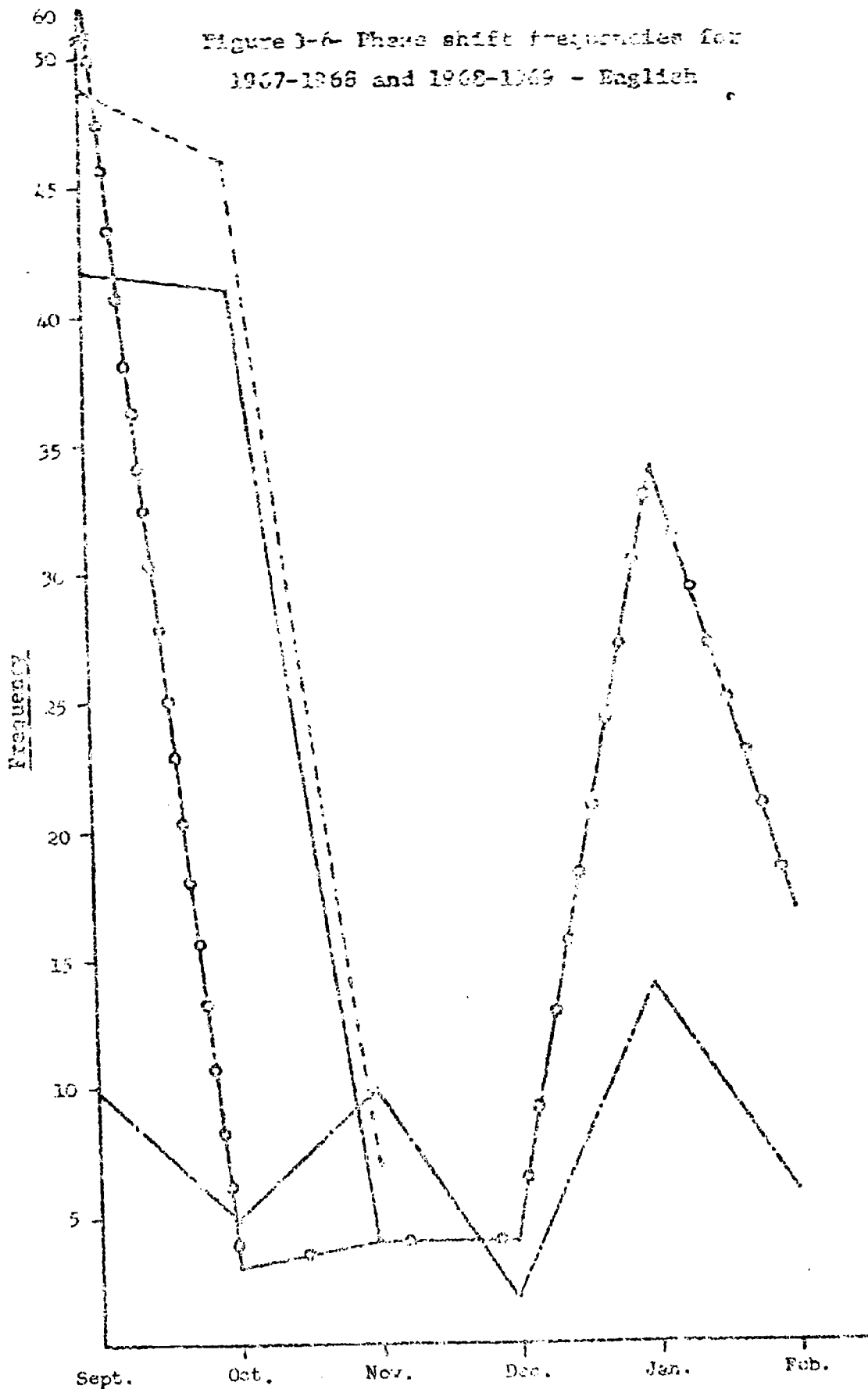

45

- '67-'68 School initiated
- - - - - '67-'68 Student initiated
- · - · - '68-'69 School initiated
- - ○ - ○ '68-'69 Student initiated

Figure 5-7 - Phase shift frequencies
for 1967-1968 and 1968-1969 - American History

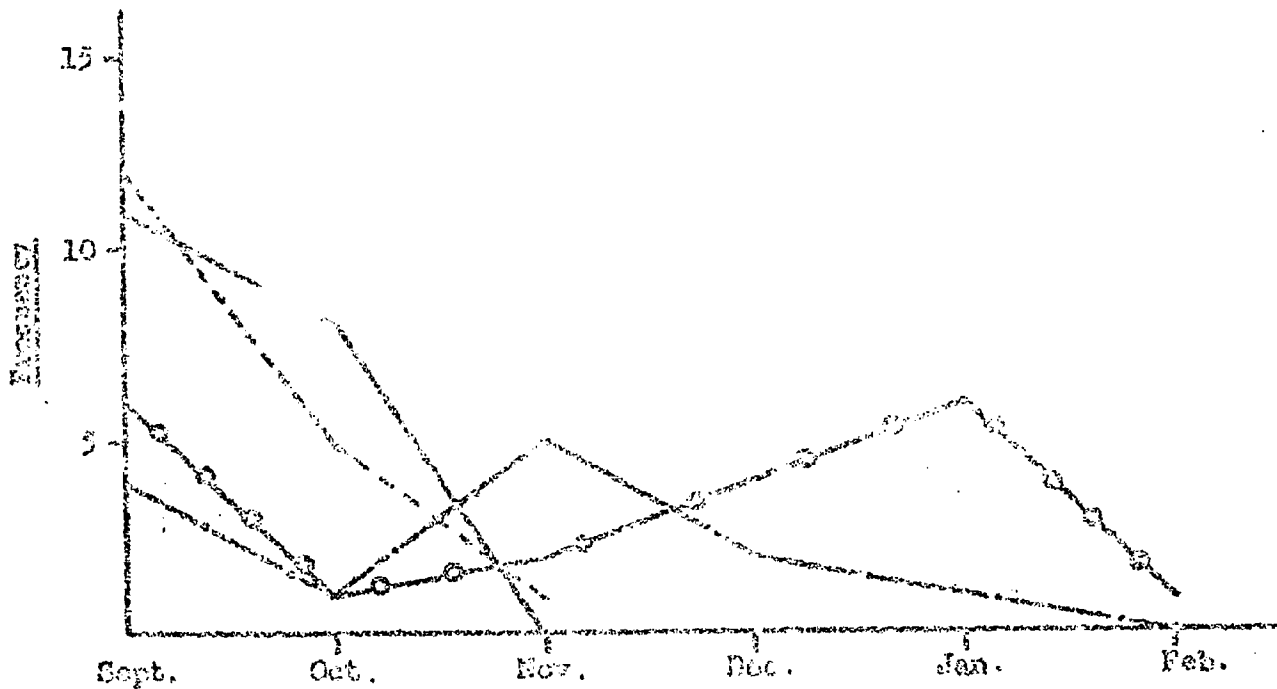

----- 1967-'68 School initiated
----- 1967-'68 Student initiated
----- 1968-'69 School initiated
○----- 1968-'69 Student initiated

Figure 7-6- Phase shift frequencies
for 1960-1969 - Mathematical Concepts

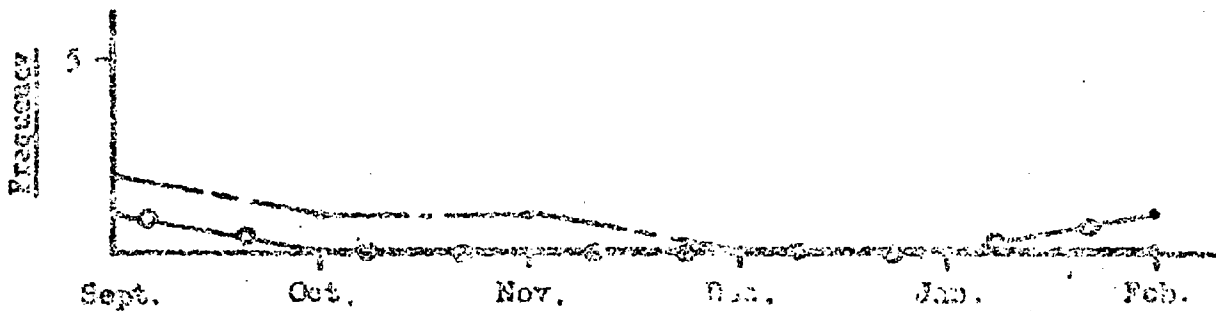

----- 1968-69 School initiated
●---●---● 1968-69 Student initiated

Note: Only one phase of Mathematical Concepts was offered during 1967-1968, and therefore no phase shift could occur during that year.

Figure 3-9 - Phase shift frequencies for
1967-1968 and 1968-1969 - combined across
course and initiator

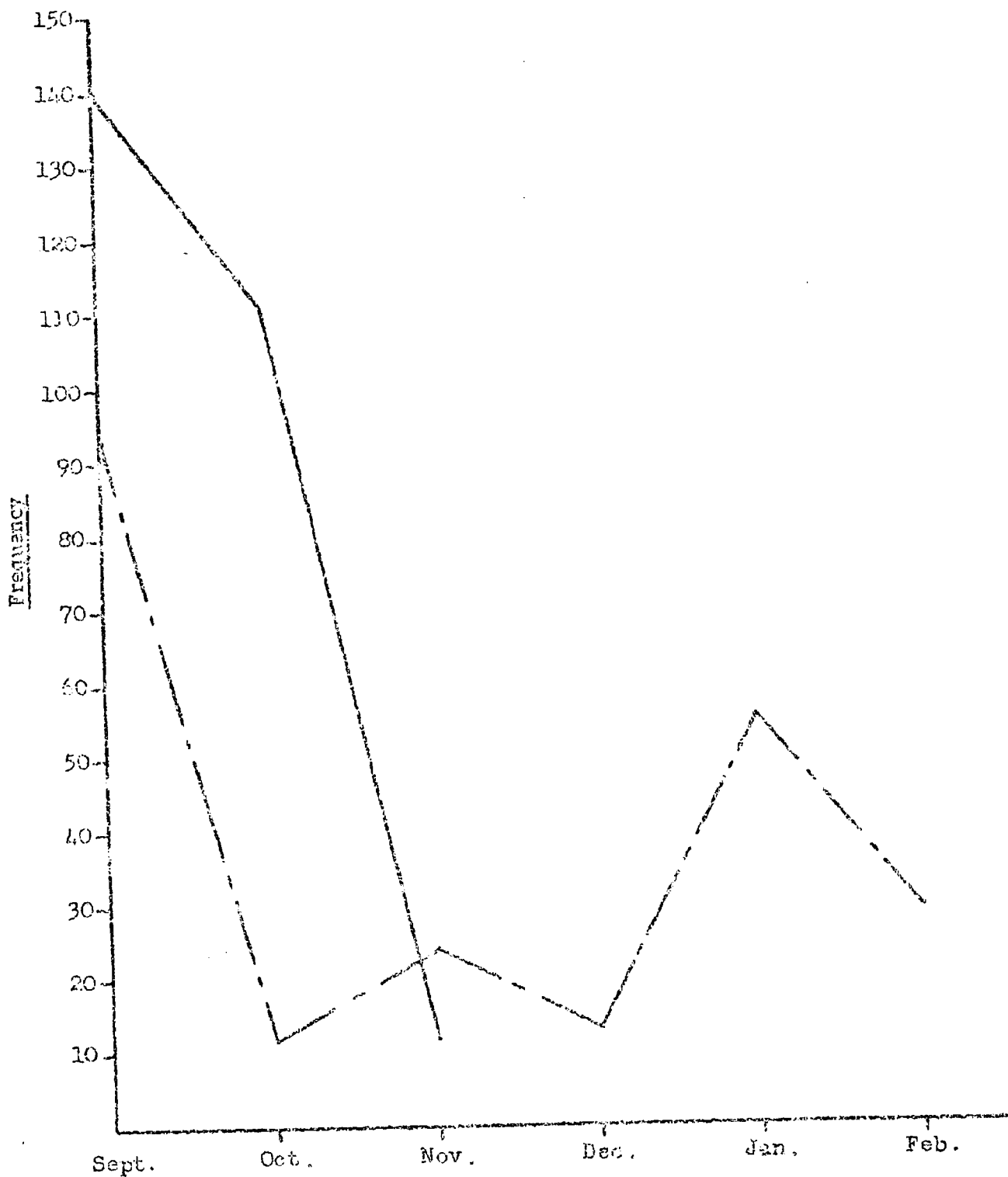

possible effects of the information feedback procedures. The following comments on the obtained phase shift data should be considered in this light.

Comparative data for the two years are available only for the months of September, October, and November, since Melbourne reported that there were no phase shifts after November in 1967-1968. Figure 3-9 shows that the total number of phase shifts for September-November was clearly smaller during 1968-1969, as had been hypothesized. The general pattern of frequent shifts at the beginning of the first semester followed by a sharp decline, with a moderate increase at the beginning of the second semester, is characteristic of most of the 1968-1969 individual course graphs. Mathematical Concepts, which exhibited virtually no phase shifts at all, was the single exception. Examination of the progress test means for Mathematical Concepts reveals that the two phases were almost identical with respect to achievement. It therefore seems reasonable that little phase shifting occurred, since there was perhaps little difference between the phases and the students perceived this.

Relative to the numbers of students enrolled, there was little difference among the four courses in either year with respect to phase shift frequency. In September of 1967, the percentages of enrollees who shifted phase in Biology, English, and American History were 5%, 6% and 5% respectively. In September of 1968, the corresponding percentages were 2%, 4%, and 2% in Mathematical Concepts.

Inspection of Figures 3-5 to 3-7 (Biology I, English, and American History) reveals some interesting characteristics but few consistencies. In 1967-1968, both school and student initiated phase shifts show marked

declines in frequency between September and November. In 1968-1969, a slight upward trend in November was evidenced in all three courses. Student initiated phase shifts predominated in all three courses during the second semester of 1968-1969, perhaps suggesting that students were making use of test information. The large number of student (relative to school) initiated shifts in English during September 1968 could not be related to progress test results, but might be a result of school administrative procedures.

Other evidence of phase placement effectiveness may be found in the degree to which students accepted (and faculty approved) the suggested placements at the time of registration. Records were kept of individual Fall 1968 registrations in each of the eleven courses for which suggested phase placements were provided. Table 3-14 shows that, overall, the majority (56%) of students accepted suggested placements, and that overphasing (24%) was more frequent than underphasing (14%). Note that percentages do not add to 100% because only phase selections differing from the recommended phase by one are tabulated. The remaining percentage represents phase selection deviations of more than one from the recommendation, in either direction.

The overall order of accept-phase, overphase, and underphase holds for Sophomores, Juniors, and Seniors. However, it is most pronounced for Sophomores, and becomes less pronounced as year in school increases. In comparing phase registration behavior across courses, it should be remembered that, for the first seven courses listed in Table 3-14, the course designations have the same meaning regardless of year in school, since Melbourne High School is ungraded. However, the last four "courses"

listed are really subject areas, which include a variety of courses both within and across year in school. Thus their meaning is not specific, particularly across year in school.

Table 3-14 - Fall 1968 Registration Percentages

	Sophomores			Juniors			Seniors			Total		
	%	%+	%-	%	%+	%-	%	%+	%-	%	%+	%-
English	64	22	12	55	31	11	47	36	1	56	29	11
American History	50	44	2	44	48	5	52	42	3	49	45	3
Biology I	67	15	17	57	28	12	48	38	14	64	19	16
Plane Geometry	85	9	6	90	4	6	88	13	0	88	7	5
Algebra I	48	27	23	49	33	13	56	13	0	49	29	19
Algebra II	71	16	13	77	13	10	80	4	16	75	13	12
Chemistry I	76	2	5	68	8	23	71	8	11	62	6	17
Mathematics (other than Plane Geometry, Alg. I, Alg. II)	31	53	5	34	26	25	50	8	34	41	23	25
History (other than Am. Hist.)	57	14	15	40	11	33	39	15	34	42	13	31
Biology II	50	14	29	50	15	27	48	38	11	49	29	18
Physical Science	<u>41</u>	<u>36</u>	<u>11</u>	<u>38</u>	<u>16</u>	<u>26</u>	<u>35</u>	<u>12</u>	<u>40</u>	<u>37</u>	<u>18</u>	<u>30</u>
Total	61	25	11	57	23	15	48	22	20	56	24	14

% = percent of students receiving phase placement recommendations who registered for the phase recommended
 %+ = percent of students receiving phase placement recommendations who registered for the phase one higher than that recommended
 %- = percent of students receiving phase placement recommendations who registered for the phase one lower than that recommended

For each of the first seven courses listed in Table 3-14, the overall order of accept-phase, overphase, and underphase is duplicated. Examination of the cell entries for each of these courses indicates that, in most cases, the same result obtains within each year in school. In the case of the last four subject areas listed in Table 3-14, the accept-phase

category contains a majority of the cases, but the overphase-underphase relationship shows no clear pattern. This is probably due in part to the non-specificity of these categories mentioned previously.

Summary and Recommendations for Further Research

The two principal elements of the project were the development of custom made achievement tests ("progress tests") in three subject areas, and the provision of phase placement recommendations to Fall 1968 registrants in eleven subject areas. Both of these project elements contributed to the overall project goal of providing students and staff with information relevant to the decisions of phase choice.

Curriculum differences among Brevard County high schools were in part responsible for the decision to limit the project to a single school. Melbourne High School was selected as the project school by Brevard County personnel. It should be emphasized that the effectiveness of developed materials and procedures was studied for that school alone. Additional research is necessary before the developed phase placement procedures can be extended to other schools.

Sets of progress tests were developed to measure attainment of course objectives in Biology, Mathematics, and English. Progress tests were not developed in American History because of extreme diversity among Melbourne American History teachers with respect to methods, materials, and course objectives. American History tests selected for administration in Melbourne were not well received by teachers, and their use was discontinued midway through the first project year. The experience in Melbourne emphasized the fact that before a system of information feedback similar to that developed in this project can be implemented, there must exist

some degree of curricular consensus at the classroom level. Although additional workshops might help teachers to achieve this, they cannot create consensus where in fact it does not exist.

Three methods of developing suggested phase placements were employed in this project. Two were newly developed, and the third had been in use by Melbourne High School for some time. The choice of method to use for each subject area was dependent upon what data were available. All three methods were demonstrated to be feasible. Because differences among placement methods were completely confounded by differences among courses, it was not possible to assess the relative effectiveness of the three methods. To untangle the effects of "course" and "placement method" would require a design in which randomly selected subsets of students within each course received placement recommendations developed by different methods. This degree of experimental control was judged to be contrary to the project philosophy of interfering as little as possible with the functioning of the school. Such a procedure remains a possibility for further research, however.

Data descriptive of student registration and phase shift behavior were gathered and analyzed. A majority of students did register in phases suggested for them. Again, it was not possible to assess the effects of various information feedback elements upon phase shifting behavior without substantially controlling (and perhaps distorting) the normal operation of the school.

In Fall 1967, the content of the predictor test battery (Florida Ninth Grade State Testing Program) was completely altered. In order to obtain predictor scores for Sophomores entering Melbourne High School in

Fall 1968, the former battery, in addition to the new battery, was administered in Fall 1967. It was planned to develop prediction equations during the 1968-1969 school year based on the data from the new battery. Because the necessary contractual agreement was not reached, these new prediction equations were not developed. Neither of the two newly developed phase placement methods was used by Melbourne High School for its Fall 1969 registration. Neither of the methods can be used until the necessary data analyses are performed. The system of information feedback was conceived from the beginning as a continuing, self-correcting process. It requires periodic data analysis to determine the extent to which existing procedures are still relevant to a changing student body and a changing curriculum. Without a continuing supportive research effort, the system might soon become a useless anachronism.

The role of the progress tests in the information feedback system was largely an informal one. Scores and interpretive materials were provided to the school, but were not used to develop updated phase placement recommendations. Further research is needed to determine the usefulness of progress test scores in modifying initial phase placement recommendations on the basis of current course achievement. If progress test data prove to be effective in this regard, the data analysis procedures developed in this project could be used to provide students with updated phase placement recommendations at several points throughout the school year.

ADMINISTRATIVE CONTROL ELEMENTS:

Administrative Roles and Student Information Systems*

The New York Institute of Technology has completed three years of cooperative involvement in selected educational management development with the Brevard County School System, and Melbourne High School in particular.

Before proceeding with the more technical aspects of this summary report of the cumulative activities of the New York Institute of Technology during the three year period, a brief discussion of relevant enveloping climate and environmental circumstances will provide the rational basis for the chronology of changing emphasis and perspectives.

During the program period, there have been personnel changes including four project directors, two principals, seven vice principals and a major faculty turnover at Melbourne High School, three Brevard County Superintendents, three new Brevard County High Schools, broad changes in County philosophy pertinent to model high school programs, the utilization and discard of County computer-based information and record systems, a teacher strike, a County attempt at integration, an active vocal (and perhaps militant) organization of Faculty, and widespread and significant reappraisal of issues of autonomy or model replicable school systems.

It is important to recognize that these factors, and their impact are not peculiar to Melbourne High School, or, in fact, to Brevard

*

This section of the report was largely prepared by Dr. Bertram Spector, New York Institute of Technology, with the assistance of Dr. Robert Jones and Mr. Ernest O'Dierno. 55

County High Schools but represent a national soul-searching attempt to identify systems and patterns that are educationally sound and acceptable to all participants in the educational world, including students, parents, teachers, administrators, and the community and political structures with which these parties interact.

No Utopian system has been developed. Nevertheless, the study of the process of educational change under conditions of environmental change has yielded insight into several crucial principles and elements which in themselves may be considered an achievement of no minor consideration. There is little doubt, for example, that the political tone of a community may be a more important factor (eg., de facto segregation issues) than any change of innovational educational improvement in methods and resources, or technological development in materials and media. There is likewise little doubt that each influences the other which suggests a novel unified interactive approach. This is another way of emphasizing what is well known already - but rarely applied - the removal of barriers that cause educational isolationism in a community system. One key item in this development of an approach to change is the AR factor* (attitude receptivity). The AR factor lags the intellectual receptivity which can be achieved through concentrated orientation and seminar sessions relatively rapidly. The AR factor takes time and patience. It is the emotional counterpart of intellectual receptivity, both of which are prerequisite for successful implementation of strategies and concepts that are foreign to experience.

*

The author apologizes for his introduction and identification of two well known words, as a factor, but they have yet to be stressed with the uniqueness they deserve.

Working with administration and faculty at Melbourne High School, two areas of importance to Melbourne High School were selected as prime developmental targets.

1. Student Capability Profile for Guidance and Prediction
2. Organizational Restructure and Role Delineation

The information subsystem identified as Student Capability Profile is important for successful implementation of the nongraded High School philosophy. Based upon personal, historical, performance, affective, and predictive data considered significant for guidance officers, faculty and students, a condensed profile was developed which was compatible with data processing needs, and written in machine-independent language. A sample profile sheet appears on the following page. It provides a better basis for advisers to recommend and students to select any of five phases (differentiating intensity levels and degree of difficulty) of four different disciplines, namely: English, Mathematics, Science, and Social Studies for initial entrance each semester, and for transfer to other phases during a semester as deemed best in the interests of each student.

The Organizational Restructure and Role Delineation of Melbourne High School seeks to define in objective terms a minimal staff with responsibilities and authorities that facilitate the goals of a nongraded high school, and permits easy transition where desired. An analysis of what was and is was carried out through the three years of the program, but the assistance of Dr. Robert Jones of Nova University during the Spring of 1969 and his extensive dialogue with faculty and administration (recorded) has focused the structural and functional needs

INTELLIGENCE CAPABILITY PROFILE BREVARD COUNTY (FLORIDA) NON-GRADED SCHOOL PROJECT DATE OF ADMISSION

I.D. NO. SCHOOL -- YEAR 1 YEAR 2 YEAR 3

PHASES PREPARED AND COMPLETED PREF. COMP. PREF. COMP. PREF. COMP. 2. STUDENT APTITUDE

ENGLISH A. DAT SCORES (PERCENTILE) B. EXPRESSED MAJOR APTITUDE

MATHEMATICS YP 1 YR 2 YR 3 YP 1 YR 2 YR 3

SCIENCE 1. VERBAL REAS. 1. HUMANITIES

SOCIAL STUDIES 2. NUM. ABILITY 2. SCIENCES

OTHER 3. ABST. REAS. 3. FINE ARTS

3. PAST PERFORMANCE 4. CLERICAL 4. RECREATIONAL

A. ACHIEVEMENT 5. TECH. REAS. 5. MANIPULATIVE

LAST AVG. 6. SPACE REL. 6.

ENGLISH 7. LANG. SPELL. 7.

MATHEMATICS 8. LANG. GRAM. 8.

SOCIAL STUDIES 9. 9.

OTHER 10. 10.

4. STYLES OF LEARNING 5. ACHIEVEMENT TESTS (RECORDED IN PERCENTILE RANK)

(DEGREE OF INDIVIDUALIZATION) 1965 1966 1967 A. STANDARD 1965 1966 1967 P. SCHOLASTIC APTITUDE TEST (SAT)

ENGLISH 1. ENGLISH YP 1 YP 2 YP 3

MATHEMATICS 2. NUM. COMP. 1. VERBAL

SCIENCE 3. MATHEMATICS 2. QUANTITATIVE

SOCIAL STUDIES 4. READING C. FLORIDA WINTF GRADE TESTING

OTHER 5. SCIENCE 1. MET. ACHIEV. (MAT) 2. SCHOOL APT. (SCAP)

7. CODES 6. SOC. STUD. A. READING A. VERBAL

ENGLISH 7. SPELLING B. LANGUAGE B. QUANT.

MATHEMATICS SCIENCE C. ALITH. COMPUT. C. TOTAL

SCIENCE SOCIAL STUDIES D. ARITH. PROF SOL

OTHER SOCIAL STUDIES E. SOCIAL STUDIES

7. CODES F. SCIENCE

* (IDENTIFIES UNSUCCESSFUL COURSE), X (SEMESTER ABSENCE EXCEEDS 9)

FAV (FAVORABLE), UNF (UNFAVORABLE)

of the organizational requirements in a very constructive manner. Following the research, a number of conferences were held at which the current principal, Mr. Richard Gillespie, project director, Mr. Daniel Scheueter, Dr. Robert Jones and Dr. Bertram Spector reviewed the results and reached consensus on the nature of restructure possible and desirable at this time.

The following section summarizes the results of the organizational analysis of Melbourne High School and the rationale for suggested changes to incorporate an appropriate student information system. Information used in this report was obtained in the Spring semester of 1969 from available written materials and extensive interviews with students, teachers, and administrators of Melbourne High School. An attempt has been made to describe Melbourne High School as it is presently organized and as it presently functions with little or no attention given to the developmental history of the school nor to the socio-political conditions existing in Brevard County. This report suggests some organizational changes from the standpoint of increasing the efficiency of internal operations. The question of implementation strategy, however, is left to the responsible local persons plus whatever outside help they might seek.

Role Delineations of Administrative Staff

In this section of the report are listed the major responsibilities of each administrative officer as they were described in the interviews previously mentioned. The chain of command can probably be seen more clearly in the organizational chart on the following page than from the verbal descriptions that follow. The descriptions are intended to specify the activities and the responsibilities of each person as they are presently conceived and functioning

PRESENT ORGANIZATIONAL CHART OF MELBOURNE HIGH SCHOOL

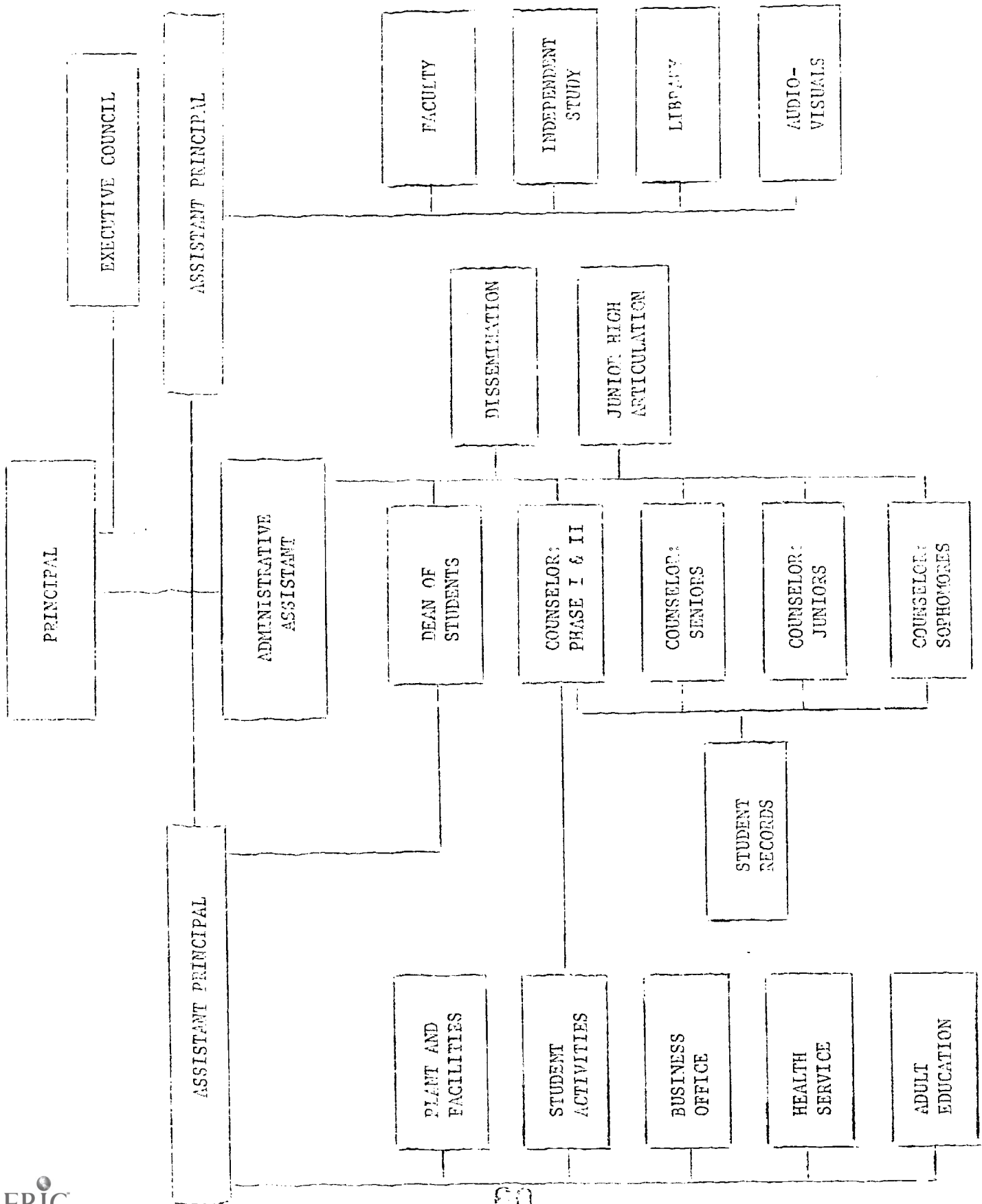

The Executive Council was included in this section because it serves a communication function from the students and faculty to the administrators.

Principal

1. Chief administrator of the school.
2. Responsible to the Superintendent.
3. Interprets School Board policies, along with the Superintendent for the operation of the school.
4. Represents the school to parents, social agencies, and the community at large.
5. Plans for the total operation of the school including budgeting and the allocation of resources.
6. Evaluates administrative staff and those teachers going on continuing contracts.
7. Makes final decision on hiring of new personnel or discharging of present personnel.
8. Participates in planning and other county-wide activities with the central staff of the Superintendent's office.
9. Verifies all reports to the Superintendent as well as those to the outside agencies such as the State Department of Education.

Administrative Assistant to the Principal

1. Carries out specific tasks for which responsibility has been delegated by the Principal.
2. Serves as Director of Dissemination including responding to general correspondence relating to the program and arranging to meet the requests of visitors in so far as possible.
3. Functions as the Coordinator of Guidance in terms of establishing the general nature of the program. Also serves as the counselor to students who are prospective college students, especially during the students' senior year.
4. Coordinates articulation with the junior high schools to prepare those students for admission to Melbourne High School.
5. Assists with student disciplinary cases involving personal matters with female students.

Vice Principal of Administration

1. Supervises the operation of the physical plant.
2. Supervises the operation of the business office.
3. Works with the Dean of Students on the more serious discipline problems.
4. Assists in problems involving teacher-student conflicts.
5. Works with parents of students, especially in the case of discipline problems.
6. Supervises student activities.
7. Assists in evaluation of teachers for promotion and tenure.
8. Director of Adult Education program of evening studies.
9. Carries out specific tasks for which responsibility has been delegated by the Principal.

Vice Principal of Academic Programs

1. Helps teachers identify behavioral objectives for courses.
2. Works with teachers on the content of courses and the development of new courses.
3. Works with groups of teachers as well as individuals to help improve instruction in the classroom.
4. Coordinates all academic programs including independent studies.
5. Provides general supervision for library.
6. Provides general supervision for audio-visual center.
7. Screens new teacher applications.
8. Assigns teachers to courses and to teams.
9. Supervises teacher trainees serving on internships.
10. Coordinates in-service training programs for teachers.
11. Evaluates teacher performance for promotion and tenure.
12. Coordinates special programs and grants of an academic nature.
13. Carries out specific tasks for which responsibility has been delegated by the Principal.

Coordinator of Independent Studies

1. Defines the program of Independent Studies in collaboration with the Vice Principal of Academic Programs.
2. Disseminates information about the program to faculty and students.
3. Coordinates assignment of students to preceptors and monitors each project for progress.

Dean of Students

1. Enforces school rules concerning attendance and discipline.
2. Functions as a part of the Guidance Department but works closely with the Vice Principal of Administration.

Counselor of Seniors

1. Works with twelfth grade students.
2. Helps some students with collage selection, although most of this work is done by the Administrative Assistant to the Principal.
3. Checks student records to be sure they meet graduation requirements.
4. Processes requests for phase changes.

Counselor of Juniors

1. Works with eleventh grade students.
2. Keeps student records up to date.
3. Processes requests for phase changes.
4. Registers new students during the year.

Counselor of Phase 1 and 2 Students

1. Works with all students, regardless of grade, who are in Reading Phase 1 or Communications Phase 2.
2. Maintains Student Activities Calendar for Vice Principal of Administration. Required to be on campus at night when clubs meet.
3. Serves 1½ hours cafeteria duty one day a week.

Executive Council

The Council is the formal mechanism by which recommendations can be made to the administration from the faculty, counseling staff, and student body. The Council is composed of one teacher from each subject matter area (department), one guidance counselor, and the President of the Student Council.

Functioning of the Present System

Interviews with the persons who now hold the above described positions plus interviews with several teachers and students provided information which suggests that, although Melbourne High School offers a program with considerably more flexibility than most high schools, maximum efficiency has yet to be reached in terms of matching students with program opportunities. Some characteristics about the way in which the system is presently functioning indicate areas of possible change. If appropriate alternatives could be implemented, the operation of the program could be smoother resulting in increased efficiency with efficiency being defined as providing the maximum opportunity for each student to work at his own level in each subject matter area.

The major set of problems centers around the placement of students in the present system of organizing the curriculum into phases. Apparently, the five tracks (phases) are not enough to give the homogeneous groups they desire as evidenced by the further splitting of Phase 3 into segments A and B. The student volitional method of choosing phases also tends to reduce the homogeneity of the groups. Phasing of students is accomplished primarily by past performance and teacher evaluation, although student choice can generally override those factors. Phase Prediction Examinations have been developed for a portion of the curriculum.

Some teachers and counselors reported that a few of the students take advantage of the phasing system in a negative way. Some students who believe they are going to fail a particular class will attempt to phase into another one where they hope there are better chances for a higher grade. Apparently some teachers would argue that such activities are the way in which students find their most appropriate level of working while other teachers would say that such practices encourage quitting when the going gets tough. Also, some students drop one class and manage to wait several days before signing up or reporting to the new class. That this can happen appears to result from the overload of paper work of the counselors as they process the phase change requests and maintain the student records manually.

There is some question whether phasing up is as feasible as phasing down. The higher phases cover subject matter at a greater depth and have a tendency to move faster, thereby placing a great burden upon the student who dares to phase up after the beginning of the semester.

Perhaps the greatest bottle neck in the implementation of the phasing system is in processing the paper work. As it now stands, students request a phase change from their counselors who have the responsibility of getting permission from the teacher of the class being dropped and the teacher of the class being added, plus checking to see what the change will mean to the student in terms of graduation requirements. The counselors for sophomores, juniors, and seniors now appear to function essentially as clerks who process student registration and phase change requests.

Specifications for an Automated Student Information System

The need for an automated student information system was documented in the previous section of this report. The establishment of such a system with the capability of monitoring student progress within courses as well as toward graduation, and to process phase change requests would be the single most important change that could be made to facilitate the operation of the phasing system at Melbourne High School.

Development of an automated student information system to carry out the function of record keeping would be a simple programming task. Similarly, the function of phase changing and the function of checking graduation requirements would be relatively easy. Before the system could monitor progress within courses, however, the behavioral objectives of each course would have to be fixed and a series of progress achievement tests constructed. The work of the Educational Testing Service has provided a start toward such a network of tests. Once all of the tests are in use, a reliable Phase Prediction System could be generated to suggest to students the probable consequence of selecting any of the phase alternatives.

The automated student information system would need the following capabilities:

Registration of New Students in the 10th Grade

1. Indicate to each student the requirements for graduation.
2. Indicate to each student the courses available.
3. Indicate to each student the available options of phasing, grading system (Satisfactory - Unsatisfactory, A-B-C-D-F, and Pass - Fail Agreement), and teachers.
4. Indicate to each student his phase predictions and the information upon which the predictions were based, e.g., past grades, achievement tests, ability tests, and other special tests or information.

5. Accept student choices.
6. Print out master schedule based upon student choices.

Registration of Continuing Students at the Beginning of a Semester

1. Scan the permanent record of each student and indicate to him the remaining requirements for graduation.
2. Indicate to each student the courses not already successfully completed.
3. Same as for 10th grade.
4. Same as for 10th grade.
5. Same as for 10th grade.
6. Same as for 10th grade.

Requests for Phase Changes or Class Changes Within a Phase

1. Accept the request for phase or class change including the specific reason for the request.
2. Check and report to student whether or not the requested class meets a graduation requirement.
3. Check and report to the student if the requested class is available to the student. If the answer is "no", state the reason, e.g., class full, student has already taken the course, student does not meet entrance requirements, etc.
4. If answers to 2 and 3 above are "yes", or if student chooses an elective rather than a required course, check and report to the student concerning permission of the teacher of the class being dropped and of the teacher of the class being added.

Suggested Organizational Structure for Incorporating an Automated Student Information System

While the New York Institute of Technology provided for the computer programming necessary for the implementation of an automated student information system, the necessity for adding to the Malbourne High School staff at least one data processing person was obvious. Additional persons to fill the capacities of Key Punch Operator and Clerical Assistant would

also be needed in the near future. These persons could be added to the present administrative staff without any organizational changes.

Ultimately a new organizational structure would be advisable in order to more efficiently cluster the functions of the administrators. The job descriptions could then be more easily specified in a manual for succeeding persons. That each person brings special skills and competencies to a position which tend to modify the job description over time is not denied. Neither, however, should the organization be dependent upon the uniquenesses of its administrators to the extent that the functions could not be identified and job descriptions spelled out in writing.

What is identified in the organizational chart that follows is an advanced state of reorganization to be reached in stages which could more efficiently administer Melbourne High School under its present conception of operation which is highly influenced by the Phasing System of Curriculum Organization. Any changes of school philosophy affecting the phasing of students would necessarily influence the organizational structure. However, the organization system depicted should be able to administer a variety of programs aimed at individualized instruction assuming the availability of the automated student information system.

New Job Description

The role of the Principal would remain the same as would that of the Executive Council. A Curriculum Committee, which has been recently formed at Melbourne High School, is attached to the Executive Council. The fixed assignments of the Administrative Assistant to the Principal have been reduced to one - the dissemination service. This position needs to be more flexible in schedule in order to be of maximum service to the Principal.

SUGGESTED ORGANIZATIONAL STRUCTURE FOR
INCORPORATING AN AUTOMATED STUDENT INFORMATION SYSTEM

Figure 4-2

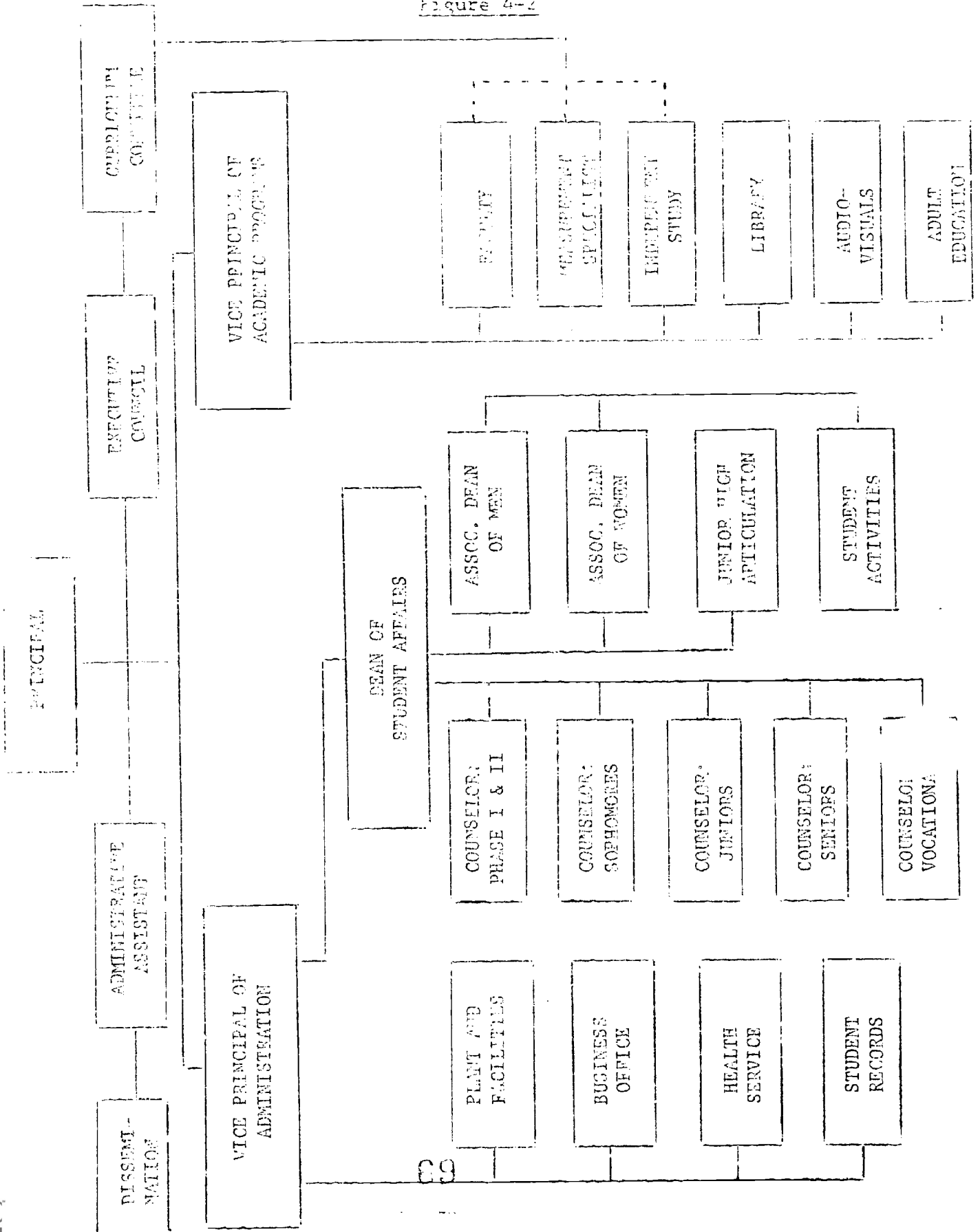

A person in charge of student affairs is recommended at the Vice Principal level. This person would coordinate all student activities of a non-academic nature. A secretary could keep the student activities calendar in this office. A Dean of Women would be added who would report to the Vice Principal of Student Affairs along with the Dean of Men. These Deans would serve primarily to maintain discipline and attendance. The Guidance Department would be coordinated by this Vice Principal. As the student record keeping would now be automated and under the aegis of Administration, the counselors would be free to work with students more along the lines advocated by the American Personnel and Guidance Association.

Student Activities and Adult Education would be transferred away from the Vice Principal of Administration while this position would pick up the responsibility for the student records and the associated data processing.

The Vice Principal of Academic Programs would assume the responsibility for the Adult Education Program. A Measurement Specialist would be added to this group to help the faculty develop the progress achievement tests necessary for the phasing system.

Implications for Teacher Roles

As the faculty moves toward specifying behavioral objectives for each course and as they participate in the development of the needed progress achievement tests, the alternative of repackaging the curriculum into more convenient "units" may look attractive to them. Electing such an alternative would tend to shift the curriculum toward a more individualized instructional program for each student than is possible with the present phasing system. With each student working his way through a series of

curriculum units, progressing at his own pace according to achievement tests, the grouping of students into grades and phases would be needed less and less.

Repackaging the curriculum is a time-consuming activity. Teachers would likely find themselves spending more time on writing materials and less time imparting information as a lecturer. Communication of information to students would probably be done mostly through programmed instruction and multi-media devices. Through the use of study guides, students would spend more time organizing and synthesizing information and less time memorizing the synthesis of some teacher.

The point is that the roles of the students and the teachers are probably going to change somewhat with the introduction of an innovative student information system which can efficiently match student to material or at least track students through a complex curriculum structure. Not the least of those affected will be the counselors who will be relieved of the burden of their clerical tasks in order to work with students on matters of educational, vocational and personal interest.

APPENDIX A

TEST BOOKLETS

Booklet No.

23	BIOLOGY-BSCS I (For Phases 3, 4, and 5)
22	BIOLOGY I (For Phases 1 and 2)
21	BIOLOGY A (Across Phases)
26	BIOLOGY-BSCS II (For Phases 3, 4, and 5)
25	BIOLOGY II (For Phases 1 and 2)
24	BIOLOGY B (Across Phases)
28	BIOLOGY-BSCS III (For Phases 1 and 2)
27	BIOLOGY III (For Phases 1 and 2)
29	BIOLOGY-BSCS IV (For Phases 3, 4, and 5)
73	BIOLOGY-BSCS I (For Phases 3, 4, and 5)
72	BIOLOGY I (For Phases 1 and 2)
71	BIOLOGY A (Across Phases)
76	BIOLOGY-BSCS II (For Phases 3, 4, and 5)
75	BIOLOGY II (For Phases 1 and 2)
74	BIOLOGY B (Across Phases)
78	BIOLOGY-BSCS III (For Phases 3, 4, and 5)
77	BIOLOGY III (For Phases 1 and 2)
79	BIOLOGY-BSCS IV (For Phases 3, 4, and 5)
30	BASIC MATHEMATICS I (Whole Numbers)
31	BASIC MATHEMATICS II (Fractions)
32	BASIC MATHEMATICS III (Decimal and Per Cent)
33	BASIC MATHEMATICS IV (Measurement and Denominate Numbers)
34	ENGLISH II-A (For Phase 2)
35	ENGLISH III-A (For Phase 3)
36	ENGLISH IV-A (For Phase 4)
37	ENGLISH II-B (For Phase 2)
38	ENGLISH III-B (For Phase 2)
39	ENGLISH IV-B (For Phase 4)
40	ENGLISH II-C (For Phase 2)
41	ENGLISH III-C (For Phase 3)
42	ENGLISH IV-C (For Phase 4)
43	ENGLISH II-D (For Phase 2)
44	ENGLISH III-D (For Phase 3)
45	ENGLISH IV-D (For Phase 4)

The measures contained herein
may not be reproduced without
permission.

REPRODUCED FROM THE NATIONAL ARCHIVES
SERIALS SECTION BY MICROFICHE ONLY
SERIALS SECTION

23

LM Mayer
... AND ORGANIZATIONS OPERATING UNDER AGREEMENTS WITH THE NATIONAL ARCHIVES FOR INFORMATION. FURTHER REPRODUCTION OF THIS INFORMATION IS PERMITTED ONLY THROUGH THE INFORMATION SYSTEMS CENTER, NATIONAL ARCHIVES.

FORM PBC6

BIOLOGY-BSCS 1 (For Phases 3, 4, and 5)

Time—40 minutes

YOU ARE TO INDICATE ALL YOUR ANSWERS ON THE SEPARATE ANSWER SHEET. No credit will be given for anything written in the test book. After you have decided which of the suggested answers you want to give for a question, blacken the corresponding space on the answer sheet.

Example:

- Chicago is a
- (A) state
- (B) city
- (C) country
- (D) continent

Sample Answer

A	B	C	D
<input type="radio"/>	<input type="radio"/>	<input type="radio"/>	<input type="radio"/>

Give only one answer to each question; no credit will be given for multiple answers. If you wish to change an answer, erase your first line completely and mark your new choice.

DO NOT WRITE IN THESE SPACES UNTIL YOU ARE TOLD TO DO SO.

Note for Teachers: This test is based on the BSCS, Molecules to Man (Part 1 and 2).

Copyright © 1967
by
Biological Sciences Curriculum Study
All rights reserved.
Reproduced by permission.

1. Classification systems are man-made and are
 - (A) acceptable to all taxonomists.
 - (B) unchanging and reliable.
 - (C) subject to modification.
 - (D) a permanent part of biology.

2. A scientist uses controls in conducting research because
 - (A) controls become his standards.
 - (B) all scientific work uses controlled experiments.
 - (C) he needs controls to direct the investigation.
 - (D) he must control the experiment or he will get wrong answers.

3. Which one of the following groupings includes the most kinds of animals or plants?
 - (A) Species
 - (B) Order
 - (C) Genus
 - (D) Phylum

4. The controlled experiment is essential to the testing of a hypothesis because it
 - (A) tests many aspects of a problem.
 - (B) uses a trial-and-error method.
 - (C) is necessary in the experiment.
 - (D) insures that a single part of the problem is tested at a time.

5. A definition of the term animal which will separate animals from plants is not easily given because
 - (A) it is not defined precisely in the textbook.
 - (B) exceptions to most characteristics given in such a definition can usually be found.
 - (C) animals are obviously animals and plants are obviously plants.
 - (D) some plants are green but no animals are green.

Questions 6-7

6. An insect of Species A is found in large numbers in an area in which many people suffer from disease H. To demonstrate that disease H is transmitted by these insects, it would be necessary to
 - (A) learn more about the insect's life history.
 - (B) prevent the insects from biting people.
 - (C) find the disease germs in the insect's body.
 - (D) let some of the insects bite people who are not suffering from disease H.

 7. The area is now sprayed with insecticide X which kills most of the insects of Species A. If this insect were the transmitter of disease H, we now would expect
 - (A) no people would have the disease.
 - (B) all people with disease H to recover.
 - (C) fewer new cases of disease H to develop.
 - (D) disease H to disappear completely.
-
8. A scientist collects data relevant to a problem because
 - (A) all research is designed to produce data.
 - (B) relevant data lead to the solution of a problem.
 - (C) relevant data are the only data produced.
 - (D) all data are relative.

 9. The procedure of scientists testing the secretions of hundreds of molds to find new antibiotics is known as
 - (A) a controlled experiment.
 - (B) trial-and-error.
 - (C) qualitative experimentation.
 - (D) quantitative experimentation.

GO ON TO THE NEXT PAGE.

Questions 10-14

Over a wide area of the United States the oak tree is threatened by the disease called oak wilt. The disease is caused by a fungus. How is the disease spread?

Hypothesis I. The disease is spread by carriers such as insects.

Hypothesis II. The disease is spread from tree to tree by contact of the roots.

- Key: (A) A fact which supports Hypothesis I
(B) A fact which supports Hypothesis II
(C) A fact which supports both hypotheses
(D) A fact which supports neither hypothesis
10. The disease-causing fungus can grow on the ash, dogwood, the wild cherry and other trees.
1. The top of the diseased tree begins to wilt and turn brown, then the lower limbs become involved.
 2. In a stand of oaks the roots of neighboring trees become grafted to one another.
 3. The fungus grows best at temperatures of 13°-24°C.
 4. Single trees (not those in groups) often become infected if they have been damaged by wind or lightning.

-
11. If Darwin were living today, he could test his atoll-formation hypothesis because
- (A) biologists can classify animals more accurately now.
 - (B) future glaciation can be predicted.
 - (C) deep borings into the atoll can be obtained.
 - (D) navigation to atolls is quite easy.

Question 16 refers to the following chart.

Patient	Complaint	Symptoms
I	High fever	Profuse sweating
II	Sore eyes	Watery discharge from eyes
III	A common cold	A runny nose
IV	Soils	Watery-pus discharge

The hypothesis that best accounts for all of these symptoms is

- (A) sick people always have fever which causes sweating.
 - (B) people with runny noses often have colds.
 - (C) excessive water discharge seems to accompany illnesses.
 - (D) all illnesses result in pus formation.
17. A scientist performed an experiment on a subject which was believed to be thoroughly understood. The results of the scientist's work contradicted many former experiments. Which of the following statements represents the correct scientific attitude to take concerning this?
- (A) The scientist must have made a mistake when he performed the experiment.
 - (B) The results could be valid, but further tests must be made to determine if this is so.
 - (C) Since everything was already known about the subject, the scientist's experiment was unnecessary.
 - (D) The scientist must be right, because he had all the data from previous experiments to work with.
18. These animals are multicellular and have 2 layers of cells, a digestive tract or cavity with one opening, radial symmetry, a network of nerve cells, and a sac-like body.
- (A) Mollusks
 - (B) Echinodermata
 - (C) Coelenterata
 - (D) Annelida
19. Before a scientist can classify a newly discovered specimen of plant or animal, he must make a careful study of its
- (A) relationships in the plant and animal community.
 - (B) size.
 - (C) structure.
 - (D) adaptability.

GO ON TO THE NEXT PAGE.

scientist recognizes the importance of selecting appropriate techniques for conducting his research because

- (A) he knows that techniques affect his results.
- (B) he is limited to techniques which can be followed in his laboratory.
- (C) he knows only one technique will give the result he is seeking.
- (D) he is limited to techniques he has tried in the past.

Questions 21-25 refer to the following diagram.

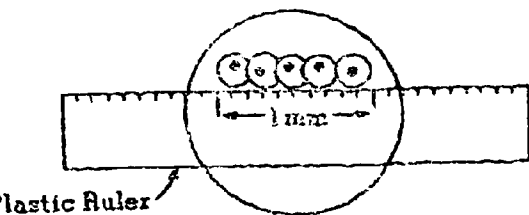

A clear plastic ruler has been placed across the center of the field and a row of cells can be seen. How many microns make up a millimeter.

What is the average cell length in microns?

- (A) 100 microns
- (B) 200 microns
- (C) 400 microns
- (D) 1,000 microns

What is the average cell length in millimeters?

- (A) 1 mm.
- (B) .1 mm.
- (C) .2 mm.
- (D) .5 mm.

Approximately how many cells could be seen if the microscope were changed to high power?

- (A) None
- (B) One
- (C) Five
- (D) About ten

Approximately how long is the nucleus?

- (A) 1 micron
- (B) 75 microns
- (C) 200 microns
- (D) 1,000 microns

25. If the diameter of the low-power field of your microscope was found to be 2 millimeters and the ratio between the low-power and high-power fields was 10, what would the diameter of the high-power field be in millimeters?

- (A) .2 mm.
- (B) 20 mm.
- (C) 40 mm.
- (D) 200 mm.

Questions 26-27

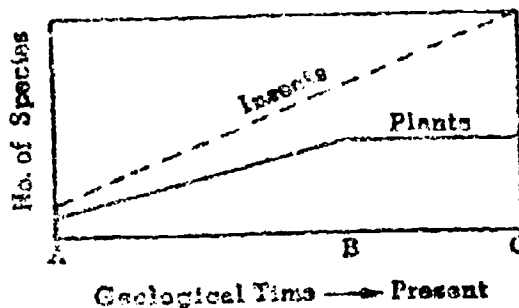

26. Which of the following best explains the increases in species of flowering plants?

- (A) Insects carried the seeds to a variety of habitats.
- (B) New insect forms pollinated new plant species.
- (C) New species of flowers are evolving.
- (D) The number of flowers increased to offset the number eaten by insects.

27. The numbers of species of insects from time B to time C seem to be

- (A) exceeding its usefulness.
- (B) increasing geometrically.
- (C) dependent upon the number of species of flowers.
- (D) independent of the number of species of flowers.

GO ON TO THE NEXT PAGE.

evidence supports the theory of evolution?

fossil remains which are similar to living forms.

fossil remains found at great depths which are related to living forms.

fossil remains which have been traced to living forms by structural resemblance.

sequence of fossils showing a pattern of structural similarities to a present form.

Which of the following statements best explains why organisms under different magnification seem to move at different speeds? The area observed under

high power is smaller and the organisms seem to cover the observed area more quickly.

High power is larger than under low power and the organisms seem to cover the observed area more slowly.

Low power is smaller than under high power and, the organisms seem to cover the area more quickly.

Low power is larger than under high power and the organisms seem to cover the area more quickly.

30. Which of the following statements best explains why organisms under magnification move in and out of focus?

(A) The experimenter makes slight shifts in the adjustment mechanism.

(B) There is a failure to maintain a steady source of light for the microscope.

(C) The organisms move in and out of different levels within the fluid.

(D) The experimenter does not keep careful and steady observation.

IF YOU FINISH BEFORE TIME IS CALLED, CHECK YOUR WORK ON THIS TEST.

BIOLOGY I (For Phases 1 and 2)

Time—40 minutes

YOU ARE TO INDICATE ALL YOUR ANSWERS ON THE SEPARATE ANSWER SHEET. No credit will be given for anything written in the test book. After you have decided which of the suggested answers you want to give for a question, blacken the corresponding space on the answer sheet.

Example:

Chicago is a

- (A) state
- (B) city
- (C) country
- (D) continent

Sample Answer

A	B	C	D
<input type="radio"/>	<input type="radio"/>	<input type="radio"/>	<input type="radio"/>

Give only one answer to each question; no credit will be given for multiple answers. If you wish to change an answer, erase your first line completely and mark your new choice.

DO NOT OPEN THIS BOOK UNTIL YOU ARE TOLD TO DO SO.

Note for Teachers: This test is based on the ESCS Special Materials 51-514.

Developed by Educational Testing Service pursuant to a subcontract funded by the U. S. Department of Health, Education, and Welfare, Office of Education.

79

- Which of the following best describes the basis of a good classification system?
 - It is based only on similarities among organisms.
 - It is based only on differences among organisms.
 - It is based on similarities as well as differences among organisms.
 - It is based on neither similarities nor differences among organisms.
- The classification system used in biology is based primarily on
 - structure
 - function
 - age
 - sex
- If the object you are looking at under your microscope is too dark, it could NOT be brightened by
 - opening the diaphragm
 - switching to the high-power objective lens
 - focusing
 - using a thinner specimen on your slide
- The process through which an animal gives rise to offspring is called
 - metabolism
 - organization
 - reproduction
 - classification
- If an organism appears to be 1 centimeter across when viewed with the 10X eyepiece and 10X objective, what is the actual size of the organism?
 - 1/100 cm.
 - 1 cm.
 - 10 cm.
 - 100 cm.
- Which of the following best describes how a scientist considers a classification system?
 - A useful system that can change
 - An unchanging system
 - A system based on similar functions
 - A system that is not really necessary
- Which of the following would give you the LEAST specific information about an organism that you are attempting to classify?
 - Whether it is a plant or an animal
 - Whether it is a toad or a frog
 - Whether it is a butterfly or a moth
 - Whether or not it has a backbone
- If 500 seeds weigh 10 grams, one seed would probably weigh
 - 2 grams
 - 5 grams
 - .65 gram
 - .02 gram
- Which of the following is a correct procedure for the care of a microscope?
 - Carrying it in one hand
 - Keeping it away from the edge of the table
 - Cleaning the objective with your handkerchief
 - Returning the setting to high power before putting it away
- In which of the following pairs are the animals most different?
 - Jellyfish..fish
 - Cats..lions
 - Dogs..foxes
 - Alligators..crocodiles
- Which of the following has the largest number of animals within its classification?
 - Class
 - Genus
 - Phylum
 - Kingdom
- The ratio of magnification of the eyepiece to the low-power objective to the high-power objective is approximately
 - 1:1:1
 - 1:1:4
 - 1:2:1
 - 1:4:1
- Bubbles should be removed from a temporary slide prepared in the laboratory by
 - heating the slide
 - adding more water to the slide
 - gently tapping the slide
 - pushing down on the slide's cover slip
- If one switches from low to high power when observing a specimen under a microscope, the
 - distance between the stage and objective decreases
 - distance between the stage and objective increases
 - distance between the stage and objective remains the same
 - high-power objective will touch the stage
- Approximately how much greater magnification do you get when you change from low power to high power?
 - $2\frac{1}{3}\times$
 - $4\frac{1}{3}\times$
 - $6\frac{1}{3}\times$
 - $10\frac{1}{3}\times$

GO ON TO THE NEXT PAGE.

1. Biological classification is based primarily on

- (A) physiology (B) structure
- (C) size (D) shape

2. Which of the following animals has a skeleton most similar to that of man?

- (A) Frog (B) Grasshopper
- (C) Crayfish (D) Centipede

3. Which of the following is a correct statement about living things?

- (A) All things that move are alive.
- (B) It is difficult to decide whether some things are alive or not alive.
- (C) Most living things produce their own food.
- (D) An individual animal must reproduce in order to be considered alive.

4. If 20 pins are required to balance a scale containing 1 ounce of a certain material, 400 pins would balance how many ounces of the same material?

- (A) 2 oz. (B) 20 oz. (C) 50 oz. (D) 200 oz.

5. Which of the following are most similar?

- (A) Frogs and birds (B) Snakes and mice
- (C) Dogs and wolves (D) Cats and dogs

6. A good grouping system should

- (A) serve a useful purpose for the user
- (B) be based on qualities that are different for all observers
- (C) use different characteristics throughout
- (D) not bring out differences if they exist

7. The many differences between living things is called

- (A) reproduction (B) diversity
- (C) metabolism (D) circulation

8. The easiest and most widely accepted way to determine the number of trees in a large forest of a known area is to count

- (A) the trees in a number of selected plots throughout the forest and use this figure to estimate the total number
- (B) all the trees
- (C) the trees in one section and use this figure to estimate the total number
- (D) the trees in a section in the middle and use this figure to estimate the total number

9. The ability of an organism to make copies of itself is called

- (A) metabolism (B) population
- (C) reproduction (D) evolution

10. Which of the following is the most nearly correct statement about scientific grouping systems?

- (A) They are subject to change.
- (B) All scientists agree on the same system.
- (C) Once placed in a group, a plant or animal will stay in that group.
- (D) The grouping systems are based on a single characteristic.

11. One would expect to find the greatest density of people per acre in the

- (A) city slums (B) suburbs
- (C) rural areas (D) small towns

12. Which of the following would be the most accurate way of determining the weed population in a school yard that is 100 feet by 200 feet?

- (A) Counting the weeds in 1 square foot and then calculating the number of weeds
- (B) Counting the weeds in 5 one-foot plots and then calculating the number
- (C) Counting the weeds in 10 one-foot plots and calculating the number
- (D) Counting all the weeds in the school yard

13. Which of the following number of samples would usually be the most accurate for determining the size of a population?

- (A) 1 (B) 5 (C) 10 (D) 20

14. You are given a sealed box containing a living organism. You could help determine the contents of the box by all of the following EXCEPT

- (A) shaking the box (sound)
- (B) weighing the box
- (C) noting the color of the box
- (D) measuring the height of the box

GO ON TO THE NEXT PAGE.

81



Questions 15-17 refer to the following study.

Three students counted the weeds in three different plots. Student A counted 9, Student B counted 8, Student C counted 7. The plot that each measured was 2 feet long and 6 feet wide.

- 15. The average number of weeds per plot was
(A) 5 (B) 6 (C) 7 (D) 8
- 16. The area of the plot of ground that each student counted was
(A) 8 sq. ft. (B) 12 sq. ft.
(C) 16 sq. ft. (D) 25 sq. ft.
- 17. Each weed in the area is known as
(A) an individual (B) a population
(C) a random sample (D) an average

Questions 18-19 refer to the following figures.

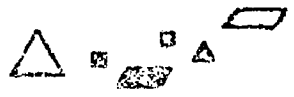

- 18. Which of the following would be the best basis for arranging the blocks above into two groups?
(A) Shape (B) Size (C) Thickness (D) Color
- 19. Which of the following would be the best basis for arranging the blocks above into three groups?
(A) Shape (B) Size (C) Thickness (D) Color

Questions 20-24 refer to the parts of the microscope and the care and use of the microscope.

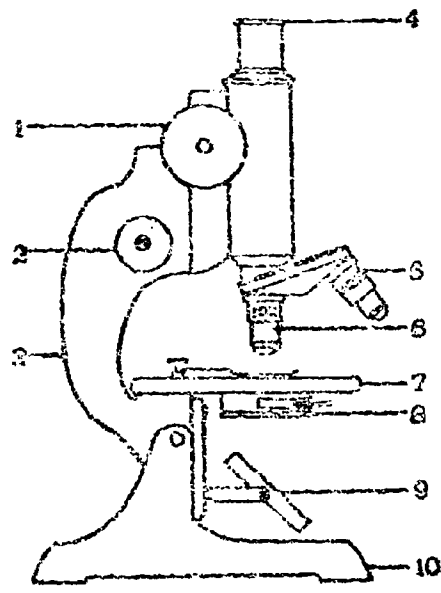

- 20. The part labeled 1 is called the
(A) eyepiece (B) low-power objective
(C) coarse adjustment (D) diaphragm
- 21. What part is used to make fine adjustments?
(A) 1 (B) 2 (C) 6 (D) 8
- 22. What part should be washed after each use?
(A) 4 (B) 5 (C) 6 (D) 7
- 23. Which of the following is NOT a good rule for the handling and use of the microscope?
(A) Keep the microscope away from the edge of the table.
(B) Carry the microscope with both hands.
(C) Clean the lens with paper or cloth.
(D) Make sure the microscope setting is on low power before putting it away.
- 24. When the eyepiece and high-power objective (43x) is used to observe a specimen, the specimen is magnified
(A) 10 times (B) 43 times
(C) 53 times (D) 430 times

GO ON TO THE NEXT PAGE.

Questions 25-27 refer to the following plots.

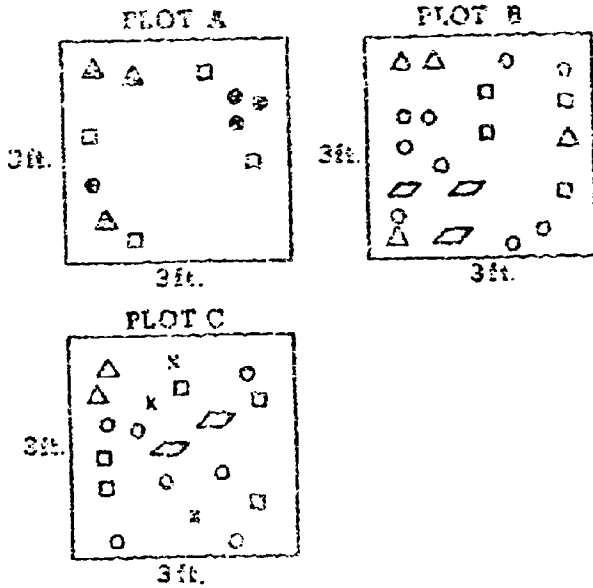

25. Which plot has the greatest number of individuals?
 (A) A only (B) B only (C) C only
 (D) Both B and C, which have the same number
26. How many groups of individuals are there in plot A?
 (A) 1 (B) 2 (C) 3 (D) 4
27. Which of the following statements about the number of groups in the plots is correct?
 (A) There are more groups in plot A than plot B.
 (B) There are more groups in plot B than plot A.
 (C) There are the same number of groups in both plot A and plot B.
 (D) There are more groups in plot A than plot C.

Questions 28-30 refer to the following grouping system.

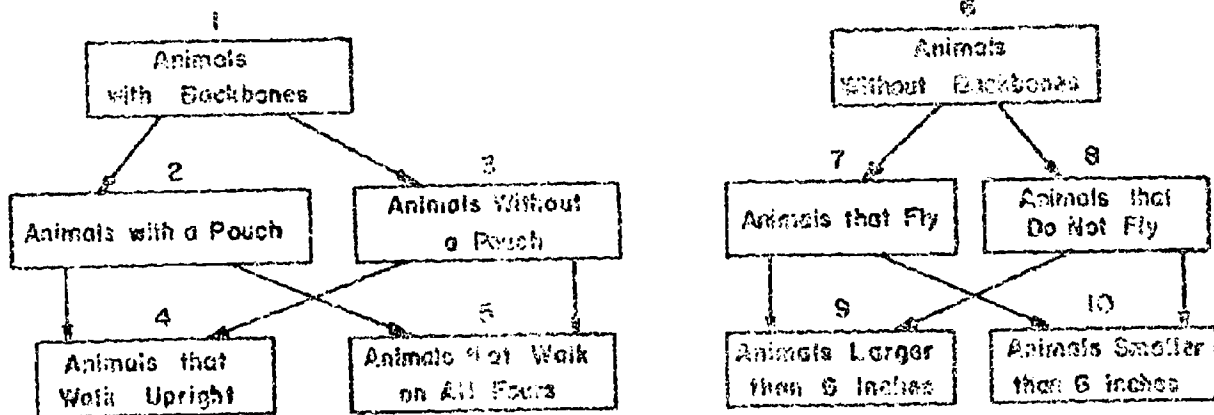

28. How would man be classified in this system?
 (A) 1, 3, 4 (B) 1, 2, 4
 (C) 6, 3, 4 (D) 1, 2, 10
29. How would an adult American grasshopper be classified in this system?
 (A) 1, 7, 10 (B) 6, 7, 10
 (C) 6, 8, 10 (D) 4, 6, 7
30. How would an opossum be classified in this system?
 (A) 1, 2, 5 (B) 1, 2, 4
 (C) 1, 3, 6 (D) 1, 3, 5

IF YOU FINISH BEFORE TIME IS CALLED, CHECK YOUR WORK ON THIS TEST.

FORM PBC2

BIOLOGY A (Across Phases)

Time—40 minutes

YOU ARE TO INDICATE ALL YOUR ANSWERS ON THE SEPARATE ANSWER SHEET. No credit will be given for anything written in the test book. After you have decided which of the suggested answers you want to give for a question, blacken the corresponding space on the answer sheet.

Example:

Chicago is a

- (A) state
- (B) city
- (C) country
- (D) continent

Sample Answer

A	B	C	D
<input type="checkbox"/>	<input checked="" type="checkbox"/>	<input type="checkbox"/>	<input type="checkbox"/>

Give only one answer to each question; no credit will be given for multiple answers. If you wish to change an answer, erase your first line completely and mark your new choice.

DO NOT OPEN THIS BOOK UNTIL YOU ARE TOLD TO DO SO.

Note for Teachers: This test is based on the BSCS Special Materials 51-514 and Molecules to Man, chapters 1 and 2.

Developed by Educational Testing Service pursuant to a subcontract funded by the U. S. Department of Health, Education, and Welfare, Office of Education.

1. Which of the following best describes the basis of a good classification system?
 - (A) It is based only on similarities among organisms.
 - (B) It is based only on differences among organisms.
 - (C) It is based on similarities as well as differences among organisms.
 - (D) It is based on neither similarities nor differences among organisms.
2. The classification system used in biology is based primarily on
 - (A) structure
 - (B) function
 - (C) age
 - (D) sex
3. If the object you are looking at under your microscope is too dark, it could NOT be brightened by
 - (A) opening the diaphragm
 - (B) switching to the high-power objective lens
 - (C) focusing
 - (D) using a thinner specimen on your slide
4. The process through which an animal gives rise to offspring is called
 - (A) metabolism
 - (B) organization
 - (C) reproduction
 - (D) classification
5. If an organism appears to be 1 centimeter across when viewed with the 10x eyepiece and 10x objective, what is the actual size of the organism?
 - (A) 1/100 cm.
 - (B) 1 cm.
 - (C) 10 cm.
 - (D) 100 cm.
6. Which of the following best describes how a scientist considers a classification system?
 - (A) A useful system that can change
 - (B) An unchanging system
 - (C) A system based on similar functions
 - (D) A system that is not really necessary
7. Which of the following would give you the LEAST specific information about an organism that you are attempting to classify?
 - (A) Whether it is a plant or an animal
 - (B) Whether it is a toad or a frog
 - (C) Whether it is a butterfly or a moth
 - (D) Whether or not it has a backbone
8. If 500 seeds weigh 10 grams, one seed would probably weigh
 - (A) 2 grams
 - (B) 5 grams
 - (C) .05 gram
 - (D) .02 gram
9. Which of the following is a correct procedure for the care of a microscope?
 - (A) Carrying it in one hand
 - (B) Keeping it away from the edge of the table
 - (C) Cleaning the objective with your handkerchief
 - (D) Returning the setting to high power before putting it away
10. In which of the following pairs are the animals most different?
 - (A) Jellyfish...fish
 - (B) Cats...lions
 - (C) Dogs...foxes
 - (D) Alligators...crocodiles
11. Which of the following has the largest number of animals within its classification?
 - (A) Class
 - (B) Genus
 - (C) Phylum
 - (D) Kingdom
12. The ratio of magnification of the eyepiece to the low-power objective to the high-power objective is approximately
 - (A) 1:1:1
 - (B) 1:1:4
 - (C) 1:2:1
 - (D) 1:4:1
13. Bubbles should be removed from a temporary slide prepared in the laboratory by
 - (A) heating the slide
 - (B) adding more water to the slide
 - (C) gently tapping the slide
 - (D) pushing down on the slide's cover slip
14. If one switches from low to high power when observing a specimen under a microscope, the
 - (A) distance between the stage and objective decreases
 - (B) distance between the stage and objective increases
 - (C) distance between the stage and objective remains the same
 - (D) high-power objective will touch the stage
15. Approximately how much greater magnification do you get when you change from low power to high power?
 - (A) $2\frac{1}{3}\times$
 - (B) $4\frac{1}{3}\times$
 - (C) $6\frac{1}{3}\times$
 - (D) $10\frac{1}{3}\times$

Questions 16-20 refer to the numbered parts of the diagram below.

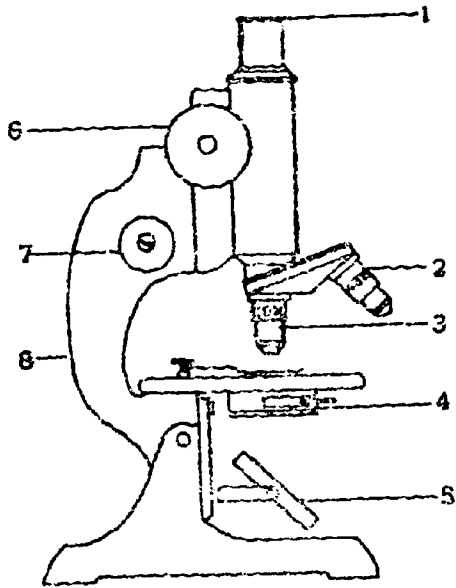

17. If structures 4 and 5 are in the proper adjustment and you still cannot see light, which of the following probably needs adjustment?
 (A) 1 (B) 2 (C) 6 (D) 8
18. Which of the structures shown is used for a coarse adjustment?
 (A) 2 (B) 3 (C) 6 (D) 7
19. When putting a microscope away, you should
 (A) tilt 8 back
 (B) align 2 with the barrel
 (C) align 3 with the barrel
 (D) close 4
20. Which of the following structures is used primarily to regulate the amount of light that enters the microscope?
 (A) 1 (B) 2 (C) 3 (D) 4

After adjusting a microscope for use with the high-power objective, one should look at the specimen by moving

- (A) 2 downward (B) 2 upward
 (C) 3 downward (D) 3 upward

GO ON TO THE NEXT PAGE.

Directions: Each passage in this part is followed by a number of questions. In answering the questions you are expected to use your knowledge of biology as well as the information given you. For each question select the answer you think best and blacken the corresponding space on the answer sheet.

Questions 21-25

In the sixteenth century, trained cheetahs were found in every hunting lodge in Europe. Even today, in India, imported cheetahs are used to hunt antelope. A hooded cheetah is taken near a herd by a bullock cart, and its hood and leash are removed. It rushes to bring down its prey, and holds it by the throat until the attendant arrives for the dispatch.

The cheetah was thought to be the world's fastest runner, with a top speed estimated at 70 to 90 miles per hour. However, a recent film study revealed its top speed to be 56 miles per hour, so the title for fastest runner went to a pronghorn buck, clocked at 61 miles per hour. Adult cheetahs reach 4 feet in length and 135 pounds in weight. The coat is short-haired, yellow, and heavily black-spotted. The cheetah closely re-

sembles the leopard. In contrast to leopard spots, which are large, open rosettes, cheetah spots are small, solid, and set close together. A characteristic "dark-teardrop" marking characterizes its face. Unlike all other cats, the cheetah does not have claw sheaths. The claws remain exposed at all times, although the cheetah can partially retract its claws. The claws are similar to those of a dog in that they are dull, poor for ripping, and impossible to grip with because they cannot spring from the paws. Although cheetahs were once found in large numbers in open grassland scrub in Africa and Western Asia, the population is rapidly declining, and they are considered to be extinct in India and most of Asia. Only very strict conservation measures can insure their survival and save them from extinction.

21. According to the description of the passage, which of the following pictures is a cheetah?

(A)



(B)

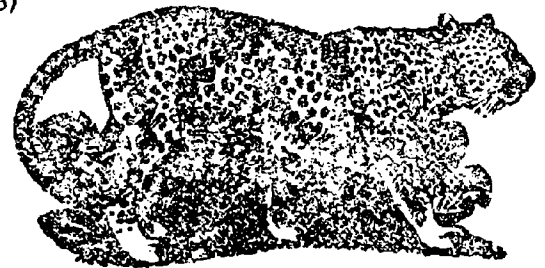

(C)

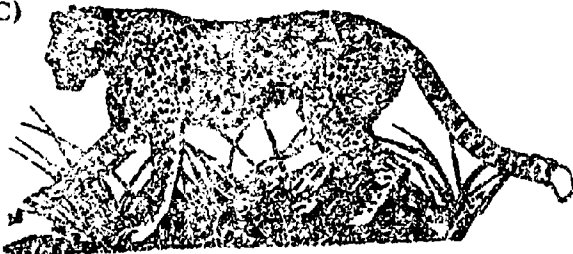

(D)

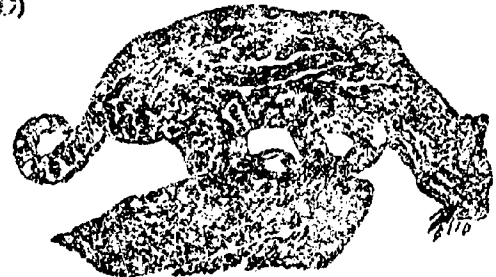

22. Today, the greatest number of cheetahs in the wild state can be found in
 (A) Europe (B) India (C) Arabia (D) Africa

23. Present evidence places the top speed of the cheetah at
 (A) 55 m.p.h. (B) 61 m.p.h.
 (C) 70 m.p.h. (D) 90 m.p.h.

24. It can be inferred from the passage that the cheetah most commonly eats which of the following?
 (A) Vegetation of open grassland and scrub
 (B) Small mammals and birds
 (C) Reptiles and frogs
 (D) Man

25. According to the passage, the claws of the cheetah resemble those of the dog in that they are
 (A) sharp
 (B) protected by sheath
 (C) poor for gripping surfaces
 (D) excellent for slipping food

Questions 26-30

The porpoise is an air-breathing, warm-blooded mammal with a body temperature about the same as that of man. Technically, a porpoise is a small whale, a toothed whale as opposed to the baleen whale, which grows much larger and has no teeth. Fifty known species of dolphins and porpoises inhabit all the oceans of the earth and some of the warm rivers.

The porpoise has a remarkable sonar or echolocating ability. He sends out sharp, clicking sounds and hears echoes from his clicks. Although its ears are as small as pinholes, its sense of hearing is incredibly keen. A stronger echo on one side indicates the direction of prey or predator. The time interval between sending and receiving tells the distance of the object; variations in echo sound reveals its size or nature.

Porpoises are descended from land animals, although their earliest ancestors came from the ocean. The land-mammal ancestor of the porpoise went through a long process of readapting to life in water. Its body grew streamlined and its legs disappeared. However, a porpoise still has finger bones in its flippers. Its nose evolved into a blowhole, one large nostril atop the head, with inner and outer valves to seal out the water. When it surfaces for air, about once a minute, a porpoise opens the blowhole wide and breathes in four to ten quarts of air in less than half a second. The porpoise developed tail flukes for propulsion; however, these flukes grow out horizontally, not vertically like those of fish.

26. Which of the following is approximately the same for both porpoise and man?
 (A) Habitat (B) Body temperature
 (C) Size of ears (D) Number of nostrils

27. By estimation of the time interval between sending and receiving a noise, a porpoise can determine the
 (A) direction of the object
 (B) depth of the object
 (C) character of the object (prey or predator)
 (D) distance to the object

28. Which of the following is an adaptation of the porpoise to a water habitat?
 (A) Keen sense of smell
 (B) A blowhole with valves
 (C) Warm-bloodedness
 (D) Body covered with fur

29. The rate of breathing of man compared with that of a porpoise is approximately
 (A) one half as fast
 (B) the same
 (C) two times faster
 (D) twenty times faster

30. A shark can be most easily distinguished from a porpoise by its
 (A) teeth (B) vertical tail fins
 (C) color (D) eating habits

IF YOU FINISH BEFORE TIME IS CALLED, CHECK YOUR WORK ON THIS TEST.



BIOLOGY-BSCS II (For Phases 3, 4, and 5)

Time—40 minutes

YOU ARE TO INDICATE ALL YOUR ANSWERS ON THE SEPARATE ANSWER SHEET. No credit will be given for anything written in the test book. After you have decided which of the suggested answers you want to give for a question, blacken the corresponding space on the answer sheet.

Example:

Chicago is a

- (A) state
- (B) city
- (C) country
- (D) continent

Sample Answer

A	B	C	D
<input type="checkbox"/>	<input checked="" type="checkbox"/>	<input type="checkbox"/>	<input type="checkbox"/>

Give only one answer to each question; no credit will be given for multiple answers. If you wish to change an answer, erase your first line completely and mark your new choice.

DO NOT OPEN THIS BOOK UNTIL YOU ARE TOLD TO DO SO.

Note for teachers: This test is based on the BSCS, Molecules to Man, Chapters 3, 4, 5, and 6.

Copyright © 1966
by
Biological Sciences Curriculum Study.
All rights reserved.
Reproduced by permission.

39

- Which of the following is not a heterotroph?
 - Human.
 - Mushroom.
 - Frog.
 - Maple tree.
- Which of the following statements represents a belief in spontaneous generation?
 - Corn is planted and fails to germinate.
 - A white rat has 8 black offspring.
 - Frogs come from mud.
 - Flies develop on decaying food.
- If a compound were a protein one could correctly conclude it was
 - constructed from amino acids.
 - soluble in water.
 - made of carbon, hydrogen and oxygen only.
 - a small molecule.
- The use of bacteria in studies of natural selection is
 - not possible because of their disease-producing capabilities.
 - advantageous due to the large numbers of individuals produced.
 - limited; the information gained cannot be applied to other organisms.
 - not accepted as a valid experimental approach to the problem.

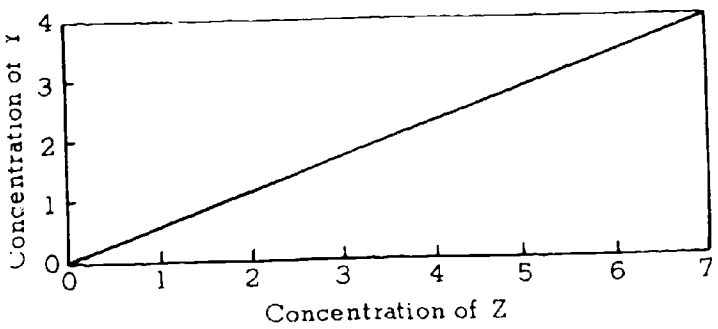

- What conclusion can be made on the basis of the graph?
 - An increase in the concentration of Z caused an increase in the concentration of Y.
 - The concentration of Y increased with time.
 - The concentration of Z is related to the concentration of Y.
 - There is no relationship between the concentrations of Y and Z.

- Miller's electrical sparking device was an attempt to duplicate conditions as they were on earth during the time of the primitive atmosphere. The electrical spark was meant to represent
 - heat conditions.
 - volcanic eruptions.
 - ultraviolet radiation.
 - lightning.

Questions 7-9 refer to the equation

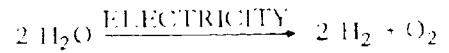

- 2
 - 3
 - 4
 - 5
- How many kinds of atoms are represented?
 - How many kinds of molecules are represented?
 - How many molecules are represented?

- When two amino acids are bonded chemically
 - energy is released.
 - energy is added to ADP.
 - water is released.
 - water is added.
 - In the electrolysis of water why is twice as much hydrogen gas as oxygen gas produced?
 - Oxygen is more easily compressed.
 - 2 atoms of hydrogen to 1 atom of oxygen are produced.
 - Oxygen is twice as dense as hydrogen.
 - Hydrogen occupies twice as much space as oxygen.

GO ON TO THE NEXT PAGE.

Questions 12-14

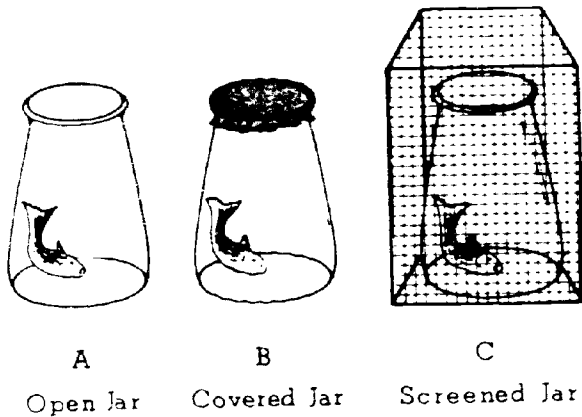

12. If spontaneous generation were to be established one would expect to find maggots in
- (A) A and B only.
 (B) B and C only.
 (C) C only.
 (D) A, B, and C.
13. If flasks A and B were used together, A would serve as a
- (A) conclusion.
 (B) control.
 (C) source of flies.
 (D) hypothesis.
14. Redi's original hypothesis, that flies were the source of maggots, could be established if there were maggots in
- (A) A.
 (B) B.
 (C) B and C.
 (D) A and B.

15. Which of the following is an example of fermentation?
- (A) Formation of glucose by green plants.
 (B) Breakdown of ATP into ADP.
 (C) Production of alcohol from glucose.
 (D) Production of carbon dioxide from glucose.

16. Although Madagascar is separated from Africa only by a narrow strait, many plants and animals common on the mainland are unknown on the island. This fact illustrates the principle of
- (A) great environmental differences between Africa and Madagascar.
 (B) evolutionary equilibrium.
 (C) evolution in isolated populations.
 (D) succession.

Questions 17-19

A swamp near a boy's camp was sprayed with DDT at weekly intervals. The summer attempt to control the mosquito problem

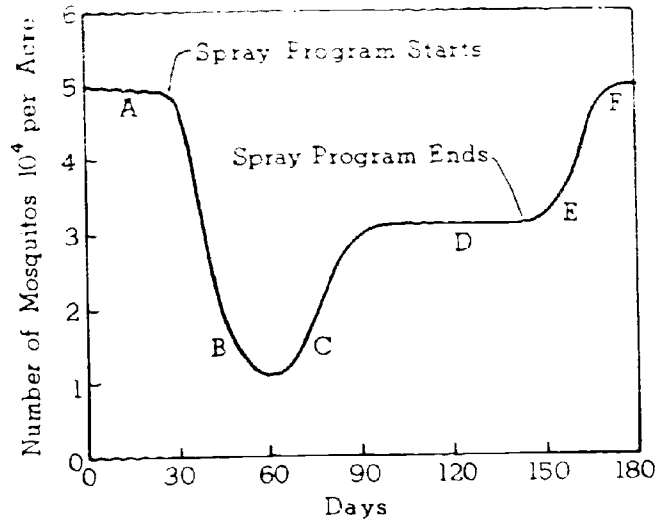

17. The most probable reason for the decreasing effectiveness of the campaign as the summer progressed was that the
- (A) mosquitos became immune to the DDT.
 (B) mosquitos resistant to DDT lived and produced offspring.
 (C) DDT was used at irregular intervals.
 (D) the DNA of the mosquito population was not affected.
18. Not all of the mosquitos were killed at the time of the first spraying. The best explanation is that
- (A) the weather early in the summer was probably rather cool.
 (B) most of the mosquitos were adults.
 (C) environmental factors varied slightly as the summer progressed.
 (D) natural variation existed within the population.
19. Doubling the dose at the time of the initial spraying probably
- (A) would not have resulted in a 100 percent kill.
 (B) would have caused the mosquitos to be killed more rapidly.
 (C) would not have altered the results of the campaign.
 (D) would have caused all of the mosquitos to die.

10. Of 357 weeds germinating on a 2' x 3' plot of ground, 62 reached maturity. Which of the following aspects of Darwin's theory of natural selection can best be applied to this observation?
- (A) All members of a species vary in their traits.
 - (B) Many variations of a species are inherited.
 - (C) There is a struggle for existence among members of a species.
 - (D) Favorable variations are passed on to offspring and in time great differences arise.
11. According to the heterotroph hypothesis, the first complete animal body found on earth probably resembled
- (A) an ameba.
 - (B) a sponge.
 - (C) a Paramecium.
 - (D) a Chlorella.

Questions 22-23 refer to the following diagram.

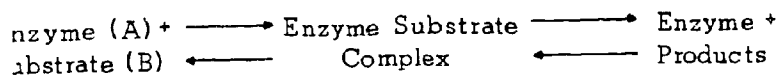
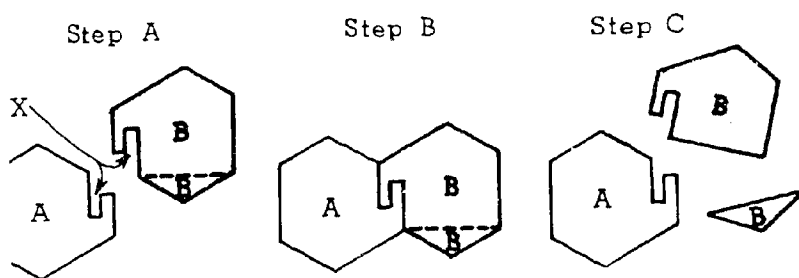

2. Reactions between enzyme (large molecules) and substrate (usually small molecules) can be explained by
- (A) surface configuration in general.
 - (B) surface configuration at active sites (X).
 - (C) enzyme specificity.
 - (D) a specific size relationship between enzyme and substrate molecules.
3. Whether the reaction proceeds to the left or to the right depends directly upon
- (A) relative concentrations of enzyme and substrate.
 - (B) relative concentrations of substrate and substrate products.
 - (C) the energy state of the whole system.
 - (D) the condition of the environment surrounding the systems.

Questions 24-25 refer to the following diagram.

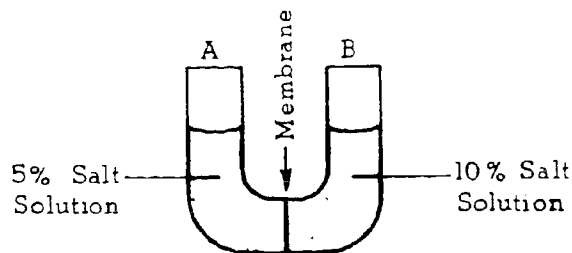

The U-shaped tube contains solutions of salt water separated by a membrane impermeable to salt.

24. On which side of the tube will the water level rise?
- (A) Side A.
 - (B) Side B.
 - (C) Both sides.
 - (D) Neither side.
25. The water level will remain constant on both sides of the tube when
- (A) all the water is on side A.
 - (B) all the water is on side B.
 - (C) the salt concentration becomes 7.5% on both sides.
 - (D) the water concentration becomes 90% on side A and 95% on side B.

GO ON TO THE NEXT PAGE.

Questions 26-28 refer to the following graph.

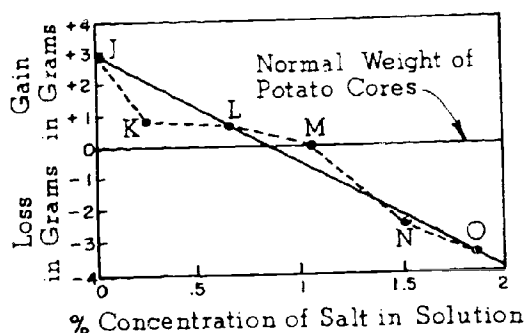

The above graph shows the results obtained when six potato cores of equal weight were placed in six different concentrations of salt water.

26. The dots J, K, L, M, N, and O represent
- (A) variables.
 - (B) assumptions.
 - (C) hypotheses.
 - (D) data.
27. Cores J, K, and L are above the normal weight line because
- (A) there was a flow of water from each core.
 - (B) salt entered the cores.
 - (C) water entered the cores and increased their weight.
 - (D) all these cores weighed more than three grams.
28. If there were no change in the weight of a potato core after immersion in salt solution it could mean that
- (A) water could not enter the core.
 - (B) water could not leave the core.
 - (C) salt concentration inside the core was equal to the concentration outside.
 - (D) the membrane is not permeable to salt.

29. Many reactions occur more readily when the temperature of the substances is increased because
- (A) the kinetic energy of the molecules is increased.
 - (B) the kinetic energy of the molecules is decreased.
 - (C) heat increases the force of attraction.
 - (D) the potential energy of the molecules is increased.
30. The most nearly correct statement applying to both the heterotroph and spontaneous generation hypotheses is
- (A) both assumed evolution occurred.
 - (B) both assumed living things could originate from nonliving material.
 - (C) both assumed that all microorganisms came from nonliving material.
 - (D) both required the passage of long periods of time.

IF YOU FINISH BEFORE TIME IS CALLED, CHECK YOUR WORK ON THIS TEST.

BIOLOGY II (For Phases 1 and 2)

Time—40 minutes

YOU ARE TO INDICATE ALL YOUR ANSWERS ON THE SEPARATE ANSWER SHEET. No credit will be given for anything written in the test book. After you have decided which of the suggested answers you want to give for a question, blacken the corresponding space on the answer sheet.

Example:

Chicago is a
 (A) state
 (B) city
 (C) country
 (D) continent

Sample Answer

A B C D

Give only one answer to each question; no credit will be given for multiple answers. If you wish to change an answer, erase your first line completely and mark your new choice.

DO NOT OPEN THIS BOOK UNTIL YOU ARE TOLD TO DO SO.

Note for Teachers: This test is based on the BSCS Special Materials S15-S32.

Developed by Educational Testing Service pursuant to a subcontract funded by the U. S. Department of Health, Education, and Welfare, Office of Education.

04

1. The factor that sets man apart from all other animals is his
(A) speed (B) strength
(C) intelligence (D) number
2. Examples of decomposers include
(A) deer (B) trees (C) owls (D) bacteria

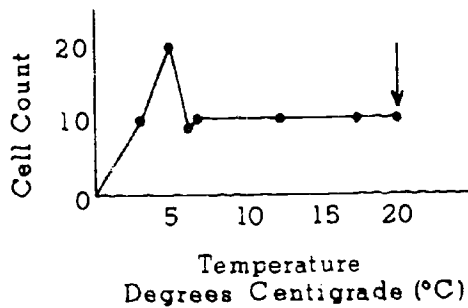

3. The arrow to the point on the graph above represents which of the following?
(A) 10°C and a cell count of 10
(B) 10°C and a cell count of 20
(C) 20°C and a cell count of 10
(D) 20°C and a cell count of 20
4. Which of the following is NOT one of the wounds that man has inflicted on his environment?
(A) The smog over cities
(B) The pollution of rivers
(C) The erosion of farmland
(D) The succession of animals in a food chain
5. Of the following, which would be the best way to test the hypothesis that yeast grows fastest in the dark?
(A) Growing yeast cells in the dark only
(B) Growing yeast cells in the light only
(C) Growing yeast cells in both dark and light
(D) Growing yeast cells in both dark and light at the same temperature
6. The interaction of all living and nonliving things is called
(A) a community (B) an ecosystem
(C) a food chain (D) a food web

7. Of the following, energy flow in a food chain most closely resembles a
(A) closed pipeline
(B) fire hose
(C) garden hose with many holes in it
(D) large pond
8. Which of the following statements about energy in a food chain is correct?
(A) More energy is retained in the living system than is lost.
(B) More energy is lost in the living system than is retained.
(C) The same amount of energy is retained in the living system as is lost by the living system.
(D) All energy is retained in the living system and none is lost.
9. Which of the following is a hypothesis that might be tested?
(A) The number of cells counted in a drop of water
(B) The number of dandelions counted in a square foot of land
(C) The weight of a block of wood
(D) The statement that decreasing the amount of sunlight decreases the number of yeast cells
10. Which of the following correctly describes a first-order consumer?
(A) It is eaten by more than one animal.
(B) It is eaten by one animal only.
(C) It feeds on one animal only.
(D) It feeds on more than one animal.

GO ON TO THE NEXT PAGE.

11. Which of the following graphs best illustrates an increase in gill-cover beats with an increase in temperature?

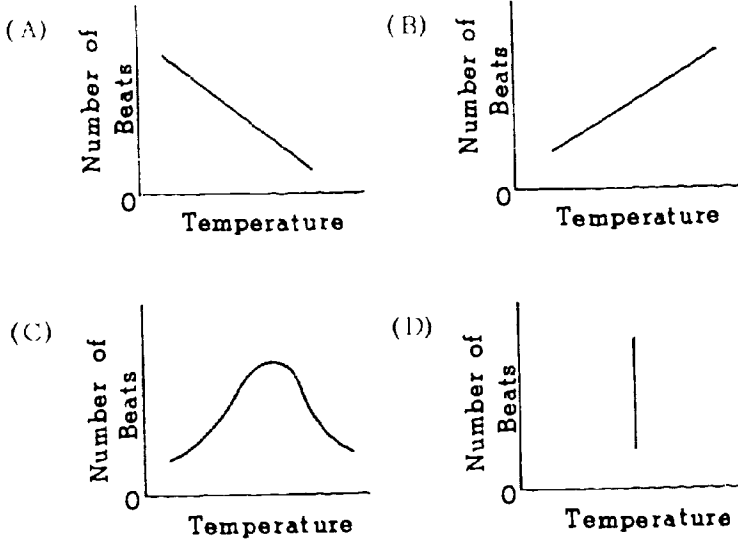

12. Which of the following graphs best illustrates a rise in the number of yeast cells followed by a fall and then another rise?

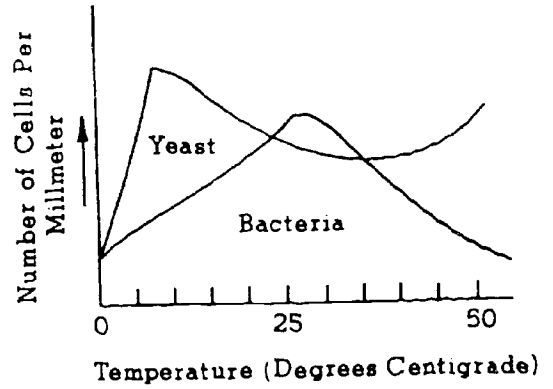
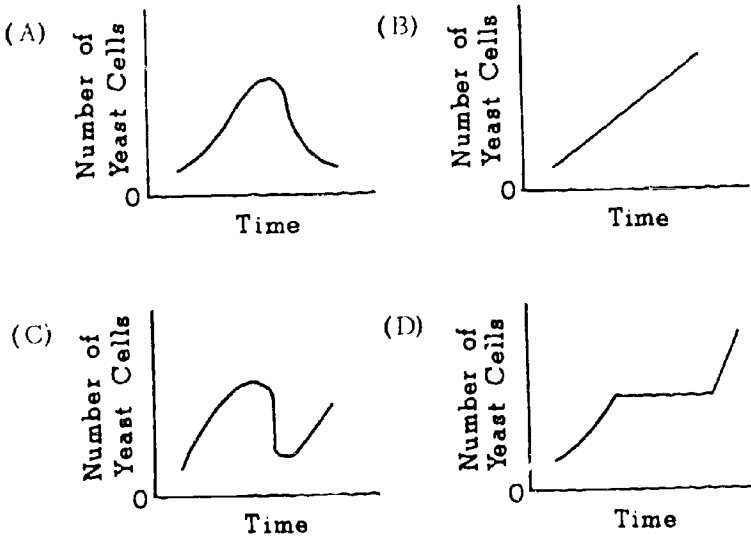

POPULATION OF YEAST AND BACTERIA AT DIFFERENT TEMPERATURES

13. The graph above indicates that there are
- (A) always more yeast cells than bacterial cells
 - (B) more yeast cells than bacterial cells at the start of the experiment
 - (C) more bacterial than yeast cells at 50°C
 - (D) more bacterial than yeast cells at 27°C

GO ON TO THE NEXT PAGE.

	Days				
	1	2	3	4	5
Number of Trees Cut	2	7	6	9	3

14. Which of the following graphs is correct for the information given in the chart above?

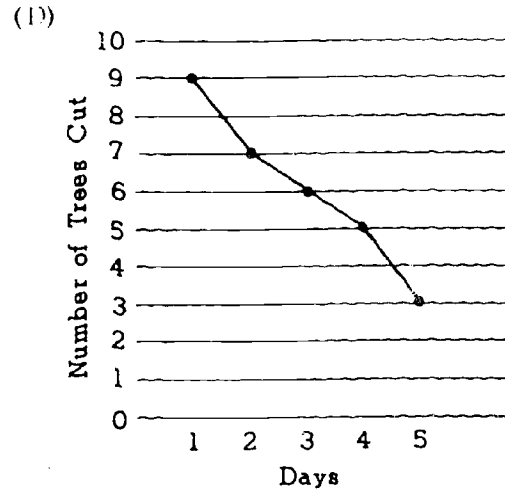
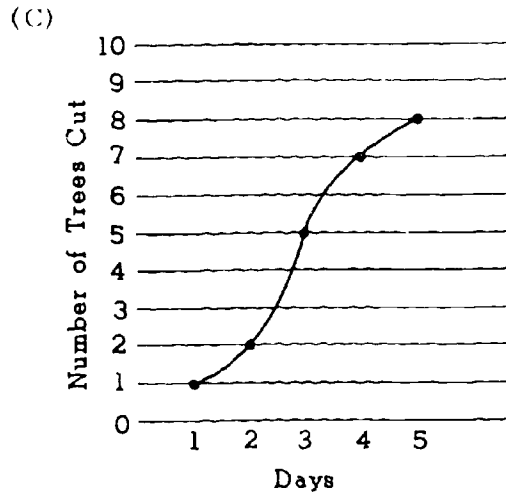
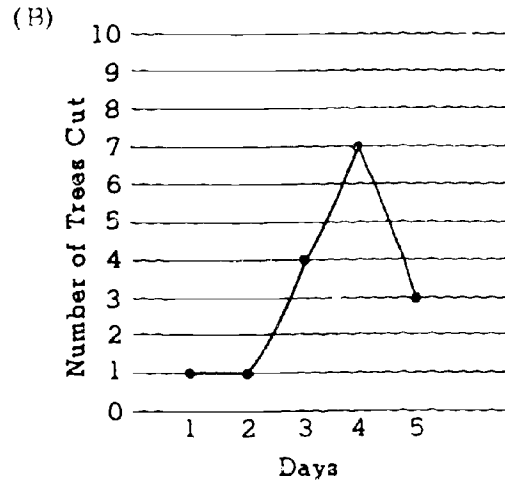
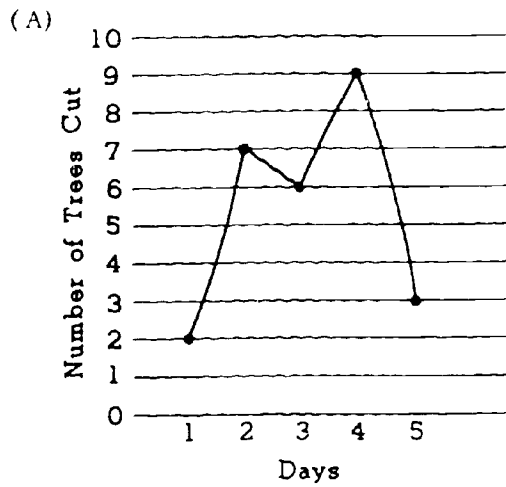

GO ON TO THE NEXT PAGE.

Questions 15-16 refer to the following diagram.

The following transfers were made and three yeast cells were found in test tube 3.

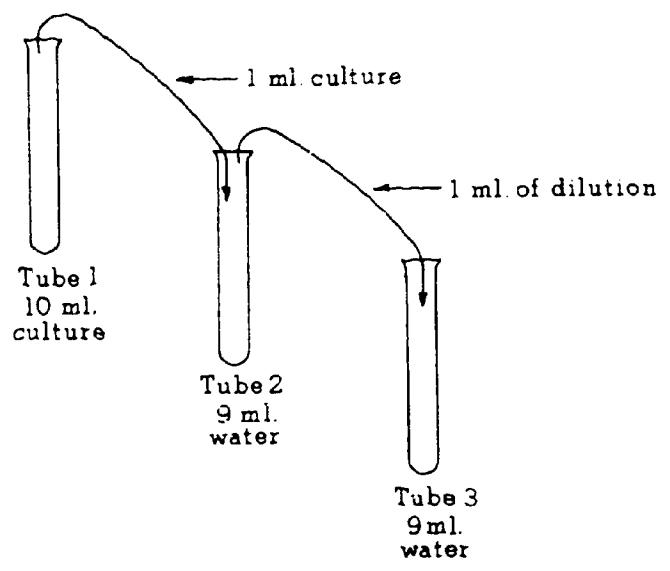

15. How many yeast cells are there in a drop taken from test tube 1 ?
 (A) 9 (B) 30 (C) 90 (D) 300
16. The reason for making dilutions as shown in the diagram above is to
 (A) make the counting of cells easier
 (B) give the yeast more food
 (C) give the yeast a chance to reproduce
 (D) provide more air for the yeast

Questions 17-18 refer to the following diagrams of a plot of land that was observed over a period of 50 years. The figures represent the type of plant found during the year that a population survey was made.

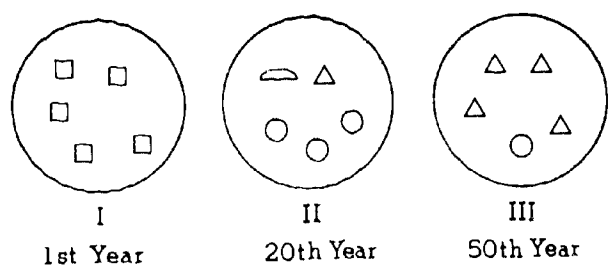

17. Which of the above populations was probably the first stage in succession?
 (A) □ (B) △ (C) ◐ (D) ○

18. Which of the above populations was probably the climax stage in the succession?
 (A) □ (B) △ (C) ◐ (D) ○

Questions 19-21 are based upon a food chain that involves grass-grasshopper-frog-snake.

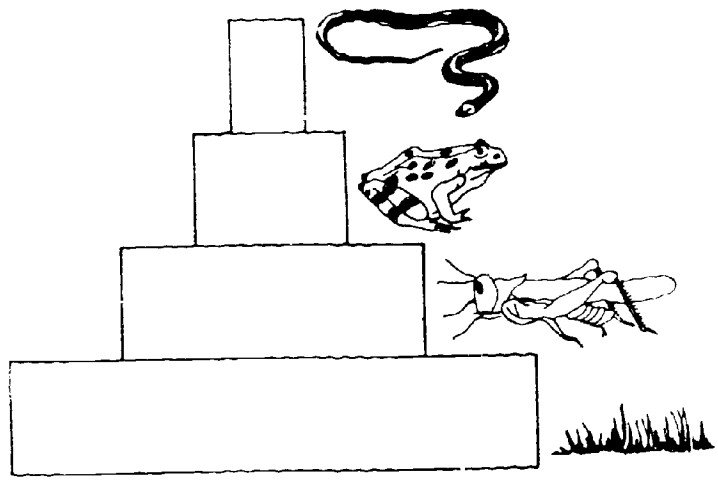

19. Which of the following is the producer?
 (A) Grass (B) Frog
 (C) Snake (D) Grasshopper
20. Which of the following is a first-order consumer?
 (A) Grass (B) Frog
 (C) Snake (D) Grasshopper
21. Which of the following is a second-order consumer?
 (A) Grass (B) Frog
 (C) Snake (D) Grasshopper

GO ON TO THE NEXT PAGE.

ns 22-24 refer to the following pictures.



I



II

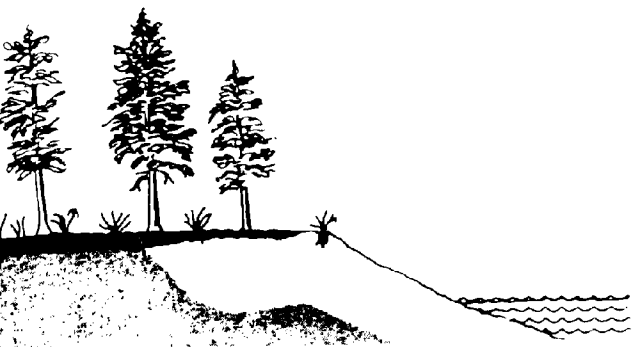

III



IV

he four pictures above represent stages in

- (A) a climax (B) a succession
(C) one ecosystem (D) a food web

f IV shows a relatively stable, slowly changing
community, it is called a

- (A) food web (B) succession
(C) climax (D) "wound" of man

24. You would expect to find the fewest species in the
soil represented in

- (A) I (B) II (C) III (D) IV

GO ON TO THE NEXT PAGE.

Questions 25-27 refer to the following diagram.

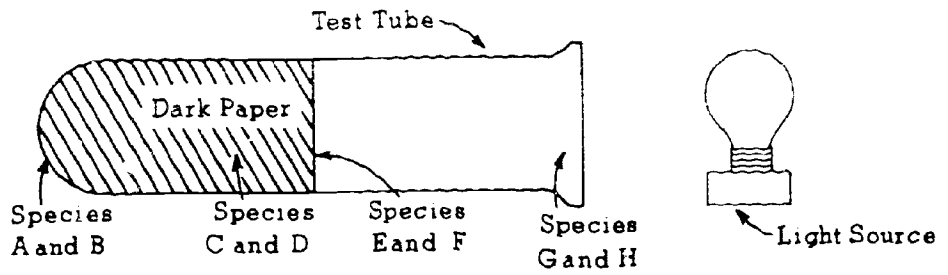

25. Which of the following would be the most likely food chain?
- (A) Species G would eat species H.
 - (B) Species E would eat species A.
 - (C) Species H would eat species C.
 - (D) Species A would eat species F.

26. Which of the following would most likely live at the deepest level in a pond?
- (A) Species A (B) Species C
 - (C) Species E (D) Species G

27. Which of the following would most likely be a producer?
- (A) Species B (B) Species C
 - (C) Species D (D) Species H

Questions 28-30 refer to the graph below.

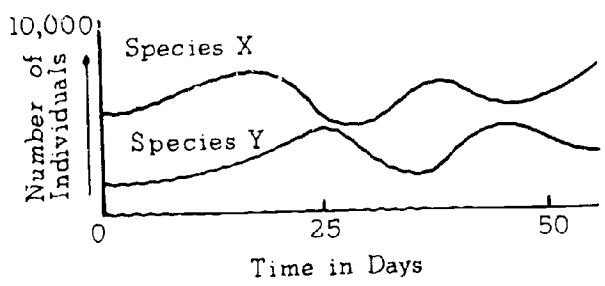

28. Which of the following is a correct statement that is based on information contained in this graph?
- (A) Species X and species Y reach peak growth at the same time.
 - (B) The number of individuals of species Y is equal to the number of individuals of species X.
 - (C) Species X starts to increase at the same time that species Y starts to increase.
 - (D) The changes in population of species X are similar to the changes in population of species Y.

29. Which of the following hypotheses is supported by information given in the graph?
- (A) Species X has a larger population than species Y on day 25.
 - (B) Both populations decrease then increase.
 - (C) Species Y is interacting with species X.
 - (D) Species X was not as large at 50 days as it was at 2 days.

30. If species X and Y are in the same food web, which of the following is most probably true?
- (A) Species X is eating species Y.
 - (B) Species Y is eating species X.
 - (C) Species Y is the producer.
 - (D) Species Y has more total energy than species X.

FORM P8C4

BIOLOGY B (Across Phases)

Time—40 minutes

YOU ARE TO INDICATE ALL YOUR ANSWERS ON THE SEPARATE ANSWER SHEET. No credit will be given for anything written in the test book. After you have decided which of the suggested answers you want to give for a question, blacken the corresponding space on the answer sheet.

Example:

Chicago is a

- (A) state
- (B) city
- (C) country
- (D) continent

Sample Answer

A	B	C	D
<input type="checkbox"/>	<input checked="" type="checkbox"/>	<input type="checkbox"/>	<input type="checkbox"/>

Give only one answer to each question; no credit will be given for multiple answers. If you wish to change an answer, erase your first line completely and mark your new choice.

DO NOT OPEN THIS BOOK UNTIL YOU ARE TOLD TO DO SO.

Note for Teachers: This test is based on the BSCS Special Materials S15-S32 and Molecules to Man, chapters 3, 4, 5 and 6.

Developed by Educational Testing Service pursuant to a subcontract funded by the U. S. Department of Health, Education, and Welfare, Office of Education.

- Which of the following would be a hypothesis?
 - (A) Watching birds fly south in the winter
 - (B) Stating that birds fly south because of lack of food
 - (C) Taking a population count of birds
 - (D) Dissecting a bird in a biology class

- The energy of motion is called

- (A) potential energy
- (B) chemical energy
- (C) stored energy
- (D) kinetic energy

- In preparing for an experiment with yeast, after the medium has been poured into a test tube and covered, the very next step is to

- (A) cool the medium
- (B) sterilize the medium
- (C) inoculate the medium
- (D) store the medium in a dark container

- In one experiment to determine the effect on the growth of a certain species of plant by exposing the plants to various amounts of light, the control would be plants grown under

- (A) normal light conditions
- (B) the minimum amount of light exposure
- (C) the maximum amount of light exposure
- (D) an absence of any light

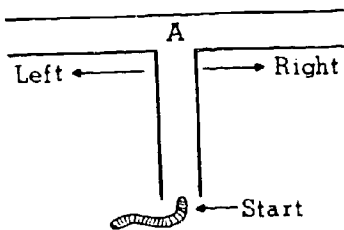

- An experimenter claims that earthworms will always turn right when they come to point A in a T tube as shown above. Which of the following would be the best test of this hypothesis?

- (A) Observe a large number of earthworms as they travel through the T tube.
- (B) Block off the right side of the tube and observe whether the earthworms turn left.
- (C) Wire the left side of the tube so that the earthworms will receive a slight shock if they turn left.
- (D) Make the right side of the tube narrower and see whether the earthworms turn left.

- In counting yeast cells, it was found that there were 5 yeast cells in the following area.



How many cells are there per cubic millimeter?

- (A) 5
- (B) 10
- (C) 25
- (D) 50

- A person's reaction time is slow at birth, becomes faster up to the age of 30, then gradually becomes slower. Which of the following graphs best illustrates this idea?

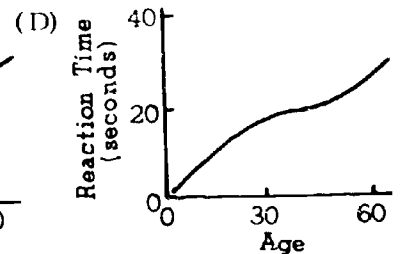
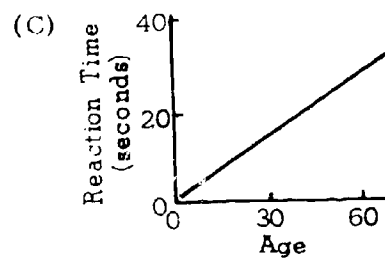
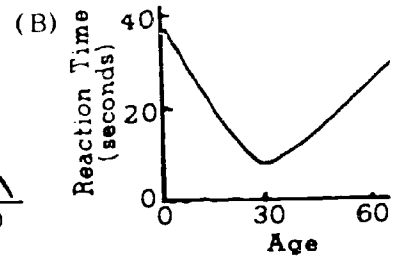
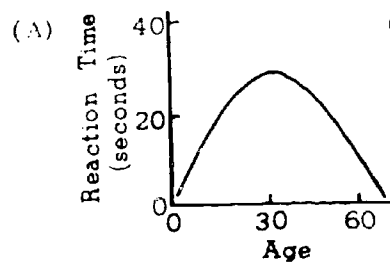

GO ON TO THE NEXT PAGE.

8. A certain population of animals grows rapidly at first, stops growing for a time, and then resumes growth at a slow rate. Which of the following graphs illustrates the growth pattern of the population?

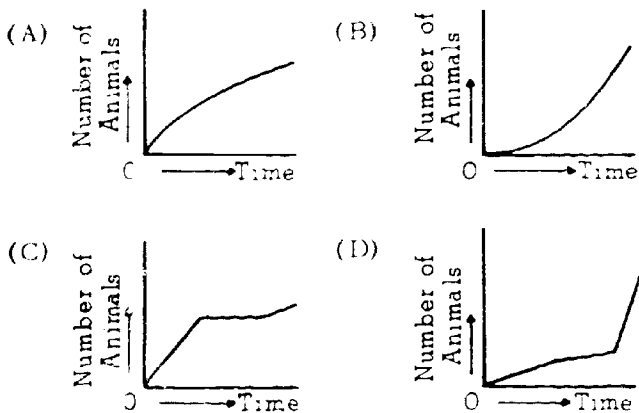

Questions 9-10 refer to the following graph.

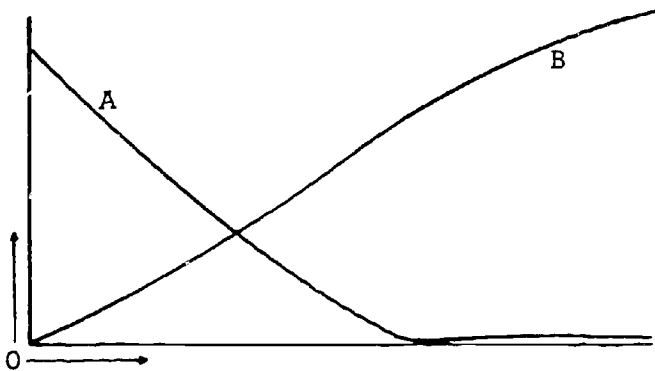

9. Of the following, which is the best statement about the information in the graph?

- (A) A eats B.
- (B) B eats A.
- (C) The presence of B causes a decline in A.
- (D) The presence of B does not affect A.

10. The graph could represent which of the following?

- (A) A, the buffalo population, versus B, man's westward movement
- (B) A, the production of corn, versus B, modern farming methods
- (C) A, speed, versus B, improvement in airplane design
- (D) A, the discovery of modern drugs, versus B, deaths of children

11. If a person states that there is life on Mars, his statement would be considered

- (A) a fact
- (B) an observation
- (C) a hypothesis
- (D) a law

Questions 12-14 refer to the following experiment.

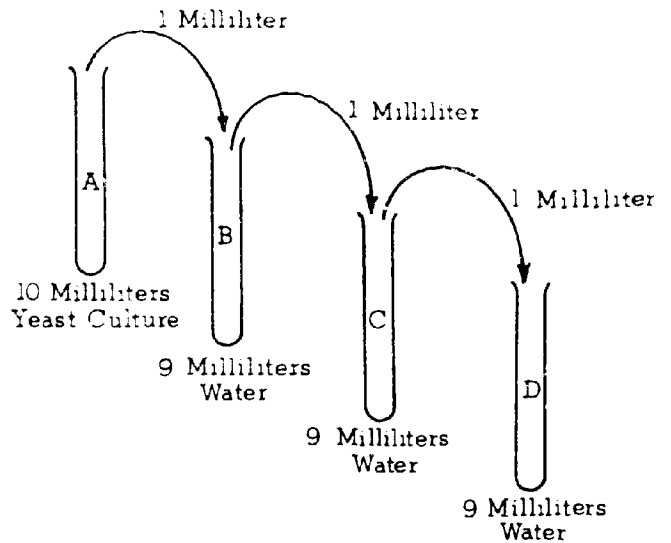

12. The purpose of the procedure above is to

- (A) dilute the yeast culture and make counting easier
- (B) increase the number of yeast cells in test tube B
- (C) determine whether yeast cells reproduce by budding
- (D) increase the concentration of yeast cells in test tube D

13. If there were 10,000 yeast cells in test tube A, how many yeast cells would you expect to find in test tube D?

- (A) 10,000 (B) 1,000 (C) 100 (D) 10

14. What is the ratio of the number of cells in test tubes A, B, C, and D?

- (A) 1:1:1:1 (B) 4:3:2:1
- (C) 10:5:2:1 (D) 1,000:100:10:1

GO ON TO THE NEXT PAGE.

Questions 15-16 refer to the following graph.

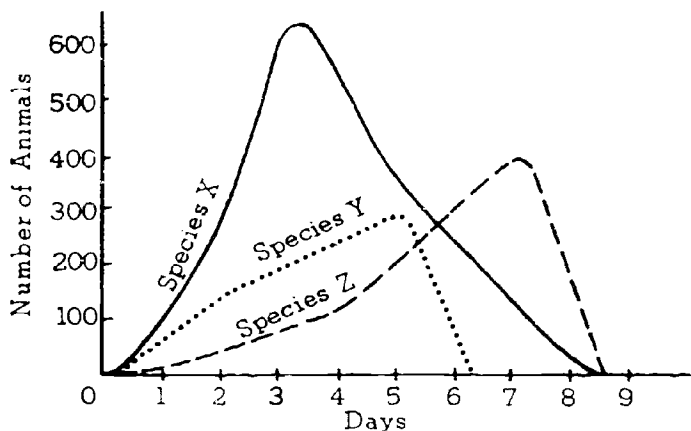

5. On which of the following days would there be the greatest number of animals of all three species combined?
 (A) Day 2 (B) Day 4 (C) Day 5 (D) Day 8
6. On which of the following days would there be the LEAST difference between the number in the largest group and the number in the smallest group?
 (A) Day 2 (B) Day 3 (C) Day 4 (D) Day 6

Questions 17-20 refer to the following graph.

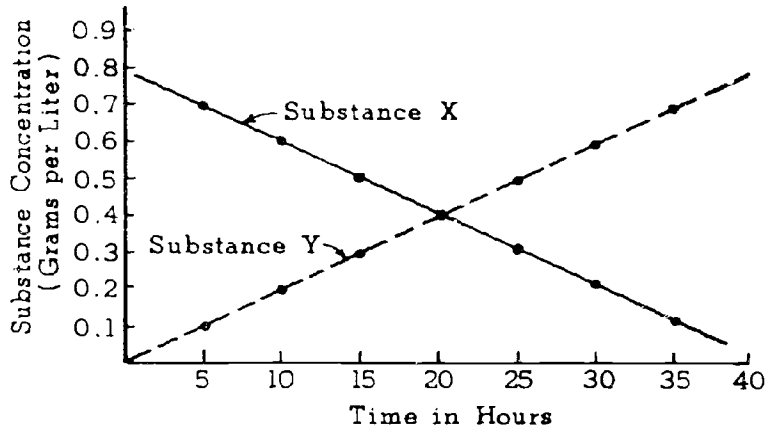

17. Which of the following conditions would result in a graph like the one above?
 (A) Substance Y is using substance X to make a new substance.
 (B) Substance X needs substance Y to survive.
 (C) Substances X and Y are used very rapidly at first and then very slowly.
 (D) As the length of time increases, the rate of loss or gain in the concentration of each substance changes greatly.
18. Substance X is equal in concentration to substance Y at about
 (A) 10 hr. (B) 20 hr. (C) 30 hr. (D) 40 hr.
19. What is the concentration of each substance at 10 hours?
 (A) X = 0.1 and Y = 0.6
 (B) X = 0.6 and Y = 0.2
 (C) X = 0.2 and Y = 0.6
 (D) X = 0.3 and Y = 0.3
20. What is the ratio of substance X to substance Y at 10 hours?
 (A) 1:1 (B) 2:1 (C) 3:1 (D) 4:1

GO ON TO THE NEXT PAGE.

Directions: Each passage in this part is followed by a number of questions. In answering the questions you are expected to use your knowledge of biology as well as the information given you. For each question select the answer you think best and blacken the corresponding space on the answer sheet.

Questions 21-26 refer to the following passage.

The Squid

Cephalopods (octopuses, squid, and cuttlefish) are members of the Mollusca group, and are among the most highly organized invertebrate animals. They have no external shell and are often called valveless mollusks. Other mollusks are clams and oysters, which have two shells (bivalves), and snails, which have one shell (univalves). Cephalopods are distinguished by tentacles, which project from their head and are used for both food-getting and walking. If a squid wants to go somewhere in a hurry, however, it draws water into the body chamber and squirts it out through a tapered funnel, which can be turned forward, backward, or even sideways.

Squid can change color more rapidly than chameleons. Color changes are brought about by contraction and expansion of many chromatophores, elastic sacs of pigment embedded in the skin. In addition, many squid have light organs and produce vivid displays of flashing light. The light is caused by a chemical reaction similar to that which creates the biological "cold light" of fireflies.

The eye of the squid is remarkably similar to that of man. The eyeball has an eyelid, a cornea, and a pupil. Unlike man's, the squid's eye has no blind spot. For certain functions, the squid's eye is even better than that of man.

Dissections of squid indicate that they eat worms, shrimp-like animals, fish, and other squid. On the other hand, squid are eaten by a host of enemies, from the sperm whale down to the common mackerel. Man is one of the squid's greatest enemies. He uses the cuttlebone, the internal shell of a cuttlefish, as a dietary supplement for canaries and parakeets. Japan uses a great quantity of squid for food and fertilizer. In Newfoundland, vast numbers of squid are frozen in large blocks and sold as codfish bait.

21. Which of the following terms correctly applies to the squid?
(A) Vertebrate (B) Univalve
(C) Bivalve (D) Cephalopod
22. A squid's tentacles function primarily in
(A) vision (B) jetting ink
(C) food-getting (D) digestion.
23. In a squid, which of the following structures functions primarily in color changes?
(A) Cuttlebone (B) Chromatophore
(C) Light organ (D) Funnel
24. The eye of squid has all of the following EXCEPT
(A) a cornea (B) an eyelid
(C) a pupil (D) a blind spot
25. Which of the following is NOT generally part of a squid's diet?
(A) Shrimp-like animals (B) Sperm whale
(C) Worms (D) Fish
26. According to the passage, man uses cephalopods to provide all of the following EXCEPT
(A) fertilizer (B) bait for catching fish
(C) cuttlebones (D) light for luring fish

GO ON TO THE NEXT PAGE

Questions 27-30 refer to the following passage.

A recent study shows that adding fluorides to vitamin pills is an effective way of reducing tooth decay in children who live in areas where no fluoridated water is available. A decline in tooth decay of up to 63 per cent was found in temporary teeth and 43 per cent in permanent teeth of children who took fluoridated vitamins daily for 36 months. Theoretically, the supplement will yield its greatest benefit when taken from birth to about age 10, the period of tooth formation. Starting the fluorides early is important because calcium begins to be deposited in the teeth long before they erupt through the gums. The vitamin-fluoride mixture would supply about the same amount of fluoride as would be taken in drinking water. The cost would be inexpensive in homes where vitamins are now taken. Present methods of fluoridation include adding sodium fluoride to drinking water and adding fluoride to tooth pastes.

27. Fluorides are apparently added to the vitamins in the form of
- (A) a pure element
 - (B) an impure element
 - (C) a compound
 - (D) either a compound or an element
28. The passage indicates that teeth need
- (A) neither fluorine nor calcium
 - (B) fluorine but not calcium
 - (C) calcium but not fluorine
 - (D) both calcium and fluorine
29. If 50 children in every 100 have decay in temporary teeth when no fluorides are used, according to the passage approximately how many children per hundred will have decay in temporary teeth after fluoridated vitamins are used?
- (A) 10 (B) 20 (C) 30 (D) 40
30. The passage suggests that those who favor fluoridating water instead of vitamins would support their plan by saying that
- (A) everybody drinks water but only some people take vitamins
 - (B) a different substance is used in fluoridating water from the one used in vitamins
 - (C) fluorides are more effective on temporary teeth than on permanent teeth
 - (D) some fluorides are poisonous but others are not

IF YOU FINISH BEFORE TIME IS CALLED, CHECK YOUR WORK ON THIS TEST.

BIOLOGY-BSCS III (For Phases 3, 4, and 5)

Time—40 minutes

YOU ARE TO INDICATE ALL YOUR ANSWERS ON THE SEPARATE ANSWER SHEET. No credit will be given for anything written in the test book. After you have decided which of the suggested answers you want to give for a question, blacken the corresponding space on the answer sheet.

Example:

Chicago is a

- (A) state
- (B) city
- (C) country
- (D) continent

Sample Answer

A B C D

Give only one answer to each question; no credit will be given for multiple answers. If you wish to change an answer, erase your first line completely and mark your new choice.

DO NOT OPEN THIS BOOK UNTIL YOU ARE TOLD TO DO SO.

Note for teachers: This test is based on the BSCS, Molecules to Man, Chapters 7, 8, 9, 10, and 11.

Copyright © 1966
by
Biological Sciences Curriculum Study.
All rights reserved.
Reproduced by permission.

- DNA is important in heredity because it is
 - (A) a large molecule.
 - (B) found in the nucleus.
 - (C) composed of pyrimidines.
 - (D) able to replicate.
- Plant cells can usually be distinguished from animal cells because plant cells possess
 - (A) cell walls and mitochondria.
 - (B) Golgi bodies and central vacuoles.
 - (C) cell walls and central vacuoles.
 - (D) chromosomes and mitochondria.
- If the sequence of purines and pyrimidines in a segment of a DNA strand were: cytosine, guanine, adenine, thymine, adenine, then the sequence in a complementary strand of newly made messenger RNA would be
 - (A) cytosine, uracil, adenine, guanine, uracil.
 - (B) guanine, cytosine, uracil, adenine, uracil.
 - (C) uracil, adenine, cytosine, uracil, guanine.
 - (D) cytosine, guanine, uracil, uracil, adenine.

- In a rare disease condition in human beings the mitochondria are found to have an abnormal structure. This condition is most likely correlated with the disturbance in cell
 - (A) energy supply.
 - (B) protein formation.
 - (C) food supply.
 - (D) division.
- Schwann's study of cell contents rather than cell walls led to the recognition of
 - (A) cork cells.
 - (B) animal cells.
 - (C) root cells.
 - (D) orchid cells.

Questions 8-9

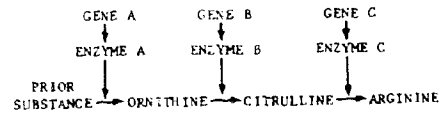

The diagram represents the "one gene-one enzyme" hypothesis as it applies to the production of arginine in the pink mold Neurospora.

Questions 4-5 refer to the following chart.

EXPERIMENT	ADDED	RESULTS
EXPERIMENT A TYPE X NO CAPSULES LIVE NUTRIENTS ADDED	TYPE Y ENCAPSULATED DEAD	TYPE X ENCAPSULATED LIVE
EXPERIMENT B STERILE DISH NUTRIENTS ADDED	TYPE Y ENCAPSULATED DEAD	NOTHING
EXPERIMENT C TYPE X NO CAPSULES LIVE NUTRIENTS ADDED	NOTHING ADDED	TYPE X ONLY

- In the above experiment which are the controls?
 - (A) A and C
 - (B) B and C
 - (C) A and B
 - (D) A only
- What was the question that prompted this series of experiments?
 - (A) What is the nature of RNA ?
 - (B) Do Pneumococcus Type Y bacteria with capsules transform into Pneumococcus Type X without capsules?
 - (C) Why do Pneumococcus Type Y bacteria have capsules?
 - (D) None of the above

- If ornithine were added to the medium in place of the prior substance, the plant would survive if genes
 - (A) B and C are actively producing enzymes B and C.
 - (B) A and B are actively producing enzymes A and B.
 - (C) A and C are actively producing enzymes A and C.
 - (D) C is actively producing enzyme C.
- If the medium on which this model were normally grown were prepared without the prior substance present, the plant would probably die unless
 - (A) enzyme A was added to the medium.
 - (B) gene C was destroyed.
 - (C) ammonia was added to the medium since it is necessary for the production of the amino acid, arginine.
 - (D) ornithine, citrulline, or arginine was added to the medium.

GO ON TO THE NEXT PAGE.

10. The concept of fermentation is considered important to the heterotroph hypothesis because
- (A) free oxygen is thought to have not been present in the early atmosphere.
 - (B) utilization of the sun's energy required a fermentation condition.
 - (C) methane, ammonia, water vapor and hydrogen are considered to have been the principal gases present in the early atmosphere.
 - (D) the primitive heterotroph needed oxygen to obtain energy.
11. A nucleotide differs from a nucleic acid molecule in that
- (A) it is more complex.
 - (B) the compounds present in it are not present in nucleic acid.
 - (C) it always has ribose.
 - (D) it is always simpler in structure.
12. A guinea pig was injected with a radioactive amino acid. Thirty minutes later tissue analysis showed that the protein of the ribosomes had over twice as much radioactivity per gram as the protein of any other cell part. This experiment tends to support which of the following hypotheses?
- (A) Messenger RNA transmits the hereditary traits from DNA to the ribosomes.
 - (B) Radioactive amino acid will be found at the site of protein formation.
 - (C) Radioactive protein is easier to detect and identify than ordinary protein.
 - (D) Ribosomal RNA is a replica of chromosomal DNA.

14. If the green cellophane were left on the aquarium for several weeks we might expect
- (A) cellular respiration of H to be reduced because of the collection of excess CO_2 in the water.
 - (B) an increase in the use of ATP by both H and A due to reduction of carbohydrate production.
 - (C) cellular fermentation to increase in both H and A as a result of O_2 reduction.
 - (D) death of both H and A due to accumulation of excess H_2O in the cells.
15. By studying the results of experiments with bacter and some viruses one can better interpret the role of DNA in higher forms because
- (A) the DNA of the above mentioned forms is present in the same amounts.
 - (B) the chemical make-up of the three forms is similar.
 - (C) only virus DNA is parasitic in the cells of higher forms.
 - (D) genetic activity of all the organisms studied seems to be tied to DNA.
16. Although nucleic acids are usually replicated accurately, occasionally chemical accidents result in
- (A) changes which in turn modify the cell processes controlled by the nucleic acids.
 - (B) failure of the DNA to unzip.
 - (C) changes which cause cytosine to bond with adenine.
 - (D) none of these.

Questions 13-14

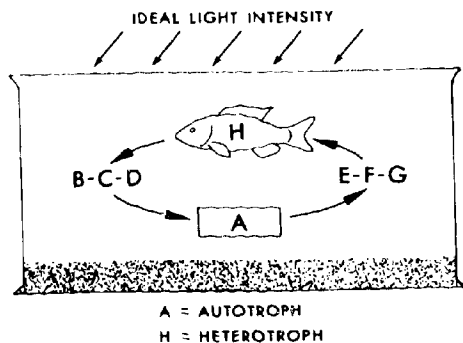

GO ON TO THE NEXT PAGE.

13. If a green cellophane paper were placed over the aquarium for several days, the activity of A that would probably reduce respiration in H would be
- (A) increase of oxygen production.
 - (B) increase of CO_2 absorption by H.
 - (C) increase of CO_2 absorption by A.
 - (D) reduction of carbohydrate production.

109

Questions 17-18 refer to the following graph.

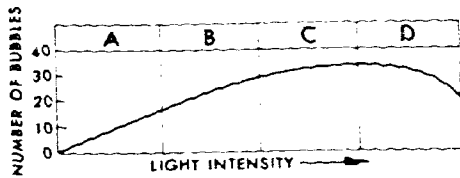

An immersed water plant was exposed to light of gradually increasing intensity over a period of several hours. At regular intervals, one-minute counts were made of the number of oxygen bubbles released from the plant.

17. The number of bubbles released from the plant
 - (A) was directly proportional to the light intensity throughout the experiment.
 - (B) caused the light to become more intense as the experiment progressed.
 - (C) probably decreased in size as the experiment progressed.
 - (D) was correlated with light intensity for most of the experiment.

18. The release of oxygen bubbles is most useful as an indication of the rate of
 - (A) respiration. (B) photosynthesis.
 - (C) growth. (D) metabolism.

19. Viruses have no ribosomes and yet are able to duplicate themselves with new protein coats. How might this best be explained?
 - (A) Some other structure in the virus is the site of protein synthesis.
 - (B) Protein is obtained directly from cells in which they grow.
 - (C) Since viruses reproduce inside a host cell, they use the cell's ribosomes.
 - (D) Viruses lack messenger RNA and therefore have no need for ribosomes.

20. In the light reaction part of photosynthetic light energy
 - (A) absorbed by chlorophyll is transformed into chemical energy.
 - (B) is trapped and three carbon sugars are formed.
 - (C) is used to produce proteins.
 - (D) is used to produce lipids.

Questions 21-24

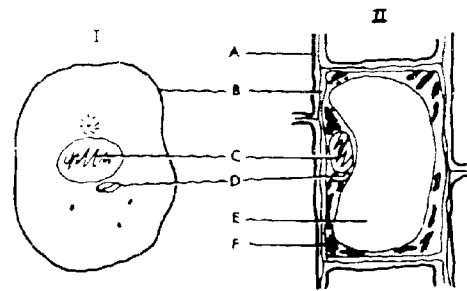

21. With structure C removed a cell could not
 - (A) reproduce.
 - (B) provide its own energy.
 - (C) exchange materials with the environment.
 - (D) secrete.

22. A multicellular organism, whose cells possess structure A, is most likely
 - (A) dead. (B) large. (C) immobile. (D) small.

23. If structure F is green, the presence of many of these structures allows the organism to
 - (A) reproduce.
 - (B) exchange material with the environment.
 - (C) secrete.
 - (D) make its own food.

24. During cell division structure C would cease to exist and its contents would become visible as
 - (A) Golgi bodies. (B) plastids.
 - (C) chromosomes. (D) mitochondria.

25. Virchow's statement that "all cells arise from pre-existing cells" relates the cell theory to
 - (A) spontaneous generation. (B) the nucleus.
 - (C) the theory of evolution. (D) Robert Hooke.

26. Which of the following conclusions is NOT correct?
 - (A) DNA replication occurs prior to mitosis.
 - (B) The amount of DNA is at a maximum during cell division.
 - (C) DNA is at a minimum just after mitosis is completed.
 - (D) The amount of DNA in a new daughter cell begins to increase immediately.

BIOLOGY III (For Phases 1 and 2)

Time—40 minutes

YOU ARE TO INDICATE ALL YOUR ANSWERS ON THE SEPARATE ANSWER SHEET. No credit will be given for anything written in the test book. After you have decided which of the suggested answers you want to give for a question, blacken the corresponding space on the answer sheet.

Example:

Chicago is a
 (A) state
 (B) city
 (C) country
 (D) continent

Sample Answer

A B C D

Give only one answer to each question; no credit will be given for multiple answers. If you wish to change an answer, erase your first line completely and mark your new choice.

DO NOT OPEN THIS BOOK UNTIL YOU ARE TOLD TO DO SO.

Note for Teachers: This test is based on the BSCS Special Materials S32-S70.

Developed by Educational Testing Service pursuant to a subcontract funded by the U. S. Department of Health, Education, and Welfare, Office of Education.

- The ultimate source of energy for almost all living things on Earth is
(A) carbon dioxide (B) chlorophyll
(C) sunlight (D) water
- The chemical energy that is stored in food is released in the process of
(A) excretion (B) ingestion
(C) assimilation (D) respiration
- Energy in living things is most often lost in the form of
(A) ATP (B) heat (C) work (D) light
- Which of the following is an element?
(A) Hydrogen (B) Carbon dioxide
(C) Water (D) Glucose
- Which of the following foods provides the greatest number of calories?
(A) 1 egg
(B) 1 slice of white bread
(C) 1 orange
(D) $\frac{1}{4}$ cup of peanut butter

- When elodea is placed in a solution of bromothymol blue and exposed to sunlight, you would expect the color of the solution to
(A) remain the same
(B) change from blue to yellow
(C) change from blue to yellow and back to blue
(D) change from yellow to blue

- Which of the following activities probably requires the most energy per hour?
(A) Bowling (B) Ballroom dancing
(C) Swimming (D) Golfing
- Which of the following would probably result from immersing your hand for 5 minutes in a beaker containing a quart of water at 10°C?
(A) The temperature of the water will increase.
(B) The temperature of the water will decrease.
(C) The temperature of the water will remain the same.
(D) The temperature of the water will first decrease and then rapidly increase.
- Which of the following is a form of kinetic energy?
(A) The Sun shining on a plant
(B) A stick of dynamite
(C) A tank full of gasoline
(D) A falling rock

Questions 6-7

Bromothymol blue changes from blue to yellow in the presence of carbon dioxide.

- The liquid in which of the following test tubes would change color from blue to yellow in the shortest period of time?

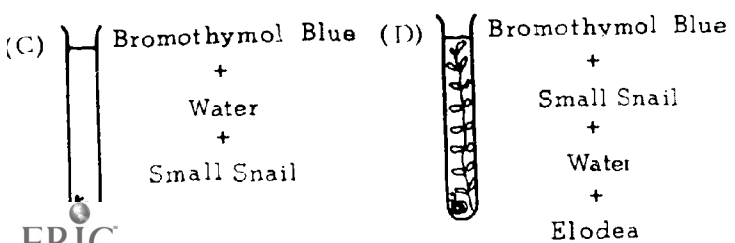
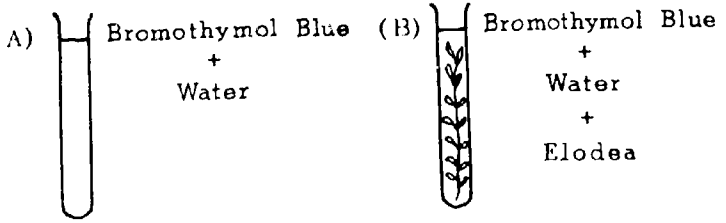

- In comparing two slides under the microscope, one finds that cork differs from elodea in that cork has only
(A) a cell nucleus (B) a cell wall
(C) chloroplasts (D) cytoplasm
- Check cells have all of the following EXCEPT
(A) chloroplasts (B) nuclei
(C) mitochondria (D) cell membranes

GO ON TO THE NEXT PAGE.

A biologist measured the amount of oxygen used and the amount of carbon dioxide produced by sprouting wheat grains. Which of the following graphs would represent the data he obtained?

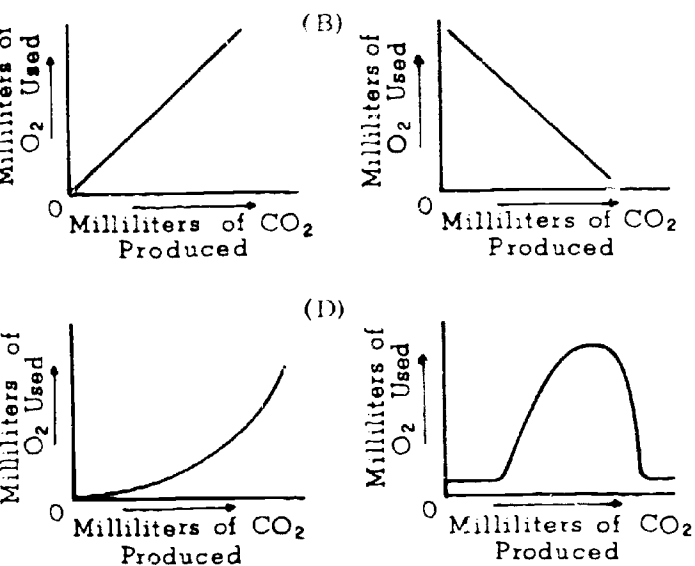

A whale that eats a squid is obtaining energy that can be described as

- (A) radiant (B) kinetic
(C) chemical (D) mechanical

Questions 15-16

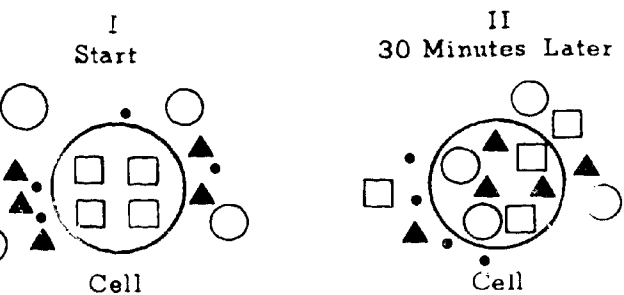

The size of the figures represents the relative size of molecules.

Which of the following is a valid conclusion regarding the movement of substances into the cell above?

- (A) The movement of substances into the cell depends on the size of the molecules.
(B) There is no movement of molecules out of the cell.
(C) None of the substances reaches a balance in which there are equal numbers of molecules inside and outside the cell.
(D) The molecules of one of the substances did not enter the cell.

16. All of the following conclusions can be drawn from the data above EXCEPT:

- (A) Materials are entering the cell.
(B) Materials are leaving the cell.
(C) Entry of materials into the cell is not determined by the size of the molecule alone.
(D) Diffusion can account for the movement of all of the materials into and out of the cell.

17. Which of the following scientists was the first to suggest that all cells come from other cells?

- (A) Hooke (B) Leeuwenhoek
(C) Lavoisier (D) Virchow

18. Which of the following is a correct statement about an enzyme?

- (A) It is used up in a reaction.
(B) It performs a specific function.
(C) It forms a permanent compound with a substrate.
(D) It is usually involved in many changes of a substrate.

19. In burning a certain food, the temperature of 10 milliliters of water rises 10 degrees centigrade. How many simple calories did the food contain?

- (A) 10 (B) 20 (C) 100 (D) 1,000

20. How many atoms are present in a molecule of H_2O_2 (hydrogen peroxide)?

- (A) 1 (B) 2 (C) 3 (D) 4

21. Cell structures that function primarily in energy transfer and use are called

- (A) mitochondria
(B) vacuolar membranes
(C) nucleoli
(D) centrosomes

GO ON TO THE NEXT PAGE.

Questions 22-25

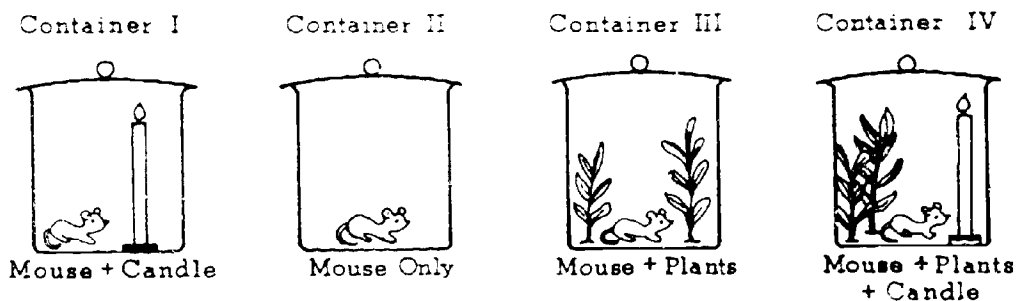

22. The mouse would live the longest period of time in container
 (A) I (B) II (C) III (D) IV
23. The mouse would live the shortest period of time in container
 (A) I (B) II (C) III (D) IV
24. Which of the following scientists carried out experiments similar to those shown above?
 (A) Priestley (B) Van Helmont
 (C) Hooke (D) Beaumont
25. In living things, the breakdown of a molecule to obtain energy is started by
 (A) oxygen (B) carbon dioxide
 (C) enzymes (D) heat
-
6. Algae have been sent along in space capsules with experimental animals to provide a source of
 (A) oxygen (B) carbon dioxide
 (C) hydrogen (D) helium
7. Which of the following gases makes up the greatest percentage of the atmosphere?
 (A) Oxygen (B) Nitrogen
 (C) Hydrogen (D) Carbon dioxide
28. All of the following are parts of an atom EXCEPT
 (A) proton (B) neutron
 (C) electron (D) betatron
29. A molecule of which of the following substances is probably largest in size?
 (A) Carbon dioxide (B) Water
 (C) Glucose (D) Protein

GO ON TO THE NEXT PAGE.

Substance	Relative Size of Molecules (Larger Number = Larger Size)	Units Entering Cell After 1 Hour
1	1	5,400
2	2	4,200
3	3	2,100
4	4	3,300

30. Which of the following would be the best interpretation of the data above?
- (A) The size of the molecules controls the rate of diffusion into the cell.
 - (B) Something in addition to the size of the molecules affects the rate at which materials enter the cell.
 - (C) The size of the molecules has nothing to do with the movements of molecules into the cell.
 - (D) Something other than the size of the molecules is the most important factor in the movement of materials into the cell.

IF YOU FINISH BEFORE TIME IS CALLED, CHECK YOUR WORK ON THIS TEST.

FORM QBC1

BIOLOGY - BSCS IV (For Phases 3, 4, and 5)

Time—40 minutes

YOU ARE TO INDICATE ALL YOUR ANSWERS ON THE SEPARATE ANSWER SHEET. No credit will be given for anything written in the test book. After you have decided which of the suggested answers you want to give for a question, blacken the corresponding space on the answer sheet.

Example:

Chicago is a

- (A) state
 (B) city
 (C) country
 (D) continent

Sample Answer

A	B	C	D
<input type="checkbox"/>	<input checked="" type="checkbox"/>	<input type="checkbox"/>	<input type="checkbox"/>

Give only one answer to each question; no credit will be given for multiple answers. If you wish to change an answer, erase your first line completely and mark your new choice.

DO NOT OPEN THIS BOOK UNTIL YOU ARE TOLD TO DO SO.

Note for teachers: This test is based on the BSCS, Molecules to Man, Chapters 12, 13, and 14.

Copyright © 1966

by

Biological Sciences Curriculum Study.

All rights reserved.

Reproduced by permission.

Questions 1-3

This paragraph is used to show the relationship between competition and cooperation, and the problems of cooperation when organisms act as one unit. If a Volvox cell were removed from its colony it would round off slightly into the shape of a teardrop. This cell closely resembles Chlamydomonas, except it cannot reproduce and perpetuate itself.

- The fact that a single Volvox cell is almost identical to Chlamydomonas cells can be best explained biologically by
 (A) genetics. (B) evolution.
 (C) cell theory. (D) cooperation.
 - The process whereby the colony will replace the cell taken away from it is
 (A) coordination. (B) specialization.
 (C) integration. (D) regeneration.
 - The function of this Volvox cell in the colony is probably
 (A) reproduction.
 (B) more specialized than one removed from the colony.
 (C) less specialized than a Chlamydomonas cell.
 (D) the same as an individual.
-
- Both plants and animals are made of tiny units called cells. They use oxygen to release energy from their food and they store food reserves as fat. These facts
 (A) prove all life had a common origin.
 (B) support the idea that being alive is about the same in all living things.
 (C) indicate that plants evolved from animals.
 (D) support the idea that animals have gradually evolved from plants.
 - The principle of division of labor in biology involves
 (A) the production of varied agricultural crops.
 (B) competition among organisms.
 (C) differentiation of cells into tissues having different functions.
 (D) growth, so there are more cells to do the work.

Questions 6-10

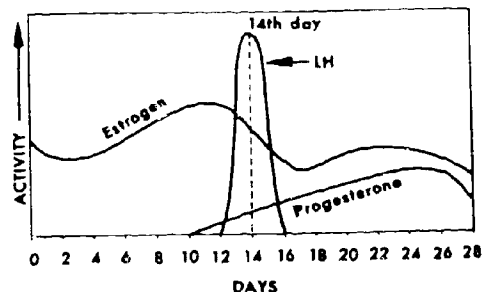

- From the data in the graph one can infer that a result of an increase in the amount of estrogen in the blood is
 (A) to start the menstrual flow.
 (B) to cause the direct formation of a corpus luteum.
 (C) production of progesterone.
 (D) production of FSH.
- In this graph the rupturing of the ovary surface and the release of an egg occurs
 (A) between the 16th and the 26th day.
 (B) between the 12th and the 16th day.
 (C) on the 10th day.
 (D) on the 28th day.
- Progesterone secretion decreases at about the 28th day because
 (A) the corpus luteum degenerates.
 (B) the corpus luteum appears.
 (C) the process of fertilization has occurred.
 (D) ovulation has occurred.
- The hormone levels in this cycle are controlled by the
 (A) uterus.
 (B) ovaries.
 (C) uterus and the ovaries.
 (D) uterus, ovaries and pituitary gland.
- Progesterone is often described as the pregnancy hormone because it
 (A) prepares the uterus to receive the egg.
 (B) stimulates ovulation.
 (C) stimulates estrogen production.
 (D) stimulates the corpus luteum.

11. A nuclear change that is necessary for sexual reproduction is
- (A) the development of a new individual from a single cell.
 - (B) illustrated by the development of a willow tree from a cutting.
 - (C) the fusion of two gametes' nuclei.
 - (D) the creation of a new individual through meiosis from the doubling of the number of chromosomes.
12. When the pituitary gland is removed from immature female rabbits, their ovaries do not develop normally. When the pituitary gland is removed from mature female rabbits, the ovaries and uterus stop functioning. These observations lead to the conclusion that
- (A) the ovaries influence the uterus.
 - (B) the pituitary gland influences the ovaries and uterus.
 - (C) the ovaries and uterus influence the pituitary.
 - (D) there is a feedback of hormones from the ovaries to the pituitary.
13. In a normal body cell of a dogfish or shark there are 24 chromosomes. How many chromosomes are found in each gamete?
- (A) 6 (B) 12 (C) 24 (D) 48
14. Egg cells with the smallest percentage of yolk are usually associated with reproduction in
- (A) amphibians
 - (B) reptiles
 - (C) birds
 - (D) mammals
15. In an experiment M. C. Niu placed a salt solution in both dish A and dish B. He then placed mesoderm tissue into dish A, for three hours. He removed the mesoderm tissue from dish A and then placed top ectoderm tissue in both dishes A and B. The most precise statement of the hypothesis that Niu was testing would be
- (A) ectoderm and mesoderm may both be necessary for cell differentiation.
 - (B) mesoderm may be derived as a distinct tissue from undifferentiated tissues in the embryo.
 - (C) mesoderm may produce a chemical which induces ectoderm to differentiate.
 - (D) ectoderm may produce a chemical which induces mesoderm to differentiate.
16. Small fragments of ectodermal tissue from a frog embryo can survive in a salt solution. When mesoderm from a particular region of the embryo (dorsal lip) is placed in contact with the ectodermal tissue, differentiation of ectoderm into nerve cells can occur. No such differentiation occurs in the presence of any other parts of the embryo. On the basis of this evidence alone, which of these hypotheses is supported?
- (A) Ectoderm cells differentiate into nerve cells when activated by material from the mesoderm.
 - (B) Mesoderm destroys a substance in ectoderm cells, preventing their differentiation.
 - (C) In order to differentiate ectoderm cells do not need nutrient substances from other embryonic cells.
 - (D) In order to differentiate ectoderm cells need physical support from other cells.
17. The fact that a boy's initials were carved in a tree four feet above the ground and after 12 years will be found at the same height shows that
- (A) the meristem was damaged and therefore prevented any vertical growth.
 - (B) once plant cells are formed they do not change.
 - (C) if necessary, mature tissues can develop into new organs.
 - (D) tissue used for vertical growth is found at the tips of stems.
18. Which organism would most likely carry on the process of pollination?
- (A) Lily (B) Fern
 - (C) Moss (D) Mushroom
19. From the point of view of evolution, the greatest advantage of sexual reproduction is
- (A) variety of animals which it can produce.
 - (B) consistency of traits that will appear generation after generation.
 - (C) continuance of the species.
 - (D) fact that a smaller percentage of eggs is fertilized.
20. The prime benefit of internal fertilization is
- (A) a shorter life cycle.
 - (B) a greater number of offspring.
 - (C) protection and nourishment for the developing organism.
 - (D) sexual reproduction.

Questions 21-25 require the selection of the correct statement of the interpretation of the following graph.

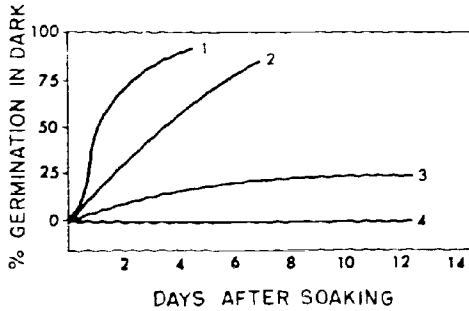

The interpretation is

- (A) illogical but not refuted by data.
- (B) rejected on the basis of evidence presented.
- (C) supported by the evidence.
- (D) logical but the experiment is not designed to test it.

1. Number 4 seeds require more time for germination.
2. Number 3 seeds have a lower germination percentage in the dark than number 2 seeds.
3. If number 3 seeds were germinated in the light, their percent germination would probably increase.
4. Number 1 has the best germination capacity.
5. Number 4 may require light for germination.

Questions 26-30

What processes are in favor of division of labor in Volvox against the tendencies for each cell to be independent like those of Chlamydomonas?

- (A) Logical hypothesis
- (B) Illogical hypothesis
- (C) Logical hypothesis but unrelated to the problem
- (D) Not a hypothesis; an empirical statement or a biological generalization

26. A single celled organism must carry on all the life functions itself in order to survive.
27. Volvox does not move in dark water, but if a beam of light were passed through the water, the colony would move toward it.
28. The larger the organism, the greater the number of natural enemies.
29. Each cell of a colony must have all the life functions.
30. A specialized cell can perform certain functions more effectively than a nonspecialized cell.

IF YOU FINISH BEFORE TIME IS CALLED, CHECK YOUR WORK ON THIS TEST.

FORM K - PBC6

BIOLOGY-BSCS I (For Phases 3, 4, and 5)

Time—40 minutes

YOU ARE TO INDICATE ALL YOUR ANSWERS ON THE SEPARATE ANSWER SHEET. No credit will be given for anything written in the test book. After you have decided which of the suggested answers you want to give for a question, blacken the corresponding space on the answer sheet.

Example:

Chicago is a

- (A) state
 (B) city
 (C) country
 (D) continent

Sample Answer

A	B	C	D
<input type="checkbox"/>	<input checked="" type="checkbox"/>	<input type="checkbox"/>	<input type="checkbox"/>

Give only one answer to each question; no credit will be given for multiple answers. If you wish to change an answer, erase your first line completely and mark your new choice.

DO NOT OPEN THIS BOOK UNTIL YOU ARE TOLD TO DO SO.

Note for Teachers: This test is based on the BSCS, Molecules to Man, Chapters 1 and 2.

Copyright © 1967

by

Biological Sciences Curriculum Study.

All rights reserved.

Reproduced by permission.

Classification systems are man-made and are

- (A) acceptable to all taxonomists.
- (B) unchanging and reliable.
- (C) subject to modification.
- (D) a permanent part of biology.

A scientist uses controls in conducting research because

- (A) controls become his standards.
- (B) all scientific work uses controlled experiments.
- (C) he needs controls to direct the investigation.
- (D) he must control the experiment or he will get wrong answers.

Which one of the following groupings includes the most kinds of animals or plants?

- (A) Species
- (B) Order
- (C) Genus
- (D) Phylum

The controlled experiment is essential to the testing of a hypothesis because it

- (A) tests many aspects of a problem.
- (B) uses a trial-and-error method.
- (C) is necessary in the experiment.
- (D) insures that a single part of the problem is tested at a time.

A definition of the term animal which will separate animals from plants is not easily given because

- (A) it is not defined precisely in the textbook.
- (B) exceptions to most characteristics given in such a definition can usually be found.
- (C) animals are obviously animals and plants are obviously plants.
- (D) some plants are green but no animals are green.

Questions 6-7

6. An insect of Species A is found in large numbers in an area in which many people suffer from disease H. To demonstrate that disease H is transmitted by these insects, it would be necessary to

- (A) learn more about the insect's life history.
- (B) prevent the insects from biting people.
- (C) find the disease germs in the insect's body.
- (D) let some of the insects bite people who are not suffering from disease H.

7. The area is now sprayed with insecticide X which kills most of the insects of Species A. If this insect were the transmitter of disease H, we now would expect

- (A) no people would have the disease.
- (B) all people with disease H to recover.
- (C) fewer new cases of disease H to develop.
- (D) disease H to disappear completely.

8. A scientist collects data relevant to a problem because

- (A) all research is designed to produce data.
- (B) relevant data lead to the solution of a problem.
- (C) relevant data are the only data produced.
- (D) all data are relative.

9. The procedure of scientists testing the secretions of hundreds of molds to find new antibiotics is known as

- (A) a controlled experiment.
- (B) trial-and-error.
- (C) qualitative experimentation.
- (D) quantitative experimentation.

GO ON TO THE NEXT PAGE.

Questions 10-14

Over a wide area of the United States the oak tree is threatened by the disease called oak wilt. The disease is caused by a fungus. How is the disease spread?

Hypothesis I. The disease is spread by carriers such as insects.

Hypothesis II. The disease is spread from tree to tree by contact of the roots.

Key: (A) A fact which supports Hypothesis I
(B) A fact which supports Hypothesis II
(C) A fact which supports both hypotheses
(D) A fact which supports neither hypothesis

10. The disease-causing fungus can grow on the ash, dogwood, the wild cherry and other trees.
11. The top of the diseased tree begins to wilt and turn brown, then the lower limbs become involved.
12. In a stand of oak the roots of neighboring trees become grafted to one another.
13. The fungus grows best at temperatures of 18^o-24^oC.
14. Single trees (not those in groups) often become infected if they have been damaged by wind or lightning.
-
15. If Darwin were living today, he could test his atoll-formation hypothesis because
- (A) biologists can classify animals more accurately now.
- (B) future glacialation can be predicted.
- (C) deep borings into the atoll can be obtained.
- (D) navigation to atolls is quite easy.

Question 16 refers to the following chart.

patient	Complaint	Symptoms
I	High fever	Profuse sweating
II	Sore eyes	Watery discharge from eyes
III	A common cold	A runny nose
IV	Boils	Watery-pus discharge

The hypothesis that best accounts for all of these symptoms is

- (A) sick people always have fever which causes sweating.
- (B) people with runny noses often have colds.
- (C) excessive water discharge seems to accompany illnesses.
- (D) all illnesses result in pus formation.
17. A scientist performed an experiment on a subject which was believed to be thoroughly understood. The results of the scientist's work contradicted many former experiments. Which of the following statements represents the correct scientific attitude to take concerning this?
- (A) The scientist must have made a mistake when he performed the experiment.
- (B) The results could be valid, but further tests must be made to determine if this is so.
- (C) Since everything was already known about the subject, the scientist's experiment was unnecessary.
- (D) The scientist must be right, because he had all the data from previous experiments to work with.
18. These animals are multicellular and have 2 layers of cells, a digestive tract or cavity with one opening, radial symmetry, a network of nerve cells, and a sac-like body.
- (A) Mollusks
- (B) Echinodermata
- (C) Coelenterata
- (D) Annelida
19. Before a scientist can classify a newly discovered specimen of plant or animal, he must make a careful study of its
- (A) relationships in the plant and animal community.
- (B) size.
- (C) structure.
- (D) adaptability.

20. A scientist recognizes the importance of selecting appropriate techniques for conducting his research because
- (A) he knows that techniques affect his results.
 - (B) he is limited to techniques which can be followed in his laboratory.
 - (C) he knows only one technique will give the result he is seeking.
 - (D) he is limited to techniques he has tried in the past.

Questions 21-25 refer to the following diagram.

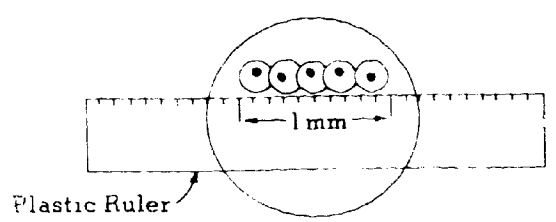

A clear plastic ruler has been placed across the middle of the field and a row of cells can be seen. 1,000 microns make up a millimeter.

1. What is the average cell length in microns?
 - (A) 100 microns
 - (B) 200 microns
 - (C) 400 microns
 - (D) 1,000 microns

2. What is the average cell length in millimeters?
 - (A) 1 mm.
 - (B) .1 mm.
 - (C) .2 mm.
 - (D) .5 mm.

3. Approximately how many cells could be seen if the microscope were changed to high power?
 - (A) None
 - (B) One
 - (C) Five
 - (D) About ten

4. Approximately how long is the nucleus?
 - (A) 1 micron
 - (B) 75 microns
 - (C) 200 microns
 - (D) 1,000 microns

25. If the diameter of the low-power field of your microscope was found to be 2 millimeters and the ratio between the low-power and high-power fields was 10, what would the diameter of the high-power field be in millimeters?
- (A) .2 mm.
 - (B) 20 mm.
 - (C) 40 mm.
 - (D) 200 mm.

Questions 26-27

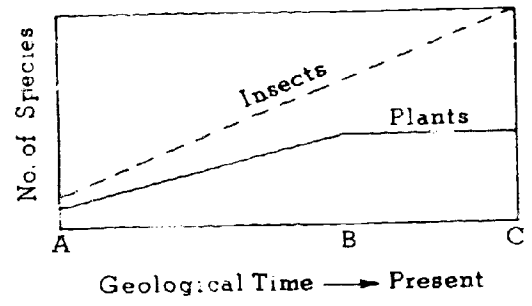

26. Which of the following best explains the increases in species of flowering plants?
 - (A) Insects carried the seeds to a variety of habitats.
 - (B) New insect forms pollinated new plant species.
 - (C) New species of flowers are evolving.
 - (D) The number of flowers increased to offset the number eaten by insects.

27. The numbers of species of insects from time B to time C seem to be
 - (A) exceeding its usefulness.
 - (B) increasing geometrically.
 - (C) dependent upon the number of species of flowers.
 - (D) independent of the number of species of flowers.

28. What evidence supports the theory of evolution?
 - (A) Fossil remains which are similar to living forms.
 - (B) Fossil remains found at great depths which are related to living forms.
 - (C) Fossil remains which have been traced to living forms by structural resemblance.
 - (D) A sequence of fossils showing a pattern of structural similarities to a present form.

29. Which of the following statements best explains why organisms under different magnification seem to move at different speeds? The area observed under
- (A) high power is smaller and the organisms seem to cover the observed area more quickly.
 - (B) high power is larger than under low power and the organisms seem to cover the observed area more slowly.
 - (C) low power is smaller than under high power and the organisms seem to cover the area more quickly.
 - (D) low power is larger than under high power and the organisms seem to cover the area more quickly.

30. Which of the following statements best explains why organisms under magnification move in and out of focus?
- (A) The experimenter makes slight shifts in the adjustment mechanism.
 - (B) There is a failure to maintain a steady source of light for the microscope.
 - (C) The organisms move in and out of different levels within the fluid.
 - (D) The experimenter does not keep careful and steady observation.

31. What is a hypothesis?
- (A) A tentative solution to a problem
 - (B) A theory
 - (C) An experimental fact
 - (D) A clue

32. A biologist formulates hypotheses, performs experiments to test his hypotheses, makes careful observations, keeps accurate records of his findings, and
- (A) usually finds his data supports his hypotheses.
 - (B) evaluates his data carefully but often ignores that which does not support his hypotheses.
 - (C) makes an important discovery each time he performs a new experiment.
 - (D) carefully evaluates his findings, alters his hypotheses to account for new facts, and tests again.

33. Linnaeus would have disagreed with which of the statements?
- (A) Organisms can be classified according to similarities of structure.
 - (B) The basic categories of classification are: kingdom, phylum, class, order, family, genus, specie.
 - (C) Species are fixed and unchanging.
 - (D) Classification should take into account that certain forms of life have evolved from other forms.

Questions 34-35 refer to the following diagram.

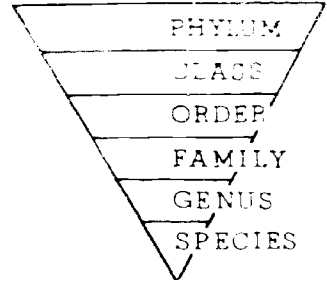

When considering the categories of classification it is possible to imagine an upside-down triangle with phylum on top, as illustrated, and species at the bottom. Answer the following questions based on the drawing above.

34. As we consider the organisms from species to phylum there is an increase
- (A) in unity.
 - (B) in diversity.
 - (C) in structural similarity.
 - (D) in color similarity.
35. As we consider the animal kingdom from phylum to species there is a(n)
- (A) decrease in size.
 - (B) increase in diversity.
 - (C) increase in relationship.
 - (D) increase in different kinds.
-
36. Aristotle, perhaps the first scientist to seriously attempt to classify plants and animals, based his classification of animals on
- (A) their size.
 - (B) what the animals ate.
 - (C) where the animals lived.
 - (D) animal bone structure.

GO ON TO THE NEXT PAGE.

Directions: Pick out the animal which is LEAST related (according to biological classification) to the other four.

- (A) bat
- (B) blue jay
- (C) flying squirrel
- (D) honey bee

- (A) grasshopper
- (B) mosquito
- (C) spider
- (D) butterfly

39. (A) snake
(B) lizard
(C) frog
(D) alligator

40. (A) catfish
(B) bass
(C) mackerel
(D) whale

IF YOU FINISH BEFORE TIME IS CALLED, CHECK YOUR WORK ON THIS TEST.

BIOLOGY I (For Phases 1 and 2)

Time—40 minutes

YOU ARE TO INDICATE ALL YOUR ANSWERS ON THE SEPARATE ANSWER SHEET. No credit will be given for anything written in the test book. After you have decided which of the suggested answers you want to give for a question, blacken the corresponding space on the answer sheet.

Example:

Chicago is a

- (A) state
- (B) city
- (C) country
- (D) continent

Sample Answer

A	B	C	D
<input type="checkbox"/>	<input checked="" type="checkbox"/>	<input type="checkbox"/>	<input type="checkbox"/>

Give only one answer to each question; no credit will be given for multiple answers. If you wish to change an answer, erase your first line completely and mark your new choice.

DO NOT OPEN THIS BOOK UNTIL YOU ARE TOLD TO DO SO.

Note for Teachers: This test is based on the BSCS Special Materials SI-S14.

Developed by Educational Testing Service pursuant to a subcontract funded by the U. S. Department of Health, Education, and Welfare, Office of Education.

127

1. Biological classification is based primarily on
(A) physiology (B) structure
(C) size (D) shape
2. Which of the following animals has a skeleton most similar to that of man?
(A) Frog (B) Grasshopper
(C) Crayfish (D) Centipede
3. Which of the following is a correct statement about living things?
(A) All things that move are alive.
(B) It is difficult to decide whether some things are alive or not alive.
(C) Most living things produce their own food.
(D) An individual animal must reproduce in order to be considered alive.
4. If 20 pins are required to balance a scale containing 1 ounce of a certain material, 400 pins would balance how many ounces of the same material?
(A) 2 oz. (B) 20 oz. (C) 50 oz. (D) 200 oz.
5. Which of the following are most similar?
(A) Frogs and birds (B) Snakes and mice
(C) Dogs and wolves (D) Cats and dogs
6. A good grouping system should
(A) serve a useful purpose for the user
(B) be based on qualities that are different for all observers
(C) use different characteristics throughout
(D) not bring out differences if they exist
7. The many differences between living things is called
(A) reproduction (B) diversity
(C) metabolism (D) circulation
8. The easiest and most widely accepted way to determine the number of trees in a large forest of a known area is to count
(A) the trees in a number of selected plots throughout the forest and use this figure to estimate the total number
(B) all the trees
(C) the trees in one section and use this figure to estimate the total number
(D) the trees in a section in the middle and use this figure to estimate the total number
9. The ability of an organism to make copies of itself is called
(A) metabolism (B) population
(C) reproduction (D) evolution
10. Which of the following is the most nearly correct statement about scientific grouping systems?
(A) They are subject to change.
(B) All scientists agree on the same system.
(C) Once placed in a group, a plant or animal will stay in that group.
(D) The grouping systems are based on a single characteristic.
11. One would expect to find the greatest density of people per acre in the
(A) city slums (B) suburbs
(C) rural areas (D) small towns
12. Which of the following would be the most accurate way of determining the weed population in a school yard that is 100 feet by 200 feet?
(A) Counting the weeds in 1 square foot and then calculating the number of weeds
(B) Counting the weeds in 5 one-foot plots and then calculating the number
(C) Counting the weeds in 10 one-foot plots and calculating the number
(D) Counting all the weeds in the school yard
13. Which of the following number of samples would usually be the most accurate for determining the size of a population?
(A) 1 (B) 5 (C) 10 (D) 20
14. You are given a sealed box containing a living organism. You could help determine the contents of the box by all of the following EXCEPT
(A) shaking the box (sound)
(B) weighing the box
(C) noting the color of the box
(D) measuring the height of the box

GO ON TO THE NEXT PAGE.

Questions 15-17 refer to the following study.

Three students counted the weeds in three different plots. Student A counted 9, Student B counted 8, Student C counted 7. The plot that each measured was 2 feet long and 6 feet wide.

- 15. The average number of weeds per plot was
(A) 5 (B) 6 (C) 7 (D) 8
- 16. The area of the plot of ground that each student counted was
(A) 8 sq. ft. (B) 12 sq. ft.
(C) 16 sq. ft. (D) 25 sq. ft.
- 17. Each weed in the area is known as
(A) an individual (B) a population
(C) a random sample (D) an average

Questions 18-19 refer to the following figures.



- 18. Which of the following would be the best basis for arranging the blocks above into two groups?
(A) Shape (B) Size (C) Thickness (D) Color
- 19. Which of the following would be the best basis for arranging the blocks above into three groups?
(A) Shape (B) Size (C) Thickness (D) Color

Questions 20-24 refer to the parts of the microscope and the care and use of the microscope.

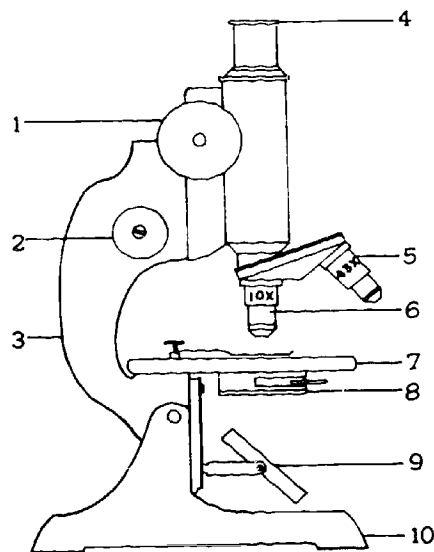

- 20. The part labeled 1 is called the
(A) eyepiece (B) low-power objective
(C) coarse adjustment (D) diaphragm
- 21. What part is used to make fine adjustments?
(A) 1 (B) 2 (C) 6 (D) 8
- 22. What part should be washed after each use?
(A) 4 (B) 5 (C) 6 (D) 7
- 23. Which of the following is NOT a good rule for the handling and use of the microscope?
(A) Keep the microscope away from the edge of the table.
(B) Carry the microscope with both hands.
(C) Clean the lens with paper or cloth.
(D) Make sure the microscope setting is on low power before putting it away.
- 24. When the eyepiece and high-power objective (43x) is used to observe a specimen, the specimen is magnified
(A) 10 times (B) 43 times
(C) 53 times (D) 430 times

Questions 25-27 refer to the following plots.

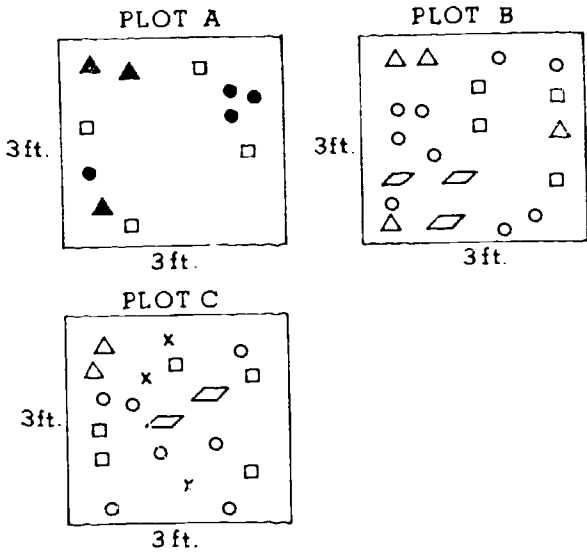

25. Which plot has the greatest number of individuals?
 (A) A only (B) B only (C) C only
 (D) Both B and C, which have the same number
26. How many groups of individuals are there in plot A?
 (A) 1 (B) 2 (C) 3 (D) 4
27. Which of the following statements about the number of groups in the plots is correct?
 (A) There are more groups in plot A than plot B.
 (B) There are more groups in plot B than plot A.
 (C) There are the same number of groups in both plot A and plot B.
 (D) There are more groups in plot A than plot C.

Questions 28-30 refer to the following grouping system.

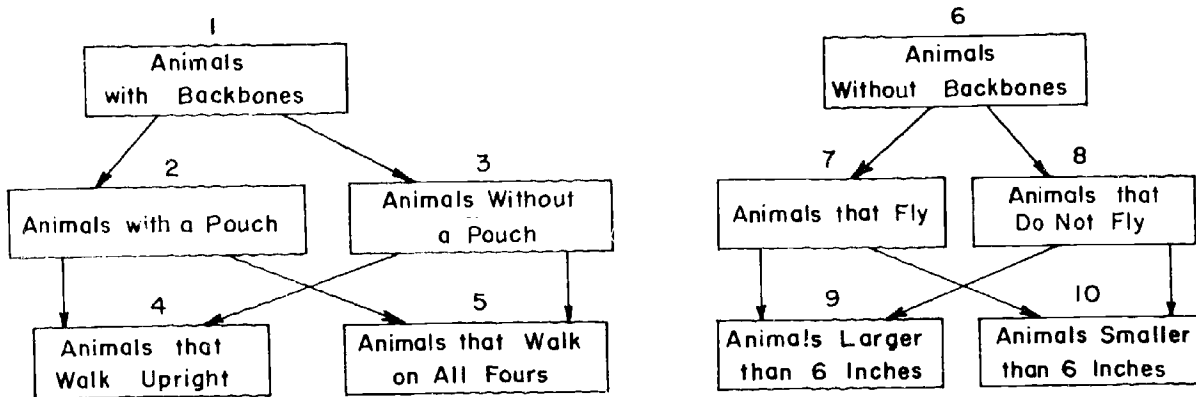

How would man be classified in this system?

- (A) 1, 3, 4 (B) 1, 2, 4
 (C) 6, 3, 4 (D) 1, 2, 10

How would an adult American grasshopper be classified in this system?

- (A) 1, 7, 10 (B) 6, 7, 10
 (C) 6, 8, 10 (D) 4, 6, 7

30. How would an opossum be classified in this system?

- (A) 1, 2, 5 (B) 1, 2, 4
 (C) 1, 3, 4 (D) 1, 3, 5

31. If you were asked to place blue whales, bluebirds, blue jays, blue-colored ticks, and bluefish into a single category, you would classify them by

- (A) size
- (B) presence of backbone
- (C) color
- (D) swimming ability

32. If you were attempting to classify an organism, knowing which of the following would give you the most specific information?

- (A) Whether it has a backbone
- (B) Whether it is a butterfly or a moth
- (C) Whether it is living or nonliving
- (D) Whether it is a plant or an animal

33.

List I

List II

slacks
 necktie
 paintbrush
 nails
 baking soda
 lettuce
 milk
 potatoes

baking soda
 lettuce
 milk
 nails
 necktie
 paintbrush
 potatoes
 slacks

If you were asked which of the lists above would be more useful on a shopping trip, with which of the following answers would you most agree?

- (A) Both lists are equally good.
- (B) List II is better because the items are listed in alphabetical order.
- (C) List I is better because items that can be bought in the same place are grouped together.
- (D) List I is better because the heavier items are listed last.

Questions 34-36 refer to the following pictures.

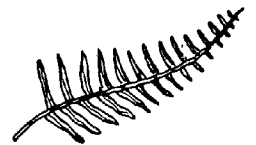

34. If you were to classify all of the above into only two groups, which of the following would be acceptable?

- (A) Objects that fly; objects that do not fly
- (B) Objects that are animals; objects that are plants
- (C) Objects that are minerals; objects that are animals
- (D) Objects that are warm-blooded and alive; objects that are cold-blooded and alive

36. If a person classified the above into seven different categories, he would give greatest consideration to

- (A) diversity
- (B) similarity
- (C) living vs. nonliving
- (D) plant vs. animal

35. If you were to use three groups, which of the following would be the best classification?

- (A) Plants; animals; nonliving
- (B) Living; nonliving; animals
- (C) Animals with backbones; animals without backbones; plants
- (D) Green plants; nongreen plants; animals

37. Which of the following animals has a skeleton outside of its body?

- (A) Frog
 - (B) Grasshopper
 - (C) Bird
 - (D) Man
-

Questions 38-40 refer to the following diagram.

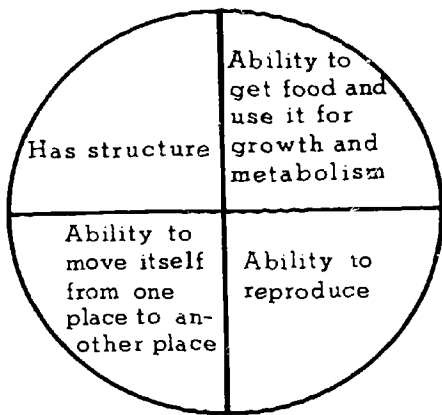

39. Into how many of the sections above would a bird fit?

- (A) 1 (B) 2 (C) 3 (D) 4

40. Into how many of the sections above would a tree fit?

- (A) 1 (B) 2 (C) 3 (D) 4

Into how many of the sections above would a rock fit?

- (A) 1 (B) 2 (C) 3 (D) 4

IF YOU FINISH BEFORE TIME IS CALLED, CHECK YOUR WORK ON THIS TEST.

FORM K-PBC2

BIOLOGY A (Across Phases)

Time—40 minutes

YOU ARE TO INDICATE ALL YOUR ANSWERS ON THE SEPARATE ANSWER SHEET. No credit will be given for anything written in the test book. After you have decided which of the suggested answers you want to give for a question, blacken the corresponding space on the answer sheet.

Example:

Chicago is a

- (A) state
- (B) city
- (C) country
- (D) continent

Sample Answer

A	B	C	D
<input type="checkbox"/>	<input checked="" type="checkbox"/>	<input type="checkbox"/>	<input type="checkbox"/>

Give only one answer to each question; no credit will be given for multiple answers. If you wish to change an answer, erase your first line completely and mark your new choice.

DO NOT OPEN THIS BOOK UNTIL YOU ARE TOLD TO DO SO.

Note for Teachers: This test is based on the BSCS Special Materials S1-S14 and Molecules to Man, chapters 1 and 2.

Developed by Educational Testing Service pursuant to a subcontract funded by the U. S. Department of Health, Education, and Welfare, Office of Education.

1. Which of the following best describes the basis of a good classification system?
(A) It is based only on similarities among organisms.
(B) It is based only on differences among organisms.
(C) It is based on similarities as well as differences among organisms.
(D) It is based on neither similarities nor differences among organisms.
2. The classification system used in biology is based primarily on
(A) structure (B) function (C) age (D) sex
3. If the object you are looking at under your microscope is too dark, it could NOT be brightened by
(A) opening the diaphragm
(B) switching to the high-power objective lens
(C) focusing
(D) using a thinner specimen on your slide
4. The process through which an animal gives rise to offspring is called
(A) metabolism (B) organization
(C) reproduction (D) classification
5. If an organism appears to be 1 centimeter across when viewed with the 10× eyepiece and 10× objective, what is the actual size of the organism?
(A) 1/100 cm. (B) 1 cm.
(C) 10 cm. (D) 100 cm.
6. Which of the following best describes how a scientist considers a classification system?
(A) A useful system that can change
(B) An unchanging system
(C) A system based on similar functions
(D) A system that is not really necessary
7. Which of the following would give you the LEAST specific information about an organism that you are attempting to classify?
(A) Whether it is a plant or an animal
(B) Whether it is a toad or a frog
(C) Whether it is a butterfly or a moth
(D) Whether or not it has a backbone
8. If 500 seeds weigh 10 grams, one seed would probably weigh
(A) 2 grams (B) 5 grams
(C) .05 gram (D) .02 gram
9. Which of the following is a correct procedure for the care of a microscope?
(A) Carrying it in one hand
(B) Keeping it away from the edge of the table
(C) Cleaning the objective with your handkerchief
(D) Returning the setting to high power before putting it away
10. In which of the following pairs are the animals most different?
(A) Jellyfish, fish (B) Cats, lions
(C) Dogs, foxes (D) Alligators, crocodiles
11. Which of the following has the largest number of animals within its classification?
(A) Class (B) Genus
(C) Phylum (D) Kingdom
12. The ratio of magnification of the eyepiece to the low-power objective to the high-power objective is approximately
(A) 1:1:1 (B) 1:1:4 (C) 1:2:1 (D) 1:4:1
13. Bubbles should be removed from a temporary slide prepared in the laboratory by
(A) heating the slide
(B) adding more water to the slide
(C) gently tapping the slide
(D) pushing down on the slide's cover slip
14. If one switches from low to high power when observing a specimen under a microscope, the
(A) distance between the stage and objective decreases
(B) distance between the stage and objective increases
(C) distance between the stage and objective remains the same
(D) high-power objective will touch the stage
15. Approximately how much greater magnification do you get when you change from low power to high power?
(A) $2\frac{1}{3}\times$ (B) $4\frac{1}{3}\times$ (C) $6\frac{1}{3}\times$ (D) $10\frac{1}{3}\times$

Questions 16-20 refer to the numbered parts of the diagram below.

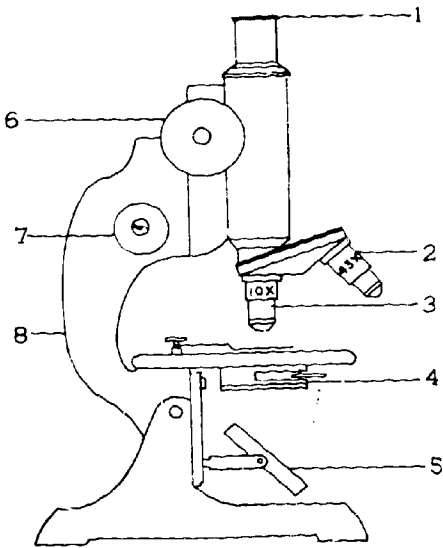

6. After adjusting a microscope for use with the high-power objective, one should look at the specimen by moving
- (A) 2 downward (B) 2 upward
(C) 3 downward (D) 3 upward

17. If structures 4 and 5 are in the proper adjustment and you still cannot see light, which of the following probably needs adjustment?
(A) 1 (B) 2 (C) 6 (D) 8
18. Which of the structures above is used for a coarse adjustment?
(A) 2 (B) 3 (C) 6 (D) 7
19. When putting a microscope away, you should
(A) tilt 8 back
(B) align 2 with the barrel
(C) align 3 with the barrel
(D) close 4
20. Which of the following structures is used primarily to regulate the amount of light that enters the microscope?
(A) 1 (B) 2 (C) 3 (D) 4

GO ON TO THE NEXT PAGE.

Directions: Each passage in this part is followed by a number of questions. In answering the questions you are expected to use your knowledge of biology as well as the information given you. For each question select the answer you think best and blacken the corresponding space on the answer sheet.

Questions 21-25

In the sixteenth century, trained cheetahs were found in every hunting lodge in Europe. Even today, in India, imported cheetahs are used to hunt antelope. A hooded cheetah is taken near a herd by a bullock cart, and its hood and leash are removed. It rushes to bring down its prey, and holds it by the throat until the attendant arrives for the dispatch.

The cheetah was thought to be the world's fastest runner, with a top speed estimated at 70 to 90 miles per hour. However, a recent film study revealed its top speed to be 56 miles per hour, so the title for fastest runner went to a pronghorn buck, clocked at 61 miles per hour. Adult cheetahs reach 4 feet in length and 135 pounds in weight. The coat is short-haired, yellow, and heavily black-spotted. The cheetah closely re-

sembles the leopard. In contrast to leopard spots, which are large, open rosettes, cheetah spots are small, solid, and set close together. A characteristic "dark-teardrop" marking characterizes its face. Unlike all other cats, the cheetah does not have claw sheaths. The claws remain exposed at all times, although the cheetah can partially retract its claws. The claws are similar to those of a dog in that they are dull, poor for ripping, and impossible to grip with because they cannot spring from the paws. Although cheetahs were once found in large numbers in open grassland scrub in Africa and Western Asia, the population is rapidly declining, and they are considered to be extinct in India and most of Asia. Only very strict conservation measures can insure their survival and save them from extinction.

21. According to the description of the passage, which of the following pictures is a cheetah?

(A)



(B)



(C)

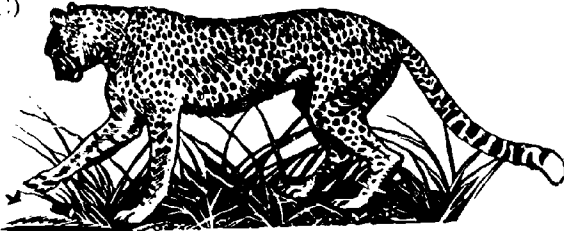

(D)



22. Today, the greatest number of cheetahs in the wild state can be found in
(A) Europe (B) India (C) Arabia (D) Africa
23. Present evidence places the top speed of the cheetah at
(A) 56 m.p.h. (B) 61 m.p.h.
(C) 70 m.p.h. (D) 90 m.p.h.
24. It can be inferred from the passage that the cheetah most commonly eats which of the following?
(A) Vegetation of open grassland and scrub
(B) Small mammals and birds
(C) Reptiles and frogs
(D) Man
25. According to the passage, the claws of the cheetah resemble those of the dog in that they are
(A) sharp
(B) protected by sheaths
(C) poor for gripping surfaces
(D) excellent for ripping food

Questions 26-30

The porpoise is an air-breathing, warm-blooded mammal with a body temperature about the same as that of man. Technically, a porpoise is a small whale, a toothed whale as opposed to the baleen whale, which grows much larger and has no teeth. Fifty known species of dolphins and porpoises inhabit all the oceans of the earth and some of the warm rivers.

The porpoise has a remarkable sonar or echolocating ability. He sends out sharp, clicking sounds and hears echoes from his clicks. Although its ears are as small as pinholes, its sense of hearing is incredibly keen. A stronger echo on one side indicates the direction of prey or predator. The time interval between sending and receiving tells the distance of the object; variations in echo sound reveals its size or nature.

Porpoises are descended from land animals, although their earliest ancestors came from the ocean. The land-mammal ancestor of the porpoise went through a long process of readapting to life in water. Its body grew streamlined and its legs disappeared. However, a porpoise still has finger bones in its flippers. Its nose evolved into a blowhole, one large nostril atop the head, with inner and outer valves to seal out the water. When it surfaces for air, about once a minute, a porpoise opens the blowhole wide and breathes in four to ten quarts of air in less than half a second. The porpoise developed tail flukes for propulsion; however, these flukes grow out horizontally, not vertically like those of fish.

26. Which of the following is approximately the same for both porpoise and man?
(A) Habitat (B) Body temperature
(C) Size of ears (D) Number of nostrils
27. By estimation of the time interval between sending and receiving a noise, a porpoise can determine the
(A) direction of the object
(B) depth of the object
(C) character of the object (prey or predator)
(D) distance to the object
28. Which of the following is an adaptation of the porpoise to a water habitat?
(A) Keen sense of smell
(B) A blowhole with valves
(C) Warm-bloodedness
(D) Body covered with fur
29. The rate of breathing of man compared with that of a porpoise is approximately
(A) one half as fast
(B) the same
(C) two times faster
(D) twenty times faster
30. A shark can be most easily distinguished from a porpoise by its
(A) teeth (B) vertical tail fins
(C) color (D) eating habits

Questions 31-35 refer to the following chart.

THE EVOLUTION OF REPTILES AND BIRDS

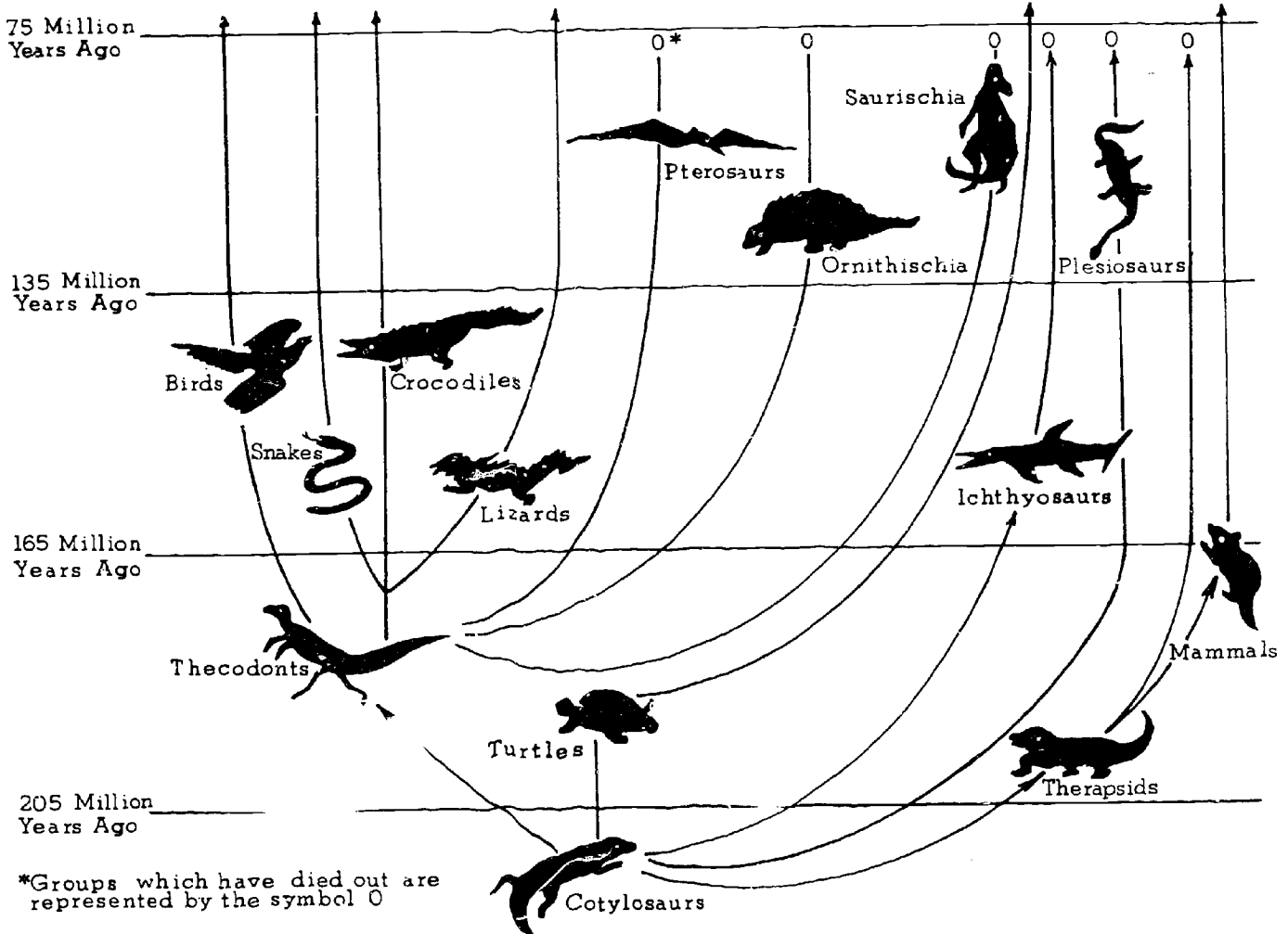

31. All of the following have come from thecodonts EXCEPT
 (A) crocodiles (B) snakes
 (C) lizards (D) turtles
32. Of the following, snakes appear to be most closely related to
 (A) ichthyosaurs (B) pterosaurs
 (C) mammals (D) turtles
33. Apparently there are no present-day descendants of
 (A) cotylosaurs (B) thecodonts
 (C) ornithischia (D) turtles

34. The ancestors of all the reptiles living today are
 (A) thecodonts (B) turtles
 (C) cotylosaurs (D) crocodiles
35. Which of the following presently existing forms of life came into being most recently?
 (A) Crocodiles (B) Thecodonts
 (C) Mammals (D) Turtles

Questions 36-37

36. If a microscope were built with an eyepiece that magnified 20x and an objective that magnified 50x, how much would it magnify an object?
- (A) 70x (B) 100x (C) 500x (D) 1,000x

37. Compared to the usual microscope used in high school classes, this microscope would magnify an object
- (A) approximately twice as much
 (B) about the same
 (C) slightly less
 (D) approximately half as much

Questions 38-40 refer to the following chart.

KEY TO COMMON PINES BASED ON NUMBER AND CHARACTERISTICS OF NEEDLES

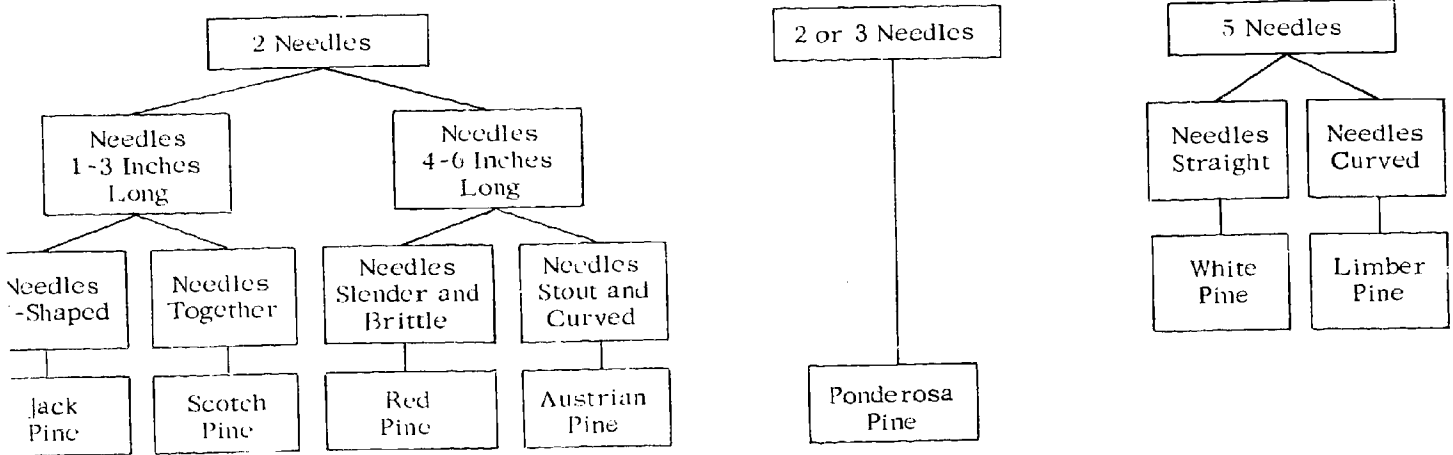

Which of the following would be the best statement to make about a pine tree that has needles 8 inches long in bundles of two?

- (A) It is a jack pine or a Scotch pine.
 (B) It is an Austrian pine that has long needles.
 (C) It is a white pine that grows in good soil.
 (D) It cannot be classified according to the key.

If a pine tree has half of its needles in bundles of two and half in bundles of three, it is a

- (A) white pine
 (B) red pine
 (C) ponderosa pine
 (D) jack pine

40. If a pine tree has needles that are 2 inches long and are spread apart, and have two needles to a bundle, it is a

- (A) ponderosa pine
 (B) red pine
 (C) jack pine
 (D) Scotch pine

IF YOU FINISH BEFORE TIME IS CALLED, CHECK YOUR WORK ON THIS TEST.

BIOLOGY-BSCS II (For Phases 3, 4, and 5)

Time—40 minutes

YOU ARE TO INDICATE ALL YOUR ANSWERS ON THE SEPARATE ANSWER SHEET. No credit will be given for anything written in the test book. After you have decided which of the suggested answers you want to give for a question, blacken the corresponding space on the answer sheet.

Example:

Chicago is a

- (A) state
- (B) city
- (C) country
- (D) continent

Sample Answer

A	B	C	D
<input type="checkbox"/>	<input checked="" type="checkbox"/>	<input type="checkbox"/>	<input type="checkbox"/>

Give only one answer to each question; no credit will be given for multiple answers. If you wish to change an answer, erase your first line completely and mark your new choice.

DO NOT OPEN THIS BOOK UNTIL YOU ARE TOLD TO DO SO.

Note for teachers: This test is based on the BSCS, Molecules to Man, Chapters 3, 4, 5, and 6.

Copyright © 1966
by
Biological Sciences Curriculum Study.
All rights reserved.
Reproduced by permission.

- Which of the following is not a heterotroph?
 - Human.
 - Mushroom.
 - Frog.
 - Maple tree.
- Which of the following statements represents a belief in spontaneous generation?
 - Corn is planted and fails to germinate.
 - A white rat has 8 black offspring.
 - Frogs come from mud.
 - Flies develop on decaying food.
- If a compound were a protein one could correctly conclude it was
 - constructed from amino acids.
 - soluble in water.
 - made of carbon, hydrogen and oxygen only.
 - a small molecule.
- The use of bacteria in studies of natural selection is
 - not possible because of their disease-producing capabilities.
 - advantageous due to the large numbers of individuals produced.
 - limited; the information gained cannot be applied to other organisms.
 - not accepted as a valid experimental approach to the problem.

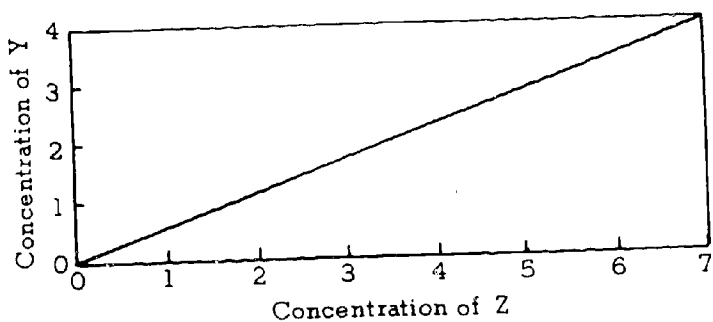

- What conclusion can be made on the basis of the graph?
 - An increase in the concentration of Z caused an increase in the concentration of Y.
 - The concentration of Y increased with time.
 - The concentration of Z is related to the concentration of Y.
 - There is no relationship between the concentrations of Y and Z.

- Miller's electrical sparking device was an attempt to duplicate conditions as they were on earth during the time of the primitive atmosphere. The electrical spark was meant to represent
 - heat conditions.
 - volcanic eruptions.
 - ultraviolet radiation.
 - lightning.

Questions 7-9 refer to the equation



- 2
 - 3
 - 4
 - 5
- How many kinds of atoms are represented?
 - How many kinds of molecules are represented?
 - How many molecules are represented?

 - When two amino acids are bonded chemically
 - energy is released.
 - energy is added to ADP.
 - water is released.
 - water is added.
 - In the electrolysis of water why is twice as much hydrogen gas as oxygen gas produced?
 - Oxygen is more easily compressed.
 - 2 atoms of hydrogen to 1 atom of oxygen are produced.
 - Oxygen is twice as dense as hydrogen.
 - Hydrogen occupies twice as much space as oxygen.

GO ON TO THE NEXT PAGE.

Questions 12-14

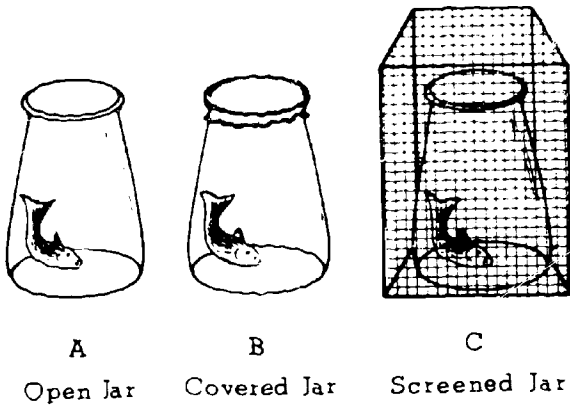

12. If spontaneous generation were to be established one would expect to find maggots in

- (A) A and B only.
- (B) B and C only.
- (C) C only.
- (D) A, B, and C.

13. If flasks A and B were used together, A would serve as a

- (A) conclusion.
- (B) control.
- (C) source of flies.
- (D) hypothesis.

14. Redi's original hypothesis, that flies were the source of maggots, could be established if there were maggots in

- (A) A.
- (B) B.
- (C) B and C.
- (D) A and B.

15. Which of the following is an example of fermentation?

- (A) Formation of glucose by green plants.
- (B) Breakdown of ATP into ADP.
- (C) Production of alcohol from glucose.
- (D) Production of carbon dioxide from glucose.

16. Although Madagascar is separated from Africa only by a narrow strait, many plants and animals common on the mainland are unknown on the island. This fact illustrates the principle of

- (A) great environmental differences between Africa and Madagascar.
- (B) evolutionary equilibrium.
- (C) evolution in isolated populations.
- (D) succession.

Questions 17-19

A swamp near a boy's camp was sprayed with DDT at weekly intervals one summer in an attempt to eliminate a mosquito problem.

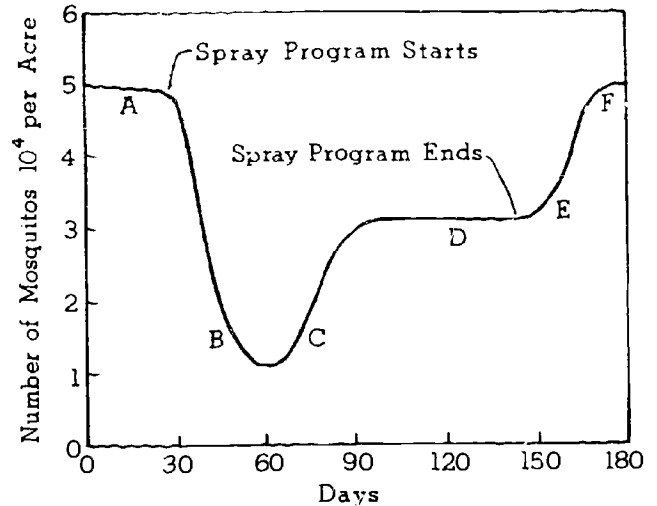

17. The most probable reason for the decreasing effectiveness of the campaign as the summer progressed was that the

- (A) mosquitos became immune to the DDT.
- (B) mosquitos resistant to DDT lived and produced offspring.
- (C) DDT was used at irregular intervals.
- (D) DNA of the mosquito population was not affected.

18. Not all of the mosquitos were killed at the time of the first spraying. The best explanation is that

- (A) the weather early in the summer was probably rather cool.
- (B) most of the mosquitos were adults.
- (C) environmental factors varied slightly as the summer progressed.
- (D) natural variation existed within the population.

19. Doubling the dose at the time of the initial spraying probably

- (A) would not have resulted in a 100 percent kill.
- (B) would have caused the mosquitos to be killed more rapidly.
- (C) would not have altered the results of the campaign.
- (D) would have caused all of the mosquitos to die.

20. Of 357 weeds germinating on a 2' x 3' plot of ground, 62 reached maturity. Which of the following aspects of Darwin's theory of natural selection can best be applied to this observation?
- (A) All members of a species vary in their traits.
 - (B) Many variations of a species are inherited.
 - (C) There is a struggle for existence among members of a species.
 - (D) Favorable variations are passed on to offspring and in time great differences arise.
21. According to the heterotroph hypothesis, the first complete animal body found on earth probably resembled
- (A) an amoeba.
 - (B) a sponge.
 - (C) a Paramecium.
 - (D) a Chlorella.

Questions 22-23 refer to the following diagram.

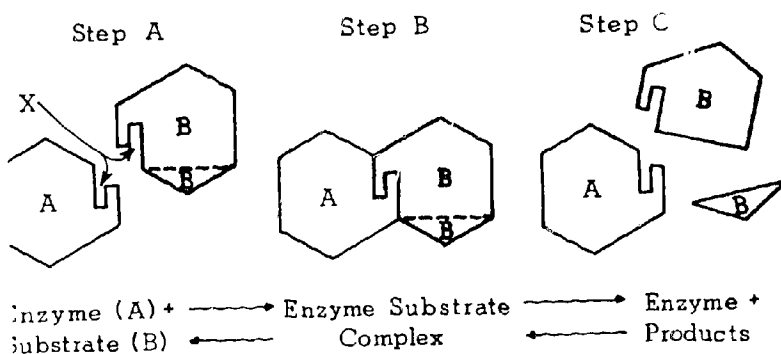

22. Reactions between enzyme (large molecules) and substrate (usually small molecules) can be explained by
- (A) surface configuration in general.
 - (B) surface configuration at active sites (X).
 - (C) enzyme specificity.
 - (D) a specific size relationship between enzyme and substrate molecules.
23. Whether the reaction proceeds to the left or to the right depends directly upon
- (A) relative concentrations of enzyme and substrate.
 - (B) relative concentrations of substrate and substrate products.
 - (C) the energy state of the whole system.
 - (D) the condition of the environment surrounding the systems.

Questions 24-25 refer to the following diagram.

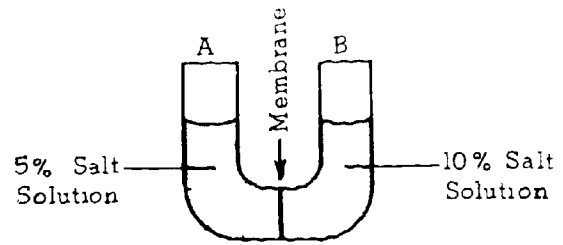

The U-shaped tube contains solutions of salt water separated by a membrane impermeable to salt.

24. On which side of the tube will the water level rise?
- (A) Side A.
 - (B) Side B.
 - (C) Both sides.
 - (D) Neither side.
25. The water level will remain constant on both sides of the tube when
- (A) all the water is on side A.
 - (B) all the water is on side B.
 - (C) the salt concentration becomes 7.5% on both sides.
 - (D) the water concentration becomes 90% on side A and 95% on side B.

GO ON TO THE NEXT PAGE.

Questions 26-28 refer to the following graph.

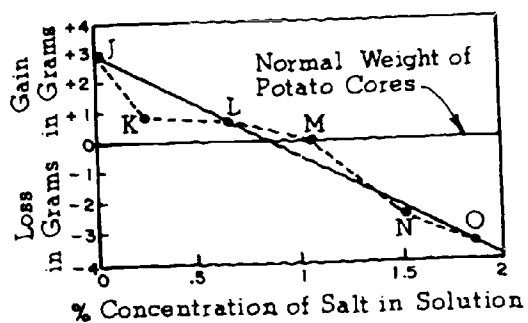

The above graph shows the results obtained when six potato cores of equal weight were placed in six different concentrations of salt water.

26. The dots J, K, L, M, N, and O represent
- variables.
 - assumptions.
 - hypotheses.
 - data.
27. Cores J, K, and L are above the normal weight line because
- there was a flow of water from each core.
 - salt entered the cores.
 - water entered the cores and increased their weight.
 - all these cores weighed more than three grams.
28. If there were no change in the weight of a core after immersion in salt solution it could mean that
- water could not enter the core.
 - water could not leave the core.
 - salt concentration inside the core was equal to the concentration outside.
 - the membrane is not permeable to salt.

29. Many reactions occur more readily when the temperature of the substances is increased because
- the kinetic energy of the molecules is increased
 - the kinetic energy of the molecules is decreased
 - heat increases the force of attraction.
 - the potential energy of the molecules is increased.
30. The most nearly correct statement applying to both the heterotroph and spontaneous generation hypotheses is
- both assumed evolution occurred.
 - both assumed living things could originate from nonliving material.
 - both assumed that all microorganisms came from nonliving material.
 - both required the passage of long periods of time.
31. Because of the similarity between the blood of the horseshoe crab and the blood of the spider, it is assumed that
- both evolved from a common ancestor.
 - both will also show a close structural similarity.
 - parallel evolution of blood types has taken place.
 - all crabs and spiders have similar blood types.
32. Which did Lamarck and Darwin have in common?
- Both are responsible for the origin of the idea of organic evolution.
 - Both attempted to explain how evolution occurs.
 - Both attempted to explain mutation.
 - Both believed that organisms change.

GO ON TO THE NEXT PAGE.

3. Which one of the following statements would be an illustration of Darwin's theory of evolution?
- (A) People who acquire a good body tan will have children born with a slight tan.
 - (B) If a mother plays a piano during pregnancy she will have a musically gifted child.
 - (C) Birds avoid eating the viceroy butterfly because of its close resemblance to the monarch butterfly.
 - (D) The breeding of greyhounds for speed changes the inheritance of the animal permanently.
4. The term biogenesis is used to sum up evidence that
- (A) cells are formed by division of other cells.
 - (B) cells can divide to form complete organisms.
 - (C) living organisms cannot use nonliving material.
 - (D) living organisms are descended from other living organisms.
5. If we assume that species do not change, we would expect
- (A) the simplest fossils in the oldest rocks.
 - (B) the simplest fossils in the newest rocks.
 - (C) the same kind of fossils in old and new rocks.
 - (D) no fossils in any rocks.
6. The biologist might describe a newly discovered organism like a plant but not like an animal if he discovered that it had special structures which he could recognize as
- (A) chloroplasts.
 - (B) chromosomes.
 - (C) Golgi bodies.
 - (D) cell membranes.

Questions 37-40

ACTIVITY OF AN ENZYME

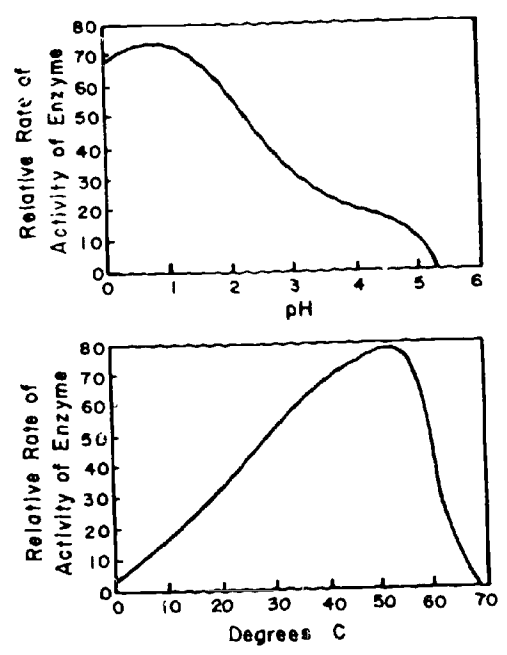

37. The enzyme will work best in
- (A) an acid medium.
 - (B) an alkaline medium.
 - (C) a neutral medium.
 - (D) none of these.
38. The enzyme will work best at a temperature of
- (A) 10-30° C.
 - (B) 30-40° C.
 - (C) 40-50° C.
 - (D) 50-60° C.
39. Enzyme activity stops at a pH of
- (A) 0.
 - (B) 2.
 - (C) 5.
 - (D) 6.
40. The information in the graphs
- (A) will apply to all enzymes.
 - (B) will apply to no other enzymes.
 - (C) may apply to other enzymes.
 - (D) will apply to all living things.

IF YOU FINISH BEFORE TIME IS CALLED, CHECK YOUR WORK ON THIS TEST.



BIOLOGY II (For Phases 1 and 2)

Time—40 minutes

YOU ARE TO INDICATE ALL YOUR ANSWERS ON THE SEPARATE ANSWER SHEET. No credit will be given for anything written in the test book. After you have decided which of the suggested answers you want to give for a question, blacken the corresponding space on the answer sheet.

Example:

Chicago is a
 (A) state
 (B) city
 (C) country
 (D) continent

Sample Answer

A B C D

Give only one answer to each question; no credit will be given for multiple answers. If you wish to change an answer, erase your first line completely and mark your new choice.

DO NOT OPEN THIS BOOK UNTIL YOU ARE TOLD TO DO SO.

Note for Teachers: This test is based on the BSCS Special Materials S15-532.

Developed by Educational Testing Service pursuant to a subcontract funded by the U. S. Department of Health, Education, and Welfare, Office of Education.

1. The factor that sets man apart from all other animals is his
(A) speed (B) strength
(C) intelligence (D) number
2. Examples of decomposers include
(A) deer (B) trees (C) owls (D) bacteria

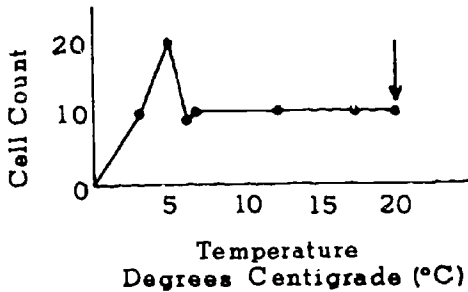

3. The arrow to the point on the graph above represents which of the following?
(A) 10°C and a cell count of 10
(B) 10°C and a cell count of 20
(C) 20°C and a cell count of 10
(D) 20°C and a cell count of 20
4. Which of the following is NOT one of the wounds that man has inflicted on his environment?
(A) The smog over cities
(B) The pollution of rivers
(C) The erosion of farmland
(D) The succession of animals in a food chain
5. Of the following, which would be the best way to test the hypothesis that yeast grows fastest in the dark?
(A) Growing yeast cells in the dark only
(B) Growing yeast cells in the light only
(C) Growing yeast cells in both dark and light
(D) Growing yeast cells in both dark and light at the same temperature
6. The interaction of all living and nonliving things is called
(A) a community (B) an ecosystem
(C) a food chain (D) a food web

7. Of the following, energy flow in a food chain most closely resembles a
(A) closed pipeline
(B) fire hose
(C) garden hose with many holes in it
(D) large pond
8. Which of the following statements about energy in a food chain is correct?
(A) More energy is retained in the living system than is lost.
(B) More energy is lost in the living system than is retained.
(C) The same amount of energy is retained in the living system as is lost by the living system.
(D) All energy is retained in the living system and none is lost.
9. Which of the following is a hypothesis that might be tested?
(A) The number of cells counted in a drop of water
(B) The number of dandelions counted in a square foot of land
(C) The weight of a block of wood
(D) The statement that decreasing the amount of sunlight decreases the number of yeast cells
10. Which of the following correctly describes a first-order consumer?
(A) It is eaten by more than one animal.
(B) It is eaten by one animal only.
(C) It feeds on one animal only.
(D) It feeds on more than one animal.

GO ON TO THE NEXT PAGE.

11. Which of the following graphs best illustrates an increase in gill-cover beats with an increase in temperature?

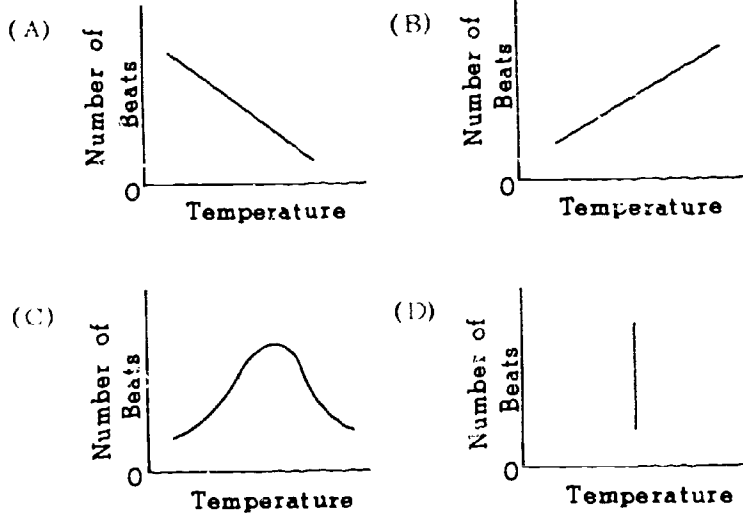

12. Which of the following graphs best illustrates a rise in the number of yeast cells followed by a fall and then another rise?

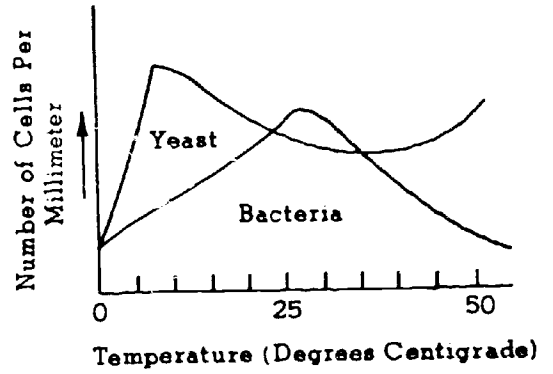
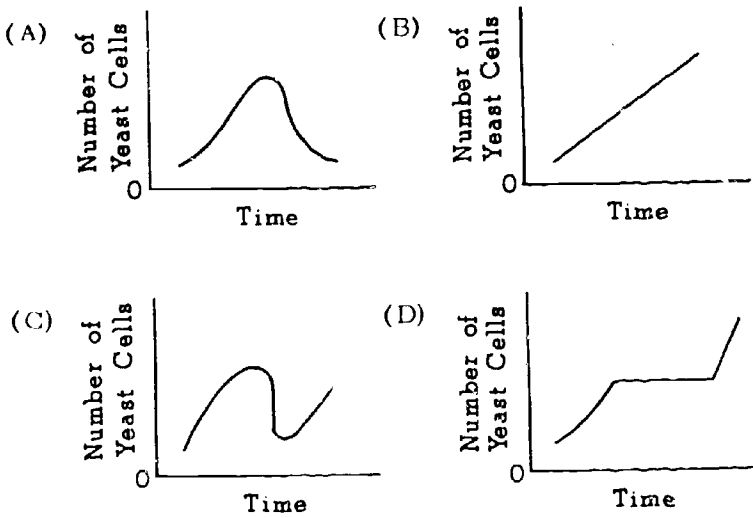

POPULATION OF YEAST AND BACTERIA AT DIFFERENT TEMPERATURES

13. The graph above indicates that there are
- (A) always more yeast cells than bacterial cells
 - (B) more yeast cells than bacterial cells at the start of the experiment
 - (C) more bacterial than yeast cells at 50°C
 - (D) more bacterial than yeast cells at 27°C

GO ON TO THE NEXT PAGE.

	Days				
	1	2	3	4	5
Number of Trees Cut	2	7	6	9	3

14. Which of the following graphs is correct for the information given in the chart above?

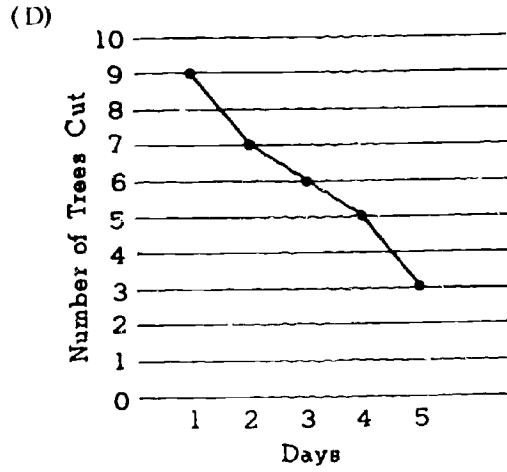
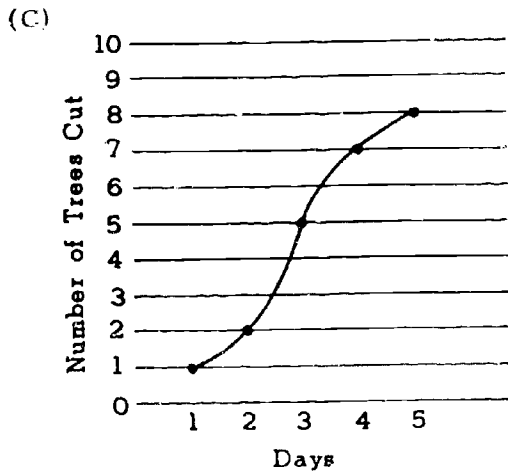
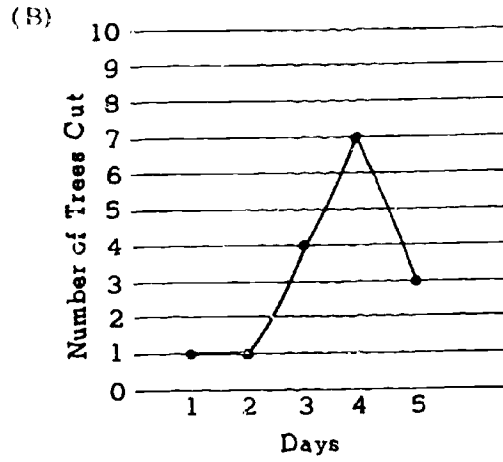
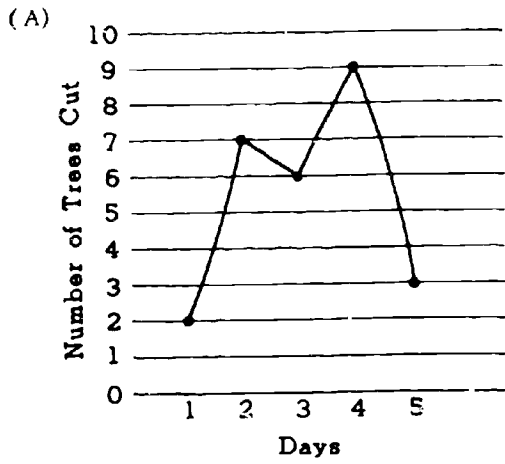

GO ON TO THE NEXT PAGE.

143

Questions 15-16 refer to the following diagram.

The following transfers were made and three yeast cells were found in test tube 3.

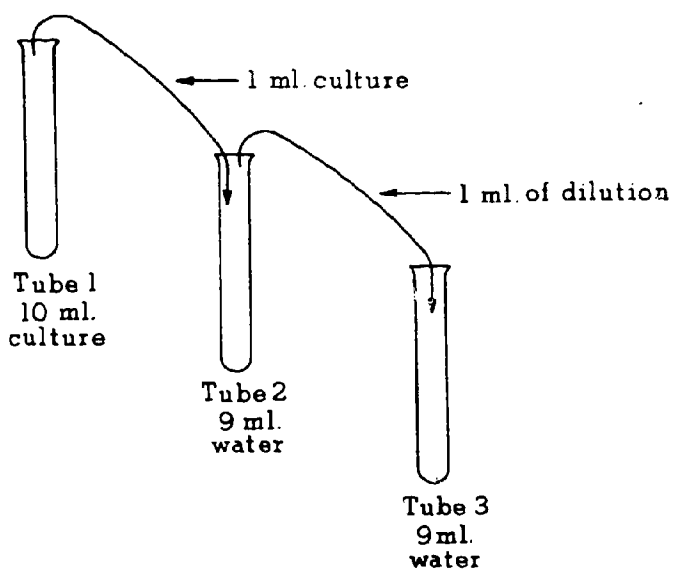

15. How many yeast cells are there in a drop taken from test tube 1 ?
 (A) 9 (B) 30 (C) 90 (D) 300
16. The reason for making dilutions as shown in the diagram above is to
 (A) make the counting of cells easier
 (B) give the yeast more food
 (C) give the yeast a chance to reproduce
 (D) provide more air for the yeast

Questions 17-18 refer to the following diagrams of a plot of land that was observed over a period of 50 years. The figures represent the type of plant found during the year that a population survey was made.

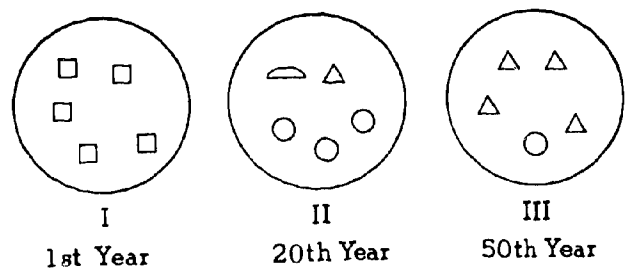

17. Which of the above populations was probably the first stage in succession?
 (A) □ (B) △ (C) ◐ (D) ○
18. Which of the above populations was probably the climax stage in the succession?
 (A) □ (B) △ (C) ◐ (D) ○

Questions 19-21 are based upon a food chain that involves grass-grasshopper-frog-snake.

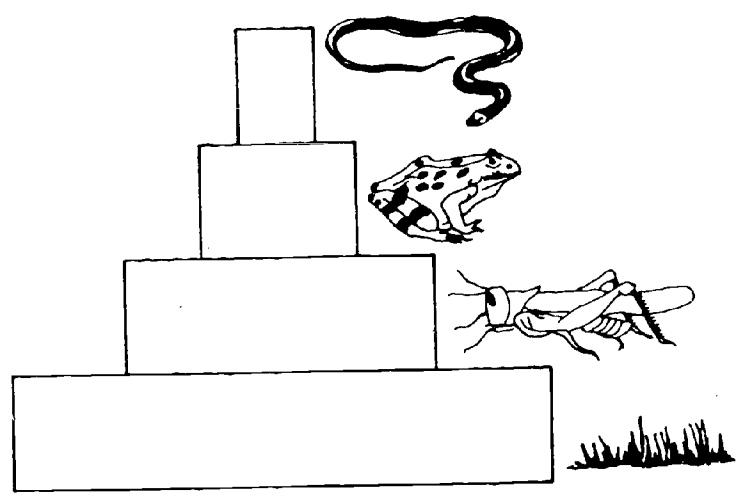

19. Which of the following is the producer?
 (A) Grass (B) Frog
 (C) Snake (D) Grasshopper
20. Which of the following is a first-order consumer?
 (A) Grass (B) Frog
 (C) Snake (D) Grasshopper
21. Which of the following is a second-order consumer?
 (A) Grass (B) Frog
 (C) Snake (D) Grasshopper

GO ON TO THE NEXT PAGE.

Questions 22-24 refer to the following pictures.



I

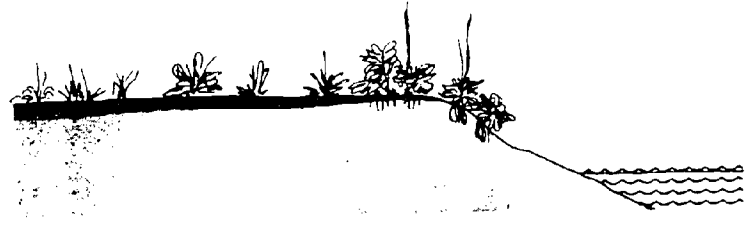

II

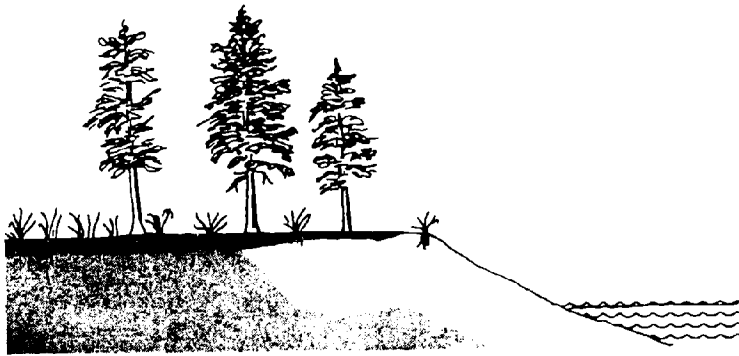

III

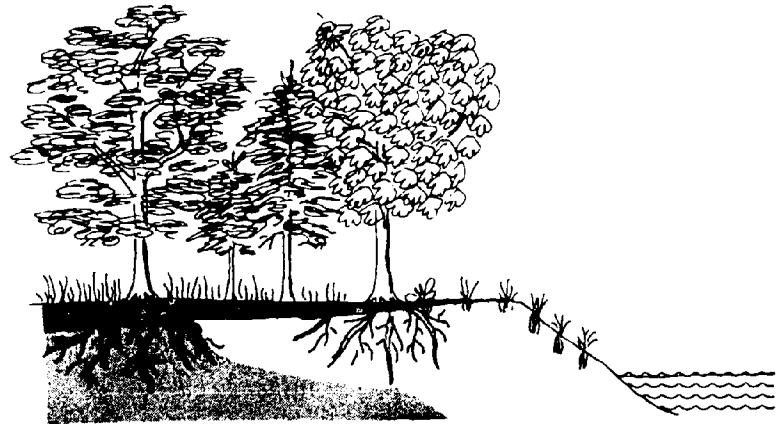

IV

22. The four pictures above represent stages in
(A) a climax (B) a succession
(C) one ecosystem (D) a food web

23. If IV shows a relatively stable, slowly changing community, it is called a
(A) food web (B) succession
(C) climax (D) "wound" of man

24. You would expect to find the fewest species in the soil represented in
(A) I (B) II (C) III (D) IV

GO ON TO THE NEXT PAGE.

Questions 25-27 refer to the following diagram.

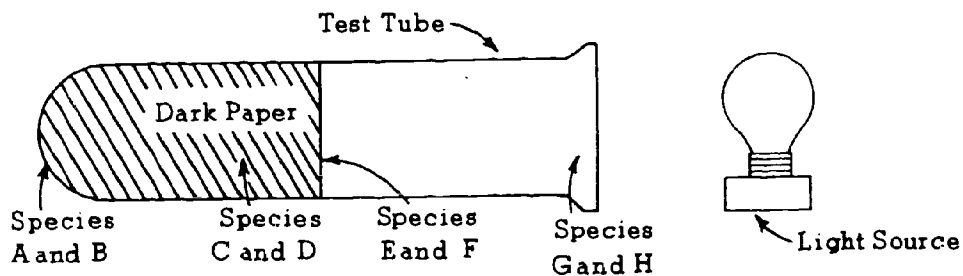

25. Which of the following would be the most likely food chain?

- (A) Species G would eat species H.
- (B) Species E would eat species A.
- (C) Species H would eat species C.
- (D) Species A would eat species F.

27. Which of the following would most likely be a producer?

- (A) Species B (B) Species C
- (C) Species D (D) Species H

26. Which of the following would most likely live at the deepest level in a pond?

- (A) Species A (B) Species C
- (C) Species E (D) Species G

Questions 28-30 refer to the graph below.

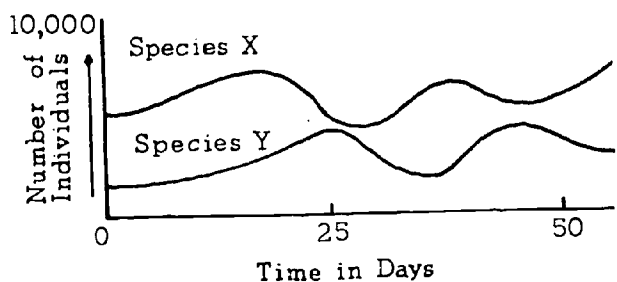

28. Which of the following is a correct statement that is based on information contained in this graph?

- (A) Species X and species Y reach peak growth at the same time.
- (B) The number of individuals of species Y is equal to the number of individuals of species X.
- (C) Species X starts to increase at the same time that species Y starts to increase.
- (D) The changes in population of species X are similar to the changes in population of species Y.

29. Which of the following is a hypothesis and NOT a fact?

- (A) Species X has a larger population than species Y on day 25.
- (B) There is an increase and a decrease in the number of individuals.
- (C) Species Y is interacting with species X.
- (D) Species X is larger at 21 days than it is at 26 days.

30. If species X and Y are in the same food web, which of the following is most probably true?

- (A) Species X is eating species Y.
- (B) Species Y is eating species X.
- (C) Species Y is the producer.
- (D) Species Y has more total energy than species X.

GO ON TO THE NEXT PAGE.

Questions 31-32 refer to the diagram below.

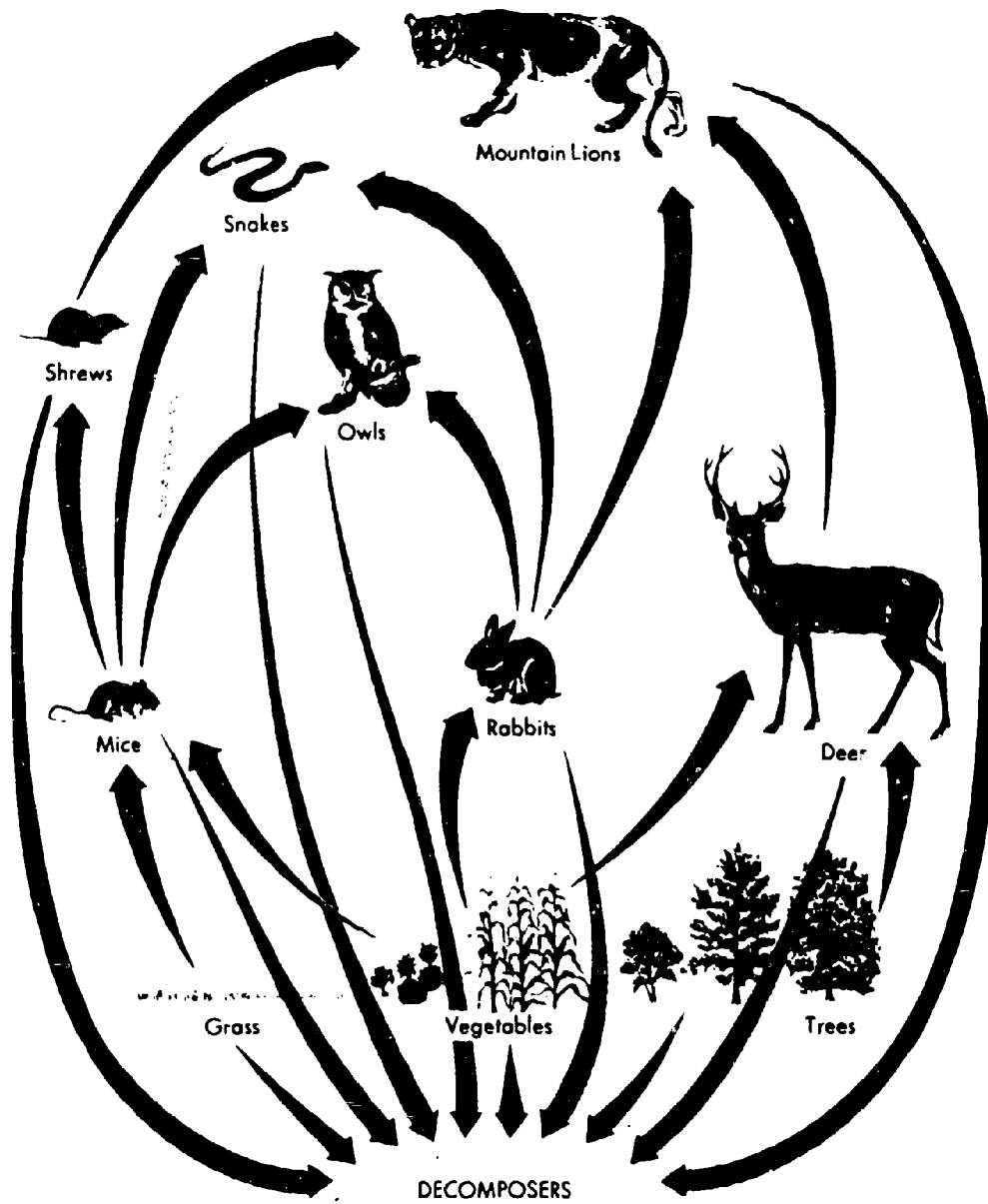

31. According to the chart, which of the following do NOT eat rabbits?

- (A) Shrews
- (B) Snakes
- (C) Owls
- (D) Mountain lions

32. Which of the following do NOT eat green plants?

- (A) Rabbits
- (B) Mice
- (C) Deer
- (D) Owls

33. Another term used for light energy is

- (A) radiant energy
- (B) chemical energy
- (C) position energy
- (D) stored energy

Questions 34-36 refer to the graph below.

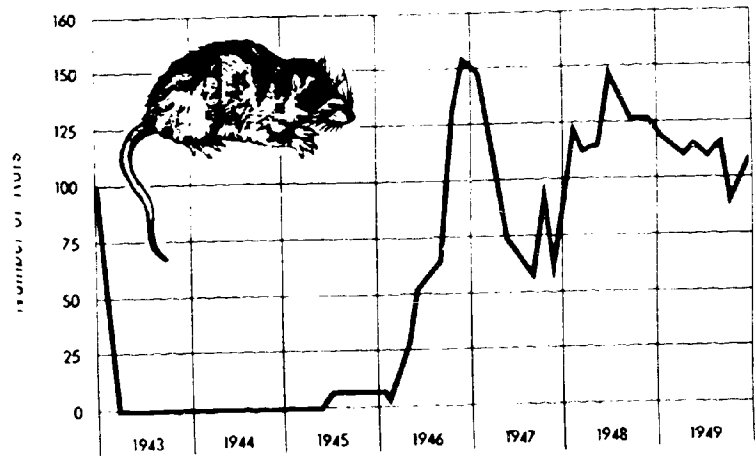

GRAPH OF BROWN RATS IN A CITY BLOCK,
BALTIMORE, MARYLAND

34. According to the chart, which of the following is a correct statement about the rat population in Baltimore?
- (A) At one time there were no rats in Baltimore.
 - (B) At the end of 1949 the rat population was decreasing.
 - (C) The rat population was greater in 1945 than in 1947.
 - (D) In 1965 there were no rats in Baltimore.
35. If a large number of cats were brought into Baltimore at the end of 1949, one would expect the rat population to
- (A) increase
 - (B) decrease
 - (C) stay the same
 - (D) first increase and then decrease slightly
36. If cats were the only factor to affect the rat population, one would expect that the cat population was highest in
- (A) 1943
 - (B) 1946
 - (C) 1947
 - (D) 1949

Questions 37-40 refer to the diagrams below.

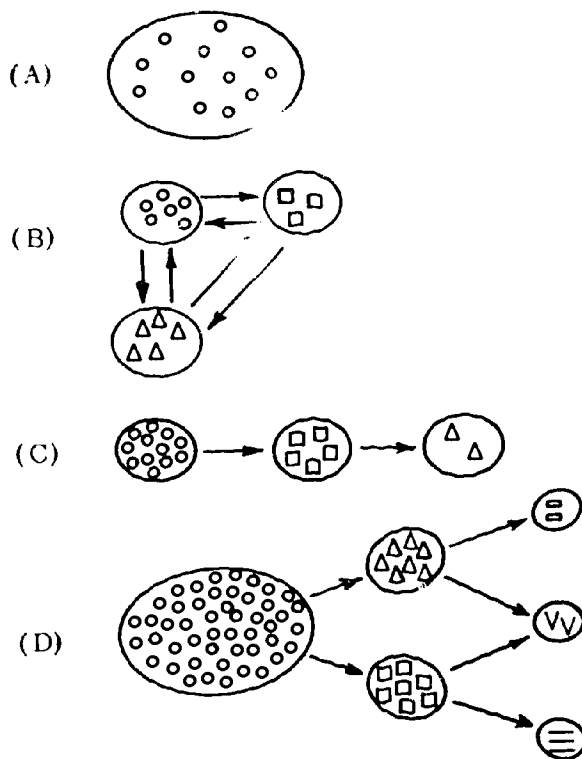

37. Which of the above represents a population made up of only one kind of individual?
38. Which of the above best represents a food web?
39. Which of the above best represents a food chain?
40. Which of the above best represents a community?

IF YOU FINISH BEFORE TIME IS CALLED, CHECK YOUR WORK ON THIS TEST.

BIOLOGY B (Across Phases)

Time~40 minutes

YOU ARE TO INDICATE ALL YOUR ANSWERS ON THE SEPARATE ANSWER SHEET. No credit will be given for anything written in the test book. After you have decided which of the suggested answers you want to give for a question, blacken the corresponding space on the answer sheet.

Example:

Chicago is a

- (A) state
- (B) city
- (C) country
- (D) continent

Sample Answer

A	B	C	D
<input type="checkbox"/>	<input checked="" type="checkbox"/>	<input type="checkbox"/>	<input type="checkbox"/>

Give only one answer to each question; no credit will be given for multiple answers. If you wish to change an answer, erase your first line completely and mark your new choice.

DO NOT OPEN THIS BOOK UNTIL YOU ARE TOLD TO DO SO.

Note for Teachers: This test is based on the BSCS Special Materials S15-S32 and Molecules to Man, chapters 3, 4, 5 and 6.

Developed by Educational Testing Service pursuant to a subcontract funded by the U. S. Department of Health, Education, and Welfare, Office of Education.

- Which of the following would be a hypothesis?
 - (A) Watching birds fly south in the winter
 - (B) Stating that birds fly south because of lack of food
 - (C) Taking a population count of birds
 - (D) Dissecting a bird in a biology class

- The energy of motion is called
 - (A) potential energy
 - (B) chemical energy
 - (C) stored energy
 - (D) kinetic energy

- In preparing for an experiment with yeast, after the medium has been poured into a test tube and covered, the very next step is to
 - (A) cool the medium
 - (B) sterilize the medium
 - (C) inoculate the medium
 - (D) store the medium in a dark container

- In one experiment to determine the effect on the growth of a certain species of plant by exposing the plants to various amounts of light, the control would be plants grown under
 - (A) normal light conditions
 - (B) the minimum amount of light exposure
 - (C) the maximum amount of light exposure
 - (D) an absence of any light

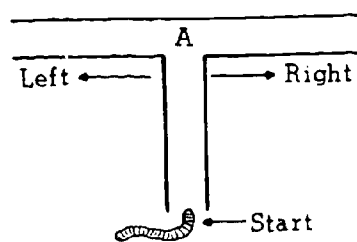

- An experimenter claims that earthworms will always turn right when they come to point A in a T tube as shown above. Which of the following would be the best test of this hypothesis?
 - (A) Observe a large number of earthworms as they travel through the T tube.
 - (B) Block off the right side of the tube and observe whether the earthworms turn left.
 - (C) Wire the left side of the tube so that the earthworms will receive a slight shock if they turn left.
 - (D) Make the right side of the tube narrower and see whether the earthworms turn left.

- In counting yeast cells, it was found that there were 5 yeast cells in the following cube.

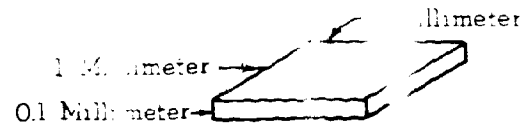

- How many cells are there per cubic millimeter?
- (A) 5 (B) 10 (C) 25 (D) 50

- A person's reaction time is slow at birth, becomes faster up to the age of 30, then gradually becomes slower. Which of the following graphs best illustrates this idea?

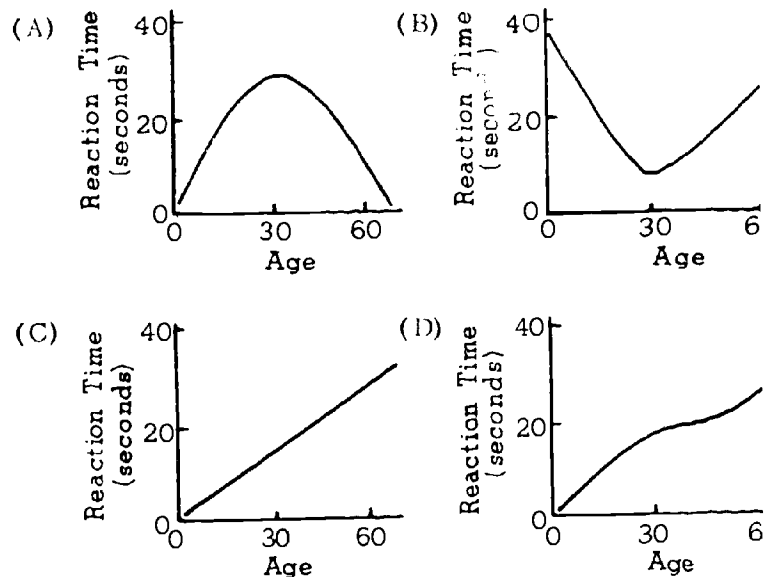

GO ON TO THE NEXT PAGE.

8. A certain population of animals grows rapidly at first, stops growing for a time, and then resumes growth at a slow rate. Which of the following graphs illustrates the growth pattern of the population?

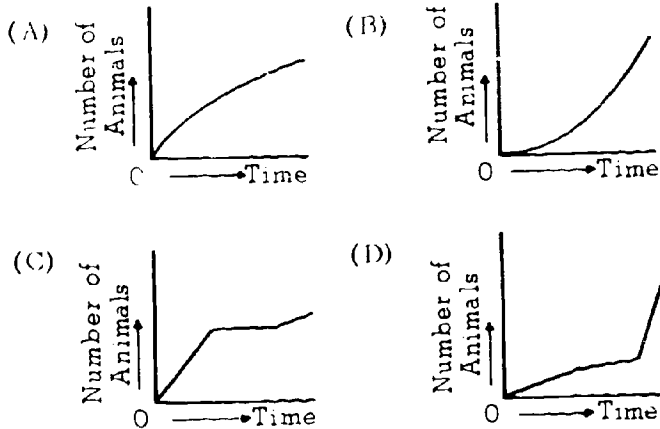

Questions 9-10 refer to the following graph.

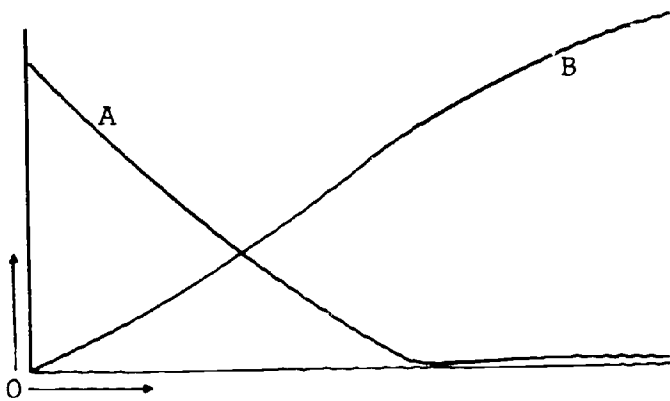

9. Of the following, which is the best statement about the information in the graph?
- A eats B.
 - B eats A.
 - The presence of B causes a decline in A.
 - The presence of B does not affect A.
10. The graph could represent which of the following?
- A, the buffalo population, versus B, man's westward movement
 - A, the production of corn, versus B, modern farming methods
 - A, speed, versus B, improvement in airplane design
 - A, the discovery of modern drugs, versus B, deaths of children

11. If a person states that there is life on Mars, his statement would be considered
- a fact
 - an observation
 - a hypothesis
 - a law

Questions 12-14 refer to the following experiment.

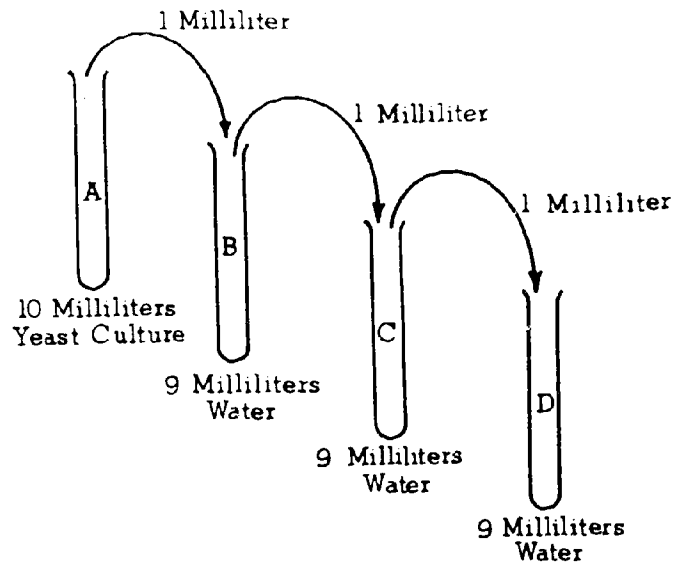

12. The purpose of the procedure above is to
- dilute the yeast culture and make counting easier
 - increase the number of yeast cells in test tube B
 - determine whether yeast cells reproduce by budding
 - increase the concentration of yeast cells in test tube D
13. If there were 10,000 yeast cells in test tube A, how many yeast cells would you expect to find in test tube D?
- 10,000
 - 1,000
 - 100
 - 10
14. What is the ratio of the number of cells in test tubes A, B, C, and D?
- 1:1:1:1
 - 4:3:2:1
 - 10:5:2:1
 - 1,000:100:10:1

GO ON TO THE NEXT PAGE.

Questions 15-16 refer to the following graph.

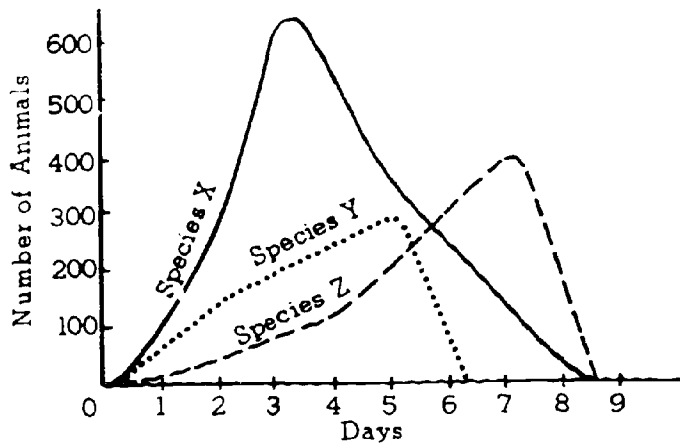

15. On which of the following days would there be the greatest number of animals of all three species combined?
 (A) Day 2 (B) Day 4 (C) Day 5 (D) Day 8
16. On which of the following days would there be the LEAST difference between the number in the largest group and the number in the smallest group?
 (A) Day 2 (B) Day 3 (C) Day 4 (D) Day 6

Questions 17-20 refer to the following graph.

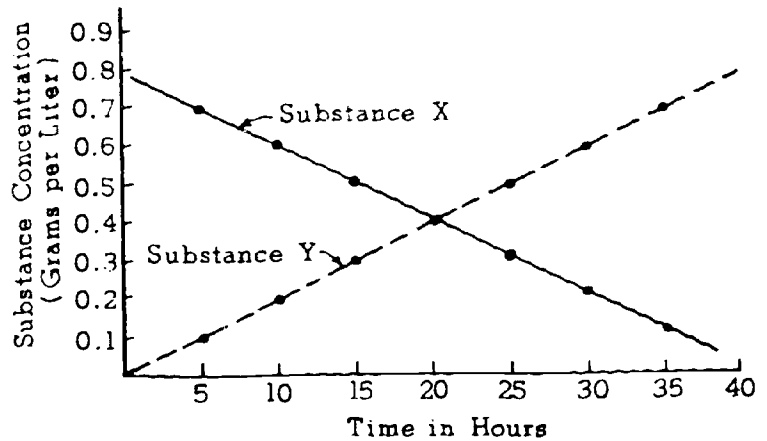

17. Which of the following conditions would result in a graph like the one above?
 (A) Substance Y is using substance X to make a new substance.
 (B) Substance X needs substance Y to survive.
 (C) Substances X and Y are used very rapidly at first and then very slowly.
 (D) As the length of time increases, the rate of loss or gain in the concentration of each substance changes greatly.
18. Substance X is equal in concentration to substance Y at about
 (A) 10 hr. (B) 20 hr. (C) 30 hr. (D) 40 hr.
19. What is the concentration of each substance at 10 hours?
 (A) X = 0.1 and Y = 0.6
 (B) X = 0.6 and Y = 0.2
 (C) X = 0.2 and Y = 0.6
 (D) X = 0.3 and Y = 0.3
20. What is the ratio of substance X to substance Y at 10 hours?
 (A) 1:1 (B) 2:1 (C) 3:1 (D) 4:1

Questions 21-26 refer to the following passage.

The Squid

Cephalopods (octopuses, squid, and cuttlefish) are members of the Mollusca group, and are among the most highly organized invertebrate animals. They have no external shell and are often called valveless mollusks. Other mollusks are clams and oysters, which have two shells (bivalves), and snails, which have one shell (univalves). Cephalopods are distinguished by their tentacles, which project from their head and are used for both food-getting and walking. If a squid wants to go somewhere in a hurry, however, it draws water into its mantle, which can be turned forward, backward, or even sideways.

Squid can change color more rapidly than chameleons. Color changes are brought about by contraction and expansion of many chromatophores, elastic sacs of pigment embedded in the skin. In addition, many squid have light organs and produce vivid displays of flashing light. The light is caused by a chemical reaction similar to that which creates the biological "cold light" of fireflies.

The eye of the squid is remarkably similar to that of man. The eyeball has an eyelid, a cornea, and a pupil. Unlike man's, the squid's eye has no blind spot. For certain functions, the squid's eye is even better than that of man.

Dissections of squid indicate that they eat worms, shrimp-like animals, fish, and other squid. On the other hand, squid are eaten by a host of enemies, from the sperm whale down to the common mackerel. The sperm whale is one of the squid's greatest enemies. He uses the squid's cuttlebone, the internal shell of a cuttlefish, as a dietary supplement for canaries and parakeets. Japan uses a great quantity of squid for food and fertilizer. In Newfoundland, vast numbers of squid are frozen in large blocks and sold as codfish bait.

- 21. Which of the following terms correctly applies to the squid?
(A) Vertebrate (B) Univalve
(C) Bivalve (D) Cephalopod
- 22. A squid's tentacles function primarily in
(A) vision (B) jetting ink
(C) food-getting (D) digestion
- 23. In a squid, which of the following structures functions primarily in color changes?
(A) Cuttlebone (B) Chromatophore
(C) Light organ (D) Funnel
- 24. The eye of squid has all of the following EXCEPT
(A) a cornea (B) an eyelid
(C) a pupil (D) a blind spot
- 25. Which of the following is NOT generally part of a squid's diet?
(A) Shrimp-like animals (B) Sperm whale
(C) Worms (D) Fish
- 26. According to the passage, man uses cephalopods to provide all of the following EXCEPT
(A) fertilizer (B) bait for catching fish
(C) cuttlebones (D) light for luring fish

GO ON TO THE NEXT PAGE.

Questions 27-30 refer to the following passage.

A recent study shows that adding fluorides to vitamin pills is an effective way of reducing tooth decay in children who live in areas where no fluoridated water is available. A decline in tooth decay of up to 63 per cent was found in temporary teeth and 43 per cent in permanent teeth of children who took fluoridated vitamins daily for 36 months. Theoretically, the supplement will yield its greatest benefit when taken from birth to about age 10, the period of tooth formation. Starting the fluorides early is important because calcium begins to be deposited in the teeth long before they erupt through the gums. The vitamin-fluoride mixture would supply about the same amount of fluoride as would be taken in drinking water. The cost would be inexpensive in homes where vitamins are now taken. Present methods of fluoridation include adding sodium fluoride to drinking water and adding fluoride to tooth pastes.

Questions 31-34 refer to the following graphs.

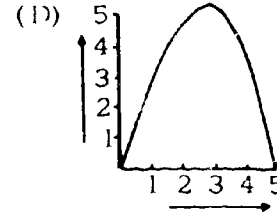
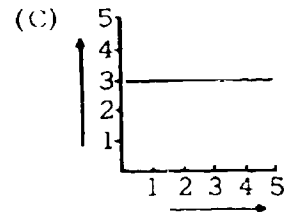
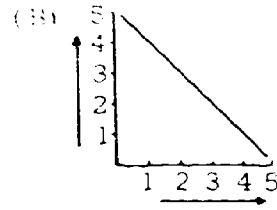
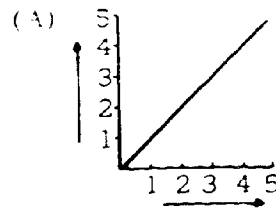

27. Fluorides are apparently added to the vitamins in the form of
- (A) a pure element
 - (B) an impure element
 - (C) a compound
 - (D) either a compound or an element
28. The passage indicates that teeth need
- (A) neither fluorine nor calcium
 - (B) fluorine but not calcium
 - (C) calcium but not fluorine
 - (D) both calcium and fluorine
29. If 50 children in every 100 have decay in temporary teeth when no fluorides are used, according to the passage approximately how many children per hundred will have decay in temporary teeth after fluoridated vitamins are used?
- (A) 10 (B) 20 (C) 30 (D) 40
30. The passage suggests that those who favor fluoridating water instead of vitamins would support their plan by saying that
- (A) everybody drinks water but only some people take vitamins
 - (B) a different substance is used in fluoridating water from the one used in vitamins
 - (C) fluorides are more effective on temporary teeth than on permanent teeth
 - (D) some fluorides are poisonous but others are not

Select the graph above that best represents the following statements.

31. The amount of O_2 used is equal to the amount of CO_2 produced.
32. The amount of enzyme is exactly the same at the start as at the finish.
33. A person runs slowly at first, speeds up, and then slows down again.
34. A big block of ice is broken down into smaller blocks.

GO ON TO THE NEXT PAGE

PROTEIN REQUIREMENTS
BASED ON BODY WEIGHT

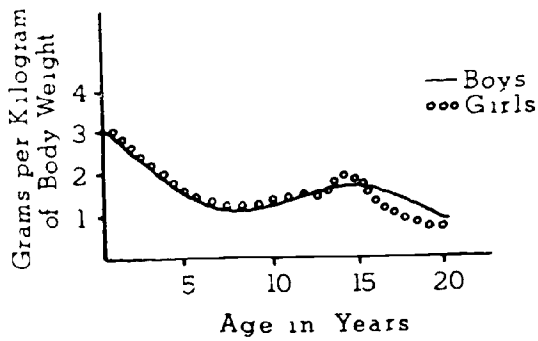

It can be correctly concluded from the data that the protein requirement per kilogram of body weight is highest in

- (A) children under 4 years
- (B) boys
- (C) 12-year-old boys
- (D) 20-year-old girls

According to the chart, the protein requirement in grams per kilogram of body weight of 20-year-olds is compared with 4-year-olds is approximately

- (A) $\frac{1}{4}$ as much
- (B) $\frac{1}{2}$ as much
- (C) equal
- (D) $1\frac{1}{2}$ as much

Which of the following would be the best conclusion to make based on the data in the graph?

- (A) The protein requirements of boys and girls differ greatly.
- (B) The protein requirements of boys and girls are the same until about 12 years of age and then there is some variation.
- (C) The protein requirements of 20-year-old girls are higher than those of 20-year-old boys.
- (D) The protein requirements of 5-year-old boys are greater than those of 5-year-old girls.

TREE GROWTH WITH AGE

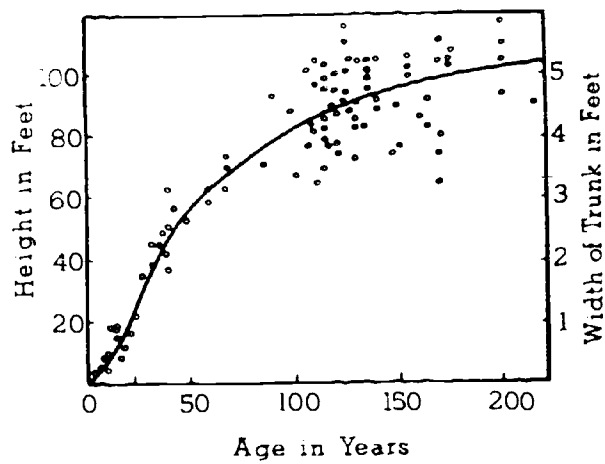

38. During which of the following periods of time does a tree grow fastest?

- (A) 0-25 years
- (B) 50-75 years
- (C) 75-100 years
- (D) 100-125 years

39. A tree that is 25-years-old will be twice as tall when it reaches

- (A) 50 years
- (B) 75 years
- (C) 100 years
- (D) 150 years

40. According to the chart, the greatest variation in the height of trees plotted occurs between

- (A) 0-25 years
- (B) 25-50 years
- (C) 150-175 years
- (D) 175-200 years

IF YOU FINISH BEFORE TIME IS CALLED, CHECK YOUR WORK ON THIS TEST.

FORM K-PBC8

BIOLOGY-BSCS III (For Phases 3, 4, and 5)

Time—40 minutes

YOU ARE TO INDICATE ALL YOUR ANSWERS ON THE SEPARATE ANSWER SHEET. No credit will be given for anything written in the test book. After you have decided which of the suggested answers you want to give for a question, blacken the corresponding space on the answer sheet.

Example:

Chicago is a

- (A) state
- (B) city
- (C) country
- (D) continent

Sample Answer

A	B	C	D
<input type="checkbox"/>	<input checked="" type="checkbox"/>	<input type="checkbox"/>	<input type="checkbox"/>

Give only one answer to each question; no credit will be given for multiple answers. If you wish to change an answer, erase your first line completely and mark your new choice.

DO NOT OPEN THIS BOOK UNTIL YOU ARE TOLD TO DO SO.

Note for teachers: This test is based on the BSCS, Molecules to Man, Chapters 7, 8, 9, 10, and 11.

Copyright © 1966
by
Biological Sciences Curriculum Study.
All rights reserved.
Reproduced by permission.

- DNA is important in heredity because it is
 - a large molecule.
 - found in the nucleus.
 - composed of pyrimidines.
 - able to replicate.
- Plant cells can usually be distinguished from animal cells because plant cells possess
 - cell walls and mitochondria.
 - Golgi bodies and central vacuoles.
 - cell walls and central vacuoles.
 - chromosomes and mitochondria.
- If the sequence of purines and pyrimidines in a segment of a DNA strand were: cytosine, guanine, adenine, thymine, adenine, then the sequence in a complementary strand of newly made messenger RNA would be
 - cytosine, uracil, adenine, guanine, uracil.
 - guanine, cytosine, uracil, adenine, uracil.
 - uracil, adenine, cytosine, uracil, guanine.
 - cytosine, guanine, uracil, uracil, adenine.

- In a rare disease condition in human beings the mitochondria are found to have an abnormal structure. This condition is most likely correlated with the disturbance in cell
 - energy supply.
 - protein formation.
 - food supply.
 - division.
- Schwann's study of cell contents rather than cell walls led to the recognition of
 - cork cells.
 - animal cells.
 - root cells.
 - orchid cells.

Questions 8-9

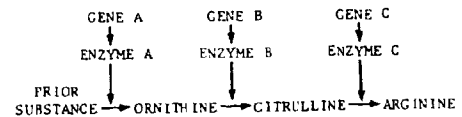

The diagram represents the "one gene-one enzyme" hypothesis as it applies to the production of arginine in the pink mold Neurospora.

Questions 4-5 refer to the following chart.

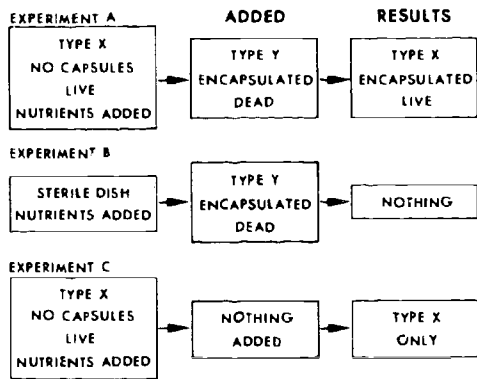

- In the above experiment which are the controls?
 - A and C
 - B and C
 - A and B
 - A only
- What was the question that prompted this series of experiments?
 - What is the nature of RNA ?
 - Do Pneumococcus Type Y bacteria with capsules transform into Pneumococcus Type X without capsules?
 - Why do Pneumococcus Type Y bacteria have capsules?
 - None of the above

- If ornithine were added to the medium in place of the prior substance, the plant would survive if genes
 - B and C are actively producing enzymes B and C.
 - A and B are actively producing enzymes A and B.
 - A and C are actively producing enzymes A and C.
 - C is actively producing enzyme C.
- If the medium on which this model were normally grown were prepared without the prior substance present, the plant would probably die unless
 - enzyme A was added to the medium.
 - gene C was destroyed.
 - ammonia was added to the medium since it is necessary for the production of the amino acid, arginine.
 - ornithine, citrulline, or arginine was added to the medium.

GO ON TO THE NEXT PAGE.

10. The concept of fermentation is considered important to the heterotroph hypothesis because
- (A) free oxygen is thought to have not been present in the early atmosphere.
 - (B) utilization of the sun's energy required a fermentation condition.
 - (C) methane, ammonia, water vapor and hydrogen are considered to have been the principal gases present in the early atmosphere.
 - (D) the primitive heterotroph needed oxygen to obtain energy.

11. A nucleotide differs from a nucleic acid molecule in that
- (A) it is more complex.
 - (B) the compounds present in it are not present in nucleic acid.
 - (C) it always has ribose.
 - (D) it is always simpler in structure.

12. A guinea pig was injected with a radioactive amino acid. Thirty minutes later tissue analysis showed that the protein of the ribosomes had over twice as much radioactivity per gram as the protein of any other cell part. This experiment tends to support which of the following hypotheses?
- (A) Messenger RNA transmits the hereditary traits from DNA to the ribosomes.
 - (B) Radioactive amino acid will be found at the site of protein formation.
 - (C) Radioactive protein is easier to detect and identify than ordinary protein.
 - (D) Ribosomal RNA is a replica of chromosomal DNA.

14. If the green cellophane were left on the aquarium for several weeks we might expect
- (A) cellular respiration of H to be reduced because of the collection of excess CO₂ in the water.
 - (B) an increase in the use of ATP by both H and A due to reduction of carbohydrate production.
 - (C) cellular fermentation to increase in both H and A as a result of O₂ reduction.
 - (D) death of both H and A due to accumulation of excess H₂O in the cells.

15. By studying the results of experiments with bacteria and some viruses one can better interpret the role of DNA in higher forms because
- (A) the DNA of the above mentioned forms is present in the same amounts.
 - (B) the chemical make-up of the three forms is similar.
 - (C) only virus DNA is parasitic in the cells of higher forms.
 - (D) genetic activity of all the organisms studied seems to be tied to DNA.

16. Although nucleic acids are usually replicated accurately, occasionally chemical accidents result in
- (A) changes which in turn modify the cell processes controlled by the nucleic acids.
 - (B) failure of the DNA to unzip.
 - (C) changes which cause cytosine to bond with adenine.
 - (D) none of these.

Questions 13-14

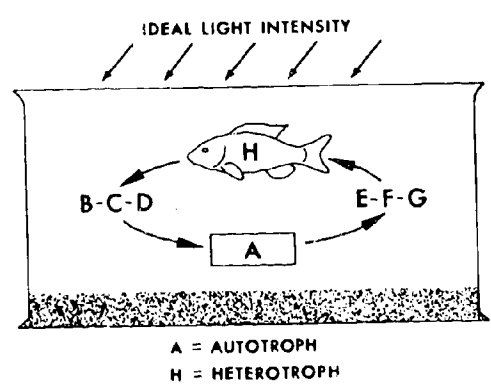

GO ON TO THE NEXT PAGE.

13. If a green cellophane paper were placed over the aquarium for several days, the activity of A that would probably reduce respiration in H would be



- (A) increase of oxygen production.
- (B) increase of CO₂ absorption by H.

Questions 17-18 refer to the following graph.

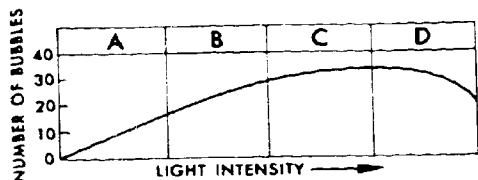

An immersed water plant was exposed to light of gradually increasing intensity over a period of several hours. At regular intervals, one-minute counts were made of the number of oxygen bubbles released from the plant.

17. The number of bubbles released from the plant
 - (A) was directly proportional to the light intensity throughout the experiment.
 - (B) caused the light to become more intense as the experiment progressed.
 - (C) probably decreased in size as the experiment progressed.
 - (D) was correlated with light intensity for most of the experiment.

8. The release of oxygen bubbles is most useful as an indication of the rate of
 - (A) respiration. (B) photosynthesis.
 - (C) growth. (D) metabolism.

9. Viruses have no ribosomes and yet are able to duplicate themselves with new protein coats. How might this best be explained?
 - (A) Some other structure in the virus is the site of protein synthesis.
 - (B) Protein is obtained directly from cells in which they grow.
 - (C) Since viruses reproduce inside a host cell, they use the cell's ribosomes.
 - (D) Viruses lack messenger RNA and therefore have no need for ribosomes.

10. In the light reaction part of photosynthetic light energy
 - (A) absorbed by chlorophyll is transformed into chemical energy.
 - (B) is trapped and three carbon sugars are formed.
 - (C) is used to produce proteins.
 - (D) is used to produce lipids.

Questions 21-24

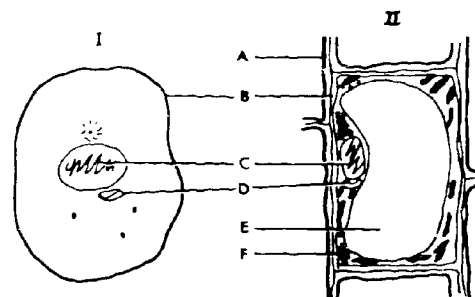

21. With structure C removed a cell could not
 - (A) reproduce.
 - (B) provide its own energy.
 - (C) exchange materials with the environment.
 - (D) secrete.

22. A multicellular organism, whose cells possess structure A, is most likely
 - (A) dead. (B) large. (C) immobile. (D) small

23. If structure F is green, the presence of many of these structures allows the organism to
 - (A) reproduce.
 - (B) exchange material with the environment.
 - (C) secrete.
 - (D) make its own food.

24. During cell division structure C would cease to exist and its contents would become visible as
 - (A) Golgi bodies. (B) plastids.
 - (C) chromosomes. (D) mitochondria.

25. Virchow's statement that "all cells arise from pre-existing cells" relates the cell theory to
 - (A) spontaneous generation. (B) the nucleus.
 - (C) the theory of evolution. (D) Robert Hooke.

26. Which of the following conclusions is NOT correct?
 - (A) DNA replication occurs prior to mitosis.
 - (B) The amount of DNA is at a maximum during cell division.
 - (C) DNA is at a minimum just after mitosis is completed.
 - (D) The amount of DNA in a new daughter cell begins to increase immediately.

Questions 27-30 refer to the following structural formulas.

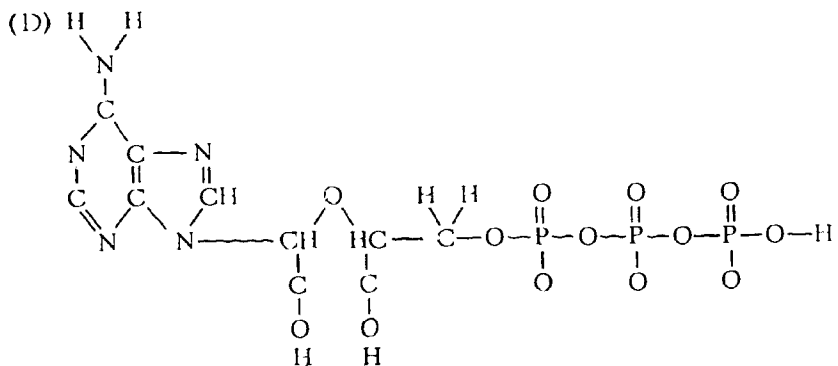
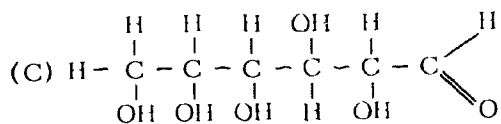
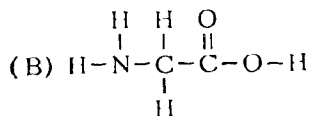
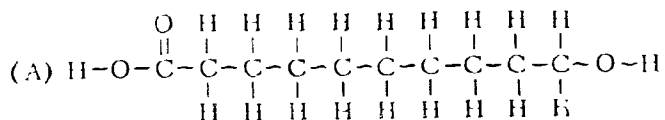

27. A building block of protein

28. Formed in the mitochondria

29. Acted upon by the fermentation process

30. Often found combined with glycerol

GO ON TO THE NEXT PAGE

- All nucleotide molecules contain the same kind of
- (A) ribose sugar.
 - (B) purine.
 - (C) pyrimidine.
 - (D) phosphoric acid group.

34. Evidence that the candle uses something in the air that is also needed by the mouse would be shown best by an experiment using containers
- (A) A and B
 - (B) B and E
 - (C) A and D
 - (D) B and D

Questions 32-35

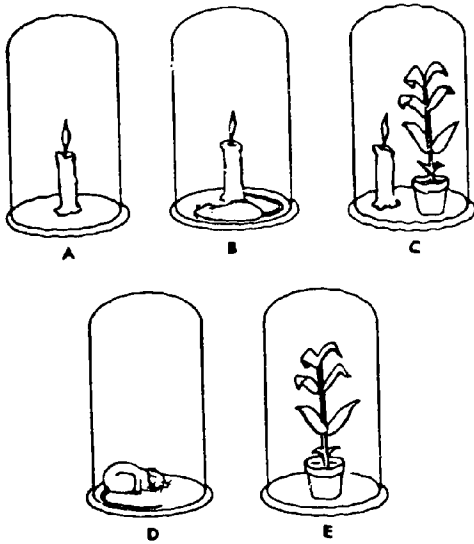

35. At the end of the experiment when the candles were out, the mouse dead, the amount of oxygen remaining in Container A, as compared with the amount of oxygen remaining in B, would be
- (A) slightly more
 - (B) double
 - (C) half
 - (D) the same

36. If a chemical could be used that would prevent spindle formation in plant cells, which activity would probably be affected?
- (A) Formation of cell membranes
 - (B) Separation of the chromatids
 - (C) Division and separation of the centrioles
 - (D) Formation of chromatin

That combustion and respiration are alike would be shown best by an experiment that contains

- (A) A
- (B) A and B
- (C) A and D
- (D) B and C

That some plant and animal functions are different could be shown best by an experiment using containers

- (A) D and E
- (B) B and C
- (C) C and E
- (D) C and A

Questions 37-40

Four of the principle tools used to study cells are the microscope, aniline dyes, chemical analysis, and the electron microscope. Assume that the order of uses of these tools is as listed in the key. The questions are statements which were made in the past or are acceptable today. In each case certain tools had to be developed before these statements could have been made. Select the tool which permitted the statement to be made, recognizing that each depended on an earlier one.

- KEY: (A) Microscope
 (B) Aniline dye
 (C) Micro-chemical techniques
 (D) Electron microscope

37. The nucleus contains threadlike structures called chromosomes.
38. The outer boundary of the cytoplasm is a continuous structure.
39. Within each cell is a single spherical structure, the nucleus.
40. One of the principle components of the chromosome is DNA.

BIOLOGY III (For Phases 1 and 2)

Time—40 minutes

YOU ARE TO INDICATE ALL YOUR ANSWERS ON THE SEPARATE ANSWER SHEET. No credit will be given for anything written in the test book. After you have decided which of the suggested answers you want to give for a question, blacken the corresponding space on the answer sheet.

Example:

Chicago is a

- (A) state
- (B) city
- (C) country
- (D) continent

Sample Answer

A	B	C	D
<input type="checkbox"/>	<input checked="" type="checkbox"/>	<input type="checkbox"/>	<input type="checkbox"/>

Give only one answer to each question; no credit will be given for multiple answers. If you wish to change an answer, erase your first line completely and mark your new choice.

DO NOT OPEN THIS BOOK UNTIL YOU ARE TOLD TO DO SO.

Note for Teachers: This test is based on the BSCS Special Materials S32-S70.

Developed by Educational Testing Service pursuant to a subcontract funded by the U. S. Department of Health, Education, and Welfare, Office of Education.

- The ultimate source of energy of almost all living things on Earth is
 - carbon dioxide
 - chlorophyll
 - sunlight
 - water
- The chemical energy that is stored in food is released in the process of
 - excretion
 - ingestion
 - assimilation
 - respiration
- Energy in living things is most often lost in the form of
 - ATP
 - heat
 - work
 - light
- Which of the following is an element?
 - Hydrogen
 - Carbon dioxide
 - Water
 - Glucose
- Which of the following foods provides the greatest number of calories?
 - 1 egg
 - 1 slice of white bread
 - 1 orange
 - $\frac{1}{4}$ cup of peanut butter

Questions 6-7

Bromothymol blue changes from blue to yellow in the presence of carbon dioxide.

- The liquid in which of the following test tubes would change color from blue to yellow in the shortest period of time?

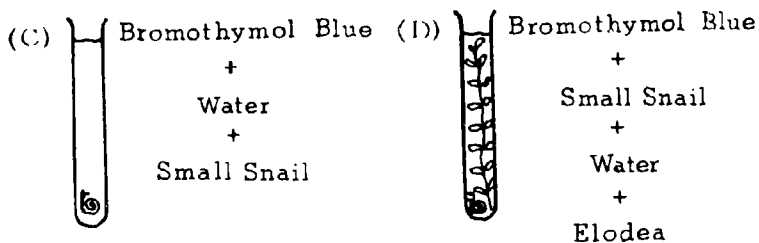
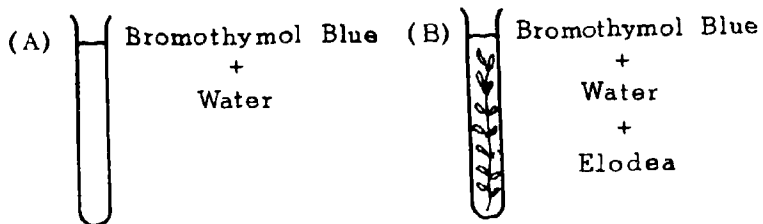

- When elodea is placed in a solution of bromothymol blue and exposed to sunlight, you would expect the color of the solution to
 - remain the same
 - change from blue to yellow
 - change from blue to yellow and back to blue
 - change from yellow to blue

- Which of the following activities probably requires the most energy per hour?
 - Bowling
 - Ballroom dancing
 - Swimming
 - Golfing
- Which of the following would probably result from immersing your hand for 5 minutes in a beaker containing a quart of water at 10°C ?
 - The temperature of the water will increase.
 - The temperature of the water will decrease.
 - The temperature of the water will remain the same.
 - The temperature of the water will first decrease and then rapidly increase.
- Which of the following is a form of kinetic energy?
 - The Sun shining on a plant
 - A stick of dynamite
 - A tank full of gasoline
 - A falling rock
- In comparing two slides under the microscope, one finds that cork differs from elodea in that cork has only
 - a cell nucleus
 - a cell wall
 - chloroplasts
 - cytoplasm
- Cheek cells have all of the following EXCEPT
 - chloroplasts
 - nuclei
 - mitochondria
 - cell membranes

GO ON TO THE NEXT PAGE.

13. A biologist measured the amount of oxygen used and the amount of carbon dioxide produced by sprouting wheat grains. Which of the following graphs would represent the data he obtained?

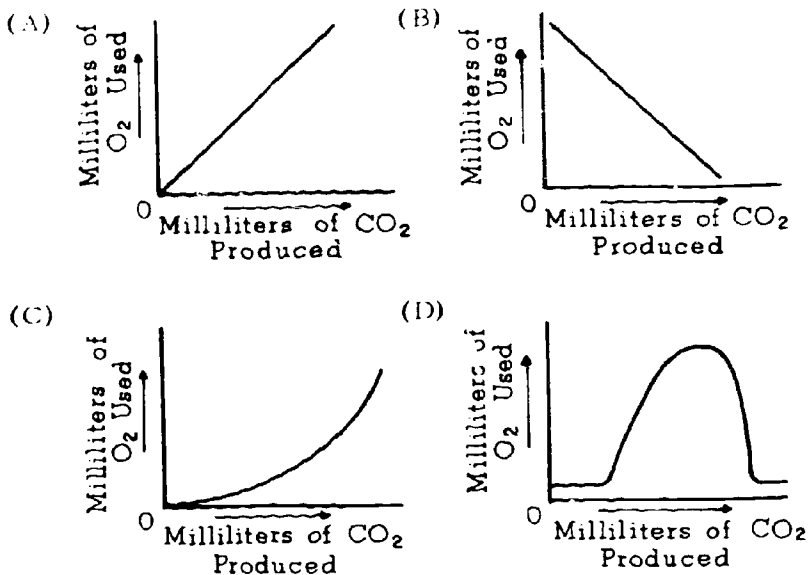

14. A whale that eats a squid is obtaining energy that can be described as
 (A) radiant (B) kinetic
 (C) chemical (D) mechanical

Questions 15-16

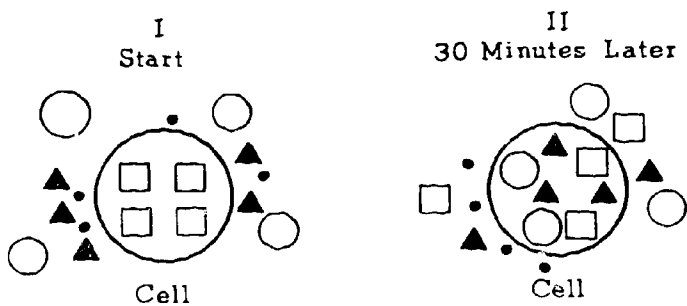

The size of the figures represents the relative size of the molecules.

15. Which of the following is a valid conclusion regarding the movement of substances into the cell above?
 (A) The movement of substances into the cell depends on the size of the molecules.
 (B) There is no movement of molecules out of the cell.
 (C) None of the substances reaches a balance in which there are equal numbers of molecules inside and outside the cell.
 (D) The molecules of one of the substances did not enter the cell.

16. All of the following conclusions can be drawn from the data above EXCEPT:
 (A) Materials are entering the cell.
 (B) Materials are leaving the cell.
 (C) Entry of materials into the cell is not determined by the size of the molecule alone.
 (D) Diffusion can account for the movement of all of the materials into and out of the cell.

17. Which of the following scientists was the first to suggest that all cells come from other cells?
 (A) Hooke (B) Leeuwenhoek
 (C) Lavoisier (D) Virchow

18. Which of the following is a correct statement about an enzyme?
 (A) It is used up in a reaction.
 (B) It performs a specific function.
 (C) It forms a permanent compound with a substrate.
 (D) It is usually involved in many changes of a substrate.

19. In burning a certain food, the temperature of 10 milliliters of water rises 10 degrees centigrade. How many simple calories did the food contain?
 (A) 10 (B) 20 (C) 100 (D) 1,000

20. How many atoms are present in a molecule of H₂O₂ (hydrogen peroxide)?
 (A) 1 (B) 2 (C) 3 (D) 4

21. Cell structures that function primarily in energy transfer and use are called
 (A) mitochondria
 (B) vacuolar membranes
 (C) nucleoli
 (D) centrosomes

GO ON TO THE NEXT PAGE

Questions 22-25

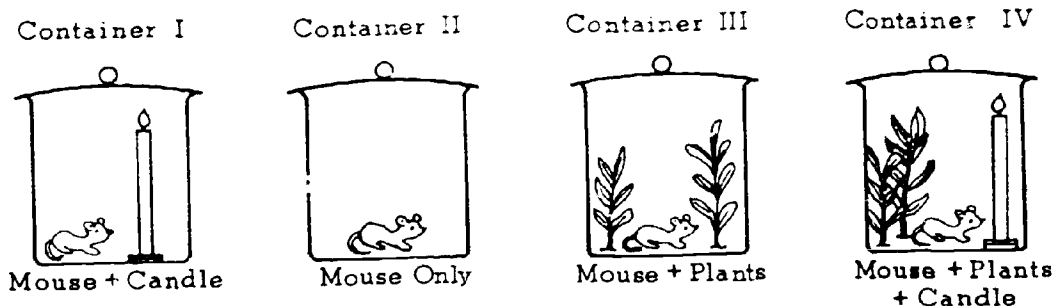

22. The mouse would live the longest period of time in container
(A) I (B) II (C) III (D) IV
23. The mouse would live the shortest period of time in container
(A) I (B) II (C) III (D) IV
24. Which of the following scientists carried out experiments similar to those shown above?
(A) Priestley (B) Van Helmont
(C) Hooke (D) Beaumont
25. In living things, the breakdown of a molecule to obtain energy is started by
(A) oxygen (B) carbon dioxide
(C) enzymes (D) heat

-
26. Algae have been sent along in space capsules with experimental animals to provide a source of
(A) oxygen (B) carbon dioxide
(C) hydrogen (D) helium
27. Which of the following gases makes up the greatest percentage of the atmosphere?
(A) Oxygen (B) Nitrogen
(C) Hydrogen (D) Carbon dioxide
28. All of the following are parts of an atom EXCEPT
(A) proton (B) neutron
(C) electron (D) betatron
29. A molecule of which of the following substances is probably largest in size?
(A) Carbon dioxide (B) Water
(C) Glucose (D) Protein

GO ON TO THE NEXT PAGE.

Substance	Relative Size of Molecules (Larger Number = Larger Size)	Units Entering Cell After 1 Hour
1	1	5,400
2	2	4,200
3	3	2,100
4	4	3,300

30. Which of the following would be the best interpretation of the data above?
- (A) The size of the molecules controls the rate of diffusion into the cell.
 - (B) Something in addition to the size of the molecules affects the rate at which materials enter the cell.
 - (C) The size of the molecules has nothing to do with the movements of molecules into the cell.
 - (D) Something other than the size of the molecules is the most important factor in the movement of materials into the cell.

GO ON TO THE NEXT PAGE

Questions 31-32 are based on the following apparatus that was used to do four experiments.

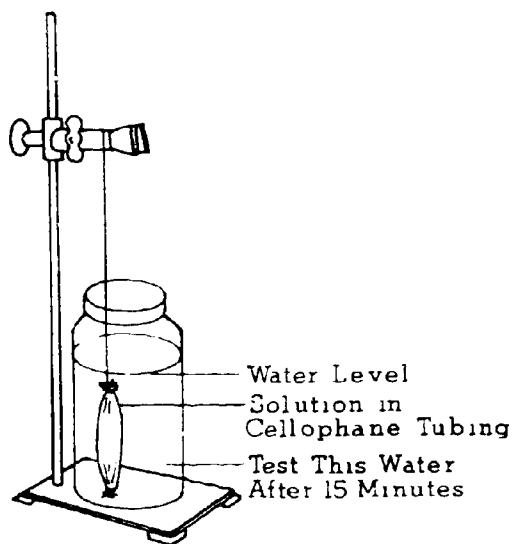

Results of Tests after 20 Minutes

Experiment	I	II	III	IV
Starch present in cellophane tube	Yes	No	No	Yes
Sugar present in cellophane tube	Yes	Yes	No	No
Starch present in water	No	No	No	Yes
Sugar present in water	Yes	Yes	No	No

At the start of which experiment was there sugar and starch in the cellophane bag and nothing in the water?

- (A) I
- (B) II
- (C) III
- (D) IV

32. Sugar and starch were not added to either the bag or the water in experiment

- (A) I
- (B) II
- (C) III
- (D) IV

Food	Calories per Gram
A	7
B	$6\frac{1}{2}$
C	$7\frac{1}{2}$
D	$7\frac{1}{4}$

33. An ounce of which of the foods above would give off the most heat when burned?

- (A) A
- (B) B
- (C) C
- (D) D

Questions 34-36

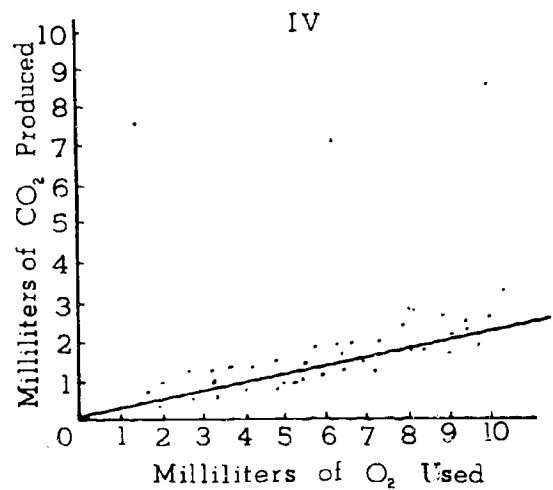
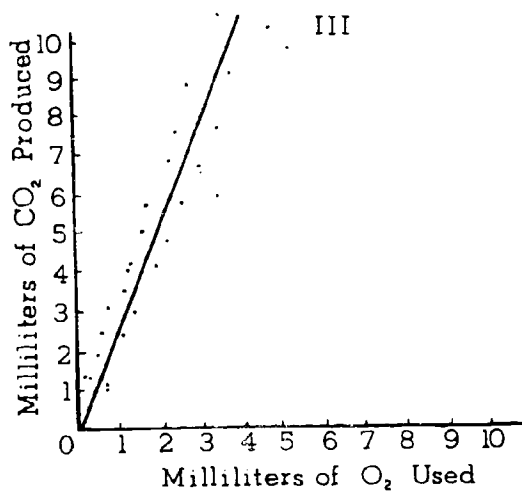
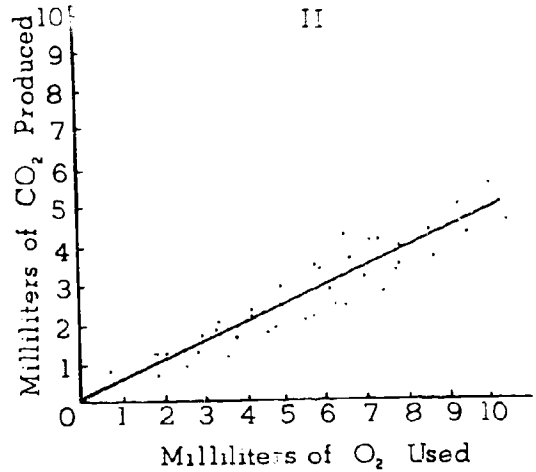
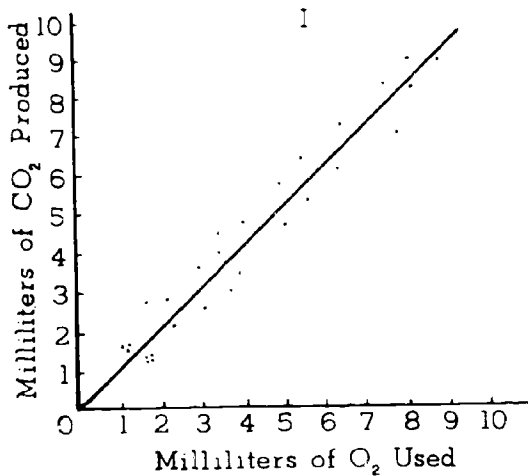

34. If germinating radish seeds use 2 milliliters of O_2 to produce 1 milliliter of CO_2 , which of the graphs above best represents this ratio?

- (A) I
- (B) II
- (C) III
- (D) IV

35. If resting sunflowers have a ratio of 1.0 for $\frac{CO_2 \text{ produced}}{O_2 \text{ used}}$, which of the graphs above best represents this ratio?

- (A) I
- (B) II
- (C) III
- (D) IV

36. For which graph would you most question a the measurements?

- (A) I
- (B) II
- (C) III
- (D) IV

GO ON TO THE NEXT

Questions 37-38 are based upon the following diagrams.

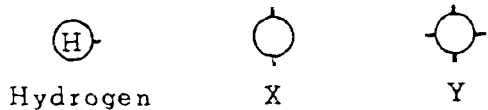

What is the greatest number of hydrogen atoms that can bond with an atom of element X?

- (A) 1
- (B) 2
- (C) 3
- (D) 4

If a hydrogen atom were attached to each bond of an atom of element Y, which of the following would be the correct molecular formula?

- (A) YH
- (B) YH₂
- (C) YH₃
- (D) YH₄

Questions 39-40

General Formula

Fuel + oxygen + starter = carbon dioxide + water + _____

39. The blank space should be filled in with the word

- (A) energy
- (B) oxygen
- (C) enzyme
- (D) photosynthesis

40. All of the following could be the fuel for this reaction EXCEPT

- (A) coal
- (B) oil
- (C) wood
- (D) light

IF YOU FINISH BEFORE TIME IS CALLED, CHECK YOUR WORK ON THIS TEST.

BIOLOGY - BSCS IV (For Phases 3, 4, and 5)

Time—40 minutes

YOU ARE TO INDICATE ALL YOUR ANSWERS ON THE SEPARATE ANSWER SHEET. No credit will be given for anything written in the test book. After you have decided which of the suggested answers you want to give for a question, blacken the corresponding space on the answer sheet.

Example:

Chicago is a

- (A) state
- (B) city
- (C) country
- (D) continent

Sample Answer

A	B	C	D
<input type="checkbox"/>	<input checked="" type="checkbox"/>	<input type="checkbox"/>	<input type="checkbox"/>

Give only one answer to each question; no credit will be given for multiple answers. If you wish to change an answer, erase your first line completely and mark your new choice.

DO NOT OPEN THIS BOOK UNTIL YOU ARE TOLD TO DO SO.

Note for teachers: This test is based on the BSCS, Molecules to Man, Chapters 12, 13, and 14.

Copyright © 1966

by

Biological Sciences Curriculum Study.

All rights reserved.

Reproduced by permission.

Questions 1-3

This paragraph is used to show the relationship between competition and cooperation, and the problems of cooperation when organisms act as one unit. If a Volvox cell were removed from its colony it would round off slightly into the shape of a teardrop. This cell closely resembles Chlamydomonas, except it cannot reproduce and perpetuate itself.

1. The fact that a single Volvox cell is almost identical to Chlamydomonas cells can be best explained biologically by
 - (A) genetics.
 - (B) evolution.
 - (C) cell theory.
 - (D) cooperation.

2. The process whereby the colony will replace the cell taken away from it is
 - (A) coordination.
 - (B) specialization.
 - (C) integration.
 - (D) regeneration.

3. The function of this Volvox cell in the colony is probably
 - (A) reproduction.
 - (B) more specialized than one removed from the colony.
 - (C) less specialized than a Chlamydomonas cell.
 - (D) the same as an individual.

4. Both plants and animals are made of tiny units called cells. They use oxygen to release energy from their food and they store food reserves as fat. These facts
 - (A) prove all life had a common origin.
 - (B) support the idea that being alive is about the same in all living things.
 - (C) indicate that plants evolved from animals.
 - (D) support the idea that animals have gradually evolved from plants.

5. The principle of division of labor in biology involves
 - (A) the production of varied agricultural crops.
 - (B) competition among organisms.
 - (C) differentiation of cells into tissues having different functions.
 - (D) growth, so there are more cells to do the work.

Questions 6-10

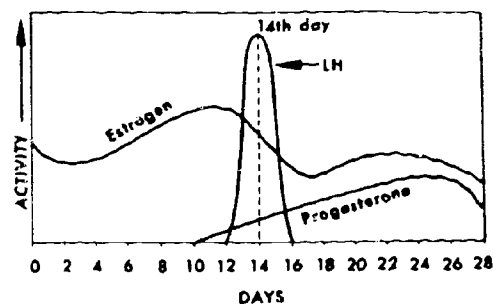

6. From the data in the graph one can infer that a result of an increase in the amount of estrogen in the blood is
 - (A) to start the menstrual flow.
 - (B) to cause the direct formation of a corpus luteum.
 - (C) production of progesterone.
 - (D) production of FSH.

7. In this graph the rupturing of the ovary surface and the release of an egg occurs
 - (A) between the 16th and the 26th day.
 - (B) between the 12th and the 16th day.
 - (C) on the 10th day.
 - (D) on the 28th day.

8. Progesterone secretion decreases at about the 28th day because
 - (A) the corpus luteum degenerates.
 - (B) the corpus luteum appears.
 - (C) the process of fertilization has occurred.
 - (D) ovulation has occurred.

9. The hormone levels in this cycle are controlled by the
 - (A) uterus.
 - (B) ovaries.
 - (C) uterus and the ovaries.
 - (D) uterus, ovaries and pituitary gland.

10. Progesterone is often described as the pregnancy hormone because it
 - (A) prepares the uterus to receive the egg.
 - (B) stimulates ovulation.
 - (C) stimulates estrogen production.
 - (D) stimulates the corpus luteum.

11. A nuclear change that is necessary for sexual reproduction is
- (A) the development of a new individual from a single cell.
 - (B) illustrated by the development of a willow tree from a cutting.
 - (C) the fusion of two gametes' nuclei.
 - (D) the creation of a new individual through meiosis from the doubling of the number of chromosomes.
12. When the pituitary gland is removed from immature female rabbits, their ovaries do not develop normally. When the pituitary gland is removed from mature female rabbits, the ovaries and uterus stop functioning. These observations lead to the conclusion that
- (A) the ovaries influence the uterus.
 - (B) the pituitary gland influences the ovaries and uterus.
 - (C) the ovaries and uterus influence the pituitary.
 - (D) there is a feedback of hormones from the ovaries to the pituitary.
13. In a normal body cell of a dogfish or shark there are 24 chromosomes. How many chromosomes are found in each gamete?
- (A) 6 (B) 12 (C) 24 (D) 48
14. Egg cells with the smallest percentage of yolk are usually associated with reproduction in
- (A) amphibians
 - (B) reptiles
 - (C) birds
 - (D) mammals
15. In an experiment M. C. Niu placed a salt solution in both dish A and dish B. He then placed mesoderm tissue into dish A, for three hours. He removed the mesoderm tissue from dish A and then placed top ectoderm tissue in both dishes A and B. The most precise statement of the hypothesis that Niu was testing would be
- (A) ectoderm and mesoderm may both be necessary for cell differentiation.
 - (B) mesoderm may be derived as a distinct tissue from undifferentiated tissues in the embryo.
 - (C) mesoderm may produce a chemical which induces ectoderm to differentiate.
 - (D) ectoderm may produce a chemical which induces mesoderm to differentiate.
16. Small fragments of ectodermal tissue from a frog embryo can survive in a salt solution. When mesoderm from a particular region of the embryo (dorsal lip) is placed in contact with the ectodermal tissue, differentiation of ectoderm into nerve cells can occur. No such differentiation occurs in the presence of any other parts of the embryo. On the basis of this evidence alone, which of these hypotheses is supported?
- (A) Ectoderm cells differentiate into nerve cells when activated by material from the mesoderm
 - (B) Mesoderm destroys a substance in ectoderm cells, preventing their differentiation.
 - (C) In order to differentiate ectoderm cells do not need nutrient substances from other embryonic cells.
 - (D) In order to differentiate ectoderm cells need physical support from other cells.
17. The fact that a boy's initials were carved in a tree four feet above the ground and after 12 years will be found at the same height shows that
- (A) the meristem was damaged and therefore prevented any vertical growth.
 - (B) once plant cells are formed they do not change.
 - (C) if necessary, mature tissues can develop into new organs.
 - (D) tissue used for vertical growth is found at the tips of stems.
18. Which organism would most likely carry on the process of pollination?
- (A) Lily (B) Fern
 - (C) Moss (D) Mushroom
19. From the point of view of evolution, the greatest advantage of sexual reproduction is
- (A) variety of animals which it can produce.
 - (B) consistency of traits that will appear generation after generation.
 - (C) continuance of the species.
 - (D) fact that a smaller percentage of eggs is fertilized.
20. The prime benefit of internal fertilization is
- (A) a shorter life cycle.
 - (B) a greater number of offspring.
 - (C) protection and nourishment for the developing organism.
 - (D) sexual reproduction.

Questions 21-25 require the selection of the correct statement of the interpretation of the following graph.

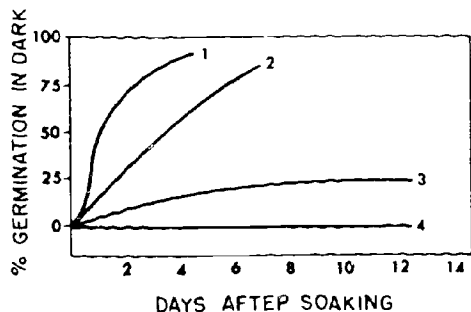

The interpretation is

- (A) illogical but not refuted by data.
- (B) rejected on the basis of evidence presented.
- (C) supported by the evidence.
- (D) logical but the experiment is not designed to test it.

- . Number 4 seeds require more time for germination.
- . Number 3 seeds have a lower germination percentage in the dark than number 2 seeds.
- . If number 3 seeds were germinated in the light, their percent germination would probably increase.
- . Number 1 has the best germination capacity.
- . Number 4 may require light for germination.

Questions 26-30

What processes are in favor of division of labor in Volvox against the tendencies for each cell to be independent like those of Chlamydomonas?

- (A) Logical hypothesis
- (B) Illogical hypothesis
- (C) Logical hypothesis but unrelated to the problem
- (D) Not a hypothesis; an empirical statement or a biological generalization

- 26. A single celled organism must carry on all the life functions itself in order to survive.
- 27. Volvox does not move in dark water, but if a beam of light were passed through the water, the colony would move toward it.
- 28. The larger the organism, the greater the number of natural enemies.
- 29. Each cell in a colony must have all the life functions.
- 30. A specialized cell can perform certain functions more effectively than a nonspecialized cell.

GO ON TO THE NEXT PAGE.

31. What is the evidence for coordinated activity of the cells in a Volvox Colony?
- (A) All flagella beating at the same time.
 - (B) Photosynthesis activity in all cells is due to presence of chlorophyll.
 - (C) Injury of one or several of the cells does not cause the death of the colony.
 - (D) Movement of flagellae allows the colony to move in a particular direction.

Questions 32-35

KEY: The statement refers to

- (A) mitosis
- (B) meiosis
- (C) mitosis and meiosis
- (D) neither mitosis nor meiosis

- 32. Monoploid cells are formed.
- 33. The resulting cell contains one chromosome of each pair.
- 34. The resulting cells are body cells.
- 35. The resulting cells could be sperm cells.

Questions 36-40

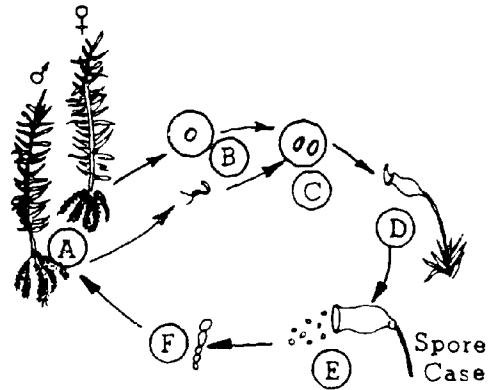

KEY: (A) Monoploid
 (B) Diploid
 (C) Sporophyte
 (D) Gametophyte

- 36. What is the chromosome number for the plants, A
- 37. What is the chromosome number for the cells, B ?
- 38. What is the chromosome number of C ?
- 39. To what generation does the structure D belong?
- 40. To what generation does the structure F belong?

IF YOU FINISH BEFORE TIME IS CALLED, CHECK YOUR WORK ON THIS TEST.

FORM PBC1

BASIC MATHEMATICS I (Whole Numbers)

Time--40 minutes

YOU ARE TO INDICATE ALL YOUR ANSWERS ON THE SEPARATE ANSWER SHEET. No credit will be given for anything written in the test book. After you have decided which of the suggested answers you want to give for a question, blacken the corresponding space on the answer sheet.

Example:

Chicago is a

- (A) state
- (B) city
- (C) country
- (D) continent

Sample Answer

A B C D

Give only one answer to each question; no credit will be given for multiple answers. If you wish to change an answer, erase your first line completely and mark your new choice.

DO NOT OPEN THIS BOOK UNTIL YOU ARE TOLD TO DO SO.

Developed by Educational Testing Service pursuant to a subcontract funded by the U. S. Department of Health, Education, and Welfare, Office of Education.

Basic Mathematics

Whole Numbers

Time—40 minutes

Directions: Read each of the following problems carefully. Complete the work required using a separate worksheet or scratchwork. Do not write in the test booklet. Consider each choice and then indicate the best answer in the appropriate space on the answer sheet.

1. Which is the greatest sum?

- (A) $8 + 9$
- (B) $8 + 7$
- (C) $6 + 7$
- (D) $8 + 8$

2. The numeral name for thirty-six thousand fifty-four is

- (A) 3,654
- (B) 36,54
- (C) 36,054
- (D) 36,540

3. Divide: $100 \overline{)384,000}$

- (A) 384
- (B) 3,840
- (C) 38,400
- (D) 384,000

4.
$$\begin{array}{r} 4 \\ 0 \\ 2 \\ 8 \\ 3 \\ + 6 \\ \hline \end{array}$$

- (A) 13
- (B) 22
- (C) 23
- (D) 33

5. Which of the following differences is least?

- (A) $7 - 4$
- (B) $13 - 9$
- (C) $12 - 6$
- (D) $16 - 5$

6. $32 + 32 + 32 + 32 + 32 = 32 \times \square$

What number goes in the box?

- (A) 5
- (B) 4
- (C) 1
- (D) 0

7. There are 25 students in a class. There are 2 boys and 3 girls not present. How many students are present?

- (A) 5
- (B) 6
- (C) 19
- (D) 20

8. Round 5,862 to the nearest hundred.

- (A) 6,000
- (B) 5,900
- (C) 5,860
- (D) 5,800

9. $8 \times 6 =$

- (A) 5×10
- (B) 6×13
- (C) 3×16
- (D) 4×11

10. $8 \overline{)243}$

The remainder in the division problem above is

- (A) 0
- (B) 3
- (C) 5
- (D) 7

11. Last year Bob's father received \$11,530 salary, \$5,350 commission, and \$945 bonus. What was the father's total income for the year?

- (A) \$16,625
- (B) \$16,725
- (C) \$17,725
- (D) \$17,825

12. From 934 take 358.

- (A) 1,292
- (B) 696
- (C) 576
- (D) 424

13. $27 \times 1,000 =$

- (A) 270,000
- (B) 27,000
- (C) 2,700
- (D) 270

14. Which gives a quotient equal to 3×6 ?

- (A) $3 \overline{)57}$
- (B) $5 \overline{)85}$
- (C) $9 \overline{)117}$
- (D) $7 \overline{)126}$

15. The numeral name for two hundred twelve thousand, four hundred twenty-six is

- (A) 220,426
- (B) 220,246
- (C) 212,426
- (D) 212,062

16. Which is less than 24 ?

- (A) 5×5
- (B) 4×7
- (C) 6×4
- (D) 7×3

17.
$$\begin{array}{r} 82 \\ 46 \\ 73 \\ 65 \\ +28 \\ \hline \end{array}$$

- (A) 304
- (B) 284
- (C) 285
- (D) 294

18. Which difference is greatest?

- (A) $65 - 32$
- (B) $83 - 51$
- (C) $71 - 43$
- (D) $51 - 26$

19. Which gives a quotient that is greatest?

- (A) $4 \overline{)32}$
- (B) $6 \overline{)54}$
- (C) $5 \overline{)25}$
- (D) $3 \overline{)21}$

20. $6 + 3 + 8 + 0 + 9 =$

- (A) 16
- (B) 25
- (C) 26
- (D) 36

21.
$$\begin{array}{r} 485 \\ \times 65 \\ \hline \end{array}$$

- (A) 31,525
- (B) 27,425
- (C) 26,805
- (D) 5,335

22.
$$\begin{array}{r} 17,947 \\ -13,799 \\ \hline \end{array}$$

- (A) 3,148
- (B) 4,058
- (C) 4,148
- (D) 14,248

23. $7 + (5 + 3) = 7 + (3 + \square)$

What number goes in the box?

- (A) 3
- (B) 5
- (C) 8
- (D) 15

The square of 11 is

- (A) 13
- (B) 22
- (C) 44
- (D) 121

Which is least?

- (A) $10 \times 100 \times 10$
- (B) $100 \times 10 \times 1,000$
- (C) $100 \times 10 \times 100$
- (D) $1,000 \times 0 \times 1,000$

How many sheets of writing paper are in 29 packages, each containing 500 sheets of writing paper?

- (A) 14,500
- (B) 1,450
- (C) 529
- (D) 145

$5(11 + 6) =$

- (A) 22
- (B) 61
- (C) 85
- (D) 330

$$\begin{array}{r} 357 \\ 246 \\ 468 \\ 197 \\ +609 \\ \hline \end{array}$$

- (A) 1,677
- (B) 1,877
- (C) 1,887
- (D) 1,987

Two cities, 525 miles apart, are to be marked on a map with the scale: 1 inch = 75 miles. How many inches apart should they be on the map?

- (A) 3
- (B) 5
- (C) 7
- (D) 9

30. $9 \times 3 \times 8 = 8 \times \square \times 3$

What number goes in the box?

- (A) 216
- (B) 9
- (C) 8
- (D) 3

31. The neighborhood branch of the public library has 23,019 fiction books, 9,814 nonfiction books, 295 reference books, and 572 magazines. What is the total number of books and magazines?

- (A) 23,700
- (B) 32,690
- (C) 33,500
- (D) 33,700

32. $6 + \Delta + 15 = 15 + 6$

What number goes in the triangle?

- (A) 0
- (B) 1
- (C) 6
- (D) 21

33. $\Delta \times \Delta = 64$

What number goes in each triangle?

- (A) 4,096
- (B) 32
- (C) 16
- (D) 8

34. Divide: $\overline{337} \overline{)95,708}$

- (A) 284
- (B) 296
- (C) 304
- (D) 319

35. $3 \times \Delta \times 8 = 12 \times 2$

What number goes in the triangle?

- (A) 0
- (B) 1
- (C) 13
- (D) 24

In Questions 36-40, read the problem and then choose the letter of the operation that you would need to use.

36. At the shopping center, Mary spent 25 cents, 10 cents, and 50 cents. How much did she spend altogether?
- (A) Add
(B) Subtract
(C) Multiply
(D) Divide
37. In a grade school there were 30 classes and 25 pupils in each class. How many pupils were there altogether?
- (A) Add
(B) Subtract
(C) Multiply
(D) Divide
38. John had 9 cents and wanted to buy a tablet worth 16 cents. How much more did he need?
- (A) Add
(B) Subtract
(C) Multiply
(D) Divide
39. Ann deals 52 cards into 4 equal piles. How many cards are in each pile?
- (A) Add
(B) Subtract
(C) Multiply
(D) Divide
40. At Sebring, Florida, a Ford was driven for 12 hours at an average speed of 151 miles per hour. How far did it travel?
- (A) Add
(B) Subtract
(C) Multiply
(D) Divide

41. Round 364,407,605 to the nearest million.

- (A) 364,000,000
(B) 364,400,000
(C) 364,410,000
(D) 365,000,000

42.
$$\begin{array}{r} 9,561 \\ 87 \\ 83,579 \\ 602 \\ 5,418 \\ + 16,574 \\ \hline \end{array}$$

- (A) 105,821
(B) 114,821
(C) 115,821
(D) 115,921

43.
$$\begin{array}{r} 693 \\ \times 907 \\ \hline \end{array}$$

- (A) 638,761
(B) 628,551
(C) 627,551
(D) 67,221

44. $108,730 - 89,967 =$

- (A) 18,763
(B) 18,863
(C) 19,753
(D) 29,873

45. $\Delta \times \square = 36$

Which of the following values of Δ and \square make the statement above true?

- (A) $\Delta = 16$
 $\square = 2$
(B) $\Delta = 9$
 $\square = 4$
(C) $\Delta = 6$
 $\square = 16$
(D) $\Delta = 15$
 $\square = 3$

$$(7 \times 2) + (7 \times 9) = 7 \times \boxed{}$$

Which of the following goes in the box above?

- (A) (2×9)
- (B) $(9 + 16)$
- (C) $(2 + 9)$
- (D) (9×16)

49. If the difference between 50 and a smaller number is 21, then the smaller number is

- (A) 71
- (B) 63
- (C) 39
- (D) 29

A farmer has 39 rows of apple trees each containing 24 trees. Each tree produces 12 bushels of apples. Which of the following tells how many bushels of apples all the trees produced?

- (A) $(39 \times 24) + (39 \times 12)$
- (B) $39 \times 24 \times 12$
- (C) $39 + 24 + 12$
- (D) $39 + (24 \times 12)$

50. In 18 basketball games, Mike Jones made 126 field goals (2 points each) and 90 free throws (1 point each). What was his scoring average in points per game?

- (A) 16
- (B) 17
- (C) 18
- (D) 19

Divide: $692 \overline{)365,489}$

- A) 428 remainder 649
- B) 509 remainder 691
- C) 518 remainder 423
- D) 528 remainder 113

IF YOU FINISH BEFORE TIME IS CALLED, CHECK YOUR WORK ON THIS TEST.

FORM PBC2

BASIC MATHEMATICS II (Fractions)

Time—40 minutes

YOU ARE TO INDICATE ALL YOUR ANSWERS ON THE SEPARATE ANSWER SHEET. No credit will be given for anything written in the test book. After you have decided which of the suggested answers you want to give for a question, blacken the corresponding space on the answer sheet.

Example:

Chicago is a

- (A) state
- (B) city
- (C) country
- (D) continent

Sample Answer

A	B	C	D
<input type="checkbox"/>	<input checked="" type="checkbox"/>	<input type="checkbox"/>	<input type="checkbox"/>

Give only one answer to each question; no credit will be given for multiple answers. If you wish to change an answer, erase your first line completely and mark your new choice.

DO NOT OPEN THIS BOOK UNTIL YOU ARE TOLD TO DO SO.

Developed by Educational Testing Service pursuant to a subcontract funded by the U. S. Department of Health, Education, and Welfare, Office of Education.

BASIC MATHEMATICS II
FRACTIONS

Time—40 minutes

Directions: Read each of the following problems carefully. Complete the work required using a separate worksheet for scratchwork. Do not write in the test booklet. Consider each choice and then indicate the best answer in the appropriate space on the answer sheet.

1. How many $\frac{1}{3}$'s make 1 ?

- (A) 4 (B) 3 (C) 2 (D) 1

2. $\frac{1}{2} + \frac{1}{3} = \frac{\square}{6}$

What number goes in the box above?

- (A) 2 (B) 3 (C) 5 (D) 6

3. $\frac{2}{3} \times \frac{6}{8} =$

- (A) $\frac{1}{6}$ (B) $\frac{1}{4}$ (C) $\frac{1}{3}$ (D) $\frac{1}{2}$

4. $\frac{6}{8} \div \frac{3}{4} =$

- (A) 1 (B) $\frac{2}{3}$ (C) $\frac{1}{2}$ (D) $\frac{1}{4}$

5. One inch is what fractional part of one foot?

- (A) $\frac{1}{36}$ (B) $\frac{1}{16}$ (C) $\frac{1}{12}$ (D) $\frac{1}{3}$

6. Which of the following is equal to a whole number?

- (A) $\frac{42}{6}$ (B) $\frac{42}{12}$ (C) $\frac{24}{14}$ (D) $\frac{8}{12}$

7. $\frac{4}{6} =$

- (A) $\frac{1}{3}$ (B) $\frac{14}{21}$ (C) $\frac{9}{12}$ (D) $\frac{12}{16}$

8. Dividing by $1\frac{1}{2}$ is the same as multiplying by

- (A) $\frac{2}{3}$ (B) $\frac{3}{4}$ (C) $\frac{4}{3}$ (D) $\frac{3}{2}$

9. Which of the following is NOT equal to a whole number?

- (A) $\frac{6}{9}$ (B) $\frac{2}{2}$ (C) $\frac{6}{3}$ (D) $\frac{12}{4}$

10. $\frac{36}{15} =$

- (A) $1\frac{1}{2}$ (B) $2\frac{2}{5}$ (C) $2\frac{2}{3}$ (D) $3\frac{1}{15}$

11. $\frac{13}{16} - \frac{3}{4} =$

- (A) $\frac{10}{12}$ (B) $\frac{10}{16}$ (C) $\frac{1}{8}$ (D) $\frac{1}{16}$

12. The value of a fractional number is not changed if one

- (A) multiplies by 1 or a number equivalent to 1
(B) multiplies by the reciprocal of the number
(C) multiplies by 0
(D) divides the number by itself

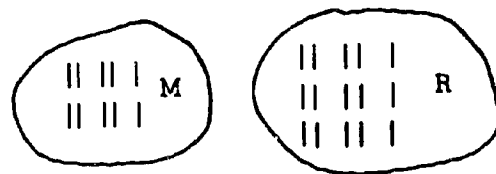

13. What is the ratio of set M to set R above?

- (A) $\frac{2}{5}$ (B) $\frac{2}{3}$ (C) $\frac{3}{4}$ (D) $\frac{3}{2}$

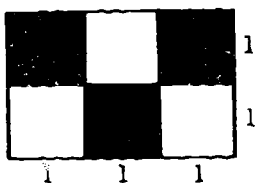

14. What fractional part of the rectangle with dimensions as shown above is shaded?

- (A) $\frac{1}{6}$ (B) $\frac{1}{3}$ (C) $\frac{3}{8}$ (D) $\frac{1}{2}$

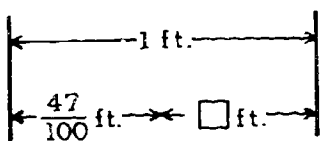





15. What number goes in the box above?

- (A) $\frac{9}{8}$ (B) $\frac{53}{100}$ (C) $\frac{1}{2}$ (D) $\frac{47}{100}$

16. One may think of a fraction as a comparison of two numbers called "numerator" and "denominator." This comparison is made by

- (A) addition (B) subtraction
(C) multiplication (D) division

17. In which of the following does the shaded portion most nearly represent $\frac{2}{3}$ of the whole?

- (A) 
- (B) 
- (C) 
- (D) 

18. $\frac{3}{4} + \frac{5}{6} =$

- (A) $\frac{15}{24}$ (B) $\frac{8}{10}$ (C) $1\frac{1}{2}$ (D) $1\frac{7}{12}$

19. What is the ratio of the length 2 feet to the length 3 yards?

- (A) 2 to 9 (B) 1 to 6 (C) 1 to 3 (D) 2 to 3

20.
$$\begin{array}{r} 13\frac{3}{5} \\ - 9\frac{2}{3} \\ \hline \end{array}$$

- (A) $4\frac{14}{15}$ (B) $4\frac{1}{15}$ (C) $3\frac{14}{15}$ (D) $3\frac{4}{5}$

21. Which of the following is equal to thirteen tenths?

- (A) $\frac{130}{1,000}$ (B) $\frac{23}{20}$ (C) $\frac{130}{100}$ (D) $\frac{130}{10}$

22. Which of the following fractions is three times as great as $\frac{1}{9}$?

- (A) $\frac{1}{27}$ (B) $\frac{1}{12}$ (C) $\frac{1}{6}$ (D) $\frac{1}{3}$

23. $\frac{3}{8} + \frac{3}{8} + \frac{3}{8} + \frac{3}{8} + \frac{3}{8} + \frac{3}{8} =$

- (A) $\frac{3}{4} + \frac{3}{4}$
(B) $\frac{1}{3} + \frac{1}{3} + \frac{1}{3} + \frac{1}{3}$
(C) $\frac{6}{8} + \frac{6}{8} + \frac{6}{8}$
(D) $\frac{1}{4} + \frac{1}{4} + \frac{1}{4}$

$\frac{1}{2}$

24. Which fraction below is one-half of the fraction above?

- (A) $\frac{1}{2 \times \frac{1}{2}}$ (B) $2 \times \frac{1}{2}$ (C) $\frac{1}{2 \times 2}$ (D) $\frac{1 \times 2}{2}$

25. In order to reduce a fraction to its lowest terms, one should
- (A) add the same number to the numerator and to the denominator
 - (B) subtract the same number from the numerator and from the denominator
 - (C) multiply the numerator and denominator by the least common multiple
 - (D) divide the numerator and denominator by the greatest common divisor



6. In the rectangle above, the shaded portion is most nearly what fractional part of the rectangle?

- (A) $\frac{1}{4}$ (B) $\frac{1}{2}$ (C) $\frac{3}{4}$ (D) $\frac{4}{3}$

7. If $\frac{1}{2} + \frac{1}{3} + \square = 1$, what fraction goes in the box?

- (A) $\frac{1}{12}$ (B) $\frac{1}{6}$ (C) $\frac{1}{3}$ (D) $\frac{1}{2}$

$$\begin{array}{r} 3. \quad 4\frac{5}{9} \\ \quad 12\frac{1}{6} \\ \quad + 3\frac{7}{9} \\ \hline \end{array}$$

- (A) $19\frac{1}{2}$ (B) $20\frac{1}{9}$ (C) $20\frac{1}{2}$ (D) 22

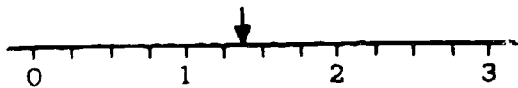

The arrow above is pointing closest to

- (A) $1\frac{1}{4}$ (B) $1\frac{3}{8}$ (C) $1\frac{3}{4}$ (D) $2\frac{5}{8}$

30. Which of the following is equal to a whole number?

- (A) $\frac{2}{3} \times \frac{3}{4}$
- (B) $\frac{2}{5} \times \frac{10}{4}$
- (C) $\frac{1}{2} \times \frac{1}{2}$
- (D) $\frac{3}{2} \times \frac{5}{3}$

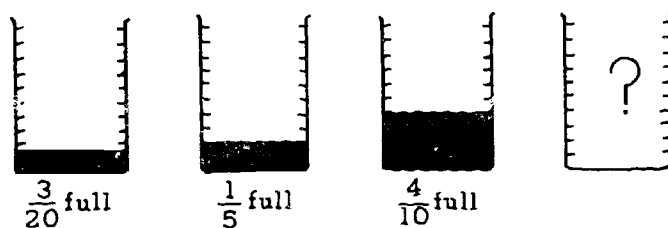

31. Four identical containers are shown above. If the contents of the three containers on the left are poured into the empty container, what fractional part of the empty container will be filled?

- (A) $\frac{13}{20}$ (B) $\frac{7}{10}$ (C) $\frac{3}{4}$ (D) $\frac{4}{5}$

32. Which of the following is between $\frac{3}{5}$ and $\frac{3}{4}$?

- (A) $\frac{1}{2}$ (B) $\frac{7}{10}$ (C) $\frac{5}{6}$ (D) $\frac{17}{20}$

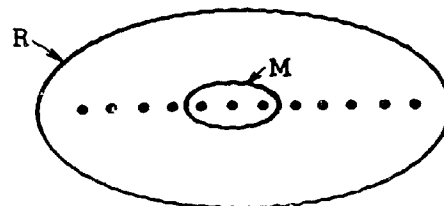

33. In the figure above, set M is what fractional part of set R?

- (A) $\frac{3}{4}$ (B) $\frac{3}{5}$ (C) $\frac{1}{3}$ (D) $\frac{1}{4}$

What is the least common multiple of 5, 6, and 10?

- (A) 20 (B) 24 (C) 30 (D) 60

Which of the following is in the same ratio as 2 to 3?

- (A) $\frac{10}{20}$ (B) $\frac{20}{35}$ (C) $\frac{16}{24}$ (D) $\frac{9}{12}$

If $\frac{1}{2} \times \frac{1}{2} \times \frac{1}{2} \times \square = 3$, what number goes in the box?

- (A) 6 (B) 12 (C) 18 (D) 24

Which of the following is NOT equal to $\frac{9}{16}$?

- (A) $\frac{3}{4}$ (B) $\frac{18}{32}$ (C) $\frac{27}{48}$ (D) $\frac{45}{80}$

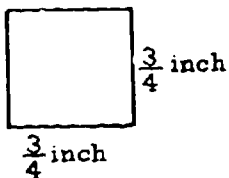

Note: Figures not drawn to scale.

The square above would most nearly fill which of the following squares?

- (A) $\begin{array}{|c|} \hline 0.4 \\ \hline \text{sq. in.} \\ \hline \end{array}$ (B) $\begin{array}{|c|} \hline 0.6 \\ \hline \text{sq. in.} \\ \hline \end{array}$ (C) $\begin{array}{|c|} \hline 0.7 \\ \hline \text{sq. in.} \\ \hline \end{array}$ (D) $\begin{array}{|c|} \hline 0.9 \\ \hline \text{sq. in.} \\ \hline \end{array}$

$\left(2\frac{1}{2} + 3\frac{2}{3}\right) - 1\frac{5}{6} =$

- (A) $7\frac{11}{12}$ (B) $5\frac{1}{3}$ (C) $4\frac{1}{2}$ (D) $4\frac{1}{3}$

If $2 \times \square \times \frac{3}{2} = 1$, what fraction goes in the box?

- (A) $\frac{1}{3}$ (B) $\frac{2}{3}$ (C) $\frac{3}{2}$ (D) $\frac{3}{1}$

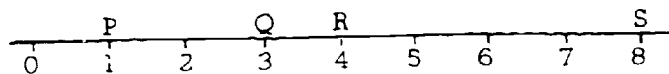

41. Which of the following is equal to the ratio of PQ to RS above?

- (A) $\frac{2}{8}$ (B) $\frac{3}{8}$ (C) $\frac{2}{4}$ (D) $\frac{3}{4}$

42. If $\frac{1}{2} \times \frac{1}{2} \times \frac{1}{2} + \square = 1$, what number goes in the box?

- (A) $\frac{1}{8}$ (B) $\frac{7}{8}$ (C) 4 (D) 8

43. $\left(\frac{3}{5} \cdot \frac{1}{4}\right) \div \frac{1}{4} =$

- (A) $\frac{3}{80}$ (B) $\frac{3}{5}$ (C) $\frac{5}{3}$ (D) $\frac{80}{3}$

PORTIONS OF THE ACADEMIC YEAR DEVOTED TO THREE SPORTS

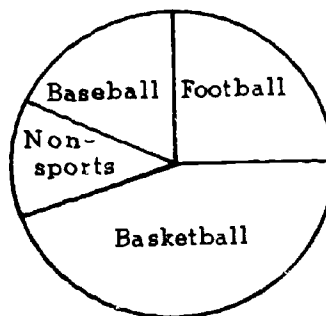

44. Using the graph above, which of the following is most nearly true?

- (A) Basketball season lasts more than half of the academic year.
 (B) Baseball season lasts at least one-fourth of the academic year.
 (C) Football season lasts about one-fourth of the academic year.
 (D) Baseball season lasts about one-half of the academic year.

Which of the following is ordered from least to greatest?

- (A) $\frac{5}{12}, \frac{7}{16}, \frac{2}{3}$
- (B) $\frac{2}{3}, \frac{7}{16}, \frac{5}{12}$
- (C) $\frac{2}{3}, \frac{5}{12}, \frac{7}{16}$
- (D) $\frac{7}{16}, \frac{5}{12}, \frac{2}{3}$

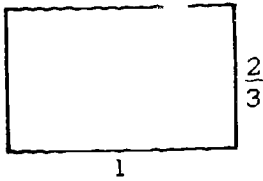

How many of the rectangles above would be required to make a perfect square?

- (A) 2 (B) 4 (C) 6 (D) 8

Dan made a scale drawing of a basketball floor 90 feet long and 54 feet wide. On the drawing the floor is $7\frac{1}{2}$ inches long and $4\frac{1}{2}$ inches wide. On Dan's scale 1 inch represents how many feet?

- (A) 12 (B) 9 (C) 8 (D) 6

48. $3 + \frac{1}{10} + \frac{4}{100} + \frac{1}{1,000} + \frac{5}{10,000} =$

- (A) $3\frac{1,415}{10,000}$
- (B) $3\frac{1,415}{1,000}$
- (C) 14
- (D) 31,1415

49. $\frac{1}{3}$ of 30 is the same as $\frac{1}{5}$ of

- (A) 50 (B) 20 (C) 10 (D) 6

50. $\frac{\frac{2}{3} + \frac{4}{5}}{\frac{11}{5}} =$

- (A) $\frac{36}{56}$ (B) $\frac{2}{3}$ (C) $\frac{7}{8}$ (D) $\frac{242}{75}$

IF YOU FINISH BEFORE TIME IS CALLED, CHECK YOUR WORK ON THIS TEST.

FORM QBC1

BASIC MATHEMATICS III (Decimals and Per Cent)

Time—40 minutes

YOU ARE TO INDICATE ALL YOUR ANSWERS ON THE SEPARATE ANSWER SHEET. No credit will be given for anything written in the test book. After you have decided which of the suggested answers you want to give for a question, blacken the corresponding space on the answer sheet.

Example:

Chicago is a
 (A) state
 (B) city
 (C) country
 (D) continent

Sample Answer

A B C D

Give only one answer to each question; no credit will be given for multiple answers. If you wish to change an answer, erase your first line completely and mark your new choice.

DO NOT OPEN THIS BOOK UNTIL YOU ARE TOLD TO DO SO.

Developed by Educational Testing Service pursuant to a subcontract funded by the U. S. Department of Health, Education, and Welfare, Office of Education.

BASIC MATHEMATICS III
DECIMALS AND PER CENT

Time—40 minutes

Directions: Read each of the following problems carefully. Complete the work required using a separate worksheet or scratchwork. Do not write in the test booklet. Consider each choice and then indicate the best answer in the appropriate space on the answer sheet.

$$\begin{array}{cccc} & P & Q & \\ & \downarrow & \downarrow & \\ 6, & 6 & 4 & 3 \end{array}$$

1. In the numeral above, the digit marked by arrow P has a place value how many times the place value of the digit marked by arrow Q?

- (A) $\frac{1}{10}$
(B) 5
(C) 10
(D) 100

2.
$$\begin{array}{r} 8.05 \\ 3.51 \\ 2.49 \\ +7.06 \\ \hline \end{array}$$

- (A) 20.91
(B) 21.11
(C) 22.81
(D) 31.71

3. $1 + \frac{5}{10} + \frac{2}{1,000} =$

- (A) 1.502
(B) 1.52
(C) 0.152
(D) 0.1502

4.
$$\begin{array}{r} 108.62 \\ - 97.83 \\ \hline \end{array}$$

- (A) 11.89
(B) 11.79
(C) 10.79
(D) 1.79

5. $0.16 \div 0.0032 =$

- (A) 50
(B) 5
(C) 0.05
(D) 0.005

6. $80.02 \times 10,000 =$

- (A) 0.0008002
(B) 0.8002
(C) 80,020
(D) 800,200

7. Which of the following is two hundred and thirty-four thousandths?

- (A) 234,000
(B) 200.34
(C) 200.034
(D) 0.234

8. $542.3 - 64.23 =$

- (A) 0
(B) 578.07
(C) 588.17
(D) 588.7

9. $\frac{3}{8} =$

- (A) 0.125
(B) 0.375
(C) 0.625
(D) 6.25

10. $70 \div 0.35 =$

- (A) 0.2
(B) 2
(C) 20
(D) 200

11. $0.048 \times 0.05 =$

- (A) 0.0024
(B) 0.024
(C) 0.24
(D) 2.4

12. $7.114 - 8.96 =$

- (A) 6.308
- (B) 7.115.04
- (C) 7.105.14
- (D) 7.105.04

13. $0.75 =$

- (A) $\frac{1}{2}$
- (B) $\frac{2}{3}$
- (C) $\frac{3}{4}$
- (D) $\frac{5}{6}$

14. $83.2 \div 1,000 =$

- (A) 83,200
- (B) 8,320
- (C) 0.832
- (D) 0.0832

15. $0.0015 =$

- (A) 15%
- (B) 1.5%
- (C) 0.15%
- (D) 0.015%

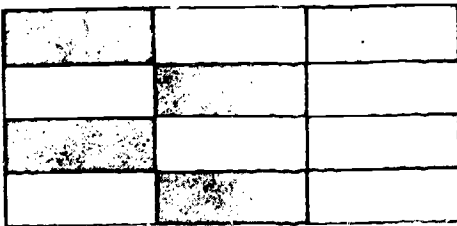

16. The rectangle above is divided into 12 equal rectangles. What per cent of the figure is shaded?

- (A) 6%
- (B) 25%
- (C) 40%
- (D) 50%

17. $65\% =$

- (A) $\frac{65}{1,000}$
- (B) $\frac{65}{100}$
- (C) $\frac{65}{10}$
- (D) $\frac{65}{1}$

18. $\frac{13}{25} =$

- (A) 17%
- (B) 38%
- (C) 52%
- (D) 63%

19. Change 72 per cent to a fraction in lowest terms.

- (A) $\frac{100}{72}$
- (B) $\frac{25}{18}$
- (C) $\frac{72}{100}$
- (D) $\frac{18}{25}$

20. $3\frac{2}{5} =$

- (A) 340%
- (B) 325%
- (C) 32.5%
- (D) 3.4%

21. 0.464579 lies between

- (A) 0.464 and 0.465
- (B) 0.45 and 0.46
- (C) 0.405 and 0.406
- (D) 0.5 and 0.6

22. $788.98 \div 38.3 =$

- (A) 206
- (B) 26
- (C) 20.6
- (D) 2.06

$$9.07 \times 0.125 =$$

- (A) 1.13375
 (B) 1.2125
 (C) 11.3375
 (D) 121.25

$$44.4 =$$

- (A) $4(100 + 10 + 1)$
 (B) $44.4(10 + 1 + \frac{1}{10})$
 (C) $4(10 + 1 + \frac{1}{10})$
 (D) $4.4(10 + 1)$

$$0.91 \frac{2}{3} - \frac{2}{3} =$$

- (A) 0.91
 (B) 0.50
 (C) 0.375
 (D) 0.25

How much money is 103 ten-dollar bills?

- (A) \$1,300
 (B) \$1,030
 (C) \$1,003
 (D) \$103

$$49.2 + 0.871 + 6.45 =$$

- (A) 2.008
 (B) 20.08
 (C) 50.716
 (D) 56.521

$$300\% \times 6.75 =$$

- (A) 1.815
 (B) 18.35
 (C) 19.25
 (D) 20.25

$$0.3 \times 0.5 \times 0.42 =$$

- (A) 0.63
 (B) 0.62
 (C) 0.063
 (D) 0.062

$$30. \frac{9}{0.45} =$$

- (A) 0.2
 (B) 2
 (C) 20
 (D) 200

31. Which of the following is greatest?

- (A) 17.6
 (B) 1.76
 (C) 0.176
 (D) 0.0176

$$32. 83\frac{1}{3}\% =$$

- (A) $\frac{7}{8}$
 (B) $\frac{5}{6}$
 (C) $\frac{3}{4}$
 (D) $\frac{2}{3}$

$$33. 0.7 \div \frac{1}{100} =$$

- (A) 0.007
 (B) 0.07
 (C) 7
 (D) 70

34. 6 is what per cent of 0.06 ?

- (A) 10,000%
 (B) 1,000%
 (C) 100%
 (D) 10%

$$35. \frac{0.30}{0.03} + \frac{0.03}{0.30} =$$

- (A) 11
 (B) 10.1
 (C) 1.1
 (D) 0.101

36. To the nearest hundredth, $36.8473 =$

- (A) 36.8
- (B) 36.84
- (C) 36.85
- (D) 3,700

37. 0.6% of $1,500 =$

- (A) 9
- (B) 90
- (C) 900
- (D) 9,000

38. A boy ran a distance of 440 yards in 53.04 seconds. On his next race he ran the 440 yards in 51.95 seconds. By how many seconds did the boy reduce his time?

- (A) 1.09
- (B) 1.19
- (C) 2.09
- (D) 2.19

39. $\frac{0.1 \times 0.001}{\frac{0.01}{0.1}} =$

- (A) 1
- (B) 0.1
- (C) 0.01
- (D) 0.001

40. All of the following groups are written in descending order from left to right EXCEPT

- (A) 0.04, 0.006, 0.10
- (B) 3.1, 1.3, 1.13
- (C) 2.02, 2.002, 0.202
- (D) 948, 849, 498

41. 16 is 50 per cent of what number?

- (A) 8
- (B) 12
- (C) 24
- (D) 32

42. Seventy per cent of the pupils in a sixth grade class volunteered for a paper drive, but only 50 per cent of the volunteers reported on the day of the drive. What per cent of the sixth grade class reported for the drive?

- (A) 20%
- (B) 35%
- (C) 40%
- (D) 55%

43. During a sale a dress is marked down from \$15 to \$10. The reduction represents what per cent of the original sales price?

- (A) 5%
- (B) 25%
- (C) $33\frac{1}{3}\%$
- (D) 40%

44. Pencils that sell for 10¢ each can also be bought in lots of 3 for 25¢. The savings on a box of 24 pencils are

- (A) \$0.20
- (B) \$0.40
- (C) \$0.50
- (D) \$0.60

TEAM RECORDS

Team	Games Won	Games Played
Red	9	10
Blue	12	15
Gold	10	12
Green	6	9

45. Which team above won the highest per cent of games it played?

- (A) Red
- (B) Blue
- (C) Gold
- (D) Green

GO ON TO THE NEXT PA

Final Grades of
400 Freshmen

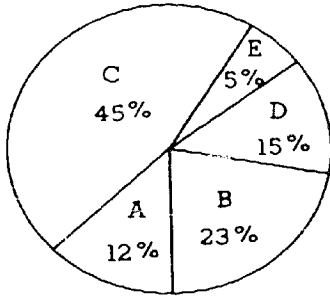

According to the graph above the total number of freshmen receiving grades of either A, C, D, or E is

- (A) 77
- (B) 92
- (C) 230
- (D) 308

If a man borrowed \$100 and one year later pays back \$106, the annual rate of simple interest, expressed as a decimal, is

- (A) 0.06
- (B) 0.6
- (C) 6
- (D) 60

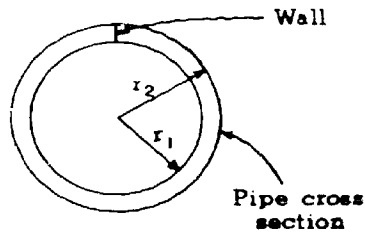

Pipe Dimensions

Pipe I		Pipe II	
r_1	1.24"	r_1	1.24"
r_2	1.67"	r_2	1.92"

48. According to the data above, the wall of pipe II is how many inches thicker than the wall of pipe I?

- (A) 0.25
- (B) 0.35
- (C) 0.43
- (D) 0.68

49. How many layers of metal, each 0.023 inches thick, are needed to have a total thickness of 2.3 inches?

- (A) 10
- (B) 100
- (C) 1,000
- (D) 10,000

50.
$$\frac{1.000 - \frac{1}{1000}}{0.999} =$$

- (A) 0.001
- (B) 0.999
- (C) 1.000
- (D) 1.999

IF YOU FINISH BEFORE TIME IS CALLED, CHECK YOUR WORK ON THIS TEST.

BASIC MATHEMATICS IV
(Measurement and Denominate Numbers)
Time—40 minutes

YOU ARE TO INDICATE ALL YOUR ANSWERS ON THE SEPARATE ANSWER SHEET. No credit will be given for anything written in the test book. After you have decided which of the suggested answers you want to give for a question, blacken the corresponding space on the answer sheet.

Example:

Chicago is a
(A) state
(B) city
(C) country
(D) continent

Sample Answer

A	B	C	D
<input type="checkbox"/>	<input checked="" type="checkbox"/>	<input type="checkbox"/>	<input type="checkbox"/>

Give only one answer to each question; no credit will be given for multiple answers. If you wish to change an answer, erase your first line completely and mark your new choice.

DO NOT OPEN THIS BOOK UNTIL YOU ARE TOLD TO DO SO.

Developed by Educational Testing Service pursuant to a subcontract funded by the U. S. Department of Health, Education, and Welfare, Office of Education.

BASIC MATHEMATICS IV

Measurement and Denominate Numbers

Time—40 minutes

Directions: Read each of the following problems carefully. Complete the work required using a separate worksheet for scratchwork. Do not write in the test booklet. Consider each choice and then indicate the best answer in the appropriate space on the answer sheet.

The following information can be used by you in solving any of the problems. In some problems you may not need it.

Circle of radius r:

Area = πr^2

Circumference = $2\pi r$

The number of degrees of arc in a circle is 360.

The measure in degrees of a straight angle is 180.

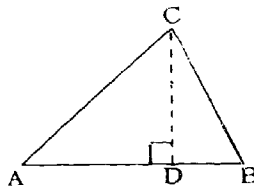

Triangle:

The sum of the measures in degrees of the angles of a triangle is 180.

If $\angle CDA$ is a right angle, then

(1) area of $\triangle ABC = \frac{AB \times CD}{2}$

(2) $AC^2 = AD^2 + DC^2$

Definitions of symbols:

$<$ is less than

$>$ is greater than

\perp is perpendicular to

\leq is less than or equal to

\geq is greater than or equal to

\parallel is parallel to

Note: Figures which accompany problems in this test are intended to provide information useful in solving the problems. They are drawn as accurately as possible EXCEPT when it is stated in a specific problem that its figure is not drawn to scale. All figures lie in the plane unless otherwise indicated.

In this test, all numbers used are real numbers.

Given: 1 ton = 2,000 pounds. Add:

5 tons	450 pounds
2 tons	1,000 pounds
	1,700 pounds
+ 14 tons	850 pounds

- (A) 23 tons 0 pounds
- (B) 22 tons 1,900 pounds
- (C) 22 tons 1,100 pounds
- (D) 22 tons 1,000 pounds

READING

Mileage at End	36870
Mileage at Start	36742

- 3. When Jim made a trip up the coast from Melbourne, Florida, he recorded the data above. If he used exactly 8 gallons of gasoline for the trip, what was his average rate of gasoline consumption in miles per gallon?

- (A) 12.8
- (B) 16
- (C) 18
- (D) 22

- 4. A rectangle 3 yards long and 3 feet wide contains how many square feet?

- (A) 9
- (B) 27
- (C) 81
- (D) 108

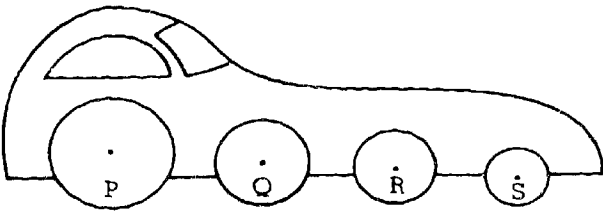

In a drag race which of the wheels on the super hot rod above will make the most number of turns?

- (A) P
- (B) Q
- (C) R
- (D) S

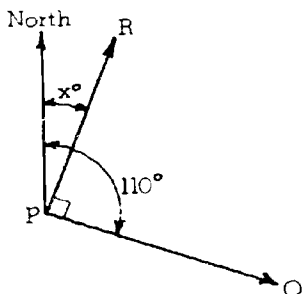

5. Road PQ on the map above has a heading (an angle of) 110° from North. If road PR is perpendicular to road PQ, what is the heading x of road PR?

- (A) 20°
- (B) 90°
- (C) 200°
- (D) 280°

6. The ruling count of Transylvania ordered that one of two units of length be used: the batwing or the rattail. If one batwing = 3.14 rattails, how many batwings separate two werewolves that are 28.26 rattails apart?

- (A) 0.09
- (B) 0.9
- (C) 9
- (D) 90

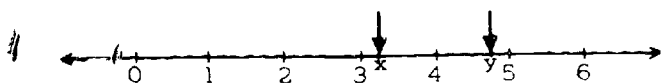

7. On the number line above, if $x + y = 8$, which of the following could be the values of x and y ?

- (A) $x = 4.5$; $y = 3.5$
- (B) $x = 3.75$; $y = 4.25$
- (C) $x = 3.30$; $y = 4.75$
- (D) $x = 3.25$; $y = 4.75$

8. Subtract:

$$\begin{array}{r} 5 \text{ gallons } 2 \text{ quarts} \\ - 2 \text{ gallons } 3 \text{ quarts} \\ \hline \end{array}$$

- (A) 3 gallons 1 quart
- (B) 2 gallons 3 quarts
- (C) 2 gallons 2 quarts
- (D) 2 gallons 1 quart

9. The volume of a cube is 27 cubic feet. The area in square feet of one face of this cube is

- (A) 9
- (B) 8
- (C) 6
- (D) 3

10. If the circumference of a circle is 6π inches, then the area in square inches of the circle is

- (A) 3π
- (B) 6π
- (C) 9π
- (D) 12π

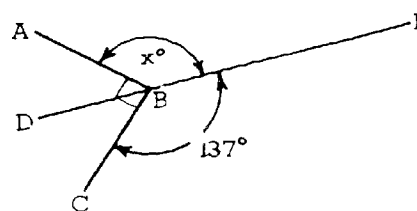

11. In the figure above, if DBE is a straight line, then $x =$

- (A) 47
- (B) 133
- (C) 137
- (D) 143

12. The scale on a road map is 1 inch = 250 miles. An actual distance of 75 miles is represented on the map by a segment measuring what fraction of an inch?

- (A) $\frac{3}{10}$
- (B) $\frac{1}{2}$
- (C) $\frac{3}{4}$
- (D) $\frac{4}{5}$

GO ON TO THE NEXT PAGE.

In the formula $A = \pi r^2$, the constant π represents the ratio

- (A) $\frac{\text{radius}}{\text{diameter}}$
- (B) $\frac{\text{area}}{\text{circumference}}$
- (C) $\frac{\text{circumference}}{\text{radius}}$
- (D) $\frac{\text{circumference}}{\text{diameter}}$

If the side of a square measures $2\frac{7}{8}$ inches, the number of inches in the perimeter of the square is

- (A) $8\frac{17}{64}$
- (B) $9\frac{1}{4}$
- (C) $11\frac{1}{2}$
- (D) $12\frac{3}{4}$

Add:

$$\begin{array}{r} 21^{\circ} 42' 13'' \\ 49^{\circ} 57' 34'' \\ +12^{\circ} 36' 18'' \\ \hline \end{array}$$

- (A) $82^{\circ} 15' 5''$
- (B) $83^{\circ} 16' 5''$
- (C) $84^{\circ} 16' 5''$
- (D) $85^{\circ} 16' 35''$

-4, 0, 6, x

If the average of the four integers shown above is 2, then x =

- (A) 4
- (B) 6
- (C) 8
- (D) 10

17. How many square feet of surface area are exposed to the wind by one side of a triangular sail with a base of 8 feet and a height of 10 feet?

- (A) 9
- (B) 18
- (C) 40
- (D) 30

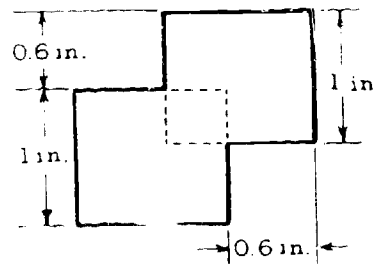

18. Two squares each with side 1 inch overlap as shown above. What is the area in square inches of the region enclosed by the darkened segments?

- (A) 0.72
- (B) 1.84
- (C) 2
- (D) 2.16

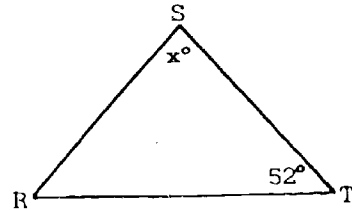

19. In $\triangle RST$ above, if $RS = ST$, then x =

- (A) 52
- (B) 60
- (C) 64
- (D) 76

GO ON TO THE NEXT PAGE.

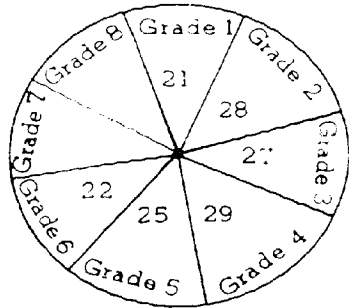

20. The graph above shows the enrollment by grade in a school of 216 students. What is the average enrollment per grade?
- (A) 27
 (B) 26
 (C) 25
 (D) It cannot be determined without knowing the enrollments of grades 7 and 8.

Drill	Diameter
P	$\frac{1}{8}$ inch
Q	$\frac{3}{8}$ inch
R	$\frac{5}{8}$ inch
S	$\frac{7}{8}$ inch

21. Which drill listed in the table above could be used to enlarge a hole 0.378 inches in diameter but could not be used to enlarge a hole 0.629 inches in diameter?
- (A) P
 (B) Q
 (C) R
 (D) S
22. Of the following metric units of length, which is the largest?
- (A) Kilometer
 (B) Hectometer
 (C) Millimeter
 (D) Decameter

23. Subtract:

$$\begin{array}{r} 11 \text{ yards } 2 \text{ feet } 5 \text{ inches} \\ - 7 \text{ yards } 2 \text{ feet } 10 \text{ inches} \\ \hline \end{array}$$

- (A) 3 yards 1 foot 3 inches
 (B) 3 yards 1 foot 7 inches
 (C) 3 yards 2 feet 7 inches
 (D) 4 yards 0 feet 7 inches

24. Multiply:

$$\begin{array}{r} 11 \text{ hours } 20 \text{ minutes } 9 \text{ seconds} \\ \times 8 \\ \hline \end{array}$$

- (A) 3 days 17 hours 47 minutes 12 seconds
 (B) 3 days 18 hours 41 minutes 12 seconds
 (C) 3 days 19 hours 36 minutes 22 seconds
 (D) 3 days 21 hours 58 minutes 2 seconds
25. In a tank that contains a certain number of cubic yards of gasoline, the number of cubic feet of gasoline is how many times the number of cubic yards?
- (A) 3
 (B) 9
 (C) 12
 (D) 27
26. Which of the following figures has the smallest area?

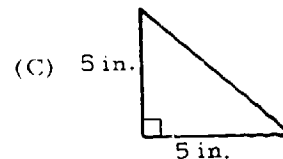
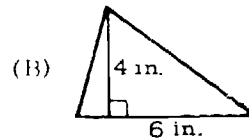
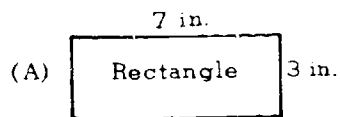

If the degree measures of the three angles of a triangle are equal, then the three sides of this triangle are

- (A) equal
- (B) perpendicular
- (C) parallel
- (D) unequal

How many millimeters are equal to 4.3 centimeters?

- (A) 0.043
- (B) 0.43
- (C) 43
- (D) 430

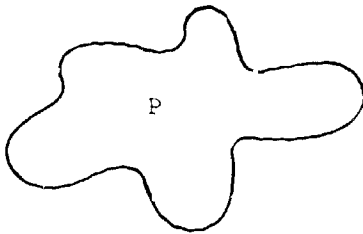

Unit of Area Measure To Scale	Number of Area Units in P
■	32.5
■	26.4
■	21.8
□ R	x

The area of region P above is measured with three different units of measure. The data obtained are shown in the table above. If region P is measured with unit R, which of the following could possibly be the value of x?

- (A) 19.2
- (B) 23.6
- (C) 28.7
- (D) 33.1

30. Divide:

$$6 \overline{) 27 \text{ bushels } 2 \text{ pecks } 2 \text{ quarts}}$$

- (A) 4 bushels 1 peck 6 quarts
- (B) 4 bushels 2 pecks 3 quarts
- (C) 4 bushels 2 pecks 4 quarts
- (D) 4 bushels 3 pecks 2 quarts

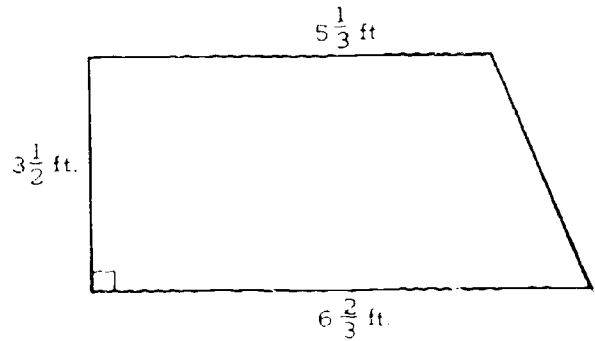

31. What is the area in square feet of the trapezoid-shaped wing shown above?

- (A) 42
- (B) $36\frac{1}{2}$
- (C) $32\frac{1}{3}$
- (D) 21

32. Nine-sixteenths of a pound is

- (A) less than 8 ounces
- (B) equal to 8 ounces
- (C) greater than 8 ounces but less than 9 ounces
- (D) equal to 9 ounces

GO ON TO THE NEXT PAGE.

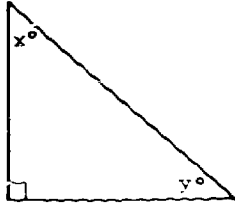

33. In the figure above, $x + y =$

- (A) 180
- (B) 90
- (C) 60
- (D) 45

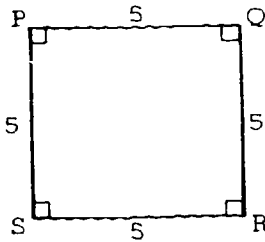

34. In the figure above, $\frac{\text{area of PQRS}}{\text{perimeter PQRS}} =$

- (A) $\frac{1}{2}$
- (B) $\frac{4}{5}$
- (C) $\frac{5}{4}$
- (D) $\frac{2}{1}$

35. If one number-ten can holds 1 quart 14 ounces, what is the total number of quarts and ounces in a dozen number-ten cans?

- (A) 22 quarts 8 ounces
- (B) 20 quarts 12 ounces
- (C) 18 quarts 4 ounces
- (D) 17 quarts 8 ounces

36. A regulation specifies that a room provide 32 cubic feet of air space for each occupant. If a certain room is designed for 36 people and has a floor area of 128 square feet, its height in feet is

- (A) $\frac{15}{2}$ feet
- (B) 8 feet
- (C) 9 feet
- (D) 10 feet

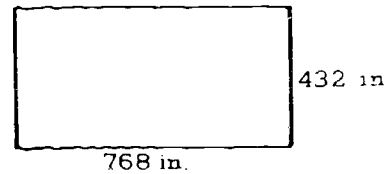

37. The area in square feet of the rectangle above is

- (A) $\frac{768 \times 432}{144}$
- (B) $\frac{768 \times 432}{12}$
- (C) $\frac{768 \times 432}{9}$
- (D) $\frac{768 \times 432}{3}$

38. The measure of an obtuse angle is

- (A) less than 90°
- (B) equal to 90°
- (C) greater than 90° but less than 180°
- (D) greater than 180°

39. A revolving sprinkler wets an area with a diameter of 14 feet. Exactly how many square feet will it wet in one complete revolution? (Use $\frac{22}{7}$ for π .)

- (A) 44
- (B) 88
- (C) 154
- (D) 616

FOOD VALUES FOUND IN RICE

Proteins 15%	Fats 3%	Minerals 7%	Carbohydrates 50%	Water n%	Others 5%
-----------------	------------	----------------	----------------------	-------------	--------------

Note: Figure not drawn to scale

40. In the graph above, the amount of protein found in rice is what fractional part of the amount of water found in rice?
- (A) $\frac{1}{2}$
 - (B) $\frac{3}{4}$
 - (C) $\frac{5}{6}$
 - (D) $\frac{4}{3}$

How many yards of fence are needed to enclose completely a rectangular field that measures 208 feet by $87\frac{1}{2}$ feet?

- (A) $98\frac{5}{6}$
- (B) $99\frac{1}{2}$
- (C) 197
- (D) 591

A rab worth \$2.80 was devalued until it was worth only \$2.40. The dollar value of 100 rabs would be how much less after devaluation than before devaluation?

- (A) \$ 4
- (B) \$24
- (C) \$28
- (D) \$40

What is 140 per cent of 20 pounds 15 ounces?

- (A) 8 pounds 6 ounces
- (B) 28 pounds 5 ounces
- (C) 29 pounds 5 ounces
- (D) 50 pounds 4 ounces

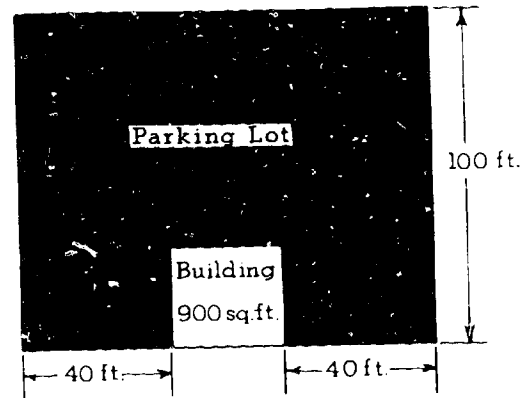

44. The square building in the figure above occupies 900 square feet of a rectangular property. What is the area in square feet of the parking lot?
- (A) 11,000
 - (B) 10,100
 - (C) 8,000
 - (D) 7,100

GO ON TO THE NEXT PAGE.

45. If a cylindrical tank 35 feet high and 12 feet in diameter holds $7\frac{1}{2}$ gallons per cubic foot, what is the total capacity in gallons of the tank? (Volume of a cylinder = $\pi r^2 h$.)

- (A) $(12 \times 35 \times \frac{15}{2}) \pi$
- (B) $(6 \times 6 \times 35 \times \frac{2}{15}) \pi$
- (C) $(6 \times 6 \times 35 \times \frac{15}{2}) \pi$
- (D) $(12 \times 35 \times 35 \times \frac{2}{15}) \pi$

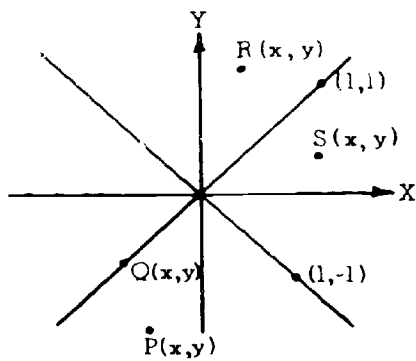

46. In the graph above, for which lettered point is $x < y$?

- (A) P
- (B) Q
- (C) R
- (D) S

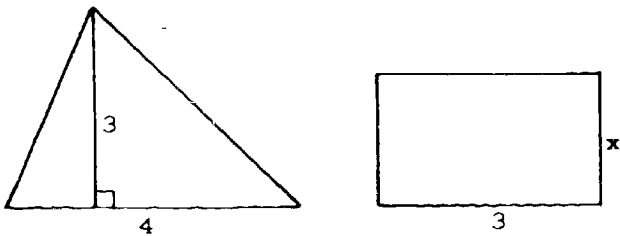

47. If the triangle and rectangle above have equal areas, then $x =$

- (A) 2
- (B) 3
- (C) 4
- (D) 6

207

JANUARY 1 READING IN KILOWATT HOURS

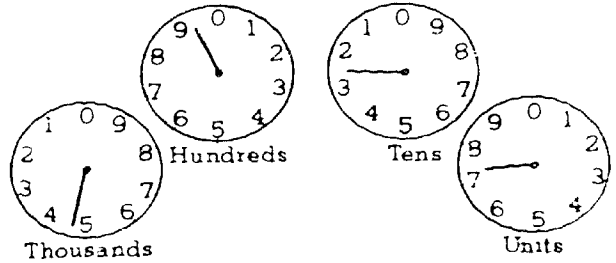

FEBRUARY 1 READING IN KILOWATT HOURS

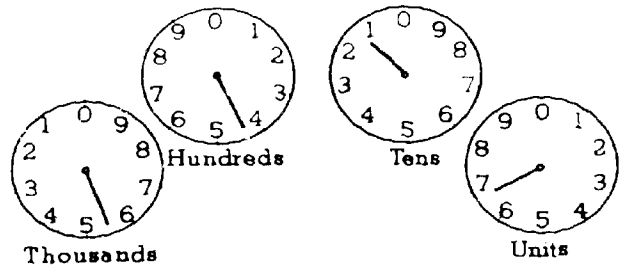

48. The figures above show the electric meter readings on January 1 and February 1. How many kilowatt hours of electricity were used during this period?

- (A) 389
- (B) 489
- (C) 589
- (D) 599

49. If S is the length of one side of a square whose area is equal to its perimeter, then $S =$

- (A) 1
- (B) 2
- (C) 4
- (D) 16

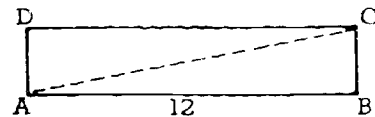

50. In the rectangle above, if diagonal AC is 13 units in length, then the number of square units in the area of $ABCD$ is

- (A) 60
- (B) 78
- (C) 96
- (D) 156

FORM PEC1

ENGLISH II-A (For Phase 2)

Time—40 minutes

YOU ARE TO INDICATE ALL YOUR ANSWERS ON THE SEPARATE ANSWER SHEET. No credit will be given for anything written in the test book. After you have decided which of the suggested answers you want to give for a question, blacken the corresponding space on the answer sheet.

Example:

Chicago is a
(A) state
(B) city
(C) country
(D) continent

Sample Answer

A B C D

Give only one answer to each question; no credit will be given for multiple answers. If you wish to change an answer, erase your first line completely and mark your new choice.

DO NOT OPEN THIS BOOK UNTIL YOU ARE TOLD TO DO SO.

Developed by Educational Testing Service pursuant to a subcontract funded by the U. S. Department of Health, Education, and Welfare, Office of Education.

208

SECTION I

SPELLING

Time—5 minutes

Directions: From each group below, select the word that is misspelled. Then on the answer sheet blacken the corresponding space. If all words in the group are spelled correctly, blacken space D. No group has more than one misspelled word.

- A) accross
B) accident
C) accurate
D) no error
- A) curious
B) pronounce
C) amoung
D) no error
- A) disappear
B) discribe
C) discover
D) no error
- A) climb
B) dumb
C) lamb
D) no error
- A) peach
B) teach
C) speach
D) no error
- A) similar
B) familar
C) calendar
D) no error
- A) through
B) bough
C) cough
D) no error
- A) alright
B) almost
C) altogether
D) no error
9. (A) achieve
(B) believe
(C) recieve
(D) no error
10. (A) surprise
(B) persuade
(C) pursue
(D) no error
11. (A) ioneliness
(B) ninety
(C) courageous
(D) no error
12. (A) comittee
(B) parallel
(C) embarrass
(D) no error
13. (A) hoping
(B) grabing
(C) sleeping
(D) no error
14. (A) said
(B) bread
(C) fed
(D) no error
15. (A) feather
(B) leather
(C) wheather
(D) no error
16. (A) turkies
(B) ladies
(C) enemies
(D) no error

- a) necessary
- b) procession
- c) successful
- d) no error

19. (A) discipline
(B) fascinate
(C) license
(D) no error

- a) knowledge
- b) pledge
- c) privilege
- d) no error

20. (A) truly
(B) sincerely
(C) cruelly
(D) no error

IF YOU FINISH BEFORE TIME IS CALLED, GO ON TO SECTION II.

SECTION II

LANGUAGE

Time—5 minutes

Directions: Each of the questions or incomplete statements below is followed by four suggested answers or completions. Select the one which is best in each case and then blacken the corresponding space on the answer sheet.

23. All of the following are pronounced with the same vowel sound EXCEPT

- (A) rough
- (B) enough
- (C) stuff
- (D) cough

24. In which group are the words arranged from the most general to the most specific?

- (A) dog, terrier, animal, Spot
- (B) Spot, dog, terrier, animal
- (C) animal, dog, terrier, Spot
- (D) terrier, animal, Spot, dog

25. Which of the following words would NOT be found on a dictionary page that begins with glaring and ends with gloat?

- (A) glue
- (B) glaze
- (C) glint
- (D) glen

24. Which of the following is arranged from the fastest way of getting the news to the public to the slowest?

- (A) Motion pictures, television, newspapers, magazines
- (B) Television, newspapers, magazines, motion pictures
- (C) Newspapers, magazines, motion pictures, television
- (D) Magazines, motion pictures, television, newspapers

25. "Our family doctor, Allen Simpson, who bought the old Daniels farm, soon grew tired of the ten-mile drive to the hospital."

What is the complete subject in this sentence?

- (A) Our family doctor,
- (B) Our family doctor, Allen Simpson,
- (C) Our family doctor, Allen Simpson, who bought the old Daniels farm,
- (D) Our family doctor, Allen Simpson, who bought the old Daniels farm, soon grew tired

IF YOU FINISH BEFORE TIME IS CALLED, GO ON TO SECTION III.

SECTION III
ENGLISH EXPRESSION

Time—15 minutes

Directions: Some of the following sentences are correct according to the requirements of standard written English. Some are incorrect. No sentence contains more than one error.

You will find that the error, if any, is underlined and lettered. Assume that all other elements of the sentence are correct and cannot be changed.

If there is an error, select the one underlined part that must be changed in order to make the sentence correct, and mark the corresponding space on the answer sheet.

If there is no error, mark answer space D.

See how these examples are marked:

EXAMPLES	ANSWERS
1. He spoke <u>bluntly</u> and <u>angrily</u> to <u>we</u> spectators. <u>No error</u>	1. <input type="checkbox"/> A <input type="checkbox"/> B <input checked="" type="checkbox"/> C <input type="checkbox"/> D
2. He works every day <u>so that</u> he will be <u>financially</u> independent <u>in</u> his old age. <u>No error</u>	2. <input type="checkbox"/> A <input type="checkbox"/> B <input type="checkbox"/> C <input checked="" type="checkbox"/> D

AS SOON AS YOU UNDERSTAND THE DIRECTIONS, BEGIN WORK ON THE PROBLEMS.

26. Friday was the hottest day of the year, and Morgan
should not of stayed in the sun so long. No error
27. The people which had planned to return home from
the convention by train were stranded by the strike.
No error
28. Marshall asked his brother whether he had
remembered to get the bait? No error
29. Almost everyone who comes to New Orleans vis
the old French Market. No error
30. You may not build a fire on the beach without th
you get permission from the Coast Guard. No
31. If Mr. Briggs would have been quieter, he prob
would have caught more fish. No error
32. Albert had just sat down and began to loosen hi
tie when the doorbell rang. No error

212

Whenever a Northerner hears of the Indian River,
they think immediately of oranges and grapefruit.
No error

Dr. Zhivago continued to write optimistically
even during those troubled times when people
had hardly nothing to eat. No error

Joe and Mark fish in the canal it is the best place
in the county. No error

After the game Coach Turner told the reporters
that the team had played it's best game of the
season. No error

Why would a man insist on staying indoors on a
beautiful spring day? No error

Even though he was starving, the stray dog
could not eat a thing that was offered by either
my wife or I. No error

39. The record album does not belong to Peter's
sister, but the two books are her's. No error

40. Antarctica resembles mars more than it does the
part of the world that we inhabit. No error

41. Robert said to his teacher, "Mr. Francis, I would
like to work on this project all next week."
No error

42. Although Fred is Pauline's twin, his eyes are
much bluer than his sister. No error

43. Only the first of the three launchings were
successful. No error

44. The climate of northern Canada and Alaska is
so severe that very few animals can survive a
typical winter. No error

45. Surfing requires considerable more skill than
most people would imagine. No error

IF YOU FINISH BEFORE TIME IS CALLED, GO ON TO SECTION IV.

SECTION IV

READING

Time—15 minutes

Directions: Each of the questions or incomplete statements below is followed by four suggested answers or completions. Select the one which is best in each case and then blacken the corresponding space on the answer sheet.

46. Plays are usually divided into
- (A) stanzas and cantos
 - (B) acts and scenes
 - (C) verses and choruses
 - (D) paragraphs and chapters
47. Which of the following would be most helpful to someone who is planning an automobile trip?
- (A) An atlas
 - (B) A dictionary
 - (C) An almanac
 - (D) An encyclopedia
48. The time and place of a story's occurrence are called its
- (A) theme
 - (B) setting
 - (C) plot
 - (D) viewpoint
49. "If you are ready and eager to grasp an opportunity before someone else does, you will be successful."
- Which of the following familiar expressions is an accurate restatement of the sentence above?
- (A) The early bird catches the worm.
 - (B) Don't count your chickens before they're hatched.
 - (C) A stitch in time saves nine.
 - (D) We'll cross that bridge when we come to it.
50. Every week Mother makes a careful list of all the things that she needs from the grocery store.
- Mother is
- (A) hungry
 - (B) wasteful
 - (C) efficient
 - (D) informative
51. Miss Roberts had never seen a jacket like the one that Professor Johnson was wearing, and she decided to ask him where he had bought it.
- Miss Roberts spoke to Professor Johnson because
- (A) he was a stranger
 - (B) she was jealous
 - (C) he was her friend
 - (D) she was curious
52. Fred didn't know that the Wagner Building had been torn down, and for a little while he couldn't figure out where he was.
- Fred was
- (A) confused
 - (B) destructive
 - (C) stupid
 - (D) angry
53. Which of the following refers to prose rather than to poetry?
- (A) Verse form
 - (B) Rhyme scheme
 - (C) Metric pattern
 - (D) Topic sentence
54. The turning point or point of highest interest in a story, play, or long narrative poem is known as the
- (A) prologue
 - (B) climax
 - (C) rising action
 - (D) surprise ending
55. Which of the following is probably the best way to begin to understand a poem?
- (A) Read a biography of the poet.
 - (B) Find a list, and interpret the symbols in the poem.
 - (C) Discover the meter and rhyme scheme of the poem.
 - (D) Determine the plain-sense meaning of the poem.
56. All of the following characters appear often in stories EXCEPT
- (A) a cruel stepmother
 - (B) an athletic grandmother
 - (C) a hard-boiled detective
 - (D) an absent-minded professor

Questions 57-60 refer to the following passage. Read the passage carefully and then answer the questions.

I have always wondered at the passion many people have to meet the celebrated. The prestige you acquire by being able to tell your friends that you know famous men proves only that you are yourself of small account. The celebrated develop a technique to deal with the persons they come across. They show the world a mask, often an impressive one, but take care to conceal their real selves. They play the part that is expected of them and with practice learn to play it very well, but you are stupid if you think that this public performance of theirs corresponds with the man within.

In line 1 the word "passion" means most nearly

- A) love
- B) privilege
- C) desire
- D) opportunity

58. Which of the following statements can be supported by the passage?

- (A) The author feels that famous men are easily angered.
- (B) The author dislikes famous men.
- (C) The author has little respect for those who wish to meet famous men.
- (D) The author feels that famous men enjoy their fame.

59. The passage implies all of the following about those who have a passion to meet the celebrated EXCEPT that they are

- (A) stupid
- (B) deceived
- (C) insignificant
- (D) playing a part

60. "The celebrated develop . . ." (line 5)

In a structure such as this, which of the following does NOT indicate that "celebrated" is a noun?

- (A) It is preceded by the and followed by a verb.
- (B) In combination with the ("The celebrated") it can be replaced by "Famous men."
- (C) Its -ed ending usually marks a word as a noun.
- (D) It is used as a subject.

IF YOU FINISH BEFORE TIME IS CALLED, CHECK YOUR WORK ON THIS TEST.

FORM PBC2

ENGLISH III-A (For Phase 3)

Time—40 minutes

YOU ARE TO INDICATE ALL YOUR ANSWERS ON THE SEPARATE ANSWER SHEET. No credit will be given for anything written in the test book. After you have decided which of the suggested answers you want to give for a question, blacken the corresponding space on the answer sheet.

Example:

Chicago is a
(A) state
(B) city
(C) country
(D) continent

Sample Answer

A B C D

Give only one answer to each question; no credit will be given for multiple answers. If you wish to change an answer, erase your first line completely and mark your new choice.

DO NOT OPEN THIS BOOK UNTIL YOU ARE TOLD TO DO SO.

Developed by Educational Testing Service pursuant to a subcontract funded by the U. S. Department of Health, Education, and Welfare, Office of Education.

SECTION I

SPELLING

Time—5 minutes

Directions: From each group below, select the word that is misspelled. Then on the answer sheet blacken the corresponding space. If all words in the group are spelled correctly, blacken space D. No group has more than one misspelled word.

- | | |
|---|---|
| 1. (A) similar
(B) familar
(C) calendar
(D) no error | 9. (A) surprise
(B) persuade
(C) pursue
(D) no error |
| 2. (A) alright
(B) almost
(C) altogether
(D) no error | 10. (A) appearance
(B) attendance
(C) convenience
(D) no error |
| 3. (A) achieve
(B) believe
(C) recieve
(D) no error | 11. (A) heighth
(B) lngth
(C) width
(D) no error |
| 4. (A) disappear
(B) discribe
(C) discover
(D) no error | 12. (A) accommodated
(B) recommended
(C) ommitted
(D) no error |
| 5. (A) discipline
(B) fascinate
(C) license
(D) no error | 13. (A) villain
(B) mariaige
(C) against
(D) no error |
| 6. (A) comittee
(B) parallel
(C) embarrass
(D) no error | 14. (A) cemetary
(B) sanitary
(C) temporary
(D) no error |
| 7. (A) knowledge
(B) pledge
(C) priviledge
(D) no error | 15. (A) convertible
(B) regrettable
(C) illegible
(D) no error |
| 8. (A) equiping
(B) benefiting
(C) dining
(D) no error | 16. (A) necessary
(B) procession
(C) successful
(D) no error |

- (A) sophomore
- (B) atheletic
- (C) extraordinary
- (D) no error

19. (A) loneliness
(B) ninety
(C) courageous
(D) no error

- (A) preferred
- (B) ordered
- (C) occured
- (D) no error

20. (A) fourty
(B) thorough
(C) flour
(D) no error

IF YOU FINISH BEFORE TIME IS CALLED, GO ON TO SECTION II.

SECTION II
LANGUAGE

Time—5 minutes

Directions: Each of the questions or incomplete statements below is followed by four suggested answers or completions. Select the one which is best in each case and then blacken the corresponding space on the answer sheet.

1. Our family doctor, Allen Simpson, who bought the old Daniels farm, soon grew tired of the ten-mile drive to the hospital.
What is the complete subject in this sentence?
(A) Our family doctor.
(B) Our family doctor, Allen Simpson.
(C) Our family doctor, Allen Simpson, who bought the old Daniels farm.
(D) Our family doctor, Allen Simpson, who bought the old Daniels farm, soon grew tired
2. In preparing a report on a young dramatist who has just had his first play produced on Broadway, which of the following sources would probably be most helpful?
(A) Current Biography
(B) Encyclopaedia Britannica
(C) The card catalogue
(D) Who's Who in America
23. Which of the following sentences is most similar in structure to "I brought her a book for her birthday"?
(A) I think she has gone away for her vacation.
(B) I called her a coward for her behavior.
(C) I bought a new car for my birthday.
(D) I read her a story in the evening.
24. Which of the following terms is LEAST emotional in connotation?
(A) Demagogue
(B) Journalist
(C) Political hack
(D) Horse doctor
25. In which group are the words arranged from the most general to the most specific?
(A) dog, terrier, animal, Spot
(B) Spot, dog, terrier, animal
(C) animal, dog, terrier, Spot
(D) terrier, animal, Spot, dog

IF YOU FINISH BEFORE TIME IS CALLED, GO ON TO SECTION III.

SECTION III
ENGLISH EXPRESSION

Time—15 minutes

Directions: Some of the following sentences are correct according to the requirements of standard written English. Some are incorrect. No sentence contains more than one error.

You will find that the error, if any, is underlined and lettered. Assume that all other elements of the sentence are correct and cannot be changed.

If there is an error, select the one underlined part that must be changed in order to make the sentence correct, and mark the corresponding space on the answer sheet.

If there is no error, mark answer space D.

See how these examples are marked.

EXAMPLES	ANSWERS
<p>1. He spoke <u>bluntly</u> and <u>angrily</u> to <u>we</u> <div style="display: flex; justify-content: space-around; width: 100%;"> A B C </div> spectators. <u>No error</u> <div style="display: flex; justify-content: space-around; width: 100%;"> D </div> </p>	<p>1. <input type="checkbox"/> <input type="checkbox"/> <input checked="" type="checkbox"/> <input type="checkbox"/></p>
<p>2. He works every day <u>so that he will</u> <div style="display: flex; justify-content: space-around; width: 100%;"> A </div> be <u>financially</u> independent <u>in his</u> <div style="display: flex; justify-content: space-around; width: 100%;"> B C </div> old age. <u>No error</u> <div style="display: flex; justify-content: space-around; width: 100%;"> D </div> </p>	<p>2. <input type="checkbox"/> <input type="checkbox"/> <input type="checkbox"/> <input checked="" type="checkbox"/></p>

AS SOON AS YOU UNDERSTAND THE DIRECTIONS, BEGIN WORK ON THE PROBLEMS.

26. After the game Coach Turner told the reporters

A

that the team had played it's best game of the season.

B
C

No error

D

27. The requisites needed for a successful

A

whaling voyage always included a sound ship,

B

courageous men, and a year's supply of food.

C

No error

D

28. According to the policeman's report, among the

A
B

missing articles were a tape recorder and two

C

transistor radios. No error

D

29. Surfing requires considerable more skill than

A
B

most people imagine. No error

C
D

30. In all colleges a community of values is createc

A

which students, though differing in their indivi

B
C

beliefs, conform generally to certain institutio
standards. No error

D

GO ON TO THE NEXT PA

31. If Mr. Briggs would have been quieter, he probably
 would have caught more fish. No error
 A B C D
32. Because Ferguson has not been well all week, the
 doctor will forbid him to play in the game against
 Georgia Tech. No error
 A B C D
33. Friday was the hottest day of the year, and Morgan
 should not of stayed in the sun so long. No error
 B C D A
34. The men who huddled in the corner of the
 cell, knowing that they were going to die at
 sunrise. No error
 A B C D
35. Although Miss Swenson did not usually drink milk,
 she admitted that it tasted delicious on a hot after-
 noon. No error
 A B C D
36. Although Fred is Pauline's twin, his eyes are much
 bluer than his sister. No error
 C D A B
37. The educated youngster of today, pampered by
 parents and teachers alike, are least afflicted with
 the drudgery of providing the essentials of human
 existence. No error
 A B C D
38. Dr. Zhivago continued to write optimistically
even during those troubled times when people
 had hardly nothing to eat. No error
 A B C D
39. The jet almost flew halfway across the Pacific
before the pilot or copilot was aware of the leak
 in the hydraulic system. No error
 A B C D
40. The problem is not in deciding which subject to
 study first, but to find the time to study at all.
No error
 A B C D
41. Even though he was starving, the stray dog
would not eat a thing that was offered by either
 my wife or I. No error
 A B C D
42. On his first day at Dayton High School, Jack saw
 many of his old friends from elementary school
 and Mr. White, his new teacher, was there, too.
No error
 A B C D
43. In Fitzgerald's novel, "This Side of Paradise,"
it presents a picture of a young man's search
 for happiness and security in a world of shifting
 values. No error
 A B C D
44. Professor Anderson's survey revealed that a
 student's reasons for reading are as numerous as
their reasons for doing anything else. No error
 A B C D
45. Although William Shakespeare is quoted
more than any author, he is commonly read
only in academic circles. No error
 A B C D

IF YOU FINISH BEFORE TIME IS CALLED, GO ON TO SECTION IV.

SECTION IV
LITERATURE

Time—15 minutes

Directions: Each of the questions or incomplete statements below is followed by four suggested answers or completion. Select the one which is best in each case and then blacken the corresponding space on the answer sheet.

46. The time and place of a story's occurrence are called its
(A) theme (B) setting (C) plot (D) viewpoint
47. The moan of doves in immemorial elms,
And murmuring of innumerable bees
These lines are notable for their use of
(A) simile (B) hyperbole
(C) allusion (D) onomatopoeia
50. From the passage we can assume that those who meet the celebrated are all of the following EXCEPT
(A) stupid (B) deceived
(C) insignificant (D) playing a part
51. Which of the following statements can be supported by the passage?
(A) The author feels that famous men are easily angered.
(B) The author dislikes famous men.
(C) The author has little respect for those who wish to meet famous men.
(D) The author feels that famous men enjoy their fame.

Questions 48-51 refer to the following passage. Read the passage carefully and then answer the questions.

- I have always wondered at the passion many people have to meet the celebrated. The prestige you acquire by being able to tell your friends that you know famous men proves only that you are yourself of small account. The celebrated develop a technique to deal with the persons they come across. They show the world a mask, often an impressive one, but take care to conceal their real selves. They play the part that is expected of them and with practice learn to play it very well, but you are stupid if you think that this public performance of theirs corresponds with the man within.
- (5) self of small account. The celebrated develop a technique to deal with the persons they come across. They show the world a mask, often an impressive one, but take care to conceal their real selves. They play the part that is expected of them and (10) with practice learn to play it very well, but you are stupid if you think that this public performance of theirs corresponds with the man within.

48. In line 1 the word "passion" means most nearly
(A) love (B) privilege
(C) desire (D) opportunity
49. "The celebrated develop . . ." (line 5)
In a structure such as this, which of the following does NOT indicate that "celebrated" is a noun?
(A) It is preceded by the and followed by a verb.
(B) In combination with the ("The celebrated") it can be replaced by "Famous men."
(C) Its -ed ending usually marks a word as a noun.
(D) It is used as a subject.

GO ON TO THE NEXT PAGE

2. "I shall have more to say when I am dead" is an example of
- (A) paradox (B) satire
(C) flash back (D) cliché

53. Which of the following comes closest to the meaning of "To live on in mankind is far more than to live in a name"?
- (A) Names really mean nothing.
(B) It is better to be alive than to be dead.
(C) People quickly forget a person after his death.
(D) Accomplishments are more important than reputations.

Questions 54-56 refer to the following poem. Read the poem carefully and then answer the questions.

The Eagle

He clasps the crag with crooked hands;
Close to the sun in lonely lands,
Ringed with the azure world, he stands.

The wrinkled sea beneath him crawls;
He watches from his mountain walls,
And like a thunderbolt he falls.

54. The poem makes use of all of the following poetic devices EXCEPT
- (A) hyperbole (B) alliteration
(C) personification (D) allusion
55. The "azure world" (line 3) is the
- (A) sky (B) cliff (C) nest (D) sea
56. Which of the following words best describes the impression created by the poem?
- (A) Despair (B) Power
(C) Laziness (D) Benevolence

-
57. Which of the following is probably the best way to begin to understand a poem?
- (A) Read a biography of the poet.
(B) Find, list, and interpret the symbols in the poem.
(C) Discover the meter and rhyme scheme of the poem.
(D) Determine the "plain-sense" meaning of the poem.

GO ON TO THE NEXT PAGE.

Questions 58-63 refer to the following passage. Read the passage carefully and then answer the questions.

A friend of mine has an electric fence round a piece of his land, and keeps two cows there. I asked him one day how he liked his fence and whether it cost much to operate. "Doesn't cost a damn thing,"

- (5) he replied. "As soon as the battery ran down I unhooked it and never put it back. That strand of fence wire is as dead as a piece of string, but the cows don't go within ten feet of it. There's no need to watch 'em anymore. They learned their lesson the first few days."

- (10) Apparently this state of affairs is general throughout the United States. Thousands of cows are living in fear of a strand of wire which no longer has the power to confine them. Freedom is theirs for the asking. Rise up, cows! Take your liberty while despots snore. And rise up too, all people in bondage everywhere! The wire is dead, the trick is exhausted. Come on out!

58. Which of the following statements best defines the relationship of paragraph 2 to paragraph 1 ?
- (A) Paragraph 2 presents specific examples of concepts developed in paragraph 1.
 (B) Paragraph 2 generalizes from the specific example in paragraph 1.
 (C) Paragraph 2 narrows the meaning of paragraph 1.
 (D) Paragraph 2 reverses the meaning of paragraph 1.
59. Which of the following best describes the theme of this passage?
- (A) Conformity (B) Escape
 (C) Farming (D) Fences

60. The attitude of the farmer is best described as
 (A) cynical (B) smug (C) lazy (D) cruel
61. As used in this passage, "Take your liberty" (line 15) implies that people
 (A) are free but do not realize that they are
 (B) must be willing to fight for their freedom
 (C) should question arbitrary restraints
 (D) must assume responsibility for their condition
62. In line 11, the word "general" functions as
 (A) the object of the verb "is"
 (B) an adjective modifying "this state of affairs"
 (C) a predicate nominative
 (D) an adverb modifying "throughout"
63. The meaning of the last two sentences: "The wire is dead, the trick is exhausted. Come on out!" best conveyed by which of the following statements?
 (A) Men cannot be controlled by mere devices.
 (B) Men need not fear the things that are used to restrain animals.
 (C) People who take action will find their fears groundless.
 (D) People can attain their freedom, for despots are inefficient.

GO ON TO THE NEXT PAGE

64. Passage to India!
Struggles of many a captain, tales of many a sailor dead,
Over my mood stealing and spreading they come,
Like clouds and cloudlets in the unreach'd sky.

These lines present an example of

- (A) blank verse (B) literary ballad
(C) free verse (D) narrative prose

65. The turning point or point of highest interest in a story, play, or long narrative poem is known as the

- (A) prologue (B) climax
(C) rising action (D) surprise ending

IF YOU FINISH BEFORE TIME IS CALLED, CHECK YOUR WORK ON THIS TEST.

FORM PBC3

ENGLISH IV-A (For Phase 4)

Time—40 minutes

YOU ARE TO INDICATE ALL YOUR ANSWERS ON THE SEPARATE ANSWER SHEET. No credit will be given for anything written in the test book. After you have decided which of the suggested answers you want to give for a question, blacken the corresponding space on the answer sheet.

Example:

Chicago is a

- (A) state
- (B) city
- (C) country
- (D) continent

Sample Answer

A	B	C	D
<input type="checkbox"/>	<input checked="" type="checkbox"/>	<input type="checkbox"/>	<input type="checkbox"/>

Give only one answer to each question; no credit will be given for multiple answers. If you wish to change an answer, erase your first line completely and mark your new choice.

DO NOT OPEN THIS BOOK UNTIL YOU ARE TOLD TO DO SO.

Developed by Educational Testing Service pursuant to a subcontract funded by the U. S. Department of Health, Education, and Welfare, Office of Education.

SECTION 1
LANGUAGE

Time—10 minutes

Directions: Each of the questions or incomplete statements below is followed by four suggested answers or completions. Select the one which is best in each case and then blacken the corresponding space on the answer sheet.

- 1. Which group contains words that are Latin borrowings?
(A) magnum, canine, data
(B) prologue, synthetic, pentagon
(C) eerie, awkward, friendly
(D) patio, mesa, tomato
- 2. Which of the following will NOT transform The roses are blooming. into a dependent clause?
(A) Because (B) When (C) If (D) But
- 3. In preparing a report on a young dramatist who has just had his first play produced on Broadway, which of the following sources would probably be most helpful?
(A) Current Biography
(B) Encyclopaedia Britannica
(C) The card catalogue
(D) Who's Who in America

- 7. Which of the following has a derivational rather than an inflectional ending?
(A) man's (B) girlish
(C) climbed (D) oxen
- 8. I. The girl who played jazz was dropped from the band.
II. The girl, who played jazz, was dropped from the band.

Which of the following is NOT a reasonable conclusion to be drawn from the sentences above?

- (A) In I, more than one girl was in the band.
- (B) In II, more than one girl was in the band.
- (C) In I, the girl may have been dropped because she played jazz.
- (D) In II, the girl may have been dropped merely because she was a girl.

Questions 9-10 refer to the following dictionary entry. Read the entry carefully and then answer the questions.

cal·i·co \kal·i·ko\ n, pl calicoes or calicos
[Calicut, India] 1 a: cotton cloth imported from India
b Brit: a plain white cotton fabric that is heavier than muslin c: any of various cheap cotton fabrics with figured patterns 2: a blotched or spotted animal (as a piebald horse) —calico adj

- 4. Expressions such as scratch the launch, release the umbilical cord, and go up in the cherry picker are examples of
(A) portmanteau words
(B) occupational idiom
(C) folk etymology
(D) euphemisms
- 5. Our family doctor, Allen Simpson, who bought the old Daniels farm, soon grew tired of the ten-mile drive to the hospital.
What is the complete subject in this sentence?
(A) Our family doctor,
(B) Our family doctor, Allen Simpson,
(C) Our family doctor, Allen Simpson, who bought the old Daniels farm,
(D) Our family doctor, Allen Simpson, who bought the old Daniels farm, soon grew tired
- 6. Which of the following sentences is most similar in structure to "I brought her a book for her birthday"?
(A) I think she has gone away for her vacation.
(B) I called her a coward for her behavior.
(C) I bought a new car for my birthday.
(D) I read her a story in the evening.

- 9. This dictionary entry is most likely to be found on a page which has as its first and last words
(A) calculate and call
(B) cauldron and ceiling
(C) cackle and cairn
(D) California and calypso

- 10. This dictionary entry indicates all of the following about calico EXCEPT that it
(A) may be used as either a noun or an adjective
(B) has a more specific meaning in England than in the United States
(C) is pronounced differently in England, India, and the United States
(D) has two acceptable spellings for the plural form

IF YOU FINISH BEFORE TIME IS CALLED, GO ON TO SECTION II.

SECTION II
ENGLISH EXPRESSION

Time—10 minutes

Directions: Some of the following sentences are correct according to the requirements of standard written English. Some are incorrect. No sentence contains more than one error.

You will find that the error, if any, is underlined and lettered. Assume that all other elements of the sentence are correct and cannot be changed.

If there is an error, select the one underlined part that must be changed in order to make the sentence correct, and mark the corresponding space on the answer sheet.

If there is no error, mark answer space D.

See how these examples are marked:

EXAMPLES	ANSWERS
1. He spoke <u>bluntly</u> and <u>angrily</u> to <u>we</u> A B C spectators. <u>No error</u> D	1. A B C D <input type="checkbox"/> <input type="checkbox"/> <input checked="" type="checkbox"/> <input type="checkbox"/>
2. He works every day <u>so that he will</u> A be <u>financially</u> independent <u>in his</u> B C old age. <u>No error</u> D	2. A B C D <input type="checkbox"/> <input type="checkbox"/> <input type="checkbox"/> <input checked="" type="checkbox"/>

AS SOON AS YOU UNDERSTAND THE DIRECTIONS, BEGIN WORK ON THE PROBLEMS.

11. We often came upon the animal's tracks, but we were never able to discover it's lair. No error

2. According to the foreman, the reason for all the accidents are the lack of safety devices on the high-speed machinery. No error

3. The problem is not in deciding which subject to study first, but to find the time to study at all. No error

4. The reputation of a writer usually declines soon after his death; Faulkner, however, is still placed highly on the list of great American writers. No error

5. Fleming discovered penicillin not because he was hunting for it, but because he became curious about something he had observed. No error

6. The requisites needed for a successful whaling voyage included a sound ship, courageous men, and a year's supply of food. No error

7. Because we were nervous and inexperienced, the director wanted Joan and I to arrive before the other members of the cast. No error

8. Robert Frost was the kind of a man who saw cosmic implications in the most ordinary events. No error

19. Making a road in colonial days consisted of clearing fallen timber, marking the trail, and laying logs over swampy places. No error

20. "Aren't you even going to try?" asked Dr. Green? No error

21. The Millers spent their vacation at Cape Cod because their neighbors had such a good time at Hyannis the previous summer. No error

22. On his first day at Dayton High School, Jack saw many of his old friends from elementary school and Mr. White, his new teacher, was there, too. No error

23. Although William Shakespeare is quoted more than any author, he is commonly read only in academic circles. No error

24. In all colleges a community of values is created in which students, though differing in their individual beliefs, conform generally to certain institutional standards. No error

25. Having stepped out of bounds at the five-yard line, the halfback's touchdown was nullified. No error

26. "I don't know," said Mr. Borstal, "why you will not learn that 'deer' has the same form in the plural." No error

228

27. The students selected for the special program
 were those who had demonstrated their competence
A B
 through interviews, compositions, or by being
C
examined. No error
(C) D

28. To the inexperienced visitor, New York presents
 three major problems: finding one's way on the
A B
 subway, discovering an inexpensive restaurant,
C
 and getting across town at five o'clock. No error
D

29. The educated youngster of today, pampered by
 parents and teachers alike, are least afflicted
A B
 with the drudgery of providing the essentials of
C
 human existence. No error
D

30. The jet almost flew halfway across the Pacific
A
before the pilot or copilot was aware of the leak
B C
 in the hydraulic system. No error
D

IF YOU FINISH BEFORE TIME IS CALLED, GO ON TO SECTION III.

SECTION III
LITERATURE

Time—20 minutes

Directions: Each of the questions or incomplete statements below is followed by four suggested answers or completions. Choose the one which is best in each case and then blacken the corresponding space on the answer sheet.

The turning point in a narrative is usually called the

- (A) epilogue (B) finale
(C) exposition (D) climax

"I shall have more to say when I am dead" is an example of

- (A) paradox (B) satire
(C) flash back (D) cliché

"Sweet Love, where can I find thee?" presents an illustration of

- (A) alliteration (B) allusion
(C) apostrophe (D) assonance

Which of the following comes closest to the meaning of "To live on in mankind is far more than to live in a name"?

- (A) Names really mean nothing.
(B) It is better to be alive than to be dead.
(C) People quickly forget a person after his death.
(D) Accomplishments are more important than reputations.

Questions 35-37 refer to the following passage. Read the passage carefully and then answer the questions.

When I had found one body cast upon the shore, it would affect me more. I sympathized rather with the wind and waves, as if to toss and mangle these poor human bodies was the order of the day. I saw that miseries might be multiplied, as on the field of battle, but they no longer affected us in any degree as exceptions from the common lot of humanity.

It is the individual and private that demands our sympathy. A man can attend but one funeral in the course of his life, can behold but one corpse.

The speaker is less affected than he might be because he

- (A) is not personally involved
(B) sees so many corpses
(C) has often seen death before
(D) believes that death is useful

36. Where was the speaker when he confronted death?

- (A) On a beach (B) In a graveyard
(C) On a battlefield (D) In a chapel

37. What is the main point of the second paragraph?

- (A) Death is such a common experience that it has no meaning.
(B) A man cannot bear to behold death more than once.
(C) Man is not concerned if many people die at one time.
(D) Death has its greatest impact upon us when we consider one death.

38. All of the following are stock characters EXCEPT

- (A) a faithful servant
(B) an absent-minded professor
(C) a hard-boiled detective
(D) a kind stepmother

Questions 39-41 refer to the following poem. Read the poem carefully and then answer the questions.

No egg on Friday Alph will eat,
But drunken he will be
On Friday still. Oh, what a pure
Religious man is he!

39. Which of the following best describes the tone of the poem?

- (A) Indulgent (B) Sarcastic
(C) Moralistic (D) Unconcerned

40. Why does Alph refrain from eating eggs on Friday?

- (A) He does not like eggs.
(B) His drunkenness keeps him from eating anything.
(C) His faith restricts his diet on Friday.
(D) He will eat them, but only if he gets drunk first.

41. What word can be substituted for "pure" to make the poem state what it now implies?

- (A) Sham (B) True (C) Foolish (D) Holy

42. A paragraph that reports a series of events is most likely to use the words in which group?
- (A) Probably, apparently, certainly
 (B) Although, because, therefore
 (C) Above, below, alongside
 (D) Then, next, last

Questions 43-48 refer to the following passage. Read the passage carefully and then answer the questions.

- A friend of mine has an electric fence round a piece of his land, and keeps two cows there. I asked him one day how he liked his fence and whether it cost much to operate. "Doesn't cost a damn thing," he replied. "As soon as the battery ran down I unhooked it and never put it back. That strand of fence wire is as dead as a piece of string, but the cows don't go within ten feet of it. There's no need to watch 'em anymore. They learned their lesson the first few days."
- (5) (10)

- Apparently this state of affairs is general throughout the United States. Thousands of cows are living in fear of a strand of wire which no longer has the power to confine them. Freedom is theirs for the asking. Rise up, cows! Take your liberty while despots snore. And rise up too, all people in bondage everywhere! The wire is dead, the trick is exhausted. Come on out!
- (15)
43. Which of the following statements best defines the relationship of paragraph 2 to paragraph 1 ?
- (A) Paragraph 2 presents specific examples of concepts developed in paragraph 1.
 (B) Paragraph 2 generalizes from the specific example in paragraph 1.
 (C) Paragraph 2 narrows the meaning of paragraph 1.
 (D) Paragraph 2 reverses the meaning of paragraph 1.

44. Which of the following best describes the theme of this passage?

(A) Conformity (B) Escape
 (C) Farming (D) Fences

45. The attitude of the farmer is best described as
- (A) cynical (B) smug (C) lazy (D) cruel

46. As used in this passage, "Take your liberty" (lines 15-16) implies that people
- (A) are free but do not realize that they are
 (B) must be willing to fight for their freedom
 (C) should question arbitrary restraints
 (D) must assume responsibility for their conditions

47. In line 11, the word "general" functions as
- (A) the object of the verb "is"
 (B) an adjective modifying "this state of affairs"
 (C) a predicate nominative
 (D) an adverb modifying "throughout"

48. The meaning of the last two sentences: "The wire is dead, the trick is exhausted. Come on out!" is best conveyed by which of the following statements?
- (A) Men cannot be controlled by mere devices.
 (B) Men need not fear the things that are used to restrain animals.
 (C) People who take action will find their fears groundless.
 (D) People can attain their freedom, for despots are inefficient.

49. The moan of doves in immemorial elms,
 And murmuring of innumerable bees

These lines are notable for their use of

(A) simile (B) hyperbole
 (C) allusion (D) onomatopoeia

50. Passage to India!
 Struggles of many a captain, tales of many a sailor dead,
 Over my mood stealing and spreading they come
 Like clouds and cloudlets in the unreach'd sky.

These lines present an example of

(A) blank verse
 (B) literary ballad
 (C) free verse
 (D) narrative prose

GO ON TO THE NEXT PAGE

Questions 51-54 refer to the following poem. Read the poem carefully and then answer the questions.

I see them in foul dug-outs, gnawed by rats,
And in ruined trenches, lashed by rain,
Dreaming of things they did with balls and bats,
And mocked by hopeless longing to regain
Bank-holidays, and picture shows, and spats,
And going to the office on the train.

Who are the "them" referred to in line 1 ?

- (A) Baseball players (B) Soldiers
- (C) Indians (D) Commuters

Line 4 provides an example of which of the following?

- (A) Personification (B) Symbolism
- (C) Internal rhyme (D) Metonymy

- 53. In this poem, "going" (line 6) functions as
 - (A) an object of the preposition by, as does longing
 - (B) a modifier of the pronoun them, as does Dreaming
 - (C) an object of the preposition with, as are balls and bats
 - (D) an object of the infinitive to regain, as are Bank-holidays, picture shows, and spats

- 54. Which of the following is NOT true about bank holidays, picture shows, spats, and going to the office on the train as they are used in this poem?
 - (A) They indicate social and financial security.
 - (B) They symbolize good times.
 - (C) They indicate the high morale of the dreamers.
 - (D) They represent peace to the dreamers.

-
- 55. "There is one thing in the world worse than being talked about, and that is not being talked about" is an example of an
 - (A) anecdote (B) epigram
 - (C) anagram (D) epitaph

IF YOU FINISH BEFORE TIME IS CALLED, CHECK YOUR WORK ON THIS TEST.

FORM QBC1

ENGLISH II-B (For Phase 2)

Time—40 minutes

YOU ARE TO INDICATE ALL YOUR ANSWERS ON THE SEPARATE ANSWER SHEET. No credit will be given for anything written in the test book. After you have decided which of the suggested answers you want to give for a question, blacken the corresponding space on the answer sheet.

Example:

Chicago is a

- (A) state
- (B) city
- (C) country
- (D) continent

Sample Answer

A	B	C	D
<input type="checkbox"/>	<input checked="" type="checkbox"/>	<input type="checkbox"/>	<input type="checkbox"/>

Give only one answer to each question; no credit will be given for multiple answers. If you wish to change an answer, erase your first line completely and mark your new choice.

DO NOT OPEN THIS BOOK UNTIL YOU ARE TOLD TO DO SO.

Developed by Educational Testing Service pursuant to a subcontract funded by the U. S. Department of Health, Education, and Welfare, Office of Education.

234

SECTION I
SPELLING

Time—5 minutes

Directions: From each group below, select the word that is misspelled. Then on the answer sheet blacken the corresponding space. If all words in the group are spelled correctly, blacken space D. No group has more than one misspelled word.

- (A) surely
 - (B) remotely
 - (C) extremely
 - (D) no error
- (A) goddess
 - (B) wellfare
 - (C) until
 - (D) no error
- (A) which
 - (B) where
 - (C) when
 - (D) no error
- (A) average
 - (B) beverege
 - (C) college
 - (D) no error
- (A) stretch
 - (B) pitch
 - (C) attatch
 - (D) no error
- (A) laundry
 - (B) complimentary
 - (C) surgery
 - (D) no error
- (A) scream
 - (B) dream
 - (C) gleam
 - (D) no error
- (A) vegetable
 - (B) athelete
 - (C) mathematics
 - (D) no error
- 9. (A) excape
 - (B) excuse
 - (C) exceed
 - (D) no error
- 10. (A) dried
 - (B) spied
 - (C) ride
 - (D) no error
- 11. (A) article
 - (B) specticle
 - (C) particle
 - (D) no error
- 12. (A) forteen
 - (B) fifteen
 - (C) sixteen
 - (D) no error
- 13. (A) designate
 - (B) resign
 - (C) asignment
 - (D) no error
- 14. (A) document
 - (B) argument
 - (C) monument
 - (D) no error
- 15. (A) distroy
 - (B) divine
 - (C) divide
 - (D) no error

GO ON TO THE NEXT PAGE.

- 16. (A) quality
(B) quilt
(C) quantity
(D) no error
- 17. (A) safely
(B) sincerely
(C) wholly
(D) no error
- 18. (A) peculiar
(B) nucular
(C) regular
(D) no error

- 19. (A) duel
(B) mule
(C) fuel
(D) no error
- 20. (A) friend
(B) siege
(C) wierd
(D) no error

IF YOU FINISH BEFORE TIME IS CALLED, GO ON TO SECTION II.

SECTION II
LANGUAGE

Time--10 minutes

Directions: Each of the questions or incomplete statements below is followed by four suggested answers or completions. Select the one which is best in each case and then blacken the corresponding space on the answer sheet.

1. Which of the following words has the same vowel sound as rough?

- (A) staff
- (B) froth
- (C) gruff
- (D) cliff

2. The children in the audience squirmed uncomfortably and waited for the play to begin.

What is the complete subject in this sentence?

- (A) The children
- (B) The children in the audience
- (C) The children in the audience squirmed uncomfortably and waited
- (D) The children in the audience squirmed uncomfortably and waited for the play

All of the following words would be found on a dictionary page that begins with rotary and ends with roulette EXCEPT

- (A) roster
- (B) rotten
- (C) rough
- (D) rotor

Dwelling is a neutral description of the place where someone lives. Shack is a negative description. Which of the following is the most positive description?

- (A) Hut
- (B) Building
- (C) Mansion
- (D) Lodging

A person will use princess rather than prince when he

- (A) wants to show possession
- (B) is referring to more than one person
- (C) wants to change the noun into an adjective
- (D) is referring to a woman

26. I. Where did you meet your new friend, Mabel?
II. Where did you meet your new friend Mabel?

Which of the following is a reasonable conclusion to draw from the sentences above?

- (A) Mabel is addressed in I, talked about in II.
- (B) Mabel is talked about in I, addressed in II.
- (C) Mabel is addressed in both I and II.
- (D) Mabel is talked about in both I and II.

27. Which of the following is NOT a pair of homonyms?

- (A) meet. . meat
- (B) flee. . flea
- (C) deed. . dead
- (D) feet. . feat

28. The referee was booed vigorously by a few of the spectators.

The sentence above is a passive of which of the following?

- (A) The referee booed a few of the spectators vigorously.
- (B) A few of the spectators were booed vigorously by the referee.
- (C) The spectators were booed vigorously by a few of the referees.
- (D) A few of the spectators booed the referee vigorously.

29. Bypass is made up of a combination of words. Which of the following combines the same kinds of words in the same way?

- (A) Railroad
- (B) Overthrow
- (C) Dugout
- (D) Evergreen

30. Adding an e to the end of hid will

- (A) change the pronunciation of the interior vowel
- (B) create a different part of speech
- (C) change the pronunciation of the final consonant
- (D) create a two-syllable word



SECTION III
ENGLISH EXPRESSION

Time ~ 10 minutes

Directions: Some of the following sentences are correct according to the requirements of standard written English. Some are incorrect. No sentence contains more than one error.

You will find that the error, if any, is underlined and lettered. Assume that all other elements of the sentence are correct and cannot be changed.

If there is an error, select the one underlined part that must be changed in order to make the sentence correct, and mark the corresponding space on the answer sheet.

If there is no error, mark answer space D.

See how these examples are marked:

EXAMPLES	ANSWERS
1. He spoke <u>bluntly</u> and <u>angrily</u> to <u>we</u> spectators. <u>No error</u>	1. <input type="checkbox"/> A <input type="checkbox"/> B <input checked="" type="checkbox"/> C <input type="checkbox"/> D
2. He works every day <u>so that he will</u> be <u>financially</u> independent <u>in his</u> old age. <u>No error</u>	2. <input type="checkbox"/> A <input type="checkbox"/> B <input type="checkbox"/> C <input checked="" type="checkbox"/> D

AS SOON AS YOU UNDERSTAND THE DIRECTIONS, BEGIN WORK ON THE PROBLEMS.

31. Unfortunately, the team's best center has broke
his ankle. No error

32. Almost every one of those machines have been
damaged at least once by inexperienced operators.
No error

33. Whenever a batter hits a home run, he gains
confidence in his baseball ability. No error

34. The detectives asked Mr. Marks to give them a
exact description of the thief. No error

35. Straining mightily but getting nowhere, the puppies
proved that they were still to young to pull the
sled. No error

36. This here brand of paint is the best that we have
ever used. No error

37. The fumes from the engine gave Maynard one of
the worse headaches he had ever had. No error

The mechanics in Barney's Garage always have
 new business because they have a reputation for
 careful work. No error

You cannot teach a person to ride a horse simply
 by having them read a book. No error

Most universities believe that scholarship money
 should be awarded to the people which need it
 most. No error

Mitchell never forgave his younger brother
 for being able to ride a horse better than him.
No error

Miss Wilder will not leave her third graders
 begin a second book until they have finished
 reading the first. No error

An old saying tells us that a mans' home is his
 castle. No error

The people on Third street were the first to learn
 that the parade had been canceled. No error

45. Unfortunately, the end had ran out of bounds
 before he caught the ball. No error

46. Without them to help us, it would have been
 impossible to repair the barn before the first
 snowfall. No error

47. More than half of the population of the United States,
 is concentrated in the cities. No error

48. Last evening the Downings drove around the block
 several times so that everyone could see there
 new car. No error

49. The arguments presented by Senator Fackler were
 so convincing that he gained the support of an
 overwhelming majority of the voters. No error

50. Many a new driver has come perilously close to
 death because they have not really learned to
 control an automobile. No error

IF YOU FINISH BEFORE TIME IS CALLED, GO ON TO SECTION IV.

SECTION IV

READING

Time—15 minutes

Directions: Each of the questions or incomplete statements below is followed by four suggested answers or completions. Select the one which is best in each case and then blacken the corresponding space on the answer sheet.

51. To set the scene of a story, an author usually tells
- (A) when and where the action takes place
(B) what the characters' names are
(C) what made him write the story
(D) how the story ends
52. Most people considered Jack second to none in surfing.
- Jack was
- (A) afraid to surf alone
(B) first to arrive at the beach
(C) very good at surfing
(D) new at surfing
53. When her mother finished talking to her, Mary stomped up the stairs and slammed the door.
- Mary probably slammed the door because she was
- (A) frightened
(B) angry
(C) careless
(D) lazy
54. At the formal dinner, Hank felt like a fish out of water.
- Hank was
- (A) ill at ease
(B) thirsty
(C) pleased with himself
(D) angry
55. Knowing that Roy would call at any moment, Marge excused herself from the table and stood out near the telephone.
- Marge excused herself from the table because she
- (A) wanted to call up Roy
(B) had heard the telephone ring
(C) felt alone and wanted to talk to somebody
(D) wanted to be the one to answer the telephone
56. When Fred saw all the changes that had taken place, he could hardly believe his eyes.
- _____ was
- (A) blind
(B) amazed
(C) stupid
57. When Mrs. Jones finally finished buying the clothes for all her children, all she could think about was sitting down and getting her shoes off.
- Mrs. Jones was
- (A) tired
(B) hungry
(C) lazy
(D) sad
- Questions 58-59 refer to the following poem. Read the poem carefully and then answer the questions.
- Frenchmen have no ear drums.
Paris is the loveliest city in the world,
Until she opens her mouth.
Should the French go forth to battle, armed only with
taxi horns,
They would drive all before them.
58. In this poem, the poet recalls Paris mainly through the sense of
- (A) smell
(B) sight
(C) touch
(D) hearing
59. Which of the following is the best meaning of "all" (line 5) ?
- (A) The enemy on the battlefield
(B) People who use taxicabs in Paris
(C) Frenchmen in the army
(D) Talkative taxi drivers from Paris
60. No one can expect to be happy all the time.
Which of the following familiar expressions most accurately restates this sentence?
- (A) An ounce of prevention is worth a pound of cure.
(B) Time and tide wait for no man.
(C) All work and no play makes Jack a dull boy.
(D) Into each life a little rain must fall.

GO ON TO THE NEXT PAGE

Questions 61-64 refer to the following passage. Read the passage carefully and then answer the questions.

It rained with thunder on Friday night, but the sun rose hot on Saturday without a cloud. We were at sea—there is no other adequate expression—on the plains of Nebraska. I made my observations from the top of our wagon, and sat shirtless by the door upon that perch to spy about me, and to spy in vain for something new. It was a world almost without a feature; an empty sky, an empty earth. From front and back, the line of the trail stretched from horizon to horizon, like a cue across a billiard table. On either hand, the green plains ran till they touched the skirts of heaven.

Where is the speaker?

- A) On a boat
- B) In a plane
- C) On a wagon
- D) In a billiard parlor

As used in this passage, "to spy" (line 6) means:

- A) to look suspiciously
- B) to gaze absentmindedly
- C) to scan watchfully
- D) to watch secretly

63. The expression "we were at sea . . . on the plains" (lines 2-4) indicates that

- (A) the plains were vast and featureless
- (B) the speaker was riding on a prairie schooner
- (C) the thunderstorm had flooded the plains
- (D) the speaker was sick from the motion of the wagon

64. All of the following contribute to the image of the billiard table (lines 10-11) EXCEPT the

- (A) greenness of the plains
- (B) cloudlessness of the sky
- (C) appearance of the trail
- (D) flatness of the plains

65. A story is called fictional if it

- (A) tells about things that happened long ago
- (B) does not tell about people
- (C) finds fault with something
- (D) tells about things that did not happen in real life

IF YOU FINISH BEFORE TIME IS CALLED, CHECK YOUR WORK ON THIS TEST.

ENGLISH III-B (For Phase 3)

Time—40 minutes

YOU ARE TO INDICATE ALL YOUR ANSWERS ON THE SEPARATE ANSWER SHEET. No credit will be given for anything written in the test book. After you have decided which of the suggested answers you want to give for a question, blacken the corresponding space on the answer sheet.

Example:

Chicago is a

- (A) state
- (B) city
- (C) country
- (D) continent

Sample Answer

A	B	C	D
<input type="checkbox"/>	<input checked="" type="checkbox"/>	<input type="checkbox"/>	<input type="checkbox"/>

Give only one answer to each question; no credit will be given for multiple answers. If you wish to change an answer, erase your first line completely and mark your new choice.

DO NOT OPEN THIS BOOK UNTIL YOU ARE TOLD TO DO SO.

Developed by Educational Testing Service pursuant to a subcontract funded by the U. S. Department of Health, Education, and Welfare, Office of Education.

SECTION 1

SPELLING

Time—5 minutes

Directions: From each group below, select the word that is misspelled. Then on the answer sheet blacken the corresponding space. If all words in the group are spelled correctly, blacken space D. No group has more than one misspelled word.

- | | |
|--|--|
| 1. (A) surely
(B) remotely
(C) extremely
(D) no error | 10. (A) rhythm
(B) crystal
(C) criticism
(D) no error |
| 2. (A) goddess
(B) wellfare
(C) until
(D) no error | 11. (A) article
(B) specticle
(C) partiele
(D) no error |
| 3. (A) disasterous
(B) lustrous
(C) prosperous
(D) no error | 12. (A) permanent
(B) competent
(C) pleasent
(D) no error |
| 4. (A) brilliant
(B) lenient
(C) efficient
(D) no error | 13. (A) designate
(B) resign
(C) asignment
(D) no error |
| 5. (A) stretch
(B) pitch
(C) attatch
(D) no error | 14. (A) document
(B) argument
(C) monument
(D) no error |
| 6. (A) laundry
(B) complimentary
(C) surgery
(D) no error | 15. (A) distroy
(B) divine
(C) divide
(D) no error |
| 7. (A) narrative
(B) primative
(C) figurative
(D) no error | 16. (A) quality
(B) quilt
(C) quaity
(D) no error |
| 8. (A) bookkeeper
(B) fullfill
(C) dissolve
(D) no error | 17. (A) temperamenc
(B) goverment
(C) puzzlement
(D) no error |
| 9. (A) accidentally
(B) practically
(C) artistically
(D) no error | |

- 18. (A) peculiar
- (B) nucular
- (C) regular
- (D) no error

- 19. (A) suspicious
- (B) delicious
- (C) precious
- (D) no error

- 20. (A) undoubtably
- (B) probably
- (C) regrettably
- (D) no error

IF YOU FINISH BEFORE TIME IS CALLED, GO ON TO SECTION II.

SECTION II
LANGUAGE

Time—10 minutes

Directions: Each of the questions or incomplete statements below is followed by four suggested answers or completions. Select the one which is best in each case and then blacken the corresponding space on the answer sheet.

21. pale. . pail
 through. . threw
 pleas. . please
 feet. . feat
- The pairs of words above are
- (A) homonyms
(B) synonyms
(C) antonyms
(D) pseudonyms
22. The children in the audience squirmed uncomfortably and waited for the play to begin.
- What is the complete subject in this sentence?
- (A) The children
(B) The children in the audience
(C) The children in the audience squirmed uncomfortably and waited
(D) The children in the audience squirmed uncomfortably and waited for the play
23. He is the short plumber's helper.
- Which of the following is an accurate explanation of the problem presented by the sentence above?
- (A) Short is an adjective, but the sentence calls for the adverb shortly.
(B) In plumber's, the apostrophe is in the wrong place.
(C) The verb does not agree in number with the subject.
(D) In its written form the sentence can mean two different things.
24. Dwelling is a neutral description of the place where someone lives. Shack is a negative description. Which of the following is the most positive description?
- (A) Hut
(B) Building
(C) Mansion
(D) Lodging
25. i. Maxwell, the electrician, answered as soon as we called.
 ii. The man, who was called Maxwell, answered immediately.
- Which of the sentences above contain(s) an appositive?
- (A) I only
(B) II only
(C) Both I and II
(D) Neither I nor II
26. i. Where did you meet your new friend, Mabel?
 ii. Where did you meet your new friend Mabel?
- Which of the following is a reasonable conclusion to draw from the sentences above?
- (A) Mabel is addressed in I, talked about in II.
(B) Mabel is talked about in I, addressed in II.
(C) Mabel is addressed in both I and II.
(D) Mabel is talked about in both I and II.
27. All of the following are portmanteau (blend) words EXCEPT
- (A) brunch
(B) bookshelf
(C) motel
(D) smog
28. The referee was booed vigorously by a few of the spectators.
- The sentence above is a passive of which of the following?
- (A) The referee booed a few of the spectators vigorously.
(B) A few of the spectators were booed vigorously by the referee.
(C) The spectators were booed vigorously by a few of the referees.
(D) A few of the spectators booed the referee vigorously.

29. Bypass is made up of a combination of words. Which of the following combines the same kinds of words in the same way?
- (A) Railroad
 - (B) Overthrow
 - (C) Dugout
 - (D) Evergreen
30. All of the following words could be found on a dictionary page that begins with mendacity and ends with mercantile EXCEPT
- (A) mental
 - (B) meprobamate
 - (C) mercenary
 - (D) menu

IF YOU FINISH BEFORE TIME IS CALLED, GO ON TO SECTION III.

SECTION III
ENGLISH EXPRESSION

Time—10 minutes

Directions: Some of the following sentences are correct according to the requirements of standard written English. Some are incorrect. No sentence contains more than one error.

If you find that the error, if any, is underlined and lettered. Assume that all other elements of the sentence are correct and cannot be changed.

If there is an error, select the one underlined part that must be changed in order to make the sentence correct, and mark the corresponding space on the answer sheet.

If there is no error, mark answer space D.

As shown in these examples are marked.

EXAMPLES	ANSWERS
1. He spoke <u>bluntly</u> and <u>angrily</u> to <u>we</u> spectators. <u>No error</u>	1. <input type="radio"/> A <input type="radio"/> B <input checked="" type="radio"/> C <input type="radio"/> D
2. He works every day <u>so that he will</u> be <u>financially</u> independent <u>in his</u> old age. <u>No error</u>	2. <input type="radio"/> A <input type="radio"/> B <input type="radio"/> C <input checked="" type="radio"/> D

AS SOON AS YOU UNDERSTAND THE DIRECTIONS, BEGIN WORK ON THE PROBLEMS.

Mark Twain held many different jobs, including the outing of steamboats on the Mississippi river. No error

A B C D

35. The scout put notches in some of the trees so as the hikers could find the way back to camp. No error

A B C D

The fumes from the engine gave Maynard one of the most headaches he had ever had. No error

A B C D

36. Spider Davies, lighter and less experienced than any other competitor, was nevertheless confident that the tournament would end in a match between the champion and he. No error

A B C D

These kind of wild mushrooms must be examined with great care. No error

A B C D

The British admiral seized the ship on the morning

A

37. Apparently the use of seat belts has greatly reduced the amount of serious injuries caused by automobile accidents. No error
38. Although the team had won every game in January, it played very badly during February and March. No error
39. The harbor master warned that sailing to close to the jetty could be disastrous. No error
40. Most universities believe that scholarship money should be awarded to the people which need it most. No error
41. Like Emerson, his trusted friend, Thoreau wanted only the freedom to explore the meaning to his own existence. No error
42. Nicholas II. the last of the Russian tsars had two consuming interests, cards and dominoes. No error
43. An old saying tells us that a mans' home is his castle. No error
44. The people on Third street were the first to leave that the parade had been canceled. No error
45. Pablo's monkey likes to play with a rope, climb trees, and catching peanuts in his teeth. No error
46. For breakfast yesterday we had honey, most of which ended up on my brother's chin. No error
47. More than half of the population of the United States is concentrated in the cities. No error
48. Last evening the Downings drove around the block several times so that everyone could see there car. No error
49. The arguments presented by Senator Fackler were so convincing that he gained the support of an overwhelming majority of the voters. No error
50. Many a new driver has come perilously close to death because they have not really learned to drive an automobile. No error

IF YOU FINISH BEFORE TIME IS CALLED, GO ON TO SECTION IV.

SECTION IV
LITERATURE

Time—15 minutes

Directions: Each of the questions or incomplete statements below is followed by four suggested answers or completions. Choose the one which is best in each case and then blacken the corresponding space on the answer sheet.

To set the scene of a story, an author usually tells

- A) when and where the action takes place
- B) what the characters' names are
- C) what made him write the story
- D) how the story ends

Which of the words in which of the following groups are most likely to be used to show the passage of time?

- A) there, beside, behind
- B) because, for, so
- C) then, next, while
- D) if, and, but

Questions 53-57 refer to the following poem. Read the poem carefully and then answer the questions.

Frenchmen have no ear drums,
Paris is the loveliest city in the world,
Until she opens her mouth,
When the French go forth to battle, armed only with their
horns,
They would drive all before them.

Which of the following is the best meaning of "until" (line 6) ?

- A) The enemy on the battlefield
- B) People who use taxicabs in Paris
- C) Frenchmen in the army
- D) Talkative taxi drivers from Paris

Which of the following best describes the sense of this poem, the poet recalls Paris mainly

- A) smell (B) sight (C) touch (D) hearing

55. According to the poet, Paris is not only beautiful, but also

- (A) warlike (B) turbulent
- (C) noisy (D) defenseless

56. Which of the following is another way of saying "Should the French go forth to battle" (line 4) ?

- (A) The French ought to go to war.
- (B) If the French were to go to war
- (C) Would the French go to war?
- (D) When the French go to war

57. "Until she opens her mouth" (line 3) is an example of

- (A) alliteration (B) simile
- (C) personification (D) onomatopoeia

58. No one can expect to be happy all the time.

Which of the following familiar expressions most accurately restates this sentence?

- (A) An ounce of prevention is worth a pound of cure.
- (B) Time and tide wait for no man.
- (C) All work and no play makes Jack a dull boy.
- (D) Into each life a little rain must fall.

GO ON TO THE NEXT PAGE.

Questions 59-63 refer to the following passage. Read the passage carefully and then answer the questions.

It rained with thunder on Friday night, but the sun rose hot on Saturday without a cloud. We were at sea—there is no other adequate expression—on the plains of Nebraska. I made my observations from the top of our wagon, and sat shirtless by the hour upon that perch to spy about me, and to spy in vain for something new. It was a world almost without a feature; an empty sky, an empty earth. Front and back, the line of the trail stretched from horizon to horizon, like a cue across a billiard table. On either hand, the green plains ran till they touched the skirts of heaven.

59. All of the following contribute to the image of the billiard table (line 10) EXCEPT the
- (A) greenness of the plains
 - (B) cloudlessness of the sky
 - (C) appearance of the trail
 - (D) flatness of the plains
60. The expression "we were at sea . . . on the plains" (lines 2-4) indicates that the
- (A) plains were vast and featureless
 - (B) speaker was riding on a prairie schooner
 - (C) thunderstorm had flooded the plains
 - (D) speaker was sick from the motion of the wagon
61. The expression "to spy in vain for something new" (lines 6-7) indicates that the
- (A) speaker had been expecting to meet someone
 - (B) rain had covered everything on the plains
 - (C) bright sun had temporarily blinded the speaker
 - (D) scene always seemed to be the same
62. The mood of this scene can best be described as one of
- (A) joy and anticipation
 - (B) vastness and emptiness
 - (C) security and confidence
 - (D) heaviness and grayness
63. What are the physical features that dominate the scene that the speaker describes?
- (A) The sun and the storm
 - (B) The trail and the wagon
 - (C) The sky and the plains
 - (D) The sea and the clouds
64. A story is called fictional if it
- (A) tells about things that happened long ago
 - (B) does not tell about people
 - (C) finds fault with something
 - (D) tells about things that did not happen in real life
65. This city now doth like a garment wear
The beauty of the morning . . .
- Which of the following poetic devices is found in the passage above?
- (A) Simile (B) Alliteration
 - (C) Hyperbole (D) Onomatopoeia

FORM QBC3

ENGLISH IV-B (For Phase 4)

Time—40 minutes

YOU ARE TO INDICATE ALL YOUR ANSWERS ON THE SEPARATE ANSWER SHEET. No credit will be given for anything written in the test book. After you have decided which of the suggested answers you want to give for a question, blacken the corresponding space on the answer sheet.

Example:

Chicago is a

- (A) state
- (B) city
- (C) country
- (D) continent

Sample Answer

A	B	C	D
<input type="checkbox"/>	<input checked="" type="checkbox"/>	<input type="checkbox"/>	<input type="checkbox"/>

Give only one answer to each question; no credit will be given for multiple answers. If you wish to change an answer, erase your first line completely and mark your new choice.

DO NOT OPEN THIS BOOK UNTIL YOU ARE TOLD TO DO SO.

Developed by Educational Testing Service pursuant to a subcontract funded by the U. S. Department of Health, Education, and Welfare, Office of Education.

SECTION I
LANGUAGE

Time—10 minutes

Directions: Each of the questions or incomplete statements below is followed by four suggested answers or completions. Select the one which is best in each case and then blacken the corresponding space on the answer sheet.

1. The children in the audience squirmed uncomfortably and waited for the play to begin.

What is the complete subject in this sentence?

- (A) The children
- (B) The children in the audience
- (C) The children in the audience squirmed uncomfortably and waited
- (D) The children in the audience squirmed uncomfortably and waited for the play

2. He is the short plumber's helper.

Which of the following is an accurate explanation of the problem presented by the sentence above?

- (A) Short is an adjective, but the sentence calls for the adverb shortly.
- (B) In plumber's, the apostrophe is in the wrong place.
- (C) The verb does not agree in number with the subject.
- (D) In its written form the sentence can mean two different things.

- I. Maxwell, the electrician, answered as soon as we called.
- II. The man, who was called Maxwell, answered immediately.

Which of the sentences above contain(s) an appositive?

- (A) I only
- (B) II only
- (C) Both I and II
- (D) Neither I nor II

- I. It's raining cats and dogs.
- II. The rain continued its pounding.

Which of the following describes the underlined words in the sentences above?

- (A) They are contractions in both sentences.
- (B) They are possessive pronouns in both sentences.
- (C) The word in I is a contraction; the word in II is a possessive pronoun.
- (D) The word in I is a possessive pronoun; the word in II is a contraction.

5. All of the following are portmanteau (blend) words EXCEPT

- (A) brunch
- (B) bookshelf
- (C) motel
- (D) smog

6. The referee was booed vigorously by a few of the spectators.

The sentence above is a passive of which of the following?

- (A) The referee booed a few of the spectators vigorously.
- (B) A few of the spectators were booed vigorously by the referee.
- (C) The spectators were booed vigorously by a few of the referees.
- (D) A few of the spectators booed the referee vigorously.

7. Bypass is made up of a combination of words. Which of the following combines the same kinds of words in the same way?

- (A) Railroad
- (B) Overthrow
- (C) Dugout
- (D) Evergreen

8. Security-Automatic Fire Extinguishers

Which of the following is the acronym for the commercial name given above?

- (A) SAFE
- (B) Safex
- (C) Sec-Aut
- (D) Sec-O-Fire

GO ON TO THE NEXT PAGE.



Questions 9-10 refer to the following dictionary entry. Read the entry carefully and then answer the questions.

cal'is-then'ics, or, more properly but less usually, cal'lis-then'ics (kāl'Is-thēn'īks), n.; see ICS. [Gr. kallos beauty + sthenos strength.] a) The science of bodily exercise without apparatus or with light hand apparatus, to promote strength and gracefulness (when used in this sense, sing.) b) Exercises of this sort (when used in this sense, pl.) - cal'is-then'ic (-īk), cal'is-then'i-cal (-ī-kāl), adj.

9. I. Calisthenics is important to a coach.
 II. Calisthenics are good for the body.
 III. Yesterday's calisthenics has made me stiff.

According to the dictionary entry, in which of the sentences above do the subject and verb show proper agreement?

- (A) I only
 (B) II only
 (C) I and II only
 (D) I, II, and III

10. The dictionary entry indicates all of the following about calisthenics EXCEPT that it
- (A) has two acceptable spellings as a noun
 (B) may be used to refer to two different things
 (C) has two acceptable forms as an adjective
 (D) may be used as a verb as well as a noun

IF YOU FINISH BEFORE TIME IS CALLED, GO ON TO SECTION II.

SECTION II
ENGLISH EXPRESSION

Time—15 minutes

Directions: Some of the following sentences are correct according to the requirements of standard written English. Some are incorrect. No sentence contains more than one error.

You will find that the error, if any, is underlined and lettered. Assume that all other elements of the sentence are correct and cannot be changed.

If there is an error, select the one underlined part that must be changed in order to make the sentence correct, and mark the corresponding space on the answer sheet.

If there is no error, mark answer space D.

How these examples are marked:

EXAMPLES	ANSWERS
1. He spoke <u>bluntly</u> and <u>angrily</u> to <u>we</u> spectators. <u>No error</u>	1. <input type="checkbox"/> A <input type="checkbox"/> B <input checked="" type="checkbox"/> C <input type="checkbox"/> D
2. He works every day <u>so that he will</u> be <u>financially</u> independent <u>in his</u> old age. <u>No error</u>	2. <input type="checkbox"/> A <input type="checkbox"/> B <input type="checkbox"/> C <input checked="" type="checkbox"/> D

AS SOON AS YOU UNDERSTAND THE DIRECTIONS, BEGIN WORK ON THE PROBLEMS.

The "Morning Messenger," scooping the "Daily Herald," published an exclusive account of Captain Madison's attempt of crossing the Atlantic in a rowboat. No error

Though not so good as her mother, the frozen pie was better than any that Muriel had ever made herself. No error

Spider Davies, lighter and less experienced than any other competitor, was nevertheless confident that the tournament would end in a match between the champion and he. No error

14. Without she can go with us, Joe's little sister will scream when we leave for the beach. No error

15. Along with the telephone, the radio, and the other agencies of communication, the automobile ended the isolation of the farmer. No error

16. La Rochefoucauld observed that we are never able to pardon them whom we have injured. No error

GO ON TO THE NEXT PAGE.



17. Neither radio nor television, though each provides instant communication, offer the companionship of a sympathetic listener. No error
18. Apparently the use of seat belts has greatly reduced the amount of serious injuries caused by automobile accidents. No error
19. Specialists employed by one big corporation are not, in most cases, isolated from others of their kind who would work for another employer. No error
20. Because he wanted his speech to be as effective as possible, Senator Merlin revised it several times before the broadcast. No error
21. Like Emerson, his trusted friend, Thoreau wanted only the freedom to explore the meaning to his own existence. No error
22. The scout put notches in some of the trees so as the hikers could find the way back to camp. No error
23. Although he had been studying for hours, Bill still had to read a poem, answer some questions, and to write a composition for Mr. Thompson's class. No error
24. When William James died, the Boston "Evening Transcript" referred to him as "the greatest of contemporary Americans." No error
25. The arguments presented by Senator Fackler were so convincing that he gained the support of an overwhelming majority of the voters. No error
26. The harbor master warned that sailing to close to the jetty could be disastrous. No error
27. Judging the shift in the direction of the wind accurately, enabled Captain O'Connell to gain almost thirty seconds on the Australian yacht. No error
28. Teachers seem to have greater influence upon students when the relationship between faculty and students is fairly informal. No error
29. Last evening the Downings drove around the block several times so that everyone could see there new car. No error
30. No one member of the clean-up committee had too much work to do because each member contributed an hour of their time. No error

Ronald begged his Mother to fry some chicken
or supper. No error
C D

On opening night, Francean's stage fright made
her forget the lines that she learned perfectly
during rehearsals. No error
B C D

Ablo's monkey likes to play with a rope, climb
trees, and catching peanuts in his teeth. No error
A B C D

34. When the premier arrived in Paris, the city
appeared to be prepared for an inevitable doom.
No error
A B C D

35. Nicholas II, the last of the Russian csars had two
consuming interests, cards and dominoes. No error
A B C D

YOU FINISH BEFORE TIME IS CALLED, GO ON TO SECTION III.

SECTION III
LITERATURE

Time—15 minutes

Directions: Each of the questions or incomplete statements below is followed by four suggested answers or completions. Select the one which is best in each case and then blacken the corresponding space on the answer sheet.

36. The words in which of the following groups are most likely to be used to show passage of time?
- (A) there, beside, behind
(B) because, for, so
(C) then, next, while
(D) if, and, but
39. Which of the following is suggested by the poet's proof of the statement "Frenchmen have no ear drums"?
- (A) Parisians do not seem to hear the noise of their city.
(B) The French are not bothered by the noise of battle.
(C) The appearance of the French is unattractive.
(D) Parisians are excitable and talk too loudly.

Questions 37-41 refer to the following poem. Read the poem carefully and then answer the questions.

Frenchmen have no ear drums.
Paris is the loveliest city in the world.
Until she opens her mouth.
Should the French go forth to battle, armed only with their
taxi horns,
They would drive all before them.

37. Which of the following is another way of saying the same thing as "Should the French go forth to battle" (line 4) ?
- (A) The French ought to go to war
(B) If the French were to go to war
(C) Would the French go to war?
(D) When the French go to war
38. According to the poet, Paris is not only beautiful, but also
- (A) warlike
(B) turbulent
(C) noisy
(D) defenseless
40. "Until she opens her mouth" (line 3) is an example of
- (A) alliteration
(B) simile
(C) personification
(D) onomatopoeia
41. This poem uses the verse form of
- (A) blank verse
(B) an ode
(C) a sonnet
(D) free verse
42. Around me, bright ----- shakes out her
drenched hair,
And pipes a tune to banish Winter's care.
Which of the following would be most meaningful and appropriate in the lines above?
- (A) Evening
(B) June
(C) Noon
(D) April

GO ON TO THE NEXT

Questions 43-46 refer to the following passage. Read the passage carefully and then answer the questions.

It rained with thunder on Friday night, but the sun rose hot on Saturday without a cloud. We were at sea—there is no other adequate expression—on the plains of Nebraska. I made my observations from the top of our wagon, and sat shirtless by the door upon that perch to spy about me, and to spy in vain for something new. It was a world almost without a feature; an empty sky, an empty earth. In front and back, the line of the trail stretched from horizon to horizon, like a cue across a billiard table. On either hand, the green plains ran till they touched the skirts of heaven.

Which of the following contribute to the image of the billiard table (lines 10-11) EXCEPT the

- A) greenness of the plains
- B) cloudlessness of the sky
- C) appearance of the trail
- D) flatness of the plains

Which of the following are the physical features that dominate the scene that the speaker describes?

- A) The sun and the storm
- B) The trail and the wagon
- C) The sky and the plains
- D) The sea and the clouds

The expression "to spy in vain for something new" (lines 6-7) indicates that the

- A) speaker had been expecting to meet someone
- B) rain had covered everything on the plains
- C) bright sun had temporarily blinded the speaker
- D) scene always seemed to be the same

The mood of this scene can best be described as one of

- A) joy and anticipation
- B) vastness and emptiness
- C) security and confidence
- D) heaviness and grayness

47. Our graves, that hide us from the searching sun,
Are like drawn curtains when the play is done.

Which of the following is NOT a sound reason for thinking that these two lines have been taken from traditional poetry?

- (A) The simplicity of the phrasing
- (B) The capitalization of the lines
- (C) The rhythm of the lines
- (D) The similarity in the pronunciation of the last word in each line

48. Which of the following statements provides the best example of metaphor?

- (A) Better to have loved and lost than never to have loved at all.
- (B) The young center fielder caught the ball against the fence.
- (C) Even a politician has to make a decision eventually.
- (D) Life is a thread with an unseen end.

GO ON TO THE NEXT PAGE.

Questions 49-54 refer to the following passage. Read the passage carefully and then answer the questions.

- What the United States needs is a good five-cent word to describe itself. We have invented a new social system—perhaps the most interesting social contraption since the corset—but we haven't yet thought up a name for it. So we keep on trying to describe it with a set of labels that were devised long ago to fit something entirely different. This confuses everybody. We are in much the same fix as an air line which would insist on referring to its jet planes as Covered Wagons. Now, this insistence would preserve the fine old pioneering tradition, all right, but a certain number of elderly passengers inevitably would complain that they couldn't find the reins. The Minute Women of America would keep trying to hitch the plane to a span of oxen. And foreigners—who often take our sentimental language literally—would, scoffing at our Oregon Trail mentality, try to sell us their up-to-date conveyances, such as the trolley car.
49. The first sentence is an allusion to the expression: "What this country needs is a good five-cent -----."
(A) word (B) cigar (C) label (D) hot dog
50. The second paragraph makes use of
(A) an extended analogy
(B) a complicated paradox
(C) a chronological arrangement of details
(D) an answer to a problem in the first paragraph
51. The last sentence of the passage (lines 16-19) is an example of
(A) hyperbole (B) synopsis
(C) irony (D) understatement

52. The expression "Covered Wagons" (line 10) is an example of what the author calls
(A) a good five-cent word
(B) scoffing
(C) a set of labels
(D) sentimental language
53. Judging from the last sentence (lines 16-19), which of the following would the author be most likely to think about foreigners?
(A) They are not so modern as Americans.
(B) They are not very good businessmen.
(C) They do not like the United States.
(D) They do not understand American slang.
54. All of the following contribute to the informality of the passage EXCEPT
(A) "social contraption" (lines 3-4)
(B) "much the same fix" (lines 8-9)
(C) "to hitch the plane" (line 15)
(D) "a span of oxen" (lines 15-16)
-
55. This city now doth like a garment wear
The beauty of the morning . . .
Which of the following poetic devices is found in passage above?
(A) Simile (B) Alliteration
(C) Hyperbole (D) Onomatopoeia

IF YOU FINISH BEFORE TIME IS CALLED, CHECK YOUR WORK ON THIS TEST.

FORM QBC4

ENGLISH II-C (For Phase 2)

Time—40 minutes

YOU ARE TO INDICATE ALL YOUR ANSWERS ON THE SEPARATE ANSWER SHEET. No credit will be given for anything written in the test book. After you have decided which of the suggested answers you want to give for a question, blacken the corresponding space on the answer sheet.

Example:

Chicago is a

- (A) state
- (B) city
- (C) country
- (D) continent

Sample Answer

A	B	C	D
<input type="checkbox"/>	<input checked="" type="checkbox"/>	<input type="checkbox"/>	<input type="checkbox"/>

Give only one answer to each question; no credit will be given for multiple answers. If you wish to change an answer, erase your first line completely and mark your new choice.

DO NOT OPEN THIS BOOK UNTIL YOU ARE TOLD TO DO SO.

Developed by Educational Testing Service pursuant to a subcontract funded by the U. S. Department of Health, Education, and Welfare, Office of Education.

SECTION I

SPELLING

Time—5 minutes

Directions: From each group below, select the word that is misspelled. Then on the answer sheet blacken the corresponding space. If all words in the group are spelled correctly, blacken space D. No group has more than one misspelled word.

- (A) ever
- (B) very
- (C) evry
- (D) no error

- 9. (A) handsome
- (B) bothersome
- (C) lonsome
- (D) no error

- (A) fourty
- (B) fifty
- (C) sixty
- (D) no error

- 10. (A) lovley
- (B) valley
- (C) only
- (D) no error

- (A) meant
- (B) dent
- (C) speant
- (D) no error

- 11. (A) bargain
- (B) captain
- (C) against
- (D) no error

- (A) Tuesday
- (B) Wendsday
- (C) Thursday
- (D) no error

- 12. (A) wisdom
- (B) wistle
- (C) wicked
- (D) no error

- (A) burglar
- (B) grammar
- (C) beggar
- (D) no error

- 13. (A) coward
- (B) through
- (C) forward
- (D) no error

- (A) frozen
- (B) horizen
- (C) dozen
- (D) no error

- 14. (A) begin
- (B) engin
- (C) virgin
- (D) no error

- (A) ladys
- (B) monkeys
- (C) lilies
- (D) no error

- 15. (A) lease
- (B) peace
- (C) cease
- (D) no error

- (A) doesn't
- (B) haven't
- (C) won't
- (D) no error

- 16. (A) Febuary
- (B) August
- (C) November
- (D) no error

- 17. (A) seventh
- (B) eighth
- (C) ninth
- (D) no error

- 18. (A) apple
- (B) bannana
- (C) melon
- (D) no error

- 19. (A) bows
- (F) nose
- (C) toes
- (D) no error

- 20. (A) terrific
- (B) alligator
- (C) tomorrow
- (D) no error

IF YOU FINISH BEFORE TIME IS CALLED, GO ON TO SECTION II.

SECTION II
LANGUAGE

Time—10 minutes

Directions: Each of the questions or incomplete statements below is followed by four suggested answers or completions. Select the one which is best in each case and then blacken the corresponding space on the answer sheet.

Which of the following has the same vowel sound as loud?

- (A) cough
- (B) enough
- (C) fund
- (D) down

Which of the following is a pair of homonyms?

- (A) nun. . none
- (B) cold. . hot
- (C) raise. . race
- (D) miserly. . frugal

The suffix that will change allow, read, perish, and agree from verbs to adjectives is

- (A) -ive
- (B) -able
- (C) -ent
- (D) -ify

They ----- all the dishes on the table.

When inserted in the sentence above, which of the following verb forms indicates either present or past tense?

- (A) use
- (B) see
- (C) put
- (D) leave

John will be at the library from one to three on Sunday.

In normal conversation, to in the sentence above is pronounced like the underlined word in

- (A) Two books are on the table.
- (B) I went too.
- (C) Stand by for the boat to leave. to!
- (D) You don't mean to say anything so foolish.

26. Which of the following does NOT contain the prefix de-?

- (A) deaden
- (B) debase
- (C) depend
- (D) detract

27. The sound of the initial consonant of zone is heard in all of the following EXCEPT

- (A) dazzle
- (B) has
- (C) scissors
- (D) mansion

28. In which of the sentences below does the verb indicate future tense?

- (A) The whooping crane is now almost extinct.
- (B) Key deer have developed a taste for cigarette butts.
- (C) The race will be over at noon.
- (D) They should have waited.

29. Which of the following is a pronoun?

- (A) threat
- (B) their
- (C) Theodore
- (D) then

30. Goes the King hence tonight?

Which of the following is the most accurate modern English version of the line from Shakespeare given above?

- (A) Does the King come here tonight?
- (B) Tonight the King goes from there, does he?
- (C) Is the King going away tonight?
- (D) Does the King, therefore, go forth?

IF YOU FINISH BEFORE TIME IS CALLED, GO ON TO SECTION III.

SECTION III
ENGLISH EXPRESSION

Time—10 minutes

Directions: Some of the following sentences are correct according to the requirements of standard written English. Some are incorrect. No sentence contains more than one error.

You will find that the error, if any, is underlined and lettered. Assume that all other elements of the sentence are correct and cannot be changed.

If there is an error, select the one underlined part that must be changed in order to make the sentence correct, and mark the corresponding space on the answer sheet.

If there is no error, mark answer space D.

See how these examples are marked:

EXAMPLES	ANSWERS
1. He spoke <u>bluntly</u> and <u>angrily</u> to <u>we</u> spectators. <u>No error</u> A B C D	1. A B C D <input type="checkbox"/> <input type="checkbox"/> <input checked="" type="checkbox"/> <input type="checkbox"/>
2. He works every day <u>so that he will</u> be <u>financially</u> independent in his old age. <u>No error</u> A B C D	2. A B C D <input type="checkbox"/> <input type="checkbox"/> <input type="checkbox"/> <input checked="" type="checkbox"/>

31. We looked out across the tree tops and seen big,
black rain clouds gathering over the mountains.
A B C

No error
D

32. The girls decided to wait for the bus to the
beach, but us boys thought we could get there
faster by walking. No error
A B C D

33. With his usual angelic look, Ralph promised his
mother that he would not do nothing mischievous
all day. No error
A B C D

34. Without you take good care of your new bicycle, it
will not last more than six months. No error
A B C D

35. Mrs. Forest could not determine the source of her
children's pains. No error
A B C D

36. Our vacations at the shore has been more exciting
than those in the mountains. No error
A B C D

37. When the defenders began to fire heavy weapons,
every man in the attacking company flung themself
to the ground. No error
A B C D

38. As he makes his slow journey inland, Dr. Park's
came to know many West African tribes. No error
A B C D

A moderate pace is probably least strenuous for most walkers. No error
C A B D

Did you know that the pelican is the state bird of Louisiana? No error
C A D

Susan and Beth were happy but nervous when they missed. Finch told them that they could dance in the school show. No error
A B C D

Roswell would have done his job, the rest of the construction crew could be sleeping comfortably at the camp by now. No error
A B C D

43. Studies indicate that for many students, French is not so difficult a language to learn than German. No error
A B C D

44. One of the results of the flood was the loss of all the maple trees along Harbor Drive. No error
A B C D

45. Historians who have compared the strategies of Napoleon and Caesar agree that Napoleons' were less brilliant. No error
A B C D

IF YOU FINISH BEFORE TIME IS CALLED, GO ON TO SECTION IV.

SECTION IV

READING

Time—15 minutes

Directions: Each of the questions or incomplete statements below is followed by four suggested answers or completions. Select the one which is best in each case and then blacken the corresponding space in the answer sheet.

46. A stitch in time saves nine.

Which of the following presents an illustration of this familiar expression?

- (A) Even though he missed the whole first period, Joe was glad that he had gone to the game.
- (B) Joe was disappointed because his favorite actor had not received an award.
- (C) Joe knew that he probably would not have enough money, but he was too excited to worry.
- (D) Even though he was almost certain that he had enough gas, Joe filled the tank anyway.

Questions 47-48 refer to the following poem. Read the poem carefully and then answer the questions.

Look—on the topmost branches of the world
The blossoms of the myriad stars are thick.

47. In these lines, the stars are compared to

- (A) branches on a tree
- (B) flowers on a tree
- (C) fireworks
- (D) decorations on a carpet

48. In these lines, the comparison helps the reader to feel that

- (A) the sky is connected to the earth
- (B) stars are lonely and distant
- (C) the sky is turning darker
- (D) the stars are very bright

49. Needing thirty cents to buy the gum, Earl fished around in his pocket until he found the coin he needed to go with his quarter.

What did Earl find in his pocket?

- (A) A piece of gum
- (B) A quarter
- (C) A fish
- (D) A nickel

50. Mabel knew she was wrong, but she did not want to give in.

Mabel was

- (A) tired
- (B) stubborn
- (C) brave
- (D) smart

51. It is a good thing that Charlie controlled his temper or there would have been real trouble.

Charlie was

- (A) content
- (B) cold
- (C) angry
- (D) bossy

52. When Lois asked Don who had won the election, he just shrugged his shoulders.

Don probably shrugged his shoulders because he

- (A) did not know who had been elected
- (B) wanted Lois to scratch his back
- (C) did not like to answer Lois' questions
- (D) wanted to prove how smart he was

53. Jerry overslept this morning, and now he can hardly wait for lunch.

Jerry is

- (A) lazy
- (B) hungry
- (C) sleepy
- (D) grumpy

GO ON TO THE NEXT PAGE

Questions 54-57 refer to the following poem. Read the poem carefully and then answer the questions.

And naked to the hangman's noose
 The morning clocks will ring
 A neck God made for other use
 Than strangling in a string.
 5) And sharp the link of life will snap,
 And dead on air will stand
 Heels that held up as straight a chap
 As treads upon the land.

What is probably meant by "morning clocks" in line 2)?

- A) Alarm clocks
- B) Roosters
- C) Town criers
- D) Church bells

The poem describes

- A) an execution
- B) a battle
- C) an illness
- D) a robbery

Which of the following expressions from the poem contains a pun?

- A) "naked to the hangman's noose" (line 1)
- B) "clocks will ring a neck" (lines 2-3)
- C) "the link of life" (line 5)
- D) "treads upon the land" (line 8)

The speaker regards what is described in the poem as something that

- A) does not concern him
- B) is necessary
- C) is wrong
- D) he does not want to talk about

Questions 58-60 refer to the following passage. Read the passage carefully and then answer the questions.

The human animal originally came from out-of-doors. When spring begins to move in his bones, he just must get out again. One time, in the spring, our grandmothers used to give us nasty brews from (5) herbs to purify our blood of the winter's corruptions. They knew something was the matter with the boys. They could have saved trouble by giving them a pole, a string and a hook. Some wise ones (among them my own) did just that.

58. The pronoun "They" in line 7 refers to

- (A) "our grandmothers" (line 4)
- (B) "nasty brews" (line 4)
- (C) "winter's corruptions" (line 5)
- (D) "the boys" (line 6)

59. What is the popular name for the "ailment" talked about in the paragraph?

- (A) Cabin fever
- (B) Tired blood
- (C) Spring fever
- (D) Wanderlust

60. What does the author recommend as a cure for the "ailment"?

- (A) Working hard
- (B) Drinking tonics
- (C) Receiving blood transfusions
- (D) Going fishing

IF YOU FINISH BEFORE TIME IS CALLED, CHECK YOUR WORK ON THIS TEST.



FORM QBC5

ENGLISH III-C (For Phase 3)

Time—40 minutes

YOU ARE TO INDICATE ALL YOUR ANSWERS ON THE SEPARATE ANSWER SHEET. No credit will be given for anything written in the test book. After you have decided which of the suggested answers you want to give for a question, blacken the corresponding space on the answer sheet.

Example:

Chicago is a

- (A) state
- (B) city
- (C) country
- (D) continent

Sample Answer

A	B	C	D
<input type="checkbox"/>	<input checked="" type="checkbox"/>	<input type="checkbox"/>	<input type="checkbox"/>

Give only one answer to each question; no credit will be given for multiple answers. If you wish to change an answer, erase your first line completely and mark your new choice.

DO NOT OPEN THIS BOOK UNTIL YOU ARE TOLD TO DO SO.

Developed by Educational Testing Service pursuant to a subcontract funded by the U. S. Department of Health, Education, and Welfare, Office of Education.

SECTION I

SPELLING

Time—5 minutes

Directions: From each group below, select the word that is misspelled. Then on the answer sheet blacken the corresponding space. If all words in the group are spelled correctly, blacken space D. No group has more than one misspelled word.

- (A) exaggerate
- (B) sheriff
- (C) writting
- (D) no error

- 9. (A) handsome
- (B) bothersome
- (C) lonsome
- (D) no error

- (A) dilinquent
- (B) disciple
- (C) disaster
- (D) no error

- 10. (A) municiple
- (B) multiple
- (C) triple
- (D) no error

- (A) heir
- (B) heirarchy
- (C) weird
- (D) no error

- 11. (A) bargain
- (B) captain
- (C) against
- (D) no error

- (A) sincerly
- (B) clearly
- (C) queerly
- (D) no error

- 12. (A) wisdom
- (B) wistle
- (C) wicked
- (D) no error

- (A) burglar
- (B) grammar
- (C) beggar
- (D) no error

- 13. (A) mathematics
- (B) irrigation
- (C) medecine
- (D) no error

- (A) frozen
- (B) horizen
- (C) dozen
- (D) no error

- 14. (A) lease
- (B) peace
- (C) cease
- (D) no error

- (A) ladys
- (B) monkeys
- (C) lilies
- (D) no error

- 15. (A) begin
- (B) cngin
- (C) virgin
- (D) no error

- (A) coward
- (B) through
- (C) forward
- (D) no error

- 16. (A) practice
- (B) exercise
- (C) prize
- (D) no error

GO ON TO THE NEXT PAGE.

1-4

17. (A) receive
(B) seize
(C) deceive
(D) no error

18. (A) fraction
(B) complexion
(C) predixion
(D) no error

19. (A) awful
(B) plentiful
(C) beautiful
(D) no error

20. (A) terrific
(B) alligator
(C) tommorrow
(D) no error

IF YOU FINISH BEFORE TIME IS CALLED, GO ON TO SECTION II.

SECTION II
LANGUAGE
Time—10 minutes

Directions: Each of the questions or incomplete statements below is followed by four suggested answers or completions. Choose the one which is best in each case and then blacken the corresponding space on the answer sheet.

24. Give Henry the book.

- In the sentence above, Henry is the
- A) subject of the verb give
 - B) direct object of the verb give
 - C) indirect object of the verb give
 - D) appositive following the verb give

25. Which of the following is a pair of homonyms?

- A) nun. . none
- B) cold. . hot
- C) raise. . race
- D) miserly. . frugal

26. The suffix that will change allow, read, perish, and agree from verbs to adjectives is

- A) -ive
- B) -able
- C) -ent
- D) -ify

27. They ----- all the dishes on the table.

When inserted in the sentence above, which of the following verb forms indicates either present or past tense?

- A) use
- B) see
- C) put
- D) leave

25. John will be at the library from one to three on Sunday.

In normal conversation, to in the sentence above is pronounced like the underlined word in

- (A) Two books are on the table.
- (B) I went, too.
- (C) Stand by for the boat to heave to!
- (D) You don't mean to say anything so foolish.

26. The man on trial is a flabby, hard-eyed gambler from a suburb of Atlanta.

A more sympathetic writer would describe the man above as

- (A) heavy-set, keen-eyed
- (B) stolid, shifty-eyed
- (C) weighty, wall-eyed
- (D) ponderous, steely-eyed

GO ON TO THE NEXT PAGE.

Questions 27-29 refer to the following poem. Read the poem carefully and then answer the questions.

- O my leisure's addressed
 To composing of verse
 Which, if hardly the bessest,
 Might be easily werse;
 (5) And, the spelling I use
 Should the critics condemn,
 Why, I have my own vuse
 And I don't think of them.
 Yes, I have my own views;
 (10) But the teachers I follow
 Are the lyrical Miews
 And the Delphic Apollow.
 Unto them I am debtor
 For spelling and rhyme,
 (15) And I'm doing it bebtor
 And bebtor each thyme.

27. In line 4 the poet writes werse to show that in English
- (A) werse is a common misspelling for worse
 - (B) verse cannot rhyme with worse
 - (C) several spellings may be used for the same vowel sound
 - (D) the consonants in worse cannot be pronounced with the same sound as those in werse

28. In line 7, vuse means

- (A) use
- (B) vase
- (C) vows
- (D) views

29. Lines 15-16 reveal the writer's sympathy for spellers who have difficulty with

- (A) silent letters and synonyms
- (B) silent letters and homonyms
- (C) synonyms and homonyms
- (D) antonyms and synonyms

30. Goes the King hence tonight?

Which of the following is the most accurate modern English version of the line from Shakespeare given above?

- (A) Does the King come here tonight?
- (B) Tonight the King goes from there, does he?
- (C) Is the King going away tonight?
- (D) Does the King, therefore, go forth?

IF YOU FINISH BEFORE TIME IS CALLED, GO ON TO SECTION III.

SECTION III
ENGLISH EXPRESSION

Time—10 minutes

Some of the following sentences are correct according to the requirements of standard written English. Some are incorrect. No sentence contains more than one error.

Underline the error, if any, in each sentence. Assume that all other elements of the sentence are correct and cannot be changed.

If there is an error, select the one underlined part that must be changed in order to make the sentence correct, and mark the corresponding space on the answer sheet.

If there is no error, mark answer space D.

These examples are marked:

EXAMPLES	ANSWERS
1. He spoke <u>bluntly</u> and <u>angrily</u> to <u>we</u> spectators. <u>No error</u>	1. <input type="checkbox"/> A <input type="checkbox"/> B <input checked="" type="checkbox"/> C <input type="checkbox"/> D
2. He works every day <u>so that he will</u> be <u>financially</u> independent in his old age. <u>No error</u>	2. <input type="checkbox"/> A <input type="checkbox"/> B <input type="checkbox"/> C <input checked="" type="checkbox"/> D

AS SOON AS YOU UNDERSTAND THE DIRECTIONS, BEGIN WORK ON THE PROBLEMS.

Visitors to the museum are forbidden against taking photographs that require flashbulbs. No error

A B C D

Two girls decided to wait for the bus to the beach, but the boys thought we could get there faster talking. No error

A B C D

As recently as a hundred years ago very few great mountains anywhere have been ascended or even attempted. No error

A B C D

34. Both Hardy and Grant are strong contenders for the nomination, but Hardy is the most likely choice. No error

A B C D

35. The storm was so severe that neither planes or trains could get to Minneapolis. No error

A B C D

36. Our vacations at the shore has been more exciting than those in the mountains. No error

A B C D

GO ON TO THE NEXT PAGE.

273

37. When the defenders began to fire heavy weapons, every man in the attacking company flung themselves to the ground. No error
- A
B C D
38. A reader may not understand all the implications of an idea even after studying it carefully. No error
- A B C D
39. What has emerged out from this collection of data is the fact that Professor Grantham has been right all along. No error
- A B C D
40. Waving his arms wildly, Morton insisted, that he had obeyed the speed limit. No error
- A B C D
41. During his vacation in Canada, Mr. Chester particularly enjoyed hiking, fishing for trout, and to sail on Timber Lake. No error
- A B C D
42. If Roswell would have done his job, the rest of the construction crew could be sleeping comfortably at the camp by now. No error
- A B C D
43. Studies indicate that for many students French is not so difficult a language to learn than German. No error
- A B C D
44. One of the results of the flood was the loss of all the maple trees along Harbor Drive. No error
- A B C D
45. Historians who have compared the strategies of Napoleon and Caesar agree that Napoleons' were less brilliant. No error
- A B C D
46. Easter Island, now well known for it's gigantic brooding statues, was discovered in 1722 and th ignored for almost a hundred years. No error
- A B C D
47. The editor asked Howard to do a series of articles on those high school teachers who include units of modern math in their courses. No error
- A B C D
48. The new chairman speaks quiet, but he exerts great influence on the committee. No error
- A B C D
49. Unfortunately, the campaign became so bitter that neither candidate could hurl enough insults at each other. No error
- A B C D
50. The senators realized immediately that Ambrose McClelland and him would debate only the mai issues. No error
- A B C D

IF YOU FINISH BEFORE TIME IS CALLED, GO ON TO SECTION IV.

SECTION IV
LITERATURE

Time — 15 minutes

Directions: Each of the questions or incomplete statements below is followed by four suggested answers or completions. Choose the one which is best in each case and then blacken the corresponding space on the answer sheet.

Proverb: A stitch in time saves nine.

Which of the following presents an illustration of this familiar expression?

- A) Even though he missed the whole first period, Joe was glad that he had gone to the game.
- B) Joe was disappointed because his favorite actor had not received an award.
- C) Joe knew that he probably would not have enough money, but he was too excited to worry.
- D) Even though he was almost certain that he had enough gas, Joe filled the tank anyway.

Questions 52-55 refer to the following poem. Read the poem carefully and then answer the questions.

And naked to the hangman's noose
The morning clocks will ring
A neck God made for other use
Than strangling in a string.

- C) And sharp the link of life will snap,
And dead on air will stand
Heels that held up as straight a chap
As treads upon the land.

What is the occasion for the poem?

- A) A man is going to be executed.
- B) Someone is dressing for work.
- C) A man is preparing for a storm.
- D) Someone is being held up and robbed.

What is probably meant by "morning clocks" in line 2)?

- A) Alarm clocks
- B) Roosters
- C) Town criers
- D) Church bells

54. Which of the following expressions from the poem contains a pun?

- (A) "naked to the hangman's noose" (line 1)
- (B) "clocks will ring a neck" (lines 2-3)
- (C) "the link of life" (line 5)
- (D) "treads upon the land" (line 8)

55. The speaker regards what is described in the poem as something that

- (A) does not concern him
- (B) is necessary
- (C) is wrong
- (D) he does not want to talk about

56. Which of the following statements about folk ballads is NOT true?

- (A) Ballads were originally passed on by word of mouth.
- (B) Ballads employ frequent repetition of words or lines.
- (C) Ballads usually tell a story.
- (D) Ballads employ a standard line of five metric feet.

GO ON TO THE NEXT PAGE.

Questions 57-60 refer to the following poem. Read the poem carefully and then answer the questions.

I saw a man pursuing the horizon
 Round and round they sped.
 I was disturbed at this;
 I accosted the man.

(5) "It is futile," I said,
 "You can never . . ."
 "You lie," he cried,
 And ran on.

57. What does the speaker of the poem see the man doing?
- (A) Trying to finish a nearly completed task
 (B) Trying to get some rest after working hard
 (C) Trying to achieve something that is impossible
 (D) Trying to live a fruitful and secure life
58. In saying that "It is futile" (line 5), the speaker of the poem is being
- (A) amusing and witty
 (B) reasonable and rational
 (C) mocking and heartless
 (D) haughty and pompous
59. Line 8 reveals that the man is
- (A) despairing because the speaker of the poem has accosted him
 (B) cheerful in the face of difficulties, but likely to tire soon
 (C) obsessed with his pursuit and determined to continue
 (D) eager to continue the conversation, but too close to his goal to stop
60. The poem establishes a contrast between which of the following?
- I. Rationality and idealism
 II. Life and death
 III. Sensitivity and callousness
- (A) I only
 (B) I and II only
 (C) I and III only
 (D) II and III only

Questions 61-65 refer to the following passage. Read the passage carefully and then answer the questions.

(1) Willie-Slim Arvin was the dogcatcher. (2) got only one hundred dollars a month, and he was a respected man. (3) He maintained a modest enough home in Greenwood, but he and his wife were close county and state political bigwigs. (4) Willie-Slim father was a smalltime politician. (5) His son had hardly enough education to write his name, and since couldn't qualify for any kind of work except hard labor—which he refused to do—his father had got the position of dogcatcher.

62. Willie-Slim became dogcatcher mainly through efforts of
- (A) his wife and himself
 (B) county and state politicians
 (C) his father
 (D) the people of Greenwood
63. The speaker's attitude toward Willie-Slim and people who knew him is first made apparent through the use of the
- (A) past tense of the verb in sentence 1
 (B) specific sum of one hundred dollars in sentence 2
 (C) conjunctions between the clauses in sentences 2 and 3
 (D) repeated use of the pronoun he in sentences 2 and 3
64. Willie-Slim could not qualify for any kind of work except hard labor because he was
- (A) sickly
 (B) ignorant
 (C) modest
 (D) proud
65. The speaker's attitude toward politicians is most apparent in the use of
- (A) "dogcatcher" (sentence 1)
 (B) "respected" (sentence 2)
 (C) "modest enough" (sentence 3)
 (D) "bigwigs" (sentence 3)

61. The expressions "blushing bride" and "clinging vine" are both
- (A) examples of paradox
 (B) clichés
 (C) examples of satire
 (D) personifications

FORM QBC6

ENGLISH IV-C (For Phase 4)

Time—40 minutes

YOU ARE TO INDICATE ALL YOUR ANSWERS ON THE SEPARATE ANSWER SHEET. No credit will be given for anything written in the test book. After you have decided which of the suggested answers you want to give for a question, blacken the corresponding space on the answer sheet.

Example:

Chicago is a

- (A) state
- (B) city
- (C) country
- (D) continent

Sample Answer

A	B	C	D
<input type="checkbox"/>	<input checked="" type="checkbox"/>	<input type="checkbox"/>	<input type="checkbox"/>

Give only one answer to each question; no credit will be given for multiple answers. If you wish to change an answer, erase your first line completely and mark your new choice.

DO NOT OPEN THIS BOOK UNTIL YOU ARE TOLD TO DO SO.

Developed by Educational Testing Service pursuant to a subcontract funded by the U. S. Department of Health, Education, and Welfare, Office of Education.

SECTION I

LANGUAGE

Time—15 minutes

Directions: Each of the questions or incomplete statements below is followed by four suggested answers or completions. Select the one which is best in each case and then blacken the corresponding space on the answer sheet.

Which of the following uses a technical vocabulary including the words fricassee, mousse, torte, gumbo, flan, and rosemary?

- (A) A pharmacist
- (B) A chef
- (C) A fashion designer
- (D) A hairdresser

Give Henry the book.

In the sentence above, Henry is the

- (A) subject of the verb give
- (B) direct object of the verb give
- (C) indirect object of the verb give
- (D) appositive following the verb give

am slim.
you are thin.
he is skinny.

The predicate adjectives above are similar in their

- (A) denotations but unlike in their connotations
- (B) connotations but unlike in their denotations
- (C) degree of formality and precision
- (D) degree of informality and use of

Penalty has the same root as

- (A) pen
- (B) depend
- (C) spent
- (D) penitent

John will be at the library from one to three on Monday.

In normal conversation, to in the sentence above is pronounced like the underlined word in

- (A) Two books are on the table.
- (B) I went, too.
- (C) Stand by for the boat to heave to!
- (D) You don't mean to say anything so foolish.

The man on trial is a flabby, hard-eyed gambler from a suburb of Atlanta.

A more sympathetic writer would describe the man as

- (A) heavy-set, keen-eyed
- (B) stolid, shifty-eyed
- (C) weighty, wall-eyed
- (D) ponderous, steely-eyed

Questions 7-10 refer to the following poem. Read the poem carefully and then answer the questions.

O my leisure's addressed
To composing of verse
Which, if hardly the blessed,
Might be easily verse.
(5) And, the spelling I use
Should the critics condemn,
Why, I have my own vuse
And I don't think of themn.

Yes, I have my own views:
(10) But the teachers I follow
Are the lyrical Miews
And the Delphic Apollow.
Unto them I am debtor
For spelling and rhyme,
(15) And I'm doing it bebtor
And bebtor each thyme.

- 7. In line 4 the poet writes verse to show that in English
 - (A) verse is a common misspelling for worse
 - (B) verse cannot rhyme with worse
 - (C) several spellings may be used for the same vowel sound
 - (D) the consonants in worse cannot be pronounced with the same sound as those in verse
- 8. In line 7 vuse means
 - (A) use
 - (B) vase
 - (C) vows
 - (D) views
- 9. In lines 9-12, the writer of the poem says that his spelling rules come from
 - (A) the amusing puns he read at Delphi
 - (B) the muse of poetry and his own poetic inspiration
 - (C) the amusing teachers and critics who have inspired him
 - (D) his musings while traveling in Greece and Rome
- 10. Lines 15-16 reveal the writer's sympathy for spellers who have difficulty with
 - (A) silent letters and synonyms
 - (B) silent letters and homonyms
 - (C) synonyms and homonyms
 - (D) antonyms and synonyms

11. There will be trouble at the lake tomorrow.

There in the sentence above is an

- (A) expletive
- (B) indirect object
- (C) objective complement
- (D) adverb of place

12. Goes the King hence tonight?

Which of the following is the most accurate modern English version of the line from Shakespeare given above?

- (A) Does the King come here tonight?
- (B) Tonight the King goes from there, does he?
- (C) Is the King going away tonight?
- (D) Does the King, therefore, go forth?

13. Delicatessen, kindergarten, dumb, and loafer have come into English from

- (A) French
- (B) German
- (C) Latin
- (D) Russian

14. I. Long live the King.
II. Long lives the King.

Which of the following accurately describes the verb in the sentences above?

- (A) Both verbs describe something in the future.
- (B) Both verbs describe a situation which is contrary to fact.
- (C) The verb in I refers to a hoped-for result; in II an actual situation.
- (D) The verb in I refers to an actual situation; in II a hoped-for result.

15. Strong (or irregular) verbs in English usually form the past tense by

- (A) an internal vowel change
- (B) the addition of -ing to the root
- (C) the addition of the suffix -ed, -d, or -t
- (D) the use of a prefix

IF YOU FINISH BEFORE TIME IS CALLED, GO ON TO SECTION II.

SECTION II
ENGLISH EXPRESSION

Time—10 minutes

Directions: Some of the following sentences are correct according to the requirements of standard written English. Some are incorrect. No sentence contains more than one error.

You will find that the error, if any, is underlined and lettered. Assume that all other elements of the sentence are correct and cannot be changed.

If there is an error, select the one underlined part that must be changed in order to make the sentence correct, and mark the corresponding space on the answer sheet.

If there is no error, mark answer space D.

Show how these examples are marked:

EXAMPLES	ANSWERS
1. He spoke <u>bluntly</u> and <u>angrily</u> to <u>we</u> <div style="margin-left: 100px;">A B C</div> spectators. <u>No error</u> <div style="margin-left: 200px;">D</div>	1. A B C D <input type="checkbox"/> <input type="checkbox"/> <input checked="" type="checkbox"/> <input type="checkbox"/>
2. He works every day <u>so that he will</u> <div style="margin-left: 150px;">A</div> be <u>financially</u> independent in his <div style="margin-left: 100px;">B C</div> old age. <u>No error</u> <div style="margin-left: 200px;">D</div>	2. A B C D <input type="checkbox"/> <input type="checkbox"/> <input type="checkbox"/> <input checked="" type="checkbox"/>

AS SOON AS YOU UNDERSTAND THE DIRECTIONS, BEGIN WORK ON THE PROBLEMS.

The young actress never suspicioned that the great

A

producer would be watching her performance on

B C

opening night. No error

D

19. The weight of the snow is too much for the old

A B

beams of the barn, and the roof began to sag

C

dangerously. No error

D

When the defenders began to fire heavy weapons,

A

every man in the attacking company flung themselves

B C

to the ground. No error

D

20. In closing, the speaker summarized his case

A B

against fluoridation. No error

C D

One out of every four visitors to the New Jersey

A

shore spend some time in Atlantic City.

B C

No error

D

21. The judges decided that Mrs. Carey's pickles

A

were superior than any of the others at the fair.

B C

No error

D

22. During his vacation in Canada, Mr. Chester
particularly enjoyed hiking, fishing for trout,
and to sail on Timber Lake. No error
A B C D
23. When we were children, my father used to give
my brother and I a bath every Saturday. No error
B C D
24. You should not attempt to pull out the poison ivy,
which is very thick, unless you wear heavy gloves.
No error
A B C D
25. Since millions of years the oceans have been changing
the shorelines of the continents. No error
A B C D
26. Although a telephone call would of been sufficient,
Mr. Thompson insisted on writing for tickets.
No error
A B C D
27. The reserve, piety, and sense of justice
that Queen Mary maintained throughout her
life was acquired early. No error
A B C D
28. Studies indicate that for many students French is
not so difficult a language to learn than German.
No error
A B C D
29. It was difficult for Marty to talk calm about the
adventures he had had on his uncle's ranch.
No error
A B C D
30. Man is gaining scientific knowledge faster than
the wisdom to use it well. No error
A B C D
31. Historians who have compared the strategies of
Napoleon and Caesar agree that Napoleons' were
less brilliant. No error
A B C D
32. What has emerged out from this collection of data
is the fact that Professor Grantham has been right
all along. No error
A B C D
33. Easter Island, now well known for it's gigantic,
brooding statues, was discovered in 1722 and then
ignored for almost a hundred years. No error
A B C D
34. The editor asked Howard to do a series of article
on those high school teachers who include units of
modern math in their courses. No error
A B C D
35. Every thirty minutes the radio station will broad
an announcement to remind we citizens to vote
before the polls close at seven o'clock. No error
A B C D

IF YOU FINISH BEFORE TIME IS CALLED, GO ON TO SECTION III.

SECTION III
LITERATURE

Time—15 minutes

Directions: Each of the questions or incomplete statements below is followed by four suggested answers or completions. Choose the one which is best in each case and then blacken the corresponding space on the answer sheet.

Questions 36-39 refer to the following poem. Read the poem carefully and then answer the questions.

I saw a man pursuing the horizon;
Round and round they sped.
I was disturbed at this;
I accosted the man.

(5) "It is futile," I said,
"You can never . . ."

"You lie," he cried,
And ran on.

36. What does the speaker of the poem see the man doing?

- (A) Trying to finish a nearly completed task
- (B) Trying to get some rest after working hard
- (C) Trying to achieve something that is impossible
- (D) Trying to live a fruitful and secure life

37. In saying that "It is futile" (line 5), the speaker of the poem is being

- (A) amusing and witty
- (B) reasonable and rational
- (C) mocking and heartless
- (D) haughty and pompous

38. Line 8 reveals that the man is

- (A) despairing because the speaker of the poem has accosted him
- (B) cheerful in the face of difficulties, but likely to tire soon
- (C) obsessed with his pursuit and determined to continue
- (D) eager to continue the conversation, but too close to his goal to stop

39. The poem establishes a contrast between which of the following?

- I. Rationality and idealism
- II. Life and death
- III. Sensitivity and callousness

- (A) I only
- (B) I and II only
- (C) I and III only
- (D) II and III only

40. Which of the following statements about folk ballads is NOT true?

- (A) Ballads were originally passed on by word of mouth.
- (B) Ballads employ frequent repetition of words or lines.
- (C) Ballads usually tell a story.
- (D) Ballads employ a standard line of five metric feet.

GO ON TO THE NEXT PAGE.

Questions 41-44 refer to the following poem. Read the poem carefully and then answer the questions.

Jenny kiss'd me when we met,
 Jumping from the chair she sat in;
 Time, you thief, who love to get
 Sweets into your list, put that in!
 Say I'm weary, say I'm sad,
 Say that health and wealth have miss'd me,
 Say I'm growing old, but add,
 Jenny kiss'd me.

41. The subject of this poem is the
- (A) difference in age between Jenny and the speaker of the poem
 - (B) cruelty of time in taking Jenny from the speaker of the poem
 - (C) ridiculousness of the actions of a little girl
 - (D) importance of a brief incident in one man's life
42. The first two lines emphasize which of the following characteristics of Jenny?
- (A) Youth
 - (B) Beauty
 - (C) Liveliness
 - (D) Wit
43. The last four lines of the poem deal mainly with
- (A) change that Jenny's kiss has made
 - (B) contrast between the importance of Jenny's kiss and the rest of the speaker's life
 - (C) effect that Jenny's kiss had in restoring youth and health to the speaker
 - (D) contrast between the poverty of the speaker and the spiritual richness of Jenny
44. In the context of the poem, time is called a thief primarily because it
- (A) never allows anything to last
 - (B) takes away the troubles of the world
 - (C) enables us to forget bitter moments
 - (D) changes things continually

GO ON TO THE NEXT PAGE

ns 45-50 refer to the following passage. Read
sage carefully and then answer the questions.

Willie-Slim Arvin was the dogcatcher. (2) He
one hundred dollars a month, and he was a re-
man. (3) He maintained a modest enough apart-
Greenwood, but he and his wife were close to the
nd state political bigwigs. (4) Willie-Slim's
was a smalltime politician. (5) His son had
nough education to write his name, and since
n't qualify for any kind of work except hard
which he refused to do—his father had got him
tion of dogcatcher. (6) Though the state had
a law that dogs should be tagged, hundreds of
ed dogs lived in the streets. (7) The aged
dogs that had outlived their usefulness, the un-
anine females, the puppies no one wanted—many
from other towns—were turned loose in Green-
find homes or go wild, sleep in the cliffs, run
, and attack cattle and sheep.

use of "and" in sentence 2 emphasizes the
cause-effect relationship between the two clauses
fragility of the logical relationship between the
two clauses
increasingly rapid rhythm as the sentences move
toward a climactic statement
increasingly complex structure of the sentences
as they comment on man's social behavior

ation to sentence 2, sentence 3 can best be
ribed as
similar in tone and structure, and providing a
fuller explanation
identical in structure, but contradictory in
statement
identical in structure and tone, and providing
detailed examples
similar in structure, but contrasting in tone

- 47. The speaker's attitude toward Willie-Slim and the people who knew him is first made apparent through the use of the
 - (A) past tense of the verb in sentence 1
 - (B) specific sum of one hundred dollars in sentence 2
 - (C) conjunctions between the clauses in sentences 2 and 3
 - (D) repeated use of the pronoun he in sentences 2 and 3

- 48. The speaker's attitude toward politicians is most apparent in the use of
 - (A) "dogcatcher" (sentence 1)
 - (B) "respected" (sentence 2)
 - (C) "modest enough" (sentence 3)
 - (D) "bigwigs" (sentence 3)

- 49. The author says that dogs were turned loose in Greenwood in order to show that
 - (A) Willie-Slim's irresponsibility was well known
 - (B) it was difficult to be a dogcatcher in Greenwood
 - (C) Willie-Slim did not want to do hard labor
 - (D) the people of Greenwood refused to cooperate with the dogcatcher

- 50. A major change in the structure of the paragraph occurs after sentence
 - (A) 2
 - (B) 3
 - (C) 4
 - (D) 5

IF YOU FINISH BEFORE TIME IS CALLED, CHECK YOUR WORK ON THIS TEST.



FORM QBC7

ENGLISH II-D (For Phase 2)

Time—40 minutes

YOU ARE TO INDICATE ALL YOUR ANSWERS ON THE SEPARATE ANSWER SHEET. No credit will be given for anything written in the test book. After you have decided which of the suggested answers you want to give for a question, blacken the corresponding space on the answer sheet.

Example:

Chicago is a
 (A) state
 (B) city
 (C) country
 (D) continent

Sample Answer

A	B	C	D
<input type="checkbox"/>	<input checked="" type="checkbox"/>	<input type="checkbox"/>	<input type="checkbox"/>

Give only one answer to each question; no credit will be given for multiple answers. If you wish to change an answer, erase your first line completely and mark your new choice.

DO NOT OPEN THIS BOOK UNTIL YOU ARE TOLD TO DO SO.

Developed by Educational Testing Service pursuant to a subcontract funded by the U. S. Department of Health, Education, and Welfare, Office of Education.

SECTION I

SPELLING

Time—5 minutes

Directions: From each group below, select the word that is misspelled. Then on the answer sheet blacken the corresponding space. If all words in the group are spelled correctly, blacken space D. No group has more than one misspelled word.

1. (A) artist
(B) dentist
(C) forist
(D) no error
2. (A) modren
(B) children
(C) lantern
(D) no error
3. (A) sister
(B) docter
(C) brother
(D) no error
4. (A) bright
(B) slight
(C) fight
(D) no error
5. (A) dense
(B) sense
(C) fense
(D) no error
6. (A) groop
(B) swoop
(C) food
(D) no error
7. (A) hospital
(B) animal
(C) cannibal
(D) no error
8. (A) speach
(B) scream
(C) streak
(D) no error
9. (A) important
(B) pleasant
(C) correspondant
(D) no error
10. (A) wonder
(B) anser
(C) thunder
(D) no error
11. (A) school
(B) schedule
(C) scheme
(D) no error
12. (A) consience
(B) patience
(C) sentence
(D) no error
13. (A) refusal
(B) quarrel
(C) resemble
(D) no error
14. (A) elephant
(B) photograph
(C) telephone
(D) no error
15. (A) interduction
(B) interesting
(C) interrupt
(D) no error
16. (A) genuine
(B) margin
(C) medicine
(D) no error

- (A) leaf
- (B) thief
- (C) reaf
- (D) no error

- (A) treat
- (B) asleep
- (C) clean
- (D) no error

- 19. (A) palm
- (B) caim
- (C) salmon
- (D) no error

- 20. (A) coffin
- (B) offen
- (C) soften
- (D) no error

IF YOU FINISH BEFORE TIME IS CALLED, GO ON TO SECTION II.

SECTION II

LANGUAGE

Time—10 minutes

Directions: Each of the questions or incomplete statements below is followed by four suggested answers or completion. Select the one which is best in each case and then blacken the corresponding space on the answer sheet.

21. Which of the following has the same vowel sound as broad?

- (A) jail
 (B) tall
 (C) flood
 (D) laugh

22. Over the fence is out.

What is the complete subject in this sentence?

- (A) Over
 (B) fence
 (C) out
 (D) Over the fence

23. The words youthful, beautiful, and painful suggest that -ful converts

- (A) nouns to verbs
 (B) nouns to adjectives
 (C) verbs to nouns
 (D) verbs to adverbs

24. Mosquito, lasso, siesta, patio, and canyon are words that English has borrowed from

- (A) Spanish
 (B) French
 (C) Dutch
 (D) Italian

25. On what syllable does the accent fall in the word inseparable?

- (A) First (B) Second (C) Third (D) Fourth

26. I. You don't have any money, do you?
 II. You have some money, don't you?

Which of the following describes the sentences above?

- (A) Both questions expect "no" answers.
 (B) Both questions expect "yes" answers.
 (C) Sentence I expects a "no" answer, sentence II a "yes" answer.
 (D) Sentence I expects a "yes" answer, sentence II a "no" answer.

27. The initial consonant of zinc is pronounced like the final consonant of

- (A) as (B) lash (C) marriage (D) face

Questions 28-30 refer to the following dictionary entry. Read the entry carefully and then answer the questions.

crim'son (krīm'z'n), n. [Sp. cremesín, ult. fr. Ar qirmiz kermes, fr. Skr. kṛmī worm, insect.] Any of several colors, ranging in hue from red to bluish-red of high saturation and low brilliance. See COLOR.
 -adj. Of the color crimson; hence, sanguinary; blood -v. t. & i. To make or become crimson.

28. According to the dictionary entry, which of the following is closest in meaning to the word crimson?

- (A) Wet (B) Dim (C) Low (D) Red

29. According to the dictionary entry, which of the following statements about crimson is true?

- (A) It can begin with either c or k.
 (B) It has at least two acceptable pronunciations.
 (C) It may be used as more than one part of speech.
 (D) It should usually be written with a capital letter.

30. According to the dictionary entry, all of the following are sources of the English word crimson EXCEPT

- (A) Spanish
 (B) French
 (C) Arabic
 (D) Sanskrit

GO ON TO THE NEXT PAGE

The words stares and stairs are

- (A) homonyms
- (F) antonyms
- (C) acronyms
- (D) synonyms

Which of the following is the least objectionable way of indicating that someone is underweight?

- (A) She is thin.
- (B) She is skinny.
- (C) She is slim.
- (D) She is scrawny.

The th in the word this is pronounced like the th in

- (A) thick
- (B) path
- (C) threw
- (D) that

34. In which of the following sentences is going to a future tense?

- (A) They are going to the fair in Harold's jalopy.
- (B) Out-of-season rates will apply both going to and coming from Europe.
- (C) Witnesses must not discuss the evidence they are going to give.
- (D) Going to Paris is my idea of a wonderful vacation.

35. Which of the following sentences contains an appositive?

- (A) Mary Murray, the tennis champion, will speak at the rally.
- (B) Yes, Mary Murray is coming to the rally.
- (C) Mary Murray, who went to Central High, will speak at the rally.
- (D) She is the Mary Murray who won all the prizes for tennis.

IF YOU FINISH BEFORE TIME IS CALLED, GO ON TO SECTION III.

SECTION III
ENGLISH EXPRESSION

Time—10 minutes

Directions: Some of the following sentences are correct according to the requirements of standard written English. Some are incorrect. No sentence contains more than one error.

You will find that the error, if any, is underlined and lettered. Assume that all other elements of the sentence are correct and cannot be changed.

If there is an error, select the one underlined part that must be changed in order to make the sentence correct, and mark the corresponding space on the answer sheet.

If there is no error, mark answer space D.

See how these examples are marked:

EXAMPLES	ANSWERS
1. He spoke <u>bluntly</u> and <u>angrily</u> to <u>we</u> A B C spectators. <u>No error</u> D	1. A B C D <input type="checkbox"/> <input type="checkbox"/> <input checked="" type="checkbox"/> <input type="checkbox"/>
2. He works every day <u>so that he</u> will A be <u>financially</u> independent in his B C old age. <u>No error</u> D	2. A B C D <input type="checkbox"/> <input type="checkbox"/> <input type="checkbox"/> <input checked="" type="checkbox"/>

36. Sergeant Bergen is never hard on the men which
 A B
 do their jobs carefully. No error
 C D

37. Despite Coach Mather's fears, the plans
 A
 for the game worked out excellent. No error
 B C D

38. Our club are supposed to hold elections in June for
 A B C
 the following year. No error
 D

39. We soon realized why Mrs. Franklin would not
 A B
leave Clyde keep his chemistry set. No error
 C D

40. Lucy admitted that she had took her little brother's
 A B C
 blanket. No error
 D

41. A sonic boom, like other explosive sounds is
 A
result of an abrupt change in pressure. No error
 B C D

42. The coat could not have fit Arnold better if it
 A B C
 been made especially for him. No error
 D

43. One Floridian reported that the reason the ba
 A
 eagle is dying out is that they eat fish pois
 B C
 by DDT. No error
 D

44. Although we shouted and waved our arms to w
 A
 ed of the thin ice, He edged closer and clos
 B C
 the dangerous spot. No error
 D



Whenever John had some spare time he
could have visited the local bowling alley and
practiced to improve his game. No error

Ernon did not realize that he could have looked up
the area of New Jersey in a atlas or almanac.
No error

Every large American corporation has its own
training program in England. No error

48. "I'll call you," said the salesman, as soon as your
order has been filled. No error

49. Although it was almost may, there were still
patches of snow in the shaded spots beside the
buildings. No error

50. Frank left the dining car just as the train pulled
onto the station. No error

IF YOU FINISH BEFORE TIME IS CALLED, GO ON TO SECTION IV.

SECTION IV

READING

Time—15 minutes

Directions: Each of the questions or incomplete statements below is followed by four suggested answers or completions. Select the one which is best in each case and then blacken the corresponding space on the answer sheet.

51. A book of myths contains stories about

- (A) gods and goddesses
- (B) pioneers
- (C) cowboys and Indians
- (D) ancient kings and queens

Questions 52-53 refer to the following statement. Read the statement carefully and then answer the questions.

"It must be a hundred and thirty in here," Mrs. Prentiss told her husband. "Why don't you turn on the air conditioner again?"

52. Mrs. Prentiss probably feels

- (A) neglected
- (B) angry
- (C) hot
- (D) nervous

53. What Mrs. Prentiss is saying is probably

- (A) an accurate report
- (B) an exaggeration of the truth
- (C) a lie to hide the truth
- (D) an alibi

54. The decorator said, "What this room needs is a little more contrast. Almost everything in it is the same shade of blue."

The decorator thinks that the room is

- (A) beautiful
- (B) cheap
- (C) dull
- (D) bare

55. "If you're ever in Kingston, be sure to drop in

The speaker is

- (A) inviting someone to visit
- (B) hoping for a second chance
- (C) asking for a favor
- (D) giving orders

56. "Look for it in the card catalog. If it's not listed there, I guess we don't have it."

The speaker is a

- (A) druggist
- (B) storekeeper
- (C) bookkeeper
- (D) librarian

Questions 57-58 refer to the following poem. Read the poem carefully and then answer the questions.

I see, and know not why,
Thorns live and roses die.

57. These lines ask why

- (A) men are false
- (B) poverty is the lot of all men
- (C) pain endures
- (D) beauty is permanent

58. In these lines, the roses stand for life's

- (A) hope
- (B) beauty
- (C) gaiety
- (D) restlessness

GO ON TO THE NEXT PAGE

Which of the following is especially characteristic of tall tales?

-) Exaggeration
-) Rhyme
-) Surprise endings
-) Symbolism

When describing the king of Assyria going into battle with his army, a poet has written, "The Assyrian came down like a wolf on the fold." The phrase "like a wolf on the fold" means like a wolf

-) who has been wounded
-) attacking sheep
-) howling at the moon
-) battling with another wolf

The phrase "like a wolf on the fold" is

-) an apostrophe
-) a paradox
-) an understatement
-) a simile

Questions 62-64 refer to the following passage. Read the passage carefully and then answer the questions.

Emily told Julia, "You know that I never say anything bad about anybody, but I think that Don is very conceited. I asked him to go to the party with me, and he said that he had to play basketball. As if the team really needed him!"

62. How does Emily feel about Don?
- (A) She is angry with Don.
 - (B) She is afraid of Don.
 - (C) She is eager to help Don make friends.
 - (D) She is certain that Don will see his mistake.
63. The only fact that we learn from Emily is that
- (A) Don is conceited
 - (B) Don has refused to go to a party with Emily
 - (C) Emily never says anything bad about anybody
 - (D) Don does not play basketball very well
64. Why did Emily say what she said about Don?
- (A) She dislikes him.
 - (B) She wants to warn Julia.
 - (C) She wants to get back at him for refusing her invitation.
 - (D) She thinks that Julia will go to the party with him.

-
65. The story of King Arthur and the story of Ichabod Crane are examples of
- (A) novels
 - (B) proverbs
 - (C) histories
 - (D) legends

IF YOU FINISH BEFORE TIME IS CALLED, CHECK YOUR WORK ON THIS TEST.



FORM QBC-

ENGLISH III-D (For Phase 3)

Time— 40 minutes

YOU ARE TO INDICATE ALL YOUR ANSWERS ON THE SEPARATE ANSWER SHEET. No credit will be given for anything written in the test book. After you have decided which of the suggested answers you want to give for a question, blacken the corresponding space on the answer sheet.

Example:

Chicago is a
 (A) state
 (B) city
 (C) country
 (D) continent

Sample Answer

A	B	C	D
<input type="checkbox"/>	<input checked="" type="checkbox"/>	<input type="checkbox"/>	<input type="checkbox"/>

Give only one answer to each question; no credit will be given for multiple answers. If you wish to change an answer, erase your first line completely and mark your new choice.

DO NOT OPEN THIS BOOK UNTIL YOU ARE TOLD TO DO SO.

Developed by Educational Testing Service pursuant to a subcontract funded by the U. S. Department of Health, Education, and Welfare, Office of Education.

SECTION I

SPELLING

Time—5 minutes

Directions: From each group below, select the word that is misspelled. Then on the answer sheet blacken the corresponding space. If all words in the group are spelled correctly, blacken space D. No group has more than one misspelled word.

1. (A) knives
(B) roofs
(C) chiefes
(D) no error
2. (A) wisely
(B) wizdom
(C) wizard
(D) no error
3. (A) dumb
(B) kingdom
(C) dominion
(D) no error
4. (A) senscational
(B) sensible
(C) descend
(D) no error
5. (A) cozy
(B) browze
(C) daze
(D) no error
6. (A) challenge
(B) parallel
(C) rellish
(D) no error
7. (A) hospital
(B) animal
(C) cannibal
(D) no error
8. (A) speach
(B) scream
(C) streak
(D) no error
9. (A) important
(B) pleasant
(C) correspondant
(D) no error
10. (A) hopefully
(B) carfully
(C) wishfully
(D) no error
11. (A) period
(B) idiot
(C) iodine
(D) no error
12. (A) consience
(B) patience
(C) sentence
(D) no error
13. (A) refusal
(B) quarrel
(C) resemble
(D) no error
14. (A) elephant
(B) telephone
(C) photograph
(D) no error
15. (A) interduction
(B) interesting
(C) interrupt
(D) no error
16. (A) genuine
(B) margin
(C) medicine
(D) no error

- handicap
- (B) handwriting
- (C) handiman
- (D) no error

- (A) treat
- (B) asleep
- (C) clean
- (D) no error

19. (A) mainl
(B) final.v
(C) tradit.only
(D) no error

20. (A) coffin
(B) offen
(C) soften
(D) no error

IF YOU FINISH BEFORE TIME IS CALLED, GO ON TO SECTION II.

SECTION II
LANGUAGE

Time—10 minutes

Directions: Each of the questions or incomplete statements below is followed by four suggested answers or completions. Select the one which is best in each case and then blacken the corresponding space on the answer sheet.

21. flammable—inflammable
ravel—unravel
passive—impassive

The pairs of words above are

- (A) synonyms even though the set to the right has negative prefixes
(B) antonyms because each word in the set to the right has a negative prefix
(C) not necessarily related in meaning at all
(D) different in meaning because they came into the language under different circumstances

22. The words youthful, beautiful, and painful suggest that -ful converts

- (A) nouns to verbs
(B) nouns to adjectives
(C) verbs to nouns
(D) verbs to adverbs

23. Over the fence is out.

What is the complete subject in this sentence?

- (A) Over
(B) fence
(C) out
(D) Over the fence

24. The presence in English of words like bamboo, calico, gingham, and shawl reflect English contacts with

- (A) Africa
(B) Europe
(C) South America
(D) Asia

25. All of the following have the same underlying structure as dull-witted EXCEPT

- (A) sharp-toothed
(B) double-jointed
(C) well-dressed
(D) even-tempered

26. I. You don't have any money, do you?
II. You have some money, don't you?

Which of the following describes the sentences above?

- (A) Both questions expect "no" answers.
(B) Both questions expect "yes" answers.
(C) Sentence I expects a "no" answer, sentence II a "yes" answer.
(D) Sentence I expects a "yes" answer, sentence II a "no" answer.

27. I. I'll walk home.
II. Mr. Warren shoveled the snow from his
III. The batter got a walk with the bases loaded

The use of the word walk in the above sentences demonstrates that

- (A) context may change the meaning of a word
(B) a word has only one meaning
(C) verbs were derived from nouns
(D) nouns were derived from verbs

Questions 28-30 refer to the following dictionary entry. Read the entry carefully and then answer the questions.

crimson (krĭm'z'n), n. [Sp. cremesín, ult. fr. Ar. qirmiz kermes, fr. Skr. krmi worm, insect.] Any of several colors, ranging in hue from red to bluish-red of high saturation and low brilliance. See COLOR.
-adj. Of the color crimson; hence, sanguinary; bloody.
-v. t. & i. To make or become crimson.

28. According to the dictionary entry, which of the following would come closest to the meaning of crimson?

- (A) Wet (B) Dim (C) Low (D) Red

GO ON TO THE NEXT PAGE

According to the dictionary entry, which of the following statements about crimson is true?

- (A) It can begin with either c or k.
- (B) It has at least two acceptable pronunciations.
- (C) It may be used as more than one part of speech.
- (D) It should usually be written with a capital letter.

According to the dictionary entry, all of the following are sources of the English word crimson EXCEPT

- (A) Spanish
- (B) French
- (C) Arabic
- (D) Sanskrit

Which of the sentences below is ambiguous?

- (A) Raving maniacs can be dangerous.
- (B) Blasting rocks can be dangerous.
- (C) Singing songs can be fun.
- (D) Playing cards can be expensive.

Which of the following sentences contains an appositive?

- (A) Mary Murray, the tennis champion, will speak at the rally.
- (B) Yes, Mary Murray is coming to the rally.
- (C) Mary Murray, who went to Central High, will speak at the rally.
- (D) She is the Mary Murray who won all the prizes for tennis.

Questions 33-35 refer to the following selection. Read the selection carefully and then answer the questions.

- (1) The Lord is my shepherd; I shall not want.
 - (2) He maketh me to lie down in green pastures;
 - (3) He leadeth me beside the still waters.
33. Which of the verbs in the selection above could be used as an intransitive verb when these words were written although it now normally calls for a direct object?
- (A) is (B) want (C) maketh (D) leadeth
34. In line 3, still can best be paraphrased as
- (A) eternal
(B) lasting
(C) quiet
(D) medicinal
35. Maketh and leadeth are
- (A) first person, present tense
(B) third person, present tense
(C) first person, past tense
(D) third person, past tense

IF YOU FINISH BEFORE TIME IS CALLED, GO ON TO SECTION III.

SECTION III
ENGLISH EXPRESSION

Time—10 minutes

Directions: Some of the following sentences are correct according to the requirements of standard written English. Some are incorrect. No sentence contains more than one error.

You will find that the error, if any, is underlined and lettered. Assume that all other elements of the sentence are correct and cannot be changed.

If there is an error, select the one underlined part that must be changed in order to make the sentence correct, and mark the corresponding space on the answer sheet.

If there is no error, mark answer space D.

See how these examples are marked:

EXAMPLES	ANSWERS
1. He spoke <u>bluntly</u> and <u>angrily</u> to <u>we</u> spectators. <u>No error</u>	1. <input type="checkbox"/> A <input type="checkbox"/> B <input checked="" type="checkbox"/> C <input type="checkbox"/> D
2. He works every day <u>so that he will</u> be <u>financially independent</u> in his old age. <u>No error</u>	2. <input type="checkbox"/> A <input type="checkbox"/> B <input type="checkbox"/> C <input checked="" type="checkbox"/> D

36. The foreman did not know what the reasons for the men's complaint was, but he agreed to do what he could for them. No error
37. Despite Coach Mather's fears, the plans for the game worked out excellent. No error
38. Miss Alden's students have hardly any homework to do. No error
39. We soon realized why Mrs. Franklin would not leave Clyde keep his chemistry set. No error
40. Should you fail to return a library book on time, a small fine will be imposed. No error
41. A sonic boom, like other explosive sounds is the result of an abrupt change in pressure. No error
42. The coat could not have fit Arnold better if it had been made especially for him. No error
43. One Floridian reported that the reason the bald eagle is dying out is that they eat fish poisoned by DDT. No error
44. When Jim has returned from the museum and he will be ready to give the class a report on the exhibit. No error

Whenever I find some spare time he would have
visited the local bowling alley and practiced
to improve his game. No error

The primary reason that there are so many auto-
 mobile accidents is not that modern automobiles
 are built bad. No error

Some industrial designers have claimed that the
 average European aircraft is superior over the
 average American plane. No error

"I'll call you," said the salesman, as soon as your
 order has been filled." No error

Because the senator saw the bank as already too
 powerful, he did everything he could to delay its
 further development. No error

The Calgore River splashes down a hillside and
 then flows quietly through a valley of very incom-
 parable beauty. No error

51. Scouts for basketball teams look for players who
 have the coordination to control the ball, unusual
 height, or they have great speed. No error

52. Unfortunately, Maria's voice produces not only
 lovely sounds, as well as tones that will make any
 listener wince. No error

53. When they investigated the lawyer's absence, the
 reporters discovered that he was meeting with
 Commissioner Dahlgren for the past two days.
No error

54. Dr. McNale's interpretation of the data is different
 from that offered by the two biologists in their
 recent articles. No error

55. During the earthquake not one of our workers left
 their machines despite the threat of serious injury.
No error

IF YOU FINISH BEFORE TIME IS CALLED, GO ON TO SECTION IV.

SECTION IV
LITERATURE

Time—15 minutes

Directions: Each of the questions or incomplete statements below is followed by four suggested answers or completions. Select the one which is best in each case and then blacken the corresponding space on the answer sheet.

56. In describing the king of Assyria going into battle with his army, a poet has written "The Assyrian came down like a wolf on the fold." The phrase "like a wolf on the fold" means like a wolf
- (A) who has been wounded
(B) attacking sheep
(C) howling at the moon
(D) battling with another wolf

57. The phrase "like a wolf on the fold" is
- (A) an apostrophe
(B) a paradox
(C) an understatement
(D) a simile

58. A story that makes fun of another story or of the way an author writes is called
- (A) a cartoon
(B) an epigram
(C) a parody
(D) an anecdote

Questions 59-61 refer to the following poem. Read the poem carefully and then answer the questions.

I see, and know not why,
Thorns live and roses die.

59. These lines ask why
- (A) men are false
(B) poverty is the lot of all men
(C) pain endures
(D) beauty is permanent
60. The form of these lines is that of
- (A) free verse
(B) a ballad stanza
(C) blank verse
(D) a rhymed couplet
61. In these lines, the roses stand for life's
- (A) hope
(B) beauty
(C) gaiety
(D) restlessness

62. A book of myths contains stories about
- (A) gods and goddesses
(B) pioneers
(C) cowboys and Indians
(D) ancient kings and queens

Questions 63-66 refer to the following passage. Read the passage carefully and then answer the questions.

- We crossed the sand hills near the scene of Indian stagecoach robbery and massacre of 1856 wherein the driver and guard perished, and all the passengers but one, it was supposed; but (5) this must have been a mistake, for at different times afterwards on the Pacific coast I was personally acquainted with a hundred and thirty-three people who were wounded during that massacre and barely escaped with their lives. There was no doubt of the truth of it—I had it from their own

63. The word "wherein" (line 3) refers to
- (A) sand hills (line 1)
(B) near the scene (line 1)
(C) robbery and massacre (line 2)
(D) 1856 (line 2)
64. The actual number of survivors of the massacre probably
- (A) none (B) one (C) 133 (D) 134
65. The statement "but this must have been a mistake" (lines 4-5) can best be described as
- (A) a tongue-in-cheek remark
(B) an overstatement
(C) an objective comment
(D) a slip of the tongue
66. Which of the following best sums up the point of the passage?
- (A) Travel was very dangerous in the 1850's.
(B) People like to believe that they were part of dramatic incidents.
(C) Small incidents are often exaggerated into massacres.
(D) Testimony from reliable witnesses is more trustworthy than hearsay.

Items 67-70 refer to the following poem. Read the poem carefully and then answer the questions.

The Waning Moon

Like a dying lady, lean and pale,
She totters forth, wrapped in a gauzy veil,
Out of her chamber, led by the insane
And feeble wanderings of her fading brain,
The moon arose up in the murky East,
White and shapeless mass.

- 67. The poem is a
 - (A) description of the rising moon
 - (B) lyric praising the antiquity of the moon
 - (C) query concerning the influence of the moon
 - (D) statement of the revulsion caused by the appearance of the moon

- 68. "Waning" in the title is reinforced by all of the following EXCEPT
 - (A) "dying lady, lean and pale" (line 1)
 - (B) "wrapped in a gauzy veil" (line 2)
 - (C) "her fading brain" (line 4)
 - (D) "The moon arose in the murky East" (line 5)
- 69. All of the following emphasize the regal qualities of the moon EXCEPT
 - (A) "lady" (line 1)
 - (B) "veil" (line 2)
 - (C) "chamber" (line 3)
 - (D) "East" (line 5)
- 70. The word "Waning" in the title refers to the moon
 - (A) after it has been full
 - (B) as it becomes full
 - (C) during the winter
 - (D) at sunrise

IF YOU FINISH BEFORE TIME IS CALLED, CHECK YOUR WORK ON THIS TEST.



ENGLISH IV-D (For Phase 4)

Time—40 minutes

YOU ARE TO INDICATE ALL YOUR ANSWERS ON THE SEPARATE ANSWER SHEET. No credit will be given for anything written in the test book. After you have decided which of the suggested answers you want to give for a question, blacken the corresponding space on the answer sheet.

Example:

Chicago is a
(A) state
(B) city
(C) country
(D) continent

Sample Answer

A B C D

Give only one answer to each question; no credit will be given for multiple answers. If you wish to change an answer, erase your first line completely and mark your new choice.

DO NOT OPEN THIS BOOK UNTIL YOU ARE TOLD TO DO SO.

Developed by Educational Testing Service pursuant to a subcontract funded by the U. S. Department of Health, Education, and Welfare, Office of Education.

SECTION 1

LANGUAGE

Time — 15 minutes

Directions: Each of the questions or incomplete statements below is followed by four suggested answers or completions. Select the one which is best in each case and then blacken the corresponding space on the answer sheet.

1. The initial consonant sound of visit is to be found in all of the following EXCEPT
 - (A) flivver
 - (B) of
 - (C) stevedore
 - (D) physics
 2. The words youthful, beautiful, and painful suggest that -ful converts
 - (A) nouns to verbs
 - (B) nouns to adjectives
 - (C) verbs to nouns
 - (D) verbs to adverbs
 3. Which of the following is NOT true of words such as therefore, however, and nevertheless?
 - (A) They are usually transition words.
 - (B) They can join independent clauses.
 - (C) They normally connect nouns in a series.
 - (D) They may appear at the beginning of sentences.
 4. The presence in English of words like bamboo, calico, gingham, and shawl reflect English contacts with
 - (A) Africa
 - (B) Europe
 - (C) South America
 - (D) Asia
 5. All of the following have the same underlying structure as dull-witted EXCEPT
 - (A) sharp-toothed
 - (B) double-jointed
 - (C) well-dressed
 - (D) even-tempered
- Questions 6-7 refer to the following sentences.
- I. The boy's family insists that he live in the dormitory.
 - II. The boy's family insists that he lives in the dormitory.
6. From sentence I it can logically be inferred that
 - (A) his family is insisting on what it believes to be a desirable arrangement
 - (B) he was living in the dormitory but is no longer living there
 - (C) although he cannot be found, his family is certain that he lives in the dormitory
 - (D) he has decided to live in a dormitory against the wishes of his family
 7. From sentence II it can logically be inferred that
 - (A) his family is insisting on what it believes to be a desirable arrangement
 - (B) he was living in the dormitory but is no longer living there
 - (C) although he cannot be found, his family is certain that he lives in the dormitory
 - (D) he has decided to live in a dormitory against the wishes of his family
 8. Do is emphatic in
 - (A) Do you need a new overcoat?
 - (B) I do need a new overcoat.
 - (C) I need a new overcoat, and you do too.
 - (D) They do overcoat repairs at the tailor shop.
 9. Miss Kent is too ----- for the job.
Which of the following words would complete the sentence above in the most flattering way?
 - (A) chiidish
 - (B) immature
 - (C) infantile
 - (D) young

Fitzgerald's title Tender Is the Night is syntactically unusual in that

- A) the predicate adjective precedes the verb
- B) the predicate noun precedes the verb
- C) Is lacks a subject
- D) Night is the object of Is

Which of the sentences below is ambiguous?

- A) Raving maniacs can be dangerous.
- B) Blasting rocks can be dangerous.
- C) Singing songs can be fun.
- D) Playing cards can be expensive.

Which of the following sentences contains an appositive?

- A) Mary Murray, the tennis champion, will speak at the rally.
- B) Yes, Mary Murray is coming to the rally.
- C) Mary Murray, who went to Central High, will speak at the rally.
- D) She is the Mary Murray who won all the prizes for tennis.

Questions 13-15. Read the selection carefully and then answer the questions.

- 1) The Lord is my shepherd; I shall not want.
- 2) He maketh me to lie down in green pastures.
- 3) He leadeth me beside the still waters.

Which of the verbs in the selection above could be used as an intransitive verb when these words were written although it now normally calls for a direct object?

- A) is (line 1)
- B) want (line 1)
- C) maketh (line 2)
- D) leadeth (line 3)

Line 3, still can best be paraphrased as

- A) eternal
- B) lasting
- C) quiet
- D) medicinal

maketh and leadeth are

- A) first person, present tense
- B) third person, present tense
- C) first person, past tense
- D) third person, past tense

16. In origin, the English nouns boss, coleslaw, cookie, Santa Claus and waffle are

- (A) Dutch
- (B) Irish
- (C) French
- (D) Australian

17. Which of the following has the same final sound as laughs?

- (A) dances
- (B) matches
- (C) sighs
- (D) talks

18. The writing symbols used by the ancient Egyptians are called

- (A) hieroglyphs
- (B) ideograms
- (C) runes
- (D) alphabets

19. Conjugating the verb speak reveals that in the present tense the form changes only in the

- (A) first person singular
- (B) second person singular
- (C) third person singular
- (D) third person plural

20. Miss Kent is too ----- for the job.

Which of the following words would complete the sentence in the most negative and critical way?

- (A) childish
- (B) immature
- (C) young
- (D) youthful

the history of the French has been determined in large part by the ownership of its land. No error

Even though we knew that Henry could not throw as far as Fred, we all hoped that the ball would get first base before the runner. No error

When Jim has returned from the museum and he is sure to report his opinion of the exhibit. No error

According to the principles he preached, the plain left his comfortable position and worked among the very poor. No error

During the Renaissance through the eighteenth century the countertenor was the most popular of singer in Europe. No error

Tomorrow our classmates would choose between you and I, but tonight no one could have guessed we were rivals. No error

"I'll call you," said the salesman, as soon as your car has been filled." No error

34. The engine of the new S6-X tanker is being studied carefully by a Senate committee because it will carry most of the crude oil imported by this country. No error

35. The man was obviously weak, nevertheless, he attempted to carry the box himself. No error

36. Scouts for basketball teams look for players who have the coordination to control the ball, unusual height, or they have great speed. No error

37. The commandant canceled all recreation periods until the prisoners were willing to give him the information he wanted. No error

38. Mrs. Norton is the teacher which has done most to show me how much fun mathematics can be. No error

39. You cannot be appointed as a postal clerk without you take the examination. No error

40. During the earthquake, not one of our workers left their machines despite the threat of serious injury. No error

IF YOU FINISH BEFORE TIME IS CALLED, GO ON TO SECTION III.



SECTION III
LITERATURE

Time—15 minutes

Directions: Each of the questions or incomplete statements below is followed by four suggested answers or completions. Select the one which is best in each case and then blacken the corresponding space on the answer sheet.

Questions 41-44 refer to the following poem. Read the poem carefully and then answer the questions.

Of Treason

Treason doth never prosper; what's the reason?
For if it prosper, none dare call it treason.

41. The poem is
- (A) a fable
 - (B) an epitaph
 - (C) a lyric
 - (D) an epigram
42. Which of the following is a sentiment similar to the statement of the poem?
- (A) An eye for an eye, a tooth for a tooth.
 - (B) Might makes right.
 - (C) Power corrupts, absolute power corrupts absolutely.
 - (D) Judge not, lest ye be judged.
43. The basic structure of the poem is
- (A) statement, illustration, conclusion
 - (B) observation, theory, proof
 - (C) statement, question, answer
 - (D) analysis, question, analysis
44. The word "prosper" means most nearly
- (A) grow
 - (B) succeed
 - (C) make money
 - (D) overcome

Questions 45-50 refer to the following passage. Read the passage carefully and then answer the questions.

The old criticism of life at sea—poor and bad conditions—is, in the main, no longer valid. Admittedly there are still a few of the older ships where the living accommodation leaves much to be desired, but these can't last much longer, nor will they be the subject of sentimental tears when they do finally end up at the breakers. Almost all new ships being built now have excellent quarters for every member of the crew. Food and victuals, whilst varying greatly from ship to ship and from company to company, is on the whole pretty fair. It is to be hoped that the days of skimping and saving on ships' catering bills are on the way out.

45. The passage is best described as
- (A) expository
 - (B) descriptive
 - (C) narrative
 - (D) anecdotal
46. All of the following contribute to the informal style of the passage EXCEPT
- (A) "can't" (line 5)
 - (B) "excellent quarters" (line 8)
 - (C) "skimping and saving" (line 12)
 - (D) "on the way out" (line 13)
47. In relation to the first sentence, the second sentence serves to
- (A) provide a specific illustration
 - (B) contradict
 - (C) qualify a generalization
 - (D) compare

GO ON TO THE NEXT PAGE

beginning of the last sentence is

forceful
tentative
emotional
metaphoric

author is most probably a

professional seaman
designer of sailing ships
ship owner
tourist who frequently travels by ship

major point of the passage is that

sailors deserve good food and quarters
things are better at sea, but life on the land is
still better
conditions at sea have improved, but even more
improvements can be made
life aboard ship is still monotonous, no matter
how comfortable it has become

ory that makes fun of another story or of the
an author writes is called

a cartoon
an epigram
a parody
an anecdote

Questions 52-55 refer to the following poem. Read the poem carefully and then answer the questions.

The Waning Moon

And like a dying lady, lean and pale,
Who totters forth, wrapped in a gauzy veil,
Out of her chamber, led by the insane
And feeble wanderings of her fading brain,

- (5) The moon arose up in the murky East,
A white and shapeless mass.
52. The poem is a
- (A) description of the rising moon
(B) lyric praising the antiquity of the moon
(C) query concerning the influence of the moon
(D) statement of the revulsion caused by the appearance of the moon
53. All of the following emphasize the regal qualities of the moon EXCEPT
- (A) "lady" (line 1)
(B) "veil" (line 2)
(C) "chamber" (line 3)
(D) "East" (line 5)
54. The word "Waning" in the title refers to the moon
- (A) after it has been full
(B) as it becomes full
(C) during the winter
(D) at sunrise
55. "Waning" in the title is reinforced by all of the following EXCEPT
- (A) "dying lady, lean and pale" (line 1)
(B) "wrapped in a gauzy veil" (line 2)
(C) "her fading brain" (line 4)
(D) "the moon arose up in the murky East" (line 5)

IF YOU FINISH BEFORE TIME IS CALLED, CHECK YOUR WORK ON THIS TEST.

APPENDIX B

PROPOSED STUDENT PROFILE

310

English	100000	100000	100000	100000	100000	100000	100000	100000	100000
Math	100000	100000	100000	100000	100000	100000	100000	100000	100000
Science	100000	100000	100000	100000	100000	100000	100000	100000	100000
Soc Stud	100000	100000	100000	100000	100000	100000	100000	100000	100000
Other	100000	100000	100000	100000	100000	100000	100000	100000	100000

1967

1967	English										Math										Science										Soc Stud										Other									
	100000	100000	100000	100000	100000	100000	100000	100000	100000	100000	100000	100000	100000	100000	100000	100000	100000	100000	100000	100000	100000	100000	100000	100000	100000	100000	100000	100000	100000	100000	100000	100000	100000	100000	100000	100000	100000	100000	100000	100000										

1968	English	Math	Science	Soc Stud	Other
100000	100000	100000	100000	100000	100000

1968	100000	100000	100000	100000	100000	100000	100000	100000	100000	100000	100000	100000	100000	100000	100000	100000	100000	100000	100000	100000	100000	100000	100000	100000	100000	100000	100000	100000	100000	100000	100000	100000	100000	100000	100000	100000	100000	100000	100000	100000	100000
------	--------	--------	--------	--------	--------	--------	--------	--------	--------	--------	--------	--------	--------	--------	--------	--------	--------	--------	--------	--------	--------	--------	--------	--------	--------	--------	--------	--------	--------	--------	--------	--------	--------	--------	--------	--------	--------	--------	--------	--------	--------

100000	100000	100000	100000	100000	100000	100000	100000	100000	100000	100000	100000	100000	100000	100000	100000	100000	100000	100000	100000	100000	100000	100000	100000	100000	100000	100000	100000	100000	100000	100000	100000	100000	100000	100000	100000	100000	100000	100000	100000	100000	100000	100000
--------	--------	--------	--------	--------	--------	--------	--------	--------	--------	--------	--------	--------	--------	--------	--------	--------	--------	--------	--------	--------	--------	--------	--------	--------	--------	--------	--------	--------	--------	--------	--------	--------	--------	--------	--------	--------	--------	--------	--------	--------	--------	--------



	yr1	yr2	yr3
Math.
Science
Social Studies
Other

A. DAT SCORES

yr1	yr2	yr3
100	100	100
90	90	90
80	80	80
70	70	70
60	60	60
50	50	50
40	40	40
30	30	30
20	20	20
10	10	10

Verbal
 Math
 Reading
 Science
 Social Studies
 Writing
 Total

	yr1 FAV	yr1 UNF	yr2 FAV	yr2 UNF	yr3 FAV	yr3 UNF
Arts	C		C		C	
Physical	C		C		C	
Other	C		C		C	

B. Expressed major aptitudes

	0	1	2	3	4	5	6	7	8	9
...



Grade 4 Student Achievement Report

Student Name	Grade	Reading	Language Arts	Math	Science	History	Physical Education	Art	Music	Other

4. Final Student Grade Tracking

Final Student Achievement Report

Reading	Verbal
Lang.	Quant.
Arith.	Total
Co.	
Arith.	
Dr. Test	
Science	
Other	

Final Predictions for Next Semester

English	
Math	
Science	
Studies	
Other	

FILMED FROM BEST AVAILABLE COPY

S										
D										
E										
C										
L										
I										
D.										

