

DOCUMENT RESUME

ED 056 557

FL 002 467

AUTHOR Oh, Choon-Kyu
TITLE Aspects of Korean Syntax: Quantification, Relativization, Topicalization, and Negation.
INSTITUTION Hawaii Univ., Honolulu. Dept. of Linguistics.
PUB DATE Aug 71
NOTE 235p.; Doctoral dissertation published in Working Papers in Linguistics, v3 n3 Jun 1971

EDRS PRICE MF-\$0.65 HC-\$9.87
DESCRIPTORS *Connected Discourse; *Deep Structure; Doctoral Theses; Grammar; *Korean; Linguistic Theory; Negative Forms (Language); *Semantics; Sentences; Surface Structure; Syntax; Transformation Generative Grammar; Transformations (Language); *Transformation Theory (Language)

ABSTRACT

By offering solutions to long-standing problems like quantification, relativization, topicalization, and negation in Korean syntax, the present dissertation aims to show the limitations of any approach which concentrates on the sentence as a linguistic unit or which takes semantics to be interpretative. One possible solution suggested here is a topic-by-topic approach, with the idea that there are two basic types of sentences: introductory sentences which introduce the existence of an object or fact, and other sentences which assert things other than the existence of that item. Chapter two covers quantification; chapter three discusses restrictive and non-restrictive clauses; chapter four considers topicalization; and chapter five deals with negation. Appendix one discusses formal constraints on the deletion of reflexive pronouns and considers the role of presupposition in grammar in the area of pronominalization by deletion. Other appendixes list the rules used in the paper and Korean particles. A bibliography is included.
(Author/VM)

From: Working Papers in Linguistics; Vol. 3,
No. 3, June 1971.

ASPECTS OF KOREAN SYNTAX: QUANTIFICATION, RELATIVIZATION,
TOPICALIZATION, AND NEGATION

A DISSERTATION SUBMITTED TO THE GRADUATE DIVISION OF
THE UNIVERSITY OF HAWAII IN PARTIAL FULFILLMENT
OF THE REQUIREMENTS FOR THE DEGREE OF

DOCTOR OF PHILOSOPHY

IN LINGUISTICS

AUGUST 1971

U.S. DEPARTMENT OF HEALTH, EDUCATION & WELFARE
OFFICE OF EDUCATION

THIS DOCUMENT HAS BEEN REPRODUCED EXACTLY AS RECEIVED FROM THE
PERSON OR ORGANIZATION ORIGINATING IT. POINTS OF VIEW OR OPINIONS
STATED DO NOT NECESSARILY REPRESENT OFFICIAL OFFICE OF EDUCATION
POSITION OR POLICY.

BY

Choon-Kyu Oh

Dissertation Committee:

Charles-James N. Bailey, Chairman
Lewis S. Josephs
Gary J. Parker

ED056557

FL 002 467

Copyright © 1971

by Choon Kyu Oh

**"PERMISSION TO REPRODUCE THIS
COPYRIGHTED MATERIAL HAS BEEN GRANTED
BY Choon-Kyu Oh**

**TO ERIC AND ORGANIZATIONS OPERATING
UNDER AGREEMENTS WITH THE U.S. OFFICE OF
EDUCATION. FURTHER REPRODUCTION OUTSIDE
THE ERIC SYSTEM REQUIRES PERMISSION OF
THE COPYRIGHT OWNER."**

DEDICATION

To my teacher

Charles-James Nice Bailey, who has been probably the first thesis chairman with so much interest and care in his student and who has awoken in me an intensive interest in the search of the principles of language, and

to my wife

Soung-Ei Oh, who has willingly and lovingly taken the severe ordeal of four years, sacrificing almost everything that belongs to her, and even financially supporting my study with the money exchanged with painful labor,

I dedicate this thesis with deep appreciation.

FOREWORD

One of my most pleasant experiences as a faculty member and as a co-editor of these Working Papers has been the supervising of Choon-Kyu Oh's doctoral dissertation. This student's innate knack for handling the complex materials of modern generative semantics has enabled him in a brief eight months of concentrated labor to produce a work that will make many contributions to the theory of generative semantics. I have been mainly concerned with putting all relevant materials into Oh's hands and with questioning his proposals in any way in which I have thought they were weak, since I have had to leave the technicalities of Korean syntax to my colleague Lewis Josephs. Both of us, together with Gary Parker, the other co-editor of this publication, have gone over every word in this writing with as critical an eye as possible. The result is one that we feel has few weaknesses and many strengths. We are pleased to commend it to the readers of this series with the certainty that they will find many things in it to interest and profit them. We sincerely hope that Oh will reap the rewards of his diligence and remain true to the quality of work he has exhibited here.

C.-J. N. Bailey

ABSTRACT

Chomsky used to claim that only the syntactic component is generative, while the phonological and semantic components are interpretative. The base component was supposed to be solely responsible for meaning, and transformations were not supposed to change meaning. As the discipline of linguistics has advanced since then, we have come to see the limitations of this approach, and linguists such as Lakoff, Ross, and McCawley have claimed that the semantic component is generative. Since the adoption of generative theory in syntactic analysis, almost all linguistic arguments have centered around the sentence. However, this sentential approach has resulted in the insolubility of many problems, such as pronominalization, topicalization, quantification, relativization, and negation.

By offering better solutions to long-standing problems like quantification, relativization, topicalization, and negation in Korean syntax, the present dissertation aims to show the limitations of any approach which concentrates on the sentence as a linguistic unit or which takes semantics to be interpretative. It is true that at the present stage there are still many problems to be solved within the generative-semantic, discourse-centered approach (the problem of deciding the boundary of a discourse being only one of them). One possible solution suggested here is a topic-by-topic approach--viz. the view that there are two basic types of sentences: an introductory sentence which introduces

the existence of an object or fact, and other sentences which assert things other than the existence of that item. The same sentence can be introductory for one NP and non-introductory for another NP in the larger sentence. Naturally, an introductory sentence is ordered before the other types of sentence.

In Chapter Two, Carden's analysis of quantification is reviewed and its limitations are indicated and circumvented. It is shown how the concept of the introductory sentence enables the grammar correctly to predict and explain many problems related to quantification. The validity of the suggested approach is tested on negating and interrogating sentences which contain quantifiers and other indefinite phrases consisting of an adjective plus a noun. Carden's explanations of the peculiar properties of quantifiers observed by him are carried further by showing that quantifiers cannot be predicates of introductory sentences. Adjectives which occur in a non-introductory sentence are negated exactly the way adjectives are when moved into an introductory sentence by a rule that generates non-restrictive relative clauses, which rule is also responsible for moving quantifiers. In Chapter Three, restrictive and non-restrictive relativizations are discussed. Different underlying structures are suggested for them and justified. RESTRICTIVE-RELATIVE-CLAUSE FORMATION is shown to be a copying rule. It copies an introductory sentence into the following sentence. This copying rule is the opposite of the rule, NON-RESTRICTIVE-RELATIVE-CLAUSE FORMATION, except that the former

is not a simple permutation rule.

The definition of definiteness adopted in this dissertation suggests a neat solution to an age-old problem in Korean--nin and ka as subject particles (the counterparts of Japanese wa and ga), which is discussed in Chapter Four. In Chapter Five, the author shows how a NEG-INCORPORATION rule is needed for the correct description of negation in Korean. In an Appendix, the role of presupposition in grammar is illustrated with one of the major processes in Korean syntax, pronominalization by deletion.

The writer tries to show throughout how the generative-semantic approach alone can handle in a natural manner the problems discussed here, by importing the notion of presupposition into syntax.

LIST OF ABBREVIATIONS*

COM	COMITATIVE
DIR	DIRECTIONAL
DLM	DELIMITER
NEG	NEGATIVE MARKER
NOM	NOMINALIZER
NT	NOT-TRANSPORTATION
O	OBJECT-MARKER
PL	PLURALIZER
Q	QUANTIFIER
QT	QUOTATIONAL
QUES	QUESTION
REL	RELATIVIZER
RET	RETROSPECTIVE
S	SUBJECT-MARKER
T	TOPIC-MARKER

*For the names of rules, see Appendix II.

TABLE OF CONTENTS

ABSTRACT	iii
LIST OF ABBREVIATIONS	vi
Chapter I INTRODUCTION	1
Chapter II QUANTIFICATION	4
2.1 Introduction	4
2.11 NOT-TRANSPORTATION	4
2.12 Verb of denial in Korean and English	10
2.13 EQUI-NP DELETION and REFLEXIVIZATION	13
2.14 CONJUNCTION REDUCTION	20
2.2 The derivation of indefinite NP's modified by adjectives	31
2.21 Other negations and questions	40
2.22 EQUI-NP DELETION and REFLEXIVIZATION	49
2.23 CONJUNCTION REDUCTION	56
Chapter III RELATIVIZATION	60
3.1 Introduction	60
3.11 Introductory sentence and related matters	62
3.12 RESTRICTIVE CLAUSE FORMATION and the definiteness of NP's	66
3.13 NR-FORMATION	87
3.2 Some possible objections	95
3.21 Direction of embedding in NR-FORM and the problem of ambiguity of a NR	96
3.22 Stacked restrictive relative clauses	103

3.3	Other related problems	110
3.31	Derivation of generic nouns	111
3.32	Identity and referentiality of NP ^s	119
3.33	Implications made by the hierarchy of anaphora ..	124
Chapter IV	TOPICALIZATION	127
4.1	Introduction	127
4.11	Definite NP and TOPICALIZATION	129
4.12	Further restriction on TOPICALIZATION	134
4.13	TOPICALIZATION as a postcyclic rule	139
4.14	Restriction on the applicability of TOPICALIZATION	144
4.2	The so-called objective <u>ka</u> (or <u>ga</u>)	148
Chapter V	NEGATION	159
5.1	Introduction	159
5.2	The NEG-TRANSPORTATION approach	161
5.21	The illegitimacy of NT with <u>hata</u>	162
5.22	The theoretical implications of <u>ha</u> -DELETION	169
5.3	The NEG-INCORPORATION approach	173
5.31	The correct derivation of negation	177
5.32	Justification of the NEG-INCORPORATION	178
APPENDIX I	FORMAL CONSTRAINTS ON THE DELETION OF REFLEXIVE PRONOUNS	185
APPENDIX II	LIST OF RULES	197
APPENDIX III	LIST OF KOREAN PARTICLES	199
NOTES	201
BIBLIOGRAPHY	218

CHAPTER ONE: INTRODUCTION

In writing the present dissertation, the writer has kept the following goals in mind: to show some of the limitations of concentrating on the sentence in the description of a language and of excluding semantics from the generation of sentences, as well as to show how some long-standing problems in Korean can be handled with new insights in a non-ad-hoc manner. The writer mostly follows the abstract approach to syntactic analysis of linguists like Lakoff, Ross, and McCawley, with slight modifications, particularly in the manner of utilizing discourse information in formulating transformational rules: I have used presuppositional information in the structural description of transformational rules, as well as in the conditions on their applicability. Recently, the advantages of discourse analysis have been noticed by grammarians like Longacre and his followers, but they have unfortunately not taken full advantage of the discoveries and insights made available by generative-transformational theory.

To achieve the goals mentioned at the outset, the writer has chosen to discuss the most controversial problems in language description today--quantification and relativization, which are dealt with in Chapters Two and Three, respectively--employing both Korean and English data to illustrate and corroborate arguments. It is the author's belief that such deep processes as quantification and relativization are shared among languages throughout the world. But because of this, the rules in this writing are

formulated in such a way that the similarities between the English and Korean formulations stand out conspicuously. Explicit characterizations of such terms as definiteness, specificity, and correferentiality have been necessitated in order to account for various aspects of quantification and relativization which have been obscured by the loose use of such terms in the past.

I have introduced a new concept, the introductory sentence (abbr. intro-S), which is either asserted or presupposed in a discourse. This has been done with a view to clarifying the definiteness of NP's. An intro-S is a sentence which establishes or registers the knowledge of the existence of any fact or thing denoted by a certain NP. Once this knowledge has been registered in the mind of a hearer, that NP becomes definite. If the knowledge that a speaker possesses has not been shared with a hearer, then such an NP is merely specific, not definite. NP's have to be at least [+ specific] and also identically indexed to be correferential, as will be shown.

Many linguists have noticed the limitations of current theory, particularly in its distinction between optional and obligatory rules. There has been no formal mechanism to indicate the degree of optionality of a rule. The author has not supplied any such mechanism in the present work, but has at least attempted to show some of the characteristics of optionality. Very few rules are optional in the sense of being in absolutely free variation. Most rules which have been known to be optional are in fact rules

concerning which speakers do not share the presupposition which conditions the applicability of the rule in question (for a concrete example, see Appendix I).

I have been able to explain the long-debated question regarding the difference between nin and ka (Japanese wa and ga, respectively) by clarifying the feature [definite] and by introducing distinct formal and material functions of NP's. If an NP carries new information in a sentence, it is used formally; otherwise, materially. It is shown in Chapter Four that only materially-used NP's can be topicalized by attaching nin. Although negation in Korean has drawn much attention from Korean syntacticians, most of their writings have been merely descriptive, and hardly explanatory. The utilization of logical formulations in linguistic description, advocated by G. Lakoff and McCawley, has enabled the author to account for many facts concerning Korean negation that have so far been neglected.

It is the author's humble hope that this work will contribute to the study of syntax by introducing certain phenomena from Korean syntax to non-Korean linguists that will lead to greater clarification of the principles of generative grammar and perhaps of the analysis of English itself. I also hope to make modern discoveries of generative semantics more easily available to Korean grammarians.

CHAPTER TWO: QUANTIFICATION

Introduction

2.1. In his attempt to explain some idiosyncratic behavior of quantifiers (abbr. Q), Carden (1970) distinguished between post- and pre-determiner Q's and identified post-determiners with other adjectives.¹ He claimed that the pre-determiners were higher predicates in the deep structure which are lowered to the pre-determiner position by his lowering rule. However, it appears that the same distinction made between post- and pre-determiner Q's is to be made in other adjectives as well. A review of Carden's arguments for a higher-predicate analysis of Q's in the light of Korean data reveals that the distinction made for Q's should not be made in terms of their position before or after the determiner, as Carden did, but in terms of the definiteness of the NP's which they modify.² Although Carden's arguments are for English, it will be shown that the same principle which accounts for English quantification also accounts for Korean quantification. In the sections that follow, Korean data will be contrasted with corresponding English data.

2.11. NOT TRANSPORTATION (abbr. NT). Carden (39-40) claims that a pre-determiner Q is negated by a negative marker (abbr. NEG) attached to a not-transportation (NT) verb, but other kinds of adjectives which occur in a complement clause after a NT verb are not negated by such a NEG on the NT-verb.³ In other

words, 1a is synonymous with 1b, but not with 1c; and 2a with 2b, but not with 2c; ex. 3a, however, is synonymous not with 3b, but with 3c:

- (1) a. John doesn't think the attractive girls left.
 b. John thinks the attractive girls stayed (= did not leave).
 c. John thinks the unattractive girls left (not attractive).
- (2) a. John doesn't think the many girls left.
 b. John thinks the many girls stayed.
 c. John thinks the few girls left.
- (3) a. John doesn't think that many (of the) girls left.
 b. John thinks that many girls stayed.
 c. John thinks that not many girls left.

Carden (40-41) further argues that the Q many which is negated in 3c must come from a higher predicate in the deep structure, since the NEG attached to a NT-verb negates the highest predicate in the complement sentence, as shown here:

- (4) a. John doesn't think that the boys who left will catch the train.
 b. John thinks that the boys who left will not catch the train.
 c. John thinks that the boys who stayed will catch the train.

The correctness of the above generalization is clearly demonstrated by the fact that 4a is synonymous with 4b, but never with 4c. However, in order to ascertain the correctness of the distinction

between a pre-determiner Q, on the one hand, and a post-determiner Q and all other adjectives, whether definite and indefinite, on the other hand, let us investigate some parallel cases in Korean.

In Korean, the scope of a NEG depends on the presence or absence of the particle n̄n 'delimiter' (abbr. DLM) after the nominalizer.⁴ If the particle is present, the scope of a NEG includes the entire complement; otherwise, only the highest predicate of the complement sentence is negated. (Full discussion of the various kinds of negation is postponed until Chapter Five.) Only two types are considered for present purposes. Thus, the following two sentences--the first with n̄n and the second without it--are not synonymous, as indicated by the English translations:

(5) John-ka ka-ci ani-hayessta

John-S go-NOM not-did

'John did not go (= 'John stayed').

(6) John-ka ka-ci-n̄n ani-hayessta

John-S go-NOM-DLM not-did

'It is not the case that John went.'

Now, consider the following:

(7) a. ¹John-ka ka-n-kes-n̄n ani-ita

John-S go-REL-thing-DLM not-is

'It was not John who went.'

b. John-ka ká-n-kes-n̄n ani-ita

'John did not go.'

- (8) a. ká yeyppi-n yeca-ka nathana-n-kes-nin ani-ita
 the pretty-REL girl-S appeared-REL-thing-DLM not-is
 'It was not the pretty girl who appeared.'
- b. ká yeyppi-n yeca-ka náthana-n-kes-nin ani-ita
 'The pretty girl did not appear.'
- (9) a. yeyppi-n yeca-ka nathana-n-kes-nin ani-ita
 'It was not pretty girl(s) that appeared.'
- b. *yeyppi-n yeca-ka náthana-n-kes-nin ani-ita
 ?'Pretty girls did not appear.'
- (10) a. mánhá-n salam-ka ka-n-kes-nin ani-ita
 Many-REL people-S went-REL-DLM not-is
 'It was not many people that went.'
- b. *manhá-n salam-ka ká-n-kes-nin ani-ita
 ?'Many people did not go.'

In 7 and 8, the embedded subjects are definite, whereas those of 9 and 10 are indefinite. This definite-vs.-indefinite distinction in the subject NP's of embedded sentences seems to be responsible for the difference in the readings of 7 and 8, on the one hand, and 9 and 10, on the other hand; that is, with the former, the NEG outside the complement sentence can negate either the subject or the predicate of the embedded sentence, depending on where the heaviest accent is. Only the accented part is negated. However, only one interpretation is possible for an indefinite subject NP of an embedded sentence, viz. NEG always negates the subject NP.

For additional support of the above analysis, let us consider one other kind of negation:

- (11) a. Jóh^h-ka kassta-ko-n^hn sayngkakha-ci ani-hanta
 John-S went-QT-DLM think-NOM not-do
 'I do not think that it was John that went.'
- b. John-ka kássta-ko-n^hn sayngkakha-ci ani-hanta
 'I think that John did not go.'
- (12) a. ká^h yeyppi-n yeca-tá^hl-ka nathanassta-ko-n^hn sayngkakha-ci
 the pretty-REL girl-PL-S appeared-QT-DLM think-NOM
 ani-hanta
 not-do
 'I do not think that it was the pretty girls that
 appeared.'
- b. ká^h yeyppi-n yeca-tá^hl-ka náthanassta-ko-n^hn sayngkakha-ci
 ani-hanta
 'I think that the pretty girls did not appear.'
- (13) a. má^hnh^h-n salam-tá^hl-ka kassta-ko-n^hn sayngkakha-ci
 many-REL man-PL-S went-QT-DLM think-NOM
 ani-hanta
 not-do
 'I do not think that it was many men that went.'
- b. *má^hnh^h-n salam-tá^hl-ka kássta-ko-n^hn sayngkakha-ci
 ani-hanta
 'I think that many men did not go.'
- (14) a. yé^hyppi-n yeca-tá^hl-ka nathanassta-ko-n^hn sayngkakha-ci
 ani-hanta
 'I do not think that it was pretty girls that appeared.'

(14) b. *yeyppi-n yeca-tɨl-ka nathanassta-ko-nin sayngkakha-ci
ani-hanta

'I think that pretty girls did not appear.'

Again, in 11 and 12, which have surface sentence subjects which are definite, the most heavily accented words are negated--either the subject or the predicate of the complement sentence. But in 13 and 14, which have indefinite subjects, the predicate of the complement (viz. kassta or nathanassta) cannot be negated with a NEG attached to an NT-verb of the matrix clause. Thus, both the (a) and (b) sentences of 11 and 12 are grammatical, whereas the (b) sentences of 13 and 14 are not.

What is important here is that a distinction is not drawn between pre-determiner Q and the rest, but between definite and indefinite subjects, regardless of whether they are modified by Q or some other kind of modifier. Carden's higher-predicate analysis seems to be applicable not only to 10 and 13, but also to 9 and 14, where a non-Q adjective modifies an indefinite subject.

Does this insight from Korean syntax apply also to English? The question seems to be a reasonably simple one, if we consider 15:

- (15) a. John doesn't think that attractive girls left.
b. John thinks that attractive girls stayed.
c. John thinks that non-attractive girls left.

For 15a, the interpretation seems to proceed in the following manner: the universe of girls is divided into two groups; attractive ones and non-attractive ones. If the embedded subject

were definite, as in 1a, our topic would be limited to that definite group. All that 1a says is that none of the attractive group left and we do not commit ourselves to any further information in this sentence. On the other hand, since the embedded subject is not definite in 15a, this sentence carries--in addition to the information that none of the attractive group left--the sense that some girl(s) left and that girl (or those girls) must therefore belong to the non-attractive group. In other words, 15a is synonymous with 15c--not with 15b, as would be expected, if Carden's analysis were correct. In short, if the higher-predicate analysis applies to any pre-determiner Q, it should also apply to all indefinite NP's modified by any adjective.

2.12. Verb of denial in Korean and English.⁵ Carden (41-42) has claimed for 16 and 17, but not 18, that we have to presuppose the existence of Whig candidates and many candidates, respectively, but deny that they won.

(16) John denies that the Whig candidates won.

(17) John denies that the many candidates won.

(18) John denies that many candidates won.

On the other hand, 18 presupposes that there are candidates who won, and denies that there were many of them. At this point, we may profitably return to further data from Korean:

(19) a. John-nin Mary-ka cukess-im-lil puinhayessta

John-T Mary-S died-NOM-O denied

'John denied that it was Mary that died.'

(19) b. John-n_n Mary-ka cúkess-_{im}-l_{il} puinhayessta

'John denied that Mary died.'

(20) a. John-n_n k_i tases/manh_i-n haksayng-ka ikyess-_{im}-l_{il}

John-T the five/many-REL students-S won-NOM-O

puinhayessta

denied

'John denied that it was the five/many students that

won.'

b. John-n_n k_i tases/manh_i-n haksayng-ka ikyess-_{im}-l_{il}

puinhayessta

'John denied that the five/many students won.'

(21) a. John-n_n k_i yeyppi-n yeca-ka nathanass-_{im}-l_{il}

John-T the pretty-REL girl-S appeared-NOM-O

puinhayessta

denied

'John denied that it was the pretty girl that appeared.'

b. John-n_n k_i yeyppi-n yeca-ka nathanass-_{im}-l_{il}

puinhayessta

'John denied that the pretty girl appeared.'

(22) a. John-n_n manh_i-n/tases haksayng-ka cukess-_{im}-l_{il}

John-T many-REL/five students-S died-NOM-O

puinhayessta

denied

'John denied that it was many students that died.'

b. *John-n_n manh_i-n haksayng-ka cúkess-_{im}-l_{il} puinhayessta

'John denied that many students died.'

- (23) a. John-nán yeyppé-n yoca-ka náthanas-s-é. l-l puinhayessta
 John-T pretty-REL girl-S appeared-10 -0 denied
 'John denied that it was pretty girls that appeared.'
- b. *John-nán yeyppé-n yoca-ka náthanas-s-é. -l-l puinhayessta
 'John denied that pretty girls appeared.'

As we see here, numerals seem to behave much like Q's, and so do indefinite NP's modified by descriptive adjectives. In 19-21, where the underlined NP's are definite, we have ambiguity as to which part of the embedded sentence is negated. This ambiguity again will be removed by auxiliary devices, viz. prosodic features. In 22 and 23, however, only the adjective or Q modifying the subject NP is negatable; note that yeyppé-n 'pretty' in 23 is not even a Q. The special treatment of Q, as opposed to descriptive adjectives, seems to lose ground at this point. This is not due to a syntactic phenomenon peculiar to Korean, as is shown by the following parallel English sentences:

(24) John denies that rich candidates won.

(25) John denies that the rich candidates won.

Although the speaker assumes in 25 that there were rich candidates and denies their having won, in 24 he denies that the assumed victorious candidates were rich. In the latter case, rich behaves just like Carden's pre-determiner Q. If it can be justified that many in 18 is derived from the predicate of an underlying higher sentence, the same process may legitimately be inferred for the derivation of 24.

2.13. EQUI-NP DELETION and REFLEXIVIZATION. Carden (45)

makes the following peculiar claim concerning 26:

What is important to the present argument is that, in sentences like ([26a]), where the identical, co-referential noun phrases are modified by a true adjective ("Whig"), the following facts hold: A. The sentence without deletion ([26a]) is ungrammatical. B. The sentence without deletion ([26a]) is synonymous with the sentence with deletion ([26b]).

Carden claims further that the same is true of only a post-determiner Q (as in 27); but that neither 'fact A' nor 'fact B' is true of a pre-determiner Q (as in 28):

(26) a. *The Whig candidates_i expect the Whig candidates_i to be elected.

b. The Whig candidates expect to be elected.

(27) a. *The many candidates_i expect the many candidates_i to be elected.

b. The many candidates expect to be elected.

(28) a. All the candidates_i expect all the candidates_i to be elected.

b. All the candidates expect to be elected.

Now, let us turn to Korean data:

(29) a. moti-n kyoin-tal-nin_i moti-n kyoin-tal-ka_i chenkuk-ey
all-REL believer-PL-T all-REL believer-PL-S heaven-to
ka-l-kes-lal kitayhanta
go-REL-thing-O expect

'All believers expect all believers to go to heaven.'

(29) b. moti-n kyoin-til-nin (caki-ka) chenkuk-ey ka-l-kes-lil
kitayhanta

'All believers expect to go to heaven.'

*(30) a. *John-nin_i John-ka_i chenkuk-ey ka-l-kes-lil kitayhanta

*'John_i expects John_i to go to heaven.'

b. John-nin (caki-ka) chenkuk-ey ka-l-kes-lil kitayhanta

'John expects to go to heaven.'

In Korean, the deletion of any embedded NP correferential with the matrix NP seems to be semantactically conditioned in most cases. This matter is fully discussed in the next chapter. But, for the present purpose, I will consider only instances in which the deleted NP or reflexive pronoun is correferential with the matrix NP. Thus, even though 30a is ungrammatical, or at least very unnatural, a forced interpretation could make it synonymous with 30b. On the other hand, 29a is not only grammatical, but semantically different from 29b. This seems to correspond well with the above generalization of Carden's. However, one very interesting phenomenon is revealed in the use of the reflexive pronoun in 29b: when the NP in the embedded sentence is correferential with the NP in the matrix sentence, the reflexive pronoun should be singular, as in 29b. If a plural form is used, exact correferentiality is lost.

Unlike English, Korean allows what I propose calling inclusive as well as exclusive reflexivization. Inclusive reflexivization is the replacement of a singular NP with a plural reflexive pronoun. Exclusive reflexivization is the replacement of

a singular NP with a singular reflexive pronoun. These processes are respectively illustrated in 31 and 32:

(31) John-n̄n caki-ney-ka ikilila-ko mitko-issta

John-T (him)self-PL-S win-QT believe

'John believes that they (lit. 'themselves'; i.e. his own group) will win.'

(32) John-n̄n caki-ka ikilila-ko mitko-issta

'John believes that he himself will win.'

In 31, caki-ney (or -t̄l) may mean 'John and those with him', understood as fellow-students in his school or the like. With the distinction between inclusive and exclusive reflexivization clarified, we can easily explain why ambiguity exists only in 29, but not in 30. For it is only in 29a that the two varieties of reflexivization are possible. In other words, both types of reflexivization are allowed only where the subject is not definite, which fact is made clear in the following sentences:

(33) a. Samoa-salam-n̄n Samoa-salam-ka moyoktangha-n̄n-kes-l̄l

Samoa-people-T Samoa-people-S be-ridiculed-REL-thing-O

mos-chamn̄nta

cannot-stand

'Samoans cannot bear to have Samoans ridiculed.'

b. Samoa-salam-n̄n caki-ney-ka moyoktangha-n̄n-kes-l̄l

mos-chamn̄nta

'Samoans cannot bear to have their fellow people ridiculed.'

(33) c. Samoa-salam-nān (caki-ka) moyoktangha-nān-kes-lāi
mos-chamñanta

'Samoans cannot bear to have themselves ridiculed.'

(34) a. yongkamha-n salam-nān yongkamha-n salam-lāi chanmihanta
brave-REL people-T brave-REL people-O admire

'Brave people admire brave people.'

b. *yongkamha-n salam-nān caki-ney (or -tāi)-lāi

brave-REL people-T self-PL-O

chanmihanta

admire

c. yongkamha-n salam-nān caki-lāi chanmihanta

'Brave people admire themselves (= 'Every brave man admires himself').

When an indefinite member of a presupposed grouping is chosen as the subject of the higher sentence, a correferential subject of the embedded sentence may be reflexivized exclusively (i.e. in the singular form), as in 33c; if the subject of an embedded sentence is correferential with only part of the group denoted by any NP in the higher sentence, then reflexivization is inclusive, as illustrated in 33b. If a grouping is not presupposed, inclusive reflexivization is rendered impossible; e.g. 34b. But even in such instances, a non-pronominalized repetition of the NP is allowed only where inclusive reflexivization would have been permitted. It seems that 33a and 34a are parallel to 35 and 36, respectively:

- (35) a. John-n_in_i John-ka_j moyoktangha-n_in-kes-l_il mos-chamn_inta
 'John_i cannot bear to have John_j ridiculed.'
 b. John-n_in (caki-ka) moyoktangha-n_in-kes-l_il mos-chamn_inta
 'John cannot bear to be ridiculed.'
- (36) a. John-n_in_i John-l_il_j chanmihanta
 John-T John-O admire
 'John_i admires John_j.'
 b. John-n_in caki-l_il chanmihanta
 'John admires himself.'

Just as the use of the identical NP John without correferentiality does not justify pronominalization in 36a, so the use of the identical NP yongkamha-n salam 'brave man' cannot justify pronominalization in 34a--either in the form of a reflexive pronoun or of complete deletion--unless the identical expression presupposes some sort of grouping, in which case inclusive reflexivization is allowed. Exs. 33 and 34 also show that Carden's (45) generalization, quoted at the beginning of this section, is also applicable to a 'true' adjective as well as a pre-determiner Q, only if the NP is indefinite.

To recapitulate, the factor that determines the deletability of repeated NP's (e.g. 26-28) and the applicability of exclusive reflexivization (e.g. 29, 30, 33, and 34) is not the modifying function of a Q, but rather the definiteness of the NP modified. That this is not peculiar to Korean is evident from the following English sentences:

(37) a. Blonde girls expect blonde girls to be specially treated.

b. Blonde girls expect to be specially treated.

Even though a true adjective occurs in 37, neither A or B in Carden's generalization quoted on page 13 holds. In short, Carden seems to have been wrong in assuming that the two uses of Whig candidates and all candidates in 26a and 28a are correferential. They are not. What Carden calls 'fact A' and 'fact B' in the quotation above both hold true only when the NP modified by an adjective--Q or not--is definite; if the NP is indefinite, neither claim holds.

With this misconception about correferentiality corrected, we can revise the generalization concerning sentences like 26-28. The following facts hold if and only if identical NP's in a matrix sentence and in a sentence embedded in it are correferential:

A. Sentences without deletion are ungrammatical. B. Sentences without deletion are synonymous with sentences which have undergone the deletion of the NP in question. Furthermore, when the NP construction is definite, the non-correferential NP's refer to two different groups or to separate individuals; whereas when the NP construction is indefinite, the non-correferential NP's refer to different members of a group.

Furthermore, the definite-indefinite distinction becomes logically impossible with NP's modified by a universal Q, such as all and every. Thus, the syntactic difference between 28a and 28b

reflects the following semantic difference: 28a can be paraphrased as 38a, and 28b as 38b; these in turn may be represented in logical terms as 39a and 39b, respectively:

- (38) a. There is a candidate such that he wants all the candidates to be elected, and that is true of all the candidates.
- b. There is a candidate such that he wants to be elected, and that is true of all the candidates.
- (39) a. $(\forall x) ((\forall y) [x \text{ want } y \text{ be elected}])$
- b. $(\forall x) (x \text{ want } [x \text{ be elected}])$

Carden (46) made the same claim for REFLEXIVIZATION as for EQUI-NP DELETION. Sentences without reflexivization are ungrammatical when identical correferential NP's occur within a single sentence. But Carden claimed this to be true only of NP's that are modified by true adjectives or post-determiner Q's, as in 41 and 42:

- (41) a. *The foolish men_i pity the foolish men_i.
- b. The foolish men pity themselves.
- (42) a. *The many men_i pity the many men_i.
- b. The many men pity themselves.
- (43) a. All the men_i pity all the men_i.
- b. All the men pity themselves.
- (44) a. John pities John.
- b. John_i pities himself (= John_i).

The two occurrences of men in 43a are not correferential at all,

just as the two identical NP's in 44a are not.

2.14. CONJUNCTION REDUCTION. So far, I have been treating reasonably clear-cut cases. But the dichotomy between definiteness and indefiniteness of NP's is not sufficient adequately to account for the following. An additional feature is required.

(45) a. Good rules_i are explicit, and good rules_i are easy to read.

b. Good rules are (both) explicit and easy to read.

(46) a. Few (of the) rules_i are explicit, and few (of the) rules_i are easy to read.

b. Few (of the) rules are (both) explicit and easy to read.

(47) a. The few rules_i are explicit, and the few rules_i are easy to read.

b. The few rules are explicit and easy to read.

Carden (48) claims that 45a and 47a, where the noun-modifiers are not pre-determiner Q's, are amenable to conjunction reduction without involving any change in the meaning, whereas with 46a, where a pre-determiner Q is found, conjunction reduction changes the sense even when the two subjects are correferential. But in what sense are they correferential? Below, I will provide an explicit definition of correferentiality which will ensure that non-correferential subjects will not be subject to conjunction reduction. The lack of synonymy between 46a and 46b, as opposed to the synonymy of 45a with 45b and 47a with 47b, does not seem to come from the fact that 46 alone has a pre-determiner Q, as Carden

would like to argue. This is convincingly demonstrated in 48:

(48) a. All the good rules_i are explicit, and all the good rules_i are easy to read.

b. All the good rules are (both) explicit and easy to read.

Even though the noun-modifier in question here is a pre-determiner Q, conjunction reduction is possible without any apparent change in meaning.

However, the analytical task has not yet been completed. So far, we have only managed to explain some problems in terms of definiteness and a somewhat clearer understanding of correferentiality, though without being really explicit. Some further questions that should be answered are the following: How does one know whether NP's are correferential or not? And what is the correlation between correferentiality and definiteness? The subjects in 47a and 48a are definite and correferential, while those in 45a and 46b are indefinite and correferential. Clearly, indefiniteness does not entail non-correferentiality. Why should this be so? This leads us to a two-dimensional scale rather than the single distinction between definite and indefinite NP's. The additional distinction that crosses the other seems to be a distinction between 'specific' and 'non-specific'.⁶ There are four logical possibilities: [+ definite, + specific], [+ definite, - specific], [- definite, + specific], and [- definite, - specific]. Definiteness in the sense used here signifies what is already registered in the knowledge of both the speaker and the hearer.

Specificity signifies something which, although not necessarily registered in the knowledge of the hearer, nevertheless has a determined identification. This definition logically obviates the possibility of the combination [+ definite, - specific] from ever occurring. In other words, definiteness implies specificity, although the converse is not necessarily true. Proper nouns, for example, are definite, and therefore necessarily specific.

Now, we can define correferentiality as the relation between NP's which are identically indexed and are both [+ specific], regardless of whether they are definite or not; e.g. the subjects of 47a and 48a, which are both definite, are correferential. But NP's do not have to be definite to be correferential, as is shown by the subjects of 45b and 46b--which are [+ specific] but not [+ definite]. The subjects of 46a, however, are not even [+ specific] and therefore are not correferential; consequently, they cannot be definite. Let us turn to some relevant Korean data:

(49) a. yek-ey-to manh^h-n salam-ka iss-ko, keli-eyse-to manh^h-n
 station-at-loc many-REL people-S are-and street-on-too
 salam-ka poiessta
 many-REL people-S were-seen
 'Many people were at the station, and many people were
 seen on the street.'

b. manh^h-n salam-ka yek-ey-to iss-ko keli-eyse-to poiessta
 'Many people were at the station and also were seen on
 the street.'

- (50) a. ecey-to manhi-n salam-ka oass-ko, neyil-to manhi-n
 yesterday-too many-REL people-S came-and tomorrow-too
 salam-ka o-lkesita
 many-REL people-S will-come
 'Many people came yesterday, and many people will come
 tomorrow.'
- b. manhi-n salam-ka ecey-to o-ass-ko neyil-to o-lkesita
 many-REL people-S yesterday-too came-and tomorrow-too
 will-come
- (51) a. hakkyo-ey-to mikuk-salam-ka iss-ko, samuso-ey-to
 school-at-too American-people-S are-and office-at-too
 mikuksalam-ka pointa
 Americans-S are-seen
 'Americans are at the school, and Americans are to be
 seen at the office.'
- b. mikuk-salam-ka hakkyo-ey-to iss-ko samuso-eyse-to
 American-people-S school-at-too are-and office-at-too
 pointa
 are-seen
- (52) a. ecey-to John-ka oass-ko, neyil-to John-ka o-lkesita
 Yesterday-too John-S came-and tomorrow-too John-S will-come
 'John came yesterday, and John will come tomorrow.'
- b. John-ka ecey-to oassko neyil-to o-lkesita
 John-S yesterday-too came-and tomorrow-too will-come

Each of the pairs of sentences in 49-52 is synonymous, despite

differences in definiteness and also in specificity. These, however, should not be considered to be counterexamples to what has been claimed above. For in Korean, as long as some contrasted items (e.g. the [b] sentences of 49-52) are overtly present in the conjuncts, correferentiality is not required for further reduction (viz. reduction by CONJUNCTION REDUCTION) to occur. But when such items are not present, correferentiality seems to be the determining factor in deletion, as illustrated below:

(53) a. manhi-n kyoin-ka sul-lil mek-ko, manhi-n kyoin-ka

many-REL believers-S liquor-O eat-and many-REL

nolim-lil hanta

believers-S gambling-O do

'Many believers drink, and many believers gamble!'

b. manhi-n kyoin-ka sul-lil mek-ko nolim-lil hanta

(54) a. manhi-n hakca-ka Latine-lil malha-ko, manhi-n

many-REL scholars-S Latin-O speak-and many-REL

hakca-ka Latine-lil ssanta

scholars-S Latin-O write

'Many scholars speak Latin, and many scholars write

Latin.'

b. manhin hakca-ka Latine-lil malha-' Latine-lil ssanta

c. manhi-n hakca-ka Latine-lil malha-ko ssanta

For these Korean data, one might postulate two different 'dialect' groupings: Group A consists of those speakers for whom only correferential NP's are deletable; Group B, those for whom non-

correferential NP's can also be deleted and for whom, as a consequence, the (b) sentences of 53 and 54 may be ambiguous. For those in Group A, the (a) and (b) sentences of 53 and 54 are never synonymous. For both groups, 54b can be further reduced to 54c only if the NP's in question are correferential; the (a) sentences can never be grammatical with correferential NP's.⁷ In other words, for Group A, the (a) sentences have disjunctive, while the (b) sentences have conjunctive, co-ordination. For those in Group B, the co-ordination in the (a) sentences is disjunctive; the co-ordination in the (b) sentences, either conjunctive or disjunctive. For instance, 53a can only mean for either group that many believers either get drunk or gamble. Ex. 53b, however, can mean for Group A that many believers both get drunk and gamble. Both interpretations of 53b are possible for Group B, so that this sentence can mean either that many believers either get drunk or gamble, or that many believers both get drunk and gamble.

But the characteristics of 53, where Q is used, are also found in 55 and 56, where true adjectives are used:

(55) a. pangthangha-n salam-ka sul-lil mek-ko, pangthangha-n

corrupt-REL people-S liquor-O eat-and corrupt-REL

salam-ka nolim-lil hanta

people-S gambling-O do

'Corrupt people drink, and corrupt people gamble.'

b. pangthangha-n salam-ka sul-lil mek-ko nolim-lil hanta

'Corrupt people drink and gamble.'

(56) a. milyen^ha-n salam-ka khal-l^l kal-ko, milyen^ha-n salam-ka
 foolish-REL people-S sword-O sharpen-and foolish-REL
 khal-l^l hwitul^hnta
 people-S sword-O flourish

'Foolish men sharpen the sword, and foolish men flourish
 the sword.'

b. milyen^ha-n salam-ka khal-l^l kal-ko khal-l^l hwitul^hnta

'Foolish men sharpen the sword and flourish the sword.'

c. milyen^ha-n salam-ka khal-l^l kal-ko hwitul^hnta

'Foolish men sharpen and flourish the sword.'

(57) a. kⁱ yeyppⁱ-n yeca-ka sul-l^l mek-ko, kⁱ yeyppⁱ-n yeca-ka
 the pretty-REL girl-S liquor-O eat-and the pretty-REL
 nol^hm-l^l hanta

girl-S gambling-O do

'The pretty girl drinks, and the pretty girl gambles.'

b. kⁱ yeyppⁱ-n yeca-ka sul-l^l mek-ko nol^hm-l^l hanta

'The pretty girl drinks and gambles.'

(58) a. John-ka sul-l^l mek-ko, John-ka nol^hm-l^l hanta

'John drinks, and John gambles.'

b. John-ka sul-l^l mek-ko nol^hm-l^l hanta

'John drinks and gambles.'

Only when the subjects of 56a are correferential can 56b be further
 reduced to 56c for all speakers. However, in 57 and 58, where
 definite and correferential NP's are found, a disjunctive
 interpretation--that the pretty girl either drinks or gambles, or

that John either drinks or gambles--is impossible for both sentences.

But what causes so-called 'dialectal' discrepancies like the above? The NP's in question in 55 and 56 are the kind that are called generic here. The term generic seems to have been used to denote two completely different things, as is illustrated in the following sentences:

(59) kolay-n̄n pholyutongmul-i-ciman, sange-n̄n mulkoki-ita
 whales-T mammalian-are-but sharks-T piscine-are
 'The whale is mammalian, but the shark is piscine.'

(60) John-n̄n kh̄i-ciman, Tom-n̄n cakta
 John-T tall-but Tom-T short
 'John is tall, but Tom is short.'

(61) kolay-ka yeki-ey-to iss-ko, kolay-ka ceki-ey-to issta
 whales-S here-too are-and whales-S there-too are
 'There are whales here, and there are whales there too.'

One use of generic denotes an entire class as opposed to what is not in the class. Contrary to popular belief, the generics that are used this way are as definite as proper nouns (compare the subjects of 59 and 60). We may say that kolay 'whale' is a name for the whole class, as John is a name for an individual. The other use of the term refers to part of the membership of a class denoted by a common noun, in which case the generic is indefinitely used, as in 61. The first type, denoting a representation of an entire class, will be hereafter termed representative-generic; the latter, denoting a representation of part of membership of a class,

partitive-generic.⁸ Incidentally, this explains why Kuno (1970:I-4) has grouped definite NP's and generic NP's into a single class, which can be foregrounded with the postposition wa in Japanese. It also explains why Carden (ch.1, n. 4) puts generics into the same group as Q's. Kuno was referring to representative-generics, and Carden, to both types of generic.

Returning to 55 and 56, if the subjects of the (a) sentences are representative-generic, naturally the sentences are synonymous with the (b) sentences. Otherwise, if the subjects are not correferential, conjunction reduction is impossible. However, there are some speakers of Korean that would allow conjunction reduction even when partitive-generics are not correferential, provided that ambiguity is logically impossible--as in 62-64. But for most speakers, the (b) sentences of 62-64 are unacceptable as reduced forms of the (a) sentences:

- (62) a. manh̃-n salam-ka cuk-ko, manh̃-n salam-ka pusang-l̃l
 many-REL people-S died-and many-REL people-S injury-O
 ipessta
 got
 'Many people died, and many people got injured.'
- b. *manh̃-n salam-ka cuk-ko pusang-l̃l ipessta
 *'Many people died and got injured.'

- (63) a. yeyppi-n yeca-ka nolay-lil puliess-ko, yeyppi-n yeca-ka
 pretty-REL girls-S songs-O sang-and pretty-REL girls-S
 piano-lil chiessta
 piano-O played
 'Pretty girls sang songs, and pretty girls played the
 piano.'
- b. *yeyppi-n yeca-ka nolay-lil pulless-ko piano-lil
 chiessta
 'Pretty girls sang songs and played the piano.'
- (64) a. sey salam-ka cukess-ko, sey salam-ka pusang-lil ipessta
 three men-S died-and three men-S injury-O got
 'Three men died, and three men got injured.'
- b. *sey salam-ka cukess-ko pusang-lil ipessta
 *'Three men died and got injured.'

To sum up, conjunction reduction is possible only when the subject NP's are correferential. When the correferentiality of two NP's is not explicitly indicated either positively or negatively-- i.e. when a Q, a numeral, or a descriptive adjective is the modifier of a [- specific] NP--a reduced sentence has the conjunctive reading of its predicates (e.g. 53b and 54b). But an unreduced sentence has the disjunctive reading of the predicates (e.g. 53a and 54a). The disjunction in the latter case can be either inclusive or exclusive. If exclusive, the reduced and unreduced sentences cannot be synonymous. If inclusive, they may be synonymous.

2.15. Questions. Carden (48) claimed that only when a pre-determiner Q is involved, as in 65b, does an interrogative

sentence question a modifier. Otherwise, it questions the highest predicate of the sentence. But what about ex. 66, where a non-Q adjective modifies the indefinite NP? The modifier of girls is a true adjective, viz. pretty, and yet the sentence cannot question the highest predicate, apply, without also questioning the descriptive adjective:

- (65) a. Did the cholera patients survive? (Questions survive.)
 b. Did many patients survive? (Questions many.)
 c. Did the many patients survive? (Questions survive.)
- (66) Did pretty girls apply?

In Korean, marked (unexpected) and unmarked (normal) accent indicates what part of a sentence is questioned. Thus:

- (67) a. k^í khollela hwanca-t^íl-ka salanamass-o? (Marked accent)
 the cholera patient-PL-S survived-QUES
 'Was it the cholera patients that survived?'
- b. k^í khollela hwanca-t^íl-ka s^íalanamass-o? (Unmarked accent)
 'Did the cholera patients survive?'
- (68) a. k^í yeyp^í-n yeca-t^íl-ka ^íngmohayess-o? (Marked accent)
 the pretty-REL girl-PL-S applied-QUES
 'Was it the pretty girls that applied?'
- b. k^í yeyp^í-n yeca-t^íl-ka ^íngmohayess-o? (Unmarked accent)
 'Did the pretty girls apply?'
- (69) a. y^íeyp^í-n yeca-t^íl-ka ^íngmohayess-o? (Marked accent)
 'Were the girls who applied pretty?'
- b. *y^íeyp^í-n yeca-t^íl-ka ^íngmohayess-o? (Unmarked accent)
 'Did pretty girls apply?' (Questions apply.)

(70) a. manhi-n yeca-til-ka ingmohayess-o? (Marked accent)

many-REL girl-PL-S applied-QUES

'Was it many girls that applied?'

b. *manhi-n yeca-til-ka ingmohayess-o? (Unmarked accent)

'Did many girls apply?' (Questions apply.)

From the descriptions so far given, the reader will probably have gathered that correferentiality--i.e. identical indexes on [+ specific] NP's--is the determining factor in EQUI-NP DELETION and CONJUNCTION REDUCTION, where two or more NP's are involved, whereas a difference in definiteness is a sufficient condition for different interpretations when only one NP is involved. Since sentences 67-70 have only one subject, the conditioning factor in them is definiteness. As the translations show, in the (a) sentences of 67 and 68--where the subject NP's are definite--both (b) and (c) readings are possible with the different (marked and unmarked) accents. In 69 and 70, whose subject NP's are indefinite, only the (b) readings are possible, since one cannot talk about something whose existence is not presupposed in either the physical or an imaginary universe.

The derivation of indefinite NP's modified by adjectives.

2.2. So far, we have used Carden's own arguments to prove that the anomalous characteristics of pre-determiner Q's are not peculiar to Q's but are true of all indefinite NP's modified by adjectives. It has just been assumed that Carden's higher-predicate analysis was correct for these. But it would be well not to accept

this too hastily, in the absence of a search for counterevidence.

There seem to be two different classes of predicate adjectives: (A) those which can have both definite and indefinite subjects; and (B) those which can have only definite subjects.

- (71) a. *Man is many.
 b. *Men are many.
 c. Those men were many.⁹
 d. The men who came were many.

- (72) a. Man is tough.
 b. (Certain) men are tough.¹⁰
 c. Those men were tough.
 d. The men who came were tough.

Many, five, and the like are of the second group; and tough, pretty, and so on are of the first group. In other words, definiteness in a noun has to be established by some previous sentence for a (B) adjective to be used with that noun, as illustrated by 73 below:

- (73) a. (Certain) men died; and the men were many.
 b. *(Certain) men were many; and they died.

Suppose 73a is stated by X and negated by Y, as in 74.

- (74) X: (Certain) men died; and the men who died were many.
 Y: You are wrong.

Since we are dealing with two conjuncts, we can think of three logical possibilities for the scope of negation: negation of the first conjunct only, negation of the second conjunct only, and negation of both conjuncts. But as shown below, one possibility

(viz. a) is in fact logically ruled out:

- (75) a. *It is not true that (certain) men died; and the men were many.
- b. (Certain) men died; and it is not true that the men were many.
- c. It is not true that (certain) men died; and it is not true that the men were many.

Ex. 75a is inconceivable because the ground for the proposed definiteness of the second occurrence of men is absent. The negation of the first conjunct entails the impossibility of the second conjunct. Out of three mathematical possibilities, we are left with only two: negation of both conjuncts, or negation of the second conjunct. Similar arguments could be made for (A) adjectives; note, therefore, the following:

(76) X: (Certain) men got hurt; and those men were left behind.

Y: You are wrong.

(77) a. *The statement that (certain) men got hurt is not true; and those men were left behind.

b. (Certain) men got hurt; and it is not true that those men were left behind.

c. It is not true that (certain) men got hurt; and it is not true that those men were left behind.

Ex. 77a is ungrammatical since the existence of the men is negated in the first sentence. In other words, if any existential assertion of an NP is negated in a conjunct, the following conjuncts do not

contain verbs that have the NP as their subject until the existence of the NP has been established again. This seems to present itself as a strong candidate for a universal aspect of language. Exactly the same patterns as in English are found in Korean:

(78) a. *(etten) salam-t̃il-ka manhassta

certain man-PL-S were-many

*'(Certain) men were many.'

b. yeki-ey o-n salam-t̃il-ka manhassta

here-to came-REL man-PL-S were-many

'The people who came here were many.'

c. k̃i salam-t̃il-ka motu-iessta

the man-PL-S were-all

? 'The people were all.'¹¹

(79) a. (etten) salam-t̃il-nin kanghayessta

certain man-PL-T were-strong

'(Certain) men were strong.'

b. yeki-ey o-n salam-t̃il-ka kanghayessta

here-to came-REL man-PL-S were-strong

'The men who came here were strong.'

c. k̃i salam-t̃il-ka kanghayessta

the man-PL-S were-strong

'The men were strong.'

In Korean, in contrast with English, the use of the definitizer, k̃i 'the', is limited to situations where definiteness is conditioned by overt expressions (i.e. not entailed by an

unexpressed presupposition). Karttunen (1971:29-30) lists the following as the non-linguistic environments conditioning the use of the definite article in English (the numbering is mine):

- (80) Anything in the immediate environment of the speaker and the hearer towards which their attention is directed becomes a discourse referent whether it has been explicitly mentioned or not.
- (81) In every discourse, there is a basic set of referents which are known to exist although their existence has neither been asserted nor observed during the discourse itself. This set is determined by the common understanding the participants believe they share with regard to their environment.
- (82) A discourse referent is established without any explicit introduction, provided that its existence can be inferred with some degree of certainty from the existence of another referent by an implication with which the listener supposedly is familiar. The status of the derived referent is the same as that of its premise.

The above general characterizations are illustrated below by the sentences which are identically numbered:

- (80') a. 1. The roof is leaking.
 2. Look at the picture on the wall.
 3. Fetch him out of the bed.
- o. 1. cipung-ka saynta
 roof-S leaks
 'The roof leaks.'
2. pyek-wi-iy kɨlim-lɨl po-la
 wall-on-of picture-O look-IMP
3. kɨ-lɨl chimtay-eyse kkɨcipenay-la
 him-O bed-from fetch-out-IMP

(81') a. 1. Man can (now) go to the moon.

2. He went to see the doctor.

3. Mary went to the beach.

b. 1. inkan-ka tal-ey kanta

man-S moon-to goes

2. ki-nin iysa-eykey kassta

he-T doctor-to went

3. Mary-nin haysuyokcang-ey kassta

Mary-T beach-to went

(82') a. 1. I was driving on the freeway the other day when suddenly the engine began to make a funny noise. I stopped the car, and when I opened the hood, I saw that the radiator was boiling.

b. 1. yocennal kosoktolo-lil tallin-in-tey kapcaki eyncin-ka
 the-other-day highway-O was-running-and suddenly
 isangha-n soli-lil nay-ki-sicakhayessta. cha-lil
 engine-S strange-REL noise-O make-NOM-began car-O
 mec-ko hus-lil ye-ni latieytha-ka kkilh-ko-issessta
 stopped-and hood-O opened-and radiator-S was-boiling

Note that ki is not added before any of the underlined NP's which were definitized in English. None of the above three generalizations by Karttunen is valid for Korean.

In the previous section, definiteness was defined as what is assumed to be registered in the knowledge of both the speaker and the hearer. Thus, in an example like 83a below, the existence of

the book is already known to the speaker--in our terms, it is specific--but not yet known to the addressee. After 83a is said to the person addressed, the existence of the book is also registered in his mind, and is therefore definite. Correferentiality has been defined as what is identically-indexed and [+ specific]. Indefinite NP's can be correferential, as is shown by the reflexivization and pronominalization found in 83b and 83c, respectively:

- (83) a. I bought a book yesterday; and I lent the book to John.
 b. A man killed himself last week.
 c. A man killed his wife in the town today.

The above discussion has made clear, I hope, the differences between Korean k̄i and English the which cause so many mistakes in English when it is spoken by native speakers of Korean, and which explain why English speakers put superfluous k̄i's in their Korean. To reiterate, Koreans do not use k̄i except when a registering in the knowledge of the hearer is overtly caused by the speaker, either by previous utterances or by deictic expressions (e.g. 84b and 84c). Thus, the underlined words below are definite: the first is definitized by a previous linguistic utterance; and the rest, by deictic expressions, most probably with pertinent gestures:

- (84) a. nay-ka ecey chayk-l̄l sassn̄n-tey, k̄i chayk-l̄l John-ka
 I-S yesterday book-O bought-and the book-O John-S
 pillyekassta
 borrowed-from-me
 'I bought a book yesterday, and John borrowed it from me.'

(84) b. *i chayk-lil ilke-la*

this book-O read-IMP

'Read this book.'

c. *ce chayk-lil ili kaceo-la*

that book-O here bring-IMP

'Bring that book here.'

Both i 'this' and ce 'that' are used when the indicated items are present to both speaker and addressee. The particle i is used with reference to closer items, while ce is used for more distant ones. The definite-marker ki 'the' seems to be possible only when an NP has been overtly registered in the knowledge of the addressee by the speaker through some previous linguistic expression.¹² In the next chapter, I discuss extensively how ki can be considered to be the pro-form of a restrictive relative clause. I assume that Karttunen's generalizations as to definitization are universal. For although definite NP's are not overtly marked in Korean output sentences, the definiteness of NP's is revealed in relativization and topicalization. Returning to 78 and 79, the ungrammaticality of 78a results from the fact that manhta 'be many' is a (B) adjective and therefore cannot have an indefinite NP as its subject.

Even though overt marking of definiteness is a language-particular matter, as is clearly demonstrated by the difference between what is found in Korean and what is found in English, the verb feature $[[\pm \text{definite}] \text{ ____}]$ seems to be universal. Thus, 85b is ungrammatical for the same reason that 73b is ungrammatical:

(B) adjectives cannot be predicates of the first occurrence of any NP unless the ground for definitization is supplied by extra-linguistic means, as in exs. 80-82. One simply does not use (B) adjectives as predicates of sentences which establish the existence of the particular item in question.

(85) a. (etten) salam-t̄l-ka cukessta; k̄ilentey k̄i salam-t̄l-ka

certain man-PL-S died and the man-PL-S

manhassta

were-many

'(Certain) men died; and the men were many.'

b. *(etten) salam-t̄l-ka manhassta; k̄ilentey k̄i salam-t̄l-ka

certain man-PL-S were-many and the man-PL-S

cukessta

died

*'(Certain) men were many; and the men died.'

There are only two possibilities of negating 85a: either the negation of the whole statement or that of the second conjunct, but never the negation of only the first. Thus, 86a is synonymous with 86c, but never with 86b below:

(86) a. (etten) salam-t̄l-ka cukess-ko k̄i salam-t̄l-ka

certain man-PL-S died-and the man-PL-S

manhassta-ko-ha-ciman, k̄i kes-n̄in sasil-ka ani-ita

were-many-QT-say-but the thing-T fact-S not-is

'It was said that (certain) men died and the men were

many; but it is not true.'

(86) b. *(etten) salam-t̄l-ka cukessta-ko-ha-n̄n-kes-n̄n sasil-ka
 certain man-PL-S died-QT-say-REL-thing-T fact-S
 ani-ita; k̄ilentey k̄i salam-t̄l-ka manhassta
 not-is and the man-PL-S were-many
 'It is not true that (certain) men died; but the men were
 many.'

c. (etten) salam-t̄l-ka cukessta; k̄ilentey k̄i salam-t̄l-ka
 certain man-PL-S died and the man-PL-S
 manhassta-ko-ha-n̄n-kes-n̄n sasil-ka ani-ita
 were-many-QT-say-REL-thing-T fact-S not-is
 '(Certain) men died; but it is not true that the men
 were many.'

Ex. 86b is ungrammatical for the reason that is given above. I will now turn to justifying what I have merely described in section 2.1.

2.21. Other negations and questions. Carden recognized the intricate relations between definiteness of subject NP's and Q's, but did not notice that what I am calling (A) adjectives also behave in the same way. He recognized, in effect, that when Q's occur before the determiner they are not only indefinite but non-specific. Q's, which are the predicates of a higher underlying sentence according to the Lakoff-Carden hypothesis, should be the predicates of definite subject-NP's. This will be illustrated in 87b, the logical transcription of 87a below:

(87) a. (Certain) men left; I do not think that the men were many.

b. ((Certain) men left) • (I think [~[(the) men were many]]))

According to De Morgan's Theorems, $\sim(p \cdot q) \equiv \sim p \vee \sim q$.

So far as the truth value of a statement is concerned, we are left with three possibilities: $\sim p$, $\sim q$, or $(\sim p \cdot \sim q)$. But I have already discussed how $\sim p$ implies $(\sim p \cdot \sim q)$ when the occurrence of an NP establishes its existence in the first conjunct and the NP is repeated in the following conjunct. Therefore, there are only two possibilities of negating a sentence like 74: either negating both conjuncts, as in 75c, or negating only the second conjunct, as in 75b. Sentence 75c, however, is implied by 75a, which negates only the first conjunct.¹³ But interesting apparent counterexamples to what are given in Karttunen (10) are quoted as 88 below:

- (88) a. Peter said that John did not catch a fish and eat the fish for supper.
- b. George did not steal an apple and eat it.
- c. John did not buy a bracelet, nor did he give the bracelet to Mary.

These sentences look anomalous because they have negative markers on both conjuncts, despite the fact that the negation of the first conjunct should imply that of both conjuncts. In other words, negation is redundantly marked in 88. This is, however, not a real counterexample, since this redundant marking is used only when one is negating a conjunction both conjuncts of which have been claimed by others. This is not even exceptional, for each conjunct in any conjunction would have to carry NEG to be negated: Only the first conjunct of 89a is negated in 89b, just because NEG occurs

only in the first conjunct; both conjuncts are negated in 89c simply because NEG occurs in both conjuncts in that example.

- (89) a. John likes reading; and he dislikes swimming.
 b. John does not like reading; and he dislikes swimming.
 c. John does not like reading; but he does not dislike swimming.

If the negation had not been redundantly marked, 88 would have been ungrammatical for the same reason that makes 75a ungrammatical.

Another difficulty with the proposals being put forward here arises when the correferential NP's in the conjuncts are all definite, as in 90a. This has been correctly described by Carden (56) as derived from 90b. In the following sections, I hypothesize that all the embeddings under discussion are derived from underlying conjunctions. In examples like 90, $\sim(p \cdot q)$ is equivalent to $\sim p \vee \sim q \vee (\sim p \cdot \sim q)$; $\sim p$ does not imply $(\sim p \cdot \sim q)$. Why then is it that the NEG attached to a NT-verb, think, negates only left in the following examples?

- (90) a. I don't think that the five men left.
 b. I don't think that the men, who were five (in number), left.

Two solutions, which are not mutually exclusive, suggest themselves. One explanation would be that most, if not all, non-restrictive relative clauses are outside the tree containing the matrix sentence. In other words, they are mostly interpolations by the speaker, almost like a performative declaration. According to this proposal, 90b would have 91a as its deeper structure. The

logical transcription would be 91b:

(91) a. I don't think that the men left; and the men were five
(in number).

b. (I think [\sim [the men left]]) . ((the) men five (in number))

To make this point clearer, I would like to state what probably has been always assumed: all restrictive relative clauses definitize head nouns. To put it differently, no already definite NP's may be modified by restrictive relative clauses. So 92 could be used only when two or more John's are presupposed to exist in the shared knowledge of speaker and hearers:

(92) I am not talking about the John who is Mary's brother, but
the John who is Tom's brother.

According to this analysis, all the restrictive relative clauses should have come from the first conjunct, where the existence of the head noun is announced. Such a conjunct will be named an introductory sentence (abbr. intro-S). An intro-S is a conjunct which introduces the existence of a fact or a thing. Notice that 93a could be derived from 93b, but not from 93c.

(93) a. The men who have come from Hawaii are successful.

b. (Certain) men have come from Hawaii; and the men are
successful.

c. The men have come from Hawaii; and the men are
successful.

In negating 93a, one could negate either the second conjunct or both conjuncts of 93b, but never only the first conjunct in the

sentence. It is clear from this that when a conjunction the first conjunct of which is an intro-S is within the scope of a NEG, that NEG cannot negate the first conjunct without negating the second conjunct also. If the embedded complement includes a non-restrictive relative clause, the latter is usually outside the scope of the NEG which stands above the matrix verb.

The second explanation would be closely related to what has been stated in the previous section: In a sentence with a definite subject, the accented part of the sentence--whether subject or predicate--is negated by the NEG above the matrix verb. Thus, to make 1a synonymous with 1b, left in 1a should be accented; to make it synonymous with 1c, attractive there should be the most heavily accented part. The sentences of 1 are repeated here for convenience:

- (1) a. John doesn't think the attractive girls left.
 b. John thinks the attractive girls stayed.
 c. John thinks the unattractive girls left.

This reveals a very interesting aspect of negation: NEG negates the most heavily accented part of the sentence within its scope. This characteristic of language eliminates two possibilities in the negation of embedded conjunction. Above, we noted that $\sim(p \cdot q)$ is equivalent to $\sim p \vee \sim q \vee (\sim p \cdot \sim q)$. In the negation of an embedded sentence including a non-restrictive relative clause (abbr. NR), the negation of the conjunct which represents that NR--either $\sim p$ or $\sim q$ --is not possible, because that conjunct is buried in the subject NP and sheltered from the reach of negation, so to speak.

This gives us a reason for believing that modifiers of embedded indefinite subjects are to be derived from an underlying second conjunct, as shown in 94 and 95, since only in that event is the previous explanation of (B) adjectives not contradicted. (See below for ways in which both types of adjectives parallel each other.)

(94) a. Many girls applied.

b. (Certain) girls applied; and the girls were many.

(95) a. Pretty girls applied.

b. (Certain) girls applied; and the girls were pretty.

The intro-S's in 94 and 95 have applied as their verb. Here, a rule is needed to derive 94a and 95a from 94b and 95b, respectively, since the (a) sentences carry two pieces of information, and a single sentence carries only one piece of information in the deep structure. The rule to be formulated immediately below seems to operate only when the NP_i in the first conjunct refers to unspecified members of the universe denoted by that NP, i.e. it is a partitive generic. There is a further constraint on the application of rule 96: the predicate of the second conjunct must be a simple attributive adjective. Now, the rule is formulated as 96; the marked (m) stress of a NP is a falling contour.

(96) NR (Adj-Pr) FORMATION (abbr. NR [Adj-Pr] FORM)¹⁴

(W,	NP _i	, X)	S ₁	.(NP _i , ADJ)	S ₂
1	2	3	4		
	[- definite - specific]	⟨+ presupposed⟩			
⇒	1,	4 + 2,	3,	∅	
		⟨m stress⟩			

So far, I have explained why the NEG immediately dominating a sentence whose subject is indefinite and is modified by an adjective negates the adjective (e.g. many in 3a and attractive in 15a) but not the predicate of the embedded complement (e.g. left in 3a and 15a). Exactly the same arguments apply to implicit negation and questions.¹⁵ Consider the following:

- (97) a. John denies that many candidates won.
 b. John denies that rich candidates won.
 c. John denies that the rich candidates won.
- (98) a. Did many candidates win?
 b. Did rich candidates win?
 c. Did the rich candidates win?

Simplified logical interpretations follow:

- (97') a. ((Certain) candidates won) • (John deny ((the) candidates many))
 b. ((Certain) candidates won) • (John deny ((the) candidates rich))
 c. ((Certain) candidates rich) • (John deny ((the) candidates won))
- (98') a. ((Certain) candidates won) • (I ask you ((the) candidates many))
 b. ((Certain) candidates won) • (I ask you ((the) candidates rich))
 c. ((Certain) candidates rich) • (I ask you ((the) candidates won))

If we deny or question an intro-S, then the succeeding sentences become ungrammatical, since the definiteness of the NP's in the second conjunct would now have to be unmotivated. At this point, I will introduce RESTRICTIVE RELATIVE CLAUSE FORMATION (abbr. RR-FORM), a rule which will be discussed in greater detail in Chapter Three. RR-FORM copies an intro-S into a conjoined following sentence which shares an NP with it. This rule moves in the opposite direction from NR (Adj-Pr) FORM. The (c) sentences of 97' and 98' will be relativized by RR-FORM. In 98'c, the relativized sentence will be further transformed into a question after the deletion of the performative clause. Rule 96 will derive the (a) and (b) examples of 97 and 98 from the respective sentences of 97' and 98'; and RR-FORM will derive the (a) and (b) of 97" and 98":

- (97") a. John denies that the candidates that won were many.
 b. John denies that the candidates that won were rich.
- (98") a. Were the candidates that won many?
 b. Were the candidates that won rich?

I will now attempt to formulate the Korean version of NR (Adj-Pr) FORM. Let us reconsider 12, 13, and 14, which are repeated below for convenience:

- (12) k̄i yeyppi-n yeca-t̄al-ka nathanassta-ko-n̄an sayngkak-ha-ci
 the pretty-REL girl-PL-S appeared-QT-DLM think-NOM
 ani-hanta
 not-do
 'I do not think that the pretty girls appeared.'

(13) manh̄i-n salam-t̄il-ka kassta-ko-n̄in sayngkakha-ci ani-hanta
 many-REL man-PL-S went-OT-DLM think-NOM not-do

'I do not think that many men went.'

(14) yeyppi-n yeca-t̄il-ka nathanassta-ko-n̄in sayngkakha-ci ani-
 pretty-REL girl-PL-S appeared-OT-DLM think-NOM not-
 hanta

do

'I do not think that pretty girls appeared.'

Simplified logical interpretations would be along the lines of the following:

(12') ((etten) yeca-t̄il yeyppessta)·(((k̄i yeca-t̄il
 certain girl-PL were-pretty the girl-PL
 nathanassta)~) sayngkakhanta)
 appeared think

(13') ((etten) salam-t̄il kassta)·(((k̄i salam-t̄il manhassta)~))
 certain man-PL went the man-PL were-many
 sayngkakhanta
 think

(14') ((etten) yeca-t̄il nathanassta)·(((k̄i yeca-t̄il
 certain girl-PL appeared the girl-PL
 yeyppessta)~) sayngkakhanta)
 were-pretty think

The rule which would turn these into their respective surface structures, viz. 12-14, can be again formulated as 96. Since all Korean attributive modifiers of NP's are actually surface relative

clauses, item 4 of 96 has to be relativized in Korean when transported ahead of item 2. However, this Korean version of NR (Adj-Pr) FORM should not be confused with RR-FORM; the two rules move in opposite directions. Exs. 13' and 14', from which NR (Adj-Pr) FORM derives the complements of 13 and 14, respectively, are transformed into 13'' and 14'' by RR-FORM:¹⁶

(13'') ka-n salam-t̃il-ka manhassta

went-REL man-PL-S were-many

'The men who went were many.'

(14'') nathana-n yeca-t̃il-ka yeyppessta

appeared-REL girl-PL-S were-pretty

'The girls who appeared were pretty.'

2.22. EQUI-NP DELETION and REFLEXIVIZATION. As a result of our definition of correferentiality, we have been able to describe EQUI-NP DELETION and REFLEXIVIZATION adequately (cf. 2.13 and 2.14). Consider now the following sentences and the logical interpretations which are easily posited along the lines of what has been said already:

(99) a. Many students expected many students to be admitted.

((Certain) students_i expected ((certain) students_j be admitted) • ((the) students_j be many)) • ((the students_i were many)

b. The students who expected many students to be admitted were many.

c. Many students expected the students who would be admitted to be many.

(99) d. The students who expected the students who would be admitted to be many were many.

e. Many students expected to be admitted.

((Certain) students_i expected ((the) students_i be admitted)) • ((the) students_i were many)

(100) a. Democratic candidates expected Democratic candidates to win.

((Certain) candidates_i expected (((certain) candidates_j win) • ((the) candidates_j be Democratic))) • ((the) candidates_i were Democratic)

b. The candidates who expected Democratic candidates to win were Democratic.

c. Democratic candidates expected the candidates who would win to be Democratic.

d. The candidates who expected the candidates who would win to be Democratic were Democratic.

e. Democratic candidates expected to win.

((Certain) candidates_i expected ((the) candidates_i win)) • ((the) candidates_i were Democratic)

(101) a. John expected John to be admitted.

(John_i expected (John_j be admitted))

b. John expected to be admitted.

(John_i expected (John_i be admitted))

In the (a) sentences of 99 and 100, the existence of the subject NP's of the complement sentences was newly introduced in the first

conjuncts, which would have been impossible had the NP's been correferential with the matrix subject NP's of the first major conjuncts. In the (e) sentences, however, all subject NP's except the first NP modified by certain are definitized by the matrix part of the first conjunct, and definiteness is not extra-linguistically conditioned; as a result, they are correferential. These exactly correspond to 101a and 101e, respectively.

Furthermore, since both NR (Adj-Pr) FORM and RR-FORM are clearly optional rules, we have nine possibilities of combination when two double-conjunct conjunctions are considered. Only four of them will be dealt with here, since each of the other five depends on the non-application of either or both of these two rules. The four combinations to be dealt with here are: (i) NR (Adj-Pr) FORM + NR (Adj-Pr) FORM; (ii) NR (Adj-Pr) FORM + RR-FORM; (iii) RR-FORM + NR (Adj-Pr) FORM; and (iv) RR-FORM + RR-FORM. The (a), (b), (c), and (d) sentences of 99 and 100 are the (i), (ii), (iii), and (iv) cases, respectively. Since all of them are from the same underlying structure, they are synonymous. The (b), (c), and (d) sentences all show that the identity of the NP's in the (a) sentences is accidental; in other words, the NP's are not necessarily conterminous sets, but may be so in a given situation. Accidentally identical NP's are not correferential and therefore are not subject to EQUI-NP DELETION.¹⁷ The same arguments also apply to REFLEXIVIZATION. Let us consider the following:

(102) a. Many men love many men.

((Certain) men_i love (certain) men_j) • ((the) men_i are many) • ((the) men_j are many)

b. The men who many men love are many.

c. The men who love many men are many.

d. *The men who the men who love are many are many.

e. Many men love themselves.

((Certain) men_i love men_i) • ((the) men_i are many)

(103) a. Haughty men hate haughty men.

((Certain) men_i hate (certain) men_j) • ((the) men_i are haughty) • ((the) men_j are haughty)

b. The men who haughty men hate are haughty.

c. The men who hate haughty men are haughty.

d. *The men who the men who hate are haughty are haughty.

e. Haughty men hate themselves.

((Certain) men_i hate men_i) • ((the) men_i are haughty)

(104) a. John loves John. (x loves y)

b. John loves himself. (x loves x)

In 102a and 103a, the existence of both underlined NP's in the first conjunct is newly introduced: they are not correferential with each other. In 102e and 103e, however, all the NP's except the first one are definite because of the prior occurrence of the NP in the first conjunct; this shows that they are correferential. We see a direct parallel between these and the respective sentences in 104.

Even though we have three conjuncts conjoined in 102a and 103a, we have only two possible conjunctions of two conjuncts each: conjunction of the first and the second conjuncts, and conjunction of the first and the third conjuncts. Conjunction of the second and the third conjuncts is impossible, since the NP's of the two conjuncts are not correferential with each other. Again, we have four possible combinations for the application of NR (Adj-Pr) FORM and/or RR-FORM: the (a), (b), (c), and (d) sentences of 102 and 103 are the (i), (ii), (iii), and (iv) cases described above, respectively. The ungrammaticality of 103d is accounted for by Ross's (1967:66-88) Complex-NP Constraint. The ungrammaticality of 102d is also caused by the fact that a Q cannot be the predicate of an intro-S and consequently cannot be the predicate of a restrictive relative clause.

The above examples seem to show the correctness of the assumption that NR (Adj-Pr) FORM and RR-FORM are not crucially ordered with respect to each other. This also appears to be the case in Korean. Consider the following:

- (105) a. manhi-n haksayng-tal-ka manhi-n haksayng-tal-ka
 many-REL student-PL-S many-REL student-PL-S
 suyong-tcylila-ko kitayhayssta
 be-admitted-QT expected
 'Many students expected many students to be admitted.'
 ((etten) haksayng-tal_i kitayhayssta ((etten) haksayng-
 tal_j suyong-toyta) • ((ka) haksayng-tal_j manhata)) • ((ka)
 haksayng-tal_i manhata)

(105) b. manh̄i-n haksayng-t̄il-ka suyong-toy-ki-l̄il kitayha-n
 many-REL student-PL-S be-admitted-NOM-O expected-REL
 haksayng-t̄il-n̄in manhassta
 student-PL-T were-many

'The students who expected many students to be admitted
 were many.'

c. manh̄i-n haksayng-t̄il-ka suyong-toy-l haksayng-t̄il-ka
 manh̄ilila-ko kitayhayessta

'Many students expected the students who would be
 admitted to be many.'

d. suyong-toy-l haksayng-t̄il-ka manh̄ilila-ko kitayha-n
 haksayng-t̄il-n̄in manhassta

'The students who expected the students who would be
 admitted to be many were many.'

e. manh̄i-n haksayng-t̄il-ka (caki-ka) suyong-toylila-ko
 kitayhayessta

'Many students expected to be admitted.'

((etten) haksayng-t̄il_i kitayhayessta ((k̄i) haksayng-t̄il_i
 suyong-toyta))-((k̄i) haksayng-t̄il_i manhassta)

(106) a. akha-n salam-t̄il-ka akha-n salam-t̄il-ka ton-l̄il
 wicked-REL man-PL-S wicked-REL man-PL-S money-O
 pel-ki-l̄il kitayhayessta
 make-NOM-S expected

'Wicked men expected wicked men to make money.'

((etten) salam-t̄il_i kitayhayssta (((etten) salam-t̄il_j ton
 pelta))-((k̄i) salam-t̄il_j akhata)))-((k̄i) salam-t̄il_i akhata)

(106) b. akha-n salam-t̄l-ka ton-l̄l pel-ki-l̄l kitayha-n
 wicked-REL men-PL-S money-O make-NOM-O expected-REL
 salam-t̄l-n̄n akhayessta
 man-PL-T were-wicked

'The men who expected wicked men to make money were
 wicked.'

c. akha-n salam-t̄l-ka ton-l̄l pel-n̄n salam-t̄l-ka
 akha-ki-l̄l kitayhayessta

'Wicked men expected the men who would make money to be
 wicked.'

d. ton-l̄l pel-n̄n salam-t̄l-ka akha-ki-l̄l kitayha-n
 salam-t̄l-n̄n akhayessta

'The men who expected the men who would make money to
 be wicked were wicked.'

e. akha-n salam-t̄l-ka (caki-ka) ton-l̄l pel-ki-l̄l
 kitayhayessta

'Wicked men expected to make money.'

((etten) salam-t̄l_i kitayhayessta ((k̄) salam-t̄l_i ton
 pelta)) • ((k̄) salam-t̄l_i akhayessta)

The (a)-(d) sentences are all synonymous in 105 and 106, and are
 different from the respective (e) sentences. These exactly parallel
 the corresponding English sentences of 102 and 103. It should be
 clear at this point why REFLEXIVIZATION (except the inclusive type,
 where applicable) is possible in the (e) sentences.

2.23. CONJUNCTION REDUCTION. Let us consider 45 and 46

together with 107:

- (45) a. Good rules_i are explicit; and good rules_i are easy to read.
 b. Good rules are (both) explicit and easy to read.
- (46) a. Few (of the) rules are explicit; and few (of the) rules are easy to read.
 b. Few (of the) rules are (both) explicit and easy to read.
- (107) a. Pious men are good sons; and pious men are good fathers.
 b. Pious men are both good sons and good fathers.

In 45, the NP's are what I have earlier termed representative-generic; they are therefore definite and, consequently, correferential. In 46 and 107, however, we are talking about part of the membership of the group (partitive-generic), as shown in the logical formalism below:

- (46') a. (((Certain) rules_i explicit) • ((the) rules_i few)) •
 (((certain) rules_j easy to read) • ((the) rules_j few))
 b. (((Certain) rules_i explicit) • ((the) rules_i easy to read)) • ((the) rules_i are few)
- (107') a. (((Certain) men_i good sons) • ((the) men_i pious)) •
 (((certain) men_j good fathers) • ((the) men_j pious))
 b. (((Certain) men_i good sons) • ((the) men_i good fathers)) •
 ((the) men_i pious)

In other words, the existence of the NP's is introduced in both major conjuncts of the (a) sentences, while all of the subject NP's are definitized by the first occurrence of the NP in the first

conjunct of the (b) statements. Therefore, the predicates are conjunctively co-ordinated in the (b) statements but disjunctively co-ordinated in the (a) statements. If shared NP's in conjunction are representative generics, they are necessarily correferential.

Let us return to data from Korean:

(108) a. manhâ-n salam-tâl-ka cuk-ko, manhâ-n salam-tâl-ka

many-REL man-PL-S died-and many-REL man-PL-S .

pusang-lâl ipessta

injury-O got

'Many men died, and many men got injured.'

((etten) salam-tâl_i cukessta) • ((kî) salam-tâl_i

manhassta) • ((etten) salam-tâl_j pusang ipessta) •

((kî) salam-tâl_j manhassta)

b. *manhâ-n salam-tâl-ka cuk-ko pusang-lâl ipessta

? 'Many men died, and got injured.'

((etten) salam-tâl_i cukessta) • ((kî) salam-tâl_i pusang

ipessta) • ((kî) salam-tâl_i manhassta)

(109) a. yeyppi-n yeca-tâl-ka nolay-lâl pulless-ko, yeyppi-n

pretty-REL girl-PL-S song-O sang-and pretty-REL

yeca-tâl-ka violin-lâl khyessta

girl-PL-S violin-O played

'Pretty girls sang songs, and pretty girls played the

violin.'

((etten) yeca-tâl_i nolaypulsessta) • ((kî) yeca-tâl_i

yeyppessta) • ((etten) yeca-tâl_j violin khyessta) •

((kî) yeca-tâl_j yeyppessta)

(109) b. *yeyppi-n yeca-täl-ka nolay-läl puli-ko violin-läl
khyessta.

*(((etten) yeca-täl_i nolay pullessta)•((kâ) yeca-täl_i
violin khyessta))•((kâ) yeca-täl_i yeyppessta)

Although the deep structures in 108b and 109b are logically impossible, their very logical impossibility seems to allow at least some speakers to use the surface structures in 108b and 109b as reduced forms of the (a) sentences. In other words, when the (b) sentences of 108 and 109 are used, they are unambiguously understood as the reduced forms of the respective (a) sentences. Some of these speakers seem to have pushed this generalization of CONJUNCTION REDUCTION a little further, so that even when ambiguity is possible--as in 110 below--conjunctions can be reduced. Thus, in the speech of those people 110b can mean either what is given in the logical interpretation of 110a, or what is given in that of 110b:

(110) a. manhi-n kyoin-täl-ka sul-läl mek-ko, manhi-n kyoin-

many-REL believer-PL-S liquor-O drink-and many-REL

täl-ka topak-läl hanta

believer-PL-S gambling-O do

'Many believers drink, and many believers gamble.'

(((etten) kyoin-täl_i sul mekta)•((kâ) kyoin-täl_i

manhta))•(((etten) kyoin-täl_j topakhanta)•((kâ)

kyoin-täl_j manhta))

b. manhi-n kyoin-täl-ka sul-läl mek-ko topak-läl hanta

(((etten) kyoin-täl_i sul mekta)•((kâ) kyoin-täl_i

topakhanta))•((kâ) kyoin-täl_i manhta)

However, when a subject NP refers to a group with a smaller membership (cf. 111), it is more easily specifiable, and consequently the generalization of the CONJUNCTION-REDUCTION rule seems to be prohibited in the speech of all speakers. Thus, no speaker regards 111b as synonymous with 111a:

- (111) a. myet kyoin-täl-ka sul-läl mekess-ko, myet kyoin-täl-ka
 a-couple believer-PL-S liquor-O drank-and a-couple
 topak-läl hayessta
 believer-PL-S gambling-O did

'A couple of believers drank, and a couple of believers gambled.'

((etten) kyoin-täl_i sul mekessta) • ((kä) kyoin-täl_i
 myet-iessta) • ((etten) kyoin-täl_j topak hayessta) •
 ((kä) kyoin-täl_j myet-iessta)

- b. myet kyoin-täl-ka sul-läl mek-ko topak-läl hayessta

'A couple of believers drank and gambled.'

((etten) kyoin-täl_i sul mekessta) • ((kä) kyoin-täl_i
 topak hayessta) • ((kä) kyoin-täl_i myet-iessta)

CHAPTER THREE: RELATIVIZATION

Introduction

3.1. In the last chapter, I have extensively discussed how what I called B adjectives--Q's and numerals--can have only definite subjects; that is, how they cannot be predicates of introductory sentences (abbr. intro-S).¹ Thus, in 1 and 2, which include Q's (B adjectives), the (b) structures are ungrammatical; in 3 and 4, which include A adjectives, both the (a) and (b) structures are well-formed:²

- (1) a. ((certain) men died) • ((the) men were many)³
 b. *((certain) men were many) • ((the) men died)
- (2) a. ((etten) yeca-t̄l ñngmohayessta) • ((k̄) yeca-t̄l
 certain girl-PL applied the girl-PL
 manhassta)
 were-many
- b. *((etten) yeca-t̄l manhassta) • ((k̄) yeca-t̄l
 certain girl-PL were-many the girl-PL
 ñngmohayessta)
 applied
- (3) a. ((certain) girls applied) • ((the) girls were pretty)
 b. ((certain) girls were pretty) • ((the) girls applied)
- (4) a. ((etten) yeca-t̄l ñngmohayessta) • ((k̄) yeca-t̄l
 certain girl-PL applied the girl-PL
 yeyppessta)
 were-pretty

- (4) b. ((etten) yeca-t̄il yeyppessta) • ((k̄i) yeca-t̄il
 certain girl-PL were-pretty the girl-PL
 ñngmohayessta)
 applied

(I have parenthesized the and its Korean equivalent k̄i because, although I do not believe they are in the deep structure, I believe their addition will facilitate interpretation. I also parenthesize certain and its Korean equivalent etten because they are optionally deletable.)

In Chapter Two, I have also discussed two rules--NR (Adj-Pr) FORM (rule 99 in ch. 2), which will be further generalized in this chapter, and RR-FORMATION--which move in the opposite directions.⁴ NR (Adj Pr) FORM moves the second conjuncts of the structures in 1-4 into the respective intro-S's, thus deriving the sentences of 5-8 after the application of other rules like RELATIVE CLAUSE REDUCTION and ADJECTIVE PREPOSING;⁵ whereas RR-FORMATION copies intro-S's into the second conjuncts in 1-4, and derives the respective sentences of 9-12.⁶ I will show later in this chapter that NR (Adj Pr) FORM is a special case of NON-RESTRICTIVE RELATIVE CLAUSE FORMATION.

(5) a. Many men died.

b. *Men who died were many.

(6) a. manhi-n yeca-t̄il-ka ñngmohayessta

many-REL girl-PL-S applied

b. *ñngmoha-n etten yeca-t̄il-ka manhassta

applied-REL certain girl-PL-S were-many

- (7) a. Pretty girls applied.
 b. Certain girls who applied were pretty.
- (8) a. yeyppi-n yeca-t̄l-ka ñngmohayessta
 pretty-REL girl-PL-S applied
 b. ñngmoha-n etten yeca-t̄l-ka yeyppessta
 applied-REL certain girl-PL-S were-pretty.
- (9) a. The men who died were many.
 b. *The men who were many died.
- (10) a. ñngmoha-n yeca-t̄l-ka manhassta
 applied-REL girl-PL-S were-many
 b. *manh̄i-n yeca-t̄l-ka ñngmohayessta
 many-REL girl-PL-S applied
- (11) a. The girls who applied were pretty.
 b. The girls who were pretty applied.
- (12) a. ñngmoha-n yeca-t̄l-ka yeyppessta
 applied-REL girl-PL-S were-pretty
 b. yeyppi-n yeca-t̄l-ka ñngmohayessta
 pretty-REL girl-PL-S applied

Exs. 9b and 10b are grammatical sentences, if the relative clauses there are non-restrictive; however, those relative clauses cannot be conceived as restrictive without making the whole sentences ungrammatical. This ungrammaticality seems to come from the impossible underlying structures 1b and 2b.

3.11. Introductory sentence and related matters. The present analysis of RELATIVIZATION is based on the approaches of Thompson (1967, 1970a, and 1970b) and Drubig (1968), both of whom

claim that relative clauses are derived from underlying conjunctions. There are crucial differences, however, between my analysis and theirs, which will be made clear as we proceed. One of the differences is the adoption of intro-S in the present analysis. An intro-S, which is introduced in Chapter Two and briefly illustrated above (in the present chapter), is a sentence which introduces the existence of a fact or thing in the 'possible world' (in the sense used by G. Lakoff 1971). There are two types of intro-S. Type I is an overt assertion of the existence of a fact or thing. In Type II, the existence of the item in question is not overtly asserted, but implied in the assertion of something other than its existence. Thus, the sentences in 13 are overtly expressed in 14 (Type I), while they are merely implied in 15 (Type II). Intro-S's like 13a or 13b will be called simple intro-S.

(13) a. There was a man.

b. There is a girl.

(14) a. There was a man who tried to conquer the world.

b. There is a girl who is practising the piano in the hall.

(15) a. A (certain) man tried to conquer the world.

b. A (certain) girl is practising the piano in the hall.

The synonymy of 14 and 15 indicates underlying conjunctions for the sentences of 15. Therefore, I propose that the sentences of 14 are Type II intro-S's, viz. combinations of the sentences in 13 and an additional statement:

(16) a. (There was man_i) • (man_i tried to conquer the world)

b. (There is girl_i) • (girl_i is practising the piano in the hall)

The sentences of 14 are derived from 16 by right-to-left embedding. It will be shown later in this chapter that right-to-left embedding is a case of NR-FORMATION (cf. rules 79 and 89), except when the shared NP of the left conjunct is unspecified; neither shared NP can be the head noun of any relative clause unless both NP's are correferential with each other, and to be correferential they have to be [+ specified]. In Chapter Two, 'correferentiality' was defined as 'identical specificity'. From this definition, it is self-evident that unspecified NP's cannot be correferential. Therefore, rules like RELATIVIZATION or PRONOMINALIZATION, which are based on the correferentiality of the shared NP's, cannot apply to any conjunction the left conjunct of which contains a [- specified] shared NP.

The sentences of 15 are derived from 16 by left-to-right embedding (cf. rule 47). For convenience of reference, I will name basic conjunction any conjunction that consists of an intro-S and another sentence which shares an NP with the intro-S (e.g. 1-4). After the embedding in question has been performed, the second conjuncts of 16 will be turned into the corresponding structures of 17 below:

(17) a. *Man who there was tried to conquer the world.

b. *Girl who there is is practising the piano in the hall.

Since the mere assertion of the existence of a man or a girl without any additional information about him or her cannot be considered to be additional knowledge for the hearer, the relative clauses in 17 are not sufficient to definitize the head nouns, but

only to make the nouns [+ specified] --thus marking the nouns with certain, which is optionally deletable. By the principle of redundancy deletion, which will be discussed in Appendix I, relative clauses which carry only redundant information will be deleted, and the respective sentences of 15 are generated as the result.

Type I intro-S's (e.g. 14a and 14b) are different from Type II intro-S's (e.g. 15a and 15b) in the following manner: Type I sentences make an overt assertion of the existence of the item denoted by the shared noun. By contrast, predicates of Type II intro-S's which assert the existence of the item have been deleted and do not appear in the surface. However, since Type II intro-S's must contain an existential assertion of an item in the deep structure--as illustrated by 15a and 15b, my referring to 15 as an intro-S seems to be justifiable. These are derived from 17a and 17b, respectively, as a result of the deletion of the relative clauses. In this analysis, then, both Type I and Type II intro-S's assert the existence of a fact or a thing--the former, by a surface assertion; the latter, by an embedded relative clause which does not appear on the surface.

Since either type of intro-S ultimately asserts the existence of a fact or a thing, it seems logical to arrange the underlying sentences so that an intro-S comes before other sentences which assert something else than the existence of the item in question and presume such an assertion. This does not mean that all the underlying conjuncts are sequentially ordered in such a way that a

· sentence which asserts an earlier event comes before a sentence which asserts a later event. In other words, only the ordering of an intro-S with respect to other conjuncts seems to be fixed in the deep structure. Thus 18b, which reverses the logical ordering shown in 18a, is impossible, whereas 19b which reverses the sequential ordering shown in 19a is still grammatical:

(18) a. A man_i tried to conquer the world, but the man_i could not rule his own home.

b. *The man_i could not rule his own home, but a man_i tried to conquer the world.

(19) a. A man_i failed in the exam twice, but the man_i passed it this year.

b. A man_i passed the exam this year, but the man_i had failed in the exam twice.

3.12. RESTRICTIVE-CLAUSE FORMATION and the definiteness of

NP's. An interesting observation has been made by Smith (1964) as to the intricate relations between her three classes of determiners and two types of relative clauses--restrictive clauses (hereafter RR) and non-restrictive clauses (abbr. NR). Smith (39) summarizes her observation in the following quotation:

The three classes are named Unique, Specified, and Unspecified, to indicate that they are distinct from the traditional definite and indefinite determiners: with R relatives, Unspecified determiners occur: any, all, etc.; with R and A [Appositive = my NR] relatives, Specified: a, the, \emptyset ; with A relatives only, Unique: \emptyset (proper names).

Smith's observation is illustrated by the following sentences:

(20) John, who knows the way, has offered to guide us.

- (21) *John who is from the South hates cold weather.
- (22) *Any book, which is about linguistics, is interesting.
- (23) Any book which is about linguistics is interesting.
- (24) He pointed to a certain dog, which was looking at him hopefully.
- (25) He pointed to a certain dog which was looking at him hopefully.
- (26) The book, which is about linguistics, is interesting.
- (27) The man who fixed the radio left this note.

Thus, with unique nouns, relative clauses must be NR (e.g. 20) if the sentence is to be grammatical (cf. 20 and 21). With unspecified nouns, only a RR can co-occur (cf. exs. 22 and 23). With specified nouns, both RR and NR can co-occur (cf. 24 with 25 and 26 with 27).

Interesting as it is, the above observation seems to miss some crucial points: (1) As to the inherent correlation between the specificity and the definiteness of NP's, I have made it clear in Chapter Two that definiteness necessarily implies specificity, although the reverse is not true. It also appears that the uniqueness of NP's implies their definiteness. (2) The cause-effect relation between determiners and relative clauses; in other words, what should be investigated is not just which determiner can co-occur with what type of relative clause, but rather whether specificity or definiteness is caused by the co-occurring relative clause or by something else. Thus, in 25 above, the specificity of dog is caused by the relative clause, whereas dog in 24 is already

specific before the relative clause is added. Man in 27 has become definitized by the relative clause there, while the source of the definiteness of book in 26 is other than the relative clause.

With these points in mind, I will explicitly define the restrictiveness of a relative clause. A relative clause is restrictive only if it makes an NP specific. This definition of restrictiveness is confirmed by Jespersen (1964: 91), who wrote:

Adjuncts may be either restrictive or non-restrictive. The former kind gives a necessary determination to its primary, which it specifies so as to keep it distinct from other things or beings having the same name; e.g. a red rose as distinct from a white rose. [Emphasis mine]

Since definiteness implies specificity, any relative clause that definitizes an NP modified by it is also restrictive. And all other relative clauses are non-restrictive.

Given the above analysis, then, the ungrammaticality of 21 is not at all surprising: Since we stipulate that definitization cannot be performed twice, John, which is already used as definite noun in 21, cannot be modified by a RR, whose function is to definitize its head noun.⁷ The ungrammaticality of 22 seems to be conditioned by presuppositions that not all books are interesting and that not all books are about linguistics, rather than by the inherent nature of any as an unspecified modifier. For a NR can follow an 'unspecified' NP, as in 28:

(28) Any American, who would necessarily be conscious of freedom, would like the idea.

It is not my contention, however, that Smith is wrong in claiming that unspecified NP's cannot be modified by non-restrictive relative

clauses; but rather that any used in the sense of all--that is, as universal Q--is not [- specified] but [+ definite]. This claim will be justified later in this chapter.

To put differently the points made so far, if a head noun itself is already definite or specific, the relative clause modifying the head noun will be understood as a NR; otherwise, as a RR. Thus, the underlined NP's in 29-31 are definite before relative clauses are attached.⁸ Consequently, the relative clauses are necessarily NR's:

(29) yenge-lil hal-cul-lil al-nin_S Kim-nan thongyekkwon-ka
 English-O speak-NOM-O know-REL Kim-T interpreter-S
 toyesta
 became

'Kim, who could speak English, became an interpreter.'

(30) ene-lil kaci-n_S inkan-nan hatangtongmul-kwa poncilcekilo
 language-O has-REL man-T lower-animals-with essentially
 talita
 differ

'Man, who has language, differs essentially from lower animals.'⁹

(31) thayyangkye-iy cungsim-i-n thayyang-to sil-nin uncikikoissta
 solar-system-of center-is-REL sun-too in-fact is-moving
 'The sun, which is the center of the solar system, actually moves.'

However, the definiteness of the underlined NP's above is nullified in a situation where the identity of the referent denoted by those

'NP's is lost because of multi-reference. Compare the following sentences with sentences 29-31:

(29') nalk-in_S Kim-nan enehakca-i-ko, celm-in_S Kim-nan
 old-REL Kim-T linguist-is-and young-REL Kim-T
 sahyhakca-ita
 sociologist-is

'The Kim who is old is a linguist, and the Kim who is young is a sociologist.'

(30') isipseyki-ey sal-nan inkan-nan tongkul-ey sal-nan_S inkan-
 twentieth-century-in lives-REL man-T cave-in lives-REL man-
 pota te thalakhayesta

than more corrupt-is

'Man of the twentieth century is more corrupt than man of the cave period.'

(31') ecey ci-n_S thayyang-kwa neyil tti-l thayyang-ka kathi-n
 yesterday set-REL sun-and tomorrow rise-REL sun-S same-REL
 thayyang-i-m-lil nu-ka isimhalya
 sun-is-NOM-O who-S will-doubt

'Who would doubt that the sun which set yesterday and the sun which will rise tomorrow are the same sun?'

In 29, Kim is no longer definite, since the reference made by it is not unique in the present discourse and the speaker does not presuppose the hearer's knowledge of any particular Kim to whom he is referring until he attaches sufficient restriction for that purpose. As to 30', although we all share the knowledge of the existence of generic man, we can think of man at different times in

history, in which case the NP loses its definiteness. The same argument can be made about the sun in 31'. In other words, until the existence of a particular item denoted by any NP is registered in the hearer's knowledge, no NP is inherently definite in all situations. To be more exact, NP's can be used definitely, but no NP's are inherently definite. Besides, whether any NP is understood as definite or not seems to depend on the scope of the hearer's knowledge. Consider the following:

(32) Australia-ey sal-nān kangaroo-nān cinkihā-n tongmul-ita
 Australia-in live-REL kangaroo-T rare-REL animal-is
 'Kangaroos, which live in Australia, are rare animals.'

(33) Australia-iy namccok-ey sal-nān kangaroo-nān yangsunhata
 Australia-of South-at live-REL kangaroo-T gentle
 'The kangaroos which live in the southern part of Australia are gentle.'

The non-restrictive interpretation of the relative clause in 32 comes from the hearer's knowledge that kangaroos are found only in Australia. If kangaroos were understood to live only in the southern part of Australia by the hearer, the relative clause of 33 would also be interpreted non-restrictively. In normal cases, however, the same NP kangaroo would be taken to be definite in 32 and indefinite in 33, since kangaroos live not only in the South of, but all over, Australia--and only in Australia. In other words, the definiteness of an NP seems to depend upon hearers' presuppositions: if any NP is understood to have a unique reference--proper noun, representative generic, etc.--it is

definite according to the definition of definiteness just suggested;¹⁰ otherwise, an NP has to be modified by a RR to become definite.

Now, let us consider the underlying structure of a RR. Type II intro-S's play a crucial role in the account of relativization, as in that of quantification in Chapter Two. With respect to the derivation of 15, I have argued that 17 is derived after the first conjunct of the sentences in 16 is embedded into the second conjunct.¹¹ The relative clauses in 17 make the head nouns specific and afterwards get deleted, allowing the respective structures of 15--Type II intro-S's--to be generated. Therefore, all NP's are specific in Type II intro-S's. RR-FORMATION is possible only in basic conjunctions--conjunctions in which the first conjunct is an intro-S. Before I present my own analysis, I shall briefly recapitulate those made by Thompson (1970a and 1970b) and Drubig (1968).

Thompson (1970b: 43-44) does not appear to believe in the basic ordering of conjuncts, let alone the notion of an intro-S.¹² To her, both 35a and 35b are equally good as the underlying structure of 34. And she claims that a speaker's presuppositions about a hearer's knowledge determine which conjunct to embed into which conjunct.

(34) I met the girl who speaks Basque.

(35) a. (I met girl_i) • (girl_i speaks Basque)

b. (Girl_i speaks Basque) • (I met girl_i)

Thus, Thompson claims that when both conjuncts are presupposed to be new information, the following four synonymous sentences will be derived:

(36) I met a girl, and she speaks Basque.

(37) There's a girl who speaks Basque, and I met her.

(38) I met a girl who speaks Basque.

(39) A girl I met speaks Basque.

If the first conjuncts in 35, but not the second conjuncts, were presupposed to be shared by the hearer, then the respective sentences of 40 would be derived:

(40) a. The girl I met speaks Basque.

b. I met the girl who speaks Basque.

In other words, conjuncts which are presupposed to be shared by the hearer are embedded into conjuncts which carry new information; they then definitize the head noun.

However, the following consequences of the no-basic-order hypothesis seem to suggest that the ordering of underlying conjuncts is fixed: (1) Under the no-order approach, 35a and 35b are in fact the same. Therefore, sentence 36 should be semantically (if not presuppositionally) identical with 37; and 38, with 39--since the pairs of sentences are the outputs of the identical transformations applied to the supposedly identical underlying structure. But many native speakers I have checked with have expressed doubt that the sentences are semantically identical. (2) Another important difficulty arises in this approach when we consider a conjunction in which one conjunct includes a Q predicate. Thus, according to Thompson's analysis, all the sentences of 42-45 should be grammatical, and furthermore the pairs of 42-43 and 44-45 should be semantically identical. In addition, all the sentences 42-45 should

be synonymous with one another, since they are derived from the identical underlying structure 41.

(41) (Certain girls_i applied) • ((the) girls_i were many)

(42) Many girls applied.

(43) *Girls who applied were many.

(44) There were (certain) girls that applied, and they were many.

(45) *There were certain girls that were many, and they applied.

But 43 is ungrammatical, because the subject of many (a Q) is not definite.¹³ Ex. 45 is ungrammatical, since many cannot be the predicate of a RR.

(46) *I met the girls that were many.

(3) Furthermore, since there is no basic ordering for this analysis, a situation is conceivable where the second conjunct of 41 would be presupposed, in which case 46 would be derived. Notice that the relative clause in 46 is claimed to be restrictive, as in 40a and 40b. But again, 46 is ungrammatical. More exactly, a relative clause with a Q predicate cannot be restrictive because of the nature of such predicates. These problems do not arise in a fixed-order analysis having the restriction that a Q is not allowed to be the predicate of an intro-S. (4) Above all, the no-order analysis makes it impossible to give a syntactic explanation of the distinction between RR and NR. It will be shown in the analysis suggested by the present writer that presuppositions can be syntactically explained in a non-ad-hoc manner. (5) In the no-order analysis, the choice between certain and the as determiners

of a noun seems to depend entirely on presuppositions; one cannot account for the choice in terms of syntactic rule. The fixed-order analysis accounts for the choice in the syntactic rule formulation, as will be shown below (compare rule 58 with 79 or 89).

Drubig (1968) recognizes the fixed order of underlying conjuncts, although he is not clear as to why the conjuncts have to be ordered the way he claims. He (34) graphically shows how RR-FORMATION (he calls this LEFT SISTER ADJUNCTION, since the left conjunct is adjoined to the right conjunct) is formed as shown in 47 below:

(47) LEFT SISTER ADJUNCTION (RESTRICTIVE)

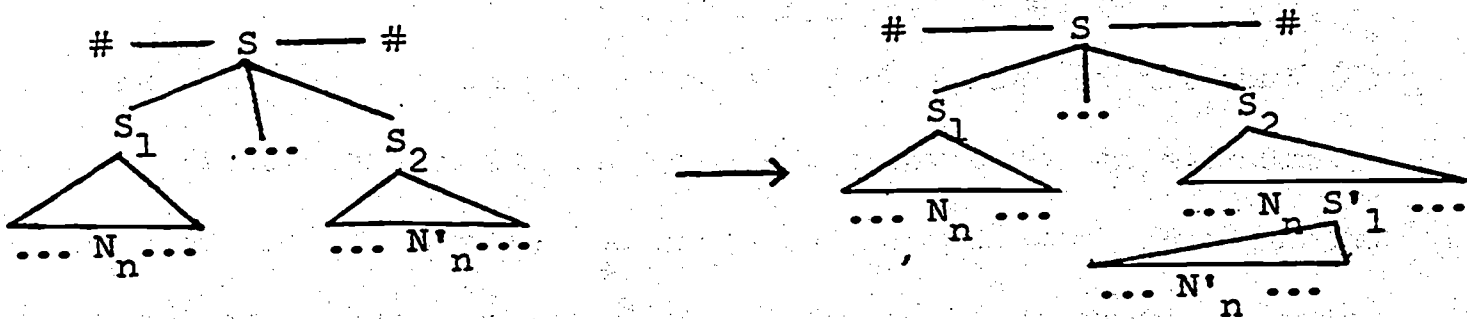

The formulation of RR-FORM which is suggested by Drubig will be illustrated with ex. 48 below:

(48)

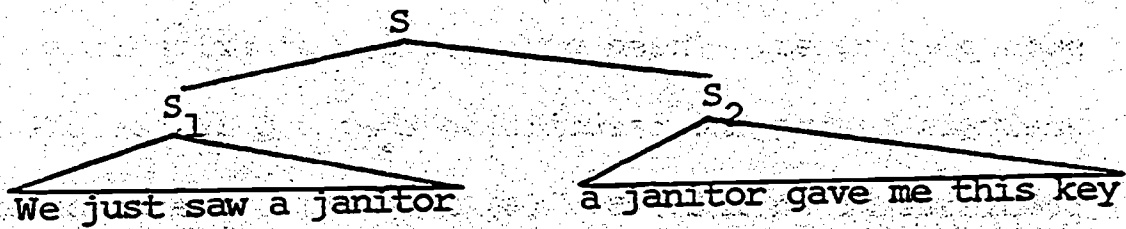

The structure 49 is derived after the left conjunct of 48 is sister-adjoined to the shared noun in the right conjunct by LEFT SISTER ADJUNCTION.

(49)

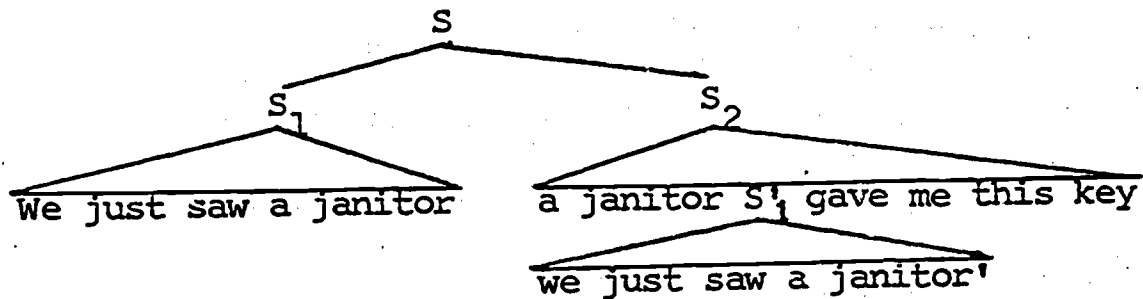

Drubig (36) argues that both NP's have feature [- mentioned], but LEFT SISTER ADJUNCTION changes the feature value in the NP in the right conjunct to [+ mentioned]. The feature [+ mentioned] is responsible for definitization of the NP. As a result, 49 becomes 50:

(50) We just saw a janitor, (and) the janitor that we just saw gave me this key.

The parenthesized and is derived at a later stage, being conditioned by various factors such as asserted, presupposed, or implied topics which are shared between the conjuncts, and the semantic relatability of the conjuncts, etc. (For a detailed discussion, cf. R. Lakoff 1970). Drubig (38) further argues that 'either the antecedent sentence S_1 [in my terms, an intro-S] or the restrictive relative clause S'_1 can be deleted'. Thus, if the intro-S is deleted, ex. 51 will be derived.

(51) The janitor that we just saw gave me this key.

(52) We just saw a janitor, (and) the janitor gave me this key.

However, Drubig does not mention what is the factor that determines which sentence is to be deleted--whether an intro-S to yield 51, or a RR to derive a structure like 52. One might argue that the speaker's presuppositions about the hearer's knowledge seem to be

the crucial factor. If the speaker presupposes that the information carried by an intro-S is already shared by the hearer, then the intro-S (viz. the first conjunct of 50) gets deleted. Otherwise, the relative clause is deleted.

But this kind of argument is clearly contradictory. For if a speaker presupposes the existence of any fact or object to be known to the hearer, an intro-S would, by definition, not be needed from the outset. Thus, hardly anyone would claim that the (a) sentences in 53-55 come from the respective (b) trees below:

(53) a. The sun rises in the morning.

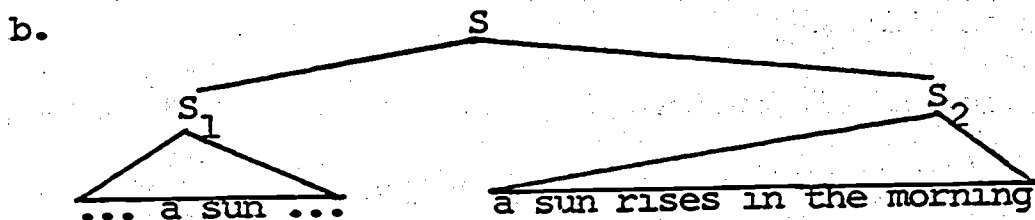

(54) a. The roof is leaking.

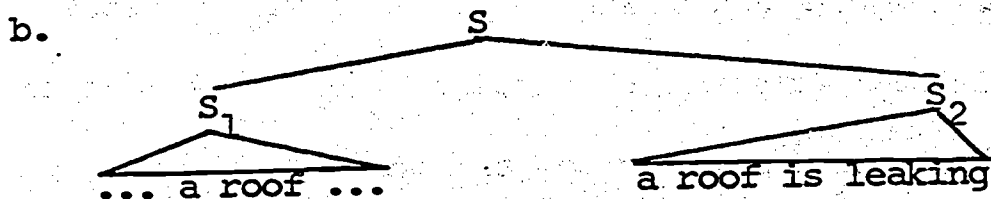

(55) a. My car broke down. I opened the hood.

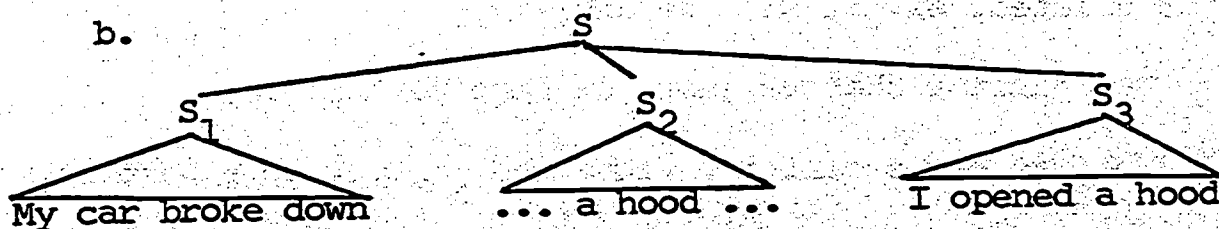

Not that these are inconceivable, but that even if these ultimately represent the correct analysis, one would have to postpone using them until one could sort out asserted, presupposed, and implied levels of information in the deep structure.¹⁴ It is clearly

necessary to assume that the existence of any fact or object is not shared by the hearer, in order that an intro-S may be used. Therefore, the deletion of an intro-S cannot be conditioned by the presupposition that the information carried by an intro-S has already been shared--since, if the information had already been shared, the intro-S would not have been needed from the outset. Besides, the fact that the information is shared means that what is being deleted is actually not an intro-S.

As a matter of fact, I claim that intro-S's are never deleted. Only RR's are deletable, and only under certain conditions. It seems to me that the relative distance between S_1 and S_2 is a determining factor. In other words, when the speaker presupposes that the two sentences (S_1 and S_2) are too far apart from each other for him to expect that the hearer still remembers the existence of the particular item, the speaker must repeat the intro-S, viz. as a RR. On the other hand, if the two sentences are relatively close to each other, the RR which is S_1 copied into S_2 is automatically deleted. Only very seldom would anybody follow an intro-S immediately with another sentence which overtly contains the intro-S as a RR. This situation is found in 56:

(56) John bought a car, and the car which John bought will soon break down.

In a situation where the speaker has incorrectly presupposed the hearer's knowledge and accordingly deleted the RR, a hearer most probably would ask, for instance, 'What car are you talking about?', as a response to such a statement as 'The car will break down'.

Notice what the speaker's normal response would be to such a question. Would it not be something like 'The car which John bought', where a RR is recovered?

There is an apparent counterexample to this generalization: there is a situation where the deletion of a RR is not allowed even when the existence of that particular item is clearly presupposed to be remembered by the hearer. Note that B's question in dialogue 57 below uses which rather than what: which is used when one wants to definitize what is already specific, whereas what is used when one wants to either specify or definitize what is not yet specific. B's question implies that the RR in the last sentence in A is incorrectly deleted. It must be present.

(57) A: John bought a Ford, and Mary bought a Chevy. But the car will soon break down.

B: Which car do you mean?

The points made so far are the following: (1) there is no deletion of intro-S's (=S₁); (2) a RR is deleted only when it is not used deictically (viz. as a demonstrative) and when the speaker presupposes the hearer to remember the existence of the head noun; (3) when a RR is used deictically--that is, when the hearer's question contains which rather than what--the deletion of that RR is impossible.

With those points in mind, let us attempt to formulate the rule, RR-FORM. I have already pointed out that the intro-S of an NP always precedes another conjunct which shares the NP in the underlying structure.¹⁵ It has also been pointed out that RR-FORM

is possible only in basic conjunction. In other words, if the shared NP is already definite, then a RR cannot modify it. Now, RR-FORM is formulated as 58:

(58) Korean RESTRICTIVE-RELATIVE-CLAUSE FORMATION (abbr. RR-FORM)

(W, NP_i, X) intro-S (Y, NP_i, Z)
 1 2 3 4 5 6

A. \Rightarrow (1, 2, 3) - (4, (1, 3+REL)_S#5, 6)

B. \Rightarrow (4, (1, 3+REL)_S#5, 6)

(58') English RESTRICTIVE-RELATIVE-CLAUSE FORMATION

(W, NP_i, X) intro-S (Y, NP_i, Z)
 1 2 3 4 5 6
 [- definite]

A. \Rightarrow (1, 2, 3) - (4, 5 # (REL + 2)#(1, \emptyset , 3)), 6)
 [+ definite]

B. \Rightarrow (4, 5 # (REL + 2)#(1, \emptyset , 3)), 6)
 [+ definite]

where 2 has already been pronominalized because of its prior occurrence.

RR-FORM (A) is a copying rule: it simply copies and Chomsky-adjoints an intro-S to the shared NP in the following conjunct. I will illustrate this rule with 60, which I suggest as the underlying structure of 59. RR-FORM (A) will derive 61 from 60:

(59) John pointed to the dog which was looking at him.

(60) ((Certain) dog_i was looking at John) - (John pointed to dog_i)

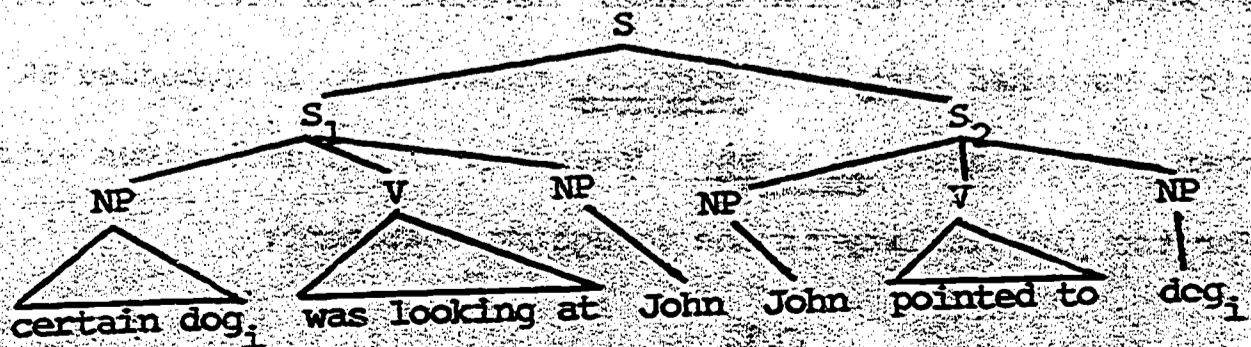

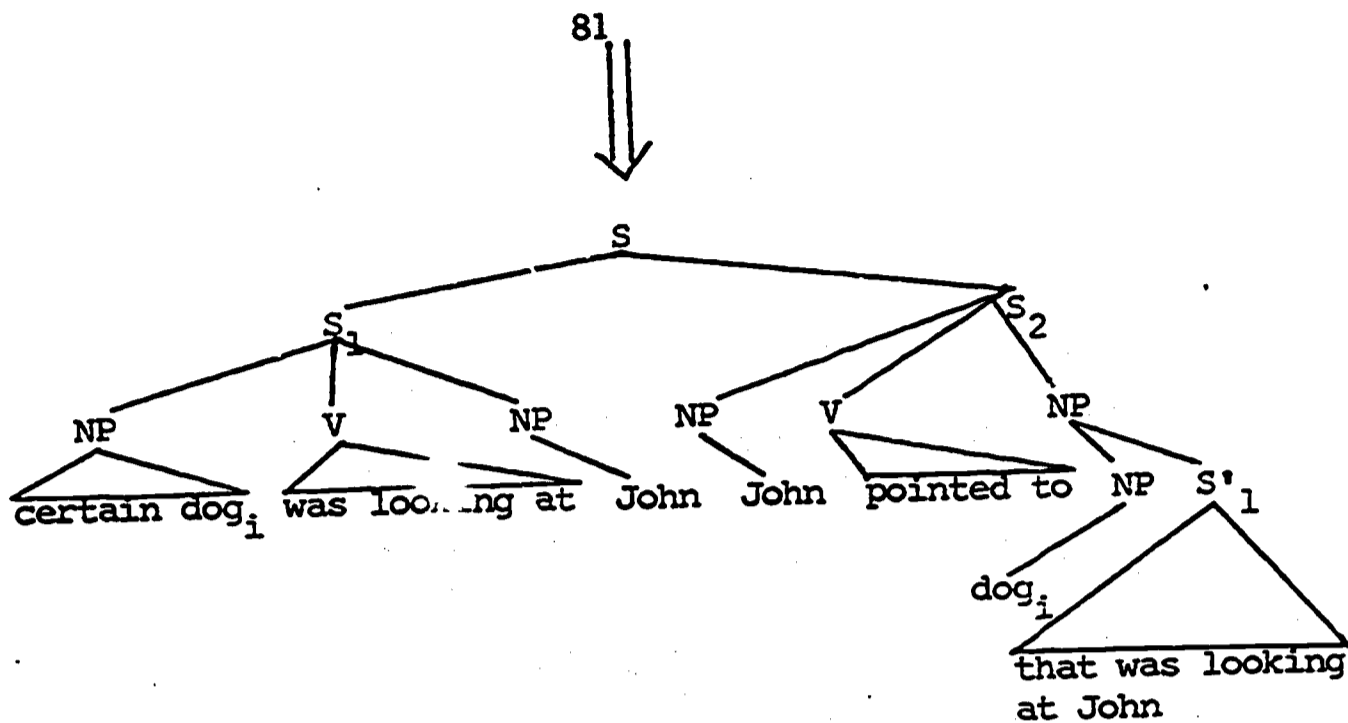

(61) ((certain) dog_i was looking at John) • (John pointed to dog_i that was looking at him)

I assume that such deep-level rules as QUANTIFICATION and RELATIVIZATION are similar in their formulation among many languages, although their similarity might have been blurred in minor ways by some superficial grammar change. In formulating rules, I have tried to show the maximum universality of these rules. Thus, RR-FORM (A) is formulated in such a way that a shared NP in a copied intro-S is deleted by the same rule that copies the intro-S into the following conjunct, instead of being changed to a wh-word and moved to the front of the relative sentence. The rule formulation also suggests that some sort of particle (=REL) is attached to the relative clause. We have some hints that English might have had that as a particle attached to an embedded RR rather than as a relative pronoun. Jespersen (1964: 395) gives evidence for the plausibility of the foregoing statement:

The wh-pronouns were originally interrogative, but in Middle English which, whom, and who came into use as relative pronouns (in the order indicated) and have since then been gaining ground at the expense of that, chiefly in the last few centuries and in the more pretentious kinds of literature. One of the reasons for this preference was probably that these pronouns reminded classical scholars of the corresponding Latin pronouns.

Rule 58' may have to have some minor change as a contemporary English rule. Since definite NP's are marked in English and RR-FORM (A) definitizes the head noun, this rule has to be further revised so that the head noun gets marked with the. RR-FORM (A), as is formulated in 58, is valid for contemporary Korean. No revision is necessary because in Korean definite NP's are not marked. Thus, ex. 62 is turned into 63 by RR-FORM (A), from which other rules like PARTICLE INSERTION and REFLEXIVIZATION derive the surface structure 64.¹⁶

(62) ((etten) kay_i John palapoko-issessta) • (John kay_i kalikhissta)
 certain dog John was-looking-at John dog pointed-to

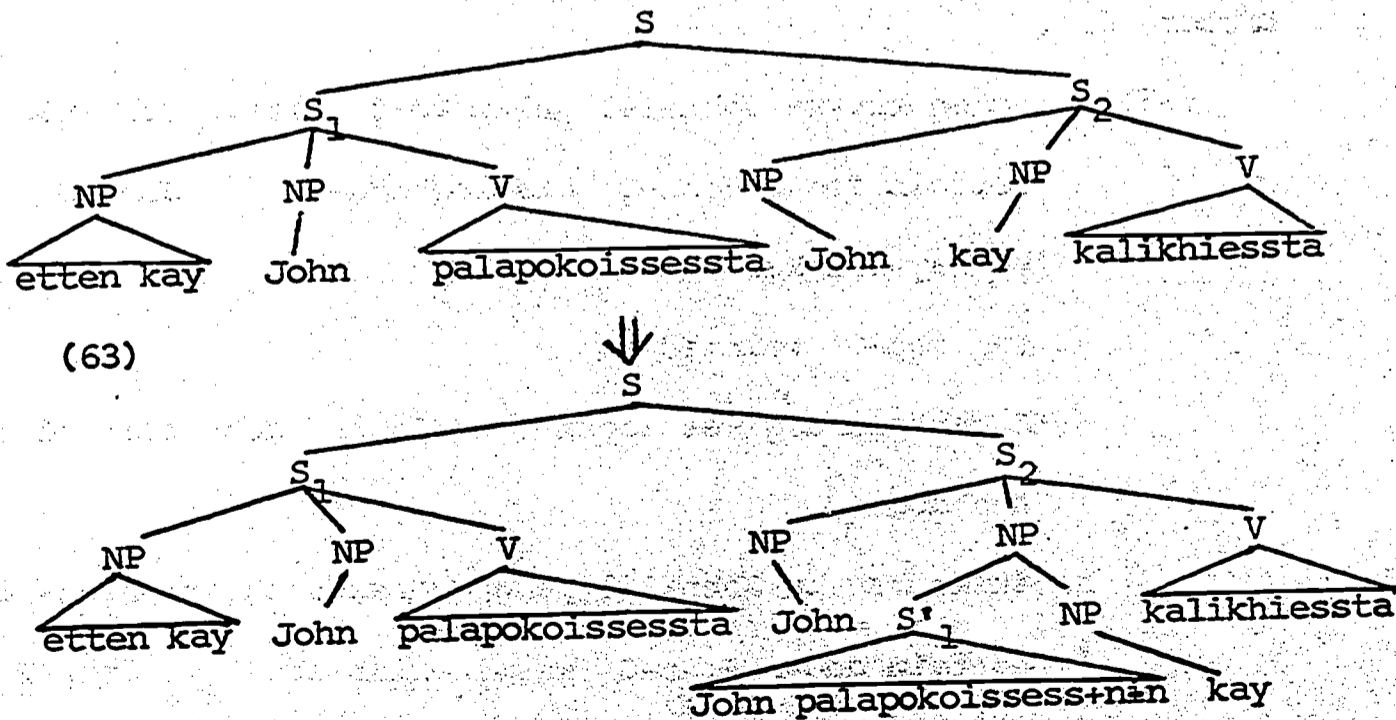

(63) ((etten) kay_i John palapokoissessta) (John (John
 certain dog John was-looking-at John John
 palapokoissess-nān)#kay kalikhiessta)
 was-looking-at-REL dog pointed-to

(64) (etten) kay-ka John-lāi palapokoissessta. John-nān
 certain dog-S John-O was-looking-at John-T
caki-lāi palapokoiss-te-n kay-lāi kalikhiessta
 himself-O was-looking-at-REL dog-O pointed-to
 'A certain dog was looking at John. John pointed to the
 dog that was looking at him.'

If the speaker presupposes the two conjuncts of 64 to be too far apart for him to expect the hearer to remember the first conjunct, then the relative clause (the underlined part of the second conjunct of 64) will remain; otherwise, it will be pronominalized by kā. The former case will result in 65a; and the latter, 65b:

- (65) a. etten kay-ka John-lāi palapokoissessta. John-nān
 certain dog-S John-O was-looking-at John-T
 kā kay-lāi kalikhiessta
 the dog-O pointed-to
 'A certain dog was looking at John. John pointed to the dog.'
- b. etten kay-ka John-lāi palapokoissessta ... John-nān
 certain dog-S John-O was-looking-at John-T
caki-lāi palapokoiss-te-n kay-lāi kalikhiessta
 himself-O was-looking-at-RET-REL dog-O pointed-to

RR-FORM (B) is a chopping rule, which moves and Chomsky-adjoints an intro-S to the shared NP in the following conjunct.¹⁷
The process will be illustrated again by deriving 66 from 59.

(66) John pointed to a dog that was looking at him.

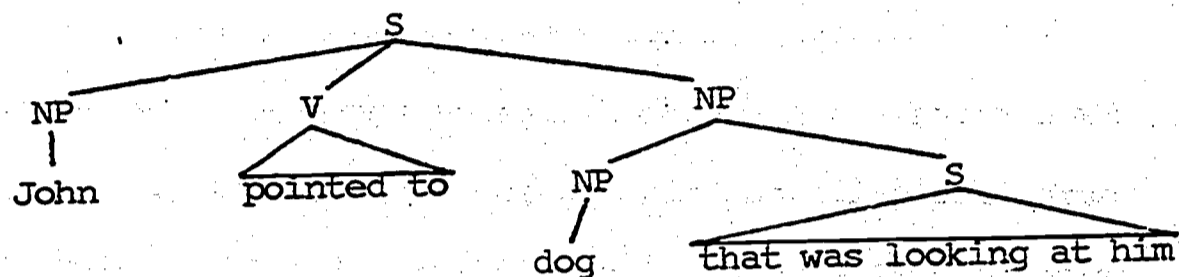

Notice that here the head noun (= dog) is not a repeated NP; i.e. there is no correferential NP (= dog) before 66 is stated, since the intro-S has been moved into the second clause of 66 as a RR. This is to be contrasted with 61, where, although the intro-S has been copied into S_2 , the original S_1 still remains where it was. The head noun (= dog) is a repeated noun in 61, but not in 66. Therefore, it is definitized only in 61. By formulating RR-FORM (B) as 58, I claim that any RR modifying an indefinite NP is the output of RR-FORM (B) (a chopping rule).

RR-FORM (B) will derive 68 from 67:

(67) (enceynka han sakong_i na cukilyehayessta) • (ecey na
 one-time one sailor me tried-to-kill yesterday I
 sakong_i mannassta)
 sailor met

(68) ecey na-nin enceynka na-lil cukilyeha-n (han) sakong-lil
 yesterday I-T one-time me-O tried-to-kill-REL one sailor-O
 mannassta
 met

'Yesterday I met a sailor who once tried to kill me.'

Even though in Korean definite NP's are not syntactically marked as such, one still can distinguish between a RR (A) and a RR (B) by testing a RR with han 'one' or 'certain':¹⁸ only RR (B) tolerates han between relative clause and head noun: e.g. 68.

To emphasize the correctness of the approach suggested in 58, I will compare it with Thompson's. For the derivation of RR's modifying indefinite NP's, Thompson (1967: 94) suggests the following two steps, which are quoted along with her own examples (the numbering is mine):

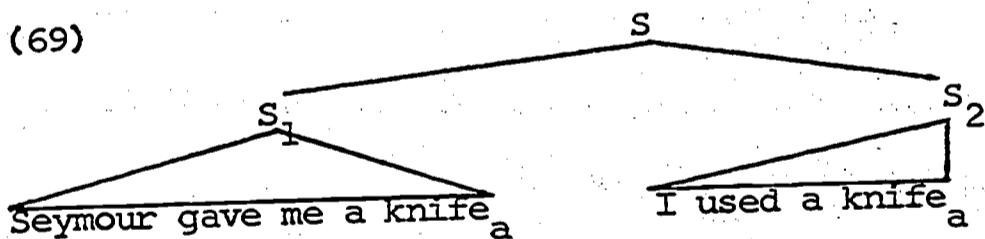

Step 1 (optional): embed by copying S_1 into S_2 ¹⁹
 Step 2 (optional): delete the original S_1

--If this rule is applied, the result is:

(70) I used a knife which Seymour gave me.

--If this second option is not chosen, however, the a in S_2 must be changed to the since it is a repeated occurrence, and the result is:

(71) Seymour gave me a knife, and I used the knife that Seymour gave me.

In contrast with this, Thompson (1967: 95) suggests the following four steps of derivation for RR's modifying definite NP's:

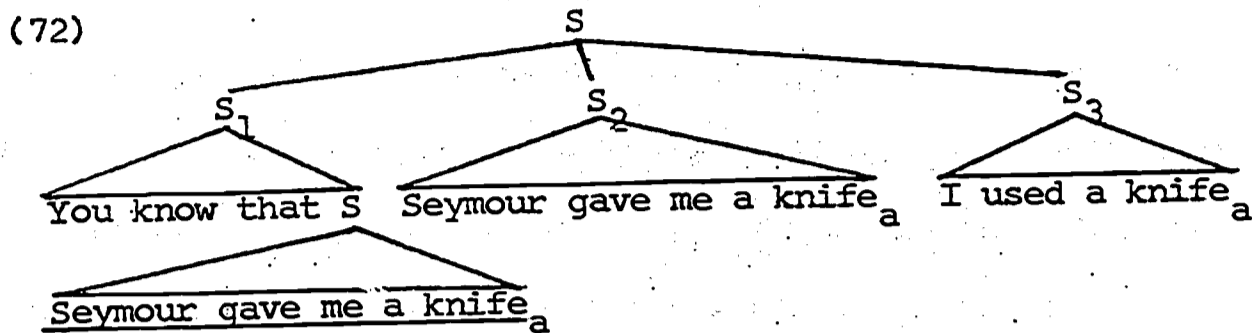

- (73) I used the knife which Seymour gave me.
 Step 1 (optional): embed S_2 into S_3 by copying
 Step 2 (obligatory): delete the original S_2 since it is a
 repetition of S_1
 Step 3 (obligatory): change a in S_3 to the because this NP is a
 repeated occurrence of the one in S_1
 Step 4 (obligatory): delete S_1

The choice of Step 1 and Step 2 in the first quotation is similar to my RR-FORM (B), while the choice of only Step 1 is similar to my RR-FORM (A). But the approach suggested by Thompson in the second quotation above creates peculiar problems. First of all, what if we pass over Step 1, since it is optional? Steps 2, 3, and 4 will automatically apply to the underlying structure, deriving 74:

(74) I used the knife.

In what sense is 74 synonymous with 73, which is the result of having chosen optional Step 1? Second, the relative ordering between the rule changing a to the and the rule deleting the first conjunct is very vague--in the first quotation, S_1 -DELETION precedes DEFINITIZATION; whereas in the second quotation, S_1 -DELETION follows DEFINITIZATION. If we fix the rule ordering so that DEFINITIZATION precedes S_1 -DELETION, there is no way of deriving 70 under Thompson's analysis; on the other hand, if the order is reversed, 73 and 74 can never be derived. Third, according to her analysis, the identity of the second conjunct of

· sentence 71 and sentence 73 is accidental. But my position is that, on the contrary, 73 is simply the second conjunct of 71. Note that there is no semantic difference between the two sentences. Last, the deep structures are not motivated--the occurrence of S_2 is not explained--and the optionality of the various steps seems completely ad hoc. The presuppositional difference which is ultimately responsible for the definite-indefinite distinction of the head noun is not as clearly expressed either in the deep structure or in the transformational rules, as is done in my 58.

3.13. NR-FORMATION. Let us now turn to the derivation of a NR. From the characterization of the restrictiveness of a relative clause suggested in the present analysis--a relative clause is restrictive when it makes the head noun specific--it becomes clear that NP's which are already definite cannot be definitized by a RR (e.g. 21).²¹ Thus, I have shown in 26 and 27, which I repeat here for convenience,

(26) The book, which is about linguistics, is interesting.

(27) The man that fixed the radio left this note.

that when the head noun is definite, the relative clause on the surface could be either a RR or NR: if it is the relative clause that definitizes the noun, then the clause is a RR; otherwise, a NR.

In the present approach, the source of definiteness of book in 26 is presupposed to be known to the hearer and is not expressed on the surface, whereas that of man in 27 is overtly expressed as the underlined relative clause. Therefore, it is naturally expected

that a request for further information about the head noun is only possible in 26. The sentence by B in 26 can be appropriate in some situations, but never 27'B.

(26') A: The book, which is about linguistics, is interesting.

B: What book are you talking about?

(27') A: The man who fixed the radio left this note.

?B: What man are you talking about?

Therefore, I suggest 76 as the underlying structure of 75.

(75) I just saw the janitor, who gave me this key.

(76) (... (certain) janitor_i ...) intro-S ((I just saw (the) janitor_i) ((the) janitor_i gave me this key))

In 76, the ... notation stands for the information of the intro-S that was given in the previous discourse. The intro-S in 76 makes both occurrences of janitor in the second conjunct definite; the process is illustrated by the tree of 77.

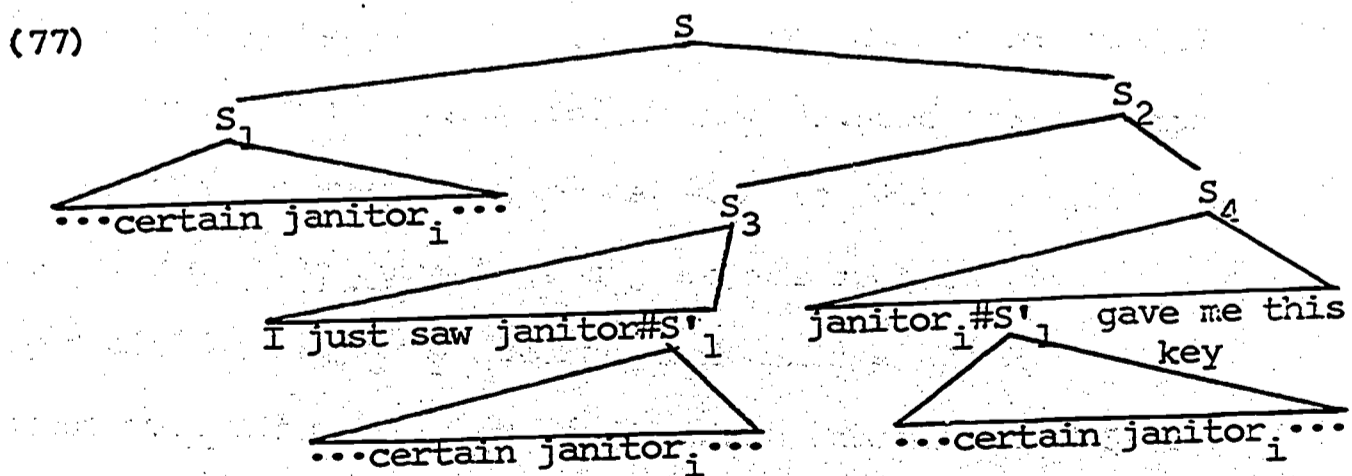

The distribution of the intro-S in both minor conjuncts (viz. S₃ and S₄) in the second major conjunct (viz. S₂) can be explained by the principle of distribution. The principle of distribution is diagrammatically shown here: $X(Y + Z) = XY + XZ$. The S₂ of 77 is transformed into 78 after S₁ has been copied into both S₃ and S₄ by

the opposite direction here--the second conjunct is embedded into the first conjunct in 79, while 58 embeds the first conjunct into the second conjunct. Second, NR-FORM is a chopping rule--NR-FORM does not only copy the second conjunct into the first conjunct, but completely moves it. Therefore, the deletion of a NR is not allowed; deletion is allowed only when recovery is possible. Third, the shared NP in the second conjunct should be definite in 79. Last, there is no specification as to whether the first conjunct in 79 is an intro-S or non-intro-S, while in 58 the first conjunct has to be an intro-S. Sentence 78 is an example of rule 79 in which the first conjunct is not an intro-S. For an example of 79 in which the first conjunct is an intro-S, consider the following:

- (81) a. (I just saw a certain janitor_i) • (janitor_i gave me
this key)
- b. (I just saw a certain janitor) • (the janitor that I just
saw gave me this key)
- c. (I just saw a certain janitor) • (the janitor gave me
this key)

To satisfy the structural description of 79, RR-FORM (A) has to apply to copy the first conjunct of 81a into the second conjunct. Then the head noun will be definitized, as shown in 81b. Since an intro-S immediately precedes the second conjunct, the relative clause in the second conjunct of 81b will be deleted. As a result, 81c will be derived. Then, 79 will operate to derive 82 from 81c.

- (82) I just saw a janitor, who gave me this key.

In this approach, the difference between 75 and 82 is correctly shown to be the presence of a third conjunct in the deep structure of 75 only. In other words, with 75, the speaker presupposes that the hearer knows about the janitor, even before 75 is stated; while with 82 he does not. Since the shared NP in the second conjunct has to be definite in 79, and since RR definitizes NP's, RR-FORM necessarily has to precede NR-FORM. This ordering of the two rules is well illustrated in the following examples from Drubig 1968: 38, which are repeated here as 83 and 84:

(83) The man who murdered the old lady, who nevertheless managed to escape, was caught the next day.

(84) *The man, who nevertheless managed to escape, who murdered the old lady was caught the next day.

Sentence 84 is ungrammatical, since the head noun is indefinite when a NR is attached, and later gets definitized by a RR; the rule ordering is reversed.

Let us compare the present analysis once more with Thompson's. Thompson (1967: 92) claims that 85 is the underlying structure of 75:

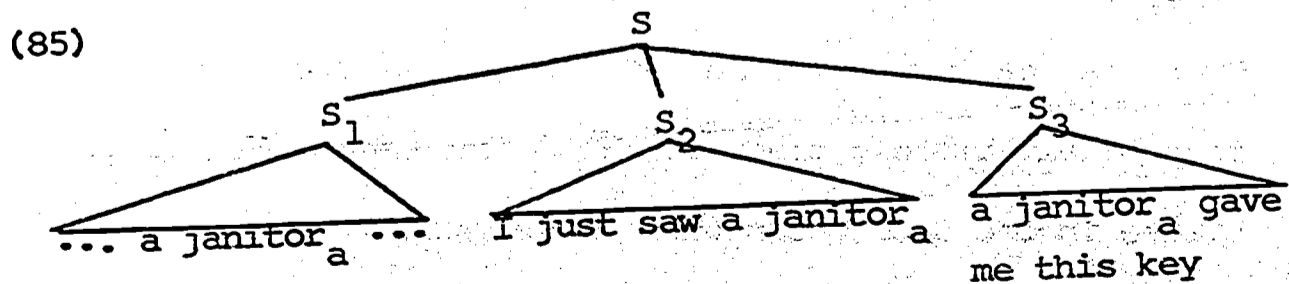

And she suggests the following three steps of derivation of a NR:

Step 1 (optional): embed S_3 into S_2

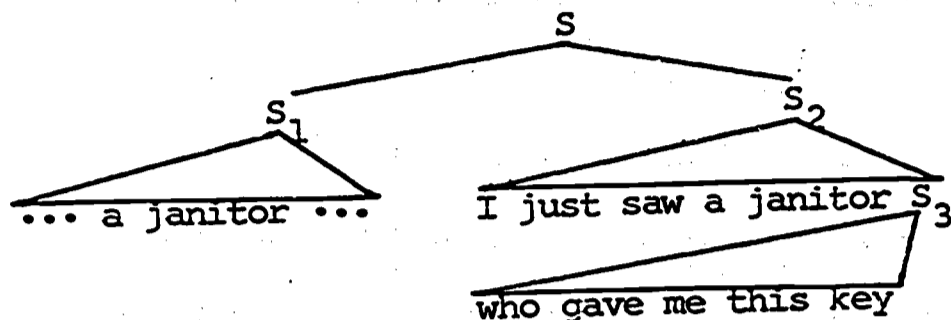

Step 2 (obligatory): replace a in S_2 by the since it is a repeated occurrence of the NP in S_1

Step 3 (optional): delete S_1

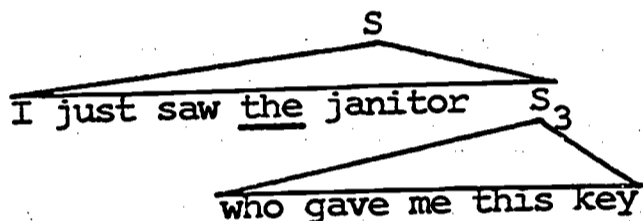

I see two difficulties in Thompson's analysis of NR: (1) It is not clear what the consequences of deleting S_1 in the third step would be--in other words, the information carried by S_1 is rendered irrecoverable. Deletion, in the theory being advocated by me in this writing, is possible only under the condition of recoverability. Thompson (1967: 93) seems to believe that S_1 is not recoverable anyhow. But I have shown at various places in this chapter that RR is always recoverable. One simply has to ask 'What (NP)?' to recover the deleted RR. Besides, if S_1 were not recoverable, what would the output be like when we did not choose optional step 3 of the above quotation? (2) Since step 1 precedes step 2 in the quoted approach of Thompson's, the shared NP in S_3 of 85 is not definite when the embedding of S_3 into S_2 is performed; in other words, the feature specification of item 5 in 79 is absent. This makes it impossible to have a generalized single rule to derive

the (a) sentences of 86-88 from the respective (b) structures. It also has to be specified that S_1 is deletable in 87, but not in 86 or 88:

- (86) a. I just met a janitor, who gave me this key.
 b. (I just met a janitor)·(janitor gave me this key)
- (87) a. I just met the janitor, who gave me this key.
 b. (... a janitor ...)·(I just met a janitor)·(a janitor gave me this key)²²
- (88) a. I just met John, who gave me this key.
 b. (I just met John)·(John gave me this key)

The Korean version of NR-FORM is more complex than 79. Korean does not have a NR paralleling 86a. In other words, the Korean rule needs one additional feature specification on the NP in the first conjunct, viz. [+ definite], as is shown in the formulation of 89:

(89) Korean NON-RESTRICTIVE RELATIVE CLAUSE FORMATION:

(W,	NP_i	,	X)·(Y,	NP_i	,	Z)
	[+ definite]			[+ definite]		
1	2		3	4	5	6

⇒ 1, (4, ∅, 6 + REL)#2, 3

Thus, ex. 82 can be paraphrased only as 82'a, but never as 82'b:

- (82'a) a. na-nān etten suwi-lāi pangkām mannass-nāntey, kī-ka
 I-T certain janitor-O now met-and he-S
 i key-lāi na-eykey cupṭita
 this key-O me-to gave

'I just met a janitor, who gave me this key.'

(82') b. *na-nān i key-lāi na-eykey cu-n etten suwi-lāi

I-T this key-O me-to gave-REL certain janitor-O

pangkām mannassta

just met

'I just met a janitor, who gave me this key.'

Notice that the first conjunct of 89 may not be an intro-S. I will illustrate 89 with the following sentences:

(90) a. Spain-e-lāi hal-cul-lāi al-nān kī salam-nān

Spanish-O speak-NOM-O know-REL the man-T

thongyekkwan-ka toyyessta

interpreter-S became

'The man, who could speak Spanish, became an interpreter.'

b. (kī salam thongyekkwan toyyessta) • (kī salam Spanish

the man interpreter became the man Spanish

hal-cul alassta)

speak-NOM knew

(91) a. taylyuk-eyse cala-n John-nān sem-lāi silhehanta

continent-on grew up-REL John-T island-O dislikes

'John, who grew up on the continent, dislikes the island.'

b. (John sem silhehanta) • (John taylyuk-eyse calassta)

John island dislikes John continent-on grew-up

The (b) sentence of 90 is derived from a still deeper structure 90c:

- (90) c. (... etten salam_i ...) · ((salam_i Spain-e hal-cul alta) ·
 certain man man Spanish speak-NOM know
 (salam_i thongyekkwon toyessta)
 man interpreter became

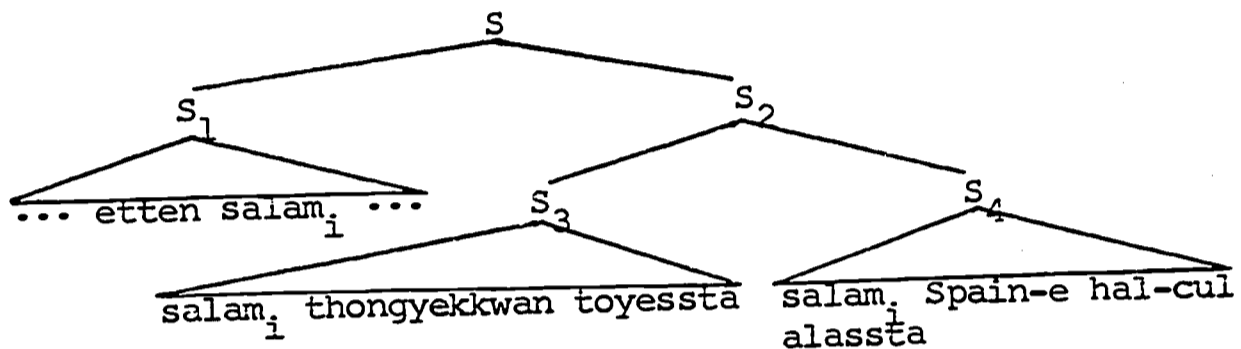

- (90) d.

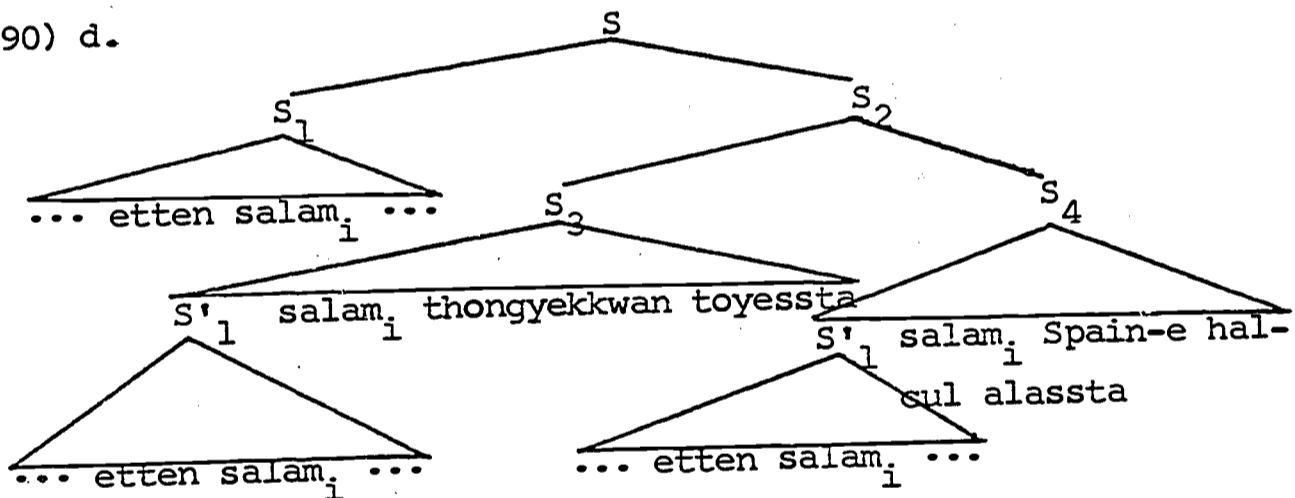

RR-FORM (A) (58) will derive 90d from 90c. With respect to the derivation of 65, I claimed above that in Korean a RR is pronominalized where it would be deleted in English--viz. when an intro-S is not too far away. Thus, RR-PRONOMINALIZATION derives 90b from 90d. Now NR-FORM (89) will apply to 90b and 91b, and as the result, the respective (a) sentences are derived.

Some possible objections

3.2. In this part, I will defend the suggested analysis of RELATIVIZATION by discussing some possible objections:

- (1) objections concerning the direction of embedding in NR-FORM;
 - (2) objections concerning 'stacked' restrictive relative clauses--
- this is not allowed in the present analysis, since definitization can occur only once.

3.21. Direction of embedding in NR-FORM and the problem of ambiguity of a NR. One thing to be mentioned at this point is that the NR-FORM rule can be alternatively formulated in such a way that embedding can be done in either direction--the left conjunct into the right one, or the right conjunct into the left one--unless of course the first conjunct is an intro-S. The reason that I have formulated the rule the way I have done is merely for the sake of simplicity of description: if the first conjunct of 79 is an intro-S, the different direction of embedding will generate a different kind of relative clause. Therefore, in order to make NR-FORM apply in either direction, we have to describe both situations separately: (1) the situation where one conjunct is an intro-S and (2) the situation where neither conjunct is an intro-S. As far as I can see, the ordering of underlying conjuncts does not make any difference so long as neither conjunct is an intro-S. But if the conjunct which is realized as a NR is a later parenthetical insertion by the speaker as in 92 below, a difference does arise. It is obvious that such a parenthetical NR is a second conjunct.

(92) a. John said that he met Mary, who lives in Texas.

b. (John said that he met Mary_i). (Mary_i lives in Texas)

When the second conjunct is a parenthetical insertion, NR-FORM

moves from right to left only. Thus, 93, where NR-FORM moves from left to right, is not synonymous with 92:

(93) a. Mary, who John said he met, lives in Texas.

b. (Mary_i lives in Texas) • (John said he met Mary_i)

In 94, however, both the (b) and (c) structures seem to be equally good underlying structures of the (a) sentence:

(94) a. John, who has grown up on the continent, dislikes the island.

b. (John_i has grown up on the continent) • (John_i dislikes the island)

c. (John_i dislikes the island) • (John_i has grown up on the continent)

But NR-FORM, as formulated in this chapter, is simpler for the following reasons: (1) Since with parenthetical expressions only right-to-left embedding applies, and since in other conjunctions which do not include an intro-S neither direction seems to make any semantic difference, the present analysis with right-to-left embedding accounts for the derivation of both parenthetical and non-parenthetical NR's. (2) Since in a basic conjunction--a conjunction which contains an intro-S--only right-to-left embedding is NR-FORM, and again since in non-basic conjunction neither direction of embedding makes any difference, the present analysis will account for both cases.

The present rule formulation of NR-FORM (79 and 89) offers an interesting solution to the ambiguity problem illustrated in the

following sentence from McCawley 1967, quoted here as 95:

(95) John said that he saw the woman who lives at 219 Main St.

95 can be paraphrased either as 96 or as 97:

(96) John said, 'I saw the woman who lives at 219 Main St.'

(97) John said, 'I saw X, and X is the woman that lives at 219 Main St.'

(where X can stand for any noun, such as Mary or Sam's married sister). McCawley (17-18) suggests the following underlying structures for both readings of 96 and 97, which are quoted here as 96' and 97', respectively.

(96')

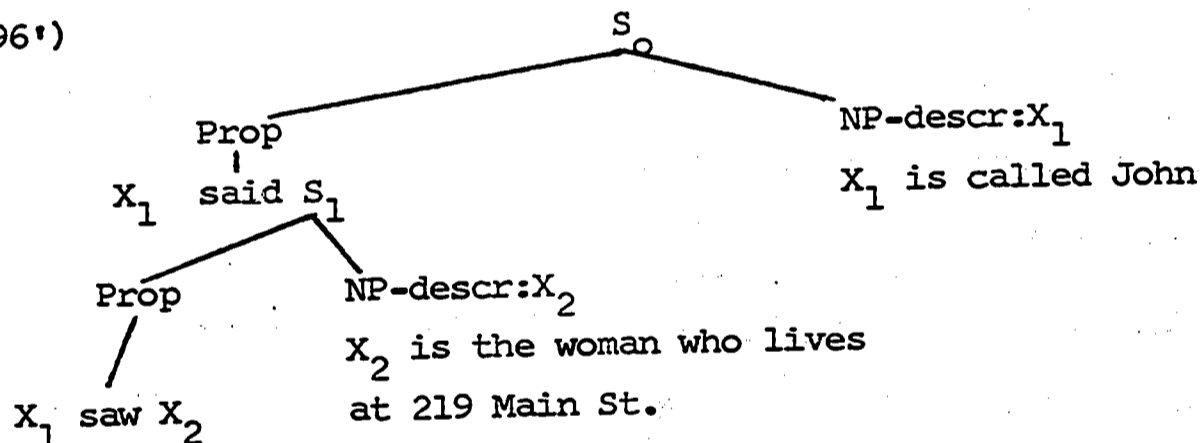

(97')

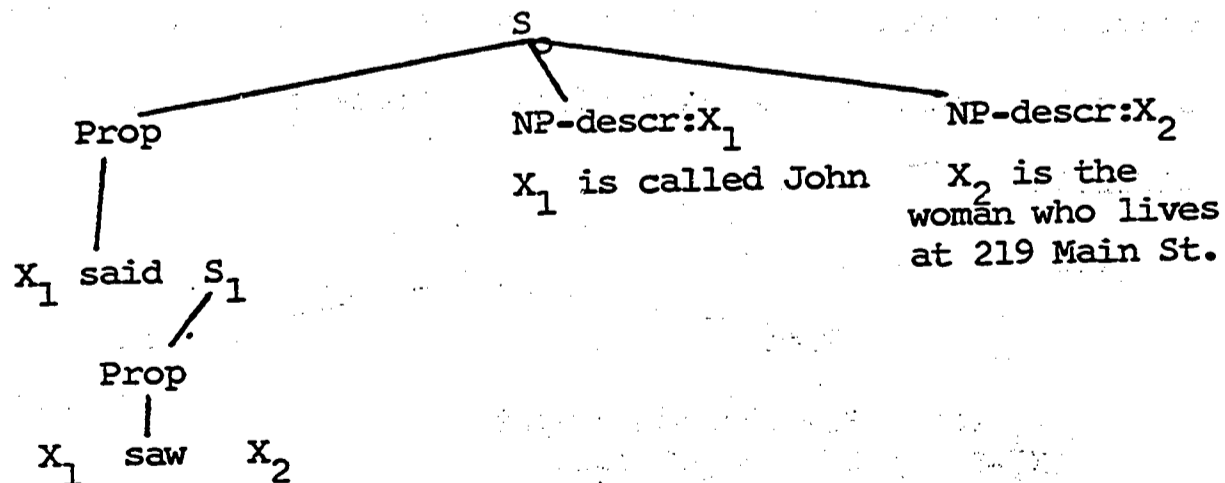

In other words, the description of X₂ is made by the speaker of S₁ (= John) in 96', while in 97', it is made by the speaker of S₀.

An instance is found in Korean which is exactly parallel, except that the complicated honorific system of Korean (which is conditioned by the social relations between the speaker and the referent) syntactically obviates the ambiguity in some situations. Thus, as long as the social status of the subject in 98 and that of the speaker of the sentence are markedly different, there will be no ambiguity in interpreting the following sentence:²³

(98) Suk-ka (na-eykey) Seoul-ey sal-nin acumma-ka oass-te-iako
 Sook-S me-to Seoul-in lives-REL lady-S came-RET-QT
 malhayessta
 said

'Sook said that the lady who lives in Seoul dropped by!'

Suppose a situation where Sook is a house-maid, Kyungsuk is the daughter of the house to whom the maid is supposed to use an honorific title like acumma 'lady', and the speaker is Kyungsuk's brother, who will never call her 'acumma'. In such a situation, there is no ambiguity as to the source of information of the underlined part in 98. According to McCawley's analysis, 98' will underlie 98:²⁴

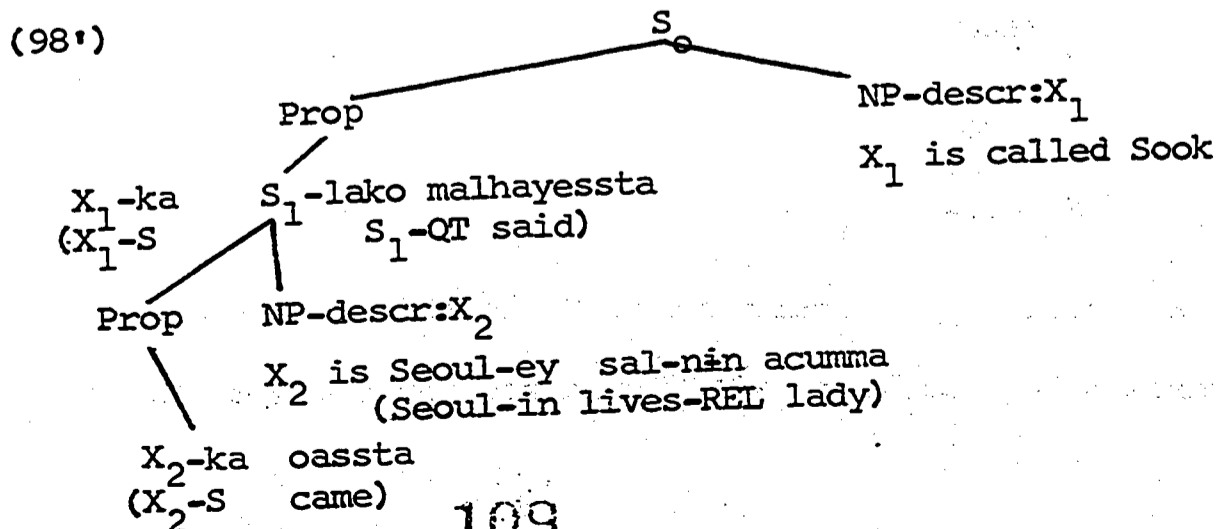

NR-FORM (79) will derive 99bii from 99bi, after the application of such a rule as PRONOMINALIZATION, which replaces John with he. The deletion of X seems to depend on the speaker's presupposition of the hearer's familiarity with X: If the speaker presupposes that the hearer is familiar with X, then he will delete X. In that case, the deletion of who is is automatic. This will generate 95 in its 97-reading; if the speaker presupposes that the hearer is not familiar with X, then he will leave X (e.g. 100):

(100) John said that he saw Mary, (who is) the woman that lives at 219 Main St.

The derivation of 98 exactly parallels this. Conjunctions 101a and 101b underlie the 98'-reading and 98"-reading of 98, respectively:

(101) a. ((etten) acumma_i Seoul-ey salta) • (Suk (acumma_i
 certain lady Seoul-in lives Sook lady
 oassta)-lako malhayessta)
 came-QT said

b. ((etten) acumma_i Seoul-ey salta) • ((Suk (X oassta)-lako
 malhayessta)) • (X acumma_i ita))

Sentence 98 in its 98'-reading is the surface output of the second conjunct of 101a after RR-FORM (A) has copied the intro-S there. As to the derivation of 98 in its 98"-reading, the second conjunct of 101b will be realized as 101bi after the intro-S is copied. NR-FORM (89) will derive 101bii from 101bi:

(101) b. i. Suk-ka X-ka oass-te-lako malhayess-n̄ntey, X-n̄n

Sook-S X-S came-RET-QT said-and X-T

Seoul-ey sal-n̄n acumma-ita

Seoul-in lives-REL lady-is

ii. Suk-ka Seoul-ey sal-n̄n acumma-i-n X-ka oass-te-lako

Sook-S Seoul-in lives-REL lady-is-REL X-S came-RET-QT

malhayessta

said

If the speaker presupposes the hearer to know that X is Seoul-ey sal-n̄n acumma 'the lady from Seoul', then -i-n X 'X, who is' is deleted. As the result, 98 is derived; otherwise, X will remain, as is illustrated in 102a and 102b. Those two sentences are synonymous with each other, since 102b is derived from 102a after RELATIVE-REDUCTION has been applied:

(102) a. Suk-ka Seoul-ey sal-n̄n acumma-i-n Kyengsuk-ka oass-te-

lako malhayessta

'Sook said that Kyengsuk, who is the lady from Seoul,

dropped by.'

b. Suk-ka Seoul-ey sal-n̄n Kyengsuk acumma-ka oass-te-

lako malhayessta

'Sook said that Lady Kyengsuk, who lives in Seoul,

dropped by.'

Thus, the ambiguity of McCawley's example is neatly explained in the present approach by purely syntactic rules, all of which are natural and independently motivated in the grammar!

3.22. Stacked restrictive relative clauses. Another possible argument which could be raised against the present analysis of RELATIVIZATION concerns a 'stacked' clause. A stacked clause is defined by the UCLA Syntax Study Group (1968: 466) in the following way:²⁵

Relative clauses are said to be stacked if a structure exists such that the first clause modifies the head noun, the second modifies the head noun as already modified by the first clause, the third modifies the head noun as already modified by the first clause as in turn modified by the second clause, and so on.

When the head noun is modified by only one RR and one or more NR's, there is no problem. Thus, 103 has only one RR and 104 has no RR, as shown by the phrases:

(103) The short happy life of Francis Macomber.= That part of his life which was happy, which was short.

(104) She has a short, blue, cashmere coat. = She has a coat, which is short, (and which is) blue, and (which is) cashmere.

However, when two or more RR's are stacked modifiers of a head noun-- as in 105--it appears that we have a direct contradiction to the generalization that a NP can be modified by a RR only once: this is because an NP can be specified or definitized only once.²⁶

(105) I want to buy a watch that keeps good time that's cheap.

(106) There is a watch that keeps good time and is cheap, and I want to buy it.

(107) There are watches that keep good time, and some (out)of them are cheap. I want to buy one of them.

But 105 is synonymous with 107, not with 106.²⁷ In other words, I suggest 108 as the underlying structure of 105.

(108) ((Certain) watches_x are cheap) • (some watches_y out of watches_x keep good time) • (I want to buy one out of watches_y)

In a situation where the speaker presupposes that the first two conjuncts of 108 are shared by the hearer--i.e. that the hearer knows of some particular cheap watches and also knows that some of them are of good quality--the derivation will be like this: (1) the first conjunct of 108 is copied into the second conjunct by RR-FORM (A); (2) the second conjunct, which now has the shared NP definitized and includes the copy of the first conjunct as a RR, is in turn copied into the last conjunct. This generates the intermediate structure of 109:

(109) ((Certain) watches_x are cheap) • (some watches_y out of watches_x keep good time) • (I want to buy one watch out of the watches that keep good time out of the watches that are cheap)

We are concerned with only the last conjunct of 109 in the present discussion.

In a situation where the speaker does not presuppose that any of the conjuncts in 108 is shared by the hearer, the derivation will be the following: RR-FORM (B) will embed the first conjunct of 108 into the second conjunct, the outcome of which will in turn be embedded into the last conjunct. The intermediate structure of

110 will be generated as a result.

(110) I want to buy one watch out of the watches that keep good time out of the watches that are cheap.

In both English and Korean, we need a rule which deletes a possessive particle (English out of; Korean cungeyse) and an adjacent NP if an identical NP is present on the opposite side from the NP to be deleted: that is, X out of X in English is realized as X, after out of X is deleted; in Korean, X cungeyse 'among' is deleted from X cungeyse X, after which the second X remains. I will call the rule which deletes of X or X cungeyse REPEATED-NP DELETION (abbr. REPT-NP DEL). REPT-NP DEL deletes out of the watches from both the last conjunct of 109 and that of 110. Then 105 will be ambiguously derived.

In Korean, we have more interesting evidence in favor of the present analysis. If the first conjunct of 111 is embedded as a RR into the second conjunct, 112 will be derived:

(111) ((etten) sikey-t₁ sikan cal macnanta).((k₁) sikyey-t₁_x
 certain watch-PL time very correct the watch-PL
 cungeyse (yakkan-iy) sikyey-t₁_y ssassta).(na (k₁)
 among some-of watch-PL were-cheap I the
 sikyey-t₁_y cungeyse sikyey hana sako-siphta)
 watch-PL among watch one buy-want

115

- (112) ((sikan cal mac-nân)_S sikyey-tâl_X cungeyse (yakkan-iy)
 time very correct-REL watch-PL among some-of
 sikyey-tâl_Y ssassta)·(na (kâ) sikyey-tâl_Y cungeyse
 watch-PL cheap I the watch-PL among
 sikyey hana sako-siphta)
 watch one buy-want

If the first conjunct of 112 is embedded into the last conjunct, 113 is derived. Although 113 is grammatical as it stands, it needs adjustment rules to become a well-accepted structure. Such adjustment rules include REPT-NP DEL, which will delete sikyey-tâl cungeyse 'out of the watches' before the occurrence of identical NP (= sikyey). The degree of deletability of Korean NP-cungeyse seems to be much lower than that of English of NP. In other words, in English of NP has to be deleted almost obligatorily regardless of the distance between that phrase (of-NP) and an identical NP; but in Korean, unless NP-cungeyse is immediately followed by an identical NP, the phrase (NP-cungeyse) is only optionally deleted. Thus, sentences 113-115 are all grammatical, but 116 is not:

- (113) na-nân ((sikan-ka cal mac-nân)_S sikyey-tâl cungeyse
 (ssa-n)_S)_S sikyey hana-lâl sako-siphta
 'I want to buy one of the watches that are cheap from
 among the watches that keep good time.'
- (114) na-nân ((sikan-ka cal mac-nân)_S sikyey-tâl cungeyse
 (ssa-n)_S)_S sikyey hana-lâl sako-siphta
- (115) na-nân ((sikan-ka cal mac-nân)_S (ssa-n)_S)_S sikyey
 hana-lâl sako-siphta

(116) ?na-nin ((sikan-ka cal mac-nin)_S (ssa-n)_S)_S sikyey-til
 cungeyse sikyey hana-lil sako-siphta

These Korean examples illustrate a very interesting, but perhaps obvious, feature of language, namely that, just as in constructing a building, so in language, we need processes for the final touch, as well as the more basic building processes.

The suggested analysis of stacked RR clauses offers a very neat solution to one of Thompson's problems (1970b: 50): Thompson realized that 117 and 118 have different underlying representations, but she did not specify in what way they are different.

(117) Three boys who had beards were at the party.

(118) Three boys, who had beards, were at the party.

Let us revert to the underlying structures of these, keeping in mind the suggestions made in this chapter. First of all, if one remembers the direction of embedding in RR-FORM and NR-FORM, viz. RR-FORM embeds left conjuncts in right conjuncts, while NR-FORM moves right conjuncts in the left conjuncts, it is easy to reconstruct the order of the underlying conjuncts: (1) (boys had beards) and (2) (boys were at the party). Since 117 has conjunct (1) as a RR, and since RR-FORM moves the left conjunct into the right conjunct, conjunct (1) must precede conjunct (2) in the underlying structure of 117. But in 118 the conjuncts are in the opposite order in the deep structure, since NR-FORM moves conjuncts in the opposite direction from that in which RR-FORM moves them. So far as these two conjuncts are concerned, both conjuncts are

ordered as shown in 117a and 118a, respectively:

(117) a. ((Certain) boys_i had beards) · (boys_i were at the party)

(118) a. ((Certain) boys_i were at the party) · (boys_i had beards)

In the first conjunct of 117a, the speaker is not talking about any particular group of boys who happen to have beards, but about all the boys in question who had beards. Therefore, unless 117a is modified somehow, it will mean that all the boys who had beards were at the party. This is not the meaning of 117. Since 117 means only 'some of the boys who had beards', 117a will have to be revised as 117b:

(117) b. ((Certain) boys_x had beards) · (some boys_y out of boys_x were at the party)

The third conjunct that has to appear in the deep structure of 117 and 118--viz. (boys were three)--includes a numeral (a B adjective). Remember that B adjectives can have only definite NP's as subjects. So, the subject NP boys of the third conjunct has to be definite. This NP is correferential with boys_y underlined in the second conjunct in 117b, and with boys_i in the first conjunct in 118a. The long and short of all this is that this third conjunct is posited after the second conjunct in 117b, but after the first conjunct in 118a, as shown in 117c and 118b, respectively:

(117) c. ((Certain) boys_x had beards) · (some boys_y out of boys_x were at the party) · (boys_y were three)

d. (Some boys_y out of boys_x who had beards were at the party) · (boys_y were three)

- (117) e. Three boys out of the boys who had beards were at the party.
- (118) b. ((Certain) boys_x were at the party) • (boys_x were three) •
(boys_x had beards)
- c. ((Certain) boys_x, who had beards, were at the party) •
(boys_x were three)

The derivation of the surface forms of 117 and 118 from these underlying structures is obvious. After the first conjunct of 117c is embedded into the second conjunct and definitizes the correferential NP (= boys_x), 117d is generated. Conjunction 118c is generated after the last conjunct of 118b is embedded into the first conjunct by NR-FORM. NR (Adj Pr) FORM, which was discussed in Chapter Two (rule 96), moves the last conjunct of 117d and 118c into the first conjunct there and generates 117e and 118, respectively. Sentence 117 is derived from 117e, after REPT-NP DEL deletes of boys. The semantic difference between 117 and 118 is shown in the underlying representations, viz. 117c and 118b. Also, the derivation from these basic structures is effected by three already existing rules--viz. RR-FORM, NR-FORM, and REPT-NP DEL.

Thompson (1970b: 43) has also pointed out that 119a and 120a have different meanings. The semantic difference is caused by the different underlying structures of 119b and 120b, respectively:

- (119) a. I have three students who are flunking.
- b. ((Certain) students_x are flunking) • (I have some students_y of students_x) • (students_y are three)

(120) a. I have three students, and they are flunking.

b. (I have students_x) · (students_x are three) · (students_x
are flunking)

To derive 119a, it is necessary to let RR-FORM apply to the first two conjuncts of 119b, then to let NR (Adj-Pr) FORM apply to this output and to the third conjunct, and finally to let REPT-NP DEL apply to the final output. If RR-FORM (A) applies to the first and last conjuncts of 120b, and is followed by the application of NR (Adj-Pr) FORM to the first two conjuncts, 120c is generated:

(120) c. I have three students, and the students that I have
are flunking.

RR-DEL (deletion of the underlined clause in 120c) and PRONOMINALIZATION (changing the students to they) together generate 120a from 120c.

In sum, I suggest that any sentence with NP's modified both by Q's and RR's has three conjuncts in its deep structure: a first conjunct which is ultimately realized as a RR, a third conjunct which has a Q as its predicate, and a second conjunct which has a NP_i out of NP_j construction such that NP_i is correferential with an NP of the last conjunct and such that NP_j is correferential with one of the first conjunct.

Other related problems

3.3. In this section, three related problems--(1) the derivation of generic nouns, (2) identity and referentiality of NP's, and (3) implications made by the hierarchy of anaphora--

will be discussed. The position which the author has taken on representative generics and correferentiality will be further justified.²⁸

3.31. Derivation of generic nouns. It has been previously claimed that there are two usages of generic nouns: representative and partitive. A representative generic refers to all the members of a class. A partitive generic refers to non-specific members of some class. Compare 121 and 122:

(121) Women, who are talkative, are good informants.

(122) Women who are talkative are good informants.

(123) Talkative women are good informants.

Women in 121 is an example of a representative generic, and any representative generic is definite, in view of the definition of definiteness suggested in the present dissertation--viz. that a NP is definite if the speaker presupposes its existence to be shared by hearers. Since the head noun (women) in 121 is already definite, the modifying relative clause can only be non-restrictive. On the other hand, women in 122 is not a representative generic, and since it is not specific, it cannot be definite. Therefore, the relative clause has to be a RR. This is because an unspecified NP cannot be modified by a NR. Since both 121 and 122 can be further reduced to 123 by RELATIVE CLAUSE REDUCTION and ADJECTIVE PREPOSING, 123 is ambiguous. Sentence 123 has yet a third reading: those women who are good informants are talkative. The underlying structure of the third reading is 124a. Sentence 123 with the third reading carries

heavy accent on the preposed adjective (= talkative).

- (124) a. ((Certain) women are good informants) • ((the) women are talkative)
- b. The women who are good informants are talkative.
- c. Talkative women are good informants (= 'It is talkative women that are good informants').

Exs. 124b and 124c are derived from 124a by RR-FORM (A) (rule 58') and NR (Adj-Pr) FORM (ch. 2, rule 96), respectively. Note that RR (A) \equiv NR (marked NP accent; see rule 96 of Chapter Two), and RR (B) \equiv NR (unmarked accent).

The semantic dissimilarity between 122 and 124b indicates that 124a cannot underlie 122. What could be the underlying structure of 122? Carden (1970:35) claims that 'generics and quantifiers, which form a semantic class, also form a syntactic class and share a higher-verb deep structure'. But he does not explain why this should be the case. The relation between generics and Q's is clearly revealed in the following underlying structures of 121 and 122, which will be justified later:

- (121) a. ((Women_x are good informants) • (women_x are talkative)) • (women_x are all)
- b. (All women are good informants) • (all women are talkative)
- c. All women, who are talkative, are good informants.
- (122) a. ((Certain) women_x are talkative) • ((women_x are good informants) • (women_x are all))
- b. (Women_x that are talkative are good informants) • (women_x that are talkative are all)

(122) c. All women that are talkative are good informants.

In the derivation of 121, NR (Adj-Pr) FORM embeds the last conjunct of the (a) structure into both conjuncts within the first major conjunct by the principle of distribution.²⁹ This generates the (b) conjunction, from which NR-FORM (rule 79) generates the (c) sentence. In the derivation of 122, the (b) conjunction is derived after the first conjunct of the (a) structure is embedded into both conjuncts in the second major conjunct by RR-FORM. NR (Adj-Pr) FORM generates 122c from 122b.

At this point, we need a rule which creates generics out of universally quantified NP's. This rule, GENERIC FORMATION, seems to be wide-spread among the languages of the world. The rule simply drops all in English and the corresponding phrase moti-n 'all' in Korean; cf. the following formulation:

(125) GENERIC FORMATION:

$$\begin{array}{ccccccc}
 W, & \{ \text{All} & & \text{NP} & X & \xrightarrow{\text{OPT}} & 1, \quad \emptyset, \quad 3 \\
 & \{ \text{moti-n} \} & & \underbrace{\hspace{1.5cm}} & & & \\
 1 & 2 & & 3 & & &
 \end{array}$$

Rule 125 derives 121 and 122 from the respective (c) sentences.

The derivations of 126d and 127d in Korean exactly parallel those of 121 and 122 in English:

(126) a. ((yeca-t₁ malssengkkuleki-ita)·(yeca-t₁
 girl-PL trouble-makers-are girl-PL
 sutasilewta))·(yeca-t₁ motu-ita)
 are-talkative girl-PL all-are

- (126) b. (moti-n yeca-ti_l_x malssengkkuleki-ita) • (moti-n
all-REL girl-PL trouble-makers-are all-REL
yeca-ti_l_x sutasilewta)
girl-PL talkative
- c. sutasilew-in moti-n yeca-ti_l-n_n malssengkkuleki-ita
talkative-REL all-REL girl-PL-T trouble-makers-are
- d. sutasilew-in yeca-ti_l-n_n malssengkkuleki-ita
'Girls, who are talkative, are trouble-makers.'

- (127) a. ((etten) yeca-ti_l_x sutasilewta) • ((yeca-ti_l_x
certain girl-PL talkative girl-PL
malssengkkuleki-ita) • (yeca-ti_l_x motu-ita)
trouble-makers-are girl-PL all-are
- b. (sutasilew-in yeca-ti_l_x malssengkkuleki-ita) • (sutasilew-
talkative-REL girl-PL trouble-makers-are talkative-
in yeca-ti_l_x motu-ita)
REL girl-PL all-are
- c. moti-n sutasilew-in yeca-ti_l-n_n malssengkkuleki-ita
all-REL talkative-REL girl-PL-T trouble-makers-are
- d. sutasilew-in yeca-ti_l-n_n malssengkkuleki-ita
'Girls who are talkative are trouble-makers.'

In the derivation of 126, NR (Adj-Pr) FORM moves the last conjunct of the (a) structure into both conjuncts within the first major conjunct by the principle of distribution, thus deriving the (b) conjunction, from which NR-FORM (rule 89) derives the (c) sentence. In the derivation of 127, the first conjunct of the (a) structure

is embedded into both conjuncts in the second major conjunct--by the principle of distribution--and derives the (b) conjunction, from which NR (Adj-Pr) FORM derives the (c) sentence. Rule 125 generates 126d and 127d from the respective (c) sentences. The underlying structure suggested for 127d explains the difference between generic NP's modified by RR (e.g. 127d) and other indefinite adjective + NP phrases like 128c, the deep structure of which does not include a universal quantifier: cf. 128a.

- (128) a. ((etten) yeca-t̄l_x ñngmohayessta) • (yeca-t̄l_x sutas̄lew-
 certain girl-PL applied girl-PL talkative-
 essta)
 were
- b. ñngmoha-n yeca-t̄l-ka sutas̄lewessta
 applied-REL girl-PL-S talkative-were
- c. s̄utas̄lew-ñ yeca-t̄l-ka ñngmohayessta
 'Talkative girls applied.'

In 128c, the primary accent is on sutas̄lew-ñ 'talkative', since the adjective has been moved from the second conjunct. Sentence 128b is derived from 128a by RR-FORM, and NR (Adj-Pr) FORM generates 128c from 128a.

So far, I have merely shown without any justification that generics can be analyzed as having been derived from NP's modified by universal Q's. The negation of sentences shows that the approach suggested above is the correct one. When a sentence with a preposed adjective (e.g. 124c and 128c) is within the scope of a

negative marker (= NEG), the NEG negates the heaviest-accented part--the preposed adjective. Thus, negations of 124c and 128c are given below with their paraphrases:

(124) d. I don't think that talkative women are good informants.

e. It is not talkative women that are good informants.

(128) d. sutasilew-in yeca-til-ka ingmohayessta-ko-nin

talkative-REL girl-PL-S applied-OT-DLM

sayngkakha-ci ani-hanta³⁰

think-NOM not-acc

'I do not think that talkative women applied.'

e. ingmoha-n yeca-til-ka sutasilew-in yeca-til-ka

applied-REL girl-PL-S talkative-REL girl-PL-S

ani-iessta

not-were

'The girls who applied were not talkative girls.'

Compare these with the negations of generics (e.g. 122 and 127d). Exs. 122d and 127e, which are the negations of 122 and 127d, are synonymous with 122e and 127f, respectively, but never with 122f and 127g.

(122) d. The claim that women who are talkative are good informants is not correct.

e. It is not true that given any woman, if she is talkative, then she is a good informant.

f. Good female-informants are not talkative.

(127) e. sutasilew-in yeca-tal-nan malssengkkuleki-la-nan
 talkative-REL girl-PL-T trouble-makers-are-REL
 mal-nan kecis-ita
 claim-T false-is

'The claim that women who are talkative are trouble-
 makers is false.'

f. yeca-nan nuku-itenci sutasilew-amyen malssengkkuleki-
 girl-T whoever talkative-if trouble-maker
 la-nan mal-nan kecis-ita
 is-REL claim-T false-is

'The claim that whatever women are talkative are
 trouble-makers is false.'

g. malssengkkuleki-i-n yeca-tal-nan sutasilew-ci ani-hata
 trouble-makers-are-REL girl-PL-T talkative-NOM not-do
 'Girls who are trouble-makers are not talkative.'

Thus, a sentence like 127e is used when the speaker's expectations based on the generalization that all talkative women are trouble-makers has been upset by a certain woman who is not a trouble-maker.

From now on, I will use only 122 by way of an illustration.

A logical representation of 122e, which is a paraphrase of 122d, is given below as 122g:

(122) g. $\sim (x) (\text{Talkative}_x \supset \text{Good Informant}_x)$

'It is not the case that given any x, if x is Talkative,
 x is a Good Informant.'

To reconstruct the correct underlying structure, the following

127

replacement rules will be used:³¹

(129) De Morgan's Theorem:

$$\sim(p \cdot q) \equiv (\sim p \vee \sim q)$$

'negation of a conjunction of positive sentences is equivalent to a disjunction of negative sentences.'

(130) Material Implication:

$$p \supset q \equiv (\sim p \vee q)$$

'implication of q by p is equivalent to disjunction of negative p and positive q.'

According to 130, ex. 122g is equivalent to 122h, which is in turn equivalent to 122i by 129:

(122) h. $\sim(x) (\sim \text{Talkative}_x \vee \text{Good Informant}_x)$

'It is not the case that given any x, x is either Good Informant or not Talkative.'

i. $\sim(x) (\text{Talkative}_x \cdot \sim \text{Good Informant}_x)$

'It is not the case that given any x, x is never both Talkative and not Good Informant.'

At this point, we need a Q negation rule which is given here as 131:

(131) Quantifier-Negation:³²

$$\sim(\forall) \bar{\alpha}_v \equiv (\exists v) \sim \bar{\alpha}_v$$

Rule 131 means that the negation of universal quantification ($\sim[\forall] \bar{\alpha}_v$) is equivalent to the existential quantification ($\exists v$) of a negated statement ($\sim \bar{\alpha}_v$). According to 131, ex. 122i is equivalent to 122j:

(122) j. $(\exists x) (\text{Talkative}_x \cdot \sim \text{Good Informant}_x)$

'There is at least one x such that x is both Talkative and not a Good Informant.'

Thus, all the representations of 122g-j are equivalent to each other. Notice that 122e is a paraphrase of 122d, which is the negation of 122--a sentence with a generic. Since 122e is represented as 122g, the underlying structure of 122 (with affirmative meaning) should be the negation of 122g: anything negative logically becomes positive if negated again. Sentences 132g-j are the rough English renderings of the negations of 122g-j. These are the underlying structures of 122, a sentence with a generic noun.

(132) g. For all women, it is true that, if they are talkative, they are good informants.

h. It is true of every woman that she is either a good informant or not talkative.

i. It is true of every woman that she cannot be both talkative and not a good informant.

j. There is no woman such that she is both talkative and not a good informant.

It is clear that the claim on which the analyses of 122 and 127 are based--viz. that generic nouns are derived from nouns modified by a universal Q--has been justified in the logical representations and replacement rules.

3.32. Identity and referentiality of NP's. Identity and correferentiality of NP's frequently serve as conditioning factors

for PRONOMINALIZATION, REFLEXIVIZATION, or EQUI-DELETION. Thus, Karttunen (1971:3) lists the following three deletability conditions, which must obtain simultaneously:

(133) DELETABILITY CONDITIONS:

- a. Identical Constituent Structure
- b. Morpheme-for-Morpheme Identity
- c. Correferentiality

It has to be emphasized that 133a-c are not surface conditions, but conditions which are operative at a deep level. The identical NP (viz. all the Democrats) in 134 is not subject to deletion, even though all the above conditions--133a-c--are met on the surface.

(134) All the Democrats want all the Democrats to be elected.

(135) John wants to be elected.

(136) John wants Tom to be elected.

The impossibility of deleting the superficially identical and correferential NP in 134 is clearly revealed from the following deep structure of 134:

(134') (Democrats_x want ((Democrats_y [will] be elected) •

(Democrats_y be all))) • (Democrats_x are all)

In the first major conjunct of 134', there is no correferentiality between the subject of the matrix sentence and either of the embedded conjunct subjects; and therefore condition (c) of 133 is violated.

Only under the present approach does it seem possible to maintain these conditions for deletability in a neat and clear manner. Consider the following:

(137) I bought a red flower, (and) I want to give the flower to Mary.

If relative clauses were underlying embeddings, a serious difficulty would arise with respect to the application of RELATIVIZATION or PRONOMINALIZATION to a sentence like 137--133b is violated. The NP of the first conjunct in 137 is not identical with that of the second conjunct in this example. But in the present approach-- which claims that all relative clauses are derived from independent conjuncts in the deep structure--the difficulty discussed above does not arise. In what is suggested here, 137 will have 138 as its underlying structure:

(138) (I bought (certain) flower_x) • ((I want to give flower_x to Mary) • (flower_x is red))

To derive 137, the first conjunct of 138 is copied into the second conjunct by RR-FORM (A) (rule 58), and as the result, the shared NP in the second conjunct is definitized (cf. 137a). Then the RR is deleted, since the intro-S immediately precedes it (cf. 137b); there is no danger of the hearer's having forgotten the information carried by the intro-S. Finally, NR (Adj-Pr) FORM embeds the last conjunct into the first conjunct, thus deriving 137 from 137b:

(137) a. (I bought (certain) flower) • (I want to give the flower that I bought to Mary) • (flower is red)
 b. (I bought (certain) flower) • (I want to give the flower to Mary) • (flower is red)

Let us now consider 139:

(139) I want to give a red flower that I bought to Mary.

Sentence 139 is obviously synonymous with 137. If one wants to analyze a relative clause as an underlying embedding, 137 may be the underlying structure of 139. However, one cannot derive 139 from 137 without violating the deletability conditions of 133.

But it is being now proposed that there are several reasons why 139 can be easily derived from 138, which also underlies 137.

The derivation of 139 from 138 is made in the following manner:³²

(1) After the first conjunct of 138 is copied into the third conjunct by RR-FORM (A), the RR thereby produced is deleted. And the first conjunct is embedded into the second conjunct by RR-FORM (B). Then 140a is derived. (2) After the second conjunct of 140a is embedded into the first conjunct by NR-FORM (rule 79), 140b is derived:

- (140) a. I want to give a flower that I bought to Mary, (and)
the flower is red.
b. I want to give a flower that I bought, which is red,
to Mary.

(3) RELATIVE CLAUSE REDUCTION and ADJ-PREPOSING will derive 139 from 140b. In the proposed analysis, then, none of the deletability conditions have to be violated, since in the deep structure all adjectives were predicates of individual conjuncts.

The same line of argument holds for Korean too. Sentence 141 is synonymous with 142:

(141) na-nān (han) pulkī-n kkoçh-līl sass-nāntey, kī kkoçh-līl
 I-T one red-REL flower-O bought-and the flower-O
 Mary-eykey cuko-siphta
 Mary-to give-want
 'I bought a red flower, and I want to give the flower
 to Mary.'

(142) na-nān na-ka sa-n pulk-in kkoçh-līl Mary-eykey cuko-siphta
 I-T I-S bought-REL red-REL flower-O Mary-to give-want
 'I want to give a red flower that I bought to Mary.'

The sentences of 141 and 142 are not synonymous for the reason that 142 is derived from either sentence of 141, but because both of the sentences share the same underlying structure, viz. 143:

(143) (na (etten) kkoçh_x sassta) • ((na kkoçh_x Mary-eykey
 I certain flower bought I flower Mary-to
 cuko-siphta) • (kkoçh_x pulkta))
 give-want flower red

For 141, the derivation proceeds as follows: (1) the first conjunct of 143 is copied into the second conjunct there by RR-FORM (A), and the RR in the second conjunct--(directly following the intro-S)--is deleted; (2) the third conjunct is embedded into the first conjunct by NR-FORM (rule 89). For the derivation of 142: (1) the first conjunct of 143 is copied into the last conjunct by RR-FORM (A), and the RR resulting thereby is deleted; (2) the first conjunct is embedded into the second conjunct by RR-FORM (B); (3) the third conjunct is embedded into what is now the first conjunct by NR-FORM.

3.33. Implications made by the hierarchy of anaphora.

G. Lakoff (1968b:33) has divided definite NP's into four groups and proposed the hierarchy shown below:

- (144) 1. Proper names (e.g. Dirksen)
 2. Definite descriptions (e.g. the man in the blue suit)
 3. Epithets (e.g. the bastard)
 4. Pronouns (e.g. he)

Lakoff claims that the same relation between antecedent and anaphora exists between NP's of higher group and NP's of lower group as the relation that exists between definite NP's and pronouns. Thus, the (b) sentences below are all ungrammatical, while the (a) sentences are good only if the underlined NP's are correferential:

- (145) a. Napoleon entered the room, and he announced that Jean-Luc would hang.
 b. *He entered the room, and Napoleon announced that Jean-Luc would hang.
- (146) a. Napoleon entered the room, and the bastard announced that Jean-Luc would hang.
 b. *The bastard entered the room, and Napoleon announced that Jean-Luc would hang.
- (147) a. Napoleon entered the room, and the emperor announced that Jean-Luc would hang.
 b. *The emperor entered the room, and Napoleon announced that Jean-Luc would hang.

- (148) a. The emperor entered the room, and he announced that Jean-Luc would hang.
- b. *He entered the room, and the emperor announced that Jean-Luc would hang.
- (149) a. The emperor entered the room, and the bastard announced that Jean-Luc would hang.
- b. *The bastard entered the room, and the emperor announced that Jean-Luc would hang.
- (150) a. The bastard entered the room, and he announced that Jean-Luc would hang.
- b. *He entered the room, and the bastard announced that Jean-Luc would hang.

This indicates that there is some sort of hierarchy, which determines the ordering of definitizing clauses in the underlying structure. As expected, definite NP's, which are more restricted in the sense that the scope of their reference is narrower, are higher in the hierarchy. Proper nouns are the most restricted and therefore highest in the hierarchy: consequently, they are ordered first. The pronoun he can refer to any male and so cannot occur before a proper noun in the deep structure. To put it differently, if two definite NP's which are correferential are used in the same discourse, the possibility of ambiguity as to the identity of referent is least where there is a proper noun and greatest where there is a pronoun. To be effective, then, it is understandable that the identity of any NP is confirmed with a term which has the

" least possibility of ambiguity; after the identity of the two has been clearly established, effective communication will not be diminished by referring to the NP with a somewhat more ambiguous term.

CHAPTER FOUR: TOPICALIZATION:

NEN VS. KAIntroduction

4.1. Geach (1950) discusses two uses of an NP which he calls the formal use and the material use, which in turn were borrowed from Aquinas. Geach (465) goes on to characterize these in the following manner:

A noun or noun phrase is used materially if it stands for an object (suppositum, res naturae), but formally if it is a predicate expressing a property (forma, natura, essentia) ...
If a noun or noun phrase is used by itself to name some object in the environment, then its use must be regarded as material, whether it is a proper noun or not.

Thus, the subject NP of an existential sentence is used formally, since it fills the blank of 'something is ____'. Accordingly, the (a) sentences below are synonymous with the (b) sentences:

(1) a. There was a dog.

b. Something was a dog.

(2) a. A dog chased Mary.

b. Something was a dog; and the dog chased Mary.

Ex. 2a has conjoined predicates in the deep structure--one asserting the existence of a dog, and the other asserting its having chased Mary. In other words, 2a as a single sentence does not assert the existence of any dog, but that of a specific dog, viz. the one that is specified by the predicate of the sentence! After the utterance of this sentence, the existence of this specific dog is also hereafter a presupposition of any hearers

and is therefore definitized. Naturally, definite nouns will not occur as subjects of existential sentences, as is illustrated in 3:

(3) *John existed.

(4) Nimrod existed (= did exist).

But then, how could it be that Nimrod in 4--which is as definite as John--could be used as the subject of an existential sentence? The difference between 3 and 4 is to be explained as follows: in 3, John is definite, i.e. his existence is presupposed by both the speaker and hearers, so that it is not necessary to assert his existence afterwards, whereas 4 is acceptable only when the existence of Nimrod is doubted by the hearers and the speaker feels the need to convince the hearers further of the existence of 'the mighty hunter against Jehovah'.

Indefinite NP's modified by adjectives, which I have extensively discussed in the foregoing chapters, could all be considered to be instances of the formal use of NP.¹ We can expand our term here, so that NP's used formally include those NP's which supply the new information in a sentence. In Korean, the distinction between NP's used formally and NP's used materially is syntactically marked by particles. Formal NP's, in an expanded sense, may include definite NP's; but indefinite NP's are never used materially. A plausible solution to the long-debated and notorious problem of nin vs. ka (Japanese wa vs. ga) suggests itself along the lines of our approach to definite and indefinite NP's.

4.11. Definite NP and TOPICALIZATION. An NP used formally cannot be topicalized, since it is the part of a sentence which delivers the key information. To put it differently, definiteness is a necessary, although not sufficient, condition for an NP to be topicalized. Thus, an NP in its intro-S can never be topicalized.² This is clearly brought out in the following sentences:

(5) a. manh-in yeca-t̄l-ka ñngmohayessta

many-REL girl-PL-S applied

'Many girls applied.'

b. ((etten) yeca-t̄l_i ñngmohayessta) • ((k̄i) yeca-t̄l_i

certain girl-PL applied the girl-PL

manhassta)³

were-many

c. *((etten) yeca-t̄l_i manhassta) • ((k̄i) yeca-t̄l_i

ñngmohayessta)

(6) a. tases (myeng-iy) yeca-t̄l-ka ñngmohayessta

five person-of girl-PL-S applied

'Five girls applied.'

b. ((etten) yeca-t̄l_i ñngmohayessta) • ((k̄i) yeca-t̄l_i tases

certain girl-PL applied the girl-PL five

(myeng)-iessta)

persons-were

c. *((etten) yeca-t̄l_i tases (myeng)-iessta) • ((k̄i) yeca-t̄l_i

ñngmohayessta)

The (c) structures above are impossible because Q's and numerals

belong to B adjectives (cf. 2.2), which cannot have indefinite NP's as subjects--the first conjuncts of the (c) sentences have B adjectives as predicates of intro-S's. In Chapter Two (2.21), I showed that indefinite NP's modified by adjectives are formally-used NP's by pointing out that NEG, which always negates new information in a sentence, negates those adjectives. Naturally, such indefinite NP's cannot be topicalized.

TOPICALIZATION is formulated in the following manner:

(7) TOPICALIZATION (abbr. TOPZN):

X,	NP	+ Particle,	Y
	[+ definite]		
1	2		3

⇒ (2 + nān)#(1, ∅, 3)

Thus, the (b)-(d) sentences in ex. 8 are derived from the (a) sentences by TOPZN:

(8) a. John-kwa suyoil-ey hakkyo-ey kanta⁴

John-with Wednesday-on school-to go

'I go to school with John on Wednesday.'

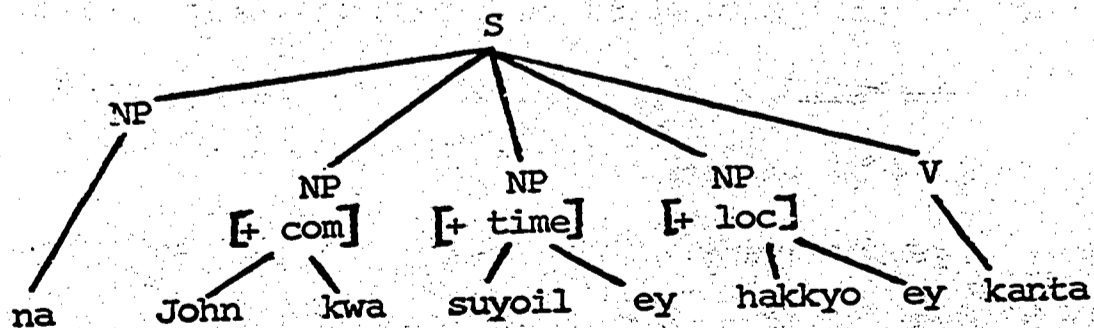

(8) b. John-kwa-n_{n̄}n, suyoil-ey hakkyo-ey kanta

'As for John, I go to school with him on Wednesday.'

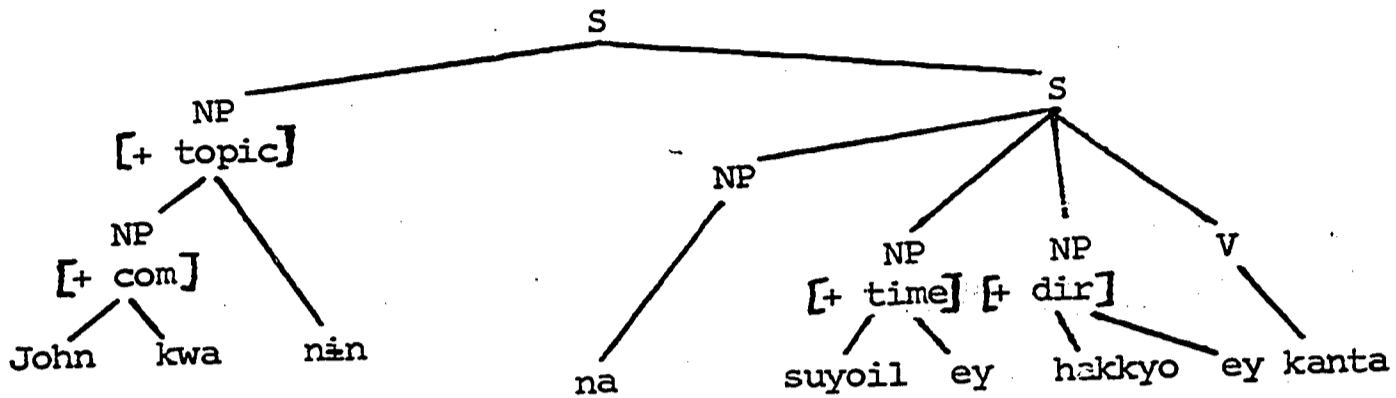

c. suyoil-ey-n_{n̄}n, John-kwa hakkyo-ey kanta

'As for Wednesday, I go to school with John.'

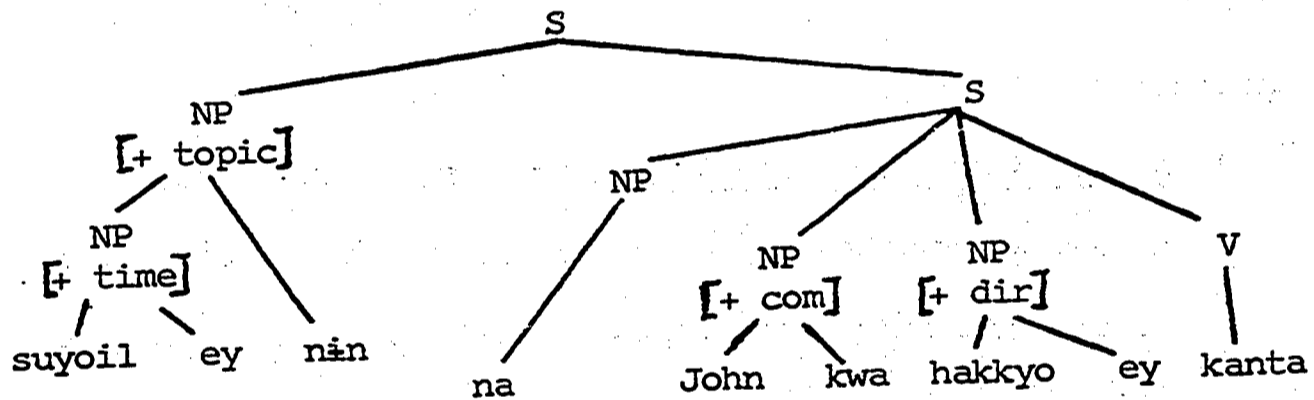

d. hakkyo-ey-n_{n̄}n, John-kwa suyoil-ey kanta

'As for school, I go there with John on Wednesday.'

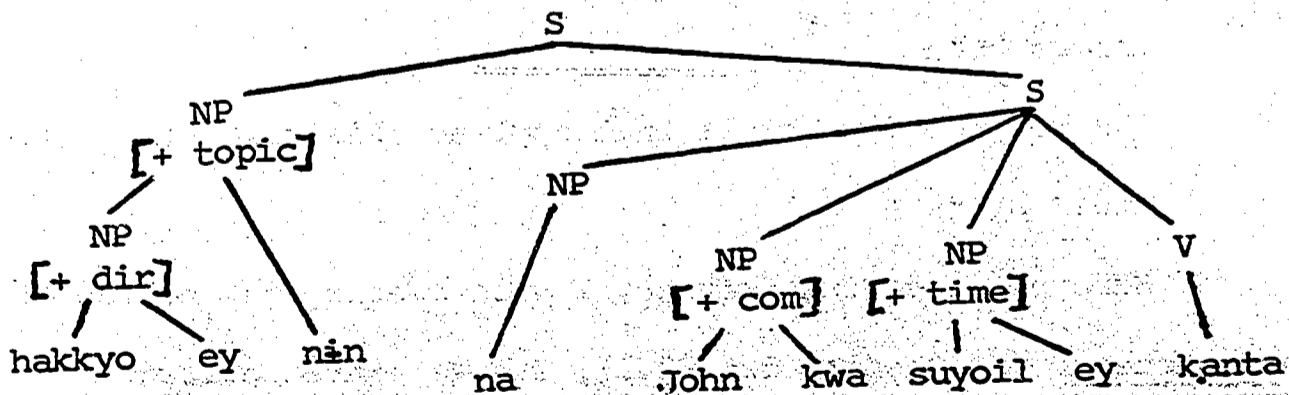

Further restrictions on TOPZN will be discussed in next section.

The reason why TOPZN cannot apply to any indefinite NP's modified by adjectives is that NR (Adj-Pr) FORM (ch. 2, rule 96)

does not definitize a head noun which is in an intro-S. Thus, 5a and 6a will become ungrammatical if the subjects are topicalized:

(5') a. *manh-in yeca-tál-nán ñngmohayessta
many-REL girl-PL-T applied

*'As for many girls, they applied.'

(6') a. *tases (myeng-iy) yeca-tál-nán ñngmohayessta
five person-of girl-PL-T applied

*'As for five girls, they applied.'

As expected, however, if the whole subject NP's in 5'a and 6'a are definitized by RR-FORM (cf. 3, rule 58), then the NP's can be topicalized as shown below:

(5'') ipeney ñngmoha-n manh-in yeca-tál-nán motu siptay-iessta
this-time applied-REL many-REL girl-PL-T all teen-agers-were
'As for the many girls that applied this time, they were
all teen-agers.'

(6'') ipeney ñngmoha-n tases (myeng-iy) yeca-tál-nán siptay-yessta
this-time applied-REL five (person-of) girl-PL-T all teen-
agers-were
'As for the five girls that applied this time, they were all
teen-agers.'

Before proceeding further, I will clarify the notion of definiteness. In Chapter Two (2.1), I have characterized definiteness as something registered in the knowledge of both speaker and hearers. I have also claimed that there are several ways in which a speaker may inform his hearers of the existence of

something. But only when definitization is the result of either a deictic marker in the deep structure or a restrictive relative clause can a Korean NP be marked with ki. Restrictive relative clauses have been extensively discussed in Chapter Three (3.12). The deictic markers are the following: i 'this'; ce 'that (over there)'; and ki 'that (there)'. The usages of these demonstratives are illustrated below:

(9) i kes-nin pissa-n chayk-iyo

this thing-T expensive-REL book-is

'This is an expensive book.'

(10) ce chayk-nin Einstein-cenki-iyo

that book-T Einstein('s)-biography-is

'That book over there is Einstein's biography.'

(11) ki chayk-nin ecey sasso

that book-T yesterday bought

'I bought that book yesterday.'

The word i is used with reference to what is close to the speaker, regardless of whether it is close to the hearer or not (e.g. 9); ce, when the reference is made to what is far from both the speaker and hearer (e.g. 10); and ki, when the object referred to is far from the speaker, but close to the hearer (e.g. 11).

In Chapter Two, I discussed and illustrated the ways in which NP's which are definitized by non-linguistic devices in English are not marked as definite in Korean. The examples (ch. 2, exs. 80-82) used in that chapter are repeated below for convenience:

(12) a. The roof is leaking.

b. cipung-ka saynta
 roof-S leaks

(13) a. The moon is rising.

b. tal-ka ttiko-issta
 moon-S is-rising

(14) a. I was driving on the freeway the other day when suddenly the engine began to make a funny noise. I stopped the car, and when I opened the hood, I saw that the radiator was boiling.

b. yocennal kosoktolo-lil talli-nante-y, kapcaki eyncin-ka
 the-other-day freeway-0 ran-and suddenly engine-S
 isangha-n soli-lil nay-ki sicakhayessta. cha-lil mec-ko
 strange-REL noise-0 make-NOM began car-0 stopped-
 and
hus-lil yel-ni latieytha-ka kkalhko-issessta
 hood-0 opened-when radiator-S was-boiling

All the English nouns underlined above are marked with the, while their Korean counterparts are not marked with ka. Notice that the subject markers are ka instead of nan in the most natural translations of the respective English sentences, although the subject NP's of 9-11--which are definitized by a linguistic device--are topicalized in the most natural discourse.

4.12. Further restriction on TOPICALIZATION. In 4.11, I claimed that definiteness is a necessary, but not a sufficient, condition for TOPZN. In other words, for TOPZN to apply, an NP has

to be not only [+ definite], but also [+ mentioned].⁵ The feature [+ mentioned] implies [+ definite], but the reverse is not necessarily true. This explains why subject NP's used materially are sometimes marked with nān (topicalized) and sometimes with ka (not yet topicalized). Consider the following:

(15) a. sensayng-ka (na-lā1) ttayliesseyo.

teacher-S me-O beat .

'The teacher beat me!'

b. sensayng-nān (na-lā1) ttayliesseyo

(16) a. cipung-ka ecey-puthe sayko-isseyo

roof-S yesterday-from has-been-leaking

'The roof has been leaking since yesterday.'

b. cipung-nān ecey-puthe sayko-isseyo

To make clear what I have just said, let us consider some environments where one sentence, but not the other, in 15 and 16 can be used. When a boy, coming home from school, cries for his parents' sympathy over an event that had happened at school that day, he would use 15a, but not 15b. Sentence 15b is possible only when sensayng 'teacher' has been already introduced by either speaker or hearer as topic of the present discourse--e.g. after the boy stated 'the teacher was angry at my behavior, and he called me to the front, and then ...'. Suppose an old widow, complaining about her relatives' being little concerned about herself, picks out the roof that has been leaking since yesterday. She will definitely choose 16a and might continue:

(16') a. kīlayto kocheçulye-nān salam hana epseyo

but fix-willing-REL man even-one is-not

'but there is not even one man who is willing to fix it
for me.'

Sentence 16b is possible only when the roof has already been mentioned in the present discourse by such a statement as 'I could not sleep in the sleeping room, because the roof was leaking. In fact, ...'. In this respect, TOPZN closely corresponds to definitizer marking: I previously claimed that only when definitization is performed by a linguistic device is kā 'the' attached to the NP. The same thing can be said about TOPZN--namely, that an NP can be topicalized only when it is linguistically definitized in the present discourse.⁶

The next question to be asked is whether any materially-used NP must be topicalized if it is linguistically definitized in the present discourse. We seem to have another limitation on current transformational theory which employs only an obligatory-optional distinction in rule applicability. Some rules can be as low as five percent optional while other rules are as high as ninety-five percent optional. If all these are just described as optional, disregarding the degree of optionality, we surely are losing some very significant generalization. For native speakers know, and will tell us, that one case is 'correct but rarely said/heard; whereas another case may be described as what is almost always said/heard'. TOPZN is an optional rule, but the degree of

optionality seems to be very low--that is, the rule is almost, but not quite, obligatory. Some non-linguistically conditioned, but systematic (rule-governed) variation might exist here, but the investigation of such variation is far beyond the scope of the present dissertation.

My formulation of the TOPZN rule (rule 7) indicates that this rule has to be ordered after PARTICLE INSERTION.⁷ Basically, there are two types of particles: functional and contextual. A functional particle is essentially a case marker that shows the function in the sentence of the NP to which it is attached (e.g. ka 'subject', lɪl 'object', eyse 'locative', eykey 'dative', ey 'time'), whereas a contextual particle offers a cue to the contextual relation of the NP to which it is attached--e.g. to 'too', man 'only', or ya 'at least'. Both types of particles are transformationally inserted into a sentence. Functional particles are divided into two subgroups: those that are inserted by cyclic rules (ka and lɪl), and others that are inserted by pre-cyclic rules. All these are formulated below:

(17) SUBJECT-PARTICLE INSERTION:⁸
 NP, NP V $\xrightarrow{\text{OBLIG}}$ 1 + ka, 2
 1 2

(18) OBJECT-PARTICLE INSERTION:
 NP, NP, V $\xrightarrow{\text{OBLIG}}$ 1, 2 + lɪl, 3
 1 2 3

(19) DATIVIZATION:⁹
 [[X, V]_S]_{NP}, NP, AFFECT \Rightarrow 1, 3 + eykey, 2
 1 2 3 4

(20) to-INSERTION:
$$\begin{array}{ccccccc} (X, & Z), & (Y, & Z) & \implies & 1, & 2, & 3 + \underline{to}, & 4 \\ 1 & 2 & 3 & 4 & & & & & \end{array}$$

The following data suggest that these various particle rules are ordered in the following way: (1) precyclic rules that insert functional particles (e.g. 19); (2) precyclic rules that insert contextual particles (e.g. 20); and lastly (3) cyclic rules that insert functional particles (e.g. 17 and 18):

(21) a. John-man-ka hapkyekhayessta

John-alone-S passed (the exam).

'Only John passed the exam.'

b. Mary-ka John-man-lil salanghanta

Mary-S John-alone-O loves

'Mary loves only John.'

(22) Mary-ka John-eykey-man senmul-lil cuessta.Mary-S John-tc-alone gift-O gave

'Mary gave a gift only to John.'

In 21, man precedes ka and lil, thus suggesting that Step 2 above precedes Step 3; in 22, eykey precedes man, suggesting that Step 1 precedes Step 2.

The utilization of information across sentences as well as information within a sentence in a rule formulation enables a grammar to describe presuppositions rather neatly.¹⁰ Since the particle that appears in the structural description of 5

includes both contextual and functional particles, and since some functional particles are inserted by cyclic rules (17 and 18), TOPZN must be either a later cyclic rule or a postcyclic rule. It will be shown below that TOPZN is a postcyclic rule.

4.13. TOPICALIZATION as a postcyclic rule. Kuno (1970:

Note I) observed two different uses of Japanese wa, viz. thematic (= topicalized) and contrastive, and three uses of ga, viz. descriptive, exhaustive, and objective--all of which seem to be applicable to Korean without radical revision. These are illustrated below:

(23) John-nin enehakca-ita

John-T linguist-is

'John is a linguist.'

(24) John-nin enehakca-iciman, ki-iy anay-nin enehakca-ka

John-T linguist-is-but he-of wife-T linguist-S

ani-ita

not-is

'John is a linguist, but his wife is not.'

(25) cipung-ka saynta

roof-S leaks

'It is the roof that is leaking.'

(26) cipung-ka saynta

roof-S leaks

'The roof is leaking.'

(27) John-nin yenge-ka yuchanghata

John-T English-S fluent-is

'As for John, his English is fluent.'

Thematic wa (or Korean nin) corresponds to my topicalized NP

(e.g. 23). As for the contrastive wa (or Korean nin)--e.g. 24--I

merely conjecture that it is inserted by some precyclic rule which inserts a contextual particle. I make the above conjecture for the

following reasons: (1) We need contextual information to use it;

(2) it is semantically closer to the delimiting wa (or nin)--which will be discussed in Chapter Five--than to thematic wa (or nin);¹¹

(3) unlike thematic wa (or nin), contrastive wa (or nin) can occur in an embedded sentence.¹² Thus, ex. 28 is grammatical only when

John-nin is contrastively used:

(28) Mary-nin John-nin ecey hakyo-ey ka-nkes kathta-ko malhayessta

Mary-T John-DLM yesterday school-to went-NOM appear-OT said

'Mary said that John appeared to have attended school yesterday

(although Tom did not).'

To facilitate an understanding of the matter for those readers who do not know Korean or Japanese, I offer these parallels from English:

(29) a. John likes Mary (= 'What John does is like Mary').

b. John likes Mary (= 'It is John who likes Mary', or

'The one who likes Mary is John').

In 29b, John is used exhaustively. A sentence like 29b can also be used as an answer to a question like 'Who likes Mary?'. A sentence

like 29a may be used as an answer to a question like 'What did you say about John?'. John is used descriptively in 29a. An exhaustive ga (or ka)-phrase is a formally-used NP, which carries new information; a descriptive ga-phrase is a materially-used NP which is not yet topicalized. Exhaustive ga carries the primary accent, while descriptive ga does not. The difference between 25 (exhaustive) and 26 (descriptive) is made clear in their underlying structures 25' and 26' below:

(25') ((etten) kes saynta).((k \dot{i}) kes cipungita)

certain thing leaks the thing roof-is

(26') (cipung saynta)

Objective ga will be separately discussed later in this chapter.

Kuno (I-12) further observed that thematic wa in Japanese never occurs in an embedded clause. He attempted to explain this in the following manner:

The distinction between the thematic wa and the descriptive ga and the exhaustive ga neutralizes in subordinate clauses. All three are realized as ga, shown in the following [the number is mine]:

(30) a. Anata-wa John ga nihongo-ga dekiru koto o sitte-
You *wa Japanese is able that know
-to speak

imasuka

'Do you know that John can speak Japanese?'

b. John ga suki na ko wa Mary desu
*wa fond is girl is
-of

'The girl that John likes is Mary.'

The above sentences do not respectively have the interpretation 'that John and only John can ...', and 'The girl that John and only John likes ...'.

It cannot be questioned that Kuno is correct in stating that thematic wa never occurs in the embedded sentence.¹³ Put otherwise, TOPZN never applies until all the cyclic rules have operated on the final cycle, and therefore cannot apply to any sentences other than the topmost sentence. But it is hard to agree that a previously topicalized NP can become detopicalized in an embedded sentence, as is implied in the above quotation from Kuno. Of course, there is no a priori reason why it should not. However, it appears to me not only to be unmotivated, but also an unnecessary complication of the grammar. What seems to be the fact is that TOPZN simply may not apply to any sentence except the topmost one.

But what about the other side of Kuno's observation--that exhaustive and descriptive ka's (or ga's) are also neutralized in the embedded sentence? I should like to suggest that Kuno may have been misled by inadequate or incorrect examples. Ex. 30a above, for instance, definitely leans toward a descriptive interpretation of its embedded subject. In other words, it is easier to think of situations where the ga-phrase is descriptively used. However, rare as it is, a situation is conceivable in which the speaker might ask his hearer if he knew that it was John, not somebody else, that could speak Japanese, in which case John-ga would carry the accent and naturally an exhaustive meaning.

But the claim that exhaustive ka's (or ga's) are neutralized with descriptive ka's (or ga's) in the constituent sentence can be more easily falsified in the following examples,

where an exhaustive interpretation is called for by the situation:

(31) a. anata-wa Jóhn-ga katu-to omoimasu-ka

You-T John-S win-QT think-QUES

'Do you think that the winner will be John?'

b. anata-wa Jóhn-ga okane-o nusunda koto-o sitteimasu-ka

You-T John-S money-O stole thing-O know-QUES

'Do you know that it was John who stole the money?'

c. watakusi-wa Jóhn-ga katu-to-wa omowanakatta

I-T John-S win-QT-DLM thought-not

'I did not think that the winner would be John.'

Exactly the same arguments can be made for the Korean equivalents of the above:

(32) a. tangsin-nān Jóhn-ka ikilila-ko sayngkakha-seyyo?

You-T John-S win-QT think-QUES

'Do you think that the winner will be John?'

b. tangsin-nān Jóhn-ka ká ton-lil humcheka-nkes-lil

You-T John-S the money-O stole-NOM-O

aseyyo?

know-QUES

'Do you know that it was John that stole the money?'

c. na-nān Jóhn-ka ikilila-ko-nān sayngkakha-ci mos-

I-T John-S win-QT-DLM think-NOM not-

hayessta

did

'I did not think that the winner would be John.'

As is clearly shown in the English renderings, the ka (or ga)-phrases above are all subjects which are exhaustively (or formally) used and which are not neutralized in the embedded sentence. It follows that there is no neutralization of the uses of NP in the embedded sentence. It also follows that the non-occurrence of thematic nin (or wa) in the embedded sentence is due, not to neutralization, but to the fact that TOPZN is a postcyclic rule.

4.14. Restrictions on the applicability of TOPICALIZATION.

In this section, I will discuss the two problems of determining where TOPZN is to be blocked and where it is obligatory. TOPZN is blocked for exhaustive (or formal) ka-phrases. Why should this be so? This question will be answered in the derivations of exhaustively, and formally, used NP's. The exhaustive ka and descriptive ka are distinguished from each other by the presence or absence of the main accent on the beginning of the NP. The two uses of ka are also semantically distinct. Certainly the different degree of accent cannot be considered responsible for this semantic difference. Let us consider the following sentences by way of illustration:

(33) a. sensayng-ka (na-lil) ttayliesseyo

teacher-S me-O beat

'The teacher beat me.'

b. sensayng-ka (na-lil) ttayliesseyo

'It was the teacher that beat me.'

(34) a. cipung-ka sayyo

roof-S leaks

'The roof leaks.'

b. cipfung-ka sayyo

'It is the roof that is leaking.'

Whereas the (a) sentences of 33 and 34 are simple statements, the underlined NP's in the (b) sentences carry the key information of the sentences, as is indicated in the translation. The (b) sentences come from underlying conjunctions, as already shown with respect to ex. 5 in sect. 4.11.

According to the suggested analysis, sentences 33 and 34 will have the following underlying structures (here irrelevant details are ignored, such as speech level or tenses):¹⁴

(33') a. ((sensayng)_{NP} (na)_{NP} (ttayliessta)_V)_S
 teacher me beat

b. (((etten) salam)_{NP} (na)_{NP} (ttayliessta)_V)_S • (((kî)
 certain man me beat the

salam)_{NP} (sensayng)_{NP} (ita)_V)_S
 man teacher is

(34') a. ((cipung)_{NP} (saynta)_V)_S
 roof leaks

b. (((etten) kes)_{NP} (saynta)_V)_S • (((kî) kes)_{NP} (cipung)_{NP}
 certain thing leaks the thing roof

(ita)_V)_S

IF PREDICATE PREPOSITION (abbr. PRED PREP) -- an instance of which is

NR (Adj-Pr) FORM (ch. 2, rule 96)--applies to 33'b and 34'b, we will have 33b and 34b, respectively; if RR-FORM (ch. 3, rule 52) applies instead, the respective (c) sentences below will be derived. The respective (b) and (c) sentences in 33 and 34 are synonymous with each other.

(33) c. na-lil ttayli-n salam-nin sensayng-ita

me-O beat-REL man-T teacher-is

'The man who beat me is the teacher.'

(34) c. say-nin kes-nin cipung-ita

leaks-REL thing-T roof-is

'The thing that is leaking is the roof.'

All that is needed to account for ka being marked on a formally-used NP in the (b) sentences of 33 and 34, and for nin being used after a relativized NP in the (c) sentences, is to order the two rules (NR [Adj-Pr] FORM and RELATIVIZATION) after PARTICLE INSERTION.¹⁵ To be exact, the shared subject NP's in the intro-S's--the first conjuncts of 33'b and 34'b--are always marked with ka, and these NP's are not subject to TOPZN because of their indefiniteness. In the derivation of the (b) sentences of 33 and 34, the subject particle has been originally inserted by PARTICLE INSERTION in the intro-S, and later PRED PREP moves the predicates of the second conjuncts into the intro-S's and replaces the subject NP's of the original intro-S's with those predicates. In the derivation of the (c) sentences, the subject NP's of the second conjuncts of 33'b and 34'b are marked with ka by (cyclic) PARTICLE INSERTION. Then

RR-FORM (A) (ch. 3, rule 58) definitizes those NP's, to which TOPZN applies. The correctness of the rule-ordering suggested above becomes clearer from the consideration that PARTICLE INSERTION is a cyclic rule.

On the other hand, TOPZN seems to be obligatory with habitual and gnomic statements. Consider the following:

- (35) a. inkan-nin manmul-iy yengcang-ita
 man-T all-the-things-of master-is
 'Man is the master of all the things.'
- b. kolay-nin pholyutongmul-ita
 whale-T mammalian-is
 'The whale is mammalian.'
- c. John-nin maywel hanpenssik kyohoy-ey kanta
 John-T every-month once church-to goes
 'John goes to church once a month.'

If the subject NP's above can ever be marked with ka, then they are automatically interpreted formally or exhaustively. This seems to indicate that in habitual or gnomic statements TOPZN is completely obligatory. In other words, the habitual or gnomic character of the statement functions exactly like linguistic definitization. The automatic formal interpretation of ka-phrases in the above sentences can be easily explained, since the other type of ka (viz. descriptive) will immediately be switched to nin by obligatory TOPZN.

The so-called objective ka (or ga)

4.2. By introducing the concept of a formal NP (an NP moved from the second conjunct into an intro-S) and that of a material NP (an NP used in sentences other than intro-S), and by restricting TOPZN in such a manner that it applies only when the NP is definite, I hope that I have neatly described and explained the complicated uses of nin vs. ka. But Kuno (1970, Note III) claims that there is a third use of ga (or ka) phrase, which he calls objective ga (or ka). Objective ka is illustrated below:

(36) John-nin yenge-ka yuchanghata

John-T English-S fluent-is

'John is fluent in English.'

(37) John-nin toum-ka philyohata

John-T help-S necessary

'John needs help.'

(38) John-nin sul-ka masi-ki silhessta

John-T liquor-S drink-NOM disliked.

'John did not feel like drinking.'

But the term 'objective ka' does not seem to me to have adequate motivation, at least in Korean, since the verbs yuchanghata 'be fluent', philyohata 'be necessary', and silhta 'be unlikable' are, like static adjectives in English, never transitive, and since the subjects of these verbs are always ka-phrases and never thematic nin-phrases (assuming that TOPZN applies only once to a sentence).¹⁶

Two alternative analyses are conceivable in deriving 36 and 37. First, 36 and 37 seem to be derived from deeper structures

36' and 37':

(36') John-iy yenge-ka yuchanghata¹⁷

John-of English-S fluent-is

'John's English is fluent.'

(37') toum-ka John-eykey philyohata¹⁸

help-T John-to necessary

'John needs help.'

TOPZN applies to 36' and 37' and derives the following:

(36'') John-iy-nin yenge-ka yuchanghata

(37'') John-eykey-nin toum-ka philyohata

We need a rule which deletes all particles except the last one when they are in juxtaposition. I will call this rule PARTICLE-DELETION (abbr. PART-DEL). PART-DEL is obligatory when nin follows functional particles; otherwise, optional. PART-DEL derives 36 and 37 from 36'' and 37'', respectively. But some serious difficulties arise in this first approach: First, there is no way to derive 39a by this approach:

(39) a. na-nin John-ka yenge-ka yuchanghata-nin kes-lil

I-T John-S English-S fluent-is-NOM-O

mollassta¹⁹

did-not-know

'I did not know that John is good in English.'

b. na-nin John-iy yenge-ka yuchanghata-nin kes-lil

mollassta

c. *na-nin John-nin yenge-ka yuchanghata-nin kes-lil

mollassta

If we follow the analysis suggested as the first alternative, 39a must be derived from 39b by TOPZN. But TOPZN is a post-cyclic rule and can be applied only once. The consequence of this is that there is no way of switching John-iy in 39b to John-ka in 39a. Even if it were possible for TOPZN to change John-iy to John-nān, there is still needed a detopicalization rule which switches nān to ka, in order to derive 38a from 38c. A second and more crucial difficulty that arises with the first approach suggested is the derivation of 40a:

(40) a. na-nān Jōhn-ka yenge-ka yuchanghata-nān kes-līl

mollassta

'I did not know that it was John who was fluent in English.'

b. (na mollassta ((X-iy yenge yuchanghata) • (X John ita)))

I have pointed out earlier in this chapter that NP's used formally (or exhaustively) cannot be topicalized; therefore even if detopicalization were justifiable, it would be impossible to derive 40a from the suggested underlying structure 40b. Does this mean that we have to go back to Kuno's analysis and claim that John in 39 and 40 is the underlying subject, and that yenge 'English' is actually an object, despite the particle ka?

The second alternative analysis, which seems to me to be the correct one, suggests that an optional rule precedes TOPZN and changes John-iy in 39b to John-ka in 39a under certain conditions which I will explain. Is this rule, however, independently

justifiable? In the sentences that follow, the (b) sentences seem to be derived from the respective (a) sentences by a rule which I call CASE AGREEMENT; it is an optional rule.

(41) a. John-nān kī kay-īy kkoli-lāl ccalānta

John- the dog-of tail-0 cuts

'John cuts the tail of the dog.'

b. John-nān kī kay-lāl kkoli-lāl ccalānta

John-T the dog-0 tail-0 cuts

(42) a. kī kay-īy kkoli-ka ccallieciessta

the dog-of tail-S was-cut

'The tail of the dog was cut.'

b. kī kay-ka kkoli-ka ccallieciessta

the dog-S tail-S was-cut

CASE AGREEMENT changes the particle īy 'of' in an NP_i -īy NP_j construction so as to agree with the particle of the head NP (= NP_j). Thus, in 41 īy is switched to lāl to agree with the particle attached to kkoli 'tail'. And in 42 īy is changed to ka to agree with the particle attached to the head noun kkoli. Thus, the (a) sentences of 41 and 42 are synonymous with the respective (b) sentences. Compare these with the following:

(43) a. John-nān kī kay-īy pap-lāl epcillessta

John-T the dog-of food-0 turned-over

'John turned over the food of the dog.'

b. *John-nān kī kay-lāl pap-lāl epcillessta

John-T the dog-C food-0 turned-over

(44) a. $k\ddot{i}$ $kay\text{-}\ddot{i}y$ $pap\text{-}ka$ $epcilleciessta$
 the dog-of food-S is-turned-over
 'The food of the dog is turned over.'

b. * $k\ddot{i}$ $kay\text{-}ka$ $pap\text{-}ka$ $epcilleciessta$
 the dog-S food-S is-turned-over

The (b) sentences of 43 and 44, which are derived from the respective (a) sentences by CASE AGREEMENT, are not grammatical. The only difference between 41 and 42 on the one hand and 43 and 44 on the other hand is that NP_i and NP_j are in an inalienable relationship only in 41 and 42.²⁰ In other words, NP_i and NP_j must be in inalienable relation with each other in order for CASE AGREEMENT to apply to $NP_i\text{-}\ddot{i}y\text{-}NP_j$ construction. Thus, kay 'dog' and pap 'food' are not in an inalienable relation, which explains the ungrammaticality of 43b and 44b. Exs. 43b and 44b are grammatical, however, if the NP_i (= kay in this case) is formally used; that is, CASE AGREEMENT seems to be applicable to a formally used NP_i any time, regardless of whether the relation between NP_i and NP_j is inalienable or not.

In this second approach the difficulties that arise with the suggested first approach naturally cease to arise. The first difficulty is the derivation of 39b from 39a, to which CASE AGREEMENT--independently needed in Korean syntax--supplies a simple derivation. The second difficulty has to do with the derivation of 40a from 40b. CASE AGREEMENT supplies another ready solution here: PRED PREP and COMPLEMENTATION will derive 40c from 40b; and CASE

AGREEMENT derives 40a from 40c, since CASE AGREEMENT is applicable to all formally-used NP_i's in an NP_i -i-y NP_j construction.

- (40) c. na-nān Jōhn-i-y yenge-ka yuchanghata-nān kes-lāl
 I-T John-of English-S fluent-is-NOM-O
 mallassta
 did-not-know

The third case of the so-called 'objective ka' is discussed below. Consider the following:

- (38') a. John-nān sul-lāl masi-ki(ka) silhessta
 John-T liquor-O drink-NOM-S unlikable
 'John did not feel like drinking.'
- b. John-nān sul-ka masi-ki(ka) silhessta
 John-T liquor-S drink-NOM-S unlikable
- c. *John-nān sul-lāl (or -ka) masi-ki-lāl silhessta

Kuno (III-9) claimed 'that action-verbals take o and state-verbals ga for object marking' and went on to characterize the verb mi-ta 'want to see' as a state-verbal. He seems to imply--correctly, I think--that the feature of the last verbal governs the whole complex verb when two or more verbs are combined and function like a simple verb. This combination of verbals which function as a simple verb I will call an agglutinated verb. Furthermore, I will call agglutinative verbal a verbal which combines with other verbs and behaves like a simple verb. All agglutinative verbals are intransitive.²¹ Another characteristic of agglutinative verbals is that embedded subject and matrix dative NP's are always

correferential--in other words, the person who drinks and the person who hates to drink are correferential with each other in 38'b.

The verb silhta 'be disliked' can have the nominalizer ki only when embedded subject and matrix dative NP's--cf. 38'e--are correferential with each other, as shown by the ungrammaticality of 45b. But silhta can have the nominalizer nān kes 'that', even when they are not correferential, as shown by the grammaticality of 45a below:

- (45) a. John-nān Mary-ka sul-līl masi-nān kes-ka silhessta
 John-T Mary-S liquor-O drink-NOM-S disliked
 'John did not like Mary's drinking.'
- b. *John-nān Mary-ka sul-līl masi-ki-ka silhessta
 John-T Mary-S liquor-O drink-NOM-S disliked
 *'John did not like John's drinking.'

Since silhta with nān kes is not an agglutinative verbal, such a feature as [- transitive] of silhta will never influence the preceding verb when nān kes is its nominalizer; and therefore 46b is impossible:

- (46) a. John-nān sul-līl masi-nān kes-ka silhessta
 John-T liquor-O drink-NOM-S was-disliked
 'John disliked drinking.'
- b. *John-nān sul-ka masi-nān kes-ka silhessta
 John-T liquor-S drink-NOM-S was-disliked

I will discuss the derivation of 38 with a view to putting more explicitly what has been merely implied so far. The suggested

underlying structure of 38'a and 38'b is 38'd below:

(38') d.

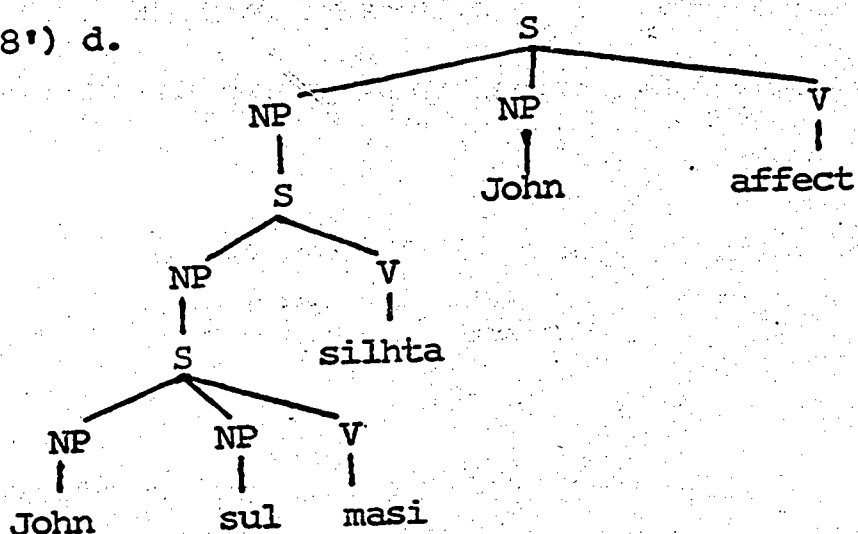

In order to derive the surface structures from this underlying structure, we need the following rules:

DATIVIZATION (rule 19)

PARTICLE INSERTION (rule 17 and 18)

TOPICALIZATION (rule 7)

PARTICLE DELETION (cf. 4.2)

REFLEXIVIZATION (appendix I, rule 7)

COMPLEMENTATION

PREDICATE PROMOTION

All these rules except PREDICATE PROMOTION are independently needed in Korean syntax. The first four rules have already been discussed. If the NP is correferential to a matrix NP, REFLEXIVIZATION either changes an embedded NP to caki '-self' or completely deletes it under the condition that ambiguity does not result thereby.²²

COMPLEMENTATION adds one of the nominalizers ki, nān kes, im, or ko.

PREDICATE PROMOTION is an optional minor rule which applies frequently in agglutinative languages like Korean. PREDICATE

PROMOTION simply raises an embedded predicate and amalgamates it with the matrix predicate to create a complex verb which behaves like one verb. The features of the second verb govern the complex verb. This is formulated as 4.

(47) PREDICATE PROMOTION (abbr. PRED PROM):

$$\underbrace{x \ [y, \ v_1]}_1 \ s, \ v_2 \xrightarrow{\text{OPT}} 1, \ [2 + 3]_v$$

I have previously shown that DATIVIZATION is a precyclic rule and that TOPZN and PARTICLE DELETION are postcyclic rules. The rest of the rules are cyclic and are applicable in the following order: PARTICLE INSERTION, REFLEXIVIZATION, COMPLEMENTATION, PRED PROM. These will be illustrated with 38.

First, DATIVIZATION will apply to 38'd and derive 38'e:

(38') e.

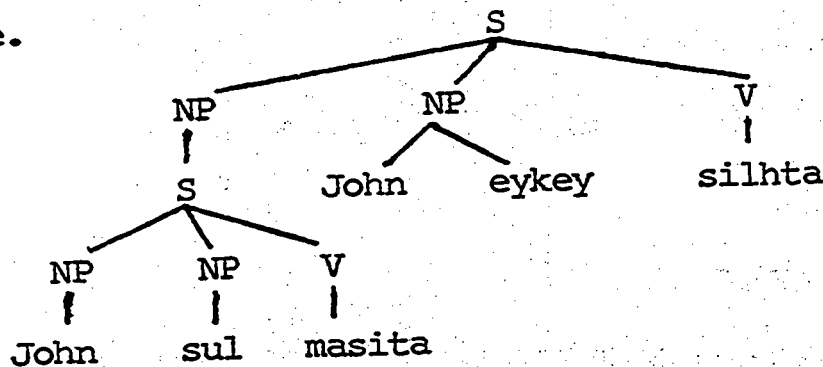

In the first cycle, only PARTICLE INSERTION is applicable and derives 38'f from 38'e:

(38') f.

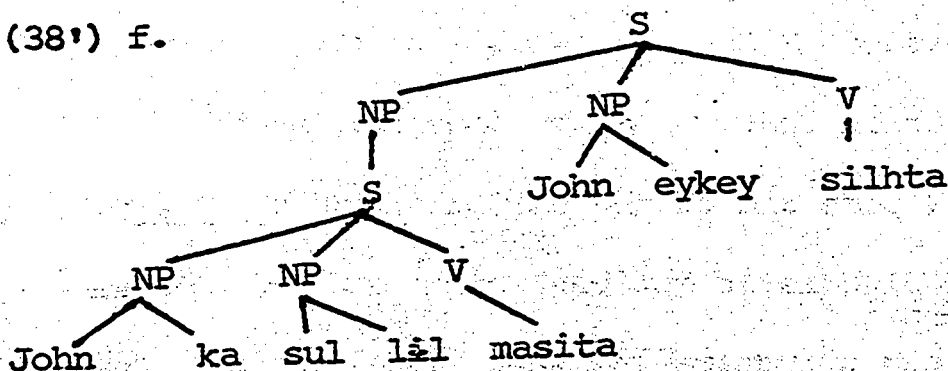

On the second cycle, PARTICLE INSERTION, REFLEXIVIZATION, and COMPLEMENTATION apply and derive 38'g from 38'f:

(38') g.

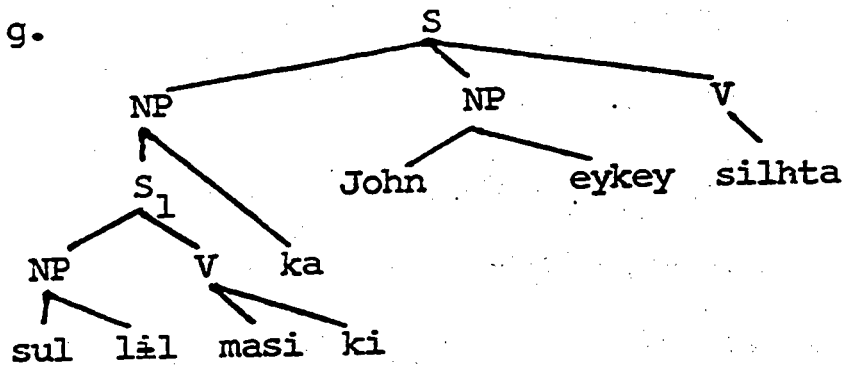

Since PRED PROM is an optional rule, it may or may not apply; if it applies, 38'h will be derived after S_1 has been pruned:²³

(38') h.

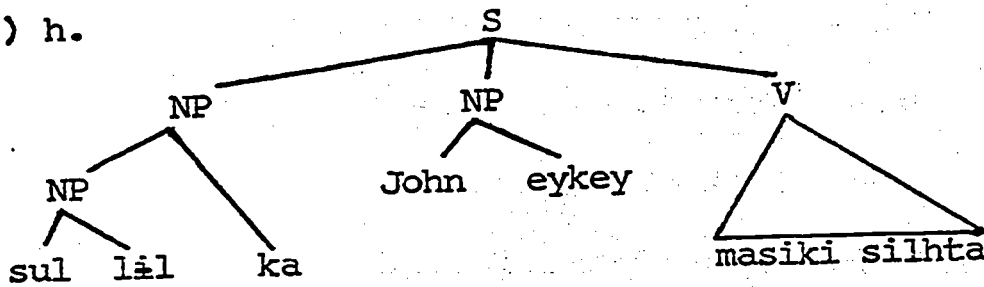

Postcyclic TOPZN and PARTICLE DELETION will apply and derive 38'a and 38'b from 38'g and 38'h.

Thus, all three cases of so-called 'objective ka' are shown to be underlying subject markers. Now we do not have to weaken or compromise the generalization that ka always is a subject marker and lâl is an object marker. The difference between exhaustive ka and descriptive ka has been shown to correspond to the formal vs. material distinction in the NP. The analysis suggested in this chapter also indicates that the distinction between the use of exhaustive ka and that of descriptive ka is not restricted to ka-phrases. This is shown below:

(48) a. na-nin Mary-lil salanghanta

I-T Mary-O love

'I love Mary'

(na Mary salanghanta)

b. na-nin Mary-lil salanghanta

I-T Mary-O love

'It is Mary that I love.'

(na X salanghanta) • (X Mary ita)

I X love X Mary is

(49) a. John-iy tongsayng-ka ikiessta

John-of brother-S has-won

'John's brother has won.'

(John-iy tongsayng ikiessta)

b. John-iy tongsayng-ka ikiessta

'It is John's brother that has won.'

(X-iy tongsayng ikiessta) • (X John ita)

As far as nin-phrases are concerned, thematic nin has been shown to be derived by TOPZN, and contrastive nin has been claimed to be a contextual particle which is derived by some precyclic rule.

CHAPTER FIVE: NEGATION

Introduction

5.1. The present analysis of Korean syntax seems to shed some light on another problem which has recently drawn a great deal of attention from native generative syntacticians--Negation. In Korean, there are two ways of negating sentences, illustrated below:

(1) a. ai-ka canta

child-S sleeps.

'The child sleeps.'

b. ai-ka ani-canta

child-S not-sleeps

'The child does not sleep.'

c. ai-ka ca-ci(lil) ani-hanta

child-S sleep-NOM-O not-does

'The child does not sleep.'

(2) a. Mary-nin yeyp̄p̄ta

Mary-T pretty

'Mary is pretty.'

b. Mary-nin ani-yeyp̄p̄ta

Mary-T not-pretty

'Mary is not pretty.'

c. Mary-nan yeyp̄p̄i-ci ani-hata

Mary-T pretty-NOM not-does

'Mary is not pretty.'

In the (b) sentences, NEG is simply posited before the verb, whereas in the (c) sentences three things happen: (1) the original verb is nominalized--always with ki 'to'. (2) The verb hata 'do' is used as a verb of the main clause. This verb--viz. hata--which is used in negating sentences is a different lexical item from a transitive verb hata 'do'. The difference between these two verbs will be discussed in 5.32. (3) NEG is added before hata. I will call the negation which is exemplified by the (b) sentences above Type I negation, and the sort that is exemplified by the (c) sentences, Type II negation.

Basically, three approaches to negation in Korean are conceivable: (1) an analysis which postulates separate underlying structures for both types; (2) an analysis which adopts NEG-TRANSPORTATION (abbr. NT); (3) an analysis which adopts NEG-INCORPORATION (abbr. NI). The NT approach and the NI approach will be extensively discussed in 5.2. and 5.3, respectively. The separate-underlying-structure analysis postulates two different underlying structures for Type I and Type II negations. According to this analysis, 1'b and 1'c below would be the underlying structures of 1b and 1c, respectively:

(1') b.

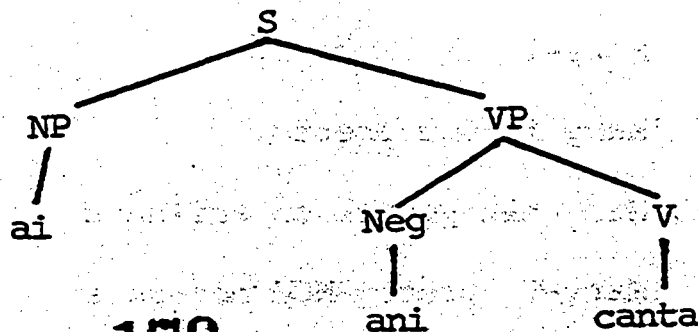

(1') c.

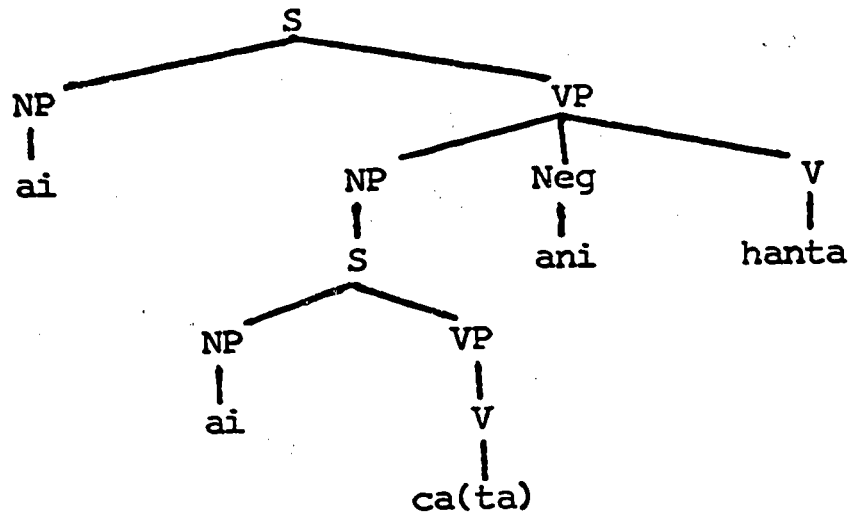

Song (1967:58-60) has suggested such analyses. But in view of the fact that the two types are completely synonymous with each other, it appears that there is no motivation for postulating separate deep structures.

The NEG-TRANSPORTATION approach

5.2. The NT approach has been suggested by Lee (1970:175 et seq.). Lee (177) postulates 3 as the underlying structure for both 1b (Type I) and 1c (Type II), justifying his position by claiming that 'at present, there is no well-motivated rule' by which sentences like 1b can be derived from 4:

(3)

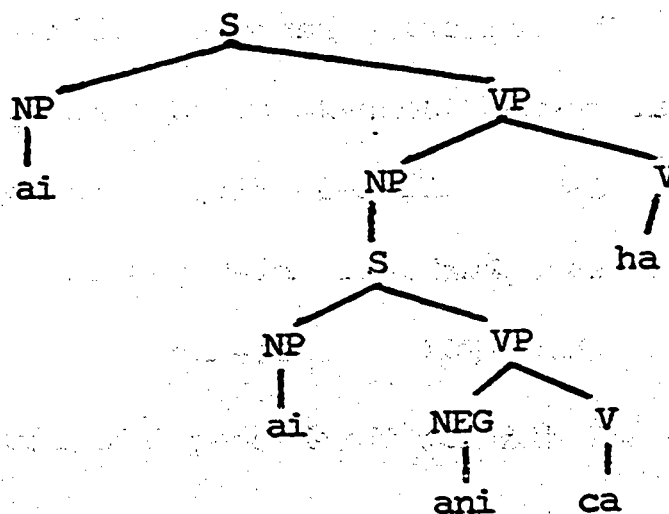

(4)

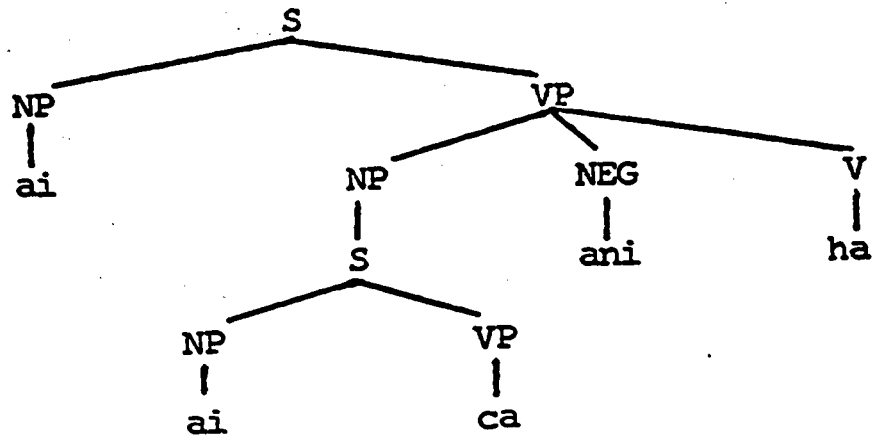

This analysis of the derivation of 1b will be discussed in 5.22. For the derivation of 1c from 3, Lee has no choice but to raise the NEG into the higher sentence from the embedded sentence, where NEG is originally postulated. For this purpose he uses NT. But the use of NT will be shown below to be absolutely illegitimate.

5.21. The illegitimacy of NT with hata. In the first place, hata is not what can be called a NT verb.¹ An example of a NT verb is sayngkakhata 'to think'. There are two readings of sayngkak-hata: a NT reading and a non-NT reading. These two readings are syntactically marked in Korean with different nominalizers: ko with a NT reading and nān kes with a non-NT reading. The following sentences illustrate the two readings:

(5) a. na-nān (John-ka tases sikan pakkey(nān) kongpuhayessta-ko)

I-T John-S five hours other-than-DLM studied-QT

sayngkakha-ci ani-hayessta

think-NOM not-did

'I did not think that John studied more than five hours.'

(5) b. *na-nin (John-ka tases sikan pakkey[nin] kongpu-hayessta-
 I-T John-S five hours other-than-DLM studied-
 nin kes-lil) sayngkakha-ci ani-hayessta
 NOM-O think-NOM not-did

c. na-nin (John-ka tases sikan man kongpu-hayessta-nin kes-
 I-T John-S five hours only studied-NOM-
 lil sayngkakha-ci ani-hayessta
 O think-NOM not-did

'I did not remember that John studied only five hours.'

With sayngkak-hata 'think' in its NT reading--viz. 5a--the speaker is giving his opinion or judgment about the truth value of a certain statement, while with the verb in its non-NT reading one claims one's involvement in the mental process of thinking. Naturally, sayngkak-hata in its NT-reading cannot be negated in the deep structure. For if one makes no judgment--i.e. if the verb is negated--no object of judgment is needed! I suggest, then, that the underlying structure of 5a is 5'a, not 5'b:²

(5') a.

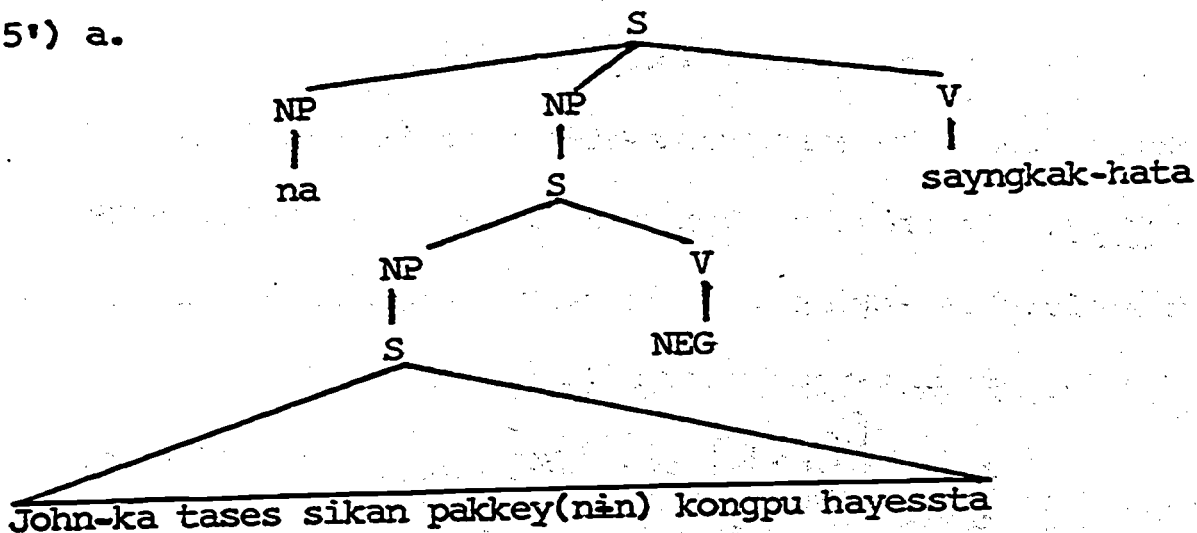

(5') b.

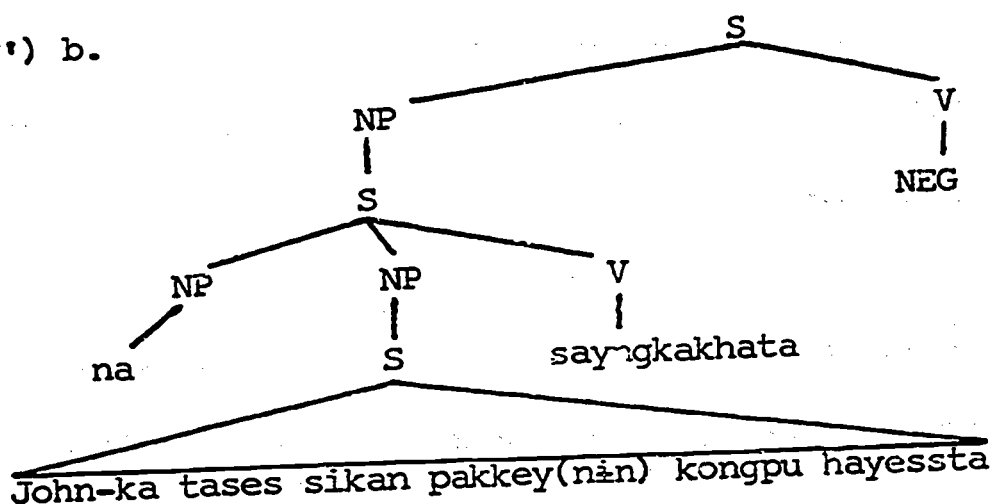

The correctness of postulating 5'a instead of 5'b as the underlying structure of 5a is clearly demonstrated by the fact that in Korean it is possible to use pakkey 'other than' only in a negative sentence: Thus, sentence 6b, which has pakkey in an affirmative sentence, is ungrammatical.

(6) a. John-nan tases sikan pakkey kongpu-ha-ci ani-hayessta

John-T five hour other-than study-NOM not-did

'John studied only five hours.'

b. *John-nan tases sikan pakkey kongpu-hayessta

'John studied only five hours.'

c. John-nan tases sikan man kongpu-hayessta

'John studied only five hours.'

Notice that the embedded sentence of 6a--which is affirmative--has pakkey. In order to derive 5a from 5'a, NEG-TRANSPORTATION must therefore be applied. This rule is formulated as follows:

(7) NEG-TRANSPORTATION (abbr. NT)

$$\begin{array}{rcl}
 X, & \left[\left[\left[Y \right]_S \right]_{NP}, \text{ NEG} \right]_S & Y \quad \text{NT-verb} \\
 1, & \left[\left[\left[2 \right]_S \right]_{NP}, \text{ } \right]_S & 4 \\
 \xrightarrow{\text{OPT}} & \left[\left[1, \left[\left[2 \right]_S \right]_{NP}, \emptyset, 4 \right]_S \right]_{NP}, & 3
 \end{array}$$

That NT is an optional rule is shown by the grammaticality of 5c below--where NT has not applied to 5'a--and by the synonymy of 5a with 5c:

- (5) c. na-nān (John-ka tases sikan pakkey kongpuha-ci ani-
 I-T John-S five hour other-than study-NOM not
 hayessta-ko) sayngkakhanta
 did-QT think

'I think that John has studied only five hours.'

To substantiate Lee's claim that NT generates 1c from 3, it is necessary to show that hata is a NT verb. But the following facts clearly indicate that it is not a NT verb: (1) If hata is a NT verb, and if 3 is the correct underlying structure of 1c, then 1d below--where NT has not applied to 3--should be grammatical, since NT is an optional rule. But 1d is not grammatical:³

- (1) d. *ai-ka ani ca-ki(lil) hanta
 child-S not sleep-NOM-O does

'The child does not sleep.'

(2) The following features of Karttunen's A verbs are not required for Korean NT verbs. Karttunen (1969) divides verbs into two groups: A and B.⁴ When an A verb occurs in the predicate of a matrix sentence, the following conditions obtain: (a) The subject of a matrix verb and that of a constituent sentence are necessarily the same; (b) the embedded verb is tenseless in the deep structure; (c) time adverbials cannot remain in the embedded sentence; (d) negating or interrogating the matrix verb implies the same also

with respect to the embedded verb, etc. These characteristics are illustrated in comparison of 8 (an A verb) and 9 (a B verb):

- (8) a. *John managed (for) Mary to run.
 b. *John managed to have run.
 c. *John managed to see Mary tomorrow.
 d. *John did not manage to see Mary, but saw her.
- (9) a. John expected Mary to run.
 b. John expected Mary to have run.
 c. John expected to see Mary tomorrow.
 d. John did not expect to see Mary, but saw her.

Compare these with the following Korean sentences, all of which have hata as their matrix verb:

- (10) a. *John-nin (Mary-ka mek-ki-to)_S hayessta
 John-T Mary-S eat-NOM-too did
 *'John did Mary's also eating.'
- b. *John-nin ka-ass-ci ani-hata
 John-T go-PAST-NOM not-does
 *'John does not went.'
- c. *John-nin neyil Mary-lil manna-ki-to hayessta
 John-T tomorrow Mary-O meet-NOM-too does
 *'John did meeting Mary tomorrow.'
- d. *John-nin (Mary-lil manna-ci)_S ani-hayess-ina
 John-T Mary-O meet-NOM not-did-but
 Mary-lil mannassta
 Mary-O met
 *'John did not meet Mary, but met Mary.'

The verb hata behaves exactly like A verbs. Now, the crucial question here is whether NT verbs belong to the class of A verbs or to that of B verbs. We may now compare the behavior of sayngkak-hata 'think'--a typical NT verb--with the characteristic behavior of A verbs.

- (11) a. John-nān (Mary-ka mek-īlila-ko)_S sayngkakhayessta
 John-T Mary-S eat-QT thought
 'John thought Mary would eat.'
- b. John-nān (Mary-ka ka-ass-īlilako)_S sayngkakhanta
 John-T Mary-S went-QT thinks
 'John thinks that Mary went.'
- c. John-nān (neyil Mary-līl manna-lilako)_S sayngkakhayessta
 John-T tomorrow Mary-O meet-QT thought
 'John thought that he would meet Mary tomorrow.'
- d. John-nān (Mary-līl manna-lilako)_S sayngkakha-ci ani-
 John-T Mary-O meet-QT think-NOM not-
 hayessina, Mary-līl mannassta
 but Mary-O met
 'John did not think that he was going to meet Mary, but he did meet her.'

Ex. 11 exactly parallels 9 (not 8). This fact shows that the NT verbs belong to the class of B verbs. Therefore hata--which is an A verb--is not a NT verb.

Another argument against the utilization of the NT rule in the derivation of a Type II negation (which is illustrated by the

derivation of 1c from 3) is related to the analysis of a double negation. Consider the following:

(12) John-nin ani mek-ci-lil ani-hayessta

John-T not eat-NOM-O not-did

'It is not the case that he did not eat.'

Lee (194-6) suggests that 12 has 12' as its underlying structure:

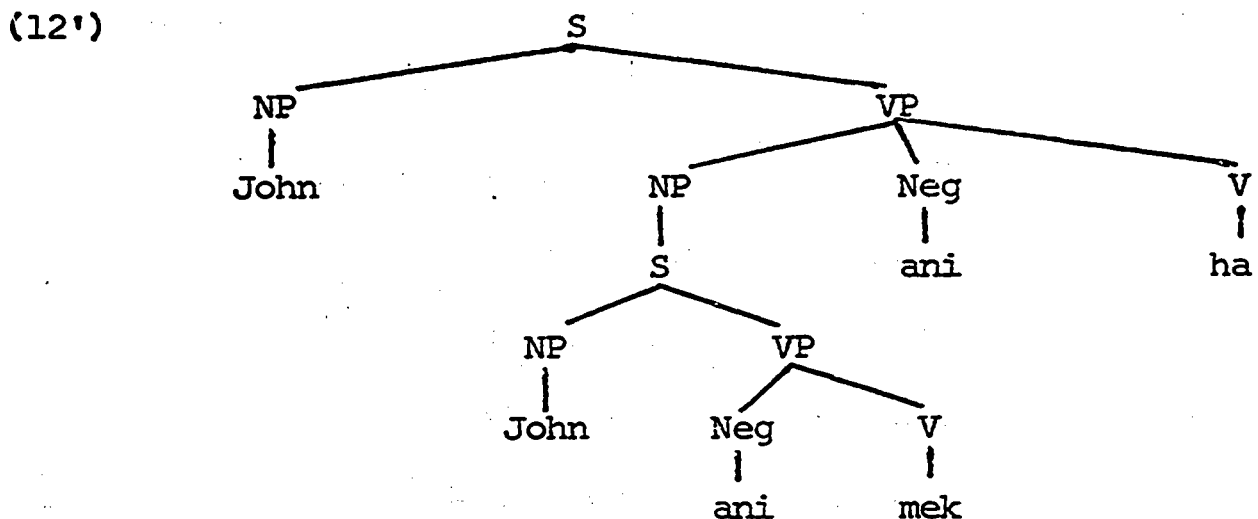

If NEG is allowed to be attached to the matrix verb hata in 12', why not also in 1c? The reason offered by Lee (177) for such a distinction--viz. there is no well-motivated rule to derive a sentence like 1c from a structure like 4--does not seem sound. For NEG-LOWERING, which lowers NEG from the matrix sentence into the embedded sentence (e.g. the derivation of 1c from 4), is as well motivated as NEG-RAISING, which is suggested by Lee's NT analysis. Besides, it is now accepted by most analysts that NEG comes from a higher predicate in the deep structure. This lends an additional support to NEG-LOWERING. Independent justification for the higher-predicate analysis of NEG will be given later.

Till now, I have shown that the NT approach is not the correct analysis of negation in Korean by showing that hata is not

a NT verb: With hata used in Type II negation, NT should be obligatory, although NT is actually optional with other NT verbs; and hata behaves like A verbs, although other NT verbs belong to the class of B verbs. Another argument against the NT approach is related to the derivation of lb from 3.

5.22. The theoretical implications of ha-DELETION. In order to derive Type I negation, one needs a rule to delete hata, since the NT approach postulates that hata is present in the deep structure of every single sentence--as illustrated by 3. This rule of ha-DELETION is responsible for the derivation of lb from 3. Lee (125) formulates ha-DELETION in the following manner:

$$(13) \text{ ha-DEL-2}^5$$

$$X - S \begin{bmatrix} X - V \\ [- N] \end{bmatrix} S - \text{ha} - X \xrightarrow{\text{OBLIG}} 1 \ 2 \ 3 \ \emptyset \ 5$$

Before I discuss the implications contingent on hata in the deep structure of every sentence and the application of 13 to derive Type I negation, I will comment on the formulation of rule 13. Immediately after presenting the rule, Lee adds that 'the feature specification [viz. [- N]] is necessary in order not to delete the verb hata of a denominal verb'. Korean has a group of verbs which are formed by adding hata--which corresponds to Japanese suru--to some nouns. Thus, kongpu 'research' is a noun, but kongpu-hata 'to study' is a verb. For another example, taceng 'kindness' is a noun, but taceng-hata 'to be kind' is a verb. Lee calls these verbs denominal verbs. In the above rule formulation, Lee identifies verbalizing hata with negativizing hata; the latter is

used as the higher predicate of a Type II negation. However, the feature [+N] is rather peculiar if viewed as an inherent property of a verb--it is hard to allow a [+N] verb in our theory. Furthermore, the difference between the two hata's is revealed in the negations of sentences which contain them. Consider the following:

(14) a. John-nān uphyo mo̩-ki-ləl ani-hanta

John-T stamp collect-NOM-O not-does

'John does not do stamp-collecting.'

b. *John-nān uphyo mo̩-ci-ləl ani-hanta

'John does not do stamp-collecting.'

(15) a. *John-nān uphyo-ləl mo̩-ki(ləl) ani-hanta

John-T stamp-O collect-NOM-O not does

'John does not collect stamps.'

b. John-nān uphyo-ləl mo̩-ci-ləl ani-hanta

'John does not collect stamps.'

That hata in 14 is a verbalizer is shown by its comparison with hata in 16:

(16) a. John-nān uphyo sucip-ləl ani-hanta

John-T stamp collection-O not-does

'John does not do stamp collecting.'

b. John-nān uphyo-ləl sucip-hanta

John-T stamp-O collects

'John collects stamps.'

Sentence 16a is semantically identical with 14a. The only difference between 14a and 16a is that 16a has the Sino-Korean morpheme

sucip 'collection' in place of the Korean nominalized form mo-i-ki 'collecting', which occurs in 14a. All Sino-Korean words function as nouns; in order to function as verbs, verbalizing hata has to be suffixed to them. And in Korean there is a restriction that no denominal verb is derivable from a pure Korean nominalized form. Therefore, 14a cannot be transformed into 14c below:

- (14) c. *John-n_n upyo-l_l mo-i-ki ani-hanta
 John-T stamp-O collect-NOM not does
 'John does not collect stamps.'

The compound word mo-i-ki hata 'collect' does not function like a single verb, as sucip-hata 'collect' does. Anyhow, hata in both 14a and 16a is clearly the same morpheme as verbalizing hata which makes kongpu 'research' into a verb. The difference between negativizing hata--e.g. 15--and verbalizing hata--e.g. 14 and 16--is then the following: Only before negativizing hata does the nominalizer ki change to ci by a morphophonemic rule. This is shown by the ungrammaticality of 15a. But ki cannot be changed before verbalizing hata, as shown by the ungrammaticality of 14b.

This idiosyncrasy of negativizing hata is further illustrated by the following example:

- (17) a. na-n_n John-ka ilt_{ing} ha-ki-n_n ani-palanta
 I-T John-S top do-NOM-DLM not-hope
 'I do not hope that John will take the first place.'
- b. *na-n_n John-ka ilt_{ing} ha-ci-n_n ani-palanta
 'I do not hope that John will take the first place.'

(18) a. John-ka ilt̃ing ha-ci-ñn ani-hayessta

John-S top do-NOM-DLM not-did

'John did not take the first place.'

b. *John-ka ilt̃ing ha-ki-ñn ani-hayessta

'John did not take the first place.'

The idiosyncrasy of negativizing hata that ki changes to ci in negative sentence when it is used is ignored in Lee's formulation of rule 13.

What then is the theoretical implication of postulating hata as a higher predicate of every sentence? Actually, a sentence with triple negation is grammatical; e.g. 19:

(19) Speaker A: John-ka i yak-l̃l mek-ci ani-ha-myen

John-S this medicine-O take-NOM not-does-if

etteckey ha-lkkayo?

what do-shall

'What if John will not take this medicine?'

Speaker B: John-ka mek-ci ani-ha-ci mos-ha-ci ani-ha-lkkayo?

John-S eat-NOM not-does-NOM not-does-NOM not-do-shall

'Wouldn't it be unreasonable to expect that John

would not take this medicine?'

If we pursue Lee's reasoning--that since hata appears in negation, it has to be in the deep structure of every sentence, whether negated or not--then because of 19B, every sentence has to have at least three levels of embedding with three higher hata verbs in the deep structure. In other words, since 19B would have 19'B as its

182

underlying structure, 20 must have 20' as its underlying structure:

(19') B.

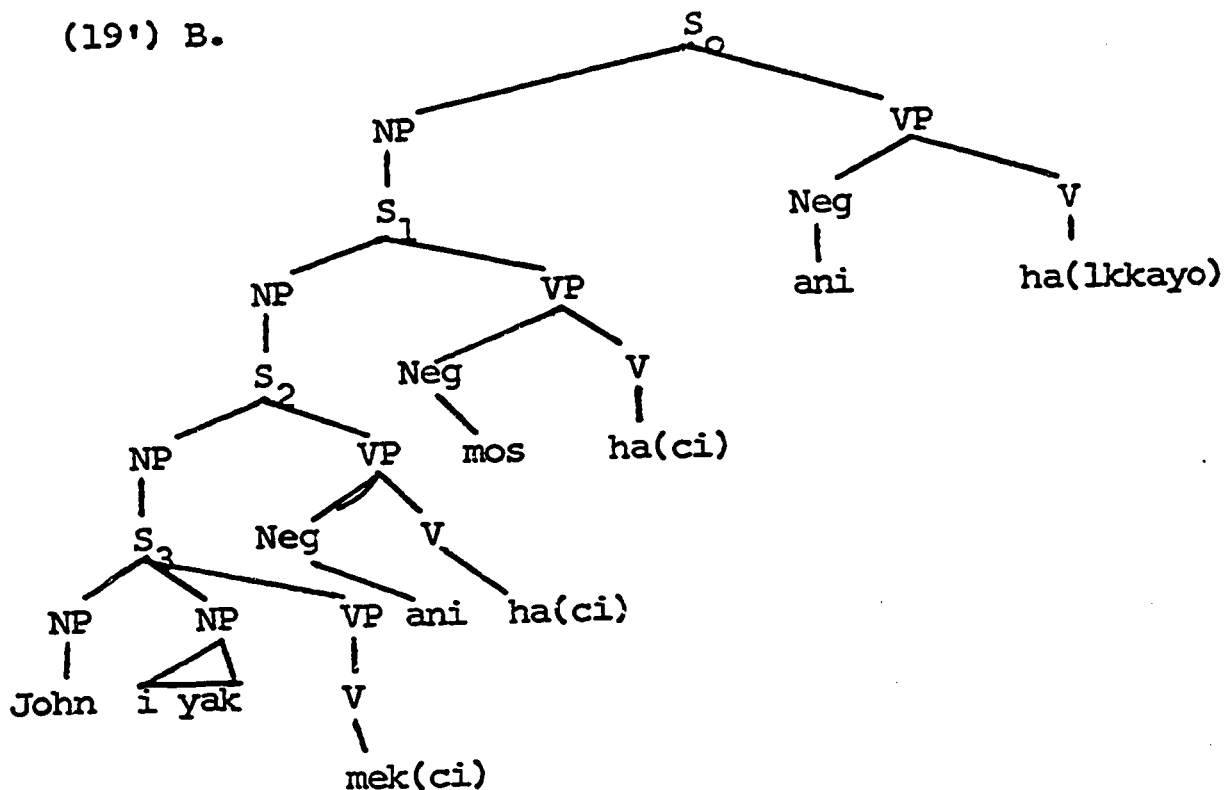

(20) John-ka i yak-lil mek-ilkkayo?

John-S this medicine-O eat-will

'Will John take this drug?'

(20')

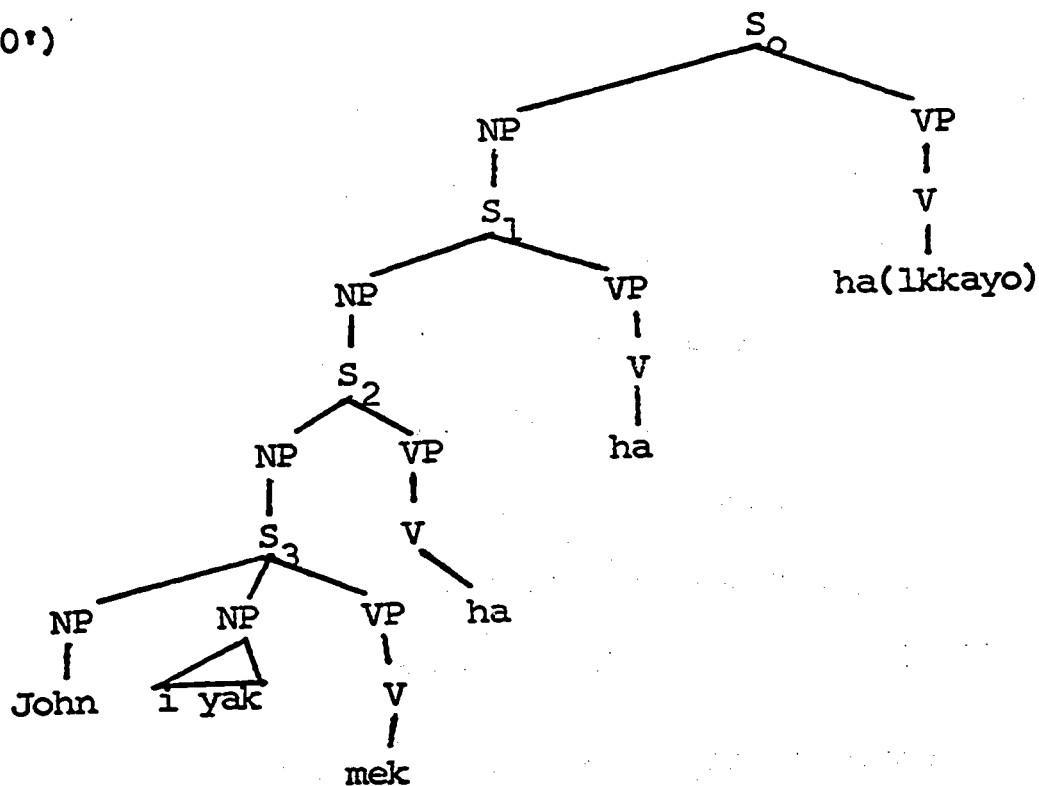

This would mean that every single sentence had to have at least three hata verbs in its deep structure! Three is of course an arbitrary limit. Theoretically, there is no limit to the possible depth of negative embeddings, and so a sentence may have an unlimited number of hata's in its deep structure. The NT approach (which suggests postulating hata as the underlying higher predicate of every sentence and deleting hata in affirmative sentences) is simply incorrect. To reiterate the points made so far, the NT approach cannot be correct because negativizing hata is not an NT verb and hata-DELETION causes the awkward problems discussed above.

The NEG-INCORPORATION approach

5.3. The last possible way of analyzing negation in Korean-- which I will show to be the correct one--has NEG as the next higher predicate. Both 1b and 1c (which are repeated below for convenience) will have 21 as their underlying structure in this analysis:

(1) b. ai-ka ani-canta

child-S not-sleeps

'The child does not sleep.'

c. ai-ka ca-ci(lil) ani-hanta

child-S sleep-NOM-O not does

'The child does not sleep.'

(21) (((ai canta)_S NEG)_S PRESENT)_S

child sleep

Because of the irrelevancy of tense here and in the interests of

.simplifying the exposition, I have so far ignored the status of TENSE in the discussion of underlying structures. But I will discuss TENSE from now on, since it is directly relevant to negation in Korean. I will still ignore the performative marker (particles distinguishing declarative, interrogative, and imperative sentences), which is ultimately derived from a performative verb (for details, see Lee 1970, ch. 2). The tree diagram for 21 is given below:

(21')

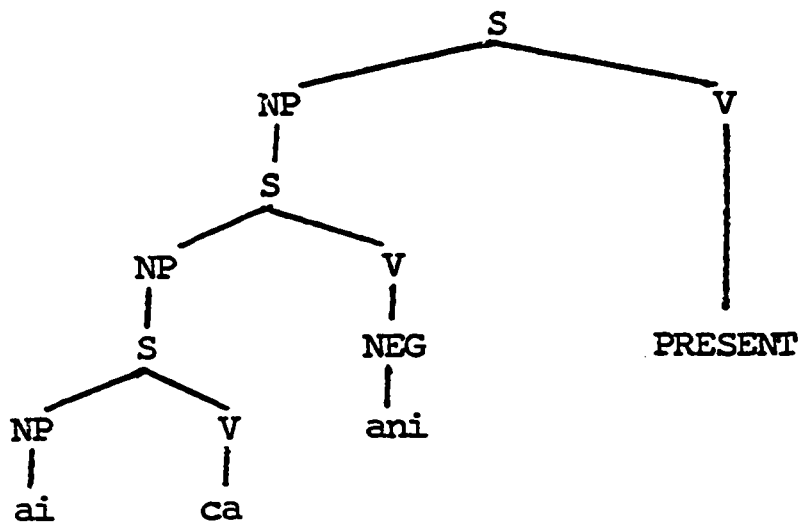

In order to derive surface structures from 21, we need the following two rules:

(22) NEG-INCORPORATION (abbr. NI)

$$\begin{array}{ccccccc} [X, & V]_S, & \text{NEG} & \xrightarrow{\text{OPT}} & 1, & [3 + 2]_V, & \emptyset \\ 1 & 2 & 3 & & & & \end{array}$$
(23) ha-ADDITION (abbr. ha-ADDIT)⁶

$$\begin{array}{ccc} X, & \left[\left\{ \begin{array}{l} \text{NEG} \\ Y \text{ CONTEXTUAL PARTICLE} \end{array} \right\} \right]_V \\ 1 & 2 \\ \xrightarrow{\text{OBLIG}} & 1, \quad 2 + \text{ha} \end{array}$$

NI is a rule similar to ADVERBIALIZATION (abbr. ADVB), which lowers a higher predicate into a lower clause, making it also an adverb. ADVB is illustrated in the derivation of 24a from 24b here:⁷

(24) a. Jonn-ka pplalikey tallinta

John-S fast runs

'John runs fast.'

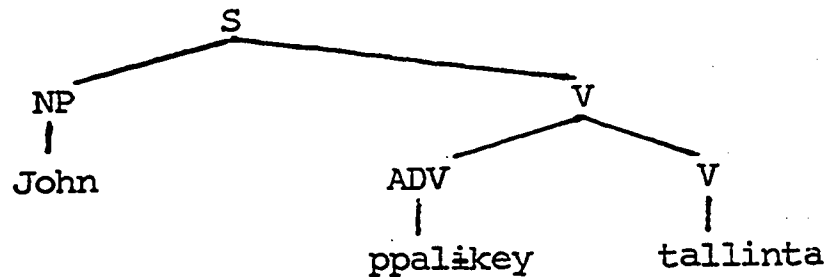

b. (((John tallinta)_S ppalita)_S PRESENT)

John run fast

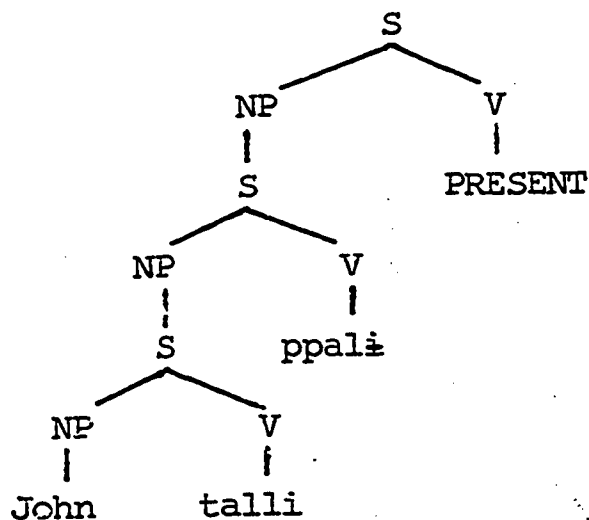

The ha-ADDIT rule is needed when NEG is to be realized as the surface verb--i.e. when NEG has not been lowered by NI--or when contextual particles (e.g. to 'too', ya 'at least', man 'only') are attached to the verb. The latter is illustrated by the derivation of 25a from its underlying structure, 25b:

(25) a. John-nin Mary-lil manassta. (kiliki) John-nan Mary-lil

John-T Mary-O met and John-T Mary-O

chacaka-ki-to hayessta

visit-NOM-too did

'John met Mary, and he even visited her.'

(25) b. ((John Mary mannata)_S PAST) • ((John Mary
meet

chacakata)_S PAST)
visit

c. ((John Mary mannata)_S PAST) • ((John Mary
chacakota-to) PAST)
too

One instance of CONTEXTUAL PARTICLE INSERTION (ch. 4, rule 20) applies to 25b and attaches the contextual particle to 'too' to the verb. The resultant derived constituent structure satisfies the second part of the structural description of 23. Therefore 23 applies and attaches hata. Then 23 generates 25a from 25c after the application of COMPLEMENTATION and TENSE SPELLING.⁸

5.31. The correct derivation of negation. If NI applies to the underlying structure 21, ex. 26 will be derived:

(26)

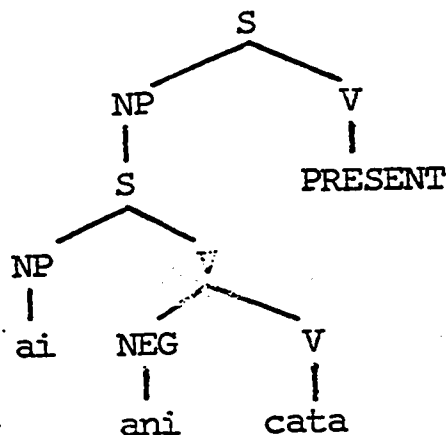

Then TENSE SPELLING and PARTICLE INSERTION (ch. 4, rule 17) will finally derive lb from 26. If optional NI does not apply to 21, na-ADDIT will automatically apply and generate 27:

(27)

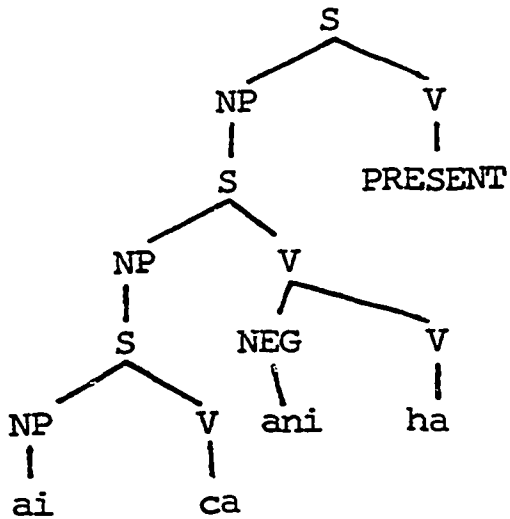

COMPLEMENTATION (cf. 4.2) and TENSE SPELLING will generate lc from 27.

5.32. Justification of the NEG-INCORPORATION analysis.

First of all, the infinite-regress problem--which was discussed in 5.22 as a difficulty of the NT approach--does not arise with NI analysis. Thus, sentences 19B and 20 will have 19"B and 20" as their underlying structures in the NI analysis:

(19") B.

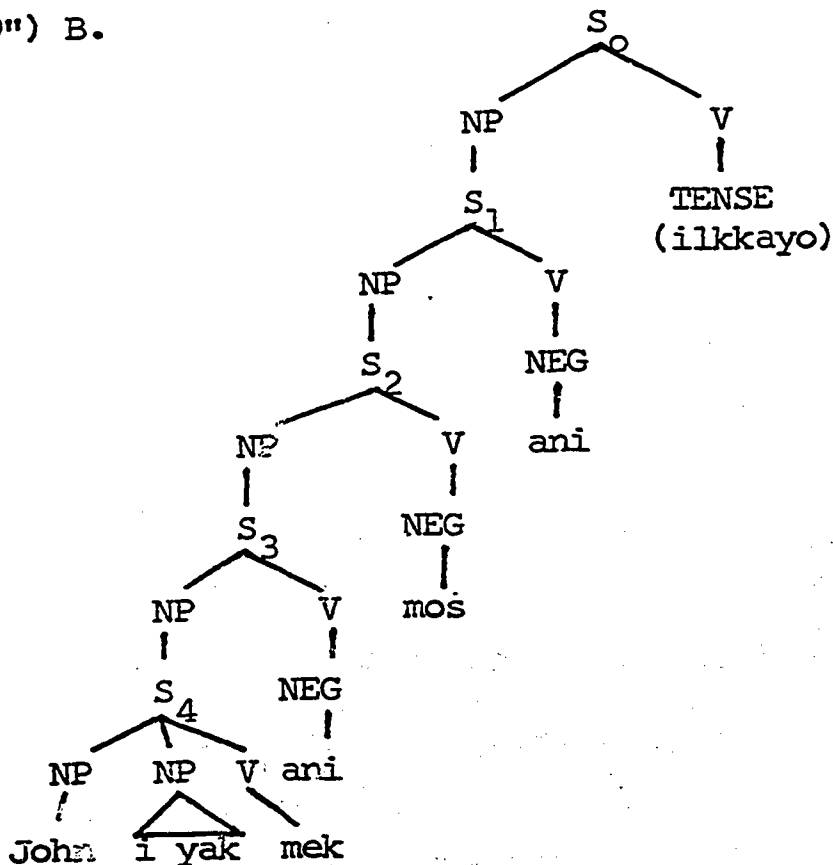

(20")

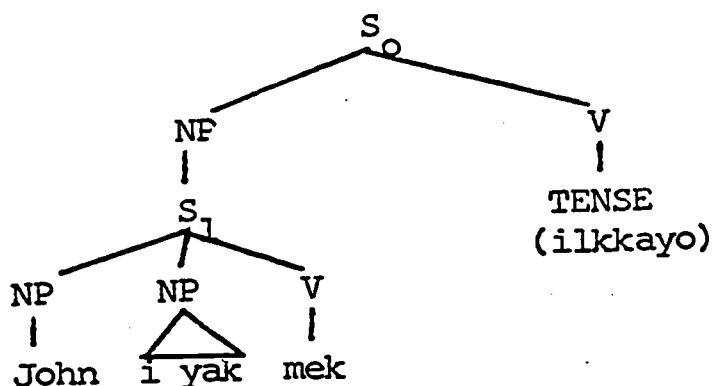

The diagram 19"B has more embeddings than 20", just as 28a has more embeddings than 28b:

(28) a. John knew that he would pass the exam.

b. John will pass the exam.

The ha-ADDIT rule will apply to 19"B and generate 29, from which COMPLEMENTATION and TENSE SPELLING will generate 19B:

(29)

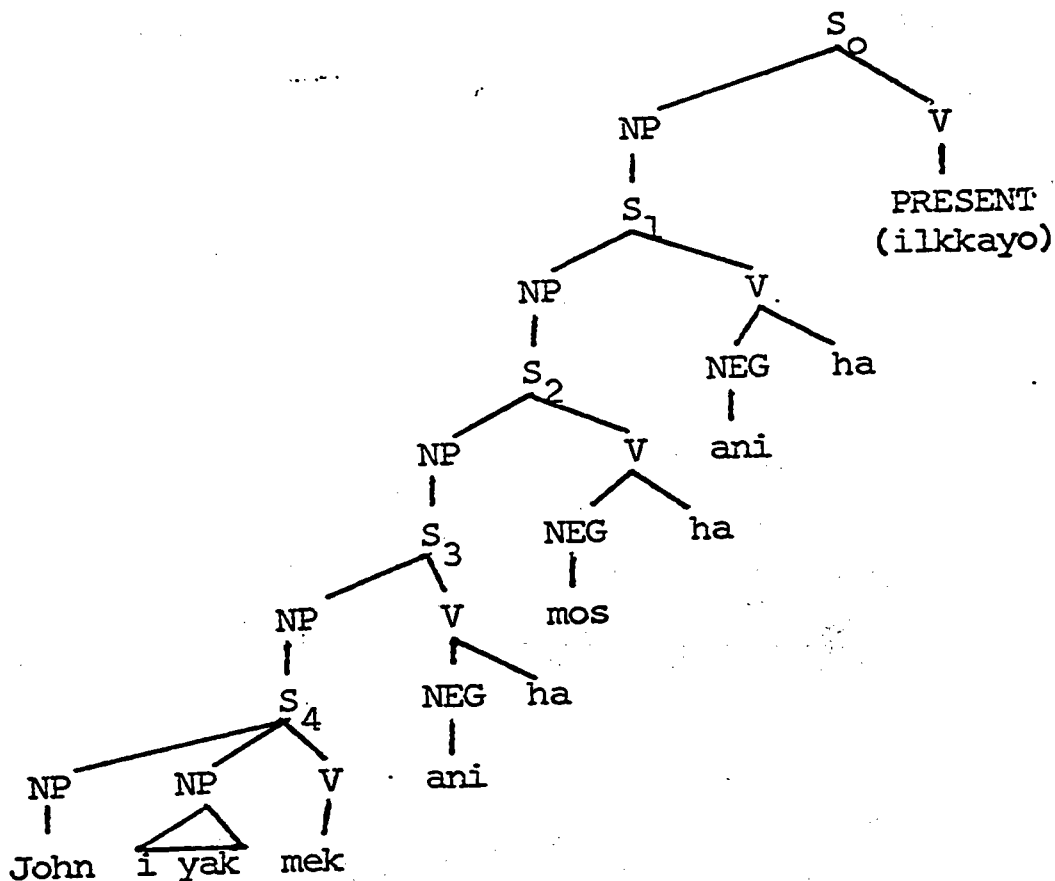

Second, the idiosyncrasy of negativizing hata is explained in a natural manner. Only before a NEG followed by a transformationally inserted hata does ki become ci. In other words,

there are two hata's: hata₁, which is in the lexicon; and hata₂, which is not in the lexicon, but added to a sentence by a transformation.⁹ Only before hata₂ does ki become ci. The difference between hata₁ and hata₂ is illustrated in the derivations of 14a and 15b, which are repeated here for convenience:

(14) a. John-nān uphyo moī-ki-līl ani-hanta
 John-T stamp collect-NOM-O not-does
 'John does not do stamp collecting.'

(15) b. John-nān uphyo-līl moī-ci-līl ani-hanta
 John-T stamp-O collect-NOM-O not-does
 'John does not collect stamps.'

The underlying structures of the above sentences are given below:

(14')

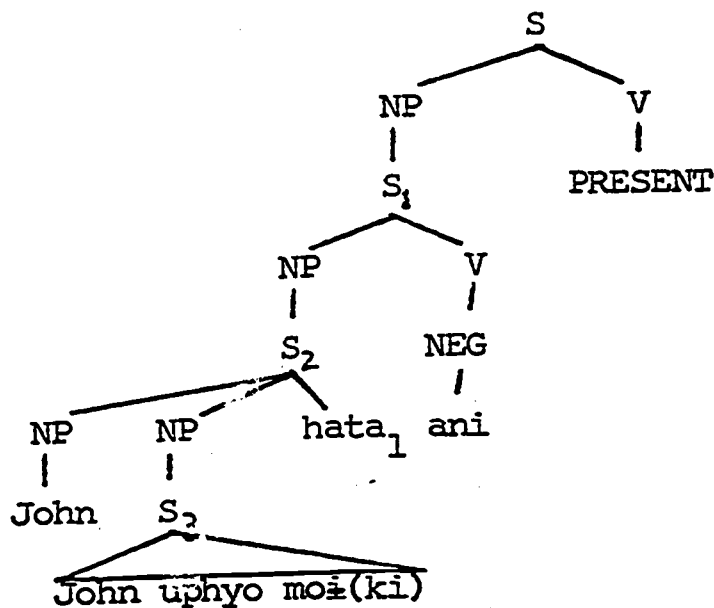

(15')

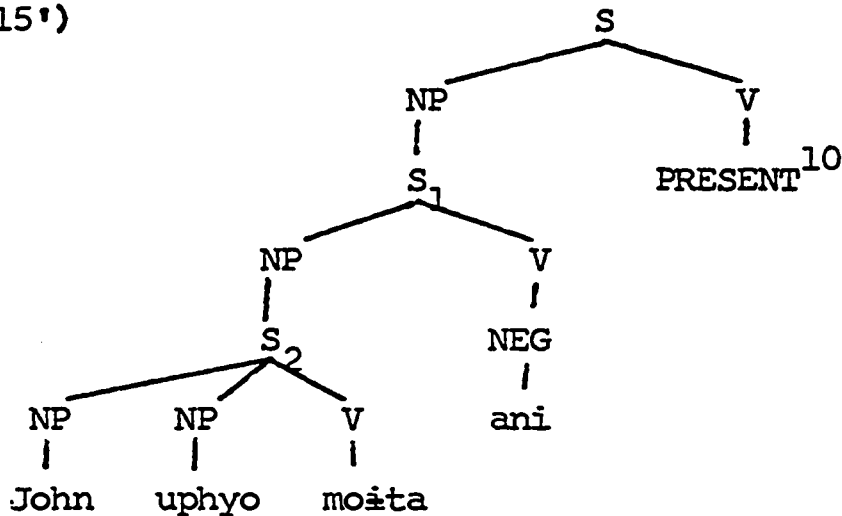

If NI applies to 14', then 14a will ultimately be generated; if not, 14c will be generated:

(14) c. John-nān uphyo moi-ki-lā1 ha-ci ani-hanta

John-T stamp collect-NOM-O do-NOM not-does

'John does not do stamp collecting.'

If NI does not apply to 15', then 15b will be derived; but if it does, 15c will be derived:

(15) c. John-nān uphyo-lā1 ani-moita

John-T stamp-O not-collect

'John does not collect stamps.'

There is no way to derive 14d and 15d. They are therefore ungrammatical:

(14) d. *John-nān uphyo ani moi-ki-lā1 hanta

'John does not do stamp collecting.'

(15) d. *John-nān uphyo-lā1 moi-ki-lā1 ha-ci ani-hanta

'John-T does not collect stamps.'

Third, the NI approach enables us to keep the generalization that the lexical item hata 'do' (hata₁) is a verb which does not

have a sentential object. It might seem that 14' constitutes a counterexample to the foregoing, but in fact S_3 in 14' must be an idiom, which functions like a single lexical item rather than a sentence. Therefore, a sentence like 14' is not a counterexample to the generalization just given. Consider the following:

(30) a. uli-n \dot{n} n quiz macchu-ki-l \dot{l} l hanta

we-T quiz fill-NOM-O do

'We play a quiz game.'

b. uli-n \dot{n} n quiz macchu-ki-l \dot{l} l ani hanta

(31) a. John-n \dot{n} n 1500-mi talli-ki-l \dot{l} l ani hayessta

John-T 1500-meter run-NOM-O not did

'John did not participate in the 1500-meter race.'

b. *John-n \dot{n} n olay talli-ki(l \dot{l} l) ani hayessta

John-T long run-NOM-O not did

'John did not run long.'

The nominalized phrases can be objects of hata₁ only when in idioms or when used as names of games or hobbies, as in the underlined words of 30a, 30b, and 31a. As the nominalized phrase of 31b is not used as an idiom or as the name of a game, hata in 31b cannot be hata₁. If hata in 31b were hata₂, then nominalizing ki should have been changed to ci. Furthermore, such naming does not in Korean allow particles within or between Sino-Korean words, nominalized forms used as idioms, or their combinations. The (b) phrases below are all odd:

(32) a. cencayng yukacok touw-ki cukan

war the bereft help-NOM week

'The week for helping the war-bereft.'

b. *cencayng-iy yukacok-lil touw-ki-iy cukan

war-of the bereft-O help-NOM-of week

(33) a. tayhanminkuk toklip kinyem il

Korea independence celebration day

'The Independence day of Korea.'

b. *tayhanminkuk-iy toklip-lil kinyem-iy il

Korea-of independence-O celebration-of day

If 31b had lacked lil in the underlined phrase, a forced interpretation--viz. that John did not play a game called olay-talliki 'long race'--might have been possible. But as it is, 31b is completely ungrammatical.

Lastly, Song (1967:59-61) has correctly commented on the awkwardness of 34 and 35 below, in contrast with the grammaticality of 36 and 37, although he did not 'know the precise nature of the discomfort felt by native speakers when they hear[d] (i) and (ii) in 2 [my 34 and 35], which are perfectly grammatical and readily acceptable...with other particles like nin, to, ya.'

(34) *pi-ka o-ki-lil hanta

rain-S come-NOM-O does

'It rains.'

(35) *nalssi-ka chuw-ki-ka hanta

weather-S cold-NOM-S does

'The weather is cold.'

(36) uli-nān pi-ka o-ki-lāl kitalinta

we-T rain-S come-NOM-O wait

'We wait for rain to come.'

(37) nalssi-ka chuw-ki-to hata

weather-S cold-NOM-too does

'The weather is extremely cold.'

The ungrammaticality of 34 and 35 has been neatly accounted for by my formulation of ha-ADDIT. For hata is added when contextual particles are attached to a verb, or when NEG is the only constituent of a verb (cf. rule 23). Structures like 34 and 35 do not satisfy the structural description of ha-ADDIT from the outset, and so hata in 34 and 35 cannot be hata₂, which is transformationally inserted. Can the hata there be hata₁, which is in the lexicon? Subjects should be agents with hata₁, but pi 'rain' (subject in 34) and nalssi 'weather' (subject in 35) are not agents, and therefore hata in 34 and 35 cannot be hata₁, either. In other words, hata in 34 and 35 cannot be motivated at all. That is why 34 and 35 are not grammatical.

APPENDIX I: FORMAL CONSTRAINTS ON THE DELETION
OF REFLEXIVE PRONOUNS

G. Lakoff (1971:340) argues that 'the principles governing the distribution of morphemes will involve presuppositional information'. He illustrates his claim by the following phenomenon:

- (1) a. I get my paycheck tomorrow.
b. ?*I get a cold tomorrow.
- (2) a. The astronauts return to the earth tomorrow.
b. ?*The astronauts return safely tomorrow.
- (3) a. Sam gets a day off tomorrow.
b. ?*Sam enjoys his day off tomorrow.

Although all the events described by the above sentences are in the future tense, for some reason the deletion of will is allowed only with the (a) sentences. The only possible explanation seems to be that only when a future event has been arranged, will can be deleted. In other words, the (b) sentences of 1-3 normally describe events which are not arranged beforehand: therefore the deletion of will is blocked. However, in a rather unusual situation such as when it has been arranged for me to be injected with cold germs in a medical experiment, 1b can be perfectly grammatical. The conclusion is that grammar cannot be presupposition-free without rendering many important generalizations impossible.

Another case where presupposition is absolutely needed for syntactic explanation may be mentioned. In Korean, as in Japanese,

pronominalization by deletion is one of the major processes which have made the so-called 'syntactic component' unmanageably complicated, simply because the theory has not allowed presupposition in syntax. Consider the following:

- (4) a. ?*John-nān caki-ka Shakespeare-lā1 caki-īy chinku-tā1-
 John-T (him)self-S Shakespeare-O (him)self-of friend-
 eykey ilkecu-ki-lā1_s cohahanta
 PL-to read-NOM-O likes
 'John likes to read Shakespeare for his friends.'

- b. John-nān Shakespeare-lā1 chinku-tā1-eykey ilkecu-ki-lā1
 cohahanta
 'John likes to read Shakespeare for his friends.'

- (5) a. John-nān Mary-lā1 ponay-nān taysin caki-ka ka-keysstako
 John-T Mary-O send-instead of (him)self-S go-will-QT
 malhayessta
 said
 'John said that he would go himself instead of sending
 Mary.'

- b. ?*John-nān Mary-lā1 ponay-nān taysin ka-keysstako
 malhayessta
 'John said that he would go himself instead of sending
 Mary.'

- (6) a. John-nān caki-ka ecey cecilī-n silsu-ey tayhayese
 John-T (him)self-S yesterday made-REL mistake-about
 sakwahayessta
 apologized
 'John apologized for the mistake that he made yesterday.'
- b. John-nān ecey cecilī-n silsu-ey tayhayese sakwahayessta
 'John apologized for the mistake that he made yesterday.'

The subject of each embedded sentence in 4-6 is correferential with that of the respective matrix sentence. The underlying structures of 4-6 are shown as 4'-6' below:

- (4') John-nān John-ka Shakespeare-līl John-iy chinku-tāl-eykey
 John-T John-S Shakespeare-O John-of friend-PL-to
 ilkecu-ki-līl cohahanta
 read-NOM-O likes
- (5') John-nān John-ka Mary-līl ponay-nān taysin John-ka
 John-T John-S Mary-O send-instead of John-S
 ka-keyss-tako malhayessta
 go-will-QT said
- (6') John-nān John-ka ecey cecilī-n silsu-ey tayhayese
 John-T John-S yesterday made-REL mistake-about
 sakwahayessta
 apologized

REFLEXIVIZATION, which is formulated below, applies to these structures and derives the (a) sentences of 4-6, respectively:

(7) REFLEXIVIZATION:

$$\underbrace{U \text{ NP}_i \text{ W}}_1 [X, \text{ NP}_i, \underbrace{Y}]_3 \text{ Z} \implies 1, \text{ caki}, 3$$

Sentences 4-6 represent three cases which are different from each other in regard to the deletability of the reflexive pronoun:

(1) the deletion is obligatory in 4; (2) the deletion is blocked in 5; (3) the deletion is up to the individual speaker's judgment in 6. I will show below how the introduction of presupposition into grammar enables it to explain this apparently random phenomenon. The explanation will be provided case by case.

Case 1, where the deletion is obligatory. As in 4, the deletion of reflexive pronoun is also obligatory in the following sentence:

- (8) a. ?*John-n_{in} caki-ka Mary-l_l salhayha-n hyem_y-l_l
 John-T (him)self-S Mary-O murdered-REL suspicion-O
 patassta
 received

'John was suspected to have murdered Mary.'

- b. John-n_{in} Mary-l_l salhayha-n hyem_y-l_l patassta.

'John was suspected to have murdered Mary.'

Compare 4 and 8 with 9 and 10, where the reflexive pronoun is optionally deletable:

optionally deletable:

- (9) a. John-n_{in} caki-ka Shakespeare-l_l ilkey-toy-ki-l_l palanta
 John-T (him)self-S Shakespeare-O read-become-NOM-O hopes
 'John hopes that he will be appointed to read Shakespeare.'

(9) b. John-n_n Shakespeare-l_l ilkey-toy-ki-l_l palanta

'John hopes that he will be appointed to read Shakespeare.'

(10) a. John-n_n caki-ka Mary-l_l salhayha-n yayki-l_l hayessta

John-T (him)self-S Mary-O murdered-REL story-O did

'John told the story of (his) having killed Mary.'

b. John-n_n Mary-l_l salhayha-n yayki-l_l hayessta

'John told the story of (his) having killed Mary.'

What could be the factors that make the deletion of reflexive pronouns obligatory in 4 and 8, while optionally leaving the pronouns in 9 and 10? Could it be conditioned by the different verb in the embedded sentences? It could not, since 8 and 10 have the same embedded verb salhay hata 'murder', but only in 8 is the deletion obligatory. Could the different complementizers cause the difference in deletability? No, for 4 and 9 have identical complementizers, although they differ in the deletability of the reflexive pronouns. It does not follow, however, that we are dealing with complete randomness. In fact, there is one consistent factor that helps to explain the situation. The difference in deletability seems to come from the different matrix verb: in Korean (but not in English), one cannot like (= coahata) to read if that reading is done by others, although one can hope (= palata) that others may read. And on purely semantic grounds, it would hardly be possible for one to be suspected of (= hyem_ny-l_l patta) others' having committed murder, even though one can talk about (= yayki-l_l hata) a murder's having been committed by others.

In other words, 4 and 8 have matrix verbs which require embedded subjects to be correferential with matrix subjects, and therefore there is no possibility of ambiguity as to the identity of the embedded subject when the embedded subject is deleted. The matrix verbs of 9 and 10 do not, on the other hand, require correferentiality between the subject of an embedded sentence and that of a matrix sentence. A generalization can be made tentatively as follows: if the matrix verb is lexically marked for correferentiality between the subject of an embedded sentence and that of a matrix sentence, then the reflexive pronoun which is in the embedded sentence must be deleted.

Now, consider the following:

(11) a. ?*John-n_{in} caki-ka chuw-ta-ko malhayessta

John-T (him)self-S cold-QT said

'John said that he was cold.'

b. John-n_{in} chuwta-ko malhayessta

'John said that he was cold.'

(12) a. ?*John-n_{in} caki-ka suyeng-l_{il} ha-ko siphta-ko

John-T (him)self-S swimming-O do-NOI want-QT

malhayessta

said

'John said that he wanted to swim.'

b. John-n_{in} suyeng-l_{il} ha-ko siphta-ko malhayessta

'John said that he wanted to swim.'

(13) a. ?*John-n_{in} caki-ka enehak-l_l cenkongha-keyssta-ko
 John-T (him)self-S linguistics-O major-will-QT
 malhayessta

said

'John said that he would major in linguistics.'

b. John-n_{in} enehak-l_l cenkongha-keyssta-ko malhayessta

'John said that he would major in linguistics.'

(14) a. ?*John-n_{in} caki-ka chayk-l_l sacu-ma-ko Mary-eykey

John-T (him)self- book-O buy-will-QT Mary-to

yaksokhayessta

promised

'John promised Mary that he would buy a book for her.'

b. John-r_{in} chayk-l_l sacu-ma-ko Mary-eykey yaksokhayessta

'John promised Mary that he would buy a book for her.'

Lee (1970) has ascertained that morphemes like keyss or ma 'future intention' and several perceptual verbs like chuw-ta 'feel cold' or siphta 'feel like' can only be used in embedded sentences whose subjects are correferential with the subjects of the next-higher sentences.¹ There is no possibility of ambiguity as to the identity of the embedded subject in such instances. But in 11-14, it is the verb of the embedded clause that requires correferentiality between the embedded subject and the matrix subject, unlike 4 and 8-10, where the matrix verb requires correferentiality.

The generalization that has been made with respect to 4 and

8-10 must now be expanded:

- (15) If the subject of the embedded sentence is required to be correferential with that of the matrix sentence either because of the matrix verb or because of the embedded verb, the embedded subject is obligatorily deleted.

Case 2, where the deletion of a reflexive pronoun is blocked. It is easy to think of counterexamples like 5 and 16 to the expanded generalization given immediately above:

- (16) John-nān caki-ka suyeng-līl ha-ko siphta-ko malhayessta
 John-T (him)self-S swimming-O do-NOM want-QT said
 'John said that he wanted to swim himself.'

However, the NP's that are reflexivized in 5 and 16 are formally or exhaustively used--they are key information in the embedded sentences. That caki 'himself' in 5 and 16 is used formally can be demonstrated by the direct narrative counterparts to 5 and 16:²

- (5') a. John-nān 'Mary-līl ponay-nān taysin nā-ka kakeyssta'
 John-T Mary-O send-instead of I-S go-will
 hako malhayessta
 QT said
 'John said, "I will go myself instead of sending Mary."'
- b. *John-nān 'Mary-līl ponay-nān taysin na-nān ka-keyssta'
 T
 hako malhayessta
 'John said, "I will go instead of sending Mary."'

(16') a. John-nān 'nā-ka suyeng-ləl ha-ko siphta' hako

John-T I-S swimming-O do-NOM want QT

malhayessta

said

'John said, "I want to swim myself."'

b. John-nān 'na-nān suyeng-ləl ha-ko siphta' hako

malhayessta

'John said, "I want to swim."'

The direct quotations seem to be treated as independent of their matrix sentences so far as the cycle is concerned: i.e. post-cyclic rules--which apply only after the final cycle--can apply in a direct quotation before it itself is embedded. Therefore, if the underlined phrases na-ka in 5'a and 16'a had been used materially, they could have been topicalized. However, the ungrammaticality of 5'b and the lack of synonymy between 16'a and 16'b show that TOPZN is blocked. Furthermore, 5'a and 16'a can be grammatical only when the underlined phrases are heavily accented. The fact that TOPZN is blocked in 5'a and 16'a and the fact that the NP's must be accented in that eventuality demonstrate that caki in 5 and 16 stands for formally used NP's. These reflexive pronouns that stand for NP's used formally cannot be deleted, as shown by the ungrammaticality of 5b and the lack of synonymy of 16a with 12b. Since an NP used formally carries the key information of a sentence, its deletion will necessarily result in ambiguity as to the identity of the referent; therefore, reflexive pronouns that replace NP's used formally are

not deletable. Now I can expand the previous generalization to read that only when the speaker presupposes that ambiguity does not result can reflexive pronouns be deleted.

Case 3, where the deletion is up to the individual speaker's judgment. By expanding the generalization to say that the reflexive pronoun should be automatically deleted when the speaker does not presuppose resultant ambiguity, I have shown that the deletability of a reflexive pronoun is actually conditioned by an individual speaker's judgment. With the previous two cases, then, speakers of Korean share presuppositions: In case 1, I have dealt with those sentences concerning which speakers share a presupposition that ambiguity is not possible; in case 2, we find sentences concerning which speakers share the presupposition that ambiguity is inescapable when an embedded NP is deleted. In case 3, I will deal with those sentences about which speakers share no presupposition concerning any resultant ambiguity. Thus, consider the following sentences:

(17) a. John-n_{in} caki-ka Mary-kwa heyeci-te-n nal-l_{il}

John-T (him)self-S Mary-with separate-RET-REL day-O
kiekhakoissta
remembers

'John remembers the day when he left Mary.'

b. John-n_{in} Mary-kwa heyeci-te-n nal-l_{il} kiekhakoissta

'John remembers the day when he left Mary.'

Sentences 17a and 17b are equally grammatical and are synonymous.

The deletion of the reflexive pronoun is optional here, not in the sense that the presence or absence of it depends on a speaker's unconditioned choice, but in the sense that the deletion is left to a speaker's judgment as to situational need--if the speaker presupposes that ambiguity will beset the identity of an embedded NP when the reflexive pronoun is deleted, he will (mandatorily) leave it; otherwise, he will obligatorily delete the reflexive pronoun.

In fact, this obligatory deletion of redundant information--which is dependent on the speaker's presupposition that resultant ambiguity is unlikely--is not limited to the deletion of reflexive pronouns in embedded sentences. Thus, 18Bi is rather awkward as a response to 18A, since the information carried by the underlined na-ka (or -nān) is clearly redundant. Notice that the choice between 18Bi and 18Bii is not unconditionally left to the speaker: the choice of 18Bii is in fact mandatory.

(18) Speaker A: (tangsin-nān) cikām etey kaseyyo?
 you-T now where go-QUES
 'Where are you going?'

Speaker B: i. na-nān cikām hakkyo-ey kapnita
 I-T now school-to go
 'I am going to school now.'
 ii. hakkyo-ey kapnita
 '(I) go to school (now).'

Then the generalization on deletion of redundant information in

~ Korean can be given in the following manner:

(19) When and only when the speaker presupposes that resultant ambiguity is not likely may reflexive pronouns conveying redundant information be deleted.

G. Lakoff (1971:340) calls such a general constraint as 19 a global constraint. A global constraint conditions the applicability of transformational rules. In my approach, then, the obligatoriness or optionality of a rule depends on global constraints in the grammar.

APPENDIX II: LIST OF RULES*

ADJECTIVE PREPOSING	3.1
CASE AGREEMENT	4.2
COMPLEMENTATION	4.2
CONJUNCTION REDUCTION	2.14
DATIVIZATION	ch. 4, rule 19
DEFINITIZATION	3.12
EQUI-NP DELETION	2.13
LEFT-SISTER-ADJUNCTION	ch. 3, rule 47
NR (Adj-Pr) FORM	ch. 2, rule 96
NR-FORM	ch. 3, rule 58
NOT-TRANSPORTATION	ch. 5, rule 7
OBJECT PARTICLE INSERTION	ch. 4, rule 18
PARTICLE DELETION	4.2
PARTICLE INSERTION	ch. 4, rules 17-20
PREDICATE PREPOSITION	4.14
PREDICATE PROMOTION	ch. 4, rule 47
PRONOMINALIZATION	3.11
REFLEXIVIZATION	Appendix I, rule 7
RELATIVE CLAUSE REDUCTION	3.1 and 3.21
REPT-NP DELETION	3.22
RR-FORM	ch. 3, rule 58
RR-PRONOMINALIZATION	3.13
S ₁ -DELETION	3.12

SUBJECT PARTICLE INSERTION	ch. 4, rule 27
<u>to</u> -INSERTION	ch. 4, rule 20
TOPICALIZATION	ch. 4, rule 7

•The ordering of these rules is so complicated that the determination of their precise formulation is beyond the scope of the present dissertation. For part of the rule ordering, see sect. 4.2.

APPENDIX III: LIST OF KOREAN PARTICLES

ci	morphophonemic variant of <u>ki</u>
ciman	but
cul	NOM
cungeyse	from among
ey	time
ey	directional (moving toward inanimate nouns)
ey(se)	locative
eykey	directional (moving toward animate nouns)
in	NOM
iy	of
ka	S
ki	NOM
ko	QT
ko	and
kwa	with
l	REL with future meaning
la	IMP
lil	O
man	only
myen	if
n	REL
ney	PL
ni	when

n̄n	T
n̄n	DLM
(n̄n)tey	and
pakkey	other than
pota	than
puthe	from
te	RET
tey	see <u>n̄n tey</u>
t̄l	PL
to	even, too
to	but
wi	on

NOTES ON CHAPTER TWO

Pre- and post-determiner Q's are illustrated in 1 and 2 below, respectively:

- (1) a. All (of) the boys
 b. Many (of the) boys
- (2) a. The many boys
 b. The five boys

For further explanation, see Carden 1970:36-39.

²Carden's arguments III, IV, V, and VIII in his book are not applicable to Korean, as far as I can see.

³NT-verbs are those verbs that allow the NEG in the embedded sentence to be raised. Such verbs as think and believe are NT-verbs, and therefore the (a) and (b) sentences below are synonymous with each other:

- (1) a. I think that the train will not start until noon.
 b. I do not think that the train will start until noon.
- (2) a. I believe that John will not ever date any girl.
 b. I do not believe that John will ever date any girl.

Although the embedded sentences of 1b and 2b do not contain NEG, the underlined morphemes (which cannot occur in an affirmative sentence) indicates that the NEG on the matrix verbs have been raised. For further discussion, see Lakoff 1970:145-65 and Baker 1970b.

⁴I owe this term, delimiter, to Yang.

⁵For an analysis of implicitly negative verbs, see

Klima 1964b:294.

⁶For further discussion of definiteness and specificity of NP's, see Bailey 1967:29-55.

⁷The correferential NP's may be repeated when they are the words that carry the new information of a sentence (formally-used NP's).

- (1) Jóhn-ka cenhwa-ił hayessko, Jóhn-ka kkoch-lıl sawassta
 John-S telephone-O did-and John-S flower-O brought
 'It was John who made the phone call, and it was John who
 brought the flower.'

⁸See sect. 3.31 for the suggested underlying structures of generic nouns.

⁹Some native speakers of English are dubious about the acceptability of this sentence. But even such speakers accept 1 below:

- (1) Those men were many in number.

¹⁰A sentence like 72b is here termed an intro-S. For a detailed analysis of an intro-S, see sect. 3.11.

¹¹The fact that all is not used as an overt predicate seems to be peculiar to current English.

¹²There are two different kı's: one is a demonstrative kı, which is used to refer to something that is close to the hearer but far apart from the speaker; the other is the pro-form of a relative clause. For an example of the second kı, see 84a of this chapter.

¹³I claim in sect. 3.11 that 1a below is a derived structure which 1b underlies:

(1) a. A certain man tried to conquer the world.

(There was man_i) · (man_i tried to conquer the world)

If the second conjunct of 1b alone is within the scope of a NEG, 2 will be derived:

(2) A certain man did not try to conquer the world.

If 1a is within the scope of a NEG, 3 will be derived:

(3) No man tried to conquer the world.

'There was not a man such that he wanted to conquer the world.'

¹⁴This rule is actually a rule schema consisting of NR-FORM, RELATIVE-CLAUSE REDUCTION, and ADJECTIVE-PREPOSING. This rule reads as NR-FORM applying to a clause with an adjective predicate.

¹⁵The verb deny is derived from say that ... not. The rule not-HOPPING applies and raises not to the matrix verb. The derived structure not say is realized as deny by a lexical spelling rule. See Klima 1964b:294 for other words which make implicit negation.

¹⁶It appears that we rarely use stative verbs in an intro-S unless such additional phrases as TIME, LOCATION co-occur or the stative verb carries sufficient information to determine the identity of a referent in a particular situation. For this reason, I excluded 12' in illustrating the application of RR-FORM here.

¹⁷Accidentally identical NP's are those NP's which have identical forms only on the surface, as a result of different transformational rules from distinct deep structures. Thus, flying planes in 1 and flying planes in 2 are accidentally identical

to each other.

(1) Flying planes can be dangerous (= 'To fly planes can be dangerous').

(2) Flying planes can be dangerous (= 'Those planes that are flying can be dangerous').

NOTES ON CHAPTER THREE

¹See sect. 2.2 for two types of adjectives.

²This also explains why B adjectives cannot be predicates of restrictive relative clauses, for restrictive relative clauses will be shown later in this chapter to be copies of an intro-S.

³The discussion of tense will be ignored for the sake of simplicity in exposition until Chapter V.

⁴For the formulation of RR-FORM, see rule 58 of this chapter.

⁵RELATIVE-CLAUSE REDUCTION deletes relative pronoun + be, and ADJECTIVE-PREPOSING moves an adjective ahead of the NP it modifies, as illustrated below:

(1) I bought a flower which is red.

(2) *I bought a flower red.

(3) I bought a red flower.

⁶The terms copying and chopping are here used in the sense that Ross uses them for reordering transformations. A copying type of movement rule leaves a trace, but a chopping one does not. See Ross 1967, sect. 6.2.1, for details.

⁷Proper nouns can be used as [- definite]. Cf exs. 29'-31' of this chapter and the succeeding discussion.

⁸For different sources of definiteness, see exs. 80-82.

⁹The noun man in this case is used as a generic noun as the horse, a horse, and horses are in the following examples:

(1) A horse is a faithful animal.

(2) The horse is a faithful animal.

(3) Horses are faithful animals.

Generics have been claimed to be definite in the sense suggested in the present dissertation.

An interesting analysis of the definite article in connection with generic nouns has been suggested by Vendler (1968:11-25). Vendler argues that 2 is derived from 2' below:

(2') The (animal that is) horse is a faithful animal. .

Vendler's work had been brought to my attention only after this dissertation had been finished.

¹⁰For the definition of representative and partitive generic, see pp. 27-28.

¹¹Since it is mostly Type II intro-S that is relevant in the discussion, from now on I will refer to it simply as an intro-S.

¹²In Thompson 1967, she seems to imply the ordering of basic conjuncts by distinguishing left-to-right embedding from right-to-left embedding. But in Thompson 1970b, she seems to contradict what she had claimed earlier.

¹³See sect. 2.2 for detailed discussion of why Q's cannot have indefinite subjects.

¹⁴I do not use this term, deep structure, in the traditional sense that means a base component. Lakoff and Ross (1967) have convincingly claimed that there is no such level. I mean by this term a logical or semantic level underlying surface structures generated from it.

¹⁵See sect. 3.11 for details concerning intro-S's and the basic ordering of an intro-S with respect to other conjuncts.

¹⁶See Appendix I for details concerning REFLEXIVIZATION and the deletability of reflexive pronouns.

¹⁷See note 6 of chapter 3 for the definition of a chopping rule.

¹⁸Subject NP's modified by a RR-(B) cannot be topicalized, as shown by the ungrammaticality of 1 below:

(1) ?*ecey na-lil cuki-lyeha-n han sakong-nin spei-iessta
 yesterday me-O kill-tried-REL one sailor-T spy-was
 'A sailor who tried to kill me yesterday was a spy.'

(2) ecey na-lil cuki-lyeha-n sakong-nin spei-iessta
 'The sailor who tried to kill me yesterday was a spy.'

¹⁹Under the present analysis, step 1 is obligatory, as shown by the ungrammaticality of 1a;

- (1) a. *Seymour gave me a knife_i; and I used a knife_i.
 b. Seymour gave me a knife_i; and I used the knife_i.

The second occurrence of any correferential NP has to be definite because of the obligatoriness of step 1.

²⁰The deletion of S_1 seems to me to be a complete mistake.

²¹For some apparent counterexamples, see sect. 3.22.

²²What I suggest as the underlying structure of 87a is different from 87b. I suggest 1 below as the underlying structure of 87a; note the additional brackets in my suggested underlying structure.

- (1) (... a janitor ...).((I just met a janitor).(A janitor gave me this key))

²³The interrelation among speaker, hearer, referent are intricately involved in the Korean honorific system. See Lee 1970:87-93 for details.

²⁴Particles are actually inserted by later transformations, but added here to facilitate the interpretation.

²⁵A stacked clause is similar to Chomsky's nested construction. For further discussion of this matter, see Chomsky 1965:12.

²⁶Somehow, speakers accept sentences like 1 (where a RR in which the shared NP is the subject follows a RR in which the shared NP is non-subject) more readily than sentences like 2 (where the ordering of the RR's is opposite from what is given above):

(1) There are many people that I know that do not know me.

(2) There are many people that do not know me that I know.

Bailey 1969 has made an interesting experiment, in which a very neat implicational scale of acceptability is revealed to be conditioned by different types of RR's, relative pronouns, etc.

²⁷Copula agreement and number agreement seem to be later rules, in spite of Lakoff-Ross's (1966) suggested rule ordering. These authors claim that RELATIVE-CLAUSE FORMATION comes later than NUMBER AGREEMENT and COPULA AGREEMENT. But then, we could not explain the agreement in a surface structure like 105.

²⁸For the definition of this term, see pp. 27-28.

²⁹For the definition of this term, see p. 88.

³⁰See sect. 5.3 for the suggested analysis of negation.

³¹For explanations of rules 129-131, see Copi 1969:41-46 and 122-30. The Greek letter phi in rule 131 represents any property symbol.

³²In other words, 138 is converted into 1 below by the principle of distribution.

(1) ((I bought (certain) flower_x) • (I want to give flower_x to Mary)) • ((I bought (certain) flower_x) • (flower_x is red))

Since the intro-S is given in the first major conjunct, the same intro-S in the second major conjunct is necessarily presupposed by the speaker to be shared by hearers. Therefore, only RR-FORM (A) is possible in the second major conjunct.

NOTES ON CHAPTER FOUR

¹See sect. 2.2 for the derivation of indefinite N_i's modified by adjectives.

²See sect. 311 for the definition of intro-S.

³We have two distinct etten's in Korean: one which means 'certain', and the other which means 'which'. We are here dealing with etten in the first reading.

⁴The features [+ com], [+ loc], [+ dir], and [+ time] are derived from predicates of higher sentences in the deep structure. Then some low-level rules give phonological shapes to these features, which are realized as particles on the surface. For an example of the process of lowering such higher predicates into lower sentences, see rule 19 of this chapter.

⁵This feature, [+ mentioned], is suggested by Dr. Rig (1968). An NP is [+ mentioned], if it has been mentioned in the discourse in which a given sentence is used.

⁶Generic nouns behave similarly and get topicalized. In gnomic sentences, TOPZN actually becomes obligatory. See . 147 for an example.

⁷For detailed discussion of Korean particles, see Yang 1971.

⁸Since Korean is a SOV language, the first NP in the NP, NP, V construction is the subject, and the second NP is the object.

⁹For convenience of exposition, I use the English word affect. But I assume that this represents an abstract verb, which

determines the relation between a dative NP and an embedded sentence.

¹⁰Lakoff 1971 has made it very clear that presuppositional information conditions the applicability of transformational rules. But I have shown in the present dissertation that this presuppositional information has to be incorporated in the structural description of a rule.

¹¹The fact that both contrastive wa (or nin) and exhaustive ga (or ka) are normally accented and the fact that both of them carry new information of sentences might suggest that they are related. But for the present, I do not have any further evidence to conclude that they are (or are not) related.

¹²One might wish to argue that since both thematic nin and contrastive nin need contextual information, these two nin's are actually not distinct from each other. But in that case, the fact that only contrastive nin can occur in an embedded sentence cannot be explained.

¹³Direct quotations behave differently from other embedded sentences. TOPZN applies to a direct quotation which is embedded into other performative sentences. See pp. 192-93 for a discussion of this matter.

¹⁴Martin (1964:408) claims that Korean has the following six speech levels: plain, intimate, familiar, polite, authoritative, and deferential. For different analyses of speech levels in Korean, see Lee 87-93, and Song 15-23.

¹⁵PREDICATE PREPOSING, one example of which is NR (Adj-Pr) FORM, is a rule schema consisting of NR-FORM (e.g. derivation of 1b

from 1a) and RELATIVE-CLAUSE REDUCTION (e.g. derivation of 1c from 1b). In case the predicate of the second conjunct is an adjective, ADJECTIVE PREPOSING is included in that schema. Otherwise, a replacement occurs, as illustrated by the derivation of 1d from 1c below:

- (1) a. (x killed Mary) • (x is John)
 b. X, who is John, killed Mary.
 c. X, John, killed Mary.
 d. John killed Mary.

¹⁶ Contrastive n̄n can mark the subject NP's of these verbs.

¹⁷ John-iy is derived from some deeper structure like

John-ka ha-n̄n 'which John does' by some sort of relative-clause reduction rule. For some discussion of RELATIVE-CLAUSE REDUCTION in Korean, see Ree 1969, ch. 3.

¹⁸ For the derivation of dative NP's, see rule 19 in this chapter.

¹⁹ The morpheme series n̄n kes is a derived form of la-ko ha-n̄n kes 'thing which they say...' by deleting ko ha 'they say'. For simplicity of description, I gloss n̄n kes as NOM here.

²⁰ For some discussion of 'inalienability', see Fillmore 1968:61.

²¹ For examples of agglutinative verbal, see Kuno 1970:III 19-21.

²²For the specific condition for deleting reflexive pronouns,
see Appendix I.

²³For S-pruning, see Ross 1967:41-102.

NOTES ON CHAPTER FIVE

¹For a discussion of NT verbs, see ch. 2, n. 3.

²See ch. 4, n. 8.

³Lee might want to argue that obligatory ha-DELETION will automatically delete hata. But in 5.22, I have shown that ha-DEL is not motivated in Korean syntax. Besides, if Korean has obligatory ha-DEL, the grammar cannot explain the difference in grammaticality between the sentences in 1 and those in 2 below:

(1) a. *i kong-ka ttwi-ki-lâl hanta

this ball-S bounce-NOM-O does

'This ball does bounce.'

b. *i kong-ka ttwi-ki-ka hanta

this ball-S bounce-NOM-S does

'This ball does bounce.'

c. *John-nân achim-puthe cenyek-kkaci yelsimhi kongpuha-

John-T morning-from evening-till hard study-

ki-lâl hanta

NOM-O does

'John does study hard from morning till evening.'

(2) a. i kong-ka ttwi-ki-to hanta

this ball-S bounce-NOM-even does

'This ball even bounces.'

b. i kong-ka ttwi-ki-nân hanta

this ball-S bounce-NOM-DLM does

'This ball does at least bouncing.'

(2) c. John-nin achim-puthe cenyek-kkaci yelsimhi kongpuha-ki-to
 John-T morning-from evening-till hard study-NOM-even
 hanta
 does

'John even studies hard from morning till evening.'

For a detailed explanation, see 5.22.

⁴The following are some examples of A and B verbs.

A verbs			B verbs		
<u>manage</u> ,	<u>remember</u> ,	<u>see fit</u>	<u>decide</u> ,	<u>plan</u> ,	<u>expect</u>
<u>venture</u> ,	<u>dare</u> ,	<u>have sense</u>	<u>try</u> ,	<u>be</u> {	<u>ready</u>
					<u>eager</u>
					<u>willing</u>
<u>be</u> {	<u>lucky</u>	} <u>enough</u>			
	<u>kind</u>				
	<u>fortunate</u>				

A verbs are just the expressions of speaker's feeling or judgment of the subject. This is similar to what Kajita (1967) calls semi-auxiliary verbs.

⁵Lee (65) has another rule which deletes ha, which he calls ha-DEL-1.

⁶For the discussion of contextual particles, see pp. 137-39.

⁷If ADVB does not apply to 24b, COMPLEMENTATION automatically applies to the lowest sentence of 124b, and 1 below will be derived:

(1) John-ka talli-nin kes-ka ppalita

John-S run-REL thing-S (= NOM) is-fast

'It is fast that John runs.'

⁸TENSE-SPELLING adds a tense morpheme (e.g. ess for the past, nin for the present tense of action verbs) to verb roots.

⁹Verbalizing hata, which was discussed in p. 159, is one example of hata₁.

¹⁰As I have claimed, hata₂ is not in the deep structure, but transformationally inserted in sentences later.

NOTES ON APPENDIX I

¹Perceptive verbs like chuwta 'feel cold', silhta 'disliked', always have the first-person, singular subject if in the present tense; if the tense of those verbs is past, there is no such restriction on the subject (e.g. ex. 3):

(1) na-nān chum-ka chuko-siphta

I-T dance-S dance-want

'I feel like dancing.'

(2) *ne (or kī)-nān chum-ka chuko-siphta

you (or he)-T dance-S dance-want.

'You (or he) feel like dancing.'

(3) kī-nān chum-ka chuko-siphessta

'He felt like dancing.'

This seems to be so because one can only be sure of one's own perceptions at a given moment.

²For the definition of the formal use of an NP, see sect. 4.1.

REFERENCES

- Austin, J. L. 1955. How to do things with words. Oxford: Oxford University Press.
- Bach, Emmon. 1968. Nouns and noun phrases. Universals in linguistic theory, ed. by Emmon Bach and Robert T. Harms, 90-122. New York: Holt, Rinehart and Winston, Inc.
- Bailey, C.-J. N. 1967. Transformational outline of Marshallese syntax. Ann Arbor: University Microfilms. Chicago: University of Chicago.
- _____. 1969. Marked and unmarked orderings of two relative clauses modifying the same antecedent. Working Papers in Linguistics, University of Hawaii, 1:10.239-44.
- _____. 1970a. The instrumental case, purpose and result clauses, and the underlying sentential operator cause. Working Papers in Linguistics, University of Hawaii, 2:9.155-60.
- _____. 1970b. Trying to talk in the new paradigm. Working Papers in Linguistics, University of Hawaii, 2:9.39-54.
- Baker, C. L. 1970a. A note on scope of quantifiers. Linguistic Inquiry 1.138-40.
- _____. 1970b. Double negatives. Linguistic Inquiry 1.169-86.
- Bouton, L. 1969. Identity constraints on the do-so rule. Papers in Linguistics 1.231-47.
- Brame, M. K. 1970. A derived nominal requiring a non-sentential source. Linguistic Inquiry 1.547-49.
- Browne, Wayles. 1970a. Noun phrase definiteness in relatives and questions: evidence from Macedonian. Linguistic Inquiry 1.267-70.
- _____. 1970b. More on definiteness markers: interrogatives in Persian. Linguistic Inquiry 1.359-63.
- Buysens, E. 1959. Negative contexts. English Studies 40.163-69.
- Carden, Guy. 1970a. Logical predicates and idiolect variation in English. Cambridge, Mass.: Aiken Computation Laboratory, Harvard University. (Report NSF-25.)

- Carden, Guy. 1970b. A problem with primacy. *Linguistic Inquiry* 1.523-33.
- Casagrande, Jean. 1970. A case for global derivational constraints. *Papers in Linguistics* 2.449-59.
- Choi, H. B. 1961. *Uli malpon [A Korean grammar]*. Seoul: Chong um sa.
- Chomsky, Noam. 1965. *Aspects of the theory of syntax*. Cambridge: M.I.T. Press.
- _____. 1970. Remarks on nominalization. *Readings in English transformational grammar*, ed. by R. Jakobson and P. S. Rosenbaum, 184-221. Waltham, Mass.: Ginn and Company.
- _____. 1971. Deep structure, surface structure, and semantic interpretation. (To appear in *An interdisciplinary reader in philosophy, linguistics, and psychology*, ed. by D. D. Steinberg and L. A. Jakobovits. Cambridge, Mass.: Cambridge University Press.)
- Copi, Irving M. 1967/1969. *Symbolic logic*. New York: The Macmillan Company.
- Dahl, Östen. 1970. Some notes on indefinites. *Language* 46.33-41.
- Drubig, Bernhard. 1968. Some remarks on relative clauses in English. *Journal of English as a Second Language* 3.23-40.
- Fillmore, Charles J. 1963. The position of embedding transformations in a grammar. *Word* 19.208-31.
- _____. 1968. The case for case. *Universals in linguistic theory*, ed. by Emmon Bach and Robert T. Harms, 1-88. New York: Holt, Rinehart and Winston, Inc.
- _____. 1970. The grammar of hitting and breaking. *Readings in English transformational grammar*, ed. by R. Jakobson and P. S. Rosenbaum, 120-33. Waltham, Mass.: Ginn and Company.
- Harris, Z. S. 1964. *Discourse analysis. The structure of language*, ed. by Jerry Fodor and Jerrold Katz, 355-83. Englewood Cliffs, N.J.: Prentice-Hall, Inc.
- Hetzron, R. 1970. Nonverbal sentences and degrees of definiteness in Hungarian. *Language* 46.899-927.
- Huddleston, Rodney. 1971. A problem in relative clause reduction. *Linguistic Inquiry* 2.115-16.

- Jackendoff, Ray S. 1968a. Quantifier in English. Foundations of Language 4.422-42.
- _____. 1968b. On some incorrect notions about quantifiers and negations. (To appear in Studies in transformational grammar and related topics, principal investigator: S. J. Keyser. [ASCRL-68-0032.] Waltham, Mass.: Brandeis University.)
- _____. 1968c. Speculations on presentences and determiners. Unpublished.
- _____. 1969. An interpretative theory of negation. Foundations of Language 5.218-41.
- _____. 1971. Gapping and related rules. Linguistic Inquiry 2.21-36.
- Jacobs, Roderick and Peter Rosenbaum. 1970. Readings in English transformational grammar. Waltham, Mass.: Ginn and Company.
- Jespersen, Otto. 1964. Essentials of English grammar. Forge Village, Mass.: University of Alabama Press.
- Josephs, Lewis S. 1971. Tense and aspect in Japanese relative clauses. (To appear in Language, 1971.)
- Kajita, Masaru. 1967. A generative-transformational study of semi-auxiliaries in present-day American English. Tokyo: Sanseido Company LTD.
- Karttunen, Lauri. 1967. The identity of noun phrases. (Publication no. P-3756.) Santa Monica, California: The RAND Corporation.
- _____. 1968. What do referential indices refer to? (Publication no. P-3854.) Santa Monica, California: The RAND Corporation.
- _____. 1969. A-verbs and B-verbs. Unpublished.
- _____. 1971. What makes definite noun phrases definite? (Publication no. P-3871.) Santa Monica, California: The RAND Corporation.
- Kim, S.-H. P. 1967. A transformational analysis of negation in Korean. Unpublished Ph.D. dissertation. Ann Arbor: University of Michigan.

- Kiparsky, Paul and Carol Kiparsky. 1970. Fact. Progress in linguistics: a collection of papers, ed. by Manfred Bierwisch and Karl E. Heidolph. The Hague: Mouton and Company.
- Klima, Edward S. 1964. Negation in English. The structure of language, ed. by Jerry A. Fodor and Jerrold J. Katz, 246-323. Englewood Cliffs, N.J.: Prentice-Hall, Inc.
- Koutsoudas, Andreas. 1968. On wh-words in English. Journal of Linguistics 4.267-73.
- Kuno, Susumu. 1970. Notes on Japanese grammar. (Report NSF-27.) Cambridge, Mass.: Aiken Computation Laboratory, Harvard University.
- Kuroda, S.-Y. 1968. English relativization and certain related problems. Language 44.244-66. (Reprinted in Modern studies in English, ed. by David Reibel and Sanford Schane, 1969.)
- Lakoff, George. 1965. On the nature of syntactic irregularity. (Report NSF-16.) Cambridge, Mass.: Aiken Computation Laboratory, Harvard University.
- _____. 1966a. Stative adjectives and verbs in English. (Report NSF-17.) Cambridge, Mass.: Aiken Computation Laboratory, Harvard University.
- _____. 1966b. A note on negation. (Report NSF-17.) Cambridge, Mass.: Aiken Computation Laboratory, Harvard University.
- _____. 1966c. Deep and surface grammar. (Duplicated.) Bloomington: Indiana University Linguistics Club.
- _____. 1968a. Instrumental adverbs and the concept of deep structure. Foundations of Language 4.4-29.
- _____. 1968b. Counterparts, or the problem of reference in transformational grammar. (Duplicated.) Bloomington: Indiana University Linguistics Club.
- _____. 1969. On derivational constraints. Papers from the fifth regional meeting of the Chicago linguistic society, ed. by Binnick et al., 117-39. Chicago: Department of Linguistics, University of Chicago.
- _____. 1970a. Linguistics and natural logic. Ann Arbor, Michigan: Phonetics Laboratory, the University of Michigan.

- Lakoff, George. 1970b. Pronominalization, negation, and the analysis of adverbs. Readings in English transformational grammar, ed. by R. Jakobson and P. S. Rosenbaum, 145-65. Waltham, Mass.: Ginn and Company.
- _____. 1970c. Repartee, or a reply to 'negation, conjunction, and quantifiers'. Foundations of Language 6.389-422.
- _____. 1970d. An example of a descriptively inadequate interpretative theory. Linguistic Inquiry 1.539-42.
- _____. 1970e. Global rules. Language 46.627-39.
- _____. 1971a. On generative semantics. (To appear in An interdisciplinary reader in philosophy, linguistics, and psychology, ed. by D. D. Steinberg and L. A. Jakobovits. Cambridge, Mass.: Cambridge University Press.)
- _____. 1971b. Presupposition and relative well-formedness. (To appear in An interdisciplinary reader in philosophy, linguistics, and psychology ed. by D. D. Steinberg and L. A. Jakobovits. Cambridge, Mass.: Cambridge University Press.)
- _____, and John R. Ross. 1966. On the ordering of transformational rules. (Duplicated.) Bloomington: Indiana University Linguistics Club.
- _____. 1967. Is deep structure necessary? (Duplicated.) Bloomington: Indiana University Linguistics Club.
- _____. 1970. A derived nominal requiring a sentential source. Linguistic Inquiry 1.265-67.
- Lakoff, Robin. 1968. Abstract syntax and Latin complementation. Cambridge, Mass.: M.I.T. Press.
- _____. 1969. Some reasons why there can't be any some-any rule. Language 45.608-15.
- _____. 1970a. If's, and's, and but's about conjunction. Unpublished.
- _____. 1970b. Tense and its relation to participants. Language 46.838-49.
- Langendoen, D. T. 1970. The 'can't seem to' construction. Linguistic Inquiry 1.25-36.
- Lee, M. S. 1969. Nominalizations in Korean. Seoul: Language Research Center, Seoul National University.

- Lee, H. B. 1970. A study of Korean syntax. Seoul: Pan Korea Book Corporation.
- Lindholm, J. M. 1969. Negative-raising and sentence pronominalization. Papers from the fifth regional meeting of the Chicago linguistic society, ed. by Binnick et al., 148-58. Chicago: Department of Linguistics, University of Chicago.
- Martin, Samuel. 1964. Speech levels in Japan and Korea. Language in culture and society: a reader in linguistics and anthropology, ed. by Dell Hymes, 407-15. New York: Harper & Row, Publishers.
- McCawley, James. 1967. Meaning and the description of languages. Kotoba no Uchu 2:9-11. Tokyo: [name of publisher not available].
- _____. 1968a. The role of semantics in a grammar. Universals in linguistic theory, ed. by Emmon Bach and Robert T. Harms, 125-69. New York: Holt, Rinehart and Winston, Inc.
- _____. 1968b. Concerning the base component of a transformational grammar. Foundations of Language 4.243-369.
- _____. 1970a. English as a VSO language. Language 46.286-99.
- _____. 1970b. Where do noun phrases come from? Readings in English transformational grammar, ed. by R. Jakobson and P. S. Rosenbaum, 166-83. Waltham, Mass.: Ginn and Company.
- Morgan, Jerry L. 1969. On the treatment of presupposition in transformational grammar. Papers from the fifth regional meeting of the Chicago linguistic society, ed. by Binnick et al., 167-77. Chicago: Department of Linguistics, University of Chicago.
- Oh, Choon-Kyu. 1970. Spurious counterexamples to the complex NP constraint including a 'variably crazy rule' in Korean syntax. Working Papers in Linguistics, University of Hawaii, 2:9.105-24.
- Partee, B. H. 1968. Negation, conjunction, and quantifiers: syntax vs. semantics. Foundations of Language 4.153-65.
- Perlmutter, D. M. 1970. On the article in English. Progress in linguistics: a collection of papers, ed. by M. Bierwisch and K. E. Heidolph. The Hague: Mouton and Company.

- Perlmutter, D. M. 1968. Deep and surface structure constraints in syntax. Unpublished Ph.D. dissertation. Cambridge, Mass.: M.I.T.
- _____. 1970. Surface structure constraints in syntax. *Linguistic Inquiry* 1.187-256.
- _____, and John Ross. 1970. Relative clauses with split antecedents. *Linguistic Inquiry* 1.350.
- Postal, Paul. 1969. On so-called 'pronouns' in English. *Modern studies in English*, ed. by David Reibel and Sanford Schane, 201-24. Englewood Cliffs, N.J.: Prentice-Hall, Inc.
- Ree, Joe J. 1969. Some aspects of Korean syntax. Unpublished Ph.D. dissertation. Bloomington: Indiana University.
- Reibel, David and Sanford Schane (eds.). 1969. *Modern studies in English*. Englewood Cliffs, N.J.: Prentice-Hall, Inc.
- Rivero, M. L. 1970. A surface structure constraint on negation in Spanish. *Language* 46.640-66.
- Rosenbaum, Peter S. 1967. Phrase structure principles of English complex sentence formation. *Journal of Linguistics* 3.103-18.
- _____. 1970. A principle governing deletion in English sentential complementation. *Readings in English transformational grammar*, ed. by R. A. Jacobs and P. S. Rosenbaum, 20-29. Waltham, Mass.: Ginn and Company.
- Ross, John R. 1963. *Negation*. Unpublished.
- _____. 1966. Relativization in extraposed clauses. (Report NSF-17.) Cambridge, Mass.: Aiken Computation Laboratory, Harvard University.
- _____. 1967. Constraints on variables in syntax. Unpublished Ph.D. dissertation. Cambridge, Mass.: M.I.T.
- _____. 1969a. Auxiliaries as main verbs. (*Studies in Philosophical Linguistics* series, 1), 77-102.
- _____. 1969b. Guess who. *Papers from the fifth regional meeting of the Chicago linguistic society*, ed. by Binnick et al., 252-86. Chicago: Department of Linguistics, University of Chicago.
- _____. 1970. On declarative sentences. *Readings in English transformational grammar*, ed. by R. S. Jacobs and P. S. Rosenbaum, 222-72. Waltham, Mass.: Ginn and Company.

- Rutherford, W. E. 1970. Some observations concerning subordinate clauses in English. *Language* 46.97-115.
- Sadock, Jerrold M. 1969a. Super-hypersentences. *Papers in Linguistics* 1.1-15.
- _____. 1969b. Hypersentences. *Papers in Linguistics* 1.283-370.
- Schotta, S. G. 1969. The relative pronoun system of old saxon. *Papers in Linguistics* 1.182-93.
- Smith, Carlota. 1961. A class of complex modifiers in English. *Language* 36.342-65.
- _____. 1964. Determiners and relative clauses in a generative grammar of English. *Language* 40.37-52. (Reprinted in *Modern studies in English*, ed. by David Reibel and Sanford Schane, 1969.)
- Song, S. C. 1967. Some transformational rules in Korean. Unpublished Ph.D. dissertation. Bloomington: Indiana University.
- Stockwell, R. P., et al. 1968. Integration of transformational theories on English syntax. Unpublished.
- Thompson, S. A. 1967. Relative clauses and conjunctions. *Working Papers in Linguistics, The Ohio State University*, 1.80-99.
- _____. 1970a. Relative clause structures and constraints on types of complex sentences. *Working Papers in Linguistics, The Ohio State University*, 6.20-40.
- _____. 1970b. The deep structure of relative clauses. *Working Papers in Linguistics, The Ohio State University*, 6.41-58.
- Vendler, Zeno. 1968. Adjectives and nominalizations. (*Papers on formal linguistics*, 5.) The Hague: Mouton and Company.
- Yang, I. S. 1971. A study of delimiters and case markers in Korean. Unpublished Ph.D. dissertation. Honolulu: University of Hawaii. (In preparation.)
- Zwicky, Arnold M. Jr. 1968. Naturalness arguments in syntax. *Papers from the fourth regional meeting of the Chicago linguistic society*, ed. by Bailey et al., 94-102. Chicago: Department of Linguistics, University of Chicago.