

DOCUMENT RESUME

ED 056 523

EM 009 381

AUTHOR Volk, John  
TITLE The Reston, Virginia, Test of the Mitre Corporation's Interactive Television System.  
INSTITUTION Mitre Corp., McLean, Va.  
REPORT NO MTP-352  
PUB DATE May 71  
NOTE 24p.; Paper presented at a press conference on the Time-Shared, Interactive Computer-Controlled Information Television system

EDRS PRICE MF-\$0.65 HC-\$3.29  
DESCRIPTORS Audio Equipment; \*Cable Television; Communication (Thought Transfer); Community Services; Computers; \*Interaction; \*On Line Systems; Televised Instruction; Video Equipment; Video Tape Recordings

ABSTRACT

A description of how the time-shared, interactive, computer-controlled, information television (TICCIT) system will be implemented with a low cost home terminal system is offered in this paper. The equipment which comprises the demonstration system is described as consisting of three major elements--home terminal, computer facility, and communication link. The projected development and current state of each element in relation to interactive cable television is discussed. Equipment designed to alleviate some of the problems of maximizing channel capacity, such as low cost video tape recorders and specially designed couplers and decoders which serve as a refresh memory for the home terminal, is also described. The demonstration software package, designed to include both educational and community service material, is briefly outlined. (SH)

**MTP-352**

**U.S. DEPARTMENT OF HEALTH,  
EDUCATION & WELFARE  
OFFICE OF EDUCATION**  
THIS DOCUMENT HAS BEEN REPRO-  
DUCED EXACTLY AS RECEIVED FROM  
THE PERSON OR ORGANIZATION ORIG-  
INATING IT. POINTS OF VIEW OR OPIN-  
IONS STATED DO NOT NECESSARILY  
REPRESENT OFFICIAL OFFICE OF EDU-  
CATION POSITION OR POLICY.

**THE RESTON, VIRGINIA, TEST OF  
THE MITRE CORPORATION'S INTERACTIVE  
TELEVISION SYSTEM**

**JOHN VOLK**

**MAY 1971**

**THE**  
**MITRE**  
**CORPORATION**  
**WASHINGTON OPERATIONS**

## ABSTRACT

This report describes how the MITRE Corporation will combine its TICCIT (time-shared, interactive, computer-controlled, information television) system with a low-cost home terminal system of its own invention to demonstrate the feasibility of using standard television receivers as remote (home) computer-driven displays. The computer is located at MITRE's facility in McLean, Virginia; the home terminals are in Reston, Virginia. The signals will be transmitted from MITRE to Reston by microwave link and thence by cable TV into the various Reston homes. Home terminal users will communicate with the MITRE computer through their 12-button push-button phones. The report also describes all the main components of the system.

## ACKNOWLEDGMENT

Most of the design of this program and the engineering of the hardware was completed by K. J. Stetten and R. P. Mayer before the author joined MITRE, and he is indebted to both of them for editorial assistance in preparing this paper.

## TABLE OF CONTENTS

SECTION		PAGE
I	INTRODUCTION	1
II	DEMONSTRATION SYSTEM	2
	INTERACTIVE TELEVISION	2
	COMPUTER FACILITY	4
	COMMUNICATION LINK	7
	RESTON CABLE SYSTEM	7
	HOME TERMINAL	8
	COUPLER/DECODER	13
III	DEMONSTRATION SOFTWARE	17
	INTENT	17
	CONTENT	17
	Educational Material	17
	Community Service Material	18

## LIST OF ILLUSTRATIONS

FIGURE		PAGE
1	Reston Test Overall System Block Diagram	3
2	Demonstration System Computer Facility	5
3	Demonstration System Home Terminal	9
4	Terminal Installed in Home	10
5	Magnetic Tape Pattern (Tape seen from Magneto-Sensitive Surface)	11
6	Tape Path on Helical Scan Recorder	12
7	SONY AV-3400 Video Tape Recorder	14
8	MITRE Coupler/Decoder	15

## SECTION I INTRODUCTION

During the spring and summer of 1971, The MITRE Corporation will test the feasibility of combining its TICCIT (time-shared, interactive, computer-controlled, information television) system with a low-cost home terminal system of its own invention, which utilizes a standard television receiver as a display. During the tests, computer-generated information, including voice and still pictures, emanating from MITRE's facility in McLean, Virginia, will be transmitted over a microwave link to Reston, Virginia, where the signal will be picked up and broadcast to various locations in Reston by cable TV. Users at the various locations in Reston will communicate with the MITRE computer through their 12-button push-button phones. The Reston Transmission Company, a subsidiary of Continental Telephone Company, is cooperating with MITRE in the test by providing certain services, including the use of its cable TV system.

Engineering tests of the system will begin in mid-May, and early public demonstrations are planned for the first week of July.

The goals of the Reston test are threefold: (1) to demonstrate a working engineering model of MITRE's low-cost computer-driven display in the home; (2) to demonstrate the feasibility of the hardware approach to operators of cable TV systems and manufacturers of video tape recorders; (3) to interest the social-science community in the tremendous near-term impact this type of hardware, coupled with strong supporting software, will have on the lives of people.

MITRE, a nonprofit Federal Contract Research Center formed to supply technical advice to various government agencies, is enjoined from producing and marketing the hardware associated with the TICCIT system to be tested in Reston and is carrying out this work wholly in the public interest.

## SECTION II DEMONSTRATION SYSTEM

The equipment that comprises the demonstration system (see Figure 1) will establish the feasibility of MITRE's new approach to the use of home television receivers as remote computer-driven displays. Some of the equipment has been specially selected or constructed to make the tests as realistic as possible. Other equipment, such as MITRE's 360/50 computer, is being used simply because of its convenience and availability. The demonstration system, which is not a prototype of a proposed operational system but only a feasibility model, consists of three major elements:

- (a) home terminal
- (b) computer facility
- (c) communication link

### INTERACTIVE TELEVISION

In a standard TV transmission, new picture frames are transmitted 30 times per second, providing motion pictures without noticeable flicker. Even when still pictures are transmitted, the same picture frame is repeated over and over 30 times per second. Generally, motion pictures are not required for interactive communications with a computer. In MITRE's new system, still pictures are transmitted to homes via cable TV. Although cable TV provides a large number of TV channels (up to 40 are available in some systems), interactive communications would simply not be practical if each home terminal required its own TV channel. MITRE's solution to this problem is to have as many as several hundred active terminals share each available channel. Then a requested picture is transmitted only once (rather than 30 times) per second. A special device installed to record this picture at the terminal location and play it back 30 times per second refreshes the home television's picture. The computer incorporates an encoded address of the particular requesting home in each picture frame it sends. The home refresh device examines the address of each received picture frame and only records those with the right address. Thus, 6,000 terminals may conduct simultaneous interactive communications at the rate of one frame every 10 seconds with the computer using only ten channels of the cable.

In the demonstration system, standard push-button telephones and "dial-up" lines are used for transmission between the home terminal user and the computer. When a user



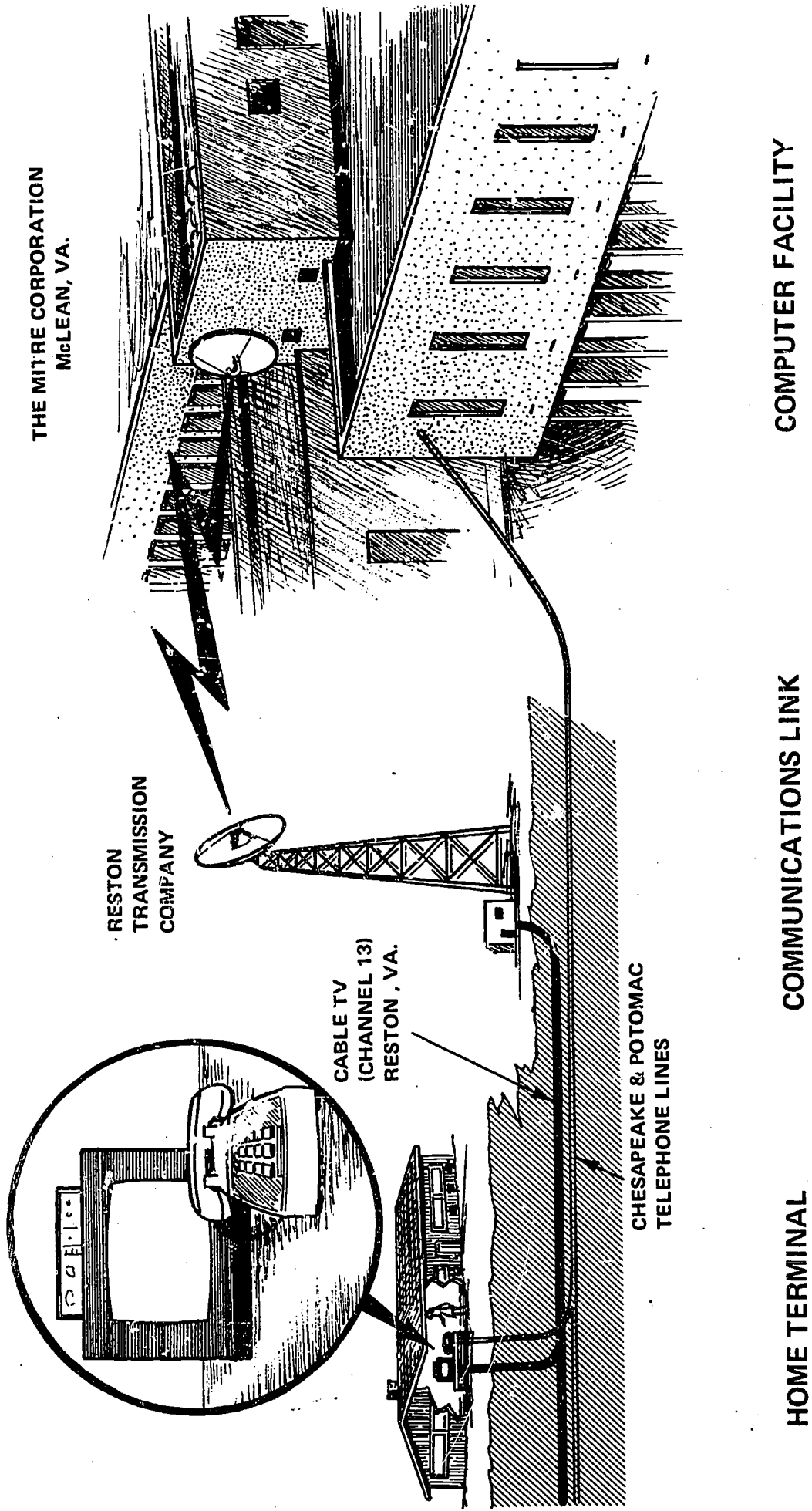

Figure 1. Reston Test Overall System Block Diagram

requests information from the system, he simply dials the MITRE computer's phone number. The computer automatically signals with a beep when it is ready for interactive communication. The computer then displays on the home TV a directory of services and tells the user to depress the number on his phone of the one he is interested in. Essentially, the computer asks for directions or answers to questions, and in response the user depresses the appropriate keys on his phone. In an operational system, several attractive options to push-button phones are available, particularly standard electronic typewriter keyboards and two-way cable TV

To augment the TV display, the computer can also generate supporting audio messages to home terminals via the telephone link. (There are several other straightforward methods for transmitting supporting audio messages in an operational system using the cable TV rather than a telephone link.)

## COMPUTER FACILITY

In a future operational system, the computer facility will probably consist of several specially selected low-cost (less than \$40,000) high-speed minicomputers, and associated low-cost peripherals. The MITRE computer facility to be used in conjunction with this demonstration, however, includes an IBM 360/50 computer with 512,000 bytes of core storage, eight IBM 2314 disc drives, an IBM 2702 communication coupler, six type 403 AT&T modems, a Honeywell 516 minicomputer, a Data Disc TV character generator, and specially developed MITRE subsystems. Figure 2 is a block diagram of this facility.

The 360/50 has overall system control and, during the test program, will be running special TICCTT software while also executing other MITRE computer programs. The data base for the TICCTT system is stored on the 2314 disc memories.

Six standard phone lines are terminated in type 403 modems to convert push-button information requests into a digital format acceptable to the type II telegraph controllers on the IBM 2702 communication controller. The 403s also provide automatic call answering and disconnect. A special circuit is connected to one of the telephone lines to allow injection of audio answer-back.

The Honeywell 516 serves the 360/50 as a sophisticated controller for MITRE's Data Disc TV character generator. Essentially, the 360/50 passes a string of control

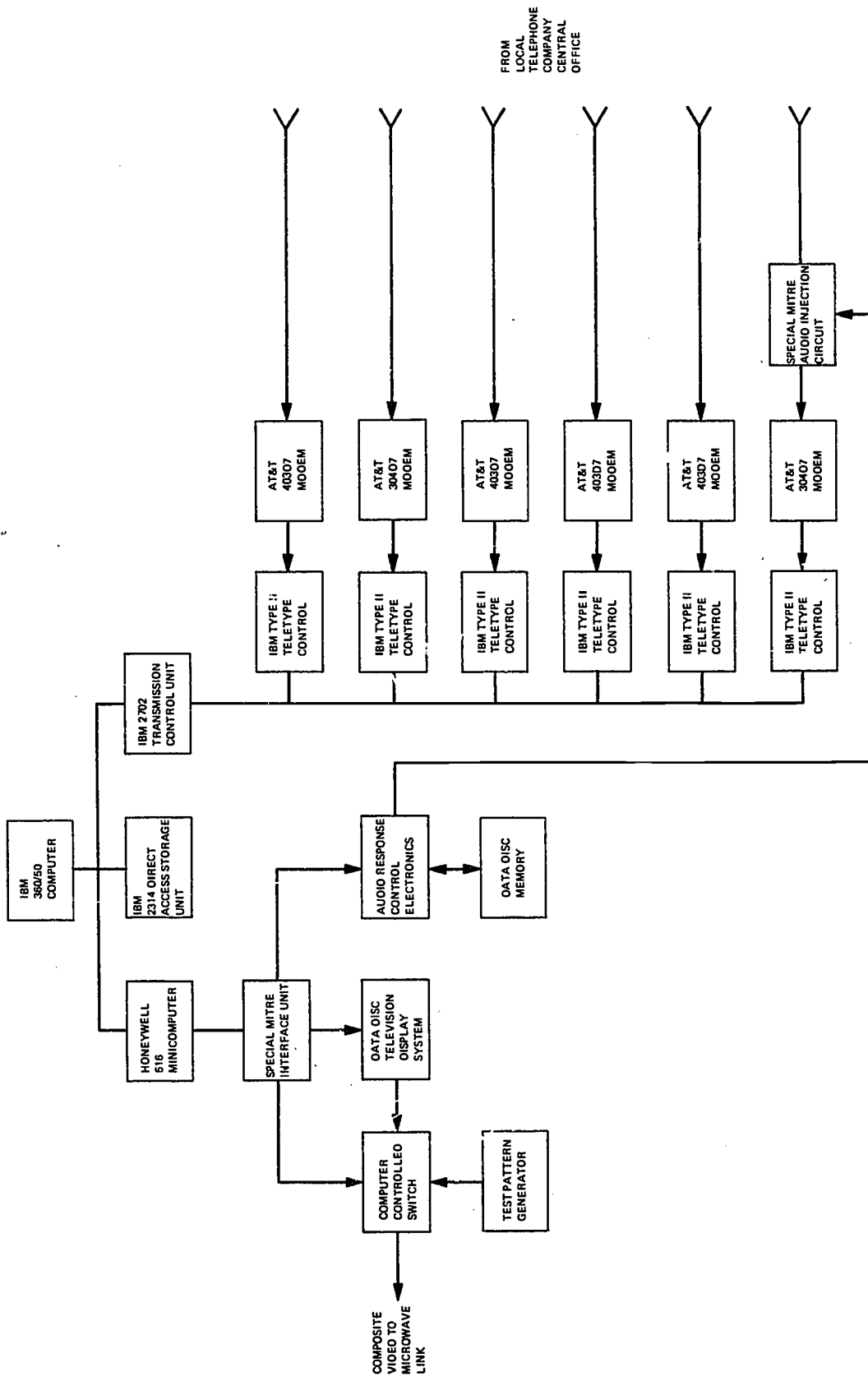

Figure 2. Demonstration System Computer Facility

characters and encoded picture frame data through the selector channel to the 516. Software in the 516 interprets the data string and, in turn, generates and transmits required control commands and alphanumeric data to the Data Disc character generator at a rate and time dictated by the generator. The 516 forces the Data Disc to write the "address" of the receiving terminal in the transmitted picture frame.

A standard TV picture frame is composed of 525 horizontal lines of pictorial information. These 525 lines are numbered from 0 through 524 from the top of the screen. In normal TV transmission, an interlace technique is used to transmit the TV picture. In the first 1/60th of a second, all even-numbered (0, 2, 4, etc.) lines are sequentially transmitted; in the second 1/60th of a second picture frame, the odd-numbered lines are transmitted. Because of the characteristics of the home-refresh device chosen and the desire to maximize the use of each TV channel, MITRE's demonstration system does not use the interlace capability of standard TV. MITRE's transmitted picture frames contain only every other line of a standard picture, which allows us to send up to 60 different pictures every second, rather than 30.\* The address data are encoded near the last line of each previous transmitted picture frame as a sequence of 16 black or white elements, each measuring 1/16th of the line length. Using 16 elements allows addressing up to 32,000 different home terminals. A signal-to-noise analysis has shown that this scheme will be extremely reliable. The address data is written on standard TV line 480 for even frame pictures and line 481 for odd frame pictures. The encoding information is not visible on the home TV screen.

The Data Disc character generator, with a specially designed MITRE interface, provides a standard TV signal picture containing up to 800 characters (16 lines of 50 characters each). The character set consists of 96 alphanumerics including digits, upper and lower case alphabet, and a variety of common symbols. The character generator can also operate in a graphic mode producing arbitrary computer-controlled pictures.

A special low-cost digital audio-response system will be included in the demonstration system. Under the immediate control of the 516 computer, especially designed and built MITRE hardware will generate selected audio messages.

---

\*This results in a 30-percent reduction in vertical resolution, which is barely noticeable for ordinary photographs and makes no difference whatever with alphanumeric characters.

## COMMUNICATION LINK

MITRE's new approach for mass home use of TICCIT both needs and makes practical the use of the greater channel capacity now available through cable TV. MITRE believes that combining TICCIT with cable TV offers many greatly needed but formerly unavailable services, that TICCIT can be an attractive revenue-producing product for cable TV (MITRE estimates that future home terminal operation will cost the cable operator about 10¢ per hour), and that the availability of TICCIT only on the cable will encourage people in large metropolitan areas to subscribe to cable TV.

## RESTON CABLE SYSTEM

Two separate coaxial cables enter each home in Reston (one denoted A, the other B). Each cable can presently carry 12 channels. By replacing some equipment, it would be possible to increase the system's capacity to 40 channels. The system is 100 percent underground, and all new homes in the town are wired for it as they are constructed. At the present time, 1,750 homes are wired to the system, and by the end of this year the number will approach 3,000. The system carries seven Washington stations, three Baltimore stations, and three local-programming channels. The local programs include a 24-hour time and weather service, a combination 24-hour news wire stock market report and local announcement channel, and a local service presently producing about 3½ hours of programming shown twice a week. The system also carries 14 FM stations.

In the demonstration system, MITRE will be using channel 13 on the A cable. Since all of Reston is wired to the system, we will be able to demonstrate the TICCIT terminal in any home with a 12-button push-button phone.

The pictorial output of the TICCIT system's computer facility is a standard composite video signal. The communication link carries this video data to homes, businesses, community centers, and schools in Reston. The video signal, as shown in Figure 1, is first transmitted from MITRE's McLean facility to the Reston Cable TV head end (the point at which all TV signals enter the cable TV system and are first amplified) via a microwave link. At Reston Cable TV's head end, the received composite video signal is placed on channel 13.

The one-way microwave link was designed under MITRE's direction by Telcom, Incorporated. Terrain considerations precluded a direct path from MITRE's facility to Reston; therefore, an active repeater is located on a tall building close to MITRE's facility.



The carrier frequency of the microwave link is 6537 megahertz; the bandwidth of the link is 4.25 megahertz.

#### HOME TERMINAL

As shown in Figure 3, the home terminal in the demonstration system uses a standard television receiver, a video tape recorder, and a specially designed coupler/decoder.\* The television receiver used in the system is not modified in any manner. Figure 4 is a photograph of the terminal installed in a home.

The video tape recorder (VTR) serves as the refresh memory. A recording technique known as helical scan is used in the demonstration system's video tape recorder (and in most other low-cost video tape recorders). In normal home audio tape recorders, the recorded information is parallel with its path of motion (see Figure 5). With a helical scan video tape recorder, the recording track is at an acute angle from the direction of the tape motion. Each slanted recording track is about seven inches long and contains all the pictorial information for a 1/60th-of-a-second picture frame. The adjacent recording tracks contain the picture information for the picture field 1/60th of a second before and after. The tape recorder that plays and records this tape looks much the same as a home audio reel-to-reel type recorder; the main difference is the mechanism to write the slanted picture frames. The VTR has a drum around which the tape makes a loop in a helical fashion (see Figure 6). Two record/playback heads are located within the drum and spin at a rate such that a track is transversed in 1/60th of a second (about 1800 ppm). As the heads make one revolution (because of the helical winding of the tape around the drum), they follow slanted tracks on the tape that is wrapped around the drum. The take-up and supply reels and their controlling mechanisms move the tape so that in 1/60th of a second the tape moves only enough so that the record/playback heads are positioned over the beginning of the next slanted track as they start to move down across them.

The interesting and important feature of this type of video tape recorder for this application is that, if the take-up and supply reel mechanism is disabled, the tape recorder may record a 1/60th of a second picture frame and then play it back continuously.

---

\*Patent applied for.

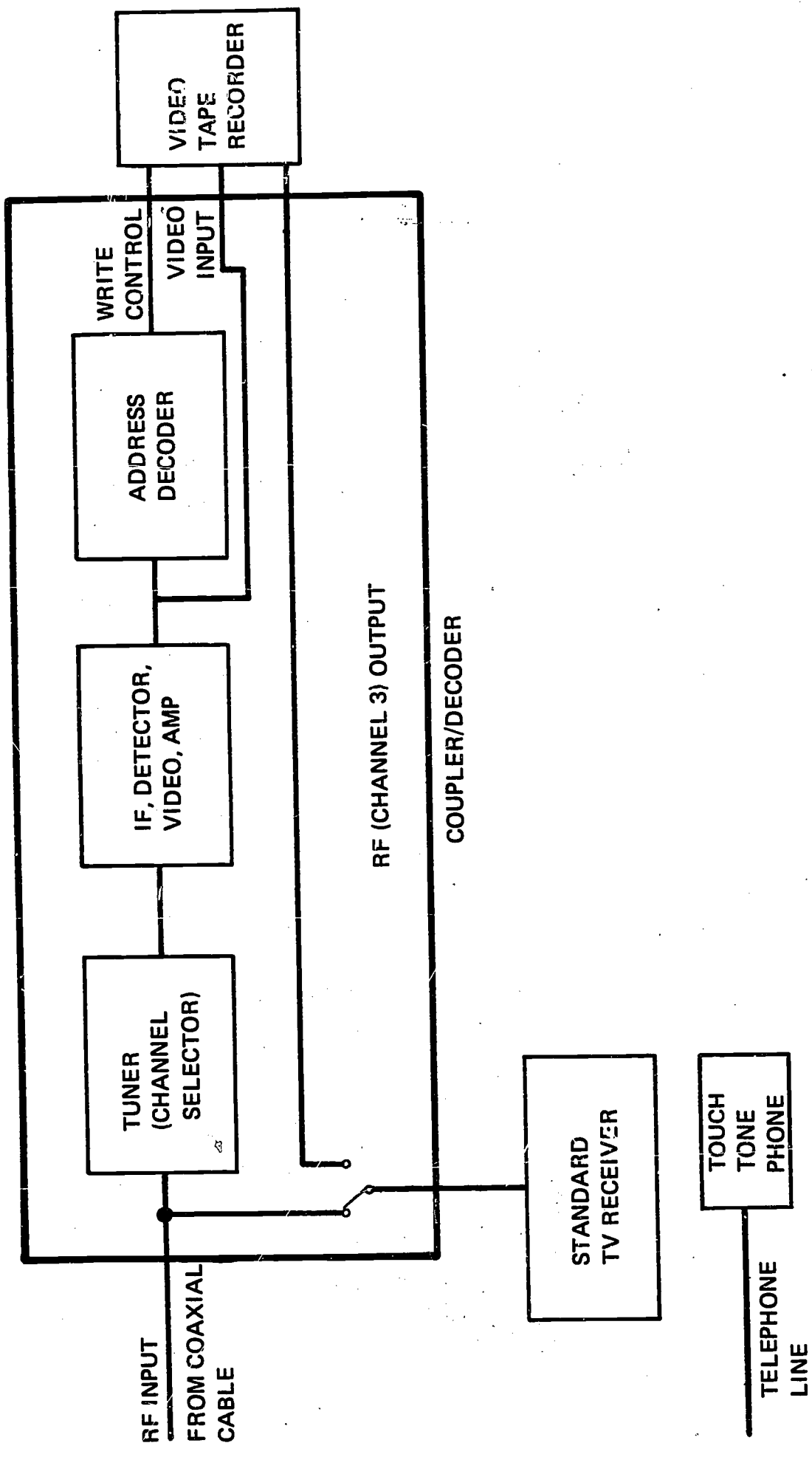
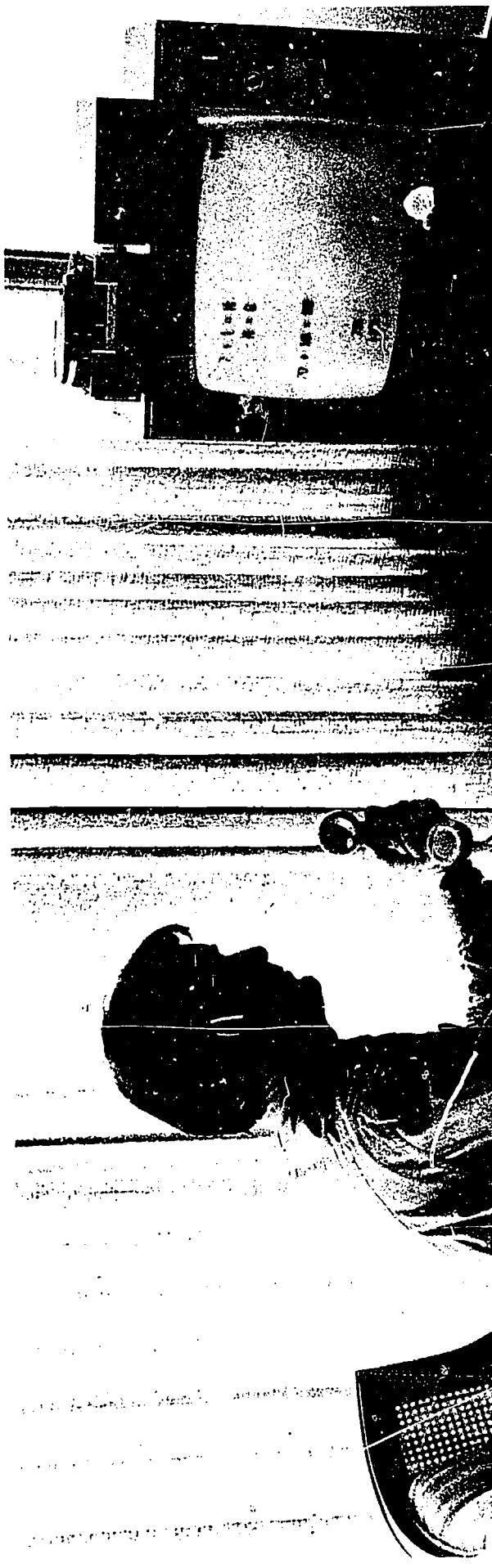
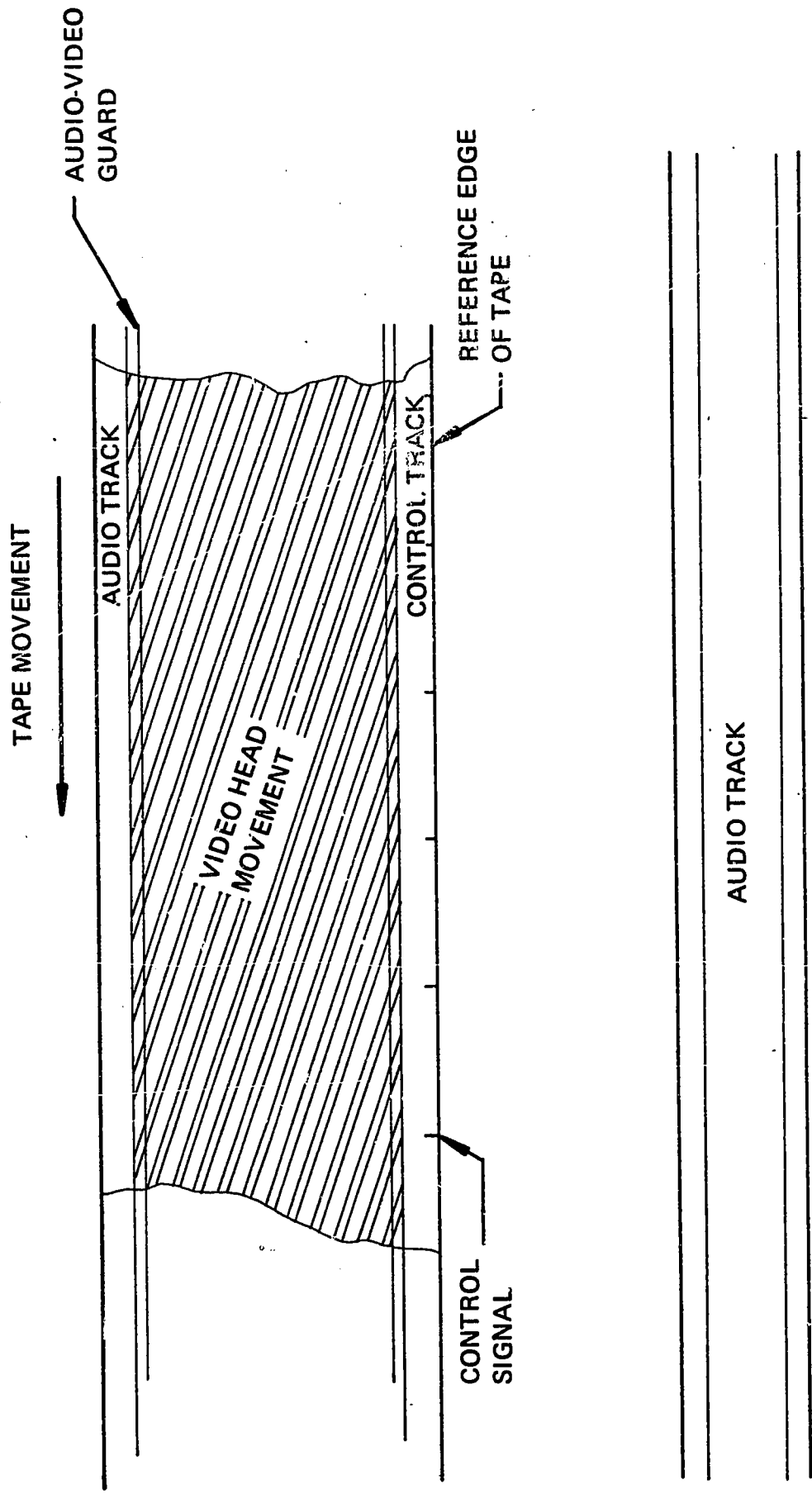

Figure 3. Demonstration System Home Terminal



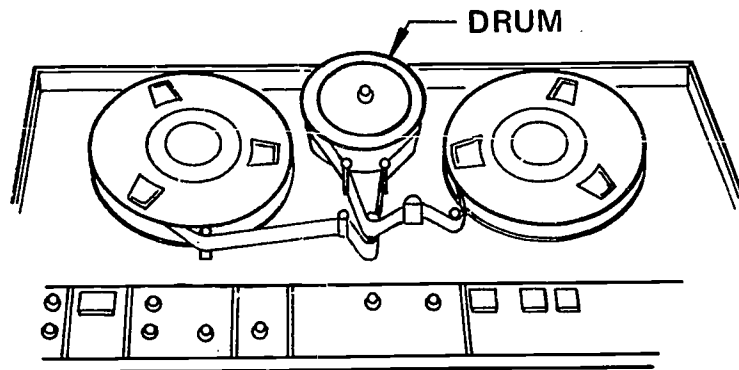

**Figure 4. Terminal Installed in Home**



REGULAR HOME SINGLE TRACK AUDIO TAPE

Figure 5. Magnetic Tape Pattern (Tape seen from Magneto-Sensitive Surface)



VIDEO TAPE RECORDER

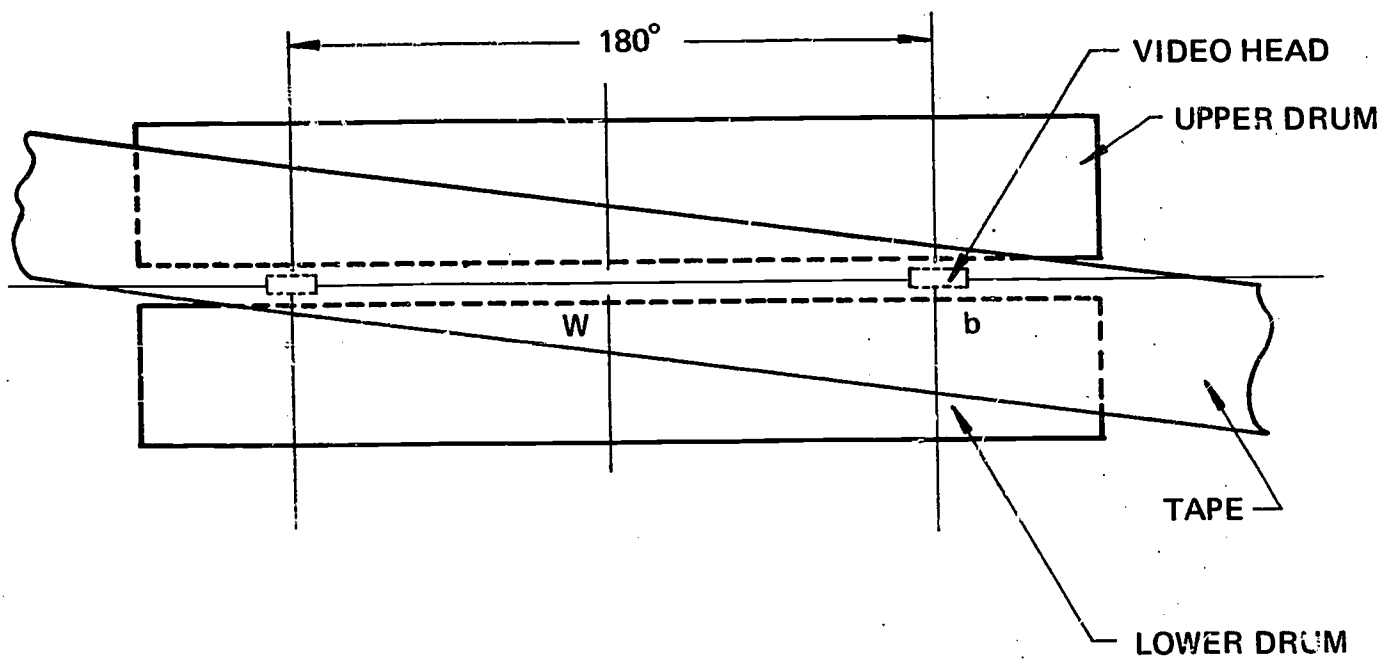

Figure 6. Tape Path on Helical Scan Recorder

Video tape recorders are still too expensive for average home use: however, in the next year, several companies, including SONY and Ampex, will be introducing cassette video tape recorders which the manufacturers claim will sell at \$700–\$800, later at \$400–\$500. The low cost of these new units, along with their ease of use and the recorded material being prepared for concurrent release (close to an even split between specialized educational material and X-rated movies) leads MITRE to think that these recorders will be a market success because of their entertainment value per se and because of their potential contributions to education. The video tape recorders will be available in both color and black-and-white with full gray scale. In the demonstration system, a SONY battery-operated, over-the-shoulder portable AV-3400 recorder is used as the TV refresh device because it is the closest representative of the future low-cost cassette VTR's. Figure 7 is a photograph of the AV-3400.

#### COUPLER/DECODER

The video tape recorder is driven by a composite video signal coming from the coupler/decoder, which also provides some control signals for the tape recorder mechanism. The coupler/decoder, as shown in Figure 8, has a TV tuner, an IF strip, and a detector so that the video tape recorder can record material from any TV channel. The decoder and control portion of the hardware examines lines 480 and 481 of each received picture frame and compares the black-and-white pattern with the address pattern set in the decoder. (In the demonstration system, this pattern is set up by subscriber-operated switches.) If, and only if, the transmitted picture's address matches the decoder's address, will the control electronics place the recorder in the record mode for the entire picture frame (slightly less than 1/60th of a second). At the completion of the frame, the recorder will be placed automatically back in the playback mode. During all operations in the computer display mode, the tape recorder tape motion hardware is inhibited. In the private mode, 512 channels of video pictures will be active and selectable by the subscriber-operated sub-channel switches to show the capability of this time-sharing approach.

Other switches on the coupler-decoder include an overall mode select switch, a main channel selector, and a tape advance switch. The mode switch has four positions: OFF; NORMAL TV, which allows regular off cable TV reception; COMPUTER (CH13), which places the terminal in TICCIT mode providing main channel selector is set to 13;

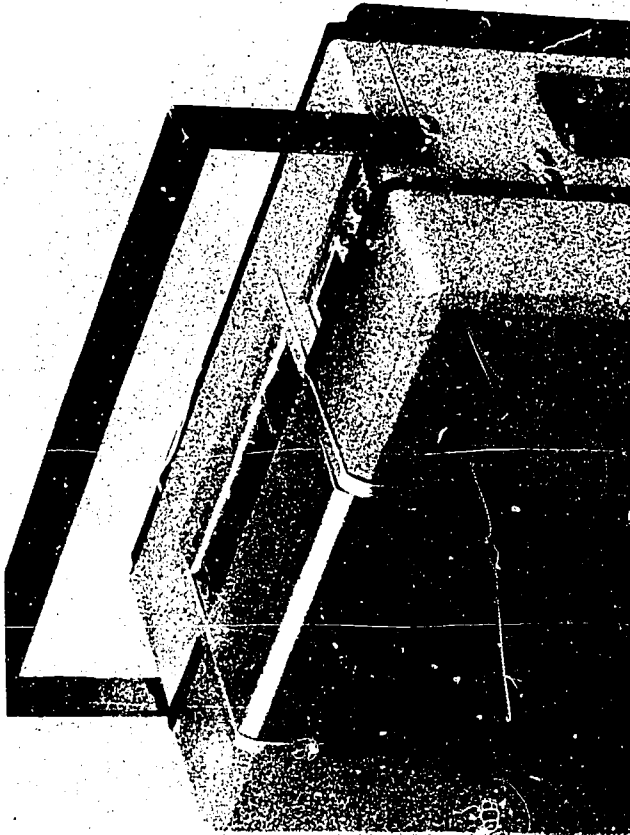

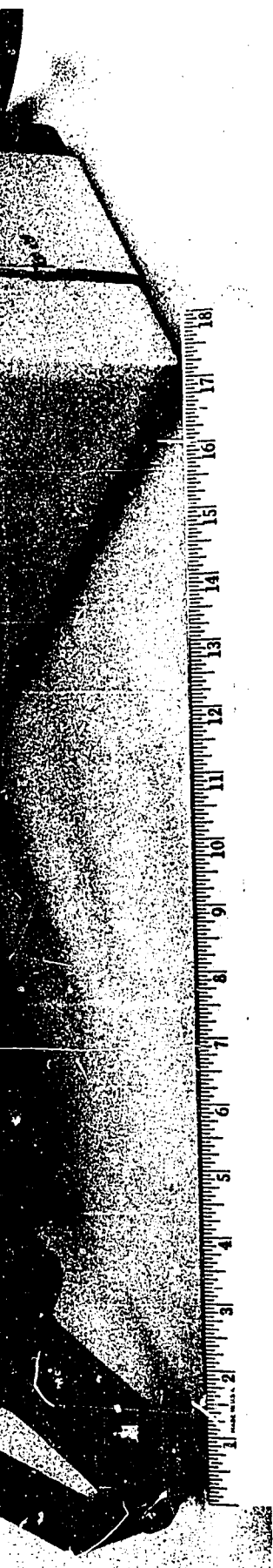

Figure 7. SONY AV-3400 Video Tape Recorder





TAPE ADVANCE



**Figure 8. MITRE Coupler/Decoder**

and TAPE RECORD PLAYBACK, which allows recording and playing back of TV programs selected with main channel selector. The tape advance switch will be implemented in the future to make still copies (on video tape) of TICCIT frames. The public/private switch places the terminal in the interactive (private) mode or the broadcast (public) mode where the subchannel switch selects information to be displayed. It should be noted that each home terminal will have a distinctive private address. With the addressing scheme employed in the demonstration system more than 30,000 unique private addresses are available.

A test message will be incorporated to facilitate system testing and home TV set alignment. A switch on the computer/decoder puts a test pattern on the home TV. A TV camera, synchronized to the character generator at the computer, is trained on a test pattern that includes a clock with a sweep second hand. Once a second for a period of slightly less than one-sixteenth of a second, the camera composite video output signal is transmitted instead of the character generator output. Preceding the test pattern message, a special "address" code is output by the character generator. This special address will enable any properly functioning home terminal in the test mode to record and display the test message. One-second steps in the clock's sweep second hand will confirm proper operation.

The home terminal uses a standard 12-button push-button telephone as a data entry/request device. As discussed in Section III, the push-button phone offers a wider capability for computer information retrieval control than is immediately apparent. As has been discussed above, in an operational system, a more elaborate keyboard would probably be used for more extensive and prolonged communications with the computer.

### SECTION III DEMONSTRATION SOFTWARE

#### INTENT

A small sample software package is being prepared for the demonstration system to provide software for engineering check-out and to give viewers of the demonstration system a glimpse of what a substantial software effort in an operational system could produce. Some of the software package has been specially developed for the demonstration system; other software being demonstrated was previously developed in the TICCIT project.

#### CONTENT

The software package will be composed of interactive educational and community service material. The educational material will offer two varieties of computer-aided education: one aimed at teaching in a very direct method; the other reinforcing previously explained subjects through drill and practice. The community service material is oriented toward the needs of the citizens of Reston and is designed to show how easily a wide variety of timely and topical material can be provided to the individual at his request.

#### Educational Material

The first educational program is called "Carry" and was authored by Bob Eicholz (principal author of the best-selling Addison-Wesley Elementary School Mathematics Series) of the University of Texas' Computer-Assisted Instruction Laboratory. This program teaches children who know how to add two single-digit numbers to add any two-digit numbers together. (The program teaches the concepts of carrying; hence, its name.)

The other educational program in the system is aimed at fourth-grade level arithmetic students. It is a five-day drill-and-practice course that provides both a pre-test and a post-test. The lessons for each day are presented on five levels. The total package consists of 27 lessons of 14 problems each; both the pre-test and post-test courses have 16 problems. The material was authored by Patrick Suppes's group at Stanford University.

### Community Service Material

Community service material is both broadcast to all TICCIT terminals continuously and sent on demand. The broadcast information is selectable by the TICCIT user through the use of the subchannel switches on his coupler/decoder. Information sent on demand is selected via the push-button phone (with the public/private switch on the coupler/decoder in the private position). In the Reston demonstration users will receive a simulated daily ski report, baseball scores, the local weather forecast, racing forms from Pimlico and Shenandoah Downs, the report of the most active stocks on the New York Exchange and the American Exchange and a local fishing report. Information on demand will include classified advertisements (jobs, apartments, merchandise, pets, etc.) the Reston Telephone Directory, a weekly calendar of special community events and a weekly TV guide. The range of this material is far smaller than what will be available under an operational system.