

DOCUMENT RESUME

ED 055 803

SE 012 045

TITLE General Physics, Physics 12 [Science Curriculum Materials].

INSTITUTION Rochester City School District, N.Y.

PUB DATE 70

NOTE 264p.

EDRS PRICE MF-\$0.65 HC-\$9.87

DESCRIPTORS *Curriculum Guides; Grade 12; *Physics; Resource Materials; *Science Activities; *Secondary School Science; *Teaching Guides

ABSTRACT

The Physics 12 curriculum guide represents one in a series of science guides especially designed to provide for the pupil whose primary interests are in non-science fields. The program provides study in physics in which fundamental concepts and understandings are developed, mathematical concepts are limited, and students are encouraged to relate physical concepts and understandings to daily experiences. An emphasis is placed on laboratory activity with the expectation that most of the understandings will develop from such experiences. Activities are contained in these five units: measuring matter at rest, matter in motion, heat energy, energy transfer by wave motion, and light waves. (Author/PR)

6055803

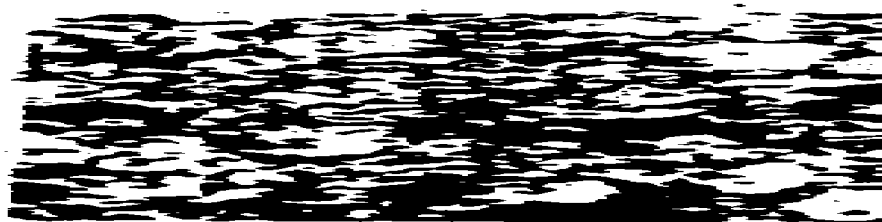
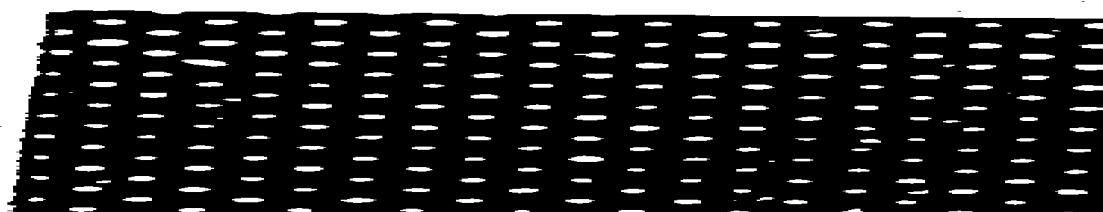
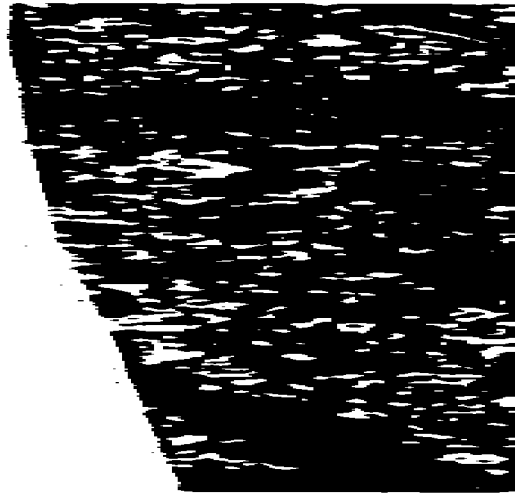

SE 012 045

ERIC

TY SCHOOL SCIEN

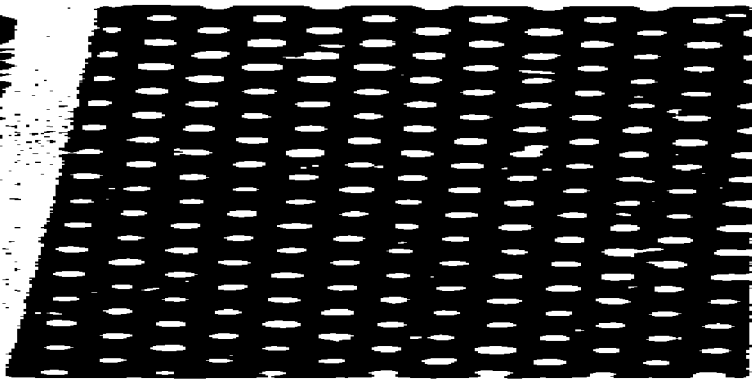
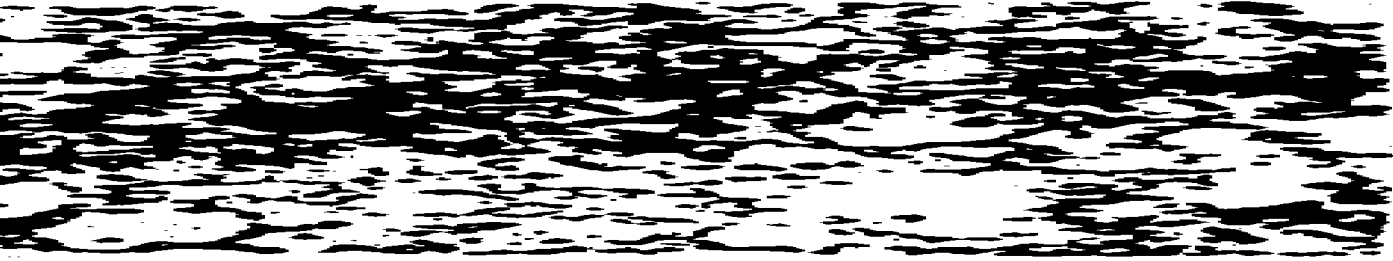
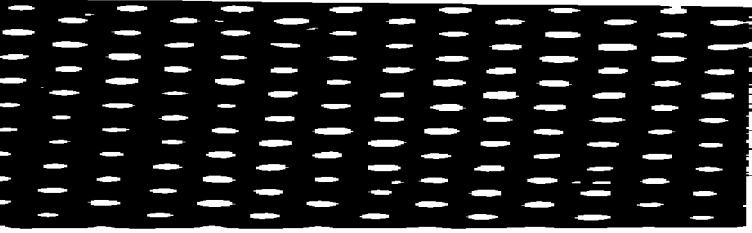
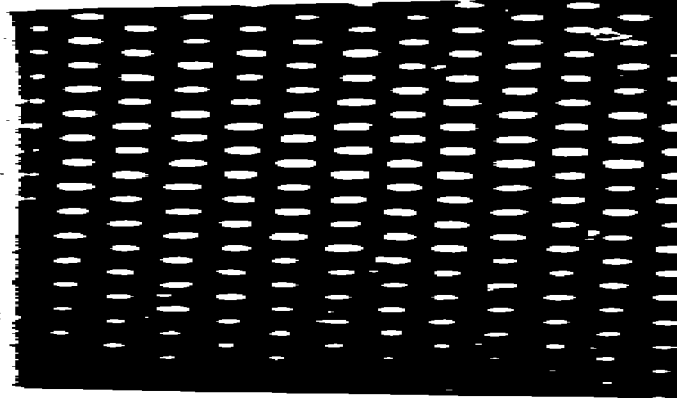
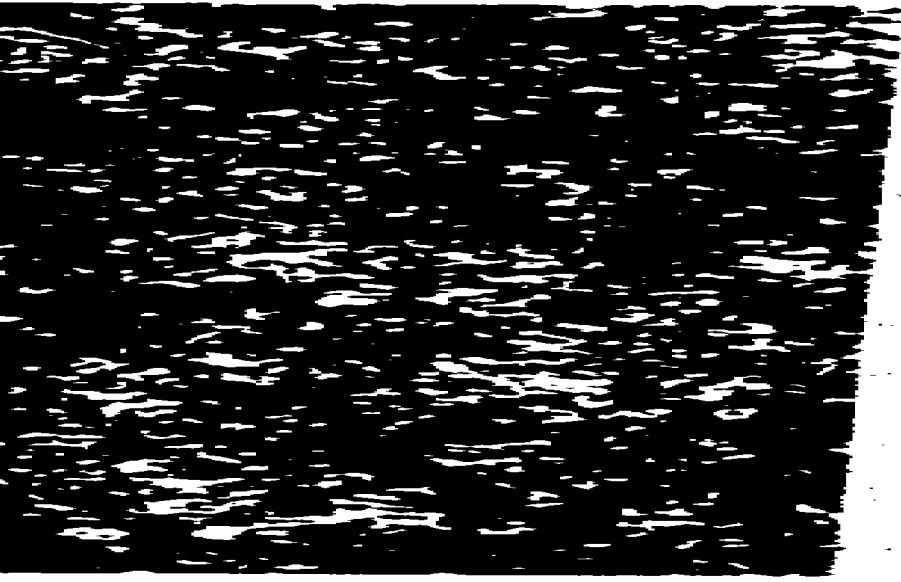

DISTRICT • ROCHESTER, NEW YORK

SCIENCE CURRICULUM MATERIALS

U.S. DEPARTMENT OF HEALTH,
EDUCATION & WELFARE
OFFICE OF EDUCATION
THIS DOCUMENT HAS BEEN REPRO-
DUCED EXACTLY AS RECEIVED FROM
THE PERSON OR ORGANIZATION ORIG-
INATING IT. POINTS OF VIEW OR OPIN-
IONS STATED DO NOT NECESSARILY
REPRESENT OFFICIAL OFFICE OF EDU-
CATION POSITION OR POLICY.

GENERAL PHYSICS
PHYSICS 12

1970

SCIENCE

PHYSICS 12

ED055803

1970

DIVISION OF INSTRUCTION
City School District
Rochester, New York

ACKNOWLEDGMENT

This Physics 12 curriculum guide represents one in a series of science guides especially designed by the Division of Instruction to provide for the pupil whose primary interests are in non science fields, whose interests, goals, and career objectives may be different from those who take the Regents science sequence: biology, chemistry, and physics. The emphasis in the Physics 12 program is to provide for a study of physics in which fundamental concepts and understandings are developed, mathematical manipulations are used as tools for understanding, and with course content functional in terms of a pupil's daily environment. The purpose of the program is to develop appreciations in non scientists for the work of science and its relations to the common good. Science so permeates every aspect of daily living that pupils must be familiar with the basic assumptions and methods of science if they are to become effective members of an informed electorate.

Emphasis throughout this physics course is placed on teacher flexibility in selecting, modifying and using this guide as determined by appropriate classroom interests. Emphasis is given to laboratory activities from which most of the understandings should develop. These laboratory activities also serve to develop an appreciation of scientific methods and to increase the ability and willingness of each student to change beliefs and opinions on the basis of objective evidence.

These attributes are among the desirable outcomes of this physics course.

Material changes in content and sequence for a Physics 12 program were suggested by teachers and members of the Science Council during the 1968-69 and 1969-70 school years. These suggestions were reviewed and revised by Mr. Robert J. Stevenson, Jefferson High School, and Mr. Thomas M. Bohrer of West High School, both experienced physics teachers. Dr. Samuel W. Bloom, director of Science, edited and prepared the final manuscript for publication.

Dr. George J. Rentsch
Assistant Superintendent
for Instruction

Secretaries:

Miss Carol VandenBerg
Mrs. Blanche Greenholtz

Summer - 1970

TABLE OF CONTENTS

	Page
Acknowledgment.....	i
Foreword.....	iv
Message to Teachers.....	iv
Teacher Flexibility.....	v
Laboratory Orientation.....	v
Repetition of Course Content.....	v
Mathematical Computations.....	vi
Relevancy.....	vi
Each Student is a Consumer.....	vii
Reading Skills.....	xii
Textbooks and Multimedia Instructional Materials.....	xiv
Suggested Time Sequence.....	I-1 to I-27
Unit I - Measuring Matter at Rest.....	II-1 to II-59
Unit II - Matter in Motion.....	III-1 to III-79
Unit III - Heat Energy.....	IV-1 to IV-29
Unit IV - Energy Transfer by Wave Motion.....	V-1 to V-30
Unit V - Light Waves.....	
Appendix	
Key Words.....	2

FOREWORD

This tentative course of study in the physical sciences combines two components: one, a revision of the citywide Physical Science syllabus, 1960; two, a modification of the State Education Department's General Physics - An Experimental Syllabus, 1970. The objective of the Physics 12 is to provide a program of studies for the upper level high school student (grades 11 or 12) with an interest in, and a desire to learn, some of the basic concepts in physics and their application to everyday activities.

This course is designed to serve both the student whose formal education is terminal at the conclusion of secondary school and the student planning further education but whose primary interests are in fields not directly related to science. This course in physics is chiefly for the student whose interest and goals may be different from those who take the Regents physics course.

The past decade has seen many important changes in the science courses offered in secondary schools. The greater depth of treatment in the Science 7-8-9 program resulted in revised upper level science courses with increased depth and specialized content designed largely for the science-oriented pupil whose goals usually included medicine, engineering and other specialized fields of science. The Regents program does not provide appropriately for the non-scientist, for the student interested in physics as a function of general education

or for the terminal student. Thus, the need has developed for a program of studies with objectives differing from the Regents Physics syllabus.

The Bureau of Secondary School Curriculum Development of The State Education Department has recognized the limited base for Regents Physics and has been developing a program of studies called General Physics - An Experimental Syllabus since 1967. This program, General Physics, has been used experimentally at two Rochester high schools, Jefferson High School and Madison High School. In each case, the General Physics program as developed by the State Education Department was found to be inappropriate and wanting for youth in an urban community.

In developing the Physics 12 curriculum guide, the general outlines and concepts developed in General Physics were utilized and retained with modifications made for the specific needs of the City School District. The basic changes have been the limiting of mathematical emphasis to the use of arithmetical manipulations as tools for understanding, limiting the depth of content matter to the interests and needs of the pupils, and the extension of the concepts covered from the theoretical to the practical. Additions made in the Physics 12 program include emphasis upon the applications of physical principles to the functional aspects of the student's immediate environment...his neighborhood.

The aim of the Physics 12 program is to provide a course of study in physics in which fundamental concepts and understandings are developed; where mathematical concepts are limited; and where students are encouraged to relate physical concepts and understandings to daily experiences. An emphasis is placed on laboratory activity with the expectation that most of the understandings will develop from such experiences.

Samuel W. Bloom

MESSAGE TO TEACHERS

This Physics 12 curriculum guide has been developed in terms of classroom needs. The regular Regents program in Physics is not designed nor is it suitable for students whose goals, interests, and objectives are in areas other than science. Yet, it is desirable and quite essential that the non science major become familiar with the basic concepts and understandings inherent in the area of physics. Students, as individuals and as members of society, should have functional knowledge of their immediate environment in terms of fundamental basic physical principles. These principles should be related to the pupil's needs, interests, activities, and daily experiences.

Teacher Flexibility

As a teacher, you have latitude and flexibility in developing your program in Physics 12. This course of study should serve only as a guide. It is the expectation of the curriculum committee that the basic concepts and understandings listed will be covered throughout the year. However, feel free to change, delete or modify the pupils' experiences and activities as determined by the class or by individual students.

Laboratory Orientation

This is a laboratory oriented program. Plan to provide as many different student activities as possible. Teacher demonstrations should be held to a minimum with individual pupils or small groups performing the exercises for the larger group. The units and laboratory exercises are designed on a five time a week basis for a school year.

Repetition of Course Content

Care was taken in developing this curriculum guide to avoid repetition between Physics 12 and previous sciences taken by students. While some of the basic concepts may have been previously encountered in ninth grade science, it is hoped that at this grade level a more mature attitude and appreciation can be developed by expanding and deepening the understandings involved.

Mathematical Computations

Mathematical computations should be kept at a minimum and used only as a tool to develop understandings. When mathematical manipulations are needed, teach the class the fundamentals. Don't assume that every class member can manipulate numbers. Avoid any manipulations more complex than a simple ratio, solution for one unknown, a simple proportion, or simple geometric constructions. Even the effect of forces can be understood using the simplest type of mathematical computation.

Relevancy

Illustrations, sample activities, laboratory experiences, classroom discussions should be related closely to the everyday activities, interests and environment of the individual. When discussing power, relate it to the automobile. The use of electric power should be related to the home or factory. Pascal's principle is related to the garage hoist. The lever can be related to the crowbar or "jimmy". Get pupils interested in their immediate environment to which they can relate through knowledge and familiarity.

Each Student is a Consumer

A skillful teacher will develop his program about the needs of individual class members. Relate basic physical principles to the consumer interest of the pupil. Why are certain auto tires preferred to others? (Heat/friction). Why should a power tool have a three-wire cord? (Electricity/safety). Why is motor oil graded? (Viscosity/heat/friction). How does a rheostat work in an electrical circuit? (Ohm's Law), et cetera.

Reading Skills

Teachers cannot assume that students entering a Physics 12 science class are reading at the eleventh or twelfth grade level of comprehension. The facts are different. In an average high school classroom, teachers find a reading range from the fourth grade level to eleventh or higher levels. Anticipate lower reading levels for pupils enrolling in Physics 12 and be prepared to deal with poor readers. Moreover, reading and reading skills in physics are unique to the subject and pupils must be taught how to read the physics text, how to follow instructions, how to do an experiment, how to study physics. Physics has a special, technical vocabulary which must be understood before the concepts can be comprehended.

Many of the problems of reading physics materials are the common problems in all content fields. These problems appear exaggerated in physics due to the specialized vocabulary. If a teacher is to be successful teaching the concepts in physics, he must also be a reading teacher and teach pupils how to approach the reading of physics material. Five steps should be considered in a physics reading lesson:

- a. developing reading of the material
- b. the initial reading of the material
- c. developing word recognition skills
- d. discussion and rereading
- e. follow-up activities

Ways of Meeting Problems in
Reading Physics Material

A. Difficulties of Vocabulary

In order to develop the concepts of physics through the use of language, the learner must use the exact language of science and relate it to his own experience and his reading.

A physics book contains a considerable vocabulary of scientific words and these words must be taught and understood. It is important that the teacher anticipate vocabulary difficulties.

Most physics textbooks have some means of calling the attention of the pupil to a technical term when it is first introduced: bold-face or italicized type. The teacher's job is to convince students that they cannot consider that they have mastered the reading until they have learned the spelling, pronunciation, and the meaning of a term. Students must stop, look at the word, vocalize it, read the definition, read and reread it until they are able to assign a definite meaning to it in their minds.

B. Difficulties of Concepts

The explanation of scientific experiments is often difficult for pupils. Some students accept what they observe without trying to understand the explanation. Others will try to understand but need help, while still others will perform experiments and will read and understand the explanation without help. Each of these groups need a different approach to instruction. Diagrams, similes and every aid possible should be used to clarify those concepts that cannot be made functional by experiments. Guided discussions often aid in clarifying concepts.

C. Difficulties Related to Diagrams

Many diagrams are found in science material. In order to understand the discussion, the diagram must be read and studied. Some pupils find diagrams difficult to read because they do not connect the discussion of a diagram to the diagram itself. The teacher can often help the student by showing him that pictured in the diagram are facts that come within the student's experience. The teacher should teach students how to read diagrams, beginning with very simple concrete illustrations and proceeding to more abstract generalized ones.

D. Difficulties in Following Directions

In physics many experiments are performed which require the student to read directions. These directions should be read slowly and thoughtfully so that the experiment may be followed step by step. Specific training will be necessary. As the student reads directions and does experiments, the teacher should detect any difficulty the student may be having and give added instruction.

E. Difficulties in Seeing Relationships and Formulating Generalizations

Seeing relationships and forming generalizations may be difficulty for some pupils. They need many examples, opportunities for observation, and activities in order to consider relationships and to reach conclusions or generalizations.

The rate of reading physics materials needs to be slower than the rate at which pupils read in other content areas. It is important to help students adjust their rate of reading to the purpose at hand.

F. Difficulties in Differentiating Facts from Opinions

Students should be guided toward developing abilities to differentiate between fact and opinion in their reading; to recognize the difference between books written for entertainment and those which are sources of accurate science information; to learn the importance of copyright dates and authors in determining whether reading materials are authentic or not; to question the accuracy of what appears in print; and to check conflicting statements with other reliable sources.

Skills in reading physics materials need to be developed. Teachers have the responsibility of teaching pupils to read physics materials, meaningfully.

Textbooks and Multimedia Instructional Materials

Finding a suitable textbook for Physics 12 is a difficult task. The reading levels of most physics textbooks are beyond the range of many students except the more able. There is no one textbook currently available that combines the concepts to be learned at a reading level that can be comprehended by all class members. Teachers should plan to use multiple textbooks written for different reading levels, films, filmstrips, single concept films, tapes and other instructional media in developing their day-by-day series of activities.

Appropriate physics films are available from the Educational Communications Department. A film catalog listing current films is available in each school. A special listing of science films is prepared for each science teacher early in the school year. Be certain you obtain a copy. New films are continually being added to the film library. As new films are received, schools are notified. Similarly, special programmed learning materials are available for individual pupil use. A list of such materials may be obtained from the Programed Learning Office, 410 Alexander Street.

Many other types of instructional aids are available to assist teachers enrich and improve their instructional programs. Plan a visit to the Preview Center early in the school year to examine the latest materials available for teacher use.

Although teachers are generally limited to the use of physics textbooks available at their school, they have greater choices in the selection of the expendable laboratory manuals or workbooks. Laboratory manuals are revised frequently and purchased annually by the school or pupils with teachers directly involved in the selection process.

Select the laboratory guides which more nearly meet the requirements of your class. You may, even, wish to use several different workbooks in the same classroom, this is your option. In the selection of workbooks, be especially sensitive to reading levels, kinds and quantity of activities, appropriateness of concepts, practical applications, et cetera. Avoid any laboratory workbook which is wordy, with an overload on technical terms, with a limited number of pupil activities, and which is remote from the objectives of the Physics 12 program

SUGGESTED TIME SEQUENCE

This suggested time sequence is included only as a guide to teachers. Teachers should feel free to modify this time schedule as indicated by the interests of the class. Sufficient time has been incorporated into each unit to allow for a penetration in depth, for the use of extensive illustrations and experimentation, and for the application of physical principles into technological fields.

<u>Unit</u>	<u>Title</u>	<u>Weeks</u>
I	Measuring Matter at Rest	4
II	Matter in Motion	8
III	Heat Energy	10
IV	Energy Transfer by Wave Motion	8
V	Light Waves	8
	Total	38

UNIT I

MEASURING MATTER AT REST

UNIT I. MEASURING MATTER AT REST

I. Measurement of Length

- A. Errors of measurement
- B. Indirect measurements
- C. Linear relationships

II. Measurement of Volume

- A. Liquid measurement
- B. Measurement of solids

III. Measurement of Mass

IV. Properties of Matter

- A. Density
 - 1. Solids
 - 2. Liquids
- B. Specific Gravity
- C. Elasticity
 - 1. Elastic limit
 - 2. Spring balance

V. Archimedes' Principle

- A. Law of buoyancy

REFERENCE OUTLINEMAJOR UNDERSTANDINGS AND
FUNDAMENTAL CONCEPTS

I. Measurement of length

Standard measurements of length are the meter in the metric (MKS) system and the foot in the English system.

Scientific measurements are usually made using metric units.

One hundred centimeters equals one meter. One thousand meters equals one kilometer.

$$1 \text{ m} = 100 \text{ cm.} = 1,000 \text{ mm.}$$

$$1,000 \text{ m} = 1 \text{ km.}$$

A. Errors of measurement

Errors in measurement may be caused by the measuring instrument and/or the individual making the measurement.

Measuring instruments must be used properly to get accurate measurements

MATERIALS

meter stick

ACTIVITIES

Measure the length of various objects having dimensions not exceeding the length of a meter stick.

Let lab partners assist in measuring each other's height.

Use both inch and centimeter measures.

Measure the length of an object with the meter stick lying flat and with meterstick lying on edge.

Compare the measurements.

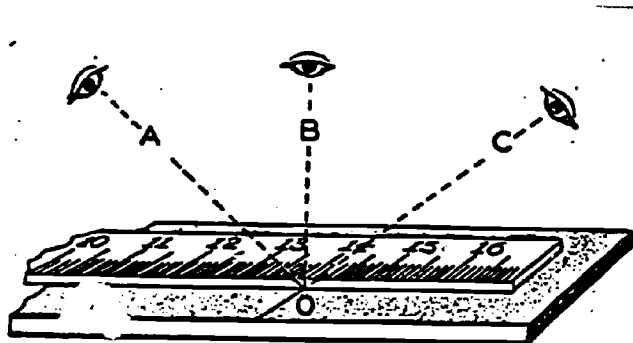

Fig. 1. Incorrect method of measuring

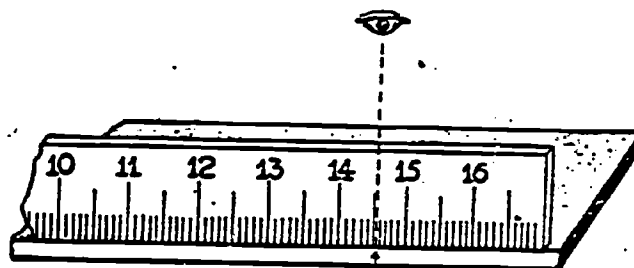

Fig. 2. Correct method of measuring

Key Words

meter
metric system

REFERENCE OUTLINE

B. Indirect measurement .

MAJOR UNDERSTANDINGS AND
FUNDAMENTAL CONCEPTS

An indirect measurement is the average of the sum of the measurement of many uniform objects.

Some measurements are too small (or too large) to be measured by direct means.

MATERIALS

text
meter stick
caliper
micrometer

ACTIVITIES

Measure the thickness of a textbook page indirectly by dividing the thickness of many sheets by the number of sheets.

A meter stick is too crude an instrument to measure the thickness of one sheet of paper directly. To measure the thickness of a page indirectly, divide the thickness of a number of pages by the number of pages.

Page thickness measured indirectly may be compared with the thickness measured directly with a micrometer caliper.

REFERENCE OUTLINE

MAJOR UNDERSTANDINGS AND
FUNDAMENTAL CONCEPTS

*Very great distances may be
measured using mathematical means.

*optional

MATERIALS

double meter
stick
2 straws
pin
protractor
tape

ACTIVITIES

*Show that greater distances can be measured by triangulation, using a double meter stick, soda straws and a protractor.

Have students measure the angle at the soda straw shown using the protractor to measure the angle.

From a table prepared by the teacher with a given base line, students can calculate the distance. (See next page for table).

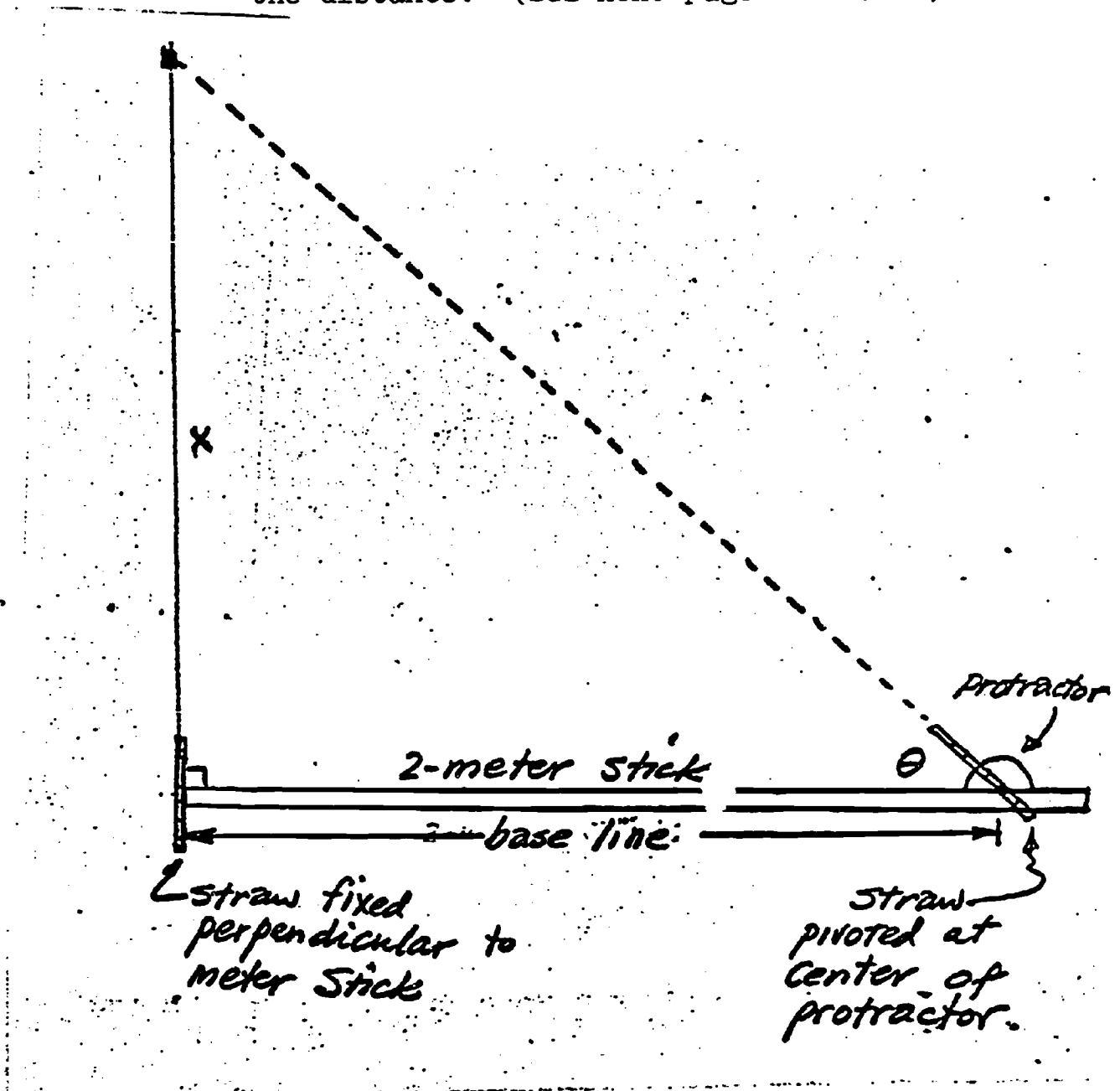
Key Words

triangle
protractor

REFERENCE OUTLINE

MAJOR UNDERSTANDINGS AND
FUNDAMENTAL CONCEPTS

MATERIALSACTIVITIES

Example of a conversion table for base line of 190 cm.

Angle θ	Distance X	Angle θ	Distance X
70°	523 cm.	80°	1078 cm.
71°	551 cm.	81°	1200 cm.
72°	572 cm.	82°	1350 cm.
73°	622 cm.	83°	1548 cm.
74°	663 cm.	84°	1806 cm.
75°	709 cm.	85°	2178 cm.
76°	762 cm.	86°	2720 cm.
77°	824 cm.	87°	3622 cm.
78°	893 cm.	88°	5450 cm.
79°	977 cm.	89°	11080 cm.

Note: The use of trigonometric functions is beyond the scope of this course.

REFERENCE OUTLINE

C. Linear Relationships

MAJOR UNDERSTANDINGS AND
FUNDAMENTAL CONCEPTS

One inch equals 2.54 centimeters.

1 m = 100 cm. = 1000 mm

1 cm. = 10 mm.

1 m = 100 cm = 39.37 inches

1 km. = 1000 m = 0.62 mile

MATERIALS

centimeter ruler
1/10 inch ruler

ACTIVITIES

Measure accurately the length of several different objects using in each case a centimeter scale and a decimal inch scale.

(Rulers marked in tenths are not common in the classroom, A tenths scale may be constructed from 1/10 inch graph paper, Otherwise, this activity can be used to emphasize the inconvenience of converting the fractions to the English system into tenths.)

Compare the measurements made to determine the number of centimeters per inch.

Key Words

centimeter
kilometer

REFERENCE OUTLINE

II. Measurement of Volume

A. Liquid Measurement

MAJOR UNDERSTANDINGS AND
FUNDAMENTAL CONCEPTS

Volume is a three dimensional measurement, length x width x height.

Small volumes are measured in centimeters...cm³.

One liter equals 1000 cubic centimeters (cm³).

Except for very precise work, the following relationship holds:

$$1 \text{ liter} = 1000 \text{ ml} = 1000 \text{ cm}^3$$

$$1 \text{ ml} = 1 \text{ cm}^3$$

The graduated cylinder is used to measure the volume of liquids at room temperature.

Measuring instruments must be used properly to get accurate measurements.

MATERIALS

graduated
cylinder

ACTIVITIES

Measure the volume of a liquid using a graduated cylinder.

Compare the measurement of volume of a liquid when the cylinder is vertical and when it is tilted.

Compare the measurement of volume of a liquid at top of meniscus and the bottom.

Compare the measurement of volume of a liquid with cylinder at eye level and above and below eye level.

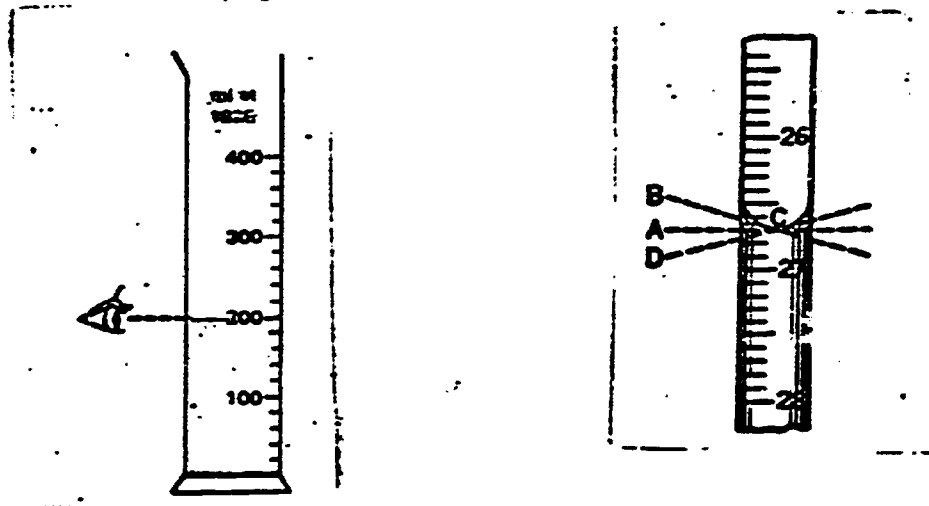
Key Words

graduated
cylinder
meniscus

REFERENCE OUTLINE

MAJOR UNDERSTANDINGS AND
FUNDAMENTAL CONCEPTS

B. Volume Measurement of
Solids

The volume of regularly shaped solids can be determined by direct measurement with a cm. scale (ruler).

$$\text{Volume} = \text{length} \times \text{width} \times \text{height}$$

The volume of irregularly shaped objects may be measured indirectly by the water displacement method.

MATERIALS

graduated cylinder
overflow can

ACTIVITIES

Measure the volume of a solid by the
water displacement method.

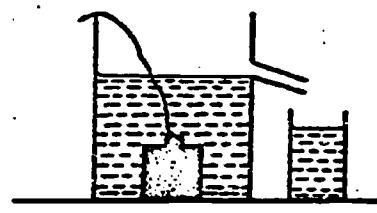
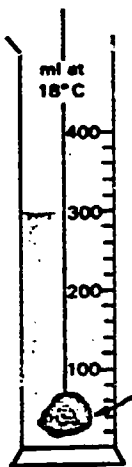
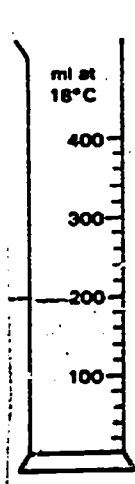
Key Words

irregular

REFERENCE OUTLINE

MAJOR UNDERSTANDINGS AND
FUNDAMENTAL CONCEPTS

The volume of very small, irregularly shaped objects, may be measured indirectly by the water displacement method.

MATERIALSACTIVITIES

If a solid can be immersed in a large graduate containing a liquid, the volume of the solid is the difference between the final and the initial readings.

If an object is too large to fit into a graduate, an overflow can be used. The can is filled to overflowing and the flow of water allowed to stop of its own accord. The object to be measured is carefully immersed and the displaced water caught in a graduate. The volume of displaced water is the volume of the object.

Measure the volume of uniform small objects such as paper clips, brads etc. by dividing the volume of many objects by the number of objects.

Key Words

water displacement
volume

REFERENCE OUTLINE

III. Measurement of Mass*

MAJOR UNDERSTANDINGS AND
FUNDAMENTAL CONCEPTS

The fundamental unit of mass in the metric (MKS) system is the kilogram.

$$1 \text{ kg} = 1000 \text{ grams (g)}$$

The unit of mass in the English system of measurement is the pound.

$$1 \text{ kg} = 2.2 \text{ lb.}$$

$$1 \text{ lb.} = 454 \text{ g}$$

$$1 \text{ g} = 0.001 \text{ mg}$$

$$1 \text{ lb} = 16 \text{ oz.}$$

*The distinction between mass and weight should be covered in the unit dealing with forces. Weight is a force. It is a measure of the gravitational force on an object of given mass at a specific location. At this point in the course, the units of mass and weight will be used interchangeably since weight determinations are made under similar circumstances.

MATERIALSACTIVITIES

Using either a platform balance or a Dial-O-Gram, have pupils learn to use the balance through the weighing of some common objects selected at random.

Weigh objects to the nearest 0.1 g.

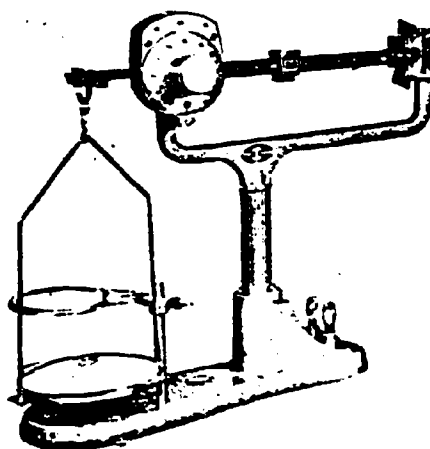
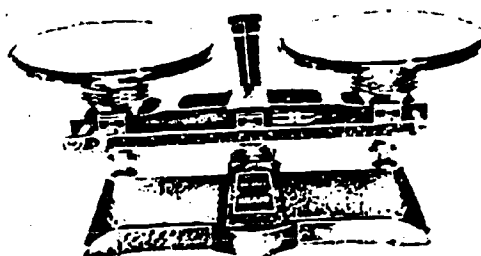
Key Words

kilogram
gram
pound
ounce

REFERENCE OUTLINEMAJOR UNDERSTANDINGS AND
FUNDAMENTAL CONCEPTS

IV. Properties of Matter

A. Density

Density is defined as the mass per unit volume.

$$\text{Density} = \text{mass/volume}$$

1. Solids

Grams per cubic centimeter is a unit of density

$$D = \text{g/cm}^3$$

2. Liquids

Grams per milliliter is a unit of density.

$$D = \text{g/ml}$$

The density of water is one gram per milliliter at 4°C.

B. Specific Gravity

Specific gravity is the ratio of the mass of a given volume of a substance to the mass of the same volume of water.

The specific gravity of water is one.

MATERIALS

hydrogrometer

ACTIVITIES

Measure the mass and volume of various solids and compute their densities.

Both regular and irregular shaped objects should be used with a range of densities from less than one to more than one. Plan to use the same specimens for specific gravity determinations.

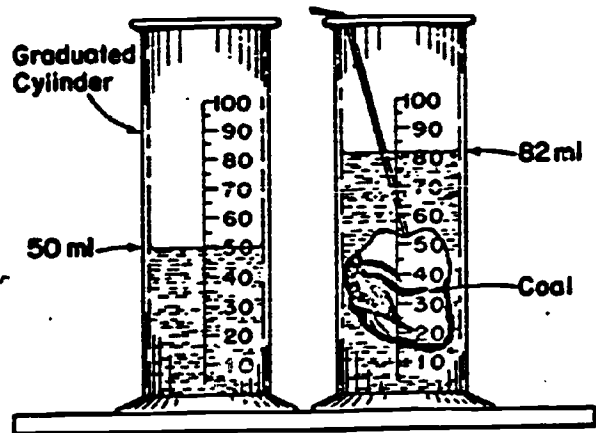

Measuring the volume of an irregular solid by measuring the volume of water it displaces.

Key Words

density
 specific gravity
 ratio
 hydrometer

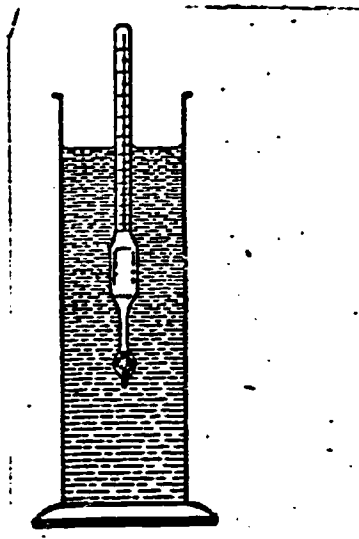

REFERENCE OUTLINE

MAJOR UNDERSTANDINGS AND
FUNDAMENTAL CONCEPTS

C. Elasticity

The length of a coiled spring increases regularly as equal weights are added.

The length of a spring decreases regularly as equal weights are

An object is elastic if it returns to its original shape when the force is removed.

1. elastic limit

An object will not return to its original shape if its elastic limit has been exceeded.

MATERIALS

spring
weights
meter stick
coat hanger
clamp

ACTIVITIES

Suspend a spring. Observe change in length as equal weights are added or removed.

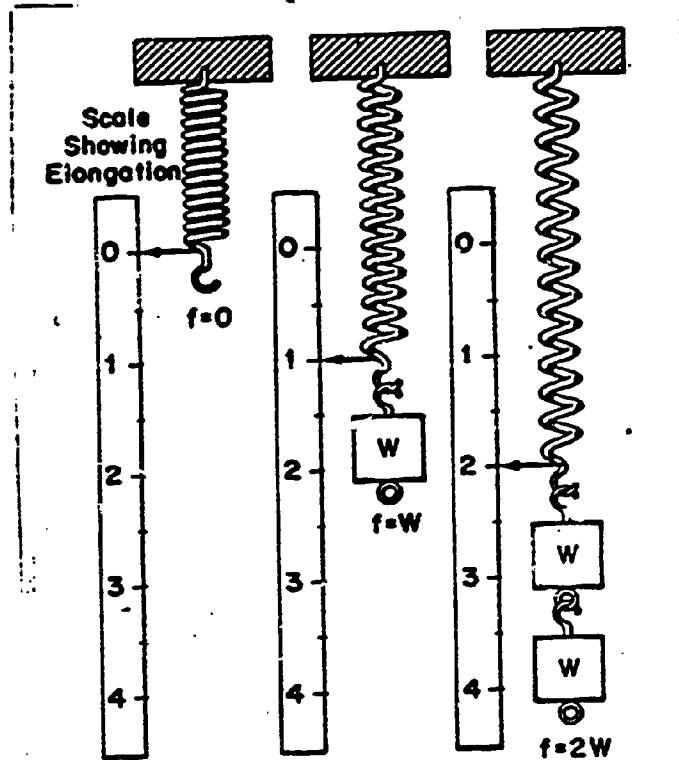

Clamp a piece of coat hanger wire horizontally. Observe the displacement of the pointer as equal weights are added. Continue adding weights until elastic limit is exceeded. Remove weights. Does the wire return to its original position?

Key Words

elastic
elongation
stretch

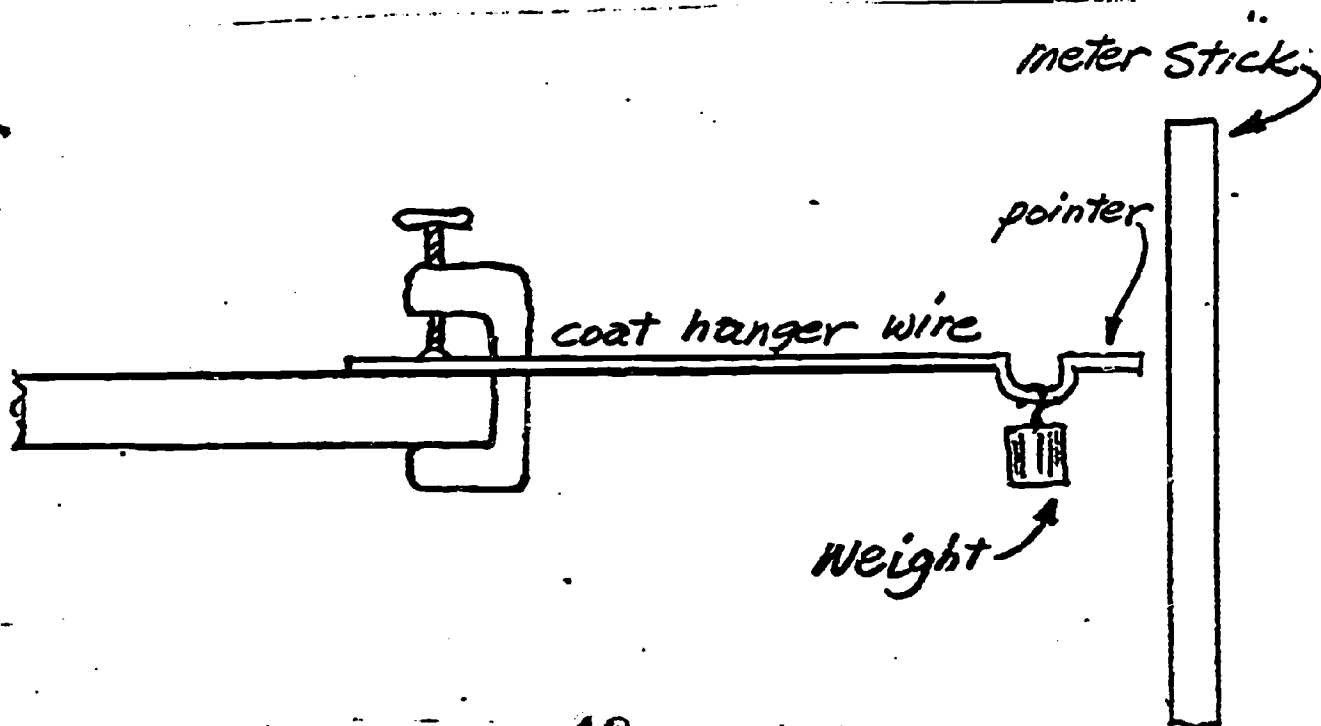

REFERENCE OUTLINE

2. Spring balance

MAJOR UNDERSTANDINGS AND
FUNDAMENTAL CONCEPTS

A calibrated spring may be used to measure force, a pull or push.

A pound is a unit of force.

Weight is a force.

Weight is a measure of the pull of gravity on matter.

In any one place on the earth, the weights of all bodies are proportional to their masses. For all practical purposes, the weight of a body can be used as a measure of its mass; and, the mass of a body as a measure of its weight.

A mass is a property of a body of matter; a weight is a force (gravity) acting upon that body.

MATERIALS

spring balance
platform balance

ACTIVITIES

Examine the face of a spring balance.
Measure the distance between scale divisions.
Are the divisions uniformly spaced?

Principle of operation of the
spring balance.

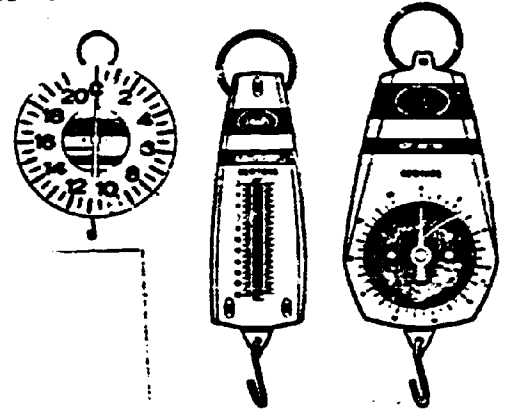
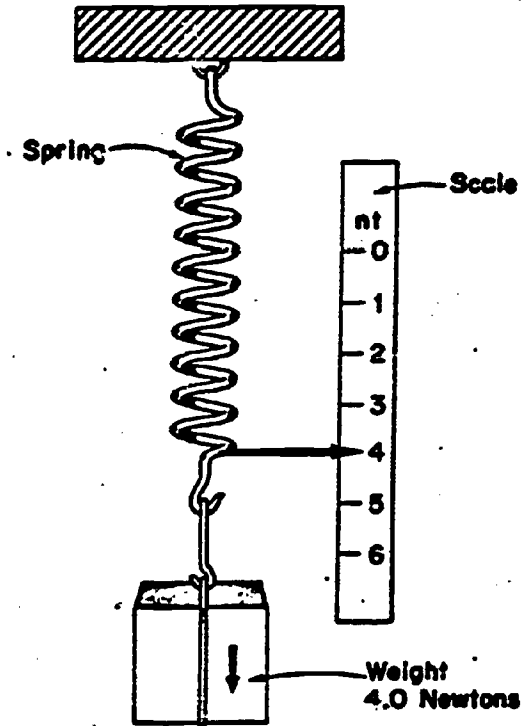
Key Words

mass
weight
force
gravity

Compare the weights of several objects as measured by a spring balance with the weights determined by a platform balance.

REFERENCE OUTLINE

V. Archimedes' Principle

A. Law of Buoyancy

MAJOR UNDERSTANDINGS AND
FUNDAMENTAL CONCEPTS

An object submerged in water appears to lose weight.

The apparent loss of weight of a submerged object is equal to the weight of the displaced fluid.

An object floats when the weight of the displaced liquid equals or is greater than the weight of the object.

The denser a liquid, the higher an object floats in that liquid.

MATERIALSACTIVITIES

Weigh an object denser than water in air and then submerged in water. Submerge the object in an overflow can and weigh the displaced water. Compare the weight of the displaced water and the apparent loss of weight of the submerged object.

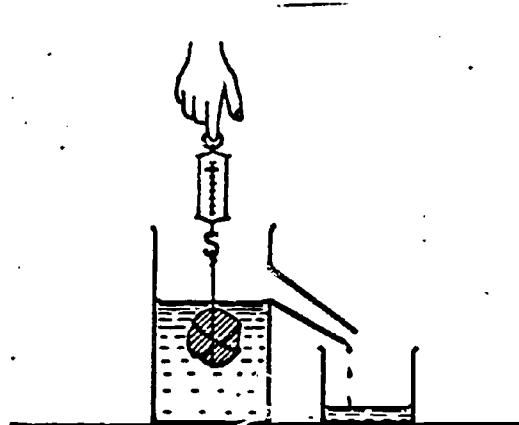
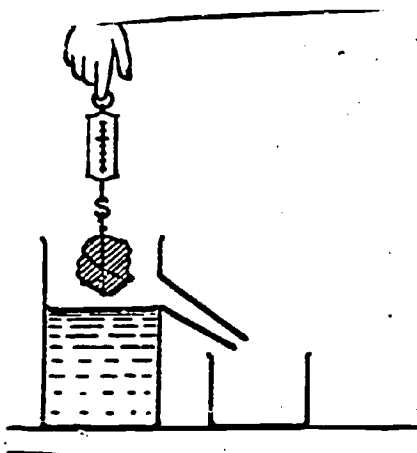

Weigh an object less dense than water. Float this object in an overflow can. Weigh the displaced water.

Float a weighted pencil in a cylinder of water. Note water level on pencil. Repeat using liquids of different densities.

Key Words

buoyancy
submerge

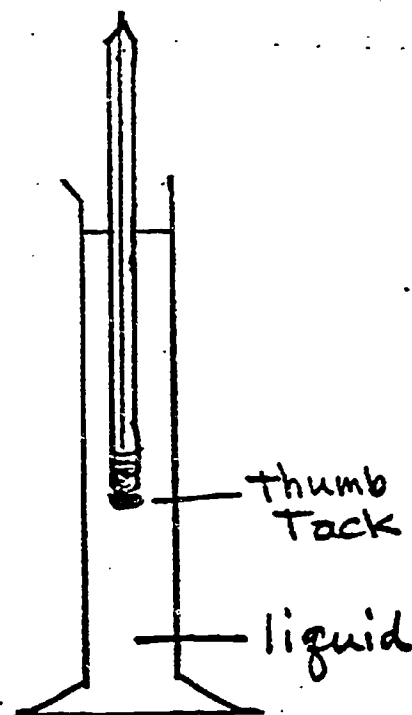

UNIT II

MATTER IN MOTION

UNIT II. MATTER IN MOTION

I. Time

- A. The Pendulum
 - 1. Frequency
 - 2. Period
 - 3. Amplitude

II. Motion

- A. Uniform Linear Motion
 - 1. Speed and Velocity
 - 2. Uniform Motion
- B. Accelerated Linear Motion
 - 1. Free fall
 - 2. Simultaneous velocities

III. Laws of Motion

- A. Newton's First Law of Inertia
- B. Newton's Second Law
 - 1. Acceleration and Force
 - 2. Acceleration and Mass
- C. Newton's Third Law
 - 1. Action and Reaction
 - 2. Conservation of Momentum

IV. Friction

- A. Sliding friction
- B. Starting friction
 - 1. Surface materials
- C. Rolling Friction

V. Work Units

- A. Work Units
- B. Energy
 - 1. kinetic
 - 2. potential
- C. Power

REFERENCE OUTLINE

I. Time

A. The pendulum

MAJOR UNDERSTANDINGS AND
FUNDAMENTAL CONCEPTS

Time is measured by any regularly recurring event.

The second is a unit of time.

MATERIALS

lead bob
string
meterstick

ACTIVITIES

Working in pairs, count the number of oscillations of a "second" pendulum for 100 heartbeats.

(Note a "second" pendulum has a period of 1 second and a length of approximately 25 cm. A 2 "second" pendulum is approximately one meter in length. This pendulum is a teacher project setup in advance.)

Construct a simple pendulum by tying a dense bob to a light string. If the free end of the string is passed through a slit in a stopper, the length may be varied easily.

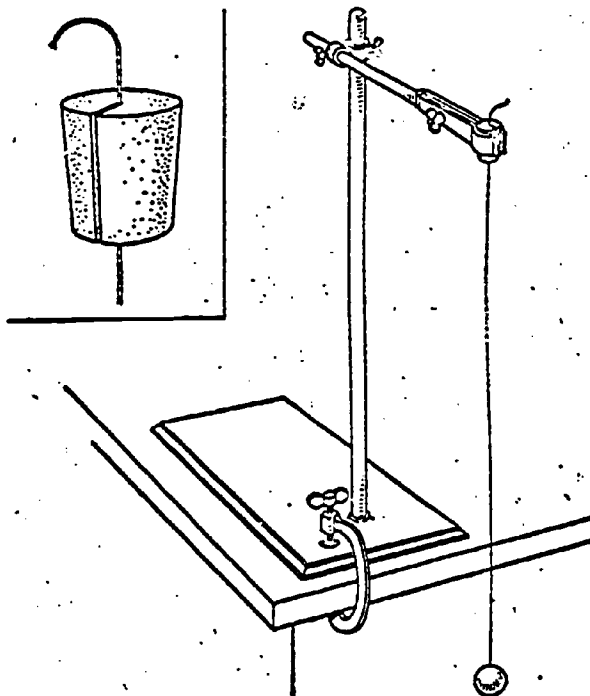
Key Words

pendulum
lead bob

REFERENCE OUTLINEMAJOR UNDERSTANDINGS AND
FUNDAMENTAL CONCEPTS

1. frequency

The number of complete swings of a pendulum per second is called the frequency.

2. period

The time for one complete swing of a pendulum is called its period.

As the length of a pendulum increases, the period of the pendulum increases.

The duration of any regularly recurring event is known as its period.

The period of a pendulum depends only on its length. It does not depend on the mass of the bob or upon the amplitude of the swing (providing that the swing is small).

3. amplitude

The amplitude is the swing from its farthest point to its equilibrium position. That is, the amplitude of a pendulum is the distance between the lowest position of the bob and the highest position at either side of center.

MATERIALS

stop watch or
second timer

ACTIVITIES

Start the pendulum swinging and count the number of complete swings, over and back during a 100-second interval. Calculate the number of complete swings per second by dividing the total number of swings by 100.

[Note to teacher: If the pendulums are shorter than 25 cm, the frequency will be greater than 1 cycle per second.]

Repeat measuring the period of the pendulum for two more trials: one, with a shortened length of the pendulum; two, with a longer length.

tape timer kit

Measure the period of a tape timer. The tape is pulled through a timer for a few seconds. The period of the timer is the number of seconds divided by the number of spaces made during that time.

Key Words

frequency
period
amplitude

REFERENCE OUTLINE

II. Motion

A. Uniform linear motion

1. Speed and velocity

MAJOR UNDERSTANDINGS AND
FUNDAMENTAL CONCEPTS

Average speed is calculated by dividing distance traveled by elapsed time.

Feet per second and meters per second are units of speed.

At 60 miles/hr., what is the speed per second?

$$\text{Speed/sec} = \frac{60 \text{ miles} \times 5280 \text{ ft.}}{3600 \text{ sec.}}$$

$$= 88 \text{ ft/sec}$$

A graph may be used to illustrate motion. Speed at different time periods is illustrated by the height of the bar on the graph.

MATERIALS

tape timer kit
meterstick

ACTIVITIES

Use a tape timer to record the motion of a student. A tape is attached to a student. Starting from rest, the student moves a few steps away from the timer and then stops.

The period of the time should be known. Measure distance covered and elapsed time recorded on the tape. Record the distance covered by the elapsed time.

Relate the concept of speed to everyday activities. For example, discuss the speed of a moving vehicle such as an automobile to the reaction times for stopping. If the reaction time of a driver is 3 seconds at 60 mi/hr, the vehicle travels 264 ft. before the brakes are applied. At this level, students are car conscious. Whenever possible relate physical principles being discussed in class to the everyday interests of the individual.

Note: For general purposes no distinction between "speed" and "velocity" is made in this syllabus.

Cut the tape at every tenth dot and mount on a sheet of paper, as shown in the diagram.

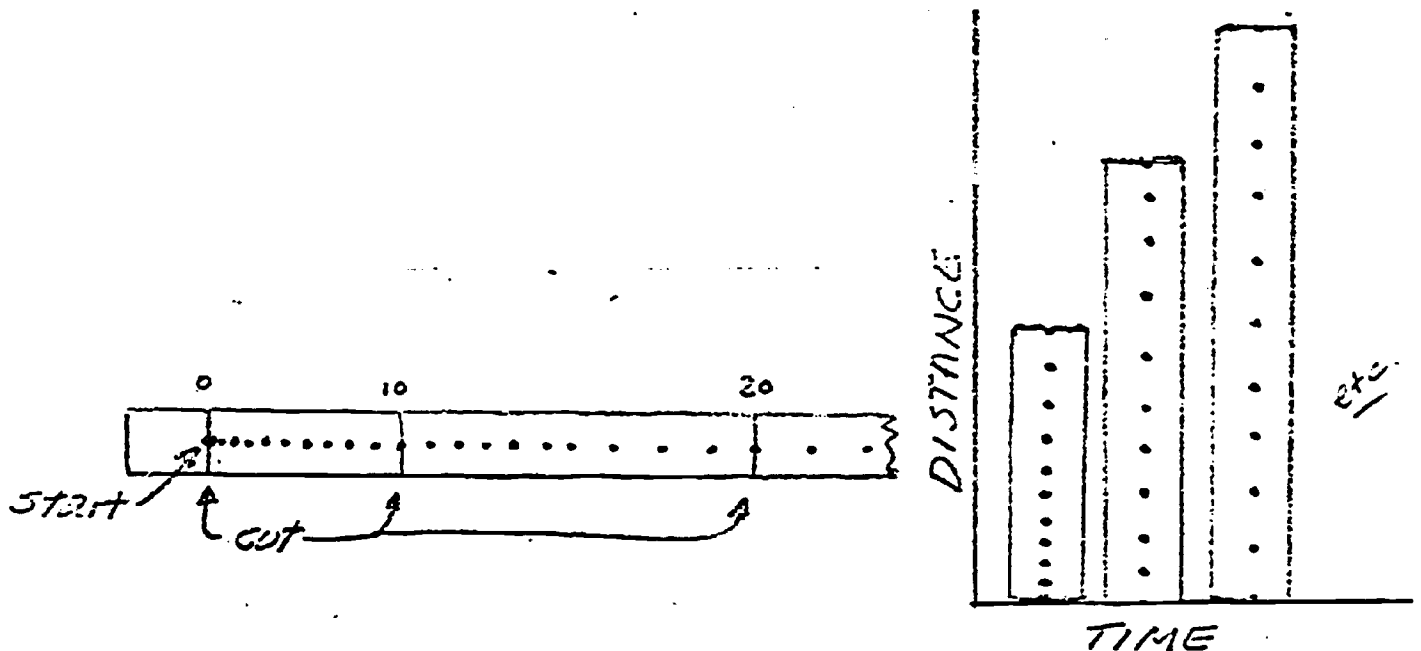

REFERENCE OUTLINE

MAJOR UNDERSTANDINGS AND FUNDAM
FUNDAMENTAL CONCEPTS

2. Uniform motion

Uniform linear motion results when equal distances are covered in equal time periods.

MATERIALS

tape timer kit

ACTIVITIES

Record on a timing tape the uniform motion of a student walking from a timer.

If the timer is started after a few steps have been taken, the resulting walking motion is generally uniform.

Cut the tape at every tenth dot and mount on a sheet of paper.

The ten dot tape segments should be of nearly equal length.

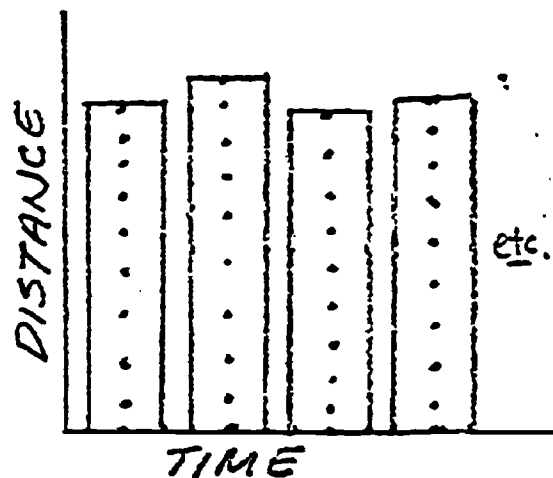

An air puck or piece of dry ice may be used to illustrate uniform linear motion.

Key Words

speed
uniform motion
accelerated
motion

REFERENCE OUTLINE

B. Accelerated linear motion

MAJOR UNDERSTANDINGS AND
FUNDAMENTAL CONCEPTS

Accelerated linear motion results when equal changes of velocity occur in equal time periods.

Accelerated linear motion results when increasing (or decreasing) distances are covered in equal time periods.

MATERIALS

ACTIVITIES

Record on a timing tape the motion of a cart undergoing uniform linear acceleration.

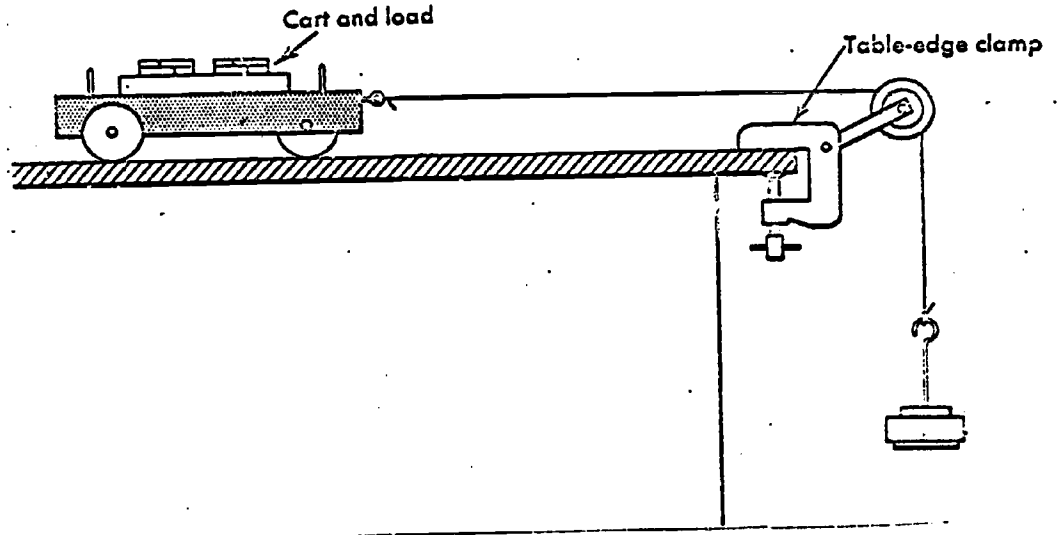

Time the motion from rest.

Cut tape at every tenth dot and mount on a sheet of paper.

The height of the tape segments should increase as illustrated by the diagram.

If the initial dots on the tape are too crowded, a larger weight may be used to produce a larger acceleration.

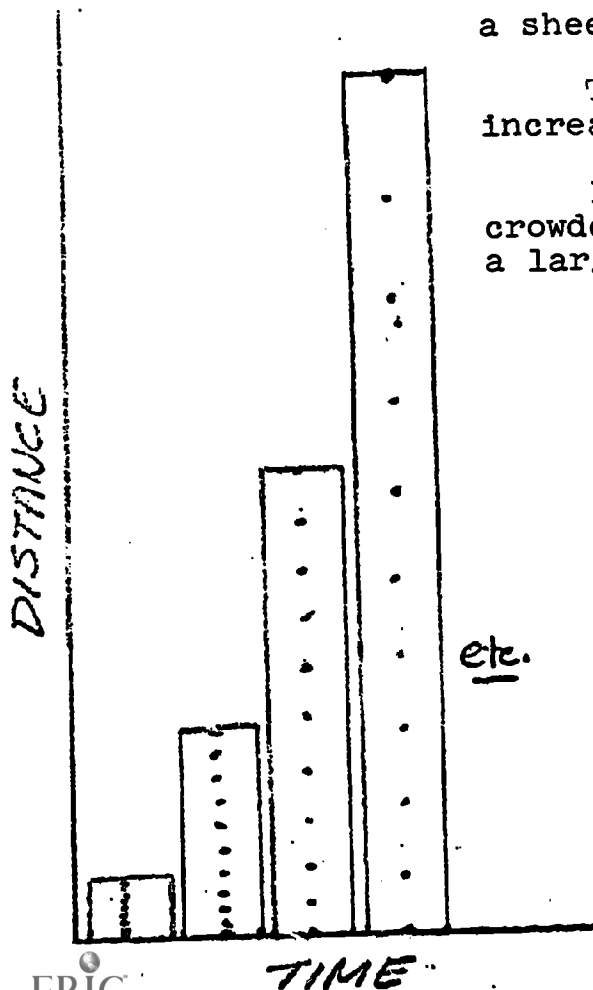

REFERENCE OUTLINEMAJOR UNDERSTANDINGS AND
FUNDAMENTAL CONCEPTS

1. Free fall

Free-fall is accelerated linear motion.

The acceleration of free-fall is the same for all objects.

This acceleration is represented by "g". Because it is the gravitational pull of the earth that causes bodies to fall, their downward acceleration is called the acceleration of gravity and is designated by the letter g. The value of g is about 980 cm per sec. per second or about 9.8 meters per sec. per second (32 ft. per second per second.)

The value of g varies slightly from place to place on the earth's surface.

The principles of a freely falling body assumes no air resistance, i.e., a vacuum.

In a vacuum, all bodies near the surface of the earth fall at the same rate.

Bodies do not fall freely through air. Air friction slows up the rate of fall.

Air resistance reduces the rate of fall of a parachute to a safe final speed.

MATERIALSACTIVITIES

Record on timing tape the motion of a falling object.

Cut the tape at every tenth dot and mount on a sheet of paper.

Compare graph with the graphs of uniform linear motion and accelerated linear motion.

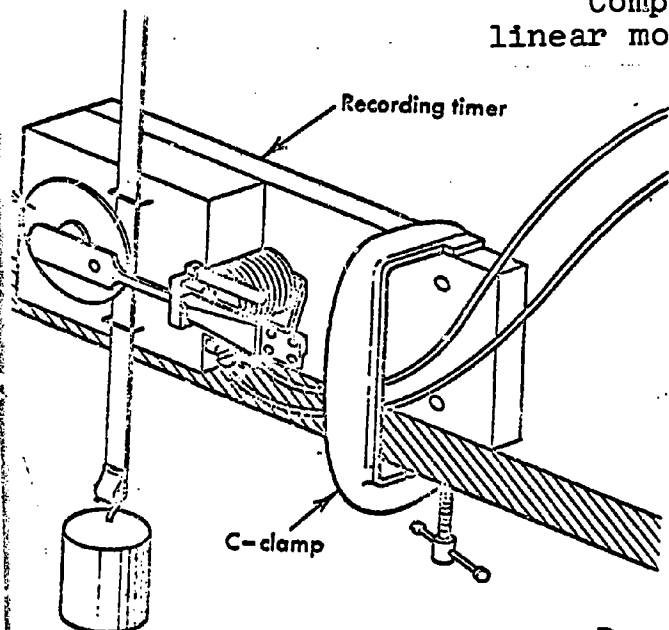

Drop large and small dense masses from a considerable height. When released simultaneously, their impact is simultaneous.

Key Words

"g"
acceleration of
gravity

Suspend two balls of the same size as high as possible above the floor by means of electromagnets. One ball is iron; the other is wood with a nail in it. (Two steel balls of different sizes may also be used.) Immediate release is obtained by covering the pole of each magnet with a piece of cellulose tape. The magnets are connected, through a switch, to a dry cell. When the switch is opened, the balls will drop from the same height onto a metal pan or into a metal wastebasket, making a single sound as they strike.

REFERENCE OUTLINEMAJOR UNDERSTANDINGS AND
FUNDAMENTAL CONCEPTS

The presence of air and the shape of a freely falling body affects the rate of fall. The principles of free fall assume a vacuum.

All falling motion is NOT free fall.

In air the fall of dense objects through small distances approximates free fall.

*The value of g may be determined experimentally.

Note to teacher: Formulae throughout this course are used as tools to enhance understandings. Memorization of formulae and rote applications are discouraged.

*optional

MATERIALSACTIVITIES

Time the fall of a small dense object several times.

Time the fall of a large dense object over the same distance several times.

The average time of fall for both masses is nearly identical.

The dependence of air resistance on area and the concept of terminal velocity can be shown with a sheet of paper. Dropped in a horizontal position, it quickly reaches its terminal velocity. Dropped edgewise, it plummets to the floor. Crumpled loosely, it falls quickly, but does not keep pace with a metal ball or coin dropped at the same time. Wadded into a tight ball and dropped with a metal object, it falls along with the other, and strikes the floor at about the same time.

The "guinea-and-feather" tube is used to show that the acceleration of freely falling objects is independent of mass if air resistance is eliminated. This is a large glass tube containing a feather and a coin. At normal pressure the feather flutters and the coin plunges as expected when the tube is inverted. But when air is removed, the feather and the coin drop together.

Key Words

stopwatch
free fall

*Time repeated falls of a dense mass over a distance with a stopwatch. Measure height of fall.

An open stairwell and a large ball bearing work well. Release the ball with no initial downward velocity. The value of "g" may be computed:

$$g = 9.80 \text{ m/sec}^2$$

REFERENCE OUTLINE

MAJOR UNDERSTANDINGS AND
FUNDAMENTAL CONCEPTS

MATERIALS

ACTIVITIES

Another method of measuring g is to use an electric clock to measure the time required for an object to fall a known distance.

A steel ball is supported by an electromagnet. A hand-switch simultaneously turns off the magnet releasing the ball, and starts the electric clock. The ball strikes a switch at the bottom of its fall and turns off the clock. Make the necessary measurements for several different distances of free fall calculate g for each

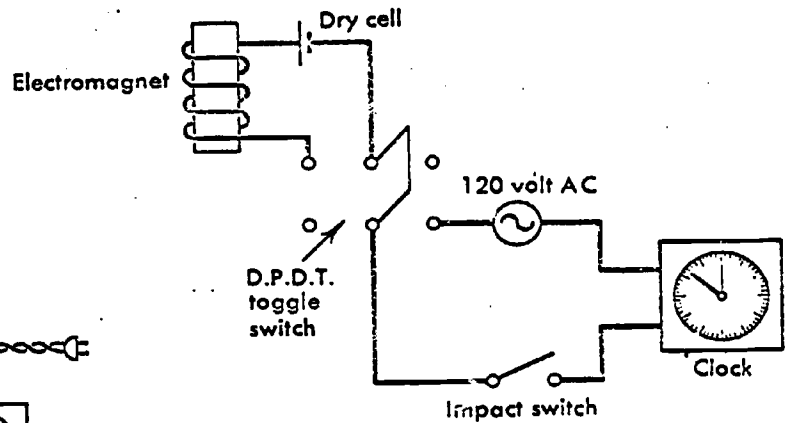
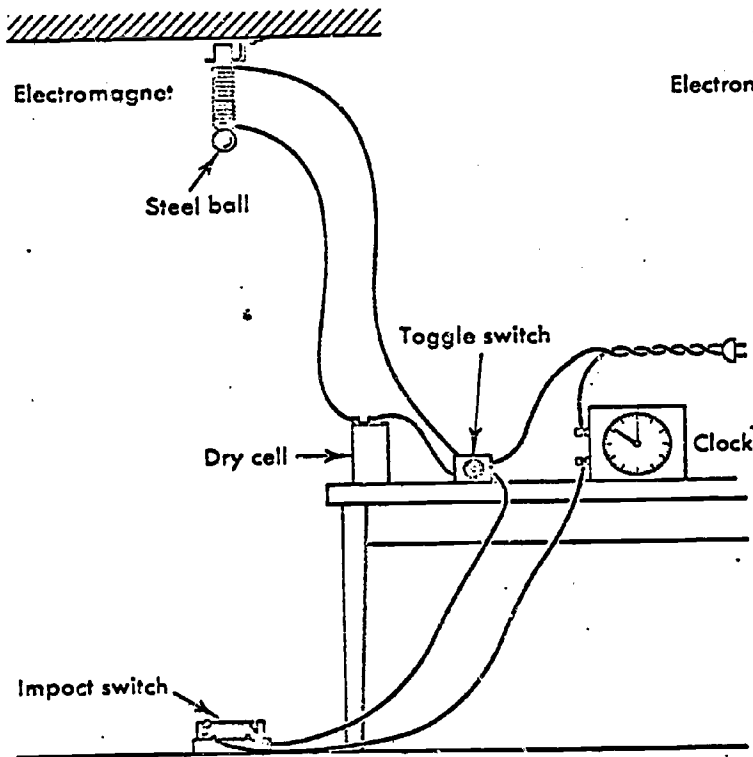

CIRCUIT DIAGRAM

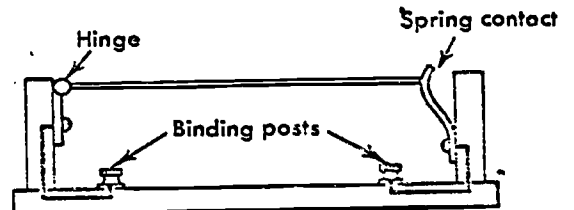

THE IMPACT SWITCH

REFERENCE OUTLINE

MAJOR UNDERSTANDINGS AND
FUNDAMENTAL CONCEPTS

ACTIVITIES

*The fall of a metal ball is intercepted by a lath about 120 cm long swinging from a nail fitting loosely onto a hole near one end.

The period of swing of the pendulum is first found, using a clock to time, say, 100 swings. The ball, which has a small hook attached, is then blackened and hung from a thread which passes over smooth nails and also pulls aside the lath from the vertical position, as shown in the diagram. On burning the thread, the ball and lath are released **simultaneously** and the ball will hit the lath. From the position of impact, the distance fallen vertically by the ball in one quarter of the period of the lath can be found.

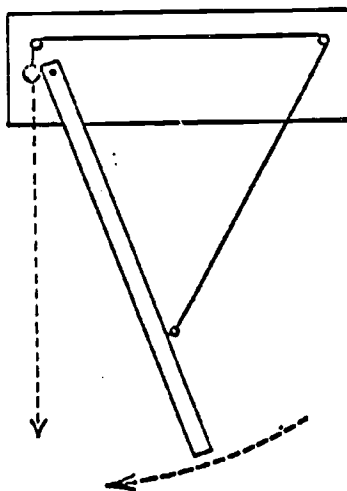

The value of "g" may be calculated from the length ~~and period of a~~ pendulum.

Use $g = \frac{4\pi^2}{T^2}$ to calculate the numerical value of "g".

To reduce error to a minimum increase the length of the pendulum, A length less than ten feet introduces **substantial** error.

REFERENCE OUTLINE

2. *Simultaneous velocities

MAJOR UNDERSTANDINGS AND
FUNDAMENTAL CONCEPTS

*"g" is not affected by horizontal motion.

*optional

Simultaneously drop and project horizontally two masses. The times for the fall are equal.

Several simple devices are available commercially for projecting one ball horizontally at the instant of releasing another to drop vertically. A successful homemade version uses a hacksaw blade.

Bend and drill a small piece of sheet metal to form two small platforms which can be bolted to the end of a hacksaw blade. The blade is then clamped in a vise and a marble, or steel ball, is placed on each platform. When the blade is drawn sideways and released, one marble is shot horizontally and the other is dropped vertically at the same time. They can be heard to strike the floor together

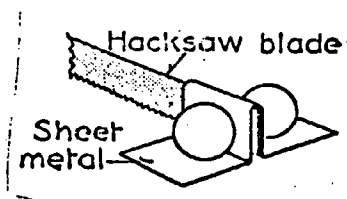

REFERENCE OUTLINEMAJOR UNDERSTANDINGS AND
FUNDAMENTAL CONCEPTS

Gravity acts upon bodies at all times whether at rest or in motion.

A body in horizontal motion has two forces acting upon it: the forward velocity and the force of gravity which pulls and accelerates it downward.

A bullet fired horizontally and a bullet dropped from the same height at the same time will both reach the ground at the same time.

MATERIALSACTIVITIES

The famous anecdote about the falling monkey will serve as a build up for an interesting demonstration. A hunter aimed his gun directly at a monkey hanging from the branch of a tree, assuming that the bullet would travel a perfectly straight path. At the instant he fired, the monkey let go and dropped toward another branch. Did he hit the monkey?

The "gun" is a one foot length of $\frac{3}{8}$ " or $\frac{1}{2}$ " tubing used as a blow gun. A boiler gauge tube is satisfactory. The bullet is any short cylinder or ball that moves smoothly in the tube. A piece of chalk used as the projectile will make a mark on the target. The monkey is a piece of sheet iron 3 or 4 inches square, or a small can, which is held to the "branch" by an electromagnet. A piece of cellulose tape over the pole of the magnet insures prompt release when the circuit is broken.

The circuit for the magnet includes a switch at the muzzle of the gun. The switch is the only tricky part of the apparatus. The simplest arrangement is a short length of copper wire which rests on two wires projecting from the gun and is brushed off by the bullet. A better and more permanent device is a switch which automatically resets itself after having been disturbed. It is made of a light strip of metal, held in place by two loops of wire around the tube. On one end is a blob of solder to serve as a weight, and on the other a short length of wire which acts as the trigger. Adjust the wire so that the projectile brushes against it as it emerges. Make connection to the two rings on the tube. The switch must be very light to prevent disturbance of the trajectory.

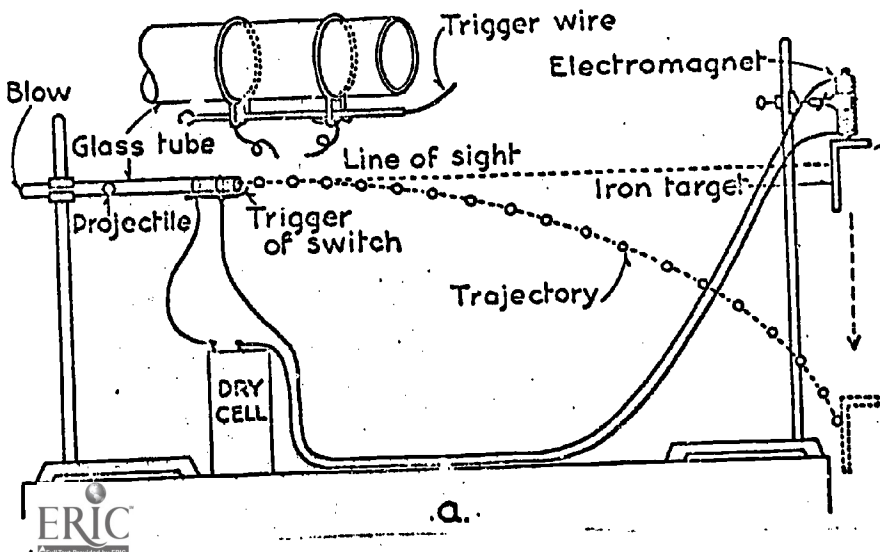

Line up the gun by sighting through it on the target. Blow the bullet out hard enough to catch the target before it reaches the floor. After demonstrating with the "hunter" and "monkey" on the same level, raise the "monkey" so that the gun must be aimed at an upward angle.

REFERENCE OUTLINE

III. Laws of motion

A. Newton's First Law of Inertia

MAJOR UNDERSTANDINGS AND
FUNDAMENTAL CONCEPTS

An object at rest remains at rest unless an unbalanced force acts on it.

The tendency of an object to resist change in its state of rest or motion is characteristic of the object and is called its inertia.

An object in motion continues in motion with no change in speed unless an unbalanced force acts on it.

MATERIALSACTIVITIES

Inertia is sometimes a difficult concept for students to grasp, yet they are familiar with examples of inertia in their daily lives. Illustrate examples of inertia:

- . Why are seat belts desirable in automobiles?
- . What are the advantages of shoulder harness?
- . Why are heavy fly wheels used in machines?

Snatch a piece of paper from underneath a glass of water after having shown that the glass can be dragged along by gently pulling the paper.

Stand a book on edge on a strip of paper and show that, if pulled slowly the book will move along with the paper, if pulled more quickly the book will fall over and the paper is snapped out, the book remains standing.

Rest a coin on a card placed flat on the tip of one finger. Flick the card out from under the coin with a finger of the other hand. The card should be about the size of a calling card, and the coin a quarter or larger in order to make the demonstration effective.

Key Words

inertia

Make a stack of 5 or 6 checkers and knock the bottom one out by striking it with a ruler. Repeat until you are down to the last checker. Coins can be used, and a hacksaw blade or knife blade used flat to strike out the bottom one.

REFERENCE OUTLINE

MAJOR UNDERSTANDINGS AND
FUNDAMENTAL CONCEPTS

MATERIALSACTIVITIES

Suspend a massive ball such as a 12-pound shot by a cord. The shot should be drilled at ends of a diameter for hooks. A similar cord is attached to the bottom. A gentle pull on the lower cord breaks the one supporting the weight. The falling ball may be caught in the hand or allowed to drop into a bucket of sand or onto a pad of rags. A sudden pull achieved by swinging the arm breaks the lower cord. Have pieces of string of the proper length and with loops tied in the ends ready for quick replacement.

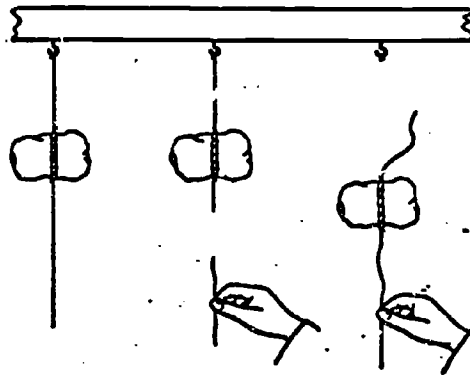

Hang a heavy ball with a hook on one side, as a pendulum. Using a length of light cord, show that the pendulum can be drawn aside if pulled gently, but that the cord breaks if yanked suddenly, resulting in almost no displacement of the pendulum. Attach the side string to a fixed upright, using a length that will be slack until the pendulum reaches the bottom of its arc. Draw the pendulum toward the upright and release. Note that the cord will break when it is pulled taut.

REFERENCE OUTLINE

MAJOR UNDERSTANDINGS AND
FUNDAMENTAL CONCEPTS

MATERIALSACTIVITIES

Use a large knife to cut part way through an apple or a potato. Then strike the knife, cutting-blade up, on the edge of the table to slice through completely. Or with the knife part way through the object, hold it in the air and strike the back of the knife a sharp blow to finish the cut.

Secure a small stick 18 to 20 cm in length. If no other stick is available a lead pencil will do. Fold a newspaper and place it near the edge of a table. Place the stick under the newspaper on the table and let about half the stick extend over the edge. Strike the stick a sharp blow with another. Inertia should cause the one on the table to break in two parts.

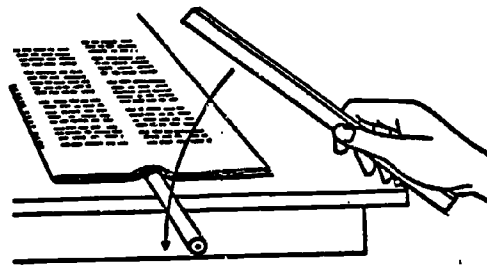

Secure a fresh egg and a hard-boiled egg. Give each of them a spinning motion in a soup dish or a plate. Observe that the hard-boiled one spins longer. The inertia of the fluid contents of the fresh one brings it to rest sooner.

REFERENCE OUTLINE

MAJOR UNDERSTANDINGS AND
FUNDAMENTAL CONCEPTS

MATERIALSACTIVITIES

Arrange several inclines to illustrate the law of inertia as applied to a moving body.

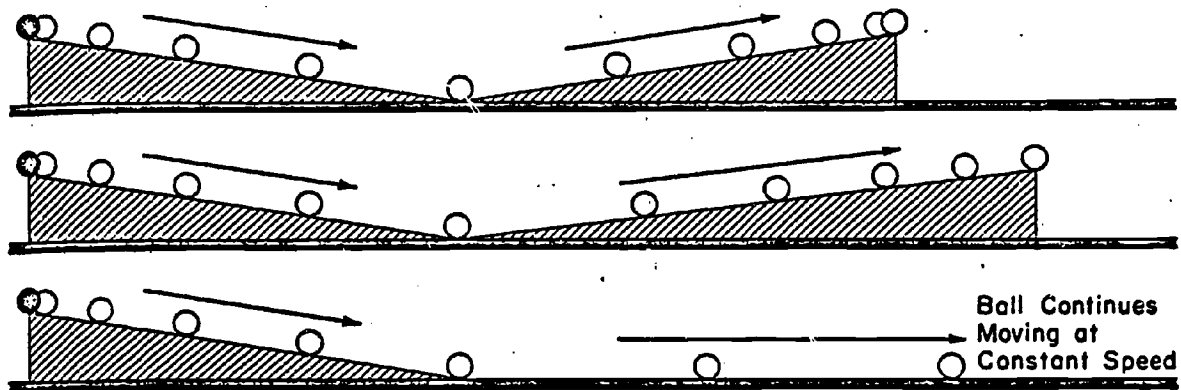

REFERENCE OUTLINE

- B. Newton's Second Law
 - 1. Acceleration and Force

MAJOR UNDERSTANDINGS AND
FUNDAMENTAL CONCEPTS

An unbalanced force acting on an object will cause the object to accelerate. As the unbalanced force acting on an object increases, the acceleration of the object increases.

MATERIALSACTIVITIES

Observe the increase in speed of cart when accelerated successively by increasing forces.

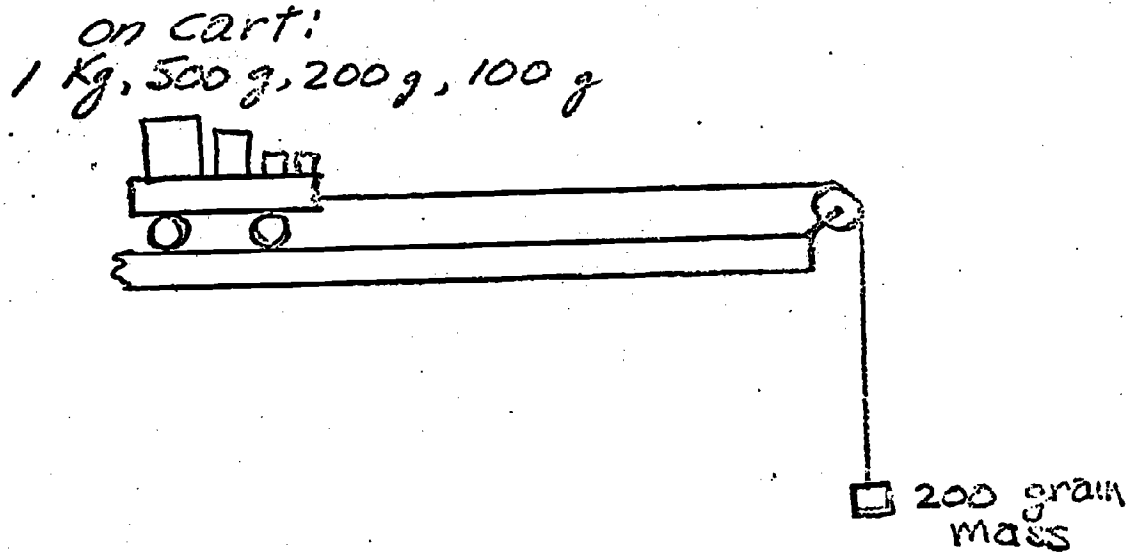

Release cart from rest and observe increase in speed. Add 200 g from cart to suspended 200 g mass. Release cart from rest and observe the increase in speed. Compare these accelerations.

Continue transferring masses in 200 g increments from cart to suspended masses.

Note: This may be timed by tape timer, but visual observation is generally satisfactory.

Key Words

acceleration
force

REFERENCE OUTLINE2. Acceleration
and massMAJOR UNDERSTANDINGS AND
FUNDAMENTAL CONCEPTS

As the mass of an object increases, the acceleration caused by a given force decreases.

The acceleration imparted to a mass is directly proportional to the force producing it.

MATERIALSACTIVITIES

Observe the change in speed of different masses accelerated by the same force.

Accelerate an empty cart from rest by suspending a 500 g mass from the end of the string. Repeat adding 1 kg masses to the cart and note changes in acceleration. Compare the accelerations of the cart as masses are added. This may be timed by tape but visual observation is generally satisfactory.

An interesting practical variation of the above may be performed in the parking lot. A car with driver only is accelerated in low gear over a measured short distance and timed by stopwatch.

The trial is repeated with car full of students. The times may be compared. The acceleration in each case may be calculated if the distance is known.

The larger the mass of a body, the smaller is the acceleration a given force imparts to it.

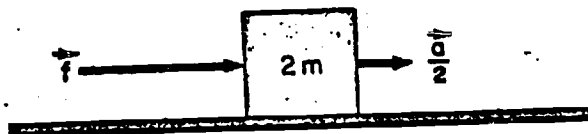
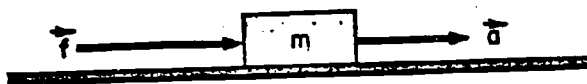
KEY WORDS

mass

REFERENCE OUTLINEMAJOR UNDERSTANDINGS AND
FUNDAMENTAL CONCEPTS

C. Newton's Third Law

1. Action/reaction

When an object exerts a force, it does so on another object and this second object also exerts a force on the first.

Forces always occur in pairs. For any applied force, there is an equal opposing force.

MATERIALSACTIVITIES

Jet propulsion is made possible by action and reaction.

Fit a small cardboard stabilizer to the neck of a balloon by means of adhesive tape. Inflate the balloon, and close the mouth with your fingers. When the air contained under pressure in the balloon is allowed to escape, the balloon will be propelled forward by the force of the escaping air. This is the principle used in rockets and jet engines.

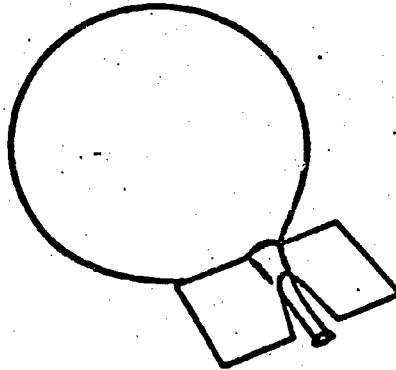

Action and reaction with a roller skate.

Place a roller skate on a smooth floor. Step on the roller skate with one foot and take a step forward with the other. Observe that the skate moves backward in the opposite direction.

Key Words

action
reaction

REFERENCE OUTLINEMAJOR UNDERSTANDINGS AND
FUNDAMENTAL CONCEPTS

2. *Conservation of
momentum

momentum = mass x velocity

*optional

Momentum can be explained by the 2nd and 3rd laws of Newton.
Treat qualitatively.

MATERIALSACTIVITIES

Observe the motion of two lab carts forced apart by a compressed spring.

To show a water jet, use a one-foot length of light, flexible rubber tubing. Tie a piece of string about 6 inches long on the tube at two points, so as to pull it into an approximate right angle turn. Attach the tube to the water faucet and turn on the water cautiously. With the water flowing gently, the tube stands out in a most unnatural position. If the water is turned on hard for a moment, its writhing is most instructive, but will shower water on a good portion of the classroom.

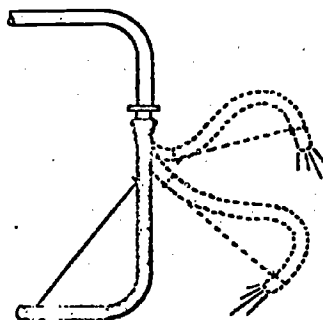

Action and reaction are equal.

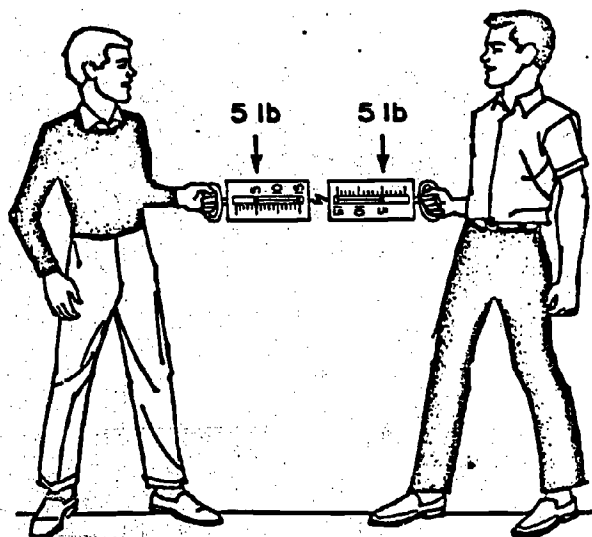

REFERENCE OUTLINE

MAJOR UNDERSTANDINGS AND
FUNDAMENTAL CONCEPTS

[Faint, illegible text, likely bleed-through from the reverse side of the page]



ACTIVITIESMATERIALS

Put some water in a small bottle, stopper it with a solid rubber stopper, hang it horizontally by two strands of light wire (No. 30) and heat it cautiously. When the stopper pops out, the bottle will recoil and some of the hot water will be spilled vertically below the support. All three of these phenomena should be discussed and explained in terms of Newton's law of motion and the law of conservation of momentum.

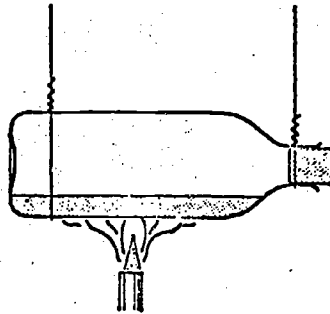

Prepare a platform approximately 1x4x5 inches. Suspend it as a swing by thin wire (No. 30 for example) from four screw eyes in the corners. Attach a strip of rubber (a heavy rubber band will do) to two nails near one end of the platform and hold it back with a loop of string passing over a support made of a bent nail, and down to a nail on the opposite side of the swing. If a ball such as a heavy pendulum bob is placed in the pocket formed by the rubber, and the string is burned by a match flame held below the nail, the ball will be shot out and the platform will recoil.

Prepare loops of string of the same length so that the "gun" can be reloaded quickly to compare the effects on the bullet and the swing when balls of different weights are shot.

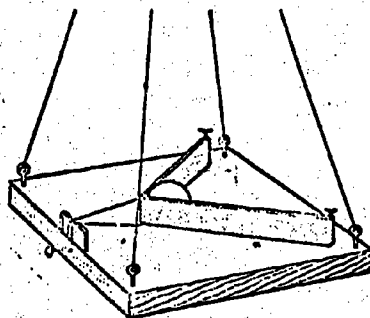

REFERENCE OUTLINEMAJOR UNDERSTANDINGS AND
FUNDAMENTAL CONCEPTS

IV. Friction

A. Sliding friction

Friction is a force opposing the motion of one surface against another.

Friction increases as the force pushing the surfaces together increases.

1. Materials

The force of friction depends on the nature of surfaces in contact.

B. Starting friction

Starting friction is greater than sliding friction.

MATERIALSACTIVITIES

Measure the frictional force by dragging a block of wood across a flat level surface at a constant speed with a spring balance.

Load the block by placing weight on it and measure the frictional force. Repeat this several times increasing the weight on the block.

Show that starting friction is greater than sliding friction. Pull horizontally with a spring balance on a loaded wood block resting on the table. Take the balance reading just as the block starts to move, and again when it is sliding steadily.

Note: There is much less traction on a slippery surface while the wheels of an auto are spinning than when they are turning at a low enough speed so that they do not slip. Also, in applying the brakes, friction between tires and the road decreases as soon as a skid starts. The greatest stopping force is obtained by a brake pressure just under that which locks the wheels.

Measure the friction by the method described between the wood block and a wood surface, and compare it with the value obtained by sliding the block across a glass or metal surface. Or change the surface friction by setting the block on a square of paper and dragging it across the original surface.

Show the effect of lubrication by wiping the surface with a light coat of oil and measuring the friction.

Drag the block across fine sandpaper.
(Coarse sandpaper will produce less friction than fine sandpaper.)

REFERENCE OUTLINE

C. Rolling friction

MAJOR UNDERSTANDINGS AND
FUNDAMENTAL CONCEPTS

Rolling friction is less than sliding friction.

Moving surfaces may be held apart by fluids to reduce friction.

MATERIALSACTIVITIES

Slide a cylindrical kilogram mass across the desk top; then turn it on its side, and roll it, to compare the retarding force of sliding friction and rolling friction.

Place wooden dowels under a heavily loaded wooden block.

Measure the force necessary to move the block with a spring balance.

Cut out a disc of cardboard about 10 cm in diameter. With a red-hot pin, burn a hole through the center. Saw a small spool in half and glue the original end of one half over the middle of the disc. Place a tube which just fits the hole in the spool into the neck of a small balloon, using cotton or a rubber band to secure the joint. Blow up the balloon, pinch the neck, insert the tube into the hole in the spool. Place the disc on the table and release the air. The expanding air, escaping through the hole in the disc, will lift the card so that, given a flick, it will shoot across the table with practically no friction.

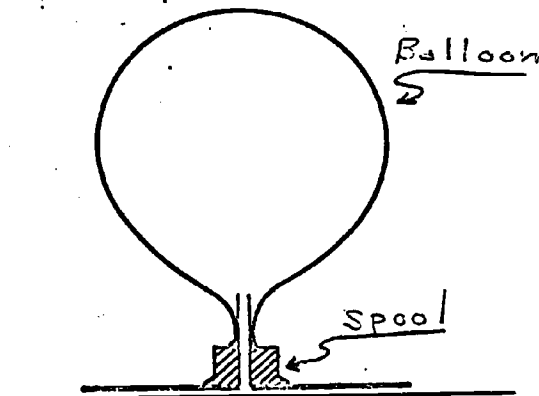

REFERENCE OUTLINE

V. Work*

A. Work units

MAJOR UNDERSTANDINGS AND
FUNDAMENTAL CONCEPTS

Work is done when a force moves an object.

Work is calculated by multiplying the force exerted by the distance through which the force acts.

The foot pound is a unit of work in the English system.

$$\begin{aligned} \text{Work} &= \text{force} \times \text{distance} \\ W &= f \times s \end{aligned}$$

*With rapidly moving classes, teachers are encouraged to use the MKS system. However, until the metric system is in more general use, work units and power should be expressed in common parlance, i.e., foot-pounds; the rate of doing work in horsepower.

Teachers may wish to expand this unit and the concept of work to simple machines with a discussion of the mechanical advantage of various machines.

MATERIALS**ACTIVITIES**

Calculate the work done against gravity by measuring the vertical distance traveled when a known weight is raised. Use common laboratory examples.

Have pupils calculate the work done when climbing a flight of stairs or lifting an object.

Measure the horizontal distance and force necessary to move an object at a uniform speed using the illustration for sliding friction.

KEY WORDS

work
foot-lb.

REFERENCE OUTLINEB. Energy

1. Kinetic

Work may be stored and recovered.
This stored work is energy.

The energy an object has because of its motion is known as kinetic energy. The energy of an object which is not due to its motion is known as potential energy.

Kinetic energy = energy of motion

2. Potential

Potential energy = energy of position

Energy and work are measured in the same units (ft-lb. in the English System).

Work = force x distance

Example of a work problem:

A boy lifts a 30 lb rock 2 ft.
What work does he do?

Solution:

The boy must pull upward with a force of 30 lb to raise the rock.
Hence,

$$F = 30 \text{ lb} \quad \text{distance (s)} = 2 \text{ ft}$$

$$W = \text{force} \times \text{distance} = f \times s$$

$$W = 30 \text{ lb} \times 2 \text{ ft} = 60 \text{ ft-lb.}$$

Similar problems may be used to illustrate the concept of work, i.e., the movement of matter through space.

When the rock is raised 2 feet, it has stored 60 ft-lb of potential energy in the rock. As the rock falls, the potential energy is changed to kinetic energy. Work is done to change kinetic energy into potential energy.

MATERIALSACTIVITIES

A rubber band is anchored to a table top and attached to a lab cart loaded with bricks. Work is done by pulling the cart so that the rubber band is stretched a small amount. Release the cart and note the speed of the cart.

Repeat several times increasing the stretch on the rubber band.

Note: Work is done stretching the rubber band. The rubber band in turn does work moving the cart.

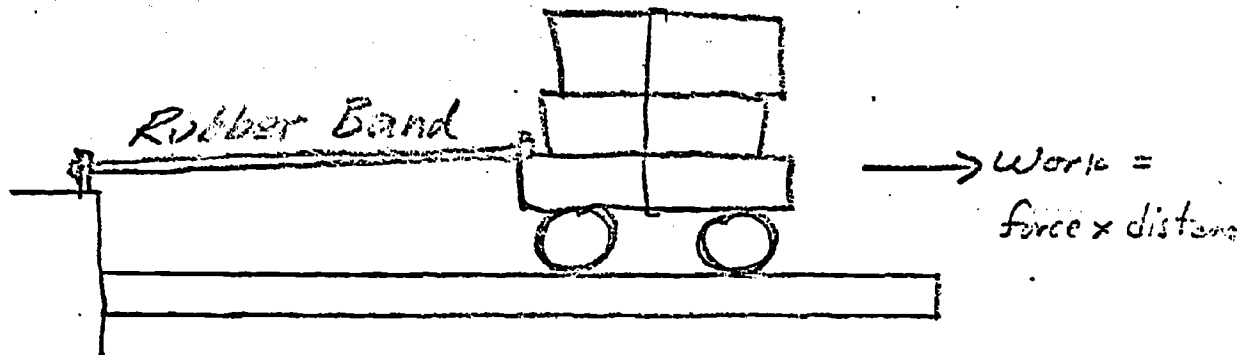
KEY WORDS

kinetic
potential
work

REFERENCE OUTLINEMAJOR UNDERSTANDINGS AND
FUNDAMENTAL CONCEPTS

The gravitational potential energy of a raised object is equal to the work done to raise it, and depends on an object's weight and the height to which it is raised.

At the top of the swing, the potential energy of the pendulum is greatest and the kinetic energy is zero. At the bottom of the swing, the kinetic energy is greatest and the potential energy is zero.

The kinetic energy of a moving object increases as the speed of the object increases.

MATERIALSACTIVITIES

Potential energy and the work done by a falling object can be shown with a simple device. Drive a nail into a piece of soft wood by allowing a weight to fall on it. The cylindrical steel or brass weight is guided by a large diameter glass tube, or a cardboard mailing tube 2 or 3 feet long. Start the nail straight with a hammer.

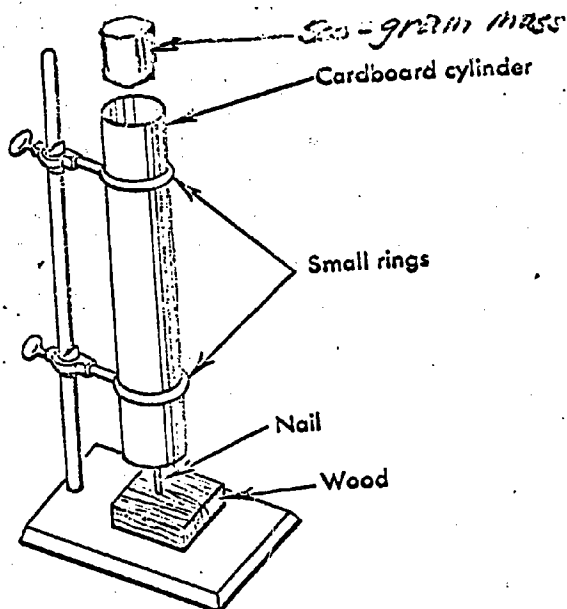

Set up a simple pendulum. Observe its change in speed as it oscillates.

Place a lab cart so that it will be struck by a pendulum bob at the bottom of its swing. Draw the bob aside to increasing heights. Observe the effect of these impacts.

Note: Cushion the impact area of the cart with a soft material such as sponge. The mass of the pendulum bob should be of the same order of magnitude as the mass of the cart.

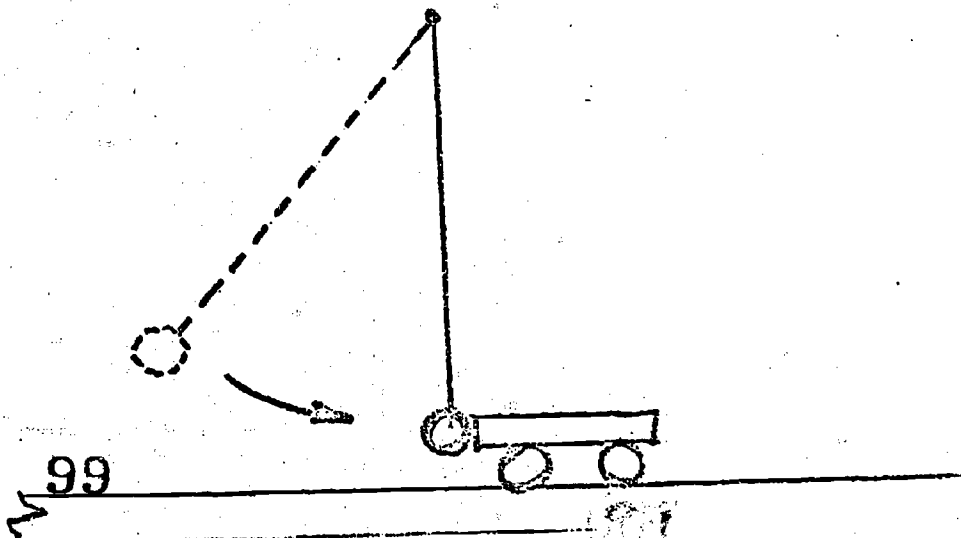

REFERENCE OUTLINEMAJOR UNDERSTANDINGS AND
FUNDAMENTAL CONCEPTS

The kinetic energy of a moving object increases as the mass of the object increases.

MATERIALSACTIVITIES

A double incline plane can be made of strips of glass and a cylindrical weight allowed to roll back and forth. Glass strips up to two feet in length and several inches wide are often discarded by glaziers. The slope of the inclines should be very gentle, perhaps 1 to 50. The period of such an arrangement is long enough to permit identification of the various energy states as they occur.

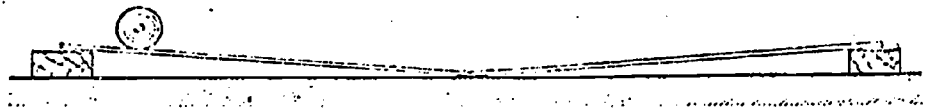

The "cum-bak" is an interesting child's toy which can be used to illustrate energy concepts. It consists of a cardboard cylinder containing a rubber band stretched between its ends and along its axis. From the center of the rubber band hangs a weight. When the cylinder is rolled, the weight winds up the rubber band. When the initial kinetic energy has been used, the rubber band unwinds, making the toy come back.

The commercial toy car and plastic track sets sold under such names as "Hot Wheels", "Johnny Lightning", etc., may be used to illustrate the conversion of gravitational potential energy to kinetic energy.

REFERENCE OUTLINE

MAJOR UNDERSTANDINGS AND
FUNDAMENTAL CONCEPTS

MATERIALSACTIVITIES

A teacher demonstration of kinetic energy showing the dependence on mass and speed may be performed with strips of glass and a set of standard masses. A small mass such as 20 grams is dropped onto the horizontal glass strip from increasing heights until the plate shatters. Set up another sheet of glass and drop a larger mass such as 100 grams. Increase the height from just above the glass strip to a point which results in shattered glass.

If similar sheets of glass are used, the energy needed to shatter the strip remains reasonably uniform. Associate the speed of the mass at impact with the height of release. Note that the necessary kinetic energy may be supplied by a small mass with large speed or large mass with small speed.

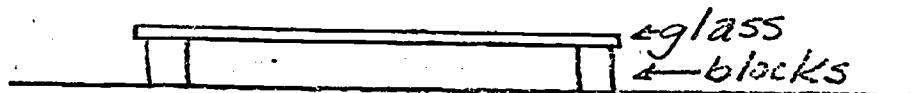
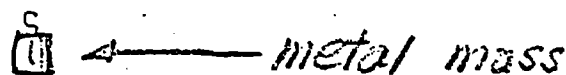

Note: Danger of splintered glass.

Place a string through an empty thread spool and stretch the string across the classroom. Strike the spool with a rubber stopper on a dowel stick to propel the rider along the string. Show that the greater the mass of the rubber stopper and/or the greater its velocity as it hits the spool, the greater will be the kinetic energy applied.

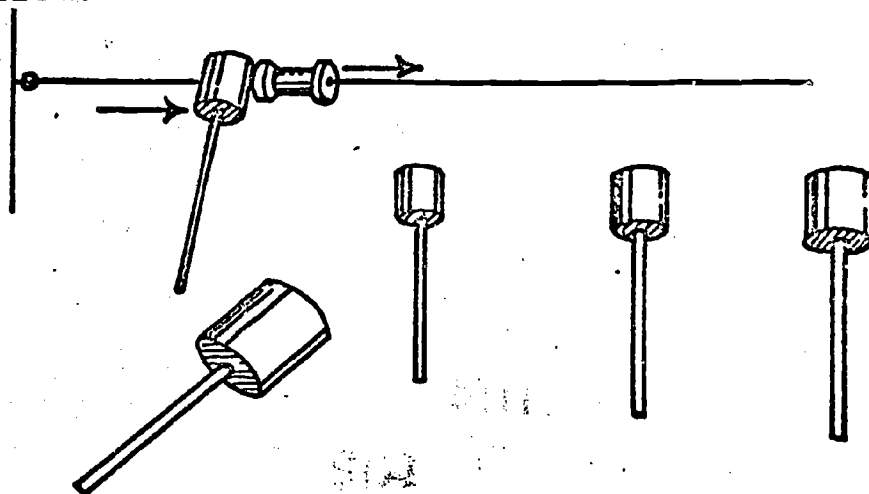

REFERENCE OUTLINEMAJOR UNDERSTANDINGS AND
FUNDAMENTAL CONCEPTS

C. Power

Power is the rate at which work is done or the rate at which energy is expended.

The foot pound per second is a unit of power.

The horse power is a unit of power equal to 550 foot-pounds per second.

$$\text{Power} = \frac{\text{work}}{\text{time}}$$

The watt is the unit of power commonly used to measure the power of electrical devices.

$$746 \text{ watts} = 1 \text{ horsepower}$$

MATERIALSACTIVITIES

Pupils may measure the power they can develop in running upstairs. The work done is the product of the student's weight, the number of steps and the height of the risers. (The teacher should make certain that pupils doing this activity are in good health before allowing the trial.)

Point out that such a large power (in many cases more than one horsepower) can only be developed by a human being for brief and infrequent periods.

The time is recorded in seconds. The amount of work done each second is power.

The power developed by a 140 lb. student running up a flight of stairs with a vertical distance of 7 feet in 2 seconds is computed as follows:

$$\text{Work} = 140 \text{ lb.} \cdot x 7 \text{ feet}$$

$$\text{Work} = 980 \text{ ft-lb.}$$

$$\text{Power} = 980 \text{ ft-lb.} / 2 \text{ seconds} = 0.89 \text{ ft-lb/sec.}$$

To determine the horsepower compare the power of the student to the rate at which a horse performs work:

$$\text{Horsepower} = \frac{490 \text{ ft-lb/sec.}}{550 \text{ ft-lb/sec}}$$

$$= 0.9 \text{ (approx.)}$$

KEY WORDS

power
foot-pounds
horsepower
watt

REFERENCE OUTLINE

MAJOR UNDERSTANDINGS AND
FUNDAMENTAL CONCEPTS

MATERIALSACTIVITIES

The rated horse power of gasoline engines is a test block rating. In reality the power at rear wheels is generally far less, e.g. a 3200 pound car capable of 0-60 mi/hr in 10 seconds requires 35.2 hp at the rear wheels, yet under the hood sits a V-8 rated at 200 or more h.p.

The school parking lot may be used to provide the horse power available at the rear wheels of any car if three variable can be measured. Find the weight of the car from the registration. Accelerate the car over a measured distance and record the time.

Using these figures of weight (in pounds), distance (feet) and time (seconds) the following formula may be used to compute horse power.

$$\frac{0.0003 W s^2}{t^3}$$

where w = weight (pounds)

s = distance (feet)

t = time (seconds)

The result of this is the horsepower available at the rear wheels.

UNIT III
HEAT ENERGY

UNIT III. HEAT ENERGY

I. Heat and Temperature

A. Internal Energy

1. Heat and Work
2. Unit of heat measurement

B. Temperature Scales

1. Subjective temperature
2. Objective temperature
3. Heat measurement
 - a. Fixed points

II. Expansion of Materials by Heat Energy

A. Expansion of solids

1. Solids expand when heated
2. Rate of expansion
3. Differential expansion of materials

III. Conservation of Energy

A. Law of Heat Exchange

1. Specific heat

B. Change of Phase

1. Freezing point
2. Melting point
 - a. Depression of freezing point
 - b. Change in volume when freezing
3. Vaporizing and Evaporation
 - a. Heat of vaporization
 - b. Evaporation
 - c. Sublimation
4. Condensing
 - a. Change in boiling point
 - b. Effect of pressure on boiling point

C. Heat transfer

1. Conduction in solids
 - a. Rate of conduction
2. Heat transfer in gases
3. Heat transfer in liquids
 - a. Convection currents in liquids
 - b. Convection currents in gases

IV. Radiant Energy

- A. Surface effects
- B. Unequal heating of earth's surface
- C. Heat absorption
- D. Radiation
 - 1. Infrared waves
 - 2. Radiometer

REFERENCE OUTLINEMAJOR UNDERSTANDINGS AND
FUNDAMENTAL CONCEPTSI. Heat Energy

A. Internal energy

Work done on an object may be stored in the object as an increase in its temperature.

1. Heat and Work

Work can be transformed into heat and heat transformed into work.

An increase in temperature is a measure of increased heat energy in a body.

MATERIALSACTIVITIES

Place water in a 500-ml. beaker or other container until the container is about half full. Determine the temperature of the water. Remove the thermometer. Beat the water for one minute with a manually-operated egg beater (or an electric egg beater). Determine the temperature.

Bend a piece of iron wire back and forth rapidly and feel it to note the rise in temperature.

Hold a rubber band lightly against the lips and quickly stretch it, noting the rise in temperature. After it has been held stretched for a few moments, allow it to contract quickly. It will feel cooler as a result of doing work. (Use of the lips as temperature sensitive devices has an interesting historical background. The blind scientist John Gough first performed this experiment in 1802.)

Draw a heavy nail out of a board, using a claw hammer, and feel its increased temperature.

Rub the palms of the hands rapidly together.

Pound a piece of lead hard several times and note the temperature rise.

A large smooth-headed nail can be held in chuck of a hand drill, pressed head down into a shallow hole in a block of wood and rotated rapidly. The smoke which soon arises is an indication of the temperature rise that results.

KEY WORDS

work
heat
temperature

A cardboard mailing tube containing lead shot and stoppered at both ends can be shaken for a few minutes. A noticeable increase in temperature can be felt.

REFERENCE OUTLINE

2. Unit of heat

MAJOR UNDERSTANDINGS AND
FUNDAMENTAL CONCEPTS

The energy stored in hot objects may be transferred to colder objects.

This transferred energy is known as heat.

Heat is a form of energy and is measured in a unit called the calorie.

One calorie is the heat necessary to raise the temperature of one gram of water one degree Celsius.

MATERIALSACTIVITIES

Heat a mass of metal in a container of boiling water. Place the mass of hot metal in cold water. Measure the temperature of the boiling water, the cold water and the cold water with hot metal.

Compare the temperatures of the metal and cold water before and after mixing.

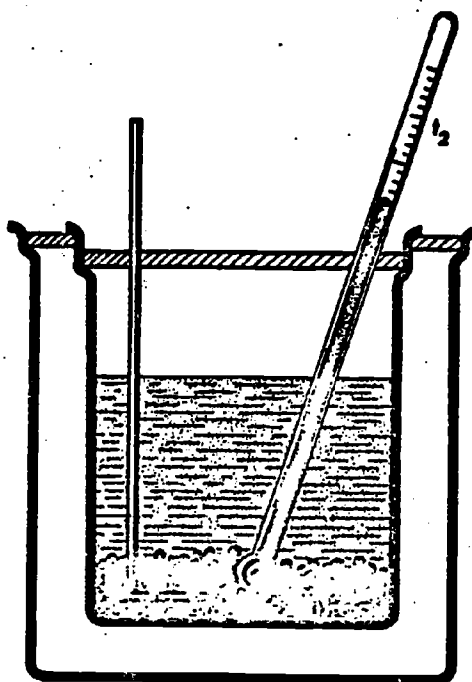

Calorimeter with lead shot, thermometer, stirrer, and water.

KEY WORDS

calorie

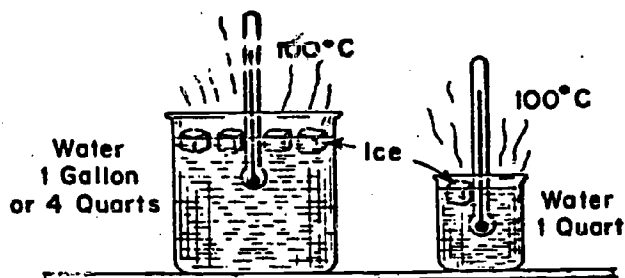

A gallon of water can supply 4 times as much heat as a quart of water at the same temperature.

REFERENCE OUTLINEMAJOR UNDERSTANDINGS AND
FUNDAMENTAL CONCEPTS

A. Temperature Scales

1. Subjective
Temperature

Body sensation is not a reliable measure of temperature. Previous body sensation affects later sensation.

2. Objective
Temperature

A thermometer is a reliable temperature measuring device.

MATERIALS

ACTIVITIES

Place one hand in a container of cold water, and the other in a container of hot water. After a few moments, place both hands in a container of water at body temperature. Compare the resulting temperature sensation. (Note: The temperature range of the middle container may be between 95-100°F.)



Are the temperature sensations we feel good indicators of the actual temperature?

KEY WORDS

thermometer

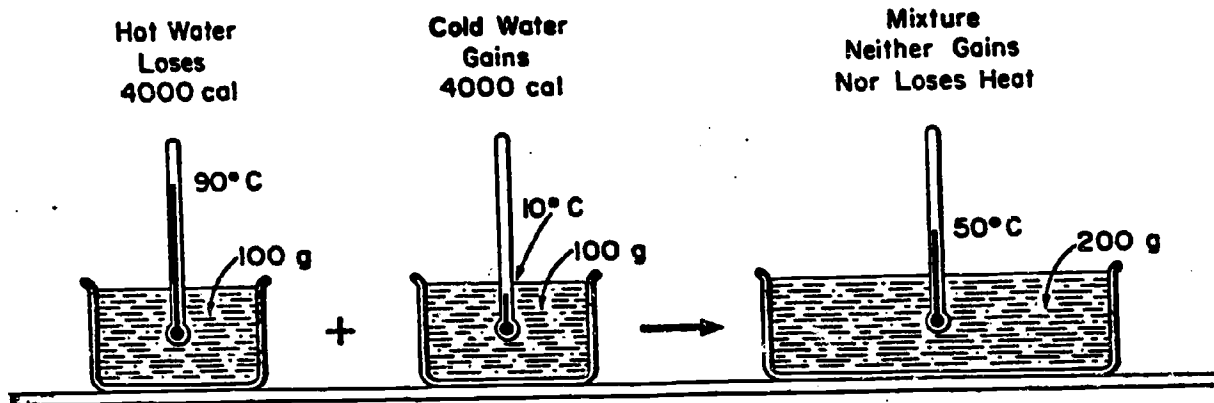

The heat lost by the hot water is gained by the cold water.

REFERENCE OUTLINE

3. Heat Measurement

a. Fixed Points

MAJOR UNDERSTANDINGS AND
FUNDAMENTAL CONCEPTS

The boiling and freezing points of water are known as the fixed points on a temperature scale.

These fixed points for the Fahrenheit scale are 212 degrees and 32 degrees.

These fixed points for the Celsius scale are 100 degrees and 0 degrees.

The Celsius degree is larger than the Fahrenheit degree.

The fixed points may be used to calibrate a blank thermometer.

Matter generally expands when heated and contracts when cooled.

Determine the boiling and freezing points of water on the Fahrenheit and the Celsius thermometer scales by this suggested method.

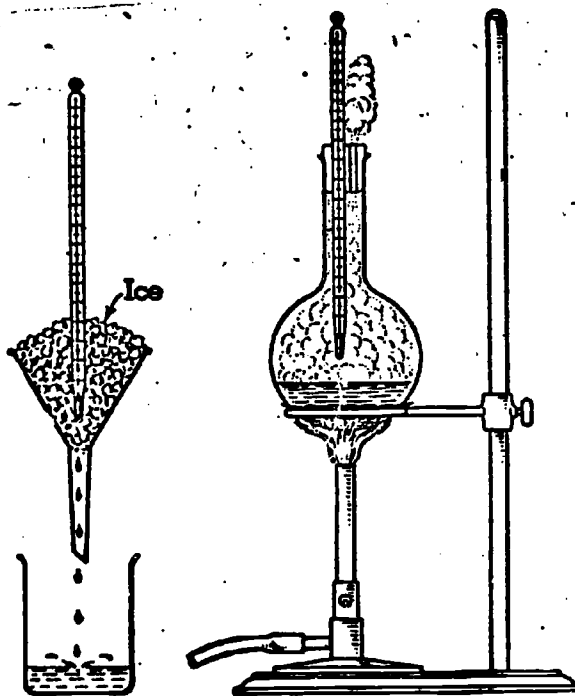

Note: Lubricate thermometer before attempting to insert into two hole stopper.

KEY WORDS

Boiling Point
Freezing Point
Celsius
Fahrenheit

The calibration of a blank thermometer is an interesting and valuable experience. These uncalibrated thermometers can be purchased from scientific equipment dealers. Run a piece of sandpaper along one side to roughen it enough to take pencil marks, without impairing visibility of the mercury column. Locate the freezing and boiling points of water in the usual way. Using a metric rule, mark off the space between these points in 10 equal lengths, thus locating intervals 10 degrees apart. Mark off individual degrees somewhere near the middle of the scale and test the accuracy of the result by comparing its reading with a commercially calibrated thermometer when both are in the same beaker of hot water. Agreement within a degree is easy to achieve.

REFERENCE OUTLINEII. Expansion by Heat
Energy of MaterialsA. Expansion of
Solids

1. Solids expand
when heated.

MAJOR UNDERSTANDINGS AND
FUNDAMENTAL CONCEPTS

Most solids expand when heated and contract when cooled.

The rate of expansion of solids is small.

MATERIALSACTIVITIES

Make a pendulum, using a loop of No. 28 chromel wire to support a 500-gm. mass as the bob. The support rod may be of any insulating material. Resistance wire of other gauge and material can be used. Connect the wire to the 120-volt mains through a rheostat of appropriately high wattage. With a 30-cm. pendulum of No. 28 chromel wire, a 25-ohm rheostat gives good control.

Adjust the length of the pendulum until it clears the desk top by about 1/4 inch while the wires are cold. Plug in the device and decrease the rheostat setting until the oscillating pendulum lengthens enough to scrape the desk because of the expansion of the wire. If the clearance is adjusted properly, the bob will not touch the desk until the glowing wires make the rise in temperature evident.

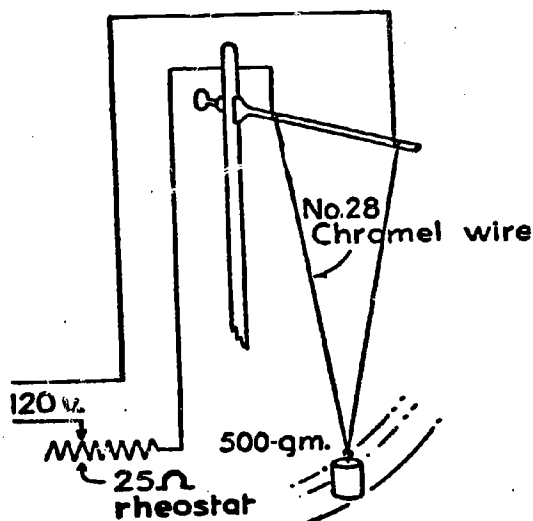
KEY WORDS

Expand
Contract

REFERENCE OUTLINE

MAJOR UNDERSTANDINGS AND
FUNDAMENTAL CONCEPTS

With few exceptions, metals expand when heated and contract when cooled.

MATERIALSACTIVITIES

A simplified form of the wire suspended pendulum may be performed by the students. Swing a pendulum suspended by a fine wire so that the bob just clears the base over which it swings. Heat the wire with a burner until the bob touches the base.

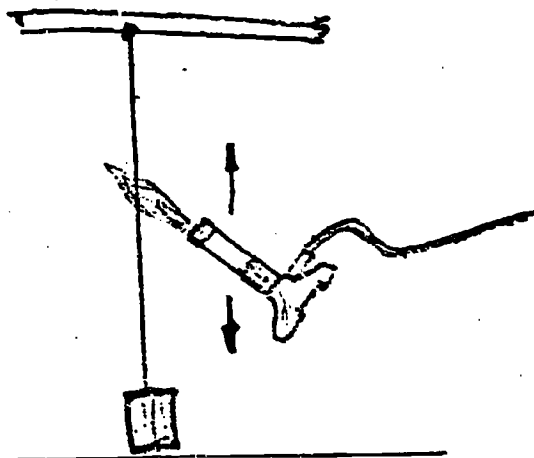
KEY WORDS

pendulum

Make sure that a strip of iron is securely fastened to a block of wood by means of large tacks at the ends as shown. Play a colorless Bunsen burner flame back and forth on the metal and observe any change in the shape of the iron. If the wood gets hot enough to burn, pour a little water on it. Observe the changes in the shape of the iron as it cools.

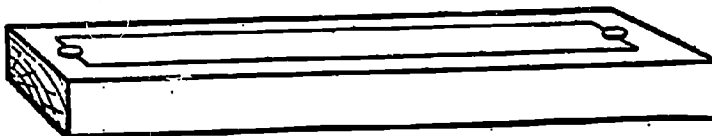

REFERENCE OUTLINE

MAJOR UNDERSTANDINGS AND
FUNDAMENTAL CONCEPTS

Electrical energy may be converted into heat.

Metal wire expands when heated by an electric current.

MATERIALSACTIVITIES

A long wire is stretched between supports on the lecture table and heated electrically. A rheostat of 20-amp capacity is included in the circuit. When R is 3 ohms, a 6-ft length of No. 20 nichrome wire will be heated to a bright yellow color on a 110-v line. The expansion and consequent sagging of the wire are made visible by hanging over it a white strip of asbestos or a small card held by a paper clip.

If an iron wire is used, the sagging is temporarily checked near 800°C , the recalescence temperature. A change in the crystal form of the iron occurs at this temperature. The reverse effect occurs on cooling. A vertical scale placed behind the wire may help to make its motion more evident. The conversion of electrical energy to heat may be noted by the color changes in the wire.

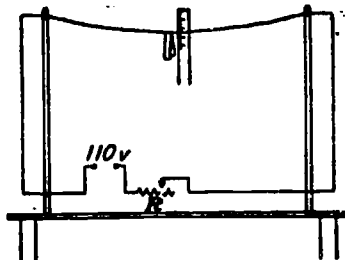
KEY WORDS

REFERENCE OUTLINEMAJOR UNDERSTANDINGS AND
FUNDAMENTAL CONCEPTS

2. Rate of Expansion

Most solids expand at different rates when heated.

MATERIALSACTIVITIES

The coefficient of linear expansion apparatus may be used to illustrate linear expansion of metals. Explain that the lever multiplies the distance expanded. This may be computed by comparing the distance B-C with A-B. Use several different metal rods.

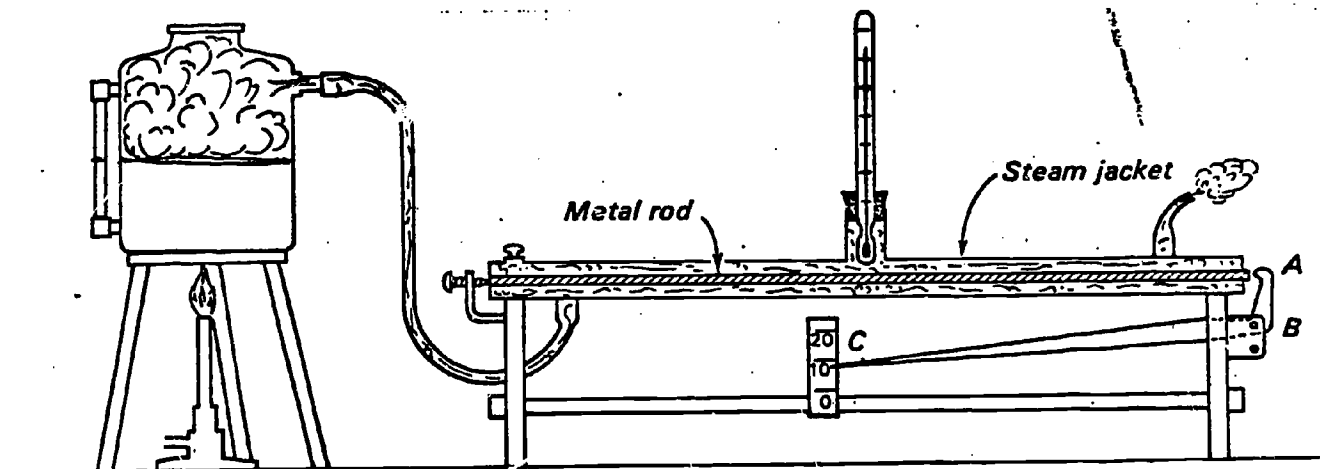
KEY WORDS

The expansion of rods or tubes of various metals, such as brass, iron, aluminum, invar, is shown by a number of standard pieces of apparatus. The specimen is clamped at one end; the other end rests on a needle free to roll on a glass plate or smooth surface. The needle carries a straw or other light pointer moving over a scale. The flame of a Bunsen burner is moved at a steady rate along the sample from one end to the other, and the change of the indicator needle noted.

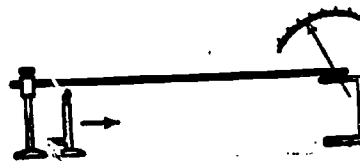

REFERENCE OUTLINE

MAJOR UNDERSTANDINGS AND
FUNDAMENTAL CONCEPTS

MATERIALSACTIVITIES

Get a piece of stout copper tubing about 2 m. long. Lay it on a table and fix one end by a clamp. Underneath the other end put a piece of bent knitting needle or bicycle spoke to act as a roller. A thin strip of balsa wood about 1 m. long fixed to the roller by sealing wax will show any movement of the rod resting on it.

Blow steadily down the tube at the fixed end, and the expansion of the tube caused by the hot breath will be detected by this arrangement. Now pass steam through, and the pointer will make a complete revolution or more, depending on the diameter of the roller. Repeat the experiment after the roller and pointer have been moved nearer to the loose end of the rod. Compare the results.

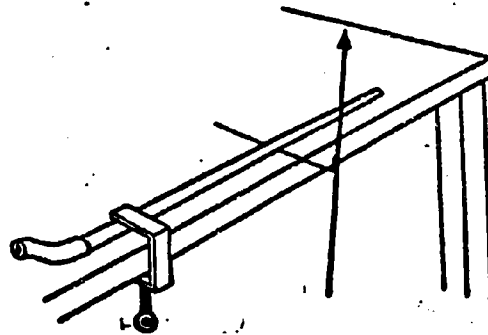
KEY WORDS

A short link of wire is attached to the center of the long electrically heated wire. A thread from the link is wrapped once or twice around a spindle carrying a light, balanced pointer and is kept taut by a weight or spring. Expansion of the wire is indicated by motion of the pointer.

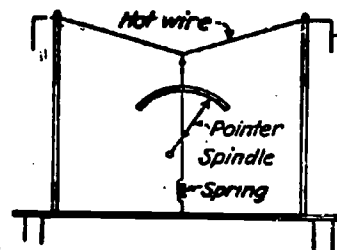

REFERENCE OUTLINE

3. Differential
Expansion of
Materials

MAJOR UNDERSTANDINGS AND
FUNDAMENTAL CONCEPTS

Different solids expand at different rates when heated.

A bimetal bar will change its shape when heated.

MATERIALSACTIVITIES

Varying rates of expansion of different solids may be shown by this method. Cut strips of sheet copper and iron of the same size--approximately 20cm. x 2cm. Clamp one end of the pair flat to a block of wood on the tabletop. Support the other end with a similar wood block. Between the free ends of the two pieces of metal place a darning needle thrust through a light, balanced cardboard pointer.

Heat the metal strips between the wood supports as impartially as possible with a bunsen burner flame. The pointer will turn, indicating their difference in expansion rate.

A similar pair of thin metal strips may be riveted or soldered together and will bend in response to temperature changes. If rivets are used, place them close together. If soldered, be sure not to heat the resulting bar to the melting point of the solder.

Commercially supplied bimetal bars are more durable and show a significant response to temperature change.

KEY WORDS

Bimetal bar

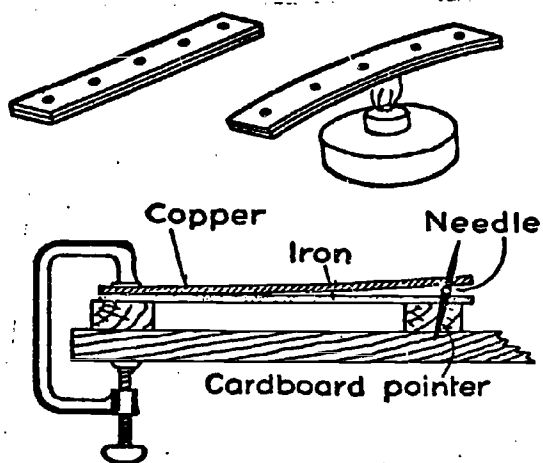

REFERENCE OUTLINE

MAJOR UNDERSTANDINGS AND
FUNDAMENTAL CONCEPTS

Thermostats operate on the principle of the unequal expansion and contraction of different materials.

MATERIALSACTIVITIES

A lamp, or bell, or both can be controlled by use of a compound bar provided with contact points. In the arrangement shown, the contact screws are adjusted so that the lamp is lit at normal temperature. When the bar is warmed with a match, the bell rings (an alarm indicating too high a temperature). After removal of the match flame the thermostat cools, turns off the alarm and turns on the light (indicating that it is still in operation).

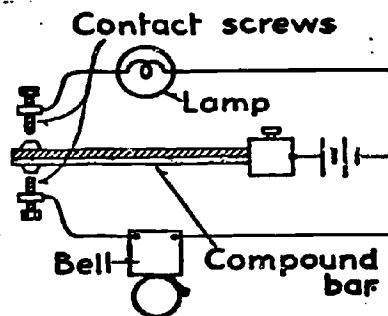

Show available commercial thermostats such as are used to control heating systems, electric irons or other devices. In each case connect the thermostat in a circuit with a flashlight bulb and dry cell and show it in operation by heating with a bunsen burner flame. The thermostat in irons, toasters, etc., frequently takes the form of a bimetal disc.

KEY WORDS

thermostat
control

REFERENCE OUTLINEB. Expansion of
LiquidsMAJOR UNDERSTANDINGS AND
FUNDAMENTAL CONCEPTS

Liquids expand when heated and contract when cooled.

Note: Water is an exception. Water expands when cooled between 4°C and its freezing point.

Different liquids expand at different rates when heated.

MATERIALSACTIVITIES

Fill a flask with colored water. A one hole stopper with a length of glass tubing is inserted. As the stopper is pressed into the neck of the flask, water rises in the tube. Mark the level of the water in the tube. Apply heat to the flask. The water level drops slightly at first as the glass expands and then rises as the water is heated and expands at a greater rate.

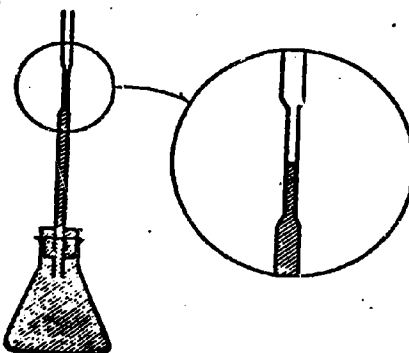
KEY WORDS

A comparison of the expansion of different liquids is possible. Identical test tubes are filled with the liquids to be tested and one-hole stoppers each containing a 6-inch length of glass tubing are inserted in the test tubes. If air is excluded, the liquid will rise in the tubing when the stopper is pressed into place. Adjust the liquid levels to be the same and support the test tubes side-by-side, using clamps and ring stands. When a beaker of hot water is raised so that the test tubes are equally immersed, the difference in expansion rates is apparent. The magnitude of the effect is increased by using larger containers, or tubing with a smaller bore.

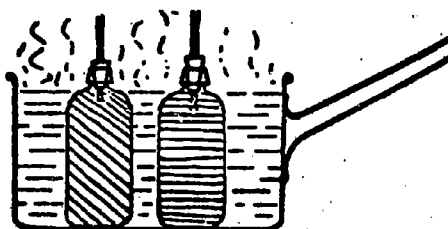

REFERENCE OUTLINE

MAJOR UNDERSTANDINGS AND
FUNDAMENTAL CONCEPTS

C. Expansion of
Gases

Gases expand when heated and
contract when cooled.

MATERIALSACTIVITIES

Expansion of gas may be shown by a flask provided with one-hole stopper and a length of glass tubing. Warm the bulb flask so that air bubbles out. As it cools, the decrease in pressure of the enclosed air allows water to rise in the tube.

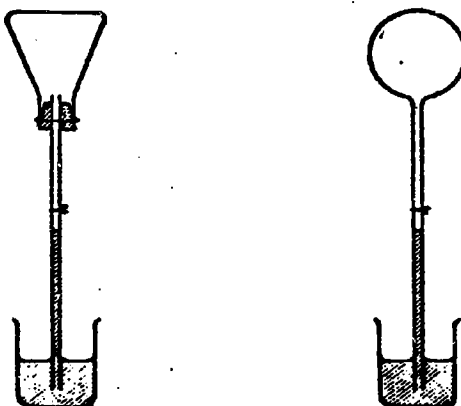
KEY WORDS

Another device for showing the expansion of a gas with increased temperature uses a flask and a solid stopper. A light coating of wax is wiped on the stopper so that it is airtight, but not too snug mechanically, the flask is heated gently and the stopper pops out.

REFERENCE OUTLINE

1. Rate of expansion of gases

MAJOR UNDERSTANDINGS AND
FUNDAMENTAL CONCEPTS

Gases expand at the same rate when heated.

The rate of expansion of gases is greater than that of liquids.

Different gases, unlike metals and liquids, expand and contract at nearly the same rate over a normal temperature range providing the pressure is constant.

MATERIALSACTIVITIES

The fact that different gases expand by approximately the same amount for identical temperature changes is troublesome to demonstrate. The following has proven to be a satisfactory method of showing this important fact. Support two test tubes side-by-side on a ring stand. Fit them with identical J-tubes dipped into a beaker of colored water. One test tube, which is to contain air, has a one-hole stopper. The other uses a two-hole stopper with a removable plug in one hole. Blow illuminating gas through this extra hole until it has bubbled freely from the beaker below for several seconds. Then quickly replace the stopper. You now have nearly identical enclosed volumes of two different gases, and a method of comparing their changes in volume when subjected to equal temperature changes.

Warm the test tubes gently with a burner to drive out some of the gases, allow them to cool and adjust the heights of the two columns of water to the same level by careful maneuvering of the stoppers and of the plug.

The test tubes may be warmed by raising a beaker of hot water so that they are equally immersed, and cooled by using ice water.

KEY WORDS

rate of expansion

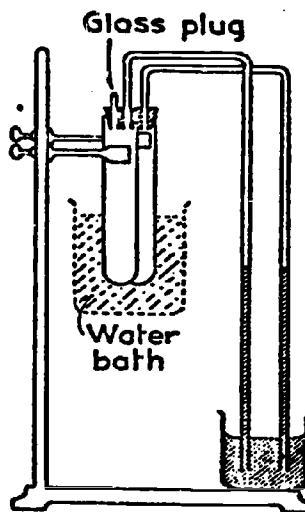

REFERENCE OUTLINEMAJOR UNDERSTANDINGS AND
FUNDAMENTAL CONCEPTS

III. Conservation of Energy

When two objects at different temperatures are brought together, the heat energy gained by the cold object equals the heat energy lost by the hot object.

A. Law of Heat Exchange
(2nd law of
Thermodynamics)

Heat flows from a body at the higher temperature to one at a lower temperature.

MATERIALSACTIVITIES

Add equal masses of water at its freezing point and at its boiling point to a foam plastic cup. Stir with a thermometer and measure the final temperature. Compare the temperature changes of the hot and cold water.

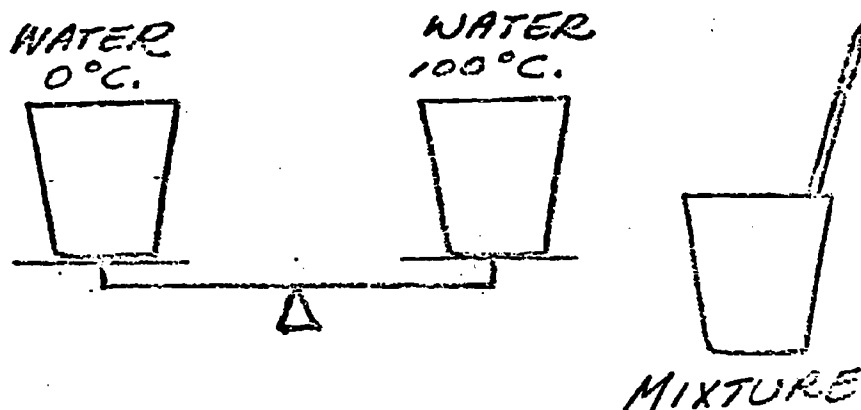

Calculate the heat lost by the hot water and heat gained by the cold water.

KEY WORDS

conservation

Heat exchange for water may be calculated:

$$\text{heat (calories)} = \text{mass (H}_2\text{O)} \times \text{temp. change}$$

(grams) (°C)

REFERENCE OUTLINE

MAJOR UNDERSTANDINGS AND
FUNDAMENTAL CONCEPTS

Equal masses of different materials at the same temperature contain different quantities of heat energy.

Water contains more heat energy per gram than almost any other material.

1. Specific Heat

Specific heat is the amount of heat necessary to raise one gram of a material one Celsius degree.

The specific heat of water is one.

The specific heat of water is very high compared with that of most other substances.

MATERIALSACTIVITIES

Add a mass of metal at the boiling point of water to an equal mass of water near its freezing point in a foam plastic cup. Stir with a thermometer and measure the final temperature.

Repeat using a different metal.

Note: Pb and Al have specific heats of .03 and .22 and give good results. Metals such as Fe (.11), Cu (.09) and Zn (.09) will yield intermediate results.

Compare the final temperatures of these mixtures to the final temperature of the hot-cold water mixture of the previous activity.

[Note: Metal samples of equal mass are commercially available from science supply companies.]

The specific heat of metals may be computed by dividing the temperature change of the water by the temperature change of the metal, or

$$\text{Specific heat} = \frac{\text{temp. change of water}}{\text{temp. change of metal}}$$

KEY WORDS

(for equal masses of material)

specific heat

Discuss the significance of the high specific heat of water to: a) climate; b) use in heat transfer systems; c) use in nuclear reactors.

REFERENCE OUTLINEMAJOR UNDERSTANDINGS AND
FUNDAMENTAL CONCEPTS

B. Change of Phase

1. Freezing Point

Heat must be removed from a substance during freezing.

The temperature at which a material becomes a solid is its freezing point.

The heat energy absorbed in melting or liberated in freezing a unit mass of a substance is a constant. This is the heat of fusion.

Each pure substance has its unique heat of fusion. The heat of fusion of water = 80 calories/gram.

MATERIALSACTIVITIES

A beaker contains crushed ice with about 30 ml. of alcohol poured over it. The temperature of this mixture will remain at about -15°C . A small test tube containing water and a thermometer stands in the beaker. The water level should be a little higher than the level of the freezing mixture. Allow the test tube and its contents to cool taking periodic temperature readings. Draw a graph of the result.

Note: Since this may be the student's first encounter with systematic data taking and graphing, it is suggested that students be provided with a printed data sheet and graph paper.

Time, min	Temp, $^{\circ}\text{C}$	Time, min	Temp, $^{\circ}\text{C}$	Time, min	Temp, $^{\circ}\text{C}$	Time, min	Temp, $^{\circ}\text{C}$	Time, min	Temp, $^{\circ}\text{C}$
$\frac{1}{2}$		$4\frac{1}{2}$		$8\frac{1}{2}$		$12\frac{1}{2}$		$16\frac{1}{2}$	
1		5		9		13		17	
$1\frac{1}{2}$		$5\frac{1}{2}$		$9\frac{1}{2}$		$13\frac{1}{2}$		$17\frac{1}{2}$	
2		6		10		14		18	
$2\frac{1}{2}$		$6\frac{1}{2}$		$10\frac{1}{2}$		$14\frac{1}{2}$		$18\frac{1}{2}$	
3		7		11		15		19	
$3\frac{1}{2}$		$7\frac{1}{2}$		$11\frac{1}{2}$		$15\frac{1}{2}$		$19\frac{1}{2}$	
4		8		12		16		20	

KEY WORDS

freezing point

melting point

REFERENCE OUTLINE

MAJOR UNDERSTANDINGS AND
FUNDAMENTAL CONCEPTS

MATERIALS

ACTIVITIES

The straight line portion of the graph will show no temperature change as the water freezes into ice.

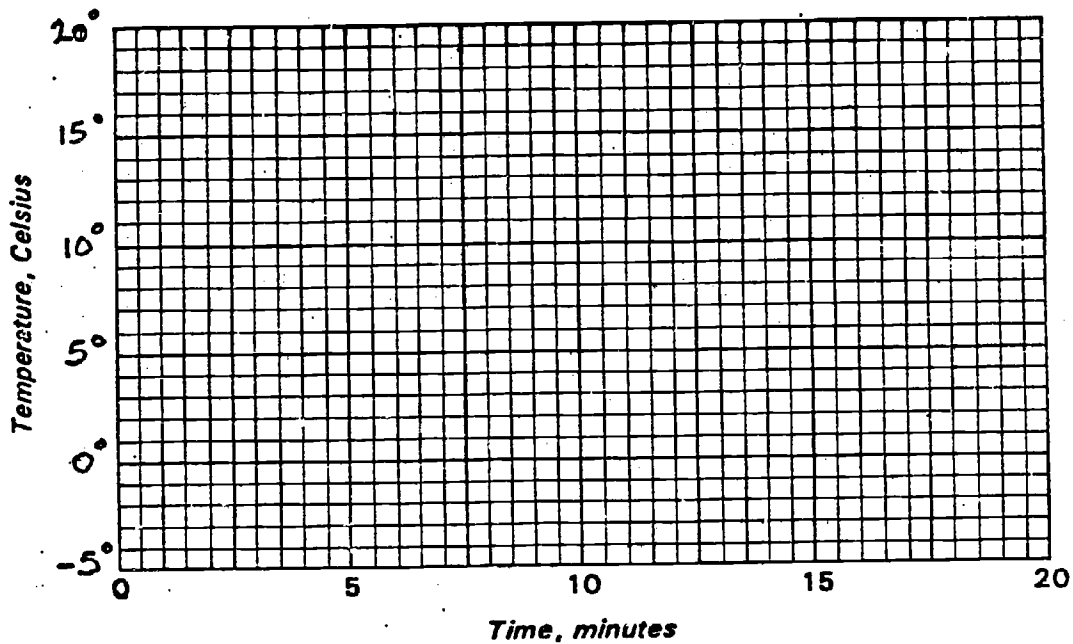

KEY WORDS

REFERENCE OUTLINEMAJOR UNDERSTANDINGS AND
FUNDAMENTAL CONCEPTS

2. Melting Point

Heat must be added to melt a substance. The temperature of a material does not change during melting.

The temperature at which a material changes from a solid to a liquid is its melting point and is the same as its freezing point.

- a. Factors affecting the melting point or freezing point

The addition of a salt to water will change (lower) the freezing point of the mixture.

Common salt (sodium chloride) melts ice and snow on highways by lowering the freezing point of water.

A mixture of common salt and calcium chloride helps to melt ice on roads if the temperature is within a given range.

MATERIALSACTIVITIES

Measure the temperature of a small container of crushed ice at half-minute intervals. Stir continually until all ice is melted and the ice water warms. Graph the results as in the previous activity.

Note: Heat energy to melt the ice flows from the surroundings but produces no temperature change in the ice water mixture.

Balance empty foam cups on a platform scale. Add equal weights of water at the same temperature. Then drop some chopped ice into one of the calorimeters, and an equal weight of ice water into the other. Compare the temperature changes of the contents of the two calorimeters.

Measure the temperature of a mixture of crushed ice and salt in a foam plastic cup. Since many lab thermometers are calibrated to -10°C , some estimating may be necessary to determine the final lowest temperature.

A mixture of 33 parts NaCl to 100 parts crushed ice yields a possible temperature of -21.3°C or -6.3°F .

KEY WORDS

Relate this depression of the freezing point of water to the use of NaCl as a method of removing ice and snow. What are disadvantages to the use of salt on roads for ice removal?

REFERENCE OUTLINE

b. Change in Volume
with Freezing

MAJOR UNDERSTANDINGS AND
FUNDAMENTAL CONCEPTS

Water expands when it freezes.

MATERIALSACTIVITIES

Fill a test tube with water, add a little ink or potassium permanganate for coloring and insert a one-hole stopper containing a 6-inch piece of glass tubing. Press the stopper down until water appears in the tubing. If the tubing is drawn out so as to decrease its bore, the effect to be observed will be increased.

Immerse the test tube in a jar containing a freezing mixture (chopped ice and alcohol or salt). The change in volume of the water as it cools can be observed by the changing level of the water in the tube. When

the water starts to freeze, the level in the tube rises quickly and finally water overflows from the open end.

If, after dropping, the water level remains stationary for a while, the water is probably undercooled. A sharp jar of the test tube and its contents will initiate the freezing, causing the water level to leap upward quickly.

Relate this expansion to the use of antifreeze solutions in automobile cooling systems.

KEY WORDS

antifreeze

REFERENCE OUTLINEMAJOR UNDERSTANDINGS AND
FUNDAMENTAL CONCEPTS3. Vaporizing and
Evaporation

Heat must be added to boil a substance. The temperature of a pure material does not change during boiling.

The temperature at which a material boils is its boiling point.

a. Heat of
Vaporization

The heat necessary to change one gram of water to one gram of water vapor at the same temperature is called the heat of vaporization.

The heat of vaporization of water is approximately 540 calories per gram. .

The rate of evaporation of a liquid is increased by heating.

Water (liquid) changes to water vapor (gas) as the temperature rises.

The temperature of a pure material remains constant during condensation or evaporation.

MATERIALSACTIVITIES

Slowly heat a container partially filled with water stirring continually. Record the temperature at half-minute intervals until boiling has occurred for several minutes.

Record the results on a temperature-time graph as in previous activities.

The nearly horizontal part of the graph represents heat added to change water to water vapor with no temperature change.

The features observed in raising the temperature of water to the boiling point and in boiling the water are less familiar than most students think. With a bunsen flame, heat a clean glass flask about half full of clear water. Have a two-hole stopper fitted with a thermometer and a short, bent delivery tube in the mouth of the flask. Note the following:

○ Almost as soon as heating is started, air, which has been dissolved in the water, is evolved as small bubbles which rise to the surface.

○ While the water is being heated, its temperature near the surface is not very different from its temperature near the bottom. Visible evidence of the convection currents can be seen by looking through the water at some bright object on the other side and noting the shimmering.

○ Steam bubbles at first form on the bottom and collapse as they come in contact with the cooler water above. The water is not boiling until the steam reaches the surface.

○ The temperature of water boiling furiously is the same as when boiling quietly.

○ The temperature of the steam above the surface of the boiling water is nearly the same as that of the boiling water. At this point the phenomenon of bumping may be encountered. The water ceases to boil for a few seconds, then bubbles of steam rise

violently to the surface. The temperature of the water rises above its boiling point while it is quiet, and drops sharply when the steam bubbles form.

○ The steam in the flask and at the end of the delivery tube is invisible. The cloud that is often called "steam" is really a cloud of water droplets.

○ Steam bubbles increase in size rapidly as they rise in the water in contrast to the negligible change in size of air bubbles.

KEY WORDS

heat of vaporization
water vapor
boiling

REFERENCE OUTLINEMAJOR UNDERSTANDINGS AND
FUNDAMENTAL CONCEPTS

b. Evaporation

Evaporation is a cooling process.

MATERIALS

alcohol
ethyl chloride
Freon
thermometer

ACTIVITIES

Cause air to move across a thermometer by waving it about. Note any temperature change.

Fasten a wick moistened with water to the bulb of the thermometer and wave it. Note any temperature change.

Substitute a wick with alcohol and wave about. Note any temperature change.

The evaporation of the liquid causes the cooling not the movement of air.

Take the temperature of a volatile liquid—alcohol or ether while it is in the bottle, to show that it is not appreciably different from room temperature. Then remove the thermometer and watch its indication drop as the liquid on the bulb evaporates. Using a small piece of cloth, such as a psychrometer wick, around the bulb increases the effect.

Ethyl chloride is used by physicians to produce local anaesthesia by cooling. This volatile liquid can be purchased in drug stores. It is usually sold in a small bottle, fitted with a valve and jet nozzle. The rapid evaporation of ethyl chloride and the resultant intense cooling can be demonstrated by squirting a small amount of liquid on the students' hands.

KEY WORDS

evaporation

Similarly, Freon gas may be used to illustrate the cooling effects of evaporation.

REFERENCE OUTLINE

C. Sublimation

MAJOR UNDERSTANDINGS AND
FUNDAMENTAL CONCEPTS

Some substances pass directly from the solid to the gas phase.

MATERIALS

naphthalene
paradichlorbenzene

ACTIVITIES

Some naphthalene mothballs or paradichlorobenzene crystals are heated in a beaker. A watchglass containing water is placed on the top of the beaker. The material in the beaker melts and vaporizes, but condenses in the solid state on the cool watchglass, forming a beautiful crystal array. See if the class knows the easiest way of cleaning such a watchglass. Of course, the easiest (though slowest) way is to set it aside for a while and let the material sublime. Try this.

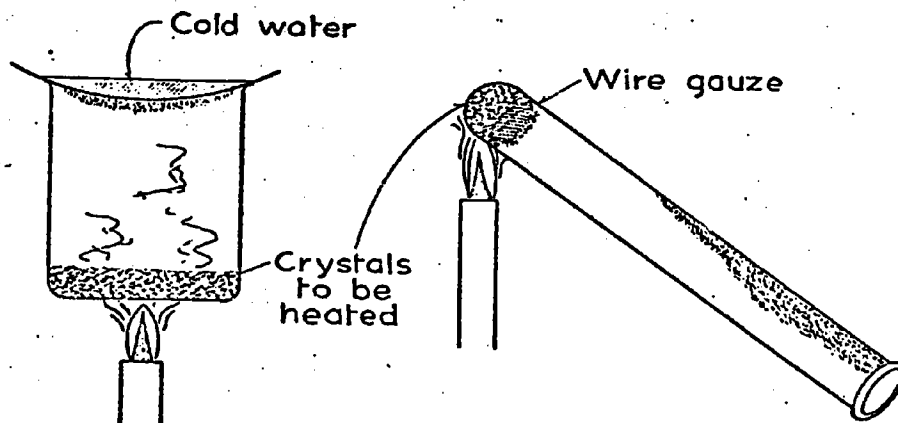

The sublimation of a solid can be shown by heating some iodine crystals in a test tube. Hold them in place with a small piece of wire gauze or a little wad of steel wool. Heat gently with the test tube inclined downward. The material will vaporize without melting, and resume the crystalline state on the cool lower part of the tube. The beautiful violet vapor of the iodine makes its use particularly effective.

KEY WORDS

sublimation

The solid form of carbon dioxide known as "dry ice" sublimates. An alcohol "dry ice" mixture provides a low temperature bath, -72°C , useful for low temperature demonstrations. An alcohol thermometer will be necessary for any measurements, since mercury freezes at -39°C .

A reference to the gas bearing and friction may be made here. Small pieces of CO_2 , if given a small push on a smooth level surface seem to glide frictionlessly in a uniform continuous motion.

REFERENCE OUTLINEMAJOR UNDERSTANDINGS AND
FUNDAMENTAL CONCEPTS

4. Condensing

Heat must be removed to condense a gas into a liquid.

The temperature of a pure substance does not change while condensing.

Condensation takes place at the same temperature as vaporization.

The temperature at which a material condenses is its boiling point.

During vaporization, heat is absorbed by the boiling liquid and stored in the resulting gas as internal energy.

This stored heat energy is released when the gas condenses back to its liquid form.

a. Change in boiling point

The boiling point of water is raised by the addition of a dissolved salt.

MATERIALSACTIVITIES

A qualitative demonstration serves to introduce the concept of heat of vaporization. Balance empty foam cups on a platform scale. Add equal weights of cool water at the same temperature. Take temperature readings to show that steam and the boiling water from which the steam is evolved are at essentially the same temperature.

Allow steam to bubble into cool water in one of the cups until several grams have been added, and measure the rise in temperature. Then add an equal weight of boiling water to the other cup and measure its temperature change. Compare the two to show that the steam supplies more heat than the boiling water at the same temperature.

Add salt or sugar to the boiling water to show the resulting increase in boiling temperature. The sudden increase in the rate of boiling when the material is first added is due to the formation of steam bubbles on the sharp edges of the little crystals.

KEY WORDS

condense
pressure

REFERENCE OUTLINEMAJOR UNDERSTANDINGS AND
FUNDAMENTAL CONCEPTSb. Pressure and the
Boiling Point

Increased pressure raises the boiling point of water.

Food cooks more quickly in a pressure cooker.

MATERIALSACTIVITIES

Increase the pressure on the surface of boiling water by the following method. Half fill a flask and close with a two-hole stopper containing a thermometer and a right-angle delivery tube.

Twist the stopper tightly into the neck of the flask. Connect a long right-angle tube to the delivery tube with a rubber connection, and insert the long arm of the tube deep in water in a cylinder. Boil the water in the flask vigorously. Read the temperature of the steam and record.

Remove the delivery tube from the water before discontinuing the heating. Note that pressure upon the boiling water has been increased by an amount equal to the water pressure at the lower end of the delivery tube.

Note: A 12 inch head of water will produce about one degree Celsius increase in boiling point. This activity may be related to the use of a pressure cooker.

KEY WORDS

pressure cooker

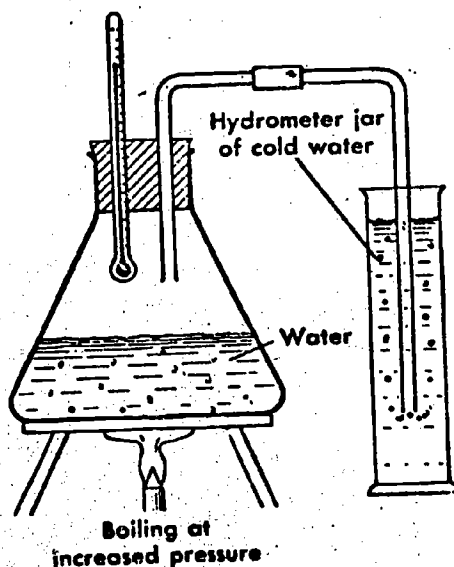

REFERENCE OUTLINEMAJOR UNDERSTANDINGS AND
FUNDAMENTAL CONCEPTS

Decreased pressure lowers the boiling point of water.

Water boils below 100°C , as the pressure on its surface is lowered.



MATERIALSACTIVITIES

(Teacher Demonstration)

This demonstration is a familiar classroom favorite, amazing to the uninitiated and sound in its instructional features.

Boil water hard for several minutes in a round bottomed flask. Remove the heat and stopper the flask. Using a towel or a clamp to handle the flask of hot water, invert it in a ring, and raise a beaker of water so that the stoppered mouth of the flask is submerged. This prevents air from leaking past the stopper. The space above the water now contains very little air, the water vapor at a pressure determined by its temperature. Cool the top of the flask by pouring cold water over it. This causes the vapor pressure to decrease and the water in the flask to boil. With care in the initial handling of this experiment, the water can be boiled at room temperature by cooling the flask with ice, or with a pad soaked in a volatile liquid.

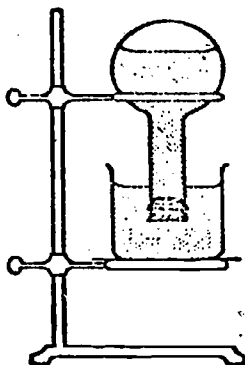
KEY WORDS

A special flask, having a reversed curvature of the bottom, is produced commercially for this demonstration. Ice can be placed in the cup thus formed, and condensation of the vapor within the flask is made more easily visible.

It may be desirable to use a one-hole stopper containing a thermometer so that the temperature of the boiling water can be taken. If this is done, make sure that the thermometer is a tight fit in the stopper. If the thermometer slides smoothly in the hole, wrap a rubber band tightly around it on the outside of the stopper so that atmospheric pressure cannot force it into the flask as cooling progresses.

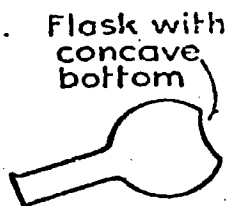

REFERENCE OUTLINE

MAJOR UNDERSTANDINGS AND
FUNDAMENTAL CONCEPTS

MATERIALSACTIVITIES

If a good vacuum pump is available, it is possible to lower the boiling point of water until it is the same as the freezing point. On the plate of the vacuum pump place an evaporating dish containing about 20 ml. of concentrated sulfuric acid. Mount a watchglass containing the water to be frozen over the acid by means of a pipestem triangle. Use as small a bell jar as will enclose the apparatus.

As the pressure drops, the water boils, the vapor being absorbed by the acid. The water temperature drops as a result of this rapid evaporation. If the pump is sufficiently effective, and the vacuum system free of leaks, the boiling continues until the freezing point is reached, and the last steam bubbles have to break through the ice to emerge.

If the pump and vacuum system are known to be in good shape and the experiment does not succeed, the acid may not be sufficiently concentrated. The same acid should not be used repeatedly for this purpose. Apparent failure of the experiment may be due to undercooling of the water which will reveal itself when freezing does occur by the suddenness of formation of the ice crystals.

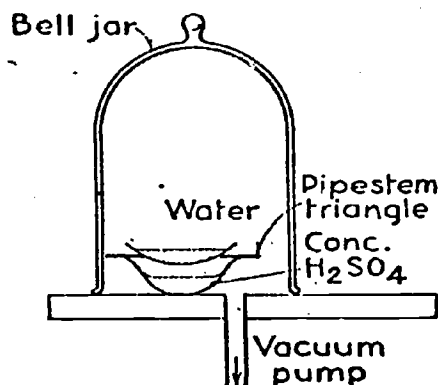
KEY WORDS

vacuum

Note: Calcium chloride or commercial dessicants may be substituted for the concentrated sulfuric acid.

Why is it necessary for astronauts to wear pressure clothing and travel in a pressurized cabin in travel through space? Relate these facts to the principle that the boiling point of a liquid is lowered under reduced pressure.

REFERENCE OUTLINEMAJOR UNDERSTANDINGS AND
FUNDAMENTAL CONCEPTS

C. Heat Transfer

Heat energy transfers from the hot region of a solid to a colder region.

1. Conduction
in Solids

Heat energy travels through solids by a process called conduction.

MATERIALSACTIVITIES

Heat one end of a metal strip to which small uniform metal objects have been "glued" with wax.

Sheet copper strips 12 inches long and one inch wide are prepared and one cent pieces are attached at one inch intervals. Small washers may be substituted for one cent pieces. The end of the copper strip is bent ninety degrees to reach into a beaker of boiling water.

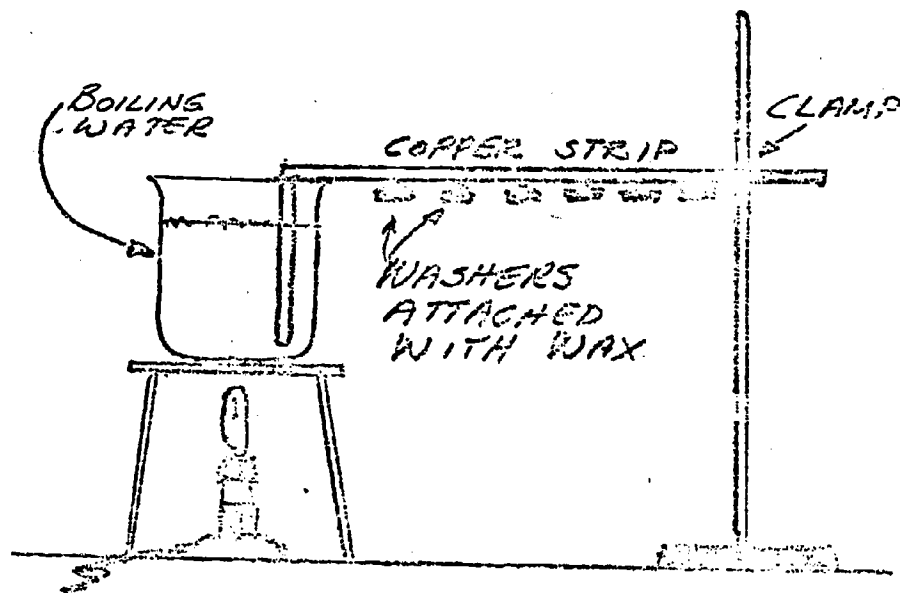
KEY WORDS

transfer
conductor

A variation of this exercise may be performed with temperature sensitive copying paper, e.g. "Thermofax", covering the metal strip. The advance of the temperature increase along the bar may be noted by the darkening of the paper.

REFERENCE OUTLINEMAJOR UNDERSTANDINGS AND
FUNDAMENTAL CONCEPTS

- a. Rate of Conduction Metals vary in their ability to
conduct heat energy.

MATERIALSACTIVITIES

Copper, iron and aluminum wires of similar dimensions, same gauge and length, are twisted together at one end to make a conductometer.

Heat from a burner is applied at the junction. The relative conductivity of these metals is judged by the order of fall of small metal objects attached to the wires with wax.

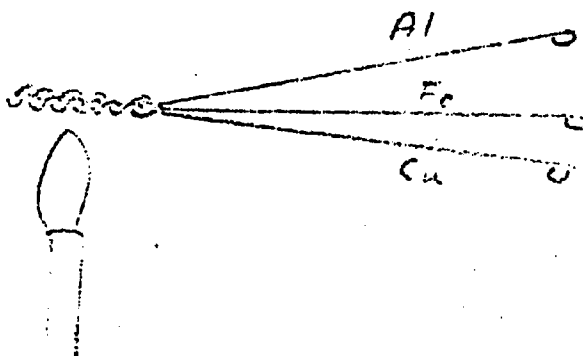

Note: If the conductivity of copper is assumed to be 1 on a scale of 0-1, then aluminum is .5 and iron is .16.

KEY WORDS

conductivity

REFERENCE OUTLINE

MAJOR UNDERSTANDINGS AND
FUNDAMENTAL CONCEPTS

2. Heat Transfer
in Gases

Warm air is less dense than cold
air.

MATERIALSACTIVITIES

Tie strings around the necks of two large flasks. Suspend the flasks from each end of a yardstick or meter stick. Suspend the center of the stick from a support as shown in the diagram and find the point at which the flasks just balance each other.

Now heat one of the flasks with the flame of a burner. This will expand the air and drive some of it out of the flask. The air in the heated flask will then weigh less than the air in the unheated flask and the flasks will no longer balance each other exactly. Try to bring them back into balance by heating the other flask.

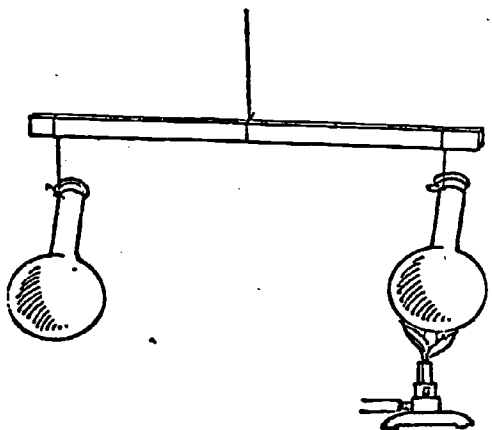
KEY WORDS

dense

REFERENCE OUTLINEMAJOR UNDERSTANDINGS AND
FUNDAMENTAL CONCEPTS3. Heat Transfer
in Liquids

Currents are set up in liquids caused by differences in density of the liquid due to temperature differences.

a. Convection
Currents
in Liquids

MATERIALSACTIVITIES

Place approximately 400-ml. of water in a 500-ml. beaker. Set the beaker on a tripod. Apply heat to the center of the bottom of the beaker. Add two or three crystals of potassium permanganate or two or three drops of ink to the water. Note the direction of the currents as shown by the movement of the coloring material.

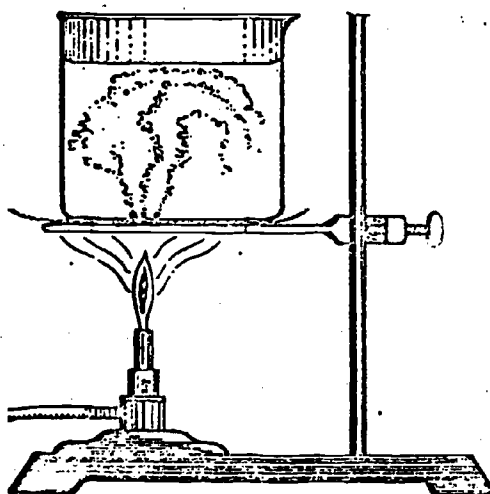
KEY WORDS

convection
currents

Fill a beaker with water. Put some grated blotting paper particles or sawdust in the water and give them time to settle to the bottom. Now place the beaker over flame and begin to heat it. Observe the paths taken by the particles of paper. The paper particles follow the convection currents set up in the water.

REFERENCE OUTLINE

MAJOR UNDERSTANDINGS AND
FUNDAMENTAL CONCEPTS

1. The student should understand that the Earth is a sphere and that it rotates on its axis. This rotation causes the day and night cycle. The student should also understand that the Earth is tilted on its axis, which causes the seasons.

MATERIALSACTIVITIES

Fit an ink bottle or paste jar with a cork carrying two pieces of glass tubing as shown in the diagram. One piece of tubing should be drawn out to a jet like the end of a medicine dropper. This tube should be put just through the cork and should extend about two inches above. The other tube should be just level with the cork and extend nearly to the bottom of the bottle. Fill the bottle with very hot water that has been coloured deeply with ink.

Now fill a large glass jar such as a battery jar or cookie jar with very cold water. Rinse off the ink bottle and quickly place it on the bottom of the large jar. Observe what happens. Can you explain this?

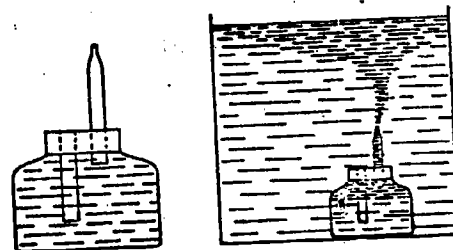

The small bottle may be filled with warm water and a few drops of phenolphthalein solution and a small amount of a hydroxide added to the large battery jar and stirred well.

Commercially prepared convection loops are available. Cork dust or dye in the water illustrates convection currents set in motion when tube is heated at bottom corner.

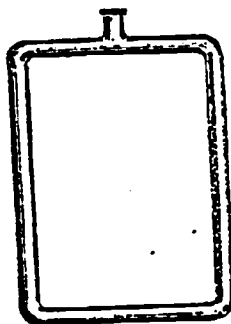
KEY WORDS

REFERENCE OUTLINE

MAJOR UNDERSTANDINGS AND
FUNDAMENTAL CONCEPTS

- b. Convection
Currents in
Gases

Currents are set up in gases caused by differences in density of the gases due to temperature differences.

Transfer of heat energy by currents in liquids and gases is known as convection.

MATERIALSACTIVITIES

Obtain a circular disk of thin sheet metal, eg., the cut out from a coffee can or large fruit juice can or disposable aluminum pie pans. Cut teeth in the circumference and pivot it on a bent knitting needle. Hold it above a candle flame, and it will revolve rapidly. A paper spiral supported on a knitting needle will revolve in a similar way.

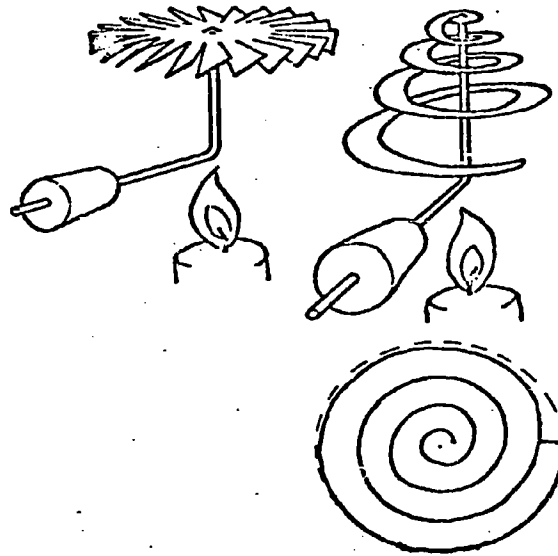
KEY WORDS

REFERENCE OUTLINE

- IV. Radiant Energy
 - A. Surface Effects

MAJOR UNDERSTANDINGS AND
FUNDAMENTAL CONCEPTS

Dark surfaces radiate heat energy at a greater rate than light surfaces.

Dark surfaces absorb heat energy at a greater rate than light surfaces.

MATERIALSACTIVITIES

Secure three tin cans of the same size. Paint one white, inside and out, and another one black; leave the third one shiny. Fill the three cans with warm water at the same temperature. Record the temperature. Place cardboard covers on each can, set them on a tray, and then put them in a cool place. Record the temperature of the water in each can at five-minute intervals. Was there a difference in the rate of cooling? Which surface was the best radiator of heat? Which the poorest?

Next fill the cans with very cold water, record the temperature, cover each can and place them in a warm place or in the sun or equidistant from strong lamp or heater coil.

KEY WORDS

absorb
radiate

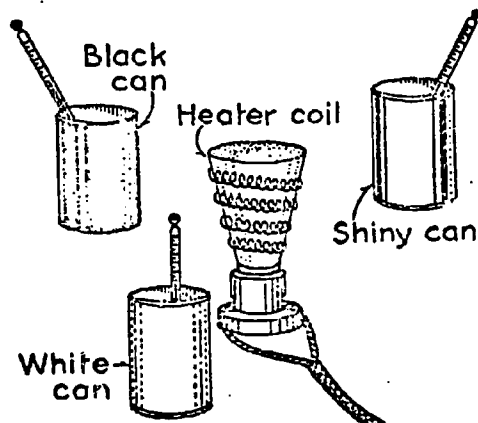

REFERENCE OUTLINE

B. Unequal heating
of the earth's
surface

MAJOR UNDERSTANDINGS AND
FUNDAMENTAL CONCEPTS

Unequal heating of land and water
surfaces by the sun cause con-
vection currents (wind).

MATERIALSACTIVITIES

To show the unequal heating of land and water, place some soil in one beaker and fill the other to the same level with water. Allow the containers to remain in a shaded place until their temperatures are the same. Then set the beakers in direct sunlight. Support a thermometer in each dish with the bulb just covered.

Read the thermometers every 10 minutes during a class period and determine which gains faster. Relate the results to the development of land and sea.

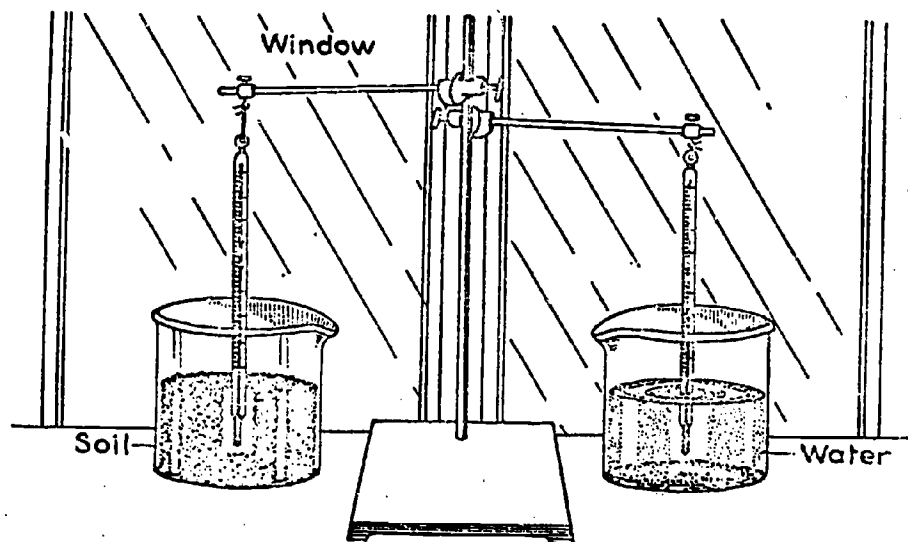
KEY WORDS

wind
radiant energy

REFERENCE OUTLINE

MAJOR UNDERSTANDINGS AND
FUNDAMENTAL CONCEPTS

C. Heat absorption

Surface materials affect rate of heat absorption.

MATERIALSACTIVITIES

Another simple way to show unequal rates of absorption of heat is shown in the diagram. Pour equal amounts of water into two test tubes, one of which is covered with soot. Insert thermometers in each and set the two tubes side by side in direct sunlight. Compare the temperatures after a period of about 20 minutes. Relate the results to the causes of local winds.

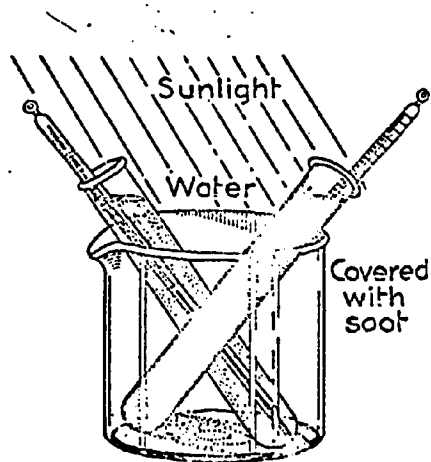
KEY WORDS

REFERENCE OUTLINE

MAJOR UNDERSTANDINGS AND
FUNDAMENTAL CONCEPTS

MATERIALSACTIVITIES

An interesting variation to show the heating effect of radiation on surfaces is to prepare two flasks as shown. Cover one flask with aluminum foil; the other with black paper. Connect to a manometer.

Expose the flasks to a source of radiant energy. Note changing levels in the manometer.

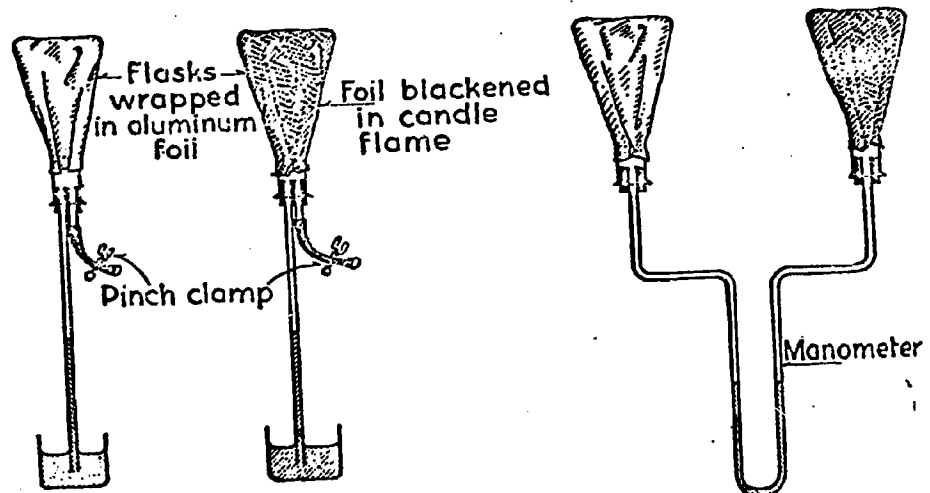
KEY WORDS

REFERENCE OUTLINEMAJOR UNDERSTANDINGS AND
FUNDAMENTAL CONCEPTS

D. Radiation

1. Infrared waves

The transfer of heat energy by waves is known as radiation.

Radiant heat energy is transferred in the infrared portion of the electromagnetic spectrum.

Infrared radiations are in the invisible portion of the spectrum.

MATERIALSACTIVITIES

Heat lamps used to treat muscular ailments produce infrared radiations which are longer than those of visible light. The accompanying diagram shows an effective way to produce infrared rays and shows how they can be focused in the same manner as visible light. The iodine solution stops the visible light but allows the longer infrared wave lengths to pass through.

The ability of the infrared rays to pass through this solution can be related to their use in taking aerial photographs through fog and haze.

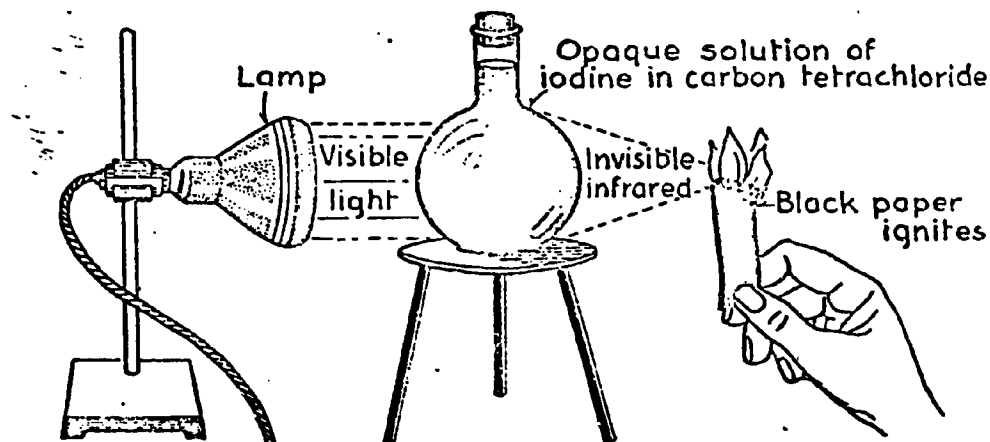
KEY WORDS

invisible waves

A radiometer or heat sensitive paper may be substituted for the black paper. To see the radiometer speed increased by putting an opaque material between it and the arc is surprising to a class. The position of the flask with respect to the radiometer is critical. The focal point can be located by moving the hand about beyond the flask.

REFERENCE OUTLINE

MAJOR UNDERSTANDINGS AND
FUNDAMENTAL CONCEPTS

2. Radiometer

A radiometer detects infrared radiations.

MATERIALSACTIVITIES

The radiometer is a fascinating device, and useful in the classroom as a detector of radiation. The unequal heating of the dark and silvered sides of its vanes and the recoil resulting when air molecules rebound from one side faster than from the other may be understood by the class.

The vanes can be made to turn by bringing a burning match or bunsen burner near. Response to infrared rather than visible radiation should be shown by using a heated metal object or a hot electric iron.

After having it rotate quite rapidly, removal of the source of heat will cause it to slow down, stop and reverse its rotation as the dark side of the vanes cool more quickly than the polished side. Substituting a beaker of ice water for the source of heat, or swabbing the glass envelope with alcohol or ether brings about a greater response.

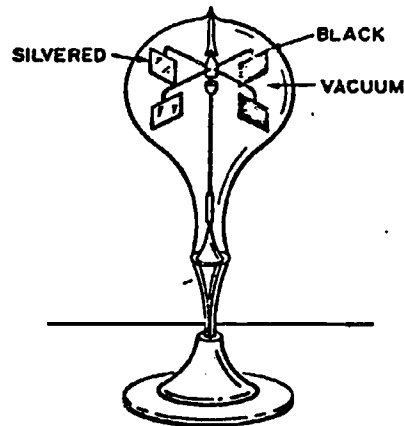

Radiometer.

KEY WORDS

UNIT IV

ENERGY TRANSFER BY WAVE MOTION

UNIT IV

ENERGY TRANSFER BY WAVE MOTION

I. Energy Transfer

- A. Velocity
- B. Frequency
- C. Amplitude
- D. Wave length

II. Sound

- A. Produced by vibrating object
- B. Transmission of sound
 - 1. Solids
 - 2. Liquids
 - 3. Air
- C. Characteristics of Sound
 - 1. Frequency (pitch)
 - a. length of vibrating string
 - b. mass of string
 - c. tension of string
 - d. length of air column
 - 2. Resonance
 - 3. Wave length
 - 4. Speed
 - 5. Amplitude

REFERENCE OUTLINE

I. Energy transfer

A. Velocity

MAJOR UNDERSTANDINGS AND
FUNDAMENTAL CONCEPTS

Energy is transferred by waves.

The speed at which energy moves from a source is called the wave's velocity.

MATERIALSACTIVITIES

Let waves transfer energy from one student to another by a long rope. Let one student shake a rope and the other passively hold the free end.

Drop an object into a container of water. Observe the resulting motion of a cork at opposite side.

Transfer energy between two students by means of a spring. Note the effects of a shaking motion, the compression and sudden release of a few coils and a twisting motion.

KEY WORDS

velocity

REFERENCE OUTLINE

B. Frequency

MAJOR UNDERSTANDINGS AND
FUNDAMENTAL CONCEPTS

The number of vibrations per second (vps) is known as a wave's frequency.

The Hertz, one vibration per second, is a unit of frequency.

C. Amplitude

The energy transmitted by a wave depends on the distance through which the energy source vibrates.

MATERIALSACTIVITIES

Produce energy waves in the rope by shaking the hand slowly for a short time period, e.g. 10 seconds. Count the number of downward strokes of the hand. Repeat shaking the rope rapidly. Calculate the number of vibrations per second by dividing the number of strokes by ten.

Produce energy waves in a rope by shaking the hand over a small distance. Repeat shaking the hand over a large distance. Maintain the same frequency. Compare the waves produced and the energy transmitted.

KEY WORDS

frequency
amplitude

REFERENCE OUTLINE

D. Wave length

MAJOR UNDERSTANDINGS AND
FUNDAMENTAL CONCEPTS

The distance energy moves during one vibration is called its wave length.

MATERIALS

ripple tank
stroboscopic
light

ACTIVITIES

Measure the length of a projected wave image using a ripple tank and a stroboscope.

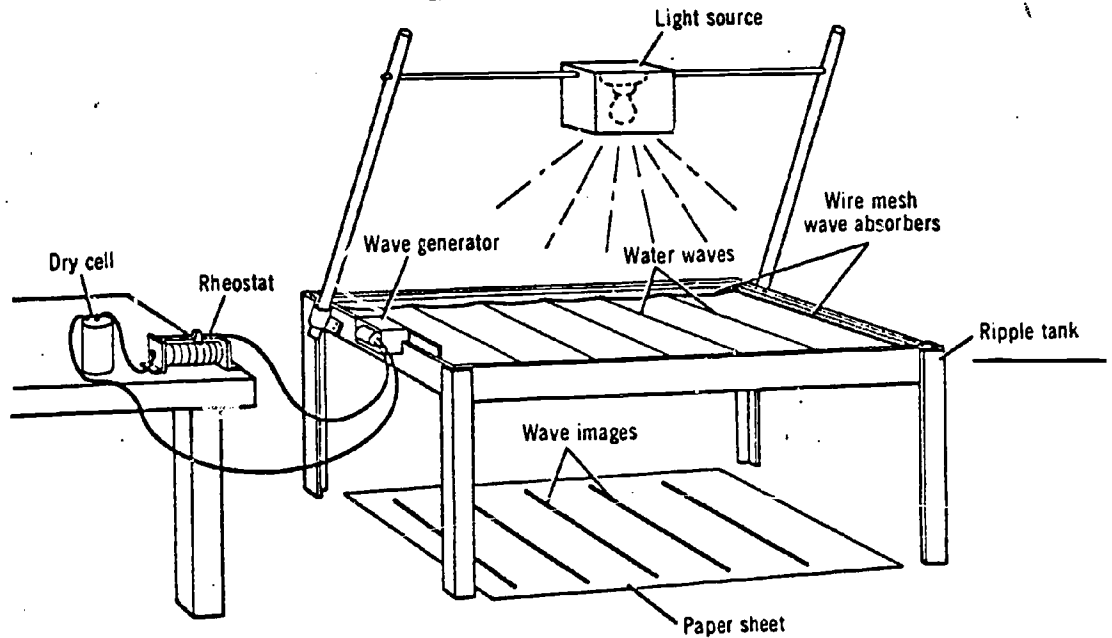

Rotate the hand held stroboscope at varying speeds until the motion of the waves is apparently stopped.

KEY WORDS

wave length

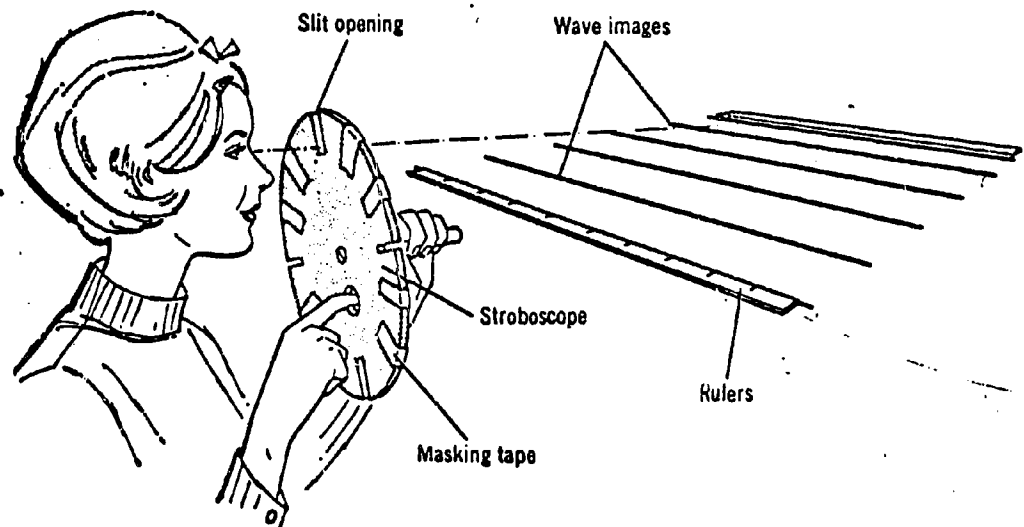

Using the stroboscope to measure wavelength.

An alternate method involves using a stroboscopic light source to "stop" the waves.

REFERENCE OUTLINE

MAJOR UNDERSTANDINGS AND
FUNDAMENTAL CONCEPTS

MATERIALSACTIVITIES

Note to teacher: The distance between bright line images is one wave length, i.e. the distance from crest one water wave to the crest of the adjoining water wave.

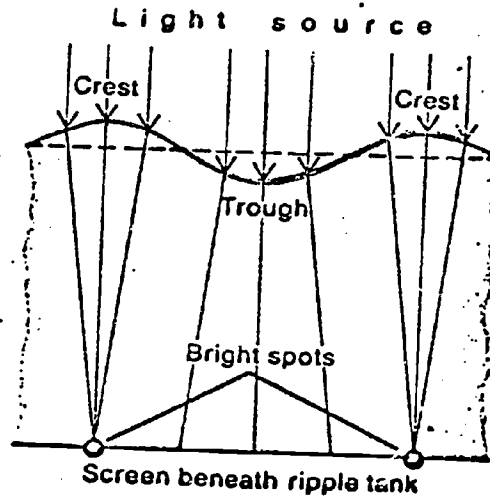
KEY WORDS

crest
trough

REFERENCE OUTLINE

MAJOR UNDERSTANDINGS AND
FUNDAMENTAL CONCEPTS

II. Sound

- A. Produced by a vibrating object

Sound is produced by vibrating objects.

Sound is transmitted by longitudinal waves through materials (solids, liquids, gases). In contrast, light and other electromagnetic waves are transverse waves and can pass through a vacuum such as outer space.

MATERIALS

tuning fork

ACTIVITIES

Let the students try to produce sound from as many different sources as possible from materials in the classroom. What do these sounds have in common?

E.g., place a vibrating tuning fork in a beaker of water; snap edge of ruler held on edge of desk; blow through a drinking straw which has one end with corners cut and flattened; pluck stretched rubber band; hold hand against vocal chord while humming.

KEY WORDSvibrating
sound

REFERENCE OUTLINE

MAJOR UNDERSTANDINGS AND
FUNDAMENTAL CONCEPTS

B. Transmission of
Sound

1. Solids

Sound is transmitted through solids.

MATERIALS

tuning forks
 spoon
 string

ACTIVITIES

Strike a tuning fork and hold its base on a table top; put your ear to the table top.

Tie a spoon at the center of a long piece of string, e.g. four to five feet long. Hold each end with your fingertips. Press both ends to your ears and bend down so that the string and the spoon hang freely. Hit the spoon lightly.

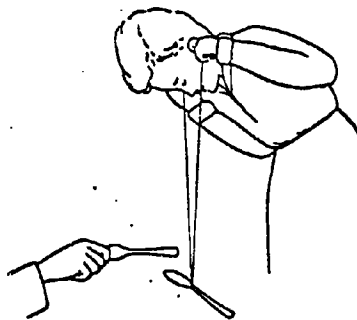

Fasten the bases of two paper cups or tin cans to a length of string. If the string is stretched nearly taut, one cup may be used as a transmitter and the other as receiver.

KEY WORDS

transmit

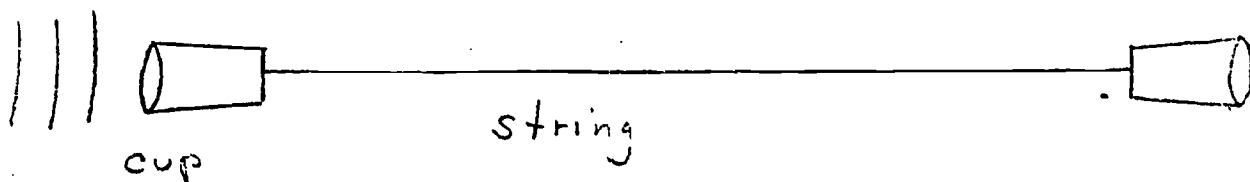

REFERENCE OUTLINE

2. Liquids

MAJOR UNDERSTANDINGS AND
FUNDAMENTAL CONCEPTS

Sound is transmitted through liquids.

3. Air

Sound is transmitted through air.

Sound does not travel in a vacuum.

MATERIALS

tuning forks

ACTIVITIES

Strike a tuning fork and wait until the vibrations become inaudible. Then place the handle between the teeth*. The sound will again be heard.

The handle of the tuning fork may also be placed against the bone behind the ear.

Place the stem of a vibrating tuning fork into a container of water that is resting on a table top. Place your ear to the table top.

Demonstrate the effect on the sound when a bell jar containing a ringing bell is evacuated and then when the air is allowed to re-enter the jar slowly.

KEY WORDS

vacuum

*Use extreme caution when placing a vibrating tuning fork on a tooth.

REFERENCE OUTLINE

C. Characteristics
of sound

1. Frequency

MAJOR UNDERSTANDINGS AND
FUNDAMENTAL CONCEPTS

The frequency of a sound wave
determines the pitch of the
sound.

MATERIALS

meter stick

ACTIVITIES

Clamp a meter stick to a table and cause it to vibrate.

Change the length of the end free to vibrate. Compare the frequencies of the vibrating meter sticks. Compare the sounds produced.

Demonstrate changes in pitch with tuning forks of different frequencies.

KEY WORDS

frequency
pitch

REFERENCE OUTLINE

- a. length of a string

MAJOR UNDERSTANDINGS AND FUNDAMENTAL CONCEPTS

The length of a vibrating string determines the pitch of the sound produced.

As the length of the string decreases, the pitch increases.

- b. mass of string (diameter)

*As the mass of the string increases, the pitch decreases.

- c. tension of string

As the tension of a string increases, the pitch of the sound produced increases.

*Thickness of a vibrating string affects the pitch.

MATERIALS

sound box
(violin)

ACTIVITIES

Apply a constant force to a length of stretched string. Pluck the string and note the pitch of the sound produced. Shorten the string by moving the bridge and note the pitch of the sound.

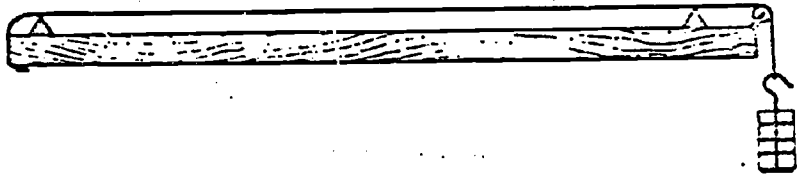

Apply similar forces to two strings of equal length but different diameter. Pluck the strings and compare the pitches of the sounds produced.

Apply increasing force to a string of constant length. Compare the pitches of the sounds produced.

KEY WORDS

REFERENCE OUTLINE

- d. length of an air column

MAJOR UNDERSTANDINGS AND FUNDAMENTAL CONCEPTS

Air columns can be made to vibrate and produce sound. The length of the vibrating air column determines the pitch of the sound produced.

As the length of the air column decreases, the pitch increases.

MATERIALSACTIVITIES

Flatten an end of a soda straw; cut both corners off the flattened end. Blow into the flattened end to produce vibrations. Cut off open end of straw bit by bit. Compare the pitches of the sounds produced.

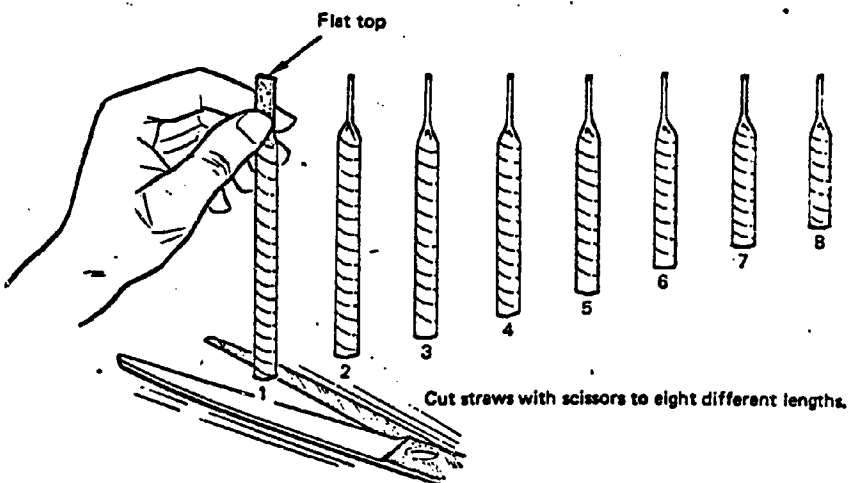

Blow across the mouth of a test tube or bottle. Add water to the container in small increments. Compare the pitches of the sounds produced.

KEY WORDS

air column

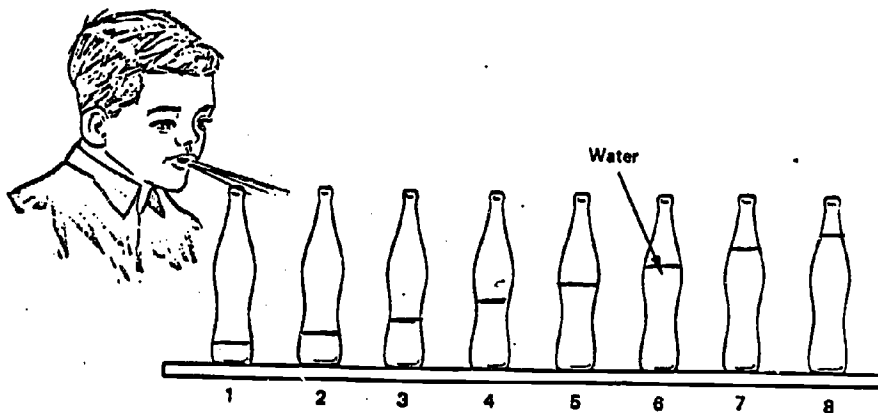

REFERENCE OUTLINE

2. Resonance

MAJOR UNDERSTANDINGS AND
FUNDAMENTAL CONCEPTS

Every object has a natural frequency of vibration. Resonance occurs when one vibrating object causes another object of the same natural frequency to vibrate.

MATERIALS

sympathetic
tuning forks

ACTIVITIES

Have a pupil hold the mouth of one bottle close to his ear without obstructing the opening. Now blow strongly across the mouth of another similar bottle until you produce a strong, clear note. Every time you do this, resonant vibrations are set up in the second bottle. These produce a weaker, though similar, note which your pupil can hear distinctly.

Place two tuning forks of the same frequency in a line so that the tines of each fork vibrate in the same plane. Set one fork into vibration and then stop it. Observe that the other has begun to vibrate. Repeat trying forks of different frequencies which are not integral multiples.

Place the tube in the position shown so that the water in the jar closes the tube at the water level. The air column can then be made longer or shorter by simply raising or lowering the tube in the clamp.

Set the tuning fork in vibration by striking it upon a piece of soft wood and hold it just above the open end of the tube as shown.

While the fork is vibrating, slide the tube up and down in the clamp until a position is found where the sound is loudest.

KEY WORDS

resonance

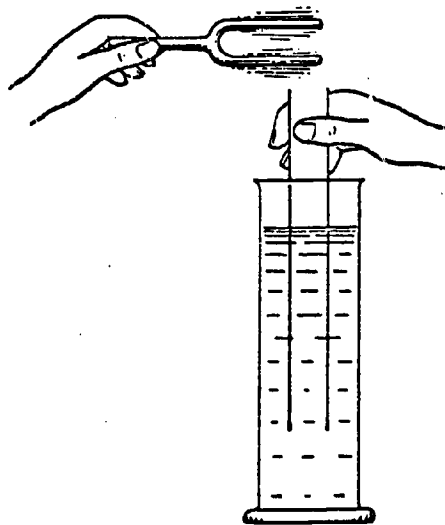

REFERENCE OUTLINE

3. Wave length

MAJOR UNDERSTANDINGS AND
FUNDAMENTAL CONCEPTS

As the frequency of a sound increases, the wave length decreases.

High pitch sound has short wave lengths.

The highest audible sounds are in the neighborhood of 20,000 vibrations per second, the lowest about 20 cycles per second.

The distance between two successive crests or two successive troughs is called one wave length.

MATERIALS

resonance tube
tuning fork

ACTIVITIES

Use the resonance tube of the previous activity to measure the wave length of sound. The wave length of a sound is approximately four times the length of the air column.

The air column is measured from the level of the water to the top of the tube.

Repeat using different frequency tuning forks. How does the wave length change when different frequencies are used?

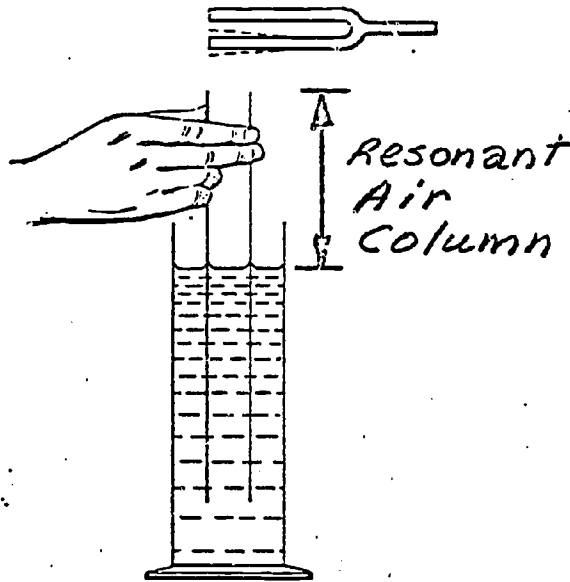
KEY WORDS

wave length

REFERENCE OUTLINE

4. Speed
5. Amplitude

MAJOR UNDERSTANDINGS AND
FUNDAMENTAL CONCEPTS

*The velocity of a sound wave is found by multiplying its frequency by its wave length.

The amplitude of a sound wave determines the loudness of the sound.

*Speed of sound in air is about 1090 ft/sec. at 0°C and normal air pressure. The speed of sound increases with rising temperatures at about two feet per second per Celsius degree.

MATERIALSACTIVITIES

Calculate the speed of sound by multiplying the frequency of a sound wave by its wavelength. Use the measurements from the previous exercise.

Observe the changes in loudness that occur when a taut string of constant length is plucked with increasing force. Note the change that occurs in the amplitude of the string.

KEY WORDS

amplitude

REFERENCE OUTLINE

MAJOR UNDERSTANDINGS AND
FUNDAMENTAL CONCEPTS

MATERIALS

oscilloscope
microphone
transformer
amplifier

ACTIVITIES

The various characteristics of sound can be neatly demonstrated by use of a microphone and cathode-ray oscilloscope. A carbon microphone in series with two dry cells and a step-up transformer is easy to arrange, but has very limited frequency response. A small PM speaker may be used as a dynamic microphone through a step-up transformer, or a crystal microphone and amplifier can be used. In any event, the need for amplification and the best method of coupling microphone to oscilloscope are determined by the equipment on hand.

If the demonstrator has a good musical ear, whistling is the most convenient method of producing pitches. Toy whistles which can be fingered to produce different pitches are available. An audio-frequency oscillator, amplifier and speaker give good control over frequency and volume of sound.

The relationship between the pattern on the oscilloscope screen and the sound waves should be explained. It is important to understand that the visible pattern is a graph--and not a picture.

Some of the demonstrable points are:

- . Distinction between music and noise.
- . Cause of differences in pitch.
- . Cause of differences in loudness.
- . Cause of differences in tone quality. Waveforms of sounds produced by different instruments can be investigated. It is more convenient to make differing tones by singing the vowel sounds all on the same pitch.
- . Cause of beats. The difference in frequencies of the two sounds can be shown by turning the synchronization off in the scope, setting its sweep so that one of the sounds is stopped and then noting the drift of the pattern of the other sound. Then both sounds are produced together, resulting in periodic cancellation and reinforcement.

Standard sound effect records may be used.

UNIT V
LIGHT WAVES

UNIT V - LIGHT WAVES

I. Light

A. Straight line travel

1. Inverse square law

B. Reflection

1. Angle of incidence
2. Angle of reflection
3. Reflection by mirrors

- a. virtual image
- b. reversal of image

4. Refraction

- a. Characteristics of refraction
- b. Prisms
- c. Lenses

- 1) convex
- 2) concave
- 3) focal length
- 4) magnifier

REFERENCE OUTLINE

MAJOR UNDERSTANDINGS AND
FUNDAMENTAL CONCEPTS

I. Light

A. Straight line
travel

Light travels in straight lines.

MATERIALS

candle
light source

ACTIVITIES

Visually align several pins inserting them into a soft material. Draw a line connecting the pinholes. Compare the line passing through the pinholes with a line drawn with a straight edge.

Cut one end of a cardboard box so that a margin of about half an inch of the cardboard remains along the sides and ends. Paste a thin, unruled paper the size of the original end of the box smoothly over the cut-out end of the box. Put the cover on the box.

In the center of the opposite end of the box punch a small hole with a sharp pencil point. In front of the box set a lighted candle or an incandescent lamp. On the side of the lamp toward the box set up a cardboard shield in which two holes have been punched, one above the other, opposite the bright part of the light. Move the box toward the lamp until two bright spots appear on the paper end. Cover the upper hole of the shield. Which spot disappears?

Repeat this test with the other hole in the shield. Which spot now disappears?

Hold a half-meter stick alongside the box and shield in such a position that the upper hole in the shield and the hole in the camera are opposite the edge of the meter stick. Does the spot on the paper screen, produced by the light through the hole in the shield, lie opposite the edge of the meter stick?

Remove the shield between the light and the camera. What now appears on the paper at the other end of the box?

KEY WORDS

Cut four pieces of cardboard about 10 cm square. Tack them to small wood blocks so that they will stand upright. Punch a small hole through each card at exactly the same place so that when the cards are set up and arranged in a straight line you can look straight through all four holes. Place a candle flame so that it can be seen by looking through all the cards spaced about 30 cm apart. Now pull one of the cards a little out of line with the others and try to look through them at the candle flame. Can you see it? Why not? What does this show?

REFERENCE OUTLINE

MAJOR UNDERSTANDINGS AND
FUNDAMENTAL CONCEPTS

MATERIALSACTIVITIES

Set up a flashlight at one end of a piece of rubber garden hose about 36 inches long. Curve the tube. Do you see the light? Now straighten the tube by fastening it to a yardstick with rubber bands. Shine the light into it. Now can you see the light?

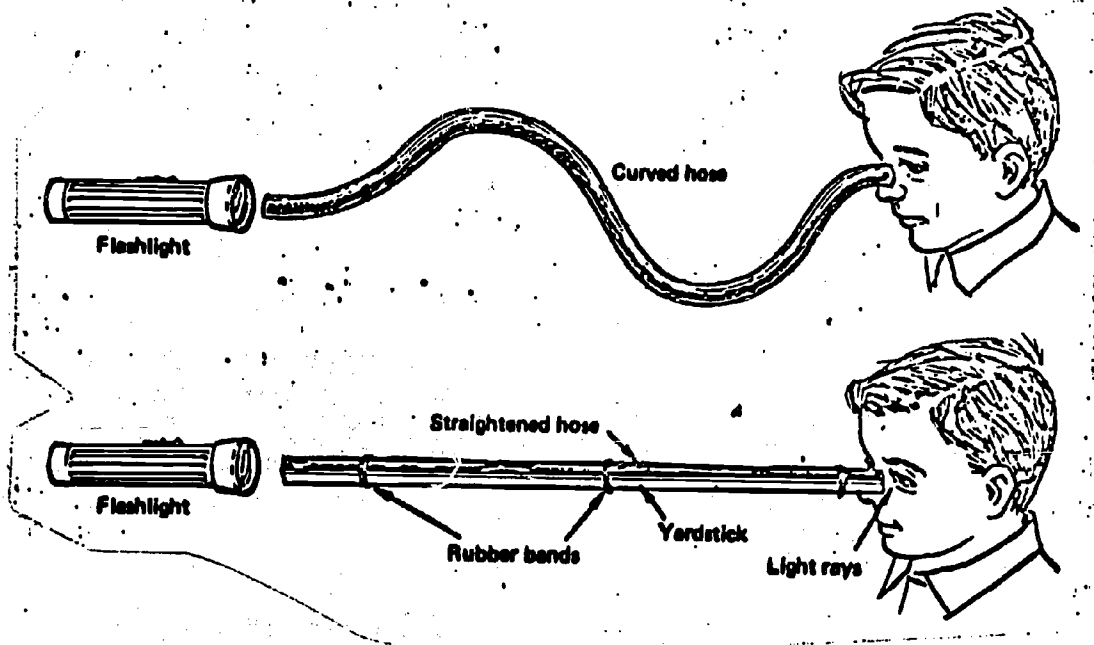

Obtain four shoe boxes of exactly the same size. Turn over the box so that the bottom is the top side. Find the center of each box by drawing diagonal pencil lines. Punch a hole in each center. Line up the boxes as shown, using a long stick. Carefully remove the stick. Darken the room and shine your flashlight through the holes. Can you see the light at the end? Now move Box D out of line. What happens? Repeat the experiment.

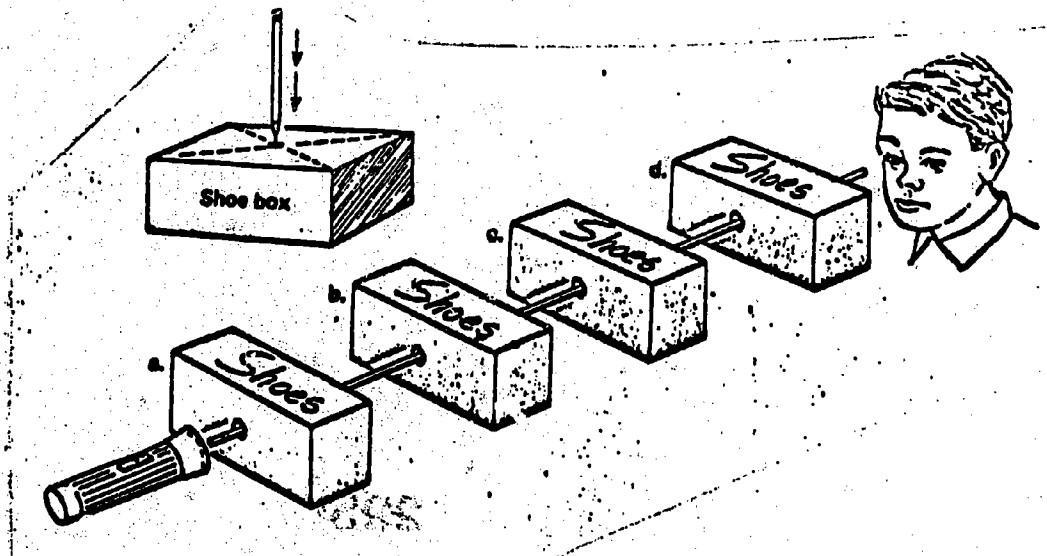
KEY WORDS

REFERENCE OUTLINEMAJOR UNDERSTANDINGS AND
FUNDAMENTAL CONCEPTS

The path of light can be seen as light travels through dust or smoke particles.

The dust particles suspended in the air reflect the light beam to the eye. The edges of the light beam are straight lines.

Straight lines of light are called rays.

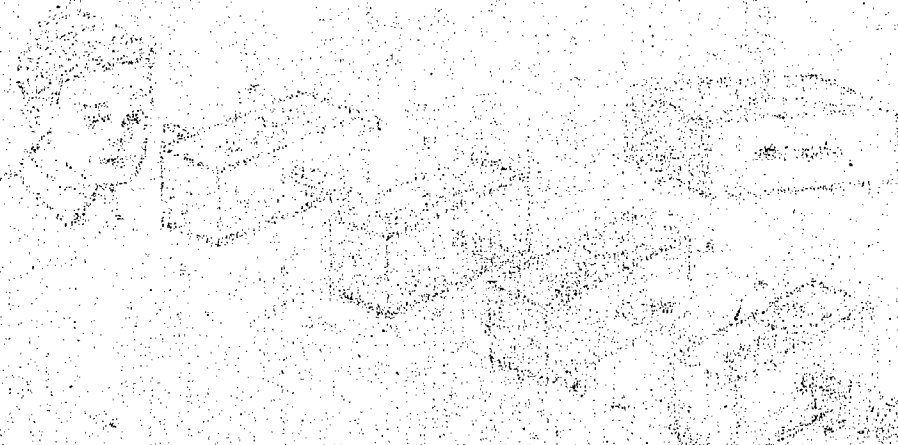

MATERIALSACTIVITIESWhat you learn:

When light travels inside of one substance (in this case the substance is air), it travels in a straight line.

A smoke box may be constructed from a shoe box, black paper, clear plastic food wrap and a smoke source. Cut an opening in the cover of a shoe box leaving a 1/2 inch to one inch margin of cardboard.

Cover this opening with the plastic wrap. Cut three 1/4" diameter circular holes in one end of the box. Line the back of the box with black paper. The source of smoke is a petri dish with a piece of cotton wet with ammonium

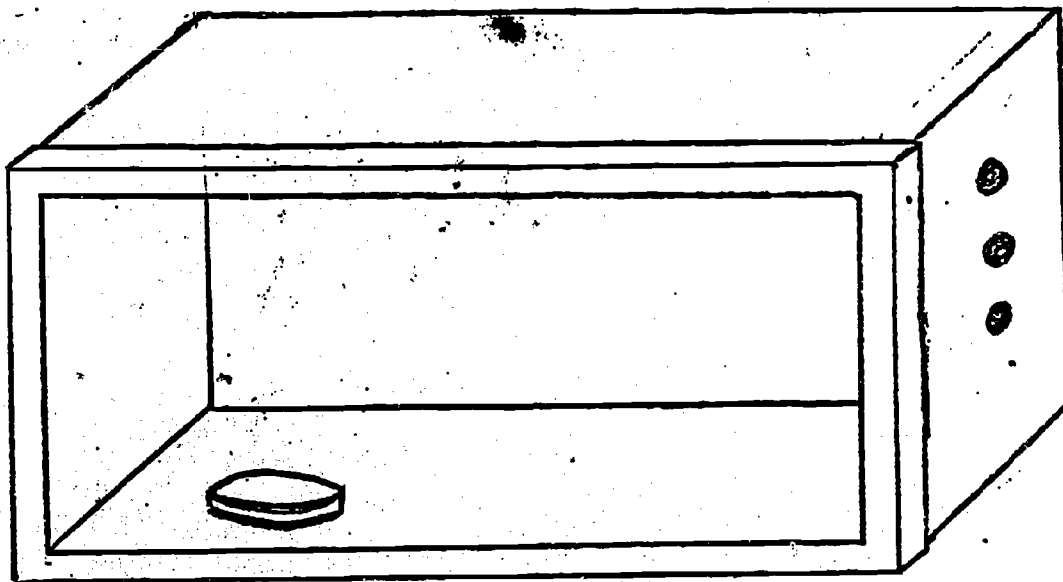
KEY WORDS

rays

hydroxide and another piece of cotton wet with dilute hydrochloric acid. The smoke is ammonium chloride.

REFERENCE OUTLINEMAJOR UNDERSTANDINGS AND
FUNDAMENTAL CONCEPTS

When an opaque object cuts off the light rays from a source of light, the space behind the object is in darkness. These dark areas are called shadows.

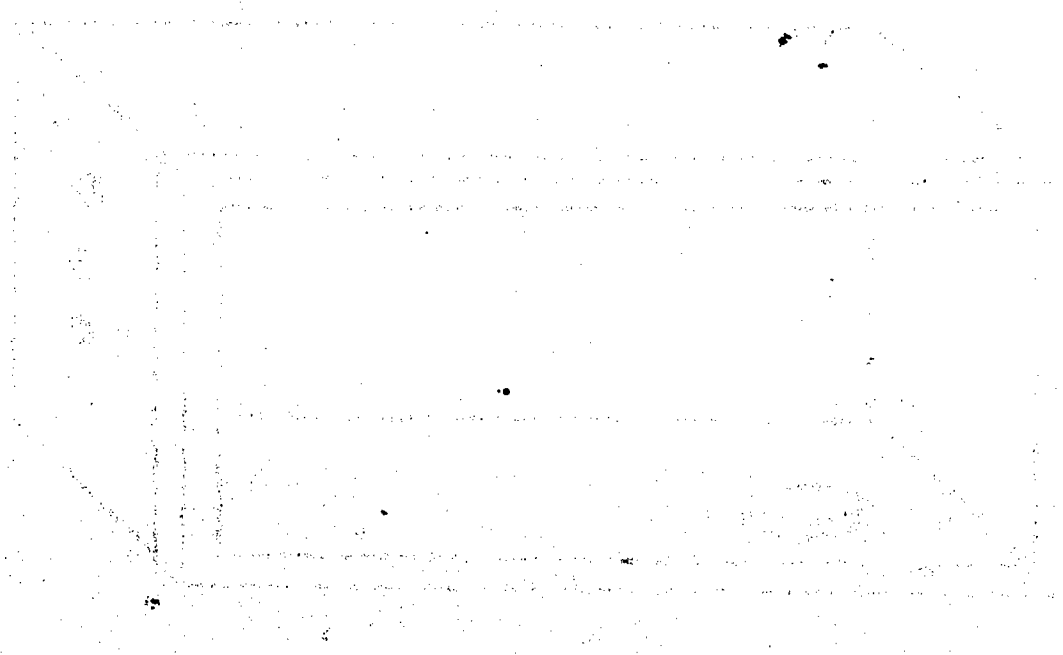

Self low order to state...
...at ...

MATERIALSACTIVITIES

When a light source illuminates the smoke particles, the path of the light ray is delineated.

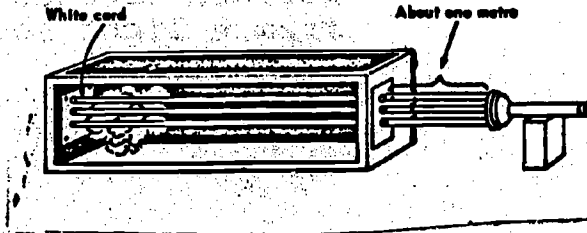
KEY WORDS

shadow

REFERENCE OUTLINE

1. Inverse square law

MAJOR UNDERSTANDINGS AND FUNDAMENTAL CONCEPTS

Light spreads out from a source.

The illumination received by a surface depends on its distance from a light source.

*The area of illumination varies indirectly as the square of its distance from the source.

*The inverse square law is an important concept for pupils to grasp. A number of laboratory exercises in photometry is desirable. Teach pupils how to solve for one unknown in the relationship:

$$\frac{cp_1}{d_1^2} = \frac{cp_2}{d_2^2}$$

MATERIALSACTIVITIES

Set up a double meter stick and supports. At one end place a clear lamp with a horizontal filament parallel to meter stick. One foot from the end of the filament place a card having a one inch square cutout. Place a transparency with a grid of one inch squares immediately beyond the card with the cutout. Note the number of illuminated squares. Place the grid one foot from the card with cutout and count illuminated squares. Continue this procedure at one foot increments.

Note the illuminating lamp is of the variety supplied for PSSC ripple tank apparatus, i.e. having a single straight horizontal filament.

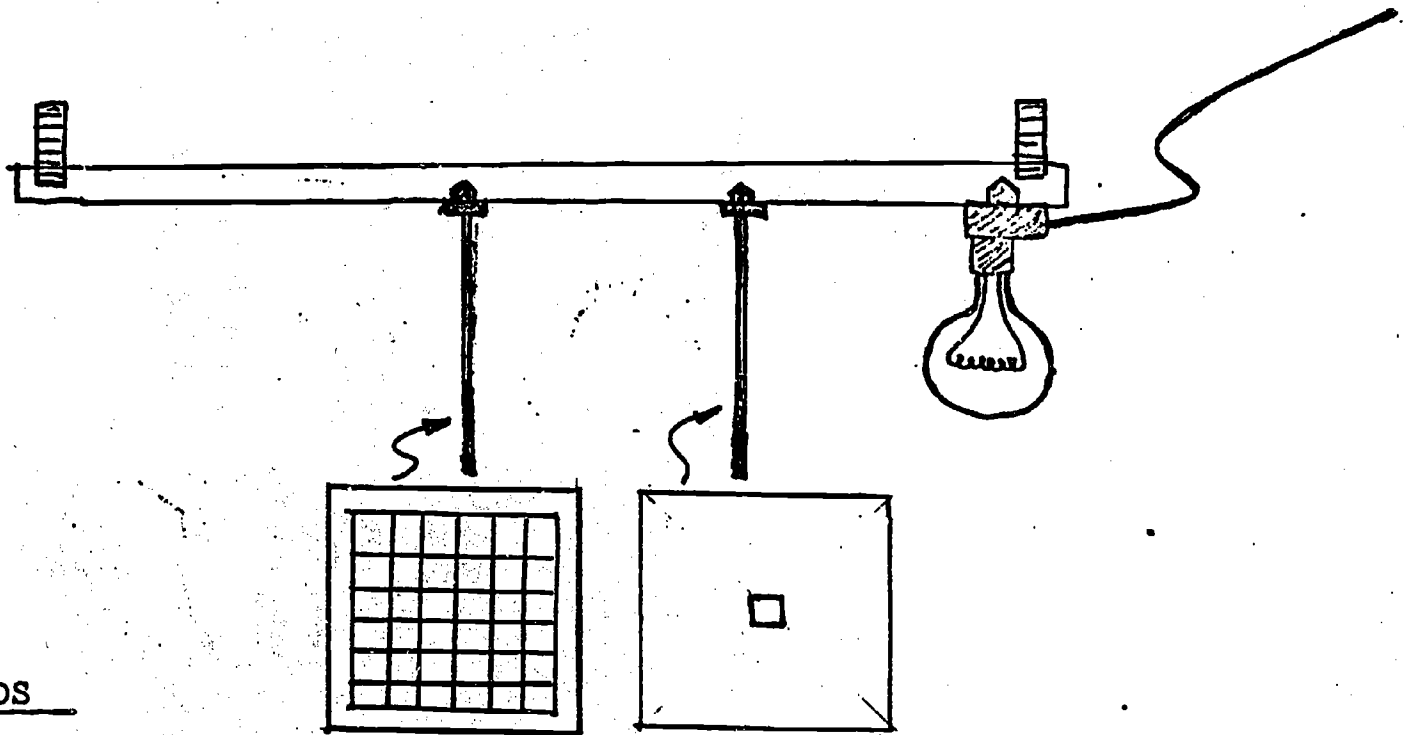
KEY WORDS

REFERENCE OUTLINE

B. Reflection

1. Angle of incidence

2. Angle of reflection

MAJOR UNDERSTANDINGS AND FUNDAMENTAL CONCEPTS

The path of light may change when light strikes the boundary between materials and rebounds.

This rebounding is known as reflection.

A line perpendicular to a surface is known as a normal.

The angle formed by the incoming light ray and the normal is known as the angle of incidence.

The angle formed by the reflected light ray and the normal is known as the angle of reflection.

The angle of incidence equals the angle of reflection.

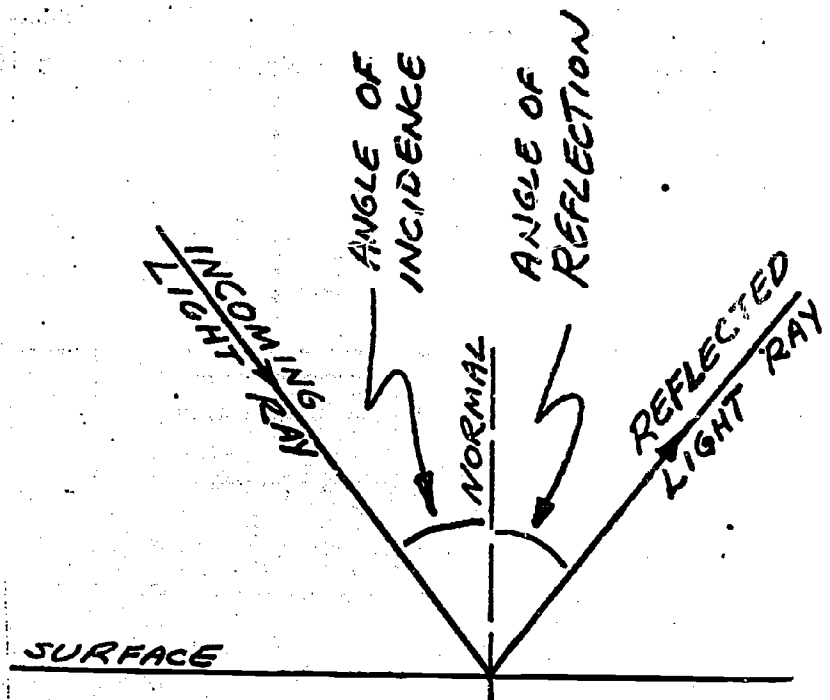

MATERIALSACTIVITIES

Assemble a board and card with slit as shown in the diagram. Place a strong light where a slit may be turned toward it. Place a sheet of paper on the board and let light from the distant lamp fall through the slit across the page. In the path of this light, stand the mirror on edge and note the position of the reflected light. With a pencil, place a dot on the paper in the center of the path of light as it comes through the slit, another dot at the center of the illuminated line on the mirror, and another dot in the center of the reflected beam of light at some distance from the mirror.

Draw a line along the reflecting surface of the mirror. If the reflecting surface is the back of the mirror, move the second dot directly back to this line.

Remove the page from the board. Connect the second dot to the first by a solid line and label this line the incident ray. Connect the second dot to the third and label this line the reflected ray. Show the direction of light in each path by an arrow. At the second dot, where the light falls upon the mirror, erect a dotted perpendicular to the mirror and label this line the normal.

KEY WORDS

reflection
normal
angle of incidence
angle of reflection

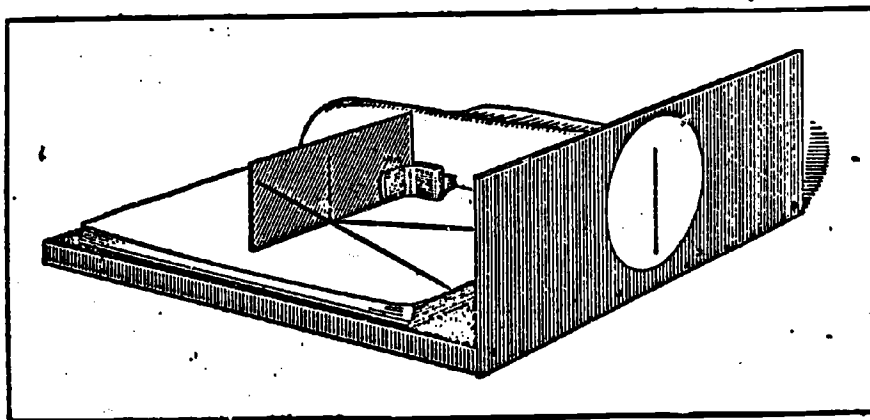

REFERENCE OUTLINE

MAJOR UNDERSTANDINGS AND
FUNDAMENTAL CONCEPTS

MATERIALSACTIVITIES

Hold a comb so that the sun's rays shine through the teeth and fall on a piece of white cardboard. Tilt the cardboard so that the beams of light are several inches long and then place a mirror diagonally in their path. Note that the beams of light strike the mirror and are reflected at the same angle. Turn the mirror slightly and notice how these angles change.

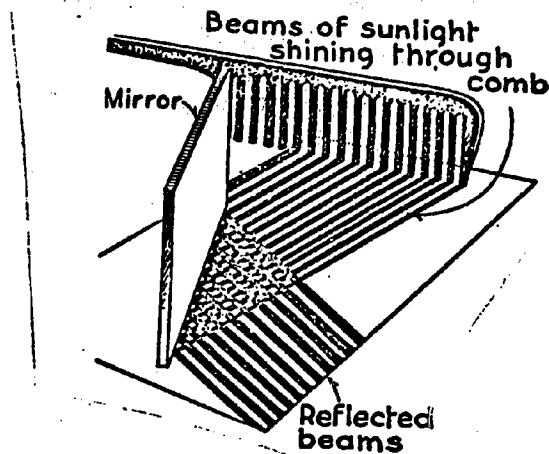

Draw a broken line on a piece of paper with a ruler. Next draw a straight line from it at any angle. Set a small mirror in an upright position at the point where the two lines meet. Turn the mirror until the reflection of the dotted line is in line with the real dotted line. Now look into the mirror and line up one edge of your ruler with the reflection of the straight line. Draw this line with your pencil and measure the angles on each side of the broken line with a protractor.

KEY WORDS

Repeat this experiment several times changing the size of the angle each time. The evidence should show that light is always reflected at the same angle that it strikes the mirror.

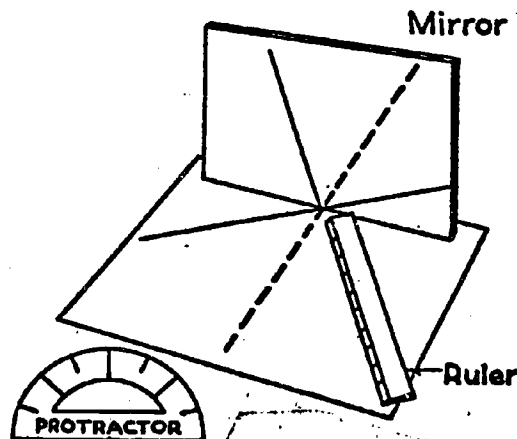

REFERENCE OUTLINE

MAJOR UNDERSTANDINGS AND
FUNDAMENTAL CONCEPTS

MATERIALSACTIVITIES

Use the smoke box previously illustrated or cut a slit about one-fourth inch wide in one end of a small cardboard box. Be sure to cut the slit all the way to the bottom of the box. Set the box on one side and place it in bright sunlight. Turn the box so that the beam of sunlight falls along the bottom of the box as shown in the diagram.

Next lay a pocket mirror in the box so that the beam of sunlight strikes it. The reflected beam will now be seen against the bottom of the box as shown.

Set a second mirror in the opposite end of the box to reflect the beam a second time.

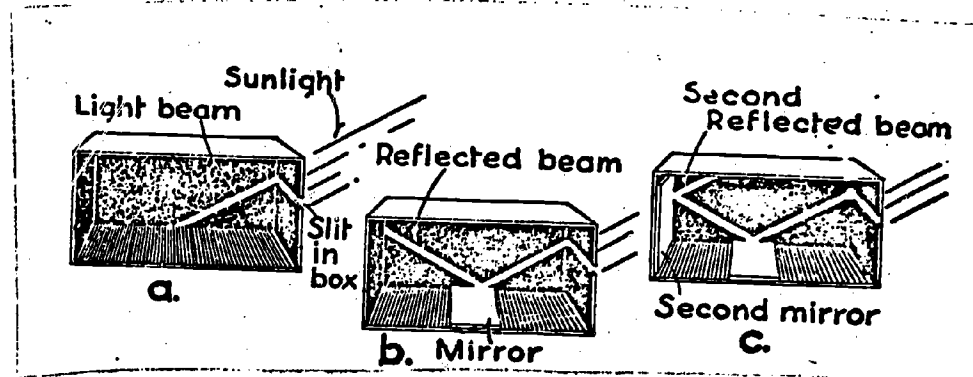

Tilt each mirror at a slightly different angle. Note that the angle at which the beam strikes the mirror is always equal to the angle of the reflected beam.

KEY WORDS

REFERENCE OUTLINE3. Mirror
reflectionMAJOR UNDERSTANDINGS AND
FUNDAMENTAL CONCEPTS

Image formed by a plane mirror appears to be behind the mirror, is the same size as the object, and is as far from the mirror as the object.

In the reflection of light from a plane mirror surface, the image distance equals the object distance.

MATERIALSACTIVITIES

Draw a line across the middle of the page. Label this line the mirror. On your side of the line draw a quadrilateral with sides not less than one and one half inches and not parallel. Label the corners A, B, C, D, as indicated.

Stand the glass plate with the front surface along the mirror line. Darken the upper half of the page with the shadow box. Stand a pin on corner A of the quadrilateral and, by looking into the mirror toward the space behind the glass, observe the image of the pin. Set a second pin where the image appears to be. In like manner establish the positions of the images of the other corners. Label the images of the corners A', B', C', D'.

Remove the glass plate. Connect the image corners in order by dotted lines and label the resulting quadrilateral the image. Measure and record the lengths of the sides on the lines forming the object and image. From each corner of the image and of the object draw dotted perpendiculars to the mirror line. Measure and record on these lines the distances of the corners from the mirror.

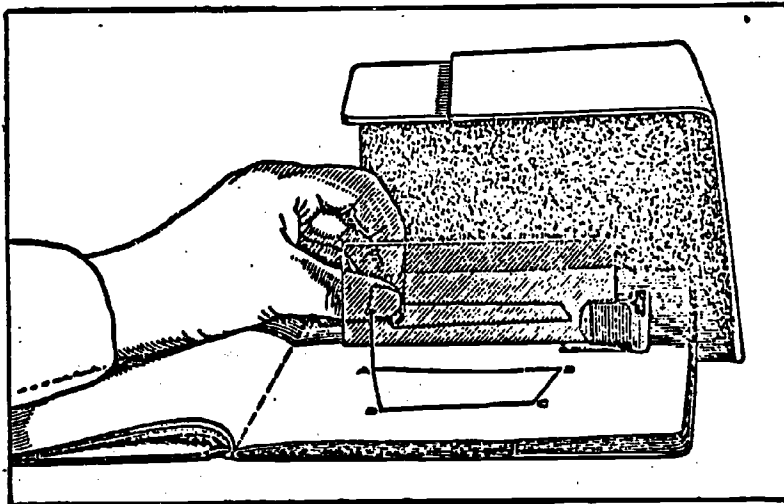
KEY WORDS

REFERENCE OUTLINE

a. Virtual image

MAJOR UNDERSTANDINGS AND FUNDAMENTAL CONCEPTS

*The image formed by a plane mirror is virtual, cannot be projected on a screen, and is upright with respect to the object.

*Consider the real light rays as solid lines and virtual light rays as dotted lines in tracing light diagrams.

MATERIALSACTIVITIES

A very instructive and entertaining illusion may be assembled with two candles and a pane of window glass. The candles, as nearly identical as possible, are mounted on opposite sides of the vertical piece of glass. The rear candle is carefully placed at the position of the image of the front one formed by the glass. When only the front candle is burning, both appear to be lit, the virtual image of the flame appearing on the unlit candle. The glass plate must be large enough so the image can be seen from all parts of the classroom. The instructor can hold his finger in the "flame" of the rear candle without burning it, or expound a new method of "fireproofing" paper. When the rear candle or the glass is moved, the fact that only one candle is lit is immediately obvious. When the illusion is adjusted for best coincidence of candle and image, the object and image distances to the reflecting surface can be measured and of course will be equal. The fact that the image and object lie on a line perpendicular to the glass and that the image is virtual, erect and the same size as the object should be noted.

For an amusing variation, mount the unlit candle in a beaker, and pour water into it. Finally the flame appears to be under water.

KEY WORDS

virtual image
real image

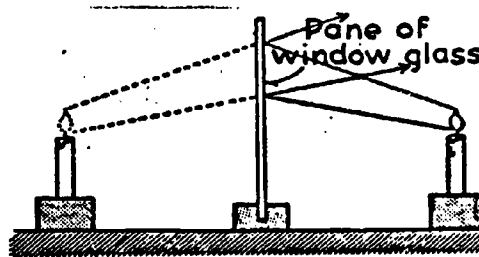

REFERENCE OUTLINE

B. Reversal
of image

MAJOR UNDERSTANDINGS AND
FUNDAMENTAL CONCEPTS

The image formed by a plane mirror
is reversed.

An image viewed in a plane mirror
if "flipped" over, i.e., printed
material, for example, appears
backward.

MATERIALSACTIVITIES

Observe the reversed image of any printed material as seen in a single plane mirror.

Stand two mirrors at right angles to each other with their edges touching. These edges may be hinged with tape. Place printed material in front of the mirrors with its midline opposite the junction of the mirrors. Look at its reflection and compare with the image seen with a single mirror.

It is possible for a person to see himself as others see him by looking in the right angle mirrors just described. Most pupils do not realize that the image they see in a single mirror is reversed and that they have probably never seen themselves as they appear to others. Arrange for each pupil to see his true image by using the mirror arrangement.

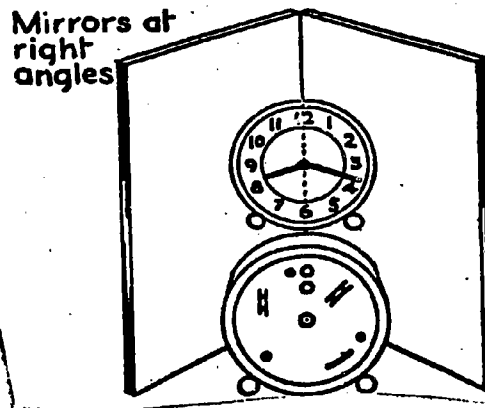
KEY WORDS

reversed

REFERENCE OUTLINEMAJOR UNDERSTANDINGS AND
FUNDAMENTAL CONCEPTS

4. Refraction

a. Characteristics
of refraction

The path of light may change when light passes from one transparent material to another. The bending of light is called refraction.

When light passes obliquely from air into a more dense material, the light is bent toward the normal.*

When light passes obliquely from a more dense material into air, the light is bent away from the normal.

When the path of light is normal, no bending occurs.

*Note to teachers: Although the concepts listed on this page are scientifically accurate, they are not meaningful to pupils. Simplify the terms in discussions within the class. For example, instead of "obliquely" use "angle". Instead of "more dense" material, state the material such as air to glass, air to water, etc. Use practical illustrations as frequently as possible.

MATERIALSACTIVITIES

*Shine a beam of light into the smoke box as in previous experiments. Fill a large rectangular bottle with water and add a few drops of milk or a pinch of starch or flour to make the water cloudy. Cork the bottle. Fill the box with smoke. Hold the bottle at right angles to the beam of light and observe the direction of the light through the water. Next tilt the bottle at different angles to the beam of light and observe how the path of light through the bottle is affected.

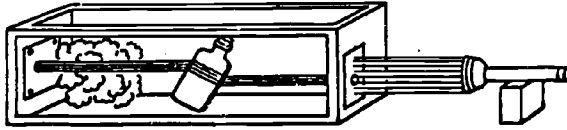

As an alternative, a beaker of water with a few drops of milk may be placed in the smoke box. A slit is cut into the top and a light is held at an angle other than 0° or 90° .

KEY WORDS

refraction

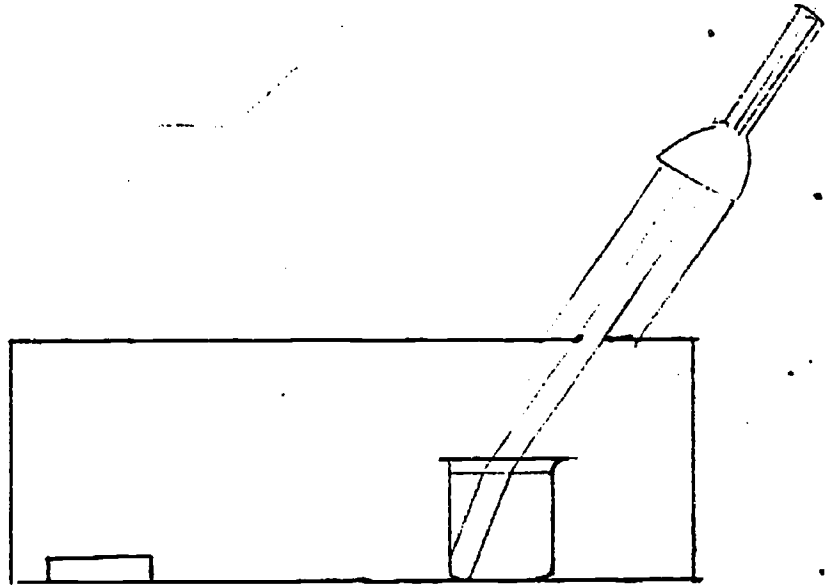

*Unless a question is raised by a student, do not enter upon a discussion of colloidal dispersions at this time.

REFERENCE OUTLINE

MAJOR UNDERSTANDINGS AND
FUNDAMENTAL CONCEPTS

MATERIALSACTIVITIES

The bending of light may be measured by the direct ray method. Assemble a board with slit as shown for reflection and cover with a sheet of paper.

In place of the mirror substitute a glass block. Outline the block. Trace the path of the light rays into and out of the block. Draw the normals at the points light enters and exits the block. Compare the angles in air and in glass where light enters the glass. Compare the angle in glass and in air where light exits the block.

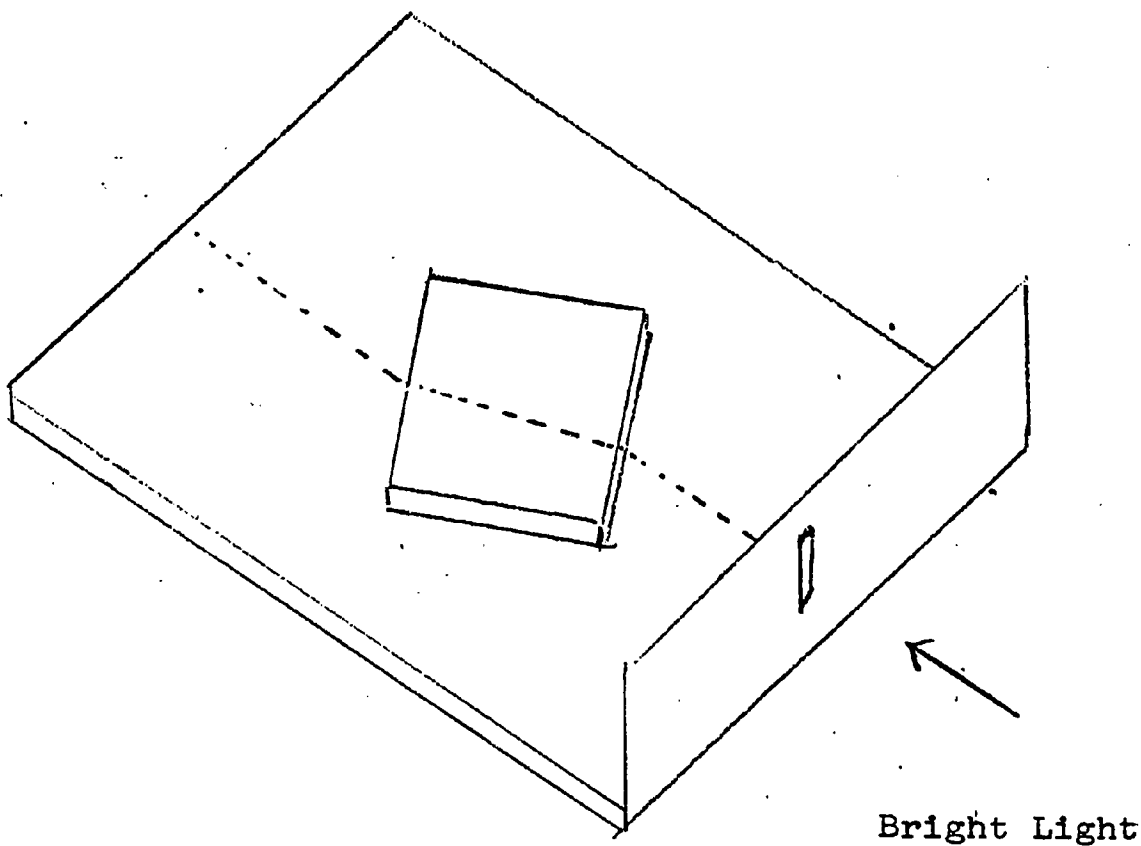
KEY WORDS

REFERENCE OUTLINE

b. Prisms

MAJOR UNDERSTANDINGS AND
FUNDAMENTAL CONCEPTS

Prisms are triangular pieces of glass.

When white light from the sun or other source passes through a prism, the light is separated into a spectrum, like a rainbow.

White light is composed of light of different wavelengths.

Since the speed of colored light is not the same in glass as in air, the white light is "broken" down into its various wavelengths.

MATERIALSACTIVITIES

Replace the glass block with a prism and repeat the exercise.

Note: The results are predictable if care is taken in choosing the angle and the point of incidence. The ray will be bent toward the base upon entering and upon exiting.

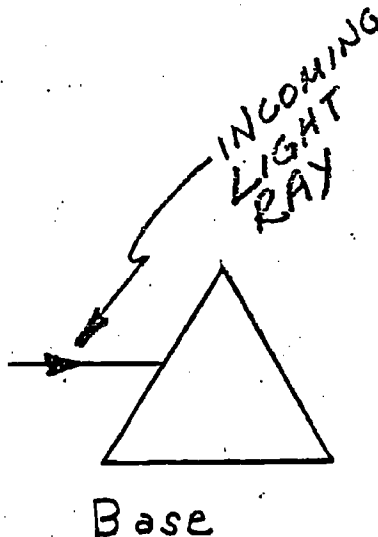

Use the smoke box with a glass prism in the single beam of light and observe how the beam is bent: on entering the glass surface; again, on passing from the glass back into the air.

KEY WORDS

prism
colored light
spectrum

REFERENCE OUTLINE

C. Lenses

MAJOR UNDERSTANDINGS AND
FUNDAMENTAL CONCEPTS

The convex lens converges parallel light rays at a point known as the principal focus.

The concave lens diverges parallel light rays.

The distance between the lens and the principal focus is known as the focal length of the lens.

MATERIALS

convex lenses
light source
smoke box

ACTIVITIES

Use the smoke box to investigate the behavior of light in lenses.

Fill the box with smoke and hold a double convex lens in the path of the three beams of light so that the middle beam strikes the center of the lens. Observe the beams on the opposite side of the lens from the source of light. How are they affected?

Repeat the experiment using a double concave lens. Compare the observations made in this experiment with those made using a prism. Think of the double convex lens as made up of two prisms put together base to base and the double concave lens as two prisms put together tip to tip.

KEY WORDS

focal length
convex
concave

REFERENCE OUTLINE

1. Convex lens

MAJOR UNDERSTANDINGS AND
FUNDAMENTAL CONCEPTS

When the object is at a large distance from the converging lens, the image is smaller than the object, inverted with respect to the object and can be projected on a screen.

An image which can be projected on a screen is known as a real image.

When the object is very close to the lens, the image is larger than the object, upright with respect to the object and cannot be projected on a screen.

An image which cannot be projected on a screen is known as a virtual image.

2. Concave lens

A concave lens produces images which are virtual, smaller than the object and upright.

MATERIALSACTIVITIES

Darken all the windows in a room but one. Have a pupil hold a lens in the window directed at the scene outside. Bring a piece of white paper slowly near the lens until the image picture is formed. What do you observe about the position of the image? The color? The size?

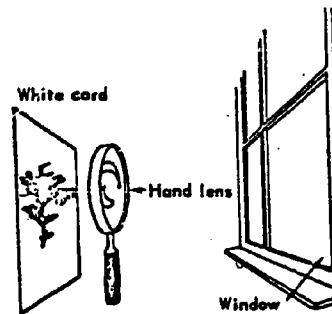

Using a double convex lens held very close to a printed page, view the print through the lens. Slowly increase the distance between page and lens while viewing the image. Note the changes which take place in the image, the position, color and size. Try to project an image on a screen when the object is very close to the lens.

KEY WORDS

concave

Repeat the preceding two exercises with a concave lens. Does an image form in either exercise? What type of image forms? Compare the image with the object in relation to size, position and color.

REFERENCE OUTLINE

3. Focal
length

MAJOR UNDERSTANDINGS AND
FUNDAMENTAL CONCEPTS

The focal length of a convex lens may be found by determining the blur point of a virtual image.

A convex lens is one that is thicker at the center than at the edges.

Parallel rays of light passing through a convex lens tend to come to a point.

The focal length of a convex lens may be found by determining the point at which the image of a very distant object forms.

MATERIALS

optical bench
convex lens

ACTIVITIES

Estimate the focal length of a converging lens. Start with the distance between lens and object very small. Increase this distance until the image blurs. This blurring occurs when the object distance is approximately one focal length.

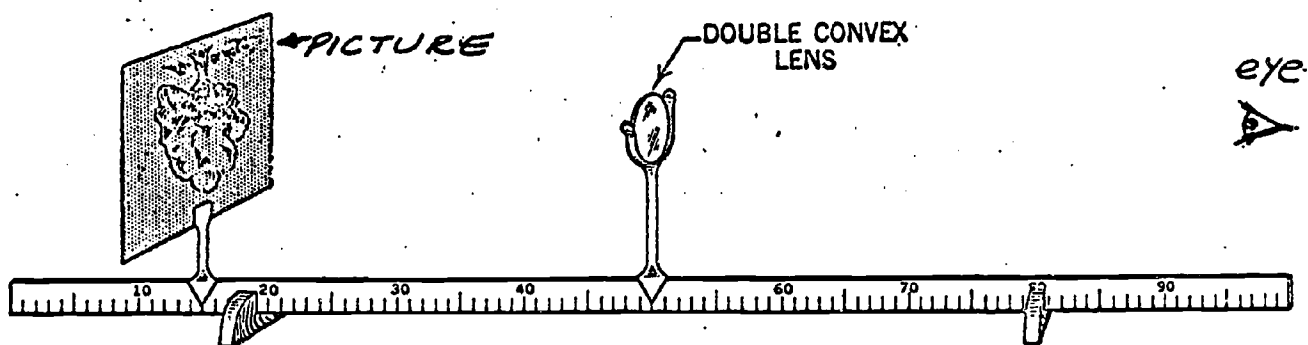

Set up an optical bench as shown. Clamp the lens holder and place the holder on the 50-cm division of the meter stick. Place on the meter stick a screen 10 cm square. Point the meter stick toward the sun, if possible. Then move the screen along the meter stick until a position is found where the image of the sun on the screen is as nearly as possible a point. The distance from the lens to the screen is approximately the focal length of the lens.

KEY WORDS

focal length

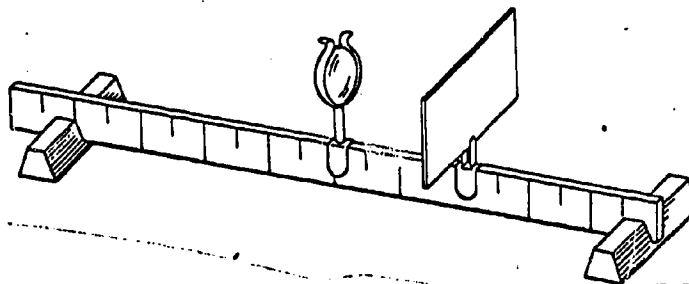

Note for teacher: Light rays from very distant objects are assumed to be nearly parallel.

REFERENCE OUTLINEMAJOR UNDERSTANDINGS AND
FUNDAMENTAL CONCEPTS

The convex lens produces images which are smaller than the object, closer to the lens than the object is, inverted and real when the object is more than two focal lengths from the lens.

This optical system is found in the camera.

The convex lens produces images which are larger than the object, farther from the lens than the object is, inverted and real when the object is between one and two focal lengths from the lens.

This optical system is found in the projector.

The convex lens produces no real image when the object is less than one focal length from the lens.

MATERIALS

optical bench

ACTIVITIES

Set up an optical bench using a converging lens.

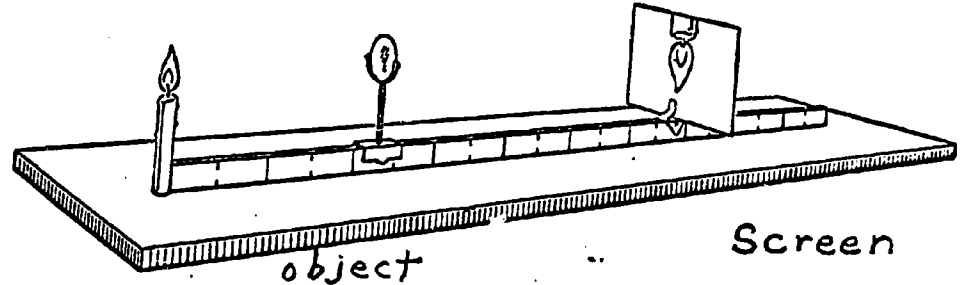

Adjust the object distance to more than two focal lengths, preferably three, four or five.

Adjust the screen to form a sharp image. Note the image size, distance, position and type.

Using an optical bench adjust object distance to less than two focal lengths but more than one focal length. Adjust the screen to form a sharp image. Note the image size, distance, position and type.

KEY WORDS

image
principal focus
focal point

Using an optical bench adjust the object distance to less than the focal length. Attempt to adjust screen to form a sharp image.

REFERENCE OUTLINE

4 Magnifier

MAJOR UNDERSTANDINGS AND
FUNDAMENTAL CONCEPTS

The convex lens may be used as a simple magnifier when the object distance is less than one focal length.

MATERIALSACTIVITIES

Focus a double convex lens over some lined paper. Compare the number of spaces seen outside the lens with a single space seen through the lens. The lens shown in the diagram magnifies three times.

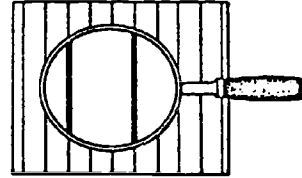

Use a pair of lenses to make a telescope.

Arrange a long focus lens on the end of the optical bench pointing at some scene through a window. As in the previous experiment, bring a white cardboard up on the opposite side of the lens to the place where the sharpest image of the scene is formed. Now bring a short focus lens up behind the cardboard until the cardboard is a little nearer the lens than its focal length. Remove the cardboard and look through the two lenses at the scene.

Produce a compound microscope from a pair of lenses.

Arrange a short focus lens on the optical bench. Place a lighted candle behind a piece of window screen on one side of the lens. On the other side of the lens place a white cardboard sheet at the point where the clearest image of the screen is formed. Remove the cardboard sheet and place another double convex lens slightly farther away than where the cardboard was. Look through both lenses at the screen. It will appear enlarged.

KEY WORDS

magnifier

APPENDIX

KEY WORDS

Unit I: MEASUREMENT

buoyancy
centimeter
density
elastic
elongation
force
graduated cylinder
gram
gravity
hydrometer
irregular
kilogram
kilometer
mass
meniscus
meter
metric system
ounce
pound
protractor
ratio
specific gravity
stretch
submerge
triangle
volume
water displacement
weight

KEY WORDS

Unit II: MATTER IN MOTION

Accelerated motion
acceleration
acceleration of gravity
action
amplitude
foot-lbs.
force
free fall
frequency
"g"
horsepower
inertia
kinetic
lead bob
mass
pendulum
period
potential
power
reaction
speed
stopwatch
uniform motion
watt
work

KEY WORDS

Unit III: HEAT ENERGY

absorb
antifreeze
boiling
boiling point
calorie
Celsius
condense
conductivity
conductor
conservation
contract
control
convection
currents
dense
expand
evaporation
Fahrenheit
freezing point
heat
heat of vaporization
invisible waves
melting point
pendulum
pressure
pressure cooker
radiant energy
radiate
rate of expansion
specific heat
sublimation
temperature
thermometer
thermostat
transfer
vacuum
water vapor
wind
work

KEY WORDS

Unit IV: WAVE MOTION

air column
amplitude
crest
frequency
pitch
resonance
sound
transmit
trough
vacuum
velocity
vibrating
wave length

KEY WORDS

UNIT V: LIGHT WAVES

angle of incidence
angle of reflection
colored light
concave
convex
focal length
focal point
image
magnifier
normal
principal focus
prism
rays
real image
reflection
refraction
reversed
shadow
spectrum
virtual image