

DOCUMENT RESUME

ED 054 927

SE 011 306

AUTHOR

Maben, Jerrold William

TITLE

How Far a Star. A Supplement in Space Oriented Concepts for Science and Mathematics Curricula for Intermediate Grades.

INSTITUTION

National Aeronautics and Space Administration, Washington, D.C.

SPONS AGENCY

Office of Education (DHEW), Washington, D.C.

PUB DATE

69

NOTE

112p.

EDRS PRICE

MF-\$0.65 HC-\$6.58

DESCRIPTORS

\*Aerospace Technology; \*Astronomy; Instructional Materials; \*Intermediate Grades; \*Mathematics; Measurement; Resource Materials; \*Science Activities; Scientific Principles

ABSTRACT

Space science-oriented concepts and suggested activities are presented for intermediate grade teachers of science and mathematics in a book designed to help bring applications of space-oriented mathematics into the classroom. Concepts and activities are considered in these areas: methods of keeping time (historically); measurement as related to time, distance, and astronomy, including lunar photographs and measurement activities; communication in space, sound, and satellites; measuring the atmosphere; and measuring and interpreting the light from stars. A glossary of space terms, an aerospace bibliography, and a subject index are included. (PR)

EDO 54927

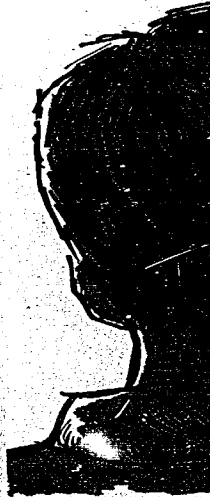

SE 011 306

A SUI

Prepared by t

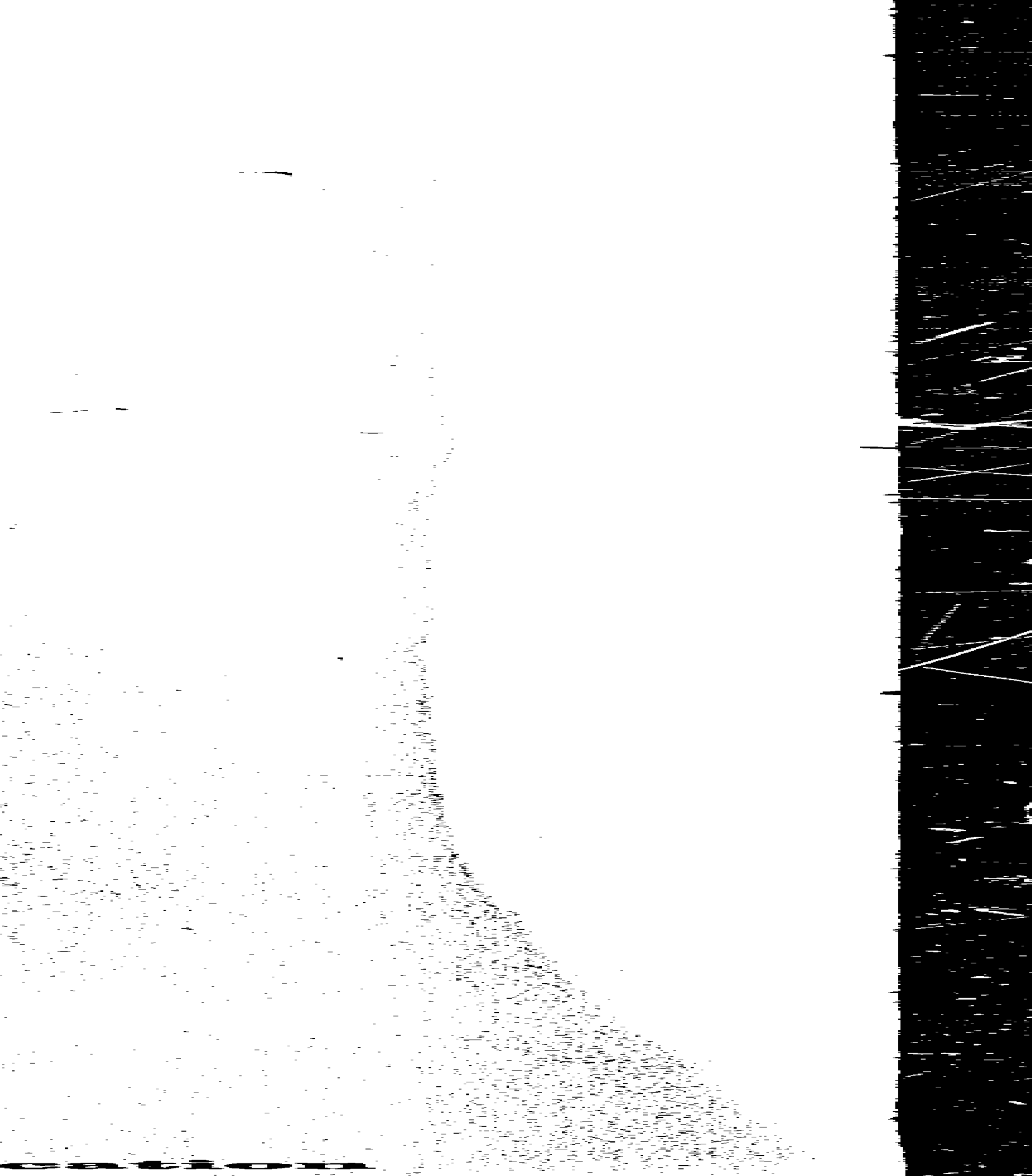

# HOW FAR A STAR

A SUPPLEMENT IN SPACE ORIENTED CONCEPTS  
FOR SCIENCE AND MATHEMATICS CURRICULA FOR INTERMEDIATE GRADES

Prepared from materials furnished by the National  
Aeronautics and Space Administration in cooperation  
with the United States Office of Education by a  
Committee on Space Science Oriented Mathematics

1969

ERIC  
Full Text Provided by ERIC



## CONTENTS

<b>Chapter I</b>	
<b>THE MYSTERY OF TIME</b> .....	1
History of Time, Early Timekeepers, Sundial Model, Mechanical Timekeepers, The Foucault Pendulum, Time in Space, Review of Scientific Notation, Rendezvous in Space	
<b>Chapter II</b>	
<b>MEASURING THE UNKNOWN</b> .....	17
Time Standards, Need for Better Timekeepers, Units of Time, Limits and Errors, Earth as a Timekeeper, Rotation and Revolution, Sidereal and Solar Days, The Moon, Phases and Motions, Measuring with the Vernier and Ruler, Distances in Space, Errors in Measurement, Satellite Orbits, Ranger Photographs, Moon Measurements with Scale, Moon Atlas, Measurement Techniques	
<b>Chapter III</b>	
<b>"EMPTY" SPACE</b> .....	67
Discussion of Space, Communication in Space, Sound, Satellite Communication, Weather Satellites, Weather over Earth	
<b>Chapter IV</b>	
<b>THE MEASURE OF OUR ATMOSPHERE</b> .....	79
History, Atmospheric Levels, Nature of Gases, Weather Observations, Volume, Density, and Pressure, Measurement of the Upper Atmosphere, Density, Temperature, Instruments of Measurement	
<b>Chapter V</b>	
<b>WHAT LIGHT CAN TELL US</b> .....	97
Measurement, Direct and Indirect, Stars, Brightness and Magnitude, Celestial Coordinates, Spectra of Light, Wavelength, Identification of Spectra, Model Spectroscope and its Application	
<b>Chapter VI</b>	
<b>TO THE FUTURE</b> .....	109
People and the Space Program	
<b>GLOSSARY</b> .....	111
<b>BIBLIOGRAPHY</b> .....	121
<b>INDEX</b> .....	123

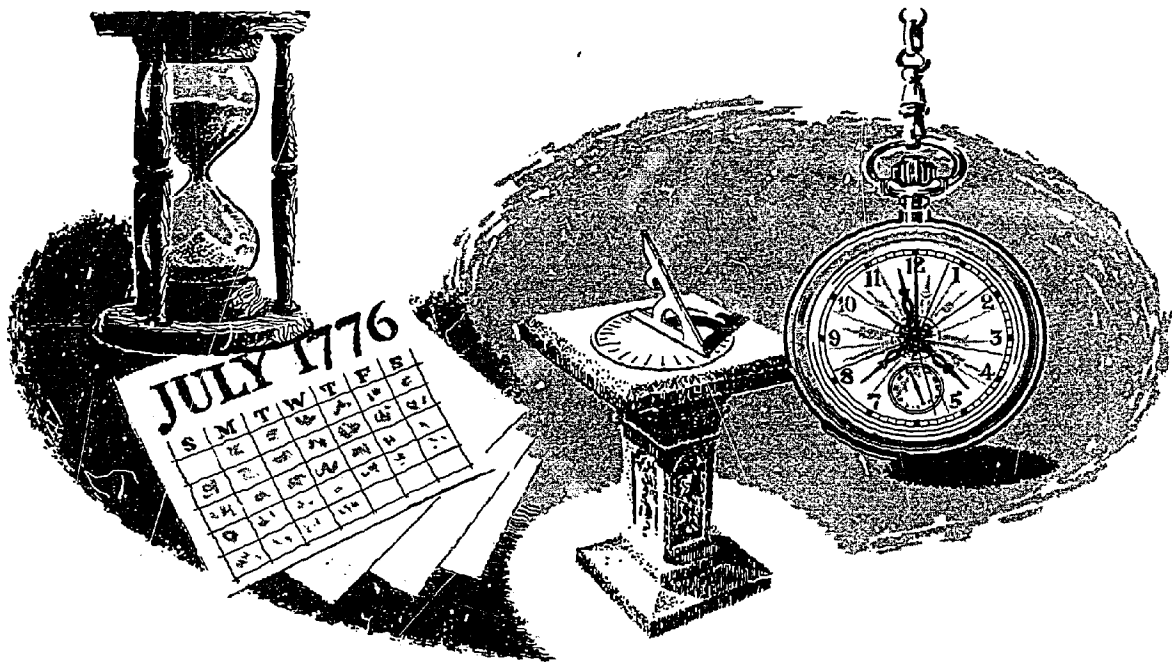

Chapter I

**THE MYSTERY OF TIME**



## THE MYSTERY

The measurement of time is a puzzle. We may think of it as a way of describing the interval between "before" and "after". In order to describe the measure of this interval, man invented clocks. For example, when there were no clocks no one could describe when the sun rose and set; how the moon moved among the stars; and why season followed season. There were no calendars or clocks to measure days, weeks, months, years and hours.

When does time begin, when does it end? Could you imagine your world if time could not be measured? In what situations is time important to you? How accurate are you in judging time? How could the duration of the event in Figure I-2 be described?

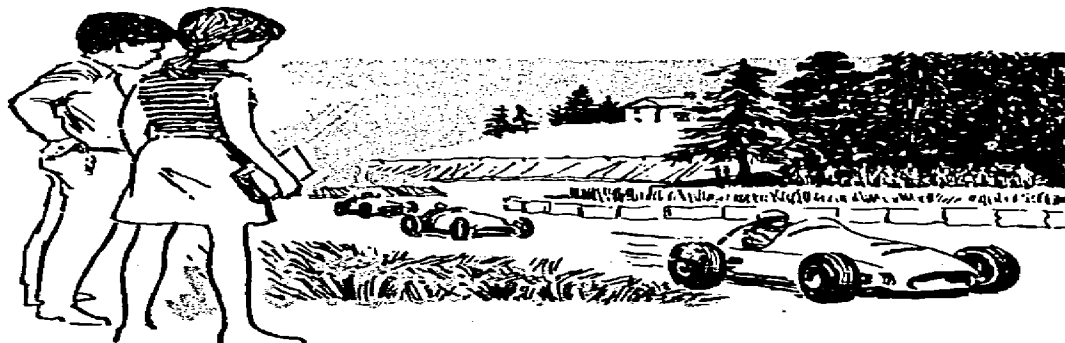

*Figure I-2*

Right now, without looking up, write down what time of day it is. Check your estimate. How close were you? Is this accurate enough for you to "keep on time?" Could you judge a race or time an experiment by estimating duration? Compare your ability to tell the measure of time with that of your friends.

Try timing some events with an ordinary clock. How long does it take you to walk the length of your room or to go to school? Make a record of several trials. Have someone else measure the time and compare your results. Make some other measures of time such as the interval between a lightning flash and the sound of thunder, or the length of time that NASA's Echo satellite is visible to you, (Figure I-3). Today we tend to take time for granted. Most of us may never really have thought



You can usually judge the length of an inch with reasonable accuracy. But one hour of time may seem much longer than another. Have you heard the saying, "There is nothing more plentiful than time?" Certainly this is true when you are waiting eagerly for something pleasant to happen. But when you are enjoying yourself at a party, you would be more likely to agree with another proverb, "Time flies."

So we need a way of measuring time that is the same for play-time, work-time of just plain "waiting" time. Write what you know to be our basic methods of time measurement. Did you include stop watches, rotation of Earth, the atomic clock, and star transits?

Early measurement methods were inexact. As our lives become more complex, we need to measure time more accurately. But an exact measure is still one of the most perplexing problems of our space age and the search for an exact *standard* of time measurement continues.

Early Americans recorded the duration of time in such units as moons and winters. Is it possible to imagine a NASA/Goddard Space Flight Center scientist saying an OGO (Orbiting Geophysical Observatory) satellite has been in orbit for "five moons?" Obviously, the units of moons and winters are not very useful today. However, they do raise a question common to all units of measurement — where does the measure begin and where does it end? Whatever unit of measure we use should give the measure of time meaning. It needs to help us to understand the duration between "before" and "after."

Early man, like today's space scientists, needed to know enough about the passage of time to make predictions so that he could give order to his life. Copy and complete Figure I-4 to list ways early man used time for prediction. Make a similar list for modern man. You can see that we now need a more accurate measurement of time than in the past.

Beginning about 4000 B.C. the civilizations of Babylonia and Egypt flourished in the valleys of the Tigris, Euphrates, and Nile Rivers. Did you know that these nations are credited with the invention of calendars as well as the sciences of astronomy and mathematics?

SOME APPLICATIONS OF TIME PREDICTIONS	
EARLY MAN	MODERN MAN
crop planting	solar flares
flock movement	launch windows
the first frost	satellite orbits
river floods	_____
food animal migrations	_____
_____	_____
_____	_____
_____	_____
_____	_____
_____	_____

Figure I-4

Read the history of Central America and find another people who made very accurate predictions by using unusual methods (Fig. 1-5).

To the Babylonians we credit those parts of our measuring system based on their mystic number twelve. Perhaps this was because astronomers observed that there seemed to be twelve full moons in the course of a year. Can you list those parts of our present measurement systems which involve twelve as a factor? For example, the Babylonian circle had 360 degrees ( $12 \times 30$ ). There are 24 hours in a day ( $12 \times 2$ ), 60 minutes in an hour ( $12 \times 5$ ), 360 days in a year ( $12 \times 30$ ).

As one of the first observations made by man was that the seasons reoccurred after a period of about twelve moons, the measure of a year was considered to be about twelve moons. Each moon was named in relationship to some event in the life of plants and animals or some sacred observance. Each month began at sundown of the day when the new crescent moon was seen in the sky.

You can easily calculate that lunar months (30 days) add up to 336 days, which is shorter than the solar year or the 365 day

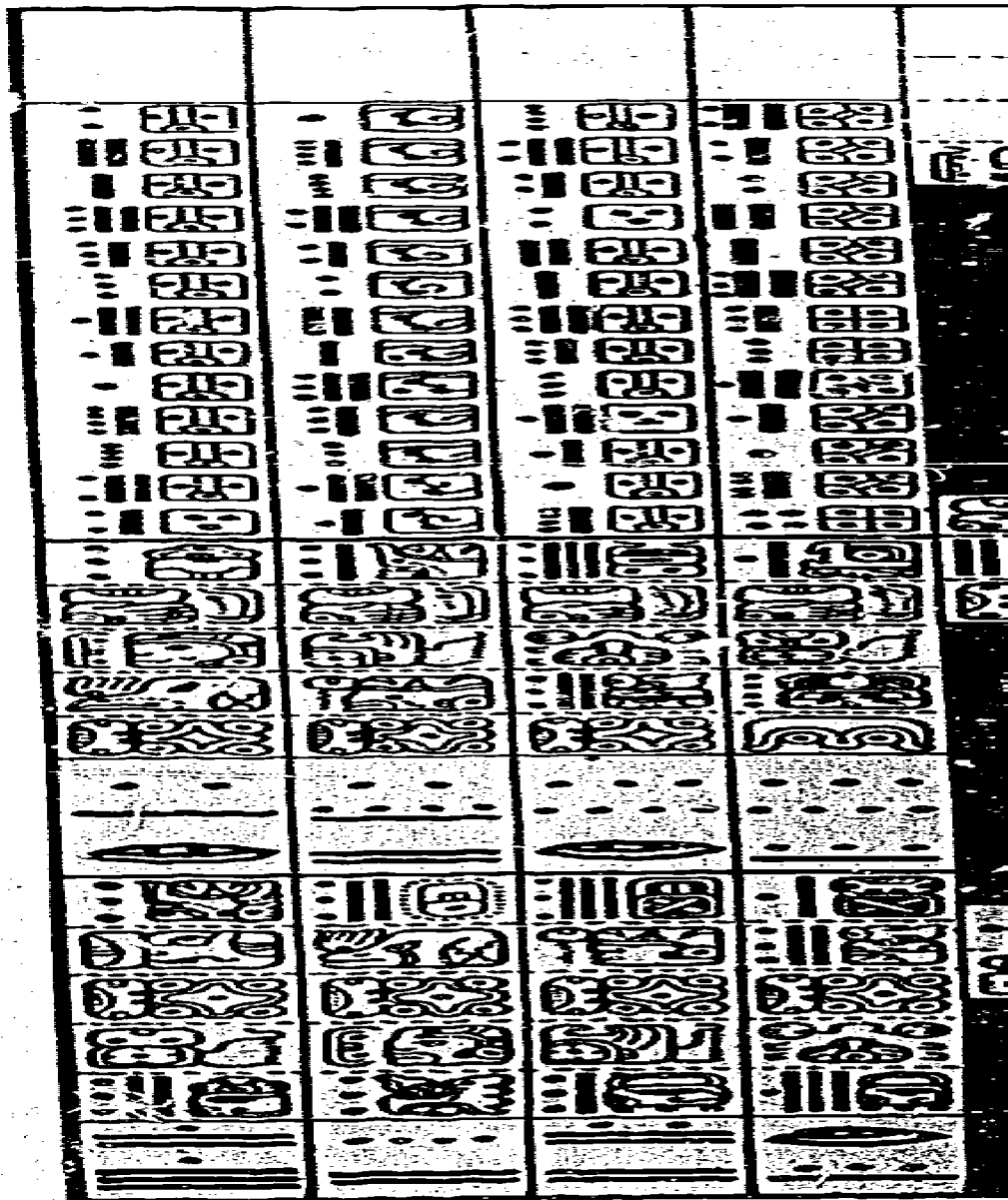

Figure I-5. A 1,500 year calendar which describes the motion of the moon in a year period.

late that twelve about 28 or 29 348 days which day Babylonian asonal year. As



Old Mayan manuscript of Venus over a 104

a result, lunar calendars (Figure I-6), needed an extra month every few years in order to match the seasons and make time predictions more exact.

Certain lunar measured calendars have been retained for use today. The calendar used in some sections of India, the Hebrew religious calendar, and the Christian method for fixing the date of Easter employ the phases of the moon as a means of measuring time. Probably no one in all Babylonia, Egypt, Greece or Rome had ever thought of a clock, yet these people could measure the passage of time, appropriate to the needs of their culture.



Figure I-6

When man first tried to tell time by observing the movement of our planet, Earth, it was as difficult as it would be for you to tell time from a clock which had neither hands nor face. Lost, forever in the years before history was written, are the works of the early men who watched the moving shadows cast by the sun, and used them to mark the passage of time, (Figure I-7). Let's examine how you can make measurements similar to those of the "lost" scientists.

From sunrise to sunset, mark the end of a shadow cast by a utility pole, flag pole, fence post or other vertical staff. Record





Figure I-7

the length for every hour as in Figure I-8. What means can you devise to accurately determine the end of the shadow; measure the time intervals; and mark shadow lengths? What kinds of tables, graphs, scale drawings, etc., can you develop to keep a record of your results?

You can investigate the way time can be determined by the sun's rays and how the tilt of Earth's axis causes sunlight to strike Earth at different angles. Using the methods developed for Figure I-8, record shadows cast over a long period of time. If possible, mark the shadow's position directly on the surface of the playground, your driveway or other permanent location. If not, record them on a large piece of chart paper or wrapping paper. Again note the exact location of the pole's shadows at the same time each day and record the length

and position of the shadow at various times during the day. Keep a record for the school year then you can compare the positions and lengths of the shadows at the beginning of the school year, during the winter, during the spring and at the end of the school year.

To help you understand the different shadow lengths, conduct the following investigation. Place an unshaded lamp, to serve as a sun, in the center of a darkened room. Attach a small stick or a figure made of pipe cleaners to a world globe. Place the globe about 2 or 3 meters from the "sun" so that its axis is tilted  $23\frac{1}{2}$  degrees toward the "sun." Measure the shadow cast by the stick. Move the globe to the other side of the unshaded bulb, placing it exactly the same distance from the lamp as it was before. Do not change the tilt of the axis. It will now tilt away from the "sun." Measure the shadow's length. Was the shadow longer when the axis was tilted toward or away from the

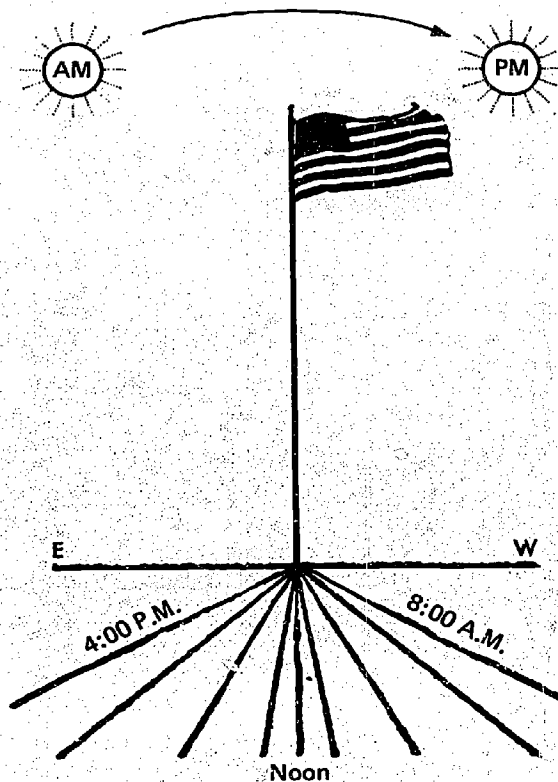
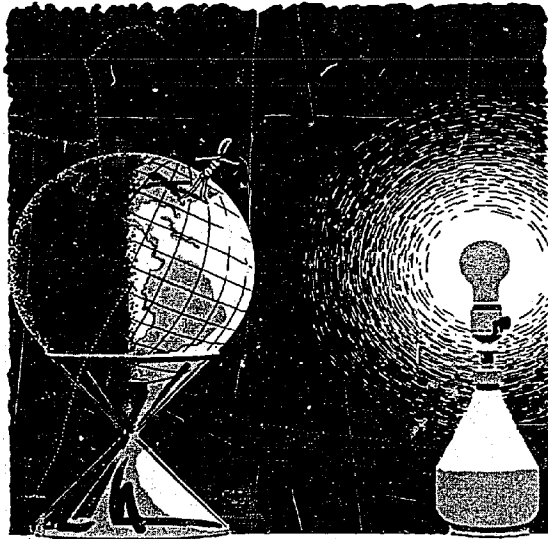

Figure I-8

sun? You can see that the actual shadow length will vary according to the object you placed on the globe. Remember the



place on Earth which is receiving the most direct rays will have the shortest shadows. What would you *hypothesize* if you moved the globe (tilted the same amount and in the same direction) to other positions equidistant from the sun?

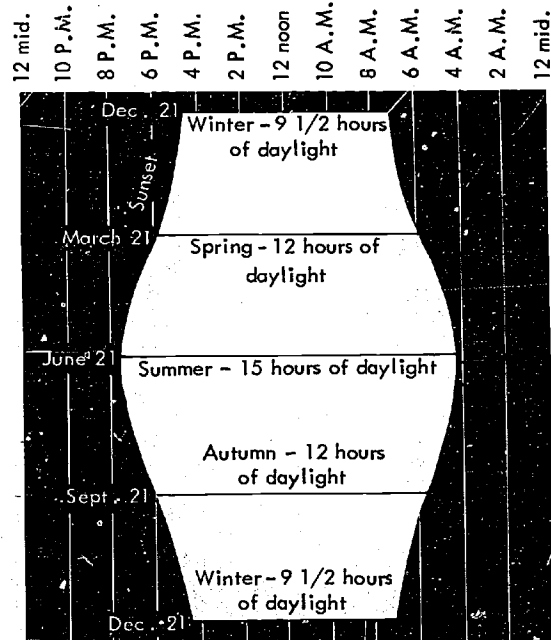

Figure I-9

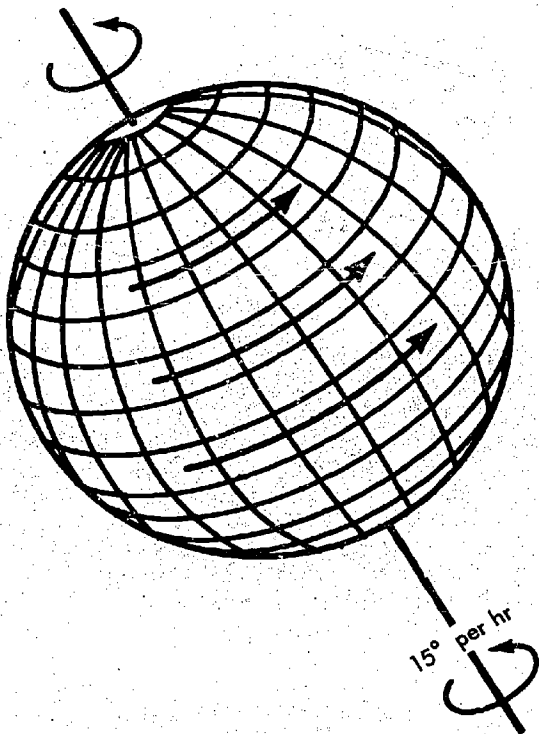

Figure I-10

You also know from daily observations that the number of hours of daylight varies throughout the year. Figure I-9 illustrates how the hours of daylight and darkness vary at the NASA/Goddard Space Flight Center, Greenbelt, Maryland, U.S.A.

If we recognize that the changes in your shadows and the apparent position of the sun are due to the motion of Earth in space, we must notice that there are two distinct major motions. The first you have just investigated: the movement of Earth in its orbit around the sun, revolution. The second motion, of course, is the rotation of Earth on its axis (Figure I-10).

Earth makes a complete rotation on its axis in about 23 hours and 56 minutes. We call this a sidereal or star day. Our solar day, however, is a few minutes longer than this because as Earth rotates it continues to revolve around the sun, (Figure I-11). Due to variations in orbital speed our solar day

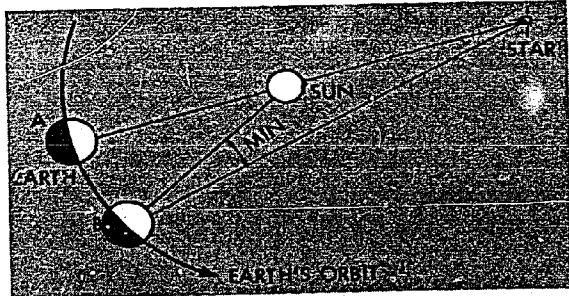

Figure I-11

varies from 23 hours 59 minutes to a little over twenty four hours.

If we seek to determine how far the sun will appear to move in the sky in one hour, we calculate that if Earth rotates a complete circle of  $360^\circ$  in twenty four hours, the number of angular degrees for each hour of rotation equals  $360/24$  or  $15^\circ$  per hour. The sun then will appear to move  $15^\circ$  per hour.

If we select the point where the sun is shining directly on Earth as solar noon, we can tell the time at various points around the globe by moving  $15^\circ$  in either direction (Figure I-12).

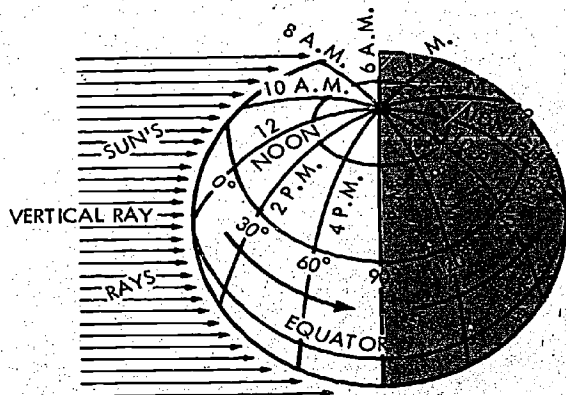

Figure I-12

These hour lines are the meridians. The *Prime Meridian* which passes through Greenwich, England, serves as a starting point for measurement east and west around the globe. (Figure I-13.)

To summarize, Earth rotates from west to east. Therefore, the sun's apparent path is from east to west and your shadow records move from west to east. The sun's apparent motion across the sky can be used to measure time.

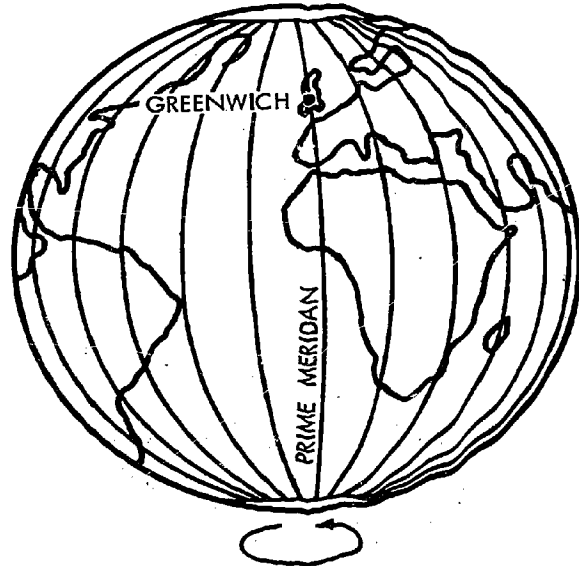

Figure I-13



Figure I-14

Prior to 2000 B.C., the first known shadow clock (Figure I-14) was built. This gave a measure to parts of the day.

A stick was joined to a long, narrow piece of wood to form a T (Figure 15). The piece of wood had markings which represented hours of the day. This took up a lot of space and was later replaced by the sundial which was both more convenient and more accurate.

Based on observations that the length of the shadow changed with the seasons, the sundial was developed to permit allowances for position on Earth and the seasons of the year. You have seen how your own shadow charts could be used to tell





Figure I-15

time. But a major difficulty would be to make charts that would be correct regardless of the season or your position on Earth.

You can build a measurement instrument that will record local sun time corrected for position and season. Your sundial will have four parts (Figure I-16). The shadow stick or gnomon (pronounced nō'mān), the equatorial ring on which to read gnomon shadows, the equatorial ring support, and the base are the four parts of the sundial. Use stiff cardboard or flexible metal for construction of the gnomon, the equatorial ring, and support. If cardboard is used, a weather-resistant spray will make your

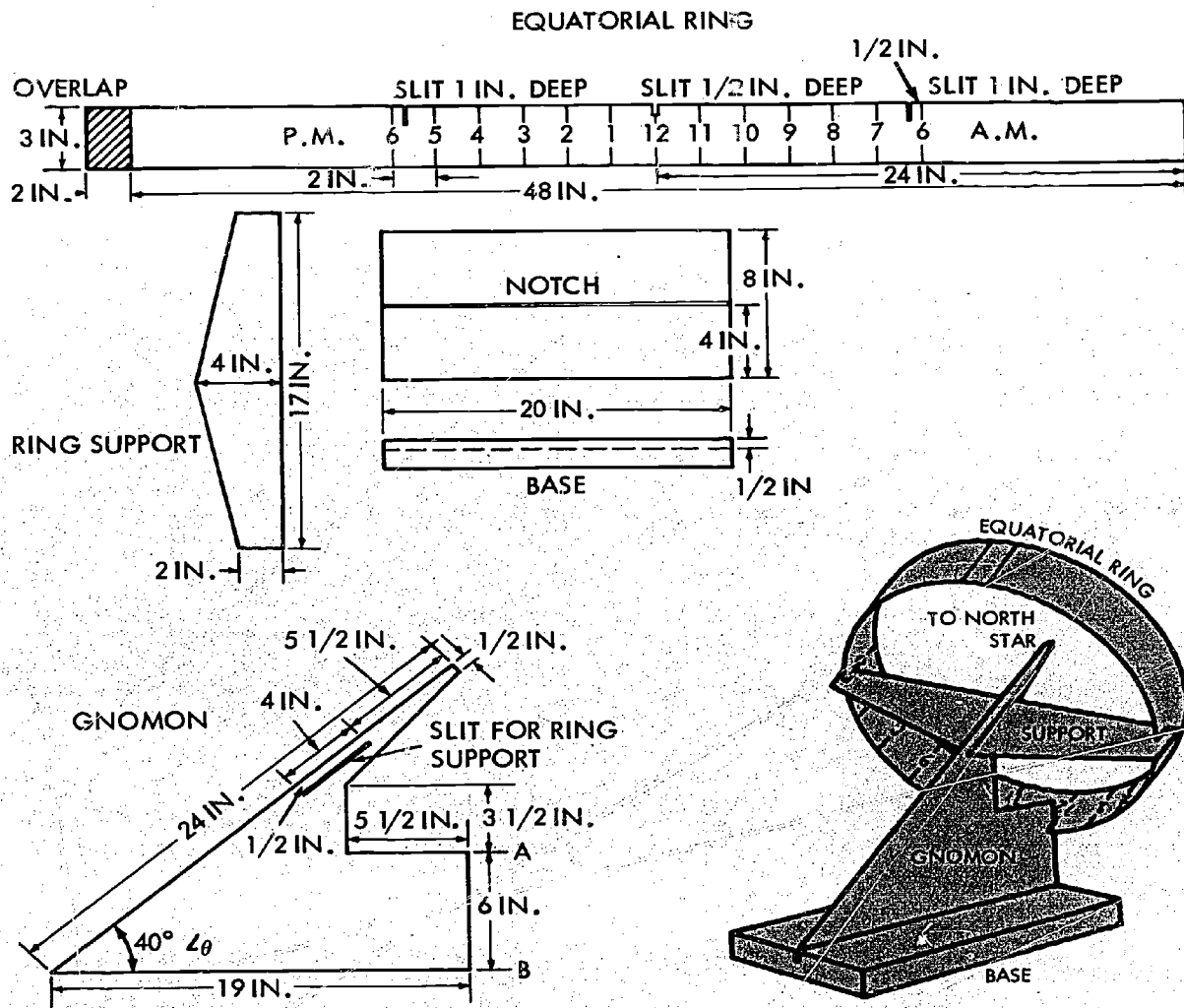

Figure I-16

Figure I-17

sundial more permanent. The base is made of wood.

Note, when constructing the gnomon, the angle  $\theta$  (called "theta") should be equal to your local latitude. Your local latitude may be determined from a map. Measure this angle carefully with a protractor. In Figure I-16, the distance AB is given for a latitude of  $40^\circ$ . If your latitude is less than  $40^\circ$ , angle  $\theta$  will be less than  $40^\circ$ . If your latitude is greater than  $40^\circ$ , angle  $\theta$  will be greater than  $40^\circ$ .

After making the parts according to the dimensions in Figure I-16, bend the equatorial ring into a circle with the markings on the inside, and fasten the two inch overlap with glue. Slide the gnomon into the notch of the wooden base and insert the equatorial ring support into the gnomon. After the equatorial ring slits are hooked on the supports, your sundial should look like Figure I-17.

In use, your sundial should be on a level surface with the gnomon pointing due North. North may be determined at night from the position of the North Star, Polaris, or in the daytime by using a compass. On sunny days, the time is read from the position of the leading edge of the gnomon shadow on the equatorial ring scale. This will be your *local solar time*.

Civilizations using sundials sought to overcome difficulties such as cloudy days and darkness by the use of devices that did not depend on Earth's rotation. Two such devices were water clocks and hour glasses. Both inventions were based on the principle of rate of flow.



Figure I-18

About 800 or 900 B.C. the water clock, a clepsydra (klep' se-dre), was developed. It was a bowl with a small hole in the bottom. When the bowl was filled, the water dripped out slowly. By marking the inside of the bowl with lines, time was measured as the water level became lower.

The trouble with the clepsydra (which means water thief) was that someone had to fill the bowl as soon as the water ran out. Then too, the rate of water flow changed as the reservoir emptied and, of course, a frozen water clock was not a good measuring device!

As the art of glass blowing progressed during the 8th Century A.D., the sand glass or hour glass was invented. Using sand instead of water, the grains emptied out of one glass vessel through a hole into another glass vessel of the same size. The sand glass proved best for measuring short periods of time. A three-minute glass, for instance, may be used in your home to time boiling eggs or telephone calls. But you would need many many sand glasses to measure a whole day in hours, minutes, and seconds. And someone would have to be there to turn the glass over when the top vessel is empty.



Figure I-19

Throughout the evolution of better time keeping, more accurate mechanical devices have been sought. All mechanical clocks have several things in common: hands, dials, bells or other ways to mark the passing of time; the escapement or regulation devices; and a source of power. We often think of the pendulum in this connection.

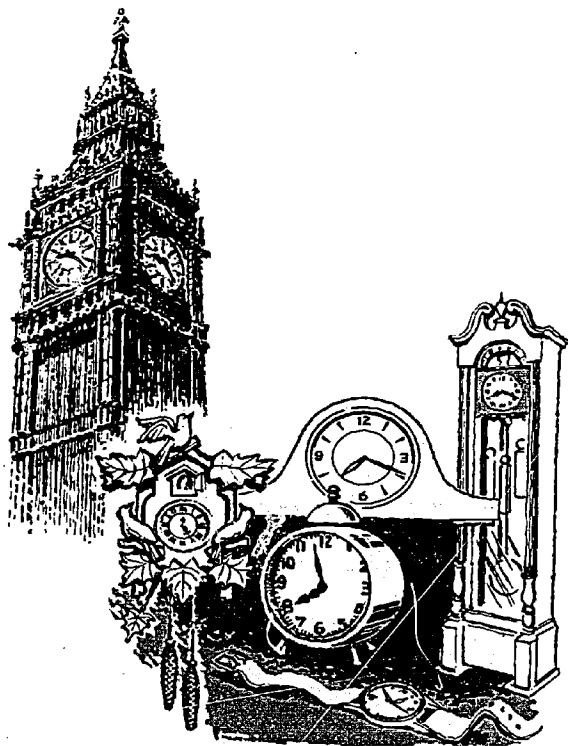

Figure I-20

When he was only nineteen, Galileo is reported to have used his pulse as a means to measure time for the comparison of the swing times of a pendulum. A more detailed account of Galileo's experiment is given in another book in this series, *From Here, Where?* pp. 82 ff.

You can compare Galileo's measurements with experimental results of your own by constructing a simple pendulum.

Tie a small weight such as a bolt or lead sinker, to a string about 10 to 15 inches long and let it hang down as you hold the other end of the string. Now pull the weight, a pendulum bob, to one side and release it (Figure I-21). It will begin swinging back and forth.

Cut the string in half and repeat your observations. What change do you observe in the period of time measured for a complete swing? The period will be shorter. The length of the string ( $L$ ) and the period of the swing ( $T$ ) are related. As the length of the string is changed the period of swing

varies. A simple relationship of  $L$  to  $T$  is as follows:

$$\frac{L_1}{L_2} = \frac{\sqrt{L_1}}{\sqrt{L_2}}$$

Your experimental results should be very close to this relationship. They would be exact, except that the usual experimental errors in timing swings, measuring length, and determining the end of the swing will incur slight differences.

To check your observations, make a table of your results like Figure I-22. Notice that you have two variables in the construction of your pendulum; the length of the pendulum, and the weight of the



Figure I-21

EXPERIMENT TRIAL	LENGTH IN CENTIMETERS	TIME FOR 5 SWINGS	AVERAGE PERIOD FOR ONE SWING
A	20	_____	_____
B	40	_____	_____
C	50	_____	_____
D	80	_____	_____
E	100	_____	_____
F	160	_____	_____
G	180	_____	_____
H	200	_____	_____
I	320	_____	_____

Figure I-22

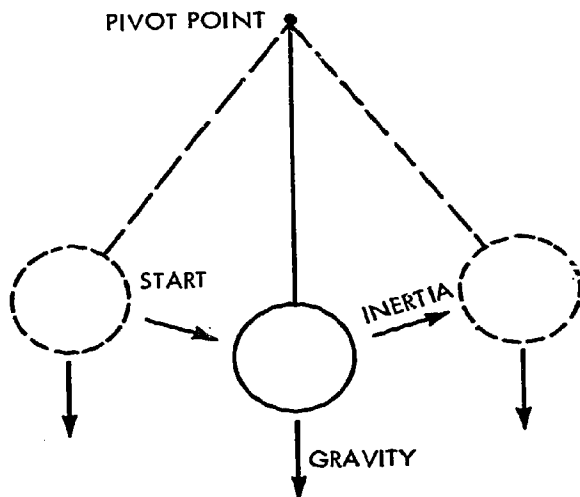

Figure I-23

bob. As you use your pendulum, another variable is the size of the arc used to start the pendulum swinging. We are interested in measuring the time necessary for one complete swing of the pendulum.

Time five successive swings for the pendulum lengths as in Figure I-23. Measure length from the pivot point to the center of the bob. Use a complete swing cycle (back and forth) of the bob as the *period*. You will find that a support for your pendulum, such as a thumbtack over a doorway or a ladder, will help your investigation. From your measurement of five periods, find the average for one period. For example, if you obtained five complete swings in twelve seconds, the average period for one swing would be  $12/5 = 2.4$  seconds.

At the top of the arc, gravitational force directs the pendulum bob toward the center of Earth. The string acts as a control on the direction of fall. Inertia, according to Newton's first law of motion, carries the bob to the top of the other side of the arc (Figure I-23). There the bob reaches the point where Earth's gravitational forces are greater than inertial forces and the bob swings back.

If no other forces acted on the pendulum, we would have perpetual motion. However, friction at the pivot and friction between the moving pendulum parts and air molecules result in the pendulum gradually slowing to a stop.

Figure I-24 illustrates how these principles are applied to a mechanical clock. The pendulum regulates the motion and the hanging weight provides the energy to overcome the action of frictional forces. You may see a similar arrangement in some "cuckoo" clocks. One of the cuckoo weights is for the pendulum mechanism, the other is to operate the cuckoo.

Figure I-23 shows how gravitational forces cause the downward movement of the bob and inertial movement forces it to the end of its arc. You know that the force of gravity depends on many factors; altitude, the shape and density of Earth, and Earth's rotation. As a consequence, a pendulum clock moved from one location to another on Earth or in space would not keep the same time. Therefore, most clock pendulums have a screw adjustment to correct for local variations.

The movement of our Earth on its axis in space also has another effect on the motion of pendulums. The French physicist Jean Bernard Leon Foucault used this motion to demonstrate that Earth rotates on its axis.

Foucault suspended a very long pendulum from the ceiling of a high room and set the pendulum in motion. After observing the pendulum for many hours, he discovered that the pendulum was not swinging in the same *geographical direction* as it was when it started. That is, if his pendulum was swinging back and forth toward one wall of the room, it gradually would appear to change its direction toward

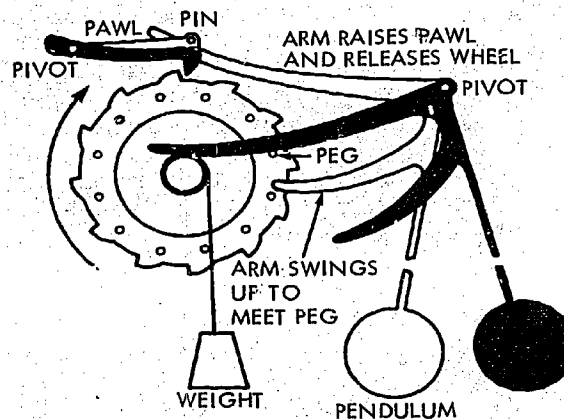

Figure I-24



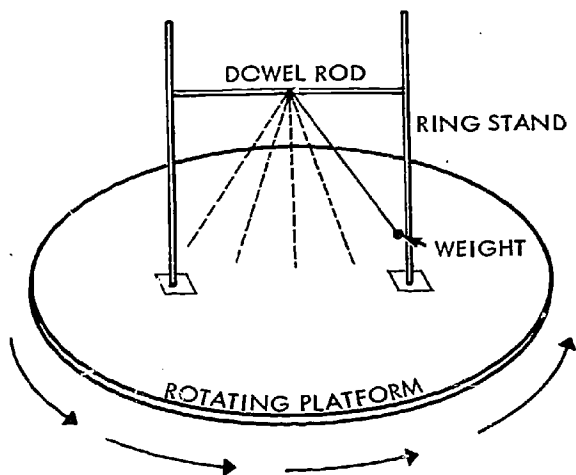

Figure I-25

the next wall and so on until the pendulum appeared to be swinging back in the direction of its starting point.

By doing the following project you can examine Foucault's reasoning that Earth and the observer are moving in relation to the direction of swing of the pendulum.

You will need: a rotating mechanism (phonograph turntable, piano stool or lazy Susan; support, such as wood dowel; heavy weight, such as a lead sinker; string; square wastebasket, ring stand or other support; and clamps (Figure I-25).

Tie the weight to one end of a string about 60 centimeters long. Attach the other end to a 1½ foot piece of dowel or broom handle about 30 centimeters long. Place the dowel across the top of a wastebasket, ring stand or other support, allowing the weight to swing freely. Place the support on top of the lazy Susan or piano stool. Set the pendulum in motion and then rotate the lazy Susan or piano stool *very* slowly.

See if the swing direction changes with respect to the platform. As Earth moves under the pendulum, the pendulum appears to change the direction of its swing. A swinging pendulum at the North Pole would appear to make a complete turn, 360°, in 24 hours. As you move toward the Equator, the effect becomes less pronounced and a longer and longer period is necessary to make a 360° change. At a point exactly perpendicular to the axis of

Earth, the Equator, there would be no apparent change in direction since at this point Earth is no longer "turning under" the pendulum.

*What's up There?*, another book in this series will provide you with some useful information on applications of pendulum principles in satellite instruments. Read particularly the section on using three pendulum accelerometers to provide measurement of satellite position, pp. 61-67.

How would you describe the distance between two cities? Was your answer in units of miles or hours? If your response was in hours, you would be using the language of astronomers. Astronomers use the term *light-year* to indicate the distance to nearby stars. A light-year is the distance light would travel in one year at a rate of about 300,000 kilometers per second.

Our closest star after the sun is Proxima Centauri. Proxima Centauri is about 4.3 light years away, or the same distance that light will travel in 4.3 years at the rate of 300,000 kilometers per second. How far away is Proxima Centauri in kilometers? To find out, first calculate how far light travels in one year. To make this calculation, you will need to multiply 300,000 by the number of seconds in one minute (60), the number of minutes in one hour (60), the number of hours in a day (24), the number of days in a year (365¼), = (300,000) × (60) (60) (24) (365¼), = (300,000) × (31,557,600) = 9,467,280,000,000 = 9.46728 × 10<sup>12</sup> kilometers.

A generally used value for the light year is 9.46 × 10<sup>12</sup> kilometers (read as nine and forty six hundredths times ten to the twelfth power kilometers). Therefore, the distance to Proxima Centauri would be 4.3 × 9.46 (10<sup>12</sup>) = 40.578 × 10<sup>12</sup>. In scientific notation, it is 40.67 (10<sup>12</sup>), and would be read as "forty and sixty seven hundredths times ten to the twelfth power."

If you do not understand scientific notation, copy and complete Figure I-26. Then read pp. 4-5 and p. 80 in *What's up There*, the first book of this series.

In our space age, time is an important factor to us. When do you launch a space vehicle so that it will get where you want it to go, and arrive when you wanted it to get there? For example, suppose you

Power	Means	Equals	Read As
$10^2$	$10 \times 10$	100	one hundred
$10^3$	$10 \times 10 \times 10$	1,000	one thousand
$10^4$	$10 \times 10 \times 10 \times 10$	?	?
$10^5$	?	?	?
$10^6$	?	1,000,000	?
$10^7$	?	10,000,000	?

Figure I-26

planned to have your rocket rendezvous in space with another spacecraft. Since a rocket carries only a limited amount of fuel and spends most of its time coasting in space, you would have to leave Earth at just the right time to arrive in position alongside the vehicle with which you wish to rendezvous. There would be no use arriving in orbit on one side of Earth when the rendezvous vehicle was on the other side.

Let's suppose you wish to rendezvous over a particular point in the Atlantic Ocean. Assume that an Agena target vehicle in orbit travels about 5 miles per second and that it takes about 90 minutes for Agena to orbit Earth. You can see that if you wish to meet the Agena in orbit at one point over Earth's surface, you will have that opportunity once every 90 minutes. In addition, if you do not want to miss Agena by more than 5 miles, your take-off will have to be accurate within one second. Every 90 minutes there will be a *one second* interval during which you must launch to accomplish your rendezvous as planned. That *one second* time interval is called a *launch window*.

Figure I-27 shows events which are possible during different periods of time. One of the shortest periods we know is the length of time it takes a proton to revolve once in the nucleus of an atom. The largest period of time we know about is our estimate of the age of the universe.

As man has passed through time for many, many years on his journey to civilization, he has learned that he lives in a world of many rhythms. He found rhythms high in the sky, and buried deep in the rocks. He found rhythms in the heart of the atom, and out in the far reaches of space. And, besides those that he found in nature, he learned how to make many

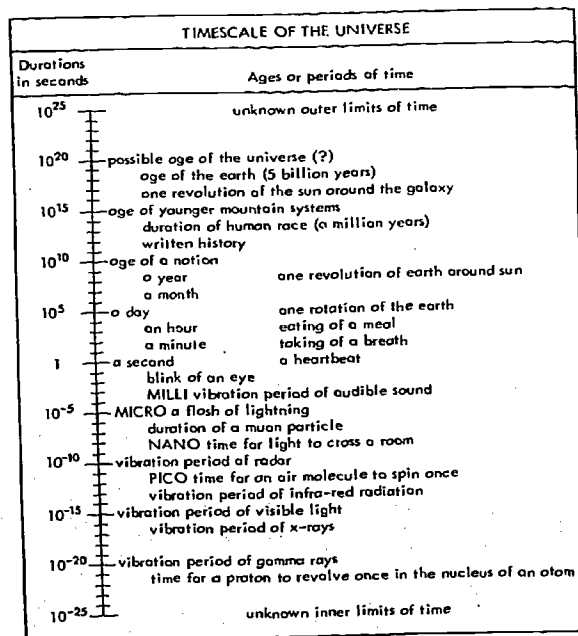
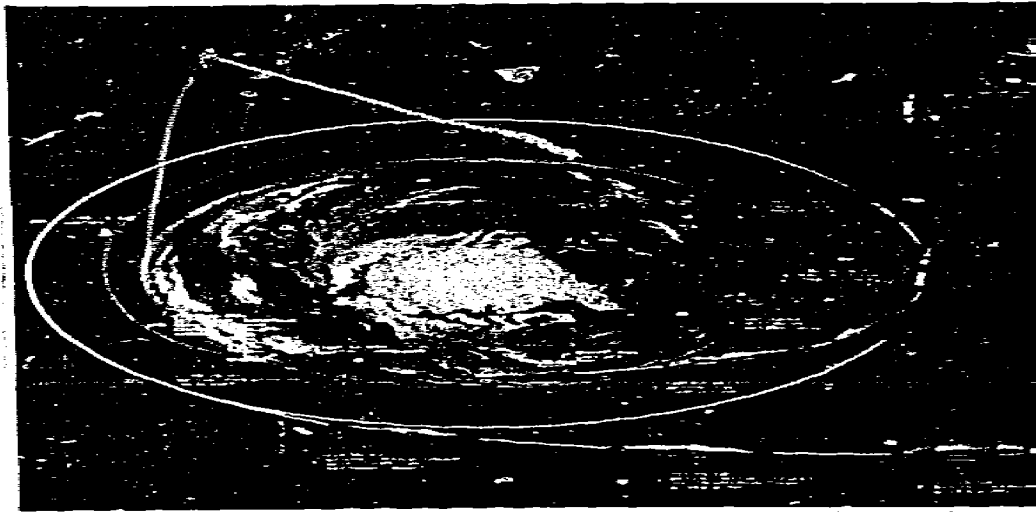

Figure I-27

more. By mastering these rhythms he developed the art of measuring time. So now he can measure time, not only for seconds, days, and years — not only for centuries — but for billions of years on the one hand, and a billionth of a second on the other. But his mastery of rhythm means more than the measurement of time. It means an increasing understanding of nature. His knowledge of rhythms not only lights up the hidden, dark corners of the past, but it also helps him to plan for the future. Armed with knowledge of the rhythms of the universe, man continues to pass through time.

In the next chapter we will see what has been done to standardize our time so that we all can "be on time."



*To get to the moon and back  
-timing is vital*

1  
2  
3  
4  
5  
6  
7  
8  
9  
10  
11  
12  
13  
14  
15  
16  
17  
18  
19  
20  
21  
22  
23  
24  
25  
26  
27  
28  
29  
30  
31  
32  
33  
34  
35  
36  
37  
38  
39  
40  
41  
42  
43  
44  
45  
46  
47  
48  
49  
50  
51  
52  
53  
54  
55  
56  
57  
58  
59  
60  
61  
62  
63  
64  
65  
66  
67  
68  
69  
70  
71  
72  
73  
74  
75  
76  
77  
78  
79  
80  
81  
82  
83  
84  
85  
86  
87  
88  
89  
90  
91  
92  
93  
94  
95  
96  
97  
98  
99  
100  
101  
102  
103  
104  
105  
106  
107  
108  
109  
110  
111  
112  
113  
114  
115  
116  
117  
118  
119  
120  
121  
122  
123  
124  
125  
126  
127  
128  
129  
130  
131  
132  
133  
134  
135  
136  
137  
138  
139  
140  
141  
142  
143  
144  
145  
146  
147  
148  
149  
150  
151  
152  
153  
154  
155  
156  
157  
158  
159  
160  
161  
162  
163  
164  
165  
166  
167  
168  
169  
170  
171  
172  
173  
174  
175  
176  
177  
178  
179  
180  
181  
182  
183  
184  
185  
186  
187  
188  
189  
190  
191  
192  
193  
194  
195  
196  
197  
198  
199  
200  
201  
202  
203  
204  
205  
206  
207  
208  
209  
210  
211  
212  
213  
214  
215  
216  
217  
218  
219  
220  
221  
222  
223  
224  
225  
226  
227  
228  
229  
230  
231  
232  
233  
234  
235  
236  
237  
238  
239  
240  
241  
242  
243  
244  
245  
246  
247  
248  
249  
250  
251  
252  
253  
254  
255  
256  
257  
258  
259  
260  
261  
262  
263  
264  
265  
266  
267  
268  
269  
270  
271  
272  
273  
274  
275  
276  
277  
278  
279  
280  
281  
282  
283  
284  
285  
286  
287  
288  
289  
290  
291  
292  
293  
294  
295  
296  
297  
298  
299  
300  
301  
302  
303  
304  
305  
306  
307  
308  
309  
310  
311  
312  
313  
314  
315  
316  
317  
318  
319  
320  
321  
322  
323  
324  
325  
326  
327  
328  
329  
330  
331  
332  
333  
334  
335  
336  
337  
338  
339  
340  
341  
342  
343  
344  
345  
346  
347  
348  
349  
350  
351  
352  
353  
354  
355  
356  
357  
358  
359  
360  
361  
362  
363  
364  
365  
366  
367  
368  
369  
370  
371  
372  
373  
374  
375  
376  
377  
378  
379  
380  
381  
382  
383  
384  
385  
386  
387  
388  
389  
390  
391  
392  
393  
394  
395  
396  
397  
398  
399  
400  
401  
402  
403  
404  
405  
406  
407  
408  
409  
410  
411  
412  
413  
414  
415  
416  
417  
418  
419  
420  
421  
422  
423  
424  
425  
426  
427  
428  
429  
430  
431  
432  
433  
434  
435  
436  
437  
438  
439  
440  
441  
442  
443  
444  
445  
446  
447  
448  
449  
450  
451  
452  
453  
454  
455  
456  
457  
458  
459  
460  
461  
462  
463  
464  
465  
466  
467  
468  
469  
470  
471  
472  
473  
474  
475  
476  
477  
478  
479  
480  
481  
482  
483  
484  
485  
486  
487  
488  
489  
490  
491  
492  
493  
494  
495  
496  
497  
498  
499  
500  
501  
502  
503  
504  
505  
506  
507  
508  
509  
510  
511  
512  
513  
514  
515  
516  
517  
518  
519  
520  
521  
522  
523  
524  
525  
526  
527  
528  
529  
530  
531  
532  
533  
534  
535  
536  
537  
538  
539  
540  
541  
542  
543  
544  
545  
546  
547  
548  
549  
550  
551  
552  
553  
554  
555  
556  
557  
558  
559  
560  
561  
562  
563  
564  
565  
566  
567  
568  
569  
570  
571  
572  
573  
574  
575  
576  
577  
578  
579  
580  
581  
582  
583  
584  
585  
586  
587  
588  
589  
590  
591  
592  
593  
594  
595  
596  
597  
598  
599  
600  
601  
602  
603  
604  
605  
606  
607  
608  
609  
610  
611  
612  
613  
614  
615  
616  
617  
618  
619  
620  
621  
622  
623  
624  
625  
626  
627  
628  
629  
630  
631  
632  
633  
634  
635  
636  
637  
638  
639  
640  
641  
642  
643  
644  
645  
646  
647  
648  
649  
650  
651  
652  
653  
654  
655  
656  
657  
658  
659  
660  
661  
662  
663  
664  
665  
666  
667  
668  
669  
670  
671  
672  
673  
674  
675  
676  
677  
678  
679  
680  
681  
682  
683  
684  
685  
686  
687  
688  
689  
690  
691  
692  
693  
694  
695  
696  
697  
698  
699  
700  
701  
702  
703  
704  
705  
706  
707  
708  
709  
710  
711  
712  
713  
714  
715  
716  
717  
718  
719  
720  
721  
722  
723  
724  
725  
726  
727  
728  
729  
730  
731  
732  
733  
734  
735  
736  
737  
738  
739  
740  
741  
742  
743  
744  
745  
746  
747  
748  
749  
750  
751  
752  
753  
754  
755  
756  
757  
758  
759  
760  
761  
762  
763  
764  
765  
766  
767  
768  
769  
770  
771  
772  
773  
774  
775  
776  
777  
778  
779  
780  
781  
782  
783  
784  
785  
786  
787  
788  
789  
790  
791  
792  
793  
794  
795  
796  
797  
798  
799  
800  
801  
802  
803  
804  
805  
806  
807  
808  
809  
810  
811  
812  
813  
814  
815  
816  
817  
818  
819  
820  
821  
822  
823  
824  
825  
826  
827  
828  
829  
830  
831  
832  
833  
834  
835  
836  
837  
838  
839  
840  
841  
842  
843  
844  
845  
846  
847  
848  
849  
850  
851  
852  
853  
854  
855  
856  
857  
858  
859  
860  
861  
862  
863  
864  
865  
866  
867  
868  
869  
870  
871  
872  
873  
874  
875  
876  
877  
878  
879  
880  
881  
882  
883  
884  
885  
886  
887  
888  
889  
890  
891  
892  
893  
894  
895  
896  
897  
898  
899  
900  
901  
902  
903  
904  
905  
906  
907  
908  
909  
910  
911  
912  
913  
914  
915  
916  
917  
918  
919  
920  
921  
922  
923  
924  
925  
926  
927  
928  
929  
930  
931  
932  
933  
934  
935  
936  
937  
938  
939  
940  
941  
942  
943  
944  
945  
946  
947  
948  
949  
950  
951  
952  
953  
954  
955  
956  
957  
958  
959  
960  
961  
962  
963  
964  
965  
966  
967  
968  
969  
970  
971  
972  
973  
974  
975  
976  
977  
978  
979  
980  
981  
982  
983  
984  
985  
986  
987  
988  
989  
990  
991  
992  
993  
994  
995  
996  
997  
998  
999  
1000





Chapter II

**MEASURING THE UNKNOWN**

## MEASURING THE UNKNOWN

In order to describe the measure of outer space, we need to consider distance as it relates to time. We can experience, or "feel," the measure of time and distance used in our day to day living. We cannot "feel" the measure of outer space. So we must use mathematical models to help us describe measures that are beyond our senses, our "feelings."

Let's begin with some measurements we know and can feel. Then use these to develop ways to describe the measure of things we may never feel and distances which we may never travel.

Everyday we are using measurements which we know by feeling. Some are the result of simple observations such as the height of a step as we approach a stairway, the time of day when we are hungry or sleepy, or the speed of an approaching car as we cross the street. Simple procedures for measuring distance are estimating by eye, ear, or by using a rule or tape measure. Obviously we cannot use these to measure the distance to an orbiting satellite or the speed of Earth as it orbits the sun. Today we have to describe very large and very small measures such as one angstrom (0.00000001 ( $10^{-8}$ ) centimeters), the time of one nanosecond (0.000000001 ( $10^{-9}$ ) seconds), or the speed of light (186,000 miles per second).

Remember also that measurement simply supplies information to help a scientist — or you — to answer a question or to solve a problem. Measurement is subject to error. So we must develop precise instruments and use them carefully. What appears to be a correct answer may turn out to be incorrect if more precise measuring instruments and techniques are used to collect the information.

Now let's attempt to make some measurements which we can "feel" to help us to understand the more precise instruments used by our space age scientists today.

Take your pulse: Count the pulsations in a minute of time. What is your pulse rate in pulses per minute? Have some of your friends take their pulse counts. Do pulse counts vary? Some of the factors that effect pulse counts include activity, rest, age, and emotion.

Most people have a pulse rate of about 72 pulses per minute. We will use this as a standard for this exercise. Is your own rate higher or lower than our selected *standard*? If 72 pulses occur in one minute, then the average number of standard pulses *per second* is  $72/60$  or 1.2 pulses in one second. Twenty seconds of clock time would be equal to  $20 \times 1.2$ , or 24 pulses of "heart time."

If we were to keep time in "standard heart time," we could develop a scale as follows:

Clock Time	Heart Time
1 second	1.2 pulses
1 minute	72.0 pulses

In space science, however, we need a way to describe very long periods of time — and very short periods. Sometimes we are able to use *smaller* numbers by introducing *larger* units. For example, instead of saying 365 days, we describe this period of time as one year. We also say one mile instead of 5,280 feet. It is more convenient to use the larger *unit* and the smaller *number*.

If we introduce larger units into standard heart time, we may describe 1,000 pulses as 1 kilopulse. The word "kilo" comes to us from the Greek language and is translated as "one thousand." We may substitute 1 megapulse for 1,000 kilopulses, "mega" from the Greek meaning great. Summarizing we may say:

$$1,000 \text{ pulses} = 1 \text{ kilopulse}$$

$$1,000 \text{ kilopulses} = 1 \text{ megapulse}$$



Figure II-2

Clock Time	Read as:	Heart Time	Scientific Notation
1.0 second	one second	1.2 pulses	1.2 pulses
0.1 seconds	one tenth	0.12 pulses	$1.2 \times 10^{-1}$ pulses
0.01 seconds	one hundredth	0.012 pulses	$1.2 \times 10^{-2}$ pulses
0.001 seconds or 1 millisecond	one thousandth	0.0012 pulses or 1.2 millipulses	$1.2 \times 10^{-3}$ pulses
0.000001 seconds or 1 microsecond	one millionth	0.0000012 pulses or 1 micropulse	$1.2 \times 10^{-6}$ pulses
0.000000001 seconds or 1 nanosecond	one billionth	0.0000000012 pulses or 1.2 nanopulses	$1.2 \times 10^{-9}$ pulses
0.000000000001 seconds or 1 picosecond	one trillionth	0.0000000000012 pulses or 1 picopulse	$1.2 \times 10^{-12}$ pulses

Table II- 1

How many pulses are in a megapulse?

1 megapulse = 1,000 kilopulses

1 megapulse = 1000 x 1000 pulses

1 megapulse = 1,000,000 or 1 million pulses

Now we can add these to our table.

1 hour            4,320.0 pulses or  
                      4.32 "kilopulses"

1 day             103.68 "kilopulses"

1 year            37,842 "megapulses"

We could describe the five hour drive from New York to Washington, D. C. in standard heart time, as taking 21,600 pulses or 21 kilopulses, plus 600 pulses. Mariner IV's trip to Mars took seven months. Seven months equals 3 megapulses, plus 1 kilopulse, plus 104 pulses of standard heart time.

An exceptional high school sprinter can run the 100 yard dash in 9.8 seconds. From Table II-1 we standardized 1 second as 1.2 pulses. So we are able to express this in "standard" heart time as 100 yards in  $9.8 \times 1.2$ , or 11.76 pulses. He is able to average 1 yard per  $11.76/100$ , or 0.1176 pulses over the 100 yard distance. The Ranger IX's pictures of the moon were recorded to the thousandth of a second (0.001 seconds). This would be equal to 12 ten-thousandths of a pulse, or 0.0012 of a pulse.

Converting our table to standard heart time, we have:

0.001 pulses        = 1 millipulse  
                              =  $10^{-3}$  pulses

0.001 millipulses = 1 micropulse  
                              =  $10^{-6}$  pulses

0.001 micropulses = 1 nanopulse  
                              =  $10^{-9}$  pulses

0.001 nanopulses = 1 picopulse  
                              =  $10^{-12}$  pulses

Our heart time is based on an imaginary standard heart, pulsating at a rate of 72 pulses per minute. If we were to keep time in standard heart time, our standard heart would be placed in the National Bureau of Standards at Washington, D.C. It might be placed next to the standard meter and standard kilogram (Figure II-3).

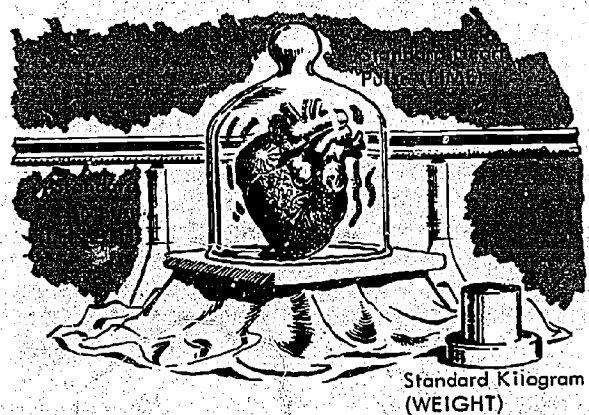

Figure II-3

Prior to the invention of our familiar mechanical and electrical clocks, the pulse was used as one of man's timing methods. You know how Galileo discovered the principle of the pendulum by timing the swing of a cathedral chandelier with his

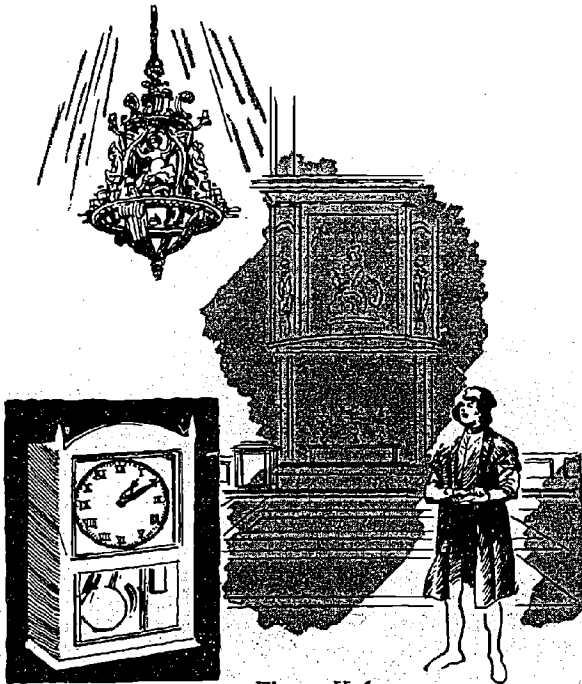

Figure II-4

pulse beat. Huygens (Hi'gens) used Galileo's discovery of the principle of the pendulum to regulate the first mechanical clock.

Run in place for 15 seconds. Now take your pulse rate in pulses per minute. Compare this rate to your rate when you were at rest.

Pulse rate at rest     ?  
 Pulse rate after running     ?

Your heart speeds up and slows down. Our standard heart also would vary with changes in conditions such as pressure, oxygen supply, temperature, food supply, and activity. Consider, for example, what would happen to our methods of measuring if the foot became longer or shorter, or if the pound became heavier or lighter. Although standard heart time is a possibility and was useful in the past, it is obvious that scientists have attempted to find other timekeepers which show less variation. The following exercises will help you understand another historical timekeeping method.

The answers for the exercises in this Chapter will be found at the end of this Chapter.

Exercises:

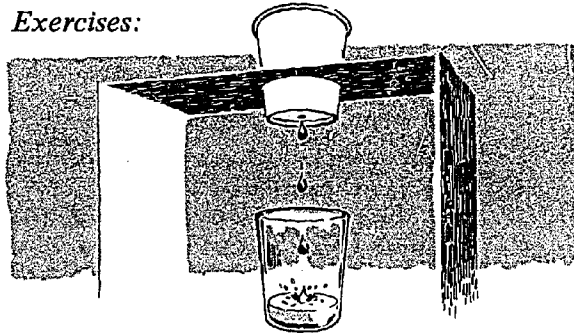

Figure II-5

- 1.a. With a pin, punch a small hole in the bottom of a paper cup. Fill the cup with water. Place the cup over another cup, so that the water drips into the second cup. Suggestion: Make the hole large enough so that you have 50 to 80 drops per minute. Count the number of drops of water in one minute of time. Record the drops in a minute. Repeat, counting the number of drops in a minute. Repeat the procedure three more times. Record your results in a table like the one below:

Test 1	<u>    ?</u>	drops in 1 minute
Test 2	<u>    ?</u>	drops in 1 minute
Test 3	<u>    ?</u>	drops in 1 minute
Test 4	<u>    ?</u>	drops in 1 minute
Test 5	<u>    ?</u>	drops in 1 minute
Total	<u>    ?</u>	drops in 5 minutes

Table II-2

Compute the average number of drops per minute. We will consider this number as the *standard* in *Drop Time*.

- b. Copy and complete the following using your standard drop time:

Clock Time	Drop Time
(1) 1 second	<u>    ?</u> drops
(2) 1 minute	<u>    ?</u> drops (standard)
(3) 1 hour	<u>    ?</u> drops or <u>    ?</u> kilodrops
(4) 1 day	<u>    ?</u> kilodrops
(5) 1 year	<u>    ?</u> kilodrops or <u>    ?</u> megadrops



Remember:

1,000 drops = 1 kilodrop  
1,000 kilodrops = 1 megadrop

Table II-3

- c. How many drops in a megadrop?
2. A satellite orbits the earth in 90 minutes. How long is this in Drop Time?
3. Mariner IV took 22 pictures of the planet Mars in 25 minutes.
  - a. How long did it take Mariner IV to take 22 pictures in Drop Time?
  - b. How long did it take in Drop Time to take 1 picture?
4. What are some of the problems in keeping time with drops of water?

The measures we use effect our understanding of modern space science and technology. The development of measurement and the instruments needed have grown as a matter of convenience. As the need arose for man to better understand the world and to make measurements of "non-ordinary" distances, as in the solar system, man produced more precise instruments to obtain more accurate measurements.

Long ago man was able to describe distance by his arms' width, a step or pace, or the width of his palm. When there was little communication, the length of the measuring unit was of little consequence: a trip along a trapping line, one or two days; and winter, one or two months away. It would not make much difference.

When families grouped into tribes, tribes into nations, and as nations came into contact with each other, communication of measures was needed. With the railroad, automobile, airplane, radio, telephone, television, and satellite networks, man has found that it was necessary to *standardize* his methods of measure. No longer could he pace off a distance, spread his arms, or measure the height of a wall with his hand; people of different sizes yielded various results.

The method of defining these ancient units has disappeared from daily use and in their place have come other methods. As detailed earlier, man's observations and ability to observe, have resulted in a system of units and standards used throughout the world.

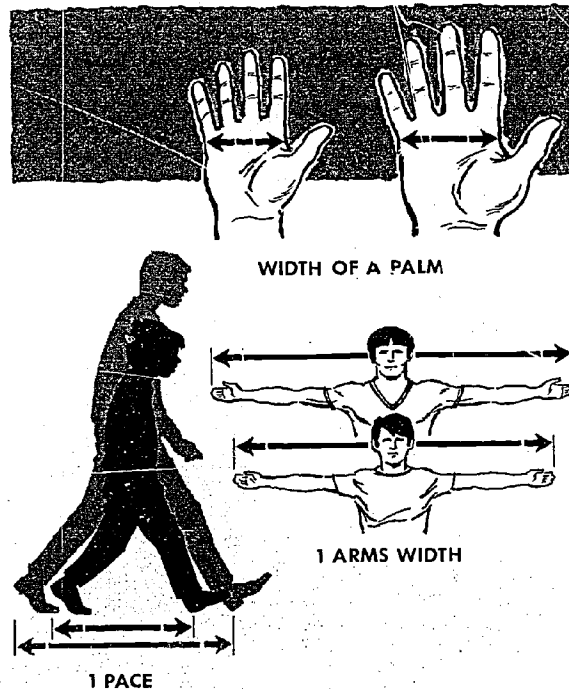

Figure II-6

Let us investigate the instruments and techniques used to determine distance, scale, and time. A few thousand years ago, man's ability to measure was determined by the precision of his eye. What he could see, he could estimate and therefore measure.

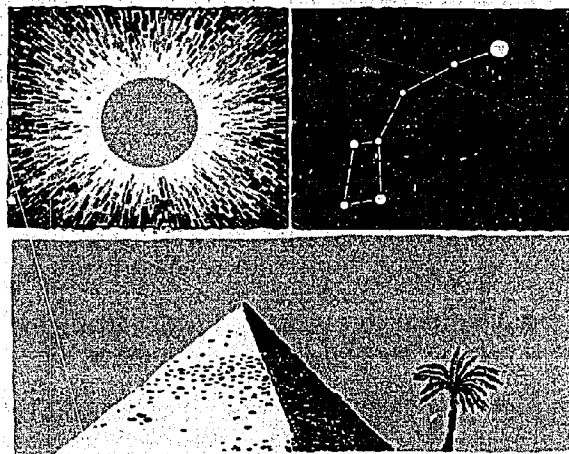
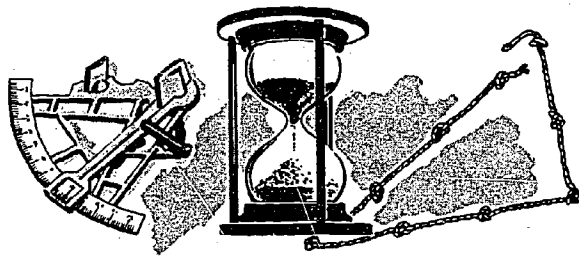

Figure II-7

- a. The Sun is brighter than the star, Polaris.
- b. The pyramid is taller than the tree.

Early instruments were developed so that man could measure more accurately.



Sextant  
(ANGLE)

Hour Glass  
(TIME)

Knotted Rope  
(DISTANCE)

Figure II-8

He now could measure the mile to the yard, foot, inch, and fraction of an inch. Light could be measured in terms of the brightness of the sun, candle, or color. Time could be determined in units of the year, month, day, hour, minute, second, or fraction of a second.

More precise instruments enabled scientists to make observations that had not been possible before. Ancient theories gave way as new ideas were supported by more accurate measurements.

By 1600, scientists began to specialize and to consider themselves primarily as physicists, astronomers, biologists, chemists, and engineers. Each of the new sciences required special measurement techniques, and measurement became more accurate.

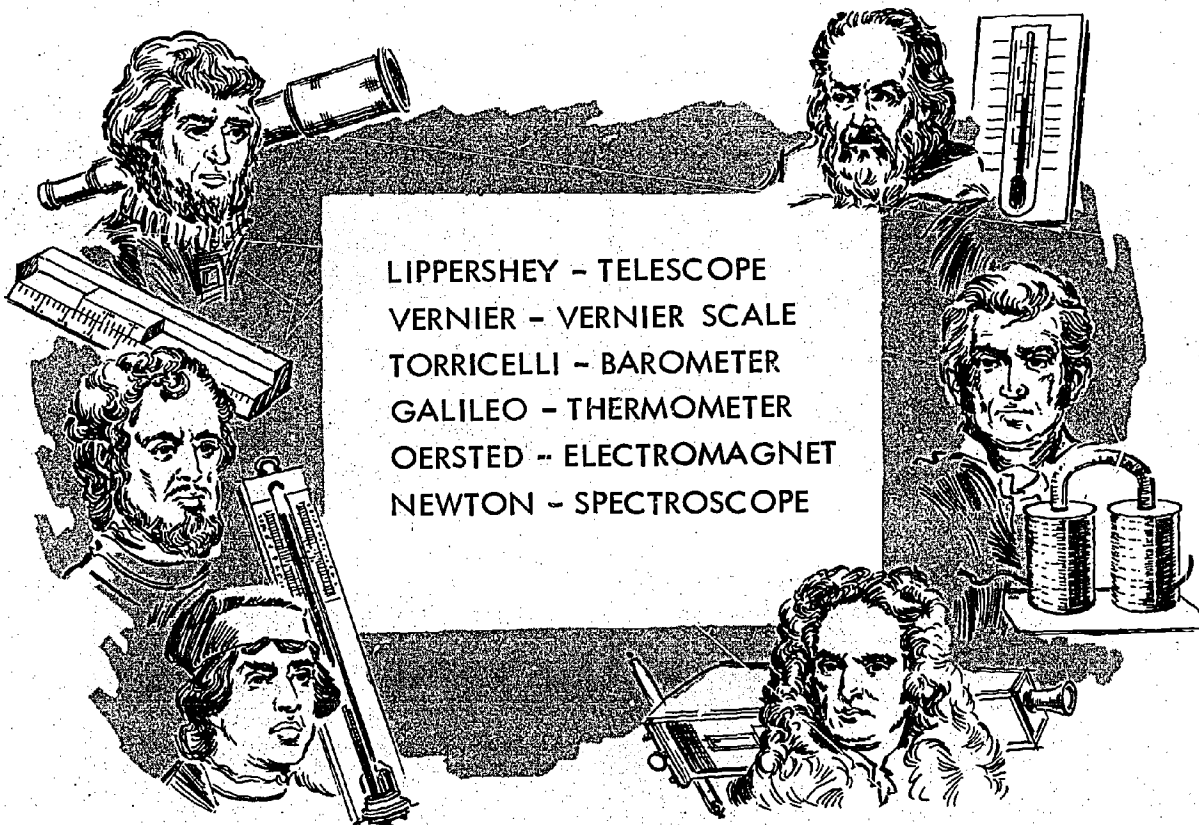

LIPPERSHEY - TELESCOPE  
 VERNIER - VERNIER SCALE  
 TORRICELLI - BAROMETER  
 GALILEO - THERMOMETER  
 OERSTED - ELECTROMAGNET  
 NEWTON - SPECTROSCOPE

Figure II-9

Scientists could measure positions on Earth, distances between cities, and the diameter of Earth.

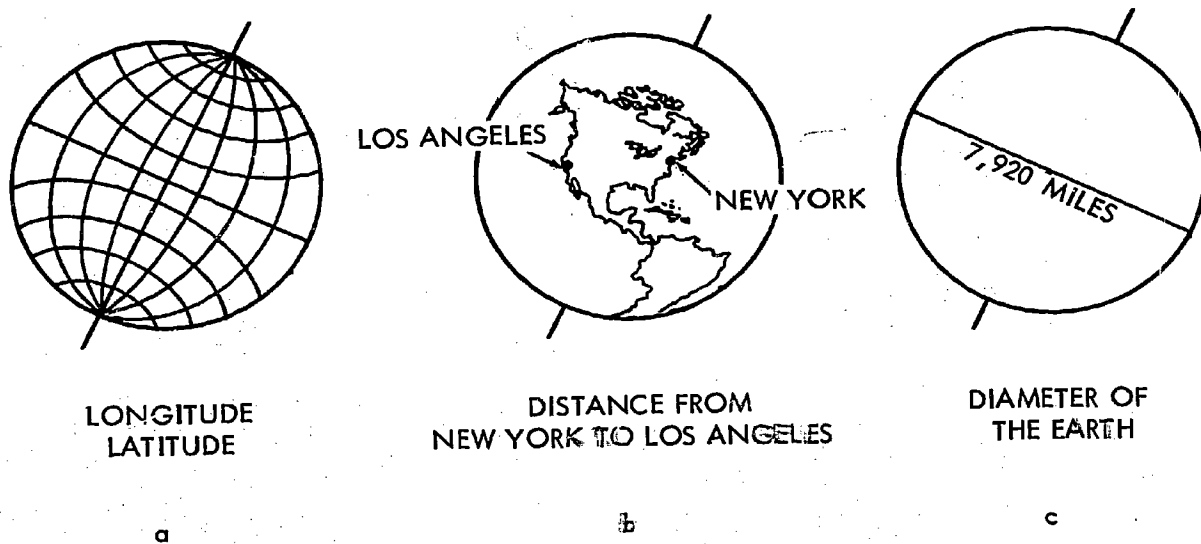

Figure II-10

They could "Reach Out" into space and measure the diameter of the moon, the brightness of the sun, and the tremendous distances to the stars.

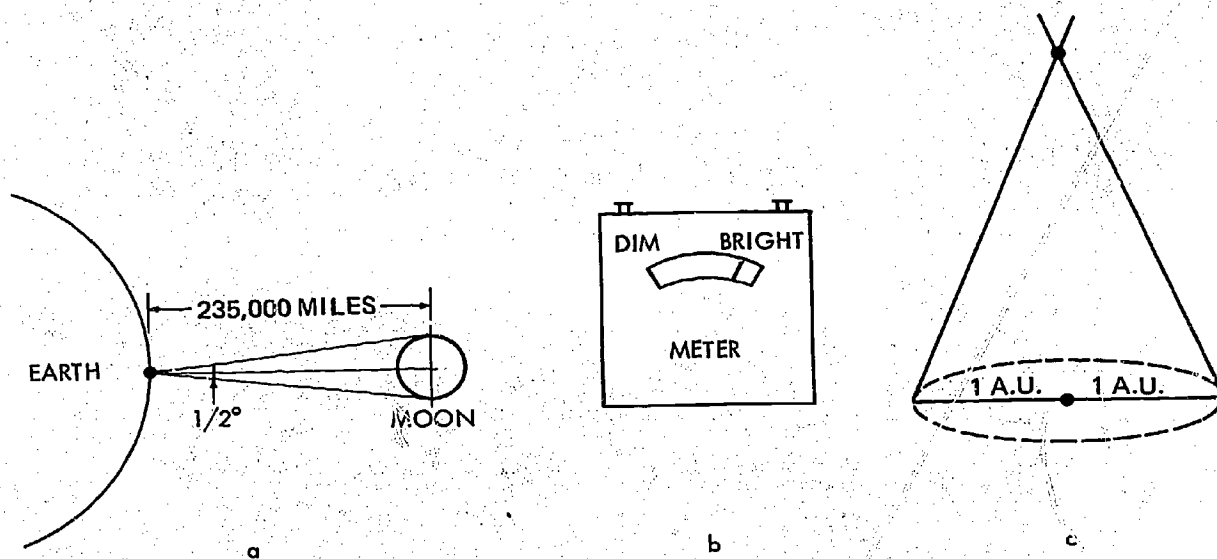

Figure II-11

He could more accurately determine the length of a year, the time of day, or the time it "took" for a ball to drop from a tower.

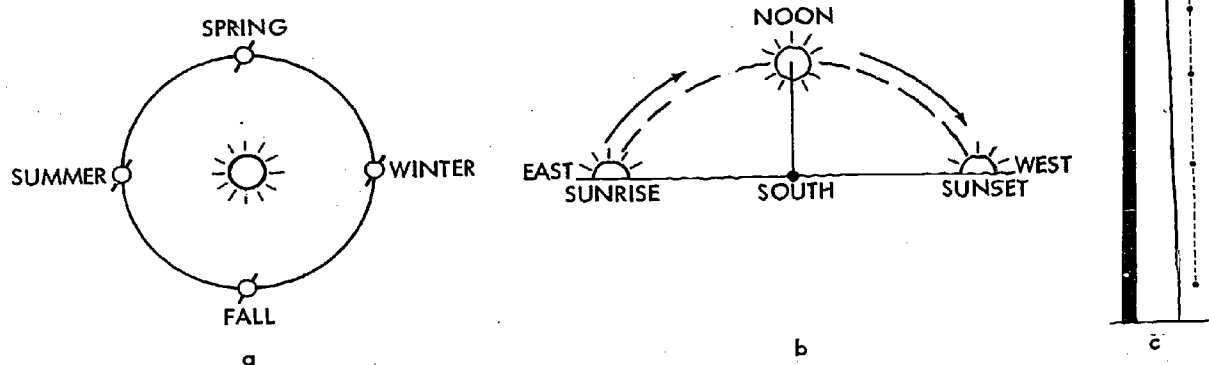

Figure II-12

Old ideas and concepts gave way to the new theories brought about by these approaches.

Ancient Theory		Modern Theory
Earth	- Flat Fixed	Round, pear shaped, Moving
Planets	- Orbit the Earth	Orbit the Sun
Atmosphere	- "4 ethers"	Oxygen, nitrogen, $\text{CO}_2$ , $\text{H}_2\text{O}$ . . .

Table II-4

In order to describe the measure of objects which cannot be seen or felt, today's scientists do not always think in terms of the mile or the foot, the sun's brightness or the candle, the year or the second, but deal in fractions of units. Many scientists are concerned with distances such as of 0.00000001 centimeters (one angstrom), light measured in terms of 0.0001 candles (one ten-thousandth of a candle) and time in terms of the nano-second (0.00000001 seconds), one billionth of a second.

Even with modern procedures, man's ability to measure depends upon the precision of his instruments and his skill in reading or interpreting these instruments.

Because instruments are subject to error, the scientist, as we do, must recognize the limits of his own ability and of his measuring devices. One of the primary concerns of the scientist is to reduce experimental error. Errors are reduced by better technique and more precise instruments.

We will now see how scientists have refined their techniques and instruments in the measurement of time, distance, and scale.

Time measurement must have had its origin in the mind of man as he watched day follow night and the seasons pass. So, it is not surprising that man finally chose the sun as the basis for measuring time. (Figure II-13).



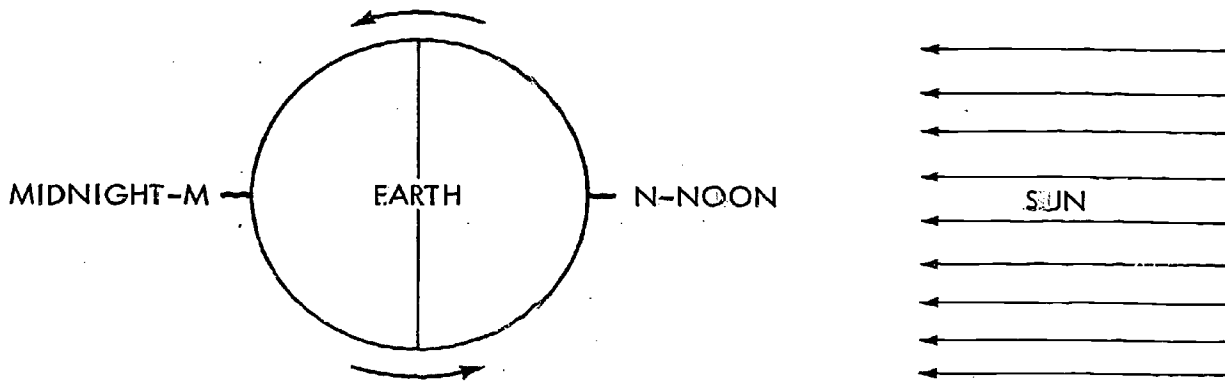

Figure II-13

From Apollo driving the sun across the sky, to the sun revolving around Earth, and to finally Earth revolving around the sun, man has utilized the periodic motion of Earth as an almost perfect "standard" of time. The basic units of time became the day, the month, and the year.

We accept the fact that Earth rotates on its axis once a day and Earth revolves around the sun once a year. But, what is a day? What is a year?

In Figure II-13, Earth makes one rotation from M to N to M every 24 hours.

Our day begins at midnight and ends at midnight. Figure II-14 compares Earth to a giant 24 hour clock.

Point A, Figure 14, rotates around the center of Earth, C, and at the end of 24 hours it would have completed one rotation, or a circle. For our purposes, we will assume 360 degrees in a circle and noon as our 0° and 24 hour point. The mathematical symbol for the word degree is °. We are able to relate hours of time to degrees of a circle, just as we related heart time to clock time as in Table II-1. For a

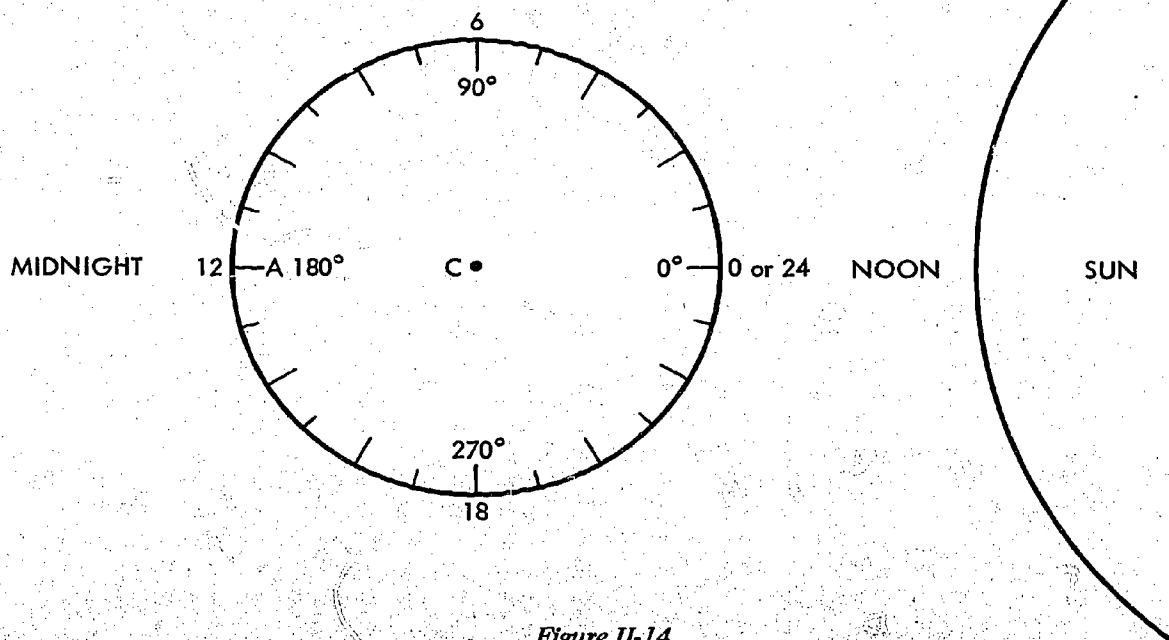

Figure II-14

more detailed discussion of hours of time and degrees of a circle, reference is made to another book of this series, Shapes of Tomorrow, Chapter 3, pp. 61-64.

Do not confuse the terms minutes and seconds of arc with minutes and seconds of time.

When speaking of angles, we say degree of arc, or:

- 1° (one degree) of arc = 60' (sixty minutes) of arc
- 1' (one minute) of arc = 60" (sixty seconds) of arc

Notice the symbol for minutes of arc is ', and the symbol used for seconds of arc is ''.

Earth Time	=	Angle in degrees of arc
1 revolution	=	1 circle
24 hours	=	360 degrees
1 hour	=	15 degrees of arc
4 minutes	=	1 degree of arc
1 minute	=	15 minutes of arc
4 seconds	=	1 minute of arc

Table II-5

Trace the protractor at the end of the chapter. Cut it out and use it to measure the angles in Figure II-15. Record your answers. Compare your answers with those given. How accurately do you measure? What can you say about your instrument (the protractor)?

We can actually speak of time in terms of an angle, Figure II-14. If we use the position of the sun at 12:00 noon as a starting point

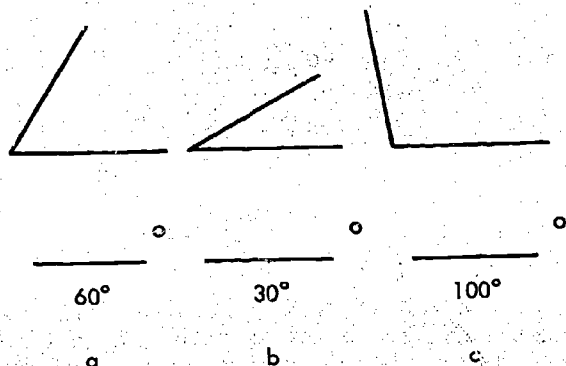

Figure II-15

of 0 hours, then 6 hours later at 6 P.M., the sun is at an angle of 90° or 6 hours.

$$1 \text{ hour} = 15^\circ \quad 6 \text{ hours} = 90^\circ$$

At 12:00 midnight, the sun is at an angle of 180° or 12 hours. At 6 A.M., the sun is at an angle of 270° or 18 hours. At 12 Noon, the sun is back at 0° or 0 hours. We have completed 24 hours or 360°.

We use the sun's position as seen from Earth as a reference for our time. Therefore, when we give our local time, we are actually speaking of the *hour angle of the sun*. This term is used by astronomers and space scientists to describe time.

Consider Figure II-16. We are looking down at Earth from above the North Pole,

Angle in degrees of arc

1 circle  
360 degrees  
15 degrees of arc  
1 degree of arc  
15 minutes of arc  
1 minute of arc

N. Points A, B, C, D, and E represent satellite tracking stations. The hour angle of the sun from position A is 0 hours. Therefore, the time is 12:00 Noon. Compare the hour angle of the sun from the other four points. What time is it at each position, when it is 12:00 Noon at position A? See Table II-6.

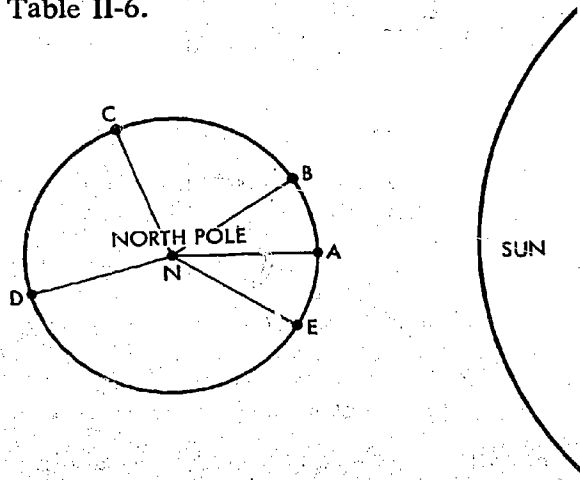

Figure II-16

Position	Time	Angle of the Sun	Hour Angle
A	12:00	0° 0'	0 hours 0 minutes
B	2:16 PM	34° 0'	2 hours 16 minutes
C	7:24 PM	111° 0'	7 hours 24 minutes
D	1:00 AM	195° 0'	13 hours 0 minutes
E	10:30 AM	337° 30'	22 hours 30 minutes

Table II-6

5.a. Trace and carefully cut out the cardboard earth, Figure II-18. Center the earth over the circle below in Figure II-19. Push a straight pin or small paper fastener through point N on the earth and through the center of the circle as indicated, so that the earth freely rotates around the pin. Align the arrow marked New York, at 0 hours or 12:00 Noon.

b. What time is it at New York? 12:00 Noon.

When is it 12:00 Noon at New York.

- (1) What time is it in Greenwich?
- (2) What time is it in Moscow?
- (3) What time is it in Tokyo?
- (4) What time is it in Los Angeles?

c. Rotate New York counter-clockwise 90° or 6 hours.

- (1) What time is it now in New York?
- (2) What is the hour angle of the sun from this position?

With New York at this position, what time is it now at:

- (3) Greenwich, England
- (4) Moscow, Russia
- (5) Tokyo, Japan
- (6) Los Angeles, California

d. (1) How many hours difference was represented by rotating New York 0° to 90°?

As you rotated New York from 0° to 90°, how many hours did:

- (2) Greenwich, England rotate?
- (3) Moscow, Russia rotate?
- (4) Tokyo, Japan rotate?
- (5) Los Angeles, California rotate?

e. Rotate New York in the same direction, counter-clockwise, to 270° or

18 hours. Make a table like the one below and record the time now at:

	Time	Angle of the Sun
New York	_____	_____
Greenwich	_____	_____
Moscow	_____	_____
Tokyo	_____	_____
Los Angeles	_____	_____

Table II-7

Note to student: We have been concerned with only the hour angle of the sun, therefore, local time. We have not taken up the change from one day to another, Monday to Tuesday, etc., or standard time.

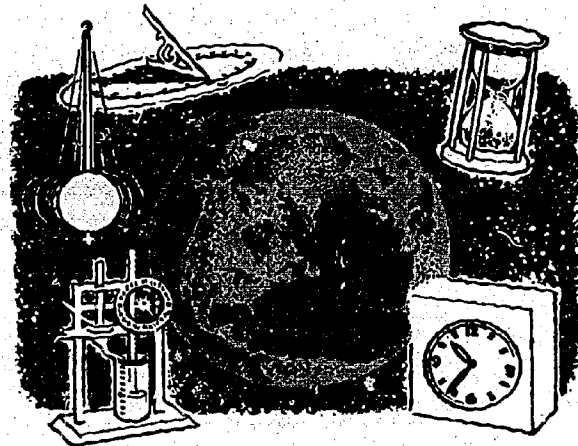

Figure II-17

As instruments improved and the accuracy of measurements increased, man began to doubt the simple motion of his planet. As we found the pulse could not be

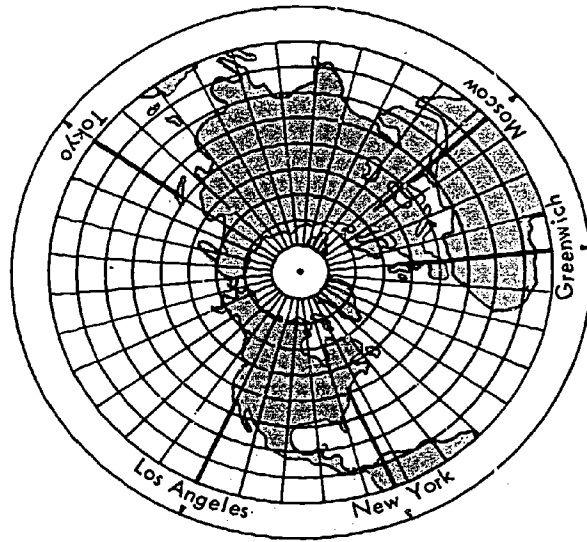

Figure II-18

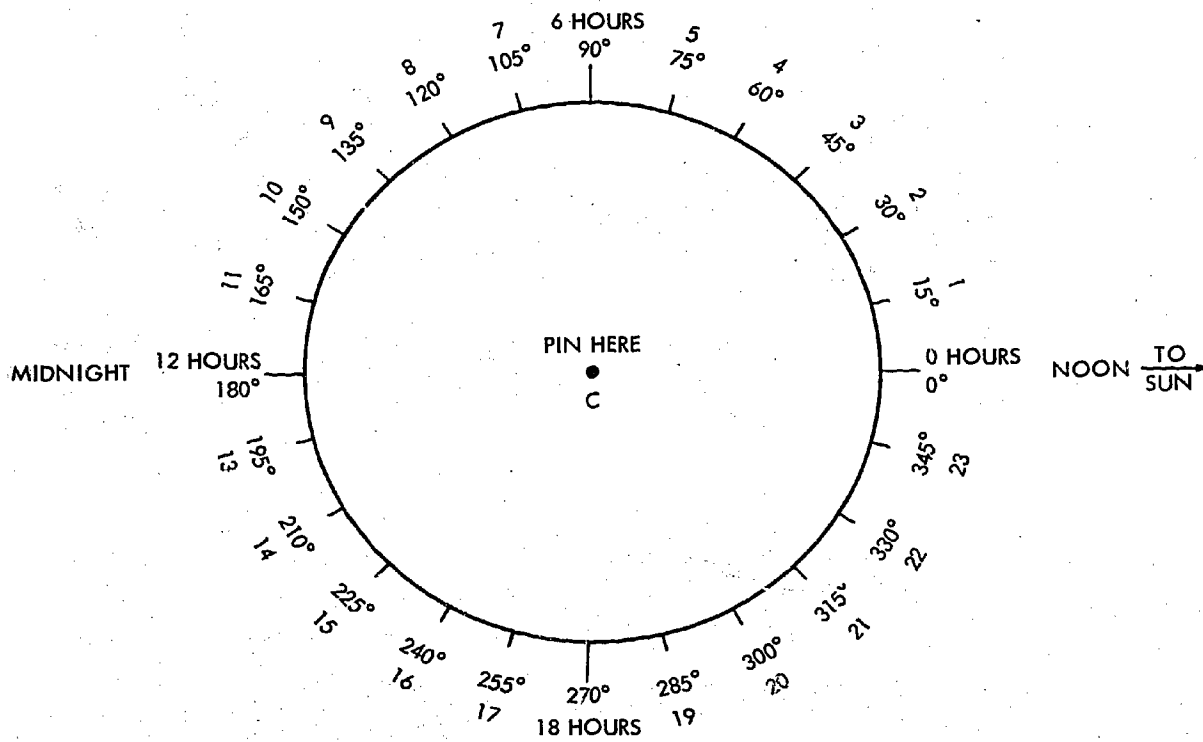

Figure II-19

29/30

used as a standard for time, man found that Earth was no longer an acceptable time standard.

Observations of the stars created the first doubt of Earth's simple motion. The stars appear to move  $1^\circ$  farther to the west each night. This is the same as saying a star rises four minutes earlier each night. Remember from Table II-5, we are able to show that an angle of  $1^\circ$  is equal to four minutes of time. We are able to explain this observation by taking into account Earth's revolution around the sun.

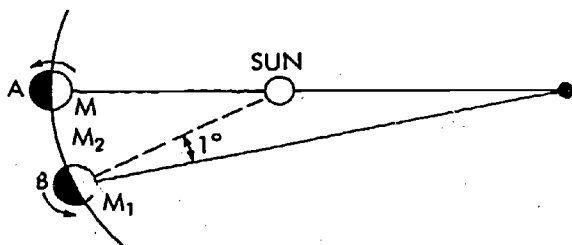

Figure II-20

When Earth is at position A, Figure II-20, the sun and a distant star are in a line as seen from M on Earth. Note that scale and angles are exaggerated for clarity. After one Earth rotation the star would appear to have returned to position M. However, Earth has moved to position B due to its revolution around the sun. The Earth must rotate about one degree or four minutes before the sun appears to return to position  $M_2$ . Therefore it takes 23 hours and 56 minutes for Earth to complete a star day, *sidereal day*, and 24 hours to complete a sun day, *solar day*.

A sidereal day = 23 hours 56 minutes  
A solar day = 24 hours

Another observation which cast doubt on Earth as an accurate timekeeper was that Earth's revolution around the sun did not take 365 days but about  $365\frac{1}{4}$  days. Every four years a day is gained. This does not seem to be very important, but over hundreds of years we would find that the seasons would be confused. Spring would begin in the summer, summer in the fall, fall in the winter and winter in the spring.

Further it was finally discovered that Earth's orbit around the sun was not circular but a nearly circular ellipse as in Figure II-21.

The Earth does not move at a uniform speed as it revolves around the sun. At its closest approach to the sun, perihelion, Earth is at a distance of about 91,500,000 miles from the sun. At its greatest distance from the sun, aphelion, Earth is about 94,500,000 miles from the sun.

Aphelion	94,500,000 miles
Perihelion	91,500,000 miles
Average distance	93,000,000 miles

Table II-8

The Earth is at perihelion in winter and at aphelion in summer. For purposes of illustration, Figure II-21 was constructed with a greatly exaggerated elliptical orbit of Earth. One of the laws concerning planetary motion states that a planet will move faster in its orbit when it is closest to the sun and slower when it is farthest from the sun. As shown in Figure II-21, again exaggerated, Earth moves from A to B in one day in January. It will move a smaller distance, C to D, in one day in July.

As previously shown, Figure II-20, the difference between the solar and sidereal day is due to the distance that Earth revolves in its orbit.

Although exaggerated, the distance traveled from A to B in January is greater than C to D in July. Due to this difference, the solar day is somewhat shorter in July and longer in January. If we were keeping time with a watch, we would find the sun would be about eight minutes behind the watch in spring and about eight minutes ahead of the watch in fall. Our watch time does not speed up in July or slow down in January. We keep time as

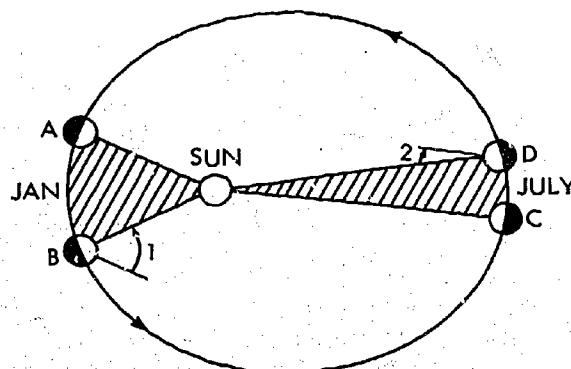

Figure II-21



an average, or we speak of the average or mean solar day as 24 hours. Our clocks and watches which run at a uniform rate during the year, actually keep average or mean time.

Another reason that solar days are not uniform in length of time is due to the fact that the axis on which Earth rotates is not perpendicular to the plane of Earth's orbit. This produces some interesting observations in the sky. For the present it will be sufficient to say that this phenomenon alone would cause the sun to be ten minutes behind a watch in February and August and ten minutes ahead in May and November.

By adding the effects of Earth's orbit and the axis of Earth, we arrive at truly complicated observations as in Table II-9:

Month	Minutes
February	15 minutes, watch behind the sun
May	4 minutes, watch behind the sun
July	6 minutes, watch behind the sun
October	16 minutes, watch ahead of the sun

Table II-9

Apparent solar time was accurate enough for our ancestors. It is not nearly accurate enough for the aerospace age. With our precise instruments we have turned from Earth's rotation, to a calculated average or mean time.

Another early timekeeper was our nearest neighbor in space, the Moon. Man was able to estimate the time of night from the appearance of the moon and its position in the sky. More recently, scientists have investigated the moon not as a timekeeper, but as a landing place for Man's first venture into outer space.

As you know, the moon orbits Earth at an average distance of about 240,000 miles.

As illustrated in Figure II-22, the moon passes from position 1, to 2, to 3, to 4, and returns to position 1 as it orbits Earth. One lunar orbit takes about 30 days. Notice the orbit of the moon is approximated as a circle. Remember a circle has 360°. If the moon completes one orbit or 360° in 30 days, then it moves 12° in one day!

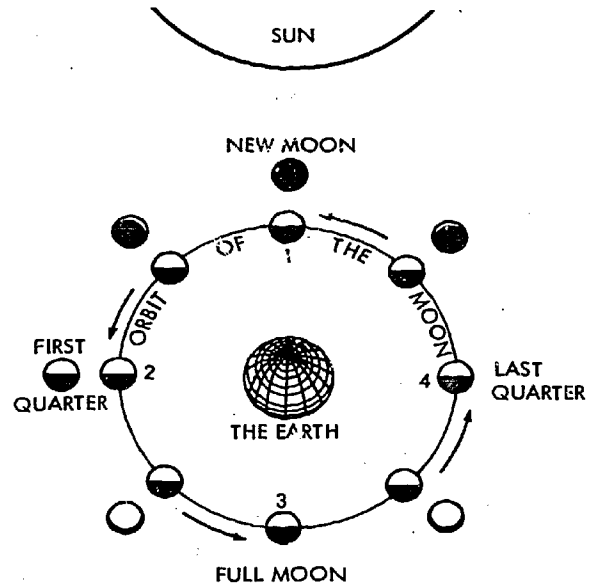

Figure II-22

$$\frac{360^\circ}{30 \text{ days}} = 12^\circ \text{ in one day}$$

If the moon is at position 1, Figure II-22, seven and one-half days later it would be at position 2. The moon would have moved 7½ days at 12° per day or 90° in 7½ days. From position 2 it would move to position 3, and it would be 90° from position 2, or 180° from position 1. At position 3, the moon would have orbited 270° in 22½ days. Returning to position 1, the moon has completed a 360° orbit in 30 days. Each day the moon would appear to have moved 12° in the sky.

Look again at Figure II-22. When the moon is at position 1, the moon is between the sun and Earth. As the moon passes between the sun and Earth, one of three things occurs as shown in Figure II-23.

Throughout the year, as the moon orbits Earth (Figure II-23) it can appear to pass above the sun, a; below the sun, c; or directly between the sun and Earth, b. Positions a and c occur most frequently. Position b infrequently occurs. What do we call the phenomena when the moon passes directly across the disc or face of the sun as in position b? In any event, position a, b, and c, in Figure II-23 could

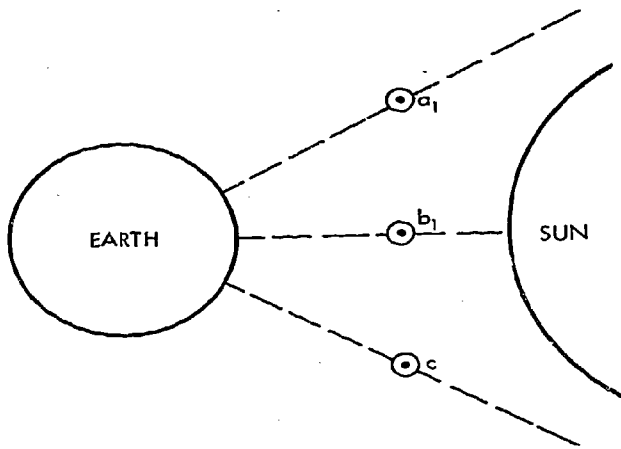

Figure II-23

represent the moon at position 1 in Figure II-22. Therefore once each month the moon does appear to pass "between" the sun and Earth. Why don't we notice this when it occurs? We only "see" it occur when the moon is at position b (Figure II-23).

Again refer to Figure II-22. If we are looking from Earth at the moon, position 1, we are looking directly into the sun. Can you see any object in the sky in the daytime except for the sun?

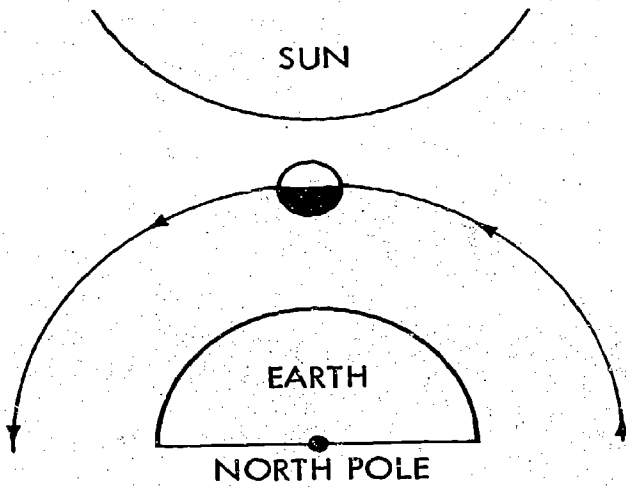

Figure II-24

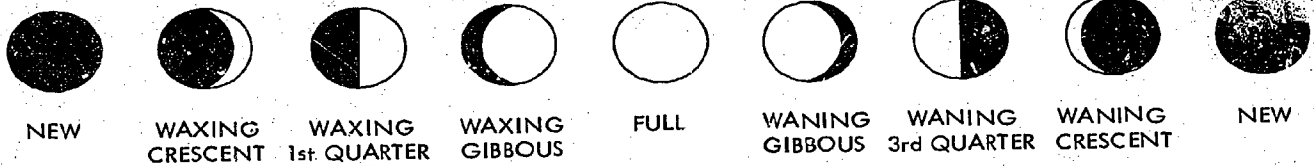

Figure II-26

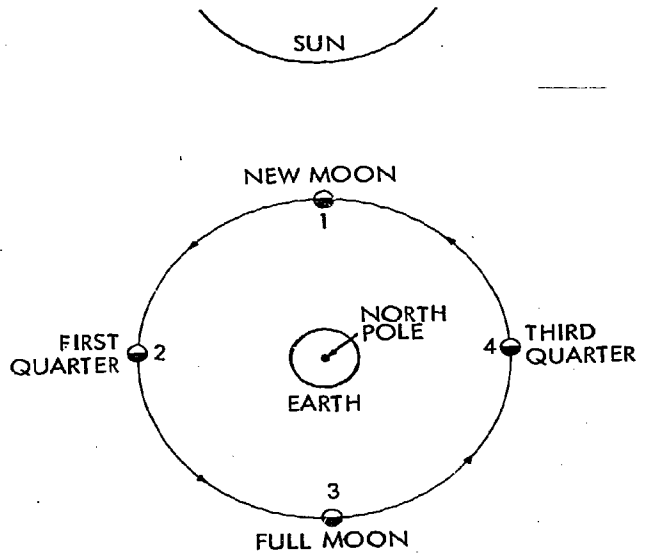

Figure II-25

When the moon, sun and Earth are in position as illustrated by Figure II-24, the lighted side of the moon is the side toward the sun. Besides being in the daytime sky, we are looking at the dark side of the moon. Can we see the moon as illustrated in Figure II-24? No It would be in the sky, but we could not see it.

When the moon is at position 1, (Figure II-25) we refer to the moon as a new moon. Seven and one-half days later, when the moon is at position 2, the moon is referred to as the first quarter. The 15 day old moon at position 3, is called the full moon. At position 4, 22½ days after new moon, the moon is called the third quarter. 7½ days after third quarter or 30 days after new moon, the moon is back at position 1 and is again referred to as the new moon.

When speaking of the moon, useful terminology is illustrated in Figure II-26. As the lighted side of the moon visible from Earth becomes larger, new moon to full moon, the moon is said to be *waxing*. As the lighted side as seen from Earth becomes smaller, full moon to new moon,

the moon is said to be *waning*. If the moon's lighted side as seen from Earth is larger than a quarter and smaller than full, the moon is said to be *gibbous*. If the lighted side of the moon as seen from Earth is less than a quarter but greater than when at new moon the moon is said to be a *crescent*.

Why is the quarter moon called quarter? How much of the moon is always lighted by the sun?  $\frac{1}{2}$ . How much of that lighted half do we see at the quarter phase?  $\frac{1}{2}$ .  $\frac{1}{2} \cdot \frac{1}{2} = \frac{1}{4}$ , or we see  $\frac{1}{4}$  of the moon's surface at the quarter phases. Using the vocabulary previously described, let us attempt to describe where the moon "goes" in the daytime.

To better understand the "wanderings" of the moon and to use the moon as a time-keeper we will make two assumptions. First, we will tell time by the position of the sun, and second, we will assume that the sun rises into the eastern sky at 6:00 AM, is directly south in the sky at 12:00 noon, and sets in the west at 6:00 PM (Figure II-27).

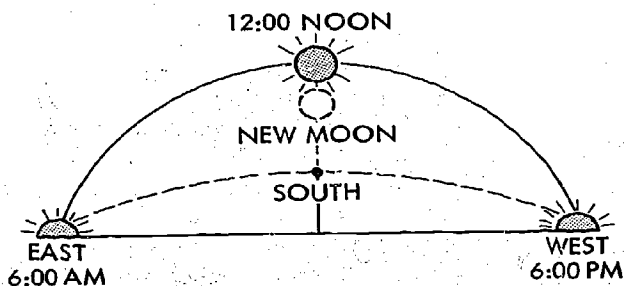

Figure II-27

You are facing south in Figure II-27. East is to the left and west is to the right. The sun is high in the sky, directly south. What time is it in Figure II-27? 12:00 Noon. What time did the sun rise on this day? 6:00 AM. What time does the sun set on this day? 6:00 PM. If the sun rises at 6:00 AM and sets at 6:00 PM, how many hours does the sun spend in the sky on this day? 12 hours. How many hours do we see the sun this day? 12 hours. We see the sun all day unless, of course, it's cloudy or raining. We will assume clear days and nights.

In Figure II-27, we observe the moon at the phase we described as new moon. Re-

member when the moon is at this position in its orbit, the moon is passing "between" the sun and Earth. Figure II-27 illustrates the moon passing below the sun's position as seen from Earth. Read the following question slowly. Reread it. If the sun is directly south at 12:00 noon, and the new moon is directly south when the sun is directly south, what time is it when the new moon is in the south? 12:00 Noon. Remember we tell time by the position of the sun! If the new moon is directly south at 12:00 noon, what time was it when the new moon rose in the east? 6:00 AM. If the new moon rises at 6:00 AM, is directly south at 12:00 noon, what time does it set? 6:00 PM. Or we say the new moon sets when the sun \_\_\_\_\_. Sets. Do you see the new moon set? No. The new moon sets in the fading light of the sun. The new moon rises at 6:00 AM and sets at 6:00 PM. How many hours is the new moon in the sky? 12 hours. How many hours do you see it on this day? You don't. It is only in the sky when the sun is in the sky. Also recall that at new moon we are observing the dark side of the moon. The lighted side is toward the sun. (Figure II-24).

Therefore the new moon phase is the phase of the moon that we cannot see. It is not visible to the unaided eye. The new moon is only in the sky in the daytime. It has already set in the west before darkness and is not seen in the nighttime sky.

#### New Moon

Rises . . . . .	6:00 AM
Sets . . . . .	6:00 PM
Hours in the sky . . . . .	12 hours
Is seen . . . . .	0 hours

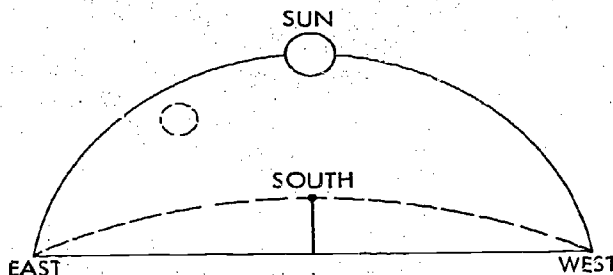

Figure II-28



Figure II-28, represents the moon three days after new moon. The moon has moved 3 days or  $36^\circ$  in its orbit around Earth. What time is represented by Figure II-28? 12:00 Noon. The sun is due south. If the sun rises at 6:00 AM and sets at 6:00 PM, what time did the moon rise in Figure II-28? 9:00 AM. The moon is about three hours "behind" the sun. Did you see the moon of Figure II-28 when it rose in the east? No. It is daylight at 9:00 AM. If you are outside looking at the moon in Figure II-28, could you see it? No. The time is 12:00 Noon.

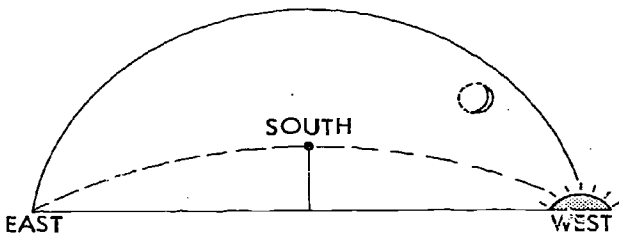

Figure II-29

Figure II-29 represents the 3 day old moon at sunset, 6:00 PM. Do you see the 3 day old moon at sunset? Yes. The moon has moved out of the glare of the sun. What time will the 3 day old moon set? 9:00 PM. If the 3 day old moon rose at 9:00 AM and sets at 9:00 PM, how many hours is it in the sky? 12 hours. How many hours do you see it? 3 hours. It is observed from 6:00 PM until 9:00 PM when it sets in the west. Could you observe the 3 day old moon at 12:00 midnight? No. It has already set.

The three day old moon is considered a *crescent* as it is between the quarter moon and the new moon phase. The three day old crescent moon is said to be waxing. The lighted side is becoming larger as the moon is moving from the new moon to full moon phase. The moon at this position in its orbit is then described as a *3 day old waxing crescent moon*.

#### 3 Day, Waxing, Crescent Moon

Rises . . . . .	9:00 AM
Sets . . . . .	9:00 PM
Hours in the sky . . .	12 hours
Is seen . . . . .	3 hours, 6:00 PM to 9:00 PM

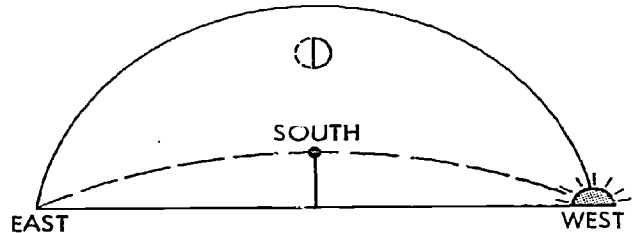

Figure II-30

In Figure II-30 the sun is setting in the west. What time is it? 6:00 PM. The  $7\frac{1}{2}$  day old first quarter moon is directly south in the sky at sunset. What time is the first quarter in the south? 6:00 PM. If the first quarter moon is in the south at 6:00 PM, what time did it rise? 12:00 Noon. Did you see it when it rose in the east? No. The sun was high in the sky. What time will the first quarter moon set? 12:00 Midnight. Will you see it as it sets? Yes. It is night. If the first quarter moon rises at 12:00 noon and sets at 12:00 midnight, how many hours is the first quarter moon in the sky? 12 hours. How many hours do you see it? 6 hours. The first quarter moon is observed from sunset until it sets about midnight.

#### Waxing First Quarter

Rises . . . . .	12:00 Noon
Sets . . . . .	12:00 Midnight
Hours in the sky . . .	12 hours
Is seen . . . . .	6 hours, 6:00 PM to 12:00 Midnight

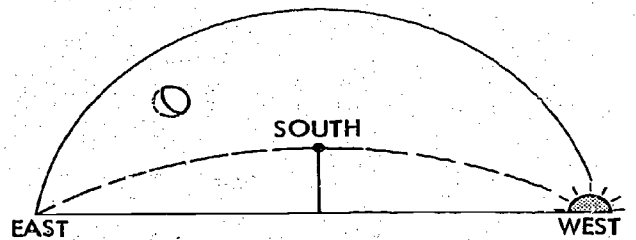

Figure II-31

Figure II-31 represents the 10 day old waxing gibbous moon. The ten day old gibbous moon is about 9 hours "behind" the sun. The sun is setting in Figure II-31 and the gibbous moon is toward the south-east. What time did the waxing gibbous moon rise? 3:00 PM. Did you see it rise?

No. What time will it be in the south? 9:00 PM. What time will it set? 3:00 AM. Do you see it as it sets? Yes. If it rises at 3:00 PM and sets at 3:00 AM, how many hours is it in the sky? 12 hours. How many hours is it visible? 9 hours.

**10 Day, Waxing Gibbous Moon**

Rises . . . . . 3:00 PM  
 Sets . . . . . 3:00 AM  
 Hours in the sky . . . 12 hours  
 Is seen . . . . . 9 hours, 6:00 PM to 3:00 AM

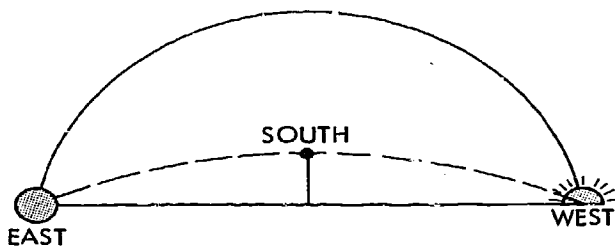

Figure II-32

In Figure II-32 the full moon is rising as the sun is setting. Notice that the full moon is opposite the sun in the sky, twelve hours "behind" the sun. What time is illustrated by Figure II-32? 6:00 PM. The sun is setting. If the full 15 day moon rises at 6:00 PM, do you see it as it rises? Yes. The sun is setting. The full moon rises as the sun sets. What time will the full moon be directly south? 12 Midnight. What time will the full moon set? 6:00 AM. The full moon sets as the sun rises. How many hours is the full moon in the sky? 12 hours. How many hours do you see it? 12 hours. The full moon is seen all night from sunset to sunrise.

**Full Moon**

Rises . . . . . 6:00 PM  
 Sets . . . . . 6:00 AM  
 Hours in the sky . . . . 12 hours  
 Is seen . . . . . 12 hours, sunset to sunrise

Notice in Figure II-33 that the sun is rising. What time is it? 6:00 AM. If the 18 day old waning gibbous moon is in the southwest at sunrise, what time was it due

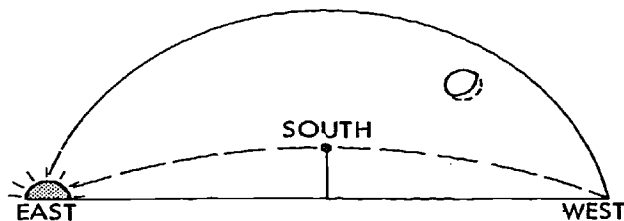

Figure II-33

south? 3:00 AM. What time did it rise in the east? 9:00 PM. Do you see it as it rises? Yes. If the 18 day old waning gibbous moon rises at 9:00 PM, what time will it set? 9:00 AM. Will you see it when it sets? No. It will disappear from view in the southwest as the sun rises in the east, setting three hours later.

**15 Day, Waning Gibbous Moon**

Rises . . . . . 9:00 PM  
 Sets . . . . . 6:00 AM  
 Hours in the sky . . . 12:00 hours  
 It is seen . . . . . 9 hours, 9:00 PM to 6:00 AM

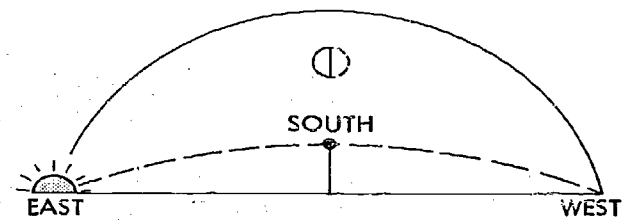

Figure II-34

Figure II-34 represents the waning third quarter moon.

**Exercises:** See if you can answer these questions without looking back at the various figures.

- 6.a. The sun is rising in the east, therefore the time indicated in Figure II-34 is \_\_\_\_\_.
- b. The third quarter moon is directly south at \_\_\_\_\_ or \_\_\_\_\_.
- c. The third quarter moon rises at \_\_\_\_\_.
- d. Do you see the third quarter moon rise?
- e. The third quarter moon sets at \_\_\_\_\_.
- f. Do you see the third quarter moon set?

- g. How many hours is the third quarter moon in the sky?
- h. How many hours do you see it?
- i. The third quarter moon is seen from \_\_\_\_\_ to \_\_\_\_\_.
- j. If a quarter moon is observed in the sky at 10:30 PM, is this the waning third quarter?
- k. 22 day old, waning third quarter?
  - (1) Rises . . . . . \_\_\_\_\_
  - (2) Sets . . . . . \_\_\_\_\_
  - (3) Hours in the sky . . . . . \_\_\_\_\_
  - (4) It is seen . . . . . \_\_\_\_\_ hours, from \_\_\_\_\_ to \_\_\_\_\_

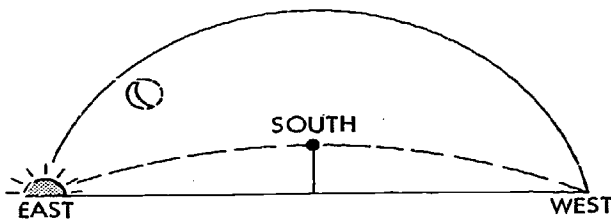

Figure II-35

Figure II-35 represents the 27 day old waning crescent moon.

- 7.a. What time is indicated by Figure II-35?
- b. In what direction is the crescent moon in Figure II-35?
- c. What time did the waning crescent moon rise?
- d. Did you see it when it rose?
- e. What time is the waning crescent in the south?
- f. What time does the waning crescent set?
- g. Do we observe the waning crescent moon setting?
- h. How many hours is the waning crescent moon in the sky?
- i. How many hours do we see it?
- j. 27 day old, waning crescent moon:
  - (1) Rises . . . . . \_\_\_\_\_
  - (2) Sets . . . . . \_\_\_\_\_
  - (3) Hours in the sky . . . . . \_\_\_\_\_
  - (4) Is seen . . . . . \_\_\_\_\_ hours, from \_\_\_\_\_ to \_\_\_\_\_

The moon continues in its orbit. As the moon again passes "between" the sun and Earth, the moon returns to the new moon phase and the lunar cycle is repeated.

8.a. Identify the following phases and the approximate time. In all cases you are looking south.

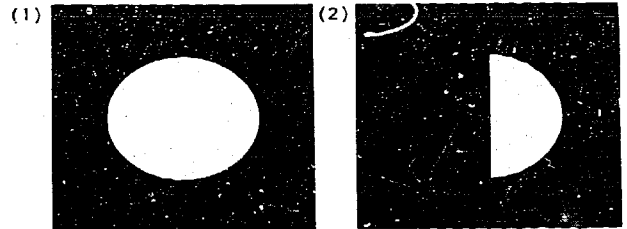

FULL MOON  
TIME \_\_\_\_\_

PHASE \_\_\_\_\_  
9:00 PM

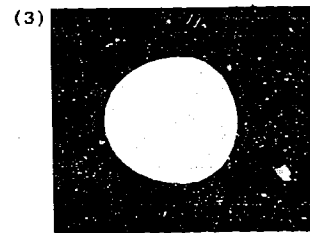

WAXING GIBBOUS  
TIME \_\_\_\_\_

Figure II-36

b.

IDENTIFY PHASE, TIME OR DIRECTION

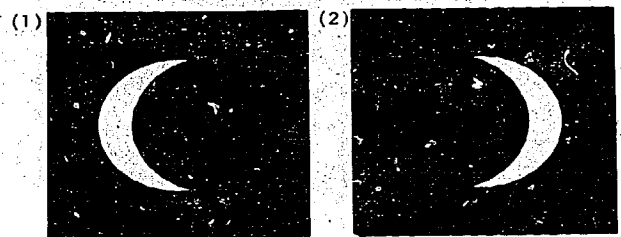

WANING CRESCENT  
TIME \_\_\_\_\_  
SOUTHEAST

PHASE \_\_\_\_\_  
6:00 PM  
SOUTHWEST

Figure II-37

**Caution:** In the previous section, we have stated that you cannot "see" the moon in the daytime sky. However, there are times when you can see the moon when the sun is still in the sky. This occurs when the moon is near the full phase. This is due to the sun's light being bent, refracted, as it passes through Earth's atmosphere. At this time, the brilliant moon stands out against the deep blue of the early evening or early morning sky.

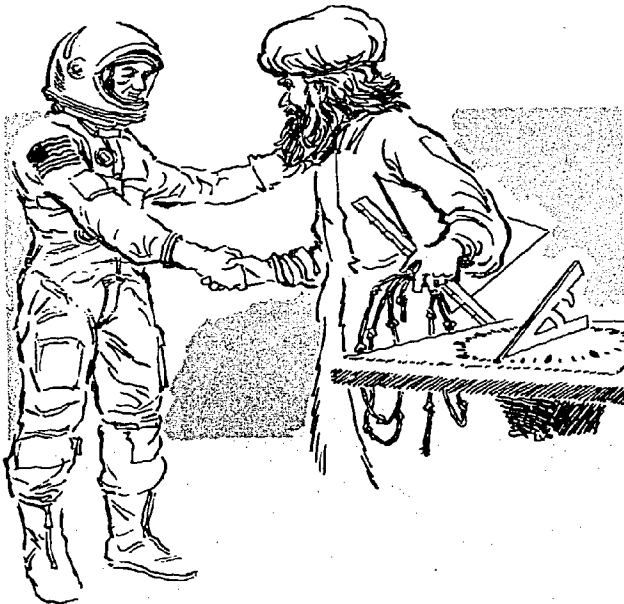

Figure II-38

In the preceding sections, we have seen the development of the measurement of time. We will now apply the same basic principles and procedures to the direct measurement of distance, and later to indirect measurement of distance with a scale.

Current methods of measuring ordinary distances are familiar to all of us. However, with recent advances in the space sciences, the need to measure accurately becomes exceedingly important. Let us consider the line below, Figure II-39.

You could estimate that the line was less than a foot, a few inches, or between 3 and 4 inches. You could do this by basic observation, and if this served our purposes, this is an acceptable answer. However, to make a more accurate measurement than this, we would use a standard ruler. (At this point, you should copy and cut out the standard ruler, inches; and metric ruler, centimeters, found at the end of the chapter.) Measure the length of the line with the standard ruler in inches. The result of your measurement indeed shows that the line is less than a foot, it is a few inches in length, and is in fact between 3 and 4 inches. With the ruler, you can describe the length of the line more accurately than with your eye. You are now able to describe the line as being between  $3\frac{1}{2}$  and 4 inches. You could also say more accurately that the length of the line was between  $3\frac{3}{4}$  and 4 inches. A table of your measurement steps could be as follows:

Measurement Step	Greater than	Less than
1	3 inches	4 inches
2	$3\frac{1}{2}$ inches	4 inches
3	$3\frac{3}{4}$ inches	4 inches

Repeating your measurement with a centimeter ruler the following information could be obtained:

Measurement Step	Greater than	Less than
1	9 centimeters	10 centimeters
2	9.5 centimeters	10 centimeters
3	9.7 centimeters or 97 millimeters	9.8 centimeters or 98 millimeters

Table II-10

To attempt to read our measurements as  $3\frac{7}{8}$  inches or 97.5 millimeters, would be to exceed the precision of our instrument, in this case, the ruler. Errors to be cor-

Figure II-39

sidered in a measurement experiment such as this would include:

- The width of the printed line on the ruler
- The angle from our eye to the ruler
- Texture of the paper
- Placement of the ruler on the printed page.

If it were necessary to make a more accurate measurement, we would turn to a more precise instrument, for example, a vernier scale. This device enables us to determine the length of the line with a greater degree of accuracy.

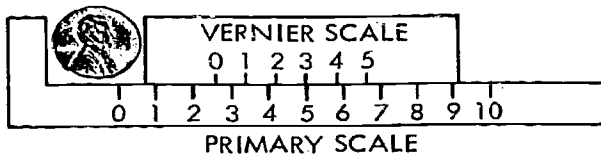

Figure II-40

The vernier scale is a common attachment to measuring instruments, such as the ruler, micrometer, or protractor. The vernier is used to determine a fraction of division on the main scale that is the *primary scale* as in Figure II-40. Vernier graduations are different from the primary scale, but bear a simple relation to it. For example, the vernier represented by Figure II-40 is so arranged that it reads 0.2 or  $1/5$  of a division on the primary scale. In order to make a reading like this, five divisions on the vernier scale must equal four divisions on the primary scale (Figure II-41). Each vernier scale division is equal to  $4/5$  of a primary scale division. The difference in the length of the divisions is called the "least count" of the vernier. By using the principle of "least count," we could construct a vernier to read  $1/32$  or  $1/64$  inches, or 0.5 millimeters, 0.1 millimeters, and so on.

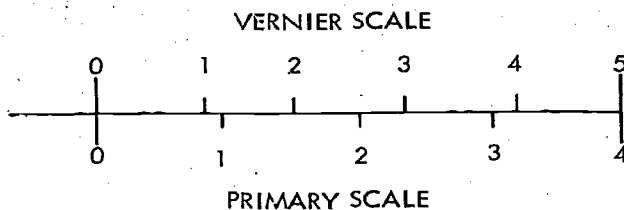

Figure II-41

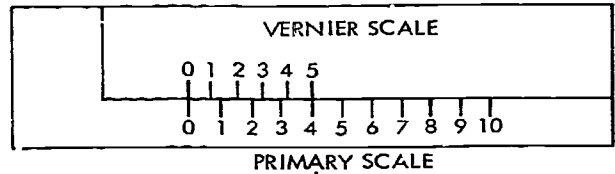

Figure II-42

In reading the vernier measurement of the penny in Figure II-40 two readings must be taken. The first reading is to determine the position of the vernier 0 on the primary scale. Prior to the measurement, the vernier 0 is at primary 0, (Figure II-42). Then to read the diameter of the penny, Figure II-40, the vernier 0 is between 2 and 3 units on the primary scale. This tells us that the diameter of the penny is between 2 and 3 units. The second reading will determine the fraction of the scale unit. In this reading, we must determine which vernier division coincides most directly with a primary scale division. Upon inspection of Figure II-40, we see that the vernier scale is arranged as follows:

Vernier Scale	Primary Scale
0 falls between	2 and 3
1 falls between	3 and 4
3 coincides with	5
4 falls between	5 and 6
5 falls between	6 and 7

Vernier 3 coincides with a primary scale division, and therefore, is the division which represents the fraction of a primary scale division. If one vernier division is equal to 0.2 of a scale division, then three vernier divisions equal 0.6 of a primary scale division. Our actual reading is obtained by adding the vernier reading to the primary scale reading.

Primary Reading	2.0 units
Vernier Reading	0.6 units
Diameter of penny	2.6 units

In this manner, we are able to directly measure the diameter of the penny with a high degree of accuracy by making use of an instrument of greater precision than a standard rule.

At this time, the student should carefully read the directions below and then

copy and cut out the vernier at the end of this chapter.

**Directions:**

*Carefully:*

- (1) Copy and cut out the vernier
- (2) Cut along Line C to A
- (3) Cut along Line B to A

The vernier scale should slide freely and evenly along the primary scale. The smallest unit on the main scale is  $\frac{1}{4}$ " or  $\frac{8}{32}$  inches. The vernier scale is read in  $\frac{1}{32}$  inches. This vernier is read the same way as outlined above. The primary scale is read to the nearest  $\frac{1}{4}$  or  $\frac{8}{32}$  inches plus the vernier reading up to  $\frac{7}{32}$  inches.

*Example:* Place the vernier over the line in Figure II-39. We are able to see that the vernier 0 is between  $3 \frac{3}{4}$ , that is  $3 \frac{24}{32}$ , and 4 inches. The vernier 3 coincides most closely with a primary scale division. The line then measures  $3 \frac{24}{32}$  inches +  $\frac{3}{32}$  inches or  $3 \frac{27}{32}$  inches.

It should be noted that this measurement is more accurate than the measurement obtained with the standard ruler or vernier primary scale because the vernier is more precise than the ruler. However, it again should be noted that the same kinds of errors involved with the ruler measurement are included with the vernier measurement. In this case, the errors are more critical because of the accuracy of the measurement. In actual practice, vernier scales have been designed to measure to the nearest 0.001 inches (one-thousandth of an inch).

Let us approximate one of the fundamental distances of astronomy, the astro-

nomical unit. The astronomical unit, A.U., is the average distance between the center of the sun and the center of Earth. Astronomers have spent hundreds of years in observing and calculating to refine this basic measurement.

Figure II-43 represents Earth's orbit of the sun. It is drawn to scale, 1" equals 48 million miles. To simple inspection, the orbit of Earth appears as a circle. If we were to carefully measure Figure II-43, we would find that Earth's orbit is not a circle, but elliptical, slightly oval. If we were to report our measurement of the astronomical unit to a group of scientists, we would include in our report:

1. Aphelion
2. Perihelion
3. Average distance from the sun
4. Eccentricity of Earth's orbit

The above four characteristics are referred to as the primary orbital elements pertaining to the shape of Earth's orbit. From these four elements, a scientist could reproduce our drawing of Earth's orbit.

Aphelion	_____ miles
Perihelion	_____ miles
Average Distance	_____ miles
Eccentricity	_____ miles

To determine Earth's farthest point from the sun, aphelion, we would measure the distance from the sun, (s) to  $E_1$  (Figure

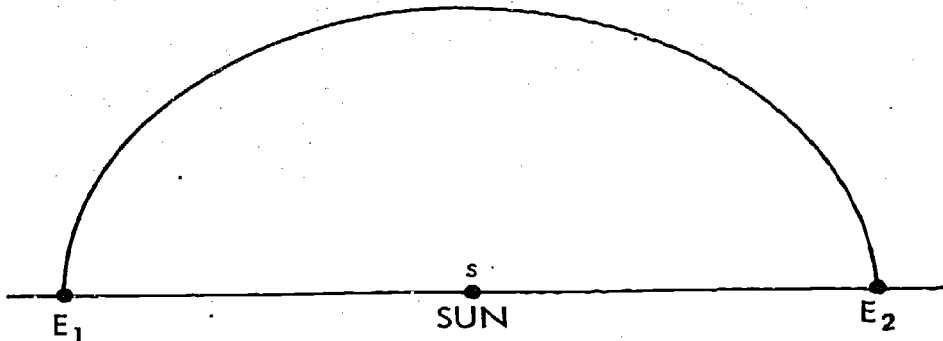

Figure II-43



II-43). This distance is  $1 \frac{31}{32}$  inches. If 1 inch equals 48 million miles, then  $1 \frac{31}{32}$  inches equals 94,500,000 miles. At  $E_1$ , aphelion, Earth is 94,500,000 miles from the sun. To determine Earth's closest point to the sun, perihelion, we would measure the distance from the sun (s) to  $E_2$ . This distance is  $1 \frac{29}{32}$  inches. With a scale of 1 inch equals 48 million miles,  $1 \frac{29}{32}$  inches equals 91,500,000 miles. At  $E_2$ , perihelion, Earth is 91,500,000 miles from the sun. To determine the average of Earth's distance from the sun, we could add the aphelion distance to the perihelion distance and divide the sum by two. This would give us Earth's average distance as 93,000,000 miles. However, to reduce the possibility of error due to measurement, we could take a number of measurements around Earth's orbit.

If we made the indicated measurements in Figure II-44, we would tabulate the results in a table as follows:

Measurement	Altitude	Scale Inches
1	a-s	$1 \frac{31}{32}$
2	b-s	$1 \frac{31}{32}$
3	c-s	$1 \frac{30}{32}$
4	d-s	$1 \frac{31}{32}$
5	f-s	$1 \frac{29}{32}$
6	$E_2$ -s	$1 \frac{28}{32}$
7	g-s	$1 \frac{29}{32}$
8	h-s	$1 \frac{29}{32}$
9	i-s	$1 \frac{29}{32}$
10	j-s	$1 \frac{31}{32}$
11	k-s	$1 \frac{31}{32}$
12	$E_1$ -s	$1 \frac{31}{32}$
Sum =		$23 \frac{8}{32}$

Table II-11

If we were to sum the 12 measurements, and divide by 12, we would have an average, or mean Earth-sun distance of:  $23 \frac{8}{32} / 12 = 1 \frac{30}{32} = 1 \frac{15}{16}$  inches.

From the scale, one inch equal to 48 million miles,  $1 \frac{15}{16}$  inches equals 93 million miles.

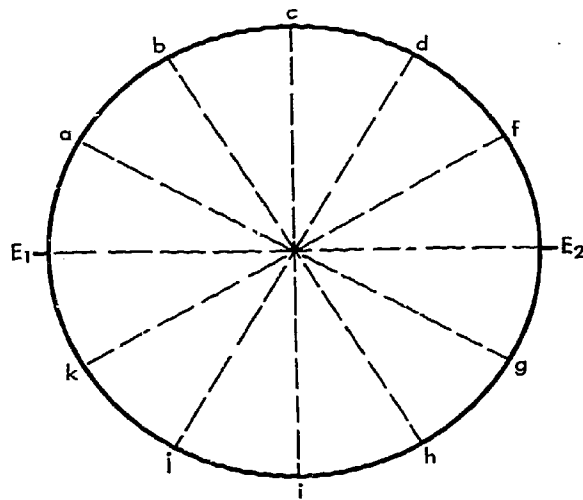

Figure II-44

At this point we have

Aphelion  $94.5 \times 10^6$  miles

Perihelion  $91.5 \times 10^6$  miles

Average distance  $93.0 \times 10^6$  miles

1 A.U. = 93 million miles,  $93.0 \times 10^6$  miles

Table II-12

The eccentricity of Earth's orbit is a measure of the "roundness" of the orbit or ellipse. If Earth's orbit was a perfect circle, the eccentricity would be 0. The eccentricity of an ellipse is always less than 1. The closer the eccentricity to 1, the more elliptical the orbit.

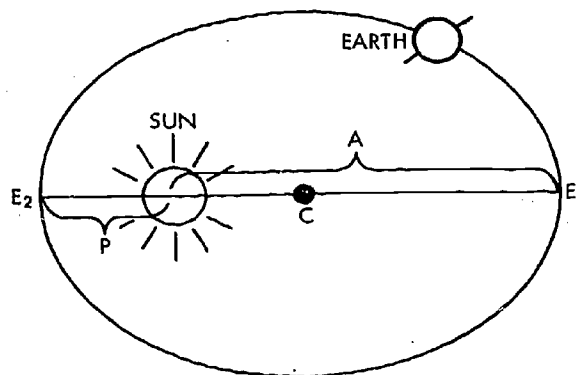

Figure II-45

For purposes of illustration, the elliptical orbit of Earth has been exaggerated in Figure II-45. Notice that the sun is not at the center of the ellipse, C. The Earth at position E<sub>1</sub> is at aphelion at a distance from the center of the sun of A. The Earth in position E<sub>2</sub> is at perihelion at a distance of P from the center of the sun. We are able to express the eccentricity of Earth's orbit in terms of the aphelion (A) and perihelion (P) distances.

$$\begin{aligned} \text{Eccentricity, } e &= \frac{A - P}{A + P} \\ e &= \frac{94,500,000 - 91,500,000}{94,500,000 + 91,500,000} \\ e &= \frac{3,000,000}{186,000,000} = \frac{3}{186} = \frac{1}{63} \\ e &= 0.016 \end{aligned}$$

Since the eccentricity is small, 0.016, as compared to 1, we know Earth's orbit is nearly circular.

To interpret these results, consider the accuracy of our measurement. Your vernier is able to measure to the nearest 1/32 of an inch. Therefore, each measurement is subject to an error of 1/32 inches (1/64 inches below the value and 1/64 inches above the value). Thus, the measurement, in the case of average Earth-sun distance 1 15/16 inches, should be written 1 15/16 ± 1/64 inches. If we were to convert this number to miles, 1 inch equals 48,000,000 miles, we would show that the average Earth-sun distance to be 93,000,000 ± 750,000 miles. Our report of the primary

orbital elements of Earth would now appear as:

Aphelion 94.5 x 10<sup>6</sup> ± 7.50 x 10<sup>3</sup>  
 Average Distance 93.0 x 10<sup>6</sup> ± 7.50 x 10<sup>3</sup>  
 Perihelion 91.5 x 10<sup>6</sup> ± 7.50 x 10<sup>3</sup>  
 Eccentricity 0.016

The astronomical unit, A.U., would have a value of 93 x 10<sup>6</sup> miles plus or minus 7.50 x 10<sup>3</sup> miles. With today's standards, our measurements of Earth's orbit are not very realistic and are subject to error.

With the advent of the space age, man has continued to refine this basic measurement. Table II-13 illustrates some recent history of the measurement of the astronomical unit.

If we were to report the orbital elements of a satellite, we would report the same four primary characteristics as we did for Earth's orbit. For satellites which orbit Earth, we refer to the highest point in orbit as apogee and the low point as perigee. Apogee and perigee are measured from the *center of Earth*, but generally are reported from the *surface of Earth*.

Although scientists measure and make their calculations based on the satellite's distance from the center of Earth, the altitude of a satellite is reported to the general public as the average distance of the satellite from the surface of Earth.

That is to say, altitude of Echo I is reported as 1,000 miles and not as 4,960 miles.

S<sub>1</sub> is a satellite at apogee at a distance A from the center of Earth. S<sub>2</sub> represents the perigee of the satellite at a distance of P from the center of Earth, Figure II-46.

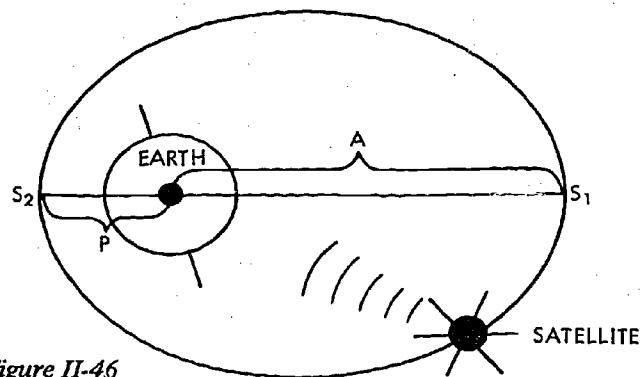

Figure II-46

Number	Source of measurement and data	A.U. in millions of miles	Experimenter's Estimate of A.U. value range
1	Newcomb, 1895	93.28	93.20 ---- 93.35
2	Hinks, 1901	92.83	92.79 ---- 92.87
3	Noteboom, 1921	92.91	92.90 ---- 92.92
4	Spencer Jones, 1928	92.87	92.82 ---- 92.81
5	Spencer Jones, 1931	93.00	92.99 ---- 93.01
6	Witt, 1933	92.91	92.90 ---- 92.92
7	Adams, 1941	92.84	92.77 ---- 92.92
8	Brower, 1950	92.977	92.945 ---- 93.008
9	Rabe, 1950	92.9148	92.9107 ---- 92.9190
10	Millstone Hill, 1958	92.874	92.873 ---- 92.875
11	Jodrell Bank, 1959	92.876	92.871 ---- 92.882
12	S. T. L., 1960	92.9251	92.9166 ---- 92.9335
13	Jodrell Bank, 1961	92.960	92.958 ---- 92.962
14	Cal. Tech., 1961	92.956	92.955 ---- 92.957
15	Soviets, 1961	92.813	92.810 ---- 92.816

Table II-13

*Example:* Echo I was orbited in August of 1960. Apogee was measured as 5,010 miles and perigee as 4,910 miles. What are the four primary elements as to the shape of the orbit? (Use 3,960 miles as the average Earth radius)

$$\text{Apogee} = 5,010 - 3,960 = 1,050 \text{ miles}$$

$$\text{Perigee} = 4,910 - 3,960 = 950 \text{ miles}$$

$$\text{Average Distance} = \frac{1,050 + 950}{2} = 1,000 \text{ miles}$$

$$\text{Eccentricity} = \frac{5,010 - 4,910}{5,010 + 4,910} = \frac{100}{9,920} = 0.01$$

$$\text{Apogee} = 1,050 \text{ miles}$$

$$\text{Perigee} = 950 \text{ miles}$$

$$\text{Average Distance} = 1,000 \text{ miles}$$

$$\text{Eccentricity} = 0.01$$

Table II-14

*Exercises:*

9. Explorer 1, the first United States

satellite launched January 31, 1958, had an apogee measured to be 5,533 miles and a measured perigee of 4,184 miles. Report the four primary orbital elements as to the shape of the satellite's orbit.

- Apogee . . . . . \_\_\_\_\_ miles
- Perigee . . . . . \_\_\_\_\_ miles
- Average Distance . . . \_\_\_\_\_ miles
- Eccentricity . . . . . \_\_\_\_\_

Table II-15

10. Explorer III launched June 28, 1958, had a reported apogee of 1,740 miles and a reported perigee of 118 miles. What are the four primary orbital elements as to the shape of the orbit?

- Apogee . . . . . \_\_\_\_\_ miles
- Perigee . . . . . \_\_\_\_\_ miles
- Average Distance . . . \_\_\_\_\_ miles
- Eccentricity . . . . . \_\_\_\_\_

Table II-16

Thus far we have been concerned with direct measurement of distance and time. We can now extend these ideas to indirect measurement with a scale.

*Figure II-47  
Earth Based  
Photograph*

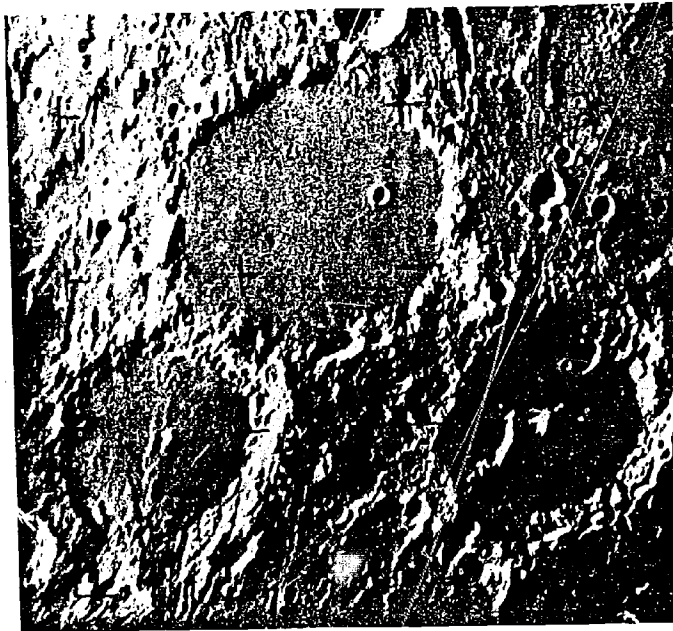
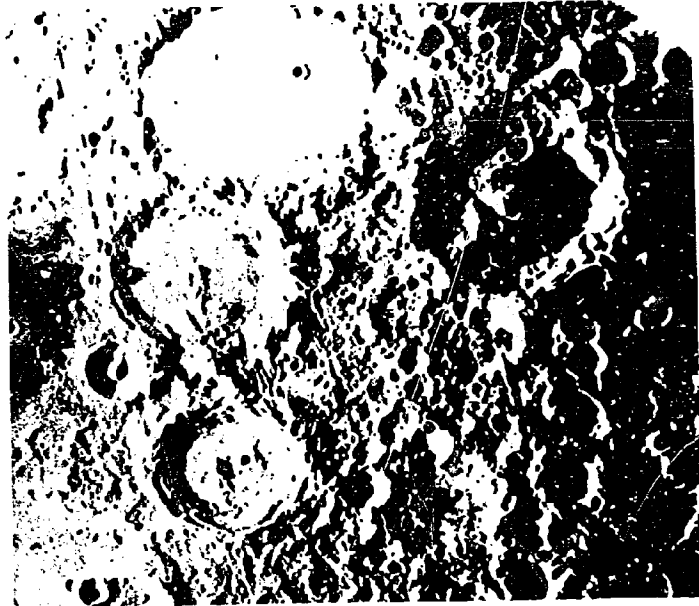

*Figure II-48  
Ranger IX  
Photograph*

Figure II-47 shows the surface of the moon as photographed from Earth. Figure II-48 is of the *same area* of the moon as photographed by Ranger IX on March 24, 1965.

These photographs are of particular interest because Earth based measurements of Ptolemaeus (the large crater at the top of both photographs) estimate the average

diameter to be over 90 miles. Analysis of Ranger's IX pictures determined the average diameter to be about 94 miles. The Earth based picture represented by Figure II-47 was taken at a distance of about 240,000 miles and Figure II-48 when Ranger IX was about 470 miles from the surface of the moon.



In both instances and using similar methods, scientists were able to conclude that the diameter of Ptolemaeus was about 90 miles. Although the moon is seen by the unaided eye at a distance of 234,000 miles and with a first class telescope at an equivalent distance of 500 miles, Ranger's cameras "see" it at an equivalent distance of  $\frac{1}{2}$  of a mile.

The best Earth-based photograph is able to resolve, see clearly, lunar surface features as small as 1,000 feet. Later we shall compare this figure with the resolution of Ranger IX photographs.

You can use Ranger photographs to estimate size and distance on the moon, if you understand the grid system of the Ranger camera.

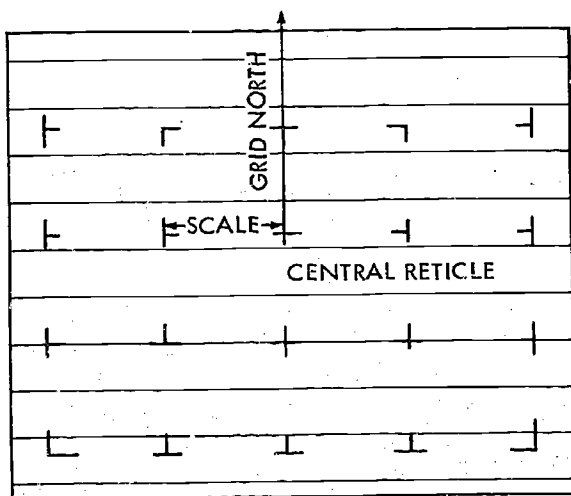

Figure II-49

The grid system is superimposed on the camera face. The grid crosses of Figure II-49 are called reticles, (ret'-i-kels). The center cross mark on the camera face is called the central reticle. Grid north is defined as a straight line drawn from the central reticle to the middle reticle in the north margin. Grid north differs from true lunar north depending upon spacecraft position, camera attitude, and the altitude of Ranger above the moon.

Actual distances on the moon can be calculated from the camera scale. The scale is the ratio of the distance between the central reticle and the reticle immediately to the left and the distance visible between the two points on the lunar surface. In the

actual analysis of Ranger photographs, there are both north-south and east-west scales.

The scale also changes as we measure toward the margin of the photograph due to the curvature of the moon, the camera angle, and the longitude of the photographed region. For our purposes of illustration, we will assume a flat surface, make measurements with an average scale and assume north-south and east-west scales to be equal.

Now we will examine in detail two major characteristics affecting our use of the Ranger camera grid system: camera angle and satellite altitude. The camera angle is the view of the moon as seen from a particular camera, such as camera A, of Ranger IX. This instrument was built for a camera angle of  $25^\circ$ . Figure II-51 represents Ranger IX as it approached the surface of the moon and is drawn to scale, 1 inch equals 250 miles. At an altitude of 1,300 miles, Camera A with a field of view of  $25^\circ$  would "see" a circular area of the moon as in Figure II-50.

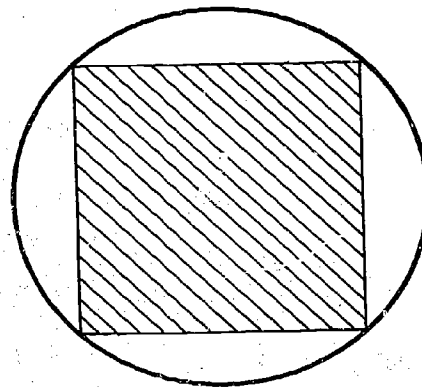

Figure II-50

Camera A uses a mask on the light sensitive electronic tube in place of camera film. The resulting image of the moon is the portion of the full  $25^\circ$  view represented as the shaded area in Figure II-50.

The area of the moon's surface seen by Camera A's tube would depend upon the altitude of the satellite. The altitude, Figure II-51, is the distance from the spacecraft to the surface directly below. At an



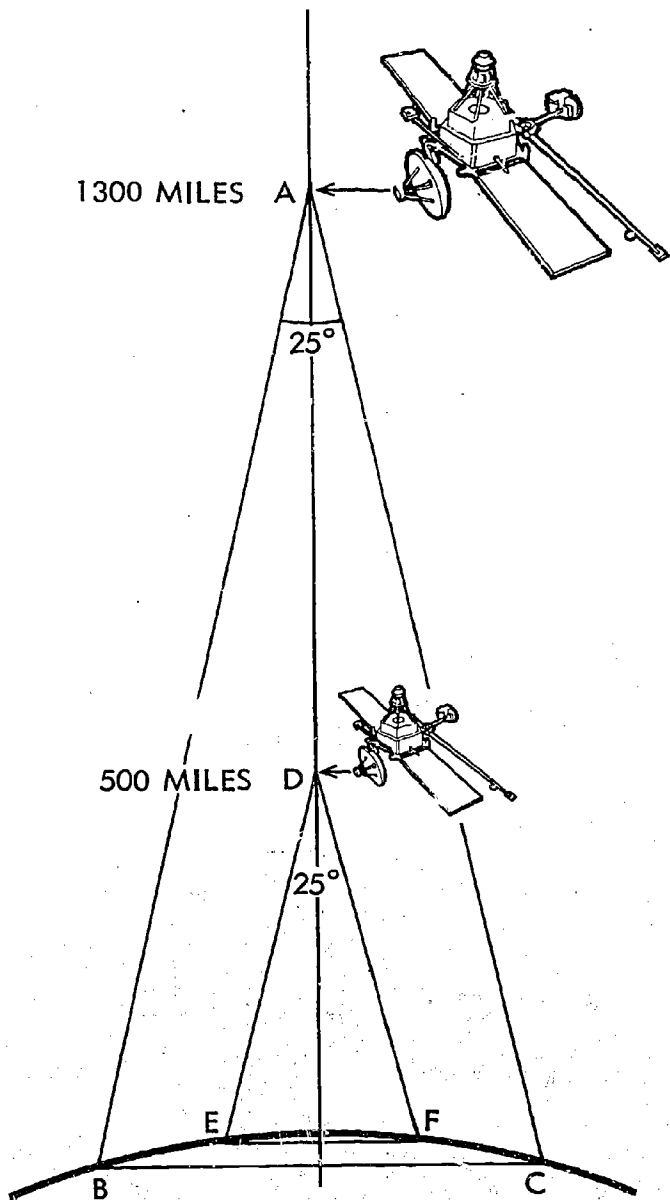

Figure II-51

altitude of 1,300 miles, Position A, Figure II-51, Ranger IX viewed a square about 492 miles on a side, BC. This is a surface area of the moon of 492 miles by 492 miles or 242,064 square miles and could resolve features of 2,600 feet. At an altitude of 500 miles, position D, Ranger IX's camera A could photograph a square of about 186.8 miles on a side, EF, or a surface area of 186.8 x 186.8 or 34,894 square miles. At this altitude, Camera A could resolve surface features of 1,000 feet.

As the altitude continues to decrease, the area photographed decreases, and the resolution increases. We could compile our data as in Table II-17.

These figures are approximations and will afford us a general understanding of the scientific principles of measurement underlying the successful Ranger missions.

Remember at an altitude of 1,300 miles, the camera is able to view a square approximately 492 miles on a side. The 492 miles represents the distance from the reticle on the left margin to the reticle at the right margin. The distance represented between two reticles, average scale, would be 492 miles divided by 4 or 123 miles. This distance is represented by 1 5/8 inches. Therefore, 1 inch would equal 76 miles. We may set up a table for scales at various altitudes, Table II-18.

Ranger 9	Camera A	Camera Angle 25°
Altitude (Miles)	Surface area (Square miles)	Resolution (feet)
1. 1300	242,064	2,600
2. 500	34,894	1,000
3. 250	10,000	500
4. 100	1,697	200
5. 4.5	4	9

Table II-17

Altitude (miles)	Length of side (miles)	Average Scale (miles)	1 inch equals (miles)
1300	492.0	123.0	76
475	186.8	46.7	29
250	100.0	25.0	15
100	41.2	10.3	6.4
4.5	2.0	0.5	0.3

Table II-18

Refer to Figures II-47 and II-48. The three large craters found in the photographs are Ptolemaeus (top center), Albategnius (lower right), and Alphonsus (lower left). The scale for Figure II-47 is 1 inch equals 80 miles.

Use your standard ruler to measure the diameter of the crater Ptolemaeus. A close estimate of the diameter from rim to rim would be 1.2 inches. To calculate the diameter of Ptolemaeus in miles:

$$\frac{1 \text{ inch}}{80 \text{ miles}} = \frac{1.2 \text{ inches}}{X \text{ miles}}$$

$$x = 80 \cdot 1.2$$

$$x = 96 \text{ miles}$$

The scale for Figure II-48, a Ranger photograph, is 1 inch equals 65 miles. Measure Ptolemaeus in Figure II-48 with your ruler. You will find the diameter to be 1.4 inches. Calculating the diameter in miles,

$$\frac{1 \text{ inch}}{65 \text{ miles}} = \frac{1.4 \text{ inches}}{X \text{ miles}}$$

$$x = 65 \times 1.4$$

$$x = 91.0 \text{ miles}$$

We repeat the procedure for the craters Alphonsus and Albategnius and record the measurements in Table II-19.

Comparing the results of the measurements, we find that the diameter of the craters in Figure II-47 varies from those obtained in Figure II-48. We can attribute the variation in your measurement to:

- One measurement
- Irregular shaped craters
- Problem in determining the rim of the crater
- Black and white shading
- Not measuring through the center of the crater

	Scale 1 inch =	Scale Diameter	Diameter
Ptolemaeus	Earth 80 miles	1.2 inches	96.0 miles
	Ranger 65 miles	1.4 inches	91.0 miles
Alphonsus	Earth 80 miles	0.75 inches	60.0 miles
	Ranger 65 miles	0.9 inches	58.5 miles
Albategnius	Earth 80 miles	0.9 inches	72.6 miles
	Ranger 65 miles	1.1 inches	71.5 miles

Table II-19

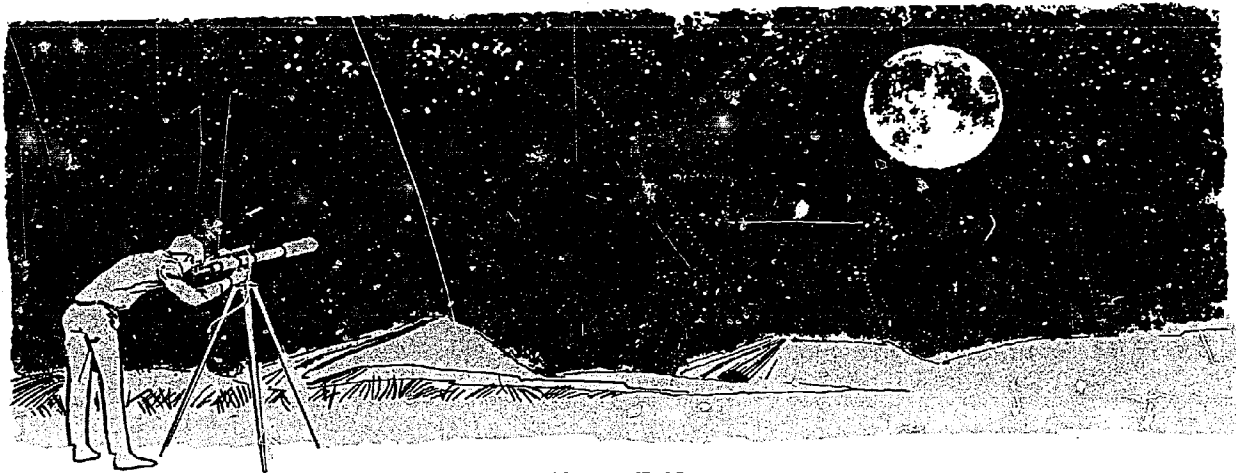

Figure II-52

To reduce the occurrence of experimental error, we can repeat the procedure we used in determining the astronomical unit earlier in this chapter. In this manner, we would speak of the average diameter of

the crater. This value would certainly be more representative and better understood.

Measuring ten random diameters of each of the craters in Figures II-47 and II-48, we collect our data as follows, Table 20:

	Ptolemaeus		Alphonsus		Albategnius	
Trial	Earth-based	Ranger	Earth-based	Ranger	Earth-based	Ranger
1-	1.20	1.30	0.75	0.90	0.90	1.10
2-	1.15	1.40	0.80	0.95	0.85	1.20
3-	1.10	1.40	0.75	1.00	1.00	1.30
4-	1.00	1.45	0.80	1.10	0.95	1.35
5-	1.10	1.50	0.85	1.05	1.00	1.20
6-	1.15	1.40	0.80	0.95	0.90	1.05
7-	1.20	1.30	0.80	1.00	1.05	1.15
8-	1.20	1.45	0.70	1.10	1.00	1.10
9-	1.10	1.50	0.75	1.05	1.00	1.10
10-	1.15	1.40	0.80	1.00	0.95	1.20
Total	11.35	14.10	7.80	10.10	9.60	11.75
<u>Total</u>	<u>11.35</u>	<u>14.10</u>	<u>7.80</u>	<u>10.1</u>	<u>9.60</u>	<u>11.75</u>
No. of Trials	10	10	10	10	10	10
Average Diameter (Inches)	1.13	1.41	0.78	1.01	0.96	1.17
Average Diameter (Miles)	90.4	91.0	62.4	65.7	76.8	76.1

Table II-20

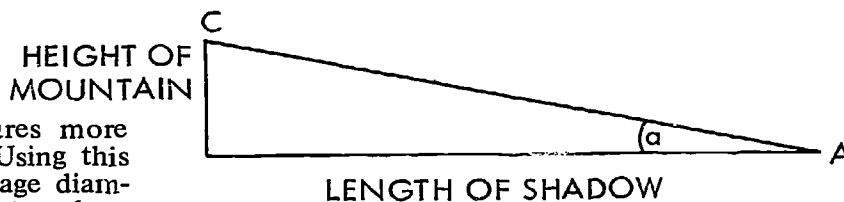

Figure II-53

By this procedure, our figures more closely agree with each other. Using this procedure to determine the average diameters of the craters, we have tended to reduce the possibility of experimental or random error. The greatest possibility of error in our determinations would be a constant error. To reduce the constant error, we would go back over our procedures and recheck our determinations of:

- a. Calibration and precision of measuring instruments
- b. Distance to moon
- c. Calculation of scale
- d. Determination of the center of the crater
- e. Definition of rim of the crater

By continuing to refine our procedures and calculations, we continue to increase the accuracy of our measurements.

Using the same basic procedure, we are able to calculate the approximate altitude of the mountains on the moon. Turn to Figure II-58. The mountain in the photograph is referred to as the central peak of Alphonsus. The scale on this photograph is 1" equals 6.4 miles. When the photograph was taken, the sun was at an angle of 11° to the surface of the moon. You can measure the length of the shadow as 0.5 inches. Our scale drawing would appear as Figure II-53. For purposes of illustration, we magnify our scale 6 times or say, 3" equals 3.2 miles.

From Figure II-53, you are able to determine  $\angle a$  as 11°, the angle of the sun. The line AB represents the length of the shadow of the mountain, 3 inches or 3.2 miles. Line CB represents the altitude of the mountain. If you measure CB, you find it is 5/8 inches long. We determine the approximate altitude of the mountain as follows:

$$\frac{3 \text{ inches}}{5/8 \text{ inches}} = \frac{3.2 \text{ miles}}{X \text{ miles}}$$

$$X = \frac{5/8 \cdot 3.2}{3}$$

$$X = 0.66 \text{ miles}$$

To convert our answer into feet, we continue as follows:

$$1 \text{ mile} = 5,280 \text{ ft.}$$

$$0.66 \text{ miles} = 3,400 \text{ ft.}$$

The altitude of the central peak of Alphonsus is about 3,400 ft.

Students familiar with trigonometry may make more accurate determinations by use of the tangent formula.

$$\tan 11^\circ = \frac{\overline{CB}}{\overline{AB}}$$

$$0.1944 = \frac{\overline{CB}}{3.2}$$

$$\overline{CB} = .1944 \times 3.2$$

$$\overline{CB} = 0.62 \text{ miles}$$

$$1 \text{ mile} = 5,280 \text{ ft.}$$

$$0.62 \text{ miles} = 3,273 \text{ ft.}$$

The altitude of the central peak of Alphonsus is about 3,300 ft.

Using the above methods, astronomers have determined from both Ranger and Earth-based photographs craters up to about 180 miles in diameter and mountains towering over the surface of the moon more than 25,000 ft.

Many new and striking ideas about the Moon have resulted from the Ranger, and Surveyor photographs. There is still a great deal more to learn from the Ranger and Surveyor photographs. In fact, scientists will be studying these pictures for years to come.



Figure II-54

Figures 55, 56, 57, 58 and 59 are Ranger IX photographs of the crater Alphonsus. You have seen that the scale changes with the altitude of the satellite. It is necessary to set up a series of scales to measure surface features. The scales may be approximated by a number of scale drawings as represented by Figure II-51.

*Exercises:*

11. Measure the crater marked II in Figures II-55, 56, 57. Determine its average diameter.

Crater II	Scale	Average Diameter
a. Figure II-55	1" = 76 miles	___ miles
b. Figure II-56	1" = 29 miles	___ miles
c. Figure II-57	1" = 15 miles	___ miles

12. Determine an approximate diameter for the crater marked III, Figures 55 and 56.

Crater III	Scale	Average Diameter
a. Figure II-55	1" = 76 miles	___ miles
b. Figure II-56	1" = 29 miles	___ miles

13. From Figure II-59, determine the diameter of various craters. Scale 1" = 0.3 miles. Then, pick out the smallest structure visible to your eye, and calculate its size in feet.

14. On the enclosed Atlas of the moon, Figure II-60, locate and mark the impact point of the following moon satellites. Remember that North is to the bottom of the page, East to the left, and West is to the right.

- a. Ranger VII—Impacted 7/13/64 —  
Lat. 10° S  
Long. 20° W
- b. Ranger VIII—Impacted 2/20/65 —  
Lat. 2° N  
Long. 2° E
- c. Ranger IX—Impacted 3/24/65 —  
Lat. 13° S  
Long. 2° W
- d. Surveyor I—Softlanding 6/1/66  
Lat. 2° S  
Long. 4° W
- e. Surveyor II—Failed, Impacted  
9/20/66  
Seathing Bay area, SE  
of Copernius
- f. Surveyor III—Softlanding 4/19/67  
Lat. 3° S  
Long. 23° W
- g. Surveyor IV—Impacted 7/16/67  
Lat. 0° N  
Long. 1° W
- h. Surveyor V—Softlanding 9/10/67  
Lat. 1° N  
Long. 23° E
- i. Surveyor VI—Softlanding 11/9/67  
Lat. 0° N  
Long. 1° W
- j. Surveyor VII—Softlanding 1/10/68  
Lat. 40° S  
Long. 11° W



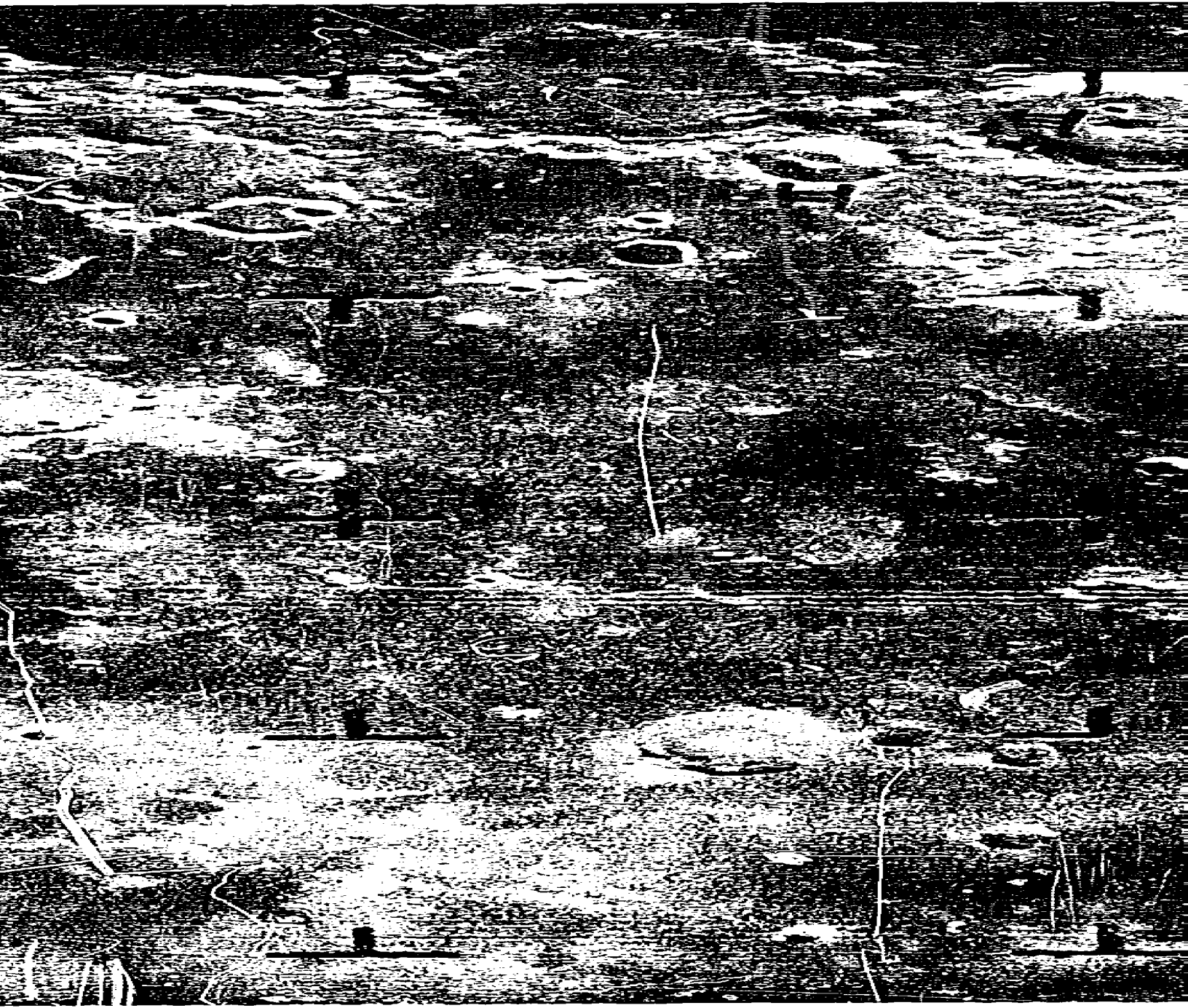

*Figure II-55*

51/52  
52







ERIC  
Full Text Provided by ERIC

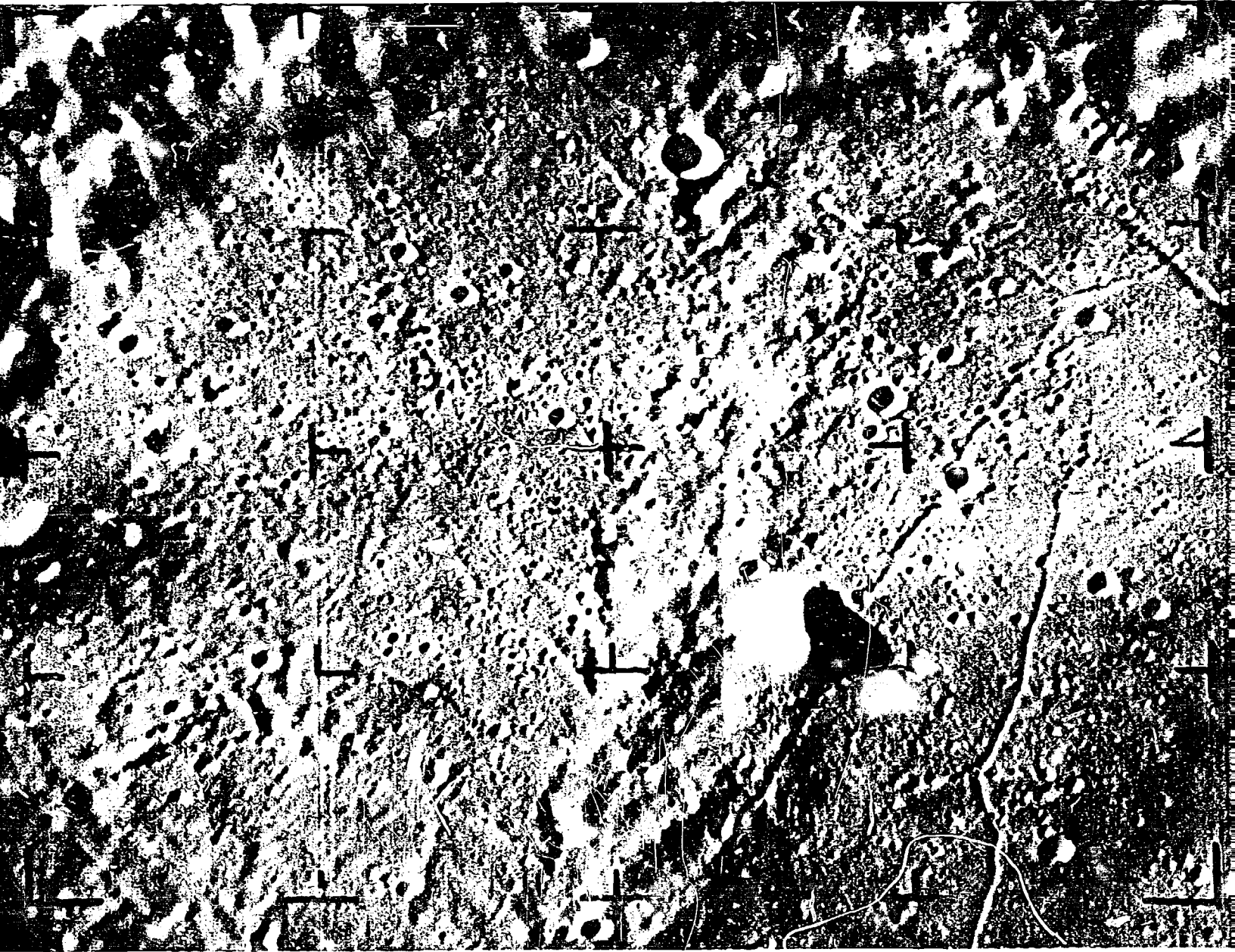

Altitude  
100 miles  
Scale  
10.3 miles  
1" = 6.4 miles

Figure II-58

57/58  
55



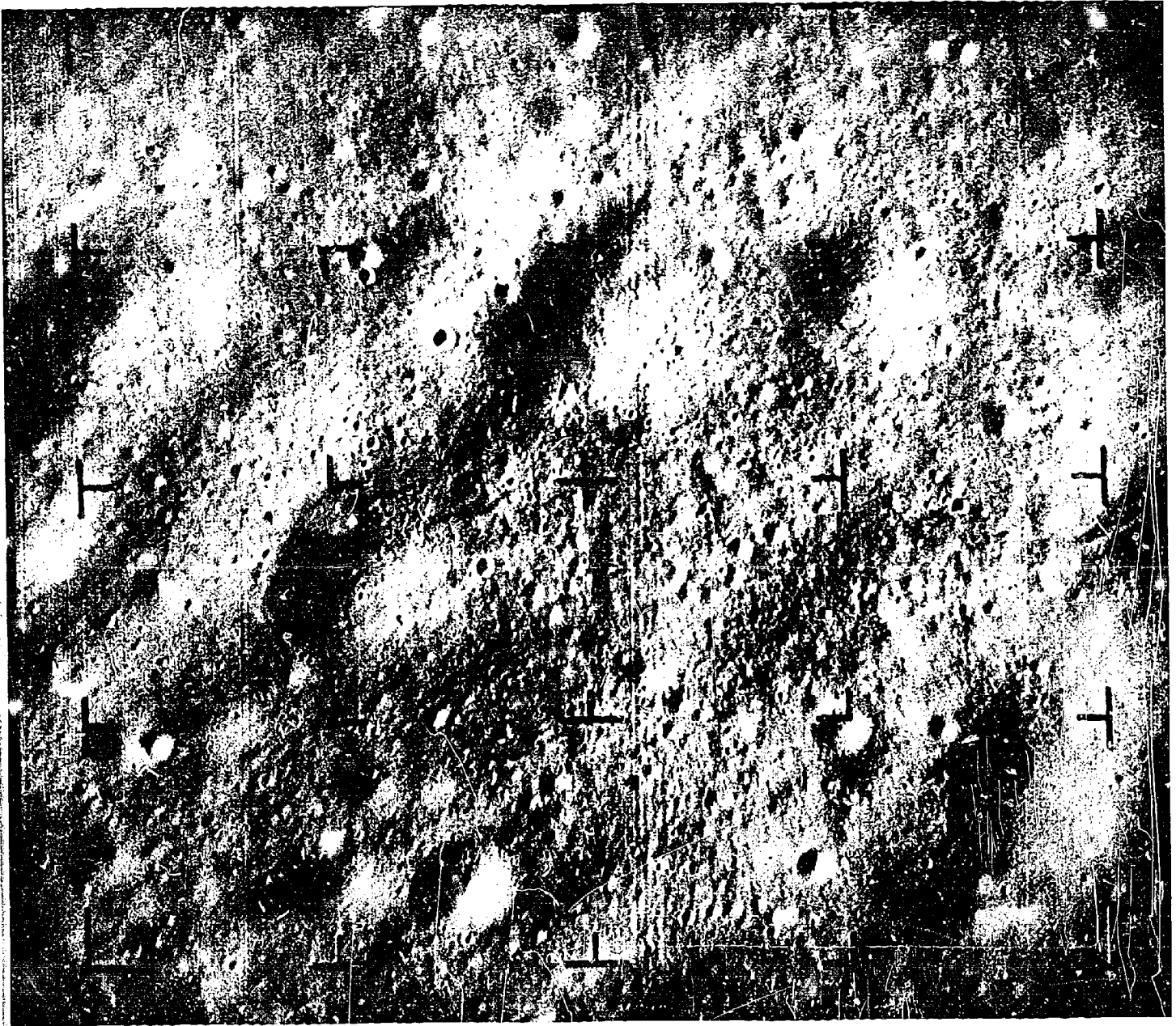

Altitude  
4.5 miles

Scale  
0.5 miles

1" = 0.3 miles

*Figure II-59*

# Lunar Map

This map of the moon is based on the original drawing by Karel Andel, published in 1926 as *Mappa Selenographica*.

## MOUNTAINS AND VALLEYS

- |                    |                   |
|--------------------|-------------------|
| a. Alpine Valley   | n. Laplace Prom.  |
| b. Alps Mts.       | o. Leibnitz Mts.  |
| c. Altai Mts.      | p. Pico           |
| d. Apennine Mts.   | q. Piton          |
| e. Carpathian Mts. | r. Pyrenees Mts.  |
| f. Caucasus Mts.   | s. Rheita Valley  |
| g. D'Alembert Mts. | t. Rhiphaeus Mts. |
| h. Doerfel Mts.    | u. Rook Mts.      |
| i. Haemus Mts.     | v. Spitzbergen    |
| j. Harbinger Mts.  | w. Straight Range |
| k. Heracles Prom.  | x. Straight Wall  |
| l. Hyginus Cleft   | y. Taurus Mts.    |
| m. Jura Mts.       | z. Teneriffe M    |

## LUNAR CRATERS

- |                  |                 |                    |                       |                    |
|------------------|-----------------|--------------------|-----------------------|--------------------|
| 1. Abenezra      | 48. Bullialdus  | 93. Eichstädt      | 164. Lambert          | 237. Proclus       |
| 2. Abulfeda      | 49. Burckhardt  | 91. Encke          | 165. Landsberg        | 238. Protogoras    |
| 3. Agatharchides | 50. Bürg        | 95. Endymion       | 166. Langrenus        | 239. Ptolemaeus    |
| 4. Agrippa       | 51. Calippus    | 96. Epigenes       | 167. Lassell          | 240. Purbach       |
| 5. Albategnius   | 52. Campanus    | 97. Eratosthenes   | 168. Lec              | 241. Pythagoras    |
| 6. Alexander     | 53. Capella     | 98. Euclides       | 169. Lehmann          | 242. Pytheas       |
| 7. Aliacensis    | 54. Capuanus    | 99. Eudoxus        | 170. Letronne         |                    |
| 8. Almanon       | 55. Cardanus    | 100. Euler         | 171. Leverrier        | 243. Rabbi Levi    |
| 9. Alpetragius   | 56. Casatus     |                    | 172. Lexell           | 244. Ramsden       |
| 10. Alphonsus    | 57. Cassini     | 101. Fabriciu      | 173. Licetus          | 245. Regiomontanus |
| 11. Apianus      | 58. Catharina   | 102. Faraday       | 174. Lilius           | 246. Reichenbach   |
| 12. Apollonius   | 59. Cavalerius  | 103. Fermat        | 175. Lindenau         | 247. Reiner        |
| 13. Arago        | 60. Cavendish   | 104. Fernelius     | 176. Linné            | 248. Reinhold      |
| 14. Archimedes   | 61. Celsius     | 105. Firmicus      | 177. Littrow          | 249. Repsold       |
| 15. Archytas     | 62. Cepheus     | 106. Flamsteed     | 178. Lohrmann         | 250. Rhaeticus     |
| 16. Aristarchus  | 63. Chacornac   | 107. Fontenelle    | 179. Longomontanus    | 251. Rheita        |
| 17. Aristillus   | 64. Cichus      | 108. Fracastorius  | 180. Lubiniecky       | 252. Riccioli      |
| 18. Aristoteles  | 65. Clairaut    | 109. Fra Mauro     |                       | 253. Römer         |
| 19. Arzachel     | 66. Clausius    | 110. Franklin      | 181. Maclear          | 254. Ross          |
| 20. Asclepi      | 67. Clavius     | 111. Furnerius     | 182. Macrobius        | 255. Rothmann      |
| 21. Atlas        | 68. Cleomedes   |                    | 183. Mädler           | 256. Sacrobosco    |
| 22. Autolycus    | 69. Colombo     | 112. Gambart       | 184. Magelhaens       | 257. Santbech      |
| 23. Azophi       | 70. Condamine   | 113. Gassendi      | 185. Maginus          | 258. Sasserides    |
|                  | 71. Condorcet   | 114. Gauricus      | 186. Mairan           | 259. Saussure      |
| 24. Baco         | 72. Conon       | 115. Gauss         | 187. Manilius         | 260. Scheiner      |
| 25. Bailly       | 73. Cook        | 116. Gay-Lussac    | 188. Manzinus         | 261. Schickard     |
| 26. Barocius     | 74. Copernicus  |                    | 189. Maraldi          | 262. Schiller      |
| 27. Bayer        | 75. Crüger      | 117. Geber         | 190. Marinus          | 263. Schröter      |
| 28. Beaumont     | 76. Curtius     | 118. Geminus       | 191. Maskelyne        | 264. Seieucus      |
| 29. Bernouilli   | 77. Cuvier      | 119. Gemma Frisius | 192. Maupertuis       | 265. Sharp         |
| 30. Berzelius    | 78. Cyrillus    | 120. Goclenius     | 193. Maurolycus       | 266. Simpelius     |
| 31. Bessel       |                 | 121. Godin         | 194. Mayer, Tobias    | 267. Snellius      |
| 32. Bettinus     | 79. Damoiseau   | 122. Goodacre      | 195. Menelaus         | 268. Sosigenes     |
| 33. Bianchini    | 80. Daniell     | 123. Grimaldi      | 196. Mercator         | 269. Stadius       |
| 34. Biela        | 81. Davy        | 124. Gruithuisen   | 197. Mersenius        | 270. Stevinus      |
| 35. Billy        | 82. Dawes       | 125. Guericke      | 198. Messala          | 271. Stöfler       |
| 36. Birmingham   | 83. De Gasparis | 126. Gutenberg     | 199. Messier          | 272. Strabo        |
| 37. Birt         | 84. Delambre    | 127. Hahn          | 200. Metius           | 273. Struve        |
| 38. Blancanus    | 85. De la Rue   | 128. Hainzel       | 201. Meton            | 274. Struve, Otto  |
| 39. Blanchinus   | 86. Delaunay    | 129. Halley        | 202. Milichius        |                    |
| 40. Boguslawsky  | 87. Delisle     | 130. Hansteen      | 203. Miller           | 275. Tacitus       |
| 41. Bohnenberger | 88. Deluc       | 131. Harpalus      | 204. Monge            | 276. Taruntius     |
| 42. Bond, W. C.  | 89. Descartes   | 132. Hase          | 205. Moretus          | 277. Theaetetus    |
| 43. Bonpland     | 90. Diophantus  | 133. Heinsius      | 206. Mösting          | 278. Thebit        |
| 44. Borda        | 91. Dollond     | 134. Helicon       | 207. Mutus            | 279. Theophilus    |
| 45. Boscovich    | 92. Doppelmayer | 135. Hell          | 208. Nasiredin        | 280. Timaeus       |
| 46. Bouguer      |                 | 136. Heraclitus    | 209. Neander          | 281. Tiniocharis   |
| 47. Boussingault |                 | 137. Hercules      | 210. Nearchus         | 282. Torricelli    |
|                  |                 | 138. Herigonius    | 211. Nicolai          | 283. Triessnecker  |
|                  |                 | 139. Herodotus     |                       | 284. Tycho         |
|                  |                 | 140. Herschel      | 212. Oken             | 285. Ukert         |
|                  |                 | 141. Herschel, J.  | 213. Orontius         |                    |
|                  |                 | 142. Hesiodus      | 214. Palisa           | 286. Vendelinus    |
|                  |                 | 143. Hevelius      | 215. Pallas           | 287. Vieta         |
|                  |                 | 144. Hippalus      | 216. Parrot           | 288. Vitiello      |
|                  |                 | 145. Hipparchus    | 217. Parry            | 289. Vitruvius     |
|                  |                 | 146. Horrebow      | 218. Peirce           | 290. Vlacq         |
|                  |                 | 147. Horrocks      | 219. Petavius         | 291. Walter        |
|                  |                 | 148. Hortensius    | 220. Philolaus        | 292. Weiss         |
|                  |                 | 149. Humboldt, W.  | 221. Phocylides       | 293. Werner        |
|                  |                 | 150. Hypatia       | 222. Piazza           | 294. Wilhelm I     |
|                  |                 |                    | 223. Picard           | 295. Wilkins       |
|                  |                 |                    | 224. Piccolomini      | 296. Wurzelbauer   |
|                  |                 |                    | 225. Pickering, W. H. |                    |
|                  |                 |                    | 226. Pictet           | 297. Zach          |
|                  |                 |                    | 227. Pitatus          | 298. Zagut         |
|                  |                 |                    | 228. Pitiscus         | 299. Zuchius       |
|                  |                 |                    | 229. Plana            | 300. Zupus         |
|                  |                 |                    | 230. Plato            |                    |
|                  |                 |                    | 231. Playfair         |                    |
|                  |                 |                    | 232. Plinius          |                    |
|                  |                 |                    | 233. Pontanus         |                    |
|                  |                 |                    | 234. Pontécoulant     |                    |
|                  |                 |                    | 235. Posidonius       |                    |
|                  |                 |                    | 236. Prinz            |                    |
|                  |                 | 161. Landsberg C   |                       |                    |
|                  |                 | 162. Lagrange      |                       |                    |
|                  |                 | 163. Lalande       |                       |                    |

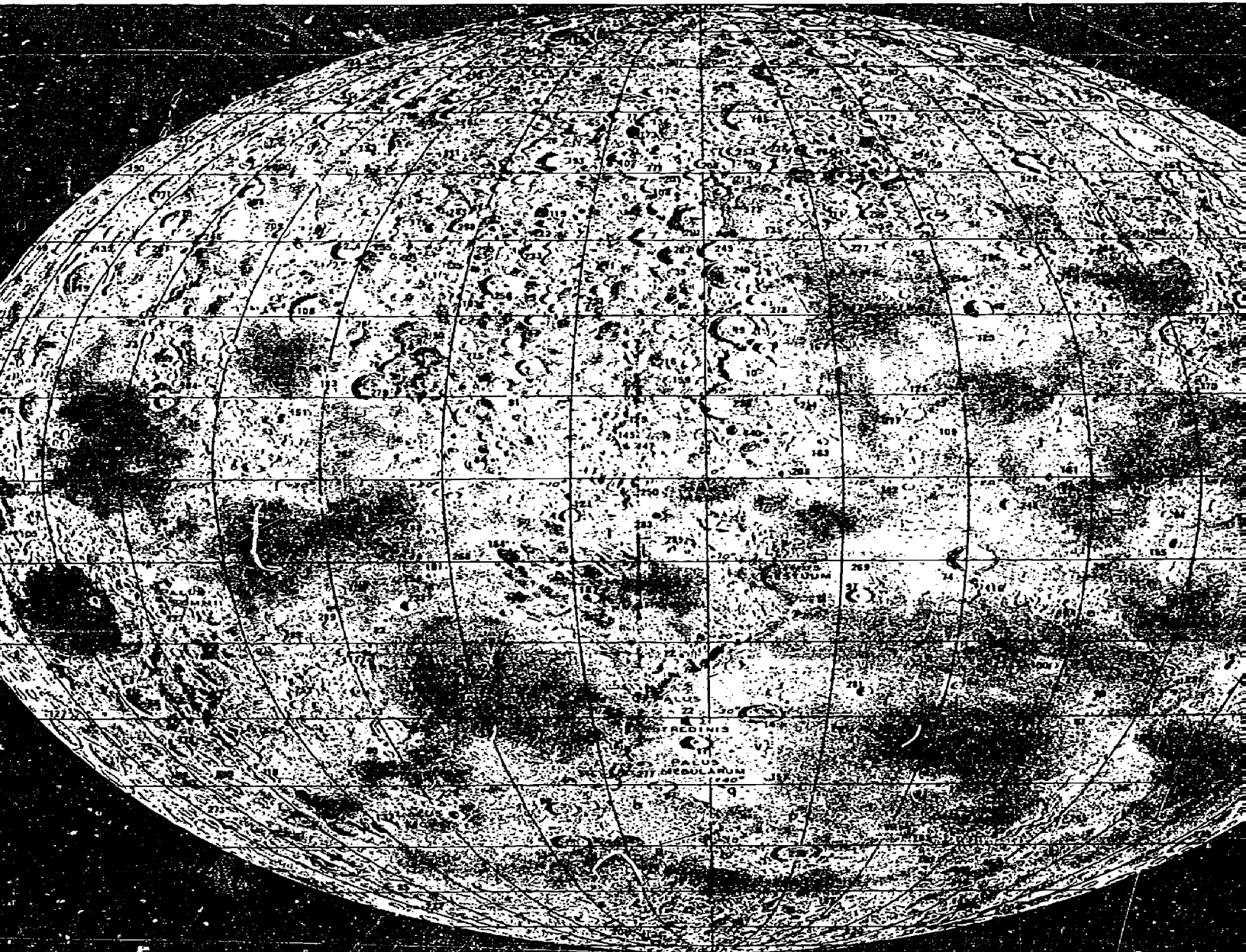

*Figure II-60*



## Answers to Chapter II

- 1.a. The standard number of drops per minute is found by dividing the total number of drops by the number of minutes, in this case, 5.
- b. (1)  $\frac{\text{Standard}}{60}$   
 (2) Standard  
 (3) Standard x 60 or  $\frac{\text{Standard} \times 60}{1,000}$   
 (4)  $\frac{\text{Standard} \times 60 \times 24}{1,000}$   
 (5)  $\frac{\text{Standard} \times 60 \times 24 \times 365}{1,000}$   
 or  $\frac{\text{Standard} \times 60 \times 24 \times 365}{1,000 \times 1,000}$
- c. (1) 1,000 x 1,000 = 1,000,000  
 =  $1 \times 10^6$  = 1 million
2. Standard x 90
- 3.a. Standard x 25  
 b.  $\frac{\text{Standard} \times 25}{22}$
4. Some problems encountered when using drop time are as follows:  
 a. All drops are not the same size.  
 b. The number of drops per minute would vary depending upon how full the cup is. Try this.  
 c. As the opening became larger after continued use, the water would drop out faster.  
 d. You have to keep filling the cup.  
 e. In cold weather, the water could freeze, and in high temperatures, the water could boil.  
 As early as 1400 B.C., the Egyptians constructed water clocks and they were used almost 2,000 years as time-keepers.
- 5.a. Complete as instructed.  
 b. (1) about 4:45 PM  
 (2) about 7:15 PM  
 (3) about 2:15 AM  
 (4) about 8:45 AM
- c. (1) 6:00 PM  
 (2) 6 hours  
 (3) about 10:45 PM  
 (4) about 1:15 PM  
 (5) about 8:15 AM  
 (6) about 2:45 PM
- d. (1) 6 hours  
 (2) 6 hours  
 (3) 6 hours  
 (4) 6 hours  
 (5) 6 hours
- 5.e. 

	Time	Angle of the Sun
New York	6:00 AM	18 hours
Greenwich	about 10:45 AM	22 hours 45'
Moscow	about 1:15 AM	1 hour 15'
Tokyo	about 8:15 PM	8 hour 15'
Los Angeles	about 2:45 AM	14 hour 45'
- 6.a. 6:00 AM  
 b. 6:00 AM or sunrise  
 c. 12 midnight  
 d. Yes, it is dark when it rises  
 e. 12 noon  
 f. No, it is daylight when it sets  
 g. 12 hours  
 h. 6 hours  
 i. 12 midnight to 6:00 AM  
 j. No, the waning third quarter does not rise until midnight.  
 k. (1) Midnight  
 (2) Noon  
 (3) 12  
 (4) 6 hours, from Midnight to 6:00 AM
- 7.a. 6:00 AM  
 b. Southeast  
 c. 3:00 AM  
 d. Yes, it is still dark at 3:00 AM  
 e. 9:00 AM  
 f. 3:00 PM  
 g. No, it is still light at 3:00 PM  
 h. 12 hours  
 i. 3 hours  
 j. (1) 3:00 AM  
 (2) 3:00 PM  
 (3) 12 hours  
 (4) 3 hours, from 3:00 AM until 6:00 AM

8.a. (1) Full Moon  
Midnight

(2) 1st Quarter  
9:00 PM

(3) Waxing Gibbous  
9:00 PM

b. (1) Waning Crescent  
6:00 AM  
Southeast

(2) Waxing Crescent  
6:00 PM  
Southwest

9.a. Apogee 1,573 miles

b. Perigee 224 miles

c. Average  
Distance 898.5 miles

d. Eccentricity 0.14

10.a. Apogee 1,740 miles

b. Perigee 118 miles

c. Average  
Distance 929 miles

d. Eccentricity 0.17

11. Average Diameter

a. about 24.5 miles

b. about 25 miles

c. about 24.5 miles

12. Average Diameter

a. about 52 miles

b. about 51 miles

13. Smallest features visible in Figure 61  
are about 500 feet.

14. Add other satellites and landings, to the  
map of the moon as they occur. You  
can obtain their position from your  
local newspaper.

63/64

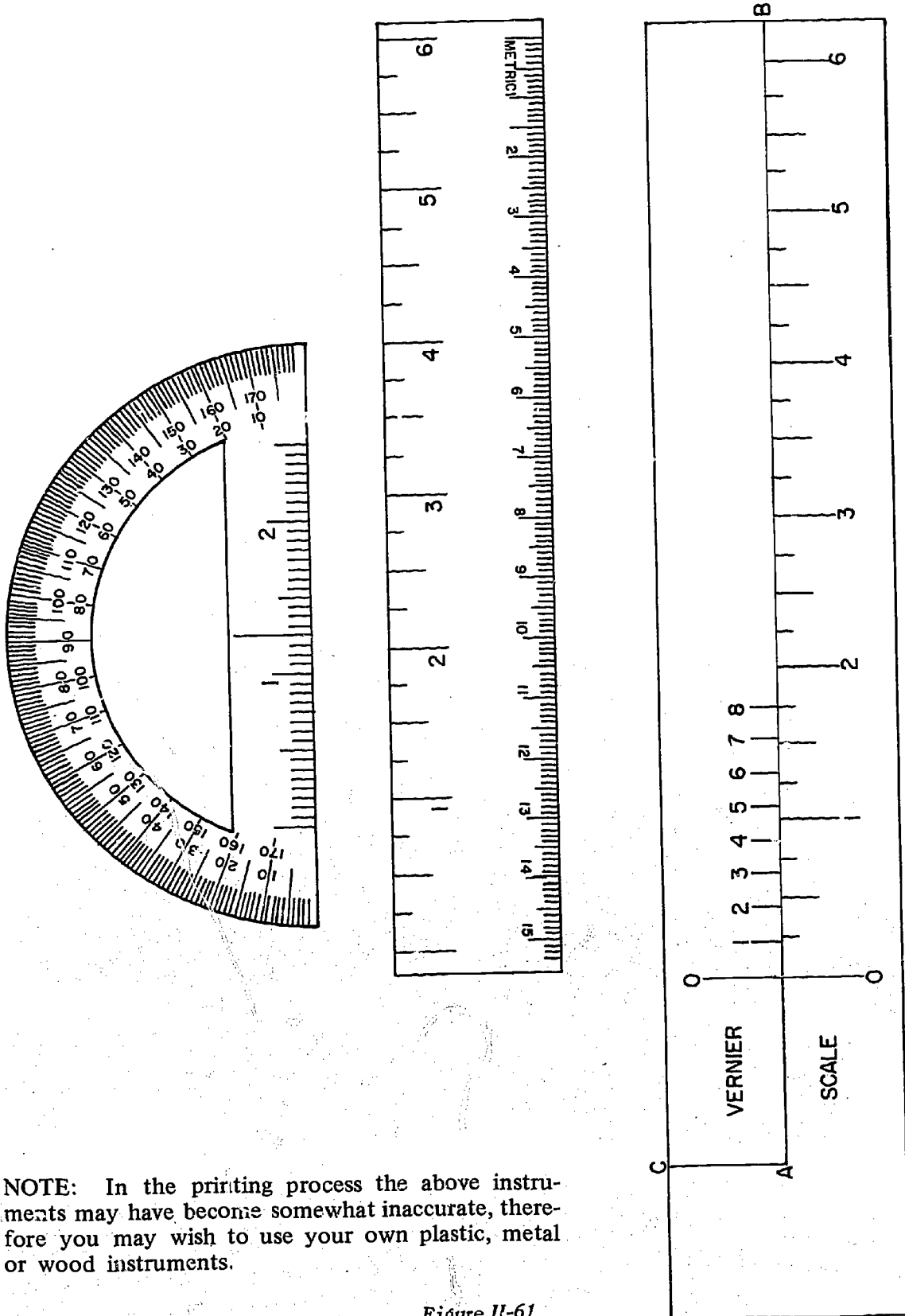

NOTE: In the printing process the above instruments may have become somewhat inaccurate, therefore you may wish to use your own plastic, metal or wood instruments.

Figure II-61

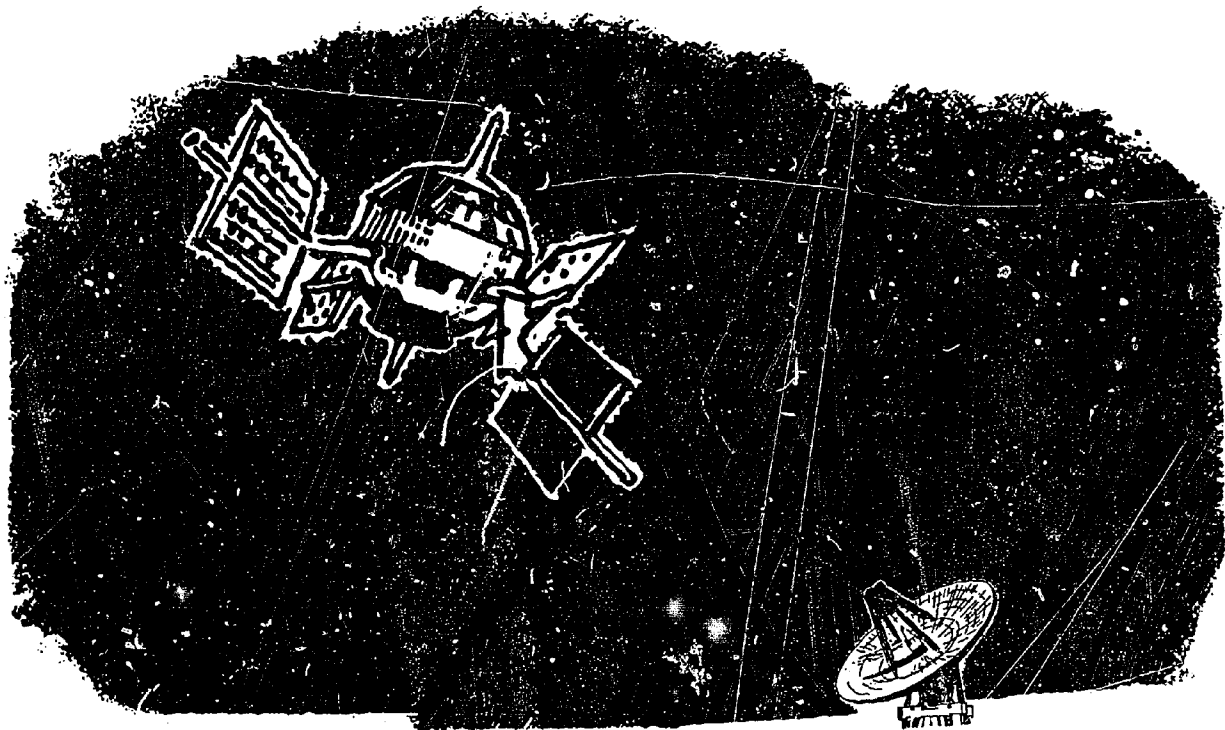

Chapter III  
**"EMPTY" SPACE**

## "EMPTY" SPACE

How is it possible to describe the measure of "empty" space which contains only about 1 particle of material per cubic mile? The content of "empty" space contains a wind that travels faster than the speed of sound, strong enough to produce the tail of a comet, a wind which cannot be seen but can be measured (Figure III-2 and III-3). These are the solar winds - high temperature electrified gases from the surface of the sun. Also throughout space there are fields of gravity, electricity, and magnetism which can be used to describe its measure.

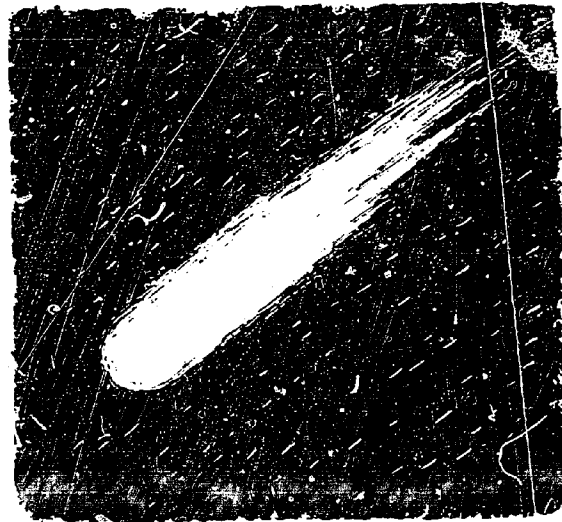

Figure III-2

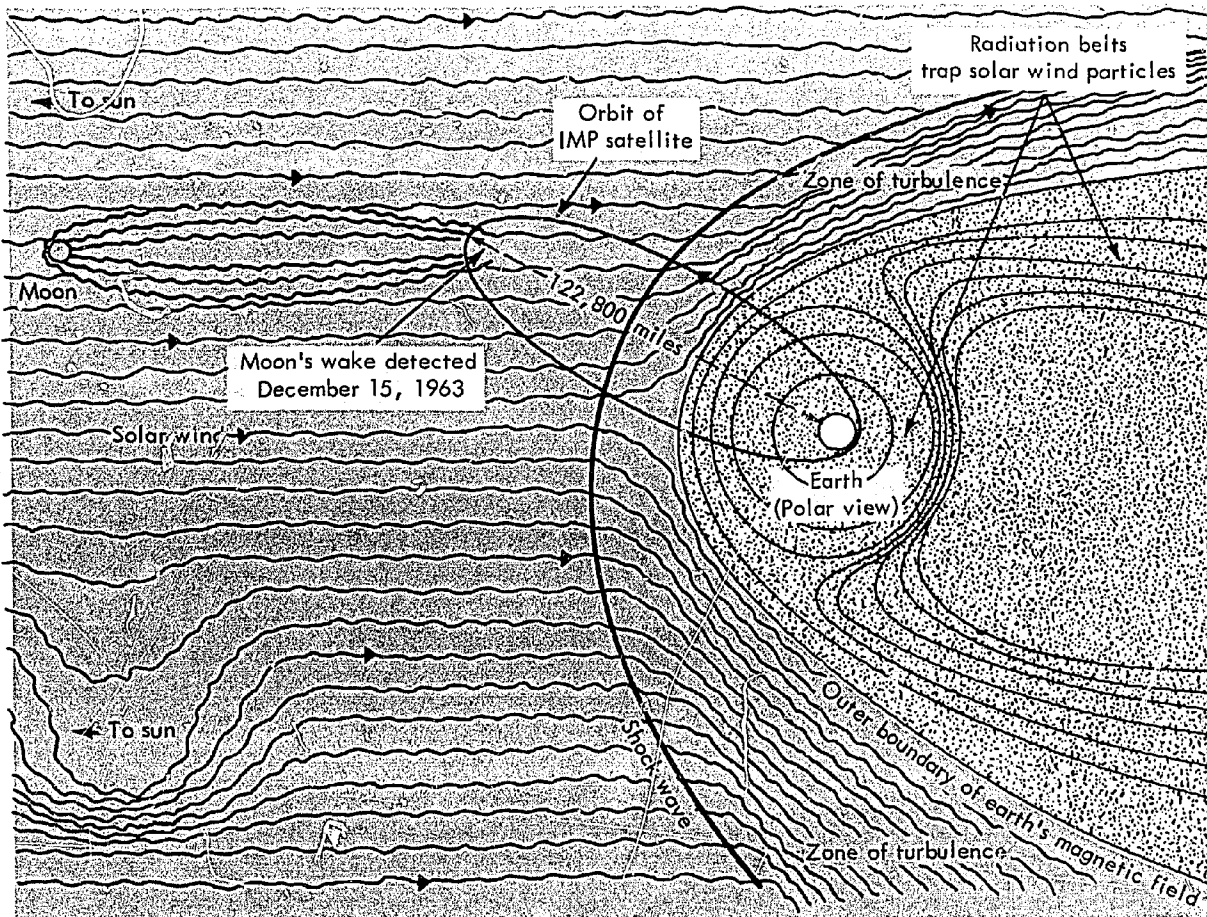

Figure III-3



By applying mathematics we can now make a good guess (hypothesis) as to what is out there. Orbiting satellites in this vast "empty" region are making measurements, assembling data, and transmitting this information to Earth as radio signals. Instruments change the sounds to numbers. By using the numbers, scientists can build a "mathematical model" of the space we cannot see, but the measure of which we can describe. Today we see space in the world around us through our *ideas* as well as with our *eyes*. Although we marvel at the sight of nature, we have learned to build a better understanding of it by using numbers to invent shapes for those parts of nature, which our eyes cannot see. Satellites can send sounds back to Earth, which can be changed to numbers. Numbers can be used to represent measurement.

One of the most important things we have to do then is first to have a basic understanding of sound. As we progress we shall see how an orbiting satellite can use just 2 tones, or sounds, to send the measure of space back to Earth.

Sound travels in the form of a wave. One way of picturing a wave is to tie one end of a heavy string to some solid object (Figure III-4). If the free end of the rope is given a quick snap, a wave travels along the rope, hits the solid object and sometimes is reflected back to your hand. However we do not think sound waves actually travel in this manner. Sound waves begin

when an object is vibrated. These vibrations are passed into the air by alternately pushing the air particles together, and then allowing the particles to spread apart. These compressions and rarefactions as they are called, travel outward from the source as a series of ever enlarging hollow spheres. (Figure III-5). Sound waves can also be reflected or echoed.

When an object such as a tuning fork, or guitar string vibrates, it does so with a certain frequency. This simply means that in a given unit of time, usually one second, the object moves back and forth a certain number of times. As an example, "middle C" on the piano has a frequency of 256 cycles per second. In one second the wire

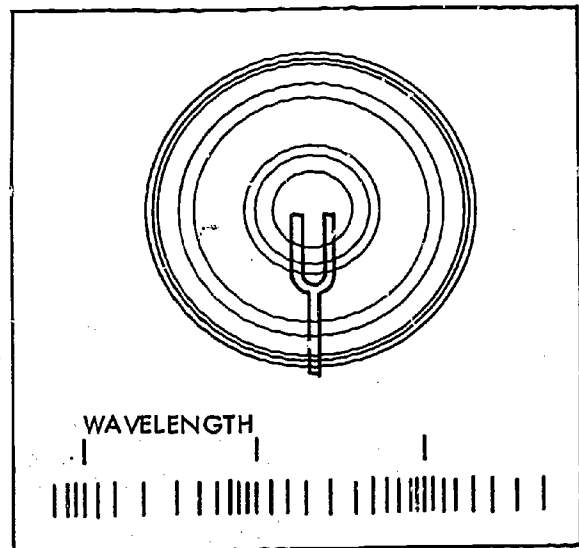

Figure III-5

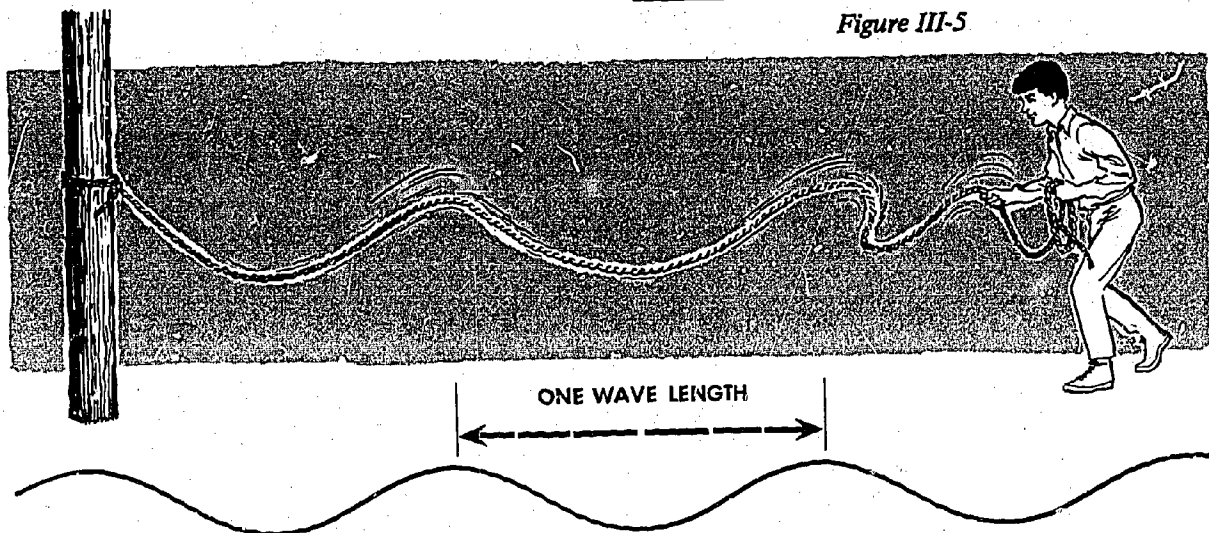

Figure III-4



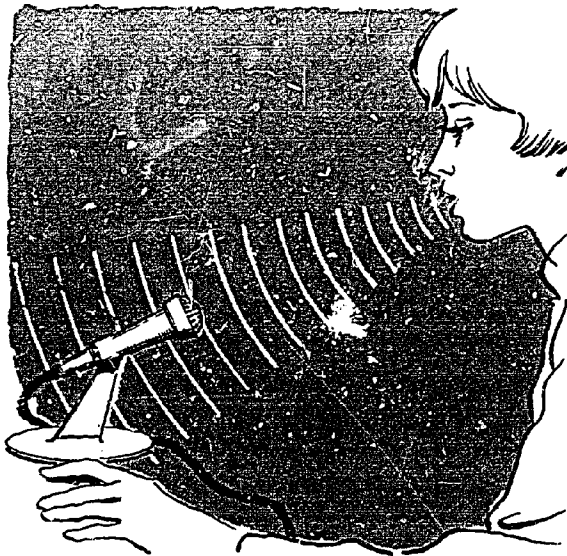



Figure III-6

moves back and forth 256 times. This results in 256 compressions and rarefactions (sound waves) being sent out into the air every second.

When your ear hears the piano note, your ear drum also vibrates 256 times a second. At any point within the range of this sound, 256 sound waves go past every second. If we know how far it is from one wave to the next, we can soon compute how fast the waves are traveling. This is often compared to a railroad train passing a crossing. If twenty cars go past in a minute and each car is fifty feet long, then 20 cars per minute  $\times$  50 feet per car equals 1000 feet per minute — which is the velocity of

the train. With sound waves the statement is “velocity equals number of vibrations per second (frequency) times distance from one wave to next (wavelength), or  $v = f \times l$ .”

Now to measure the length of a sound wave. Imagine a wave like this  and a second wave identical to the first . But suppose the second wave travels just a wave length behind the first:

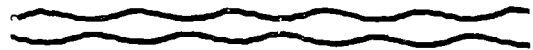

What wave will result if they are added together? The “hills” of one wave are added to the “valleys” of the other wave, and the result could be represented like this . These waves cancelled each other when they were added together.

Now imagine the two waves are traveling exactly together:



This wave will result if they are added together:



It will result in a wave with the same frequency but higher hills and deeper valleys — a stronger wave or a louder sound.

If two sound waves cancel each other silence results. If two sound waves strengthen or re-enforce one another, a much louder sound results. The effect of sound waves re-enforcing one another is called resonance.

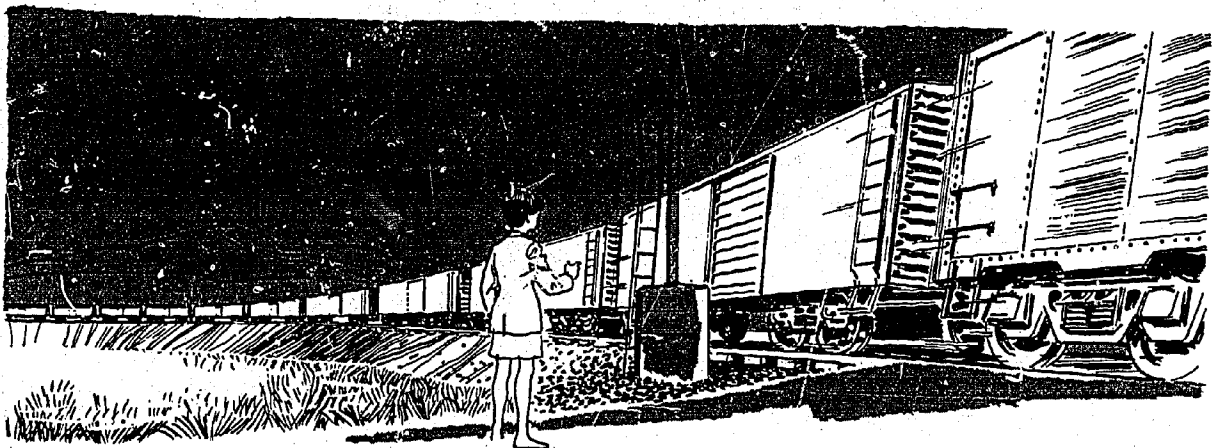

Figure III-7

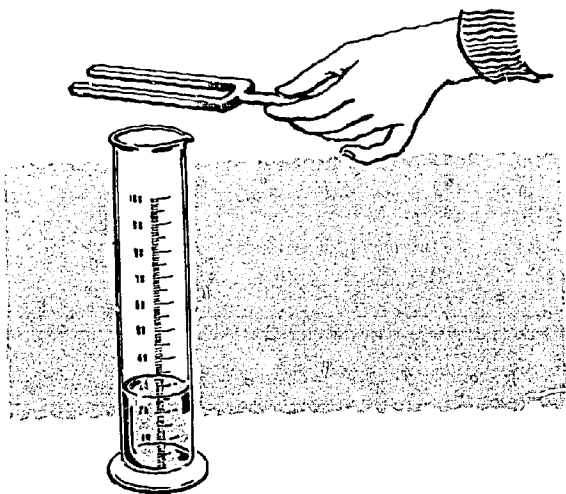

Figure III-8

We can use resonance to help us measure the length of a sound wave. We will need a graduated cylinder of at least 100 milliliter capacity, a tuning fork with a frequency of 700 cycles per second or higher, a metric ruler, and a small amount of water.

If the vibrating tuning fork is held over the open end of the cylinder, Figure III-8, the compressions and rarefactions travel down to the closed end of the cylinder, are reflected from the bottom of the cylinder, and travel back out the open end of the cylinder. A louder sound, or resonance, will occur if the cylinder is just the right length so that a compression and rarefaction travel down it, reflect and arrive back at the open end while the tuning fork is completing one-half of its vibration. During the other half-vibration, a compression and rarefaction are produced in the opposite direction, and add to the compression and rarefaction emerging from the cylinder to make the sound louder.

In other words, resonance will occur if the length of the cylinder is exactly one-fourth the length of the sound wave. Resonance can also occur if the length of the cylinder is three-fourths of a wave length, or one and one-fourth wave length, or one and three-fourths wave length, etc. Can you decide why the cylinder cannot be one-half wave length or one wave length long for resonance to occur?

Hold the vibrating fork over the open end of the cylinder. If resonance does not occur with an empty cylinder, slowly, very slowly, add water to the cylinder until the volume of sound increases sharply. When resonance occurs, measure the distance from the top of the cylinder to the surface of the water.

Continue to add water slowly to the cylinder while the vibrating fork is held over the top. If resonance occurs again, measure the distance from the top to the surface of the water. The difference between these two measurements is *one-half wave length*.

If resonance does not occur again with this cylinder, then the distance from the top to the surface of the water represents one-fourth of a wave length, and should be multiplied by four to give the wave length.

Once the wave length has been measured, and with the frequency of the tuning fork known, the speed of sound can be calculated from  $v = f \times \lambda$ . You should be able to measure the speed of sound to be about 335 meters per second.

If you discover errors in your measurement, perhaps you can think of ways of improving your techniques. Does the diameter of the cylinder have any effect on wave length? The longer the wave length you use, the smaller will be your error of measure. Do you think differences in temperature or pressure of the air could cause errors of measurement?

The speed of sound is dependent upon air temperature. Can sound be used to measure temperature in the upper atmosphere? When rockets became available for scientific use, methods for measuring temperature with sound were devised. One technique has proved very valuable.

As the rocket soars upward, special grenades are ejected from it one after another, so they explode with bright flashes and loud noises, Figure III-9.

Ground based radar tracking station and special photographic trackers are used to pinpoint the location of each explosion. Meanwhile, sensitive microphones are used to detect the sounds of the explosions when they arrive at the ground, and differences between arrival times are computed and recorded electronically.

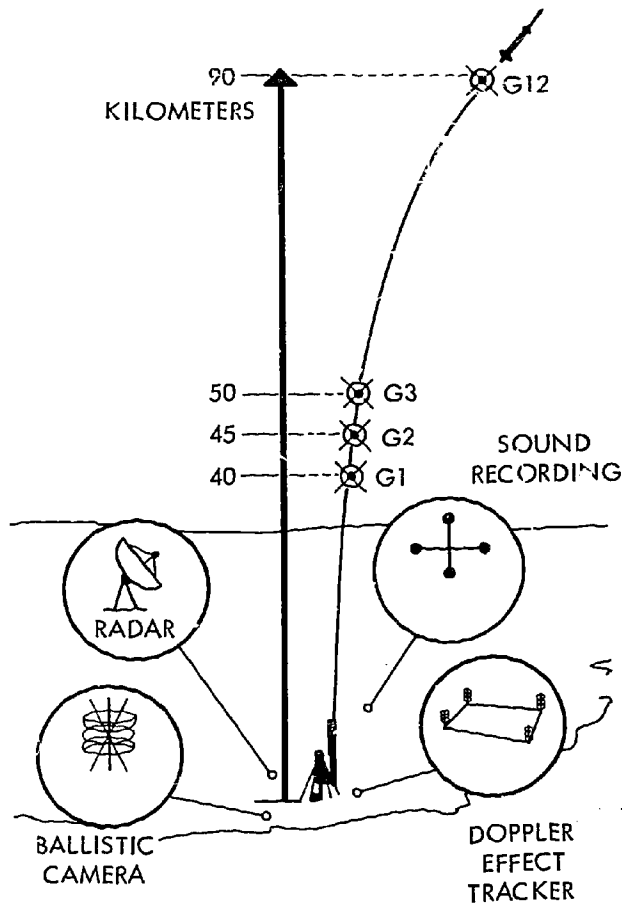

Schematic diagram of the grenade-experiment system. Radar, ballistic camera, and Doppler tracking systems are indicated. Each individual system or combination of systems suffices for the experiment. Sound recording site is preferably located directly under the rocket trajectory. G1, G2, G3, and G12 indicate various altitudes of grenade explosions.

Figure III-9

Using the relationship that Velocity equals Distance divided by Time ( $V = D/T$ ), distance being the difference in altitude between successive explosions, and time, the interval between recorded sounds, the velocity of sound within the altitude interval can be computed.

We have all heard the "beep-boop-beep" of Vanguard I, one of America's first satellites, Figure III-10.

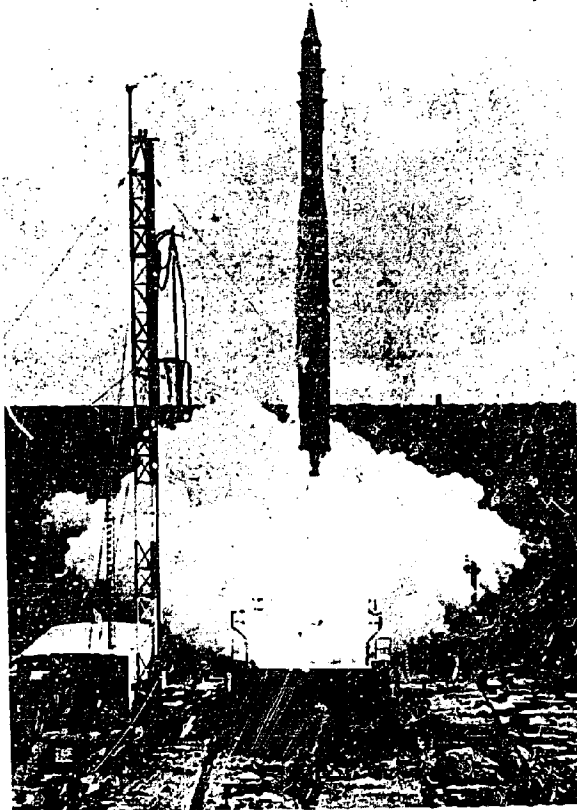

Figure III-10

The tones are the voice of the satellite. What do these tones from space mean? What is the satellite "saying?" What languages does the satellite use? The satellites transmit their information back to earth by transmitting a special kind of number called a *binary number*. We are all familiar with numbers which contain the numerals 0, 1, 2, 3, 4, 5, 6, 7, 8, and 9. A binary number contains only 1 and 0 yet can be used to represent any number of items.

The binary system is based on 2's instead of 10's like our ordinary numeration system. Here is a 7 place binary numeral 1 1 1 1 1 1 1. It means:  $1(64) + 1(32) + 1(16) + 1(8) + 1(4) + 1(2) + 1(1) = 127$ . Each place in a binary numeral contains a digit which is twice the value of the digit in the previous place. In a binary numeral a (1) is used to indicate that the place is filled and a (0) is used to indicate that it is not. Binary numerals are

useful because any value can be written using only two different digits, (1 and 0). Thus the 7 digit binary numeral 1010101 means:  $1(64) + 0(32) + 1(16) + 0(8) + 1(4) + 0(2) + 1(1) = 85$ . How would you write the binary numeral for 36? (Answer:  $100100 = 1(32) + 0(16) + 0(8) + 1(4) + 0(2) + 0(1) = 36$ . Space vehicles utilize the binary number system which can represent any quantity. Can you write a binary numeral for each of these: 0, 1, 2, 3, 4, 5, 6, 7, 8, 9?

Answer:

$$\begin{aligned}
 0 &= 0(1) = 0 \\
 1 &= 1(1) = 1 \\
 10 &= 1(2) + 0(1) = 2 \\
 11 &= 1(2) + 1(1) = 3 \\
 100 &= 1(4) + 0(2) + 0(1) = 4 \\
 101 &= 1(4) + 0(2) + 1(1) = 5 \\
 110 &= 1(4) + 1(2) + 0(1) = 6 \\
 111 &= 1(4) + 1(2) + 1(1) = 7 \\
 1000 &= 1(8) + 0(4) + 0(2) + 0(1) = 8 \\
 1001 &= 1(8) + 0(4) + 0(2) + 1(1) = 9
 \end{aligned}$$

A satellite could send back information in the binary system in any way that was needed.

A satellite may transmit any number by transmitting back only two different musical notes or tones. A high note could indicate the digit (1) and a low note the digit (0). Beep, Beep, Boop could stand for the binary numeral 110 which means  $1(4) + 1(2) + 0(1)$  or  $4 + 2 + 0 = 6$ . This could represent six things or be the digit 6 in a base ten numeral. How could you send the digits 5 and 6 representing 56 with *beeps* and *boops*? Think up others.

When Mariner IV passed by Mars it sent pictures of the Martian landscape using binary numbers. Mariner IV's camera saw the Martian landscape in terms of different light intensities. The electronic equipment onboard the spacecraft interpreted various light intensities as different numbers and then transmitted each number back to Earth. On Earth each number was translated back to a light intensity and the picture of Mars was constructed. Figure III-11.





## MOSAIC OF TIROS PHOTOGRAPHS



WEATHER MAP, MAY 20, 1960, WITH TIROS CLOUD DATA

Figure III-12

Satellite observations helped to develop models of the world's weather. Before 1960, weather observations were limited, and weather maps contained vast blank regions over oceans, deserts, and other sparsely populated areas.

Since April 1, 1960, NASA TIROS (Television Infra Red Observation Satellite) Weather satellites have enabled meteorologists to obtain photographs of large areas of Earth and therefore to deal with weather on a hemispheric or even global basis.

TIROS photographs look much like the cloud cover over Earth, but must be transferred to charts to produce a geometric model for detailed weather analysis.

Figure III-12 shows how TIROS I made history by yielding data which related cloud patterns to weather. The top photograph in Figure III-12 is a mosaic of TIROS photographs covering about one-fourth of Earth's surface. The lower picture is of a weather map based on the mosaic.

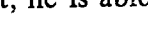
From this weather map, meteorologists are able to identify and locate areas of low pressure, L, indicating cloud cover and possibly precipitation, or high pressure areas, H, with clear skies and fair weather. He is also able to locate weather fronts, , cold fronts and, , warm fronts. From the position of the front, he is able to estimate when the weather will change at a given location.

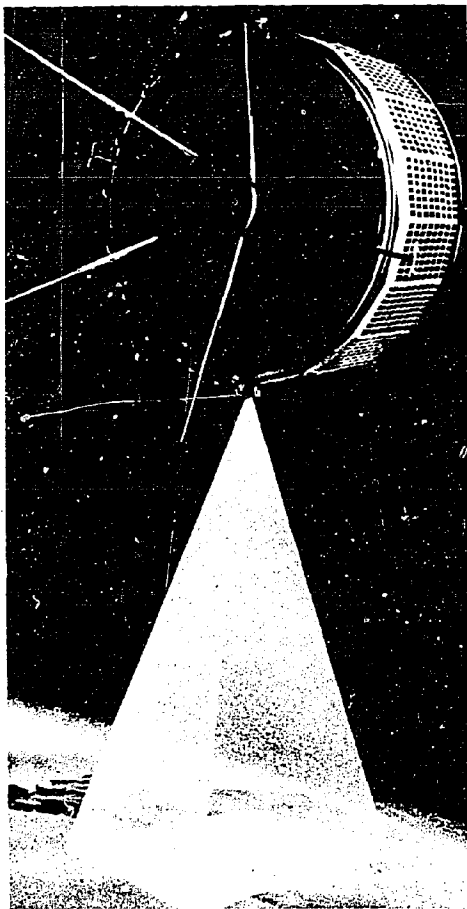

Figure III-13

To obtain more complete coverage of Earth, TIROS IX, Figure III-13, was launched January 22, 1965. The ninth in the TIROS series was the first satellite to photograph the entire sunlit portion of Earth on a daily basis.

Early TIROS satellites were placed in an east-west orbit and were able to photograph only 25% of Earth's cloud cover per day. TIROS IX was launched into a north-south orbit, Figure III-14, and was able to provide total coverage due to the relationship of the satellite's movement and Earth's rotation. As the satellite orbits north-south, Earth rotates east-west under it. Also, TIROS IX was placed in almost a sun-synchronous orbit. That is to say, the normal westward drift of the orbit is the same as Earth's motion around the sun. This placed the sun continuously opposite Earth and provided for constant and favorable lighting for the photographing of Earth, Figure III-15.

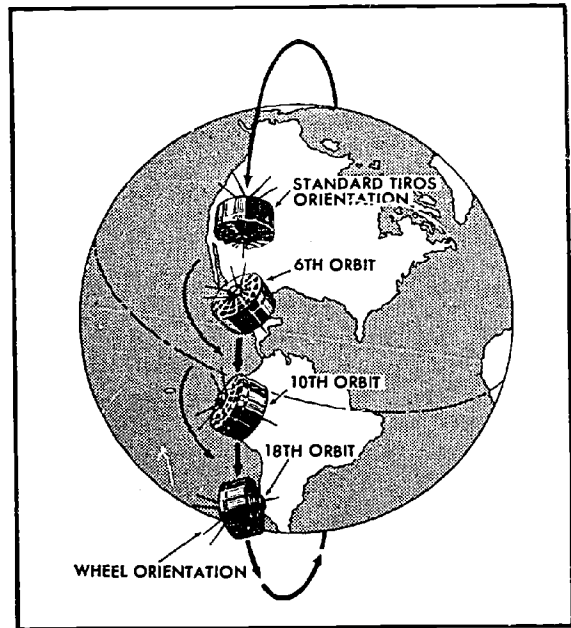

Figure III-14

Another factor in the improved coverage by TIROS IX was the position of its TV cameras. Earlier TIROS satellites had cameras on the base of the drum-shaped spacecraft. At times, when the base was turned away from Earth, the cameras looked into space. TIROS IX's cameras were mounted on opposite sides of the drum. As the satellite slowly "cartwheeled" through space, the cameras photographed Earth as it came into view, Figure III-13.

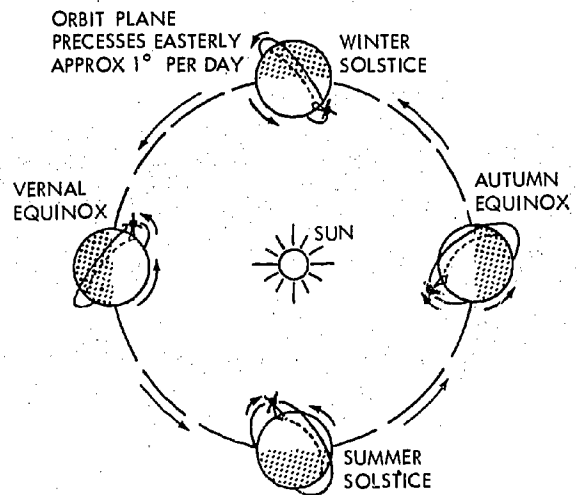
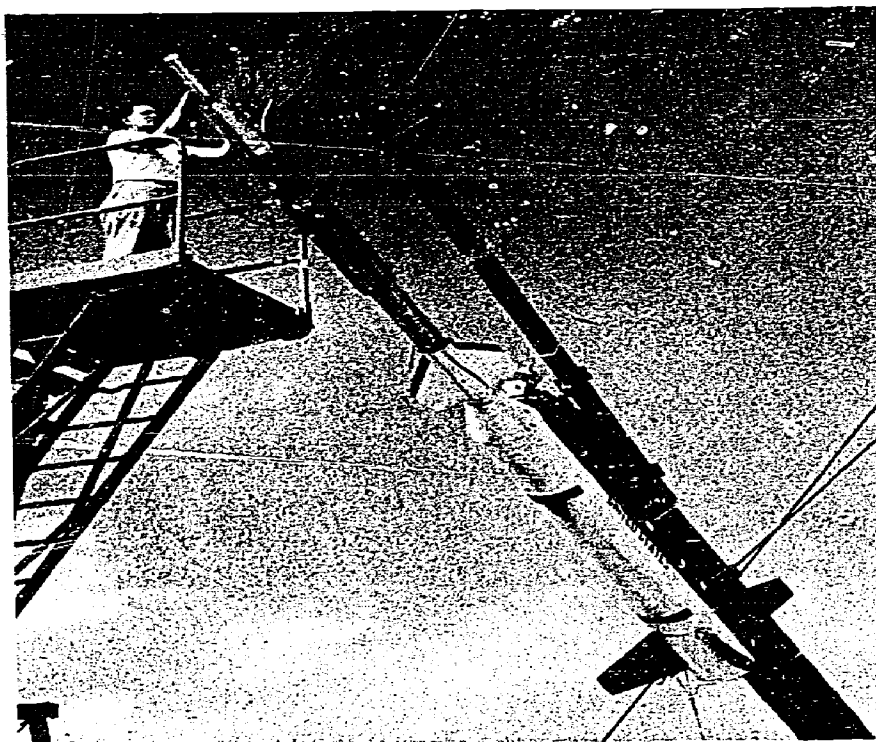

Figure III-15

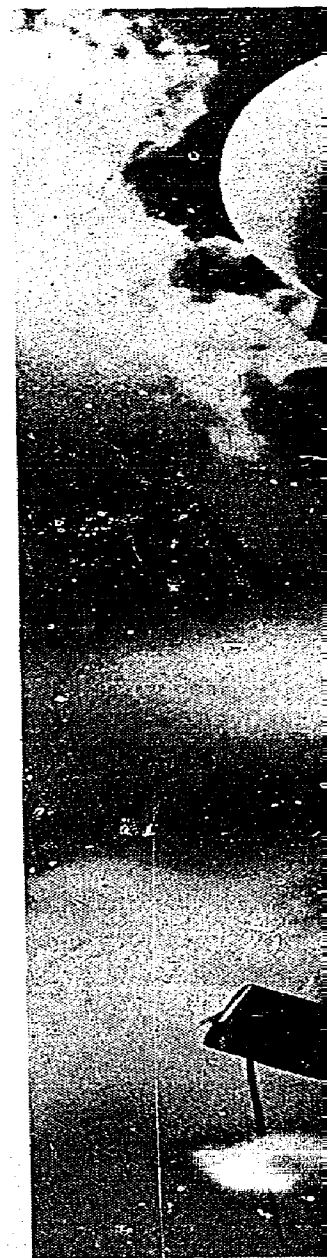

*Figure III-16*

From analysis of early weather models, meteorologists realized that accurate prediction and understanding of weather dynamics could only result from more complete observations of greater areas of the globe which would have to be taken from greater altitudes above Earth. The two major techniques used to provide this information are sounding rockets, Figure III-16, and the TIROS, TOS, Nimbus, and ESSA meteorological satellite programs. (The ESSA satellites of the Environmental Science Services Administration of the Department of Commerce utilize TIROS technology on an operational basis.)

Construction of meteorological models and weather charts requires mathematical data on cloud cover, atmospheric pressure, winds at various altitudes, temperature, and moisture.

These data can be secured by radiosonde stations which send balloons aloft several times daily. Each balloon carries equipment to provide data on atmospheric wind, pressure, temperature, and moisture. This balloon technique secures a vertical sampling of the atmosphere up to about thirty kilometers (18 miles) above the surface, Figure III-17.



As far as ext  
mathematical  
radiosonde ob  
geographical li

Eventually  
fined, but no  
servations an  
ments are p  
materials, equ  
niques are r  
knowledge of



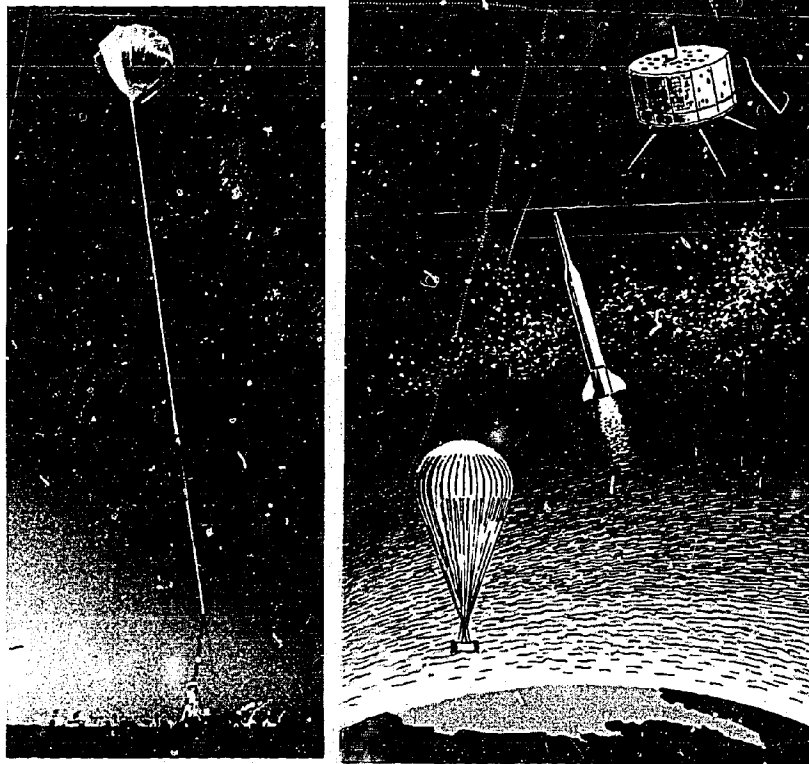

#### Chapter IV

## THE MEASURE OF OUR ATMOSPHERE



## THE MEASURE OF OUR ATMOSPHERE

"Explorer Flight Successful" --So read the headlines in November 1935, referring to the then amazing flight in which two men, sealed in a metal gondola, flew a balloon to the astounding altitude of 72,395 feet (about 22 kilometers) and returned safely to Earth. In January, 1958, another "Explorer" flew successfully, this time to orbit Earth, at altitudes exceeding 1000 miles (over 1,600 kilometers). The mission of both "Explorers" included "scientific exploration of the upper atmosphere." Man's idea of "the upper atmosphere" changed in those 23 short years. This chapter illustrates how scientists have developed ways to measure a now very near and important part of space -- the atmosphere.

Until the development of powerful rockets during World War II, almost all research of the upper atmosphere (Figure IV-2) was limited to observations which could be made from the ground or by instruments carried by balloons. Instruments carried

aloft by these balloons could seldom achieve altitudes greater than about 30 kilometers (18 miles). Sounding rockets have been developed to help fill this void between the instrument carrying balloons and the orbiting satellites, Figure IV-3. The sounding rockets have been immensely valuable in collecting information about our upper atmosphere. The sounding rockets are similar to those vehicles used in the exploration of space, but are usually smaller. Their altitude is limited so they do not depart from the environment of Earth which they are designed to explore.

The Earth and its atmosphere, Figure IV-4, can be thought of as a "system." At Earth's surface, gases and other materials are leaving the atmosphere to become part of solid Earth. What do you think happens to the materials which enter the lower atmosphere from Earth? Some will work their way into the upper atmosphere, and some substances in the upper atmosphere will move down into lower layers. Considerable "trading" has occurred between the parts of the Earth-atmosphere system.

But what happens at the outer boundaries of the atmosphere? More trading occurs. Substances which once were part of solid Earth leave. New materials are captured from space to one day become part of solid Earth, Figure IV-5. Studying the way these "trades" are being made (and have been made from Earth's beginning) could provide information about Earth both now and at the time of its formation.

In order to better understand Earth today, we need to know when, where, and to what extent changes and events are taking place in the upper atmosphere. To do so requires the ability to locate and describe phenomena as they occur.

The concept of a "system" is important in science. Select a group of objects at random. Devise a system in which each object is an integral part of an operating system. For example a ruler, a protractor, an art gum eraser, and a pencil could be made into a "teeter-totter" system, (Figure IV-6). A glass, some water and a cork stopper could produce another; pieces of

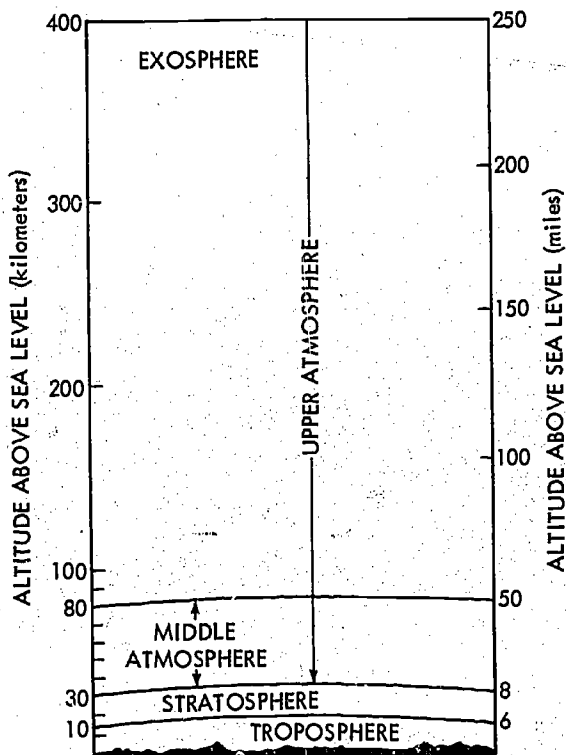

Figure IV-2

wire, a socket, a dry cell, a switch, and a cell holder would be another. When the various parts act together, we have a system. In a system, changes in one part, produce changes throughout the system.

Not all scientists carrying out research of the upper atmosphere are interested in the same phenomena. Each experimenter requires specific data, such as obtained from a particular altitude, or coinciding with special events taking place on the sun, or timed with passages of a satellite overhead, Figure IV-7.

Meteorologists ask: "What factors present in the upper atmosphere affect the weather?" In the troposphere, the lowest layer of atmosphere where nearly all weather is "made," changes in temperature and pressure, wind speed and direction, humidity, precipitation and cloud cover affect the system which we call our weather.

In addition to reporting present weather conditions, the purpose of the measurements is to note any trends or patterns that seem to be developing. When a pattern in the Earth-atmosphere system is detected, it is possible to make certain predictions as to what the weather is likely to be in the near future.

To make these predictions, we must rely upon the fact that the troposphere consists of gases which are free to flow or move within the system under the combined effect of all forces acting upon them. Upper layers of the atmosphere consist of gases which rest upon the lower layers. Changes taking place in the upper layers of the atmosphere may result in various forces being exerted upon lower layers.

The upper atmosphere is, therefore, studied because of its unique position with respect to space. We need to know what

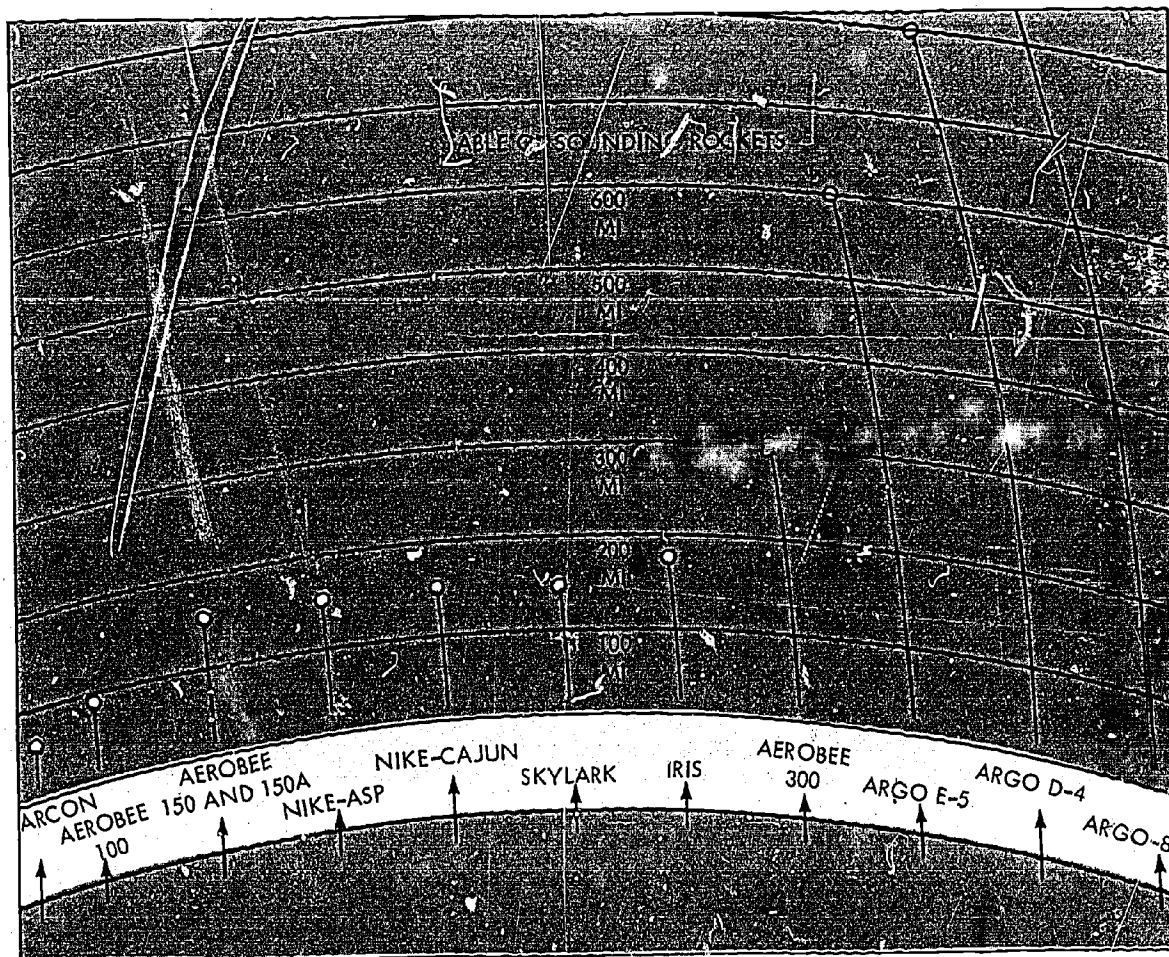

Figure IV-3

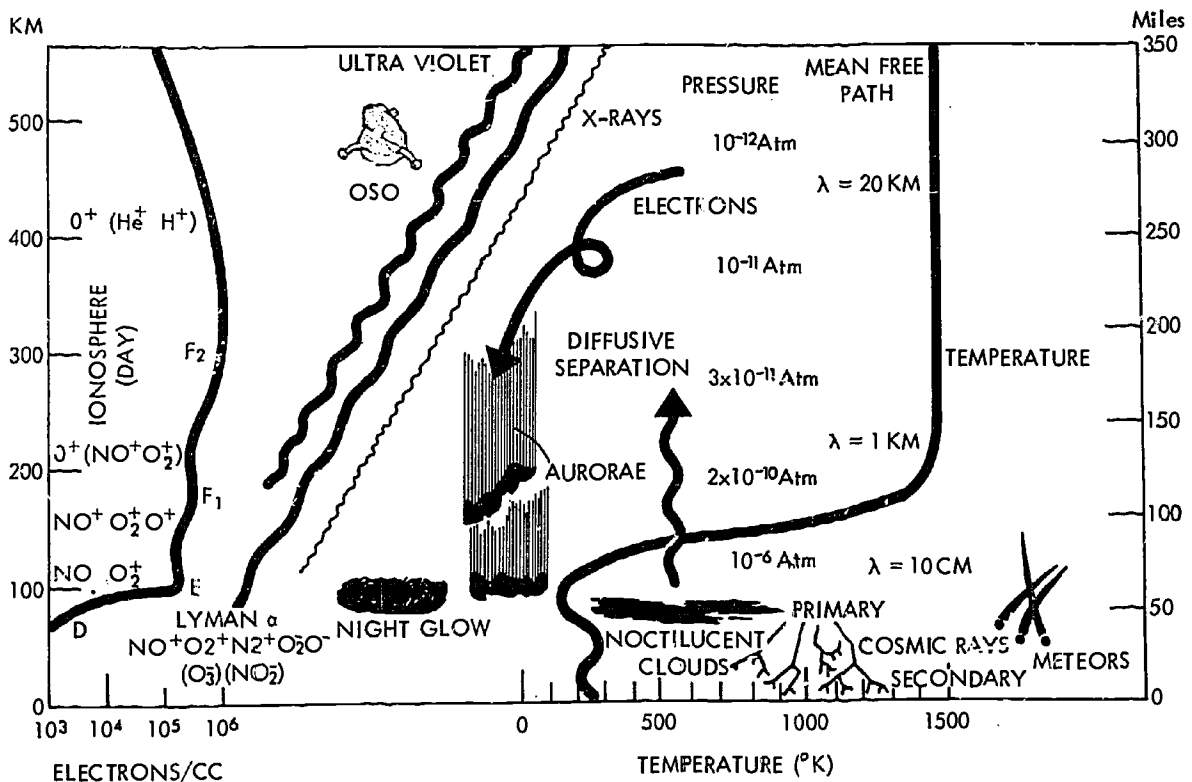

Figure IV-4

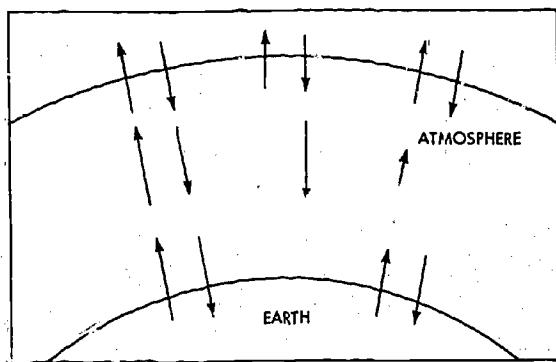

Figure IV-5

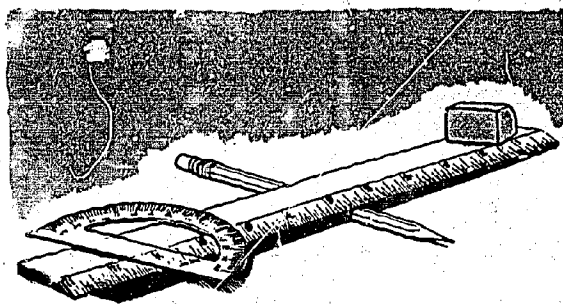

Figure IV-6

effects are produced by phenomena such as incoming solar radiation, solar wind, meteors and cosmic rays. These data may provide evidence related to phenomena such as aurora, magnetic storms, and night glow. The gases of the upper atmosphere are subjected to many external and internal forces. They react to these forces accordingly.

The nature and behavior of gases near the surface of Earth has occupied the attention of a large number of scientists for a great many years. More recently, the necessity of understanding the behavior of gases and fluids at high altitudes has occupied the attention of space scientists. On July 17, 1929, Dr. Robert H. Goddard was the first investigator to successfully launch a scientific payload. This first payload consisted of a barometer, a thermometer and a camera. Figure IV-8 shows Dr. Goddard, second from the right, with colleagues holding the rocket used in the flight of April 19, 1932.

At any given time, a reasonable description of the state of a gas is provided by measuring three quantities; density,

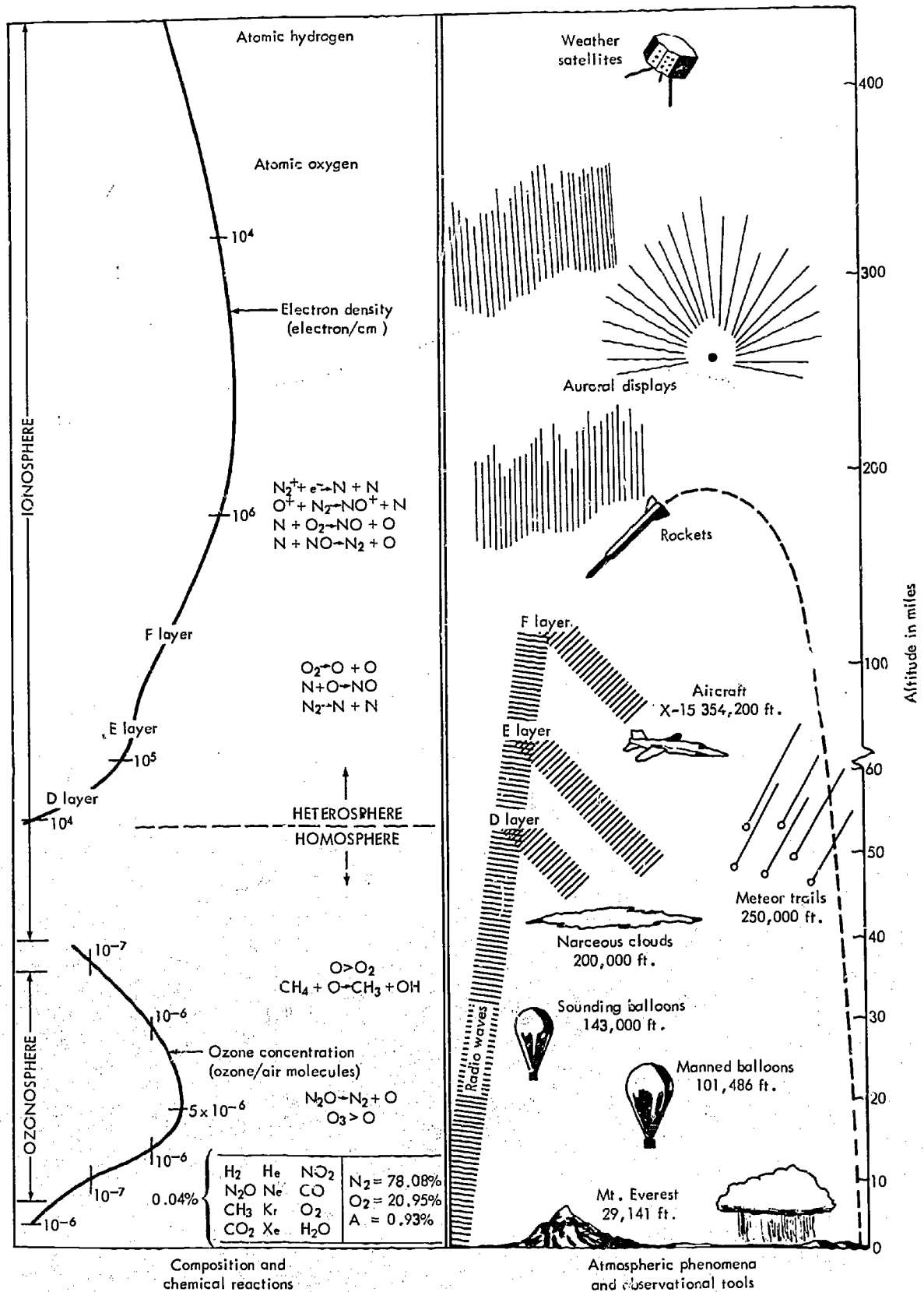

Figure IV-7



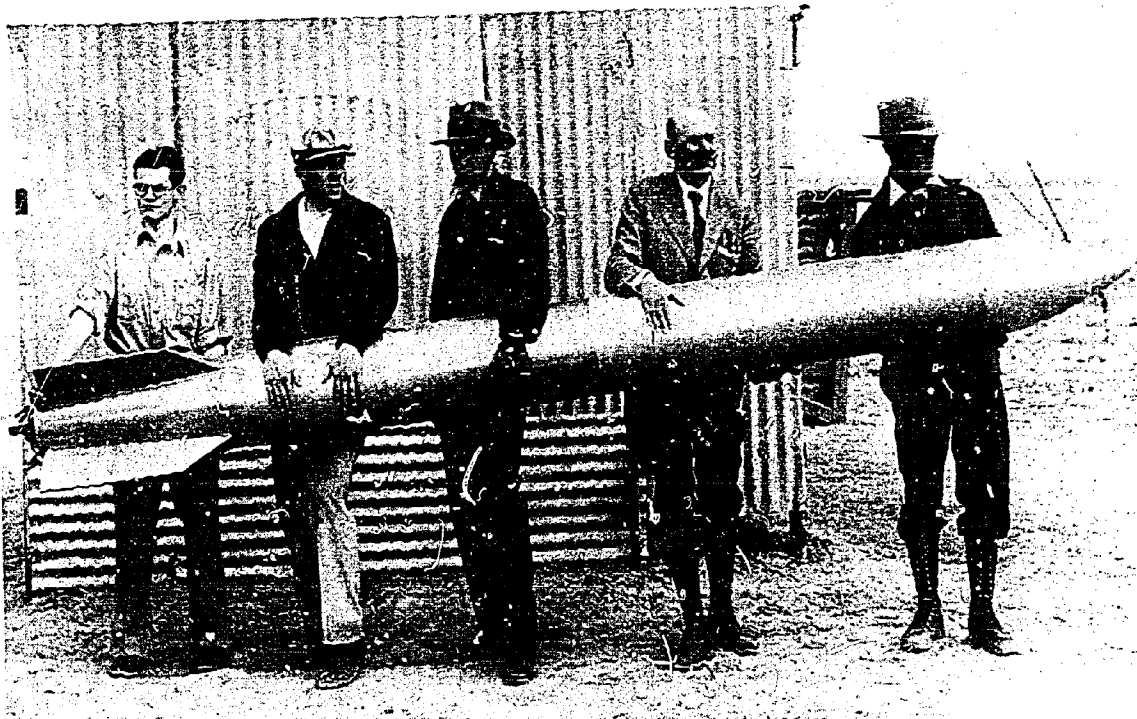

Figure IV-8

temperature, and pressure. Difficulties in measuring the volume of the atmosphere surrounding Earth are apparent. Since density is closely related to volume, the measurement of density can be substituted as an indirect method in the measurement of volume.

What shall we measure? We must learn to measure (1) density, (2) temperature, and (3) pressure.

You have probably made many atmospheric measurements such as pressure, temperature, cloud formations, precipitation, etc. The data that you have collected is similar to information obtained from scientific upper atmosphere measurements.

*Try this:* During a one week period make a number of different measurements in relation to Earth's atmosphere. Select specific times to make your measurements — several hours apart three or four times each day. Develop charts, graphs, tables, etc. to record your observations. How many different kinds of data can you gather? (You will need a physics text and one for geometry and to know how to use the index.) Include some of the following in addition to others you may devise.

a. Make a mercurial barometer. Record atmospheric pressure readings in millimeters of mercury.

b. Record air temperatures in different locations around your home and school. Select open, paved, grassy, shady, or, wood areas. Use a centigrade scale thermometer.

c. Use an anemometer to record wind speeds. Record data in kilometers per hour. Make measurements in different locations.

d. Record vane revolutions per minute of a Crookes radiometer placed in different locations. Devise filter systems for use when revolutions are too rapid to count.

e. Take measurements with a light meter and record values in foot candles. Use a solar cell with a voltmeter and record values in millivolts. Compare results.

f. Use a geiger counter and record background "noise."

g. Devise methods of determining cloud height, speed, and cloud types.

h. Launch helium balloons. Record direction, speed, rate of ascent and altitude when last visible.

i. Use a radio to determine long-distance radio reception. Compare broadcast, long



wave and short wave, bands. Use maps or a globe to show station locations and distances in kilometers. List station frequency in kilocycles or megacycles per second.

j. Determine what gaseous and solid particles are added to the atmosphere by automobile, industry, homes, etc. in your own community.

k. Develop means of determining visibility distance.

l. Use a simple method, such as that shown in Figure IV-9, to estimate air turbulence.

Volume is the term used to describe an enclosed space. Stated in another way, volume is the measure of the amount of space enclosed within defined boundaries. Volume has three dimensions, length, width and depth or height. Units used to express volume are called "cubic units," such as cubic inches or cubic centimeters. The development of the measurement of volume from units of length is an intriguing story, and may provide some interesting reading for you.

Measuring volumes of gases at the surface of Earth is practical, for a gas may be enclosed within containers of fixed dimensions. Measuring volumes of gases high in the atmosphere presents new problems. Gases in the atmosphere are not enclosed within containers, and the atmosphere itself may not have measurable boundaries. Figures IV-10 and IV-11 illustrate some of the difficulties of placing a package of measurement instruments into orbit. Figure IV-11 shows Explorer XIX fully inflated whereas Figure IV-10 shows the same satellite packed into its canister and extending outward from the fourth stage of a Scout launch vehicle.

One way to solve this problem is to obtain *samples* of gases from the atmosphere. When samples are collected however, the volumes of the samples are predetermined by the sizes of containers used for collection. Consequently, if all samples have identical volumes, some other unit of measurement must be used to compare them.

A common method for comparing one sample with another is to measure the amount of material in each. The *amount*

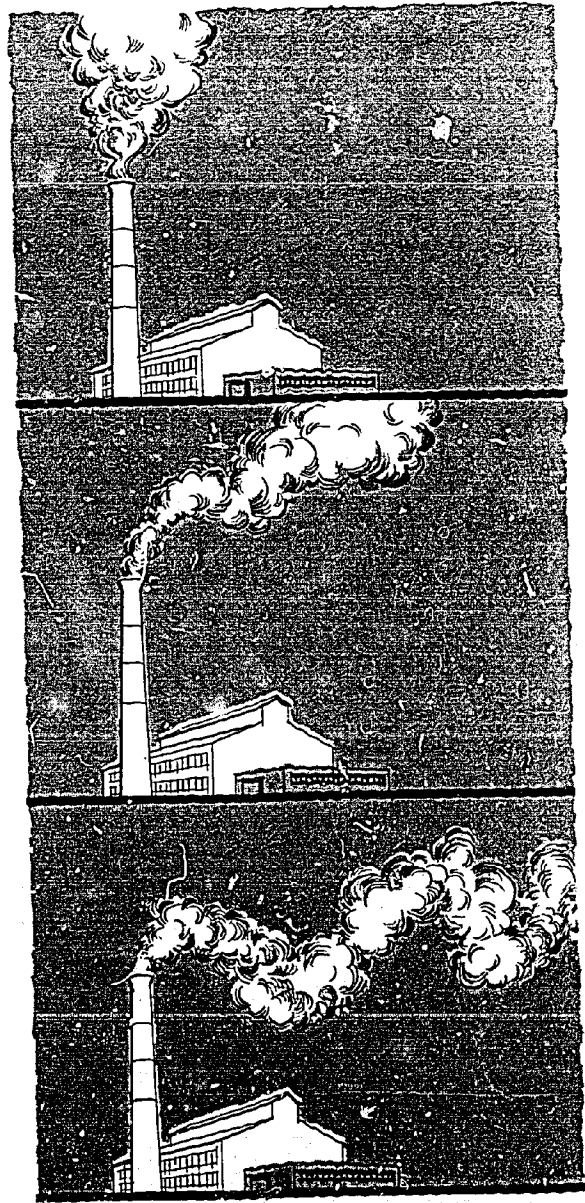
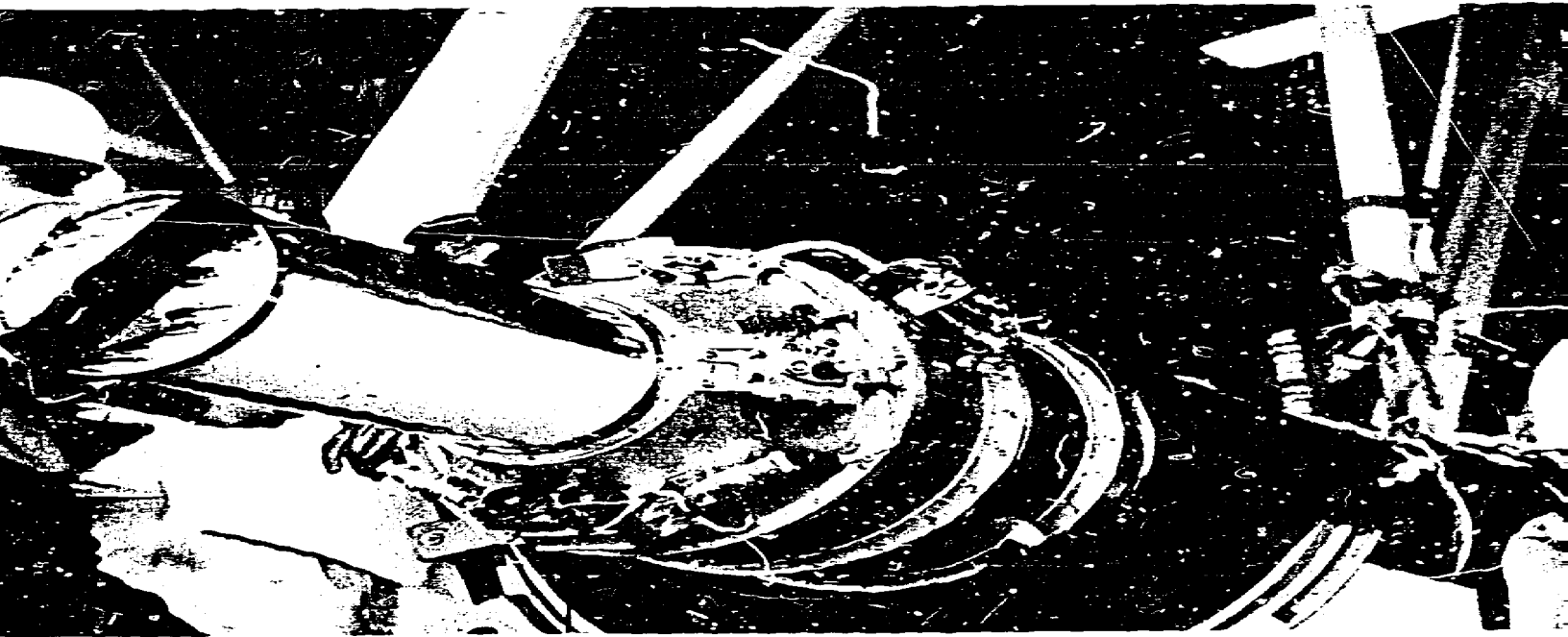

Figure IV-9

of material present in a substance is called its mass, not its weight.

Weight is often defined as the force of attraction which exists between a *mass* and Earth. Mass remains the same for any place. Your mass, your number of atoms, will be the same on the moon as on Earth. However, since the moon's gravity is less than that of Earth, your moon weight would be less than your Earth weight. Your weight on Earth will also vary at different Earth locations: the Equator, at the





*Figure IV-10*

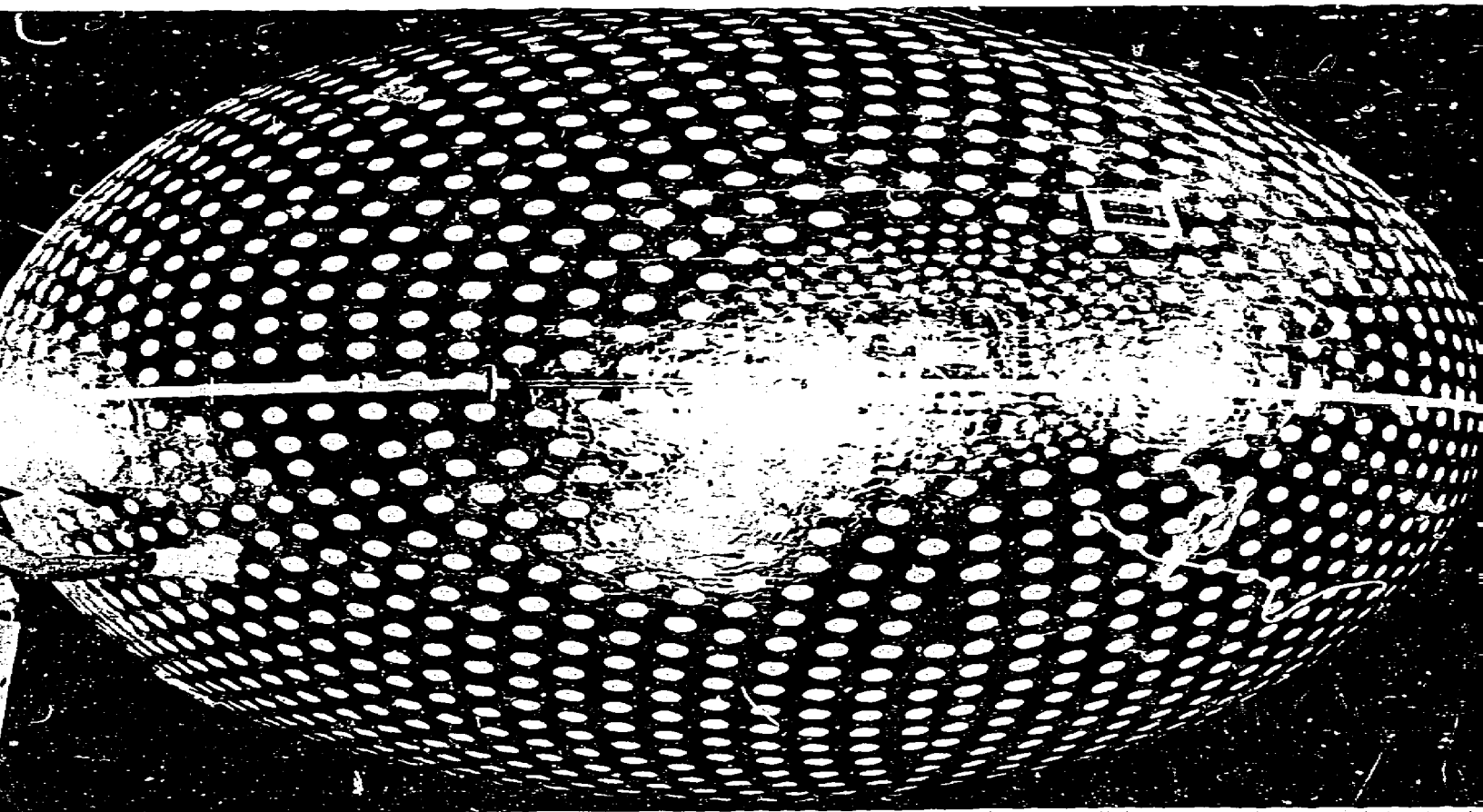

*Figure IV-11*

[Faint, illegible text, possibly bleed-through from the reverse side of the page]

Poles, in a deep mine, on a mountain top, etc. To change the mass of an object it would be necessary to alter the number of atoms it contains. As the Aerobee rocket successfully lifts off to the atmosphere, (Figure IV-12) its weight changes as the distance from Earth increases and both weight and mass are decreasing as rocket fuel is consumed.

Suppose a sample of air is obtained from the troposphere, and the mass of this sample is measured as *6 grams*. With a sounding rocket, a sample of air with equal volume is recovered from the upper atmosphere. The mass of this sample is measured as *1 gram*. Which of the following statements would be a better conclusion to draw from this evidence?

- a. The *mass* of the air in the upper atmosphere is less than the *mass* of air in the troposphere.
- b. Volume for volume, the *mass* of the air in the upper atmosphere is less than the *mass* of air in the troposphere.

Only masses of small volumes of air were measured, not masses of the entire atmosphere, but the volumes were *equal*. On what basis could masses of samples be compared if volumes were not equal? This is a question of some practical importance. Measuring instruments carried as payload on rockets are limited by the size and shape of the rocket itself.

Masses of samples can be compared only if the mass of each sample is related to its volume. To illustrate, suppose that one sample of air recovered has a volume equal to 870 ml. (milliliters) and a mass equal to 27 grams.

What would be the mass of 1 ml. of this sample? What would be the mass of 1 ml. of a sample with volume equal to 860 ml. and mass equal to 25 grams? To find these answers it is necessary for you to divide the measure of *mass* by the measure of *volume* for each sample. As a result of this division, the samples are described as having a certain measure of mass *for each unit of volume*. This is the concept of *density*.

Scientists would define density as "the mass per unit of volume." Mathematicians would define it as  $D = M/V$ , which is read as: "density equals mass divided by volume." You will also notice that density



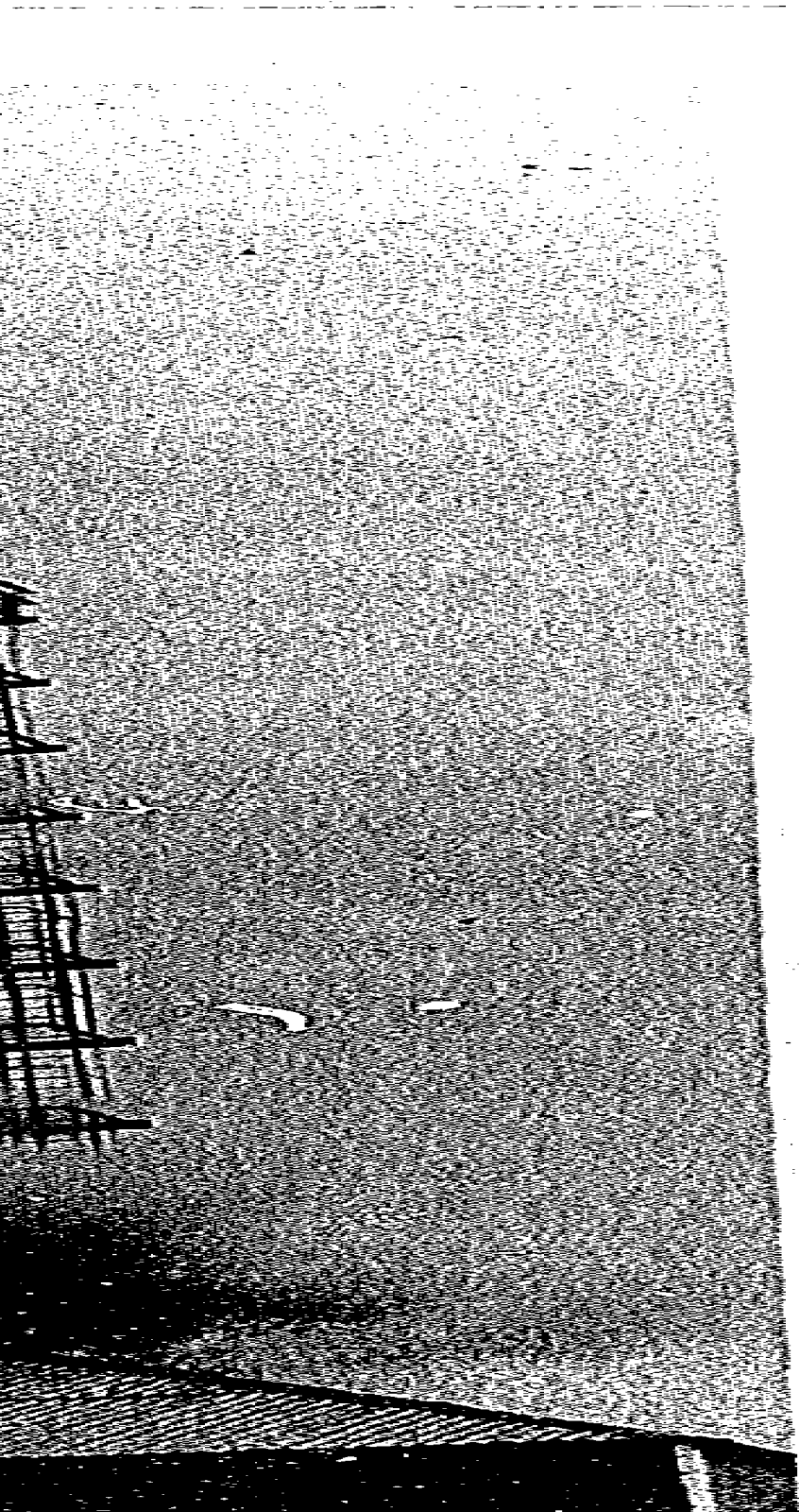

ERIC

Full Text Provided by ERIC

ERIC

Full Text Provided by ERIC

ERIC

Full Text Provided by ERIC

ERIC

Full Text Provided by ERIC

ERIC

Full Text Provided by ERIC

ERIC

Full Text Provided by ERIC

ERIC

Full Text Provided by ERIC

Poles, in a deep mine, on a mountain top, etc. To change the mass of an object it would be necessary to alter the number of atoms it contains. As the Aerobee rocket successfully lifts off to the atmosphere, (Figure IV-12) its weight changes as the distance from Earth increases and both weight and mass are decreasing as rocket fuel is consumed.

Suppose a sample of air is obtained from the troposphere, and the mass of this sample is measured as *6 grams*. With a sounding rocket, a sample of air with equal volume is recovered from the upper atmosphere. The mass of this sample is measured as *1 gram*. Which of the following statements would be a better conclusion to draw from this evidence?

- a. The *mass* of the air in the upper atmosphere is less than the *mass* of air in the troposphere.
- b. Volume for volume, the *mass* of the air in the upper atmosphere is less than the *mass* of air in the troposphere.

Only masses of small volumes of air were measured, not masses of the entire atmosphere, but the volumes were *equal*. On what basis could masses of samples be compared if volumes were not equal? This is a question of some practical importance. Measuring instruments carried as payload on rockets are limited by the size and shape of the rocket itself.

Masses of samples can be compared only if the mass of each sample is related to its volume. To illustrate, suppose that one sample of air recovered has a volume equal to 870 ml. (milliliters) and a mass equal to 27 grams.

What would be the mass of 1 ml. of this sample? What would be the mass of 1 ml. of a sample with volume equal to 860 ml. and mass equal to 25 grams? To find these answers it is necessary for you to divide the measure of *mass* by the measure of *volume* for each sample. As a result of this division, the samples are described as having a certain measure of mass *for each unit of volume*. This is the concept of *density*.

Scientists would define density as "the mass per unit of volume." Mathematicians would define it as  $D = M/V$ , which is read as: "density equals mass divided by volume." You will also notice that density

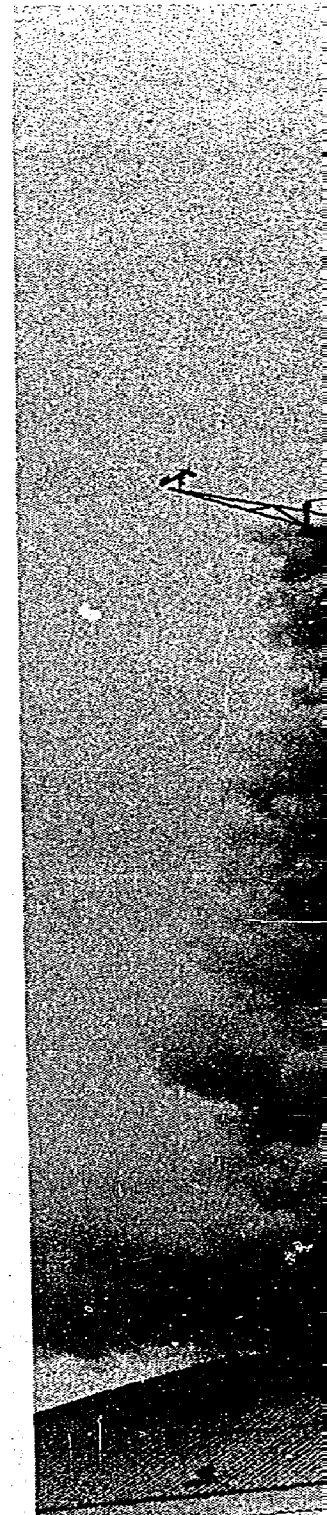

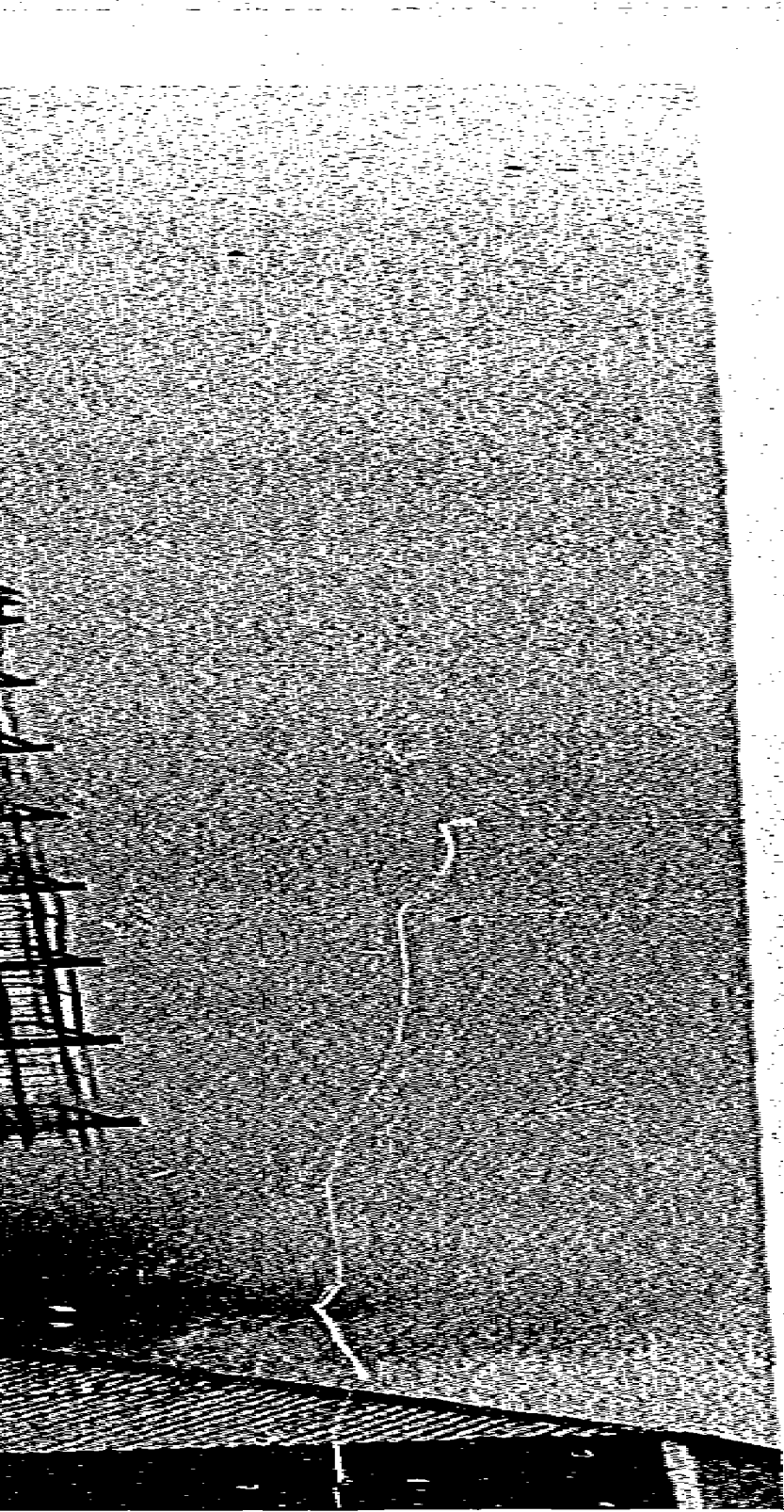



varies directly with mass and inversely with volume. The principle is the same. Density is calculated by dividing the measure of mass by the measure of volume.

When density is stated, *units of measure must always be included.* Thus, the density of the first sample of air would be stated as 0.031 g/ml., read as "zero point zero three one grams per milliliter" or 31 thousandths grams per milliliter." The mass of the second sample would be stated as 0.029 g/ml., read as "zero point zero two nine grams per milliliter," or "29 thousandths grams per milliliter."

Do you think these two samples of air could have been obtained from the same place at the same time? Give your reasons. If the second sample was obtained from a higher altitude than the first sample, what might you hypothesize about the nature of the atmosphere? Remember density decreases as altitude increases.

Defining our problem about the atmosphere in another way, we say "density is a measure of the amount of material present within a given space at a given time." Due to this fact we consider both volume and density to describe samples from the upper atmosphere. With this in mind, imagine that you are riding at a speed of 20 kilometers per hour in a motor boat, and you stick your hand up into the air. Imagine the push of air on your hand. Now imagine that you cautiously place your hand into the water alongside the boat as it continues to move at 20 kilometers per hour, (Figure IV-13). Compare the push on your hand made by water with the push made by air.

Next imagine that you are an astronaut in a spacecraft orbiting around the earth at 17,500 mph. As you prepare to leave your spacecraft to take a "walk in space," you open the hatch and cautiously raise your hand (Figure IV-14). Imagine the force you would feel on your hand and compare it with the force from the water and air. Which would you expect to be most dense: Water, air or "empty" space? Least dense? Give your reasons.

Answers to these questions can be made on the basis of the amount of push or force against your hand due to resistance offered by substances through which your hand is moving. The greater the density of the material, the greater the resistance; or the

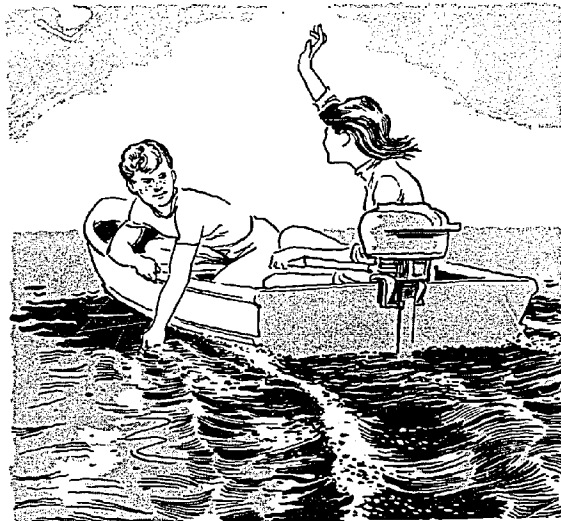

Figure IV-13



Figure IV-14

greater the resistance, the greater the density of the material.

With your hand you made a crude measurement of the density of air and water. Your measurement was only to determine which was greater or which was less. How can we refine this method of measuring so that it will provide accurate information about atmospheric density?

One group of scientists worked out the following system. Imagine a light hollow sphere being released from a sounding rocket at the very top of its trajectory, Figure IV-15. As the sphere falls back to Earth, it must pass through the atmosphere. Since the falling object is spherical, resistance of the atmosphere will always be directed against

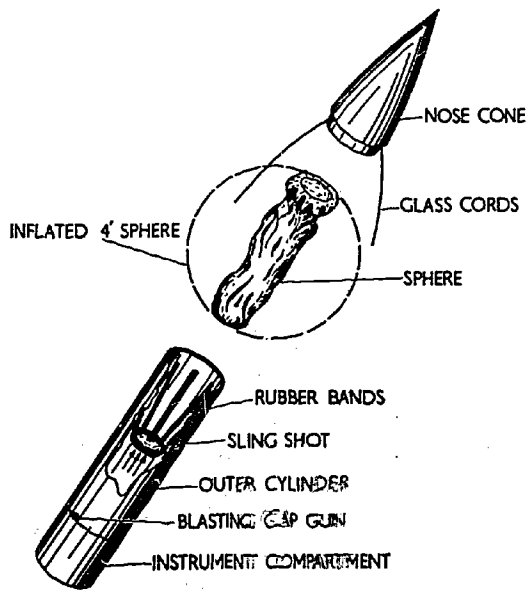

Figure IV-15



Figure IV-16

an equal amount of surface area. The rate at which the sphere falls depends upon the resistance of the air it is falling through. The amount of resistance depends upon *density* of the air.

Therefore, the rate of descent can be used to indirectly measure air density at various altitudes. Radar measurements provide continuous information about the rate at which the sphere is descending. Additional data from this method include the sideward motion of the sphere during the free fall which in turn provides information concerning wind speed and direction in the upper levels of the atmosphere. Figure IV-16 illustrates a type of sphere used for

experiments above 30 kilometers. Space scientists determine atmospheric density by this method.

Figures IV-17 and IV-18 are graphs showing the results of one such experiment. Figure IV-17 shows the radar plots of altitude and the computed rate of descent for each altitude. Figure IV-18 gives atmospheric density calculated for each rate of descent of the sphere.

Use these two graphs as sources of information to build a new graph as in Figure IV-19, showing the density of the atmosphere compared to altitude. For example, at 40 km the rate of descent is 40 m/sec from Figure IV-17, and a rate of descent of 40 m/sec indicates a density of  $4.0 \text{ gm/m}^3$  from Figure IV-18. So on Figure IV-19, at altitude 40 km, plot density as  $4.0 \text{ gm/m}^3$ . Secure graph paper as in Figure IV-19 and continue to plot the other values and then connect your plotted points with a smoothly curved line.

The completed graph will show the density of the atmosphere as it was measured to be on a particular day. Many such measurements must be made from a number of different locations before a complete picture of the density of the atmosphere can be well known.

Use the graph you have constructed. Figure IV-19 to determine the density of the atmosphere at an altitude of 50 km.; 55 km.; 65 km.

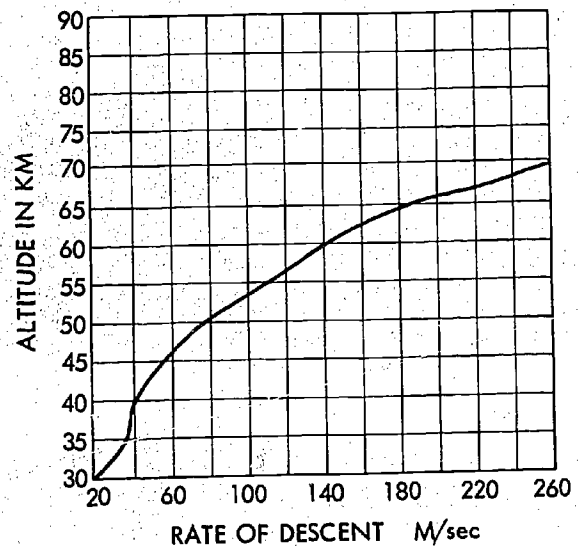

Figure IV-17



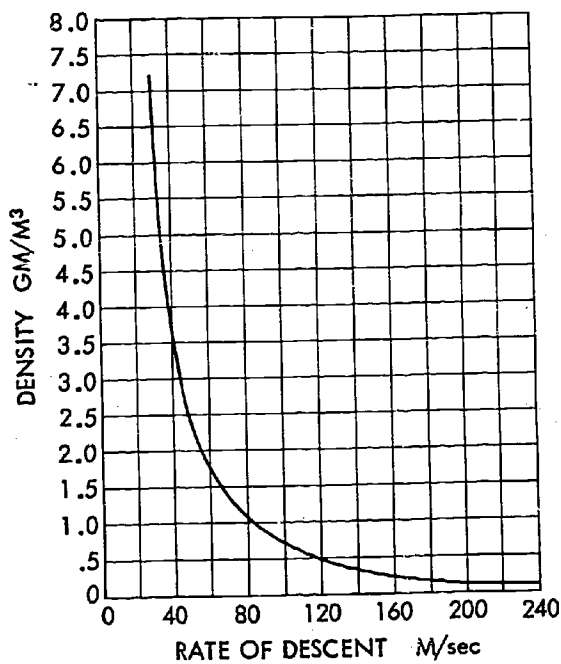

Figure IV-18

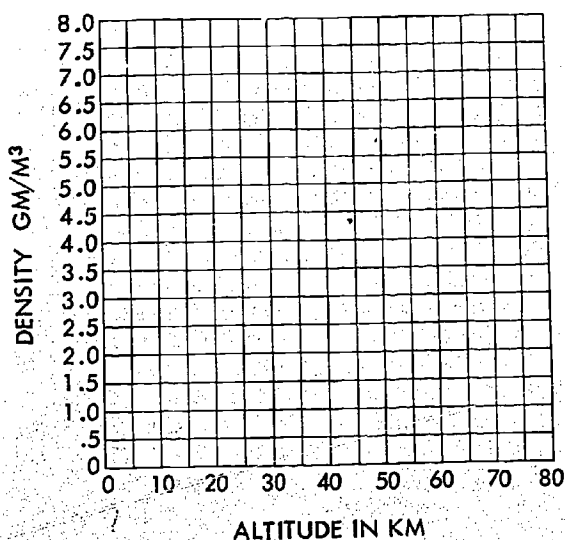

Figure IV-19

You should find  $1.1 \text{ gm/m}^3$ ,  $0.60 \text{ gm/m}^3$  and  $0.21 \text{ gm/m}^3$ .

Imagine you are a scientist working on a project concerned with the study of the atmosphere of Mars, and entrusted with designing an experiment to measure density of the Martian atmosphere. From what you know about the Martian atmosphere, what changes or modification in the sphere drop method of measuring density might you

investigate? How would the lack of ground stations for radar; telemetry; allowances for probable mass of Mars; and unknown Martian winds influence your thinking? Remember all you have learned about the measurement of gases.

The density of a gas is influenced by temperature. Temperature is something all of us have learned about intuitively in much the same way we have learned about brightness of light, shadings of color, loudness of sound, or smoothness of texture. Although we can "feel" temperature, we need to know about its measure.

If asked to describe what is meant by temperature, a common answer is, "temperature is how hot or how cold something is." This implies that an entire range of temperatures must exist. Cool, warm, icy, searing, lukewarm, balmy, hot, or cold are but a few words used to express temperatures. These words are descriptive — they describe how the temperature of an object "feels." A temperature value could be assigned to each term. Using the proper term, it is possible to communicate to someone else the description or value of the temperature which a certain object possesses.

Use Figure IV-20 to develop a scale of descriptive terms. Ask others you know to prepare similar lists. Compare lists. Particularly notice words used within specific temperature ranges. If others are asked to describe or place a value on this same temperature, a major weakness of the scale becomes apparent. A descriptive scale is *subjective* — a personal estimate of judgment or opinion is required by each person using it. Prove this subjectiveness to yourself very quickly. Listen to the comments of your classmates as they describe the temperature of outer space, or the surface of the sun, or the heat shield of a spacecraft as it re-enters the atmosphere, Figure IV-21. Words chosen to describe temperatures vary from person to person. We soon know that we cannot adequately describe temperatures without using numerical values to describe the measure of "hot," "cold," "warm," etc.

Describing temperature with numerical values rather than words has interesting possibilities. It is possible to express a greater range and variety of temperatures.

Each numeral has a fixed value while the value of a word depends upon judgment of the user. If temperatures can be expressed as numerals, then instead of estimates, temperatures can be measured.

Temperatures are measured with thermometers. It may seem that to measure the temperature of the upper atmosphere, it is only necessary to send up a thermometer, and the temperature would be expressed as a numerical value, Figure IV-22. Unfortunately, all is not that simple. To understand why, we must find answers to

---

---

---

searing

---

---

---

hot

---

---

---

warm

---

---

---

balmy

---

---

---

lukewarm

---

---

---

cool

---

---

---

cold

---

---

---

icy

---

---

---

Figure IV-20

the fo  
ture is  
someth  
eter m  
momet  
merals  
thermo  
expres  
mean?  
used to  
atmosph

To  
value o  
scale w  
for m  
parent

If a  
over th  
the ba  
of the  
the "b  
stand  
that "

ing questions: (1) If  
ned by how hot or  
"feels," how does a  
re temperature? (2)  
measures temperature  
y are the numerals plac  
er? (3) If tempera  
s numerical values, wh  
Can ordinary thermo  
asure temperatures in  
mate making a judgm  
emperature on whatev  
oose, we must develop  
g changes of temper  
n small changes.  
all balloon is stretch  
outh of a clean, dry g  
will hang loosely dov  
le as shown in Figure  
-balloon system" is a  
or 3 minutes in a pa  
' quite warm to the

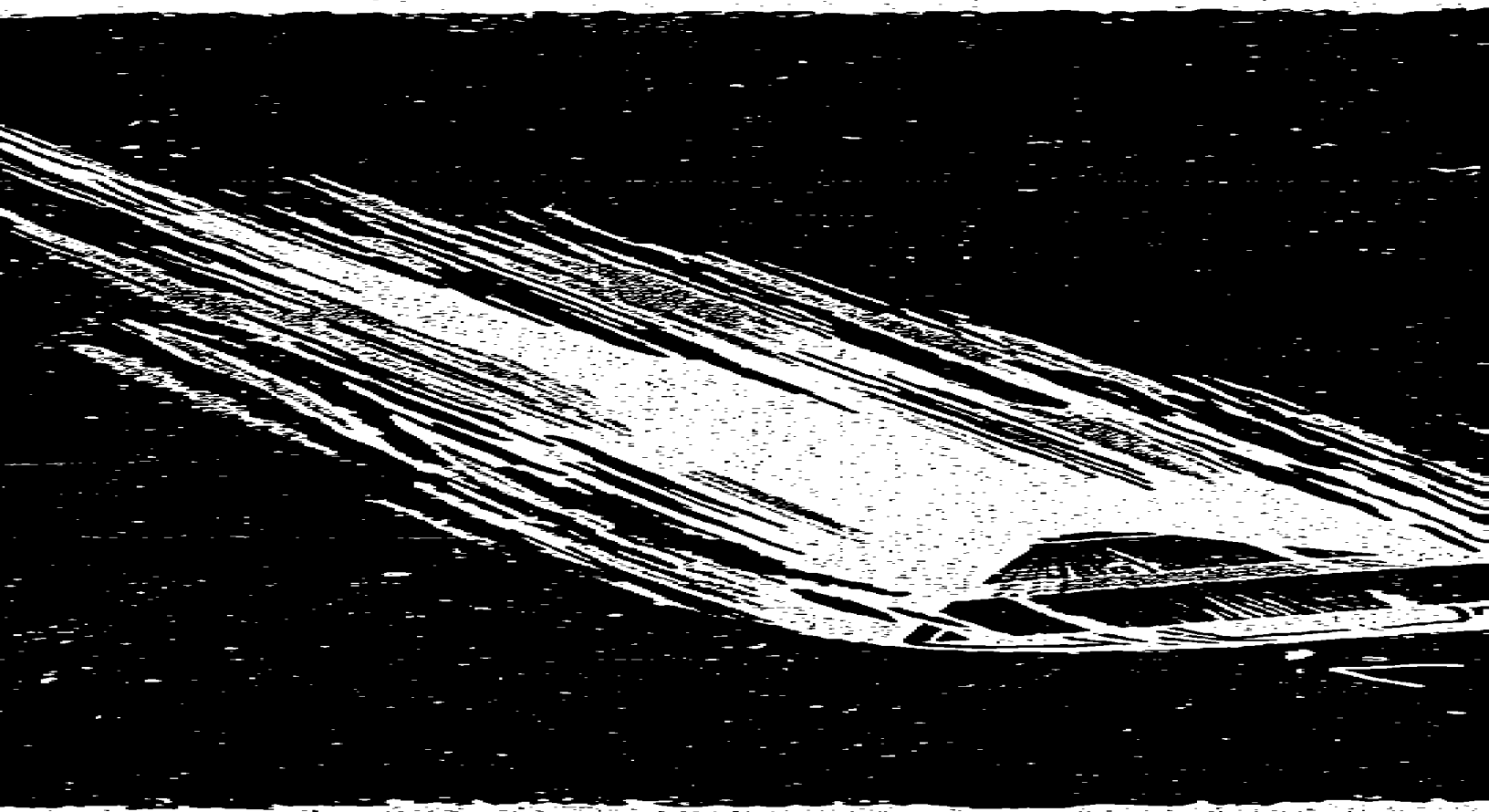

Figure IV-21

11/11/11

ERIC

balloon will become partially inflated as shown in Figure IV-24a. The circumference of the balloon can be measured with a piece of string as shown in Figure IV-24b. Finally, if the bottle-balloon system is removed from the pan of warm water and allowed to cool, the balloon will slowly collapse to a position similar to its original position as in Figure IV-23. Could the air in the bottle change volume during this activity? What evidence supports your answer? Suppose the bottle-balloon system were placed

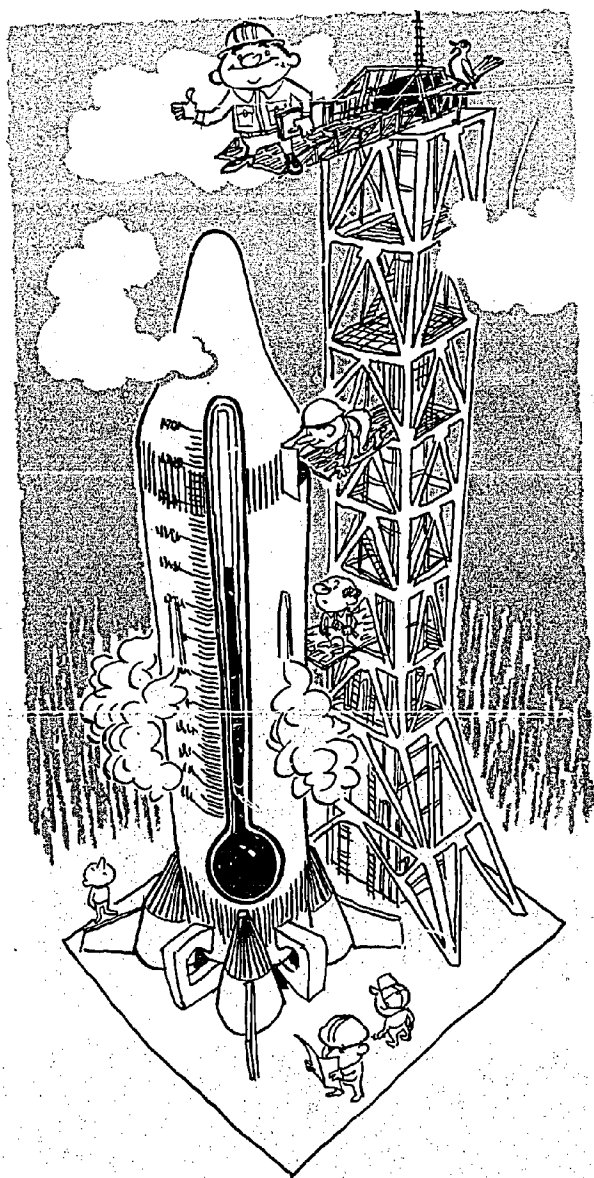

Figure IV-22

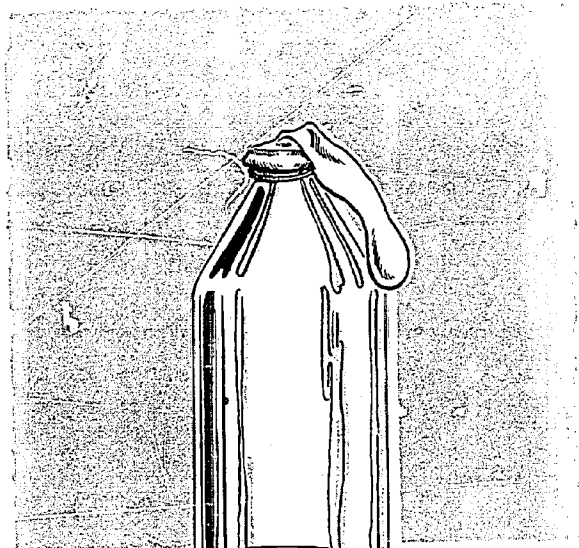

Figure IV-23

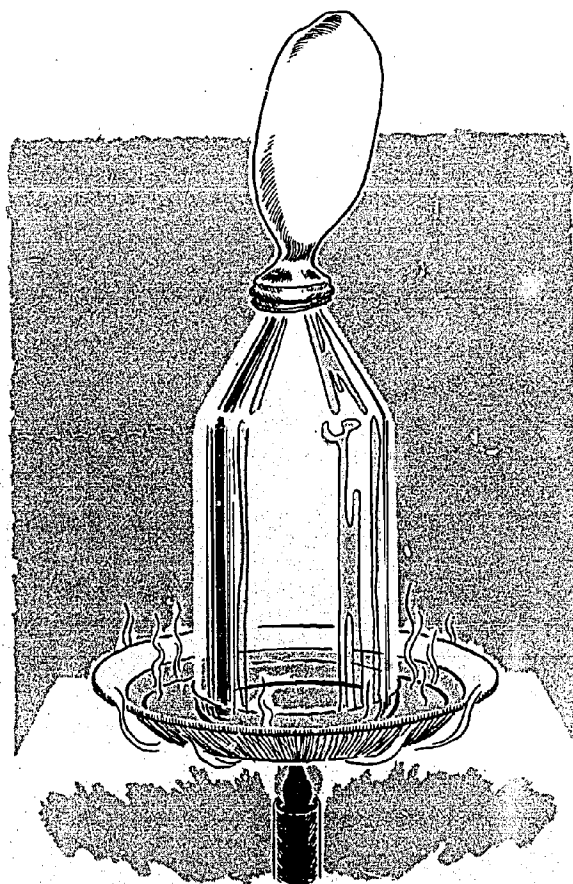

Figure IV-24a



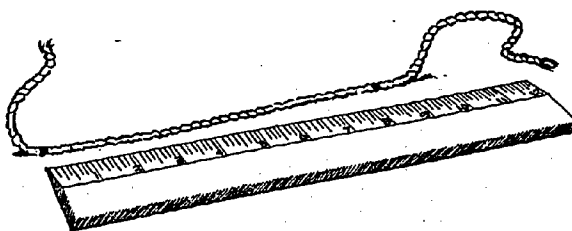
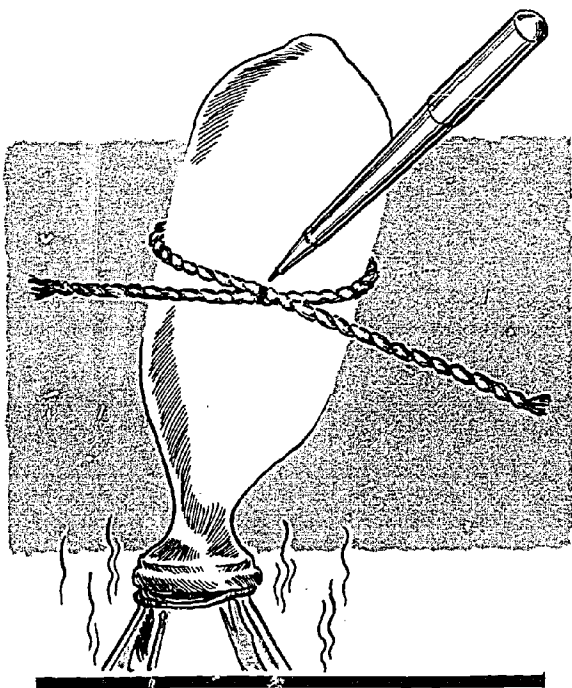

Figure IV-24b

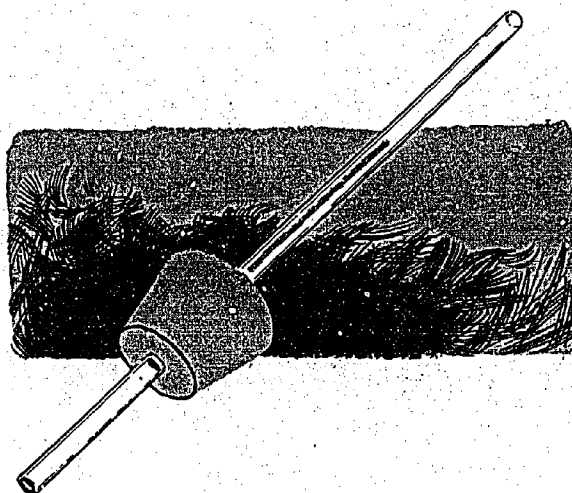

Figure IV-25

in the refrigerator — can you predict what might happen?

Consider these questions: How can you check the accuracy of your prediction? How was a temperature change converted into a number?

Fill a bottle to the top with water. Add a few drops of food coloring to make the water easier to observe. Select a one-hole stopper of the right size to fit tightly into the bottle. A piece of glass tubing about 12-15 cm long is pushed through the hole in the stopper so that it projects out of the bottom of the stopper about 2 cm (Figure IV-25). Use extreme care in pushing the glass tubing through the stopper. To avoid injury or breakage, do *not* force the tubing through the stopper. (A small amount of soapy water, or glycerine may be used to lubricate the stopper and tubing so that the tubing will slide more easily.)

The stopper is fitted tightly into the mouth of the bottle and forced down slightly so that some water is displaced up into the glass tubing (Figure IV-26). The position of the water in the tubing can be marked with a grease pencil or a small piece of masking tape.

After the bottle has been transferred to a pan of water quite warm to the touch, the system is observed for changes. 3 to 5

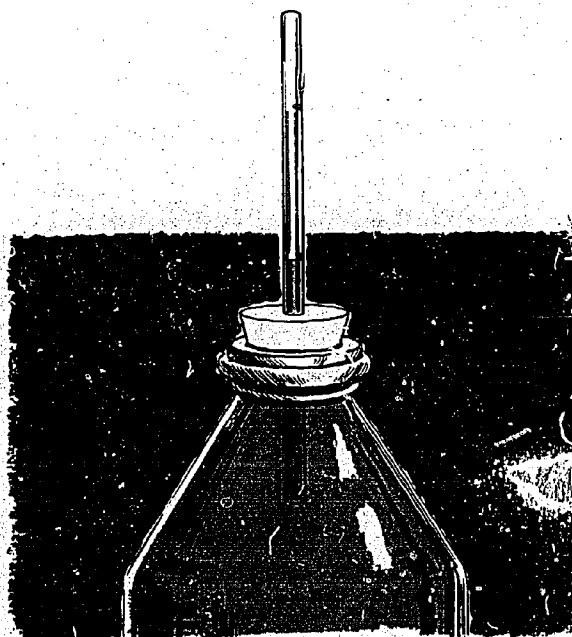

Figure IV-26

minutes later, the position of the liquid in the tube will be higher than the original position as illustrated by Figure IV-27. This change in position may be measured with a ruler.

Next, the bottle is removed from the pan of warm water and allowed to cool. The water in the tubing may not return to its original position.

If it should not, could you offer a possible explanation? Did the water change volume in this activity? How was the temperature change converted into a number? Remember what we have discussed so far about density.

We can also use a measure of the physical properties of wire to measure temperature. Take a piece of fine wire (about B & S gauge #24 or #26). About 50 cm of the wire is suspended horizontally between two firmly fixed supports, but not tightly stretched, Figure IV-28. A weight, such as a small juice can filled with water or sand is suspended from the wire so that the weight swings freely. The vertical distance from the table surface to the bottom of the weight is measured with a ruler (Figure IV-29).

A portion of the wire is then heated using a small flame from a candle, alcohol lamp or small burner. (Caution: If you

carry out this activity, use extreme care with open flames. Never allow any part of your body or portion of your clothing to come close to a flame. Girls must be especially careful with their hair.)

If the vertical height of the weight is now measured it shows the weight is lower than its original position. Next heat a larger portion of the wire by moving the flame back and forth along it slowly. Again, the height of the weight above the table top is measured. What do you predict about this measurement?

If the wire is allowed to cool, and the height of the weight is measured, how do you predict this measurement will compare with the original measurement? Be very

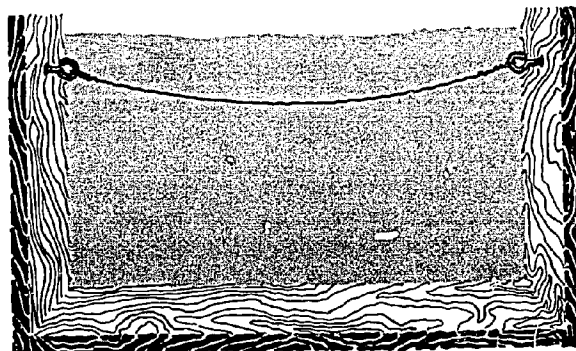

Figure IV-28

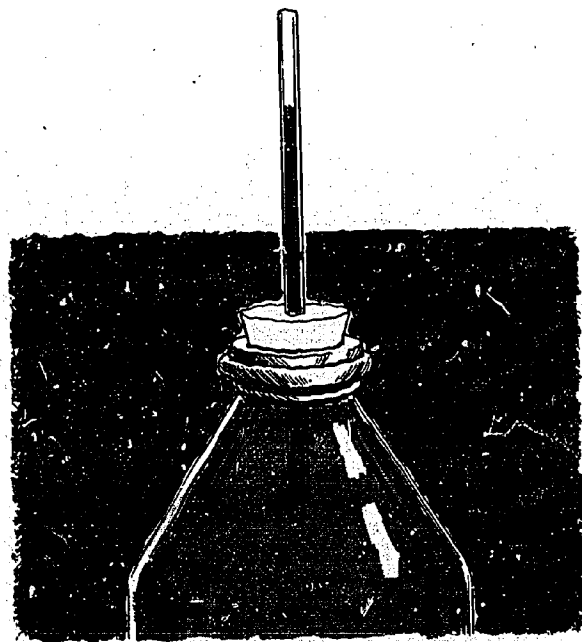

Figure IV-27

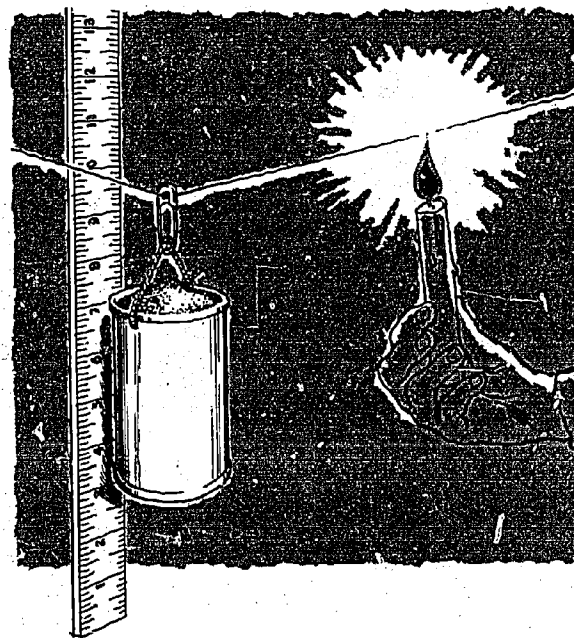

Figure IV-29

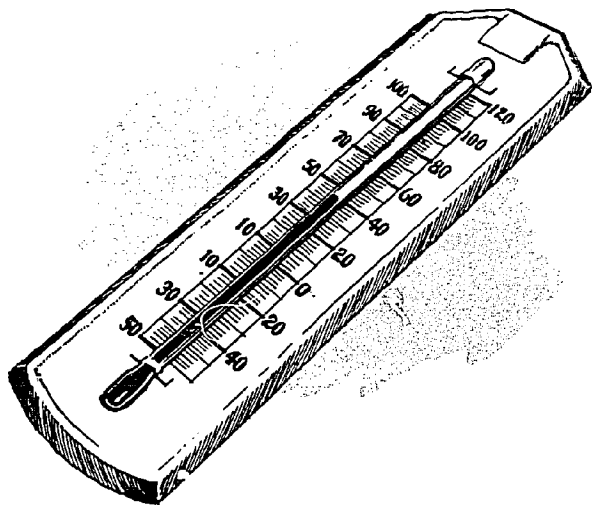

Figure IV-30

careful when you answer the next question. Consider the evidence you have available. Did the wire change volume during this activity?

Although generalizing from a small number of observations can be dangerous, it appears that a relationship has been discovered. It appears that matter expands when warmed and contracts when cooled. The danger of generalizing from so few observations will become very apparent if you substitute a long rubber band for the wire, or cool the water down to freezing. It also appears that the amount of expan-

sion or contraction is related to the amount of temperature change, so not only can temperature changes be detected, but the amount of change can be measured. Perhaps you can think of some ways to use each piece of equipment just described as a thermometer to measure temperature? What advantages or disadvantages will each have? How might these thermometers be improved?

Perhaps the most common thermometers are those constructed of a glass tube filled with a liquid, usually alcohol or mercury, Figure IV-30. Most of the liquid is contained in a bulb attached to one end of a long stem. A very fine opening, called a capillary tube extends down the center of the long stem. When the liquid expands, it is "pushed down" the capillary, and when cooled it contracts and is "pulled" back into the bulb. The total volume of the capillary is so small, that a very small change in the volume of the liquid produces a large displacement in the position of the liquid in the capillary. In this way small changes of temperature can be detected, but since the stem is usually long, these changes can be detected over a large range of temperatures.

Refinement and miniaturization of the instruments you have just investigated enable scientists of our space age to find out a great deal about the upper atmosphere without actually going there.



Chapter V

**WHAT LIGHT CAN TELL US**

## WHAT LIGHT

We can expand what we know by our ability to measure accurately. The result of thousands of years of measuring, thinking, and calculating have been saved and passed on to you. The depths of space have yielded some of their strange and impressive secrets. Much of the new description of space has been gained because we have learned to interpret the "jumbled language" of light and other electromagnetic radiation.

We have known for a long time that many forms of radiation reach Earth from outer space. Only recently have we been able to develop instruments and techniques to "crack the code." In every case we have found that methods of measurement were only good for a short time. Eventually, the objects we needed to measure were too big, too small, too close, or too far away to be measured directly. So we have had to invent indirect ways of measuring things which we cannot touch, turn, or arrange in order to make our task possible.

Fortunately, these excursions into the unknown are not so complex that only a specially trained person can have some understanding about them. You step on a scale to measure your weight, and you stand next to yard sticks to measure your height. If you measure your height and weight this way, you are measuring directly. It would not be as easy to measure



Figure V-2





the height of something as tall as Saturn V, Figure V-3. You could climb to the top of the gantry and measure one tape length at a time until you got down, but this would be difficult. It would probably be better and easier to measure this larger distance *indirectly*.

Space science had its start far back in the misty beginnings of human history. Ancient man stood alone under the splendid twinkling of the night sky and he wondered. The questions that came to his mind, stirring his curiosity, are similar to the thoughts you would have today. Questions about stars come to mind easily. How far away are they? What are they? These and all the other questions can be answered only if we *measure*. But what is there about a star that you can possibly measure?

The invention and development of the telescope has not changed *what* we can measure. Even with the 200 inch Mt. Palomar light-collector, we still measure the brightness and position of stars to obtain the fundamental measurements necessary to describe space and its contents. In addition to these two measurements, by 1800, space scientists learned how to make the light from a star give off a rainbow — its



Figure V-4

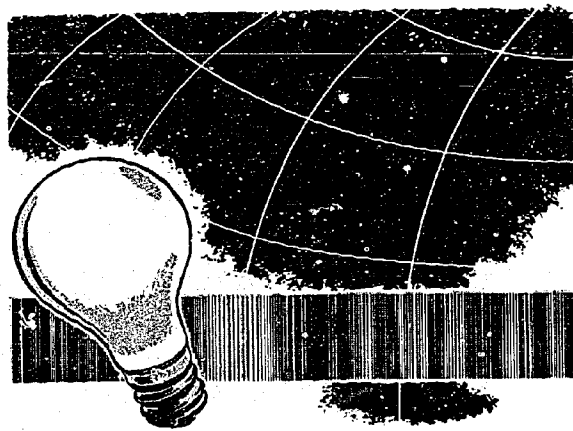

Figure V-5

spectrum. We get nothing else — just brightness, position, and spectrum, Figure V-5.

The unequal brightness of the stars is easily seen by anyone who looks at the night sky. The luminosities have great range. Some stars are so brilliant that they catch our eye immediately. Others are so dim that they are barely spots in the darkness, Figure V-6. Between these extremes we find all the other possible degrees of brightness.

About 1800 years ago Claudius Ptolemy organized a book that listed the brightness of every star visible to the ancient astronomers. The brightness of a star as seen by the unaided eye was called the *magnitude* of the star. Long before Ptolemy, it had been accepted that the brightness of a star would be classified as one of 6 different magnitudes. A first magnitude star would be extremely bright. About 20 stars were bright enough to be rated 1st magnitude. A star dimmer than 1st magnitude had a higher number such as 2nd, 3rd, 4th or 5th magnitude. Finally the stars that were barely visible were called 6th magnitude. When telescopes came into common use, the system of magnitudes had to be extended, for now astronomers were able to see many stars dimmer than the 6th magnitude.

Astronomers however were faced with a problem. They had to figure out just what 7th magnitude would be. How much dimmer than 6th magnitude would a 7th magnitude star be? In order to do this, the difference between the brightness of any of the other magnitudes had to be measured.

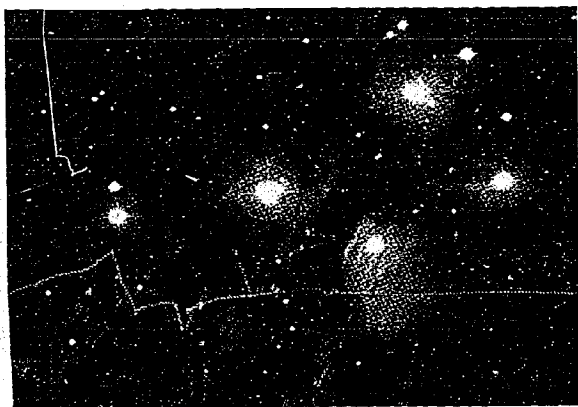

Figure V-6

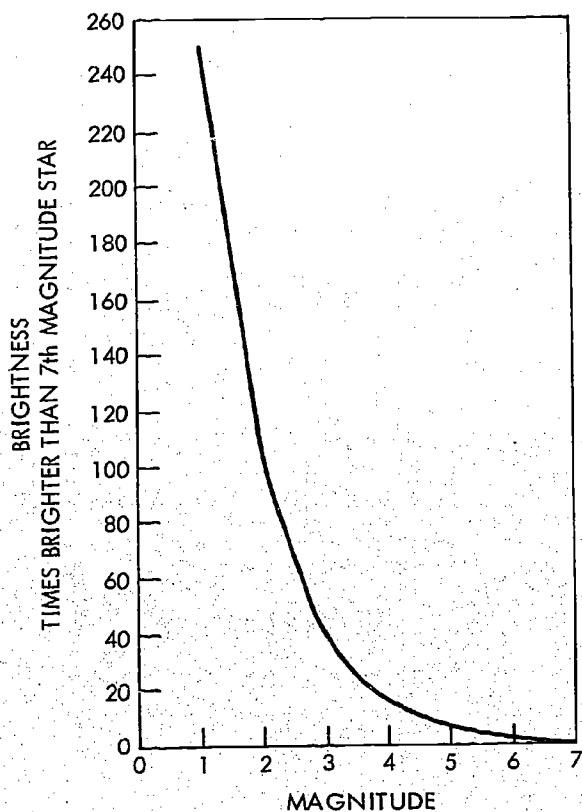

Figure V-7

In 1856 Pogson determined that this difference was 2.5. So a first magnitude star was about 2.5 times brighter than a second magnitude star. A 1st magnitude star would be  $2.5 \times 2.5$  or 6.3 times brighter than a 3rd magnitude star. Use Figure V-7 to determine how much brighter than a 7th magnitude star a 3rd magnitude star is.

Are all stars of the same brightness? If they are then the apparent differences in brightness are caused by differences in the distance between the stars and Earth. Close stars would be bright and far away stars would be dim.

It could also be that all stars are the same distance from Earth, and their difference in brightness is caused by their chemical make-up.

For a long time man did not know why some stars appear brighter than others. The answer came by studying the position of the stars, and their spectra.

Stars are moving all the time. If you go out and look at the night sky and then look again an hour later, you will see that the stars have moved. We know that this apparent movement is caused by the rotation of Earth.

The patterns of the stars, the constellations, appear to stay the same. For this reason the stars are sometimes called "fixed." In Ptolemy's book "The Almagest," he had recorded the position of the fixed stars. This was done by measuring angles.

When we look at the night sky it appears that we are standing at the center of a black dome which we call the celestial sphere. Since it does appear to be a sphere we can measure position using angles.

In order to use angular measurement you must choose a starting point. In establishing latitudes and longitudes to measure position on Earth, the Equator and the Prime Meridian have been chosen as starting points. Similarly, the extension of Earth's equator on to the sky was chosen as one starting point. Any star on this line would be on the celestial equator (Figure V-8).

The position of any star can be partially described by measuring the angle from the celestial equator to the star, as seen from Earth. The name given to this measurement is declination. Since declination can be above or below the celestial equator, it is called North (+) declination or South (-) declination (Figure V-9). But declination does not do the whole job. If a star is found at  $25^\circ$  South (-) declination, it could be anywhere on the dashed circle shown in Figure V-9.

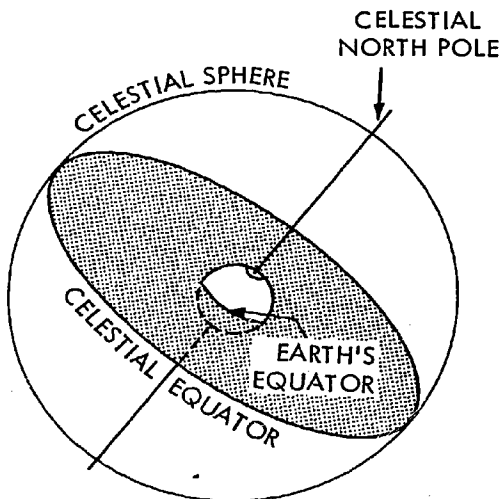

Figure V-8

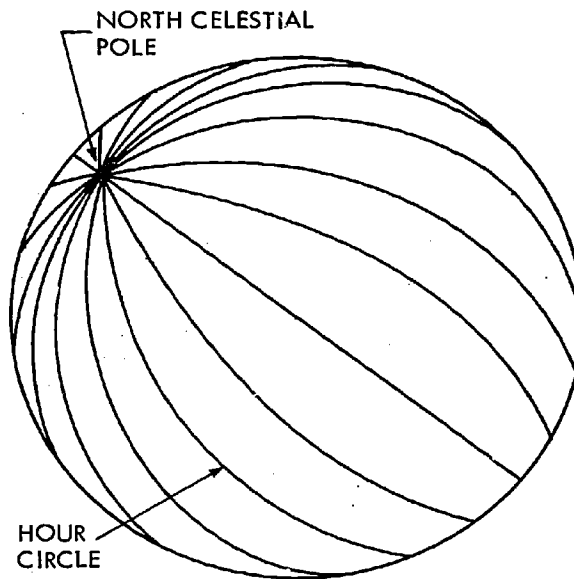

Figure V-10

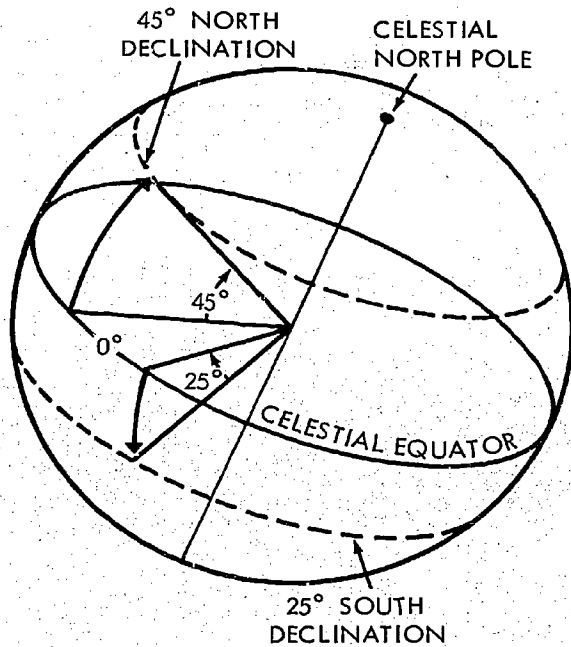

Figure V-9

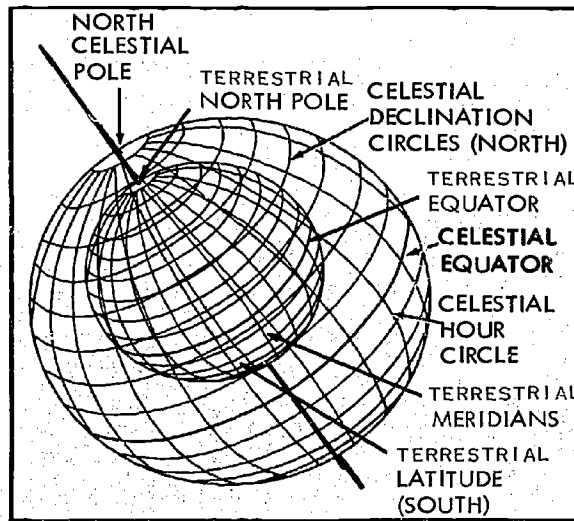

Figure V-11

A second reference line is employed to locate star position. This is done by dividing the celestial sphere into hour circles as shown in Figure V-10.

Combining these two systems of imaginary lines on the celestial sphere (Figure V-11), the hour circles correspond to earth

meridians or lines of longitude. Celestial parallels of declination correspond to terrestrial (earth) latitude.

If you imagine Figure V-10 sliced in half at the celestial equator, you have space cut up like an orange (Figure V-12). When this is done, we are able to measure angles around the celestial equator. But we need a starting point for space measurements just as we need the Prime Meridian for terrestrial measurement. Astronomers selected

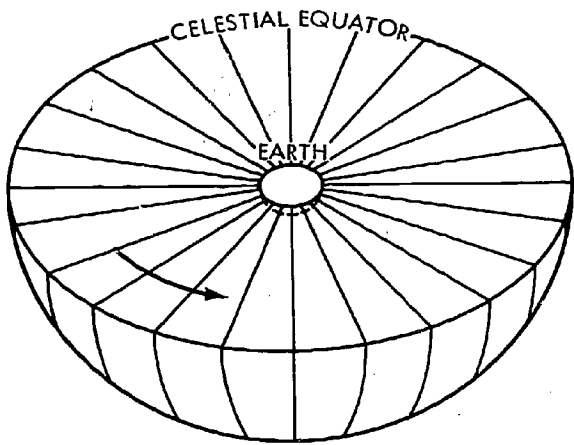

Figure V-12

the place where the sun appears to cross the celestial equator on its trip North.

There are two days each year when the sun is directly over the equator. These days are called *equinoxes* because the hours of daylight (12) and the hours of darkness (12) are equal. The equinox that marks the beginning of Northern hemisphere Spring occurs when the sun crosses the celestial equator on its way North (Figure V-13). This point is called the vernal equinox and is used as a beginning place in measuring angles eastward along the celestial equator (Figure V-14). These angles are called right ascension and are measured from the vernal equinox to the point where the hour circle of a star intersects the celestial equator.

Right ascension angles, for convenience in astronomical measurement by clocks, are also expressed by hours, minutes and seconds. Thus, a right ascension coordinate of  $15^\circ$  would be one hour of time.

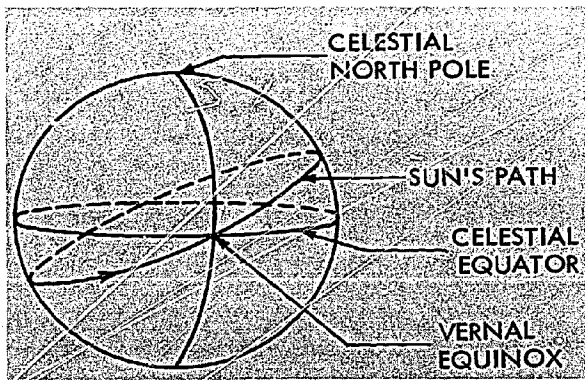

Figure V-13

RIGHT ASCENSION      DECLINATION

ALDEBARAN	$60.5^\circ$ (4h 34')	$16^\circ 26'$ NORTH
RIGEL	$75.2^\circ$ (5h 13')	$8^\circ 14'$ SOUTH
BETELGEUSE	$75.9^\circ$ (5h 53')	$7^\circ 24'$ NORTH
CASTOR	$105.5^\circ$ (7h 32')	$31^\circ 58'$ NORTH
MERAK	$165^\circ$ (11h 00')	$56^\circ 34'$ NORTH

Figure V-15

We find, then, that the position of a star can be described by giving two angles. These angles are called right ascension and declination. The position of some well known stars is given in Figure V-15. In 1718 Halley discovered that the positions of the "fixed" stars were not fixed. He found that positions of stars had changed. They were not in the places given in Ptolemy's *Almagest*. This opened a new age in astronomy. Within 20 years, the distance to a star was measured.

The light from stars can also tell us much. If we analyze it we have some idea of the composition of a star, what it is made of. When we notice the beauty of a rainbow, sunlight falling on raindrops, we are really seeing light broken into a spectrum. When light passes through triangular shaped glass, the light is broken up into a spectrum. Isaac Newton was the first to

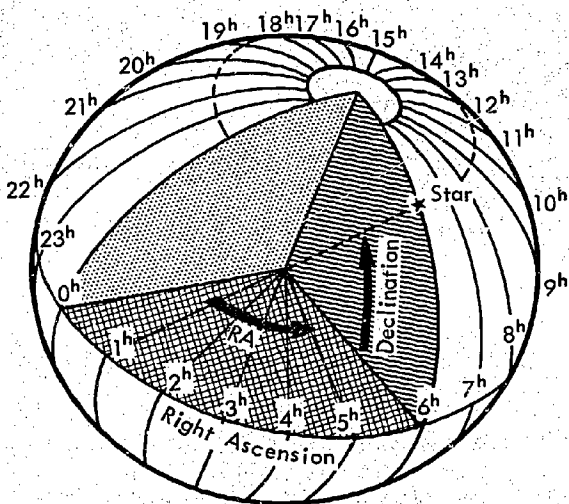

Figure V-14



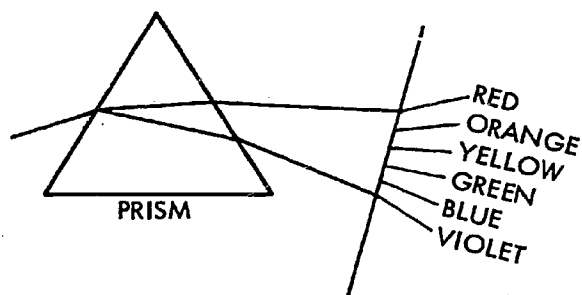

Figure V-16

investigate this. No matter how this is done, the spectra are always in the same order: red, orange, yellow, green, blue, and violet.

You can investigate this "rainbow" if you have a glass prism (Figure V-16). Better still, you can make a simple spectroscope in just a few minutes if you follow the directions below. With a spectroscope you can examine spectra of incandescent lights, fluorescent lights, sunlight, or other light sources.

The principle behind the formation of spectra is best explained by imagining that light has properties similar to waves on water. When waves come from different sources, they interfere with each other. Sometimes the light waves add together and make bright bands. At other locations they subtract from each other, producing bands of darkness. This is what happens when light goes through a replica diffraction grating.

It is one thing to read about spectra. It is far better to see one for yourself. A spectrometer can be made easily. Here is what you need:

1. **Replica diffraction grating.** This is what makes the spectrometer work. If you cannot get one in school, they can be purchased from scientific supply houses for about 25¢, or borrow one from a physics teacher.
2. **Razor blades.** A double-edge blade can be broken in half so that the two edges can be used. For safety reasons you may prefer to use two single-edge blades.
3. **Cardboard box.** It must come with a removable top. The box has to be deep enough to hold your diffraction grating. This is probably a little

over two inches. The box can be any depth more than this. The box should also be about twice as long as it is wide. A shoe-box usually does a fine job.

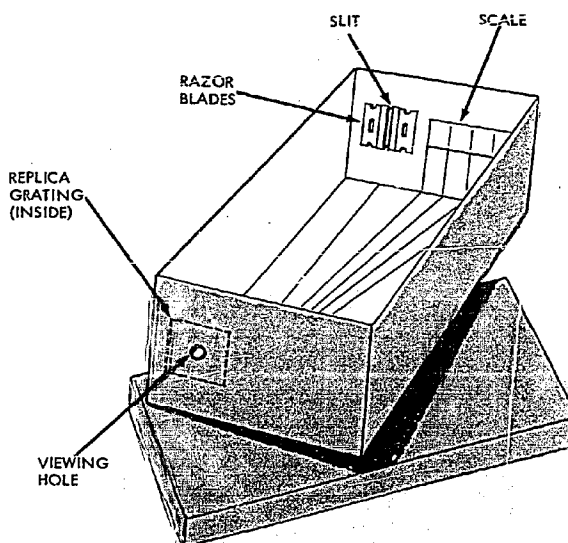

Figure V-17

Cut a slit in the far left side of the narrow end of the box. The position of the slit is shown in Figure V-17. The slit should be about 1/8 inch wide and 1 inch high. Fasten the razor blades so the slit is very narrow, less than 1/32 inch if possible. The two edges must be parallel.

Cut a circular hole about 1/4 inch in diameter in the near left corner. Make sure that the center of the hole is on a straight line with the slit at the other end. Now cover the eye hole with the replica diffraction grating. Before you tape the grating in place be sure you have it positioned properly. The rulings should be vertical. Make sure you can see a spectrum. Put the top on the box.

At this point you have a spectroscope. If you look in the eyehole, and point the slit at a light source, you will see a spectrum off to the right. But all you can do at this point is look. If you want to be able to measure, you need a scale. You can make a scale on any piece of white paper. Mark the paper at the distances shown in Figure V-18. If your spectrometer is

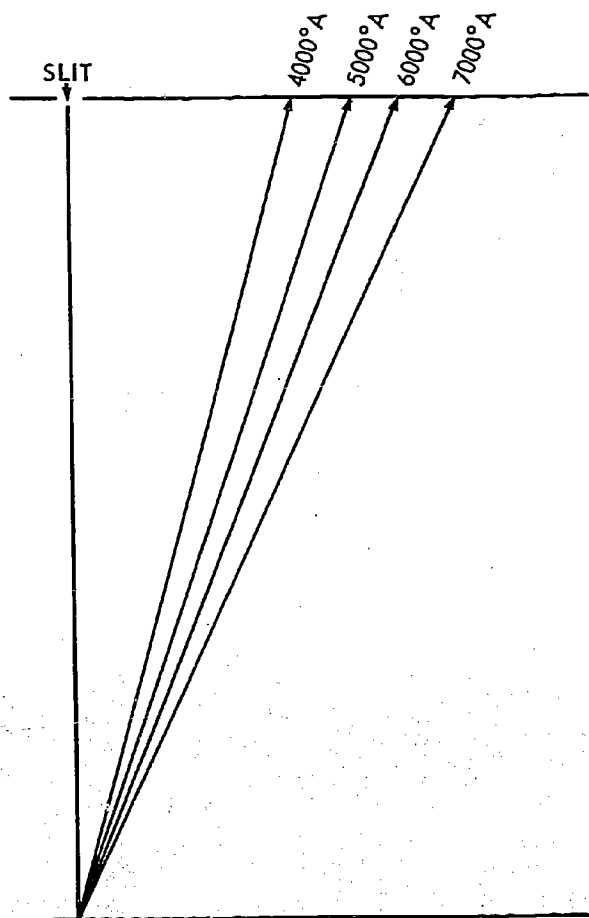

Figure V-18

larger, copy Figure V-18. Cut this out and extend the lines until they reach your scale. Then mark off your scale 4000, 5000, 6000, and 7000 Å. Remember that we measure light spectra in *angstroms*—the different wavelengths of light give us different colors. One angstrom is 0.00000001 centimeters (Chapter II). It may be too dark inside the box to see the scale. If this is true, cut a small rectangular opening, in the top of the box. This opening is cut above the scale. Now you are ready to use your spectrometer.

1. Allow light to enter the slit. **BE CAREFUL. DO NOT LOOK AT THE SUN. DO NOT ALLOW THE IMAGE OF THE SUN TO BE IN THE SLIT.** Look at the spectrum on your scale. Examine it. Notice the order of the colors. Notice if they

blend into each other. By definition, the colors are divided at the following places on your scale:

- Violet — less than 4,500 Å
- Blue — 4,500 to 5,000 Å
- Green — 5,000 to 5,700 Å
- Yellow — 5,700 to 5,900 Å
- Orange — 5,900 to 6,100 Å
- Red — more than 6,100 Å

Place a piece of red cellophane in front of the slit. Notice if any of the colors are absorbed. Try other colors of cellophane, or colored glass. In each case, compare the color of the absorber and the colors transmitted.

2. Look at a fluorescent light. Notice the bright lines on the spectrum. Notice the scale position. Look for bright green at about 5,000 Å, and yellow about 5,800 Å.
3. Burn some salt in a gas flame in a dark room. Look at the spectrum. This time you get no rainbow, instead you see a bright yellow line at 5,900 Å.

In 1814 Joseph Fraunhofer was using an improved version of the spectrometer. When he looked at sunlight, he discovered that the entire spectrum was marked by hundreds of black lines. Some were darker than others. He made a map of these lines as shown in Figure V-19. If you are interested in spectra and the abbreviations shown below get yourself a good physics book and a chemistry book and read about them.

Did you see these lines when you looked at sunlight through your spectroscope? No. Try this technique.

Take your spectrometer and fasten a piece of wax paper over the slit. The precautions given here are necessary. *Under no condition should you point the slit of your spectrometer directly at the sun.* Instead, place a piece of plate glass on top of a sheet of black paper. Line up the glass so that the image of the sun reflects from the surface. Now look at the *image* of the sun on the glass. You will probably see two kinds of black lines. Some run horizontally through the entire spectrum. These are to be ignored. They are caused by the unevenness of the razor blades in the slit. The vertical black lines are the ones that made Fraunhofer famous. The darkest

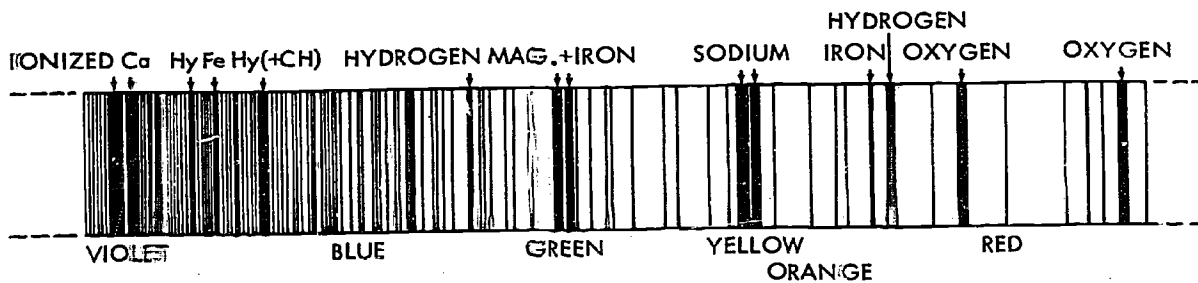

Figure V-19

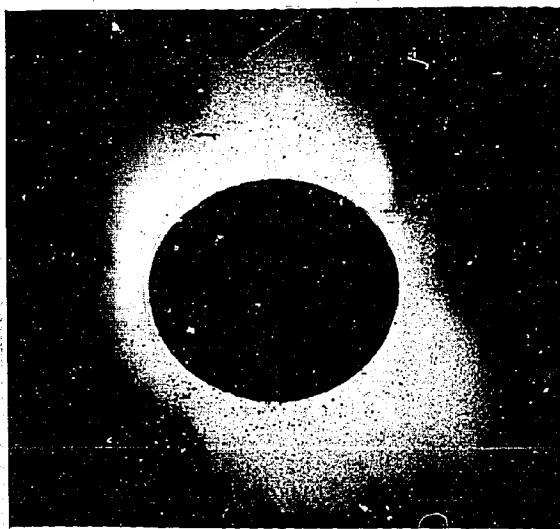

Figure V-20

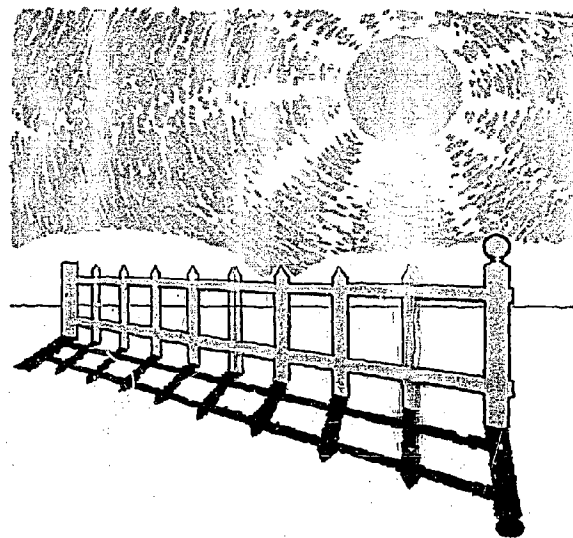

Figure V-21

and clearest should be found in the yellow and in the area where green becomes blue. It took 50 years for human minds to figure out what caused these black lines.

The sun is a sphere of hot gases surrounded by a layer of cooler gases. The surface of the sun, the part we can see, gives off the entire spectrum of light. We know that if we blot out the disc of the sun, we can see a layer that glows. This happens naturally during a solar eclipse, Figure V-20. This outer layer of gases is part of the sun's atmosphere. It is cooler than the surface. If it was hotter than the sun's surface, we would always see the atmosphere, not just during an eclipse. The different elements found in the cooler atmosphere of the sun cause the black lines in the solar spectrum by absorbing some of the colors radiated from the sun's surface.

For example, when sunlight falls on a picket fence, the fence slats absorb light from the sun. We say "the slats cast a shadow" (Figure V-21). In a way, the elements in the atmosphere of the sun act like the slats in the fence. They absorb light and make "shadows." But there is something very special about the shadows. When light strikes a wood slat, none of the visible light goes through the wood. But when the light of the sun passes through the solar atmosphere, the gases only stop certain regions of the spectrum, causing the black lines as in Figure V-19.

Why are only certain colored lines stopped by the atmosphere of the sun? The answer has to do with the nature of atoms and the arrangement of their protons, neutrons, and especially the electrons. We represent atoms with drawings like Figure

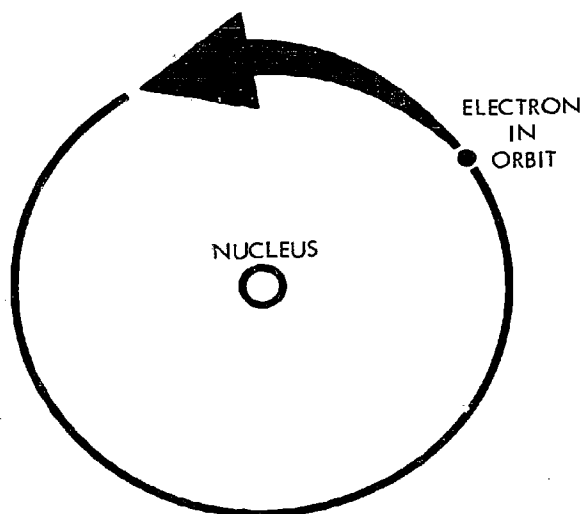

Figure V-22

V-22. This is a model of the hydrogen atom. The electron is in orbit around the proton in the nucleus. The electron remains the same distance from the nucleus, just as Earth stays about the same distance from the sun. But what would happen to the size of Earth's orbit if Earth received more energy? It would be larger. If an electron received energy, it moves away from the nucleus. If an electron loses energy, it moves toward the nucleus. Electrons can gain or lose energy by absorbing or giving off light.

In the experiments with the spectrometer, you observed the spectrum given off by heated salt. A bright yellow line was present. This line, which is really two lines close together, is caused by the electrons of the sodium atom losing energy and falling closer to the nucleus. The reason that sodium when heated has a different spectrum than any other substance is that no other atom has the same number of electrons in the same orbits as the sodium atom. So only the electrons of sodium can make the moves that give off this array of bright lines shown in Figure V-23.

Use the same set-up that produced the bright yellow sodium line. Burn salt and observe the bright yellow line at about 5900 Å on your scale. Now place a 200 watt light one or two feet behind your burning salt. This time when you look

through your spectrometer you may observe a dark line at 5900 Å.

This time the electrons are absorbing energy from the light of the bulb. Sodium electrons are gaining energy and moving away from the nucleus. This motion is the exact opposite of the fall-in that gave off the yellow light. It takes in, or absorbs, the yellow light, leaving black lines. The black lines in sunlight that Fraunhofer first noticed are caused the same way.

In 1859 Bunsen (he also invented the burner) and Kirchhoff discovered that each different element gives off its own special colors of a spectrum. No two substances have the same absorption. They all have their own set of spectral "shadows." Spectra are as good to identify elements as finger prints are to identify people. They are all different.

By studying the Fraunhofer lines in sunlight, astronomers have found 67 of the 103 elements we find on Earth on the sun. But the sun is not the only star with absorption lines in its spectrum. We can use the same methods to obtain the chemical composition of all stars which yield a spectrum.

We have seen that the only direct measurements we can make in space are those that describe the position, the brightness, and the spectrum of a star. In *Shapes of Tomorrow* of this series, you can see how we use these direct measurements to make indirect measurements describing the distance to stars and their temperatures.

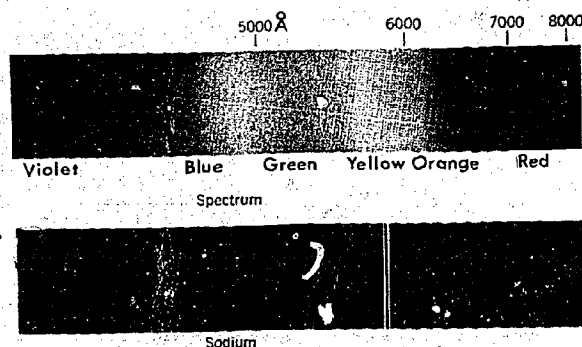

Figure V-23. A continuous spectrum at the top. A bright line spectrum of sodium below. The double line of the sodium atom falls in the yellow region at about 5,800 Å wavelength.



## TO THE FUTURE

### A Special Word for the Student

Wait! Before we close, let's pick up and dust off the heart clock we so quickly and carelessly discarded. And once more set it upon the table next to the International Standards, which are so unbelievably precise they can calibrate our new measuring instruments. Look at it pulsating next to the gleaming platinum meter so accurate that it can measure the wavelength of the orange-red line of Krypton 86, and next to the mysterious atomic clock whose vibrating crystals can measure time to the nano second... ( $10^{-9}$ ) seconds. Take another look at our heart clock that speeds up at times of stress and slows down during periods of rest. Perhaps, in a way, it represents the energy, the work, and the minds of the men and women who created these very accurate instruments for measuring distances and times that we cannot ever hope to experience or "feel."

Next time you sit in front of the television set and watch the launching of a space vehicle, just for a second think of our heart clock. As the background voice calls out; 5, 4, 3, 2, 1 - Ignition - Lift off, "all systems go," and finally "conditions nominal, we have another successful space flight." Instead of thinking only about the flash of flame, the billowing clouds of smoke, and the arching beauty of the gleaming rocket soaring across the sky, give a thought to the people who have worked years to make this launch a success.

Think of the project group which has worked for 2, 3, or more years in order to bring all the experiments and components together for this instant.

We could also think of the experts of the world-wide tracking networks ready and waiting for the first "beep" of the signaling satellite. We may think of the stress engineer, who analyzed, reduced, and rebuilt each supporting structure to tolerances only the computer could predict; the draftsman who designed; the engineer who tested; the mathematician who calculated; the machinist who drilled and ground; the optician who calibrated the lenses; and the secretary who filed and typed; these are the people who made this all possible and whose hearts speed up a little at the approach of the launch window. Listen carefully to the sounds of outer space, listen to the countdown of Freedom 7, and the launch of America's first man to orbit Earth. In the midst of whirling computers, spinning tapes, and crackling intercoms, we hear and "feel" the quickening pulse of the human heart.

Look up and see Echo, Tiros, Apollo, OGO, and many other space explorers as brilliant points in the starry field, announcing the achievements and hopes of the human mind.

No, our International Heart Clock is not a worthless standard. It represents Man in the Space Age—now ending its first decade.

*The material as presented in this publication is representative of the judgments of the authors and does not express the official policy of the Department of Health, Education and Welfare.*



**GLOSSARY  
OF  
SPACE RELATED TERMS**

## A

**Absorption** – The process in which incident electromagnetic radiation is retained by a substance.

**Absorption Lines** – The pattern of dark spectral lines against the background of a bright continuous spectrum: produced by a cooler gas absorbing energy from a hotter source behind it.

**Altitude** – The height of a position or object above sea level: (of a star) – the angle from the horizon to a star measured along a vertical circle.

**Anemometer** – A weather instrument used to measure wind speed.

**Angle** – The intersection of two lines with a common end point.

**Angstrom (Å)** – A unit of length, used chiefly in expressing short wavelengths,  $10^{-8}$  centimeters.

**Aphelion** – That orbital point farthest from the sun when the sun is the center of attraction. That point nearest the sun is called "perihelion." The aphelion of the earth is  $1.520 \times 10^{18}$  cm from the sun.

**Apogee** – In an orbit about the earth, the point at which the satellite is farthest from the earth; the highest altitude reached by a sounding rocket.

**Astronomical Unit (abbr AU)** – In the astronomical system of measures, a unit of length usually defined as the distance from the Earth to the Sun, approximately 92,900,000 statute miles or 14,960,000 kilometers. It is more precisely defined as the unit of distance in terms of which, in Kepler's Third Law,  $n^2 a^3 = k^2 (1 + m)$ , the semimajor axis  $a$  of an elliptical orbit must be expressed in order that the numerical value of the Gaussian constant,  $k$ , may be exactly 0.01720209895 when the unit of time is the ephemeris day.

In astronomical units, the mean distance of the Earth from the Sun, calculated from the observed mean motion  $n$  and adopted mass  $m$  is 1.00000003.

**Atmosphere** – The envelope of air surrounding the earth; also the body of gases surrounding or comprising any planet or other celestial body.

**Atom** – The smallest particle of an element that exhibits the properties of the element.

**Atomic Clock** – A precision clock that depends for its operation on an electrical oscillator (as a quartz crystal) regulated by the natural vibration frequencies of an atomic system (as a beam of cesium atoms or ammonia molecules).

**Axis** – (pl. axes) 1. A straight line about which a body rotates, or around which a plane figure may rotate to produce a solid; a line of symmetry. 2. One of a set of reference lines for certain systems of coordinates.

## B

**Babylonia** – An ancient empire in SW Asia, in the lower Euphrates valley. The period of greatness, 2800 BC to 1750 BC.

**Barometer** – A common instrument used to measure the pressure exerted by the earth's atmosphere. Includes the mercury and aneroid barometers.

**Brightness** – A measure of the luminosity of a body.

**Bunsen, Robert Wilhelm** – 1811 - 99. A German chemist.

## C

**Camera Angle** – A major characteristic of a camera that limits the view of a particular camera by a predetermined setting.

**Celestial Equator** – The great circle on the celestial sphere midway between the celestial poles.

**Clepsydra** – A device for measuring time by the regulated flow of water or mercury through a small opening.

**Compression** – The half of a sound wave in which air or medium is compressed to greater than its normal density.

## D

**Declination** – The angular distance of an object north or south of the celestial equator and measured in degrees along the object's hour circle.

**Degree** – A unit on a suggested scale of measurement. Used to describe the measurement of temperature, time, distance, and angles.

**Density** – The mass of a substance per unit volume.

**Diffraction Grating** — A metal or plastic plate containing ruled parallel lines used to bend or spread light waves after the light has passed through a narrow slit in an opaque body.

## E

**Eccentricity** — The amount by which a figure deviates from a circular form, as an orbit.

**Echo-I** — A large plastic balloon with a diameter of 100 feet launched on August 12, 1960 by the United States and inflated in orbit. It was launched as a passive communications satellite, to reflect microwaves from a transmitter to a receiver beyond the horizon.

**Ecliptic** — The apparent annual path of the sun among the stars; the intersection of the plane of the earth's orbit with the celestial sphere.

This is a great circle of the celestial sphere inclined at an angle of about  $23^{\circ} 27'$  to the celestial equator.

**Electromagnetic Radiation** — Energy propagated through space or through material media in the form of an advancing disturbance in electrical and magnetic fields existing in space or in the media. Also called simply "radiation."

**Electron** — The subatomic particle that possesses the smallest possible electric charge.

The term "electron" is usually reserved for the orbital particle whereas the term "beta particle" refers to a particle of the same electric charge inside the nucleus of the atom.

**Ellipse** — A plane curve constituting the locus of all points the sum of whose distances from two fixed point called "foci" is constant; an elongated circle.

The orbits of planets, satellites, planetoids, and comets are ellipses; center of attraction is at one focus.

**Equinoxes** — The two points on the celestial sphere where the celestial equator intersects with the ecliptic.

**Explorer** — A series of scientific satellites designed to explore outer space.

## F

**Foucault, Jean Bernard Leon** — 1819 - 68, French Physicist.

**Fraunhofer, Joseph von** — 1787 - 1826, German optician and physicist.

**Fraunhofer Lines** — Dark lines crossing the continuous spectrum of the sun or similar source. The lines result from the absorption of some wavelengths by layers of cooler gases.

**Freedom 7** — The first American manned space flight. Piloted by Alan B. Shepard on May 5, 1961. This suborbital mission lasted 19 minutes and reached an altitude of 116 miles.

**Frequency** — The number of waves leaving or arriving at a position per unit of time.

**Friction** — The force that resists the sliding or motion of one object in contact with another.

## G

**Galileo** — 1564 - 1642, Italian physicist and astronomer.

**Geiger Counter** — An instrument for detecting and counting ionizing particles, used to determine the degree of radioactivity.

**Gnomon** — A vertical shaft or stick used for determining the altitude of the sun or the position of a place by noting the length of a shadow. Used as part of a sundial.

**Gravity** — The force imparted by the earth to a mass on, or close to the earth. Since the earth is rotating, the force observed as gravity is the resultant of the force of gravitation and the centrifugal force arising from this rotation.

**Grid System** — A system of lines used to determine dimension or direction by means of a scale.

## H

**Halley, Edmund** — 1656 - 1742, British Astronomer.

**Hour Angle** — The angle between the celestial meridian and the hour circle of a celestial object.

**Huygens, Christian** — 1629 - 95, Dutch mathematician, physicist, and astronomer.



**Hypothesis** — An idea or guess proposed as an explanation for the occurrence of phenomena.

#### I

**Inertia** — The tendency of an object, as a result of its mass, to continue in motion at a constant speed or to remain at rest.

#### J

#### K

**Kilo** — A prefix meaning "thousand" used in the metric or other scientific systems of measurement.

**Kirchoff, Gustav Robert** — 1824 - 87, German physicist.

#### L

**Latitude** — The angle from earth's equator to a point on Earth as measured along a terrestrial meridian.

**Light Year** — The distance light travels in one year at rate of 186,000 miles per second (300,000 kilometers per second). Equal to  $5.9 \times 10^{12}$  miles.

**Longitude** — The angle between the Prime meridian and the terrestrial meridian through a point on earth.

**Luminosity** — The brightness of a star or object as compared to a standard such as the sun.

**Lunar Eclipse** — The partial or total obscuration of the sun's light on the moon, caused by the passage of the earth between the sun and moon.

#### M

**Mariner** — The initial unmanned exploration of the planets is being conducted in the United States under the Mariner program. Mariner 2, launched August 26, 1962, passed within 21,000 miles of Venus on December 14, 1962, and radioed to earth information concerning the infrared and microwave emission of the planet, and the strength of the planet's magnetic field.

On July 14, 1965, Mariner IV snapped the first close-up pictures ever taken of another planet as it sped by Mars at distances ranging from 10,500 miles to 7,400 miles. Beside providing close-up

photographs of Mars and scientific data pertaining to the physical characteristics, Mariner IV confirmed the original finding of Mariner II relative to interplanetary space. Future flyby missions to both Venus and Mars are planned.

**Mass** — The measure of the amount of matter in a body, thus its inertia. The weight of a body is the force with which it is attracted by the earth.

**Mega** — A prefix meaning multiplied by one million as in "megacycles."

**Meridian** — A great circle which passes through the zenith directly north and south.

**Micro** — 1. A prefix meaning divided by one million. 2. A prefix meaning very small as in "micrometeorite."

**Micrometeorite** — A very small meteorite or meteoritic particle with a diameter in general less than a millimeter.

#### N

**Nanosecond (Abbr nsec)** —  $10^{-9}$  second. Also called "millimicrosecond."

**NASA (Abbr)** — National Aeronautics and Space Administration.

**Neutron** — A subatomic particle with no electric charge, and with a mass slightly more than the mass of the proton.

Protons and neutrons comprise atomic nuclei; and they are both classed as nucleons.

**Newton, Sir Isaac** — 1642 - 1727, British scientist, mathematician, and philosopher.

**North Pole** — The point at which northern end of earth's axis intersects the surface of earth.

**Nucleus** — The positively charged core of an atom with which is associated practically the whole mass of the atom but only a minute part of its volume.

A nucleus is composed of one or more protons and an approximately equal number of neutrons.

#### O

**OGO** — The Orbiting Geophysical Observatories are designed to broaden our knowledge of Earth and space and how the sun influences and affects both. OGO is designed to carry about 20 different experi-



ments. The advantage of OGO is that it makes possible the observation of numerous phenomena simultaneously for prolonged periods of time. OGO I was launched September 4, 1964 and OGO II October 14, 1965.

**Orbit** — 1. The path of a body or particle under the influence of a gravitational or other force. For instance, the orbit of a celestial body is its path relative to another body around which it revolves.  
2. To go around the earth or other body in an orbit.

**Orbital Elements** — A set of 7 parameters defining the orbit of a satellite.

## P

**Pendulum** — An object suspended from a fixed point able to move back and forth by the action of gravity and momentum.

**Perigee** — That orbital point nearest the earth when the earth is the center of attraction.

That orbital point farthest from the earth is called "apogee." Perigee and apogee are used by many writers in referring to orbits of satellites, especially artificial satellites, around any planets or satellite, thus avoiding coinage of new terms for each planet and moon.

**Perihelion** — That orbital point nearest the sun when the sun is the center of attraction.

That orbital point farthest from the sun is called "aphelion." The term "perihelion" should not be confused with "parhelion," a form of halo.

**Period** — The interval needed to complete a cycle. Often used in reference to time of complete orbit.

**Pico** — A prefix meaning divided by one million million.

**Precession** — Change in the direction of the axis of rotation of a spinning body, as a gyroscope, when acted upon by a torque.

The direction of motion of the axis is such that it causes the direction of spin of the gyroscope to tend to coincide with that of the impressed torque. The horizontal component of precession is called "drift," and the vertical component is called "topple."

**Pressure (Abbr p)** — As measured in a vacuum system, the quantity measured at a specified time by a so-called vacuum gage, whose sensing element is located in a cavity (gage tube) with an opening oriented in a specified direction at a specified point within the system assuming a specified calibration factor.

**Primary Body** — The spatial body about which a satellite or other body orbits, or from which it is escaping, or towards which it is falling.

The primary body of the moon is the earth; the primary body of the earth is the sun.

**Proton** — A positively-charged subatomic particle having a mass slightly less than that of a neutron but about 1847 times greater than that of an electron. Essentially, the proton is the nucleus of the hydrogen isotope  $1H^1$  (ordinary hydrogen stripped of its orbital electron). Its electric charge ( $+4.8025 \times 10^{-10}$  esu) is numerically equal, but opposite in sign, to that of the electron.

Protons and neutrons comprise atomic nuclei; they are both classed as "nucleons."

**Protractor** — An instrument, graduated in degrees of arc, for plotting or measuring angles.

**Proxima Centauri** — A star in the constellation Centaur at a distance of about 4.3 light years.

**Ptolemy, Claudius** — 127 - 151 AD, Greek mathematician, astronomer, and geographer.

## Q

## R

**Radiometer** — A device used to measure some property of electromagnetic radiation. In the visible and ultraviolet regions of the spectrum, a photocell or photographic plate may be thought of as a radiometer. In the infrared, solid state detectors such as photoconductors, lead sulfide cells and thermocouples are used, while in the radio and microwave regions, vacuum tube receivers, often with parametric or maser preamplifiers, are the most sensitive detectors of electromagnetic radiation.

**Radiosonde** — A balloon-borne instrument for the simultaneous measurement and transmission of meteorological data.

**Ranger** — A program designed to send back to Earth a number of high-resolution pictures of the Moon's surface, and to show features at least one-tenth to one-hundredth the size of features discernible from Earth. Ranger VII was successful on July 31, 1964. Ranger VIII was successful in meeting its objectives on February 20, 1965 and Ranger IX on March 24, 1965. More than 17,000 high resolution photographs were received from the three satellites.

**Rarefaction** — The half of a sound wave in which the air or medium is expanded to less than its normal density.

**Refraction** — The bending of a beam of light as it passes from one medium into another in which the index of refraction is different.

**Relative Humidity (Abbr rh)** — The (dimensionless) ratio of the actual vapor pressure of the air to the saturation vapor pressure.

**Rendezvous** — The event of two or more objects meeting at a preconceived time and place.

A rendezvous would be involved, for example, in servicing or resupplying a space station.

**Resolving Power** — The ability of a telescope or lens system to separate objects which are very close together.

**Resonance** — 1. The phenomenon of amplification of a free wave or oscillation of a system by a forced wave or oscillation of exactly equal period. The forced wave may arise from an impressed force upon the system or from a boundary condition. The growth of the resonant amplitude is characteristically linear in time. 2. Of a system in forced oscillation, the condition which exists when any change, however small, in the frequency of excitation causes a decrease in the response of the system.

**Reticle** — The crosses located on the grid system of the Ranger cameras. Used to determine distance and direction by scale.

**Revolution** — Motion of a celestial body in its orbit; circular motion about an axis usually external to the body.

In some contexts the terms "revolution" and "rotation" are used interchangeably; but with reference to the motions of a celestial body, "revolution" refers to the motion in an orbit or about an axis external to the body, while "rotation" refers to motion about an axis within the body. Thus, the earth revolves about the sun annually and rotates about its axis daily.

**Right Ascension** — The angle as measured along the celestial equator from the vernal equinox eastward to the hour circle of the celestial object.

**Rotation** — Turning of a body about an axis within the body, as the daily rotation of the earth. See Revolution.

## S

**Satellite** — 1. An attendant body that revolves about another body, the primary; especially in the solar system, a secondary body, or moon, that revolves about a planet. 2. A man-made object that revolves about a spatial body, such as an Explorer I or a TIROS satellite orbiting about the earth.

**Saturn** — A family of launch vehicles developed by the U.S. to ultimately place three men on the moon.

**Scale** — A reduction or increase in size or dimension of an object in proportion resulting in a model.

**Sidereal Day** — The time or interval between two consecutive meridian crossings of a star.

**Solar Eclipse** — The partial, total, or annular obscuration of the sun's light on the earth by the passage of the moon between earth and the sun.

**Solar Wind** — A stream of protons constantly moving outward from the sun. Synonymous with solar plasma.

**Solar System** — The group of planets and their satellites, and other celestial objects which are under the gravitational influence of the sun.

**Sounding Rocket** — A rocket designed to explore the atmosphere within 4,000 miles of the earth's surface.

**Space** — 1. Specifically, the part of the universe lying outside the limits of the earth's atmosphere. 2. More generally,

the volume in which all spatial bodies, including the earth, move.

**Spacecraft** — Devices, manned or unmanned, which are designed to be placed into an orbit about the earth or into a trajectory to another celestial body.

**Spectrometer** — An instrument which measures some characteristics such as intensity, of electromagnetic radiation as a function of wavelength or frequency.

**Spectrum** — 1. In physics, any series of energies arranged according to wavelength (or frequency); specifically, the series of images produced when a beam of radiant energy, such as sunlight, is dispersed by a prism or a refraction grating. 2. Short for "electromagnetic spectrum" or for any part of it used for a specific purpose as the 'radio spectrum' (10 kilocycles to 300,000 megacycles).

**Star Transit** — The passage of a star across the celestial meridian.

**Sundial** — An instrument for indicating the time of day from the position of a shadow cast by the sun.

**Surveyor** — The United States program for the scientific exploration of the surface and subsurface of the moon. Surveyor was designed to soft land on the moon and explore the physical, chemical, and mineralogical properties at the landing site. This information was relayed back to Earth by means of extremely high resolution photographs. These pictures revealed lunar particles a few centimeters in size.

The Surveyor missions:

Surveyor I	June 1, 1966	
Surveyor II	September 20, 1966	Unsuccessful
Surveyor III	April 19, 1967	
Surveyor IV	July 16, 1967	Unsuccessful
Surveyor V	September 10, 1967	
Surveyor VI	November 11, 1967	
Surveyor VII	January 10, 1968	

The successful Surveyor missions have returned to Earth thousands of photographs of the lunar surface as well as classic photographs of Earth.

## T

**Telescope** — An optical or radio instrument used to observe celestial objects.

**Temperature** — A measure of the average energy of motion of the molecules of a substance.

**Thermometer** — Any instrument used to measure the expansion and contraction of a substance due to changes in the motion of molecules.

**TIROS (Television Infra Red Observation Satellite)** — A series of United States meteorological satellites designed to observe the cloud coverage of the earth and measure the heat radiation emitted by the earth in the infrared.

**Troposphere** — That portion of the atmosphere from the earth's surface to the tropopause; that is, the lowest 10 to 20 km of the atmosphere. The troposphere is characterized by decreasing temperature with height, appreciable vertical wind motion, appreciable water vapor content, and weather. Dynamically, the troposphere can be divided into the following layers: surface boundary layer, Ekman layer, and free atmosphere.

## U

## V

**Vanguard I** — Launched in 1958, analysis of the orbit this satellite revealed that Earth is not symmetrically oblate, but bulges in the southern hemisphere.

**Vernier Scale** — A movable, graduated scale, used for the measuring of fractional units of the primary scale.

**Volume** — The size or measure of space or matter in three dimensions.

## W

**Wavelength** — The distance from one point on a wave to the corresponding point on the next wave.

**Weight** — The force with which an earth-bound body is attracted toward the earth.

**Weightlessness** — A condition in which no acceleration, whether of gravity or other force, can be detected by an observer within the system in question.

Any object falling freely in a vacuum is weightless, thus an unaccelerated satellite orbiting the earth is "weightless" although gravity affects its orbit. Weightlessness can be produced within the atmosphere in aircraft flying a parabolic flight path.

X

Y

Z

**Zenith** — That point on the celestial sphere vertically overhead. The point  $180^\circ$  from the zenith is called the "nadir."

## AN AEROSPACE BIBLIOGRAPHY

- Abell, George, *Exploration of the Universe*. New York: Holt, 1966.
- Adler, Irving, *Seeing the Earth from Space*. New York: Day, 1962.
- Asimov, Isaac, *The Double Planet*. New York: Abelard-Schuman, 1960.
- \_\_\_\_\_, *Satellites in Outer Space*. New York: Random, 1964.
- Astronauts Themselves, The, *We Seven*. New York: Simon & Schuster, 1962.
- \_\_\_\_\_, *Aviation Weather for Pilots and Flight Operation Personnel*. Washington: Superintendent of Documents, 1965.
- Bell, Joseph N., *Seven Into Space*. New York: Hawthorn, 1960.
- Bergaust, Erik, *Reaching for the Stars*. New York: Doubleday, 1961.
- Blair, Thomas A. and Robert G. Fite, *Weather Elements*. Englewood Cliffs, N.J.: Prentice Hall, 1965.
- Cantylaar, George, *Your Guide to the Weather*. Cranbury, N.J.: A. S. Barnes Co., 1964.
- Chester, Michael, *Rockets and Spacecraft of the World*. New York: Norton, 1964.
- Day, John H., *The Science of Weather*. Reading, Mass.: Addison-Wesley, 1966.
- Egan, Philip, *Space for Everyone*. Chicago: Rand McNally, 1961.
- Frutkin, Arnold W., *International Cooperation in Space*. Englewood Cliffs, N.J.: Prentice, 1965.
- Gamow, George, *Gravity*. New York: Doubleday, 1962.
- Gatland, K. W. editor, *Spaceflight Today*. Fallbrook, Cal.: Aero, 1964.
- Glasstone, Samuel, *Sourcebook on Space Sciences*. Princeton, N.J.: VanNostrand, 1965.
- Goddard, Robert H., *Rockets*. New York: American Rocket Society, 1946. (Reprint of 1919 and 1935 Smithsonian Reports)
- Hawkins, Gerald S., *Splendor in the Sky*. New York: Harper & Row, 1961.
- Hicks, Clifford B., *The World Above*. New York: Holt, 1965.
- Hoyle, Fred, *Astronomy: A History of Man's Investigation of the Universe*. New York: Doubleday, 1962.
- \_\_\_\_\_, *Of Men and Galaxies*. Seattle: University of Washington, 1964.
- Huffer, Charles M. and others, *An Introduction to Astronomy*. New York, 1967.
- Ley, Willy, *Rockets, Missiles, and Space Travel*. New York: Viking Press, 1961.
- Longstreth, T. Morris, *Understanding the Weather*. New York: Collier Books, 1962.
- Mehrens, H. E., *The Dawning of the Space Age*. Ellington AFB, Texas: Civil Air Patrol, 1963.
- Meitner, John G. editor, *Astronautics For Science Teachers*. New York: Wiley, 1965.
- \_\_\_\_\_, *Meteorology for Army Aviation*. Washington: Superintendent of Documents, 1963.
- Moore, Patrick, *Guide to Mars*. New York: Macmillan, 1961.
- \_\_\_\_\_, *A Guide to the Planets*. New York: Norton, 1960.
- \_\_\_\_\_, *Picture History of Astronomy*. New York: Grosset, 1961.
- \_\_\_\_\_, *The Solar System*. New York: Criterion, 1961.
- Newlon, Clarke, *Famous Pioneers in Space*. New York: Dodd, Mead, 1963
- Pickering, James S., *Astronomy for Amateur Observers*. New York: Fawcett, 1960.
- Pothecary, I.J.W., *The Atmosphere in Action*. New York: St. Martin's Press, 1965.
- Richardson, Robert S., *Astronomy in Action*. New York: McGraw-Hill, 1962.
- Riehl, Herbert, *Introduction to the Atmosphere*. New York: McGraw-Hill, 1965.
- \_\_\_\_\_, *Space Science Series*, 14 books, New York: Holt, 1965.
- Al'endt, Myrl H., *The Mathematics of Space Exploration*.
- Emme, Eugene M., *A History of Space Flight*.
- Faget, Max, *Manned Space Flight*.
- Gardner, Marjorie H., *Chemistry in the Space Age*.
- Goodwin, Harold Leland, *The Images of Space*.
- Henry, James P., *Biomedical Aspects of Space Flight*.
- Hunter II, Maxwell W., *Thrust Into Space*.
- Hymoff, Edward, *Guidance and Control of Spacecraft*.
- Jaffe, Leonard, *Communications in Space*.
- Naugle, John E., *Unmanned Space Flight*.
- Stern, Phillip D., *Our Space Environment*.
- Sutton, Richard M., *The Physics of Space*.
- Wedger, Jr., William K., *Meteorological Satellites*.



- Young, Richard S., *Extraterrestrial Biology*.
- Stine, G. Harry, *A Handbook of Model Rocketry*. Chicago: Follett, 1965.
- Thompson, Phillip and Robert O'Brien, *Weather*. Morristown, N.J.: Silver Burdett, 1965.
- Trinklein, F. E. and C. M. Huffer, *Modern Space Science*. New York: Holt, 1961.
- Vaeth, J. Gordon, *Weather Eyes in the Sky*. New York: Ronald, 1965.

#### SELECTED REFERENCES

- \_\_\_\_\_, *Aerospace Age Dictionary, The*, Clarke Newton, compiler. New York: Watts, 1965.
- \_\_\_\_\_, *Aerospace Education Bibliography*, 3rd Edition, EP-35. Washington: Superintendent of Documents.
- \_\_\_\_\_, *LaRousse Encyclopedia of Astronomy*, Lucien Budaux and G. De-Vaucouleurs, editors, New York: Putnam, 1962.
- Moser, Beta C., *Space-Age Acronyms*. New York: Plenum, 1964.

#### PERIODICALS

- Aviation Week and Technology*. Weekly. c/o Fulfillment Manager. PO Box 430, Highstown, N.J. 08520. \$8 per year.
- Technology Week*. Weekly. American Aviation Publications, 1001 Vermont Avenue, N.W., Washington, D.C. 20005. \$5 per year.
- Review of Popular Astronomy*. Six times a year. Sky Map Publications, 214 South Bemiston, St. Louis, Missouri 63105. \$4 per year.
- Sky and Telescope*. Monthly. Sky Publishing Corporation, 49-51 Bay State Road, Cambridge, Mass. 02138. \$6 per year.
- Skylights*. 9 times a year. National Aerospace Education Council, 616 Shoreham Building, 806 15th Street, N.W., Washington, D.C.
- Spaceflight*. 6 times a year. Sky Publishing Corporation, 49-51 Bay State Road, Cambridge, Mass. 02138. \$3.50 per year.

#### OTHER BOOKS OF THIS SERIES

- \_\_\_\_\_, *What's Up There*. Washington: Superintendent of Documents, 1964.
- \_\_\_\_\_, *From Here, Where*. Washington: Superintendent of Documents, 1965.
- \_\_\_\_\_, *Shapes of Tomorrow, The*. Washington: Superintendent of Documents, 1967.

## INDEX

- A**  
Aerobee, 88  
Albategnius, 47  
Almagest, 101, 103  
Alphonsus, 47, 49  
anemometer, 85  
angstrom, 19, 25, 105  
angular degrees, 8  
aphelion, 31, 40-42  
apogee, 42, 43  
Apollo, 26  
apparent motion, 8  
astronomical unit, 40  
  measurement of, 40, 41  
Atlas of the Moon, 61  
atmosphere, 84  
  clouds, 85  
  Mars, 74  
  samples, 82  
  troposphere, 81  
  upper, 81  
atmospheric density, 88-91  
atom, 107  
  electron, 107  
  neutron, 107  
  nucleus, 107  
  proton, 107  
atomic clock, 109  
axis, 6
- B**  
Babylonia, 4  
barometer, 83, 85  
binary number, 73, 74  
brightness, 100  
Bunsen, 107
- C**  
calendar, 4  
  lunar, 5  
celestial equator, 101-103  
clepsydra, 10  
clock,  
  atomic, 107  
  electrical, 21  
  hour glass, 10  
  mechanical, 10, 12  
  shadow, 8  
  sundial, 8  
  water, 10, 21  
clouds, 75-77, 85  
compression, 71-73  
crescent moon, 32-37  
Crookes radiometer, 85
- D**  
declination, 101-103  
density, 85-96  
diffraction grating, 104, 105  
direct measurement, 38, 99  
drop time, 21
- E**  
Earth,  
  altitude, 12  
  aphelion, 31, 40-42  
  axis, 6, 12, 13, 32  
  density, 12  
  eccentricity, 40-43  
  Equator, 13, 101  
  latitude, 10, 102  
  longitude, 102  
  North Pole, 13, 27  
  orbit, 7, 32, 40  
  perihelion, 31, 40-42  
  phases, 7  
  Prime Meridian, 101, 102  
  revolution, 7, 31  
  rotation, 4, 7, 10  
  seasons, 7  
eccentricity, 40-43  
Echo I, 3, 42  
eclipse, 41  
Egypt, 4  
electrical clock, 21  
electron, 107  
ellipse, 31  
Equator, 13  
equatorial ring, 9  
equinox, 103  
errors, 19, 38  
  experimental, 48, 49  
  measurement, 39, 42, 72  
Explorers, 43, 81, 86
- F**  
first quarter, 32-37  
forces,  
  friction, 12  
  gravitational, 12  
Foucault, 12  
  pendulum, 12  
Fraunhofer, 105, 107  
  lines, 105  
Freedom, 7, 109  
frequency, 72  
friction, 12  
From Here, Where, 11  
full-moon, 32-37
- G**  
Galileo, 11, 21  
gases, 83-92  
  density, 83-96  
  pressure, 83-96  
  temperature, 83-96  
  volume, 83-96  
Geiger counter, 85  
gibbous moon, 32-37  
gnomon, 9  
Goddard, Robert H., 83, 85  
gravitational force, 12  
Greenwich, England, 28, 29
- H**  
Halley, 103  
hour angle of the sun, 27  
hour circle, 102, 103  
Huygens, 21  
hypothesis, 7, 70, 89
- I**  
indirect measurement, 38, 100  
inertia, 12  
instruments, 85  
  anemometer, 85  
  barometer, 83  
  Crookes radiometer, 85  
  Geiger counter, 85  
  metric ruler, 65  
  micrometer, 39  
  precision of, 19  
  protractor, 65  
  radiosonde, 77  
  ruler, 65  
  telescope, 100  
  thermometer, 83  
  tuning fork, 70-72  
  vernier scale, 39, 40
- J**
- K**  
Kirchhoff, 107
- L**  
latitude, 10  
launch window, 14  
least count, 39  
light measurements, 100, 101  
light year, 13  
longitude, 102  
luminosity, 100

**M**

magnetic radiation, 99  
 Mariner IV, 20, 22, 74  
 Martian atmosphere, 91  
 Mars, 20  
 mass, 86-91  
 Maya, 5  
 measurement, 19  
   angstrom, 19, 25  
   degrees, 26, 27  
   direct, 38, 39  
   indirect, 38, 100  
   light, 103, 104  
   light year, 13  
   nanosecond, 19, 25  
   scale, 49  
   standard, 22  
   units, 19  
 mechanical clock, 10, 12  
 meridians, 8  
   Prime, 8, 101, 102  
   terrestrial, 8  
 metric ruler, 65  
micrometer, 39  
 Moon, 32  
   Atlas, 61  
   crescent, 32-37  
   first quarter, 32-37  
   full, 32-37  
   gibbous, 32-37  
   longitude, 45  
   new, 32-37  
   third quarter, 32-37  
   waning, 32-37  
   waxing, 32-37  
 motion of Earth, 31

**N**

nanosecond, 19, 25  
 NASA/Goddard Space  
   Flight Center, 4, 7  
 neutron, 107  
 new moon, 32-37  
 Newton, 12, 100  
 North Pole, 13, 27  
 North Star, 10, 22  
 Northern Hemisphere, 7  
 nucleus, 107

**O**

OGO, 4  
 orbits, 40  
   Earth, 7, 32, 40  
   satellites, 41-43

**P**

pendulum, 10-13, 21  
   average period, 12  
   bob, 10  
   Foucault, 12  
   period, 10, 11  
 perigee, 42, 43  
 perihelion, 31, 40-42  
 period of the pendulum, 12  
 Pogson, 101  
 Polaris, 10, 22  
 precision of instruments, 19  
 pressure, 77, 85-96  
 primary scale, 39, 40  
 Prime Meridian, 8, 101, 102  
 proton, 107  
 protractor, 27, 39, 65  
 Proxima Centauri, 13  
 Ptolemaeus, 44, 47  
 Ptolemy, 100  
   Almagest, 101, 103

**Q****R**

radiation,  
   light, 99  
   magnetic, 99  
 radiosonde, 77  
 Ranger IX, 20, 44-61  
   altitude, 45  
   camera A, 45  
   camera angle, 45  
   grid north, 45  
   grid system, 45  
   resolution, 45, 46  
   reticle, 45, 46  
   scales, 45  
 rarefaction, 70-73  
 refraction of light, 38  
 rendezvous, 14  
   rocket, 14  
   spacecraft, 14  
 resolution, 45  
 resonance, 71, 72  
 revolution, 7, 31  
 right ascension, 103  
 rotation, 10, 31  
 ruler, 38, 47, 65, 95

**S**

sand glass, 10  
 satellites,  
   Echo I, 3, 42

Explorer, 43, 81, 86  
 Mariner IV, 20, 22, 74  
 OGO, 4  
 Ranger IX, 20, 44-61  
 Surveyor, 50  
 Tiros, 75-79  
 Vanguard, 73  
 satellite orbit, 42, 43  
   apogee, 42, 43  
   eccentricity, 40-43  
   mean distance, 42, 43  
   perigee, 42, 43  
 Saturn V, 99, 100  
 scale measurement, 49  
 scientific notation, 13  
 seasons, 7  
 shadows,  
   lengths, 6, 49  
 Shapes of Tomorrow, 27, 107  
 sidereal day, 7, 31  
 solar,  
   day, 7, 31  
   eclipse, 32, 106  
   noon, 8  
   system, 22  
   time, 10  
   wind, 69, 70, 83  
 solar spectrum, 106, 107  
 sounding rockets, 81, 82, 89-91  
 sound waves, 70  
   compressions, 70-73  
   frequency, 70-73  
   rarefactions, 70-73  
   resonance, 70-73  
   wavelength, 70-73  
 space,  
   mathematical model, 70  
 spacecraft rendezvous, 14  
 spectrum, 103-107  
 spectroscope, 104-107  
   diffraction grating, 104, 105  
   model, 104  
 speed of sound, 72, 73  
 standard heart time, 19, 21  
 standard of measurement, 72  
 star,  
   absorption lines, 105  
   apparent motion, 101  
   brightness, 101  
   day, 71, 31  
   declination, 101-103  
   luminosity, 101  
   magnitude, 101  
   North Star, 10, 22  
   Polaris, 10, 22

Proxima Centauri, 13  
spectrum, 103-107  
sun,  
  apparent position, 8, 27  
  hour angle, 27  
sundial, 8-10  
  equatorial ring, 9  
  gnomon, 9  
  model, 9  
Surveyor, 50  
system,  
  earth-atmosphere, 81  
  operating, 81, 82

clepsydra, 10  
wavelength, 104-107  
waxing moon, 32-37  
weight, 86-91  
What's Up There?, 13

## **XYZ**

## **T**

telescopes, 101  
temperature, 83-96  
thermometer, 83, 85-96  
third quarter moon, 32-37  
time,  
  drop, 21  
  hour circles, 26, 27  
  hours, 27  
  kilo, 19-22  
  local, 28  
  mean, 32  
  mega, 19-22  
  midnight, 26-29  
  minutes, 27  
  nanoseconds, 19, 25  
  shadows, 8, 91  
  solar, 10  
  standard heart, 19, 20  
TIROS (Television Infra  
  Red Observation Satellite)  
  75-79  
troposphere, 81  
tuning fork, 70-72

## **U**

Units of measurement, 19  
upper atmosphere, 81

## **V**

Vanguard I, 73  
vernier, 49, 40  
  least count, 39, 40  
  primary scale, 39, 40  
  scale, 39, 40  
volume, 86-96

## **W**

waning moon, 32-37  
water clock, 10, 21