

DOCUMENT RESUME

ED 052 067

SE 012 093

AUTHOR Segerstrom, Harold G.
TITLE Science for Children K-3.
INSTITUTION New York State Education Dept., Albany. Bureau of
Elementary Curriculum Development.
PUB DATE 71
NOTE 135p.; 1971 Reprint
EDRS PRICE MF-\$0.65 HC-\$6.58
DESCRIPTORS *Curriculum Guides, *Elementary School Science,
Grade 1, Grade 2, Grade 3, *Instructional Materials,
Kindergarten, *Science Activities, *Science Units

ABSTRACT

This handbook has been prepared as an aid to teachers, supervisors, and administrators as they select and organize science programs in the elementary grades. It has been organized around six large subject areas: living things; our growing bodies; air, water, and weather; the earth and its composition; the solar system and beyond; and matter and energy. The handbook is organized by grade level in each of the six major areas of study. Each unit contains: (1) purpose of the unit; (2) introduction of the unit; (3) experiences relating to the unit; (4) enrichment; (5) organization and use of information gained (projects, questions); (6) basic understandings to be gained; and (7) vocabulary. (JG)

U.S. DEPARTMENT OF HEALTH,
EDUCATION & WELFARE
OFFICE OF EDUCATION
THIS DOCUMENT HAS BEEN REPRO-
DUCED EXACTLY AS RECEIVED FROM
THE PERSON OR ORGANIZATION ORIG-
INATING IT. POINTS OF VIEW OR OPIN-
IONS STATED DO NOT NECESSARILY
REPRESENT OFFICIAL OFFICE OF EDU-
CATION POSITION OR POLICY.



012 093

ERIC
Full Text Provided by ERIC

ED052067

SCIENCE FOR CHILDREN K-3

1971 Reprint

THE UNIVERSITY OF THE STATE OF NEW YORK
THE STATE EDUCATION DEPARTMENT
BUREAU OF ELEMENTARY CURRICULUM DEVELOPMENT
ALBANY, 1965

THE UNIVERSITY OF THE STATE OF NEW YORK

Regents of the University

		<i>Years when terms expire</i>
JOSEPH W. MCGOVERN, A.B., LL.B., L.H.D., LL.D., D.C.L., <i>Chancellor</i>	New York	1984
EVERETT J. PENNY, B.C.S., D.C.S., <i>Vice Chancellor</i>	White Plains	1985
ALEXANDER J. ALLAN, JR., LL.D., LITT.D.	Troy	1978
CHARLES W. MILLARD, JR., A.B., LL.D., L.H.D.	Buffalo	1973
CARL H. PFORZHEIMER, JR., A.B., M.B.A., D.C.S., H.H.D.	Purchase	1972
EDWARD M. M. WARBURG, B.S., L.H.D.	New York	1975
JOSEPH T. KING, LL.B.	Queens	1977
JOSEPH C. INDELICATO, M.D.	Brooklyn	1974
MRS. HELEN B. POWER, A.B., LITT.D., L.H.D., LL.D.	Rochester	1976
FRANCIS W. MCGINLEY, B.S., LL.B., LL.D.	Glens Falls	1979
MAX J. RUBIN, LL.B., L.H.D.	New York	1980
KENNETH B. CLARK, A.B., M.S., PH.D., LITT.D.	Hastings on Hudson	1986
STEPHEN K. BAILEY, A.B., B.A., M.A., PH.D., LL.D.	Syracuse	1982
HAROLD E. NEWCOMB, B.A.	Owego	1983
THEODORE M. BLACK, A.B.	Sands Point	1981

President of the University and Commissioner of Education

EWALD B. NYQUIST

Executive Deputy Commissioner of Education

CORDON M. AMBACH

Deputy Commissioner for Elementary, Secondary and Continuing Education

THOMAS D. SHELDON

Associate Commissioner for Instructional Services

PHILIP B. LANGWORTHY

Assistant Commissioner for Instructional Services (General Education)

BERNARD F. HAAKE

Director, Division of Curriculum Development

WILLIAM E. YOUNG

Chief, Bureau of Elementary Curriculum Development

ROBERT H. JOHNSTONE

Chief, Bureau of Science Education

HUGH B. TEMPLETON

FOREWORD

Educators who are concerned with the planning of a program for today's elementary schools accept the responsibility of making science a part of the total program. They appreciate the significant impact of scientific development upon the life of everyone. They realize that science education must be included in every program which seeks the best possible development of our children in preparing them for effective living in a world of rapid change — a world of electronics, of nuclear energy, and of startling biological advances.

Children in their formative years must be started along avenues toward acquiring an appreciation of truth and intellectual honesty, as well as toward developing a talent for objective and critical thinking. Such routes may well lie in the area of science where there exists an especially rich source of educational experiences. Many types of activities, such as discussing, reading, manipulating, collecting, and experimenting, contribute to the growth of the child and will be useful to him as he develops into an informed and productive citizen.

It is toward these ends that the Bureau of Elementary Curriculum Development has been working for a number of years. New York was the first State to produce a course of study in elementary science. Under the leadership of Helen Hay Heyl, retired Chief of the Bureau of Elementary Curriculum Development, and Dr. Warren W. Knox, Assistant Commissioner for Instructional Services (General Education), *Elementary Science, Grades 1-6*, was distributed to classroom teachers in 1931. Revisions of the original program were made in 1939 and 1942.

This publication, although substantially different in format and content, is just one more step in the continuing effort to keep science instruction up-to-date and stimulating. As were its predecessors, *Science for Children* has been prepared as an aid to teachers, supervisors, and administrators as they select and organize science programs in the elementary grades.

This publication has been developed by the Bureau of Elementary Curriculum Development. Major contributors were Robert W. Kelley, State Education Department; Charles M. Mitchell, formerly of the Department and now on the staff at the State University College at Plattsburgh, and Dr. William A. Stebbins of the State University College at Brockport. It was prepared for publication by Harold G. Segerstrom of the Bureau staff.

We are indebted also to the many people throughout the State who have reviewed and contributed to the manuscript. Without the help of these hundreds of teachers and administrators, this guide could not have been produced.

This volume carries with it the sincere hope that it will serve to further the improvement of science education in our State.

WILLIAM E. YOUNG
*Director, Division
of Curriculum Development*

ROBERT H. JOHNSTONE
*Chief, Bureau of Elementary
Curriculum Development*

Contents:

FOREWORD 2

INTRODUCTION 6

Areas of study 6

General format 6

ORGANIZATION CHART 134-135



a LIVING THINGS

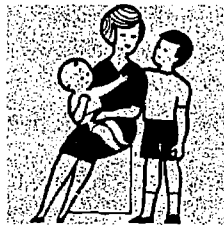

b OUR GROWING BODIES

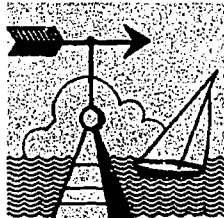

c AIR, WATER, AND WEATHER



d THE EARTH AND ITS COMPOSITION

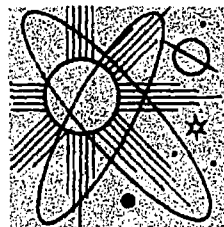

e THE SOLAR SYSTEM AND BEYOND



f MATTER AND ENERGY

Kindergarten	First Grade	Second Grade	Third Grade
10	36	66	100
16	44	74	109
19	48	78	113
23	53	83	119
27	57	89	124
31	61	94	129

INTRODUCTION

The format incorporated in this handbook represents a substantial departure from previous publications produced by the Department. For this reason, the reader is urged to read this introduction carefully in order to acquaint himself with the design, purpose, and intent of this organization.

Areas of study

Science for Children has been organized around six large subject areas:

- a LIVING THINGS
- b OUR GROWING BODIES
- c AIR, WATER, AND WEATHER
- d THE EARTH AND ITS COMPOSITION
- e THE SOLAR SYSTEM AND BEYOND
- f MATTER AND ENERGY

All of these areas overlap and are interrelated with no clear division between them. There is no intent on the part of this handbook to imply that all of science is composed of six basic areas, and the teacher is cautioned not to give our children such an impression. This division is simply one of many possible ways of organizing the content of science for efficient teaching and learning in the elementary school.

The teacher should constantly point out the common threads which cut across all areas of science. The subject should not be presented as a number of seemingly unrelated topics. Unless these unifying themes are made evident, the science program will develop into a patchwork of various topics rather than a woven pattern with a basic and continuing design. For example, the production and transfer of heat energy plays a major role in our own life processes, our personal health, the weather around us, the geological structure of the earth, the composition of distant stars, and the operation of everyday machines.

- PURPOSE OF THE UNIT
- INTRODUCTION OF THE UNIT
 - *Motivating activities*
 - *Motivating questions*
- EXPERIENCES RELATING TO THE UNIT
- ENRICHMENT
 - *Questions to stimulate further thought*
 - *Topics for additional exploration*
- ORGANIZATION AND USE OF INFORMATION GAINED
 - *Projects*
 - *Questions to guide a summary of experiences*
- BASIC UNDERSTANDINGS TO BE GAINED
- VOCABULARY

General format

This handbook is organized by grade level in each of the six major areas of study. Each such unit follows a sequential teaching pattern incorporating suggested activities for the teacher as well as the pupil. The format is consistent through all grade levels and is organized as follows:

Before using the material in this handbook the reader should be aware of three points:

1. *Under no circumstances should a teacher attempt to use all the activities listed in any unit. The material herein presented should be regarded as a reservoir of ideas, and from these a program should be developed. Because of the diversity in our schools and local communities, no singly designed program could possibly be ideal for all schools. Therefore, the selections in this publication are many and varied in order to provide an adequate resource for all schools.*

2. *The grade-level placement of activities and their arrangement within the unit are only suggested and are not to be interpreted as mandatory. It is possible, for example, that the enrichment material suggested for one grade may be used as motivating experiences for a later grade.*

3. *The wide range in subject matter incorporated in this publication should make it acceptable as a companion to any series of science textbooks. If a school wishes to build its science program around the design of a particular series of texts, it may find appropriate activities in this handbook to augment the text-centered course. On the other hand, the general outline of this publication may serve as the core of a science program with many science books used for supplementary reading and exploration.*

Explanation of format

APPARATUS AND MATERIALS. A list of apparatus and supplies precedes each unit. This list includes the materials which would be needed in order to perform all the activities described in the unit. Items such as paper, pencils, scissors, crayons, tape, and so on have been assumed to be readily available and therefore are not included in these lists.

PURPOSE OF THE UNIT. Each unit in this handbook has been developed around a single principle or purpose. The initial statement which appears at the beginning of the unit is directed to the teacher for his own orientation and is not suggested as an introductory statement for the pupil. It is strongly suggested that the reader look over the list of "basic understandings to be gained" located toward the end of each unit in order to better understand the purpose stated at its beginning.

INTRODUCTION OF THE UNIT. It is generally agreed that learning proceeds most effectively when the learner is interested in, and motivated toward, the subject at hand. For this reason, a number of motivating activities and motivating questions have been included in each unit of this handbook. These activities and questions should be presented in an open-ended fashion so that they will lead to further questioning rather than to "an answer."

EXPERIENCES RELATING TO THE UNIT. A substantial portion of science education should involve direct experiences on the part of the learner. Touching, manipulating, testing, and experimenting are useful and effective avenues for learning. Many activities can and should be undertaken by children. Some, however, are better performed as demonstrations by the teacher. Teacher demonstrations are especially in order when safety becomes a factor. Young children should not handle very sharp tools, explosive or corrosive chemicals, or electrical apparatus other than battery operated. The teacher may also find it best to perform demonstrations for his class if costly apparatus is involved so that breakage will not become a problem. In addition, very young children may not have developed sufficient coordination to make the necessary fine adjustments for a particular laboratory setup. At such times, the teacher should let the children observe rather than perform.

However, when safety is not a factor and equipment is neither extremely costly nor complex, every possible effort should be made to allow the individual pupil to carry out his own science experiences.

Field work is included within the collection of *Experiences Relating to the Unit*. The term field work includes any learning experience which takes place beyond the walls of the regular classroom. Besides trips to the woods, parks, and playgrounds, visits to various areas within the school building are also suggested.

Field trips to specific places may be repeated one or two times during the child's elementary school experience to emphasize different understandings. For example, a trip to a zoo may be used with kindergarten children to point out the variety of animals. First-grade children may visit a zoo to observe how animals move about. The zoo provides an excellent place for second-grade children to learn about the food habits of various animals.

ENRICHMENT. Because individual differences exist among pupils in their general ability and interests, suggestions for enrichment have been incorporated in each unit. Some children will have the ability and desire to explore beyond the normal classroom work. The suggestions for enrichment may be given to individual pupils or an entire class may pursue one of these additional topics.

ORGANIZATION AND USE OF INFORMATION GAINED. Both projects and questions are suggested in this section for tying together and reviewing the various activities undertaken during the study of the unit.

BASIC UNDERSTANDINGS TO BE GAINED FROM THE UNIT. These statements summarize the concepts which should be developed through the activities included in the unit. These basic understandings relate directly to the introductory statement given as the *Purpose of the Unit*.

VOCABULARY. The vocabulary list comprises the words which pertain to the unit and which should be familiar to the children at each grade level. Young children should be able to incorporate these words in their speaking vocabulary while the teacher may wish to incorporate these words in the spelling lists of older children. Some very interesting work can be initiated by studying the derivation of many scientific words through stems, roots, and historic origins.

Future revision

The reader is invited to submit his most successful and effective science activities to the Bureau of Elementary Curriculum Development so that they may be considered for inclusion in future editions of this handbook. In this way the elementary science program across the State may continuously improve. Any activities which are submitted will be carefully read and whenever appropriate will be incorporated as revisions are made.

Kindergarten

a LIVING THINGS

b OUR GROWING BODIES

c AIR, WATER, AND WEATHER

d THE EARTH AND ITS COMPOSITION

e THE SOLAR SYSTEM AND BEYOND

f MATTER AND ENERGY

Kindergarten

a LIVING THINGS

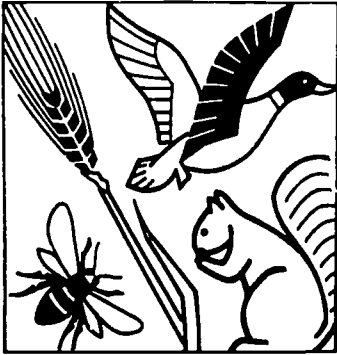

PURPOSE OF THE UNIT: *to become aware of living things around us*

Apparatus and materials

1. Animal, small (goldfish, hamster)
2. Animals, picture book
3. Ant observation nest
4. Aquarium
5. Bags, paper
6. Bird feeder, materials
7. Carrot
8. Coat hanger
9. Coffee can
10. Potato
11. Potted plant
12. Record, animal sounds
13. Seed—beans and corn kernels
14. Terrarium, materials
15. Wire screen

INTRODUCTION OF THE UNIT**Motivating activities**

1
Set out on a table a rock, a potted plant, and a small animal (goldfish, earthworm, hamster, insect, etc.) in an appropriate container. Have the children describe the differences among these three things. What similarities are there? Which ones are alive? Why? What characteristics seem to be peculiar to living things?

2
Divide a bulletin board area into two parts. Display pictures of living things which may be familiar to the children in one section (a few common plants and animals such as a dog, a cat, a horse, a bird, a boy, or a girl). Repeat in the other section with nonliving things. The children may participate in this activity by telling the teacher where to put each picture as she holds it up.

3
Display pictures of pets and farm animals.

4
Show a picture book of animals. Talk about where each lives and where it may be seen such as on a farm or in a zoo.

5
Set up a small aquarium or fish bowl for one or two goldfish. A small turtle may be used in addition to or instead of the fish if a flat rock is provided for a resting place. If a small green slider turtle is used, it should be fed bits of raw beef (not fat) and lettuce and fruit. Place a desk lamp so that it shines on part of the tank. It will help maintain the turtle's appetite by keeping it warm.

6
Bring a pet animal to school for a day.

7
Children like to tell about some of their experiences with animals, both wild and tame. They also like to tell about gardens or plants they help care for at home.

Motivating questions

1. Are all things alive?
2. What are some different living things?
3. Can you name some things that are not living?
4. Where can we find living things?
5. How is a plant different from an animal?
6. What living things help us? How?
7. What are seeds?
8. Where do plants live? Animals?

EXPERIENCES RELATING TO THE UNIT**Teacher-directed activities**

1
Have the children bring in a variety of small animals at different times. Observe and discuss their needs and habits. Help the children to assume the responsibility for the care of these animals. Wild animals should be released in their natural habitat after a few days. Pets from home should be used to a large extent.

2
Make a collection of various potted plants. Include as many different types of plants as possible. Point out the various shapes and sizes. What do plants need to stay healthy?

- 3
Use flannel-board cutouts to show animals found in the yard, farm, meadow, forest, pond, park, and other places.
- 4
Build a bird feeder and place it where it can be seen from the schoolroom window. Children should help take care of the feeder. Observe various birds which visit the feeder regularly. Note birds that may be seen during the various seasons. Place different kinds of food on the feeder. Some birds have a preference for certain foods.
- 5
Make a seed collection. Show pictures of plants that grow from these seeds. The children will be able to find many seeds in the fall.
- 6
In the early spring collect some twigs from forsythia, pussywillows, or apple trees, and force their budding by placing them in containers of water in the classroom.
- 7
Cut the top off of a carrot and place it in a saucer of water. Observe the growth after several days.
- 8
Suspend a potato in a glass tumbler by placing toothpicks in each side. Pour water in the tumbler to cover the lower portion of the potato and observe the new growth which takes place. Be sure that at least two "eyes" are submerged.
- 9
Read stories to the children about farm animals, pets, and zoo animals.
- 10
Show the class pictures of different kinds of animals such as snakes, turtles, frogs, birds, and fur-bearing animals.
- 11
Talk about pictures of different kinds of plants such as shade trees, fruit trees, plants we eat, and flowers.
- 12
Children like to imitate actions and sounds of other things. They may close their eyes while the teacher makes a sound of a particular animal and asks the children what animal might make this sound. Clues may be given by asking, "If you were walking along the street and heard a tapping in a tree, what do you think it might be?" The children may join in by taking turns imitating an animal. The rest of the class then tries to guess which animal or group of animals might make the sound.
- 13
Try some sensory experiences. Place some familiar examples of living things into paper bags. Children reach in the bags to feel the contents and with just their hand as a guide, guess the contents. Such things may be used as some kernels of corn, a leaf, a piece of celery, a feather, and a piece of fur.
- 14
Play an observation game with the children. Place several objects on a desk in front of the children. Give them a short time (25-30 seconds) to look at everything on the desk; then remove the objects or block them from view. See how many objects the children remember. Add interest to this activity by varying the number and kind of objects. Relate this experience to observation of things about us.
- 15
Make a simple woodland terrarium. Include a small container of water and some small animals such as a frog, a toad, a salamander, or a land snail. A gallon mayonnaise jar from the cafeteria works well.

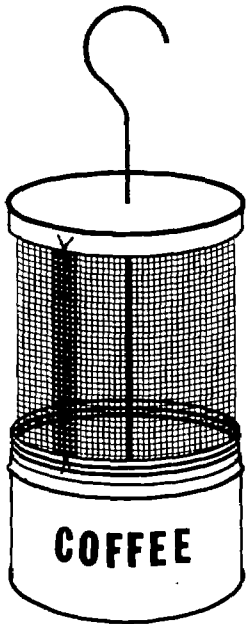

Activities for children

16 Have an ant observation nest for the children to observe. These are commercially available or may be simply constructed. The queen ant must be included if the colony is to be self-perpetuating.

17 ← A coffee-can insect cage will provide a place for observation of such insects as caterpillars, spiders, and grasshoppers. Cocoons collected by the teacher or children may be kept in such a container to observe the emergence of the insect. To make this cage, roll a piece of wire screen 10 x 16 inches into a cylinder 10 inches long. This cylinder will just fit in a coffee can. Stitch the seam of the wire cylinder, put the coffee-can lid in place and you have a sturdy cage. If desired, a hanger may be added to the cage. Punch a nail hole in the center of the lid and another in the center of the bottom. Insert a piece of wire coat hanger, bend it over, underneath, and fashion a hook at the top.

18 Read stories about where animals live. Begin with familiar animals such as pets and farm animals.

- 1 Have the children draw :
 - a. A very big animal (elephant, horse)
 - b. A very small animal (ant, mouse)
 - c. A very big plant (tree)
 - d. A very small plant (grass, moss)

2 Play an imitation game where children act out silently the movements of various familiar animals. The other children try to guess the name of the animal.

3 Plant a bean seed or a kernel of corn in a coffee-can planter (or other similar container which will hold water, such as a milk carton with its top cut off). The seed will get a good start in garden soil that is not too coarse. Place the container in a well-lighted place, water it when needed, and observe the growth of the plant.

4 Bring a pet to class. Tell what it is (for example, a collie dog or a Siamese cat), where it came from, how it is cared for, and other interesting things about it.

5 Paint pictures of animals on large paper and arrange these around the room to form a zoo parade.

Fieldwork

1 Take a walk around the school area and look for living things and evidence of living things.

2 Take a trip in the vicinity of the school to make observations through the use of the various senses. Feel the bark of two different kinds of trees; listen for animal sounds (bird calls, insect calls); look at the shapes of leaves, coloration of birds and insects; smell the fragrance of a pine cone or some flowers.

3 Visit a flower garden and become familiar with some of the common flowers.

4 Take a trip to see wildflowers in bloom, and again when they have gone to seed. Notice the number and variety of plants and where they grow. Such trips may be used to collect specimens for the classroom.

5

In some places throughout the State it will be practical to visit a zoo, game farm, or other place where a collection of animals is housed.

6

Take seasonal trips to observe changes which take place during different times of the year. A particular tree may be visited during each season to note its appearance. Perhaps the children will note changes in animals found near the school or in parks. They may witness bird migration during the spring and fall.

7

Trips may be taken around the school area to discover animal homes. Look under window ledges, in trees and shrubs, along the foundation of the building, under rocks, and under logs.

ENRICHMENT

Questions to stimulate further thought

1. How small can living things be? (Why should we not sneeze or cough in someone's face?)
2. What are the largest living animals?
3. What are the largest living plants?
4. Do animals care for their young? Can you think of some animals which do not care for their young?
5. How do living things depend on or help each other?
6. Which animals occur in the greatest numbers?

Topics for additional exploration

1

Animal and plant characteristics. A game can be played with children which can be conducted at any level of difficulty and from which the class can profit. Describe a plant or animal and let the children name it. Examples:

- a. Name an animal with only two legs (bird, man).
- b. Name an animal with no legs (fish, snake).
- c. Name an animal with no fur (frog, etc.).
- d. Name an animal with no eyes (worm).
- e. Name a plant that isn't green (mushroom).

2

Animal homes. Describe or show pictures of animal homes (nest, hive, hole in tree, swamp, etc.). Have the children name or describe what animal lives in each place.

3

Animal sounds. Listen to records of animal sounds and ask the children to name them.

4

Baby animals. Many baby animals resemble their parents. Pictures may be used to illustrate these similarities.

5

Seasons. The term seasons can be clarified by making a circular chart, divided into four seasons. In each section place a picture depicting how plants and animals change during the spring, summer, fall, and winter. Use the same technique with pictures of children's clothes and recreational activities.

ORGANIZATION AND USE OF INFORMATION GAINED

Projects

- 1
Have the class bring in pictures of living things and arrange them around the room in order of size.
- 2
Display pictures of many things. Have the children separate them into two groups, living and nonliving things.
- 3
Make a collection of seeds. These may be arranged by size or shape. Seeds may be displayed on bulletin boards by making a pocket from plastic wrapping material which may be tacked or stapled to the board. Seeds may also be glued to cardboard.
- 4
Make an exhibit that illustrates some of the experiences children may encounter through the use of their senses. Divide a bulletin board into five sections. Each section is designated with a labeled picture or a cutout to represent each of the basic senses: seeing, touching, tasting, hearing, and smelling. Pictures or examples of things will illustrate some basic experiences which the children have experienced through these senses.
- 5
Make individual terrariums utilizing plants that can be found locally.
- 6
Make a collection of animal houses. Include some samples such as bird nests, abandoned hornet nests, and cocoons. Pictures of caves, beaver homes, etc., can supplement the collection.

**Questions to guide
a summary of experiences**

1. How can we tell if a thing is living or not living?
2. What are the differences between plants and animals?
3. Where do plants live?
4. Where do animals live?
5. What do plants need in order to live?
6. What do animals need in order to live?
7. Are there many kinds of animals?
8. Are there many kinds of plants?

BASIC UNDERSTANDINGS TO BE GAINED FROM THIS UNIT

1. All things are either living or nonliving.
2. Living things can be plant or animal.
3. There are many kinds of plants and animals.
4. Plants and animals need food, air, and water to live.
5. Green plants need light to grow.

VOCABULARY

animal ear eye living mouth nose plant seed

Kindergarten

b OUR GROWING BODIES

GROWTH

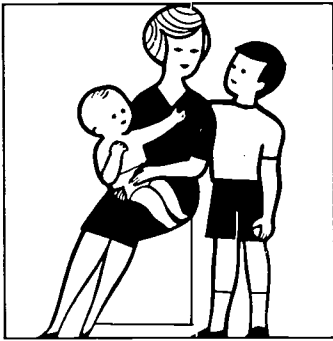

PURPOSE OF THE UNIT: *to develop an interest and understanding of growth*

Apparatus and materials: Clay

INTRODUCTION OF THE UNIT

Motivating activities

- 1 Weigh each child and measure his height. The school nurse or teacher may do this. Perhaps some of the children can weigh and measure others.
- 2 Make a picture display of growing children from babies to adults for the bulletin board.
- 3 Ask children if they have baby brothers or sisters. Let them tell how small (or big) they are.
- 4 Ask children how much they weighed when they were born. Let them get the information from parents if they don't know.
- 5 Compare birth weight with present weight.

Motivating questions

1. Are we all the same size?
2. Were we all the same size when born?
3. Do we stay the same size?
4. Do other things grow?
5. Can we see ourselves grow?
6. Can we feel ourselves grow?
7. Can we hear ourselves grow?
8. Do we all grow to be the same size?
9. How do we know we are growing?
10. Why do we want to grow?

EXPERIENCES RELATING TO THE UNIT

Teacher-directed activities

- 1 Have children observe plants and animals that are in the classroom. Have them note the difference in size of the same type of plants and animals.
- 2 Have children stretch themselves, stand on tiptoes, reach up with their hands. Have any of these activities increased their height?

Activities for children

- 1 Have class find pictures of grown children and adults.
- 2 Have children draw pictures of people showing differences in size (a family out for a walk).
- 3 Have children construct models of other children in clay showing large and small children.
- 4 Have children who have been to a circus describe the midget, the giant, the fat lady or man.
- 5 Have children name other people they know who are "grown-up."

Fieldwork

1
Walk around the school area and look for small seedlings of trees, then find the same tree grown to maturity.

2
Take children to a zoo, farm, or home where there are animals of various ages and sizes. Observe characteristics of young and older animals.

ENRICHMENT**Questions to stimulate further thought**

1. Do all things grow?
2. Do living things keep growing always?
3. How big would you like to be? Why?
4. Are there living things so small that we can't see them?
5. Why do living things start small and grow larger?

Topics for additional exploration

1
Characteristics of people. Some people are tall, and some are short; some are thin, and some are heavy. All of these people have grown, however.

2
What is needed to make children grow? Allow children to enumerate the things they know about food, sleep, exercise, etc.

ORGANIZATION AND USE OF INFORMATION GAINED**Projects**

1
Have children bring in pictures of people showing variations in size (tall, thin, heavy, short).

2
Collect a series of pictures showing growth progress from birth to maturity. Have children arrange them in proper sequence.

Questions to guide a summary of experiences

1. Are all babies the same size when born?
2. Are all kindergarten children the same size?
3. Do all babies normally grow larger?
4. Are people the only things which grow larger?
5. Do we ever stop growing?
6. What do we need to help us grow?
7. Why do all children need to grow?

BASIC UNDERSTANDINGS TO BE GAINED FROM THIS UNIT

1. All living things grow.
2. All living things are not the same size.
3. We cannot tell how big we will become.
4. For growth, we need certain basic things such as food, water, light, air, and exercise.

VOCABULARY

giant growth height measure midget weight

Kindergarten

C AIR, WATER, AND WEATHER

PURPOSE OF THE UNIT: *to determine the nature of air*

AIR

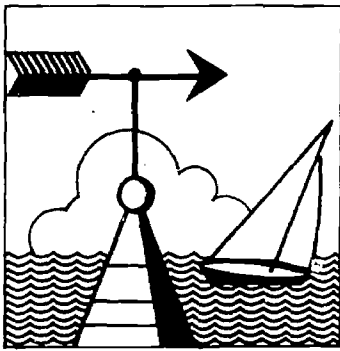

Apparatus and materials

1. Drinking straws
2. Straight pins
3. Paper
4. Pencils with erasers
5. Water tumblers

INTRODUCTION OF THE UNIT

Motivating activities

- 1
Have the children bring a container of air to class. See how many have a cover on the container. See if anyone can bring an otherwise empty container with *no* air in it.
- 2
Make a display of large pictures of the action of the wind, clothes blowing on a line, windmills, sailboats, kites, hurricanes, or storms at sea.
- 3
Read a story about the wind and how it affects people.
- 4
Fly a kite at recess on a breezy day. A box kite will fly easily without the need of a tail.
- 5
Point out evidences of the wind. Observe the flag in the schoolyard or on a nearby building. Look for smoke rising from chimneys. Observe trees.

Motivating questions

1. Can we see air?
2. Can we smell air?
3. Can we taste air?
4. Can we hear air?
5. Can we feel air?
6. Does air ever help people?
7. Does air ever hurt people?
8. Can we tell when there is air in something?
9. Can we tell when there is no air in something?

EXPERIENCES RELATING TO THE UNIT

Teacher-directed activities

- 1
Sing songs about the wind. Act out the parts of swaying trees, waves of water, or flying leaves.
- 2
Blow through a straw. Can anything be seen coming out of the end? Now put the straw in water to show bubbles of air in water.

Activities for children

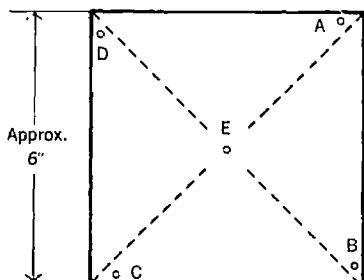

1 Make pin wheels. White or colored paper can be used. After each child has cut his paper, the teacher can use a straight pin to mount the pin wheel in the eraser of a pencil. If a breeze can be had by opening the classroom door and a window, the children will not have to run to have the wheel operate. Safety precautions are advised in the dispersal of the pins.

- ← (1) Cut paper into a square.
- (2) Cut along dotted lines.
- ↘ (3) Bend, but do not fold corners, so that dots A, B, C, D fall over center dot E. Push a straight pin through the center (all dots) and into the eraser of a pencil.

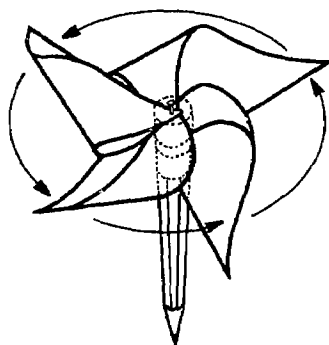

2 Make fans by folding paper in accordion fashion. How do these make wind for us? Color the fans.

3 Color or paint pictures of some observations made of how moving air affects things.

4 Put a balloon under a book or some other light object, and see if you can blow up the balloon. Does it lift the object?

5 Hold a cardboard with its edge into the wind. What happens as the cardboard is turned so the wind strikes the flat side?

Fieldwork

1 Take the class out of doors at different times to observe calm air, gentle breeze, and strong wind. Have children face into the wind and away from the wind.

2 While out of doors observe flags, wind blowing seeds, dust devils on the playground, or in the street. Pick up some grass and let it fall toward the ground. Watch the wind carry it.

3 While out of doors, try to find places where the wind is not blowing very hard, and places where it seems to be blowing hardest.

ENRICHMENT

Questions to stimulate further thought

1. How do we keep the air in our homes warm in winter time?
2. How do we use air to make our work easier?
3. What is a wind vane?
4. What would you like to do if you were the wind?

Topics for additional exploration

1 *Wind direction.* Because the wind pushes against things we can see, such as trees, smoke, and flags, we can tell the wind is blowing.

2 *Use of air.* There are many ways in which air helps us. We are cooled or warmed by air. We ride on air (tires); air pushes sailboats and is used for many toys (balloons, balls).

ORGANIZATION AND USE OF INFORMATION GAINED

Projects

1. Collect pictures which show the effect of the wind.
2. Bring in a toy or homemade sailboat and demonstrate how it works.
3. Make toy parachutes from handkerchiefs, strings, and small weights.

Questions to guide a summary of experiences

1. What is wind?
2. How can you tell when the wind is blowing?
3. What does the wind do?
4. Do you like the wind in summer? Why?
5. Do you like the wind in winter? Why?
6. In what ways can you feel air?

BASIC UNDERSTANDINGS TO BE GAINED FROM THIS UNIT

1. Air is all around us.
2. We can feel air, but we cannot see it.
3. We can see what air does.
4. Moving air is called wind.
5. Air can warm us or cool us.

VOCABULARY

air

blow

breeze

wind

Kindergarten

d THE EARTH AND ITS COMPOSITION

PURPOSE OF THE UNIT: *to learn about rocks*

ROCKS



Apparatus and materials

1. Gravel
2. Pebbles
3. Rocks
4. Rocks containing fossils

INTRODUCTION OF THE UNIT

Motivating activities

- 1 Display pebbles or larger rocks of various colors and shapes.
- 2 Show pictures of mountains, gorges, and boulders.
- 3 Display a rock containing a few fossils.
- 4 Arrange a bulletin board display showing where rocks are found. Some are found as boulders in fields, as stone walls, in sidewalks, as cliffs, as mountains, and in creek beds. A few pictures showing how stone is used could be included.

Motivating questions

1. Have you ever been in the mountains? What did you see there?
2. Where is the biggest rock you ever saw?
3. Can you think of a place where there is no rock or stone?
4. How do we use rocks?

EXPERIENCES RELATING TO THE UNIT

Teacher-directed activities

- 1 A permanent, growing, classroom exhibit of interesting rocks can be made with the aid of the children.
- 2 Show the children a rock. Tell them a story about this rock. Tell where it was picked up. Describe the shape and color and the various colored grains visible on the fresh surface of the coarse-grained rocks. Show them that it is hard, drop it on the floor, step on it, try to scratch it with a fingernail. Drop it in a tumbler of water. See it sink to the bottom. It is heavier than water.
- 3 Keep a rock on a table in a conspicuous place in the room for a few days. Call the children's attention to it each day. Does it grow or change? Explain that it takes a long time for rocks to change in nature.

Activities for children

- 1 Children may bring in rocks that they have found on their way to school or around their homes. They may tell the class where the rocks were found and why they were brought to class. Each specimen can be labeled with the name of the child who brought it to the room. Short pieces of masking or adhesive tape can be used for labels.
- 2 Some of the children will undoubtedly remember visiting interesting areas where they have seen unusual rocks or rock formations. They may be able to describe what they saw to the class.
- 3 Separate rocks into piles according to size.
- 4 Separate rocks into piles according to color.
- 5 Separate rocks into piles according to shape.

6
Separate rocks into smooth, rough, sharp, soft, and hard groups. Activities numbered three through six will give the pupils experiences with rocks and will help in describing and naming rocks. Number, color, and shape concepts will also be developed in these activities.

Fieldwork

1
Take the class out into a playground or a nearby field and collect various rocks.

2
A nearby rock outcropping or excavation not only can show the children where we can get our stone, but also give them an idea of what lies below the surface of the ground.

ENRICHMENT

Questions to stimulate further thought

1. Are there very large boulders or rock exposures in fields or parks near the school? If so, how do you think they got there?
2. Where do we get the jewels that decorate our rings and bracelets?
3. Are rocks important? Name some things we do with rocks.

Topics for additional exploration

1
Identification of pebbles. Pebbles are about the size of marbles and are smooth.

2
Identification of gravel. Gravel is composed of loose rounded particles of broken rock.

3
Inside of rocks. Note: Use caution when cracking rocks. Flying fragments can be dangerous. Wrap each rock in a piece of cloth, place it on a hard surface such as another rock and hit it sharply with a hammer. Children may be curious about what rocks or pebbles look like on the inside. Rocks may be cracked open to show freshly exposed surfaces. These can be compared with the worn unbroken surfaces. Look at them carefully to see if different grains (minerals) can be seen.

ORGANIZATION AND USE OF INFORMATION GAINED

Projects

1
Bring in pictures of the land which show rock (mountains, waterfalls).

2
Draw or paint pictures of some of the rocks. Some specimens will provide an abundance of color.

Questions to guide a summary of experiences

1. Where do pebbles and gravel come from?
2. If you could not see, how could you tell rocks from other things?
3. How do we know rocks are not living things?
4. How do rocks feel when you touch them?
5. Can we see different colors in some rocks?
6. Are some rocks larger than others?

BASIC UNDERSTANDINGS TO BE GAINED FROM THIS UNIT

1. Rocks are hard, nonliving things.
2. Rocks have various colors, sizes, and shapes.
3. Gravel and pebbles are small pieces of rock.
4. Some rocks feel rough and others feel smooth.
5. There are many kinds of rocks.

VOCABULARY

pebble

mountains

rock

waterfalls

Kindergarten

e THE SOLAR SYSTEM AND BEYOND

PURPOSE OF THE UNIT: *to learn what the sun does for us and to understand that the earth is very large*

SUN

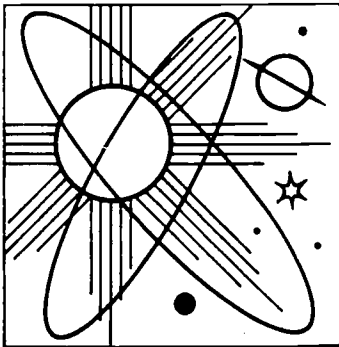

Apparatus and materials

1. Clay
2. Flashlight or filmstrip projector
3. Globe
4. Tape, masking
5. Tumblers, water

INTRODUCTION OF THE UNIT

Motivating activities

1
Take children out of the building on a bright, sunny day. Have them stand in the shade of the school building or a tree. Have them stand in the direct sunlight for a few minutes. Is there a difference? Why? Where would you rather be in winter? In summer?

2
Ask the children to look out the window and describe how far they can see. Not much of the earth can be seen when they stay in one place. Ask them where they might go to see more of the earth from one place. This might be the highest place in the building, on a hilltop, or in an airplane.

3
Discuss how long it may take to go from one place to another, from home to school, to another town, and methods of traveling.

Motivating questions

1. Is the earth big?
2. How big do you think it is?
3. What is the sun?
4. When do we feel warm?
5. What does the sky look like during the day?
6. What does the sky look like during the night?
7. Can you make a shadow?

EXPERIENCES RELATING TO THE UNIT

Teacher-directed activities

1
Place a glass of water in direct sunlight and another in shade. After an hour or so, test the water in each by sticking your finger in to see which is warmer.

2
At this age children have little or no conception regarding the vastness of space. To them the sun and the moon may seem very small in comparison with what they see on earth. Have children describe what the sun looks like as it is rising and setting. Have them describe the moon in the same manner. Compare the size of the sun and moon to known objects. Does the sun appear large? Small?

3
Sunlight shining through the classroom window will make a bright area on the floor. Mark one corner of the sunlit area with some masking tape early in the day. Every 15 minutes or half hour, place another piece of tape to mark the new location of the sunlight. Ask the children why they think the sunlight moves.

4
Shadow experiences may be conducted in the classroom using a flashlight, floodlight, or filmstrip projector. Hold different objects in front of the light source. Trace some of them on paper. Do shadow shapes look like the objects casting them?

5
Some conception of the size of the earth may be impressed on the children by discussing the time it takes to travel from place to place.

6
Obtain a large globe. Place a piece of modeling clay on the globe that marks your approximate location. Relate this to the rest of the earth. Discuss distances children have traveled.

Activities for children

1 Ask children to observe and talk about the time it takes for the sun to change from being overhead to setting. Does it seem to be about from lunch time to supper time?

2 Children may paint pictures of the sky. This usually gives some indication of their conceptions.

3 The children should be encouraged to observe shadows on their way to and from school. Discuss objects that make long shadows, unusual shadows, and small shadows.

4 Have children observe the shadow cast by the school. How does it change during the day? Could this have any influence on how they might dress for outdoor play?

Fieldwork

1 Take children to a point (a hill or high up in a building) where they can get a good view of the land. Discuss differences in the landscape, high and low places, streams, lakes, ponds, etc. The land is not the same in all places. In a large city, discuss parks, a college campus, or vacant lots.

2 Take the children out to the play area on a sunny morning. Locate the sun, but do not have children look directly at it. Where does a shadow appear? Have children point to the top of their shadow and notice the position of their arm. At noontime, the children may check their shadow in the same manner. What do they notice about the shadow?

ENRICHMENT

Questions to stimulate further thought

1. Could you use your shadow to help you tell when it is time for lunch?
2. Where is the sun on cloudy days?
3. What would happen if the sun did not shine for a long time?
4. What do we mean when we refer to "the man in the moon"?

Topics for additional exploration

1 *Cloudy days.* When the sun is hidden behind a cloud cover, there usually isn't enough light to form a shadow.

2 *Shadows.* The size and shape of an object determines the type of shadow cast. Long shadows are formed in early morning and late afternoon when the sun is low in the sky.

3 *Moonlight.* Moonlight is light from the sun that is reflected by the moon.

4 *Comparing sizes.* The earth is larger than its satellite, the moon.

ORGANIZATION AND USE OF INFORMATION GAINED

Projects

1 Children, with the help of the teacher, can make silhouette pictures of themselves for a Mother's Day project.

**Questions to guide
a summary of experiences**

1. How big is the earth?
2. How do shadows change during the day?
3. Where does the moon get its light?
4. If the sun is on one side of you, where will your shadow be?
5. Can you see more of the earth from a high place?
6. How does the sun help us?

BASIC UNDERSTANDINGS TO BE GAINED FROM THIS UNIT

1. We live on the earth.
2. The earth is very large.
3. The sun gives us light and heat.
4. Light reflected from the moon helps us see at night.

VOCABULARY

above (up)	beneath (down)	earth	east
moon	opposite	shadow	sky
			west

Kindergarten

f MATTER AND ENERGY

PURPOSE OF THE UNIT: *to become aware of the sounds around us*

SOUND

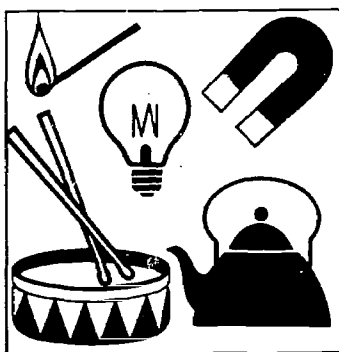

Apparatus and materials

1. Milk bottle, pint
2. Milk bottle, quart
3. Recordings, taped sounds
4. Ruler
5. Tape recorder

INTRODUCTION OF THE UNIT**Motivating activities**

- 1 Identify sounds we hear all the time.
- 2 Demonstrate some musical toys.
- 3 Play some simple musical instruments.
- 4 Display some instruments which make sounds to warn us — bell, horns, sirens, etc.
- 5 Listen to some music, either recorded or from the piano.
- 6 Play some chords on the piano which are pleasant to listen to and some that are not musical.

Motivating questions

1. Can you hear many sounds?
2. Do we like to hear all kinds of sounds?
3. How do we hear?
4. What sounds do we all hear every day?
5. What sounds do we hear only occasionally?

EXPERIENCES RELATING TO THE UNIT**Teacher-directed activities**

- 1 Have children hold their hands over their eyes while the teacher moves about the room. Can children tell when the teacher is close to them? When the teacher stops walking, can the children tell where she is located in the room? The teacher may write on the chalkboard, open a book, or shuffle papers while children have their eyes closed. See if they can recognize the sounds.
- 2 Sounds may be clearer when we are facing the direction of their source. The teacher may make a sharp sound while the group faces toward the source. Have them turn around so that their backs are to the sound. Make the sound again. Was the sound clearer when the group faced the source? Show how our ears "scoop in" sounds.
- 3 Tape recordings or records may illustrate some sounds that are used as warnings such as car horns, sirens, train horns, and school fire bells. An audio-visual director may have recordings of sounds in nature that warn of danger, such as fire crackling, thunder, and others.
- 4 Ask children to be absolutely quiet and listen for 30 seconds. Identify the sounds they hear. Try to describe their source and location. Have them cover their ears. Can they hear as many sounds?
- 5 Listen to some recorded sounds and decide which ones are pleasant to the ear. What sounds are unpleasant? Ask children to name some sounds they have heard that are unpleasant. What is noise?

Activities for children

- 1 Children may duplicate familiar sounds and ask other children to guess what sound they are making.
- 2 Tap a pint milk bottle with a ruler or pencil. Now tap a quart milk bottle. Is the sound different? Tap a quart bottle with a narrow top.
- 3 As the children work or play in groups, call attention to the sounds they make. Is noise produced when everyone is talking at once?
- 4 Have children name sounds which are "summertime" sound, "nighttime" sounds, "city" sounds, "farm" sounds. Have them classify and name other sounds.

Fieldwork

- 1 Record sounds made in the classroom on a tape recorder. Use them for identification of specific sounds, differences between pleasant sounds and noise, soft sounds and loud sounds.
- 2 Visit various areas in or near the school building to notice what things produce noise.

ENRICHMENT

Questions to stimulate further thought

1. How do animals use their ears to keep out of danger?
2. Why does a dog prick up his ears when he hears a noise?
3. Many jobs use certain sounds. What special sounds are used by policemen, firemen, truckers, and others?
4. How do sounds differ?
5. What would our life be like if we couldn't hear?

Topics for additional exploration

- 1 *Sound loudness.* Some sounds are louder than others. How are quiet sounds produced? Loud sounds?
- 2 *Sound pitch.* Some sounds are high (squeaks), and some are low (truck or tuba).
- 3 *Sound recording.* We can keep sounds (records and tapes) to hear over and over, as we can keep pictures (photographs and paintings) to see again and again.

ORGANIZATION AND USE OF INFORMATION GAINED

Projects

- 1 Collect pictures for a bulletin board display of objects or situations which produce noise. Place "pleasant" noises on one side of board, and "dangerous or unpleasant" noises on the other side.

Questions to guide a summary of experiences

1. What things make sounds?
2. How do we hear?
3. What good does it do us to hear?
4. How do sounds differ?
5. How do we use sounds?

BASIC UNDERSTANDINGS TO BE GAINED FROM THIS UNIT

1. Sounds are made by people, animals, and moving objects.
2. Sounds travel in all directions.
3. We hear sounds with our ears.
4. Sounds may be pleasant or unpleasant.
5. Sounds can warn us of danger.

VOCABULARY

hear noise pleasant sound travel

First Grade

a LIVING THINGS

b OUR GROWING BODIES

c AIR, WATER, AND WEATHER

d THE EARTH AND ITS COMPOSITION

e THE SOLAR SYSTEM AND BEYOND

f MATTER AND ENERGY

First Grade

a LIVING THINGS

HOW AND WHY LIVING THINGS MOVE

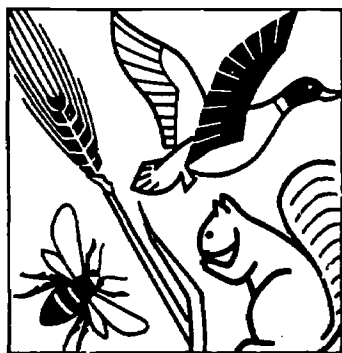

PURPOSE OF THE UNIT: *to become aware of how
and why living things move*

Apparatus and materials

1. Ant observation nest
2. Aquarium
3. Coffee-can cage
4. Containers, shallow
5. Jars, wide-mouth gallon
6. Plants, potted (geranium, coleus)
7. Reading glass or hand lens
8. Snakes, small (in appropriate containers)
9. Terrariums
10. Thermometer
11. Turtles
12. Seeds, lima bean
13. Sponges

INTRODUCTION OF THE UNIT

Motivating activities

- 1 Talk about and list familiar animals and the means by which they move (hop, crawl, fly, run).
- 2 List some things that you think might make animals move (food, other animals, fear, sudden noise or movement, enemies).
- 3 Display pictures of animals, such as a squirrel, duck, wading bird, deer, and cat; have children tell how the animals' feet or legs are especially adapted to moving about.
- 4 Exhibit a variety of animals, in terrariums or other containers, which illustrate different methods of movement (snail, snake, toad or frog, turtle, mouse or hamster).
- 5 Make a bulletin board display picturing some common birds.
- 6 Show some pictures of animals with two legs, four legs, or six legs; animals that crawl, swim, or fly.
- 7 Explain that some animals remain in one place as adults (barnacles, anemones).
- 8 Place a potted plant near a window so the leaves will turn to face the sun. Call attention to the movement of tree branches when the wind blows.

Motivating questions

1. Why do animals move?
2. Can a plant move?
3. What are some animals that move fast?
4. Can you name some slow-moving animals? Some animals that seem not to move at all?
5. What animals can fly?
6. What are some other ways that animals move?
7. How do animals take care of their young?
8. Have you seen many kinds of plants? Where?
9. What things do animals need in order to live?
10. What do plants need in order to live?

EXPERIENCES RELATING TO THE UNIT

Teacher-directed activities

Note: Since many of the activities described for this age level involve observation, a reading glass or hand lens should be available for the children's use.

1 The teacher may use the terrarium to teach about places where animals live. The natural requirements of plants and animals should be considered when terrariums are assembled. Empty gallon mayonnaise or pickle jars may be obtained from the cafeteria for this purpose.

2 Aquariums may be utilized as centers of interest. These may be stocked with native fish in pond or stream water. Tropical fish may be used, but usually require

more care than native fish. Children will observe the movements, feeding habits, and other characteristics of fish, as well as the balance in nature.

3

Turtles are interesting classroom pets. They may be housed in a variety of containers depending upon the nature of the turtle. The children will be able to observe how the turtle moves in water and on land. They can discuss the characteristics of the turtle, its food, habits, structure, color, etc. They will see that young turtles resemble adults. If both land and water turtles are available, compare their feet.

4

Small snakes may be kept in terrariums or other types of containers. The movements of snakes are rather unique and interesting. The children will observe that snakes have dry skin and are not "slimy." The teacher may point out some of the unjustifiable beliefs about snakes. For example, there is no reason to believe that snakes form a hoop and roll downhill or that snakes "milk" cows.

5

Certain small mammals, such as domestic rabbits, hamsters, or white mice, are easy to care for in the classroom. Children may note and discuss how they move and the types of food they eat. The teacher may discuss the natural home of similar animals. If the animals have young, the children will have the opportunity of observing how the parent animals care for their offspring.

6

During certain seasons of the year children will probably bring amphibians, such as frogs, toads, and salamanders, to school. These may be kept in terrariums, large-mouthed gallon jars, or shallow pans. The teacher may ask where the specimens were found. This will usually lead to a discussion of where these animals live. The children can also observe how these animals move and the types of food eaten by many amphibians. Some frogs can be taught to eat a small piece of hamburger dangled on a long piece of string in the frog's view. If the animals are kept for only a day or two they will need water but not food, since they can live on stored body fat.

7

The movements of various water insects are fascinating. They may be kept in wide-mouthed gallon jars of water. Water beetles, dragonfly nymphs, water striders (not spiders), water boatmen, and back swimmers are quite common and may be obtained in small ponds and streams.

8

Ants are amazing little insects and their activities may be readily observed in the classroom. Ant observation nests are commercially available, or they may be constructed from scrap materials. Mound building ants may be collected along with dirt from the ant hill and placed in a large glass jar covered with fine screening. Carpenter ants (ants that live in wood) may be kept in a quart jar with a fine screen or cheesecloth top. Place a piece of the wood collected with the ants in the container. Ants will feed on sugar and water.

9

The locomotion of snails and slugs may be observed in an aquarium or a terrarium.

10

Various insects such as grasshoppers, crickets, beetles, and praying mantes may be kept in coffee-can insect cages. Children will be able to compare their movements and note their preferences for food. The teacher may discuss the importance of some insects to man; some being helpful, some being harmful. Insects are important as a source of food for some birds and some animals.

11
Collect caterpillars with their food plants; normally the food plant will be the plant the caterpillar was found on. A coffee-can cage (see Kindergarten, Living Things) makes a good container. Children should note the caterpillar's manner of movement, the fact that a caterpillar seems to have legs at both ends of the body or, in some cases, all along the body; actually, only the three pairs immediately behind the head are true legs. The caterpillar of the monarch butterfly, which is still available when school opens in September, is an ideal insect for this activity. It is a colorful, conspicuous caterpillar commonly found on milkweed.

12
A most interesting type of animal movement is illustrated by the fresh water crayfish (sometimes incorrectly referred to as a crab). These interesting animals may be kept in shallow glass or metal containers of water. They will eat bits of meat, fish, or earthworm. Provide a small stone house for them to hide under. Notice the direction in which the crayfish moves when disturbed. Does it move rapidly?

13
The flight of birds or their movement on the ground can usually be observed from the schoolroom window. Do some birds hop? Do some birds walk? An opportunity for a closer observation of a bird may be possible if one of the children brings a pet bird to class for a few days.

14
Display some evidence of homes constructed by animals, such as a bird's nest, a hornets' nest, or a cocoon. Discuss animals which do not make homes, but which find a suitable place to occupy as a home.

15
Show some pictures of the homes of animals such as the beaver, fox, squirrel, rabbit, and bear. Discuss how man sometimes makes homes to attract certain animals.

16
Make a display of pictures which show the different environments of animals, such as the forest, beach, pond, stream bank, meadow, and rocky place. The teacher may call attention to the types of plants that grow in these areas.

17
Exhibit a variety of plants which the children may have observed during past experiences. Include some house plants, garden plants, water plants in an aquarium, and some wildflowers. Talk about places where children have observed plants growing. From the discussion, children should come to realize that there are many kinds of plants and they grow in a variety of places.

18
Woodland terrariums may be used to call attention to some of the plants which live in a woodland habitat. Some of these might include a fern, partridge berry, mosses, ground pine, pine seedling, fungus, and lichen. Terrariums also serve to illustrate some of the conditions necessary for plants and animals, such as temperature, water, air, and light. If a terrarium which has a glass cover is placed in direct sunlight, the temperature inside the container may become unbearable for animals such as amphibians and reptiles. The growth of a mold on the plants is usually an indication of a lack of air or of dying plants. A small thermometer placed in one corner will record the temperature inside the container.

19
Place two potted plants, such as geranium or coleus, in a well-lighted place in the room. Water one of the plants regularly, but deprive the other plant of all water. Observe what happens to the plant which did not receive water after a period of time. Both plants receive the same amount of air and light, but the one which lacks water will begin to wilt and die.

20

Demonstrate how plants depend upon water for growth. Obtain three sponges and place two of them in shallow containers that will hold water. Pour enough water into the containers to moisten the sponges. Place the third sponge on a dry plate. Sprinkle some grass seed on all three sponges. Keep two sponges moist. Place the containers out of direct sunlight. The seeds on the wet sponges will begin to sprout in a few days. The seeds on the dry sponge will not germinate because they lack moisture. Remove the water from one of the containers and observe what happens to the sprouting plants. When the source of water is removed, they will die. Sprinkle some seeds on a damp sponge and place it in a cold place (refrigerator). Check the seeds in a few days.

21

Plants depend on sunlight for growth. Obtain two potted plants. Place one of the pots in a closet and the other in the classroom. Keep both plants watered. Observe the plants at 3-day intervals. The plant in the light will remain healthy. The one placed in the dark area will lose its vigor and will die if left in the dark for an extended time.

22

During discussions with the children, the teacher should emphasize the fact that plants are incapable of moving about as animals do. Children will undoubtedly become aware of this through their experiences and observations.

23

The teacher may select a picture of a common bird which children may observe during a particular season. Place this on a bulletin board with the questions "Have you seen this bird today?" "Where?" "When?"

24

A number of high-quality color films are available which show various animals in their natural habitats. Since even lengthy observation in the field will result in only limited study, films can be a very effective teaching device in this particular area.

Note: Individuals or groups of children will benefit most from their experiences with plants and animals if they are permitted to share in the responsibility of their care. Children should be free to make individual or small group observations of living things in the classroom. Whenever possible, they may handle animals with care and have the opportunity to examine plant life closely.

Activities for children

1

Children may imitate or describe the movements of a particular animal. The other members of the class try to guess the name of the animal.

2

Young children may have a better understanding of the function of seeds if they can examine one closely. Each child should have a lima bean seed soaked in water overnight. With the aid of the teacher he can break it open and find the tiny plant inside. He will see the miniature root, stem, and leaves. For a closer look, place the tiny plant under a magnifier.

3

Using the information gained from observation and class discussions, children may briefly act out and describe a short story of a plant or animal, then ask "What am I?" Example: I like to live in or near water. I carry my house with me and I can hide from other animals in it. I cannot walk very well on land but can move fast in the water. When winter comes I bury myself in mud and sleep until spring. In the summer I like to rest in the sun on a log or rock. What am I?

4
Have each child bring a plant (or part of a plant) to class. They may tell where it came from, where it usually grows, the name (if known), and any other facts they have learned about it.

5
Watch for birds during the different seasons. During fall the children may discuss the absence of certain birds. In the winter they may talk about winter visitors from the north. During the spring, children will be aware of birds returning from the south where they have spent the winter.

6
On the way to and from school, look for animals. Discuss what they were doing. Talk about how they move. Name all the different kinds of animals seen on the way to school.

7
The teacher may help the children arrange dry winter bouquets. Ask the children to bring in some dried plants and seed pods which are found in fields, along roadsides, and in vacant lots in late fall. The bouquet may be arranged in a clay base. Study the seeds and plants for dispersal characteristics.

Fieldwork

1
Take a walk around the school building to look for different animals and animal homes. Evidences of a variety of insects can be found almost everywhere, even on a surfaced play area. Look for cocoons or egg cases under window sills, between bricks, in the grass, or on tree trunks. Children will note that the protective coloration of some animals makes them difficult to see. Turn over some stones or dig up some soil to look for signs of animal life. Look for birds in trees or on buildings near the school. What other animals live in trees?

2
Most school grounds are planted with a variety of native and introduced plants. Children can become familiar with some of the common trees and other plants. Notice the difference in the leaves of trees and the colors of flowers. Note some of the different plants that grow in the grass. In some localities the children may be taken for walks along the streets, in parks, and to other nearby places.

3
Take seasonal walks in the vicinity of the school building to note the changes in plants and animals.

4
A visit to a zoo is possible for schools in some localities. The children have the opportunity to observe the movements and characteristics of a variety of animals.

5
A winter walk around the school building will give children the opportunity to look for animal tracks in the snow. If pictures of animal tracks have been studied, identification will be easier. The tracks may serve as a clue to the movements of some animals. Can you find the tracks of a hopping bird? A walking bird? What do squirrel tracks look like? Can you find tracks of an animal whose tail leaves an impression in the snow?

6
Field trips may be used for collecting purposes. Children will enjoy helping to gather materials for a terrarium or an aquarium, or collecting other things for an interest center. Collecting trips provide an excellent opportunity to talk about good conservation practices.

7

Children will enjoy taking trips to look for wildflowers. They will particularly enjoy the woodland wildflowers during the spring and fall seasons. It will not be possible for children to visit woodland areas in all localities. However, there are wooded areas in some city parks and places set aside for wildflower gardens. Some of the most unusual wildflowers, often considered weeds, grow along roadways, railroad tracks, and in vacant city lots. Discuss the need for conservation. How did the seeds get to these places?

8

Take a walk along a stream or visit a pond. It is almost always possible to see an abundant variety of wildlife near water. Look for frogs, salamanders, turtles, fish, snails, water insects, birds, and evidences of other animals. Observe the different kinds of plants which grow in and near the water.

9

Visit a pet store to see the variety of animals on display. Observe the characteristics of different animals, movement, eating habits, or other special things. Children probably will want to question the shop owner about the care and feeding habits of animals.

10

Take a trip to an animal shelter. Children will learn about the care and treatment of pets. They will become aware of the care of pets without homes.

ENRICHMENT

Questions to stimulate further thought

1. Can you name some animals that move by one method when they are young and by another method in their adult form?
2. How do you think animals can find their way during long trips?
3. Can plants live without sunlight?
4. Where would you find great numbers of animals living?
5. If plants cannot move, how do you account for the weeds which appear in gardens?
6. How do disease germs travel from one person to another?

Topics for additional exploration

1

Migration. In addition to moving about locally for food and warmth, some animals migrate (travel) great distances. The robin, the elk, and the salmon are interesting examples.

2

Domesticated animals. After man domesticates wild animals, they often become dependent on him for food.

3

Hibernation. Some animals which do not migrate in winter hibernate during seasons of food scarcity.

4

Animal movements. Some more unique methods of animal locomotion are used by the squid, the inchworm, the earthworm, and the flying squirrel.

5

Adaptation for survival. Some plants and animals can survive under conditions which are not suitable for other plants and animals.

ORGANIZATION AND USE OF INFORMATION GAINED

Projects

- 1 Have the children make a large mural showing animal homes. Draw and color the animals; then cut them out and paste the animals on the mural paper.
- 2 Make a chart listing the ways animals move. Headings might include two legs, four legs, six legs, crawl, fly, and swim. Pictures of animals can be placed on the chart.
- 3 Show the children how to make small terrariums from bowls or glass jars.
- 4 Make experience charts to summarize field trips, observations, and how we take care of our turtle (or other animals and plants, aquarium, etc.).
- 5 Make a collection of seeds and tell how they are moved from the plant to the place where they will grow.
- 6 Make a leaf collection. Have any of these leaves ever moved from place to place?
- 7 The teacher can sketch in backgrounds for murals showing where animals live: pond, meadow, forest, backyards, gardens, etc. Children can make cutouts of appropriate animals and place them on the mural paper.

**Questions to guide
a summary of experiences**

1. How do animals differ from plants in the way they get their food?
2. How do animals move from place to place?
3. What parts of their bodies do animals use in moving about?
4. What are some animals that do not seem to move from place to place?
5. Where do animals live? Do all animals make homes?
6. How many kinds of plants can you name? Are there any others?
7. Can plants move from place to place?
8. What do plants and animals need in order to live?

BASIC UNDERSTANDINGS TO BE GAINED FROM THIS UNIT

1. Most animals can move from place to place.
2. Animals move in different ways.
3. Animals live in many kinds of places.
4. There are many kinds of plants.
5. Most plants cannot move about as animals do.
6. Certain conditions (temperature, water, etc.) are necessary for living things.

VOCABULARY

animal	crawl	fly	home	hop	move
<hr/>					
nest	plant	run	seed	swim	walk

First Grade

b OUR GROWING BODIES

PURPOSE OF THE UNIT: *to become aware of the relation
of food to growth*

FOOD TO GROW ON

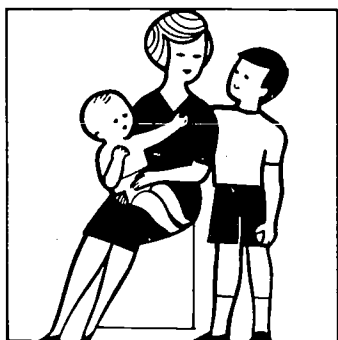

Apparatus and materials: Hamsters or white rats

INTRODUCTION OF THE UNIT

Motivating activities

- 1
Have children collect pictures of foods for the bulletin board. Include a few pictures of desserts — they serve a purpose later in the unit.
- 2
Discuss the various states in which we get our food — raw, fresh, frozen, canned, dehydrated, and cooked.
- 3
Invite the school cafeteria manager or the school nurse-teacher to the room for talks about eating the right foods for growth.
- 4
Ask the school nurse-teacher to explain the use of the Wetzel Grid (or A.M.A. growth charts) as a means of determining individual growth progress.

Motivating questions

1. What is food?
2. Do we all need food?
3. Do we all need the same amount of food?
4. Do animals need food?
5. Do plants need food?
6. Why do we need food?
7. What foods are especially good for us?
8. Do you like all kinds of foods?
9. Do you like fruit? Name some fruits.
10. Do you like vegetables? Name some vegetables.
11. Do you like milk?
12. Do you like meat?

EXPERIENCES RELATING TO THE UNIT

Teacher-directed activities

- 1
A bulletin board prepared with pictures of Fundamental Four groups of foods or the Basic Seven groups of foods will portray the foods considered essential to growth and development.
- 2
Explain what these different groups of foods give us in the way of nutrients. These pictures can form the basis for an explanation of the difference between a "food" and a "nutrient."
- 3
Some things which we like and eat often are obviously missing from the illustration mentioned above. Discuss the absence from the charts of such edibles as candy, cake, and pie, and explain why they are not included as essential foods.
- 4
Read stories that include foods eaten by children in other countries. Compare these foreign foods to the foods shown on the charts in the room. This may lead to a discussion of growth by children who eat foods different from those we are used to eating. This discussion can obviously be related to the earlier explanation of nutrients.

5
With careful explanation and supervision, one or two animals (hamsters, white rats, etc.) in the room may be deprived of food or placed on a very limited diet for a few days. A few days should be sufficient to show lack of growth, perhaps actual loss of weight. Care must be exercised, however, to provide the animals with water. This latter point can lead to a discussion of our need for water even though it may not be listed as an essential food.

Activities for children

1
Have children bring a list of, or tell, what they had to eat for breakfast and dinner the day before.

2
Have children tell what they chose for lunch from the foods in the cafeteria.

3
Let the children compare the food they had to eat with the lists of recommended foods on the bulletin board.

4
Have the children tell what they feed their pets at home. Discuss what is fed to the animal pets in the classroom.

5
Some children may come from homes where bird feeders are used in the winter. Have these children tell what things the birds eat. Explain (or have them explain) why these birds need this food to avoid possible starvation.

6
Some children may have watched a mother robin feed worms to the young robins in the nest. The children may tell about this, showing the universal need for food.

Fieldwork

1
On a trip to the local florist, nursery, or farm, have children ask what plants get for food and how they get this food. Examine packages of plant food.

2
If possible, go to a zoo or animal farm to see small animals and discuss with the keeper or owner the feeding of small animals.

3
On a visit to a supermarket, one may find, in addition to food for children, food such as bird seed, cat food, and dog food. The listed contents may be discussed in terms of growth.

ENRICHMENT

Questions to stimulate further thought

1. Why do we eat so many different kinds of food?
2. What happens if we eat too little food?
3. What happens to us if we eat too much food?
4. How can we tell if we have had too much or too little to eat? (An explanation of appetite as a poor indicator of food need may be good at this point. Reliance on height, weight, age, and body-build tables is a better basis for comparison.)
5. What should we eat for breakfast? Why?
6. What kinds of foods are best for growing?

Topics for additional exploration

1
The food we eat. What happens to the food we eat? Children can be given the rudimentary facts of digestion, absorption, and assimilation.

2
Growth. Why do we all grow differently in height and weight? Explain some facts of heredity and the individual growth characteristics that are found within the "normal" range.

ORGANIZATION AND USE OF INFORMATION GAINED

Projects

1
Have children bring in pictures of children eating, of adults eating, and compare the foods shown with those listed on the food charts.

2
Prior to lunch time, let the children select from the cafeteria menu the foods they will actually select to eat from those available that day. Have them check with the recommended foods to discover if they are proper foods.

3
Using the Wetzel Grid, or similar growth and development charts, discuss children's progress in growth.

Questions to guide a summary of experiences

1. Is all food equally good for our growth?
2. What foods are especially good for growth?
3. Do all living things need food for growth?
4. Must we all eat exactly the same foods if we all wish to grow?
5. What are some other things we need in addition to food if we wish to grow?

BASIC UNDERSTANDINGS TO BE GAINED FROM THIS UNIT

1. Certain kinds of foods are necessary for growth.
2. Some foods are better for us than others.
3. Food alone does not determine how we grow.
4. We need more of some kinds of food than others.

VOCABULARY

appetite	citrus fruit	diet	digestion
<hr/>			
fertilizer	florist	nutrition	starve

First Grade

C AIR, WATER, AND WEATHER

PURPOSE OF THE UNIT: *to determine the nature of air*

AIR

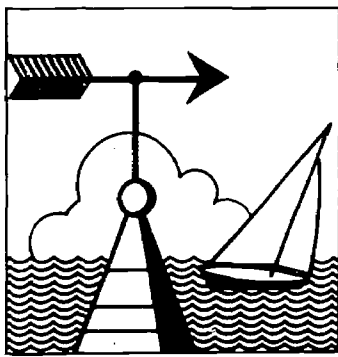

Apparatus and materials

1. Bag, plastic
2. Balloons
3. Bowl
4. Cup, paper
5. Dish
6. Fan, electric
7. Milkweed pod
8. Seeds, windblown
9. Shoebox
10. Tumbler, glass

INTRODUCTION OF THE UNIT

Motivating activities

- 1
Make a bulletin board display illustrating air at work. Include pictures of a bird in flight, a glider, an airplane, a windmill, and an electric fan.
- 2
Show newspaper or magazine pictures of destructive forces of air such as hurricanes and cyclones.
- 3
Show a filmstrip on clouds, rain, and snow.
- 4
Blow up a balloon. Why does it get bigger? Let some air out. Why does it get smaller?
- 5
Have someone blow up a balloon, measure it around the middle with a string, and then tie it to the window sill (outside) for a while. Bring it back inside and measure it with the string again. Is the balloon bigger or smaller? Leave it in the room until it warms up. Measure it again. Does the balloon get bigger again? Does air change size as it gets colder or warmer?

Motivating questions

1. Does air take up space?
2. What things have you seen the wind carrying through the air?
3. Do clothes hung outdoors dry better on a calm day or a windy day?
4. Where is the sun on a cloudy day?

EXPERIENCES RELATING TO THE UNIT

Teacher-directed activities

- 1
Keep a chart for a week or a month to show wind direction. Record this each day at the same time (recess time). Perhaps this could be done twice a day, the first thing in the morning and the last thing before dismissal, to see if wind direction may change in the same day. Does the wind always come from the same direction? Does it seem to change within a few hours? Does it change its strength?
- 2
Demonstrate the effectiveness of moving air in the drying process. Wet three handkerchiefs. Hang one on a string in front of a fan. Hang another on a string in a corner of the room. Roll the third into a ball and put it in a waxpaper bag. Have children feel each handkerchief after varying intervals of time. Have them discuss their findings.
- 3
Using two handkerchiefs of the same size, wet both. Place one on the window ledge. Hang the other handkerchief outside the window and close the window on one edge to hold it in place. Compare the handkerchiefs to see which dries first.
- 4
Early in the fall get a pod from a milkweed. Keep the pod in a shoebox until it opens. Many hundreds of seeds will be available for demonstrations in the future. Release a single seed from an arm's reach above the floor. Watch how slowly it settles to the floor. Repeat outside the building. Notice that even in a quiet classroom, the air is in motion.

5
Place an ice cube on a dish and observe it every 5 minutes or so. Fill half of a paper cup with water and place it in the cafeteria freezer. Discuss the observations. Is water always a liquid?

6
To show that air takes up space, wad up a paper napkin and press it into the bottom of a glass tumbler. Place the tumbler mouth downward into a tank or a large jar of water. Remove it from the water and see that the napkin is still dry. There was no room for the water to get into the glass because it was already filled— with air. Repeat the procedure but tip the tumbler after it is submerged. Point out bubbles of air escaping and water entering.

7
To show that air takes up space, the following demonstration can be performed. Hold up a small "empty" plastic bag. Ask children if there is anything in it. Wave the bag through the air to trap some air, then twist the open end closed. Ask children if there is anything in it now. While still grasping the closed end of the bag, place it on a desk. Then place a heavy book on the bag. The children will see that the bag with a little air in it will support the book. If the bag didn't have anything in it, it could not support the book.

8
To show that "air is everywhere," put snow, blotting paper, and soil into glasses of water. Ask the children to explain the escaping bubbles.

9
Read poems about the wind, such as "The Wind" by Robert Louis Stevenson. Show how the force of the wind is suggested in the poem. (This will not be "science" as we usually consider it, but rather, a language arts activity.)

Activities for children

1
Have children observe each other as they inhale and exhale. Why do we get larger when we breathe in? Measurements of the difference can be made with a string or tape measure.

2
Wet two areas on the chalkboard with a damp sponge or cloth. Fan one of the spots and allow the other to dry normally. Which spot disappears more quickly? Why?

3
When snow is available, take a number 10 can or a similar-sized container outside and fill it with snow. To approximate the density of natural snowfall, do not pack. Bring it inside and place it near a source of heat. Observe periodically until the snow completely disappears. What is left? What happened to the snow? Is there a difference between the depth of snow that was put into the container and the depth of the water that is left? Discuss the difference.

Fieldwork

1
Go out to the school lawn or playground on a windy day. Pick some grass from the lawn, hold it at eye-level, then drop it. The teacher may mark how far the wind carries the grass by sticking a pencil or ruler in the ground. This experience may be repeated on calm days and very windy days.

2
Take children out on the playground on different days to observe the shape, size, and apparent height above the ground of clouds.

3

Take a walk near the building to find other seeds which depend on the wind to move them. Several varieties may be found in cities by visiting parks, tree-lined streets, or vacant lots. Some seeds are constructed so they will be easily transported by wind, with little parachutes, on wings, or they are light enough to be blown through the air.

ENRICHMENT

Questions to stimulate further thought

1. Even with rocket travel, people will probably never live on the moon as they live on the earth. Why?
2. When ice gets warm enough, it melts and becomes a liquid. What other things melt when they are heated?
3. How do clouds help us decide upon our activities?
4. Where does our drinking water come from? How did it get there?

Topics for additional exploration

1

Helpful wind. Wind helps to scatter and move many things. Seeds and boats are but two examples. Winds also help to change our weather.

2

Harmful wind. Winds can be especially harmful to shipping at sea and to coastal areas. In dry areas it can cause dust storms. Winds also help spread forest fires.

3

Uses of air. Air can be used to fill and shape things for us. It fills automobile tires, swimming toys, and balloons.

ORGANIZATION AND USE OF INFORMATION GAINED

Projects

1

Make up a collection of seeds which use the wind as an agent of dispersal: dandelion, milkweed, cattail, grass, maple, ailanthus, elm, and pine. An example of each may be enclosed in some plastic wrap and stapled or taped closed. These may then be mounted on a bulletin board or large chart paper.

2

Collect pictures of various kinds of boats. In what way is each special? A similar collection of airplanes may be made.

3

Children may make a small collection of pictures cut from magazines showing various types of weather, such as snowy, rainy, bright, or clear.

Questions to guide a summary of experiences

1. What is wind?
2. How can you tell which way the wind is blowing?
3. How can you tell how hard the wind is blowing?
4. How is the wind useful to people?
5. How can wind cause harm to people?
6. Where do the rain and snow come from?
7. How do we know that air takes up space?
8. How does the wind help carry plant seeds from one place to another?

BASIC UNDERSTANDINGS TO BE GAINED FROM THIS UNIT

1. Air takes up space.
2. Most containers which we say are empty are really filled with air.
3. The surface of the earth is warmed in the daytime and cools at night. This in turn warms or cools the air above it.
4. Winds move at different speeds and from different directions.
5. Winds can carry plant seeds.
6. Winds help things to dry.
7. Winds are sometimes harmful.
8. Rain and snow come from water vapor (clouds) in the air.
9. Clouds have different shapes.

VOCABULARY

destructive

east

evaporation

hurricane

liquid

north

parachute

recreation

solid

south

transportation

west

First Grade

d THE EARTH AND ITS COMPOSITION

SAND, SOIL, AND USES OF STONE



PURPOSE OF THE UNIT: *to learn about sand, soil, and uses of stone*

Apparatus and materials

1. Cement
2. Concrete, small piece
3. Cups, paper
4. Display of rough and polished building stone
5. Hand lens
6. Jar, gallon
7. Microprojector
8. Rocks or broken brick
9. Sand
10. Sandstone or shale
11. Soil

INTRODUCTION OF THE UNIT***Motivating activities***

- 1
Show pictures of beaches and deserts.
- 2
Show pictures of freshly plowed farm land.
- 3
Use a bulletin board to display pictures of uses of stone around the home and the school.
- 4
Exhibit a piece of concrete with a "What is it?" label. Let children guess what it is and discuss their answers. Talk with them about where it could have come from.
- 5
Put some soil collected from different locations, and some sand in separate open containers. Place them where children may see them and feel the contents if they wish.

Motivating questions

1. Where have you seen sand?
2. What does sand look like?
3. Did any sand or dirt ever get into your mouth? Eye? How did it feel?
4. What is soil? Where is it found?
5. How are soil and sand alike?
6. Have you ever seen anyone using stone? How?
7. Ask children to recall what they learned about stone in kindergarten.

EXPERIENCES RELATING TO THE UNIT***Teacher-directed activities***

- 1
Place small rocks or pieces of brick in a cloth bag or wrap them in heavy cloth. Strike the bag of rocks with a hammer repeatedly. Open the bag and note the soil that was formed.
- 2
Put a cup of soil or sand in a gallon jar three-quarters full of water. Shake the contents thoroughly and let it settle into layers according to the size of the particles. If sand is used, make sure it is not too well sorted to show layering.
- 3
Use a microprojector to show magnified images of sand grains to the class. Note the shape and the size of the grains. Discuss the causes of rounding.
- 4
Discuss with the children some of the uses of stone that may be familiar to them. These might include roads, sidewalks, houses, and works of art.
- 5
Display some rough and polished sections of building stone (from a stonemason or monument works). Use pictures to show how they are used.
- 6
Take the children through the school building to look for places where stone (natural or man-made) is used.

Activities for children

- 1 Examine sand and soil with a hand lens.
- 2 Rub two pieces of sandstone or shale together. Collect the residue formed on a piece of paper.
- 3 Examine a piece of concrete and a piece of brick with a hand lens. Can you find some natural stones that look like these? How are they alike? How are they different?
- 4 Touch and feel sand and soil. How do they feel?
- 5 Mix a cup of cement with one-half cup of water. Pour the mixture into a plastic container or paper cup. Let it set overnight. Pour off any excess water, remove it from the container, and let it dry. Have you made stone? Is it hard? Make different shapes with homemade molds.

Fieldwork

- 1 Take children out to the school yard or a neighboring area to collect a small pail of dirt (soil). Dump this on a tray to see what the land (or soil) is made of.
- 2 Take a trip to visit a stonecutter. See what kind of stone (hard, flat, colored) he is using. Notice the tools he uses to cut the rock.
- 3 Visit a place where a new house or larger building is being built. Look for uses of stone. Find out why it is used. Find out why concrete is poured between a wall of boards (forms). Why are chimneys made of brick?

ENRICHMENT

Questions to stimulate further thought

1. How did the Indians make use of stone?
2. Why are some rocks formed in layers?
3. How does a volcano form new rock?
4. Does rock rust in the out-of-doors?
5. What is the road to the school made of?
6. Can anything live in sandy places?
7. Do animals live in the soil?

Topics for additional exploration

- 1 *Weathering.* Rock is broken into sand and soil by rubbing, chipping, and frost action.
- 2 *Rock particles.* When rock particles are very fine they are called clay.
- 3 *Plant food in soil.* Most plants require soil that has decaying life in it as well as sand.
- 4 *Uses of sand.* Sand is used for play, making concrete, and putting out fires.

First Grade

e THE SOLAR SYSTEM AND BEYOND

EARTH, SUN, AND MOON

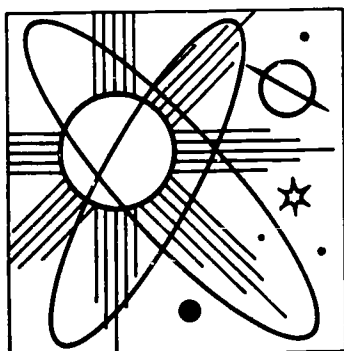

PURPOSE OF THE UNIT: *to learn about the relationship of the earth, the sun, and the moon*

Apparatus and materials

1. Balls, playground, varied sizes
2. Flashlight or filmstrip projector
3. Globe
4. Marbles
5. Sailboat, toy
6. Volley ball

INTRODUCTION OF THE UNIT**Motivating activities**

- 1 Make a bulletin board display showing some pictures of places and things on earth (mountains, lakes, forests, oceans, and clouds). Also display pictures of the surface of the sun and moon.
- 2 Show pictures of the earth that have been taken from rockets or high-flying airplanes.
- 3 Show pictures depicting the four seasons.

Motivating questions

1. When can we see the moon?
2. Is the moon as large as the earth?
3. Is the earth as large as the sun?
4. Is the moon or the sun nearer the earth?
5. What is the shape of the earth?
6. Do you dress differently in summer than you do in winter?
7. Is the air part of the earth?
8. What do we find on earth?
9. Would you like to go to the moon? Why?

EXPERIENCES RELATING TO THE UNIT**Teacher-directed activities**

- 1 To show that the earth is round, exhibit a globe of the earth. Examine the land and water areas. Find our country.
- 2 Talk about things children like to do in the spring, summer, fall, and winter. How does the change in seasons affect their activity?
- 3 To help children understand that the apparent size of objects is related to our distance from them, have the pupils stand at the back of the room and hold a volleyball about 10 feet in front of them. Have each child fully extend one arm and "measure" the size of the volleyball with a pencil or ruler as shown. Next, carry the volleyball to the front of the room and have the children measure its size again. Has the size changed? What happens to the size of the ball as it is moved toward the children? Follow this activity with a discussion of the size of airplanes in the sky, distant trees, houses, and other objects.

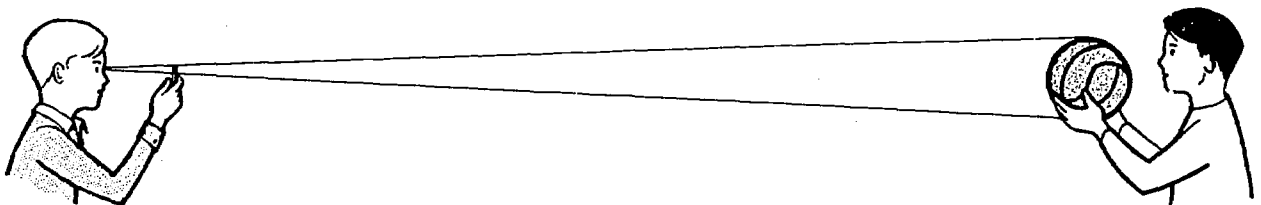

- 4 Observe objects at a great distance. How do they appear when we move closer to them? The sun is larger than the earth, but because of its great distance, it looks smaller.

5. Clarify the difference between seasons of the year, such as spring and fall, the rainy and dry seasons.

6. When the moon is in the daytime sky, take the children outside to observe its position on successive days. Ask the children if the moon is in the sky at night when it is also visible during the day. The moon is only visible in the daytime sky when it is on the same side of the earth as the sun. It is important that young children have first-hand observational experiences when studying the sun, moon, and stars.

Activities for children

1. Make a collection of round objects. Project light on them and check their shadows.

2. Have children follow the movements of the moon across the sky during the period of study. Each day, at the same time, check to see if the moon is visible. Continue this for at least 28 days. Report on observations. Is it always in the same place in the sky?

3. Slide a toy sailboat over a globe. Which part of the boat disappears first? Use a boat which is very small compared to the size of the globe. When a sailor sees a distant ship begin to come into view, what part will he see first?

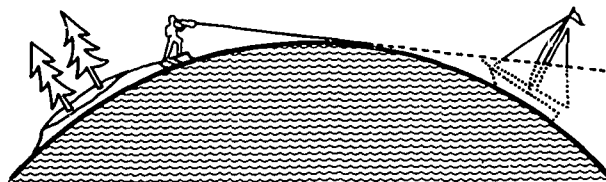
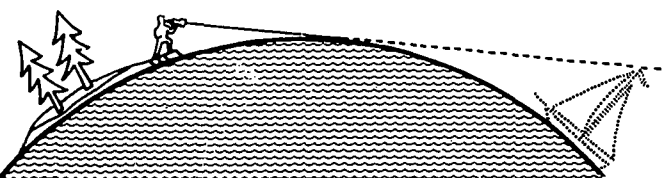

4. Obtain some different-sized balls, such as rubber playground balls, tennis balls, baseballs, golf balls, and marbles. Move your hand over the surface of each. Notice that the larger balls have the more gradual curve. Use this to explain the largeness of the earth and the apparent flat surface.

Fieldwork

1. Take the children for a walk to a nearby place which will allow them a good open vista, and review what they observed in kindergarten (hills, valleys, sky, water, etc.). Discuss distance and size with reference to landscape. A field experience of this nature may serve as a motivating activity for the introduction of the unit.

ENRICHMENT

1. If you could go to the moon, would it look larger as you approach it? Why? If you looked back at the earth, would it look smaller? Why?
2. Where does our water in lakes, oceans, and rivers come from?
3. Is the sun larger than the earth and the moon?
4. Do you think there might be life on our moon?
5. What would happen if the earth moved closer to the sun?

Questions to stimulate further thought

**Topics for
additional exploration**

1
Seasons. Because the direct rays of the sun shift from our northern hemisphere to our southern hemisphere and back, we have changing seasons. Seasonal changes affect plants, animals, and the weather. The word *season* is also used to describe such time spans as growing season, rainy season, baseball season, and football season.

2
Life on earth. Life is possible on the earth because our planet is located at the right distance from the sun. If we were much closer to the sun, the sun's heat would be too intense. At a greater distance there wouldn't be enough heat. In addition, the earth has an atmosphere of air which supplies us with oxygen and protects us like a blanket from harmful rays of the sun.

ORGANIZATION AND USE OF INFORMATION GAINED

Projects

1
Make a picture book using descriptive pictures to illustrate the different seasons. For example: summer — swimming and camping; fall — football and autumn colors.

2
Describe some of the figures that we might imagine when we look at the moon such as the "Man in the Moon" and "Jack and Jill." Use a good photograph of the moon taken through a telescope and post it on a display board.

3
Collect pictures of the moon. Many are available in magazines and newspapers.

4
Collect pictures of the sun.

5
Draw pictures of the earth as it might look from distant space.

**Questions to guide
a summary of experiences**

1. What surrounds the earth?
2. What do we see in the daytime sky?
3. What is the shape of the earth?
4. What do we know about the size of the sun?
5. What do we know about the size of the moon?
6. Where does the moon get its light?

BASIC UNDERSTANDINGS TO BE GAINED FROM THIS UNIT

1. The earth is round.
2. There is air all around the earth.
3. The sun is much larger than the earth.
4. The four seasons of the earth are spring, summer, fall, and winter.
5. The moon is smaller than the earth.
6. Sometimes we see both the moon and the sun in the sky.

VOCABULARY

distance globe rise season

set

surround

travel

First Grade

f MATTER AND ENERGY

PURPOSE OF THE UNIT: *to become aware of the effects
of heat and light around us*

HEAT AND LIGHT

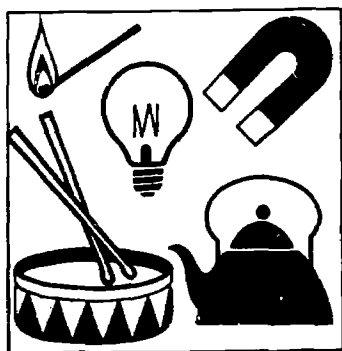

Apparatus and materials

1. Box, shoe
2. Candles
3. Paper, blueprint
4. Tweezers
5. Wire

INTRODUCTION OF THE UNIT

Motivating activities

1
Display pictures on the bulletin board showing various sources of light, such as the sun, fire, lightning, flashlight, lamps, etc. Have the children bring objects from home which give light.

2
Compare the clothing we wear outdoors with the clothing we wear indoors. Why are there differences?

Motivating questions

1. How can we tell when it is light and when it is dark?
2. How can we tell when something is hot or cold?
3. When do we like it dark? Light?
4. When do we want heat? Cold?

EXPERIENCES RELATING TO THE UNIT

Teacher-directed activities

1
For thousands of years, before 1880, man's major source of controllable light was the candle. Using adequate safety precautions, have children observe a burning candle and tell all they can about it, including colors, shape, and motion. Let children pass a piece of wire through the flame. Is the flame hard (solid)? Wet (liquid)? Hold a small piece of paper, about the size of a postage stamp, with tweezers and bring it about one-half inch from the side of the flame. (It will not burn.) From well above the flame, lower the paper slowly and see that the paper starts to burn before it comes within a half inch of the fire. What does this show about the direction the heat moves?

2
Show pictures of forest fires or burning buildings. Discuss how safety precautions and thoughtfulness could have spared such damage.

3
Explain the reasons for the fire drill procedures in the school.

4
Invite a member of the fire department to visit the class and discuss fire precautions in the home and school.

5
Discuss the heating system in the classroom. Why is it needed? What makes it warm? Arrange for the school custodian to show the children the central heating system for the building.

Activities for children

1
Have the children name all the things they can think of which produce light.

2
Have children name all the ways they use heat at home.

3
Using the direct sunlight or light from a slide projector, have children form shadow shapes on the wall or floor.

4
Have all children face a sunlit wall. Stand behind them and use familiar objects (book, pencil, purse, etc.) to cast shadows for them to see. Have them guess what the object is. Is there a relationship between the shape of the object and its shadow?

5
Find a cardboard box, such as a shoe box, that has an overlapping cover. Cut a round hole, about 1 inch in diameter, near each end of the cover. Place a picture in the bottom of the box, replace the cover, and lay a card over one of the holes. Now ask someone to look into the open hole and tell what the picture is. This is, of course, impossible because the card prevents light from entering the hole and illuminating the picture. Next, move the card to admit some light. The light that enters the box through the hole is now reflected from the picture into the eye. Some pupils, and even some adults, do not realize that light travels from objects into our eyes and not vice versa. This experience should help to correct such misconceptions.

Fieldwork

1
Walk through the school corridors and locate all the fire alarm bells. Why are there so many? How are they turned on? Why are "false alarms" serious?

2
Visit the local firehouse to see the fire trucks and other fire-fighting equipment.

3
Compare the lighting fixtures in the classroom with those in the hallways, gymnasium, and auditorium. How do they differ? Why?

ENRICHMENT

Questions to stimulate further thought

1. If we lived in complete darkness, how would our lives be different?
2. Many things that produce heat also produce light. What things can produce heat without light?
3. Why does the sun seem warmer in the summer than in the winter? This is an excellent time to clear up the misconception that the "earth is nearer the sun."
4. How do traffic lights help us in our daily living?

Topics for additional exploration

1
Photography. Simple prints can be made by laying familiar objects such as scissors or keys on blueprint paper and exposing them to light for several seconds. Develop the paper by washing in cold water, then relate it to the film in a camera. Blueprint paper can be obtained in art or photographic stores and in some drugstores.

2
Lighthouses. Where are lighthouses built and for what purpose?

ORGANIZATION AND USE OF INFORMATION GAINED

Projects

1
Collect magazine pictures showing how man produces and uses light.

Questions to guide a summary of experiences

1. Where does light come from?
2. What good does light do us?
3. What is a shadow?
4. Where or from what can we get heat?
5. Name some uses for heat.

BASIC UNDERSTANDINGS TO BE GAINED FROM THIS UNIT

1. Light lets us see.
2. Shadows are made when light is blocked.
3. The sun, fire, and electric lamps produce light and heat.
4. Heat has many uses.
5. Fire may cause great damage.

VOCABULARY

cold

dark

heat

light

safety

shadow

Second Grade

a LIVING THINGS

b OUR GROWING BODIES

c AIR, WATER, AND WEATHER

d THE EARTH AND ITS COMPOSITION

e THE SOLAR SYSTEM AND BEYOND

f MATTER AND ENERGY

Second Grade

a LIVING THINGS

PLANTS AND ANIMALS — THEIR FOOD

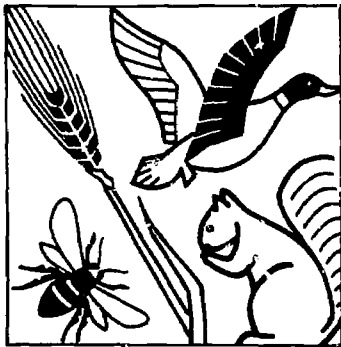

PURPOSE OF THE UNIT: *to learn how plants and animals obtain their food*

Apparatus and materials

1. Bird feeder
2. Egg incubator
3. Food coloring or ink
4. Frogs' eggs
5. Lima beans (seed)
6. Monarch caterpillar
7. Plants, potted (geranium, coleus)
8. Seeds (pumpkin, squash, bean)
9. Turtles
10. Water tumblers

INTRODUCTION OF THE UNIT

Motivating activities

- 1
Have the children care for classroom plants. Provide a variety of plants, such as geraniums, coleus, African violets, cactus, or other succulents. The children can root cuttings from geraniums or coleus, plant them in milk container "pots" after the roots have developed, and take them home.
- 2
Have the children assume the responsibility for feeding any classroom pets (fish, parakeet, rabbits).
- 3
Display some examples of animal foods. Include such things as a leaf that has been chewed by an animal, a golden rod gall (a swelling on the stem of the golden rod plant), sea shells with holes drilled in them, some seeds which have been gnawed (acorn), moth holes in clothing, and dead wood with insect holes.
- 4
Display some pictures that show animals feeding on a variety of foods: Cows eating grass, hummingbirds on flowers, birds catching insects or worms, squirrels feeding on seeds, insects eating garden plants.
- 5
Show some pictures of green plants and plants without a green coloration (fungi).
- 6
Exhibit pictures that denote growth changes in living things.

Motivating questions

1. How does your house pet get its food? What kind of food does it eat?
2. How do you care for plants at home? At school?
3. Do all living things need food? Why?
4. Can all living things eat the same kind of food?
5. Have you ever watched an animal try to catch another animal in order to eat it?
6. Of all the wild animals and birds that live in your community, which ones remain there all year?
7. Why are some animals absent part of the year?
8. How do plants and animals change as they grow?

EXPERIENCES RELATING TO THE UNIT

Teacher-directed activities

- 1
All green plants make their own food (sugar) out of water and a part of the air (carbon dioxide). It is the green part of the plant (chlorophyll) that makes the food. How many different kinds of plants can you name that have green leaves? Call attention to classroom plants. Do you feed these plants in the same manner that you feed animals?
- 2
Remove a green plant from its pot or uproot a native plant. Show the various parts of the plant to the children. Point out the leaves, stem, roots, and flower. Compare the thickness of the stem and roots to the leaves and leaf stems.
- 3
Exhibit separately various parts of plants such as a root (carrot), a stem (celery), leaves (cabbage, lettuce), bulbs (underground stem; i.e., tulip, narcissus), and seeds (orange, apple). Point out the fact that because plants store food, they are a valuable source of food for animals.

4

Many animals have preferences for certain parts of plants. Discuss some animals that feed on leaves, some that seem to prefer roots, bulbs, stems, or seeds. Name some that seem to eat almost anything. What part of the potato plant do we eat?

5

Keep some animals in the classroom that eat only plants for food. A variety of animals such as a rabbit, hamster, insect (grasshopper, cricket), caterpillar, slug, land snail, and a mouse may be used.

6

Aquariums or terrariums may be used to house animals that depend on other animals for food. Frogs, toads, salamanders, snakes, turtles, certain insects, and young mammals may be observed to note what they eat and how they obtain it. Have the children observe how frogs and toads catch their prey. Watch how turtles get their food. Do they have teeth? The praying mantis has a unique way of capturing its food. Snails may be observed feeding on plants in an aquarium. Turtles may be used to illustrate animals that eat both plant and animal matter.

7

The teacher may show pictures of other animals having similar food habits such as bears, skunks, raccoons, opossums, and foxes. During the spring season tadpoles and frogs are easily collected. This is an appropriate time to call the children's attention to the difference in food habits of the frog and the toad. During the frog's early stages of development (tadpole stage), its food is plant matter. When the frog matures, its chief food is animal matter.

8

Animals obtain their food in a variety of ways. Some animals have unique ways of capturing their food and others have unusual body parts which help them obtain food. Some spiders trap their food in webs; fish swim after their food; frogs and toads use their tongues; praying mantes remain motionless; woodpecker's bills help them get food; some animals pounce on their food, and others run after their food. The teacher will be able to add many more to this list. The ways in which some animals obtain their food may be observed from classroom pets. The teacher may supplement the observations with pictures. Ask the children to name the food an animal eats as well as how it gets its food.

9

The teacher will be able to provide children with certain experiences to demonstrate how living things change as they grow. Collect some frogs' eggs and observe the changes in the life of the frog from the egg to adult. Keep caterpillars in the classroom and observe them as they spin their cocoons (form a chrysalis), then change to the adult form. The monarch caterpillar, which can be found on milkweed plants in the fall, will complete its life cycle in a relatively short time in the classroom. It is doubtful that children of this age will be able to collect the eggs of moths or butterflies. The teacher should point out that these insects do lay eggs. Children will note changes in plants as they grow from seeds. Young plants may be compared with mature plants to point out similarities and differences. Many living things change with the seasons. Observe the seasonal change of a certain tree from the classroom window. Some changes in living things occur rapidly and others change more slowly.

10

The teacher may discuss and illustrate "food chains" without using this term. Pictures may be used to show life in a pond. Minute living organisms are fed upon by water insects, which are eaten by larger animals, such as fish and turtles, and then the fish are eaten by man, larger fish, otters, etc. Relate this to life in a meadow or a forest. Where does man fit in? Green plants are always at

the beginning of any food chain. A fresh-water aquarium stocked with water plants and pond life will illustrate a simple food chain.

11
Read stories about animals which migrate or hibernate. Discuss the reasons for such animal behavior.

12
Baby animals are cared for in various ways. A discussion centering around how a mother animal feeds her young should point up some differences. Included in such a discussion should be mammals, birds, reptiles, insects, and amphibians. Children are often amazed to discover that many animals give no care to their young.

13
Films and/or filmstrips can be used to show the food-getting processes of various animals and to clarify other basic understandings about living things.

Activities for children

1
Children will benefit from firsthand observation of plants and animals in the classroom. They will note animal feeding habits by helping to feed them. They will have a better understanding of the needs of plants if they help care for them. The teacher can supplement their observations through discussions, visual aids, and field trips.

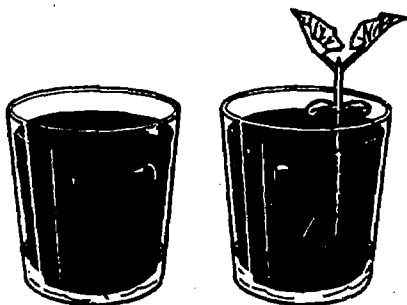

2
Supply each child with the leaf of a green plant for close examination. Look at the top of the leaf. Compare it with the underside of the leaf. Feel the texture of the leaf. Break off a portion of the leaf and smell it. The children may taste the leaves of the mint plant and those of leafy vegetables, if the leaves are clean and free from harmful microorganisms or insecticides. Does the leaf have a stem? What is the shape of the leaf? What is the color of the leaf? Do some leaves change color? Each teacher will develop techniques for extending this experience.



3
The roots of a plant grow down into the soil and the young shoots (stem and leaves) grow upward. Cut a piece of blotting paper to fit around the inside of a tumbler. Place some crumpled paper inside the tumbler to keep the blotting paper tight against the sides. Insert some pumpkin, squash, bean, or other large seeds between the blotting paper and the glass about halfway from the bottom. Pour just enough water into the bottom of the tumbler to wet the blotting paper. Observe the growth of the seeds until they are well sprouted. Do the roots grow down? Which way do the shoots grow? Remember to keep the blotting paper always moist. Turn the tumbler on its side and observe for a few days. Invert the tumbler and support it between two books or blocks of wood. Is there a change in the direction of growth of the roots and the stems? Due to the plant's response to gravity, no matter how the seed is placed in the soil, the roots grow down and the stems grow upward.

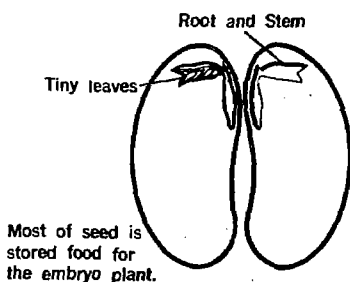

4
Green plants need light to make their food. A seed in the ground does not receive any light, but begins its growth (germinates) from food which has been stored around the tiny plant. Children can easily remove the covering from large lima beans which have been soaked in water overnight. The stored food can be split in two, exposing the tiny plant. Children will note the amount of stored food available to the tiny plant. They can open other seeds to compare the amount of food. They will see that seeds differ in the amount of food stored in them.

5

The material surrounding the tiny plant in a seed provides food for the plant to grow until the plant is able to make its own food. As the plant grows, it generally absorbs the stored food. By the time the food is used up, the plant has broken through the surface of the earth, its leaves receive sunlight, and the plant can begin making its own food. Fill a tumbler with good garden soil. Plant some large seeds in the container to a depth of about 2 inches so that they are visible through the glass. Plant one or two of the seeds at the bottom of the container. Water the seeds when needed with a small amount of water. Observe the seeds as they sprout. You will notice that as the seeds grow, the food supply becomes smaller until eventually it is used up. What happens to the seeds that were planted deep in the soil? If they sprout, repeat the experience with a deeper container. You will find a depth where the food supply will be exhausted before the plant breaks through. If the seedling fails to reach the surface after a week, dig it up for observation.

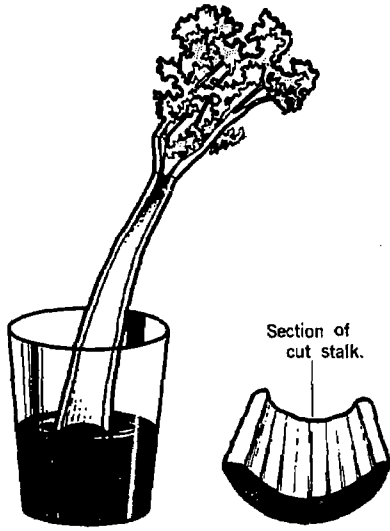

6

The stems not only store food but carry water and food from the soil to other parts of the plant. Provide each child or group with a fresh leafy stalk of celery from which $\frac{1}{2}$ " has just been cut off of the bottom. Place the lower part of the stalk in a container of water which has been colored with food coloring (or ink). Leave the stalk in this container and observe it every half hour. After a few hours, the teacher can cut off sections of the stem to see where it is colored. The leaves will become colored if the demonstration is continued for an hour or two. Using white carnations provides dramatic results.

7

Collect one or two sprouting maple seeds (or other tree seeds) in the spring. These can usually be found in various stages of growth. Observe the tiny growing tree. Do the leaves resemble the parent tree? Note that some of the young plants will have used up some of the food supply which has been stored in the seed. Plant some of these tiny trees and see if they will grow in the classroom.

8

Tell about seasonal observations of birds. Observe how some animals prepare for winter. Children will see animals gathering food for winter use. They can tell about changes in their pets. The coats of fur-bearing animals become thicker as cold weather approaches. Perhaps the children will notice the absence of some animals, such as snakes, frogs, and turtles.

9

Select an interesting animal and draw or paint a picture showing how it gets its food.

10

Paint a picture of a classroom plant.

11

Draw pictures of baby animals.

Fieldwork

1

Select a tree near the school building. Beginning in September, visit the tree periodically during the different seasons. Note the changes in the tree as it goes through its yearly cycle. What is the name of the tree? What shape are the leaves? What color are the leaves in the fall? What animals live in the tree? How does the tree help us?

2

Visit a vegetable garden. Find examples of leaves, roots, stems, bulbs, and seeds. Discuss the parts of various plants which are used for food.

3
Take a trip to a greenhouse. Ask questions about the care of certain plants. Find out how new plants are grown from mature plants. Find out how long it takes for some plants to grow.

4
Children can observe evidences of animal food near a pond, stream, or swamp. They might see the remains of a crayfish which has been fed upon by a raccoon or the remains of turtle eggs which have been devoured by a skunk, fox, or raccoon. Perhaps they will find the shells of seeds that provided a meal for a squirrel or a member of the mouse family.

5
Take a walk around the school following a heavy storm. Look for uprooted trees to observe the roots which held the tree in the ground. Examine branches which have broken off of trees. Note the size of fallen trees. (Children living in areas bounded by large bodies of water can visit beaches following heavy storms and high water. An unusual quantity and variety of living things will be found among the debris which has washed up on the beach.)

ENRICHMENT

Questions to stimulate further thought

1. In the winter, when the leaves drop off a tree, how does it live?
2. Not all plants are green, but only green plants can make their own food. How does a mushroom (or other fungus) live?
3. A chicken (bird) has no teeth. How, then, does it grind its food?
4. Some animals hunt other animals for food at night. How do they find their food?
5. Have you watched a robin hunting for worms on a lawn? Why does the bird cock its head to one side?
6. How do animals breathe during hibernation in the winter?
7. How do some plants trap insects for food?

Topics for additional exploration

1
The abundance of life. Plants and animals have adapted so that they live nearly everywhere — on land, in water, and in air.

2
Requirements for life. All living things must have food and water.

3
The source of food. Only green plants can make food. All living things depend directly or indirectly on the food that was made by green plants. This food-making process is called photosynthesis.

4
Green plants do not take in food through their roots. Green plants get minerals and water from the soil, but they manufacture their food.

5
Contents of a seed. All seeds contain a baby plant (embryo) with a supply of food for it to live on as it begins to grow.

6
Parts of a plant. Each part of a plant has a use. Roots absorb water and minerals from the soil. Stems hold the leaves up to receive light. Leaves manufacture food. Flowers and fruit produce seeds. Seeds are necessary for the survival of the species.

7.
Winter adaptation. In winter when the food is more difficult to find, some animals migrate to other regions; some live on food they have previously stored and others hibernate, living on the food stored in their bodies.

ORGANIZATION AND USE OF INFORMATION GAINED

Projects

1
Collect pictures of animals and arrange in groups according to their eating habits.

2
Show the importance of hawks and owls by collecting information about their food habits.

3
Exhibit some examples of nongreen plants.

4
Arrange some pictures showing the life cycle of a frog, a butterfly, or a moth.

5
Draw a mural depicting the dependence of animals on each other and on plants for food (a food chain). The mural may depict the relationships between water, forest, meadow, or beach animals that eat smaller animals or plants and then in turn are eaten by larger animals.

6
Draw a large simple diagram illustrating how green plants make food.

7
Label the prominent parts of a plant on chart paper.

8
Display pictures illustrating the various ways in which animals get their food. Include some of the structural adaptations which are used by animals (bills, tongues, mouth parts).

9
Exhibit the various parts of plants which may be used for food.

10
Display pictures of animals that migrate.

11
Display pictures of animals that hibernate.

12
It has been suggested (see Activity 1, Fieldwork) that the class select a tree and observe its seasonal cycle during the school year. Record observations and integrate with art and language arts.

13
Use pictures to illustrate the seasonal activities of animals.

14
Keep winter bird lists with colored pictures, if possible.

15
Place a bird feeder near the classroom window. During warmer months bird baths may be placed near the window.

16
Young chickens hatch from eggs. There are small commercial incubators available which may be used in the classroom to observe the development from egg to chick. *Only fertile eggs will hatch.* Fertile eggs can be obtained at a hatchery.

**Questions to guide
a summary of experiences**

1. Can you name some animals that eat plants?
2. Can you name some animals that eat other animals?
3. What animals eat both plants and meat?
4. Can you name some animals that have special ways of getting their food?
5. Where do plants get their food? What do they need?
6. Why does a plant have roots?
7. Why does a plant have a stem?
8. Why does a plant have leaves?
9. How are baby mammals fed?
10. How are baby robins fed?
11. How are baby turtles fed?
12. Why do some animals hibernate?
13. Why do some animals migrate?
14. Can you tell about animals that eat smaller animals or plants and in turn are eaten by larger animals?
15. Why are green plants the basic source of food?
16. How do living things change as they grow?

BASIC UNDERSTANDINGS TO BE GAINED FROM THIS UNIT

1. Some animals eat plants.
2. Some animals hunt other animals for food.
3. Green plants make their own food.
4. Green plants store food in their roots, stems, leaves, bulbs, and seeds.
5. Some animals move from place to place with the seasons in order to find food.
6. Living things change as they grow.

VOCABULARY

amphibian	aquarium	bird	bulb	fish
<hr/>				
hibernate	insect	leaves	mammal	migrate
<hr/>				
reptile	root	season	seed	spider
<hr/>				
	stem	terrarium		

Second Grade

b OUR GROWING BODIES

TEETH — TO HAVE AND TO KEEP

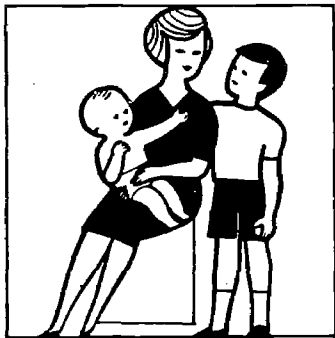

PURPOSE OF THE UNIT: to develop an understanding and appreciation of good dental health

Apparatus and materials

1. Dilute hydrochloric acid
2. Extracted tooth
3. Glass flask
4. Mirrors
5. Plaster models of jaws and teeth
6. Toothbrushes

INTRODUCTION OF THE UNIT

Motivating activities

- 1
The best possible "teachable moment" for a dental health lesson is when one of the pupils has a toothache or when one of the pupils has just lost one of his deciduous teeth. Interest at this point will usually be high.
- 2
Pictures of healthy and diseased teeth are readily available for display on the bulletin board. The local health department can often supply them for the teachers.
- 3
The science department in most districts will have a model of the upper and lower jaws which will show teeth in their proper relationship.
- 4
Pictures in magazines often show people smiling and their smiles are occasionally marred by missing teeth. These could be displayed alongside other pictures showing smiling people with no teeth missing.
- 5
Children could relate stories about "When I had a toothache" or "When my tooth was loose and came out."

Motivating questions

1. Does everybody have teeth?
2. Why do we have teeth? Stress speech and appearance as well as chewing.
3. Why do we lose our baby teeth?
4. What will happen if we lose our permanent teeth?
5. Do foods help us to have healthy teeth? How?
6. What foods are especially important?
7. How do we keep our teeth clean?
8. How many pupils have their own toothbrushes?
9. When do you use your toothbrush?
10. How many children go to the dentist?
11. Why do you go to the dentist?
12. Does the dentist help you? How?
13. Do animals have teeth?
14. How do they keep their teeth clean?
15. Do your pets at home ever have a toothache?
16. Do you take your pets to the dentist?

EXPERIENCES RELATING TO THE UNIT

Teacher-directed activities

- 1
Allow children to examine extracted teeth which can usually be obtained from a local dentist.
- 2
The school dental-hygienist may come to the classroom, or the class may visit her office where she can show children the material she scrapes from the surface of teeth. She can explain the relationship of this material to decay.
- 3
Using either a paper or plaster model of teeth, the teacher or dental-hygienist can demonstrate the proper method of cleaning the teeth with a toothbrush and dentifrice.

4
Putting a tooth in an acid bath will cause a small tooth to dissolve. Such a demonstration is illustrative of the decay process in teeth. Observing the action of the acid on the tooth and knowing the hardness of teeth, children may then be prompted to ask how such a hard substance can decay. Other things which are softer often decay (rot). Some explanation of the part bacteria (animals too small for us to see) play in the decay process is important. These small animals need food.

Note: the teacher must exercise caution when handling acids.

Activities for children

1
A child who has lost a baby tooth may bring it to school for others to see and this tooth may be compared with an extracted tooth. Children can see that the root of a deciduous tooth is not as large as the root of a permanent tooth. This may be due in part to resorption — a natural process.

2
Allow children an opportunity to eat some sticky food such as peanut butter and crackers, a dried fig, or date. Have them tell how their teeth feel; let them look at their own teeth in a mirror to see particles of the sticky food remaining on and around the teeth. Follow this by allowing children to eat crisp, crunchy food such as an apple, celery, or carrot. Repeat the observations. This illustrates the abrasive and cleaning qualities of some foods.

3
With the help of local druggists, the local dental society, or by contacting toothbrush manufacturers it is often possible to obtain free toothbrushes for an entire class. With the aid of small hand mirrors, children can have the opportunity to practice brushing in the classroom, observing their own techniques, and learning the proper method of brushing the teeth. Those experiencing difficulty can be helped by the teacher.

Fieldwork

1
A trip to any fruit or vegetable market or perhaps to the cafeteria will often show fruit and vegetables which are spoiling. The characteristic sour odor or taste will be readily observed. This is indicative of acid formation.

2
A trip to a veterinarian will introduce many animals with strong teeth. The veterinarian can explain why some animal food is in the form of dog biscuits, big bones, etc.

ENRICHMENT

Questions to stimulate further thought

1. When should we brush our teeth?
2. Why is milk a good food for strong teeth?
3. Why should we eat fruits and vegetables?
4. Why do teeth ache when they decay?
5. Would it be possible to always have our permanent teeth?
6. Why do the teeth of some people decay more (faster) than the teeth of other people?

Topics for additional exploration

1
Eruption of teeth. Teeth do not erupt simultaneously. We lose some of our baby teeth and permanent teeth replace them slowly. This takes from about age 6 to age 18 or 20. Permanent teeth are larger because, as we grow, our jaws grow larger. To fill this larger space, larger and stronger teeth are needed.

2
Importance of baby teeth. They are needed for chewing solid foods and for speech. They aid in the spacing of permanent teeth and in guiding these into their proper positions.

3
Functions of different teeth

Incisors — cutting

Cuspids — tearing

Bicuspid (premolars) — breaking food into small particles

Molars — crushing food into smaller bits

ORGANIZATION AND USE OF INFORMATION GAINED

Projects

1
 Have the children compose the final line for the verse of "Merrily we brush our teeth, brush our teeth, brush our teeth; Merrily we brush our teeth . . ." (Sung to the tune of "Merrily We Roll Along.")

2
 Have children keep charts which show when they brush their teeth at home. From their discussions they should recall these times: upon arising, after breakfast, after lunch (when not in school), after dinner, and before bed.

3
 Have children draw pictures of their upper and lower jaws showing baby teeth, missing teeth, and permanent teeth, if any. They may also show those teeth that have been repaired.

**Questions to guide
 a summary of experiences**

1. What foods are good for teeth?
2. What foods may be harmful to teeth?
3. What can each of us do to keep our teeth healthy?
4. How should we brush our teeth?
5. Why do we go to the dentist regularly?

BASIC UNDERSTANDINGS TO BE GAINED FROM THIS UNIT

1. Teeth decay because of acids produced in the mouth by bacterial action on food.
2. Sweet, sticky food is more harmful to our teeth than coarse, crisp food.
3. We can protect our teeth by brushing *after* we eat.
4. Even with good personal care, we need to have our teeth looked at regularly by the dentist.

VOCABULARY

acid bacteria bicuspid caries cuspid

decay dental hygienist dentifrice erupt extract

incisor molar permanent

Second Grade

C AIR, WATER, AND WEATHER

OUR DEPENDENCE ON AIR

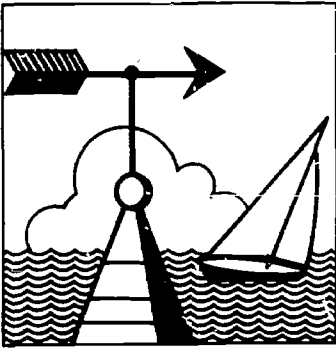

PURPOSE OF THE UNIT: *to become aware of how we depend on air and how we measure some of its characteristics*

Apparatus and materials

1. Alcohol, rubbing
2. Glass, small pane
3. Kettle, tin
4. Magnifiers
5. Pie dishes or gallon jar tops, throw-away type
6. Thermometers (indoor and outdoor)
7. Wide-mouthed jars (different sizes), three

INTRODUCTION OF THE UNIT

Motivating activities

- 1 Place a thermometer outside a classroom window. Call the children's attention to it. Compare it with the indoor thermometer.
- 2 Arrange a bulletin board display with pictures illustrating how weather affects work and play.
- 3 Show pictures of familiar plants and animals, and discuss their need for air and water.
- 4 Discuss the weather report for the day.
- 5 Show pictures of places having little or no water.
- 6 Have the children use inexpensive thermometers to find the coldest and warmest spots on the school grounds.
- 7 Does each day (in order) get colder as winter approaches? Does each day get warmer as summer approaches?

Motivating questions

1. What do thermometers tell us? How warm is it today?
2. How do we dress for changes in the weather?
3. Is it possible to live without air? Why? Can a fly or a clothes moth larva live without air? How can you find out?
4. Can we see water vapor in the air?
5. What things are necessary for life?

EXPERIENCES RELATING TO THE UNIT

Teacher-directed activities

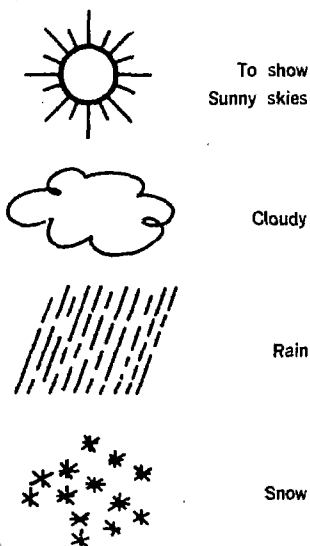

1 Make a simple weather chart (calendar) using symbols to represent different types of weather. Record temperatures twice a day, early morning and late afternoon of the school day. The temperature should be entered on the chart. Keep the chart for 2 or 3 weeks during each season. Figures such as a child in a bathing suit, a snowman, and falling leaves could be cut out to represent the type of weather. The following symbols may be used:

2 Place six small containers (throw-away pie dishes or gallon jar tops) holding equal amounts of water in various places in the room, in the window, in corner of the room, on a desk or counter, on the floor, and on top of a high place. Observe to see which evaporates most rapidly and how long it takes for each to become dry. Compare and discuss.

3 Locate a puddle after a rainstorm, and see how long it takes to evaporate. Does all the water evaporate?

4 Put equal amounts of water into two similar containers, such as jar caps. Put one container of water in a cold place and one in a warm place. Observe to see how long each requires to evaporate.

5
Place several containers with equal amounts of water in various places outside the room, in a corner of the building, out of the sun, on the window sill, etc. Compare their rates of evaporation.

6
Boil some water in a tea kettle until steam comes out of the spout. Hold a cool window pane over the escaping water vapor. Water droplets will form on the glass pane.

7
Obtain three large jars of different sizes. Place three candles on a flat board wide enough to accommodate the jars. Light the candles and have the pupils place the jars over all the candles at the same time. Which candle burns the longest? Can you tell why?

8
Periodically check the room thermometer to find the temperature that is most comfortable. At what temperatures are most children too warm? Too cold? What causes the temperature to vary?

Activities for children

1
Have children blow on the backs of their hands. Does it feel cool? Why? Evaporation of moisture from the skin makes it feel cool. Dab the back of each child's hand with a wet paper towel and have him blow on it again. Repeat using rubbing alcohol. Which has the greatest cooling effect? Why? Can the children think of a way to demonstrate that alcohol evaporates faster than water? Can they smell the alcohol? Why? Note: when liquid alcohol evaporates and seems to disappear, it is still present as a vapor in the air. When water evaporates, the water vapor is also present in the air, although we are unable to notice it.

2
Children may make model thermometers from oak tag and two equal pieces of red and white ribbon sewn together. The children may move the red tape to indicate the temperature from day to day.

3
Ask children to imagine that they are drops of water falling from a cloud. Tell the story of the things that might happen to them and the different places they might go.

Fieldwork

1
Take the children outside on a cold snowy day. Supply enough magnifiers so there is one available for each group of two or three children. Those wearing dark garments will be able to observe the various shapes of snow crystals under the magnifier as they fall on their clothes. Take some dark cloth for those without dark clothing. What do the crystals look like? Count the number of points on the crystals. This experience only works on cold days when the snowflakes do not melt as they land on the garments.

2
Take the class out-of-doors when the snow is several inches deep. Take temperature readings at the surface of the snow and at the bottom of the snow cover. What are the results? Why?

ENRICHMENT

1. What would happen to our surroundings if it never rained again?
2. What crystals, other than snowflakes, are found in nature?

*Questions to stimulate
further thought*

3. What is a candle snuffer? Why does it work?
4. What other ways, besides using a thermometer, are there for telling how hot or cold it is?

Topics for additional exploration

1
Thermometers. There are many types and shapes of thermometers. Some are closed glass tubes filled with a red liquid (colored alcohol), and some are filled with silver-colored liquid (mercury). Others may operate with no liquid at all.

2
Fire and air. Coal and wood fires are stirred from time to time so air can get to the fuel. Campfires should be built to allow good circulation of air.

3
Humidity. The evaporation of moisture from our bodies helps to keep us cool. On a warm summer day when the humidity is low, our bodies lose moisture to the surrounding air rapidly, thus cooling us. When the humidity is high, we are uncomfortable because there is much moisture in the air, and the moisture from our bodies does not evaporate as readily.

ORGANIZATION AND USE OF INFORMATION GAINED

Projects

1
Children may wish to draw pictures of snowflakes they have seen under magnifiers. Snowflake designs can be cut from paper.

2
Children may make a simple scrapbook with pictures showing the type of clothing worn during different seasons or under varying weather conditions.

3
Pictures may be collected to show how we use air, water, and fire.

4
Make a large chart with a picture of a big thermometer on it. At the side of the thermometer, paste pictures of people wearing different clothes. Have people wearing winter clothes at the bottom, people wearing light clothing near the top, and people wearing clothes for moderate weather in between. Discuss the need for choosing clothing appropriate to the weather.

5
← Hang thermometers at 1-foot levels in the room, beginning at the floor. Hourly temperatures during a full school day can be recorded on a graph as illustrated. This will show height-temperature relationship, as well as temperature variations during the day. (This will not work well in a room where the air is recirculated.)

6
Keep a record of the temperature on days when it snows. See if it snows most on very cold days or on days when the temperature is near freezing.

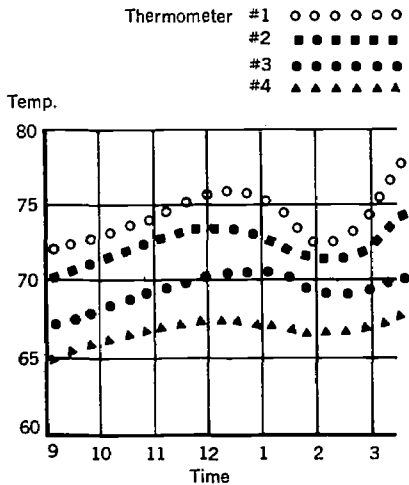

Questions to guide a summary of experiences

1. What does fire need in order to burn?
2. How can we tell it is going to rain?
3. How does water from puddles, lakes, and oceans get back into the air?
4. What is a cloud?
5. What are thermometers used for?
6. How does weather affect our work and play?
7. What happens to the rain and snow after it falls to the ground?

BASIC UNDERSTANDINGS TO BE GAINED FROM THIS UNIT

1. Fire needs air to burn.
2. Plants and animals generally need air to live.
3. A thermometer measures temperature.
4. Temperature is a measure of "hotness."
5. A cloud is made of water droplets or tiny ice crystals.
6. Weather affects our work and play.
7. Water evaporates from puddles, lakes, and oceans to go into the air again.

VOCABULARY

evaporation

moisture

temperature

thermometer

water vapor

Second Grade

d THE EARTH AND ITS COMPOSITION

SOIL



PURPOSE OF THE UNIT: *to learn where soil comes from and why it is important to us*

Apparatus and materials

1. Beans
2. Bottles; three tall, narrow, olive bottles
3. Boxes, plastic
4. Brick, broken
5. Cans, four small
6. Can, sprinkling
7. Cans, tin
8. Cloth, white cotton
9. Cotton
10. Flowerpots
11. Hand lens
12. Hardware cloth, $\frac{1}{4}$ -inch square
13. Jars
14. Jars, screw-top
15. Jars, two wide-mouth gallon
16. Nails
17. Paint, white
18. Shale or sandstone
19. Splash sticks (1 foot x 3 feet x $3\frac{1}{2}$ inches)
20. Stocking, nylon
21. Tape, adhesive

Motivating activities**INTRODUCTION OF THE UNIT**

1
Examine soils brought to school by pupils. Compare the color, texture, content of sand, clay, and decayed plant material of soils from different locations.

2
Show pictures of things which depend on the soil. This may be arranged with a container of soil (jar or plastic box) affixed to a bulletin board with strings or strips of colored paper joining pictures of plants, people, and animals.

3
Many excellent films and filmstrips are available which may be used to introduce this unit.

4
Display pictures of plants which grow in different types of soil (desert plants, mountain plants). Explain the importance of climate to plant growth.

Motivating questions

1. Where have you seen soil?
2. Is all soil the same color?
3. Are all soil particles the same size?
4. What can we find in the soil?
5. What animals live in the soil?
6. What things do we get from the soil?
7. Does soil move from place to place?

EXPERIENCES RELATING TO THE UNIT**Teacher-directed activities**

1
Rub two pieces of shale or sandstone together. Collect the soil (clay or sand). Rub a soft rock with a hard one. See how long it takes to make even a little sand. It has taken millions of years to produce all the sand and soil on earth.

2
Sort soil into its parts by pouring a cup of soil into a large jar of water. Stir or shake briskly, then allow the jar to stand. Observe the layers of soil which form in the jar. Teacher may label the layers "course sand, fine sand, silt, clay, etc." Label the water "water with dissolved minerals."

3
Soil which is composed of fine particles or contains a good deal of organic material will hold water better than other soils. Obtain four identical small cans. Cut the tops and bottoms out of the cans. Cover one end of each can with a piece of nylon stocking and tie it in place with several turns of string. Each can will hold a different soil sample. When an equal amount of water is poured into it, the amount of water that drips out of the bottom of each can into collecting jars can be measured.

4
Demonstrate how organic material helps to hold water, thus decreasing the amount of water which runs off along the surface of the ground. Obtain two wide-mouthed gallon jars and two pieces of $\frac{1}{4}$ " hardware cloth, cut to a size that will fit in the jars. Bend the hardware cloth into a U shape to form a basket, and bend its edges over the jar edge so it will be self-supporting. Pour water into both jars within an inch or so of the top. Collect two lumps of soil from just under the sod, one from natural sod area on the school grounds and the other from a heavily farmed cultivated field. Place each on the hardware screen and lower them into the water. Which soil crumbles apart and falls to the bottom of the jar?

5
Obtain three tall, narrow bottles, such as olive bottles. After a heavy rain fill one of the bottles with water from a small stream which obtains some of its water from a cultivated field. Fill the other two bottles with stream water coming from a woodland and from a good meadow or pasture. Label each, then let the samples stand for a few days until they settle. Observe daily and record observations.

6
To illustrate the water runoff of lands plowed on the contour as opposed to up-and-downhill plowing, cut eight pieces of adhesive tape into strips 3 inches long by $\frac{1}{4}$ inch wide. Place these on the outside of a classroom window pane where they are easily observed. Four of them should be placed vertically side by side spaced about $\frac{1}{4}$ " apart. Arrange the other four horizontally in the same manner either to one side or below the other strips. During a rainy day when the rain is pelting the window pane these strips of tape will show simply and graphically the difference between contour plowing and up-and-downhill plowing.

7
Make splash sticks from 2 boards 1 inch thick, 3 or 4 inches wide, and $3\frac{1}{2}$ feet long. Sharpen one end. Paint them white and draw lines across the boards at 1-foot intervals beginning with the sharpened end. You may further divide these into inches if you wish. Cut tin shields from tin cans which will be the same width as the boards and about 8 inches long. Nail these to the top of the boards. These shields help to prevent the rain from washing splashed soil off the boards. Find an area that is bare of soil cover and drive one of the boards into the ground. Follow the same procedure in a place where the grass is heavy. Each should be driven about 6 inches into the ground. Observe each after a heavy rain. Compare the amount of soil splashed and the height it is splashed on each stick. A similar effect may be observed by filling a sprinkling can full of water. Hold it at the same height above each stake (3 to 5 feet) and sprinkle the same amount of water about a foot from each stake.

8
Moving air transports soil and contributes to the wearing-down process. Build up some sand hills on a tray or in a sandbox, and turn a fan on the contents. Place something behind the container to catch the blowing sand.

Activities for children

1
Place some pieces of broken brick in a screw-top jar half filled with water. Cover the jar and shake it vigorously 25, 50, 100 times. Note the difference in shape of the pieces after each 25 shakes. When finished, pour the water through a piece of white cotton cloth. The cloth will trap small particles of brick which have been ground off by shaking.

2
Rub two pieces of shale together or hammer shale into a powder. Add a few drops of water to powder to produce clay.

3
Put some rich garden soil in a screw-top jar two-thirds full of water. Screw on the top, shake the jar, and then let it stand. After a few moments the rocky particles will settle to the bottom but some material will float. Skim off this floating material for examination with a hand lens. It is organic material (decayed plant remains).

4
Plant two bean seeds in a pot of cotton. Plant two other beans in a pot of soil. Keep both pots moist. Is there any difference in the bean plants produced after 1 week? 2 weeks? 3 weeks? How does a plant use soil?

5
Plant a few radish seeds in a small cup of clean, washed sand. Plant a few radish seeds in a similar cup of rich soil. Keep both plantings watered. (The sand will tend to dry out faster.) In a few days both plantings should sprout and grow, but a week or two of further growth will show differing rates.

6
Plant three flowerpots with soil from the following places: Subsoil found at a depth of 3 feet which may be found along a roadbank, topsoil from a pasture which has never been plowed, and soil from an eroded hillside. Plant three or four beans in each pot. Keep them well watered and place them in a warm sunny place. Plant three or four beans in cotton and keep moist. Observe and compare the growth rate over a period of 3 or 4 weeks. Record your observations and compare the results.

7
Soil contains particles of broken rock. Put a paper cup full of soil into a jar of water. Let this stand for about 30 minutes; then slowly pour off the excess water. Examine the soil at the bottom of the jar. Rub it through your fingers. Do you feel tiny bits of rock? Examine this under a hand lens.

Fieldwork

1
Take a walk around the playground and notice the variations in the soil. This may not be feasible for some schools, so nearby areas or parks may have to be utilized.

2
Go outside after a rainstorm and study a puddle of water. Why is it muddy? Collect a sample in a glass jar and take it back to the classroom. Let it stand for a few days to observe the dirt (soil particles) which settles at the bottom of the container.

3
Visit a steep hill or a recently made road cut to see soil and how rain has moved it.

4
Look for evidences of soil movements in small gullies or ditches on the playground, and places where water has flowed out and deposited pebbles and soil.

5
Observe nearby areas for evidences of miniature gullies and ditches, transported sand, and other examples of erosion.

6
Locate a freshly dug bank or road cut near the school. Examine the exposed soil. Can layers be seen?

ENRICHMENT

Questions to stimulate further thought

1. Why do we believe that the earth is very, very old?
2. How does the farmer conserve his soil?
3. Why are trees planted around reservoirs that supply water for people?
4. Could life on earth exist without rock and soil?
5. What things are necessary for good soil?
6. How do we know how far the great ice sheet went during the ice ages? How could we tell where a bulldozer stopped working?

**Topics for
additional exploration**

- 1
Origin of sand. All sand comes from rocks.
- 2
Topsoil. Topsoil consists of sand, clay, and organic material in varying proportions.
- 3
Water erosion. Running water is the most important agent of erosion.
- 4
Sand erosion. Wind-blown sand has a scouring effect and can wear down large rocks.
- 5
Soil enrichment. As plants and animals die and decay, they enrich the soil. The enriched soil is then returned to a new generation of plants and animals. This cyclic use of materials is found in many instances in nature.
- 6
The soil as a reservoir. The soil acts as a great reservoir. Without this ability to hold water, most plant and animal life could not exist on land.
- 7
Soil movement. Man, as well as nature, moves soil from place to place.
- 8
Earthworms improve our soil. Earthworm casts, soil which has been brought to the surface around earthworm holes, play an important role in soil conservation, particularly in the spring.

ORGANIZATION AND USE OF INFORMATION GAINED

Projects

- 1
Using small glass containers, collect soil samples from various nearby places. Label these with their locality and exhibit them to show how they differ in color and makeup.
- 2
Make a scrapbook collection of pictures illustrating good conservation practices and poor conservation practices.
- 3
Look on seed packages for words that tell about the soil. Find out what these mean: rich soil, clay, loam, coarse sand, acid soil, etc.
- 4
Exhibit a piece of rock, such as limestone or sandstone. Show the process of soil formation with graded sizes of rock particles beginning with the piece of limestone and ending with the soil. Include pictures which illustrate some of the forces which break down the rock, such as water, wind, heat, and ice. Compare a freshly broken surface to a weathered surface.
- 5
Make a miniature farm to illustrate dependence on the soil.

**Questions to guide
a summary of experiences**

1. How does sand and soil get carried from where you live into the ocean?
2. Why are some soils different from others?
3. Why do plants need soil? Can you think of at least three reasons?
4. Which kinds of soil are able to hold water?
5. How is soil formed?
6. Why do we need to conserve topsoil?

BASIC UNDERSTANDINGS TO BE GAINED FROM THIS UNIT

1. Rocks are constantly being worn down or broken by wind, water, temperature changes, plants, and chemical action.
2. Different kinds of soil are formed from different kinds of rock.
3. Soil contains bits of broken rock and decaying plant and animal matter.
4. Most plants need soil which contains organic matter.
5. Soils differ in their ability to hold water.
6. Topsoil is a valuable resource and should be conserved.

VOCABULARY

clay	conserve	humus	loam
mud	silt	soil	wear

Second Grade

e THE SOLAR SYSTEM AND BEYOND

HOW THE SUN AFFECTS US

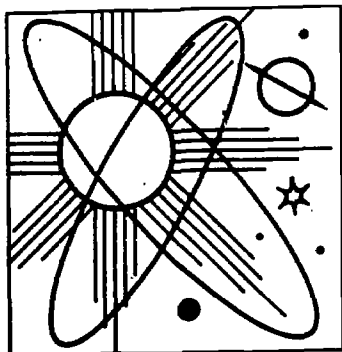

PURPOSE OF THE UNIT: *to learn what the solar system is*

Apparatus and materials

1. Electric lamp
2. Flashlight or filmstrip projector
3. Globe
4. Tape, masking

INTRODUCTION OF THE UNIT

Motivating activities

1 Arrange a bulletin board display illustrating earth features, such as land, water, and air. Choose pictures showing mountains, oceans, river valleys, cultivated land, forests, and plains regions. Relate this to the children's previous experiences when they took a trip around the school building to observe land formations.

2 Take the children outside early in the day to observe where the sun comes up. Repeat after noon to observe where the sun is setting.

3 Arrange a library table with some books about the sun, seasons, and stars which are appropriate to the group's ability levels.

Motivating questions

1. What is the sun?
2. Which is most distant from the earth: the moon, the clouds, the sun, or the stars? Which is closest?
3. Can you see the stars in the daytime? Why?
4. What causes day and night?
5. How do the changes of seasons affect us?
6. Does the earth move?
7. Where does the sun rise?
8. Do stars really have five points?
9. Is one side of the earth always light and the other side always dark?

EXPERIENCES RELATING TO THE UNIT

Teacher-directed activities

1 Young children sometimes fear the dark. The cause of day and night may be shown with a rotating globe and a light, such as a flashlight or filmstrip projector. Darken the room and place the globe about 10 feet in front of the light source. Attach a piece of colored paper or tape on the globe to approximate your location. Notice that as one side of the globe is lighted, the other side is dark. The sun shines all the time and in all directions, but shines on only half of the earth at one time. Have a child rotate the globe until the colored patch is in darkness. Make sure the globe is rotated in the correct direction (west to east). Turn the globe slowly so children will see their own area come into the light and disappear into darkness. This also shows how the sun seems to rise in the east and set in the west.

2 Two children, one holding a globe, may show the earth's movement around the sun. One child represents the sun and remains stationary, while the other holding the globe walks in a circle around the sun in a counterclockwise direction (west to east). (The earth's path around the sun is not a perfect circle but is almost a circle.) This movement of the earth is called revolution. Now have the child with the globe spin the globe (west to east) as he walks around the sun. This shows another movement of the earth, rotation.

3 The revolution of the earth around the sun and the tilt of the earth on its axis cause the four seasons. Station four children around a large circle facing each other. In the center of the circle, place a bright source of light such as a 100-watt electric bulb. Each child will have a globe with the axis inclined. Make sure all the globes are inclined so the North Poles all point in the same direction, as

toward an imaginary North Star over the teacher. Have the child holding the globe whose North Pole is inclined toward the light, raise his hand. What season of the year would this be? (Summer) If the globe is rotated while it is held in this position, the children will see that the Northern Hemisphere is having longer days and shorter nights. Note that the globes held by two of the children will show equal light on both hemispheres denoting spring and fall. The fourth globe, having its North Pole tilted away from the light, represents winter when we have shorter days and longer nights. For this demonstration, one globe may be used. It may be moved to each position in a counterclockwise direction (west to east). Revolve a globe about a light, rotating the globe as it is moved. This demonstrates that these two movements are occurring at the same time. Each revolution takes 1 year, while each rotation takes 24 hours. Have the children tell what has happened to the earth in a year.

4
Show filmstrips and movies which describe how seasonal changes affect plants and animals, how animals prepare for winter, signs of spring, and trees in winter.

5
Discuss how seasonal changes affect children's activities. Have a bulletin board display which illustrates some examples of seasonal changes.

6
Place a 100-watt electric lamp on a table. A cylinder of construction paper may be fitted around the bulb to protect the children's eyes, if necessary. When the bulb has been lighted long enough to generate heat, have the children gather around and feel the warmth. Now have them move to the opposite side of the room. Remove the shade from the lamp. Can they feel heat from the bulb? No, because they are too far away. The sun is our nearest star. It gives us light and heat. Other stars are suns, too, but they are too far away to provide us with heat.

7
To show that brightness and size are related to distance, have the children gather around you at one end of a long corridor. Turn on a small flashlight and notice its size and brightness. Carry the light to the opposite end of the hallway and the light source will look smaller and dimmer. Stars and planets appear small and faint because they are so far away.

Activities for children

1
Keep a daily record of the time the sun rises and sets. This information can usually be found in daily newspapers. Notice the gradual lengthening or shortening of the day. Relate this information to the changes in season, if possible.

2
Check in a newspaper to find a date when the moon rises shortly after the sun sets. For homework, ask children to watch the moonrise.

Fieldwork

1
Take children to a warm sunny place outside the building near a paved area. Feel the ground, then feel the paved area. Is there a difference in their temperatures? Why?

2
Take children out to the play area a number of times on a sunny day to observe the sun's movements. Do not look directly at the sun. Can you see any stars in the sky? Why? Review what was learned about shadows in previous grades. Can the moon be seen in the daytime sky at times? Ask children if they have ever seen the sun at night. Talk about where the sun rises and where it sets. We can tell direction with the sun. It rises in the east and sets in the west. Have children stand so that their right hand is pointing east and their left hand is

pointing west. What direction would be in front of them? Behind them? What is another way of locating north?

3

Arrange to take the children outdoors on a clear night when the moon is visible. Locate the Big Dipper for them. The two stars forming the cup of the dipper opposite the handle are pointer stars that point to the North Star. Does the North Star help us to know direction at night? Talk about movements of the moon across the sky. Discuss where the sun rose and set that day. Relate this to the position of the moon in the sky and ask the children where they think it will set.

ENRICHMENT

Questions to stimulate further thought

1. Can you think of a way to prove that the sun is farther away than the clouds?
2. What would happen if the earth did not rotate?
3. Why is only one side of the moon visible to the earth?
4. How did the Indians count time?

Topics for additional exploration

1

Solar heating. In the summertime, the Northern Hemisphere receives the more direct rays from the sun. In the winter, the Northern Hemisphere is tipped away from the direct solar rays and, therefore, the heating effect is lessened.

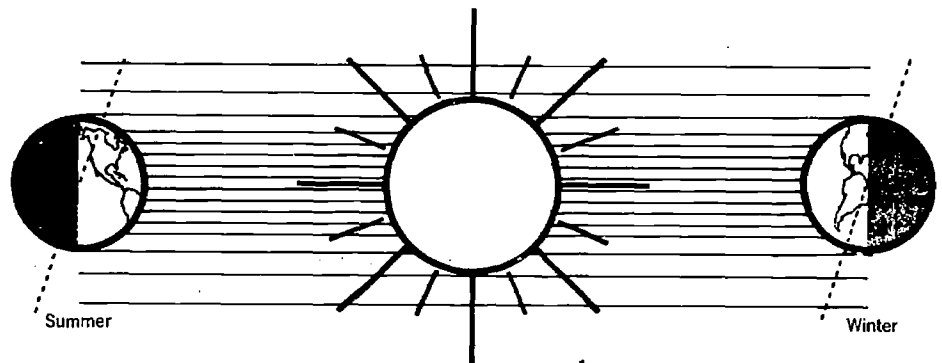

2

Radiant energy. The energy reaching us from the sun and stars is called radiant energy.

3

Shadows. Longer shadows are formed during the winter because the sun remains lower in the sky.

4

Noontime sun. The sun is highest in the sky at midday. During the summer months, it is almost directly overhead at noon.

ORGANIZATION AND USE OF INFORMATION GAINED

Projects

1

Make a mural showing the sun's path through the sky. Place this on the south wall of the room so it corresponds with the actual movements of the sun (east on the mural towards the east). Show the difference between the location of the sun in the sky during winter and summer.

- 2
Make a large chart showing the Big Dipper and the North Star.
- 3
Draw or paint pictures of the sun and moon.
- 4
Using a small globe and light source make a model showing the cause of day and night.
- 5
Make murals depicting the different seasons. Children may make cutouts from old cloth to place on the mural of such objects as trees, animals, water, and the sun.
- 6
Make a large mural showing the relation of the earth's position in its orbit to the sun for the various seasons. Pictures illustrating typical seasonal activities may be used to correspond with the earth's position.

**Questions to guide
a summary of experiences**

1. What causes day and night?
2. What is a year?
3. Where is the sun at night?
4. In which direction does the sun seem to move across the sky?
5. If the sun is in your eyes on the way to school in the morning, what direction are you facing?
6. How can we tell direction at night?
7. What is our nearest star?
8. Why do the stars in the night sky seem so small?
9. Are the sun and stars always shining?
10. Why does the moon shine?
11. What does the earth receive from the sun?

BASIC UNDERSTANDINGS TO BE GAINED FROM THIS UNIT

1. The earth revolves around the sun.
2. The earth revolves around the sun once in our year.
3. The rotation of the earth causes day and night.
4. The changes of seasons affect man, plants, and animals.
5. We can tell direction by the sun and stars.
6. The sun rises in the east and sets in the west.
7. The sun and stars are always shining.
8. The moon is the earth's nearest natural neighbor.
9. Stars vary in size, brightness, and distance from us.
10. Stars look small because they are so far away.

VOCABULARY

axis direction orbit revolve

rotate season sunrise sunset

Second Grade

f MATTER AND ENERGY

MATTER

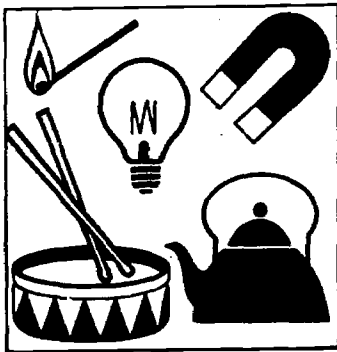

PURPOSE OF THE UNIT: *to become aware of the great variety of materials around us and some of their properties*

Apparatus and materials

1. Hot plate or canned heat
2. Household ammonia or bleach
3. Ink, red
4. Jar, large mayonnaise
5. Jars; pint, quart, and half-gallon
6. Medicine dropper
7. Pie tin
8. Waxed paper
9. Wood block or brick

INTRODUCTION OF THE UNIT**Motivating activities**

1
Have one child describe a common object (pencil, chalk, book, shoe, etc.) which is being held behind a screen so the rest of the class cannot see it. Limit descriptive terms to properties of the object rather than how it is used, and have class guess what the object is. After a few tries, have class consider which properties are most useful when describing objects.

2
Play the game "Animal, Vegetable, or Mineral."

Motivating questions

1. What is our world made of?
2. What is the difference between metal and plastic?
3. Why are automobiles built of metal rather than wood?
4. What are some of the values of plastics?

EXPERIENCES RELATING TO THE PROBLEM**Teacher-directed activities**

1
Ask the children to name all the various materials they can find in the classroom. They will probably identify such material as wood, cloth, glass, metal, paper, or clay. Write these materials on the board as they are named. After a good-sized list has been completed, ask the children if they think that there might be some they could have overlooked. Are there some materials outside which are not in the classroom?

2
Develop the concepts of "solid," "liquid," and "gas." There are many ways of approaching such understandings, a very simple one being by relating to touch and feeling. We can only touch the outsides of solids, and they tend to hold their shape. We can push our fingers into liquids, pour them, see them, and they have no firm shape. They take the shape of their containers. We cannot usually feel a gas or touch it. Gases spread out in all directions if not contained.

3
Demonstrate the properties of solids, liquids, and gases.

- (a) **SOLIDS.** A wooden block or a brick will serve as an example. Have the children describe its properties: size, color, shape, weight, etc. After the solid object has been described, point out that these properties are quite permanent.
- (b) **LIQUIDS.** A pint of water which has been colored with a few drops of red ink will serve as an example. Let the children describe its properties: volume, color, weight. Raise a question as to the shape of this liquid. If the children describe the shape of the bottle or container, pour the liquid into a different jar. What is its shape now? What is its shape while it is being poured? Try to establish the concept that the volume of the liquid stays the same — liquids have no shape of their own.
- (c) **GASES.** Place a teaspoon of household ammonia or bleach in a large mayonnaise jar and screw the cover on tightly. After an introductory discussion of gases (referring to the air as an example) have the children describe the gas contained in the jar. Ask them to consider its color, volume, shape, weight, etc. Then open the jar and have children file past it. This should help them to realize a basic property of gas, namely, that when not contained it will spread out in all directions, including upwards.

Activities for children

1
Provide each pupil, or pair of pupils, with a 12-inch square of wax paper. Using a medicine dropper, place three or four separate drops of water on the paper. Ask the children to observe these drops and find out everything they can about them. They may use their five senses. Push the drops around; poke them with a pencil point. After a time, list on the board the properties discovered by the children. These will probably include shape, color, movement, taste, odor, feel, ability to separate and to mix.

2
Have children give examples of materials in each of the following general classifications:

hard	can be bounced	will melt
soft	can be bent	metal
can be stretched	will float	will burn

Point out that although there are many different materials, some of them are alike in some ways.

Fieldwork

1
Pupils from the high school science club may be available to demonstrate a few interesting concepts concerning the properties of matter, such as the melting points of metals, the sublimation of iodine crystals, the weight of a small container of mercury, etc.

ENRICHMENT**Questions to stimulate further thought**

1
Liquids must be kept in containers. How can we find the weight of water in a cup without including the weight of the cup?

2
Not everything in our world is composed of matter. Name some of the things which we use in the classroom that are not matter, take up no space, and have no weight.

Topics for additional exploration

1
Changes of state. Materials can change their states. Place an ice cube in a pie tin over a source of heat. Discuss the properties of solid water, liquid water, gaseous water (vapor). What other materials can change state?

ORGANIZATION AND USE OF INFORMATION GAINED**Projects**

1
Cut out pictures from magazines to be pasted in the appropriate section of a large chart (or tacked to bulletin board) showing the uses man has for such materials as wood, metal, plastic, glass, etc.

Questions to guide a summary of experiences

1. What is meant by matter?
2. What are the three different forms of matter?
3. What is a solid?
4. What is a liquid?
5. What is a gas?

BASIC UNDERSTANDINGS TO BE GAINED FROM THIS UNIT

1. Our world is made of many different kinds of matter (material).
2. Matter may be solid, liquid, or gas.
3. Solids have a definite volume and shape.
4. Liquids have a definite volume but take the shape of their container.
5. Gases have no definite volume or shape.
6. Many materials are enough alike to be grouped into "families," such as metals, plastics, etc.

VOCABULARY

compress	gas	liquid	matter
metal	plastic	solid	volume

Third Grade

a LIVING THINGS

b OUR GROWING BODIES

c AIR, WATER, AND WEATHER

d THE EARTH AND ITS COMPOSITION

e THE SOLAR SYSTEM AND BEYOND

f MATTER AND ENERGY

Third Grade

a LIVING THINGS

PURPOSE OF THE UNIT: *to learn how living things survive in their environment*

THE ENVIRONMENT OF LIVING THINGS

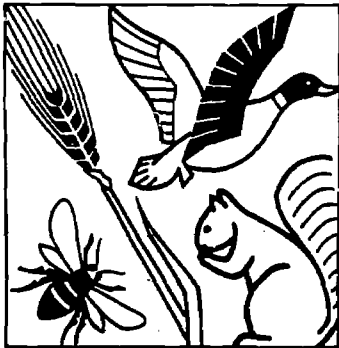

Apparatus and materials

1. Animals, small (frogs, turtles)
2. Aquarium
3. Bird nest
4. Insect cages, homemade
5. Materials for building bird houses
6. Moth and butterfly specimens, mounted
7. Plant galls
8. Samples of wood, cloth, and food
9. Terrariums
10. Thermometer

INTRODUCTION OF THE UNIT

Motivating activities

1
Have the children name various animals and tell where they live (desert, mountains, arctic, forests, oceans, lakes, meadows, backyard, etc.). List the animals named and their habitats on the board. Then have the children arrange an exhibit of pictures showing the animals in relation to their natural environment.

2
Plan a conservation bulletin board and divide it into two sections, one which will illustrate how man is disrupting the interdependence of living things by draining swamps and marshlands, polluting water, killing certain animals, and by carelessness which results in forest fires.

The other section can be devoted to the positive things man is doing in an attempt to conserve wildlife and natural resources such as the establishment of national parks, game refuges and sanctuaries, the forest fire prevention program, soil conservation programs, and wildlife research and management.

3
Exhibit some materials that demonstrate man's dependence on living things. Include wood, cloth, and food.

4
Use a "Nature Quiz" board to motivate children's interest in living things and conservation practices. Keep the display simple by using such things as tree bark, wildflowers, cocoons, bird feathers, and birds' nests. Change the display weekly. Do not tell the children what the object is until they have had an opportunity to guess. Use this technique to introduce a discussion about animal protection, adaptation, and conservation.

5
Many excellent color movies and filmstrips are available which show how animals are protected from their enemies and how they are adapted to live in their environment. The camera takes the children vicariously into the world of plants and animals which otherwise would be impossible to observe.

6
Ask children to tell about the useful things we get from animals.

7
The children can tell about the food they have eaten that day. List their source, plant or animal.

Motivating questions

1. Where do we get our clothing?
2. What things that we use come from plants?
3. In what ways has man made use of cattle?
4. What useful plants and animals does man get from the ocean?
5. What kinds of plants grow in the desert?
6. What is the importance of forest fire prevention?
7. Where do animals live?
8. How does a bird escape from its enemies?
9. Are hawks and owls important to man? Explain.
10. What do we mean by helpful insects? Harmful insects?
11. Why is man attempting to protect certain animals and plants?

EXPERIENCES RELATING TO THE UNIT

Teacher-directed activities

1
The adaptations of living things to their environment and their protective devices probably can best be observed in the classroom on a limited scale through the use of aquariums and terrariums. Other special containers may be used for certain animals. One of the most popular types of terrariums is the woodland terrarium. The construction of terrariums depends upon the teacher's ability to obtain the necessary materials. Make a woodland terrarium containing plants which require a moist habitat. A small toad, wood frog, spotted and red-backed salamander or red newt, land snails, land turtles, and garter snakes are some of the animals which may be used in such terrariums. Note their choice of food. What parts of the terrarium do they prefer?

Note: Since we cannot exactly duplicate the natural environment of these animals, this activity also shows that animals can quickly adapt to a somewhat different habitat.

2
Show the class how a turtle's shell helps to protect it from enemies. Some turtles can close up like a box.

3
Some animals are protected by their color. Catch a tree frog in the spring. Place it in a glass container with a small amount of water in the bottom. A piece of tree bark larger than the frog will provide a place for it to climb out of the water. Cover the container with screening or cloth. Note the color of the tree frog against the bark. Replace the bark with a large green leaf, twig, or stalk. Observe the frog after an hour, and you will see that it has changed color to blend it with its surroundings. Place the frog against the inside surface of the container. You will note tiny suction cups at the end of its toes. Compare this with other frogs. The tiny spring peeper also has suction cups on its toes. How does this adaptation help these frogs?

4
A desert terrarium is unusual and requires little care. Children can bring cactus plants from home or they may be purchased from greenhouses, supermarkets, and other stores. They will note many differences between this type of terrarium and other types. It is made differently, has different plants, does not require as much moisture, requires more light, and will house animals different from those in the woodland terrarium. Desert lizards such as horned toads are good inhabitants for this terrarium and may be obtained from biological supply houses. Some of the interesting things which children may observe about these reptiles is their protective coloration which blends in with their surroundings, and their ability to bury themselves in sand to escape detection, as well as for warmth during the cool nights. In addition to its ugly appearance, this interesting desert dweller has other protective devices to discourage animals of prey. When disturbed, it may scamper quickly away or remain still, puff up its body, and squirt blood from the corners of its eyes. The horny scales which protrude from the horned toad's body discourage most animals who might make a steady diet of this reptile. Despite its appearance and defensive actions, the animal is quite harmless.

5
Show pictures and discuss how some animals are adapted to their environment. Discuss the flight of birds in relation to their search for food. Not all birds fly. Discuss such birds as the ostrich and the penguin and how they are adapted to obtain food.

6
Show pictures of animals which make use of their tails in their environment such as the opossum, monkey, and beaver.

- 7 Exhibit some mounted specimens of moths and butterflies. Discuss their color and how they can blend in with their surroundings.
- 8 Keep some insects in the classroom housed in homemade cages or other containers. Certain insects such as the grasshopper, the walking stick, the praying mantis, and many beetles exhibit a protective coloration or structure which makes them difficult to find.
- 9 Display pictures of animals that depend upon camouflage or other devices for protection from other animals. Fawns (young deer) are not only protected by their color but also have no scent for the first few days after birth.
- 10 Discuss the need for game laws and other regulations relating to conservation.
- 11 Talk about the unnecessary destruction of such animals as snakes, birds of prey, foxes, and bats due to superstition, fear, or because the general public is uninformed about the value of these animals.
- 12 Point out current activities in the community that disrupt the interdependence of living things. This might lead to a discussion about the spraying of trees with insecticides, some of which not only kill destructive insects, but birds, other animals, and useful insects.
- 13 Discuss positive action that is being taken in the community to insure the survival of natural areas, birds, and other animals.
- 14 Borrow some mounted specimens of birds, mammals, and other exhibits. These can usually be obtained from the high school biology teacher, fish and game clubs, or museums. The specimens may be used to point out how certain animals are adapted to live in certain places.
- 15 Find out why the following have been given legal protection: robin, herring gull, great horned owl, red-tailed hawk, mallard duck. Look up information about birds which are protected in New York State.

Activities for children

- 1 Organize a class or small group nature club. Find out how you can help protect certain animals and plants. Engage in activities such as maintaining bird feeding stations, building birdhouses, and planting trees. Check with your local conservation official or a fish and game club member for worthwhile activities.
- 2 Children can collect uninhabited birds' nests during late fall and winter. Bring these to class and first tell where they were found (on the ground, in shrubs, near the ground, in trees, etc.). Tell about the size of the birds that made the nest comparing them with birds of known size. Try to guess the name of the bird. Take the nests apart on a piece of paper to see what materials are used by birds to construct nests. Separate the materials from each nest into groups. The children will note that birds differ in their selection of materials for nest building. Some nests may be constructed entirely from one kind of material while others will contain a variety of materials. Birds use grass, mud, horse or cow hair, snakeskin, lichens, paper, root particles, and many other things to build nests.
- 3 Examine a variety of plant galls.

4.
Draw some moths or butterflies on construction paper. Color these using pictures as references, then cut them out. Experiment by placing these cutouts against different colored backgrounds to see which is the most suitable for the insects' protection. Backgrounds can be made by using crayons, chalk, or powder paint on paper. Some may be plain, colored, or varicolored to blend with the insect's color.

5
This activity will emphasize the effect of coloration on an animal's ability to conceal itself. The children will represent birds (predators) and toothpicks can represent animals (caterpillars). Half of the toothpicks are colored to match the background, and the other half uncolored. These are scattered on the school lawn, and in a predetermined period of time, teams of children pick up all the caterpillars they can find. The children can compare the number of uncamouflaged caterpillars with the camouflaged ones which are picked up. The children will note the role of color in the selection of food by predators.

6
Try to determine whether birds have a preference for certain materials in nest building. During the spring season, hang colored yarn, string and strips of paper on bird feeders outside the classroom window. Which materials are most often taken by birds? Which kind of bird prefers which materials?

7
Divide the class into two or three groups, each group forming a circle. Each child in a group writes the name of a living thing on a card without duplicating anyone else's efforts. Some examples could be — mouse, corn plant, hawk, fox, tree, robin, worm, etc. One child in each group has a ball of twine. He tells how he depends on one of the other living things and carries the ball of twine to the child holding that card. He must, of course, hold one end of the twine as he passes the ball to the next child. This child in turn tells his story and passes the ball of twine to the next child and so on. When the activity is finished, the trail of string connecting the students will look like the web of life, the interdependency of living things.

8
Children may bring in plants, animal skins, flowers, seeds, wood, etc., and try "What Is It?" quizzes with their classmates.

Fieldwork

1
Visit a museum to view dioramas which depict interdependence of living things. Other dioramas may illustrate the usefulness of plants and animals in the scheme of nature. Visit Indian exhibits to note the ways in which they got their food and clothing.

2
Take a trip to nearby areas to find different insect galls; some may be collected to take back to the classroom. The galls may be found on the stems of goldenrod plants, pussy willows, willow trees, oak tree leaves and twigs, maple leaves, and the stems of rose bushes. The teacher can open these galls to look for the tiny insect forms inside.

3
A visit to a pond or stream is an excellent place for a field trip to familiarize children with animal coloration, interdependence of living things, and the adaptation of living things to their environment. Frogs at the water's edge blend well with their surroundings, and may not be seen until they leap into the water. The frog's long and powerful rear legs help it spring to the safety of the water. Fish may be difficult to see as they remain motionless on the bottom or in the shadow of a rock. Certain insects skim across the top of the water, while others resemble

sticks; some have powerful wings which allow them to move about rapidly. Snakes or turtles may be sunning themselves on banks or partially submerged logs. Tracks in the mud provide evidence of animals which inhabit the area.

4

Walk around the school building to look for insects. Watch bees as they gather nectar from flowers to make honey. Look for frothy masses on leaves of grass or stems of plants. Scrape the mass away, and, inside, you will find a little green insect, the young of the spittle bug, better known as a frog hopper. Overturned stones, tree bark, pieces of cardboard, and other debris offer many hiding places for insects in the spring. A number of striking insects may be observed around late fall flowers. Note how they tend to select blossoms that match their own colors.

5

Go on a bird walk around city streets or in parks. Note the kinds of food birds are eating. In the spring you may be able to watch birds such as orioles, sparrows, or robins as they build their nests. Notice where nests are built. Some birds will have their young before the end of the school year. Locate the nest of a bird and watch as the parents feed their young. Note the kinds of food the adults bring to the nest. Call the children's attention to the colors of birds. The coloration helps them to blend in with their surroundings, thus offering some protection from their enemies. Look for a male and female of the same kind of bird. In most cases the male is more striking than the female. Why is the female dull colored?

6

Children in some areas of the State will be able to take trips to a mud flat. What do you observe about birds feeding in the area? What special adaptations of their beak and feet do these birds have? What evidences of living things can be observed along the surface of the mud flat? Dig down into the mud to see what evidences of animals may be found. How are they adapted to live in this habitat? Look for the remains of animals that have been washed ashore.

7

Visit nature sanctuaries, game refuges, or arboretums. Such places may offer a variety of habitats, as well as an abundance of living things. Combine some of the previously mentioned techniques for observations.

ENRICHMENT

Questions to stimulate further thought

1. What is meant by the phrase *balance of nature*? Is nature ever in balance?
2. What is the largest potential source of food?
3. Can animals (other than man) communicate with others of their kind? How does the ability to communicate help animals survive?
4. What do you think is the oldest living thing? How have the oldest living things survived so long?
5. What is the purpose of bird song? Do all birds sing?
6. Which animals live the longest? The shortest?
7. Has man given domestic animals an environment in any way like those they lived in when they were wild?
8. What is the largest living animal?
9. How can you tell the age of a tree? Do trees have to adapt to their environment in order to survive?
10. What do we think caused the dinosaurs to become extinct?

**Topics for
additional exploration**

1
Insectivorous plants. Unusual plants such as the pitcher plant and the Venus's fly-trap will be interesting to children. These plants have peculiar adaptations for trapping insects, which provide one of their sources of food. They can be obtained from science supply houses and other commercial establishments. With a little care, "insect-eating plants" survive successfully in the classroom. Some interesting color films are available which describe the natural history of these plants.

2
Temperature preferences. Plants and animals survive under different temperature conditions. A temperature level which may be comfortable to human beings could be unpleasant for other living things. Animals react quickly to small temperature changes in their environment, and these have considerable effect on where animals live and their activity. Tie a long string to a thermometer or attach it to a yardstick and take temperature readings down a hole in a hollow tree, down a woodchuck hole, in a rock crevice, deep in a wood pile, etc. Note: The thermometer must be withdrawn and read quickly before the outside temperature affects it.

3
Lizards. Some children will be particularly interested in the study of reptiles. We usually think of lizards as inhabitants of dry or desert regions in the west. However, there are a few local areas in southeastern New York State and locally in the western part of the State where lizards may be found.

4
National parks. The establishment of national parks, monuments, and forest regions has been and continues to be important for several reasons. They provide areas for recreation, wildlife, and research, and also preserve natural areas for future generations. These areas also provide protected habitats for plants and animals that might otherwise have been lost forever. Find out where national parks are located. Are there any game refuges or nature sanctuaries near the school?

5
The overproduction of life. Animals which have a low rate of survival produce many offspring. This allows sufficient numbers to live to produce the next generation (frogs, toads, mice, insects, etc.).

6
Aquatic mammals. Many mammals such as whales and porpoises are adapted to spend their entire lives in the ocean.

7
Extinction. During the past years, some animals have become extinct, some due to poor conservation practices and others because of their inability to adapt to a changing environment. Man is currently taking steps to assure the preservation of certain animals that are nearing extermination.

ORGANIZATION AND USE OF INFORMATION GAINED

Projects

1
Exhibit such items as cloth, wood, fur, food, and leather which represent man's dependence on living things.

2
Paint murals depicting forests, ponds, meadows, deserts, shores, and other habitats of living things.

3 Exhibit pictures and make reports on animals which are being protected to prevent them from becoming extinct.

4 Make a display that tells the story of how an animal becomes extinct.

5 Construct dioramas that show the typical habitat for a certain animal, such as a fox, a skunk, a bear, a squirrel, and a bird. Dioramas can be constructed in different-sized cardboard containers. Materials which may be helpful include twigs, plastic clay, styrofoam, pieces of sponge, small mirrors for water, wood scraps, plaster of Paris, and wire screening.

6 Collect some common nuts, seeds, and fruits that are important to wildlife and man.

7 Construct a chart with various columns to show how different animals are protected in nature. The headings may read as follows: Flight, color or camouflage, speed, and pretending (opossum plays dead). List or picture animals under the different headings.

8 Make a descriptive display of a tree. Include a twig, flower, fruit, seed, leaf, and bark. These can be mounted on a piece of cardboard beside a drawing which illustrates the general shape and size of the tree.

9 Make some wildlife posters in conjunction with National Wildlife Week. Write to the National Wildlife Federation, 1214 16th Street N.W., Washington, D.C. 20006, for helpful literature.

10 Draw or paint the picture of a tree on mural paper. Next to the picture, list the things which make trees important, such as homes for animals, source of food and shelter, and uses by man.

11 List all the foods eaten by the class in 1 day (or the menu of the school lunches) on one side of a chart. Connect the food and a picture of its source with a string or a dark line drawn on the chart. The same procedure can be followed for the clothes which the children wear.

12 Build birdhouses or bird-feeding stations.

**Questions to guide
a summary of experiences**

1. How does man depend on living things?
2. Can you give some examples of how living things depend on each other?
3. How are plants and animals able to live in certain places like deserts, swamps, oceans, and fields?
4. What are some of the ways that animals are protected from their enemies? Do plants have any protection?
5. How can people help to protect living things? Why should people protect certain animals and plants?

BASIC UNDERSTANDINGS TO BE GAINED FROM THIS UNIT

1. Plants and animals depend on other living things for their well-being.
2. Many plants and animals are adapted to live in certain kinds of places.

3. Many animals have special adaptations which protect them from their enemies.
4. Man depends on other living things for his food, clothing, and shelter.
5. Man should exercise good conservation practices so as not to disrupt the interdependence of living things.

VOCABULARY

amphibian	coloration	conservation	depend	domestic
escape	extinct	flight	forest	game
habitat	insect	mammal	marsh	meadow
nest	plant and animal homes			pond
	protection	reptile	survive	swamp

Third Grade

b OUR GROWING BODIES

**SLEEP, REST,
RELAXATION**

PURPOSE OF THE UNIT: *to acquaint the pupil with the importance of sleep and rest and to learn the fundamentals of conscious relaxation*

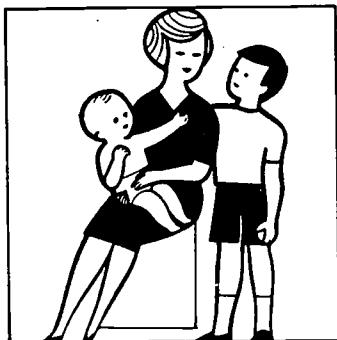

INTRODUCTION OF THE UNIT**Motivating activities**

- 1
Have children tell a story about the latest they have ever stayed up at night. Also let them tell how they felt the next morning.
- 2
Have children recall when they took naps in the afternoon. Have them tell how they felt before and after the nap.
- 3
Third-grade children can usually tell when they go to bed and when they get up. From these figures, they can readily compute the hours they sleep each night.
- 4
The children can tell stories which relate the sleeping habits of younger brothers and sisters, of older siblings, and of adults.

Motivating questions

1. Can you tell when you are asleep?
2. What do you do when you are tired?
3. How do you feel when you are tired?
4. How do you feel when you are rested?
5. Can someone else tell when you feel tired? How?
6. Can you tell when other persons are tired?
7. How does a kitten look when it sleeps?
8. Do you like to play games when you are tired?
9. Why do you think we need sleep?
10. Why do children need more sleep than adults?

EXPERIENCES RELATING TO THE UNIT**Teacher-directed activities**

- 1
The teacher may ask which children may have seen some late show on television. They may be able to tell how they felt about getting up in the morning, about coming to school, and about doing their work in school on the following day.
- 2
If pets are available in the classroom or at home, have children observe how often and under what circumstances they sleep.
- 3
Show pictures of babies and children at sleep. Point out some features involved in good sleep such as a good bed, adequate blankets, an open window, quiet, and, perhaps, darkness.
- 4
Read a story to the class that involves the sleep of animals. It might be especially good for them to hear about the long hibernation of some animals.

Activities for children

- 1
Have children make a tight fist and then relax the hand. Ask them to do this several times, each time relaxing the hand more. Does the hand tire? Does it need to rest?
- 2
While children rest their heads on their arms on top of their desks, play a recording of soft music. If the shades are drawn in the room, the reaction may be very significant. Let the pupils tell how it made them feel.

3
As children rest their heads on their arms folded on the desks, speak to them in low, even tones, directing them to make their heads heavy on their arms, letting their heads become heavier and heavier.

4
The children's physical education teacher will be happy to co-operate in this activity. Ask her to give children a chance to walk as little wooden soldiers and then to walk as "Raggedy Ann," the rag doll. They can learn about relaxation from this, as well as contraction.

5
The children may ask their parents why they should go to bed at a certain time or get a certain amount of sleep. Some may bring back many excellent reasons.

6
Following a period of physical education, most children will be glad to sit down. Discuss this in terms of rest, which is a cessation of activity or a slowing down of the activity.

7
The children may observe their fathers or older brothers when they come home from work and sit down to rest before dinner. Perhaps they can observe men in the family as they mow lawns, shovel sidewalks; or work in the garden. They may see them stop and rest periodically. A discussion of the need for rest may follow.

Fieldwork

1
A visit to farm, zoo, or veterinarian's place of business may give children a chance to see some animals which are very active, while some are resting and others are sleeping. Discuss these three aspects of living.

2
A visit to a pet shop may show some birds (canaries, etc.) that are asleep, while others are awake and flying about in their cages. All living things need rest and sleep. Birds and animals will help to provide some proof of this universal need.

ENRICHMENT

Questions to stimulate further thought

1. What happens to us when we sleep?
2. Do we ever go to sleep even when we want to stay awake?
3. How can you tell when you need sleep?
4. How can you tell when you didn't sleep enough?
5. How can you tell when you are rested?
6. How can you tell when you have had enough sleep?
7. Can you sleep better when you are excited or when you are relaxed?
8. What happens to our bodies when we sleep? (Emphasize the repair of tissue.)
9. Do we ever move while we sleep?

Topics for additional exploration

1
Physiological changes during sleep. Some discussion can take place about the slower rates of breathing and heart beat during sleep, the almost complete relaxation of all muscles, and the fact that we are unaware of what goes on around us. Children will be interested in the fact that our nervous systems, and especially our sensory perceptions, function at a low level during sleep.

2
The need for rest periods. To avoid fatigue in the day, we need to rest during the day. Even short periods of rest help to revive us. Without these rest periods, we become too tired (fatigued) and even a night's sleep may not completely rest us.

ORGANIZATION AND USE OF INFORMATION GAINED

Projects

1
 Keep a chart in the classroom on which children can record the amount of sleep they had on each school night for a period of 1 or 2 weeks. To this chart may be added a column in which children may show whether they had to be awakened in the morning or if they woke up naturally.

2
 Give children the opportunity to write and act out a short story which involves both younger and older people in the family and the problems of sleep and rest.

Questions to guide a summary of experiences

1. What happens to us when we sleep?
2. Why is rest almost like sleep?
3. How much sleep does each of us need?
4. Why should we try to go to bed at the same time each night?
5. When is it easy for us to sleep?
6. When is it difficult for us to sleep?

BASIC UNDERSTANDINGS TO BE GAINED FROM THIS UNIT

1. Sleep is essential to life.
2. Rest before fatigue is considered better than rest following fatigue.
3. Sleep comes easily in the proper atmosphere.
4. Lack of sleep affects us emotionally as well as physically.
5. The art of relaxation can be learned, and relaxation helps us to avoid fatigue.

VOCABULARY

contraction

emotions

nerves

relaxation

sensory

ventilation

Third Grade

C AIR, WATER, AND WEATHER

PURPOSE OF THE UNIT: *to determine the cause of the wind*

WIND

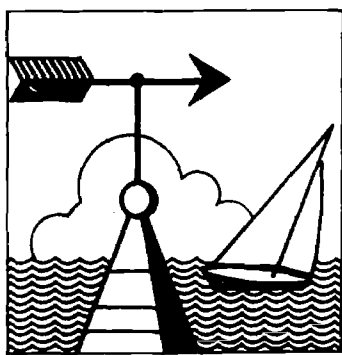

Apparatus and materials

1. Anemometer
2. Aquarium
3. Bag, plastic
4. Balloon
5. Beakers
6. Bunsen burner
7. Connection box
8. Cork
9. Flask, Pyrex
10. Flasks with one-hole rubber stoppers
11. Tube, glass
12. Tumblers, glass

INTRODUCTION OF THE UNIT

Motivating activities

- 1 Arrange a bulletin board showing the destruction caused by hurricanes or tornadoes.
- 2 Let the class inspect an "empty" plastic bag. If the class agrees that it is indeed empty, close the open end securely with an elastic band. Have a pupil place a book on the bag. Why won't the bag flatten out? Is the bag really empty?
- 3 Set up a simple feather vane, made from a feather on a pin or needle. This will be very unsteady in the seemingly windless classroom.
- 4 Use an anemometer for a "What Is It?" display.
- 5 Show the class pictures of windmills. Ask what they are used for. What makes them operate?

Motivating questions

1. How do we use the wind to help us work?
2. How do we use the wind to help us play?
3. Can you see the wind? If not, how do you know that air is in motion?
4. How can the wind help us?
5. How can wind harm us?
6. Which way is the wind blowing now?
7. Does the wind always blow in the same direction near the ground as up where the clouds are? How can you tell?

EXPERIENCES RELATING TO THE UNIT

Teacher-directed activities

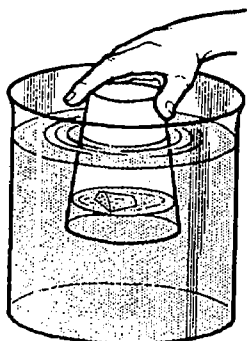

1 To show that air is a real substance, and that it takes up space, lower a glass tumbler, mouth downward, into an aquarium which is nearly filled with water. With the other hand, lower a second tumbler, fill it with water, and hold it mouth downward over the first one. Now pour the air from the first glass upward into the second glass. With both glasses held under water, pour the air from one to the other several times.

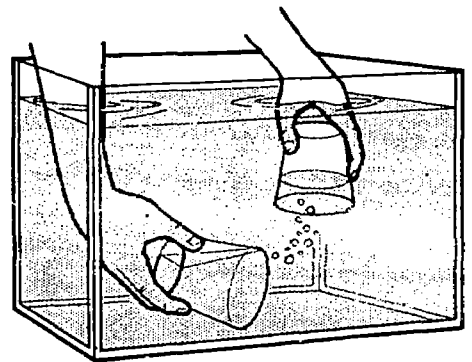

2 Air is a real substance and occupies space. This can be demonstrated by lowering a glass tumbler mouth downward into a vessel of water. Observe that the water does not fill the glass. This shows that air takes up space. The demonstration is still more convincing if the glass is lowered over a floating cork or if a dry piece of paper has first been pushed into the bottom of the glass.

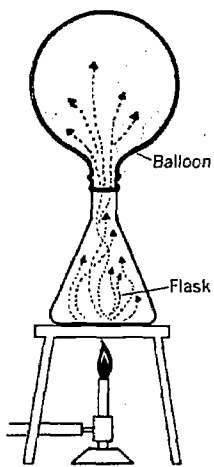

3 To demonstrate the effect of heating and cooling air, stretch a balloon over the mouth of a flask. Use a Pyrex flask to safeguard against breaking. Heat the flask with a flame to warm the air inside. To cool the air, remove the flask from the flame with tongs or a heavy glove, and place it in cool water. Have the children explain what they observe. Note: If necessary, a Pyrex baby bottle may be substituted for the flask.

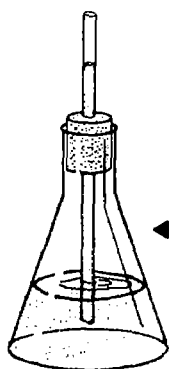

4 To demonstrate the expansion of heated air, put about 1 inch of colored water in a flask. Insert a long glass tube through a one-hole stopper and place it in the flask. The level of the liquid in the tube can be adjusted by blowing into the tube. Warm the air in the flask by placing your hand around the flask. Why does this make the liquid rise in the tube?

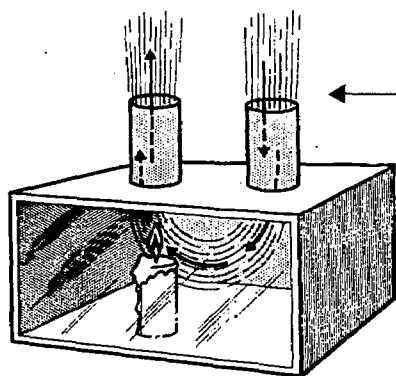

5 Demonstrate the movement of warm and cool air with a convection box. This single demonstration will make a lasting impression on the children and give them a clear understanding of air movements. In order to see the motion of the air currents, a tightly twisted paper towel can be lighted with a match and then the flame blown out. The towel will continue to smolder and give off quantities of smoke. Hold the smoking paper first over one chimney and then the other.

Activities for children

1 To see the expanding effect of heated air, give each child or group of children a flask fitted with a long glass tube and a one-hole rubber stopper. Have them invert this and immerse the end of the tube in a beaker of water. Warm the flask with the palms of the hands. Observe. This activity is more effective if the children are given air thermometer tubes in place of the flask and tube.

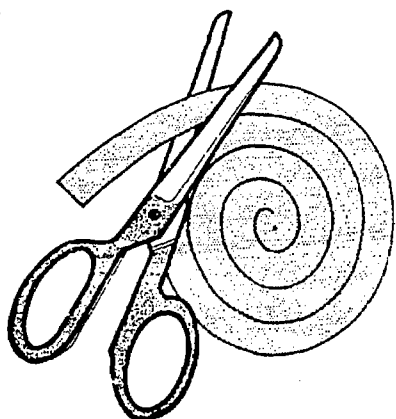

2 Draw a spiral on a sheet of paper. Cut out the spiral and suspend it by a thread as shown in the diagram. Hang the spiral over a heat source such as a radiator or light bulb. Explain the observed motion.

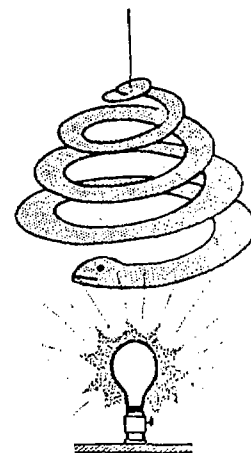

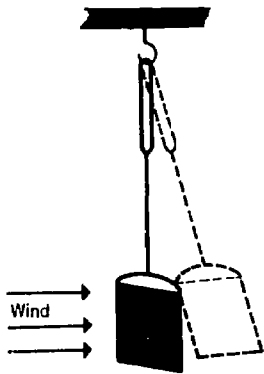

Fieldwork

3
Make a large wall chart-calendar for a month. Each school day, write in the appropriate space the direction from which the wind is blowing. Use the flag at the top of the school flagpole or the smoke from a nearby industrial chimney as an indicator. Discuss the changes in direction.

4
Hang a fly swatter so it is free to swing in the wind. Notice the angle it makes from vertical in a light breeze and a strong wind. Can this be calibrated in any way to tell wind speed? Can the children make or discover other devices to tell relative wind speeds?

1
Arrange to take a trip to an airport or a local weather bureau to observe the wind sock and the wind speed indicator (anemometer). Why are the people at the airport interested in the wind speed and direction? Why is the weather bureau interested in the wind speed and direction? A weather bureau trip may be difficult to arrange. Call well in advance of the planned trip.

2
Take the children out-of-doors on a warm sunny day. Find a place in the direct sunlight where a macadam (blacktop) surface meets the lawn. Have the children place one hand on the paved surface and the other hand on the grass. Does the sun heat all parts of the earth equally? Which area is hottest? Over which area will the air be heated the most? Can they explain how such conditions can cause a breeze?

3
Take the class to a nearby weedy field on a windy day. Have the children lie down, face up, and see how hard the wind blows against their faces. Have them kneel with their faces even with the tops of the weeds. Let them stand. Where is the wind the strongest? The weakest? Where might insects go on a windy day? Why?

ENRICHMENT

Questions to stimulate further thought

1. How do soaring birds remain in the air without flapping their wings?
2. Why are you unable to fly?
3. In a home heated by forced hot air, each room usually has several grills. Does warm air come from each of these? Why?
4. What places on the globe (or map of the earth) are most apt to have great quantities of warm air rising up into the atmosphere?

Topics for additional exploration

1
Thermals. Rising masses of hot air are used by glider pilots to keep their crafts in the air for many hours.

2
Early ballooning. Adventurers once took flights in great balloons filled with hot air.

3
Wind speed. Gales, hurricanes, and tornadoes have winds of very high velocity, the latter reaching 200-300 miles per hour or more.

4
Old sailing routes. The routes followed by the great sailing ships of the last century as they crossed the Atlantic Ocean were carefully developed. Why were these routes followed?

5
Cyclone cellars. In the central United States, cyclone cellars are built near farm dwellings. What is their purpose?

ORGANIZATION AND USE OF INFORMATION GAINED

Projects

1
 Make a chart to record the wind direction for a month and the weather which follows the next day. Are any patterns noticeable?

2
 Make a mural showing an area of land with the sun warming the surface near the center and warm air rising over this heated section. To replace the warm air which has risen, cooler air moves into the center from both sides, thus causing local winds.

3
 Construct a simple wind vane as shown in the diagram.

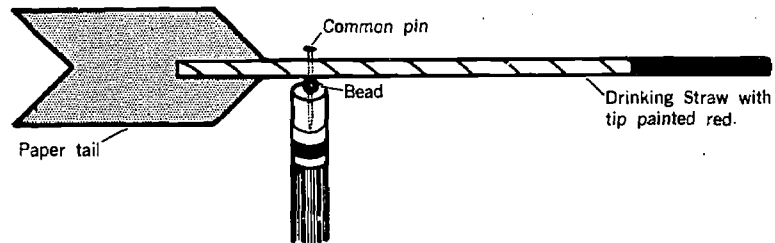

4
 Construct a simple wind-speed indicator as shown in diagram.

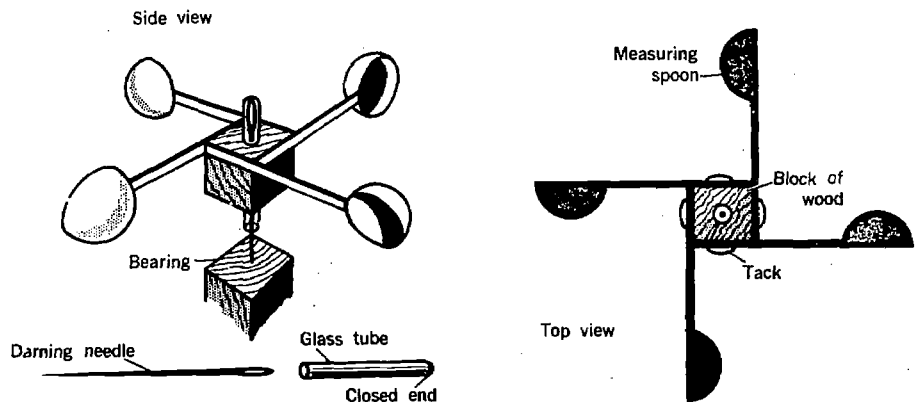

**Questions to guide
a summary of experiences**

1. How do we know that air is a real substance?
2. What happens to air when it is heated?
3. What happens to air when it is cooled?
4. What causes the wind?
5. How do we determine wind direction?
6. Why should people open their windows at the top and the bottom for best ventilation?
7. How do we determine wind speed?

BASIC UNDERSTANDINGS TO BE GAINED FROM THIS UNIT

1. Air is a real substance and occupies space.
2. Air expands when heated.
3. Cooled air contracts and moves downward.
4. Heated air moves upward.
5. Wind is moving air.
6. Local winds are caused by unequal heating of the earth's surface.
7. Wind direction is indicated by a wind vane.

VOCABULARY

bubble	contract	direction	east
--------	----------	-----------	------

expand	invert	north	south
--------	--------	-------	-------

space	temperature	west	wind
-------	-------------	------	------

Third Grade

d THE EARTH AND ITS COMPOSITION

THE CHANGING SURFACE OF THE EARTH

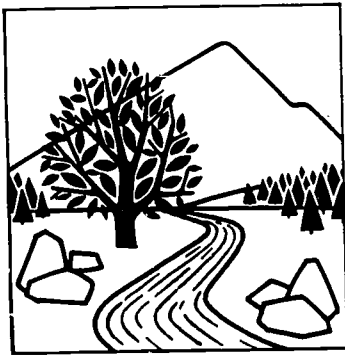

PURPOSE OF THE UNIT: *to learn about the constantly changing surface of the earth*

Apparatus and materials

1. Can, sprinkling
2. Clay, modeling
3. Cups, paper
4. Jar, screw-top
5. Pencils
6. Plaster of Paris
7. Rock with lichen
8. Sand table
9. Soap, liquid
10. Volcanic stones or materials

INTRODUCTION OF THE UNIT

Motivating activities

- 1
Display pictures of alpine-type mountains, volcanoes, surf along the shore, flooded areas, and glaciers.
- 2
Present films or filmstrips showing the Bad Lands, Grand Canyon, Niagara Falls, and a dust storm.
- 3
Read a story about or an account of a major earthquake.
- 4
Display a collection of stones and other materials which are volcanic in origin.
- 5
Discuss earth changes which have occurred in the local area. Investigate various sources of information for the cause; geological history of the area, present-day evidence, and time of occurrence. Examples: Palisades, Mohawk Valley, Adirondack Mountains, Helderberg Escarpment, mineral springs, waterfalls, glacial erratics or other glacial deposits, potholes, chasms and gorges, Finger Lakes region, and faults.
- 6
Show pictures of a river delta. Discuss how it forms and how it helps to build up the earth's surface. Locate a delta on a map of the United States. Show where the shoreline was before the delta was deposited.

Motivating questions

1. Can you think of something that never changes?
2. Can you list some of the things around us that change from day to day?
3. What changes take place more slowly?
4. What changes do you think might have taken place in the area near your school?
5. Have you ever visited a place in New York State where changes in the earth have taken place? What caused these changes?
6. How do we know that our State was once covered by a great sheet of ice?

EXPERIENCES RELATING TO THE UNIT

Teacher-directed activities

- 1
Discuss any landscape feature that is familiar to the children. Will it be there tomorrow? Next summer? Next year? In 1,000 years?
- 2
Set up a sand table. Build up hills and valleys. Pour water from a sprinkling can on the miniature hills and valleys and discuss the results. Relate this experience to an occurrence in nature.
- 3
Read about the buried city of Pompeii. Look at pictures of active volcanoes and discuss what is happening. Where are there any active volcanoes today?
- 4
Show a rock with a lichen (a simple plant resembling some mosses) growing on it. Explain to the children that such plants help to break up rock and make soil for the growth of other plants. Though these plants are not a great destructive force in nature, they do play an important role.

Activities for children

- 1 Pour a mixture of plaster of Paris and water into a paper cup. Into it, stick a greased (liquid soap or shortening) pencil or wooden spoon, which is to be removed when the plaster sets. When the plaster has set, remove the paper cup, fill the hole with water, and place the cast in a freezing compartment. The freezing water expands and cracks the cast just as it cracks rocks.
- 2 Look for pictures of trees growing out of rocks.
- 3 Write a story about what your town looked like in the distant past.
- 4 Fill a screw-top jar completely with water and replace the cap. Place this inside a plastic bag and put it in the freezing compartment of a refrigerator (outside the window if the temperature is below freezing). After a few hours, the water will freeze and expand, breaking the glass jar. Water which seeps through cracks in rocks may freeze and expand in a similar manner, thus breaking rocks apart. This action destroys many miles of roadway each winter.
- 5 Students may report on trips taken with relatives to areas noted for prominent earth features. (See Introduction of the Unit.)
- 6 Find out from a friend or parent how some local spot looked 25 years ago. Report to the class.

Fieldwork

- 1 The examples of earth features listed previously under "Introduction of the Unit" would be interesting places to visit. The feasibility of such a trip depends upon the location of the school. Certain areas of the State are well endowed with examples of physical features of the earth's surface.
- 2 Take a trip to a museum where displays illustrating physical features of the earth and changes which have taken place are exhibited.
- 3 Arrange a trip to a nearby area which shows evidences of glacial features and deposits. In large cities such evidence can often be found in parks.
- 4 Visit a place where running water has washed away some soil. Perhaps there may be such a place on the school ground or on a nearby hillside.

ENRICHMENT

Questions to stimulate further thought

1. Does erosion take place faster on the moon than on the earth? Why?
2. Why have the Egyptian pyramids been able to last 5,000 years?
3. What is chalk? How was it formed?
4. What ages do different scientists consider the earth to be?
5. Are there any glaciers in the United States? Where are they found?
6. Where does all the material eroded from the land go? What happens to it eventually?

Topics for additional exploration

- 1 *Earth-leveling forces.* Some forces are working to level off the surface of the earth. High spots are worn down and low spots are filled.

2
Earth-raising forces. Some other forces keep producing irregularities in the earth's surface, such as crustal movements and earthquakes.

3
Ancient land forms. There have been periods in the earth's history when the land has been very flat with great, shallow seas.

4
Age of mountains. The earth is very old and man has been on it for a relatively short time, so a "young" mountain may seem to us to be very old.

5
Erosion. The process of wearing down and moving rock and soil is called erosion.

6
Causes of erosion. The major causes of erosion are water, wind, ice, and gravity.

7
New York glaciers. The glacier that once covered New York State was about 1 mile thick in some places. Geologists believe the glaciers retreated northward from our State within the last 10,000 years.

ORGANIZATION AND USE OF INFORMATION GAINED

Projects

1
Make papier-maché or plastic clay models of mountains, volcanoes, rivers, canyons, or glaciers.

2
Draw a map of North America (use an opaque projector or outline maps, if necessary) and indicate the part that was covered by glaciers during the Ice Age.

3
Collect magazine pictures showing the action of water, wind, or ice in wearing down the land.

4
Make dioramas or shadow boxes of land surface features.

5
Make a collection of weathered objects, such as wood and rock. Label these as examples of weathering due to water, ice, wind, and heating, or any combination of these.

6
Paint a mural of an interesting place such as the Grand Canyon, Mount Hood, an Alaskan glacier, or the Palisades.

7
Make a mural of a beach scene showing surf pounding against the beach and interesting forms made from wave action on a rocky shore line.

8
Make a bulletin board display of pictures which illustrate the various forces of nature, such as Niagara Falls, Watkins Glen, Bryce Canyon National Park, Yosemite National Park, Letchworth Gorge, and Mount McKinley.

Questions to guide a summary of experiences

1. How do we know the earth is changing?
2. What can we see to make us believe that the rain slowly wears down hills?
3. How is the earth being built up?
4. Where do pebbles and gravel come from? Where does sand come from?
5. What are three forces that are wearing away the earth's surface features?
6. What happens to the material that is worn away from mountains and hills? Where does it go?

BASIC UNDERSTANDINGS TO BE GAINED FROM THIS UNIT

1. The surface of the earth is constantly changing.
2. Rocks can be broken apart by heat (sun), freezing, water, and plants.
3. Mountains and hills are being worn down.
4. Running water is largely responsible for the wearing-down process (erosion).
5. Earthquakes, volcanoes, and slower earth movements are constantly building up new mountains.

VOCABULARY

canyon	dust storm	earthquake	erosion
glacier	gorge	mountain	volcano

Third Grade

e THE SOLAR SYSTEM AND BEYOND

COMPOSITION OF THE SOLAR SYSTEM

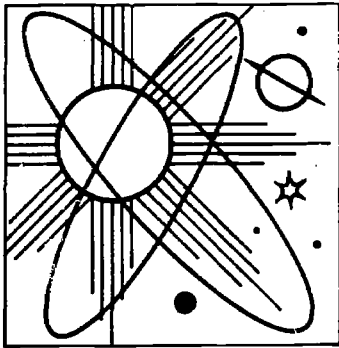

PURPOSE OF THE UNIT: *to learn about the composition of our solar system*

Apparatus and materials

1. Ball, silver-colored or Christmas
2. Binoculars
3. Filmstrip projector
4. Flashlight
5. Solar system chart
6. Telescope

INTRODUCTION OF THE UNIT

Motivating activities

- 1
Show films or filmstrips about the solar system or sun's family.
- 2
Display a collection of pictures of planets.
- 3
Display a large chart of the solar system.
- 4
Show pictures of the surface of the moon.

Motivating questions

1. Where is the earth located?
2. What is the earth?
3. Are there other planets?
4. What is the moon?
5. Does the moon always look the same?
6. What are orbits?
7. Does the earth stay in one place?
8. Can you see any objects in the night sky which seem closer and brighter than the stars?
9. Is the surface of the moon different from the surface of the earth?

EXPERIENCES RELATING TO THIS UNIT

Teacher-directed activities

- 1
Suspend a silvery ball or Christmas ornament in a darkened room. Can you see it very well? Shine a flashlight on it. Where does it get its light? The moon is the earth's satellite and shines from reflected sunlight. It is the closest object to the earth that we can see in the sky, except for man-made satellites.
- 2
Only one side of the moon is visible from the earth because the same side always faces the earth. Ask a child to walk around the room while he keeps himself facing north or some other fixed direction. Do you see different parts of his head as he passes around the room? Do you see the side, front, and back? Now have the pupil follow the same path but walk normally. See that only one side will be toward the class. They never see his other side. Point out carefully that the demonstrator has "rotated" one time while he "revolved" one time.
- 3
Show a picture of the moon as viewed from the earth through a telescope. The moon and its surface features can be seen. If an atmosphere of air surrounded the moon, would we be able to distinguish its surface features as clearly as we can? If there is no air on the moon, can there be any water?
- 4
What holds us to the surface of the earth? Drop some objects from your hand. They will fall downward or toward the center of the earth because of an unseen force called gravity. The earth is kept in its orbit around the sun because of the gravitational force between the sun and the earth. Have children speculate on what would happen if gravity suddenly stopped. The earth's speed about the sun counters the effect of the sun's gravity.

5

You will find nine known planets on a chart of the solar system. One of them will be the earth. The chart will show that all of the planets travel in paths around the sun. These paths are nearly circular and are called orbits. The larger the orbit, the more slowly the planet moves through its orbit.

6

Set up a globe and light source projector as shown in the diagram. Darken the room as much as possible and turn on the projector. Children standing at position B will see half of a circle of lighted surface corresponding to a "quarter moon." Viewing from position C allows the children to see a whole circle of lighted surface which corresponds to a "full moon." From position A the viewer sees only the dark side or "new moon." Positions X and Z will show crescent and gibbous phases in order.

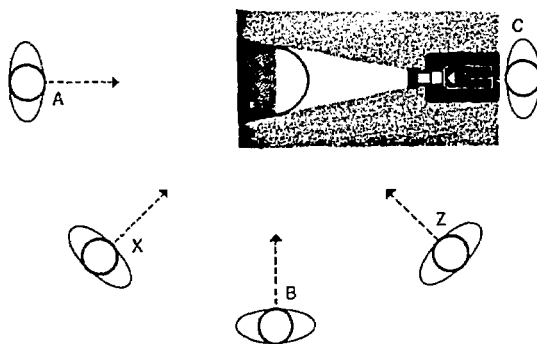

Activities for children

1

Make a large mural of the solar system. Cut models of the planets and sun out of construction paper and place them on the mural. Show their orbits. Children should be reminded that the sizes will not be accurate, particularly the sun, because of the space involved.

2

Have children report on individual planets.

3

Make models of the nine planets and the sun out of construction paper, scaled to their approximate sizes. Hang these from the ceiling of the room. Emphasize to the children that room space does not allow for accurate representation of the solar system.

4

Draw pictures of the planets and the solar system.

5

Have the children observe the day and night phases of the moon during the month, and record their daily observations on a blank calendar. Write in the date on the calendar and draw a picture of the moon as it appeared on that date. The children will notice the gradually changing shape of the moon as it goes through its phases. Note the hour the moon was observed.

Fieldwork

1

Experiences concerning the solar system are most valuable when the children can work outdoors. On nights when planets are visible, they may gather together with the teacher to observe some of the planets, such as Jupiter, Saturn, Venus, and Mars. If optical aids are available, make use of them. The moon is a spectacular sight through a good pair of binoculars if a telescope is not available.

ENRICHMENT

Questions to stimulate further thought

1. How did the planets get their names?
2. Have people always believed the sun to be the center of the planetary system?
3. Could there be other planets in our solar system besides the ones we have studied?
4. Do you think there could be other solar systems in the universe?
5. What would happen if the orbital speed of the earth suddenly became faster?
6. Who was Galileo?

Topics for additional exploration

1
Inertia and gravity. Two forces act on the planets to keep them in their orbits around the sun; inertia tends to make them move off in a straight line, and gravity pulls them into circular paths.

2
The sun's motion. Children may assume that the sun is stationary as the planets orbit around it. However, it is moving through the universe at a tremendous speed.

3
The sun. The sun is an average size star. Many of the stars visible in the night sky are hundreds of times bigger than our sun.

4
Motion of the stars. Stars appear to rise and set due to the rotation of the earth.

5
Other planetary systems. There are millions of stars in the universe, some of which may have their own planetary systems.

6
Composition of stars. Our sun and other stars are made up of very hot gases.

ORGANIZATION AND USE OF INFORMATION GAINED

Projects

- 1
Make a diorama illustrating the surface of the moon.
- 2
Children may do short reports on how the sun and stars are alike.
- 3
Have children report on stories that have appeared in the paper about meteors and meteorites.

Questions to guide a summary of experiences

1. What do we call the sun with its planets and their satellites?
2. How many known planets are in the solar system?
3. Why does the moon shine?
4. Do the planets move?
5. What is an orbit?
6. What is the sun made of?
7. Why does the moon appear to change shape?
8. Does the moon have an atmosphere?
9. How does the earth stay in its orbit?

BASIC UNDERSTANDINGS TO BE GAINED FROM THIS UNIT

1. The sun is the center of our solar system.
2. The sun is composed of hot glowing gases.
3. There are nine known planets in the solar system.
4. The earth is one of these nine planets.
5. The nearly circular paths of the planets around the sun are called orbits.
6. The planets and the moon shine only by reflected light.
7. The same side of the moon always faces the earth.
8. The apparent shape of the moon depends on the position of its sunlit surface that we can see.
9. There is no air or water on the moon.

VOCABULARY

atmosphere gravity inertia meteor orbit

phases planet solar system Mercury Venus

Earth Mars Jupiter Saturn Uranus

Neptune Pluto

Third Grade

f MATTER AND ENERGY

MAGNETISM



PURPOSE OF THE UNIT: *to discover some of the effects of magnetism*

Apparatus and materials

1. Board, thin
2. Candles
3. Cardboard tube
4. Compasses, magnetic
5. Cork
6. Glass, sheet
7. Iron filings
8. Magnets, assorted and bar
9. Nails, 4-inch
10. Needle, darning
11. Needle, knitting
12. Ruler
13. Shellac or mucilage
14. Thread
15. Tin can lid
16. Tumbler, glass

INTRODUCTION OF THE UNIT

Motivating activities

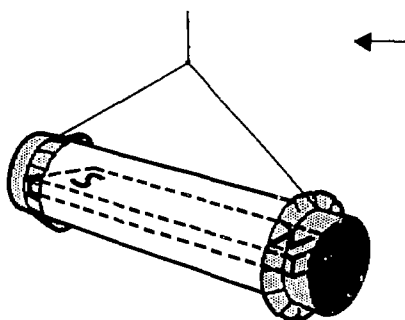

1 Place a bar magnet (preferably alnico) in a small cardboard tube. Cover ends with paper so the magnet is not visible. Support with thread as shown in diagram. Have children observe that the tube will always come to rest in the same position and speculate as to the reason. Can they "prove" what is in the tube without looking inside? *Note: Magnetic interference may complicate this activity. As with all experiments, the teacher should try this activity before presenting it to the class.*

2 Place some magnets of assorted sizes and shapes on a table with various common objects such as chalk, eraser, pencil, paper clips, paper, nail, marble, and thumb-tacks. Let children "experiment" with these objects.

3 Put a paper clip in a tumbler of water. Nearby place a magnet and a note reading "Can you get the clip out of the glass without touching the water?"

Motivating questions

1. What is a magnet?
2. What kinds of things will a magnet attract?
3. Will one magnet attract another magnet?
4. Of what use are magnets to us?

Note: Magnets lose their strength as a result of improper handling and storage. As children use equipment, care should be taken to point out the basic considerations for the handling of magnets:

1. Bar magnets should be stored in pairs, with *unlike* poles together.
2. Horseshoe or U-shaped magnets should be stored with a "keeper" across the ends.
3. Hammering, hitting, or dropping magnets will weaken them.
4. Heating a magnet will weaken or destroy its magnetism.

EXPERIENCES RELATING TO THE PROBLEM

Teacher-directed activities

1 Although children can experiment with a number of materials to determine which substances are attracted to magnets, most third graders have already had some experience in this area. To make use of such past experience, have the class decide before actually testing whether or not certain objects would be attracted by a magnet. Include with the objects to be discussed, a dime, a gold ring, a small square of aluminum foil, and a piece of copper wire. Such nonmagnetic metals will probably lead to interesting class discussion. After the class has made its decisions, test all objects with a magnet. Using any misclassified objects as examples, point out why it is important for scientists to experiment rather than guess at outcomes.

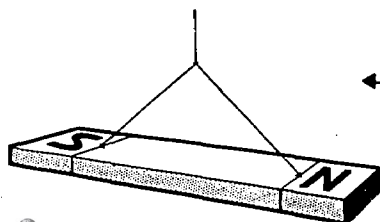

2 Suspend a bar magnet or a magnetized knitting needle as illustrated. When the magnet stops turning, use a tab of colored paper or tape to mark the end of the magnet which points toward a particular object in the room (door, bulletin board, flag, bookshelf, etc.). Tap the magnet lightly and allow it to swing freely. Will it always return to its original position?

3 Display several magnetic compasses. Discuss the importance of the compass to people in places such as a jungle, a desert, or on the ocean.

4 Magnetism will pass through some materials and not others. Obtain a sheet of glass, a thin board, an old phonograph record, a piece of cardboard, and the lid of a large tin can. Place a thumbtack on each of these objects and move a strong magnet under them. If the tack can be moved through the object, the magnetism must be passing through. This will not happen through the can lid (or any other object made of iron). Let the children experiment, observe, and discuss until they discover that magnetism does not pass through materials which are magnetic.

5 Lay a strong bar magnet under a sheet of glass (or stiff cardboard). Sprinkle iron filing over the glass and note the pattern formed. Gently tapping the edge of the glass will help the magnetic pattern form. Blueprints of the magnetic fields can be made by substituting blueprint paper for the glass, and exposing to strong light.

Activities for children

1 Provide the children with bar magnets and paper clips and allow them the opportunity to "feel" the effect on the clips and other objects of various materials.

2 Provide each child or small group of children with a pair of bar magnets, and ask them to determine how they affect each other. From observations made by children, develop some generalizations about the behavior of magnets such as: The strength of a magnet is located at its ends or poles, unlike poles attract each other, and either end of a magnet will attract iron.

3 To show that any object which is attracted to a magnet has itself become a magnet, have children touch a paper clip to the end of a magnet. Touch a second clip to the bottom of the first. If the magnet is fairly strong, a sizable chain can be constructed by this process. Why do the clips stay together? Remove the first clip from the magnet to see how long the magnetism lasts.

4 Children may make small magnets by magnetizing common nails. Give each child a 4-inch nail, a bar magnet, and some paper clips. Have children stroke the nail in *one direction* with one end of the magnet (not with a back and forth motion) about 25 times. Use magnetized nail to pick up clips. How many can be lifted by the nail? Drop the nail on the floor a few times to determine the effect of dropping on a magnet. Will it pick up as many clips?

5 Some magnets are stronger than others. Ask children how the strength of magnets can be measured. Three possible methods are listed below, but any valid method suggested by pupils should be tried.

(a) Strength rated in terms of the number of clips a magnet can lift. Make a number of trials with each magnet to show that this number may vary somewhat.

(b) Place a nail between the poles of two magnets. Pull magnets apart slowly and the nail will remain with the stronger magnet. Repeat to see if the result is the same.

(c) Place a nail at the end of a ruler as illustrated, and move a magnet slowly toward the nail. Note the distance from which the magnet will make the nail roll toward it. The stronger the magnet, the greater the distance it will be able to attract the nail.

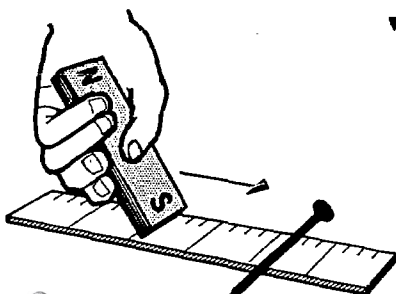
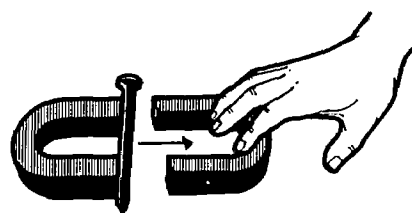

Fieldwork

- 1 Take a compass out in the play area, as far as possible from iron fences and/or the school building to determine which way is north. Once north is located, how do we find south, west, and east?

Questions to stimulate further thought

1. Why are the ends of a magnet referred to as the north and south poles?
2. Why are some magnets bent in a "U" or "horseshoe" shape?
3. Why must compasses be mounted so they can turn very easily?

Topics for additional exploration

- 1 *Magnetic materials.* Besides iron, cobalt, and nickel are also magnetic. Although our 5-cent pieces do not contain enough nickel to display magnetic properties, Canadian nickels do contain enough to be readily attracted by magnets.
- 2 *Lodestone.* Lodestones are natural magnets and were believed to have magical powers by ancient people. They are a form of iron ore called magnetite.
- 3 *North magnetic pole.* Compasses actually point to an area near Victoria Island (North Canada) rather than towards the geographic North Pole. Mapmakers and navigators must compensate for this declination.

ORGANIZATION AND USE OF INFORMATION GAINED**Projects**

- 1 Find out how magnets are used in our homes in such things as can openers, cabinet door fasteners, refrigerator door fasteners, knife racks, tack hammers, and toys.
- 2 Make permanent displays of magnetic patterns. Place a glass plate over a strong magnet. Over the glass lay a sheet of paper which has been covered with shellac or mucilage and sprinkle on iron filings. When dry, patterns can be displayed on the bulletin board.
- 3 A floating compass can be made if one magnetizes a darning needle by stroking it in one direction with a strong magnet. Place the magnetized needle on a thin slice of cork and keep it in place with a few drops of candle wax. Float the cork and needle in a glass jar of water. Compare the direction indicated by the floating compass with that indicated by a standard compass. It is important that objects made of iron are remote from this "compass."

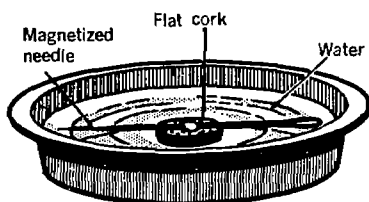
**Questions to guide a summary of experiences**

1. What things do magnets attract?
2. Does one magnet affect another magnet? How?
3. Where on a magnet is its strength greatest?
4. Through what materials will magnetism pass?
5. How can a magnet be made?
6. How is a compass made?
7. What is a compass used for?

BASIC UNDERSTANDINGS TO BE GAINED FROM THIS UNIT

1. Magnets attract things made of iron.
2. Magnets are strongest at their ends or poles.
3. Magnetic force can act through some materials.
4. Magnets repel as well as attract each other.
5. A compass can be used to determine direction.
6. A compass is a magnet which can turn easily.

VOCABULARY

attract	compass	direction	lodestone
<hr/>			
magnet		pole	repel

ORGANIZATION OF ELEMENTARY SCHOOL SCIENCE

	I. LIVING THINGS	II. GROWING BODIES	III. AIR, WATER, AND WEATHER
KINDER-GARTEN	<ol style="list-style-type: none"> All things are either living or nonliving. Living things can be plant or animal. There are many kinds of plants and animals. Plants and animals need food, air, and water to live. Green plants need light to grow. 	<ol style="list-style-type: none"> All living things grow. All living things are not the same size. We cannot tell how big we will become. For growth, we need certain basic things, such as water, food, light, air, and exercise. 	<ol style="list-style-type: none"> Air is all around us. We can feel air but we cannot see it. We can see what air does. Moving air is called wind. Air can warm us or cool us.
GRADE 1	<ol style="list-style-type: none"> Most animals can move from place to place. Animals move in different ways. Animals live in many kinds of places. There are many kinds of plants. Most plants cannot move about as animals do. Certain conditions (temperature, water, etc.) are necessary for living things. 	<ol style="list-style-type: none"> Certain kinds of food are necessary for growth. Some foods are better for us than others. Food alone does not determine how we grow. We need more of some kinds of food than others. 	<ol style="list-style-type: none"> Air takes up space. Most containers which we say are empty are really filled with air. The surface of the earth is warmed in the daytime and cooled at night. This in turn warms or cools the air above it. Winds move at different speeds and from different directions. Winds can carry plant seeds. Winds help things to dry. Winds are sometimes harmful. Rain and snow come from water vapor (clouds) in the air. Clouds have different shapes.
GRADE 2	<ol style="list-style-type: none"> Some animals eat plants. Some animals hunt other animals for food. Green plants make their own food. Green plants store food in their roots, stems, leaves, bulbs, and seeds. Some animals move from place to place with the seasons in order to find food. Living things change as they grow. 	<ol style="list-style-type: none"> Teeth decay because of acids produced in the mouth by bacterial action on food. Sweet, sticky food is more harmful to our teeth than coarse, crisp food. We can protect our teeth by brushing after we eat. Even with good personal care we need to have our teeth looked at regularly by the dentist. 	<ol style="list-style-type: none"> Fire needs air to burn. Plants and animals generally need air to live. A thermometer measures temperature. Temperature is a measure of "hotness." A cloud is made of water droplets or tiny ice crystals. Weather affects our work and play. Water evaporates from puddles, lakes, and oceans to go into the air again.
GRADE 3	<ol style="list-style-type: none"> Plants and animals depend on other living things for their well-being. Many plants and animals are adapted to living in certain kinds of places. Many animals have special adaptations which protect them from their enemies. Man depends on other living things for his food, clothing, and shelter. Man should exercise good conservation practices so as not to disrupt the interdependence of living things. 	<ol style="list-style-type: none"> Sleep is essential to life. Rest before fatigue is considered better than rest following fatigue. Sleep comes easily in the proper atmosphere. Lack of sleep affects us emotionally as well as physically. The art of relaxation can be learned, and relaxation helps us to avoid fatigue. 	<ol style="list-style-type: none"> Air is a real substance and occupies space. Air expands when heated. Cooled air contracts and moves downward. Heated air is moved upwards. Wind is moving air. Local winds are caused by unequal heating of the earth's surface. Wind direction is indicated by a wind vane.
GRADE 4	<ol style="list-style-type: none"> Living things (plants) are produced by similar living things. Some plants grow from seeds. Seeds are produced by flowers. Fruit develops from the flower. Seeds are distributed by explosion, wind, water, and animals. Some plants produce bulbs or tubers while lower plants such as molds, fungi, and ferns reproduce by spores. New plants can be grown from leaves or stems of other plants. Living things (animals) are produced by similar living things. Many animals lay eggs, others bear living young. Some animals feed and protect their growing young. Some animals produce many young at a time. Some simple (microscopic) animals reproduce by breaking apart. 	<ol style="list-style-type: none"> Digestion is the process of breaking food down into smaller chemical parts so it can be used by the body. Only complete digestion of food can give us the full benefits of what we eat. The undigestible portion of food (cellulose) is necessary for the normal functioning of intestines. Different parts of the digestive tract have quite different functions in the total process. We are able to eat what we wish rather than choose foods of the same type because the entire digestive system functions whenever we eat. Activity and emotions may have an adverse effect on digestion. 	<ol style="list-style-type: none"> Water evaporates into invisible vapor. When water vapor cools, it condenses into liquid. Condensed water vapor falling to the ground is called precipitation. Rain, snow, sleet, and hail are all forms of precipitation. Some precipitation soaks into the ground while some runs off into streams, lakes, and oceans. Excessive precipitation causes great damage by erosion and flood. The process of continuous evaporation and condensation is called the water cycle.
GRADE 5	<ol style="list-style-type: none"> Animals require oxygen from the air, and they give off carbon dioxide. Animals digest their food so that it can be absorbed and circulated to all parts of their bodies. Animals are composed of cells. The cells use food and oxygen to produce energy for growth and movement. There are many different kinds of animal cells; nerve, muscle, blood, bone, and skin are the most common. The smallest animals are composed of a single cell, while larger animals are composed of millions of cells. Plants are composed of cells. Green plants can produce their own food by the process of photosynthesis. Green plants combine carbon dioxide with water to produce their food (sugar). Sunlight provides the energy for the process of photosynthesis. Green plants are the first link in any food chain. 	<ol style="list-style-type: none"> A wound is any break in the skin. The body has ways of controlling bleeding, but often it is best if we assist. Bacteria are all around us and they can enter the body through any break in the skin. Cleanliness is very necessary to avoid infection in a wound. Even a clean cloth may have bacteria on it. We should cover cuts with sterile cloth if possible. This allows no dirt or bacteria to enter the body. Whenever a blood vessel is cut, bleeding will occur. The amount of bleeding depends on the number and size of the vessels cut. 	<ol style="list-style-type: none"> Air is a mixture of oxygen and other gases. Air takes up space and has weight. Air exerts pressure. A barometer measures air pressure. Pressure in moving air is less than pressure in still air. Air heats when it is compressed and cools when it expands. The air surrounding the earth is called the atmosphere. The three layers of the atmosphere are the troposphere, the stratosphere, and the ionosphere.
GRADE 6	<ol style="list-style-type: none"> Scientists have arranged plants and animals into similar groups in order to study them. Classification of living things is based on their structure. Classification emphasizes the development of simple forms of life into more complex forms. Living things have developed into complex organisms very slowly during millions of years. Many different kinds of plants and animals live together in nature and depend on each other for food. 	<ol style="list-style-type: none"> To achieve physical fitness there is a need for strenuous physical activity. Physical fitness helps us do most everything we try easier and better than when we are not physically fit. Food, rest, and sleep are important helps in achieving physical fitness. Physical fitness ultimately depends on how strong the heart muscle is because we depend on it for oxygen and food in the cells and for taking away waste products. Increase in strength of all muscles, including the heart, depends on exercise. 	<ol style="list-style-type: none"> The conditions of the atmosphere are measured by various weather instruments. Atmospheric conditions vary from place to place and from time to time. Low pressure areas are generally associated with stormy weather and high pressure areas are generally associated with fair weather. The general movement of our daily weather across the country is from west to east. The Weather Bureau predicts the weather from the measured conditions of the atmosphere. The weather map shows the daily conditions of our atmosphere.

(WITH SUGGESTED GRADE PLACEMENTS)

IV. THE EARTH AND ITS COMPOSITION	V. THE SOLAR SYSTEM AND BEYOND	VI. MATTER AND ENERGY
<ol style="list-style-type: none"> 1. Rocks are hard, nonliving things. 2. Rocks have various colors, sizes, and shapes. 3. Gravel and pebbles are small pieces of rock. 4. Some rocks feel rough and others feel smooth. 5. There are many kinds of rocks. 	<ol style="list-style-type: none"> 1. We live on the earth. 2. The earth is very large. 3. The sun gives us light and heat. 4. Light reflected from the moon helps us see at night. 	<ol style="list-style-type: none"> 1. Sounds are made by people, and animals, and moving objects. 2. Sounds travel in all directions. 3. We hear sounds with our ears. 4. Sounds may be pleasant or unpleasant. 5. Sounds can warn us of danger.
<ol style="list-style-type: none"> 1. The land on which we live is made up of rock and soil. 2. Sand is broken bits of rock. 3. Soil is made of broken-down rock and decayed plant and animal material. 4. Stone is used as a building material. 5. Stone which is used to build things is strong and hard. 6. Stone is used in many ways around the house and in schools. 	<ol style="list-style-type: none"> 1. The earth is round. 2. There is air all around the earth. 3. The sun is much larger than the earth. 4. The four seasons of the earth are spring, summer, fall, and winter. 5. The moon is smaller than the earth. 6. Sometimes we see both the moon and the sun in the sky. 	<ol style="list-style-type: none"> 1. Light lets us see. 2. Shadows are made when light is blocked. 3. The sun, fire, and electric lamps produce light and heat. 4. Heat has many uses. 5. Fire may cause great damage.
<ol style="list-style-type: none"> 1. Rocks are constantly being worn down or broken by wind, water, temperature changes, plants, and chemicals. 2. Different kinds of soil are formed from different kinds of rock. 3. Soil contains bits of broken rock and decaying plant and animal matter. 4. Most plants need soil which contains organic matter. 5. Soils differ in their ability to hold water. 6. Topsoil is a valuable resource and should be conserved. 	<ol style="list-style-type: none"> 1. The earth revolves around the sun. 2. The earth revolves around the sun once in our year. 3. The rotation of the earth causes day and night. 4. The change of seasons affects man, animals, and plants. 5. We can tell direction by the sun and stars. 6. The sun rises in the east and sets in the west. 7. The sun and stars are always shining. 8. The moon is the earth's nearest natural neighbor. 9. Stars vary in size, brightness, and in distance from us. 10. Stars look small because they are so far away. 	<ol style="list-style-type: none"> 1. Our world is made of many different kinds of matter (material). 2. Matter may be solid, liquid, or gas. 3. Solids have a definite volume and shape. 4. Liquids have a definite volume but take the shape of their containers. 5. Gases have no definite volume or shape. 6. Many materials are enough alike to be grouped into "families" such as metals, plastics, etc.
<ol style="list-style-type: none"> 1. The surface of the earth is constantly changing. 2. Rocks can be broken apart by heat (sun), freezing, water, and plants. 3. Mountains and hills are being worn down. 4. Running water is largely responsible for the wearing-down process (erosion). 5. Earthquakes, volcanoes, and slower earth movements are constantly building up new mountains. 	<ol style="list-style-type: none"> 1. The sun is the center of our solar system. 2. The sun is composed of hot glowing gases. 3. There are nine known planets in the solar system. 4. The earth is one of these nine planets. 5. The nearly circular paths of the planets around the sun are called orbits. 6. The moon and planets shine only by reflected light. 7. The same side of the moon always faces the earth. 8. The apparent shape of the moon depends on the position of its sunlit surface that we can see. 9. There is no air or water on the moon. 	<ol style="list-style-type: none"> 1. Magnets attract things made of iron. 2. Magnets are strongest at their ends or poles. 3. Magnetic force can act through some materials. 4. Magnets repel as well as attract each other. 5. A compass can be used to determine direction. 6. A compass is a magnet which can turn easily.
<ol style="list-style-type: none"> 1. Rocks are grouped as igneous, sedimentary, and metamorphic. 2. Igneous rocks form when magma or lava cools. 3. Sedimentary rocks are formed when sand or other sediment is compressed and converted into rock. 4. Metamorphic rocks are formed from other rocks which have been heated or squeezed into new forms. 5. Rocks are composed of minerals. 6. Three common rock-forming minerals are quartz, feldspar, and mica. 7. Fossils are evidence of life in the past and may be found in sedimentary rock. 8. A geologist is a scientist who studies the history of the earth and the rocks and minerals which make up the earth's surface. 	<ol style="list-style-type: none"> 1. Our temperature zones are caused by the tilt of the earth's axis. 2. The seasons are caused by the tilt of our axis and the position of the earth in its orbit. 3. The sun is an average-size star. 4. The planets shine by reflected sunlight. 5. The planets vary in size and distance from the sun. 6. The planets and their satellites are held in their orbits by gravity and inertia. 7. The moon rises at a different time each day. 8. The tides are caused by the gravitational pull of the sun and the moon. 	<ol style="list-style-type: none"> 1. Heat is a form of energy. 2. Heat energy is used to run many machines. 3. Heat is produced by fire, friction, and electricity. 4. Metals are good conductors of heat; wood is a poor heat conductor. 5. Heat from friction is wasted energy. 6. Friction makes it difficult to slide one object along another. 7. Friction is reduced by the use of bearings and lubrication. 8. Friction is useful in stopping moving things. 9. Machines are used to make work easier.
<ol style="list-style-type: none"> 1. The interior of the earth is hot. 2. Geysers and hot springs bring dissolved minerals to the earth's surface. 3. Volcanoes, earthquakes, and geysers are earth-building forces. 4. Weathering and erosion wear down the surface of the earth. 5. Water, wind, chemical reactions, temperature changes, and plant growth slowly disintegrate rock. 6. Disintegrated rock is moved to lower areas by water, ice, and wind. 7. Topsoil is often lost faster than it is replaced. 8. Topsoil contains sand, silt, clay, and humus. 9. Soil conservation practices include crop rotation, terracing, and contour farming. 10. The ocean has been made salty by the dissolved minerals that streams have carried into it. 11. Limestone caves are formed by action of water as it seeps down through rocks. 12. The depletion of resources, including soil, changes the way we live. 	<ol style="list-style-type: none"> 1. The solar system is composed of the sun, planets, satellites, planetoids, meteors, and comets. 2. There are various theories describing the origin of our solar system and the universe. 3. The sun is a sphere of hot gases. 4. Disturbances (storms) on the sun's surface are called sunspots. 5. The volume of the sun is about 1 million times the volume of the earth. 6. The planets rotate as they revolve. 7. Our sun is an average-size star. 8. Galaxies are huge collections of stars. Our galaxy is called the Milky Way. 9. The stars in our sky seem to revolve around the earth because of the earth's rotation. 10. Constellations are groups of stars which appear to outline a figure. 11. Different constellations come into view with the change in seasons. 	<ol style="list-style-type: none"> 1. Static electricity can be produced by friction. 2. Electricity can be generated by moving wires through a magnetic field of force. 3. Electricity from the generating plant comes into our homes through wires. 4. We change electrical energy into heat, light, magnetism, and sound for our use. 5. A switch is used to start and stop the flow of electricity in a circuit. 6. Some materials are electrical conductors and some are electrical insulators. 7. Fuses and circuit breakers protect our homes from electrical accidents.
<ol style="list-style-type: none"> 1. Rocks are mixtures of minerals. 2. Minerals are naturally occurring inorganic substances and have a definite chemical composition. 3. Minerals have definite physical properties. 4. Minerals may be identified by color, hardness, and other characteristics. 5. Minerals that can be mined profitably are usually called ores. 6. Minerals are nonrenewable resources and should be used wisely. 	<ol style="list-style-type: none"> 1. Planets differ in physical characteristics such as size, motion, gravity, atmosphere, and temperature. 2. Forces man must consider when sending rockets into space are gravity, inertia, and friction. 3. Energy released from the sun is called solar radiation. 4. When the moon blocks the sunlight from the earth, a lunar eclipse occurs. 5. When the earth blocks the sunlight from the moon, a lunar eclipse occurs. 6. The phases of the moon result from our viewing various amounts of the lighted side of the moon. 7. Our units of time are based on astronomical motions. 8. Astronomers use telescopes, spectroscopes, and cameras in their observations. 9. The great distances through space are often measured in light years. 10. Our knowledge of astronomy has developed as the result of the work of many scientists over many years. This knowledge is incomplete and always subject to questioning and change. 	<ol style="list-style-type: none"> 1. Matter is composed of very small particles called atoms. 2. Groups of atoms join together to form molecules. 3. A substance composed of only one kind of atom is called an element. 4. There are over 100 known elements. 5. Elements can combine to form compounds. 6. Chemical changes result in the formation of new substances. 7. The combustion of fuel is a chemical change which releases energy. 8. Physical changes do not result in the formation of new substances. 9. Matter may be solid, liquid, or gas depending on the behavior of its molecules. 10. Some atoms are radioactive and release energy. 11. Man has learned to use the energy released from radioactive materials, which is called nuclear energy.