

DOCUMENT RESUME

ED 050 561

EM 008 921

AUTHOR Bernstein, Bernard R.; Gonzalez, Barbara K.
TITLE Learning, Retention and Transfer, Volume I of II.
INSTITUTION Honeywell, Inc., Minneapolis, Minn.
SPONS AGENCY Naval Training Device Center, Orlando, Fla.
PUB DATE Feb 71
NOTE 219p.; Final Technical Report, June 1968 through June 1969

EDRS PRICE MF-\$0.65 HC-\$9.87
DESCRIPTORS Computer Assisted Instruction, Computer Based Laboratories, Feedback, *Learning, Mediation Theory, Military Training, *Mnemonics, Recall (Psychological), Research Design, *Retention, Simulation, Simulators, Skill Development, Task Analysis, Taxonomy, *Training Techniques, *Transfer of Training, Visualization

ABSTRACT

The planning activities in this research program included a review of the applied and theoretical literature in the field of learning, retention, and training, a selection of an appropriate taxonomy of tasks, a survey of Naval jobs to determine critical tasks from the standpoint of training, a series of technical meetings with consultants, and a conceptual design for a general purpose computer-based, experimental apparatus. Two experiments were designed and conducted in order to try out the newly developed set of research requirements and to provide a data base for subsequent investigations. These experiments dealt with training and transfer of procedural skills. At the end of the first experiment subjects were asked to suggest ways of improving the effectiveness of training. These suggestions were used to modify training for the second experimental group. On the basis of these experiments it was concluded: that trainee feedback can be of value in increasing training effectiveness, that "imagery" can play an important role in promoting procedural skills, and that training effectiveness can be achieved through the use of low-cost paper and pencil simulation of the operational task. (JY)

ED050561

U.S. DEPARTMENT OF HEALTH, EDUCATION & WELFARE
OFFICE OF EDUCATION
THIS DOCUMENT HAS BEEN REPRODUCED EXACTLY AS RECEIVED FROM THE PERSON OR ORGANIZATION ORIGINATING IT. POINTS OF VIEW OR OPINIONS STATED DO NOT NECESSARILY REPRESENT OFFICIAL OFFICE OF EDUCATION POSITION OR POLICY.

Technical Report: NAVTRADDEVCEM 68-C-0215-1

VOLUME I OF II

LEARNING, RETENTION AND TRANSFER

B. E. Bernstein and B. K. Gonzalez

Raytheon, Inc.
Systems and Research Division
Research Department
St. Paul, Minnesota 55113

Contract N61339-68-C-0215
NAVTRADDEVCEM Task No. 7014-1

February 1971

FOR DISTRIBUTION SYSTEMS

Approved for public release; distribution unlimited.

NAVAL TRAINING DEVICE CENTER

ORLANDO, FLORIDA

INDC

1

TECHNICAL REPORT: NAVTRADEVCEEN 68-C-0215-1

LEARNING, RETENTION AND TRANSFER

ABSTRACT

This research program consisted of two main tasks. The first task was the development of a set of requirements for a long-term program of learning, retention, and transfer research. The requirements were based on five planning activities:

- A brief review of the relevant literature
- Selection of an appropriate taxonomy of tasks
- A survey of Naval jobs to determine critical tasks from the standpoint of training
- Organization and management of technical meetings with consultants
- A conceptual design for a general purpose L, R, and T apparatus

The second task was the design and conduct of two initial experiments in order to execute a preliminary trial of the newly developed set of research requirements and to provide a data base for subsequent investigations. These experiments dealt with training and transfer of procedural skills. For this purpose, a laboratory apparatus was constructed to represent military procedural tasks. Operation of this apparatus by the subject involved the learning of facts, principles, and procedures and the recall of this information in the solution of specific problems. The task resembled the operation of a military communication system.

In Experiment I, 10 subjects were presented with 50 communications problems, 20 each on two consecutive days. Dependent measures were response time and accuracy. Evidence of learning was provided by both measures, but this appeared to be more sensitive than accuracy.

In Experiment II, 10 subjects were presented with 50 communications problems, 20 each on two consecutive days. Dependent measures were response time and accuracy. Evidence of learning was provided by both measures, but this appeared to be more sensitive than accuracy.

The results of these experiments indicate that the apparatus is suitable for the study of learning, retention, and transfer of procedural skills. The apparatus is suitable for the study of learning, retention, and transfer of procedural skills. The apparatus is suitable for the study of learning, retention, and transfer of procedural skills.

The results of these experiments indicate that the apparatus is suitable for the study of learning, retention, and transfer of procedural skills. The apparatus is suitable for the study of learning, retention, and transfer of procedural skills.



FOREWORD

This project is concerned with developing and instituting a program of research on human learning, retention, and transfer which will lead to improved training methods for the Navy.

This report makes a good start toward developing a comprehensive plan to guide the design of research on learning, retention, and transfer of military skills. The report: (1) identifies four types of tasks as the most critical ones to study in this program of research; (2) offers informational papers on each of these four task types, as well as on related topics, composed by experts in the field especially for the present project; (3) contains an extensive (albeit incomplete) bibliography related to the study of learning, retention, and transfer for military training purposes; (4) presents alternate conceptual plans for the design of systems of experimental materials which can be used to effect any conceivable experiment under this project; (5) suggests a set of guidelines for the design of the experimental research.

Further, the experimental phase of the research program has been initiated with two experiments. One of the outcomes of these initial experiments is to bring us closer to defining the conditions of fidelity that are required for effective training. In addition, the experiments tested the value of a new approach (called "imagery") to the old training practice of providing visual aids to the trainee.

It is critical to the mission of the NAVTRADEVGEN to have information about the nature and effects of training variables and techniques (such as fidelity of simulation and "imagery") on the learning, retention, and transfer of military-type tasks. For the most part, such information is sorely lacking. Thus, because this information must be painstakingly acquired through research and because of the broadness of scope of the research area, it is especially important to have a plan for the research which is attuned to the present state of the art and which serves as a rational guide toward the goals. The plan for research presented within will be expanded and perfected as the necessity to do so is indicated. Future research will pursue the lines of investigation opened by this year's work and extend the scope of study to include other training and task variables of relevance to military training.

Arthur S. Blatwes

ARTHUR S. BLATWES
Human Factors Laboratory

TABLE OF CONTENTS

<u>Section</u>		<u>Page</u>
I	INTRODUCTION.....	1
	Statement of the Problem.....	1
	Basic Approach	1
II	PROGRAM PLANNING PHASE - DEVELOPMENT OF A RESEARCH STRATEGY.....	3
	Planning Activities	3
	Literature Review.....	3
	Task Taxonomy	5
	Survey of Naval Jobs.....	9
	L, R, and T Technical Meetings	9
	Apparatus Planning.....	14
	Program Requirements	14
III	EXPERIMENTAL PHASE - PURPOSE AND APPROACH ...	19
	Statement of the Problem	19
	Fidelity of Simulation.....	19
	Imagery.....	20
	Trainee Feedback	21
	Approach to the Problem	22
	The Need for a Procedural Skills Task.....	22
	Experiment I	23
	Experiment II.....	24
IV	EXPERIMENTAL PHASE - EXPERIMENT I.....	25
	Method	25
	Apparatus	25
	Subjects	29
	Procedure	29
	Results	33
	Learning Effects	33
	Independence of Performance Measures.....	35
	Equivalence and Internal Consistency of Problem Sets .	36
	Subjects' Verbal Reports	36
	Discussion and Conclusions.....	40
V	EXPERIMENTAL PHASE - EXPERIMENT II	41
	Method	41
	Apparatus	41

NAVTRADEVCEEN 68-C-0215-1

<u>Section</u>	<u>Page</u>
Subjects.....	41
Procedure.....	41
Results	43
Imagery.....	43
Fidelity of Simulation.....	43
Discussion and Conclusions	47
REFERENCES	48
APPENDIX A BIBLIOGRAPHY.....	51
APPENDIX B L, R, AND T TECHNICAL MEETINGS REPORT....	67
APPENDIX C JOB TRAINING AND TESTING CONSOLE (JTTC) REPORT	69
APPENDIX D TASK ANALYSIS FOR IDEAL SYSTEM OPERATION.	101
APPENDIX E MANUAL OF INSTRUCTIONS - EXPERIMENT I	107
APPENDIX F IMAGERY SEQUENCES	121
APPENDIX G MANUALS OF INSTRUCTION - EXPERIMENT II ...	133

LIST OF ILLUSTRATIONS

<u>Figure</u>		<u>Page</u>
1	Development of Task/Behavior Categories.....	6
2	Applicability of Task/Behaviors to Learning Theory Principles.....	7
3	Predictability of Task/Behaviors to Learning Theory Principles	8
4	Subject's Console	26
5	Experimenter's Console	27
6	L, R, and T Laboratory	28
7	Mean Time to Complete Subroutines of Problem Blocks..	34
8	Mean Percent Accuracy on Problem Blocks.....	35
9	Mean Time to Complete Each Subset of Problems	37
10	Mean Percent Accuracy on Each Subset of Problems.....	37
11	Experimental Design - Experiment II	42
12	Effects of Imagery and Fidelity of Simulation on Response Time.....	44
13	Effects of Imagery and Fidelity of Simulation on Accuracy	44

LIST OF TABLES

<u>Table</u>		<u>Page</u>
1	Priority of Naval Tasks for Study in L, R, and T.....	10
2	Types of Problems Used in L, R, and T Experiments I and II.....	30
3	Scoring Method.....	34
4	Analysis of Variance Summary - Accuracy Data.....	38
5	Analysis of Variance Summary - Time Data	39
6	Analysis of Variance Summary -- Response Time During Training.....	45
7	Analysis of Variance Summary -- Arcsin Transformed Percent Accuracy Scores (radians) During Training	45
8	Analysis of Variance Summary -- Response Time During Transfer.....	46
9	Analysis of Variance Summary -- Arcsin Transformed Percent Accuracy Scores (radians) During Transfer	46

SECTION I
INTRODUCTION

STATEMENT OF THE PROBLEM

For training technology to provide a useful basis for the design of highly effective training systems, a sound data base of principles relating to learning, retention, and transfer (L, R, and T) processes needs to be established. Because of the large number of variables affecting L, R, and T, any attempt to provide a useful data base for application to the wide variety of Navy activities would require a systematic and long-term program of research. The Naval Training Device Center (NTDC) has awarded to Honeywell Inc. a contract for the development of such a program of research.

This program would draw from and build upon what has already been done in L, R, and T. It was therefore decided that a major portion of the first year would be devoted to research strategy formulation. Experimentation during the first year was viewed in part as the preliminary steps of a validation process for the research strategy.

This research program, although initiated by Honeywell, will at some future time become an in-house activity of NTDC. Therefore, the development of the program has been closely coordinated between Honeywell and NTDC.

BASIC APPROACH

Activities for the first year of this program included two basic tasks, the implementation of five planning techniques, from which the research strategy could be developed, and the conduct of two initial experiments, for validation of the strategy.

The following five mechanisms provided data for setting long-term research requirements:

- Brief Review of the Relevant Literature -- The major purpose of the literature review was to determine the extent to which psychological research has produced useful principles for training system designers. A second purpose was to find out what information previous research could furnish concerning variables which affect learning, retention, and transfer, i. e., experiments which have dealt with L, R, and T within the same experimental design.
- Selection of an Appropriate Taxonomy of Tasks -- Because of the wide variety of skills trained by the Navy, it is important that research findings be organized as they relate to various classes of behavior. To provide a consistent basis for behavior categorization, it was deemed necessary to select a taxonomy of tasks. A well defined list of task categories permits the organization of research findings so that they can be effectively applied to the skills required in Navy jobs.

NAVTRADEV CEN 68-C-0215-1

- Survey of Naval Jobs to Determine Critical Tasks from the Standpoint of Training -- Because of the breadth of the field encompassed by this program, it was necessary to be highly selective in the initial research problems studied. The primary basis for selection was the types of tasks to be investigated. The decision was made to select for study critical Naval tasks, and tasks which present major problems in training, on the basis of an existing taxonomy.
- Organization and Management of Technical Meetings with Consultants -- A series of technical meetings was planned to aid in selection of research problems having maximum priority and to help develop a long-term research strategy. Participants in these meetings were acknowledged experts from each of the major areas defined by the three previous planning activities. The basic goal of the L, R, and T meetings was to provide concentrated technical sessions by drawing from the knowledge of prominent psychologists associated with military, industrial, and academic institutions. Such an approach is regarded as more effective than the use of consultants on an individual basis, a procedure which forfeits the benefits of group interaction.
- Conceptual Design for A General Purpose L, R, and T Research Apparatus -- Because of the long-term nature of this program, it seemed advisable to anticipate the apparatus problems produced by the study of a variety of behavior categories. With such planning, the building of a separate apparatus for each program phase could be avoided. Furthermore, by developing an integrated system it would be possible to study complex tasks and jobs composed of two or more tasks. On this basis a study was conducted to generate requirements for the design of a general purpose L, R, and T research apparatus.

After these activities were completed, two experiments were conducted. These experiments were designed to reflect program requirements generated as part of the research strategy. Moreover, the initial experiments provide a data base for later research.

SECTION II

PROGRAM PLANNING PHASE - DEVELOPMENT
OF A RESEARCH STRATEGY

PROCEDURE

All of the planning mechanisms described earlier were designed for the same basic purpose, to aid in the development of a sound set of program requirements for L, R, and T research. These activities were by no means conducted independently of each other. However, for simplicity, each is described separately here in terms of procedures, results, and conclusions.

Literature Review

A review of both the applied and theoretical literature on L, R, and T was initiated at the outset of the program. A bibliography of L, R, and T books and research reports is contained in Appendix A. It very quickly became apparent that establishing criteria of relevance was a major problem. It was clearly necessary to be selective because of the abundance of research involving learning, retention, or transfer. On the other hand, virtually no experiments were discovered which attempted to establish parametric relations among variables affecting learning, retention, and transfer. Therefore, the bibliography is merely a representative list of relevant publications and is not intended to be exhaustive.

The survey reinforced Mackie and Christensen's (1967) finding that psychological research has traditionally failed to provide results which are translatable to principles for training device and training program designers. A number of problems to which the present research program must address itself, before translatable research can be accomplished, were identified in the literature review. These include the following:

- Experiments have traditionally concentrated on the effects of a variety of stimuli on performance during learning, after some retention interval (memory), or on some transfer task. Only a very limited attempt has been made to determine the extent to which conditions which benefit learning are also the conditions which facilitate retention and transfer. However, those studies which have examined this problem suggest that, in general, the better the original learning, the better the retention (Deese and Hulse, 1967). This idea is reflected in the term "resistance to forgetting or extinction" in relation to the degree of original learning. Moreover, the assumption is often made that transfer is limited by retention. One notable exception to this assumption was a finding by Bunch (1936) which showed a significant decrease in savings score (improvement on retention test over equivalent point during acquisition) as a function of length of retention interval but very little change in amount of transfer. Also, there is some evidence that conditions of high intratask interference during learning facilitate intertask transfer (Battig, 1966). Further research aimed at understanding the basis of

NAVTRADEVCEEN 68-C-0215-1

exceptions to the general rule that learning limits retention and transfer seems warranted.

- A major factor associated with the applicability of research findings is the extent to which the laboratory representation of a task is related to the operational task. For example, it is likely that findings from laboratory studies employing nonsense syllable list learning have very limited applicability to the procedural learning involved in the job of the air traffic controller or the sonarman. For training effectiveness to be improved, it is necessary that laboratory research use tasks which, relate to tasks performed by Navy personnel.
- Closely related to the previous point is the fact that a fully satisfactory taxonomy of tasks is not presently available. One approach to developing a suitable taxonomy is to group tasks according to common principles. The taxonomy construction should, therefore, be coordinated with an active research program. However, the development of such a taxonomy is not considered a task of the L, R, and T program. The literature review did, however, reinforce the previously expressed need for obtaining a taxonomy which could relate tasks studied in the laboratory to tasks performed by Naval personnel.
- Psychological research is often designed to answer some basic theoretical question about L, R, and T. This kind of theory testing has often had very little utility for training technology. The designer of training programs operates on a pragmatic basis. He primarily needs information on techniques of training which promote retention and transfer, as opposed to underlying theoretical explanations for the superiority of one technique over another. For this reason, the selection of variables for study in the present program should take into consideration operational factors, i. e., those which affect training effectiveness.
- The traditional model of transfer proposed by Osgood (1949) has been tested experimentally in a number of studies. In general, the model has fared well. The problem is that, again, the laboratory conditions of similarity between task elements lack translatability to the operational setting. Recent approaches to the problem of understanding the conditions which promote transfer (Wittrock, 1968) seem more applicable to the problems of Naval training. One of these newer approaches is termed mediated generalization and is based on the idea that language permits man to generalize and discriminate among situations. A second approach (Gagne and Paradise, 1961) views relatively complex learning situations as habit hierarchies, with superordinate skills depending on transfer from subordinate skills.

- In the area of cognitive skills, i.e., skills involving language, psychologists are becoming increasingly aware that subjects are not passive in learning situations. Marx (1969) recently emphasized this point when, referring to subjects, he stated:

"He selects stimuli; he chooses certain items to work with first; he uses mnemonic devices and codes and mediates relations between items; and sometimes he reconstructs, on the basis of linguistic knowledge, what he has learned without actually remembering much more than the substance of what he has studied. Sometimes these operations on the part of the learner are referred to as 'strategies' (p. 364)."

Marx goes on to state that although the scientific investigation of learning and memory have revealed a significant amount of knowledge about underlying processes, the restricted conditions of the laboratory (control of strategies) permit few generalizations to the real world. For the L, R, and T program to have relevance to the Navy's operational training problems, further knowledge about strategic behavior as related to a wide variety of independent variables is necessary.

Task Taxonomy

The literature regarding task taxonomies was reviewed to find the most suitable taxonomy for relating laboratory findings to specific Naval tasks. The U.S. Air Force was recently concerned with essentially the same problem, leading to a review of existing task taxonomies. This review, by Ginsberg, McCullers, Meryman, Thomson, and Witte (1966), concluded that no single taxonomy is, in an overall way, clearly superior to any other. The most serious problem with these taxonomic efforts has been the absence of empirical validation. There is no apparent way to judge the extent to which a taxonomy successfully categorizes behaviors based upon its ability to predict behavior from existing experimental data without a systematic set of validation experiments.*

Selection of a taxonomy for use in the L, R, and T program was, therefore, not made in terms of established predictive validity. The taxonomy chosen, that of Willis and Peterson (1961), was specifically developed to provide guidelines for the development and utilization of training devices. Primarily for this reason, this taxonomy seemed most suitable for the L, R, and T program. This taxonomy also seemed to be a reasonable one in terms of the task/behavior categories used. These categories are at three levels of specificity (Figure 1), with the most general level containing three categories, Level II having six subcategories, and Level III having 19 task/behaviors.

The 19 task/behaviors are combined into three matrices with 13 principles of learning relating to stimulus manipulation, response manipulation, and other experimental conditions. The first two matrices correspond to the applicability (Figure 2) and predictability (Figure 3) of each task/behavior with each learning principle, as indicated by entries in the 247 cells. The third matrix represents a combination of the first two. From the third

* A further discussion on this topic is provided in Appendix B, p. p. 14-19.

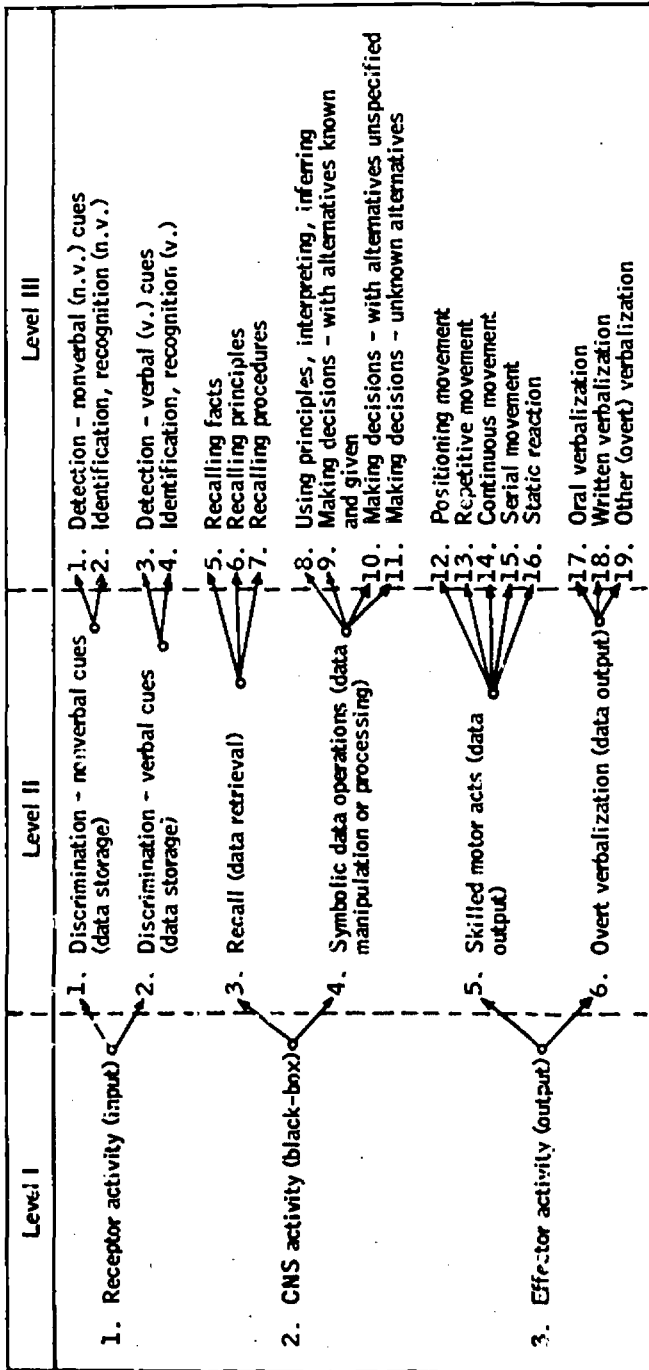

Figure 1. Development of Task/Behavior Categories (Willis and Peterson, Vol. II: Methodology)

TASK/BEHAVIOR CATEGORY		LEARNING PRINCIPLE												
		1. stimulus reception	2. stimulus context	3. stimulus generalization	4. contiguous occurrence	5. response repetition	6. response context	7. reinforcement delay	8. reinforcement quality	9. reinforcement magnitude	10. reinforcement schedule	11. motivation	12. mediation/competition	13. individual differences
1.	non-verbal detection													
2.	non-verbal identification													
3.	verbal detection													
4.	verbal identification													
5.	recalling facts													
6.	recalling principles													
7.	recalling procedures													
8.	using principles, inferring													
9.	making decisions - alternatives given													
10.	making decisions - alternatives unspecified													
11.	making decisions - alternatives unknown													
12.	positioning movement													
13.	repetitive movement													
14.	continuous movement													
15.	serial movement													
16.	static reaction													
17.	oral verbalization													
18.	written verbalization													
19.	other (overt) verbalization													

Figure 2. Applicability of Task/ Behaviors to Learning Theory Principles (Willis and Peterson, Vol. II: Methodology)

TASK/BEHAVIOR CATEGORY	LEARNING PRINCIPLE												
	1. stimulus reception	2. stimulus context	3. stimulus generalization	4. contiguous occurrence	5. response repetition	6. response context	7. reinforcement delay	8. reinforcement quality	9. reinforcement magnitude	10. reinforcement schedule	11. motivation	12. mediation/competition	13. individual differences
1. non-verbal detection	■												
2. non-verbal identification		■											
3. verbal detection			■										
4. verbal identification				■									
5. recalling facts					■								
6. recalling principles						■							
7. recalling procedures							■						
8. using principles, inferring								■					
9. making decisions - alternatives given									■				
10. making decisions - alternatives unspecified										■			
11. making decisions - alternatives unknown											■		
12. positioning movement	■											■	
13. repetitive movement													■
14. continuous movement													
15. serial movement													
16. static reaction													
17. oral verbalization													
18. written verbalization													
19. other (overt) verbalization													

Figure 3. Predictability of Task/Behaviors to Learning Theory Principles (Willis and Peterson, Vol. II: Methodology)

matrix, one may explicitly formulate inferences for training device utilization. In a sense, this third matrix approximates the state of the art, as of 1961, for the relationship between learning theory and military training across taxonomic categories of behavior. Little if any evidence suggests that this situation has improved substantially over the last decade.

In general, the principles summarized by Willis and Peterson are so general or are so irrelevant to the kinds of learning involved in Naval tasks that little use of them can be made by training specialists.

Survey of Naval Jobs

The breadth of the field encompassed by learning, retention, and transfer, made it necessary to be selective in choosing problems and types of tasks to study early in the program. Consistent with the idea that translatable research should be based upon operational training considerations, the decision was made to select experimental tasks which are representative of critical Naval skills.

From job descriptions contained in the U. S. Navy Enlisted Occupational Handbook, a list of critical Naval jobs, with apparent training problems, was constructed. Honeywell personnel who have firsthand knowledge of the Navy broadened the list to include commissioned officers. Each job was then analyzed in terms of Willis and Peterson's 19 Level III tasks. A frequency count of tasks occurring in critical jobs was used to produce a rank ordering of the 19 tasks. This priority listing, which was reviewed with NTDC personnel for confirmation, is contained in Table 1. The tasks found to be of highest priority were the following:

- Recalling facts, principles and procedures
- Recognition/identification - nonverbal cues
- Detection - nonverbal cues
- Symbolic data operations (problem solving/decision making)

Moreover, this analysis suggested that a general situation with which the L, R, and T program should concern itself, is one in which an operator is monitoring one or more displays which present relatively infrequent signals that must be rapidly detected, accurately categorized and, depending on the category within which they occur, responded to with the correct procedures. Problems associated with the selection of procedures involve symbolic data operations and vary in type depending upon degree of uncertainty and knowledge of alternatives. Examples of operational situations of this type include radar, sonar, and ECM system operation. While it is recognized that operators must frequently operate in a time-sharing fashion, the initial L, R, and T should be devoted to the study of relatively "pure" tasks. Once sufficient data has provided an understanding of single tasks, they can be combined to form complex jobs.

L, R, and T Technical Meetings

Topics covered at these meetings were selected on the basis of the survey of Naval jobs. Each of the speakers and discussants is a recognized expert in a category of taxonomic behavior. The task of the speakers was to provide a review of the current knowledge in his area of specialization and to make recommendations for research. The following is a list of participants and their topics:

Table 1. Priority of Naval Tasks for Study in L, R, and T

Rank	Task	Relation to Navy Job	Comments
2(a)	Recalling facts	Prevalent following - Central to all maintenance jobs and the majority of operational jobs (e.g., aircraft pilot, damage controlman, signalman, electronics technician, etc.)	Corresponds to storage and retrieval of verbal information (psychology of verbal learning) - particularly important because of association with almost all jobs
2(b)	Recalling principles		
2(c)	Recalling procedures		
4	Recognizing/identification - nonverbal cues	Pattern recognition - includes scope interrelation (radar-sensor-operational) and maintenance jobs (diagnosis of equipment faults)	Particularly difficult to train this skill
5	Detection - nonverbal cues	Vigilance - Detection of targets on radar and sensor displays and detection of equipment malfunctions by operators and maintenance personnel	Training - a major problem because of typical infrequency with which signals occur
6	Using principles, interpreting, inferring	Elementary logic - Diagnosis of equipment malfunctions by maintenance personnel, ship handling, navigation, etc.	Requires training of judgment - largely ignored in psychological literature
7	Decision making - alternatives known	Diagnosis of complex system malfunctions by maintenance personnel - common to virtually all critical operational jobs	An extension of (6)
8, 9(a)	Decision making - alternatives unspecified	Threat evaluation and weapon assignment (command decisions) - Also plays a less frequent part in complex system malfunction diagnosis	Although highly critical - is currently being investigated under a separate contract
8, 9(b)	Decision making - alternatives unknown		
10, 5(a)	Stair reactions	Crewery - Maintaining proper sight-target relationship and maintenance - Welding and soldering tracing tasks (e.g., ship steering and aircraft piloting)	State-of-the-art training probably satisfactory, widely studied - critical only in aircraft situations
10, 5(b)	Continuous movement		
12	Serial movement	Typing, telegraphy, equipment checkout (e.g., yeoman, signalman, electronics maintenance)	
13, 5(a)	Detection - verbal cues	Monitoring communications equipment (e.g., signalman, aircraft pilot)	Psychologically very similar to 5
13, 5(b)	Identification - verbal cues	Identifying verbal stimuli or cues (e.g., codes, diagrams, symbols, etc.) included in operational jobs (e.g., ECM, signalman, machine accountant, etc.) and maintenance jobs (reading schematics)	Although a critical training problem is heavily dependent on recall of facts (see 2)
15	Positioning movement	Operating controls and material handling (common to most equipment operation and maintenance jobs)	Although a very frequently occurring task is not a critical training problem
16	Repetitive movement	Common to jobs requiring manual skills (e.g., carpentry and metal work) and maintenance of equipment (using tools)	More a selection problem than a training problem
17	Writing, verbalization	Maintaining logs (quarter master, pilot, etc.), writing instructions (miscellaneous officers jobs)	See 16
18	Oral verbalization	Verbal communications (pilot, radioman) giving orders (to officers)	Not a critical training problem
19	Other verbalization	Use of hand signals and conventionalized signals (e.g., yeoman and aviation hostess/male)	See 18

NAVTRADEVCEEN 68-C-0215-1

General Research Strategy	K. L. Laughery - paper State University of N. Y. at Buffalo W. H. Teichner - discussant American Institutes for Research
Implications of CAI, to L, R, and T	L. M. Stolurow - paper Harvard University D. J. Klaus - discussant Underwood Olivetti, Inc.
Vigilance and Signal Detection	J. S. Warm - paper University of Cincinnati H. J. Jerison - discussant University of California, Los Angeles
Decision Making	A. F. Kanarick - paper Honeywell Inc.
Pattern Perception	M. D. Arnoult - paper Texas Christian University H. C. Ellis - discussant University of New Mexico
Procedural Skills	P. W. Fox - paper University of Minnesota G. E. Briggs - discussant Ohio State University

In addition to the speakers and discussants, several scientists from industrial and government laboratories were invited to take part. Although these guests did not make formal presentations, they did participate in the discussions. The following individuals were present:

G. L. Bryan - Office of Naval Research
H. J. Clark - U. S. Air Force, Wright Patterson AFB
W. L. Fox - Human Resources Research Office, George Washington University
C. M. Harsh - Office of Naval Research
E. I. Jones - U. S. Navy Personnel Research Activity
T. Mara - General Dynamics, Electric Boat Division
A. F. Smode - Dunlap and Associates

The following NTDC and Honeywell scientists were also in attendance:

A. Blaiwes - NTDC
B. R. Bernstein - Honeywell

NAVTRADEVCCEN 68-C-0215-1

R. Feuge - Honeywell
W. Lane - NAVTRADEVCCEN
G. S. Micheli - NAVTRADEVCCEN
J. J. Regan - NAVTRADEVCCEN
L. P. Schrenk - Honeywell

The conference took place over a three-day period. A court stenographer recorded the proceedings and prepared a verbatim transcript. Copies of the transcript were distributed to the speakers and discussants after the meetings. Each participant made any necessary modifications to his paper and prepared summary statements expressing his views on the other topics covered at the Technical Meetings.

A report of the L, R, and T Technical Meetings is included as Appendix B. The basic conclusions from the meetings are as follows:

- The majority of participants agreed with the necessity for selecting research problems on the basis of operational training considerations. This approach was suggested in contrast with the more traditional tendency of allowing theoretical issues to dictate experimental questions. Some attendees felt that useful theories would emanate from this more pragmatic type of research.
- The original intent of this program was to establish principles describing the relations among variables affecting learning, retention, and transfer. A number of participants contended that transfer should be given primary concern because all training programs ultimately lead to the transfer of knowledge in some operational situation. Also, because transfer is in a sense a measure of retention, to measure retention separately from original learning may at times be unnecessary. Further, it was suggested that retention of a transferred skill is more important than the retention of training content because training effectiveness is measured in terms of performance on the criterion task.
- The point was made that, until now, taxonomies have been organized on the basis of apparent similarities and differences among tasks. Moreover, such taxonomies tend to reflect the ingenuity of specific authors in applying some logical structure to a wide range of behaviors. It has been very difficult to weigh the utility of one taxonomy against another.

A classification system based upon fundamental processes of behavior should provide a more reliable framework for characterizing tasks. An alternative approach is to develop a taxonomy of process, in which similar behaviors are clustered according to their underlying psychological mechanisms, e.g., short-term memory, association formation, logical deduction, etc. To accomplish this requires research to discover the nature of these mechanisms. This idea substantiates the earlier-stated conclusion, derived from the literature survey, that the development of an adequate taxonomy requires close coordination with research planning. Laughery (see Appendix B) suggested this approach as an adequate means of solving the taxonomy problem.

NAVTRADEVCEEN 68-C-0215-1

- Several participants expressed dissatisfaction with the traditional S-R approach to research. The behavioristic treatment of the human subject as a black box which responds to stimuli in a very mechanical way appears to have a number of serious shortcomings. There was considerable emphasis on exploration of processes internal to the learner. References were made to recent experiments which investigated the learner's ability to employ various strategies in acquiring, storing, and retrieving information. It was further suggested that valuable information about such strategies could be obtained through post-experimental debriefings of subjects. From these verbal reports, the experimenter may be able to identify alternative strategies for a given learning situation.
- Closely related to the previous point is the argument for studying individual differences in L, R, and T. Only recently has any real effort been made to determine the conditions of learning which are optimal for different individual subjects.
- Some discussion centered on the conditions of learning which promote transfer. Issue was taken with the generally held view that the more similar the original learning situation is to the transfer situation the higher the percentage of transfer. Several discussants viewed the intratask interference/intertask facilitation hypothesis as very relevant to the problems of military training.
- The traditional treatment of transfer has emphasized the transfer of specific learning. The suggestion was made that the L, R, and T program deal with nonspecific transfer; i. e., training people to become more effective learners. This concept is sometimes referred to as "learning to learn". The implication of this idea is that it might be profitable to provide a type of basic generalized training so that later specific training would be more rapid and more effective. Validation of this idea requires that data be obtained concerning techniques of effective learning (to be discussed later under the rubric of learning strategies).
- Although the majority of the discussions centered on stimulus and organismic variables, one particularly important point was made regarding response parameters. Psychologists seem to be far more concerned with measuring accuracy than with measuring latency of responses. The suggestion was made that both types of measures should be taken and related to one another.
- Another methodological consideration which is of major concern to the program is experimental design. Because the number of variables which could be investigated is enormous, it is most important that experiments be designed for maximum efficiency. Dr. Briggs recommended that L, R, and T investigators consider the advantages of randomized block designs, instead of

full factorial designs. He argued that interactions tend to be the exception rather than the rule, and further, that third- or fourth-order interactions tend to be incomprehensible.

Apparatus Planning

The conduct of a system requirements study for an integrated, computer-based, experimental apparatus has been accomplished at Honeywell's Marine Systems Center. A report describing this activity is contained in Appendix C.

The purpose of this apparatus is to permit L, R, and T research to be carried out, over the long-term, without constructing a new piece of equipment for each task. The device, for which a systems concept has been developed, has been named the Job Training and Testing Console (JTTC). It is essentially similar to several other automated laboratory systems rather than being an advance on the state of the art. However, the concept is for a highly flexible unit capable of representing each of Willis and Peterson's 19 task/behavior categories. The recommended configuration was developed by determining the minimal number of display and response requirements and by analyzing the tradeoffs existing among degree of automation, cost complexity, reliability, etc.

PROGRAM REQUIREMENTS

From the foregoing discussion of planning activities, it is clear that conclusions tended to complement one another. No fundamentally conflicting recommendations resulted from the various planning efforts. Based on these analytical efforts, the following list of program requirements seems justified:

- Research will be aimed at determining parametric relations among variables which affect learning, retention, and transfer, but primary emphasis will be on transfer.
- The design of laboratory tasks will be based upon the skills required of Naval personnel in critical operational jobs -- signal detection, recognition/identification, procedural skills, and symbolic data operations (e.g., decision making),
- Variables of interest will be studied across taxonomic categories of behavior, thereby aiding in the development of a taxonomy of processes. Also, continued attention will be given to other efforts at developing taxonomic systems.
- Experimental variables will be selected on the basis of relevance and criticality in operational training situations, e.g., fidelity of simulation, time devoted to training, duration between training and transfer to the operational task, etc.
- Levels of variables to be studied will be based on operational levels; e.g., task complexity, duration of training, etc., will be fixed on the basis of those operational jobs to which generalization is desired.

NAVTRADEVCEEN 68-C-0215-1

- Research will permit, but not emphasize, evaluation of the utility of alternative theoretical approaches to transfer of training, i. e., identical elements theories, mediated generalization, and habit hierarchies.
- Research approaches will not be bound by the traditional S-R paradigm but will treat the human organism as an active information processing and storage system, capable of using idiosyncratic strategies to facilitate performance. This includes variables related to attention, concept formation, mediational processes, information reduction and creation, and information coding processes.
- Measures of learning will be compared in terms of their ability to predict retention and transfer.
- Experimental designs will be selected with the realization that no individual study is intended to stand alone; rather, each will be designed to contribute to an integrated body of knowledge.

These requirements will apply to all phases of the program. It is necessary to specify the features of the initial studies from these requirements. In particular, it appears necessary to choose specific variables on some rational basis. Unfortunately, there is no simple set of rational criteria for selecting variables. However, if the program is to be of a long-term nature, it is not critical to justify the selection of one particular set of variables as long as it is of unquestioned relevance and importance. The following list contains variables which, because of their priority, are deemed appropriate to investigate in early phases of the program.

- Degree of similarity between training and transfer tasks (fidelity of simulation)
- Learning strategies, e. g., mnemonics, rehearsal, imagery
- Type of task, i. e., taxonomic category
- Complexity and difficulty of task
- Amount of original practice
- Instruction versus practice
- Time interval between training and transfer sessions
- Measures of performance (time versus accuracy) as related to criterion of acceptable performance

Early experiments will tend to be exploratory, i. e., will tend to incorporate more variables at fewer levels than later experiments, in order to identify variables and procedures which seem promising. Those which fail to produce significant or practical effects will be dropped. Those which are effective will be retained for more detailed study. Initial experiments will tend to be small, thereby minimizing the time and money invested in the study of high-risk

variables. As experimental procedures become more refined and as hypothesized effects become more certain, larger designs may be employed.

Earlier experiments will be designed to emphasize the relations between learning and transfer. When a learning variable has been identified which seems to be critical to transfer, further research will concentrate on establishing effects of retention interval. This approach is based on the fact that retention, in the Naval training application, refers to the time elapsing between training and transfer to the criterion task. There is thus no point in obtaining forgetting curves unless it has been established that the variable in question relates to the trainees' ability to perform the operational task on the basis of the training he has received.

As was mentioned earlier, initial L, R, and T research will concentrate on relatively pure task/behavior categories, e.g., detecting nonverbal signals, making decisions - alternatives specified, etc. When the effects of relevant variables have been established, categories will be combined to form more complex tasks. This does not suggest that the combining of taxonomic categories must wait until all information about each has been obtained. Rather, combinations can be studied in relation to relatively small sets of critical variables.

One notable exception to this requirement has, however, already been made. The recalling of facts, principles, and procedures, although existing as three categories in the Willis and Peterson taxonomy, will be combined in the initial procedural skills research. At present, there seems to be no basis for assuming that memory processes vary as a function of whether the to-be-remembered material is a set of facts, principles, or procedures. Murd (1961) has shown that learning and retention do not necessarily depend on number of letters or words. The critical variable is the number of subjective units of information (chunks). For example, if an initial word triggers the recall of the rest of a sentence, the sentence may be remembered better than an individual word.

The construction of laboratory tasks will be, as stated earlier, based on operational tasks. Specific tasks will be patterned after Naval tasks possessing the taxonomic behaviors. This requirement does not, of course, guarantee that all research findings will have maximum generality to the corresponding operational situations. However, high face validity should be a first step in the development of basic research tools possessing predictive validity. In any event, present-day Psychology offers no basis, other than face validity, by which to determine the extent of generality from one task to another.

The determination of predictive validity will be accomplished by applying principles, which are formulated on the basis of L, R, and T research findings, to the training of operators of Naval Systems. This validation will be done periodically in the program to check on the utility of research results. In so doing, it is hoped that a basis for defining the conditions for generality will be established.

Four classes of behavior were determined to be critical from a training standpoint in the conduct of Naval tasks. Because of the limited resources

available for this program, it is necessary, at least initially, to limit investigation to only one behavioral class of tasks. Procedural skills (recalling and using facts, principles, and procedures) were chosen because of their ubiquity in Naval jobs. Therefore, the initial L, R, and T experiments will determine effects of the previously listed high-priority variables on subjects' ability to recall facts, principles, and procedures in the operation of a system.

Procedural skills are suggested for study during both the first and second years of the program. Initial research on some other category of skill may begin toward the end of the second year. Symbolic data operations appears to be a good candidate for a second task to be studied. Because of the dependence of decision making and problem solving skills on the ability to recall procedural information, the initial data may apply most directly to symbolic data operations tasks. Moreover, it should be possible, with relatively minor modifications, to use the task developed for the study of procedural skills to study decision making and problem solving.

By the end of the second year of the program, an attempt will be made to test derived principles in an operational training situation. The first step in accomplishing this validity check will be to survey Naval jobs for tasks containing relatively pure procedural components. The validity of training principles will be assessed by designing an experimental training program including the use of such principles. This program will be compared with a control group undergoing training similar to that currently in use by the Navy.

The findings of validation experiments will provide information about the translatability of L, R, and T research to Naval training. Limitations in translatability will be analyzed to determine how future research should be altered to increase its utility. In this way experimental tasks should become increasingly better from the viewpoint of permitting research findings to be translated into principles of effective training.

SECTION III

EXPERIMENTAL PHASE - PURPOSE AND APPROACH

STATEMENT OF THE PROBLEM

Two initial L, R, and T experiments were run as a means of implementing the plan of research described in earlier parts of this report. More specifically, two fundamental purposes were served by L, R, and T Experiments I and II -- (a) to demonstrate the feasibility of satisfying specific program requirements which evolved from the planning activities, and (b) to provide an initial base of data for the L, R, and T of procedural skills. The variables chosen for study in the first two investigations were among those listed earlier as being of high priority.

Fidelity of Simulation

A basic concern of training system designers is the extent to which the training situation must simulate the operational task. Clearly, the training system cannot provide perfect fidelity unless the operational system is itself the vehicle for training. In general, fidelity of simulation is correlated with cost to produce training systems. To achieve high levels of cost-effectiveness, only those characteristics of the operational task should be simulated which are essential to produce criterion-level transfer performance in a minimum of training time.

From both a common sense point of view and, to some extent, from a psychological viewpoint, one would predict a greater degree of transfer the more similar the training situation is to the operational situation.

According to Osgood's (1949) model, transfer is greatest when the stimuli and responses of the two tasks are identical. More recent models based upon similarities and differences in stimuli and responses (e.g., Houston, 1964, and Martin, 1965) make essentially the same predictions.

A second conceptual approach to transfer of training research is the notion that transfer can be achieved through "mediated generalization" (Wittrock, 1968). The term "mediated verbal transfer", coined by Osgood (1961), is sometimes used to refer to this same process. The basic idea is that people can generalize to and discriminate among different situations by abstracting features from these situations and generating verbal descriptors. In this way, two tasks may involve different physical responses yet can be represented by the same verbal mediator. For example, in situation A, the subject must turn a potentiometer in a clockwise direction to increase the intensity of a desired output signal. In situation B, a lever must be pushed forward to increase the signal intensity. Because the population stereotypes for pushing forward and turning clockwise are similar, i.e., resulting in an increased output, one would predict a high level of transfer from one of these tasks to the other.

Through mediated generalization it may be possible to train subjects to make appropriate responses even though they do not practice the actual responses during the training session. If true, this hypothesis would have important implications for the training of Navy equipment operators. If trainees can be

effectively taught to operate hardware via a paper and pencil representation of the task, significant gains in cost-effectiveness would be realized. Practice on a paper and pencil simulation may involve writing the numbers of multiple-position switch settings, checking controls selected, indicating the names of controls activated, etc. During transfer, the trainee would be required to translate the written form of responding to the actual physical responses of switch actuating, knob turning, etc.

The effectiveness of this kind of low-fidelity training was recently examined by Grimsley (1969) on an operational U. S. Army procedural task. Grimsley found no significant differences in criterion task performance among three groups of subjects differing in the fidelity of simulation provided during training, for retention intervals of as long as one month. One group was trained on a functioning duplicate of the tactical equipment; the second learned on a nonfunctioning version; and the third group received practice on a full-size artist's representation of the hardware.

Prior to Grimsley's experiment, other studies of training effectiveness, with relatively low-fidelity representations of the operational equipment, yielded similar results (e. g., Mahler and Bennett, 1950; Newton, 1959; and Wilcoxin, Davy and Webster, 1954). Each of these studies was performed with an actual military system serving as the criterion task. However, the extent to which the previous research involved procedural skills was varied from one experiment to another. In other words, the tasks employed were not designed to deal solely with the recall and application of facts principles and procedures.

The present investigations involved a task which was explicitly designed to involve only procedural learning. If the results of this experiment are consistent with those of Grimsley then it would suggest that results obtained from a laboratory device can be comparable to actual military tasks when both involve procedural learning.

Imagery

A second purpose of the initial L, R, and T experiments was to evaluate imagery as a means of enhancing rapid learning and promoting transfer. In a recent review article, Paivio (1969) cites an impressive list of experiments which consistently indicate that imagery can play a major role in learning verbal material. The learning involved in a procedural task is predominately verbal. Therefore, it would seem that imagery could be used to advantage in the training of procedural skills.

Imagery, as related to retention, denotes the use of visual mental representations of relatively concrete objects as the mediator for storage. A familiar example of this phenomenon is our ability to recall the number of windows in a room though we have never bothered to count them. By visualizing the room from memory, we may actually be able to count the windows from the mental image.

Mnemonicists (memory experts) are able to recall very long lists of items on a one-trial learning basis. The essential technique is the so-called one bun, two-shoe method (Yates, 1966). By associating the first item to be learned with bun, the second with shoe, etc., and generating bizarre images to represent the associations, a seemingly impossible list of items can be learned almost immediately.

This technique appears to involve two essential features; (a) word pegs and (b) mental visual representations. The word pegs are items which have been previously overlearned, and therefore, the learner is able to relate new material to old material with the old items serving as mediators for the new. The use of images apparently provides a facilitating effect by making the to-be-remembered association more vivid.

Senter (1968) conducted a list-learning experiment in which subjects were trained to use this mnemonic technique and compared their performance with control subjects who were not familiar with the use of imagery. The imagery group exhibited much more rapid learning than the control group.

Paivio (1963) found that the image arousing potential (I) of word pegs was an important variable independent of instructions to use imagery. More recent list-learning experiments by Paivio (e.g., Paivio, Yuille and Madigan, 1968; and Paivio, Yuille, and Smythe, 1966) provide clear evidence that I is even more powerful than meaningfulness as a determinant of learning.

It would seem that the mediational value of imagery could be applied to the teaching of facts, principles, and procedures in at least two ways. One method would involve the rote memory of lists of facts, principles, and procedures by subjects who had been trained to use the one-bun, two-shoe technique. A second application of the imagery principle seems much less laborious for the learner. In this case, a series of images describing the operation of a system which the subject is more familiar with are provided. The more familiar routine could act as a peg for the learning of the system operations being trained.

Post-Experimental Reports

The third aspect of these initial experiments involves the use of feedback from subjects as the basis of modifying the structure and/or content of training. The basic question is whether subjects or trainees are capable of providing useful information to guide training system designers.

The notion of using trainee feedback as an aid to training system design is related to the previously discussed topic of learning strategies. Because the designer of training programs, or the writer of experimental instructions, is generally naive about strategies used by subjects in a given learning situation, he cannot know how training content can best be structured to facilitate the use of effective strategies. It is not until the experiment is run and postexperimental inquiry is made of subjects that the experimenter becomes at all knowledgeable about the roles played by strategies in the learning task. Of course, this information is wasted unless a second investigation is run, making use of strategic information.

The identification of effective learning strategies from subjects' post-experimental verbal reports has been accomplished within a paired-associate context (Martin, Boersma, and Cox, 1965, a, b; and Boersma, Conklin, and Carlson, 1966). Subjects' descriptions of their strategies provided the basis for a taxonomy of associative strategies. The taxonomy contains seven categories of strategic behavior ranked according to what the authors call cue complexity.

The highest level of cue complexity corresponds to the imagery-based mnemonic technique discussed earlier. Martin, et al., found a significant positive correlation between the level of strategy employed and speed of learning.

The present research is an attempt to determine whether subjects can verbalize strategies in procedural learning in a fashion similar to that demonstrated by Martin, et al., and Boersma, et al., in paired-associate learning. Assuming such information can be obtained, its value as a basis for modifying training programs may be empirically evaluated.

APPROACH TO THE PROBLEM

The approach taken in the study of procedural skills was to develop an apparatus which is similar in many ways to military equipment. The procedural skills device would permit tasks to be performed which required subjects to learn facts, principles, and procedures and to use this information in the operation of the equipment. By creating a learning and transfer situation similar to that found in the Navy, it increased the likelihood that the effects of those variables studied could more easily be translated into basic principles for operator training.

The Need For a Procedural Skills Task

The most basic requirement of a laboratory task involving procedural learning, from which translatable findings can be obtained, is the elicitation of behavior comparable to that found in the operation of military systems. For the task to be purely procedural, it is imperative that other categories of behavior contribute as little variance to performance as possible.

To the knowledge of this writer, no such experimental device is commercially available. Previous research on procedural tasks has been accomplished with either existing military equipment (Grimsley, 1969), or an apparatus has been fabricated in a laboratory (Brown, Briggs, and Naylor, 1963), thereby remaining the property of the builders. It was, therefore, necessary to design and build such a device for the L, R, and T program.

Although procedural learning is predominately verbal, there are major differences between military procedural tasks and verbal learning tasks traditionally used in psychological laboratories. Because of these differences, described below, a paired-associate or other form of list learning task was unsatisfactory for the purposes of this program.

One such difference is in the size of the basic unit of learning. The most commonly used verbal learning tasks employ paired-associate, free recall, or serial anticipation techniques. For each of these methods, the verbal unit is usually a trigram, syllable, or word. In contrast, the unit of learning for procedural tasks is often a sentence or phrase containing a number of words.

While it is probably possible to structure the learning of facts, principles, and procedures into one of the orthodox verbal learning methods, it would not seem to be the best method of training. Because the information to be recalled is necessary during the course of performing the job, training would probably be more effective when practice in recalling procedural information is given during the performance of the task.

Another basic difference between verbal and procedural learning tasks has to do with logical relationships among items to be remembered. Items in a list of paired-associates have traditionally been unrelated. However, more recent research, as discussed by Jung (1968), shows that when such relationships do exist, learning is faster. In a procedural task, facts, principles, and procedures tend to be related to one another in fairly logical ways, visually as a function of the structure of the system. For this reason, knowledge of certain relationships often triggers recall of specific items of needed information.

Finally, procedural tasks in the military differ from rote learning experimental tasks in terms of the content of what is memorized. Operators of complex systems do not resort to memory for all information required for their job because, often, there is simply too much to remember. In such cases, the operator relies on reference material. When reference sources are available, operators need only remember the location and nature of the information. In verbal learning experiments, however, the learner attempts to memorize all items contained in the list and, depending upon the method, sometimes the order of occurrence of the items.

Information availability may have implications for the criterion of performance used in an investigation. In orthodox verbal learning tasks, the criterion of learning is usually an accuracy measure, i. e., either the number of trials required to attain some level of accuracy or the accuracy achieved after a fixed number of trials. Because information is more accessible in procedural tasks, accuracy is probably not a very sensitive measure of performance. Time would seem to be more appropriate as the dependent variable.

Experiment I

Experiment I was designed as a pilot study for future investigations, using the newly developed procedural skills task, and was designed to accomplish the following:

- Because this task had never been used before, it seemed necessary to determine the presence of procedural problems prior to the introduction of experimental treatments.
- Experiment I would provide baseline data on learning and transfer. Moreover, by scoring subjects' performance in terms of time and accuracy, it was possible to determine the relative sensitivity of each measure.
- Experiment II was to be a transfer of training design in which performance during original training would serve as a control for the respective transfer conditions, and therefore two sets of equivalent problems were required. Experiment I was designed to permit a comparison of performance on these two sets of problems.
- This initial investigation permitted the collection of post-experimental verbal reports from subjects concerning their use of strategies and suggestions for modifications to training. These data could then be incorporated into the design of Experiment II.

NAVTRADEVCEEN 68-C-0215-1

Experiment II

This investigation is the first experiment of the L, R, and T program designed to provide data translatable into principles for military training. The following hypothesized principles were tested within a procedural skills setting:

- Feedback from trainees can be used to improve the effectiveness of training.
- Imagery, when appropriately incorporated in training, promotes rapid acquisition of skills and high-level transfer effects.
- Cost-effective training can be achieved by the use of accurate paper and pencil representations of operational equipment during practice.

SECTION IV
EXPERIMENTAL PHASE - EXPERIMENT I

METHOD

Apparatus

The experimental task in Experiment I was the operation, by the subject, of a mock communication system. Two units of equipment constituted the apparatus; the subject's console (Figure 4) and the experimenter's console (Figure 5). Figure 6 shows the complete laboratory facility.

Equipment operated by the subject included a panel of indicators and switches (Communications Control Console) and an information display. The Communications Control Console (CCC), located directly in front of the seated subject, housed all displays and controls necessary for operating the system. The information display, which contained all the facts, principles, and procedures was a Kodak Random Access Carousel slide projector and a 5 x 7-inch back-illuminated Polacote screen. Subjects accessed 35-mm slides with a selector located at the bottom left of the CCC. An index slide provided information about the location of all other slides.

The experimenter's control panel was connected electrically to the CCC. The experimenter's unit performed two functions, it permitted display of the communications problems to the subject and it provided to the experimenter information concerning the subjects' responses. A Hunter Timer, positioned at the left of the experimenter's panel, was used to record the elapsed time, to 0.1 second, from the presentation of a problem until its completion.

The CCC was arranged in three sections. At the left of the panel were three displays (IEE readouts) which presented input information. One display showed the designating number of the initiator of the communication (sender). Below the sender's number was the receiver's number. At the bottom left of the CCC was a readout which contained the priority of the requested transmission.

The central part of the CCC contained 18 Microswitch transilluminated push-buttons. The top three switchlights were used to select a frequency for communication between the sender and the CCC. Below the frequency selectors was a 3 x 5 matrix of switchlights which performed the following functions:

- They indicated which channels were in use and the priority of the message in that channel. Message priority was indicated by the color of the illuminated indicator.*
- They were used to select a channel for transmission of messages to receivers.

* Note - Each switchlight was divided into four sections. Priority one messages were shown by the top two sections illuminated red, priority two was signalled by green in the lower left section, and priority three gave a white indication in the lower right section.

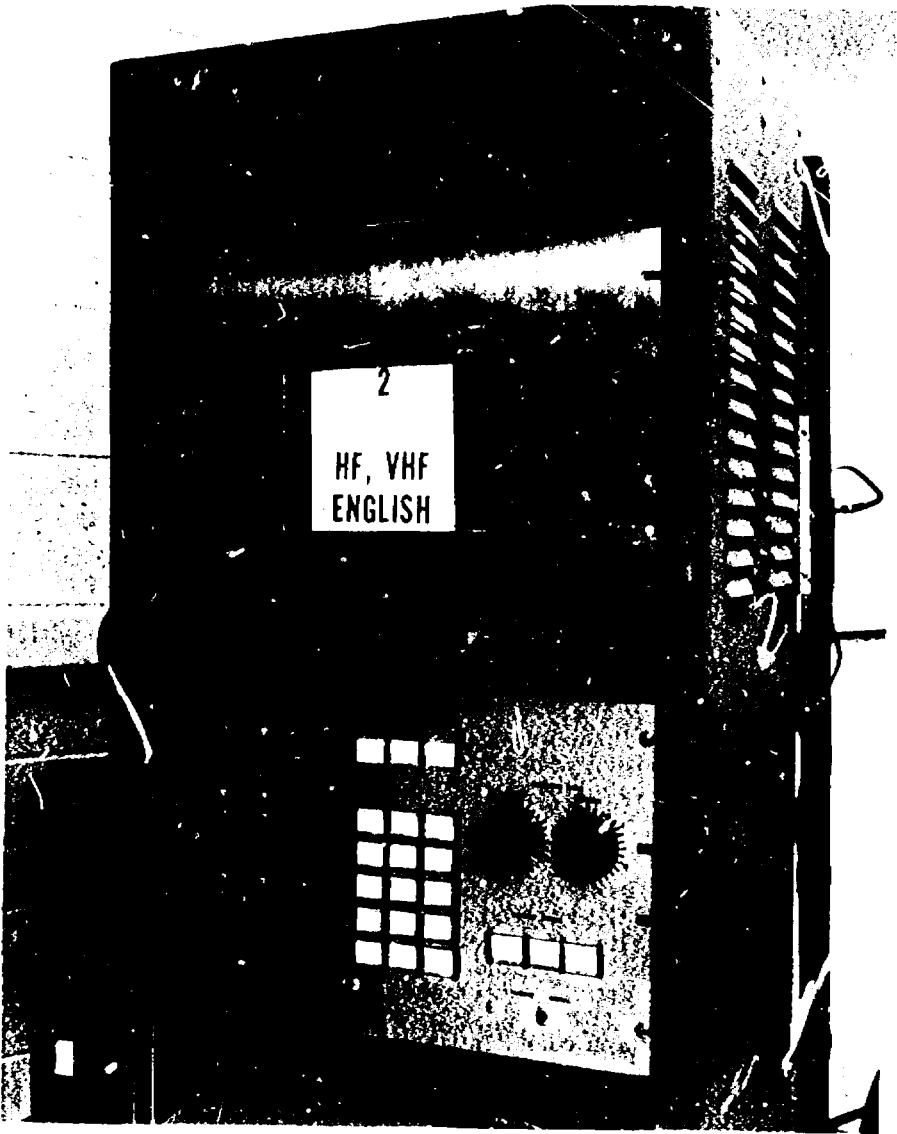

Figure 4. Subject's Console

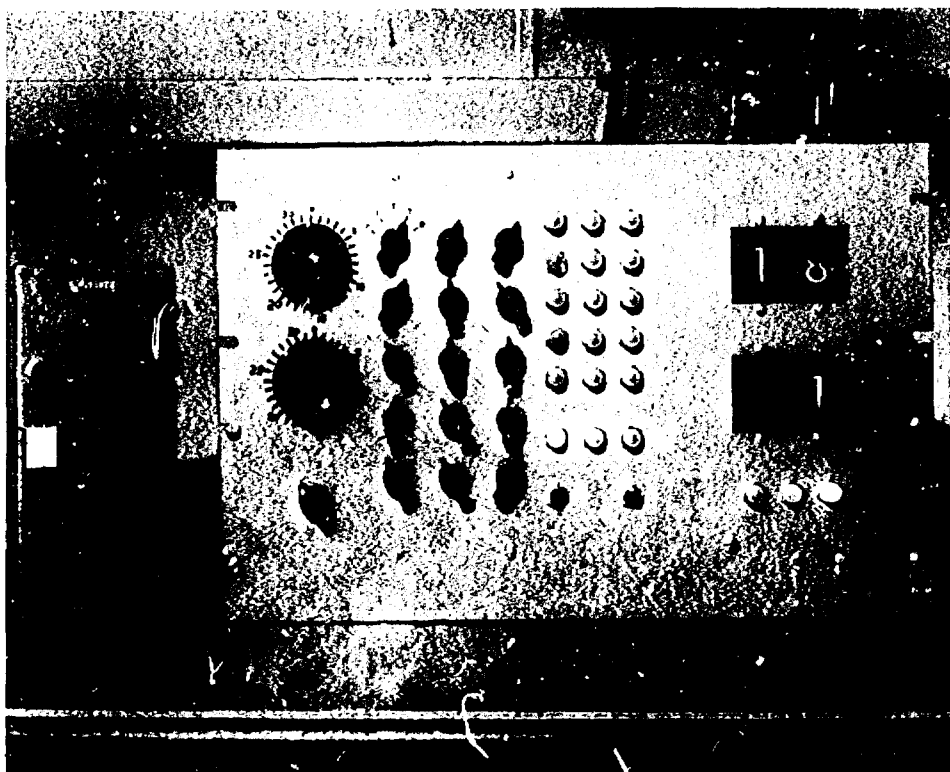

Figure 5. Experimenter's Console

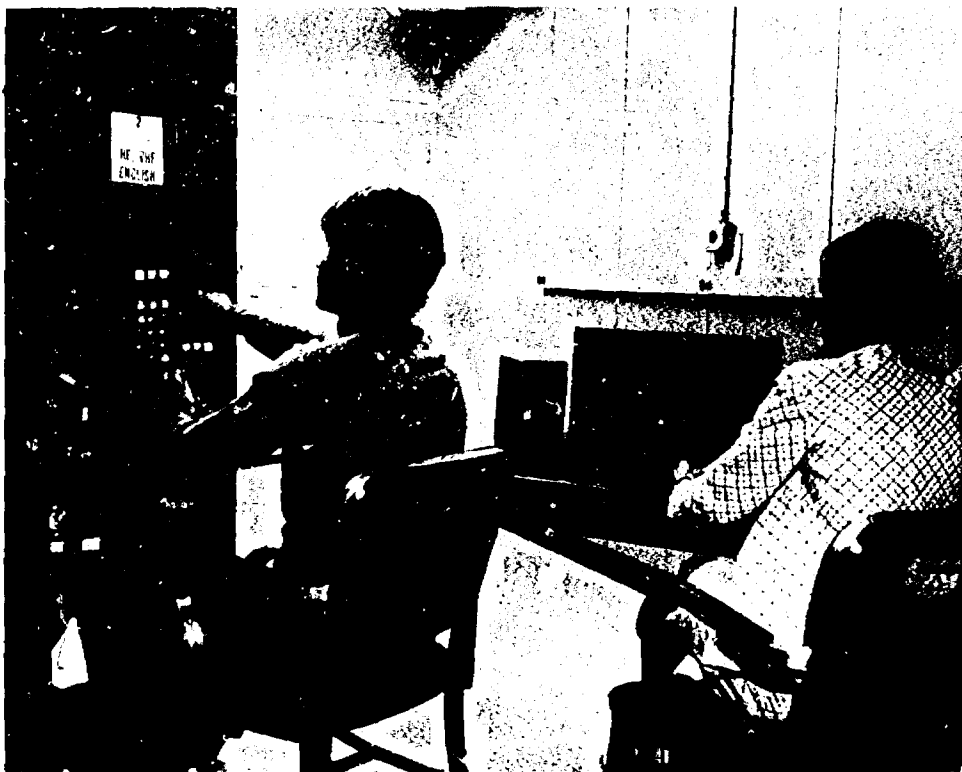

Figure 6. L, R, and T Laboratory

NAVTRADEVCCEN 68-C-0215-1

The output section was located at the right side of the CCC. Two 32-position rotary switches, called "patching dials," were used to select the number of the sender and the receiver for each communication. Three Microswitch switchlights were used for: (1) connecting the sender and receiver, (2) transmitting standby signals, and (3) transmitting busy signals. A momentary pushbutton, at the bottom right of the panel ("transmit signal" switch) stopped the timer, and thereby signalled the end of a subroutine.

Two sets of 30 problems (Set A and Set B) were used. These sets were designed to be equivalent in terms of the principles and procedures used. They differed, however, in specific ways, i. e., in terms of the particular subscribers involved and the priorities of messages occupying communication channels. Within each set of 30 problems, 13 categories existed. These categories are listed in Table 2.

The problem sets were divided into five subsets, each containing six problems. Problems involved either one, two or three subroutines. Each subset of problems totaled 12 subroutines. In this way, it was hoped that each subset of problems would be approximately equal in difficulty.

Subjects

Ten male subjects ranging in age from 18 to 25 were used in the experiment. These volunteers were undergraduate students from the University of Minnesota and Hamline University. Subjects were paid on the basis of their performance on the task and were so informed prior to the start of the experiment. Pay ranged from \$2.50 to \$4.00 per hour.

Procedure

The subject's task was to arrange for the transmission of messages from one system subscriber (sender) to another (receiver). To provide the reader a better understanding of this task, a task analysis was performed according to Kurke's (1961) method for each of the operational sequences (Appendix D). The task analysis also served as the basis for specifying the steps involved in ideal operation of the system and was helpful in organizing the manual of instructions used during training (Appendix E).

Modes of Operation -- Although there were 13 categories of problems, only the following four basic modes of operation existed:

- Subscriber to Subscriber (S-S) Mode
- Subscriber to Terminal to Subscriber (S-T-S) Mode
- Interrupt Routine
- Deny Sender's Request to Communicate

The selection of the appropriate routine was dependent on subscriber operating characteristics (language and operating frequency), priority of the requested transmission, and availability of channels. Each of the 25 subscribers could transmit or receive on one, two, or three frequencies, i. e., high frequency (HF), very high frequency (VHF), and ultra high frequency (UHF). Each subscriber was also associated with one of five languages, English, German, Greek, Spanish, or Swedish. Language and frequency characteristics were provided on the 35-mm slides and could be selected for presentation on the information display.

NAVTRADEVCEEN 68-C-0215-1

Table 3. Types of Problems Used in L, R, and T Experiments I and II

Problem Type	Number Presented
Subscriber to Subscriber (S-S)	4
Subscriber to Terminal to Subscriber (S-T-S) due to language disparity	3
S-T-S -- due to frequency disparity	3
S-T-S -- due to frequency and language	2
S-T-S rather than interrupt	2
Interrupt (STBY)/SS	2
Interrupt (BUSY)/SS	2
Interrupt (STBY)/S-T-S (language)	2
Interrupt (BUSY)/S-T-S (language)	2
Interrupt (STBY)/S-T-S (frequency)	2
Interrupt (BUSY)/S-T-S (frequency)	2
Deny Request (STBY)	2
Deny Request (BUSY)	2
Total	30

All communications were conducted using either the S-S or S-T-S modes. In some cases, the interrupt mode was used but always in conjunction with either the S-S or S-T-S mode. Some problems involved a request under conditions which precluded the use of either the S-S or S-T-S modes. In these cases, the sender's request to communicate had to be denied.

S-S Mode -- When the sender and receiver used the same frequencies and the same language and a channel was available on their common frequency, the S-S mode was used. To complete an S-S communication the following procedure was used:

- (1) Select sender's number on the left "patching dial"
- (2) Select receiver's number on the right "patching dial"
- (3) Select the uppermost unoccupied channel on the least occupied common frequency

NAVTRADEVCCEN 68-C-0215-1

- (4) Activate the "connect" switch
- (5) Activate the "transmit signal" switch

S-T-S Mode -- The S-T-S routine was used under any of the following conditions: (a) Either a language disparity existed, (b) sender and receiver had different operating frequencies, or (c) there was an open channel within the receiver's capability, but not the sender's. The S-T-S routine was completed in two discrete parts. The first part included the following steps:

- (1) Select sender's number on the left "patching dial"
- (2) Select position 1 (terminal address) on the right "patching dial"
- (3) Select a frequency within the sender's capability
- (4) Activate the "connect" switch
- (5) Activate the "transmit signal" switch

After completion of this subroutine, the message had been transmitted from the sender to the CCC. To relay from the CCC to the receiver, the following subroutine was employed:

- (1) Select position 1 on the left "patching dial"
- (2) Select the receiver's number on the right "patching dial"
- (3) Select the uppermost open channel within the least-occupied frequency usable by the receiver
- (4) Activate the "connect" switch
- (5) Activate the "transmit signal" switch

Interrupt Routine -- The interrupt routine was used when the requested transmission was of a higher priority than one or more of the messages occupying usable channels. In these cases the subject signaled the subscribers, using the to-be-interrupted channel that they must discontinue communication. If the interrupted channel contained a priority-two message, a standby signal was given, indicating that the interruption was temporary. An interrupted priority-three transmission was given a busy signal, indicating a longer-duration interrupt. The following steps constituted the interrupt routine:

- (1) Select position 30 on both "patching dials"
- (2) Select the channel to be interrupted
- (3) Activate "standby" or "busy" for priority-two or priority-three transmissions, respectively

NAVTRADEVCEEN 68-C-0215-1

- (4) Activate the "transmit" switch
- (5) Wait for the channel to be cleared (indicated by the offset of the illuminated channel indicator)

As stated earlier, the interrupt routine was always used in conjunction with either the S-S or S-T-S routine. If the transmission was S-S, the channel was interrupted first and the S-S routine followed. However, when interruption was used with S-T-S, it occurred after the receipt of the message by the terminal and prior to the relay of the message to the receiver.

Deny Sender's Request to Communicate -- When all channels within the receivers frequency capability were occupied with equal or higher priority messages than that currently requested for transmission, the request had to be denied. Requests were denied in the following way:

- (1) Select position 1 on the left "patching dial"
- (2) Select sender's number on the right "patching dial"
- (3) Select any frequency usable by the sender
- (4) Activate "standby" switch for priority-one and -two requests and the "busy" switch for priority-three requests
- (5) Activate the "transmit signal" switch

Test Sessions -- Subjects were given approximately one and one half hours of training. The training session included the following phases:

- (1) The experimenter read the manual verbatim to the subject.
- (2) The experimenter presented five example problems to the subject and aided him, to the extent necessary, in the completion of the problems.
- (3) A 10-minute rest period was given.
- (4) Thirty training problems were administered, with knowledge of results (KR) given after each problem. The KR was complete; i. e., any and all mistakes were pointed out and corrections were provided.

Twenty-four hours after training, subjects returned for a transfer session. At the start of the second session, the subjects were informed that they would receive another set of 30 problems similar to those they had worked the previous day. Again, complete KR was given after the completion of each problem.

Half the subjects were given problem set A in training and problem set B at transfer, and the other subjects were given the two sets in reverse order. The order of subsets was counterbalanced across subjects. For example,

NAVTRADEVCCEN 68-C-0215-1

subject 1 was given subsets in the order 1-2-3-4-5, subject 2 received order 2-3-4-5-1, etc. Each subject received the same order at transfer as he had during training. The order of problems within subsets was randomized.

A trial (one problem) consisted of the following steps:

- (1) The experimenter programmed the CCC.
- (2) The experimenter said "ready."
- (3) The CCC was illuminated by the experimenter, automatically starting the timer.
- (4) The subject attempted to solve the problem. Each subroutine was timed separately. At the completion of one subroutine of a problem containing two or three steps, the experimenter turned the CCC off for several seconds. When the CCC had been reprogrammed, it was again turned on, and the subject began the next subroutine.
- (5) At the completion of each subroutine, the experimenter recorded the time.
- (6) KR was administered at the end of each problem.

After both the training and transfer sessions, the subjects were requested to indicate any criticisms they had about the training they had received and to describe what they felt was important to learn and how they went about learning it. To further assess subjects' strategies, they were asked to imagine that they were asked by a good friend, about to take part in the experiment, for suggestions which might aid that friend in the performance of the task. The subjects' suggestions were recorded.

RESULTS

Learning Effects

Two measures of performance (i.e., response time and accuracy) were taken during the training and transfer sessions.

Response Time -- This measure referred to the elapsed time between the beginning and completion of a subroutine. If a subroutine was omitted, an elapsed time of 60 seconds was given.

Figure 7 shows the average time taken by subjects to complete subroutines during training and transfer sessions. A steep learning curve is apparent during training; however, additional practice effects seem to be minimal during the transfer session. There appears to be no retention loss over the 24 hours between training and transfer. To the contrary, some evidence of reminiscence is apparent in the data.

Accuracy -- The accuracy data are given as percentages of subroutines correctly processed. The percentages were calculated according to a standard scoring method (Table 3), which deducted points from each subroutine for

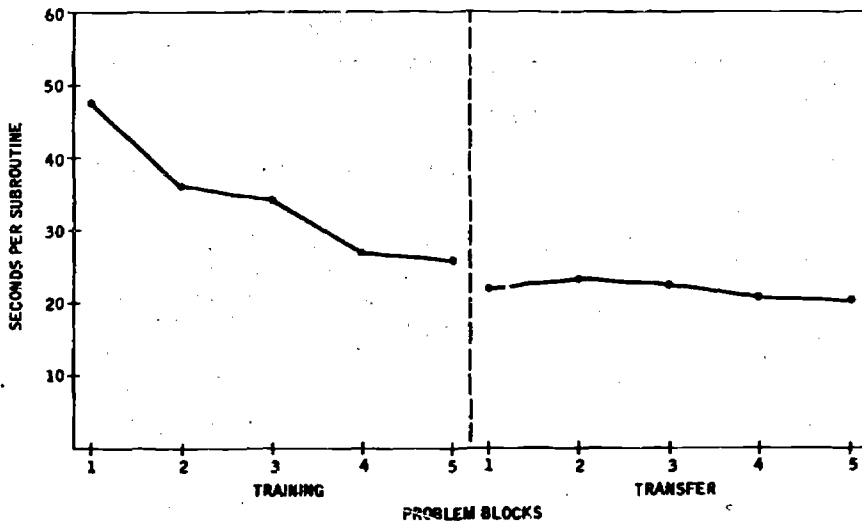

Figure 7. Mean Time to Complete Subroutines of Problem Blocks

Table 3. Scoring Method

Error Type	Penalty (deduct)
Routine Selection Errors	
SS instead of STS (major)	5
STS instead of SS (minor)	2
Unnecessary interrupt (major)	3
Unnecessary cancel (major)	3
General Failures in Procedure Following (no credit)	5 (per step)
Patching Errors	
Simple dialing error (minor)	1
Procedural error (major)	3
Channel/Frequency Select Error	
Minor choice error	1
Major choice error	3
Wrong Output Selected	
Minor error	1
Major error	3
Order of Steps Error	
Interrupt before S → T (minor)	1
Others (major)	3

procedural errors. The more serious the error, the greater the scoring penalty. A maximum of five points was awarded for each subroutine. For example, a subject who interrupted a channel unnecessarily had three points deducted from his score. If the problem could have been solved by using a single S-S communication, involving only one subroutine, the subject's score for that problem would have been $(5-3)/5$ or 40 percent. If, however, the problem required two subroutines, the subject's score would have been $(10-3)/10$ or 70 percent. Likewise, a three-step problem in which one three-point error was made would have resulted in a score of $(15-3)/15$ or 80 percent.

The accuracy data are shown in Figure 8. Average initial accuracy was above 80 percent and, by the end of training, was above 95 percent. Performance during transfer remained at approximately the 95 percent level. The absence of a significant retention loss was consistent with the time data.

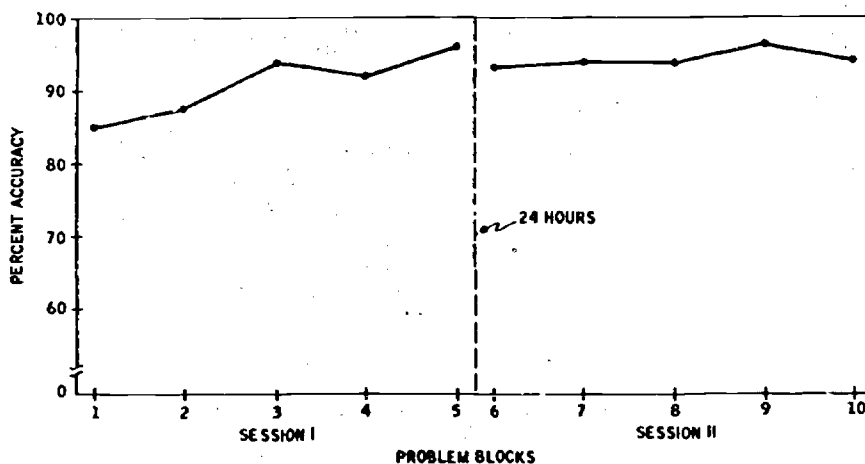

Figure 8. Mean Percent Accuracy on Problem Blocks

Independence of Performance Measures

The data clearly suggest that accuracy is a less sensitive measure of performance than is time. An important question is the extent to which time and accuracy measures are correlated. If highly correlated, it would seem reasonable to consider only time. For this reason, Pearson Product Moment Correlation Coefficients were performed on the time and accuracy scores. The r 's for Sets A and B were -0.35 and -0.33 , respectively. The negative correlations reflect the fact that numerically high time scores indicate lower performance levels, while the opposite is true for accuracy scores. However, neither correlation coefficient was statistically reliable.

Equivalence and Internal Consistency of Problem Sets

T-tests were performed on the time and accuracy scores for problem sets A and B, and the two sets were not found to differ significantly from each other on either measure. The internal consistency of the two problem sets is shown in Figures 9 and 10. Figure 9 provides the mean response time and Figure 10 the mean accuracy scores for each subset of six problems. Table 4 is a summary of two analyses of variance (ANOVA) on accuracy scores testing the effects of the subsets. Similar ANOVAs were done on time scores (Table 5). None of the F ratios were significant at the 5-percent level of confidence, suggesting that there was no significant variation in subset difficulty.

Subjects' Verbal Reports

The subjects expressed general satisfaction with the structure and content of training. However, several felt that more learning was produced by practice problems than with the information contained in the manual, and they would have liked additional practice prior to the presentation of training problems.

Most subjects were not able to provide concrete information about learning strategies. Many mentioned, however, that they did not attempt to memorize the procedures in a rote fashion.

Two subjects felt that it was much more important to understand the role of the operator in the overall system than to try to memorize all the facts and rules given in the manual. These subjects recognized that the procedures were logical in terms of the structure of the system. Both of these subjects indicated that they formed mental images of the operator in relation to the rest of the system. One subject imagined that messages travelled through his body, entering one arm and exiting through the other. The other subject described his image in words to this effect:

The operator of this system is kind of the "big man." He has control over all the subscribers, in terms of their ability to communicate with one another. It is important to understand what happens to communication links in terms of you, the operator. When you really understand this, it isn't at all difficult to operate the system, because the procedures are fairly logical.

Both subjects who indicated using imagery scored above the group mean during training and transfer.

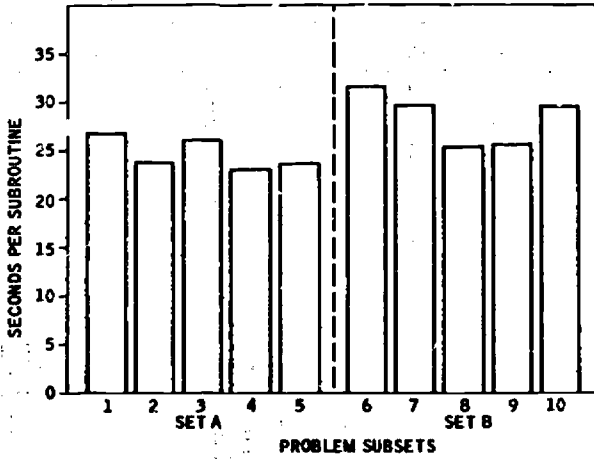

Figure 9. Mean Time to Complete Each Subset of Problems

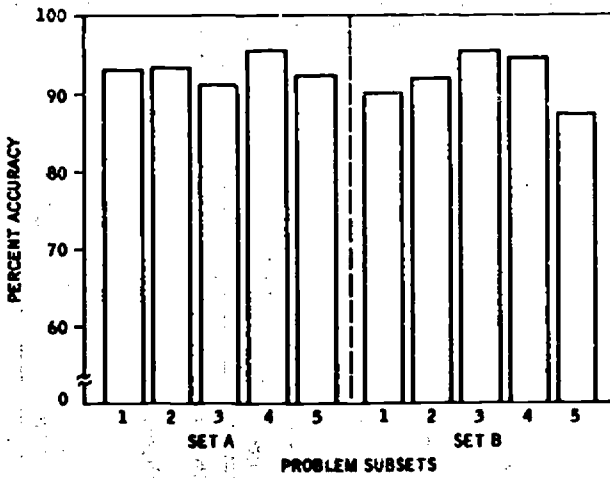

Figure 10. Mean Percent Accuracy on Each Subset of Problems

Table 4. Analysis of Variance Summary - Accuracy Data

Set A				
Source of Variance	Sum of Squares	df	Mean Square	F
Between subjects	339.8	9		
Within subjects	485.2	40		
Subsets	33.9	4	8.48	<1
Residual	451.3	36	12.53	
Total	825.0	49		
Set B				
Source of Variance	Sum of Squares	df	Mean Square	F
Between subjects	643.2	9		
Within subjects	802.8	40		
Subsets	172.8	4	43.20	2.47 (N.S.)
Residual	630.0	36	17.50	
Total	1,446.0	49		

Table 5. Analysis of Variance Summary - Time Data

Set A				
Source of Variation	Sum of Squares	df	Mean Square	F
Between subjects	17,893.4	9		
Within subjects	27,037.6	40		
Subsets	3,933.9	4	983.47	1.53 (N.S.)
Residual	23,104.5	36	641.79	
Total	40,997.1	49		
Set B				
Source of Variation	Sum of Squares	df	Mean Square	F
Between subjects	137,781.7	9		
Within subjects	104,454.4	40		
Subsets	11,083.8	4	2770.95	1.07 (N.S.)
Residual	93,370.6	36	2593.63	
Total	242,236.1	49		

DISCUSSION AND CONCLUSIONS

The performance data give evidence that this task can be a useful laboratory device for the study of procedural skills within the L, R, and T framework. The relatively low levels of trial to trial variability in performance was a welcome, but somewhat unexpected, finding. The acquisition curves, particularly in the case of response time, show strong evidence of learning. The rather meager improvement in accuracy was not surprising since subjects always had access to all necessary facts, principles, and procedures.

The obtained difference in acceleration for the two performance measures probably relates to the instructions that were used. Subjects were told to operate as rapidly as possible while maintaining high levels of accuracy. Although such instructions are open to interpretation by the subjects, most apparently strove to minimize errors and to increase speed as they became more certain of the correct procedures. On this basis, it is not surprising that the correlation between time and accuracy was low. However, further research on the effects of time-versus-accuracy sets seems to be warranted.

The absence of significant differences between sets A and B will permit future transfer of training experiments to utilize either Woodworth and Schlosberg's (1954) Plan 3 or Plan 5. Both plans offer two principal advantages; i. e., (1) no additional control group need be employed, and (2) there is no need to match subject groups. Although Plan 5 does not require the use of equivalent tasks, the use of matched problem sets adds experimental precision by reducing residual variance stemming from task differences.

The verbal reports of subjects provided some evidence that imagery can play a useful role in the learning of this task. Subjects gave no indication, however, that they used imagery as a mnemonic in the memorizing of specific facts, principles, and procedures. Instead, it appears that images of underlying system structure lead to more rapid acquisition of performance skills.

SECTION V
EXPERIMENTAL PHASE - EXPERIMENT II

METHOD

Apparatus

The subject's task was identical to that of Experiment I. Consequently the hardware and problems were the same as those used in the previous investigation.

Additional 35-mm slides were prepared for the presentation of imagery. These 13 transparencies depicted, in cartoon form, sequences of activities involved in commercial air travel which were analogous to the transmission of messages from one subscriber to another. The cartoons are shown in Appendix F.

Subjects

Forty male subjects ranging in age from 18 to 40 years took part in the experiment. All subjects were undergraduate students from the University of Minnesota. Subjects were paid on the same basis as in Experiment I. Subjects were assigned to conditions at random.

Procedure

Four subject groups were formed within a 2 x 2 factorial arrangement (Figure 11). The order of presentation of problem blocks was counterbalanced in the same manner as in the previous experiment. Again, half the subjects in each group received problem set A during training and B during transfer, and the reverse order was true for the other subjects.

The procedures employed which differed from those of Experiment I were as follows. First, from the experience gained in the conduct of the initial investigation, several of the subjects' suggestions were incorporated into the second experiment. Modifications were made in the manual for added clarity, based upon questions raised by subjects in Experiment I. When questions did arise, in the present experiment, the experimenter would refer the subject to appropriate sections of the manual or slides on the information display.

Another change was the incorporation of sample problems into the manual. The manual contained a script, to be read verbatim by the experimenter, while each of the sample problems was presented. A total of five problems were administered. These were of the types: S-S, S-T-S, S-S/Interrupt, and Deny Sender's Request.

Because Experiment II involved four combinations of treatment conditions during training, it was necessary to develop four versions of the manual -- imagery-high fidelity, imagery-low fidelity, no imagery-high fidelity, and no imagery-low fidelity. These manuals are reproduced in Appendix G.

TRAINING		TRANSFER	S No.
INSTRUCTIONS	PRACTICE		
NO IMAGERY	LOW FIDELITY TASK A	TASK B	1-5
	LOW FIDELITY TASK B	TASK A	6-10
	HIGH FIDELITY TASK A	TASK B	11-15
	HIGH FIDELITY TASK B	TASK A	16-20
IMAGERY	LOW FIDELITY TASK A	TASK B	21-25
	LOW FIDELITY TASK B	TASK A	26-30
	HIGH FIDELITY TASK A	TASK B	31-35
	HIGH FIDELITY TASK B	TASK A	36-40

Figure 11. Experimental Design - Experiment II

The high-fidelity manual, with the exceptions discussed previously, was very similar to the manual used in Experiment I. However, low-fidelity subjects were trained with the front panel of the CCC covered, and references to the equipment were accomplished with an artist's drawing of the panel. Practice was administered using a "paper and pencil" representation of the task; so instead of operating controls, subjects wrote their responses on copies of the front panel drawings. Differences between responding on the actual panel and the paper and pencil version necessitated appropriate wording changes in the low-fidelity manual.

Subjects in the imagery group were given a 5-minute presentation of cartoon slides, showing situations occurring in the course of commercial air-travel, which are analogous to each of the communications routines. The text of the commentary accompanying each slide was contained in the manual and read verbatim to the subjects. Subjects in the no-imagery condition were instead given 5 minutes to study the manual just prior to the presentation of sample problems.

Experiment I was conducted with a 24-hour retention interval between training and transfer sessions. To create an experimental task closer to operational training situations, a one-week retention interval was used in Experiment II.

A final change in procedure was incorporated as an additional attempt to provide for greater translatability of results. Although training again included KR after each problem, transfer was conducted without KR.

RESULTS

Performance during training and transfer was measured in terms of response time (Figure 12) and percent accuracy (Figure 13). Evidence of learning is provided by both performance measures. The acquisition curves for the response times were somewhat steeper than those for accuracy. ANOVAs on time (Table 6) and accuracy* (Table 7) during learning showed a blocks effect significant beyond the 0.01 level of confidence.

Evidence of forgetting can be seen by comparing scores for the final blocks of the training session with the initial blocks of the transfer session (Figures 12 and 13). However, by the third block of the transfer session, subjects had regained about the same level of performance attained by the end of training. ANOVAs on the time (Table 8) and accuracy (Table 9) data for the transfer session yielded blocks effects significant at beyond the 0.05 and 0.01 levels, respectively.

Imagery

Subjects trained under the imagery condition consistently outperformed the no-imagery subjects on the basis of time (Figure 12). The difference in response time (approximately 25 percent) during training (Table 6) was statistically reliable ($p < 0.01$). The higher levels of performance for subjects trained with imagery carried over to transfer (Table 8), and again the difference was significant at the 0.01 level of confidence.

The time data (Figure 12) suggest that imagery produced its effect more during early blocks than during later blocks. This interaction between blocks and imagery was statistically significant ($p < 0.01$) both during training (Table 6) and during transfer (Table 8). There was no evidence that response accuracy (Figure 13) was affected by the presentation of imagery during training.

Fidelity of Simulation

Subjects who received low-fidelity training seemed to solve the training problems more rapidly (Figure 12). This difference was, however, not statistically reliable (Table 6). There was no evidence that low-fidelity training differed from high-fidelity training in terms of the accuracy subjects achieved on the training problems (Figure 13 and Table 7).

Fidelity of simulation had an apparent effect on initial response times in the transfer session (Figure 12). Low-fidelity training seemed to cause subjects to respond less rapidly on the first block of problems than when high-fidelity training was administered. This difference diminished rapidly so that, by block 2, low-fidelity and high-fidelity subjects were performing at very nearly the same rates. This interaction between blocks and fidelity of simulation, during training, was statistically significant at the 0.01 confidence level.

*Note: The arcsin transformation was applied to the percent accuracy scores used in the ANOVA.

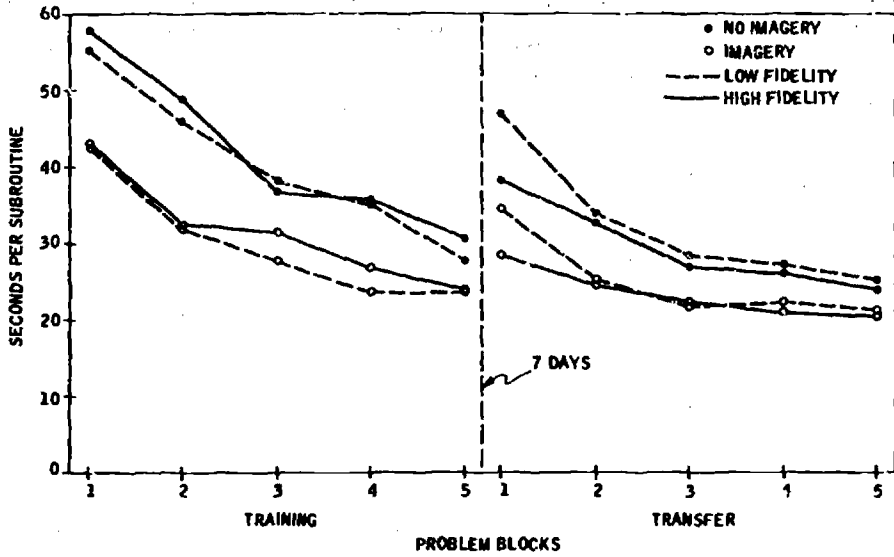

Figure 12. Effects of Imagery and Fidelity of Simulation on Response Time

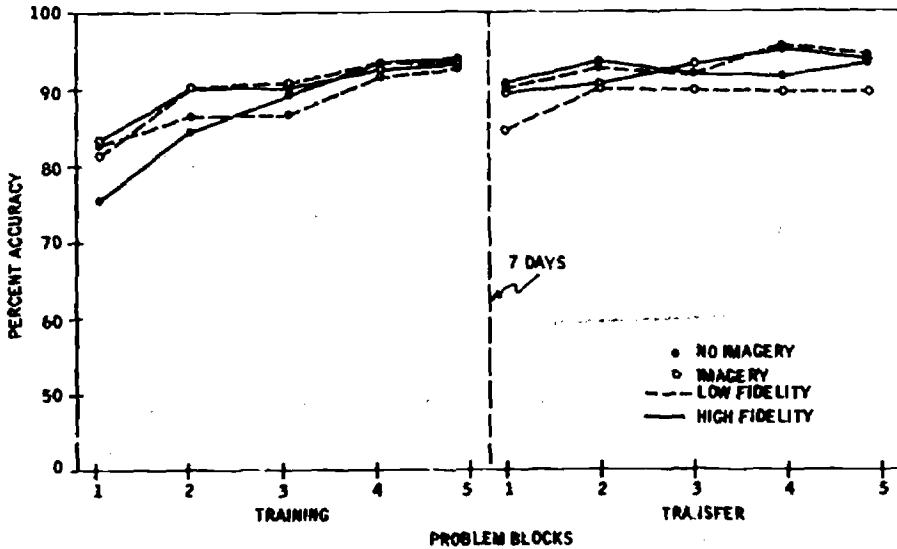

Figure 13. Effects of Imagery and Fidelity of Simulation on Accuracy

NAVTRADEVCEEN 68-C-0215-1

Table 6. Analysis of Variance Summary -- Response Time During Training

Source of Variation	df	MS	F
Fidelity (F)	1	105.56	<1
Imagery (I)	1	5486.28	12.86*
Blocks (B)	4	3295.25	80.16*
FI	1	0.01	<1
FB	4	1.92	<1
IB	4	174.64	4.25*
S(FI)	36	426.53	
FIB	4	34.52	<1
TxS(FI)	144	41.11	

*p < 0.01

Table 7. Analysis of Variance Summary -- Arcsin Transformed Percent Accuracy Scores (Radians) During Training

Source of Variation	df	MS	F
Fidelity (F)	1	0.0025	<1
Imagery (I)	1	0.0604	<1
Blocks (B)	4	0.5071	12.59*
FI	1	0.0290	<1
FB	4	0.0263	<1
IB	4	0.0252	<1
S(FI)	36	0.1066	
FIB	4	0.0350	<1
TxS(FI)	144	0.0403	

*p < 0.01

NAVTRADEV CEN 68-C-0215-1

Table 8. Analysis of Variance Summary -- Response Time During Transfer

Source of Variation	df	MS	F
Fidelity (F)	1	252.23	1.34
Imagery (I)	1	2239.14	11.88*
Blocks (B)	4	1270.48	59.87*
FI	1	14.91	<1
FB	4	87.31	4.11*
IB	4	88.79	4.18*
S(FI)	36	188.53	
FIB	4	4.58	<1
TxS(FI)	144	21.22	

*p < 0.01

Table 9. Analysis of Variance Summary -- Arcsin Transformed Percent Accuracy Scores (radians) During Transfer

Source of Variation	df	MS	F
Fidelity (F)	1	0.0229	<1
Imagery (I)	1	0.1071	<1
Blocks (B)	4	0.1119	3.54*
FI	1	0.1086	<1
FB	4	0.0106	<1
IB	4	0.0100	<1
S(FI)	36	0.1654	
FIB	4	0.0504	<1
TxS(FI)	144	0.0316	

*p < 0.05

Performance on the transfer problems, as measured by percent accuracy, did not appear to be affected by fidelity of simulation during training (Figure 12 and Table 9).

DISCUSSION AND CONCLUSIONS

The data of this investigation strongly suggests that imagery can play an important role in promoting procedural skills. Subjects who received imagery performed approximately 25 percent more rapidly than did the controls. An interesting implication of this result is the fact that imagery subjects could have been given additional problems during the training period, without increasing the total time devoted to training over that devoted to training by the non-imagery subjects. Had this been done, the difference in performance between the two groups at transfer may have been even greater.

The higher performance of imagery subjects supports the notion that trainee feedback can be of value in terms of improving training effectiveness. The specific method of promoting understanding of the structure of the system was based in part on the post-experimental reports of subjects and an attempt at applying the concept of imagery as a mediational technique. Apparently, useful strategies can be provided to subjects who would not otherwise have employed them.

The effect of fidelity of simulation in the present experiment supports earlier findings (e.g., Grimsley, 1969) that training effectiveness can be achieved through the use of low-cost paper and pencil simulations of the operational task.

It should be noted, however, that initial performance, in the transfer session, suffered somewhat when training occurred under low-fidelity conditions. This finding, although of little importance in tasks such as those studied here, can be important under other circumstances. When "one-shot" transfer is critical (e.g., emergency procedures), high-fidelity training may be a requirement.

REFERENCES

Battig, W. F. Facilitation and interference. In E. A. Bilodeau (ed.), Acquisition of Skill, New York: Academic, 1966.

Boersma, F. J., Conklin, R. C., and Carlson, J. E. Effects of reporting associative strategies on the retention of paired associates. Psychonomic Science, 1966, 5, 436-464.

Brown, D. R., Briggs, G. E., Naylor, J. C. The retention of discrete and continuous tasks as a function of interim practice with modified task requirements. Technical Document Report No. AMRL-TDR-63-35, May 1963.

Bunch, M. E. The amount of transfer in rational learning as a function of time. Journal of Comparative Psychology, 1966, 22, 325-337.

Deese, J., Hulse, S. H. The Psychology of Learning. New York: McGraw-Hill, 1958.

Gagne, R. M., and Paradise, N. E. Abilities and learning sets in knowledge acquisition. Psychological Monographs, 1961, 75, No. 14 (whole No. 518).

Ginsberg, R., McCullers, J. C., Merryman, J. J., Thompson, C. W., Witte, R. S. A review of efforts to organize information about human learning, transfer, and retention. Technical Report No. AMRL-TR-66-23, Wright-Patterson AFB, Ohio, 1968.

Houston, J. P. Verbal transfer and interlist similarities, Psychological Review, 1964, 71, 412-414.

Jung, J. Verbal Learning, New York: Holt, Rhinehard and Winston, Inc., 1968.

Kurke, Martin I. Operational sequence diagrams in system design. Human Factors, 1961, 66-73.

Mackie, R. R., and Christensen, P. R. Translation and application of psychological research. Human Factors Research, Inc. Technical Report F6-1, 1967.

Mahler, W. R., and Bennett, G. K. Psychological studies of advanced Naval air training: evaluation of operational flight trainers. Tech. Report SPECDEVCEEN 999-1-1, Office of Naval Research Special Devices Center, Port Washington, September 1950.

Martin, C. J., Boersman, F. J., and Cox, D. L. A classification of associative strategies in paired-associate learning. Psychonomic Science, 1952, 3, 455-456.

NAVTRADEVCEEN 68-C-0215-1

Martin, C. J., Cox, D. L., and Boersma, F. J. The role of associative strategies in the acquisition of P. A. material an alternative approach to meaningfulness. Psychonomic Science, 1965, b. 3, 463-464.

Marx, M. H. Learning: Processes, New York: MacMillan Co., 1969.

Newton, J. M. Training Effectiveness as a Function of Simulator Complexity. Technical Report NAVTRADEVCEEN 458-1, Training Device Center, Port Washington, N. Y., Sept. 1959.

Osgood, C. F. The similarity paradox in human learning: a resolution. Psychological Review, 1949, 56, 132-143.

Osgood, C. E. Comments on Professor Bousfield's paper. In C. N. Cofer (ed.), Verbal Learning and Verbal Behavior, New York: McGraw-Hill, 1961, pp. 91-106.

Paivio, A. Learning of adjective-noun paired associates as a function of adjective-noun word order and noun abstractness. Canadian Journal of Psychology, 1963, 17, 370-379.

Paivio, A., Yuille, J. C., and Smythe, P. C. Stimulus and response abstractness, imagery and meaningfulness and reported mediators in paired associative learning. Canadian Journal of Psychology, 1966, 20, 362-377.

Paivio, A. Mental imagery in associative learning and memory. Psychological Review, 1969, 76, 241-263.

Senter, R. J., Houter, G. An experimental study of a mnemonic system. Psychonomic Science, 1968, 10, 289-290.

Wilcoxon, H. C., Davy, E., and Webster, J. C. Evaluation of the SNJ Operational Flight Trainer, Technical Report SPECDEVCEEN 999-2-1, Special Devices Center, Port Washington, N. Y., March 1954 (Contractor: Psychological Corporation).

Willis, M. P. and Peterson, R. O. Deriving Training Device Implications from Learning Theory Principles. Vol. II: Methodology, Tech. Report NTDC 784-2, Port Washington, New York, 1961.

Wittrock, M. C. Three conceptual approaches to research. In R. M. Gagné and W. J. Gebhard (eds.), Learning Research and School Subjects, Itasca-Illinois-Peacock, 1968.

Yates, F. A. The Art of Memory. Chicago: University of Chicago Press, 1966.

APPENDIX A
BIBLIOGRAPHY

Adams, J.A. Psychomotor response acquisition and transfer as a function of control indicator relationships. Journal of Experimental Psychology, 1954, 48, 10-14.

Adams, J.A. Human Memory. New York: McGraw-Hill, 1967.

Ammons, R., Willing, L. Acquisition of motor skills: IV. Effects of repeated periods of massed practice. Journal of Experimental Psychology, 1956, 51, 118-127.

Ammons, R.B. Acquisition of motor skills: I. Quantitative analysis and theoretical formulation. Psychological Review, 1947, 54, 263-281.

Ammons, R.B. Knowledge of performance. ADC Technical Report 54-14, February 1954, 1-32.

Ammons, R.B., Carol, H., Morgan, R.L. Transfer of training in a simple motor skill along the speed dimension. (WADC) Wright Air Development Center Technical Report 53-498, March 1954.

Aronov, B.M. The influence of consistent and inconsistent guidance on human learning and transfer. Journal of Educational Psychology, 1958, 49, 80-85.

Asch, S.E., Ebenholtz, S.M. The process of free recall: Evidence for non-associative factors in acquisition and retention. Journal of Psychology, 1962, 54, 3-31.

Asher, J.J. The total physical response approach to second language learning. The Modern Language Journal, January, 1969, 53, 3-17.

Attneave, F., Arnoult, M.D. The quantitative study of shape and pattern perception. Psychological Bulletin, 1956, 53, 452-471.

Bahrack, H.P. Retention curves: Facts or artifacts? Psychological Bulletin, 1964, 61, 188-194.

Bahrack, H.P. The ebb of retention. Psychological Review, 1965, 72, 60-73.

Bahrack, H.P., Noble, M.T. Motor behavior. In Sidowski (ed.), Experimental methods and instrumentation in psychology. New York: McGraw-Hill, 1966.

Bahrack, H.P. Relearning and the measurement of retention. Journal of Verbal Learning and Verbal Behavior, 1967, 6, 89-94.

Baker, C.H., Young, P. Feedback during training and retention of motor skills. Canadian Journal of Psychology, 1960, 14, 257-264.

- Baller, W., Jahnke, W. Effects of difficulty level, temporal position of feedback and content of verbal material on retention. Psychological Reports, 1967, 21, 645-648.
- Battig, W.F. Facilitation and interference. In E.A. Bilodeau (Ed.), Acquisition of Skill. New York: Academic Press, 1966.
- Battig, W.F. A shift from negative to positive transfer under the a-c paradigm with increased number of C-D control pairs in mixed list. Psychonomic Science, 1966, 4, 421-422.
- Battig, W.F. Symposium on coding and conceptual processes in verbal learning. Journal of Verbal Learning and Verbal Behavior, 1966, 5, 177-181.
- Biel, W.L. Training programs and devices. In Gagne (Ed.), Psychological Principles in System Development. New York: Holt, Rinehart, Winston, 1962.
- Bilodeau, E.A., Bilodeau, I.M. Motor skills learning (the article is from Acquisition of skill.) Annual Review of Psychology, 1961, 12, 243-280.
- Bilodeau, E.A., Levy, M.C. Long-term memory as a function of retention time and other conditions of training and recall. Psychological Review, 1964, 71, 27-41.
- Bilodeau, E.A., (Ed.) Acquisition of skill. New York: Academic Press, 1966.
- Bilodeau, I.M. Transfer of training across target sizes. Journal of Experimental Psychology, 1965, 70, 135-140.
- Blick, K.A., Bilodeau, E.A. Interpolated activity and the learning of a simple skill. Journal of Experimental Psychology, 1963, 65, 515-519.
- Boersma, F.J., Conklin, R.C., Carlson, J.E. Effects of reporting associative strategies on the retention of paired-associates. Psychonomic Science, 1966, 5, 463-464.
- Braun, H.W., Heymann, S.P. Meaningfulness of material, distribution of practice; and serial position curves. Journal of Experimental Psychology, 1958, 56, 146-150.
- Briggs, G.E., Naylor, J.C. The relative efficiency of several training methods as a function of transfer task complexity. Journal of Experimental Psychology, 1950, 56, 492-500.
- Briggs, G.E., Johnston, W.A. Team training research. Technical Report: NAVTRADEVCCEN 1327-2, November 1965, 1-27.
- Briggs, G.E., Naylor, J.C. Team versus individual training, training task fidelity and task organization effects on transfer performance by three-man teams. Journal of Applied Psychology, December 1965, 49, 387-392.

NAVTRADEVCCEN 68-C-0215-1

- Briggs, G. E., Johnston, W. A., Influence of a change in system criteria on team performance. Journal of Applied Psychology, 1966, 50, 467-472.
- Briggs, G. E., Johnston, W. A. Laboratory research on team training. Technical Report: NAVTRADEVCCEN 1327-3, May 1966, 1-56.
- Briggs, G. E., Johnston, W. A. Team training. Technical Report: NAVTRADEVCCEN 1327-4, June 1967, 1-79.
- Briggs, G. E. The relative efficiency of several training methods as a function of transfer task complexity. Journal of Experimental Psychology, 1962, 64, 505-512.
- Brown, D. R., Briggs, G. E. Naylor, J. C. The retention of discrete and continuous tasks as a function of interim practice with modified task requirements. Technical Document Report No. AMRL-TDR-63-35, May 1963, 1-18.
- Bugelski, B. R., Cadwallader, T. A reappraisal of the transfer and retroaction surface. Journal of Experimental Psychology, 1956, 52, 360-366.
- Bunch, M. E. The amount of transfer in rational learning as a function of time. Journal of Comparative Psychology, 1936, 22, 325-337.
- Bush, W. J., Gregg, D. K., Smith, E. A. Some interactions between individual differences and modes of instruction. AMRL-TR-65-228, December 1965, 1-19.
- Carlson, J. E., Boersma, F. J., Conklin, R. C. Effects of post-learning activities on the retention of paired-associates. Psychonomic Science, 1967, 8, 543-544.
- Carpenter, D. R., Greenhill, L. P. Instructional films - list of reports and summaries of results of research. Navy, Spec. Dev. Cen. 269-7-61X, February, 1957
- Clarke, A. D., Cooper, G. M. Age and perceptual motor transfer of training. Perceptual and Motor Skills. 1964, 19, 849-850.
- Chambers, R. M. Transfer of training among components of a complex velocity control task. NADC-MA Lab. Report, 1959, 5920.
- Clifton, C., Jr. Initial transfer in the mediation of paired associates. Journal of Experimental Psychology, 1966, 71, 168-176.
- Clifton, C., Jr. Response transfer as a function of verbal association strength: Group verbal learning. Journal of Experimental Psychology, 1966, 71, 780-781.
- Cooper, E. H., Pantle, A. J. The total-time hypothesis in verbal learning. Psychological Bulletin, October 1967, 68, 221-234.
- Coppage, E. W., Harcum, E. R. Temporal vs. structural determinants of primacy in strategies of serial learning. Journal of Verbal Learning and Verbal Behavior, 1967, 6, 487-491.

Cotterman, T.E. Task classification: An approach to partially ordering information on human learning. Technical Report WADC-TR58-374. Ohio: Wright-Patterson AFB, 1959.

Cox, J.A. Application of a method of evaluating training. Journal of Applied Psychology, 1964, 48, 84-87.

Cratty, B.J. Comparison of learning a fine motor task with learning a similar gross motor task using kinesthetic cues. Research Quarterly, 1962, 33, 212-221.

Cyr, C., Thune, L.E., Erickson, S.C. Studies in transfer learning: Effect of methods of instruction on operator proficiency. Defense Documentation Center - No. 419624, 1957.

Dallett, K.M. Effects of within-list and between-list acoustic similarity on the learning and retention of paired associates. Journal of Experimental Psychology, 1966, 72, 667-677.

Dallett, K.M. The transfer surface reexamined. Journal of Verbal Learning and Verbal Behavior, 1962, 1, 92-94.

Day, R.H. Relative task difficulty and transfer of training in skilled performance. Psychological Bulletin, 1956, 53, 160-167.

Deese, J., Hulse, S.H. The Psychology of Learning. New York: McGraw-Hill, 1958.

Deutsch, J.A. A system for shape retention. Psychological Review, 1962, 69, 492-500.

Dodwell, P.C. A coupled system for coding and learning in shape discrimination. Psychological Review, 1964, 71, 148-159.

Dooley, R.P., Newton, J.M. Transfer of training between quickened and unquickened displays. Perceptual and Motor Skills, 1965, 21, 11-15.

Dornbush, R.L. Shadowing in bisensory memory. The Quarterly Journal of Experimental Psychology, 1968, 20, 225-231.

Duncan, C.P. Transfer after training with single versus multiple tasks. Journal of Experimental Psychology, 1958, 55, 63-72.

Elliott, T.K. A comparison of three methods for presenting procedural troubleshooting information. AMRL-TR-66-191, December 1966, 1-38.

Elliott, T.K. The Maintenance task simulator (MTS-2). A device for electronic maintenance research. Application and operation. AMRL-TR-67-140. Ohio - Wright-Patterson AFB, 1967, 1, 1-35.

Elliott, T.K. The maintenance task simulator (MTS-2). A device for electronic maintenance research. AMRL-TR-67-140, Maintenance Data, October 1967, II, 1-193.

Ellis, H.C. The transfer of learning. New York: MacMillan, 1965.

NAVTRADEVCEEN 68-C-0215-1

Ellis, N. C., Lowes, A. L., Mathey, W. G., Norman, D. A. Pilot performance, transfer of training and degree of stimulation. III. Performance of non-jet experienced pilots versus simulation fidelity, Technical Report. NAVTRADEVCEEN 67-C-0034-1, August 1968, 1-65.

Farber, I. E. The things people say to themselves. American Psychologist, 1963, 18, 186-197.

Feuge, R. D., Ellis, H. C. Generalization gradients in recognition memory of visual form: The role of stimulus meaning. Journal of Experimental Psychology, 1969, 79, 288-294.

Finch, G., Cameron, F., (Ed.). Air Force Human Engineering, Personnel and Training Research. Washington, D. C., National Academy of Sciences, 1965.

Fleishman, E. A., Fruchter, B. Component and total task relations at different stages of learning a complex tracking task. Perceptual and Motor Skills, 1965, 20, 1305-1311.

Fleishman, E. A., Parker, J. F., Jr. Factors in the retention and relearning of perceptual motor skills. Journal of Experimental Psychology, 1962, 64, 212-226.

Folley, J. D., Jr., Woods, R. H. Comparison of three modes of instruction for the operation of a complex oscilloscope. AMRL-TR-66-195, March 1967, 1-62.

Fox, W. L. Forgetting a simple motor task, Psychonomic Science, 1966, 6, 301-302.

Fuchs, A. H. The progression-regression hypotheses in perceptual-motor skill learning. Journal of Experimental Psychology, 1962, 63, 177-182.

Gagne, R. M., Foster, H., Crowley, M. E. The measurement of transfer of training. Psychological Bulletin, March 1948, 45, 97-130.

Gagne, R. M., Baker, K. E., Foster, H. On the relation between similarity and transfer of training in the learning of discriminative motor tasks. USN-SDC-Tech. Report 316-1-5, 1949.

Gagne, R. M., Paradise, N. E. Abilities and learning sets in knowledge acquisition. Psychological Monographs - No. 14, 1961, 75.

Gagne, R. M. Military training and principles of learning. American Psychologist, 1962, 17, 83-91.

Gagne, R. M. The acquisition of knowledge. Psychological Review, 1962, 69, 355-365.

Gagne, R. M. The conditions of learning. New York: Holt, Rinehart, Winston, 1965.

Gannon, D. R., Noble, C. E. Familiarization (n) as a stimulus factor in paired-associate verbal learning. Journal of Experimental Psychology, 1961, 62, 14-23.

NAVTRADEVCEEN 68-C-0215-1

Garner, W. R., Whitmarsh, J. R. Form and amount of internal structure as factors in free-recall learning of nonsense words. Journal of Verbal Learning and Verbal Behavior, 1965, 4, 257-266.

George, C. E., George, R. H., Boutwell, J. Research memorandum - pilot studies of team effectiveness. HumRRO, February 1963, 1-66.

Ginsberg, R., McCullers, J. C., Merryman, J. J., Thompson, C. W., Witte, R. S. A review of efforts to organize information about human learning, transfer and retention. AMRL-TR-66-23. Ohio: Wright-Patterson, March 1966.

Glanzer, M., Glaser, R. A review of team training problems. American Institutes for Research. Technical Report, September 1955, 1-65.

Glanzer, M., Glaser, R., Klaus, D. J. The team performance record: An aid for team analysis and team training. American Institutes for Research. Technical Report, December 1956, 1-24.

Glanzer, M., Glaser, R. Techniques for the study of group structure and behavior: I. Analysis of structure. Psychological Bulletin, September 1959, 56, 317-332.

Glaser, R., Klaus, D. J. Proficiency measurement: Assessing human performance. In Gagne' (Ed.), Psychological variables in system development. New York: Holt, Rinehart, and Winston, 1967.

Glaser, R., Klaus, D. J., Egerman, K. Increasing team proficiency through training, the acquisition and extinction of a team response. AIR-B64-5/62-TR, May 1962, 1-59.

Glaser, R. Training Research and Education - In Glanzer, M. Experimental study of team training and team functioning. New York: Science Editions. John Wiley, Sons, 1965, Chapt. 13, 379-407.

Goggin, J. P. Retroactive and proactive inhibition in the short term retention of paired associates. University Microfilms Inc., Ann Arbor, Michigan, 1964, 1-65.

Goldstein, D. A., King, W. J. Transfer retention for verbal and motor tasks. Electric Boat Co., U411-61-064, 1 April 1961, 1-29.

Goldstein, D. A., Newton, J. M. Transfer of training as a function of task difficulty in a complex control situation. Journal of Experimental Psychology, 1962, 63, 370-375.

Goodnow, J. J., Pettigrew, T. F. Effect of prior patterns of experience upon strategies and learning sets. Journal of Experimental Psychology, 1955, 49, 381-389.

Goulet, L. R., Barclay, A. Comparison of paired-associate transfer effects between the A-B, C-A and A-B, B-C paradigms. Journal of Experimental Psychology, 1965, 70, 537-539.

NAVTRADEVCEEN 68-C-0215-1

- Goulet, L.R. Degree of learning and transfer of training. Psychonomic Science, 1967, 8, 245-246.
- Greenhill, L.P., Tyo, J. Instructional film production, utilization and research in Great Britain, Canada and Australia, rapid mass learning, Penn. State U., SDC-269-7-1, May 1949, 1-27.
- Gregg, L.W., Simon, H.A. An information processing explanation of one-trial and incremental learning. Journal of Verbal Learning and Verbal Behavior, 1967, 6, 780-787.
- Grimsley, D.L. Acquisition, retention and retraining. Effects of high and low fidelity in training devices. Technical Report 69-1, February 1969, 1-24.
- Hall, J.F. The psychology of learning. New York: J. B. Lippincott Co., 1966.
- Hammerton, M. Retention of learning in a difficult tracking task. Journal of Experimental Psychology, 1963, 66, 108-110.
- Hammerton, M. Measures for the efficiency of simulators as training devices. Ergonomics, 1967, 10, 63-66.
- Hanes, R.M., Borchers, J.M. Team versus individual performance in tactical judgment. T6-367, 14 June 1960, 1-8.
- Harcum, E.R. Parallel functions of serial learning and tachistoscopic pattern perception. Psychological Review, 1967, 74, 51-62.
- Harmon, J.M., Oxendine, J.B. Effect of different lengths of practice periods on learning of a motor skill. Research Quarterly, 1961, 32, 34-41.
- Hart, J.T. Memory and the memory - monitoring process. Journal of Verbal Learning and Verbal Behavior, 1967, 6, 685-691.
- Helmick, J.S. Pursuit learning as affected by size of target and speed of rotation. Journal of Experimental Psychology, 1951, 41, 121-125.
- Hilgard, E.R. and Sait, E.M. Estimates of past and of future performances as measures of aspiration. American Journal of Psychology, 1941, 54, 102-108.
- Hintzman, D.L. Articulatory coding in short-term memory. Journal of Verbal Learning and Verbal Behavior, 1967, 6, 312-316.
- Hoban, C.F., Jr., Van Ormer, E.B. Instructional film research (rapid mass learning) 1918-1950. SDC-269-7-19, December 1950, 1-179.
- Holding, D.H. Transfer between difficult and easy tasks. British Journal of Psychology, 1962, 53, 397-407.
- Holding, D.H. Principles of training. London: Pergamon, 1965.
- Hoinzie, M.J., Hardcare, L.E., Weiner, J. Transfer of training as a function of stimulus and response integration of paired-associates. Journal of Experimental Psychology, 1967, 74, 383-388.

NAVTRADEVCCEN 68-C-0215-1

- Hooprich, E.A., Steinemann, H. A review of electronics training research literature. Navy, NPRA STB-67-1, August 1966.
- Horrocks, J.E., Krug, R.E., Heerman, E. Team training II: Individual learning and team performance. NAVTRADEVCCEN 198-2, August 1960, 1-58.
- Horrocks, J.E., Heerman, E., Krug, R.E. Team training III: An approach to optimum methods and procedures. NAVTRADEVCCEN 198-3, August 1961, 1-66.
- Houston, J.P. Verbal transfer and interlist similarities. Psychological Review, 1964, 71, 412-414.
- Howell, W.C. On the heterogeneity of stimulus and response elements in the processing of information. Journal of Experimental Psychology, 1962, 63, 235-243.
- Hull, C.L. Principles of Behavior. New York: Appleton-Century, 1943.
- Jahnke, J.C. Postrest motor learning performance as a function of degree of learning. Journal of Experimental Psychology, 1961, 62, 605-611.
- Jakobovits, L.A., Lambert, W.E. Mediated satiation in verbal transfer. Journal of Experimental Psychology, 1962, 64, 346-351.
- Johnson, R.B. Recognition of nonsense shapes as a function of congruence among components of pretraining task. *PhD dissertation*, 1965, 36, 270-276.
- Jung, J. Transfer of training as a function of degree of first-list learning. Journal of Verbal Learning and Verbal Behavior, 1962, 1, 197-199.
- Kanner, J., McClure, A.H. Varied versus identical repetition in filmed instruction on micrometer reading. AF, PTRC TARI-LN-56-11, April 1956, 1-16.
- Karlin, L., Mortimer, R.G. Effects of visual and verbal cues on learning a motor skill. Journal of Experimental Psychology, 1962, 64, 608-614.
- Karlin, L., Mortimer, R.G. Effect of verbal, visual, and auditory augmented cues on learning a complex motor skill. Journal of Experimental Psychology, 1963, 65, 75-79.
- Kasschau, R.A., Dollio, H.R. Response transfer mediated by meaningfully similar and associated stimuli using a separate list design. Journal of Experimental Psychology, 1967, 74, 146-148.
- Kausler, D.A., Kanoti, G.H. R-S learning and negative transfer effects with mixed list. Journal of Experimental Psychology, 1963, 65, 201-205.
- Keppel, G. Problems of method in the study of short-term memory. Psychological Bulletin. January 1965, 63, 1-13.
- Keppel, G., Underwood, B.J. Proactive inhibition in short-term retention of single items. Journal of Verbal Learning and Verbal Behavior, 1962, 1, 153-161.

NAVTRADEVCCEN 68-C-0215-1

- Kimble, G.A. Performance and reminiscence in motor learning as a function of the degree of distribution of practice. Journal of Experimental Psychology, 1949, 39, 500-510.
- Kimble and Skatel. Relationship between two kinds of inhibition and the amount of practice. Journal of Experimental Psychology, 1952, 44, 355-359.
- Kintz, B.L. Equal rest-work ratios under massed and distributed practice. Iowa Academic Sci., 1962, 69, 496-502.
- Klippel, A. G. An exploratory investigation of the effects of ambiguity in training materials on sonar cue judgments. Tech. Bulletin 65-13-U.S. Naval Personnel Research Activity, April, 1965, 1-11.
- Knight, J., Gray, J.A. Degree of learning, proactive interference and retention. Nature, 1967, 216, 406-407.
- Krueger, W. C. F. Learning during directed attention. Journal of Educational Psychology, 1917, 8, 239-240.
- Kurke, Martin I. Operational sequence diagrams in system design. Human Factors, 1961, 66-73.
- Lachman, R., Field, W.H. Recognition and recall of verbal material as a function of degree of training. Psychonomic Science, 1965, 2, 225-226.
- Lavery, J.J. Retention of a skill following training with and without instructions to retain. Perceptual and Motor Skills, August, 1964, 18, 275-281.
- Lavery, J.J. Retention of a skill as a function of display/hand movement ratio during training. Perceptual and Motor Skills, 1964, 19, 626.
- Lawrence, D.H. The evaluation of training and transfer programs in terms of efficiency measures. The Journal of Psychology, 1954, 38, 367-382.
- Lee, W. ROC curves for recognition of visual patterns. Psychonomic Science, 1965, 2, 51-52.
- Lewis, M.E., Teichner, W.H., The effect of various modes of rehearsal on short-term recall. Technical Report: NAVTRADEVCCEN 1303-1, June 11, 1964, 1-22.
- Lordahl, D.S., Archer, E.J. Transfer effects on a rotary pursuit task as a function of first-task difficulty. Journal of Experimental Psychology, 1958, 56, 421-426.
- Maccaslin, E.F. A tentative taxonomy of task demands. Paper Presented at the American Psych. Assoc. Convention, September, 1963, 1-6.
- Mackie, R.R., Christensen, P.R. Translation and application of psychological research - Human Factors Research Inc. Technical Report 761-1, January, 1967, 1-142.

NAVTRADEVCCEN 68-C-0215-1

Mackworth, J.F. Presentation rate, repetition and organization in auditory short-term memory. Canadian Journal of Psychology, Rev. Canadian Psychology, 1965, 19, 304-315.

Martin, C.J., Boersma, F.J., Cox, D.L. A classification of associative strategies in paired-associate learning. Psychonomic Science, 1965, 3, 455-456.

Martin, C.J., Cox, D.L., Boersma, F.J. The role of associative strategies in the acquisition of P-A material: An alternate approach to meaningfulness. Psychonomic Science, 1965, 3, 463-464.

Martin, E. Transfer of verbal paired associates. Psychological Review, September, 1965, 72, 327-343.

Marx, M.H. Learning: Processes. Chapter 16 - current status and prospects. The Macmillan Comp. Collier-Macmillan, 1969, Chapter 16, 364-365.

McGoech, J.A. Influence of association value upon the difficulty of nonsense syllable lists. Journal of Genetic Psychology, 1930, 37, 420-430.

McGoech, J.A. The Psychology of Human Learning. New York: Longmans, Green, 1942.

McGuire, W.J. A preliminary study of the use of an instructional film in teaching a motor skill. AF, PTRC TARL-LN-55-57, December, 1965, 1-11.

Mechanic, J.A. Response activities and the mechanism of selectivity in incidental learning. Journal of Verbal Learning and Verbal Behavior, 1967, 6, 389-397.

Melton, A.W. The taxonomy of human learning: Overview. In A.W. Melton (Ed.), Categories of human learning, New York: Academic Press, 1964.

Micheli, G.S. Augmenting feedback and transfer of training. NAVTRADEVCCEN IH-41, U.S. Naval Training Device Center, March, 1966, 1-83.

Michels, K.M., Zusne, L. Metrics of visual form. Psychological Bulletin, 1965, 63, 74-86.

Miller, G.R. Extraexperimental transfer in serial recall. Journal of Verbal Learning and Verbal Behavior, 1963, 2, 494-497.

Miller, R.B. Task and part-task trainers and training. AF, WADD TR 60-469, June, 1960, 1-89.

Miller, R.B. Task taxonomy: Science or technology? Ergonomics, 1967, 10, 167-176.

Mohr, D.R. The contributions of activity to skill learning. Research Quarterly, 1960, 31, 321-350.

Morrill, C.S., Davies, B.L. Target tracking and acquisition in three dimensions using a two-dimensional display surface. Journal of Applied Psychology, 1961, 45, 214-221.

NAVTRADEVCEEN 68-C-0215-1

Muckler, P.A., Nygarrrd, J.E., O'Kelly, L.I., and Williams, A.C. Jr. Psychological variables in the design of flight simulators for training. WADC Technical Report 56-369; Weighi, Patterson A. F. B., 1959.

Mukherjee, B.N. Learning efficiency in a psychomotor test as a function of initial skill. Engineering and Industrial Psychology, 1959, 1, 138-142.

Mukherjee, B.N. Application of cononical correlational analysis to learning data. Psychological Bulletin, 1966, 65, 9-21.

Murdock, B. B. Jr. The retention of individual items. Journal of Experimental Psychology, 1961, 62, 618-625.

Murdock, B. B. Jr. Short-term retention of single paired-associates. Journal of Experimental Psychology, 1963, 65, 433-443.

Murdock, B. B. Transfer designs and formulas. Psychological Bulletin, 1957, 54, 313-326.

Murdock, B. B. Jr. The immediate retention of unrelated words. Journal of Experimental Psychology, 1960, 60, 222-234.

Namikas, A. Motor skill transfer as a function of intertask interval and pretransfer task difficulty. Journal of Experimental Psychology, 1960, 59, 109-112.

Naylor, J.C. Parameters affecting the relative efficiency of part and whole training methods: A review of the literature. Tech. Report: NAVTRADEVCEEN 950-1, February 18, 1962. 1-34.

Naylor, J.C., Briggs, G.E. Long term retention of learned skills: A review of literature. ASD Tech. Report 61-390. Ohio; Wright, Patterson, A. F. B., August 1961.

Naylor, J.C., Briggs, G.E. Effects of task complexity and task organization on the relative efficiency of part and whole training methods. Journal of Experimental Psychology, March, 1963, 65, 217-224.

Naylor, J.C., Briggs, G.E. Team training effectiveness under various conditions. Journal of Applied Psychology, August, 1965, 49, 223-229.

Naylor, J.C., Briggs, G.E., Reed, W.G. The effects of task organization, training time, and retention interval on the retention of skill. AF, AMRL-TDR 62-107-, Wright-Patterson, September, 1962, 1-20.

Newman, E., Ammons, R.B. Acquisition and long term retention of a simple serial perceptual-motor skill. Journal of Experimental Psychology, 1957, 53, 159-161.

NAVTRADEV CEN 68-C-0215-1

Noble, M., Trumbo, D. Further evidence on secondary task interference in tracking. Journal of Experimental Psychology, 1967, 73, 146-149.

Norman, D.A. Toward a theory of memory and attention. Psychological Review, 1968, 75, 522-536.

Olivier, K., Kausler, D.H. Transfer in the A-B, C-B paradigm as a function of stimulus class. Psychonomic Science, 1966, 5, 47-48.

Olton, R.M. The effect of a mnemonic upon the retention of paired-associate verbal material. Journal of Verbal Learning and Verbal Behavior, 1969, 8, 43-48.

Osgood, C.E. The similarity paradox in human learning: A resolution. Psychological Review, 1949, 56, 132-143.

Osgood, C.E. Comments on Professor Bousfield's paper. In C.N. Cofer (Ed.), Verbal Learning and Verbal Behavior, New York: McGraw-Hill, 1961, 91-106

Overing, R.L., Travers, R.M. Variation in the amount of irrelevant cues in training and test conditions and the effect upon transfer. Journal of Educational Psychology, 1967, 58, 62-68.

Parker, J.F., Jr., Fleishman, E.A. Use of analytical information concerning task requirements to increase the effectiveness of skill training. Journal of Applied Psychology, 1961, 45, 295-302.

Paivio, A. Mental imagery in associative learning and memory. Psychological Review, May, 1969, 76, 241-263.

Phillips, J.L., Shiffrin, R.M., Atkinson, R.C. Effects of list length on short-term memory. Journal of Verbal Learning and Verbal Behavior, 1967, 6, 303-311.

Plutchik, R., Petti, R. Rate of learning on a pursuit rotor task at a constant work-rest ratio with varying work and rest periods. Perceptual Motor Skills, 1964, 19, 227-231.

Plutchik, R. Strategies of Research design in psychology. Technical Report: NAVTRADEV CEN IH-129, August, 1967, 1-21.

Postman, L. The effects of language habits on the acquisition and retention of verbal associations. Journal of Experimental Psychology, 1962, 64, 7-19.

Postman, L. Transfer of training as a function of experimental paradigm and degree of first list learning. Journal of Verbal Learning and Verbal Behavior, 1962, 1, 109-118.

Postman, L. Studies of Learning to learn: II: Changes in transfer as a function of practice. Journal of Verbal Learning and Verbal Behavior, 1964, 3, 437-447.

Postman, L., Stark, K. Studies of learning to learn: Transfer from serial to paired associate learning. Journal of Verbal Learning and Verbal Behavior, 1967, 6, 339-353.

NAVTRADEVCEEN 68-C-0215-1

- Poulton, E.C., Freeman, P.R. Unwanted asymmetrical transfer effects with balanced experimental designs. Psychological Bulletin, 1966, 66, 1-8.
- Purdy, B.J., Lockhart, A. Retention and relearning of gross motor skills after long periods of no practice. Research Quarterly, 1962, 33, 265-272.
- Rachman, S. Disinhibition and the reminiscence effect in a motor learning task. British Journal of Psychology, 1962, 53, 149-157.
- Rand, G., Seymour, W. Postural status as a factor in memory. Journal of Verbal Learning and Verbal Behavior, 1967, 6, 268-271.
- Richardson, A. Mental practice: A review and discussion. Part II. The Research Quarterly, January, 1965, 38, 263-273.
- Richardson, J. Implicit verbal chaining as the basis of transfer in paired associate learning. Journal of Experimental Psychology, 1963, 76, 109-115.
- Ryan, E. D. Effects of stress on motor performance and learning. Research Quarterly, 1962, 33, 111-119.
- Schepers, J.M. A components analysis of a complex psychomotor learning task. Psychologia Africana, 1962, 9, 294-329.
- Schohan, B. Human factors recommendations for the design of cockpit procedures trainers. American Inst. for Res, September, 1958, 1-49.
- Schroth, M.L. The function of stimulus predifferentiation pretraining in complex problem - solving. Psychonomic Science, 1968, 10, 123-124.
- Senter, R.J., Hauder, G. An experimental study of a mnemonic system. Psychonomic Science, 1968, 10, 289-290.
- Senter, R.J., USAF Instructors Journal. Retraining for remembering.
- Siegel, A.I., Richlin, M., Federman, P. A comparative study of "transfer through generalization" and "transfer through identical elements" in technical training. Journal of Applied Psychology, 1960, 44, 27-30.
- Singer, R.N. Transfer effects and ultimate success in archery due to degree of difficulty in initial learning. Research Quarterly, 1966, 37, 532-537.
- Sinha, A.K.P., Prasad, M.B. Transfer as a function of the method of first task learning. Journal of General Psychology, 1962, 66, 311-314.
- Smith, K.R., Van Ormer, E.B. Learning theories and instructional film research (rapid mass learning). Technical Report SDC 269-7-6, June, 1949, 1-12.
- Steinemann, J.H. An evaluative survey of electronics training in military and civilian organizations. Navy, NPRA STB 65-11, 1-105.
- Stolorow, M. A taxonomy of learning task characteristics. AMRL-TDR 64-2. Ohio: Wright, Patterson, A. F. B., January, 1964.

Suddon, F.H., Lavery, J.J. The effect of amount of training on retention of a simple motor skill with 0 and 5 trial delays of knowledge of results. Canadian Journal of Psychology, 1962, 16, 312-317.

Swink, J., Trumbo, D., Noble, M. On the length-difficulty relation in skill performance. Journal of Experimental Psychology, 1967, 74, 356-362.

Taylor, Ann B., Ikion, A.D. Continuity hypothesis and transfer of training in paired-associate learning. Journal of Experimental Psychology, 1964, 68, 573-577.

Thune, L.E. The effect of different types of preliminary activities on subsequent learning of paired-associate materials. Journal of Experimental Psychology, 1950, 40, 423-438.

Tiechner, W.H., Reilly, R., Sadler, E. Effects of density on identification and discrimination in visual symbol perception. Journal of Experimental Psychology, 1961, 61, 450-494.

Trumbo, D., Noble, M., Ulrich, L. Number of alternatives and sequence length in acquisition of a step-function tracking task. Perceptual and Motor Skills, 1965, 21, 563-569.

Trumbo, D., Noble, M., Ulrich, L. Verbal coding and display coding in the acquisition and retention of tracking skill. Journal of Applied Psychology, 1965, 49, 368-375.

Trumbo, D., Cross, K., Noble, M., Ulrich, L. Task predictability in the organization, acquisition, and retention of tracking skill. Journal of Experimental Psychology, 1965, 70, 252-263.

Tulving, E., Arbuckle, T.Y. Input and output interference in short-term associative memory. Journal of Experimental Psychology, 1966, 72, 145-150.

Turnage, T.W., McCullough, T.A. Letter-sequence and unit-sequence effects during learning and retention. Journal of Experimental Psychology, 1968, 76, 141-146.

Underwood, B.J. Associative transfer in verbal learning as a function of response similarity and degree of first list learning, Northwestern University, Journal of Experimental Psychology, 1951, 42, 44-53.

Underwood, B.J., Schultz, R.W. Meaningfulness and verbal learning, Philadelphia: Lippincott, 1960.

Uhr, L. Pattern recognition computers as models for form perception. Psychological Bulletin, 1963, 60, 40-73.

Vanderplas, J.M. Transfer of training and its relation to perceptual learning and recognition. Psychological Review, 1958, 65, 375-385.

NAVTRADEVCCEN 68-C-0215-1

Vanderplas, J.M., Garvin, E.A. Complexity, association value, and practice as factors in shape recognition following paired-associates training. Journal of Experimental Psychology, 1959, 57, 155-163.

Vanderplas, J.M., Garvin, E.A. The association value of random shapes. Journal of Experimental Psychology, 1959, 57, 147-154.

Vanderplas, J.M. Associative processes and task relations in perceptual learning. Perceptual and Motor Skills, 1963, 16, 501-509.

Vanderplas, J.M., Sanderson, W.A., Vanderplas, J.N. Some task-related determinants of transfer in perceptual learning. Perceptual and Motor Skills, 1964, 18, 71-80.

Vanderplas, J.M., Sanderson, W.A., Vanderplas, J.N. Statistical and associational characteristics at 1100 random shapes. Perceptual and Motor Skills, 1965, 21, 4-14.

Van Dusen, F., Schlosberg, H. Further study of the retention of verbal and motor skills. Retention of Verbal and Motor Skills, August, 1948, 38, 526-534.

Waring, G. Rationale for forced choice performance report. Psychometrics, 46, 52-53.

Weiner, B. Role of success and failure in the learning of easy and complex tasks. Journal of Personality and Social Psychology, 1966, 3, 339-344.

Weiner, E.L. Transfer of training from one monitoring task to another. Ergonomics, 1967, 10, 649-658.

Weingartner, H. Associative structure and serial learning. Journal of Verbal Learning and Verbal Behavior, 1963, 2, 476-479.

Weitz, J. Criteria and transfer of training. Psychologica Reports, 1966, 19, 195-210.

Wickens, D.D., Born, D.G., Allen, C.K. Proactive inhibition and item similarity in short-term memory. Journal of Verbal Learning and Verbal Behavior, 1963, 2, 440-445.

Williams, A.C., Briggs, G.E. On target versus off-target information and the acquisition of tracking skill. Journal of Experimental Psychology, 1962, 64, 519-525.

Williges, R.C., Johnston, W.A., Briggs, G.E. Role of verbal communication in teamwork. Journal of Applied Psychology, 1966, 51, 473-478.

Willis, M.P., Peterson, R.O. Deriving training device implications from learning theory principles. Vol. I.: Guidelines for training device design development and use. Technical Report: NAVTRADEVCCEN 784-1, 1961, 1-81.

NAVTRADEVCEEN 68-C-0215-1

APPENDIX B
L, R, AND T TECHNICAL MEETINGS REPORT

The complete report of the L, R, and T Technical Meetings, including papers presented and summary statements of the views of the participants, is contained in Volume II.

67/68

17 72

APPENDIX C

JOB TRAINING AND TESTING CONSOLE (JTTC) REPORT *

BACKGROUND AND STATEMENT OF THE PROBLEM

The objective of the Learning, Retention, and Transfer (L, R, and T) contract is the experimental investigation of all meaningful combinations of variables affecting L, R, and T processes. To accomplish this aim, a long-term research program will be required. During the course of this research, experiments will be conducted which deal with a number of taxonomic categories of human behavior. Variations in type of task will require apparatus which presents stimuli simulating those encountered in high-priority Naval jobs. Likewise, a capability for measuring a rather wide variety of responses will be required. This suggests that apparatus requirements will very likely change over the course of the program.

One approach to the problem of obtaining suitable apparatus is to simply procure or fabricate devices when the need for such equipment arises. It would seem, however, that operating in this manner would create a never-ending problem. Relatively minor changes in the nature of experimentation could result in the need for major modifications in experimental facilities. As an example, consider the problem of conducting two concurrent experiments which differ only in terms of the sensory modality used for the presentation of stimuli. If the first investigation required visual presentation and the second employed auditory inputs, two basically different pieces of apparatus would be needed. If both studies required the subject to respond in a like manner, the hardware would have to be rewired (assuming the experiment involved a closed-loop system) to accommodate the change in mode of stimulus presentation. Of course, if the method of responding also differed between these two experiments, even more work would be required to prepare for the second investigation.

The development of a generalized L, R, and T experimental facility would minimize recurring apparatus development efforts prior to the conduct of each experiment. The task of Honeywell's Marine Systems Center/California was to develop a preliminary concept for such a generalized device. This report documents the approach taken in defining a recommended facility. Further, the analysis of various experimental requirements are detailed, alternative concepts and their associated specifications are suggested, trade-off considerations are discussed, and recommendations for equipment selection are provided.

* Prepared for Honeywell Systems and Research Division by Terry J. Wong and Manuel E. Quintana of the Honeywell Marine Systems Center/California.

DEVELOPMENT OF BASIC REQUIREMENTS

A myriad of techniques and devices are used in the experimental study of human behavior and, more specifically, the investigation of L, R, and T. The basic problem is to determine the essential experimental equipment features that are common denominators and to incorporate these as requirements for a generalized device. In the present study, four analytic approaches were used in accomplishing this task: (1) assessment of the basic psychological L, R, and T paradigm, (2) analysis of equipment features used in related psychological experiments, (3) analysis of system requirements for operational use, and (4) analysis of high-priority Naval Tasks.

Such an approach generally follows that of Parker and Downs (1961) and Miller (1960). In all cases, the selection of effective training apparatus involves matching apparatus characteristics to the human performance studied. The apparatus selected must be the best suited for training subjects and measuring responses in the specific performances required for study. It is also obvious that, in the selection of candidate training devices, the kinds of human performance required by military systems must be evaluated.

Assessment of the Basic Experimental Paradigm

The basic paradigm in any psychological experiment involves a stimulus and the response to that stimulus. To attain scientific status, the stimulus and response variables must necessarily be defined in some measurable quantitative terms so that a meaningful relationship between the two can be determined. In addition, the time element involved in the entire stimulus and response sequence plays an important role, and it is usually measured and controlled in exact terms.

Depending on the classification system, man is credited with numerous senses used to detect the stimuli in his environment. The typical list of used senses includes: vision, audition, taste, olfaction, touch, equilibrium, kinesthesia, pain, temporal and temperature. In the typical L, R, and T situation, most of these senses do not play a dominant role; only three - vision, audition, and touch - are used extensively.

Almost any of man's motor acts can be used, directly or indirectly, to signal a response to a given stimulus. Thus the mechanism used in measuring the stimulus "value" need not be the specific receptor of a specific stimulus. For higher-order response chains such as normally encountered in an L, R, and T situation, this statement is particularly true. The meaning of the motor behavior (i. e., response) is arrived at by mutual agreement between the observer and the subject or else is conventional for the task under consideration. The response must be capable of being recorded and measured by the observer. Practical considerations in theoretical studies, and existing conditions in actual operations, dictate that the fingers, hands, arms and the oral/verbal channels be the most often used.

A similar argument could be presented for the use of "convenient" (and normally used) receptor channels. To study the underlying processes of L, R, and T, esoteric stimuli are neither required nor necessary.

A tentative conclusion is that, in the design of a multipurpose device for the pragmatic study of L, R, and T, the stimulus presentation should concentrate on the visual, tactual and auditory senses. The response modes may safely be limited to oral communication and action by the upper extremities.

Analysis of Equipment and Experiment Features

As a means of verifying this conclusion with specific data and to determine the nature of apparatus used in L, R, and T experiments, a brief survey was made of the relevant psychological literature. Two publications were chosen for sampling, The Journal of Experimental Psychology and Human Factors. The former served to represent "pure" research and the latter "applied" research in the area. Issues circa 1957-1969 were sampled, and 100 experiments related to some aspect of L, R, and T were analyzed. This sampling excluded special training problems in which obviously unique equipment or elaborate simulators were required.

Of the 100 experiments sampled, the stimulus modes used were: visual 66, auditory 24, visual and auditory 7, and tactual 3. The response modes used (Table C1) were: oral 45, manual 45, (fingers, hands and arms), combined oral and manual 3, and physiological measures 6; one was variable (experimenter observation).

Based on this sampling, 97 percent of the experiments used the visual and auditory channels for introducing the stimulus; the remaining 3 percent used the tactile sense. For the subject's responses, 93 percent used oral verbalization and manual action of the upper extremities. In almost all the experiments, instructions were given by voice. All subjects were seated.

The overwhelming preponderance of investigations used visual and auditory modes with verbal and arm/hand responses. This seems consistent with what one finds in real-world tasks. Thus, it is reasonable to extend these stimulus and response modes to L, R, and T research in general.

A different analysis was directed toward extracting the essential features of the various devices used in these studies. A summary of the findings is shown in Table C2. It is apparent that the slide projector is a commonly used piece of apparatus. Its functions are to present a visual image of varying complexity and content on a surface for a defined time interval and sequential order. The stimulus card also serves the same basic function, and this applies to the remainder of the apparatus used to present visual stimuli. The minor differences among them are along the continuum of degree of automation. The only slightly unusual characteristic in the entire list in Table C2 is provided by the tachistoscope; its duration of visual stimulus presentation is 1/5 second or less, and it can present "split images. From an engineering

Table C1. Summary of Response Modes

Frequency	Response Mode	Description
45	Oral	Direct talking with experimenter
45	Manual	Button pushing, writing, drawing, guiding stylus, pointing, turning dial
3	Oral/manual	Combination of above (oral and manual)
6	Physiological measures	Galvanic skin response, electroencephalogram, electroretinogram, etc.
1	Multiple	Observed by experimenter for multiple responses

Table C2. Summary of Stimulus Modes and Prime Apparatus

Frequency	Stimulus Mode	Prime Apparatus/Content
24	Visual	Slide, movie projector
13	Visual	Stimulus card (3X5, 4X6, 8X10)
10	Visual	Memory drum
6	Visual	Light panel bank
4	Visual	Word list
4	Visual	Booklet
3	Visual	Tachistoscope
1	Visual	30-inch stimulus wheel
1	Visual	Dial of ammeter
12	Audio	Sound generator (oscillator, buzzer)
11	Audio	Tape recorder
1	Audio	Verbal (oral) presentation
1	Audio/Visual	Photograph, strobelight, sound tape
1	Audio/Visual	IEE readout, computer, type keys
1	Audio/Visual	Bina Vu display, punch tape
1	Audio/Visual	Buzzer, light bank, stylus, pacer
1	Audio/Visual	Oscilloscope, teaching machine
1	Audio/Visual	Slide projector, polygraph, switch bank
1	Audio/Visual	Oscilloscope, light bank, switch bank
1	Tactile	Rectigraph, dermohmeter, electrode
1	Tactile	Finger vibrator
1	Tactile	Electrode

NOTE: With very few exceptions, instructions to subjects were given verbally, and subjects were seated during the experiment.

standpoint, the conclusion may be drawn that a CRT can perform all of the various functions of these devices for stimulus presentation, with the possible exception of chromaticity.

Considering auditory stimulus presentations, the essential function is the presentation of a sound (i. e., signal) of varying complexity and meaning to the subject for a defined time interval and in some sequential order. Basically, auditory signals have the same parameters as visual signals; i. e., waveform characteristics.

A directory listing the experimental equipment used by the behavioral scientist is supplied by Sidowski (1969) in a "Buyer's Guide." A compendium of this directory, excluding most of the infra-human studies and electro-physical-chemical equipment, is given in Table C3. The only significant additions to Table C2 are the electronics equipment used to record and reduce data and mechanisms used to program and facilitate a given experiment. Thus the actual equipment functions are in close agreement with the foregoing analysis.

The functions performed by various devices are fundamentally simple and quite straightforward. It is only the content of the medium and certain specific mechanisms that differ from one experiment to another. This is the case regardless of the specific theory or the taxonomic scheme (e. g., Willis and Peterson, 1961; Cinsberg, 1966; Fleishman, 1969).

Analysis of System Requirements for Operational Use

In addition to stimulus and response requirements, various operational considerations are also important in the design of a test-trainer device. One consideration is the number of subjects run per experimental session. Studies in which subjects are run one at a time are inefficient. The requirement for running multiple subjects is dictated by conditions in which gaming, cooperative and competitive tactics and strategy are investigated. Admittedly, however, there are occasions when it is desirable to concentrate on one subject at a time. Thus, a desirable feature in equipment and operational design is sufficient flexibility to permit data collection from either single or multiple subjects.

Sometimes the distance of the stimulus from the subject may have to be varied. For this reason, plus the multiple subjects requirement above, the stimulus portion and the response portion of the device should be designed as separable units. These units in turn should be separated from the control unit. Moreover, it is often desirable to preclude undue influence on the subjects by the presence of the experimenter or the control devices.

Another consideration is the physical and sensory differences among individual subjects. Provision for varying the intensity of stimuli input should be included. The design of the device should consider anthropometric variation, e. g., differences in viewing height relative to level of the subject's eyes, seating and the dimensions of the working surface.

Table C3. List of Devices Used by the Behavioral Scientist

Audio/visual, record player	Memory drum
Audiometers	Microphones
Automated instructional systems	Motors, servo, stepping, synchronous
Card punches	Multiplexers, analog, digital
Card readers	Noise generators (oscillator)
Cathode ray tube	Oscillographs
Character recognition equipment	Oscilloscopes
Circuit board, connector, modules	Paper, chart (all types)
Commutators, switching	Paper tape, punches, reader
Computer, general, digital, analog	Photoelectric devices
Computer typewriter and keyboards	Plotters
Connectors	Projectors, film and/or slide
Converters, analog/digital, digital/analog	Readers, photoelectric, tape, card
Converters (magnetic or paper), tape-to-tape, card-to-tape, tape-to-card	Readout indicators and displays
Counters, decoder, readout, stepping	Recorders, chart, event
Curve tracers	Relays
Data loggers, terminal	Signal averaging
Earphones and headsets	Slope reader
Electrodes	Sound equipment
Electroluminescence	Stop watches
Encoders, keyboard	Switches (all kinds)
Eye movement monitors	Tachistoscopes
Film reels	Tape recorders, audio, video
Filters and lenses, optical	Teaching devices, automated
Frequency counters, Discriminator	Television, closed-circuit
Galvanic skin responses (GSR)	Timers (all kinds)
Keyboard encoders, input	Tracking equipment

Control over the process of the experiment is another consideration. Provisions must be made for such factors as the timing of stimulus and response elements, the rate and mode of inputs to the subjects, the presence or absence of feedback to the subject and the recording of responses from the subjects. Provisions must also be made for various pacing techniques, i. e., self-pacing, experimenter pacing, or automatic pacing.

A very important consideration is the accommodation by the experimental equipment for future needs. Therefore, a modular concept is a necessity. Ideally, a defective subsystem should not disable the entire device. In case of failure, the replacement of a module should be simple to accomplish. Space should be provided for equipment additions or modifications to the basic device. The interconnections between modules or units should be easily accomplished and quite flexible.

Analysis of High-Priority Naval Tasks

A list of priority Naval tasks based on Willis and Peterson's (1961) taxonomy is given in Table C4. These tasks involve recall, identification, recognition, detection, decision making, and serial and continuous movement behaviors. Stimuli for all of these tasks can be presented through the visual and auditory channels and responded to by the upper extremities and oral communication. This task list provided another source of data used in the establishment of device design requirements.

Summary

This subsection has presented the major psychological considerations concerning the design of apparatus to be used in the study of L, R, and T. Certain of these considerations concern the basic experimental model while others deal with the type of behavior to be studied using the device. The important questions to be answered in the design of an effective device are:

- Is the equipment appropriate to the tasks for which it will be used?
- Is the equipment easily maintained?
- Does the equipment present stimuli in a sufficient number of modes?
- Can the subject respond to these stimuli in a rapid and economical manner?
- Does the equipment accurately measure the subject's response?
- Is guidance provided which will direct a trainee toward correct responses?
- Is there a provision for reinforcing the trainee for correct responses and successful performance?
- Can the equipment be easily modified to accommodate growth requirements?

Table C4. Priority of Naval Tasks

Tasks (in rank order)	Relation to Navy Jobs
Recalling facts, principles, procedures	Procedure following--Critical to all maintenance jobs and the majority of operational jobs (e.g., aircraft pilot, damage controlman, signalman, technicians).
Recognition/identification--nonverbal cues	Pattern recognition--Includes scope interpretation (radar and sonar operators) and maintenance jobs (recognition of equipment faults).
Detection--nonverbal cues	Vigilance--Detection of targets or radar and sonar displays and detection of equipment malfunctions by operators and maintenance personnel.
Using principles, interpreting, inferring	Elementary logic--Diagnosis of equipment malfunctions by maintenance personnel, ship handling.
Decision making--alternatives known	Diagnosis of complex system malfunctions common to virtually all critical operational jobs.
Decision making--alternatives unspecified or alternatives unknown	Threat evaluation and weapon assignment (command decisions)--also plays a less frequent part in complex system malfunctions for diagnosis.
Static reaction or continuous movement	Gunnery--Maintains proper sight-target relationship and maintenance of welding and soldering tracing tasks (e.g., ship steering and aircraft piloting).
Serial movement	Typing, telegraphy, equipment checkout (e.g., yeoman signalman, electronics maintenance jobs).
Detection identification--verbal cues	Monitoring communications equipment (e.g., signalman, aircraft pilot). Identifying verbal stimuli or cues (e.g., codes, diagrams, symbols, etc.) included in operational jobs (e.g., ECM, signalman, machine accountant etc.) and maintenance jobs (reading schematics).
Positioning movement	Operating controls and material handling (common to most equipment operation and maintenance jobs).
Repetitive movement	Common to jobs requiring manual skills (e.g., carpentry and metal work) and maintenance of equipment (using tools).
Written verbalization	Maintaining logs (quartermaster, pilot), writing instructions (miscellaneous officer's jobs)
Oral verbalization	Verbal communications (pilot, radiomen), giving orders (all officers)
Other verbalization	Use of hand signals and conventionalized signals (e.g., signalman and aviation boatswains mates)

DESIGN AND OPERATIONAL FUNCTIONAL SPECIFICATIONS

Based on the foregoing requirements analyses, the basic functional features of a training and testing device are developed below. For the task of conceptualizing a preliminary design, the functional features of a device are more important than the specific hardware that might be involved. This is because the functional allocations are more amenable to ingenious and imaginative manipulation than is hardware once it is selected.

Presentation Functions

The device shall provide for two basic stimulus modes, visual and audio. Other stimulus modes are of secondary importance and shall be provided for as growth capabilities for future requirements.

Visual Stimulus--The device shall be capable of presenting both still and dynamic visual images. Desirable features are those exhibited by slide projectors, movie projectors, and CRTs. Specifically, the necessary device features are:

- Slide Projector--Zoom lens permitting focusing from 1 to 15 feet; remote focus and control; accommodation of slides of various sizes (35- to 70-mm); large slide capacity tray with random and serial presentation capability; and, ability to introduce an image on a rear-screen at variable range and duration (1/10 second to 15 minutes).
- Movie Projector--Zoom lens permitting focus from 1 to 15 feet; remote control; slow and fast motion capability (12 to 32 fps); and, automatic load and rewind.
- CRT--Color and black and white; sufficient screen size for viewing by subject(s) from 20 feet; resolution equalling a high-quality slide projector; remote control; static and dynamic presentation; and, electronic image generation.

Audio Stimulus--The device should have the capability of presenting pure tones and complex audio messages. Desirable features would be those exhibited by sound generators, tape recorders, and loudspeakers and headphones. Specifically, these necessary device features are:

- Tape Recorder--Large tape-reel capacity (minimum 7-inch diameter); a minimum of two speeds, 7-1/2 and 3-3/4 ips; full fidelity range for recording and playback, 50 Hz to 15 kHz \pm 5 db at 7-1/2 ips and 100 Hz to 9 kHz at \pm 8 db at 3-3/4 ips; possible synchronism with visual presentation; and digital tape counter.

NAVTRADEVCEEN 68-C-0215-1

- Amplifier -- Two channels with 25 watts per channel; 20 Hz to 20 kHz \pm 2 db are desirable; volume and loudness control; balance control; equalization control. The capability for two-channel inputs would permit study of voice communication and pattern recognition (see Rappaport, 1957, 1962, 1963; Giarretto, 1968).
- Sound Generator -- Should be capable of generating discreet and continuous tones as well as white noise over the total frequency range (20 Hz to 20 kHz).
- Loudspeakers -- Two, each with full fidelity range, acoustic suspension type; 35 Hz to 15 kHz; of compact size; and with 25-watt handling capability.
- Headphones -- Stereo type with full fidelity range, 35 Hz to 15 kHz at \pm 5 db.

Response Functions

The subject(s) should be provided with the manual response function capabilities found in a keyboard (or teletype) and/or a pushbutton array, a writing surface (e. g., tablet) and a joystick. A means of oral message transmission must also be available. Necessary devices are:

- Keyboard -- Keys capable of transmitting numbers, letters and signs to form words or phrases.
- Pushbutton Array -- A bank of pushbuttons, variable in number, capable of presenting some (coded) message from one medium to another.
- Tablet -- A flat surface allowing individuals to inscribe writings, drawings, or other graphics.
- Joystick -- A single-stick device permitting cursor control along all points of a surface.
- Microphone -- Either a desk- or headset-type for oral communication.

Control Functions

The experimenter's control over the processes and events of the experiment should be complete and capable of remote execution. Each element involved in stimulus presentation and response treatment should be time controllable with a range from zero seconds to approximately 5 minutes. Variation in timing control would apply to the rate, sequence, duration of both stimulus

and response, from the onset to the termination of the experiment. Presentation may be serial (continuous or intermittent) or random; repeat will be possible. The response of the subject to the stimulus should be readily recorded.

Controlling operations should be programmed and executable by either manual or automated means. Provisions should be made to permit pacing by the subject(s), the experimenter, or an interaction of these persons. The observer should have, at his selection, complete knowledge of the subject's behavior; the observer may or may not allow task feedback to the subject(s) by means of the visual or audio channels.

Design Features

The equipment items of the testing and training device should be designed using a modular concept as a guideline. The stimulus, response and control equipment should be separate units capable of being moved independently of one another. Within each of these units should be provision and space for future additions and modification. Removal and repair should be easily accomplished. Malfunctions in the modules should be easily identified and isolated and should not completely disable the device. Interconnections, wiring and hookups between modules and units should be flexible and easily achieved.

The device design should consider individual differences in various sensory and anthropomorphic attributes. Controls for varying the intensity of various stimuli should be provided. The size and dimensions of the device should accommodate subjects of different physical characteristics. The design should assume that the subject is normally in a seated position.

SPECIFIC DESIGN CONCEPTS

Using the specifications developed, this subsection details the two most salient concepts considered feasible for the job testing and training device.

Concept A - Automated System

Concept A is characterized by automation and the simplicity of the stimulus and response equipment/units. Figures C1, C2, and C3 illustrate the concept.

All visual stimuli can be presented on a single CRT. This is a practicality based on the fact that the CRT can serve all the visual presentation functions enumerated in the preceding section. Audio stimuli are presented through loudspeakers or headphones.

All manual responses are made via a Rand Tablet, or its equivalent, while the oral (verbal) responses are made through a microphone.

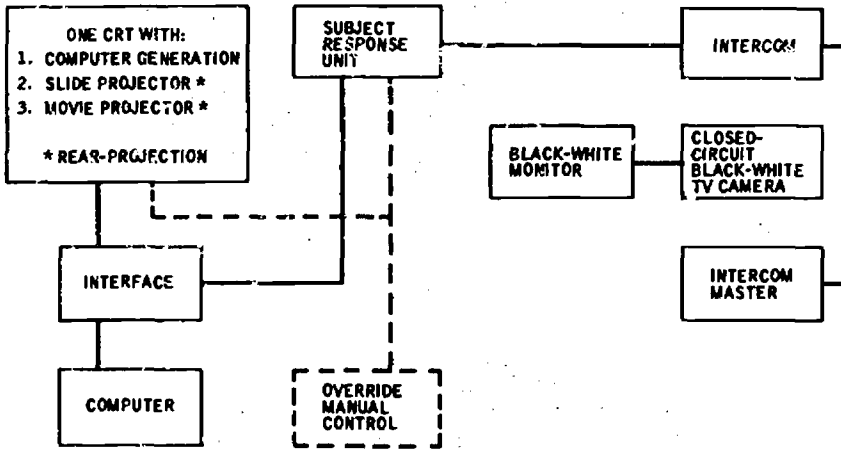

Figure C1. Concept A - Automated System with Rear-Projection CRT and Computer Generation

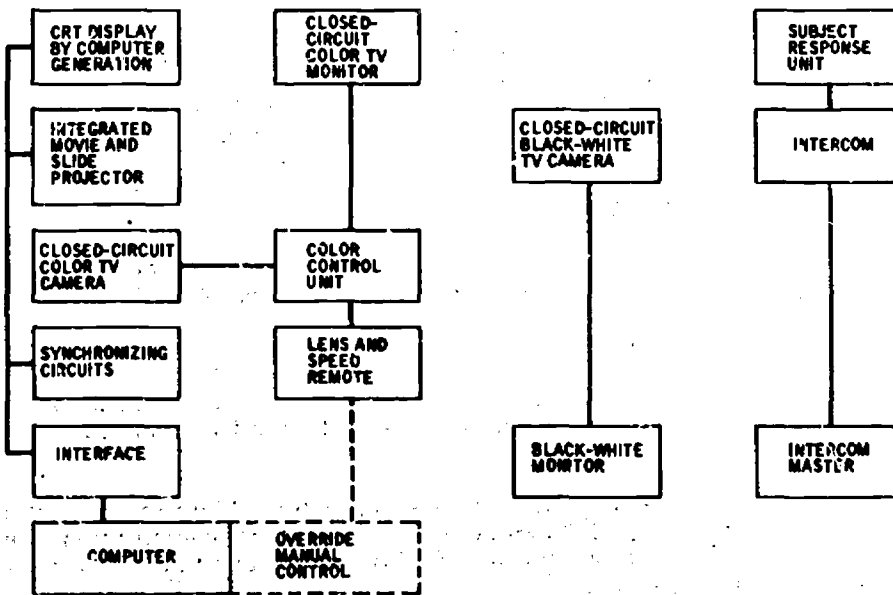

Figure C2. Concept A (Alternate) - Automated System with Closed-Circuit TV

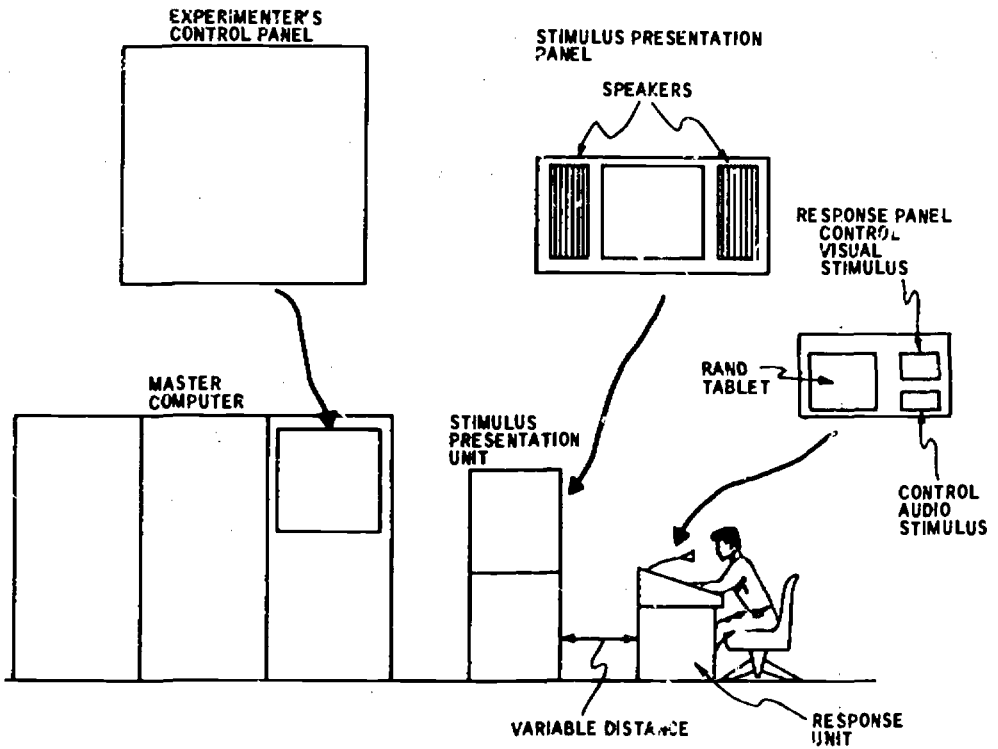

Figure C3. Concept A Component Units

At the heart of the design concept is the computer and its supporting peripheral equipment and software. The observer serves primarily to start the experiment or to select specific tests. The stimulus presentations and response recordings are executed by the computer complex. In this manner, all systems components are interwoven and controlled from a single source. All stimulus items (i. e., various sounds, spoken words, written words, all forms of drawing, sketches and numbers) are programmed and are called up by the computer and presented through the CRT and the speakers (or earphones). The subject's responses, in turn, are directed back to the computer for recording and scoring. On-line and off-line functions are used depending on the experimental design, the length of the experiment, the number of subjects, and the availability of computer time.

Different programs for different experiments would be developed and stored in the computer memory banks (i. e., magnetic tapes, discs, paper tapes, etc.). Over a period of time, an entire library of programs would be accumulated. A specific program would be called up by the observer via a selection keyboard control.

The details of the functions of the features of this design are as follows: Static displays (e. g., background formats such as maps, etc.) and dynamic displays can be placed separately or concurrently on the CRT. This can be accomplished by either of two methods. One method would be the rear-projection of slides on the CRT's surface in conjunction with electronically generated alphanumeric and graphic displays superimposed on the same surface (see pages 89-90 for details). An alternate method would begin with a TV camera taking images directly from a slide projector, movie projector, or some other medium such as a text, a map or an actual scene (see Figure C2). Depending on the source of the images, the background format would be static or moving. Dynamic superimposition would then be added by standard electronic processes. Such a method of visual stimulus presentation can afford almost limitless possibilities for experimental content.

The Rand Tablet, used in conjunction with an electronic stylus similar to a light-pen, is an extremely useful and flexible tool. The tablet can accommodate many types of response data on the x-y coordinate. When properly utilized it can serve a wide range of purposes, for it "communicates" easily with many make of computers (Davis and Ellis, 1964, 1967). The Grafon 1010A is an example in current production and widely used. It measures 10-1/4 by 10-1/4 inches; thus with 100-point resolutions per inch it produces 1024 x 1024 (or 1,048,576) possible points of coded information. In some applications all of these points can be coded and used. However, for many L, R, and T applications lower resolution could be tolerated. When data demands were light, the allocation of 1/2-, 3/4- or 1-inch point resolutions on both the x and the y axis would give 20 x 20, 13 x 13 (approximate) or 10 x 10 information "cells" respectively. A valuable feature of the Rand Tablet is that these individual cells can be coded in many ways. With appropriate software modifications, the tablet can assume the function of many items of response measuring equipment. The tablet may be configured as a keyboard with any arrangement, a pushbutton bank with almost any matrix size, a surface for writing, or any two-dimensional movement performed by a joystick. This

versatility is possible because the computer can sense and respond to coded information in a programmed manner, regardless of whether the signal is coming from a simulator or from the "real" thing. As a result, the Rand Tablet is a highly versatile tool.

The use of transparent plastic overlays further increases the tablet's flexibility. For example, if a keyboard is required in the experiment, an overlay depicting the keyboard can be fabricated and placed over the tablet. With a properly designed program, the area below the overlay can be coded to represent some specific sign, letter, or number. By touching a specific coded area with the stylus, the particular symbol is called out (via the interface) for processing by the computer. A Rand Tablet overlay can have almost any content (e. g., a map to be used for target search or a diagram to be used for circuit analysis).

In addition to the transparent overlay, image projection on the back of the tablet is possible by using a slide projector or a similar device. The possibilities here are also wide in terms of providing response means.

Some of the present uses of the Rand Tablet include: editing text, composing formats, generating forms, designing, sketching and routine digitizing. Handwriting analysis, pattern analysis, tracking, and "3-D" dynamic analysis, are also possible applications.

In addition to the visual stimulus and response features mentioned above, concept A also provides for auditory stimuli and responses. Auditory stimuli are produced by a tape recorder and introduced to the subject through stereo speakers or headphones. The sound input can be adjusted from off to full volume. The stereo speakers are the normally used stimulus channel. Plugging the headphones into the jack cuts off the speakers and switches the sound to the headphones. Oral communication is provided by a microphone mounted on top of the response table; the microphone can be adjusted to any user position by manipulating the gooseneck stand.

By varying the links between subject and observer or between the subjects themselves, various communication and interaction studies can be performed.

In Concept A, even if the experiment involves a dozen or more subjects, the computer can easily record the responses.

Under this concept, the centrality of the control and the unity of the stimulus and response equipment offer numerous possibilities for use other than experimentation on L, R, and T. Using remote linkages, psychological experiments involving the participation of other laboratories are distinct possibilities. It is quite conceivable that an experiment might be conducted with the simultaneous participation of principals which are geographically separated. In this situation, the computer-programmed and -controlled stimulus would be sent out via closed-circuit or other transmission means to a receiver and outputted on a CRT monitor. The responses would be relayed back by similar means to the control center for the necessary processing. This arrangement could be ideal in gaming experiments.

Concept B - Computer Aided System

The details of specific controlling and monitoring functions are discussed under Concept B.

Concept B is characterized by computer-assisted operation under human monitoring with diverse methods for presenting the stimulus and recording the response. Figures C4, C5 and C6 illustrate this concept.

The basic functions described in Concept A are retained, but the methods of execution are different.

Concept A uses a single CRT for all visual presentations. Concept B would use, in addition to a CRT, a slide projector and a movie projector, each with a different presentation surface. The rationale for this is given on page 90.

Instead of using a Rand Tablet for all response inputs, Concept B would use a keyboard, a pushbutton array and a joystick in combination. The experiment-controlling functions are still centralized, but the observer is the prime controller and monitor of the stimulus events. He is aided by the computer in certain selected functions.

Unlike Concept A, an elaborate control console exists whereby the observer selects and generates stimulus inputs to the subject. This console has such modules as a keyboard, a microphone, a bank of switches for selection of program subroutines, control for selecting and manipulating the projectors and the CRT, and a feedback monitor from the subjects (see Figures C5 and C6).

The stimulus presentation mechanisms are housed in three separate bays, one each for the CRT, the slide projector, and the movie projector. A possible variation would use only two bays, with the still and movie projectors integrated into one unit. The CRT would possess static and dynamic image capability, the latter being introduced into the system by observer action with computer assistance.

The subject can make responses using the keyboard, pushbutton array, or joystick. The specific mechanism used would depend on the experimental requirement. Written, syntactical responses would require using the keyboard; a multiple-choice situation could use the pushbutton array; and in a tracking situation the subject would use the joystick. These mechanisms would be activated as required.

The more important control and monitoring functions in Concept B are listed below; numbers correspond to those in Figure C6.

- (1) Clock: Gives real time status to the observer.
- (2) Speaker: Used primarily for communication between observer and subject. Volume control is mounted below the speaker.
- (3) TV Monitor: Used to observe the behavior of the subject(s). Controls for brightness, contrast, focus are located below the CRT.

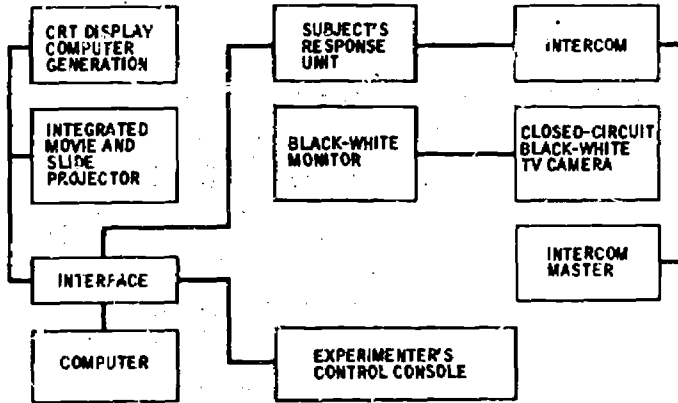

Figure C4. Concept B - Computer-Aided System

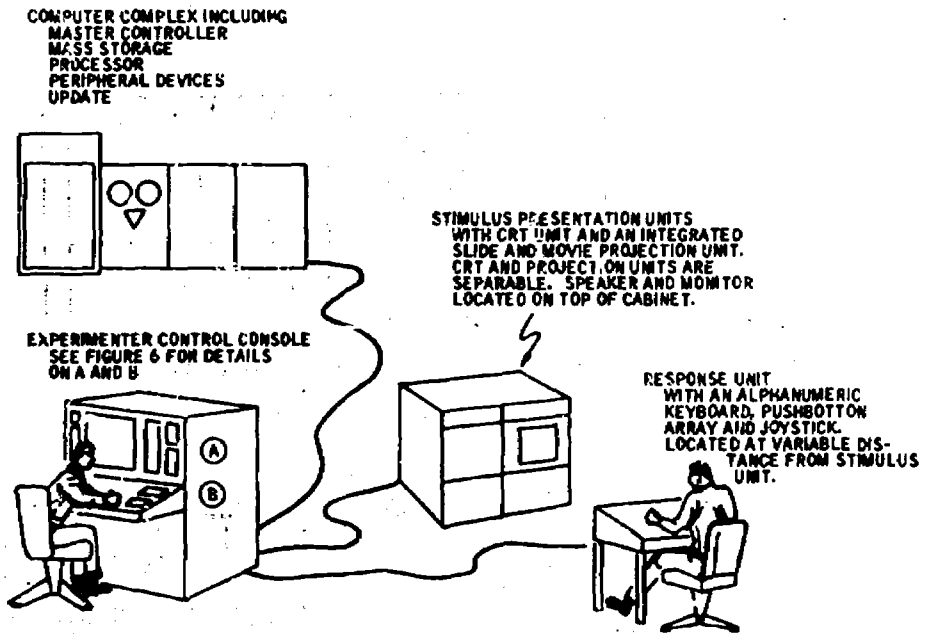
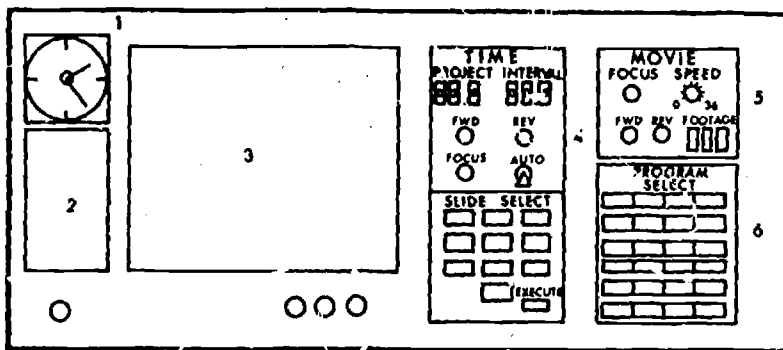
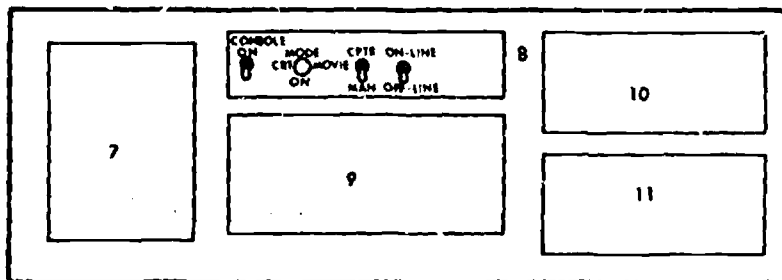

Figure C5. Concept B Component Units



PANEL A



PANEL B

Figure C6. Concept B Controller Panels

NAVTRADEVCCEN 68-C-0215-1

- (4) Slide projection control module. The subcomponents of this module are:
- (a) Time Controls -- Thumbwheels are used to enter the length of time, in seconds, for selected stimuli to be presented as well as the time between presentations. Time interval is selectable between 00.1 and 99.9 seconds.
 - (b) Focus -- The sharpness of the images on the screen can be remotely adjusted. Feedback as to proper focus is obtained by verbal exchange with the subject viewing the image.
 - (c) Fwd and Rev -- This control permits a series of slides to be projected in either a forward or reverse sequence.
 - (d) Auto-Manual -- The "Auto" position allows a sequence of slides to be projected in a programmed sequence. The "Manual" mode permits actuation only by the "Fwd" or "Rev" button each time a new slide is desired.
 - (e) Random Select-Execute -- Allows the random selection of slides with a magazine load. The desired slide is selected by depressing the number buttons; the selected slide is then projected by depressing the "Execute" control.
- (5) Movie projection control module. The subcomponents of this module are:
- (a) Focus -- Used to remotely adjust the sharpness of a moving picture image on a screen. Proper focus is known from feedback given by subject.
 - (b) Speed-fps -- Used to adjust the frame speed from stop to slow to accelerated motion.
 - (c) Fwd and Rev -- This control allows movie images to be projected in a forward or reverse sequence.
 - (d) Footage -- Gives indication of reel status in terms of how much has been projected and how much is remaining. Can be used to select given portions of film by denoting footage position.
- (6) Programmed Mode. Contains a bank of 25 pushbuttons to select and actuate any one of 25 programmed operations.
- (7) Option: Spaces to allow any control addition, e. g., inclusion of a Read Tablet for graphic outputs by the subject.
- (8) Console Control. Located near the center of the console and allows observer to select controls required for operating the system. These are:
- (a) On-Off -- Activates and deactivates the entire system, i. e., the control console, all computer equipment, subject's console, etc.

- (b) Mode Select -- Selects the operation of either the CRT, slide projector or the movie projector.
 - (c) Computer-Manual -- Allows the execution of the experiment to be either computer or manually controlled.
 - (d) On Line-Off Line -- Allows either on-line or off-line input/output operations.
- (9) Alphanumeric Keyboard: Used to enter text material and data to CRT or the computer. Allows program modification and interchange with subjects.
- (10) Option: Space to locate additional controlling or monitoring devices.
- (11) Keyboard: Contains a group of keys to implement off-line functions. Used primarily in computer mode for clearing memory, editing, and relocating inputs.

Other Concepts

Concepts A and B represent the extreme and the middle of a continuum, from full automation to completely manual operations. Variations of these two concepts are, of course, possible and might have advantages for certain specific experimental conditions. For example, the automated scheme (Concept A) can have multiple visual presentation surfaces, or the response may be made using the keyboard, pushbutton or joystick. The manually controlled scheme (Concept B) could use only the CRT for stimulus presentation.

An additional concept would be one of complete manual operation. There would be slide and movie projectors, a memory drum, a tachistoscope, etc., for stimulus presentation. The subjects would respond by writing on paper, or using whatever equipment is supplied. The actual operation of an experiment would have minimum mechanical aids (and cost).

It is immediately apparent that this concept is not worth considering in light of NTDC's needs for conducting research, the complexity of which, must parallel the kinds of tasks performed by the operators of Naval systems. Only simple experiments could be run because the observer would become increasingly overloaded as task complexity increased. Also, without a computer, equipment requirements would change with succeeding investigations, since such changes could not be accommodated by software modification. Finally, it would be virtually impossible to conduct multiple-subject studies.

EQUIPMENT AVAILABILITY AND COST

There are two ways to bring the design concepts into reality. One is to initiate an R&D program to custom design and build all the necessary equipment. A preferable alternative is to search the market for off-the-shelf equipment and integrate these items, as modules, into a functioning system.

Because of the limited scope of this work, the second alternative was chosen to determine the feasibility of the concepts. It appears that system requirements can be met with commercially available equipment.

This section deals with hardware selection. For the most part, the information is based on sales brochures, articles in trade publications and discussions with sales engineers. Hence, the quality, reliability and operability of the hardware have not been verified by actual test. However, engineering judgment and analysis was exercised before they were selected for inclusion in this report. Only major hardware items such as the CRT and related equipment, the slide and movie projector, the Rand Tablet, the keyboard, the joystick, and certain sound equipment items are discussed along with some computer software considerations.

The CRT and Related Equipment

Two types of CRT displays can fulfill the device requirements. These are the raster (spot scanning) and the stroke (controlled motion) methods of display generation.

In general, for display information generation by computer, the picture resolution of rasters is not as high as that of the stroke. The former is used where the static background is very complex and is slowly but continuously updated. In addition the raster CRT display requires more software support than the stroke method.

The raster-type generated CRT color presentation requires a large computer memory to obtain good color resolution for each picture presented. For example, a computer-generated raster color image with a horizontal and vertical resolution of 512 x 512 lines would need a minimum of eight levels of intensity (three bits) for good image definition. Additionally, three bits would be needed for color selection for each element. This would require a total of $512 \times 512 \times 3 \times 3 = 2,359,300$ bits for the display. At a nominal expense of 3 cents per bit, a memory system would cost \$78,000.

When computer display generation using the raster method is compared with the stroke method, the latter is less expensive as far as software is concerned. This is because the stroke method requires, in general, fewer programmed points to generate a given picture.

A typical stroke system capable of alphanumeric CRT display may be obtained from Information Displays, Incorporated. This system is capable of displaying a full-page format of text as well as randomly positioned vector and alphanumeric symbols. Up to 630 alphanumerics or special symbols with a choice of 64 different characters can be displayed on one CRT. Text entry can be made via keyboard or by computer program, with spacing, line advance, carriage return, etc., capability. The CRT display will interface with any type computer as well as with any type of digital system. The equipment is entirely solid-state. This alphanumeric CRT display system is available for \$40,000 to \$80,000 depending on the options chosen.

NAVTRADEVCCEN 68-C-0215-1

An alternate stroke CRT display system capable of displaying 36 alphanumeric symbols in red, green, or blue colors on a 17-inch color display tube is available from Ferranti-Packard Electric Limited. The display console presents stored information sent from a computer located at a remote site. The information is transmitted to the console where it is processed by means of transistorized logic and then stored in a temperature-controlled ferrite-core memory. The display tube will accommodate 20 lines of 20 characters of 3/8-inch dimension with at least a 30 percent adjustability in character height. Price without interface is about \$32,000.

As previously stated, visual presentation using a single CRT can also be accomplished with a closed-circuit TV system. A TV camera takes the desired input from either a slide projector, a movie projector, or a CRT and outputs the presentation on a monitor CRT. It should be noted that, in this case, two CRT's are involved -- the CRT viewed by the subject and the CRT generating the images. The former is a monitor (raster) type with high resolution and does not require complicated software support. The latter is computer operated and does require software support. While it may seem redundant, the latter is necessary for generating static and dynamic displays when either the slide or movie projector can not be used.

The associated TV camera can be operated remotely to swing horizontally to view a desired output display or, at extra cost, electronic switching can be used.

Equipment for synching the CRT display rate and the moving-picture frame rate with the scan rate of the TV camera would also be required, especially with the variable frame rate of the moving picture projector. A closed-circuit TV color system with remote control would cost \$15,000 to \$18,000 and can be obtained from Cohu Electronics, Inc.

Options for rear projection of both slide and moving pictures can be accomplished with either stroke or raster techniques of symbol generation. The rear-projection technique readily lends itself to the stroke method of displaying random vectors and alphanumeric characters on one cathode ray tube. The static image can be projected directly onto the CRT by a computer or manually controlled slide projector. The vector and alphanumeric information can be displayed in color, if desired, by employing a color CRT. A rear-projected alphanumeric, vector display utilizing stroke methods for generating symbols can be more efficiently used in a display mode where the display information is not too complex (e. g., a topographical display) for a background.

A black-and-white rear-projection CRT, in either 7- or 19-inch diameter, may be obtained from Sylvania for \$1600 or \$2500 respectively. A four-color 19-inch CRT may be obtained on special order for \$50,000. Other rear-projection black and white CRT's are available from Westinghouse. A two-rear-window 10-3/4-inch diameter CRT costs approximately \$2,600, a single-window 7-inch model costs \$800. A CRT diameter of 19-inches or larger is probably desirable for L, R, and T usage (Neal, 1968).

For rear projection on a CRT or on a regular screen, slide and movie projector equipment is required.

Slide Projector

There are numerous slide projectors on the market that use an efficient rotary magazine. Two satisfactory types are random-access models manufactured by Kodak and Hoppman Corporation. These instruments can be placed over a Carousel rotary tray with no modification or special tools required, and can call up any slide in any order within 2 seconds. In addition, they have remote focus and forward and reverse controls. Both items cost about \$795.

Another acceptable device that can perform all the above functions is the Selectroslide manufactured by Spindler and Soupe. This unit uses its own specially designed rotary magazine and can handle up to either 48 or 96 slides. The Selectroslide costs \$1596 to \$2422, depending on lens and slide options chosen.

Movie Projector

A movie projector that meets device requirements is the Bell and Howell No. 552. This unit can be remotely operated for focus, rate, on-off, and forward and reverse. It can automatically load film and has a large reel capacity. The cost of the projector is \$770.

Slide and Movie Projector Integration

A console manufactured by the Hoppman Corporation, Model CPS 48, has the capability of displaying both slides and moving pictures on one screen (including a CRT). This unit can do all that the slide and movie projectors mentioned above can do and has additional special features. It can use any other projector with suitable lens and mounting. In addition to 2 x 2 and 3-1/4 x 4-inch slides, this unit can also project 8 x 10-inch transparencies and opaque pictures, and it is relatively easy for the operator to switch from one medium to another. The capability of superimposing two different slides on a screen and the ability to synchronize sound with tape is also included. The screen size can be either 25 x 34, 36 x 48, or 50 x 70 inches, all of which are suitable for use in a multiple-subject run condition (Neal, 1968).

Cost of the CPS 48 with the Bell and Howell No. 552, Kodak AV 900 and special lens is \$4,985. If the Spindler-Soupe unit is substituted for the Kodak unit, \$1,000 to \$1,700 more must be added to the cost. The superimposed image feature costs \$400 for either 2 x 2 or 3-1/4 x 4-inch slides or \$440 for a combination of these two sizes. The sound synchronizer is an additional \$475.

The Hoppman projector and CRT modules are usable for either Concept A or Concept B depending on the method of incorporation. For example, the slide projector can be used with a rear-projection CRT or by itself using a regular screen. The computer-operated CRT can be used as a direct interface with a subject, or it can provide images to a CRT monitor via a TV camera.

The Rand Tablet

The Rand Tablet, one of the manual response mediums, has already been discussed in detail. Two commercial versions, the Galagon 1010A and the 2020, are available from Bolt, Beranek and Newman. The tablet itself sells for about \$9,000. With certain interface and recording equipment the cost is between \$21,000 to \$33,000. A less expensive version is to be available from Sylvania, but no specific data on this system are available at this time.

Keyboard

A self-contained keyboard, with each key coded to a selected specification, is available from Control Research Corporation. Individual keys and integrated circuitry afford complete flexibility in arrangement and number. The keyboard can interface directly with digital printers, CRT display systems, computers or other information storage systems. The standard keyboard generates a coded output in standard seven-bit ASCII format and is available for \$300 to \$400.

Joystick

The joystick can be used to control a cursor or vector on the random vector alphanumeric CRT display for target tracking training. Digital information, in accordance with the direction and force applied to the joystick, is sent to the computer and there processed into commands for the movement of the cursor on the CRT display. A two-axis isometric joystick with such capabilities can be obtained from Measurement Systems, Incorporated, with prices starting at \$1,000. Pulse output circuits for use with digital-controlled equipment and displays are available as extra-cost options.

Sound Equipment Items

The field of sound recording and reproduction offers a wide choice of equipment available for a reasonable price. The overall quality of sound equipment from most of the major manufacturers is high. The selection of the following items for the designed device is representative of equipment in this area:

- **Loudspeakers** -- Many speaker systems are available on the market that meet the fidelity and power handling requirements specified. The acoustic suspension types are most desirable, primarily because of their compact size. Manufacturers such as Acoustic Research (AR) and KLH have several acceptable models. The AR-3 is recommended and costs about \$225.
- **Headphones** -- As with loudspeaker systems, there are many high-quality headphones on the market that meet design requirements. Most of the headphones costing over \$25 from reputable makers such as Koss, Telex and Superex are acceptable.

NAVTRADEVCEEN 68-C-0215-1

- Amplifier -- Stereo amplifiers with 25 watts, or more, per channel are desirable for driving the acoustic-suspension-type speakers or for use with multiple speakers. Acceptable amplifiers for the device are: Sherwood S9500BS at \$190, Scott 299F at \$180, or the AR 120 at \$225.
- Tape Deck -- The tape deck can be used with the pre-amp features of the above amplifiers. The versatile, three-speed models such as the Sony 560-D at \$300 or the Ampex 1450, also at \$300, are acceptable.

Other Items

Two-way telephone communications between subject and observer can be provided by an intercom system. The observer should be able to communicate with as many as 30 subjects simultaneously or independently. The typical cost for a communications system is \$270 for one master station and 10 substations; more stations can be provided at extra cost.

The observer can view his subject's physical reactions by employing an inexpensive closed-circuit television system. Since exceptional TV picture resolution is not needed, a commercial black and white TV receiver can be used with a closed circuit TV camera that has an RF output. The Vidicon camera, which would be acceptable, costs about \$300. The monitor sells for an additional \$355. The mounting hardware required is not included in these prices.

Engineering time and effort would be required to totally integrate all the modules into a working unit. These costs would add substantially to the overall expenditure.

A control console which would allow an experimenter to make stimulus inputs and otherwise interface with subjects is required for Concept B. This console would require rather extensive design effort.

TRADEOFF CONSIDERATIONS

This subsection evaluates the two design concepts by considering such factors as inherent value, cost, engineering constraints, and practicality.

Advantages and Disadvantages

Concept A -- Concept A has several inter-related attributes which make it attractive. These are: a high degree of experimental control; ease of operation; and flexibility of use. These attributes will be discussed in detail.

The positive features of Concept A are:

NAVTRADEVCEEN 68-C-0215-1

- Experimental Control -- The experimenter has a superior arrangement in terms of equipment and the running of his studies. By careful planning and programming, all relevant variables affecting stimulus and response ... the timing, the quality and quantity of input and output, the recording of data, etc., are precisely controlled and executed. This high degree of precision is not achieved with other approaches.

An experiment that is completely programmed and computer executed provides a constant, invariable condition to all subjects. This minimizes, if not eliminates, many extraneous and undesirable influences which are usually present. The human experimenter can make errors in presenting the stimulus; he can unintentionally deviate from a standard testing procedure; or he may unknowingly communicate hints or cues to subjects. Subtle personal interaction between experimenter and subject can easily affect the outcome of an experiment.

- Ease of Operation -- Concept A minimizes the task loading on the observer. The automation of stimulus presentation, experimental sequencing, and response recording frees the observer to focus his attention upon the essence of the experiment rather than be concerned with mechanical operations.
- Flexibility of Use -- Within the framework of L, R, and T experiments, there are numerous possibilities for studies using the given basic equipment. For example, the possibility of setting up a wide network of participants in various geographical regions is worth considering seriously. Beyond L, R, and T studies, the basic apparatus could also be used for any experiments requiring the stimulus and response modes described.

Concept A also has its liabilities. Although the described system is possible to implement, the realization of its potential could be extremely costly, difficult to support, and not as reliable as desired:

- Cost -- In addition to the basic cost of the equipment, Concept A has a high software cost factor. The writing of a simple computer program usually takes about a week including various debugging. The present rate for programming varies from about \$350 (for programmer technician) to about \$1500 (for consultant) per 40 hours of work. A complex program can take months to complete and involve many people.
- Difficulty of Software Support -- A basic rule of thumb is that the more complex the experiment or the less structured the response conditions, the more software or programming

required. Concept A is almost totally dependent on high quality programming. Without it, the system will not work.

For example, the simple requirement for projecting a sequence of images on the CRT screen necessitates, among other things, a logic for projector interrupt to projector output data routine. Since the timing of the projected sequence is important, the incorporation of an internal programmed time clock or the intervention of a real-time clock is needed. The program has to be tied in precisely with the terminal equipment and other supportive devices.

The requirement for recording the responses from subjects must also be considered. Among other things an analysis of the various characteristics of the response is needed; the requirements as to whether to record the incoming response data on magnetic tape or to temporarily store it in memory has to be investigated and coordinated with on-line and off-line functions. Thus, the programming requirement for response recording is complicated. This complexity is increased many-fold if programming includes dynamic interactive responses such as are found in decision-making tasks.

Therefore, the acquisition of a workable program can be involved and complicated. A completely thorough analysis of the experimental situation is needed and all contingencies must be accounted for and dealt with correctly for the concept's potential to be realized.

- Reliability -- The fact that only a single stimulus surface and a single response unit are used imposes a high reliability requirement on the equipment. If either one fails the system becomes inoperable. Even the highly reliable modern electro-mechanical components do fail at times. This can be a serious problem if there is no provision for "spare" or redundant modules in the system.

Concept B -- Concept B represents a compromise between automatic and manual control which gives this design certain virtues and faults. The main advantages of Concept B are as follows:

- Programming -- One of the prime advantages of Concept B is that it is not totally dependent on perfected computer programming (and automation). The observer can introduce and manipulate stimulus inputs at will from his control console. He has greater freedom and flexibility within the experimental environment.
- Cost -- The equipment in Concept B would be less expensive than for Concept A. There are fewer items (e. g., the closed-circuit TV system for stimulus presentation would be eliminated), and the items that are used are less sophisticated. The

amount and complexity of software is not as great. The reduction in costs -- from the standpoint of time and effort -- would be significant.

- Reliability -- The fact that multiple stimulus and response equipment are used offers alternatives to the observer who is controlling the experiment. If one module fails there are still others available for use.

The primary disadvantage of Concept B is that the execution of experiments would not have the degree of precision found with complete programming and automation. Neither would it have the consistency of experimental conditions from one subject to another. The frailties of the human observer might possibly enter into the experiment.

Other Considerations

The above are the major advantages and disadvantages of Concepts A and B. To a large extent, these considerations are theoretical and general. (This statement also applies to the details of the systems in other sections). To make either concept a reality requires more practical considerations, all of which can be reduced to one main factor -- cost.

The basic types of equipment for possible use for each of the concepts have been enumerated. For Concept A, the cost ranges between approximately \$74,000 and \$189,000; for B, the range is \$45,000 to \$91,000. For both concepts, the difference in the price reflects selecting extremes among the equipment options available. For example, the higher price for both A and B includes an expensive special-order 19-inch color CRT with rear projection; the lower price includes a regular 19-inch black and white type (\$50,000 versus \$2,500). For Concept A, the higher price includes a large Rand tablet plus much peripheral equipment, while the lower price has a small Rand Tablet with only the essential interface equipment (\$35,000 versus \$21,000).

Yet these prices alone do not tell the full story. It would be erroneous to believe that by investing these sums either of the conceptualized systems could be obtained. The money would merely buy the basic, essential mechanisms required for the multiple-purpose device.

The true cost would depend on the approach taken to actualize the concept. Two approaches could be taken: One would be to purchase the off-the-shelf items and build them into an operating system. In this case, additional money would be needed for cabinetry and equipment housing, engineering packaging of the hardware, logic design for the control and actuation of all the equipment, and systems integration. The other approach would undertake an engineering project to achieve a custom-built system. The task would include provision for detailed specifications, performing the necessary research and development, designing the equipment, and building the designed equipment.

It is difficult to estimate the cost for this second approach, but it would be much higher than the first.

Implicit in the operation of either system A or B is the computer and its necessary peripheral equipment. The computer system would, of course, not be a cost factor if this were already available. To acquire the basic system, however, even with a relatively slow speed and small memory capacity, the cost would be about \$30,000. The Honeywell 316, with a speed of 3.0 microseconds and memory capacity of 4K, including paper tape punch, paper tape reader, card reader and teletype equipment is in this price range. Higher speed and a larger memory capacity would be more expensive. The Honeywell 516, working at 0.9 microsecond would cost an additional \$15,000. Additional memory costs about \$8,000 per 4K. Thus a basic computer system with 20K of memory would cost between \$60,000 and \$75,000.

In all likelihood, the software support required to operate the system would cost more than the hardware. Good programming requires long hours of careful planning, analysis, writing and debugging. The greater the degree of automation, the greater the requirement for comprehensive programming. If automation or semi-automation is adopted for the multipurpose device, then programming is a constant recurring cost in the system.

SUMMARY AND RECOMMENDATION

The purpose of this task was to develop conceptually a multipurpose device for the experimental study of learning, retention, and transfer. The basic requirements for psychological experimentation were examined, and the functional features of the device were enumerated.

It is apparent that, to substantially improve upon a mere "collection" of mechanical devices, some degree of computer-assistance is desirable and necessary. Two major concepts were developed, one essentially automated and the other a combination of manual and automatic operation.

From a conceptual point of view, the automated version would be the ideal way to perform experiments. However, to achieve this goal might push the present state-of-the-art. There are still limitations in computer software and hardware.

Thus, the combination of automatic and manual operation is more practical and more easily attainable. Concept B would have a significantly lower procurement and operating cost. Operations of the device would not be totally dependent on "perfect" programming, for a human operator can back up the computer when necessary.

In Concept B, the two-bay method of presenting visual stimuli is preferable to the three-bay method. One bay would be used for the CRT and the other bay would be used for the slide-movie projector combination. It is also recommended that a Rand Tablet be added to the system as soon as possible.

Components for this system are listed in Table C5. Also included are cost figures, part numbers and the supplier's name. The cost of integrating all these components into a specific system was not estimated.

REFERENCES

Carlson, R. D., Computer Graphics and Manufacturing. Information Display, 1969, Jan/Feb. 6 (1) 48-52.

Davis, M. R., Ellis, T. O., The Rand Tablet: A man-machine graphic communication device. AFIPS Conference Proceedings, Vol. 26, 1964, Fall Joint Computer Conference, San Francisco, Calif.

Davis, M. R., Ellis, T. O., The Rand Tablet: A man-machine graphic communication device. Information Display, 1967, 4 (4), 85-90.

Decision Sciences Laboratory, Electronic Systems Division, AFSC, USAF. Development of Techniques for the Automatic Control of Experiments in a Psychology Laboratory. Technical Documentary Report Number ESD-TDR-4 65-175. February 1965.

Fleishman, E. A., Performance Assessment based on an empirically derived taxonomy. Human Factors, 1967, 9 (4), 349-365.

Giarretto, H., The effect of stereoscopy on the recognition of patterns in visual noise. Human Factors, 1968, 10 (5), 513-522.

Ginsberg, Rose, McCullers, J. C., Meryman, J. J., Thomson, C. W. and Witte, R. S., A review of efforts to organize information about human learning, transfer, and retention. AMRL-TR-66-23, Wright-Patterson AFB, Ohio, 1966, Mar.

Miller, R. B. Task and Part Task Trainers and Training. WADD Technical Report 60-479. June 1960.

Neal, A. S., Legibility requirements for educational television. Information Display. July/Aug. 1968, 5 (4), 39-44.

Parker, J. F., Jr. and Downs, J. E. Selection of Training Media, ASD Technical Report 61-473, September 1961.

Rappaport, M., The role of redundancy in the discrimination of visual forms. Journal of Experimental Psychology, 1957, 53, 3-10.

Rappaport, M., Two ears - but simultaneous messages. Paper presented at 7th Annual Human Factors Society Meeting, 1963.

Rappaport, M. A., A method of increasing voice communication channels. SRI Project No. 1M-3711-600, Palo Alto, Calif., Stanford Research Institute 1962.

NAVTRADEVCEEN 68-C-0215-1

Sidowski, Joseph B., Buyer's Guide. American Psychologist, Mar., 1969, 24 (3), 309-334.

Willis, M. P., and Peterson, R. O., Deriving training device implications from learning theory principles. Vol. II: Methodology, Technical Reports: NAVTRADEVCEEN 784-2, Port Washington, N. Y., 1961.

Willis, M. P. and Peterson, R. O., Deriving training device implications from learning theory principles. Vol. I: Guidelines for training device design development and use. Technical Report: NAVTRADEVCEEN 784-1, Port Washington, N. Y., 1961.

APPENDIX D
TASK ANALYSIS FOR IDEAL SYSTEM OPERATION

A task analysis was performed which served as the basis for specifying the steps involved in ideal operation of the communication system. This analysis is diagrammed on the following pages.

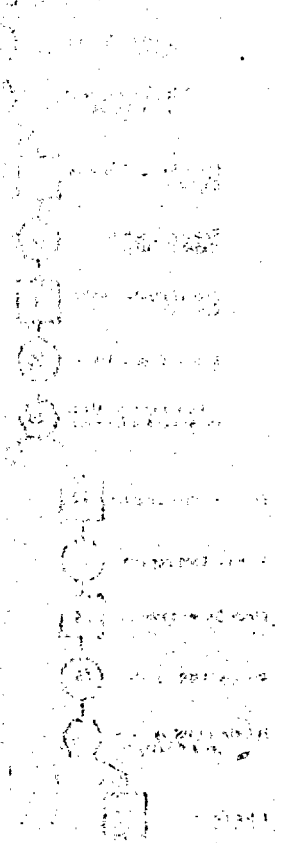

NAVTRADEVEN 68-C-0215-1

ROUTINE I (S-S)

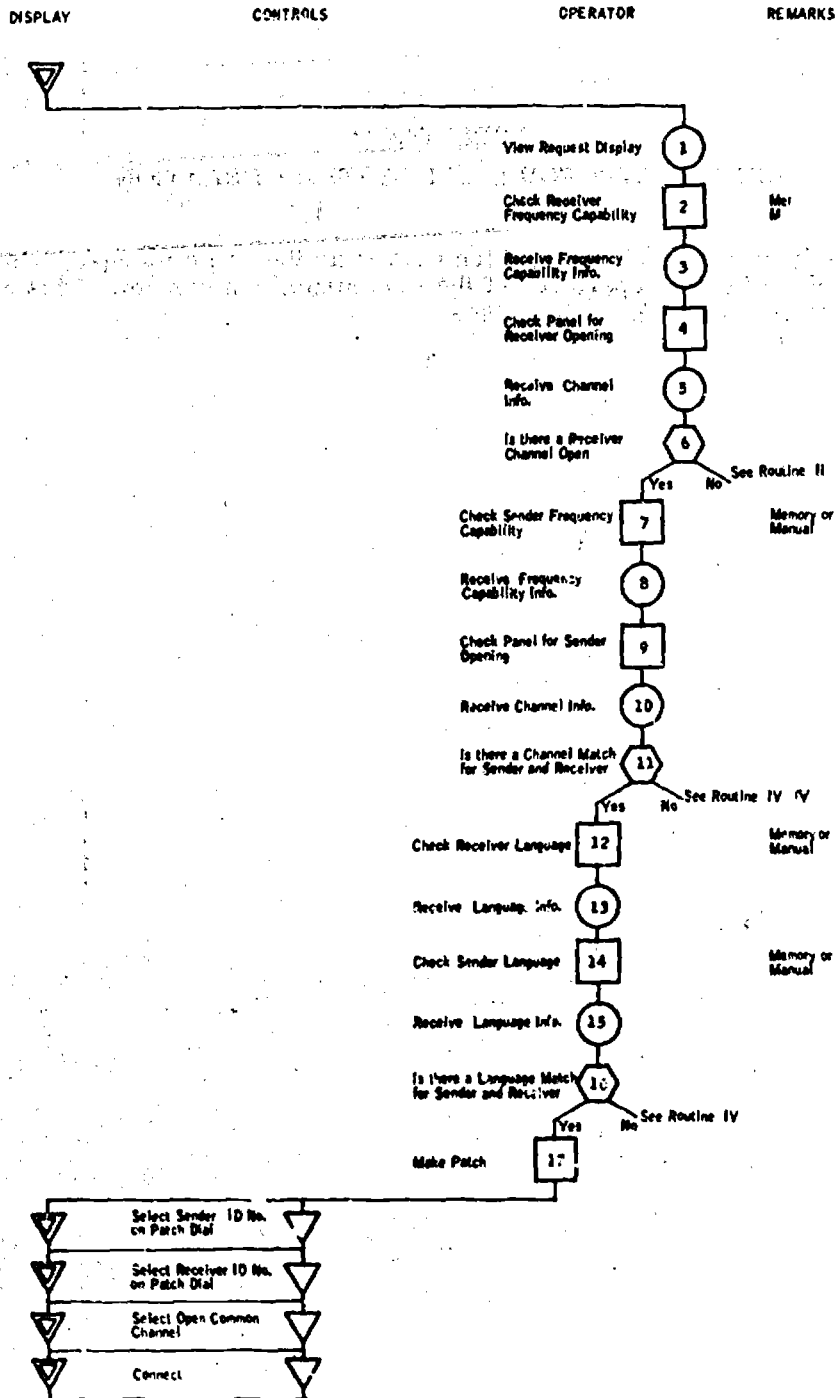

002

102

108

APPENDIX E

MANUAL OF INSTRUCTIONS - EXPERIMENT I

INTRODUCTION

This experiment is the first in a series of studies investigating ways to improve training of complex-system operators.

You will be asked to learn to operate a communications system similar in some ways to that used in worldwide communication networks. Your task, as an operator, will be to man the Communications Control Console (CCC), which is the hub of the communications system.

The purpose of the communications system is to enable a group of communication facilities or Subscribers, located at relatively great distances from one another, to transmit and receive messages among themselves. Because of the distances involved and the limited range of each subscriber's radio equipment, the CCC is necessary to provide signal boosting or amplification. In other words, all messages from one subscriber to another must pass through the CCC. When the CCC is involved only for amplification, the communication routine will be referred to as SUBSCRIBER to SUBSCRIBER (S-S).

However, not all transmissions can be made in such a simple manner. Because there are variations in the type of radio equipment (frequency) used by the subscribers, it is not always possible for one subscriber to receive messages from another's transmitter. In these cases it is mandatory that the originator of the message send it to the CCC on the originating subscriber's

frequency. It must then be transmitted from the CCC to the receiving subscriber, on the latter's frequency. This process occurs in two discrete steps; i. e., Sender to CCC and CCC to Receiver. This more complex form of communication will be referred to as SUBSCRIBER to TERMINAL to SUBSCRIBER (S-T-S).

In addition to frequency disparity, there are sometimes cases where two communicating Subscribers employ different languages. When instances of language disparity occur it is also necessary to employ the S-T-S mode of operation. The identical S-T-S routine is used to overcome both language and frequency disparities. In fact, it is sometimes the case that both types of disparity are present. Remember, the important thing is that processing of the message at the CCC is necessary before it can be relayed to the receiver. However, you need not be concerned with just how the processing takes place; but only with the fact that two steps are involved in communicating in the S-T-S mode.

A third mode of operation is sometimes used. This mode is necessary because there is only a limited number of channels on which subscribers can receive messages. When a subscriber requests that he communicate with another subscriber, through the CCC, and all channels usable by the receiving subscriber are occupied, the console operator must determine whether the present message is of a higher priority than any of those currently occupying usable channels. When the incoming message is of higher priority, one of the channels must be opened. This requires that the operator interrupt some lower priority communication. Interrupting a channel merely opens that channel to the receiver. The interrupt routine is used in conjunction with either the S-S or S-T-S routine.

Finally, there sometimes exists the situation where all usable channels are occupied with equal or higher priority communications than that being requested. In this case the CCC operator must inform the requesting

subscriber that he must wait to transmit. This is accomplished in two ways, depending upon the priority of the requested message.

During training you will have access to all materials, procedures, and rules. You should try to master these during training so that you will refer to them as little as possible in the later testing session. Scoring is based on both accuracy and time needed to complete the communications link, which is called a patch, so it is to your benefit not to have to refer to the reference materials during the testing session.

There will be two phases of training. In the first, you will be given time to learn some of the rules and procedures of the communication system. You will also be given the list of subscribers, the language of each, and his frequency capabilities to study.

In the second training phase, you will be given some practice problems with assistance from the experimenter, if necessary. Then you will do 30 problems on your own.

During the final session, you will be given 30 additional problems of the same type to do on the communication console.

GENERAL SYSTEM CHARACTERISTICS

The Communications Control Console is the device which makes possible the patching of one subscriber to another so that they can communicate. The console has five channels on each broadcast frequency: High Frequency (HF), Very High Frequency (VHF), and Ultra High Frequency (UHF). Some subscribers have only one frequency capability, some have two, and some have all three capabilities.

Each subscriber communicates in only one language: English, German, Spanish, Greek, or Swedish.

When a subscriber requests that a patch be made between him (Sender) and another subscriber (Receiver), he places a priority on his communications request. Priority One is extremely urgent and must be patched if at all possible. Priority Two is very important but not urgent. Priority Three is used for routine communications which should be completed but can wait if necessary.

These three factors, Frequency, Language, and Priority, must be considered each and every time you make a patch between sender and receiver. Tables summarizing the rules associated with these three factors are provided. Table 1 (page) gives the frequency rules; Table 2 (page) the language rules; and Table 3 (page) the priority rules.

At the left of the CCC are three transilluminated panels. The top panel displays the SENDER identification number, the middle one displays the RECEIVER identification number, and the bottom panel displays the priority of the call currently being requested.

NAVTRADEVCCEN 68-C-0215-1

The center of the CCC contains frequency and channel information. The top row of switch-lights are frequency selectors. When activated, each switch selects a frequency; either HF, VHF, or UHF. In the unactivated position, the top half of the indicator is illuminated. When activated, both top and bottom are illuminated. These switches called Frequency Selectors, are to be used to link a SENDER to the TERMINAL (console operator) or to link the TERMINAL to the SENDER.

Below the frequency selectors are the three columns of channel selectors for HF, VHF, and UHF communication. These switch-lights serve two functions. First, they are used to select a channel through which a communication to a receiver is made. Second, they provide information about which channels are currently in use and the priorities of these messages. Priority information is provided according to the following color code:

- Red - A PRIORITY 1 message is currently occupying the channel
- Green - A PRIORITY 2 message is currently occupying the channel
- White - A PRIORITY 3 message is currently occupying the channel
- No illumination - Channel unoccupied

The upper right section of the panel contains the PATCHING DIALS. These are two rotary switches which are numbered clockwise from 0 to 31. Lettering on the panel is in units of 5, but there is a switch position for all numbers zero through 31. The left dial connects the SENDER and the right dial connects the RECEIVER.

NAVTRADEVGEN 68-C-0215-1

Below the patching dials are three OUTPUT SIGNAL switches, BUSY, STANDEY, and CONNECT. They are illuminated in the top half when the switches are not activated and wholly illuminated when activated.

Below the OUTPUT SIGNAL switches is a TRANSMIT signal pushbutton. After you have selected an output signal, you must always activate the transmit signal pushbutton.

During the presentation of problems, you will have access to all necessary information. This information is contained on 35 mm slides. You will notice that a slide selector is located on the shelf before you. Above the CCC is a screen which displays the selected slide. I will now demonstrate the use of the information display.

OPERATIONAL REQUIREMENTS

SUBSCRIBER TO SUBSCRIBER

The simplest and most straightforward mode of communication is S-S. This mode can be used only if all the following conditions pertain:

1. There is a common language
 2. There is a common frequency
 3. There is an open channel on the common frequency
-

SUBSCRIBER TO TERMINAL TO SUBSCRIBER

The communication must be processed S-T-S, if any of the following conditions exist:

1. There is a language disparity
 2. There is a frequency disparity
 3. There is an open channel within the receiver's capability, but not the sender's.
-

CHANNEL CLEARING

The Interrupt routine is used when both of the following conditions exist:

1. There is no open channel within the receiver's capability

2. There is at least one channel usable by the receiver which is occupied by a lower priority message.
-

COMMUNICATION REQUEST DENIAL

A communications patch cannot be made and the incoming request is denied if both of the following conditions are present:

1. There is no open channel within the receiver's frequency capability; and
2. All channels within the receiver's frequency capability are occupied with messages of equal or higher priority.

PROCEDURES

To process a communication request, the Operator must decide which mode and which procedure to use.

To make a simple S-S patch, the Operator executes the following routine:

1. Select **SENDER Identification Number (ID)** on the left **PATCHING DIAL**
 2. Select **RECEIVER ID** on right **PATCHING DIAL**
 3. Select an appropriate **CHANNEL**
 4. Activate **CONNECT OUTPUT SIGNAL**
 5. Activate **TRANSMIT** signal
-

S-T-S ROUTINE

To make an S-T-S patch, the Operator must:

1. Select **SENDER ID** on left **PATCHING DIAL**
2. Select position 1 on right **PATCHING DIAL**
3. Select a **FREQUENCY** within sender's capability
4. Activate **CONNECT OUTPUT SIGNAL**
5. Wait for **CONNECT** light to go off
6. Select position 1 on left **PATCHING DIAL**
7. Select receiver ID on right **PATCHING DIAL**
8. Select an appropriate **CHANNEL**

9. Activate CONNECT OUTPUT SIGNAL
 10. Activate TRANSMIT signal
-

CHANNEL CLEARING ROUTINE

To interrupt a channel, the Operator uses the following routine:

1. Select position 30 on both PATCHING DIALS
 2. Select CHANNEL to be interrupted
 3. Activate BUSY or STANDBY OUTPUT SIGNAL depending on the priority of the interrupted channel
 4. Wait for CHANNEL to be opened
 5. Activate TRANSMIT signal
-

COMMUNICATION REQUEST DENIAL ROUTINE

To deny a communication request:

1. Select position 1 on left PATCHING DIAL
2. Select sender ID on right PATCHING DIAL
3. Select any FREQUENCY within sender's capability
- 4a. Activate STANDBY OUTPUT SIGNAL if sender's request was Priority 1 or Priority 2
- 4b. Activate BUSY OUTPUT SIGNAL if sender's request was Priority 3
5. Activate TRANSMIT signal

TABLE 1
FREQUENCY RULES

1. Subscribers can communicate directly (S-S) only on channels common to both parties.
2. If there is no open channel common to both, go to S-T-S mode. (See Priority Rules.)
3. If common channels are in use and cannot be interrupted (See Priority Rules) and there is no open channel usable by the receiving subscriber, a patch cannot be made and the sender's request is denied. (See Priority Rules.)
4. If channels are open on more than one usable frequency, use a channel on the least-occupied frequency.

TABLE 2
LANGUAGE RULES

1. Subscribers can communicate directly (S-S) only in a common language.
2. If there is no common language, the message must be translated (S-T-S).

TABLE 3
PRIORITY RULES

PRIORITY (P-1) MESSAGE

- If all channels within the receiver's capability are filled with P-1, deny sender's request and place sender on STANDBY.
- If all channels are filled with P-1 and/or P-2, interrupt the uppermost P-2 and then proceed with the patch.
- If all channels are filled with P-1, P-2, and/or P-3, interrupt the uppermost P-3 and then proceed with the patch.

PRIORITY (P-2) MESSAGE

- If all channels are filled with P-1 and/or P-2, deny sender's request and place sender on STANDBY.
- If all channels are filled with P-1, P-2, and/or P-3, interrupt the uppermost P-3 and then proceed with the patch.

PRIORITY (P-3) MESSAGE

- If all channels are filled, deny sender's request and place sender on BUSY.

FINAL OPERATING INSTRUCTIONS

The initiation of a communication problem is signalled by the onset of the various indicators on the CCC panel. Your task is to process or deny each communication request as rapidly as possible, consistent with very high levels of accuracy. Your performance will be evaluated in terms of the average time required to complete each problem. Although you will be paid a minimum of two dollars per hour, you can earn as much as four dollars per hour by operating at highest levels of performance. It is vital that each communication be processed without errors, but you should not delay unnecessarily.

We are very much aware that your task in this experiment is very complex. The high difficulty thereby produced is necessary in order to adequately simulate the kinds of jobs performed by equipment operators in actual systems. Therefore, you must make an attempt to grasp the basic function of the system rather than simply memorizing rules and procedures. Do not hesitate to look up information until you are very confident that you have this knowledge.

During the presentation of problems, you will have access to all necessary information. This information is contained on 35-mm slides. You will notice that a slide selector is located on the shelf before you. Above the CCC is a screen which displays the selected slide. I will now demonstrate the use of the information display.

Before the presentation of each problem, I will say "ready". If there are no questions at this time, we will begin the first problem - - - - READY.

APPENDIX F
IMAGERY SEQUENCES

As part of Experiment II, 35-mm slides were prepared which depicted, in cartoon form, sequences of activities involved in air travel which were analogous to the transmission of messages from one subscriber to another. These imagery sequences, identified by the slide numbers called out in the manuals of instruction (Appendix G), are shown on the following pages.

NAVTRADEV CEN 68-C-0215-1



124

122

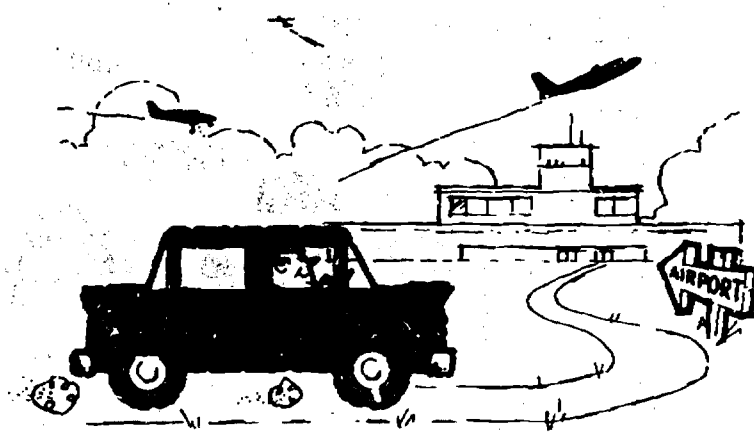

Slide 41

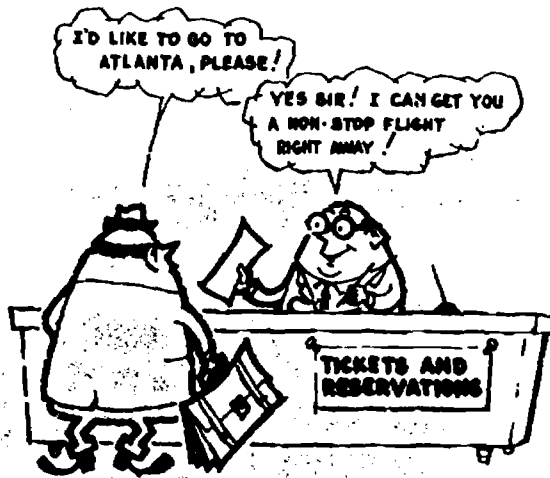

Slide 42

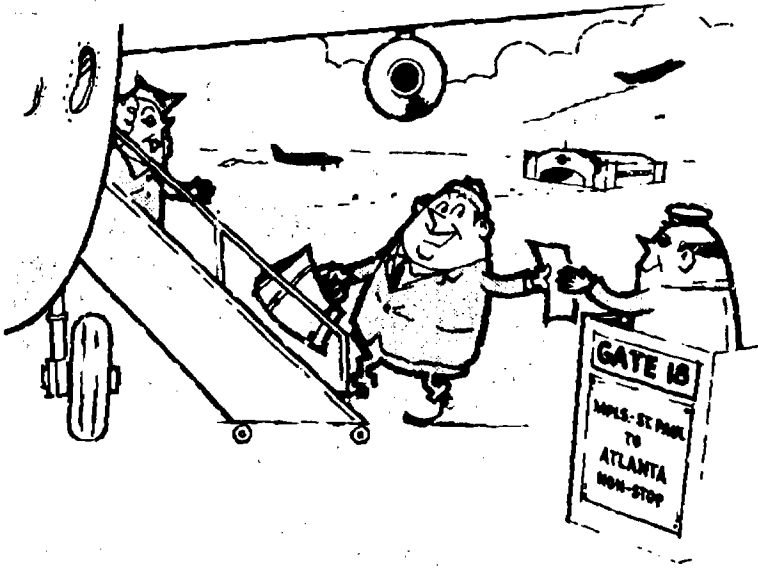

Slide 43

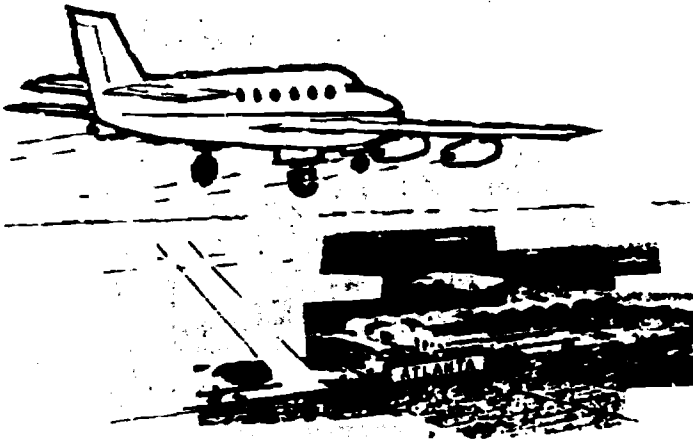

Slide 44

NAVTRADEVCEEN 68-C-0215-1



127

128



Slide 45

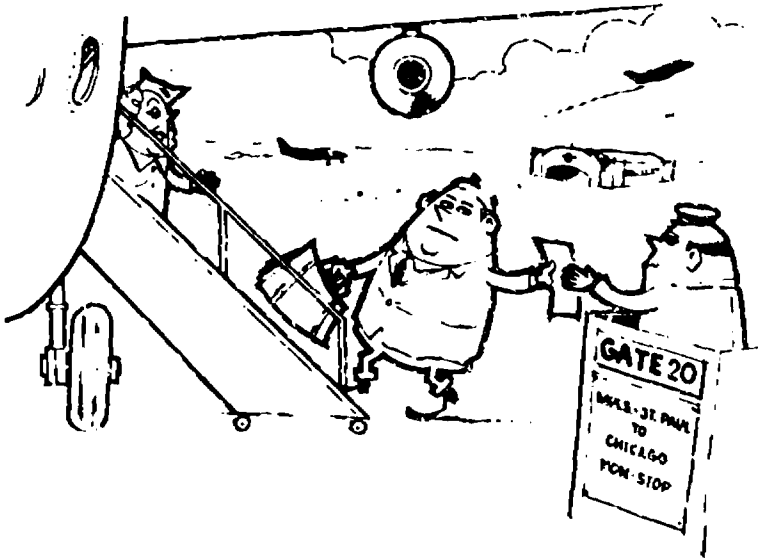

Slide 46

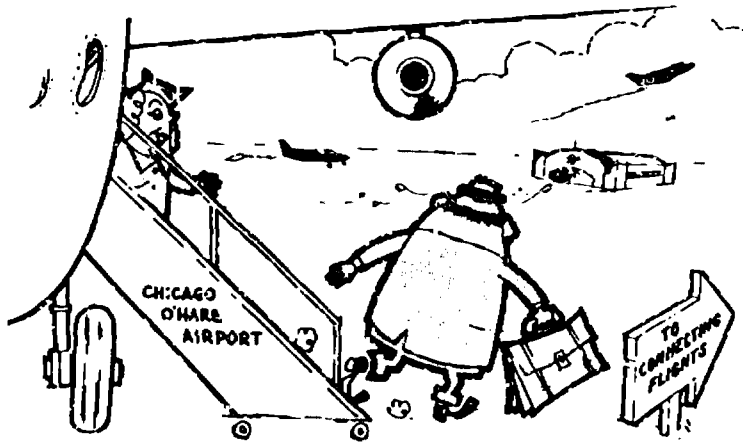

Slide 47

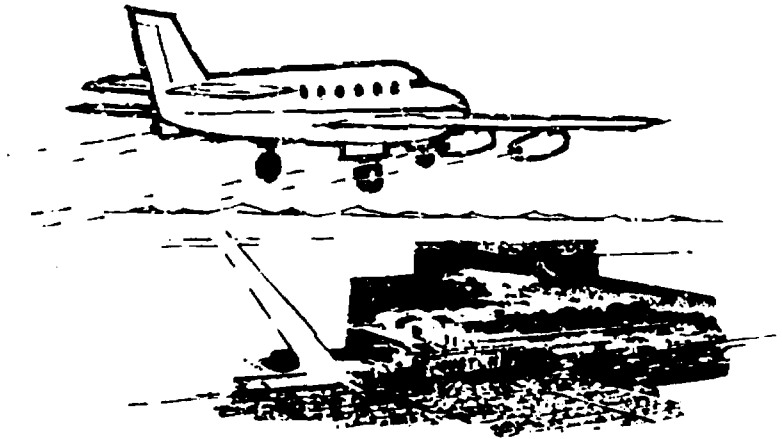

Slide 48

NAVTRADEVCEEN 68-C-0215-1

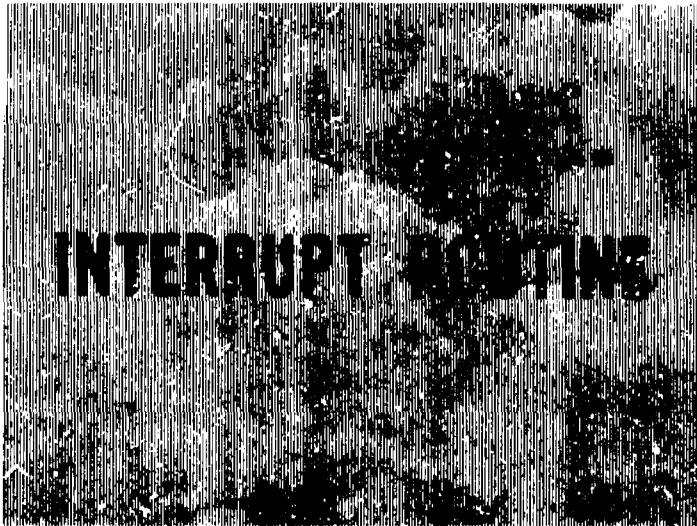

130ⁱ
128



Slide 49

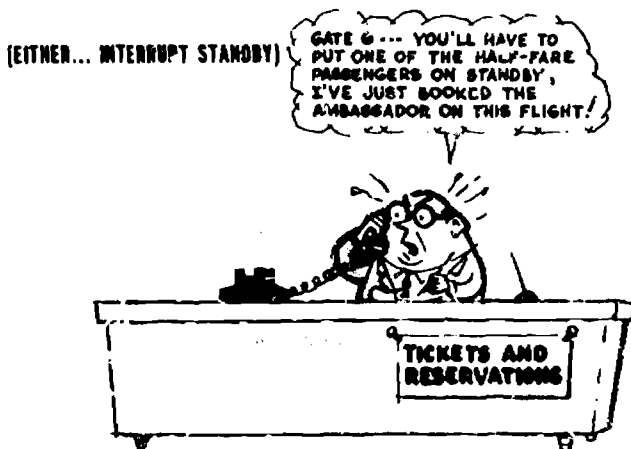

Slide 50

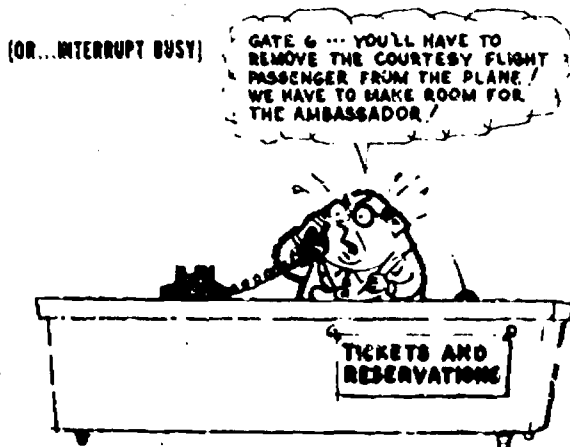

Slide 51

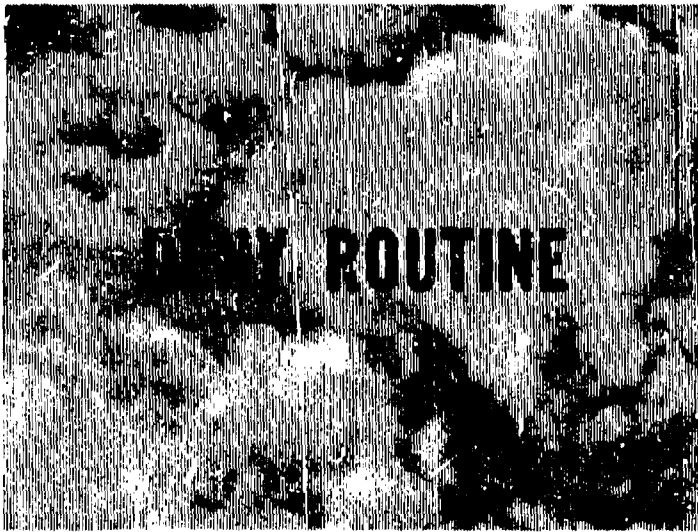

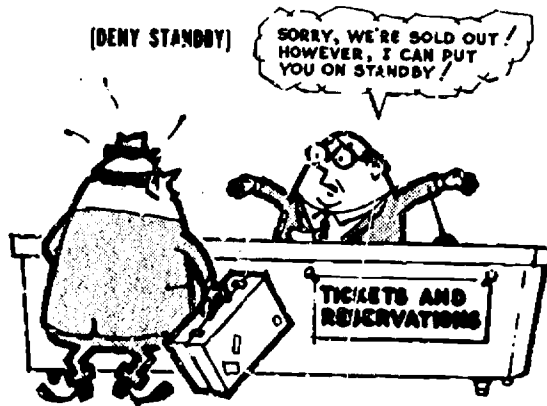

Slide 52

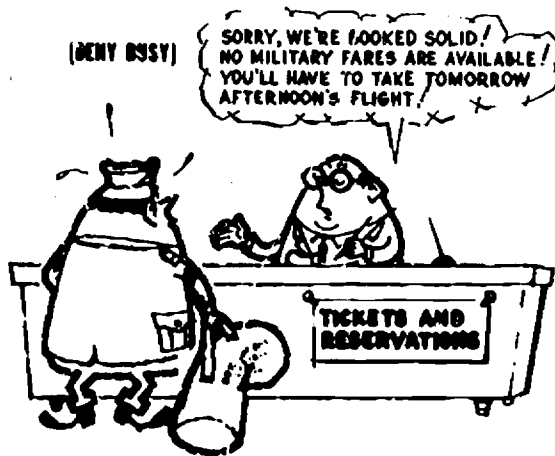

Slide 53

APPENDIX G
MANUALS OF INSTRUCTION - EXPERIMENT II

Because Experiment II involved four combinations of treatment conditions during training, it was necessary to develop four versions of the manual. These are reproduced in this appendix and are identified as follows:

- No Imagery, Low Fidelity Manual
- No Imagery, High Fidelity Manual
- Imagery, Low Fidelity Manual
- Imagery, High Fidelity Manual

NO IMAGERY, LOW FIDELITY MANUAL

INTRODUCTION

This experiment is the first in a series of studies investigating ways to improve training of complex-system operators.

You will be asked to learn to operate a communications system similar, in some ways, to that used in worldwide communications networks. Your task, as an operator, will be to operate the Communications Control Console (CCC), which is the hub of the communications system.

There will be two phases of training. In the first phase you will learn operating characteristics of the system. In the second phase you will be given a series of 30 training problems involving the operation of the CCC. You will return one week from today. At that time you will be given an additional set of 30 problems, in order to measure how well you remember what you have learned here today.

The purpose of this communications systems is to enable a group of communication facilities or Subscribers, located at relatively great distances from one another, to transmit and receive messages among themselves. Because of the distances involved and the limited range of each subscriber's radio equipment, the CCC is necessary to provide signal boosting or amplification. In other words, all messages from one subscriber to another must pass through the CCC. When the CCC is involved only for amplification, the communication routine will be referred to as SUBSCRIBER to SUBSCRIBER (S-S).

However, not all transmissions can be made in such a simple manner. Because there are variations in the type of radio equipment (frequency) used by the subscribers, it is not always possible for one subscriber to receive messages from another's transmitter. In these cases it is mandatory that the originator of the message send it to the CCC on the originating subscriber's

NAVTRADEVCEEN 68-C-0215-1

frequency. It must then be transmitted from the CCC to the receiving subscriber, on the latter's frequency. This process occurs in two discrete steps; i. e., Sender to CCC and CCC to Receiver. This more complex form of communication will be referred to as SUBSCRIBER to TERMINAL to SUBSCRIBER (S-T-S).

In addition to frequency disparity, there are sometimes cases where two communicating Subscribers speak different languages. When instances of language disparity occur it is also necessary to employ the S-T-S mode of operation. The identical S-T-S routine is used to overcome both language and frequency disparities. In fact, it is sometimes the case that both types of disparity are present. The major difference between the S-S and the S-T-S modes is that a delay at the CCC is necessary before the S-T-S message can be relayed to the receiver. Remember, two separate steps are necessary in the S-T-S mode, while one step is used in the S-S mode.

A third mode of operation is sometimes used. This mode is necessary because there are only a limited number of channels through which Subscribers can receive messages. When a subscriber requests that he communicate with another subscriber, through the CCC, and all channels usable by the receiving subscriber are occupied, the console operator must determine whether the present message is of a higher priority than any of those currently occupying usable channels. When the incoming message is of higher priority, one of the channels must be opened. This requires that the operator interrupt some lower priority communication. Interrupting a channel merely opens that channel to the receiver. The interrupt routine is used in conjunction with either the S-S or S-T-S routine.

Finally, there sometimes exists the situation where all usable channels are occupied with equal or higher priority communications than that being requested. In this case the CCC operator must inform the requesting subscriber that he must wait to transmit.

GENERAL SYSTEM CHARACTERISTICS

The Communications Control Console is the device which makes possible the patching of one subscriber to another so that they can communicate. The console has five channels on each broadcast frequency: High Frequency (HF), Very High Frequency (VHF) and Ultra High Frequency (UHF). Some subscribers have only one frequency capability, some have two, and some have all three capabilities.

Each of the 25 subscribers communicates in only one language: English, German, Spanish, Greek, or Swedish.

When a subscriber requests that a patch be made between him (Sender) and another subscriber (Receiver), he places a priority on his communications request. Priority One is extremely urgent and must be patched immediately if at all possible. Priority Two is very important but not urgent. Priority Three is used for routine communications which can wait if necessary.

Frequency, Language, and Priority, must be considered each and every time you make a patch between sender and receiver. Tables summarizing the rules associated with these three factors will be provided.

Let us now see what the CCC looks like. At the left of the CCC are three transilluminated panels. The top panel displays the SENDER identification number, the middle one displays the RECEIVER identification number, and the bottom panel displays the priority of the call currently being requested.

The center of the CCC contains frequency and channel information. The top row of switch-lights are frequency selectors. When activated, each switch selects a frequency; either HF, VHF or UHF. In the unactivated position, the top half of the indicator is illuminated. When activated, both top and bottom are illuminated. These switches called Frequency Selectors, are to be used to link a SENDER to the TERMINAL (console operator) or to link the TERMINAL to the SENDER. This is a point which is frequently confused.

NAVTRADEV CEN 68-C-0215-1

Remember, the Frequency Selectors are used only for communication between the CCC and the Sender. Also, it is important to remember that you can always use a frequency selector, even when all channels are occupied. Below the frequency selectors are the three columns of channel selectors for HF, VHF, and UHF communication. These switch-lights serve two functions. First, they are used to select a channel through which a communication to a receiver is made. Second, they provide information about which channels are currently in use and the priorities of these messages. Priority information is provided according to the following color code:



- A PRIORITY 1 message is currently occupying the channel (lighted portion is red)

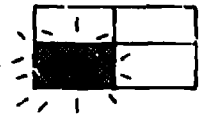

- A PRIORITY 2 message is currently occupying the channel (lighted portion is green)



- A PRIORITY 3 message is currently occupying the channel (lighted portion is white)



- channel unoccupied (no illumination)

The upper right section of the panel contains the PATCHING DIALS. These are two rotary switches which are numbered clockwise from 0 to 31. Lettering on the panel is in units of 5, but there is a switch position for all numbers zero through 31. The left dial connects the SENDER and the right dial connects the RECEIVER.

Below the patching dials are three OUTPUT SIGNAL switches, BUSY, STANDBY, and CONNECT. They are illuminated in the top half when the switches are not activated, and wholly illuminated when activated.

NAVTRADEVCCEN 68-C-0215-1

Below the OUTPUT SIGNAL switches is a TRANSMIT signal pushbutton. After you have selected an output signal, you must always activate the transmit signal pushbutton.

During the presentation of problems, you will have access to all necessary information. This information is contained on 35 mm slides. You will notice that a slide selector is located on the shelf before you. Above the CCC is a screen which displays the selected slide. I will now demonstrate the use of the information display.

OPERATIONAL REQUIREMENTS AND PROCEDURES

To process a communication request, the Operator must decide which mode and which procedure to use.

SUBSCRIBER TO SUBSCRIBER

The simplest and most straightforward mode of communication is S-S. This mode can be used only if all the following conditions pertain:

1. There is a common language
2. There is a common frequency
3. There is an open channel on the common frequency

Now here is a sample problem to illustrate the S-S mode. Let us look up Sender and Receiver capabilities. In this case the Sender is number 8 and the Receiver is number 17. We have provided slips of paper for your convenience in noting Subscriber information. Each slip must be thrown away after each problem. We see that they do speak the same language; they have a common frequency, in fact they have two frequencies in common, viz., HF and UHF; and there are open channels on both common frequencies. Since there are an equal number of open channels on both frequencies, you can use either one.

To make a simple S-S patch, the Operator executes the following routine:

1. Select **SENDER Identification Number (ID)** on the left **PATCHING DIAL**. For now, simply write the number 8 on your response sheet here
2. Select **RECEIVER ID** on right **PATCHING DIAL**, i. e., write in the number 17 here.
3. Select an appropriate **CHANNEL**, i. e., the uppermost unoccupied one. Do this by placing an X here.
4. Activate **CONNECT OUTPUT SIGNAL**
5. Activate **TRANSMIT** signal. For now we will use this switch instead.

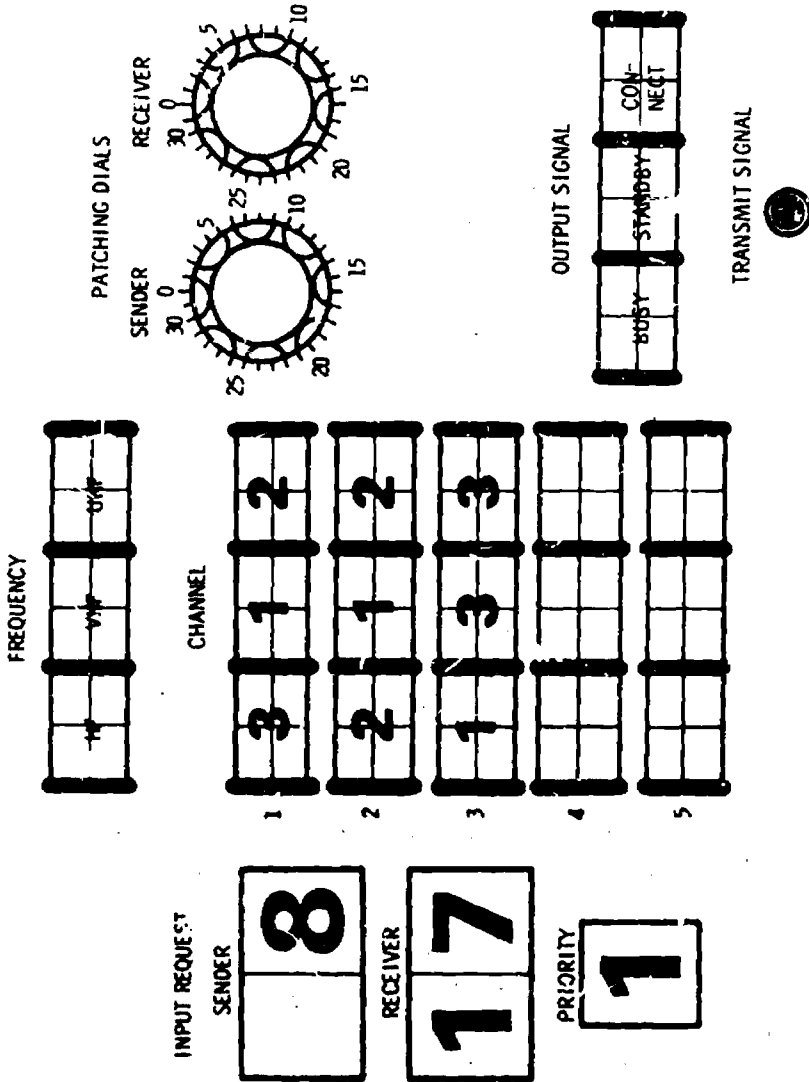

SAMPLE 1

SUBSCRIBER TO TERMINAL TO SUBSCRIBER

The communication must be processed S-T-S, if any of the following conditions exist:

1. There is a language disparity.
2. There is a frequency disparity.
3. There is an open channel within the receiver's capability, but not the sender's.

Here is a sample S-T-S problem involving subscriber 4 and subscriber 12. (Look up 4 and 12). We see that 4 speaks Spanish and 12 speaks German. Therefore we must use S-T-S because of language disparity. Even if both spoke the same language we would have to go to S-T-S because 4 has only HF, while 12 has VHF and UHF.

S-T-S ROUTINE

To make an S-T-S patch, the Operator must:

1. Select SENDER ID on left PATCHING DIAL.
2. Select position 1 on right PATCHING DIAL (Position 1 is the terminal address).
3. Select a FREQUENCY within sender's capability; in this case only HF can be used.
4. Activate CONNECT OUTPUT SIGNAL.
5. Activate TRANSMIT SIGNAL.
6. Wait for panel lights to flash; but for now, wait for this light to go back on.
7. Select Position 1 on left PATCHING DIAL.
8. Select receiver ID on right PATCHING DIAL.
9. Select a CHANNEL within the receiver's capability. Here, since VHF has three open channels and UHF only one, we will use VHF.
10. Activate CONNECT OUTPUT SIGNAL.
11. Activate TRANSMIT SIGNAL.

NAVTRADEV CEN 68-C-0215-1

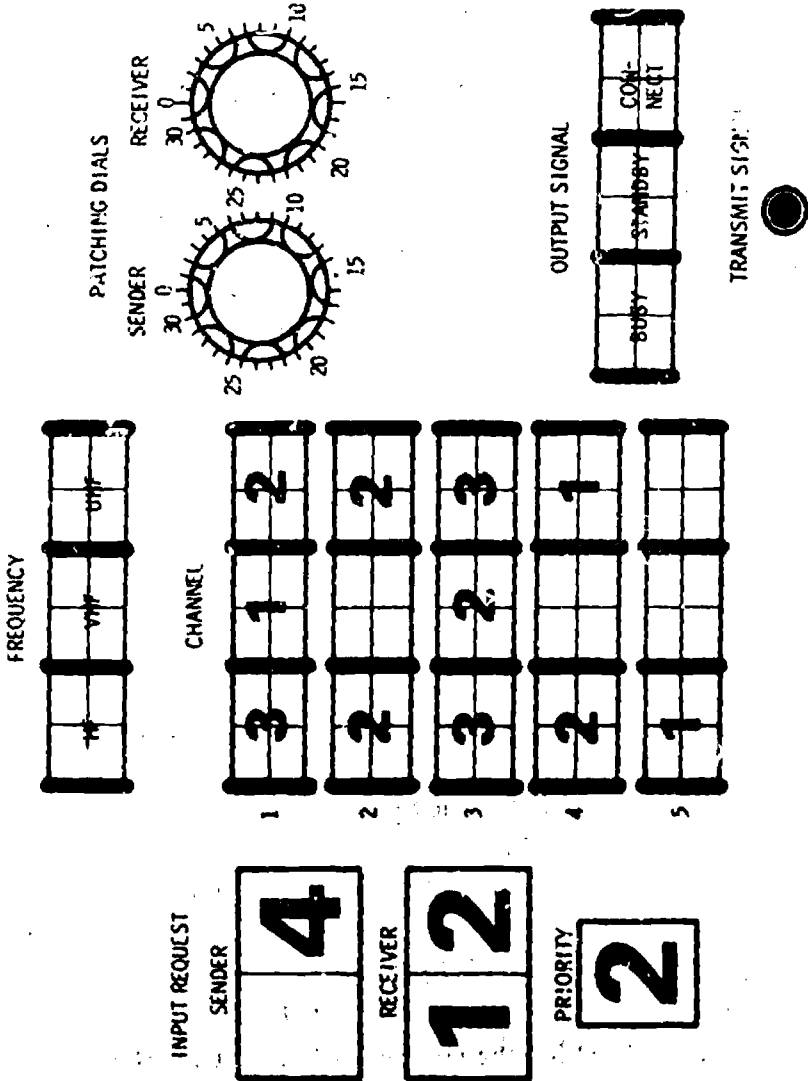

SAMPLE 2

CHANNEL CLEARING

The Interrupt routine is used when both of the following conditions exist:

1. There are no open channels within the receiver's capability; and
2. There is at least one channel usable by the receiver which is occupied by a lower priority message.

We will now look at two problems which require use of the interrupt routine. The first problem involves subscriber 18 who wishes to communicate with subscriber 22. We see that both subscribers are English speaking and that they each have HF and VHF capability. Now looking at the channel/priority indications, we can see that all HF and VHF channels are in use. Since all channels other than HF 2 have priority ones and twos, HF 2 having priority 3 occupancy, we will select HF 2 for interruption. The general rule governing such situations is that we interrupt the lowest priority channel.

CHANNEL CLEARING WITH S-S ROUTINE

To interrupt a channel, the Operator uses the following routine:

1. Select position 30 on both PATCHING DIALS
2. Select CHANNEL to be interrupted
3. Activate BUSY if interrupting a priority 3 or STANDBY for a priority 2. In this case we give a BUSY signal.
4. Activate TRANSMIT SIGNAL
5. Wait for CHANNEL to be opened

Now, having cleared HF channel 2, we can proceed to communicating by S-S. In other words, we first select 18 on the left patching dial and 22 on the right patching dial. We now select channel HF 2, select CONNECT, and finally activate TRANSMIT SIGNAL.

NAVTRADEVCCEN 68-C-0215 -1



INPUT REQUEST
SENDER
18

RECEIVER
22

PRIORITY
1

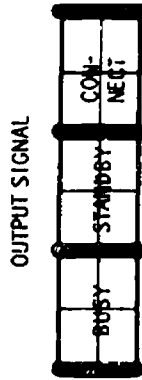
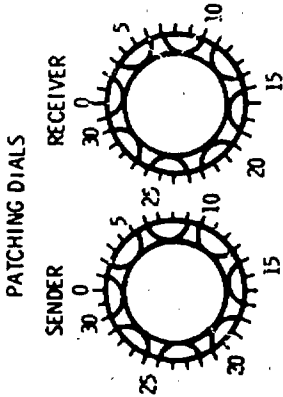
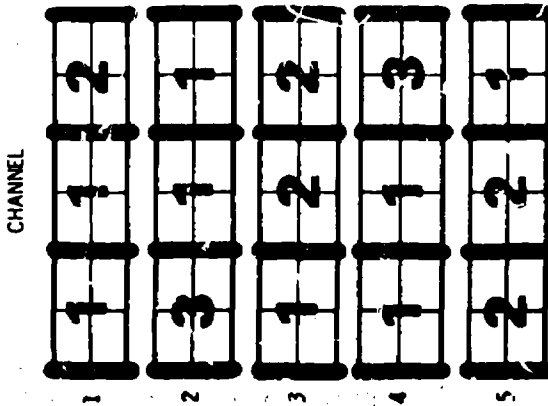

TRANSMIT SIGNAL

SAMPLE 3

NAVTRADEVCCEN 68-C-0215-1

In the second problem, subscriber 20 requests communication with subscriber 21. Number 20 has HF and VHF, while 21 has all frequencies. Both speak German. If there were open channels on either HF or VHF, we could use the S-S routine. However, both HF and VHF channels are all occupied. Moreover, HF and VHF contain all priority 1 communications and therefore must not be interrupted. The only remaining possibility for communicating is to use S-T-S, first bringing the message into the terminal through either HF or VHF frequency, and then interrupting UHF 1 and using it to reach the receiver.

CHANNEL CLEARING WITH S-T-S ROUTINE

To accomplish an interrupt S-T-S routine we use the following procedures:

1. Select Sender number, in this case number 20 on left PATCHING DIAL.
2. Select position 1 on right PATCHING DIAL.
3. Select an appropriate FREQUENCY; in this case either HF or VHF.
4. Select CONNECT OUTPUT SIGNAL
5. Activate TRANSMIT SIGNAL

At this point the message is transmitted to the terminal. Receipt of the message is signalled by a flashing of the panel lights. Now we interrupt the desired channel, viz. UHF 1, in the same manner as in the previous problem, i.e.:

1. Select position 30 on both PATCHING DIALS.
2. Select UHF CHANNEL 1
3. Activate STBY since we are interrupting a priority 2 message.
4. Activate TRANSMIT SIGNAL
5. Wait for channel to be opened

Now we can proceed with completion of the second part of the S-T-S procedure.

1. Select position 1 on left PATCHING DIAL
2. Select position 21 on right PATCHING DIAL
3. Select UHF CHANNEL 1

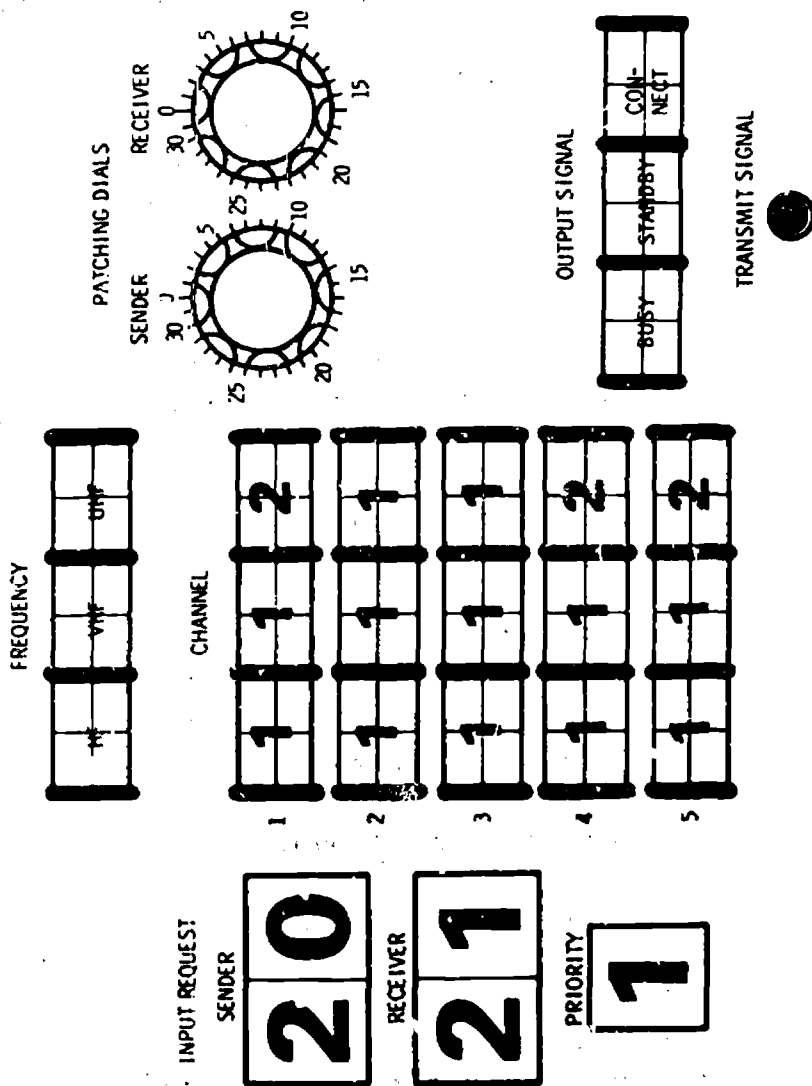

SAMPLE 4

4. Select CONNECT OUTPUT SIGNAL
5. Activate TRANSMIT SIGNAL

COMMUNICATION REQUEST DENIAL

A communications patch cannot be made and the incoming request is denied if both of the following conditions are present:

1. There is no open channel within the receiver's frequency capability; and
2. All channels within the receiver's frequency capability are occupied with messages of equal or higher priority.

The final sample problem illustrates this situation. Subscriber 15 wishes to communicate with Subscriber 19. We find that Subscriber 15, the sender, has HF and VHF capability, and Subscriber 19, the receiver, has only HF capability. Looking at the channel/priority indicators, we see that all five HF channels are occupied with priority 1 and 2 messages. Since the sender wishes to communicate a priority 2 message, and the receiver's frequency capability is occupied with messages of equal or higher priority, a channel cannot be interrupted and the sender's request to communicate must be denied.

To deny a communication request:

1. Select position 1 on left PATCHING DIAL
2. Select sender ID on right PATCHING DIAL
3. Select any FREQUENCY within Sender's capability
- 4a. Activate STANDBY OUTPUT SIGNAL if sender's request was Priority 1 or Priority 2
- 4b. Activate BUSY OUTPUT SIGNAL if sender's request was Priority 3

In this case, we activate STANDBY

5. Activate TRANSMIT SIGNAL

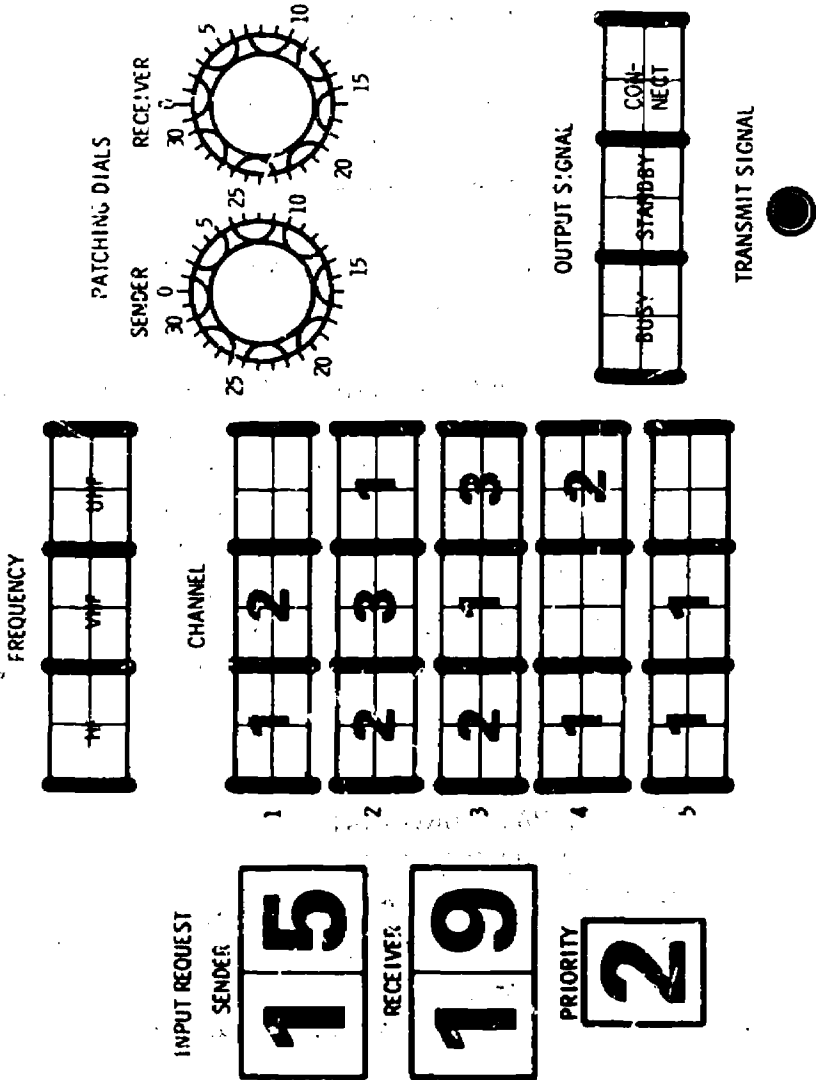

SAMPLE 5

TABLE 1 (SLIDE #27)

FREQUENCY RULES

1. Subscribers can communicate directly (S-S) only on channels common to both parties.
2. If there is no open channel common to both, go to S-T-S mode. (See Priority Rules.)
3. If common channels are in use and cannot be interrupted (See Priority Rules) and there is no open channel usable by the receiving subscriber, a patch cannot be made and the sender's request is denied. (See Priority Rules.)
4. If channels are open on more than one usable frequency, use a channel on the least-occupied frequency.

TABLE 2 (SLIDE #28)

LANGUAGE RULES

1. Subscribers can communicate directly (S-S) only in a common language.
2. If there is no common language, the message must be translated (S-T-S).

TABLE 3

PRIORITY RULES

TO PROCESS A PRIORITY (P-1) MESSAGE (SLIDE #29)

- If all channels within the receiver's capability are filled with P-1, deny sender's request and place sender on STANDBY.
- If all channels are filled with P-1 and/or P-2, interrupt the uppermost P-2 and then proceed with the patch.
- If all channels are filled with P-1, P-2, and/or P-3, interrupt the uppermost P-3 and then proceed with the patch.

TO PROCESS A PRIORITY (P-2) MESSAGE (SLIDE #30)

- If all channels are filled with P-1 and/or P-2, deny sender's request and place sender on STANDBY.
- If all channels are filled with P-1, P-2, and/or P-3, interrupt the uppermost P-3 and then proceed with the patch.

TO PROCESS A PRIORITY (P-3) MESSAGE (SLIDE #31)

- If all channels are filled, deny sender's request and place sender on BUSY.

FINAL OPERATING INSTRUCTIONS

We are very much aware that your task in this experiment is complex. The high difficulty thereby produced is necessary in order to adequately simulate the kinds of jobs performed by equipment operators in actual systems. Therefore you must make an attempt to grasp the basic function of the system rather than simply memorizing rules and procedures. Do not hesitate to look up information until you are very confident that you have this knowledge.

Your task is to process or deny each communication request as rapidly as possible, consistent with very high levels of accuracy. Your performance will be evaluated in terms of the average time required to complete each problem. Although you will be paid a minimum of two dollars per hour, you can earn as much as four dollars per hour by operating at highest levels of performance. It is vital that each communication be processed without errors, but you should not delay unnecessarily.

Before the beginning of each problem I will say "ready." Each problem will then begin when the lights on the CCC become illuminated; or for now, when this light turns on.

NO IMAGERY, HIGH FIDELITY MANUAL

INTRODUCTION

This experiment is the first in a series of studies investigating ways to improve training of complex-system operators.

You will be asked to learn to operate a communications system similar, in some ways, to that used in worldwide communications networks. Your task, as an operator, will be to operate the Communications Control Console (CCC), which is the hub of the communications system.

There will be two phases of training. In the first phase you will learn operating characteristics of the system. In the second phase you will be given a series of 30 training problems involving the operation of the CCC. You will return one week from today. At that time you will be given an additional set of 30 problems, in order to measure how well you remember what you have learned here today.

The purpose of this communications systems is to enable a group of communication facilities or Subscribers, located at relatively great distances from one another, to transmit and receive messages among themselves. Because of the distances involved and the limited range of each subscriber's radio equipment, the CCC is necessary to provide signal boosting or amplification. In other words, all messages from one subscriber to another must pass through the CCC. When the CCC is involved only for amplification, the communication routine will be referred to as SUBSCRIBER to SUBSCRIBER (S-S).

However, not all transmissions can be made in such a simple manner. Because there are variations in the type of radio equipment (frequency) used by the subscribers, it is not always possible for one subscriber to receive messages from another's transmitter. In these cases it is mandatory that the originator of the message send it to the CCC on the originating subscriber's

frequency. It must then be transmitted from the CCC to the receiving subscriber, on the latter's frequency. This process occurs in two discrete steps; i. e., Sender to CCC and CCC to Receiver. This more complex form of communication will be referred to as SUBSCRIBER to TERMINAL to SUBSCRIBER (S-T-S).

In addition to frequency disparity, there are sometimes cases where two communicating Subscribers speak different languages. When instances of language disparity occur it is also necessary to employ the S-T-S mode of operation. The identical S-T-S routine is used to overcome both language and frequency disparities. In fact, it is sometimes the case that both types of disparity are present. The major difference between the S-S and the S-T-S modes is that a delay at the CCC is necessary before the S-T-S message can be relayed to the receiver. Remember, two separate steps are necessary in the S-T-S mode, while one step is used in the S-S mode.

A third mode of operation is sometimes used. This mode is necessary because there are only a limited number of channels through which Subscribers can receive messages. When a subscriber requests that he communicate with another subscriber, through the CCC, and all channels usable by the receiving subscriber are occupied, the console operator must determine whether the present message is of a higher priority than any of those currently occupying usable channels. When the incoming message is of higher priority, one of the channels must be opened. This requires that the operator interrupt some lower priority communication. Interrupting a channel merely opens that channel to the receiver. The interrupt routine is used in conjunction with either the S-S or S-T-S routine.

Finally, there sometimes exists the situation where all usable channels are occupied with equal or higher priority communications than that being requested. In this case the CCC operator must inform the requesting subscriber that he must wait to transmit.

GENERAL SYSTEM CHARACTERISTICS

The Communications Control Console is the device which makes possible the patching of one subscriber to another so that they can communicate. The console has five channels on each broadcast frequency: High Frequency (HF), Very High Frequency (VHF) and Ultra High Frequency (UHF). Some subscribers have only one frequency capability, some have two, and some have all three capabilities.

Each of the 25 subscribers communicates in only one language: English, German, Spanish, Greek, or Swedish.

When a subscriber requests that a patch be made between him (Sender) and another subscriber (Receiver), he places a priority on his communications request. Priority One is extremely urgent and must be patched immediately if at all possible. Priority Two is very important but not urgent. Priority Three is used for routine communications which can wait if necessary.

Frequency, Language, and Priority, must be considered each and every time you make a patch between sender and receiver. Tables summarizing the rules associated with these three factors will be provided.

Let us now see what the CCC looks like. At the left of the CCC are three transilluminated panels. The top panel displays the SENDER identification number, the middle one displays the RECEIVER identification number, and the bottom panel displays the priority of the call currently being requested.

The center of the CCC contains frequency and channel information. The top row of switch-lights are frequency selectors. When activated, each switch selects a frequency; either HF, VHF or UHF. In the unactivated position, the top half of the indicator is illuminated. When activated, both top and bottom are illuminated. These switches called Frequency Selectors, are to be used to link a SENDER to the TERMINAL (console operator) or to link the TERMINAL to the SENDER. This is a point which is frequently confused.

NAVTRADEV CEN 68-C-0215-1

Remember, the Frequency Selectors are used only for communication between the CCC and the Sender. Also, it is important to remember that you can always use a frequency selector, even when all channels are occupied. Below the frequency selectors are the three columns of channel selectors for HF, VHF, and UHF communication. These switch-lights serve two functions. First, they are used to select a channel through which a communication to a receiver is made. Second, they provide information about which channels are currently in use and the priorities of these messages. Priority information is provided according to the following color code:

 - A PRIORITY 1 message is currently occupying the channel (lighted portion is red)

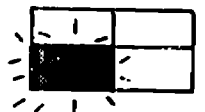
 - A PRIORITY 2 message is currently occupying the channel (lighted portion is green)

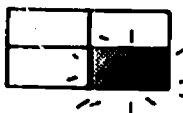
 - A PRIORITY 3 message is currently occupying the channel (lighted portion is white)

 - channel unoccupied (no illumination)

The upper right section of the panel contains the PATCHING DIALS. These are two rotary switches which are numbered clockwise from 0 to 31. Lettering on the panel is in units of 5, but there is a switch position for all numbers zero through 31. The left dial connects the SENDER and the right dial connects the RECEIVER.

Below the patching dials are three OUTPUT SIGNAL switches, BUSY, STANDBY, and CONNECT. They are illuminated in the top half when the switches are not activated, and wholly illuminated when activated.

NAVTRADEV CEN 68-C-0215-1

Below the OUTPUT SIGNAL switches is a TRANSMIT signal pushbutton. After you have selected an output signal, you must always activate the transmit signal pushbutton.

During the presentation of problems, you will have access to all necessary information. This information is contained on 35 mm slides. You will notice that a slide selector is located on the shelf before you. Above the CCC is a screen which displays the selected slide. I will now demonstrate the use of the information display.

OPERATIONAL REQUIREMENTS AND PROCEDURES

To process a communication request, the Operator must decide which mode and which procedure to use.

SUBSCRIBER TO SUBSCRIBER

The simplest and most straightforward mode of communication is S-S. This mode can be used only if all the following conditions pertain:

1. There is a common language
2. There is a common frequency
3. There is an open channel on the common frequency

Now here is a sample problem to illustrate the S-S mode. Let us look up Sender and Receiver capabilities. In this case the Sender is number 8 and the Receiver is number 17. We have provided slips of paper for your convenience in noting Subscriber information. Each slip must be thrown away after each problem. We see that they do speak the same language; they have a common frequency, in fact they have two frequencies in common, viz., HF and UHF; and there are open channels on both common frequencies. Since there are an equal number of open channels on both frequencies, you can use either one.

To make a simple S-S patch, the Operator executes the following routine:

1. Select **SENDER Identification Number (ID)** on the left **PATCHING DIAL**
 2. Select **RECEIVER ID** on right **PATCHING DIAL**
 3. Select an appropriate **CHANNEL**, i. e., the uppermost unoccupied one
 4. Activate **CONNECT OUTPUT SIGNAL**
 5. Activate **TRANSMIT signal**
-

NAVTRADEVCEEN 68-C-0215-1

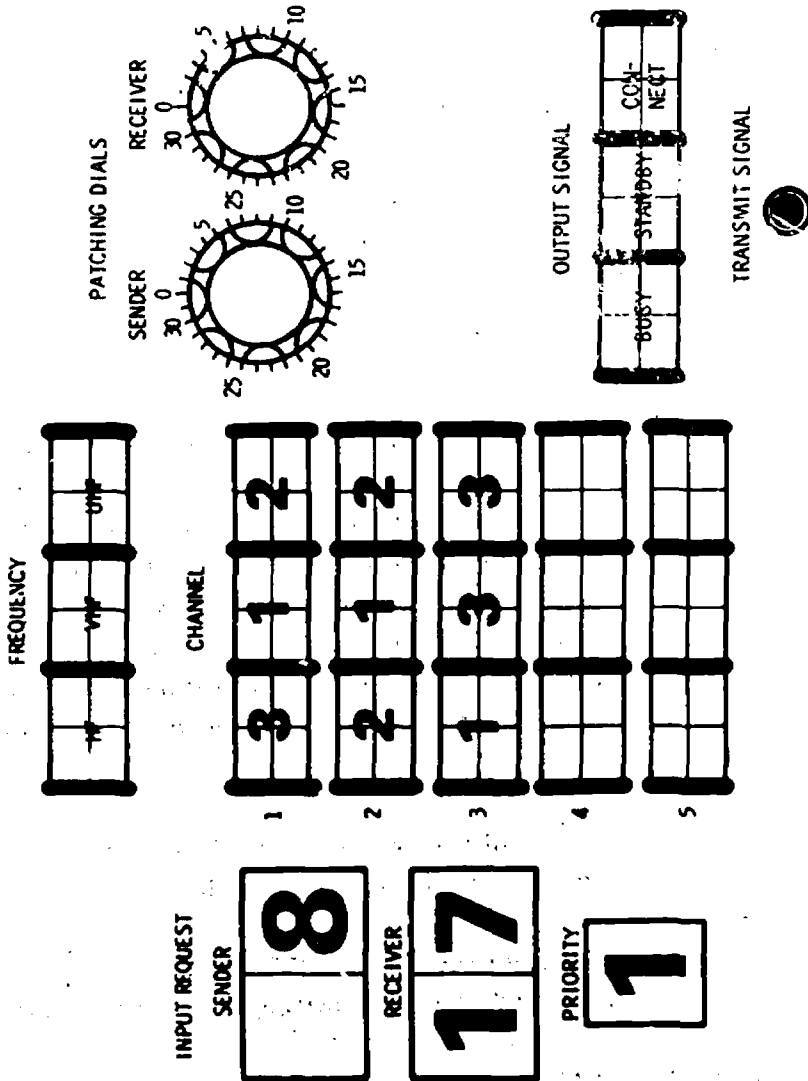

SAMPLE 1

SUBSCRIBER TO TERMINAL TO SUBSCRIBER

The communication must be processed S-T-S, if any of the following conditions exist:

1. There is a language disparity.
2. There is a frequency disparity.
3. There is an open channel within the receiver's capability, but not the sender's.

Here is a sample S-T-S problem involving subscriber 4 and subscriber 12. (Look up 4 and 12). We see that 4 speaks Spanish and 12 speaks German. Therefore we must use S-T-S because of language disparity. Even if both spoke the same language we would have to go to S-T-S because 4 has only HF, while 12 has VHF and UHF.

S-T-S ROUTINE

To make an S-T-S patch, the Operator must:

1. Select **SENDER ID** on left **PATCHING DIAL**.
2. Select position 1 on right **PATCHING DIAL** (Position 1 is the terminal address).
3. Select a **FREQUENCY** within sender's capability; in this case only HF can be used.
4. Activate **CONNECT OUTPUT SIGNAL**.
5. Activate **TRANSMIT SIGNAL**.
6. Wait for panel lights to flash; but for now, wait for this light to go back on.
7. Select Position 1 on left **PATCHING DIAL**.
8. Select receiver **ID** on right **PATCHING DIAL**.
9. Select a **CHANNEL** within the receiver's capability. Here, since VHF has three open channels and UHF only one, we will use VHF.
10. Activate **CONNECT OUTPUT SIGNAL**.
11. Activate **TRANSMIT SIGNAL**.

NAVTRADEVCCEN 68-C-0215-1

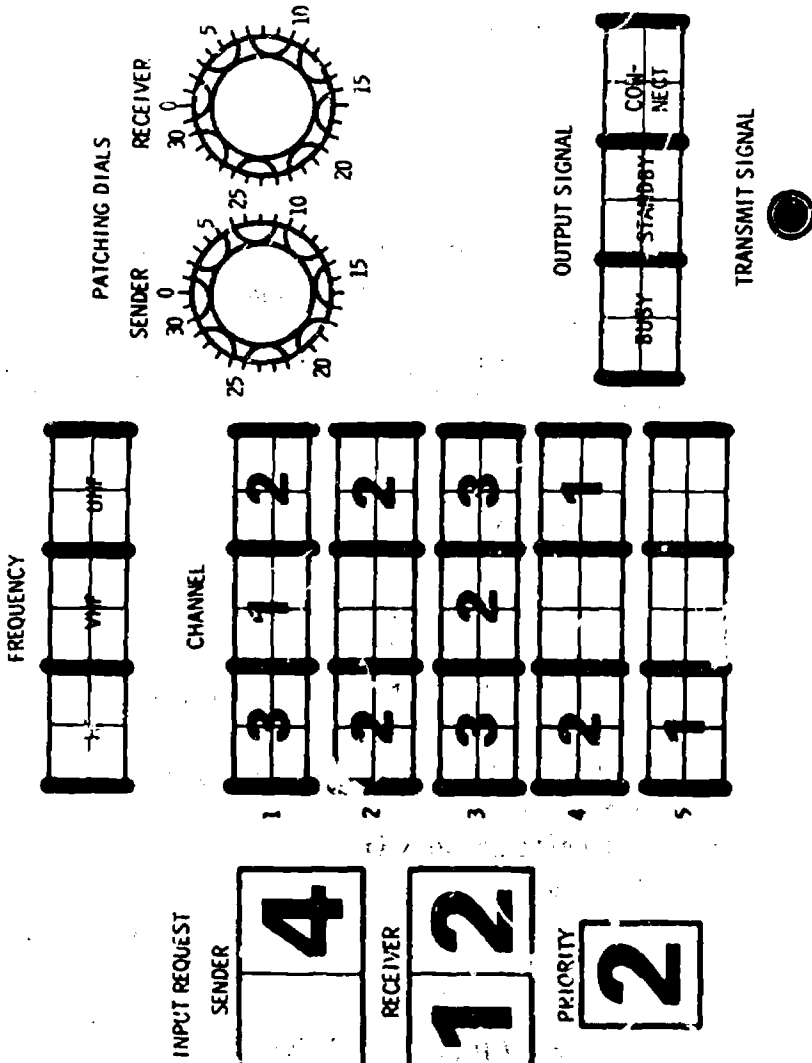

SAMPLE 2

CHANNEL CLEARING

The Interrupt routine is used when both of the following conditions exist:

1. There are no open channels within the receiver's capability; and
2. There is at least one channel usable by the receiver which is occupied by a lower priority message.

We will now look at two problems which require use of the interrupt routine. The first problem involves subscriber 18 who wishes to communicate with subscriber 22. We see that both subscribers are English speaking and that they each have HF and VHF capability. Now looking at the channel/priority indications, we can see that all HF and VHF channels are in use. Since all channels other than HF 2 have priority ones and twos, HF 2 having priority 3 occupancy, we will select HF 2 for interruption. The general rule governing such situations is that we interrupt the lowest priority channel.

CHANNEL CLEARING WITH S-S ROUTINE

To interrupt a channel, the Operator uses the following routine:

1. Select position 30 on both PATCHING DIALS
2. Select CHANNEL to be interrupted
3. Activate BUSY if interrupting a priority 3 or STANDBY for a priority 2. In this case we give a BUSY signal.
4. Activate TRANSMIT SIGNAL
5. Wait for CHANNEL to be opened

Now, having cleared HF channel 2, we can proceed to communicating by S-S. In other words, we first select 18 on the left patching dial and 22 on the right patching dial. We now select channel HF 2, select CONNECT, and finally activate TRANSMIT SIGNAL.

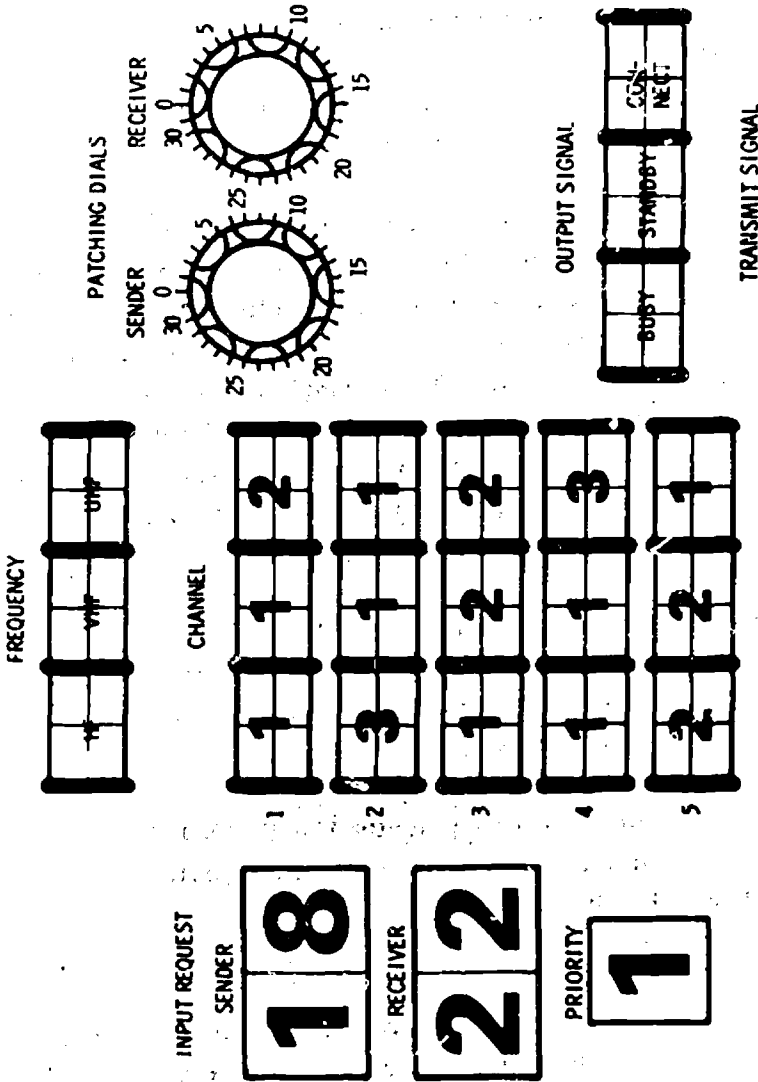

SAMPLE 3

NAVTRADEVCCEN 68-C-0215-1

In the second problem, subscriber 20 requests communication with subscriber 21. Number 20 has HF and VHF, while 21 has all frequencies. Both speak German. If there were open channels on either HF or VHF, we could use the S-S routine. However, both HF and VHF channels are all occupied. Moreover, HF and VHF contain all priority 1 communications and therefore must not be interrupted. The only remaining possibility for communicating is to use S-T-S, first bringing the message into the terminal through either HF or VHF frequency, and then interrupting UHF 1 and using it to reach the receiver.

CHANNEL CLEARING WITH S-T-S ROUTINE

To accomplish an interrupt S-T-S routine we use the following procedures:

1. Select Sender number, in this case number 20 on left PATCHING DIAL.
2. Select position 1 on right PATCHING DIAL.
3. Select an appropriate FREQUENCY; in this case either HF or VHF.
4. Select CONNECT OUTPUT SIGNAL
5. Activate TRANSMIT SIGNAL

At this point the message is transmitted to the terminal. Receipt of the message is signalled by a flashing of the panel lights. Now we interrupt the desired channel, viz. UHF 1, in the same manner as in the previous problem, i. e. :

1. Select position 30 on both PATCHING DIALS.
2. Select UHF CHANNEL 1
3. Activate STBY since we are interrupting a priority 2 message.
4. Activate TRANSMIT SIGNAL
5. Wait for channel to be opened

Now we can proceed with completion of the second part of the S-T-S procedure.

1. Select position 1 on left PATCHING DIAL
2. Select position 21 on right PATCHING DIAL
3. Select UHF CHANNEL 1

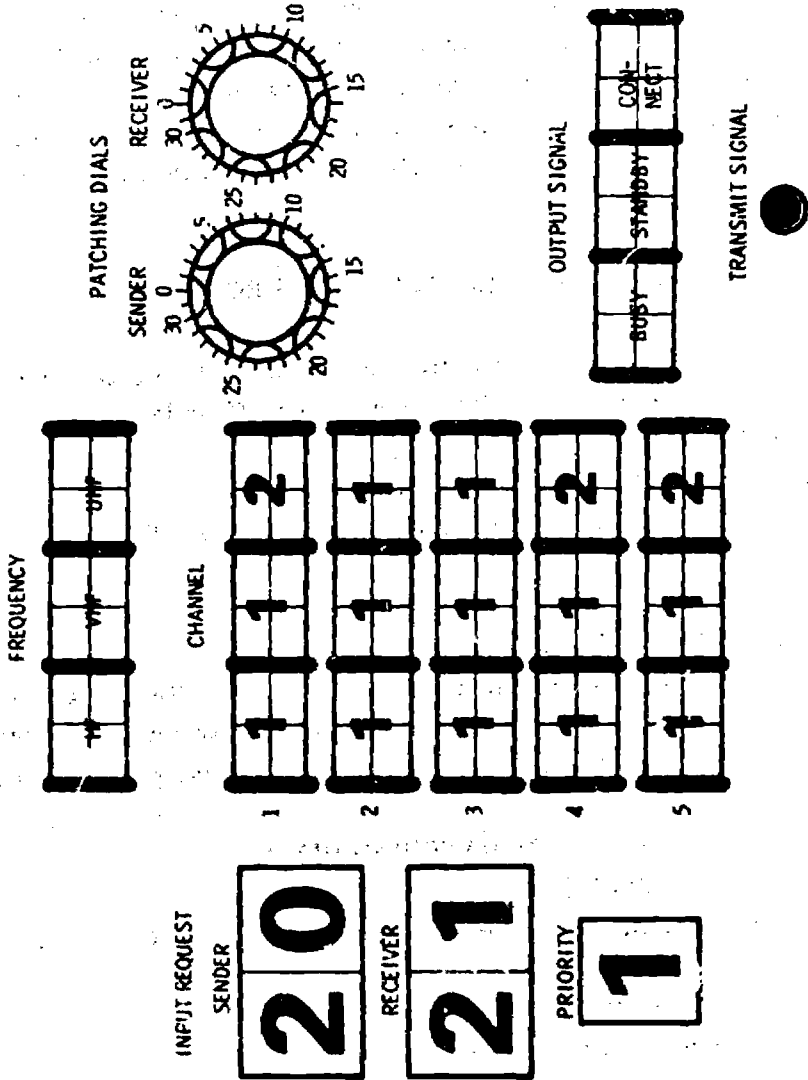

SAMPLE 4

4. Select CONNECT OUTPUT SIGNAL
5. Activate TRANSMIT SIGNAL

COMMUNICATION REQUEST DENIAL

A communications patch cannot be made and the incoming request is denied if both of the following conditions are present:

1. There is no open channel within the receiver's frequency capability; and
2. All channels within the receiver's frequency capability are occupied with messages of equal or higher priority.

The final sample problem illustrates this situation. Subscriber 15 wishes to communicate with Subscriber 19. We find that Subscriber 15, the sender, has HF and VHF capability, and Subscriber 19, the receiver, has only HF capability. Looking at the channel/priority indicators, we see that all five HF channels are occupied with priority 1 and 2 messages. Since the sender wishes to communicate a priority 2 message, and the receiver's frequency capability is occupied with messages of equal or higher priority, a channel cannot be interrupted, and the sender's request to communicate must be denied.

To deny a communication request:

1. Select position 1 on left PATCHING DIAL
2. Select sender ID on right PATCHING DIAL
3. Select any FREQUENCY within Sender's capability
- 4a. Activate STANDBY OUTPUT SIGNAL if sender's request was Priority 1 or Priority 2
- 4b. Activate BUSY OUTPUT SIGNAL if sender's request was Priority 3

In this case, we activate STANDBY

5. Activate TRANSMIT SIGNAL

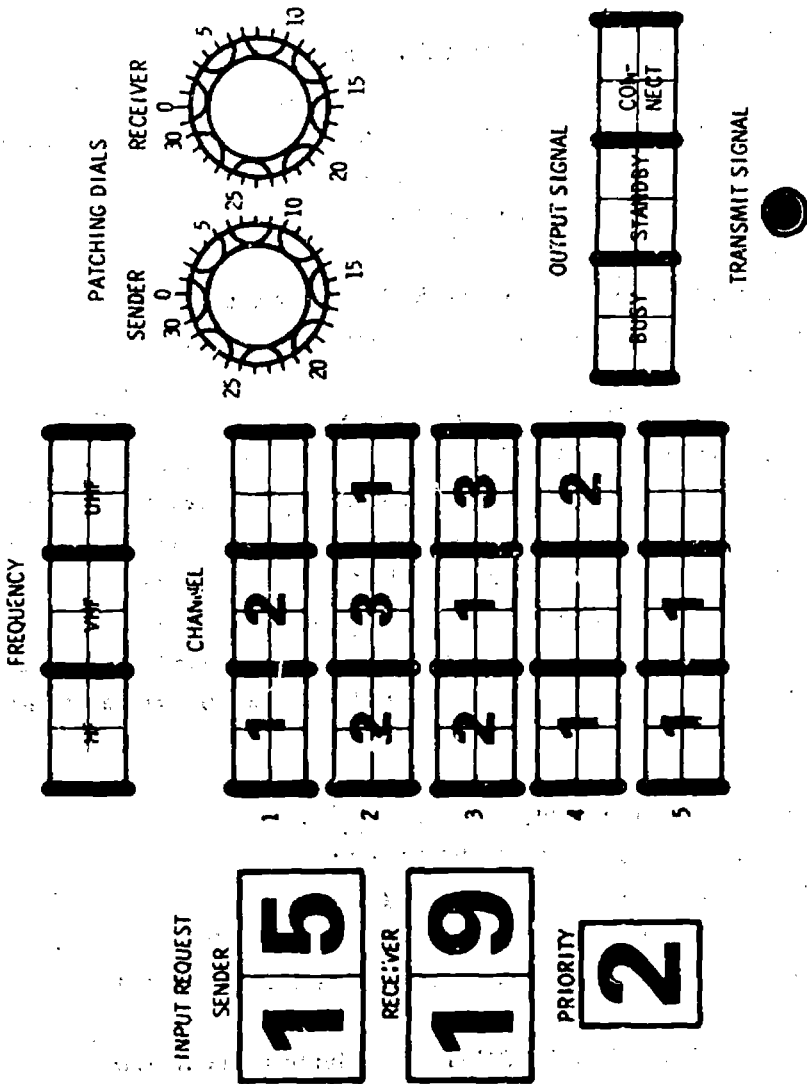

SAMPLE 5

TABLE 1 (SLIDE #27)

FREQUENCY RULES

1. Subscribers can communicate directly (S-S) only on channels common to both parties.
2. If there is no open channel common to both, go to S-T-S mode. (See Priority Rules.)
3. If common channels are in use and cannot be interrupted (See Priority Rules) and there is no open channel usable by the receiving subscriber, a patch cannot be made and the sender's request is denied. (See Priority Rules.)
4. If channels are open on more than one usable frequency, use a channel on the least-occupied frequency.

TABLE 2 (SLIDE #28)

LANGUAGE RULES

1. Subscribers can communicate directly (S-S) only in a common language.
2. If there is no common language, the message must be translated (S-T-S).

TABLE 3

PRIORITY RULES

TO PROCESS A PRIORITY (P-1) MESSAGE (SLIDE #29)

- If all channels within the receiver's capability are filled with P-1, deny sender's request and place sender on STANDBY.
- If all channels are filled with P-1 and/or P-2, interrupt the uppermost P-2 and then proceed with the patch.
- If all channels are filled with P-1, P-2, and/or P-3, interrupt the uppermost P-3 and then proceed with the patch.

TO PROCESS A PRIORITY (P-2) MESSAGE (SLIDE #30)

- If all channels are filled with P-1 and/or P-2, deny sender's request and place sender on STANDBY.
- If all channels are filled with P-1, P-2, and/or P-3, interrupt the uppermost P-3 and then proceed with the patch.

TO PROCESS A PRIORITY (P-3) MESSAGE (SLIDE #31)

- If all channels are filled, deny sender's request and place sender on BUSY.

FINAL OPERATING INSTRUCTIONS

We are very much aware that your task in this experiment is complex. The high difficulty thereby produced is necessary in order to adequately simulate the kinds of jobs performed by equipment operators in actual systems. Therefore you must make an attempt to grasp the basic function of the system rather than simply memorizing rules and procedures. Do not hesitate to look up information until you are very confident that you have this knowledge.

Your task is to process or deny each communication request as rapidly as possible, consistent with very high levels of accuracy. Your performance will be evaluated in terms of the average time required to complete each problem. Although you will be paid a minimum of two dollars per hour, you can earn as much as four dollars per hour by operating at highest levels of performance. It is vital that each communication be processed without errors, but you should not delay unnecessarily.

Before the beginning of each problem I will say "ready". Each problem will then begin when the lights on the CCC become illuminated.

IMAGERY, LOW FIDELITY MANUAL

INTRODUCTION

This experiment is the first in a series of studies investigating ways to improve training of complex-system operators.

You will be asked to learn to operate a communications system similar, in some ways, to that used in worldwide communications networks. Your task, as an operator, will be to operate the Communications Control Console (CCC), which is the hub of the communications system.

There will be two phases of training. In the first phase you will learn operating characteristics of the system. In the second phase you will be given a series of 30 training problems involving the operation of the CCC. You will return one week from today. At that time you will be given an additional set of 30 problems, in order to measure how well you remember what you have learned here today.

The purpose of this communications systems is to enable a group of communication facilities or Subscribers, located at relatively great distances from one another, to transmit and receive messages among themselves. Because of the distances involved and the limited range of each subscriber's radio equipment, the CCC is necessary to provide signal boosting or amplification. In other words, all messages from one subscriber to another must pass through the CCC. When the CCC is involved only for amplification, the communication routine will be referred to as SUBSCRIBER to SUBSCRIBER (S-S).

However, not all transmissions can be made in such a simple manner. Because there are variations in the type of radio equipment (frequency) used by the subscribers, it is not always possible for one subscriber to receive messages from another's transmitter. In these cases it is mandatory that the originator of the message send it to the CCC on the originating subscriber's

NAVTRADEV CEN 68-C-02 15-1

frequency. It must then be transmitted from the CCC to the receiving subscriber, on the latter's frequency. This process occurs in two discrete steps; i. e., Sender to CCC and CCC to Receiver. This more complex form of communication will be referred to as SUBSCRIBER to TERMINAL to SUBSCRIBER (S-T-S).

In addition to frequency disparity, there are sometimes cases where two communicating Subscribers speak different languages. When instances of language disparity occur it is also necessary to employ the S-T-S mode of operation. The identical S-T-S routine is used to overcome both language and frequency disparities. In fact, it is sometimes the case that both types of disparity are present. The major difference between the S-S and the S-T-S modes is that a delay at the CCC is necessary before the S-T-S message can be relayed to the receiver. Remember, two separate steps are necessary in the S-T-S mode, while one step is used in the S-S mode.

A third mode of operation is sometimes used. This mode is necessary because there are only a limited number of channels through which Subscribers can receive messages. When a subscriber requests that he communicate with another subscriber, through the CCC, and all channels usable by the receiving subscriber are occupied, the console operator must determine whether the present message is of a higher priority than any of those currently occupying usable channels. When the incoming message is of higher priority, one of the channels must be opened. This requires that the operator interrupt some lower priority communication. Interrupting a channel merely opens that channel to the receiver. The interrupt routine is used in conjunction with either the S-S or S-T-S routine.

Finally, there sometimes exists the situation where all usable channels are occupied with equal or higher priority communications than that being requested. In this case the CCC operator must inform the requesting subscriber that he must wait to transmit.

GENERAL SYSTEM CHARACTERISTICS

The Communications Control Console is the device which makes possible the patching of one subscriber to another so that they can communicate. The console has five channels on each broadcast frequency: High Frequency (HF), Very High Frequency (VHF) and Ultra High Frequency (UHF). Some subscribers have only one frequency capability, some have two, and some have all three capabilities.

Each of the 25 subscribers communicates in only one language: English, German, Spanish, Greek, or Swedish.

When a subscriber requests that a patch be made between him (Sender) and another subscriber (Receiver), he places a priority on his communications request. Priority One is extremely urgent and must be patched immediately if at all possible. Priority Two is very important but not urgent. Priority Three is used for routine communications which can wait if necessary.

Frequency, Language, and Priority, must be considered each and every you make a patch between sender and receiver. Tables summarizing the associated with these three factors will be provided.

Let us now see what the CCC looks like. At the left of the CCC are three transilluminated panels. The top panel displays the SENDER identification number, the middle one displays the RECEIVER identification number, and the bottom panel displays the priority of the call currently being requested.

The center of the CCC contains frequency and channel information. The top row of switch-lights are frequency selectors. When activated, each switch selects a frequency; either HF, VHF or UHF. In the unactivated position, the top half of the indicator is illuminated. When activated, both top and bottom are illuminated. These switches called Frequency Selectors, are to be used to link a SENDER to the TERMINAL (console operator) or to link the TERMINAL to the SENDER. This is a point which is frequently confused.

NAVTRADEV CEN 68-C-0215-1

Remember, the Frequency Selectors are used only for communication between the CCC and the Sender. Also, it is important to remember that you can always use a frequency selector, even when all channels are occupied. Below the frequency selectors are the three columns of channel selectors for HF, VHF, and UHF communication. These switch-lights serve two functions. First, they are used to select a channel through which a communication to a receiver is made. Second, they provide information about which channels are currently in use and the priorities of these messages. Priority information is provided according to the following color code:

- 

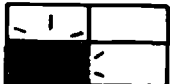
- A PRIORITY 1 message is currently occupying the channel (lighted portion is red)
- 

- A PRIORITY 2 message is currently occupying the channel (lighted portion is green)
- 

- A PRIORITY 3 message is currently occupying the channel (lighted portion is white)
- 

- channel unoccupied (no illumination)

The upper right section of the panel contains the PATCHING DIALS. These are two rotary switches which are numbered clockwise from 0 to 31. Lettering on the panel is in units of 5, but there is a switch position for all numbers zero through 31. The left dial connects the SENDER and the right dial connects the RECEIVER.

Below the patching dials are three OUTPUT SIGNAL switches, BUSY, STANDBY, and CONNECT. They are illuminated in the top half when the switches are not activated, and wholly illuminated when activated.

Below the OUTPUT SIGNAL switches is a TRANSMIT signal pushbutton. After you have selected an output signal, you must always activate the transmit signal pushbutton.

During the presentation of problems, you will have access to all necessary information. This information is contained on 35 mm slides. You will notice that a slide selector is located on the shelf before you. Above the CCC is a screen which displays the selected slide. I will now demonstrate the use of the information display.

In order to help you better visualize the logical structure of this communications network, we have made a series of cartoon slides. The cartoons depict various air travel situations. We have chosen the air travel problems because of its strong, conceptual similarity to the operation of this communication system.

In the following cartoon series, it will aid you to think of the tickets and reservations agent as serving a similar function to what you are doing as operator of the CCC. The analogy is that in the air travel situation the agent arranges for the traveler to go from one place to another in the most expeditious manner. Likewise the CCC operator arranges for messages to efficiently get from one place to another.

The simplest type of air travel is the direct or non-stop flight from one place to another. This is analogous to the S-S communication routine because, in both cases, the pathway is direct and unobstructed. The first series of slides depict the sequence of events that a traveler goes through in making a non-stop flight.

(SHOW SLIDE #41)

"In Slide 1, we see the traveler arriving at the airport."

(SHOW SLIDE #42)

"Here the traveler is requesting to get from Minneapolis/St. Paul to Atlanta." The agent handles the request by ticketing the passenger on a non-stop flight, just as you might arrange a simple S-S communication patch."

(SHOW SLIDE #43)

"The passenger is shown at the beginning of his trip."

(SHOW SLIDE #44)

"We now see the traveler arriving at his destination."

In the next series of slides we depict a travel problem very similar to the S-T-S communication routine:

(SHOW SLIDE #45)

"In this case the traveler cannot get a direct flight to Houston. The agent therefore arranges for the traveler to first fly to Chicago and to change planes there for one to Houston. This is equivalent to sending a message from the originating subscriber to the terminal and then redirecting the message from the terminal to the receiving subscriber."

(SHOW SLIDE #46)

"Here again the traveler is starting his trip."

(SHOW SLIDE #47)

"The passenger is now in Chicago on his way to the connecting flight; just as a message would be at the CCC about ready to be relayed to the receiver."

(SHOW SLIDE #48)

"Again, we see the plane reaching its final destination - in this case - Houston."

As we mentioned earlier, there are times when a message cannot be transmitted because of a lack of open channels. Likewise, there are times when no seats are available on airplanes.

NAVTRADECEN 68-C-0215-1

However, sometimes certain passengers have a greater need to get on a flight than other passengers who have already been ticketed. In the same sense, certain communications have a higher priority for getting their messages processed.

(SHOW SLIDE #49)

"This cartoon shows a VIP requesting a place on a flight which is already full. However, the ticket agent is going to make it possible for the Ambassador to get on the plane."

(SHOW SLIDE #50)

"In order to make room for the Ambassador, it is necessary to place a lower priority passenger on **STANDBY**. This means that as soon as a seat becomes available, the bumped passenger will get it."

(SHOW SLIDE #51)

"In this cartoon we have the air travel equivalent of the interrupt - BUSY routine. The passenger being bumped has the lowest priority i. e., even lower than in the previous case. Therefore, the passenger being bumped is simply refused passage on this flight and must wait for an indefinite period."

The next two slides show the air travel equivalent of the deny routine, first for the DENY/STANDBY, and then for DENY/BUSY. Again, STANDBY versus BUSY is a case of relative priority.

(SHOW SLIDE #52)

"This passenger can't immediately get on the plane, but will as soon as a seat becomes available."

(SHOW SLIDE #53)

"This passenger simply will not be able to take this flight and must wait for another."

Notice the difference between these last two slides. In the first case, the passenger was a regular fare and therefore had higher priority than the Sergeant, who would have gotten a half-fare ticket. Think of the similarity between this situation and that of communication subscribers with different priorities. Just as the full fare passenger gets preferential treatment, so does the priority 1 or 2 request as compared with the priority 3 requestor.

OPERATIONAL REQUIREMENTS AND PROCEDURES

To process a communication request, the Operator must decide which mode and which procedure to use.

SUBSCRIBER TO SUBSCRIBER

The simplest and most straightforward mode of communication is S-S. This mode can be used only if all the following conditions pertain:

1. There is a common language
2. There is a common frequency
3. There is an open channel on the common frequency

Now here is a sample problem to illustrate the S-S mode. Let us look up Sender and Receiver capabilities. In this case the Sender is number 8 and the Receiver is number 17. We have provided slips of paper for your convenience in noting Subscriber information. Each slip must be thrown away after each problem. We see that they do speak the same language; they have a common frequency, in fact they have two frequencies in common, viz., HF and UHF; and there are open channels on both common frequencies. Since there are an equal number of open channels on both frequencies, you can use either one.

To make a simple S-S patch, the Operator executes the following routine:

1. Select **SENDER Identification Number (ID)** on the left **PATCHING DIAL**. For now, simply write the number 8 on your response sheet here.
2. Select **RECEIVER ID** on right **PATCHING DIAL**, i. e., write in the number 17 here.
3. Select an appropriate **CHANNEL**, i. e., the uppermost unoccupied one. Do this by placing an X here.
4. Activate **CONNECT OUTPUT SIGNAL**
5. Activate **TRANSMIT** signal. For now we will use this switch instead.

NAVTRADEVCCEN 68-C-0215-1

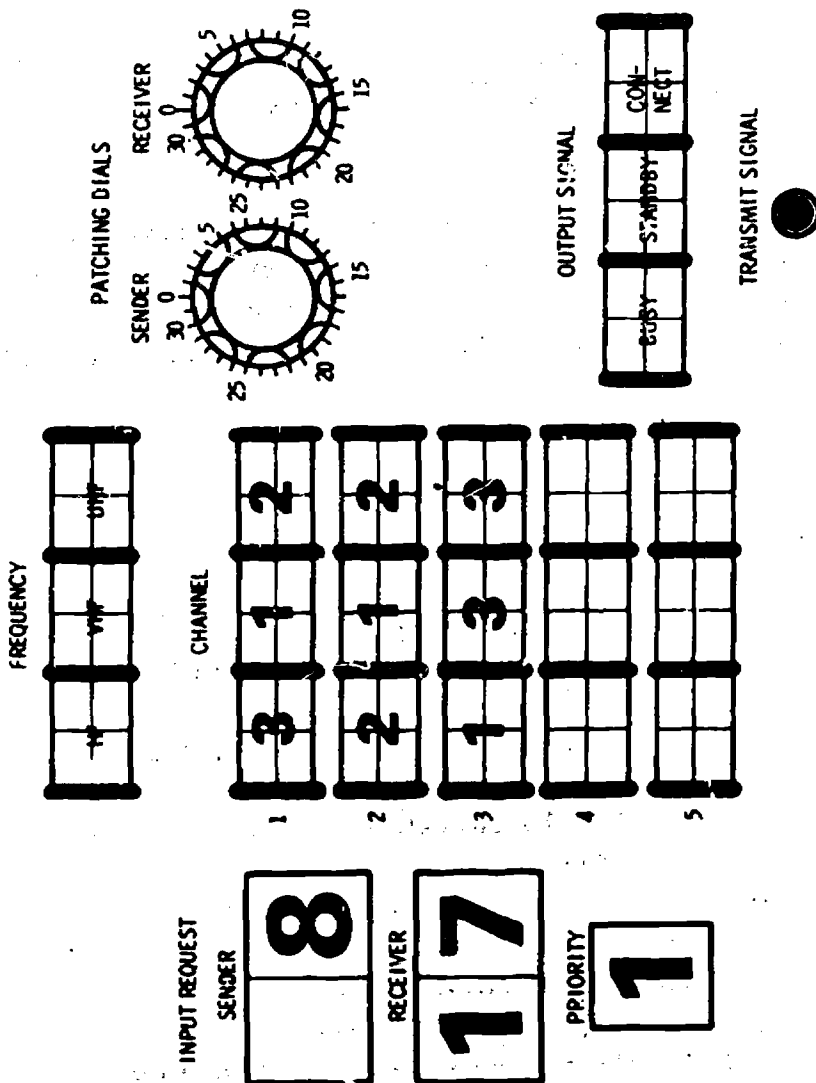

SAMPLE 1

SUBSCRIBER TO TERMINAL TO SUBSCRIBER

The communication must be processed S-T-S, if any of the following conditions exist:

1. There is a language disparity.
2. There is a frequency disparity.
3. There is an open channel within the receiver's capability, but not the sender's.

Here is a sample S-T-S problem involving subscriber 4 and subscriber 12. (Look up 4 and 12). We see that 4 speaks Spanish and 12 speaks German. Therefore we must use S-T-S because of language disparity. Even if both spoke the same language we would have to go to S-T-S because 4 has only HF, while 12 has VHF and UHF.

S-T-S ROUTINE

To make an S-T-S patch, the Operator must:

1. Select **SENDER ID** on left **PATCHING DIAL**.
2. Select position 1 on right **PATCHING DIAL** (Position 1 is the terminal address).
3. Select a **FREQUENCY** within sender's capability; in this case only HF can be used.
4. Activate **CONNECT OUTPUT SIGNAL**.
5. Activate **TRANSMIT SIGNAL**.
6. Wait for panel lights to flash; but for now, wait for this light to go back on.
7. Select Position 1 on left **PATCHING DIAL**.
8. Select receiver **ID** on right **PATCHING DIAL**.
9. Select a **CHANNEL** within the receiver's capability. Here, since VHF has three open channels and UHF only one, we will use VHF.
10. Activate **CONNECT OUTPUT SIGNAL**.
11. Activate **TRANSMIT SIGNAL**.

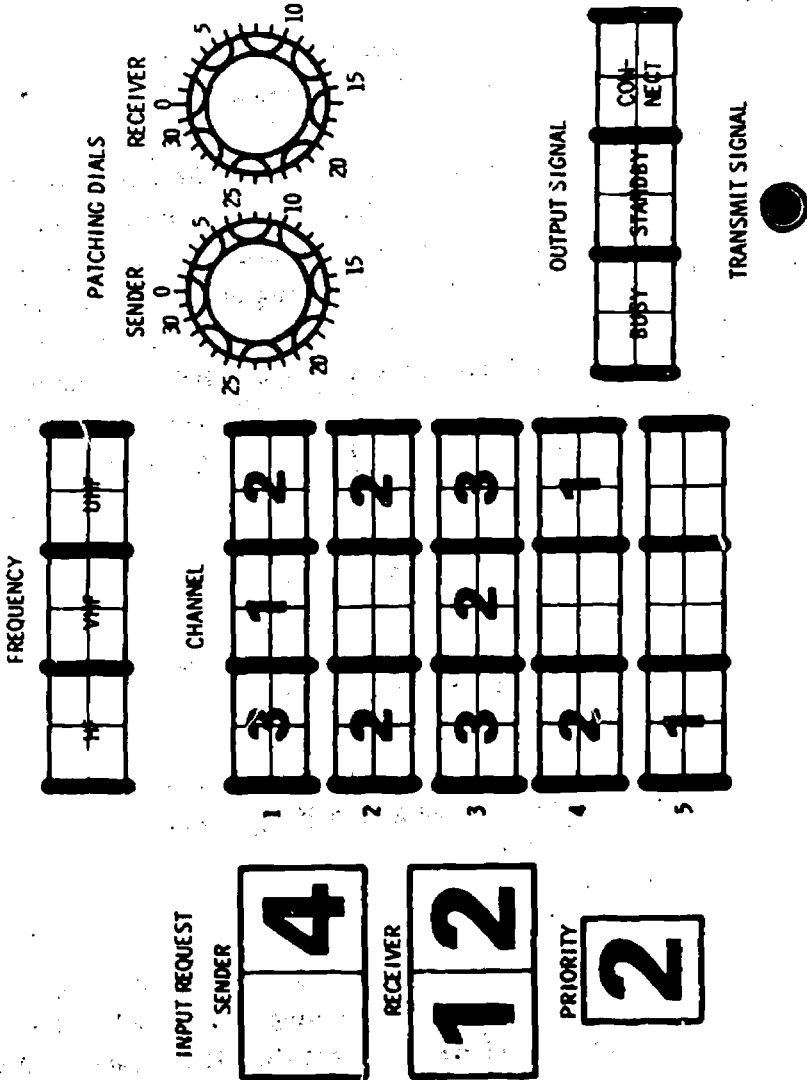

SAMPLE 2

CHANNEL CLEARING

The Interrupt routine is used when both of the following conditions exist:

1. There are no open channels within the receiver's capability; and
2. There is at least one channel usable by the receiver which is occupied by a lower priority message.

We will now look at two problems which require use of the interrupt routine. The first problem involves subscriber 18 who wishes to communicate with subscriber 22. We see that both subscribers are English speaking and that they each have HF and VHF capability. Now looking at the channel/priority indications, we can see that all HF and VHF channels are in use. Since all channels other than HF 2 have priority ones and twos, HF 2 having priority 3 occupancy, we will select HF 2 for interruption. The general rule governing such situations is that we interrupt the lowest priority channel.

CHANNEL CLEARING WITH S-S ROUTINE

To interrupt a channel, the Operator uses the following routine:

1. Select position 30 on both PATCHING DIALS
2. Select CHANNEL to be interrupted
3. Activate BUSY if interrupting a priority 3 or STANDBY for a priority 2. In this case we give a BUSY signal.
4. Activate TRANSMIT SIGNAL
5. Wait for CHANNEL to be opened

Now, having cleared HF channel 2, we can proceed to communicating by S-S. In other words, we first select 18 on the left patching dial and 22 on the right patching dial. We now select channel HF 2, select CONNECT, and finally activate TRANSMIT SIGNAL.

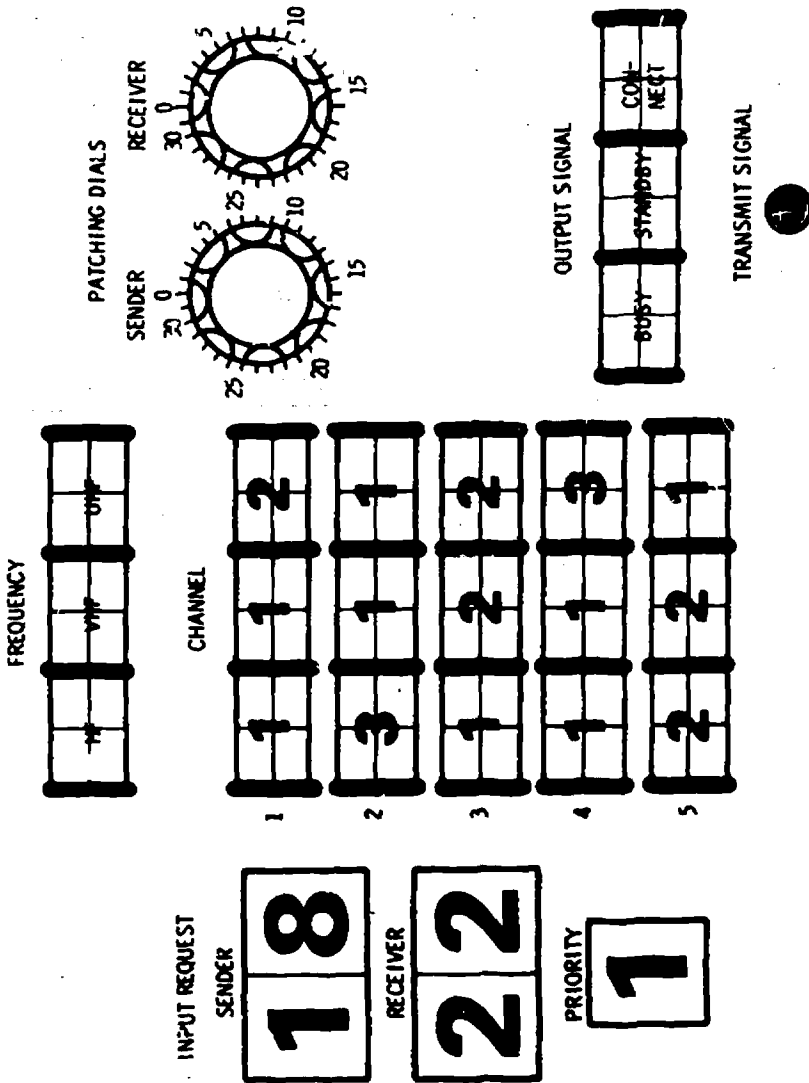

SAMPLE 3

NAVTRADEVCEEN 68-C-0215-1

In the second problem, subscriber 20 requests communication with subscriber 21. Number 20 has HF and VHF, while 21 has all frequencies. Both speak German. If there were open channels on either HF or VHF, we could use the S-S routine. However, both HF and VHF channels are all occupied. Moreover, HF and VHF contain all priority 1 communications and therefore must not be interrupted. The only remaining possibility for communicating is to use S-T-S, first bringing the message into the terminal through either HF or VHF frequency, and then interrupting UHF 1 and using it to reach the receiver.

CHANNEL CLEARING WITH S-T-S ROUTINE

To accomplish an interrupt S-T-S routine we use the following procedures:

1. Select Sender number, in this case number 20 on left PATCHING DIAL.
2. Select position 1 on right PATCHING DIAL.
3. Select an appropriate FREQUENCY; in this case either HF or VHF.
4. Select CONNECT OUTPUT SIGNAL
5. Activate TRANSMIT SIGNAL

At this point the message is transmitted to the terminal. Receipt of the message is signaled by a flashing of the panel lights. Now we interrupt the desired channel, viz. UHF 1, in the same manner as in the previous problem, i. e.:

1. Select position 30 on both PATCHING DIAL 3.
2. Select UHF CHANNEL
3. Activate STBY since we are interrupting a priority 2 message.
4. Activate TRANSMIT SIGNAL
5. Wait for channel to be opened

Now we can proceed with completion of the second part of the S-T-S procedure.

1. Select position 1 on left PATCHING DIAL
2. Select position 21 on right PATCHING DIAL
3. Select UHF CHANNEL 1

NAVTRADEVCCEN 68-C-0215-1

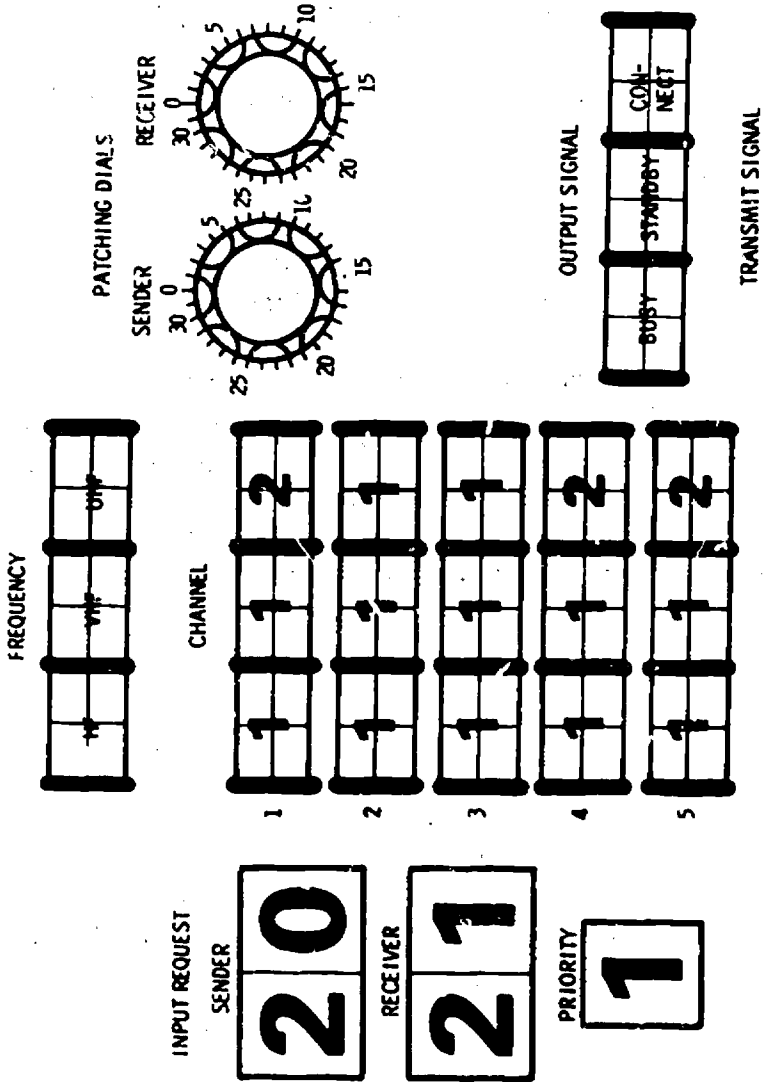

SAMPLE 4

4. Select CONNECT OUTPUT SIGNAL
5. Activate TRANSMIT SIGNAL

COMMUNICATION REQUEST DENIAL

A communications patch cannot be made and the incoming request is denied if both of the following conditions are present:

1. There is no open channel within the receiver's frequency capability; and
2. All channels within the receiver's frequency capability are occupied with messages of equal or higher priority.

The final sample problem illustrates this situation. Subscriber 15 wishes to communicate with Subscriber 19. We find that Subscriber 15, the sender, has HF and VHF capability, and Subscriber 19, the receiver, has only HF capability. Looking at the channel/priority indicators, we see that all five HF channels are occupied with priority 1 and 2 messages. Since the sender wishes to communicate a priority 2 message, and the receiver's frequency capability is occupied with messages of equal or higher priority, a channel cannot be interrupted, and the sender's request to communicate must be denied.

To deny a communication request:

1. Select position 1 on left PATCHING DIAL
2. Select sender ID on right PATCHING DIAL
3. Select any FREQUENCY within Sender's capability
- 4a. Activate STANDBY OUTPUT SIGNAL if sender's request was Priority 1 or Priority 2
- 4b. Activate BUSY OUTPUT SIGNAL if sender's request was Priority 3

In this case, we activate STANDBY

5. Activate TRANSMIT SIGNAL

NAVTRADEVCCEN 68-C-0215-1

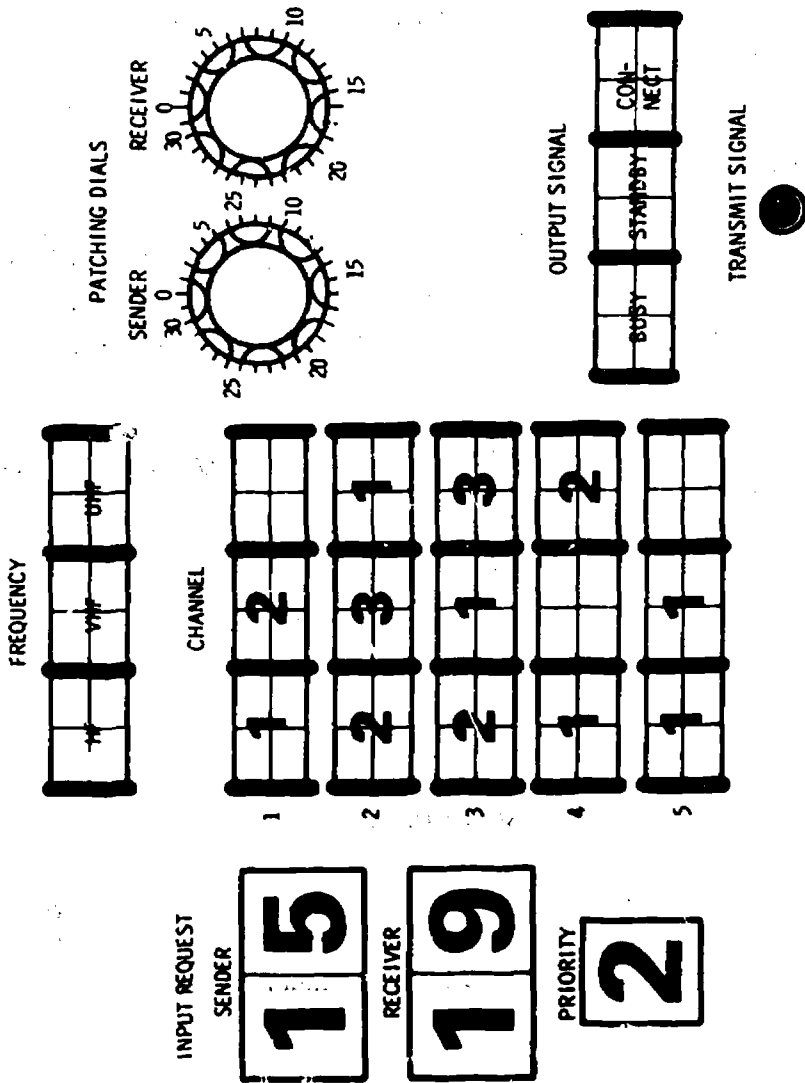

SAMPLE 5

NAVTRADEV CEN 68-C-0215-1

TABLE 1 (SLIDE #27)

FREQUENCY RULES

1. Subscribers can communicate directly (S-S) only on channels common to both parties.
2. If there is no open channel common to both, go to S-T-S mode. (See Priority Rules.)
3. If common channels are in use and cannot be interrupted (See Priority Rules) and there is no open channel usable by the receiving subscriber, a patch cannot be made and the sender's request is denied. (See Priority Rules.)
4. If channels are open on more than one usable frequency, use a channel on the least-occupied frequency.

TABLE 2 (SLIDE #28)

LANGUAGE RULES

1. Subscribers can communicate directly (S-S) only in a common language.
2. If there is no common language, the message must be translated (S-T-S).

TABLE 3

PRIORITY RULES

TO PROCESS A PRIORITY (P-1) MESSAGE (SLIDE #29)

- If all channels within the receiver's capability are filled with P-1, deny sender's request and place sender on STANDBY.
- If all channels are filled with P-1 and/or P-2, interrupt the uppermost P-2 and then proceed with the patch.
- If all channels are filled with P-1, P-2, and/or P-3, interrupt the uppermost P-3 and then proceed with the patch.

TO PROCESS A PRIORITY (P-2) MESSAGE (SLIDE #30)

- If all channels are filled with P-1 and/or P-2, deny sender's request and place sender on STANDBY.
- If all channels are filled with P-1, P-2, and/or P-3, interrupt the uppermost P-3 and then proceed with the patch.

TO PROCESS A PRIORITY (P-3) MESSAGE (SLIDE #31)

- If all channels are filled, deny sender's request and place sender on BUSY.

FINAL OPERATING INSTRUCTIONS

We are very much aware that your task in this experiment is complex. The high difficulty thereby produced is necessary in order to adequately simulate the kinds of jobs performed by equipment operators in actual systems. Therefore you must make an attempt to grasp the basic function of the system rather than simply memorizing rules and procedures. Do not hesitate to look up information until you are very confident that you have this knowledge.

Your task is to process or deny each communication request as rapidly as possible, consistent with very high levels of accuracy. Your performance will be evaluated in terms of the average time required to complete each problem. Although you will be paid a minimum of two dollars per hour, you can earn as much as four dollars per hour by operating at highest levels of performance. It is vital that each communication be processed without errors, but you should not delay unnecessarily.

Before the beginning of each problem I will say "ready." Each problem will then begin when the lights on the CCC become illuminated; or for now, when this light turns on.

IMAGERY, HIGH FIDELITY MANUAL

INTRODUCTION

This experiment is the first in a series of studies investigating ways to improve training of complex-system operators.

You will be asked to learn to operate a communications system similar, in some ways, to that used in worldwide communications networks. Your task, as an operator, will be to operate the Communications Control Console (CCC), which is the hub of the communications system.

There will be two phases of training. In the first phase you will learn operating characteristics of the system. In the second phase you will be given a series of 30 training problems involving the operation of the CCC. You will return one week from today. At that time you will be given an additional set of 30 problems, in order to measure how well you remember what you have learned here today.

The purpose of this communications systems is to enable a group of communication facilities or Subscribers, located at relatively great distances from one another, to transmit and receive messages among themselves. Because of the distances involved and the limited range of each subscriber's radio equipment, the CCC is necessary to provide signal boosting or amplification. In other words, all messages from one subscriber to another must pass through the CCC. When the CCC is involved only for amplification, the communication routine will be referred to as SUBSCRIBER to SUBSCRIBER (S-S).

However, not all transmissions can be made in such a simple manner. Because there are variations in the type of radio equipment (frequency) used by the subscribers, it is not always possible for one subscriber to receive messages from another's transmitter. In these cases it is mandatory that the originator of the message send it to the CCC on the originating subscriber's

NAVTRADEVCCEN 68-C-0215-1

frequency. It must then be transmitted from the CCC to the receiving subscriber, on the latter's frequency. This process occurs in two discrete steps; i. e., Sender to CCC and CCC to Receiver. This more complex form of communication will be referred to as SUBSCRIBER to TERMINAL to SUBSCRIBER (S-T-S).

In addition to frequency disparity, there are sometimes cases where two communicating Subscribers speak different languages. When instances of language disparity occur it is also necessary to employ the S-T-S mode of operation. The identical S-T-S routine is used to overcome both language and frequency disparities. In fact, it is sometimes the case that both types of disparity are present. The major difference between the S-S and the S-T-S modes is that a delay at the CCC is necessary before the S-T-S message can be relayed to the receiver. Remember, two separate steps are necessary in the S-T-S mode, while one step is used in the S-S mode.

A third mode of operation is sometimes used. This mode is necessary because there are only a limited number of channels through which Subscribers can receive messages. When a subscriber requests that he communicate with another subscriber, through the CCC, and all channels usable by the receiving subscriber are occupied, the console operator must determine whether the present message is of a higher priority than any of those currently occupying usable channels. When the incoming message is of higher priority one of the channels must be opened. This requires that the operator interrupt some lower priority communication. Interrupting a channel merely opens that channel to the receiver. The interrupt routine is used in conjunction with either the S-S or S-T-S routine.

Finally, there sometimes exists the situation where all usable channels are occupied with equal or higher priority communications than that being requested. In this case the CCC operator must inform the requesting subscriber that he must wait to transmit.

GENERAL SYSTEM CHARACTERISTICS

The Communications Control Console is the device which makes possible the patching of one subscriber to another so that they can communicate. The console has five channels on each broadcast frequency: High Frequency (HF), Very High Frequency (VHF) and Ultra High Frequency (UHF). Some subscribers have only one frequency capability, some have two, and some have all three capabilities.

Each of the 25 subscribers communicates in only one language: English, German, Spanish, Greek, or Swedish.

When a subscriber requests that a patch be made between him (Sender) and another subscriber (Receiver), he places a priority on his communications request. Priority One is extremely urgent and must be patched immediately if at all possible. Priority Two is very important but not urgent. Priority Three is used for routine communications which can wait if necessary.

Frequency, Language, and Priority, must be considered each and every time you make a patch between sender and receiver. Tables summarizing the rules associated with these three factors will be provided.

Let us now see what the CCC looks like. At the left of the CCC are three transilluminated panels. The top panel displays the SENDER identification number, the middle one displays the RECEIVER identification number, and the bottom panel displays the priority of the call currently being requested.

The center of the CCC contains frequency and channel information. The top row of switch-lights are frequency selectors. When activated, each switch selects a frequency; either HF, VHF or UHF. In the unactivated position, the top half of the indicator is illuminated. When activated, both top and bottom are illuminated. These switches called Frequency Selectors, are to be used to link a SENDER to the TERMINAL (console operator) or to link the TERMINAL to the SENDER. This is a point which is frequently confused.

NAVTRADEV CEN 68-C-0215-1

Remember, the Frequency Selectors are used only for communication between the CCC and the Sender. Also, it is important to remember that you can always use a frequency selector, even when all channels are occupied. Below the frequency selectors are the three columns of channel selectors for HF, VHF, and UHF communication. These switch-lights serve two functions. First, they are used to select a channel through which a communication to a receiver is made. Second, they provide information about which channels are currently in use and the priorities of these messages. Priority information is provided according to the following color code:

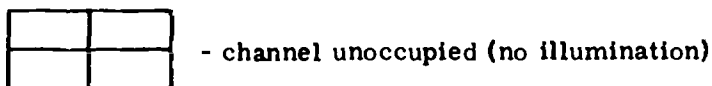
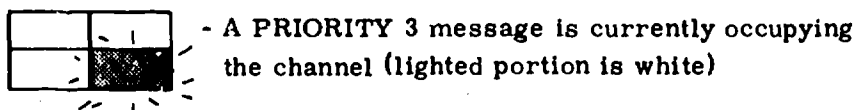
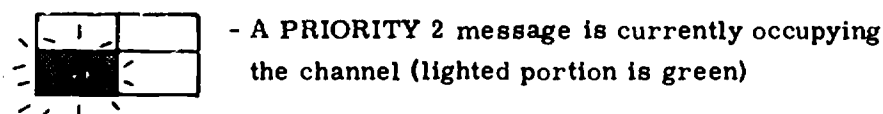
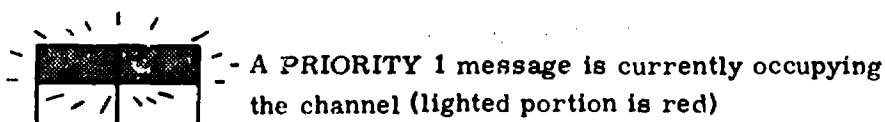

The upper right section of the panel contains the PATCHING DIALS. These are two rotary switches which are numbered clockwise from 0 to 31. Lettering on the panel is in units of 5, but there is a switch position for all numbers zero through 31. The left dial connects the SENDER and the right dial connects the RECEIVER.

Below the patching dials are three OUTPUT SIGNAL switches, BUSY, STANDBY, and CONNECT. They are illuminated in the top half when the switches are not activated, and wholly illuminated when activated.

Below the OUTPUT SIGNAL switches is a TRANSMIT signal pushbutton. After you have selected an output signal, you must always activate the transmit signal pushbutton.

During the presentation of problems, you will have access to all necessary information. This information is contained on 35 mm slides. You will notice that a slide selector is located on the shelf before you. Above the CCC is a screen which displays the selected slide. I will now demonstrate the use of the information display.

In order to help you better visualize the logical structure of this communications network, we have made a series of cartoon slides. The cartoons depict various air travel situations. We have chosen the air travel problems because of its strong, conceptual similarity to the operation of this communication system.

In the following cartoon series, it will aid you to think of the tickets and reservations agent as serving a similar function to what you are doing as operator of the CCC. The analogy is that in the air travel situation the agent arranges for the traveler to go from one place to another in the most expeditious manner. Likewise the CCC operator arranges for messages to efficiently get from one place to another.

NAVTRADEV CEN 68-C-0215-1

The simplest type of air travel is the direct or non-stop flight from one place to another. This is analogous to the S-S communication routine because, in both cases, the pathway is direct and unobstructed. The first series of slides depict the sequence of events that a traveler goes through in making a non-stop flight.

(SHOW SLIDE #41)

"In Slide 1, we see the traveler arriving at the airport."

(SHOW SLIDE #42)

"Here the traveler is requesting to get from Minneapolis/St. Paul to Atlanta." The agent handles the request by ticketing the passenger on a non-stop flight, just as you might arrange a simple S-S communication patch."

(SHOW SLIDE #43)

"The passenger is shown at the beginning of his trip."

(SHOW SLIDE #44)

"We now see the traveler arriving at his destination."

In the next series of slides we depict a travel problem very similar to the S-T-S communication routine:

(SHOW SLIDE #45)

"In this case the traveler cannot get a direct flight to Houston. The agent therefore arranges for the traveler to first fly to Chicago and to change planes there for one to Houston. This is equivalent to sending a message from the originating subscriber to the terminal and then redirecting the message from the terminal to the receiving subscriber."

NAVTRADEV CEN 68-C-0215-1

(SHOW SLIDE #46)

"Here again the traveler is starting his trip."

(SHOW SLIDE #47)

"The passenger is now in Chicago on his way to the connecting flight; just as a message would be at the CCC about ready to be relayed to the receiver."

(SHOW SLIDE #48)

"Again, we see the plane reaching its final destination - in this case - Houston."

As we mentioned earlier, there are times when a message cannot be transmitted because of a lack of open channels. Likewise, there are times when no seats are available on airplanes.

NAVTRADEVEN 68-C-0215-1

However, sometimes certain passengers have a greater need to get on a flight than other passengers who have already been ticketed. In the same sense, certain communications have a higher priority for getting their messages processed.

(SHOW SLIDE #49)

"This cartoon shows a VIP requesting a place on a flight which is already full. However, the ticket agent is going to make it possible for the Ambassador to get on the plane."

(SHOW SLIDE #50)

"In order to make room for the Ambassador, it is necessary to place a lower priority passenger on STANDBY. This means that as soon as a seat becomes available, the bumped passenger will get it."

(SHOW SLIDE #51)

"In this cartoon we have the air travel equivalent of the interrupt - BUSY routine. The passenger being bumped has the lowest priority i. e., even lower than in the previous case. Therefore, the passenger being bumped is simply refused passage on this flight and must wait for an indefinite period."

The next two slides show the air travel equivalent of the deny routine, first for the DENY/STANDBY, and then for DENY/BUSY. Again, STANDBY versus BUSY is a case of relative priority.

(SHOW SLIDE #52)

"This passenger can't immediately get on the plane, but will as soon as a seat becomes available."

(SHOW SLIDE #53)

"This passenger simply will not be able to take this flight and must wait for another."

Notice the difference between these last two slides. In the first case, the passenger was a regular fare and therefore had higher priority than the Sergeant, who would have gotten a half-fare ticket. Think of the similarity between this situation and that of communication subscribers with different priorities. Just as the full fare passenger gets preferential treatment, so does the priority 1 or 2 request as compared with the priority 3 requestor.

OPERATIONAL REQUIREMENTS AND PROCEDURES

To process a communication request, the Operator must decide which mode and which procedure to use.

SUBSCRIBER TO SUBSCRIBER

The simplest and most straightforward mode of communication is S-S. This mode can be used only if all the following conditions pertain:

1. There is a common language
2. There is a common frequency
3. There is an open channel on the common frequency

Now here is a sample problem to illustrate the S-S mode. Let us look up Sender and Receiver capabilities. In this case the Sender is number 8 and the Receiver is number 17. We have provided slips of paper for your convenience in noting Subscriber information. Each slip must be thrown away after each problem. We see that they do speak the same language; they have a common frequency, in fact they have two frequencies in common, viz., HF and UHF; and there are open channels on both common frequencies. Since there are an equal number of open channels on both frequencies, you can use either one.

To make a simple S-S patch, the Operator executes the following routine:

1. Select **SENDER Identification Number (ID)** on the left
PATCHING DIAL
 2. Select **RECEIVER ID** on right **PATCHING DIAL**
 3. Select an appropriate **CHANNEL**, i. e., the uppermost unoccupied one
 4. Activate **CONNECT OUTPUT SIGNAL**
 5. Activate **TRANSMIT** signal
-

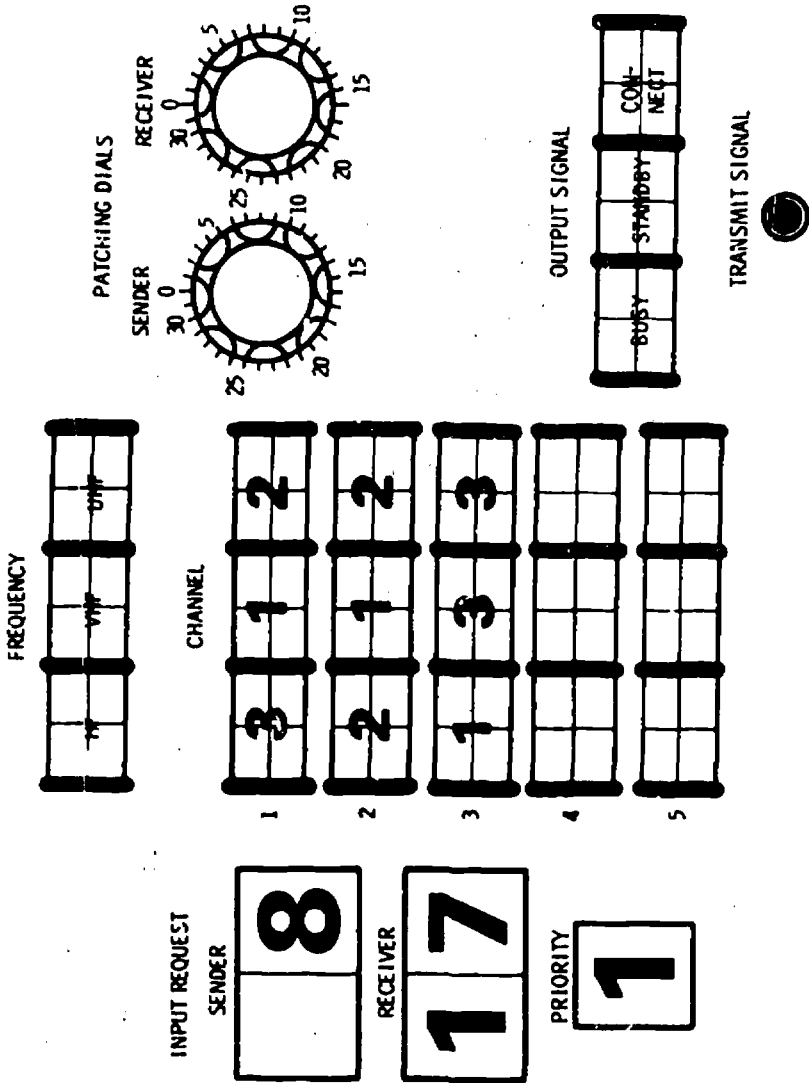

SAMPLE 1

SUBSCRIBER TO TERMINAL TO SUBSCRIBER

The communication must be processed S-T-S, if any of the following conditions exist:

1. There is a language disparity.
2. There is a frequency disparity.
3. There is an open channel within the receiver's capability, but not the sender's.

Here is a sample S-T-S problem involving subscriber 4 and subscriber 12. (Look up 4 and 12). We see that 4 speaks Spanish and 12 speaks German. Therefore we must use S-T-S because of language disparity. Even if both spoke the same language we would have to go to S-T-S because 4 has only HF, while 12 has VHF and UHF.

S-T-S ROUTINE

To make an S-T-S patch, the Operator must:

1. Select SENDER ID on left PATCHING DIAL.
2. Select position 1 on right PATCHING DIAL (Position 1 is the terminal address).
3. Select a FREQUENCY within sender's capability; in this case only HF can be used.
4. Activate CONNECT OUTPUT SIGNAL.
5. Activate TRANSMIT SIGNAL.
6. Wait for panel lights to flash; but for now, wait for this light to go back on.
7. Select Position 1 on left PATCHING DIAL.
8. Select receiver ID on right PATCHING DIAL.
9. Select a CHANNEL within the receiver's capability. Here, since VHF has three open channels and UHF only one, we will use VHF.
10. Activate CONNECT OUTPUT SIGNAL.
11. Activate TRANSMIT SIGNAL.

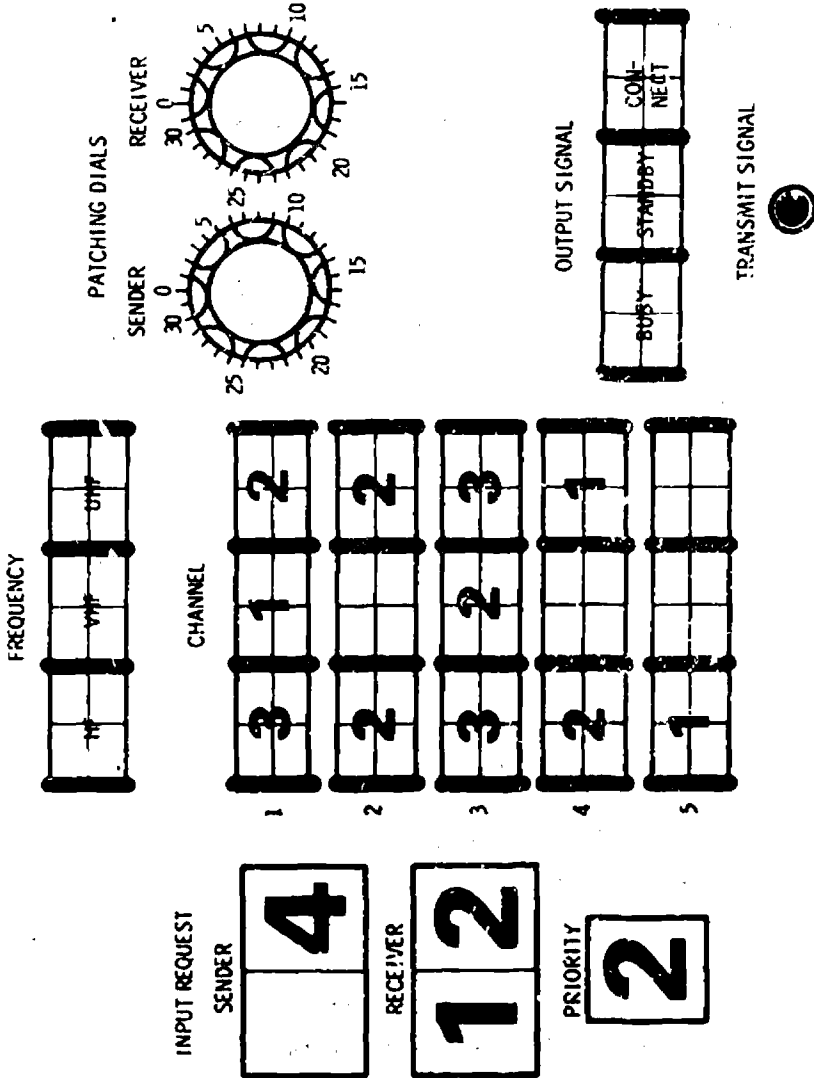

SAMPLE 2

CHANNEL CLEARING

The Interrupt routine is used when both of the following conditions exist:

1. There are no open channels within the receiver's capability; and
2. There is at least one channel usable by the receiver which is occupied by a lower priority message.

We will now look at two problems which require use of the interrupt routine. The first problem involves subscriber 18 who wishes to communicate with subscriber 22. We see that both subscribers are English speaking and that they each have HF and VHF capability. Now looking at the channel/priority indications, we can see that all HF and VHF channels are in use. Since all channels other than HF 2 have priority ones and twos, HF 2 having priority 3 occupancy, we will select HF 2 for interruption. The general rule governing such situations is that we interrupt the lowest priority channel.

CHANNEL CLEARING WITH S-S ROUTINE

To interrupt a channel, the Operator uses the following routine:

1. Select position 30 on both PATCHING DIALS
2. Select CHANNEL to be interrupted
3. Activate BUSY if interrupting a priority 3 or STANDBY for a priority 2. In this case we give a BUSY signal.
4. Activate TRANSMIT SIGNAL
5. Wait for CHANNEL to be opened

Now, having cleared HF channel 2, we can proceed to communicating by S-S. In other words, we first select 18 on the left patching dial and 22 on the right patching dial. We now select channel HF 2, select CONNECT, and finally activate TRANSMIT SIGNAL.

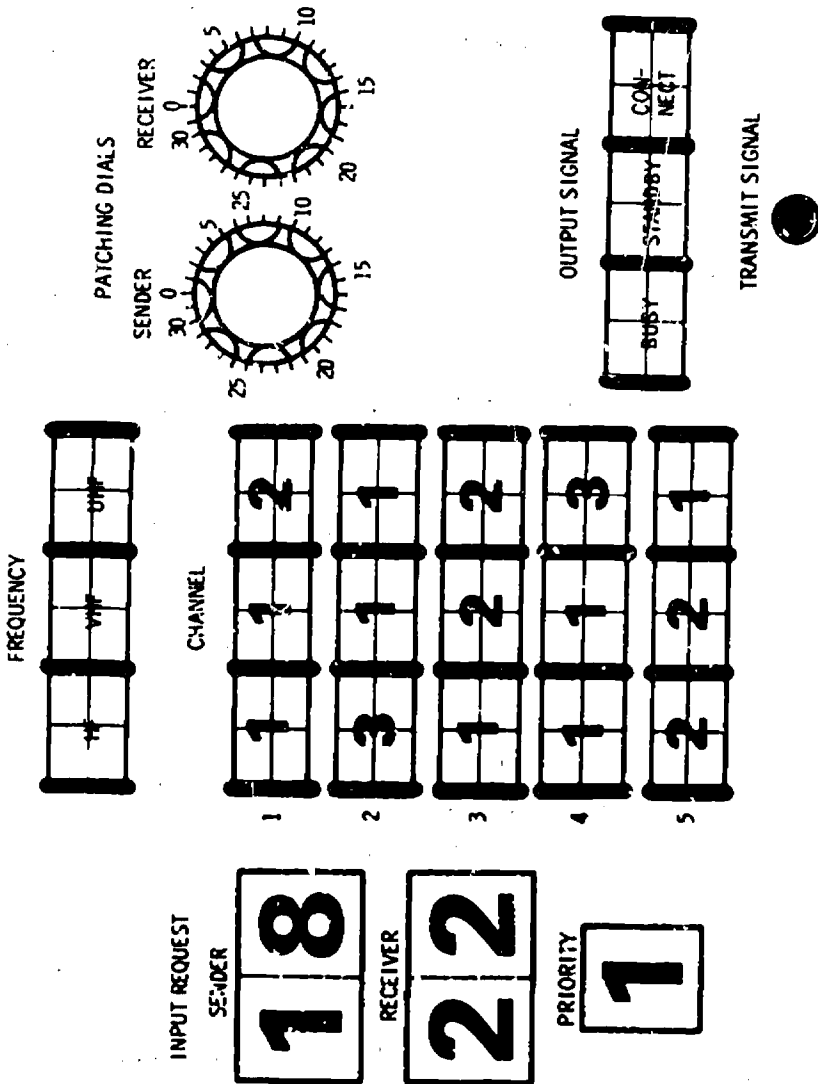

SAMPLE 3

NAVTRADEVCCEN 68-C-0215-1

In the second problem, subscriber 20 requests communication with subscriber 21. Number 20 has HF and VHF, while 21 has all frequencies. Both speak German. If there were open channels on either HF or VHF, we could use the S-S routine. However, both HF and VHF channels are all occupied. Moreover, HF and VHF contain all priority 1 communications and therefore must not be interrupted. The only remaining possibility for communicating is to use S-T-S, first bringing the message into the terminal through either HF or VHF frequency, and then interrupting UHF 1 and using it to reach the receiver.

CHANNEL CLEARING WITH S-T-S ROUTINE

To accomplish an interrupt S-T-S routine we use the following procedures:

1. Select Sender number, in this case number 20 on left PATCHING DIAL.
2. Select position 1 on right PATCHING DIAL.
3. Select an appropriate FREQUENCY; in this case either HF or VHF.
4. Select CONNECT OUTPUT SIGNAL
5. Activate TRANSMIT SIGNAL

At this point the message is transmitted to the terminal. Receipt of the message is signalled by a flashing of the panel lights. Now we interrupt the desired channel, viz. UHF 1, in the same manner as in the previous problem, i. e. :

1. Select position 30 on both PATCHING DIALS.
2. Select UHF CHANNEL 1
3. Activate STBY since we are interrupting a priority 2 message.
4. Activate TRANSMIT SIGNAL
5. Wait for channel to be opened

Now we can proceed with completion of the second part of the S-T-S procedure.

1. Select position 1 on left PATCHING DIAL
2. Select position 21 on right PATCHING DIAL
3. Select UHF CHANNEL 1

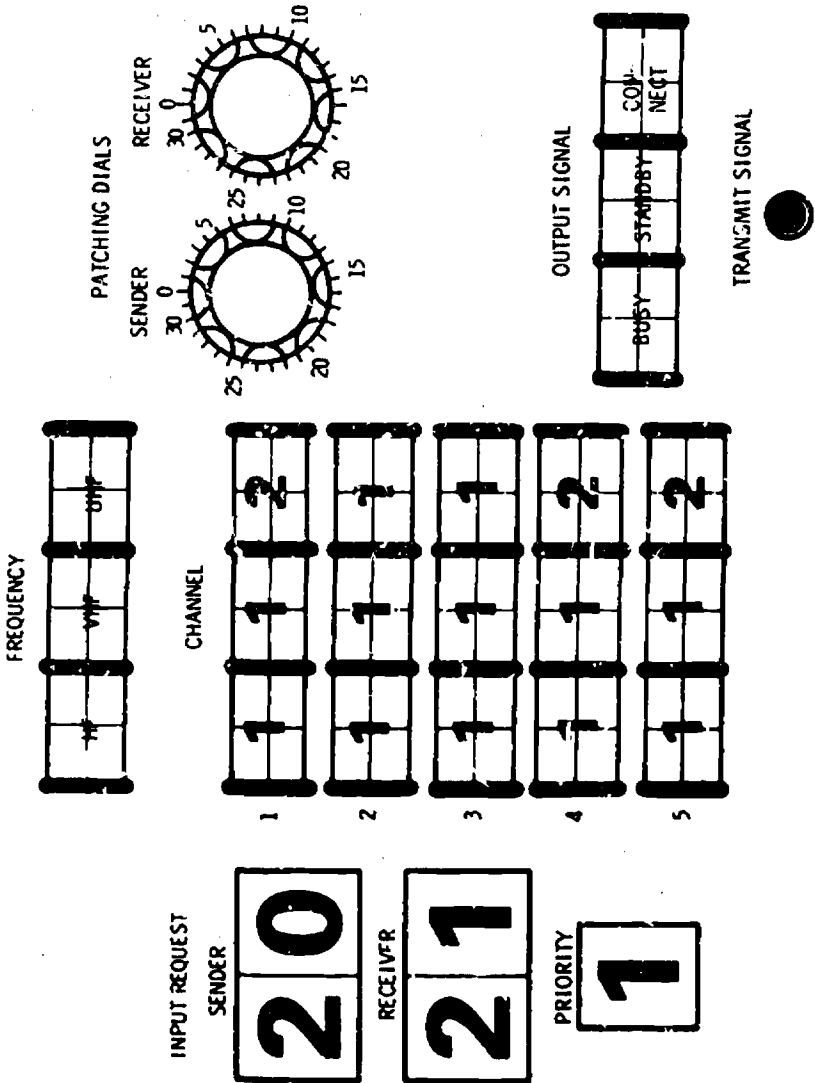

SAMPLE 4

4. Select CONNECT OUTPUT SIGNAL
5. Activate TRANSMIT SIGNAL

COMMUNICATION REQUEST DENIAL

A communications patch cannot be made and the incoming request is denied if both of the following conditions are present:

1. There is no open channel within the receiver's frequency capability; and
2. All channels within the receiver's frequency capability are occupied with messages of equal or higher priority.

The final sample problem illustrates this situation. Subscriber 15 wishes to communicate with Subscriber 19. We find that Subscriber 15, the sender, has HF and VHF capability, and Subscriber 19, the receiver, has only HF capability. Looking at the channel/priority indicators we see that all five HF channels are occupied with priority 1 and 2 messages. Since the sender wishes to communicate a priority 2 message, and the receiver's frequency capability is occupied with messages of equal or higher priority, a channel cannot be interrupted, and the sender's request to communicate must be denied.

To deny a communication request:

1. Select position 1 on left PATCHING DIAL
2. Select sender ID on right PATCHING DIAL
3. Select any FREQUENCY within Sender's capability
- 4a. Activate STANDBY OUTPUT SIGNAL if sender's request was Priority 1 or Priority 2
- 4b. Activate BUSY OUTPUT SIGNAL if sender's request was Priority 3

In this case, we activate STANDBY

5. Activate TRANSMIT SIGNAL

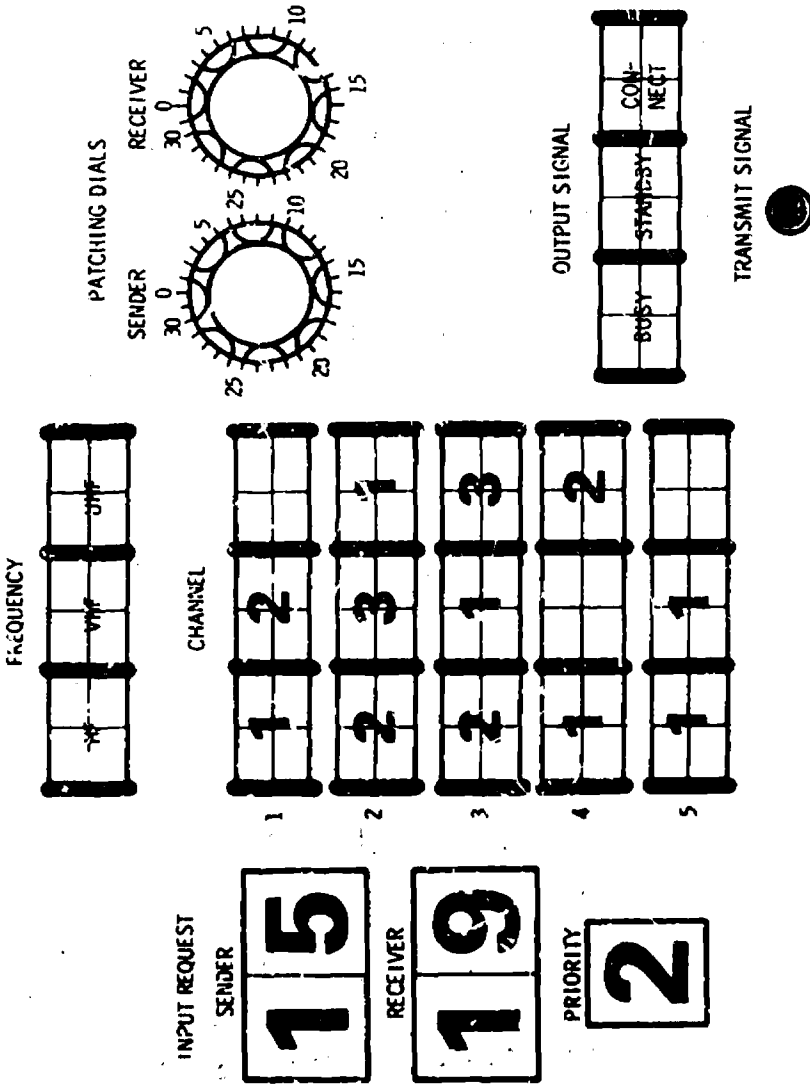

SAMPLE 5

NAVTRADEVEN 68-C-0215-1

TABLE 1 (SLIDE #27)

FREQUENCY RULES

1. Subscribers can communicate directly (S-S) only on channels common to both parties.
2. If there is no open channel common to both, go to S-T-S mode. (See Priority Rules.)
3. If common channels are in use and cannot be interrupted (See Priority Rules) and there is no open channel usable by the receiving subscriber, a patch cannot be made and the sender's request is denied. (See Priority Rules.)
4. If channels are open on more than one usable frequency, use a channel on the least-occupied frequency.

TABLE 2 (SLIDE #28)

LANGUAGE RULES

1. Subscribers can communicate directly (S-S) only in a common language.
2. If there is no common language, the message must be translated (S-T-S).

TABLE 3

PRIORITY RULES

TO PROCESS A PRIORITY (P-1) MESSAGE (SLIDE #29)

- If all channels within the receiver's capability are filled with P-1, deny sender's request and place sender on STANDBY.
- If all channels are filled with P-1 and/or P-2, interrupt the uppermost P-2 and then proceed with the patch.
- If all channels are filled with P-1, P-2, and/or P-3, interrupt the uppermost P-3 and then proceed with the patch.

TO PROCESS A PRIORITY (P-2) MESSAGE (SLIDE #30)

- If all channels are filled with P-1 and/or P-2, deny sender's request and place sender on STANDBY.
- If all channels are filled with P-1, P-2, and/or P-2, interrupt the uppermost P-3 and then proceed with the patch.

TO PROCESS A PRIORITY (P-3) MESSAGE (SLIDE #31)

- If all channels are filled, deny sender's request and place sender on BUSY.

FINAL OPERATING INSTRUCTIONS

We are very much aware that your task in this experiment is complex. The high difficulty thereby produced is necessary in order to adequately simulate the kinds of jobs performed by equipment operators in actual systems. Therefore you must make an attempt to grasp the basic function of the system rather than simply memorizing rules and procedures. Do not hesitate to look up information until you are very confident that you have this knowledge. However, the slide projector may only be used during a problem; never between problems.

Your task is to process or deny each communication request as rapidly as possible, consistent with very high levels of accuracy. Your performance will be evaluated in terms of the average time required to complete each problem. Although you will be paid a minimum of two dollars per hour, you can earn as much as four dollars per hour by operating at highest levels of performance. It is vital that each communication be processed without errors, but you should not delay unnecessarily.

Before the beginning of each problem I will say "ready". Each problem will then begin when the lights on the CCC become illuminated.

DOCUMENT CONTROL DATA - R & D

(Security classification of title, body of abstract and indexing annotations must be entered when the overall report is classified)

1. ORIGINATING ACTIVITY (Corporate Author) Honeywell Inc. Systems and Research Division, Research Department St. Paul, Minnesota 55113		2a. REPORT SECURITY CLASSIFICATION Unclassified	
		2b. GROUP NA	
3. REPORT TITLE LEARNING, RETENTION AND TRANSFER, Volume I of II			
4. DESCRIPTIVE NOTES (Type of report and inclusive dates) Final Technical Report, June 1968 through June 1969			
5. AUTHOR(S) (Full name, middle initial, last name) Bernard R. Fernstein, Barbara K. Gonzalez			
6. REPORT DATE February 1971	7a. TOTAL NO. OF PAGES 221	7b. NO. OF REFS 26	
8a. CONTRACT OR GRANT NO. N61339-68-C-0215	8b. ORIGINATOR'S REPORT NUMBER(S) 12126-FR1		
8c. PROJECT NO. 7846-1	8d. OTHER REPORT NO(S) (Any other numbers that may be assigned this report) NAVTRADEVCEEN 68-C-0215-1 Vol. I		
9. DISTRIBUTION STATEMENT Approved for public release; distribution unlimited.			
11. SUPPLEMENTARY NOTES		12. SPONSORING MILITARY ACTIVITY Naval Training Device Center Orlando, Florida	
13. ABSTRACT This research program consisted of two main tasks. The first task was the development of a set of requirements for a long-term program of learning, retention, and transfer research. The requirements were based on five planning activities: <ul style="list-style-type: none">• A brief review of the relevant literature• Selection of an appropriate taxonomy of tasks• A survey of Naval jobs to determine critical tasks from the standpoint of training• Organization and management of technical meetings with consultants• A conceptual design for a general purpose L, R, and T apparatus The second task was the design and conduct of two initial experiments to validate the research requirements and to provide a data base for subsequent investigations. These experiments dealt with training and transfer of procedural skills. For this purpose, a laboratory apparatus was constructed to represent military procedural tasks. Operation of this apparatus by the subject involved the learning of facts, principles, and procedures and the recall of this information in the solution of specific problems. The task resembled the operation of a military communication system.			

(continued)

14. KEY WORDS	LINK A		LINK B		LINK C	
	ROLE	WT	ROLE	WT	ROLE	WT
Learning Retention Transfer of training Training research Fidelity of simulation Imagery						

A BSTRACT (continued)

In Experiment I, 10 subjects were presented with 60 communications problems, 30 each on two consecutive days. Dependent measures were response time and accuracy. Evidence of learning was provided by both measures, but time appeared to be more sensitive than accuracy.

At the end of experimental sessions, subjects were requested to provide information about ways in which they tried to learn the task, and suggestions for improving the effectiveness of training. This information was used to modify training for an experimental group in Experiment II.

Experiment II employed four groups of subjects in a 2 x 2 factorial arrangement. From subjects' verbal reports in Experiment I, a modified form of training, involving the presentation of "imagery" to aid in understanding system operation, was given to half the subjects. The second variable studied was the effect on transfer performance of high versus low fidelity of simulation during training.

Results suggested that imagery can play an important role in promoting procedural skills, and that training effectiveness can be achieved through the use of low-cost paper and pencil simulation of the operational task.