

DOCUMENT RESUME

ED 050 475

EA 003 499

AUTHOR Griffin, C. W., Jr.
TITLE Systems: An Approach to School Construction.
INSTITUTION Educational Facilities Labs., Inc., New York, N.Y.
PUB DATE Feb 71
NOTE 90p.
AVAILABLE FROM Educational Facilities Laboratories, 477 Madison Avenue, New York, N.Y. 10022 (\$2.00)

EDRS PRICE MF-\$0.65 HC-\$3.29
DESCRIPTORS Architecture, *Construction Costs, *Educational Facilities, Educational Research, Facility Requirements, Management Systems, Performance Criteria, *School Construction, *School Design, *Systems Approach

ABSTRACT

This report describes some programs that attempt to raise the quality of school buildings without raising the cost of building them. Educational changes have required new sets of spaces in schoolhouses, whose specifications could only be met by changes in building technology and in construction management. This triumvirate of change emerged in the form of the systems approach to school construction, which necessitates an improvement in building technology, but demands a revolution in management techniques. Five cases of school construction using the systems approach are presented to acquaint educationists with the advantages of systems applications. (Author/BA)



Educational Facilities Laboratories, Inc. is a non-profit corporation established by the Ford Foundation to help schools and colleges with their physical problems by the encouragement of research and experimentation and the dissemination of knowledge regarding educational facilities.

Board of Directors

Milton C. Mumford, Chairman
Chairman of the Board, Lever Brothers Company

Alvin C. Eurich, Vice Chairman
President, Academy for Educational Development, Inc.

Clay P. Bedford
Former President, Kaiser Aerospace & Electronics

James C. Downs, Jr.
Chairman of the Board, Real Estate Research Corporation

Henry Dreyfuss
Corporate Advisor

Morris Duane
Attorney, Duane, Morris and Heckscher

Edwin D. Etherington
Former President, Wesleyan University

Harold B. Gores
President, Educational Facilities Laboratories

J. E. Jonsson
Honorary Chairman of the Board, Texas Instruments, Inc.

Philip M. Klutznick
Chairman of the Board, Urban Investment and Development Co.

Howard S. Turner
President, Turner Construction Company

Benjamin C. Willis
Superintendent of Schools, Broward County, Florida

Officers

Harold B. Gores, President
Alan C. Green, Secretary and Treasurer

Staff

John R. Boice, Project Director
Ben E. Graves, Project Director
Peter Green, Editor
Catherine Slade, Librarian
Lillian Sloves, Publications Associate
Danae Volto, Information Associate
Mary C. Webb, Assistant Treasurer
Ruth Weinstock, Research Associate

U.S. DEPARTMENT OF HEALTH,
EDUCATION & WELFARE
OFFICE OF EDUCATION
THIS DOCUMENT HAS BEEN REPRO-
DUCED EXACTLY AS RECEIVED FROM
THE PERSON OR ORGANIZATION ORIG-
INATING IT. POINTS OF VIEW OR OPIN-
IONS STATED DO NOT NECESSARILY
REPRESENT OFFICIAL OFFICE OF EDU-
CATION POSITION OR POLICY.

SYSTEMS

AN APPROACH TO SCHOOL CONSTRUCTION
BY C. W. GRIFFIN, JR.



ED050475

03 499

ERIC
Full Text Provided by ERIC

Library of Congress Catalog No.
78-154625
First printing February 1971

Copies of this publication are available at \$2.00 from EFL, 477 Madison Avenue, New York, N.Y. 10022.

CONTENTS

Foreword	6
Introduction	8
Toronto's Study of Educational Facilities SEF	24
Montreal's Research in School Facilities RAS	48
California's School Construction Systems Development SCSD	58
Adapting Systems Building	76
University Residential Building Systems URBS	82
Conclusion	92
Glossary	94

FOREWORD

This report tells about some of the programs that attempt to raise the quality of primary and secondary schoolhouses without raising the cost of building them. In construction language this is called improving the quality-cost ratio. Three of the programs started from scratch by asking the question "What and how do we want to teach?" and then finding architectural solutions. Other programs apply those solutions to other sets of circumstances without starting the whole evaluation process over again.

The common thread among these programs is the systems approach to building. Systems building used to be a rather mysterious subject understood only by its disciples. Now, the success of systems in California and Toronto has spread its acceptance among architects and educators. This report is intended to spread the good word further.

EFL contributed funds to the programs illustrated here and actively participated in their establishment and development. The foundation, in turn, received support and encouragement from its Board of Directors to venture into pioneering programs for making constructive changes in educational facilities.

Educational Facilities Laboratories

INTRODUCTION

In a pell-mell race to provide sufficient schoolhouses to stay abreast of the rising school population since World War II, the nation built innumerable schools that were 30 years out of date before the plans were off the drawing boards. Their designed-in obsolescence was not willful, but resulted from an antipathy toward the major changes developing in education, building technology, and construction management.

Educational changes required a new set of spaces in schoolhouses, which could only be fulfilled through changes in technology. But these two changes could not function properly without a change in management. This triumvirate of change emerged in the technique of the systems approach to school construction.

In broad terms, a systems approach simply means that a problem will be solved in an orderly process that will define the goals, analyze the means of achieving them, and then carefully organize the actual achievement. In construction, the systems approach necessitates an improvement in building technology, but it demands a revolution in management techniques.

Systems construction does not guarantee cheaper buildings, but it can result in lower construction costs than conventional buildings. Apart from costs, the systems approach produces buildings that provide all the facilities that owners but seldom get from their

buildings. And because systems construction is much faster than traditional building, it leads to earlier occupancy of buildings.

These factors are significant for the choice of a systems approach to educational buildings, but systems would not have succeeded unless ERL had aggregated a market large enough to justify the cost of developing the technology. This occurred in California, and, when that project succeeded, related projects gained momentum in other parts of the continent.

The need for school buildings is real. During the 20 years between 1945 and 1965, the total of students in kindergarten through university rose from 29.7 million to 51.2 million. But as construction costs spiral upward at double the over-all inflation rate, the enthusiasm to accommodate all these bodies is waning, and taxpayers are resisting paying for new schools by rejecting bond issues: they approved 80% five years ago, but only about 40% in 1970.

Even the schools that have been built lack the facilities, amenities, and environmental comfort standards they deserve. Schools have always lagged behind the comfort standards for office and retail buildings. Constructing an unairconditioned office building is unthinkable, whereas it is normal to build an unairconditioned school. But the nation is slowly learning that an inferior educational environment tends to

produce inferior education, and so the trend in today's schools is toward improvements in building quality.

The revolution in instructional techniques has an especially heavy impact on school design. In the modern school, team teaching, differentiated staffing, and individualized instruction for a broadened spectrum of student groupings have created new demands for flexibility in the partitioning of learning areas. Films, slides, or large-scale television lectures may be shown to groups of 150 or more students. The old standard 30-ft-sq classroom for 30 students is now only one of many sizes of instruction spaces. Seminar discussions in smaller groups, or even individual instruction, pose a different set of partitioning needs, sometimes demanding large, column-free areas with little or no partitioning. Yet until the arrival of the School Construction Systems Development (SCSD) program, few schools could afford a standard set of relocatable partitions that could provide the spatial flexibility of the SCSD systems.

Now, eight years after the first systems-building project in the U.S., 12 manufacturers are producing standard relocatable partitions that can be used with several lighting-ceiling, structural, and airconditioning components. And there are increasing numbers of manufacturers supplying these other systems-building products.



A Lagging Industry

There are many reasons for the building industry's failure to respond spontaneously to its challenges. Obstacles to technological progress include thousands of outdated building codes that discourage innovation and standardization, restrictive union rules that bar factory fabrication or mechanized field assembly, and a general lack of performance standards and tests for evaluating and approving new building products.

Basically, however, this failure springs from the industry's fragmented organization. For decades the building industry has operated within a warped organizational structure of vaguely defined responsibilities. On a typical school project there is an architect with his consulting engineers, a general contractor, and several subcontractors installing products made by a host of manufacturers. A series of communication gaps—between owner and architect, between architect and manufacturer, between manufacturer and subcontractor—discourage new approaches. The manufacturers of different components generally work in isolation, unconcerned with over-all integration of their products in the total building system. Trapped in the building industry's labyrinthine structure, each segment of the industry pursues its own specialty, often oblivious, and always powerless to control the entire process. Moreover, the entire

industry is dominated by mistrust: of architect by client, of general contractor by architect, of subcontractor by contractor.

Perhaps the most technologically stultifying aspect of industry fragmentation is the manifold division of the annual \$3.6 billion school construction market. The tiny markets represented by thousands of school districts cannot sustain the research and development effort needed to produce new building components.

Breaching the Corridor

ERL functions as an organizational stimulant to the creaking, rusty machinery of the section of the building industry concerned with educational facilities. This antiquated machinery has changed little since construction of the little red schoolhouse, and today's conventional schools have progressed too little beyond that primitive edifice. Systems building projects have demonstrated a method of reorganizing the cumbersome building process into a rational, orderly process, freed of the building industry's built-in frictions and obstructions.

The need for this fresh review of school design and construction is illustrated by lagging development in the structural framing of schools. Around 1900, California's classrooms were limited largely by the prevailing structural technology of that era. Wood joists could economically span 24 ft, so classrooms were built at that width with joists spanning from an exterior wall to a corri-

corridor in the center of the building. This enabled designers to stretch the length of a classroom parallel to the corridor, but never change its width. When steel and reinforced concrete beams became available, classroom width increased to 30 ft, but rooms could not be extended after construction because the corridor walls were always in the way.

Before SCSJ started, open-plan schools were gaining favor with educators searching to improve the interaction between a teacher and students. These schools were built with large column-free interiors, but each was designed individually with no standardization or carry-over of technology from one to another. In the SCSJ program, instead of following in the deeply worn rut of conventional design and construction, the staff made technology the servant instead of the master. To provide the flexibility needed to accommodate mass lectures for 150 students anywhere in the general learning space, the SCSJ staff chose 60 ft as the minimum span necessary to satisfy a user requirement of expanding in two directions: parallel to and across a corridor. Confronted with this new requirement (plus many others), the competing structural manufacturers were stimulated to produce a major, economical innovation, instead of continuing traditional industry practice.

Technical results than in its organizational achievement. Few informed industry experts doubted the capacity of U.S. building product manufacturers to produce drastically improved hardware under the right conditions. Creating the right conditions, however, was the major problem, and here EFL played the key role by convincing the first California school district to commit itself to use building components that were not fully developed, and a new method for awarding bids. It also assembled the required market by recruiting other school districts to join the program, created the expert SCSJ staff, and provided \$680,000 for the users' research and development program.

The Anatomy of Systems

Ideally, systems building proceeds through four stages:

- Study of user requirements
- Establishment of performance standards for the building subsystems or entire system
- Integration of individual building subsystems into a coordinated building system
- Testing of components (or subsystems) to assure that they satisfy the performance standards

In a sophisticated systems-building program, a benefit-cost analysis governs the choice among alternative products.

In writing user requirements, a systems-building staff must liberate itself from a built-in prejudice for

the chief significance of the SCSJ program lies less in its tech-

existing technology. Instead of asking, for example, "How can I improve partitions?" the basic question is, "What is the best way to divide space?" For open-space elementary schools, the answer may be 6-ft-high bookcases or screens. In a modern elementary school, with carpets and acoustical ceilings, visual insulation may be a more critical job for a space divider than acoustical insulation.

A recent development in systems-building policy for electrical work offers a better lesson on the need for liberation from existing construction industry practice. Largely because of code obstacles and consequent delays, electrical work (except for the lighting-ceiling subsystem) was omitted from the SCSD building system. This work was done in the conventional way, and in some cases, conduits were buried in the concrete floor topping and fed upward inside partitions to supply wall outlets. Thus when partitions are relocated in those SCSD schools, the conduit risers must be cut flush with the floor and capped.

This troublesome, expensive operation is avoided in more recent systems building in Toronto and Montreal. Performance criteria for these programs require location of the electrical distribution network within the ceiling space: wires feed downward to outlets for the floor below. Responding to the old problem restated in the new terms, industry produced flexible electrical networks that allow easy, convenient electrical change.

As a basic task in setting performance standards, a systems building staff analyzes a building into its parts in a far more rational way than in the conventional construction process. On a conventional school project, the different subcontracts are often divided on the basis of materials. On a systems-built school, the building system is broken into *subsystems*, logically defined for a specific function.

As an example illustrating the flaws in normal industry practice, the traditional inclusion of masonry for both exterior walls and interior partitions in one subcontract creates the diffused responsibility that plagues the construction industry, since masonry is only one material used in walls and partitions. On a systems-built school, interior partitions and exterior walls become two separate subsystems, designed for two distinct functions and divided into separate contracts. The manufacturer of each subsystem is responsible for all materials included in that subsystem.

Subsystem manufacturers must **integrate individual subsystems** with other subsystems—structural, lighting-ceiling, plumbing, airconditioning—at each *interface*, or common boundary, with other subsystems. A *module* (or basic dimensional unit) standardizes the dimensions of lighting colfers, ceiling panels, structural joists spacings, etc. Though there are exceptions to this general rule, room dimensions are multiples

Subsystem Compatibility April 1970

Structure Lighting-Ceiling HVAC April, 1971	Anning-Johnson AJ Armstrong C-60/30 Armstrong C-90/60 Butler LC-300 Ceiling Dynamics LAMBDA** Ceiling Dynamics MOD 11-V Ceiling Dynamics MOD V Ceiling Dynamics OMEGA-V Combed FIVE PLUS FIVE Down COORDINATOR Keene SPEC 10 Keene SPEC 30 Keene SPEC 50 Keene SPEC 60 Keene SPEC 70 Keene SPEC 90 Lok MC-5A/C Lok CUSTOM Luminous Ceilings TEC 11 Luminous Ceilings TEC V Luminous Ceilings TEC VI Luminous Ceilings TEC VII Soundlock SOUNDLINE Sunbeam IS 1000 Sunbeam IS5000 Sunbeam IS9000 SYNCON	Butler SPACE GRID DYNA-FRAME Francin RAS*** Haven-Busch JOISTRUSS** Inland-Tyerson Macomber V-LOK P.C.A. DUOTEX** Romac MODULOC SYNCON Structural
Carrier Air Conditioning Chrysler Airtemp MZU Trane CLIMATE CHANGER* Worthington CMC MULTITEMP*		
Acme SERIES "E" American Air Filter AZRM Dunham Bush RTMZ ITT Nesbitt RTMZ Lennox DMS-1 Lennox DMS-2 Lennox DMS-3 Mammoth ADAPTA-AIRE Mammoth ADAPTA-ZONE Schmenauer MULTIZONE* York MULTIZONE*		
Butler SPACE GRID DYNA-FRAME Francin RAS*** Haven-Busch JOISTRUSS** Inland-Tyerson Macomber V-LOK P.C.A. DUOTEX** Romac MODULOC SYNCON		

*** indicates product in development.
 ** indicates product on market, but not in full production.
 * indicates data incomplete in this product.

of the module—i.e., 15, 20, 25, or 100 ft for the normal 5-ft module.

The last stage in developing a building system is **testing the integrated subsystems**. As an interesting and progressive example, Toronto's new school building system was tested by the Canadian Standards Association. The CSA conducted part of its testing in a laboratory, e.g., partitions' denting resistance, carpet flameproofing, and lighting intensity. Other subsystem characteristics were measured in an instrumented test building, where, as one example, the airconditioning subsystem was checked for airflow, temperature, humidity control, acoustical performance, etc.

One of the major advantages of the systems-building performance concept is that it unifies responsibility for achieving satisfactory results in the hardware; the manufacturer bears responsibility for fabricating components and for installing them. In contrast, the traditionally fragmented organization of the building industry, with its hopelessly divided responsibility, invites a round or two of buck passing, litigation, and unsatisfactory, unfair settlements in case of hardware failure.

Under the traditional building process, an airconditioning subsystem, for example, is designed by a mechanical engineer, who often incorporates components produced by several different manufacturers. A mechanical contractor installs the ducts and equipment, and another

subcontractor may install the controls. If the assembled subsystem doesn't work, the blame could take the following circuit: the owner calls the architect, who calls the manufacturer (or manufacturers), who calls the control subcontractor, who calls the engineer, who may start the cycle anew. The fragmented organization makes it almost impossible to fix responsibility.

On a systems-built project, the division of responsibility is clear-cut: the mechanical engineer still bears responsibility for proper design. But a single contractor (normally the manufacturer) bears single responsibility for satisfactory performance of all airconditioning hardware and for its proper installation.

Pioneering Systems

The first systems-building program in the U.S., the California school districts' SCSD program, focused on one of the building industry's most frustrating failures—the ceiling clutter. Under the conventional building process, an architect often patterns details of a new project on a recently completed building. His engineering consultants—structural, mechanical, and electrical—fit their components together as best they can with the available products.

The entire design team must beware of new products, since there are few standards for measuring their performance. Despite some recent progress, notably among airconditioning manufacturers, building product manufacturers have gener-



Hard floor surface, chairs attached to desks, and exposed ceiling contribute to harsh interior of classroom.

ally contributed little toward establishment of uniform performance standards. They have traditionally preferred to compete on the basis of proprietary advertising claims, not on the basis of widely recognized performance standards. The American Society of Testing and Materials' fire-resistance tests, used by Underwriters' Laboratories and Factory Mutual in classifying floor-ceiling assemblies, partitions, curtain walls, etc., are models of subsystem performance tests. But unlike these ASTM fire-resistance tests, construction industry testing standards generally refer merely to individual materials, not to assembled components or subsystems. There are tests for felt strength, vapor barrier permeance, and thermal-insulation heat conductivity, but no generally recognized testing standard for weather resistance or water permeance of the whole, built-up roofing subsystem comprising these different components. Yet subsystem performance, not individual material quality, is what ultimately concerns the building owner. He wants to know, for example, that the airconditioning subsystem, with its air intakes, fans, ducts, compressors, condensers, refrigerant, expansion valves, etc., can deliver 100 cubic feet per minute of conditioned air to a given space, not whether a circulating fan motor delivers 100 horsepower.

Architects, in particular, are wary of innovation. They have fewer criteria for assessing quality for their com-

ponents than engineers, and many manufacturers have refused to guarantee their products' performance or durability. A rising tide of malpractice suits has made design conservatism the better part of valor. The unhappy consequence is normally a haphazard assembly of structural framing, lighting fixtures, ducts, and pipes crammed into the ceiling space, with little thought given to maintenance or future change. Designed for a 40-year life, today's conventional school, frozen into a mold destined for early obsolescence, is an almost certain future remodeling expense. Growing demands for flexibility in dividing interiors and improved environmental quality will predictably make this year's conventional school more outmoded in 2010 than a 40-year-old school is today.

The SCSD program dramatically broke this dreary cycle of design inertia. The first indispensable step integrated 13 school districts into a single construction agency, the First California Commission on School Construction Systems, empowered to take bids on the various building system subsystems. This large market gave successful manufacturers expectation of a reasonable profit to offset research and development costs that couldn't conceivably be justified for a single school, custom-built in accordance with conventional practice. Equally important, the SCSD program required cooperation among the different manufacturers of components sand-

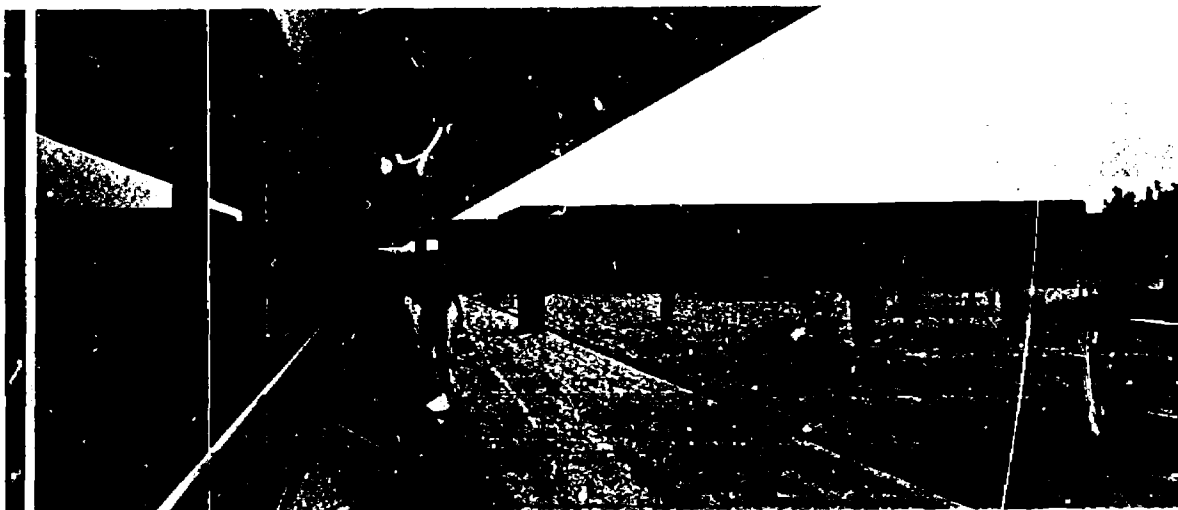

wicked in the ceiling space (structural framing, lighting-ceiling fixtures, airconditioning, plus relocatable partitions) to produce compatible subsystems. A 5-ft-sq (horizontal) module extended the standardization already used in screw threads, electrical fixtures, etc., to the building scale itself.

The SCSD performance standards stimulated development of a packaged airconditioning subsystem with *flexible fiberglass ducts*, readily bent, lengthened, or shortened to accommodate individual control in any space arrangement attainable with the relocatable partitions, in zones as small as 450 sq ft (half a classroom). The other components occupying the ceiling space—steel trusses with their lateral bracing and

concave pyramidal lighting coffers—were designed to accommodate unobstructed rearrangement of the air-conditioning ducts, and the ceiling runners supporting the coffers were designed with and without air diffusers, as required for each use.

Reactive Bonus

As a beneficial byproduct, the mere ability to create widely varying divisions of space has stimulated educators' imaginations. Freed from the barriers of fixed standard spaces, teachers can experiment with new and changing instructional groups and teaching techniques.

"It allows me to experiment with team teaching without being committed to it for 40 years," says one administrator about his SCSD

school. Another praises the new freedom afforded his teachers to mix large and small instructional groups in whatever proportions they find best.

"A building open to change is opening the eyes of our teachers," is another educator's summing up.

A major alteration at Oak Grove High School illustrates the benefits of flexibility. For its fall term, 1970, Oak Grove's science department radically revised its curriculum. It features individualized instructional "packets" instead of conventional group instruction. A second change in the four-year-old building completely reoriented the building from its original layout. Originally the laboratories and science resource centers were divided by *subject* (chemistry, physics, biology). The new layout divides the space by *function*, without regard to subject matter.

At an estimated cost of \$20,000, this alteration is not cheap. But it would be economically prohibitive in a conventional school. Thus if it had been built with conventional components, Oak Grove's science building would be obsolete at the age of 4 years. With nearly 40 years of projected useful life remaining, it may see many more changes as instructional techniques continue to improve and change.

Architects should be able to do a better job in their original design of building schools than on con-

ventionally built schools. Relieved of the irritating technical details of connecting and fitting components together (a task more efficiently done by manufacturers), the architect of a systems school can focus more effort on apportioning space and on creating an esthetically attractive educational environment. Far from confining the architect, as some uninformed laymen and even some professionals have charged, standard systems components liberate the architect's imagination in arranging their countless combinations. The standard kit of subsystems is no more confining than the piano composer's keyboard or the painter's palette.

Beneficent Waves

Since construction of the first SCSD school in 1966, the components developed under the program have spread throughout the U.S.--into more than 1,300 North American schools. Thus SCSD achieved for itself the classic aim of foundation research. Once their immediate purpose is attained, many research projects sink beneath the surface, leaving barely a trace. But the waves generated by the \$680,000 investment in SCSD are still radiating from the original project, elevating school design standards, cutting costs, and accelerating construction schedules in many scattered parts of the U.S. and Canada.

Since SCSD, ERIC has sponsored other systems-building programs.

With 75% of each school's cost represented by systems-designed components, Metropolitan Toronto's Study of Educational Facilities (SEF) program extends systems building into a new dimension. To the basic SCSD subsystems, SEF adds exterior walls, plumbing, roofing, electrical distribution, flooring, and several other components not included in SCSD. As previously indicated, the SEF electric-electronic subsystem constitutes a radical improvement over SCSD's conventional electrical distribution. It helps to adapt Toronto's schools to the new audio-visual, computer instruction techniques with minimal effort. Toronto is already conducting some of the world's boldest experimentation in individualized, nongraded education, and SEF schools will encourage use of a whole panoply of modern, audio-visual instructional techniques.

SEF has added significance as the world's first truly open building system. (The subsystems in an *open building system* are widely interchangeable, whereas the subsystems of a closed building system are locked into one system.) Theoretically, an open system produces greater economy, because you can ideally choose the most economical candidate in each category. Closed-system bidding should, however, produce better integration of subsystems. On the closed-system route, Montreal's Research in School Facilities (Recherches en Aménagement Scolaires--RAS) program dis-

Dissimilar exteriors of these two Florida schools illustrates that systems construction need not produce standardized facades.

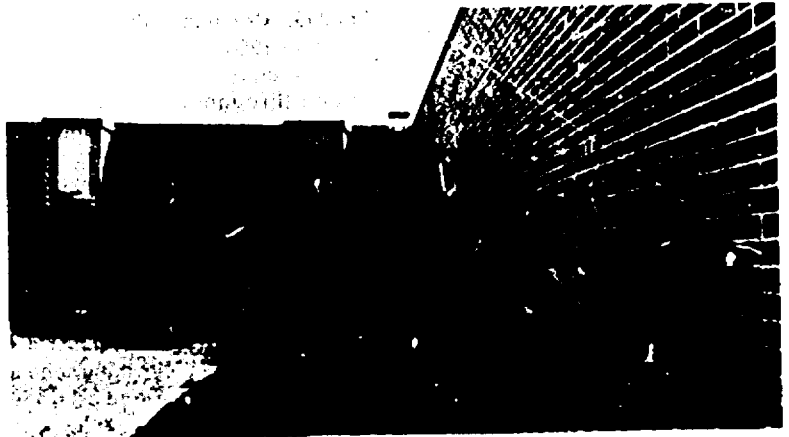
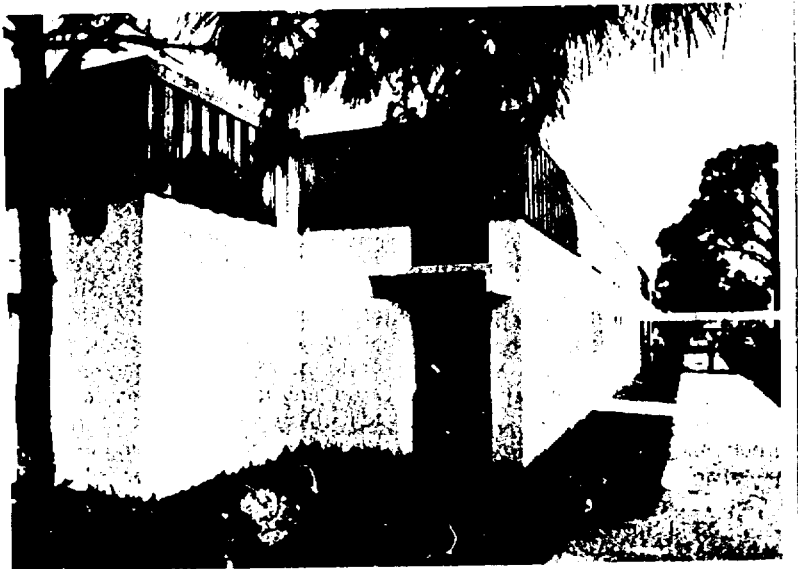

plays some architecturally elegant and ingeniously designed hardware.

SEF is now spawning its own systems-building programs — Detroit's Systems Building Study (for multi-story school additions) and Boston's Building Systems Study, whose first phase will include construction of two large elementary schools each seating 1,000 students.

These applications programs exploit the construction speed, economy, and quality of the products and procedures from the development programs, without adding significant advances of their own. As a notable example, Florida's Schoolhouse Systems Project (SSP) has achieved progressive cost savings through three statewide building programs. Florida's taxpayers have profited from the intensified competition among subsystem manufacturers. While conventional construction costs have been skyrocketing over the past two years, SSP has achieved an 18% reduction in bid prices for three basic building subsystems.

SSP has also achieved equally dramatic construction time savings. Under the new contracting procedures facilitated by the systems-building process, school boards can get completed schools up to eight months earlier. And the preliminary cost estimates available for subsystems minimize the cost-control problems that harass school boards

in North America.

Still other EFL programs are extending systems building into university construction. By June, 1970, subsystems were under test for multi-story dormitories for the University Residential Building System (URBS) under development for the University of California. Another type of program, the Academic Building System (ABS), is now in a preliminary planning stage for the University of California and Indiana University.

The course of these systems-building programs illustrates the coordinated progress of performance criteria and the manufacturers' response to these demands. Since the original SCSD program, the sound-insulation requirement for relocatable partitions has steadily risen. The URBS criteria for its dormitory partitions pushes manufacturers to the economical limit of today's technology. Airconditioning criteria for the more extreme Canadian climate are tougher than for the earlier SCSD program, notably in an added requirement for winter humidification.

Systems building is but one of many technologies that dominate society. We expect from it the same rewards as from other technologies: economy, speed, utility, and quality. If systems delivers these, there is no reason why it should not play a major role in building schools for the considerable task of educating youth in an expanding and often bewildering world created by technology.

TORONTO'S STUDY OF EDUCATIONAL FACILITIES

SEEF

Toronto's Study of Educational Facilities (SEF) program is the world's first truly open building system, the most ambitious effort yet made to apply the technological and managerial ingenuity of North American industry to the problems of building construction. It extends the whole concept of systems building into a new dimension. In the SEF program, 75% of the total \$28 million construction volume (all costs in this chapter are Canadian dollars which were 7% less than U.S. at the time of these events) comprises systems-designed components. In contrast, California's earlier School Construction Systems Development (SCSD) program incorporated only 50% of each building's cost in systems-designed components.

Toronto's new Roden School, the first of 22 schools and one office building scheduled for completion by mid-1971, has already demonstrated the time and cost savings attainable through the SEF systems-building process. In contrast to the 14 to 18 months required for conventional construction, Roden's construction took only 7 months, thereby saving 7 to 11 months.

Total bid for the 10 SEF subsystems comprising the 23 buildings was \$21 million. This is about the same cost as constructing 23 traditional buildings without any of the advantages of the SEF systems schools. Metro estimates that it would cost 30% more to build traditional schools with facilities and services equal to schools.

Flexibility is the key word in assessing both the educational and technological significance of the SEF program. SEF schools will be learning laboratories, offering Toronto's educators the spatial flexibility needed to accommodate groups of one to 150 or more. The conventional 30-student class is only one of many groupings used in a modern school. A radically improved electric-electronic subsystem will facilitate use of new audio-visual teaching aids. Organized into teams for cooperative teaching, educators can turn these new schools into a microcosm of the outside world, encouraging a range of educational experience impossible in the traditional eggcrate school with its uniform classroom cells and other built-in obstacles to learning. With their packaged airconditioning, long-span structural framing, relocatable partitions, flexible lighting, interchangeable furniture elements, and other advanced subsystems, SEF schools will readily accommodate drastic interior changes. No SEF schools will ever cause the costly, harassing delays or exorbitant renovation expense required to adapt conventional schools to contemporary needs.

As a less obvious, but even more far-reaching benefit, the SEF program offers the clearest preview yet of a more efficient process for building schools. The traditional process of programming, designing, and building schools involves a host of people—school administrators,

educational consultants, cost consultants, architects, engineers, contractors, manufacturers, and suppliers—all working within a structure of blurred responsibilities. This warped organization hampers educational and technological innovation; it punishes failure to a far greater degree than it rewards success and thus promotes timidity and inertia.

SEF revamped the entire process. Educators set the basic building performance criteria, translated into technical standards by the SEF architect-engineer staff. Manufacturers were given clear-cut responsibility for producing satisfactory components and installing them, and the general contractor's role became exclusively managerial. The Canadian Standards Association, with its job of certifying building component performance, may be pioneering a nationwide, or possibly, a continental standardization of systems-building testing and installation criteria.

Soil for Systems

For its second major systems building project, EFL selected Toronto largely because of that city's unusual political structure. It has a metropolitan government (Metro) that embraces five boroughs and the city of Toronto. The Metropolitan Toronto School Board handles finances centrally, but most education functions remain autonomous with each borough.

Since there are 450,000 pupils and 20,000 teachers in the metropolitan area, the School Board carries considerable financial clout: It spends about \$50 million annually to build 20 to 30 new schools. With such a large market, manufacturers can sustain research and development programs for high-quality building components. And, with the Metropolitan Toronto School Board to administer the construction program, SEF avoided the basic political and legal problems that handicapped the systems program in California's 13 separate school districts.

As still another advantage, the Metro School Board's continuing construction program formed a solid base for a systems-building experiment. Major U.S. cities have been more concerned with meeting immediate racial and social crises than in undertaking long-range research and development efforts on school building. Toronto has been able to avert many of these racial and social problems. Consequently Toronto not only offered the required context and quantity; it offered the required demand for quality. Toronto has the momentum of a continuing school modernization program that enables it to assimilate the latest building technology. During a 30-year construction drought, attributable to the Great Depression and World War II, no new schools were built in Toronto. But in 1955, the city began replacing its old schools. By the early 1960's, 40% of the city's schools were less than 10 years old.

Thus Toronto's schools have escaped the fate of schools in U.S. central cities, where the continued influx of poor blacks and the concurrent exodus of prosperous whites and industries has plunged them into a deepening crisis fed by expanding needs and shrinking resources. In Toronto, with Metro financing of welfare and education, the central city escapes the inequitable burdens thrust on New York, Chicago, Philadelphia, and other major U.S. cities.

Metro finances an area-wide school construction program, approves operating budgets for the six local borough school boards, and distributes provincial grants. Though local boards remain autonomous in operating their local districts, the central board sets attendance areas, thereby averting inefficiencies and problems created by municipal boundaries. As a consequence, Toronto's uniformly advanced schools are ready to move on to the next stage. For Toronto, the next stage is systems building.

Accompanying Toronto's school modernization program is a progressive educational policy that is attracting teachers from the U.S. as well as other parts of Canada. Free from the overwhelming problems of U.S. ghetto schools, Toronto has educational challenges of less desperate proportions—chiefly, the linguistic and cultural assimilation of manageable numbers of foreign immigrants. Not only are Toronto's central city schools better built than

most U.S. central cities' schools; they are also better equipped.

A light administrative hand encourages Toronto's teachers to experiment, says Dr. John S. Murray, Academic Director for the SEF program. Backed by the Ontario Institute for Studies in Education, Toronto has moved beyond the rigid administratively prescribed curriculum guides that often deter effective instruction in schools. In the past two decades, Canada has moved from an elitist education policy modeled on the British system to the U.S. ideal of universal, individualized education. (In the mid-1940's Canada had proportionately half as many high school and college graduates as the U.S.) Toronto leads in putting the Canadian version of this ideal into practice.

Laboratories for Learning

For Toronto, the 1970's promise to be a decade of bold educational experimentation. School principals can try new techniques of team teaching and nongraded education without the fear of failure inspired by some authoritarian school bureaucracies. Toronto's educators reject the traditional concept of education, which in practice has meant the transmission of a stable set of cultural values, preparation of the academically successful for higher education, and training of the rest for clearly demarcated vocations. They rate intellectual creativity and ingenuity over the mastery of prescribed subject matter; they rate

self-reliance over the traditional virtue of obedience.

Under the traditional concept of education, the teacher is the *active* (talking) agent, and the student is the *passive* (listening) agent, soaking up the teacher's wisdom like a psychic sponge, ready to squeeze out the approved answers on cue. The static eggcrate school, with its fixed uniform classroom cells lining two sides of a corridor, is the logical, static architectural expression of this static, authoritarian concept of education.

Modern educators take a humbler view of their role. In the modern school, a dynamic model replaces the old static model; the student becomes the more active participant in the educational process, and the teacher becomes more an inspirational and intellectual catalyst, less a lecturing encyclopedia. From top to bottom in the administrative hierarchy, Toronto's educators admit that they don't have all the answers. They are committed to bold and varied educational experimentation, free of the cautious timidity that keeps tamer educators safely snuggled in their comfortable rut. According to this view, the school should be a microcosm of the outside world; education is a lifelong process merely formalized in the schoolroom; and the school's task is to equip students for the jolts and unpredictable vocational challenges in a tumultuous world that has little need for tamed human parrots. The flexibility of a systems-designed

school adapts it to bold educational experimentation.

Reform for Reading

Toronto's experimentation invaded the realm of the three R's with demonstrable success before SEF programs went into operation. An experiment in reading instruction for the Carrison Road School's Grade 6 students (11-year-olds) indicates the benefits of individualized reading instruction. After six months of an experimental program in which the standard readers were replaced with novels, newspapers, or other reading matter chosen by the children, a test group of 32 students scored dramatic gains in all reading categories. Tested by the Gates Reading Survey for vocabulary, comprehension, speed, and accuracy, these students compressed average gains of from one to four years of reading level into a half year's reformed instruction.

As an ancillary benefit, the experience was more enjoyable as well as more productive than conventional reading instruction. One intelligent boy, bored with the reader-oriented instruction previously given, read more than 25 books in the six-month experimental period.

What prompted the reform was the recognition of the basic flaw in traditional reading instruction. Like convicts under mandatory sentence, beginning with the insipid Dick and Jane stories in first grade, children have been subjected to standard readers. Something is obviously

wrong with forcing every child to read the same book at roughly the same time. Division into two or more reading groups is too crude a palliative to correct the basically false premise of reader-based instruction.

The reading ability of these 11-year-old, Grade 6 students ranged from Grade 3 to Grade 11 (from normal age 8 to age 16). Compounding the problem posed by this tremendous range in ability was a tremendous range of interests. Why not adapt the school to the outside world, where adults are allowed to read what they like? Why not treat the students as individuals with the ability to make their own choices?

In the continuing program, 120 Grade 6 students receive reading instruction programmed as follows:

- For the large majority who can assimilate it, individualized instruction in a large room. The children bring books, newspapers, or magazines from home or from a library. Like pleasure-reading adults, they can exchange the books at will. They discuss plot, theme, style, or technique with teachers.

- For less proficient readers, three small rooms are set apart for specialized instruction. Two contain small-group, teacher-led discussions of short stories, novels, and poems. A third room, for lagging readers is equipped as a reading laboratory, with a tachistoscope (to accelerate reading speed) and other audio-visual equipment. The goal is

to move everyone into the main group as soon as possible.

School for Self-Reliance

Spatial divisions for programs like the Garrison Road School's pioneering reading reform will be more easily achieved in SEF schools than in the best of conventional schools. Dewson Elementary, a new open-space school built via the conventional construction process, indicates the superior and more readily changed educational environment that is available in the new SEF schools. It also demonstrates the kind of educational experimentation that SEF schools will encourage.

Visiting Dewson Elementary is an enlightening experience. To a visitor whose memories of elementary school evoke scenes of drab solemnity and tranquillity, Dewson's colorful, semi-carnival atmosphere, with its hanging pennants and ubiquitous art work, may seem inappropriately festive, and the bustling activity in the large open areas, with many small bodies in apparently random motion, presents an aspect of subdued pandemonium. It is like a first visit to the New York Stock Exchange, where it seems incredible that the traders rushing frantically around the paper-littered floor are actually processing an orderly flow of business transactions.

Yet behind the apparent chaos there is a structure, maintained by the less immediately visible teachers. Dewson's open spaces constitute an



SEF schools improved on the environment of traditionally-built, non-graded schools such as Dewson Elementary School, above.

educational marketplace. Though the activity may at first appear random, it is nonetheless purposeful. But it represents a multitude of individual purposes, not the synthetic order of a drill team.

Dewson is a nongraded school with team teaching in three open-space floors of 7,500 sq ft area each, partitioned into different-sized spaces that open into one another. On each of these floors a teaching team of 9 or 10 (comprising teachers, teachers' aides, and volunteers) has two age groups (corresponding to two former grades) of roughly 200 children. On the third floor, with the 10- and 11-year-olds, the 9-member teaching team divides its functions into specialties, like a college teaching staff. Instead of a standard curriculum for everyone, the students can follow their strengths and interests. In those few conventional elementary schools offering drama and school newspaper, these activities are extracurricular luxuries—treats for talented students. At Dewson, however, these creative pursuits are an integral part of the individualized curriculum, open to any student who feels attracted to them.

The individualized curriculum gives Dewson's open-space learning areas an initial impression of chaos. After planning a log of his day's activities in the morning, each child makes his own individual way through the day. These individual schedules express Dewson's goal of attaining self-reliance.

Though the conventionally designed two-year-old Dewson school is a tremendous improvement over the old standard eggcrate design, it still falls short of the comfort, flexibility, and electrical convenience of the SEF schools. SEF schools will further facilitate the kind of bold educational experiments under way at Dewson.

Historical Background

The idea for a systems approach to school facilities found three enthusiastic supporters among the government officials of the province of Ontario who had been interested in the SCSD project. The men, the Honourable William G. Davis, Minister of Education, Dr. Kenneth F. Prueter, Chairman of the Advisory Committee on School Design, and Frank Nicol, the Director of School Planning and Research, believed that Toronto would be the ideal city for a project similar to SCSD. Metropolitan Toronto School Board agreed in principle, and its Chairman, Barry G. Lowndes, and its Director, William J. McCordic, joined their provincial government colleagues in sponsoring a proposal for the Study of Educational Facilities. Metro accepted the proposal and agreed to finance it providing it would be reimbursed with any funds from other sources such as foundations.

During the period when the possibility of the project was being discussed, and later when the proposal

was being drawn up, the principals were encouraged and aided by Jonathan King, who was then Vice President of EFL and is now head of the systems division of Caudill Rowlett Scott in Houston. King also urged Metro to submit a proposal to EFL for financial aid for SEF. Subsequently, in 1966, SEF received the first allocation of funds from EFL that eventually covered about one-third of the \$1.2 million study.

By September, 1966, a permanent project staff had been created under two co-directors: Hugh J. Vallery, academic director, and Roderick G. Robbie, technical director. Vallery, a 25-year veteran of the Toronto Board of Education, was formerly a secondary school principal, and is now Superintendent of Academic Studies for Metro. Robbie was a partner in the architectural and planning firm of Robbie, Vaughan & Williams, and is now president of Environment Systems International, with offices in Toronto and several U.S. cities.

Under these two directors, the staff grew to 25, but the work force has now diminished to 6. The Study is now headed by Dr. John S. Murray, academic director and Peter D. J. Tirion, technical director.

Rod Robbie is quick to attribute success of the project to "A multitude of men who sweated millions of hours planning, researching, and developing the educational and technical specifications and the actual components to meet them."

The SEF staff called in consultants in nine technical areas, but in addition, it had to work to achieve the cooperation of lawyers, designers, city building officials, labor officials, manufacturers, fire departments, educators, and politicians. SEF also benefited from an advisory committee that followed progress keenly and critically.

The SEF program aimed first at assessing the educational process from kindergarten through high school and determining the quantity and quality of required space and the required flexibility in dividing, servicing, and equipping it. These educational needs were then translated into technical performance criteria.

Technical goals are fourfold:

- To promote flexibility in interior space division through modular design.
- To promote building subsystem and component development of improved quality at reduced cost.
- To investigate mixed-use development, i.e., integrating schools with apartment or offices, etc.
- To analyze the problems of short-term accommodation and develop a relocatable building system.

Before starting this educational study, the SEF staff knew that plenty was wrong with the old school design standards. They were burdened with wasteful rules and formulas through the years like rocks

in a glacier. The formula allowing 10 sq ft of auditorium space for each high school student produced reasonable results for a school of 1,000 enrollment. But for a 2,200-pupil high school built during the 1960's, it yielded a half-acre of expensive enclosed space used only a few hours each week.

Educators would prefer to use this largely wasted money for a host of more essential things—for airconditioning for year-round use, for expanded shop or library space, for music rooms, for added science facilities, or simply for more general learning areas.

The old specifications were also unsatisfactory for elementary schools. Libraries, for example, had traditionally been omitted from Toronto's elementary schools. Yet, according to Metro Education Director William J. McCordic, libraries are needed by younger children as a training ground for intellectual discovery. Toronto's new elementary schools now provide 5 or 6 sq ft of library space per pupil.

The expense of building frozen space, via the traditional building process, is illustrated by a Metro Toronto high school built in 1961 at a cost of \$4.5 million. Within four years of its completion, this building required a \$2-million alteration program, to adapt it to a changed academic use. Not only did this alteration cost roughly 40% of the original construction cost; it also removed

much of the building from use for six or seven months.

To stimulate industry interest in its program, SEF canvassed 270 manufacturers and contractors in early 1967; staff members held 120 meetings with building industry representatives. The goals were stated modestly. Industry was not asked for radical innovations in responding to the first SEF building system: it was asked to organize existing skills, technology, and capital resources for modern, efficient production.

The academic study was pursued with equal vigor. Hugh Vallery and Rod Robbie visited schools throughout Canada and the U.S. in 1967 to investigate at first hand the continent's most innovative schools and educational systems. Research groups, seeking a broad range of information for establishing user requirements, concurrently searched through a mound of educational and architectural periodicals. The program administrators appointed 30 educational committees involving 300 people.

Because of this research, user requirements received more intense analysis in the SEF program than in any other systems-building program. Three separate academic reports (for elementary, intermediate, and secondary levels) assess the impact of urbanization, mass media, and changing ethical standards on child and adolescent psychology. In a general discussion, each narrows its focus onto edu-

cational needs, analyzing Toronto's current cost-ceiling formula and recommending changes.*

In its third and longest section, each report presents detailed discussion of the different kinds of space—general science laboratory areas, visual arts, audio-visual service areas, general learning areas, etc.—plus tabulated environmental criteria for each. These tables contain air-conditioning, visual, and acoustical criteria, plus required electrical and mechanical services. They form the bases for the technical performance criteria that guided manufacturers' research and development.

Setting Performance Criteria

The SEF program bid 10 basic subsystems representing more than 75% of the total construction cost for the 23 buildings. Four of the subsystems, like SCSD, are aimed at eliminating the inefficient ceiling clutter of most conventional projects. These are structure, air-conditioning (or atmosphere), lighting-ceiling, and partitions. To these, SEF has added other major subsystems: vertical skin (exterior walls), electric-electronic, roofing, plumbing, and another subsystem comprising carpets, gymnasium flooring, and hardware. Another SEF subsystem comprises casework, locker, and other furniture.

*These reports are available for \$10 per copy from Ryerson Press, 299 Queen Street West, Toronto, Ontario, Canada: E.1 Educational Specifications and User Requirements for Elementary (K-6) Schools, E.2 Intermediate Schools, E.3 Secondary Schools.

In dividing the building system into subsystems, the SEF technical staff stressed *function*, not *material*, as the unifying criterion. A conventional construction project may have as many as five subcontractors on a curtain-wall subsystem: a precast concrete fabricator, a metal window frame manufacturer, a glazier, a sealant supplier, and an erection subcontractor. If the wall leaks, the stage is set for several rounds of buck-passing. Is the architect to blame for poor design? Is the precast concrete fabricator at fault for not meeting dimensional tolerances? Did the sealant supplier furnish defective material? Did the erector damage the assembled wall units in hoisting them into place?

Under the systems-building concept, such questions become matters of purely technical, as opposed to legal, interest. The subsystem contractor bears full responsibility for his product's design, fabrication, and installation. Low bidder for the SEF vertical skin was a consortium comprising four precast fabricators, plus Pittsburgh Plate Glass, for aluminum trim and glass. If these walls leak, the Metropolitan Toronto School Board will know whom to blame. The subsystems contractor, Beer-Precast-Precon Murray, Ltd., bears full responsibility for its product's performance.

Like SCSD, SEF established 5 ft as the basic horizontal module (i.e., the basic dimensional planning unit that is multiplied by integers for area

Chart reproduced from SEF E2,
Educational Specifications and
User Requirements for
Intermediate Schools

Level	Square Feet 175/ Teaching Station	Area Common Area
-------	--------------------------------------	---------------------

Environmental Criteria

Atmospheric Criteria	Desirable	Tolerance	Remarks
Temperature			
outside	> 90 F°	78°	± 2°
temperature	< 0 F°	72°	± 2°
Relative Humidity			
outside	> 90 F°	50%	± 5%
temperature	< 0 F°	30%	± 5%
Outside Air			Double glazing
CFM per sq ft	0.3 to 0.8		> 0.15
CFM per person	15 to 30		> 8
Air Changes			
per hour	6 to 8		> 5
Air Movement			
velocity: FPM	25 to 40		± 10
Room Pressure			
in. WG	+0.10		> +0.05
Air Filter Efficiency			
> 5µ	80%		> 85%
< 4µ	45% to 80%		—
Odors Body, Chemicals			
Population			
sq ft/person	0		
Heat Gain			
source	watts		BTUH
lighting	2 to 4/sq. ft		
AV equipment	—		
Projector:	—		

Visual Criteria

Visual Performance Index (VPI)	83.0	ft Candles	N/A
View Out Opt	View In Opt	Blackout	Yes
Daylight Opt	Level Control	Yes	Privacy
			No

Acoustic Criteria

Ambient Noise Level	NC 35 max						
Reverberation Time	Frequency: cps	125	250	500	1000	2000	
(in seconds)	max			N/A			
	min			N/A			
Generated Noise Level:	Frequency: cps	31.5	125	500	2000	8000	
(in db re 0002 dynes/cm ²)	design level	58	77	89	75	60	

Acoustic treatment of floor and ceiling is recommended.
Reverberation time calculation is not meaningful.
Speech reinforcement may be required.

Services

Mechanical Services	Remarks		
CW No	HW No	Steam No	Gas No
Air No	Drain No	Exhaust No	
Other			
Electrical Services	Remarks		
PA Yes	Inter-com Yes	Handset Yes	Bell Tel No
Program System Yes		Clock System Yes	TV Terminal Yes
Computer Terminal No		Underfloor Duct System No	
Power 120V - 1Ø for AV equipment			
Other Consider induction loop system			

Consider separate control use of local PA speakers in connection with AV equipment

dimensions). As a well-established module for office construction, the 5-ft dimension readily accommodates the standard 4-ft length of a fluorescent tube, which fits nicely into a 5-ft ceiling coffer. The 5-ft module is also the largest grid that will meet the space requirements of the SEF academic research study, and so will reduce joints to a minimum. It is approved by most manufacturers, most partitions align with it, and the 5-ft ceiling grid is tranquil to the eye.

For evaluating performance, the SEF staff set three basic parameters: function, cost, aesthetics, with varying emphasis from subsystem to subsystem. As further constraints, subsystems must be "simple, rugged, jointless in appearance and free from any specific architectural style." To assure that the cost does not exceed conventional cost, the Metro School Board's limit of \$20.85 per sq ft was established as the SEF program's maximum acceptable cost.

SEF sought significant technical improvement over the SCSD schools in several respects—notably, the electric-electronic subsystem. In a conventional building, the proliferating electrical services are uncoordinated. The fire alarm, clock, intercommunication, telephone, AM-FM special broadcast receivers all have their own separate circuits; they form a multitude of separate, little subsystems. Access to outlets for audio circuit television, computer terminals, overhead projectors, or

slide projectors, and other audio-visual equipment remains inconvenient and largely unplanned. Why not unify these many electrical-electronic components into one subsystem planned for easy, convenient access, change, or addition? SCSD relied upon partitions to carry electrical distribution down from the ceiling to the user, but open plans have been eliminating more and more partitions.

SEF's answer constitutes an electrical revolution, according to Jonathan King. "Its coordinated, plug-in distribution network and its pogo-sticks bring electrical energy to the user regardless of the presence or absence of partitions."

The key to SEF's solution was a provision in the performance criteria banning the use of subfloor conduit and limiting the solution to the ceiling space. Receptacles both for power (to run TV receivers, projectors, even vacuum cleaners) and for communication (for public address, intercom, telephone, etc.) had to be fixed rigidly to the lighting-ceiling.

Conventional subfloor electrical services are unsatisfactory for several reasons. They are relatively inaccessible, requiring tedious work in breaking through a concrete floor topping. To move one electric outlet requires three services: electrician, mason, and carpet patcher. Moreover, the repair of the broken floor is seldom subject to professional supervision. Instead of patching the access hole with concrete,

the repair crew may use plywood. After some years of this treatment, the hidden floor topping may resemble a slice of Swiss cheese, with seriously impaired fire resistance. Basically, the problem is a lot of work and a variety of building craftsmen to make even the simplest alteration.

SEF's airconditioning problem was tougher than SCSD's mainly because of the severe Canadian climate, with its continental extremes. In the mild California climate humidification is not required, since temperatures rarely drop below 50F. But in Toronto, where winter temperatures occasionally fall below zero, humidification is needed to prevent sinus and throat irritation in dry interiors. At 0F outside temperature, unhumidified interiors heated to 70F have relative humidities around 4%. SEF's performance criteria require seven times that amount, or 30% relative humidity. (In summer, when dehumidification is required, the airconditioning must reduce relative humidity to 50% at 90F outside temperature.)

Cooling is required in the Toronto schools for two basic reasons, according to SEF's Technical Researcher, John Rankin. In the altered learning space of open schools, with their large interior areas, the heat loads generated by lighting and busy occupants are less readily dissipated than in a naturally ventilated two-classroom-wide egg-crate school. As a result, artificial cooling is required when outside



Performance criteria for interior climate of SEF learning areas.

temperatures rise above 55F. Moreover, the prospective year-round use of the school plant, anticipated long before the 40-year expected lives of the SEF buildings are over, would make cooling necessary for the hot Toronto summers.

"Year-round use of schools will come," Rankin predicts. "The three-month summer vacation is a vestige of a vanished agrarian economy, which required children to help with the crops. A 12-month school year is better attuned to an urban society. The more efficient use of our capital plant and equipment would pay the additional cost of cooling about five times over. For the roughly 6% ad-

ditional cost for cooling, you get 33% greater use of your whole capital investment."

The flexibility required for SEF air-conditioning calls for a mechanical service module serving a minimum 4,000 sq ft, with each module divided into 10 control zones. These control zones must, in turn, be divisible into subzones of 150 sq ft (the size of a small office) each capable of individual thermostatic control.

These requirements are, of course, superimposed on the more normal airconditioning requirements for air changes, volume, and movement,

plus air filtration efficiency. And for this unique airconditioning subsystem SEF set a target price of \$3.14 per sq ft, 10% less than the average cost of the Toronto schools' conventional subsystems, most of which lack cooling and also omit humidification.

Since first-cost economy for a cheap, short-lived airconditioning subsystem ultimately proves expensive, SEF required each airconditioning bidder to submit calculations for a hypothetical school designed for 7,000 degree-days of heating and 1,000 full-load hours of cooling for one year's operation for a 20-year life at 6% interest (8.7% annual owning cost). In addition, each bidder was required to specify and bid for a maintenance program to insure full performance of his equipment. This provided SEF with an evaluation of the real cost of maintaining the equipment over a 5-year period with extensions to a 15-year term.

In return for such arduous chores, SEF offered the manufacturers a guaranteed mass market, 20 times bigger than a single school, with a minimum of 1 million sq ft.

The Big Question—Open or Closed?

In deciding to go for an open instead of a closed building system, Robbie and the SEF staff gambled with higher stakes for a bigger victory. In an "open" system, the subsystems are interchangeable. In a "closed" system, they are compati-

ble only with the other subsystems constituting that particular closed system. As a minimum requirement for the open SEF building system, each bidder had to demonstrate his subsystem's compatibility with at least two manufacturers at each interface with other subsystems. By the laws of probability, this requirement assures virtually universal compatibility among all proposed subsystems.

For each vertical skin (exterior wall) bidder, this open-system requirement meant compatibility with at least 18 other bidders, 2 at each of the vertical skin's "mandatory interface" with 9 other subsystems. (One mandatory interface occurs, for example, where the airconditioning baseboard heating elements abut the walls.)

For the partition and structural bidders the job was only slightly easier; they required compatibility with 8 subsystems, or 16 other bidders. Airconditioning, electrical-electronic, and lighting ceiling had 6 or 7 mandatory interfaces.

Despite the obvious disadvantages of assuring such promiscuous compatibility, the SEF staff believed that the competitive benefits outweighed the liabilities.

"With a closed system, you can easily get locked in with a weak subsystem or two as part of an otherwise good building system," says Peter Tirlion. "Suppose the airconditioning subsystem in a closed build-

ing system costs 20% more than another manufacturer's. With a closed system you're stuck with the high-cost airconditioning manufacturer. In an open system, you can take the low bidder."

"The manufacturers of each subsystem in a winning closed system are largely insulated from competition, and the total price must almost necessarily be higher than the price for an open system."

The open system represents a more sophisticated stage of a free-enterprise economy, according to Tirlion.

"Up until 1915 or so, phonograph records would play only on one manufacturer's record player. This may have given some manufacturers a temporary advantage, but it was obviously bad for the consumer. Ultimately, the 'open system' came to the record world, and everybody profited. Consumers gained greater freedom; manufacturers got bigger total markets. An open system encourages competition and stimulates innovation."

Tirlion's argument gets support from Nathan King: "The open system not only stimulates more competition initially; it provides for cyclical renewal of competition. Not one of the successful subsystems' manufacturers for SEF's first building system can rest assured that he will win an award in the next SEF building system, which may be bid within the next few years. There are plenty of hungry challengers willing, and possibly able, to compete on com-



parable terms when the next round of bids goes out."

Not everyone is entranced with open systems, particularly vendors of closed systems. Architect Frank Nicol of Macfran, Ltd., a product development firm, says SEF should have offered a closed system approach as an alternate to its open system. He believes that a well-designed closed system can, under ideal conditions, produce more efficient integration of subsystems.

But sad experience has uncovered a flaw in closed systems. If, for any reason, one subsystem contractor in a closed building system withdraws from a construction program, the entire program may be seriously threatened, since there is no readily available substitute contractor. On some projects built under the closed SCSD building system, the structure-lighting-ceiling contractor caused delays that raised costs and slowed progress. Under a similar emergency, SEF should have no difficulty in finding a substitute contractor: the open-system bidding made several other manufacturers' structural subsystems compatible with the subsystems in the winning building system.

The Bidding Stage

Rigorous enforcement of its bidder prequalification criteria was the key to SEF's success, according to Rod Robbie, SEF's first technical director. Manufacturers and other prospective bidders had to present proof of their financial capacity and

their manufacturing and installation expertise to carry at least 250,000 sq ft of construction per month, the construction tempo expected now that the SEF program is rolling. A total of 60 bidders applied for pre-qualification; before bids were due, the total had dwindled to 36.

"By maintaining specified standards for bidders' prequalification, we established SEF's credibility with industry," says Robbie. "We let the bidders know that they would have to compete on fair terms and that we meant what we said in our performance criteria. We scrupulously disqualified late bidders. This policy encouraged the midgets to compete with the giants; we played no favorites. SEF established the kind of vigorous competitive climate needed to stimulate innovation."

Proposals from the 36 bidders for the 10 subsystems produced over 1 million possible building systems. (Each of 4 vertical skin manufacturers had to demonstrate compatibility with at least 2' x 512 building systems.) Analyzing this data was a job for the computer, which was programmed to identify only those building systems which claimed to meet all SEF performance and economic criteria. More than 13,000 building systems (semifinalists) satisfied these criteria.

In a further refinement that was needed to cut the problem down to manageable size, the SEF staff programmed the computer to identify the 30 least costly building systems

meeting the mandatory interface and performance criteria. These 30 finalists were intensively investigated and evaluated, in accordance with the aesthetic and functional criteria mentioned earlier.

With the low bidders tentatively identified (pending results of the testing program), the victorious bidders began work on user catalogs, which contain detailed technical information, drawings, and quoted unit prices for all components in their subsystems. A roughly four-month interval, following the tentative bid award in January, 1969, was allowed for catalog preparation and testing.

Testing was conducted in a small (13,000 sq ft), two-story addition to Toronto's Eastview School. Air diffusers, lighting-ceiling components, partitions, and other relocatable subsystems were moved 10 times. To pass the test, each subsystem was limited to a 10% drop in performance—an average of 1% loss per relocation.

The test building also served to demonstrate compatibility of the various subsystems—whether, for example, the partitions could be readily connected to the ceiling assembly, or whether the ceiling assembly could be connected to the curtain walls, as the manufacturers had claimed. All 10 tentative winners passed the test and received final bid awards.

the final stages of design and construction, architects and engi-

neers use the various subsystems manufacturers' catalogs to design individual schools, and the Metropolitan Toronto School Board lets contracts for the minor amount of nonsystems work such as site work and foundations. For each project, a local board (representing one of the six local governments combined into Toronto Metro) hires a construction manager on a fee basis, like the professional designers. In contrast with the normal general-contractor role on a conventional construction project, the construction manager on an SEF project does none of the actual construction work, and he has no financial dealings with subcontractors. His sole function is to manage construction, a professionalized part of the general contractor's more variegated role. The construction manager's restricted specialized function removes some intrinsic conflicts of interest that exist in the general contractor's role. The notorious "bid-shopping" practice, in which general contractors first submit bids for subcontracted items and then "shop" for the cheapest rather than the highest quality subcontract they can negotiate, is eradicated under the SEF arrangement.

A unique escalator clause updates the unit prices originally submitted by the subsystem manufacturers in January, 1969. Prices are tied to basic labor-material indexes prepared for each specific subsystem—e.g., steel erectors' wages for the structural steel. This represents a

SUB-SYSTEMS	GROSS COST PER SQ FT		
	Oct. 1967 Average	Target	Bid Results
Structure	\$ 2.30	\$ 2.07	\$ 2.27
Atmosphere	3.14	2.83	2.92
Lighting/Ceiling	1.42	1.28	1.67
Interior Space Div.	2.39	2.15	2.09
Vertical Skin	2.11	1.90	1.83
Plumbing	1.37	1.24	.98
Electric/Electronic	.75	.68	1.15
Casework and Furniture	.67	.79	.87
Roofing	.87	.79	.72
Finishes	.88	.80	.61
Non-Systems	5.44	4.75	4.27
Total	\$21.54	\$19.28	\$19.38

Summary of gross cost per sq ft for 3 elementary schools and one intermediate school.

refinement over the cruder escalation clause in the SCSD contracts. That contract specified use of the *Engineering News-Record* cost index, which is tied to over-all average labor rate increases and a combination of basic construction materials. The ENR index is generally unsuited to lighting-ceiling, electric-electronic, and other technically sophisticated subsystems.

Subsystems Solutions

With bids totaling \$19.38 per sq ft, less than 1% over its target price, SEF achieved its twin goals of improved building quality at reduced cost.

Though it failed to meet the target price of \$0.68 per sq ft, the electric-electronic subsystem offers the most dramatic improvement over its conventional counterpart. In fact, the \$1.15-per-sq-ft cost of this subsystem is more than 50% higher than the average cost of conventional electrical work. But the added flexibility, convenience, and reduced maintenance and alteration costs of the subsystem produced by Industrial Electrical Contractors, Ltd. (IEC) more than offset its relatively high first cost.

The IEC electric-electronic subsystem offers unprecedented freedom in relocating, adding, or removing electrical outlets. Key to the subsystem is a 4-ft-long distribution box that consolidates all interior electrical services—347-volt lighting, 24-volt light switching, 120-volt utility

power, and low-voltage communication circuits—for PA, intercom, clocks, and fire alarms. Located in the ceiling space at grid intersections 60 ft apart, the distribution boxes serve surrounding areas within a 42-ft radius—the maximum distance of any point from the 60-ft grid intersections.

Specially designed extension cords (cordsets) carry these electrical circuits through the ceiling to desired outlet points. These cordsets are protected with thick vinyl jackets required by fire regulations. They are equipped with unique pin-plug configurations, so they cannot be accidentally misconnected to conventional extension cords. A snap-in locking device assures the integrity of the connection.

IEC has several techniques for shielding the subceiling extensions of the cordsets. Cord extensions will fit inside demountable partitions. Where outlets occur on the inside face of exterior walls, or on permanent masonry partitions, special floor-to-ceiling channels are mounted on those surfaces. Made of lightgauge steel, these channels measure 2 x 11 in. in plan cross section. They are equipped to mount clocks, manual fire alarms, intercom speakers, amplifiers, and light switches.

For the more difficult problem of bringing electrical service down into a large open space, IEC designed an ingenious lightgauge steel floor-to-ceiling "service column," which

serves the same function as the wall-mounted channels. The largest of these service columns is roughly 4 x 11 in. in plan cross section. In a library, for example, an architect might cluster a group of carrels, equipped with everything from reading lamps to computer terminals to television plugged into the nearby service column.

The service column offers almost unlimited flexibility. It can be located at any intersection in the 5 x 5-ft ceiling grid. It is easily assembled, connected, or dismantled. The winning airconditioning subsystem, submitted by Canada Electric Co., Ltd., and International Telephone & Telegraph (Canada), Ltd., features rooftop, multizone packaged units made by ITT's Nesbitt subsidiary. At a bid price of \$2.92 per sq ft, the Nesbitt airconditioning subsystem barely missed the target price of \$2.80 per sq ft and decisively beat the cost of inferior conventional subsystems, whose higher average cost of \$3.14 usually omitted cooling

The Nesbitt award scored another impressive systems-building victory for zoned, factory-packaged airconditioning over central airconditioning subsystems. The massive chillers, fan assemblies, and large cooling towers required for large central subsystems are fading competitively as field labor costs continue skyrocketing. The rooftop Nesbitt packaged units barely beat a multizone subsystem. But it beat three types of central

airconditioning, ranging from \$3.63 to \$3.86 per sq ft. The Nesbitt airconditioning even demonstrated lower maintenance costs than central subsystems, which are generally conceded to be more durable.

Basically, the Nesbitt airconditioning is an "all-air" subsystem (i.e., no piped water) supplemented with electric baseboard heating elements or wall-mounted convectors. The high operating cost of electric heating is reduced by use of heated liquid refrigerant, used to cool interior space in moderate weather, to heat the air circulated to peripheral spaces. The main electric heating elements work only in the coldest weather. Outdoor air is used for cooling at outdoor temperatures below 55F.

Air distribution illustrates the open-system compatibility required by the SEF performance criteria. The Nesbitt subsystem could work either with special rectangular diffusers furnished by the airconditioning contractor or with linear diffusers built into the lighting-ceiling subsystem.

As the bids turned out, the linear air diffusers were used. Flexible aluminum duct segments connect 12-in.-diameter rigid fiberglass supply mains to the metal ceiling coffers. Return air travels through the ceiling plenum to the main vertical air shaft, 5 x 10 ft in plan. This shaft also contains 10 supply ducts plus control wiring.

Flexibility is achieved as follows: Each packaged airconditioning unit, located in a rooftop penthouse, serves 4,000 to 8,000 sq ft. For each "mechanical module," there are 10 basically controlled zones serving, say, 800 sq ft. Primary control for each of these zones is achieved by varying the proportions of hot and cold air through damper adjustments in the various zones' mixing boxes. To achieve individual temperature control in small 150- to 200-sq-ft spaces within each zone, open-wire electric heating elements are (or can be) added to all but the warmest space within each zone. The heating elements respond to thermostatic demand for warmer air, warming the local air above the basic temperature in the supply main.

An electronic Master Logic Panel monitors and coordinates heating and cooling demands from all air-conditioned spaces for maximum operating economy. Mechanical refrigeration turns on only when a zone control sensor detects a need for more cooling than the outside air can supply. In a similar manner, mechanical refrigeration turns off whenever outside air temperature drops below 55F.

Sound isolation is aided by lining ducts with 1-in.-thick fiberglass insulation. The refrigeration compressor is mounted on springs to damp its vibrations and prevent transmission of vibration (and consequent noise irritation) through the building. Even the refrigerant lines are isolated from the compressor with

flexible, braided couplings. Other equipment is similarly isolated from the structure: main blower motors, fan shaft assemblies, condenser and exhaust fans. Acoustical insulation is applied to the underside of the refrigerant deck panel.

Casework, made of brightly colored, self-skinning rigid polyurethane foam, is another innovative SEF subsystem. The 400 parts furnished by manufacturer Cameron-McIndoo, Ltd., can be assembled into an almost infinite number of combinations. This versatility enhances their utility and reduces waste. Tote boxes become drawers fitted into casements. A flat panel serves either as a teacher's desk top or as a vertical divider. Desks have legs that children can adjust for height. Shelves are fitted and locked in place by spring-loaded dowels. A special device converts a standard horizontal table into a tilted drafting table.

In addition to its primary storage and related functions, the casework serves as visual insulation. For small children in an open school, visual insulation may be more important than acoustical insulation, according to Peter Tirion. Semi-partitions made of 6-ft-high casework can form a suitable visual barrier to hide distracting movement from small, roving eyes. With its bright, warm colors, the casework also enlivens the SEF interiors.

SEF's Significance

Beyond its local goals of obtaining better value for money and enhanc-

ing the environmental quality of Toronto's schools, the SEF program had a more ambitious long-term goal, stated by ex-technical director Rod Robbie:

"SEF wants to build up a large pool of systems-building suppliers for future projects in Canada and the U.S. If we can help find markets for products of the unsuccessful bidders, we will take a big step toward creating a truly open system. Each of the almost limitless combinations of compatible building subsystems would form a building system with its own unique cost and performance characteristics."

The first SEF building system generated strong architectural controversy about the stark exterior precast concrete walls. These walls are included in the SEF system, but in the SCSD program exterior walls were left to the discretion of the individual school's architect. Both these approaches raise criticism. SEF for forcing an architectural vernacular upon the public, and SCSD for permitting designers to clad structures with ill-fitting, custom-made garments.

In Toronto, SEF staff members agree that the walls are stark, but defend them as satisfying the best combination of cost, function, and aesthetics. Later schools were built with exposed aggregate panels that contrast with smooth spandrel beams to relieve the monotony of plain concrete.

Although SEF is not an unqualified architectural success, its value as a model of the system-building process scores high. No previous program has so thoroughly and so beneficially changed the roles of the building team members. The major change is the expanded role of the manufacturer. His previously untapped potential was more fully exploited in the SEF program than ever before.

One example is the manufacturer's role in accommodating framing deflection above a partition tied to the structure. Formerly this was a problem for the architect-engineer who had to design a detail for it. Under SEF it was a manufacturer's problem, a "mandatory interface" on which the structural manufacturer and the partition manufacturer had to work cooperatively to prevent buckling of a partition under a transfer of loading.

Such problems logically belong to manufacturers because they have the expertise and the production experience to solve them. Contractors and manufacturers have perennially criticized architects for designing impractical details that are difficult either to produce or to install or perhaps both.

In the SEF program the manufacturer was given full scope for his expanded role. He was not restrained by the inhibiting specifications of the conventional construction project. He was required to consult and cooperate with other manufacturers.

Alternate rows of wall panels contrast smooth concrete with exposed aggregate.





Toronto was first to include exterior walls as a subsystem.

He even had to concern himself with aesthetics.

The most basic gain offered by systems building is, of course, production efficiency. The expanded SEF market created an entirely different competitive climate for Westeel-Rosco, Ltd., the winning partition contractor. At \$3.5 million, the SEF partition contract was one of the largest contracts Westeel-Rosco ever got, according to Hank L. Levelt, manager of the company's Systems Division.

"The large SEF market enabled us to invest about \$150,000 in R and D," says Levelt. "That's more than the total partition contract on one isolated school. We built an automated production plant, designed especially to turn out SEF partitions. Computerized production control cut about 15% from our normal low-volume custom-fabricating methods."

Because of the predictable quantities of solid panels, doors, etc., the Westeel-Rosco plant can produce a large supply of partition panels long before the remaining SEF schools are under construction. By stocking these panels, the company smooths the demand curve and averts drowning in the flood of orders when the SEF construction program gains full momentum.

On conventionally built schools, with no guaranteed mass market and all 22 schools going out for separate bids, there would have been no research and development, no com-

puterized, automated production plant, and no innovation.

Though the manufacturer takes over some of the architect's traditional functions in a systems-building project, the architect's role nonetheless remains crucial. On Toronto's SEF schools, architects can devote full attention to the creation of a stimulating educational environment. They can forget about window caulking, roof flashing, and other irritating details that have traditionally deflected them from larger concerns. Under the systems-building concept, responsibility for that phase of the work goes to the experts who understand it, the product manufacturers.

The architect's role retains most of its former importance despite its change, but the general contractor plays a truly different role on a systems-built project. On an SEF school, the general contractor is no longer a broker selecting subcontractors and taking bids. His role changes to that of a construction manager, a professional charged with scheduling and coordinating the work of the subsystems contractors. The general contractors who rose from the carpenters' ranks and remain dedicated to the old ways will be out of place on a systems-built project, except perhaps as foundation contractors.

As demonstrated by the Metropolitan Toronto School Board, an active owner role is vital to successful systems building. Owners who want

good buildings cannot afford to rely passively on professional and industrial experts. They must play an active role, as the Metro school board did in creating an atmosphere conducive for labor and business to negotiate contentious issues long before construction started.

After protracted negotiations Rod Robbie persuaded the Canadian Standards Association to become the testing consultants for SEF to inspect and certify fabrication and installation of subsystems. This practice could be the precursor of national systems' certification, extending the principle of Underwriters' Laboratories or Factory Mutual's fire-resistance labeling into the general field of building products. If similar agencies in the U.S. assume this role, and if the CSA expands into other systems-building programs, the stimulus toward sophisticated testing and performance criteria will propel the building industry into a new era of technological progress with economy and quality for all.

MONTREAL'S RESEARCH
IN SCHOOL FACILITIES

RAIS

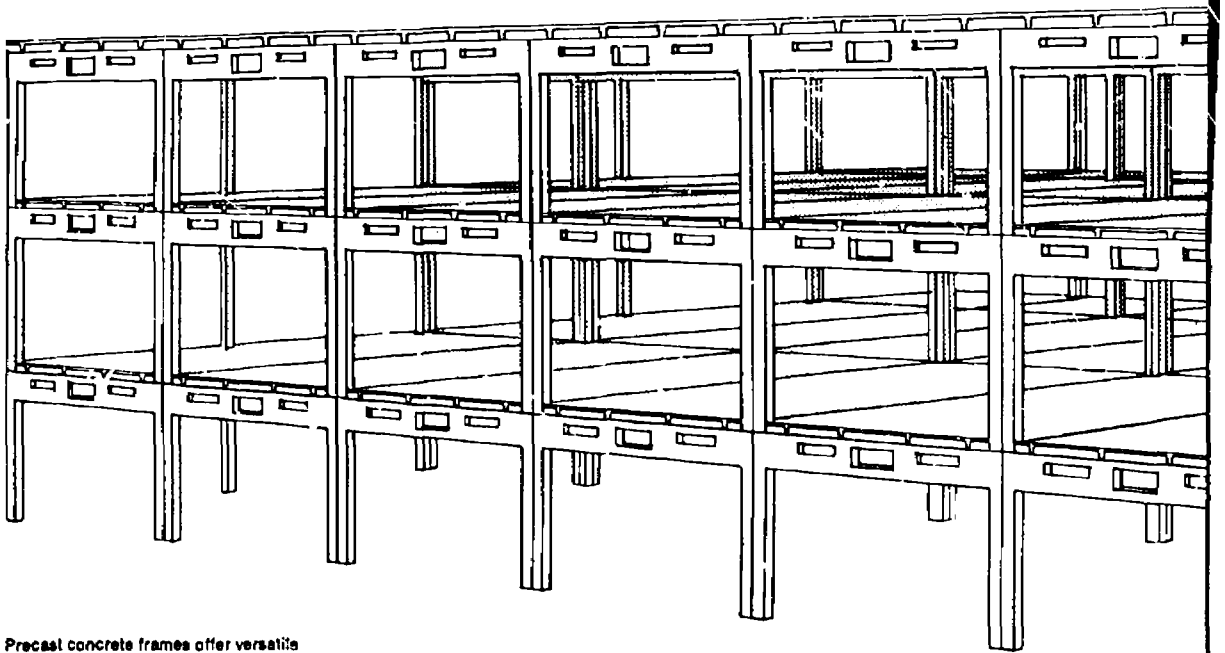

Precast concrete frames offer versatile planning in three directions. Concrete meets Montreal's stringent fire codes.

The closed building system developed for the Montreal Catholic School Commission (MCSC) had to satisfy severe user requirements. This is because the MCSC, the larger of Montreal's two separate public school systems, is following a recommendation of the Parent Report on education in the Province of Quebec to build comprehensive (in French, polyvalent) schools in place of separate academic and vocational secondary schools. A com-

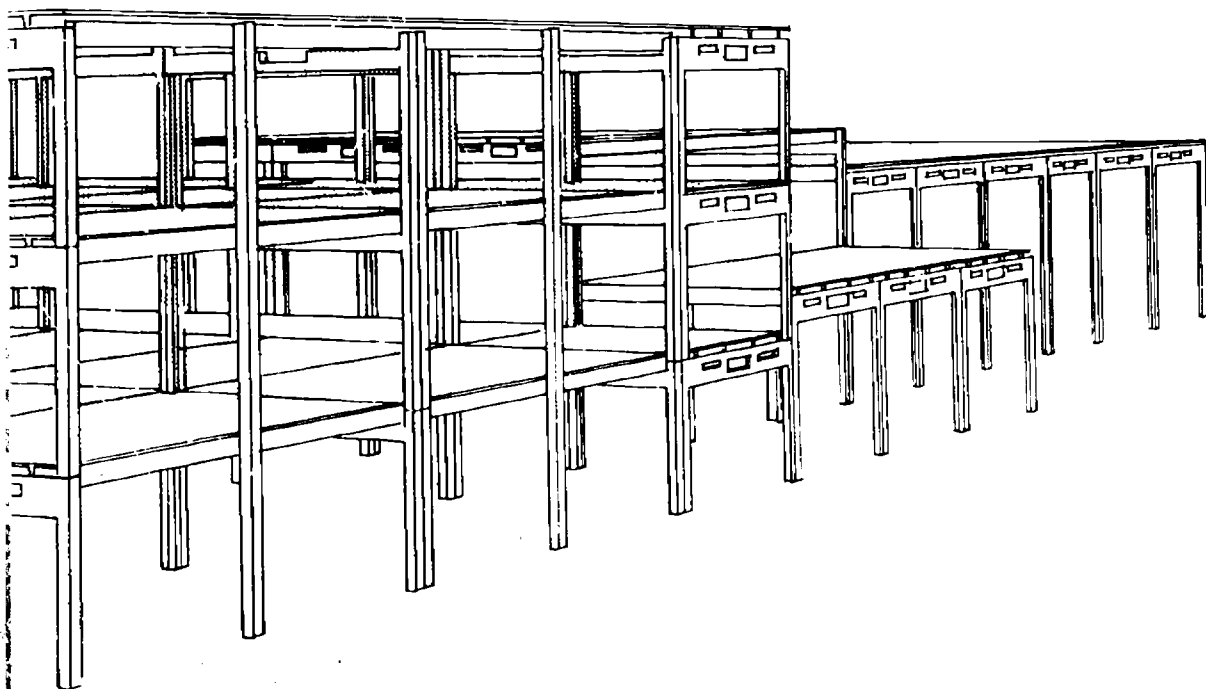

prehensive school's greater range of spatial uses naturally imposes more rigorous user requirements than a more specialized school, either vocational or academic.

The Research In School Facilities (Recherches en Aménagement Scolaires—RIAS) is part of a larger study of education undertaken for the MCSC by the Montreal research Institut de Recherches et de
ERIC Informations Economiques et

Scientifiques (IRNES). EFL is contributing one-third of the \$1 million cost of the RAS study, and MCSC the other two-thirds. Like Toronto's SEF program, RAS is seeking construction economy, long-term maintenance economy, quality, flexibility, and speed.

Technically, RAS is significant as the first North American school systems-building program with a concrete structural frame. One reason

114

for this is that concrete has a natural advantage over structural steel in a jurisdiction governed by ultra-conservative fire-resistance provisions. Second, the successful concrete bidder, Francon, Ltd., overcame a long-standing problem of how to integrate the structural subsystem with the airconditioning subsystem.

Montreal's approach to systems building originally included eight subsystems, but these were cut to five. Several factors contributed to the elimination of three subsystems. IRNES lacked the time required to thoroughly investigate performance criteria for all originally planned subsystems and could not give manufacturers sufficient time to develop them. IRNES thus eliminated exterior walls, roofing, and plumbing. Another reason for eliminating the exterior wall was to leave the facades for each school to the architect's individual expression.

Once this decision was made, the elimination of roofing as a subsystem was mandatory, because flashing details at roof-wall intersections would vary with individual projects, and this variation would ruin any possibility of a standardized systems' solution. Failure to placate labor opposition to prefabrication helped to kill the proposed plumbing subsystem.

The remaining five subsystems comprised the four basic ceiling-sandwich subsystems — structure, lighting-ceiling, airconditioning, and

partitions—plus electric-electronic. Early in 1970, a test structure was erected to try out the major subsystems and test their interface compatibility. For its final five subsystems, RAS anticipates a 13% reduction from conventional construction cost estimates.

What made RAS an essentially closed system, as opposed to the open SEF building system, was simply one difference in bidding requirements. In the SEF program, each manufacturer had to make his subsystem compatible with two manufacturers' subsystems at each mandatory interface, whereas the RAS performance criteria required compatibility with only one manufacturer at each interface.

The RAS manufacturers thus bid as closed-system teams; the total price of five subsystems competed against similar bid totals tendered by competitive teams. In SEF's open bidding, each bidder bid as an individual; the lowest bidder with a satisfactory product in each subsystem category won that contract.

Though the number of manufacturers bidding on each program was comparable, the difference in total building systems is startling. In Toronto, SEF identified 13,000 different building systems claimed to be compatible by the bidders; in Montreal, IRNES identified only 11 such systems. Of these 11 building systems, only 3 satisfied the budget limitations set by the MCSC. In the SEF program, which was governed

by the same conventional construction cost limit, 4,000 identified building systems qualified.

Efficient Integration

Defending the RAS closed-system strategy, architect Michel Bezman, IRNES technical director for the RAS program until mid-1970, cites better hardware as the chief advantage of closed-system bidding.

"By requiring documented compatibility among our five subsystems bidders, we think we got technically better, more architecturally elegant subsystem integration than SEF. From each manufacturer, we demanded details showing precisely how a subsystem was integrated into at least one complete building system. SEF required only a statement from the manufacturer that his subsystem was integrated with others."

"In addition to better integration, we think we got better prices," says Bezman. "Because a manufacturer was required to detail a practical technique for integrating his subsystem at each interface, he knew precisely what material and labor it took to integrate his subsystem with others—so many steel angles, field-welded, or whatever. With this information, he could bid an exact price. In SEF, however, each manufacturer might have included a little extra in his bid, to allow for unforeseen contingencies."

ability, Bezman recalls that a structural and ceiling manufacturer claimed compatibility, but had omitted required secondary bracing members. The IRNES staff found the omission, but Bezman doubts it would have been discovered in SEF.

Moreover, after the tentative bid award immediately before mock-up testing, SEF was deeper in the dark than RAS, says Bezman. IRNES knew precisely what kind of connections, component supports, diffusers, and other hardware elements it was getting. In the mock-up test building, the IRNES staff checked tolerances, architectural appearance, and unforeseeable bugs. SEF had to test not only the foregoing items, but also the manufacturers' integrative concepts.

As the best example of RAS subsystem integration, Bezman cites the graceful transition between Lennox Industries' airconditioning ducts and the Electrolier Corporation's lighting coffers. From a strategic grid of fixed, rectangular steel ducts, short vertical cylindrical fiberglass sections feed air down into cruciform plenum boxes located at the common corners of four light-ceiling coffers. Any arm of this cruciform plenum box can be designed for linear air diffusion, with the steel light coffers forming the bottom half of the diffuser duct segments. Linear diffusers, with varied baffle patterns, can deflect air in any direction through the lighting coffer joints in the ceiling plane. Where diffuser

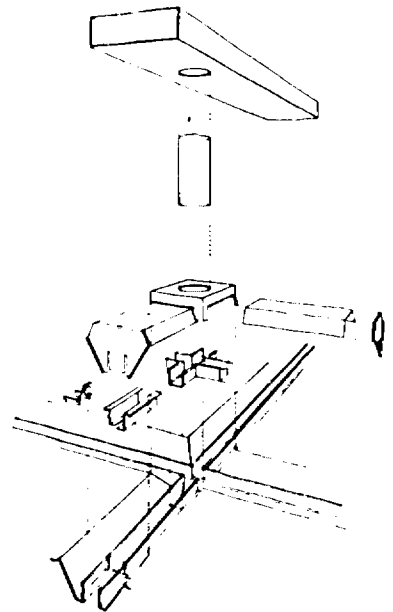

Airconditioning and lighting components integrate gracefully in ceiling.

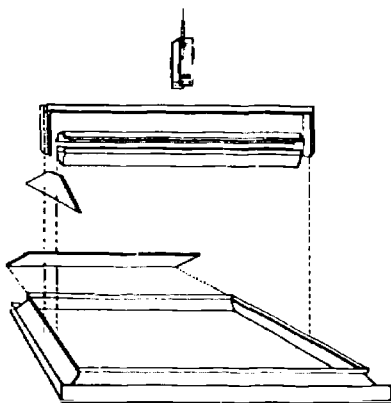

Stirrup, second component from top, holds ceiling coffer (bottom). Air ducts (not shown) sit atop stirrup.

duct arms are omitted, the plenum box is sealed with a hexagonal cover, and the joint between lighting coffers can serve as an air return to the ceiling plenum, which conveys air back to a mechanical room.

According to Bezman, Electrolier could readily adapt this integrative concept to accommodate another manufacturer's airconditioning subsystem.

As another example of superior subsystem integration, the technique of supporting lighting-ceiling coffers and airconditioning ducts displays the advantage of closed-system integration. Hanger bars, field-welded to plates precast into the soffits of the precast concrete floor framing members, support lightgauge steel stirrups shaped like an elongated inverted U. The vertical legs of these stirrups support the (typically) 5 x 5 ft lighting-ceiling coffer frames. The horizontal legs of these stirrups support metal airconditioning ducts, rectangular in cross section. This ingenious double-duty stirrup resulted from the close collaboration of manufacturers concerned with perfecting only one closed building system, according to Bezman. Open-system bidding, he says, would have hindered the stirrup's development.

The RAS lighting-ceiling subsystem is elegantly integrated also at the ceiling plane. In a common 1½-in. open joint left between ceiling frames (normally at the 5 x 5 ft grid lines) you can insert an air diffuser,

designed to throw air in different directions; leave it open as an air return to the ceiling plenum; close it with a U-shaped metal strip; or anchor a partition with a telescopic head detailed to accommodate the worst structural deflection. As still another (fifth) possibility, the RAS building system's electrical-electronic service columns attach to the ceiling in the same manner as the partitions.

Integration of the precast structural system with the airconditioning required another major adaptation. Concrete beams are usually formed with solid webs that force designers to hang airconditioning ducts below them. In contrast, the lightweight steel trusses generally used in school building systems provide easy access for ducts to penetrate their abundant triangular web openings. Designing concrete girders with rectangular openings to accommodate ductwork requires special design to resist shearing stresses. It also requires some minor, but nonetheless additional factory work in forming the openings. The structural subsystem contractor produced girders with ample web openings designed for easy piercing by airconditioning ducts. These girders are precast with two columns to form a portal frame that looks like a soccer goal post. The frames carry precast double or single T sections spanning up to 80 ft which form the floors or roofs.

Structural concrete was favored by the unusually severe Montreal fire



code, which requires much greater fire resistance than the Toronto code or most modern U.S. codes. For four-story buildings—the height limit for both SEF and RAS schools—the Montreal code requires a basic 3-hour rating, with 4 hours for such key structural elements as columns and bearing walls. (To qualify for a given fire rating, a building component must withstand a test fire of progressively rising temperature to 2000F or so.) Toronto requires only a basic 1-hour fire rating, with 2 hours for columns.

To gain a given fire rating for concrete is relatively simple; you merely use a more porous aggregate and/or increase the concrete coverage over reinforcing steel. Structural steel, however, requires a fire-resistant envelope or encasement to avoid the sudden buckling collapses characteristic of fire-weakened steel.

In Montreal, merely to open the competition to structural steel required lengthy negotiations with the city's building code officials. Before RAS, Montreal's ultra-conservative code required direct encasement of steel framing with concrete or other fire-resistant material. IRNES convinced the code officials to reduce this requirement to methods approved by Underwriters' Laboratories and Factory Mutual. These agencies test and fire-rate floor-ceiling assemblies as whole units, consistent with actual conditions

experienced in a building.

Even in its self-imposed performance criteria (i.e., requirements beyond the statutory requirements for safe construction) the RAS program is a little more severe than SEF. The RAS partitions, for example, satisfy the best acoustical performance criteria yet required in a school-construction program (STC40), yet at 2¼ in. thick, they are the thinnest partitions made for systems-built schools. (Compared with conventional 4-in.-thick partitions, these 2¼-in.-thick partitions add 7 sq ft of usable floor space—nearly 1% to a 30 x 25 ft interior classroom.) Manufactured by B. K. Johl, Inc., these metal-faced partitions can be dismantled for relocation or for replacement of only one face, like the SCSD and SEF partitions.

The RAS electrical-electronic subsystem exemplifies sophisticated systems building. Like SEF's, the basic RAS electrical distribution is in the ceiling space. But it eliminates all horizontal wiring runs below the ceiling (the runs that cause the greatest difficulty in renovation work). Thus, RAS went further than previous developments in systematizing this subsystem.

The electrical-electronic subsystem's integration with the partitions is especially ingenious. Vertical wiring extensions from the ceiling can be threaded through specially designed metal door jambs, or through tubular partition jointing sections, to reach light switches. Elimination of conduit runs inside partition

cross sections also permits use of thin, space-conserving partitions.

Exploiting Evolution

Explaining why he believes the RAS program produced better hardware than SEF, Michel Bezman resorts to an evolutionary view of systems building. Like SCSD, RAS is part of a second stage in systems-building's evolution. Ultimately, architects will fit together building subsystems and components listed with performance characteristics in a general systems catalog.

This third, and final stage of systems building will offer widespread open competition among building product manufacturers selling products of general compatibility, with varying performance characteristics suited to individual requirements, tastes, and budgets. A general open building systems' catalog would contain, for example, a broad spectrum of lighting-ceiling subsystems. Each would be compatible with a wide range of modular structural framing, airconditioning, partitions, electrical-electronic, and other interfacing subsystems. Weighing the different factors—acoustical quality, architectural appearance, durability, interchangeability of panels, lighting intensity, quality, flexibility, and price—an architect would select the particular model he desired.

SEF, Bezman says, may have sacrificed quality and possibly some slight economy in attempting to leap prematurely from the first to the third stage of systems building.

The first stage of systems building started in Europe after World War II. Industrialized housing production was the only way to rebuild the war-ravaged countries. A continuing program of government subsidies generated the required housing volume to justify mass production. Industrialized construction of schools was first used in Great Britain. It reached a high level with the Consortium of Local Authorities Schools Program (CLASP). Although the CLASP building system offered little real flexibility, it did standardize a set of modular dimensions and offer some competition among various manufacturers furnishing standard building components.

The early building systems lacked one of the two requisites of systems building. The European industrialized builders neither analyzed user needs nor defined the functions of the various subsystems. They set no new performance criteria or mandatory interfacing requirements with other subsystems. Until CLASP began offering some minor options, European industrialized builders offered no real user flexibility at all. Floor and roof spans, partition locations, utilities, etc., were either totally or virtually frozen. In his original design, an architect had no freedom; he was stuck with a stock set of room sizes and arrangements. His only design freedom entailed a choice from several commercially available exterior wall finishes. French schools built with a heavy precast concrete "build-

ing system" froze the building into the familiar eggcrate, with no possibility of change.

Thus in the North American sense of the term, these early buildings did not qualify as true building systems, according to Bezman. They merely industrialized the traditional building process—perfecting production techniques for casting and curing precast panels, creating sophisticated jointing details, and solving other technical problems. By greatly reducing the uncertainties and expense of field labor, i.e., by maximizing factory production, they did cut construction costs. But they offered essentially the same traditional building product to users.

The RAS program illustrates this difference between the traditional and the systems approach in analyzing user needs. In traditional school programming, the architect is simply told to provide so many classrooms, with so many square feet. The RAS program had to go much deeper in analyzing the user needs for MCSC. RAS buildings must accommodate nongraded education with its added demands on a school plant.

From the Montreal educators, the RAS staff requested flow charts depicting the activities for teaching each subject. From these flow charts, they saw that, for example, no single specialized geography room could satisfy all the needs. A school needs large spaces for mass lectures to groups of 100 to 150 by a university professor on taped TV

film. It also needs smaller spaces, possibly including traditional classrooms, for explanation and discussion in groups of 12 to 30. Finally, to complete the final assimilative stage of the educational process, the school needs different spaces, with electrically-electronically equipped carrels, for individual or team research projects. Viewed afresh in this light, school design becomes the problem of creating a suitable environment for a changing teaching-learning process — not merely the provision of so many static teaching spaces.

With the analysis of user needs, subsystem functions, and performance criteria, first achieved in California's School Construction Systems Development (SCSD) program, systems building moved into its second stage. We are still in the second stage, according to Bezman, and we can't force the evolutionary process without inevitable loss in technical quality. Industry must have time to analyze the complex interfacing problems—studying, for example, alternatives in fabrication techniques and field assembly. As a simple illustration, the field-welding technique for connecting the RAS ceiling stirrups to the structural subsystem may be more economically replaced by some kind of threaded insert designed to accommodate horizontal dimensional tolerances. Perfecting these techniques takes time.

The previously cited numbers—4,000 financially qualifying subsystems for

SEF vs. 3 for RAS—depict the differences between SEF's open-system approach vs. RAS's closed-system approach. Inspired by the principle, "Variety is the spice of competition," the SEF staff rated the stimulus to competition higher than the benefits of thorough and immediate coordination of subsystems. The Toronto approach trades additional post-bid development for greater competition. In contrast, the Montreal approach sacrifices a probable loss in future competition to earlier, superior integration of components.

The question of which route is best—open or closed—can't be answered at least until the next stage of the SEF and the expected continuation of the RAS program. Viewed in a broad perspective, the open- vs. closed-system controversy merely concerns a different strategy aimed at the same target. At bottom, it pits two opposing opinions on industry's capacity to respond to competitive pressure.

CALIFORNIA'S SCHOOL
CONSTRUCTION SYSTEMS
DEVELOPMENT

SSSD

52

The success of SCSD, which was the first systems-built school program in North America, encouraged other states and cities to explore their own paths to systems building. Until California built its systems schools, designers and educators had only been able to project the benefits of the buildings and the education programs in terms of school experiences in other countries. SCSD gave everyone a chance to see that systems worked in the U.S. economy.

The initial success was scored under open public bidding both for the components and for contracts to build individual schools using the components. This differs from the usual European pattern where one manufacturer dominates the design and construction of the building.

The completed schools also successfully demonstrated that they possessed all the predicted virtues of variety of space and flexibility to accommodate change. And, since these virtues stemmed from a building constructed with components, owners of commercial and industrial buildings adopted systems construction. Thus SCSD sired a family of systems buildings that is still growing.

More than 1,300 schools, a construction volume valued at \$1 billion-plus, contain one or more subsystems developed through the SCSD program. In ever growing numbers, building product manufacturers are competing in the burgeoning sys-

tems-building market. For each of the four major subsystems introduced by SCSD—structure, airconditioning, lighting-ceiling, and relocatable partitions—from 6 to 12 manufacturers are qualified to compete. Most of these subsystems are available on a nationwide basis. Local school boards all over the U.S. have adapted SCSD performance criteria to their own local requirements. While conventional building costs have been skyrocketing over the past several years, systems-building costs have remained relatively stable.

The spatial flexibility provided by these new subsystems has already proved its feasibility and economy. In several SCSD high schools, the staffs have made extensive changes required to adapt their schools to modern instructional techniques. From a practical viewpoint, these changes would have been impossible in conventionally built schools with fixed partitions.

Nonetheless, despite their achievements, many SCSD schools fell short of the potential created by the new hardware. Successful use of the SCSD building system requires a skill, imagination, and sensitivity still lacking among many U.S. architects; SCSD project architects did not produce instant educational utopia. Despite the availability of excellent sound-damping components, the architects failed in varying degrees to create a suitably quiet learning environment. Human errors

and the ubiquitous communications gap hampered the program. Success depended chiefly on the skill of each project architect. But to a comparable degree, school administrators and school boards share credit or blame.

Another factor must be weighed in judging SCSD schools. As a new program inspired by high, even naive hopes, SCSD suffers the liability of being judged against an ideal rather than a realistic standard. Even the critics admit that SCSD schools are generally far better than conventional schools.

SCSD's mission was widely misunderstood, even by some architects who participated in the program. The goal was never political, to perpetuate an administrative empire extending through the state of California. The goal was merely to stimulate systems buildings. SCSD hoped to educate manufacturers, architects, engineers, contractors, and school boards to adopt the systems approach, which had been used so successfully in Europe. The developing free-wheeling competition springing from SCSD's original school construction program, with one manufacturer's subsystem competing against another's, is precisely what the program's sponsors hoped it would produce. The disappearance of the First California Commission in School Construction Systems, the legal entity created to conduct the bidding of the SCSD components was not only antici-

pated, but planned. Yet at least one participating architect interpreted this disappearance as a program failure.

SCSD's Birth Pains

California became the logical U.S. choice for a systems-building program because of its rapid growth into the nation's most populous state. By the early 1960's, California was building 40 classrooms a day, at an average statewide school construction volume of \$300 million a year. Moreover, despite its strong ultra-conservatives dedicated to preserving traditional modes of education, California has many venturesome educators eager to experiment with new educational concepts, techniques, and facilities. More than any other state, California needed new schools, built fast and economically, equipped to accommodate new instructional techniques. Standard school plans, the perennially proposed solution in those days, had been rejected because (a) they provide no demonstrable economy, and (b) they provide no flexibility for varied school needs. To find an alternative solution, *Architectural Forum* and EFL sponsored a national conference on the problem in September, 1961. In attendance were Charles D. Gibson, Chief of the Bureau of School Planning, State Department of Education, Sacramento, California; Anthony Part, Deputy Secretary, Department of Education, United Kingdom; Warren Schmidt, Assistant

Commissioner, New York State Education Department; Rufus Putnam, Superintendent of Schools, Minneapolis, Minnesota; William Pena, partner, Caudill Rowlett Scott, architects, Houston, Texas; Ezra Ehrenkrantz, architect; J. Stanley Sharp, partner, Ketchum & Sharp, architects, New York City; John Hinchliffe, Director, Commercial Products, Northrop Corp.; W. W. Dedon, Project Engineer, Northrop Corp.; George E. Martin, Director, Marketing Research & Distribution, Kawneer Co.; Dr. Harold B. Gores, President, EFL; Jonathan King, Secretary, EFL; Douglas Haskell, Editor, *Architectural Forum*; and Walter McQuade, Senior Editor, *Architectural Forum*.

The participants agreed that mass-produced building components could meet the demand for standardization and still provide the broad range of solutions insisted upon by architects and educators. They also agreed that, to accomplish this, someone would have to create a market for about \$30 million of school construction.

To start the ball rolling, Frank Fiscalini, a school superintendent from San Jose, Calif., offered 3 proposed schools from his district as the nucleus of the required \$30-million market that would eventually include 13 schools.

Buoyed by this enthusiastic lead, EFL financed a \$50,000 feasibility study by Stanford University's School Planning Laboratory which

led to the formation of SCSD in early 1962. Ezra D. Ehrenkrantz, a San Francisco architect eager to adapt lessons learned from two years on a Fulbright scholarship in Great Britain studying industrialized school building programs, was appointed SCSD project architect. His educational counterpart was Dr. James Laurits, a former Palo Alto high school principal. (Dr. John R. Boice, of Stanford's School Planning Laboratory, succeeded Laurits as SCSD project coordinator in 1963, and now heads the ERI-supported Building Systems Information Clearinghouse.) The School Planning Laboratory served as the grantee administering the program.

The young SCSD staff got plenty of organizational support. An advisory committee comprising distinguished architects and educators from all over the U.S. was created to monitor developmental work and counsel the staff on specific problems. The California State Department of Education, through its Bureau of School Planning Chief, Charles Gibson, fulfilled its early promise to cooperate.

SCSD's legal problems began with the task of creating a legal entity empowered to assemble the \$30-million market required to sustain manufacturers' research and development. The 13 originally participating school districts formed the First California Commission on School Construction Systems. After some initial doubts, the commission's legal authority to take bids was finally established. School districts in

the state of California can legally join together to do anything they can do individually.

Other legal problems arose. Immediately following the nomination of five successful component contractors in January, 1964, a disappointed loser challenged the validity of performance specifications (used here for the first time for large-scale contracts for building products) as a legal basis for awarding bids. (For some unexplained reason, this question had not occurred to the suing manufacturer six months earlier at a pre-bid conference, where the SCSD staff explained the performance specifications.) The Commission successfully defended itself against the lawsuit, and the awards stood.

Despite hundreds of meetings with architects, engineers, contractors, and subcontractors, other misunderstandings arose, notably protests from structural engineers using the Inland Steel Products Company's structural subsystem on the various school projects. The structural engineer of one project even refused to put his seal on the structural drawings, thereby disavowing the required professional responsibility. (He argued that the manufacturer should assume responsibility for the structural design.) In settling these disputes and resolving misunderstandings, the SCSD staff established a solid basis for succeeding systems-built projects.

Ezra Ehrenkrantz attributes the final success of the SCSD program to

rough equality of sacrifice as the price of obtaining cooperation among the various building industry groups. Manufacturers had to put more effort into new development; unions had to accept more prefabricated components; architects and engineers had to work from unfamiliar new catalogs; general contractors lost their freedom of choice in selecting subcontractors for components representing roughly half the total contract price. Functions and responsibilities were drastically changed or reapportioned. But no one group had to bear the entire burden.

Evolution, Not Revolution

A naive disillusion with SCSD set in after the initial wave of publicity, according to architect Chris Arnold, a former SCSD staff member and vice president of Building Systems Development (BSD), which is headed by Ehrenkrantz. It occurred after thousands had visited the SCSD mock-up building and the SCSD story had reached the *Reader's Digest* and other magazines and newspapers.

"At first acquaintance with SCSD, some school administrators thought they had discovered a panacea for their school construction problems—faster construction and a better school at 10% to 20% cost saving," says Arnold. "But when they continued their inquiries into systems building, they discovered that it wasn't easy magic. They had to use their standard methods of

soliciting and awarding bids; they had to retain sophisticated architects who were informed about systems building."

Now that the initial disappointment has been dispelled, progress in systems building is proceeding at a sure, steady pace, according to Arnold.

"Systems still encounter tremendous inertia. Like other building industry changes, it's coming by slow evolution, not overnight revolution. But school subsystems are quietly entering the building industry's mainstream. Manufacturers, contractors, and school boards are learning the new process."

Interest in systems now stands at an all-time peak, according to John Boice of Building Systems Information Clearinghouse (BSIC). BSIC is financed by EFL to maintain industry liaison on systems building and to make information on systems building available to schools, colleges, architects, engineers, and manufacturers.

Published BSIC matrixes demonstrate the evolution of the original SCSD system into an open building system. There are now, for example, 11 different manufacturers' lighting-ceiling subsystems compatible with the original Lennox airconditioning subsystem, which is now available in 3 models. And 9 lighting-ceiling subsystems are compatible with one of Lennox's competitors, ITT Nesbitt.

Inquiries received by BSIC reveal the different motives underlying interest in systems building. Roughly 40% of the inquiries come from school boards. Confronted with record building construction cost rises, they naturally seek economy. But speed is an equally popular goal. After procrastinating beyond their decision deadlines, some school boards want the secret of planning and building a school within six months. A roughly equal number of commission-hunting architects seek information that will enhance their capabilities and their image as informed systems specialists to impress their prospective school board clients. About 10% of BSIC's inquiries come from manufacturers hoping to enter the competition. A still smaller number come from contractors confronted with actual, or prospective, problems in managing the construction of systems-built projects.

New Products for New Needs

Inspired by the British CLASP building system and other European models, the SCSD program went far beyond the standardization and industrialization that marked its European predecessors.

"SCSD set a precedent for writing hardware descriptions," says Robert Blake, chief of the research and development staff in HEW's Facilities Engineering and Construction Agency. "This first set of educational performance specifications is one of the most important docu-

ments in the history of systems building."

The establishment of optimum spans for floor or roof framing members shows how the SCSD staff translated a simple user requirement into performance criteria. As a key requirement for SCSD schools, the educators wanted economical unobstructed academic areas which would span two conventional 30-ft-wide classrooms. With roof structural members spanning 60 to 70 ft, partitions in the predominantly one-story schools can be arranged for large spaces without running afoul of columns traditionally located along corridors separating two 30-ft classrooms.

To meet this spanning requirement, Inland Steel Products developed an ingenious structural system of lightweight steel joists with light-gage steel decks serving triple structural duty. This system was designed by Robertson Ward, Jr., an architect, and The Engineers Collaborative of Chicago. In addition to its primary duty as deck support for insulation and roofing membrane, the light-gage steel serves as top chord for the joists and as a diaphragm transmitting lateral loads to the walls. (Integrated with this structural subsystem, Ward's design of steel lighting coffers, inserted between joists' webs, also won an SCSD contract.)

Responding to other SCSD performance criteria, the building industry produced two new commercially available subsystems:

- packaged airconditioning flexible enough to accommodate a tremendous range of room sizes and layout changes

- an economical set of movable and relocatable partitions designed to meet the special problems of education

The genesis and subsequent evolution of the relocatable partition subsystem is a classic illustration of the systems building process. Included in the SCSD partition contract were three basic types:

- standard fixed
- relocatable
- operable and relocatable

The "operable and relocatable" category included two subtypes: a folding panel partition of high acoustical insulation value, equipped with a door, to provide a wall with work surfaces—tack- and chalkboard; and an accordion-type partition also of high acoustical value which did not provide a working surface. Both operable partition subtypes had to be removable by a trained crew within one week. All operable partitions had to open under a 25-lb lateral force so that a 95-lb teacher can handle them.

The key provision concerned the structural self-supporting feature required of these relocatable, operable partitions. In conventionally designed schools, it is usually prohibitively expensive to move an operable partition. They are normally suspended from a floor or roof

beam designed to carry the extra loading. To be acoustically effective, they must weigh at least 3 lb per sq ft. Connection details to the framing above normally consist of bolts and wood blocking. In addition to the arduous task of removing these connections, relocation of operable partitions normally requires the strengthening of a beam supporting the relocated partition, usually by expensive field welding.

The alternative to beam strengthening—predesigning floor and roof members to carry operable partition loads—could raise structural costs by 5% to 10%.

For both folding-panel and accordion partitions, the SCSD solution was a self-supporting "goalpost" frame. A hidden steel truss (within the goalpost crossbar) carries the partition load. The posts (legs of the inverted U goalpost frame) are stabilized with connections to columns or adjoining partitions. To relocate the partition, workmen dismantle and reassemble the entire frame.

The More the Merrier

The SCSD partitions also illustrate the proliferation of manufacturers and the continued improvement of various performance characteristics in response to open competition. By October, 1969, at least 12 manufacturers were working on the integration of 19 different partition subsystems, designed for compatibility with a wide range of other subsystems meeting SCSD performance criteria.

The original Hauserman demountable SCSD partition, called Double-Wall, consists of a steel stud frame with steel floor and ceiling channels. Steel-wrapped gypsum board panels clip to the frame without mechanical fastening. The interior space behind the panels serves as a utility raceway. Where higher acoustical performance is required, they can be backed with additional gypsum board panels.

Removing Hauserman's Double-Wall partition is an elaborate procedure. It requires the following steps:

- 1 Snap off metal base strip from floor channel
- 2 Pry off two facing panels
- 3 Remove steel studs
- 4 Remove electrical conduit
- 5 Remove floor and ceiling channels

By eliminating much of this work, the new Hauserman Ready-Wall speeds the dismantling process by 15 to 20 times—from 2 lineal ft per man-hour to about 35 lineal ft per man-hour.

A spring-loaded steel bar anchors the Ready-Wall partition to a ceiling runner section; at the floor, the partition can have rubber feet for bearing on tile or continuous rows of gripping teeth for bearing on carpet. To remove the Ready-Wall partition, workmen cock the springs with a special tool that releases the ceiling-anchored bars' doweling action. They then simply remove the

ceiling clip, without taking the entire partition assembly apart.

Hauserman has plenty of competition in this second generation of relocatable partitions. Some can be dismantled at the rate of 70 lineal ft per man-hour, twice the dismantling rate of Ready-Wall. At the ceiling, these partitions are anchored with spring-loaded dowels fitting into key inserts or with magnetized connectors. On carpeted floors, they are anchored with Velcro (an extremely rough-surfaced, friction-gripping nylon); on tile floors, with a continuous plastic foam pad.

These portable partitions (including Ready-Wall) are not, however, direct competitors of Double-Wall. Thinner and lighter, they cannot accommodate electrical conduit and plumbing lines between their facings; they generally have a lower sound-insulating value; they lack the one-side face-changing feature of the SCSD partitions; and the joint gaskets of some detract from their appearance. In short, they complement, but do not replace, the heavier, thicker demountable class of partition.

Alan Smith, of William Blurock & Partners, an architectural firm in Corona del Mar, California, which designed two of the architecturally distinguished original SCSD schools, cites as one example of these lightweight partitions a partition made by Advanced Equipment Corporation. Manufactured in 5 x 10-ft units, this partition weighs less than 3 lb per sq ft; its total unit

weight of 125-150 lb can be readily handled by two custodians. Facing panels consist of pressed fibreboard with vinyl fabric skin. Sandwiched between them is a honeycombed paper stiffening core.

"These partitions are generally unsuitable for high schools, where you need good acoustical insulation between classrooms," says Smith. "But they are excellent for an open-plan elementary school, where the partitions function more as visual barriers and you need flexibility for frequent changes.

"You pay a higher price for these lightweight partitions. But you recover the additional cost after a few relocations," adds Smith.

As another substitution for an original SCSD subsystem Smith cites Lok Products Company's lighting-ceiling. With its plane ceiling and luminescent lighting panels, it offers less lighting flexibility (i.e., variations in direct and indirect lighting) than the original Inland Steel Products Company lighting-ceiling subsystem. But where this variety is not needed, the Lok lighting-ceiling offers lower cost and simpler installation as overriding assets. Simply suspended with wires from the framing above, the ceiling runners and infill panels form a diaphragm providing the required lateral resistance for partitions.

The greatest commercial success from the SCSD program is the multi-zone, rooftop airconditioning produced by Lennox Industries. These

rooftop units have found uses outside school construction--in offices, shopping centers, recreation centers, dormitories, and other buildings requiring flexibility. As the demand for flexible airconditioning units expands market opportunities, however, Lennox faces a growing list of competitors.

Evaluation of SCSD Schools

Exploiting the use of the advanced subsystems available under the SCSD program, architects displayed the same broad range of ability that they display on conventional schools. Because of the heightened expectations of SCSD schools, the architect's role is at least as important on an SCSD project as on a conventionally built school. In effect, the SCSD program depressed the scale of architectural appreciation: success was applauded less enthusiastically, failure condemned more harshly, than on conventional school projects.

Among the better examples of SCSD school design is El Dorado High School in Placentia, Calif., designed by architect William Blurock & Partners of Corona del Mar. El Dorado's campus-style design suits southern California's mild climate. Between classes, students walk across exterior courts separating individual buildings housing English, Social Studies, Mathematics, Language, and other academic departments.

The centrally located library displays the benefits of SCSD flexibil-

ity. As part of its function as a multimedia information center within easy access of the surrounding buildings, El Dorado's library contains counseling offices. Normally, counseling offices are integrated with the administrative offices. But El Dorado's administrators had good reasons for departing from the conventional administrative-counseling consolidation. The library location offers easy access to counseling information—job descriptions, classifications, and available opportunities for students. Moreover, separation of the counseling offices frees them of the disciplinary atmosphere that hovers over the administrative offices.

"There are some liabilities to the library location," admits Vice Principal Jerry Jertberg. "The isolation causes some inconvenience. Counselors and administrators now have to schedule meetings once or twice a week on special problems. But in general, we think the benefits far outweigh the liabilities."

The built-in SCSD flexibility permitted El Dorado to experiment with this new arrangement without permanently living with it. The 65-ft clear spans of the library roof trusses free a large area for unlimited partition relocation. The flexible airconditioning and lighting-ceiling subsystems permit the school's administrators to scrap the plan and relocate the counseling offices whenever they want.

Changes made at nearby Sonora High School, also designed by Blurock's firm, demonstrate the alteration savings attributable to the SCSD building components. (Sonora's design, as a single giant building, displays an extreme in the great range of architectural concepts embodied in SCSD schools.)

Within two years of the school's completion in late 1966, Sonora's English department chairman wanted to expand the English resource center. Originally built with an area of 875 sq ft, the resource center was aligned with three classrooms. As part of the change, one classroom was eliminated. Most of its area went into larger classrooms, required for larger English groups planned for a revised English curriculum. The additional area incorporated in the resource center went into a private, shelf-bounded cove for individual showings of filmstrips from Sonora's abundant collection. (It includes "Death of a Salesman," "Pygmalion," and "Our Town.") This private cove supplemented the resource center's other audio-visual facilities—headsats, playback tape recorders, opaque projector, etc.

The changes entailed the removal of 180 lineal ft of partition and re-erection of 125 lineal ft, plus installation of two doors, and removal of electrical ducts, convenience outlets, and television jacks located within the removed partitions. Two air supply ducts and diffusers, and two

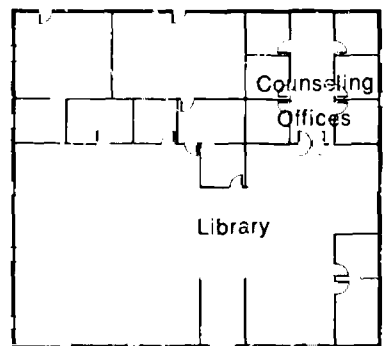

El Dorado High School counseling offices in library give access to information and separation from formality of administration offices.

ceiling return slots also had to be relocated.

Cost of this work was about \$12.50 per lineal ft. A conventional school generally could not accommodate these changes. In the rare circumstances where it could, the alteration cost would be roughly doubled.

A precise estimate for alteration of conventional construction indicates a cost 85% higher than the actual cost of alterations in the SCSD Oak Grove High School in San Jose. Within a year of its completion in mid-1967, several changes were required to adapt several buildings to curriculum changes. In the Mathematics Department, a partition change was required to convert two standard classrooms into a large team-teaching space, plus a small testing area. Similar partition relocations enlarged a resource library and created three small-group meet-

ing rooms out of storage space in the Science Department and a small seminar room in the English Department.

Because of the complex nature of this renovation, its cost rose to \$25 per lineal ft of relocated partition. But the precisely estimated cost for removing and replacing conventional partitions of equivalent quality was \$46 per lineal ft.

The Benefits of Flexibility

A drastic future change planned for the Oak Grove Science Department best illustrates the intimate connection between educational policy and the physical environment needed to carry it out. It also shows the need for great flexibility to accommodate changes in educational policy. A frozen pattern of interior space can pose a tremendous obstacle to progress.

In the change to individualized instruction from group instruction, the goal is to raise the estimated 75% or so achievement-aptitude ratio, normally attained through traditional, group-oriented instruction, to 100%. (Achievement-aptitude ratio indicates the student's academic achievement measured against his inherent aptitude.) The individualized approach of adapting each student's curriculum to his special needs offers the only hope of eventually achieving this goal, says Jack Grube, chairman of Oak Grove's Science Department.

The key element in Oak Grove's planned change to individualized science instruction is the "packet," an educational unit involving comprehension of a scientific concept, or related set of concepts. In Science 1 (normally for freshmen) these educational packets cover seven topics, each divided into about three concepts. A student gets credit for comprehending a concept by correctly answering 70% of the test questions on that concept. In trial uses of the packet technique, Oak Grove students favored it over conventional, group-oriented instruction.

Individual initiative and responsibility are stressed throughout this planned new process. The student makes his own contract with the teacher to complete a certain number of packets. His academic load will thus depend on some combination of ambition and self-confidence. Most students will take about 7 units per semester. But fast and slow students are freed from the inevitable group-oriented pressure, up or down, toward mediocrity. Each student sets his own pace, rescheduling only when his preliminary optimism or, more happily, his pessimism, proves unfounded.

In this process, the teacher plays the role of fireman, not policeman. "The students want the teachers' skills on their terms, not his," says Grube. "They'll go as far as they can on their own initiative, using sources recommended for each packet. When they need help, they'll get it

on an individual basis, or in small groups assembled to resolve common misunderstandings."

The physical changes planned for the Science Building will greatly facilitate the new instructional procedures. The new spaces will be divided by *function*, not by *subject*. There will be three general learning areas:

- For *motivation* (student as spectator) a large lecture hall for groups up to 150.
- For *direct experience* (student as participant) a long laboratory space, extending the building's full length.
- for *assimilation* (student as researcher) a large L-shaped science resource center.

The proposed alteration entails removal of two partitions dividing an existing materials distribution room from two flanking laboratories: one for chemistry-physics, the other for biology. This new elongated space will become the general, all-purpose laboratory. Removal of another long partition will join the existing science resource center to an existing chemistry-physics-biology resource center, creating a large L-shaped general resource center. Other partition changes will produce a new laboratory materials distribution room and move all small-group discussion rooms to the periphery of the resource center. In a simple conversion, an existing laboratory (for Science 1) will become a special projects laboratory. Only the

61

lecture hall will remain unchanged. [See plan.]

In addition to accommodating the planned instructional changes, the planned open areas will also facilitate efficient use of the teaching team. The large open areas offer the only hope of staffing the Science Building with a 10-member teaching team comprising 6 teachers and 4 student teachers. (Advanced students will aid this team as unofficial lab assistants.) The planned L-shaped open resource center, now consisting of two partitioned spaces, was originally three spaces. Manpower requirements for this area will have dropped to one-third the original requirement. After its two-stage change, made within three years of its opening, Oak Grove's Science Building will be unrecognizable.

The cost of this conversion will not be cheap; it will range around \$20,000. But for a conventionally designed school, such radical change would be prohibitively costly and time-consuming.

A less drastic, but similar, reform of El Dorado High School's English Department also illustrates the benefits of SCSD flexibility. English Department Chairman Ed Walsh plans to individualize the instruction of 375 ninth-grade pupils. Educational packets, similar to Oak Grove's science packets, will replace the traditional classroom curriculum. As one cognitive goal, for example, the students must learn to

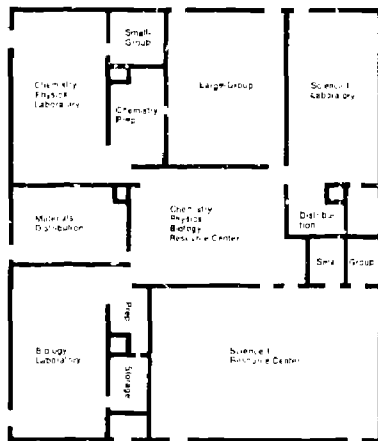

Relocatable partitions enabled original plan, left, of science department to be transformed into open instructional areas, below, at minimum cost.

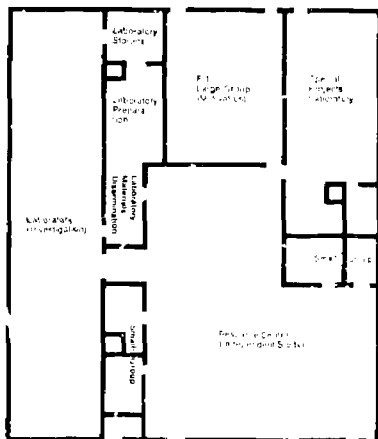

write in five basic sentence patterns. When they satisfy this requirement, students will move from a basic writing classroom into other areas—for example, into a large, 1,500-sq-ft room for 70 or 80 students. Through such large groupings, the El Dorado

English staff will make more efficient use of films, educational television, and overhead projection of transparencies showing graphic grammar instruction.

To create this large viewing-lecture room will require removal of a relocatable partition now dividing two 750-sq-ft classrooms. It will doubtless be only the first of many changes in the remaining 35 or 40 years of projected life for the English building.

SCSD Failures-- the Unused Potential

In general, despite the noteworthy exceptions, educators have not exploited the potential of their SCSD schools, according to Frank Fiscalini, Superintendent of San Jose's East Side Union High School District, which includes Oak Grove. As the first school administrator committed to the SCSD program, Fiscalini is dedicated to using the systems approach in education as well as for construction.

"The systems approach is the only new concept of significance in educational planning in the last 100 years," says Fiscalini. "Teacher education still lags; we still teach teachers to teach in a conventional classroom. They are competent in their mastery of their subject matter, but generally unresourceful in adapting new audio-visual techniques to instruction. As a result, the SCSD schools are still not used to their full potential. There was a com-

munication gap between the SCSD staff and the school principals and teachers, who never really learned what SCSD schools can do."

Some failures to exploit SCSD schools are at an elementary level. A high school social studies teacher, with outstretched arms signifying his exasperation, plaintively asks, "How can I hang a screen on this partition?" Apparently he was never informed of, or has never discovered, the picture-rail mounting at the top of the partition. It makes screen and picture hanging a simple operation.

On a larger scale, penny-saving, dollar-wasting school budgets and/or shortsighted administration policies have squandered opportunities for long-range economy. The Fullerton Union High School District turned down the 5-year airconditioning contract available from the manufacturer, Lennox Industries. Maintenance work done by school district maintenance men appears to have been unsatisfactory. It is difficult to get qualified airconditioning mechanics to work for school districts; they can make at least 50% more working for a manufacturer or contractor. Thus in retrospect the Fullerton policy seems shortsighted.

The SCSD staff included the mandatory offer of a maintenance contract in the airconditioning subsystem bid to assure long-term economy, according to ex-SCSD project architect Ezra Ehrenkrantz.

1/3

"Bids on airconditioning are usually based on first cost only," says Ehrenkrantz. "On surveying maintenance costs, our staff found that some school districts paid up to 40% of first cost for the first year's maintenance, and 10% to 20% was not unusual. Moreover, the manufacturers told us that bid award on first cost only forces them into providing minimum durability. We asked, 'Why not include a five-year maintenance contract as an owner option along with first cost?' It's better and cheaper than paying for repairs after one year."

Failure to take the airconditioning maintenance contract, at the least, threatens the loss of a major economy of the SCSD building system.

SCSD recommendations were ignored in other areas. Contrary to these recommendations, carpet was laid *after* partitions were erected in both Sonora and Oak Grove High Schools. As a consequence, renovation costs were raised (by 13% at Sonora) for splicing a strip of carpet over the bare concrete after the partitions were removed.

The Biggest Complaint

The loudest, most common complaint about SCSD schools concerns acoustical performance. In a BSIC survey of students at Harbor High School in Santa Cruz, "noise isolation between rooms" was overwhelmingly rated "poor" (by three-quarters of 156 surveyed students and 13 of 23 teachers). An in-

significant number gave this school an acoustically "good" rating.

Harbor High School is one of the poorest SCSD schools acoustically. But the over-all acoustical rating of 10 SCSD high schools is disappointing. In a BSIC survey, 51% of the students and 55% of the teachers rated noise isolation between spaces "good" or "OK." Acoustical design is, beyond all doubt, the weakest aspect of the SCSD schools. It is far less a failure of hardware than a failure to use it properly.

"Acoustical control is the major problem of the semi-open school plan," says John Boice. "Many architects relying on the carpet to absorb noise, failed to specify the perforated acoustical ceiling panels available from the lighting-ceiling manufacturer.

"SCSD issued a suggested guide prepared by an acoustical consultant. It was generally ignored by the architects and engineers on the various projects. A special acoustical wall facing was designed and produced by the partition manufacturer. For one reason or another, not one was ever used.

"The SCSD schools' acoustical problems spring chiefly from the open ceiling plenum and the more open plans. In conventional buildings, permanent partitions extend through the ceiling, sealing each room acoustically. The open ceiling is indispensable for flexibility in

space arrangement, but it exacts an acoustical price. Despite warnings from the SCSD staff, most architects ignored the problem, or at least underrated it."

Even the better examples of SCSD architecture have acoustical problems. El Dorado High School loses productive use of a considerable amount of interior space because of excessive noise. Each of El Dorado's separate academic buildings has a large interior court, typically 25 ft wide, with peripheral classrooms entered through 5- or 10-ft-wide openings. According to the architect's brochure, each interior court "becomes a part of the learning environment," depicted in renderings as a lively scene of play rehearsals and students wearing headsets while studying intently at carrels.

The courts have not worked that well. They generally function merely as oversized corridors, lost for study and other student activities because of poor noise control. The 10-ft-wide openings in the English building's classrooms virtually nullify the intrinsically good acoustical insulating quality of the relocatable partitions. Because noise travels freely through these 10-ft-wide openings, activities in one classroom sometimes disturb the occupants of the adjacent classroom. One morning in the bustling English building, the sound of a Mae West movie on television disturbed the neighboring room's occupants, who were taking the sound reflected off an

entrance wall opposite the adjoining 10-ft classroom openings.

Before formally considering the architect's recommendation to apply acoustical surfacing to the offending wall, the school administrators want to assess the acoustical effects of narrowing the 10-ft-wide classroom openings. Current plans call for reducing those openings to either 5-ft or 6-ft 8-in. width.

It seems clear that buildings destined for intensive academic use—English, mathematics, social studies, languages—require more rigorous acoustical design than buildings used for less intellectually demanding activities. There are few complaints about noise in the Commerce Building, which is designed essentially the same as the academic buildings. This building's noise level, roughly that of a typical business office, is not objectionable for typing, operating business machines, and performing other commercial operations.

Where academic areas contain more conventionally designed enclosed classrooms with doors, as in the Casa Roble High School in Carmichael, the teachers are generally satisfied with acoustical performance. According to Dr. Ferd J. Kiesel, Superintendent of the San Juan Unified School District, there are no complaints about Casa Roble's acoustics.

The preliminary data from BSIC's noise isolation survey indicates another important factor in the acous-

tical rating. The *more* individualized the instruction, the *fewer* the acoustical complaints. Thus the shift toward more informal instructional techniques apparently abates the noise problem. Individualized instruction, with small groups and individuals simultaneously pursuing their own activities in the same space, seems naturally to require less rigorous noise control than traditional instruction, with teachers continually lecturing to large classes.

In assessing SCSD schools, one must constantly remember the conventional schools that they replace. Some remarks by Josh Burns, a BSD architect working with John Boice at BSIC, help to put the SCSD shortcomings into perspective.

"Some errors were systems errors, resulting from an unfamiliarity with the new products. Others were simply design errors perpetuated through the years on both conventional and systems-built schools."

Users mitigate their otherwise free-wheeling criticism when reminded of conventional school buildings. Teachers are not unanimous in urging closed classrooms or even narrowing the typically 10-ft-wide openings at El Dorado. Some like the freer, more open atmosphere, viewing it as an escape from the cloistered environment of the conventional classroom cell.

Even the acoustical problems tend to diminish for teachers who remember the problems of old buildings.

"In many ways, the open plan alleviates distractions," says El Dorado's Vice Principal Jertberg. "In old school buildings, the clack-clack-clack of a woman's heels in a terrazzo corridor could disrupt an entire class: everybody would crane to see her as she passed by the classroom door, like prisoners stealing a glimpse of the outside world."

For some SCSD schools, no apologies are necessary. New teacher candidates overwhelmingly seek assignment to the two SCSD schools in Huntington Beach Union High School District says Superintendent Max L. Forney.

Dr. Forney's district paid SCSD high tribute in building the 3,000-student Edison High School as a virtually identical twin of the Fountain Valley High School, the first SCSD project under construction. Opened in September, 1969, three years after its prototype, the new high school contains all the basic SCSD subsystems, but with some new suppliers as a result of changed market conditions.

Viewed from a broad perspective, SCSD was a success. Despite a few bugs in some projects, the SCSD buildings do fly. Future buildings stemming from this pioneering program will doubtless fly higher.

103 664

ADAPTING SYSTEMS BUILDING

Converts to school systems building display a tremendous range of faith --from high divers to toe dippers. Toronto's true believers plunged deep into an almost totally systematized building program; Chicago's more cautious school administrators are starting with use of a single SCSD subsystem, the roof-mounted, multi-zone airconditioning. Despite many other variations, however, school systems-building programs take one of two general forms:

- Primary or developmental systems-building programs, modeled on the SCSD program, which directly stimulate technological innovation. In these programs, new performance criteria are written for building subsystems, and large markets are organized to sustain original research and development by building product manufacturers.

- Secondary systems-building programs merely exploit the speed, economy, flexibility, and quality of building products already developed under the primary programs. Because these secondary programs need little research and development, they can thrive on smaller markets than developmental programs.

The product development work undertaken in the SCSD, SEF, RAS, and URBS programs is indispensable to systems-building progress. These developmental programs promote an essential dialogue between users and suppliers of school building products. From this dialogue,

educators and architects learn whether their cooperatively written performance requirements are commercially practicable, and suppliers learn about educational needs which can be satisfied by their products. The large markets organized for primary systems-building programs guarantee adequate sales volume to assure profits for a successful manufacturer, or at least to justify their efforts as a rational business risk.

Ultimately, however, the secondary programs are similarly indispensable in establishing systems building as the normal process for school construction. In mechanical terms, the primary programs overcome inertia and resistance to progress, but only secondary programs can sustain the momentum and make systems building a self-generating process. Without successful secondary programs the construction industry will inevitably topple back into its traditional rut, and the fragmented markets will again make technological innovation too risky an economic gamble for product manufacturers. To change the metaphor, you can't continue reinventing and selling the wheel forever. At some point the world must assimilate the message.

Fortunately, the unique user needs of different school districts can be fulfilled with hardware designed for similar, though not identical, user needs. As merely one example, variation in desired lighting level can be

accommodated by the same lighting-ceiling subsystems. By exploiting existing products, secondary systems-building programs can vastly expand the market for these products. In accord with free enterprise theory, the expanded markets will attract more manufacturers into competition, enabling them to offer a multitude of compatible, modular subsystems. Architects will then choose structural framing, lighting-ceiling, partitions, curtain walls, air-conditioning, furniture, and other subsystems from a giant catalog. From the relatively few commercially available subsystems on the market today, the school subsystems available in the future should expand into hundreds, conveniently catalogued for direct comparison in performance, durability, architectural elegance, and economy.

A start toward this next stage in systems evolution is well under way. Systems-developed components are in hundreds of school buildings all over North America. Toronto's SEF has already inspired two systems-building program starts, in Boston and Detroit. RAS will undoubtedly be adapted by other cities. Systems-building projects vary in size from statewide programs to single school buildings. To show how secondary programs of such widely varying scope can nonetheless realize similar systems economies, Florida's statewide Schoolhouse Systems Project, and a single school project in Merrick, N.Y., have been chosen for more detailed investigation.

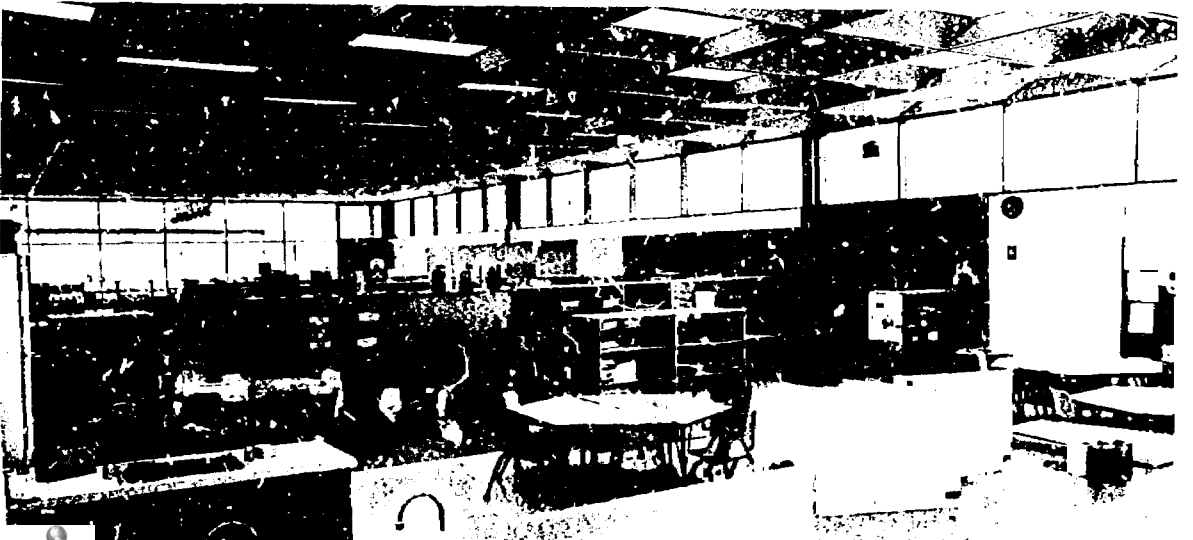

Florida's Schoolhouse Systems Project

Florida's Schoolhouse Systems Project (SSP) displays continued progress in cutting costs and speeding school construction attainable through a staged series of systems-building programs. SSP's first three systems-building programs have been dramatically successful in fulfilling the project's three goals: improving construction speed, economy, and quality. Armed with the solid evidence of its continuing SSP program, the State's Department of Education plans to extend systems building into two primary programs; one for community college and university construction, the other for developing a portable building system.

Construction speed is SSP's most dramatic achievement. For eight SSP secondary schools, the systems approach cut nearly 40% from concurrent conventionally built schools' construction schedules, and for 14 elementary schools the construction time was cut by 12%. Over-all project time savings (from programming through design and construction) were less impressive, but as architects, engineers, contractors, and administrators become accustomed to the new process, these other phases should be similarly shortened.

Progressive cost savings have also been achieved through SSP's open-systems building. In the first SSP action program, the total bid

on three basic subsystems (structural, lighting-ceiling, and airconditioning) was roughly comparable with conventional costs. After two years, the bid dropped 11% in three succeeding SSP construction programs. Allowing for a ½% monthly cost escalation, the SSP staff estimates this 11% reduction at an effective 18% saving.

Intensified competition among a growing number of subsystems' manufacturers is the key to SSP's economy. The structural subsystem best illustrates these improved, competitively honed prices. In the first SSP program, awarded in October, 1967, Macomber's V-LOK won with a unit price of \$1.62 per sq ft. Macomber won again in the second program, awarded in August, 1968, with a bid of \$1.28 per sq ft. In the third program, however, Romac Steel pared nearly 10% from Macomber's previously winning bid, supplanting Macomber with a bid of \$1.16 per sq ft.

For all other subsystems, the cost reduction was less regular as well as less dramatic than the nearly 30% drop in structural costs. But the over-all trend was drastically downward, with new challengers defeating the old SCSD winners. Lennox Industries, the original SCSD airconditioning winner, also won the first SSP program's airconditioning contract. But Hill-York (with ITT-Nesbit equipment) won the second and third SSP program awards. E.F. Hauserman, the winner

SSP Costs for Three Subsystems (Structure, HVAC, Lighting—Ceiling)

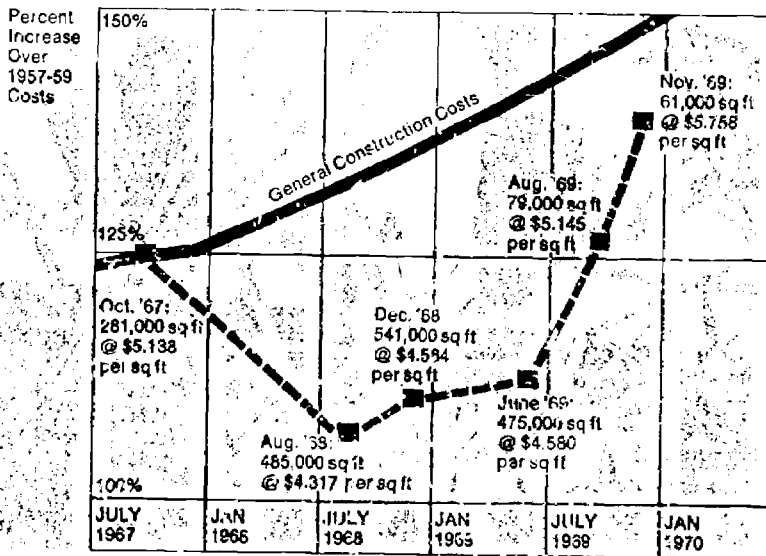

Chart based on cost comparison data from Florida State Board of Education.

of the second SSP program's demountable partition award, was underbid by Mills Company in the third program.

As an agency of the Florida Department of Education, headed by State Commissioner of Education, Floyd T. Christian, SSP extends volume purchasing principles practiced in other areas to reduce the state's educational costs. As one notably successful example, the state, acting as purchasing agent for the local school boards, bought buses in 1970 for the same unit price paid by local-

ities in 1958. Ultimately, through SSP, the state hopes to purchase building subsystems on a similar bulk basis. In effect, the state would become a middleman between manufacturers and users. It would order subsystems on a state-wide basis with a provision for extending unit prices for an agreed length of time. The subsystem contractors would fill orders as they came in from local school districts for projects not included in the original bids.

Through SSP, the state has moved a measurable distance toward its ulti-

mate goal. The 30 SSP schools contracted between October, 1967, and October, 1969, constituted over 20% of the \$70 million annual state expenditures for new schools and additions. In guaranteeing the subsystems' markets for its three-staged systems-building programs, SSP avoided the SCSD's "dropout" problem during the long product-development period. SSP's performance criteria can be satisfied by currently available subsystems.

SSP's adaptation of SCSD criteria shows how any state can adapt these criteria to local conditions. The major change concerned structural design loads: deletion of California's earthquake requirements and substitution of Florida's hurricane wind loadings. The three stages of SSP also reflect general progress in such universally applicable criteria as lighting standards. In the second and third programs, the SSP staff substituted as an alternate the newer, more sophisticated Visual Performance Index (VPI). It adds contrast and other characteristics of lighting quality to the cruder, older criteria of illumination level and glare control.

The Florida program also adds its unique lessons on the minimum construction volume required to make a systems-building program economically profitable. At 100,000 sq ft (roughly \$2 million), the SSP staff found the cost of systems building equal to conventional cost. At 500,000 sq ft (roughly \$10 million

volume) subsystem costs dropped about 20% below conventional cost.

The SSP program again demonstrates the construction industry's reflexive resistance to change. Though they supported the original research program that ultimately produced SSP, many Florida architects at first opposed the construction program itself. Now, however, the Florida Association of the American Institute of Architects supports the program.

Prescription for Speed

A small-scale project in Merrick, a New York City suburb, indicates that a single project can be built with cost and time savings without waiting to aggregate several projects to create a market. Caudill Rowlett Scott, architect for this \$1.1 million project in Merrick's Union Free School District No. 25, estimates it will be completed 10-15 months earlier than with conventional construction. Also, the economy achieved with the four basic subsystems (structure, lighting-ceiling, air conditioning, and roofing), which represent 30% of the total construction cost, is estimated to cut 4% from the total cost. An additional cost saving of another 10% or so comes from the accelerated construction schedule, which nullifies 10 months of cost escalation at 1% per month.

The dramatic time saving stems from a combination of systems building with "fast-track" schedul-

Fast-Track Scheduling

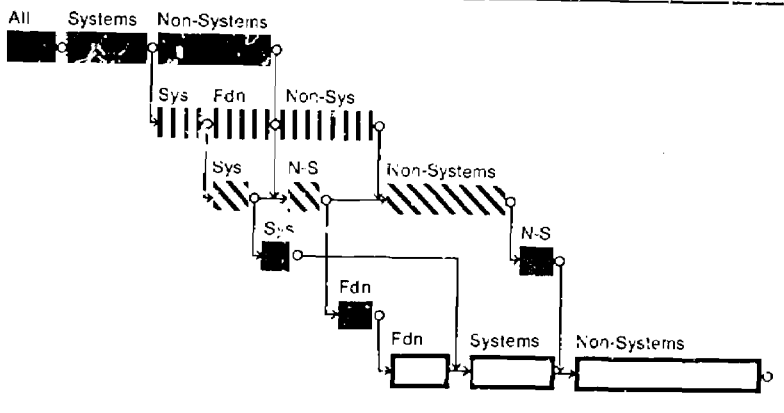
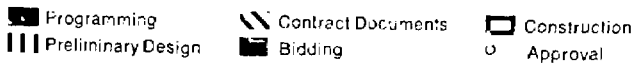

Fast-track scheduling shortens over all design and construction time by overlapping activities that normally would not be done until the one ahead is completed.

ing. This construction management technique telescopes the traditional serial or linear sequence of programming-design-construction into a shorter sequence of overlapping stages. Systems building and fast-track scheduling are natural partners in cutting building delivery time. By combining these two techniques, architects Heery & Heery, Inc., rushed two Athens, Ga., elementary schools to completion only 169 days after signing a design contract. Pre-bidding of subsystems before general contract awards produces the major time saving, and

the added fast-track schedule compression enhances the time savings already gained through the systems approach.

The problem given to the architect was to add 26,000 sq ft within 10 months after receiving the architect's commission. The new space was required to avoid further overcrowding in a district already staging classes in rented basements and a church.

To rely on the conventional construction process was obviously hopeless. In conventional construc-

tion, the programming, design, and construction stages follow in a linear sequence; one stage starts only after the preceding stage ends. Under the normal lump-sum general contract, all design details and specifications must be completed long before the prime contract awards.

The basic contract-staging strategy was as follows:

- Stage I comprised four basic subsystem contracts (structure, lighting-ceiling, airconditioning, and roofing). Prebidding of these contracts was necessary to avoid material delivery delays and to facilitate the architects' subsequent design work, using known components for the basic systems design.

- Stage II, comprising three basic contracts (general construction, electrical, and plumbing) followed eight weeks later. These three non-systems contracts could be delayed because they required less lead time for manufacturers' production scheduling than the earlier subsystems' contracts.

The price of this accelerated schedule, with its overlapping, coordinated project stages, is early commitment. With fast-track scheduling you lose the luxury of delaying the decision to build; you must commit yourself to build the project long before the final contract is let. Programming and design must proceed in a more rigorous, controlled way. Decisions at each stage become irrevocable. Project stages must be bid in a more logical order.

Design decisions must parallel the manufacturers' and contractors' work. In fast-track scheduling, you cannot afford communication gaps between owner, architect, manufacturers, and contractors.

Actually, the Merrick project only partially displays the potential benefits of fast-track scheduling, according to CRS partner, Charles B. Thomsen. In true fast-track scheduling appropriate for larger projects, a construction manager working with the architect coordinates design and construction and monitors the Critical Path Method (CPM) network. The critical path (i.e., the diagrammed sequence of operations that control the time required to complete the project) becomes hypercritical. Because it increases the degree of interdependence, a fast-track project is more dependent on completion of key operations than a conventional project. On large-scale (\$5 million to \$10 million) projects that justify the full fast-track treatment, the construction management consultant becomes indispensable for the complex work of coordinating the many simultaneous activities of a large building project.

Because it takes longer to build a building than to design it, the key to accelerating the over-all building process is to telescope design and construction as much as possible, i.e., to start construction as soon as possible after completion of the minimum required design work. Systems-building and fast-track

scheduling achieve this goal for the following reasons:

- Postponement of final design decisions on precise room layouts and sizes is permitted by the flexibility of the relocatable partitions, multizone airconditioning, etc., which can be set for final location late in the over-all construction process.

- Prebidding of subsystems (the more the better) allows early commitment to construction, with assurance that the project will meet the budget. (With a prebid of 65% to 70% subsystems, plus an early foundation contract amounting to 10% to 15%, the total 80% prebid would assure the architect and his client that they could bid the remaining 20% within the budget, according to Thomsen.)

Time savings attainable on a large project with a large number of subsystems and the full fast-track treatment range up to 45%, says Thomsen. With fast-track scheduling applied to otherwise conventional construction, time savings are limited to about 25%.

Time savings not only deliver desperately needed buildings at an earlier date, they also contribute large cost savings during periods of rapid building-cost escalation.

"At the current rate of 1% monthly construction cost rise, you lose \$50¢ for each hour's delay on a \$10 million project. A six-month earlier construction start at today's escalation rates cuts an additional 6% from the total building cost," says Thomsen.

UNIVERSITY RESIDENTIAL BUILDING SYSTEM

URBS

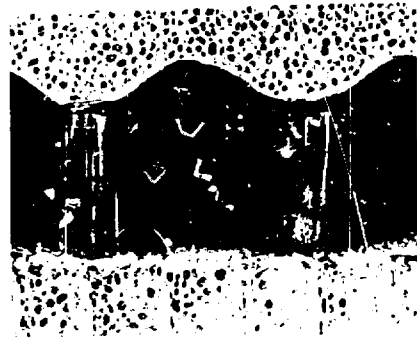
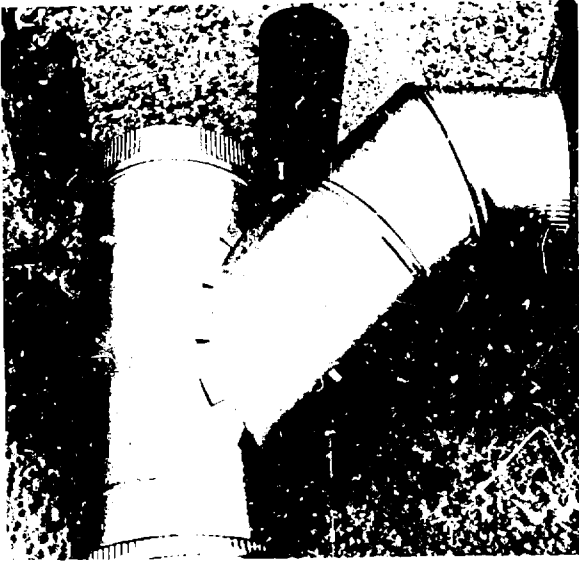

Hollow URBS floors enable ducts to extend in two directions. Ducts are laid on precast concrete bottom slab, arched forms are installed atop slab columns, and top slab is cast on them.

The University of California's University Residential Building System (URBS) extends systems building into the construction of student dormitories. EFL initiated the project, and has contributed two-thirds of the \$600,000 cost of administering it. A successful URBS program would doubtless become a prototype for housing the nation's proliferating college student population, expected to grow from 7.2 million in 1970 to 9.7 million by 1977.

Judged by the manufacturers' final designs and bids on three basic subsystems representing 35% of total building cost, URBS will achieve its three goals:

- Significantly improved environmental quality
- Construction cost savings totaling 10%, plus additional savings in maintenance and alteration costs
- Flexibility to accommodate radical interior changes over the next 40 years for the benefit of the occupants, the colleges, and the mortgaging institutions.

Construction of a full-scale test building at the plant site of Airtel Company, the structure-ceiling contractor, was completed in Santa Fe Springs, California (about 20 miles east of Los Angeles), in June, 1970. Construction on the first project, a \$2.5 million complex on the UC San Diego campus began in 1970. Designed by architect Dale Naegele & Associates of La Jolla, this first project consists of eight buildings,

four or five stories high, for 350 student dwelling units.

Another URBS project, scheduled to start in early 1971 at UC's Irvine campus, will contain 300 units in five clusters of seven-story buildings, designed by William Pereira & Associates of Los Angeles. By 1975, total URBS construction volume should reach 2,000 units on four of UC's nine campuses. Use of the URBS building system promises to spread to other universities. By 1975 the total dormitory units built out of state may exceed California's total. These units will contain three basic subsystems (structure-ceiling, heating-ventilating-cooling, and partitions) chosen like SCSD's components on the basis of bidding performance specifications.

The history of URBS is a later parallel of the history of SCSD. In November, 1965, inspired by the earlier success of the SCSD program, UC officials established the URBS program with the aid and encouragement of EFL. Administering the program was the UC's Vice President for Physical Planning and Construction of the University, Elmo R. Morgan, who was succeeded in August, 1970 by Robert J. Evans. UC's project director for the URBS program is architect R. Clayton Karitz.

UC retained Building Systems Development (BSD), of San Francisco, as consultant for evaluating user needs, translating them into performance criteria and subsystem specifications, integrating the URBS

building system, and writing the contract documents. BSD is headed by architect Ezra Ehrenkrantz, former technical director for SCSD. The firm includes other former SCSD staff personnel—notably architect Christopher Arnold, a BSD vice president, Vernon C. Bryant, and Peter Kastl.

Like SCSD, the URBS program is moving through four stages:

- Compilation of user requirements
- Contract documents, bid invitations
- Bid evaluation, subsystem contract awards
- Design and construction of individual projects

URBS has moved through stage III and is now conducting tests in the test building before moving into stage IV.

User Requirements

Flexibility is again the key, as it was in the SCSD program. The 40-year useful life required for URBS buildings will span 10 generations of university students, through an era that will predictably bring many currently unpredictable changes. Moreover, the URBS building system had to correct many shortcomings in UC's existing dormitories, which are inadequate for present as well as future needs.

BSD's survey of student needs and wants dredged up some previously



unknown (or ignored) user facts of life—notably the lesson that freedom ranks higher than environmental quality in the students' ranking of dormitories.

This lesson was underscored by the example of several existing dormitories and married student apartments with wood-framed, wood-stud bearing partitions faced with gypsum board and inferior heating, ventilation, lighting, electricity, and interior finishes. These residences are also noisy and dirty, but because they are free of the rigid regulations imposed on better dormitory units, these inferior buildings are generally preferred by the students.

Some World War II converted units of especially low quality are highly prized because they give students freedom of interior decor, i.e. freedom from janitorial dominance. BSD's student survey revealed widespread resentment against regulations that restrict individual interior decoration with an almost universal ban on tacking or taping on wall surfaces of the newer dorms

Student criticism concerned more than restrictions against individual decoration. Lack of quiet and personal privacy was a common complaint made to the BSD staff. "There's no place to cry out my problems but the toilet stall," complained one co-ed. Students also want more electrical outlets and storage space for their abundant electrical appliances—clocks, coffee

pots, toothbrushes, hairdryers, typewriters, record players, radios, TV sets, and guitars. In the design of most existing dormitories, building programmers had overlooked the unastounding fact that women need more storage space—much more—than men. "Furniture showrooms," the students' term for large common lounge spaces, were condemned as largely wasted space, used only by a few couples or by students entertaining visiting parents.

The specific needs of special classes of students also need attention. Graduate students need a greater variety of study spaces—for typing, for spreading library resource material over larger desk areas, or even for access to a time-shared computer. Physically handicapped students need ground floor or ramp access.

BSD's survey of user requirements, however, only began with a record of student needs and wants. It had to incorporate many other constraints—notably cost, long-term trends in building occupancy, and university policy. In addition to the students, the investigation included university housing officers, deans of students, central and campus administrators, instructors, and plant officers, and their counterparts in other universities. The process required continued consultation among BSD, the UC administrative staff, the building industry, and the at URBS advisory committees.

The High Cost of Low-Cost Buildings

As a basic major decision, Type V construction (the wood-framed buildings now preferred by students) was eliminated by BSD and the UC staff as ultimately uneconomical. In the long run, cheap buildings are costly; each additional dollar per year in annual repair or maintenance nullifies a \$20 saving in original construction cost. Type V construction costs are 14% less than the cost of conventional construction of higher quality (\$14.67 vs. \$17.15 per sq ft). But this first cost saving is soon lost in higher maintenance costs. Moreover, the loss in flexibility and the maximum three-story height limit for this construction further undermines its economy. As land costs continue skyrocketing, now at a national rate of about 12% a year, the economy of high-rise construction will predictably increase. The maximum URBS project building height was accordingly set at 13 stories, a limit required to qualify reinforced concrete structures for earthquake resistance under the state building code.

Performance Criteria

From BSD's analysis of user needs came the URBS concept of the flexible living area (FLA). The FLA could accommodate:

- Rooms (for one or two single students) organized into suites for up to 10 students, with living room and bath for each suite

- Apartments (for married students) with living room, kitchen, and bath

- Apartments for single students who prefer to live alone.

The limit of 10 students per suite springs from several factors. The state fire code requires an extra exit for a living unit containing more than 10 occupants. The 10-occupant limit also avoided the need for a 1-hour fire-rated partition (with a similarly rated door) within the flexible living area of 2,000 sq ft or less. Since 10 students can be comfortably quartered in less than 2,000 sq ft, the chosen occupancy limit for suites was thus a convenient figure. It combined great economic benefits with no discernible design liabilities.

The URBS building system must, of course, allow complete flexibility in converting 10-student suites into single rooms or married (and unmarried) student apartments, or vice versa. To meet these flexible occupancy requirements, the URBS program had to achieve radical improvements over typical dormitories built in the United States. In the Midwest, for example, the prevailing dormitory design tradition aligns rooms for two students along two sides of a corridor, with the transverse partitions supporting the floors. Since the bearing partitions can't be removed, the room sizes are locked into a rigid pattern.

To build such confining structures today for service until the year 2010

betrays an appalling lack of imagination. It fails both to allow for changing student constituencies and rising living standards. A drastic rise in the proportion of graduate students can dramatically raise the demand for single-occupancy rooms. Graduate students are far more likely to need privacy (for a more intense and less gregarious college life) than typical undergraduates.

A major goal of the URBS program is to abolish the barracks atmosphere of traditional dormitories, which often put 50 students into 25 identical rooms under one administrative unit. The greater variety readily attainable in URBS will add grace and privacy to university life.

Technical Feasibility

In translating user requirements into technical performance criteria, BSD had to compromise technically between the ideal and the practical. Compromise was necessary not merely to reduce costs, but also to limit the development stage to the scheduled 14 months. Yet BSD had to press for technologically practicable products that had not been marketed. Existing products lacked many desirable and readily attainable features. And flexibility in adapting existing subsystems to the required room changes was non-existent.

In acoustical performance, by far the chief complaint against SCSD's, there was no area for compromise. URBS acoustical standards

are considerably higher than those for existing college dormitories; they press manufacturers close to their current technological limits. The minimum Sound Transmission Coefficients (STC) of STC50 for fixed partitions and STC40 for demountable partitions are the best levels currently attained by available products. And the maximum noise transmission levels set for the airconditioning subsystems are beyond many manufacturers' current capabilities. BSD experts have required field tests of acoustical performance as well as laboratory tests, which often do not correlate closely with actual field performance.

Consultation with manufacturers enabled BSD to balance the challenge against the required response and get satisfactory bids for the three major subsystems. A dialogue with airconditioning manufacturers resulted in attainable performance standards for individual student temperature control and for open windows and ventilation at reasonable operating levels. Talks with furniture manufacturers indicated a previously unexploited potential for designing durable furniture for wall mounting or stacking as well as floor mounting. However, furnishing bids were not accepted since the costs were not felt by UC to be demonstrably better than conventional furniture.

Changes in Performance Criteria

Despite the basic similarity of approach, the URBS performance cri-

teria differ from SCSD's in many respects. The 13-story height limit poses more severe fire requirements for URBS than for SCSD's maximum 2-story buildings. Lighting was a major component of the SCSD ceiling subsystem, requiring elaborate provisions for reorienting light troffers to maintain minimum illumination levels in corners. The key factor in URBS lighting, however, is not illumination intensity; it is simply individual control. Because conventional domestic lighting is adequate for dormitory needs, lighting was omitted from URBS subsystems.

Like the SCSD building system, the URBS building system nonetheless focuses on the ceiling space, with three basic subsystems:

- Structure-ceiling
- Heating-ventilating-cooling
- Partitions

The structure-ceiling performance criteria call for constant depth from floor to ceiling surface below and a maximum span of 35 ft to provide interiors free of obstructive columns and interior bearing walls. Columns of variable square cross section must carry up to 13-story loads. Other structural requirements concern accommodation of stair and mechanical openings, earthquake resistance, and adaptability to sloping sites.

The URBS airconditioning performance requirements differ more drastically from SCSD's than the structure-ceiling. With their large

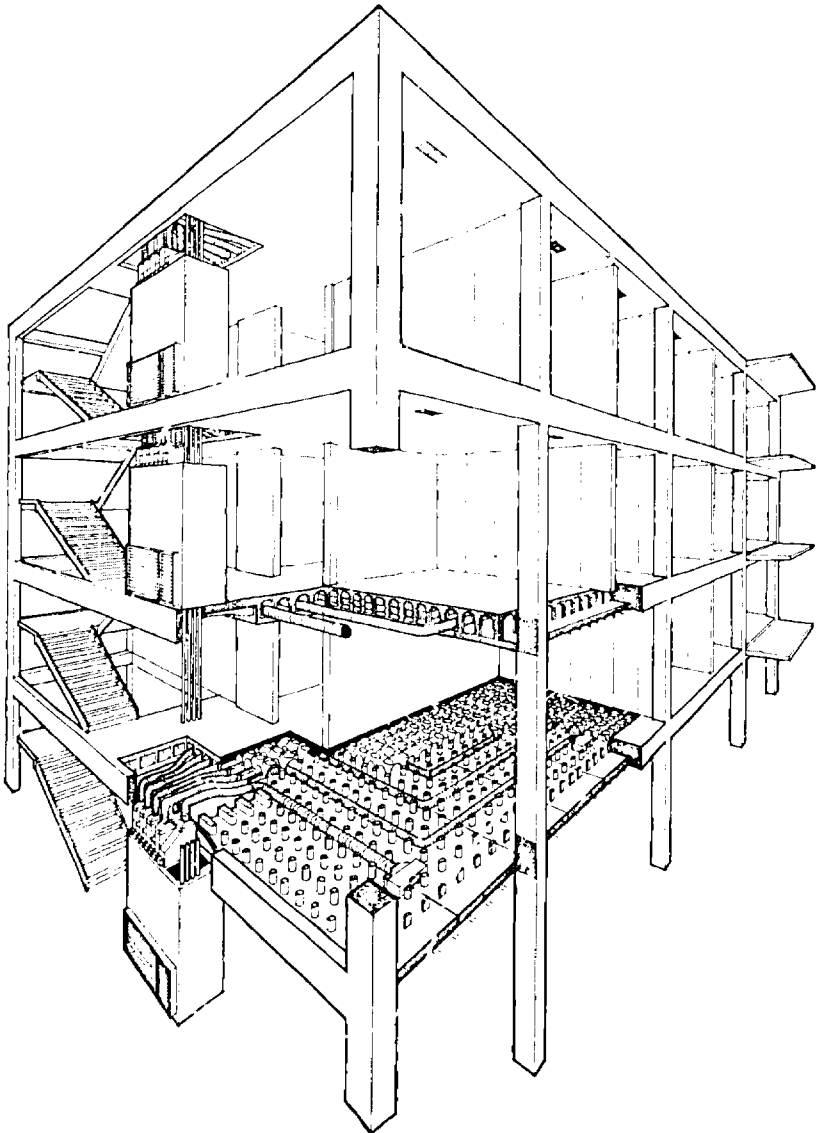

(sometimes vast) interior areas, SCSD schools in southern California require cooling about 90% of the time, and windows are rarely opened.

URBS, however, has neither of these two limitations. All URBS living units are peripheral. Thus they will generally lack the heat gains generated by people in heavily occupied interior spaces. Moreover, in conformance with the greater freedom always demanded in a residential as opposed to a vocational environment, the URBS windows are operable. Cooling is less important in URBS than in SCSD; it will doubtless be a less exercised option in many areas of California where heat is not severe.

URBS airconditioning, like SCSD's, must be available as heating and ventilating with provision for either initial or later addition of cooling. These requirements represent a significant improvement over conventional dorms, which provide neither mechanical ventilation nor cooling and no provisions for adding them. The URBS' advisory committee found many existing dorms in the university system (and at other colleges) rather smelly. Recirculation of return air from one living unit to another is prohibited where living units have kitchens.

URBS airconditioning must also be capable of neutralizing the excessive heat gains or losses in corner living units. Automatic and manual control is required for the small-

est living unit (min. 90 sq ft). Areas of 2,000 sq ft must be divisible into 8 zones, all individually controlled for varied temperature.

To satisfy student demands for freedom of interior decor, BSD partition performance specifications call for a wide variety of finishes—including paint, vinyl, natural wood, chalkboard, tackboard, and glass—plus the capability for hanging pictures or applying temporary wall coverings.

As previously stated, they also require more rigorous sound-insulating quality than SCSD partitions. The URBS fixed partitions require a 1-hour fire rating; demountable partitions must be incombustible.

The URBS market proved too small to produce a competitive price for a systems-designed bathroom. Nonetheless many ideas, e.g., a tub-shower fixture, may be incorporated in URBS. In any event, the switch from gang baths to smaller, residential-scale bathrooms promises greater privacy for the students and less maintenance expense for cleaning services.

The URBS furnishings subsystem went the way of the bathroom units; after a long negotiating process it was decided that the furniture failed to cut conventional costs sufficiently to justify acceptance.

In its present state, URBS is a closed building system. But, like SCSD, it can grow into an open system, according to BSD's Chris Arnold. The

entry of new bidders and bidders not successful in the first round of bidding into the marketplace will, as in SCSD, transform URBS into an open system. To gain entry into the market, new subsystems must be compatible with existing subsystems at their many interfaces. The anticipated parallel process should extend URBS into the national market for constructing university housing. The original URBS manufacturers will almost certainly perfect their prototype subsystems with second-generation models. Hampshire College in Amherst, Massachusetts, is already in advanced planning of the first non-Californian URBS building.

Bidding Procedure

Again as in the SCSD program, bid awards for the URBS subsystem contracts were unit prices based on several hypothetical building segments representing anticipated use of the subsystems. Actual prices are adjusted for their inexorable inflationary rise by the ENR construction cost index. With the datum price index set at June, 1968, prices are adjusted to each project's contract-signing date. Bid prices also contained "campus multipliers," which adjust prices to the different labor and transportation costs for sites all over California.

During a 13-month bidding period, the program moved through three stages: Stage I preliminary design approval qualified a competitor for Stage II final design approval, which

in turn qualified him for consideration for a final (Stage III) priced proposal.

During the extended bidding, 29 contenders for the five original subsystem contracts spent about \$4 million in research and development. Many dropped out before the final, bid-submitting stage. Some failed to meet the rigid performance standards; others failed to beat the cost of conventional subsystems; and some simply stumbled over technological hurdles. And at the last minute, some manufacturers that had survived the first two stages were denied bidding performance bonds.

The eight manufacturers who survived two stages of this rugged Darwinian struggle included three for the structure-ceiling, two for furnishings, and one each for HVAC, partitions, and bathroom.

On a conventional job, such a scarcity of bidders could be financially disastrous; the single bidders would have a monopoly. But in the URBS program even a single bidder still had plenty of competition—in conventional costs. Thus, from the bidding viewpoint, the URBS program was a can't-lose deal for the owner. UC lost nothing when all bathroom bids failed to beat the cost of conventional bathrooms. It gained, however, when the two remaining single bidders, HVAC manufacturer Air-temp Division of Chrysler Corporation and partition manufacturer Hughan Interior Walls, Inc., beat

their conventional competition and so won contracts.

The subsystems contractors' work on each project will be coordinated by a construction manager. His job also includes coordination of the subcontractors' work on the conventional construction (foundations, walls, plumbing, electrical distribution, etc.) which constitutes roughly 65% of each project's total cost.

Final Subsystems

The final subsystem bids, accepted only on the basic three subsystems representing 35% of total construction cost, cut conventional total cost by 8%. Cost estimate for these three subsystems for a conventionally built dormitory was \$12.08 per OGSF (outside face to outside face of exterior walls plus one-half covered, but unenclosed areas). Comparable cost for an URBS building is \$11.05 per OGSF. The structure-ceiling and partition subsystems cut the cost of conventional sub-components by 22%.

The structure-ceiling subsystem supplied by Airfloor Company, of Santa Fe Springs, California, has a cast-in-place concrete frame (columns and spandrel beams or exterior bearing walls). Floor members span up to 35 ft. The smooth concrete ceiling surfaces can be conventionally painted, stipple-painted, or plastered.

The floor framing is ingeniously designed to double as return air plenum for the airconditioning sub-

system and as a space for supply ducts and for plumbing and electrical services. The bottom sections of these floor members consists of 4-in.-thick precast concrete sections, prestressed to resist tensile bending stresses. Metal air supply ducts and other utilities fit into a central void created by a metal-formed grid of concrete posts and two-way arched soffit forms for the underside of a cast-in-place concrete floor slab. The 18-in. depth of this floor construction cuts 8½ in. from the 26½-in. depth of typical conventional framing, a \$0.17 per-sq-ft reduction in exterior wall costs alone.

Airfloor Company was the ultimate winner of the structure-ceiling contract. Interpace, the original winner, withdrew from URBS competition when the project volume was reduced from 4,500 units to 2,000.

The HVAC subsystem supplied by the Airtemp Division of Chrysler Corporation provides all mechanical equipment, ductwork, and accessories for heating and ventilating, plus the required option for adding cooling.

Unlike SCSD airconditioning, which requires flexible, accessible ducts, the URBS supply ducts are fixed in their permanent enclosure within the floor-ceiling space. But as later explained, this HVAC subsystem will nonetheless accommodate the required range of potential room sizes. Supply ducts feed through diffusers located about 2 ft

in from the exterior walls and spaced adjacent to the windows; air returns to the ceiling plenum through the central part of the two-way diffuser opening.

URBS airconditioning differs in other ways from SCSD's. The Lennox SCSD airconditioning consists of packaged units: the chillers, heaters, circulating fans, duct networks, and controls offer a complete independent service for each 3,600-sq-ft area. To eliminate the need for piped water as the heating or cooling agent, Lennox used direct-expansion refrigeration, which cools the air as it blows directly over coils containing the refrigerant.

For the much taller range of URBS buildings, however, these self-sufficient units are not appropriate, since many campuses have central chilling and heating plants. URBS airconditioning exploits the economy of central heating and cooling, with water piped to multizone units serving up to 2,000 sq ft through eight diffusers. Located at each floor in the end walls, with air intake and exhaust through the wall, these units force air over copper coils heated or cooled to respond to different requirements.

Central boilers and chillers and pumps can be located on the roof or in the basement, or the multizone units can be fed from the campus central plant.

The winning partition subsystem, supplied by Vaughan Interior Walls, Inc., features a heavier unit than

SCSD. These fire-rated demountable and fixed partitions are made of laminated gypsum board. They are supported laterally by a small hidden aluminum runner channel anchored to the concrete floor and by an exposed anodized aluminum trim channel at the ceiling. Compressible gaskets can absorb floor-slab deflections up to 1 in. (½ in. above or below the nominal ceiling plane) and maintain the acoustical seal required to meet the rigorous performance standards.

Partition surfaces are smooth or textured, with options for epoxy paint, vinyl, redwood, tackboard, chalkboard, glass, or supporting surface for student-applied finishes, ranging from velvet to sketching paper. It is relatively easy to change the finished surface on one or both sides without dismantling the entire partition. The partitions incorporate vertical channels with hanging devices for pictures or temporary displays and furniture.

CONCLUSION

The schoolhouse has always served as a container from which we drew knowledge, but now the container itself has influenced the thinking of industry and commerce. Since systems construction has provided a better quality schoolhouse, it also seemed a logical way to build better factories, offices, colleges, airports, and housing. Systems applications are universal since any type of building will benefit from an analytical approach to its design and a well-organized method of managing and constructing it.

The federal government, through the Department of Housing and Urban Development, attempted to aggregate a market for housing systems with Operation Breakthrough. HUD invited proposals to meet its performance specifications for the design, financial management, and construction of housing. Over 500 companies responded, and 22 were selected to build on one or more of 9 sites in 8 cities. Each of the 22 had demonstrated to HUD that its design could be built economically and eventually be mass-produced.

School builders no longer need to start systems building from first principles. There is now sufficient knowledge, experience, and technology to enable any district on the continent to build a single school through the systems approach. The processes and products have been well tried out, and more than 50 companies manufacture structural, lighting, heating, mechanical, and

demountable and portable partition subsystems. The development projects in Florida and Georgia illustrate that school districts can build upon the systems work pioneered by others. And these two states are not alone; at the end of 1970, over 200 systems schools were in use or in development in 33 states.

The degree of success of the systems approaches described in this book depend partly upon the performance criteria. If the criteria are incomplete or inaccurately described, the responses will not be satisfactory and the quality of the environment will fall short of expectation. The environmental standards in California's pioneering SCS D program were often based on intuition because the planners did not have access to research evidence. Later programs in Toronto and Montreal benefited from the earlier experiences and are based on more sophisticated criteria.

Although a great deal of research and development in systems construction on this continent has been directed toward educational facilities, EFL, somewhat paradoxically, would like the resulting buildings not to be exclusively for educational purposes. Systems should be the means to obtaining good quality environment for people, and if a space can provide the ideal comfort for one type of occupation, it should be able with minimal rearrangement to provide the same amenities for another type of occupation. Hence,

today's schoolhouse would become tomorrow's health facilities, social center, or even commercial space.

Chameleon spaces make economic sense considering the momentum of migration in and out of U.S. cities. Some schoolhouses are withering from the lack of warm bodies to populate them, while in an adjacent district trailers are pulled into school yards to alleviate the crush of students in the classrooms. When a schoolhouse is declared redundant it usually sits idly deteriorating because it cannot be used for anything else but teaching. This need not happen if the buildings are flexible enough to be economically converted for another use.

But the primary purpose of schoolhouses is to serve education, and for this we still have to improve the environment for learning. Systems moved us forward a long way toward an ideal school environment, and EFL continues to seek techniques to complement this major advance.

GLOSSARY

86

GLOSSARY OF SYSTEMS-BUILDING TERMS

Building System An assembly of building subsystems and components, and the rules for putting them together in a building. Normally these components are mass-produced and used for specific generic projects in a construction program.

Closed Building System A building system whose subsystems are restricted to that one building system. It is produced through a single manufacturer or a commercial association of manufacturers or through bidding conditions requiring that subsystems be compatible with only one manufacturer's subsystem at each interface.

Compatibility The ability to integrate two or more different building subsystems (e.g., structure and air-conditioning) at their interfaces.

Industrialized Building System A building system organized to convert raw materials by capital-intensive activities such as mechanization and automation. Non-industrialized building is a labor-intensive activity.

Interface A common boundary, or connection between two subsystems, e.g., bolted clamps anchoring relocatable partitions to lighting coffer frames at the ceiling plane.

coffer, ceiling panel, structural unit, or other basic subsystem. Room dimensions are usually multiples of the module, and the module itself, normally 5 ft for schools, may be a multiple of some smaller spatial dimension needed to accommodate small building components, e.g., lockers.

Open Building System A building system whose subsystems are interchangeable with other subsystems. Open systems are usually produced in response to bidding conditions requiring each subsystem to be compatible with two or more subsystems at each interface (thus assuring virtually universal interchangeability).

Performance Criteria Technical requirements for subsystems, specifying what they must do instead of what they must look like or be made of, i.e., that they must meet certain standards of strength, fire resistance, durability, insulating quality. Performance bidding retains maximum freedom for bidders to select materials and fabrication and installation methods.

Performance Specification A construction specification in which subsystems are qualified by their ability to satisfy needs, not by their conformance with a narrowly defined descriptive or hardware specification.

User Requirements Stated criteria, sometimes in technical terms, designed to satisfy teachers' and students' needs. For example, the

general user requirements of a comfortable thermal environment may be translated into specific user requirements, e.g., 78F temperature, with a tolerance of $\pm 2F$, when outside temperature exceeds 90F. This user requirement would later be incorporated into the performance criteria of the airconditioning subsystem.

Subsystem Part of a building system, defined for a specific function, and comprising components and materials needed to fulfill that function, e.g., the airconditioning subsystem with its chillers, fans, pumps, ducts, temperature and humidity controls, etc.

Systems Building A process for building construction, featuring (1) study of user requirements, (2) establishment of performance criteria, (3) integration of subsystems into a coordinated whole, and (4) testing (or certification) of subsystems.

Other Publications From EFL

Copies of the following publications are available at the prices listed. Please enclose payment with orders. Educational Facilities Laboratories, 477 Madison Avenue, New York, N.Y. 10022.

A College in the City: An Alternative
A report of a new approach to the planning of urban campuses, with facilities dispersed through the community, designed to serve community needs and to stimulate community redevelopment. (1969) \$1.50

Bricks and Mortarboards

A guide for the decision-makers in higher education: how the colleges and universities can provide enough space for burgeoning enrollments; how the space can be made adaptable to the inevitable changes in the educational process in the decades ahead. (1964) \$2.00

Campus in the City

A short report on the physical problems of urban colleges and universities making a commitment to their communities. It underscores higher education's role as a catalyst in re-making cities. (1958) \$0.50

College Students Live Here

A report on the what, why, and how of college housing; reviews the factors involved in planning, building, and financing student residences. \$1.25

Design for ETV/Planning for Schools with Television

A report on facilities, present and future, needed to accommodate instructional television and other new educational programs. (1960) (Revised 1968) \$2.00

Design for Paperbacks: A How-to Report on Furniture for Fingertip Access

Physical solutions to the problems of displaying paperback books for easy use in schools. (1968) \$0.50

Educational Change and Architectural Consequences

A report on school design that reviews the wide choice of options available to those concerned with planning new facilities or updating old ones. (1968) \$2.00

The Impact of Technology on the Library Building

A position paper reporting an EFL conference on this subject. (1967) \$0.50

The Schoolhouse in the City

An essay on how the cities are designing and redesigning their schoolhouses to meet the problems of real estate costs, population shifts, segregation, poverty, and ignorance. (1966) \$0.50

The School Library: Facilities for Independent Study in the Secondary School

A report on facilities for independent study, with standards for the size of collections, seating capacity, and the nature of materials to be incorporated. (1963) \$1.25

School Scheduling by Computer/ The Story of GASP

A report of the computer program developed by MIT to help colleges and high schools construct their complex master schedules. (1964) \$0.75

SCSD: The Project and the Schools

A second report on the project to develop a school building system for a consortium of 13 California school districts. (1965) \$2.00

Transformation of the Schoolhouse

A report on educational innovations in the schoolhouse during the next decade. With financial data from the year 1968. (1969) Free

PROFILES OF SIGNIFICANT SCHOOLS

A series of reports which provide information on some of the latest developments in school planning, design, and construction.

Schools Without Walls

Open space and how it works. (1965) \$0.50

Three High Schools Revisited

Andrews, McPherson, and Nova. (1967) \$0.50

Middle Schools

Controversy and experiment. (1965) \$0.50

On the Way to Work

Five vocationally oriented schools. (1969) \$0.50

The Early Learning Center

A Stamford, Conn. school built with a modular construction system provides an ideal environment for early childhood education. (1970) \$0.50

Joint Occupancy

How schools can save money by sharing sites or buildings with commerce or housing. (1970) \$1.00

Schools for Early Childhood

Ten examples of new and remodeled facilities for early childhood education. (1970) \$2.00

CASE STUDIES OF EDUCATIONAL FACILITIES

A series of reports which provide information on specific solutions to problems in school planning and design.

9 Air Structures for School Sports

A study of air-supported shelters as housing for playfields, swimming pools, and other physical education activities. (1964) \$0.75

12 The High School Auditorium: Six Designs for Renewal

Renovation of little-used auditoriums in old and middle-aged schools to accommodate contemporary educational, dramatic, and music programs. (1967) \$0.75

13 Experiment in Planning an Urban High School: The Baltimore Charette

A two-week meeting enabled community people to tell educators and planners what they expect of a school in a ghetto. (1969) \$1.00

TECHNICAL REPORTS

2 Total Energy

On-site electric power generation for schools and colleges, employing a single energy source to provide heat, air conditioning, and hot water. (1967) \$1.25

3 20 Million for Lunch

A primer to aid school administrators in planning and evaluating school food service programs. (1968) \$1.25

4 Contrast Rendition in School Lighting

A discussion of requirements for school lighting, with 18 case studies. (1970) \$1.25

5 Instructional Hardware: A Guide to Architectural Requirements.

(1970) \$1.25

College Newsletter

A periodical on design questions for colleges and universities. Free

New Life for Old Schools Newsletter

A periodical on revitalizing outmoded schools. Free

FILMS

The following films have resulted from EFL-funded efforts and are available for loan or purchase as indicated:

To Build a Schoolhouse

A 28-minute color film outlining the latest trends in school design. Available on loan without charge from EFL in care of Association Films, Inc., 600 Madison Avenue, New York, N.Y. 10022, and for purchase at \$93.45 from EFL.

Room to Learn

A 22-minute color film on The Early Learning Center in Stamford, Connecticut, an open-plan early childhood school with facilities and program reflecting some of the best current thinking. Prepared by The Early Learning Center under a grant from EFL and available on loan with-

out charge from Association Films, Inc., 600 Madison Avenue, New York, N.Y. 10022, and for purchase at \$125.00 from The Early Learning Center Inc., 12 Gary Road, Stamford, Conn.

A Child Went Forth

A 28-minute color film on inner-city and ghetto schools and school building problems. Available on loan without charge from Modern Talking Picture Service, Inc., 2323 New Hyde Park Road, New Hyde Park, Long Island, New York 11045 or for purchase at \$75.00 from The Library, American Institute of Architects, 1735 New York Avenue, N.W., Washington, D.C. 20006. A 45-minute version is available for purchase from Larry Madison Productions, Inc., 253 E. 49 Street, New York, N.Y. 10017.

Design: Michel Goldberg
Production: Angela Perretta
Printing: Georgian Lithographers, Inc.

Photography:
James Brett p.75
Gerald Gard p.15
Alex Gray p.27
Jonathan King pp.10,43
Rondal Partridge pp.9,17,18,70,82,84
George Zimbel pp.22,32,34,36,41,44,46,78