

DOCUMENT RESUME

ED C50 063

SP 007 110

AUTHOR Starr, John W., 3rd., Ed.  
TITLE Resource Handbook--Matter and Energy. A Supplement to Basic Curriculum Guide--Science, Grades K-6.  
INSTITUTION Gary City Public School System, Ind.  
PUB DATE 68  
NOTE 237p.  
EDRS PRICE MF-\$0.65 HC-\$9.87  
DESCRIPTORS \*Curriculum Guides, Elementary School Curriculum, \*Elementary School Science, \*Energy, Grade 1, Grade 2, Grade 3, Grade 4, Grade 5, Grade 6, Kindergarten, \*Matter, \*Science Education, Science Units

ABSTRACT

GRADES OR AGES: Grades K-6. SUBJECT MATTER: Science; matter and energy. ORGANIZATION AND PHYSICAL APPEARANCE: The guide is divided into the following six units: 1) Composition of Matter, with 27 concepts; 2) Light, with 20 concepts; 3) Heat, with 14 concepts; 4) Sound, with 12 concepts; 5) Electricity and Magnetism, with 17 concepts; and 6) Friction and Machines, with 11 concepts. Each unit is subdivided into initiatory activities, developmental activities, evaluation, vocabulary, children's books, and films. The guide is mimeographed and spiral-bound with a soft cover. OBJECTIVES AND ACTIVITIES: Activities are given for each concept in the six units. The objectives involve an understanding of the concepts and a correct interpretation of the results of the experiments. INSTRUCTIONAL MATERIALS: The materials needed for each activity are listed. The bibliographies and film lists included in each unit are annotated. STUDENT ASSESSMENT: Samples of evaluation items are included in each unit to help the teacher develop an informal testing program. (MBM)

ED050063

RESOURCE HANDBOOK - MATTER AND ENERGY  
(A supplement to Basic Curriculum Guide - Science)  
Grades K - 6

U.S. DEPARTMENT OF HEALTH,  
EDUCATION & WELFARE  
OFFICE OF EDUCATION  
THIS DOCUMENT HAS BEEN REPRODUCED EXACTLY AS RECEIVED FROM THE PERSON OR ORGANIZATION ORIGINATING IT. POINTS OF VIEW OR OPINIONS STATED DO NOT NECESSARILY REPRESENT OFFICIAL OFFICE OF EDUCATION POSITION OR POLICY.

BOARD OF  
SCHOOL TRUSTEES

Mr. Donald Belec, President  
Mr. Andrew D. White, Vice-President  
Mr. Theodore Nering, Jr., Secretary  
Dr. Montague M. Oliver, Member  
Dr. James F. Wygant, Member

Dr. Clarence E. Swingley, Acting Superintendent of Schools  
Dr. Haron J. Battle, Assistant Superintendent-Instruction  
Dr. Norman R. Turchan, General Elementary Supervisor  
Dr. William H. Watson, General Supervisor-Curriculum Development  
Dr. John W. Starr, 3rd, Elementary Supervisor

SCHOOL CITY OF GARY  
Gary, Indiana

1968

## A C K N O W L E D G M E N T S

I wish to express appreciation to the members of the Elementary Science Materials Committee for their extra effort in the preparation of this publication. The publication is a composite of materials which have been developed previously, combined with new material. Much of the material presented in this publication is the result of their intensive work and effort.

Pelham Chatman, Teacher	Brunswick School
Emmalynn Deal, Teacher	Washington School
Stella Hartley, Teacher	Aetna School
Elizabeth Jadoon, Teacher	Nobel School
Gerald Lind, Teacher	Melton School
Geneva Taylor, Teacher	Duncan School

Final Preparation and Editorial Work

By

Dr. John W. Starr, 3rd

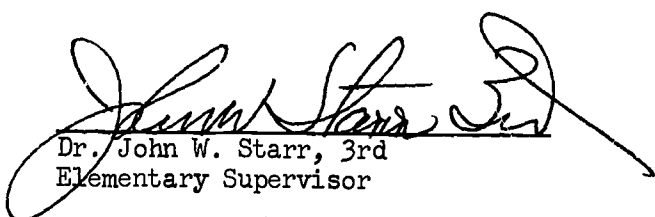

Dr. John W. Starr, 3rd  
Elementary Supervisor

## PREFACE

The teaching of science in the elementary school is a responsibility of major significance. Through our efforts, pupils should be helped to gain an understanding of science in the development of our culture. Likewise, we should emphasize the development of the ability to write and recognize social uses of science in daily life. In developing the ability to understand their natural environment, the pupils must also have a complete understanding of the process involved.

There is a need to continuously improve teaching and learning in science. New materials of instruction, new teaching approaches, and the continuing responsibility to meet the individual needs of students place great demands on all professional staff members to appraise the quality of teaching and learning in science. This publication represents an effort on the part of staff members within our school system to assist all staff members in improving the teaching and learning in science. It is hoped that all staff members who use this publication will find it to be of value.

  
Norman R. Turchan  
General Elementary Supervisor

PART I - COMPOSITION OF MATTER

Initiatory Activities.....	3
Developmental Activities.....	3
Concept	
Matter occupies space and has weight.....	3
Every kind of material has its own characteristics.....	4
All matter is composed of tiny moving particles called molecules, which can be broken down into atoms.....	4
An atom is made of small particles. The basic particles are the protons, neutrons and the electrons.....	6
Matter is found in three basic states; solid, liquid, and gaseous.....	7
Solids have a shape of their own and occupy a definite space; molecules of gas are far apart and move rapidly.....	8
Liquids have no definite shape but take the shape of that part of the container which they occupy; molecules of a liquid are close together, but free to move about.....	9
Gases have no definite shape and occupy all available space; molecules of gas are far apart and move rapidly.....	10
The state of matter may be changed by the addition or removal of heat....	10
Different kinds of molecules require different amounts of heat energy to change their state.....	11
Air pressure is the push of air molecules in all directions.....	12
The atoms of the molecules in a compound are held together by the force of chemical bonds.....	13
Materials having only one kind of atoms are elements.....	13
Scientists around the world have agreed to certain symbols to represent all elements.....	13
Each of the elements gives off its own color (or mixture of colors) of light when heated sufficiently.....	14
Elements can be chemically combined to form compounds.....	15
A chemical change takes place if there is a change in the structure of the molecules and a new substance is formed.....	16

Compounds can be taken apart as well as put together.....	18
In a mixture, each element keeps its own characteristics.....	21
Group tests may be used to analyze unknown substances.....	22
When a material burns, a chemical change takes place.....	24
Chemical changes are involved in everything we do.....	25
Research in chemistry has helped to make life better for all of us.....	27
Some materials may dissolve in liquids to make solutions. Other materials do not dissolve and may form a suspension.....	27
Atoms can be divided. Some atoms split spontaneously; they possess natural radioactivity.....	28
Nuclear energy can be released in two ways: fission and fusion.....	32
Nuclear energy is now being used for many peaceful purposes.....	33
Evaluation (Sample Items).....	35
Vocabulary.....	39
Children's Books.....	41
Films.....	45

## COMPOSITION OF MATTER

### Initiatory Activities

Have the children:

1. Read life stories of some of the great scientists and discuss their contributions to our way of living.
2. Bring some objects to class such as a piece of iron or some other object and discuss their characteristics.
3. Make an exhibit of pictures showing the importance of chemical change. These might show the making of pottery, glass, cement, or paper.
4. Bring newspaper or magazine clippings of stories of newly developed materials.
5. Examine the appearance, feel, smell, and taste of selected forms of matter.

### Developmental Activities

CONCEPT - Matter occupies space and has weight.

#### 1. Problem

Does air occupy space?

#### Materials

Drinking glass or jar, deep bowl (preferably transparent), water.

#### Procedure

Ask a pupil to place the inverted glass into the bowl of water. Point out to the children that the water rises only a little way into the glass. Why? Is the upper portion of the glass empty? Tip the glass to a horizontal position and observe that water now fills the glass, as bubbles come out.

#### Results

The space taken up by the air will be filled with water only when the glass is tilted to let the air escape, as shown by the bubbles.

#### Conclusion

Air occupies space.

#### 2. Demonstration

Have pupils collect several small objects in the classroom, such as a book, a chalk board eraser, a box of crayons, etc. Discuss whether these objects are solids, liquids or gases. Do they take up space?

Try to put two of them in the same place. Is this possible? Arrange and list these objects according to size. Have each child handle each object to get the feel of its weight. Arrange and list in order of weights. Discuss with pupils the idea that these are examples of solid matter. They have weight and occupy space.

CONCEPT - Every kind of material has its own characteristics.

1. Observe

Have the children observe and list the differences noted between pairs of various materials, such as a piece of wood and a piece of iron, a sheet of paper and a sheet of tin, a small bottle of mercury and the same size bottle of water, an orange and a rubber ball. Discuss the characteristics of various materials.

2. Ask children to collect examples of different types of common substances such as sand, concrete, wax, wood, steel, glass, rubber, plastic or sugar. Discuss how each is used. Ask the children to write nonsense stories in which they substitute one material and try to use it as another material is used, for example: using concrete for windows or glass for sidewalks; or using sand on their breakfast cereal. Discuss the idea that each material is used in ways best suited to its characteristics.

CONCEPT - All matter is composed of tiny moving particles called molecules, which can be broken down into atoms.

1. Problem

Since molecules cannot be seen, what evidence do we have that they actually exist?

Materials

Perfume, saucer.

Procedure

Ask one pupil to pour the perfume in the saucer while other members of the class raise their hands when they detect the odor. Lead a discussion of observations with such questions as: Did the people nearest the source of the odor or farthest from it smell it first? Did they see anything move from the source to their noses?

Results

While nothing was seen moving through the air, it is evident that molecules moved from the source and slowly spread out over the room.

Conclusion

The sense of smell gives evidence that molecules exist.



## 2. Problem

Since molecules cannot be seen, what evidence do we have that they actually exist?

### Materials

Medicine dropper, ink, glass of water.

### Procedure

Ask one child to put a drop of ink into the water. Does the ink stay in one place or does it spread throughout the water? Now, place the whole dropper of ink gently on the bottom of the glass, without squirting out the ink. Observe what happens to the ink.

### Results

Molecules of ink were carried through the water by the movement of water molecules.

### Conclusion

Our sense of sight gives evidence of the presence of molecules, even though we can't see them as individuals.

## 3. Demonstration

To help children visualize the spaces between molecules, using three jars of equal size, mark the halfway point on each. Fill one jar halfway with marbles and ask children to "pretend" they are molecules in a substance. To show that there is space between the marbles (molecules) pour a second jar half full of sand into the first jar. Discuss the idea that in this case, two halves do not make one whole, for the sand has filled much of the space between the marbles. To show that there is still space between the grains of sand, pour the third jar half full of water, into the first jar.

To show there is space between the molecules of a liquid, mix four ounces of water with four ounces of rubbing alcohol. Discuss why the resultant volume is less than eight ounces. A variation of this demonstration may be done by using water and salt.

## 4. Make Models

To show that different atoms make up molecules of a substance, have children construct models of molecules of common substances from pith balls (or styro-foam balls) and stiff wire. They can paint the atoms different colors to show the different elements present and label the model with its common name and chemical formula. Water ( $H_2O$ ) can be two green balls and one red ball. Glucose, a type of sugar ( $C_6H_{12}O_6$ ), can be six black balls, twelve green balls and six red balls. Pictures showing molecular structure may be found in reference books to help guide the pupils.

## 5. Demonstration





To help children visualize an atom, use a short piece of copper wire; cut it in half. Using only one of the halves each time, repeat the process until only a speck remains. Ask the children to keep dividing copper wire in their imagination. Finally a particle would be arrived at that would limit the cutting process, for it could be divided no more and still be the element copper. This particle is an atom of copper.

Help the children visualize the size of molecules by asking them to imagine that a drop of water is magnified to the size of the earth. The molecules would then be the size of baseballs. Imagine how many baseballs it would take to fill the earth.

CONCEPT - An atom is made of small particles. The basic particles are the protons, neutrons, and electrons.

### 1. Draw

Have the children make drawings of atoms of the first five elements (hydrogen, helium, lithium, beryllium, and boron) using different colors to show the various types of particles. Using the drawings, have them construct a chart similar to this one.

	MODEL	ELEMENT	SYMBOL	Number of Electrons	Number of Protons	Number of Neutrons	Atomic Mass
1		HYDROGEN	H	1	1	0	1
2		HELIUM	He	2	2	2	4
3		LITHIUM	Li	3	3	4	7
4		BERYLLIUM	Be	4	4	5	9
5		BORON	B	5	5	6	11

2. Bulletin Boards (Exhibits and Displays)

Using small paper disks of three colors (to represent the protons, neutrons and electrons) and yarn (to show the orbits of the electrons) guide children to construct a bulletin board on the structure of an atom such as carbon. The particles should be labeled with their names and the type of electrical charge they possess. In the fifth and sixth grades, additional figures may be constructed showing the isotopes of the main figure.

3. Make Models

Beginning with the simple hydrogen atom, have pupils construct models from balls of clay and wire.

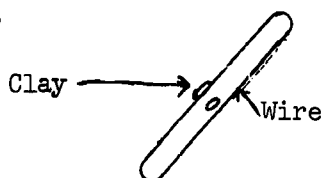

CONCEPT - Matter is found in three basic states; solid, liquid, and gaseous.

1. Charts

Have pupils construct a chart that classifies pictures of familiar solids, liquids and gases under the proper headings.

Have pupils construct a chart with the headings: "Solids," "Liquids," and "Gases". On the left side, list characteristics such as; takes up space, has weight, has shape of its own, has no shape of its own, has definite size, has no definite size. Have children complete the chart by placing X's in the appropriate spaces to show characteristics of solids, liquids, and gases.

	Solid	Liquid	Gas
Takes up space	X	X	X
Has weight	X	X	X
Has shape of its own	X		
Has no shape of its own		X	X
Has definite size	X	X	
Has no definite size			X

2. Draw

Ask children to draw molecules as they appear in a solid, a liquid, a gas, and to illustrate the distance between molecules and the motion of the molecules.

3. Demonstration

Play a test game. Display matter, or pictures of various materials, in different states. Ask children to identify the states. Discuss ways in which we can distinguish between solids, liquids and gases.

4. Bulletin Boards (Exhibits and Displays)

Let children arrange a display of different objects and substances that illustrate the three states of matter. Let the children tell what each substance shows and what the characteristics of each state are.

CONCEPT - Solids have a shape of their own and occupy a definite space. Molecules of a solid are very close together.

1. Problem

Do solids have a definite shape?

Materials

Block of wood.

Procedure

Ask pupils to try and change the shape of the block of wood with their hands.

Results

The shape of the block cannot easily be changed.

Conclusions

This shows that molecules of a solid are held firmly together; a solid has a definite shape and a size of its own.

2. Demonstration

We can feel the shape of some things (solids). Ask children to collect solid objects. Set up a display table where all children may examine and feel the objects. Place different objects in a glass, or a box. Does their shape change? What do we now know about solid things? Discuss the fact that solids will keep their shape unless something is done to change it.

CONCEPT - Liquids have no definite shape but take the shape of that part of the container which they occupy; molecules of a liquid are close together, but free to move about.

1. Problem

Do liquids have a shape of their own?

Materials

Water, containers of various shapes, such as a test tube, a saucer, a milk bottle, a medicine bottle.

Procedure

Ask children to observe a test tube of water. What shape does the water have? Pour the water into another container. Has the shape of the water changed? Repeat this procedure with all the containers.

Results

Children should notice that while the same amount of liquid was used, its shape changes according to its container.

Conclusions

Liquids change their shape to conform to their containers. They can do this because their molecules are free to slide around each other.

2. Demonstration

We can feel that some things are wet (liquids). Ask children to bring in various liquids. Let the children feel some of the liquids with their fingers. Pour some water into a small bottle. Pour the same water into a shallow dish. Pour the same water into other containers. What do we now know about wet things (liquids). (Discuss the characteristics of liquids that will allow them to change their shape to fit their container.)

Ask a child to try to pour the water from a full quart jar into a pint jar (over a sink). Have children observe what happens and discuss the idea that liquids have a size of their own.

CONCEPT -- Gases have no definite shape and occupy all available space -- molecules of a gas are far apart and move rapidly.

1. Research

Ask a committee of pupils to do library research, and report to the class on some of the ways in which gases are used in everyday life, such as in balloons, tires, stoves, carbonated water, yeast, breads, and dirigibles.

2. Demonstrations

Some things (gases) do not have any certain shape. Using a basketball and an air pump, demonstrate that you can force a large amount of gas into a small space. Discuss whether this would be possible with a liquid. Let the air out of the basketball and ask the pupils if they can grab it and mold it into some definite shape. Why not? Discuss the ideas that gases have no shape of their own (they will take the shape of their container); they have no definite size (molecules will spread farther apart to fit the size of the container, or come closer together when forced into a smaller container).

CONCEPT -- The state of matter may be changed by the addition or removal of heat. The degree of motion of the molecules in a substance determines whether the substance is a solid, a liquid, or a gas.

1. Problem

How can we show the three states of matter?

Materials

Ice cubes, beaker, tripod stand, alcohol or gas burner.

Procedure

Ask children to fill the beaker with the ice cubes. In what state is the ice? How do you think the molecules are moving? Place the beaker on the tripod and apply heat. What change takes place? Are the molecules moving faster or slower than they were in the solid state? Apply heat until the water is boiling. What change is taking place now? How are molecules of water vapor moving compared to the solid and liquid states?

Results

As heat is applied, the molecules will move faster, until a change of state occurs.

Conclusions

Heat may cause a substance to change states. (This is a physical change.) Molecules move faster as they progress from the solid state through the liquid state to the gaseous state.

## 2. Observe

Light a candle and let it burn. Ask the children to write down what they observe. Is a change of state taking place? A drawing of the candle can be made with the solid, liquid, and gaseous states labeled.

## 3. Draw

Ask children to make drawings illustrating the distance between the molecules in the solids, liquids, and gases.

Ask children to draw, in three stages, what happens to molecules of ice when heat is applied.

CONCEPT - Different kinds of molecules require different amounts of heat energy to change their state.

## 1. Problem

Is the same amount of heat energy required to melt all solids?

### Materials

Pat of butter, small wax candle, piece of lead, an iron nail, alcohol or propane gas burner, heat resistant pan.

### Procedure

Have children place the different solids in the pan. Apply heat. Do they all melt at the same time? Do they all melt?

### Results

The different solids will melt at various times, depending on the amount of heat energy used. The heat, produced by a classroom burner, should melt the sample of lead, but will not be high enough to melt the nail.

### Conclusions

Melting is the changing of a solid to a liquid. Some solids require more heat energy to melt than others.

## 2. Charts, Maps, or Graphs

Obtain a Fahrenheit thermometer and a Celsius (centigrade) thermometer. Compare the markings. Have children make a chart indicating the differences between the two thermometers.

CONCEPT - Air pressure is the push of air molecules in all directions.

1. Problem

How can we show air pressure? Is there air pressure on us right now?

Materials

Hard-boiled egg, milk bottle, newspaper, matches.

Procedure

Peel the shell from the hard-boiled egg. Crush a small piece of newspaper, light it and put it in the milk bottle. Place the egg on the mouth of the milk bottle. The paper will soon burn up and the egg will then enter the bottle.

Results

The burning paper causes the air in the bottle to expand and some of it is forced out, making the egg bounce a little. The fire goes out when the oxygen in the air in the bottle is depleted. Then the air in the bottle cools and contracts. Since the air on the inside exerts less pressure than the air on the outside, the outside air forces the egg into the bottle.

Conclusions

Air has weight, the weight of our atmosphere causes air pressure on all things on earth.

2. Demonstrations

Showing Air Pressure

Fill a glass with water. Place a flat cardboard on top of the glass. Hold the glass with one hand, and the cardboard firmly with the other. Invert the glass over a sink or pan. Remove the hand holding the cardboard. Observe how the cardboard is held to the glass by air pressing against it.

Showing How Air Pressure Affects Pouring

Punch a hole in a tin can containing a liquid. Ask a pupil to try to pour the liquid. Punch another hole across from the first. Try pouring again. Why does the liquid flow better when two holes have been cut? Point out to the class that air pressing on the liquids trying to come through one hole holds the liquid back. When two holes are punched, air presses on the liquid through the second hole forcing it out through the other hole.

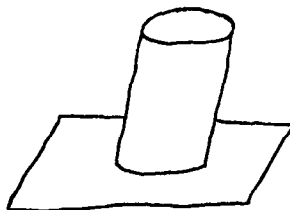

Showing Air Pressure



CONCEPT - The atoms of the molecules in a compound are held together by the force of chemical bonds.

-- Make Models

Using clay and wooden sticks, have children construct molecular models; clay balls representing the individual atoms and sticks representing the idea of the bonds holding the atoms together. Discuss what would happen if there were no bonds to hold the atoms together.

CONCEPT - Materials having only one kind of atoms are elements.

1. Charts, Maps, or Graphs

Using a map of the United States, have children locate places where common elements are found in nature, such as gold, iron, lead, silver, sulfur, and nickel. Information of this type can easily be found in geography books and encyclopedias.

2. Research

Ask children to read about some common elements. Suggest that individuals report on one element. Reports could answer such questions as: Where is it found? How was it discovered? What are its characteristics? Is it abundant or scarce? In what ways is it used?

3. Bulletin Boards (Exhibits and Displays)

Ask pupils to make a collection of articles, or pictures of articles made up primarily of a common element, such as coal, silver jewelry, gold jewelry, copper wire, lead solder, aluminum foil and an iron nail. Display these articles with the element's name and symbol.

CONCEPT - Scientists around the world have agreed to certain symbols to represent all elements.

1. Charts, Maps, or Graphs

Display a chart of the periodic table in which all the elements and their chemical symbols are shown. Let the children discuss why the elements are grouped in families as they are. Discuss some of the elements with which the children are familiar.

2. Research

Have a committee of children make up a notebook describing many of the elements. After finding the basic characteristics of the elements, let children make "flash cards" on 3 x 5 index cards, with the element's name on one side and symbol and characteristics of the element on the other side. These cards can be used in a test game or in practicing to identify the elements.

Ask children to do library research on the figures used by ancient chemist to represent the chemicals with which they worked. Another group of children may do research on John Dalton and the symbols he devised. A third group could do their research on Jons Jakob Berzelius, the man who developed our present system of symbols. After all research is finished, have children construct a chart comparing the symbols of the three methods for some of the common elements.

3. Bulletin Boards (Exhibits and Displays) "What Are My Elements?"

Arrange pictures or drawings of common substances on one side of a bulletin board; and in the other side mount symbols of elements in random order. Let children use colored yarn to connect the substances with the elements of which they are made. For example: Water would be connected to H and O. Sand would be connected to S and O. Salt would be connected to Na and Cl.

CONCEPT - Each of the elements gives off its own color (or mixture of colors) of light when heated sufficiently.

1. Problem

How can chemists test substances by burning?

Materials

Pliers, alcohol or gas burner, pan of water, a dime, salt, borax.

Procedure

Hold the dime with the pliers; wet the dime and dip it in the salt. Hold it in the flame. What color flame is noticed? Wash the dime and repeat the procedure with the borax. Do we have the same color flame?

Results

The salt will burn with a yellow flame, while burning borax will produce a green flame. This is an identification of the sodium in the salt and boron in the borax.

Conclusions

Different elements give off different colors of light when heated sufficiently.

2. Draw

After research on the spectrum of visible light and the spectroscope, ask children to make drawings of special lines of a few of the elements, as shown in reference books. Compare these to a drawing of the spectrum of sunlight.

3. Research

Ask a group of children to do library research on the spectroscope. They should try to find out how it works and how it is used, especially in the field of astronomy.

CONCEPT - Elements can be chemically combined to form compounds.

-- Problem

Do elements combine chemically to form a compound?

Materials

Iron filings, powdered sulphur, test tube, magnet, alcohol burner.

Procedure

Mix iron filings and sulphur together and place the mixture in a test tube. Heat the mixture until it glows. Allow to cool and examine it. Remove the contents of the tube by breaking it. Touch the substance with a magnet.

Iron and sulfur mixture

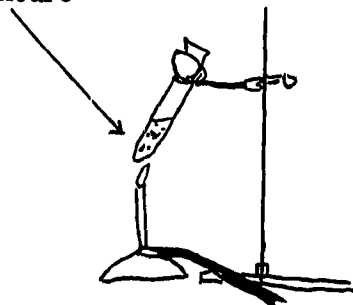

Results

The iron filings and the sulphur can no longer be distinguished from each other. The substance does not cling to the magnet.

Conclusions

A new substance, the compound iron sulfide, has been formed. A compound is composed of two or more elements combined chemically. The two elements have lost their individual characteristics and the compound has formed new characteristics of its own.

CONCEPT - A chemical change takes place if there is a change in the structure of the molecules and a new substance is formed.

1. Problem

What is a chemical change?

Materials

Two large nails, paint, glass jar.

Procedure

Paint one nail and let it dry. Do not paint the other nail. Pour a little water into a jar. Stand both nails in the jar of water. Cover the jar and allow it to stand for several days.

Results

The unpainted nail will be rusted; not the painted one.

Conclusions

A new substance has been formed - oxygen from the air unites with the iron in the unpainted nail to form the compound iron rust. The painted nail did not rust because the paint prevented the oxygen from uniting with the iron. The rusting of iron is a chemical change.

2. Problem

What causes a nail to rust?

Materials

Three test tubes, three stoppers, three nails.

Procedure

Put the first nail in a test tube with only air and stopper it. Place the second nail in a test tube with tap water and stopper it. Place the third nail in a test tube with water that has just been boiled and stopper the test tube. Allow test tubes to stand for a few days. Compare how the three nails rust in each case.

Results

The nail in the second tube should have more rust than the other two.

Conclusions

Rust appears quickest when water is near. Water speeds up the uniting of the iron in the nail with the oxygen in the air. In the case of the boiled water, quite a bit of the oxygen has been expelled by the burning.

### 3. Problem

Is it possible to slow down chemical change?

#### Materials

Two glass tumblers, and milk.

#### Procedure

Place a small amount of milk in each of the glasses. Place one glass of milk in a refrigerator. Place the other glass of milk in a warm place and allow both glasses to stand for several days.

#### Results

The milk in the warm place will sour. The milk in the refrigerator will not.

#### Conclusions

The souring of milk is a chemical change. This chemical change and similar chemical changes are slowed down by keeping substances cool.

### 4. Demonstrations                      Showing a Chemical Change - A Crystal Garden

Have children gather these materials: coke or small piece of brick, saucer, salt, laundry bluing, Mercurochrome, household ammonia. Pupils should notice and list the characteristics of each of these materials. Pupils then mix together in a bowl 4 tbsp. salt, 4 tbsp. water, 4 tbsp. bluing, 1 tbsp. ammonia, and a few drops of Mercurochrome. Pour this mixture over the pieces of coke or brick which are in the saucer. Place the saucer where it will not be disturbed. Crystals will start to form within one-half hour and will continue to grow for several days. Discuss with the class the characteristics of this new substance formed by this chemical change.

CONCEPT - Compounds can be taken apart as well as put together.

1. Problem

How can we clean silverware by the use of chemistry?

Materials

Tarnished silverware, aluminum pan, water, salt, baking soda, alcohol or gas burner.

Procedure

Ask children to measure two quarts of water, two teaspoons of baking soda, and two teaspoons of salt and mix together in the pan. Bring this solution to a boil and then remove from the flame. Place the tarnished silverware in the hot solution. After a few minutes, remove silverware, rinse and dry.

Results

The compound, silver sulfide, has been taken apart. The sulfur in the tarnish has been attracted to the aluminum pan, leaving the silver clean.

Conclusions

Compounds can be taken apart. This is a chemical change.

2. Problem

Can wood, a compound, be taken apart chemically?

Materials

Wood splint, alcohol or gas burner.

Procedure

After asking children to do research on the compound cellulose in wood and discussing that it is made of carbon, hydrogen and oxygen, burn the wood splint. Is this a chemical change? What is left of the wood splint? What happened to the hydrogen and oxygen?

Results

After burning, the carbon of the cellulose in wood is left, the the hydrogen and oxygen is forced out into the air.

Conclusions

Burning wood is a chemical change that causes compounds to be taken apart.

### 3. Problem

Is mercuric oxide an element, a compound, or a mixture?

#### Materials

Mercuric oxide powder, test tube, test tube holder, towel paper, alcohol or gas burner.

#### Procedure

Pour not more than  $1/8$  teaspoon of mercuric oxide powder into the test tube. Roll the paper towel into a plug and place it in the mouth of the tube. Then support the test tube just over the blue part of the burner flame. after a minute or two, look at the side of the tube about halfway up. What do you see? Light a wood splinter and let it burn a little. Then blow out the flame. Quickly remove the paper plug and plunge the glowing splinter into the test tube. What happens? Put the paper plug back in and heat the test tube until all of the mercuric oxide powder is gone. Now use a splinter to scrape together some of the silvery material in the test tube. Pour it into a small dish. What is the material? Do you think mercuric oxide is an element, compound, or a mixture?

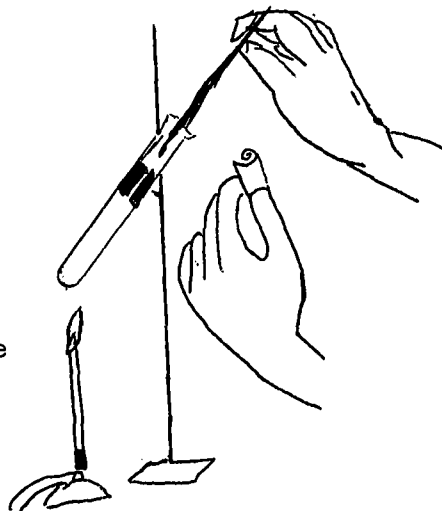

#### Results

That oxygen is released from the mercuric oxide is shown by insertion of the glowing splint into the test tube; it will burst into flame. The material remaining is mercury.

#### Conclusions

Mercuric oxide is a compound. This is an example of breaking a compound apart into its elements.

### 4. Problem

Can water, a compound, be taken apart chemically? (Electrolysis of water)

#### Materials

Water, large glass beaker or large-mouthed jar, six volt battery, two lengths of insulated wire (approximately one foot long), two carbon rods from flashlight batteries, sodium sulfate (or washing soda), adhesive tape, matches, wood splint.

### Procedure

Attach a carbon rod to an end of each wire, with the other ends attached to the terminals of the battery. Stir one spoonful of sodium sulfate into a beaker  $\frac{3}{4}$  full of water. (Explain that the purpose of the sodium is to help the electric current to flow easily through the water.) Place the carbon rods on the bottom of the beaker and cover each with a test tube full of water. Bubbles should begin to collect in each of the test tubes, about twice as fast in one as in the other. (Why not at the same rate?) With your thumb, close the mouth of the test tube first filled with the gas. Lift the tube out of the water, mouth down. Bring a lit match to the mouth of the tube and remove thumb. What happens? Why? When the second tube is full of gas, close its mouth with your thumb and remove from water with mouth up. Light a wood splint, let it burn briefly and blow out the flame. Remove your thumb and plunge the glowing splint into the test tube. What happens? Why is this reaction different from that of the first test tube?

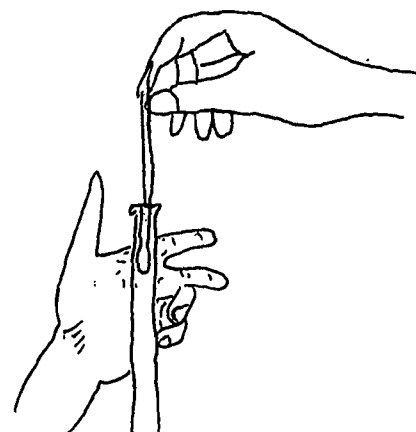
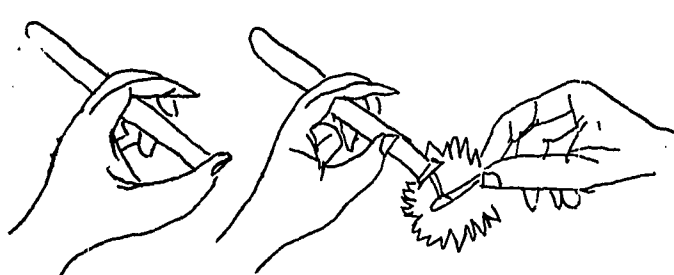
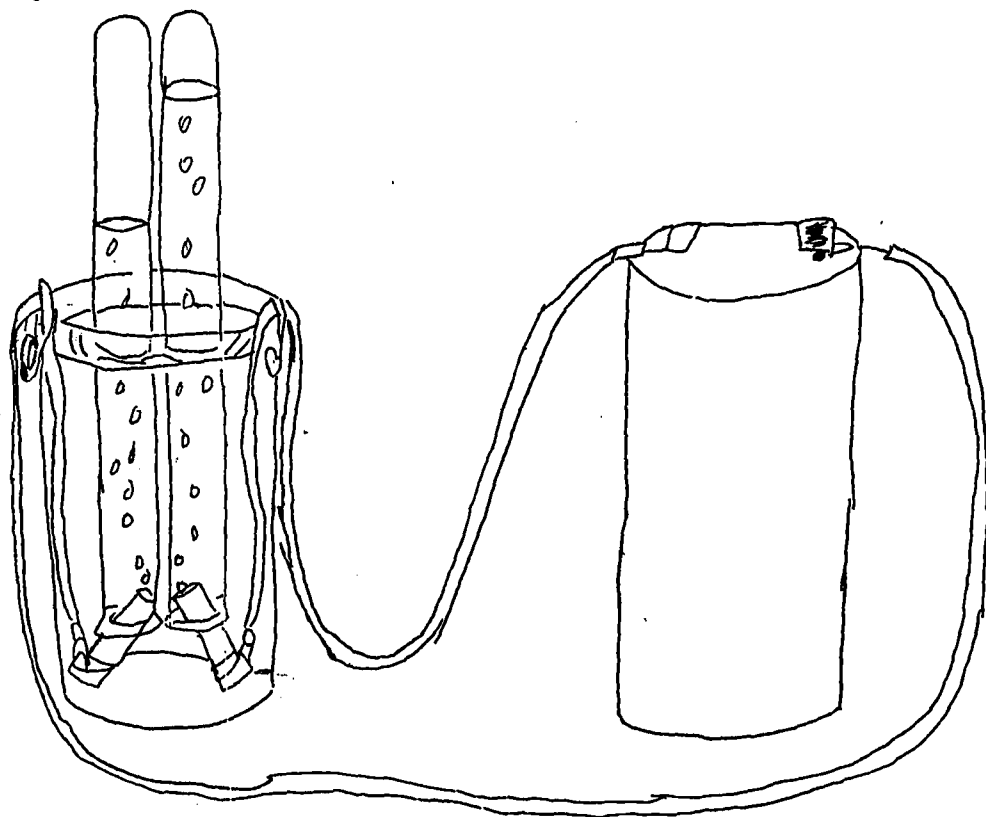



## Results

In this experiment, hydrogen and oxygen will collect in the two test tubes. The hydrogen will collect faster because there is twice as much hydrogen as oxygen in water. When a match is applied to the first tube the contents will burn with a soft "pop!" (This is the test for hydrogen.) When a glowing splint is plunged into the second tube of gas, the splint will burst into flame. (This is the test for oxygen.)

## Conclusions

The compound water can be broken apart into separate elements of oxygen and hydrogen.

### 5. Research

Ask some pupils to do research and prepare a report on the progress of changing iron ore to iron.

CONCEPT - In a mixture, each element keeps its own characteristics.

#### -- Problem

Will a mixture of sulphur and iron filings form a new substance?

#### Materials

Powdered sulphur, iron filings, magnet.

#### Procedure

Place iron filings and sulphur, side by side, on a sheet of paper. Have pupils examine both substances and list most noticeable characteristics of both. (Sulphur is yellow and does not cling to the magnet, iron filings are black and cling to the magnet.) Mix the two elements together and examine the mixture. Place the magnet in the mixture.

#### Results

While the mixture looks a bit different from the two separate elements, they can still be distinguished. The filings will cling to the magnet, but the sulphur will not.

#### Conclusions

A mixture is simply a combination of two or more elements which are not chemically united. The elements in it may be mixed in any proportion without losing their identity. No chemical change has taken place and no new substance has been formed.

CONCEPT - Group tests may be used to analyze unknown substances.

1. Problem

How can we test for acids, bases and neutrals?

Materials

Red and blue litmus paper, small cups, various liquids such as: lemon juice, vinegar, salt water, sugar water, tap water, ammonia, boric acid, fresh milk, and sour milk.

Procedure

Have children place the substances to be tested in paper cups. Touch each substance with both blue and red litmus paper. Is there a change in either piece of paper?

Results

If the red litmus paper turns blue, the substance is a member of a group of materials called bases (or alkalis). If the blue litmus paper turns red, it is an acid. If there is no color change on either paper, the substance is neutral. Substances may be tested with litmus paper to group them as acids, bases or neutrals.

2. Problem

How can we test for acids, bases, and neutrals?

Material

Two red cabbage leaves, boiling water, wooden spoon, heat resistant bowl, beaker, vinegar, ammonia.

Procedure

Cut the red cabbage leaves into small pieces and place them in the bowl. Add one cup of boiling water. Use the wooden spoon to squeeze out as much of the cabbage juice as possible. Allow the juice to stand for an hour or more, or until the cabbage liquid is purple in color. Pour some of the liquid into a beaker. Ask a child to add several drops of vinegar to the cabbage juice. Why does the liquid turn red? Now add ammonia, drop by drop, while stirring. Notice the color change back to purple and then to greenish-blue as more drops of ammonia are added. Why?

Results

The cabbage juice is used as an indicator. When the vinegar is added, the color change to red indicates the presence of acid in the vinegar. Adding ammonia will neutralize the substance and then the greenish-blue color will indicate the presence of a base in the ammonia.

Conclusions

Cabbage juice may be used to test liquids and group them as acids, bases and neutrals.

3. Problem

How can we test for starch?

Materials

Eye dropper, iodine, small portions of several types of food, such as bread, sugar, cooked macaroni, and cornflakes.

Procedure

Ask a pupil to place drops of iodine on each of the food samples. Does anyone notice any reaction?

Results

The reddish-brown color of iodine changes to dark blue or blue-black when it comes in contact with starch. (It should be noticed that the potato and grain products contain starch.)

Conclusions

Iodine can be used to test substances for the presence of starch.

4. Problem

How can we test for carbon dioxide?

Materials

Straw, test tube, limewater.

Procedure

Fill the test tube halfway with limewater. Ask a pupil to blow through the straw into the limewater. Is there a change in the limewater?

Results

The change in the appearance of the limewater from clear to milky is an indication that carbon dioxide is present in the breath.

Conclusions

Limewater can be used to test for the presence of carbon dioxide.

5. Demonstration - Paper Chromatography

Have children place drops of green, red and blue ink on strips of newsprint. The strips should be about one inch wide and six inches long. The drops of ink should be placed about one inch from the end of the strip. Colors should be combined on strips. Place the strips, with the ink drops at the lower end in a drinking glass containing  $\frac{1}{2}$  inch of water. (Strips should be creased down the middle so they will stand in the glass.) Let the strips stand for fifteen to thirty minutes. Ask children to observe and discuss what has happened. As the water soaks up through the paper, it carries each of the different colored inks up at a different rate. Chemists use this same method for separating a mixture into its parts, so that each part can be analyzed separately.

CONCEPT - When a material burns, a chemical change takes place.

1. Problem

Is matter changed by burning?

Materials

Sugar, test tube, alcohol or gas burner, test tube holder, paper towel.

Procedure

Place one teaspoon of sugar in the test tube. Ask children to note the characteristics of the sugar. Heat slowly and observe the change taking place. Where is the moisture on the sides of the test tube coming from? Place paper towel over the mouth of the test tube. Notice the dampness. Continue heating until the material is black. When the material has cooled, have the children compare its characteristics to those of the sugar. Is this a new substance.

Results

The sugar has been changed into a new substance, carbon. Hydrogen and oxygen have been released in the form of water vapor.

Conclusions

Burning produces a chemical change. A new substance has been formed. Compounds differ in their properties from the elements they are composed of.

2. Observe

Burn a wood splint completely and lead children to discuss their observations of what takes place. Are the characteristics of the ashes the same as the characteristics of the wood splint? How are they different?

Have a pupil bring in an unused charcoal briquet and the ashes of a burnt one. Examine both and observe the difference burning has made.

CONCEPT - Chemical changes are involved in everything we do.

1. Problem

How can we show chemical changes take place in the digestive process?

Materials

Unsalted crackers.

Procedure

Give an unsalted cracker to each pupil. Ask them to take a bite of the cracker and notice its taste. Does the taste change while the cracker is being slowly chewed?

Results

The cracker at first tastes starchy, but after mixing with the water in saliva, the starch is changed to sugar.

Conclusions

This is an example of the many chemical changes continually taking place in our bodies.

2. Observe

Ask children to observe their mothers at work in the kitchen during one week. Have them compile a list of all chemical changes they noticed taking place.

3. Field Trip

Visit a local manufacturing plant to discover how chemical changes are used in the production of goods.

Visit a fire station to find out some chemical ways of putting out fires.

4. Research

Pupils may do individual or group reports on various topics such as the manufacturing of plastics, steel, glass, petroleum products, and how they are used; the spoiling of food; rotting of food; fading of fabrics; and the burning of fuel.

Ask the class to choose a chemical change they feel is important and learn as much about it as they can: raw materials used, energy involved, waste products left, and how the characteristics of the furnished product differ from those of the raw materials used.

Ask pupils to find out what elements and compounds are found in air. Reports may be given on how some of these elements are used or what happens to the air that is taken into our bodies.

5. Bulletin Boards (Exhibits and Displays)

Have children collect pictures showing various chemical changes. Arrange them on a bulletin board under such headings as "Chemical Changes In Our Home," or "Chemical Changes In Industry."

6. Make Models

Construct a working model of a chemical fire extinguisher.

Making a Fire Extinguisher Model

Push a short glass tube with a jet tip into a rubber stopper. Wrap bicarbonate of soda in a sheet of toilet tissue. Attach soda package to tube with a rubber band.

Fill bottle half full of mixture of one part vinegar and one part water. Put in the stopper.

Hold stopper firmly in place with two fingers. Turn bottle upside down. The  $\text{CO}_2$  formed by mixing vinegar and soda drives water out in powerful jets.

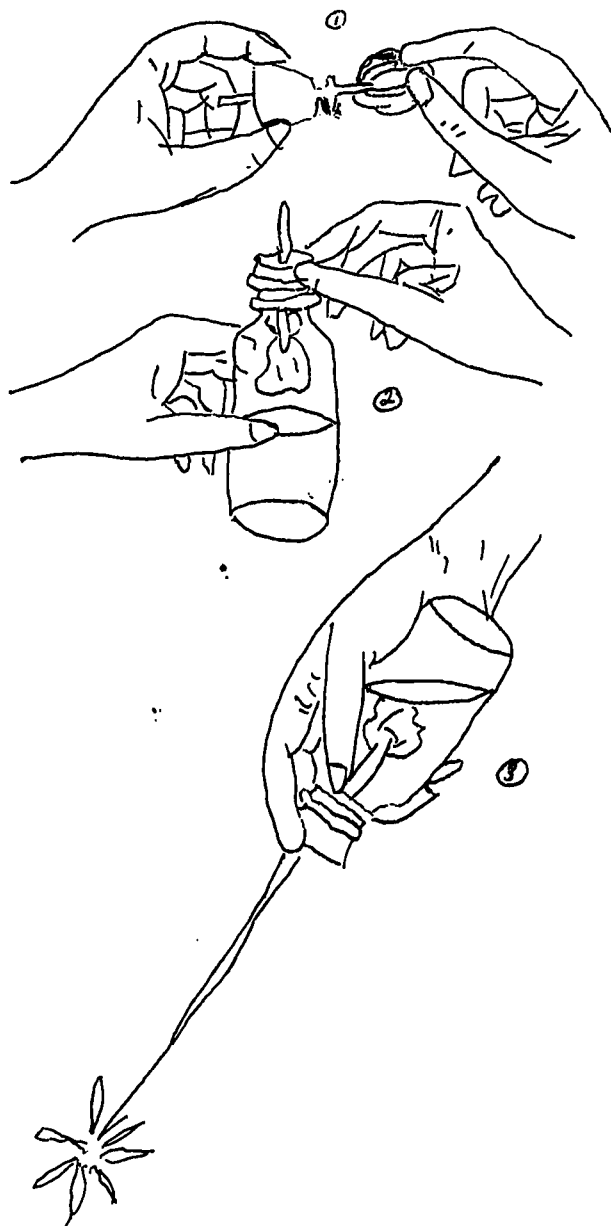

CONCEPT - Research in chemistry has helped to make life better for all of us.

1. Research

Discuss with children how different life is for us now compared to the way of life in various periods of the past. Suggest that individual reports may be based on the contributions of famous scientists. Possible subjects in the field of chemistry are: Dalton, Curie, Einstein, Lavoisier, Priestly, Davy, Boyle, and Democritus.

2. Collect

Ask children to collect labels from food cans, bottles and packages. Have them look for the names of chemicals used for preserving the food. Reports can be done on how some of these chemicals work.

Ask a group of children to prepare a report on synthetic materials for clothing. Have them try to find out ways cloth is made from wood, milk, coal, sand, straw and beans. To receive information about this topic, have the class write letters to textile manufacturers for materials.

3. Bulletin Boards (Exhibits and Displays)

Have children compile information and collect pictures of various things derived from coal. Mount a picture of coal and connect it to pictures of such things as drugs, dyes, and perfumes.

CONCEPT - Some materials may dissolve in liquids to make solutions. Other materials do not dissolve and may form a suspension.

1. Problem

Do materials "disappear" when dissolved in a liquid?

Materials

A tablespoon of salt, a glass, warm water.

Procedure

Put the salt into the glass. Pour in the water and stir until the salt "disappears." Discuss whether the salt has actually disappeared or is still present. How can we find out? Taste the water. Discuss that while the salt can no longer be seen it is still present -- the grains of salt separate into molecules which move in between the molecules of water. Let the glass stand for a few days.

Results

The salt present in the solution is left unchanged after the water evaporates.

Conclusions

Although some materials may dissolve in liquid to form a solution, they are still present.

## 2. Problem

What happens when oil is mixed with water?

### Materials

Test tube or small jar, oil, water.

### Procedure

Fill a test tube half full of water. Add about  $\frac{1}{2}$  inch of oil. Does the oil mix with the water? Cover the mouth of the test tube with your thumb and shake it as strongly as you can. What happens? Is this a mixture or a compound? Let the mixture stand awhile. Now what has happened to the mixture?

### Results

The oil will not be dissolved in the water. When left standing, the oil will rise to form a layer on top of the water.

### Conclusions

Adding oil to water will not form a compound; it is simply a mixture in a suspension. Small particles of a material are suspended in another material, but not dissolved in it.

CONCEPT - Atoms can be divided. Some atoms split spontaneously; they possess natural radioactivity.

## 1. Problem

How can we observe natural radioactivity?

### Materials

Magnifying glass, clock or watch with a luminous dial.

### Procedure

Darken the room. Have children observe the luminous dial with a magnifying glass. What do they notice? Point out that the dial is painted with phosphorous in which a tiny amount of radium is mixed. What could be causing this reaction?

### Results

Tiny "sparks" of light are noticed. This is caused by the radioactive decay of the radium causing the phosphorous to shine.

### Conclusions

Radium possesses natural radioactivity. Atomic energy may be changed to light energy.



## 2. Charts, Maps, or Graphs

Point out to children that the understanding of the atom that led to atomic energy has taken over two thousand years. Have them construct a time line showing the history and development of atomic energy.

- |           |   |
|-----------|---|
| 485 B.C.  | Democritus called very small particles that could not be divided <u>atoms</u> .   |
| 384 B.C.  | Aristotle said the atom did not exist.  |
| 1592 A.D. | Pierre Gassendi advanced the theory that atoms must have some type of magnetic attraction to hold them together.  |
| 1661      | Robert Boyle called basic substances <u>elements</u> .  |
| 1670      | Anton van Leuwenhoek used the microscope for studying crystalline structures.   |
| 1772      | Antoine Lavoisier discovered that elements combine.   |
| 1808      | John Dalton stated that matter consists of atoms held together by an unknown force.   |
| 1811      | Amedeo Avogadro developed the theory of molecules.  |
| 1827      | Robert Brown actually saw the movement of atoms. The "Brownian Movement" was named in his honor.  |
| 1895      | Wilhelm Konrad Roentgen discovered the X-Ray.   |
| 1896      | Henri Becquerel found that uranium salts were radioactive.  |
| 1898      | Pierre and Marie Curie discovered that radium was also highly radioactive.  |
| 1903      | Sir Ernest Rutherford and Frederick Soddy found that some atoms split themselves to pieces through their action.  |
| 1905      | Albert Einstein set forth his famous $E = MC^2$ equation. This theory of relativity explains that matter and energy are both the same but in different forms. |
| 1911      | Sir Ernest Rutherford discovered and named the core of the atom the <u>nucleus</u> .  |
| 1912      | Frederick Soddy developed the theory of isotopes.   |

1913	Niels Bohr depicted the atom similar to a small solar system. He showed that the electron whirls around the nucleus. His diagram is used as the symbol of the atom.
1926	Han Geiger invented the Geiger radiation counter.
1931	E.O. Lawrence built the first cyclotron.
1932	John Cockcroft proved that destruction of the atom released energy.
1934	Irene and Frederic Joliot-Curie found that exposure to radiation made other substances radioactive.
1938	Otto Hahn and Fritz Strassmann split the uranium atom.
1938	Lise Meitner escaped from Germany. She proved that splitting uranium atoms could release enormous amounts of energy. She called this process <u>fission</u> .
1942	Enrico Fermi and Arthur Compton built the first atomic reactor at Stagg Stadium in Chicago.
1945	Hiroshima and Nagasaki, Japan were devastated by the atomic bomb.
1951	Electricity produced by an experimental atomic laboratory at ARCO, Idaho, lighted an incandescent lamp.
1955	Nuclear powered submarine, <u>Nautilus</u> , was successfully launched.
1958-1959	Experiments were made with atomic powered engines for interplanetary travel.
1959	More radioisotopes were used in medicine.

### 3. Resource Person

Ask a civil defense worker or someone who can obtain a Geiger counter to explain its use and how it works to the class.

### 4. Research

Ask children to do research on uranium and radium to find out more about their natural radioactivity.

5. Demonstration

Showing Radioactive Rays

(Constructing a Cloud Chamber)

Materials

One pound jar (clear glass -- peanut butter or fruit jar), thumbtack, black velvet, dull black paint, strip of weather stripping or heavy felt, one pound coffee can, slab of dry ice or tray of ice cubes and salt, rubbing alcohol, speck of radium from clock dial, strong flashlight or slide projector, model airplane glue or rubber cement.

Procedure

You can construct a cloud chamber by following the diagram. First glue in the weather stripping and black velvet. Paint the inside cover black; glue a thumbtack in the center of the jar cover. Paint the empty coffee can and thumbtack black to eliminate reflections, and put in a false bottom as shown. Crush enough dry ice to cover the top of the false bottom to a thickness of one inch. (Caution: Use gloves when handling dry ice.)

Soak the weather stripping in rubbing alcohol. Glue a speck of radium to the thumbtack point, and cover the bottom of the cover with alcohol. Screw cover tightly on jar, and place on ice as illustrated. Set a slide projector or strong beam flashlight to one side of the jar. Place hand on top of jar, and observe from top of jar.

It may take from five to fifteen minutes for the clouds to condense. Then, cobweb-like trails will appear near the bottom of the chamber. These are the radiation rays. Can you identify the kinds of rays being given off?

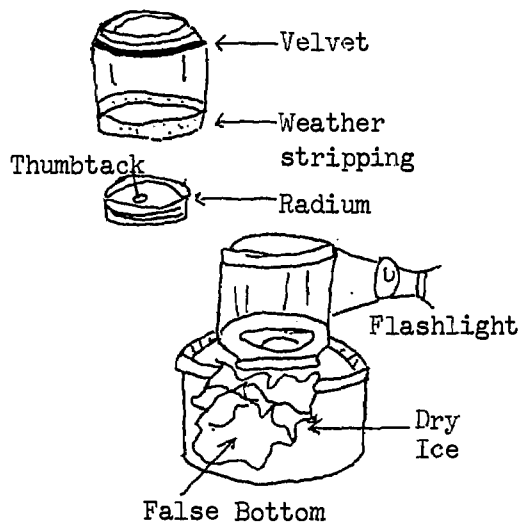

Alpha-Ray Trail



Beta-Ray Trail



Gamma-Ray Trail

CONCEPT - Nuclear energy can be released in two ways: fission and fusion.

1. Problem

How can we show a chain reaction?

Materials

Box of wooden matches, metal tray or asbestos sheet, pail of sand or water.

Procedure

Break about 20 matches about  $\frac{1}{4}$ " from the head and arrange on the pan similar to diagram 1. Light the first match head and ask children to notice the speed at which the flame travels. Repeat the experiment with additional matchsticks laid crosswise as in diagram 2. Is the reaction different?

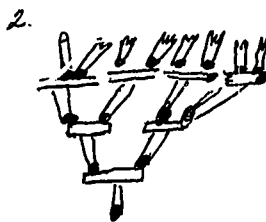

Results

These are both examples of chain reactions; the first is uncontrolled while the second is controlled.

Conclusions

Control rods slow down a chain reaction.

2. Charts, Maps, or Graphs

Assist children in drawing their own interpretation of what happens in fission and fusion on two charts for comparison.

3. Teaching Resources

Teachers may write to Atomic Energy Commission, Educational Services Branch, Washington, D.C. for teaching materials related to nuclear energy.

4. Research

Have the class do research on the destructive power of the atomic bomb. Let this lead to a serious discussion of the responsibilities involved in the possession of the knowledge of atomic energy and the importance of international cooperation.

CONCEPT - Nuclear energy is now being used for many peaceful purposes.

1. Drama

Let children try to foretell the future by writing a short play which illustrates how life might be one hundred years from now, including many uses of atomic energy.

2. Research

Have children find out how atomic energy is being used in electric generators and to propel ships. See if they can find out why it has not been used to run automobiles and airplanes.

3. Bulletins Boards (Exhibit and Displays)

Have children bring in clippings from newspapers and magazines dealing with nuclear energy. These should be reported to the class and placed on a current news bulletin board or a scrapbook.

### Evaluation

Included here are samples of evaluation items which could be used in developing your own informal testing program. These suggested types of items cover the particular science area that has been developed in this section of the handbook. This also means they could be used to help develop informal testing to cover large areas of information (monthly, mid-year, end of year testing). These are by no means complete tests as such. You will have to adapt and develop items to meet your particular class's own individual needs and differences.

Write the number of the word groups in column A, in the space before the item, in column B, that it best matches:

Column A	Column B
1. Has a definite shape	(5) a. Evaporate
2. Always in motion	(3) b. Heat
3. Causes change from solid to liquid	_____ c. Cold
4. Molecules roll and slide around each other	(2) d. Molecules
5. Liquid to a gas	(1) e. Solid
	(4) f. Liquid
	_____ g. Condense

Complete the sentences:

1. The smallest single particle of a substance is called a (molecule).
2. When a solid is heated, the speed at which its molecules vibrate (increases).
3. When a gas is cooled sufficiently, the state of matter formed is (liquid).
4. When sugar dissolves, it separates into its (molecules).

Answer the following:

1. What are the states of matter? Give an example of each state.

(The states of matter are gas, liquid, and solid. Air is a gas; water is a liquid; ice is a solid. [Many other answers possible.] )

2. Describe the motion of molecules in each of the states of matter.

(In solids the vibrating molecules don't move from place to place. They vibrate in place as though locked together. In liquids, the molecules are not locked together and slide and roll over one another. In gases, the molecules are farther apart and move faster. They have less attraction for one another than in solids and liquids.)

Here are some different forms of energy. In the blank after the form of energy, tell whether the energy is kinetic, potential or a combination of the two:

1. steam (Potential)
2. falling water (Kinetic)
3. food (Potential)
4. wind (Kinetic)
5. falling bomb (Kinetic-Potential)

Complete each of these sentences by drawing a line under the correct word or phrase that belongs in the blank space:

1. The number of elements is about  
a. 50            b. 100            c. 150            d. 200
2. The energy we get from the atom is called  
a. molecular energy            b. solar energy            c. electronic energy  
d. nuclear energy
3. The burning of wood is classified as  
a. slow nitrification            b. solar energy            c. slow oxidation  
d. rapid oxidation
4. Rust forms when oxygen combines with  
a. tin            b. iron            c. zinc            d. aluminum
5. The nucleus of the common hydrogen atom consists of  
a. one neutron            b. one proton            c. one electron  
d. one neutron and one proton

A list of terms is given below. Select the term from the list that goes with each statement. Write the term in the space before the statement.

Electric motor	Temperature	Contraction	Gasoline engine
Expansion	B.T.U.	Calorie	

1. (Expansion) due to more rapid vibration of molecules.
2. (Temperature) a measure of the vibration of molecules.
3. (B.T.U.) heats one pound of water to 1° Fahrenheit.
4. (Contraction) heated bar cooled.
5. (Gasoline engine) converts heat energy to mechanical energy.

Identify the following:

1. Along with her husband, she succeeded in separating a new element from pitchblende. She called it polonium. (Marie Curie)
2. This Swedish chemist is famous as the inventor of dynamite. (Alfred Nobel)
3. This French scientist discovered the radio-activity of uranium. (Henri Becquerel)

Draw a line under the word in the parentheses that should be used to make a correct sentence:

1. A (solid, liquid, gas) has no size of its own.
2. A (solid, liquid, gas) has a definite shape.
3. The changing of a liquid or a gas to a solid is called (condensation, evaporation, freezing).
4. A (physical, chemical) change produces a new material.
5. The rusting of iron is a (physical, chemical) change.

On the blank after each material listed below, tell whether the material is a solid, a liquid, or a gas.

- |             |          |                 |          |
|-------------|----------|-----------------|----------|
| 1. rock     | (Solid)  | 6. ice          | (Solid)  |
| 2. hydrogen | (Gas)    | 7. baking soda  | (Solid)  |
| 3. mercury  | (Liquid) | 8. syrup        | (Liquid) |
| 4. air      | (Gas)    | 9. mirror       | (Solid)  |
| 5. oil      | (Liquid) | 10. water vapor | (Gas)    |

Answer the following:

1. Explain what is meant by a chemical change.  

(In a chemical change new kinds of matter are formed. Atoms are rearranged to form different molecules with different chemical and physical properties.)
2. Of what chief particles are atoms made? Where are these particles located in the atom?  

(Protons - in the nucleus: Neutrons - in the nucleus: Electrons - Whirl about the nucleus.)

Underline the correct answer in each of the following sentences:

1. Molecules always
  - a. stand still
  - b. move in circles
  - c. move in a straight line
  - d. move in every direction
2. Odors can be smelled at a distance because
  - a. we have keen noses
  - b. particles are bumped about
  - c. air particles do not vibrate
  - d. we like pleasant odors
3. When a molecule at the top of a liquid gets bumped up into the air, the process is called
  - a. condensation
  - b. precipitation
  - c. evaporation
  - d. conduction



## Vocabulary

One of the strongest keystones of scientific efficiency lies in its vocabulary. The scientist says things precisely, accurately, and briefly. Probably one of the greatest quarrels the science teacher may have with the elementary level teaching today is vocabulary. The science teacher can have no use for vocabulary that is not precise and accurate. Precision on vocabulary is necessary for understanding and meaning of the concept or process being learned.

The words listed below are the basic vocabulary for the indicated area of study. After each word has been introduced, its meaning is to be maintained and extended at each succeeding level of study.

acid	low-energy-substance
analysis	mass-energy
atom	matter
attract	molecule
base	mixture
binding force	neutron
chemical bond	nuclear energy
chemical change	nucleus
chemical energy	neutral
chromatography	output energy
condensation	oxidation
compound	physical change
conservation of mass-energy	proton
diffuse	repel
element	solid
electron	solution
energy	spectroscope
energy transfer	states of matter
fission	suspension
fusion	U-235
gas	vibrate
high-energy-substance	
input energy	
isotope	
kindling temperature	
law of conservation of energy	
liquid	

### Children's Books

Books are a very essential part of the instructional materials in elementary schools which provide superior learning experiences for children. The selection of these books poses a difficult problem for librarians, teachers, and administrators because the science field is broad and increasing in scope and elementary school science programs are varied in nature. Some of the more common specific difficulties in choosing books are: (1) finding materials which deal with the varied interests of children; (2) locating material which gives information correlated with the local school district's instructional guide; (3) finding books of appropriate reading difficulty; and (4) selecting the best books from the many available.

The following list gives help related to the first three difficulties presented. Indirectly, it also helps with the fourth difficulty, for the best books cannot be selected until they are located. Further, the brief annotations should be of help in determining which books may be best for a given class. Finally, time should be saved in the selection the best list if some information about the reading difficulty of available books is provided. It is hoped that this list will suggest for elementary teachers books that are supplementary to basic text series, and that these books will have value either as sources of information or for recreational reading.

It is always hazardous to specify an exact grade placement for a book because of variations in pupil reading ability in any class group, and because of different uses made of books. Consequently, the lowest grade level for pupil use is indicated. At lower levels these same books may be useful if the teacher reads to children.

This list has been adapted from the publication of Children's Catalog (1966).

- Beeler, Nelson F. Experiments in Chemistry (by) Nelson F. Beeler (and) Franklyn M. Branley; illus. by A.W. Revell. Crowell 1952 152p illus \$3.50 "Chemistry as a part of our everyday life illustrated by experiments with flour, milk, paints, salt, and other materials available in the kitchen. Explicit instructions, many diagrams and illustrations.
- Eronowski, J. Biography of an Atom, by Millicent E. Selsam; illus. with pictures by Weimer Pursell and with photographs. Harper 1965 43p illus. \$2.95 (4-6)  
"This is the biography of a single atom -- what it is like, where it came from and its place in the world. There are about one hundred different kinds of atoms, but this story will be about an atom of carbon because carbon is found in every living cell, and its atoms therefore enter into your life and mine."
- Faraday, Michael The Chemical History of a Candle; illus. by Jeanyee Wong. Foreword by E. N. daC. Andrade; biographical introduction by Sir J. Arthur Thomson. Crowell 1957 158p illus \$2.75 "A reprint of lectures on the physical phenomena of a candle which serve as an introduction to the laws governing natural philosophy. Originally delivered at the Royal Institute of London in 1860."

Freeman, Ira M. All About the Atom; illus. by George Wilde. Random House 1955 146p illus (Allabout bks) \$1.95 (4-7) "The author "gives a fairly simple and understandable explanation of the atom, its structure, nuclear fission, and the uses to which atomic energy is and may be put, and traces the history of the concept of the atom and the scientific discoveries that brought us to the Atomic Age."

Freeman, Ira M. All About the Wonder of Chemistry; illus by George Wilde. Random House 1954 148 illus (Allabout bks) \$1.95 "A clearly written introduction to the field of chemistry. A well-illustrated explanation of the molecular composition of compounds adds to the value of the book. There is a description of the making of steel and the processing of other metals, and one chapter is devoted to fibers and plastics, including textiles made from synthetic fibers. There is also brief information about careers in the field of chemistry."

Freeman, Mae Fun With Chemistry, by Mae and Ira Freeman. Random House 1944 58p illus \$1.95 (4-7) "Dr. and Mrs. Freeman present twenty-five interesting experiments which can be done at home with materials found in the kitchen or medicine cabinet. None of them is dangerous or messy; all of them provide an easy and entertaining method of learning the basic principles of chemistry."

Freeman, Mae The Story of Chemistry, by Mae and Ira Freeman; Random House 1962 82p illus (The Random House Easy-to-Read science lib) \$1.95 (3-6) This "book explains briefly the principles and something of the historical development of chemistry and discusses the part it plays in industry and in the everyday life of man."

Freeman, Mae The Story of the Atom, by Mae and Ira Freeman; illus. by René Martin. Random House 1960 81p illus \$1.95 (3-6) "The authors explain simply and clearly molecular and atomic structure, natural and synthetic 'splitting' of atoms, and modern nuclear research and progress. Well-placed emphasis on peacetime uses of the atom."

Haber, Heinz The Walt Disney Story of Our Friend The Atom. Golden Press 1956 165p illus \$4.95 (5-7) "This is a fascinating, well-written, scientifically accurate explanation of a difficult subject. Immediate interest is aroused through the technique of comparing the atom and man to the fisherman and the genie in 'Aladdin's Lamp.' Historical development of man's growing awareness of the presence of the atom and its significance is excellent."

Irwin, Keith Gordon Chemistry: First S-t-e-p-s; illus. by Julio Granda. Watts. F. 1963 49p illus \$2.59 (5-7) "The essential facts about chemistry and chemical elements are presented in non-technical language with experiments." "A table of 40 important elements, a list of materials and supplies for use in the experiments, and contents well indexed make this a useful book for teachers as well as young chemist."

Kohn, Bernice The Peaceful Atom; illus. by Zenowij Onyshkewych. Prentice-Hall 1963 72 p illus \$3.50 (3-5) "A description of atoms, their structure, size, and composition, and a discussion of atomic power, reactors, and the many beneficial uses of radioisotopes and atomic energy in medicine, transportation and industry."

Lewellen, John B. The Mighty Atom; Knopf 1955 58 illus \$2.59 (3-5) "Describes the structure of the atom with its powerful nucleus and its ever-changing outer shell. The two methods of releasing the powerful energy contained within the atom are described and the destructive and constructive possibilities that may result are discussed."

Meyer, Jerome S. Picture Book of Chemistry; illus. by Richard Floethe. Lothrop 1950 40p illus \$2.75 (5-7) "In simple, but not written-down text, the author gives children an idea of the importance of chemistry; and introductory information about atoms, solids, liquids, gases, etc... The many illustrations add to the attractiveness of the book."

Roberson, Paul Chemistry by Experiment; illus by Eric Thomas. Day 1965 48p illus (Finding out about science) \$2.52 (3-5) An "introduction to the science of chemistry. In simple language with numerous apt illustrations, the author outlines experiments to demonstrate the fundamental importance of chemistry to plant and animal life. Directions are given for assembling simple pieces of equipment and obtaining supplies necessary to performing the various experiments."

### Films

These films are available from the Central Audio-Visual Department. Contact your building A-V Coordinator to arrange for the use of these films.

All films should be previewed to determine suitability for use with your particular class.

Atomic Energy - Inside the Atom 14 min. Col. Grades 5 & 6

This film shows evidence of atoms breaking up as seen in cloud chambers and a Geiger counter, used to detect radioactive substances. All atoms are not radioactive. Non-radioactive substances can be made radioactive. It shows the many ways radioactive substances can be used as a medicine, and how to produce heat, power and light.

Chemical Change 12 min. Col. Int.

In understanding terms and simple experiments, the film explains some of the chemical changes that are taking place all around us. It illustrates the difference between physical and chemical change and demonstrates some of the tests used by chemists in which chemical changes play a part.

Controlling Atomic Energy 13½ min. Col. Grades 5 & 6

This film briefly reviews subject matter concerned with structure and behavior of atoms. It then proceeds with details on radiation, fission, a portrayal of controlled fission, and potential peacetime uses of nuclear energy.

Electrons at Work 14 min. Col. Grades 5 & 6

An electron carries an electric charge. They are far too small to be seen but we can observe things they do. Electrons have mass and can move objects by colliding with them. All objects are made of atoms and all atoms contain electrons. Objects with like charges repel each other - those with unlike charges attract each other. The fact that electrons can be controlled makes them useful in many ways.

Evidence for Molecules and Atoms 19 min. Col. Grades 5 & 6

Scientists often use circumstantial evidence to prove the existence of unseen things. Circumstantial evidence indicates that air and water are made up of small particles - these small particles that are called molecules. The structure and properties of crystals suggest that they are made of tiny building blocks. Atoms are the building blocks from which molecules are made.

Fallout 14 min. Col. Int.

This film explains what fallout is (dust particles of a nuclear explosion). What to do about radioactive matter--how to know if there is a fallout--and what you can do about it are explained.

Force of Gravity 10 min. B & W Int.

The ways in which gravity pulls all objects downward toward the center of the earth are depicted by such examples as water flowing from a high level through a pipe and the pull of gravity on a human being when his weight is measured on a scale. Questions at the end test children's absorption and point out essential facts of gravity.

Gravity the Mighty Pull 13½ min. Col. Pri. & h

This film shows how gravity affects our lives and explains what it is. It portrays the relationship of earth and moon; and the effect of gravity on tides. It includes experiments and tests on weightlessness that will be encountered by astronauts.

How Materials Are Alike and Different 11 min. Col. Int.

All materials occupy space and have weight, but differ in their properties. Observations and simple tests acquaint us with some of these properties -- density, flexibility, elasticity, solubility and tensile strength. Laboratory methods of testing properties are shown and we learn how the properties of a material determine its use.

How Materials Are Changed 13½ min. Col. Int.

The film considers important characteristics and properties of substances: introduces concepts relating to structure of matter, elements and compounds, chemical changes.

How to Change a Chemical Reaction 28 min. B & W Int.

Using two chemicals, potassium iodate and sodium bisulfite, Mr. Wizard demonstrates how reaction takes place in solution. He shows that chemical changes can be timed and predicted and that they are affected by such variables as temperature, proportion of chemicals, amount of acidity. An electronic thermometer, magnetic mixer and photo cell are used and explained to test and predict chemical change.

How We Get Our Power 10 min. B & W Int.

This film explains how all our power comes from nature, wind, water, fuels, explosives, and the atom.

Nature of Energy, The 10 min. B & W Int.

This picture clarifies the scientific concept of energy simply and interestingly; shows the relationships of atomic energy to other forms of energy, by bringing to your classroom the bold outlines basic to understanding the scientific studies and more specialized units of electricity, sound, light, and heat.

Our Friend the Atom 50 min. Col. Int. Parts I & II

The fable of Aladdin's lamp introduces a history of development of atomic theory. It covers contributions of Democritus and other early scientists, Einstein's equation, and current concept of atomic and nuclear structure. The experiment demonstrates the process of atomic fission. Peaceful uses of atomic energy in power plants, medicine, etc., are discussed by Heinz Haber.

Particles of Matter

13½ min. Col. Int.

An interesting and informative discussion between an author of juvenile science books and one of his young readers, provides the subject matter of this film concerning essential theories and understandings relating to mass and energy. Properties of matter are treated. The size, structure, properties, and behavior of atoms which compose matter are illustrated by use of models, animation, and live photography.

Simple Changes in Matter

10 min. B & W Int.

On a hot summer day a young boy observes many changes in the world around him. The same observations are then demonstrated in laboratory situations depicting how matter changes in response to heat and light. Liquids, solids, and gases are covered.

Wonders of Chemistry

11 min. B & W Int.

Nylon hose and two inquisitive children introduce a discussion of elementary chemistry. The fact that all substances are made of approximately 100 basic elements is stressed with concrete examples. It is explained that elements cannot be broken down into more defined parts and yet by uniting elements into compounds everything in the universe has been created. Contributions of chemistry to life are indicated.

You Can Beat the A-Bomb

20 min. B & W Int.

The film describes the various "scopes" of the effect of the atomic bomb blast, and the protective measures to be taken by civilians before, during, and after explosion.

PART II - LIGHT

Initiatory Activities..... 51

Developmental Activities..... 51

    Concept

    Images are formed when light rays, from an object, are brought to focus by a lens..... 51

    Light energy may be changed to other forms of energy..... 54

    We see the color of things when light shines on them..... 54

    Light is very important to plants..... 57

    Shadows form when things block the light..... 59

    The sun gives us a light..... 60

    Sunlight is a mixture of many colors..... 63

    Light changes the color of some things..... 64

    Light travels in a straight line..... 66

    We are able to see things because they either give off light or reflect light to our eyes..... 67

    In every light source, there is some form of energy transformed to light energy..... 68

    Light is bent or refracted when it passes from a medium of one density to another..... 70

    Light behaves in some respects like waves and in others like particles.... 72

    Some light is of too low a frequency (infrared) or of too high a frequency (ultraviolet) for the human eyes to see..... 73

    Light waves like sound waves, possess the properties of amplitude, frequency and speed..... 74

    The eye resembles a camera in many ways..... 75

    All optical instruments are extensions and modifications of the sense of sight..... 76

    Light that is not reflected or does not pass through objects is absorbed by them..... 79



Concept (Continued)

Different materials obstruct light in varying degrees.....	80
Light can be reflected in various ways from various types of surfaces; some scatter the light while others do not.....	81
Evaluation (Sample Items).....	85
Vocabulary.....	87
Children's Books.....	89
Films.....	91

## LIGHT

### Initiatory Activities

Have the children:

1. Display a group of books about light in the science center.
2. Prepare a bulletin board illustrating historically interesting sources of illumination.
3. Examine flat and curved mirrors. Note the distortion observed when an image is viewed in a curved mirror.
4. Prepare a bulletin board of pictures in which large expanses of blue sky are visible. The title of the bulletin board display might read "What Causes the Sky to Appear Blue?"
5. Discuss the importance of good lighting in taking good photographs.
6. Place as many of the following as are available on the science table: magnifying glass, microscope, inexpensive telescope, opera glasses, binoculars. Have the children look through these instruments. After they all have had an opportunity to look, discuss what could be seen with the instrument that could not be seen with the naked eye.

### Developmental Activities

CONCEPT - Images are formed when light rays, from an object, are brought to focus by a lens.

#### 1. Problem

How can we project a picture on a screen?

#### Materials

Cardboard box, four inch hand lens, tape, lamp cord, bulb, two pieces of wire, candy box, lamp guard, light socket, asbestos sheet.

#### Procedure

Cut round holes in the carton and the candy box. Each hole should be a little smaller than the lens. Place the holes of the carton and candy box so that they coincide with one another. Hold the candy box in place with the wire. Now cut a small hole on the side of the carton and pull the lamp cord through the hole. Screw the lamp bulb with the lamp guard over the bulb into the socket. Cut off the cover of the carton and tape the bottom edges so that light will not escape. Place the lens over the hole and hold it in place with wire. Use a piece of cardboard for a cover and place it over the open end of the carton, bending the cardboard in half. Tape half of the cover close to the lens side of the carton. Plug

in the lamp and place it beneath the candy box. Hold a picture in the box and move it back and forth.

### Results

A picture will show on the wall when the light rays from the object are brought into focus.

### Conclusions

The lamp throws light on a picture on the far end of the box. The picture in turn gives off light through the lens and it is projected on the screen. The projector is focused by moving the picture back and forth inside the box.

### Caution

The lamp bulb used may be 100-150 watts. These light bulbs produce much heat and an asbestos sheet must be used under the lamp. The candy box is used to shield the lens from the direct rays of the lamp.

## 2. Problem

How do cameras take pictures?

### Materials

Carton, four inch hand lens, wire, sheet of paper.

### Procedure

Cut a round hole in an end of the carton. Be sure it is smaller than the hand lens. Fasten a lens over the hole. Point the lens towards a window. Move a sheet of paper back and forth inside the carton.

### Results

When the lens is focused, you will see a picture of a window.

### Conclusions

A camera lens makes a picture on a film in the back of a camera the same as the one made above. The light or picture focused on the film changes because of chemicals sensitive to light. The film has a picture on it.

## 3. Problem

How can we see over an object which obstructs our view?

### Materials

A long carton with a tube, two mirrors, scissors, tape, toy periscope.

### Procedure

Cut two holes in the carton and tube, about four inches long and two inches wide. Set in the tube the two mirrors at a forty-five degree angle and hold them in place by means of the tape. (Be sure the reflecting surfaces of the mirrors are facing each other.) Now hold the tube up vertically and look into the lower hole.

### Results

Objects that were obstructed can now be seen.

### Conclusions

The angle of incidence is equal to the angle of objection. The light comes from the object and strikes the top mirror and is reflected by the second mirror to our eyes.

## 4. Problem

What does the image, formed by a hand lens on a white sheet of cardboard, look like if it is held in a position close to a candle or farther away from a candle?

### Materials

Set the cardboard upright on the table by laying the cardboard against a few books. Light the candle and darken the room; move the candle about two feet away from the cardboard. Place the hand lens between the cardboard and the candle. Move the hand lens back and forth in front of the cardboard.

### Results

A picture of the candle is formed on the cardboard. If an image is not formed perhaps the candle is too close. Now move the hand lens close to the candle until an image forms on the cardboard. Have the children observe that the image of the candle is smaller and inverted when the hand lens is close to the cardboard. When the hand lens is closer to the candle the image is larger and again inverted. The children may now move the candle and cardboard further apart. Again move the hand lens in front of the cardboard and the image becomes smaller. Move the hand lens near the candle and focus. The image becomes much larger.

### Conclusions

A hand lens forms an inverted image and when it is closer to the image on the screen, the image is smaller than when the hand lens is close to the object.

CONCEPT - Light energy may be changed to other forms of energy.

-- Problem

Why can you burn a piece of paper with the aid of a hand lens?

Materials

Four inch lens (hand), sand, dish, paper.

Procedure

Fill the dish with sand and place a small piece of paper on this sand. Place the dish near the window and direct the sun's rays on the paper by means of a hand lens. Have the sun's rays come to a point on the paper.

Results

In a few minutes the paper will burn.

Conclusions

A hand lens can bend sunlight toward one point. The energy of the sun is concentrated on this point and causes much heat.

CONCEPT - We see the color of things when light shines on them. (The color of an opaque object is determined by the portion of the colors of the spectrum that it reflects.)

1. Problem

Why is a red object red?

Materials

Circle of red paper, pins or paste, green cellophane-covered flashlight, sheet of green paper.

Procedure

Paste or pin the circle of red paper on a sheet of green paper.

Take the test sheet into a very dark room.

Ask a child to shine the green cellophane-covered flashlight on the test sheet.

Is the red circle still red?

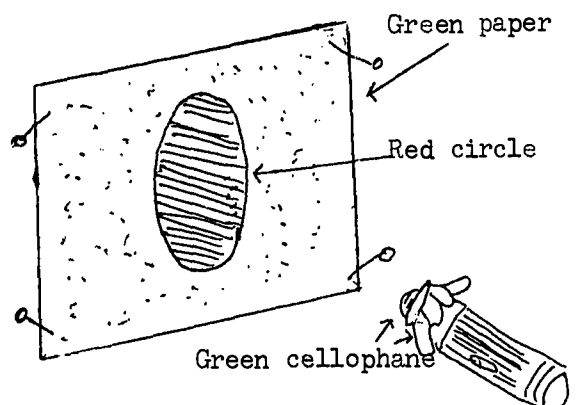

### Results

The shining of the green cellophane-covered flashlight on the test sheet in the dark room produces a black circle on a green background.

### Conclusions

A pure red object is one which reflects only red light. When white light strikes it, red is reflected. White light contains red and many other colors, too. When red light strikes it, it still looks red. If green light shines on it, there is no red light for it to reflect; therefore, it will not produce a red color. Since a red object absorbs green light, no light is reflected from the red circle and it produces the illusion of a black object.

## 2. Problem

How do we see the color of objects?

### Materials

Flashlight, one sheet each of paper: white, green, red, and blue.

### Procedure

Have a child hold the white paper perpendicular to a table and place the green sheet on the table. Ask another child to hold the flashlight at about a  $45^\circ$  angle so the light is reflected on the white paper. What color is the spot on the white paper? Do the same thing with the other papers. Point out to the children that the light of all colors of the spectrum is coming from the flashlight, yet only one color is reflected. What happened to the other colors?

### Results

All colors but the one reflected are absorbed.

### Conclusions

The color of colored objects is due to the light rays that they reflect; all other colors are absorbed.

## 3. Problem

How can we make different colors?

### Materials

Cotton swabs, water, paper cups, cups of paint, paper towel, scrap paper.

### Procedure

Place cups of different colors of paint (primary colors) on the table. Divide the class into groups (of from four to six children). Have the children try mixing different primary colors to see what the secondary colors would be. Give each group an opportunity to mix the paints. Instruct them to try mixing green, orange, etc. Show them the color wheel for the primary colors. They might make one for themselves.

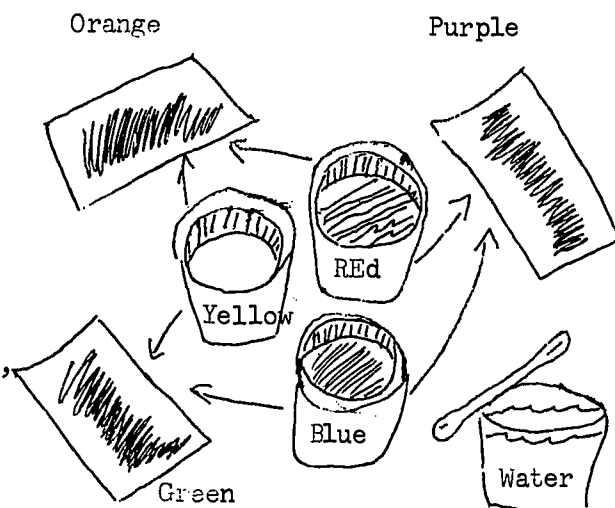

### Results

The student sees for himself that by mixing two of the primary colors, a third color (secondary color) is obtained. Yellow and blue make green. Yellow and red will make orange. Red and blue will make purple.

### Conclusions

Two primary colors when mixed will produce secondary colors.

#### 4. Observation

Have children compare lightness and darkness by turning the light in the room and closing the shades. Ask the children if they observe any difference in colors of things around them when the room is dark.

#### 5. Research

- a. Ask some students to read about the psychology of color and report to the class which colors seem to be restful, fatiguing, hot, cold, and etc.
- b. Ask students to prepare a report on color vision and color blindness.
- c. Ask some students to read about spectrosopes, how they operate, and how they are used. Have them report their findings to the class.

#### 6. Demonstration - Showing the Meaning of Color

##### Materials

Triangular glass prism, pieces of different colored glass.

##### Procedure

Hold the prism in the direct sunlight. Rotate the prism until a band of colors show on the wall. Hold a piece of red colored glass close to your

eye and look through it at the band of colors. (Red is the only color that can be seen through the glass.) Hold the other pieces of glass up to your eye one at a time. (Only one color can be seen through each piece of glass.) The color of a transparent object depends upon the color it transmits, the color that passes through it. All the other colors are absorbed by the object. Red glass transmits only red light and makes an object look red. Blue glass transmits only blue light and makes objects look blue.

CONCEPT - Light is very important to plants.

1. Problem

Do plants need light for growth?

Materials

Two (2) pots, soil, seeds.

Procedure

Ask children to plant the seeds in pots containing identical soils. Place one pot in a sunny place and the other in a dark closet. Make sure children water both pots equally. Observe pots daily to watch for sprouting seeds. In which pot do seeds sprout best? Do the same experiment with two small plants which have equally good starts. Which plant grows more healthfully?

Results

Children should observe that while seeds sprout at about the same time, the plant in the dark closet will not grow well without sunlight.

Conclusions

Light is not necessary for the sprouting of seeds, but is necessary to the growth of plants after they have sprouted.

2. Problem

How does sunlight affect the leaf of a plant?

Materials

Paper, scissors, paper clip, potted plant with large leaves.

Procedure

Cut out a mask and attach it with a paper clip to the leaf of a potted plant. A plant having large leaves is best. After several days, remove the mask and examine the leaf. What changes have occurred? Why?

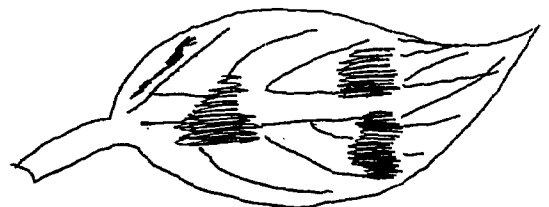
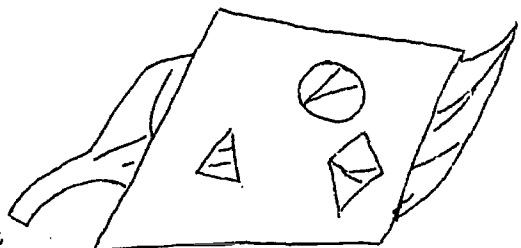



### Results

Pupils will find the leaf changed from green to a brownish color under the mask. They may assume that sunlight helps to keep the leaf green.

### Conclusions

Plants will not stay green without light.

### 3. Observe

Have children observe that plants grow toward the sunlight, as they do these activities.

- a. Wet a sponge in water and place it in a shallow bowl. Sprinkle the sponge with bird seed or grass seed and keep the sponge moist. After seeds germinate, observe how the seedlings grow toward the light. Turn the dish several times to prove the seedlings are attracted to the light.
- b. Mark one side of a potted plant growing in the room. Keep the plant placed in exactly the same position for several days. Observe the direction of the leaves of the plant after several days. Does the plant turn toward the sunlight?
- c. Cut a hole in one side of a cardboard box. Place a potted plant under the box and leave it there for several days. Remove the box and examine the plant. Did the plant grow toward the light?

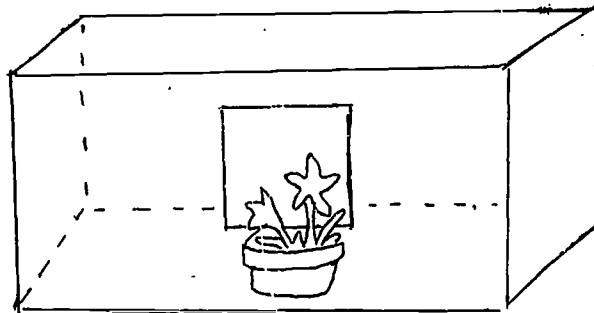

(Note: See also the booklet on living things - plants.)

CONCEPT - Shadows form when things block the light.

1. Problems

What causes a shadow?

Materials

White sheet, extension cord with reflector and large light bulb (or powerful flashlight), thumbtacks.

Procedure

Tack the sheet on a convenient place on the wall. Shine the light on the sheet and ask children to notice there is no shadow. Place a child between the source and the sheet. What is noticed? Have the child hold various opaque objects between the light and the sheet.

Results

Any opaque object placed between the light source and sheet will cast a shadow

Conclusions

Light rays do not pass through opaque objects; therefore they will cast a shadow.

2. Drama

Ask a group of children to give their ideas for a shadow play, in which the performers are between a sheet hung in the classroom and a strong light. See if the audience (on the other side of the sheet) can guess the activities going on just by observing the shadows.

3. Observe

In the morning of a sunny day, have the children stand outside with their backs to the sun, so that they may notice the length of their shadows. They might take turns measuring and recording these lengths. Do the same thing at noon. What have the children observed about their shadows? What caused this change? Through discussion, lead children to the understanding that the length of the shadow is determined by the angle of the light rays. This same thing may be demonstrated by sticking a pencil in a piece of clay and casting different shadows by changing the position of a flashlight in a dark room.

4. Draw

Ask children to draw illustrations showing exactly what happens during a solar or lunar eclipse.

## 5. Research

Ask a committee to do research on the topic of eclipses and report to the class the role that shadows play.

## 6. Demonstration

In a dark room stand as far from the wall as you can in order to light as much of it as possible with a flashlight. Ask a child to place his hand a few inches from the light source. The class should notice the large shadow it casts. Ask the pupil to move slowly away from the light while holding his hand in the beam. The class should notice that the shadow gets smaller and smaller. Through discussion, lead the class to understand that this is because fewer and fewer light rays are being cutoff.

CONCEPT - The sun gives us light.

### 1. Problem

How can we tell time by the sun? How can we find directions by using the sun?

#### Materials

Compass, wristwatch, broom handle. (This must be done outside on a sunny day.)

#### Procedure

Ask children to follow these directions to set up their sundial:

##### a. Time.

- (1) Draw a circle about four or five feet in diameter in the open sunlight.
- (2) Number clock hours as shown on sundial beginning with 6 to the west, 12 to the north, and 6 to the east (2 hrs. from 1 hr. on watch).
- (3) Place broom handle in center of circle.
- (4) Note shadow cast by sun and approximate time.

##### b. Direction.

- (1) Look at wrist watch to determine time.
- (2) Note where shadow is cast by sun and draw dial of clock with shadow pointing to approximate time.
- (3) Determine direction from shadow with 12 N, 6 E, and 6 W.

#### Results

- a. The sun casts a shadow which can be interpreted as time on a sundial.
- b. When the hour hand points toward the sun, North is in a direction halfway between the hour hand and 12 o'clock.

## Conclusions

- a. We can tell time by compass shadow and drawing dial without using a watch.
- b. We can find directions by use of a watch and sunlight.

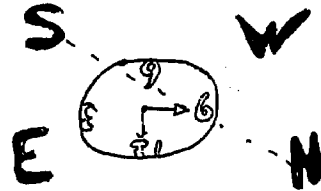
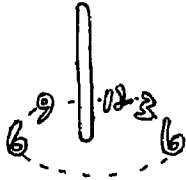

## 2. Problem

What is daylight?

### Materials

A globe, a flashlight.

### Procedure

Darken the classroom and ask a child to shine the light on the globe. Then have someone turn the globe. Ask leading questions so that children gain the following understandings.

This experiment will show that the earth is a solid ball that blocks the light rays; the part of the earth that faces the sun has daytime, while the part of the earth in the shadow has night.

### Results

The turning of the globe will show children how day follows night as the world turns.

### Conclusions

Daylight is caused by light rays that come here from the sun.

## 3. Problem

Why is it dark on cloudy days?

### Materials

Globe, flashlight, four (4) pieces of waxed paper.

### Procedure

Perform the preceding experiment and then ask a child to place a piece of waxed paper in front of the flashlight. Explain that the waxed paper is illustrating the interference of clouds. Then place a second, third and fourth piece in front of the flashlight. What happens if the clouds are more dense?

### Results

The globe will grow darker as each piece of paper is placed in front of the light.

### Conclusions

Clouds interfere with light rays coming from the sun. It is dark on a cloudy day because much of the light has been stopped by the clouds.

#### 4. Drama

Pose the question to children - What would be different for you if you woke up one morning to discover the sun had disappeared? Have each of the children contribute his ideas to be worked into a short skit to be presented to another class.

#### 5. Research

- a. Have children do research on food chains with light causing photosynthesis in plants as the first step. Have them trace the food they ate this morning back to energy in sunlight.
- b. Ask the children to find out what they can about solar cells, which transform light energy into electrical energy.

#### 6. Demonstration-

#### Why are Our Summers Hot and Winters Cold?

To show we are receiving less light in one place in winter than in summer, you will need a flashlight and chalk. Hold flashlight about six inches away from the blackboard with the rays falling straight on the board. Trace around the edge of the light.

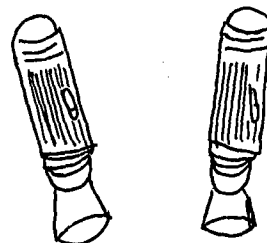

Compare the area of the two drawings on the board. Answer such questions as: Does the same amount of heat and light leave the flashlight over each area? Does the same amount of heat fall on each area? Does the same of heat and light fall on any one point in each area? In which area is most concentrated? In which area would a given point receive the most heat and light? When must the sun's rays fall most directly on us, summer or winter?

Since we receive more light and heat in the summer than in winter, the sun's rays must fall more directly on us in summer than in winter, making our summers hot and our winters cold.

CONCEPT - Sunlight is a mixture of many colors.

1. Problem

What color is sunlight?

Materials

Prisms, strong sunlight, flat surface, such as white cardboard.

Procedure

Ask a child to hold the prism in such a way that sunlight may pass through it and form a rainbow on the flat surface.

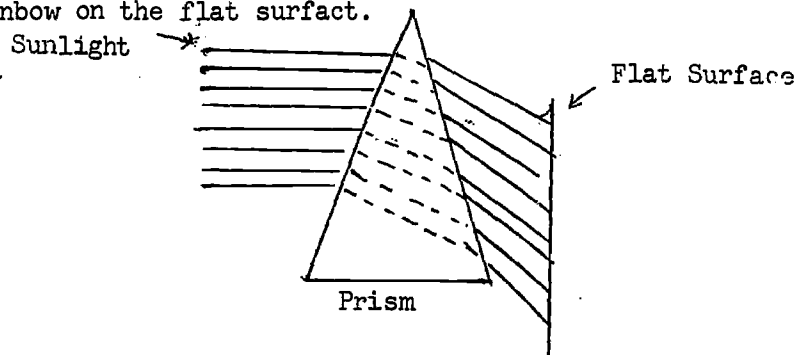

Results

Sunlight is broken down into the following sequence of colors: Red, orange, yellow, green, blue, indigo, and violet.

Conclusions

White light (such as sunlight) is composed of many colors. This arrangement of colors is known as the visible spectrum.

2. Problem

What color is sunlight?

Materials

Square-sided tray or cake pan, pocket mirror, water.

Procedure

Set the tray near a window through which bright sunlight is streaming. Fill the tray with water to a depth of one inch. Lean a pocket mirror in the water on the far side of the tray, so the sunlight falls on it after passing through the water.

Results

When the mirror is adjusted properly, a spectrum will appear on the upper part of the wall of the room, or upon the ceiling.

Conclusions

Sunlight is composed of many colors.

### 3. Observe

Ask children to observe, or recall their observations of a rainbow after a summer shower. How does it compare to a picture of the visible spectrum? What causes the rainbow?

Ask children to recall other instances in which they have noticed a spectrum, such as in a lawn spray or in a puddle that happens to contain a thin film of oil. What causes light to break into the spectrum in these cases?

### 4. Demonstrations-                      Making a Rainbow

- a. Fill a spray gun with water. Go outdoors on a sunny day and spray a thick mist; a rainbow will appear.

#### Mixing Different Colors To Get White

- b. Have children cut three inch circles from the cardboard and divide them into four equal sections. Color one quarter purple, one blue, one green, and one orange. Have a toothpick placed through the center and spin the circle very fast. The cardboard circle will appear white.

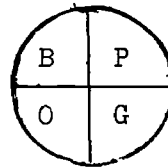

CONCEPT - Light changes the color of some things.

#### 1. Problem

How can light change the color of something?

#### Materials

Scissors, one piece each of black and red art paper, tape.

#### Procedure

Cut a design in the black paper and tape the black paper to the red paper. Tape it to a window that is in the sunlight for a few days. Have children remove the black paper and examine the red paper. What caused the change that is noticed? Experiment with other colors of paper to see if they change.

#### Results

The design that was cut in the black paper will be seen as a pink design on the red paper.

#### Conclusions

The energy of sunlight caused the exposed red paper to fade.

## 2. Problem

How are blueprints made?

### Materials

Blueprint paper, cardboard, a piece of window glass, a leaf, a basin, cold water.

### Procedure

Cut a piece of blueprint paper larger than the leaf and place it on the cardboard. Have children place the leaf on the paper, cover it with the glass and expose to sunlight for four minutes. The paper should then be dipped in a basin of cold water and laid on a flat surface to dry.

### Results

The blueprint paper will show a white print of the leaf against a blue background.

### Conclusions

Sunlight changed the color of the paper from white to blue. The light caused a chemical change, for the paper contains chemicals which are sensitive to light.

## 3. Observe

Have the children examine color negatives and positive prints of these negatives. How did the light affect the film in the camera?

In the warm weather, ask children to put a piece of adhesive tape,  $\frac{1}{2}$ " by  $\frac{1}{2}$ " on the back of one hand and leave it for a few days. Remove the patches in class and let them discover the difference blocking out the light made.

## 4. Research

Ask children to do research on early pioneers of photography, such as Dagherre, to find out their use of the idea that sunlight may cause a chemical change.



CONCEPT - Light travels in a straight line.

1. Problem

How does light travel?

Materials

Drinking straws or short lengths of rubber hose.

Procedure

Give each child a drinking straw. Ask them to look through the straw, with one eye, at various things in the room. Ask them to put a bend in the straw and look again. What is noticed?

Results/Conclusions

Things are visible through the straw only when it is straight. Light travels in a straight line.

2. Problem

How does light travel?

Materials

Cardboard strips, candle, match, modeling clay.

Procedure

Make small, equal-sized-holes in the center of four strips of cardboard. Arrange the strips so that they are standing in the modeling clay with the holes in a straight line. Put a lighted candle behind the last cardboard and ask a child to look through the holes. Can the candle be seen? Move the cardboard so that the holes are no longer in a straight line and ask the child to look again. Can the candle be seen now?

Results/Conclusions

If the holes are in a straight line the candle can be seen. When the cardboards are moved out of line, the candle cannot be seen. Light travels in a straight line.

3. Observe

Ask the children to recall their observations of lightning during a storm. Point out that while the source of light might have been very crooked, the light itself still traveled in a straight line to our eyes. Which came first, the lightning or the thunder? Point out that since they both happened at the same time and the lightning appeared first, light travels faster than sound.

Demonstration

To demonstrate the straight path that light travels, have a child clap two chalk board erasers together in the beam of light from a filmstrip projector. The tiny particles of chalk dust will make it possible for the children to observe the path of light.

CONCEPT - We are able to see things because they either give off or reflect light to our eyes.

1. Problem

What is the difference between source light and reflected light? (Direct or indirect light)

Materials

Lamp, mirror, cardboard 12" x 12".

Procedure

Turn on the lamp and ask children to observe that they can all see the bulb. Place a piece of cardboard between the children and the bulb and place a mirror on the other side of the bulb. Ask children if it would be possible to see the bulb now. Let them move to a position where the bulb is seen in the mirror and point out that the bulb is still hidden from direct view.

Results

The light from the bulb is direct light. The light from the mirror is reflected light from the bulb.

Conclusions

We receive light by two means: direct and reflected (indirect).

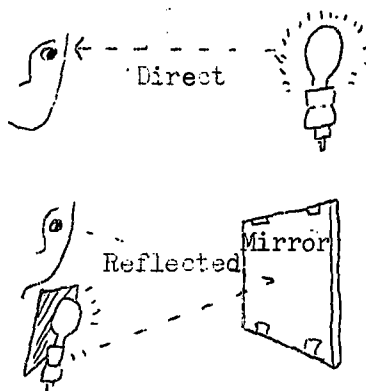

2. Charts

Have children construct a chart showing all the examples of indirect lighting they have noticed.

### 3. Observe

- a. Have children recall riding in a car at night. Why could trees, other cars, bridges, etc. be seen? On a very dark night, could you look out the side window and see things far away? Lead the children to realize that only those things that reflected back the headlights or other sources of light could be seen.
- b. Children sometimes have opportunities to observe the sky at night. Point out to them that with the help of an astronomy book, they might be able to locate some planets. Ask them to find out if there is any difference in the way planets shine as compared to stars.

### 4. Research

Give heavenly objects such as the sun, the moon, planets and stars as research topics and let children find out if the light coming from them is directed or reflected.

### 5. Demonstration- To Show How Astronomers Estimate the Temperature of Stars

With pliers, hold a nail in the flame. Children will notice the color changes as the temperature changes. The color of light given off by the nail depends upon the temperature to which it is heated. As you point this out to children, also point out that stars give off their own light, too. Scientists believe the color of light given off is a clue to its temperature, as was the color of the nail. Have children do research to find out what stars in the sky are the hottest and coolest. Where does our sun rank in comparison to the temperatures of other stars.

### 6. Bulletin Boards

Display pictures of things that give off their own light with pictures of things that only reflect light. See if the children can pick out all the pictures of one type.

CONCEPT - In every light source, there is some form of energy transformed to light energy.

#### 1. Problem

How can light energy be produced by mechanical energy?

#### Materials

Roll of electrician's tape (friction tape).

#### Procedure

Darken the room. Ask a child to hold the tape in one hand so it will unroll easily and pull the end of the tape with a quick motion. Have this repeated a few times while children watch the tape carefully. What do they notice?

## Results

A faint glow appears at the point where the tape leaves the roll.

## Conclusions

Mechanical energy can produce light energy.

### 2. Charts, Bulletin Board

Have the children make a list of the different sources of light such as: the sun, stars, fire, electric lights, on a chart. They might put down the kind of energy that was changed to light energy in each case. This might be placed on a bulletin board with pictures drawn or collected by the students illustrating each example.

### 3. Observe

Let children observe light energy being changed to mechanical energy by placing a radiometer in the sun and watching the blades spin. Compare the speeds when it is placed in various parts of the room.

### 4. Research

- a. Children may like to do research to find out what causes the spectacular light displays in our northern and southern skies, known as the Borealis and Aurora Australis.
- b. Ask groups of children to prepare reports on the contributions of Edison, Swan, Starr, and Davy to the development of the electric light.
- c. Ask children to find out what they can about the emission of energy by the laser.
- d. Some children may like to report on electrolumin-science, the process by which electric current can be changed directly to light without any heat being released.

### 5. Demonstration                      Showing Light Is Energy

If a radiometer is available, use this to demonstrate that light is a form of energy. Sunlight or light will cause the blades of the radiometer to rotate. Try to list other examples where light does work such as electric eye cameras, light meters, and others.

CONCEPT - Light is bent or refracted when it passes from a medium of one density to another.

1. Problem

How can we show refraction of light?

Materials

A round jar, water, piece of chalk, ball, various small objects.

Procedure

Have children fill the jar almost full with water. Put the objects behind the jar and look at them through the jar. What do the children notice about the objects?

Results

Objects are magnified.

Conclusions

Light rays are bent or refracted when they pass from a medium of one density to another.

2. Problem

How can we show refraction of light?

Materials

Spoon, glass of water.

Procedure

Fill a glass two thirds full of water. Ask a child to place a spoon in the glass and look at it carefully. What is noticed? Is the spoon really bent?

Results

The spoon appears to be bent or broken because the light is passing mediums of different densities, the water and the air.

Conclusions

Refraction is the bending of light when it passes from a medium of one density to a medium of a different density.

### 3. Problem

How can we show refraction of light?

#### Materials

Pitcher of water, pan, coin.

#### Procedure

Ask a child to sit in a chair with the empty pan in front of him. Place the coin in the pan so that the child can just see the edge of it. Slowly pour the water in the pan. What does the child notice?

#### Results

More and more of the coin becomes visible as the water is poured into the pan, because of the refraction of light.

#### Conclusions

Refraction is the bending of light when it passes from a medium of one density to a medium of a different density.

### 4. Observe

Have children observe objects in an aquarium and notice how they appear closer to the top than they are because of the refraction of light.

### 5. Research

Students may use a reference book on astronomy to do research on the refraction of light from objects outside of the earth's atmosphere (.starlight, the sun at sunset, etc.)

### 6. Demonstration                      Showing Light Refraction With Glass

#### Materials

A square or rectangular piece of glass at least 1/8 inch thick; a large sheet of unruled paper; a ruler; a colored crayon.

#### Procedure

Draw a straight line across the paper with the crayon. Place the paper under the piece of glass. Look straight down on the glass and paper from directly overhead. Notice that the line appears the same without the glass. Then, look at the line from an angle. Notice that the line under the glass appears to be higher than the part of the line that extends on the paper.

#### Results

The glass causes the light to be refracted. The glass bends the light rays from the line that is under the glass.

CONCEPT - Light behaves in some respects like waves and in others like particles.

1. Problem

Is light made up of particles?

Materials

Marbles, film strip projector with film, two (2) large pieces of white paper.

Procedure

Draw an X on the floor and give two children each a handful of marbles. At a given signal, let them roll the marbles all at once, along the two lines of the X so that their paths intersect. Do all the marbles go in a straight line? Why not? Point out that if light is made of particles, they should act in a similar manner. Set up the two filmstrip projectors, with film in them, so that their beams of light will cross. Focus each projector on the two pieces of white paper held by children or taped on the wall. Examine the picture from one projector and then turn on the other projector. Has the first picture changed? What should have happened if light consisted of particles?

Results

By rolling the marbles, children will see that some will scatter. No change is seen in the first picture when the second projector is turned on.

Conclusions

This proves light does not consist of particles as we know them.

2. Research

Have children do research on Sir Isaac Newton and Christian Huygens to find out what is meant by a vacuum. Would the vacuum of space provide a medium for light waves as air does for sound waves or water does for water waves?

3. Bulletin Boards

Let children collect and display pictures of as many different types of waves as they can find in old magazines. What similarities can they find among the pictures?

4. Make Models                      Construct a Ripple Tank to Study Waves

- a. Fill a glass baking dish with water.
- b. Cut a small hole in the center of a piece of waxed paper and wrap it around the top of the dish.
- c. Place two ends of the dish on two stacks of books, allowing room underneath for a flashlight to stand on end.
- d. Darken the room and tap the water through the hole with the point of a pencil.
- e. Children may use a clock or a watch with a second hand to make and record measurements of the water waves. Ask them to try their own ideas on ways to study waves with the ripple tank and report on their discoveries.

**CONCEPT** - Some light is of too low a frequency (infrared) or of too high a frequency (ultraviolet) for the human eye to see.

1. Charts

Have children make a chart of the electromagnetic spectrum, which would include the long electrical radio waves, infrared heat waves, visible light waves, ultraviolet waves, and x-rays and gamma rays. An encyclopedia or other reference books can provide a picture the children may use as a guide.

Ask children to recall if they had ever had a sunburn and how it felt. Explain that it was caused by the ultraviolet light that got through our atmosphere, which screens most of it out. Ask their reactions to what would happen if the atmosphere did not act as a screen for this ultraviolet light. Point out that many people use sun lamps for tanning and health purposes. Have children find out about the benefits and dangers of such lamps.

2. Research

Ask some children to do research on ultraviolet light and report to the class on ways it can be helpful and dangerous.

Children interested in photography may like to do research on infrared rays and how they are used in photography without visible light.

Ask some children to do research on the upper atmosphere and report to the class what they find out about the absorbing of harmful ultraviolet radiation.

Have children find out how a snake uses infrared rays for finding food.

3. Demonstration                      Infrared Rays

Burn a wood splint and explain that the only light seen is from the visible spectrum. Our eyes may see the infrared rays, which may be thought of as heat rays. Blow the fire out and have a child hold his hand near it. Infrared rays are still being emitted, but they are invisible to our eyes.



CONCEPT - Light waves, like sound waves, possess the properties of amplitude, frequency and speed.

1. Observe

Have children measure the amplitude (brightness) of light with a photographer's exposure meter. They could compare the brightness of various parts of the classroom on a sunny day and on a cloudy day. Have them measure the brightness of a flame from various distances and compare their findings.

2. Research

Ask children to find out what they can about the frequencies of the different colors of light. They could display their findings on a color chart.

Children may use reference books to find out about the work of Albert Michelson and Olans Roemer and how they measured the speed of light.

3. Demonstration      Showing The Speed of Light

Materials

Flashlight.

Procedure

Darken the room as much as possible and stand in front of the room and direct the flashlight toward the farthest-wall. Snap the light on and have the children notice how quickly the light seems to reach the wall. Turn the light on and off several times. Listen to the click of the button on the light and consider this the instant that the light leaves the lamp. Discuss the difference between the speed of sound and the speed of light.

CONCEPT - The eye resembles a camera in many ways.

1. Problem

How is the image of an object formed?

Materials

Construction paper.

Procedure

Cut the top from a box and cut a small opening in the bottom. Make a pinhole in a square of aluminum foil and tape it over the opening. Cover the open top of the box with tissue paper. Shade the tissue screen by extending black construction paper over the top and sides of the screen. Place the pinhole camera so it faces out the window or at a well-lighted object. Have children observe the image on the screen. How does it differ from the real object?

Results

The image is inverted. (In discussion of this activity, it should be mentioned that images are also formed in this manner on the back of the eyes.)

Conclusions

Light forms images. The image we see in a camera is actually up-side-down, because light travels in straight lines.

2. Observe

Have children examine with care, an unloaded camera. Ask them to try to figure out what each part does in taking a picture. How is this like the eye?

3. Bulletin Boards                      Comparison of the Eye to a Camera

Have children draw two charts and display them side by side on a bulletin board. One should be a cross section diagram of a simple box camera, with each part labeled as to its use. An unloaded camera may also be displayed on a small table, for children to study.

4. Make Models                      Another Way To Construct A Pinhole Camera

Punch a small hole in the bottom of a Dixie cup. Cover the open end with a piece of translucent paper. Cut the bottom out of a second Dixie cup and place the large end next to the translucent paper. Point the tiny hole end of the first cup at a well-lighted object and look at the translucent

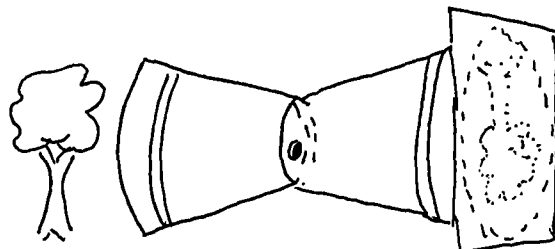

(Note: See also the booklet - The Human Body.)

paper, using the second cup as a shade for the paper. An image of the object will show on the translucent paper. The image will be upside down.

This illustrates the principle of the camera. The light is reflected from the object, through the hole, and onto the translucent paper. The light rays are stopped by the paper and the image becomes visible.

CONCEPT - All optical instruments are extensions and modifications of the sense of sight. Lenses and mirrors can be used to control the size of an image to focus light.

1. Problem

How can we show that a lens will focus light?

Materials

Magnifying glass, piece of paper, a pan of water.

Procedure

Catch sunlight with the magnifying glass and make spots of different sizes on the paper. Focus the rays of light on a small spot.

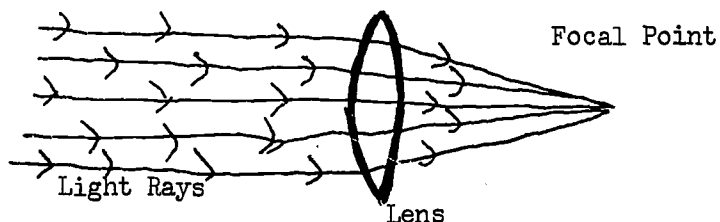

Results

The paper will start to burn. (Caution: Place the paper in the pan of water when it starts to burn.)

Conclusions

A lens can be used to focus light. Light energy may be changed to heat energy.

2. Problem

How can we focus an image with a convex lens?

Materials

Magnifying glass, white cardboard (10" by 10"), candle, several books.

Procedure

Have the children place some books on the end of a long table and prop the cardboard against them. Place the lighted candle at the other end of the table and have the shades drawn to darken the room. Have a child move the magnifying glass back and forth in front of the cardboard until an image

appears. What is noticed about this image? Now, have the lens moved back and forth in front of the candle until its image again appears on the cardboard. How is this image different from the first one?

### Results

The first image will be upside down. The second will be inverted also, but it will be larger than the first one.

### Conclusions

A convex lens can control the size of image and focus light.

## 3. Problem

How do eyeglasses correct defects of the eye?

### Materials

Sheet of white paper, two convex lenses.

### Procedure

On a sunny day, darken the room completely except for a space of about four (4) inches at the bottom of one window. Have one child hold the paper while another child focuses an image of something outside on the paper. After getting a clear picture, just as a normal eye would, move the lens a little closer to the paper so that the image is blurry. Ask a third child to hold a second lens in front of the first and adjust it so the image becomes clear again.

### Results

The first lens represents the lens in the human eye. The second lens, illustrates what the corrective eye glass can do.

### Conclusions

Eyeglasses help the eyes to focus images clearly.

## 4. Charts, Maps, or Graphs

- a. Have the children examine a telescope and a microscope and make charts comparing likenesses and differences of these two instruments.
- b. Ask children to make a time line illustrating the important discoveries made with the help of the telescope since its invention. (An almanac is an excellent source for this type of material.)

5. Observe

- a. Guide children in an examination of a filmstrip projector and an opaque projector to see how they control and use light. Ask them to construct a chart listing the similarities and differences of the two projectors.
- b. Ask children to place a drop of water on clear waxed paper or cellophane and observe how it acts as a magnifying lens when placed on a newspaper.

6. Resource Person

Ask a local optician to inform the children on the purposes of wearing eye-glasses and how they are made.

7. Draw

Have children draw diagrams of the reflecting and refracting telescopes, using a reference book as a guide. Have them compare the two types of telescopes and tell about the differences found. They might also do library research to find out about the advantages and disadvantages of each type.

8. Audio-Visual

Obtain a microprojector from the audio-visual department and demonstrate how it extends our vision so that we can study very tiny objects.

9. Research

Ask children to do research on the development of the microscope and the telescope. How have these optical instruments been great helps to science?

10. Demonstration                      How to Use a Microscope

Have a glass slide and cover slip washed and dried carefully. Ask a child to get a drop of water from an aquarium with a medicine dropper and place it on the slide. Cover this with a cover slip. Place the slide on the little table (the stage) under the tube of the microscope and fasten down with the metal clips. Screw the tube down slowly until the lower lens almost touches the cover slip. Be careful not to touch the lens as it is easily scratched. Adjust the mirror to throw light on the hole in the stage and through the water drop. Look through the eyepiece with one eye only, but keep both eyes open. While you are looking through the microscope, slowly raise the tube until the image is clear. Never lower the tube while you are looking through the eyepiece. You will see tiny living things move around in the drop of water. Other interesting slides of various materials may easily be made and viewed in the same manner.

11. Make Models                      Making a Periscope

Materials

Five pieces of heavy cardboard about 12 to 15 inches long and three or four

inches wide; two small mirrors; adhesive tape. A two pound cheese box of telescopic type may be substituted for the cardboard strips.

#### Procedure

Fasten three of the pieces of cardboard together with tape to make an elongated box with a hole low on one side and at the top of the opposite side. Attach the ends and attach the mirrors with tape or glue parallel to each other at a 45° angle. Close the box by attaching the fourth side.

#### Results

Have children prepare slides for use with the microscope, such as a human hair and an animal hair, a feather, a drop of sugar water, etc.

CONCEPT - Light that is not reflected or does not pass through objects is absorbed by them.

#### 1. Problem

Is light absorbed by all substances?

#### Materials

Flashlight, squares of colored crepe paper and wax paper (4" x 4").

#### Procedure

Darken the room and ask a student to shine the flashlight on the wall. Place sheets of crepe paper over the light one by one. What is happening? Have a child do the same thing with the wax paper.

#### Results

In each case, the light reaching the wall is less and less until no light gets through. It should be pointed out that most light rays pass through transparent objects, but there are still a few that are absorbed.

#### Conclusions

Some light is absorbed by all substances.

CONCEPT - Different materials obstruct light in varying degrees.

1. Problem

What kinds of substances will light rays pass through?

Materials

Flashlight, articles such as: glass, plastic, paper, cloth, wood, and brick.

Procedure

Have the children shine the light on each article, while they judge if the light is: (a) coming through unchanged, (b) coming through but scattered, or (c) not coming through at all.

Results

Children will be able to classify the objects in three categories; transparent, translucent, and opaque.

Conclusions

Light rays will pass through some substances, but not through others.

2. Problem

Do transparent things absorb the heat from light rays?

Materials

Sheet of black paper.

Procedure

Place the black paper near a window on which the sun is shining. Have the children feel the paper and the window and repeat in fifteen (15) minutes. What difference is noted?

Results

The black paper will feel warm, while the glass of the window through which the sun is shining remains cool.

Conclusions

Light rays warm up only those things that absorb them. Transparent objects are not warmed, for most of the light rays pass right through them.

3. Collect and Preserve

Have the children make a collection or display of materials that are transparent, translucent, and opaque. Label each type to show why they are so classified.

CONCEPT - Light can be reflected in various ways from various types of surfaces; some scatter the light while others do not.

1. Problem

What kinds of things reflect the most light.

Materials

Flashlight, pieces of paper of various colors, flat objects with various types of surfaces (such as a sponge), a book, and a dish.

Procedure

Darken the classroom and place objects on a table by a wall. Have children test each article by shining the flashlight on it at a  $45^\circ$  angle so the light will reflect onto the wall. Have them notice the amount of light on the wall in each case.

Results

The white paper reflects the most light of the paper samples. Objects with smooth surfaces reflect light better than those with rough surfaces.

Conclusions

Smooth, light-colored things reflect more light than rough, dark ones. Rough surfaces scatter light.

3. Problem

How is light reflected from a mirror?

Materials

Mirror ( at least 6" x 6"), string, tape.

Procedure

Mount the mirror on the wall and ask one student to name an object he sees in the mirror. Stretch a string from that person's position to the image on the mirror and from the mirror to the object he sees. Tape the string on the mirror and have the class examine the angles at which the string comes to and goes away from the mirror. If the class is acquainted with the use of protractors, have the angles measured.

Results

The angles are equal.

Conclusions

Light travels in straight lines. Light is reflected from a mirror in exactly the same angle in which it comes to the mirror.



### 3. Problem

Can light be reflected more than once?

#### Materials

Several mirrors, filmstrip projector.

#### Procedure

Pass out the mirrors to several children. Have the first child to catch the beam of light with a mirror and reflect it to the second child, who will reflect it to the third child and so on.

#### Results

The beam of light is reflected more than once.

#### Conclusions

Light may be reflected over and over again, until it is finally absorbed.

### 4. Charts

Ask children to observe their surroundings and construct a chart listing things as good reflectors and poor reflectors of light.

### 5. Observe

Give each child a polished teaspoon. Let them experiment with the concave and convex surfaces to observe the reflection of light rays.

In order to see around a corner, have one of the pupils hold the mirror at eye level near the classroom door and show the pupil how to adjust the mirror to be able to see something around the corner. Explain that light comes from the object to the mirror and then to the eye. In the upper grades you might discuss the idea of the angle of incidence equaling the angle of reflection.

Ask children to observe how drivers see traffic behind the car. Have them experiment with holding mirrors at eye level and then moving them to one side to see what is behind them.

### 6. Resource Person

Ask a dealer in glass goods to inform the children how different types of mirrors are made.

### 7. Research

Perhaps some children have had experiences in amusement parks or other places with distortion mirrors. If so, ask them to describe their experiences to the class and do research to find the cause of the distortion.

8. Demonstration                      Showing Multiple Reflections

- a. Stick a pin into a pad of paper. Fasten two pocket mirrors together with transparent tape and stand them so the pin is near the place where they are joined. Now move the outer edges of the mirrors slowly forward. Children should notice that there is more than one reflection of the pin; these are actually reflections reflections.

Showing Regular and Diffuse Reflections

- b. Ask a child to stand about six feet from you. Have a piece of paper on the floor midway between the two of you. Try to throw two rubber balls so that they move parallel to each other, hit the paper and bounce the ball to the child. This demonstrates regular reflection from a smooth surface. Replace the paper with a pile of pencils, erasers and other items. Throw the balls in the same way as before. This shows diffuse reflection; the way light is scattered when reflected from a rough surface.

9. Drama

Ask a group of children to pretend that they are beams of light and write about their travels. They should include encounters with transparent, translucent, and opaque objects, reflections and refractions, etc. Help them to work their ideas into a short skit.

10. Demonstration

In a darkened room, shine a flashlight on a piece of smooth metal and on a piece of steel wool. Have children observe that while both objects are metal, only the shiny metal reflects light to any great degree. Roughen the surface of the smooth metal with the steel wool and have children observe that it now reflects less than before.

Measure the candlepower of the classroom with a photometer. Explain to the children how the photometer works and how the needle moves in bright light. Measure the candlepower of various objects in the room and discuss which ones reflect the most light.

11. Make Models

Children may make a kaleidoscope to show the reflection of light. Fasten three small mirrors together with adhesive tape to form a triangle. Put bits of colored paper on a piece of window glass. Place the glass on top of the mirrors. Interesting six-sided figures can be seen, which will change their shape and color combination when the glass is tapped.

### Evaluation

Included here are samples of evaluation items which could be used in developing your own informal testing program. These suggested types of items cover the particular science area that has been developed in this section of the handbook. This also means that they could be used to help develop informal testing to cover large areas of information (monthly, mid-year, end of year testing). These are by no means complete tests as such. You will have to adapt and develop items to meet your particular class's own individual needs and differences.

Underline the correct answer in each of the following sentences:

1. If light can pass through a substance and we can also see through it, we say that the substance is  
a. translucent      b. opaque      c. transparent      d. clear
2. A substance that does not permit light to pass through it is called  
a. translucent      b. opaque      c. transparent      d. none
3. The color having the highest frequency is  
a. red      b. green      c. yellow      d. blue
4. The bending of light as it passes from one substance into another is called  
a. refraction      b. reflection      c. re-entry      d. redirection
5. Warm objects give off  
a. infrared light      b. ultraviolet light      c. blue light  
d. red light

Write the number of the word group in Column A in the space before the item in Column B that it best matches:

<u>Column A</u>	<u>Column B</u>
1. Wave theory	<u>(3)</u> a. Newton
2. Amplitude of light	<u>(5)</u> b. Mercury vapor
3. Particle theory	c. Archimedes
4. Usually travels in a straight line	<u>(4)</u> d. Light
5. Fluorescent lamp	<u>(1)</u> e. Huygens
	f. Spectrum
	<u>(2)</u> g. Exposure meter

Complete the following sentences:

1. The material through which a wave passes is called the (medium).
2. The colors into which sunlight can be separated make up a (solar spectrum).
3. When something burns, chemical energy is transferred into (heat)  
(light) energy.
4. When light waves differ in frequency, we see different (colors).
5. In a light bulb, electrical energy is transferred into (light)  
(heat) energy.

Write a brief but complete answer to each of the following:

1. In what ways are light waves similar to sound waves? How do they differ?

(They are similar in that both kinds of waves have amplitude, frequency, and speed. They differ in that sound waves require a medium to conduct them; light waves apparently do not need a medium. Light travels much faster than sound.)

2. What are some proofs that sunlight is composed of the spectrum colors?

(By means of a prism [or a drop of water] sunlight can be separated into the spectrum colors. Also, the separated spectrum colors can be re-combined to produce sunlight [white light]).

A list of terms is given below. Select the term from the list that goes with each statement. Write the term in the space before the statement.

Infrared      Ultraviolet      Green      White      Red      Violet      Yellow

1. (Violet) high frequency, visible.
2. (Infrared) low frequency, invisible.
3. (White) a mixture of all visible frequencies.
4. (Red) low frequency, visible.
5. (Ultraviolet) high frequency, invisible.

### Vocabulary

One of the strongest keystones of scientific efficiency lies in its vocabulary. The scientist says things precisely, accurately, and briefly. Probably one of the greatest quarrels the science teacher may have with the elementary level teaching is vocabulary. The science teacher can have no use for vocabulary that is not precise and accurate. Precision in vocabulary is necessary for understanding and meaning of the concept or process being learned.

The words listed below are the basic vocabulary for the indicated area of study. After each word has been introduced, its meaning is to be maintained and extended at each succeeding level of study.

amplitude  
concave lens  
convex lens  
direct relationship  
exposure meter  
focal length  
focus  
frequency  
image  
image distance  
infrared  
inverse relationship  
inverted  
light energy  
medium  
object distance  
objective lens  
ocular  
opaque  
optical  
prism  
projector  
radio telescope  
raw data  
reflecting telescope  
reflection  
refract  
refracting telescope  
spectrum  
translucent  
transparent  
ultraviolet

## Children's Books

Books are a very essential part of the instructional materials in elementary schools which provide superior learning experiences for children. The selection of these books poses a difficult problem for librarians, teachers, and administrators because the science field is broad and increasing in scope, and elementary school science programs are varied in nature. Some of the more common specific difficulties in choosing books are (1) finding materials which deal with the varied interests children; (2) locating material which gives information correlated with the local school district's instructional guides; (3) finding books of appropriate reading difficulty; and (4) selecting the best books from the many available.

The following list gives help related to the first three difficulties presented. Indirectly, it also helps with the fourth difficulty, for the best books cannot be selected until they are located. Further, the brief annotations should be of help in determining which books may be best for a given class. Finally, time should be saved in the selection of a "best" list if some information about the reading difficulty of available books is provided. It is hoped that this list will suggest for elementary teachers books that are supplementary to basic text series, and that these books will have value either as sources of information or for recreational reading.

It is always hazardous to specify an exact grade placement for a book because of variations in pupil-reading ability in any class group, and because of different uses made of books. Consequently, the lowest grade levels for pupil-use are indicated. At lower levels these same books may be useful if the teacher reads to the children.

This list has been adapted from the publication, Children's Catalog (1966).

- Adler, Irving Shadows, by Irving and Ruth Adler. Day 1961 48p illus (The Reason why ser) \$2.39 (3-5) "Some of the aspects discussed are shadows of the earth and of the moon...sundials, and some of the uses of shadows in measuring distance. Also described are uses in photography and X-ray procedures, playing with shadows (finger pictures and shadow plays); and the effect of shade on plants and animals."
- Beeler, Nelson F. Experiment in Optical Illusion (by) Nelson F. Beeler and Franklyn M. Branley illus. by Fred H. Lyon. Crowell 1951 114p illus \$3.50 (5-7)  
"Numerous diagrams and drawing here prove that seeing is not always believing. The authors explain 'why' our eyes deceive us and show how optical illusions and psychological patterns in sight play a part in everyday experience. Includes plans for home projects."
- Bulla, Clyde Robert What Makes A Shadow? illus. by Adrienne Adams. Crowell 1962 (Let's-read-and-find-out bks) \$2.95 (K-2) "The young reader learns how shadows are made by different objects, how their size and darkness may be changed, and how shadow pictures, may be projected onto a wall. More interest appeal than scientific content."
- Feravolo, Rocco V. Junior Science Book of Light; illus. by George Wilde. Garrard 1961 62p illus (Junior science bks) \$1.98 (2-4) "Basic information on light--how it travels, how it is reflected, how shadows are made, how light rays are bent. A few basic experiments are included which aid in understanding the camera, submarine periscope, the changing of shadows on a summer day, and moonlight."

- Harrison, George Russell The First Book of Light; illus. with photographs and diagrams; diagrams by Robert Winsor. Watts. F. 1962 85p illus \$2.65 (5-7) The author "discusses the importance of light, its sources and manifestations, photosynthesis, energy, human sight, instruments for measuring, magnifying, and recording light, and many phenomena such as mirages, the aurora borealis, the moiré effect et cetera"
- Healey, Frederick Light and Color; illus. by Patricia Hamilton. Day 1962 48p illus (Finding out about science) \$2.50 (3-5) "The basic physical properties of light are revealed in this discussion of visible light. Helpful experiments and instructive illustrations give insights into reflection, refraction, color blending, and other light phenomena. A greater appreciation of the sun as man's ultimate source of energy is gained."
- Kettelkamp, Larry Shadows; written and illus. by Larry Kettelkamp. Morrow 1957 63p illus \$2.94 (3-6) The book "deals with shadows, from the viewpoints of both amusement and usefulness. Suggestions are given for shadow animals made with the hands, cardboard figures for Chinese shadow plays, a shadow stage, and human shadow plays. The second half of the book discusses, and illustrates with experiments, their uses to science, such as in measuring time, in astronomy, X ray, and aerial photography."
- Meyer, Jerome S. Prism and Lenses; illus. by John Polgreen. World Pub. 1959 63p illus \$2.75 (5-7) The author "explains the principles of light as well as the practical applications of prisms and lenses. Using examples the reader can test and observe for himself, he demonstrates refraction and dispersion of light. Beginning with the historical theories of light, he traces the changing concept of just what light is."
- Paschel, Herbert P. The First Book of Color; drawings by Caru Studios. Watts, F. 1959 45p illus \$1.95 (5-7) This book "explains the nature of light and tells why we see things in color. Uses of color in printing, and the sign and signal 'language' of color are other phases discussed. Instructions are given for many easy-to-do experiments with color."
- Pine, Tillie S. Light All Around, by Tillie S. Pine and Joseph Levine; illus. by Bernice Myers. McGraw 1961 46p illus (Whittlesey House Publications) \$2.50 (2-4) "Nighttime and daytime light is all around, and the authors show where it can be found and how it can be used. Moonlight, sunlight, and electric light are discussed. Reflected light is explained, and there are instructions for many easy experiments."
- Munch, Theodore W. What is Light; pictures (by) Gregory Orloff. Benefic Press 1960 47p illus (What is it ser) \$1.80 (2-4) "This book defines light, and its sources and tells how light rays act and are bent. It tells about lenses, the eye, color and light energy."



## Films

These films are available from the Central Audio-Visual Department. Contact your building A-V Coordinator to arrange for the use of these films.

All films should be previewed to determine suitability for use with your particular class.

How to Bend Light 11 min. Col. Gds. 5 & 6

This film shows that light travels in straight lines and that light can be bent; it can be reflected from objects. Light that is bent continues to travel in straight lines after it is bent. Light bends when it passes from one material to another - for example, from air to glass. Prisms can bend light in this way. Lenses can bend light to magnify objects or to focus images.

Light and Color 14 min. Col. Gds. 5 & 6

The film shows that light and color are related. White light is made up of many different colors of light. Objects appear bright if they reflect a lot of light to our eyes. White objects reflect a lot of light. Dark objects absorb a lot of light. Color depends on the ability of an object to absorb certain colors and reflect other colors back to our eyes. Color also depends on the kind of light that is illuminating the objects we look at. Each element, when heated, displays a characteristic set of colors. Scientists use these sets of colors as "fingerprints" to identify elements.

Light and Dark 6 min. Col. Pri., Int.

This film is one of the Art in Action Series. Striking camera studies in light, shadow and gradations of color illustrate the meaning of values in art. Children are encouraged to find out, by experimentation with lights and dark objects, what value is, what it does, and how it makes them feel.

Light and Its Story 13½ min. Col. Gds. 3 & 4

Simple, graphic demonstrations, dramatically supplied by a science professor to a scientifically curious boy, explain the sources, characteristics and usefulness of light. Through the use of live photography and animation your pupils learn how the sun, directly and indirectly, provides practically all of the earth's light. It also describes man's development of new sources of light and new methods of controlling and utilizing the natural sources.

Prove It with a Magnifying Glass 11 min. Col. Pri., Int.

This film is designed as an introduction to the scientific method. It was made for the young child. It uses a child's first science experiences with a simple instrument (magnifying glass) to illustrate the concept: prove it yourself.

Science of Light 11 min. Col. Pri., Int.

This film explains the basic principles of light and sight, and demonstrates them through experiments. It explores how we see, speed of light, absorption, reflection, and refraction.



PART III - HEAT

Initiatory Activities..... 95

Developmental Activities..... 95

    Concept

        Fuels must be heated to the kindling temperature before they will burn... 95

        Temperature changes are involved in evaporation, condensation, melting,  
        and freezing..... 97

        Heat energy may be transferred by conduction, radiation, or convection... 99

        Different materials absorb heat at different rates.....102

        A thermometer measures the coldness or hotness of a substance.....104

        Fires give off heat and light and need oxygen to burn.....106

        Heat is a form of energy that can be obtained in many different ways....111

        Clothing keeps us warm because it prevents the body from losing heat too  
        rapidly.....114

        Cooling is the removal of heat.....116

        Almost all substances expand when heated and contract when cooled.....117

        Different materials vary in their ability to conduct heat; materials that  
        conduct heat slowly are called insulators.....121

        Heat is the energy of moving molecules; as a substance gets warmer, its  
        molecules move more rapidly; as it cools less rapidly.....122

        A change of state may result from the addition or removal of heat from  
        substance..... 123

        The temperature (heat intensity) of a body is measured in degrees.....126

Evaluation (Sample Items).....129

Vocabulary.....131

Children's Books.....133

Films.....135

## HEAT

### Initiatory Activities

Have the children:

1. Display books about heat or fire on the science table. Encourage the children to examine and read them during appropriate times.
2. Prepare a bulletin board display of pictures showing various sources of heat utilized by man.
3. Display a variety of types of thermometers on the science table.
4. Prepare a bulletin board illustrating the destructiveness of fire.
5. Follow the natural leads provided by a previous science or social studies unit in which concepts related to heat were developed.

### Developmental Activities

CONCEPT - Fuels must be heated to the kindling temperature before they will burn.

#### Problem

Before an object will burn, what is needed?

#### Materials

Candle, spoon, cloth.

#### Procedure

Strike a match and hold the match close to the wick. Have the children observe the wick closely and see that the candle does not burn until the wax on the wick melts. The wax had to be heated before it would burn. After the candle has burned for a time, blow out the flame and place a lighted match in the smoke.

#### Results

Observe that the candle will light again even though the match is not near the wick.

#### Conclusion

An object must be heated before it will burn. The white condensed wax will burn if it is heated.

### Problem

What is spontaneous combustion?

### Materials

2 lb. coffee can.  
Small can (top lid removed).  
Thermometer.  
Cotton rags.  
Linseed oil.  
Newspaper.

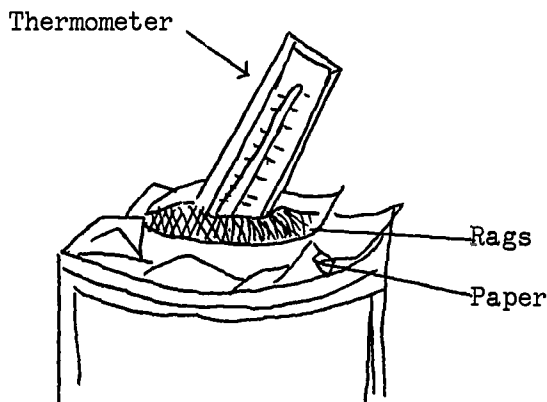

### Procedure

Guide children in conducting this experiment by following these steps:

- Soak rags in linseed oil.
- Stuff small can about  $\frac{3}{4}$  full of soaked rags and insert the thermometer. Fill the rest of the can with rags.
- Crumble newspaper into the bottom of the large can, and then place the small can in the center of the large one.
- Continue putting newspaper around the small can until it is completely insulated on side and bottom.
- Put newspaper around the top of the can, but allow the top of the thermometer to be seen.
- Write down the thermometer's reading at the beginning of the experiment and observe the change of temperature during the day.

### Results

There will be a steady rise in temperature during the day.

### Conclusions

The chemical reaction of the oil with the air causes heat. This heat, because of the insulation, is unable to escape rapidly and raises the temperature of the materials; this hastens the chemical reaction and in turn produces more heat. This entire reaction starts slow but speeds up as time passes, until the kindling point (temperature) is reached. Then materials will burst into flames. (Caution: If this is left for any length of time, it must be in a place where damage will not result if it bursts into flames.)

### Research

Some children may do research on the subject of the common match. They can report to the class when and how it was invented, what it is composed of and how it works.

#### 4. Demonstration

Show children the relationship between friction and heat by demonstrating and discussing the lighting of a "kitchen" match. First, rub the head very slowly across a striking surface and lead children to see that there must be a certain minimum of friction attained before combustion takes place. Also, compare striking a match on glass and on sandpaper with various speeds.

#### 5. Charts, Maps, or Graphs

Chart ideas: Make a list of engines that require heat to operate. Collect pictures of heat engines.

CONCEPT - Temperature changes are involved in evaporation, condensation, melting, and freezing.

#### 1. Problem

How can evaporation affect temperature?

#### Materials

Two (2) beakers or drinking glasses, alcohol, water.

#### Procedure

Pour equal amounts of water and alcohol into the two beakers. Mark the level of the liquids and allow it to stand overnight. What do the children notice by comparison the next morning? Have the children place a few drops of alcohol on one hand and a few drops of water on the other hand. Ask if there is a difference in how each hand feels. Ask the children if they think there is any relationship between this experiment and the reason we perspire on hot days.

#### Results

Alcohol will evaporate much faster than water. The hand with alcohol on it will feel cooler than the other hand because it evaporates faster.

#### Conclusions

As a liquid evaporates, heat is taken from the body. This cooling effect of evaporation is the reason for perspiration on hot days; it is our bodies' way of cooling itself. The faster liquids evaporate, the more they cool things.

## 2. Problem

Does wind affect the speed of evaporation?

### Materials

Fan, water.

### Procedure

Have a few children wet their hands and hold one hand in front of a fan, while the other hand remains still and away from the breeze. Ask them to report their reactions to the class.

### Results

The wet hand in the path of the moving air becomes cooler than the other hand and dries rapidly. The other hand remains moist for a much longer period of time.

### Conclusions

Moving air produces faster evaporation than still air. (This is why clothes dry out on the line faster on a windy day than on a calm day.) The faster a liquid evaporates, the more it will cool things.

## 3. Charts, Maps, or Graphs

Help children construct a chart of the water cycle. Discuss how heat may be involved in the changes shown.

## 4. Observe

Perhaps some children may have observed the accumulation of moisture on the inside of windows on a cold day, or on basement walls on a warm day. Lead a discussion to find out the children's ideas as to the reason for this. Some children may then do research on condensation and report to the class, while others make a list of other examples of condensation they have noticed.

CONCEPT - Heat energy may be transferred by conduction, radiation, or convection.

1. Problem

Why does heated air rise?

Materials

Candles, convection box, matches, tapers.

Procedure

Place the candles on the convection box and light the candles. Place a smoking taper over one of the candles. Have the children observe the smoke as it rises and falls.

Results

The air around the candle expands as it is heated. This air weighs less than cool air.

Conclusion

The heated air around the candle is actually being pushed up. This gives us convection air currents.

2. Problem

Is warm water lighter than cold water?

Materials

Aquarium, or battery jar, small bottle, rubber stopper, cork, beaker, hot plate, water.

Procedure

Fill the aquarium with water. Place some ink, diluted with water, in the beaker and heat. The small bottle is now filled with warm diluted ink and the stopper is placed in the bottle. This is then inverted into the aquarium or battery jar of cold water. Have the children observe the action of the warm diluted ink water.

Results

Warm water is lighter than cold water. Warm water rises because it is pushed by the cold water. The concept is used in the hot water heating system.

Conclusion

This shows the principle of heat transfer by convection.

### 3. Problem

Is warm air lighter than cooled air?

#### Materials

Large box, Saran Wrap (large enough to cover the front of the box), tape, light socket with cord, bulb for socket, joss stick, sand.

#### Procedure

Cut a hole in the side of the box. Place the lamp socket with the bulb inverted in the box and push sand through the opening on the side of the box. Cover the front of the box with Saran wrap and plug in the cord. After the lamp has been on a few minutes, light the joss stick so it will smoke. Place the smoking joss stick at the bottom of the box. Have the children observe that smoke rises and falls in the box.

#### Results

The smoke is carried up by the warm air, and when it cools, it falls again to the bottom of the box.

#### Conclusions

Warm air is lighter than cooler air. The relationship here can be made to a hot air furnace. The principle of convection is shown here; the principle of heat refers to moving heat by currents of air or water.

### 4. Problem

Can heat be transferred by light rays?

#### Materials

Piece of clean glass pane, black piece of cloth, electric light, bulb, socket.

#### Procedure

On a sunny day place a piece of clean glass in a window, it may be held up by books. Hang the black cloth so that it is a few inches behind the glass; after a few minutes, have the children feel the black cloth and also the glass. Now connect the plug for the electric light and have a child hold his hands beneath the bulb. Unplug the light and have the child observe that the cloth is heated but not the glass pane, also, the light gives off heat but the heat stops as soon as the light is out.

#### Results

Heat can be transferred by rays (infrared rays). These rays (part of light) will go through plate glass but when they are absorbed will cause heat.

### Conclusion

Application of this is radiant heat coming from a hot water radiator. However, very little of the air in a room is heated by direct radiation. These rays first heat the substance that will absorb them and then by conduction and convection the air is heated.

### 5. Problem

How does heat travel in solids?

#### Materials

Metal rod, clamp and stand, beeswax or candle wax, gas or alcohol burner.

#### Procedure

Ask children to set up the experiment by following these steps:

- a. Use a metal rod about the diameter of a pencil and from 6 to 12 inches long.
- b. Support the rod in the position shown in diagram.
- c. Make several balls of beeswax or candle wax about the size of marbles and stick to the rod on the underneath side at equal intervals.
- d. Apply a flame to the unsupported end of the rod.
- e. Lead children to discuss their ideas on why the results occurred as they did.

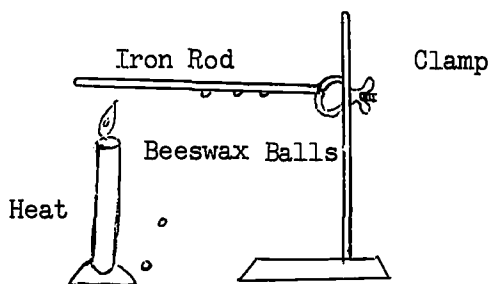

#### Results

As the heat is conducted along the rod, the beeswax or candle wax melts and drop off. Time of drops will become greater as the wax balls become farther away from the source of heat.

#### Conclusions

This is an illustration of heat transfer by both conduction and radiation. Heat is conducted more rapidly near the flame but more slowly as it is carried farther and farther away, because of heat loss due to radiation. If a rod is long enough a point will be reached where no balls will fall off because the heat of radiation is faster than the heat of conduction. If the melting point of the wax is known, it is possible to calculate the speed of conduction from point to point.



6. Problem

Does heat travel at the same speed in all solids?

Materials

Rods of glass and of metal, clamp and stand, beeswax or candle wax, gas or alcohol burner.

Procedure

Repeat the preceding experiment using the different types of rods. With a stop watch, or a wrist watch, time and record the results for comparison.

Results

The wax balls fall from the metal rod more quickly than from the glass rod.

Conclusions

Heat travels at different speeds in different solids. Metal is a better conductor of heat than glass is.

7. Demonstration

Fill a glass with hot water. Ask children to feel a metal spoon before placing it in the glass and again after it has been in the glass for a while. What do they notice? Is the portion of the spoon protruding from the water warmer than it was before? Through discussion, lead children to the understanding that this is an example of heat transfer by conduction.

8. Observe

Have children observe the heating systems of their homes. They can list examples they find of conduction, convection, and radiation of heat.

CONCEPT - Different materials absorb heat at different rates.

1. Problem

Do land and water heat and cool at the same rate?

Materials

Two (2) thermometers, a cup of sand, and a cup of water.

Procedure

Ask a pupil to place one thermometer in the cup of sand and another in the cup of water. Leave both cups in the sun for some time. Read the temperatures.

Do the temperatures differ? How? Why?

Place warmed cups in a cool place for an hour. Read the thermometers. Do the temperatures differ? How? Why?

### Results

The thermometer in the sand shows higher temperature and then a lower temperature than the thermometer in the water.

### Conclusions

Different materials absorb heat at different rates. Land heats and cools faster than water.

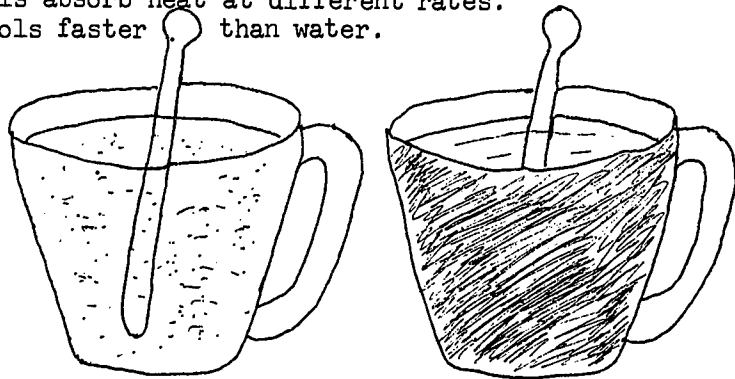

## 2. Problem

Do all materials heat at the same speed?

### Materials

Two (2) small fruit jars, black paint, thermometer, and water.

### Procedure

Paint one jar black. Fill both jars with water, being sure both jars have the same temperature. Set jars in the sunlight. After half an hour, take the temperature of the water in each jar. In which jar is the water warmer? Why didn't the water in the clear jar heat as fast as the water in the dark jar? Do all materials heat at the same speed? Would air above all surfaces heat as the same speed?

### Results

Sun's rays passed through or were reflected by the transparent materials of the jar and water. Sun's rays were absorbed by the darker surface and heat stored in the water.

### Conclusions

Different materials absorb and store heat at different rates. Dark colored materials absorb more heat than transparent or light colored materials.

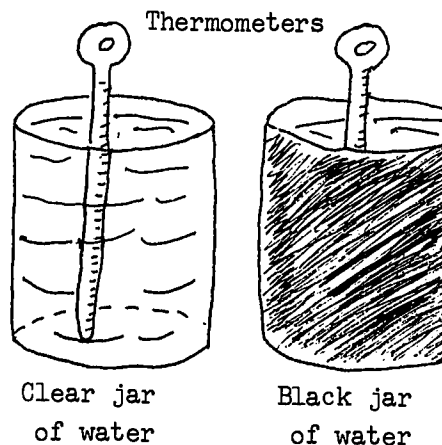

CONCEPT - A thermometer measures the coldness or hotness of a substance.

1. Problem

What does a thermometer do?

Materials

A large thermometer, several small ones, alcohol.

Procedure

Pass out the several small thermometers to the class - one to groups of four or five children. Select a chairman for each group. Take the thermometer to different parts of the building and outdoors. Have the chairman record the different readings at the different places visited.

Results

The thermometer measures the intensity of heat in an object, NOT the amount of heat in an object.

Conclusions

The thermometer measures how hot something is and not the amount of heat in the object. A small kettle of boiling water will have a temperature of 212° F and a water tank of boiling water will also have the same temperature.

2. Problem

How can we make a thermometer?

Materials

Glass tubing, one hole stopper for bottle, red ink, straw, clay.

Procedure

Fill the bottle with red ink and place the straw in the bottle. Stopper the mouth of the bottle with clay placed around the straw. Another way of doing this demonstration is by placing the glass tube in the rubber stopper and fitting the stopper in the bottle mouth.

### Results

The liquid goes up the glass tube or straw when the temperature rises and goes down into the bottle when it becomes cooler.

### Conclusion

The liquid in the thermometer expands when heated and contracts when cooled.

### 3. Problem

What is the temperature of freezing water and boiling water?

### Materials

Ice, water, beaker, hot plate.

### Procedure

Place the ice in the water and take the temperature of the ice water. Boil the water in the beaker, and take the temperature of it.

### Result

Temperature of freezing water is 32° F, and 212° F is the temperature of boiling water.

CONCEPT - Fires give off heat and light and need oxygen to burn.

1. Problem

How can we show that oxygen is important to fire?

Materials

Three (3) candles, three (3) jars of different sizes (pint, quart, gallon), matches.

Procedure

Have candles placed so that the jars may be placed over them. Light the candles and cover each with a jar. Ask the children to observe what happens to the flames. Does this happen to all three candles at the same time?

Results

When the jars are placed over the candles, the flames become weaker and finally go out. The larger the jar, the more time it will take for the flame to be extinguished.

Conclusions

Fires need the oxygen present in the air in order to burn. You can put out a fire by depleting its supply of oxygen.

2. Problem

Does carbon dioxide support combustion?

Materials

Two (2) jars, small "birthday" candles, wire, vinegar, baking soda.

Procedure

Ask children to place one spoonful of baking soda in one jar and a few spoonfuls of vinegar in the other jar. Fasten a small candle to an end of the wire and light it. Lower this candle into both jars, showing that the fire is not extinguished. Have a child pour the vinegar into the jar containing the baking soda and let the class observe the reaction. Lower the lighted candle into this jar. What happens to the flame and why?

Results

The candle flame will go out when lowered into the jar containing the mixture of baking soda and vinegar.

Conclusions

Fire cannot burn without sufficient oxygen. The acid in the vinegar causes the sodium bicarbonate to give off carbon dioxide gas. Carbon dioxide is

effective as a fire extinguisher because it is heavier than air and settles around the flame, shutting off the oxygen supply.

### 3. Problem

Does carbon dioxide support combustion?

#### Materials

Piece of dry ice, paper bag, prongs for handling dry ice, candle, matches.

#### Procedure

Place the dry ice in a paper bag and keep the bag closed for several minutes. Light the candle. Open the paper bag and slowly pour the vapor from the bag over the candle.

#### Results

The vapor will extinguish the candle flame.

#### Conclusions

A candle will not burn if its supply of oxygen is cut off. Dry ice is solid carbon dioxide. When the paper bag was allowed to stand, some of this solid vaporized, filling the paper bag with some carbon dioxide. Carbon dioxide is a colorless, odorless and tasteless gas. It is heavier than air, and therefore it can be poured onto a flame. Carbon dioxide does not support burning. It is used in fire extinguishers for this reason.



### 4. Problem

What causes a candle to burn?

#### Materials

Candle, matches.

#### Procedure

Light the candle, let it burn and then snuff it out. Immediately after snuffing out the candle, hold a lighted match about an inch or less

over the extinguished candle. Discuss with the children the observed results.

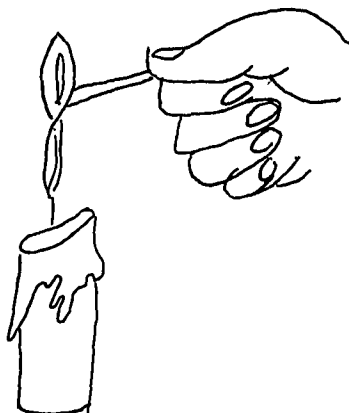

### Results

After holding the lighted match an inch or less above the extinguished candle, immediately after it has been put out, the candle will again become lighted.

### Conclusions

There is still a supply of inflammable gas immediately after you snuff a candle, either by blowing it out or pinching it with your fingers. The heated candle material is burnable regardless of whether or not the candle itself happens to be lighted. This is proved when the candle again becomes ignited. Actually it is the gaseous material that burns, not the solid candle. The flame (heat) changes the solid candle to a gas.

### 5. Problem

What is smoke?

### Materials

Candle, metal spoon.

### Procedure

Light a candle and ask children to observe it closely as it burns. Hold the metal spoon in the flame for a few seconds. What do the children notice about the spoon?

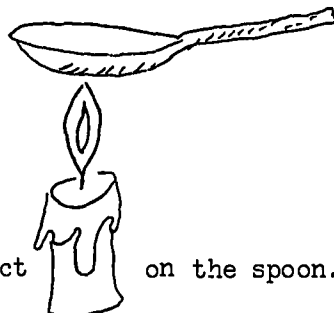

### Results

A black material (carbon) will collect on the spoon.

## Conclusions

Smoke is actually small solid particles of unburned carbon. The main part of the flame is bright yellow, and is due to actual particles of black carbon or soot which become nearly white in the flame before they finally burn. The black material which collects on the spoon is carbon which was removed from the flame before it had a chance to burn.

### 6. Research

Research may be done on the history of fire, from its early uses to its present uses. This may be done by committees set up according to certain periods of time, the stone age, medieval times, the industrial revolution, or according to the use of fire in preparation of food, to do man's work, etc.

### 7. Demonstration

Show that fire gives off heat which diminishes with the distance from the fire by hanging a thermometer one inch, two inches and four inches from the flame of an alcohol burner. Show also that the light given off is also proportionate to the distance by taking readings from a light meter at various distances from the flame.

### 8. Draw

Children may draw, in color, a diagram of the parts of a flame, similar to the one shown here. The different temperatures in the different areas of the flame should be noted.

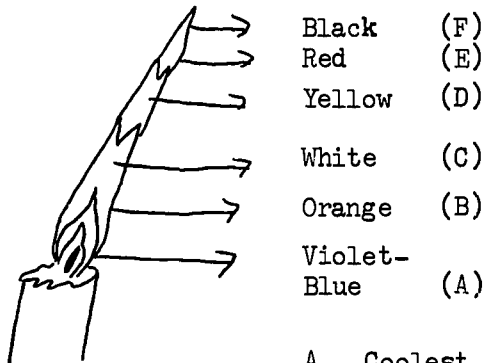

- A. Coolest part of the flame, at the wick.
- B. Ignition commences.
- C. Hottest area; white heat.
- D. Flame cooling.
- E. Very little heat.
- F. Sooty particles of unburnt carbon carried up by convection currents

After doing research on how early civilizations were dependent upon fire as a source of heat and light, let children draw pictures showing these uses of fire such as torches, campfires, oil lamps, etc.



9. Field Trips

Take a trip to a local fire station to see the equipment used to fight destructive fires and how the fire alarm system works.

10. Drama

Ask a committee of pupils to write a short skit showing the discovery of fire by prehistoric man and how he used it. Another committee might dramatize how life would be today if people had never learned to use heat.

11. Resource Person

A local fireman might be very helpful in informing the children on how to prevent fires and what to do if a fire occurs. A demonstration of the different types of fire extinguishers and their use might also be possible.

12. Bulletin Boards                    FIRE: Helpful and Harmful

Display pictures, either drawn by the students or collected from old magazines, of fire as used in helpful ways (furnaces, stoves, campfires, etc.) and compare with pictures showing the harm fire can cause (home fires, forest fires, etc.)

13. Make Models                    -                    Making a Model of a Fire Extinguisher

Push a short glass tube with a jet tip into a one-hole-rubber stopper. Wrap bicarbonate of soda in a sheet of toilet tissue. Attach soda package to the tube with a rubber band. Fill the bottle half full of a mixture of one (1) part vinegar and one (1) part water. Put in the stopper. Hold stopper firmly in place and turn bottle upside down. The carbon dioxide formed drives water out in a powerful jet.

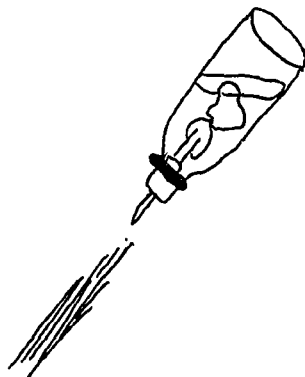

CONCEPT - Heat is a form of energy that can be obtained in many different ways.

1. Problem

How can we show that heat energy can be obtained from light energy?

Materials

Small pieces of black cloth and white cloth (same type of material).

Procedure

On a sunny day, when there is snow or ice on the ground, place both cloths on the surface of the ice or snow. After a few hours, have the children check to see under which cloth there has been the most melting.

Results

The snow or ice will melt faster under the black cloth.

Conclusions

Light energy may be changed to heat energy. Dark objects absorb more light energy and heat energy than light objects.

2. Problem

How can we show heat produced by friction?

Materials

A bow - any curved stick - with a bow-string of rope or hide.

A fire drill of cedar or hardwood.

Pivot for fire drill, made of bone, horn, or rock.

Drill a socket in it for fire drill to fit into it.

Fireboard or soft wood with a socket notched to edge of board.

Tinder - shredded bark.

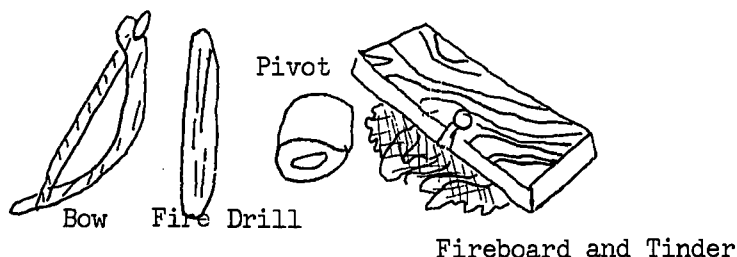

Procedure

Place tinder under notch in fireboard. Put your left foot on the fireboard to hold it steady and kneel on your right knee. Loop loose bow-string around fire drill with the bow on your right-hand side and drill

point down. Your bowstring should be taut when the drill is looped on it. Hold the drill in place in the string. Place pivot over head of fire drill and hold down with left hand. Put end of drill in the socket of fireboard and push bow straight out and back twirling the drill rapidly. The pressure of the pivot on the drill cannot be too heavy or too light. Within 30 seconds, the board will begin to smoke. Watch closely to make sure that a hot powder is drifting through the notch onto the tinder. When you think there is sufficient powder smoking, lift tinder quickly, cupping your hands around it and blow gently until flame appears.

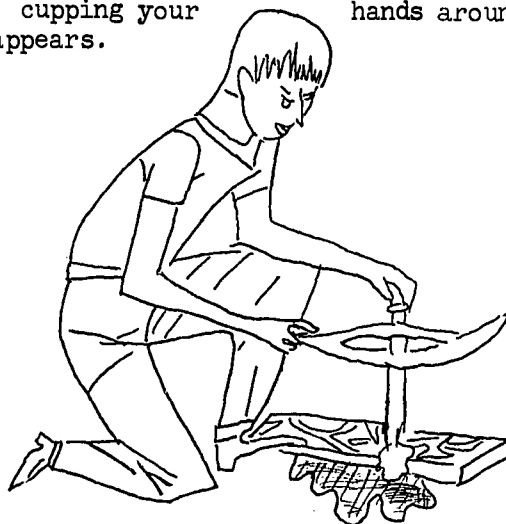

### Results

Friction produces enough heat to produce a fire.

### Conclusions

It is possible to create fire by raising wood to its burning point through friction. (Boy Scouts are taught this method of fire preparation. Most American Indians used this method of starting fires.)

### 3. Problem

How can we show heat produced by an electric current?

### Materials

One (1) "hot dog," two (2) large nails, block of wood (1" x 4" x 10"), two small pieces of wood, electric cord.\*

### Procedure

Nail the two small pieces of wood to the large block, so that the bottom of the block will not rest on the table. Drive the nails through the block (about three (3) inches apart), leaving about  $\frac{1}{4}$  of the head of each nail

Safety Note\* Be sure the electric cord is well insulated and that it is not plugged into the outlet before the wires are attached to the nails.

at the bottom of the block. Wire the ends of the electric cord around the heads of the nails and drive nails into the block to hold the wires securely. Impale the "hot dog" on the nails. Plug the end into an electric outlet. Ask children to observe the results and hypothesize as to the reason behind it.

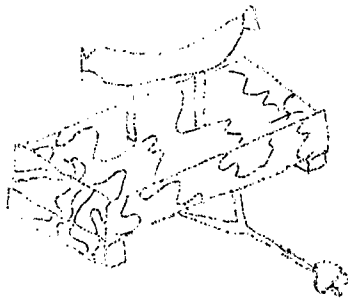

#### Results

The "hot dog" acts as a conductor of electricity. It becomes hot and finally is cooked.

#### Conclusions

Electric energy may be converted into heat energy. The "hot dog" is a conductor of electricity. Some conductors produce heat.

#### 4. Research

Ask a group of children to report on how atomic energy is now being used to produce heat energy.

Have children find out what they can on the principle behind a solar oven. Ask them to list its advantages and disadvantages.

#### 5. Demonstration

Ask children to rub their hands together briskly. What do they notice? Ask them to rub a brass or a piece of metal briskly against a woolen cloth. Lead them to notice that the metal soon becomes warm and that the faster one rubs, the hotter the metal becomes. These are examples of heat being produced by friction.

#### 6. Field Trip

Take a trip through a steel mill, oil refinery, or other large factory to see how heating and cooking are used in the production of many things we use every day.

#### 7. Observe

Have children observe heat being produced when you attach both ends of a wire to the terminals of a dry cell battery. (Do not leave the wire connected too long, for heat may greatly shorten the life of the dry cell.)

## 8. Bulletin Boards

Ask children to gather pictures from old magazines showing various sources of heat energy to display on the bulletin board.

CONCEPT - Clothing keeps us warm because it prevents the body from losing heat too rapidly.

### 1. Problem

Why do we wear heavy clothing in winter time or when it is cold?

#### Materials

Two (2) pint bottles, hot water, thermometer, length of woolen or other heavy cloth.

#### Procedure

Wrap one bottle with the cloth and ask children to fill both bottles from a pitcher of hot water. They should take the temperature of the water so that it will not be forgotten. Cork each of the bottles and set them where they may cool. After about one-half hour, take the temperature of the water in each bottle. How do they compare with each other and with previous temperature?

#### Results

The bottle with the covering of woolen cloth will keep its water warmer for a longer time than the other bottle.

#### Conclusions

Since wool is a poor conductor of heat, not as much heat escaped from the covered bottle. We wear heavy clothing during cold weather so that the heat from our bodies will not escape so easily.

### 2. Problem

Why is light colored clothing better to wear during warm weather than dark colored clothing?

#### Materials

Two (2) test tubes, white paper, black paper, thermometer, beaker or drinking glass, rubber bands.

### Procedure

Ask children to take the temperature of a beaker of cold water and record it. Then have them wrap one test tube with white paper and one with black paper. Fill both with the cold water and place side by side in the sunshine. After about thirty minutes, take the temperature of the water in each of the test tubes. Are they the same temperature? Compare these temperatures to the first temperatures recorded?

### Results

While both test tubes of water will have absorbed heat from the sun, the black test tube will have absorbed more and will be warmer; and the white paper will reflect more of the heat than the black paper does; it will also be cooler.

### Conclusion

Light-colored clothing will reflect heat better than dark-colored clothing. We will be cooler in the summer time if we wear light-colored clothing.

### 3. Bulletin Boards

Compare, by collecting and displaying pictures from magazines, the clothing worn by an eskimo and a south sea islander. Lead a discussion to emphasize the idea that temperature has a great deal to do with the type (and amount) of clothes we wear.

CONCEPT - Cooling is the removal of heat.

1. Problem

Why do we keep many foods cool in the refrigerator?

Materials

Milk, lettuce, four small jars.

Procedure

Ask children to put lettuce in two jars and milk in the other two jars. (These are examples of foods that usually need refrigeration.) Cover the jars and place one jar of milk and one jar of lettuce in the school refrigerator. Leave the other jars in the classroom where they are handy for observation. Compare all the jars once a day for one week.

Results

The milk and the lettuce at room temperature soon begin to spoil. (This process is caused by certain bacteria.) The refrigerated foods will stay fresh for a longer period and then spoil at a slower rate.

Conclusions

Refrigeration retards spoilage. It controls or slows down the action of decay-causing bacteria.

2. Research

Ask children to find out how oxygen is condensed to a liquid. They should also try to find out about important uses of liquid oxygen, such as how it is being used in our space program. (N.A.S.A. will send information on this for the asking.)

Ask children to do research on air conditioners to find out how they work.

3. Demonstration      Cooling - The Removal of Heat

Place boiling water into two tin cups. Leave one standing and place the other in a coffee can partially filled with ice. Test each with a thermometer to see which cools faster.

4. Field Trip

A trip through a steel mill, oil refinery, automobile plant, or other large factory might be organized to see how heating and cooling are used in the production of many things we use every day.

5. Observe

Compare what happens to an ice cube and a piece of "dry ice" (solid carbon dioxide) at room temperature. Ask children to find out more about the differences of "dry ice" and regular ice, such as how each is made and the uses of each.

CONCEPT - Almost all substances expand when heated and contract when cooled.

1. Problem

How do heating and cooling affect solids?

Materials

Metal ball and ring apparatus, source of heat.

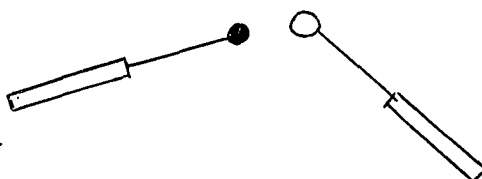

Procedure

Ask children to perform each of the following steps and note the results in each instance:

- a. Without heating either the ball or ring, try to pass the ball through the ring.
- b. Heat the ball and try to pass it through the ring.
- c. Dip the ball in cold water, then try to pass it through the ring.
- d. Heat the ring and try to pass the ball through it. Ask the children to formulate theories that will explain the results.

Results

- a. Without heat, the ball will be snug with the ring.
- b. The heated ball will not go through the ring.
- c. When the ball and ring are the same temperature, they will fit snugly.
- d. When the ring is heated, the ball will easily pass through.

Conclusions

Solids expand when heated and contract when cooled.

2. Problem

How do heating and cooling change the volume of air?

Materials

Test tube, test tube holder, one (1) hole stopper, glass tubing, beaker, colored water, alcohol or gas burner.



### Procedure

Ask pupils to set up this experiment by inverting the empty test tube, with stopper and glass tubing and place it in the test tube holder so that the end of the glass tubing is immersed in the colored water. Is the test tube really empty? Apply heat to the test tube. What is noticed at the end of the glass tubing? Why does this happen? Remove heat and allow test tube to cool. What is now noticed? Why?

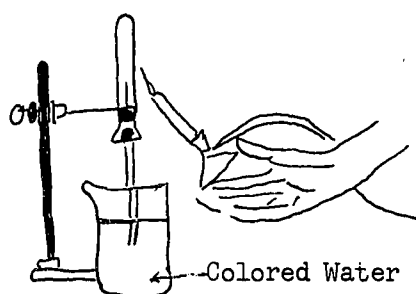

### Results

When heated, the air in the test tube expands and some of it escapes, as evidenced by the bubbles coming from the submerged end of the glass tubing. When allowed to cool the volume of air in the tube will be less than the original amount, so the colored water will travel up the glass tubing.

### Conclusions

This is an example of a gas expanding when heated and contracting when cooled.

### 3. Problem

How do heating and cooling change the volume of water?

### Materials

Test tube, test tube holder, one (1) hole stopper, glass tubing, string, alcohol or gas burner, colored water.

### Procedure

Have children fill test tube with colored water and insert stopper with glass tubing. Children should tie a string around the glass tubing at the water level. Place test tube in the holder and gently apply heat. What happens? What does this show? Remove test tube from heat. What is now noticed? Why?

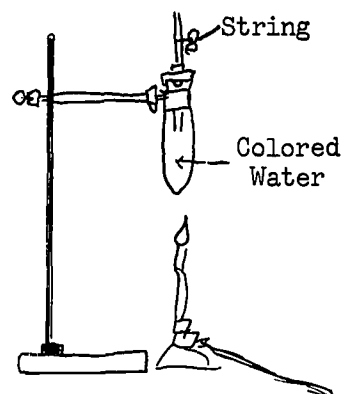

### Results

When heated, the water in the test tube will expand and force the water level in the tubing to rise. When allowed to cool, the water level will fall back to the string marker.

### Conclusion

This is an example of a liquid expanding when heated and contracting when cooled.

#### 4. Problem

How do heating and cooling change the length of a wire?

### Materials

A two ft. length of wire, two (2) rods mounted on bases, a ruler, a small weight, alcohol or gas burner.

### Procedure

Tie the ends of the wire to the rods and attach the weight in the middle. Ask a pupil to measure and record the distance from the weight, to the table. Use the burner to heat the wire by moving the flame back and forth along the length of the wire. Ask a child to measure and record the distance from weight to table now. What has happened? Allow wire to cool. Measure again.

### Results

The wire is pulled down by the weight when heated, showing that its length is increased. When allowed to cool it will resume its previous length.

### Conclusions

This is an example of a solid that expands when heated and contracts when cooled.

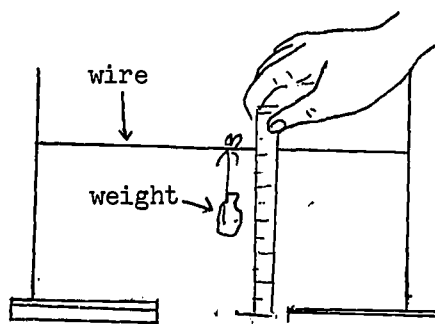

5. Demonstration - Does Water Contract When Cooled?

Fill glass jar with water, place it in a box (to catch broken glass) and set outside overnight in freezing weather, or in a freezer. Have children observe the result and discuss the cause. This shows that water is unique in that it expands just before it freezes. This also explains why ice is lighter than water.

6. Observe

Have children be on the lookout for examples of expansion and contraction caused by the rising or falling temperatures, such as tar in cracks in a road being squeezed out on a hot day or expansion points found in some bridges.

CONCEPT - Different materials vary in their ability to conduct heat; materials that conduct heat slowly are called insulators.

1. Problem

Do some substances conduct heat faster than others?

Materials

A square of metal, pad of asbestos, alcohol or gas burner.

Procedure

Heat the edge of the metal square for a few seconds and remove it from heat. Let a child touch the opposite edge. (Be sure the metal is not hot enough to cause a burn.) Heat the edge of the asbestos pad and test the same way. What difference is noted?

Results

The metal feels warm, while the asbestos does not.

Conclusions

Metal is a good conductor of heat; asbestos is an insulator.

2. Demonstrations    Showing Conduction of Heat by Various Substances

Put boiling water in metal, china, and wooden cups and have children feel the difference in the warmth of the water after about 15-20 minutes. Test the same cups by putting ice in them, covering and timing how long it takes the ice to melt in each cup.

Showing Heat Characteristics of Materials

Demonstrate the difference in heat characteristics between a kettle or pot with a wooden handle and one with a metal handle. Which handle gets hotter?

3. Observe

Obtain various types of house insulation. Let children compare them and list similarities and differences.

CONCEPT - Heat is the energy of moving molecules; as a substance gets warmer, its molecules move more rapidly; as it cools, less rapidly.

-- Problem

How do changes in temperature affect air?

Materials

Test tube, test tube holder, balloon, alcohol or gas burner.

Procedure

Attach deflated balloon to the mouth of the test tube. Attach clamp to tube and hold over heat. Ask children to watch to see what happens to the balloon as the air inside the test tube heats. Why does this happen? Place test tube and balloon away from heat. Ask children what happens to the balloon as the test tube cools? Why does this happen?

Results

As the air in the test tube was heated, it expanded, and inflated the balloon. As the air cooled, it contracted, and allowed the balloon to deflate.

Conclusions

The greater the amount of heat, the faster the molecules will move, causing expansion. Cooling will cause a decrease in the speed of the moving molecules resulting in a contraction of the material.

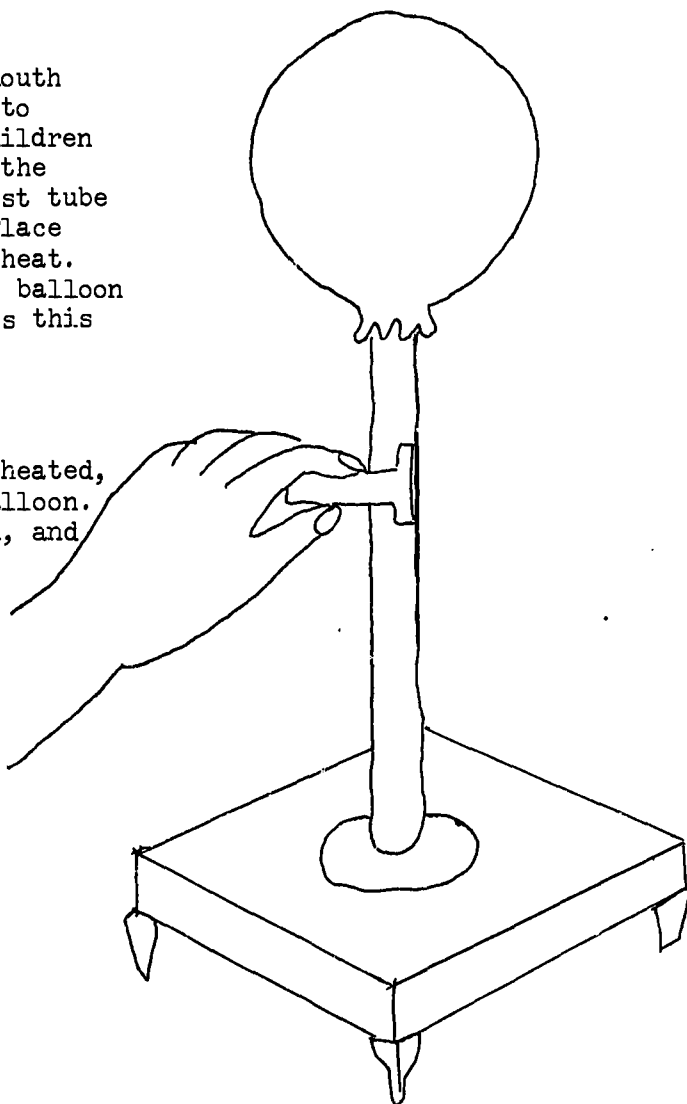

CONCEPT - A change of state may result from the addition or removal of heat from a substance.

1. Problem

What happens when water boils?

Materials

Two (2) test tubes, test tube holder, water, alcohol or gas burner.

Procedure

Have children fill the two containers with equal amounts of water and mark the level with a grease pencil. Place one tube over the burner and bring the water to a boil. After a short time, remove it from the heat and let it cool. Have children compare the heated tube to the unheated tube.

Results

The test tube which had been heated now contains less water than the unheated test tube.

Conclusions

Heating the water caused a change of state; some of the water has changed to water vapor (liquid to a gas).

2. Problem

What makes water vapor in the air condense?

Materials

Metal cup, glass of cold water, crushed ice.

Procedure

Get a shiny metal cup (or can). Be sure that the outside of the cup is dry. Pour cold water into the cup until it is about half full. Be careful not to wet the outside of the cup. Why?

Does a thin layer of moisture form on the outside? If not, add some crushed ice to the water and stir the mixture. Keep adding crushed ice until you see a layer of moisture form on the outside. You may have to add some salt to make the ice melt faster.

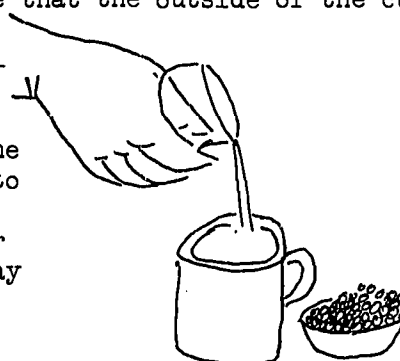

Where does the moisture on the outside of the cup come from?

### Results

The moisture on the outside of the cup is the condensation of water vapor in the air.

### Conclusions

Cooling water vapor in the air causes it to condense. Condensation is the changing of a gas or vapor to a liquid.

### 3. Problem

Do all materials have a definite melting point?

#### Materials

Pat of butter, ice cube, two plates.

#### Procedure

Place a piece of ice in a dish in a warm room. Does it stay hard or does it get soft? Does it change immediately or gradually from a solid to a liquid?

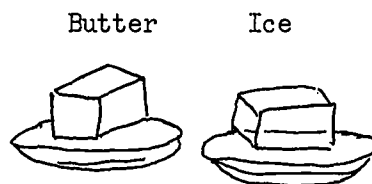

Place a piece of cold butter in a dish in a warm room. Answer the same questions for the butter that you did for the ice.

### Results

The ice begins to change immediately to a liquid, while the butter changes more gradually.

### Conclusions

The melting point is the temperature at which a solid changes to a liquid. Melting points vary according to the type of material.

### 4. Research

Assign some common materials to a group of children and ask them to find the melting points of these materials. When the research is completed, they can construct a chart comparing the melting points of these substances.

MELTING POINTS OF SOME COMMON MATERIALS

Material	°F.	°C.
Alcohol, ethyl	-179*	-117
Mercury	- 38	- 39
Carbon tetrachloride	- 9	- 23
Wood's Metal	158	70
Camphor	352	178
Tin	449	232
Lead	621	327
Aluminum	1219	660
Salt, common	1474	801
Silver	1761	961
Gold	1945	1063
Copper	1981	1083
Iron	2795	1535
Quartz (Sand)	2912-3092	1600-1700
Platinum	3224	1774
Tungsten	6098	3370

\* A minus sign (-) before a temperature means below zero.

5. Draw

Let children make and display drawings of familiar changes of state caused by changes in temperature.

6. Observe

Ask children to observe and make a list of the changes of state that they notice in nature; the falling and melting of snow; the falling rain and its evaporation when the sun comes out; etc.



CONCEPT - The temperature (heat intensity) of a body is measured in degrees.

1. Problem

Why do we usually use a thermometer to determine the temperature of a place or thing?

Materials

Three (3) glasses of water, thermometer.

Procedure

Ask children to feel the water in each of the glasses and write down their estimates of the temperatures of each. Now use a thermometer and find out the actual temperatures. Lead a discussion to see if the children think their sense of touch can be used as a reliable thermometer.

Results

While the sense of touch can tell you there is a difference between temperatures, a thermometer measures the temperatures much more accurately.

Conclusions

Exact temperatures can best be found by the use of a thermometer.

2. Research

Ask a group of children to do library research on the absolute (Kelvin), Fahrenheit and centigrade scales of measuring temperatures. Have them report to the class on their findings and explain the differences.

If the temperature in your classroom is regulated by a thermostat, ask the class how it might work. Ask a group of interested pupils to find out what they can on the thermostat through research and present their findings to the class.

3. Observe

Have children compare a medical thermometer to an outdoor thermometer and observe the differences in the way they are made and the way they work.

4. Charts, Maps, or Graphs

Ask children to prepare a bar graph or a pictograph comparing the normal body temperature of man to that of other animals.

Mount a weather thermometer on an outside window frame. Ask a group of pupils to keep a day-to-day record of the temperature changes on a line or bar graph.

5. Make Models

Construct A Simple Thermometer

Materials

A jar or flask, cork or stopper, glass tubing (1 or  $1\frac{1}{2}$  feet), and red ink.

Procedure

Fill flask with water colored with red ink to make it easily seen. Heat and close one end of tubing. Fit tubing into stopper and place stopper firmly into the flask. Some of the water will extend into the tube. Mark the distance daily. Compare the changes of height of water in the tube with daily readings on a regular thermometer.

Results

When temperature rises, the water in the tube will rise. When temperature lowers, the water in the tube lowers.

Conclusions

The rise and fall of the water in the tube occurs because of the expansion and contraction of the water in the flask as the water changes temperature. Mercury in a regular thermometer rises and falls for exactly the same reason.

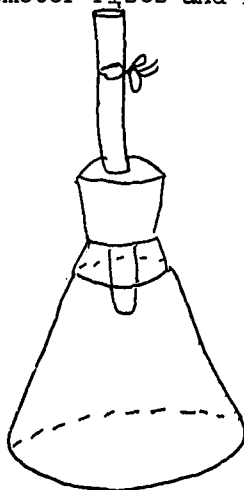

6. Make Model

Construct A Ribbon Thermometer

Materials

One foot of  $\frac{1}{4}$  inch red ribbon, one foot of  $\frac{1}{4}$  inch white ribbon, one piece of cardboard  $4\frac{1}{4}$  inches by 12 inches, one chemical thermometer which is marked with both the centigrade and the Fahrenheit scales.

### Procedure

Draw a strip of thermometer tubing  $\frac{1}{4}$  inch wide and 10 inches long down the center of the cardboard. Start the strip an inch from one end of the piece of cardboard. The outer end of the strip will then be an inch from the other end. Draw a bulb at one end of the tube. Round off the other end.

Color the bulb red. Cut a slit for the ribbon across the tube just above the bulb. Cut another slit for the ribbon half an inch or so below the top of the tube.

Put the Fahrenheit scale on the thermometer first. One inch above the top of the bulb, put a mark for  $0^{\circ}$ . Put marks every  $\frac{1}{4}$  inch above this up the tube until you have made 25 marks in tens from 10 to 250.

Put four marks  $\frac{1}{4}$  inch apart below the zero mark. These will stand for below-zero readings. Number them in tens, going down from zero to forty.

Across the tube from the  $140^{\circ}$  mark, put a mark. This will be  $60^{\circ}$  centigrade. By looking at the thermometer marked with both the Fahrenheit and centigrade scales, find out where to put the other centigrade marks.

Sew one end of the white ribbon and one end of the red ribbon together. Put the other end of the red ribbon through the slit above the bulb. Put the other end of the white ribbon through the slit near the top. Sew the ends together at the back of the thermometer. The red ribbon represents the mercury. It can be set by pulling the ribbon up or down. This cardboard thermometer furnishes a good way of showing the changes in daily temperature. A real thermometer can be used to set it.

### Evaluation

Included here are samples of evaluation items which could be used in developing your own informal testing program. These suggested types of items cover the particular science area that has been developed in this section of the handbook. This also means they could be used to help develop informal testing to cover large areas of information (monthly, mid-year, end of year testing). These are by no means complete tests as such. You will have to adapt and develop items to meet your particular class's own individual needs and differences.

#### Answer the following:

What are three things that are needed in order to have a fire?

(A substance that will burn, oxygen [air], heat)

What are three methods of putting out a fire?

(Remove fuel, exclude oxygen [air], cool burning substances)

What are some fuels that we use to produce heat?

(oil, gas, coal, wood)

Name several materials that are poor conductors of heat?

(air, wood, cloth, fur)

#### Underline the correct answer in each of the following sentences:

- The boiling point of water on the centigrade scale is  
a. 100°      b. 150°      c. 180°      d. 212°
- The number of degrees between the freezing and boiling points of water on the Fahrenheit scale is  
a. 100      b. 150      c. 180      d. 200
- The melting point of ice on the Kelvin scale is  
a. 32°      b. 173°      c. 273°      d. 373°
- Heat energy is the energy a substance possesses because of the movement of its  
a. atoms      b. molecules      c. temperature      d. centigrade

A list of terms is given below. Select the term from the list that goes with each statement. Write the term in the space before the statement:

Electric meter	Temperature	Contraction	Gasoline engine
Expansion	B.T.U.	Calorie	

1. (Expansion) is due to more rapid vibration of molecules.
2. (Temperature) is a measure of the vibration of molecules.
3. (B.T.U.) heats one pound of water 1° Fahrenheit.
4. (Contraction) occurs when heat bar is cooled.
5. (Gasoline engine) converts heat energy to mechanical energy.

Complete the following sentences:

1. If a metal rod is heated, the speed at which its molecules move is (increased).
2. If a metal rod is heated, its length (increases).
3. If a liquid is cooled, the volume usually (decreases).

Write a brief but complete answer to each of the following:

1. Why do most substances expand when heated and contract when cooled?  
 (When heated, the molecules of the substances have more energy and move faster and farther apart, causing expansion. When cooled, the molecules have less energy, move more slowly, and come closer together, causing contraction.)
2. What are two units for measuring the amount of heat energy? What can one unit of each kind accomplish so far as heating of water is concerned?  
 (British Thermal Unit [B.T.U.] One B.T.U. will heat one point of water one degree Fahrenheit. Calorie - one calorie will heat one liter of water one degree centigrade.)

Write the number of each word group in Column A in the space before the item in Column B that it best matches:

<u>Column A</u>	<u>Column B</u>
1. Measures temperature	<u>(2)</u> a. Calibration
2. Correct scale of numbers	b. 32° centigrade
3. No molecular motion	<u>(1)</u> c. Thermometer
4. Freezing point of water	<u>(4)</u> d. 0° centigrade
5. Boiling point of water	<u>(5)</u> e. 373°
	<u>(3)</u> f. 0° Kelvin
	g. Barometer

### Vocabulary

One of the strongest keystones of scientific efficiency lies in its vocabulary. The scientist says things precisely, accurately, and briefly. Probably one of the greatest quarrels the science teacher may have with the elementary level teaching today is vocabulary. The science teacher can have no use for vocabulary that is not precise and accurate. Precision in vocabulary is necessary for understanding and meaning of concept or process being learned.

The words listed below are the basic vocabulary for the indicated area of study. After each word has been introduced, its meaning is to be maintained and extended at each succeeding level of study.

absolute zero  
calibrate  
centigrade  
conductor  
contraction  
expansion  
Fahrenheit  
fuel  
furnace  
heat energy  
insulate  
insulation  
insulator  
Kelvin  
radiator  
reflected  
refrigerator  
steam  
shiny

### Children's Books

Books are a very essential part of the instructional materials in elementary schools which provide superior learning experiences for children. The selection of these books poses a difficult problem for librarians, teachers, and administrators because the science field is broad and increasing in scope, and elementary science programs are varied in nature. Some of the more common specific difficulties in choosing books are: (1) finding material which deals with the varied interest of children; (2) locating material which gives information correlated with the local school district's instructional guides; (3) finding books of appropriate reading and difficulty; and (4) selecting the best books from the many available.

The following list gives help related to the first three difficulties presented. Indirectly, it also helps with the fourth difficulty, for the best books cannot be selected until they are located. Further, the brief annotations should be of help in determining which books may be best for a given class. Finally, time should be saved in the selection of a "best" list if some information about the reading difficulty of available books is provided. It is hoped that this list will suggest for elementary teachers books that are supplementary to basic text series, and that these books will have value either as sources of information or for recreational reading.

It is always hazardous to specify an exact grade placement for a book because of variations in pupil reading ability in any class group, and because of different uses made of books. Consequently, the lowest grade levels for pupil-use are indicated. At lower levels these same books may be useful if the teacher reads to the children.

The following list was taken from the publication, Children's Catalog (1966).

- Adler, Irving Fire In Your Life; illus. by Ruth Adler. Day 1955 128p illus \$3.50 (4-7) "Beginning with some of the mythology that grew out of man's early attempts to understand and explain fire, (the author) traces man's use and control of fire for production and for improved living; what fire has meant in the development of civilization, and what its potential future uses are. A disproportionate amount of space has been given to the development of the steel industry, only one of the many modern uses of fire."
- Heat (by) Irving and Ruth Adler. Day 1964 48p illus (The "Reason Why" Bks) \$2.29 (4-6) "The authors explain (thermodynamics) the kinds and uses of heat, what it is, what it does, the heat of the sun, of the stars, and what is the hottest thing on earth."
- Hot And Cold; illus by Peggy Adler. Day 1959 128 p illus \$3.50 (5-7) "The author explains the puzzle of heat and cold and describes the experiments, devices, theories, and phenomena associated with temperature: Why smoke rises: Why a pond freezes from the top: Why an electric current makes heat: How we produce temperature less than one hundred thousandth of a degree above absolute zero: How men put heat to work."

Feravolo, Rocco V. Junior Science Book of Heat; illus. by Ernest Kurt Barth. Garrard 1964 64 p illus (Junior Science Bks) \$1.98 (3-5) "The book tells what heat is, where it comes from, how it travels, how it is measured, and what it can do. Many experiments, using easily available materials, help to explain these things.

Holden, Raymond All About Fire; illus. with drawings by Clifford Stead, Jr. and with photographs. Random House 1964 141p illus map (Allabout Bks) \$1.95 (5-7) "This book explains how fire is essential to man for cooking, heating, transportation, industry and even space exploration. Through . . . accounts of famous fires, the author shows the advances that have been made in fire-fighting techniques."

Munch, Theodore W. What is Heat; pictures (by) Gregory Orloff. Benefic Press 1960 46 illus (What is it Ser) \$1.80 (2-4) The book deals "with natural and artificial sources of heat, heat and motion, measurement techniques, and the importance of heat to man."



## Films

These films are available from the Central Audio-Visual Department. Contact your building A-V Coordinator to arrange for the use of these films.

All films should be previewed to determine suitability for use with your particular class.

Fire Called Jeremiah, A            Parts I & II            35 min.    Col.            Gds. 5 & 6

Nature took 80 years to raise a stand of full grown trees - the fire required only 10 days to level 130,000 acres of valuable timber. The factual story of a raging forest fire and the technical advances and equipment used by the ground and airborne fire fighters to bring it under control.

Fire Safety Is Your Problem                            10 min.    B & W            Pri., Int.

This film is designed to help students understand and appreciate some of the important rules of fire safety in the home and in other situations. Stress is placed upon fire prevention.

Fire Science    15 min.    Col.            Int.

This film introduces the nature of rapid oxidation, such as fire, through a variety of examples and experiments. It begins by tracing fire's history; cites and demonstrates the three essentials for fire--fuel, kindling temperature, and oxygen; Differences in the kindling temperature of various materials are demonstrated. The highly combustible nature of gasoline vapor and the danger of spontaneous combustion in oil soaked cloths is presented.

Fireman    10 min.    Col.            Pri., Int.

The film portrays the duties and activities of a company of firemen and demonstrates how firemen prepare for emergencies by caring for the fire-fighting equipment; by testing trucks, hose, ladders, and life-saving methods. It describes the work of the firemen as they answer an alarm, speed to the actual fire, and extinguish the blaze with efficient fire-fighting apparatus.

Fire: What Makes It Burn    11 min.    Col.            Pri.

Simple laboratory demonstrations are used to show what is needed to make a fire, what a flame is, how combustion takes place, and how a fire can be extinguished. The fact that fire can be dangerous and safety measures for its control are stressed and illustrated.

Heat and Its Behavior    11 min.    Col.            Int.

This film clarifies basic concepts of the nature of heat - its sources, measurement and utilization. Simplified animation illustrates that heat is molecular motion - a form of energy, and that an increase in heat produces expansion of matter because of increased molecular activity. We see that heat travels by conduction, convection, and radiation.

I'm Not A Fool With Fire

11 min. Col. Int.

The history of fire and its proper use is depicted with animation and explained by Jiminy Cricket. Discovery of steam power and its uses is also explained.

Measuring Temperature

11 min. B & W Int.

Using the thermometer as its example, this film introduces the principle of contraction and expansion. It also shows how liquid and metal thermometer work.

Story of Heat, The

13½ min. Col. Int.

This film provides a first-hand introduction to the basic sources and properties of heat. On a camping trip, they see the use of the fire-bow illustrating how friction can produce heat. Elsewhere they learn how man has harnessed heat to supply energy. Heat is graphically presented in terms of the motion of molecules. Through vivid live dramatic and animated sequences this unusual film takes us from basic scientific principles to the latest application of these principles in an atomic power plant and nuclear submarine.

Thermometers and How They Work

11 min. Col. Pri.

The film explores the three basic types of thermometers -- those made with liquids, gases, and solids -- showing by means of simple demonstrations, how each type works. An understanding of the often-difficult concept of materials expanding when heated, and contracting when cooled is provided. It reveals many different uses of thermometers in various occupations, and emphasizes the importance of temperature and how it is measured.

Things Expand When Heated

10 min. B & W Int.

This film demonstrates by animation and simple photography, the movements of molecules before and after heat is applied, showing that their accelerated movement requires more space, and therefore, causes expansion; uses many concrete examples of expansion and contraction from everyday life.

PART IV - SOUND

Initiatory Activities..... 139

Developmental Activities..... 139

    Concept

        There are many kinds of sounds..... 139

        All sounds are caused by vibrations..... 141

        Sound vibrations travel in a wave motion in all directions from their source..... 144

        Sound vibrations travel through solids, liquids, and gases..... 145

        Sounds vary in their volume, pitch, quality, and speed..... 147

        Sound waves can be directed and reflected..... 153

        Some materials are good sound absorbers..... 155

        The various parts of our ears each have a function to help us hear sounds. 156

        Sound waves are only one kind of the many invisible waves which surround us and possess the properties of amplitude, frequency, and speed..... 156

        Our larynx functions to produce sounds which we use as a means of communication..... 157

        There are some sounds too high and some sounds too low for the human ear to hear..... 158

        To fill the need for improved communication, a wide variety of instruments have been developed for the reproduction of sound waves..... 158

Evaluation (Sample Items)..... 161

Vocabulary..... 163

Children's Books..... 165

Films..... 167

## SOUND

### Initiatory Activities

Have the children:

1. Prepare a bulletin board showing various animals. The title might ask the question, "How do these animals make sounds?"
2. Discuss any problem an audience might have had in hearing a program held in the school auditorium.
3. Play a phonograph record and try to distinguish the various musical instruments.
4. Read a story in which echoes are an essential element of the plot.
5. Record a class discussion with the tape recorder. As it is played back, have the children listen to see whether they can identify the speakers voices. Note differences in pitch, intensity, and quality of voices.
6. Sit as quietly as possible for one minute. Listen to the many sounds heard in a "quiet room." Make a list of the sounds heard on the chalkboard. Discuss the causes of these sounds. Why are many of these sounds not heard during the course of normal classroom activities?

### Developmental Activities

CONCEPT - There are many different kinds of sounds.

#### 1. Problem

How are different sounds made by musical instruments?

#### Materials

Various musical instruments.

#### Procedure

Ask the music teacher to let children experiment with the instruments to see how each makes sound. Ask them to find the part of the instrument that is making the sound in each case. Let them look inside the piano to see the strings vibrating. Let them try to classify the instruments according to the way sound was made, by plucking, blowing, etc.

#### Results

Children will become acquainted with the types of sounds made by the various instruments.

#### Conclusions

Many different sounds may be made by musical instruments.

## 2. Charts

- a. Have children construct a chart listing pictures of animals from a coloring book. Have children identify the sounds the animals make.
- b. Ask children to suggest sounds they hear at home. These could be compiled on charts under such headings as "Sounds We Hear in the Kitchen," "Sounds We Hear at Night," etc.

## 3. Drama

Play a game in which the children identify sounds made by a hidden student such as a bell ringing, a balloon popping, wood being sawed, etc. They might also put their heads down on their desks and identify sounds made by a student running and walking, a light switch being turned on, someone writing on a chalk board, and so on.

## 4. Observe

- a. Let children observe the sounds of different things in the room when they are tapped with a pencil.
- b. Take a short walk with the class to listen for different sounds, such as the wind rustling leaves, car horns tooting, etc.

## 5. Audio-Visual

Play a sound effects record and have children guess what is making each sound.

## 6. Field Trip

Have children listen carefully to sounds made by animals observed on a trip to a zoo or a farm. Back in school, ask the children to name an animal they saw and imitate its sound.

## 7. Bulletin Boards

Ask children to gather pictures for a bulletin board about people working. Have them describe the different sounds. These may also be placed in a "Sound of Workers" booklet the children may construct.

## 8. Make Models

Help children to make simple rhythm instruments.

- a. Drum: Remove top and bottom from a coffee can. Cover one end with rubber from a large balloon or inner tube, pulled tight. Bind with string. Make a drum stick by padding one end of a pencil with absorbent cotton covered with a square of cloth and tied on with a string.

- b. Guitar: Cut an opening in the side of a milk carton, leaving a 1" border. Select three identical rubber bands. Make notches to keep them in place. Tune by tightening the part of the rubber bands over the opening. Pluck them to play.
- c. Chime: Suspend a tin can that has one end removed with a large knotted string through the other end. Strike with a large nail. Try cans of various sizes. Also, a length of thin plumbing pipe makes a pleasant musical chime.
- d. Cymbals: A pair of old pot covers can serve as cymbals.
- e. Rhythm blocks: Cut two wooden blocks about 3" square,  $\frac{1}{2}$ " thick. Wrap them with thumbtacks.

CONCEPT - All sounds are caused by vibrations.

1. Problem

How can we show sound is caused by vibration?

Materials

Blade of grass, piece of paper, tissue paper over comb, rubber band, toy guitar, or other musical instrument (string).

Procedure

Have pupils hold a blade of grass or piece of paper between their thumbs and blow (Figure A). Have pupils place tissue paper over a comb and hum. (Figure B) Have pupils stretch a rubber-band; pluck it; listen to it. Stop the vibrations and listen again. Ask the class if they know of any sound which is not caused by some vibrating object.

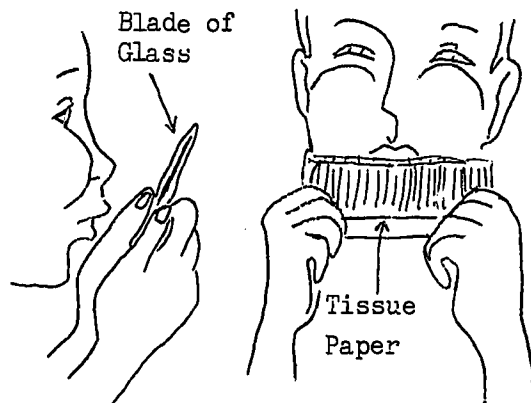

Results

These tests produced vibrations which caused sound. When vibrations ceased sound stopped.

Conclusions

Sound is caused by vibrations.

## 2. Problem

How can we show sound is made by vibrations?

### Materials

Tuning fork.

### Procedure

Set a tuning fork in motion. Place a vibrating tuning fork upright with handle on the desk.

Have children touch the desk lightly with the tips of their fingers. Have them observe the tuning fork vibrating and let them touch their fingers to it.

### Results

When an object vibrates, sound is produced. Vibrations of sound can be felt. Air vibrating around an object and near our hands can be felt. We can see the fork vibrate.

### Conclusions

When a tuning fork is vibrated, it makes the molecules of air move back and forth. Sound transmission can be thought of as wave ripples from the source of any vibrating object.

## 3. Problem

How can we see and feel sound vibrations?

### Materials

Steel knitting needle.

### Procedure

Ask a student to lay one end of the knitting needle on the edge of a table and hold it down with one hand. Snap the other end with the other hand. Ask other students to feel the air just above the needle without touching it.

### Results

Students can see the needle vibrating. Pupils can feel the air above the needle moving.

### Conclusions

Sound vibrations can be felt and heard. (Define the word "vibration" for the children before the activity is started.)

#### 4. Problem

How can sound be produced by friction?

#### Materials

Tin can, string, ice pick, button, rosin.

#### Procedure

Punch a small hole through the center of the bottom of the can. Run a piece of string two or three feet long through the hole. Tie a button on the end of the string that is inside the can. Apply rosin to the string. Ask a pupil to hold the can in one hand and the string in the other. Have him pull on the string, letting it slip through his fingers.

#### Results

Sound is produced in the can because the string causes the bottom of the can to vibrate according to the varying tensions.

#### Conclusions

Sound is caused by vibrations. Sound may be produced by friction.

#### Observe

#### Feeling Sound Vibrations

Ask children to feel vocal chords at different sound levels: a shout, a hum, a whisper.

#### Seeing Sound Vibrations

- a. Materials: A tin can or round cereal box; grains of sand.
- b. Procedure: Turn the can or box upside down and place the sand on top of it. Strike the top of the box or can with a pencil to make a sound.
- c. Results: The grains of sand will bounce up and down as the bottom of the can vibrates. Sound is caused when an object vibrates.

#### Field Trip

Visit the Museum of Science and Industry's display related to sound and communication.

#### Demonstration

Turn on a radio and have children feel the vibrations through the speaker. Take an old radio apart so that children may find and examine the vibrating source of sound.



CONCEPT - Sound vibrations travel in a wave motion in all directions from their source.

1. Problem

Does sound travel in a straight line as light does?

Materials

None.

Procedure

Ask a pupil to call to another pupil, hidden from sight around a corner of the building.

Results

The second pupil will easily hear the first pupil calling.

Conclusions

Sound does not travel in a straight line but spreads out in all directions.

2. Problem

How can we show sound vibrations travel in waves?

Materials

Tuning fork, pan of water.

Procedure

Have a child strike the tuning fork against the heel of his shoe and lower the prongs into the water.

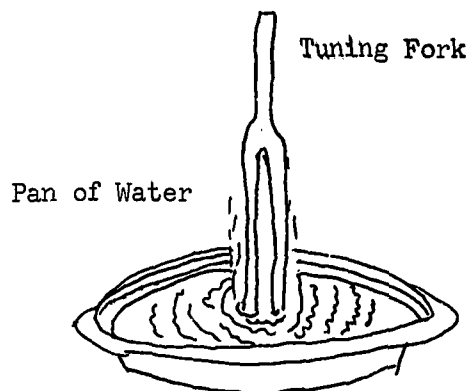

### Results

The vibrations of the tuning fork set up waves in the water.

### Conclusions

Sound vibrations travel in a wave motion.

### Observe

### Seeing Sound Waves

The Central Audio-Visual Department has an oscilloscope and microphone that teachers may use to demonstrate wave pictures with tuning forks and the voice. This will clearly show difference in wave length and rate of vibration.

### Demonstration: Showing A Vibrating Object Sets Molecules in Motion

Start a tuning fork vibrating. Hold it next to a cork suspended on a thread. This cork will represent a molecule of air. The vibrating prongs of the fork will cause the cork to swing away. Explain to the class that in a like manner, molecules are set in motion which strike against more molecules and so on. When the fork moves in the opposite direction, it leaves an almost empty space into which the air can expand. The fork then springs back, crowding the molecules again. This process sets up waves that produce the sensation of sound when they reach our ears.

CONCEPT - Sound vibrations travel through solids, liquids and gases.

#### 1. Problem

How can we show that sound travels through solids, liquids, and gases.

#### Materials

Two spoons, aquarium, water.

#### Procedure

Ask a pupil to hold two spoons under water and hit them together while another pupil listens with his ear near the side of the aquarium.

#### Results

The sound travels through the water, the glass and the air, to reach the pupil's ear.

#### Conclusions

Sounds can travel through solids, liquids, and gases.

## 2. Problem

Does sound travel in a vacuum?

### Materials

Florence flask or large milk bottle, round stick through a one-hole rubber stopper, miniature sleighbell, rubber band and a half cup of water, source of heat.

### Procedure

Secure sleighbell to the bottom of rod, place rod through the one-hole rubber stopper. Fit the stopper snugly into the Florence flask or milk bottle.

Shake the jar and listen.

Put one-third cup of water in the bottom of flask. Boil water in the bottle for several minutes without stopper. Steam drives the air out leaving only a little liquid water and steam. Remove bottle from the source of heat and immediately plug it with the prepared stopper, making sure the sleighbell is in the wide part of the bottle.

After cooling, shake the bottle and listen.

### Results

Sound will be heard when there is air in the flask. Sound will not be heard (or faintly heard) when flask contains a partial vacuum.

### Conclusions

Sound is a vibration of molecules and travels through solid, liquid, or gaseous materials. When a vacuum is established, sound cannot travel for lack of medium.

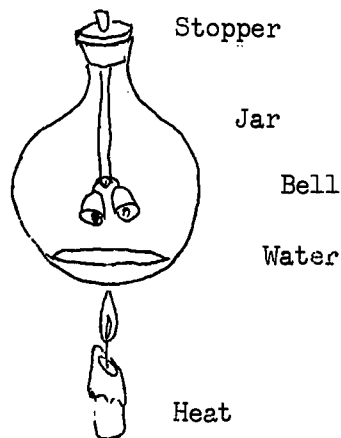

## 3. Problem

How can we show that sounds travel through solids?

### Materials

Two empty cans, string, wax, two buttons, ice pick or can opener.

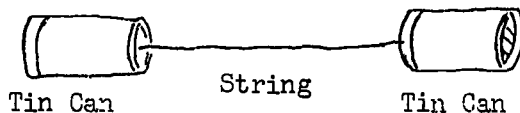

### Procedure

Punch a small hole in the center of the bottom of each can. Run wax up and down the string. Push the string through the holes and tie a button on each end. Keeping the string taut, have one student talk into one can and another student listen into the other can.

### Results

When a student talks into the can, the vibrations from his vocal chords make the bottom of the can vibrate. These vibrations are carried along the waxed string. When they reach the other can, the bottom of the can vibrates causing the adjacent air to vibrate. When the vibrations reach a person's ear drum at the other end of the string, they produce the sound of the voice.

### Conclusions

Sound vibrations travel through solids.

#### 4. Observe

Ask children to sing the same tone with their mouths open and closed. Point out that while we are making sounds with our larynx, the vibrations travel through our bones directly to the ear.

#### 5. Demonstration

- a. Transmitting sound - Tie a string around the handle of a spoon. Have a child wrap the ends of the string around his forefinger and place his fingers to his ears. He then swings the spoon so that it strikes some solid object. He will clearly hear the chime note which is transmitted through the string.
- b. Demonstrate how sound can travel through solids by having a pupil tap on the wall while in the next room. Lightly scratch on the end of a table so that the sound is not audible. Ask a pupil to place his ear on the opposite end of the table and repeat.

CONCEPT - Sounds vary in their volume, pitch, quality, and speed.

#### 1. Problem

What is pitch?

#### Materials

Bicycle, stiff cardboard.

#### Procedure

Set the bicycle so that the back wheel is free to turn. Hold the stiff cardboard firmly so that the spokes of the wheel will hit it. Have one

of the pupils turn the pedals so that the wheel will turn. Ask children to notice the pitch as the wheel turns faster and faster.

### Results

The sound is of a higher pitch when the wheel is turned faster and the spokes are hitting the cardboard more times per second.

### Conclusions

Pitch depends upon how rapidly an object vibrates.

## 2. Problem

Why is it better to have two ears than to have only one?

### Materials

None.

### Procedure

Ask a volunteer to be blindfolded and sit in the middle of the room. Ask other students each to make a noise, one at a time, while the blindfolded person points to the source of the sound. Try this again with one ear covered.

### Results

The student will lack accuracy in telling the direction of the sound source with one ear covered.

### Conclusions

The use of both ears helps us to tell from which direction a sound is coming.

## 3. Charts

Have children construct a chart diagramming the human ear. Label all parts and tell their function.

## 4. Observe

Ask children to recall the way a dog moves its ears when it is whistled at or spoken to. How are human ears different in this respect?

## 5. Resource Person

Ask a dealer in hearing aids to explain how these help a person with poor hearing and to demonstrate the different types of hearing aids.

6. Field Trip

Visit the Museum of Science and Industry to study the displays on the ear and hearing.

7. Research

Ask children to do research in health books to find out safe and unsafe practices regarding the ears.

8. Problem

How can we show sounds of different pitch?

Materials

Eight bottles of the same size, water.

Procedure

Have children fill the bottles to eight different levels. Try to get the eight tones of the scales by blowing across the tops of the bottles and increasing and decreasing the amount of water, until each bottle has correct pitch. Simple tunes might be played by students.

Results

The pitch and tone produced from blowing over the pop bottles is due to the size of the resonating chamber within the bottle. The tone and pitch can also be affected by the shape of the chamber, as well as by material from which the bottle is made.

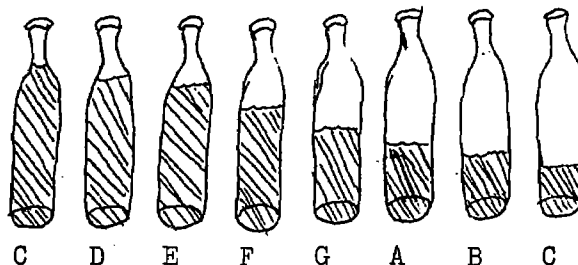

Conclusions

Sounds vary in loudness, pitch, and quality.

9. Problem

What makes sound different pitches?

Materials

Cigar box open at the top, rubber bands of varied lengths and thicknesses, string, wire.

### Procedure

Place various rubber bands around the box; tie the string and wire around the box. Have children pluck each of the different materials and notice the differences in sounds.

### Results

Sounds of various pitches are produced.

### Conclusions

By observing closely, students will observe that high pitches result from many vibrations and low pitches result from few vibrations.

Short bands will have a higher pitch than long bands.

Tight bands will have a higher pitch than loose bands.

Thin bands will have a higher pitch than thick bands.

Light materials will have a higher pitch than heavy materials.

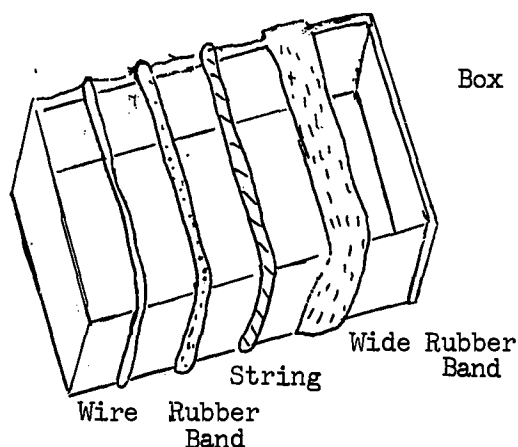

### Problem

How can we see which is faster; the speed of sound or the speed of light?

### Materials

Metal bucket, stick, track coach's blank pistol.

### Procedure

Stand on the school playground with the bucket and hit it while the students observe from about 500 feet away. Shoot off the pistol.

### Results

Children will notice the sound of the bucket being struck after they have seen it. A flash of smoke can be seen coming from the gun before the report is heard.

### Conclusions

The speed of light is faster than the speed of sound.

11. Problem

How do vibrating strings make different sounds?

Materials

Four wires of the same length:

- a. Two steel wires, same thickness (A & B).
- b. One steel wire, thinner than above two (C).
- c. One copper wire, same thickness as single steel wire.

(Frame as illustrated), two-pound weight and three pound weights.

Procedure

Arrange the four wires on a frame like the one in the sketch. A and B are made of steel of the same length and thickness. A has a two pound weight on it, B has a three pound weight. When the wire is stretched we say it has tension. C is also made of steel wire but is not as thick as A or B. D is made of copper wire which is lighter than steel wire.

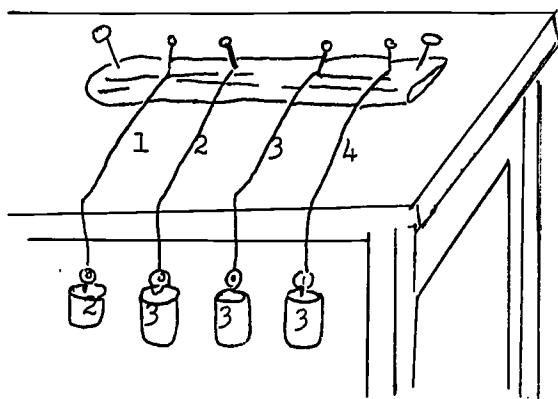

Pluck the various strings and note the difference in pitch produced.

Pluck any one string and remember the pitch.

Press the same string firmly to the table with your finger and pluck it again. Repeat with the other strings. Listen carefully.

Results

Different pitches are produced.

Conclusions

We know now that:

- a. The tension - the higher the tension the higher the pitch.  
(Same thickness and length and materials)
- b. The thickness - the thinner the string the higher the pitch.  
(Same material, same length and tension)



- c. The material - the lighter the material the higher the pitch.  
(Same length, tension, and thickness)
- d. The length - the shorter the string the higher the pitch.  
(Same material, thickness, and tension)

#### 12. Charts

Ask children to make a chart in which they classify sounds under headings as "Soft Sounds - Loud Sounds" and "Low Sounds - High Sounds."

#### 13. Observe

Let children listen to a record of music. Then play a sound effects record of noises. Have the children discuss the difference between music and noise.

#### 14. Research

- a. Have children refer to their dictionaries for the definitions of pitch (highness or lowness of sound) and volume (loudness or softness of a sound) and compare to the definitions of frequency (number of vibrations per second of a vibrating object) and amplitude (the distance a vibrating object moves from its position of rest). In sound waves, amplitude refers to volume and frequency refers to pitch.
- b. Have children find out the speed of sound in air, water, and other gases, liquids, and solids. In what medium does sound travel fastest? Why is this so?
- c. Have children try to work out how long it would take a sound (if it were strong enough) to travel from Gary to Los Angeles; to New York.

#### 15. Demonstration

Demonstrate a pitch pipe. Discuss when it is used and how it helps singers.

#### 16. Make Models

Let children make a pin harp by placing pins to various depths in a soft wood board. Pluck them and have the children notice the sounds produced. Have them try to make a musical scale by arranging the pins in proper order. To raise the pitch, drive the pin in farther; to lower the pitch, pull the pin up.

CONCEPT - Sound waves can be directed and reflected.

1. Problem

How can we show the use of a stethoscope?

Materials

Three pieces of rubber tubing each 8" long, three medium size plastic or rubber funnels, "Y" joint of glass or plastic tubing, thin wire.

Procedure

Have students place a funnel in one end of each piece of rubber tubing; join the three pieces together with the "Y" joint. Tie all connections with the wire. Have students listen to vibrating objects. Try the stethoscope on a clock or try to hear another person's heartbeat.

Results

The funnels and tubes intensify vibrations by channeling sound waves through the tubes directly to the ears.

Children can get a better concept of how sound can be channeled and intensified. Through experiments with the stethoscope, they learn about sound, about their own bodily functions such as their heartbeat before and after exercise and overcome fear of the doctor.

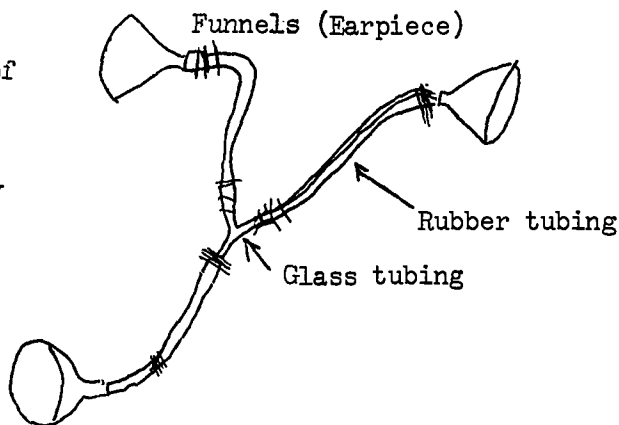

Conclusions

Sound waves can be channeled and directed by a stethoscope.

2. Problem

How can we make an echo?

Materials

None.

Procedure

Have the pupils stand about 100 feet from the side of the school building and make a loud noise, such as clapping their hands together in unison. Try the same thing in the school gym.

## Results

An echo may be heard because the hard walls reflect sound. The echo will not be heard if pupils stand closer than 55 feet to the wall. Even though the sound is still reflected, the echo will appear to be part of the original sound.

## Conclusion

An echo is a reflected sound. An echo will not be heard if the reflecting surface is too close.

### 3. Draw

Let children draw their conception of how an echo takes place.

### 4. Field Trip

Visit the Museum of Science and Industry to experience their "Whispering Gallery."

### 5. Drama

Sing "Little Sir Echo" to help dramatize the effect of reflected sound vibrations.

### 6. Observe

Experiment with echoes on the play ground. If no echo occurs, why not? If an echo occurs, time it from different spots on the playground with a stop watch. Find out the speed of sound in air.

### 7. Resource Person

Ask a doctor or the school nurse to explain the purpose of the stethoscope.

### 8. Demonstration

- a. Have a child turn his back to the class and read a few sentences from a book. Let the class discuss why they can still hear his voice.
- b. Place a watch on the table and ask children to come near to hear the ticking. Now let a student place a roll from paper toweling over the watch and listen at the other end. Lead the class in discussing why the ticking could be heard better through the tube.

### 9. Make Model

Let children construct megaphones from tagboard to see how sound is directed. Have them use the megaphones for both speaking and listening.

CONCEPT - Some materials are good sound absorbers.

1. Problem

How can we see if materials are good sound absorbers?

Materials

Cardboard box, sheet of cotton.

Procedure

Ask a pupil to speak a sentence with a cardboard box over his head. Line the box with cotton and repeat. Let children make suggestions for other materials to test.

Results

The cotton absorbs much of the sound.

Conclusions

Some materials absorb more sound than they reflect; cotton is a good sound absorber.

2. Observe

Ask children to look around at school and at home to notice places where acoustical tile is used. Have them test various types of floor covering to see which absorbs sound best.

3. Resource Person

Ask a dealer of acoustical tile to explain how his product works. Where are good places for it to be used?

CONCEPT - The various parts of our ears each have a function to help us hear sounds.

-- Problem

What purpose does the outer ear serve?

Materials

Radio.

Procedure

Tune the dial of the radio so that it is not directly on any station; try to get a steady tone or hum. Have pupils listen to it for a moment and then cup their hands behind their ears. Next have them hold their ears back flat against their heads.

Results

Hearing is better when hands are cupped behind the ears; poorer when ears are held back.

Conclusion

The outer ear helps to direct sound waves into the ear canal.

CONCEPT - Sound waves are only one kind of the many invisible waves which surround us and possess the properties of amplitude, frequency and speed.

1. Charts

Ask children to list and illustrate with pictures all examples of waves they can find.

2. Research

- a. Ask children to find out why light waves are not considered true waves.
- b. Ask children to read books on electricity and magnetism to find out how radio and television waves are made.

3. Demonstration

Drop a rock in a pan of water to show the resulting waves. Lead the children in a discussion to find the similarities and differences of sound waves as compared to water waves.

CONCEPT - Our larynx functions to produce sounds which we use as a means of communication.

1. Problem

What happens when we speak or sing?

Materials

Rubber band, drinking straw.

Procedure

Ask a pupil to stretch a rubber band tight. Ask another pupil to blow at the middle of the rubber band through a straw. Have the rubber band slackened and try again. Point out that the rubber band in this case is acting in the same manner as the human vocal cords.

Results

The rubber band vibrated and buzzed, a little deeper when it was slackened.

Conclusions

When we speak or sing, air is pushed through the vocal cords in our larynx. These vocal cords vibrate and produce sound. High sounds are produced by tight vocal cords; low sounds are produced by slackening the vocal cords.

2. Charts

Ask children to construct a chart showing the path the air takes from the lungs to the lips when sound is produced. Each part should be labeled and its function told.

3. Resource Person

Ask the school nurse to explain to the class what happens when a person becomes hoarse and "loses his voice."

4. Draw

Have children make drawings of the voice box (larynx) comparing the way the vocal cords look while singing a high note and a low note.

5. Demonstration

Have children feel their "Adam's Apple" to notice the vibrations involved in whispering, shouting, talking, and singing.

CONCEPT - There are some sounds too high and some sounds too low for the human ear to hear.

1. Resource Person

Ask the school audiometrist to inform the children how and why hearing tests are given and to discuss the normal range of hearing for humans.

2. Research

- a. Ask children to find out about animals that hear sounds too low or too high for us to hear.
- b. Have children find out what radar is and have them compare it to the bat's way of finding food.

3. Demonstration

Show the children how a "silent" dog whistle works and discuss why we cannot hear it.

CONCEPT - To fill the need for improved communication, a wide variety of instruments have been developed for the reproduction of sound waves.

1. Problem

How is speech transmitted by the telephone?

Materials

Two carbon rods (from flashlight batteries), copper wire, flashlight bulb and socket, dry cell.

Procedure

Cut three pieces of copper wire, about two feet each. Fasten a wire tightly to each of the carbon rods. Fasten the free end of the wire from the other carbon rod to the dry cell. Connect the socket and the other post of the dry cell with the third piece of wire. Touch the free ends of the carbon rods lightly together; then press them together as firmly as possible.

Results

The light bulb will burn with varying brightness depending upon the firmness of the contact. Point out to children that this is why carbon granules are used in the mouth piece of a telephone.

Conclusions

In the telephone, sound vibrations are changed to electric impulses which flow along a wire and are changed back to sound vibrations.

2. Charts

- a. Ask children to construct a chart showing what is involved in a telephone call.
- b. Have children make a chart listing the types of sound communications.

3. Drama

Ask children to enact important developments in the field of communications, from the time of the cave man to the present.

4. Observe

Let children examine an old record with a magnifying glass. Play it and let the children place a pin in the groove to determine if the variations in the groove can be felt. Push the pin through a cone of paper and ask children to discuss the resulting amplification of sound.

5. Resource Person

Ask a representative of the World Tapes for Education Programs of Anselm Forum to speak to the class about the use of tape recording for communication. This program has members in Gary communicating by tape with people all over the world.

6. Field Trip

- a. Visit the telephone company to see what happens to our calls. Observe a switchboard operator at work.
- b. Visit the Museum of Science and Industry to study the displays relating to modern communications.

7. Research

- a. Ask children to find out how phonograph records are made and mass produced.
- b. Ask children to read about and discuss the inventions of Bell, Morse, Field, Marconi, Edison and DeForest.

8. Demonstration

Make a tape recording of the children's voices. Discuss how the sound can be recorded and what produced the sound on the machines.

9. Bulletin Boards

Construct a bulletin board illustrating the various ways sound may be recorded and stored.

10. Make Models

Make a model of a telegraph. (See Electricity and Magnetism.)



### Evaluation

Included here are samples of evaluation items which could be used in developing your own informal testing program. These suggested types of items cover the particular science area that has been developed in this section of the handbook. This also means they could be used to help develop informal testing to cover large areas of information (monthly, mid-year, end of year testing). These are by no means complete tests as such. You will have to adapt and develop items to meet your particular class's own individual needs and differences.

Underline the correct answer in each of the following sentences:

1. The vocal chords vibrate in the  
a. pharynx            b. bronchial tubes            c. epiglottis            d. larynx
2. The v. p. s. tell us the - - - - - of a sound.  
a. volume            b. frequency            c. amplitude            d. speed
3. The wave length of a sound wave with a frequency of 1000 is about  
a. 1100 feet            b. 110 feet            c. 100 feet            d. 11 feet
4. The lowest number of vibrations per second that most people can hear is about  
a. 11            b. 16            c. 55            d. 110

Write the number of the word group in Column A in the space before the item in Column B that it best matches:

<u>Column A</u>	<u>Column B</u>
1. Loudness of a sound	<u>(4)</u> (1) a. Amplitude
2. Tightness of a string	<u>(1)</u> b. Volume
3. Reflected sound waves	c. Force
4. Size of a vibration	<u>(5)</u> d. Pitch
5. Depends on frequency	<u>(3)</u> e. Echo
	f. Velocity
	<u>(2)</u> g. Tension

Complete the following sentences:

1. The speed of sound waves in the air is about (1,100) feet per second.
2. The highest frequency that most people can hear is about (15,000) v.p.s.

3. If a string is lengthened, its frequency of vibration is (lowered).
4. If a little force is used in making a sound, the volume of the sound will be (low) (soft) (weak).
5. If a string is tightened, its frequency of vibration is (raised).

Write a brief but complete answer to each of the following:

1. What is the relationship between frequency and the weight of a vibrating object?

(Heavy objects vibrate more slowly than lighter objects of equal length and tension. The heavier strings on a violin or guitar vibrate more slowly than the lighter strings. They have a lower frequency and a lower pitch.)

2. What is the relationship between the amount of energy used in producing sound and the volume of the sound?

(If little energy is used to produce a sound, a soft sound of small amplitude is produced. If more energy is used, the amplitude of the vibrations is greater and the sound has greater volume or loudness.)

A list of terms is given below. Select the term from the list that goes with each statement. Write the term in the space before the statement:

Vacuum	Low amplitude	High-pitched sound	Frequency
Sound waves	High amplitude	Low-pitched sound	

1. (Low amplitude) -soft sound.
2. (High-pitched-sound) -tight vocal chords.
3. (Frequency) -number of vibrations per second.
4. (Sound waves) -caused by vibrations.
5. (High amplitude) -loud sound.

## Vocabulary

One of the strongest keystones of scientific efficiency lies in its vocabulary. The scientist says things precisely, accurately, and briefly. Probably one of the greatest quarrels the science teacher may have with the elementary level teaching today is vocabulary. The science teacher can have no use for vocabulary that is not precise and accurate. Precision in vocabulary is necessary for understanding and meaning of the concept of process being learned.

The words listed below are the basic vocabulary for the indicated area of study. After each word has been introduced, its meaning is to be maintained and extended at each succeeding level of study.

amplifier  
amplitude  
brain  
conduct  
conductor  
ear  
eardrum  
earphone  
echo  
electric vibrations  
electricity  
electromagnet  
exhale  
frequency  
hearing aid  
inhale  
International Code  
inner ear  
jet  
larynx  
lungs  
machine switching  
manual switching  
microphone  
middle ear  
outer ear  
pitch  
pluck  
sound vibrations  
sound waves  
stethoscope  
tension  
transmitter  
telegraph key  
telegraph sounder  
vibrations  
wave length

### Children's Books

Books are a very essential part of the instructional materials in elementary schools which provide superior learning experiences for children. The selection of these books poses a difficult problem for librarians, teachers, and administrators, because the science field is broad and increasing in scope, and elementary school programs are varied in nature. Some of the more common specific difficulties in choosing books are (1) finding material which deals with the varied interests of children; (2) locating material which gives information correlated with the local school district's instructional guides; (3) finding books of appropriate reading difficulty; and (4) selecting the best books from the many available.

The following list gives help related to the first three difficulties presented. Indirectly, it also helps with the fourth, for the best books cannot be selected until they are located. Further, the brief annotations should be of help in determining which books may be best for a given class. Finally, time should be saved in the selection of a best list if some information about the reading difficulty of available books that are provided. It is hoped that this list will suggest for elementary teachers books that are supplementary to basic text series, and that these books will have value either as sources of information or for recreational reading.

It is always hazardous to specify an exact grade placement for a book because of variations in pupil-reading ability in any class group, and because of different uses made of books. Consequently, the lowest grade levels for pupil-use are indicated. At lower levels these same books may be useful if the teacher reads to the children.

The following list was adapted from the publication, Children's Catalog (1966).

- Anderson, Dorothy S. Junior Science Book of Sound; illus. by Ernest Kurt Barth Garrard 1962 63p illus (Junior Science Bks) \$1.98 (K-2) "A simple introduction to sound--how it is produced, transmitted, and heard. Echoes, vibration, and resonance are explained and it is shown how sound is received in the human ear. The reader is encouraged to carry out for himself the simple experiments illustrated by the text. This book is aimed at a lower age level than most of the elementary books on sound. The facts are accurate, well presented, and attractively illustrated."
- Baer, Marian E. Sound: An Experiment Book; drawings by Jean Martinez. Holiday 1952 127 illus \$2.75 (4-7) "A well-organized book of simple and clearly illustrated experiments explaining the phenomenon of sound--sound vibration, conduction velocity, reverberation, frequency, pitch, tone. Equipment needed is, for the most part, readily obtainable in the home. The chapters on music are particularly interesting and include directions for two simple instruments that children can make themselves as well as suggestions for many amusing things they will enjoy doing."
- Beeler, Nelson F. Experiments in Sound; illus. by George Giusti. Crowell 1961 130p illus music \$3.50 (5-7) A "book about acoustics; included in the text are many suggestions for home demonstrations and simple experiments. Chapters deal with such topics as the way sound travels, the Doppler effect, musical instruments sound absorption, musical chord and mathematics. Illustrations are adequate, the index is very good, and a brief list of suggestions for further reading is included. The experiments, some of which call for special equipment, look as if they would be relatively easy and a lot of fun to do."

- Feravolo, Rocco Wonders of Sound; illus. by Christie McFall. Dodd 1962 64p illus (Dodd, Mead Wonder Bks) \$3 (3-6) Sound--what it is and what it does--is explained in easily-read text. The book covers the subject from simple vibrations to ultrasonics. The experiments offered are easily performed with materials readily at hand. A sound test with which youngsters can test their friends' recognition of sounds is also included.
- Freeman, Ira M. All About Sound And Ultrasonics; illus with drawings and diagrams by Irving Geis and with photographs. Random House 1961 141p illus (All about Bks) boards \$1.95 (5-7) Partial contents: Waves carry sound; The speed of sound; The Waves spread out; How you hear; The sounds of music; How strings make music; How pipes make music; The shape of sounds; Sounds you cannot hear; The sounds of voices; Through the sound barrier; Some scientific words used in this book. "Comprehensive coverage of the science of sound, in clear and accurate language, and in an attractive format. Explores the same material as Irving's 'Sound and Ultrasonics' (entered below) but includes a few experiments and is better illustrated."
- Irving, Robert Sounds and Ultrasonics; illus. by Leonard Everett Fisher. Knopf 1959 illus lib. bdg. \$3.09 "Interesting information that is presented in clear, crisp writing and is implemented by many... diagrams. The nature of sound is discussed and such phenomena as the Doppler effect and sound intensity described. Sound makers, including the musical instruments; the musical scale; the way in which sound travels; and the topics of animal sounds and the human hearing mechanism are discussed in separate chapters. Some of the inventions of modern science and investigations now in progress are discussed in the final chapters on recording and transmitting sound and on ultrasonics."
- Kettelkamp, Larry The Magic of Sound; written and illus. by Larry Kettelkamp, Morrow 1956 62p illus lib. bdg. \$2.94 (4-6) "By numerous black-and-white drawings closely following the simple, direct text, the author-illustrator explains many aspects of the phenomenon of sound in our daily life. Detailed descriptions of procedures for performing basic experiments in sound. A section on 'Artificial Sound Effects' as practiced to-day in radio, TV, and the movies (is included). The text is not quite as easy as the large type would seem to indicate."
- Knight, David C. The First Book Of Sound; A Basic Guide To The Science Of Acoustics illus. with drawings and photographs. Watts, F. 1960 93p illus \$1.95 (5-7) "This book tells what sound waves are, how fast they go, and why we hear. Ultrasonics, supersonics, resonance, and modern sound apparatus for experiment and discovery are also discussed. Included is a section on experiments that can be performed with simple equipment."
- Pine, Tillie S. Sounds All Around, by Tillie S. Pine (and) Joseph Levine; illus. by Bernice Myers. McGraw 1958 49p illus (Whittlesey House Publications) \$2.50 (3-5) "Activities designed to make children aware of sound around them... Coverage: what sounds can be heard, what really happens when sounds are made, how sound travels, is put to use, can be heard better, can be stopped, can be a source of fun. Scientific concepts resulting from suggested activities are spelled out."

## Films

These films are available from the Central Audio-Visual Department. Contact your building A-V Coordinator to arrange for the use of these films.

All films should be previewed to determine suitability for use with your particular class.

Communications Theory 28 min. B & W Int.

Mr. Wizard demonstrates how variations of the dot produce written language, sound and pictures. He shows how a dot becomes a code and, in Braille, how dots blend into lines and form letters. By combining dots and lines he demonstrated the language of music and how notes can be duplicated on a piano roll. A series of dots can be punched on a card and a homemade computer can translate them. Dots that form pictures in printing are shown.

Hear Better: Healthy Ears 11 min. B & W Pri. Int.

This film stresses the pleasure that comes from hearing well. In clear animations sequence, the structure of the ear is detailed and the progress of receiving air vibrations and transmitting them into sounds. General information on the care of the ear is presented.

Sounds In The Sea 15 min. Col. Int.

The development of the hydrophone revealed a new world of sound in the so-called "silent" deep. A variety of underwater creatures are identified by their own peculiar sounds. The film is a challenge to further marine life research.

Sound Of Music 10 min. B & W Int.

The film presents the characteristics of different types of musical sounds. Two youngsters meet the genial proprietor of their local store who demonstrates the principles of amplitude and frequency with the sounds and grooves of a phonograph record. On a tour of the shop, they see and hear string, bass, wood wind, reed, and percussion instruments, and derive a greater appreciation of their melodies.

Vibrations 14 min. Col. Gds. 5-6

A vibration occurs whenever an action is repeated with a more or less regular rhythm. Sound is the result of something vibrating. Two things are needed to produce a vibration; a force that pulls the vibrating objects toward a center position, and the natural tendency for a moving object to keep moving.

Waves And Energy 11 min. Col. Gds. 5-6

This film shows it takes energy from one place to another and can also be reflected. In a train of waves, the distance between two successive parts that are alike is called one wave length. The slower the frequency of a wave, the longer its wave length.

PART V - ELECTRICITY AND MAGNETISM

Initiatory Activities.....	171
Developmental Activities.....	171
Concept	
Objects made of certain materials are attracted by a magnet.....	171
Magnets have a north pole and a south pole. Magnets are strongest at their two poles.....	175
Like charges repel; unlike charges attract. Like poles of magnets repel; unlike poles attract each other.....	176
Magnets move a field of force. The earth has such a magnetic field.....	178
A compass is a magnetic needle that can turn to determine directions.....	179
There are various ways to make a magnet.....	182
A moving magnetic field can produce electricity.....	185
A flow of electric current creates a magnetic field.....	186
Radio and television both use invisible radio (electromagnetic) waves that can process many substances.....	189
Electricity for most uses comes from a powerhouse. The electric current flows from a generator through wires to many places.....	190
Electric energy can be changed to other kinds of energy.....	190
There must be a complete circuit to allow a flow of electricity.....	193
Electricity is not carried or conducted by all materials.....	196
When two different substances are rubbed together, static electricity may be produced.....	197
Electricity can be produced by chemical reactions.....	201
Electricity and magnetism are around us every day in many ways.....	202
Electricity should be created with respect, for it can be very dangerous..	206
Evaluation (Sample Items).....	207
Vocabulary.....	209
Childrens's Books.....	211
Films.....	215



## ELECTRICITY AND MAGNETISM

### Initiatory Activities

Have the children:

1. Discuss experiences they have had which are related to electricity and magnetism.
2. Display a group of books about electricity or magnetism on the science table.
3. Prepare a "do-you-know-why" bulletin board, including pictures of such devices as a doorbell, a door which opens automatically as an individual approaches, a telephone, etc. Captions under the pictures complete the question begun in the title of the bulletin board.
4. Select stories to be read aloud during the story hour, which may provide leads into the unit. A story telling of Franklin's work with lightning might be appropriate.
5. Display news clipping about a new power plant or dam that is to be completed in the near future. Discuss the effect the dam will have upon the community.
6. Discuss the number of ways that electricity or magnetism serve us at home and at school.
7. Capitalize upon experiences of the class which may lead into the unit. Appropriate experiences may be: a power failure during a storm; a fire in the community, the cause of which was attributed to faulty electrical wiring; the desire to light the Christmas tree; or the tardiness of a child because the battery failed in the family car.

### Developmental Activities

CONCEPT - Objects made of certain materials are attracted by a magnet.

#### 1. Problem

What will a magnet pick up?

#### Materials

Various kinds of objects, such as buttons, paper clips, bits of paper, wood, rubber, plastic, nails, coins, brass and iron keys, and a magnet.

#### Procedure

Have the children try to pick these objects up with a magnet plus any additional objects they wish to try. They may divide these into two piles labeled YES and NO after testing. What do the objects in the YES pile have in common?



## Results

While the children may at first notice that all items in the YES group are metals, it would be a good time for them to learn to differentiate between types of metals and through experimentation find out that all metals are not attracted to the magnet.

## Conclusions

A magnet attracts some things but not others. The things a magnet picks up contain iron or steel.

### 2. Problem

Can magnets be used to separate things?

#### Materials

Paper clips, buttons, sawdust, shoe box, magnet.

#### Procedure

Ask children to place the paper clips, buttons, and sawdust together in the shoe box and mix them thoroughly by shaking it while covered. Have a child dip the magnet in this mixture.

#### Results

The magnet will retrieve the paper clips, but not the other items.

#### Conclusions

A magnet may be used to remove iron or steel objects from a mixture.

### 3. Problem

Do magnets of different shapes do the same thing?

#### Materials

Various types and sizes of magnets, various objects to test, such as paper clips, buttons, coins, bits of metal, wood, plastic, paper, etc.

#### Procedure

Ask any children who may happen to have magnets at home to bring them to school. Test these along with the magnets at school to see if they attract the same things.

#### Results

The shapes of the different types of magnets do not change the way they work.

#### Conclusions

Magnets come in different sizes, shapes, and strengths. All magnets attract the same types of materials.

#### 4. Problem

Do magnets attract through various substances?

##### Materials

Thumbtacks, paper clips, shoe box cover, drinking glass, water, corks, string, plastic, paper, etc.

##### Procedure

Divide the class into four groups. Have each group set up one of the following experiments and have every child try it. Each group may then rotate to the next experiment and so on, until every child has had experience with each experiment.

- a. Put some tacks or paper clips on a shoe box cover and move a magnet under the cover.
- b. Put some paper clips in an empty drinking glass and move the magnet around the glass.
- c. Put some paper clips in a tumbler of water. Tie a string to a magnet and lower it into the water near the clips.
- d. Float several corks bearing thumb tacks on the lower surface in about one inch of water. Move a magnet near the sides of the plastic pan.

##### Results

In each case, the magnet's attraction is not stopped by the various substances.

##### Conclusions

Magnets can attract through such substances as cardboard, glass, water, and plastic. Magnetism passes through most substances except iron.

#### 5. Problem

How can we make a boat move with a magnet?

##### Materials

Large corks, hairpins, paper, shallow pan, water, magnet, toothpick.

##### Procedure

Cut the corks in half length-wise. Have the children cut paper sails which they affix to the corks with hairpins. Ask the children to make the toy boats move by holding a magnet near them after they have been placed in a pan of water. Children might have races between boats. Try the same thing with a boat that has its sail attached with a toothpick. Why doesn't this boat move?

## Conclusions

A magnet can move a toy boat if the boat contains iron or steel.

### 6. Drama

Assist the children in writing a play, in which, the characters move by the use of magnetism. Each figure could be cut from heavy paper and glued to a bottle cap which will serve as a base. For a stage, place a cardboard box on a table. Students can manipulate the figures by moving magnets under the figures from inside the box.

### 7. Research

Ask children to find out how a magnetometer works and why it is an aid to scientists in locating meteorites.

### 8. Demonstration

Make a thumbtack float in the air. Place a shoe box vertically on a table. Press a thumbtack into a block of wood in front of the shoe box. Put a strong horseshoe magnet on the top of the box with the ends of the magnet projecting over the edge of the box. Tie one end of a piece of thread to a thumbtack and the other end of the thread to the thumbtack on the wood block. Be sure that the thread is just a little shorter than would be needed for the thumbtack to touch the magnet. Lift the tack near the magnet and let it go. The tack will float in the air at the end of the thread.

Let the children give their ideas about the reason for this. Lead them to see that the steel thumbtack is attracted by the magnet, and the attraction is stronger than the pull of gravity on the thumbtack.

### 9. Bulletin Boards

A bulletin board display of pictures of various kinds of magnets may be set up. Along with this, a science table display of various kinds of magnets for the children to play with, may be organized.

### 10. Make Models                      Making a Magnetometer

#### Materials

A strong horseshoe magnet, a bar magnet, silk thread, a tall wide-mouthed jar, a cork to fit the opening of the jar, a piece of wire, a pail of sand.

#### Procedure

Push the wire through the center of the cork, and make a hook on one end of the wire. Tie one end of the thread to the hook and the other end to the horseshoe magnet. Put the cork into the bottle so that the magnet swings freely. This is your magnetometer. Bury the bar magnet in the sand and hold the magnetometer over it. Hold the magnetometer near a piece

of iron. In each case, the magnet of the magnetometer will move towards the other object.

CONCEPT - Magnets have a north pole and a south pole. Magnets are strongest at their two poles.

1. Problem

What part of a magnet is strongest?

Materials

Paper clips, bar magnet.

Procedure

Let children experiment with picking up the paper clips, using various parts of the magnet.

Conclusions

A magnet is strongest at its ends.

2. Problem

Are some magnets stronger than others?

Materials

Paper clips, various types of magnets (bar, horseshoe, rod) of various sizes.

Procedure

Ask children to test the strength of each magnet by dipping it into a pile of paper clips. Children may determine the relative strength of the magnets by the size of the cluster, by counting or by matching the paper clips one-for-one. Ask them to compare strengths by seeing which magnet attracts most paper clips.

Results

Some magnets pick up more clips than others.

Conclusions

Some magnets are stronger than others.

Draw

Have children sketch illustrations of both magnetized and demagnetized steel.

Research

Ask children to find out what a lodestone (natural magnet) is and when they first were discovered?

5. Demonstration                      The Molecular Theory of Magnetism

Obtain a small thin magnet from a dime store. Test the magnet with a compass and mark the N and S poles. With pliers, break the magnet into two parts. Let children test the pieces with the compass to find that each has a N and a S pole. Break each of the pieces in two. Test these pieces. The fact that each piece of the broken magnet contains a N and a S pole strengthens the theory that each molecule of magnetized steel has a N and a S pole.

CONCEPT - Like charges repel; unlike charges attract. Like poles of magnets repel; unlike poles attract each other.

1. Problem

Do substances with like charges repel or attract each other?

Materials

Pith balls, silk thread, glue, tubing, hard rubber rod.

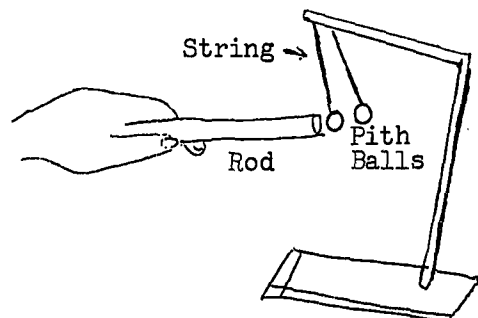

Procedure

Ask children to fasten a pith ball to each end of a silk thread about twelve inches long, sewing them with a needle or using a little glue.

Hang them from a support made of wood, bent glass tubing, or wire. Bring the balls near to a rubber rod which has been rubbed with fur or wool. Such a rod is charged negatively.

Ask children to give their ideas as to the cause for the action of the pith balls.

Results

The balls are first attracted to the rod, and then after a little while they are repelled. Sometimes it is necessary to allow the balls to roll along the rod and to rub the rod several times. Soon both the balls secure the same charge as the rod, and they are repelled by the rod and by each other.

Conclusions

Substances charged in the same way repel each other. On the other hand substances with unlike charges attract each other.

## 2. Problem

How do magnets attract each other?

### Materials

Two bar magnets, string.

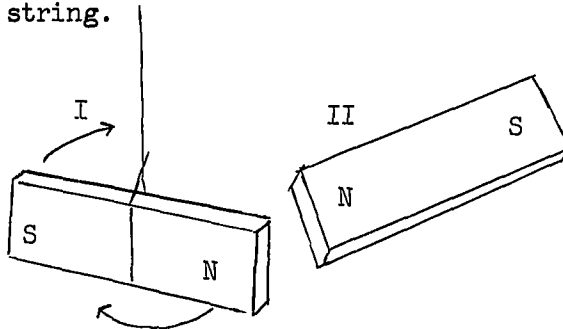

### Procedure

Label the magnets 1 and 2. Have children suspend magnet 1 so that it swings freely. Ask a child to bring the N pole of magnet 2 near the N pole of magnet 1. Repeat with the S poles of the magnets. Then have the children try bringing the opposite poles near each other.

### Results

When N poles are brought together they repel each other. When S poles are brought together, they repel each other. When a S pole and a N pole are brought together, they attract each other.

This proves one of the laws of magnetism; unlike magnetic poles attract; like magnetic poles repel.

## 3. Demonstration

### Materials

Two bar magnets; iron filings.

### Procedure

Dip the north pole of one of the magnets and the south pole of the other magnet into the filings. Bring the poles, with filing attached, toward each other. Dip the north poles of each magnet in the filings and bring them toward each other. Dip the south poles of each magnet in the filings and bring them toward each other.

### Results

The filings on the unlike poles will attract each other. The filings on the like poles will repel each other.

4. Demonstration      The Poles of An Electromagnet Can Be Reversed

Make an electromagnet (See "Various Ways of Making Magnets.") Suspend a bar magnet from its middle so that it swings freely. Have children observe that one end of the electromagnet attracts the north pole of the bar magnet while the other end repels the north pole. Reverse the wiring connections on the dry cell and repeat the above test. Help children gain the understanding that the poles of an electromagnet act in the same manner as poles of a permanent magnet, except that the poles may be reversed by reversing the direction of the electrical current.

CONCEPT - Magnets have a field of force. The earth has such a magnetic field.

1. Problem

How can we show a magnet has a field of force?

Materials

Bar magnet, large flat-bottomed glass dish, thin wood strips or books, thin piece of cork, steel pin.

Procedure

Support the glass dish with the wood strips or the books. Place the bar magnet so that the N poles lies directly under the center of the dish. Have children magnetize the steel pin (See: "Various Ways of Making a Magnet") with the head as a north pole and thrust it vertically through a thin slice of cork. Put enough water in the dish so that the head of the pin will float clear of the bottom. Ask children to place the cork and pin at various places near the N pole of the magnet and observe the line of motion of the pin.

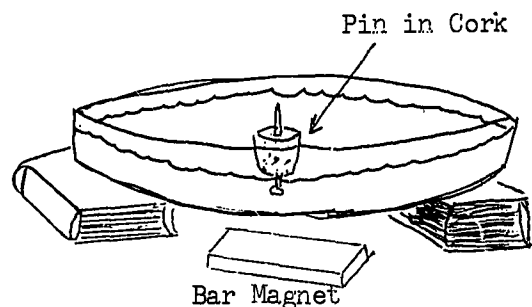

Results

The vertical needle with the north pole down moves along a line of force from north to south.

Conclusion

The paths the pin took in moving from north to south are known as lines of force. Like magnetic charges repel each other.

2. Problem

How can we illustrate a magnetic field?

Materials

Bar magnet, sheet of paper, iron filings.

Procedure

Ask children to lay a bar magnet flat on the table and cover with a sheet of paper. Sprinkle iron filings evenly over the cardboard. Tap the paper lightly. Discuss how the iron filings are affected at different distances from the magnet.

Results

The iron filings will arrange themselves along the magnetic lines of force. The filings far away from the magnet are not effected by it.

Conclusions

Magnets have a field of force. The field of force grows weaker as the distance from the magnet increases.

3. Charts, Maps, or Graphs

a. Help children to draw a map of the world showing the magnetic lines of force surrounding it.

b. Make individual maps locating the geographic poles and magnetic poles.

4. Research

Lead children to read and discuss theories of "How the Earth Became a Magnet."

CONCEPT - A compass is a magnetic needle that can turn to determine directions.

1. Problem

How can we make a compass?

Materials

Bar magnet, iron filings, needle, cork, dish of water, square of paper (larger than the dish).

Procedure

Have children magnetize the needle (See: "Various Ways of Making a Magnet.") and test it on the iron filings.



Trim slice of a bottle cork and float it in the dish of water.

Place the needle across the cork.

Mark one corner of the paper N for north, the opposite south, the corner on your right east and the one on your left west.

Set the saucer on the paper and allow the needle to come to rest.

Lift the saucer without disturbing the needle and move the paper around until the N for north and the point of the needle are in line. Move the cork and the needle so that they point to various directions; release so the cork and needle swing freely.

Magnetized Needle

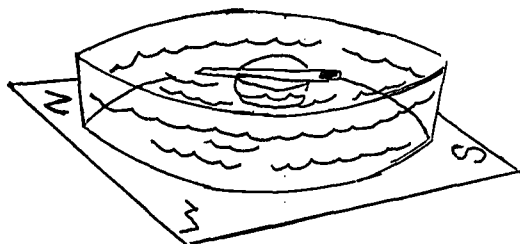

### Results

The needle and cork swing around in a north-south line. (This can be tested by having other compasses in the classroom.)

### Conclusions

The floating magnetized needle is a compass. It acts as a compass in that it continues pointing north as the dish is moved.

## 2. Problem

How is a compass helpful in finding directions?

### Materials

Compass, city map of your surrounding area.

### Procedure

After children have discovered the way a compass works, have them participate in various activities using the compass. Have them guess where north is in the classroom and check their accuracy with the compass. Have them guess which way the street in front of the school runs or the direction they take when going home. Check with compasses and a city map.

### Results

Usually the children find their guesses are not really accurate.

### Conclusions

We can be more certain of our directions if we use a compass.

### 3. Problem

How can a bar magnet be used as a compass?

#### Materials

Bar magnet, thread.

#### Procedure

Have children tie thread to the bar magnet so that it swings freely. Be sure that no iron or another magnet is near by. Allow the suspended magnet to stop turning. What happens? Try this again with another bar magnet to see if the results are the same.

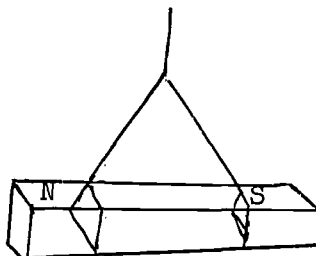

#### Results

The magnet will come to rest in a north-south direction.

#### Conclusion

A bar magnet which hangs so that it can turn easily comes to rest in a north-south position as a compass.

### 4. Problem

Why should a compass be used away from iron or other magnets?

#### Materials

Compass, iron or steel objects, magnet.

#### Procedure

After learning how to use a compass, the children may carry one around the room and hold it close to a radiator, filing cabinet, steel chair frame, etc., to see what happens. Bring it close to a magnet or another compass.

#### Results

Since the compass needle is a magnet, it is turned from its north-south position when it is near iron, steel, or another magnet.

#### Conclusions

A compass needle is a magnet. A compass needle may not act correctly when iron or steel is close to it.

5. Demonstration      How Do We Use A Compass?

Ask children to bring in compasses they have at home. Compare these and have the children note the many different varieties. Demonstrate how a compass is used. Hold one so that the needle swings freely. Make sure that there is no iron or a magnet nearby. One end of the needle will point in northerly direction. Turn the compass case so that the N on the face is under the correct point of the needle. The other directions may now be read on the face of the compass.

6. Observe

a. How can we find the name of the wind that is blowing now?

Have children observe a wind vane, chimney smoke or a flag and use a compass to determine the wind direction. We know the name of the wind if we find the direction from which it is blowing. For example, a north wind comes from the north.

b. How is a compass built?

Obtain an old or cheap compass and let the children take it apart. Have them examine the needle and the point it turns on to see how it is balanced so it may swing easily. Have them test the magnetism of the needle by touching it to iron filings or small tacks.

CONCEPT - There are various ways to make a magnet.

1. Problem

How can iron filings be magnetized?

Materials

Test tube, iron filings, compass, bar magnet.

Procedure

Fill the test tube nearly full with iron filings.

Move the end of the test tube around the compass.

Being careful not to jar the test tube, stroke it with one pole of the permanent magnet being careful to stroke in one direction only.

Move the test tube around the edges of the compass.

Notice any differences between the first and second tests.

Shake the test tube.

Retest with compass.

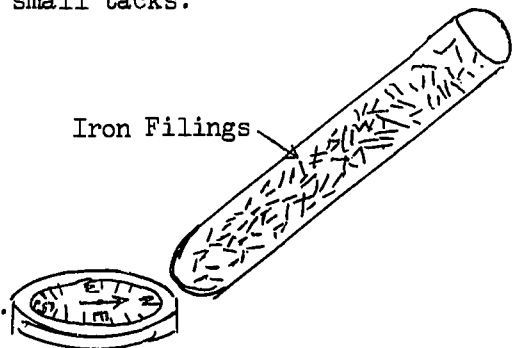

## Results

In most cases when iron filings are poured into a test tube and tested for magnetism by checking with a compass by noting its deflection, there is little or no change.

When the iron filings are magnetized by stroking with a permanent magnet, the compass needle will strongly follow the test tube.

When the filings are jarred, the needle of the compass will not follow as strongly, if at all.

## Conclusions

A tube of iron filings may be made into a magnet. When jarred, however, the iron filings are shuffled, and the effect of the magnetism disappears.

## 2. Problem

How can we use one magnet to make another?

### Materials

Bar magnet, steel knife, iron filings.

### Procedure

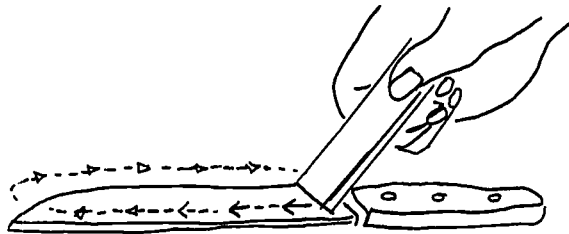

Have children test the knife to be sure it is not already magnetized by touching it to the iron filings. (If it is magnetized, hit it sharply against a solid object to demagnetize it.) Rub the knife with one end of the bar magnet in one direction only. Test the knife by touching it to the iron filings.

### Results

The knife will be magnetized and will pick up the iron filings.

### Conclusions

A new magnet may be made by stroking steel with a magnet; the metal must be stroked in one direction toward one end.

### 3. Problem

How can we make an electromagnet?

#### Materials

Large nail (or bolt), about 2 feet of insulated copper wire, dry cell battery, pins or paper clips.

#### Procedure

Have children wind about 30 turns of wire around the nail. Have them fasten one end of the wire to a terminal on the dry cell. Touch the free end to the other terminal while touching the nail to a pile of paper clips. Have children experiment to see if the strength varies by using a different thickness of wire or by changing the number of turns around the nail.

#### Results

The nail will pick up the paper clips only when there is a complete circuit.

#### Conclusions

Electricity can produce magnetism. An electromagnet is a temporary magnet.

### 4. Problem

How can we use the earth's magnetic force to make a magnet?

#### Materials

Long piece of soft iron or steel, such as an iron curtain rod; hammer; compass.

#### Procedure

Have children find north with the compass.

Hold the long piece of iron or steel in a north-south direction, with the north end pointing down somewhat more than 45 degrees from the horizontal.

Rap the rod sharply with the hammer.

Test the rod with the magnetic compass.

To reverse the magnetism, reverse the rod end to end, and rap it soundly again. To eliminate the magnetism, hold it in a east-west direction, and rap it sharply once more.

## Results

When the rod is held in a north-south direction and struck with the hammer, the needle of the compass is attracted by one end and repelled by the other.

When the rod is reversed and struck as before, the ends are changed; that which repelled now attracts, and that which attracted now repels. When the rod is held in an east-west direction and struck with the hammer, the ends have no effect on the compass.

## Conclusions

By aligning the rod with the earth's magnetic force, we can establish magnetism in the rod.

### 5. Charts, Maps, or Graphs                      Testing Magnetic Holding Power

Compare the ability of different materials to hold their magnetism as temporary magnets for a period of time. Make a chart to represent the findings. Hardened iron or steel will hold its magnetism for a long time. A nail or other object, made from soft iron, will not hold its magnetism long.

CONCEPT - A moving magnetic field can produce electricity.

#### 1. Problem

How can we produce an electric current with a magnet?

#### Materials

Bar magnet, compass, 4 feet of insulated copper wire, small drinking glass.

#### Procedure

Have children wrap 5 or 6 turns of wire around the glass and make a coil of wire. Remove the glass from the coil. The insulation should then be removed from both ends of the wire; fasten them together. Ask children to then lay the wire across the face of the compass. Pass the end of the magnet quickly through the coil as children observe the compass. Repeat, passing the magnet through the coil in the opposite direction.

#### Results

The compass needle moves in a direction dependent upon the direction of the magnet's movement through the coil.

#### Conclusions

An electric current can be produced by magnetism.

## 2. Research

- a. Ask children to find out what they can about Michael Farrady and electromagnetic induction -- the production of electric current by magnetic fields.
- b. Ask children to do research on alternating and direct current electricity and find how they are different.
- c. Ask children to read about generators and how they provide electric power for all of us.

CONCEPT - A flow of electric current creates a magnetic field.

### 1. Problem

How will an electric current produce a magnetic field?

#### Materials

Heavy copper wire about 10 inches long, iron filings, dry cell battery, a three-foot piece of number twenty-two insulated wire, a small magnetic compass.

#### Procedure

Have children connect the piece of heavy copper wire to the terminals of the dry cell and quickly dip a loop of wire into iron filings, and note how they cling. Note that when the current is turned off, the filings fall. (Do not permit the wire to complete the circuit for prolonged periods of time, as this will damage the dry cell by reducing its electrical potential.)

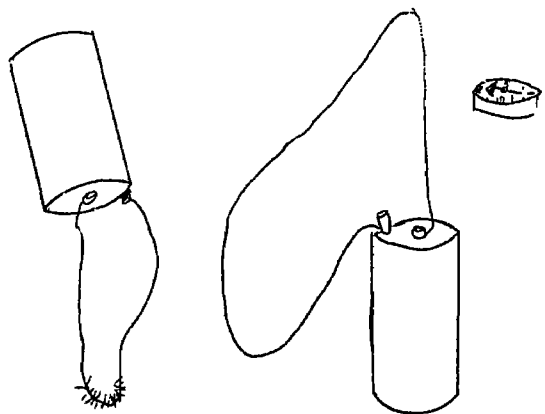

Then have the children connect a three-foot piece of #22 insulated wire across the terminals of a dry cell and arrange the wire so that one length of it is vertical.

Let them use a small magnetic compass to explore the region around this vertical wire. Note that the field surrounds the wire.

#### Results

In the first experiment the iron filings are attracted because of a magnetic field around the current. In the second experiment, the magnetic compass shows that the region around an electric current contains a magnetic field.

#### Conclusions

Every electric current produces a magnetic field around the flow of electricity.

## 2. Problem

How may we show magnetic lines of force created by electricity?

### Materials

Wire, small hollow tube of cardboard or glass, finishing nail (with small head) about as long as the tube, dry cell or transformer, switch.

### Procedure

Children may construct apparatus and perform this experiment by following these steps:

Wind the wire around the hollow tube of cardboard or glass.

Place the hollow tube over the finishing nail. Attach one of the wires to the dry cell and the other wire to the switch (see drawing).

Complete circuit by adding a wire from the push button or knife switch to the remaining terminal of the battery.

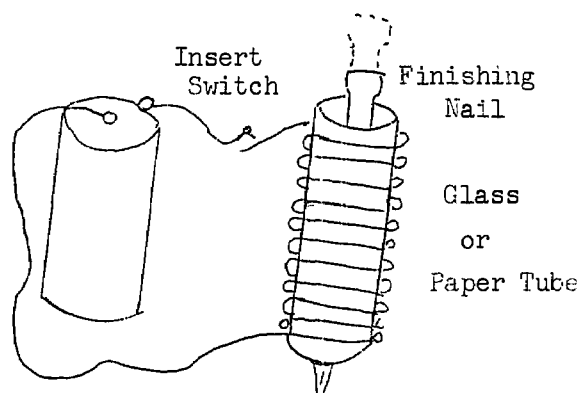

Close the switch and observe the action of the nail.

### Results

When the coil is connected to a dry cell or toy transformer, the nail will first be pulled upward. Then it will return to a resting position with the center of the nail nearly at the center of the coil.

### Conclusions

Magnetic lines of force created by electric current pull the nail with such force that it jumps. We can make an electric chime by placing a bell so that the nail will strike it as it is pulled up by the sucking coil.

## 3. Problem

How can magnetism be created with electricity?

### Materials

Two dry cell batteries, one iron bolt (about 2 inches long), 12 feet of insulated copper wire (No. 24), assortment of nails, nuts, bolts, pins, tacks, etc.



### Procedure

Show that the 2 inch bolt is not magnetized by attempting to pick up some of the assorted nuts, pins, etc.

Connect the two batteries as shown in the diagram. Remove the insulation from both ends of the wire and connect the center terminal of one battery to the outside terminal of the other battery.

Wind the remaining wire around the 2 inch bolt, leaving about one foot of free wire at both ends of wire.

After removing the insulation from both ends of the wire, connect one end to the center terminal of one battery and the other end of the wire to the outside terminal of the other battery.

Let children touch the bolt to the metal objects. Have them change the number of turns on the bolt and touch it to the objects again.

### Results

The wire wound bolt will attract the iron objects as does a permanent magnet. This magnet can be strengthened by increasing the number of turns on the bolt or by adding additional dry cells.

### Conclusions

Electricity can be used to create a temporary magnet.

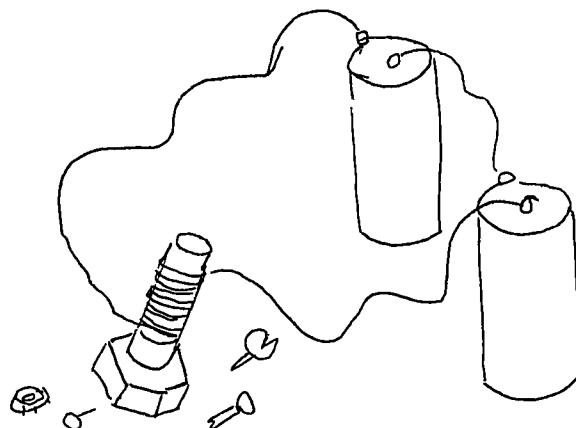

#### 4. Research

Ask two children to read about Hans Christian Oersted to find out how his work contributed to our knowledge of electricity and magnetism.

CONCEPT - Radio and television both use invisible radio (electro-magnetic) waves that can pass through many substances.

1. Problem

How can we show that radio waves pass through many substances?

Materials

Small transistor radio, large jar with lid, boxes made of cardboard and wood, paper bag, coffee can with lid, aluminum foil.

Procedure

Have children turn on the radio and tune in a station. The radio should then be surrounded by each of the other objects in turn. Have the children keep records of the experiment. Do radio waves pass through all materials?

Results

Radio waves pass easily through most materials to the radio, except metallic substances.

Conclusion

Invisible radio waves pass through many substances.

2. Drama

Guide children in writing and producing a short dramatization of historical scenes depicting the progress of radio and television.

3. Observe

Take the back off an old model radio to see the tubes and other various parts. Compare this to a modern transistor radio.

4. Resource Person

Invite a television dealer or repairman to point out basic differences between regular and color television.

5. Draw

Ask children to draw diagrams illustrating the process that takes place when we hear news on a radio or television. Start with the announcer at the station and end with the pupils hearing the news.

6. Field Trip

Arrange a class visit to a radio or television station to observe programs being broadcasted.

## 7. Research

- a. Ask research groups to prepare reports on Marconi and Hertz.
- b. Have a group of children present a report on the workings of an early crystal set and some ways it is different from today's radios.
- c. Have some children use reference books to find out what effect the stratosphere and the ionosphere have on the transmission of radio waves.
- d. Have children find out the difference between VHF and UHF television channels; the difference between AM and FM radio.
- e. Ask children to find out why television signals need relay stations and radio stations and radio signals do not need them.

CONCEPT -- Electricity for most uses comes from a powerhouse. The electric current flows from a generator through wires to many places.

### 1. Charts, Maps, or Graphs

- a. Help children make a chart of the electric circuit which brings lights to the classroom.
- b. Help children locate electrical power plants on a city map.

### 2. Resource Person

- a. Ask the school custodian to show the class where the electric cables from the powerhouse enter the building, the distribution board and fuse boxes. If possible, trace wires to electrical fixtures.
- b. Ask an electrical lineman to speak to the class and explain his work in keeping electric service intact.

### 3. Research

Ask children to find out how a generator works. How did Michael Faraday contribute to the development of the generator?

CONCEPT -- Electric energy can be changed to other kinds of energy.

### 1. Problem

How does electric current produce heat?

#### Materials

Dry cell, one length of copper wire and one length of (iron) picture wire (about 6 inches long).

### Procedure

Ask children to twist an end of the copper wire to the end of the picture wire. Connect one end to the dry cell and briefly touch the other end to the opposite terminal of the dry cell. Touch each wire to find which is warmer. (Teacher should be sure the wire does not become too hot to touch.)

### Results

The picture wire becomes much hotter than the copper wire.

### Conclusion

Iron wire heats easily when electricity passes through it.

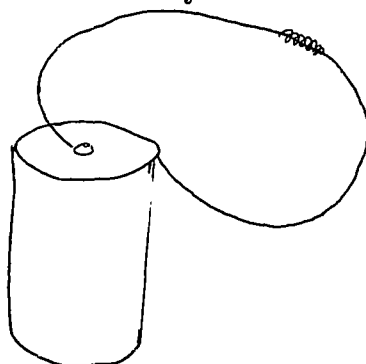

### 2. Observe

Break a light bulb in a paper sack and let children observe the filament. Obtain a clear bulb that has a burned-out filament to compare. Let children explain why a bulb will not give off light when the filament is not intact.

### 3. Field Trip

Visit an electric power plant or a factory and observe the different transformations of energy that are taking place.

### 4. Research

- a. Have children find out what type of wire is used in toasters. Why is one kind of wire better than others for this purpose?
- b. Ask children to read about Thomas Edison's life and work. They might prepare reports about his contributions to the field of science.
- c. Ask children to find out how spurts of electricity are changed to sound waves in the speaker of a radio. Observe this by taking the outside shell off an old radio.

### 5. Demonstration      What Makes Light Bulbs Give Off Light?

Make a loop (about as big around as a lead pencil) in a piece of iron picture wire. Heat this loop in a flame. What do the children notice? The loop becomes bright red and gives off light. Discuss the similarity between this

and the wire in an electric light bulb. The wire in the bulb becomes hot and gives off light because electricity is going through it. However, it does not burn up because there is no oxygen in the bulb and fire needs oxygen in order to burn. There is either a vacuum in the bulb or a gas that will not support fire.

6. Make Model                      An Electric Motor

Materials

Wire coat hanger, 60 ft. very fine insulated wire, large cork, metal contact points (may be cut from a food can), three - 10/penny nails, one - 12/penny nail, board for base, two batteries or six volt transformer.

Procedure

Make the armature. The 10/penny nail is pushed through the center of the cork and will act as bearings on which the armature will turn. The 12/penny nail is inserted through the cork in the opposite direction. It must be balanced and mounted in such a manner that it will allow the cork to rotate freely. This nail is wrapped with 20 feet of small gauge insulated wire. Wrapping must be in same direction (clockwise) on both sides of cork. Bare ends of wire are attached to contact points (A) on opposite side of the cork. Armature contact points should be made of metal and attached firmly to cork. (See end view of armature.) The mounts for the armature are made by bending 2 pieces of metal coat hanger in such a manner that they will support the armature.

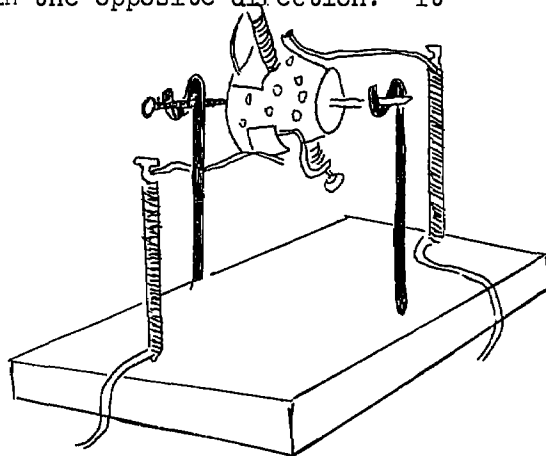

The "field" is made by driving two nails into the block so that when the armature turns, the ends of the wrapped nail on the armature will just miss the heads of the nails driven into the block. These nails are then wound with 15 feet of small gauge, insulated wire on each nail, clockwise from bottom to top of nail. The ends of the wire are bent to make contact on opposite sides of the armature. (Insulation is scraped off ends to make contract points.)

Set the armature on the mounts and balance it so it will rotate freely.

Adjust the ends of the field wires so that they contact armature "contact points."

Turn on the current.

### Explanation

The electric current flowing through the wire which is wrapped around the nail sets up a magnetic field. The metal points on the armature coming in contact with the bare wire points on the field allow the current to flow through the armature also. This in turn sets up a magnetic field around the nail which is the part of the armature. As this armature rotates, the poles of the magnetic field are reversed. This causes the like poles to be adjacent to each other. Like poles repel each other and the motor runs.

The wiring of the field and armature is done in a manner which makes it impossible for unlike (north and south) poles to come near to each other. In other words, when the end of the armature is adjacent to the top of the field nail which has a north pole charge, the current is flowing in a direction which causes this end of the armature to be a north pole also. Like poles repel each other therefore the motor rotates.

The important items in making this motor work are:

- a. The armature must rotate very freely.
- b. The contact points on the armature must be adjusted so the wire brush points contact them at exactly the time they are opposite the nail head.

CONCEPT - There must be a complete circuit to allow a flow of electricity.

#### 1. Problem

How can we show a complete circuit?

#### Materials

Dry cell; electric bell; 2 pieces of insulated wire.

#### Procedure

Be sure the children make all these connections correctly. Connect the end of one wire to the center (positive) post of the battery. Connect the other end of the wire to one of the bell posts or terminals. Connect the end of the wire to the other bell post. Touch the free end of the wire to the outer (negative) post of the battery.

#### Results

The bell will ring only when there is a complete circuit.

#### Conclusions

To have a complete circuit, the electricity must flow from the battery (source) to the place where it will be put to work (the bell), and then return through another wire to the battery (source).

## 2. Problem

How does a fuse work?

### Materials

Two dry cells, approximately 4 feet of insulated wire, small strips of tin foil (or Christmas tinsel), two paper clips, four thumbtacks, block of wood 4" by 4", push button switch.

### Procedure

Have children construct the apparatus in this manner; connect the dry cells in series. Fasten paper clips to the edge of the block in an upright position with thumbtacks. Complete wiring as shown in the diagram. Place a small strip of tin foil between paper clips (points A & B). Press the button switch and observe.

### Results

The foil "fuse" will burn through if it is thin enough.

### Conclusions

Our homes are protected from possible fires by fuses. For they will not allow wires to get too hot. When a fuse burns, there is not a complete circuit and therefore no flow of electricity.

## 3. Problem

What is a short circuit?

### Materials

Dry cell, flashlight bulb and socket, two pieces of insulated wire, pencil.

### Procedure

Have the children scrape insulation off the middle of each wire. Connect the wires to the dry cell and the socket so that there is a complete circuit. Discuss the idea that the electric current flows from the dry cell to the bulb and from the bulb back to the dry cell. Trace the path the current takes. Ask a child to make the bare parts of the wires touch by pushing them together with the eraser end of the pencil. Let children discuss the results. Let them touch the bare wires after the experiment. What is noticed?

### Results

A spark will flash where the bare wires touch and the light will go out. The wires will become hot if left touching.

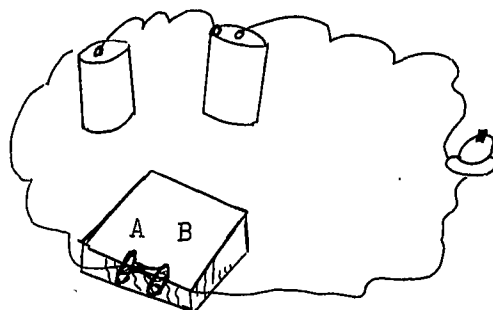

### Conclusion

When bare wires touch, an electric current will follow the shortest path. This is known as a short circuit. Short circuits are dangerous in that the wires become hot and may start a fire.

### 4. Observe

- a. Ask children to look around their homes and list the many places switches are used to open and close an electric circuit. How many different kinds of switches can they list?

#### Checking a Flashlight Switch

- b. Show your class how a flashlight switch opens and closes the circuit through which electricity flows.

### 5. Draw

Examine with pupils an electric plug used to connect a flexible cord to a wall outlet. Find the conductors and the insulators. Take an old lamp apart to find out how the current gets to a light bulb. Let children make drawings to show the path the current takes.

### 6. Research

Ask a group of children to do research and report to the class on how a complete circuit is made in a neon sign.

### 7. Demonstration                      A Series Circuit

Obtain a set of Christmas tree lights that are wired in a series. Plug them in so that all bulbs are burning and take one bulb out. Discuss why all the other bulbs went out. Lead children to the understanding that in a series circuit only one wire connects with each light, so if any one light is taken out the circuit cannot be completed and all the lights will go out.

#### A Parallel Circuit

Obtain a set of Christmas tree lights that do not go out when one bulb is taken out. Compare the wiring to the set used in the previous demonstration. Make your own parallel circuit by wiring flashlight bulbs and sockets to dry cells as shown. Lead children to understand that in this type of circuit the current is able to by-pass a bulb that has burned out and the circuit continues to operate for the other lights.

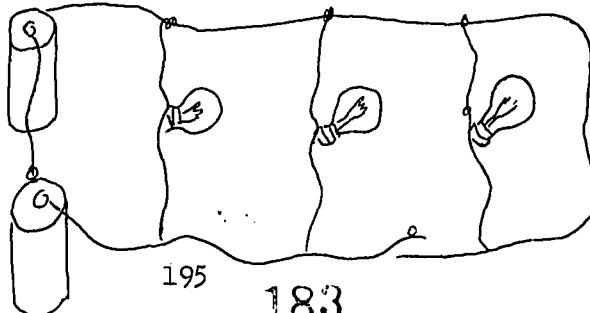



CONCEPT - Electricity is not carried or conducted by all materials.

1. Problem

What materials will conduct electricity?

Materials

Dry cell battery, several feet of #20 wire, pieces of cloth, wood, glass rubber, nails, pins, water, paper, flashlight bulb and socket, knife switch.

Procedure

Connect the dry cell to the light, the light to the switch and the switch back to the dry cell. Close the switch so that the bulb lights up. Remove the switch and in its place test the various bits of material. Let children discuss why the bulb was lit when you tested some materials and did not light when others were tested.

Results

Closing the switch made the bulb light because a complete circuit was formed. The bulb lit when the nail and the pin were tested, for they are conductors completed the circuit. The bulb did not light when the other materials were tested because they are not conductors.

Conclusions

All materials are not conductors of electricity. Metals will conduct electrical current while non-metals do not conduct electrical current.

2. Problem

Is mercury a conductor?

Materials

Small amount of mercury, small glass dish, dry cell battery, lamp and bulb, wires to connect lamp and dry cell battery.

Procedure

Discuss with children the fact that in some of the new houses and schools, switches do not make a clicking noise when you turn them on. These switches have mercury inside. You can find out how a mercury switch works, if you can get some mercury. Pour a small amount of mercury in a small glass dish. Now connect the dry cell and the lamp. In place of a switch, hold the ends of the wires on opposite sides of the dish. Now dip the ends of both wires into the mercury. What happens? Tip the dish back and forth so that the end of one of the wires no longer touches the mercury. Now what happens?

### Results

The bulb lights only when both wires are touching the mercury.

### Conclusion

The mercury completes the circuit because it is a good conductor.

### 3. Charts, Maps, or Graphs

Make a list or chart of those items which will conduct electricity and those items which will not conduct electricity. Consider the characteristics of those that will conduct electricity.

### 4. Research

Have children find out what materials are used as insulators on power lines. Why are they needed?

CONCEPT - When two different substances are rubbed together, static electricity may be produced.

### 1. Problem

How may we produce static electricity?

### Materials

Two rubber balloons, thread (two feet long), a piece of wool cloth.

### Procedure

Have children tie the inflated balloons to the ends of the thread. Space them so that they can swing and touch each other freely. Have children rub each balloon with wool. Ask a child to raise his hand near the balloons.

### Results

The balloons follow the child's arm. This is due to the fact that electricity has been produced.

### Conclusions

Electricity can be produced by friction. This electricity is called static electricity.

### 2. Problem

How may we produce static electricity?

### Materials

Sheets of 8 x 10 paper.

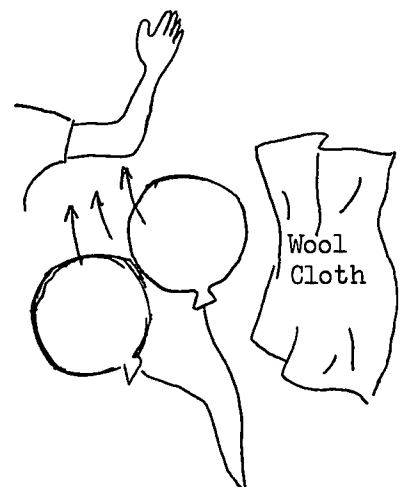

### Procedure

Have children place sheets of paper on the chalk board and rub them vigorously. Use a watch to time and record the amount of time the paper clings to the board. Compare with an unrubbed piece of paper. Try this on a humid day and on a dry day.

### Results

The rubbed sheets cling to the board but finally fall off.

### Conclusions

Rubbing paper gives it a charge of static electricity. Objects charged with static electricity may be attracted to other objects. This attraction gradually weakens. Static electricity experiments do not work as well in moist weather as in dry weather.

## 3. Problem

How may we produce static electricity?

### Materials

Two thin books, piece of window glass (about 10" x 6") small bits of tissue paper, piece of silk cloth.

### Procedure

Have children place the books on a table, leaving a space between them of about 4 inches. Have the bits of tissue paper placed in this space. Place the glass on top of the books. Ask a child to rub the glass briskly with a silk cloth.

### Results

The pieces of paper dance or attach themselves to the glass.

### Conclusions

Static electricity can be produced by rubbing silk on glass. Objects charged with static electricity may attract other objects.

### Main Concept

When two different substances are rubbed together, static electricity may be produced.

4. Charts, Maps, or Graphs      Showing Static Electricity

- a. Hold a sheet of paper and rub it briskly with the palm of the hand. Then place the paper on a wall. The paper will stick to the wall, held there by the charge produced. Next, pull the paper away. There will be a crackling noise which is really a small-sized electrical storm.
- b. Ask children to observe lightning during a storm. If such a storm occurs during school hours, it affords an opportunity for the study of lightning and thunder and the safety rules to follow during such storms. Children may compare lightning with the tiny sparks given off when they scuff their feet on a rug and then touch something. Understandings derived from a study of lightning should include; lightning is a huge electric spark; lightning results from jumps of static electricity; lightning is attracted to the tallest objects; lightning is carried easily by metals and wet substances.
- c. Ask children to comb their hair rapidly with a rubber comb. Then, bring the comb near a fine, smooth stream of water. Observe the stream bend toward the comb. Static electricity is a force.

5. Research

- a. Have children find out about the electrical experiments of the Greek philosopher, Thales.
- b. Form a research group to report to the class on the topics "What Causes Lightning?" "How Are Tall Buildings Protected From Lightning?"
- c. Ask children to read about Benjamin Franklin's work and report on his kite experiment and what it proved.

6. Demonstration      Showing Static Electricity

Materials

A sheet of thin paper, a piece of fur or woolen cloth.

Procedure

Cut a fringe along one side of the sheet of paper. Make the strips of the fringe about  $\frac{1}{2}$  inch wide and three inches deep. Hold the paper, fringe down, against the blackboard. Stroke the fringe downward with the fur or cloth a number of times. Then hold the paper in the upper corners and pull it away from the wall.

Results

The separate strips of fringe will stand out away from one another. The strips of paper all have the same kind of charge, and like charges repel one another. This helps explain why our hair will sometimes "stand on end" when we comb it on a clear, cold day.

Have children experiment with demonstrating static electricity by combing their hair briskly and picking up bits of tissue paper with their combs. Try this on a damp day and on a dry day and compare the results. Darken the room to see the sparks generated by the combing action.

Ask a pupil to rub a blown-up balloon on his hair or a woollen garment. Put it on the wall. Try this with a balloon that has not been rubbed and compare the results. The balloon that has been rubbed sticks to the wall because the rubbing gave it a charge of static electricity. Objects charged with static electricity may be attracted to other objects.

### The Nature of Static Electricity

#### Materials

Hard rubber rod or stick of sealing wax, a piece of fur or wool, glass rod, a piece of silk and two balls of pith from a cornstalk. (Watchmakers use pith in cleaning watches, so you might secure pith from them.)

#### Procedure

Suspend pith balls by a silk thread from a wood or glass frame so that they swing freely.

Rub rubber rod or sealing wax with fur or wool and bring it near pith balls. Observe pith balls are attracted towards the rod. Charged substances (rod or wax) attract uncharged substances (pith balls).

Now roll the balls about the rod allowing them to pick up charge from the rod. Observe the balls presently fly away from the rod. Like charges repel each other.

Grasp balls with hand to remove the charges and repeat experience using glass rod rubbed with silk. Note that when balls carry no charge they are attracted toward glass rod. When they are allowed to pick up a charge from the rod and therefore carry the same charge, they are repelled by the rod.

Charge pith balls with a rubber or sealing wax rod which has been rubbed with wool or fur. Rub a glass rod with a piece of silk and bring it near the pith balls. Notice pith balls charged from rubber rods are attracted by the glass rod. The pith balls charged from the rubber rod carry a charge unlike the glass rod and are attracted by it.

Substitute for pith balls any of the following materials and repeat the experiment: puffed wheat, small feather, small scrap of paper, charcoal from a burned match, a small piece of tin-foil or aluminum foil.

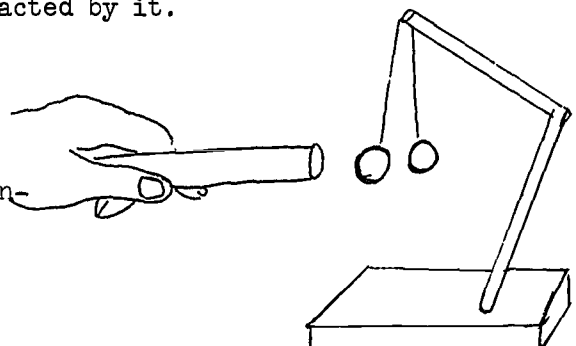

CONCEPT - Electricity can be produced by chemical reactions.

1. Problem

How can we produce electricity through chemistry?

Materials

Lemon, copper strip or a penny, zinc strip, galvanometer, thin wire.

Procedure

Cut a lemon in half and have the metal strips inserted in one half. Run a wire from each strip to the galvanometer.

Results

The galvanometer will show electricity is being produced by the reaction of the citric acid in the lemon with the metal strips.

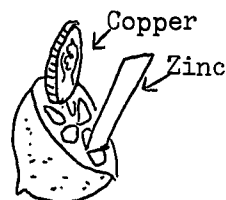

Conclusions

Electricity may be produced by chemical means.

2. Problem

How can we produce electricity through chemistry?

Materials

Penny, iron washer, paper toweling, vinegar, thin wire (#28 magnet wire is best), tape, compass.

Procedure

Have the wire wrapped around the compass about fifty times, leaving about 8 inches free at each end. The wrapped wire may be taped to the compass to hold it in place, but do not cover the face of the compass. Wet the toweling with the vinegar and have child hold it between the washer and the penny. Touch one wire end on the penny and the other wire end on the washer as children observe the compass dial.

Results

A weak current of electricity is produced by chemical reaction which is strong enough to produce a magnetic field that attracts the compass needle.

Conclusions

Electricity may be produced by chemical means.  
A flow of electricity produces a magnetic field.

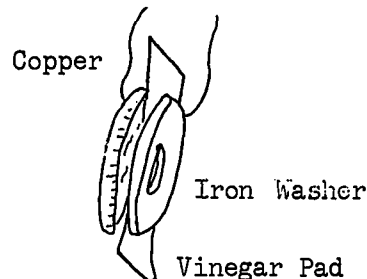

3. Charts, Maps, or Graphs

Draw cut-away charts of an automobile battery and a dry cell battery. List ways in which they are alike and unlike.

4. Observe

Let children take a flashlight battery apart to see the basic parts that make it work.

5. Resource Person

Ask a dealer in automobile batteries to explain to the class the various types and grades of batteries and how they work.

6. Research

Ask a group of children to find out what makes up an automobile battery and how it works. They might write to manufacturers for information of this type.

7. Demonstration

Producing electricity through chemical change.

Materials

A pint jar, sandpaper, alcohol or gas burner, insulated copper wire, zinc strip, carbon rod, electric doorbell, ammonium chloride is dissolved. Stir in slowly 1 tablespoon of potassium permanganate. Clean the strip of zinc with sandpaper and fasten a length of wire to it. Bend that end of the strip to hang over the mouth of the jar. Fasten another wire to the carbon rod. Connect the two wires to the doorbell and ask children to observe that it is not yet ringing. Place the zinc strip into the jar. Heat the carbon rod for several minutes to drive out impurities. Place the carbon rod into the mixture and the bell will ring. Discuss the idea that the chemicals in the jar acted on the zinc strip and the carbon rod to produce an electric current.

CONCEPT - Electricity and magnetism are around us every day in many ways.

1. Problem

How does an electric doorbell work?

Materials

Dry cell, electric door bell, push button switch.

## Procedure

Remove the cover of the doorbell so that the working part can be observed by pupils. Connect the dry cell to the doorbell and the switch. (The push button switch can be placed anywhere in the circuit.) Push the button and hold for several seconds while children observe the action.

## Results

When the current is connected and is flowing through the wires of the electromagnets (a) they become magnetized and attract the iron bar (b). The armature is pulled toward the electromagnets and the clapper hits the bell. This causes the first ring of the bell. As the armature is pulled over, the contact point (c) which is fastened to it is also pulled away from the fixed contact point. The circuit is broken.

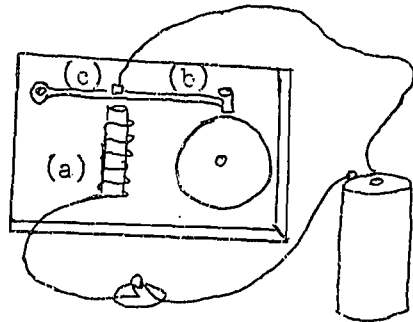

Since there isn't a current flowing through the electromagnets, they no longer attract the armature and it flies back. When the armature goes back the contact points again touch, the circuit is completed, and current flows again through the electromagnets. This attracts the armature to the electromagnets again and the whole cycle of operations is repeated. This continues rapidly as long as the button is pushed.

## Conclusions

An electromagnet is an important part of a doorbell. Without an electromagnet to attract the armature, we couldn't have doorbells.

## 2. Problem

How can we make a model telegraph set?

### Materials

A small flat board, a small block of wood, a thin T strip of tin cut from a coffee can, two iron nails, two thumbtacks, a short strip of copper or brass, some light insulated copper wire, dry cell battery.

### Procedure

Have children construct this model by following these directions carefully. Nail the small wood block on the flat board. Nail the tin T on the block. Drive two nails into the flat board so their heads are just below the tin T strip. Wrap one wire from the dry cell around the two nails and connect to the copper strip (the key), which is nailed

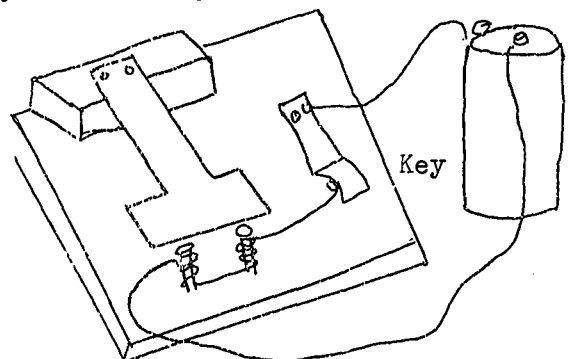



to the board at one end. Connect the second wire to a thumbtack under the loose end of the key. Press and release the key.

### Results

When the key is depressed, the current flows through the strip of metal. It flows through the wire wrapped around the two nails and an electromagnet is made. The T strip of iron clicks against the nails, as soon as the key is released, the T springs from the nails.

### Conclusions

The telegraph uses electricity and magnetism to send messages. When the key which is a conductor is pressed, the current flows in a complete circuit and the nails are magnetized.

## 3. Charts

- a. Have children make a list of the uses of electricity. Use old catalogs or magazines and have the children select pictures of electrical equipment commonly used. Using these pictures, make posters showing the various uses of electricity.
- b. Collect pictures or make a list of all the toys that require electrical energy in their operation.
- c. Make a list or collect pictures of uses for magnets or electromagnets. They are used locally for unloading ore and scrap iron. Explain that they are also used in radios, telephones, telegraph sets, electric motors, and generators.
- d. Have the children make lists of the electrical appliances used by the members of their families. After the more obvious ones have been recorded, they may think of such things as self-starters on cars, blowers in furnaces electric shavers, and many others. Farm children may be able to list more electrical devices than city or suburban children. The class might check those electrical appliances which they use themselves, such as vacuum cleaners, electric refrigerators, and electric trains. They could ask their parents to help them with their lists.

## 4. Observe

Ask the children to think of all the possessions they and their families own which were made by hand tools. They will be surprised to find out how few things they can think of which were made without the aid of power-driven machinery. They might discuss why they think we have changed from making most things by hand, as was done in colonial days, to machine-made articles.

## 5. Resource Person

Ask a representative from the telephone company to come to discuss the use of electromagnets in the telephone receiver.

## 6. Field Trip

If possible, take the children on a field trip to a farm. Have them make a list of the different machines that are run by electrical energy. After each machine listed have them write what kind of work it does. Have them find out how this work was done before electricity was used.

## 7. Research

- a. Have the children list all the things in their homes that are run by an electric motor. What does each do? Find out how the work was done before electricity was used.
- b. Have a discussion and illustrate the ways in which the lives of the children would be different if we did not have electrical power. Consider all facets of life. Include light for illumination, heat for our homes, appliances to do our everyday tasks in a better way, power to start our cars, power to run our factories, and other everyday uses of electricity.
- c. Ask children to find out what they can about Samuel F. B. Morse's life and work to help them appreciate his contribution to our civilization.
- d. Have children use reference books to find out about the electrical discoveries of Luigi Galvani, Alessandro Volta, Adren Ampere, Michael Faraday, Joseph Henry, and George Ohm.

## 8. Bulletin Boards

Gather and show pictures of various means for developing electrical power. Include pictures of hydroelectric dams, power stations run by coal or other fuel, and also mention atomic fuel as a source of electrical power.

## 9. Make Models    A Working Model of A Magnetic Crane

Ask if any children recall seeing magnetic cranes at work in junk yards or seeing pictures of them used in industry. Ask how they think these machines work and how a simple working model can be constructed. An easy model to make would require a fishing rod and reel, knife switch, large nail, dry cell, paper clips, and a length of insulated wire about 3 ft. long. Have the children construct an electromagnet (as described earlier under "Various Ways to Make a Magnet") and tie the end of the fishing line to the nail. With this device a pile of paper clips or washers may be moved from one place to another.

CONCEPT - Electricity should be treated with respect, for it can be very dangerous.

1. Charts, Maps, or Graphs      What Dangers Are Involved in Using Electricity

Make a list of rules that children should follow in handling items that are powered by electricity.

- a. Never touch an electric cord or switch with wet hands or when standing in a bathtub.
  - b. Never get electric wires wet.
  - c. Always replace worn out fuses with new fuses.
  - d. Never use any device in the fuse box in an attempt to reduce the electric bill. (The house might be reduced to ashes.)
  - e. Never touch a broken wire without disconnecting it or throwing a master switch.
  - f. Repair all broken insulation.
  - g. If a broken live wire is found after a storm, warn everyone to keep away. (Notify the electric company.)
  - h. Never touch a person in contact with a live wire. (Use a stick or rubber hose to pull him away.)
2. Ask children to bring in discarded appliance cords. They may take them apart in class to find what materials are used for insulation. Why are these materials used?

3. Resource Person

- a. Invite a resource person from Northern Indiana Public Service Company to discuss safety measures related to electricity.
- b. Ask the school nurse to inform the class what to do in the treatment for electric shock.

4. Draw

Have children make safety posters illustrating common safety rules related to electricity.

5. Research

Ask children to find out why a short circuit may be very dangerous or why it is very unwise to replace a fuse with a penny.

6. Demonstration

Use some discarded electric wire to show the class how to splice broken wires and rewrap with friction tape.

### Evaluation

Included here are samples of evaluation items which could be used in developing your own informal testing program. These suggested types of items cover the particular science area that has been developed in this section of the handbook. This also means they could be used to help develop informal testing to cover large areas of information (monthly, mid-year, end of year testing). These are by no means complete tests as such. You will have to adapt and develop items to meet your particular class's own individual needs and differences.

Read the incomplete sentences and the three endings below each sentence. Draw a line under the ending that finishes each sentence correctly.

1. An electric current is  
a battery of electricity.  
a flow of electricity.  
static electricity.
2. Good conductors of electricity are such materials as  
rubber and plastics.  
metals of all kinds.  
glass and paper.
3. Materials through which electricity does not flow easily are called  
poor conductors.  
good conductors.  
chemicals.

Fill each blank with a word taken from the following list. (You may not need to use all the words in the list. You may need to use some words more than once.)

north	south	magnet	poles	middle	ends
field	stronger	east	west	weaker	closer

1. Every magnet has a (north) magnetic pole and a (south) magnetic pole.
2. A magnet free to move will line up in a (north) and (south) direction.
3. The needle of a compass is a (magnet).
4. A magnet has a greater pull at the (ends) than at the (middle).
5. The magnetic (field) is the space around the magnet in which the magnet's force is acting.

## Vocabulary

One of the strongest keystones of scientific efficiency lies in its vocabulary. The scientist says things precisely, accurately, and briefly. Probably one of the greatest quarrels the science teacher may have with the elementary level teaching today is vocabulary. The science teacher can have no use for vocabulary that is not precise and accurate. Precision in vocabulary is necessary for understanding and meaning of the concept or process being learned.

The words listed below are the basic vocabulary for the indicated area of study. After each word has been introduced, its meaning is to be maintained and extended at each succeeding level of study.

alternating current	galvanometer
ampere	generator
attract	hydroelectric system
bulb	incomplete circuit
cable	insulator
circuit	insulation
circuit breaker	magnet
compound bar	magnetic field
complete circuit	magnetism
conductor	meter
current	repel
current electricity	short circuit
direct current	socket
discharge	solar battery
dry cell	static electricity
electrical energy	strand
electricity	switch
electromagnet	terminal
electromagnetic waves	thermostat
electron	turbine
feed back	vibrate
filament	volt
fluorescent	watt
fuse	

### Children's Books

Books are a very essential part of the instructional materials in elementary schools which provide superior learning experiences for children. The selection of these books poses a difficult problem for librarians, teachers, and administrators because the science field is broad and increasing in scope, and elementary school programs are varied in nature. Some of the more common specific difficulties in choosing books are (1) finding material which deals with the varied interest of children; (2) locating material which gives information correlated with the local school district's instructional guides; (3) finding books of appropriate reading difficulty; and (4) selecting the best books from the many available.

The following list gives help related to the first three difficulties presented. Indirectly, it also helps with the fourth, for the best books cannot be selected until they are located. Further, the brief annotations should be of help in determining which books may be best for a given class. Finally, time should be saved in the selection of the best list if some information about the reading difficulty of available books is provided. It is hoped that this list will suggest for elementary teachers books that are supplementary to basic text series, and that these books will have value either as sources of information or for recreational reading.

It is always hazardous to specify an exact grade placement for a book because of variations in pupil-reading ability in any class group, and because of different uses made of books. Consequently, the lowest grade levels for pupil-use are indicated. At lower levels these same books may be useful if the teacher reads to the children.

This list was adapted from the publication Children's Catalog (1966).

- Adler, Irving Electricity In Your Life; illus. by Ruth Adler. Day 1965 128p illus \$3.95 (5-7) "Explains the basics of electricity in a clear and concise manner giving electricity's nature, history, and many essential uses in the modern world."
- Beeler, Nelson F. Experiments With Electricity (by) Nelson F. Beeler (and) Franklyn M. Branley; illus. by A. W. Revell. Crowell 1949 145p illus \$3.50 (4-7) "Twenty-five projects with electricity including an electric buzzer, signaler, a secret door lock, a dancing doll, and an electric motor. Explanations of underlying scientific principles accompany explicit directions; a list of the simple equipment needed precedes each experiment."
- Branley, Franklyn M. Mickey's Magnet, by Franklyn M. Branley and Eleanor K. Vaughan; drawings by Crockett Johnson. Crowell 1956 illus \$2.50 (1-3) "Mickey's father gave him a magnet to pick up the pins that had spilled all over the floor. Then his...adventures in magnetism began. He found out how a magnet really works. He found out how to make a magnet out of another magnet. And he learned by himself."
- Epstein, Sam The First Book of Electricity, by Sam and Beryl Epstein; pictures by Robin King. Watts, F. 1953 63p illus \$1.95 (4-7) A "presentation, with many helpful diagrams, of the ways in which electricity works, particularly in our homes. Children are cautioned never to experiment with electric current, but several safe and informative experiments with inexpensive batteries are suggested. Included also are a list of books for further reading: and perhaps most fun of

all, directions for making, with very little equipment a telegraph set on which children can tap out messages in Morse code. Simple and safe home experiments and red and black illustrations by Robin King simplify scientific theory."

Feravolo, Rocco V. Junior Science Book of Electricity; illus by Evelyn Urbanowich. Garrard 1960 61p illus (Junior Science Bks) \$1.98 (3-5) This book "explains electricity through simple experiments that you can do yourself, the easy step by step directions and the beautifully clear pictures point out the difference between static and current electricity, how a battery works, what we mean by conductors and insulators, how the electric switch works, what a fuse does, and what we mean by a short circuit."

-----Junior Science Books of Magnets; illus. by Evelyn Urbanowich. Garrard 1960 64p illus map (Junior Science Bks) \$2.25 (2-5) "The properties and uses of magnets and electromagnets are described clearly and accurately, with the aid of easy experiments."

Freeman, Ira M. All About Electricity; illus. by Evelyn Urbanowich. Random House 1957 141p illus map (Allabout Bks) \$1.95 (5-7) "This is the story of how electricity has been successfully harnessed by man to supply power heat and light in order to make modern living safer, more comfortable and more interesting. It is also the story of those men who made this possible--Edison, Bell, Marconi and others. The principles behind their discoveries and inventions are discussed and explained. Simple diagrams help to clarify the text."

Freeman, Mae The Story of Electricity, by Mae and Ira Freeman; illus. by René Martin. Random house 1961 79 illus (Easy-to-Read Science Bks) \$1.95 (3-5) Partial contents: Electricity pushes and pulls; Charges move along; Electricity from the sky; Batteries; Experiments with a current tester; Magnets; Electric motors; Power stations; Sounds from far away; Radio and television; The electric eye; Some words of science used in this book. In simple terms with many diagrams and drawings these experienced authors explain the role of electricity in modern life. The contributions of Franklin and Edison are described."

Irving, Robert Electro-Magnetic Waves; illus. by Leonard Everett Fisher. Knopf 1960 141p illus \$3 (5-7) Seven kinds of rays "are the subject of this book. . . . One of these rays is visible to us--light. The other members of the family are invisible and they include radio waves, infrared rays, ultraviolet rays, X rays, micro waves, and gamma rays."

Pine, Tillie S. Electricity and How We Use It (by) Tillie S. Pine (and) Joseph Levine; illus. by Bernice Myers. McGraw 1962 48p illus (Whittlesey House Publications) \$2.75 (2-4) "In easy-to-read text, animated drawings, and simple experiments utilizing inexpensive materials, this introductory account explains the nature of electricity, the operation of electric circuits, and the dangers and uses of electricity."

-----Magnets and How to Use Them (by) Tillie S. Pine (and) Joseph Levine; illus. by Anne Marie Jauss. McGraw 1958 47p illus (Whittlesey House Publications) \$2.75 (1-3) "All kinds of magnets are described in this book. The authors tell what kinds of things will stick to magnets, and how magnets can work through things. They explain how to make your own magnet and how to make an electro-magnet with a dry cell."



- Reuben, Gabriel H. What is A Magnet, by Gabriel H. Reuben and Gloria Archer; pictures--Gregory Orloff. Benefic Press 1959 44p illus (The What Is It Ser) \$1.60 (3-5) Contents: This is a magnet; Magnetic poles and fields; Natural and artificial magnets; Temporary and permanent magnets; Electromagnets; Uses of magnets; What causes magnetism; Magnets can make electricity "This useful introductory book is more difficult than its format indicates."
- Syrocki, B. John What is Electricity; pictures (by) A. K. Bilder. Benefic Press 1960 45p illus (What is it ser) \$1.80 (2-4) "A general introduction to electricity, the reactions by which cells produce current, the magnetic principle behind generators, insulators, switches, fuses and the uses of electricity."
- Valens, E. G. Magnet; photographs by Berenice Abbot World Pub. 1964 unsp illus \$3 (5-7) In this book, illustrated with "photographs of actual experiments, the reader can explore for himself, step by step the basic principles of attraction and repulsion, magnetic poles and magnetic lines of force, electromagnetism, and finally even unanswered questions about the great magnetic fields of the earth and space."
- Van de Water, Marjorie Edison Experiments You Can Do; based on the original notebook of Thomas Alva Edison, prepared under the direction of International Edison Birthday Celebration Committee of the Thomas Alva Edison Foundation. Photographs Fremont Davis. Harper 1960 129 illus \$2.95 (5-7) The experiments "are grouped by subjects, e.g. insulation, carbon on button, etc. Each category is introduced by a statement about Edison's thinking and work in the area. Biographical sketch points up circumstances relating to his inventions. Directions on how to conduct the experiments are clear, and the materials are easily available."
- Waller, Leslie A Book To Begin On Electricity; illus. by Laslo Roth. Holt 1961 unsp illus (A Book To Begin On) \$2.75 (2-4) Title on spine: Electricity "A mixture of basic phenomena, applied science, history, and safety rules. Explanations contain little scientific detail. Book serves best as an historical discussion of the experiments with electricity done by the ancient Greeks, Watson, Franklin, Volta, Galvani, Faraday, Bell, Edison, and others."
- Yates, Raymond F. The Boys' Book Of Magnetism. Rev. ed. Illus. with photographs. Harper 1959 161p illus \$3.50 First published 1941 Contents: We live on a magnet; Magnets that float in the air; Toys that move with magnetism; Make these games with magnets; Magic with magnets; Electricity and magnetism; We build a big electromagnet; New miracles of magnetism A book which "will fascinate most boys and many girls. Both simple tricks and more complicated ones are clearly explained. Illustrated with excellent photographs."



## Films

These films are available from the Central Audio-Visual Department. Contact your building A-V Coordinator to arrange for the use of these films.

All films should be previewed to determine suitability for use with your particular class.

Electricity And How It Is Made 11 min. Col. Int.

This film presents concepts necessary for basic understanding of electricity at the primary grade level. It is designed to create a visual awareness of electricity - how it is produced, what it does, and how it is used to give us light, heat, sound, and power. Both static and current electricity are illustrated through a series of simple demonstrations.

Electromagnets 11 min. B & W Int.

This film explains the theory of electromagnetism by building from a simple bar magnet to a completed electromagnet made from simple home materials; shows how the electromagnet is used in the doorbell, telegraph set and many other everyday applications.

Flow Of Electricity 10 min. B & W Int.

Two children learn about the factors which affect the flow of electricity through a simple electrical circuit. The film introduces the electron theory, and shows the application of a simple circuit in a home situation.

Forces 14 min. Col. Gds. 5 & 6

A force is a push or a pull -- when forces acting on an object are balanced, the object remains motionless; when the forces are unbalanced, the object moves. Pairs of forces can change the shape of an object -- machine makes it possible to change the direction or size of a force. Three kinds of forces that act between objects not touching each other are magnetism, electricity and gravity.

How To Produce Electric Current With Magnets 11 min. Col. Gds. 5 & 6

This film shows electricity and magnetism are closely related. An electric current can produce a magnetic effect. If an iron core is placed inside a coil of wire and electric charges flow through the wire, a magnetic effect is produced. The device is called an electro-magnet. Electromagnets can attract iron and steel. Magnets can be made to produce electric currents. Also explains that machines that move magnets and coils to produce electric current are called generators.

Magnets And Their Uses 9½ min. Col. Pri., Int.

This film is designed to help students learn what magnets do, and how they are used. Magnets attract some, but not all, materials. Demonstrations, through the use of animation, show the uses, properties and characteristics of magnets.

Magnetic, Electric, And Gravitational Fields      11 min.      Col.      Gds. 5 & 6

The film shows a region of space where at every point a force can be felt, is a field; and explains a magnetic field and an electric field. Although fields cannot be seen, we can observe the effects they have on objects. Fields extend out in all directions from their source. There is a gravitational field around all objects--a gravitational field extends out from the earth in all directions.

Story of Magnetism      13½ min.      Col.      Int.

This film dramatically presents the story of the gradual development of man's knowledge of the nature of magnetism. From the early unrecorded discovery of the lodestone through the discoveries and experiments of Gilbert, Oersted and Faraday, we trace the story in authentic historical settings, down to the latest theories of scientists today. This film vividly presents and explains kinds of magnets, materials from which magnets are made, magnetic fields, electro-magnets and magnetism as source of electricity.

Thunder and Lightning      10 min.      B & W      Int.

The film explains the phenomena of thunder and lightning in simple terms, using this as a springboard for understanding static electricity; shows that by rubbing certain objects together we cause them to become charged with electricity; that all charges repel and unlike charges attract; that in a similar manner clouds become charged, and that lightning results when they discharge; and also discusses protective measures against electrical charges.

What Is Electric Current?      14 min.      B & W      Gds. 5-6

This film shows the many uses electric current has. The "stuff" in wires that can flow is called electric charge. When something pushes electric charges and makes them flow there is an electric current. The film also shows how batteries and generators act like pumps that make the electric charges flow.

PART VI - FRICTION AND MACHINES

Initiatory Activities..... 219

Developmental Activities..... 219

    Concept

    Six simple types of machines include the lever, the pulley, the wheel and axle, the inclined plane, the wedge, and screw..... 219

    An inclined plane helps us to move things more easily..... 221

    The screw is an inclined plane..... 223

    A wedge is a combination of two inclined planes..... 225

    Wheels and axles are used for making work easier by reducing friction..... 226

    Levers help us to lift things more easily. There are three classes of levers. Each has a fulcrum, a force arm and a load arm..... 229

    A pulley is a simple machine that can be used in two ways: to change the direction of the force; and to reduce the amount of force required to do work..... 232

    Friction opposes all motion. Friction results when two surfaces rub against each other..... 233

    Things move because forces act upon them..... 236

    Friction can be reduced to make work easier by using wheels, rollers, bearings or lubricants..... 239

    The energy of the wind, falling water, burning fuels the sun and the atoms are all being put to use in machines invented by man..... 241

Evaluation (Sample Items)..... 245

Vocabulary..... 247

Children's Books..... 249

Films..... 253

## FRICITION AND MACHINES

### Initiatory Activities

Have the Children:

1. Place a number of tools and toys that are simple machines on the science table.
2. Prepare a bulletin board display of pictures showing various types of simple machines. Include some pictures of complex machines that obviously include one or more of the simple machines.
3. Take a field trip to a nearby construction project to observe various machines in use.
4. Discuss the importance of machines in modern life. Have the children tell how their lives would be different if they were suddenly deprived of all machines. Discuss the accomplishments of the ancient Egyptians who had only simple machines to help them do work.
5. Display books about machines on the science table and encourage the children to examine and read them during free reading periods.
6. Prepare a display of pictures that show a contrast in ways of doing the same type of work with different types of machines.

### Developmental Activities

CONCEPT - Six simple types of machines include the lever, the pulley, the wheel and axle, the inclined plane, the wedge, and the screw.

#### 1. Charts

- a. Children could construct an illustrated vocabulary chart as they come across science words in the study of simple machines.
- b. Collect pictures of people working. What tools do they use? From a hardware or tool catalogue, cut out pictures of interesting tools for a bulletin board.

#### 2. Drama

##### Remembering Safety Rules

You could discuss safety with tools. (Scissors should be handed to someone else by the handle. When using a hammer, watch that no one is near. On a seesaw, watch your feet and hands.)

- a. This could be dramatized by letting one group of students illustrate unsafe practices while the rest of the class guesses what they are doing wrong. Children could illustrate rules such as the following and add many more of their own.

- (1) Always cut away from the body when using a knife.
  - (2) Always hold the materials you are cutting behind the path of the blade.
  - (3) Never place fingers near the blades of a lawn mower.
  - (4) When riding a bicycle use guards to prevent clothing from being tangled in the wheel.
- b. They could also discuss clippings from newspapers relating to accidents which occur because of improper use of tools.
  - c. Ask children to dramatize how they think the different types of simple machines were first used by early man.

### 3. Resource Person

Ask the custodian to show the class the various tools and machines he uses. Ask the children to classify these as simple or compound machines.

### 4. Draw

Children might like to make a mural depicting some of the ways they have noticed that work is made easier for us.

### 5. Field Trip

Go to a factory to see the different kinds of machines and tools that are used.

### 6. Research

- a. Ask children to do research to find out what tools and weapons early man used. Why are things such as the club, spear, and axe, forms of machinery?
- b. Have the children look in the dictionary to find out about the different meanings of the word "work."

### 7. Collect

Ask children to make a collection of toys or tools which are simple machines (or pictures of these objects). Have each classed as to what type of simple machine it is or if it is a combination of simple machines.

### 8. Bulletin Board

- a. Let children prepare a bulletin board of pictures showing how machines make work easier.
- b. Let children make drawings illustrating examples of the six types of

simple machines. Under these the children may list examples of these machines they have noticed at home.

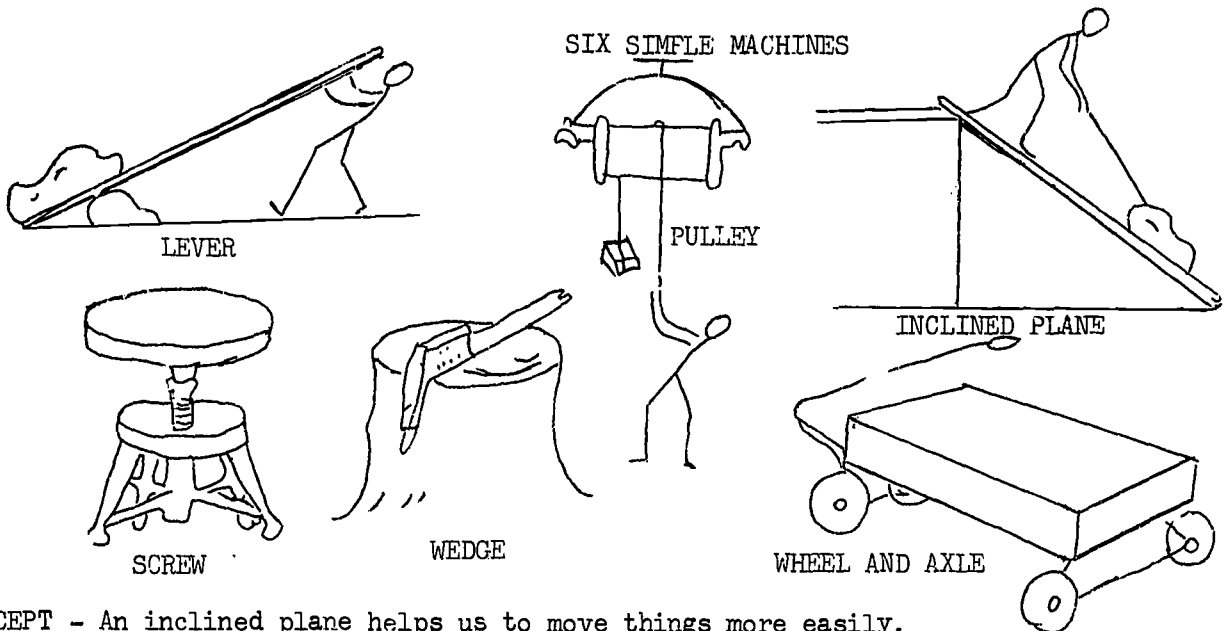

CONCEPT - An inclined plane helps us to move things more easily.

1. Problem

Does an inclined plane make work easier?

Materials

A medium thick rubber band, a skate, a wooden ruler, a thumbtack, a foot of twine, several books, a short length of board.

Procedure

With the thumbtack, attach the rubber band to the "zero" end of the ruler. Tie the twine to the other end of the rubber band and to the skate. The amount of stretch of the rubber band can now be measured on the ruler. The stretch indicates the amount of force you are using. Lift the skate with the ruler. How much does the rubber band stretch? Does the skate feel heavy? Now make an inclined plane with the board and the books. Pull the skate up the inclined plane. How much does the rubber band stretch? Does the skate feel as heavy as it did before? With an inclined plane, do you need to use more or less force than when lifting straight up?

Results

The skate is easier to move using an inclined plane.

Conclusions

Inclined planes are a great help in many lifting jobs. The ramps in garages and the sloping ends of some railroad platforms are really inclined planes.

## 2. Problem

How are inclined planes useful to man?

### Materials

Boards of different lengths,  
toy wagon, spring scale, cord.

### Procedure

Have children record and compare the force needed to move the loaded wagon in each case.

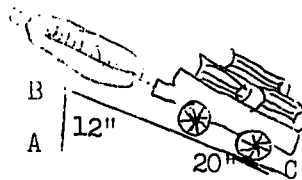

Fig. A

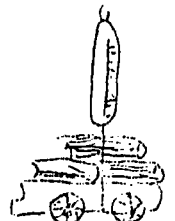

Fig. B

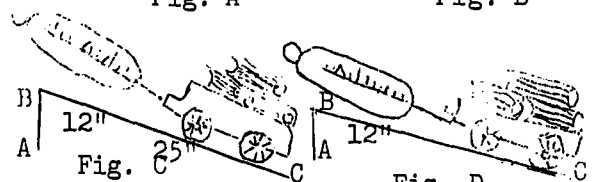

Fig. C

Fig. D

- a. Make an inclined plane with boards ABC (Fig. A).
- b. Put books in the toy wagon for weight and secure it with cord, (Fig. B).
- c. Weigh the wagon and books (Fig. B). The weight represents the amount of force required to lift the wagon.
- d. Haul wagon up incline as shown in figure A.
- e. Make another (longer) inclined plane (Fig. C).
- f. Haul loaded wagon up inclined plane CB.
- g. Record force required.
- h. Make a third inclined plane using longest board. (Fig. D).
- i. Haul loaded wagon up CB. Record force required.

### Results

Less force is required to pull the wagon up the longer inclined plane.

### Conclusions

The inclined plane helps by requiring less force. It lets us trade one factor (distance) for another (force). The longer the inclined plane, the more gentle the slant. Consequently much less force is required to ascend. Because of the greater distance traveled, the same total amount of work is required.

## 3. Observe

Let children compare pictures of ramps and stairways and discuss why both are inclined planes.

4. Demonstration      Showing Advantage of Sliding

Place a number of blocks of wood or similar objects on top of a desk or table. Have children lift the blocks to move them to the other side of the desk or table. Then, have them move the blocks by sliding or pushing them. Compare the amount of effort or force used in each case.

Showing Uses of Ramps

Consider the answers to the following questions:

- a. How are cars put on the top of auto trailer carriers?
- b. How is a heavy bulldozer put on top of its trailer?

After the idea of ramps has been discovered, arrange a demonstration within the classroom. Show how we can move a heavy object up to a table (use a low table) with the assistance of a ramp. Then, make a list or chart of pictures of all the places where children have seen ramps which make work easier. Arrange demonstrations, such as the above, using ramps and wheels in combination.

5. Bulletin Boards

Have children gather and display pictures of various examples of inclined planes.

CONCEPT - The screw is an inclined plane.

1. Problem

How is a screw useful to us?

Materials

Two pieces of wood, wood screws, screw driver.

Procedure

Have a child hold the two pieces of wood tightly together with his hands while another child tries to move the pieces. Fasten the two pieces of wood together with wood screws. Have the children try to move them apart.

Results

The force of your hand cannot hold two pieces of wood tightly together. Yet the same force can turn a screw that holds the two pieces very tightly.

Conclusions

Screws are useful because they increase force.



2. Observe

Obtain a jackscrew used to lift heavy weights and let the pupils observe how it works. Point out that the force of their arms cannot lift a car, but the same force can turn the handle of a jackscrew that lifts the car quite easily.

3. Research

Have children find out why screws are better than nails for some purposes. What advantages do nails have over screws?

Cut a piece of paper into the shape of an inclined plane. Shade edge as shown. Wrap the paper around the pencil by starting at the wide end of the paper. The demonstration shows that a screw is an inclined plane wrapped around a shaft.

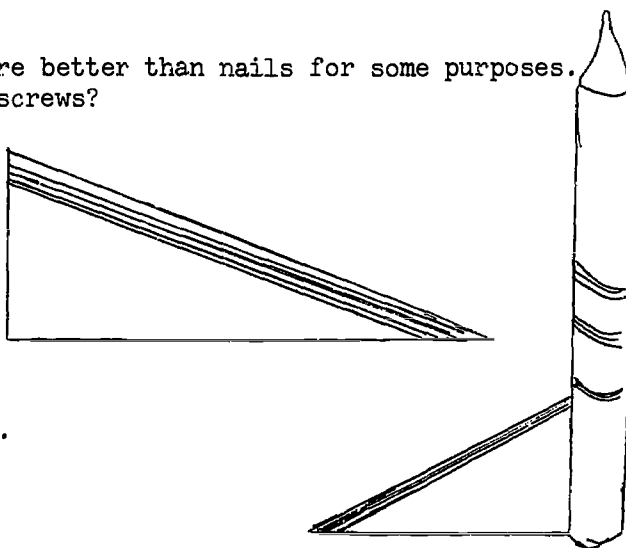

Demonstrate a food grinder in class. Take it apart so the children may find the screw.

4. Bulletin Boards

Ask children to collect and display various types of screws and tell the purpose for each.

5. Make Models      Making A Model Screw Conveyer

Materials

A 3/4 inch wood bit, a piece of cardboard about six inches long, a marble.

Procedure

Bend the cardboard so that it makes a little trough. The trough should be just wide enough for the bit to fit in snugly. Place the trough near the edge of a table. Put the bit in the trough, and then place the marble on the bit. Now turn the bit with your fingers, from right to left, and watch the marble. What happens?

Results

In the same way, large screw conveyers are used for pushing coal, ashes, and other solid materials.

Making Propellers

Have children make models of airplane and boat propellers and explain why they are screws.

CONCEPT - A wedge is a combination of two inclined planes.

1. Problem

How does the wedge make work easier?

Materials

2 nails (large), board, hammer.

Procedure

File down or cut off the point of one nail. Have a child pound both nails into the board. Which required less energy to pound?

Results

The pointed nail entered the board much easier than the nail with no point.

Conclusion

Wedges help to make work easier for us. The point of a nail is an example of a wedge.

2. Charts

Have children compile a list of wedges that are used in everyday life.

3. Observe

Let children compare a knife and an axe and discuss their uses. Ask the children to locate the double inclined planes in these machines.

4. Bulletin Boards

a. Ask children to bring in pictures of knives, axes, nails, garden stakes, the prow of a ship, a wedge being used by lumber men, etc. Display these to show the various uses of the wedge.

b. Make a display of all types of wedges that the children can gather, from the smallest pin on up. Have them write a short story to explain how each is used.

5. Research

Ask children to find examples of how plants and animals use wedges, such as the plant roots and the woodpecker's beak.

6. Demonstration

Demonstrate with an apple to show how a knife acts as a wedge in cutting away the skin.

CONCEPT - Wheels and axles are used for making work easier by reducing friction.

1. Problem

What shape rolls best?

Materials

Objects of various shapes, such as: top, ball, pencils (round & hexagonal), spring spool, tin can, wood blocks.

Procedure

Set up a plank or a sturdy piece of cardboard at a slant. Have children test each object to see if it will roll down the slant and continue rolling on the floor. Compare the distances rolled by the different objects. Conduct a "race" between a round pencil and a hexagonal pencil to see which shape rolls best.

Results

All the round objects rolled much better than objects of other shapes.

Conclusions

Round things roll best.

2. Problem

How do the wheels and axles help us to work?

Materials

Two boxes of the same size (one with wheels and one without), some heavy materials such as sand, books, etc., spring scale.

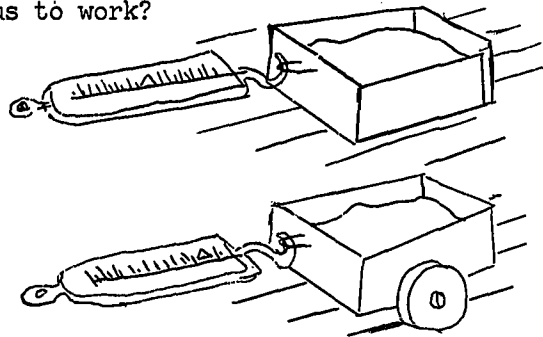

Procedure

- a. Place the sand or heavy material in the box without wheels.
- b. Attach the scale to one end of the box.
- c. Holding the other end of the scale, drag the box a distance of one yard.
- d. Make a note of the number of pounds indicated by the pointer on the spring scale while the dragging was in progress.

- e. Transfer the load to the box with wheels.
- f. By the same process move this box one yard and record the pounds indicated on the spring scale.

### Results

The pounds indicated show the differences in the amount of energy needed to move each box. More energy was needed to drag the box without wheels than the box with wheels because the entire surface of the base of the box without wheels was exposed to friction, whereas the wheels of the other box rolled over the surface to which they were exposed.

### Conclusion

The wheel and the axle are very important in reducing friction.

## 3. Problem

How do wheels reduce friction?

### Materials

Toy car, block of wood the same size as the car, small board, books.

### Procedure

Stack several books and place one end of the board on the top book to form a ramp. Ask children to place the toy car and the wood block at the top of the ramp and release them.

### Results

The car rolls down the ramp, while the wood block stays stationary or moves very slowly down the ramp.

### Conclusions

Friction may be reduced by the use of wheels. Rolling friction is less than sliding friction.

## 4. Drama

Have a group of children dramatize the historical high points in the development of the wheel and axle.

## 5. Observe

- a. Have children observe a doorknob, pencil sharpener, egg beater and bicycle wheels. What do they have in common? Help children recognize other everyday uses of the wheel and axle.

- b. Conduct a "wheel hunt" in which children look for things, inside and outside school, that move on wheels. Compile a list which can be added to when new discoveries are made.
- c. Have children examine a bicycle. Point out that the large gear on the pedals turns the small gear on the back wheel. Turn the pedals so the pupils can see the large gear move slowly but causes the small gear to move faster. Point out that if the small gear of a machine drives the large gear, the machine will move slower but will have more power.

6. Draw

Ask a group to prepare a frieze, diorama, or time line on the development of wheel and axle.

7. Research

Have children find out how steel train wheels and axles are made.

8. Demonstration                      Advantage of an Axle

Try to move a number of blocks with one finger. Then, put two pieces of chalk or other axle type rods under the blocks and try to move them. Compare the amount of effort required. Rolling makes things move more easily than sliding.

Advantage of Wheels

Materials

A roller skate or toy wagon, a moderately heavy and bulky object.

Procedure

Have a child try to slide the object across the floor. Then, place the object on the toy wagon or roller skate and move it across the room. Compare the amount of effort needed. Wheels make work easier.

Using an Axle and Gear

Materials

A milk carton, a pencil, a spool (that fits a pencil), some twine, a book.

Procedure

Near the top of the milk carton, make two holes that a pencil can pass through. Wiggle the pencil a bit until it can turn freely in the holes. After fastening the twine to the book, tie the other end tightly to the pencil. Try to lift the weight by turning the pencil with your fingers. Now push the spool onto the pencil. Be sure it fits tightly. Turn the spool and again lift the weight. Is it easier now?

CONCEPT - Levers help us to lift things more easily. There are three classes of levers. Each has a fulcrum, a force arm, and a load arm.

1. Problem

What is a first class lever?

Materials

A three-sided block of wood (fulcrum), ruler, weight.

Procedure

Have children place the middle of the ruler on the wood block. Place a weight on one end and push down on the other end.



Is this less work than picking up the weight?

Results

Less force is needed to move the weight with the lever.

Conclusions

Levers help us do work more easily. When the fulcrum is between the weight and the force, the lever is called a first class lever. Examples: Seesaw, crow bar, pump handle, scissors.

2. Problem

What is a second class lever?

Materials

A three-sided block of wood, ruler, weight.

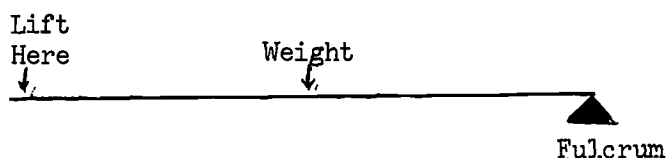

Procedure

Have children place one end of the ruler on the wood block (fulcrum) while one student holds the other end in his hand. Place the weight between the fulcrum and the student's hand. Ask the student to lift the weight. Have other children try this and decide if this is less work than is involved in picking up the weight without the lever.



#### 4. Demonstration

##### a. Materials

Ruler, blackboard eraser, a number of books.

##### Procedure

First have a child try to lift the books with one finger. Then arrange the ruler, as a lever, with the eraser as the fulcrum. Compare the amount of effort or energy required to lift the books in each case.

##### Results

Levers make our work easier.

- b. Drive a nail half-way into a board. Have children try to pull it out with their fingers. Let them then pull it out with a claw hammer. Discuss how the lever works in this case. Try pulling out a nail while holding the hammer handle close to the claw and compare how much easier it is while holding the handle farther away.
- c. Have pupils rise and stand on their toes. What are they lifting? What helps to lift themselves up? What are they balancing themselves on? Explain that this is an example of a third class lever.

##### Bulletin Boards

Have children arrange a bulletin board display depicting the uses of levers.



CONCEPT - A pulley is a simple machine that can be used in two ways: to change the direction of the force; and to reduce the amount of force required to do work.

1. Problem

How do pulleys help man in lifting weight?

Materials

Two or more pulleys, weighted pail, light rope (or strong cord), a set of draw scales.

Procedure

Have children try all four activities and compare the results.

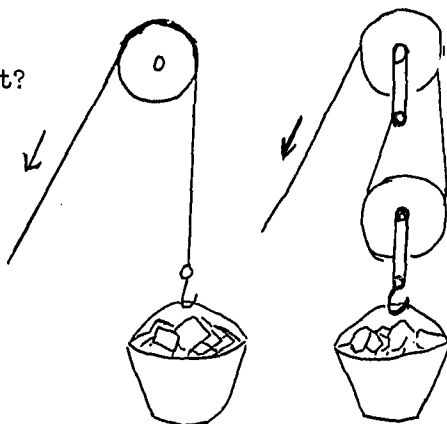

- a. Lift up weighted pail by cord and draw scales.
- b. Put small rope over the pulley. Be sure the rope is long enough to touch the floor. Tie one end of the rope securely to the handle of the pail and pull down on the end of the rope. Keep on pulling until the weight is lifted above your head.
- c. Fasten a piece of heavy cord to a hook or nail high up on the wall. Attach a weight to a pulley and put the cord through the pulley. As you pull up on the cord, the pulley moves up carrying the weight with it. This pulley is called a movable pulley because it moves along the cord. Fill a pail with stones. Weigh the pail of stones on a pair of draw scales.
- d. Fasten the pail to the pulley and the end of the cord to the draw scales. By pulling on the scales, you can lift the pail. How much force did it take to lift the pail without the pulley? How much muscle force did it take when the movable pulley was used?

Results

- a. In the first set-up, the actual weight is determined.
- b. In the second set-up with one fixed pulley, the force required is the same if the friction is omitted. This merely changes the direction of pull.
- c. In the third part with one movable pulley, the force is halved but the distance is doubled.
- d. In the fourth experiment, the force is again reduced - this time by one-half. The force can be determined by counting the number of movable strands and dividing this into the weight.

## Conclusions

Fixed pulleys and movable pulleys help us in many ways. They help us raise our windows, get the flag to the top of the pole, and help farmers to get their hay up to the hayloft. A movable pulley lifts half the load. The more pulley wheels there are, the easier it is to lift the load. Pulley blocks are used in cranes and derricks to lift heavy loads such as big pieces of steel, etc.

### 2. Charts

Make a list of all the places where we use pulleys to make work easier. Include the flag pole, draw drape rods, winches, and others.

### 3. Observe

Have the class observe the raising or lowering of the flag. Where is the fixed pulley?

### 4. Research

Have children find out how pulleys are used in heavy industrial machinery, such as cranes.

### 5. Make Models

Instruct children in making models of different types of pulleys; single-fixed, single-movable, double movable. Discuss how they are different and how they might be used. Ask them to trace the direction of movement in each case. Simple models could be made from spools, coat hangers and string.

CONCEPT - Friction opposes all motion. Friction results when two surfaces rub against each other.

### 1. Problem

How can we show friction opposes motion?

#### Materials

Round pencils, circles of cardboard (6 inches diameter).

#### Procedure

Ask the children to put their pencils through the center of the cardboard. Point out that they now have a wheel on an axle. Ask them to spin their wheels.

#### Results

The wheels will spin for a very short time and will stop, since the cardboard is rubbing against the surface of the pencil.

### Conclusions

Friction will stop a moving wheel. Friction results when two objects rub against each other.

### 2. Problem

What types of surfaces cause the most friction?

### Materials

Small block of wood, a screw eye, string, a rough wooden board, a small pane of glass, a heavy stone.

### Procedure

Fasten the string to the screw eye and screw this into the small block of wood. Place the stone on the block. Have children pull this block, first over the rough board and then over the glass.

### Results

The block with the stone will be much harder to move over the rough board than over the glass.

### Conclusion

Friction is always present when two surfaces rub against each other. The rougher the surface the stronger the friction.

### 3. Problem

Can friction be useful?

### Materials

Rope.

### Procedure

Have a boy wearing gym shoes to pull a rope opposite a boy wearing leather soled shoes. ( Be sure the boys are about the same size and weight.)

### Results

The boy with the gym shoes will be able to pull the other boy, for there is less friction with the leather soled shoes.

### Conclusions

Friction can be useful and special equipment is made so as to increase friction, such as gym shoes.

4. Problem

What are the effects of friction?

Materials

Matches, block of wood, sandpaper.

Procedure

Ask children to rub the palms of their hands together briskly and notice the results. Strike a match and let the children discuss why it lights. Have the children rub a block of wood with sandpaper and notice the results.

Results

These are all examples of friction. The children's hands grow warm and the match lights because friction produces heat. Particles of wood are worn away by the sandpaper.

Conclusions

Friction produces heat and causes wear.

5. Observe

- a. Ask children to recall walking on ice during winter. What did they notice about the difficulty of walking on ice compared to walking on dry pavement? Lead them to understand that friction is helpful in many ways.
- b. Have children observe the shapes of the fish in the aquarium and comment on why they are shaped that way. How do the hard smooth scales help the fish?

6. Research

- a. Ask a research group to prepare a report and demonstration on the way early man started fires by rubbing pieces of wood together or by striking sparks.
- b. Ask some children to find out how automobiles stop when the brake pedal is depressed.
- c. Have children report on why airplanes and submarines are "streamlined." What is fluid friction?

## 7. Demonstration

- a. Place a smooth board and a rough board at a similar angle and place a weight on each. Increase the angle until one of the weights slides to the bottom. Which one slid first? Why did it slide before the second one?
- b. Rub a piece of cotton over a rough wood board and over a pane of glass. Cotton will adhere to the board because it is held back by the rough surface. Rough surfaces produce more friction than smooth surfaces.

## 8. Bulletin Boards

Ask children to prepare a bulletin board illustrating the good and bad effects of friction. For example, it makes it possible for us to walk from one place to another, but it also causes shoe soles to wear out.

CONCEPT - Things move because forces act upon them.

### 1. Problem

How can we start something moving?

#### Materials

A brick, thin cotton string.

#### Procedure

Tie the string tightly around the brick. Have a child try to move the brick by pulling the string slowly. Then have the child try to move the brick by quickly pulling the string.

#### Results

The string will break when the child attempts to move the brick by pulling the string quickly.

#### Conclusions

A force must be applied to start an object in motion, since an object at rest resists change. The faster an object must be put into motion, the greater the force needed. Once an object is moving, only friction has to be overcome. A much smaller force is needed to keep an object moving than is needed to start it moving.

### 2. Problem

How can we use stored energy?

#### Materials

Mechanical alarm clock, mouse trap, spring, wind-up toy.

### Procedure

Set the alarm so that it will ring in a few minutes. Set the mouse trap and allow one of the children to release it by touching the plate with a ruler. Have the children stretch or compress the spring to feel it trying to force its way back to its original position. Wind up the toy and let children observe how the stored up energy makes it move.

### Results

These are all examples of energy stored in springs.

### Conclusions

Energy may be stored and then released to force things to move.

## 3. Problem

Why do things move?

### Materials

Roller skates, basketball.

### Procedure

Ask a child to put on the roller skates and stand with his feet parallel. Give him the basketball and ask him to pass it to someone by thrusting it away directly in front of him.

### Results

As the ball is pushed away, the child rolls backward on his roller skates.

### Conclusions

Objects move because force acts upon them. For every action, there is an equal and opposite reaction.

## 4. Problem

What is inertia?

### Materials

Drinking glass, a marble.

### Procedure

Lay the empty glass on the table with its open end pointing forward. Ask a child to place the marble near the bottom of the glass and push the glass forward and then quickly stop the glass.

### Results

The marble will remain in the glass until the glass stops moving; the marble will continue moving forward.

### Conclusions

Every moving object has a force that resists its stopping. This force is called inertia of motion. (Example: the forward motion of your body when your car stops suddenly.)

## 5. Problem

What is inertia?

### Materials

A drinking glass, a penny, a thin cardboard (a little larger than the top of the glass).

### Procedure

Fill the glass halfway with water. Cover the glass with cardboard and place the penny in the middle of the cardboard. Ask a child to flick the cardboard off the glass (using the same kind of motion as in shooting marbles). What happened to the penny?

### Results

The cardboard will slide off the glass, but the penny stayed in position and fell into the glass.

### Conclusions

Every resting object has a force that resists its starting to move. This force is called inertia of rest. (Example: the backward motion of your body when your car or bus starts suddenly.)

## 6. Charts or Graphs

Have children construct charts showing how machines move things in such ways as: pushing, pulling, forcing, and lifting.

Have the children draw charts of simple machines that change the direction of force. For example, in a single fixed pulley, a pull downward will result in a lift upward.

## 7. Resource Person

Ask a representative from the traffic bureau of the Police Department to inform the children on safe following distances for automobiles and why these differ with the speed of the automobile.

### Results

- a. The spoolmobile rolls along under its own power when wound up and when released.
- b. Spoolmobiles do not create their own energy. The operator puts in energy when he winds up the spoolmobile. This energy is used for self-propulsion of the spoolmobile.

CONCEPT - Friction can be reduced to make work easier by using wheels, rollers, bearings or lubricants.

#### 1. Problem

How will bearings make work easier?

#### Materials

Wood board books, marbles.

#### Procedure

Lay the board down on the floor and place 5 - 10 books on it. Have the children push or pull the board to see how much effort is needed to move it. Place the marbles under the board and let the children move the board again. Explain that the marbles are acting as bearings.

#### Results

It is easier to move the loaded board when the marbles (bearings) are under it.

#### Conclusions

Bearings reduce friction and make work easier. Rolling friction is less than sliding friction.

#### 2. Problem

How will lubrication make work easier?

#### Material

Two blocks of wood, soap.

#### Procedure

Have the children rub the two blocks of wood together. Let them apply soap to the surfaces of the blocks and rub them together again. What do they notice?



9. Research

- a. Ask the children to find out how plant leaves slowly move to catch a greater amount of sunlight. Have a group of children prepare a report on the force of gravity and its effect on motion. They might report on the experiments of Galileo pertaining to gravity.
- b. Have the children read about Isaac Newton and tell about the laws of motion and gravitation.

10. Demonstration

Release an inflated balloon and discuss with the children why the balloon is propelled forward - the principle of action - reaction. How does this compare to the rocket launchings the children have seen? Have the children collect pictures to display other examples of the action - reaction principle, such as a man rowing a boat, an airplane flying, etc.

11. Bulletin Boards

Let the children construct a bulletin board illustrating examples of Newton's Laws of Motion.

12. Make Models

A Spoolmobile

Materials

Spool, two match sticks (one long and one short), rubber band, piece of soap.

Procedure

- a. Put rubber band through the hole in the spool, and put the small match stick through one of the loops made by the rubber band.
- b. Cut the soap into a circle with its diameter about half that of the spool end.
- c. Cut a small hole in the center of the soap.
- d. Place the other loop of the rubber band through the soap and put the long match stick through this loop. Rubber band should be about twice as long as the spool. (Soap provides moderate lubrication, but soft floating soap will stall spoolmobile).
- e. It may be necessary to notch end of spool to prevent the small match stick from slipping.
- f. Notches on raised wheel ends of the spool may be made to correspond with treads on tires to provide better traction.

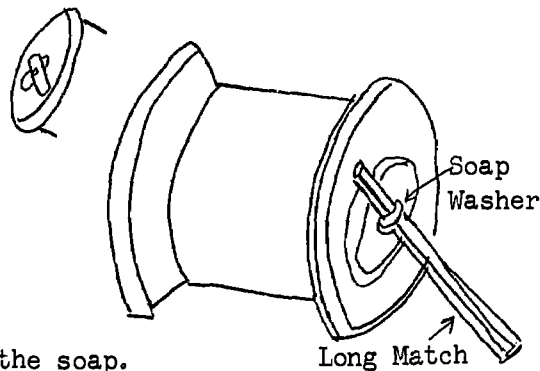

5. Research

Have the children find out how various lubricants such as graphite, oil, and etc., are produced. Develop a chart to show the steps in production from raw material to finished product.

6. Demonstration    Showing The Value of Lubrication

Arrange to have a child bring a bicycle that is in need of oil to school. Visit the playground with the class and turn the bicycle upside down. Start the front wheel spinning and observe how long it continues to spin. Then apply oil or another lubricant to the axle and then spin the wheel. Compare the length of time it continues to spin. The same thing could be done with a wagon or roller skates. Lubrication reduces friction and makes work easier.

CONCEPT - The energy of the wind, falling water, burning fuel, the sun and the atom are all being put to use in machines invented by man.

1. Problem

How does a steam turbine work?

Materials

Three inch cork disc, eight strips of tin ( $\frac{1}{2}$ " by  $1\frac{1}{2}$ "), flat board (4" square), long nail, test tube, gas burner, glass tube bent at right angle, rubber cork, pyrex flask, tripod.

Procedure

Assemble the materials as shown. Space the tin vanes evenly. Adjust the glass tube so the end is as close to the vanes as possible. Fill pyrex bottle half full of water. Heat the water.

Results

As the steam escapes from the end of the glass tube, it forces the cork disc around to the next vane. The process is repeated each time the vanes come close enough to the end of the glass tube. The more steam pressure developed, the faster the cork disc will turn.

Conclusions

Steam pressure can be used to do work. Some of our newest jet planes use this principle in their turbine engines. The steam turbine is capable of developing a great amount of power.

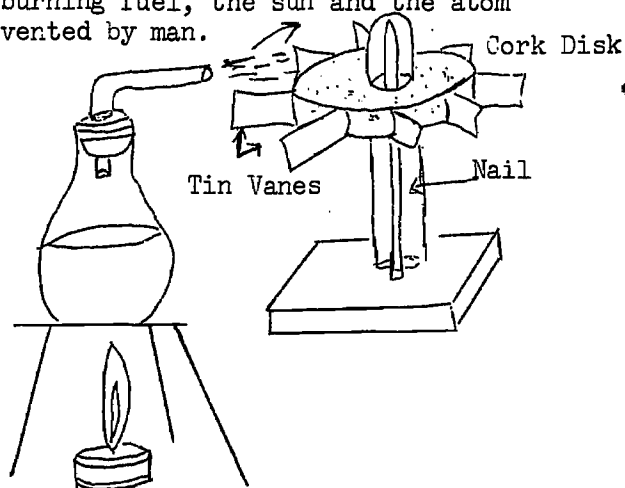

### Results

It is easier to rub the blocks together after soap has been applied.

### Conclusions

Lubrication reduces friction and makes work easier.

### 3. Problem

How can we reduce friction?

#### Materials

Two blocks of wood, oil, spring scale, two or three round pencils, thumbtacks, small weight.

#### Procedure

Have children do each activity and record and compare the results.

- a. Place a small block with string attached to tack and scale on top of large block.

Put weight on small block.

Pull scale and register reading when block begins to move.

- b. Same as (a) except that pencils are now inserted between the two blocks.
- c. Same as (a) except that a film of oil is spread between the two blocks.

### Results

The scale noted three different readings to move the same weight.

### Conclusions

More friction is evident when there are large rough surfaces. Friction between rough surfaces can be reduced by lubrication or the use of rollers.

### 4. Observe

- a. Let children take the wheels off an old roller skate to observe the bearings. Have children notice how they fit between the wheel and the axle.
- b. Put a drop of oil on a pane of glass. Ask the children to rub a finger on the unoiled part of the pane and then on the oiled part. Ask them to explain the difference they noticed.

## 2. Problem

How can we illustrate the force of steam?

### Materials

Piece of iron pipe six inches long, threaded on at least one end; rubber stopper to fit the other end; alcohol or gas burner; water; ring stand; and clamp.

### Procedure

Tighten the cap on the pipe. Place a tablespoon of water in the pipe and place the stopper in the opening. Be sure not to point the pipe at people, windows, etc. Secure the pipe to ring stand at 45° angle and heat the capped end. Let the children give their ideas about what caused the results.

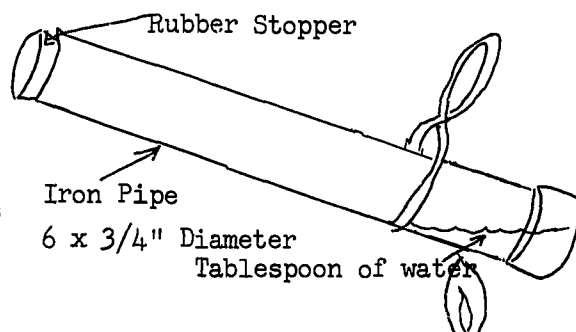

### Results

When the pipe has been heated, it generates steam which forces the stopper out with a loud "pop" and a moderately high velocity.

### Conclusions

Steam exerts tremendous force. Many machines are powered by steam.

## 3. Charts

Ask children to prepare an illustrated chart that tells how various kinds of forces help us, such as: wind - windmill; water - paddlewheel on boat; steam - steam engine; gasoline - cars; electricity - vacuum cleaner.

## 4. Observe

Place a radiometer in bright sunlight. This will show one form of energy changing to another. Ask children to find out more about solar energy and how it may be used.

## 5. Research

- a. Have children do research on how coal, electricity and gasoline have increased the usefulness of the machine.
- b. Have children find out how atomic energy is now being used as a source of power for various machines. Have them look for newspaper articles on the latest developments in this field.
- c. Have children find out what a foot-pound is and how it is used in measurement.

- d. Have children do research to find out how huge dams like the Hoover and Grand Coulee use the energy of falling water to produce electricity.

6. Bulletin Boards

Ask children to do research and exhibit their findings as drawings, pictures, etc., about scientists such as Archimedes, Samuel Colt, Henry Ford, Robert Fulton, Johann Gutenberg, James Watt, and Eli Whitney.

7. Make Models

Make a simple water-wheel to show how waterpower can be used to move things.

### Evaluation

Included here are samples of evaluation items which could be used in developing your informal testing program. These suggested types of items cover the particular science area that has been developed in this section of the handbook. This also means they could be used to help develop informal testing to cover large areas of information (monthly, mid-year, end-of-year testing). These are by no means complete tests as such. You will have to adapt and develop items to meet your particular class's own individual needs and differences.

#### Answer the following:

1. What are the three parts of a lever?  
(force arm, fulcrum, load arm)
2. What machines can be used to increase speed?  
(lever, gear)
3. What machines can be used to increase force?  
(lever, wedge)
4. What are some examples of wedges that we see in nature?  
(bills of birds, plant roots, plant shoots, snouts of some animals)

#### Underline the correct answer in each of the following sentences:

1. Friction is caused by  
a. gravity      b. things rubbing together      c. lubrication      d. using bearings
2. In an automobile, the force to turn the wheels is produced by  
a. engine      b. spark plugs      c. distributor      d. clutch
3. The force that opposes lift in a flying airplane is  
a. thrust      b. drag      c. gravity      d. push
4. The opposite to thrust is called  
a. gravity      b. pull      c. drag      d. lift

Complete the following sentences:

1. A force cannot move an object unless it exceeds the (resistance) of the object.
2. Wheels turn around on the (axle).
3. Friction between a wheel and axle can be made less by lubrication and by using (bearings [ball or roller]).
4. To move a boat forward, the propeller must push the water (backward).

Write a brief but complete answer to each of the following:

1. Explain how a liquid (such as oil) can lubricate and reduce friction.

(Molecules in solids cling to each other. Therefore, there is much friction when dry solids rub against each other. The molecules in liquids roll and slide around each other readily.)

2. Friction can often be useful. Give some examples of such cases.

(Without friction we could neither stand nor walk. We could neither start nor stop. Automobiles would slide off roads. Without friction brakes could not work. [Many other answers possible] )

A list of terms is given below. Select the term from the list that goes with each statement. Write the term in the space before the statement.

Steam	Internal-combustion-engine	Gas turbine engine
Waterwheel	Carburetor	Electromagnet Force

1. (Carburetor) supplies the engine with gasoline and air.
2. (Force) is a push or a pull.
3. (Internal-combustion-engine) burns fuel inside.
4. (Steam) water in the gaseous state.
5. (Electromagnet) needs electric current to work.

Write the number of the word group in Column A in the space before the item in column B that it best matches.

Column A

1. A push or pull.
2. Higher pressure under airplane wing.
3. Rough surface.
4. Stream of hot gases.
5. A forward force.

Column B

- (4) a. Jet
- b. Drag
- (3) c. Friction
- d. Inertia
- (1) e. Force
- (5) f. Thrust
- (2) g. Lift

## Vocabulary

One of the strongest keystones of scientific efficiency lies in its vocabulary. The scientist says things precisely, accurately, and briefly. Probably one of the greatest quarrels the science teacher may have with the elementary level teaching today is vocabulary. The science teacher can have no use for vocabulary that is not precise and accurate. Precision in vocabulary is necessary for understanding and meaning of the concept or process being learned.

The words listed below are the basic vocabulary for the indicated area of study. After each word has been introduced, its meaning is to be maintained and extended at each succeeding level of study.

axle	lift
ball bearing	load
beater	load arm
blade	lubrication
chain	machine
crank	mechanical energy
cylinder	Newton's Law of Motion
diesel engine	Newton's Third Law
drag	nuclear energy
drill	nuclear fuel
drum brake	piston
energy	pliers
external-combustion-engine	pry
force	reel
force arm	resistance
friction	rod
fulcrum	roller bearing
gasoline engine	seesaw
gear	speed
generator	steam engine
gravity	teeth
grip	thrust
internal-combustion-engine	turbine
jet	wedge
lever	weights



### Children's Books

Books are a very essential part of the instructional materials in elementary schools which provide superior learning experiences for children. The selection of these books poses a difficult problem for librarians, teachers, and administrators because the science field is broad and increasing in scope, and elementary school science programs are varied in nature. Some of the more common specific difficulties in choosing books are (1) finding materials which deal with the varied interests of children; (2) locating material which gives information correlated with the local school district's instructional guides; (3) finding books of appropriate reading difficulty; and (4) selecting the best books from the many available.

The following list gives help related to the first three difficulties presented. Indirectly, it also helps with the fourth difficulty, for the best books cannot be selected until they are located. Further, the brief annotations should be of help in determining which books may be best for a given class. Finally, time should be saved in the selection of a "best" list if some information about the reading difficulty of available books is provided. It is hoped that this list will suggest for elementary teachers books that are supplementary to basic text series, and that these books will have value either as sources of information or for recreational reading.

It is always hazardous to specify an exact grade placement for a book because of variations in pupil-reading ability in any class group, and because of different uses made of books. Consequently, the lowest grade levels for pupil-use are indicated. At lower levels these same books may be useful if the teacher reads to the children.

This list was adapted from the publication Children's Catalog (1966).

- Adler, Irving Things that Spin: From Tops to Atoms, by Irving and Ruth Adler. Day 1960 48 p. illus. \$2.39 (2-5) "Orienting the discussion in six basic facts about spinning tops, this book handles difficult concepts with clarity. By comparison with the top, the phenomena of centrifugal force, precession, and orbital motion are explained in the earth, moon, sun, stars and atoms."
- Barrow, George Your World in Motion; The Story of Energy; illus. by Mildred Waltrip Harcourt 1956 181p illus \$2.95 "Sources of energy and the ways in which it is used are graphically described and illustrated with diagrams and a few experiments. Also includes a clear explanation of the principles and future possibilities of atomic energy."
- Darby, Gene What Is A Simple Machine; pictures (by) Robert W. Friedl. Benefic Press 1961 480 illus (The What Is It Ser) \$1.80 (1-2) Contents: This is a simple machine: Levers; Wheels; Pulleys; Inclined plane; Screws; Wedge; Big machines "Written for early elementary school readers, the book depends largely on illustrations and unanswered questions to convey its ideas."
- Feravolo, Rocco Wonders Of Gravity; illus. by Robert Bartram. Dodd 1965 64p illus (Dodd Mead Wonder Bks) \$3 (4-6) "The author explains gravity in relation to matters familiar to youngsters. Included are activities to try at home, such as finding the center of gravity and producing artificial gravity."

- Froman, Robert Faster and Faster; A Book About Speed; illus. by Arnold Spilka Viking 1965 42p illus \$3 (2-4) Scientific explanations of how "snails outrun glaciers; hydroplanes outwing birds; sound travels faster than tornadoes; light, faster than satellites."
- Harrison, George Russell The First Book of Energy; illus. with line drawings and photographs. Watts, F. 1965 81p illus \$2.65 (5-7) The author "writes of what energy is; what it does; why it is important to us. Covers sound, heat electric, magnets, the sun, and the atom. Although not as exciting as a picture book or rocket launchings, it is a great deal more basic to a real understanding of rockets or almost any of the many components of our complex technology."
- Pine, Tillie S. Friction All Around, by Tillie S. Pine (and) Joseph Levine; illus Bernice Myers. McGraw 1960 46p illus (Whittlesey House Publications) \$2.50 (2-4) "Many examples from everyday activities are used to describe and explain to children the meaning of friction and its importance in the physical universe. Easily read text, animated drawings, and simple demonstrations and experiments which make use of commonplace articles and phenomena."
- Gravity All Around (by) Tillie S. Pine (and) Joseph Levine; illus. by Bernice Myers. McGraw 1963 48p illus (Whittlesey House Publication) \$2.50 (2-4) All about gravity (what it is) and how it keeps the planets in orbit, how it helps man, and how space ships will be able to escape its force. Provides numerous experiments suitable for class or home use which will benefit every child. The authors have made an unseen physical force very specific.
- Ruchlis, Hy Orbit; A Picture of Force and Motion; drawings by Alice Hirsh. Harper 1958 147 illus map \$3.50 "A provocative and informative book about some of the basic physical laws. To explain some of the phenomena of the space age, the author goes back to Newton's Laws. Discussing force and inertia, acceleration and momentum, action and reaction, gravity and resistance, the author clarifies, with very clear examples, the application of these principles in daily life. Photographs and diagrams are well chosen to illustrate the effect being discussed."
- Schneider, Herman Now Try This; by Herman and Nina Schneider; pictures by Bill Ballantine. Scott, W. R. 1947 40p illus \$3 (3-5) A "picture-science book, dealing with the different ways of moving a load. Directions are given for simple experiments that show the basic principles of friction, leverage and inclined plane."
- Sharp, Elizabeth N. Simple Machines and How They Work; illus. by Ida Scheib. Random House 1959 83p illus \$1.95 (2-4) This easy-to-read book explains the wheel, the pulley, the screw, the lever, the wedge, and the inclined plane. The author shows how they make work easier in egg beaters and pencil sharpeners, rowboats and bicycles. Deals with the oldest devices known to man and has the added attraction of describing simple and dramatic experiment that can be performed with books, marbles and rubber bands.

Syrocki, B. John What Is A Machine; pictures (by) Gregory Orloff. Benefic Press 1960 45p illus (The What Is It Ser) \$1.60 (2-4) "Explains the principles behind and many uses of the wheel, the lever, the pulley, the inclined plane, the wedge and screw, and several larger more complex machines."

Ubell, Earl The World of Push and Pull; photographs by Arline Strong. Atheneum Pubs. 1964 58p illus \$3.25 (2-5) "This science concept book on force and motion explains in clear...language the rules of push and pull: pendulums, gravity friction, buoyancy of matter, principles of the lever, centrifugal force and kinetic energy. Excellent photographs."

Wyler, Rose What Makes It Go? By Rose Wyler and Gerald Ames; illus. by Bernice Myers. McGraw 1958 64p illus (Whittlesey House Publications) \$2.75 (3-6) This book tells about the machines we ride and what makes them go, with "an explanation of virtually every mode of transportation from roller skates to rockets. Simple experiments are included to demonstrate the principles upon which inventions work. Diagrams are clear, print is large, and glossary of scientific terms, list of experimental material, and index enhance the book's usefulness."

## Films

These films are available from the Central Audio-Visual Department. Contact your building A-V Coordinator to arrange for the use of these films.

All films should be previewed to determine suitability for use with your particular class.

Building A Jet Plane 11 min. Col. Int.

This film stresses the cooperative effort of the many skilled men and women who work together to build a jet plane. We follow a jet plane from original planning through parts manufacture, sub-assembly, final assembly, ground testing, and flight testing. Finally, it is sold to an airline company.

Energy and Work 11 min. Col. Gds. 5 & 6

Works means using energy to make an object move or to make it stop moving. Energy that can be stored is called potential energy. There is potential energy stored in many things - gasoline and other fuel, hanging sandbag, a wound up rubber band, etc. The energy in moving objects is called kinetic energy. All energy can do work.

Engines and How They Work 11 min. B & W Int.

Animation and live photography are used to illustrate the principles of the common types of heat engines. Explains typical applications of the reciprocating, rotary and reaction types. Includes the automobile engine, the diesel, turbine, and turbo-jet. It provides explanation of types of engines required for use beyond earth's atmosphere.

Friction 11 min. B & W Int.

This film introduces the student to the nature of friction as a restraining force with which he must contend in everyday life. It explains the ways in which we try to increase it when it is helpful.

Friction and Its Effects 11 min. B & W Int.

Friction can help us or hinder us depending on how it is used and controlled. We are shown that when objects rub together, friction is produced - a resistance to movement, which causes heat and wear. Illustrated are the effects, uses and disadvantages of friction, and methods of controlling it.

Friction, How It Helps and Hinders 13 $\frac{1}{2}$  min. Col. Int.

Problems relating to the effects of friction and how it modifies many of our activities and devices are treated in this film. One of the Living Science Series.

Let's Look At Levers 10 min. Col. Pri. Int.

The student is shown how levers help perform work beyond the strength of man and the principles of the lever is explained with examples of machinery and games.

Machines That Move The Earth 15 min. Col. Pri., Int.

The film describes various types of construction machinery needed to make modern highways, excavations of foundations for large buildings, making of sea walls, and the building of reservoir and dam foundations. Equipment shown included drag bucket, power shovel, clam bucket, dump truck, bulldozer, motor scraper, motor grader, sheeps-foot tamper, and orange-peel bucket.

Operation Jetliner 17 min. Col. Int.

This film shows man's history of flight from the theories of Da Vinci, the historic flights of the Wright brothers, and others to the present day jet engines. Film shows behind the scenes activity of preparing the plane for a flight with its loading and unloading of baggage, mail, air-freight, and also disembarking of passengers.

Simple Machines At Sea 15 min. Col. Int.

Through the vehicle of a beautiful ship at sea, the student very quickly becomes aware of the fact that it takes only a few men, with the aid of simple machines, to sail a ship weighing a hundred tons. The lever, the inclined plane, the wedge, the screw, the wheel and axle, and the pulley are all introduced and many applications aboard ship and land are presented. The student is presented with examples of simple machines, in keeping with his everyday environment, which trade DISTANCE for FORCE and FORCE for DISTANCE.

Simple Machines: Inclined Planes 6 min. B & W Int.

A skillful combination of stop-motion photography and animation with familiar examples helps pupils recognize forms of the inclined planes, including screw and wedge plane, and to understand their function as simple machines.

Simple Machines: Levers 6 min. B.& W Int.

This film introduces the concept that the lever is a simple machine which can change the amount of force or its direction. The interrelation of force and distance is clearly presented. This film shows such familiar forms of the lever as a seesaw, nutcracker, broom and examples of more complex machines that utilize the principle of the lever.

Simple Machines: Pulleys 6 min. B & W Int.

Both the fixed pulley which changes direction and the movable pulley are examined in detail, including the block and tackle system. Effective display of motion picture techniques are used to bring out the function of different kinds of pulleys as they are seen in everyday life.

Simple Machines: Wheels and Axles 6 min. B & W Int.

This film illustrates the force and distance relationships which exist in machines utilizing the principles of the wheel and axle. The way in which working wheels of a bicycle increase force or distance is analyzed and visually demonstrated. The film examines such applications of the wheel and axle as the gear drive, belt drive and crank.

Steam Age

16 min.

Col. Int.

The film describes the development of transportation in the U.S. from the time of the Indians to the coming of the automobile. It utilizes historical re-enactments and unusual prints of the period; brings to life man's struggle to conquer the vast distance on the North American continent.

You and Machines

13½ min.

Col. Int.

Two basic machines, the lever and inclined plane, are illustrated, and their use in complex machines is portrayed.

What's So Important About A Wheel?

10 min.

Col. Pri. Int.

The film traces the history of the wheel and its subsequent development from a simple wooden cart to the modern automobile. By playing a guessing game, students are asked to identify various kinds of wheels, and are led directly into a discussion situation at the end of the film by being asked to think of other kinds of wheels and other uses for wheels.

Wheels, Belts, and Gears

12 min.

Col. Int.

An engine, a motor, or any source of power is of no use to us unless we can put its power to work. Devices we use to transfer power are wheels belts and gears. Various examples of uses of each of these are illustrated.